

## Toshiba V8700

The fault on this machine was no colour in the still picture or picture search modes, though there was some evidence of flashes of colour. As the colour was perfectly stable in normal playback, attention was paid to the still chroma stabilisation circuit – Q228, IC204 and delay line X204. Direct and delayed ( $64\mu\text{sec}$ ) signals are fed to pins 8 and 9 respectively of the i.c., the idea being that when a disturbance is detected the delayed signal is used. The output at pin 6 should be a 4.43MHz chroma signal with a burst level of around 600mV. If the burst is varying in amplitude, it can be balanced by the “still twiddler” R255. In this particular case however the burst level couldn't be stabilised. We've had this happen before, due either to the i.c. or the coupling capacitor C246. On this occasion the culprit turned out to be the delay line – proved by substitution. (The input at pin 9 of the i.c. was much lower than that at pin 8.)

S.B.

## Ferguson 3V23/JVC HR7700

Interesting to note (April issue) that others have experienced problems with the tuner/timer board due to failure of one of the TA57 transistor logic gate arrays. In the last instance we had the machine would switch to “prog set” just after being powered and refused to have anything further to do with the T/T functions, though the mechanical functions were o.k. One of the gate transistors had a collector-base leak that dragged a data line high enough to cause trouble.

S.B.

## Toshiba V9600

A couple of V9600s. The reported fault on the first one was noisy playback. So I inserted a tape which disappeared at a great rate of knots, followed by an all time record lace up. In playback there were horrible great straining noises, so the cassette was ejected – at about 90 miles an hour! It was obvious that all the motors involved were running somewhat fast, mainly due to the 14V power

rail being 22V. This was traced to failure of transistor Q902 in the d.c./d.c. converter (regulated power supply to the likes of you and I) – panel U901. A BC328 was used as a replacement – it's getting a bit like the old days when a BC109 was used as a replacement in almost every conceivable circuit.

The next machine had almost the opposite fault – it could barely turn the cassette motor, which drives the lift in the cassette compartment. This time the 14V rail was missing due to fuse F802 being high impedance. After replacing this there was very little drive, the culprit being transistor QL85 on the UT01 motor drive panel. We replaced it with a TIP31 – who was that shouted “bodge artist”?

S.B.

## Sony SLF1

Finally . . . After going on a Sony training course run by a nice guy called Rob I felt better able to tackle SLF1 faults. When ET rang up about that fault mentioned under the heading “defeat” in the March issue – the cassette wouldn't thread up – I was confidently able to tell him to change IC2 (which is the one I didn't change) instead of IC3 which issues the threading instruction. Needless to say it turned out to be IC3. You just can't win.

S.B.

## Problem with a Drum

How to make a simple head change difficult – the machine in question was a Ferguson 3V22. The head needed replacement, so I fitted a new one, then did a recording and playback. The head switching was slightly out – showing up as excessive foldover at the bottom of the picture. Out came the scope and we set the record and playback switching points. Lovely picture. Put the top on the machine and do a test card recording as a final check. Oh dear, the switching points are way off. This time they didn't want to set correctly, and even appeared to drift.

The problem had not been present prior to head change, so I thought the new head might be faulty. As

changing it was easier than thinking of another cause for the fault I went to remove the newly installed head. It was at this point that the deliberate mistake was discovered – I'd forgotten to screw the head on. No wonder the switching points were varying – the head was slowly moving around on the spindle, thus constantly altering the position of the heads relative to the switching magnets beneath.

**D.S.**

### Hitachi VT8500

Now to an Hitachi machine with a genuine fault – a VT8500 with no visual search. All other modes worked correctly, but when visual search in either direction was selected the machine went into the stop mode. It did this with both the front panel controls and the wired remote unit, so problems with the switches or the ladder network could be eliminated.

In cases like this I usually start at the microcomputer i.c. and work outwards. Not because this i.c. tends to be faulty – quite the opposite in fact. I just find it the easiest way to go about fault-finding. In this case pins 3 and 4 of the i.c., the search and reverse pins, were found to be high instead of low when visual search was selected. For once the HD44801A05 was responsible.

**D.S.**

### Ferguson 3V22

Our tea lady's grandson had posted a marble through the tape loading flap, then inserted a cassette and switched to play. The picture (after removal of the marble) and all the waveforms showed the classic symptoms of a broken head. A new drum was fitted, but the symptoms remained the same. An eagle-eyed colleague spotted that the slanted pole on the supply loading arm was not fully locating in the supply arm stopper (V-block). Although the gap was only about 1/16th of an inch, there was insufficient adjustment to take up this slack using the method described in the manual. No levers or anything seemed to be bent, and the problem was eventually solved by slackening the set screw on the take-up loading arm lever (underneath), pushing the supply loading arm slightly forward, then retightening. The tape has to run round the head properly of course!

**H.A.**

### Hitachi VT14

This machine would intermittently fail, with the "operate" light not lit. Voltage checks during the fault condition revealed that the regulators Q101, Q102 and Q103 were all off. These regulators are controlled by IC902 on the system control panel, via an inverter. IC902's power

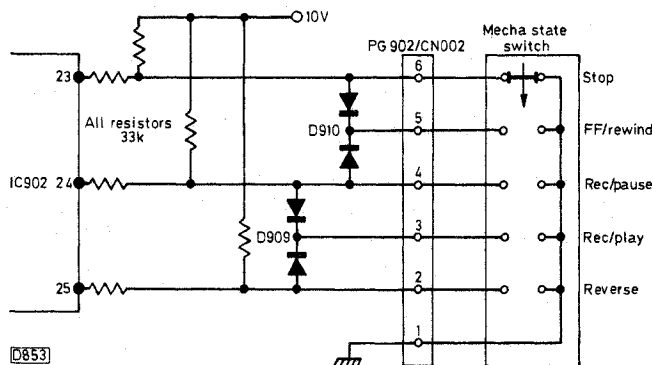

Fig. 1: Mecha state switch connections, Hitachi VT14.

control pin 3 was low instead of high as it should have been, but changing IC902 made no difference. Further checks with the machine in the stop mode under the fault condition revealed that pin 24 of IC902 was low instead of high (pin 23 should be low, pins 24 and 25 high, see Fig. 1). The mecha state switch was checked and found to be in the correct position, the fault being due to D910 being leaky. Incidentally PG902/CN002 are numbered incorrectly in the official circuit – Fig. 1 is correct.

**L.H.**

### Sony C5 and C7

The mother-in-law rang up to say that there was no sound coming out of the video (oh that it could be the other way about!). In fact the accompanying TV set produced sound when a prerecorded tape was played, but there was no sound in the E-to-E mode or with a recording made on the machine. Obviously the sound i.f. chip, a TBA120UB. A quick check with the AVO revealed that there was no voltage at pin 14, one of the input pins. This should be biased up by an internal resistor. With the machine still on, hands were placed on the board to position it ready for removal of the chip when, guess what? – sound! Bung in a 10MΩ resistor from pin 14 to the supply pin (11) and there we were. The next video in for repair was a C7. Same symptoms – and the same bodge worked again!

**H.A.**

### Remote Control Problem

I'd been handed this Ferguson infra-red remote control handset for repair during the weekend. When I opened it up on Monday I found a spare inch of wire shorting the infra-red LEDs to the supply. Remove wire and check waveform to LEDs with scope. This looked good but were the LEDs o.k.? Being infra-red, I couldn't see, and I'd nothing to try the unit out on. Suddenly a stroke of genius. Get out old monochrome TV camera and monitor and point the control unit at the camera. When it was activated, the monitor displayed white light, the TV camera's spectral response being wider than that of the human eye. Who's a clever boy then?

**H.A.**

### ITT VR3905

This machine (basically the same as the Ferguson 3V35) would load, but the capstan motor wouldn't run – except for unloading (the capstan motor also drives the reels, as with the Hitachi VT11). Checks revealed that there was no voltage at pin 3 (motor drive) of IC206, due to the motor having gone short-circuit to its metal casing.

**L.H.**

### Hitachi VT14

This machine stopped displaying timer functions only a week after delivery. The supplies to the timer board were correct, and during our investigation plug/socket 703, which links the timer and programme panels, was disconnected. The timer display then came on and continued, even after reconnecting PG/CN703. All functions were fine except that there was no channel movement up or down. Voltage checks around the programme control chip IC721 revealed that pin 13 was at approximately 1.2V instead of 10V, but the cause didn't seem to be due to anything connected with this pin. Eventually we found that C712, connected to pin 17, measured 40pF instead of 0.01μF. Replacing this capacitor restored normal operation.

**M.S.B.**

# VCR Servicing

*Mike Phelan*

Before we get down to fault finding in the 3V24/5/6, I omitted last month to mention the operation of the sawtooth generator used with the chopper that controls the supply to the reel motor drive amplifier in this machine. It employs a BA222 i.c., which we've already met used as a monostable multivibrator. For it to operate as a free-running oscillator, the input pin 5 is connected to the timing capacitor pin 1, the output being taken from this point. The squarewave that appears at pin 6 is not used.

We'll dismiss the 3V25 and 3V26 tuner/timer and charger briefly. They are very reliable but, like all portable equipment, they tend to get knocked about a bit. Nevertheless a 24/25 or 24/26 combination represents a good buy on the secondhand market if the price is right – cabinet parts are easy to obtain and are not too expensive.

## **Cabinet Assembly**

The 3V24 is, as we've seen, a very compact machine. Before doing any work it's best to remove the cabinet entirely. This is good practice when working on any equipment, to ensure that screws go back in the correct places. It's doubly important with the 3V24, as the chassis can be cracked by fitting wrong screws. Unfortunately if someone else has got there first the screws may not be correct to start with.

First remove the cabinet bottom. There are six self-tapping screws (two also secure the front feet). The front screw is longer and the rear screw shorter than the other four. Don't loose the two rubber feet. Next remove the

handle, its attachment screws, the two plated screws and the side plates. The cabinet top slides off after removing the two screws at the rear and opening the cassette lift. The front unclips. Don't loose the eject knob or the flap that covers the rear sockets. The machine cannot be battery operated with the cabinet removed.

## **Alarm Mode**

The most common fault symptom seems to be that the 3V24 goes into the alarm mode, i.e. all LEDs flashing in sequence. If this happens within six seconds or so of switching on, before any functions have been selected, check the cassette lamp. Most of the other causes of this condition relate to the solenoid control arrangements – as you'll recall, the brake and pinch solenoids are both held in by a permanent magnet and are driven electrically by a bridge circuit. Each also operates a switch to tell the microcomputer i.c. which position it's in. At switch on both solenoids are pulsed in the off direction irrespective of their initial states. If either the drive circuit is faulty or the switch doesn't operate, the alarm mode will be entered. Both the switches are rather flimsy, with open contacts moulded in a block of plastic. The metal loses its spring and the switch remains either open or closed. Usually the brake solenoid switch sticks in the closed position. Alarm is then entered when a function is selected. When the pinch solenoid switch sticks in the closed position the alarm mode is entered without a function being selected.

To gain access to the switches, take off the tracking knobs and remove the servo panel (front bottom). The brake solenoid switch is the one operated by the long bar at the front; the pinch solenoid switch is next to it, with an orange lead. Bending the contacts may work, but the switch will fail again. Replacement is best. Look out also for loose bits of mechanism due to broken plastic posts on the deck – caused by an attack of switch cleaner?

Both solenoid drive bridges give trouble. If any transistor is faulty, replace all four – X25-X28 in the case of the pinch solenoid, X21-X24 in the case of the brake solenoid. If these are defective the solenoid will be either permanently energised or repelled. The transistors are on the audio/microcomputer board and are rather inaccessible – the two bottom boards and the front one must be removed first. These devices must all be replaced with the *exact* type.

If all these things are found to be in order, check the keyscan output waveforms at pins 2, 4 and 6 of IC6 on the audio/microcomputer board – just to the left of the microcomputer i.c. (IC4). Each waveform should be 10V peak-to-peak. If one is stuck at 10V or chassis or is much reduced in amplitude, suspect IC6 – it's a buffer between the microcomputer i.c. and the keyboard.

The microcomputer i.c. itself can cause this fault, but this is unusual. Two types have been used, the  $\mu$ PD553C-066 and the later  $\mu$ PD553C-159. They are completely interchangeable. The  $\mu$ PD553C-159 has a revised program that gives certain benefits.

### Common Faults

A blank screen with no sound in the E-E mode, plus a constantly running drum motor, means that the clock oscillator has stopped. This is common with the -066 microcomputer i.c., but check the ceramic resonator first.

IC4 can also be responsible for a permanently on audio-dub LED.

If the alarm mode is entered on playback but the machine appears to be running normally, check at TP2 (drum flip-flop signal) on the servo panel. If this waveform is missing, try adjusting the pulse level control R82. Other causes are leaks in X1 and an open-circuit pickup head. A similar effect occurs when the take-up reel sensor goes open-circuit – it's located below the reel disc. Occasionally it doesn't fail completely but the machine packs up towards the end of an E120 or E180 tape, when the reel speed is slow.

Failure of the tape to take up at all points to the chopper transistor X49, the operational amplifier IC8 or the reel motor itself – 2V  $\pm$  0.3V across the motor during playback is normal. Check that the reel idler is free to move.

A very strange set of symptoms arises when the 9V fuse FS1 on the chroma panel goes open-circuit, as the 12V rail is still present. Select play and the reel and capstan motors take off, alarm is entered and the flashing LEDs are accompanied by the sound of tape being mangled.

### The Servos

Most drum servo and motor drive amplifier faults result in the drum rotating at a terrific speed (in either direction!). The most common cause is that C24 or C25 (both 4.7 $\mu$ F) in the loop filter circuit is leaky – remove them and the drum should run at the correct forward speed, though erratically. C1 and C2 (0.022 $\mu$ F) on the MDA board can also cause this. IC3 (VC1029, back to the servo board again) can also be responsible for excessive forward speed, as can a couple of its associated components, namely C34 (10 $\mu$ F) and C35 (0.01 $\mu$ F). There should be 6V  $\pm$  0.2V at pin 9 of a VC1029, as it contains its own 6V regulator.

The same remarks apply to IC5 (SFF and SREW speed control) and IC13 (capstan speed control). With these two VC1029s there will be excessive tape speed when the voltage at pin 9 is low – so much so that line lock is lost,

leading one to suspect the drum servo. The head speed is correct however, line lock being restored in the still frame and slow motion modes.

The HA11711 drum/capstan phase control i.c. can give problems but is generally reliable.

One other component in the capstan servo circuit causes trouble, C17 (0.047 $\mu$ F). It can leak or go short-circuit. It's the trapezoid (TP5) integrating capacitor – the trapezoid will either disappear altogether or be severely distorted, with rounded slopes. The result is excessive tape speed or severe wow and a noisy picture.

### Signal Circuits

The signal circuits are reasonably reliable. Picture quality with early models can be improved by changing C47 to 22 $\mu$ F, R52 to 180 $\Omega$  and replacing R62 with a shorting link. These components are on the luminance panel.

Any spillage of liquid into the machine ends up on the luminance and servo boards. Sometimes the only answer is to replace them both, as the component and i.c. leads corrode away. The LC filters on the luminance board, LPF1 and EQ1 in particular, seem to be prone to corrosion after an accident, causing either complete loss of E-E video or a negative picture (because we've altered the d.c. conditions at X6 and thus the a.g.c. amplifier in IC2).

If there's no picture, or severe limiting in both E-E and playback, the fault must lie towards the "back" end – X14, X15 or the r.f. converter. We've also had C69 (10 $\mu$ F) go open-circuit, causing cogging and field jitter, i.e. poor video l.f. response. There are lots of electrolytics in video recorders and some of them are starting to age. Don't forget to check the E-E and PB 9V rails with no picture faults – they are switched by X20/21 and, for E-E 9V, X22/23. We've actually had X22 going leaky to give E-E and playback at the same time – stereo pictures!

Most chroma faults are down to i.c.s or crystals. As always, scope the main converter first (IC2, pins 6, 8 and 9). Don't forget that if the signal is being lost at a later point on playback there'll be no gated out burst and no a.c.c. The input at pin 6 of the converter will thus be of excessive amplitude and the output at pin 9 will be severely distorted. BPF2 (4.43MHz) going open-circuit is the favourite.

### Scopes and Probes

We'll finish off by stating the importance of having a reliable, accurate scope with good probes that are correctly adjusted. X1 probes are not much use – even a 25Hz trapezoid will end up with curved sides! X10 probes must be correctly adjusted each time they're used on a different instrument, or even changed to the other Y input of the same scope. It's no use trying to look at an f.m. signal at 3 or 4MHz or so if the probe's frequency response takes a dive at 2MHz – even with a super-duper 50MHz scope. We use the Trio CS1830 scope which has a 30MHz bandwidth – adequate for our needs (up to now!). We also have some nice probes by a firm called Coline. The plugs, tips, leads and earth leads are all removable and obtainable as spares.

### Trailer

Next month a little chat on the Grundig 2  $\times$  4 Super (V2000 system) by way of a change.

## Hitachi VT9700

Intermittent no operation was the complaint with an Hitachi VT9700. At switch on all was well for five minutes after which the counter and operate light began to flash on and off though the clock remained steady. We've had problems with the voltage regulator i.c.s used in this machine. They are on the rear panel, bolted to the heatsink. In this case the 9V regulator's output was intermittent, a replacement curing the problem. **D.S.**

## Panasonic NV333

A Panasonic NV333 came in with the symptoms playback o.k., no record. In fact no stations could be tuned in with the machine in the E-E mode. The tuner proved to be faulty – only the second faulty tuner I've had in a VCR in three years. **D.S.**

## Hitachi VT8000/VT8500

There are two 1.5k $\Omega$  resistors in the Hitachi VT8000/8500 power supply circuit (syscon panel), R054 and R069. I've had both fail on several occasions, but not together. R069 has been mentioned before and gives the no record symptom as there's no not-playback 12V line when it goes open-circuit – this line supplies the tuner and the i.f. strip. When R054 goes open-circuit there's no operation, with no operation light, as the regulated 15V supply is no longer present. If you get no operation but the operation light comes on, check the 5V supply to the microcomputer IC901: I've had zener diode D055 (RD5-1EB) go short-circuit on a couple of occasions. **D.S.**

## Ferguson 3V35

The complaint with a Ferguson 3V35 was that there was no TV picture on three channels with the machine connected. Sure enough when I got there a quick check showed that with the aerial connected directly to the TV set (an old GEC model) everything was o.k. (ignoring a flat tube and half a dozen minor faults) but when the VCR was connected only BBC-2 worked, the other three channels producing a blank screen. All four channels were present in the E-E mode however. Luckily I had a Philips colour portable in the car. A quick check with this showed that all was well with the VCR – or did it? Closer examination showed that the picture was slightly noisy. In fact the VCR's aerial amplifier turned out to have marginally low gain as far as the TV set was concerned, a replacement curing the problem. Obviously something was faulty or out of adjustment in the TV set to produce a blank screen when the signal was only marginally down – in fact if it hadn't been for this the customer would probably never have noticed the slight loss of gain. **D.S.**

## Sharp VC9700

One of these popular VCRs came in with the complaint "chews tapes". On trying the machine we found that it had very little take-up torque but too much supply reel

torque. The take-up torque is adjustable but the supply reel torque isn't. To measure the take-up torque you monitor the voltage across R7783, which is in series with the reel motor. This resistor is driven by transistor Q708 which turned out to be short-circuit. **P.B.**

## Hitachi VT8500

Little did I know when my friend Geoff sent me an Hitachi VT8500 that wouldn't eject what trouble and expense it would cause. The machine wouldn't unlace and it was found that Q902 in the loading motor drive circuit (see Fig. 1) was open-circuit. The curious thing was that it turned out to be a BD131. Other transistors had been removed and replaced as well – legs were sticking out at all angles. I hate to see this sort of thing. Why can't some people be bothered to tidy up? Three i.c.s had also been soldered and may or may not have been removed. The 9V supply for this part of the circuit comes from the series regulator transistor Q060: R081 (2.2 $\Omega$ ) which is in series with this transistor was open-circuit. I replaced it with a resistor, a standard modification, but this didn't have any bearing on the main fault.

When Q902 was changed to a sturdier TIP31 the threading problem was cured. So the machine went back to Geoff with the comment that it had already received attention. Geoff phoned the following day to complain that it wouldn't wind fast forward and enquired whether I'd checked this? Well yes, play, record, rewind – but perhaps not fast forward. He also said his customer was adamant that apart from head cleaning the machine had received no servicing attention during the three years he'd had it. This time one of the transistors in IC906 (TA4193) was open-circuit. So the i.c. was replaced and Geoff took the machine back to check it for himself as a final quality control. The remote control unit didn't work due to corroded batteries and he had some difficulty in setting it for timer recordings, but apparently the customer wasn't too concerned about the timer.

A week later Geoff called with a "guess what?" comment to tell me that the Hitachi had again blown up. This time we had more accurate information. The customer had left the machine in fast forward and had subsequently returned to find it stopped and smoking. Back on the bench we found Q902 once more open-circuit and R081 burnt up. This was getting serious: it was obvious that the problem was of a somewhat unusual nature.

After replacing the defective components I left the machine in fast forward. After a while Q902 got very hot. So did IC906. This was strange as Q902 should be off for fast forward. I left the machine to cool down then put it into fast forward in order to make a few measurements. Result: there was 600mV that shouldn't be there at the base of Q902. It took some time to find the source of this voltage. Tracing back I found that it came via pins 6 and 7 of IC905 from pin 6 of IC906. Within IC906 the current was flowing via Tr4, a 265 $\Omega$  resistor, a diode and a 220 $\Omega$  resistor. Q901 and Tr1 are

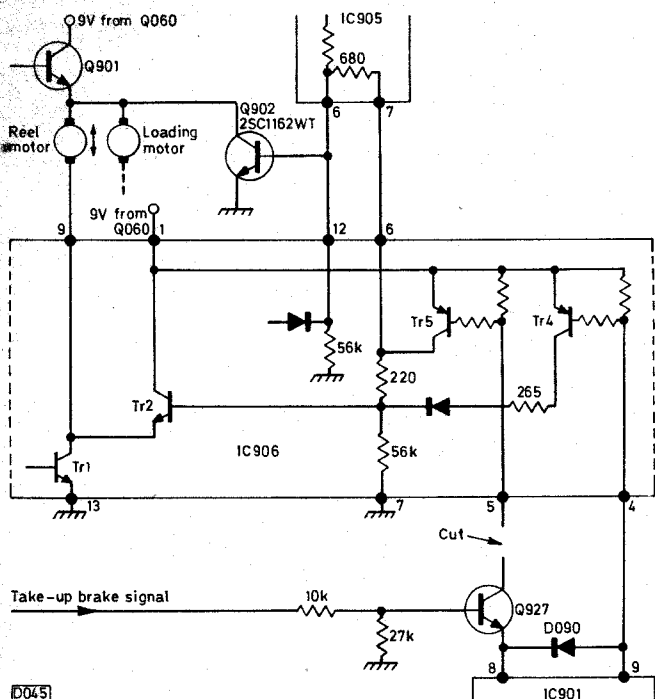

**Fig 1: Reel motor drive circuit, Hitachi VT8500. Q901/Tr1 drive the motor for fast forward; Tr2/Q902 drive the motor for rewind. Q901 and Q902 are also part of the loading motor drive circuit.**

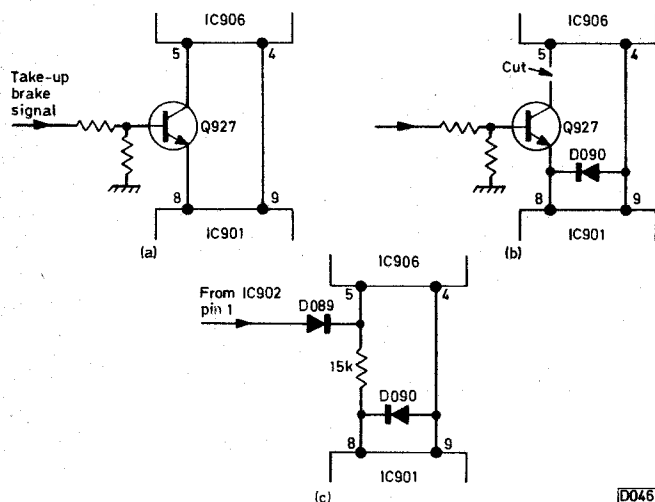

**Fig. 2: Modifications to the control circuit: (a) original version; (b) version in the faulty machine; (c) the later version.**

on for fast forward: as Tr1 heated so Tr4 turned on more until eventually Q902 turned on. At this time the only circuit I had for the machine was one that didn't show Q927: telephone calls to Hitachi confirmed that there had been modifications to this part of the control circuit.

I suggested to Hitachi that the transistor that should be used in the Q902 position, type 2SC1162WT, might have some special characteristics. It transpired that the  $V_{be}$  of a 2SC1162WT is 800mV, so some were sent for. On fitting one things were a little better, but as IC906 got hot 800mV was reached at the base of Q902 and it switched on. Cooling IC906 with freezer reduced Q902's base voltage and it switched off.

A new reel motor was tried to see if it ran without heating up IC906 too much. The temperature stability

was much improved, but not to my satisfaction as there was some 650mV at the base of Q902. Not enough margin with respect to 800mV for safety. The new reel motor was accused of consuming too much current and thus causing IC906's temperature to rise. Another new motor produced quite good results: I could run fast forward through an E180 cassette without overheating, but that 650mV was still there!

Whilst making further checks it was discovered – by accident – that if the recorder was put into the timer record mode while hot the reel motor turned in a slow rewind. This was due to Tr4 turning both Tr2 and Q902 on. As Tr2 was not fully on it got very hot.

At this point attention was directed at the circuitry around Q927, since a modification had been carried out here. The connection to the collector of Q927 had been cut, leaving pin 5 of IC906 open-circuit, and a diode (D090) had been added between pins 8 and 9 of IC901.

IC906 was replaced but the rogue 650mV persisted. Pin 4 of IC906 was disconnected and it went away. The microcomputer system-control i.c. (IC901) was next suspected and changed but we were still no nearer a solution. It was then realised that the modification had left the base-emitter junction of Q927 in circuit. Now the reverse breakdown voltage of such a junction is only 2-3V, so a leakage current path was present via D090, Q927 and the base circuit resistance. It was enough to turn Tr4 on.

Fig. 2 shows the circuit changes in this area – (a) the original version of the circuit, (b) the version in the machine in question and (c) the final version.

Whoever was responsible for the defective (b) version will probably never be known. What I do know is that the repair was carried out over a number of weeks and cost me a fortune. It cost the customer very little. I wonder who put the BD131 in? **S.B.**

### Ferguson 3V35

A one month old machine came in with the complaint "no clock display". The various supply voltages were in order but on disturbing the filament power generator subpanel, which is mounted on the reverse side of the tuner/presetter board, the display returned. Further disturbance extinguished the display but there was no visual evidence of dry-joints around the oscillator. We resoldered all the connections in this area but the intermittent fault remained. The connections inside the oscillator coil screening can were the only ones untouched: to gain access we had to remove the complete coil assembly from the board. We then spotted the cause of the trouble – a loose lump of solder on pin 6 at the base of the oscillator coil (T1) was intermittently shorting to the can. At least it made a difference from having too little solder on the connections. **K.H.-G.S.**

### Panasonic NV333

We've had several problems with this machine, as follows. **Intermittent audio erase:** Remove R4049 (4.7Ω) in the bias oscillator circuit and replace it with a shorting link.

**Intermittent chroma on record:** Connect a fast-acting diode (MA161 or MA162) between pins 11 and 12 of IC6003 on the syscon board, cathode to pin 11.

**Clock not lighting, capstan motor not turning:** No 18V regulated line due to Q1002 (2SD973) being open-circuit. **D.J.**

# VHS Hi-Fi Sound

Derek Snelling

Both VHS and Betamax machines with hi-fi sound, based on the use of f.m. and recording with rotary heads, are now available in the UK. This article deals with the system used in VHS machines, with particular reference to the Panasonic Model NV850B.

## Principles

First the principles involved. The stereo hi-fi sound is recorded on the tape as f.m. by two heads mounted on the video drum assembly. The signals are recorded beneath the normal video signal – or to be more accurate the video signal is recorded on top of the sound signals. The left and right carriers are at 1.4MHz and 1.8MHz. The arrangement of the head drum is shown in Fig. 1: the audio heads are mounted  $60^\circ$  round from the video heads and have an azimuth of  $\pm 30^\circ$  (this compares with  $\pm 6^\circ$  for the video heads). In addition, the sound head track with  $+30^\circ$  azimuth is laid down beneath the video head track with  $-6^\circ$  azimuth, thus giving a  $36^\circ$  difference to minimise crosstalk.

The sequence in which the tracks are laid down is shown in Fig. 2, starting with audio head 1 which lays down a  $26\mu$  wide track. The next head around is video head 2 which lays down a  $70\mu$  track on top of the audio one. The audio track is more strongly laid down however, using a higher record current and lower frequency. The f.m. video signal erases the upper part of the audio track but the audio is still present at a deeper level in the tape, as shown in Fig. 3. Audio head 2 next lays down a track, erasing the edge of video track 2. Finally video head 1 records its track, further erasing the edge of video track 2 and the upper part of audio track 2. We end up with  $49\mu$  wide video tracks that have  $26\mu$  wide "buried" audio tracks at their centres. Note that audio tracks 1 and 2 are not left and right: both audio signals are recorded by each head. The audio tracks are laid down at the centre of the video tracks to avoid crosstalk – if the audio track was to stray on to the adjacent video track the azimuth difference would be reduced from  $36^\circ$  to  $24^\circ$ .

The audio f.m. level on playback is lower than the video f.m. level, because of the lower frequency and the fact that the video is recorded on top. As a result, there's a danger that drop-outs may occur. To overcome this problem the f.m. detector is followed by a hold circuit which keeps the signal at the same level until the drop-out has passed. By passing the output from the hold circuit through a low-pass filter to smooth out the "kink" effective drop-out compensation is achieved – see Fig. 4.

A problem with having two rotating heads is that you must be able to switch from one to the other. For video switching the PG pulses are used. The same pulses are

used for audio head switching after being shifted by  $60^\circ$  to allow for the different positions of the heads. A further problem arises however because the switching point introduces noise. For video, the switching is arranged to occur off screen during the field blanking period. You can't do this for audio, so the hold circuit is used to maintain the audio during head switching, the head switching pulse being applied directly to the circuit.

## Practical Aspects

So much for the theory. Now for a few details of the Panasonic NV830/NV850. The sound is also recorded on the standard linear track for compatibility with other VHS machines/tapes but the linear track is mono only. The f.m.

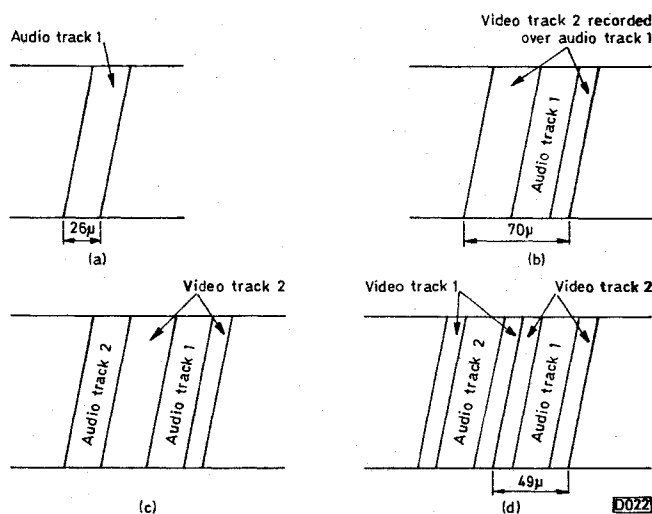

Fig. 2: Sequence in which the tracks are recorded on the tape, starting with audio head one.



Fig. 3: The audio signals are recorded at a deeper level in the tape's oxide coating than the video signals.

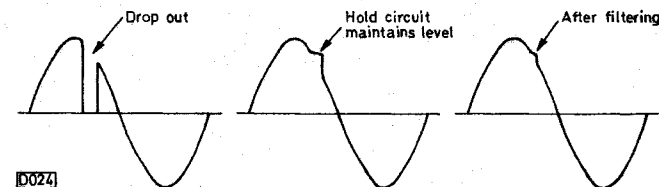

Fig. 4: Overcoming the effect of an audio drop-out.

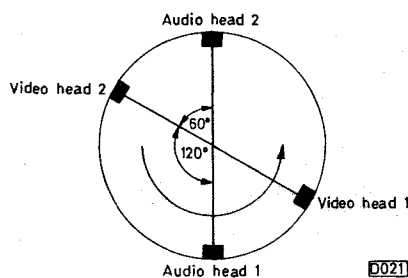

Fig. 1 (left): Positions of the video and audio heads in the drum.

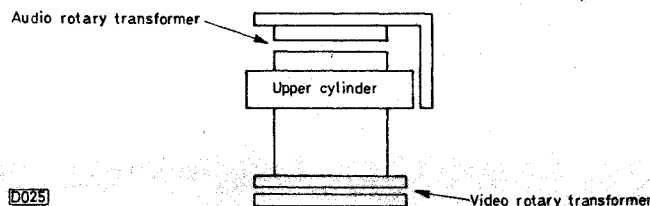

Fig. 5: Drum assembly, Panasonic Model NV850.

sound signals are passed through record level circuits that have a ganged level control with a "click" normal position: left and right record-level meters are provided. The linear audio circuit is the same as with ordinary machines. Recording can be done from the off-air TV or an external source – straight audio, a camera or a simulcast transmission (simultaneous TV and radio broadcast).

It follows from this that the machines can be used as high-quality sound only recorders. This raises a problem in that without video there's no field sync pulse to which the heads can be locked, so in this mode the field sync input to the servo is earthed and a 50Hz signal counted down from the 4.43MHz oscillator is used instead.

During record the TV set can be used to monitor either the f.m. or linear sound track – when monitoring the f.m., the E-E sound level varies with the setting of the record controls. A noise reduction system is used during both record and playback to achieve a dynamic range of 80dB. Audio dub is available but operates with the linear track only: this means that you can have a tape with a stereo track and a separate commentary on the linear track or three separate mono signals – useful perhaps for multilingual recordings. Ch. 1, 2 or linear can be separately selected during playback, which can be either via the TV set or an external sound system.

If a non hi-fi tape is played on the machine or the f.m. output from the heads drops below 50 per cent an f.m. mute circuit switches the machine to linear sound.

The f.m. sound will be affected by the tracking control of course: as the track width is narrower than that for the picture the setting is more critical – because of this one of the record-level meters doubles as a tracking meter during

**Table 1: Performance comparison.**

<i>Characteristic</i>	<i>Linear operation</i>	<i>Hi-fi operation</i>
Relative speed	23.99mm/sec	4,850mm/sec
Dynamic range	50dB	more than 80dB
Frequency response	80Hz-8kHz	20Hz-20kHz*
Wow and flutter	0-2%	less than 0-005%

\* The hi-fi frequency response is deliberately limited to 20kHz by bandpass filters.

the playback of f.m. sound (the f.m. output is fed to the meter via an a.c. to dB converter). As the audio track is in the centre of the video track, optimum audio tracking should correspond with optimum video tracking.

One of the differences between the NV830 and the NV850 is that the latter has an extra video head for super fine stills etc. Because of this the mechanical arrangement of the video/audio head assemblies used in the two machines differs. The NV850 has a separate rotating transformer mounted above the video heads for sound pick-up – see Fig. 5: the NV830 has them all combined beneath the video heads. This is probably because with five heads (NV850) crosstalk could be a problem with a combined transformer whereas with four heads (NV830) the windings can be "spaced out" more so that the problem does not arise.

### **Performance Characteristics**

Table 1 compares the performance figures for conventional linear and hi-fi sound operation.



# Twiddlers' Delight: Preset Adjustments for VHS VCRs

Derek Snelling

As anyone who's read a VCR service manual knows, it's impossible to set up or adjust a VCR without an alignment tape, an oscilloscope, a signal generator, a frequency counter and an Avometer. Or is it? Experience has shown that by carefully observing the picture and sound the following adjustments can be made on most VHS machines with no more than a blank tape and one with a known good test pattern recording:

- Drum forward and reverse search speeds.
- Drum free-running speed.
- Drum standard speed.\*
- Capstan forward and reverse search speeds.
- Capstan standard speed.\*
- Head switching points.
- Record switching (record timing).
- E-E video and sound.
- Playback video and sound.
- Video equalisation.
- The tracking presets.

For long term stability the two adjustments asterisked (\*) should if possible be done properly.

For all you twiddlers then, here's how it's done.

## Drum Speed

First the drum speed adjustments. Playback the test pattern recording. Note that drum speed changes produce a similar effect to that of a TV set's line hold control, though for different reasons. So adjust for a locked picture, setting the potentiometer at the centre of the locked range. With some machines, e.g. the Hitachi VT8000, the tracking control will operate correctly (i.e. in both directions) only with the correct drum speed setting, so check this while making fine adjustments.

Now put the machine into forward search and, ignoring the noise bars, adjust the drum forward search speed control first for a locked picture, then (fine adjustment) for best colour registration, i.e. the colour not leading or trailing the luminance. Repeat for reverse search drum speed.

## Capstan Speed

The capstan speed adjustment causes noise bars to move up or down the screen and the sound to be at the wrong speed. Adjust for no noise bars and set to the centre of the locked range. Check that the sound speed is correct.

Put the machine into forward search. The picture will have a number of noise bars – how many depends on the machine. Adjust the forward search capstan speed for stationary noise bars (note that there's no definite lock position for this adjustment, so it may not be possible to get perfectly stationary bars). Repeat for the reverse search capstan speed.

## Head Switching

The head switching point adjustments (there are two, for playback) give the effect of foldover at the bottom of

the picture if adjusted one way or field jump if adjusted the other way. Adjust for minimum foldover. Often the best method is to adjust till the picture jumps, then back off slightly, repeating this with the other preset.

The record switching (record timing) adjustment is a little more tricky. Turn the preset fully anticlockwise, zero the counter and set the machine to record. Watch the counter and each time it advances by 1 (or 2 or 5 if your machine counts fast) turn the preset one twelfth of a turn, i.e. 6 o'clock, 7 o'clock etc. When the preset is fully clockwise stop the tape and rewind to zero on the counter. Play the recording back. At some point during the recording the picture will have little or no foldover and will not be jumping. By checking the counter at this point the correct setting of the preset can be worked out. Set to this point and do a recording to check. Fine adjust if necessary.

## Preset Tracking

Now preset tracking. Record and play back a test pattern. Set the tracking control to the preset or centre position and adjust the preset control for the best picture. If the machine has slow and fast speeds, adjust the relevant presets similarly.

## E-E Video and Sound

For E-E video and sound, compare the picture and sound of a TV channel with the same channel through the VCR. Adjust the presets for the same results.

## Playback Video and Sound

Record a test pattern and play it back. Adjust the playback video and sound controls so that the playback is as close as possible to the original, being careful with the video adjustment not to get overloading on peak whites (this can give a bluish tint to peak whites or a buzz on sound).

## Video Equalisation

Video equalisation acts as a picture sharpness control. At one end you get a soft picture and at the other end a sharp picture with ringing. Adjust for the sharpest picture without objectionable ringing while playing back a test card recording.

## Warning

While all these adjustments will work as described, if more than two or three of them have to be made, particularly if they are related, it's best to use the correct test equipment and procedures as small errors in each adjustment can add up and result in a performance below par.

Finally a warning to experimenters: don't under any circumstances adjust the following controls except as detailed in the manual: white and dark clips; f.m. record level; carrier set and deviation; any colour oscillator adjustment.

## Mitsubishi HS306

Once again we've had several of these machines in the workshop for repair during the course of the month. Three of them produced an intermittently "negative" picture, similar to video overload when the E-E level is set excessively high. The cause however was dry-joints in the r.f. booster-converter. One case of intermittent no video was traced to a dry-joint in the far right-hand corner of the main board. Then a lot of machines started to come in with intermittent sound recording. Mitsubishi were contacted and said that the cause of the trouble was incorrect alignment of the audio-control head. Realignment does appear to have cured the problem. Once again however I wonder how such machines manage to leave the factory. Finally on this model a colleague traced a case of no colour on record to a faulty i.c. (IC6A0, type M51452).

D.S.

## Ferguson 3V22

The initial problem with a 3V22 was intermittent audio erasure. Nothing too serious. Clean the record/playback switches, solder the joints on the erase head and that was it. Except that on test the machine suddenly refused to perform. A quick check showed that the cassette bulb had failed. This was replaced and on the following day the machine was given a final check only to find that the E-E and playback pictures were noisy. This was eventually traced to a faulty r.f. converter. I wonder whether the other faults would have occurred in the customer's house or whether, as I suspect, they were sent specially to annoy me in the workshop?

D.S.

## Pye 65VR20/Panasonic NV370

Now to some faults on the Pye 65VR20, which of course is the Panasonic NV370. We've had two with faulty r.f. converters: one produced an intermittently snowy picture, the other no luminance or test signal after a quarter of an hour. Another machine had excessive colour on playback due to a faulty colour processing i.c. (i.c. is not really a correct description - it's an i.c. and several thick-film components on a flexible PCB which is folded in half and soldered into a slot cut into the main board).

Lastly a problem that occurred on a couple of machines after they'd been out for about two months. The symptoms were a wobbling picture with perhaps slight interference on sound, noticeable during quiet passages - similar to the effect you get when a faulty audio-control head vibrates in some Hitachi machines. While the fault seemed to be caused by vibration, the audio-control head

seemed to be blameless. We decided to phone Panasonic for help - Philips weren't considered as they haven't even been able to supply a service manual to date. Panasonic were very helpful: they'd obviously come across the problem before. The cause of the trouble is vibration from the impedance roller, caused by the tape rubbing on the washer. The cure is to remove the roller, clean and turn over the washer, lubricate the shaft and washer, refit the roller and carefully adjust the height so that the tape just clears the washer. See Fig. 1.

Whilst on the subject of Pye/Philips, we've recently taken delivery of some Philips VR6540 machines. These still use Panasonic mechanics but with Philips electronics and automatic tracking. No faults yet - but no service information either.

D.S.

## Deliberate Mistake

Did anyone else notice the deliberate mistake on BBC-2 at about 4 p.m. on January 17th? For about ten minutes they had the sound track for the test card at the wrong speed. Quite worried me for a moment when I played back a recording - I was checking for a sound fault at the time . . .

D.S.

## Sharp VC381

I've had a rush of dead VC381s recently, all with the 4A fuse blown. This has been due to either the 12V or 13V supply going up to 18V as a result of the relevant series regulator transistor going short-circuit. When replacing the transistor ensure that it makes good contact with the heatsink - often the original one didn't.

P.B.

## ITT VR3605/Ferguson 3V38

The ITT technical liaison officer gave me a useful tip on his last visit. If you've got a VR3605 on the bench with an electronic fault, once you've narrowed the fault down to a particular stage look for an open-circuit 33kΩ resistor! Apparently these resistors are rather unreliable. Here's a relevant fault we've had. The machine would play normally then suddenly stop dead, still threaded up, with the timer light flashing. This was due to R253 going high-resistance intermittently - it connects the power switch to the microcomputer i.c. (IC201) in the mechacon circuit. As a result of R253's behaviour IC201 was receiving an invalid 2.5V logic level.

For those who deal with other brands VR3605 = Ferguson 3V38 = JVC HRD110 and the same comments should apply to the VR3905/3V35/HRD120.

P.B.

## Mitsubishi HS306

The picture produced by a new machine looked as though its heads were dirty. Cleaning them (no mean task with this model) brought a reasonable picture back for a few minutes, but the fault then returned. A second go at cleaning failed to restore a good picture.

Back in the workshop I found that one head's f.m.

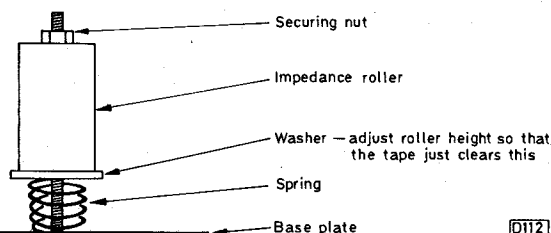

Fig. 1: Impedance roller adjustment, Panasonic NV370.

output was missing at TP2C. The head switching signal and the play 9V and record 9V lines were normal. A signal injected at the head amplifier i.c.'s input appeared at TP2C, but there was no signal here when the input was applied to the head input plug itself. The PCB track from the head was cracked – by C222. **P.B.**

### Sharp VC386

When a VC386 came in with the head drum rotating much too fast I thought I'd a power supply fault. Not so – and I'd no manual. The servo i.c.s are the same as those used in some of the older models however so a VC9700 manual was used as a guide. Luckily one of the first tests I made was on the drum FG (frequency gear) signal which was being held down. One of the coupling capacitors, C710, was short-circuit. **P.B.**

### Tatung VRH85001

This JVC clone would thread and start to run, then unthread again. The drum and capstan motors were running and there was no obvious reason for the machine to unload the tape and stop. A check around the system control i.c.s revealed the absence of the drum flip-flop signal. The drum pickup head was open-circuit. **S.B.**

### Ferguson 3V22

No colour replay was the complaint with this machine. Checks revealed that there was no output from the a.c.c. circuit in IC202 (AN305) – the signal was missing on record as well. Replacing the AN305 restored normal operation. **S.B.**

### Sanyo VTC5000

The complaint with this VCR was intermittent stopping. There was no sign of the fault when the machine was brought into the workshop, so we replaced the intermediate idler and returned it. A few weeks later the machine came back and this time we were able to see the fault. I still suspected the take-up drive – so did the microcomputer IC3001: pin 39, the take-up reel sensor input pin, had a switching waveform on it but the waveform didn't reach 0V and was only 5V peak-to-peak with a 9V supply. Pin 39 is driven by the collector of transistor Q3013 which was not being fully turned on. The reel sensor output level was 2V peak-to-peak, a bit on the low side. After removing the turntable and cleaning the optocoupler the output increased to 6V peak-to-peak. Q3013 now turned fully on and the machine worked normally. **S.B.**

### JVC HR7700

The letter that accompanied this machine was very explicit – not from one of your rain coat and wellies types. There was tracking noise that wasn't affected by the tracking control, no slow motion or still frame and occasional sound pitch variation. Being all too familiar with this model I knew that the replayed control track pulse was probably missing. It was, but came back again whilst I was prodding about. It could be heard that the sound did indeed keep fluctuating: not a lot, just every so often. The cause of the trouble was IC1, the control pulse amplifier i.c. on the servo-1 panel. It was noisy, with lumps of noise

that sometimes got into the capstan servo on its output. Fitting a new AN360 put matters right. **S.B.**

### Hitachi VT8700

This machine lost time: it was clocked as counting 72 seconds to its own minute. Obviously switched to 60Hz, so it was switched back to 50Hz with mumbles to the effect that the customer should know better. It still lost time however. A check around the clock microcomputer i.c. didn't reveal any obvious problem though there were no pulses on the Hr/Hz pin (pin 13). So the micro was changed, which is where it got a bit funny. At switch on it still counted 72 seconds to the minute. It was switched to 60Hz. After throwing the switch to 50Hz it still counted 72 seconds. Various things were blamed – diodes and the dog and Andy . . .

The Hr/Hz pin was at -25V. A diode is connected between this pin and pin 24 which was at 0V, reverse biasing the diode. It was difficult to see how the circuit worked. The diode can be changed from pin 24 to pin 25 for 12/24hr operation. This was tried and worked and the count was now correct. Change back and it's still correct. Why? Well it seems that the micro sets 50/60Hz and 12/24hr on pin 13 *when powered up*. So what I should have done was to switch to 50Hz and unplug the machine from the mains for a short while. Oh well, you live and learn! **S.B.**

### JVC HRD110/Ferguson 3V38

A JVC HRD110 rental machine had a severely damaged cassette compartment – extensive dismantling was required to replace both side cheeks. The cause of the trouble was one of the two small cogs in the pairs that drive the cassette carriage having been sheared off – one at each side that is. Once the repair had been done and the cassette compartment reinstalled for final testing the initial fault showed up.

When the operate button was pushed the machine did a shuffle with the loading mechanism and went into a very rapid rewind. Andy said that the customer had complained about this before, but had cured the problem by unplugging the machine from the mains for an hour or so.

There was no motor control signal, so both microcomputer i.c.s were blamed in turn and replaced. Still the same fault, and intermittent. After a long time spent checking various things I found that if the cassette lamp was covered the rewind didn't happen – until the machine was put on its side that is (this effect was traced to the end sensor and my bench lamp however). It was obvious that the end sensors were active, so the microcomputer i.c. must think that a cassette is in – logical things, micros. Both had been eliminated however. The micro concerned was right in what it thought – C228 which decouples the housing down detect switch turned out to be intermittently short-circuit. **S.B.**

### Special Offer!

I've a limited quantity of second-hand ex-JVC centre tolerance HR7350 (stereo/eight-event timer) VCRs for sale. I want £299.95 each for them, with a six month warranty. Anyone interested should write to me at the Newark Video Centre, 108 London Road, Balderton, Newark. **S.B.**

# Servicing Notes on the Toshiba V9600

John Coombes

This front-loader is far more prone to mechanical than electronic problems. As with most Beta machines the most common trouble is with rewind – Sanyo seem to have been the only Beta manufacturer to beat this problem. It's a great help in reducing the wear that causes the trouble if the customer uses only L250 or L500 tapes – it's seldom necessary to use a three-hour L-750 tape to record a programme.

## Poor Rewind/Playback

For poor rewind/playback first check the upper drum for wear – check for scratches or a highly polished surface with a ridge embedded in the drum. If necessary replace the drum, but be sure to check that the rubber wheel on the clutch idler assembly hasn't been chewed up – replace it if small particles of rubber are present on the surface below the idler assembly.

The next step is to connect a scope to check the playback f.m. envelope at TP101. If the waveform is as shown in Fig. 1 there's no output from one of the heads. Check that both heads are clean and that there's no dust build up due to excessive upper drum wear or maybe the use of poor quality or old tapes. If the problem persists replace the video head disc and set up with an eccentricity gauge – set to within  $1\mu\text{m}$ . When the eccentricity is correct the tracking and picture should be stable and there should be no wow or flutter.

After setting up the head disc check that the back tension is correct – if it's badly out the result will be excessive drum wear. The back tension should be 47-57 grams – if it varies by more than 10 grams from the beginning to the end of the tape replace the band brake.

If the upper drum/disc assembly has been replaced and the picture is noisy instead of clean and crisp, make a recording then play it back while checking the f.m. envelope at TP101. If the output from one head increases while that from the other falls as the tracking control is rotated the playback frequency response controls R150/R151 may need attention – check the condition of the carbon tracks. If the problem persists check the dihedral

setting (head height) which can be varied by adjusting the Allan screw on the top of the head. It's very often quicker however to replace the disc instead of working out a graph to set the head height. Adjusting the height can upset the angle of the head.

If after fitting the modified upper drum type 7037-1301 the picture is noisy in parts and the playback f.m. envelope is as shown in Fig. 2 try removing the shims between the upper drum and the support wall. This has proved to be a very successful way of getting the correct waveform (see Fig. 3). If the picture is still noisy the tape path alignment should be set up.

## Loud Howling on Playback

Loud howling on playback can be due to rubbing on the upper drum. Check the flywheel assembly – remove and clean the shaft, put a spot of oil on a cloth and lubricate the shaft then reassemble. This should clear the problem. A very dry shaft can cause sound and picture jitter.

## Squealing on Rewind

Squealing on rewind can be caused by a badly worn upper drum but is usually due to worn ceramic rollers on the guide ring. To prove this or effect a temporary cure while awaiting replacement rollers from Toshiba, turn the rollers upside down.

## Streaking across Picture

Streaking across the picture is very often caused by incorrect setting of the playback frequency response controls R150/R151. Alternatively the head disc may need replacement or, more likely, IC102 is faulty.

## Excessive Picture Jitter

Excessive picture jitter can be caused by poor tapes or a worn clutch idler assembly. Other possible causes are a faulty bearing in the drum unit or a faulty drum motor stator.

## Cassette won't Load

If the cassette won't load, check the voltage at pin 37 of IC601 while inserting the cassette in the machine. The voltage should drop from 4V to zero. If this doesn't happen check the cassette in switch S651 and that the switch lever spring hasn't dropped off. The problem can also be caused by a faulty front loading motor – first ensure that l.t. reaches the motor terminal. Also check the condition of the loading belt.

## Stops when Record/Playback Selected

If the machine stops when record/playback is selected check the setting of the leaf switch S656 and that the switch lever on the slack detector is operating correctly. It's best to check the leaf switch by replacement. Check the switch lever for being misshaped. If the auto-stop

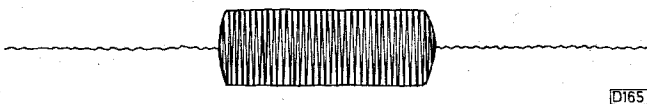

Fig. 1: No output from one head.

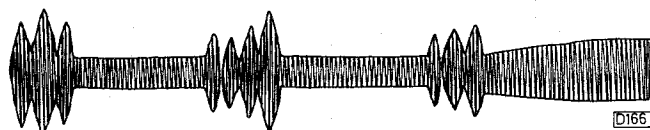

Fig. 2: Distorted f.m. playback envelope.



Fig. 3: Correct f.m. playback envelope.

doesn't operate when adjustment has been completed suspect faulty leaf switch contacts.

### **Picture Noise/Sound Wow**

In the event of noise bands on the picture and/or wow on sound, first check that the 200Hz waveform is present at TP508. If it's missing check for 200Hz at pin 1 of P503. If a 200Hz signal is present here suspect IC502 (TA75902P). Also check whether the capstan belt is dirty

or stretched. The capstan motor could be faulty. To eliminate the servo circuitry, check that the voltage at pin 7 of IC501 varies when the capstan motor is slowed.

### **Drum Motor not Operating**

If the drum fails to rotate, try rotating it by hand. If this starts the drum motor the stator is probably at fault. If the motor doesn't start the servo circuit will have to be checked.

# VHS VCR Audio/Control Heads

Derek Snelling

Many of you are probably familiar with the heads used in audio cassette recorders and may have changed one, finding no difficulty with the setting up which usually involves the adjustment of just one screw for azimuth alignment. The audio/control head assemblies used in VHS video recorders are slightly more difficult, with four adjustments that are to some extent interdependent. The purpose of this article is first to show how the two adjustments that may require alteration during the life of a head assembly should be carried out and then to provide, for the more ambitious, some guidelines on replacing an audio/control head assembly.

In the normal course of events the only adjustments required are for azimuth and tilt, to compensate either for head wear, tape wear or the fact that the manufacturer didn't set them up correctly to start with.

## Azimuth Adjustment

If the treble response on sound is lacking with prerecorded tapes and those recorded on other machines but is all right with the machine's own recordings the azimuth setting probably needs adjustment. If you have an alignment tape, use the portion with the 3kHz tone and adjust screw A (see Fig. 1) for maximum volume. If you don't have an alignment tape, use a recording made on a known good machine, the newer the better: select a recording with music and a lot of treble (violins are good) and adjust screw A for maximum treble. Note that there is no point in making this adjustment using a tape previously recorded on the machine being adjusted.

## Tilt Adjustment

If the problem is varying sound level, usually only on the machine's own recordings and often with certain tapes, the tilt may need adjustment. The cause of the problem here is that the tape is not contacting the top of the head assembly properly. This can be due to low back tension, so check this first if possible. It can also be due to a tape stretching and getting a wavy edge. If the tension is correct and the tapes aren't excessively worn, the cure is to tilt the top of the head assembly slightly forwards to improve its contact with the tape.

To do this, adjust screw B. You'll probably need a jewellers' screwdriver, and may have to clean off some of the sealing paint first. Turn the screw clockwise by no more than one full turn – adjusting any farther than this may cause the bottom edge of the head to lose contact with the tape, and as this is where the control head section is the result could be speed variation problems. To check whether the fault has been cleared, make a recording on a tape which previously showed the fault up. If the fault is still present, try further adjustment, but once a full turn in total has been made no further adjustment should be attempted – a new audio/control head assembly may have to be fitted. After making this adjustment the azimuth should be checked as previously described, with the difference that in this case the adjustment can be made

using one of the machine's own previous recordings. Note that the tilt adjustment is not made whilst playing a tape and will not "bring back" the sound on the faulty recordings, only eliminating the problem with future recordings.

## Head Assembly Replacement

Now for those brave enough to attempt head assembly replacement. If the machine has a height adjusting nut, e.g. Hitachi and Panasonic machines, removal of the head assembly complete with the base plate is a matter of undoing this and removing the assembly: unhook the spring if fitted. It's best to count the number of turns of the nut to aid refitting at the correct height. After removing the head/base plate assembly, the head assembly must be removed from the base plate by undoing screws A and C. Take care not to lose any springs. Transfer screw B from the old head assembly to the new one, counting the number of turns as you undo it and screwing it in the same number of turns on the new assembly. Refit to the base plate using screws A and C and any springs, screwing the assembly down to approximately the same height. Transfer the head PCB to the new head. Put the whole assembly back in the machine, reconnecting any springs, and screw the height nut down the same number of turns as on removal. Insert a previously recorded cassette in the machine and set it to play. Adjust the height nut for maximum sound while maintaining a locked picture, i.e. no rolling noise bar. Adjust screw A for maximum treble, then recheck the adjustment of the height nut. Screw B should not need adjusting but if necessary refer to the instructions given previously.

If the machine doesn't have a height adjusting nut – Ferguson machines for example – removal means undoing the three screws after which the head assembly can be taken out: in this case the base plate remains in the machine. Before removing it, measure the height of the audio/control head assembly above the base plate to the nearest millimetre to aid refitting. Take care not to lose the springs from under the head assembly. Transfer the head PCB to the new head assembly and fit this in the machine at the same height as previously. To adjust the height on these machines all three screws must be turned the same way a little at a time until maximum sound is

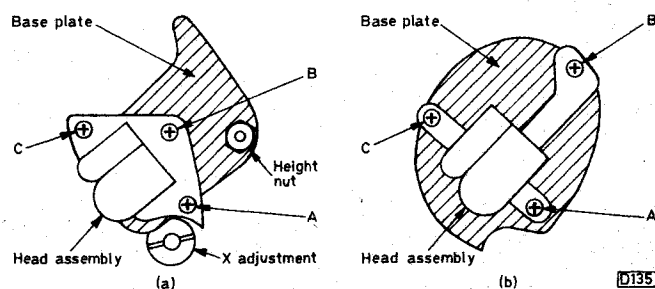

Fig. 1: Typical audio/control head assembly layouts, (a) with height adjustment nut, e.g. Hitachi models, (b) without height adjustment nut, e.g. Ferguson 3V22.

obtained. Azimuth and tilt are then adjusted as before.

The thing to remember when adjusting a new head is that the final alignment will match that of the machine on which the tape used was recorded, so be certain of the alignment of the machine whose tape you use for the

purpose.

Finally X adjustment. On some machines this is a conical screw, on others the base plate is mounted via slotted holes. In either case centre the tracking control and adjust for best picture.

# VCR Clinic

Reports from Philip Blundell, Eng. Tech., Steve Beeching, T. Eng., Derek Snelling, Michael J. Cousins, T.Eng., Dewi James and C.T. Marden

## Sharp VC9700

A fault that's becoming common on this model is tuning drift, with the clock display going dim, as the machine warms up. The tuning and display supplies are both generated on the PWB-E audio board, and we've found the cause of the fault in each case to be thermistor PR6601. It looks like a pulse ceramic capacitor and is fitted on the solder side of the board. **P.B.**

## Mitsubishi HS304

A customer's machine would play its own recordings all right but was very poor with library tapes. With the alignment tape in use we found that the f.m. signal at the output from the head amplifier was rounded off at the points corresponding with the drum entry and exit points. When the tape run along the head path was studied it could be seen to "fall off" the step in a number of places. Attention was turned to the guide rollers which were found to be loose, even though the set screws had not been disturbed. The guides were reset as per the manual and the set screws checked to ensure that they did lock the guides in position before we sealed them with paint. **P.B.**

## Ferguson 3V35/JVC HRD120

We've been having quite a few faults caused by the AL and UL switches on these and similar machines, for example the machine goes to stop one second after threading up at switch on, with or without a tape, or the machine rewinds for a couple of seconds then won't accept any further commands. Cleaning the switches has cured these faults, but it's strange to have to clean switches on such new machines.

Have you noticed that the block containing the AL and UL switches has a third switch in later models? It's connected in the cassette lowering motor circuit to prevent the microcomputer i.c. trying to eject the cassette while threaded up if it loses track of what mode it's in. **P.B.**

## Tatung VRH8400/JVC HRD120

When the operate button was depressed the operate light just flickered a bit and went out. No functions could be selected. We had visions of a complex system control fault so various checks were made to ascertain the status of the system. All the operate signals were present and correct and the "power on" signal was being passed to the power supply from the system control department. A relay in the power supply switches the supply rails: it had operated but two independent supplies were not available. The cause was the relay contacts, a new relay putting matters right. **S.B.**

## Sharp VC9100

The tape would load and the machine would run in play for a few seconds. It would then stop. The screen remained blank as the muting circuits continued to operate. All the signals that should have been present at the microcomputer i.c. were there - drum and reel rotation - and no reason for the failure could be found. So the i.c. was replaced... but the fault persisted. After much

searching we found that the AL switch was not operating, but unlike other microcomputer i.c. programs forward run was engaged. This unusual condition was misleading. The AL/VS/UL switch assembly had to be repositioned to ensure correct operation of the AL switch. **S.B.**

## Ferguson 3V22/JVC HR3320

The trouble started with fuse blowing and the 0.47Ω series resistor in the capstan motor circuit going open-circuit. It was at first thought that the associated electrolytic decoupling capacitor was going short-circuit but after a couple of weeks toing and froing the capstan motor went noisy. The bearings had failed and were going tight intermittently. **S.B.**

## JVC HR7200/Ferguson 3V29

The initial fault was that the machine would load the tape and run in play for a few seconds then stop and unlace. A check through the control circuits revealed that the reel rotation signal was missing. This was due to failure of the optocoupler, which was replaced. After completing this repair the machine was given a bench test during which a second fault was discovered: after threading up there were long delays before the pinch roller solenoid operated. This often led to unthreading via the action of the reel rotation detector circuits.

In the threading up process the tape guides are latched on to the end stops and the threading (or loading) motor carries on until the AL switch has operated. In this case however the threading motor was running out of power as the load upon it increased during the later stages of the operation and it couldn't make the final lap to the AL switch. The loading drive belt was slipping, but even after stripping out the loading mechanics and regreasing them the motor couldn't cope, so it had to be replaced. Note that removal of the threading mechanics and drum shouldn't be undertaken without due forethought! **S.B.**

## Fisher

Fisher VCR's have been known to suffer from a problem relating to the UL switch. The result is overdrive of the unthreading mechanics to such an extent that when play is next selected the machine won't run as the mechanism is jammed. The cure is to adjust the UL switch - which is made difficult by the fact that there's no provision for this! **S.B.**

## Sony SLC7

A strange sight this time - the picture pulsating sideways. I had to fetch Andy in to have a look. The left-hand side of the picture was stable but the right-hand side was moving as if the picture was being stretched horizontally.

The drum servo pulses were erratic and the sampling was thus incorrect: the problem was present in both the play and record modes. It was easiest to work in the record mode. There was a 20msec pulse, derived from the field sync pulse, at pin 12 of the drum servo i.c. (IC1) but the output at pin 13 had a duration of 80msec instead of 40msec! Clearly something was dividing by four instead of



by two. The input at pin 12 goes to a delay monostable multivibrator and then to a divide-by-two circuit within the i.c. The multivibrator has an RC network connected to it at pin 11 - R11/C11. Across C11 we had a 40msec instead of a 20msec pulse. The cause of the trouble was C11 (0.47 $\mu$ F electrolytic). The monostable multivibrator should be triggered by the field-frequency pulse after which it resets and is then triggered again. The problem was that the reset time was greater than 20msec so that it was missing every other trigger pulse and effectively dividing by two. With a second division by two introduced by the following divider the servo was being incorrectly timed. C11 seemed to be perfectly healthy but a replacement put matters right. **S.B.**

### JVC HR7650/Ferguson 3V31

This machine had an unusual fault on playback - an unstable picture, breaking up in a manner similar to a TV set with severe a.g.c. instability. The problem was where to start: most modern VCRs have progressed from mechanical record/playback switches to switching by means of i.c.s controlled by various voltage lines. It transpired that the E-E control line was energised during playback due to an emitter-collector leak in Q103 (2SB643R). This transistor is on the chroma board. **M.J.C.**

### Ferguson 3V32/JVC HR7655

This two-speed machine gave excellent results on all manually set recordings. With a timed recording however you'd get no colour on playback to start with though the colour would eventually appear. Experience has taught me that the frequency adjustments in the chroma circuitry are not usually made to a very close tolerance. A check through the various adjustments as per the manual revealed that the a.f.c. adjustment was well out of limits. Resetting R339 for  $625 \pm 5$ kHz produced correct colour with timed recordings. **M.J.C.**

### JVC HR7350

With the audio selector in the stereo position on playback the sound was accompanied by a regular blipping noise, with the selector set to A there was no sound at all and with the selector set to B there was mono sound with no blip, so the fault was clearly in one channel only. Voltage checks revealed differences between the conditions in the identical stereo sections of IC2 and IC5. We eventually found that C9 (22 $\mu$ F) in the 32dB preamplifier stage of IC2 was going short-circuit intermittently. **M.J.C.**

### Sony SLC9

The fault with this stereo machine was low, muffled sound on E-E (and hence on record) with a clicking noise coming through the monitor's speaker. A scope check on the two inputs to the record/playback switching i.c. (IC521) showed that the Ch. 1 signal was of low amplitude with disturbance present. The inputs to the preceding operational amplifier i.c. (IC520, type  $\mu$ PC1458) were in order. A new  $\mu$ PC1458 restored normal operation. **M.J.C.**

### Ferguson 3V30/JVC HR7300

No playback colour was the fault noted on the label and when the bottom audio/video board was opened up we discovered that liquid had at some time been spilt into the

machine. Unfortunately when this happens the board acts as a catchment area: the liquid lays on the component side, where its natural acidity (hopefully just fruit juice) eats through the legs of various components. In this case there were no burst gating pulses going into IC401 (AN6360): they were missing due to L407 having become a single-legged device! Fitting a replacement and cleaning off the offending dried liquid restored normal operation. **M.J.C.**

### Ferguson 3V00/JVC HR3330

The symptoms with this machine were no fast forward and intermittent picture in the playback mode. When fast forward was selected nothing happened - even the motors didn't turn - yet rewind was perfect. Playback was sometimes perfect, at other times there was a blank raster - not even noise on the screen.

We decided to tackle the fast forward problem first. From previous experience I knew that the drum motor could be operated by one of the microswitches along the front of the machine, behind the keys. Perhaps the capstan motor was switched in this way during fast forward? Fast forward was selected and each switch was tried in turn. Sure enough S4 (operate/stop) started the motor and fast forward operated normally. Careful examination then showed that due to wear on the latching bars if rewind was selected the switch operated normally but if fast forward was selected the operating lever didn't move quite far enough forward to actuate the switch. The play switch, between the other two, sometimes operated S4 and sometimes didn't. In playback this switch doesn't control the capstan motor but one of the voltage lines, via logic circuits on the mechacon board. Hence the blank screen. Luckily the wear was such that slightly bending the arm on the microswitch provided sufficient compensation. Otherwise a long job of stripping down the key mechanism would have been necessary. **D.S.**

### Panasonic NV777

In the event of intermittent non-operation of the cassette or tape loading motor replace IC6004 and IC6005 (type BA6029). There was a bad batch of these, so replace both at the same time.

C7512 (4.7 $\mu$ F, 25V) on the timer board can cause various problems - "no lights" on plugging in, time may or may not come on eventually, or the machine might switch itself off after a period of time. **D.J.**

### Sharp VC8300

Fast forward and rewind were o.k. but when play was selected the picture was in pause/still - the pause/still LED didn't light up. On investigation I found that the tape was loaded, all the motors ran but the tape was at a standstill. The pinch roller solenoid had operated, but with insufficient force to move the play idler to the engaged position. A further check showed that there was no supply across the pinch roller solenoid. On slitting the solenoid's insulation a thermal cutout was found, marked 250V, 98°C, 2A. It's not shown on the circuit diagram and was open-circuit. A replacement and a dab of Super Glue on the tape solved the problem.

This sort of thing seems to afflict the solenoids used in these Sharp models. The main solenoid is also fitted with a thermal cutout, as previous items in VCR Clinic have mentioned. **C.T.M.**

# VCR Clinic

Reports from Steve Beeching, T. Eng.,  
Derek Snelling, Philip Blundell, Eng. Tech.  
and Eugene Trundle

## Pye 65VR20/Panasonic NV370

The Pye 65VR20 is, I believe, equivalent to the Panasonic NV370, so the following fault which has come our way several times is likely to apply to both machines. The symptom is no capstan drive. This gives no fast forward, no rewind and no play, but unlike the Mitsubishi HS306 front loading and eject are not affected as a separate motor is used for these operations. The cause of the fault is the AN3822 capstan motor drive i.c. You'll probably also find that the motor supply to the i.c. is missing, due to failure of an  $0.68\Omega$  resistor. This is not shown on the circuit diagram – it feeds pin 24 of the i.c. On early machines it's fitted in place of a wire link but on later versions it's labelled as R96.

D.S.

## Faulty Eject Damping Mechanisms

A fault we've had several times recently with both the Ferguson 3V29/30 and the Hitachi VT8000 series is rapid eject due to failure of the eject damping mechanism. This is of the air-damped type and except for one tiny nylon cog is of metal construction. It's the cog that fails, splitting from the centre to the circumference. The units used on all these models are the same, so only one needs to be stocked.

D.S.

## Ferguson 3V29

The complaint with this machine was no sound in the E-to-E mode. A quick check showed that the sound was disappearing in the r.f. converter. Replacing the BA7003 i.c. in this unit cured the fault.

D.S.

## Mitsubishi HS306

No channel down was the complaint with a newly installed Mitsubishi HS306, but only when it was being operated via remote control. Channel change up and down was o.k. via the front controls, as was channel up with remote control. It's a cable remote control unit and the showroom had already checked this on another machine and found it to work correctly. A look at the circuit showed that there were only a couple of components specifically concerned with remote channel down, one of which was R712 which turned out to be missing.

D.S.

## Sony SL8000

This is an old machine. The complaint was that the whites in the picture sometimes went blue. We assumed that the customer meant the picture highlights. This could easily have been due to a fault in the modulator but in fact the deviation control needed cleaning.

S.B.

## Hitachi VT8000 Series

The modulator in this machine didn't work so a replacement was fitted. At a later date I decided to check it out as often only a series choke is open-circuit. The circuit diagram is given in the manual in the bottom left-hand corner of the tuner/i.f. page and on seeing it I was intrigued to know how power is supplied to transistors Q1, Q2 and Q6 since no direct connection is shown. Maybe this was why it didn't work! On checking through

the r.f. modulator PCB I found that the supply comes via two pins on transformer T2 – or in this case it didn't. A link soon made sure that it did. Whilst it's now o.k. for testing I won't fit it. Maybe I'll boil it . . .

S.B.

## Sharp VC9300

There was no power as the mains fuse (F9001, 2.5A) had blown. After replacing this there was no take-up spool drive while rewind and fast forward were both very slow. The reel motor was suspected at first as the drive voltage to it from pin 2 of IC7751 via the emitter-follower buffer transistor was correct. It turned out that Q7754 was open-circuit, which left just the unloading torque control resistor R7758 ( $27\Omega$ ) to chassis. This is in series with the motor: normally Q7754 would be on, which would ground the motor by shorting out R7758.

S.B.

## Panasonic Video Movie NM1

After three weeks the power supply/battery charger/modulator failed. A well known high street store quoted ten weeks for the repair, which the customer thought was unreasonable. The cause of the fault was an open-circuit resistor in the switch-mode power supply start-up circuit – R2,  $3.3k\Omega$  2W. Andy charged him £45 which I thought was extremely reasonable since it wasn't our sale and it was done in two weeks.

S.B.

## Panasonic NV333

The problem was occasional failure to record the audio track, though erase was o.k. It caused some difficulty as the fault was intermittent. In fact we checked with Panasonic's technical department to find out whether there were any problems in the audio record section. A man told me that the modification to overcome intermittent recording was to short out R4049. Ah! But this is the bias oscillator transistor's emitter resistor, and there were no erase problems. The man insisted that in the event of intermittent audio recording this modification would provide a cure. For anyone else's information, after checking D4001 and then Q4003 by replacement the fault went away.

The circuit operation here is not obvious (see Fig. 1). In the playback mode line PB is low. Zener diode D4001

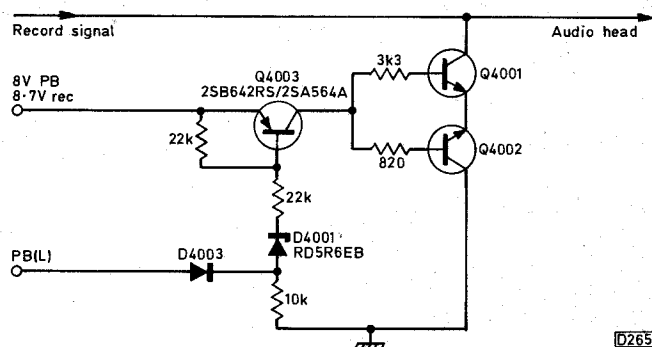

Fig. 1: Audio record/playback switching circuit used in the Panasonic NV333.

conducts and so does Q4003 since the emitter of this pnp transistor is at 8V and its base is returned to chassis via D4001. Thus Q4001 and Q4002 are on, earthing the record drive side of the audio head. In the record mode line PB is held high at 6V. This, via D4003, cuts off D4001 and all three transistors. If Q4001/2 are on in record then either D4001 or Q4003 is leaky. S.B.

## JVC HR7700/Ferguson 3V23

The tape remaining indicator came on as soon as play was selected – it should have stayed off while the VCR measured the differential reel rotation and then displayed the result as a bar segment display. In addition the tape remaining display flashed erratically. Replacing the data gate array TA2 on the tuner/timer board cleared the fault. S.B.

## Hitachi VT57

We had the same fault on two of these machines – the capstan motor intermittently stopped, with the result that unthreading took place. In the first machine the trouble was caused by a dry-joint on posistor PH1151. This removed the motor's power supply. In the second machine the motor drive switching chip IC1151 had failed. S.B.

## Ferguson 3V36

Ray was having problems with a search tuning fault on this 3V36. It wouldn't stop when it found BBC-1 though it would stop on the other stations. Investigation revealed that the sync detect line wasn't going low when BBC-1

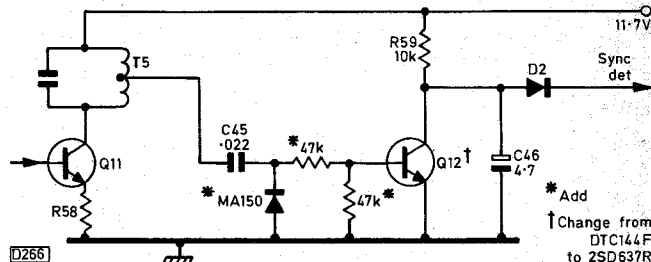

Fig. 2: Modifications to the sync detect circuit on the i.f. board, Ferguson Model 3V36.

was found, so attention was turned to the sync detecting circuit on the i.f. board. Adjusting coil T5 made the line go low on BBC-1 but then it didn't go low on BBC-2 – we also found that if the coil was tuned too far a buzz developed on sound! When I looked through past issues of *Ferguson Feedback* I found a modification for sound buzz – change Q12 to type 2SD637 and add the components shown in Fig. 2. Doing this cured the fault. What a team! P.B.

## Tatung VRH8400

A new machine straight out of the box would sometimes fail to accept a cassette fed into the front slot, due to an intermittent high-resistance contact in its “cassette housing-up” switch. Problems of a converse nature, i.e. a cassette stuck in and won't eject, have been traced to a faulty cassette housing-down switch. Strangely the equivalent JVC and Ferguson machines (Models HRD120 and 3V35 respectively) we look after haven't developed this problem – so far! The sooner Hall-effect or optical position sensors are fitted the better. E.T.

# Developments in VCRs

Part 1

Steve Beeching, T.Eng.

Two major developments in VCRs over the last year or so have been dual-speed operation, giving up to eight hours of recording and playback, and hi-fi stereo sound, with the sound signals laid down on helical tracks along with the video signal. These and other features are all part of the specification of the JVC Model HRD725 which we'll use as an example in describing recent VCR developments.

With the HRD725 JVC came up with not just a hi-fi VCR but one that has other capabilities above and beyond previous models. Apart from the hi-fi sound there are normal stereo sound tracks with Dolby, as in previous models. These tracks can be post-dubbed together as a stereo pair, or individually for bilingual use, or used to keep the original background sound with a post-dubbed commentary added.

## Six-head Drum

The HRD725's head drum has six head tips, two for hi-fi audio, two for standard video recording/playback and two for long-play video. Considerable thought was put into the use of the long-play (LP) and standard-play (SP) heads to provide noise-free visual search, still field and step-field variable playback. We'll look into all these modes of operation in some detail. I'd like to make the point at the outset that various low-cost "equivalents" of the HRD725 don't incorporate the full electronic playback processing: because of this they have noise bars in visual search and omit the variable-speed playback feature. Another point worth noting is that several machines with hi-fi sound have monaural standard audio tracks, making them non-compatible with previous stereo sound models.

The positions of the six heads in the drum are shown in Fig. 1. The audio heads are mounted 138° in advance of the following video heads. Each is 26µm thick, so the audio tracks are 26µm wide. In addition the audio heads are mounted on a plane higher than the video heads, so that the 26µm wide audio track lies within the 49µm wide

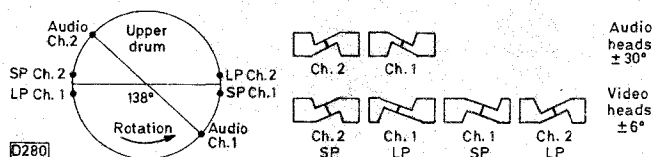

Fig. 1: Arrangement of a VHS head drum for standard/long play and hi-fi audio record/playback.

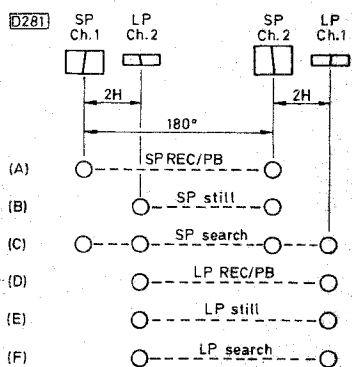

Fig. 2: Use of different heads in the various modes of operation. For SP stills one LP and one SP head is used. All four video heads are used in the SP search mode.

track traced by the following video head. The audio heads record the audio tracks prior to these being traced over by the video heads. This is one of the principles of the depth multiplex recording system used for video hi-fi sound.

The pairs of video heads are constructed as a single unit, each head having its own winding. For a reason that will become clearer later, an LP and an SP head of opposite azimuth are mounted together: they are precisely two lines apart when recording or playing. The Ch. 1 SP head is slightly thicker than 49µm while the Ch. 2 SP head is much thicker – more like 56µm (an estimate) – though each records a standard 49µm track since one head over records the excess track of the other head. To ensure this, the tape speed is such that the tape moves 49µm along during each head scan. The LP video heads are 25µm thick and record 25µm wide tracks. The advantages of having a thicker Ch. 2 SP head to get noise-free still pictures will become clearer later.

## Visual Search and Still Picture Modes

Before getting involved in the electronics, let's consider the use of the multiple heads to read the recorded video tracks in the visual search and still picture modes. Slow motion is simply the use of the capstan motor in the stepping mode to provide sequential frame displays, forward or reverse.

The head selection chart (Fig. 2) shows the differences in head thickness and gap tilt (azimuth offset). (A) shows normal record/playback, using the Ch. 1 and Ch. 2 SP heads alternately. (D) shows slow-speed record/playback, using the Ch. 1 and Ch. 2 LP heads alternately. The LP heads are also used for LP still pictures (E) and picture search (F). Noise bars are apparent therefore during the LP picture search and still frame modes. Note that it's still frame as opposed to still field.

In the SP still picture mode (B) the thicker Ch. 2 SP head is used in conjunction with the Ch. 2 LP head. The result is a still field with the same track read alternately by these two heads. This is illustrated in Fig. 3, where the advantage of using the thicker Ch. 2 SP head to cover the Ch. 2 track without missing any f.m. video signal can be seen. With the tape stationary the heads scan the tape at a more acute angle than when the tape is moving during record. The replay path is thus longer, covering at least some portion of three adjacent tracks, though the head azimuth matches only the central track. The adjacent tracks are ignored. Since it's thinner, the Ch. 2 LP head doesn't cover so much track. It can lose out at the very top and introduce noise if the tracking is not spot on. For this reason the machine's still picture quality is perfectly noise free only with its own recordings and is not necessarily clean with a library tape. This is true of most machines with still-picture and slow-motion modes.

All four heads are active in the SP picture search mode (C), in forward or reverse. At nine times normal speed each head crosses a number of tracks, some eight-nine (see Fig. 4). Each head can replay only alternate tracks since those between have the wrong azimuth. Hence the noise bar with traditional machines. The HRD725 how-

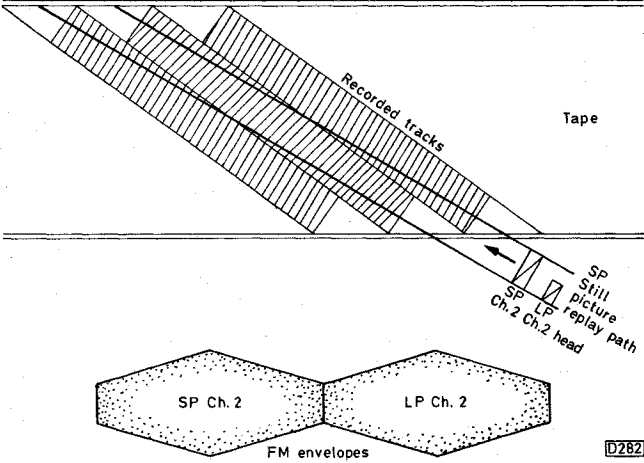

Fig. 3: SP still playback.

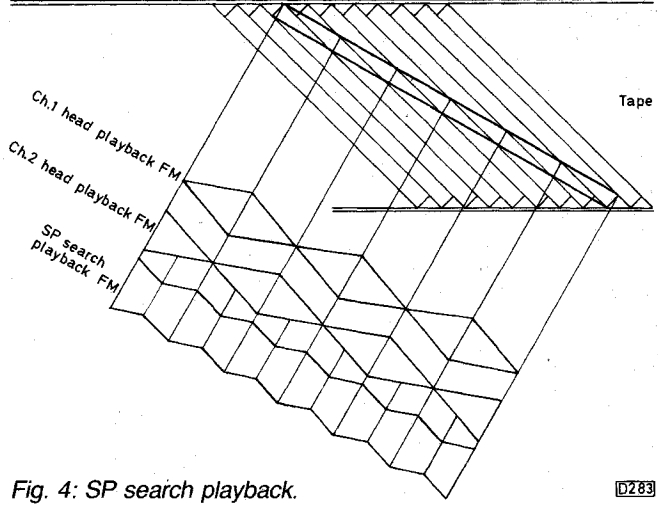

Fig. 4: SP search playback.

ever incorporates a circuit that selects the best f.m. carrier of the four at all times during the visual search mode, giving noise-free SP visual search.

**Noise-free SP Search**

Fig. 5 shows how this is achieved. Transistor switches Q1 and Q2 switch off the SP heads in the LP mode or earth the playback side of the windings in record. Q5 and Q6 provide the same action with the LP heads. For SP visual search Q1, Q2, Q5 and Q6 are all open. Selection of the outputs from the preamplifiers in IC1 and IC2 is done by the drum flip-flop signal. This is in antiphase between the LP and SP heads. IC3 selects the outputs from the SP or LP heads and routes the signal to the

playback f.m. demodulator circuitry. IC4 monitors the f.m. signals from each set of LP or SP heads: its output at pin 7 is low if the signal level from the SP heads is greater than that from the LP heads and vice versa. IC405 produces a pulse that corresponds to the peak f.m. carrier from the LP or SP heads, this pulse being used by the automatic tracking system to detect the position of the noise bar within a still picture and remove it.

The microcomputer chip IC413 controls the head switching and selection. During visual search it selects the LP or SP heads via IC419 according to the highest value of f.m. signal detected by IC4. As IC419 is clocked by the playback line sync pulses switching between heads occurs at the start of a line. The result is a noise-free SP visual search - only thin switching lines with a slight horizontal

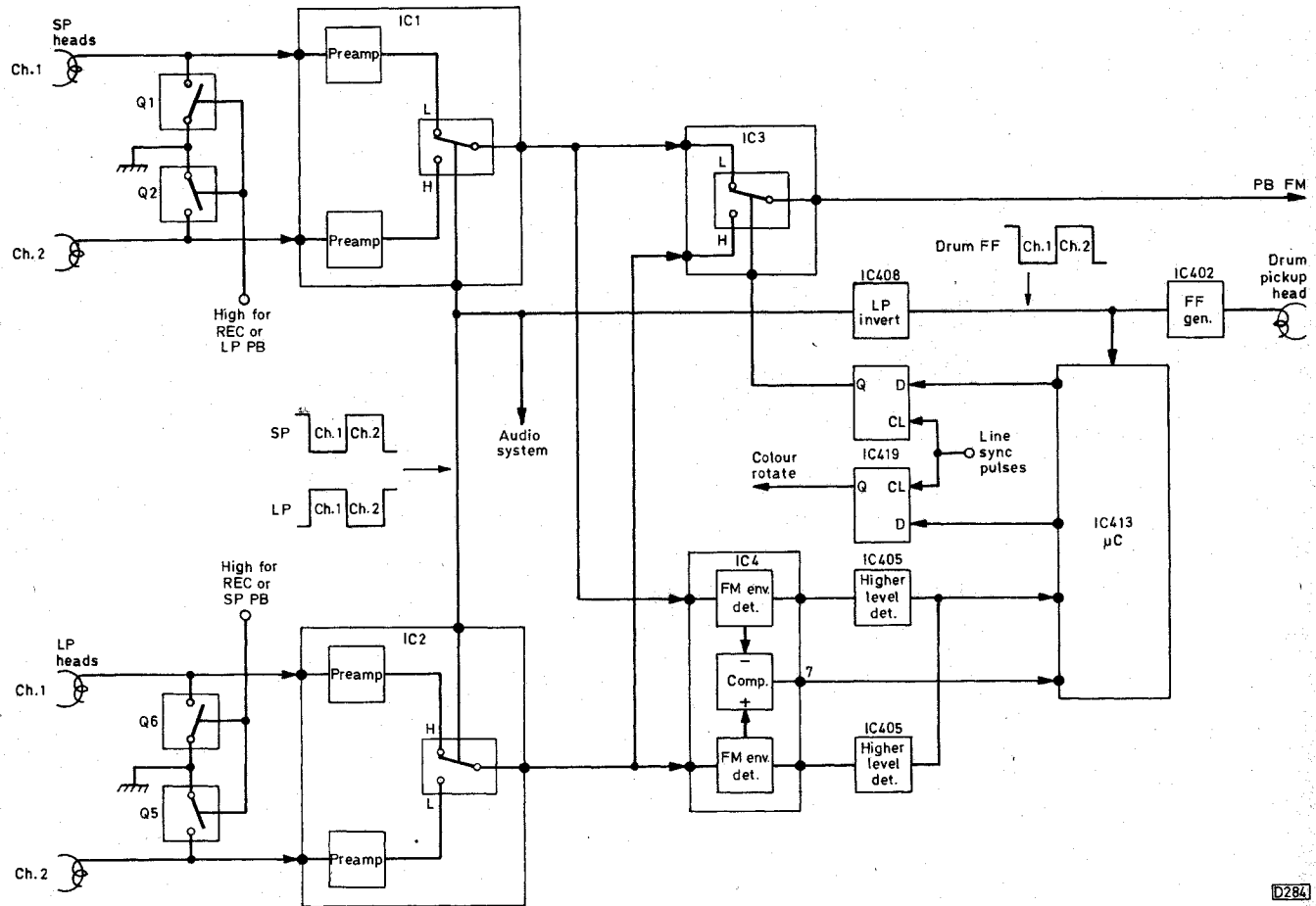

Fig. 5: Block diagram of the video head selection system.

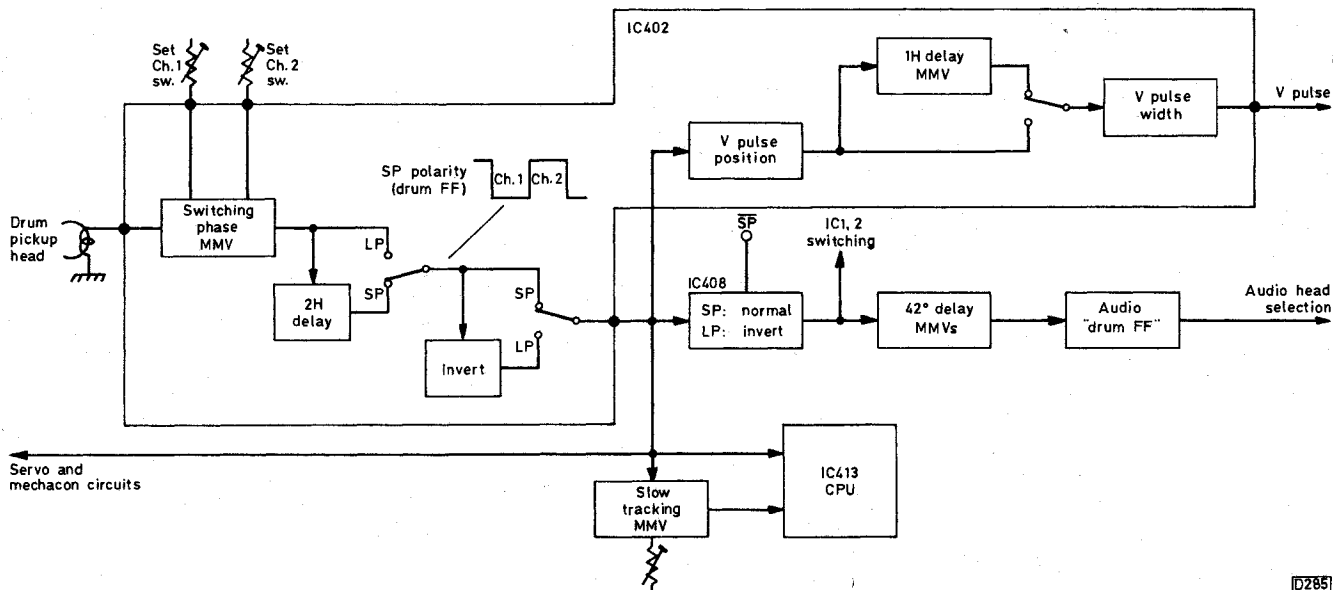

Fig. 6: Block diagram of the switch timing system.

displacement can be seen. IC413 also controls the colour phase via IC419, by issuing a colour rotate signal to the chroma circuits when head switching occurs.

### Head Switching Control

In a standard VCR the video heads are mounted 180° apart and take 40ms to complete a single revolution. Thus each head scans the tape during half a revolution, i.e. 20ms. It follows that 40ms = 360° of drum rotation and any scan angle can be expressed as an equivalent time period. The r.f. switching pulse, or drum flip-flop as I prefer to call it, is generated by the drum servo as a symmetrical squarewave. In a hi-fi/LP VCR three flip-flop trains are required – for the SP, LP and hi-fi head switching. As we saw earlier the LP heads are displaced from the SP heads by two TV lines (2H). Thus a two-line time shift is required between the SP and LP head switching flip-flops. The audio heads are displaced by a 138° advance, so a 42° delay will bring the flip-flop switching edges to the correct time.

Fig. 6 shows in block diagram form the circuitry used for this. The LP heads are the most advanced and coincide with the primary timing edges from IC402. The SP timing edges are delayed by 2H. Since the azimuths of the SP heads are opposite to those of the LP heads, inverted flip-flop pulses are required for one lot with respect to the other: the LP flip-flop pulses are taken via the inverter.

From this point the flip-flop pulse train is distributed to the other parts of the system that require head timing information. For the audio head selector circuits the flip-flop is given a 42° delay to time the edges correctly. There is also an inverter to get the switching polarity correct for audio in the LP and SP modes.

The V-pulse output circuit provides synthesised field sync pulses for use in the slow/still and visual search modes to ensure stable field locking with the tracking noise bars out of the picture area, i.e. pushed into the field sync period.

### Hi-fi Audio

For hi-fi audio recording the two left and right channel signals are frequency modulated on to two carriers at 1.4MHz and 1.8MHz respectively, the heads (see Fig. 1) having an azimuth offset of ±30°. The 26µm wide audio track is centred on (beneath) the corresponding video track as shown in Fig. 7.

Fig. 8 illustrates the depth multiplex recording principle. As the audio head has a wider gap (not track) than the video head its recording penetrates the 4µm magnetic layer on the tape to a greater depth than the corresponding video signal. The surface portion of the audio recording is then erased by the following video head as this records to a depth of only about 1µm. This leaves a two-layer magnetic recording with the audio signal below the video signal. The attenuation of the audio signal by the erasure of its top layer is only some 12dB – this varies depending on the tape energy level. Separation of the audio and video carriers during playback is achieved through the azimuth difference between the audio and video heads – the video heads at ±6° and the audio heads at ±30° “see” only their own carriers.

The f.m. deviation for hi-fi audio recording is ±150kHz. Incidentally, for Beta hi-fi the carriers are at 1.44MHz and 2.1MHz, the deviation being ±500kHz. Fig. 9 shows the VHS video and audio signal spectrums with hi-fi sound.

### Record/Playback System

The basic hi-fi record/playback system is shown in Fig. 10. The input is selected by IC5 which can accommodate simultaneous TV and f.m. radio broadcasts by allowing the machine to record TV from its tuner and hi-fi audio via an external f.m. radio input. There's a choice of a.g.c. or manual recording level, selection of the latter being indicated on an LED ladder array. The a.g.c. is of the limiter type so that noticeable variation in level with

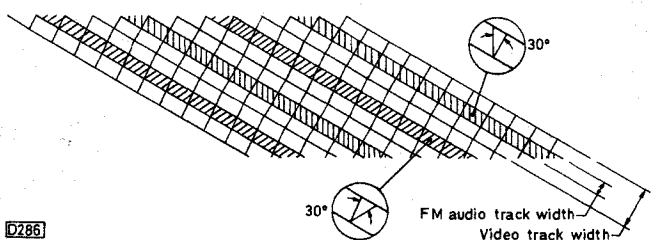

Fig. 7: VHS hi-fi track pattern.

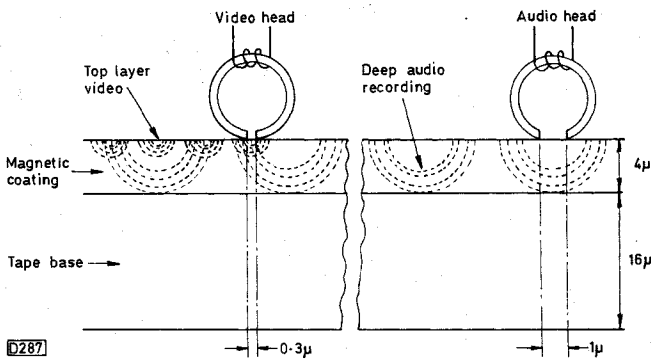

Fig. 8: The principle of depth-multiplex recording.

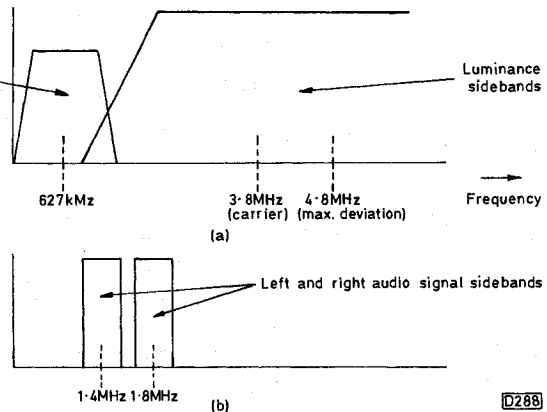

Fig. 9: Frequency spectrum for VHS hi-fi: (a) video signals, (b) the two f.m. audio signals.

sudden changes in input level – often called “breathing” – is avoided.

IC9 provides muting on power up and power down to prevent spurious noise. IC13 also contains muting control, mainly for playback purposes.

In the record mode the dynamic range of the signal is reduced by a compressor arrangement in IC15 – we’ll return to this later. Pre-emphasis is next carried out by IC12 in conjunction with the RC network connected to pin 6. The signal is then limited and passed via a low-pass

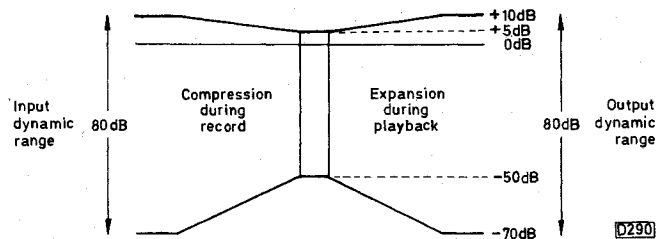

Fig. 11: Audio compression/expansion for noise reduction.

filter to the f.m. modulator in IC13. A voltage-controlled oscillator is used as the f.m. modulator. The record level control is incorporated to prevent over-recording (the f.m. modulator being driven to a deviation in excess of 150kHz). The low-pass filter cuts off at 20kHz – this reduces harmonic intermodulation, particularly from the f.m. broadcast stereo pilot tone at 38kHz. After modulation the left signal at 1.4MHz is added to the right 1.8MHz signal. The two signals are then sent to the audio heads via the record drive amplifier.

In playback the 1.4MHz and 1.8MHz signals are amplified, with a.g.c., by IC1, Q4 and Q13 and are then separated by bandpass filters before passing to their respective demodulator and dropout compensator circuits. Demodulation is performed by making use of the voltage-controlled oscillator as part of a phase-locked loop – the error signal produced by a phase comparator is the recovered audio signal. The following hold circuit eliminates audible glitches caused by dropouts and the head switching pulses – we’ll return to this. De-emphasis is then applied before the signal goes to the expander circuit to correct for the compression applied during recording.

### Signal Compression/expansion

Signal compression/expansion (see Fig. 11) is used to improve the signal-to-noise ratio significantly while maintaining an 80dB dynamic range. Compression is applied during the recording process, the playback signal being subjected to a corresponding expansion. The processes are logarithmic and a special i.c. has been developed to

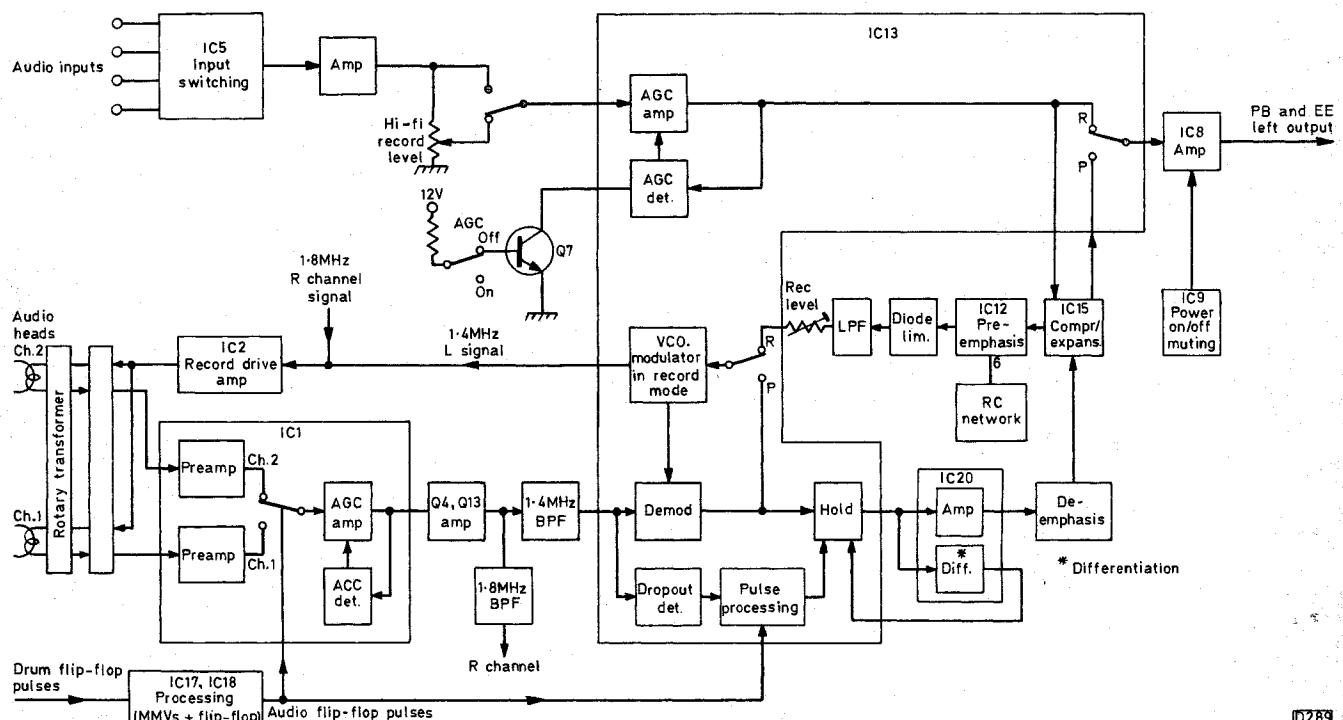

Fig. 10: Simplified block diagram showing the audio signal processing – one channel only.

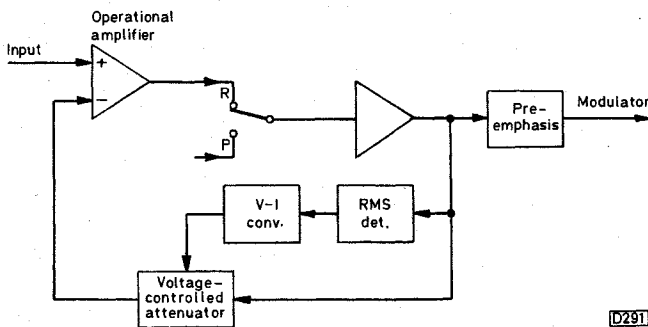

Fig. 12: Block diagram of the record compression system.

perform these operations.

In the Dolby noise reduction system only the high-frequency components of the signal are modified during record/playback. Low-level, high-frequency signals are amplified before being recorded then attenuated during playback. This reduces the tape noise level during playback. The compander/expander used in the JVC HRD725 works at all frequencies and signal levels, the frequency response being tailored by the pre-emphasis/de-emphasis networks. It provides a 10dB compression/expansion of the signal for every 60mV change with respect to a set 0dB level.

A block diagram of the record compression system is shown in Fig. 12. The input signal is applied to the non-inverting input of an operational amplifier, then to a further amplifier, before being subjected to pre-emphasis. Compression is carried out by applying feedback to the inverting input of the operational amplifier. A voltage-controlled amplifier/attenuator (VCA) is included in the feedback circuit. It's controlled by an r.m.s. detector which converts the level of the audio signal to a d.c.

control voltage. This is transformed to a control current to control the gain of the VCA.

During playback the VCA is in series with the signal path (see Fig. 13). It now works in reverse to the record mode. All frequencies that were compressed are expanded with the result, in conjunction with the pre-emphasis/de-emphasis applied, that tape noise is reduced over a much wider frequency range than that achieved with Dolby. It's not unlike the DBX system.

An r.m.s. (root mean square) detector is used since neither a mean-level nor a peak level detector will give an accurate output when a complex signal input is applied. What the r.m.s. detector does is to take the peak value of the input, square it, then take the square root of the mean value of successive squared peaks to produce an "effective value" output.

## Audio Head Switching

The drum flip-flop pulses are used to switch between the outputs from the two heads during playback. This is done to eliminate noise from the head not actually scanning the tape. As the audio heads lag the video heads by 42° the drum flip-flop pulses cannot be used directly to carry out the switching. Two monostables triggered by the drum flip-flop pulses are used in conjunction with a flip-flop multivibrator to introduce the 4.7ms delay required for the switching pulses.

## Dropout System

If a tape dropout occurs the level of the playback audio f.m. carrier falls to a level where it's insufficient to recover the audio without distortion or noise. Further noise and distortion occur during the switching between the outputs



of the two heads. Both dropout and switching noise must be removed without affecting the quality of the sound reproduction. This is done in IC13 (see Fig. 10). A switched hold circuit is used. In the event of a dropout the hold circuit, activated by a pulse from the dropout detector, holds the demodulated audio level at about 75 per cent of peak level for the duration of the dropout. De-emphasis and filtering smooth the effect of this hold action. Filtering is assisted by differentiating the audio signal and feeding the result back to the hold circuit. The audio flip-flop pulses are used to activate the hold circuit during the head switching periods.

As a check on the quality of the sound I've recorded the output from a compact digital disc on the tape. It's

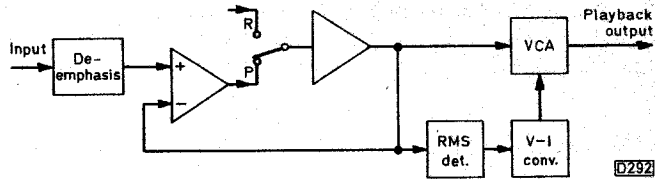

Fig. 13: Block diagram of the playback expansion system.

difficult to tell the difference between the output from the disc itself and that obtained from tape playback. In fact the system works very well.

Next month we'll look at the long-play system in more detail.

# VCR Clinic

*Reports from Christopher Holland,  
Philip Blundell, Eng. Tech., Les Harris,  
John Cahill and Eugene Trundle*

## JVC HRD120/Ferguson 3V35

With the exception of the troublesome cassette loading mechanism, mechanical problems have been virtually non-existent with this generation of JVC machines. So when I was confronted with the "no fast forward or rewind" condition I was inclined to suspect an electronic fault. On these machines fast forward and rewind drive are provided by the capstan motor, the direction being altered by reversing the polarity of the voltages at pins 1/2 of connector 28 on the main servo/mechacon panel. A check here showed that no voltage was present, and since the front indicators lighted when the relevant function was selected I felt that the operation i.c. and the microcomputer chip were probably in order. The main suspects were Q206, Q207 and IC206 which functions as a series of switches controlled by the microcomputer i.c. These switches route the capstan motor current in the required direction, the current being supplied by Q207.

Since the switching control voltages appeared to be correct the voltages at pins 2 and 8 of IC206 (input from Q207) were checked and found to be absent. Q207 was checked out of circuit and appeared to be fine so IC206 was replaced. This seemed to do the trick but while the spools turned in the fast forward and rewind modes when asked to do so they did this very slowly. It turned out to be my fault: when I replaced Q207 and refitted its heatsink I somehow managed to break the print to its collector. A few minutes spent with the soldering iron and everything was once more in order.

I've since had a further problem in this area. A machine intermittently damaged tapes because they were not being wound back into the body of the cassette during

unloading. Checks in the drive circuit just mentioned showed that adequate voltage was being made available to the drive motor at all times, so the belt that transmits this drive from the motor was checked. It turned out to be o.k. Consistent loading torque was restored only after fitting a new motor.

C.H.

## Ferguson 3V29

A slow, rolling noise bar appeared every few seconds during playback. I've encountered the symptom on a number of occasions, due to the capstan servo not locking because the control pulses are missing. Cleaning the control head normally provides a cure but on this occasion a scope check showed that the problem was in the drum servo – a trapezoid with no reference pulse was present at TP4.

I'd encountered this once before and a note in the corner of the circuit mentioned that the cause had been an open-circuit tracking control. Not this time however: the control declared its innocence when checked with an ohmmeter. Checks were next made around IC3 (HA11711). This showed that pulses were absent at pin 10. So the i.c. was very carefully removed – I've falsely accused HA11711s before. Sure enough a replacement i.c. made no difference.

Further checking finally brought me to the record phase switch preset R35 – its wiper had somehow become pushed in and no longer made contact with the track. Since the video heads appeared to have been changed at some stage I can only presume that the wiper was

dislocated by someone going through the head alignment procedure.

C.H.

### JVC HR7200/Ferguson 3V29

The card simply said "no picture" and my immediate reaction was that a simple head cleaning job would be all that was required. At switch on I was confronted with a blank raster however. As a first step I checked the camera/TV switch – most customers seem to flick this to the auxiliary position whenever anything goes wrong – but this one was in the correct position. I then noted that the channel indicator lights were o.k., and when the monitor's volume control was turned up there was good E-E audio. Off with the top cover for a quick check for foreign objects in the mechanism, then a check with the test tape. This showed that I could forget about head cleaning – a grey, unmodulated raster appeared, similar to that in the E-E mode.

Having confirmed that Ch. 4 was showing its test pattern a scope check was made at pin 24 of IC201. A good signal was present here but it was not re-entering the i.c. at pin 13. At this point I came unstuck because the circuit ceased to resemble the diagram. Then from the recesses of my mind I recalled a modified and revised diagram that JVC had kindly supplied some while back. This soon led to Q221, which had gone open-circuit base-to-emitter.

C.H.

### Sharp VC9700

These machines are renowned for not recording the sound every time. Changing the relays will often effect a cure but Sharp recommend changing C648 to 0.01 $\mu$ F and R693 to 10 $\Omega$  (0.25W) as well.

P.B.

### Sharp VC581/2/3

The loading motor circuit in these machines has been modified to prevent intermittent system control faults such as won't play after going into search, the LED lights up when a function command is given but the machine won't carry out the command, and the mechanism won't go to a given position. The modification is simply to remove C8001 (47 $\mu$ F) which is connected across the loading motor – on PWB-W.

P.B.

### ITT TR3913

Rewind and fast forward were o.k. but when play was selected the play LED lit, the brake solenoid clunked and nothing else happened. The cause of the problem turned out to be the cassette lamp – the vibration when the brake solenoid pulled in interrupted the lamp's filament – but only on playback! Which fool took this machine back to the workshop for a new cassette lamp . . .

L.H.

### Ferguson 3V29

The machine was tried out after fitting a new cassette lamp. A recording was made and this played back all right. The machine was stopped, rewound and playback was then selected again – but this time the pause, audio dub and play LEDs lit! As the fault was found to be intermittent the mechacon panel was replaced in an attempt to speed up diagnosis. This made no difference and control via the remote handset was found to give

correct operation. So the playback switch was replaced. This cleared the fault, though an Avo check on the switch failed to show the suspected high resistance. As a check the switch was fitted to another machine – the fault then showed up on this one!

L.H.

### Mitsubishi HS303

No sound erase, intermittent sound recording or no sound at all seems to be a stock fault on this machine though I've not seen it mentioned in VCR clinic. The cause is plug VK: Mitsubishi recommend soldering the wires straight to the print.

J.C.

### Mitsubishi HS302

The fault was noise bars on the screen after about two hours use. As the machine was completely enclosed in a timber cabinet I suspected heat to be the cause of the problem. A lot of time was wasted in the workshop before I found, using a hairdryer and freezer, that IC402 was faulty.

J.C.

### Fisher FVHP615

This machine ejected the tape immediately and there was no rewind. Examination showed that the tape was spilling out of the take-up spool because the take-up pulley was jamming under the chassis. A drop of oil on the pulley bearing cured the problem.

J.C.

### Mitsubishi HS303

The customer complained of a whirring noise and wobbling picture. It turned out that the capstan flywheel has a type of rubber glued to the bottom: some of this was loose and was rubbing as the capstan rotated, causing the noise. The wobbling was due to VR4A0 in the drum servo being misadjusted.

J.C.

### Toshiba V57

This machine was dead and on examination the mains fuse, located in a plastic box, had shattered. The cause was a short-circuit mains filter capacitor (0.022 $\mu$ F, 250V). I later discovered that children had been switching the machine on and off continuously with the remote control unit. Presumably this had produced spikes to cause the fault.

J.C.

### JVC HR3660/Ferguson 3V16

This one would apply to any Ferguson/JVC piano-key machine. The problem was no colour in record or playback, first intermittent then permanent. Checks showed that the chroma signal was reaching pin 13 of IC202 (AN305) which contains, amongst other things, the a.c.c. circuit and the main mixer, but there was no output at pin 11. Burst gating pulses were present at pin 1 but there was obviously no chroma feedback to pin 15. The voltage at pin 11 was abnormally high at around 10V. A bypass capacitor connected between pins 13 and 11 didn't restore colour – until pin 11 was disconnected from the print! The chip was faulty, with a low-impedance path from pin 11 to some signal-earthly point within the device. It's important to set up R216 (converter balance) and R335 (a.c.c.) when IC202 is replaced.

E.T.

# Developments in VCRs

## Part 2

Steve Beeching, T. Eng.

The first long-play VHS machines were introduced in 1983. For long-play operation the tape is run at half speed (11.7mm/sec). This has several implications. First the track width is reduced by half, from 49 to 25 microns: as this reduces the signal-to-noise figure new noise reduction techniques have been adopted. Secondly for stable playback in the long-play search modes special "jump" circuits have been designed. Further luminance signal correction is used to reduce h.f. noise.

### LP Track Characteristics

The characteristics of the LP track are determined by the slower tape speed and the extra set of LP video heads fitted to the dead drum. In some early models the LP heads were mounted at an angle of 70° with respect to the standard-play heads, though in later models the two sets of heads are mounted on single assemblies as described in Part 1 last month.

With standard-play VHS operation the tracks are laid down side-by-side with a 1.5 TV line offset between the start of each track to ensure that lines with the same colour phase lie next to each other on adjacent tracks and that the line sync pulses on adjacent tracks line up. It's not possible to achieve this symmetry in the LP mode, due to the effects of tape speed and track angle. Fig. 1 shows the difference between the SP and LP tracks: you can see that with the LP tracks shown at (b) the 0.75 line offset (half the 1.5 line SP offset) results in the adjacent line patterns being displaced. The adjacent colour phasing is also displaced: whereas lines 2 and 316 in the SP mode carry the same PAL phasing the correlation between lines 2 and 316 is shifted by 0.75 of a line in the LP mode.

The standard colour crosstalk system used in VHS machines will cope with colour crosstalk in the LP mode but extra measures are required to eliminate the increased luminance crosstalk.

### Picture Search

The main problems occur during picture search however, when due to the increased linear tape speed a video head will cross over a number (usually around five) of its own video tracks as it traverses the width of the tape. In the SP mode the line sync pulses replayed by a video head as it crosses the tracks it recorded occur in regular order – with drum speed correction – at 64µsec intervals. Picture search at the same speed will with LP tracks produce line sync pulses that are by no means at 64µsec intervals: without correction the result will be considerable picture skew (sideways pulling).

A section of recorded tape is shown in Fig. 2: the upper edge of the tape is to the right and the lower edge to the left (the slanting recorded tracks are shown horizontally to make things clearer). A ch. 1 head is shown scanning across the tracks in the forward picture search mode. The burst phase is 135° on lines shown as clear blocks and 225° on lines with diagonal-line shading. In this example the head crosses over four of its own recorded tracks.

The top line of the timing part of the diagram, line (1), shows the original signal – it's a reconstruction of the replayed lines and colour phases as the head crosses over its own ch. 1 recorded tracks, i.e. tracks 1, 2, 3 and 4. You

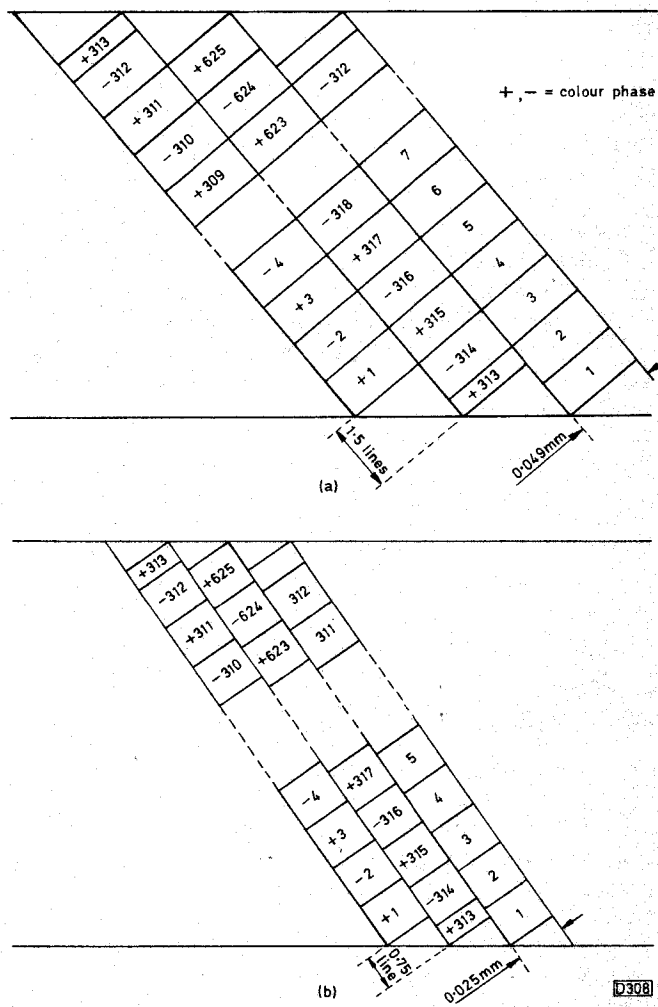

Fig. 1: SP (a) and LP (b) track characteristics.

can see that when demodulated the replayed TV lines do not occur at regular  $64\mu\text{sec}$  intervals – the irregularities are in fact at half-line intervals, i.e. the small squares of original signal are half a line long. Line (3) shows how the line sync pulses are replayed. It should be clear then that without correction there will be severe line pulling in the LP cue and review modes, due to the half-line errors in the video signal.

Correction of the half-line error is done by producing a half-line (0.5H) jump pulse. A data signal is derived from a phase-locked oscillator working at twice line frequency: when the output from this oscillator is divided by two the signal shown in line (2), a symmetrical squarewave, is produced. This signal is compared with the replayed line sync pulses in a clocked bistable. If the data signal is low when the bistable is clocked by a line sync pulse the output is low: if the data signal is high when the clocking occurs the output is high. With a clocked bistable the input level appears at the output which remains in this state until the next clock pulse arrives. This arrangement provides the 0.5H jump pulse shown in line (4).

A half-line delay is included in the playback signal path. The 0.5H jump pulse controls a switch which selects direct or delayed signals alternately – with line sync pulses as shown in lines (3) and (5). After the switching a corrected output with the errors removed is obtained.

Two methods of obtaining an 0.5-line delay have been used. The earlier method was to f.m. modulate the video on to a 14MHz carrier, feed it through an 0.5-line delay line and then demodulate it. Fairly crude, but don't forget that we're in visual search! The second and more up-to-date method is to use a 423-bit CCD serial delay line, clocking the signal through this with a 13.3MHz clock signal. 13.3MHz is equivalent to a period of  $0.075\mu\text{sec}$ : clocking 423 bits at  $0.075\mu\text{sec}$  is  $0.075 \times 423$  which is  $31.8\mu\text{sec}$  or about half a line.

If the composite video signal is being switched by a half-line period clearly the colour phase must be inverted to compensate – otherwise the PAL signal will have half a line in one phase and the second half in the other phase. To prevent this happening and to synchronise the colour phase with the video signal switching a 1H jump pulse is produced by the jump pulse generator.

Fig. 2 also shows a simplified block diagram of the above arrangements. The jump pulse generator produces the half-line frequency jump pulses from the replayed line sync pulses and the 1H jump pulse from the 7.8kHz colour ripple signal. The circuitry is usually contained within one or two i.c.s.

**Noise Reduction**

A video noise reduction system is used to improve the signal-to-noise performance. The noise to be reduced is low-frequency f.m. crosstalk between tracks – frequencies in the range 1-2MHz, forming the lower sideband of the video f.m. carrier. The  $\pm 6^\circ$  azimuth offset of the two video heads is used to reduce the pickup by one head of the other head's f.m. carrier, but the technique becomes less effective at the lower frequencies. Hence the need for the noise reduction system.

The technique used is to shift the f.m. carrier recorded by one head by 7.8kHz. The ch. 1 head records the normal 3.8-4.8MHz f.m. signal: the ch. 2 head records this with a 7.8kHz shift. Now when the ch. 1 head replays residual ch. 2 f.m. picked up from either side as crosstalk the crosstalk signal has a 7.8kHz shift – half line fre-

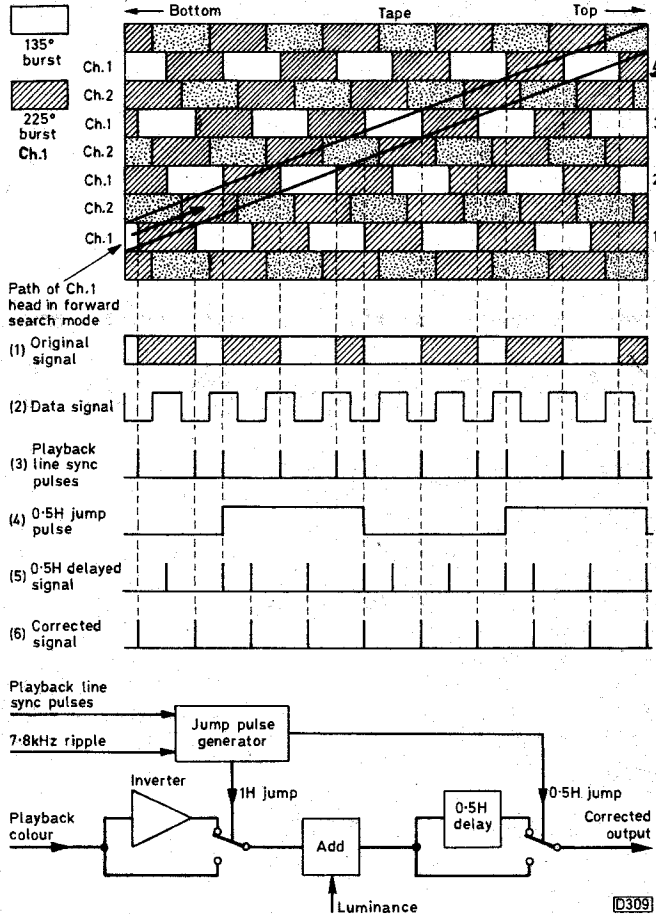

Fig. 2: Picture search in the LP mode.

quency. A signal at half line frequency will complete a cycle over a two-line period: it will have a positive polarity on one line and a negative polarity on the next, i.e. there's phase inversion on every line. The principle also holds for ch. 1 crosstalk picked up by the ch. 2 head. The point to remember is that introducing a half-line frequency shift into the recorded f.m. results in crosstalk noise that changes polarity at line rate.

One method used to apply the 0.5 line frequency shift is shown in Fig. 3. It affects the f.m. modulator in an HA11724 i.c. – you'll be able to identify the circuitry in various makes of machines. The video signal is clipped and clamped and fed to the f.m. modulator internally – though there's a test point at pin 12. The carrier frequency is set to 3.8MHz for the sync pulse tip by the 1kΩ potentiometer, the thermistor being included to provide

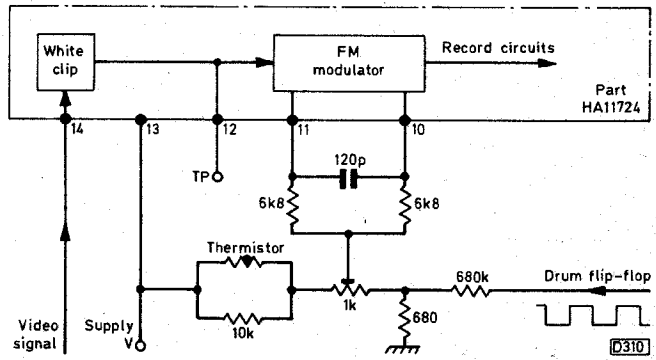

Fig. 3: One method of applying an 0.5 line frequency shift during recording for crosstalk noise reduction.

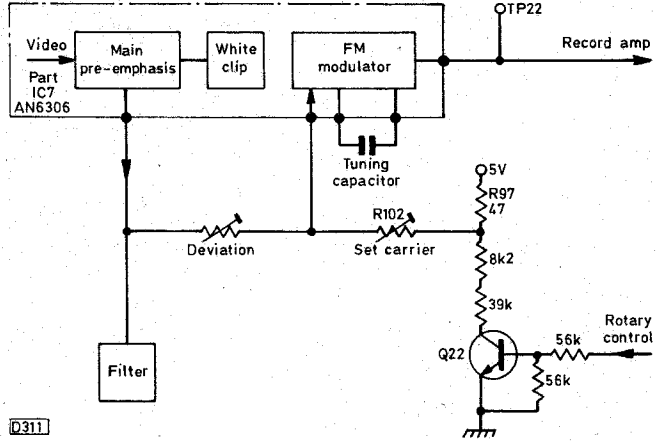

Fig. 4: The technique used in the JVC HRD725.

temperature compensation against drift. The drum flip-flop signal is applied to the circuit via a 1,000:1 potential divider, so its level at the f.m. modulator is very small. The result is that the f.m. oscillator is stepped up by 7.8kHz for the ch. 2 head and back down again to the standard frequency for the ch. 1 head. In some machines the level of the flip-flop signal is set by a potentiometer: don't touch this - setting up requires the use of a spectrum analyser.

The example shown in Fig. 4 is used in the JVC HRD725. This uses the rotary control signal, which is

derived from the drum flip-flop (see Fig. 5 last month). It controls the colour phase selection, hence "rotary". Q22 is switched on and off at 25Hz, taking the junction of R97/R102 to chassis via 47.2kΩ, again a ratio of 1,000:1. The very small shift in the d.c. level of the signal applied to the f.m. modulator results in a 7.8kHz frequency change.

Fig. 5 shows a typical playback system in which the dropout compensation delay line is also used for noise cancelling. It's easier to understand the arrangement used in the HRD725 if we look at this one first. An a.g.c. system stabilises the signal which is then fed via the dropout switch to an f.m. equaliser - in later, dual-speed machines SP/LP compensation is provided at this point. The signal is then sent along two paths, to the direct demodulator and via the one-line delay line to the delayed demodulator. The output from the delay line goes to the dropout switch, for dropout compensation, as well as to the delayed demodulator.

The output from the direct demodulator, (a), is filtered and applied to a mixer. The output from the delayed demodulator, with 180° phase-shifted noise, is filtered and used as one input to a differential amplifier. This is waveform (b). The clean signal output from the mixer, (c), is the other input to the differential amplifier whose output is waveform (d), phase-shifted crosstalk noise. Adding (a) and (d) in the mixer gives us the noise-free signal (c). Prior to the limiter the output from the differential amplifier will contain large amounts of

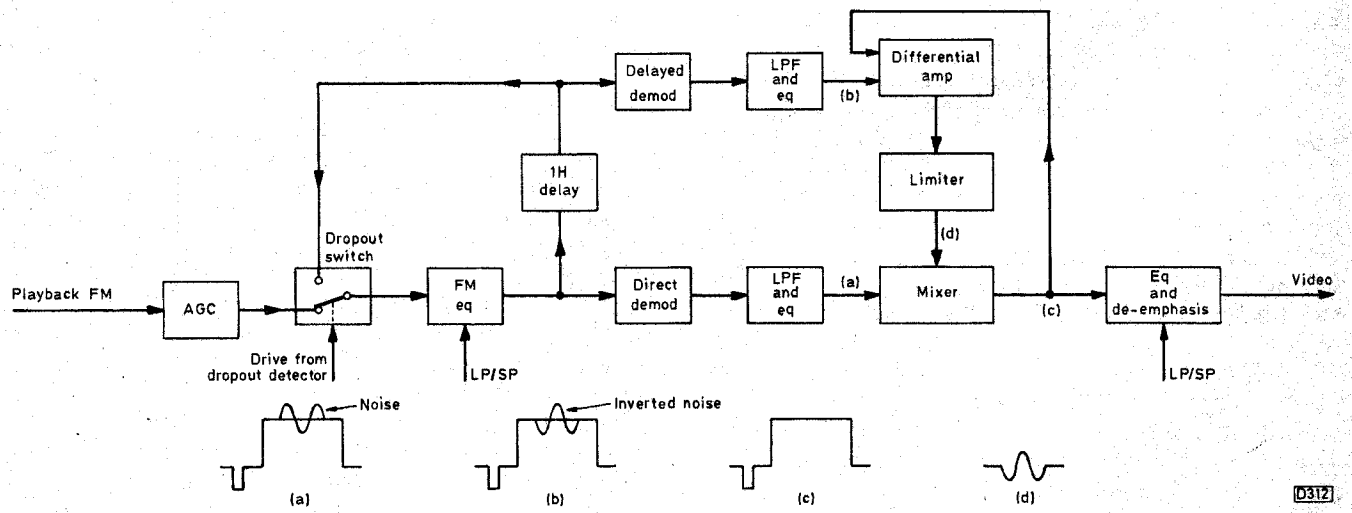

Fig. 5: Typical playback noise reduction system, with the dropout compensation delay line also used in the noise cancelling arrangement.

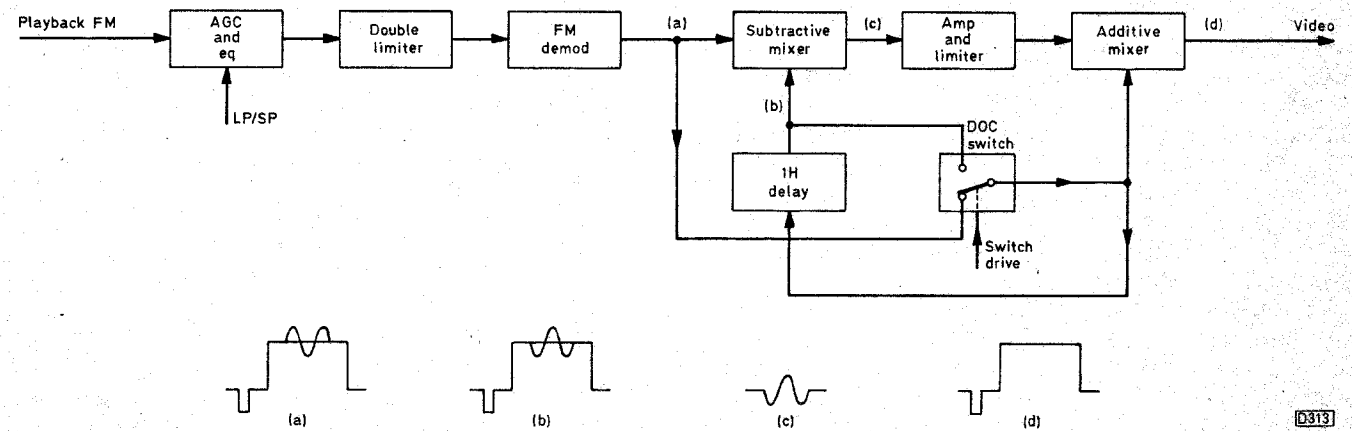

Fig. 6: Playback system used in the JVC HRD725.

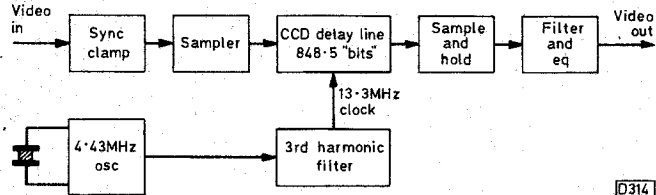

Fig. 7: Operation of the CCD delay line.

unwanted video in addition to the noise. If this was allowed through to the mixer without clipping the result would be impairment of the displayed picture.

Now to the HRD725 where other new concepts are introduced, see Fig. 6. It looks deceptively simple in block diagram form, but the circuitry used is actually very advanced. After a.g.c. and equalisation the f.m. signal passes through a double limiter and is then demodulated. In this case the delay line comes after demodulation – because a CCD (charge-coupled device) delay line is used instead of a glass delay line.

As a result of the action of the delay line the noise in signals (a) and (b) applied to the subtractive mixer is of opposite polarity. The subtractive mixer cancels the video component of the signal to leave just the noise signal (c). This is amplified and limited and applied to the additive mixer along with the direct signal (a). The mixing process this time gives noise instead of video signal cancellation, resulting in the clean signal (d). You will notice that one small licence has been taken. During a dropout the noise will be additive. This happens for only very brief periods however and is not visually perceptible.

The action of the CCD delay line is shown in Fig. 7. The analogue input is sampled and sent along the line as clocked "bits". At the output a sample-and-hold circuit restores the analogue signal. There are 848.5 "bits" within the delay line, clocked at 13.3MHz – this is conveniently obtained as the third harmonic of a 4.43MHz colour crystal oscillator. The clock period is 75nsec, the delay through the line being 63.8µsec ( $0.075\mu\text{sec} \times 848.5$ ). A further delay of 200nsec is gained in the equalisation and filtering circuit, giving 64µsec in all. The use of a delay line at baseband video improves the signal-to-noise perfor-

mance by avoiding the losses inherent in a glass delay line at low carrier levels.

Fig. 8 shows the arrangement used in the HRD725 in greater detail. The playback luminance signal enters IC8, a T8004, at pin 7. It's first clamped and then sent along two paths. The main path is via the dropout (DOC) switch to the noise-canceller section, after which it emerges at pin 2. The other path is to the noise-detector, where one-line delayed video is subtracted. In the subtraction process the video components cancel and the noise components add. The amplified noise emerges at pin 3 and is fed back in at pin 1 where it's limited to reduce high-level video spikes to the level of the noise. The noise is then subtracted from the main path video in the noise-canceller circuit.

The horizontal correlation detector monitors the signal level at the output from the noise amplifier. If there's no horizontal correlation between tracks the noise amplifier's output rises and the detector mutes the noise limiter. The noise cancelling system cannot work without horizontal correlation because the noise component will not change polarity on each line. The system then breaks down – this happens in visual search when tracks are crossed, and in slow motion and still picture when only one field is replayed continuously.

The input to the CCD chip IC9 is taken from pin 4 of IC8. The circuitry around Q30 and Q31 filters out the 13.3MHz clock switching spikes as well as introducing a 200nsec delay. The delayed signal is fed back into IC8 at pin 6 and is then clamped to prevent d.c. drift and ensure that the black levels of the direct and delayed signals are the same. The DOC switch is driven by dropout pulses derived from the f.m. a.g.c. circuit – this is standard practice. It's a cyclic dropout compensator, so that if the dropout is longer than a line the switch stays over and the signal continues to circulate. I've not found the cyclic effect as noticeable as in Grundig machines, where a single line can be repeated down the screen giving a pattern of vertical, wiggly lines.

In the concluding instalment next month we'll look at further luminance signal processing – h.f. noise reduction and picture crispening.

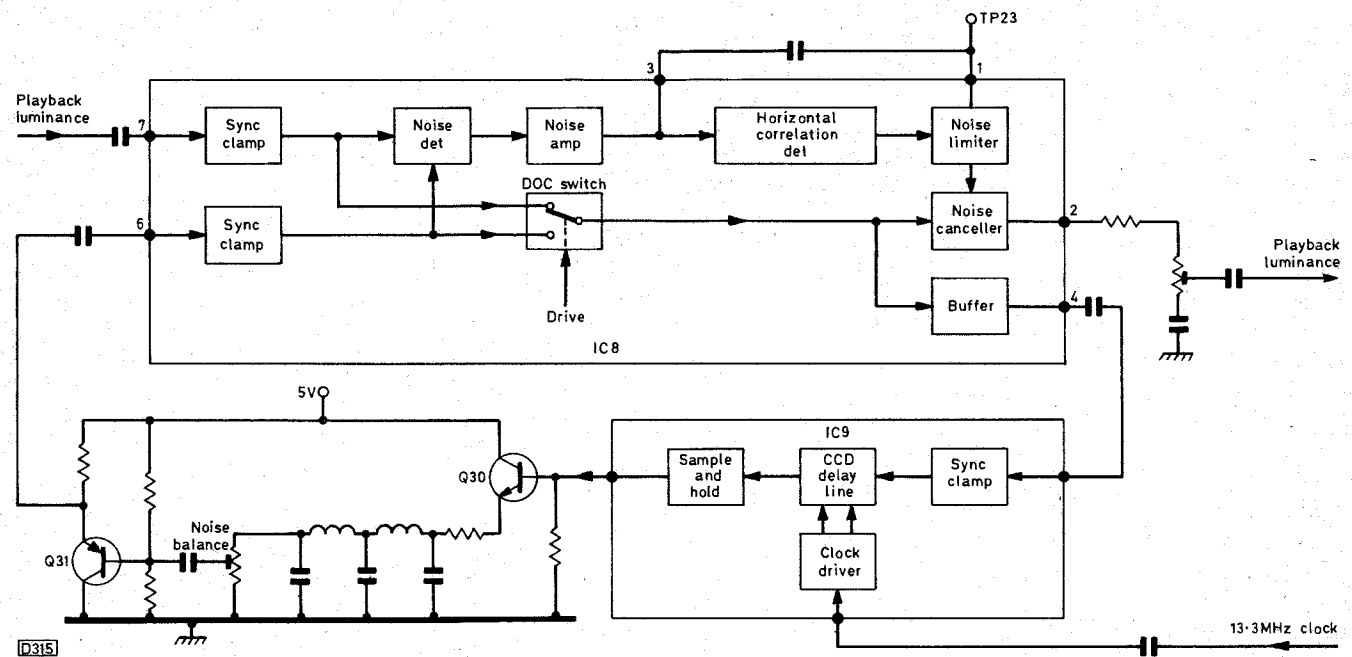

Fig. 8: Crosstalk noise cancelling system used in the JVC HRD725, shown in greater detail.

## Sanyo VT9300

There was no servo lock on record, but it would play back known good tapes. A quick check through the servo soon showed a distinct lack of monostable output pulses at pins 17 and 19 of the control track record i.c. Q101. Separated field sync pulses were present at pin 15 but were of a suspect, low level. I had to cross check with another VT9300 that the 1.25V p-p field pulses were indeed correct. The faulty component was actually C108, which is part of the monostable timing for dividing the field syncs by two. S.B.

## Hitachi VT11

This machine would thread up, run for a few seconds and then stop. The dealer who'd sent it in had already changed the capstan motor. The fault was caused by the threading motor not reaching the after loading position however. Changing this motor and the accompanying belts cured the trouble. S.B.

## JVC HR2200/Ferguson 3V24

I was interested in E.T.'s report (December issue) on a problem caused by C11 (3.3F, 1.6V) whose sole purpose is to retain the counter memory when the machine isn't powered. In the case I had the leakage was to the remote control socket print. This brought about permanent rewind by raising the voltage level on control line B2. S.B.

## Hitachi VT5500 - No Clock Display

This was difficult to solve, not because the problem was complex but because of Hitachi's aggravating production modifications not being shown in the service manual. The clock i.c. we found in the machine was an HD38845A-36. I thought at first that the dealer who'd sent it in had replaced it with the wrong type. We confirmed that the replacement was of the correct type, but it hadn't cured the fault. After lengthy tests and yet another HD38845A-36 I was getting nowhere fast. The chip just wouldn't run despite checking and double checking everything. One problem was that I was using a VT8500 service manual because the chips and circuits in the machine bore no relation to anything I could find in the VT5500 manual. It appears that there's an updated manual, reference no. 1311, so this was sent for.

It could be deduced from the VT8500 manual that the HD38630A-26 is an earlier equivalent of the HD38845A-36, then from the revised VT5500 manual that it could be an HD38630A-36 (or an HD38630A-06 or HD38630A-26, provided one, both or either sub or sub-2 PCBs are fitted). Confused? Yes, so was I.

Anyway, the i.c.'s internal clock was running but nothing else - no output strobe pulses anywhere. The -30V line was present - actually it was -45V, due to the machine being of NAFFI origin for a 220V mains supply. While I was playing around with the power supply I discovered that a 6V rail was missing, due to R954 being open-circuit. This was repaired - and the clock came on! Now this 6V line goes nowhere near the clock i.c. It just runs through the timer PCB to the programme selector

panel. What's more it doesn't even exist on the VT8500 circuit. It didn't seem possible that the 6V line could affect the clock i.c. but it did, via the programme selector. Q703 in the programme selector circuit is normally off: with the 6V supply missing it turns on via the tuning supply. This held pin 35 of the clock i.c. at chassis potential, which is a permanent interrupt, holding the i.c. off. Unfortunately the service manual incorrectly shows pin 35 as being at 0V, which means that innocent souls fault-finding wouldn't think twice about it. S.B.

## Grundig 2 x 4 Super

The problem with one of these machines was no modulator output. R25 (2.2k $\Omega$ ) which feeds the -22V supply to zener diode Di27 within the modulator was open-circuit. Another fault on one of these machines was no E-to-E audio. The TBA120T chip on the i.f. panel was defective. S.B.

## Mitsubishi HS330

The complaint with this machine was an intermittently snowy picture on long play. After much panel waggling we found that flexing the top PCB around the head amplifier section caused the fault to appear and a relay could be heard clicking in and out. The head amplifier screening can was shorting to the link by R20. P.B.

## Ferguson 3V29

A loan machine would not record sound though there was playback sound from a prerecorded tape and in the E-E mode. The audio signal was present at the record amplifier output from IC1 (TP2) and the erase oscillator was working, but there was hardly any bias signal at TP3. We found that the voltage at the collector of Q11 in the control circuit was permanently low - it should go high in the record mode. Zener diode D7 in its base circuit was short-circuit. P.B.

## Toshiba V8600

Poor pictures were obtained with both playback of a prerecorded tape and E-E operation - the pictures were "nasty", with flaring. A scope was used to check the video signal along the E-E path. Everything was o.k. up to the point where the path splits two ways - to the r.f. modulator and to the video output socket. As a quick check I fed the video output to the video input of another machine and obtained a perfect picture on the monitor. The supply to the r.f. modulator was then measured - only 4V. Switch transistor Q661 on the servo logic board was faulty. A meter check on this produced a base-emitter reading of 500 $\Omega$  both ways - I've had Q661 open-circuit on several occasions but never before has it been half way! L.H.

## Panasonic NV7200

There was no timer programming on this machine, which had been subject to liquid spillage at some time - the



timer and operation boards were affected and had received a lot of attention. The clock worked so I decided to check the programme switch. It had 5V at one side but when pressed produced only 1.5V at the other side. A replacement programme switch cured the trouble. **R.S.N.**

### **Sony SLC9**

The problem with this machine was no signal from the tuner, no clock and no programme numbers due to no 38V supply from the d.c.-to-d.c. converter module on board D (check for 38V at pin 3 of the module). **W.G.L.**

### **Panasonic NV366**

The complaint was intermittently incorrect capstan speed. The machine was put on soak test and after half an hour the capstan speed increased. A scope was used to check the capstan FG signal at TP2007 – it was missing. We

checked back to the motor and found that when this was gently tapped the speed corrected itself. A new motor restored normal results – the capstan FG generator is built into the motor. **R.S.N.**

### **Ferguson 3V31**

This machine would work all right for a short time then the drum speed would increase. The trouble was traced to IC13 ( $\mu$ PC1458). **W.G.L.**

### **Sony SLC5**

The head drum wouldn't rotate, though turning the drum by hand would get the machine to work until switched off. The fault was eventually traced to D1 (1S1555) on audio/servo board AS6 – it was short-circuit. As a check, pin 18 of the drum servo i.c. (IC1) should be at 10.8V at switch on: D1 short-circuit gives a low reading. **W.G.L.**

## **VHS the Philips Way**

**Harold Peters**

When Philips took up the VHS format to improve their share of the VCR market they were reluctant to abandon some of the features of their V2000 system. The result has been something of a compromise: machines that are indisputably VHS but have the Philips philosophy applied to their operation and use. This can be a little confusing to someone who has just got one to replace an early Japanese machine, or to engineers who have to deal with a mixture of the two types. The instruction books don't help, being multilingual (or alingual!) and badly set out – with the exception of a limited edition for the VR6462, revised in the UK. Nor does the fact that their authors, following the practice of "positive thinking", don't tell you what the things won't do. Let's try to straighten matters out. We'll look first at the differences between the Japanese and Dutch approaches, then run through the range of Pye/Philips machines released up to the time of going to press.

### **Different Approaches**

The Japanese philosophy, which up to now covers the majority of VHS/Beta machines and means that if you can operate one model you can get by on all the rest, is as follows:

- (1) The user's on/off switch is used to turn the machine on: it remains on until you turn it off again.
- (2) Timed recording programs, once entered, lock the machine so that it cannot subsequently be used or accidentally "dusted to error".
- (3) Tracking errors are compensated by adjusting a control which must be reset after the mistracked tape has been played.

The Philips philosophy, based on the electronics of their V2000 system, is totally different:

- (1) There's no on switch, only a standby button. To start the machine you merely press the button for the required function, e.g. play, wind or eject. If the machine is not used for a few minutes it automatically reverts to standby, i.e. only the clock and infra-red receiver are on.
- (2) Personal use overrides timer settings. Dad can come in with a borrowed tape and watch it despite Mother having

booked the VCR to record Coronation Street. At 7.30 Dad wonders why the display starts flashing.

(3) Tracking should be automatic. The V2000 format uses dynamic track following, with the video heads mounted on bendable arms. Compatibility precludes the use of this arrangement with the VHS system. Instead Philips use a tracking button: push it till the sparklies move out of the picture and it holds that setting while the tape is played, resetting itself at the end.

So much for the basic differences. Now let's see how they have been applied. As you'll see, only partially at first. We'll consider the machines in the order in which they were released: the model number in brackets is the Pye version, which differs only in style and presentation.

### **Philips VR6520 (65VR20)**

To get Philips VHS off the ground the initial basic Models VR6520 (65VR20) were imported from Japan – they are in fact the Panasonic NV370 with restyled fronts. Naturally they conform fully to the Japanese philosophy, with on/off switches, locked timer programming and a tracking knob. They stay on till you turn them off. What you can't do is to watch a broadcast on its own channel while the machine is in the play mode. This is a Panasonic feature introduced to avoid beat patterning in areas where the lower u.h.f. channels are in use: it can be overcome by linking pins 5 and 6 of P1 on the modulator.

### **The VR6920**

The VR6920 (no Pye version) was an adaptation of the Panasonic NV850 stereo hi-fi model. The use of helical audio recording gives sound quality comparable to that from a compact disc. It's "helical stereo only", the lateral sound track on the edge of the tape being mono only in both the record and playback modes. As with the VR6520 the broadcast channels are inhibited during playback, and since the VR6920 can be used purely as a sound recorder – in conjunction with a hi-fi – this feature prevents other members of the family watching TV while someone is using the machine as a sound recorder. If required the

remedy is the same as with the VR6520: link pins 5 and 6 of P1 on the modulator.

The Japanese philosophy of on/off switching, timer lock and a tracking knob is maintained, but Philips replaced the infra-red remote control circuitry with their own RC5 board (see January *TV*), permitting remote control to be linked to TV handsets of the flat 53 series. The handset supplied, type AV5567, controls all the VCR functions and will also control a restricted range of functions on any Philips group TV set that uses the RC5 code. Two orange buttons on the right of the "calculator" part of the keypad give selection between VCR/TV control. A word of warning here. Although it doesn't say anything about it in the instruction leaflet, the act of inserting the batteries in a new handset puts it into the TV mode. The writer, unaware of this, unpacked three samples before a chance encounter with a teletext set in the showroom told him that he hadn't received a batch of duds.

### **Model VR6560 (65VR60)**

The middle range Model VR6560 (65VR60), which is capable of programming up to five items in advance, was the first purely Philips machine. It's a top loader with the lift controlled by touch buttons. The temptation to push it down by hand should be resisted. Much of the cabinet and electronics are derived from the V2000 format Model VR2324 and the machine has the full Philips philosophy: it turns off after eight minutes of non-operation, personal use overrides the timer and tracking is by pushbutton. Setting the clock requires you to enter the date - day, month and year, even though it never asks questions about the latter.

### **Test Program**

Due to its compact size this is not the easiest machine to service. It does however contain a comprehensive test program in its microcomputer, part of which is initiated every time the machine is plugged in. The rest is detailed in the manual, but we'll mention two useful sections.

The first is the ability to read off the number of hours the machine has been used. Press standby once then press store and, while holding it down, press search (not the other way round). If you ignore the decimal point the time display will then show the total number of hours of use, i.e. 2.35 indicates 235 hours' use. To clear, release store and search and press standby once again.

The other feature of the test program useful to the servicing fraternity is a life test mode. Make up a dummy DIN plug to fit the camera socket at the back of the machine, with a diode connected between pin 4 (anode) and pin 5 (cathode). Put a tape in, unplug the machine, fit the plug and reconnect the mains supply. The machine will now play the tape to the end, rewind, replay the tape again and so forth until the mains supply is disconnected. Should an intermittent fault occur the machine will stop and an error indication, which can be looked up in the manual, will appear on the display. This is also a useful feature for display purposes.

### **The VR6460 (64VR60)**

The VR6460 (64VR60) was the first front loader with the Philips philosophy. This is considered to be a basic machine even though two programmes can be entered in the timer. A "one touch recording" counts as one of the

two, i.e. filling both timer "blocks" will prevent a "one touch" recording being made. Manual operation overrides the timer and after eight minutes of idleness the machine automatically goes to standby.

The AV5561 plug-in infra-red unit gives remote control operation: it can be used with the AV5562 handset or with many of the current range of Philips TV handsets that employ the RC5 code (more on this later). There's a built-in test program similar to the one just described, but since the machine uses a Panasonic deck which is similar to that used in the VR6520 the two features specifically mentioned above are not available.

### **The VR6462 (D464)**

The VR6462 (D464) is destined to be the basic model for the coming season and after. This two-program development of the VR6460 differs in having a Philips deck as well as Philips electronics and a built-in remote control receiver unit. This latter feature means that any user of a recently bought Philips TV set which employs the flat 53XX type handset can use this to control the majority of VCR operations. Further details will be given later. Again the full Philips philosophy applies: shutdown after eight minutes of non-operation, manual use overrides the timer and there's pushbutton controlled tracking. Also the "one touch" button requires an empty timer block to function.

A limited number of these machines came complete with an easy-to-read instruction manual printed in the UK. Its illustrations are in blue and black, so you can tell it from the "Euromanual" which is printed in red and black. Unhappily it doesn't have a code number, so if you send for a manual you'll get the Euro version. Neither manual mentions the fact that there are two versions of the machine - "swallowers" and "stoppers". If empty a swallower will accept a cassette, even if in standby, and lower it into the deck, staying in the on state. The stoppers go into the standby mode with the cassette lift down, thus preventing the insertion of a cassette until the machine has been turned on by pressing the eject button.

As with other models a comprehensive test program is built into the microcomputer chip. This is triggered on every POR (plug in) and gives fault indications that can be looked up in the manual. Its "life test" mode is similar to that of the VR6560 but you don't need a diode plug.

### **Model VR6660**

The VR6660 is a full-specification front loader with the mechanics of the VR6462 and the electronics of the VR6560, plus extras. As the shutdown after eight minutes without use and the timer lock are optional the machines can be run following either philosophy.

The most noticeable feature is an alphanumeric display beneath the standard four digit time/counter figures. The function (play, record, wind, search, timer etc.) appears on this in large letters. The second thing you notice is that everything, including setting the timer, can be done from the remote control handset. There's also audio dub and, provided you've entered the type of cassette you're using, e.g. E180, a time remaining readout can replace the conventional counter display. Like the VR6560 the clock setting requires the date with year. Once you've set it, and the TV channels it is to monitor, these details remain in store for up to three months. So there's no need to reset after every power cut and more predelivery work can be

done in the workshop.

You can override the eight minute turn off by selecting a broadcast channel during standby, turning the machine into a high-quality tuner. There's also a tamperproof lock: you open the store, enter any four digits and store them – all while the set is in standby – and the word "locked" appears on the display. Only by opening the store again, re-entering the same four digits and closing the store can the machine be unlocked. The machine cannot be used in the locked mode, but any programs booked into the timer before you locked the machine will be carried out. What if you forget the four-figure code? Hard luck! There's obviously a way to restore the machine to normal use but you'll be asked a lot of embarrassing questions (we hope) before anyone will come out and do it. If in normal use you override the timer when it should be recording a programme the machine will emit bleeps to warn you.

The POR test program is similar to the VR6560's, including a "life test" that requires the same diode plug.

### **VR6860 Matchline**

The VR6860 is the Matchline version of the VR6660. It has hi-fi stereo sound recording facilities via helical tracks, as with the VR6920, and all the features mentioned above. It should be noted that the linear track is mono only and that audio dubbing can be carried out only on the linear track.

### **Remote Control**

For the last eighteen months or so most remote control and teletext Pye/Philips TV sets have come with a flat handset that includes some VCR functions. They were originally designed for use with the later V2000 series

VCRs but will also remotely control the VR6560, VR6462, VR6660 and the Pye equivalents for the following functions: play; record; forward search; reverse search; channel change; standby; stop; pause; and a few others depending on the combination of handset/TV. Three functions are available only via the remote control handset – triple forward speed playback, normal speed reverse playback and slow forward. The TV/VCR button at the side of the unit has to be held in when VCR functions are being selected. Fast wind and fast rewind are not available via remote control – due I've been told to no one asking the designer to include them. Finding this hard to believe, I dug a bit deeper. The more plausible explanation is that the system was designed for use with V2000 machines and in this respect doesn't require wind and rewind since all V2000 machines have a "go to" feature which is quicker and more effective.

### **Service**

Hitherto Philips Service have held courses at various regional centres to train dealers' engineering staff on the servicing techniques required for new models. In the case of the VHS machines these courses have been replaced by packages of instructional material that amount to a tidier form of the notes you'd have taken had you gone on a course. In addition to the service manual each package includes a circuit description and fault-finding guide – the latter emanating, thank goodness, from Croydon itself and thus being in a language we all understand.

Issued so far are VR6920, code No. 727 17992; VR6460, code no. 722 17197; and VR6462, code no. 722 17202. Each package comes in a zip-up wallet and, at £25 a time, is a lot cheaper than sending a man on a two-day course.

# Developments in VCRs

## Part 3

Steve Beeching, T. Eng.

The playback luminance signal requires some additional processing after demodulation and adjacent track crosstalk cancellation (see last month). There's still high-frequency tape noise (in audio terms hiss) to be reduced and the picture must be crispened. In earlier machines picture sharpening was done by means of an "aperture correction" circuit. In later machines a similar but not identical technique is used: it avoids the edge noise that's so prevalent when sharpening pictures.

### Picture Sharpening Circuit

Fig. 1 shows the sharpening circuit. Q10 is an emitter-follower which in addition has a peaking coil L21 in its collector circuit: the coil has maximum response at 1-2MHz. Light h.f. filtering is used in the emitter path to reduce the h.f. response here. The h.f. component from the collector circuit is added to the signal from the emitter circuit at the junction of R41/42. The amount of h.f. signal added back is determined by the damping of the peaking circuit provided by Q12. Since this is a field effect transistor its source-drain resistance will vary with the gate bias applied: it therefore acts as a voltage-variable resistance, controlling the h.f. signal level and thus the picture

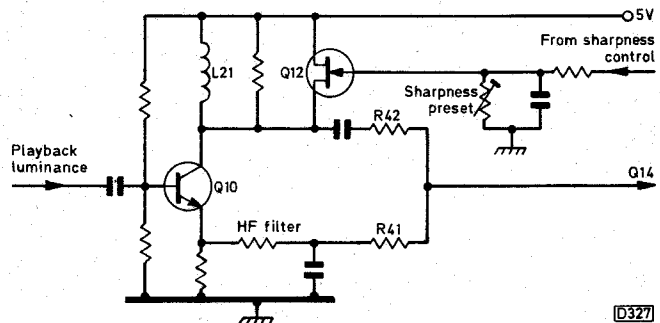

Fig. 1: New sharpness circuit.

sharpness. Since this circuit also adds picture noise it's followed by a noise-reduction system.

### Noise Reduction System

This is shown in Fig. 2. The noisy signal shown at A is buffered from the sharpness circuit by the emitter-follower Q14 whose output is split between two paths. The main path is via a low-pass filter and the buffer transistor Q15: this removes the h.f. noise but unfortunately the edges of transients are softened, as shown at E. The second path is to the emitter of Q13 via a high-pass filter: the output from this common-base stage consists of noise and large-value h.f. signal components - see waveform B. The video component has to be reduced to the general noise level to prevent it interfering later with the main path signal. This is done by the following limiter, which produces waveform C.

A portion of this waveform is returned to the base of Q14 as negative feedback, reducing the noise at this point and aiding the action of the low-pass filter. The waveform is also applied to a non-linear filter consisting of the h.f. filter components between pins 14 and 15 of IC5 and the following two diodes which are connected in reverse parallel. The output from the h.f. filter reduces the level of the general noise to less than 0.6V (1.2V peak-to-peak): this is insufficient to pass via the diodes. The wanted video signal spikes, being of higher amplitude, make the diodes to conduct, producing waveform D. When this is added to the main signal by the mixer in IC5 the result is a crispened picture, the softened edges of the video signal having been rebuilt (waveform F).

### Techniques Compared

With the earlier type of aperture corrector circuit the spike level can be adjusted by the aperture control but the

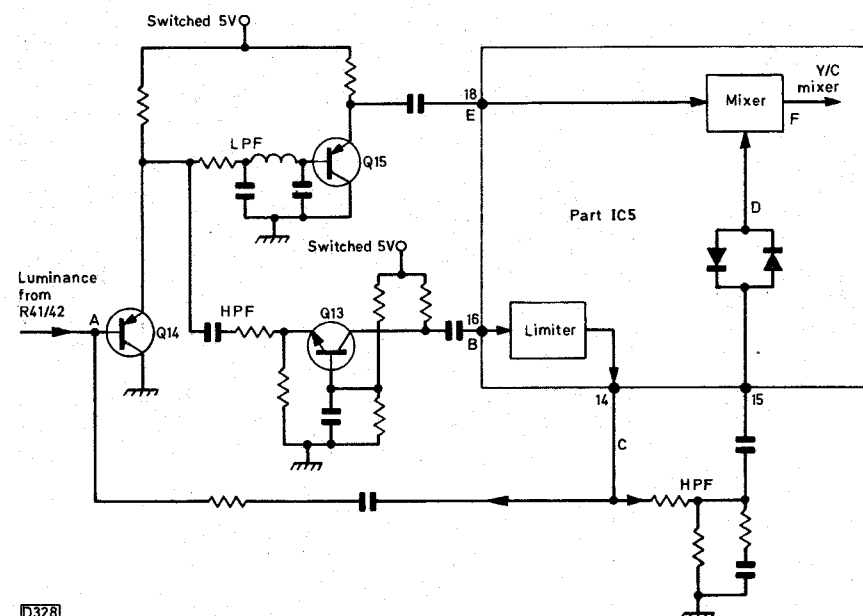
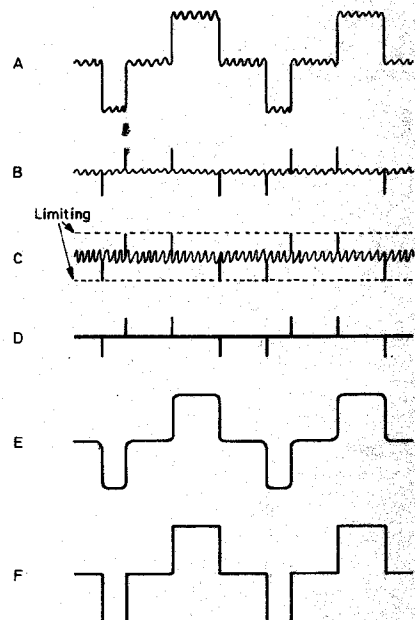

Fig. 2: Noise reduction system.



spikes contain noise which is added back to the signal to a degree where it becomes noticeable as edge noise. The newer technique, by making the h.f. variable and fixing the level of the crispener spikes, gives a greater degree of sharpening with a much reduced level of edge noise.

### Dynamic Aperture Correction

A new switch appeared at the rear of the JVC HRD725, labelled "dynamic apercon". In the Ferguson version it's labelled "local/distant", a misnomer if ever there was one. It switches the dynamic aperture control circuit, in principle a record picture crispener, in or out. Before we look at this in greater detail let's consider the effect of a picture crispener on a transition from black to white. Fig. 3 shows the effect we've just been considering - adding a derived video spike to a video signal to recondition it. The spike contains h.f. noise: if the amplitude of the spike is too high the noise will be deposited on the video signal as an overshoot. An improvement would be obtained if we could devise a way of giving emphasis to the transition with a reduced level of noise on the edges. The method that's been developed involves the production and addition during recording of preshoots as well as overshoots: this method is called dynamic aperture control.

Fig. 4 shows the system in block diagram form, with waveforms. The luminance signal to be recorded is, following a.g.c., fed to the junction of C169 and R201. We'll assume it consists of the squarewave A - a portion of white during a line period, e.g. a vertical white bar. The signal path then splits two ways: the direct path via equaliser two and the indirect path starting at R201.

L50 is an unterminated delay line of period  $t = 100\text{nsec}$ . The signal passes along the delay line to the mixer

## APOLLO MANCHESTER

FAST MAIL ORDER GB 3-4 DAYS ALL AREAS PLEASE PHONE FOR COST  
FREE LOCAL DELIVERY SAME DAY ● FITTING SERVICE £20

**2 YR GUARANTEE - QUANTITY DISCOUNTS - PILL GLASS BOUGHT**

A47 342/343X - 470 BC822/CT822/BG822/DH822	£39
470-ES822/EF822/ER822/FT822	£52
A51-220X/192X	£39
A51-161X/162/163/168	£52
510-JK822/JEB22/JDB22/JGB22/ALB22/GLB22	£52
510-VLB22(E55) DTB22/001/FPB22/RCB22/SFB22	£52
A51-590 New	£56
A51-570X/580/001/210/241	£52
A56-120X/123/140/410	£39
560-DZ822(E53)/FB22/AKB22/TB22/AWB22	£55
560-ET822/DTB22/CSB22/DMB22/DNB22	£52
A56-611X/615X	£52
A66-120X/A67-120X/140/150/200/410	£39
20AX - A56-500X/510X - A66-500X/510X	£52
30AX - A56-540X - A66-540X	£56

If your tube type is not in stock we can arrange collection - rebuilding + redeliver

PLEASE PHONE BEFORE CALLING

**061-799 0854.** 24 hour answering service

43 Clarke Crescent, Little Hulton, Worsley, Nr Manchester M28 6XL

amplifier, delayed as shown by waveform D. Since an unterminated delay line reflects a signal like a mirror, the signal also travels back through the delay line. This reflected signal will have undergone a second delay, to  $2t$  as shown in waveform B. Thus at the junction of R201/L50 we get  $A + B =$  waveform C. D is inverted by the mixer amplifier and added to C: in effect, D is subtracted from C, giving waveform E. This waveform is then passed through a noise filter and is also inverted. In addition, its level is adjusted by the gain control circuit. It's then fed to the mixer in the direct signal path, where it's added to the original signal A which has also been delayed by time  $t$  in the equaliser to give us F. When inverted E is added to F the result is waveform G: the output from the circuit is thus the original signal (delayed) to which a preshoot and an overshoot have been added on each positive and negative transition. The edges of the transients have in this way been enhanced and the picture information crispened.

The point to note is that the system works only on low-level rise and fall edges, not on high average picture signals, as inverted E is of low level. If the input is very noisy the action of the dynamic aperture corrector will have an adverse effect by crispening the noise. Hence the facility to switch it out of circuit - I suppose this is why Ferguson call it a local/distant control.

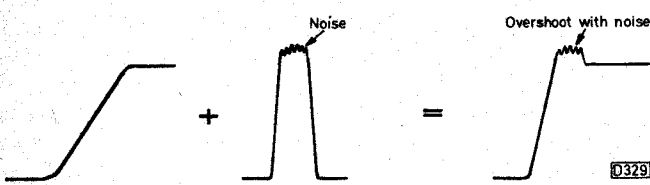

Fig. 3: Edge noise on a sharpened video signal transition.

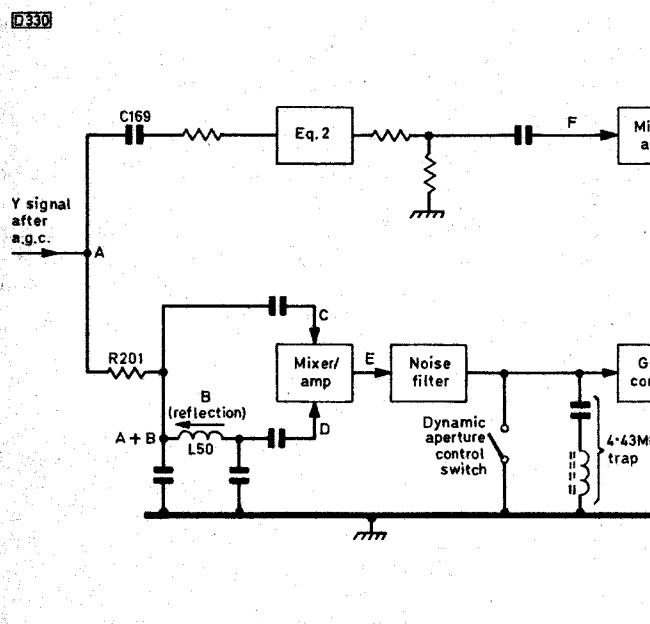
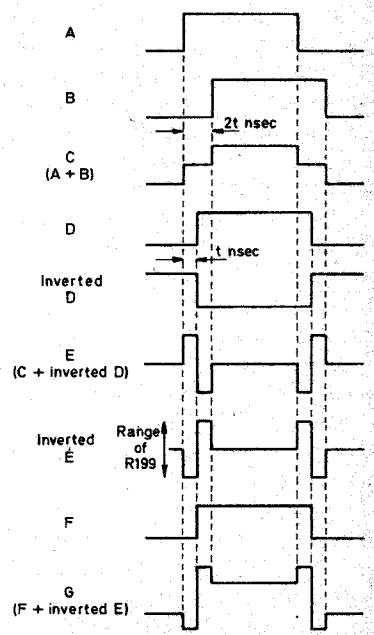

Fig. 4: Dynamic aperture correction.



## Mitsubishi HS318 and HS306

Just before Christmas we took delivery of some Mitsubishi HS318 VCRs. This model replaces the HS306. It has similar features though with infra-red instead of wired remote control. Construction inside is similar, with most of the components on the main board across the top of the machine and the clock/timer/counter on a small subpanel at the front. Access to the heads and fuses is no easier – slightly fewer screws but it's necessary to unclip three small subpanels, one with the tracking control, one with the operate switch and light, and the other with the function buttons. Locating the main panel in the upright position is a bit easier however. A couple of these machines had no sound in playback or E-E. In both cases the cause was a crack in the print near a screw hole at the rear left of the main board.

A problem that's beginning to show up on the HS306 is failure of the wired remote control system. This can usually be cured by replacing the lead and plug. Some 2.5mm plugs are slightly shorter than the ones originally fitted however, and you may find that they don't work. The solution is to file the front of the socket down slightly. **D.S.**

## Mitsubishi HS304

The problem with an HS304 was instability on the lower channels. The machine would appear to drift off tune on these stations, but when an attempt at retuning was made the machine refused to lock on the station, preferring to be just above or below the correct tuning point. A replacement tuner cured the problem. **D.S.**

## Toshiba V31

We're finding that these machines are beginning to come in with worn heads as they approach twelve months old. **D.S.**

## Hitachi VT8000 series and Ferguson 3V35/6

For those of you who like to codge the odd repair, here are a couple of tips. The first concerns the Hitachi VT8000 series, which tends to have a dry-joint on the i.f. can (see Fig. 1). To fix, burr the joint on top by hitting with a screwdriver, then solder with a high-wattage iron. This dodge should last at least six months and saves removing the i.f. can from the machine.

The second codge concerns the Ferguson 3V35/3V36. If you get one where the front loading doors keep going out of sequence, rather than replace the mechanism or the doors try burring the door hinges as shown (Fig. 2). This will force the doors over slightly to the right and stop them going out of mesh with the operating gears. **D.S.**

## Finlux/Philips VR6462

We've recently had two Finlux machines with the same fault, failure to eject the cassette. The model concerned is the equivalent to the Philips VR6462, so presumably the fault could occur on these machines as well. The cause of the fault is mechanical: a small pin comes out of one of

the operating levers. The lever in question is located under the main cam (see Fig. 3). To repair, remove the three circlips, then arm assembly A and cam B. Find the pin and refit it into the hole in the end of arm C. Use pliers to ensure a tight fit. Next find the small hair spring and refit it to the pin. Now for the tricky bit, reassembly. Push lever D as far towards the centre spindle as it will go. Fit the small metal block on to the pin and then hold arm C in such a position that as the cam is refitted the metal block locates in the slot beneath the cam, directly under hole E. The cam should push home fully with slight movement of lever F. If not, recheck the position of lever D. Refit the circlip to the cam and then refit arm A, ensuring that the pin locates in the metal block in the slot on top of the cam, then refit the remaining two circlips. Switch on and check for correct operation of the front loading and unloading mechanism. **D.S.**

## Mitsubishi HS304 and HS7000

We had an interesting fault recently with a Mitsubishi HS304. The complaint was that it took a long time to return to normal speed after visual search, particularly in the forward direction. In fact it took up to ten seconds instead of one-two seconds for the capstan to return to the normal playback speed after search. IC4A0 contains a braking circuit amongst other things, but checks around this were rather inconclusive without another machine for comparison. We found however that pin 24, the reverse output, was permanently high, varying only slightly between forward and reverse search. The pin remained high when disconnected, so the chip was suspected. I should have realised when I found we'd got one in stock that fitting it wouldn't cure the fault, and it didn't.

Further investigation around the i.c. showed that the two Hall element inputs from the capstan motor were different. One was pulsing (as it should). The other was high and steady. A quick check showed that we didn't have a motor in stock so this was bound to be the cause of the trouble. When a replacement was obtained it cured the fault.

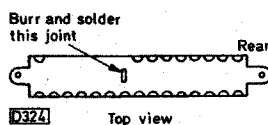

Fig. 1 (left): Dry-joint problem with the i.f. can in Hitachi VT8000 series machines.

Fig. 2 (right): A way of dealing with the front loading door problem on Ferguson 3V35/36 VCRs.

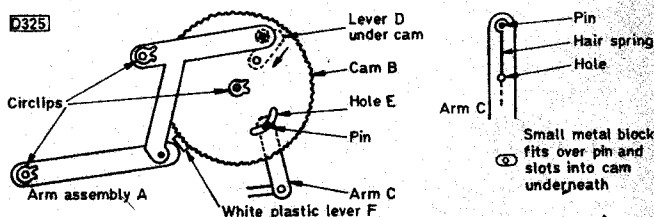

Fig. 3: Finlux/Philips eject failure problem – the small pin comes out of arm C.

Since then a colleague has had an HS700 with a similar fault. In this case the trouble occurred only in reverse search, which was slow when selected but speeded up when released before returning slowly to the play speed after about twenty seconds. Again the inputs to the i.c. (IC4A0) from the Hall elements were very different and a replacement motor cured the problem. **D.S.**

### Ferguson 3V35

The problem was no functions. After removing the top the machine was tilted over in order to remove the bottom cover. A 2p piece then slid out from the component side of the mechacon PCB. Panic stations! How many dead bits will there be? The main microcomputer chip was working but didn't respond other than to power on, i.e. there was no output to the cassette motor although "cass in" was present. Now one would normally have a check round to ascertain the status of other inputs, but as the 2p piece could have damaged the chip this had to be eliminated from the search first. Naturally fitting a new one made no difference, so a check around the pins was called for. The housing up and housing down inputs were both high which is not at all correct: in fact the cassette housing had overshot its stop position in the eject mode. It had to be wound back and then repowered to reset the microcomputer chip, after which correct operation was restored. Of course that may have been the original problem, in which case the housing switches are suspect, or the presence of the 2p piece could have held pin 37 high. We shall never know! **S.B.**

### Toshiba V65

This machine is equivalent to the JVC HRD140, but without remote control. The problem was no functions. Although new stock, the machine had a short history of peculiar problems. It had intermittently failed to respond to "power up", then subsequently to play, fast forward, rewind etc., though the "instant record" function always worked. It eventually failed completely while out on rental (clapped out as dealer Pete put it).

This time there was no power up, though the capstan motor ran for a long time before stopping. Operation code data reached pin 21 of IC601, the mechacon control i.c. The output at pin 1 didn't go fully to 0V, but when it was earthed the capstan motor didn't run. After replacing the i.c. all was expected to be well. Pin 1 went to zero, the capstan remained still but the power light stayed off. Over on the power supply the regulator wasn't switching on for a number of reasons: zener diode D3 was leaky, Q10 was also leaky from collector to base while circuit protectors CP1 and CP4 were open-circuit. Q10 must switch off to allow the supply regulator Q7/8 to come on. The junction of R12/D3 is earthed via 2.2k $\Omega$  by the microcomputer chip so the voltage here is about 1.9V: this reverse biases the zener diode and Q10 switches off.

I don't know why so many components in this part of the circuit were damaged. Stop press: Pete has just phoned to say that it keeps doing silly things like suddenly coming on or ejecting cassettes. . . **S.B.**

### Grundig VS200/VS220

A short note that may save a few headaches.

If the customer reports the display of "7" in rewind, sometimes accompanied by tape damage, the take-up motor is suffering from tight bearings when hot. It tends

to occur with motors date coded before 06/84, but later motors have been known to fail. When replacing the motor, remove the plastic cover from the brake solenoid rear mounted switch. It's not fitted on all machines: dust gets trapped here and can lock up the control micro.

If the customer uses high-grade tapes the cassette exit guide (the one on the front left corner) can unscrew due to static build up in rewind. Check the setting so that there's no tape edge curling and that the tape path is compatible, then seal it with "lock tight" or nail varnish (Passion Red is best. . .). **S.B.**

### Panasonic NV2000

The timer couldn't be programmed. The cause was that the clock i.c. failed when hot. Fixed up a can of freezer with a hole through the front panel so the customer could operate the machine - or did I change the chip on that one? **S.B.**

### Sharp VC381

The unusual problem with this machine was picture rolling on E-E and record. If it had been a VC7300 I'd have homed in on the i.f. packaged circuits. The signal at the output from the i.f. section was fine however. We followed it through IC201 but found that the field sync pulses were missing by the time the signal reached IC402. Coupling capacitor C438 (47 $\mu$ F) was low in value. **P.B.**

### Philips VR6660

The customer complained that the machine didn't pull the tape back into the cassette every time. It worked fine until I tried to eject the tape after running in rewind search. Then the jockey wheel jammed half way and tape spilled everywhere. A new jockey wheel was needed. **P.B.**

### Toshiba V8600

This machine came in for no E-E operation. The audio and video signals were both present at the input to the r.f. modulator, but there was no r.f. output. The supply to the modulator was found to be low because the modulator supply switching transistor Q661 was leaky. Fitting a replacement cured the fault.

A quick way of checking the signal from the r.f. modulator to the r.f. converter is to connect an "isolated" lead from the r.f. modulator's output to the aerial socket of a TV set. This normally gives some indication as to whether the modulator is working. **S.I.**

### Hitachi VT14

The problem with this machine was intermittent loss of sound in the E-E mode. The sound would disappear for several seconds a day, which was most irritating. Armed with a signal tracer - and a lot of patience! - we checked whenever possible the audio to and from audio board PG405 and chroma board PG751. We were eventually able to eliminate these boards. This brought us to the tuner/i.f. board, where checks on the voltages around IC881 suggested that the audio defeat circuit was operating when the fault was present. We eventually arrived at the programme PCB where we found that the programme chip IC721 was faulty, intermittently operating the audio defeat circuitry. **S.I.**

# The VPS VCR Switching System

James Fletcher

Surveys have shown that the vast majority of VCRs are used primarily to record programmes off-air for playback later at a time more convenient to the user. The one thing that the new VCR owner soon discovers however is that it won't provide more hours per day for TV watching: I wonder how many of these timed recordings are in fact subsequently watched. It's also interesting to speculate on how many people can actually understand the instructions that come with their recorders. Many modern machines offer very sophisticated timed recording facilities, often allowing the user to record different programmes at different times over a period of up to a year, or to have individual episodes of their favourite serials recorded each night for a week. Unfortunately most users never take the trouble to learn how to make full use of the timer facilities, restricting themselves to being able to record just one programme and finding this adequate for everyday purposes.

Another major problem with timed recordings is that the broadcasters don't always keep to their published schedules, leading to disappointment when a programme you've been planning to record doesn't appear on the tape, or when the film doesn't start until after the time shown in *Radio Times* so that you lose the last ten minutes and don't know who dunnit!

Such problems are not restricted to our own shores of course. To help overcome them the Germans have developed a much simpler way of controlling timed recording sessions. The system is known as VPS - video programming system - and has been developed by the W. German broadcasting organisations in conjunction with their version of BREMA, the ZVEI. It's been in operation since the autumn of last year.

With VPS each programme carries a teletext-like coded signal on line 16 of each picture. When the transmitted signal on line 16 matches information previously put into the recorder by the user, and not before, the programme will be recorded. At the end of the programme the recorder switches off - until it recognises another line 16 signal for a programme it has been asked to record. The actual time at which the programme is transmitted is unimportant therefore, since the machine won't spring into action till it recognises the appropriate signal at the start of the wanted programme. If the broadcasters would co-operate by leaving the advertisements uncoded films could be recorded without the "natural breaks", but there are presumably commercial reasons for not doing this.

For some years now the W. German broadcasters have been carrying bi-phase coded data at a rate of 2.5Mbit/s on line 16 of each TV picture, one of the so-called insertion data lines. This data is used for source information, remote control of the network, identification of stereo sound channels and the transmission of test measurement results. The VPS signals that identify each programme item use four previously spare bytes of data on line 16 - bytes 11-14, see Fig. 1. The comparator in the domestic VCR continuously checks whether information decoded from bytes 11-14 on this line matches information

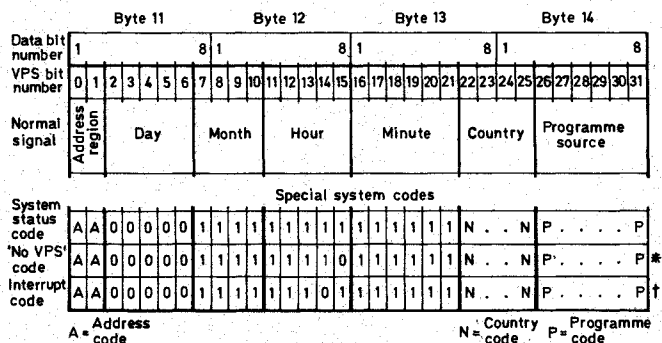

\* Switches to 'Timer' when 'No VPS' code is received  
 † Recorder pauses when 'Interrupt' code is received

Fig. 1: Format of the VPS data transmitted on line 16.

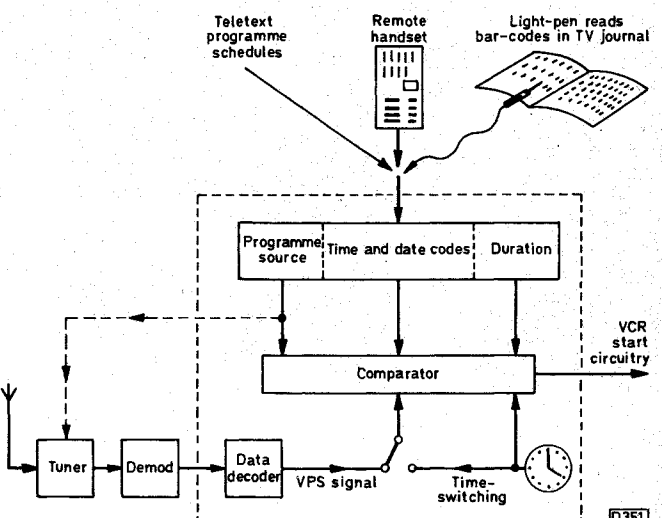

Fig. 2: Block diagram of the VPS VCR switching system.



programmed into it by the user. The system – see Fig. 2 – allows for automatic selection of VPS-controlled or timer-controlled operation of the VCR (to cope with programmes not VPS coded) and the timer can be used so that the VCR responds to VPS codes only during particular time slots, perhaps half an hour before and after the expected transmission time, thus minimising power consumption.

Feeding instructions into the machine to tell it which programmes to record can be done in several ways. Since the identification signals contain the month, date, hour and minute of the programme source, it's simple to use a remote control handset to insert the required information when prompted by a message on the screen. It's even easier to wipe a simple "light-pen" over the bar codes printed in programme timetable magazines: merely passing the pen over the codes for all the programmes you want to record sets up the required comparison signals without any further action.

Many engineers may wonder why the Germans don't make use of the standard teletext transmissions for VCR switching purposes – the IBA demonstrated that such a scheme was practical in the late seventies. The intention at that time was to use automatic teletext-controlled switching to allow UK schools' broadcasts to be transmitted and recorded at night. The UK teletext standard, on which the German one is based, actually contains a pseudo row address in magazine eight specifically for this purpose.

When asked about this the German engineers say that the lower VPS data rate of 2.5Mbit/s (compared to 6.9375Mbit/s for teletext) gives a better error rate, with simpler error detection and clock regeneration, i.e. a more reliable system. This sounds fine in theory until you

recall that the teletext system was not adopted by the W. Germans until a large number of tests had shown that the 6.9Mbit/s transmissions were reliable over a wide range of different terrains, including that of Bavaria. It also seems strange to introduce yet another decoder circuit now that millions of sets are equipped for teletext reception. A more plausible explanation for not using a teletext-based system is that with the federal structure of broadcasting in W. Germany each region has its own programming but not necessarily its own teletext service. The Germans say that to multiplex teletext signals from a central service with locally generated VCR switching signals would be extremely expensive. All regions already made use of the existing data transmissions on line 16, so it's a fairly simple matter to introduce the VCR switching bytes in each region. In the UK line 16 is used for teletext transmissions.

Grundig are now making VPS equipped VCRs, several W. German networks are transmitting the VPS switching signals, and both Austria and Switzerland have announced that they will be adopting the system shortly.

It looks as though this W. German initiative is set for considerable success, thanks to the broadcasters and manufacturers working together. In fact the VPS system could well become standard throughout Europe. The chances for an alternative, teletext-based switching system don't look too good, especially when you consider that the earlier IBA ideas were never taken up. The bar-code system of programme identification was demonstrated by the BBC several years ago, for use in conjunction with radio recorders. It was claimed however that the printers couldn't print accurate bar codes on the type of paper used for the *Radio Times*!

## Hitachi VT8000

It's finally happened – my own video went faulty! I have an Hitachi VT8000 and the other night I inserted a cassette, pressed play and after a few seconds the machine switched off. A closer look showed that after pressing play the tape laced up and the capstan and take-up spool rotated as normal though the picture, which is blanked out during lace-up, did not appear during the few seconds that the machine operated. Removing the cassette and looking inside showed that the drum was rotating, so although the machine appeared to be operating correctly, at least from the mechanical point of view, it must have thought otherwise. On trying another cassette the take-up spool refused to rotate and upon selecting stop no other function would work. Ejecting the cassette and reinserting it brought back the original fault.

Perhaps the microcomputer chip was confused – always a good standby this when you're stuck for an answer. When I unplugged the machine however and counted to ten before switching on again it went into the rewind mode without a cassette in and the only way to stop it was to unplug it again. At this point I decided to take it into the workshop next day and look at it there. In the workshop the machine reverted to its original fault condition of switching off after a few seconds in play, and it was while I was debating whether to look for the fault logically by discovering why it switched off or whether to change the microcomputer i.c. that the machine started to work normally. Whilst trying to persuade it to go faulty again I noticed a peculiar thing: if the mains was switched on with the cassette housing in the down position all was well, but if the mains was connected with the cassette housing in the up position the machine went into the rewind mode and only unplugging would stop it. At this point I decided to change the microcomputer chip (IC901, type HD44801A05). This cured the problem. I've known this i.c. to fail on at least three previous occasions, each time with obscure fault symptoms. **D.S.**

## Mitsubishi HS306 and HS318

The problem we've had with several HS306s, and the newer HS318s, is failure to load correctly. It's a mechanical problem. The front loading mechanism consists of a cassette carrier which is raised and lowered along grooves formed by two metal plates at each side. It's held in these grooves by two white nylon pieces and what happens is that one or both of these jump out of the groove for no apparent reason. They're a bit tricky to refit but once back the problem does not seem to recur. Perhaps it's caused by the customer inserting the cassette incorrectly. **D.S.**

## Hitachi VT11

I had to go out to see this machine, the complaint being intermittent tracking and sound. When I got there I discovered that the picture was all right at first. Then a rolling noise bar appeared, accompanied by fading sound – as if the audio/control head was way out of alignment. A check in this area showed that the tape was riding down the head and that the pinch roller seemed to be crooked.

In fact the pinch roller wobbled all over the place as the inner brass ring had come adrift. A replacement roller cured the problem. **D.S.**

## Toshiba V65B

We've had several of these machines come in with the complaint of intermittent sound recording, with the old sound track left on the tape. This appears to be another case of erase head plug and socket trouble – several other models by different manufacturers have suffered from this problem. Certainly removing the plug and socket and soldering directly to the head appears to have cured the problem. **D.S.**

## Ferguson 3V29

This machine came in with no clock display. Investigation revealed that the 315mA fuse had blown, and a replacement lasted only a few seconds. The 22.3V zener diode D13 and transistor Q5 (2SB642Q) turned out to be faulty – these items supply the -22V rail for the fluorescent display. **D.S.**

## Mitsubishi HS318

We've recently had two instances, both with HS318s, where the customer has managed to get two cassettes into the machine at once. How they manage this I don't know as there's a metal piece that comes up after a cassette has been inserted to prevent another one being put in. This of course makes it very difficult to get the extra cassette out afterwards. Luckily no damage was done to the machine in either case – in fact one customer said that the first cassette would play quite happily despite the presence of the second one. **D.S.**

## Mitsubishi HS700

The HS700 is prone to a customer induced fault which is rather misleading. The symptom is that the machine stops playing after a few seconds although it appears to be operating correctly. Before scoping various pulses check the still frame adjustment potentiometer. This is adjustable through the back of the machine and you'll probably find that it's been broken by over-enthusiastic use of a screwdriver by the customer. To be fair to the customer, making this a subminiature preset for customers to adjust was probably asking for trouble. We've had half a dozen cases of this fault. **D.S.**

## Panasonic NV333

The complaint with this machine was permanent eject. Normally the machine goes buzz, buzz as the loading motor overtravels to unlock the cassette carrier for eject, then reverses back to a rest position. In the rest position the cassette carrier will lock down – but not in this case as the loading motor had stopped in the unlocking position. It was not too easy at first to spot precisely what was happening – it seemed probable that the loading motor was revolving in only one direction. Attention was di-

rected to the loading motor and the VCR was switched on to reset and eject: the negative terminal then went high and the positive terminal went low, the motor turned then both terminals went high! The motor stopped in the eject position. A few more resets later it could be seen that Q6028 was being turned on by Q6025 but its collector voltage stayed high. Replacing Q6028 restored normal operation. **S.B.**

### Sharp VC482

After inserting the cassette and selecting play this machine would enter the forward visual search mode. Selecting play for a second time would produce the play mode, but without a picture. At first the video heads were suspected, but the machine's recordings (played back on a test machine) were fine. We then found that the record 9V line was still active in the playback mode. Q803 was at first suspected of being short-circuit or leaky but we then found that it was being turned on by a low output at pin 12 of IC802. The corresponding input pin 5 should have been at 0V instead of the 3V that was recorded here. So was the microcomputer chip IC801 faulty, producing a rogue output, or was IC802's input circuit at fault? It turned out to be IC802. **S.B.**

### Sony SLC7

There was no servo lock in record. This one was a bit more difficult since the reference (pin 19) and feedback (pin 20) signals were both present at IC2 and the servo locking was good in playback. We slowed down the capstan flywheel in record to check the reaction of the pulses but there wasn't any. As the pulses, or the ramp on pin 20, are derived from the capstan flywheel the pulse period should have increased. When the input signal was unplugged the pulses went away. This proved that they were derived from the incoming sync pulses and not from the capstan flywheel as they should have been. The fault was traced to the switching transistor Q25 which had an open-circuit emitter, allowing the record control pulses back to the capstan servo. When Q25 is properly switched on D15 is reverse biased and the input to the capstan servo consists of FG pulses via D16. **S.B.**

### JVC HRD120/Ferguson 3V35

Dead easy this one – no colour due to the VXO crystal block XB401 being non-operational. **S.B.**

### JVC HRD565

There was no hi-fi muting in visual search. The muting signal from the mechacon PCB is sent to the muting i.c. via R330. This is mounted on the print side and is stuck with the glue which somehow becomes conductive. It prevented pin 9 of IC208 going low because of current leakage from a higher voltage source. Removing the glue also removed the fault. **S.B.**

### Sanyo VTC5000

The problem with this machine was poor capstan servo lock when replaying its own recordings. A replacement audio/sync head improved matters but the performance was still unsatisfactory. A small servo PCB mounted on the main servo panel contains the control track record/replay circuit. Full drive from the CTL record logic was

available at the head but the replay was only about two thirds the level of the pulses obtained with a test tape. The unstable results could be seen as an intermittent interruption of the squarewave output at pin 2 of IC4501. This sent the servo off lock. I eventually got fed up trying to find out why the level was low and got over the problem by adding a 390Ω resistor in parallel with R4515, the preamplifier transistor's emitter resistor. **S.B.**

### Akai VS5

"Breakdown" it flashed. Damn nuisance that word: it's obvious that the machine has broken down since it doesn't work – we don't need to be told as well. The light had gone out, the rewind didn't rewind and there was a crackle on sound. The first two were easy: the third is down to the record/playback signal path relay RL1. It responds to a quick squirt on its contacts. **S.B.**

### Grundig VS180

This little note comes care of Grundig Pete. Very occasionally on a small number of these machines one of the reel motors fails to stop when requested, with loud squeals from the reel brakes. The logic level FKT is low and the motor drive amplifiers should be off: in some cases however capacitor C301 or C305 has been found to be leaky. The leakage is low – some 10MΩ or so – but is sufficient to prevent the amplifier turning off by biasing the inverting input. In each case C301 and C305 have been the round black disc types. **S.B.**

### Sharp VC381

An easy one for a change. The clock couldn't be reset, cured by replacing the MP2812 microcomputer chip. It's hidden beneath the display panel. **S.B.**

### Sharp VC390

This machine wasn't erasing the vision or recording the sound. We found that the erase oscillator transistor wasn't being switched on as Q602 (oscillator control) was held on because Q603 (2SC2001) was leaky. **P.B.**

### Sony SLC6

The problem with this machine was no reel functions. This was soon traced to R061 (1Ω, 1W) which supplies the collector of the upper reel motor drive transistor being open-circuit, but when this resistor was replaced the machine wouldn't thread up after accepting a cassette. After a happy hour spent chasing around the microcomputer control chip we found that the threading end switch was wrongly adjusted – the phantom fiddler had been there before us! **P.B.**

### Sharp VC381

This machine appears to use the same black electrolytics that cause so many troubles in ITT TV sets. Problems have so far shown up as faults that occur from cold – thank goodness a dash of freezer reveals the faulty component otherwise a long session with the scope would be required. Faults up to now have been in the Y/C module, common ones being C438 or C439 defective resulting in E-E luminance problems. **P.B.**

## JVC HRD140 – Ferguson 3V44/45

The latest generation of JVC VCRs have been around for about a year. Though proving to be reliable a fair number have appeared in our workshops in recent months. I'd hesitate to describe the following as stock faults: we've nevertheless encountered most of them more than once.

First a note about the circuit protectors used in the power supply. These look like two-legged transistors and appear to go open-circuit for little or no reason. Different sets of symptoms occur when the various d.c. lines produced by the power supply panel are absent. With any VCR that appears to be non-functional or has all the motors spinning at switch on, first check the unswitched 12V line and the switched 5V and 12V lines. Replacement of the appropriate circuit protector will normally provide a complete cure. Note that it's also easy to cause them to fail while you're working on a machine. The unswitched 12V line remains throughout the machine even when the front operate switch is at off, and there's no on-off switch at the back. Don't let the meter's probe slip while checking the output at plug CN3 of the power supply. Absence of the switched 5V line with the relevant circuit protector intact can be caused by Q10 and D3 on the power supply panel.

The use of resistors in place of circuit protectors is not recommended. Even very small value resistors will produce a voltage change that can interfere with normal working. Here's an example. The problem with the machine was that the drum motor would not spin when the tape loaded to the heads. This was eventually traced to someone having used a 4.7Ω resistor in place of a circuit protector in the switched 12V line.

Some other problems. The tape loading half way to the heads then returning to the cassette is due to the absence of drum pickup head pulses. I've had the lead open-circuit at the head, also a defective head where the pin fell out of the head body. If the machine plays for a few seconds then unloads, with fast forward or rewind for only a few seconds, the take-up pulses are missing: I've twice had Q1 on the deck terminal faulty – on both occasions the transistor checked o.k. on an ohmmeter.

The symptoms associated with absence of the switched 12V line are that the operate indicator comes on as soon as the machine is plugged in, the drum and capstan motors turn, the machine switching itself off after a few seconds. Should these symptoms continue after replacing the appropriate circuit protector, or if the protector is intact, check the outputs from the two loading sensors. These should give d.c. levels of 0V and 12V at pins 34 and 35 of the main microcomputer chip. If either level is wrong yet both loading arms are back in the cassette housing the timing of the gear train from the loading motor has slipped. Ideally you'll need a second open VCR to see how to put it all back together again. Why does the timing slip? Check that the back-tension arm is not fouling the left-hand loading arm during the unloading procedure.

Two problem areas with the previous generation of JVC machines were the cassette housing and a tendency for the video heads to clog with dirt very easily. The latest machines do not suffer from these problems to the same extent. If you have to remove the screening plate over the heads for any reason, take care when replacing it – it's

very easy to dry-joint Q1 on the head motor driver amplifier panel but very difficult to resolder this properly. There speaks the voice of experience!

On one occasion when I thought I had an instance of dirty heads the culprit turned out to be IC102, which is really a luminance subassembly soldered in at right-angles to the main PCB. Each to his own way of removing it. I've also had this assembly cause picture overloading after a few seconds of play, a squirt of freezer putting things right again for a further few seconds.

A case of failure to record was caused by the 9V line to pin 2 of IC101 being absent: Q111 had gone open-circuit.

An unusual problem was a VCR with no tuner channel change, being stuck on number one. A few preliminary checks failed to bring anything to light so as I'd a similar machine already on the bench I swapped the front panels. This didn't cure the fault. Back went the original front, whereupon I inadvertently discovered that the timer indicator wasn't responding to the timer switch. Deciding to follow this lead instead took me to pin 51 of the main microcomputer chip. Due to some form of corrosion there was a leak to pin 52, the 5V supply line. Cleaning the print provided a cure. A few weeks later another machine came in with the same fault symptoms and the same cause as well.

Another unusual problem was poor playback pictures with the machine's own recordings. The f.m. waveform at TP106 was continually varying in amplitude, with the output from one head occasionally disappearing altogether. The effect on the screen was that the pictures would fade into noise maybe twice or three times a minute. Examination of the record f.m. signal showed that nothing was amiss and the odd thing was that the noise appeared at different points when the same recording was played again. The answer was that no control pulses were being recorded. The cause: R438 was missing – it had never been fitted. This would have been easy to miss during a quick visual check as the picture was stable for up to twenty seconds at a time. Very good these digital servos!

There we have it then. All in all the best machine developed by JVC to date, and by quite a margin. The only design problems from a servicing point of view appear to be the bottom cover retaining screws, which can be awkward to remove, and the relatively inaccessible motor driver amplifier panel. There's also a knack to removing the bracket which holds the combined aerial amplifier/r.f. modulator unit. A weak point here appears to be the external aerial connection centre pins. We've found them to be broken on a greater number of machines than we would expect – potentially a very expensive repair. Otherwise these machines will in years to come greatly lighten the workload of harassed video engineers.

C.H.

## Ferguson 3V29/30 – JVC HR7200/7300

There have been various comments in these pages in recent months concerning the problem of loading motor belt slippage in these very popular machines. Perhaps the following notes will help. We've had a large number of

these machines through our workshops over the years and have found that a contributory factor seems to be dust on the motor and worm pulleys – the fault often occurs with VCRs that have a dusty interior, though not exclusively so. Before replacing the belt clean both pulleys and examine the two cogs that protrude into the upper part of the chassis and engage the loading rings – clean out any grit that's become embedded in hardened grease. Take care not to get any of the grease from the worm drive on the replacement belt.

Another point I've noticed is that belt slippage can occur as the machine warms up: on many occasions I've left a VCR on soak test while trying to trace a servo fault or whatever and after playing a three hour tape once or twice have found that the machine refuses to load. Most customers don't put their machines to this sort of extended use, but a case could perhaps be made for belt changing whenever one of these VCRs is brought in for service. Don't ask me how a belt stretches as a VCR warms up. Maybe the motor would be a more likely candidate for suspicion. Changing the belt however has always in my experience provided a complete cure.

Finally, I see a lot of VCRs that have been "looked at" elsewhere. A few intriguing solutions to this problem have been noted. I cannot comment on belt boiling as it's difficult to tell when a belt has been boiled, but bending the contacts of the after-loading switch is very popular: it doesn't work. Neither does replacing D3, an 11V zener diode on the mechacon panel, with a higher voltage type – the loading arms will come out of the cassette housing like greyhounds out of their traps but the belt will still slip. What will work is removing the loading motor from its bracket and elongating the bracket mounting holes using a needle file. I did this once with a local customer's machine when we'd no spare belts and told him to come back when the problem recurred: that was over a year ago, and I've not seen him since. Maybe he just didn't want to return to someone who confessed to carrying out a temporary repair. It's quicker of course to replace the belt. **C.H.**

### Sharp VC581

This was a good one! At stop the capstan rotated backwards and when play was selected the capstan stopped . . . Investigation started at the capstan forward/reverse switching i.c. (IC701) where the reverse select pin 2 was found to be high all the time. The track was traced back to D7018 via wire link J20 which was shorting to link J25. These links are at the right-hand side of the mother board. **P.B.**

### Panasonic NV7000

The fault with this machine was no sound in the E-E mode. Checks in the sound section revealed that the audio mute circuitry was operating: pin 1 of connector P4009 was high at approximately 5V. The cause of the trouble was the quad, two-input nand gate chip IC6010. Replacing this provided a complete cure. **S.I.**

### Panasonic NV333

The capstan wouldn't lock in the playback mode. Both the reference and capstan FG signals were present and on checking the d.c. voltages around the capstan servo chip IC2003 the voltage at pin 16 was found to be low at about half the correct level. Tracing this voltage back to its

source we found that the 9V supply to connection E on the system control board was missing. The cause was Q6003 being open-circuit: this transistor acts as a switch, supplying 9V except when the machine is in the record mode. **S.I.**

### Hitachi VT8000

On pressing the play button the drum motor would creep up to speed slowly, in an irregular manner. The capstan motor would then start, again in a very erratic manner. The 9V supply at PG502/6 and the 12V supply at PG502/7 were both low. The cause was traced to R054 on the system control board being high in value. **S.I.**

### Sharp VC8300

We had two of these in during the same day. The first wouldn't switch off, with the operate light always on. Q902 was found to be short-circuit. The second machine would lose the playback picture – the screen intermittently became a blank white raster. This was traced to dry-joints on plug/socket connector CD on board PWB-C. **M.D.**

### Sharp VC7700

The complaint was no play. The machine would lace up then unlace after about three seconds. We checked the inputs to the microcomputer chip and found that the source of the trouble was a false signal from the slack sensor mounted on the pinch roller bracket. Replacing this cured the problem. **M.D.**

### Panasonic NV370 with TX5500

We delivered a new Panasonic NV370 VCR and TX5500 colour receiver. This set employs a budget-type search tuning system that's difficult to fine tune exactly. We tuned in the TV channels, but when the VCR was tuned in there was loud intercarrier buzz on the ITV channel (41) in the E-E mode. We tried shifting the modulator frequency but this didn't help. It was possible to cure the problem by fine tuning the set but when the video channel was reselected the buzz returned. The problem remained even when both the TV set and the VCR were exchanged. As Panasonic had no suggestions we resorted to opening the VCR's modulator in the customer's house and adjusting the sound coil and video level potentiometer for no buzz. This cured the problem but means that the VCR is no longer compatible with other TV sets (low sound). **M.D.**

### Hitachi VT33

The problem with this machine, which had been faulty from new, was a ringing on playback of its own recordings. I replaced IC201 but the fault remained: this meant I had to think! A check through the recording signal path revealed that R222, which damps L204, was 270k $\Omega$  instead of 150 $\Omega$ . Replacing this resistor produced correct operation. **L.H.**

### Philips VHS VCR with Thorn TX9

A Philips VHS machine would work all right with any other set but on playback of some recordings via a set fitted with the Thorn TX9 chassis the top of the picture pulled and there was a white band at the top. The

problem was cured by fitting a 10dB attenuator between the TV set and the VCR. L.H.

### **GEC V4004/Hitachi VT33**

The problem with this machine was intermittent loss of colour on playback. After a few checks I suspected the

colour processing chip IC203 as I've had this fail before, but the fault remained when a new HT4239 was fitted. On making voltage checks at Q217 and Q358 I found that the 9V collector supply was only 5V, due to choke L215 in the supply line being open-circuit – the 5V was coming from pin 27 of IC203 via the base-collector junction of Q217! Normal operation was restored after replacing L215. L.H.

## Ferguson 3V29

On changing channels this machine would sometimes appear to drift off tune. Closer inspection however showed that the fault was more like a.g.c. instability. In addition the tuning was very critical and prone to smeary video, and the r.f. gain control wasn't working correctly. As the a.g.c. voltage to the tuner was correct we first tried a new tuner. This made no difference. The fault turned out to be due to the AN5111 i.f. chip. **D.S.**

## Mitsubishi HS318

There was a rather unusual fault with this machine: the TV picture went low gain when the VCR was switched on, though the channels through the machine were fine. A faulty aerial booster can cause this sort of problem but it doesn't usually depend on whether the machine is switched on or not. A check on the supply to the booster/converter showed that instead of being 9V it was at 10-12V with the VCR off, falling when the machine was switched on and the load on the lines increased. A new 9V regulator cleared the fault. **D.S.**

## Booster/converter Units

We've had four booster/converters fail recently, two in Toshiba V65Bs and two in Finlux VR1010s – all within a couple of miles of each other. Perhaps there's some environmental factor at work here. Like the Panasonics whose boosters would fail when there was a thunderstorm in the area. **D.S.**

## Mitsubishi HS304

This machine wouldn't play because the capstan motor didn't rotate, though all other functions appeared to be in order. A check at pin 17 of IC4A0, the capstan reverse output, revealed that this was permanently high. Disconnecting the pin proved that the high was coming from elsewhere – it was traced to an inverter in IC4A2. Replacing this i.c. cured the problem. **D.S.**

## Toshiba V65B

No play was the complaint with this machine. When play was selected the machine would lace up then after a few seconds it would unlace and stop. A quick check showed that the head drum wasn't rotating, though slight pressure on the plug and socket to the lower drum assembly would start it up. We stripped down the assembly and resoldered all the joints. This failed to produce a cure and no cracks could be found. A replacement lower drum assembly cured the fault. **D.S.**

## Mitsubishi HS700

Here's a tip for anyone with one of these machines that has a broken camera socket. This item is available from Mitsubishi only if you order a complete Y/C board. The later Model HS710 uses a similar camera socket however – in fact it's a better quality, metal one. This is available as

part of a terminal assembly that's very reasonably priced. Simply remove the socket from the assembly and fit it as a direct replacement in the HS700. **D.S.**

## Grundig VS180

The symptoms were no tape transport, with the winding motors running fast. This fault is indicative of a power supply line failure. Water was evident on the inside of the bottom plate however – corrosion too. Some water was found around the upper case edges but as it had been raining heavily when Andy brought the machine in we didn't worry too much. The power supply lines were all correct at the power supply edge connectors, but there were tide marks about and it was damp beneath the tuner – green with open-circuit, corroded print. It took about half a day to strip everything out, repair the print, relacquar and test.

As it was a rental machine I was concerned about where the water had come from. More to the point I kicked up merry hell with the customer for spilling water/gin/vodka or whatever into the machine. Denials all round. The wife didn't like flowers in the house and the VCR was kept within a cabinet, so it was a mystery where the water had come from. When the VCR was returned to the customer he found water inside his cabinet and inside the aerial connectors which had been plugged together in the absence of the VCR. The water was coming down through the cable, which had to be replaced. **S.B.**

## Sony SLC7

The problem with this machine was that it wouldn't change channels after it had warmed up – the trouble was intermittent. It looked like a difficult fault and we approached it with trepidation. When the fault was present the machine wouldn't change channels and the programmable timer couldn't be set, though the clock could be. Panic set in! When a channel is selected the decoder chip IC1 on the tuning panel sets the binary conditions on lines ABCD. IC1 on the timer panel counts, and when its ABCD output back to the tuning panel matches the selected channel the count stops. Count start/stop is controlled by an AND gate in IC7 (pins 1/2/3). In the fault condition the output at pin 3 of IC7 was high, indicating count, but IC1 (timer panel) wasn't counting. Why? Because it was busy doing something else. One of its strobe inputs, pin 33, was active. This could be traced back to switch S20 (clear) which was faulty, with no spring return. It opened and closed when it felt like it, stopping the channel change. **S.B.**

## Grundig 2 x 4 Super

This machine came in for a new on/off switch – the latching spring was missing. I was not prepared for what followed. After completing the switch repair a check was made and we found that the drum servo wasn't locking up. Better lock was obtained as the machine warmed up, but the drum motor would then suddenly slow down. Everything was checked and we found that the trouble

seemed to be associated with the comparator IC1501: a replacement made no difference however and for some reason output pin 13 would inexplicably go high, slowing the drum motor. Nothing was wrong with the inputs and nothing seemed to be amiss on the power panel. As a last resort agent 003-5, Grundig Pete, was contacted.

Pete said it was the power supply. Either C446 or C447 – or maybe both – had dried up. But you can't put just any capacitor in – it has to be a high-current PCB type, better still a direct Grundig replacement. Anyway replacements were fitted – and the problem remained. Pete was around like a shot. We found that there was about 0.5V peak-peak ripple across C447 – and at the chassis-connected negative pin! I didn't like this at all. Pete fitted a replacement power panel to prove that the cause of the trouble was on this panel, confirming that it was. So it was a case of narrowing down the source of a 32kHz ripple (it's a switch-mode power supply) that appeared to be everywhere on the faulty panel. It was Pete who discovered that the cause of the trouble was the 15V supply decoupler C451 (1,000 $\mu$ F) even though we had to put in a 470 $\mu$ F type temporarily until the correct type could be obtained.

**L.B.**

### **JVC HR7200/Ferguson 3V29**

No sound on E-E and recordings was due to D14 on the audio-video board being leaky. This diode forms part of the circuit used to mute the sound in the still and shuttle modes.

**L.G.**

### **Hitachi VT8000**

We've had a couple of faults recently on these machines. First no functions with the operate LED out was due to R054 (1.5k $\Omega$ ) being open-circuit. This resistor biases the regulator transistor Q053. Secondly absence of E-E sound and video with a normal test signal was due to the not-PB 12V line being absent – ZD053 in the regulator circuit was short-circuit.

**L.G.**

### **Sharp VC8581**

Intermittent recording on one of these machines was traced to a defective HA11744NT1 video processor chip (IC401). A scope check revealed that the luminance was arriving at pin 20, but there was no f.m. oscillator signal at pin 12 – and thus no f.m. output to the video heads.

**L.G.**

### **Sharp VC7750**

It's not very often that you get an electrical fault on this model – most faults are mechanical. This one was dead due to an open-circuit Darlington transistor, Q908. A replacement was fitted but on switching on the supplies were found to be low and the chopper transformer was making a squealing noise. C920 had gone low in value.

**P.B.**

### **Ferguson 3V32**

This machine had a cassette inside. When this was played it looked as if the recording consisted of line tearing. An accompanying note said that the fault was intermittent and that when it occurred a noise came from within the machine. Sure enough after an hour or so of playing this tape a noise could be heard. So while it was still playing

the top was removed. The noise was coming from the area of the audio/control head. No it wasn't the head (as with the early Hitachis) but a wire rubbing against the tape!

**P.B.**

### **JVC HR7200/Ferguson 3V29**

Intermittently stops was the complaint with this one – every so often the capstan would stop, and it wasn't dry-joints around Q216 either! We found that the pause control line went high when the fault occurred. This comes from the mechacon board where Q17 had a dry-joint at its emitter.

**P.B.**

### **Ferguson 3V35**

There was no colour on playback or record. A check at test point TP402 revealed that the amplitude of the 625kHz signal was low. Voltage checks at the pins of the HA11741 colour signal processing chip were then carried out. The voltage at pin 15 was found to be low due to C433 (0.022 $\mu$ F) being short-circuit. Several other cases of no colour with these machines have been traced to filter BPF401 – resoldering its connections often provides a cure.

**P.B.**

### **Hitachi VT9300**

This machine would load but there was no tape rotation. We removed the top cover and noticed that the capstan wasn't moving. When we removed the bottom covers we found that the capstan motor wasn't running because its bearings had seized almost solid. Removing it, cleaning and oiling provided a cure.

**M.D.**

### **Ferguson 3V24**

This portable would intermittently go into the alarm mode, with the mode indicators flashing sequentially. This would sometimes happen when the machine was switched on from standby, or if rewind or fast forward was selected. Play was normal but when we tried to select picture search the machine went into the alarm mode and we couldn't get it back into play. The machine had to be unloaded by hand before we could get anything to work. Checks were carried out on the various sensor inputs to the microcomputer chip: eventually we found that the pinch solenoid switch S17 was intermittently sticking on. Retensioning this provided a cure.

**M.D.**

### **Panasonic Clock Faults**

The NV2000 seems to be prone to clock failure – we've changed four over the past few months for faults ranging from no display to alternating between 12- and 24-hour operation. Other Panasonic machines also suffer. We've had a couple of defective clock i.c.s in the NV333 – the symptom in both cases was no display. An NV366 came in with the same fault – no display. The 36V rail was found to be missing due to the 10 $\Omega$  safety resistor R7632 being open-circuit. When this was repaired there was no hours display and the clock wouldn't set. We were just about to order a chip when we noticed a deposit on the print. Further investigation revealed that the back-up battery had gone rotten and leaked down the panel. A careful clean up and a new battery cured the problem.

**M.D.**



# Servicing the Panasonic NV7000

David Botto

We've handled a fair number of these popular VHS machines which enjoyed a wide sale. Before tackling any repairs you'll find a little time studying the circuitry a good investment. We'll consider the various sections of the NV7000 and some of the fault conditions that can occur.

## Access

To gain access for servicing is straightforward. First remove the two non-magnetic screws from the cassette cover. These are special screws, so be careful not to lose them. Next remove the two screws at the top corners at the back of the machine. You'll then be able to lift off the whole top portion of the case. Should you need to remove the bottom metal plate to expose the printed boards at the bottom of the case, place the machine upside down on a soft surface, remove the six screws that hold the plate and lift it away. Of the two PCBs thus exposed the smaller is the servo and subsystem control board and the larger the luminance and chrominance signal processing board.

To open the bottom printed panels remove three screws at the front and three at the rear. These screws are usually reddish-gold, making them easy to identify. By pushing back the front of the boards to clear the knobs and jacks etc. the boards are freed and can be swung outwards (hinged at the rear of the machine) for inspection. To remove the VCR's front panel – don't do this unless it's essential – remove three screws at the top and gently ease the panel off. It's best to start by removing just the cassette cover and top casing however.

In servicing these VCRs a special rubber bench mat, such as those supplied by Philips, RS Components, etc., is almost essential to avoid scratching or damage to the machine. You'll also find that a special magnetic screwdriver speeds things up and avoids screws being dropped into sections of the machine where they are difficult to retrieve.

## Power Supply Arrangements

Looking into the top of the machine with the top casing removed you'll see the power supply board (VEP0177A) mounted upright at the rear left-hand side. A plate behind it holds IC1501 (HA17806) and transistor Q1501 (2SA1061).

The power supply circuit, together with operating voltages, is shown in Fig. 1. The mains supply is fed via the power switch at the rear of the machine to connection points 13 and 14 on the panel, passing via the fuse, filter coil L1001 and connector P1008 to the mains transformer T1001 which has its windings so arranged that selector S1002 can provide adjustment for inputs from 110V to 240V a.c. – always check that the setting is correct.

T1001 has three secondaries providing a.c. outputs of 20V, 12V and 38V which are fed back to the board via connector P1007.

The 20V a.c. supply is fed via fuse F1002 (4A) to D1006 which produces 20V across C1007 and bridge rectifier D1001-4 which produces approximately 18.3V across C1002.

The voltage across C1002 is applied to two separate regulators. First Q1003 whose base voltage is held steady by zener diode D1015. The voltage at the emitter of Q1003 goes to pins 6 and 7 of P1002 and via D1008 to pin 1 of P1003. Secondly Q1501, via P1001/1, which produces a stabilised 12V supply at its collector. This voltage is present at P1001/5 and at pins 1-4 of P1004. The base of Q1501 is driven by a conventional control circuit whose main elements are Q1001, Q1002 and zener diode D1012. Preset R1007 provides adjustment. To set up, connect a digital voltmeter between the 12V line and chassis and adjust for exactly 12V with the machine in the stop mode. Recheck after half an hour. Get it accurate to within 0.1V. Always check this voltage before tackling obscure faults.

The 12V at pin 1 of P1003 goes via pin 1 of connector P1507 to power switch S1507 on the power/timer/NR select board which lives at the right-hand side of the front of the machine, behind the front panel. The switches on this little board are operated by three small pushbuttons on the front right-hand side of the machine. Pins 6/7 of P1002 supply pin 1 of connector P704 on the TV demodulator section board which is on the extreme right looking into the top of the machine.

The regulated 12V supply at P1004 goes to various parts of the VCR as follows. Pin 1 feeds pin 2 of connector P3007 on the luminance/chrominance board. Pin 2 feeds pin 1 of connector P2005 on the servo and subsystem panel. Pin 3 supplies pin 2 of connector P6203 on the system control II board. Pin 4 supplies pin 2 of connector P704 on the TV demodulator section.

The unregulated 20V supply produced across C1007 passes via pins 4/5 of connector P1006 to pin 3 of connector P2005 on the servo and subsystem control board and pin 1 of connector P6203 on the system control II board (this board is cunningly folded together with the system control I board and hidden inside the machine on the right-hand side, under the two main bottom PCBs – the larger is the I board and the smaller the II board). The 20V supply is also fed via the 4.7 $\Omega$ , 10W resistor R1501 and connector P1006/3 to pin 2 of connector P2005 on the servo and subsystem board.

The 20V a.c. winding on the transformer also supplies pins 1-2 of P1006. This supply goes to pins 1-2 of connector P3008 on the luminance/chrominance board, emerging from this board at pins 1-2 of connector P003 to power the PTC heater inside the little cast fitting near the back of the video heads.

The output from the 12V winding on T1001 is fed via F1003 (1A) to a second bridge rectifier, D1009-10, which develops 12V across the reservoir capacitor C1013. This supply goes to pins 5-6 of connector P1004. Pin 5 supplies pin 1 of connector P1515 on the power transistor panel while pin 6 supplies pin 4 of connector P7501 in the timer section. It also goes to pin 4 of connector P1001, then to regulator IC1501 whose 6V output appears across C1027. This supply goes via P1003/2 to P7501/5 in the timer section. It's also reduced to 5V via D1007 and is then fed via P1003/3 to P6001/1 on the system control I board.

The output from the 38V winding on T1001 goes via

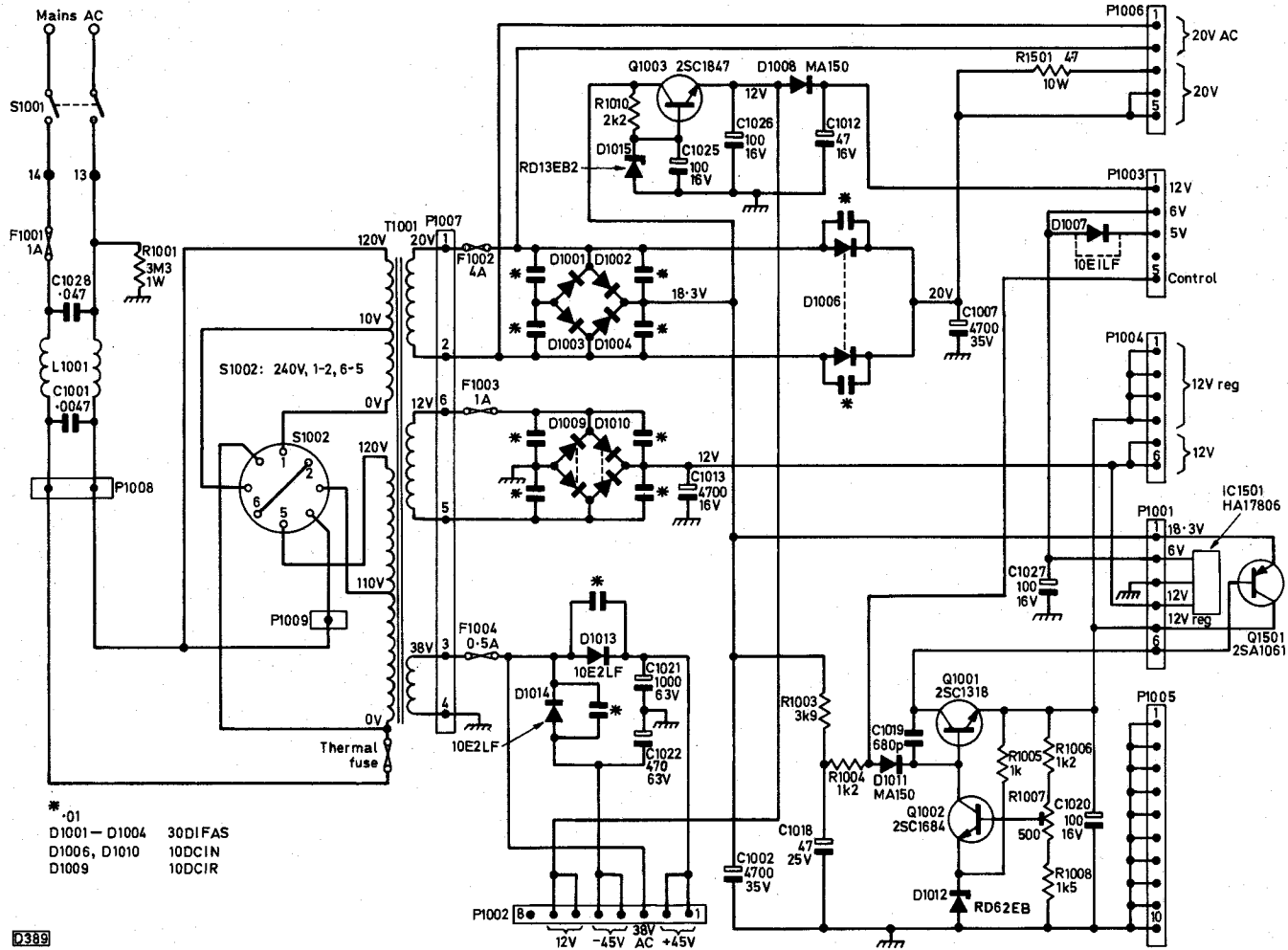

Fig. 1: Power supply circuitry used in the Panasonic NV7000.

F1004 (0.5A) to P1002/3 and to the full-wave voltage doubler circuit D1013/4/C1021/2. This produces 45V across C1021 and -45V across C1022. The positive supply goes via P1002/1 and 2 to power switch S1507 on the power/timer/NR select board. The negative supply goes via P1002/4 and 5 to P7501/3 on the timer section. The timer board can be seen from the top of the machine to the left of the TV demodulator section with the case removed.

Connector P1005 simply connects the chassis side of the power supply to all the various boards to ensure that all chassis connections are linked.

An appreciation of the power supply and its various outputs helps a great deal when servicing the NV7000.

## Power Supply Faults

A completely dead machine showing no signs of life can simply be due to failure of F1001 – it tends to die of old age. In this event fitting a new fuse will restore operation. If F1001 is blackened check the filter capacitors C1028 (0.047 $\mu$ F mylar) and C1001 (0.0047 $\mu$ F ceramic). These are usually extremely reliable but they have been known to go short-circuit.

If F1001 is in order and the machine is dead or not operating on all functions check fuses F1002-4. Before going on to check for the causes of involved faults do first ensure that the correct voltages are present at all the power supply outlets.

Regulator IC1501 sometimes fails, producing an upwards voltage surge on the 6V line. Protection diode D7542 (QA107R) on the timer board, just in front and parallel with IC7505, then goes short-circuit – probably restored permanently. With a new regulator and the 6V supply restored the machine will work normally with D7542 snipped out. Don't be tempted to leave it out – if IC1501 should fail at a later date the damage could be extensive. D7542 is a special zener diode and the correct replacement type from Panasonic must be used. When fitting, also test diode D7536 (EM1Z) on the timer board – at the right-hand side of connector P7509.

When the 12V regulator transistor Q1501 goes short-circuit the 12V supply becomes an 18-22V supply (this often happens when there's a tape in the machine). When you now press the play button nothing happens except that a rather interesting te-chunk, te-chunk noise is heard coming from somewhere inside the machine. Fortunately the excess voltage doesn't seem to do much harm. Just the same, disconnect the machine from the mains supply quickly, replace Q1501 and be sure to test transistors Q1001/2 and diodes D1011/2. With the regulated 12V supply restored and set up correctly you'll usually find that all functions are operating normally.

## Component Tester Checks

The fast easy way to check all power supply components is with a component tester (see *Television*, June

1984). With the mains supply removed and the plugs disconnected from the power board you can effectively test every transistor, diode and capacitor in minutes.

## Programmable Timer Board

We'll look now at some of the boards that have given us problems, starting with the programmable timer board. First ensure that all the supply voltages are present and correct. Measured between connector P7501 and chassis you should get readings of 3V a.c. at pin 2, -45V at pin 3, 12V at pin 4 and 6V at pin 5.

The usual cause of failure on this board, giving rise to various weird symptoms, is a faulty microcomputer chip. There are two, IC7505 (MN1400VL) and IC7506 (MN1405VM). A logic probe is ideal for fault tracing on this board: Table 1 shows the readings to expect at the pins of IC7505/6.

Before fitting a new microcomputer chip it's a good

**Table 1: Microcomputer pin conditions.**

IC7505		IC7506	
Pin	Reading	Pin	Reading
1	0V	1	0V
2	L	2	L
3	L	3	L+P
4	L	4	H
5	H+P	5	L
6	H+P	6	L
7	H+P	7	L
8	H+P	8	L
9	H+P	9	L
10	H+P	10	L
11	H+P	11	L
12	H+P	12	L
13	L	13	H
14	L	14	L
15	H	15	L
16	H+P	16	L
17	Slow pulse	17	L+P
18	L+P	18	P
19	H+L+P	19	P
20	H+L+P	20	Slow pulse
21	L+P	21	H+P
22	H+P	22	L+P
23	H+P	23	H+P+L
24	L	24	H+P+L
25	L+P	25	L+P
26	L	26	L+P
27	H	27	L
28	H	28	H
29	L+P	29	H
30	H+P	30	L+P
31	H+L+P	31	L+P
32	H+L+P	32	L+P
33	H+L+P	33	L+P
34	H+L+P	34	L+P
35	H+L+P	35	L+P
36	H+L+P	36	L+P
37	H+L+P	37	L+P
38	H	38	L+P
39	5V	39	5V
40	H+P+L(osc.)	40	H+P+L(osc.)

Notes: H=high, L=low, P=pulse.

Taken with front on button pressed but no function button pressed. Clock operating normally, reading Sun 1-07 when the readings were taken.

idea, after carefully removing the old one using a small, temperature-controlled soldering iron and good quality desoldering braid, to fit a forty-pin holder. If the fault should turn out to be elsewhere you can then easily replace the original chip - besides, it might fail at a future date...

If things seem to be otherwise in order but the clock display is rather strange the usual cause is one of the TA57 i.c.s (IC601-3). Check them with your logic probe or by replacement. There are four DN852 i.c.s on the board, IC7501-4, but we've so far never had any problems with these.

After you've carried out any repairs necessary on this board always check fuse F7601 (1AT). The clock will operate if this fuse is open-circuit but the back-up battery system won't.

The various diodes and transistors on the board can be quickly checked - they rarely fail - with your component tester. When testing be sure to desolder one end of each diode and two connections to each transistor. The small electrolytics dry up and corrode, causing mystifying faults, so examine them carefully for drying out.

## Luminance/Chrominance Panel

Fortunately few problems occur with the luminance/chrominance panel. When a fault does occur however it can be extremely puzzling due to the complex circuitry used. First a warning: don't disturb the highly critical adjustments on this panel unless this is absolutely essential - if you do you may well spend many a happy hour getting them right again!

A fault that can occur - first make sure that it's not due to the video heads - is the luminance being poorly recorded or not recorded. With a colour-bar input to the VCR, observe the waveform at TP3001 - all test points on this panel are clearly labelled. Use a 10:1 probe with the scope. You should see the complete picture signal. From here the signal goes via R3002 and C3002 to pin 1 of IC3001 (AN6310) which can fail - this i.c. contains the a.g.c., sync separator, f.m. modulator, clamp and emphasis clip stages. The signal emerges at pin 24 of this i.c. and goes via L3001/C3003 and C3005 (0.047µF, type VCY25473KX, order specially from Panasonic) back to pin 5 of the i.c. The output at pin 24 also goes via C3006, Q3031 etc. to pin 21, emerging at pin 22 and then going via the deviation control R3019 and C3018 (47µF, 6V) to pin 19. Make sure that C3018 has not dried out or lost capacitance. After passing through an internal amplifier the signal reappears at pin 18 and is then fed via a non-linear emphasis circuit and emitter-follower to pin 16. After clamping the signal goes to the emphasis clip section (see Fig. 2). The white and dark clip presets are connected to pins 10 and 12 - both these adjustments are critical. C3022 between pins 13 and 14 provides frequency adjustment (3.8-4.8MHz). Understanding what happens in this i.c. is important when servicing the luminance/chrominance panel. The output at pin 9 goes via C3025 to TP3009, where you should see the f.m. signal waveform (at approximately 5V p-p), then via the record level preset R3025 to the record amplifier which consists of transistors Q3005 (2SC2377), Q3006 (2SC2206), Q3007 (2SB641) and the associated components. Should you ever need to replace any of these transistors (they rarely fail) do use exact replacements or you may get all kinds of puzzling results.

The chrominance circuitry is reliable and despite the numbers of these VCRs we've serviced not many prob-

lems have been encountered. IC8001 (AN6360), a device used in various VCRs, can fail however. Whenever we meet this i.c. we regard it with suspicion. Perhaps we've just been unlucky.

Record signals arrive at pin 1 of IC8001 via filter FL8001 (VLF0113), the playback signals going to pin 18 via FL8002 (VLF0085). These filters – there are a number on the board – sometimes cause problems, but check the soldered joints before condemning them. You should see the standard cotton-reel colour-bar signal with burst information at TP8001 (pin 7 of IC8001).

A good monochrome playback signal with no colour may mean that the a.p.c. preset (C8050) and/or the reference oscillator preset (C8024) needs very slight adjustment. Don't turn either of these to find out because if the fault should prove to be elsewhere you'll make yourself a lot of work. Insert a tape, switch to record and set the input select switch (front of the VCR next to the tracking control) to the camera position. Connect a digital frequency counter to TP8008 via a 10:1 probe. It should indicate 4-433619MHz to within  $\pm 50\text{Hz}$  (the figure in the service manual, 4-435572 MHz, is incorrect). Next switch to the stop mode. With the counter connected to TP8002 a reading of 4-433619MHz  $\pm 10\text{Hz}$  should be obtained. If either or both of these frequencies is incorrect carefully adjust the preset capacitors as necessary. If the waveform at TP8002 is missing suspect IC8002 (AN6352). Before changing any i.c. on the board however always check the small surrounding electrolytics.

Puzzling effects can occur if one of the connector plugs on the board is not pushed right home into its socket. Check them all.

## System Control Boards

The system control I board contains the microcomputer chip IC6001 (MN1400VP) together with a variety of i.c.s packed with logic gates, inverters and other types of logic, plus the usual diodes and transistors. The only practical

way to fault-find is to use a logic probe (see details given on pages 22-23 in the November 1985 issue) after first checking the board's supply voltages. All sorts of interesting problems can occur, such as indicator LEDs flashing on and off when they shouldn't, functions refusing to

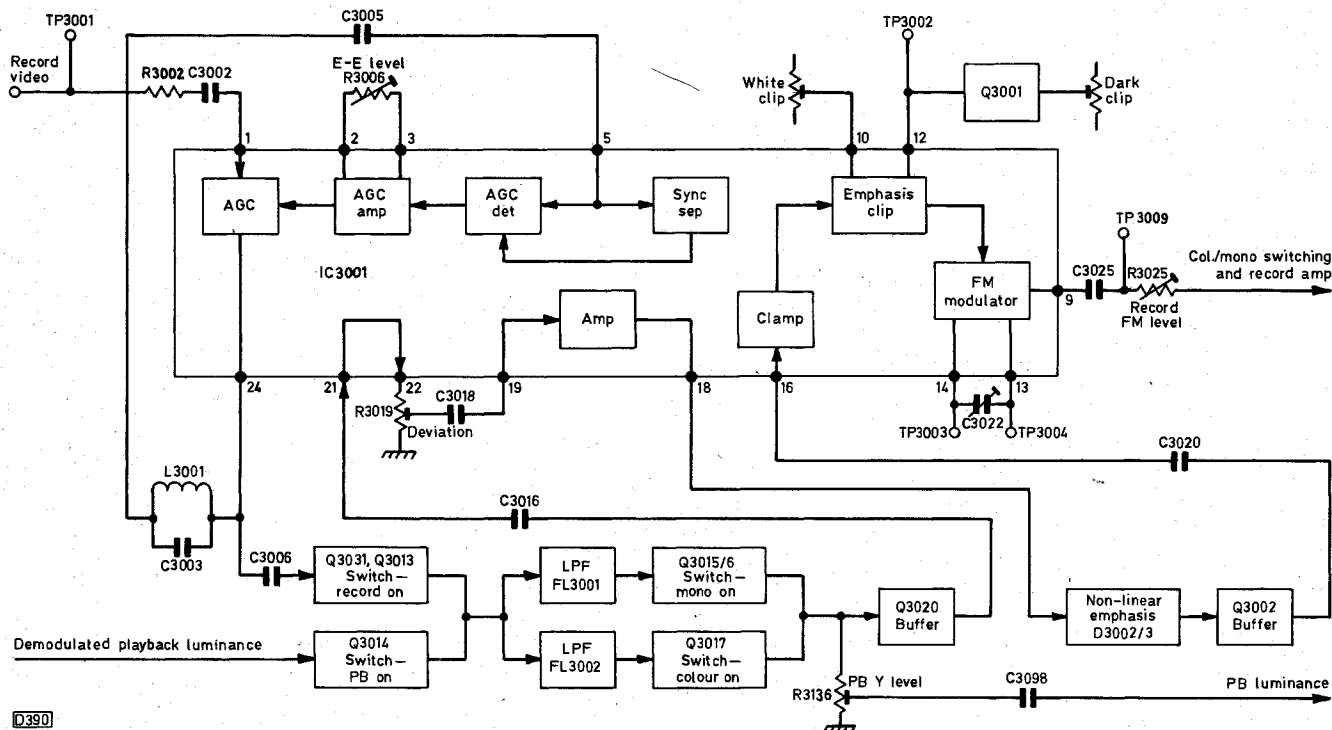

Fig. 2: Block diagram showing the luminance signal processing in the record mode.

work, motors turning on and off when they feel like it, etc. Often the fault lies in IC6001, but it can be due to a faulty logic gate or inverter in one or other of the various logic i.c.s. Favourite logic i.c.s to fail seem to be IC6002 (4081), IC6003 (4049) and IC6004/5 (both 4503s).

Interestingly, with so many of our customers owning NV7000s we've had no problems yet with the system control II board, nor with the little front panel that holds the selector switches operated by the front panel function select buttons.

In later models the system control I and II panels were replaced by a single board using a new specially developed microcomputer chip (IC6001, type MN1405VK). This seems to be more reliable than the system control I board microcomputer chip. You'll probably mostly encounter the two-board version however.

## Audio and Still Boards

The audio board has not troubled us yet and we've only rarely had faults on the still board. This latter board contains mostly NAND, AND, and OR gates plus D-type flip-flops so you need use only your logic probe and for the individual transistors your component tester.

## Servo and Subsystem Board

If the drum motor is running very fast indeed replace capacitors C2033 (0.01 $\mu$ F, 50V ceramic) and C2034 (0.068 $\mu$ F, 50V mylar) connected to pins 14 and 13 of IC2001 (AN6350). When the motor won't lock in properly first check diodes D2009/10 (both type MA150) and capacitors C2036 and C2037 (both 0.1 $\mu$ F, 50V mylar) connected to pins 11 and 9 of the i.c. If these components are in order you'll have to try replacing the i.c.

Other servo problems that cause failure of the drum motor to lock properly can be caused by IC2008 ( $\mu$ PD4011C) which contains four NAND gates and is thus easily checked. Watch out for sneaky tricks caused by diode D2012 (MA165) which is connected between pin 2 of this i.c. and chassis.

Problems in IC2002 (AN6677) can result in failure of the drum to rotate. Check Q2019 (2SD389) first however.

If the capstan motor doesn't lock in correctly the suspects are IC2001, IC2004 (AN6341) and IC2007 ( $\mu$ PD4528C). The quickest way to find out which is the culprit is by replacement.

## Various Faults

When the tape loads and then immediately unloads after pressing the play button the loading belt is probably at fault. If you need to replace this belt it's best to fit a complete new set of belts to prevent future troubles.

Noise bands running up and down the recorded picture can be caused by a faulty tracking control – this is usually due to a heavy-handed user.

If the tape won't play make sure that the cassette lamp isn't open-circuit. I know that this is an obvious fault – but one can still get caught.

If the tape unloads when a cassette is played and the counter reads 0006 to 0007 it's possible that the Hall-effect i.c. (DN838) under the supply reel is at fault. It's best to replace this by cutting the legs off the old i.c., then soldering the new one to these – this is the official instruction we had from Panasonic. This is also a good place to say how helpful the engineers at Panasonic have

been whenever we've phoned them for advice. It's appreciated, believe me!

A much more likely cause of trouble when the tape halts at 0006/7 is the capstan motor. These motors are expensive however. So carefully unplug the connector to the motor, unbolt and remove it from the machine. Take out the three screws that hold it together and separate the pieces. Don't lose any of the special parts that make up the motor. Lubricate the bearings with just the slightest trace of Castrol DWF lubricant. When reassembling lubricate the spindle – again the slightest trace – where it passes through the top plastic washer (this washer looks like an inverted top hat when removed from the motor). Don't push it down too far when reassembling. You'll nearly always find that the problem has been cured when the capstan motor is refitted.

## The Heads

Provided they are regularly cleaned the video heads enjoy quite a long life. Clean the whole video drum thoroughly before condemning them – also the audio/control and erase heads. Clean the entire tape path using only a proper video head cleaning kit and fluid. Good heads are easily ruined by incorrect cleaning materials.

A fair picture from a prerecorded cassette but a poor one from a recording made by the machine can be a sign of worn heads. You can check the heads by playing the Panasonic alignment tape (part no. VFM8100H3D) and observing the f.m. envelope at pin 10 of IC3002 (AN6320) on the luminance/chrominance board, using a scope with 10:1 probe. Make sure that the tracking control is in its fixed position. We find however that the best method, provided you've a spare drum to hand, is to try a new set of video heads. This is quick and reliable – it's done in minutes, just two screws and four soldered connections. The leads are colour coded, so it's difficult to wire them incorrectly. It's been done though! If you get a winding reversed you can end up with a nice monochrome picture, i.e. no colour.

It's always best to fit the correct heads supplied by Panasonic. You'll find it cheaper in the long run because with the correct heads fitted no or minimal adjustments should be necessary.

## Tuner/Demodulator Panel

The tuner never seems to fail but it can drift off tune after an hour or so. If this occurs first check for 12V at pins 1 and 2 of connector P704 and 45V at pin 4. Then check D7011 (RD5-1EB) and D7013 ( $\mu$ PC574JK), also transistors Q7007 and Q7019 (both type 2SA684). Another suspect is D7026 (MA150). On rare occasions IC7001 (AN5701) gives trouble.

A dusty picture in the E-to-E mode only is caused by a faulty r.f. booster unit (part no. ENPE702). Replace the unit, don't waste time trying to repair it.

## General Advice

In conclusion I'll repeat my usual advice about applying a little circuit varnish to any joints you may have resoldered – but use a tiny brush to do so. The Panasonic alignment tape is well worth having as it will save you much time in servicing and any necessary adjustments. For voltage measurements I recommend using only an accurate digital multimeter.

## Sharp VC3300

The fault with this portable machine was poor wind and rewind. The AUX brake wasn't releasing on wind/rewind though it did release on playback. The solenoid that operates the brake would pull in (as it should) then release again as the return coil was pulsed. Reference to the timing diagram in the manual showed that this shouldn't have been the case. After spending some time chasing round the brake drive circuit I had a look at the block diagram for inspiration. This revealed that a power failure signal is sent to the brake circuit from the power supply, and although the low-battery LED was out the signal line was floating at 3V. One half of operational amplifier IC901 was found to be open-circuit. Replacing the op-amp cured the fault but then the take-up spool didn't go round in playback! As this had been o.k. before I retraced my steps, one of which had been to swap over the reel drive and loading drive i.c.s. Although the circuit shows them as being of the same type one of them has an A suffix. Swapping them back restored normal operation (the A one should drive the reels).

P.B.

## JVC HR7200/Ferguson 3V29

The problem with this rather worn machine was intermittent loss of drum servo lock in search. The cause was a crack in the servo panel by connector 302.

P.B.

## Toshiba V31B

Severe overloading and no sound in the E-E mode, with the playback light permanently on, was due to Q663 being short-circuit. As a result the play-12V line was present all the time.

P.B.

## Philips/Finlux VR1010

An unusual problem with one of these machines was wow on sound and a rumbling noise coming from the capstan. The old screwdriver stethoscope trick proved that the noise was indeed coming from the bearing, but on these machines the races are riveted into the chassis. So I sent the machine back to Finlux who replaced the complete transport assembly. The noise was still there: red faces all round! If I'd tried replacing the tape servo board I may have traced the fault to a noisy TDA1432 DA converter chip. Sorry Gerry!

P.B.

## JVC HR7700/Ferguson 3V23

The fault on this machine served as a reminder that logical fault finding saves time and money through ordering the correct part first time: work on the assumption that all components are innocent until proved guilty. The complaint was no sound in the E-E mode, with the monitor producing an oscillation in the record mode. A hum test at pin 2 of IC1 (HA12005) produced no output while a similar test at output pin 6 produced results. We assumed that the i.c. was faulty, but were wrong. Further checks revealed that the voltage at pin 7 was low in both the record and playback modes. This pin is controlled by switching transistor X4 whose base was found to be

constantly high. This took us back to X44 on the mechacon board, then to IC3 (UPD4066C) on the junction board. Replacing this item finally cured the fault.

A.D.

## Hitachi VT88

This machine would accept and play cassettes properly but was loath to give them back when requested – when the cassette was ejected it was immediately taken back into the machine. We found that the cassette housing timing gears had slipped, as a result of which the cassette-in detector switch was operating too early, before the cassette had been fully ejected. Resetting the gears will provide only a temporary repair: the complete cassette housing assembly should be replaced.

A.D.

## Hitachi VT8500/8700

Failure to record was the complaint with a Hitachi VT8500: there was neither sound nor picture in the E-E mode. The supplies to the tuner and i.f. strip were correct but there was no output from the i.f. module. Fault finding here didn't look to be easy because of the close proximity of the tuner, with both modules soldered into a mother board. Just before I was about to remove the tuner/i.f. pack a picture flashed on the screen then off again: tapping the i.f. module would make the sound and picture come and go. When the i.f. module was unsoldered and its covers removed three obvious dry-joints were seen at earthing points, about a third of the way across the module from the left-hand side. Because of the difficulty experienced in removing the module we decided to do a blanket soldering job. When the module was replaced we had nice E-E vision and sound with no more problems.

A similar machine, a VT8700 in a Granada case, had a pluggable i.f. module. The complaint was the same and on opening the module the same three dry-joints were noted. Resoldering just these three joints restored normal service.

A.D.

## Sony SLC30

Crawling beat-frequency bars on the screen during playback (also in the E-E mode, though less evident) were eventually traced to a  $\pm 1$ MHz oscillation on the UN12V line. This disappeared when plug CN001 was removed from the r.f. modulator – the oscillation was modulating the regulated 9V and 12V lines. After delving around in the modulator it was found that adding an 8.2 $\Omega$  resistor in series with the UN12V line at plug CN001 (pin 3) solved the problem. It was easily fitted by cutting the print at the pin and mounting the resistor across the break.

M.P.

## Sanyo VTC5000

On playback there was a horizontal line three-quarters of the way down the screen – even with a prerecorded tape. Replacing the head disc didn't provide a cure so I tried switching over the whole cylinder motor and upper cyl-

inder from a VTC5300 (same unit!). This cleared the fault. Replacing the original upper cylinder assembly brought the fault back. On these machines the fixed head section of the transformer is mounted above the head disc in the upper cylinder: I suspect that the cause of the trouble could have been a short-circuit turn. **L.H.**

### **Toshiba V9600**

This machine had very poor rewind – it would often stop. The problem was not due to the usual upper cylinder or rewind idler wear but to the two pillars that locate into the rear underside of the cassette. They were misaligned, causing the right-hand spool to drag. Unscrewing the pillar fixing screws and relocating the pillars correctly cured the problem. **L.H.**

### **Toshiba V8600**

No output from the modulator due to Q661 being faulty – usually open-circuit base to emitter – has been mentioned before in these pages. I phoned Toshiba to see if any modifications were needed but it seems that the reason for this relatively common failing is not known. **R.B.**

### **Samsung VI510T**

The problem with this machine was perfect playback of a prerecorded tape but only noise on the screen from one of its own recordings, though the sound was good. With such symptoms the first check should be on the voltages that control the video head switching transistors at the head preamplifiers. The fault is normally due to either the

record voltage being incorrect or a playback voltage being present during record. What caused the problem with this repair was an apparent mistake in the manual: this suggests that during record there should be 12V on the record line, most easily checked at pin 26 on the Y/C panel. In fact there should be 12V here during playback with zero volts during record. Once this error had been confirmed by checking with a good machine it was easy to trace the fault to IC8 on the syscon panel. It's one of those one-sided green i.c.s with the internal components bulging through the casing. **C.H.**

### **Ferguson 3V35/3V36**

In both the playback and record modes the drum speed hunted at a regular rate. The cause of the fault was traced to R446 (270k $\Omega$ ) which had gone high in value. It's in the drum speed control circuit, connected between pins 14 and 15 of IC404, i.e. providing feedback in the drum speed error signal amplifier stage. **J.R.**

### **JVC HRD120/Ferguson 3V35. Erase Problems**

Over the years various VHS machines have suffered from problems at the full erase head. When you consider that each time a tape is played the supply loading arm pushes the erase head assembly out of its way after which the assembly springs back into position it's not surprising that with a number of machines you get dry-jointed erase heads or loose plugs at the erase head panel. The resultant symptoms vary from model to model. In all cases traces of colour from a previous recording will be left on the tape, since although the f.m. record current will remove all

traces of luminance information any strong areas of colour will remain. With the erase head out of circuit new audio is recorded normally though I have come across models where the previous audio remains as the erase head appears to be an active part of the h.f. circuit and, if not connected, the h.f. oscillator will not start up. In either case the accepted solution is to solder the leads directly to the pins of the erase head, removing the plug if one is used.

For some time I've been plagued by a couple of JVC HRD120s with very intermittent failure to record the audio signal, the previous track being left on the tape.

Soldering up the erase head made no difference – in fact on these machines if the erase head is left open-circuit the only apparent effect is smeary colour on the new recording. The problem is due to the h.f. oscillator circuit not starting up – if it doesn't start up for a particular recording it remains inactive throughout the recording. The solution that's finally come through is the following modification. Change transistor Q8 in the oscillator circuit from type 2SD638R to type 2SD638S and alter the value of C48 by soldering a 5.6nF capacitor across it. Should the same fault be encountered in the later JVC HRD140 it's worth checking the h.f. oscillator coil T1 for dry-joints. **C.H.**



# VCR Fault Analysis

Steve Beeching, T.Eng.

## Fisher FVH615 Function Fault

Once put into play the machine wouldn't respond to stop. Eject gave pause. Forward picture search was o.k. but reverse search was ignored. Obviously brain failure, but where?

The starting point here is to eliminate the main microcomputer chip and check around the various input paths to it for errors. As play could be selected – the micro followed the play routine and playback was observed – it was a fair bet that the micro was all right, though we left open the possibility that it was defective (say a 90 per cent chance that it was o.k., a 10 per cent chance that it wasn't).

The input data comes via a comparator system and the basic operation is simple once explained. When a function key is pressed an input voltage from a resistive ladder network is applied to one input of an operational amplifier that acts as a comparator. See Fig. 1. The other input, applied to the non-inverting (+) input of the comparator, consists of a staircase waveform. This is obtained from the microcomputer chip's four-bit keyscan data output lines (D0-D3) via a digital-to-analogue converter – the latter simply adds the four-bit data pulses to provide the staircase waveform. When the staircase voltage waveform at one input of the comparator equals or exceeds the voltage at the other input the comparator's output changes state. The microcomputer notes this change and checks the state of its D0-D3 outputs at this point. It compares the D0-D3 conditions with a value stored in its memory and this tells it what function has been selected. The micro then takes the appropriate action.

In the case of play the ladder network applies 3.8V to the comparator's inverting input (-) pin. The appropriate conditions on the D3-D0 (note order) lines are 0001. Table 1 shows the conditions for various functions. So play is selected when the ladder network produces 3.8V

and the D3-D0 lines are at 0001: for pause the conditions are 11mV and 1110 and for eject about 300mV and 1101. Thus if eject operates pause either the voltage value is wrong, the state of the D3-D0 lines is incorrect or the comparator chip is faulty. The voltages produced by the ladder network and the function keys checked out fine, which isolated the fault to the other side of the circuit.

One problem in practice is that the staircase waveform is not the linear affair one theoretically expects. So don't blame the microcomputer chip for nonlinearity. On the oscilloscope the microcomputer's outputs look like random pulse trains of various highs and lows.

A test routine is possible if a double-beam scope is available. Check the comparator output at pin 6 of the comparator/DA converter chip against one of the data inputs to locate a point in the data waveform of seemingly random marks and spaces where a change of output takes place. By locking the scope to that data line the other three can be checked against it and the digital conditions at the marked point where the comparator output alters can be established. In our case the comparator's output changed with different command inputs despite the data lines being in the same condition, i.e. the comparator was unable to differentiate between two different inputs.

Table 1: Function select conditions.

Function	Key voltage	D3	D2	D1	D0
Playback	3.8V	0	0	0	1
Record	3.49V	0	0	1	0
Fast forward	1.43V	1	0	0	1
Rewind	1.15V	1	0	1	0
Stop	863mV	1	0	1	1
Eject	296mV	1	1	0	1
Pause	11mV	1	1	1	0

## Book Review

"A First Class Job!" – the biography of Frank Murphy, by Joan Long. Available at £5.95 per copy including post and packing from Mrs. Joan Long, 5c Weybourne Road, Sheringham, Norfolk, NR26 8HF.

Television readers who have long memories will be particularly interested in reading Joan Long's arresting memoir of her father, who founded Murphy Radio Ltd. in the early thirties. It will also appeal to those who take an interest in the history of radio generally, from the viewpoints of the customer, the dealer and those who work in the industry.

Frank Murphy was guided in business by the principle of giving value for money, and he used the firm he founded to practice what he preached. We learn with astonishment from Joan Long's book that his active involvement with the firm lasted for little more than six years, but in that short time he contrived to take the industry by the scruff of the neck and shake it from top to bottom. Not only were his radio sets of highly distinctive style, they were sold by dealers who had an unprecedented relationship with the factory and made by workers who in the mid-thirties had probably the best conditions in the industry. How Frank Murphy achieved all this makes fascinating reading, and Mrs. Long is to be congratulated on having produced a book that holds the reader's interest from start to finish – itself a first class job!

C.E.M.

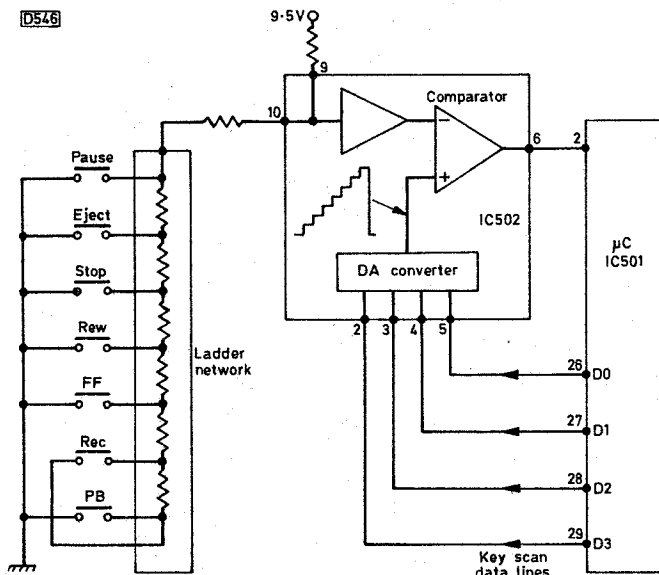

Fig. 1: Block diagram of the electronic function control system used in the Fisher FVH615. The arrangement is widely used in "electronic" VCRs.

# VCR Clinic

Reports from Derek Snelling, Les Grogan, Philip Blundell, Eng. Tech., Eugene Trundle, Mick Dutton, Nick Beer, John Coombes and William G. Lockitt, Eng. Tech.

## Philips VHS Machines

We are at present handling large numbers of Philips VHS machines that appear under various guises, e.g. the Philips VR6462, Pye DV464, Finlux VR1010 and Tatung VR8490. These are all basically the same VCR with minor differences such as remote control as standard or optional, reverse play or slow motion, etc. Several common faults have come to light.

The first may be described as no rewind, or no fast forward, or tape tangling, or intermittent play or jams. The cause is the brake solenoid sticking. A spot of oil may provide a temporary cure but replacement is required. If you are uncertain as to whether the solenoid is the cause of the problem, select rewind then fast forward without a tape in the machine. Repeat several times. During the change from one direction to the other a distinct click should be heard as the brakes operate. If you don't hear it the solenoid is at fault.

Another fault that can give rise to similar complaints is the idler wheel slipping. In this case the clicking will be heard during direction change. Cleaning the idler wheel doesn't seem to be too successful and replacement is recommended.

We have had three cases of clock failure with the display showing such things as 80.00 hours. In each case the TMS3763-28 clock chip was responsible.

If you ever need to remove a head from one of these machines don't do so unless you have a new head in stock – the replacement heads come with a couple of mica spacers that are needed to set the air gap between the head and the lower drum assembly when refitting the head. Luckily these spacers can be reused.

I've previously mentioned the no eject fault where a lever falls apart (see page 382, April 1986). It has since become apparent that replacement of the lever is necessary for a reliable repair. Whilst considering this area, we've had a couple of cases where the other lever operated from this cam has come adrift. Nothing breaks, it just comes out of the groove in the cam. The symptom in this event is that the pinch roller doesn't operate correctly. Refitting and a spot of graphite grease cures the problem.

We've had several cases of the cassette flap breaking at the hinge or the lever that operates it breaking. The cause is as yet unknown but replacing the damaged part seems to provide a lasting cure.

Finally I had an interesting fault that led me a merry dance on one of these machines. The problem was that half the front controls wouldn't operate, including the number pad. As the job was urgent the front panel, which appeared to be responsible, was replaced with a stock one and put aside for later attention. A few days later I investigated the fault more thoroughly. The faulty buttons

were all connected to the same two data lines, and a scope check showed that whenever a button connected to these lines was pressed the same waveform appeared on both lines. Easy – a short between the two lines. But a bench check on the panel revealed no measurable short. Much time was then spent checking every component on the board, to no avail. Other pressing matters then had to be seen to and a colleague took over. About half an hour later he had found the cause of the problem. My original diagnosis had been correct: there was a short between the two data lines. What I hadn't realised was that when I originally swapped the front panel over I'd unplugged one of the leads at the main board end, but when checking the panel on the bench I had unplugged it at the panel end, thus failing to check the lead from the faulty machine. The cause of the trouble turned out to be a short-circuit between two adjacent pins in one of the plugs. The strange thing was that the machine worked perfectly for two months before the fault showed up.

D.S.

## JVC HRD120/Ferguson 3V35

The complaint with this machine was no functions and inability to set the clock. The "all 9V" supply was present at the input to the mechacon board: it feeds regulator circuit Q205/D205 which produces the 5V supply for the microcomputer chip. The 9V supply was not present at the regulator however – because fusible link CP2 was open-circuit. This link, which looks like a two-legged transistor, is not shown on the circuit diagram.

L.G.

## Philips VR6460

Before replacing the aerial amplifier/r.f. modulator module when the complaint is snowy EE and off-air TV pictures check that the 12V supply to the unit is present and correct. In one case we found that the 12V regulator chip IC7002 was faulty.

L.G.

## Sharp VC9700

When changing the clock chip I5002 in this machine it's wise to remove the back-up supply capacitor C5007 as well as taking the usual static precautions to prevent damaging the new i.c. For a too bright clock display check whether D6603 is short-circuit.

P.B.

## Finlux VR1010/Philips VR6462

If you encounter one of these machines with the head drum spinning way too fast check the waveform at 3D14.

# VCR Clinic

## No Playback: JVC HR2650

Two general rules of thumb apply to VCRs that return to the stop mode a few seconds after play has been selected. First, if the tape loads to the heads, or even partially to the heads, and the machine then cuts out, the fast forward and rewind modes appearing to function correctly, suspect missing drum pick-up head pulses. If however the VCR plays for a few seconds before cutting out, while fast forward and rewind also trip out soon after selection, the problem is that the machine thinks the tape spools aren't rotating due to the absence of reel pulses or take-up pulses depending on the model in question. In this case there's usually no counter movement during the brief time that the tape is moving, since these pulses are used to drive the counter. This would apply to electronic counters and not the earlier mechanical counters, though it should be mentioned in passing that in the early JVC piano-key machines there are no take-up pulses when the counter belt is displaced.

And so to the machine under consideration. The HR2650 is a small portable VCR with stereo sound capability. It runs off a rechargeable 12V battery and has an accompanying tuner/charger unit. The fault with this one was no play, though an apparently good picture did appear for a few seconds. Fast forward and rewind were equally brief and what caught my eye was that the tape running indicator LED was illuminated all the time. All this pointed to an absence of take-up reel pulses, so the outside covers were removed and sure enough the pulses at pin 1 of connector 3 on the front control panel were found to be very weak, less than one tenth the amplitude the diagram said they should be. This voltage swing would be insufficient to activate the operational amplifier in IC6 and thus give an output to the tape running indicator, the counter and the mechaon panel. The problem was due to the reel sensor itself. Before condemning it we removed it

*Reports from Christopher Holland,  
Philip Blundell, Eng. Tech., Mick Dutton  
and Jeff Herbert, G4JJH*

and checked that there was no dirt affecting its optocoupler, something we've encountered previously with other machines.

C.H.

## Samsung V1510T

A number of these Korean made VCRs have passed through our workshops recently. Amongst the run of the mill problems of head cleaning and extracting foreign objects from the mechanism, something that seems to go with front-loading machines, we've on several occasions had no playback colour. The usual cause seems to be poor quality 4-43MHz crystals that either won't oscillate or can't be adjusted properly. If both crystal oscillator circuits work correctly however try a recording. If this shows that the drum servo is out of lock in the record mode the fault is due to the colour a.f.c. circuit which also provides sync pulses for the drum servo. Check for a bad joint at plug 11-16.

C.H.

## JVC HR7650/Ferguson 3V31

The machine JVC brought out to replace the HR7700 proved to be much more reliable. A problem I've encountered on several occasions however has been absence of any reel motor drive. A check on the mechaon panel will reveal that transistors Q18 and Q19 have blown apart physically. Further checks with an ohmmeter will show that Q10 and Q11 have also failed and will lead you to the ultimate cause of the mayhem - Q15 which will be found to be short-circuit. Don't use the nearest European style transistors as equivalents - this will only end in tears, not to mention small puffs of smoke as the replacements expire shortly afterwards.

Another problem I had with one of these machines was a complaint about intermittent failure to eject a cassette.

We could never produce the fault in the workshop and every time suggested that the owner bring along a tape that wouldn't eject. He replied that it happened only with library tapes and that this couldn't be the problem as no one else complained. Eventually the machine came in with the owner clutching a cassette. One attempt at ejecting the tape showed the cause of the problem: the library proprietor was sticking code numbers on dymo tape on the body of his cassettes in such a way that they caught on the left-hand side of the cassette housing during an attempt at ejecting them. Naturally only this model was affected. The customer was quite happy with the solution we offered: pull off the dymo tape each time and stick it back afterwards. **C.H.**

### Philips VR6460 and Clones

These machines use special Torx screws to hold the motors but the manual doesn't say which size of screwdriver is needed – and there are 25 to choose from! Many thanks to my SEME rep. Dale for telling me that it's Torx size T10. This size doesn't fit the rotating guides however – does anyone know which size does? I've had a few cases of Finlux and Marantz VCRs with too little take-up torque – this causes tape spillage on forward search. Replacing the reel motor usually cures this. **P.B.**

### Mitsubishi HS700B

Any intermittent sound or erase problems with this machine should be cured by removing plugs AF and DF and soldering the wires directly to the audio panel and the full erase head. **P.B.**

### Hitachi VT11/GEC V4100

Over a period of several weeks I struggled with one of these machines that had a very intermittent capstan speed fault. What would happen is this: the machine would play a three-hour tape all the way through without a fault, but if it was rewound and played a second time the capstan would be "held back" and rotate very slowly – even though its voltage was sufficient. Changing the capstan motor had no effect, but changing the clutch assembly seems to have cured the fault. I hope . . . **P.B.**

### Sharp VC9700

Timer display faults are quite common with this machine. The two usual ones are as follows: either no or intermittent display due to C5005 or the timer microcomputer chip I5002, or the display goes dim after an hour due to PR6601 on the audio board. **P.B.**

### Blaupunkt VCR

This machine (a Panasonic NV333 in disguise) came in because the tape was playing too fast – it looked more like search speed than play speed. The output voltage from the servo was correct and an FG pulse was being fed back from the motor. We concluded that the capstan motor was faulty: a replacement plus setting up restored normal operation. **M.D.**

### Hitachi VT7000

This portable had been dropped on to its base with the multi-plug that connects it to the timer/power supply unit

plugged in. The result was a cracked PCB around the connection socket. There's a lot of very fine print in this area and much careful work was required. We eventually got the machine to work but there was no colour. This was traced to a crack in the chroma panel under a plastic fixing lug. **M.D.**

### Ferguson 3V31

This machine wouldn't load a tape and the drum motor was running all the time. Although the loading arms were fully retracted it seemed the machine thought that loading was at least partly completed. An investigation of the lower mechanism revealed that the after-loading switch had jammed. Freeing this restored normal operation. **M.D.**

### Ferguson 3V35

The complaint was that noise bands moved up the picture at regular intervals on playback. We found that a recording made on the faulty machine had the same noise bars (tracking errors) when played back on another machine. On both machines the sound was perfect, with no wow or flutter. The capstan servo was ruled out therefore and investigations were made in the drum servo circuit. While playing the standard test tape the usual "clover leaf" strobe effect on the head drum screws could be clearly seen to rotate at regular intervals that coincided with the noise bar travelling up the screen. Since the drum servo obviously wasn't locking the drum discriminator adjustment R463 was checked as detailed in the manual. The slightest turn resulted in the picture breaking up into lines (the servo going way off speed) then returning slowly to a locked picture. It was impossible to adjust for 4.6V at TP423 with a digital voltmeter as the voltage was varying all the time.

Scope checks on the drum FG signal were normal but the output from the frequency-voltage converter in IC404 was incorrect – pulsating d.c. at pin 15 with a superimposed sawtooth, where the stable drum speed correction voltage should be. Replacing IC404 made no difference but when the feedback resistor R466 (270k $\Omega$ ) was checked it turned out to be open-circuit. Replacing R466 corrected IC404's output waveform and after R463 was adjusted a perfectly locked picture with no noise bands was obtained.

I had the same machine in a month before with a similar complaint, but at that time it could be locked by adjusting R463. I suspect that R466 goes high in value before going open-circuit and would recommend checking it whenever the drum servo requires adjustment. **J.H.**

### Hitachi VT63/GEC V4005

The drum and capstan motors both stopped just after the tape had loaded: the spool rotation sensor then returned the machine to the stop mode. When rewind or fast forward were pressed the brakes released but there was no spool rotation. This turned out to be due to loss of the 12V supply from the STK5451 regulator i.c. During motor start-up 16V is applied to the motor drive chip IC603. Once the motors are running the microcomputer i.c. switches on the regulator to provide the 12V output. The 16V line is used in the search mode to supply the extra load with the increased motor speeds. This provided the

clue. Fitting a new regulator chip (IC151) cured the trouble – the internal 12V regulator produced no output.

We've found that the capstan bearing is very often noisy on these machines, causing groaning and vibration. This can be difficult to diagnose as it's often intermittent and stops when the machine is put on end to remove the

bottom cover. Hitachi technical recommend that the capstan flywheel is removed and the chromed shaft checked for scoring. Renew if marked, then lubricate with Castrol MS3 grease. We now do this as a matter of course when these machines come into the workshop. To date lubrication has provided a cure in every case. **J.H.**

# The Toshiba V5470B

## Fault-finding guide

John Coombes

The Toshiba V5470B is a piano-key operated Betamax VCR that was on sale during 1980-81. It was of advanced design for its time, with digital capstan and drum servos and three motors, one for direct drum drive. Features include a seven-day, three-event timer; microcomputer memory tuning; freeze frame in colour with the noise bar shunted off screen; picture search with colour; a programme quick selection facility; playback speed continuously variable between normal and double speed; and wired remote control. The machine was also sold as the Bush BV6900. The following notes summarise common problems.

**(1) No results:** Check the mains fuse F801 (500mA delay type). If it's blown check the mains filter capacitor C801 (0.1 $\mu$ F) which sometimes goes short-circuit.

**(2) No results with the standby light on:** Check fuse F802 (3.15A delay type) for being open-circuit. If it has blown check the double diodes D801 (S5151) and D802 (S5151R) in the 17V supply for shorts. If necessary go on to check F803 (1A delay type) in the 24V supply. Check rectifier diodes D804/5/6/7 (all 1S1885) if F803 is short-circuit. Note that the regulated 12.4V and 12V lines are derived from the 17V supply while the regulated 16.5V line is derived from the 24V supply.

**(3) No results, ejected tape loose:** Check for a broken guide pulley belt.

**(4) No functions operational:** Check that the 12V supply is present. If so check that 7.5V is present at test point TP511 (there should be a 15V p-p squarewave here) on servo board PW2110. If this voltage is missing remove plug P507 on the board. If a short is present at this plug check whether the stop solenoid microswitch S681 is faulty - this switch can also cause intermittent deck shutdown.

**(5) Keys release:** First check the plugs/sockets on servo board PW2110. Try removing plug P903 on pause board PW2113: if the drum motor doesn't operate suspect IC501 (TM4216P) on the servo board. Alternatively the capstan motor may fail to operate: again check IC501. If the tape doesn't move check the drive belts, the play idler reel assembly and the tape path and upper cylinder.

Key release with the capstan and drum motors running too fast again means a check on IC501 and if necessary C964 (0.01 $\mu$ F) on drum drive board PW2115 - this capacitor can go short-circuit. For key release with slight drum rotation check the drum drive transistor Q961 (2SD235Y) on panel PW2115.

**(6) Play key jumps up intermittently:** Usually caused by a badly worn play idler which can damage or break the tape. If the complaint is tape creasing check and if necessary replace the play idler. If the problem is caught early and the play idler is not worn it may be possible to do a service as follows. Separate the clutch assembly and remove any dust from the felt pads, then clean the plastic face plates with alcohol. Check the rubber tyre and if shiny rotate it on a small piece of wet/dry then clean with cloth and alcohol. Refit, replace play belt and check that the play torque is 80-120g/cm.

**(7) Record key releases intermittently on a timer recording:** Check that the modification on servo board PW2110

has been carried out - R619 should be 330k $\Omega$ , not 150k $\Omega$ .

**(8) No eject:** If it is displaced, reseal the wheel that guides the loading ring. Check the rewind key. If stiff to operate it may be necessary to remove the mechanism to clean out thick hardened grease that prevents free movement. After reassembly the problem should be cleared.

**(9) Tape loading problems:** Check the adjustment of the loading drive assembly. Too close tolerance will mean excessive tape tension or no loading/unloading. Excessive tolerance means loose loading ring movement with poor performance.

**(10) Tape will not run:** Check for a faulty loading end switch. If incorrectly set, follow procedure in manual.

**(11) No play after rewind:** Check whether R581 (1k $\Omega$ ) on board PW2110 is open-circuit, then the stop microswitch which may be shorting.

**(12) No or poor rewind:** Check whether the tape is very tight. If an L750 cassette is poor on rewind check the rewind idler assembly. Replace the complete unit if the tyre is worn. Cleaning and lubrication may be all that's required if the tape is just running slow. Check that the reel brake is not sticking. If so free it and ensure that it's clean. Check that the supply reel and the fast forward/rewind belt are clean - replace the belt if it's elongated. If all these points are in order, suspect a badly worn upper drum. As a temporary measure, or to prove the point, clean it with a metal polish - this is a temporary measure only!

**(13) Tripping on rewind:** Check whether the tape is too tight, causing premature tripping. If necessary set up the rewind oscillator control R652 as specified in the manual.

**(14) Autostop solenoid inoperative:** If the plunger doesn't move freely in the solenoid housing, grease lightly. If necessary set up the solenoid position. Note that it will not release when the tape is at the end or reaches the counter memory point. It may not release when tape slack is detected or with no head rotation due to tape sticking.

**(15) Monkey chatter on cue/review:** Suspect IC601 (CX141) on servo board PW2110.

**(16) Tape damage:** A faulty pinch roller or play idler - see (6) - can be responsible for creased or broken tapes. In addition to incorrect tape path adjustment misalignment of the upper drum can cause tape damage. Failure of the slack sensor to operate will result in tangled or looped tape. Replace or set up the switch alignment as in the manual.

**(17) Wow/flutter on sound:** First check that the tape spools and pulleys are clean. Then suspect a faulty capstan motor. If the voltage at pin 1 of IC503 on panel PW2110 varies when the capstan motor is slowed down this usually indicates that the servo circuitry is working normally. Before replacing the motor (there may be noise bands in addition to wow/flutter) check the play idler and ensure that the capstan flywheel is free, clean and lubricated. If the capstan motor has to be replaced, check the tape speed and ensure that the correct capstan motor pulley is fitted - the larger the pulley the higher the speed and vice versa. The capstan motor can also be responsible for lateral picture instability, though the usual symptom is wow/flutter on sound.

**(18) Bent verticals:** Ensure that the back tension is set up correctly. If so, suspect the drum motor.

**(19) High-pitched howling:** This fault may be intermittent. Check that the capstan flywheel shaft is clean and slightly lubricated.

**(20) Video troubles:** The most common fault is loss of

output from one head. The cause could be build up of dust in the gap. Clean with a cleaner stick and alcohol. The fault may show up only with the machine's own recordings, playback of prerecorded tapes being all right. If there's a cotton-wool effect across the screen with a picture in the background suspect that one of the heads is open-circuit. Streaking across the picture is another symptom caused by a faulty head.

There are other causes of an incorrect f.m. waveform, i.e. excessive noise on the picture. Check the alignment of the tape path, also the upper drum for excessive wear or misadjustment. The record/playback switch S101 can cause intermittent noise and picture breakup if it's dirty, misadjusted or worn. If the outputs from the two heads differ when playing back a recording check the adjustment of R152/3/4/5 on board PW2108. If this doesn't do the trick the drum dihedral adjustment may be incorrect. This is a complicated adjustment – it's simpler to replace the drum. For a good picture with no wow or flutter on sound, eccentricity alignment to a setting of less than three microns must be undertaken when a new drum is fitted.

If there is no recorded video, check IC401 (TA7637P) on board PW2109 by replacement. If there's no output from Q404/5 check whether C419 (0.022 $\mu$ F) is leaky.

For smeary playback check IC402 (TA7636P) on board PW2109 by replacement.

**(21) Colour drop-out on cue/review:** Check crystal X961 on drum drive board PW2115 – it can go off frequency.

**(22) Interference on sound:** This can be caused by a faulty drum motor. Make sure that the noise suppression components L961 and C962 (0.01 $\mu$ F) on drum drive board PW2115 are in order.

**(23) Poor stills/vertical bouncing on cue/review:** Suspect

absence of the VD pulses from ICH01 (TC4528P) on speed control logic board PW2117.

**(24) No frame advance:** First ensure that the frame selector switch S982 on switch board PW2116 is operating correctly. Then check ICH03 (TC4528BP) on board PW2117 by replacement.

**(25) Still frame slipping:** Check that the frame correction control RH51 on board PW2117 is not set too high. Slightly adjust the screw to set the noise band at the bottom of the screen.

**(26) Timer not alight:** Check clock bulbs for open-circuits. This can occur when the machine is unplugged from the mains supply for the first time in a few years.

**(27) Programme timer i.c. faults:** The symptoms caused by IC861 (TC5038P) on board PW2112 can be many and varied – digits not illuminated, days not changing on programme setting or inoperative on second programme, and incorrect time settings. The timer may fail to latch, switching off from the mains for a few minutes after which the timer will reset.

**(28) No channel lights, one channel only alight or stuck on BBC-1:** Check ICA01 (TC9002AP) on selector board PW2106 by replacement.

**(29) Memory button inoperative – will not lock channel:** Check the TMM841P memory chip ICC01 on board PW2106 by replacement.

**(30) Tuning drift:** Several items on selector board PW2106 can cause this problem. The most likely cause however is the tuner unit itself – check by replacement. ICA01 (TC9002AP), ICC01 (TMM841P) and/or ICC02 (TA7619AP) on board PW2106 can all cause the trouble when warm or intermittently from cold. The other item you might need to check, again by replacement, is the 33V tuning supply stabiliser DE01 ( $\mu$ PC574JC).

## Sharp VC9300

Reel motor faults are well known on these machines (occasional refusal to either wind forward or backwards, at first "curable" by pressing the opposite button, slowly leading to complete refusal to work). Take care before replacing the motor however: the plastic sleeve on the motor shaft can sometimes ride up, causing very similar results. Listen for the motor whilst the machine isn't rewinding. If it's running, check that the sleeve hasn't ridden up the shaft – even an eighth of an inch is enough – and check that the jockey wheel isn't worn (there's no clutch, so something has to wear!). If the motor doesn't start up (common), replace it. Expensive aren't they? Incidentally, a motor out of the unit will normally run off the current supplied by an Avo on the ohms range, a useful check if start-up is the problem.

Intermittent stopping in any mode of operation (play, record, rewind, etc.) is often caused by the trip counter. This is because the take-up reel drives the motion detector via a belt, a further belt driving the counter from the detector. A worn gear in the counter can thus stop the motion detector, causing the shut down. A good tip is to reset the counter before giving the machine a test. If it always stops at a certain number you've found the cause of the fault – check by removing the counter belt before ordering a replacement. In a rare burst of honesty I must confess to knacking a counter mechanism: if you don't line up the reset button with its hole when replacing the front panel . . .

H.A.

## JVC HRD140

This machine had three faults that at first seemed to be unrelated. The drum speed was varying, the pinch roller was turning in a most erratic manner, and the resulting picture suggested that the video heads were dirty – though curiously enough there was video coming through on the top two inches of the monitor's screen. The common factor came to light when I slowed down the head drum with a finger: what seemed to be the Channel 4 test card on my test tape appeared upside down and back to front at the top of the screen. You've guessed it – the heads were spinning backwards. A check in the drum servo circuit revealed that the drum servo error voltage that's fed to the drum motor amplifier was virtually non-existent instead of the 2.8V the manual said it should have been. Zener diode D408 (5.1V) turned out to be leaky. C.H.

## Ferguson 3V23

Frame jitter or frame roll on playback with VHS machines is normally due to a problem in the area of the left-hand tape roller and shows up as part of the f.m. signal envelope being missing. Causes can be the guide roller itself, the guide roller base assembly not sitting correctly in the vee block, the base assembly being bent in such a way that the tape is not presented to the heads correctly, or insufficient back tension. The other point that can give rise to this sort of problem is incorrectly set head switching points.

The machine concerned was operating correctly in all these respects however. The f.m. signal envelope was as

perfectly formed as any I've seen, while altering the back tension by manipulating the cue head that acts as a back-tension arm produced no improvement. When the picture did stop jumping for a few seconds I could see on the monitor, with the height altered, that the switching points were spot on. The only clue was that the picture had a slightly weakish look about it, as though the video heads were worn. Since this could conceivably cause the field jitter a new drum was fitted, to no avail – furthermore the picture quality was still poor.

The search moved to the luminance panel, where test point 6 showed good line sync pulses but no field pulses, their absence being very noticeable when the machine was returned to the E-E mode. Tracing through the signal path led us to C44 (33 $\mu$ F) which, when checked with an ohmmeter, seemed to be low in value. After replacing it, refitting the original drum, and resetting the previously twiddled (in frustration) left-hand guide pole we were rewarded with a rock steady picture. C.H.

## Ferguson 3V29

The complaint was failure to record, but the actual fault was a very overloaded E-E video signal with good sound. The signal entering IC201 on the bottom luminance panel, at pin 26, was good but nothing came out at pin 5. Since all the relevant d.c. voltages around the i.c. seemed to be correct there appeared to be a good case for changing it. Needless to say this proved to be a fruitless exercise. Close comparison between the conditions in a good working machine and the faulty one eventually showed that the signal at pin 26 of the good machine sat on a d.c. level of 6V while the signal in the faulty machine was sitting on 4V d.c. Further checks showed up what should have been obvious from the start: the playback 9V line was present in the E-E mode, with the result that Q208 was switched on. The playback 9V line was there because Q103 was on: the culprit eventually turned out to be Q107 (2SB643) which was leaky. C.H.

## Ferguson 3V36

It's quite common on these machines for the mechacon microcomputer chip IC201 to "crash" and cause odd faults. Switching the mains supply off and on usually provides a cure. On this occasion however the machine wouldn't come out of standby after doing this. Checks around IC201 revealed that the clock oscillator was running, the supply was o.k. and the power switching signal was reaching the chip, but it wasn't taking any notice. The reset signal was over so quickly that it couldn't be seen on the scope, so a few d.c. checks were made in the reset pulse generator circuit. Zener diode D203 (5.1V) turned out to be leaky. P.B.

## Sharp VC3300

I had quite a few lightning damaged items after a thunder storm. One of them was a VC3300 – the strike had come along the mains, destroying the mains adaptor. When the machine was powered via the bench supply the loading,



reel and capstan motors were all going backwards. The mechacon F/R (forwards/reverse) line was found to be permanently high, but quite a few devices on three different boards are connected to it. After a lot of disconnecting pins and plugs and sockets the capstan F/R switch chip IC711 was found to be faulty.

**P.B.**

### **Sanyo VTC5000**

This machine would play prerecorded tapes all right but wouldn't play back its own recordings without having to adjust the tracking control from the click position. It had a small subpanel called the "control pulse rec/play circuit" mounted piggy-back on the main servo panel SV1 (this subpanel is not fitted on later versions). The fault turned out to be on this subpanel, which has to be unsoldered from the main servo panel before you can work on it. Oscilloscope checks revealed that the tracking pulses to pin 8 of IC4501 were of reduced amplitude and incorrect shape. The culprit was C4505, a tiny  $1\mu\text{F}$ , 50V working capacitor which was virtually open-circuit. Replacement restored normal operation.

**R.T.R.**

### **Sharp VC9700, VC381, etc.**

When replacing the cassette lamp, beware – it's not the usual 12V, 60mA type, the rating being 5V, 100mA. We found this out the hard way with a Philips VR501/79, which in New Zealand is a Sharp VC9700 clone. A normal VHS lamp produced incorrect operation of the microcomputer chip when the machine was cold. The reason for this is that the lamp current flows via R872-5 (four  $270\Omega$  resistors in parallel), the voltage drop across these resistors providing a feed to IC802. The correct lamp gives 8V but a 12V, 60mA lamp produces 4V which makes IC802 unreliable.

**B.W.**

### **Panasonic NV300/NV333**

One of these machines had the not uncommon fault of failure to record the sound. This time it wasn't caused by the bias oscillator transistor Q4014 failing to start, and

we'd already done the modification of bridging its emitter resistor R4049. To complicate things the voltages around Q4001 and Q4002, which switch the audio head from record to playback, were all wrong. The culprit turned out to be the STR1096 regulator IC1001 in the power supply. Its 9V output had gone up to 10.8V, which was enough to upset the bias on Q4001/2. Why such a small increase in the voltage on the 9V rail should completely upset Q4001/2 is hard to see, but it did. Much time had been spent changing audio transistors to no avail before the regulator was changed.

**B.W.**

### **Ferguson 3V44**

The complaint with this machine was no operation. We inserted a cassette which the machine promptly swallowed, but it wouldn't run in any mode. Neither would it eject the cassette. Attention was turned to the microcomputer chip IC601. Using a logic probe we eventually discovered that pin 32 hovered at 3.2V regardless of the position of the cassette housing switch. The cause was D628 which was leaky: instead of clamping the logic level at pin 32 to 5V it was confusing the microcomputer chip by producing an indeterminate logic level. Replacing the diode restored normal operation.

**K.N.B.**

### **Sharp VC9300**

The ticket said "deck service", the fault being the usual Sharp take-up one. I tackled the problem by removing the supply/take-up spools then cleaning and lightly lubricating the shafts. The idler was replaced and the grooves in the chassis it sits in were treated to a smear of silicone grease. All surfaces were cleaned and the tape path was given a good clean up. After doing all this and carrying out a functions check I found that the machine wouldn't reverse search. At least it wouldn't with a tape inserted. Without a tape the machine would reverse search and there seemed to be plenty of torque. Replacing the reel motor cured the fault. We get a lot of these Sharp machines with this type of fault and are forced to reflect on how badly off we would all be without "stock problems" like this. **S.L.**

# Servicing the JVC HR7300

David Botto

The JVC HR7300 VCR is a VHS machine that contains some complex circuitry. Increasing numbers are now arriving in our workshop with various problems. The following notes are intended to save you a few headaches by detailing the faults we've encountered so far.

## Access

To remove the cabinet top, unscrew and remove the two screws from the cassette lid, then the five screws in the cabinet top. This will enable you to lift the top cover and cassette lid away, revealing the interior. Don't remove the front panel unless this is essential: if you must do so, it's best to remove the bottom panel first – after removing the many screws that hold it in place. To save hours of hunting for lost screws a magnetic screwdriver with interchangeable bits is recommended (obtainable from Halfords, Tandy etc. for less than five pounds).

## Power Supply Circuitry

The circuit boards are all identified by letters and numbers. Fig. 1 shows the power supply circuitry, most of which is on the regulator board. The mains a.c. input goes first to connections 1 and 2 of the rear a.c. power panel, then via switch S005, fuse F1 (1.25AT) and the voltage selector to the primary winding of T001. When F1 feels that it's worked overlong it can fail, with the result that the whole machine goes dead. If the fuse hasn't blackened you'll probably find that a replacement will restore normal operation. In this case run the machine for at least four hours before returning it to the customer.

The secondary windings on the mains transformer produce a.c. outputs of 18.3V, 22V and from the tapped winding 34V and 46V. The following circuitry is conventional. An unregulated 22V d.c. supply for heater R001 is provided at connector points 51 and 52. A regulated -26.5V supply is provided at connector 71, regulated 13V and 12.5V supplies being provided at connectors 24 and 82/21/41/31/13 respectively. Connectors 23 and 43 provide unregulated 22V outputs while the regulated 12.5V output at connector 61 is unswitched, i.e. it's taken off prior to contact 1 of relay 1, also F8. This relay (part no. PU51258-2) has a second contact which switches the unregulated 22V outputs at connectors 23/43. Thus d.c. voltages are present at connectors 82/21/41/31/13 and 23/43 only when the relay operates. The unregulated 40V output at connector 83 goes to the tuning voltage supply regulator on the tuner/i.f. panel.

When power switch S208 on the function board is switched to "on" one side of the relay's coil is taken to chassis. As the other end is taken to the "ever" 12.5V supply the relay operates and d.c. supplies appear at 82/21/41/31/13/23/43. The earthy end of the coil is also connected to the collector of transistor Q4 (type 2SD636Q, R or S – the S version is the recommended replacement). Connector 62 links the base of this transistor via connector 52 on the presetter/timer board to pin 26 of the microcomputer chip IC201 (type UPD553C-100). In the automatic timer recording mode pin 26 of this i.c.

goes high to switch on Q4, thus operating the relay to initiate a recording. On rare occasions the relay has been known to stick, much to the annoyance of the customer who wanted to record a particular programme. If you can't use S208 to switch off in the manual mode Q4 has probably gone short-circuit.

It's essential that the regulated 12.5V supply is exactly correct. Connect a digital multimeter between connector 21 on the regulator board and chassis and, with S208 switched to "on" and the stop mode selected, adjust R5 for a reading of exactly 12.5V. Check the voltage again after running the machine for half an hour. This may save you problems at some future time.

## Power Supply Faults

If the machine on your bench refuses to respond to the commands replay, fast forward, rewind etc., check F8 (1.25AT) before looking for complex faults. This sounds obvious but it's easy to get caught. We've also known fuse F3 (2.5AT) to fail due to power transistor Q2's mica washer breaking down.

The fast and easy way to check the regulator board is first to measure the d.c. output voltages. If one or more are missing, check all the diodes and transistors in the relevant section of the circuit. This takes only minutes using a component tester. Pay particular attention to zener diodes D5 and D14. Examine the small electrolytics carefully, checking that none have dried out – these can also be checked with a component tester (details, June 1984 issue). Don't forget fuse F1 on the rear panel section if T001 doesn't produce any a.c. outputs from its secondary windings.

## Function Faults

If the tape stops after about ten or fifteen seconds in the play mode suspect IC3 (HA11711) on the servo board. This board is mounted upright at the extreme left-hand side of the machine (viewed from the front). You may be able to prove the point by alternately heating and freezing IC3. Prerecorded tapes playing o.k. but a nasty juddery jitter on the machine's own recordings can also be caused by IC3.

If the tape refuses to load suspect transistor Q8 (2SD636P, Q or R – the R type is best for replacement) on the servo board: it likes to go short-circuit base to emitter. In fact if you get strange effects from the servo board it's best to make a quick check of the eight transistors on it.

IC4 and IC5 on this board (both type M54519P or IR2403-2), though reliable, can nevertheless cause strange and puzzling effects – such as transistor Q5 (2SB641P, Q or R – the R type being again the recommended replacement) turning on instead of off in the playback mode (this sends incorrect signals to IC3, upsetting its operation). These two i.c.s are easy to check with a logic probe. Each contains seven inverters, so whatever logic conditions (high or low) you find on pins 1 to 7 should be inverted on pins 16 to 10 respectively.

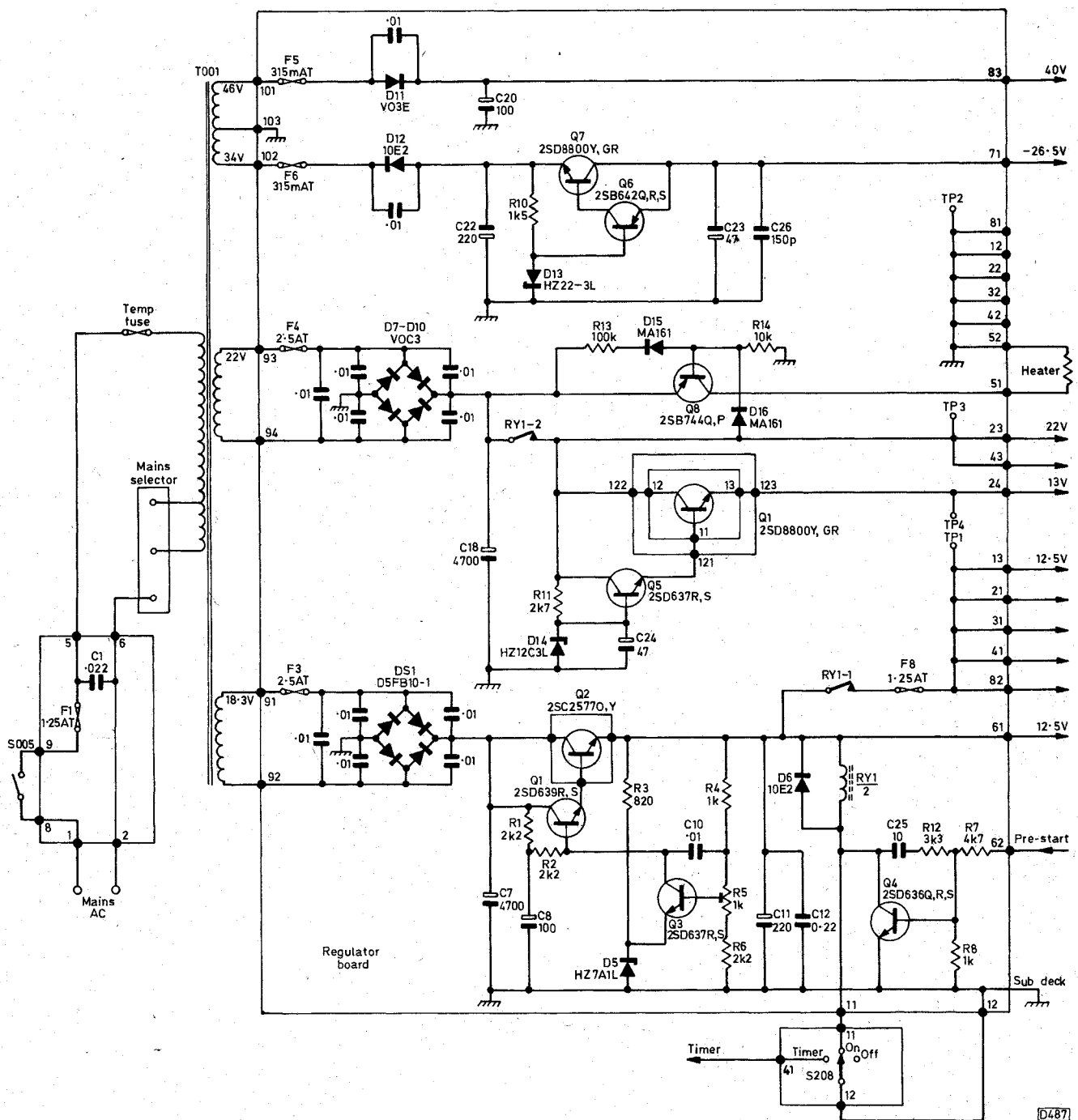

Fig. 1: Power supply circuitry used in the JVC Model HR7300.

The MDA board is mounted upright on the left of the machine next to the servo board. When the drum runs very fast, suspect IC201 (VC1029) on this board. If the capstan motor is slow in the playback mode only (Mk. 2 version) change IC205 (UPC1458C). Loss of capacitance in C213 (10 $\mu$ F, 16V electrolytic) can result in the drum motor running too fast.

Before replacing suspect i.c.s on this board always check the surrounding transistors and examine the print carefully for dry-joints.

If the loading belt (part no. PU48941-2) between the loading motor and the worm gear that drives the loading ring is slack the machine won't load correctly. It's sound policy to replace all the belts at the same time if they show the slightest sign of wear.

Another cause of the cassette tape refusing to load

correctly is the unloading switch that lives just below the loading ring. You can usually clean this switch, using just the merest trace of Castrol DWF. Clean the afterloading switch at the same time – it may save you the trouble of having to dismantle the machine after you've just put it all back together.

On rare occasions the main solenoid (part no. PU51254) goes open-circuit. The result is that the tape laces up, with no other tape movement, then the tape unlaces still looped. If you have to replace the solenoid, always check transistors Q6 and Q7 (both type 2SB744P or Q) at the same time.

If the tape laces but the head drum and capstan refuse to turn, check for cracked print at the connectors that link the servo and mechacon panels – check especially around connector 404-410 on the mechacon panel.

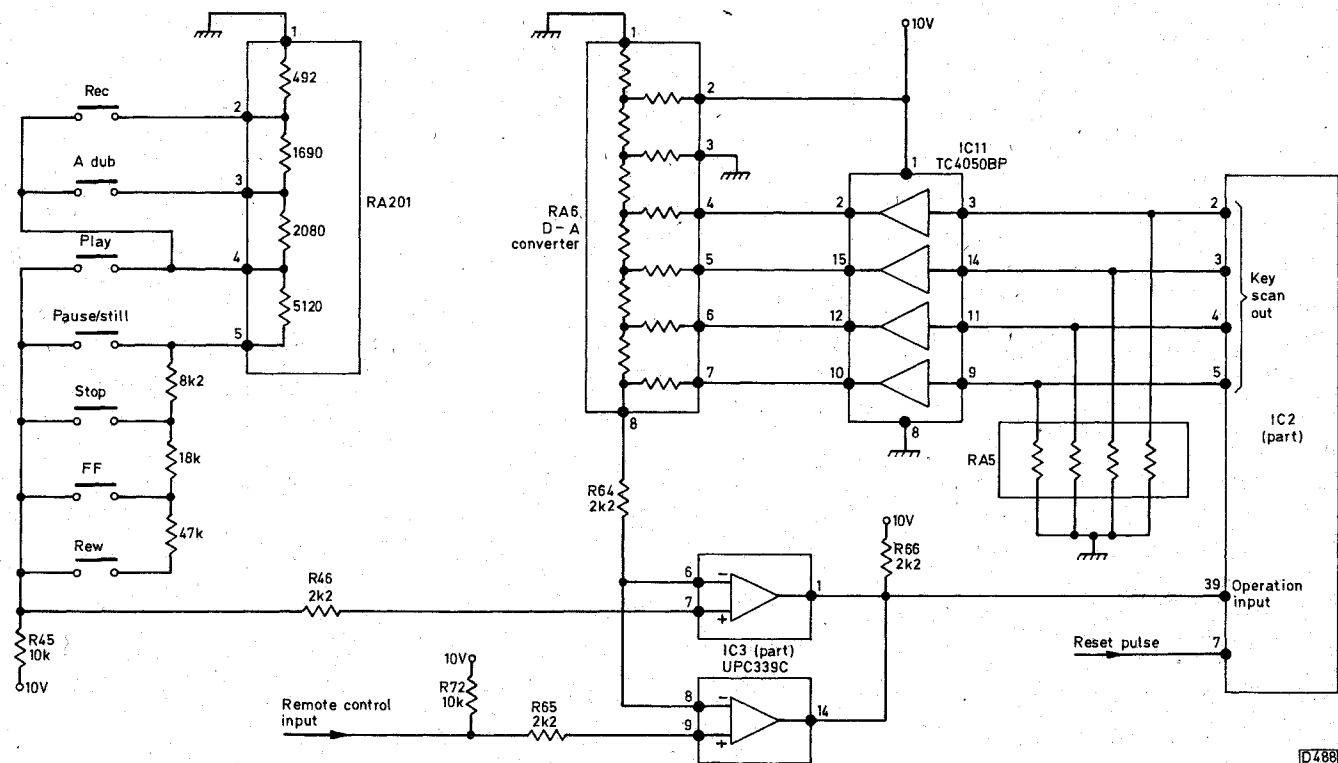

Fig. 2: Simplified circuit showing the arrangement for function selection.

If the rewind light stays on when it shouldn't the start sensor (PN202S phototransistor) may be open-circuit. If the cassette light refuses to light, thus stopping all functions, but the light itself is o.k. you'll probably find that transistor Q1 (2SB643) on the deck terminal board is short-circuit base to emitter. Also check diode D1 (MA150) and capacitor C1 (33 $\mu$ F, 16V electrolytic) on this board.

The main microcomputer control chip IC2 (UPD553C-164) lives on the mechacon board. This i.c. does occasionally cause problems, such as entering the wrong mode when a function is selected or turning on several of the function lights at once. Fig. 2 shows a simplified diagram

Table 1: Easy check logic levels for IC2.

Pin	Function	Logic level
1	Clock	H+P+L
12	Loading motor power	L
13	Loading motor reverse	H
14	Loading motor forward	H
15	Reel motor FF/rew power	H
16	Pinch solenoid hold	H
17	Pinch solenoid drive	H
18	Main solenoid hold	H
19	Main solenoid drive	H
22	Reel motor forward	H
23	Reel motor reverse	H
24	Reel motor forward	H
25	Reel motor reverse	H
37	25Hz drum FF input	H+P+L
38	10-400Hz reel sensor in	H+P+L
40	Rec safety switch in	L

Logic levels shown are those when the relevant function is active and operating. H+P+L = all LEDs alight.

Pin 40 reads H when the protective tab has been removed from the cassette.

of function selection. When a function switch is operated the voltage at pin 7 of IC3 (UPC339C) is set at a certain level. At the same time a sixteen step staircase waveform derived from IC2 via IC11 (TC4050BP) and RA6 is fed to pin 6 of IC3. This i.c. acts as a comparator: its output drives pin 39 of the microcomputer chip. Use a logic probe to check around IC2. Table 1 shows some useful logic levels at various pins of this i.c.

### Record/Playback Faults

If the machine plays prerecorded tapes nicely but the machine's own recorded tapes have no or poor video, before replacing IC202 (HA11724) on the video and audio board check the waveform (scope with 10:1 probe) at TP202. If it's missing or reduced check capacitors C221/C222 (both 330pF, 50V wkg).

No playback or record colour with the E-to-E picture normal can be caused by failure of IC401 (AN6360) or to the small electrolytics around IC401 drying out - check the capacitors first and watch out for dry-joints in this area. C414 (0.001 $\mu$ F) or C420 (0.01 $\mu$ F) being leaky can cause colour problems on playback.

If you get "unlocked" or incorrect colour, replace IC403 (AN6371). If this doesn't cure the problem suspect crystal X401: check at TP404 for a reading of 5.060572MHz  $\pm$  50Hz.

If the picture looks as if one video head is faulty check C273 (0.015 $\mu$ F) before fitting new heads. This capacitor is connected between pin 5 of IC202 and TP204 on the audio/video board.

Watch out for dry-joints and dried up small electrolytics on this board.

### Display Board

Moving now to the display board, if C404 (120pF) or C405 (220pF) start to leak the 400kHz oscillator in IC401

(UPD552C-068) will stop and there will be no clock display drive, i.e. no clock display. Use your logic probe to check for oscillation at pin 1 or 42 of IC401. These two capacitors are both rated at 50V – use replacements rated at a higher working value. C402 (47 $\mu$ F, 16V electrolytic) can lose capacitance, upsetting things in this part of the circuit.

Other things to check on the board are C401 (33 $\mu$ F, 16V electrolytic) which can dry out and upset the reset pulse, and for the usual dry-joints. Also check C406 (100 $\mu$ F, 35V electrolytic). IC401 can fail but rarely does so.

### **Presetter-timer Board**

There's another microcomputer chip on the presetter-timer board, IC201. It's the same basic type as the microcomputer chip on the mechacon panel. They are not identical however – the final three figures are important as they indicate the programming of the internal ROM. IC201 is type UPD553C-100 – be sure you get this number right when replacing the chip or the results obtained will be strange indeed. If everything seems to be inactive, check for clock oscillation at pin 42 of IC201. If the

400kHz signal is absent, check C206 (220pF) and C207 (120pF) before condemning IC201. We've yet to have a crystal fail.

### **Tuner/i.f. Board**

We've not had much trouble with the tuner/i.f. board. Low gain however is sometimes caused by C3 (0.0022 $\mu$ F).

### **Circuit Varnish**

When repairs are complete, use only a very small brush to apply circuit varnish to any joints you've soldered. This will prevent the varnish reaching parts it shouldn't, causing all sorts of nasty problems!

### **Related Models**

In conclusion, the Ferguson equivalent of the HR7300 is the 3V30, though you might find some minor circuit differences. The HR7200 and 3V29 differ from the HR7300/3V30 mainly in having a different clock-timer and the omission of Dolby noise reduction. With the HR7200/3V29 the wired remote control is an optional extra.

## Mitsubishi HS304

This machine wouldn't switch off, at least not properly. In the off position the tape functions wouldn't work but the cassette light stayed on if a cassette was inserted and the channel lights remained on – in fact normal E-E was possible. Everything worked normally in the on position. Clearly not all the power supplies were being switched off. The off signal from the operate switch was correct and was reaching the power supply, also the two switching transistors Q906/7 were working normally. But whilst the collector of Q907 went up and down with operation of the on/off switch the TU 12V regulator transistor Q905's base voltage was almost steady. The question was, where was the voltage coming from in the off position? The resistors connected to Q904 in Q905's base circuit checked out o.k., but replacing R908 and R910 cured the problem. One of them was obviously going low under load. **D.S.**

## Philips/Finlux VR1010

The complaint with this recently installed machine was jumping on all tapes. When I got there the cause was obvious: the head switching appeared to be taking place about a third of the way up the picture. Not having much experience of this type of machine I didn't fancy fault tracing in the field, but relying on the fact that most failures with newly installed VCRs are due to sillys such as dry-joints or disconnected springs I took the top off and had a look around. Whilst examining the rear board I moved a wire and one end of R3012 fell out (we all get lucky breaks sometimes). A quick check showed that it hadn't been inserted properly in the first place – refitting it cured the problem. A look at the manual when I got back to the workshop revealed that this resistor is connected to the wiper of the "position adjustment" potentiometer R3016. **D.S.**

## Philips/Finlux VCRs

The problem with this machine was a dirty head. These machines are of Philips manufacture and the symptoms are a bit different from what you normally get. If you play back a blank section of tape you don't get snow on the screen as you do with other VHS machines. You get a series of vertical black and white stripes. With a dirty head you get the same effect with the picture in the background. On this particular machine the dirt wasn't too bad and affected only the top half of the picture, i.e. the effect of the dirty heads was what appeared to be a normal picture with dark vertical striations across the top half. **D.S.**

## Ferguson 3V29/3V30

A problem we've had from time to time after transporting these machines is failure to operate – as if the bulb had gone. What happens is that the white nylon shaft which operates the switch falls out. On one side of this shaft there's a small pip that locates in a slot in the mounting hole. The shaft is put in the hole then rotated through 180° to lock it in place. It's rotated through 90° it can be locked in the down position for test purposes. What happens is that the shaft at some point gets twisted to the

unlocked position, where it will work quite happily until the VCR is moved – movement shakes the shaft out. **D.S.**

## Electronic VCRs

On any of the electronic type of VCRs if fast forward and rewind are o.k. but the machine switches off a few seconds after play has been selected check whether the pinch roller engages. If not the loading belt(s) are probably stretched. I've had this fault on the following models: Ferguson 3V29/30, Hitachi VT11 and VT8000 series, and the Panasonic NV2000 and NV7000. **D.S.**

## Panasonic Aerial Amplifiers

I feel I must disagree with David Botto when he says in his article on servicing the Panasonic NV7000 that it's not worth repairing the booster unit. This was true when the machine was under guarantee. Out of guarantee there's a great deal to be said for repairing it. I've serviced over a dozen of these units and in every case replacing Q1, Q2 and Q3 cured the fault. This takes less than a quarter of an hour and costs less than £2 – a new booster costs nearly £20. **D.S.**

## Panasonic NV370

The fault on this two-day old machine appeared to be a duff on/off switch. Pressing the button brought the VCR into action intermittently, but it couldn't be latched. When the front escutcheon was removed we discovered that the plastic on/off button wasn't pressing the switch in far enough. We confidently repositioned the switch slightly and refitted the front escutcheon. The switch now functioned correctly but during a test the machine would go dead intermittently, with the LED "on" and the tape counter indicators being extinguished for a fraction of a second. Clearly much of the original complaint was still present! A check around the power supply showed that the voltages were constantly varying by 1V or so, even when the machine appeared to be working correctly. The problem was eventually traced to the 3.9V zener diode D1002 in the regulator circuit. Unlike a lot of intermittent faults, the symptoms returned when the offending component was refitted. **K.H.-G.S.**

## Panasonic NV370

There were no functions and no display with this machine. On checking we found that the –30V line was missing. Replacing Q1102, the 30V zener diode D1109 and the safety resistor R1102 restored the functions but the mode display didn't work correctly – all functions were shown as on irrespective of the operation. Replacing Q6501 and I6501 cleared this final fault. **M.S.B.**

## Hitachi VT11

This machine loaded and ran for ten seconds then unloaded. The idler and captain were working normally. During the ten seconds when the machine operated the picture and sound were muted.

On checking the bottom of the machine I found that the loading motor was still running during the ten seconds of operation. By manually turning the loading gears the machine's mode switch slid forward and the machine worked normally. The problem is that the idler wears out quickly and the tolerance is restricted – less than 2-3mm thickness before it ceases to operate. The idler will function normally for a much longer period if the upper edge stop lip is filed down. **M.S.B.**

### **Hitachi VT33**

Somehow or other the owner of this scruffy machine had managed to get the loading gears out of alignment. The cassette housing went down but would come up three seconds later. Also the function lights worked but no function could be initiated. A phone call to Hitachi produced the information that if I linked pins 1 and 4 of PG922 and removed the carriage the machine would work without a cassette. It did too, though the idler had to be replaced first. To realign the gears is fiddly but not difficult. Unfortunately the procedure is not shown in the manual. Basically you align the arrows on the cogs with the housing up. Perhaps someone could provide a diagram that could be included in the magazine? **R.B.**

### **Finlux VR1010**

This machine had lost its tuning memory and wouldn't retune. The cause was a faulty PCD8571 memory chip. **P.B.**

### **ITT VR3916**

The hot weather brought a plague of these machines that wouldn't record the sound or erase the colour. The fault was intermittent of course. Removing the plug from the top of the erase head and soldering the wires directly to the pins seems to have put an end to the trouble. **P.B.**

### **Sharp VC9700**

The trouble with this machine was that the capstan and drum servos would intermittently begin to wow in the play mode – they didn't in search. The machine had been in recently for the usual failure to record the sound modification, and as the controls on the stand-up board are rather vulnerable I began by checking that none of them had been knocked. R745 set up o.k. in the E-E mode but the signal (TP707) was then off lock in play. The multivibrator should be locked to the PB 50Hz in playback but wasn't. The trouble was that Q710 was open-circuit. **P.B.**

### **Hitachi VT8300**

This machine wouldn't complete its loading cycle: it would start to lace up normally but not go far enough to engage the pinch roller. When the top was removed we found that there was sand in the machine. This appeared to have got inside the loading gear, causing it to be very stiff. The sub-deck had to be stripped down to component parts and everything cleaned individually before the machine would load properly. It turned out that the customer had a large dog which would come into the house after a swim in the sea, shaking itself out over the VCR which lived on the floor.

Other faults we've had on this model include lack of signals in the E-E mode due to poor soldered joints to the earthing lugs within the i.f. module, and a semi-dead machine with no output from the PB 9V transistor Q942 due to R987 (1k $\Omega$ ) being open-circuit. **M.D.**

### **Ferguson 3V29**

Sound slow and a picture with no line lock was the complaint. It seemed that both the capstan and the head servos were faulty. We started checking around the servo panel and discovered that all the voltages were haywire. The supply rail input was then found to be 16V instead of 12V. This was due to the regulator transistor being short-circuit collector to emitter. Fortunately there was no other damage. **M.D.**

### **Sharp VC7300**

It took us a week to find the cause of this fault. In the fault condition all the auxiliary motors were pulsing, but the machine would work for hours on end before the fault would appear. At last we were able to trace the cause of the trouble to a faulty 2SC1212A regulator transistor in the power supply. Fitting a BD139 with a large heatsink cured the problem. **J.R.C.**

### **Ferguson 3V36**

The complaint with this machine was no colour. Scope checks at the pins of the HA11741 colour processing chip IC401 revealed that there was no signal at pin 16 – a 4.43MHz signal from the external oscillator block XB401 should be present here. A replacement crystal block restored the colour. **R.S.N.**

### **Panasonic NV333**

A common fault with these machines is no eject damping – the gear teeth inside the damper unit break. Replacing the unit provides a cure. **R.S.N.**

### **Panasonic NV333**

There was no colour – and the monochrome picture was poor. A quick check on the chroma signal path was carried out and I then noticed that the power supply had been worked on. So I decided to check the l.t. rails. The 5V line was 1V down and couldn't be set up with R1003. A check on the previous work revealed that the 0.39 $\Omega$  0.25W fusible resistor R1001 had been replaced with a 39 $\Omega$  resistor. Much time had been wasted on this machine! **R.S.N.**

### **Panasonic NV730**

No rewind or fast forward on one of these machines was traced to the reel power transistor Q1504. **R.S.N.**

### **Philips VR6460**

The problem with this machine was low gain on the monitor and E-E paths. The 12V supplies were checked and found to be present so a new aerial amplifier/modulator unit was ordered. Fitting this cured the problem. The three transistors inside the original unit all measured o.k. **R.S.N.**

# VCR Clinic

*Reports from Steve Beeching, T. Eng., Paul Hardy, Philip Blundell, Eng. Tech., Andrew Benham, Steve Illidge, Les Grogan, Richard Roscoe and William G. Lockett, Eng. Tech.*

## The Beeching Report

Looking back over our job sheets for the last few months I see that certain repairs crop up every so often on a regular basis. Most VCR faults are random however. Here's a selection of typical faults dealt with over the past month.

Most common faults are due to mechanical wear. Lots of **Hitachi VT11** idler pulleys and some **VT33s** with the same problem. In the **Sanyo VTC5000** series replace the idlers and change the value of the resistor (R3049) in series with the reel motor drive from 2.2Ω to 1Ω – it stands up on the top left-hand corner of the PCB, beneath a heatsink. And don't forget the AL switch. It's a good idea to stock some Sharp idler pulleys as they fit Saishos and Amstrads – these need replacement every eighteen months.

I still get **Mitsubishi** machines with unsecured tape guides although it's not difficult to reset them – unless it's the **HS700** portable. One **HS700** gave the same symptoms although the fault was a broken PG delay adjuster, probably due to the side panel being hit.

A couple of **Grundig VS200s** produced a surprise. They would suddenly stop during play and for no apparent reason unthread. The problem was traced to the pinch roller bearings which were seizing. Lubrication provided a temporary cure but they must be replaced.

An old **JVC HR4100** portable kept blowing fuses. The power supply bridge rectifier was open-circuit, as was one of the two charge regulators and a 15V zener diode across the charge output. This diode is not always shown on the circuit diagram. After the power unit had been repaired fuses still blew due to a short-circuit on the 12V line within the machine. This was eventually traced to the operations panel where some idiot had interchanged connectors 51/53 and 31/33, with the result that the tape counter put a short on the power supply at 0000.

An **Hitachi VT64** would go into a lock-out condition when a cassette had been inserted and then removed. Unless the top cover was taken off that is. It would then function normally. The start sensor optotransistor was only just turning fully on from the cassette lamp. Replacing the transistor put matters right.

An **NEC PVC746** would go into rewind when powered. The cause was a low level end sensor oscillator.

If a **Grundig VS series** machine starts to thread up then stops, remove the plastic dust cover from the brake solenoid switch and give the contacts a clean. Then throw it away – not the machine, the dust cover.

**Toshiba V71s** are giving us problems due to erratic operation of the mode cam switches. Symptoms range from silly things to playing fast – the latter is due to the threading motor switching off before the threading sequence has been completed, with the result that the pinch roller has not contacted the capstan shaft fully. A modified cam switch is being supplied.

A **Sharp VC388** had no functions at all. The power supply was being held off. It was soon spotted that Q5002, a 5V regulator, had been running very hot and had failed. The very fine double-sided print was just holding on. A replacement also got very hot – due to the microcomputer chip I5002 failing and drawing excessive current. After replacing this chip all was well, but it seems rather short-sighted of Sharp to fit a regulator transistor on a PCB with such fine print that it suffers in the event of a failure.

If the clock in a **Sanyo VTC5000** resets to zero or jumps digits after a timer recording when the machine is switched back on, decoupling capacitor C3308 has gone high-impedance. Replace it with one of a higher value, say 10μF.

S.B.

## Philips VR2020

This machine would occasionally stop playing a tape. The tape would then unthread and the machine would go into what appeared to be standby, though the controls on the front wouldn't do anything – it was necessary to disconnect the mains supply for a few seconds (this resets the microcomputer i.c.). After this the machine was usable until the next failure.

After a while it became apparent that the head drum speed was varying. This was noticeable with the machine switched on in the stop mode – the audio pitch produced by the rotation of the head was varying. The voltage at pin



10 of module U280 (head servo/oscillator) was then found to be varying. As a result the d.c. conditions in the motor drive amplifier and hence the speed of the drum motor were varying. The cause was dirty contacts in the relay associated with pin 10 of the module – there are two relays selected in accordance with machine status. Fitting a new relay restored normal operation.

I've since been told that these relays (1001 and 1002) give a fair bit of trouble. Interesting that the fault managed to inhibit all the front panel controls! **P.H.**

### **Philips VR6460 and Clones**

Creasing tapes was the complaint with this one. Sure enough when the customer's tape was played a line of bright "dropouts" was displayed. The only snag was that the same "dropouts" could be seen during a recording – and on any other machines playing in the workshop at the time. The interference was coming from the head drum motor. Fitting a replacement cured the problem. **P.B.**

### **Sony SLC7**

As a newcomer to Sony VCRs I found this one rather baffling. The symptoms were no sound or picture in the play, E-E or record modes, but if play and pause were selected you got E-E displayed! I started by tracing where the E-E signals had gone. There was no TU reg 12V supply as the PB+DUB 12V line was not going to 0V in the E-E mode. This latter line was traced back to the AS3 board where Q423 was found to be leaky. **P.B.**

### **Philips VR6520/Panasonic NV370**

For no cassette tray or threading motor drive check whether R1101 on the power transformer panel is open-circuit. **P.B.**

### **Sanyo VTC9300**

The fault with this machine was that the servo lost lock on playback, whether the cassette was recorded by the machine or another one. The machine's recordings played back perfectly on a Sony SLC7. This repair was a favour for a friend who didn't want to spend money on a manual ("it's eight years old, so if it needs money spent on it I'd rather buy a new one . . ."). I'd no circuit details, but Steve Beeching provided details of the servo test points in his report in the November 1983 Clinic.

The waveform at TP104, derived from the off-tape control pulses, was jittery on playack. The capstan was cleaned and lubricated but this produced no improvement – so the fault wasn't the same as Steve's! A new set of belts was fitted and every pulley was cleaned. Still no better. I was ready to admit defeat and was just filling in the form to join the Foreign Legion when an idea struck me. Thirty seconds later I had a perfectly locked servo and a machine that was good for another eight years. In case anyone else encounters this problem, start by degaussing the control head. **A.B.**

### **Akai VS1**

This machine wouldn't operate at all – even the red power-on indicator wasn't lit. A quick check revealed that the sensor lamp was open-circuit. Replacing this enabled the machine to be switched on but the front loading mechanism wouldn't take the cassette into the machine.

We turned our attention to the loading motor drive chip IC4 on the mechacon panel. The supply voltages to pins 7 and 8 were present and the voltages at pins 5 and 6 would vary slightly as the cassette was gently pushed into the machine, but there was no output to drive the motor. The problem remained when IC4 (BA6109) had been replaced. We then found that the eject motor had failed – this had probably damaged IC4. When both these items had been replaced the cassette would load, but some machines don't know when to call it a day. It took new fast forward/rewind/play idlers to finish the job. **S.I.**

### **Hitachi VT33**

With this machine the cassette would load but the tape wouldn't lace. A complete cure was provided by replacing IC902 (M54543L) which combines the forward and reverse switching arrangement for the front loading motor. It's mounted on the system control board. **S.I.**

### **Sharp VC9300**

Every couple of weeks or so this machine would blow the 2.5A fuse (F9001). When we had finally ruled out any mains supply problems an educated guess was called for. The 13V rail is protected by a crowbar arrangement – thyristor Q903 and zener diode D901 on the mechacon panel. Replacing these components appears to have cured the problem (touch wood). **L.G.**

### **Toshiba V65**

A brand new Toshiba V65 straight from the box made a nasty clonking noise in fast forward and rewind. On stripping down the reel drive gear train we found a tiny blob of glue or varnish stuck in the teeth of the take-up reel gearing. Luckily no damage had been done and we were able to scrape the teeth clean with one of our "Walkman special" screwdrivers.

These machines are well designed from the point of view of access but there's one problem. The main board is on the top of the machine and hinges up out of the way in a similar manner to many other VCRs. It's held down by two clips and two screws. Around one of these screws there's a crimped tag on a short lead connected to an earth line on the board. So when the board is lifted up this lead goes with it and, as we know to our cost, the floating tag can and will touch PCB tracks, causing additional problems if the machine is powered. Presumably this lead was an afterthought. Whatever the story the moral is clear: if you have to work on one of these machines with the main board raised, remove the lead or cover the tag with tape. **R.R.**

### **Panasonic NV2000**

The problem with this machine was that you couldn't tune the sound and picture in together – in addition there was no sound if a prerecorded tape was played. C4019 (0.33 $\mu$ F) turned out to be open-circuit. **W.G.L.**

### **Ferguson 3V29**

The fault was no fast forward/cue and rewind/review. When stop was pressed a loop of tape was left. Circuit protector CP2 in the reel drive circuit was open-circuit. Note that in some machines a resistor (R48) is used in this position. **W.G.L.**

# VCR Fault Analysis

Steve Beeching, T.Eng.

The purpose of this new column is to analyse in greater depth than is usually possible in VCR Clinic various examples of VCR fault conditions. The aim is to outline how the causes of fault conditions can be tracked down.

## Panasonic NV366

The fault report with this machine was of a tracking error half way down the screen. As a first step a known good tape was played – half an hour of test card or a film recorded on a new VCR serves the purpose well. The results obtained did not point conclusively to a tracking error. For a start the white noise was not as intensive as that produced by a tracking bar. The top half of the picture was perfect, but from about half way down the picture was covered in white noise spots and there was a slight flickering. Static problems could be ruled out as the spots didn't have the characteristic "tadpole" shape, and anyway the earthing spring and carbon brush were in good order and making contact.

To test for a tape path error it's best to bias the tape down gently with your finger, by lightly pushing down on the top edge between the entry and exit guides. This made matters worse, producing a number of tracking crossover bars. Luck can play a part in VCR servicing: our decision to measure the replayed f.m. signal as the next step probably cut out a lot of headscratching. We found that one head was producing a full f.m. signal throughout the scan while the other one produced a signal only during the second half of the scan. Now the NV366 has four heads, the main two being designated L and R. Mounted at 90° to these are two other heads, R' and R'', which are used for still pictures and picture search. Both sets of heads use the same preamplifiers, with relays used for switching. In this case it could be proved that one of the relays was suffering from contact problems, which is not unusual in very low signal level circuits. The clue was in the half picture. Fig. 1 shows the head switching circuitry. If say the L side was o.k., it would produce a full f.m. signal during the scan. If the other relay was switching to the R'' head, 90° from the L head, it would produce an output for only half a track.

A red herring in this case was that the picture didn't show any severe jumping or flicker as the effect was hidden by the spots. A similar effect can be seen with

Betamax machines when one head has ceased to function. Also note that a mechanical fault could have been easily ruled out by the fact that a recording made on the machine would have played back perfectly on another VHS machine.

The cure was to replace the switching relays RL3501 and RL3502, not the video heads!

## Grundig VS200

The problem with this machine was no E-E picture. This could have been a customer finger problem although on Grundig VCRs there's no output signal unless the machine is in record or the programme plus or minus button is stepped on. Checks soon revealed however that not only was there no E-E signal, there was no recording on the tape either (cross-checked with another VHS machine). The screen was clean blank in the E-E monitor mode – no spots. A prerecorded film could be played back with no problems.

The starting point is to check for video output from the tuner/i.f. module. Video was found to be present right up

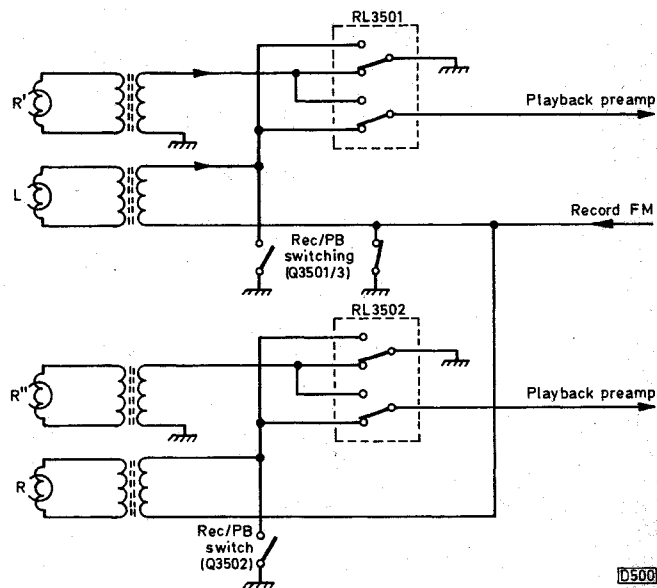

Fig. 1: Head switching arrangement used in the Panasonic NV366, shown in the playback condition.

to pin 4 of IC810 (TDA3771) on the luminance panel. It emerged at pin 18 of this i.c. and went back in at pin 12. That's where it ended. There was no output at the record output pins 15 and 17 or the monitor output pin 6. So it seemed that the chip was faulty, or was it?

It pays to check around such signal i.c.s for pulse inputs. A lot of timing, clamping and gating pulses are used and are easily overlooked. Pin 9 should have been receiving mixed syncs but nothing was present here. Tracing back took us to contact 34 on the chroma panel. The mixed sync signal that should have been present at this point comes from pin 1 of IC1155 (TDA3750). There were no pulses here either. Video was present at pin 3 of this i.c., so it seemed likely that the sync separator within the chip had failed. Several peripheral components were checked, including C1154 (22 $\mu$ F) connected to pin 2 and the network connected to pin 4 – both these pins are connected internally to the sync separator part of the chip – but no fault was found here. Replacing the i.c. cured the fault. It would be reasonable to expect some ripple at pins 2 and 4. For future reference pin 2 is at 7V d.c. with an 0.3V p-p a.c. ripple on it at 20msec periods. Absence of ripple at this point tended to confirm that the i.c. was faulty.

## Hitachi VT33

A similar fault caused much more trouble with an Hitachi VT33. The symptom was that of head failure – spots with a picture of sorts underneath, flickering vertically. In fact the dealer who'd sent it to us had written "suspect video heads" on the fault report. I decided to try new heads and when doing so was made suspicious by the fact that the wires had been removed previously. New heads didn't provide any improvement so the originals went back in. The next step was to check the f.m.

waveform obtained from the preamplifiers – pin 12 of IC202 (HT4238) would do for this purpose. A good waveform was present here, with no gaps and plenty of f.m. from each head. Back to square one, with the heads apparently eliminated.

Closer scrutiny of the picture showed that there was a lot of colour noise. So the colour was muted by connecting pin 10 of IC203 (HT4239) to chassis. The spots then went away, leaving a clear monochrome picture which was bouncing vertically – so much so that a line of text showed double. This was down to the video heads: someone had moved one of the tips so that they were no longer 180° apart. The bounce was produced by the two heads replaying different fields. New heads cured this and a good monochrome picture was obtained. So far so good.

When the colour mute was disconnected the noise reappeared, giving the impression of head failure. It could be deduced only that something within IC203 was creating the noise, but the fault persisted when a replacement was fitted. It was eventually discovered that there was no sync pulse input at pin 22 of the i.c. This had the effect of putting the a.f.c. loop out of lock. The sync pulses come from pin 27 of IC202 and were not present here either. Since the sync separator in this i.c. appeared to have failed a new chip was fitted, finally restoring normal operation.

So what were the red herrings that led us astray in this case? First the fault symptom was identical to that produced by head failure. Someone had obviously messed about with the heads. Secondly there were reasonable monochrome record/playback pictures with the colour channel inhibited: there were no signs of any luminance problems that could have been caused by lack of clamping or a.g.c. failure. This example illustrates that all is not always what it seems, and that the fault symptoms can be very misleading when timing pulses are missing.

## Ferguson 3V38/JVC HRD110

The problem with this machine was intermittent failure of the front buttons to operate. During one of the rare occasions when the fault was present we found that Q223's base voltage was high – so was the voltage at diode D225. The cause of the trouble was that Q208 was turning on very intermittently – but why? There was a partial short in the audio DIN socket, between the earth pin and the remote data pin. **S.B.**

## Intermittent Erasure

When the problem is intermittent sound erasure, which may be accompanied by no sound recording, you may also notice colour flutter due to incomplete erasure of the video tracks. If the machine is a Toshiba V65, a JVC HRD140/150 or a Ferguson 3V44/45 look for C23 on the top right-hand panel and solder a 5.6nF Mylar capacitor across it. If the machine is a Ferguson 3V31 or a JVC HR7650/7655 replace the bias oscillator module with the later type and change both relays. **S.B.**

## Sony SLC6

Failure of Q01 in this machine removed the E-E 12V supply and thus the E-E signals. **S.B.**

## Head Cleaning

This can apply to any machine, though the two in question were both Fergusons – a 3V31 and a 3V29. The fault was described as picture rolling, with the tracking control not working. A noise bar moved up through the picture and the head switching point was visible in the bottom third of the picture. Use of a scope revealed that the head switching point wandered from approximately thirty lines early right through to the field sync, but this was happening on only one channel. The cure? Clean the video heads – a piece of oxide was causing misalignment of the tape path. **A.D.**

## Ferguson 3V31

The complaint with this machine was intermittent speed variations when warm. Checks were made around the AN6341 capstan servo chip IC6 when the fault occurred. A replacement chip failed to provide a cure: all the inputs were found to be correct but the output was varying. The output goes to the TC4066 switching chip IC7. 9V entered this i.c. at pin 1 but only 6V came out at pin 2: control pin 13 was at about 5V. This pin is driven by IC22 (M54519P) which turned out to be the culprit – heating and cooling it made the fault come and go. **A.D.**

## Fisher FVHP715

As soon as this machine was plugged in a hum bar appeared on the monitor screen. A scope check revealed a 2V p-p hum ripple on the 9V supply to the combined r.f. modulator/splitter/booster unit – when this was unplugged the supply line ripple disappeared. Having had similar symptoms with a 3V16 I checked the r.f. modulator by substitution. No difference! To cut a long story short –

about changing voltage regulator i.c.s etc. – I eventually arrived at the full-wave rectified 16V line. Each rectifier diode is fed via a separate fuse, one of which was open-circuit. The result of this was that the 16V supply was half-wave rectified. **A.D.**

## Philips VR6660

The job card read "clock display faulty". In fact the bottom right and bottom grids (cA and dA) on the display were continuously on. Replacing IC2 (SN75518N) cured the fault. **A.D.**

## Sony SLC7

This machine is well known for its slow rewind and the modification kit to correct this. I've had a machine that developed the same fault again some time after fitting the kit however. The solution seems to be to remove the rubber tyres on the idler wheel (and the drive motor if the modification has not been carried out), turn them inside out and replace them. This has even obviated the need for the modification with two SLC7s. **G.J.**

## Sanyo VTC5000

The reel drive motor used in this machine has a tendency to run slow with the result that tapes get tangled. Motor replacement is obviously advised but is neither cheap nor easy. I've found that a single drop of high-quality watch oil applied to the upper bearing, which is just accessible with the cover removed, can double the life of the motor. **G.J.**

## Salora SV8200/Mitsubishi HS303

Although the machine was a Salora SV8200 we found a Mitsubishi HS303B underneath the covers. It took several seconds for the drum servo to lock: the picture wobbled and the audible note of the drum motor had a harsh tone. Monitoring the sample and hold at TP4A showed that it was fluctuating up and down. C4B8 turned out to be 100 $\mu$ F instead of 47 $\mu$ F. **R.R.**

## Toshiba V65

The 2A fuse in the power supply failed but, unexpectedly, the machine continued to work after a fashion. To save you confusion, if you have the same trouble the symptoms are as follows: clock o.k.; through signal from aerial to TV set o.k.; E-E signal has bad hum bar; eject and load o.k.; selection of play, rewind, fast forward etc. switches the machine off. **R.R.**

## ITT P4833/Ferguson 3V24

One of these portable VHS machines had a fault in the E-E and camera modes. The video signal was badly distorted, with washed out and smeary whites, weak sync and bad vision buzz on sound. The colour content was correct however, as was playback of a test tape. Following through the video input signal path brought us to IC2

(HA11703), part of which forms an a.g.c. stage. The input at pin 12 was correct but the output at pin 11 showed up all the distortions – the sync amplitude varied with picture content, in fact even the overall signal amplitude varied with picture content. So much for the a.g.c.!

From pin 11 the signal path splits. One path is the E-E one to IC3. The other returns to IC2 where after further processing, including a.g.c. circuit drive, the signal becomes the record f.m. for the video heads. This path incorporates a filter to remove the colour subcarrier

information. Just before it re-enters IC2 at pin 16 the luminance only signal is d.c. clamped by X5 (2SC2647C), which is driven by composite sync pulses from the sync separator in IC3. Because of the fault the waveforms were wrong all around this circuit, but the trusty meter showed that the d.c. conditions were correct everywhere except at X5 whose base, collector and emitter were all at the same voltage. An out-of-circuit check confirmed that this transistor was leaky – a BC184L in its place restored normal working.

**R.R.**

# Servicing Hitachi VT8000 Series VCRs

Derek Snelling

The Hitachi VT8000 series of VCRs comprises models VT8000, VT8300, VT8500 and VT8700. Similar models were released under the Granada name: in addition the mechanics were used in the Fidelity VTR1000. They were amongst the first "electronic" type VHS machines released in the UK, being on sale during the period 1980-2, and have proved to be very reliable. The VT8000 is the basic model, with a one-event, ten-day timer, visual search, freeze frame and frame advance (the noise bar is automatically shunted to the bottom of the screen), audio dub and a ten-function wired remote control system (some early machines had two-function only remote control, but the later units will work with them). The VT8500 was the "luxury" model, with a four-event timer, half and double speed playback without noise bars, a tape index system and infra-red remote control. These two initial models were subsequently replaced by the VT8300 and the

VT8700 respectively. Apart from cosmetics, the main differences with these later machines are a redesigned bottom board to incorporate an improved power supply and the various modifications introduced during the production run of the earlier models, a flashing play light during search, and continuous frame advance while the button is kept depressed. While on the subject of boards, it's worth noting that the component reference numbers on the board and those on the layout diagrams in the manual can differ - in fact the numbers on the top and bottom of the panel for the same component can differ. If in any doubt, it pays to check with the circuit diagram.

## Access

Access for servicing is as follows. The top is secured by four screws, three along the back and the other one under

Table 1: System control IC pin data

Pin	Active level	Function
<b>HD44801A05 (IC901)</b>		
1	—	Sync pulse to IC902
2	L	Activates 15V and not-PB12V lines when pin 41 is set high
3	L	Sets servo system to search mode
4	L	Capstan motor reverse
5	L	Loading operate
6	L	Unloading operate
7	L	Fast forward
8	L	Rewind
9	L	Slow reel motor drive to avoid tape slack when unloading
10	L	Reel and loading motor braking
11	L	Take-up reel braking
12	L	Main brake operate
13	L	Main brake off
15	H	Reset
21	—	5V supply
22	H	Auto rewind at tape end on supply side
23	H	Timer recording operate
24	H	Forward end sense: detects supply side tape end and stops after unloading
25	H	Rewind end sense: detects take-up side tape end and stops after unloading
26	H	High when safety tab present
27	H	Set by arrival of pause stand-by instruction
28	H	Set at completion of unloading to stop mechanism
29	H	Set at completion of loading to stop loading mechanism
30	H	Set to stop drum after unloading
31	H	Set to stop reels after unloading
32	H	Cassette holder: clears memory when pin 30, 31 or 33 is high during a timer recording
33	H	Set when dew detected or bulb fails: stops after unloading. Stop indicator will flash at 3Hz
36-9	H	4-bit data
40	H	Key signal AD conversion
41	H	Reads in the operate switch mode. When high sets pin 2 low
42	H	Search end
<b>HD44801A19 (IC901)</b>		
As above except:		
2	L	Activates 15V and not-PB12V lines when pin 13 high
13	H	Reads in operate switch mode. When high sets pin 2 low
41	L	Reads camera connected
42	L	Reads in camera data and precedes the camera pause
<b>HD38701A06 (IC902)</b>		
1	H	Stop indicator lights
2	H	Pause indicator lights in frame advance, still, RC pause, dub pause and stop pause
3	H	Rewind indicator lights
4	H	Fast forward indicator lights
5	H	Audio dub indicator lights
6	H	Record indicator lights in record and record pause
7	H	Play indicator lights in play, slow, quick, frame advance, still, record, record pause, dub, dub pause and visual search
8	H	Sync pulses from IC901
10	H	Reset
14	H	9V supply
15-8	H	4-bit data from IC901
19	H	Activates PB9V line in playback mode
20	H	Activates REC9V line in record mode
21	H	Activates audio dub
22	H	Activates pause mode
23	H	Inhibits servo and signal systems during loading
24	H	Drum rotate
25	H	Puts servo in frame advance mode
26	H	Tuner channel selection
27	H	Activates slow play mode
28	H	Activates fast play mode

the clock set flap. The bottom is secured by six screws. The front is secured by three screws along the top, revealed when the top is removed, and three screws along the front, two behind the tuner flap and one behind the memory switch flap. Removing these three items will give access to most of the machine. Note that the operate board is screwed and clipped to the front, so take care when removing this.

The audio board on the left-hand side of the machine is secured by two white nylon clips along its top edge. When these clips are released the board can be hinged down for service. The two panels sandwiched together at the rear of the machine are the visual search board (the smaller, outer one) and the luminance-chroma board (the larger, inner one). The visual search board is fixed to the other one by a white nylon hinge: just undo the two screws that secure its upper edge to the chassis and hinge it down to work on it. The luminance-chroma board is held in place by two nylon clips along its top edge, in a similar manner to the audio board, and can be hinged down in the same way. To the right of the machine are the tuner and i.f. boards, which are fairly inaccessible, and to the right of them there's the small rectifier board. Underneath there's the large servo/system control board. Access to this is by removing the four fixing screws located near each corner, then hinging the board up and rearwards. When refitting this board take care not to trap any of the wiring or distort the board too much. This leaves just a small panel tucked away to the left of the i.f. panel. This contains two regulator transistors in the VT8000/VT8500 and a large regulator i.c. in the VT8300/VT8700. The VT8500/VT8700 have an extra panel on the left-hand side of the bottom board – this is the remote receiver panel.

### Booster and RF Lead

We'll start at the r.f. end. What sort of problems can you expect? Well, I've never had a booster fail on these machines and the sockets are of a robust construction which the manufacturers of many more recent machines would do well to copy. The r.f. lead supplied with these machines has a built-in isolator which often gives problems. Repair is a simple matter however: just undo the two screws and resolder the isolating capacitors to the cable.

### Tuner, IF and Converter Sections

The tuner and i.f. sections rarely give trouble. The tuners occasionally go low gain at one end of the band or suffer from dry-joints which are made more difficult because of the number of thick-film type components used in the construction of the unit: replacement is usually necessary. The only problem with the i.f. section seems to be dry-joints at the earths where the case is soldered to the print, usually near the centre of the board, though I have had a couple of cases of dry-joints on the larger electrolytics. This board cannot be worked on in situ and has to be removed. I find that the best way of doing this is to remove the fixing screw and nylon clip from the top of the panel, open up the bottom board, then unsolder it from the small mother board it shares with the tuner. The alternative is to remove the tuner/i.f. assembly complete then remove the i.f. module from the board.

The r.f. converter (u.h.f. modulator) is reliable though I have had a couple of cases of no signals at the output. The range of the sound coil is sufficient to change from

6MHz to 5.5MHz – in fact if you get one from Hitachi it may be a German one with instructions to retune it to 6MHz.

### Video-chroma Board

Most of the circuitry on the video-chroma board at the rear is contained in three hybrid modules – IC201 for the f.m., IC202 for the video and IC203 for the chroma. Be careful here when reading the circuit diagram: the individual components within the hybrid modules and their values are shown although they are not repairable – in fact the area covered by a particular hybrid circuit is not immediately obvious. Faults on this panel tend to be confined to IC203 giving no/intermittent colour. Other failures I've had include IC202 giving no video and failure of various filters giving colour or luminance problems, also one case of no playback due to failure of IC201. I've never had to adjust any of the presets on this board although the record chroma current control should in theory be set when the heads are changed.

### Visual Search Board

The visual search board performs several functions. It shunts the noise bar off screen in pause, times how long the machine is in the pause mode, switching pause off after about ten minutes, and provides VD pulses during the various non-standard speeds. These are artificial field sync pulses that are necessary to prevent the picture rolling in the non-standard play modes. This board differs slightly from model to model. The VT8500/VT8700 have additional components for half and double speed playback. The VT8300/VT8700 have continuous frame advance while the frame advance button is depressed, unlike the VT8000/VT8500 which advance only one field until the button is released and then pressed again. The circuitry consists entirely of various logic chips so if you like these fault finding should present no problems. As yet I've not had a fault on this board. There are three or five adjustments on the board. With the VT8000/VT8300 there are controls for the speed of the frame advance (set for about one frame per second) and for the position of the noise bar (set for off screen at the bottom). Remember to advance the frame after each adjustment to check the effect. The third control is for VD pulse timing adjustment. Set this for minimum frame jitter in pause. The VT8500/VT8700 have these same three adjustments plus two extra VD pulse timing adjustments for half and double speed. The VD pulse adjustments are accessible through the rear of the cabinet, being behind a rubber plug. Different settings may be required with different TV sets.

### Audio Board

The audio board on the left of the machine contains all the audio circuitry with the exception of the microphone input amplifier which is on the bottom board. In addition, in the VT8500/VT8700 it includes the tape index system. This superimposes the SW25 pulses on the full erase head during lace-up in record. The pulses thus put on the tape can be detected during fast forward or rewind by the tape index head fitted to the end of the tape tension arm. Faults on this board seem to be confined to the relays. There are two, one for audio dub and the other for record/playback. The "rest" position for the latter is in

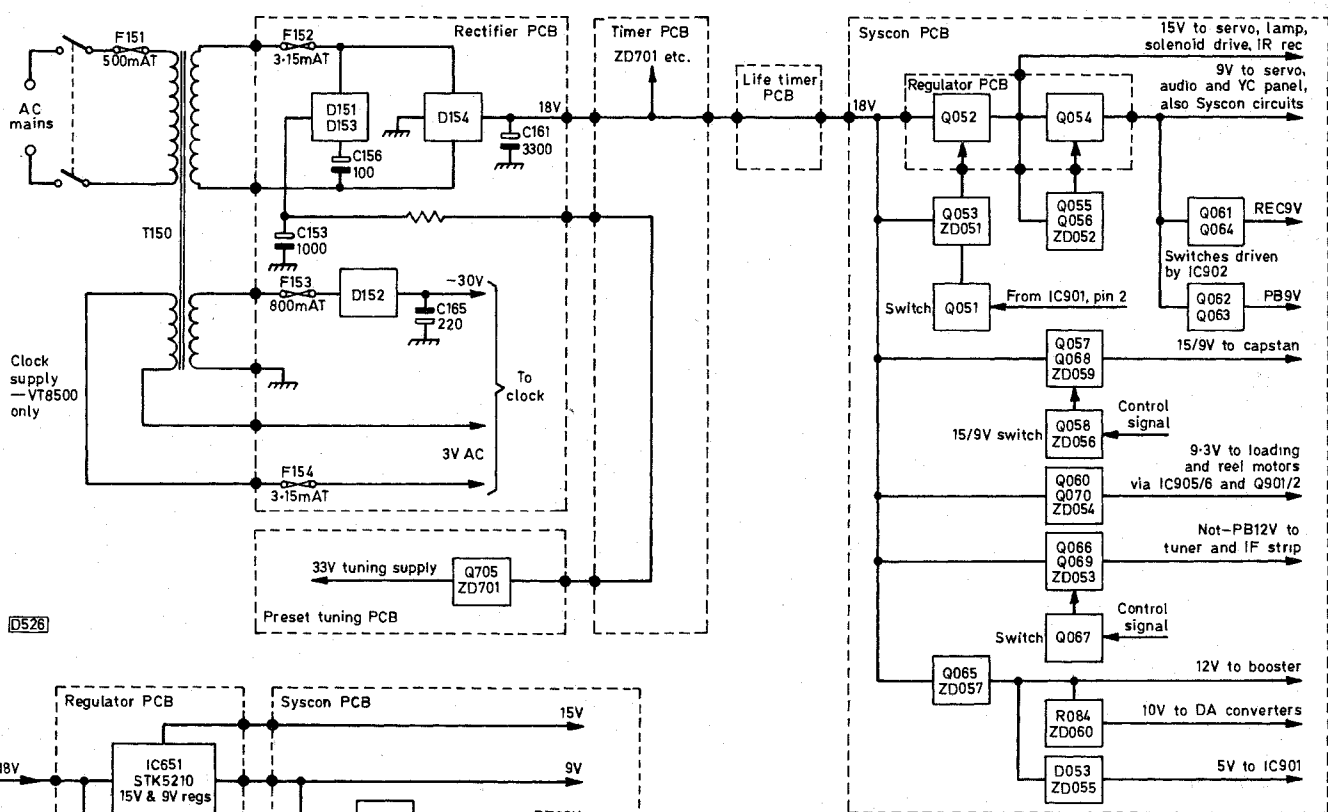

Fig. 1: Above, block diagram of the power supply arrangements used with the earlier VT8000/VT8500 machines. Left, changes introduced with the later VT8300/VT8700 machines.

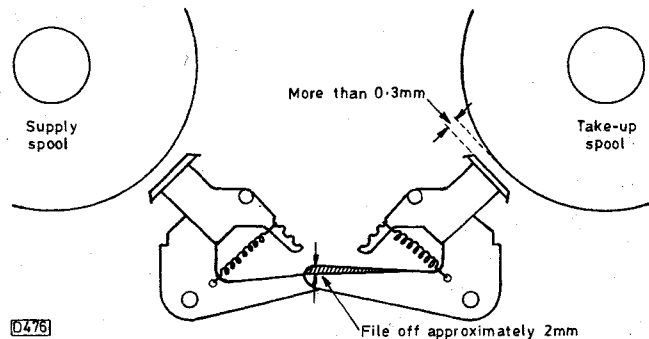

Fig. 2: Mechanical modification to cure tape damage due to looping when the machine stops after rewind.

trouble-free board. With the VT8300/VT8700 however a problem sometimes encountered is failure of one of the hinged buttons on the front. Luckily these are part of a separate detachable unit that can be bought and fitted without the need to replace the whole front.

### Clock-timer Board

The clock/timer board differs completely between the VT8000/VT8300 and the VT8500/VT8700. With the latter models there's a battery back-up and an extra -30V supply is required for the display. Faults on these panels are confined to the microcomputer chip or the various setting switches. A customer problem can arise on the VT8500/VT8700 due to the 50/60Hz switch: if this is put in the 60Hz position nothing happens until the machine is unplugged, whereupon next time it is connected the clock will assume 60Hz mains and lose time accordingly. This can sometimes happen due to a spike down the mains. In this case the cure is to unplug the machine, count to ten

record, so when it plays up it's usually playback that's affected, giving motorboating and other signs of instability. Sometimes switch cleaner works, sometimes the relay has to be replaced. The plastic covers just clip on, but remove them carefully.

### Operate Board

The operate board at the front contains the various operation switches, LEDs and associated resistors, and in addition in the VT8300/VT8700 there's a transistor and diode to make the play light flash in visual search. A



and then reconnect it. Note that the battery back-up works only when the time switch is on.

## Power Supply Arrangements

Most of the faults with these machines occur in the power supply. This is spread over three boards. First the board which contains the rectifiers – three in the case of the VT8000/VT8300, four in the case of the VT8500/VT8700 – and the smoothers. Secondly the power transistor or regulator board, which with the VT8000/VT8500 contains the 9V and 15V series regulator transistors and with the VT8300/VT8700 contains an encapsulated 9V/15V regulator, also the bulb feed resistor and open-circuit detector. The rest of the power supply circuitry is on the bottom board, mainly along the left-hand edge. Fig. 1 shows block diagrams for the two versions of the supplies.

When dealing with a power supply fault remember that most of the lines are derived from other supplies so check for the highest missing voltage and sort this out first – the others will then usually be o.k. Common power supply faults with the VT8000/VT8500 are as follows. R054 (1.5k $\Omega$ , 0.5W) goes open-circuit or high in value, giving no switched 15V or derived supplies. R069 (1.5k $\Omega$ , 0.5W) goes open-circuit or high in value, removing the not-playback 12V supply. Q051 or ZD051 faulty gives no switched 15V or derived supplies. ZD055 faulty results in no microcomputer chip 5V supply. R081 (2.2 $\Omega$ , 0.25W) open-circuit gives no 10V supply for the reel or loading motors – this resistor was replaced with a resistor in the VT8300/VT8700 to overcome the problem. In addition to these common faults I've had most of the zener diodes fail at one time or another and a colleague had a faulty bridge rectifier which had the effect of extinguishing the clock display whenever play was selected. The different power supply arrangements in the VT8300/VT8700 result in greater reliability. IC651 on the regulator board can sometimes fail, removing the switched 15V and 9V supplies. R653 (220 $\Omega$ , 0.5W) on the same board can fail with the result that the cassette lamp is without a supply although the machine will continue to operate because of the nature of the detection circuit.

When the switched supplies are missing I usually check first at the microcomputer chip (IC901) to make sure that the power control pins 41 and 2 (13 and 2 with the VT8300/VT8700) go up and down with the operate switch. If pin 2 does but pin 13/41 doesn't, the i.c. could be faulty but the problem is usually with one of the associated components. Check all voltages carefully, referring to Table 1.

## Servo and System Control Circuits

The rest of the bottom board is occupied by the system control and servo circuits. The servo circuits are essentially the same on all models although the layout differs and the VT8500/VT8700 have a few additional components for the two extra capstan speeds and a slow tracking control. Faults are usually confined to failure of the tracking control to operate correctly, caused by either the HA11711 chip or slight misadjustment of the drum servo. Capstan faults are usually due to the motor.

System control is largely carried out by two chips, IC901 and IC902. The smaller one (IC902) is the same throughout the range but there's a different version of IC901 in the later models. There are also two versions of the system control circuit for the VT8000. Faults here are

usually caused by the various diodes, especially the 5V zener diode previously mentioned (ZD055), or IC901. Failure of the index system was in one case traced to Q917. IC905 or IC906 can fail, giving no loading motor or reel motor operation respectively.

## IR Remote Control Receiver Board

The VT8500/VT8700 have an extra board next to the bottom main board. This is the infra-red remote control receiver board. Faults in this area are confined to dry-joints/cracks – also check for dud batteries in the handset.

## Solenoid Drive Board

The only board not mentioned so far is a small one present in the VT8000/VT8500. This is the solenoid drive board containing the drive transistors for the two brake solenoids – these transistors are on the main board in the VT8300/VT8700. Failure of the brakes was in one case traced to Q54.

## The Mechanics

We now move on to the mechanics. As previously mentioned the capstan motor is a source of trouble, the usual symptom being wow on sound. The video heads give very little trouble even though some machines are now approaching five years old. The audio/sync head does wear however, giving low, muffled sound or varying sound level. There was at one point a bad batch of heads bearing the number 671. They produced vibration which affected both the sound and picture. Most other faults are only now beginning to show up, as wear sets in. These are mainly failure to complete loading due to a worn loading belt, poor rewind due to a worn tyre on the supply turntable (this can usually be roughened with a needle file then cleaned with methylated spirits), and tape looping after rewind – this means that the brakes and turntables need cleaning. Ejecting at high speed or jamming whilst ejecting is usually caused by failure of the eject damper mechanism – the nylon cog tends to fall in half. This is the same mechanism as fitted to the Ferguson 3V29/30. Failure to complete loading can also occasionally be caused by incorrect setting or failure of the two loading switches located to the rear of the mechanics.

## Modifications

Finally, don't forget the various modifications that were introduced on this range. Though they've been mentioned in VCR Clinic we are repeating them here for the sake of completeness.

A hum bar on record with the VT8500/VT8700 – it can sometimes be seen in the E-E mode – can be cured by fitting a low-voltage (Mylar type suggested) 0.1 $\mu$ F capacitor across C760 on the tuner board and cutting the pink lead (chassis connection) between the tuner board and the tuning preset board.

The brake modification applies to all models. The problem is tape damage after rewind, caused by the fact that the supply spool brake comes on fractionally before the take-up spool brake, or the latter slips slightly, when the machine stops after rewind. The result is a tape loop which gets trapped in the cassette flap when the cassette is removed. There are two modifications for this, a mechanical one and an electronic one. The former consists of filing

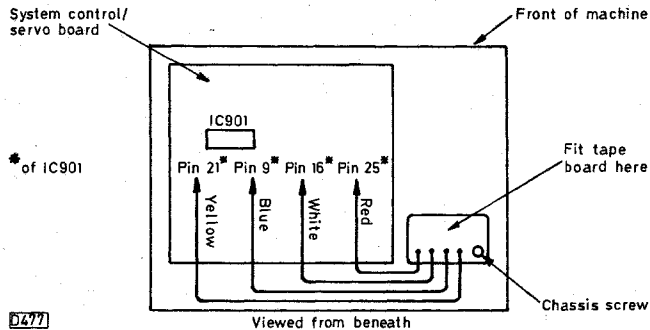

0477

Fig. 3: Electronic modification to prevent rewind looping.

a piece off one brake arm (see Fig. 2) to ensure that this brake comes on fractionally before the other. The latter

consists of fitting a small panel called the tape board next to the main board at the bottom, wiring this to IC901 as shown in Fig. 3. This is a very neat solution but requires the rewind end sensor to detect the tape end: with the VT8500/VT8700, which incorporate the tape index system, if this is switched on during rewind the tape stops when the next index pulse arrives so the modification doesn't operate. With these machines it's best to carry out both modifications.

The final modification applies to the VT8000/VT8500. The problem is that when play or record is selected the machine fails to lace up and switches off after a few seconds. The cure is to replace R081 ( $2.2\Omega$ ) on the bottom panel with a posistor, part number 0249794. Mount it in contact with the transistor heatsink on the edge of the main board.

It will probably be missing. If so check the voltages at the spindle side of the head drum optocoupler – you should find 4V and 2.5V here. If the readings are 12V and 0V the LED is open-circuit. If there's 12V on both pins the cassette LED is open-circuit – the two LEDs are connected in series. P.B.

### Panasonic Aerial Amplifiers

Like many dealers we see quite a few of the earlier Panasonic machines with low-gain aerial amplifiers. As long as EE operation is o.k., replacing Q3 usually does the trick. P.B.

### Sony SLC9

We've now had three of these machines with no off-air signals and no lights in the fluorescent display panels. In each case the cause of the trouble was failure of the d.c.-d.c. convertor (type CD-09) on power supply unit board D. This supplies the filament and operating voltages for the display panel and a 38.5V output which is the source of the varicap tuning voltage. Although the manual gives the circuit diagram the soldered sardine-can construction of this little module defied my efforts to get inside to repair it. The replacement (part no. 1-608-212-11) is expensive but the type supplied looks different – it has probably been modified to provide greater reliability.

We are now experiencing an epidemic of cracked loading gear pulleys on these machines. This causes very noisy lacing and unlacing. E.T.

### Hitachi VT63/4/5

It seems that certain production runs of these machines incorporated a batch of contaminated tape-end sensor transistors. Because this VCR design features an unusual tie-up between the end-sensors and the loading mechanism, via the syscon, misleading symptoms arise when the phototransistors leak – as they commonly do. The symptoms vary from immediate ejection of the proffered tape to what appears to be a mechanical jamming effect of the front-loading mechanism. It's easily checked (once you know!) by measuring the voltages at pins 6 and 7 of PG904 with no tape in the machine. If the voltage at either pin reads less than 9.5V replace *both* sensors. They have different part numbers: one 5381681 and one 5381682 make a pair. E.T.

### Hitachi VT39EM

The problem with this machine was low recorded and E-E sound. Playback was o.k. It seemed likely that the fault was in the i.f. strip. We were lucky since this machine has a dual i.f. strip, for use with 5.5MHz sound. Comparing the voltages in the two units revealed that output pin 5 of IC803 (AA313) in the faulty strip was low at 6V instead of 10.3V. Replacing this chip put matters right. M.D.

### Sharp VC387

Only the clock worked on this machine. We soon found that there was no 9V supply to the microcomputer chip because the little black fuse in the supply line had gone open-circuit. Replacing this brought some life back to the machine but there was no drum rotation. This time the little fuse in the 14V supply was found to be open-circuit. Much confusion was caused by the fact that these fuses

aren't shown in the circuit. We had to trace the printed tracks across several panels. M.D.

### Ferguson 3V30

Every now and again this machine would die, leaving just snow on the screen. A gentle tap anywhere on the top would restore operation. The problem was caused by dry-joints on the regulator transistor Q101. M.D.

### Sony SLC9

No clock display on this machine was caused by the d.c.-d.c. converter module in the power supply – it provides -26V and 3.5V a.c. supplies for the filament in the display. M.D.

### Ferguson 3V22

Inability to set the drum speed in one of these machines was traced to a break in the print to the wiper of the drum discriminator control. In another machine a varying capstan speed effect was caused by the plastic flywheel support rising up the capstan slightly. N.B.

### Sanyo VTC5000

Tape looping with these machines can be caused by a faulty reel motor or belt, but this problem occurs on loading or unloading. When the looping occurs on cassette ejection check the back spacing. If there's over rotation, suspect the rubber brakes. Cleaning and resetting should cure the problem. J.C.

### Sharp VC9300

This machine wouldn't accept a cassette. It was a simple fault: the cassette-in switch was broken in half. This can be seen and removal of the cassette housing will soon put matters right. J.C.

### Ferguson 3V45/JVC HRD140/Toshiba V65

In the event of no "on" or drum rotation, with the standby light on, check whether the switched 5V line is missing due to safety component CP4 being open-circuit. J.C.

### Sanyo VTC5150

The problem with this machine was a faint vertical line down the screen. It was cured by repositioning the grey lead (JW18) between the two delay lines. J.C.

### Sony SLC5/7

If the sound is o.k. with a prerecorded tape but there's no E-E or recorded sound check the voltages around the TDA120UB sound i.f. chip. If there's no voltage at pin 14 the chip is faulty – pin 14 gets its voltage via an internal resistor. W.G.L.

### Sony SLC6

In the event of no capstan motor rotation check the drive from transistor Q022. If necessary check the capstan servo i.c. (CX143A) on the system control panel. If the 12V supply is high check regulator IC001 (STK5314) on panel TP16. W.G.L.

# The Problem of Tape Damage

Christopher Holland

There's nothing quite so frustrating as a really intermittent fault. Not just the type that shows up only after a matter of minutes or hours but one that decides to rear its ugly head at intervals you can count in months. The example I have in mind concerns a JVC HR7700 video recorder that would very infrequently damage tapes. Now the average customer might be prepared to put up with say occasional momentary loss of colour or something like that but a damaged tape is a different matter. The problem was compounded by the fact that the machine in question was launched in 1981 as the most advanced home VCR of its time, a veritable "Rolls Royce of the video world" (to quote a salesman's patter that sticks in my mind). In those far off days when multi-head and HQ VCRs were no more than a twinkle in a Japanese engineer's eye the HR7700 was a truly impressive machine, with its row of touch controls, a complement of trick facilities and a tape loading mechanism that silently sucked the cassette from the user's hand, all in an elegantly styled package that said "class". Oh yes, and with a price tag to match.

## Dealing with Owners

It's this last point that has led to HR7700 owners tending to be a rather disgruntled lot. To purchase such a unit they would tend to be "video buffs" (such people used to exist in those days) so you can imagine their chagrin when, before their h.p. payments were even half cleared, they were reading about new models with superior performance at a cheaper price. Such was the pace of development. Some owners traded in their machines, normally at some financial loss, but most appear to have remained loyal to their "Rolls Royces" and just stopped buying the video magazines. That's why in my experience you have to be very careful when dealing with the owners of HR7700s or the Ferguson equivalent 3V23: they always seem to welcome reassurance about the quality of their purchase. As you hand the machine back after a service, point out the weight of the machine and say "they don't make them like that any more". You'll make a friend for life.

## Damage Every 3-4 Months

What this is leading to is the double-edged problem we had with one of these machines. Over a two year period the owner had called in at maybe three or four monthly intervals and almost apologetically informed me that it had damaged another tape. I would ask to see the damaged tape in case it offered any clues as to the cause of the problem but no tape was ever forthcoming. Now this usually means that he's watching the sort of tapes he doesn't want you to know he watches, if you know what I mean, although I found this impossible to believe in the case of this particular gentleman and his good lady wife. Well, improbable anyway. So each time I would take in the machine, remove the top covers and put it on the test bench. There were never any signs of fragments of damaged tape in the machine, and it always performed perfectly on test. When the owner called to collect it I would report this to him, tell him what a great VCR it

was, and ask him to bring it in with the damaged tape if it misbehaved again and to tell me the exact circumstances in which the damage occurred, something about which he was never certain.

## Common Causes

Now I suppose I should mention the common ways in which VHS machines can destroy tapes. The big favourite in the days of the old-style mechanical videos was for the tape to stop playing after about an hour or so as the main solenoid fired. When the cassette was ejected a loop of tape with a distinctly crunched-up appearance would be left hanging from the cassette flap cover. This problem is caused by a lack of take-up torque, which means that while the pinch roller and capstan shaft are still drawing tape past the heads the tape is no longer being spooled into the cassette. By the time the reel detector reacts and tells the machine to close down there's a length of tape around the pinch solenoid. This inevitably catches on something when an attempt is made to eject the cassette. The cure is to replace the take-up clutch. If you haven't come across this one you don't fix videos for a living! Similar damage can be caused by lack of unloading torque: on selecting the stop mode the rewind spool doesn't draw the tape back from the heads and again tape damage occurs when the cassette is ejected. This tends to occur with models that use a reel motor to perform unloading, and is normally due to failure of a component in the circuit that drives the motor in the required direction.

Another favourite is a tendency for a machine to take a thin slice off the bottom edge of the tape. Often this has no effect other than to leave thin slivers of tape deposited around the capstan flywheel shaft and pinch roller, but in bad cases it can destroy the section of tape that contains the control pulses, rendering the tape useless. This problem is caused by the lower edge of the tape lapping over the bottom of the take-up guide pole and becoming sliced or serrated by the guide pole itself or, more commonly, the bottom edge of the cassette body. The fault normally shows up at the beginning of E180 tapes and is due to one of the following: the pinch roller coming down crooked on to the capstan flywheel shaft, which obviously makes the tape creep down; excessive take-up torque, where the take-up spool tries to pull the tape back into the cassette housing faster than the pinch roller can supply it; or a faulty roller within the body of the cassette - a roller that's not perpendicular to the path of tape travel. Any VCR will of course damage the tape if the cassette is faulty, while the problem of crooked pinch rollers is largely confined to early mechanical models. Excessive take-up torque occurs mainly with later electronic VCRs that use a reel motor, where a preset is often provided to adjust the torque. The JVC portable HR2200 (Ferguson 3V24) suffered from this to some extent when it first came out.

## Condensation

One last problem that manages to catch me out on the first cold day of every autumn occurs when a VCR comes

in for repair and I innocently load a test tape to see what's wrong only to hear a sickening crunching sound. Condensation of course. The VCR has travelled for a few miles in the boot of a car and has then been brought into the warm workshop environment (can I really describe our workshops like that?). Condensation then forms on the head drum and as soon as the tape is loaded it sticks to the drum body. Before you can react six to eight feet of tape have been wound round the heads, large pieces of magnetic oxide being firmly stuck to the drum. Every year the first cold spell of winter catches me out, whereupon I try to remember to warn every customer collecting a unit to leave it at room temperature for an hour or so before switching it on after their return home.

## **Back to the HR7700**

Back to our HR7700. I wasn't certain how the tapes were being damaged, but I could discount the condensation theory since there was never any tape stuck to the open drum and the heads themselves never required cleaning. Also this is a winter problem and the fault had been reported in June, though when you consider some of the summers we've had recently maybe I shouldn't have been so certain. I could also dismiss the fault of bottom edge tape slicing since the giveaway slivers of tape were absent. My own suspicion was that the tape was not unloading from the heads when the stop function was returned, though this never occurred on the bench: there was plenty of unloading torque and the brakes weren't fouling the rewind spool.

At this stage I should mention a problem that appears to be inherent in the design of this model. If a tape is fully rewound and then stopped the rewind spool can stop suddenly, before the supply spool has been braked, resulting in a small loop of tape not being rewound into the cassette. If the tape is then ejected a small portion of it can get caught in the cassette flap. The damage is normally very slight and doesn't affect the tape too badly, but I've yet to come across an effective cure or modification. All subsequent front-loading JVC models have overcome the problem by going into rewind for a second whenever the eject button is pressed. I'd been trying to break this gently to the machine's owner, but since Rolls Royce's don't have inherent faults I had to be careful how I did it.

## **Clues at Last**

When the machine arrived again some four months after its last visit it was accompanied by a faulty cassette. Since there was a loop consisting of about a foot of tape hanging from the cassette body I felt that my initial suspicions were correct. But I was wrong: the loop consisted of the first foot of tape. When the cassette was played we found that the introduction to "Dallas" had been ruined - what good taste JVC engineer into their machines - while interrogating the owner elicited the information that it happened when the machine was used for the first time in a couple of days. It had played for a few seconds and then stopped: when the cassette was ejected the result was this loop of tape.

We were now getting somewhere, so the top cover was removed and a tape was loaded. Perfect, as were the following half dozen attempts. The same procedure was tried frequently over the next few days before the fault put in an appearance for us. We pressed play and the tape

loaded to the heads but there was no take-up reel movement. Since there were no reel pulses the machine cut out a few seconds later, leaving a length of tape around the pinch roller. Had eject been pressed the result would have been tape damage, so rewind was selected and the tape wound harmlessly back into the cassette.

A bit of thought was now needed. The fault could have been either mechanical or electronic, so a voltmeter was connected across the reel motor, at pins 111 and 112 on the mechacon panel. The front was taken off to give access to the cassette housing and after this had been removed the cassette lamp was covered and the tape loading switch was disabled. A decent view of what was happening could then be obtained. Needless to say everything worked properly.

## **Previous Attempts**

I had tried a few things during previous unsuccessful attempts at repair. Preset R1 on the mechacon panel had been adjusted to increase the take-up torque towards the upper end of its 60-140 gm/cm tolerance, though I wouldn't recommend this since it could lead to the control track being sliced off the tape. So the torque was restored to about 100 gm/cm, which might also make the fault occur with a bit more regularity. I had also covered what I felt were possible electronic faults when I had initially suspected intermittent unloading, and this is of course the same circuit that drives the reel motor during play. Four relevant 2SC2655 transistors, X18, Z22, X24 and X25, had been changed since I've had trouble with this type of transistor before. I'd also connected direct wire links from the emitters of X23 and X25 to the reel motor plug connections (111 and 112) since the PCB tracks follow a rather tortuous route on both sides of the board - while this panel is not prone to dry-joints, I'd been getting a bit desperate.

## **The Solution**

And there the machine sat for two days, meter by its side, performing perfectly each time it was put into play. The best part of a can of freezer was sacrificed to the beast to no avail, and I'd almost given up hope when it at last happened. After pressing play the arms loaded to the head, the pinch roller pulled in, the meter read 2V d.c. but the take-up spool was stationary. A fingertip applied to the reel motor pulley proved that it wasn't turning while the meter said that it should have been. Surely not an intermittent reel motor?

Remembering a tip an ingenious colleague had once passed on to me I took out the reel motor and connected it up to a 12V power supply via an ammeter. This is a good check when you suspect either a drum or capstan motor in one of the old piano-key models, and is particularly useful when preparing estimates. In such a set-up a good motor should draw 20mA or less: any more and a replacement is required. I agree that this is not a 100 per cent scientific test, but it's not let me down yet. And how did our suspect reel motor behave? On initially applying power the motor turned but required 75mA to do so. This rapidly dropped to 35mA, but never went below this. The loan of two new reel motors was obtained from a trusting source and experiments with these showed that the current never rose above 25mA with one and 30mA with the other. Got it!

Just to be sure, and by way of a belt and braces job, I

noted that the reel idler in the HR7700 appeared to be the same as that in the HR7200 (3V29) series, and since I had some of these one of them went in along with the new motor. Set up the take-up torque, make several checks over the next few days and it was time for reassembly. Naturally the machine wouldn't work at all when it was all back together again, but the panic soon subsided when I realised what I'd done - I'd fitted the front facia in such a way that the stop button was permanently engaged. This

seems to happen whenever I put the front back on one of these machines these days, something I don't recall happening when they were new. Slacking the six retaining screws and jiggling the front soon cured that, and when the owner called for his video a few days later I was able to report with all confidence that his problems were now over. For once I would appear to have been right, since I've not seen this particular HR7700 or its owner for over a year.

# Servicing Notes: Sanyo 5000 Series VCRs

John Coombes

The following notes relate to the Sanyo Models VTC5000, VTC5300 and VTC5400 which were sold during the period 1982-3.

## Model VTC5000

**(1) No results:** Check the mains fuse F5201 (315mA). The cause of it being open-circuit may be a "spikey" mains supply. If this is suspected, change the mains filter capacitor C5201 from 0.1µF to 0.0047µF (350V a.c.). If a replacement fuse blows check C5201 and the mains bridge rectifier diodes D5201-4 (type DSA17C) for shorts. The STK7216 regulator chip IC5101 can also cause fuse blowing - check by substitution. If there is no input to IC5101 (there should be 27V at pin 13) check whether C5102 (220µF) is short-circuit.

If there is 27V at pin 13 of IC5101, check whether 12V is present at pins 12 and 5 and 9V at pin 2. Check whether zener diode D5102 (BZ150) is short-circuit if the 12V supply is missing. If the 9V supply is missing check zener diode D5101 (BZ110) for being short-circuit. If still no 12V and 9V outputs replace IC5101.

You may find that IC5101 is type STK7216A. An STK7216 is supplied for replacement purposes. If one of these is used to replace an STK7216A, remove the 1kΩ, 2W metal-glaze resistor between pins 15 and 13. Failure to do this will result in ruination of the STK7216 chip.

**(2) No results with the capstan motor running very fast:** Check for 5V at pin 41 of the LM6402A095 microcomputer chip IC3001. If this voltage is absent check the 5V regulator transistor Q3001 (2SC2274E, F) by replacement. IC3001 could be the cause of the fault.

**(3) No rewind/forward drive:** This is usually due to a faulty rewind/fast forward reel drive assembly. As a temporary measure and to prove the point cleaning may restore normal operation. The assembly should be replaced however.

**(4) Improved reel motor drive:** This modification helps to overcome increased torque on the reel motor during playback or unloading. Fit a 3.3V zener diode (type GZA3-3Z or BZY88C3V3) in position D3006 and change R3049 (2.2Ω) on board SY1 to 1Ω, 0.5W (metal film).

**(5) Tape problems:** Tape creasing is quite a common problem. The most likely cause is the reel belt. Also check the reel drive assembly and the reel motor. It may be necessary to replace all these items to prevent further trouble in the future. See also note at end.

We had a problem with tape folding on one of these machines. It occurred very intermittently and was eventually traced to a faulty pinch roller.

No supply to the reel motor will ruin the tape. The cause can be IC3006 (BA6209) on the system control panel SY1.

**(6) Flashing lines on screen or picture break-up:** Make sure that the earth connections are made between the r.f. booster and the metal frame, also to the video preamplifier. All earthing straps in position will give correct operation.

**(7) Snowy picture from one head:** If the head is not dirty or faulty check IC1501 (LA7027) by replacement.

**(8) Poor definition:** There's a modification for this fault. Change C1048 on PCB VD1 from 150pF to 56pF or 68pF.

This modification also applies to Model VTC6500 where the capacitor is C1046 and to Model VTC5400 where the capacitor is C1044.

**(9) Noise bar on screen, sound not affected:** The cause is a drum servo fault. Check that the PG pulses are being generated correctly and amplified by IC4001 (BA848A) which should if necessary be checked by replacement. Then suspect IC4012 (HA11713). Again check by replacement.

**(10) Noise bars with sound flutter:** The cause is sometimes a faulty capstan motor. Also suspect loss of the FG pulses which are amplified in IC4013 (HA11713). It may be necessary to check this chip by replacement. Ensure that all plugs and sockets are making good connection.

**(11) Loss of servo lock in the record mode:** This can happen when there's a sudden change of picture content. Make the following modifications. Add a 1,000pF capacitor between pins 2 and 28 of IC1002 on board VD1 and a 56kΩ resistor between pins 13 and 14 of IC4001 on board SV1. Where very bad interference is experienced fit a noise-masking sub-board on servo PCB SV1 - it fits on the print side, behind IC4001. When this is done add a

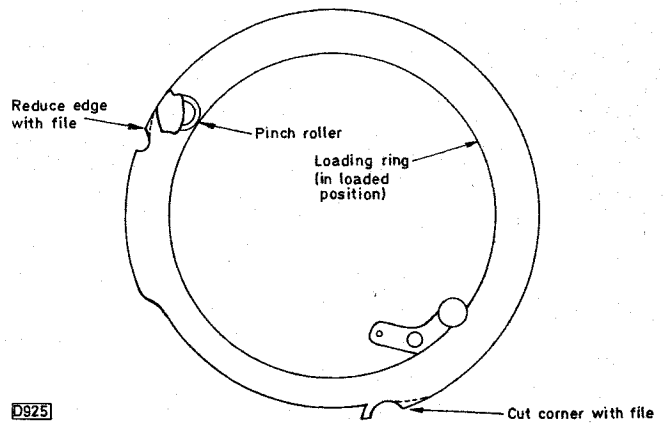

Fig. 1: Loading ring modification for the VTC5300/5400.

1,000pF capacitor (not a 56k $\Omega$  resistor) between pins 13 and 14 of IC4001, remove C4008 and change R4009 and R4010 to 4.7k $\Omega$ .

**(12) Will not playback own recordings:** If you find it necessary to reset the tracking control after making a recording check IC4501 (NJM2904S) by replacement. Check C4505 (1 $\mu$ F) which could be open-circuit.

**(13) No E-E sound:** Check for 12V at pin 5 of Q6006 (LA1365). If the voltage is high the power supply regulator chip could be defective. If the 12V supply is missing check whether R6032 is open-circuit. If R6032 overheats when replaced fit another LA1365 chip in position Q6006.

**(14) Clock problems:** For no clock display check that 9V is present at pin 1 of connector S5203 on PCB PW2. If the voltage is 7V or less check whether regulator transistor Q5202 (2SD313D, E or F) is open-circuit. If the clock intermittently flashes 8888 check for dry-joints on Q5202.

## Models VTC5300 and VTC5400

The mains fuse/filter capacitor note mentioned under (1) above also applies to these models, i.e. for mains fuse blowing when no fault can be found in the machine change the filter capacitor to 0.0047 $\mu$ F. The advice on flashing lines/picture break-up under (6) above also applies. For poor definition with Model VTC5400 see note (8) above. For loss of servo lock in the record mode with Model VTC5300 – see note (11) above – the appropriate modifications are as follows: change R1009 on board VD1 from 390k $\Omega$  to 150k $\Omega$ ; on board VD2 add a 10k $\Omega$  resistor across C1308 and a 47 $\mu$ F, 16V electrolytic across R1344, with the negative side connected to the emitter of Q1238.

Vivid white horizontal bands of interference across the

screen with the VTC5400 occur when the power transformer's insulating washer which fits between the heatsink and chassis is left off.

A case of wow on sound with the VTC5400 (capstan speed varying) was cured by replacing C4040 (0.47 $\mu$ F).

Interference on playback (white spots) can be caused by a faulty reel motor (see below). Ensure that a static brush is fitted to the drum spindle and that the power supply module fixing screws are not loose.

The main problem with these two machines relates to loading/unloading. No loading, sticking or intermittent loading occurs when the loading torque is not enough. One step to take is to remove the sharp edges of the cams on the loading ring for the load-end rollers – see Fig. 1. Then fit a modified loading belt (part no. 143-2-564T-02303). Unfortunately the problem may well have damaged the loading/reel motor which often has to be replaced. A damaged motor can cause white spots on the screen since it produces interference which is picked up by the video preamplifiers. If the loading ring sticks in the half loaded position check the loading belt and ensure that a modified one (with yellow band) is fitted. When the ring is stuck half way the drum motor will make a loud howling noise.

## General

If the tape loops when a cassette is ejected check the supply spool back spacing. If the spool rotates too far remove the spools and clean the brakes with methyl alcohol. Replace the spools if they are badly worn. The tape should then be wound back into the cassette correctly.

# Dealing with Liquid Spillage in Videocassette Recorders

**Derek Snelling**

Judging by what passes through our workshops liquid spillage into VCRs is a relatively common occurrence – certainly more so than with TV sets. During the eight years I spent servicing TV sets I encountered only one case of spillage, but with VCRs we seem to get at least one case a month on average – and once had four cases in a week.

## Causes

The causes vary but the most common are children's drinks followed by pets, tea/coffee, plant pots etc. The worst of these has to be pets, not just because the liquid is more corrosive but because of the smell, especially when resoldering suspect joints (even after washing). The corrosion that manifests itself in the form of green or white deposits on wires and print occurs not so much because of the corrosive nature of the fluid itself but because of the electrolytic action that takes place when voltage is applied to the affected circuit.

## Effects

The trouble with a spillage is that the faults usually don't show up until the corrosion is well advanced. What tends to happen is that the customer lets the VCR dry out then switches on. If the machine has been left long enough it will then probably work, but the residue left behind by the drying liquid will, with the aid of the various voltages, begin to eat into the wires and soldered joints. Eventually, perhaps after a few weeks, a wire will be eaten through or sufficient leakage will have developed between two adjacent points to cause a breakdown. Sometimes, especially when a pet abuses the machine during the night or morning, the customer may be unaware that anything untoward has happened. Just occasionally the spillage occurs when the machine is in use, in which case you will usually get to do the repair before the corrosion sets in, particularly as one or more of the fuses may have blown.

## Steps to Take

When confronted with a spillage job, what's the best way to go about repair? The first rule is to ignore the faults. They will usually be obscure, illogical and untraceable using normal fault-finding techniques. First examine the top of the cabinet and try to establish the path taken by the fluid. This will enable you to determine which panels to check for corrosion. If at all possible, each affected panel should be removed from the machine for attention in turn. In the area affected by the spillage, remove all electrolytics, i.c.s, sockets, transistors and diodes that are mounted hard against the print. Put the panel in the sink and wash it with Servisol Foam Cleanser 30, rubbing this in with a short-haired paint brush. Do both the component and the print sides of the board. Wash under the tap, then with methylated spirits or isopropyl alcohol. Finally, dry with a kitchen towel fol-

lowed by a blow from a vacuum cleaner or high-powered hairdryer (don't use the hot setting however). Be particularly careful to get the cleanser from under the various components.

Next carefully examine the area of the spillage for any signs of corrosion. Remake any doubtful joints with fresh solder. If a component's leg looks as if it's suspect, move the component. If the leg doesn't break it's probably all right. Clean the i.c.s, transistors and sockets removed from the panel in the same way, being particularly careful to clean between the legs of the i.c.s. As before, if in doubt bend a leg to see if it breaks. Refit the i.c.s, transistors and sockets on the board. Replace all the electrolytics and diodes removed from the board with new ones – they aren't expensive and it will save you a lot of fault-finding and intermittent problems later as these seem to be the components most prone to the effects of spillage.

Before reconnecting it, leave the board in a warm place for twenty-four hours to ensure that it's dry. Repeat this procedure with each affected board. Finally check the plugs to the boards in the affected areas. The leads in these plugs are usually just crimped to the pins, and if liquid gets into them they soon become intermittent. To check the plugs, remove the pins from the moulding one at a time by pressing on the exposed side of the pin with the blade of a trimming tool while pulling the attached wire. If the connection looks to be doubtful, solder the wire to the pin. Be careful not to let the solder flow down and block the pin up. In bad cases it may be necessary to bypass the plug altogether and solder the wire(s) to the board directly. In addition, in bad cases the liquid may have been drawn up the wire by capillary action: it may be necessary to strip the wire back by half an inch or so to reach clean wire.

## Testing

When all this has been done, reassemble the VCR and switch on. If the machine was not in use at the time of the accident it will probably work. If it doesn't, switch off and check again for further signs of spillage – and don't be tempted to take short cuts with the cleaning. If the machine was in use at the time of the accident you'll probably have some fault finding to do, but at least it should now succumb to normal fault-finding techniques. If you find yourself presented with a fault that doesn't appear to make sense this is a sure sign that there's still some spillage effect somewhere in the machine.

## The Mechanics

Finally a word about the effects of spillage on a machine's mechanics. It's usually best to replace any rubber components such as the pinch roller, belts or tyres that show any signs of contamination. Also clean and lubricate any sliding parts. Most importantly, clean the tape path thoroughly whether it appears to be affected or not, as it can result in repeated dirtying of the heads as the residue from the spillage is carried around by the tape.



# Servicing Mechanical VCRs

## Part 1

Mike Phelan

There must be many hundreds of the early mechanical VHS machines on the second-hand market nowadays. Because they contain many moving parts, and possibly because the principles of operation may not have been fully understood by some of those through whose hands they've passed, their condition can vary a lot. The majority of these machines are of JVC manufacture. They come under various guises however, among them Akai, Ferguson and the names used by the various rental companies. To avoid confusion we'll use the Ferguson model numbers in these articles.

To go back to basics for a moment, the term "mechanical" is generally used to refer to the first generation of VCRs in which all the tape transport functions were directly controlled by piano-type keys that activated the mechanism. In later models these functions are carried out by motors and solenoids that are under the control of a microcomputer chip; all the user has to do is to press buttons that send the appropriate input to the micro.

## Model Sequence

The first Ferguson VCR to appear in the UK was the 3292. It had a 24-hour timer and a mechanical pause control. Next came the 3V00, with a seven-day timer, a much brighter LED display (thankfully) than its predecessor, solenoid-operated pause, and a remote control unit that simply consisted of a switch to operate the pause solenoid and a length of cable. At more or less the same time the 3V16 appeared, with many new features. The pause became a freeze frame; the timer, though still of the single-shot, seven-day type, now had a repeat facility, and best of all the remote control, though still wired, was a multi-function type. By using it you can select double-

speed operation, freeze frame, normal or slow motion. The speed of the latter is variable, by means of a slider control. During the production of this model an improved version of the 3V00, known as the 3V22, appeared. The only difference apparent to the user is that the remote pause control is no longer an optional extra, but many changes took place in the circuitry and mechanism.

When working well these machines give a very good account of themselves. They are inherently very robust. The picture quality possibly falls short only of that provided by the latest machines with noise-reduction circuitry, but as there should be no problem in picking one up for two figures who's going to worry?

The tape transport mechanism is the thing we'll be concentrating on in these articles. It underwent many changes during production but there were basically only three main types. Following Ferguson, we'll refer to these as the Mark I, II and III versions. The Mk. I was used only in the 3292. The Mk. II was used in the 3V00 and, with minor modifications, the early 3V16. This machine has a different type of fast-acting capstan servo, necessary because of the "trick modes" introduced with this model, and some changes had to be made to the way in which the take-up reel clutch is driven in order to give better flutter performance. These changes were also incorporated in the 3V22.

## What to Look for

If shopping for a mechanical VCR, probably the best bet is a late 3V16. But how can the various models be identified? Bearing in mind the fact that many presentational parts are interchangeable, and that the model number shown on the label and the type of timer fitted may not be the correct ones, the following information should help.

With the 3292 the timer has two toggle switches and no push-buttons. There are three toggle switches below the channel buttons. The slide switch on the rear recessed panel doesn't have a "test" position to aid tuning the TV receiver. The pause key has a very heavy feel to it.

The 3V00 and the 3V22 are superficially very similar – you need to identify the deck mechanism to tell the difference. To do this, eject the cassette lift and peer through at the cassette lamp holder. The two types are shown in Fig. 1. The machine may have been converted to LED use of course – the bulbs are expensive and have a rather high mortality rate. All the seven-day timers have six push-buttons. There are only two toggle switches on

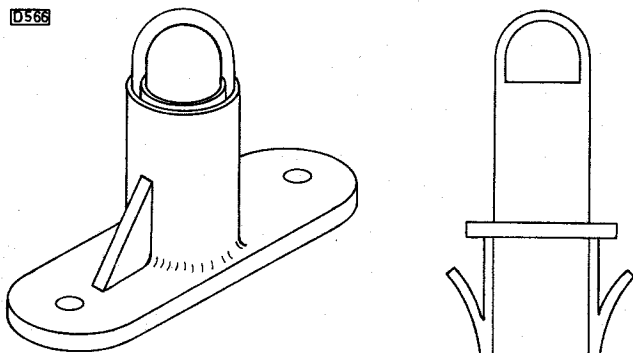

Fig. 1: Different types of cassette lamp holder. Left, Mk. I and II, right, Mk. III.

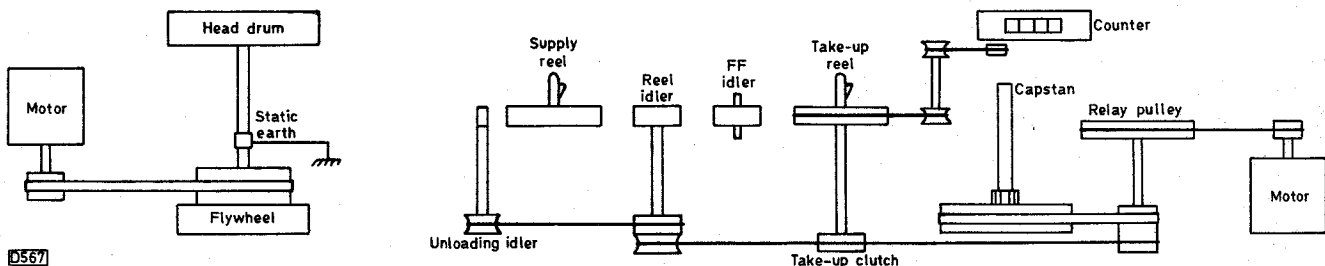

Fig 2: Drive train schematic (not to scale).

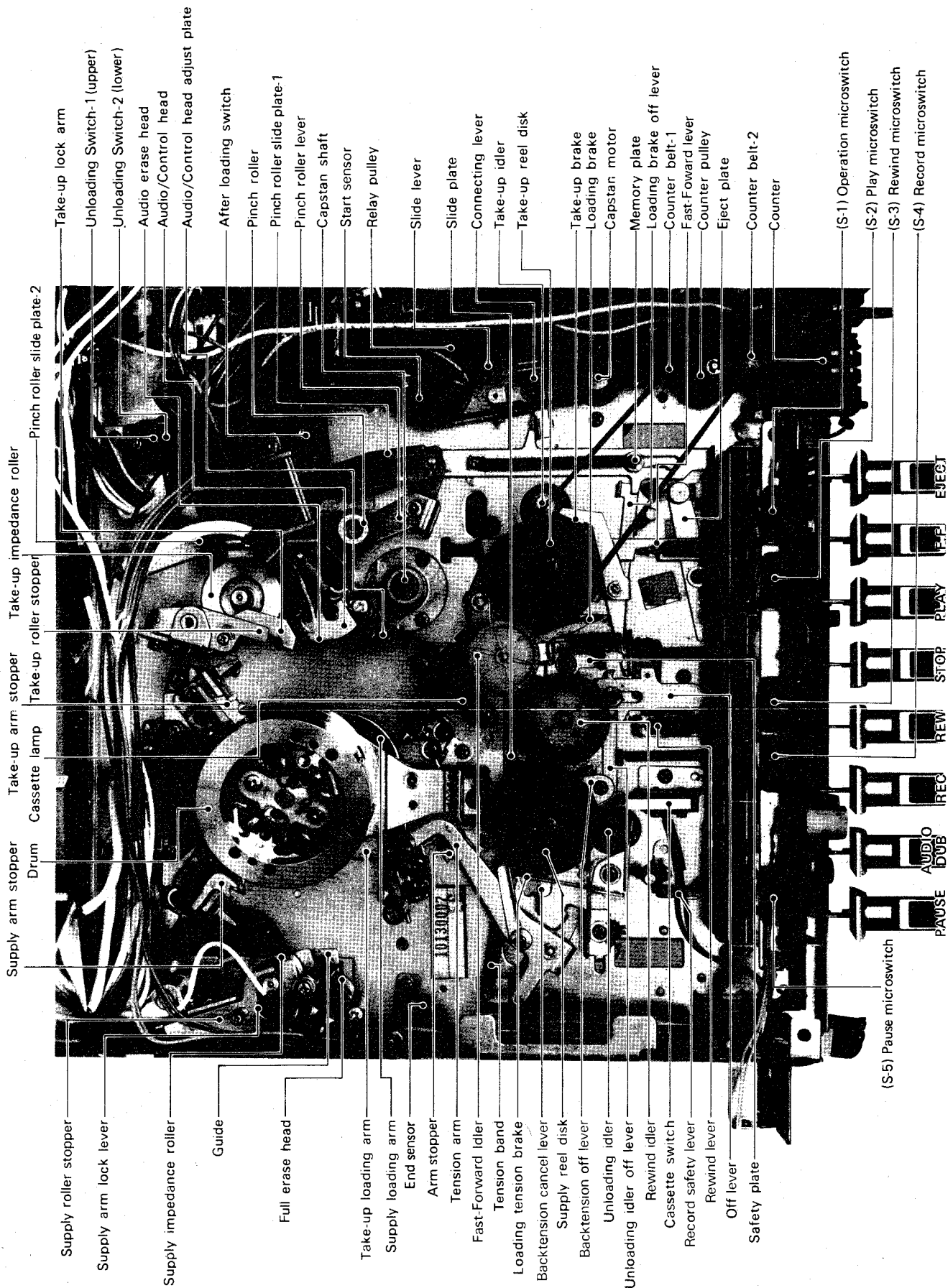

Fig. 3: Top view of the Mk. II deck.

the right and the cabinet back is plastic, not metal.

The 3V16 has a DIN socket for remote control and a timer repeat switch. These items are both located on the front, next to the tracking knob. In addition the rear panel is much deeper to accommodate the extra servo panel, now mounted at the rear, piggy-back fashion.

A good point to check when considering the purchase of a machine is whether the various screws that hold the cabinet panels seem to be the original ones - and that they've not been chewed up too much. If so, and the machine seems to be fairly unmarked, it should be a reasonable buy. One thing to look for is any signs of liquid

## New Models

A word about three new machines we've had in recently, all of the HQ type, the Toshiba V81B, Panasonic NVG7 and Mitsubishi HS337. The Toshiba machine has infra-red remote control, one-touch recording, a four-event timer, still with frame advance, a picture sharp/soft control, a counter memory and an auto-play facility whereby if you press rewind and play together it will automatically go into play after rewinding the tape. This is the first true Toshiba VHS machine we've had – the V65B was a badged version of the Ferguson 3V45. The influence of the V65B is obvious however, with a similar panel layout. The Panasonic machine has a similar specification but with a delayed one-touch record facility where the start as well as the finish time of the OTR feature can be set. It doesn't have an auto-play facility. The Mitsubishi machine is similar to the Panasonic one but has a seven-event timer and stepped type slow-motion. It's fitted with a SCART socket at the back.

Having had a chance to compare the three machines I must say that the Mitsubishi machine stands head and shoulders above the other two, which can only be described as average, even for a non-HQ machine. The Mitsubishi machine's still and slow functions are almost perfect, which for a two-head machine is very good. How they improve them on the dearer three-head machine I don't know.

D.S.

## Mitsubishi HS306

Here's a problem that occurs regularly with the Mitsubishi HS306. The complaint is a noisy picture and the cause is that the tracking control is a thumb-wheel type positioned along the bottom edge of the front of the machine. If a duster is run along the shelf in front of the machine the back of the hand brushes against the control, rotating it to the end of its track. As with most modern VCRs it's so seldom necessary to use the tracking control that most users don't even know it's there.

D.S.

## Finlux VR1010/Philips VR6462

This machine was reported to be dead, including the clock. There was just a red LED on next to the infra-red receiver, presumably because it thought the machine was receiving infra-red instructions. The power supplies are the obvious place to start with a fault of this sort. Early checks revealed that a 17V rail was at 25V. Some time was wasted before we realised that while the rail has overload protection it's not stabilised and was high due to lack of a load. Further checks led us to the 30V zener diode D6103 which was short-circuit. A replacement put matters right.

D.S.

## Philips VR6462 and Clones

Nearly half of our customers who have a Philips VR6462 or one of its clones have trouble with the timer. They usually complain about recording the wrong channel or of a blank screen. The problem is that the number used to indicate channel number during normal use is not the one used during timer setting up. This is further aggravated by

the fact that when you come to set the channel in the timer the number to watch is in front of the word programme, not the number following it as you would expect, and is in fact the same number that's used to indicate the day in the previous operation.

A minor problem with these Philips machines is that some time during the first couple of weeks' use one of the channels tends to go off tune, usually tuning itself to the next channel along the band. Retuning results in no further calls and at first I thought that customers were pressing the search and store buttons by mistake, perhaps when setting the timer. It's now happened too often however for this to be feasible. I can only conclude that some settling down in the self-tuning and memory circuits takes place.

D.S.

## GEC V4005/Hitachi VT63

We've had the following fault several times with the GEC V4005. It can also occur with the Hitachi equivalent (VT63) – in fact a technical bulletin from Hitachi helped us to cure the GEC machines. The symptoms are failure to accept a tape properly or to eject correctly, often with the mechanism bent or out of "sync". The cause is usually the end sensors. These are mounted on the front loading mechanism and should be replaced as a pair. Unfortunately the mechanism is often damaged to the point where it must be replaced as well.

The problem occurs because the machine uses the end sensors to detect whether a tape has been inserted. When the sensors go faulty the machine may attempt to load up without a tape in. Unfortunately the physical presence of a tape is required to release the latches at either side of the mechanism, so it attempts to load up with the latches locked, resulting in damage to the mechanism unless the fault is rectified fairly quickly.

D.S.

## Sony SLC6

We've had several cases of intermittent stopping or failure to unthread. The main problem is belt wear. Look inside the cassette compartment, from the right-hand side, to see if the relay pulley is running. If it is, replace all the belts. If the problem is very intermittent, for example if the threading fails after a period of standing, say overnight, carry out the following modifications. Replace the small relay pulley, the large relay pulley, and the phosphor-bronze bearing through the chassis between the two relay pulleys. Part numbers are as follows: small relay pulley, top deck (508) 3-671-171-02; large relay pulley, below deck (519) X-367-100-50; phosphor-bronze bearing, 3-671-122-01. In some cases an arm to the right of the small relay pulley may have to be changed due to the extended skirt on the new pulley.

S.B.

## Akai VS2

The problem with this machine was intermittent shutdown when starting to record or play back after a rewind. Our customer told us that the machine was overheating, which threw us completely – with this model, once a function has

shut down it won't reposer for some minutes. The cause of the trouble was found to be the loading belt – the tape loading was intermittently incomplete. **S.B.**

### **Panasonic NV7000**

In the event of an incorrect clock display at switch on from the mains, consisting of the top row of dots and a bottom row of numbers, IC7505 is being held in reset. Check zener diode D7540. **S.B.**

### **Sharp VC8300**

You will sometimes find that the output from the loading motor chip I805 (STA401) doesn't change state with change of input. If the i.c. has failed, check the motor changeover switch. It can fail, placing a short across the motor drive output – this will destroy a replacement chip if it's not put right first (part no. QSW-I 0002GE). **S.B.**

### **Grundig VS200 Series**

Take-up motors with date codes prior to 04/84 can tighten on their bearings. This and any other factors, such as poor quality tapes, that cause increased tape tension around the drum can lead to displacement of one or both video head tips. As the machine's high performance can mask the problem to some extent the clues to look for are poor reverse search performance and tracking errors at the top of the screen. Care is required and the urge to twiddle the tape guides must be resisted. Note that an unsecured cassette exit guide, next to the cassette's tape output, can also cause tracking errors at the top of the screen. If this guide becomes loose and a tape has been jammed in the machine the tape tension arm can be bent out of true.

Failure to take up the tape can be due to incorrect tape tension. During initial threading up the microcomputer chip checks the position of the tension arm via the opto-tension sensor. Reduced tape tension will result in the arm "bouncing" out of the opto-sensor slot during initial threading up. Check and set the tension: follow the instructions given in the manual but use the new value of 23-25N (gm/cm). **S.B.**

### **JVC GRC2 Camcorder**

An inexpert customer brought this camcorder back to us several times during the guarantee period, each time with red-herring symptoms of one sort or another. It finally came back with a self-recorded tape that proved the sound to be intermittent in the record mode. The fault didn't show up during a long test in the workshop and couldn't be provoked. We finally resorted to a blanket job, replacing the microphone, the BA5112LS sound chip and all the surface-mounted tantalum electrolytic capacitors in the sound section – this type of capacitor is proving to be somewhat unreliable in JVC and JVC-derived recorders. We didn't hear any more, so one of the handful of replaced suspects was faulty. Subsequent testing proved it to be the microphone. **E.T.**

### **Panasonic NV810**

The customer had had this machine for just two days when he rang to tell us that the sound from its left hi-fi channel was louder than that from its right hi-fi channel during playback – also on record unless he offset the slider audio level controls. While he was convinced that the

sound balance was wrong workshop tests showed that the signal levels in the two channels were within half a decibel of each other at the crucial 0dB level. What was wrong was the factory setting of the meter balance and sensitivity controls VR6201 and VR6202 on the operation circuit board. Incidentally these are incorrectly referred to as VR6501 and VR6502 in the setting-up instructions given in the service manual. Strange that the recording level control offset which satisfied the meters and the owner was actually introducing imbalance. We've since lined up one or two more of these machines for critical customers. **E.T.**

### **Ferguson 3V23**

This model and its JVC equivalent, the HR7700, were somewhat ahead of their time and had a very high component count compared with later full-function machines. The fault with this one was that some of the remote-control functions didn't work – those concerned with channel changing and clock setting. Remote control of the deck functions worked well. It took us longer than it should have done to track this down to a faulty data select chip (TA1, type TA57) on the tuner-timer control board. We had dallied far too long in the remote control receiver and serial-to-parallel converter sections of the mechacon circuit. **E.T.**

### **Sony SLC6**

Snowy pictures via the video was the complaint with this machine. Playback of a known good tape was fine, but looped-through signals to the TV set were very weak. Since its supply voltage was present and correct the r.f. booster was clearly in trouble. The manual gives no circuit diagram for the expensive combined r.f. modulator/booster module however – it's presented as a "black box". In view of the high cost of this item we decided to have a go amongst the four 2SC3037 npn transistors in the booster section. Once we'd worked out their pinning it didn't take long to find one whose base was 3V positive with respect to its emitter. It was Q3, and had an open-circuit base-emitter junction. No alternative we tried would work in this position so another 2SC3037 was acquired and fitted. Much cheaper than a replacement module. **E.T.**

### **ITT VR3916**

No power-on light was the symptom with this machine, the cause being loss of the switched 5V and 12V supplies. The 3.9V zener diode D3 was short-circuit and Q3 was leaky. **P.B.**

### **GEC V4005/Hitachi VT63**

This machine often produces a squeaking noise in fast forward or rewind. The cure is to remove the bar at the base of the capstan and put a dab of grease where the flywheel touches it. If the bar is badly worn a modified type with a nylon bearing is available. **P.B.**

### **Toshiba V65B/Ferguson 3V45**

There was no clock display as there was no 5V supply to the display driver IC301. The supply comes from Q401 on the timer PCB: this transistor was open-circuit between its base and emitter. **P.B.**

# Servicing Mechanical VCRs

## Part 2

Mike Phelan

Before we start this month, an addition to the list of tools required given in Part 1. A set of small, metric Allen keys, or at least one each of 1.5, 2 and 2.5mm, is essential.

### Head Drum and Motor Assembly

The video head drum is driven by a motor via a belt – the ratio of the pulley sizes gives a speed reduction of approximately 2:1. Both the motor and the drum spindle are mounted at the correct angle for the VHS system. The motor (see Fig. 1) is screwed to a bracket that's attached to the chassis. Suppression is provided by ferrite beads threaded on the leads and feedthrough capacitors that are mounted on a bracket attached to the motor. There's also a  $1\mu\text{F}$  electrolytic, and a ferroplastic disc is stuck on the motor's endplate. These measures prevent interference being picked up by the very sensitive head amplifier. The head belt is flat, and both pulleys have a raised section narrower than the belt width. This is termed "crowning", and prevents the belt coming off as follows. The belt, being under slight tension, adopts a form in which the edges follow a shorter path, i.e. the cross-section is a curve where the belt passes over the pulley. Centrifugal force tries to maintain this situation – if the belt tries to wander, one edge must travel inwards against this force. So the belt stays on.

The drum is mounted on an alloy plate that's pressed on the spindle. The upper part of the rotary transformer is cemented to this plate (see Fig. 2). The spindle rotates in two ballraces in the lower drum assembly. This is screwed to a substantial casting that carries the locating blocks for the guide rollers. The casting is in turn screwed to the deck plate and is positively located by dowels. A copper collar is mounted on the spindle beneath the lower drum. This forms the moving contact for the static earthing brush, which is carried on a small bracket with the servo pickup head. Two small magnets in the rim of the flywheel pass over the latter.

The lower drum also carries a heater, whose purpose is to remove any condensation on the head. It's actually a small, wirewound resistor that's held in contact with the lower drum, at the rear. There's even a thermostat. This is, ingeniously, a reed switch inside an annular magnet. It works on the same principle as a temperature-controlled soldering iron: at a certain temperature the magnet becomes ineffective and the switch opens.

### Changing the Head Drum

Probably the most common operation required in this part of the machine is to fit a new head drum. The symptoms of worn heads have been well enough described in these pages, so we won't repeat them here. Be careful not to damage the old drum (in case it was o.k.!) or the new one. Unsolder the four leads, remove the two screws and lift the drum off. Handle the drums with a chamois leather or tissue to avoid marking the polished surface. If the drum can't be pulled off with a reasonable amount of force, apply a hairdryer for a short while. Don't lever the drum off.

Before fitting the replacement drum examine the flange

on which the drum fits. A trapped hair or compressed spot of solder here can cause severe tracking errors which are difficult to trace, so clean the flange. Note that all the screws used around the head assembly are brass ones. Most replacement drums are of the relay pin type where the leads are connected to two plastic pegs. When soldering to these be careful not to overheat them, or to apply any pressure, as they are easily damaged. It goes without saying that the leads should be correctly connected – if one pair of connections is reversed there will be no chroma on recordings made by another machine.

### Motor Replacement

The next most common servicing operation in this area is motor replacement. This is an easy job. Remove the belt and unsolder the leads first. Remove the three screws on the bracket and out will come the motor assembly. Note which way round the motor is mounted, and where the band is mounted. Unsolder the leads from the band, then remove the pulley by slackening the Allen screw. If this is reluctant to move, apply a soldering iron to it for half a minute or so. When this is off the three screws that hold the motor can be taken out.

Fit the band to the new motor and reassemble in the reverse order. The pulley should be flush with the end of the motor spindle. It will probably be necessary to transfer the ferrite beads to the new motor. A spot of Evostick will attach them to the leads. Both sets of leads must be connected the right way round or the  $1\mu\text{F}$  capacitor will

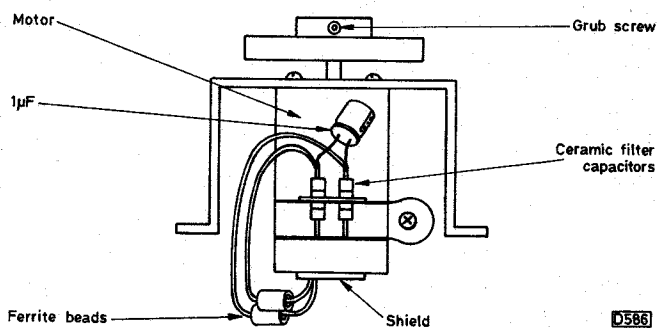

Fig. 1: The drum motor.

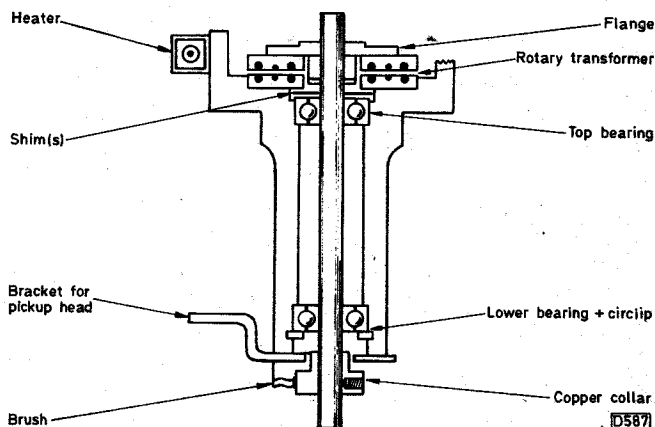

Fig. 2: The lower drum assembly.

go pop or the drum will run in the reverse direction – great for chewing tapes!

After replacing the motor it will be necessary to set up the drum servo. Ideally, the preamplifiers and switching points should be checked after drum replacement. The drum screen seems to enjoy the fate of the line output transformer cans of yesteryear – being screwed up and added to a collection of similar objects under the seat of the engineer's car. Try to find one if it's missing – it does make a difference to the amount of noise picked up.

## **The Lower Drum Assembly**

After many hours of use the lower drum assembly bearings become noisy. Attempting to lubricate them is a sheer waste of time. The races are sealed and as they are not available separately the lower drum assembly must be renewed. It's best not to dismantle the assembly anyway as there are some shims between the drum mounting flange and the upper bearing to set the drum height. Also, it's necessary to remove the assembly to gain access to the loading arms below. This is not a difficult job.

To remove the lower drum for replacement, unsolder the thin leads from the circuit board behind the drum then remove the upper drum. Take off the drum belt and flywheel and the bracket carrying the static brush and pickup head. Tie this to a convenient point or unsolder it.

Three screws hold the drum base to the deck. After removing them the entire assembly will lift off, limited by the leads to the preamplifier and the heater. If much work is to be carried out, unplug the preamplifier board and unsolder the heater leads, then remove the entire issue. To replace the lower drum only, invert the assembly, take out the screws securing the heater, then the three screws that hold the lower drum on to the base. Reassemble in the reverse order, remembering that this is a piece of precision engineering. The mating faces of the lower drum and base, the base and deck, must be clean. Otherwise the alignment will be impaired. If no new parts have been fitted, clean the copper collar and the top face of the lower drum. After reassembly, clean all the tape path surfaces. Isopropyl alcohol or even methylated spirit will do for the cleaning operations on the tape path components. Trichloroethylene and its derivatives are less suitable and some can have an embrittling effect on tempered steel parts after immersion for any length of time. The static earthing collar and brush must not be lubricated. Reassembly of the lower drum assembly is straightforward, in the reverse order to dismantling. The flywheel should go on to the spindle as far as it will, and the grub screw must be very tight. Needless to say the latter must go into the locating flat, although I've seen attempts to fit it in a different place, resulting in something less than a whole picture!

# VCR Clinic

**Reports from Christopher Holland,  
Eugene Trundle, Steve Leatherbarrow  
and Philip Blundell, Eng. Tech.**

## JVC HRD140

This machine had an unusual record fault. During any recording the picture would drop out for ten-fifteen seconds periodically, leaving noise spots on the screen as though the heads were disconnected. The sound remained perfect. This fault condition might happen five or six times during a twenty minute recording. Now intermittent record faults are always difficult to deal with as you can't be certain when the problem is occurring until the tape is played back. The best approach is to monitor possible suspect circuits during the record process.

First eliminate what isn't causing the fault. In this case for example the erase oscillator appeared to be functioning as the audio recording was good. Similarly the effect on the screen during the fault condition indicated that there was an f.m. carrier going to the video heads all the time. So two d.c. voltmeters were connected to the machine, one to the record 9V line to check that this wasn't vanishing intermittently and the other to the playback 5V line to ensure that this wasn't present when it shouldn't have been. The scope was hooked to the record f.m. signal at pin 26 of IC101. Ideally another probe would have been connected to this chip's output, at pin 3, but my second probe has been playing up recently and no probe is better than an intermittent one.

The schools' programme I was recording was so interesting that I almost missed the fault when it occurred. After a few minutes the signal displayed by the scope changed to one that was obviously unmodulated carrier. A check on the recording confirmed that a dropout had occurred at the same time. The signal in question comes from pin 44 of the luminance subpanel - a small panel soldered in at right-angles to the main panel. All the

connections here were resoldered, as I've had problems of this nature previously. But the fault couldn't be induced either by heating, freezing or physical movement. Further scope checks showed that the relevant inputs to the subpanel were o.k. when the fault occurred, i.e. the drum flip-flop at pin 33 and the luminance signal at pins 35, 39 and 41 (that second scope probe would have come in handy here). It all pointed to a replacement subpanel, or IC102 as JVC call it. Sure enough this provided the cure.

C.H.

## JVC HRD120

This machine arrived with a tape stuck in the fully loaded position. The operate button worked, but all the functions were dead. Oh yes, and the owner was in a mad hurry to get his video back. A quick check soon revealed that circuit protector CP1 in the mechacon section was open-circuit, the cause of this being a short inside IC204. This chip governs the mode control motor which in this model loads the tape to the heads.

A replacement i.c. and circuit protector didn't provide the expected cure however. The tape was still stuck round the video heads and had to be rewound into the cassette manually. Operation of any of the function buttons caused the relevant LED to light but had no other effect. As luck would have it we had another HRD120 awaiting collection. This one had required new heads and was unlikely to be collected for some time. (Has anyone else noticed an abnormally high incidence of premature head wear on these and similar machines?) A series of comparisons between the working and faulty machines led us to the conclusion that the microcomputer chip had failed. As I'd

none in stock and the owner seemed to be ringing every half hour I did what any other rational technician would have done in the same position. But having swapped over the complete panel so as to put the problem off till another day, to my amazement the new panel produced exactly the same set of symptoms.

Now was the time for a bit of logical thinking. The original fault had been failure of the mode control motor. Was any part of this circuit not incorporated on the panel? Only the motor itself, which turned out to be open-circuit. Guess where I got a replacement motor from at very short notice . . .

C.H.

### JVC GRC1 Camcorder

We've had several of these machines with no capstan servo lock. The effect of this on playback of a good tape is the cyclic appearance of noise bars across the screen. The fault is sometimes intermittent. In each case we've found the culprit to be C113 (10 $\mu$ F), a chip-type tantalum capacitor which couples the control track pulses to IC104.

Cases of excessive capstan speed due to lack of the FG signal have likewise been traced to a faulty chip-type tantalum capacitor, in this case C109.

Fortunately for access, both these capacitors are on the 04 audio/servo board. These very tiny capacitors have acquired a certain notoriety, to the point where whenever one forms any part of a suspect stage we now change – or test – it on sight. These comments also apply to the GRC2 and the Ferguson equivalents 3V41 and 3V50.

E.T.

### Hitachi VT14

“Unable to tune in” said the job card. It was possible to tune the machine to the local transmissions, but the best we had was a rolling, juddering picture with bad streaking and shading. Since this was revealed via the E-E channel the problem appeared to be in the receiver section. Right at the back end of it in fact, in the form of a low-capacitance coupling capacitor (C859). This 470 $\mu$ F, 6.3V component has to be just the right one, since space for it is very restricted. The component bill would have been much higher if we'd replaced the preset resistor potentiometer bank, on which the owner had wrecked potentiometers two and four in his attempt to “tune in the VCR properly”!

E.T.

### Finlux VR1010/Philips VR6462

Sent to deal with a phoned complaint about no response to remote control commands our field engineer took a replacement handset with him. The replacement failed to do anything for the machine, which was still under guarantee, and back at the workshop both handsets were found to be emitting IR pulses correctly.

We were misled by the fact that a pulse train was coming into 2P9 (I<sup>2</sup>C interface board) from the IR receiver unit, but that transistor Tr7460 was turned fully on, pulling down the voltage at pin 21 of IC7501. The culprit was the TDA3047 chip in the IR receiver module. Its output was sitting on a potential of about 4.8V, saturating Tr7460. Since the machine was under guarantee we replaced the plug-in IR receiver module complete.

E.T.

### Rediffusion 640/Sharp VC468

We don't see many Rediffusion VCRs. In the event this stranger proved to be a Sharp machine in disguise. It

suffered from intermittent picture rolling on playback: still-frame reproduction was also very poor. The machine was found to be capable of making a perfectly good recording, but examination of the playback f.m. carrier envelope revealed a gap of some 500 $\mu$ sec at the start of each sweep of head Ch. 1 only.

We found that the Ch. 1 playback switching-point potentiometer R743 was doing nothing: C725 (PG MM2 time-constant) on the PWB-A servo board had gone open-circuit. Replacement of this followed by resetting of the relevant presets restored a full f.m. envelope, good field sync and an excellent freeze-frame image.

E.T.

### Panasonic NV333

This was an under guarantee job wanted for Christmas – weren't they all! The complaint was buzzing sound. Investigation revealed that the E-E sound was almost normal, with just a little background hum. When a recording was made however the sound was very low, with bad buzzing. Many checks were made (all too embarrassing to report here!) in an effort to find the cause. A voice from someone who knows about such things suggested that a check on the regulated 17V rail would be fruitful. Sure enough, it read 18.45V. Near enough? Not so! Checks in the regulator transistor's base circuit revealed 1.2V across D1013. Replacing this item restored the 17V output, normal E-E sound and normal recorded sound. Odd that there should have been just this symptom and that the rail was only 1.45V out.

S.L.

### Finlux VR1010/Philips VR6462

If you come across one of these machines with either a sluggish brake solenoid or the head drum speed hunting, check for dry-joints around the smoothing capacitors in the power supply, particularly C2144.

Sound slow with wowing was the fault reported on one of these machines. A new servo board was tried to no avail so the capstan motor voltage was compared with that in another machine. The good one read 1.7V in play but the faulty one read 2.6V. The fault was still present after replacing the capstan motor and we then noticed that the left-hand rotary guide wasn't rotating. Replacing this cured the fault.

P.B.

### Ferguson 3V44

This machine wouldn't accept a tape, though it would eject one if you wound it in by hand. The cassette-in pin of IC601 was found to be permanently low, telling it that the cassette tray was lowered when this wasn't so. We found that there was a crack in the print by the cathode of D628 (this diode is on the print side of the board). The cathode normally goes to 5V but as a result of the crack it was earthed via R608.

P.B.

### Philips VR6660

The problem with this machine was failure to play – when the button was pressed all that happened was that the M in the display lit. Similarly, pressing stop gave still frame etc. This all pointed to a fault with the rows and columns connections to the customer controls. Luckily a few minutes spent making d.c. checks for shorts revealed a leak between K1 and K2. There was a stray piece of wire between two pins of plug C3.

P.B.



# Servicing Mechanical VCRs

Mike Phelan

## Part 3

In conjunction with the pinch roller the capstan drives the tape along the tape path at a constant speed. It forms part of the drive train, and a rather important part at that. Due to the critical mechanical tolerances it can give a lot of trouble.

### Capstan Drive System

Fig. 1 shows the capstan drive system in detail. The motor is mounted in an inverted position below the deck, with the pulley protruding above. A short flat belt goes from this pulley to the relay pulley, which runs in ballraces. The lower part of this pulley drives the capstan flywheel via a flat belt: it also provides the power for the reel idlers, via a square section belt. We'll deal with the latter part of the mechanism in a later article.

The capstan itself consists of a hardened, ground steel spindle which is pressed into an alloy flywheel – see Fig. 2. The spindle runs in a sintered bronze bush and to form a lower bearing there's a polypropylene plug in the retaining strap on which the rounded lower end of the spindle runs. A plastic oil fence is pushed on to the spindle above the bearing to prevent oil from the bearing creeping up the capstan spindle and getting on to the tape.

There are one or two slight differences here between models. The original 3292 capstan ran in ballraces and had no lower bearing. In the 3V16 the lower bearing is in the form of a plate rather than a strap, to carry the PCB with the capstan servo tacho printed coil. This is why the other models appear to have a few spare pillars on the deck. With the exception of the 3V16 the machines have two magnets in the flywheel rim and a pickup head on the deck chassis, the servo being a simple speed control system which compares the capstan speed with a crystal frequency (Models 3V00/3V22) or a tuning fork (Model 3292).

### Solenoid Operation

It may be worth mentioning that the portable Model 3V01 (an excellent though heavy machine) employed a very similar deck mechanism, the main difference being the way in which the stop solenoid operates. On the mains models the stop solenoid and the pinch solenoid (except for the 3292) have two windings. One consists of a few turns of thick wire and is supplied with a short, heavy current pulse to pull in the armature. The other winding consists of many turns of fine wire and is subsequently energised to hold in the solenoid. This arrangement

avoids the need to pass a heavy current through the solenoid for any length of time. Even this system would not be really suitable for a portable machine however, as the power required to operate the stop solenoid under stop-start conditions would load the battery excessively.

The solution adopted with the 3V01 is to have a small solenoid with one winding and allow the inertia of the flywheel to do the work! The flywheel rim is castellated, and when the stop solenoid operates the pivoted armature engages with the castellations. The flywheel rotation moves the armature at right-angles to its original direction of travel and operates the stop mechanism. Similar in fact to the autostop arrangement on many audio tape decks. Later portables use a permanent magnet as a hold for the solenoids.

### The Pinch Roller

The pinch roller is another very important part. It consists of a rubber covered brass tube with a tiny ballrace within. The circumference is ground to extremely fine tolerances. Fig. 3 shows the way in which the pinch roller is attached to a steel pin mounted on the pinch roller lever. The loading mechanism moves this lever almost into position, the final movement being provided by the solenoid. Except, that is, for the 3292: this model has no pinch roller solenoid, the roller being moved fully into position by the mechanism, the pause key pulling it back against a spring.

### Routine Maintenance

Most of the components mentioned here form part of the regular maintenance schedule. All the belts should be removed and cleaned and if necessary replaced. Clean the pinch roller (it's safer to remove it first). Don't use any downward pressure when removing or replacing the pinch roller screw – the lever is easily bent and this can give rise to all sorts of problems. Clean all the pulley surfaces, paying special attention to the brass part of the relay pulley – this seems to have a greater affinity for belt material! To remove the capstan belt it will of course have been necessary to remove the lower bearing strap or plate. This will enable you to remove the capstan assembly – take care that the oil fence doesn't get mislaid.

Clean the capstan spindle and apply *one* drop of oil near the bottom. You'll have to clean it again after replacing it, in case any oil has been picked up during its passage through the bearing. On the 3V16 you'll also have

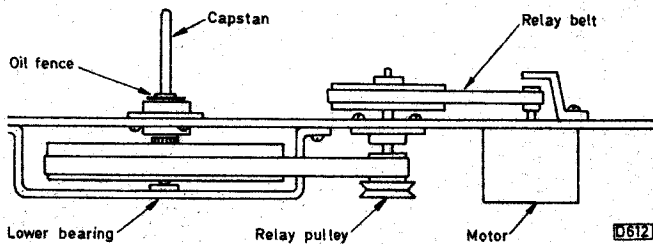

Fig. 1: The capstan drive system.

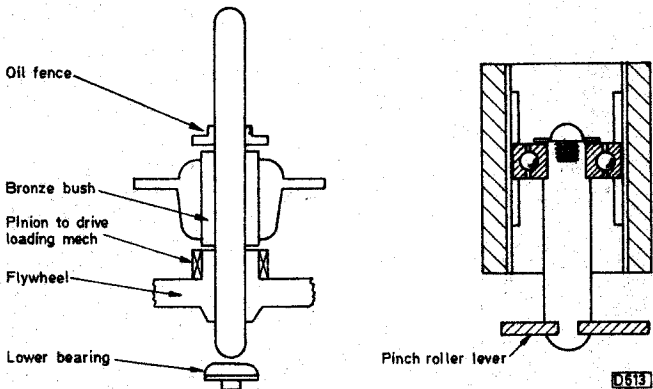

Fig. 2 (left): The capstan (Model 3292 differs).

Fig. 3 (right): The pinch roller.



Fig. 4: Different relay pulleys.

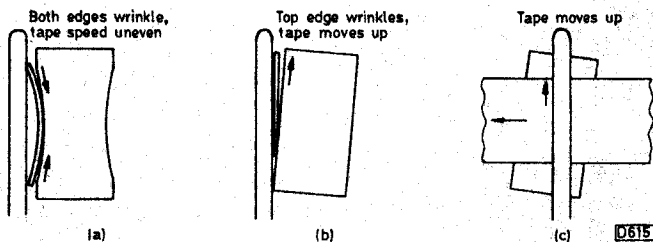

Fig. 5: Pinch roller problems (exaggerated).

to centre the tacho PCB. There's a special tool for this, but if you align it visually with the recess in the flywheel you won't be far out.

Don't oil the relay pulley or pinch roller: as the races are sealed, this would be a complete waste of time.

### Problems

The capstan motor will need replacement at some time during the life of the machine. This is less critical on the non-freeze frame models, but as the upper bearing is exposed it has a tendency to gather dust and become noisy or seize up. This can usually be repaired – see our previous series on electric motors. The correct motor must be fitted on the 3V16 – some motors that appear to be identical physically will give poor performance in the slow-motion and still modes. This can be a baffling fault: it's due to the motor armature being too heavy. The still and slow modes rely upon the tape being moved in several increments until a control pulse reaches a set position, the

drive being determined by the pulse. The wrong motor makes it impossible to achieve this.

One curious fault is caused by the oil fence not being pushed right down. If it's high enough to contact the tape the servos will go berserk! When refurbishing a second-hand machine search for this little part if it's not in place – it can end up in some unlikely spots to cause trouble.

The relay pulley can be forgotten unless the bearings become noisy – in this event replacement is the only cure. There are two types of relay pulley (see Fig. 4) as the belt arrangement in the Mk. III deck is different.

The capstan can be bent as a result of rough handling. Observation while running will show this up. A more common result of dropping the machine is that the lower bearing strap is bent by the weight of the flywheel. As a result the pulses from the pickup head will be intermittent or absent. Don't forget that these heads can develop an intermittent open-circuit.

The capstan bearing occasionally becomes dry, causing tape flutter.

### Pinch Roller Troubles

The worst part of this show is the pinch roller, though it's only fair to say that the problems are generally due to mishandling. These problems are of three types: misalignment in either the plane of tape travel or at right angles to it, and wear.

We'll consider wear first. The tape wears the roller which eventually develops a cotton-reel shape – see Fig. 5(a). As a result the edges of the tape are pushed together, causing wrinkling of the edges. This in turn modulates the control pulses with the "wrinkle frequency", typically about 0.5Hz, giving horizontal movement of the picture. Diagnosis is by laying the roller on a flat, opaque surface, or better still a mirror. No daylight should show through. Once again replacement is the only cure.

Fig. 5(b) and (c) show what happens when the pinch wheel lever gets bent. The 3292 doesn't suffer much in this respect as the lever is cast rather than being a steel pressing. Both planes of bending have a similar effect and make the tape travel up or downhill. The condition shown in Fig. 5(b) can be checked by pushing the roller towards the capstan and looking for daylight when they are in light contact. Straighten the lever carefully by hand. This type of misalignment tends to wrinkle the tape by attempting to drive one edge faster than the other. If the pinch roller leans in the direction of tape travel – Fig. 5(c) – the tape will tend to move up or down. This effect is obvious when the back tension pole is pulled back, relieving the back tension – this is the pole on the left of the deck, attached to a lever with a brake band at its end. With no back tension there should be no perceptible movement of the tape up or downwards for say ten seconds.

### The Pinch Solenoid

The pinch solenoid is relatively trouble free. Don't oil it as this will eventually cause sticking, as will any spillage that penetrates the mechanism here. The long lever that moves the solenoid is especially prone to this due to its great area of contact with the baseplate. Sluggish solenoid action (a pause before it engages) can sometimes be traced to an intermittent after-loading switch. This is the rearmost of the two microswitches near the solenoid.

Next month we'll be looking at the loading mechanism.

# Servicing the Sharp VC9300

David Botto

The Sharp VC9300 VCR is a front-loading VHS machine with a wired four-function remote control unit. It was on sale during the 1982-3 video boom period and proved to be a best-seller. We've found it to be quite reliable.

A digital multimeter is essential for voltage measurements and a logic probe and component tester (see the June 1984 and November 1985 issues of *Television*) will save you a lot of stress and time – some oscilloscopes incorporate a component tester.

## Access

Begin by removing the three screws at the back of the top cover and the one under the little panel that fits over the TV channel tuning controls. The top cover can then be lifted away to reveal the interior. A magnetic screwdriver will help to avoid the frustration that arises when searching the interior of the machine or the floor for dropped screws.

Looking into the machine you'll see the flat-mounted PWB-C Y/C PCB that handles the colour and luminance signals. After removing the two screws at the lower left and releasing the clip at the lower right the board can be lifted backwards on its hinges. A metal cover over the video heads is held by the same two screws. It's easy to forget to replace this cover: you may then experience problems with patterning.

At the front right, also laid flat, you'll find PCB PWB-U which contains the preset tuning controls. Beneath this panel there are two small PCBs which house the audio circuitry (PWB-B).

PWB-I which holds the tuner and i.f. amplifier is at the front right, mounted upright. The upright PWB-D panel behind it contains the mechanical switch circuitry.

The bottom metal cover plate comes away easily after removing three screws. The front panel can be taken off after unscrewing three more screws that hold the three lugs at the top of the front panel and releasing the clips at the bottom. Be careful not to lose the two felt pieces on the front slider switches: they tend to drop off, never to be seen again.

With the front panel removed you'll see to the right the PWB-T PCB which contains the clock circuitry and display, the tuner selector switches and LED indicators. It's held in place by a single gold-coloured screw and a top plastic clip – be careful, this clip breaks easily. The PWB-H operations circuit board is on the left.

The large PWB-A board at the bottom of the machine contains the mechanism control and servo circuitry. It can be released by removing the two gold screws near the front and two side plastic clips. After pulling out plug HA2 at the front of the board it will swing out by about 45°, allowing sufficient access for most purposes. The less you disturb the PCBs in this machine the better.

## The Power Supply

It's not particularly easy to get at power supply board PBW-P. This board is enclosed in a metal box at the top rear of the machine, under a metal support bar that runs the length of the machine and to which the two plastic hinges that carry board PWB-C are fixed.

To gain access, first remove the little black screw above mains on-off switch S901, whilst viewing the VCR from the rear. Next unscrew the black screw just above the moulded indicator arrow to the left of the aerial (antenna) input socket. Finally unscrew the two big gold screws at the top of the metal support bar. The bar support and PCB can then be lifted away and the metal box undone so that PBW-P is revealed.

The power supply circuit is shown in Fig. 1. Most of it, anyway: there's an oscillator/rectifier circuit on board PWB-A to produce some additional voltage lines and the 13V line crowbar protection circuit is also on this board.

The mains supply is fed to connection points OB1 (neutral input) and OB3 (live input) on board PWB-O, then via fuse F901 and points K908/9 to connection points K902/3 on panel PWB-Z. K902/3 connect to the mains power switch S901, then to points K901/4. The Mylar mains filter capacitor C901 is connected across K901/4. Also on this board is a special 12M $\Omega$  carbon resistor, R901. The mains supply leaves board PWB-Z at K901/4, returning to board PWB-O at K910 and K907. After passing through the filter choke L901 the supply goes via OA4/6 to the primary winding of mains transformer T901.

T901's secondary winding supplies the chopper regulator board PWB-P at connections K9002 and K9012. One side of the supply is taken to the off-board fuse F9001 via K9011 and K9001. The supply is then fed to the bridge rectifier D9001 (part no. RHDX0008GEZZ) which develops about 34V across its reservoir capacitor C9003. The positive side of this d.c. supply goes to the emitter of chopper transistor Q9001. You'll recognise this as a standard series chopper circuit, with L9002 the inductive reservoir and D9003 the efficiency diode. The output from the choke is filtered by C9007/L9003/C9008. A regulated 13V supply is obtained at K9006.

IC9001 ( $\mu$ PC393C) contains two operational amplifiers. OP1 and the associated external components act as a 30kHz oscillator whose output, developed across C9912, is taken to the inverting input of OP2. This second operational amplifier acts as a pulse-width modulator, its non-inverting input (pin 3) being fed from the collector of the error detector transistor Q9004 which senses the chopper output voltage via zener diode D9006 and the potential divider network R9016/7/8. A variable mark-space ratio output whose on/off times depend on the voltage across C9007 thus appears at pin 1 of IC9001. This drives the base of the chopper transistor via Q9003 and Q9002.

At switch-on diode D9004 charges capacitors C9009/9010 to provide a start-up supply for the chopper control circuitry. Once the chopper gets going this part of the circuit is supplied via D9005.

Panel PWB-P also contains a conventional series regulator circuit which produces a stabilised 12V supply at K9008. Q9006 is the series regulator transistor and Q9007 the error amplifier. The circuit is switched on and off by Q9005/Q9008. The base of Q9008 is taken via K9004 to connector AE3 on the mechanism control panel PWB-A, where it goes to pin 33 of the 64-pin microcomputer chip IC801. When the on switch is pressed pin 33 of this i.c. goes high and the 12V line appears. During cassette unloading pin 33 goes low, switching off the 12V line. In the timer mode pin 33 goes high when the VCR begins to

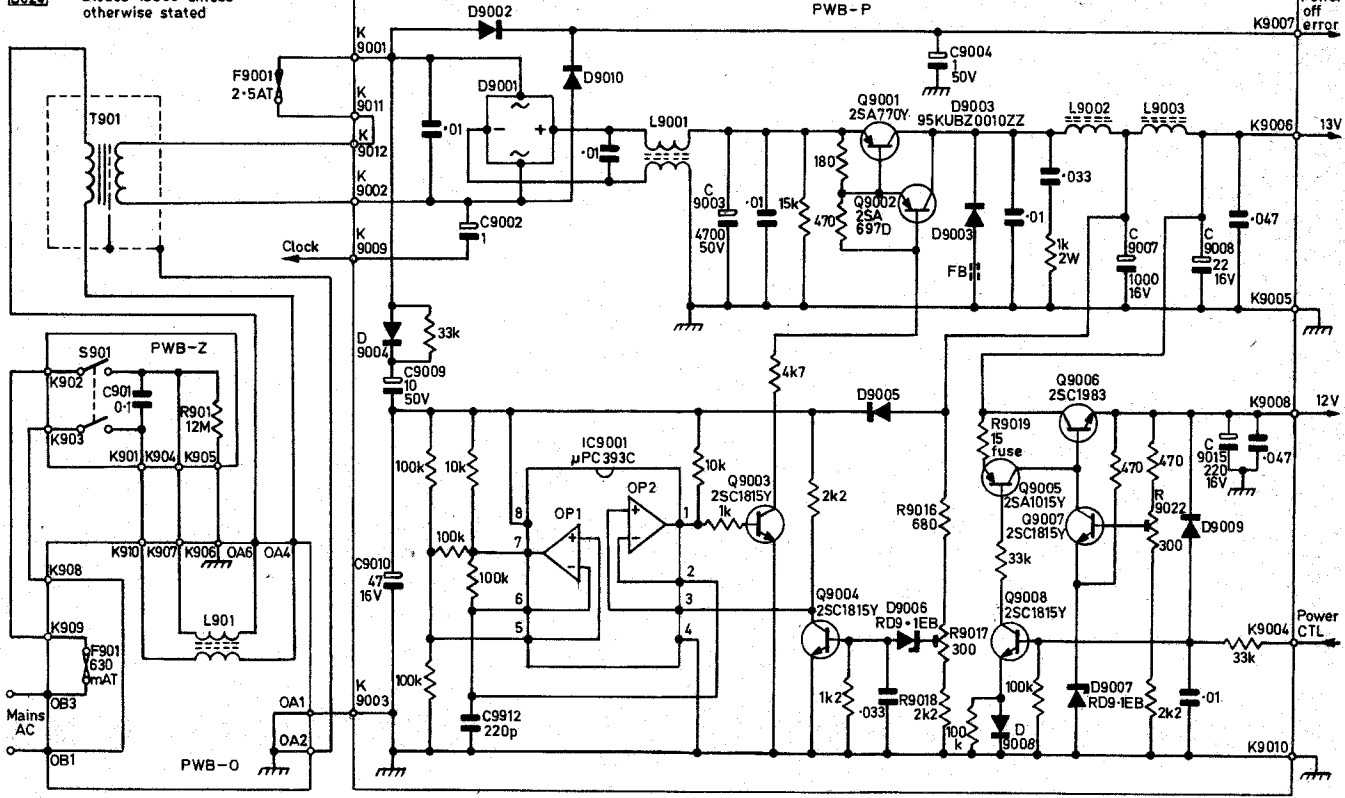

Fig. 1: The power supply circuit. A converter stage and a crowbar protection circuit are mounted on the mechacon panel.

record, establishing the 12V supply. Diodes D9002 and D9010 develop across C9004 a positive d.c. voltage that goes via K9007 to connector AE5 on board PWB-A, providing a power-off error voltage.

C9002 feeds a 50Hz signal to K9009 to synchronise the timer clock with the a.c. mains supply. This signal goes to AE4 on the mechacon board and then follows a rather roundabout route before finally arriving at pin 3 of the timer microcomputer chip IC5001 on timer board PWB-T.

**Power Supply Faults**

The first step to take with a machine that shows no signs of life is to check fuses F901 and F9001. If one of these fuses has failed and it's not a nasty black colour the failure may simply be due to old age. If so, give the machine a four-hour test before returning it to the customer. If F9001 again blows after an hour or so, the machine functioning correctly after replacement of F9001, suspect an overload on the 13V line. The cause is probably a defective component in the power supply circuitry on panel PWB-A. Use your component tester to check, in the following order, zener diode D901 (RHEX0019GEZZ), thyristor Q903 (3P1M), C915 (2.2µF), C903 (4.7µF) and zener diode D902 (RHEX0045TAZZ). The two electrolytics can dry out and corrode.

The PWB-P power supply board is very reliable, which is just as well considering how difficult it is to get at it. But you can get problems. The best place to measure the output voltages from panel PWB-P is at pins 1-6 of connector AE. This connector is located at the rear of panel PWB-A (the mechacon board), next to fuse F902. Check for 13V at pin 1 and 12V at pin 2, using your digital voltmeter.

If the 13V supply is present but the 12V supply is

missing, before you start to remove board PWB-P connect the positive supply clip of your logic probe to pin 1 of connector AE and the negative supply clip to pin 6, then check the logic level at pin 3. This should be high when the front panel "standby-on" control is pressed.

When you've established that there's a fault in the PWB-P board circuitry remove the board from its metal cover and place some insulating material between the board and the machine's chassis to prevent the print touching the chassis with the mains supply switched on. If fuse F9001 blows and turns black, start by checking the bridge rectifier D9001 for shorts.

Check the waveform at the collector of Q9003 (see Fig. 2) with a 10:1 probe. If it's missing, check transistors Q9003/4 and Q9001/2 in that order, then zener diode D9006 and diode D9005. If all seems to be in order but the oscillator circuit won't start up suspect the start-up capacitors C9009/C9010. One or other may have dried up. So far we've had no problems with IC9001.

Once you've dismantled board PWB-P and got it working it's a good idea to check the eight electrolytics for loss of capacitance and the few diodes and transistors for the slightest leakage. This takes only minutes with a component tester and could save you the frustration of having to dismantle the PWB-P board again within a week or two.

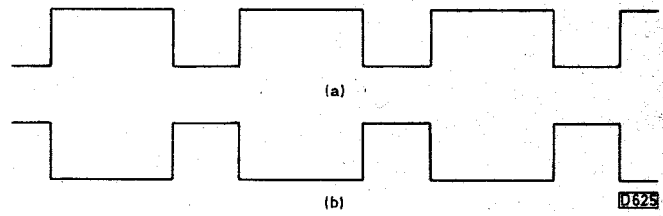

Fig. 2: Waveform at pin 1 of IC9001 (a) and at the collector of transistor Q9003 (b).

Before replacing board PWB-P in its metal box, first carefully set up the 13V line (R9017), then the 12V line (R9022), with the machine in the record mode. Recheck the voltages when the machine has been running for half an hour.

## The Luminance/chroma Panel

Fortunately few faults seem to occur on the luminance/chroma panel PWB-C. The adjustments don't seem to drift, so don't disturb them unless it's absolutely essential. Before looking for obscure faults examine the printed circuit carefully for cracks or dry-joints where it's joined to the various socket connectors. Damage can occur when the panel is opened and swung back too quickly. Be sure to clean the video heads and the audio/control and full erase heads with a proper video head cleaning kit before making further tests.

A quick check is to play a colour-bar test tape with a scope connected, via a 10:1 probe of course, to test point TP308. Adjust the scope's timebase so that you can see the head 1 and 2 signals separately.

The signal at TP308 is fed via Q305 (2SC945), filter

**Table 1: IC801 logic level checks**

Pin	Function	Condition				
		Tape stopped	Play	Record	FF	Reverse
1	Supply brake strong	L	L	L	L	L
2	Supply brake medium	L	L	L	L	L
3	Supply brake weak	L	L	L	H	L
4	Take-up brake strong	L	L	L	L	L
5	Take-up brake medium	L	L	L	L	H
6	Take-up brake weak	L	L	L	L	H
10	Fast forward LED	L	L	L	H	L
11	Rewind LED	L	L	L	L	H
12	Dub LED	L	L	L	L	L
13	Record LED	L	L	H	L	L
14	Playback LED	L	H	L	L	L
15	Pause LED (high in pause)	L	L	L	L	L
16/7	End/start sensors	L + P in all above modes				
18	Sensor stop input	H	L	L	L	L
19	Dew sensor input	L in all modes with no moisture				
20	Timer rec. indicator input	L in all modes when not on timer				
21	Timer CTL input	L in all modes when not on timer				
22	Timer rec. output	L in all modes when not on timer				
23	AL output	L	H	H	L	L
29	Oscillator	H + P on all functions				
33	Power CTL	H	H	H	H	H
34	Dew indicator output	L when normal				
35	AV mute output	L	H	L	-	L
36	DM mute	H	L	L	-	H
37	Drum rotation sensor	H	*	*	H	H
38	Reel sensor input	H	†	H	*	*
44	Sleep input	L	L	L	L	L
45	Camera remote control input	L	L	L	L	L
54	Reel motor UL/swing	L	L	L	L	L
55	Reel motor play/rec.	L	H	H	L	L
59	Reel motor VS	L	L	L	L	L
60	Reel motor FF/rew.	L	‡	‡	H	H
61	Motor reverse	L	L	L	L	H
62	LDM CTL	L	L	H	L	L
63	Cap mute	H	L	L	H	H
64	Cass. M.CTL	L	L	L	L	L

\* H + P + L

† H + P + L very slow

‡ L + P momentary

Pins 24, 26, 27 and 28 are connected to chassis.

Pins 31 and 32 are at 10V.

Pins 42, 43, 46-49 are the AD0-5 lines, L + P in all modes.

Pins 50-53 are the KE0-3 inputs, L + P in all modes.

Pins 7-9, 25, 30, 39-41 and 56-58 not connected.

FL302 and the emitter-follower Q306 (2SC945) to pin 18 of IC501 (AN6360). This device can give trouble, either failing to function at all or causing various strange effects to appear on the picture. It has been used in VCRs of various makes. Before replacing it, make sure that its 11.6V supply is present at pin 5. If this supply is missing check L502 (220 $\mu$ H) for continuity or dry-joints.

If all is well with IC501 the luminance output will be present at pin 7. It passes to pin 15 of IC402 (HA11703) where it's combined with the chroma signal. You should see the complete video signal in the record, playback or E-to-E modes at TP402.

If you think that the a.p.c. adjustment (C517) is out don't be in a hurry to adjust it. First connect a 39k $\Omega$  resistor and an 0.01 $\mu$ F capacitor in parallel between TP503 (pin 13 of IC502, AN6371) and chassis and an 18k $\Omega$  resistor between TP501 (pin 9 of IC502) and chassis (TP504 and TP506 are convenient chassis points). Select the record mode, feed a colour-bar signal to the VCR and connect an accurate digital counter via a 10:1 probe between TP502 (junction of C521/R523) and chassis (TP504). The reading should be 4.433619MHz. If it's incorrect, adjust C517 gently to obtain the correct frequency.

As with most VCRs, problems occur due to small electrolytics on the board drying out and losing capacitance. A poor signal at TP402, yet with a good signal output from the r.f. output socket to the TV set, can be due to C431 (1,000 $\mu$ F, 16V) becoming almost open-circuit. The reverse occurs if C439 (100 $\mu$ F, 10V) dries out and fails and C431 is in order.

If a signal fed to the video input socket at the rear of the machine seems weak check C201 (100 $\mu$ F, 10V) for low capacitance and/or leakage. Before condemning IC501, check C509 (47 $\mu$ F, 16V) and C502 (1 $\mu$ F, 50V).

These small electrolytics on board PWB-C are less liable to dry out than on earlier TV sets and VCRs. But if you've a puzzling fault on this board it takes only minutes to check all the small electrolytics with a component tester.

## Function Faults

A dirty or faulty reel idler assembly (part no. NIDL0005GEZZ) and/or reel motor (part no. RMOTV1008GEZZ) can cause the following problems: no or poor rewind or fast forward; the machine going into the stop mode intermittently; the tape not going back into the cassette when stop is selected; tape spilling out during playback.

To clean or replace the reel idler assembly and if necessary replace the reel motor the cassette housing has to be removed. Remove the four little red-gold screws at the sides of the housing and the two larger black screws in front, gently unplug the connector at the left and lift the housing clear. Clean the reel idler assembly and the entire tape path mechanism. If this doesn't provide a cure you may need to fit a new idler assembly or the fault may be due to the reel motor sticking or having a dead spot. It's sensible to replace the reel idler assembly when fitting a new motor.

To fit a new reel motor remove the cassette down switch and holder - two metal screws only - to reveal a little metal bracket and the two small screws that hold the reel motor (see Fig. 3). A small coiled spring has to be unhooked: it easily flies off into the unknown, so be careful not to lose it! Swing back the PWB-A mechacon

panel and the reel motor can be replaced. Note that the fault can sometimes be due to the plastic sleeve on the motor shaft riding up.

All sorts of strange and apparently complex function faults, such as tape stopping and starting or some functions not working properly or at all, can be caused by the cassette down switch (part no. QSWK0008GEZZ) and/or the little slide switch (part no. QSW0032GEZZ) sticking or making no or poor contact. It's good sense to clean and check these switches whenever you've a function fault or a machine comes in for service. They've even been known to break in half. This could save you hours of time and worry as you try in vain to find a fault in the circuitry!

Other faults such as fast forward or rewind slow or no rewind at all can be due to relay RY7751 (part no. RRLYZ0016GEZZ) sticking or failing. The associated transistor Q7754 (2SD882) likes to leak or go open-circuit, sometimes intermittently, giving similar symptoms. These two components are on the PWB-A mechacon panel.

The trip counter can be responsible for intermittent stopping due to a worn gear – the take-up reel drives the motion detector via a belt, with a further belt driving the counter from the detector. As a check, reset the counter then test the machine. If it always stops at a certain number the trip counter is responsible – as a further check remove the counter belt.

## The Converter Stage

As previously mentioned there's a converter stage on the mechacon panel (PWB-A). This consists of an oscillator and several rectifier diodes. The transformer T902 (part no. RTRNH0015GEZZ) provides anti-phase 2V a.c. outputs and feeds three rectifiers. D903 (1SS81) develops -20V across C907 (47 $\mu$ F, 150V). This supply is fed via connector AD7 to connector TB3 on timer/channel selector board PWB-T. D904 (1SS81) develops 10V across C908 (220 $\mu$ F, 25V) which goes via AD8 to TB4 on board PWB-T and via AF3 to MA9 on the cassette unit. This supply is also used on the PWB-A board itself, including pin 32 of the microcomputer chip IC801 (RHIX0074GEZZ). D905's (DX0126CE) output is developed across C909 (47 $\mu$ F, 100V) and fed via R908 (2.7k $\Omega$ , 2W safety) to connection AC1 where 50V should be recorded. This supply goes to UC2 on board PWB-U. The 2V a.c. feeds go via AD3 and AD4 to TB1/2 on board PWB-T, finally arriving at pins 20 and 38 of the clock display. When choke L902 (100 $\mu$ H) goes open-circuit, as it sometimes does, all these voltages disappear. The reservoir capacitors C907/8/9 can dry out and lose capacitance. The rest of the circuitry around transformer T902 has so far proved to be extremely reliable.

## System Control Checks

The easiest way to check the system control circuitry is to use a logic probe. First ensure that all the d.c. supply voltages are present then, with the mains supply disconnected, carefully solder two half-inch lengths of bare wire to pins 32 (V<sub>ss</sub> +) and 28 (V<sub>dd</sub>) of IC801. Connect the probe's positive supply lead to pin 32 and the negative supply lead to pin 28.

First check that an H + P logic signal is present at pin 29 (oscillator) of IC801. Then monitor the various pin levels (see Table 1). If no indication whatever is obtained at a pin that should show a logic level the connection within IC801 has failed. Should this occur, heating and freezing may sometimes temporarily restore IC801 to a working

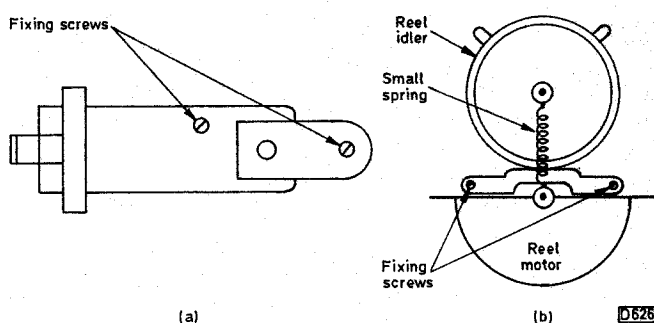

Fig. 3: Sketch of the cassette down switch, viewed from the top, (a). Sketch of the reel idler and motor viewed from the top with the cassette carriage removed (b).

condition. A connection like this can be the cause of intermittent results. When you're reasonably sure that IC801 is defective, carefully desolder and remove it, trying not to damage the device. Now fit a 64-pin i.c. socket. This gives you two advantages. If the original i.c. proves not to be faulty after all you can put it back again, and if the new one fails some time it's easily replaced.

IC803 (STA401), IC802 (IR3403) and IC804 (IR2403) are logic inverter i.c.s that can, on rare occasions, fail. Usually one output only goes open-circuit. If this happens just one function may cease or the whole system may stop. These chips are simple to check – the logic level output from each inverter should be opposite to that at its input. Don't forget to transfer the positive supply clip of your logic probe to the positive line supplying these inverter chips. If you suspect an overload in the circuitry desolder the output pins of each inverter temporarily.

We've had not problems with any of the other chips on board PWB-A.

The cassette lamp should be replaced if it has seen a fair amount of service. If you don't it's sure to fail shortly afterwards, preventing the machine from functioning.

The adjustments on board PWB-A usually don't drift. If you have any suspicions, check the small electrolytics on the board for leakage and loss of capacitance and examine the board carefully for dry-joints before wielding your small trimmer tool.

## Other Boards

The PWB-T board and the associated PWB-U board contain the clock display, timer, channel selector and tuning circuitry.

If the clock circuitry functions incorrectly or not at all, the first thing to check is that the voltages at connector TB are present and correct. These include the 2V a.c. supplies at TB1/2 which feed connections 20 and 38 of the clock display. If this a.c. supply is missing look for a dry-joint around one of the connecting sockets en route from board PWB-A. Don't overlook the 50Hz synchronising signal at TB7 – if all is well the digital multimeter reading here should be about 14.17V a.c. If it's not, suspect C9002 on board PWB-P. IC5001 (MP2812S) seldom gives trouble: before condemning it check the three transistors on the board – Q5001/3 (both 2SA733) and Q5002 (2SC945).

The channel selector switches sometimes become noisy and unreliable. The only satisfactory cure is replacement.

If the VCR doesn't erase previous recordings properly or at all in the record mode carry out a scope check, via your 10:1 probe, at TP601 (pin 8 of connector BB) on the PWB-B-1 audio board. A nice sinewave should be present here. If not, check R626 (10 $\Omega$  fusible), L602 (1mH) and

Q604 (2SC496) in that order.

Perhaps we've been fortunate, but we've never had trouble with the PWB-D fine still/mechanical switch board or the PWB-H operation circuit board.

## **In Conclusion**

If a new belt is required it's best to fit a complete set of belts to ensure future reliability. Avoid unnecessary complications by using the correct Sharp spares and recommended transistors which are readily available from Willow Vale Electronics Ltd. (11 Arkwright Road, Reading, Berks RG2 0LU, telephone 0734 876 444). They can also supply service manuals.

Before finally assembling the machine ensure that all the connecting leads are neatly tucked into their correct positions and that you've not forgotten to replace any of the small screws you may have removed during servicing.

You may come across a version known as Model VC9300E, which persons unknown sometimes bring into this country. It operates on a wide range of a.c. voltages from 95V to 250V and has an entirely different switch-mode power supply to the one described earlier. At the front there's a PAL/SECAM switch. The machine is not designed for use in the UK but it's possible, if you like a challenge, to remove the crystal filters in the sound i.f. circuit (board PBW-I) and replace them with the correct UK types. You'll then have to retune the circuitry a little.

# VCR Clinic

*Reports from Eugene Trundle, Alfred Damp, Roger Burchett, Steve Leatherbarrow and Philip Blundell, Eng. Tech.*

## Mitsubishi HS318

This newish machine came in with the complaint "no colour". A known good colour-bar tape played back in black and white, but we were relieved to find that a recording made by the machine played back in colour on another machine. A quick scope test revealed that the chroma signal got no farther than transistor Q6B0, the 627kHz playback amplifier, whose base voltage was correct at 1.6V but whose emitter read 0V. A replacement transistor cured the fault, though the base-emitter junction of the faulty one read o.k. on an ohmmeter when tested out of circuit. **E.T.**

## JVC HR2200/Ferguson 3V24

"Flashing Lights" said the owner. "It's going into the alarm mode" we told him. When we explained what might be wrong and what that might cost he went into the alarm mode too . . . Sighs of relief all round then when we found that the cassette lamp had failed.

With a new lamp fitted the lights stopped flashing, but when play was selected the head drum roared round at

about ten thousand r.p.m. There was no drum FG signal at TP7 in the servo section. None at terminals 111 or 112 on the servo board either. A new drum motor required? No, there was continuity through the FG coil at the motor connector. The trouble was due to dry-joints on the motor drive amplifier board, whose terminals 11, 12/21, 22 pass on the FG signal. **E.T.**

## Sanyo VTC9300

These golden oldies were built like battleships and give every sign of outliving all their contemporaries. One arrived in the workshop the other day with a broken belt, and was thus unable to play. A footnote on the job card, in the owner's writing, gave elaborate instructions on how to get the tape to load: hold down the cassette lid with one hand while half-pressing the eject lever with the other and simultaneously pulsing the play lever till it stays down. He'd apparently been going through this procedure for some months before the belt broke to spoil his fun. The problem was that the mains motor was not being



energised on receipt of a cassette: the cause was the fact that the loading switch (a great big microswitch bolted to the left-hand side of the deck) had gone open-circuit. Its tags and blade differ from the standard RS Components type lever microswitches in our stores so one had to be ordered from Sanyo. With it and the belt fitted, and the heads cleaned, the machine seemed to be ready for another ten years' use. **E.T.**

### **Finlux VR1030**

The problem here was that the machine would lace up then, when the play key was pressed, it would unlace again – regardless of whether a tape was inserted or not. A second symptom was that the head drum rotated so fast there was a danger of it becoming airborne.

Taking these two symptoms together led us to the head drum tacho pulse generator. This consists of an optocoupler through which a drum-mounted interrupter whizzes. It's conveniently mounted on top of the drum, making it easy to establish that no output pulses were present during the few seconds available before the sycon shut the show down. In fact the phototransistor was o.k., but the LED section had gone open-circuit. A new optocoupler assembly restored order, with the correct 12V peak negative pulse per 40msec at pin 3 of P669. **E.T.**

### **Hitachi VT33**

A weak point that's come to light is where the wires to the supply end sensor (Q141) are soldered into the cassette loading motor board. The wires are pulled tight and eventually break off, giving no rewind or review. **R.B.**

### **Hitachi VT11**

Intermittent stopping/tape snagging was the fault report with this machine. As the fault didn't show up on test a basic deck service was carried out and the pinch roller was replaced. It came back of course, this time with the tape still in the machine. It looked as though the capstan had stopped, so a new capstan motor was fitted (this cured the warbling sound). Back it came a third time. The unit was put to one side with the bottom panel unhinged. It played away merrily for hours. Eventually I caught it. The drive was there for the take-up reel but the clutch assembly that drives it underneath the deck didn't rotate. I removed it (this is easier said than done, as it was almost solid on its shaft) and after lubricating the shaft the trouble had been cured. **S.L.**

### **Sharp VC9700**

Intermittent failure to play was the fault with this machine. When the fault occurred the drum didn't rotate as the motor control voltage at plug ES2 was low (1V). The drum muting transistor Q719 was leaky. **P.B.**

### **Sanyo VCT5000**

For no E-to-E vision check relay RY1001 on board VD1 for dirty contacts. **P.B.**

### **Sharp VC8300**

This machine intermittently blew fuse F903. In the past this has often been due to a faulty drum motor, but not on this occasion. The fuse would usually blow when the tape was unthreading, so a meter was connected in the feed to

the threading motor. As there was no overload here we had to work back. The problem was eventually traced to an intermittent short in the forward/reverse switch (part no. QSWF0002GE). It's mounted by the solenoids. **P.B.**

### **JVC HRD120/Ferguson 3V35**

This machine wouldn't accept a cassette. A quick check revealed that there was no supply to the cassette motor drive chip due to the 13V supply protector CP1 on the mechacon panel being open-circuit. **P.B.**

### **Sharp VCRs with Scotch Tapes**

Since the shop down the road started to sell Scotch tapes I've had a number of cases of Sharp machines creasing only this make of tape, usually in the rewind search mode though three machines creased the tape in playback. In all cases the tape folded as it went over the drum exit guide. In most machines the search or playback tension was towards the top of the tolerance range and readjustment provided a cure. New rotating guides were required in the other machines. One wonders why the problem showed up with only this make of tape? **P.B.**

### **JVC HRD565**

Intermittent failure to eject was the complaint with this machine. The problem was to have a meter connected at the right time and in the right place. To start with we connected the meter across the cassette motor. This turned out to be a fortunate move: when the fault did occur the voltage across the motor rose but the motor stood still – a slight touch on the motor wormgear and the motor sprang to life. Replacing the motor restored normal operation. **A.D.**

### **Mitsubishi HS330**

This two-speed machine couldn't detect SP or LP and was constantly switching between speeds. When the VCR did settle the displayed picture suggested that the drum input/output guides were incorrectly set. Readjusting these guides cured the fault. **A.D.**

### **Sony SLC5**

With its own recordings there was no picture except in the pause and picture search modes. The machine worked all right with prerecorded tapes. A check on the f.m. envelope at the head amplifier board showed that one output was rising and falling, indicating a servo fault. Checks on the servo board then revealed that the CTL pulse was missing at TP11. Replacing the audio/control head cured the problem. **A.D.**

### **Fisher FVHP715**

This machine would work intermittently: when it was in the fault condition all the front indicator lights went out but the clock and counter stayed on. When we moved the machine from the soak test rack to the work bench it worked normally. We were unsure whether the trouble was due to a confused microcomputer chip or a dry-joint. When the fault eventually appeared we removed the mains plug, counted to ten and plugged in again. As the fault was still present we looked for a dry-joint. After much tapping we found one at R971 on the power board. **A.D.**

# VCR Clinic

Reports from Alfred Damp, Eugene Trundle, Steve Leatherbarrow, Philip H. Ireland and Philip Blundell, Eng. Tech.

## Panasonic NV366

This machine suffered from an intermittently noisy picture. The playback picture was very good at the start: going to search or still also produced clean pictures, but on returning to playback the picture would be noisy and the tracking control had no effect. This is a four-head machine (two for standard play and two for the search and still modes), the switching between heads being carried out by means of relays. Replacing these cured the fault. **A.D.**

## Grundig VS220

The playback picture had three white lines across it. One was central and the other two were in the bottom half of the picture. Advice was sought from Grundig who suggested removing the bottom of the drum motor and cleaning the brushes. When this was done and the machine was reassembled it worked perfectly. **A.D.**

## JVC Camera with Olympus VCR

The VCR turned out to be a Panasonic NV100 and the complaint was no recording. We found that with the camera connected to the VCR it couldn't be released from the pause mode by means of the camera's trigger. A check on the pause line input from the camera revealed a short-circuit to chassis. This cleared when the camera was unplugged. At the time this seemed strange, because it should have prevented the VCR going into the pause mode. No short-circuit could be found in the camera, but a short-circuit was present when the two units were connected. On trying another camera we found that the VCR was o.k. So the fault was in the camera or its lead. What our customer had neglected to tell us was that the lead had been repaired recently by "the man round the corner who knows about kettles". The connections to the plug at the camera end of the lead had been reversed laterally. Hence all the confusion. **A.D.**

## Sharp VC9300

This machine came in with the complaint "stops after a few seconds". When we opened it up we found that it had received unprofessional attention. The mains fuse had been replaced with several strands of 5A fuse wire and the counter belt from the take-up reel to the take-up sensor pulley was missing. As a result, the VCR went to stop after playing for a few seconds. The take-up and supply reels were well worn, as was the reel idler. In addition to all this the cassette motor continued to run when the housing was fully lowered. This was due to a deliberate solder blob. When this was removed the cassette housing stopped half way: the eject finish switch on the cassette housing was open-circuit. **A.D.**

## Hitachi VT8500

The remote control wouldn't provide channel change – the other functions worked correctly (note that channel change won't work without a cassette in the VCR). The pulses from the remote control receiver board go to the servo board and then pass to the timer board. After

processing they go to the channel selector board. C112 on the timer board was open-circuit. **A.D.**

## Hitachi VT130

This VCR's voltage-synthesis tuning would scan the band correctly but failed to lock on to any transmission. The most obvious cause of the fault, failure of the sync pulses to reach the tuning system, proved not to be the case. A scope comparison with another machine showed that the a.f.c. input to the panel didn't vary during the tuning search. Replacing the combined tuner/i.f. module cleared the fault. **P.H.I.**

## Pye 65VR20/Philips VR6520

This machine would occasionally return to stop from fast forward or rewind, especially when warm. It was noticed that the tape counter would slow down erratically without a corresponding reduction of the tape speed. The reel sensor opto-detector IC1501 proved to have reduced sensitivity when warm.

Another of these machines had no capstan rotation. The reason was loss of the unregulated 12V supply to the capstan control chip IC2004 due to fusible resistor R2096 (0-68Ω) being high in value. This device is not shown in my service manual. **P.H.I.**

## Sony SLC6 Mk. II

Low sound on ITV only was the unlikely complaint with this machine. It turned out to be true, along with a low-brightness button three neon. A look at the circuit showed that the neon is used to bias the mute drive transistor Q010. Replacing the neon, cured both faults. **P.H.I.**

## Grundig 2 × 4

There was a popping noise on the sound and a disturbance on the screen. The cause of the fault was soon found when the head screening cover was removed – the red DTF wires had been trapped under it and were shorting to chassis. **P.B.**

## Sharp VC9300

For low reel torque in all modes check for dry-joints on Q8001. This transistor is mounted at the rear of the chassis, by the head drum. **P.B.**

## Mitsubishi HS304

Stops playing after ten minutes was the complaint with this machine. The capstan was stopping as after this period of time had elapsed the capstan drive chip was hot enough to fry eggs on! The capstan motor was faulty. **P.B.**

## JVC HRD725/Ferguson 3V43

Intermittent failure to play can be due to resistance in the loading mechanism. Inspect the grease on the loading mechanism and gears as this can get hard.

If every segment of the display is on switch off immedi-

ately! Q2 in the power supply is probably short-circuit, causing the switched 12V supply to rise to 23V. Replace Q1, Q2 and D2 on the power supply panel and Q3, D13, D17, D18, D19, D20, C13, C14, L1 and IC1 on the tuner/timer board. **P.B.**

### **JVC HRD140/150/250**

There's been a change to the intermittent bias oscillator start-up modification for these machines. Add an 0.0082 $\mu$ F Mylar capacitor (previously 0.0056 $\mu$ F was suggested) across C23. **P.B.**

### **Amstrad VCR9000**

For no front loading motor rotation try giving the motor a half turn and then having another go. The motors often develop a dead spot – replacements are available for CPC. If this doesn't do the trick, try cleaning the cassette in and lift position detect switches. **P.B.**

### **Philips VR6462/Tatung 8490**

This machine refused to rewind when a cassette was present. With no cassette inserted however it happily included rewind in its repertoire of tricks! The culprit was betrayed by a potential of 4-5V at connector 4DP2. This came from the "tape begin" photodiode on the right-hand side of the deck (board P672). The diode was leaky. **E.T.**

### **Panasonic NV370/830/850**

There was severe horizontal twitching and pulling on playback – the corrugation of the verticals was even worse with self-recorded material. The fault was somewhat intermittent.

The cause of the problem was "sticking" of the impedance roller up-stream of the full erase head. For a complete and permanent cure both the white roller and its insert should be replaced. This applies to Models NV370, NV830 and NV850. In the case of the latter two models, which have hi-fi sound, correct alignment of this roller is crucial to correct tracking of the hi-fi signals and hence the quality of the audio output. **E.T.**

### **Sharp VC7700**

This machine caused some amusement in the workshop whilst it was on test: the machine would intermittently eject a tape. Pulses going astray? Take-up reel stopping? Neither of these problems were found when the top of the machine was removed. The 555 timer chips on the mechacon board were the cause of the fault. These undeniably useful i.c.s have caused all manner of problems in all manner of equipment in the past. Oh yes, and the eject flap also opened without provocation even without a tape being in. **S.L.**

### **Sharp VC383**

Playback of a prerecorded tape was fine but there was a problem when a recording was made and played back: a band a few lines deep was present, with the odd kink in it, across the screen about a third of the way down. The record switching monostable was found to be at fault. Changing the cross-coupler C714 cured the problem and all that remained was to change the reel motor and idler. **S.L.**

# Servicing Mechanical VCRs

Part 4

Mike Phelan

This month we'll start to examine the loading mechanism – it's probably the most complicated and trouble-prone part of the machine. In fairness to the manufacturer, many of the troubles stem from previous unsuccessful attempts to repair the mechanism, though wear and tear are now taking their toll as these machines are getting old. A good understanding of the principles of operation can go a long way to easing the task of curing some of the more obscure faults in this part of the machine.

When the machine is put into the play, record or audio dub mode the tape has to be extracted from the cassette and wrapped around the video head drum. This operation is followed by several others: the impedance rollers and erase head are brought into position, the pinch roller is carried towards the capstan, the back tension arm is released, and finally the guide rollers are rigidly locked. All this is done using power supplied by the capstan motor, the drive being taken from a pinion incorporated in the capstan flywheel. The drive is taken through two intermediate gears to a large gear that controls all the operations, in much the same way that an autochanger works. The process has to be performed in reverse order when stop is selected. Loading and unloading each occupy half a revolution of the large gear.

One of the intermediate gears is mounted on a rocking arm that's coaxial with the gear (see Fig. 1) to allow the drive to be engaged and disengaged.

## The Play and Stop Processes

The loading-1 and play mechanisms are shown in Figs. 2 and 3, viewed from below.

The large gear is called the timing gear – we'll keep to the manufacturer's terms to avoid confusion. This gear has two almost diametrically opposite notches in its periphery. The timing arm roller rests in one of these notches when the gear is stationary.

When the play key is depressed, either on its own or in conjunction with the record or audio dub key, the projec-

tion on the play key moves the linked play levers 1, 2 and 3. The latter has an L-shaped notch in it, in which the stud on the change lever rests. Play lever 3 is lightly spring-loaded so that the stud is in the short arm of the L. Consequently the change lever is moved, the stud at its other end allowing the gear arm to turn and engage the drive.

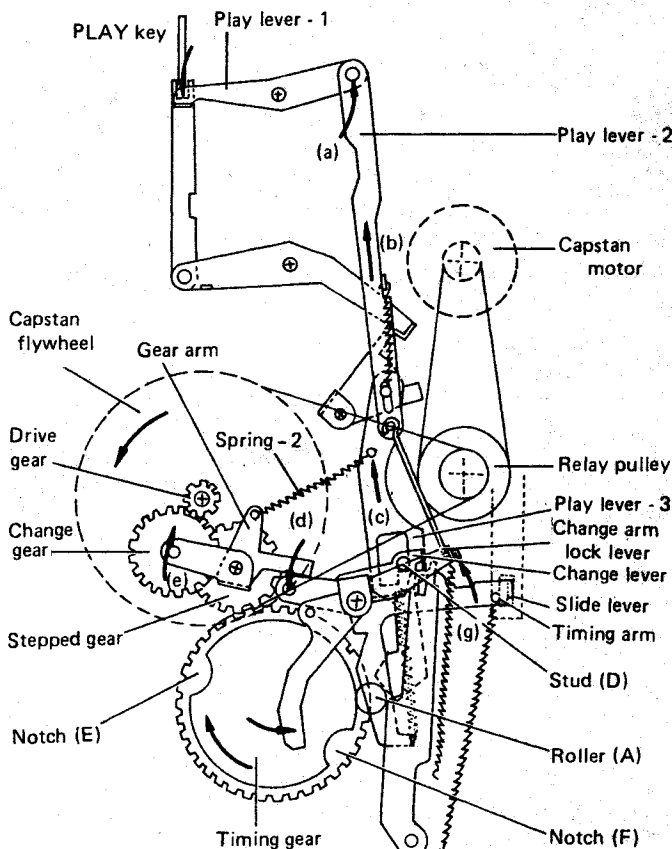

Fig. 2: The loading-1 mechanism, viewed from beneath.

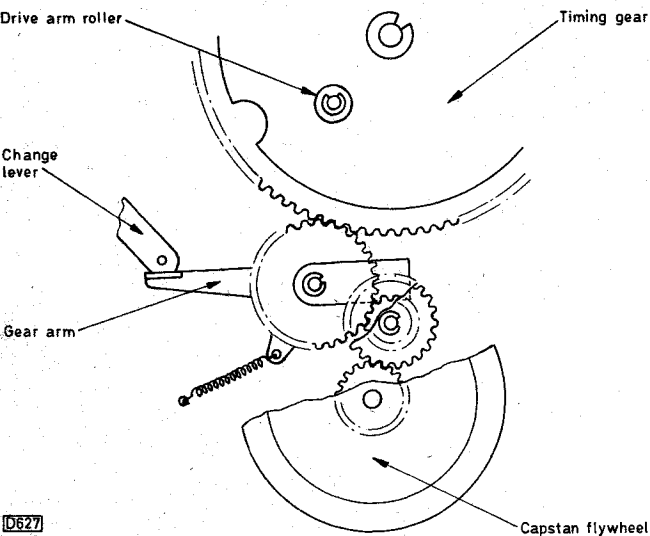

Fig. 1: The gear train between the capstan flywheel and the timing gear.

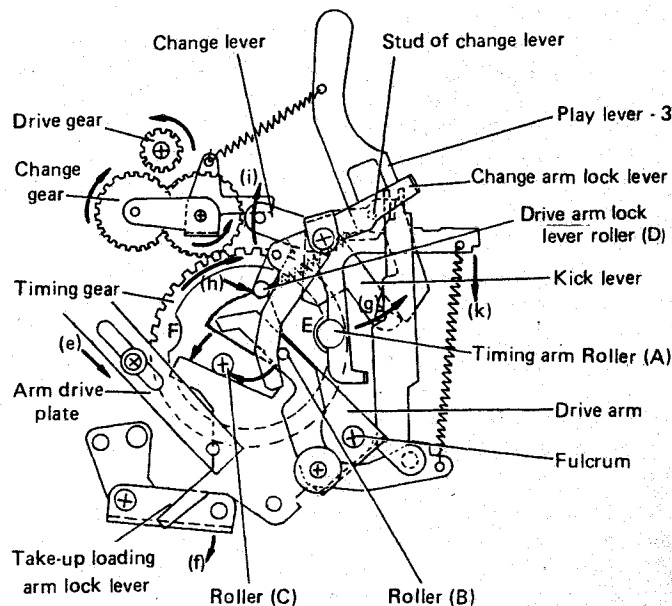

Fig. 3: The play mode mechanism, viewed from beneath.

**Table 1: Common loading mechanism faults.**

Symptom	Cause	Remedy
Loading mechanism doesn't engage at all. Change lever moves.	Gear arm seized on post due to lack of lubricant or flaking of plating.	Remove capstan and gear arm, clean bores of gears with cloth, clean post, grease and reassemble.
Similar but change lever doesn't move. Machine may work when stood on end for examination.	End play lever 3 bent where the kick lever engages. This fouls the underside of the timing gear and prevents the L notch moving the drive arm.	Straighten lever as necessary. Later machines have a large nylon washer over the L notch. It can become gunged up with sticky grease. Check this.
Loud clunk from mechanism at completion of loading. Machine then unloads.	Drive arm lock roller fails to engage with notch on drive arm, so latter springs back and unlocks the change arms, initiating the unloading cycle.	Either the timing post is loose or out of vertical. Some people find a temporary cure by leaving the cover plate off the timing gear, but this is not to be recommended (see below). The correct cure is to straighten the post and re-rivet if necessary. This can be accomplished by using a staking tool and punch (see Fig. 4).
Mechanism stalls part way through the unloading cycle. Capstan belt may come off.	Someone has left the cover plate off the timing gear and the small pivoted lever on drive arm has become wedged in chassis opening.	Replace plate. Turn mechanism manually in reverse to release.

At the same time the capstan motor is energised and the timing gear rotates clockwise, viewed from below. Play lever 2 also has a wire link to the change arm lock lever. As a result the latter rotates, allowing the drive arm lock lever roller to rest on the periphery of the drive arm. As the timing gear starts to rotate, the timing arm roller is lifted out of its notch and the large roller on the timing gear moves the drive arm until the drive arm lock lever roller engages the notch in the drive arm.

Beneath the timing gear there's a pin that collides with the kick lever just before completion of loading. This pushes play lever 3 so that the change lever stud is in the long arm of the L notch. The main reason for this is so that the change lever is free to move and disengage the drive gears. This happens when the timing arm roller drops into the notch in the timing gear, allowing the change lever to return to its resting position. By this time the loading arms etc. are in position for tape transport.

The reverse takes place to go to the stop position, the timing gear completing its rotation. This action is initiated by the play key being released either by operation of the stop key or by energising the stop solenoid. Play levers 1, 2 and 3 move towards the rear, the link on play lever 2 pushing the change arm lock lever back, lifting the locking

roller from the drive arm. Movement of the change arm lock lever also moves change arms 1 and 2 which push the change lever away from the gear arm, allowing the drive to start. The timing gear rotates, moving the drive arm back to the rest position. The loading arms return, and finally the timing arm roller enters its notch, pushing the change lever and releasing the drive.

The operation of the loading arms, pinch roller engagement, etc. and the faults that occur in this area will be covered next month. Meanwhile we'll look at some of the problems likely to be encountered with the mechanism under discussion.

### Servicing Aspects

Many of the faults here result from the extreme spring pressures involved, particularly the springs on the drive arm and change arm lock lever. There's great strain on the posts that act as fulcrums for the various parts: they eventually become loose in the deck and need re-riveting. Fault diagnosis is made easier if the mechanism is turned slowly by hand while observing its operation. This is easier if the plate on the timing gear is first removed. Probably the best way of describing fault conditions is to list some of the more common symptoms with their causes and the appropriate remedies (see Table 1). Faults affecting the parts not yet described will be dealt with later.

Some of the heavily stressed components will benefit from a small amount of moly- or copper-based grease. Only a little though – it makes a horrific mess in quantity.

You'll find that various screws in the mechanism are locked with cellulose paint. The heads sometimes get chewed up on removal. It's not a bad idea to replace all damaged screws and relock the heads of those that were originally locked. A small car touch-up pack is ideal – whatever colour you want!

Next month we'll discuss the rest of the loading mechanism – it's rather simpler than the arrangement described above, which must be one of the most complex pieces of mechanism in any domestic VCR.

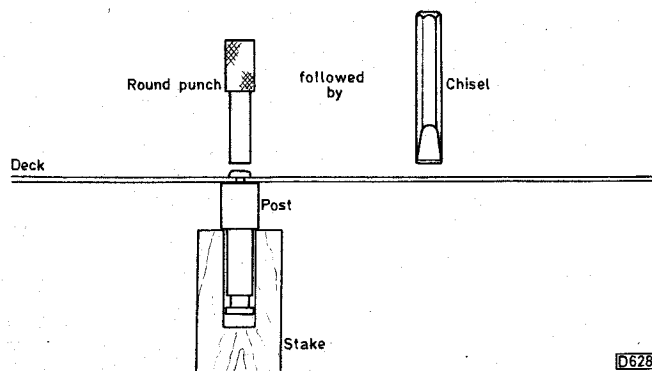

Fig. 4: Use of a stake, punch and chisel for re-riveting. Four stake sizes cover all posts in the machine.

# The Super-VHS Specification

**Steve Beeching, T.Eng.**

It's almost ten years now since I saw the first VHS video cassette recorders – the JVC Model HR3300. Some of these early machines are still in service, having stood the test of time.

## Comparisons

In all VCR systems the luminance signal to be recorded is first frequency modulated on to an h.f. carrier. It's recorded on tape as the lower sideband of the spectrum produced by this f.m. process. Fig. 1 shows the signal spectra for various VCR systems, (a) standard VHS, (b) Beta super hi-band and (c) the new Super VHS (S-VHS). As you can see, the luminance signal bandwidth, and hence the picture resolution, depend on the extent of the lower sideband frequency spectrum that can be recorded on the tape.

The advent of the 8mm video system has led to claims that this will become the new domestic VCR standard. I don't agree with this, nor do I agree that Video-8 is significantly better than the standard VHS system. The Video-8 system has been able to take advantage of developments in video tape recording technology. What if the VHS system was to take advantage of these same developments? This is where the S-VHS system comes in.

In the past, certain Betamax machines gave rather better performance than their VHS contemporaries. This was basically because the Beta system's luminance carrier deviation is slightly wider at 3.8-5.2MHz than the standard VHS carrier deviation of 3.8-4.8MHz. Whilst this higher specification didn't increase the resolution much it did significantly reduce the video noise content. As a result, greater enhancement could be used for the same signal-noise ratio than with VHS. So Beta machines could provide an apparently better bandwidth and resolution.

With the Video-8 system the luminance f.m. deviation is 4.2-5.4MHz. Since the carrier is at a higher frequency than with standard VHS or Beta, the result will be a wider lower sideband f.m. bandwidth and thus improved resolution. The wider deviation of 1.2MHz compared to standard VHS will give an improvement in signal-noise performance, but this is offset by higher density recording on the narrower 8mm tape. Further improvement is allowed for however by the use of higher grades of metal tape.

Thus to achieve improved performance with a video recording system, three factors require attention. First a higher luminance carrier frequency to enable the bandwidth and thus the resolution to be improved. Sec-

only a wider frequency deviation to improve the signal-noise performance. And thirdly an improved type of tape is required to enable the first two factors to be implemented.

The Super Beta standard is shown in Fig. 1(b) for comparison. The luminance carrier frequency of 4.8-6MHz gives increased resolution (370 lines) compared with standard Beta while the 1.2MHz deviation provides a good signal-noise ratio. Overall the performance is much better than with standard Beta.

## Super-VHS

The new Super VHS specification pushes the luminance bandwidth even farther up the scale, the carrier deviation being 5.4-7MHz. This results in a massive resolution increase from 250 to 400 TV lines while the wider 1.6MHz deviation improves the signal-noise ratio. The bandwidth of the down-converted chroma signal is increased to over 500kHz, centred on 627kHz, giving enhanced colour. The luminance white and dark clip levels have been increased to 250 per cent and 70 per cent respectively.

The new specification also reduces cross-colour effects. If you compare Fig. 1 (a) and (c) you will see that the upper sideband of the chroma signal and the lower sideband of the luminance signal no longer overlap – in fact there's a gap of some 200-300kHz.

JVC intend the new S-VHS machines to have separate luminance and chrominance inputs and outputs so that the improved cross-colour performance and bandwidth are maintained. JVC also intend to market a high-grade colour TV set with separate luminance and chroma facilities. It will take advantage of the improved S-VHS specification, though standard r.f. and composite facilities will no doubt be provided. All this is likely to upset the Euro camp with its SCART connector.

## Tape

The whole system depends on the availability of a tape capable of handling the wider bandwidth. A new tape, intended exclusively for S-VHS use, has been developed. It uses a highly efficient cobalt iron oxide material and has the high coercivity of 800-900 Oersteds (the high grade and super high grade tapes currently available have the relatively high coercivity of 720-750 Oersteds). The cassette has an identification hole so that the VCR can identify the type of tape.

There would be no point in using the new tape with

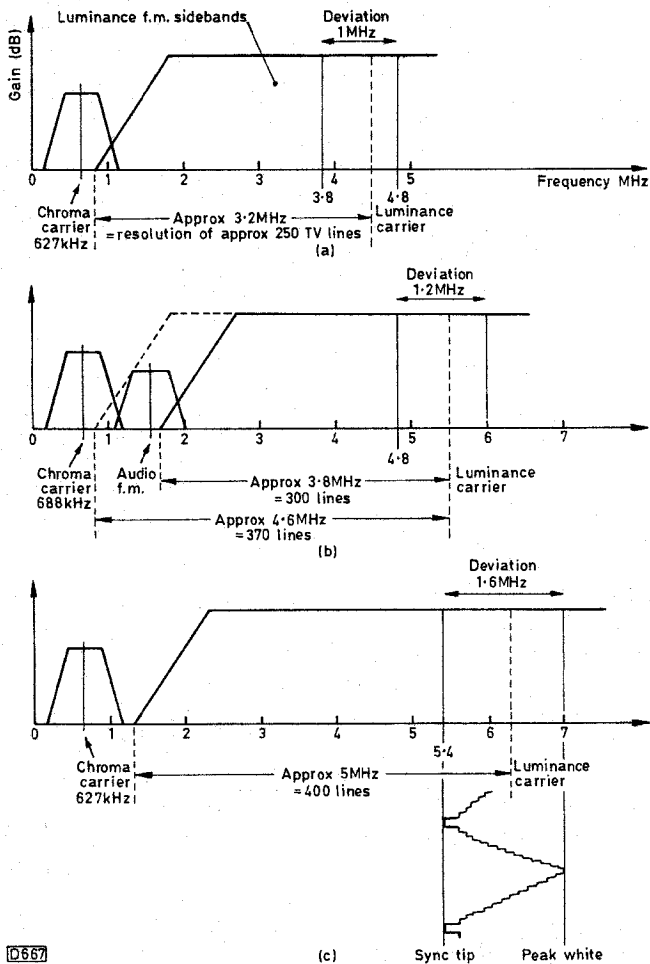

Fig. 1: Comparison between the signal spectra for various VCR systems. (a) Existing VHS. (b) Beta super hi-band. (c) The New Super-VHS specification.

current VCRs. They would not be able to erase it let alone record on it, though it may be suitable for use with some updated models to be produced later this year. The new tape will be manufactured by Fuji, Maxell, TDK and Scotch in addition to JVC.

## Recorders

The new S-VHS VCRs will have dual VHS standard capability, being able to record and playback to either specification. Current models are not able to handle S-VHS tapes.

S-VHS machines will be released this summer by JVC, Panasonic, Mitsubishi, Hitachi and Sharp – in Japan. There's no PAL version as yet, though I expect some S-VHS models to be released in Europe by the end of the year or early next year. The price is likely to be in the region of £1,000. In due course Sony will no doubt announce a new super duper Beta format to handle extended definition TV signals (EDTV), with a resolution of 500 lines. When you come across references to ED Beta some time in 1988, remember that you read about it first in *Television!*

As an aside, whilst we in the UK are still stuck with standard terrestrial TV transmissions it would nevertheless seem that the designers of C-MAC satellite TV decoders should be thinking of providing a separate chroma output. I've no doubt that it would be easy enough to modify TV sets to buffer out the chrominance. Any ideas as to which SCART pin we could hijack?

## Saisho VR9055

There was no cassette tray operation, no eject and a tape was stuck in the machine. As the motor was without power the main drive i.c., type RA6209, was suspected. After replacing this the operation was sluggish and hesitant, with intermittent eject. The motor had been checked with an external power supply (yes, the RS one E.T. reviewed in the May issue – he got his after seeing mine!), so we were back to the chip. As luck would have it however I checked the wiring to the motor. This is wrapped around the cassette compartment metal chassis, was tight and had cut through, shorting the motor's output to chassis. **S.B.**

## Sharp VC8381

There were no playback pictures and the E-E pictures showed signs of white clipping. The supply lines were correct. Rather than getting bogged down with the clipped whites attention was turned to the absence of playback pictures. IC402 had no sync pulses at pin 1 and no video signal at pin 20, though there was a video signal at pin 18. In the E-E mode there were signals at both pins 18 and 20, but the signal at pin 20 was clipped. After changing the i.c., for no good reason whatsoever, the voltages were checked. Pin 18 read 5.1V instead of 4.3V. C439 was found to be leaky. **S.B.**

## JVC HRD725

There was a background sizzle on the sound from the right-hand stereo hi-fi channel. The left-hand channel was fine. Various checks were made, including increasing the level of the right-hand 1.8MHz carrier. All to no avail. Only replacing the video heads (ouch!) provided a cure. Although the left and right audio channels are recorded by the audio heads as a mixed carrier, head wear seems to affect the right-hand channel first – presumably because of the higher frequency.

Another problem that can occur with these machines is failure of the power supply regulator transistor Q2. This can create unforeseen problems – the symptoms range from full to no display, with the capstan motor running. If Q2 has failed, change both Q1 and Q2 and check D2. As the rail voltage can increase to 20V or so a regulator circuit on the tuner panel is likely to be destroyed, so replace the following as a precaution: Q3, D13, D17, D18, D19, D20, C13, C14, L1 and IC1. **S.B.**

## Grundig VS380

Intermittent sound erasure is generally due to cracks in the solder joints on the coils around the erase oscillator. These are mounted horizontally and are subject to mechanical shock.

Low audio from the left-hand channel with an AV input was traced to failure of the input select i.c. Customers should be told not to connect plugs and sockets while the machine is powered. **S.B.**

## Grundig VS300 Series

You may sometimes find that the head drum goes around backwards. The drum motor is bidirectional and is told which way to rotate by the microcomputer chip, via a

series/parallel shift register and a four-way buffer driver. If the micro gets incorrect data from any source it tends to rotate the drum the wrong way. In one case the cause of the trouble was found to be the input data interface while in another the cause was a seized capstan motor. Drum motor winding failure will create the same problem. So remember: backwards drum rotation is only a symptom and the cause could well be something apparently not related to the drum. You must check the power rails, resets, FGs, CTL and optocoupler input to the syscon before ripping out expensive i.c.s. Ask Grundig Pete! **S.B.**

## Grundig VS380

Intermittent operation of the f.m. audio record level display was traced to a poor joint on T2049. This removed the 22V supply. **S.B.**

## Ferguson 3V44/JVC HRD140

There were no functions and no "operate" power up. After checking all the circuit protectors attention was turned to the syscon microcomputer chip which was replaced. Note that the M50730-607SP has been replaced by the M50730-610SP – I don't know why. **S.B.**

## JVC HRD180

One of these machines lost time. Replacing the clock crystal X101 and resetting C102 as per the manual cured the trouble.

With another one there were no functions and circuit protector CP4 was open-circuit. This was bridged with a piece of wire as a check but there was no 12V at pin 9 of the 12V regulator. With a new regulator fitted there were still no functions and CP4 was again open-circuit. The cause of the fault was traced to the motor drive chip IC602 which was short-circuit – a 12V, 3A power supply helped sort this out.

There was inconsistent channel selection with another of these machines – when changing channels the u.h.f. numbers would alter and the machine would be off tune. For example, if programme 9 was tuned to ch. 58, selecting 9 would result in ch. 21 or 57 appearing, though reselecting would produce ch. 58. Changing the tuning memory chip, the tuning PLL chip, then the timer/display microcomputer chip had no effect. The resets, power rails and clocks were all checked – even the timer was changed. The cause? C7 on the power panel had a dry-joint at one end. This put a ripple on the 30V line, confusing the memory chip. **S.B.**

## Panasonic Oil Clutch Motors

Heard about the new Panasonic oil clutch motors? What will we tell customers – it leaked? **S.B.**

## JVC GRC1

One of these camcorders wouldn't record. The cause was a faulty record inhibit switch.

Intermittent audio recording and no playback tracking was traced to a wire to the erase head shorting to the



servo panel – the sharp component pins penetrate the screened cable. This is a problem with portable equipment which is subject to mechanical shock.

On another of these machines intermittent audio recording was traced to a dry-joint in the oscillator circuit: all suspect joints were touched up. **S.B.**

### **NEC PVC744E**

There's a good chance that the reel motor is faulty if any of the reel drive transistors have failed (Tr11 and Tr12 usually go).

When refitting the cassette housing make sure that it doesn't catch on the back-tension band – or you'll find that the machine won't thread up. **P.B.**

### **Sony SLC6 Mk. 2**

The metal cassette flap had come off and was loose inside the machine. When it was refitted the machine would thread up but the loading ring wasn't being held in position. A quick read through the manual was needed to discover that the brake/select solenoid wasn't being pulsed. Q613 was short-circuit. **P.B.**

### **Sharp VC387**

The problem with this machine was tracking noise on playback – the noise was stationary and the tracking control had no effect. As the drum lock (TP701) and capstan lock (TP708) voltages were normal attention was turned to the tracking control which was found to be open-circuit.

For no power on but the clock working check that IC801 on the mechacon board has 9V at pin 64. If not, follow the track back and you'll probably find an open-circuit semiconductor fuse (this isn't shown on the circuit diagram!). **P.B.**

### **ITT VR3916**

We've had two more cases of no clock display. In one case R423 on the timer board was open-circuit, in the other R2 in the power supply was responsible. **P.B.**

### **JVC GXN70**

The reported problem was no colour, though a scope check showed that the CVBS output had chroma information. Investigation on the SSG/deflection panel showed that the subcarrier frequency was incorrect at about 4.42716MHz. The problem was solved by replacing crystal X701, which enabled the subcarrier frequency to be correctly set with the trimmer.

In this camera the screening cans that surround the crystal and SSG chip are extremely tricky to remove: there's a great risk of damage to the board and nearby components. **E.T.**

### **Toshiba V8600**

The accusation against this old battleship of a VCR was that it lost five minutes in each hour. Set to run in the workshop it kept better time than my wristwatch for two days on the trot. It was then returned to the customer's home, where it continued to keep exemplary time. The likelihood is that a spike or transient on the mains supply had triggered the microcomputer chip into 60Hz operation of the clock counter. In future we'll advise customers with

this sort of problem to unplug from the mains, count to ten and try again before bringing the machine to the workshop. **E.T.**

### **Sony SLC6**

The customer had no sooner taken this machine home after a workshop overhaul than he was on the phone to complain that it wouldn't thread up. This sort of problem has cropped up in the workshop too, on various makes and models. The solution lies in getting a correct microcomputer reset. The customer had switched on at the mains with the VCR operate switch already on: it's sometimes essential to apply mains power before you switch on at the front panel. **E.T.**

### **JVC HRD180**

This machine, one of the latest, came back to the workshop with a no vision recording fault. It was intermittent, like all the best ones. The effect was complete loss of picture to a screenful of snow while the sound continued. The problem lay at CN2/7 (/REC) on the video board, where a stiff ribbon cable enters from J2 on the mechacon board. The solder connection had probably broken when the 03 video board was hinged down during assembly. **E.T.**

### **JVC GZS3/S5**

The picture produced by this camera was very dark, with a pink and purple chroma overlay. Turning the colour fully down at the monitor gave us a very dark picture with only the brightest highlights (workshop lamps and windows) emerging from the blackness. The luminance signal was o.k. up to Q2 on the 01 video processing board: it then virtually disappeared. The trouble was in the black-level clamp circuit, where the /CP2 pulse ties the luminance signal to a fixed 1.7V potential during the line blanking period. This clamp reference voltage is held by a 10µF tantalum capacitor, C5, which was open-circuit. **E.T.**

### **Grundig VS180**

On most occasions a known good tape would play back perfectly but now and again the picture would begin to jump for a few seconds at intervals of 40-45secs. When playback returned to normal the fault wouldn't occur until the machine had been stopped and restarted. The time interval between the jumping sessions suggested that the problem was due to the rotation of the spools in the cassette rather than electronic trouble.

We found that when the fault occurred the back-tension tape control arm was firmly locked to the optosensor instead of being free to swing back and forth to level out tape pay-out irregularities. When the fault was not present the arm was free to trigger the sensor as it should. There's a small plastic sleeve on the control arm's stop peg. It's retained by a "hooked" end on the peg, presumably a buffer. This sleeve must have flattened a little, since now and again the hooked end would latch over the back plate of the optosensor at start up. As the owner came from afar and wanted to leave at once I slipped a small length of RS red plastic sleeving tightly over the peg-and-sleeve so that the red sleeving stopped the hook engaging. Results were first class. Note that the diagram on page 74 of the manual doesn't show either the plastic sleeve or the hooked end to the stop peg. **P.R.**

## Ferguson 3V31/JVC HR7650

The complaint with this machine was of intermittent variation in the sound level. The actual problem was not intermittent: there was variation of sound level in the record mode on certain tapes. In fact the problem was confined to a brand new Panasonic tape provided by the customer and an old test tape of ours found lying around in the workshop. Six other tapes we tried worked perfectly, while the two tapes that showed the fault worked correctly in other machines. No displacement of the tape could be seen during record, and small adjustments of the audio/control head didn't improve the situation. A cure was finally provided by a rather unscientific 90° anticlockwise turn of the right-hand tape pillar. **C.H.**

## JVC GRC1 Camcorder

Summer is here and it's time to get out the camcorder last used at Christmas! Two of them came into our workshop recently. The first needed no more than video head cleaning but the second appeared to have a more difficult fault. The complaint was that the microphone didn't work, but in fact there was no audio record or playback while the microphone gave good sound through a monitor during recordings.

I always approach these units with a great deal of caution – their intricacy and compact layout demand considerable respect. Luckily this one turned out to have no more than an open-circuit lead to the audio head. Time to repair it: five minutes. Time to uncase and case it: almost two hours – and that's following the instructions in the manual! **C.H.**

## JVC HRD140/Ferguson 3V44

This machine would work perfectly for long periods of time but occasionally the capstan would start to speed up, the effect being as if the machine was in the rapid forward search mode but with the sound unmuted. If the tape was stopped and ejected while the machine was in the fault condition the capstan motor would continue to spin. The problem was due to the presence of 10V d.c. at the base of Q603. This wasn't leaking through diodes D606, D607 or D608 but apparently came from the collector of Q603 itself. Even though the transistor read perfectly when checked with an ohmmeter a replacement 2SD637R provided a cure. **C.H.**

## Mitsubishi HS306

HS306s don't like smoky houses! The typical fault is that the machine stops playing after ten seconds and the counter doesn't move. This is due to the take-up rotation optosensor and reflective strips being dirty. Cleaning with foam cleaner is all that's required. **P.B.**

## Philips VR6462/Finlux VR1010

For low recorded sound with these machines, before suspecting an audio fault try listening very closely to see if the sound is wowing. If it is the sound is being muted, most likely due to a capstan servo fault. If it isn't wowing try cleaning and resoldering the pins to the audio/control

head where they connect to the PCB.

If you find poor take-up torque that doesn't respond to replacement of the reel idler or omega spring, remove the two reel carriers and check whether any metal debris are sticking to the magnets on the underside. So far I've had circlips, springs and hairgrips here. If they jam on, the Hall sensor's reel rotation will stop. **P.B.**

## Fisher FVHP615

This machine appeared to have a capstan servo fault: after playing for a few minutes the voices would sound like Mickey Mouse and tracking lines would appear on the screen. A look at the servo board revealed that all the i.c.s had been replaced. Someone had been beaten by this one! Luckily I noticed that the reel belt was straining when the fault occurred, so I checked the take-up torque which was much too high. What was happening was that the rewind idler was contacting the take-up spool which was in effect in the rewind and play modes at the same time. A new idler gear and leaf spring were required. **P.B.**

## Ferguson 3V35/JVC HRD120

This machine would load, run for five seconds then unload. Watching the head drum it was obvious to us that the motor was running fast. As we had only five seconds to measure voltages and scope waveforms before the machine unloaded we decided to swap the motor with one from a stock machine in order to rule it out. It proved to be innocent, so the scope would have to be connected to each test point in turn then play selected in the hope that something would show. Fortunately the first test point chosen revealed that there were no drum pick-up pulses. The pick-up head was open-circuit. **A.D.**

## Grundig VS180 and VS220

The problem with these two machines was intermittent or no play, with F1 flashing in the VS220's display and the pause light flashing in the VS180. The usual cause of this is dirty contacts on the brake solenoid switch S4. Cleaning the switch will restore normal operation – Grundig recommend removal of the plastic dust cover. **A.D.**

## Mitsubishi HS318

This machine refused to load a tape and produced a loud clicking noise from the mechanism. Cam gears A and B were jumping back as the machine tried to load. The fault was in the first nylon gear driven by the loading motor – every other tooth on the gear was either missing or badly worn. Similar mechanisms are used in the HS306/7 and HS337/8. **A.D.**

## Ferguson 3V29/JVC HRD110

The customer's complaint was that the picture was poor in the forward search mode – there was a large noise bar at the top of the screen. The reel servo voltages didn't tally with those shown in the circuit but proved to be correct when compared with those in another machine. Swapping

the servo panels failed to cure the fault so the drum motor assemblies were interchanged. This cleared the fault. When the customer was told the cost of a new drum motor he decided that it was a fault he could live with.

A.D.

### **Panasonic NV7200**

There was intermittent no play with this machine, the fault usually occurring during loading, i.e. the tape would load then unload. When the machine did load everything worked perfectly. Checks on the drum flip-flop and take-up sensor signals were inconclusive because of the nature of the fault. We next decided to run the machine without a tape and check for faults visually. While watching the mechanism during loading we noticed that the cassette lamp flickered due to vibration from the solenoid. No, it wasn't an intermittent lamp but tarnished contacts on the cassette detect leaf switch.

A.D.

### **Ferguson 3V29/JVC HRD110**

This machine would select the wrong modes, i.e. if the play and record buttons were pressed the play, pause and audio dub LEDs would light up while other buttons including stop had no effect. There were voltage changes at the input to the comparator on the mechacon board but no changes at the output pin. A check on the output from the D-A converter revealed only one staircase instead of a repeated waveform. At the microcomputer chip's key scan port each output produced only one set of pulses. A replacement microcomputer chip cured the fault.

A.D.

### **JVC HRD755**

This machine would accept a cassette but wouldn't respond to any commands either from the front controls or the remote control unit. If the machine was switched off then on again the cassette would be ejected. If the cassette was then reinserted the machine might work. The fault was eventually traced to a faulty cassette end load switch in the cassette housing.

A.D.

### **Akai VS2**

Anyone familiar with these machine would consider this fault old hat and wouldn't even reach for the service manual. The machine would load a tape, play for five seconds, then stop and unload. The reels were turning and the clover leaf pattern indicated that the drum was running at the correct speed. At this point we decided that the problem was either in the syscon or that pulses were not arriving at the syscon panel, so a service manual was ordered. When it arrived a read through the circuit description made everything clear. The reel pulses are derived from a LED and phototransistor, the LED being supplied via the cassette lamp. Replacing the lamp cured the fault. At least the initial diagnosis of missing pulses to the syscon panel was correct!

A.D.

### **Ferguson 3V36/JVC HRD225**

A very intermittent deck shutdown fault was present on this machine. It made two fruitless journeys to the workshop for soak testing before the fault put in an appearance for us. The output pulses from the take-up reel sensor were intermittently absent, triggering the syscon into the alarm mode. We discovered that these

sensors can be checked by turning each spool carrier by hand while the machine is in the standby mode with no cassette present. This should result in jumps from zero to 5V at pins 3 and 4 of CN23 on the A/S/M panel – most easily seen on a d.c. oscilloscope. This method gives you the opportunity to check the sensor optocouplers while they're being heated, cooled, prodded and generally harassed . . .

E.T.

### **Sanyo VTC5150**

Now that these machines have given a few years' service we've had several cases of tape chewing – not for the usual Sanyo reasons but because of a worn pinch roller assembly. The problem is easy to recognise: the tape becomes creased and crinkled across its full width at random intervals.

E.T.

### **JVC HRD370**

This brand new machine, straight out of the box, failed a predelivery test – the clock functions couldn't be set. In general the mode keys worked while the numerical ones didn't. The cause turned out to be a "silly": the ribbon cable from program board 23 was only half pushed home into CN5 on timer board 15. Its half-cock angle was such that the end half dozen or so of its contacts were making, hence the registration of only some of the commands. Had we not seen this a giveaway would have been that the timer could be fully set up using the remote control handset.

E.T.

### **Panasonic NV100**

This portable VCR had long been used with a JVC GXN5E camera without problems but was eventually brought in for service with the complaint that use of the camera's run/stop trigger would sometimes put the VCR into stop. On test we found that the stop mode could be invoked very intermittently by going from record to record-pause or vice versa. By a lucky chance we got another GXN5E camera in for service at the same time: the NV100 played the same tricks with this. A somewhat inconclusive scope check around the syscon microcomputer convinced us that the port expansion chip 16003 (type VCR 0060) was the culprit: replacing this cured the problem – well, we've not heard any more about it since the machine went back . . .

E.T.

### **Ferguson 3V28 Tuner/Timer**

The tuner/timer half of the 3V24/3V28 ensemble gives less hassle than its partnering VCR. This particular one got into trouble only because the yobbos at the local Youth Training Centre had knobbed it by setting the mains voltage selector to 110V. Not surprisingly the 1A mains fuse blew when it was next powered from the 240V mains supply. Several replacement fuses were fed in by the supervisor before he eventually brought it in for attention. The fuseholder is right beside the voltage selector switch, which clearly said 110V!

Under the circumstances they got off lightly. The massive mains transformer was unaffected, as were all the 1.t. fuses, the regulator transistors and main rectifiers. Damage was confined to D3 (type 10E2) going short-circuit and a burnt out safety resistor (R18, 2Ω) on the regulator panel. The resulting loss of the 40V line had mercifully cut off the main 12V regulators, while the reservoir capacitors had held out.

E.T.

# Servicing Mechanical VCRs

## Part 5

Mike Phelan

In the last instalment (June issue) we looked at the rather horrendous but clever part of the mechanism whose sole function is to make the drive arm move one way when play, record or audio dub is selected and return it when stop is selected. The bulk of the mechanics below the deck are concerned with this operation and don't cause too many problems.

The drive arm is the prime mover for the loading arms and for the first part of the pinch roller's travel, before the solenoid takes over. Subordinate functions are: moving the loading arm lock levers which operate the "stoppers" that hold the guide rollers and slant poles firmly in position; releasing the reel brakes; allowing the back-tension device to engage; and moving the take-up clutch into position.

All the electrical functions are carried out by the row of microswitches above the keys, the UL and AL switches on the deck, and the two slide switches on the audio/servo or audio only (3V16) board. The first two of the above groups mainly switch supply rails: the slide switches are concerned with audio and erase switching. Control of much of the servo and signal circuitry is achieved by switching supply rails.

### Loading Arm Mechanism

We'll start this month with the loading arm mechanism. Movement is initiated by a pin on the slide plate: it engages with a slot in the drive arm – see Fig. 1. The adjustable link at the other end of the slide plate moves the rotary lever and its two attached links which move the loading arms into position. At the completion of loading a wire link from the rotary lever partially rotates the tension cam: a projection on this passes up through a slot in the deck. This projection releases the back-tension arm from its parked position, allowing the pole to contact the tape. The back-tension device is in fact a mechanical servo: the brake is pulled off if the tape tension increases.

The drive arm also operates the loading arm lock levers. Primarily (see Fig. 2) these move the two lock arms into position during the final part of the loading cycle. These lock arms carry the alloy impedance rollers (plastic on the Mk. III deck), also the stoppers that lock the slant pole/guide roller assemblies (see Fig. 3) in position. The lock arm on the supply side also carries the full erase head. A projection on the loading arm lock lever on the take-up side moves the pinch roller slide plate (see Fig. 2) which brings the pinch roller into the pause position, releases the reel brakes, and engages the take-up clutch.

It's useful to study the detailed operation of the slant pole/guide roller assemblies as they tend to cause problems in ageing machines. Each assembly consists of a cast base into which a slant pole is pressed and a guide roller is screwed, the latter being locked with a setscrew – see Fig. 3(a). The guide roller has a plastic centre section which should rotate freely on the metal pin. The guide rollers are vertical, but the slant poles incline in opposite directions. The only other item in the slant pole base is a steel pin that engages in a notch in the locating block (part of

the drum base). This determines the height of the assembly when loaded. The slant poles also locate in a pair of V notches in each block, giving registration in the horizontal plane.

An angle bracket to carry the slant pole base is screwed on to the end of the loading arm. The base is not rigidly attached to this – it's allowed considerable freedom of movement. This is achieved by means of a screw with an integral spacer and an enlarged hole for the bracket. The purpose of this arrangement is to allow the base to be located purely by the pin and slant pole without the loading arm having any influence on its position. Furthermore, although the angle brackets are firmly screwed to the loading arms the holes are large enough to allow adjustment.

During the loading cycle, once the loading arms are in position the lock arms move forwards and the stoppers engage the guide rollers, holding each assembly rigidly. It's important that the stoppers don't play any part in moving the loading arms into position. If, through misadjustment, this happens the guide rollers and slant poles cannot be rigid.

### Problems

The problems that occur are many, and are often increased by previous unskilled repairs. The loading arms and associated parts are critical as they determine the path of the tape.

Probably the most common problem is caused by the method of driving the loading arms. They are both propelled forwards by adjustable links attached to the rotary lever. That on the take-up side has a peg which projects down through a curved slot to take the link. This peg occasionally becomes loose, requiring rivetting or replacement of the loading arm. The supply loading arm is moved by a short arm which is attached to its pivot by a single screw. The pivot has two flats to locate the short arm. If the screw works loose the flats wear and the hole in the short arm gets chewed up. The cure is to replace both components. See Fig. 4 for details of this trouble spot. To check for this problem, press play with the machine switched off, then turn the flywheel until the machine is half loaded. Grasp the right-hand (supply) loading arm and check for excessive movement in the direction of travel.

It's important that the loading arm pivots are free and lubricated – they sometimes seize up due to corrosion of the plating. Unfortunately they have to be dismantled to lubricate them – this requires removal of the lower drum assembly. A useful tip here is to unplug the pre-rec board instead of unsoldering the rotary transformer leads, then remove the board and lower drum as a unit.

Tape path errors caused by the loading mechanism require careful observation while the flywheel is being turned by hand. The pole/roller bases must not foul the deck or drum base, and they must be free to locate in the notches without being forced one way or the other. If the latter occurs the angle bracket is probably bent or misplaced. Slacken the screws, load, then tighten. Both bases

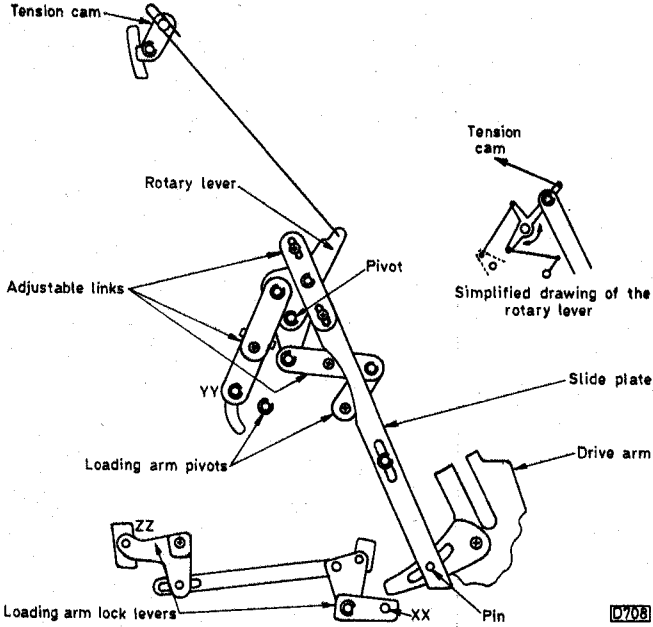

Fig. 1: Loading arm drive system.

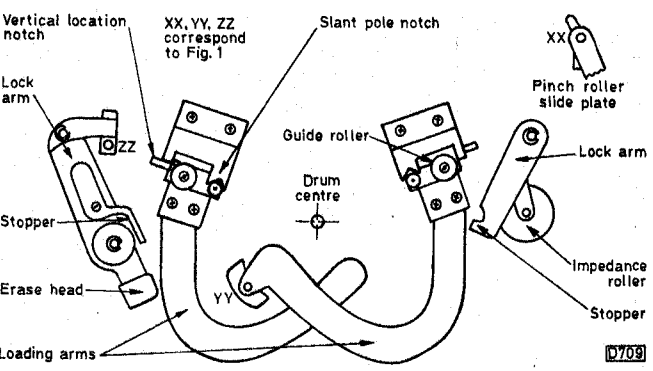

Fig. 2: Simplified diagram showing the loading arms in the almost fully loaded position.

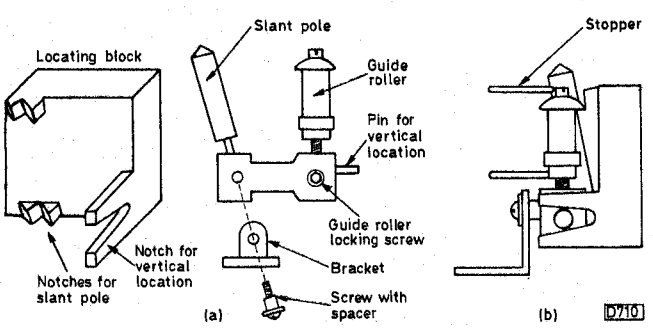

Fig. 3: (a) Details of the right-hand slant pole/guide assembly and the left-hand side opposite angle. (b) Cross section when in the loaded position.

must reach the loaded positions simultaneously. If one gets home first either the flats on the supply arm are worn or the adjustable links have been altered.

It's sometimes easier to check the movement of the loading arms after removing the slide plate, but note the positions of the polythene washers.

The back-tension cam doesn't give any trouble, but if anything is sticking here the back-tension pole can remain outside the tape loop, causing incomplete tape wrap. The result is that in the record mode approximately a third of a previously recorded picture remains - this produces a very wide noise bar on playback.

The pinch roller slide plate can get stuck to the deck

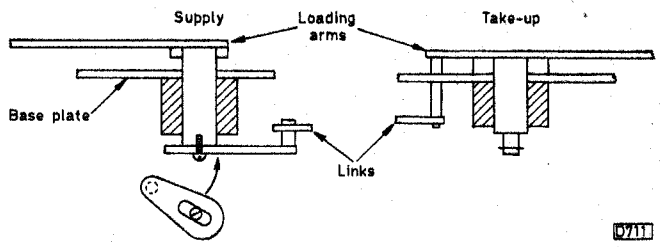

Fig. 4: Details of the loading arm links.

plate with spillage, causing sluggish action. The loading arm stoppers should contact the guide rollers squarely: watch out for misplaced erase head wiring that prevents this.

A fairly common fault with several causes is the intermittent appearance of a noise bar at the top or bottom. It can be cleared by adjusting the guide roller(s) but reappears in time. The most common cause is that the setscrew on the guide roller is loose. If it's not slackened before adjustment the thread will be damaged. Slacken only sufficiently to allow the roller to be moved - if it's too loose the tape motion can disturb the adjustment before you tighten up. The same symptom can be caused by anything that prevents positive location of the pole/roller base assembly. One reason for this can be a burr on the notch that takes the pin. Another is foreign matter compressed into the same notch. Don't forget about the drive arm lock roller (see previous instalment). If this jumps out at the completion of loading the loading arms can move back imperceptibly.

Don't alter the positions of the two locating blocks. This is no consolation if someone else has! All you can do in this case is to hope that the locking paint gives a clue to the original positions.

It goes without saying that parts such as the slant poles, guide rollers and impedance rollers should be smooth and undamaged. The same applies to the full eraser head, whose surface is rather brittle and easily damaged.

**Reel Assemblies**

There are not too many problems when it comes to the reel assemblies. The height of the reel discs, which is adjusted with shims, is not too critical, but the discs are prone to seizing on their pins, especially with the Mk. III deck. Note that the Mk. III uses plastic rings in place of circlips to retain some parts, including the reel discs.

All rubber tyres require replacement periodically. The first one to wear out is that on the take-up reel. It becomes glazed and slips instead of the clutch slipping. The result is a squeak on record and playback.

The take-up clutch is the real villain of the piece here. The felt friction washers become polished and the clutch then slips, driving the tape erratically but sufficiently to chew it up before the Hall sensor operates and stops the tape transport. The Mk. III version is better in this respect. Replacement is the only cure.

The unloading and reel idlers, and indeed the clutch, are prone to seizing up due to fluff winding itself around the spindles, but the first two give little trouble otherwise.

A loud screech on fast forward or rewind should direct attention to the counter pulley which loses its lubricant after a while. If it seizes up the machine trips out. This can be very intermittent and baffling - the clue is to watch the counter closely. A drop of oil suffices.

The brake mechanism gives little trouble if kept clean

and lubricated. Check that the unloading operation does indeed wind the tape back into the cassette – a fault here can be missed.

## **Back-tension Band**

The back-tension band needs replacement periodically, and the back tension must then be readjusted. If a gauge is not available, a rough and ready way is to set it so that in playback the right-hand impedance roller is just moving

and the back-tension lever is at about half travel. If the back-tension arm moves about considerably during playback, suspect a faulty pinch roller or take-up clutch or tyre – but try another tape first.

## **To Follow**

In the final article in this series we'll talk about the key assembly and any other odds and ends that have not so far been discussed.

## Philips VR6462

We've had a number of faults with these machines, some of which are outlined below.

When the mains supply is first applied the following initialisation procedure takes place: the cassette carriage is loaded, the rewind mode is then entered for a couple of seconds, followed by a brief spin in the fast forward mode after which the carriage is ejected. In one case the carriage loaded but after this the machine remained in the rewind mode. First thoughts were of an end sensor or even a system control fault, but we noticed that the threading-in position switch P671 (mounted close to the cassette LED) was not being operated and that the loading arms seemed rather floppy. These two symptoms led us to a sheared cog on the gear wheel that drives the loading arms. After replacing the gear wheel the machine worked normally, but the job is not one to be taken lightly – it involves removal of the heads, the head drum motor, the audio/control and erase heads, the impedance roller, the supply spool and the back tension arm before the threading-in plate can be lifted clear to give access to the drive cogs.

Inability to tune in the stations at the top end of the band was traced to the +31a rail being at 18V instead of 30V. This supply is provided by a series regulator on the tuner/i.f. panel. The 18V zener diode D6601 in this circuit was found to be leaky.

On one of these machines the test signal was displayed even with a cassette loaded and being played back. With the cassette-in switch closed, transistor T7508 on the power supply panel is, under the control of microcomputer chip IC7501, responsible for switching the test signal on and off. It was found to be open-circuit.

Excessive head speed is usually caused by an open-circuit optocoupler or cassette LED. In one case however the optocoupler interrupter (engineer's finger slicer) had come adrift from the top of the head drum. As a result the drum speed servo was open-circuit.

The job ticket attached to one machine read "completely dead". In fact there wasn't even a clock display. No faults could be found with the supply rails so we checked the voltage at the main microcomputer chip's reset pin (IC7501, pin 17). The reading was 5V, indicating that no reset was being applied to the various microcomputer chips. The reset voltage comes from IC7001 in the power supply: after a short delay it's taken low by the conduction of transistor T7125 which is connected across the reset line. T7125 was found to be open-circuit and after replacing it we had a machine that worked perfectly.

Line twitching on playback and record is the only way to describe the fault on another of these machines. We noticed that after pressing the stop control the heads very quickly ceased to spin. Spinning them by hand revealed that the drum wasn't aligned correctly – in fact it was catching on the lower drum motor assembly. Realignment, using the two mica spacing washers, cured the twitch and allowed the head drum to spin freely.

The complaint with another machine was no play or record. Rewind and fast forward were normal but when play was selected the head drum didn't attempt to rotate and after a few seconds the machine unlaced. Replacing

the drum motor drive chip IC7002 restored normal operation. L.G.

## Panasonic NV333

No rewind or fast forward coupled with no cue or review facilities pointed to the fact that there was no reel motor rotation. The reel motor drive amplifier supply comes from regulator transistor Q6023. On checking the 18V feed to this transistor the cause of the fault became apparent – Q6023's emitter was dry-jointed. L.G.

## Ferguson 3V44/JVC HRD140

The head drum would spin in reverse (clockwise) then the machine would switch off. As the voltages around the drum motor drive amplifier chip IC1 didn't reveal anything of a conclusive nature attention was turned to the servo control section. The drum error voltage at pin 1 of IC404 should be 2.8V but was found to be 0V because zener diode D408 (5.1V) was short-circuit. Replacing this diode cured the head drum fault but there was an intermittent blank raster on playback, due to absence of the playback 5V feed at pin 19 of the video processor chip IC102. The cause was a dry-joint on L116. L.G.

## Hitachi VT9300

In the forward picture search mode there was first a squeal, then a louder squeal followed by a still frame after which the machine stopped. The capstan motor was faulty. We've had to fit new capstan motors to several of these machines recently to cure various fault symptoms. N.B.

## Panasonic NV333

The following fault is becoming common and could well appear in other models: in the reverse picture search mode the tape loops into the machine. You can replace all the idlers and clutches you like, but the cause is the head drum. The engraved tracks wear thin and the tape sticks. Replacement is the only cure. N.B.

## Finlux VR1010/Philips VR6462

No luminance on record, E-to-E or playback was the fault with this machine. We found that there was no output from pin 7 of the TDA3740 chip. The input and supplies were o.k., but no sync pulses were present at pin 6. IC7051 (4016) was faulty. P.B.

## Ferguson 3V29/JVC HRD110

Are you sitting comfortably? Then I'll begin. This machine had a very odd colour fault on record. The picture was perfect with pale colours – and on monochrome – but with strong primary colours the display was obliterated by a dot pattern. Fortunately I'd once seen a similar problem with a twiddled 3V16 and homed in on the setting of the record colour level control. Turning this to maximum cured the fault, so I knew that the record colour signal

was low. Then I made the big mistake! As I had another 3V29 in the workshop I compared waveforms. The faulty machine had a low signal at pin 7 of IC401, so a happy hour was spent chasing around this chip before I found that the values of R418, R420, R421 and C421 were different in the two machines. Back to square one! D.C. checks around the record colour level control revealed that it had gone high in value. **P.B.**

### Sharp VC9300

This machine came in for chewing tapes and intermittent play/record. We initially thought that the cause of the two faults would be the same, a defective reel idler assembly, but after repairing this we found that the drum motor sometimes didn't start. If the motor was held by hand it wouldn't start when released. Also if stopped by hand while running it wouldn't restart when released. A new motor cured the fault. **A.D.**

### Mitsubishi HS337

"Smell of burning" was the complaint noted on the job card. Fortunately there were obvious physical clues. Q9A4 was cracked and discoloured and IC9A0 was short-circuit. These two items form a 30V stabiliser. **A.D.**

### Philips VKR6800 Camcorder

The customer's complaint was no picture. Connecting the unit to a monitor produced good quality pictures in all modes, E-E and playback of recordings. The fault was in the viewfinder – a dim raster in all modes. So a check was made on the supplies to the half-inch c.r.t. The cathode, control and screen grid voltages were all correct but the focus and final anode voltages were both at 900V. A short-circuit between these two electrodes could be measured on a cold check. A replacement c.r.t. had to be fitted. **A.D.**

### Sony CCDV8/Pioneer VEM800

We've had several of these camcorders with dry-joints at the soldered connections between the viewfinder socket and its mini-PCB – see the top left-hand corner of the cover photo in the April 1987 issue. The effect is intermittent viewfinder operation.

A delicate and fiddly job we've had to carry out on these V8 camcorders is replacement of a broken back-tension band around the supply turntable. When it breaks there's a juddering motion with terrible picture and sound, generally culminating in a chewed tape. **E.T.**

### Toshiba V9600

After some heartsearching with regard to the economic viability of the job the owner gave us the go-ahead to fit a new video head disc and service this middle aged machine. When the disc was fitted we found that we couldn't get a satisfactory r.f. envelope waveform: with adjustment of the tracking control one head's output would rise as the other's fell – the best that could be achieved was an unsatisfactory compromise. It seemed certain that the heads were on different levels.

Since we've had similar problems in the past with Toshiba head discs, and to save the time involved in exchanging the assembly, we fitted a shim under one fixing screw to raise the low head. The spacer was only a few microns thick – of the type that Toshiba fit between

the upper drum assembly and its mount. It worked well, permitting good replay of the alignment tape. **E.T.**

### JVC GRC2

The complaint with this camcorder was that it wouldn't turn on, though the LCD tape counter worked. We found that the machine was operating correctly in so far as the relay was being energised by a set pulse at switch on, but its armature wasn't moving. This relay is a latching type with set/reset windings. When removed from the PCB it worked perfectly but when replaced in the panel it wouldn't budge. In fact the reset winding was being half-energised by leakage in the switch-off transistor Q22 (2SD601), a surface-mounted device. This accounted for a continuous current drain of about 23mA from the power supply. **E.T.**

### Sanyo VRH1100

VCR faults are sometimes not as logical as they should be! This machine would happily load a cassette and the function indicator LEDs on the front panel would then respond to the control keys. The deck wouldn't. A case of the right hand (syscon) not knowing what the left hand (deck) was doing! The problem lay in a dry-joint at pin 2 of connector CN3010, via which the loading (mode) motor is linked to its drive circuit on the syscon board. An open-circuit loading motor would obviously have the same effect. **E.T.**

### Finlux VR1010/Philips VR6462

On more than one occasion drift of the u.h.f. modulator's output frequency has been traced to zener diode D6601 (ZTK18) in the network that supplies the modulator's varicap voltage. Unusually this and similar Philips-derived VCRs have a resistive trimmer to preset the r.f. output to channel 36: it's essential that the supply voltage to this trimmer is stable. When the fault occurs it may go unnoticed – much depends on the tuning point and the a.f.c. characteristics of the monitoring TV set. **E.T.**

### JVC HRD180

The delivery man brought this brand new machine into the workshop after an abortive attempt to install it. The E-E picture was crushed, with faces deathly white and colours washed out: the sync pulses were also affected, causing sideways pulling of parts of the picture. The culprit turned out to be IC102 (7VT2, de-emphasis) on the video/luminance board. The fault disappeared by itself, but the slightest squirt of freezer on the body of this strange looking chip would bring it back. **E.T.**

### Ferguson 3V29/JVC HRD110

This machine's channel selector system was in trouble. At switch on channel one would come up in the normal way but pressing any of the other seven buttons would bring up channel eight. There it stuck and the only way to get the tuner off channel eight was to switch the machine off and on again. We eventually discovered that each time the input select switch was moved from AUX to TV the channel indicator would step forward! All this did have a logical cause, in that D219 (on the presetter board) was leaky, inhibiting the normal action of the "step-and-scan" chip IC201. **E.T.**



## Ferguson 3V45/JVC HRD140

The fault with this machine was that the clock half of the display worked but the play/rewind/etc. half didn't. Switching off at the mains and powering up again had no effect and I couldn't find any dry-joints on the panel. Finally I removed the memory back-up capacitor for a few seconds, refitted it and then powered up. This brought the display back on again. **P.B.**

## Panasonic NVM5 Camcorder

Unloading was incomplete because the pinch roller was returning in front of the drum exit loading guide. Removing the pinch roller arm assembly and reinstalling it would clear the fault for a couple of uses, but it would then jam again. The problem was caused by excess grease on the cam gear and hardened grease in the teeth of loading gear C. Cleaning loading gear C, the sector gear and both sides of the cam gear is the only long-term solution. Careful realignment of these gears, with reference to the service manual, is essential. The NVM5 uses the same deck as the NVM1 and the Philips VKR6800. **A.D.**

## Philips VR6542/Sharp VC651

Four or five of these machines, under both brand names, have come our way over the last couple of months. All required the same repair. The symptoms vary from failure to load a cassette, failure to eject a cassette, to intermittently doing either. In all cases careful repositioning of the mode control switch was what was needed. Full details are given in the manual, but extreme care should be taken to ensure that the loading poles are in the fully unloaded position. If not the machine works but leaves a small loop of tape hanging from the cassette. These machines were all only a matter of months old. **A.D.**

## Mitsubishi HS337

This VCR had a clock fault. It lost about ten minutes a day and the clock intermittently displayed the power loss warning. A check revealed that the oscillator in IC8A0 was working intermittently. The chip, type  $\mu$ PD7516HG, had to be replaced to cure the fault. It's a surface-mounted type, about three quarters of an inch square, with 64 legs. **A.D.**

## Fitting Hi-fi Heads

Fitting new video heads in a Ferguson 3V29 is usually straightforward. Just two leads per head have to be threaded through the holes in the drum assembly. Minor irritation occurs when one of the leads bends over and

fails to go through the hole. Imagine however the irritation when fitting new heads to a hi-fi VCR with long-play facility. With two leads per head and three heads per channel (one SP head, one LP head and one hi-fi head) you have to try to get six leads of unequal length through the holes at the same time, a very frustrating and time consuming job. It needn't be however. Cut two pieces of shrink-fit sleeving, about 1.5in. long, and push these over the leads of each head. The sleeving, with the leads inside, now easily threads through the holes in the head assembly. When the head is installed the sleeving is simply pulled off. Remember only to push the shrink-fit sleeving on – don't heat it. **A.D.**

## Sony TTF1UB

The TTF1 was the tuner-timer partner to the late and lamented Beta SLF1 portable/component VCR. It has a switch-mode power supply to provide 12V. This one gave a green light indication with no load, but on connecting the SLF1 the green on LED would flicker and only a low, pulsing output voltage was available. The power supply would often then cut out altogether. The problem was due, as so often with Sony equipment, to dried up electrolytic capacitors, in this case the switching transistor couplers C618 and C619. Both are 4.7 $\mu$ F, 350V types and both were growing white fur around their legs. Maybe we were lucky not to lose the power switching transistors . . . **E.T.**

## Fisher FVHP530

This one had an audio problem for a change. There was intermittent recording of the sound, with the E-E sound disappearing when the fault was present. Playback was always o.k. During the rare appearances of the fault the output at pin 10 of IC401 disappeared, though it remained at input pin 18. The 8.6V supply to pin 15 of the i.c. simultaneously fell to 4.7V. The cause of the trouble was a partial open-circuit in transistor Q404's base-emitter junction – complete loss of sound was probably due to the action of the comparators within IC401. This chip, type BA5102A, can be responsible for an obscure no-sound fault on timed recordings (the audio signal disappears from pin 4). **E.T.**

## Hitachi VT11

These machines have two loading belts in series, which seems to be tempting fate somewhat! One that came in for service would occasionally fail to operate from cold – it was made to misbehave by being kept in a cold place. We

found that in the fault condition the take-up reel didn't turn, giving rise to a growing loop of tape until the syscon switched to stop. The second (small) loading belt was slipping, but we replaced both as a precaution. **E.T.**

### **Hitachi VT33**

Having been told that this machine didn't work at all we thought we'd an easy one. What we found was that the head drum turned all right but the tape wouldn't load and there was no response from the fast forward and rewind keys. After a prolonged foray into the syscon section we discovered that the loading mechanism was stiff. This led us to the loading motor which was virtually seized solid. A new loading motor cleared all the symptoms. **E.T.**

### **Hitachi VT5000**

All piano-key operated machines are now getting old, but this one worked well enough apart from a horrible wow on sound at varying intervals during both record and playback. At its most severe the wow was accompanied – useful clues – by horizontal white bars across the picture and a slight dimming of the fluorescent clock display. In view of these symptoms we checked the 12V regulator whose output, observed on a scope, was seen to vary somewhat when the fault was present. Tapping, flexing and probing led us to a junky 12V preset control (R662) on the servo board. Replacing this and resoldering some suspect joints in the area put everything to rights. **E.T.**

### **Panasonic Booster Amplifiers**

The ENPE716 r.f. booster is used in several Panasonic VCRs, amongst them the NV333 and NV366. We encountered one in a triple-standard Model NV390 which had been imported from the middle-east – we'd converted

it for System I sound. The complaint with it was low gain on r.f.–through. E-E, recording and playback on ch. 36 were perfect. So far as I can see there's no circuit diagram for this module, but to save the cost of a new one we decided to have a go. By trial and error we found that one of the 2SC2671 transistors had base-emitter leakage – it was marked Q3 on the board. No substitute r.f./u.h.f. transistor from our stores would give good results: we finally found a scrap booster which provided us with a 2SC2671. This restored full gain, but what the owner saved in materials largely went in labour charges! **E.T.**

### **Saisho VR805**

Faulty reel motors are a fairly common problem with these machines. New motors are readily available from Willow Vale Electronics. **N.B.**

### **Hitachi VT63/4/5/GEC V4004**

We often get the following series of events with these machines. Switch on, put in a tape, eject it. The tape in light then remains on and the machine won't accept another one. The cause is faulty end of tape sensors. **N.B.**

### **Ferguson 3V16/JVC HR3660**

The problem with this machine was that the drum speed varied after one and a half hours. The cause was dry-joints on the servo board, around the BA814 i.c. **N.B.**

### **Triumph VR9500**

Loads of these machines come in with the no rewind complaint. The cause is the idler, but don't despair – the Saisho VR805 idler fits and is available from Willow Vale Electronics. **N.B.**

# Servicing Mechanical VCRs

Part 6

Mike Phelan

The first thing we'll talk about in this final article in the series is the keyboard, or the function key assembly as it's more correctly called.

## The Key Assembly

The key assembly (see Fig. 1) consists of a rectangular metal frame that's secured to the deck. The keys are pivoted on a steel rod and located transversely by slots in the frame. Each key consists of an identical metal lever on to which a plastic knob is firmly cemented. Hairpin springs return the keys to the rest position. A pivoted latching bar locks the keys in the down position, with the exceptions of the eject, stop and pause keys. This key locking is accomplished by notches in the latch bar: steps in the key levers locate in these notches. The latch bar is actually in two parts, the smaller one on the left allowing the record and audio dub keys to be latched separately. The stop solenoid engages with a vertical tongue on the longer bar. Except for pause and eject the keys, when pressed, raise the latch bar, releasing the previous function selection. All the keys except the eject key project through slots in the deck. The pause key engages with a lever that slides through a latch, allowing the key to be alternately locked and released independently of the main latch bars.

A bank of sliding levers (the function plates) is arranged at the front of the key assembly. Their purpose is to limit the combinations of keys that can be depressed simultaneously. There's also an interlock with the mechanism to prevent eject or fast wind when the tape is laced up, even though stop has been selected. Details vary with different models. The record interlock is operated by one

of these function plates.

The two main function plates A and B extend for the full length of the key assembly and are centralised by two small springs. They both have notches in line with each key lever. These notches are of three types: a wide notch has no effect, a sloping notch allows the key to move the plate, while a narrow notch prevents key depression when the plate is moved by another key. Plate A allows the rewind and fast forward keys to lock all the others; plate B does the same for the play key. Plate E is the record interlock.

A strip of PCB carrying all the microswitches operated by the keys is mounted atop the key assembly. It also carries the record indicator lamp.

## Machine Trips after Loading

So much for the good news, now for the bad – though it's not all that bad. The key assembly suffers from a few problems that are not too difficult to put right. The most common problem applies mainly to the 3292/HR3300. It shows up when the machine apparently trips out on completion of the loading sequence. What might at first appear to be an electronic fault is actually due to wear on the play key lever (see Fig. 2) as a result of which the lock plate has a very precarious hold on it: when the loading mechanism clunks to a halt the shock jars the play key free. The cure is to replace the lever or swap it over with either the stop or pause key, as the locking latch is not used with these. The key colour will be different of course. The trouble may recur when this latter course of action is taken, as its root cause is the soft material used for the key levers. This point was put right with the

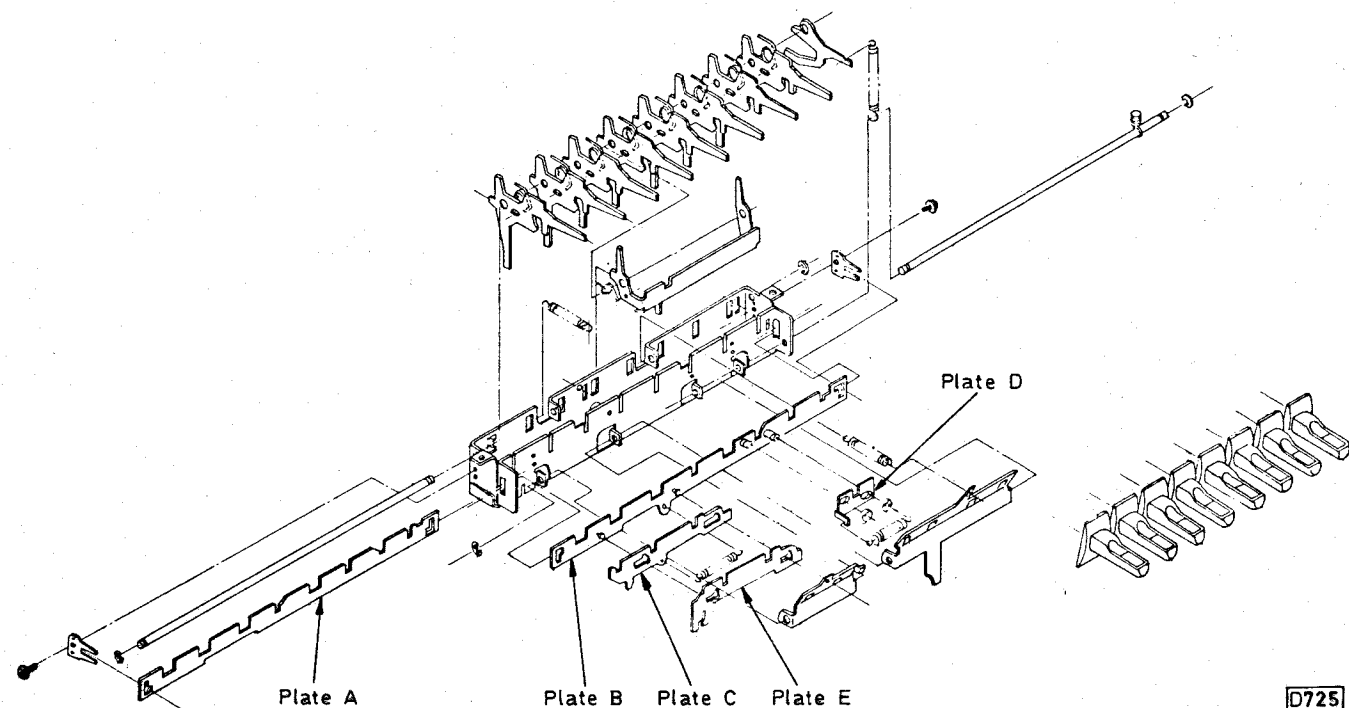

Fig. 1: The function key assembly.

D725

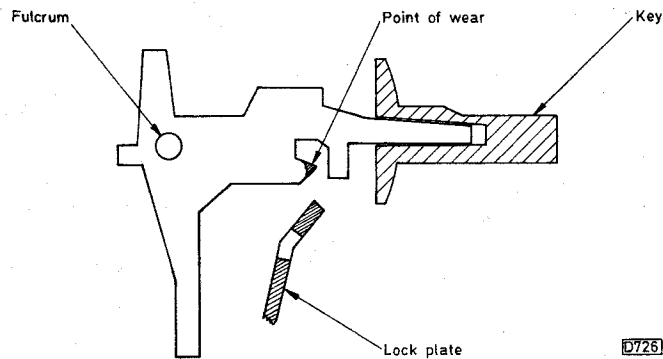

Fig. 2: Key lever assembly.

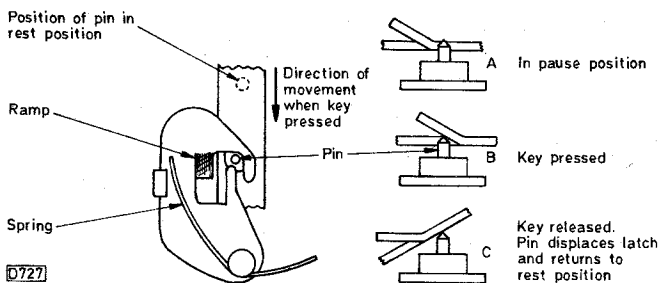

Fig. 3: The pause latch.

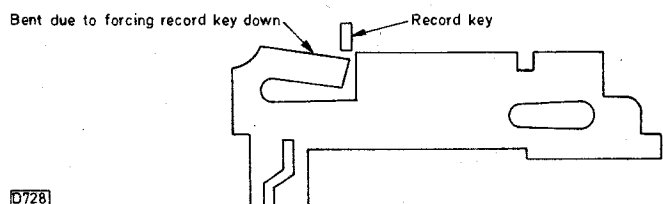

Fig. 4: Problem that occurs with function plate E.

subsequent 3V00/HR3330.

The keys are driven on to the levers and also cemented, so there's little chance of removing one without damage.

### Changing a Key Lever

To change a key lever, first remove the cabinet except for the back and right-hand side. Unsolder the record lamp leads from the audio/servo or audio PCB. Remove the function switch PCB and put it out of the way. Remove the cassette carriage, then swing the audio/servo or audio board down. Remove the circlip from the right-hand end of the key pivot bar. Note that there's another similar bar upon which the lock plates pivot. Release all the key springs by unhooking them. Carefully draw out the pivot bar, then lay the freed keys and springs on the bench in order until you reach the required key. Reassemble in the reverse order, applying a touch of moly grease to the key levers. When resoldering the record lamp leads do this neatly as there's a piece of earthed print next to the supply connection. Note also, as should be well known by now, that the rods that operate the audio dub and record/playback switches do not go into the holes in the switches.

### Switch Problems

While on the subject of these switches, although this is not strictly a mechanical fault these two switches do cause problems. The symptoms include intermittent sound on record, buzzing, no erase, etc. They can occasionally be

cleaned, but more often than not require replacement. Needless to say the same symptoms will occur if there are no screws in the audio/servo board!

### Common Faults

Another common fault is caused by the pause latch (see Fig. 3). This operates on a much-used principle employed in light switches, door catches and a multitude of other items. The idea is that a pin on a sliding bar follows a zigzag path in the spring-loaded latch: two back and forth movements are required to complete the path. A ramp releases the pin to the start position. The problem is that the latch is rather delicate and gets bent by heavy-handed use. Don't bother trying to repair it – it's well nigh impossible to get the shape right.

The other common complaint is that the record key can't be depressed. This is because someone has tried to force the record key down with a cassette with the tab knocked out inserted in the machine. The result (see Fig. 4) is that function plate E gets bent and the record key notch closes up. Repair or replace it – if you decide to repair it, note that the plate must be perfectly flat.

The other function plates will be damaged when someone tries to force keys, but can be put right by judicious use of a needle file.

### Removing the Key Assembly

It's occasionally necessary to remove the complete key assembly for renewal, or because the machine has been dropped on its front and most of the keys have been bent (in such a case the best way to tackle the job is to remove the assembly). It's a rather daunting prospect but it's not too difficult. The key frame is used as an anchorage point for springs in the brake and reel drive department, so there are several springs to be unhooked above the deck and parts below the deck to be removed to gain access to the fixing screws. The stop solenoid must be detached: ensure that the peg engages with the slot correctly when you reassemble it. Also make sure that the rewind and fast forward key lever tails project into the U-shaped ends of the levers.

### Miscellaneous Points

This virtually concludes our treatment of the mechanical side of these machines. Before we come to the end however there are one or two odds and ends that should be mentioned.

The hinge pins for the tuning door fall out and get lost, as does the spring. These pins are not listed as replacement parts, but half inch panel pins with the heads cut off will do. Check that none of the pins are loose inside the machine.

The rubber feet tend to work loose – a spot of cellulose paint on the ends of the screws inside the bottom cover cures this.

Don't stand the machine on a thick pile carpet that obscures the ventilation slots.

The remote pause socket is a prolific source of trouble due to the tags shorting against the chassis metalwork, giving permanent pause.

Well that's it! We hope that this series may prompt those who tend to avoid complicated mechanisms to have a go and revive some of these excellent but dated machines – they'll give service for a few more years yet.

# Servicing the Sony SLC6UB VCR

David Botto

We rather like the Sony SLC6UB VCR which dates from the early 1980s. It's a front-loading Betamax machine and large numbers are still giving good service. Fortunately it's straightforward to service: properly maintained, this VCR will give you an excellent picture. An optional remote control unit was available initially.

There's a Mark II version. You can distinguish at a glance between the two versions because the front panel layouts differ. In the Mark II version all the function controls except record are arranged in a straight line: in the earlier version the controls are arranged in a sort of short, cut-off T formation. Fig. 1 shows the differences.

## Access

To remove the cabinet, first remove the two screws at each side of the top cover then lift it away to reveal the inside of the VCR. If you need to work on the underside, remove the seven screws from the metal bottom plate – it will then come away easily. To remove the front panel, simply remove the three screws that pass through the lugs at the top: then lift the panel away gently. To prevent cabinet damage, we use a special rubber bench of the type available from Philips, RS Components etc. in our workshop.

The tape mechanism is to the right of the machine, viewed from the front. The tuner/timer/power block is at the left. To remove this block, take out the two screws at the lower front, then the four screws you'll see at the left-hand side looking down from the top, and finally the two screws at the top of the unit, at the rear: unplug connectors CN1007 and CN1004 from board YC18, connector CN2008 from board SS9 and connector CN5001 from board DR1. When the block is pulled slightly towards you it will lift away easily.

Board YC18, which contains the luminance and chroma circuitry, is below the cassette mechanism. With the VCR standing on its left side panel – don't forget to provide a rubber mat – remove three screws and board YC18 will hinge upwards and outwards.

## Power Supply Circuitry

As with any VCR it's a good idea to spend a bit of time studying the circuitry. This is especially true of the power supply because absence of just one voltage from this can result in puzzling symptoms.

The Mark I power supply circuit is shown in Fig. 2 – the Mark II version is almost identical.

The a.c. mains input is fed via the mains power switch S901, which is at the back of the machine, to board LF22 which contains fuse F101 and the mains filter capacitor C101. A white lead from this board goes to one end of the

mains transformer's (T901) primary winding. The red lead goes to the other end of the primary winding via the voltage selector S902. The selector's grey lead goes to the 240V tap and the blue lead to the 220V tap. It pays to check the setting of this before plugging the machine into the mains supply – someone may have put a screwdriver in the adjustment slot at the rear and turned it.

The secondary windings on the mains transformer are as follows. Two red leads from one secondary supply 16V a.c. to pins 1 and 2 of connector CN002 on board TP12. The two blue leads from another 16V a.c. winding supply pins 3 and 4 of connector CN002. The two yellow leads supply 3V a.c. to pins 5 and 6 of connector CN003 on board TP12. The remaining secondary has four tappings. The brown lead supplies 110V a.c. to pin 4 of CN003, the grey lead supplies 5V a.c. to pin 3, the violet lead supplies –20V to pin 1 while the white lead to pin 2 is the chassis connection.

The 16V a.c. supply at pins 1 and 2 of CN002 goes via fuse F002 to a bridge rectifier formed by four diodes, D301-4, all type 30D2FA. An 18V d.c. supply is developed across reservoir capacitor C002.

Note IC001 (STK5314) which is mounted on the small TP16 board. This i.c. contains two separate regulators, each with its own muting circuit. The 18V d.c. across C002 is fed to pin 8 of IC001, where it forms the input to the second regulator whose 12V output appears at pin 7. This output is taken to pins 1 and 2 of connector CN5001, where it forms the "SYS 12V d.c. supply" for board DR1.

The 16V a.c. supply at pins 3 and 4 of CN002 is taken via fuse F001 to another bridge rectifier (D305-8, all type 30D2FA) which develops 17.3V d.c. across C001. This supply is used for a number of purposes. It's taken to the collector of transistor Q255 which, together with R270 and zener diode D251, form a regulator that produces the "ever-12V" supply. The 17.3V is also fed to regulator one in IC001, at pin 6: the regulated 12V output appears at pin 4 and is taken to pins 3 and 4 of connector CN001, where it goes to the SS9 board. This supply also feeds the power indicator LED D501 via R206. A further use for the 17.3V supply is to power transistors Q002, Q009 and Q011 and the base of Q010.

When the power switch S501 on board TP14, which is mounted at the top, front left of the machine, is depressed the ever-12V supply is applied to the base of Q002 via R256. Q002 thus turns on, its collector voltage dropping to almost zero. As a result Q009 is switched off and Q011 turns on. Because Q011's collector is connected to IC001's two muting pins, 2 and 9, the result of this is that the two 12V outputs from IC001 are now present: the power lamp lights and the VCR can operate.

Q002's collector voltage also controls Q010, whose collector is connected via pin 9 of connector CN001, pin 9 of connector CN8 on the SS9 board and R624 to pin 6 of the microcomputer chip IC501. The microcomputer chip is thus informed as to whether S501 is in the on or off position.

When the machine is waiting to make a timed recording the two regulators in IC001 are switched off. At the switch-on time selected by the user IC301 (TCP4621AF) on timer board TP13 generates a signal voltage at pin 2.

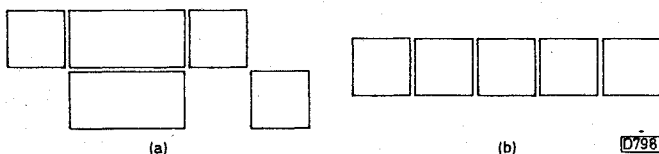

Fig. 1: Function control layout on early versions of the machine (a) and on the Mk. II version (b).

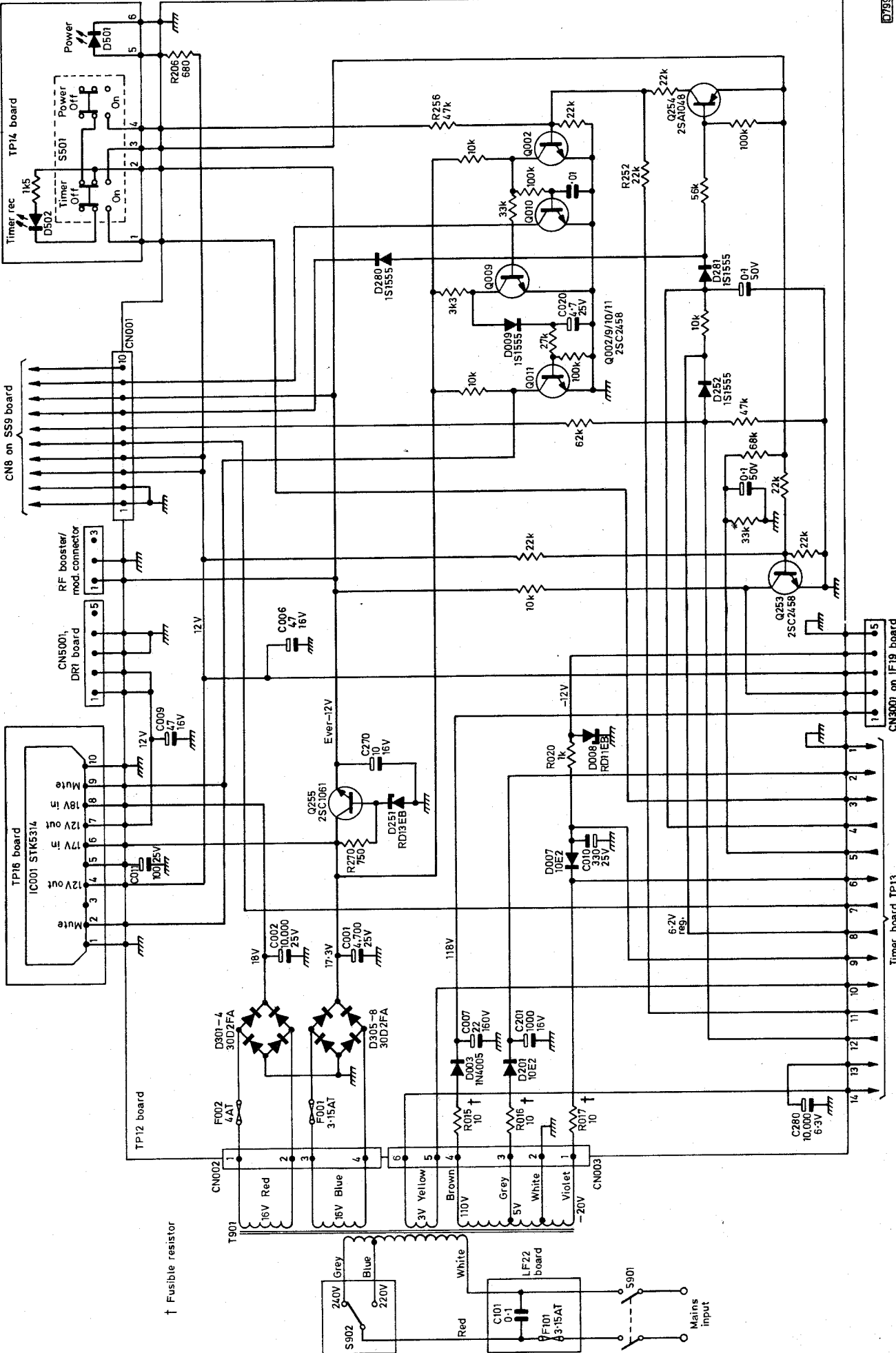

Fig. 2: Power supply circuitry used in the earlier version of the machine. The Mk. II version is almost identical.

This voltage is fed via R252 on board TP12 to the base of Q002 which thus conducts, switching on the two regulators in IC001 so that the machine comes into operation.

The 3V a.c. supply at pins 5 and 6 of connector CN003 supplies the filaments of fluorescent display FL301 on board TP13.

The 110V a.c. supply at pin 4 of CN003 is rectified by D003 which produces about 118V d.c. across C007. This voltage is taken via pin 1 of connector CN3001 to the collector of the 2SC1890A switching transistor Q011 on board IF19. At the emitter of Q011 114V is available to power the neon channel indicators and feed the 33V tuning voltage regulator circuit.

The 5V a.c. supply at pin 3 of CN003 is rectified by D201 whose output is stabilised by the 6.2V zener diode D271 on the timer board TP13. The -20V a.c. supply at pin 1 of CN003 is rectified by D007 which produces a negative d.c. supply for the timer i.c. and display circuitry on timer board TP13. D007's negative output is also fed to zener diode D008 which produces a -12V supply for board IF19.

The a.c. voltage at the junction of R017/D007 is taken to timer board TP13 where, after clipping by diodes D204/3, it provides a reference source to synchronise the timer chip IC301 at pin 30.

## Power Supply Faults

The power supply has proved to be very reliable. But problems can occur. Before investigating what may appear to be complex electronic faults in the machine check that all the d.c. outputs from board TP12 are present and correct. This could well save you the strain and frustration caused by hours of fruitless testing! Use an accurate digital voltmeter (one with a 10M $\Omega$  input resistance) to make these measurements.

The cause of a completely dead machine can simply be failure of F101 due to old age – though in our experience this occurs only on rare occasions. If fuse F002 has blown, check diodes D301-4. If fuse F001 has failed, check diodes D305-8. An overload due to a fault on one of the other boards could of course be the cause of failure of one or other of these fuses.

The first voltage check to make on the power supply is for 18V d.c. at pin 8 of IC001. The next check should be for 17V d.c. at pin 6 of IC001. If these voltages are present check that the ever-12V supply is present at pin 8 of CN001.

If this ever-12V supply is missing or incorrect, test transistor Q255 and zener diode D251 (RD13E-B1) and ensure that C270 hasn't dried up and lost capacitance. If any of these items turn out to be defective, check the value of R270 before fitting replacement(s).

The regulator chip IC001 can cause a number of problems. A machine that won't switch on, with the power light remaining off, because of the absence of the regulated 12V supply at pin 4 of IC001 suggests that the chip is faulty. An internal fault in the chip can result in anything from 14V to 18V being supplied to pins 1 and 2 of connector CN5001, causing all manner of strange conditions on board DR1 – this situation can upset or stop the capstan motor.

Before replacing IC001, check that the voltage at pins 2 and 9 is zero with the power switch in the on position. If a d.c. voltage is present, muting the two regulators in the chip, test transistors Q002, Q009, Q011 and Q010 in that order, then diode D009. If these are in order, check that 12V is present at connection 4 on board TP14 (with the

power switch on). Make sure that this voltage arrives at the end of R256 nearest to the edge of the board. Finally check R256.

Should the 118V, the -20V supply or the output from D201 be missing, remember that one of the fusible resistors R015/6/7 could be open-circuit. It's important to replace these special resistors with the correct Sony type. It's also worth checking all thirteen electrolytic capacitors on the power panel – they can lose capacitance over the years.

I'll remind you once again that you'll enjoy big savings in time and energy when you use a component tester (see *Television* June 1984) to test items on the power panel.

## Timer Board

We've not had much trouble with the TP13 timer panel – the TCP4621AF timer chip IC301 is very reliable and seldom fails. If the timer record LED D502 fails to light when the timer mode is selected, check transistor Q251 (2SC2458) first. If the timer record start switching transistor Q252 (2SC2458) fails, transistor Q002 on the power panel will not switch on in the timer mode – neither will the VCR when the time comes for the clock to switch it on.

A nasty fault is when the timer turn-on at the set time is intermittent. If this happens check the soldered joints of the connections to CN004 first (Mark II version).

## Tuner and IF Board

It's a curiosity of this machine's layout that the tuner is mounted on the power panel but connects to panel IF19. A simplified block diagram of the tuner and i.f. circuitry is shown in Fig. 3. As we've already seen, a supply of some 118V is supplied to the switching transistor Q011 on this panel.

The tuner itself is reliable and hardly ever fails. Should it tend to drift off tune, make sure that IC002 ( $\mu$ PC574J) is in order and has exactly 33V d.c. across it.

Strange things can happen if one or more of the neon channel indicator bulbs dim, as they tend to do with age. When a channel with a faulty neon bulb is selected the 114V supply will be low, and so will the bias on transistor Q010 (2SA893A). This transistor's collector is linked to the base of the 2SC2785 audio muting transistor Q001 which thus turns on, producing the puzzling symptom of poor sound on channels with dim neon indicators! The link between Q010 and Q001 is via D010, Q009 and D005; distorted sound on all channels occurs when Q009 (2SA1175) fails.

If R015 on the power panel (TP12) goes open-circuit the tuner board goes dead, the neon channel indicators remain out and channels cannot be selected.

We've perhaps been fortunate in never having to replace IC001 (CX885A) on panel IF19. R045 (100 $\Omega$ , 1/8W fusible) sometimes decides it's time to go however. This removes the supply to the sound i.f. transistor Q002 and some of IC001's pins. Before replacing R045, check Q002 (2SC2785).

An audio signal tracer is useful for checking the sound output at pin 6 of connector CN002. With a colour bar input signal, an oscilloscope connected via a 10:1 probe to pin 5 of CN002 should display a composite video signal.

## Loading Problems

What if the cassette won't load, jams on loading or tangles the tape? Before you search for complex elec-

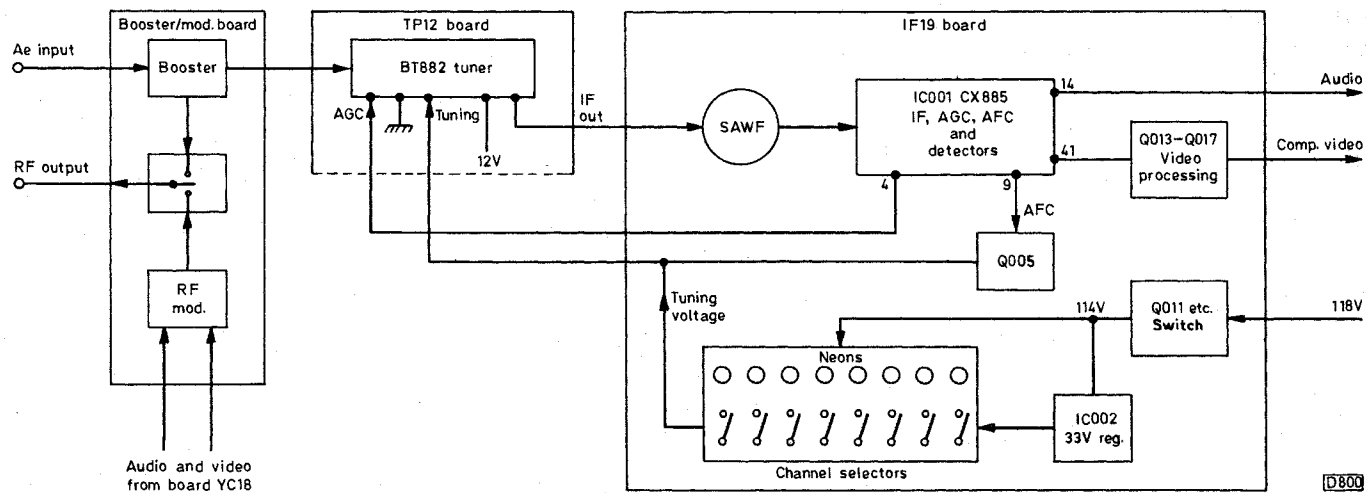

Fig. 3: Simplified block diagram showing the booster/modulator, tuner and i.f. sections of the machine.

tronic faults, check the mechanism to ensure that it's perfectly clean and free to move. To the left of the mechanism there's a little board mounted flat at the top – the TT5/FLD (front loading motor) board. It has six connections (see Fig. 4). You can check the loading sequence without inserting a cassette by carefully shorting pins 4 and 6. Next short pins 5 and 6 and the mechanism should go through the motions of loading the tape. This procedure is helpful when you want to check the loading mechanism without damaging a cassette.

At the top of the cassette mechanism there's an idler wheel that connects four belts. Clean this wheel carefully – if it's in bad shape, replace it. At the same time examine the belts. If you find that they are the original ones it's sound policy to replace the lot. If you don't the machine may well bounce back to your bench in the very near future. Belt wear can cause intermittent stopping or failure to unthread. With very intermittent problems of this sort it's advisable to replace the small relay pulley, the large relay pulley and the phosphor-bronze bearing through the chassis between the two pulleys. Be sure to clean the two microswitches on the underside of the cassette mechanism.

With the Mark II version there's an official modification to prevent tape damage when a cassette is inserted. First locate the microcomputer chip IC501 on the SS9 panel. Some extra components are required – three 1S1555 diodes and a 3.9k $\Omega$ , 1/4W carbon resistor. Carefully cut the print between pin 23 of IC501 and R530. Connect the anode of one of the diodes to pin 23 and the cathode to R530. Connect the anode of the second diode to pin 30 of

IC501 and its cathode to the junction of R530 and the first diode. Connect the anode of the third diode to pin 37 of IC501 and its cathode to pin 2. Finally connect the extra resistor across R579.

With the Mark II version various troubles such as no rewind or no fast forward can be due to nothing more than poor contact with connectors CN606 and CN608 on board DRD1. If you suspect this, remove and clean all the connectors on this board with a little Castrol DWF. In fact when removing any connector in the VCR it's good sense to clean it with just a trace of DWF before replacing it.

### Servo and System Control Circuitry

The microcomputer chip IC501 seldom gives problems, though it can fail. A logic probe is essential to check the circuitry, and a logic pulser is very useful. Table 1 shows the logic conditions at IC501's pins.

If you decide that IC501 is faulty, fit a 42-pin i.c. holder before fitting the replacement chip. If you then discover that the fault lies elsewhere it's easy to refit the original chip. It has been known for the microcomputer to refuse to reset, paralysing the system control circuitry. This can happen if the VCR is plugged into the mains with the front panel power switch depressed. You can then spend a considerable time trying to find out what has happened. The solution is to switch the power switch off and disconnect the mains supply. Then, when the mains supply is reconnected and the power switch is depressed, everything will work correctly. We've had this problem with various VCRs.

There are several Darlington transistors on the DR1 board (Mark I version). These like to fail, causing various puzzling faults. For example if Q022 (2SD1164) fails the capstan motor will stop.

The CX143A capstan servo chip IC001 on board SS9 hasn't let us down yet. If you suspect trouble in this area, check the surrounding components and make sure that the voltage at pin 24 is 12V (the power supply regulator chip could be faulty). If the capstan speed sometimes seems to vary suspect the tantalum capacitors C007 and C008 (both 0.22 $\mu$ F, 16V) connected to pins 8 and 9. We find it best to replace these with standard Sony electrolytic capacitors.

Drum motor problems can be caused by several things. Resistors R045 (1 $\Omega$ , 1W) and R060 (4.7 $\Omega$ , 1/8W fusible) on board DR1 can go open-circuit. After fitting new

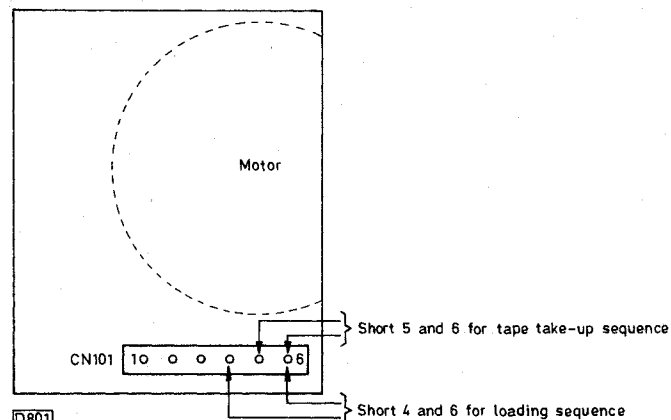

Fig. 4: Front loading board viewed from the top of the VCR.



resistors it's as well to check transistors Q017 and Q018 (both 2SC2785), Q019 (2SA1175), Q020 (2SC1061) and the Darlington transistor Q021 (2SD1164). If the drum speed is not constant the cause is likely to be the CX186 drum servo chip IC003 on board SS9 or one of the associated electrolytics.

When Q025 (2SD1164) on board DR1 (Mark I version) fails the symptom is no fast forward operation. If this transistor has failed be sure to check Q023 (2SD788) and Q024 (2SC2785) as well. On both versions of the machine, always suspect the various low-value fusible resistors. On the Mark II version (DRD1 board) resistor R665 (4.7Ω, 1/4W fusible) tends to go open-circuit with the result that the loading motor won't operate. Fortunately IC601 (M54543L) seems content to go on and on and on.

Failure of R061 (1Ω, 1W fusible) on board DR1 will stop the reel motor. So will failure of Q010 (2SD355) – it tends to go short-circuit collector to emitter. On the Mark II version failure of R653 (2.2Ω, 1W fusible) will halt the reel motor.

### YC18 Board

We've not had many problems with the YC18 board. Noise on the picture can be caused by C018 (10μF tantalum in early versions) or C016 (0.47μF, 50V electrolytic) drying out.

A nasty fault to find is no colour during pause. This is due to C083 or C084 (both 27pF, 50V working) playing up. If one is faulty it's best to replace them both. Then clean the preset RV011 (1kΩ, carbon) with a trace of Castrol DWF.

### RF4 Board

The RF4 board is mounted upright at the back of the machine, on the right-hand side. We've had few faults with this board, but watch out for Q7 (2SC945). If this transistor has only a slight leak (the leak will show up nicely on your component tester) the luminance record current will be upset. If you find that RV5 (1kΩ preset) needs constant adjustment, check Q7.

There's a fair number of 8.2Ω fusible resistors on this board, but they rarely fail.

### AD6 Board

If the cassette tape doesn't erase properly, connect a scope to pin 2 of connector CN6502. A nice 65kHz sinewave (±6.5kHz) should be present here. If not, check Q1 (2SD774) and R025 (4.7Ω, 1/4W fusible).

Relay RY1 on this board can stick, giving rise to troubles such as weak or distorted audio. Before condemning it check the 1S1555 diode D001 (1SS119 in the Mark II version).

### Booster/modulator

If there's loss of gain in the r.f. booster/modulator, causing a noisy picture in the E-E mode or weak loop-through signals, it's generally best to fit a new booster. Before discarding the old unit however check the four 2SC3037 transistors for leakage. If you replace any faulty ones there's a good chance that the booster will work correctly. Don't try substitute transistors.

### The Video Heads

When properly cared for the video heads should enjoy

**Table 1: Microcomputer chip logic levels.**

Pin	At switch on	Other conditions
1	H+P+L	H for load and play
2	H	L+P for eject
3	H	L+P for rewind
4	H	L+P for fast forward
5	H	H for load, L+P for play
6	H	H for load and play
7	L	H then L+P for load
8	H	L+P then H for record
9	H	L for load
10	H	–
11	L	H for ff video search
12	H	L for play and record
13	H	L for play
14	H	L+P for load, L for play
15	L	L for load and record, H for play
16	L	H then P for load and play
17	L	H then P then L for load, P for play
18	L	L for load, H then P then L for play
19	L	L for load, P for play
20	H	Test – always H
21	H	Voltage supply pin
22	L	H+P for eject
23	L	H for eject
24	L	H+L for load, L for play
25	L	L+P for load, L for play
26	L	L for load, H for play
27	L	L for load, H for record
28	L	H for fast forward
29	L	L for load, H for rewind
30	L	H for eject
31	L	H for pause
32	H	H for load
33	L	H when cassette in
34	L	H when cassette in
35	L	H then L for load
36	H	L for load and play
37	H	L for load and play
38	L	L for load and play
39	L	L for load and play
40	L	L for load and play
41	L	Chassis connection
42	H+P	Oscillator – always H+P

H = high, L = low, P = pulse.

a long life. Use only a proper VCR video kit to clean them. After doing so, be sure to clean the control and audio heads.

A 3mm Allen key is required to remove the two cap screws that secure the upper drum. If new video heads are fitted a special gauge available from Sony is required to position them with the necessary degree of accuracy (to

**Table 2: Board changes.**

Board	Mk. I	Mk. II
Power	TP12	TPD1
Regulator	TP16	TPD4
Timer/power switches	TP14	TPD3
Timer	TP13	TPD2
IF/tuning	IF19	IFC1
Motor/solenoid drive*	DR1	DRD1
Capstan FG control	FG2	DRD12
Front loading motor	TT5	FLD

The FS11 and FS12 cassette control switch boards in the Mk. I version are replaced by board DRD2 in the Mk. II version.

\* The circuitry on boards DR1 and DRD1 differs.

microns). Colleague Pete however possesses the amazing ability to set the heads up quickly and accurately by eye without the use of the gauge. A check afterwards always proves him to be 100 per cent accurate!

## **Board Changes**

The board numbers used in this article have mainly been those found in the Mark I version of the machine. The most important differences between the two versions are listed in Table 2.

## **Remote Control**

The remote control unit is of the wired type and plugs

into a socket at the front of the machine. The signals from this unit go via pin 1 of connector CN11 on board SS9 to R603 then D509 (the positions of these two components are interchanged in the Mark II version). If the remote control doesn't work, before condemning the unit check the print between CN11 and R603/D509.

## **Concluding Notes**

When it's necessary to replace a transistor the correct Sony type should be used. This will prevent various awkward problems arising. For a professional job it's important to apply circuit varnish to any newly soldered joints. Do this with a small brush, because circuit varnish reaching the wrong places can do horrible things.

## Ferguson 3V23/JVC HR7700

Although it would tune to channels this machine wouldn't memorise tuning data. Our first check revealed that the -24V supply at pin 9 of the memory chips was absent due to failure of X9 (2SD638). After restoring this supply there was still no channel memory. The voltage at pin 7 of the chips was 3.5V while pin 8 was at 8V. We changed the chips without curing the problem, then a bulb lit up in the dim brain. The voltage at pin 8 (Vdd) should be zero. X7 was not turning on as C19 (4.7 $\mu$ F) in its base circuit was leaky. There had been two faults, as the customer hadn't bothered when the tuning memory was first lost - he just continued to watch library tapes until the heads needed cleaning. . . .

S.B.

## Sharp VC386

This machine suffered from tuning drift which we thought was down to either the PTC (PR01) in the power supply regulator circuit, the tuning voltage regulator IC1403 or intermittent tuning potentiometers. After checking on these points, including fitting a replacement tuning potentiometer unit (this has cured previous problems on similar models), we found that the VTL-7C tuner unit was the cause of the trouble. The customer was not impressed with the cost of the tuner.

S.B.

## Amstrad TVR1

Rewind was operational but there were no forward functions. The cause was a leaky tape end phototransistor.

S.B.

## Toshiba V83

The cause of an intermittent clock display, which failed about an hour after switching the machine on, was found to be the 4MHz clock crystal XX01.

S.B.

## Ferguson 3V23/JVC HR7700

There was no tuner signal due to absence of the supply to the i.f. section of the machine. The cause was failure of transistor Q16 in the power supply.

S.B.

## Toshiba V65/JVC HRD140/Ferguson 3V44

The clock display failed after an hour or so. The cause was the TL066CP reset chip which changed the state of its output when warm, holding the clock chip in the reset condition.

S.B.

## Fidelity VTR1000

For intermittent operation of the play, wind etc. buttons, check whether the thick-film resistor BR851 on the customer control panel is dry-jointed.

P.B.

## Sharp VC9300

Loss of capstan servo lock is becoming a common problem with these machines. The symptom is often noise bars that move slowly through the picture though the sound

doesn't wow. If you check the capstan lock voltage at TP3 when the flywheel is slowed by hand you'll find that it doesn't alter. Usually waveform TP1 is missing, due either to D707 being leaky or R475 (82k $\Omega$ ) open-circuit.

If the drum and capstan servos are both wowing, check that the PB 50Hz signal is steady. If the count-down chip is faulty the signal's mark-space ratio can vary.

P.B.

## Amstrad VCR7000

If you come across one of these machines that suffers from intermittent reel stopping and the problem isn't caused by the reel motor or idler, check relay RY2001 for dirty contacts.

P.B.

## GEC V4100/Hitachi VT11

This machine gave fast forward when rewind was pressed. All other functions, including unload (which makes the capstan go backwards, as in rewind), were o.k. When a d.c. check was made on the rewind switch we found that it didn't connect properly: the 100 $\Omega$  resistance fooled the AD converter that senses which button has been pressed.

P.B.

## Panasonic NV333

The customer brought this machine in a few weeks ago, complaining about poor recording and sound coming through from other channels. After soak testing the machine for several hours no faults showed up so we returned it - suspect, faulty customer. . . . A few days later it came back, this time with a tape to show the fault - non-erasure of the previous sound track, with the chroma signal remaining. The problem was traced to dry-joints on the bias oscillator transistor Q4014.

N.B.

## Hitachi VT5000

Won't record was the rather incomplete fault description with this machine. What in fact happened was that the record button flew up when a timed recording started. The cause was a break in the sensor lamp lead, just below the pinch roller arm. Why the fault occurred only on timer recordings is uncertain - maybe temperature or settlement.

N.B.

## Panasonic NV333 onwards

We've come across an alarming number of these machines in which the 3.3F 2V memory back-up capacitors (three in each) have leaked all over the timer board. Note that the gunge will spark and bang when an iron is applied - so be prepared.

N.B.

## Sony TTF1UB

This is the tuner/timer/a.c. supply for the Sony SLF1UB portable VCR. The unit in question had no display, wouldn't change channels and wouldn't switch to standby. The cause was basically no 5V rail. R555 which is a Wickman fuse was open-circuit due to the 2SD1173

regulator transistor Q553 being short-circuit. The battery charge switching transistors Q551 and Q550 both had fair leaks. These components were all replaced – they are on board DA3. **N.B.**

### Amstrad VCR9000

Something heavy must have descended on this machine. The main board had flexed sufficiently for Q307 to come into contact with the capstan motor. Apparently the machine had been super-sensitive for some time, even to people walking across the room. No wonder – Q307 had been pushed up from the board, breaking all three solder pads. When I received the machine for repair it would usually thread up and then unthread immediately. I didn't have a manual at the time but it seems that this transistor is in the servo's reference pulse circuit. It would appear to be a stock fault in the making, so bear it in mind when tackling intermittent faults on this machine. **R.B.**

### JVC HRD566

The complaint with this machine was poor hi-fi sound – the best way to describe the effect would be motorboating. A check on the f.m. audio waveform showed that there was a period of dropout at the switching point between the two heads – see Fig. 1. A check on the f.m. audio flip-flop revealed what was happening. The flip-flop signal had a mark-space ratio of approximately 3:5 instead of 1:1. Replacing the BU2710 servo chip IC403 cured the fault. **A.D.**

### Ferguson 3V54

This machine would play for five seconds then stop. The head was spinning and the wheels were going round, so it appeared that an input signal to the mechanism control chip was missing. We found that the drum FF signal was correct but the take-up reel sensor signal was irregular. It would start at the correct amplitude and then diminish. In addition, when of the correct amplitude there was a ripple on the lower edge (see Fig. 2).

A check on the signal from the TU sensor to the buffer transistor on the deck terminal board proved that this was correct, with no ripple. The ripple appeared at the collector of this transistor. It's supplied from the switched 12V rail, which also had a ripple on it. A voltage check revealed that the voltage was low at 10.5V when the tape was running. Time to investigate the switched 12V supply more thoroughly.

The rail also supplies the tuner/i.f. board, and when this

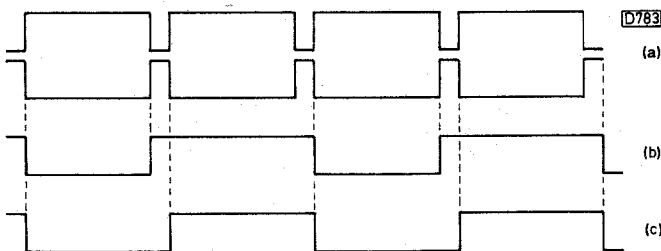

Fig. 1: Audio f.m. waveform with dropout between the head switching points (a). Incorrect 3:5 ratio audio flip-flop signal (b). Correct audio flip-flop signal (c).



Fig. 2: Take-up reel sensor signal with ripple.

was unplugged the ripple disappeared. Was the fault due to this panel drawing excessive current, or was the power supply regulator unable to supply sufficient current? As the E-E picture was good, a fault in the tuner/i.f. panel was ruled out and attention was turned to the power supply. Cold checks on the semiconductor devices here revealed that Q10, which switches the switched 12V regulator on, had high-resistance junctions while the 3.9V zener diode D3 which biases Q10's base was short-circuit. After replacing these two components the VCR worked correctly. **A.D.**

### Panasonic VW-AMC5E/B

This is an a.c. adaptor/battery charger which is supplied with the Panasonic NV-MC5 C-format camcorder. We've had two that failed to charge the battery though they were able to provide an operating voltage for the camcorder. In each case thermal fuse TF4 was open-circuit. This 130°C/3A fuse is glued to the body of the charging current regulator transistor Q7. In neither case were other or contributory faults found and neither has bounced back. This suggests that the fuses themselves were faulty. **E.T.**

### Sharp VC486H

Two faults were marked down against this machine when it came in: remote control no-go and "funny deck behaviour". The deck worked correctly for us while we diagnosed the remote control problem. The 455kHz clocks at each end of the infra-red link were operating correctly and a strong pulse signal was present at the output of the preamplifier in the machine. The culprit was the tiny LR3711M/-1 44-pin decoder chip IC812.

While we were testing the remote control system the other fault reared its horrible head: the action of the deck mechanics was wild and rather beyond description. It behaved properly after fitting a new mode switch – the "mechanism position switch". **E.T.**

### Fidelity VTR1001

This machine was very insensitive when trying to record and on loop-through, though it played back known good recordings satisfactorily. The fault was quite quickly traced to an open-circuit SWAF. Unfortunately Fidelity don't list any parts for the tuner/i.f. module. It comes as a complete replacement unit at some £45 . . . Sanyo technical came to my rescue, suggesting that a filter used in one of their Fisher models would be a suitable replacement – part no. 4-953V-05000. This proved to be the case. My thanks to Sanyo for making this suggestion. The customer was certainly pleased with the final bill as opposed to the original estimate! **P.H.**

### Sharp VC2300

This VCR presented me with my first microcomputer chip fault – the time taken to deal with it certainly reflected the fact! The pause, record and stop LEDs were all lit and there were no deck functions at all. The micro input chip IC804 had a permanent stop command at pin 14, but its inputs all appeared to be in order. The voltages around the micro output chip IC809 were all over the place, but appeared to reflect the deck status as indicated by the LEDs. Suspicion fell on the microcomputer chip itself (IC807). Pin 15, one of the four-bit output lines, was high. Disconnecting this pin put out the pause and record LEDs

and gave the fast forward and rewind functions.

After replacing IC807 the capstan wouldn't turn and the deck wouldn't load. The loading motor chip IC808 was found to be open-circuit and the loading motor itself had been damaged – it took 2A off load (a replacement took 100mA). Replacing these last two items finally put the machine in working order. With the price of Sharp spares what they are these days the repair was not cheap. **P.H.**

# Features of the Panasonic NV-D80

Harold Peters

By now we've come to expect from a top-of-the-range VCR two-speed recording, hi-fi helically recorded sound and a timer that's programmable from the remote control handset. The recently introduced Panasonic Model NV-D80 not only has these features but several more, due to three innovative extras: a digital field store, a bar-code scanner, and a deck mechanism that includes a "half-loaded" position. We'll take a brief look at these.

## Digital Field Store

As shown in Fig. 1, the NV-D80 has a digital field store in parallel with the analogue video signal path. The digital store can be brought into use not only during playback but also in the E-E mode. Amongst the new possibilities that this makes possible are:

- (1) Still frame – a jitter-free picture that doesn't stop the sound output, or the tape.
- (2) Digital strobe – a succession of still frames, controllable from one to six per second, can be flashed up on the screen, again without disrupting the sound.

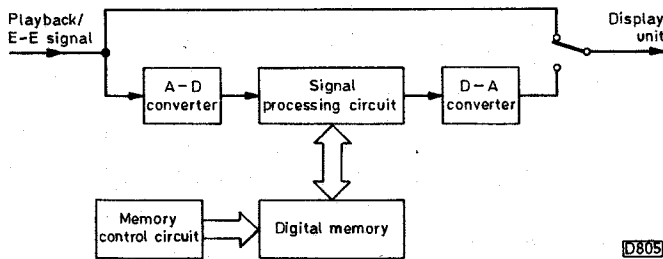

D805

Fig. 1: Block diagram of the digital system.

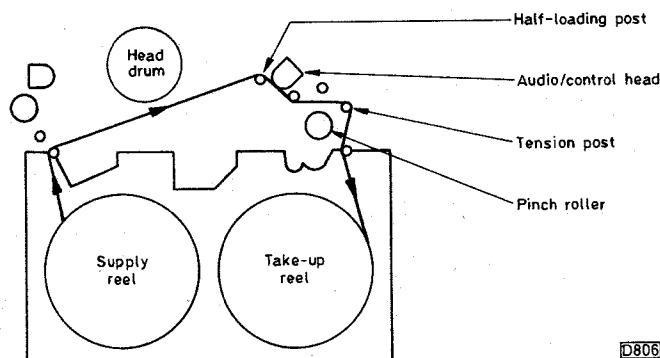

D806

Fig. 2: The deck mechanism in the half-loaded position.

① CHANNEL	② DATE	③ START TIME	④ END TIME
1	1	5	5
2	2	30	30
3	3	00	00
4	4	30	30
5	5	00	00
6	6	30	30
7	7	00	00
8	8	30	30

Fig. 3: A section of the bar-code programming sheet.

(3) Graphic effects – similar to those found on pop music video programmes.

(4) Noise reduction by adding the stored field to the analogue picture signal: the pictures add while the noise subtracts – the principle is similar to the operation of the familiar PAL delay line arrangement.

## Search Indexing

Whenever the record button is pressed at the start of a recording an index signal is recorded on the control track. Extra signals to indicate parts of a recording of particular interest can be added at places of your choosing by pressing the record button at the appropriate times. These indexed points – up to twenty per cassette – can be found rapidly during rewind or fast forward by calling up the index number of the part you want to see.

Alternatively you can use "intro scan". In this mode the tape, in fast forward, stops and plays ten seconds of picture at every index mark. When the part you want is reached you press play and the intro search ends. This feature is made possible by the half-loaded tape position shown in Fig. 2. Between each ten seconds of picture playback the tape is run in the half-loaded position, clear of the head drum and pinch roller but in close contact with the audio/control head. The tape stays in this half-loaded position during the rewind, fast forward and stop modes. This is an improvement on previous search indexing arrangements which work only in the "cue and review" mode.

## Bar Code Timer Control

In common with two other models in the current Panasonic range, the NV-D80's timer can be set at the front panel, by means of the remote control handset, or by using a bar-code scanner that comes with the machine.

The intention is that bar codes printed with the programme listings will eventually be used, as in Japan, but until copyright and printing problems have been resolved you have to do this by using the programming sheet (see Fig. 3) that comes with the machine. You simply switch the scanner on, point the sharp (LED) end of the scanner at the sheet and read off the channel, date, on and off times of the programme you want to record. Then turn the scanner round, point the blunt end at the VCR and press the transmit button. The VCR displays your information for ten seconds, gives a bleep of recognition, and switches to timer.

You have to scan the programming sheet fairly rapidly and straight. Every read-in produces a bleep, and a completed programme is given a train of bleeps. On and off times are given to the nearest half hour, with a fifth column on the programming sheet for extra minutes if needed. Since the scanner retains the last programme information, the cancel bar must be read before booking a further programme. To save on batteries the scanner switches itself off after twenty seconds of idleness.

Panasonic enthusiasts will be delighted to know that despite all the extra features the good old one-piece diecast chassis is retained.

# Room at the Back

J. LeJeune

Sid Bias, Topcut of Millthorpe's Service Manager, sat in his shirtsleeves in the heat of the Indian summer. The warm weather so late in the year discouraged activity in the Service Department and its three occupants felt languid and sleepy.

Norman Gates was soldering together another pair of dial bulbs prior to fitting them into the rear nearside lampholder on the van, wondering whether it would pass its third MOT like that. Gareth poked listlessly with a grub screwdriver in the area of a music centre's cassette mechanism. A 3V31 VCR, minus top cover and screening plate, played a recording of the German Grand Prix for no one in particular.

"Whew" said Sid, startling Gareth from his semi-coma as Norman appeared at the open door, having (he hoped) complied with the vehicle's legal lighting requirements. "Teatime" announced Sid, "do something useful Gareth."

Gareth got up from the bench, stowed the screwdriver in his shirt pocket and vanished into the outside kitchen to make his version of tea.

"Is he still fiddling with that music centre?" asked Norman.

"Perhaps he needs some guidance" replied Sid. "They aren't always the simplest of things to trouble-shoot."

Norman peered into the tape section and began to inspect it more thoroughly. The job-card note merely said that the tape speed was wrong. The 3922 was battered and stained and had clearly led a busy life.

"Where's it from?" asked Sid.

Norman looked at the job-card again. "It says the Goat and Bucket. Looks as though they use it in the bar."

"Wouldn't know" commented Sid. "Don't go there since they got that new landlord."

"New motor" said Norman decisively. "It's one of those with a built-in speed control circuit and something's gone phut in it."

"Gareth's been poking at some board or other in there" said Sid. "Probably didn't realise the speed control gear is built into the motor."

"As like as not" replied Norman. "It's all very confusing nowadays."

## The TX10

Tea arrived and was taken slowly. Sid sat at his paper-strewn desk, writing out spares orders. Norman, having explained the music centre motor to Gareth, had gone on to a TX10 he'd collected earlier in the day. It had a vertical striation about half way in from the start of the scan. Gareth was looking on, hoping to learn something.

The fault proved to be an awkward one. Nothing Norman did cleared the striation. He'd checked all the usual things - dressing the video leads away from the chopper circuit and making sure that the focus and e.h.t. leads were properly seated in the sockets in the body of the chopper transformer.

"Have you changed the chopper transistor?" asked Gareth.

"No" replied Norman. "They either work or they

don't. No in-betweens like with Sid's bottles!"

"I think Gareth could be right" said Sid. "50p it's the BU208B."

"You're on" replied Norman, delving into his pocket for a coin.

The BU208B and its insulating mica washer were changed. "We always replace the mica as well" Sid told Gareth, "it occasionally saves a call-back."

When the set was switched on the striation had gone. "Explain that" said Norman.

"Can't" replied Sid, "anyway, what about that 3V31?"

## The 3V31

The VCR had been brought in by a notably fastidious customer who complained that the still-frame picture always had a noise bar at the very bottom of the screen. Various adjustments had been tried, and the machine's electrical set-up had been declared O.K. Remembering what he'd been told on his VHS course at Gosport, that 90 per cent of all VCR troubles are mechanical, Norman prepared to check the tape transport mechanism.

Here again all seemed to be in order, but Norman noticed that if he put pressure on the loading guide assembly roller, on the feed side of the drum, the noise bar went. Adjusting the roller didn't improve the picture, only applying pressure to it did. Norman went on to establish that any pressure in the area produced the same result.

"This one can go back to Ferguson" Norman finally said. "The desk's distorted and I'm not going to be the one to bend it straight."

Since the amount of movement produced by the pressure on the deck was barely if at all visible Gareth was fascinated by the fault and expressed his amazement.

"The width of the VHS track is only 49 microns" said Norman. "This means that there are just over twenty tracks to the millimetre. Few people seem to appreciate how precise the mechanics have to be for optimum performance."

"You'd rate the mechanics as being the more important then?" said Sid.

"Certainly would" replied Norman. "Get them right and you're well on your way to sorting out most of your problems."

"What about head cleaning?" asked Gareth. "I've an uncle who uses a head cleaning tape every time before he puts a cassette in the machine - and the picture is lousy and getting worse!"

Norman held his head in mock pain. "Don't use those tapes. They don't do a complete job and they do harm when used excessively. Your uncle's machine needs new heads by the sound of it."

"It's a 3V29 and we don't have any heads for that model" said Gareth. "Would a 3V31 head do?"

"It would work" said Norman, "but the 3V31 is designed for still and slow-speed performance while the 3V29 isn't. Use a 3V31 head in a 3V29 and you get a noise effect due to lower luminance sideband crosstalk which the 3V29 doesn't cancel all that well. The 3V31 cancels the crosstalk effectively - so use the right head for the job."

## An Audio Recorder

Next on the bench was a small tape recorder. The complaint was of non-erasure of recordings and no record

bias. Gareth looked for the oscillator coil. Ten minutes later he said to Norman "can't find the oscillator coil in this cassette portable."

"It doesn't have a separate one" said Norman. "For smallness and cheapness it uses the erase head as the oscillator coil. I expect you'll find the head open-circuit if you check it with a meter."

Gareth fetched the Avo and checked the head's continuity. It read open-circuit. There weren't any in stock so Sid had to return to his desk to write out yet another spares order.

### **The 9000**

A set with the 9000 chassis had an unusually poor picture with all the symptoms of a failing tube. But a new one had been fitted not long since.

"Do you reckon we fitted a duff tube?" Sid asked Norman.

"Don't think so" replied Norman. "The feel of it's wrong. I'll check the tube's operating voltages."

Just then the phone rang. Sid picked it up. "Service Department, can I help you?" After listening he said "we'll be around later in the day, about 4.30."

"That", announced Sid, "was the Home for Distressed Gentlefolk. They want us round promptly to get their new 3V35 working with their old 26in. TV."

"That old thing" said Norman. "It's almost as old as some of the residents. The flywheel time-constant's as long as your arm."

"Nevertheless" replied Sid, "our beloved leader has flogged them a 3V35 with the assurance that it will work with their receiver, which was presented to them by the Mayor's Comfort Fund. You'd better go and do your best. What did you make of the 9000?"

"Low first anode voltage" said Norman. "R720 should be 330k $\Omega$  but reads about 600k $\Omega$ ."

"Would that give the effect of a dud tube?" asked Gareth.

"You saw for yourself" replied Norman. "Perhaps I'd better explain. Faults are a little easier to diagnose with

PIL tubes because accurate convergence depends to some extent on the first anode and focus voltages being a fixed proportion of the e.h.t. If the first anode voltage alters the convergence gets worse and you should be able to see this when you wind down the brightness. This gives you a clue, but a quick check at the tube base will reveal all. Lowering the first anode voltage is like altering a pentode valve's screen grid voltage – the accelerating effect on the electron beam is reduced and the gun assembly's 'gain' is lowered. To get a picture you have to overdrive the tube and possibly the RGB output stages as well. This gives almost the same effect as a low-emission tube except that you don't get the grey-scale shift."

Norman, working as well as talking, had replaced R720 and was about to switch the set on.

"How do you set the first anode voltage then?" asked Gareth.

"You can use a meter or do as I do" Norman answered. "As the manuals usually quote a fairly wide voltage range I start by turning the brightness and contrast to minimum, then advance the first anode potentiometer until you see flyback lines on the screen. You then know that the first anode voltage is too high, so you back off the control until the lines just disappear."

After going through this procedure Norman restored the set's brightness and contrast controls to their normal setting and checked the picture. "That's O.K." he pronounced.

"Some manuals don't give the tube's operating voltages" said Gareth.

"You're right" commented Norman. "Makes life difficult, especially when you're on your knees at the back of a set in someone's house. Whenever we get a set with a new chassis in stock I try to get half an hour alone with it and the service sheet. I measure the voltages I think I ought to know with my own meter and jot them down. It's a wise precaution – and that's why Sid keeps borrowing the manuals from my van."

"Strewth" said Sid. "Hotter than ever. Think I'll go out and see that set-up at the Old Folk's Home."

"Mind they don't keep you in" called Norman.



## Saisho VR1000

This machine produced a black-and-white picture in playback and wouldn't record. The playback whites were clipped and the syncs crushed – this explained the absence of colour, as the sync separator couldn't cope with the distorted signal. The record signal disappeared half way through an i.c., and the white clip test point TP4001 had no signal on it. Also the PB 9V line had just over half a volt on it in the record mode, suggesting a switching problem.

Three i.c.s were ordered from Mastercare, an LA7031 f.m. demodulator, LA7034 f.m. record processor and an OEC2003 power rail switcher. Fitting the LA7031 restored normal playback levels and colour, but there was still no signal at TP4001 despite healthy signals at pins 19 and 20 of the LA7034. After much mucking about we discovered what had happened. The white clip level control VR4008 had been turned right down and the dark clip level control VR4006 had been turned right up – full white clip and full dark clip leaves you with a straight line! Some further time was then spent setting the record a.g.c., carrier level and deviation (using a method described in my book!). A lot more time was spent arguing with the customer that £91 for some six hours work plus parts was justified, and that his complaint should be with the friend of a friend who had twiddled it in the first place . . .

S.B.

## JVC HRC3

The trouble here was spasmodic deck shut-down, with an alarm indication given by the stop light flashing. After a while we discovered that this was due to the drum motor running erratically – the drum would slow down dramatically just before shut-down.

Diagnosis was hampered by the intermittent nature of the fault, but we finally managed to tie the problem down to the drum motor power supply section of the switching regulator module, in which the drum speed control was becoming throttled in some way: when the motor slowed down massive correction was applied by the servo module to pin 9, but to no avail. Replacement of this expensive and oddly-shaped bunch of electronics cured the problem, as a long soak test proved.

E.T.

## Hitachi VT150

Our warehouseman Reg staggered into the workshop with this one. It had had to be replaced a few days after delivery. The customer said that when it got warm it squawked and the picture twitched laterally. After several hours running, sure enough it did just that. The squawk was in fact more of a "shush-shush" noise. It was coming from the head drum.

On switching the machine off and then rotating the drum by hand we could feel friction at one point in the turning circle, suggesting that there was a bearing or rotor clearance problem in the direct-drive motor. Accordingly a new lower drum assembly (incorporating the motor) was ordered under guarantee. We were apprehensive about fitting it, anticipating a long setting-up session – after all this is a dual-speed machine. In the event virtually no adjustment to the tape path or the electronics was re-

quired, though everything was checked. This is a tribute to the tolerances to which modern VCRs are built. E.T.

## Hitachi VT8000

The businesslike zizz as the drum motor runs up to speed in this family of machines is characteristic and unmistakable. How we would have liked to hear it from this one! It wouldn't turn on in response to its operate switch, though had we known this it did work in the timer mode. This is starting to sound like one of those test cases! Anyway, the trouble was traced to a leaky 5.1V zener diode (ZD905) in the switch-on network between the key and pin 41 of the microcomputer chip IC901.

E.T.

## Akai VS5

This machine worked properly most of the time. Occasionally however it would thread the tape then go beep-beep-beep like a VCR possessed when asked to play or record. This would be followed by unthreading, with the breakdown caption lighting up. To escape from this impasse the owner had to switch off and on again, then once more key in play or record. The automatic shut-down was due to the loading switch not being triggered – tape threading wasn't always fully completed. The cause was the loading belt slipping. Fitting a new one cured the problem.

E.T.

## Sanyo VTC5300

We've had two of these machines in for service recently, both with the same fault – a shift in the u.h.f. tuning position and a messy picture of lines and bars when each station is retuned at a higher point on the scale. The giveaway was a high level of mains hum on the E-E sound. In both cases we found that there was more than 1V peak-to-peak of sawtooth mains ripple on the 33V tuning supply line from the power supply section of the machine. Reservoir capacitor C5002 (47 $\mu$ F, 100V) was in both cases responsible, having gone low in value.

After five years or so the video heads in these and contemporary Sanyo machines are finally beginning to wear out. They seem to have been the hardest wearing of all the types fitted to Betamax machines, having long outlived those used in Sony and Toshiba machines. Unusually, replacing the Sanyo heads involves dismantling the rotary transformer, though this operation is not difficult.

E.T.

## General VGX520B

This is quite a new model, and was a complete stranger to us. Its problem lay in the tuning department, which would not self-seek no matter how much the tuning-up button was pressed. The culprit was the tuner/clock/display microcomputer chip, type  $\mu$ PC7519, which lives near the fluorescent display panel. It's a surface-mounted chip which can be removed only by cutting off all its legs (use a very sharp scalpel to do this) and clearing up all the stumps afterwards.

When the chip had been replaced we found that we

could only seek as far as the top end of Band I, as indicated in the display panel on the "VL" bar-graph. To progress to Bands III (VH) and IV/V (U) we had to fit a switch across the vacant key connections marked "band" at the bottom of the keyswitch PCB. Once all available programme settings have been assigned to u.h.f. in this way the switch can, if required, be removed since the new chip is now programmed. E.T.

### Hitachi VTTU65E

This tuner/timer partners the VT6500 VCR. One that came in for repair suffered from intermittent loss of the vision and sound signals. All the question marks vanished when we removed the top cover. The i.f. module is the same as that used in the 8000 series of "table" models, with its well known trouble of an internal dry-joint at the junction of the copper printed earth land and the tabs on the screening wall. Mystery solved! E.T.

### Hitachi VT9500

This machine had intermittent sound on E-E and playback. On removing the covers I homed in on the relays, but this time they were blameless. The fault was due to a dry-joint on C429. P.B.

### Akai VS9700

The pinch roller solenoid didn't always pull in when record was selected, though it always did when playback was selected. Tests on the mechacon board showed that the Rec/Play 12V voltage wasn't always present. It turned out that the record switch was dirty. P.B.

### Sharp VC9700

This machine was intermittently dead with no clock display. Tests around the STK772B chopper regulator chip I9001 in the fault condition showed that there was 31V at pin 7 but no 13V output at pin 6. Pins 3 and 4 feed the internal pulse-width modulator and the voltages here were both negative - clearly wrong!

These pins are also associated with the over-current protection circuit (Q9001). As it was difficult to determine whether the chip was responsible or Q9001 was telling it to shut down we disconnected pins 3 and 4 - this seemed to be the best way of tackling things. The negative voltages remained and fitting a replacement chip put the machine back on the road. It was the second machine of this type in as many weeks that needed replacement of the STK772B chip. S.L.

### JVC HRD725/Ferguson 3V43

No E-E sound and no playback sound either were the complaints here. A look at the circuit revealed an awful lot of things that could have gone wrong! A great deal of the circuitry in this machine is for audio processing.

The protection fuse CP3 was found to be open-circuit but replacing it produced no improvement. Many checks were made before we found (stumbled across?) the fact that there was no 9V supply at pin 8 of the switching chip IC5. There was voltage at pin 8 of IC17 however, which the circuit showed as being the same section of print (linked by a 220Ω resistor). As a quick check these points were cautiously linked across. This produced low, dis-

torted sound and only 3V at pin 8 of IC5. Mmm! A regulator transistor, Q16, is associated with CP3. When this was checked it was found to be short-circuit base to collector. Replacing it restored normal voltages and sound and my link could also be removed. S.L.

### Panasonic NVG7

This machine would accept a cassette then immediately eject it. Unless the end sensors are covered, immediate ejection of the carriage is normal with a Panasonic front loader when it's fooled into loading the carriage without a cassette in place. With this information in mind we suspected perhaps a leaky end sensor, and as another of these machines was available we swapped over the loading carriages. The fault persisted however. We next compared the voltages at pins 20 and 21 of the system control chip with those in the working machine - these are the end sensor inputs. The readings in the faulty machine were 5.5V against 3.2V in the other machine.

The supply voltages for the end sensor phototransistors, which are connected to pins 20 and 21, are obtained from a potential divider network (R6009/10/11/12) across the 6V rail. A check revealed that there was no voltage drop across R6009 (1kΩ) at the top of the network and an ohms check showed that there was a dead short across it. The resistor itself was blameless, as the short persisted when one leg was unsoldered. On closer inspection we noticed that R6009's other leg was very close to an adjacent print track. In fact the leg was touching the track, as a result of which R6009 was shorting itself out. When the resistor's leg was prised up the short disappeared and the machine accepted cassettes readily. L.G.

### JVC HRD120/Ferguson 3V35

It was difficult to pinpoint whether the fault was in the r.f. amplifier or the converter - it was very intermittent. We decided to remove the aerial booster unit, solder all suspect joints and refit it, but the fault was still present. Taking the same course of action with the converter unit put matters right. Prior to doing this we'd checked the supply rails and found them to be correct.

When we'd done all this we found that playback was faulty, the symptoms looking like the effect of misadjusted tape guides. The cause turned out to be different however: the back-tension brake band was broken at one end. Replacement plus back tension resetting was required. R.S.N.

### Ferguson 3V55

The job card read "dead - no functions - tape jammed". We extracted the customer's tape by rotating the tape loading motor manually. After switching on there were still no functions. A check on the power supply section revealed that there was no voltage at pin 3 of plug CN1, nor at pin 2 of CN3. The cause of the missing supply was the fact that CP1 (F10) was open-circuit. Replacing this restored normal operation. R.S.N.

### Akai VS112

The symptoms with this machine were no channel changing and blank video in the E-E mode. We found that there were dry-joints inside the aerial booster unit. Removing this unit and carrying out careful resoldering cured the problems. R.S.N.

# *Servicing Mitsubishi VCRs*

**Derek Snelling**

In this article I'll be covering the HS303/320, the HS304/330, the HS306/307, the HS700 and also mention briefly the more recent HS318/319.

## **Model HS303**

We'll start with the HS303/320. The HS303 is the basic model. Most of the electronics are on the main panel underneath. Access is by removing the top (two screws at the rear) and bottom (six screws). After undoing the three securing screws the panel can be hinged upwards. Take care when working on the machine upside down as the tuning panel on top is not secured and can short out to the metal mounting bracket.

This machine has five motors – capstan, loading, drum and two for the reels. It's on the whole a fairly reliable machine but the picture quality, particularly by current standards, is poor – this is not so noticeable if the machine is used with an old TV set.

## **Common Faults**

Failure of one of the reel motors is common, giving poor or no rewind or intermittent play. The motors are easy to check – when taken out it should be possible to spin them quite freely by hand. Any stiffness means that replacement is required.

Motorboating on sound or failure to record sound usually means that the audio relay K3F0 has dirty contacts. Cleaning may help but replacement is usually best. Failure to record while leaving the previous sound intact is caused by the plugs and sockets in the erase circuit, one on the main board and one on the head itself. Remove the plugs and sockets and solder the wires direct.

Video head wear usually shows up after about three years, giving streaks on the picture highlights. You'll often find that the head has taken on a dull appearance because the chrome has worn off. To change the head drum on this and most Mitsubishi machines you must first remove the motor coils from the top of the assembly (two screws), next remove the ring magnet (three screws) noting which way it goes on, then the drum itself (two screws). Mitsubishi head drums can be a tight fit. Heating with a hairdryer can help but whatever happens don't be tempted to try to lever the drum off with a screwdriver – all you'll succeed in doing is to damage the lower drum assembly.

Another common fault, which you get with all the Mitsubishi VCRs covered in this article, is failure to record and/or playback in colour. The problem is usually intermittent. In nearly all cases it can be cured by using a frequency counter to set up the various 4.43MHz oscillators to within 50Hz of the specified value. Just occasionally one of the crystals may have to be replaced. Before making the adjustments it's a good idea to give the trimmer capacitors a few turns to clear away any flux drawn up into the leaves during manufacture.

A final common fault with the HS303 and also some later models is failure to track prerecorded tapes or even earlier recordings made by the machine. The cause is loose tape guides. You'll find that they can be easily turned by hand. After resetting, tighten the locking screw – this is mounted

vertically next to the guide rather than on the shaft as you would expect. When correctly tightened you should be able to turn the guide by hand. Seal the locking screw with paint.

## **Model HS320**

The HS320 was an upmarket machine sold at the same time as the HS303. In many respects however it was very different. As we sold only a few I can't say much about it, but here are a few points to watch out for:

The supply photosensor is mounted on the left side panel. So if you have this board out when working on the machine the tape won't stop at the end. It's essential to refit the board in the correct position to ensure that the sensor lines up with the lamp. A panel lock switch is fitted: if this is "on", operation of most of the front panel is prevented.

Common faults are the guides, oscillator adjustments, reel motors, incorrect speed due to crystal X6A0, and failure to load correctly because the loading switches are incorrectly positioned. These switches are located by the head drum at the end of travel of the loading arms and can be adjusted from above by loosening the mounting screw. The problem can occur with the other models dealt with in this article but seems to be more common with the HS320.

## **Models HS304 and HS330**

The HS303 was replaced by the HS304. The mechanics are similar but the HS304 has a front-loading mechanism. The electronics are on two boards at the right of the machine. The top board, mounted with the components down, contains the signals circuits while the bottom board, mounted with the components up, contains most of the servo and power supply circuits. Access is by removing the top – two screws at either side. All lower board adjustments are along the right-hand edge and are easy to adjust from this side. Access to this board for service is difficult however as most of the solder side is obstructed by plastic reinforcing bars for the chassis. It's usually necessary first to remove the top board then unscrew and lift the lower board as far as the wires permit.

The HS330 is the upmarket version of the HS304 and is very similar. The main difference is the addition of an extra board above the video heads. This board caters for the dual-speed functions.

Common faults on these two machines are as follows: the guides, reel motors, oscillator adjustments and intermittent sound erase. In addition the HS304 can suffer from intermittent playback luminance, record picture, speed variation or record colour. These problems are all caused by dry-joints on IC2A0. Scrape all the varnish from the pins before resoldering. Intermittent sound recording is caused by misalignment of the audio/control head assembly. The HS304 has wired remote control: the socket is mounted on a corner of the tuner preset panel and can break off if the plug is inserted using undue force. The replacement panel is quite cheap however.

Less common faults I've had with the HS304 are: patterning/instability on certain channels due to a faulty tuner; no capstan operation due to IC4A2; failure to switch

off due to R908/910; taking a long time to come out of visual search due to a faulty capstan motor; and intermittent sound due to misalignment of the audio/control head assembly.

### Models HS306 and HS307

The HS304 and HS330 were replaced by the HS306 and HS307 respectively. They are completely different from the earlier models – the mechanics were redesigned so that only one motor is used for loading, fast forward, rewind and play (capstan) while the electronics are mounted on one main board with the clock/timer on a smaller board that's permanently fixed to the front of the main board. The two machines are identical apart from the fact that the HS307 has extra components fitted on the main board.

Access is by removing the top – two screws at either side and the front; three clips along the top, one either side and three along the bottom. For access to the head for cleaning, undo the six screws that hold the main board and the four that hold the timer board, then swing the whole assembly into the vertical position after which the head cover can be removed and the heads cleaned.

Common faults on these models are as follows: wired remote control failure (replace the plug and wire); failure of the remote control socket; mains fuse failure (upgrade to 630mA); an intermittently negative picture due to dry-joints in the booster/converter; squeaking due to lack of grease and poor centring of the head drum earthing spring; intermittent sound recording due to poor alignment of the audio/control head assembly; failure of the capstan to go in one direction due to the capstan drive chip which is mounted on the metal strip at the front of the main board; low gain due to a faulty booster/converter; intermittent or no colour due to IC6A0; and failure to front load correctly due to the nylon cassette housing guides jumping out of the grooves. Head wear is also beginning to show on these machines a bit earlier than one might expect.

### Models HS318 and HS319

The HS306/307 were replaced by the HS318/319. Again, this involved complete redesign. Access is as awkward as with the previous models. Head cleaning involves unclipping three small subpanels connected to the main board as well as the main board itself. Note that when removing the front there's a screw behind the front flap.

There are not many common faults with these machines, but failure of the front loading or loading switches is one, and this usually results in damage to one or more of the cogs. This can also happen with the HS306, but is less common with this machine. No playback or E-E sound can be due to cracks in the print at the rear left of the main board, while low gain can be caused by the 9V stabiliser that supplies the booster/converter.

### Model HS700

Most of the electronics in the portable Model HS700 are on the rear boards, with the mechacon section on the board mounted on the left-hand side. Access is by removing the back (six large and two small screws), the cassette lid (two screws) and the front (up to six small screws and clips plus one screw and the tracking knob behind the front panel). In addition, to clean the head drum properly the control panel and head cover must be removed. Undoing the three screws along the top edge of the rear panels enables them to be hinged down as one board.

The mechanics are very similar to those of the HS303/304. A point here is that the machine is designed to operate in the upright position: when used on its back the cassette housing is not strong enough to eject the tape.

Common faults with this machine are as follows: intermittent colour due to poor oscillator adjustment; poor tracking due to loose guides; reel motor failure; failure of the aerial socket; incorrect positioning of the take-up reel cog – it has a tendency to move up or down the shaft, giving intermittent play or high rewind speed, often resulting in damaged tape; stopping after a few seconds due to a broken still frame adjustment potentiometer (adjustable through the rear cover of the machine); intermittent sound recording and failure to erase the previous sound (see Model HS303). For vertical lines on dark scenes fit a 100 $\mu$ H choke across R6G3 on the chrominance/luminance board. A few tips with this model. Be careful how you refit the shield over the front controls – it can short R858 to deck, causing F902 to fail; remember to refit the counter belt if you have the cassette housing out; if you have to replace the camera socket order one for the HS710 – it's metal and available separately. The fuses are located on a small panel mounted end-on under the control panel.

### Slow Rewind

The subject of slow rewind with earlier models – the HS303, HS320 and HS700 – was dealt with in some detail in the March 1985 issue (see page 279). The first thing to check is the reel motors. If these are o.k., the values of the resistors in the feedback paths to the reel revolution detector transistor can be increased. With the HS303 and HS700 the resistors are R5K6 and R5K5, with the HS320 they are R5B4 and R5M4. To determine the value, temporarily fit a 10k $\Omega$  preset in series with a 1k $\Omega$  fixed resistor, then adjust the speed for whatever is best in the particular case.

### In General

Finally, a few words in general about these machines. In the case of dirty heads, particularly with the more recent models, it's not unusual to have to clean them two or three times to get the picture back. Some of these machines are now appearing on the secondhand market. Since they were not as widely sold as many other makes they can be bought at very reasonable prices. Provided the heads are good I'd recommend all models except the HS303/320/330 as good buys. Heads can be a problem: as they are not as widely available as other makes they tend to be rather more expensive.

# The Room at the Back

J. LeJeune

The weather was in a capricious mood. One warm and sunny day would be followed by another of thick fog or drenching drizzle. High winds would rattle many a rooftop aerial then die away to give a cold, clear day. Shirtsleeve order at lunchtime could be followed by double anoraks and moon boots a half past five.

Sid stood in the middle of the workshop and surveyed the area with displeasure. Gareth's bench resembled a Silicon Valley explosion. Integrated circuits in various attitudes of death lay around a disembowelled micro-computer. This Grapefruit Turbo-Q machine was always wrecking large quantities of i.c.s. The power unit was to blame. Andy had been wrestling with a 3V23 that needed new cassette loading rollers. He'd dropped his watchmaker's screwdriver into it with the power switched on. Something had gone pop and restoring normal service was becoming the saga of the week. Sid's own bench was occupied for once. A brand new G8 stood upon it awaiting his pleasure. He'd get to it later. How the G8 came to be brand new was a sad tale of stock-room organisation. The incident had reflected badly on the shop manager's competence - he'd since left to join the Civil Service.

A Newsound portable cassette recorder came in from the shop. Cynthia handed it to Sid, adding that "the lady says there isn't much wrong with it and she'll call back for it later, after lunch."

"Another fine mess you've got me into" grumbled Sid as he prised the bottom off the machine and peered at the belts. "She didn't get this rubbish here, I hope."

"Said she'd bought it in Petticoat Lane on a day trip to London" said Cynthia.

The belt had gone slack. Sid wondered where in the world he could get one by lunchtime. He dug into his selection, but it was no good. Then he remembered. He went into the outhouse kitchen and put on the kettle.

The Topcut van lurched back into the rear yard, with Andy and Gareth. Sid was on the phone as they came in. The rattling kettle and steam in the outhouse indicated that

a brew was on the way, so Gareth threw some teabags into the pot and poured in the boiling water. A nice hot brew was what was wanted on a day like this. But Andy's first sip produced a grimace. "Ugh, it tastes of rubber. What have you done to it?"

Sid chortled as he put the phone down. "Take a look inside the kettle and you'll see the reason why!"

Gareth disappeared and returned with the belt from the Newsound.

"You've been boiling belts again" declared Andy.

Sid explained the problem, and they all agreed that it was the only thing to do. The kettle would taste of rubber for a few days, but making the tea stronger would deal with that. They'd have to tell Mrs. Know-all that it was a temporary repair, and perhaps not charge her too much. She'd either be grateful for their honesty and return to Topcut's to buy a new machine when the belt gave out again, as it was bound to do soon, or she'd take the wretched thing elsewhere.

Andy and Gareth had been out to deal with a teletext problem. It turned out to be signal trouble and had been tricky. The problem had arisen after the erection of a crane at a nearby construction site. Even after very careful alignment of the aerial, crane movement badly upset the teletext. A very disgruntled businessman on enforced rest with a bad heart was well on the way to his next attack when Andy and Gareth had arrived. Diplomacy had placated him, two freezing hours on the roof had virtually eliminated the problem, and the crane driver had agreed to leave his tower crane in a certain position when it was not in use at night. "Servicing isn't all soldering irons and spanners" Andy had told Gareth as they drove back to the store. "It's handling people as well."

"And getting pneumonia on someone's roof" added Gareth.

The afternoon brought more enlightenment in the form of a compact disc player. It was a "no fault found" item that had bounced.

"Still won't skip forwards or backwards" complained the owner, "I tried my disc in it only an hour ago."

"Odd" muttered Andy to Sid, "it worked fine on our YEDS-1 disc yesterday."

Sid told the caller he'd send his best engineer to the house to take another look, and shortly afterwards despatched Andy with the YEDS-1 disc.

Gareth was inside a stereo teletext receiver and looked set for the afternoon, so Sid settled down to a Ferguson 22G3. The customer had complained of no operation and a chattering noise from inside the set. He plugged in and switched on. The customer was right. "These blasted relays" he commented, and soon had the contacts shorted across. He switched the set on again. There was a squealing noise from within, but no life other than that.

Andy returned with a broad smile on his face.

"Well" asked Sid, "what was it?"

"Nothing wrong with anything" replied Andy, "YEDS-1 plays perfectly, with all functions normal. She's only got one disc, 'The Phantom of the Opera' selection, and you can't skip tracks on it. It's only got track 1 - that's the whole of the disc!"

"Come and sort out this 22G3" snorted Sid, "I've got some paperwork to do."

The TX100 was still emitting a squeal and little else from its power supply. Andy remembered that Grundigs did similar things and began to look round with the Avo. The h.t. rail was short-circuit, or rather the line output transistor was. With a new transistor fitted the set worked normally and Andy removed Sid's modification to the relay, which didn't chatter now that the h.t. line was o.k. He switched the set off and turned to look at the G8. The picture was fluttering madly. "What's up with this museum piece then?" Andy called out to Sid.

"That's no more a museum piece than I am" retorted

Sid, "it's straight out of stock."

Norman appeared at the door. "New thyristor wanted there" he commented. "Stock fault: bung in a new BT106."

Andy looked as though he'd recalled some half-forgotten truths and walked over to the components drawers.

"Do we have any left?" asked Norman.

"We're getting low - there are only thirty left" grinned Andy.

Norman crossed to the 22G3 and, pressing in the power switch, said "must catch the hourly news". The set spluttered and the relay resumed its clattering. He disconnected the remote standby connector plug 18 and the clattering stopped. "An h.t. short" he mused, probably the line output transistor. It had gone again. This time a new silicone thermopad and spring clip were fitted with the replacement BU508A. "Best to change the pad and clip, just as we do with mica washers" he commented.

Gareth came over to look on. He was about to try the receiver again when Norman stopped him.

"We've got to change C75 in the line generator circuit from  $1\mu\text{F}$  to  $22\mu\text{F}$  first" he said, "it's often the cause of line output transistor failure".

With the small electrolytic replaced and PL18 reconnected the TX100 sprang to life.

Silence fell briefly on the workshop. Then Ralph Topcut strode through the door. He called to Sid who went out with him. Ten minutes later he returned, his face ashen and his normally assured manner badly dented.

"What's up?" asked Norman.

"Microwave ovens, that's what's up" replied Sid. "The DA boys won't do them without training and more pay, so we've got them."

"Anyone feel like retiring?" asked Gareth.

"Me for a start" replied Sid.

# *Servicing Notes on the Mitsubishi HS303*

*John Coombes*

Our experiences with this machine have been as follows.

**Noise bars with vertical jumping or rolling:** Check the f.m. envelope. If misshapen, the guide rollers are probably out of adjustment. As a check they can be moved by hand to restore the waveform. To set the guide rollers correctly, loosen the set screw then adjust with an Allen key for best waveform.

**Unstable picture with poor sound:** The guide rollers could be responsible (see above) but we have had the trouble due to a sticking back-tension lever. You may have to remove the whole deck, dismantle the back-tension lever, clean, grease the shaft very lightly and reassemble. Make sure the lever is of correct shape.

**Picture breaking up at top:** Check the back tension which should be 30g-cm. Excessive tension can ruin the video heads.

**Poor rewind:** Check the supply and take-up motors by replacement.

**No rewind or reverse fast search:** Could be due to a defective supply reel motor, which can be intermittently faulty. The usual cause however is the tape start sensor phototransistor Q578 (PN202S-R) – check by substitution.

**Tape looping with no cue or review, poor rewind or possibly a noise bar on the screen:** All these symptoms can be caused by a faulty reel motor. Check by substitution.

**Plays for a short time then cuts out:** Check the take-up reel motor by replacement. Make sure that the take-up pinion is set on the shaft correctly.

**Tape breaks on rewind, noisy on play and reverse or forward search:** Check whether the pinion on the take-up motor shaft has slid down or broken in two. It's best to order the part for Model HS330 as this is a complete pinion with grub screw to ensure tight fitting on the shaft, not just a tight plastic fit. The tape breaks on rewind because a loose pinion prevents the auto-slow circuit operating.

**Tape catching on eject:** Check that the loading motor is operating correctly. If the motor is in order check the brake pads on the right- and left-hand reels – adjust and set the take-up and supply brakes. Ensure that the contact surfaces are clean.

**No loading:** If loading fails to occur when the play button is pressed check the loading motor or, if there's slipping, check the loading belt by replacement.

**No sound or intermittent sound, record picture all right:** If the original sound track is still present after making a recording, remove the plugs and sockets connecting the erase head to the main board and wire direct.

**Hum on sound.** The hum may be intermittent or may become a howl. The usual cause is high-resistance contacts on the audio head switching relay K3F0. A replacement relay is best.

**Distorted or low-volume recorded sound:** If prerecorded tapes are all right, check the audio/control head assembly by replacement. If the distortion occurs a few seconds after the tape starts, check the 4066B analogue switch chip IC3F1 by replacement.

**Sound wow:** If this is more noticeable with recorded music, usually at the beginning of an E240 tape, check the pinch roller bearing. If this is the cause of the trouble replace the pinch roller. Make sure that the capstan shaft is clean. It's possible that the capstan motor is faulty – check by replacement.

**Wow and flutter with noise bands on the screen:** If cleaning the pinch roller and capstan shaft fails to cure, check the capstan motor by replacement.

**Slow forward and rewind speed:** An E180 tape should rewind in four minutes ten seconds. If not, check whether R5K7 (3.3k $\Omega$ ) has a 6.8k $\Omega$  resistor in parallel. Remove the parallel resistor – on board MC.

**Capstan speed too fast, no switch off:** If there's no waveform at pin 7 of IC4A1 (AN6341N), check this chip by replacement. If the waveform is present and correct check the 2SC2603 capstan drive transistor Q4A3 by replacement.

**Drum speed incorrect or capstan speed varies:** The symptoms are loss of line lock or sound variation respectively. Check IC4A0 (AN6350) by replacement.

**Playback picture has displaced colour, cogging, intermittently snowy:** Check for a squarewave signal at pin 25 of IC4A0 (AN6350). If missing, check back to pins 9 and 10 of IC4A6 (TC4066BP), then back to pin 7 of plug/socket VH and if necessary back to the junction of diodes D601/2 on the Y/C board.

Use a frequency counter to check that the 4.433MHz signal is present at pin 3 of IC603 (AN6342N). If crystal X601 is all right suspect trimmer VC601 (45pF). Rotate the trimmer to clean the plates (note position first). If this doesn't do the trick replace the trimmer.

**Intermittent loss of playback colour:** Check for line sync pulses at test point TP6S. If these are present check at pin 6 of IC6A0 (HA11741). Loss of line pulses here can be caused by C6E3 (150pF) going open-circuit intermittently. Check by substitution.

**No recording, playback all right:** Check the f.m. modulator circuitry or IC2B0 (AN6310) by replacement. If necessary check the carrier set trimmer VC2B0 (50pF) which can go high-impedance. Note its setting and rotate to clean the plates. Replacement of IC2B0 can involve the need to carry out carrier deviation adjustments.

**Intermittent clock operation:** C8F2 (0.47 $\mu$ F) connected to pin 9 of IC8F0 can develop a variable leak.

**No machine functions, clock all right, all front panel LEDs alight:** Check IC500 (MC14174BCP) by replacement.

**Tuning drift:** Drift with loss of the record control pulses can be caused by misoperation of the a.f.t. circuit. Check the a.f.t. defeat transistor Q102 (2SA1115E/F). If drift is affected by picture content add a shorting link across L109 and remove C132 from the circuit.

## Sharp VC8300

The playback picture showed all the symptoms of both a capstan and a drum servo fault and I initially began checking the circuits that are common to these two loops, i.e. the supply lines, IC701, IC702, IC703 etc. The scope showed that all the relevant ramps, sample pulses and sample/hold d.c. outputs were present, though they were varying wildly as the loops were unlocked. This is usually an indication that the i.c.s are in fact working, but as time went by I was driven to replace IC701 and IC702, only to find that the fault was still present.

At this point I decided to try a different line of approach. If I could prove that a drum fault was causing the capstan to unlock, or vice versa, I would have narrowed down the possibilities by fifty per cent. This was my biggest mistake – a further two hours were wasted. How did I go about it? By disconnecting the servo loops one at a time and using a variable d.c. supply instead. All this did was to prove that there was indeed a common cause, but what? Then I saw it. The f.e.t. Q703 in the drum sample/hold circuit is biased from the same point as Q707 in the capstan sample/hold circuit. A check on the d.c. conditions revealed that the gate potentials were both low. Further checks led me to the 10 $\mu$ F tantalum capacitor C731 which read 10k $\Omega$  when measured out of circuit. Needless to say the celebrations went on for some time.

Perhaps I'd have found this one sooner if the circuit had been drawn larger, as the common supply via R769 is not at all clear. That's my excuse, anyway. J.C.

## Grundig VS180

Both spools were running fast and there were no other functions. After threading up manually the machine would unthread and eject the cassette, with both spools continuing to run fast and not switching off. This would tend to suggest something wrong with the cassette eject switch, but the threading motor stopped after eject so the microcomputer chip did that all right, indicating that this chip was not faulty. After a word with Grundig Pete we decided that the most likely culprit was the M722 series-to-parallel interfacing chip, which indeed it was. We came to the conclusion that erroneous data was being sent to the microcomputer chip. The faulty chip can cause other symptoms depending on which data bit is corrupted. S.B.

## Grundig VS180

This machine had suffered transport damage while being brought back from abroad. While sorting this out we found that the machine would sometimes initialise by winding forwards and backwards very slowly. The cause was eventually discovered to be the on/off switch. It switched off the 33V supply but not the 5V supply, leaving the clock on and the machine partially operating. S.B.

## Panasonic NV333

This machine actually wore Blaupunkt livery. There was no playback colour and unfortunately it was wanted in a hurry. Although there was no proper colour there were signs of unlocked colour flickering about occasionally.

The VCO and reference oscillator frequencies were both

correct so to save time I decided to change the AN6371 and AN6363 colour signal processing chips. This didn't cure the fault, and with four or five camcorders and some cameras wanted urgently life didn't look too good. With this model it's possible to check the a.f.c. by comparing the line sync pulses at pin 3 of IC8002 with those at TP8006. I found that there was no lock in playback though the a.f.c. system was locked solid in record. There was a difference in the level of the sync pulses at pin 3 of IC8002 between playback and record, but this is normal. The only other discrepancy I discovered was that pin 9 of the chip was at 2V instead of 5.55V in playback. This led back via a switch (Q3011) to the preamplifier and drop-out detector chip IC3002. The voltage at pin 15 was low at about 2V instead of 4.8V with drop-out pulses – something to do with advancing the a.f.c. loop in the event of a drop-out. Anyway, I found that if pin 9 of IC8002 was linked to the 5V rail the machine played back in colour without need to replace the preamplifier chip. Very naughty, but the machine was old, the video heads in poor condition and the customer didn't want any more expense. After all, the customer is always right (if he pays for it). S.B.

## Grundig VS310

This machine intermittently damaged tape. Grundig Pete spotted it by chance while we were discussing other things. He put a tape in (mine) and it scrunched up! The small, flat copper-coloured guide spring fitted to the top of the audio head had broken off. S.B.

## Ferguson 3V43/JVC HRD725

The complaint with this machine was intermittent failure to make a timed recording. We confidently changed the loading belt and sent the machine on its way. It was very soon back on our bench with a note to say "same as before". This time we checked the loading process more thoroughly, and found that there was a stiff point in the mechanism at about the half-travel point in the progress of the loading arm. It turned out that loading gear 2 (under the deck) was very stiff on its shaft. It was removed, cleaned and lubricated, and after that the customer didn't report any further timer trouble. Why it never gave trouble on manual record and playback remains something of a mystery. E.T.

## Mitsubishi HS303

The job card said "picture broken up". It was, too. The head drum was rotating excessively fast, giving loss of line lock on the monitor's screen. Listening to the sound track of a prerecorded test tape suggested that all was not well with the capstan servo either. We found that adjustment of the preset drum speed control VR4A0 would restore correct drum speed, but with the potentiometer's wiper far from the factory setting and with no head drum phase lock.

A search for a common cause of this and the capstan speed error led us to check the common reference pulse feed (REF 50) at servo board connector HS7. It was missing here and at its source, pin 5 of the oscillator/divider chip IC603 on the Y/C board. The voltages around this chip were reasonably within tolerance except for that at pin 5,



which was at 5.5V instead of 3.5V. In fact the 4.43MHz crystal X601 had failed: replacing this and resetting VC601 restored normal operation. Although it's a PAL decoder type crystal its output is used exclusively for servo operation - despite the presence of the other faults the colour was normal, once the head speed had been artificially restored to normal.

Our pride at doing this repair was blunted by the fact that the customer's cheque bounced. We're still trying to get paid, but that's another story . . .

E.T.

### **Ferguson 3V23/JVC HR7700**

In my experience it's unusual for this machine to suffer from tape looping at stop. However this one would sometimes leave a loop of tape hanging from the flap of an ejected cassette. We found that the take-up spool brake was coming on after the supply spool brake because the take-up turntable tyre surface was worn to a smaller diameter than that of the supply turntable. Replacing the take-up turntable and the coil-spring that holds the brakes on cured the problem for good.

E.T.

### **Panasonic NV366**

The drum motor appeared to have a dead spot. We found that the cable connector on the motor was partially off owing to a tight run of cables. Rerouting the cables and fitting properly cured the trouble.

D.H.D.

### **Hitachi VT9500**

No sound or vision in the E-E mode was traced to a faulty TA4349 chip (IC909).

D.H.D.

### **Ferguson 3V29/30**

On playback there were noise bars on the screen, with spaghetti, low sound and the sound led captions as spoken. Resetting the tape guides put matters right.

No capstan drive was traced to a blown Wickman fuse (CPR-D - looks like a transistor).

D.H.D.

### **Ferguson 3V29/JVC HR7200**

There were two separate faults with this machine. First, when a cassette was inserted the machine would immediately go into slow rewind for a few seconds then stop. Pressing any button would then produce the alarm mode, with all the button lights flashing. The cause of this problem was a worn loading motor. It resulted in the last part of the unloading cycle being missed, so that both the after load and the unload switches were on.

The second problem was very confusing: the machine wouldn't switch off when the tape came to an end in either direction. Operating the machine without a cassette in, with the end sensors blanked and then exposed to light, proved that they were working. After much headscratching we found the cause of the problem. The cassette lamp had slipped down its holder. It still shone brightly, but was too low for the light to operate the sensors.

M.D.

### **Philips VR6462**

The problem was very low playback and E-E luminance. We checked the CVBS signal output from signals panel P302 and found that the luminance was missing. When we checked back to the TDA3740 chip IC7251 we found that there was no signal input. We moved back to the BC548

emitter-follower transistor T7301 and found that there was a signal at its base but not at its emitter. A check on the emitter voltage showed that it was high and unstable.

Changing the transistor made no difference but when we checked the resistance from its emitter to chassis we found that the reading indicated an open-circuit instead of around 400Ω (via L5201/2/3/4 and R3202/3). L5202 turned out to be open-circuit and when replaced we had normal luminance.

M.D.

### **Toshiba V9600**

This machine was continuously trying to load. The trouble was caused by QL82 in the loading motor drive circuit being short-circuit.

M.D.

### **Amstrad 4600**

This machine was brought to us brand new in a box. Its owner had travelled 350 miles from London where he'd bought it at a very discounted price. It was too much trouble for him to take it back under guarantee, so we got the job. The problem was that when play was selected the machine would go straight into forward search. All other functions worked correctly. A circuit was obtained - eventually. We then had to find a magnifying glass to sort out the very small print layout and wiring diagram. This was on the outside back page and was already tatty when we received it.

We noticed that there are capstan forward, reverse and fast commands from the microcomputer chip. These appeared to be correct when the relevant keys were pressed. When play was selected the voltage at pin 7 of the BA718 operational amplifier IC302 was lower than when search was selected. The output at pin 8 didn't alter however, so we suspected the i.c. This was duly ordered and after several weeks arrived. Fitting it cured the fault, and the customer was given a bill which meant that his trip to London turned out to be expensive.

This was the first time we've seen the inside of one of these machines. We were stuck by how well they are laid out and manufactured. Picture reproduction is also excellent.

M.D.

### **Hitachi VT64**

This machine would load the tape, play for about five seconds then unload. We found that the drum flip-flop signal from the servo i.c. was of reduced amplitude. Checks were made around the servo and syscon microcomputer chips but nothing we did restored the flip-flop signal to its correct amplitude. The flip-flop signal is also fed to the Y/C panel, and although the circuit diagram gave no clues as to what could be wrong here all became clear when the panel was removed - a liquid had been spilt into the machine at some time and was loading the flip-flop signal. The odd thing is that no other traces of liquid spillage could be found.

A.D.

### **Grundig VS180**

There was no clock/counter display. Checks around the clock chip revealed that the 256Hz clock pulses were missing. They come into the keyboard panel from the control panel on two matrix lines designated K4 and K8, and are generated by IC245 and the associated 32kHz crystal. We found that the 32kHz oscillator had stopped due to shorting vanes in an associated trimming capacitor.

A.D.

## Hitachi VT120/130

At switch on the head drum would start to rotate and would then run continuously until the machine was switched off. While this was happening the machine would happily accept a cassette and even load it up. The sensors and the sycon and servo departments were working correctly, but control pin 5 of the drum motor chip IC1651 could not be pulled down. With pin 5 isolated the voltage on it was 5V and we found that over 100mA would flow from this point to chassis. This action didn't stop the motor however! The diagnosis was internal leakage within the chip and a replacement HA13403 solved the problem. E.T.

## Sanyo VHR3100

The problem with this newish machine was that it wouldn't accept a tape. The cassette LED (infra-red light source for the tape end sensors) was not emitting because the SWD5V line was missing. This comes from the 2SA984 switching transistor Q4001 on the SY-1 board. The transistor was open-circuit at its collector. E.T.

## Hitachi VT9500

The owner of this machine had been operating it for some time via remote control only – for the very good reason that the front panel control keys didn't work. The only one that did anything was the play button: when pressed, the record and play lights lit and the machine went into the record mode. Checks revealed that the HD38750A53 function control chip IC2003 was receiving the correct supply voltage and that its oscillator section was running. Fitting a new chip cured the problem. E.T.

## Hitachi VT130

According to the job card the machine couldn't be tuned. In fact the whole receiver section was out of action, though the tuning signal was present and a good tape played back correctly. We found that the not-PB 12V supply was missing due to switching transistor Q504 being open-circuit. A BC328 turned out to be a suitable replacement for the 2SA952. The machine was a later model with an ICPN5 (200mA) protector in the 12V feed to Q504's emitter. This protector had also failed and had to be replaced. Later versions of this model have several changes and modifications which are covered in the Hitachi supplement manual no. 2705E. E.T.

## Sanyo VHR1100

The reel turntables didn't turn at all: the machine reverted to stop soon after loading and during the unloading process spilled tape all over the front of the deck. We found that fuse F3001 on board SY1 was open-circuit. An ammeter connected in its place showed that a normal few hundred milliamps passed when the forward functions were selected, but the current rose to over 2A when the reel motor was asked to go backwards.

The output section of the BA6209 reel motor drive chip IC3006 consists of a transistor bridge arrangement. One or more of the transistors here must have gone short-circuit.

A new fuse and BA6209 restored the machine to normal operation. E.T.

## Hitachi VT120

Tapes were being crunched during *cassette* loading and unloading because the left-hand tape guide was not fully retracting during the tape unload phase. In fact the loading motor was shutting down prematurely. This was cured by slight adjustment of the mechaposition switch. E.T.

## Sony CCD-V8

This camcorder would "slow forward" as soon as it was switched on, with or without a cassette being present. No tape loading would take place, and after four or five forward windings the machine would go into the alarm mode with the eject light flashing. It wouldn't eject though – for this you had to dismantle the machine and flip the switch manually.

The problem was due to a leaky start-sensor phototransistor (Q603) on board HS5. We replaced the end sensor too. It was of the same type and probably from the same production batch. E.T.

## Panasonic NV830

There was overloading on E-E. It was not the modulator this time as the u.h.f. a.g.c. was ineffective. Replacing the BN5115B i.f. chip cured the problem. S.B.

## Ferguson 3V29/JVC HR7200

The complaint was of no colour on playback of a prerecorded tape – the machine was o.k. with its own recordings. The fault description proved to be correct. On playing a prerecorded tape and tracing the signal through we found that there was a voltage drop of about 1V across C415, the input to the main converter. On removing the capacitor to fit a replacement one leg fell off. A.D.

## Ferguson 3V32/JVC HR7655

The complaint with this machine was no clock display. The display came on when the machine was plugged in, but after about half a minute it began to fade and after a minute it was completely out. Voltage checks revealed the absence of a -24V line which was restored when zener diode D233 on the tuner/timer sub power board was replaced. A.D.

## Hitachi VT63

From the initial recordings we made with this machine it looked as though the heads were faulty. But the customer's complaint was of no recording. Making further recordings proved that the heads were not faulty, as good pictures were obtained. Oscilloscope checks revealed that the video f.m. envelope was varying – and could be varied by applying pressure anywhere on the board. The f.m. signal passes from the chip via a 1kΩ resistor to the f.m. record level preset. The waveform was stable at the chip,

but varied at the other side of the 1k $\Omega$  resistor. Various filters were accused, but all proclaimed their innocence. After a lot of pushing and prodding the fault was eventually traced to the preset. It was broken, one leg having snapped close to its body. **A.D.**

### General VGX-520

This machine uses the Panasonic NV430 tape deck, so the following fault could apply to either model. The trouble was intermittent tape chewing. When the stop button was pressed during playback the tape would stop but not unload. If the tape was then ejected the loading poles would unload but the tape would not be wound back into the cassette. The cause of the fault was traced to high-resistance contacts in the mode control switch. **A.D.**

### Ferguson 3V65

We've had two almost identical cases of the 220 $\Omega$  fusible resistor that feeds the 30V regulator being open-circuit. The cause in both cases was severe corrosion and shorting on the underside of the tuner/i.f. panel in the vicinity of IC3. No leaky capacitors were found, and the cabinets showed absolutely no signs of spillage. Strange . . .

Another of these machines displayed a smeary picture in the E-E mode though playback of a test tape was good. Replacing luminance module IC101 cured the fault. **P.H.I.**

### Samsung V1-611

The fault with this machine was dead slow front loading and slow lacing followed by immediate unlacing. No loading motor voltages could be found in the manual, but comparison checks with another machine exonerated the electronics. Though the motor felt o.k. in operation fitting a replacement restored full speed loading. **P.H.I.**

### Sharp VC8300

The fault with this machine was intermittent loss of sound in the E-E and playback modes. A lot of heating, probing and flexing were necessary before we discovered the dry-joint to be on the mother board where the audio module plugs in. **P.B.**

### Marantz MV464

If one of the video heads is low the recordings can be quite good but the auto-tracking appears to go past the optimum setting. Check by connecting the scope to the output of the head amplifier (pin 6 of plug S1) and playing the alignment tape. **P.B.**

### VHS Head Drums

Here's a tip if you have trouble with a VHS head drum that's tight on its shaft. Heating it with a hairdryer for a few minutes will expand it sufficiently so that it can be freed. **P.B.**

### Fisher FVH-P906

The complaint with this machine was of no playback colour, and a test recording played back on another machine showed that it didn't record colour either. All relevant l.t. rails were correct and d.c. checks at the pins of the i.c.s involved proved inconclusive. Scope checks

revealed that the oscillators were all running, at the correct frequencies, and that while chroma was going into the main processing chip IC203 it wasn't coming out. At this stage of chroma signal processing only two chips are involved, IC203 and IC204. We replaced both in turn and found that IC204, an LC7342, was the culprit. The same chip was responsible on another occasion, with a Model FVH-P907. **D.D.**

### Toshiba V9600

We've had to change the loading belt in a number of these ageing machines recently. They seem to load all right but have trouble unloading. The manual suggests removing the loading cam drive assembly to replace the belt, but I prefer a much simpler method. Removing the two screws that hold the cassette lid opener just behind the loading gear gives easy access to the loading belt with a pair of long-nose pliers. You'll find that this is much quicker than removing the drive assembly. **D.D.**

### Samsung V1-611

The fault with this machine was no rewind or fast forward, due to a worn out idler unit. Since the machine was a new one the fault could become quite common. **R.S.N.**

### Samsung V1-611

This machine would not change channel and we discovered that there was no 12V supply from the power unit. Transistor Q2 and the i.c. stabiliser were both overheating - Q2 feeds the chip, which had no output. Replacing these items restored normal operation. **R.S.N.**

### Panasonic NV333 and NV366

The 2SC2671 transistor used in the booster amplifier is a common source of trouble with these machines. Panasonic have issued a repair kit, part no. VVK4059, which consists of a 2SC2671 transistor plus two MA161C diodes and fitting instructions. It costs only a pound or two. **J.P.C.**

### Ferguson 3V16/JVC HR3660

An early ex-rental 3V16 came into the workshop the other day. The job ticket said "no colour". We quickly discovered that the machine wouldn't play back a test tape, or record satisfactorily, if the selector switch at the rear was set to auto or colour. The picture provided by a known good tape gave the impression of severe head wear, with no sync. In the switch's monochrome position record and playback were both o.k.

When we removed the bottom cover and hinged open the Y/C panel we could see that liquid spillage had badly affected the area around IC207/8. So we decided to waste no more time. But we all know that needless curiosity has never been the mother of economic viability and I couldn't resist the challenge to find the real cause of the problem.

IC207 on the Y/C panel should receive a sync input from IC1 on the servo panel. This signal was absent. The servo panel in its turn should receive a video input from the emitter-follower transistor X7 on the Y/C board. This signal was also absent.

The input to X7 passes through a low-pass filter, LPF-2, and the previously mentioned liquid had got into the windings and rotted them. Hence no video, no sync and no colour. Nice one, Bob! **M.G.**

# Ten Years of VHS Video

Eugene Trundle

VHS video cassette recorders first appeared on the UK market in 1978. At that time no one could have anticipated the grip that VCRs were going to get on the public – the British public in particular. During the intervening ten years there has been an explosion in video technology, largely brought about by the competition between manufacturers. The domestic video tape recorder story started long before 1978 however.

## Historical Background

As long ago as 1967 Sony was selling open-reel video tape recorders in the UK at prices that just about put them within the domestic electronics sphere. But 1972 saw the real start of domestic video, when Philips introduced the N1500 video cassette recorder. It didn't sell in large numbers and had limited capabilities, but the "VCR" format represented a milestone as the first video recorder system designed specifically for home use. It had most of the basic ingredients that we know so well today: the tape enclosed in a foolproof cassette; automatic threading; helical scanning; and simple controls like those of an audio recorder. Why didn't it catch on? To start with it was relatively expensive, and had a playing time of only an hour. But perhaps more significantly it was introduced during the first great colour boom, when dealers and the public alike were devoting their time and money to the new colour sets. In addition, the tapes were rather expensive.

The appearance of the VCR-LP system in 1976, i.e. the Philips N1700 series of machines, was greeted with no greater enthusiasm or take up. Perhaps many of the same market factors were still present. One of my most vivid memories of this period relates to a stag party where certain tapes were laid on for the entertainment of a local football supporters' club, in the back room of the King's Head. The TV set was there, and beer was stacked by the crateful. The final ingredient, the video machine, was to be provided by your truly. Uproar broke out when it became apparent that the VCR and VCR-LP formats were incompatible! The twittering voices from the loudspeaker, the lines and bars on the screen, and the disgrace of being thrown out – the N1500 after me – are memories that I shall always carry.

By this time however the Japanese manufacturers were busy. After a certain amount of infighting two new formats were finalised and launched in Japan: Sony's Betamax system appeared in April 1975, while JVC's VHS system came along in September 1976. After their initial release in Japan, both systems were soon introduced and marketed in the USA, where the scanning and colour standards and the mains voltage are basically the same as those in Japan. To start with neither format was particularly successful, but sales soon picked up. VHS was supported by the US heavyweight RCA.

PAL/625/50 versions soon became available for use in Europe, where West Germany and the UK seem to have been the initial target markets. The VHS system was supported by Telefunken and NordMende in West Germany and by Thorn-EMI in the UK. In the early days most VCRs in the UK were rented and Thorn's dominance in this market, through Radio Rentals, DER and other rental

chains, soon put the VHS system in the leading position in this country. Though it couldn't be foreseen at the time, this was in effect to seal the fate of the Betamax system, largely because of the software situation – tape libraries wanted to stock just one tape format.

## The Early Days

But back to 1978 and the appearance of those first electromechanical wonders in the shops. In my role as Merlin to a lively independent dealership I saw at least as many Beta as VHS machines. The experience of the rental engineers was almost entirely with the VHS system however, and partisan feelings enlivened many a tea break at the local technical college, which we all earnestly attended. In those days the video classes were over subscribed. Now many courses don't even get started for want of support. Ironic, isn't it? As it was to turn out, we didn't have to worry too much about many of the things our lecturer drummed into us. In the fullness of time our anxieties about writing speed, extinction frequency, azimuth angles and folded sidebands came to be replaced by much more immediate problems such as can Mrs. Jenkins pay her bill, will the cat's wee eat any further into this Y/C panel, and will Mr. Murdoch ever master the timer on his machine and stop ringing us up?

Modifications to TV receiver flywheel sync circuits were a major topic in those days, and the man who could get the time-constant in the TV set right *and* fix the video was a king indeed. He might even command an extra £10 a month on his wages. My service manager at the time, the venerable Cedric Collier, examined the first VCR to arrive in the workshop and decided that it was a mechanical rather than an electrical affair. As such it was to be dealt with by the audio engineer who, it was assumed, would have more experience of this sort of thing. Having had such greatness thrust upon him Dick, our audio man, upped and left, never to be seen again. I gather that his subsequent dealings related mainly to boats and women, and maybe he was wiser than the rest of us. Anyway . . .

## Gaining Experience

We soon got to know the workings and habits of the piano-key machines, and so did the rental boys, aided by the intensive courses, booklets and so on produced by the rental companies who, at the time, were putting intense effort into staff training. We learnt how to deal with servos, how to twiddle guides, and how to set up the tape path. The Beta tape path was always the more difficult one to deal with, having six crucial guide adjustments – there are only two primary ones with VHS machines.

We also got to know how not to treat the heads! There were some enthusiastic DIY types amongst our customers, and I remember one machine that came in with no heads – both had been broken off in a ham-fisted attempt to clean them, and the lower drum had been damaged by a large screwdriver that had been used to lever up the upper drum – the better to clean the heads perhaps?

The early Beta machines were larger and heavier than their VHS counterparts, but many (myself included) felt

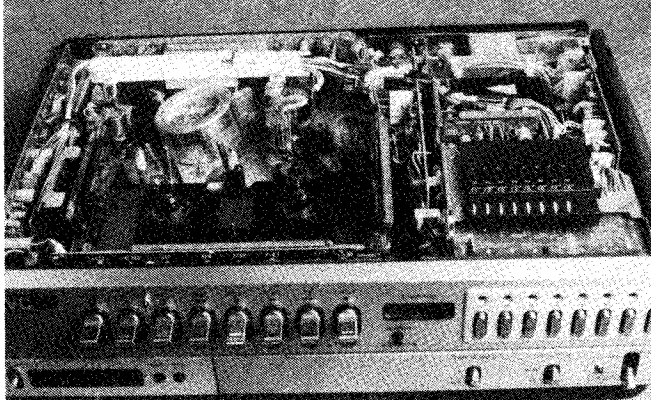

A 1978 interior – the JVC HR3300 with its top cover removed. The machine weighed 13.9kg and its one-event timer had no setting, the recording continuing until the end of the tape was reached.

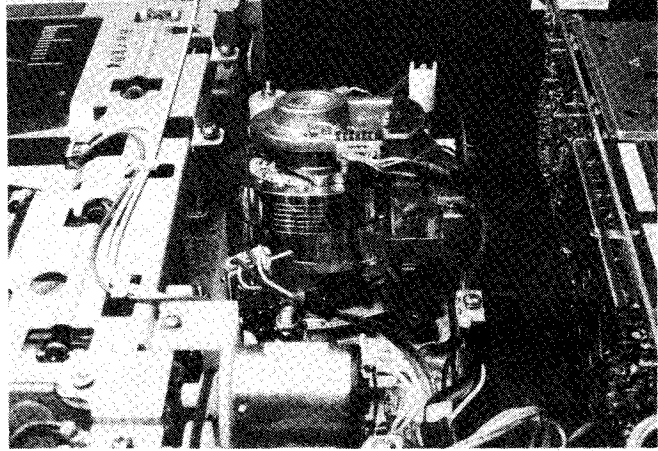

Hi-Fi sound by Panasonic. This view of the pioneering NV850 deck shows, above the head drum, the rotary transformer for the audio f.m. system.

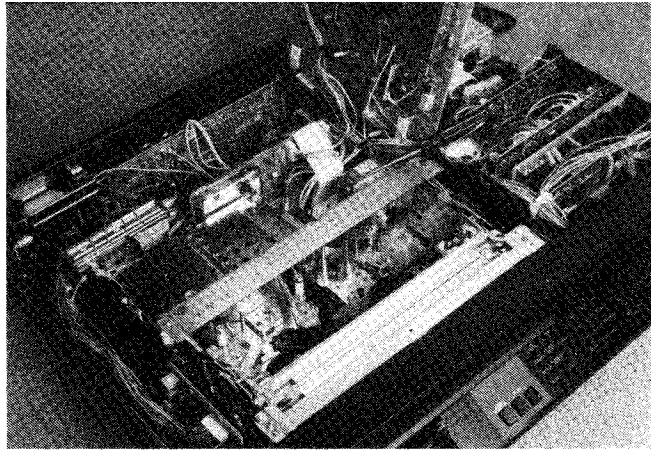

Ten years on: JVC's top of the range Model HRD550. This slim, light model will record eight programmes over a one year period, has "transmittable" timer setting, full infra-red remote control, dual-speed recording, Hi-Fi sound and a NICAM decoder for broadcast stereo sound.

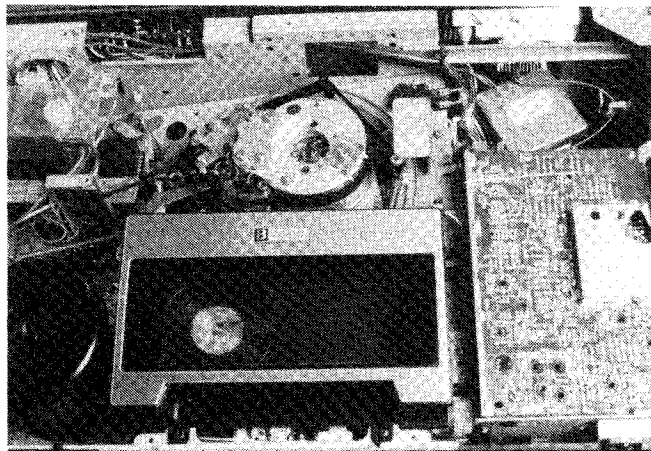

Also ran: the spacious deck layout of the Sanyo piano-key Beta Model VTC9300. The a.c. motor at the bottom left drives everything on the deck. Many more springs and levers lurk below the deck, amongst the clutches, pulleys and belts that live there.

that they produced a better picture. Some of the original bangers in both formats are still soldiering on – to this day I have a Sanyo VTC9300 in service at home. These robust old-timers in both formats all meet their Waterloo when expensive things like heads and motors wear out and the cost of repair can't be justified. With the exception of the

switches and relay contacts in these early machines the electronics have over the years proved to be incredibly reliable. Solid-state switching is far better, if a little more obscure in its workings.

There are compensations for those working on videos as opposed to tellys – no high voltages to catch you unawares and sizzle your fingers, and they don't attract those layers of filth and dust that the heat and high voltages in a TV set produce – nor do you do your back in carrying them. On the debit side, new sorts of intermittent faults came along to plague us. Many of these are to do with friction surfaces (belts, idlers, etc.) and deck sensors. They are with us still! Perhaps too there is more at stake if the diagnosis is wrong. It's embarrassing to be left with an expensive i.c., head or motor when replacement hasn't cured the problem.

A trick-motion machine, the JVC HR3660, appeared as early as 1979, with still frame, variable-speed slow motion and double-speed playback, a bucket-brigade device being used to provide sound compensation. A harbinger indeed! 1979 also saw the announcement of the Philips-Grundig developed V2000 system with its innovative (for domestic use) dynamic track following and a turn-over cassette.

### Into the Eighties

In 1980 the scene changed somewhat, with the introduction of light-touch controlled VCRs. With these a micro-computer in the system control department took the place of the levers, microswitches and mechanical interlocks used in the earlier models. This development lent itself to cordless remote control and front loading. All these features were to be found in a terrifying (to most engineers, anyway) new machine, the JVC HR7700/Ferguson 3V23. This complex ensemble of electronics and mechanics, with chain-driven rolling pin, must have had one of the highest component counts of all time in domestic equipment. It was back to college or to the textbooks to learn about microcomputers, port expanders, insert editing and goodness knows what else.

Another advance at about this time was the introduction of the first portable equipment – the piano-key operated JVC HR4100 and Sony SL3000 recorders and the GS1000, 3V06 and HVC2000 cameras. Suddenly we had to know about pick-up tubes, lenses, optics, sync generators, encoders and so on. I recently renewed my acquaintance with an early video camera when it came in for repair – a JVC GX88. The difference in weight, facilities, performance and power consumption in comparison with modern

cameras and camcorders is staggering. We've come a long way in a relatively short time.

## Test Equipment

As more and more video equipment came in for repair we decided that additional test equipment was required. Somewhat shattered by the prices, we nevertheless invested in VHS and Betamax alignment tapes, an eccentricity gauge (still the only one for miles around here!) and back-tension measuring cassettes. These were added to the torque meter, jigs and other bits that we already had.

The alignment tapes were held in great reverence, to the point of being locked in a cupboard. And thereby hangs a tale. After refusing the use of one to a trainee who wanted it to adjust guides a certain senior engineer, not a thousand miles from here, fed the pristine tape into a machine for a final check on the tape path. Having a heavy cold that day he sneezed and, disgusting to relate, showered the head drum. The latter promptly and instantly picked up the hallowed tape and wound around itself several yards of tape, with a terrible rustling and crunching sound, while the pop-eyed engineer stood frozen in amazement. I finally hit the stop button.

## Developments

The transition to electronic VCR control was widespread and swift. 1981 saw machines capable of insert and assemble edit, a rapid trend away from top loading, and the intensification of competition between manufacturers and formats.

1982 was a momentous year in which developments came thick and fast. Philips, JVC and Sony reached an agreement in principle on the Video 8 system and format – strange in the light of subsequent events! The VHS-C cassette made its appearance in portable equipment, which in those days consisted of “separates” such as the JVC HRC3, Ferguson 3V33 and the Sharp VC220N. Stereo sound capability was introduced, but on the “lo-fi” longitudinal tracks. And the first VHS machines, such as the JVC HR7650, appeared with a comb filter for luminance crosstalk compensation (the Sony SLC7, released in 1981, had been the first machine to incorporate this feature).

The effects of burning midnight oil amongst the other Japanese manufacturers started to tell in 1983. Panasonic introduced the first VHS machine with Hi-Fi sound, Model NV850, in which the sound problems associated with the use of a relatively slow-speed longitudinal track were finally banished. The sound performance of conventional VHS had been a matter of growing embarrassment to the industry – the previous year's crop of stereo machines had actually emphasised the signal-to-noise ratio shortcomings. Hi-Fi machines followed quickly from JVC, Ferguson and the others. This year also saw the introduction of dual-speed machines, initially the Hitachi VT17. Another alignment tape was needed, and you had to be more careful about setting up the tape path and the tracking, though skirmishes with Hi-Fi machines had taught us to pay more attention to these things anyway . . .

Hitachi also pioneered the solid-state (MOS) image sensor for use with portable equipment. By this time cameras and portable VCRs had become much smaller and lighter – and a damn sight more difficult to repair. Rather than the customer being weighed down physically by his gear, the engineer became morally weighed down in his attempts to service it!

The user's problems were being lightened in other ways as well. Horrifically complicated timer setting procedures were simplified with the introduction of user-friendly microchips. Instant recording, auto-rewind and cordless remote control were becoming commonplace.

1984 was another year of tremendous competition between manufacturers and formats. Sony replied to the VHS Hi-Fi sound challenge by introducing its own version, in the form of the Beta Model SLHF100. In reply to dual-speed VHS machines Grundig introduced an LP version of the V2000 format – Model 2080 had a maximum running time of sixteen hours with a single cassette. But significantly, Grundig started to produce VHS hardware. Philips and Pye also changed from V2000 to VHS, while in the Beta camp Toshiba and NEC changed over to VHS. During the year several nails were thus driven into the V2000 and Beta coffins. The traditional photographic companies like Canon, Konica, Olympus, Polaroid and Kodak were now strongly involved with video, having seen the big inroads it had made into the amateur cine market.

## Camcorders

Meanwhile JVC had introduced the first VHS camcorder, Model GRC1, which was marketed by Ferguson as the 3V41. We'd already seen VHS-C (Compact, using the small thirty-minute cassette) in the form of separate VCRs like the HRC3, but the new camcorder had a small head drum. This milestone in miniaturisation had four heads in its little drum, with a long wrap and the high speed of 2,250 r.p.m. The textbooks were confounded – they insisted that the drum must have a diameter of 62mm and rotate at 1,500 r.p.m. This didn't worry us too much because we've not yet had any faults in this area. We just marvel at the excellent compatibility of the system, and know that should we see a picture flicker at a rate of 12.5Hz with one of these machines it will be bad news!

## Events of 1985

Some of the earliest piano-key machines were wearing out and being scrapped by 1985: cannibalisation was the order of the day, and large piles of picked-over machinery grew under the benches of the vultures – we've only now cleared this lot out, having called a halt to servicing this type of machine on the basis of old age and infirmity (us as well as the machines!).

In retrospect, 1985 had most to show for the portable video enthusiast and home-editing buff. Two-piece outfits like the JVC HRS10 and Hitachi VT8 came to the fore, and Pioneer launched its MSX video computer, Model PX-7, with genlock. The Japanese developed MSX computer system seems to have gone back into the cupboard however. Panasonic introduced its NVM1 camcorder, with a full-sized cassette to give a long running time: the small drum configuration was retained, with four heads and wondrous switching.

The year saw Sony launch its first 8mm format equipment, with the excellent CCD-V8, giving us a whole new format to learn about – just in case we were getting bored. As never before, the brown goods repair brigade was having to adapt to new technologies and learn new techniques. Flying erase heads, ATF and M/U tape loading: onwards and upwards! By now however the diversity and reliability of consumer electronic equipment, the continual introduction of new models and the relatively small sales of each (especially with the portable gear), meant that many engineers were starting to lose touch with

what was going on in many fields. How many of us know much about the ephemeral Sony Betamovie record-only camcorders, with their 300° tape wrap, single-head drum and incredible time-warp tricks in the scanning and subcarrier departments?

## **Changes in 1986**

1986 saw the official demise of the V2000 format, in announcements from both Philips and Grundig, who had not made any machines of this type for many months. By this time the world-wide population of VHS machines had reached around one hundred million and was growing rapidly. There were times in the workshop when we were so busy we felt we were looking after them all! The Beta format was by now struggling hard against the odds. The Super Beta specification Model SLHF950 was perhaps its final kick. With this specification the luminance f.m. carrier frequency was raised, giving superb picture quality while maintaining reasonable compatibility. But very few were sold.

Meanwhile the picture quality provided by basic VHS was being worked on. The year saw the introduction of the first HQ machines. HQ badges proliferated, but most machines didn't use the full HQ specification. No time was lost in bringing the benefits of HQ to portable gear – the second-generation JVC C-type camcorder Model GRC2 had it.

I believe it was at about this time that there were one or two prosecutions against the proprietors of the burgeoning video libraries. It seemed that some of their soft porn was not soft enough to satisfy the censors, and a hasty clearing out of the shelves took place, based on a list that was circulated to the trade. Our shops, used to dumping any problems on the Service Department, sent us a box of suspect library tapes. Stashed under the bench, these mucky movies did much to enliven the lunch hours – our learning is not confined to electronic technology!

## **Pace of Progress Quickens**

1987 was the year when digitalisation came to the fore. Field stores began to crop up in VCRs, starting with the Hitachi VT250 picture-in-picture machine and a digital still-frame system in the Toshiba DV-80. Remote control systems in which timer programming could be composed on the handset and then transmitted to the machine in one go were becoming common. The alternative bar-code scanner (Panasonic) also made its appearance. Still on the simplified timer-setting theme, Grundig brought out the teletext-programmable Model VS540, though some problems were caused by the twelve-hour clock used by the BBC in presenting its programme schedules!

Sophisticated index search systems also appeared, along with the half-loading technique in which a loop of tape is brought into contact with the control head during fast forward and rewind to facilitate place finding. Flying erase, previously used only in Video 8 "home" machines, appeared for the first time in VHS equipment – in the Panasonic MC-10 camcorder.

At this stage the Betamax format was still hanging on, though with little technical innovation or marketing effort. Many of the older Beta machines were beginning to wear out and, faced with inevitably high quotes for head replacement, most owners opted to scrap their SLCs and VTCs in favour of new VHS machines – leaving me with a rich legacy of used Beta tapes for time-shifting and archiving on my old bangers. VHS was well and truly

affordable: the lower end of the market had for some time been in the grip of the large retailers' in-house brands, with prices around £250 or even less, and a basic Amstrad machine could be bought for under £300.

## **The Present**

This brings us to the present year. The long-awaited announcement that Sony is finally to get into VHS came early. On every level, from the boardroom to the High Street and in all their major markets, Sony and JVC have been at daggers drawn for as long as I can remember. I've often pictured the workshop car park duel that might occur should their representatives' visits ever coincide – but they haven't, yet! S-VHS should be with us sometime later this year: this new high-definition variant of the format will be a fitting crown to ten years of development.

## **In Retrospect**

These ten years have seen tremendous changes in the trade – from where I'm sitting, anyway. Virtually all the faces in my workshop have changed over the period, and many good engineers are now pursuing different careers altogether. Although the wages, rewards and recognition of engineers have improved (particularly lately) the overall equation does not seem to be an attractive one, even now. Certainly there's been a steady decline in the number of people employed in our business, and it's difficult to foresee a reversal of this trend.

But regardless of what happens in the service trade, VHS will still be with us in ten years' time for sure. By that time we may have entered what has rather ominously been called the post-industrial society. What will that mean?

## GEC V4001/Hitachi VT9300

This machine worked fine in E-E but produced just a blank raster in the playback mode. The scope showed that there was no video coming out of pin 22 of IC202, though it was going in at pin 1. Voltage checks around the i.c. revealed that pin 23 (squelch) was at 3V. The manual specifies the voltage as 4.2V, but if you trace the line back it goes to the base of Q214 which is shown as being at 0.3V. They can't both be right! The feed to this comes from the audio-jack PCB, where Q640 should be conducting in playback but wasn't - it was open-circuit. Alter your circuit diagram to show 0.3V at pin 23 of IC202 in playback!

P.B.

## Sharp VC6300

Don't be surprised if you find that you have no rewind after fitting a non-genuine belt kit in one of these machines - the rewind belt is often too small, preventing the idler from moving over far enough.

P.B.

## Ferguson 3V31/JVC HR7650

For intermittent colour in the playback mode, check for dry-joints on crystal 401 on the chroma board.

P.B.

## Amstrad VCR4500

Crinkling of the lower edge of the tape as it re-enters the cassette has become a problem with these machines. The official modification involves reducing the take-up torque by replacing the clutch gear and fitting a smaller clutch spring. In one or two instances however some tapes continue to be damaged.

We've found that a more certain modification can be carried out by fitting, in addition to the previously mentioned items, the pinch-wheel tape support as used in the VCR4600. The only problem here is that the nylon nut doesn't have a part number and is thus presumably not available. A steel nut can be used provided the thread is varnished after setting up. Replacing the pinch-roller arm doesn't appear to be necessary since in all the machines we've come across the arm has been drilled ready to accommodate this part. The relevant part numbers are as

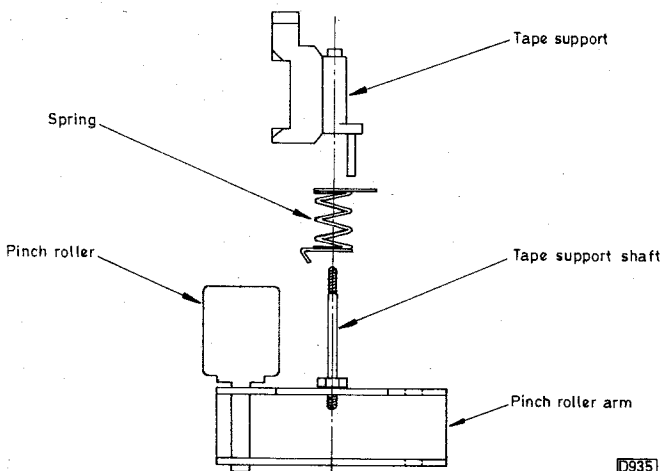

Fig. 1: The pinch wheel tape support assembly used in the Amstrad Model VCR4600.

follows: tape support 151482; tape shaft 151483; tape spring 152484; pinch-roller arm if required 150769. Fig. 1 shows these items.

P.H.I.

## Hitachi VT64

The complaint was noisy rewind, but after running two or three tapes through the machine nothing unusual could be heard. We decided to leave the machine on test on the soak bench, and after a few minutes the fault developed - but it was in playback, not rewind. Back on the work bench the machine worked normally when switched on. Time to leave it running in playback and make the tea. When I came back it was droning away nicely, but when the machine was tipped backwards to inspect its underside the noise went. Lowering it brought the noise back.

The help of a colleague was summoned: he held the machine while I looked up from beneath. Pushing the capstan flywheel up would clear the noise, and on inspection we saw that there were signs of rust deposits on the nylon plate in the middle of the flywheel support bracket. A smear of Vaseline on this plate cured the fault.

A.D.

## Fisher FVHP906

The clock worked but that was about all. The job ticket read "not playing" and the truth was that you couldn't switch the machine on. We found that the power control input to the main microcomputer chip was correct, but nothing happened at the power control output. Replacing the chip cured the fault.

A.D.

## Ferguson 3V42/JVC HRD455

The job card read "cassette jammed", but the customer had released it. On removing the top we found that the deck was in the half-loaded state. When we switched on, the loading motor tried to return the loading poles to the unloaded position but was prevented from doing so because the tension pole jammed the supply loading pole. When the loading/mode control motor bracket was removed so that we could inspect the nylon gear assembly on the underside of the deck we found that the cogs were badly worn, as was the loading gear. Replacing both these parts and setting up the loading timing cleared the trouble.

A.D.

## Amstrad VCR5200

A fully wound tape would be ejected as soon as it was inserted, but if a tape that was not fully wound was inserted it could at least be rewound, after which it would be ejected. A check on the inputs to the microcomputer chip revealed that there was a difference of 0.6V between the start and end sensor readings, the end sensor recording the lower voltage. Replacing the end sensor restored normal operation.

A.D.

## Panasonic NV430

This one was being serviced after coming back off rental. When I switched it on the capstan ran at high speed and the loading ring arms continually laced and unlaced.



When the bottom cover was removed the mode switch retaining screw was seen to be loose while the switch itself had moved. Refitting it correctly had no effect however, so a new one was fitted. This improved matters, but full order was not restored until the main cam gear and the brake actuating arms were realigned. All that was then required was a new VDV0152 loading belt. **N.B.**

### Ferguson 3V45/JVC HRD140

We're now getting a lot of these machines with the "intermittent won't play or record" complaint, and of course the loading belt has stretched. Unlike the 3V29/3V30 series in which this was also a common complaint belt replacement in these models is very straightforward – just remove the top cover, hinge up the top PCB, remove the screening can and there it is right on top. No circlips etc. to remove! **N.B.**

### Sony SL8000UB

After fitting new heads in this machine I noticed that two sections of the clock's minutes display were permanently partially illuminated. The cause of the trouble was leakage across the print leading to the digitron. Cutting out the offending areas and running leads across cured the fault. **N.B.**

### Mitsubishi HS300

The complaint with this machine was that it wouldn't play until it had been switched on for over an hour. On dismantling it the cause of the trouble was soon seen – a lazy capstan motor. New motors are no longer available, but Mitsubishi rebuild them. This necessitates return of the old one. Unfortunately the first motor I received back was completely seized due to a distorted tacho ring. **N.B.**

### Panasonic NV-G25B

The complaint with this new machine was of intermittent sound and picture dropouts. A field engineer had collected it and had noticed that the machine creased the bottom edge of the tape. On inspection we could see that the creasing occurred when the tape moved in the fully laced position (this machine has the half-lace facility so that the control head can read the tape and produce a real-time counter display). Closer inspection revealed that the pinch roller was barrel shaped and was thus distorting the tape as it passed over the capstan and the associated guide – this roller is the one that descends from above, driven by the loading motor.

A point worth making about this and other machines that use the G mechanism is that there is nothing in the manual on replacing the mode switch. It's of the rotary type, and there will be no problems provided you carefully note the position of the old one before removing it. If you do get caught, Fig. 2 shows the position in the tape ejected mode. **N.B.**

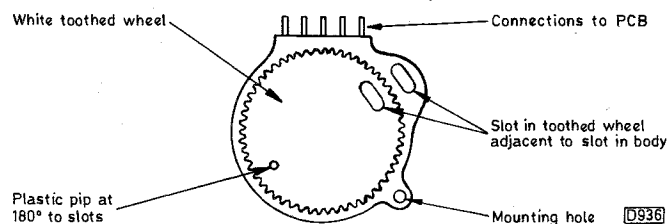

Fig. 2: Mode switch in the tape ejected mode.

### Mitsubishi HS337

We've had two or three cases of "no go" with these models – sometimes intermittent. The symptoms have been as follows. On pressing the "power" button the channel indicator has come up momentarily on 1, but the "on" LED has not lit at all. The problem is caused by failure of the SW5V line as a result of dry-joints between Q9A2 and the control PCB. Note that the circuit diagram in the manual is correct but on the board itself and the board layout diagram in the manual Q9A2's base and emitter connections are transposed. Other joints in the area are worth checking. The "on" command from the syscon microcomputer chip establishes the TU-12V line which in turn brings on the SW5V supply. **E.T.**

### Philips VR6462/Finlux 1010 etc.

The usual cause of insufficient reel torque in the record, playback and search modes in these machines is slippage (insufficient friction) in the "flying-shuttle" reel idler. We've had one or two cases where the trouble has been due to too much friction however.

The idler is retained by an elliptical spring and a circular baseplate, upon which it revolves. Excessive friction can sometimes develop between the underside of the idler and the top of the plate – the friction can be sufficient to bring the reel motor to almost a standstill in any but the fast forward and rewind modes. Once it has been confirmed that the reel brakes are not binding, i.e. the brake solenoid is not sticky, the point can be proved by pulling the idler clear of the motor drive boss, when the speed of the reel motor should zoom up for a second. Cleaning and polishing both face surfaces will cure the binding, but it's best to replace both the idler and the plate. **E.T.**

### Sanyo VHR3300

This was a difficult puzzle to solve. The machine stood accused of intermittently chewing tapes and failing to eject the cassette. It took some time to discover, while the machine was going through bouts of working and not working, that fuse 5001 on the power supply panel (PW1) was going open-circuit intermittently. When it opened and closed the sequence was that the loading arms retracted but the tape was not wound into the cassette. Eject was then permitted, with some 20cm of tape at large in the machine. Messy! **E.T.**

### Hitachi VT410

There was no colour at all during playback, though the machine recorded good colour. The chroma signal path was present and correct throughout the up-conversion circuitry, but the signal was lost at R307 which was dry-jointed to the PCB. This resistor provides matching for the 2H delay line. **E.T.**

### Baird 8940/JVC HR7350

"One channel down" said the job card. These guessing games are part of workshop life. The TV channels were all o.k., so we turned our attention to the audio channels – this machine has stereo capability on longitudinal tracks. The front-mounted audio monitor switch gave us good sound when pushed to the left, reasonable sound at its centre setting and no sound at all when pushed to the right-most position. During playback there was no output from pin 3 of the audio DIN socket unless the monitor

switch was pushed to the left: the E-E sound here was o.k. however. Plainly the LH (channel 1) playback channel was in trouble.

With two identical circuits, fault-finding in one of them is easy. IC2 on the audio/video panel looks after the LH

sound, and we found a big oscillation at some supersonic frequency at pin 1. There was a bigger dose of the same at pin 4. Playback equalisation is applied here and C9 ( $22\mu\text{F}$ , 16V), which is part of the feedback network, turned out to be open-circuit. E.T.

# VCR Clinic

*Reports from Alfred Damp, Eugene Trundle, Dave Dulson, Philip Blundell, Eng. Tech., Nick Beer, Mick Dutton and T.J. Welford*

## ITT VR3906/JVC HRD140

The complaint was no results. There were no switched 12V and 5V supplies as the power control line remained high. The power control input to the microcomputer chip in the mechacon section was correct, going low when the function button was pushed, but the control line to the power supply remained high. Replacing the mechacon micro put matters right. **A.D.**

## Hitachi VT410

This machine wouldn't accept tapes. The cassette in indicator was on, and if the cassette housing was removed the play mode could be selected. The cause of the trouble was no supply to the cassette LED – it was shorted to chassis. We found that the ribbon connector between the deck PCB and the main PCB was displaced at the main PCB. **A.D.**

## Sanyo VHR3100/VHR3300

A common complaint with these VCRs is no results. In all cases we've found that R5001, a 2.7Ω 0.5W safety resistor, has been open-circuit. No other fault has been found. With R5001 open-circuit the always-12V line drops to 5.5V and the always-5V line to 1.3V. **A.D.**

## Hitachi VT11

The drum motor was running continuously as there was apparently no supply to the motor start transistor Q601, possibly because D614 was open-circuit. Replacing this diode didn't cure the fault, but replacing Q601 did – despite the fact that a cold check out of circuit didn't show any leaks. **A.D.**

## JVC HRD370

The symptom was intermittent shut down during play. Oscilloscope tests carried out over a long period proved that the supply-reel rotation sensor signal disappeared from pin 35 of microcomputer chip IC601 a few seconds before shut down occurred. The photocouple system has only two connections to the PCB, for LED supply and the output pulses, relying on its mounting screw to earth the emitter and sensor to the deck metalwork. The screw was loose! **E.T.**

## JVC HRD230

This seems to be a fairly common fault. The symptoms, from switch on, are no eject and a squealing noise from the loading belt, rapidly followed by machine shutdown. If the machine is in play when the trouble occurs, the tape is unlaced then the squeal comes, followed by shutdown. These things stem from a loose screw that secures the deck terminal PCB under the deck. If it's not tight, earth continuity to the mode switch and the take-up FG is lost – intermittently. **E.T.**

## Panasonic NV7000

This machine, a well-worn old soldier, wouldn't play or record a three-hour tape if the supply reel was full or nearly

full. Instead it would shut down and unthread shortly after completion of tape threading. What was happening was that the supply reel was virtually unbraked, and the inertia of a full reel of tape would unwind a few centimetres of tape during threading: normal forward tape motion didn't take up this slack before the lack of supply reel rotation triggered the syscon to produce an emergency stop. On investigation we found that the felt lining had parted company with the back-tension regulator band, and the soft brake had softened to disappearing point . . . **E.T.**

## JVC HRD170

The remote control handset was first brought in on its own, with the complaint that it didn't work. It lit up our magic mirror all right, so we asked for the VCR itself. This presented a problem: the owners were quite unable to manage without it . . . A loan machine got round that. The infra-red receiver and preamplifier worked correctly, and strong pulses were reaching pin 26 of the microcomputer chip IC601. Ceramic filter CF601 was all right so the chip was suspect. A replacement – type M50731-610SP, at a net trade cost of £16.50! – solved the problem. **E.T.**

## Panasonic NV370

A nice easy problem to diagnose: there was a whopping great hum bar on the picture in all modes – E-E, record and playback. As it was a single hum bar the ripple was at 50Hz. This eliminated the main 12V supply which is derived from a full-wave bridge rectifier. We found that C1102 (2,200μF, 25V) on the power transformer panel was open-circuit, putting large dents on the regulated 12V line from Q1101. **E.T.**

## Amstrad VCR4600

This machine recorded and played back at a very slow speed. Whether the standard- or long-play mode was selected, the slow speed never varied. So the capstan motor drive voltage at pin 2 of the output driver chip IC303 was checked. It was low at about 1.2-1.5V. The regulated 18V rail was correct and the next voltage check we made was at pin 8 of the dual operational-amplifier chip IC302. The voltage here was low but the input voltage at pin 4 was high due to QR302 being nearly cut off by the pulse-width output from the servo chip IC301. This should have made the capstan motor run faster. The cause of the trouble was the first operational-amplifier in IC302 (type BA718). With 4V at its input there should have been 3V at its output, but the output voltage at pin 2 was only 1.2V. I subsequently had two more machines with the same fault. **D.D.**

## Sharp VC8300

This machine worked fine in the playback mode but its own recordings produced a very distorted, monochrome picture. Most of the i.c.s on the Y/C board had new solder on them so, expecting a difficult fault, out came the coffee, manual and scope. The video waveform at TP204 was squashed, but readjusting the white and dark clip level controls cured that – yes, the phantom twiddler had

struck again! I now had a monochrome picture on record and the frequency counter was required to get the VXO and a.f.c. controls right. But there was still no colour. A chroma signal was present at pin 3 of plug CB, so attention was directed to the head amplifier PCB where I found that the record chroma current control had been turned right down. **P.B.**

### **Ferguson 3V36/JVC HRD225**

Tuning drift was the problem here. When I checked the tuning supply at TP6 on the power supply panel I found that it was low at 20V (the manual states 45V). Various capacitors were checked but all were o.k. I then noticed that an extra 1k $\Omega$  resistor had been fitted at the factory, in series with R13. The missing voltage was being dropped across this extra resistor. Suspicion then fell on the i.f. module, where the 33V zener diode D10 was found to be leaky. Replacing this diode cured the fault – with the extra resistor fitted the voltage at TP6 becomes 33V. **P.B.**

### **JVC HR7300/Ferguson 3V30**

This machine had a capstan servo fault – the pull-in range of the phase discriminator control R10 was very poor and it couldn't be set for 6.2V at TP203. The waveform at TP5 was wrong, the positive part of the sampling pulse being much too large. A lot of time was spent checking around IC3, but no reason for the fault could be found. Over lunch I studied the block diagram and discovered that one end of C38 should be earthed in playback – it wasn't. Also pin 15 of IC4 should be at 8.6V and wasn't. IC4 (IR2403) was faulty. **P.B.**

### **Finlux VR1010/Philips VR6462/Pye DV464**

The cassette lift was inoperative as lever 242 had lost its pin. Nothing unusual about that, but when the lever was replaced the cassette lift was found to be rather sluggish in operation. I was convinced that the threading motor was faulty, and finding that an Amstrad lift motor was the same I fitted one of these to no effect. Suspicion then fell on the lift itself, but no pieces were broken off. I finally noticed that the strengthening strut across the top of the lift was bowed down: a quick bend and the tray worked a treat. **P.B.**

### **Samsung V1-626/V1-616**

This brand new stock machine would play back with very noisy chroma and record only in monochrome. I started out by assuming that one fault was the cause of both problems – not so! A scope check showed that chroma was entering IC0301 in the record mode, but it was not coming out at pin 1. Everything around the chip seemed to be o.k. – crystals running, etc. – so the chip was replaced. This gave us colour recording, after slight adjustment of the record chroma level. The other fault was cured by replacing IC0303 ( $\mu$ PC1536C). One very important point to remember with the  $\mu$ PC1534C chip (IC0301) is that pin 28 is not connected – it should be bent underneath prior to insertion or cut off. Nasty effects will occur if pin 28 is connected. **N.B.**

### **Panasonic NV333**

This machine wouldn't switch off, even if the timer button was pressed. We found that the 2.5A fuse on the mains transformer PCB was open-circuit – it's in the 14V a.c.

winding which provides the 9V and 5V lines to the syson. The switching is carried out within IC6002 (M53216P), and when this chip's supply pin was lifted the fuse remained intact. A new chip restored normal operation. **N.B.**

### **Ferguson 3V44, 3V45/JVC HRD140**

Circuit protector CP4 (ICP-N10) being open-circuit has on several occasions been found to be the cause of no red light on the power switch and no drum rotation. It seems to go open-circuit for no apparent reason. When it's open-circuit the switched 5V supply is removed. **N.B.**

### **Sony SLF1/ACF1**

The customer initially sent in just the AC-F1 unit, with the complaint that it would charge batteries but wouldn't power the machine. The correct output voltage was found to be present on the d.c. plug to the VCR, and everything lit up correctly, so the VCR itself was sent for. When it arrived the two units were connected. We found that the AC-F1 unit wouldn't switch on until the SL-F1 was disconnected. On dismantling the latter and checking the circuit diagram to look for the most likely culprit we went straight to the 22V zener diode D809 which was short-circuit. **N.B.**

### **NEC PVC744**

This machine wouldn't accept tapes due to a severed lead to the insert switch. It didn't take long to put that right but the customer had tried to force several cassettes in. As a result several levers were bent and the timing was completely out. The mechanism had to be stripped down, straightened and rebuilt. **N.B.**

### **Panasonic NV370**

The complaint was low-gain TV pictures. We assumed that the problem was failure of the amplifier in the r.f. converter, but a replacement made no difference. A more careful examination revealed that there was a large hum bar when the test signal was switched on. The 12V supply to the converter was found to be low and on moving back to the power supply we discovered that the 18V supply reservoir capacitor C1102 (2,200 $\mu$ F) was leaking. Replacing this item put matters right. **M.D.**

### **JVC HRD140/Ferguson 3V44**

The customer complained that the tape wouldn't play. When we tried we found that the tape would lace up and then immediately unlace. The head drum wasn't going round but could be seen to be twitching as if it was trying to start. Voltage checks revealed that the control from the servo was missing (no voltage at pin 2 of CN403). Tracing back we found that the 5V zener diode D408 was short-circuit, but replacing this didn't get the drum running – we also had to replace the AN6671K head motor drive amplifier chip. This required complete removal of the mechanism to gain access to the PCB. **M.D.**

### **Philips VR6462**

Jerky tape motion in reverse play and reverse picture search, with corresponding picture instability, was traced to swivelling wheel item 264 which was slipping. The wheel tyre was found to have traces of dirt on it. Scraping carefully removed the deposits and eliminated the problem. **T.J.W.**

# The Room at the Back

J. LeJeune

Ralph Topcut drummed the desk with his fingers, awaiting Sid's reply. As Sid tried to start, Ralph butted in once more.

"Well, Sid, what am I . . . no, what are you going to do about this pesky woman?" Mrs. Overton was a persistent complainer about electrical equipment that seemed to work perfectly for years in other people's homes, but not in hers. From light bulbs to microcomputers, all inexplicably failed in a short time.

"Perishing nuisance she is" moaned Sid. "I think she's incapable of leaving anything alone for more than ten minutes."

"But she can't 'get at' an electric light bulb" Ralph cut in once more. "You'd better go up to Lime Kiln Farm yourself. Take a voltmeter with you and check their generator. See what you can do to persuade her that Dazzling Discounts at Falgarth are cheaper than us."

Meanwhile Gareth the apprentice was having trouble with a flashy Philips - e.h.t. was spraying everywhere from under the tube's final anode cap, and the occasional flashover crack threatened the line output transistor.

As Sid came in he yelled "don't just stand there waiting for the thing to pack up. Switch it off and get some sealer to it."

Norman came in from his rounds carrying a dead CVC30. As he did so Sid picked up an Avo and went out, slamming the door. A moment later the van was heard to start and drove off.

"How's your temper then?" Norman asked Gareth.

"It would be a lot better if I could find the e.h.t. sealer."

"What do you want it for?"

"Sealing e.h.t."

"Ask a stupid question, I suppose" Norman returned. "We don't have any more of that stuff. It's sort of out of fashion."

"So what do I stop the fireworks with?" asked Gareth.

"I use silicone rubber like they use around the edges of baths and sinks" replied Norman. "It works a treat and you can get it almost anywhere. Trouble is my tube's in the van Sid's just taken. You'd better look at this ITT CVC30 until he comes back."

"How would you park this disconnected e.h.t. cap to stop the stuff fizzing everywhere?" asked Gareth.

"What I use is a clean, dry, empty jam jar stuck to a piece of wood" replied Norman. "Just pop the e.h.t. cap inside it."

"Any ideas about this CVC30 then?" Gareth enquired.

"Well, it's not quite dead. There's h.t. at the chopper transistor, but no drive" answered Norman. "It could be the chopper control chip. It plugs in so it's easy to change."

When this had been done the set sprang to life and produced quite a good picture for its age. But the whole set was incredibly dirty and smelt badly of tobacco smoke.

"Chances are that it's the i.c. socket" said Norman.

"Switch it off, put the old chip back and see what happens."

Gareth did as suggested and when the CVC30 was switched on again it worked.

"Solder the original chip directly into the PCB" said Norman, "and I'll wager it will go for ever despite the ravages of nicotine."

Ralph Topcut always insisted that every item serviced was thoroughly cleaned before being sent back. Cabinets were polished even though they mightn't have seen a duster for years, knobs were degreased, noisy controls replaced or given some cleaning fluid and the mains cable was checked and if necessary replaced. "All part of the service" he'd tell customers loudly, though he'd charge them for doing it.

Gareth started the restoration work on the CVC30 while Norman gazed at the open back of the Philips set. "I smell ozone" he said and went to remove the e.h.t. cap from the tube. There was a splat as a short, bright arc leapt towards his fingers. He shook his arm in pain. "Lesson number one" he said, "always discharge the tube first." He took a closer look. "This one really needs a new rubber cap" he pronounced. He scrubbed the area around the final anode connector on the tube bowl with an old toothbrush soaked in methylated spirit, then dried the area thoroughly with a cloth he kept on the radiator for the purpose. A new cap was found in a drawer and was quickly fitted in place of the smaller original. "There" said Norman, "we'll finish it off with some silicone rubber when Sid gets back with the van."

Andy, without so much as a wind-up gramophone to repair, let alone any digital audio, had picked up a 3V53 that wouldn't load the tape fully to the upper drum. Digital audio was Andy's specialist subject, the reason for his recruitment to the growing Topcut empire, but a few weeks had broadened his scope. Now he would tackle almost anything.

The VCR's mode control motor was turning, but the drive belt was slipping madly. A new belt made no difference, so he turned his attention to the mode control gear assembly and to the loading arm guide slots. The simple answer was found here - the black grease used to lubricate the mechanism during assembly had hardened and was now acting like glue. It was a strip down job, taking about half an hour.

"Do we have any grease suitable for this VCR?" Andy asked.

Norman thought about it. "We need a grease that doesn't go solid, particularly in cold weather and with age" he reasoned. "My cousin's a rough-shooting fanatic and the molybdenum-based grease he uses in his guns has those properties. Looks like someone's going to have to make a trip to the gunsmith's."

Things quietened down as the Philips set awaited the silicone grease and the 3V53 the moly grease while the CVC30 worked happily on soak test.

# Servicing Notes on the Panasonic G Deck

Nick Beer

The Panasonic G tape deck mechanism has been with us now for some eighteen months. It's fitted to VCRs with model numbers NV-G21/25/40/45, NV-H65, NV-D48 and NV-D80. Rather illogically perhaps, it was not used in Models NV-G7/10/12. These had the D1 mechanism. Matters are further confused by the fact that the NV-D48 and NV-D80 D series machines (D for digital) have the G rather than the D mechanism. Ah well!

The G deck is a rather innovative design. Apart from the direct-drive drum unit there's only one motor which is used as the direct-drive capstan and also provides the drive for the reels, loading, mode selection and front loading! The latter is achieved by the use of a clever rack and lever system. The direct-drive drum unit is of considerably reduced height. In combination with the overall compactness of the new design, this enables a very small VCR to be built, typically only 82mm high. There's only one belt in the mechanism, a toothed timing belt (VDV0159) that transfers drive from the capstan motor to the reel and loading mechanisms. Instead of being engaged in the normal "swing in" fashion, the pinch roller descends from above on a worm shaft – again driven by the loading system. A rotary mode switch provides the syscon with mode detection, the first time that Panasonic has used such a device (a linear device was previously used), also the first time that it has been mounted on the top of the mechanism. It can be seen at the rear, right-hand side of the mechanism – a white, toothed wheel.

One novel feature of these machines is the real-time counter. This is done by reading the off-tape control pulses, so the tape has to be in contact with the control head at all times. The half-lace feature helps here: as soon as the tape is inserted it laces to the half-way position, in contact with the audio/control head. So the head is decidedly offset from its usual position in a VHS deck.

All these features go to produce what is probably the best range of VCRs currently on the market. But there have been a few teething troubles with the deck – this has been the experience of dealers here in North Devon anyway. This short article aims to help by providing a roundup of stock faults to date and what to do about them. It seems that Panasonic has stopped distributing technical bulletins, so you get to know about modifications only when you phone them. As a result you could spend several hours on a deck only to find that the job could have been done in ten minutes had the appropriate information been available.

These decks can be difficult to work on if you don't know them, but when you do know their habits there are none nicer. They are very light and fairly accessible. Once you've had a few to regear you get to know them intimately. The only problem is that some of the faults have unlikely causes. So you can easily be caught if you don't know them.

## Creased or Chewed Tapes

The most common complaint we've had has been of creased or chewed tapes. This usually starts off with a rolling picture or a varying sound level. The cause is that the pinch roller becomes barrel shaped. As a result the tape rides up over the adjacent post P4, and this can be reflected back to the audio/control head. The remedy is to

fit the modified pinch roller, part no. VXL1473. To tell the difference between the old and the new type, look at the colour of the roller's metal insert bearing. If it's brass it's the old type and should be changed regardless – if it hasn't caused trouble it soon will. The new type has an aluminium coloured insert. I've had one or two of these fail, giving the same trouble, but they are a great deal more reliable.

Pinch roller replacement is fairly straightforward – simply release the plastic cap above the assembly and slide the roller up. On earlier machines this cap tends to foul the front of the cassette carriage as you pull it up, so you should gently lever it forwards and up. Panasonic recommend that the cap (part no. VMX1078) is replaced at the same time as the roller.

## Head Failure

The next common problem we've had has been failure of the VEH0343 video head used in Models NV-G21/25. Symptoms range from excessive noise bars in the trick modes to grainy recordings or no picture at all in any mode. Cleaning improves matters but the heads will still not give perfect results. In the vast majority of cases I've found that the back tension has been excessive – typically twice the specified level of 20-25g! I would suggest that this is checked whenever you work on one of these decks, and certainly every time a head is cleaned or replaced.

To remove the head drum, first take off the discharge angle (back on top again with the G deck) then withdraw the two large screws that hold the head to the lower drum. Next thoroughly remove all the solder from the eight arrowed connections to the head and ensure that each of the pins is free. If the head is stiff on its shaft, even after using a hairdryer to apply heat, use the Panasonic head puller (part no. VFK0341) for which these heads have the appropriate threaded holes. **Never** touch the three gold screws in the centre spindle of the direct-drive unit.

This problem is rather alarming as the trade price of the heads is over £50, which is a hefty charge for the customer or renter to bear now that these machines are approaching the end of their guarantee period. Panasonic tell me that the problem is under investigation. Even more alarming is the fact that we have had failure of five or more of the direct-drive units themselves. These cost over £220 trade, plus VAT of course. Until now they have been under guarantee. The problem has been that the leads from the rotary transformer to the bottom of the pins that come up to connect to the head tend to break, giving rise to faults that look as if the heads are clogging and cleaning themselves as the machine plays or records, but of course the places where they do so aren't constant.

## Timing Problems

We've had a number of odd faults that have caused timing problems. On a few occasions the timing belt has slipped, upsetting things. The symptoms are things like failure to accept a cassette, or ejection of the tape as soon as it goes in, or going into fast forward then switching off. The general rule to follow is that all the gears should line up hole to hole as per the manual for the deck – note that the manuals for the individual VCRs don't carry this

information. Unfortunately the instructions are not very accurate. Alignment should be done in the stop mode. But after this you are told how to reinstall the cassette carriage in the eject mode (page 14). So if you follow the list of instructions you'll find that things won't work – not only will they not work but the timing will go haywire again. You have to turn the page and fit the carriage as in the stop mode (page 16) – the mode to which you aligned the rest of the mechanism – though you aren't told that. Even here there's an error: in Fig. A20, page 16, second tooth of rack gear A should read first tooth. If you align the mechanism as per the manual (stop mode) and then want to run it without the carriage in you should connect a 2.2k $\Omega$  resistor across pins 4 and 3 of the flexible connector (P1503) that plugs into the carriage to trick the syscon into thinking that the insert switch has been operated. This isn't explained in the manual but is fairly obvious if you look at the circuit.

## **Audio/control Head Setting**

Another fairly common fault was the subject of a recent Test Case, though that one related to another machine. The symptom is a line of noise at the bottom of the picture with the machine's own recordings, the line disappearing in the last two or so seconds. The cause of the trouble is that the audio/control head is set too high, the control head erasing the bottom part of the video track. The customer will usually complain about low sound as well.

## **Play Arm Sticking**

The play arm sticking is something we've not encountered very often ourselves, though I know of other dealers who have. It means that the tape will be left looped out when the cassette is ejected, so you get crunched tape. Other cases have resulted in no take-up in play. Replace the arm (part no. VXL1490) and oil its pivot.

## **Noisy Machine**

A final selection of faults can be grouped under one heading, "machine noisy". The usual area where noise is generated is the capstan flywheel/rotor. At the bottom of this unit, where the timing belt engages, there's a plastic pulley that's very weak and tends to run eccentrically, causing a cyclic knocking. A similar rubbing noise can be the result of a worn capstan brake pad. Replacement of these two parts is very easy. Excessive back tension can cause a louder than normal "thrumm" from the drum. Bear in mind that as these machines have no screening can or PCB over the mechanism, while the lid is very thin, the drum tick is more noticeable. We've had the odd complaint about this, but only from someone who's being pretty fussy.

## **In Conclusion**

When servicing one of these decks it's always wise to check the tension of the timing belt. If it appears to be too slack and the machine has been in use for any length of time, don't be tempted to adjust the position of the jockey pulley – fit a new belt. There's at all times a certain amount of slack. Experience will show what's correct.

The electrical faults we've had with these machines will be included in VCR Clinic. We hope that things will soon settle down on the mechanical front. We've not yet had a fault on the latest series.

# VCR Clinic

Reports from Eugene Trundle, Dave Dulson,  
Jim Rainey, J. Olijnyk, Joe Cieszynski,  
Philip Blundell, Eng. Tech. and Nick Beer

## Tatung VRH8400/JVC HRD120/Ferguson 3V35

The problem with this one was that it would go to stop for a few seconds after embarking on any mode. It was quickly established that the cause lay with the reel-rotation sensor system – the machine would happily remain in the pause mode. The infra-red sensors used consist of a sender and a receiver, either of which can cause trouble. In this case the fault lay with the supply spool's optocoupler, whose receiver (phototransistor) was leaky. **E.T.**

## JVC HRD180

We've had several cases of failure of the large STK5481 power supply chip used in this and allied models. The switched 5V output fails while circuit protector CP3 remains intact. You'll find that the symptoms are no on-LED indication, no drum rotation when playback or record is selected, and shutdown after a few seconds in the fast forward or rewind modes. None of the replacement chips has failed to date, so maybe it was batch problems – or perhaps the design of the chip has improved. **E.T.**

## Panasonic NV180

These portable VCRs have had a longer production run than most, having been kept going to support Panasonic's excellent range of semi-professional cameras. This one came to us with the complaint that it wouldn't play. On investigation the capstan appeared to be seized solid. When the machine had been dismantled we found that the rotor of the direct-drive capstan motor was rubbing against the stator coils. Normally such contact is prevented by means of a springy clip in the bearing assembly – it clips into a waist in the motor shaft. What had happened was that the upper bearing (deck topside) had become dislodged, maybe due to an impact. Pushing this bearing home and relocating its protective cap did the trick. **E.T.**

## JVC GRC1/Ferguson 3V41

"Going on holiday tomorrow, camcorder no go" said the job ticket. Clearly a priority job... The machine wouldn't switch on, and after dismantling it we found that circuit protector CP5 had gone open-circuit. After replacing it we discovered what had happened. The cassette front flap opener had stuck in the "high" position, preventing the flap from opening. The loading motor, now thwarted in its attempts to load the tape, stalled. As a result a high current passed through CP5 until it opened. Worth remembering, especially if it should happen on an intermittent basis. **E.T.**

## Hitachi VT11 and Clones

Don't be fooled by what we thought was an intermittent fault in this and similar machines. If you touch or move C602, which is the control-track head coupler on the regulator/servo panel, the tape speed slows and the sound becomes slurred. The effect is due to 50Hz hum pick-up from your finger. This is at twice the normal control pulse rate, so the machine thinks it's got an LP tape and attempts to restore normality by switching to the LP

mode. Perhaps this is obvious, especially with hindsight! In TV sets we used to prod and poke with a pen or a screwdriver handle, for fear of shock. No such nonsense could then arise. **E.T.**

## Hitachi VT410

This machine would load a tape then shut down. If the operate switch was pressed the machine would come on for another thirty seconds and then switch off. No deck functions worked. The power supply was working correctly and checks around the syscon microcomputer chip failed to reveal anything amiss. A clue was given by pins 8 and 9 of IC901, the outputs that control the loading motor: pin 9 was high at 4.7V while pin 8 was at 0V. The system control was trying to unload but the loading motor wasn't doing anything. A quick check on the loading motor drive chip IC902 (BA6209U2) showed that its inputs were correct but there was no output. Replacing the i.c. cured the fault. **D.D.**

## Hitachi VT11

This machine would select one mode no matter which button was pressed. We found that D453 was leaky. **J.R.**

## Hinari VHL3/VHX3

If you require a play idler for this machine you can use a Sharp type, part number NIDL-0006GEZZ. They are the same unit. **J.R.**

## Panasonic NV333

The fault was no playback picture. When I read the job card I thought it would be a simple head cleaning job, but I was wrong. No picture in fact meant a blank raster. After a lot of mucking about I found that D3012 (MA165) was short-circuit, damping the output from IC3003. **J.O.**

## JVC GRC7 Camcorder

This machine would go off after three seconds. When I'd found the right page in the service manual and got the machine apart (please God, what are the chances of getting the thing back together?!) I soon found that R218 had come off print. Resoldering this put matters right. I did get it back together (just!), after several hours and several cups of coffee (black). **J.O.**

## Saisho VR705

The reported faults were no picture and poor rewind. Many thanks for a simple job this time. Replacement heads and a new reel idler were all that were required. **J.O.**

## Grundig 2 x 4 Super

This machine wouldn't accept a cassette or carry out any function. We found that the relay didn't stay in when power-on was selected. The cause of the trouble was that C446 (470µF) had lost capacitance.



Another of these machines stopped playing after a few seconds as the head drum was rotating very slowly. A quick check on the supply lines revealed a 5V ripple on the 15VR rail. C451 was low in value. It should be replaced with a Grundig part – if a standard capacitor is used there is still some ripple and the servos take a long time to lock in. **P.B.**

### **Philips VR6843-05**

The problem with this machine was intermittent failure to select record. When this happened the cassette would eject. The cause of the problem was an intermittent short across the record inhibit switch. It was on the end sensor PCB, where the leads to pins 26 and 27 had been left too long. **P.B.**

### **Hitachi VT8300**

The complaint was that at switch on smoke poured from the machine and it went dead. Initial inspection revealed that the drum motor drive amplifier was the source of the smoke – both i.c.s were cracked open. Having a scrap machine in the workshop was an immense help. Within no time a replacement panel was fitted, but it was difficult to know whether the drum motor had been damaged. So, with the drive panel disconnected, I checked that the power supply was correct and proceeded to switch on fully. There was no smoke, but neither was there any drum rotation. The 9V and 15V rails were reaching the drive panel via connector CN502, but there was no Hall bias at pin 4. Now having no Hall bias is the same as having a brush-type motor with no brushes! The 2.4V bias comes from Q513 on the main servo panel, and resistance checks showed that this was open-circuit base-to-emitter. Fitting a new transistor restored full operation – thankfully the drum motor was o.k. **J.C.**

### **Hitachi VT33**

This one belonged to a girl who lived in Zambia. She brought it back on a visit after a local service engineer had said he couldn't repair it due to lack of information and spares. The player was dead, though the clock functioned. Checks around the power supply chip IC151 revealed that the always 12V line was present but the switched 9.5, 12 and 16V outputs were missing. The power-on signal from the microcomputer should bring in the 16V regulator via pin 13 of the chip, which in turn switches on the 9.5 and 12V lines via R153 and R151/2. Replacing the 16V output with an external supply restored all the power rails. Normal operation was obtained when IC151 had been replaced, but before returning the machine to Zambia I decided that a new idler and set of belts would be prudent. **J.C.**

### **Ferguson 3V35/JVC HRD120**

This machine was brought in with the complaints "grainy picture and intermittent failure to lace up". As I'd just fitted a sensor lamp in a chargeable 3V30 I thought I'd stay with the easy ones. Things started well enough. The loading fault was due to a stretched belt. A new one was carefully fitted without removing the whole motor assembly, but there was no take-up – the belt was so slack that if it hadn't been for the flywheel bracket it would have dropped off its pulleys! This attended to I put the machine in play and noticed that the exit guide was very sluggish and didn't reach the end of its travel. The baseplate on the

loading ring had become disengaged: its pip was worn with the result that it didn't remain in its slot, consequently the spring had become undone.

Rather than struggling with what was going to be a long job anyway I decided to remove the entire mechanism from the machine, a matter of unplugging and then removing eight screws including those for the carriage. To gain access to the loading rings I then had to take out six or so screws to release the top plate with the head drum and motor, the guide poles and audio/control head etc. A further three screws held the rings in place. I tried to refit everything but the exit guide baseplate was too worn. A new assembly had to be ordered and fitted after which reassembly went remarkably well. **N.B.**

### **Panasonic NV7200**

This loan machine produced a recorded picture with high chrominance and low luminance – playback was fine. On removing the bottom cover I noticed a very small amount of spillage on the board just below the white clip control. This was cleaned off with 1-1-1 trichloroethane (RS Solvent Cleaner). The waveforms were wrong not far into the circuit, but were not drastically out. So I decided to see if the circuit could be set up as per the manual. After carrying out the dark and white clip and the luminance and chroma record current adjustments the machine performed well. One thing to note is on the white/dark clip adjustment: you should adjust the lower peak of the waveform for 175 per cent not 150 per cent as on the oscillogram. **N.B.**

### **Sony CCD-V30**

This was a brand new stock machine – the autofocus version of the Handycam. When switched on in the camera mode the picture, in both the electronic viewfinder and via the external monitor, would be o.k. for twenty-three seconds after which vertical bars at regular intervals appeared across the screen, very faint at first then becoming darker, though you could see the picture through them. After a further thirty-six seconds the picture and bars disappeared, giving way to a white raster, with a pink tinge, that appeared to have no line sync (bars across it). We'd not yet received a manual, but the shop wanted the camcorder sorted out quickly. So it was dismantled, which is no mean feat. Inside the case we found a very basic block diagram, showing the PCB locations. I located the camera d.c.-d.c. converter, which seemed to be the most likely cause of the trouble, and sure enough application of heat and freezer proved that it was thermally sensitive.

Replacing the converter is a long job, as is reassembly. The camera section is enclosed in a can, and there are all sorts of small supports. A modicum of force is required because as well as all the screws that hold it together there are some snap-fit clips. Luckily we found that when the converter had been removed the part number was written on it (1-464-727-11), saving several days' delay. **N.B.**

### **B and O VHS63**

The customer said that this machine chewed tapes. Why they continued to feed tapes in after one had been chewed is not clear, but you know customers! What had happened was that the customer had been over enthusiastic with the furniture polish. It had covered the drum and eaten into the metal – the cassette had been inserted while the drum was still wet. A new drum had to be fitted. **N.B.**

## Hitachi VT33

This machine wouldn't play or record when hot. It would thread up, but the head speed would then begin to vary, making the micro think that the head had stalled. If you went into play-pause first the machine would sometimes play all right, but not always.

A look round the head servo revealed that the 9.5V supply started to oscillate when threading was complete. Replacing the many electrolytics associated with this supply had no effect. A new STK5421 finally cured the problem. **P.B.**

## Philips VR2023

The fault with this machine was no deck functions: when a function was selected the brake solenoid rattled but nothing else happened. The cause of the trouble was absence of the +12b supply due to a dry-joint on bridge rectifier 6005. **P.B.**

## Grundig VS180

This machine would play but didn't unthread fully every time. The switch on the threading ring FA1 worked correctly but the FB switch was dirty.

Another of these machines produced noise bars on the picture every thirty seconds during playback. A lot of time was wasted checking the tape tension etc. before the scope came out. We then found that the control track pulses were missing because the control head was open-circuit. **P.B.**

## Grundig 2 × 4 Super

For no or poor braking, check the +12VR line at pin 18 of the power supply. In the machine we had the supply was intermittent because the relay contact was poor. **P.B.**

## Hitachi VT17

A problem that's becoming common is no clock display due to absence of the 10V supply on the timer panel. The cause is that Q1795 on the back-up board goes open-circuit. It's not very easy to change. **M.D.**

## Saisho VR1000

In this machine the capstan was permanently in operation. We had to obtain a manual from Mastercare - £25 for a poor quality photostat copy. It turned out that C2039 (0.022 $\mu$ F) was leaky. This took us a long time to find, not helped by the fact that the circuit is incorrect - C2039 goes from pin 3 of CD2003 to the base of Q2017, not its collector. **M.D.**

## ITT VR3907

This was a good one. The machine would wind and rewind perfectly but in play or record it would lace up, run for three seconds then shut down. The counter is electronic and counted during those three seconds. We thought this indicated that the take-up reel pulses were o.k., but we were wrong. They were there but of low amplitude because Q0610 had gone low gain. The pulses were adequate for the counter but of insufficient am-

plitude to tell the microcomputer chip that the take-up was working. It took rather a long time for the ITT supplier Hoopwell to provide the spare part - we were told that this particular machine is a Samsung clone. **M.D.**

## Pye 64VR60/Philips VR6460

This machine was in permanent rewind. The cause was that R117 (2.7 $\Omega$ ) was open-circuit. The first one took us a while to track down but we've since had several more of these machines with the same problem. **M.D.**

## Sharp VC8381

It was impossible to tune this machine to stations. We found that the tuning voltage was missing because the aux-tuner switch had poor contacts. **M.D.**

## Sharp VC9300

There was no output from the modulator. We took it apart carefully and found that L2 in the 12V supply was open-circuit. **M.D.**

## Samsung VI910

This machine came in dead. We replaced the blown fuses and switched on. The capstan started to run straight away but the operate switch did nothing. Then the fuse blew again. The cause of the trouble was the mica insulator under Q1 (2SC1983) in the power supply - it was leaky. **M.D.**

## Panasonic NV-D80

When this machine was connected to a mono audio source the audio record level VU meters didn't agree. The left level was lower. We adjusted this as laid down in the manual, with VR4004, to obtain correct balance, but then found that the left meter displayed too high a level at the lower end and too low a level at the upper end. Correct conditions were obtained when the LED level meter unit (VEK3183) was replaced. **I.B.**

## Panasonic NV-G11

The reported fault was that the machine broke a tape. A dummy cassette was inserted and play pressed. After loading a knocking noise came from the DD capstan motor. We also found that if the motor stopped at a certain position it wouldn't restart. Further investigation revealed that the cause of this was incorrect drive to one of the three pairs of coils, due to a faulty Hall effect chip mounted with the coils on the stator. **I.B.**

## Samsung VI626

In the E-E mode there was no sound and the channel couldn't be shifted from no. 1. The sound was being muted by an output (pin 13) from the  $\mu$ PC1363 channel selection chip IC800 on the front panel. This chip has two inputs, channel up and down, one of which pulses low momentarily to shift the channel. We found that the

channel up input (pin 16) was permanently low, because the 15k $\Omega$  pull-up resistor R0916 on the "joint PCB" (mounted upright on the inside of the VCR's plastic frame) was open-circuit.

I.B.

### Ferguson 3V58

This machine was completely dead, with no display or mechanical functions. We found that the supplies from the three regulator circuits were missing. The main one is the switched 12V supply which should always be present when the machine is connected to the mains. The bias for this circuit is taken from the 45V supply on the mains transformer board. It was missing because the 10 $\Omega$  safety resistor in series with the rectifier diode was open-circuit. This in turn was due to the fact that the associated reservoir capacitor C5 (47 $\mu$ F, 63V) was short-circuit. When the resistor, capacitor and diode had been replaced the machine worked fine.

I.B.

### Sanyo VHR1500

This machine chewed tapes intermittently. An accusing finger was pointed at the reel motor and the reel idler, although the torque was correct. When the machine chewed a tape a loop about two feet long was left hanging outside the cassette. Why hadn't the take-up reel sensor stopped the machine earlier?

The machine was set to play without a tape and the take-up reel was held. After about five seconds the machine entered the stop mode, which is correct. So why was so much tape left hanging from the cassette? The machine was left on one side and as expected worked perfectly for the rest of the day. Next day luck was on my side as I saw the fault occur. It wasn't the reel motor stopping. Instead the capstan motor suddenly ran at full speed. As the take-up reel was still running at the normal play speed it couldn't keep up with the amount of tape the pinch roller was pulling through. Checks around the capstan servo were about to be made when the fault cleared.

The capstan servo reference is taken from a ROM within the servo chip, the various references being controlled by data lines from the main microcomputer i.e. First thoughts were of noise on the data lines – it could have been instructing the ROM to give the wrong output. As this was going to be difficult to prove, attention was turned to the comparison signal. If this went missing or low, would the motor run fast? A series of magnets around the circumference of the motor provide the comparison signal, and with such an intermittent fault a dry-joint was a distinct possibility. It was found whilst probing around on the capstan motor board. The legs of the magnetic sensor that produces the comparison signal had not been pushed through the board when it was soldered.

A.D.

### Ferguson 3V65, FV11R etc

We've had this fault on Models 3V65 and FV11R but it could occur on any of this range of machines. The fault report stated that the "VCR stops playing or recording



Fig. 1: Correct (left) and the incorrect waveform (right) found at pin 36 of IC106 in the Ferguson 3V65.

intermittently then goes to stop". When the first machine came along we found that the take-up reel FG input waveform at pin 36 of IC106 was distorted – ideally you need a digital storage scope to be able to see this waveform correctly. Fig. 1 shows the correct and distorted waveforms.

Our first move was to replace the take-up reel photo-interrupter. To do this the tape deck has to be removed from the VCR. This necessitates removal of the head pre/rec board and disconnecting the plugs from the full erase head, the audio/control head and various earth leads. The deck terminal board then has to be removed. This involves removal of the capstan motor, disconnecting the ribbon connector and unsoldering the cassette LED. After this the deck terminal board can be removed by releasing two securing screws. We noticed that these screws had not been screwed down tightly, and both appeared to be print earthing points. As we'd got this far we went on to fit a new photo-interrupter, which apparently provided a cure.

Inspection of the print leading to one of the deck terminal board securing screws revealed that it's the only earth return for the photo-interrupter. So when the second machine came along we checked with the oscilloscope as before then carefully flexed the board near this screw to see whether the signal improved or got worse. The take-up signal was lost when the screw was given a slight anticlockwise twist, so we tightened the screw and left the machine on soak test. When the third machine appeared we simply tightened the screw. Since this episode we've had several more of these machines with a loose screw.

A.D.

### Ferguson 3V59

The fluorescent display was out but the mechanical functions worked correctly. Oscilloscope checks revealed that there was no output from the display driver chip IC1. All the supplies were correct, as was the oscillator, but there was no input data from the UPD75208CW timer chip IC101. Replacing this cured the fault.

A.D.

### Mitsubishi HS304/Salora SV8500

There was no chroma in the playback mode and on removing the top cover I could see a lovely break in the print, bang in the middle of the main panel. Repairing this restored the colour. It's a very long stretch of print that eventually connects the anode of D2A1 to C6D1.

N.B.

### Panasonic NV-G25

On checking this machine we found that there was no video information in the E-E or playback modes, though the card just said "faulty" . . . The fault showed up when the machine was unboxed. Before removing any covers I connected a scope to the video output socket and tuned the machine in, using the sound output from the monitor. Video was thus present up to this point so the trouble had to be in or around the r.f. converter. In this machine the video is fed from the convertor via a buffer on the input selector then back to the convertor. We found that the video went in at pin 12 but nothing came out at pin 14. The 5V supply was present at pin 11. Once this was established it was not difficult to trace the trouble to Q3501 (2SC2206 but a 2SD636 will do) which was open-circuit all ways round and D3502 (MA27W) which was open-circuit. To gain access to this panel it must be unsoldered from the mother board.

N.B.

## Panasonic NV-M5

We couldn't believe that this fault could happen! After the machine had been running for a while the pictures it recorded (displayed in the viewfinder) rolled sideways in a "loss of line lock" condition rarely seen nowadays. Some of the electronics in this machine must have been designed with genlock in mind since the CCD H drive chip has its own VCO, phase-locked to the camera's SSG output. This phase-locked loop was going out of sync — blowing warm air into the region of the CCD drive chip would cause loss of line lock while a blast of cold air would restore it. Normal operation at all times and temperatures was restored when the PLL trimmer on the image-sensor panel had been adjusted. This job requires much dismantling and — in theory anyway! — a set of board extension leads. E.T.

## Sanyo VHR1100

An intermittent fault on this machine took some time to trace and cure. The machine would sometimes thread up then immediately unthread again, with the head drum turning too slowly. Sometimes during play the drum and capstan would both slow down dramatically to give a screen full of noise and very slurred sound. Any attempt at diagnosis would restore normal operation. We finally found that the cause of the trouble was loss of the subcarrier reference feed at pin 42 of the servo jungle chip IC4001. The feed capacitor C1102 was going open-circuit intermittently. E.T.

## B and O VHS82-2

The complaint with this new stock machine was no E-E sound and distorted linear (longitudinal) sound playback. The loss of E-E sound was simply due to the fact that the record-level slider controls were set to minimum. Playback from the linear (lo-fi) sound track was weak and unstable, with a background whistle and hum. The problem lay in the audio head record/playback electronic switch, which was failing to earth the top of the head winding during playback. Under subpanel P550 (top of deck, adjacent to the audio head assembly) there are several surface-mounted components. The collector of T7003, which is amongst these, was not soldered to the print. E.T.

## Sony CCD-F330

The customer brought this machine back the following day, complaining that the autofocus didn't work. Sure enough it didn't — not pilot error as had been suspected. As it's a brand new model (replacing the CCD-V50) the manual hadn't arrived. Nevertheless the autofocus board (AF prefix) was soon found, the fault being traced to a dry-joint on the AF motor connection plug. The number of screening cans in camera heads seems to be increasing: to get to the AF board you have to remove the bottom one, under the lens, and remove the PCB inside to gain access to the screw that holds the bottom half of the can to the frame. With this removed you can get to the AF PCB.

The complaint with another of these machines was of no colour in the E-E and playback modes and, you've

guessed it, no autofocus. We dismantled the camera head and found two joints that had never been soldered on the large FPC: there was also a connector that had not been fitted correctly, half in and half out, between the camera and recorder sections. Having restored colour I delved into the AF PCB and found that the trouble here was a break in FPC135 as a result of which there was no AF on to the PCB. The break had occurred because the FPC had been bent at an adverse angle during assembly and when tightened up it had cracked. Meanwhile the manual had arrived, enabling us to order the part by number — getting it by description could have been tricky.

Less than a week later another of these machines came into the workshop. It was the shop's demonstration model and the complaint was of a ticking noise when the unit was on. It occurred whenever there was drum rotation, as a loom was mislocated and was catching on the bottom of the DD unit. A fair amount of dismantling was again required, just to fit a bit of Himelton which should have been done at the factory! While running the camera on test the picture disappeared. A sharp tap on the side brought it back. Another dry-joint, on the wide FPC. After reassembling it the camera wouldn't switch on due to a moulding fault in the camera standby switching assembly. N.B.

## Panasonic G Deck

Since my article on the G deck appeared in the September 1988 issue we've had several of the new range of G deck machines (Models NV-G40/G45/G48) with high back-tension. In each case the error has been corrected by replacing the back-tension arm spring with a new one from the Panasonic spares department. The new springs are a different colour, duller and not as silvery in appearance, and are minutely shorter. Only a small number of machines in this range seem to be affected. Note that the back-tension specification has been altered. Measure it with a tentelometer at the beginning of a three-hour cassette: the reading should be between 22.5-27.5g. This applies only to the G mechanism. N.B.

## Ferguson FV20

These new machines are very popular and have excellent reliability. The fault with this one was no sound. In fact there was just a buzz in the E-E and playback modes but when going through the scart socket into my monitor the sound was o.k. A new r.f. converter put matters right. N.B.

## Panasonic NV-M7

The drum would sometimes judder and stop while running and intermittently wouldn't start. The drives didn't disappear so it seemed that the DD unit itself was at fault. Fitting a replacement restored correct operation. N.B.

## Grundig VS180

The fault reported on one of these machines was "spots on play". The spots were confined to the centre of the

screen and gave the impression of a tape path fault. When the off-tape f.m. waveform was scoped however it showed that this was not the case. Adjusting the tracking had no effect of course, so I suspected a faulty drum motor. When the motor baseplate was removed the cause of the trouble could be seen — grease had built up on the brushes. When this was cleaned off the spots had gone.

A note in the March 1988 issue reported that leaky capacitors in positions C301 or C305 would result in the reel motors running all the time. In the case I had the capacitor was very slightly leaky and the reel motor rotated only when the on/off switch at the front of the machine was in the off position! **P.B.**

### **Philips VR6561/6362/6468**

Most Philips dealers will by now be dab hands at replacing the rack slider on the current models. It looks a daunting task, but is quite straightforward if you follow the guidelines in the manual. The only tips I would add are as follows. With the deck removed from the machine, use a 9V battery on the control motor to get the mechanism to the position for dismantling. And check that you've got it assembled correctly afterwards! When refitting the top plate I put the pinch roller metal crank into position first then fit the plate, finally using a wire hook to get the belt over the control motor pulley. **P.B.**

### **Hitachi VT8500**

Tape stops while playing is a common fault with these machines. Often it's because the ring magnet that operates the reel rotation sensor is loose or metal debris have stuck to the magnet causing it to jam. **P.B.**

### **Philips VR6561**

If it's powered up without a cassette this machine usually moves the tray in and then out again. With this one the tray moved in and after a few seconds the machine switched off. No, it wasn't a mechanical fault this time: the control motor drive chip IC7251 (L293b) was faulty. **P.B.**

### **Recent Ferguson VCRs**

Here are a few problems we've had with late-model Ferguson VCRs.

**Model FV11:** Intermittent playback picture — L15 faulty (off pin 13 of IC101). Poor or intermittent tracking — IC2 (VC2023A) faulty. Low gain on high channels — try repositioning the aerial lead that connects the tuner to the aerial splitter.

**Model FV12:** No functions — ICP1 open-circuit.

**Model FV14:** No E-E sound — ICP2 on the demodulator panel open-circuit.

**Model FV21:** Note that early machines have no cover over the mains fuse which is always live. **C.P.**

### **Ferguson 3V55/3V57**

When this machine was plugged into the mains the capstan motor would immediately start up and run for approximately one second. There was no clock display. The on/off LED went on and off correctly when the power button was pressed. If a tape was inserted it would be taken in and down by the carriage, but would then be sent straight out again. Also in the E-E mode all that

could be seen on the monitor was hum.

The loss of clock display was due to lack of a reset pulse for the clock/display chip IC202. If this was provided manually, by momentarily shorting across C207, the display would appear correctly. Then in the E-E mode a distorted, low-contrast picture with hum across it would be seen.

All these faults were caused by an open-circuit — not blown — fuse (F2) in the unregulated 18V power supply. When the fuse is open it disconnects one end of the transformer's centre-tapped secondary winding but the bridge rectifier still provides nearly the correct voltage from the other end. In fact with the fuse open-circuit the 18V supply is approximately 16V in standby and 13.5V in the on condition. **I.B.**

### **Sanyo VTC5600**

The capstan motor slowed. We found that there was no pulse input at pin 19 of the CX143 capstan servo chip Q413. This was in turn due to the CX186 drum servo chip Q401 being faulty. **A.D.**

### **Ferguson 3V29**

Uncontrollable and overloaded E-E video and no playback video were caused by a fault in the playback equalising filter EQ201. **A.D.**

### **Pye DV468/Philips VR6862**

This VCR would accept a tape then immediately eject it. The cause of the fault was traced to point 9B3 not being grounded by switch COD3. The switch itself was in order, the trouble being a broken lead at the deck terminal connection. **A.D.**

### **Sony SLC6**

The complaint with this machine was of intermittent noisy rewind — it made a sound like tape chewing. We found that the large fast-forward pulley (item 424) had moved sideways, twisting the fast-forward belt, because of wear in the fast-forward arm assembly. Replacing the arm assembly (item 421) cured the trouble. **A.D.**

### **Ferguson 3V36/JVC HRD225**

This machine functioned correctly apart from the fact that when unthreading the supply spool wasn't driven in order to pull in the tape as the loading arms retract. Now although this model has a reel idler to drive the spools it doesn't have a reel motor. Instead the idler is driven by a pulley which in turn is driven by a belt from the capstan. Whilst unthreading the capstan motor wasn't being driven and we found that in this mode the drive transistor Q206 was without base bias, though the 5.7V bias was present in the play and fast wind modes. A study of the circuit diagram showed that in play the capstan drive comes from the servo chip, in fast wind it comes from the CPU chip IC201 and during unthreading it's switched by the expander chip IC202 (pin 38). This pin was found to be permanently low, all the other ports relating to capstan motor operation being correct. So, having encountered a number of faulty expander chips in this model, I replaced the i.c. This made no difference! Further checks revealed that R272 (10k $\Omega$ ), a bias resistor in the drive transistor's base circuit, was open-circuit. **J.C.**

# Problems with the Philips VR2021

**B. Ross**

Three of these machines have come our way recently. The problem with the first one was that it threaded, played for about two seconds, then unthreaded. The Philips manual is helpful in providing fault-finding sections which we followed. The head drum rotated, the pinch wheel pulled in, the capstan was working and the reel motors operated correctly. Whilst working on another of these machines we realised that though the head drum in the first one rotated it did so more slowly than it should have done. Checks around the drive transistor then revealed that the voltages were about fifty per cent low, but no obvious fault could be found. We next checked the drum motor, comparing it with a known good one. The resistance of the windings, and rotation of the motor while applying meter probes, confirmed that the motor was in order.

It seemed likely that the fault was on the U280 head servo oscillator board, so a substitute known good board was fitted. Still no change. Checks around this board revealed that there were no head drum speed pulses at pin 11 – they had definitely been there earlier on when checked. These come from optocoupler P61 whose emitting diode is in series with module P60, P64 and R3001. The diode in P60 (winding motor detector) was open-circuit, a replacement curing the fault.

## **Intermittent Lock-up**

Another of these machines would operate correctly though the control system would spasmodically lock up, so that no functions, including turn off, could be selected. When this happened switching the power off for fifteen seconds, to reset the computer system, would restore normal operation. These machines have a memory clear button on the front panel, accessible when the cassette carrier is raised, but resetting this made no difference to the fault condition.

The machine was used beneath an ageing Rank colour receiver (A823 chassis). This has a thyristor power supply which we thought might have been interfering with the machine, since moving it away from the set lengthened the time between failures. The fault still occurred in the workshop however.

Some time was spent on the power supply, as the mains plug was a sloppy fit and we suspected that transient sparks and arcs travelling through the power supply could be causing problems. We then found that when trying to record manually or via the timer the channel number could be selected but not held, i.e. the channel display reverted to 00. At this point a scrap machine was dragged out of the dungeon so that panels could be swapped. The front panel keypad was o.k., but changing the U20 computer panel provided a cure.

The machine was returned after a long soak test. Three days later it was back again. This time the protection circuit was operating, switching off the relay in the power supply. This is located on the U180 motor control board. Replacing T7025 and C2028 seems to have produced a lasting cure.

## **Deck Trouble**

The third machine would also thread up then unthread after a couple of seconds. This time the problem was mechanical. During threading the pressure roller assembly didn't travel quite far enough to the end of the carriage guide and fully into the locating slots of the scan unit brackets. When the pressure roller mechanism operated the roller was not secured against the capstan. The roller could be held in by hand whilst the mechanism operated, normal playback then being obtained with a good picture.

Attempts were made, without success, to alter the

pressure roller position on the threading cord and to move the position of the cord slightly. Fitting a pressure roller from a known good machine produced no improvement either. As no way of repositioning the threading cord easily could be seen we concluded that a new cord or complete removal and rethreading would be required. Instead, the scrap machine was again raided, the cassette deck being swapped over. The machine now threaded up and played back correctly mechanically, but there was no picture as the video heads were badly corroded – liquid spillage?

The scanning unit from the original deck, known to be in good condition, was refitted. The advantage of swapping over the scan unit is that it contains the complete tape path as a subassembly, i.e. the heads, capstan, guides and motors, so that no realignment is required. We were upset to be rewarded with a weakly contrasted picture with random colour splashing and bands of static-like interference. All connections were checked and found to be o.k. Further playback then produced the good picture we'd expected. Our thoughts about this are that connector H5 from the rotary transformer to the playback amplifier may have been making poor contact or that there had been poor earth contact on one of the earthing wires.

### ***Repair Viability***

When it comes to the viability of maintaining these machines, in view of their age, the general cost of spares, the small number of machines that come in for repair and the points raised by R. Caley in a letter earlier last year (Letters, March 1988), the use of components from scrap machines has to be seriously considered. There appear to

be quite a lot of 2020 and 2021 machines on the surplus market. Can anyone advise on the cost and availability of the service program plus adaptor for tracking faults in the computer section of these machines?

---

## ***Miniature CCTV Camera***

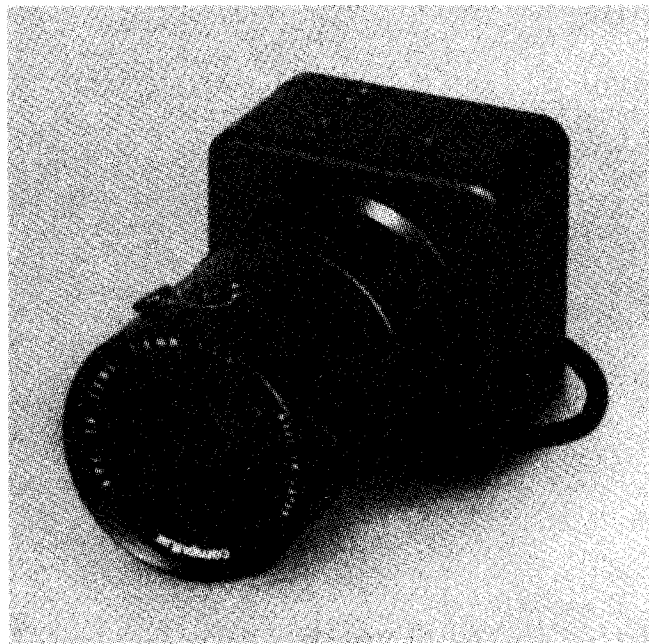

*The Crofton CCD2 is claimed to be the world's smallest CCTV camera at only 5.7 × 5.7 × 4.8cm plus lens. For further details see Teletopics, page 260.*

## Philips VR2340

For intermittent noisy playback pictures – it looks just like the effect of dirty heads – clean the earth screw connection on head preamplifier module A420. **P.B.**

## Philips VR6660

This machine was almost dead – the only sign of life was the head drum which was rotating much too fast. All the supply lines were present and disconnecting various plugs and sockets as instructed in the I2C bus fault-finding chart proved to be inconclusive. Whilst carrying out scope checks we discovered that the power-on reset signal was high all the time. Transistor 7151 was open-circuit. **P.B.**

## Mitsubishi HS318

The fault here was a very intermittent one: the drum motor would stop at random intervals during play or record. The deck would then shut down to produce the stop mode. Monitoring the drum speed control voltage was inconclusive because as soon as a probe (or a finger!) was touched on the collector of Q4A1 (drum control line) the motor's operation would revert to normal. The trouble was being caused by the motor control chip. This is part of the quite inexpensive stator assembly whose part no., 409-B-051-03, is not given in the manual. Replacing it is a rather fiddly job however. **E.T.**

## JVC HRD225/Ferguson 3V36

"Sound deteriorates when hot" was the complaint with this machine. We found that when the machine had been running for an hour or two the E-E sound became distorted and threatened to disappear altogether. The playback sound remained o.k.

A scope check showed that the audio signal coming from the receiver section was "strangled" at TP4 on the tuner/timer panel because the interstation mute circuit was coming into operation. This is based on the action of the 15.625kHz tuned circuit T5. Careful adjustment of T5 to peak up the line-rate waveform at the collector of Q11 overcame the problem. **E.T.**

## Panasonic NV788

The fault with this machine was complete loss of both the playback and E-E sound. There was no switched, regulated 12V supply to the audio panel. Tracing it to source via the video panel finally brought us to the syscon board, where regulator transistor Q6062 had 12V at its base but nothing at its emitter – the base-emitter junction was open-circuit. We replaced this 2SC1847 transistor with a BD137. Restoration of power to the audio section also brought up the back-light in the LCD counter display. Had we known about this we'd maybe have found the culprit sooner. **E.T.**

## Finlux 2030/Tatung VR8495/B & O VHS82 etc

The Philips deck used in these machines is also used in many others. We've had several cases of failure to enter the rewind search (review) mode. What happens is that when review is keyed the machine shuts down and often

ejects the tape. The culprit is the reel drive clutch (called the coupler, part no. 4822 528 20428) which binds – in one direction only! – and effectively jams the mechanism.

Apparent failure to complete the loading with these machines, with the mode motor running against a slipping belt, can easily be mistaken for failure of the load-end switch. Replacement of the switch seldom cures the trouble however. Most often the cause of the problem is broken teeth on the rack slider – the original part number was 4822 403 20202 but this has been changed to 4822 403 53377. You can see the broken teeth, at just the right position of the loading process, by peering through a hole in the deck under-surface. Replacing this assembly is no joke, but gets easier with practice – and we're getting plenty of that! **E.T.**

## JVC GRC7

A fairly common fault with this and similar camcorders is the cassette lid's securing screw working loose and falling into the mechanism. In most cases no harm is done and the machine works once the screw has been retrieved. Sometimes damage can occur however. In a recent case the screw jammed under the right-hand side (exit) guide and bent the spring, slide washer and slide plate that keep it on the curved and narrow. The sliding base of the guide then jammed at the entrance to its V notch, bringing up the emergency display of simultaneously flashing stop, play and fast forward indicator LEDs. These emergency mode indications are invaluable and are becoming more common, even on domestic machines. **E.T.**

## Toshiba V83

We've recently had three of these machines that would intermittently shut down in the record or playback mode. Observation of the deck at the moment of failure showed that the take-up reel had stopped, allowing slack tape to spill on to the deck. The problem was in each case cured by replacing the reel motor, part no. 70326539. **E.T.**

## Sony CCD-V200

The shop mentioned that the auto focus on this top of the range "professional" camcorder didn't seem to be too hot. When we checked with the Siemens star we found that the manual focus was sharp but the auto-focus system produced defocusing. The focus calibration was also off: when focused at 2 metres the reading on the focus ring was about 3 metres. The machine worked well when the plane back and auto focus had been adjusted. **N.B.**

## Grundig VS200

This VCR wouldn't accept a cassette, though the customer's complaint was that it wouldn't record! In this machine there's a safety system in the syscon circuit to prevent activation of the mechanism if the brake release solenoid hasn't been energised. After removing a diode to override this safety arrangement a cassette could be inserted. Then, intermittently but gradually becoming permanent, the brakes wouldn't release, causing a terrible



noise when the machine tried to lace, and stopping rewind and fast forward dead. The cause of the trouble was soon traced to the BC876 solenoid coil driver transistor, which is a Darlington type. **N.B.**

### **Panasonic NV-M5**

This camcorder's auto-focus system didn't work. It was a fairly simple problem to deal with as we soon found that there was no oscillator signal across pins 53/4 of IC603, due to X601 being faulty. The part no. is VSX0196. **N.B.**

### **Sony SLF1**

This one was brought in by a merchant seaman who used it on board ship. This explained the rusty aerial socket! The symptoms were as follows: the drum and take-up reel were spinning at high speed in the forward direction while the supply reel rotated in the reverse direction. The syscon in these machines is fairly complex, but when you get to know it and apply a logical fault-finding procedure you find that it rarely causes difficulty. Not long after delving into the syscon I found myself heading towards the reel servo where the switching transistor Q204 was short-circuit. **N.B.**

### **Salora SV9300/Mitsubishi HS330**

In playback the tape laced up but the sound and vision wouldn't switch from the E-E mode. We soon found that the switched 9V line was missing as the 2.5A fuse F901 in the mains transformer's 14V a.c. winding had gone open-circuit. It had died rather than blown, and a replacement held. A long soak test produced no further problems. **N.B.**

### **Panasonic NV-MS1**

The garbled message I received about this camcorder, which had been bought the day before, mentioned frame jitter in the electronic viewfinder and on the monitor. It transpired that the customer had been filming in the early morning when it was misty with hazy sunshine: on bright white scenes there was a barely perceptible 50Hz flicker. We convinced him that there was nothing to worry about and suggested the use of a filter. He then mentioned noise in fast forward and rewind. These machines — the latest S-VHS ones — are a bit noisy but this one was excessively so because of a scraping reel drive pulley. A replacement put that right. **N.B.**

### **Panasonic NV8610**

The complaint with this old tank was of intermittent overloaded vision. It was o.k. on direct video, a clue that narrowed down the fault-finding process. We soon found that the track of the 10k $\Omega$  level preset VR2 in the r.f. modulator was noisy. **N.B.**

### **Mitsubishi HS349**

On playback this VCR produced either a rolling picture or a picture with the top part blanked out. When the machine was dismantled the picture returned to normal. Tapping the servo board made the fault come and go and a check on the drum flip-flop waveform showed that when the fault was present it was not a true 1:1 squarewave. At this point the machine decided to work correctly and no amount of tapping and banging would provoke the fault. We inspected the servo board under a powerful magnifier

but couldn't find any dry-joints. So to do the utmost to prevent a comeback we resoldered all the components and wire links connected with generation of the drum flip-flop signal, from the drum pick-up pulse on CA1 through Q4B0 and Q4B1 to pin 24 of I4A0 and then from pin 11 of I4A0 to plug CE. **A.D.**

### **Panasonic NV688**

Sometimes this machine wouldn't switch from LP operation in the record mode, while in playback it would select LP by itself with an SP recording and what can only be described as LLP with an LP recording. After a lot of tapping, prodding and flexing of boards we found that the supply to the SL/LP discriminator IC2005 was varying and at times non-existent. There was a dry-joint on a wire jumper that's part of the supply. **A.D.**

### **Ferguson 3V54**

The job card said intermittent play and record and chewing tapes. When the fault was seen tape movement ceased, the tape being left in the fully laced position. The capstan motor had stopped due to a dry-joint at the emitter of Q603. I've often resoldered the connections to this transistor and Q604 when servicing these machines as the joints have always looked suspect. **A.D.**

### **Telefunken VR2931**

This VCR is similar to the Ferguson 3V65. The cause of a hum bar on the monitor screen was really quite obvious — C3 (2,200 $\mu$ F, 16V) in the supply to the 5V regulator was bulging and leaking electrolyte down the rectifier panel. **A.D.**

### **Some Quickies**

**Ferguson 3V29:** We've had several cases of no clock display due to the i.c. being faulty.

**Sharp VC651:** This machine would run for hours, days or weeks before the fault showed — there were then very wild speed variations. My first thought was a duff capstan motor, which in the circuit diagram is shown as a black box. Ordering and fitting a complete unit seems to have proved successful, touch wood! **J.O.**

### **Panasonic NV-G25**

We've recently had two of these machines with the same problems. Both were about a year old, the complaint being of a poor picture and intermittently low sound. When the video heads in these machines start to wear out you get a slight increase in overall picture noise and bands of noise in only the top third of the picture in the review mode, particularly near the beginning of a tape. The only cure as far as I know is to replace the heads. I did find that by adjusting the inlet guide by approximately a quarter of a turn the noise disappeared with a Panasonic tape, but the noise returned when a different type of tape was used. If more adjustment was tried the noise could still be cleared, but then the guide adjustment was wrong for normal playback. The low sound problem was due to audio head wear, so again replacement was necessary. The audio/control head assembly is now supplied as part no. VBR0125 instead of the original VBR0116 — perhaps the new type will last longer. **I.B.**

## Philips VR6468

At switch on the cassette carriage moved in and out as usual but the clock display was out and none of the keyboard controls worked. The +13a supply was missing at the keyboard panel as R3509 (15Ω) on panel P607 was open-circuit. P.B.

## Grundig VS400

The customer complained that when a cassette was ejected a loop of tape was sometimes left hanging out of it. The only way in which I could make the fault occur was to press stop with the machine in rewind search. The tape then wasn't drawn back into the cassette. Slight readjustment of the mecha state switch was required. P.B.

## Ferguson 3V31

The trouble with this machine was field bounce in the still frame mode, the vertical pulse control on the front panel having no effect. A dry-joint was eventually found at C75 on the servo board. P.B.

## Philips VR6462

If play is selected without a cassette inserted these machines usually provide the test pattern. This one produced the test pattern even with a cassette in! The test signal is enabled by the TPI signal on Bus C: it was high all the time because transistor 7508 was open-circuit. P.B.

## Grundig VS220

For intermittent faults such as the display goes haywire or the mechanism does odd things check the ripple on the +12Vd supply. If it's excessive either C437 or C436 has probably dried up. P.B.

## Ferguson 3V65

Playback of a test tape was good but there was a smeary E-E picture. Replacing the luminance module IC101 put this right. A.S.

## Orion VHL3

There was no sound muting in the search mode. The DTC124F digital transistor Q1025 was faulty. A.S.

## Hinari VXL5

This machine would operate for about twenty seconds in play or record then shut down. The take-up reel sensor was faulty. Here's a tip: switch to counter, press play and observe the erratic and irregular number changes. A.S.

## Amstrad TVR3

Here's an interesting one we've had with several of these new combi-units (TV plus VCR). The remote control handset operates the VCR functions but not the TV ones. The fault lies within the VCR section, associated with the remote control receiver. Ribbon cable CL8 to the front of the tuned circuit can should have six leads but a five-wire

cable is fitted, leaving a vacant hole at either end of the ribbon. Fitting a short length of wire cures the problem. So much for quality control . . . A.S.

## Hitachi VT17

The heads had worn out and were replaced. After doing this I was left with a problem: the top half of the picture was fine but the lower half was noisy and there was a definite division between the two. The cause of the fault was traced to the relay on the video drum PCB. It shorts out the trick mode heads during normal playback but was not doing its job properly. A replacement provided an effective cure. P.H.

## Philips VR6542

The problem with this machine was that recordings had intermittent colour. It was to some extent signal-dependent – a weaker signal was more prone to cause the symptom. Changing IC501 on the Y/C panel made no difference and we eventually found that the 627kHz signal was off frequency by about 70kHz. Resetting this produced reliable operation.

We've had several of these machines that don't seem to like E240 cassettes – the tape commits suicide on the mechanism though there doesn't seem to be any mechanical fault. Does anyone have any ideas about this? P.H.

## JVC HRD320

The problem with this brand new machine, straight out of the box, was that three of its buttons were inoperative – set-, set+ and Ch. set. On investigation we found that D11 on the timer/display board had been fitted back-to-front. It's part of the key-scan matrix. The diode was undamaged and fitting it the correct way round restored normal operation of all the buttons. The same symptoms would arise with other makes and models fitted with this type of timer/display board. E.T.

## Sony CCD-V30

The viewfinder tube in this camcorder displayed a picture locked to a multiple of the line rate. This occurred with both camera and playback pictures. Operation through a TV set via the r.f. modulator showed that all was well within the basic camcorder circuitry, so we concentrated on the electronic viewfinder. The line hold control RV952 was responsible for the problem, due to poor contact at the riveted end of its carbon track – flexing and twisting this little preset could restore a normal picture display. It's strange to recall that the symptom and the root cause of the fault were common with the TV sets of the sixties! E.T.

## JVC HRD110/120/Ferguson 3V35 etc

A common problem with this range of machines is that the retaining studs on cam gear 1 (PQ30028) of the cassette loading mechanism break. This allows the associated slide gears to escape, producing symptoms such as no front loading, no eject, loading system jammed etc.

The only long-term cure is to replace gear 1, but a temporary cure (while awaiting spares?) can be achieved by refitting the stud using a small self-tapping screw through the back of gear 1. The sort that RS Components used to call an "8BA binder" will work. This assumes of course that you can find the broken stump of the plastic stud! E.T.

### **Panasonic NV370**

The user's description of the fault with this machine was "no functions". At switch-on an eerie "heartbeat" noise came from within and continued until the machine switched itself off a few moments later: it was caused by the capstan motor shunting back and forth. Meanwhile eject wouldn't work.

This effect is usually due to a missing 5V rail, Q501 on the head drum assembly being open-circuit. The 5V line was intact this time, but the 12V line was missing. We quickly traced the cause of this to an open-circuit safety resistor (R1101) in the unregulated 12V supply. It appeared to have failed for its own internal reasons. E.T.

### **Panasonic NV-G45**

This machine was faulty when taken from the box. The playback picture would come and go, due to drum speed variations that could also be heard. When we turned the machine on its side to remove the bottom cover the fault cleared. While looking for a loose plug/socket connection we removed the drum cylinder and found a crack almost half way across the double-sided stator panel, between the socket and where the panel enters the drum unit. I.B.

### **Panasonic NV-M5**

This camcorder was stuck in the camera mode. Normally when the clear cover over the VTR controls is slid up to uncover them a small microswitch (SW6313) operates. It closes for camera, opens for the VTR mode, but something was wrong with the switching. When closed (camera mode) SW6313 connects the base of QR6009, a UN2113 pnp transistor with internal bias resistors, to chassis. As a result positive key-scan pulses pass to the control chip IC6001. SW6313 should be open and QR6009 off in the VTR mode. Even with QR6009's base disconnected however the pulses were getting through as the transistor had an emitter-to-collector leak. I.B.

### **Panasonic NV788**

The complaint was of a poor picture. On test however the picture was all right except in the still mode, when almost half the picture was lost in noise. Having seen this problem with other machines I checked the playback tension, suspecting that this was low (10g-cm instead of 30g-cm). The cassette carriage assembly was removed, a cassette was put in it and another one was held in the machine. A check on the back tension then proved that it was correct. I tried again with the cassette carriage refitted and spotted the cause of the problem – the back-tension post arm, which runs against the tape, moved too far to the left and rested against part of the carriage assembly. With the assembly removed the arm moved far enough to give the correct tension. The cure was to move the fixed end of the brake band to pull the arm further to the right when running then adjust the tension spring for correct back tension. This problem could very easily arise if the

brake band is replaced and the position of the back tension arm, when playing a tape, isn't checked before refitting the carriage. I.B.

### **Panasonic NV-G40**

We've had several of these machines with faulty video heads when new, but the complaint with this one was very grainy r.f. loop-through. A check on the unswitched 12V supply to the r.f. amplifier showed that this was low at about 5.2V. Further checks indicated that the rail was not being loaded excessively so attention was directed to the power supply, which is usually very reliable. Regulator transistor Q1004 (2SD1330) was soon found to be open-circuit. N.B.

### **Sony SL-F1**

The complaint with this portable machine was that it wouldn't play. We found that the pinch press lever had become disengaged from the pinch solenoid lever. When a new press lever had been fitted – the original one had a worn plastic arm – the machine played for about two-three seconds then cut out. We then found that the take-up torque was low. Since fast forward operation was perfect it seemed that the cause of the fault was servo rather than motor trouble. While checking the waveforms in the reel servo I found the rather unlikely cause of the fault – a speck of solder was bridging two contacts on adjacent print lands. At first sight it looked like a single length of track, but the short effectively joined pin 1 of IC201 (supply FG) to pin 29 of IC601 (syscon-2). Fortunately no lasting damage had been done. The short must have been present from new and it's remarkable that it had only now showed up. Our customer accepted the estimate but refused a second one for the drum surfaces causing the usual rewind trouble – apparently he rewinds his tapes in another machine! N.B.

### **Grundig 2 × 4 Super**

The customer brought this machine along in a great hurry as he wanted to record a programme. He said it wouldn't load a cassette. The cause was quickly found – the cassette-in switch CL wasn't making. As a temporary measure to enable the customer to make his recording we shorted the switch out by linking pins L1-6 and 7 on the switch board. This restored normal operations including unloading. To load it was necessary to insert a cassette then press "tape", after which the machine would load. Note that if the CL-closed signal is not present no functions are available (play, wind, etc.) even with a loaded tape. B.R.

### **Philips VR2021**

This machine would thread up and then unthread about two seconds later. The head and reels turned during this period, as they should, but the head speed was slow. A check on the voltages around the servo and motor drive amplifier circuits showed that they were incorrect, the cause being lack of signals from the head pulse optocoupler circuit on board P61. This was in turn due to the LED on the winding spool optocoupler unit P60 being open-circuit. The LEDs for P64 (tape tension optocoupler), P60 and P61 are connected in series via a limiting resistor from the 12V line. So there were no pulses to the head servo circuit. B.R.

# *A Day in the Life of . . .*

**Nick Beer**

Following Mick Dutton's very entertaining article in the December issue I thought I'd write a similar piece, but from a slightly different perspective. The difference is that I'm a purely workshop based engineer whereas Mick and I suspect many of you do a mixture of field and workshop servicing. It's my opinion that if at all practical it is far more successful and efficient to have engineers allocated to particular types of work. This is the system we employ and I'd better start by describing our organisation. We have three workshop based engineers, three field engineers and a number of field engineers/installers. One of these installers is workshop based, the others doubling as salesmen.

Installation and field service work obviously overlap, for example where an engineer is heading towards Exmoor and a VCR has to be delivered in that area. It also works the other way round, when a repair falls amongst a number of demonstrations.

Workshop paperwork, bills, spares ordering, labour claims and spares supervision are handled by a two-man workshop administration team. This arrangement allows us workshop engineers to get on with the job we want to do – repairs. Having a clearly established staffing arrangement of this type would obviously be of little point if we didn't also have well thought out workshop conditions.

The day's work starts at 9 a.m. Well, around then anyway. The nine mile journey to work can take me up to three quarters of an hour – we have severe traffic problems even here in north Devon, but they should improve when a new bypass is opened.

## **Visit to the Bill**

On this particular morning I'd left late to call in at the police station. They'd found a Salora SV6600 VCR that had been stolen from one of our rental customers twelve months earlier. They wanted me to identify it and didn't think it funny when I commented that I knew it didn't

have a beard . . . The desk sergeant took me to a ramshackle old building at the side of the station, inserted a security pass into a slot at the door and then used two keys to let us in. By the look of the door it would have fallen open had there been a gust of wind. Once the identification was over and statements were signed he asked me about hi-fi and was B and O worth the extra money. I explained the differences but this only raised further questions which seemed to be rephrased versions of the ones he'd just asked. In short he kept me talking for ages.

On arrival at the workshop I was greeted by the customary "good evening", suggesting that I was maybe a minute or two late, and a field engineer wondering whether his vehicle would ever turn up.

## **A Morning of Video**

First job of the day was to reassemble a Sony CCD-V200 pro camcorder that had been on soak test following head replacement. This completed it was dumped on the next salesman to enter the workshop so that he could put it back on display. A Panasonic NV-G21 was the next job on the clip, a rental machine brought in by a field engineer as the video heads were faulty. But there were a number of other faults. This is common with earlier versions of these machines that have been out for a while. The video heads were soon replaced (VEH0343) along with the barrelled pinch roller (old brass type VXL1743) and the capstan motor (VXP0777) which was causing a loud knocking noise while lacing. The machine was tested, the new heads were set up and the sound level was then found to be low and varying. Another stock fault. The VBR0116 head was replaced with a VBR0125, then the capstan brake, whose pad had virtually disintegrated and was causing a cyclic scraping sound, was renewed. With the new head aligned and the new improved parts fitted I didn't expect to see the machine for a long time. These

machines are very reliable electrically: it's only the weak design of the early mechanical parts that lets them down. The old parts were taken to the appropriate box in the storeman's office to be sent back if required.

The next job was one I'd been putting off for a while, a Sony CCD-F330 camcorder. I'd found the cause of no auto focus to be a break in the FPC from the auto focus sensor below the lens to the AF32 auto focus processing PCB. After confirmation with Sony I obtained a lens from the stores as the only way of replacing the offending item. Now those of you who know Sony camera head design will sympathise with the job of lens replacement. Suffice to say that it took until lunch time to reassemble the camcorder to a state in which it could be soak tested. The alignment was checked in the camera workshop and the camcorder was left soak testing until I felt like putting the case back on! By now it was lunch time and we adjourned to the tranquility of the audio room for some nourishment and to watch the news and Neighbours . . .

One of the field engineer/installers had been asked to call in on a B and O VHS82-2 VCR that wouldn't accept a cassette. He'd been advised to "collect and loan" but, being an intrepid soul, he came in to ask about the viability of trying anything while at the house. Now this machine has the plastic Philips mechanism, so I didn't want it brought in. I got a cassette carrier from the stores, showed him how to do the job (wiggling the insert switch etc.), handed him a manual in case he got stuck and opened the door for him as he and the other field engineers left to make their afternoon calls.

### ***Afternoon's Mixed Bag***

Television servicing in the workshop is limited to over the counter jobs and the real nasties, most of it being done in the field. This makes for more interesting work for us. My colleague Ian Bowden and I share the TV sets and we're lucky in that we prefer dealing with different types of fault. I'm more than happy with a dead Sony or B and O, something that many people would run a mile to avoid, while he prefers signal faults – decoders etc., the nastier the better. Salora Ipsalo faults are another of his favourites. He's also got more patience than the rest of us. He'll stick at an intermittent fault forever whereas we tend to put such problems aside a few times. Our third workshop engineer tends to stay in his audio room most of the time, away from the TVs, listening to his weird music.

Anyway I next turned attention to a brand new Salora 24K67, the last one in stock and booked to go out next day. It had multiple purity errors, discovered by one of our administrators while he was fitting teletext. He'd degaussed the c.r.t. but on switching off and on again the errors returned. I checked the degaussing circuit, found that it was working and after much deliberation accused the tube. The salesman involved was summoned and told the good news. He suggested sending the identical Luxor model of which we apparently had plenty in stock. But it has a wood coloured cabinet and the customer particularly wanted the grey Salora colour. It was then suggested that we take a tube from a new Luxor set and fit it in the Salora one. My next few words don't bear repeating, but 'twas duly done and the set worked fine. The Luxor set was put in the parts on order area.

A colleague asked for my advice on a dead Sony KV1400 and was given some. Next came a Panasonic NV333 whose card said it was repaired a month ago for the same fault. I checked the old card and found that it

had been repaired just over three months ago. The work done had been to clean clogged heads and replace the belts and idlers etc. following the customer's acceptance of our two estimates (one for head cleaning and one for attending to the very worn belts etc.). Another note had been made on the card that a lot of oxide seemed to have been shed into the mechanism, and administration had advised the customer about the use of poor quality tapes. The heads were again clogged. They were cleaned, then the machine was soak tested for a few days after which the customer was phoned and asked to collect it.

A few days later (I must follow this one through!) the machine appeared again, along with four of the owner's tapes as instructed by administration after he'd rung to say "it's gone again". Indeed the heads were clogged and cleaning restored normal operation. A look at the tapes revealed the source of the problem. They were four-hour Scotch tapes with which we've had more than a little trouble, usually resulting in this type of fault though sometimes the cassettes themselves have broken. In one I remember the front flap had snapped off in a brand new rental Panasonic NV-G40, ruining both heads. Customers buy them because of the life guarantee. A phone call to the customer finally sorted the job out. If Scotch are reading this, it happens on all makes of machine we sell and not only with your tapes. This particular machine was one of three that came in with identical troubles during the week. What we do is to advise customers of the problem and give them a Panasonic tape to use exclusively for a trial period. When this proves to be trouble free they promise to do as they are told and not buy on price.

The field engineer/installer returned with the cassette carrier still wrapped up. He said the machine was outside and seemed to have a nasty fault. When I asked about this he laughed and admitted he'd done the job and had carefully rewrapped the carrier. As if I haven't enough troubles.

### ***The Last Job***

The next job turned out to be the last of the day, another Sony CCD-V200. It appeared to have intermittently clogged heads, but this wasn't so. When it was in the fault condition the drum phasing appeared to be incorrect. This was confirmed by lightly touching the drum with a finger then releasing it – a momentarily perfect picture was then seen. The speed was correct and a check on the circuit revealed that the ATF LOCK wasn't operating. So the signal was traced from the preamplifier. After a lot of checking through all the various paths and Ian having a nose around – it being a nasty – we jointly resigned ourselves to the fact that we would have to get to a certain test point on a small PCB in the middle of the PCB sandwich across the bottom of the mechanism.

So I gently removed the right-hand side case and while gradually lifting everything out I found the cause of the trouble – the earthing strap to the case of the narration microphone was not connected, instead being lodged across the print side of the connector, to the head amplifier area. After putting this to rights the machine performed flawlessly – we've had a number of faults that could be classed as production errors on stock Sony camcorders. I have to confess that this job was not completed until the following morning. Six p.m. came just before confirmation of the fault, and I decided to leave the excitement for another day!

## Philips VR6561

This machine wouldn't play as the head didn't rotate. It would begin to turn but couldn't manage a full rotation. This pointed to one of the motor's coils not being driven. D.C. checks in the drive circuit revealed that transistor T7113 (BD135) was open-circuit.

Another of these machines had the same fault but in this case it was intermittent. There was a broken wire in the loom from the PCB to the drum motor. **P.B.**

## Grundig VS200

Tape path problems, such as the sound going off after a few seconds, are often caused by a faulty pinch roller.

No sound or no control track recording/playback can be caused by an open-circuit head winding.

Intermittent failure to initialise, especially from cold, is often caused by poor connections on the ribbon edge connectors to the sequence control module. **P.B.**

## Philips VR6362

The symptom with this machine looked like faulty video heads – until I tried the tape in another machine and found that it had been erased! The +11.8d record supply was present all the time as transistor T7701 (BC328) was short-circuit. **P.B.**

## Philips VR6561

If the idler wheel doesn't flip across to contact the reel discs, check that the block (item 257 4822 466 81643 that fits under the top plate) hasn't fallen off. **P.B.**

## Sharp VC7300

An increasingly common problem with these machines is tape slack at the end of a rewind. The loop of tape then gets crunched by the cassette flap when the tape is ejected. Much time can be spent on the reel brakes if you don't realise that the cause of the trouble lies elsewhere. At eject the loading motor, under the deck, kicks to take up the slack, via a belt coupling to the spool turntable. If the latter doesn't move, check the loading (short) belt for slippage and the clutch on the loading block assembly for excessive friction. **E.T.**

## Hitachi VT220

This machine uses a multi-legged slab type chip (STK5471) to produce the regulated power supplies. We've had several of these fail, giving the following symptoms: operate light comes on, no deck functions and a noisy "r.f.-through" picture to the TV set, this picture disappearing altogether when the VCR is switched on. It's the 12V line that fails. Use plenty of heatsink compound when replacing this device. **E.T.**

## Panasonic NV333

This fault gave us a few headaches. The machine, an older version, had no clock display. Probably IC7501 on the front panel we thought. However as soon as we removed

the screws that hold the front and main PCBs and swung these out the clock display lit up, went out, lit up and went out again. A dry-joint we concluded, wrongly. We finally got to work with our trusty component tester and found that diode D1015 (MA165), marked D15 on the print, was leaky though not short-circuit. This diode is connected to the emitter of transistor Q1002 in the power supply section, feeding a regulated 17V supply to the clock PCB. A 1N4148 is a suitable replacement. **D.B.**

## Hitachi VT130

The problem with this machine was very bad audio flutter. When an alignment tape was played a scope hooked to the audio output socket produced a display with marked wobble at the right-hand side. We found that the capstan motor drew about 140mA off load and that the waveform generated across its input connections was rough. A new motor drew 85mA and produced a much smoother waveform. When it was fitted in the machine the sound returned to normal. **E.T.**

## JVC GR-C1

The reported symptom with this early camcorder was no sound. In fact the playback audio was fine but during record no sound reached the tape and there was no output via the E-E monitor channel. We found that the audio E-E mute line was in operation. For the machine to be brought out of mute the line needs to drop below 1V. In this case it fell to only 2.3V. The cause of the problem was on the mechacon board: the cure was to remove a big blob of yellow glue in the area of Q30. **E.T.**

## Sanyo VHR3300

We've had a couple of these machines that intermittently failed to come out of standby: the clocks worked fine but there was sometimes no response from the on button. If you get this problem check the fitting of the front PCB and the clearance between it and the plastic front cover. If one of the control switches is held in the others don't work. **E.T.**

## Hitachi VT11

The fault with this machine looked very like dirty video heads but after several attempts at cleaning them it was obvious that we had to look elsewhere for the answer. A check at the playback f.m. test point produced the waveform shown in Fig. 1(a). Assuming that the heads were o.k., we decided to check the drum flip-flop waveform which was as shown in Fig. 1(b). This signal is produced by the drum pick-up pulses which were then found to have the correct mark-space ratio. So the servo chip which contains the multivibrators that generate the drum flip-flop signal was accused of being faulty. Unfortunately replacing it made no difference. Time to look closer at the drum pick-up pulses. The waveform was as shown in Fig. 1(c) – Fig. 1(d) shows the correct waveform. The small positive-going overshoot pulse circled in Fig. 1(c) was of sufficient amplitude to make the positive

monostable trigger, thus creating the incorrect drum FF signal. Replacing the Hall i.c. on the drum motor cured the fault. **A.D.**

### Hitachi VT64

The drum motor had stopped and voltage checks around the drive chip IC601 revealed that the supply voltage at pin 10 was low. This i.c. is supplied via D642 and a cold check suggested that the diode was o.k. Replacing it restored drum motor operation however. **A.D.**

### Hitachi VT17

The drum ran at full speed because there was no FG signal at the servo board. We found that there were dry-joints on the FG board within the drum motor. **A.D.**

### Panasonic NV-G21

The customer's complaint was that the cassette wouldn't eject. In fact the machine was very sluggish in lacing the tape. If the capstan motor was given a helping hand everything worked. A new capstan motor put matters right. **A.D.**

### Panasonic NV430

We at first thought that this machine had dirty video heads, but cleaning made no improvement. When the scope was connected to the head preamplifier module to check for head wear the fault cleared itself. A check on the inside of the module revealed dry-jointed connectors and earthing connections. Resoldering the faulty joints cured the fault. It's worth checking that the module fixing screws are tight and thus providing good earthing. **A.D.**

### Panasonic NV788

The fault reported by the customer was a poor picture which was worse in pause and slow motion. A field engineer had visited the house and cleaned the heads. This had improved the playback picture but didn't help very much in the still/slow-motion modes, so the machine was brought into the workshop for further investigation.

We found that the top third of the picture was noisy in the still mode, the rest of the picture looking all right. The back tension was checked and adjusted without producing any improvement and new heads made no difference. A slight improvement was obtained by adjusting the inlet

guide. We then looked at the f.m. output waveform at TP3512 – see Fig. 2. In the playback mode the normal L and R heads are used and the output was correct. In the still/slow modes however a fifth head L' is switched into circuit, replacing head R. As shown in Fig. 2 it was the output from this head that was causing the problem. Since heads R and L' share the same playback amplifier the only cause of the difference could be in the switching, which is done by relay RY3501. We didn't have a replacement in stock so the relay was removed, its cover was opened and the contacts were squirted. When the relay was refitted the fault had gone and the machine gave perfect stills and noise-free slow motion – despite the fact that the heads were the original ones. **I.B.**

### Salora SV8300/Mitsubishi HS304

This machine would ignore any tape operation function after a couple of hours' use, e.g. if the machine was in the playback mode you couldn't stop a tape without switching the machine off. If rewind was selected and the tape was allowed to rewind fully you would then find that the machine wouldn't eject. The cause of the problem was a poor leaf switch contact, FL-SW-2, which is the inner of the two leaf switches on the right-hand side of the cassette loading housing. It's the one that makes when a cassette is pushed in and is held closed by the loading cam, going open again only when the tape is fully ejected. **I.B.**

### Grundig VS200

We see a lot of these machines. They seem to be very reliable electronically but the mechanics are not so hot. Failure to initialise is often due to a faulty brake switch which is located between the reel motors. If it has a plastic cover this must be discarded and the switch changed, not just cleaned.

The reel motors are suspect if the machine chews tapes or shuts off. A light tap on the top of the reels will sometimes free a tight motor. The feed motor causes the worst problems – when it becomes tight it will jam the mechanics. Changing the motors over will often cure the problem.

We've also had a few sound heads go open-circuit recently. You need to take note of the pink slip that comes with the new head as the wiring is different. If you get this wrong you'll still have no sound. **E.M.B.**

### Grundig VS310

Faulty or worn heads can be responsible for poor reverse search. For sound wow check whether the capstan belt has split. To get to this you have to hinge out the electronics chassis – don't remove the deck or you'll never dress the wires in the right place again. If you have a different fault when it's back together check all the plugs – they are of very poor quality. **E.M.B.**

### Amstrad VCR6000/VCR6100

This fault has fooled several of our field technicians: the remote control handset can be programmed on its liquid crystal display but the VCR won't accept its commands.

When the first machine with this complaint was brought into the workshop our trusty remote control handset checker proved that the unit was transmitting something. A further check revealed that the batteries produced only 5.6V. New 6V batteries cured the problem. **A.S.**

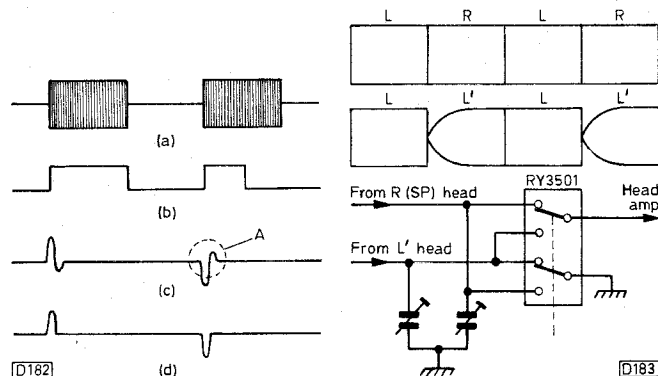

Fig. 1 (left): Waveforms associated with the Hitachi VT11 fault described above.

Fig. 2 (right): F.M. output waveforms and head switching relay, see the Panasonic NV788 fault.

# The Panasonic NV370/830/850

Nick Beer

The Panasonic NV370 is a "basic" model that was introduced as a replacement for the NV333. It incorporated several firsts including front loading, standby OTR (one-touch timer record operation), a picture sharpness control and a large multi-function fluorescent display. It has cord-linked remote control, a one event/14 day timer and a two-head drum (VEH0218). The NV830 came later and is basically a hi-fi sound version, its drum (VEH0266) incorporating two audio heads. Further features were added with the NV850, in particular an eight event/14 day timer and a third video head in the drum (VEH0231) for perfect stills and general improvement in the trick modes. In addition to the two drum-mounted audio heads the two hi-fi machines have a single mono linear audio head. The absence of a stereo linear sound track facility gave rise to a certain amount of criticism, due to the number of stereo (not hi-fi) library tapes available. The hi-fi machines both have a comprehensive infra-red remote control system, though you can't use it to set the timer. These two machines have black cases whereas the NV370 is in silver. From the servicing point of view the differences between these machines are minimal. We'll mention them as they arise.

The function display is separate from the clock/channel display, being mounted above the deck function selectors. The electronic counter is a four-digit type with electronic memory. Dew warning is given by the counter display's far right-hand digit changing to "d", something that might not be immediately obvious. Addition of standby to the OTR function already seen on some previous models allows the OTR start to be delayed by up to two hours in thirty minute steps. The NV850 has memory back-up when the mains supply is interrupted – this feature is not present on the two cheaper machines.

The mechanism is very quiet in operation – welcome after the NV7200 series! One point about its operation that I personally find annoying is that it returns to the stop position during mode selection. For example if you make a test recording then push stop and immediately after select play it won't, as with the NV7200s, go straight into play. It will unlace and relace.

## Dismantling

To remove the top cover, undo the four silver screws at the sides of the unit and pull the top upwards, gradually pulling the front edge away. The bottom cover is held by nine brass-coloured screws. It covers the entire bottom area of the machine. Later decks have just a plate over the mechanism.

The bottom, main PCB covers part of the mechanism and for a lot of work has to be unhinged. To do this you have to remove the front, operation PCB which is hinged on it. This is a similar idea to the NV333/NV366 series, but only the small operation PCB is attached, not the timer/presetter as well, previously a single unit. First remove the cabinet front by undoing the three red screws, one at each clip across the top of the front, then undoing each of these clips and the three across the bottom. After removing the two red screws in the top two corners the operation PCB can be hinged out. The main PCB can be

released by undoing the eight red screws and two clips which, with the machine stood on its back, are one third and two thirds of the way down on the right-hand side. The whole assembly can be hinged towards the back of the machine, but you will need to unsolder the earth wire to the front left-hand side of the mechanism.

The screening can over the head drum is removed by loosening the five red securing screws and then moving the can across and up to allow the screw heads to pass through the larger holes in the plate.

The capstan brake is countersprung and is mounted on the capstan flywheel support bracket.

## The Mechanism

The mechanism in all three machines is similar to the D1 type, with only minor modifications. The drum is a typical Panasonic direct-drive unit, of slightly more compact design to those previously used. There's a direct-drive capstan which also provides the kick idler drive, via the capstan belt (VDV0149). A separate motor is used for tape loading, via a loading belt (VDV0148). This is significantly smaller than the two-belt system used in the NV7000 and NV333 series machines. Front loading is performed by a carriage-mounted motor and belt (VDV0074). Mechanism state detection for the syscon is carried out by a linear mode switch (VES0246 for Models NV370/NV850, VSS0091 Model NV830) which is somewhat different in appearance from those previously used. It has a skeleton-style look, the leads being soldered directly to the contacts rather than to a PCB.

Whereas in previous models the drum static discharge angle was fitted at the top of the drum, this time it's fitted to the bottom – part no. VXS0059. Since the bracket construction is different the earlier type cannot be used. The new type rarely fails however.

Moving back up to the top of the mechanism we come to the thing that most people will probably associate with this deck for ever more, the reel idler (VXP0521). There can't be many people who didn't have to change one during the first twelve months because of tape chewing. The answer is to fit the modified type, which is far more reliable and has the length of life you'd expect. The old type is plain white while the modified type is black and white. A machine came in quite recently with the old type still fitted. It was working all right but we nevertheless changed it, as you always should – don't tempt fate!

## Mechanical Service

The majority of the jobs on the top of the deck, for example reel idler or brake band replacement, require removal of the cassette carriage. The reel idler can be replaced without doing this, but is then a more difficult operation. To remove the carriage, undo the four red bolts at each corner of the top plate, remove the multi-pin plug (P1507) on the small PCB at the rear right-hand side, then lift the carriage out. This assumes that you've already removed the screening can from the head drum, as it mounts over the front lip of the carriage.

Idler replacement is straightforward. Unhook the spring



that runs over its back edge then remove the slit washer from the shaft to allow the idler to slip up over the pivot. When fitting the replacement ensure that it is completely bedded down and mating with its drive surface. To do this, push the idler wheel towards the back of the machine against its spring while pushing it home, then fit the slit washer again. You don't get a replacement washer now with each new idler, though one comes with the maintenance kit for this series (kit part no. VUD4092, see Ian Bowden's article in the October 1988 issue of *Television*). Refit the spring and check the review torque (see later).

The brake bands are beginning to suffer from the usual Panasonic ailment: the glue on the pad dries out and the pad drops off. The result of course is virtually no back tension, the symptom looking as though one video head has failed. Replacement is marginally easier than with other Panasonic decks as the band is fixed to the back-tension lever by means of a moulded plastic spring clip instead of a second circlip. The lever will usually have to be removed to undo the old unit, but sometimes it can be pulled out from above. To fit the replacement, simply push it through the hole. Set up the back tension afterwards (see later).

## Head Drum Replacement

This was the first series of Panasonic decks to have the pin-connection style head drum instead of the flexible leads previously used. It saves a lot of time, fiddling about, and burnt fingers. The two things to watch are first that all the arrowed connections on the PCB are free after unsoldering – otherwise you'll end up with broken connections to the rotary transformer and will then need a new DD unit. Don't unsolder any connections other than those arrowed: unsolder all those arrowed even if there appear to be too many. The head section is held to the DD unit by the usual two screws. To prevent any nasty experiences, always remove them as the last job before the head and refit them first after replacement, before resoldering the pins. This is to ensure that the upper and lower drum sections are fully mated – if you solder then tighten the bolts and the head drum moves you'll crack the head PCB or damage the DD unit. The other point to note is that since there's no lead colour coding the head can be fitted the wrong way round. To prevent this, half the PCB in the drum is coloured white and there's a white mark on the DD unit: these should, not surprisingly, be matched up.

With the NV850 the DD unit is covered by the stator not present on the other two models. This has to be removed to enable the head drum to be replaced. The stator angle is held on by two bolts, one in each rear corner. There's also a multi-pin connector (P4501) which has to be removed. Underneath there's the rotor base, again held by two bolts. With this removed you'll find that the head drum (VEH0231) is secured by the usual two screws. To reinstall the stator assembly after replacing the drum calls for the stator angle adjustment jig (part no. VFK0268) to ensure correct positioning.

## Pinch and Impedance Rollers

Pinch roller replacement is straightforward. Remove the bolt that holds the dew sensor bracket, then the single circlip that holds the pinch-roller arm. Pull it off, at the same time releasing the counterspring.

One final point about the top of the deck. With the hi-fi

models when you replace the impedance roller (VDP0908) on the left-hand side, beside the erase head, or carry out any tape path adjustment, ensure very careful alignment while looking at the audio f.m. envelope. A very slight discrepancy that might not affect the picture adversely can have a dramatic effect on the audio f.m. envelope. This roller is part of the maintenance kit and should be changed at the appropriate time – no skimping!

## The Belts

The mechanism has three belts. The loading belt (VDV0148) simply slips over its two pulleys. The capstan belt (VDV0149) does the same but the support bracket over the bottom of the capstan motor has to be moved out of the way. It's not necessary to undo all three bolts: remove the two at the rearmost end and loosen the other one to enable the belt to be manoeuvred over it. The third belt is on the carriage and can be slipped off both its pulleys in alternate directions. Thus there's no need to remove any motors or brackets. The belts rarely fail but they do get to be tired looking and, being part of the 1,000 hour kit, should be changed.

## Mode Switches

The mode switches are less reliable than those on the earlier machines and are in turn more reliable than the very similar looking ones on the later NV230/NV430 series machines. Faults range from no drum rotation to being stuck in the laced-up state – in general, any weird mechanical happenings (see also the fault list). Always disconnect the deck from the mains supply before working on the mode switch, otherwise you'll end up with a retiming job. A single bolt holds the switch and should be changed along with the switch. The old switch gives you a useful guide to the positioning of the new one. You'll see a clean area around the slot, inset in the blackened, corroded area. This is where the old bolt head was located. Fit the new switch in the same way, ensuring that the white peg is correctly located on the main lever, and you won't go far wrong. Remember to write down the wiring connections to the switch. A note in the manual is worthwhile, but I've seen more than one set of wire colours.

## Take-up Torque

The take-up torque should be within the following limits for each mode. Play 105-145g/cm, fast forward and rewind over 400g/cm, review 200g/cm  $\pm$  10 per cent. If there's a large discrepancy the drive systems should be investigated (look for worn idlers etc.). Adjustment is by altering the notch to which the left-hand side of the spring is attached. This is the spring across the rear half of the reel idler.

## Back Tension

The back tension should be between 25-30g. You will very often find that the best performance, especially for searches, is with the back tension set at 30g. This figure should not be exceeded. Adjustment is by altering the position of the back-tension spring mounting bracket. This assumes that you've not changed the brake band and upset the level. If so, the back tension should be aligned with the brake band set as shown in Fig. 1.

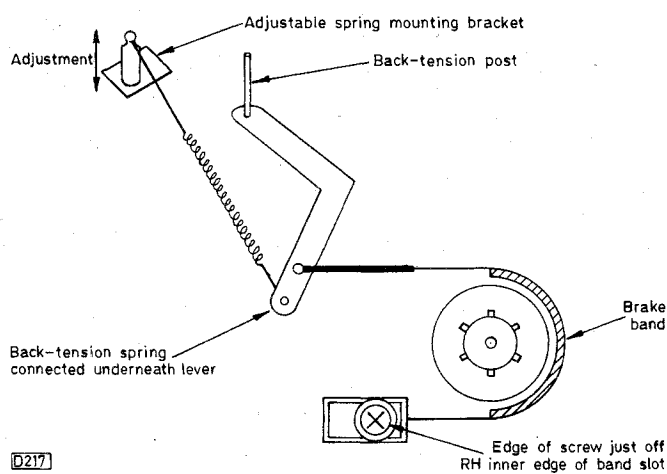

Fig. 1: The back-tension arrangement

The position of the brake band, and thus the falling range of the back-tension lever, should be set using the adjustment plate (part no. VFK0187). A few machines will not warrant this, so the diagram can be used as a guide.

### Electronic Features

In this section we'll briefly consider the circuits that are likely to require attention.

The syscon is designed around a microcomputer chip, circuit reference IC6001 as always. All three machines use the same device (MN15342VGC-3). An optosensor under the take-up reel provides detection of rotation and pulses for the electronic counter. The troublesome cassette up and down switches are mounted on the right-hand side of the carriage – see fault list. There is also an insert switch (VSM0047) in the middle of the top of the carriage.

A larger number of chips are used in the servos than in

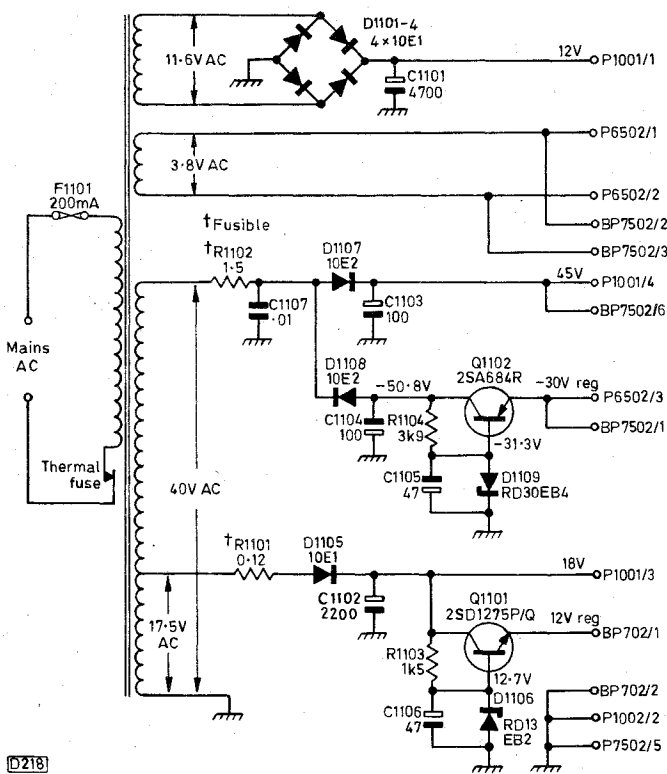

Fig. 2: The mains transformer/rectifier PCB circuit, Model NV370.

the previous models and a manual will usually be required for any in-depth fault finding.

The power supply is simple. Fig. 2 shows the mains transformer/rectifier board circuit which should help if you don't have the manual – there's a tendency with these machines for the fusible resistors to go open-circuit randomly.

There are obviously various differences in the timer/presetter arrangements used in the different models. The basic NV370 has a step up/down selection system with presets for its 16 channels, a single M54836AP chip (IC7503) being used for control. The NV850 on the other hand uses the single thumbwheel and store system that was to become familiar on later machines. It also has a back-up system for memory when there's no mains input. This takes the form of three 3.3F, 2.3V gold capacitors, as in the NV366. They suffer the same fate!

The hi-fi circuits are on two boards situated around and over the presetter PCB.

### Remote Control

The NV370's cord-linked remote control unit, part no. VSQ0330, gives control over only the basic functions play, rewind, fast forward, record and search. It works on the same switched resistance principle as the system used with the NV333/NV366. The single-screened lead is terminated with a 2.5mm two-pole plug.

The IR unit used with the hi-fi models, part no. VSQ0338, gives control over virtually everything apart from the timer and hi-fi selection functions. There are no real stock faults. Spillage is the most common cause of trouble – it can corrode the contacts of the rubber mat. The buttons tend to wear so we replace them when a machine is in for service to keep up the appearance of the unit.

### Fault List

Here's a list of some of the more common faults we've experienced with these machines.

- (1) No or slow rewind/fast forward and/or chewing tapes. Usually caused by a worn reel idler, especially if the plain white type is still fitted (see earlier remarks).
- (2) Cassette will not stay in. Cassette up/down switches on carriage faulty. See earlier comments.
- (3) No results. 5V rail missing as D1002 (3.9V zener diode) short-circuit and R1001 (0.39Ω) open-circuit.
- (4) Hum on sound and vision. C1102 (2,200µF) leaky or open-circuit. This is the reservoir capacitor for the unregulated 18V supply.
- (5) Incorrect function selection – fast forward instead of play and rewind instead of record. C6011 (0.18µF) in key scan two line faulty.
- (6) Capstan speed incorrect and will not set correctly. Can be caused by IC2001 (AN6359N) or IC2002 (MN6168VIF) – sometimes both fail together.
- (7) Drum motor does not rotate. If the outputs at pins 1, 2 and 23 of IC2005 (AN6387) are absent or "pulsing" suspect this i.c.

(8) Function display not working. Check D6504 (RD75EB) and IC6501 (MN1450BUF2). The display (VSL0030) might have an open-circuit heater.

(9) No or incorrect colour in record and playback. IC8001 (VEFC007) faulty. It's on the folded FPC.

(10) No 5V supply to capstan servo, causing shunting fore and back. Q1104 (2SD1275) in the power supply faulty.

(11) Capstan and kick idler shunting. R1101 in power supply open-circuit, usually for no apparent reason though Q1101 (2SD1275) and D1105 (10E1) may be short-circuit.

(12) Machine goes off after about three seconds. Note if when switched on the characteristic loading "shuffle" occurs. If not check the loading motor drive chip IC6003 (BA6209) as it will probably have an internal short.

(13) Horizontal picture twitch. Impedance roller (VDP0908) sticky. Replace along with its insert (VMX0541). Note previous remarks about precise adjustment with hi-fi machines.

(14) Dew indicator stays on. Try resetting the microcomputer chip IC6001 (MN15342VGC-3) by disconnecting the mains supply for a minute or so then switching back on. If this fails to cure the problem and the machine is not damp IC6001 is suspect.

(15) Capstan does not rotate. Assuming that all the supplies are present, as opposed to being excessively loaded, suspect IC2004 (AN3821K) and check the continuity of the capstan stator (VEK2038).

(16) When play is selected the machine laces but the drum doesn't rotate, the machine won't unlace then switches itself off. Suspect dirty contacts on the mode switch.

(17) Machine switches off as soon as review is selected. Mode switch faulty.

(18) Machine cuts out after a few seconds in review and the left-hand reel is slow to turn or doesn't turn at all. Replace worn reel idler.

(19) Machine cuts out after a few seconds in play, a slightly shorter time in rewind or fast forward. Check whether the electronic counter works before the machine cuts out. If not, check for reel pulses at pin 19 of IC6001. If these are not present and the supply to the optosensor (type ON2160) is present, suspect a faulty sensor. Otherwise suspect IC6001. Both items have been known to cause this fault.

(20) Grainy, black and white playback picture. Video heads worn or drum fitted wrong way round (see earlier remarks).

(21) Knocking noise, particularly noticeable in play. Check for dents in idler wheel VXP0521 and its clutch gear VDG0147 – shadow of BSR turntables! In nine cases out of ten however clutch VXP0523, under the clutch gear, is responsible. This fault will very often not be reported but will nevertheless be very evident.

(22) Mis-operation of the hi-fi channel indicator LEDs, not corresponding with switch selected. In order of probability, check QR4306 (DTC124A), QR4304 (DTC144A) and QR4301 (DTA114A).

(23) No front panel selection of play etc. possible with Model NV370. Check that the remote control unit is not plugged in, then suspect that the remote control socket is faulty.

(24) No remote control operation, front panel controls o.k., Model NV370. Suspect that the remote control unit's lead is open-circuit, particularly the screen connection. It can be replaced with normal single-screened lead if you remember to save the cable gland/strain from the old lead.

## In Conclusion

In this article we've taken a basic look at the mechanical set up and operation of these machines, the electrical make-up of the circuits that tend to give trouble and listed the more common faults. These VCRs are not old – the majority just require a mechanical overhaul and a few are now being swapped over on rental. They can be rented or sold for a very respectable price, and after a service can be expected to work well for the foreseeable future. Head wear is particularly good, but only when the back tension is set correctly. If you don't have a Panasonic account you'll find that spares are available from many advertisers in *Television*. Should replacement heads be necessary I particularly recommend those available from MCES.

## Panasonic NV7200

During the space of a week we've had two of these machines with the same fault. The symptom is that at the beginning or end of a cue or review session the machine appears to enter the still-frame mode for a few seconds then reverts to stop. The mode switch can sometimes be responsible for this. In both of these machines however the cure lay in replacing both loading belts. Slippage of these belts is more often associated with failure to complete tape loading.

E.T.

## Panasonic NV-G25

The complaint with this machine concerned LP recording: there was a poor picture, poor sound and the speed varied. We found that the results in the SP mode were not very different and that the tape was riding high past the audio/control head stack then wrinkling between the capstan and the pinch roller. The problem was caused by a faulty pinch roller – the one that lowers itself into position. A new one and a clean up restored good results in both the LP and the SP modes.

E.T.

## JVC HRD400

If you come across a case – possibly intermittent – of no E-E sound and no recorded sound check for a hairline crack in the print at the rear of the main PCB (03) adjacent to the left-hand unsoldered lug of the r.f. modulator can. It seems that the modulator “rocks” when the aerial plugs are inserted or withdrawn, stressing the PCB.

E.T.

## Panasonic NV2000

This machine had a mixed bag of symptoms: no clock display, the tuner not working, the capstan running slow and erratically and hum bars on the monitor screen. All were cleared at one stroke when C1009 (1,000 $\mu$ F, 35V) in the power supply section was replaced.

E.T.

## Hitachi VT120

The customer's report was that the picture was intermittent. On test the machine displayed a noise bar that rolled through the picture, as though there were no control pulses. Both own recordings and prerecorded tapes were affected. We found that the control pulse input to the servo i.c. was present and correct, but a check on the other waveforms around IC601 revealed that the capstan phase control pulse at pin 11 was missing. As all the inputs were correct the chip was replaced, clearing the fault.

A.D.

## Ferguson FV22L

A modification kit for this machine has been produced to deal with intermittent faults in the timer mode. The faults that occur are that the machine will switch out of a timed recording or will not stop at the selected time, the recording continuing until the end of the tape when the cassette is ejected.

This modification also cured an intermittent fault in the “instant record” mode. What would happen was that if the machine was set to record in this mode for over an hour it would turn itself off approximately one hour before the selected time.

A.D.

## Philips VR6362

This machine would switch on and off but wouldn't accept a cassette. When a 9V battery was connected across the loading motor the mechanics would thread in and out correctly, thus exonerating the eject rack and differential gear assembly. The fault was being caused by the load motor driver chip which had a short-circuit output pin – the pin that drives the load motor in the threading in direction.

A.D.

## Mitsubishi HSB30

There was no playback picture with this machine. We traced the playback f.m. into and out of IC2A1 and then to transistor Q2B2 where it disappeared. Replacing Q2B2 cleared the fault – it was open-circuit.

A.D.

## Panasonic NV-F70

This machine was completely dead. The mains fuse was intact so the fault was in the switch-mode power supply, where the primary side wasn't starting up. C1109 (1 $\mu$ F, 400V) should provide a pulse to the chopper transistor within IC1101 (STRD6008X) to get things going but there was no pulse at pin 2. The i.c. was found to have an internal short-circuit between pin 2 and pin 4 (ground), a replacement restoring normal operation. Note that there's an error on the circuit diagram, where the base and emitter of the chopper transistor are shown shorted together.

I.B.

## Panasonic NV-G12

When play was selected the drum motor didn't move so the machine cut out. This was quickly traced to an open-circuit fusible resistor, R2012 (6.8 $\Omega$ , 0.5W), which is connected from the unregulated 14V supply to the common connection of the three-phase DD drum motor. The resistance to chassis on the motor side was only 7.5 $\Omega$  – this turned out to be the resistance of one phase of the motor.

A check at connection P201 revealed where the short was – on the winding connected to pin 1. When the head amplifier was removed to check the leads the reason for this was found. One of the ten leads was trapped between the right-hand head amplifier support bracket and the main chassis. It must have been like this since the machine was made some eighteen months ago.

I.B.

## Ferguson FV10

The reported fault was that this machine wouldn't accept a tape. This was so – if a tape was manually inserted the fast forward and rewind modes would operate but play

wouldn't, as there was no drum rotation. The tape could also be ejected, but there was no carriage-stop detection and the front loading motor would keep going for a few seconds until the machine switched itself off.

The cause of these problems was loss of the switched +12V and +5V supplies due to a faulty multiregulator chip, IC801 (STK5481). It's mounted on the right-hand side of the main PCB. **I.B.**

### Philips VR6460

This machine nearly drove us round the bend. The customer's complaint was that it played back its own recordings quite well but with films from the hire shop there were wow on sound and noise bars on the picture. Our field engineer gave the machine a thorough clean up, paying particular attention to the tape path and the control head, though the machine worked perfectly while he was there.

A week or so later the inevitable repeat call came and the machine was brought back to the workshop, together with a film. Once it was opened up on the bench our first step was to try an MH2 test tape and see whether it would play this back correctly. It did. Several other tapes were tried and seemed to be o.k., but the machine flatly refused to play the film supplied. The capstan servo seemed to lose lock, as if the control pulses were missing. As the tape was suspect it was tried on another machine, which played it back normally. So now we were thoroughly confused!

After a lot of time was wasted scoping the control pulse outputs etc. and setting up the lateral position of the control head as per the manual we discovered that if the back tension was reduced by resting a finger against the tension arm the fault almost cleared. A similar effect could be obtained by increasing the pinch roller pressure. The pinch roller and back-tension band were replaced and, you've guessed it, the fault was still present!

We decided that the back tension was excessive. This was backed by our observation that the tape seemed to be very tight between the exit guide and the pinch roller. At this point the penny dropped. Could the lower drum be too shiny so that the tape was sticking to it? Changing the lower drum completely cleared the fault. The price of this unit was £220 from Philips, £150 from Panasonic. Fortunately the machine was insured! **E.M.B.**

### Ferguson FV11

The temporary field engineer accused the tuner of being the cause of no signals. He ought to have known better! There was no tuning voltage – the regulated 30V supply was being lost across R53 as there was a short from the tuner's BT pin to chassis. We found that the pin hadn't been trimmed and was shorting to the bottom cover. When this was corrected the machine still didn't tune as there was now no load on the BT rail. The control transistor had no drive from the frequency-synthesiser tuning chip IC3 as there was no 5V supply. A break was discovered in the print between IC3 and the 5V regulator IC1. **N.B.**

### Sanyo VHR1300/Salora SV6600

The customer had complained about poor pictures and the heads were badly worn. When these were replaced things looked fine. While the machine continued to play

the test tape I relocated the PCB that hinges over the mechanism: the drum and capstan servos then began to vary widely. By flexing the board both motors would stop and the machine would unlace. The fault could be provoked by prodding or poking in the servo area of the board to any degree. As the fault was so general I checked the servo d.c. supplies and found that the always 5V and 15V voltages disappeared between CN1003 and CN1004. The tracks that link these two connectors run right at the back of the panel, over the r.f. connection sockets, and were all broken in two places each. A point to note if you have a heavy-handed customer. **N.B.**

### Philips VR6462/Pye DV464

For failure to eject fully, failure to rewind a tape fully into the cassette before eject, and sometimes swallowing a cassette when attempting to extract a partially ejected cassette proceed as follows.

Check the alignment of the guide reference holes D and E on the control disc or cam gear (item 247, part no. 4822 466 21014) below the chassis. Operate the mechanism two or three times then recheck the alignment. If it has shifted, examine the V-shaped lever (item 242, part no. 4822 403 52252) and the glide block or cam follower (item 238, part no. 4822 466 813650) which is pivoted on the end of the shorter arm of item 242 and rides in the spiral groove of item 247. Sometimes the pin set into the end of the lever arm on which the guide block pivots becomes loose in its setting, allowing the guide block to float loose and the linkages to go out of sync.

If this is the case item 242 can be replaced. It can also be repaired as follows. Remove lever 242, taking care not to lose the pin if loose. Remove the pin and put it safely to one side. Also remove and take care not to lose the fine spring that surrounds the pin and locates in a small hole in the arm. This spring is not shown in the relevant diagram and doesn't have a part number – if you lose it you will have to order the lever complete.

Take the lever minus spring and pin and lay the end flat on a firm surface, vice jaws or a steel block. Give the pinhole area of the lever two or three light taps on the top and bottom with a small hammer. In this way the hole will be shrunk sufficiently to allow the pin to be pressed firmly and securely back into place. This must be done carefully, for example by lightly gripping the lever and pin between vice jaws, holding the pin in exact register and perpendicular to the surface of the lever with fine-nosed pliers or tweezers, and pressing firmly home by applying pressure from the vice. Warning: before you apply pressure make sure that the pin is on the correct face of the lever – it's possible to insert it from the other side. When the pin and lever have been correctly fitted reassemble the lever, glide block and control disc as described in the manual, paragraph 2.1.19. Finally, after checking the alignment of reference holes D and E as above test the load and eject action a few times and recheck D and E again. **J.C.P.**

### Sanyo VTC5000, VTC5150 etc

For no colour in the record mode but playback of previous recordings being o.k., check whether diode D1008 is open-circuit. When it goes open-circuit the 5.12MHz signal doesn't reach the colour down-converter. Intermittent colour recording and return to the E-E mode is caused by dirty contacts on the record/playback relay RY1001. **V.W.C.**

## Philips VR6468

This machine would accept a cassette normally, but if wind or play was selected the cassette would eject. A check revealed that the microcomputer chip thought the capstan wasn't turning even though it was! The tachometer pulses were missing – a new P687 amplifier module put that right. **P.B.**

## Philips VR6561

If play or wind was selected this machine would eject the cassette. The error memory showed that the capstan tachometer signal was missing. R3509 (15Ω) had gone high-resistance – it read about 60Ω. **P.B.**

## Philips VR6462

This machine played o.k. but wouldn't tune in a signal. We found that the tuning information pin 16 of the SAB3013 chip was at a higher voltage than it should have been as T7420 (BC547) was open-circuit base-to-emitter. **P.B.**

## Philips VR6468

There was no vision in E-E or play, though the test pattern worked. The +11.9b supply was missing as C2329 on the signals board was short-circuit. The short had also damaged transistors 7607 and 7304 (both type BC328). **P.B.**

## Philips VR6180

This machine intermittently failed to accept a cassette. If it was put into standby before the cassette was tried the display would go bright, showing that the cassette in switch was being sensed, but the tray wouldn't move. No supply voltage reached the control motor as there was a dry-joint on plug B2. **P.B.**

## Panasonic NV-G40/NV-G45

Two similar machines came in with different versions of the same fault. The first one, an NV-G40, had a reluctance to capture and lock on to channels when search tuning. It would tune all the way through the u.h.f. bands, pulling in all the local, fringe and distant channels but refusing to stop at any of them.

The manual contains no description of the search tune circuitry but did provide a clue as to the area involved. In addition to running the clock and the displays, and decoding the push-button inputs, IC7501 on the timer and operation panel provides tuning memory and digital-to-analogue conversion for the tuner and TV demodulator, via the channel select chip IC7551. During tuning search, as a signal is resolved the video from the tuner-demodulator is fed to the luminance/chrominance section and passes via the input/output CBA and emitter-follower Q3013 to pin 1 of IC3002. The sync pulses are separated and fed, together with a 15.625kHz signal, to a comparator. Presence of a signal is detected by identifying line sync pulses – this results in a low at pin 9 of IC3002. This low is fed back to pin 20 of IC7501. The

tuning scan then stops and the tuning point is locked, after which the memory button is pressed.

We found that by artificially introducing a low by momentarily shorting pin 9 of IC3002 to chassis at the point during the tuning scan when a picture was resolved it was possible to lock on to a channel. Pressing the memory button then stored the channel in the normal way. Using this technique, we were able to program all the local channels. The machine would have been usable in this state provided the user didn't move to a different area or unplug his machine long enough for the tuning memory to be lost. Resisting this temptation, also the temptation to provide an extra push-button switch to short out pin 9 during the tuning process, we pressed on.

Scoping the video waveform at the tuner-demodulator output and then tracing it along the path to pin 1 of IC3002 showed that there was no loss of signal here. Pin 9 of IC3002 should have been at 0.1V but was actually at 4.75V and didn't vary whilst tuning. Replacing IC3002 (AN5421N) cleared the fault.

The second machine, an NV-G45, had exactly the same symptoms. So after confirming channel lock by pulling down pin 9 of IC3002 we replaced this chip. This time the fault remained. Resorting to the scope we found that the video input at pin 1 of IC3002 was of very low amplitude, less than 25 per cent of that at the base of emitter-follower Q3013. Further investigation showed that one leg of C3055 (33μF, 16V) came loose from its can when moved. Replacing this capacitor finally cleared the fault. **J.C.P.**

## Sanyo VHR4350

This one led us a merry dance. The head drum wouldn't turn, though voltage was present at the drum motor and it was free to turn. The cause of the problem turned out to be dry-joints at CN823 on the deck-mounted junction PCB. As a result the motor was off earth. You have to remove the deck to gain access for resoldering – do all the joints while you are at it. **E.T.**

## Panasonic NV-G7

The mode switches used in various Panasonic decks can be troublesome. If you replace one in the D1 deck (NV-G7, NV-G10 etc.) don't use the VSS0110 type which you may have in stock for earlier models. It looks similar and fits perfectly, but electrically it's quite different, giving rise to some peculiar deck behaviour. The correct part number is VSS0135. **E.T.**

## Mitsubishi HSB20

There was a nasty buzz on the E-E sound with this new machine. We fed the output from a colour-bar generator into the machine and found that the buzz disappeared when the generator's chroma signal was switched off. Attention was therefore turned to the 6MHz filter circuit CF151. By making comparisons with a good machine we found that although the output waveforms at pin 18 of IC101 were similar they were different at the input to

CF151. After replacing various components in this area to no avail I was getting somewhat puzzled. L153, which is connected between CF151 and chassis, had been measured but as a last resort I decided to swap it over with the coil from the good machine. This cleared the fault. Both coils were identically marked and gave exactly the same resistance reading, so I can only assume that the faulty one had a couple of shorted turns or perhaps a crack in its core. C.P.

### **Panasonic NV333**

The job card said that the problem was intermittent failure to eject, also other intermittent mode failures. When I checked the machine it behaved like a video possessed. On application of power, sometimes the record LED or the pause LED would light, play was intermittent, and at other times the machine would return to stop after a few seconds. Occasionally the cassette housing would eject five seconds after the button was pressed!

My first thoughts were that perhaps the microcomputer control chip IC6001 was faulty or that maybe the mode switch was defective. With this machine however I've found that the microcomputer chip is usually innocent when there's a syscon fault. Changing it made no difference, neither did removing, cleaning, adjusting and replacing the mode switch. Detailed checks were then made in the syscon circuit. As a result I discovered that transistor Q6008 had an intermittent base-emitter open-circuit. Q6008 is driven by Q6009: they are employed by IC6001 to pulse scan its mode sensor input. H.B.

### **Salora SV6600/Sanyo VHR1300**

The problem with this machine was intermittent tuning drift. As all channels appeared to be affected we checked the 33V supply, which was slightly high. We also noticed that the panel (the timer/tuning panel) in the vicinity of the 33V regulator IC6206 was brown and showed signs of overheating. The supply to this 33V regulator chip is provided by a constant-current regulator arrangement on the power supply/system control panel. Note that there are two different circuit diagrams in the manual – this was the more complex one.

The voltages around the regulator transistor Q5004 (2SA984) didn't agree with those in the manual, but the transistor, along with diode D5003 and zener diode D5004, were all o.k. Resistor checks were then carried out. The emitter resistor R5010, which is used to sense the current, was found to be only 270Ω instead of 560Ω – the wrong value had been fitted. In addition R5015 was 560Ω instead of 1.8kΩ. Both resistors were original parts and had been in the machine for around three-four years. Maybe this was a one-off occurrence, or maybe more machines with these errors will start to show up soon. I.B.

### **Panasonic NV430**

The problem with this machine was that the optical tape-end detection wasn't working. As detection didn't occur at either end of the tape the infra-red emitter circuit was the most likely suspect. On these machines the infra-red LED is pulsed on and off by the system control chip IC6001 via the 2SD636 emitter-follower Q6006. Meter checks showed that the LED, transistor and two assorted

resistors all read correctly. But no light reached the end sensors. Scope checks then revealed that while 5V peak-to-peak pulses were arriving at the base of Q6006 the pulses at its emitter were of only 1V amplitude. Replacing this transistor restored normal operation, but it read o.k. on the meter's diode check when tested out of circuit. I.B.

### **Philips VR6760**

There was no E-E picture and no playback picture, due to the absence of any 10V supplies on the signal board (P306). Tracing back led us to an open-circuit transistor (7607) on the main board (P606). Removing the panel to replace this transistor is no easy task. It was even more frustrating when the replacement gave an impression of Vesuvius ten seconds after switching on. Further checks revealed that there was a short to chassis on the signals panel. The +10c supply stabiliser transistor on this panel was found to be burnt up and short-circuit, but the short was still present after it was removed. It was found to be in C2329, and when this and the two transistors were replaced normal operation was restored. A.D.

### **Ferguson 3V44**

This machine had no clock display though the function display worked correctly. Scope checks on the timer/display board showed that there was no output from IC401. The supply to this chip was correct, but there was no clock signal either at this chip or where it enters the board at pin 6 of CN1. The missing signal was traced back to broken print on the power supply module. Repairing this print restored the display. A.D.

### **Marantz MV762/Philips VR6860**

The complaint with this machine was "lines on the picture and a whistling noise when not in use". A trial with the test tape showed that the "lines on picture" were due to the capstan motor running at full speed. Checks around the MAB8420 servo chip IC7091 revealed that it was not supplying pulses to the D-A converter chip. A new MAB8420 put matters right. A.D.

### **Hitachi VT-M622**

This brand new stock machine came from the shop with the complaint of poor stills in the SP mode. This is not actually a fault with these machines, but it does catch the unwary. On this model preference is given to the LP mode. Thus functions such as picture search and still are of poorer quality in the SP than in the LP mode. A.D.

### **Panasonic NV-MC10/NV-MC6**

This fault occurred on an NV-MC10 but could equally well be experienced with the NV-MC6. The customer's complaint was that the speed seemed a bit fast. The capstan was rotating at maximum speed, which meant that the reels were also running at maximum speed. The output chip is mounted on the back side of the mechanism, and the servo is on the main PCB, sandwiched across the back. All in all it's impossible to fault find in this area without a set of extension leads. We found that there was no feedback from the capstan motor. A new motor (VEM0284) put matters right. N.B.

# More on the Panasonic NV333

David Botto

The popular Panasonic NV333 VCR has been around for a few years now. It has proved to be so reliable that many of our customers are reluctant to part with their machines. An article by Nick Beer in the November and December 1988 issues of *Television* provided a comprehensive servicing and fault guide. In this article we'll deal with the operation of the power supply and fault tracing in the logic circuitry used in the system control section of the machine.

## The Power Supply

Knowing exactly how the power supply operates is important for speedy servicing of a dead machine. The power supply circuit is straightforward – see Fig. 1 – and servicing presents few problems. Use of a modern digital multimeter (one with a  $\frac{3}{4}$  readout is best) and a component tester will cut service time to a minimum.

The a.c. mains input is fed to the mains transformer via fuse F1001. On rare occasions this gets tired and suddenly fails. If you find that it's the original fuse replace it to avoid a callback later.

Bridge rectifier D1001-4 produces some 15V across C1002. Note that in some machines D1001-4 comprise a single unit, type EM1Z. This 15V supply is fed to pin 1 of the STR1096 regulator chip IC1001. Pin 4 of this chip produces a regulated 9V supply which is fed to the video

circuitry on the same panel and via P1003 to other parts of the machine. You should get a reading of  $9.3V \pm 0.1V$  at TP1002. It's been known for this voltage to increase to 10V or more, causing various problems such as failure to record the sound. If the voltage on this rail exceeds the correct level don't waste time making extensive checks – replace IC1001.

Pin 5 of IC1001 provides a regulated 6V supply which is dropped to about 5V by D1008.

With the VCR on you should measure 10-65V at pin 2 of IC1001 with your DMM. This pin is connected via D1011 to pin 2 of IC6002 (M53216P) on the system control board. If pin 1 of this chip, which contains six logic inverters, receives a logic high from pin 8 of the MN1405VKF microcomputer chip IC6001 pin 2 will go low, grounding the cathode of D1011 with the result that the voltage at pin 2 of IC1001 falls to about 0.74V, cutting off the regulated 9V supply. On rare occasions D1011 goes open-circuit.

IC1001 is quite reliable but can nevertheless fail. Before you replace it make the following quick checks. Make sure that 15V is present at pin 1. Next disconnect D1011 to remove the input from the control circuitry. Finally disconnect the loads from pins 4 and 5. If none of these checks restores power, replace IC1001.

D1005-6 produce 15V across C1003. This is used to provide the motor 15V supply and also a supply for the

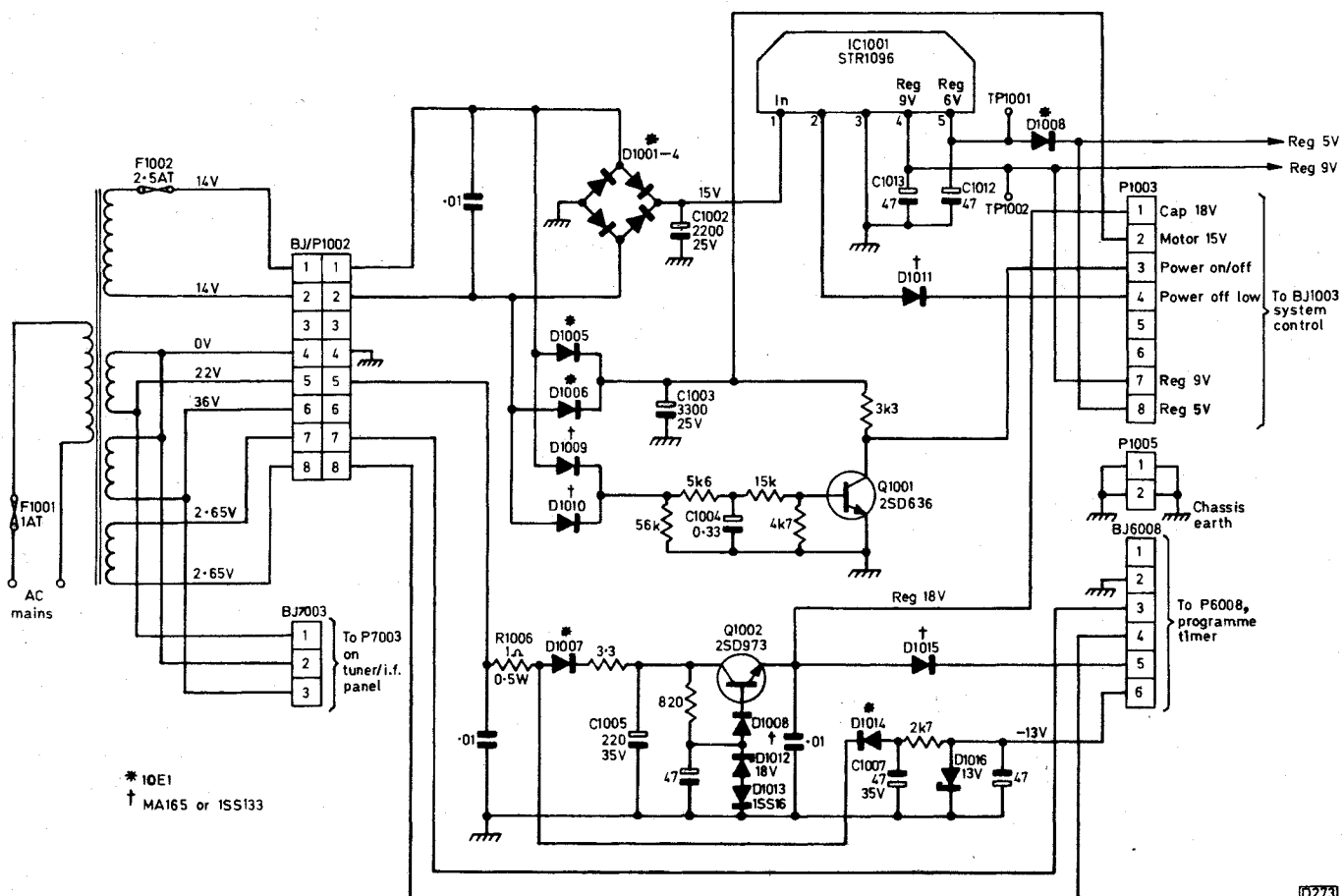

Fig. 1: The power supply circuit. Note that there are regulators elsewhere in the machine.



collector of Q1001. D1009-10 provide base bias for Q1001, which thus provides a power on/off indication at pin 3 of P1003.

The 22V output from the mains transformer is taken via the safety resistor R1006 to the cathode of D1014 and the anode D1007. D1014 develops a negative voltage across C1007. This is stabilised at -13V by zener diode D1016 and is used by the front panel control board. D1007 produces about 22V across C1005, the following regulator circuit providing a stabilised 18V output. If diode D1015 fails the clock display doesn't light. The same thing happens if Q1002 goes open-circuit.

The filaments of the clock display are provided with a 2.65V a.c. supply via pins 7/8 of BJ/P1002 and pins 3/4 of BJ/P6008.

All the components in the power supply can be quickly checked using a component tester. Remember that with time the electrolytic capacitors, especially the smaller ones, can dry out or corrode, with loss of capacitance.

### The Syscon Circuitry

The logic circuitry, including the MN1405VKF microcomputer chip IC6001, is extremely reliable. Some puzzling faults can occur in this circuitry however.

**Table 1: Logic levels at IC6001**

<i>Pin</i>	<i>Reading</i>	<i>Function</i>
1	0V	—
2	H	—
3	L	—
4	L	Stop: H goes to L
5	L	Pause: H
6	L	Fast forward/cue H
7	L	—
8	L	Power off: H
9	L	Record: H
10	L	—
11	H	—
12	P + H	—
13	H + P + L	—
14	H + P + L	—
15	H + P + L	—
16	H + P + L	—
17	H + P + L	—
18	H + P + L	—
19	H + P + L	—
20	H + P + L	—
21	L	Play: H
22	L	Play: H then L
23	L	Play: H then L
24	L	Play: H
25	L	Stop: H then L
26	0V	—
27	H	—
28	H	—
29	L	—
30	H + P + L	60Hz oscillator
31	L	—
32	L	Rewind: H
33	L	Fast forward: H
34	L	Pause: H
35	L	Play: H
36	L	Record: H
37	L	Pause: H
38	H	Pause: L
39	5V	—
40	H + P + L	455kHz oscillator

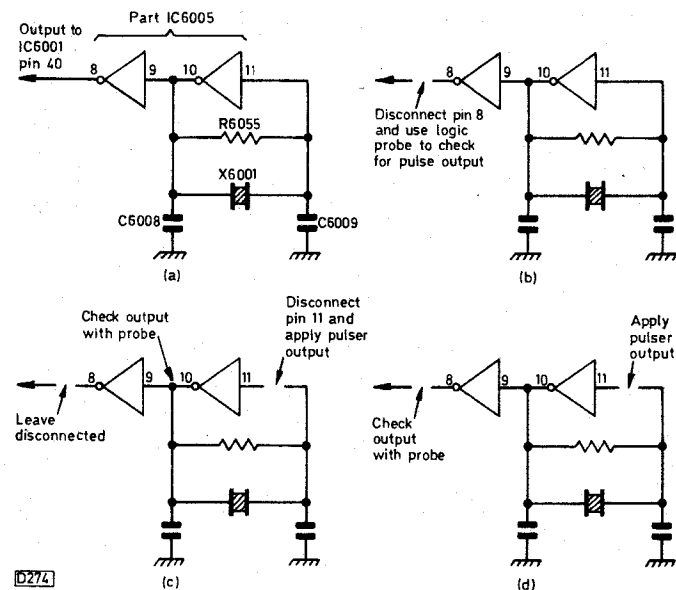

Fig. 2: Checking the 455kHz oscillator. (a) Basic Circuit. (b-d) Probe and pulser checks.

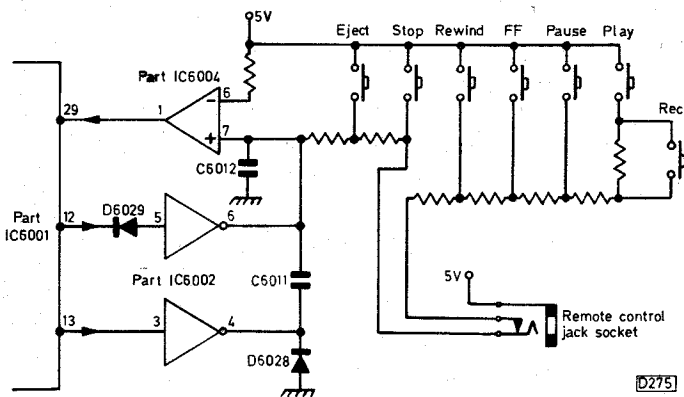

Fig. 3: Simplified analogue/digital function selector circuit (ramp circuitry).

Before you delve into the system control circuitry make sure that the problem is not a mechanical one (see *Television* November 1988). Check that the various switches such as the eject, cassette in and especially the mode switch are clean and in good order. If the drive belts are the original ones or are in any way suspect, fit a new set. You may then find that the machine works normally and that you don't need to get involved with the logic control circuitry. A slack loading belt for example will result in the capstan motor on signal remaining low when it should go high.

The usual faults in digital/microcomputer circuitry are short- and open-circuits and incorrect logic levels. Problems can also arise due to a stopped clock oscillator or, very occasionally, an off-frequency oscillator. For fast fault location you'll need a digital multimeter, a logic probe and a logic pulser. These two probes are also ideal for locating printed circuit breaks that might not be easy to detect visually. Further information on the use of these probes was given in the November 1985 and August 1987 issues of *Television*.

After making the previously mentioned mechanical checks, ensure that the d.c. supply voltages at the logic chips are present and correct. Then examine the board carefully for cracks and poor soldered joints – especially if someone else has had a go. You can then start to make checks in the logic circuitry. Table 1 shows the logic levels

associated with the various pins of the microcomputer chip IC6001. To check these, connect the probe's positive supply clip to pin 39 and the negative supply clip to pin 1.

Check the oscillator (pin 40) first. If the probe shows that oscillations are not present the most likely cause of the trouble is IC6005 ( $\mu$ PD4069UBC), see Fig. 2. This chip contains six inverters, two of which with their associated components form a 455kHz crystal oscillator. IC6002 and IC6003, both type M53216P containing six inverters each, seem to be more reliable than IC6005.

Desolder pin 8 of IC6005 and ensure that it's clear of the printed track. Touching pin 8 with the logic probe should give a pulsing signal indication. If not, check C6008 and C6009 (50V ceramic, originally 100pF later 300pF) with a capacitance checker or bridge. Then measure R6055 (1M $\Omega$ ). Crystal X6001 (V5X0100 or EF0A45501V) could fail but we've not had this. To check the two gates, start by desoldering pin 11 and applying the output from your pulser at this point: your probe should show an inverted output at pin 10. If so touch the probe on pin 8 where a reinverted signal should be present. It's much better to test inverter gates in this way rather than attempting to check them in circuit.

Once oscillations have been restored at pin 40 of IC6001 the logic circuitry, provided all else is well, should operate normally. If you've a frequency counter, check that the oscillator frequency is 455kHz, using a 10:1 isolating probe. It's been our experience however that X6001 keeps the oscillator locked to the correct frequency.

If a pulsating H + P + L signal is not present at pin 30 of IC6001, check transistors Q6013/4 (both 2SD636) and diode D6041 (MA165).

If all or nearly all the logic levels at IC6001 are high no matter what signals are applied to its inputs this is a sure indication that IC6001 has failed. Fortunately this seldom occurs.

If a particular function fails to work, check that the correct logic levels are present at the relevant pins of IC6001 then make sure that the logic inverters in IC6002/3/5 are working correctly – check as previously described.

Analogue/digital ramp circuitry is used to select different functions, see Fig. 3. IC6004 (AN6912/ $\mu$ PC339C) contains four operational amplifiers, with pin 1 feeding data to pin 29 of the microcomputer chip. It's possible for IC6004 to fail, though the most likely causes of trouble with the function controls are dry-joints on the front panel and faulty solder joints around the function selection buttons.

### Loading/eject problems

If the loading or eject operations do not work properly though the correct logic levels are present at pins 22 and 23 of IC6001, suspect transistor failure. Check Q601, Q6025, Q6030 (all type 2SD636), Q6024 (2SD1273), Q6026/7 (both 2SB819) and Q6028/9 (both 2SD1051). Then check D6050 and D6054 (both MA165) and the 12V zener diode D6042 (RD12JB2). Use of a component tester will give you a fast check on these devices.

### Reel Motor Difficulties

If the reel motor doesn't operate correctly and the logic levels at pins 24 and 25 of IC6001 are correct, check Q6016/7 (both 2SB793), Q6018/9 (2SD973) and Q6020/1 (2SD636).

# The Room at the Back

J. LeJeune

Summer had settled at Milldale and a new name had been decided upon for Topcut's Discount Store – "Electric Dreams". There had been a hot debate about this. Ralph Topcut had wanted "The Milldale Home Entertainment Centre", but Sid Bias had argued that this was not a complete description of the business since the store also sold washing machines and refrigerators. "I know that some of our customers are mad" he'd said, "but I doubt whether many of them get much entertainment out of watching their front-loaders in action with the dirty linen." So he'd won, and Electric Dreams in Terry Green's pink and green neon tubes was attracting scores of younger people into the store. It had proved to be a great success, and as a result Ralph Topcut was in a good mood.

Peace reigned in the service department. Norman Gates was deep in the bowels of a Toshiba V8600 VCR, while Andy sighed resignedly over an anonymous-looking VCR that turned out to closely resemble the Ferguson 3V35. It was probably an ex-rental job and was plagued by head speed hunting. Andy was terrified of servo systems – even though CD players, about which he was supposed to be an authority, have four of them.

## Loss of Line Drive

Young Gareth's job was a Sony KV1810 that no one else had wanted to repair. Its line driver transistor Q509 had failed. Fitting another one got the set going again but all was not well – the replacement seemed to run hot. Gareth probed around the area with a scope and found that the transistor's drive was too low. A dab with a wet finger confirmed the problem. There was ample drive on the far side of the coupling capacitor C538 (0.47 $\mu$ F). Gareth didn't like the idea of an electrolytic being run at line frequency, so he replaced it with a low-inductance Mylar type. The effect was immediate: Q509 now ran happily and was cool. He put everything back together and mercifully had no screws left over.

## Modulator Problem

Meanwhile Norman had established the cause of the Toshiba's lack of output signal and was busy changing Q661 in the modulator. He spent a few minutes with the equivalent book looking for a more powerful replacement but the terminology used was not helpful. So the Toshiba type was fitted. This restored the r.f. output and the machine was put on soak test in the E-E mode.

## Scheming

Sid sauntered over to Norman's bench and pulled a drawer open, resting his foot on it. "What do you think of this scope?" he said, showing Norman an advertisement in a popular trade magazine.

Norman briefly scanned the advertisement and looked up at Sid. "I suppose your idea is to catch Ralph T. while he's in a good mood and get us a new scope" he suggested.

"You could put it like that" replied Sid.

"In that case go for the most expensive one and haggle as long as you can. We badly need a sixty-meg scope

around here what with all the high-tech goods he's putting on the shelves out front" said Norman.

"A good point" Sid agreed. "They make extravagant claims about our service and then expect us to operate on a shoestring. It's time they backed their claims with some extravagant test equipment."

## A Couple of VCRs

Andy was not feeling too happy. He'd let his meter probe slip and the 3V35 lookalike now had two faults, the original one plus the consequences of his inattentive moment. The head drum still didn't revolve. While Sid and Norman continued to whisper together Gareth was immersed in his next job, a Sanyo VTC5000 VCR. Andy took the opportunity to nip across into the stores for a replacement IC404.

Gareth had a fierce, unreasoning hatred of the VTC5000 but was determined not to let this one get the better of him. Its capstan motor ran at top speed and Gareth concluded that the problem shouldn't be too difficult. He checked around the central control chip IC3001 and to his horror found that the 5V rail was at nearly 9V. Out came the 5V regulator transistor Q3001 but there was no spare in the stores. It looked as though a BFY50 or a 2N3053 would do. Gareth tried the former and the machine then worked normally. Very satisfactory, he thought. And time for a stroll.

Sid had gone through to the shop, waving a magazine in his hand and saying over his shoulder to Norman "I'll try him on it now – won't be long!" Norman picked up his toolbox and departed to make some outside calls.

## 3V35 Problem Solved

Gareth stopped alongside Andy and asked about his problem. "Why not take a look at Norman's 3V35 manual?" he suggested. "Norman notes every fault in his manuals and puts the correct voltages on the diagrams." As Norman was out they borrowed his 3V35 manual and found the drum speed control part of the circuit. There was a circle around R446, which should be 270k $\Omega$ . When it was removed and checked the reading was around 800k $\Omega$ ! A replacement restored normal operation and Andy remarked that making such notes seemed worthwhile.

## Sid's Return

Sid looked pleased with himself when he returned to the workshop. "Ralphie boy has just agreed to buy us a sixty-meg scope" he announced. "Trouble is, he says it should enable us to find faults in half the time."

"He can't really believe that" commented Andy.

"Oh yes he does" said Sid. "He'll expect to see it used for everything, even mending kettles. Seriously, the time will come when one won't be enough. We'll need one each."

"We'll have to prove that this one, when it comes, earns its keep" added Andy somewhat gloomily.

"That's right" replied Sid, "and the only proof Ralph Topcut understands is our output figures."

## Salora SV6600/Sanyo VHR1300

The complaint was of intermittently stopping in play or record, then being difficult to get going again. We ran the machine in the workshop for four days and it never stopped once. When it was returned the fault immediately occurred – isn't that always the way? – so back it came. This time we were able to see the fault. When play was selected the machine would lace up and would then straight away unlace and stop. Take-up was present, the capstan turned, so did the drum. As the machine started to unlace just after the capstan and take-up started, leaving insufficient time for a cutout operation from either of these functions, I checked the head switching waveform at pin 28 of IC4002 on the top PCB. It was absent. As it's fed to the system control chip to provide an indication of drum rotation (or lack of it) this was the reason for the machine stopping.

The pulses from the PG coil enter IC4002 at pin 25. There were no pulses here either, because the pick-up coil was open-circuit – the slightest pressure would correct the problem. To restore correct operation we had to order and replace the complete stator assembly.

I.B.

## Panasonic NV-G10

If the channel display comes on when the VTR switch is operated but there's no on-LED light, play or E-E, check the voltages around IC1001. If 13.5V is present at pin 6 there's a good chance that this i.c. is faulty.

P.B.

## Philips VR6180

This machine had severe colour crosstalk on playback and I hit a major snag when I looked at the manual – it had the 5V signal panel and I didn't have the supplement for this. Anyway I decided to start by changing the delay line 5102, which turned out to be the cause of the trouble. Rock on!

P.B.

## Grundig VS300

This machine wouldn't accept a cassette. If an attempt was made nothing happened except that F1 flashed on the display. On the basis of past experience with older models I homed in on the brake solenoid switch. This had dirty contacts, but when a new one was fitted it still didn't pull in. Its driver transistor T2141 (BC876) was open-circuit. For anyone not familiar with these machines, when the on/off switch is operated with no cassette inserted the brake solenoid should pull in for a moment. Sometimes the driver transistor goes short-circuit as a result of which the solenoid's thermal fuse blows. This is available as a spare part from Grundig.

P.B.

## Philips VR6660

This machine worked correctly in the playback and E-E modes. When record was selected however the monitor's screen went blank and nothing was recorded on the tape. When checks were made on the power supplies I found that the +12b line dropped in the record mode due to excessive current. Checks on the i.f. board led to the head

amplifier can P400 where C2013 was found to be short-circuit. Along the way I had a wild goose chase around the P604 system control board which was fitted with a small subpanel. This isn't shown on the circuit diagram but is included in the manual for the VR6862.

P.B.

## JVC HRS10/Ferguson 3V33

Failure of the fast forward and rewind functions, with the motor whirring followed by shutdown, might be taken for slippage in the reel drive unit. First however check that the pin on relay lever assembly 10 is not slipping out of the toe of the L-shaped slot in slide plate 9 as the control cam approaches its fast forward/rewind position. If it is, check for wear in plate 9, the lubrication of assembly 10 and the operation of the spring in assembly 10. The numbers refer to those in the exploded view of the deck mechanics shown in the service manual.

E.T.

## Tatung VRH8495/Philips Equivalents

These machines use the deck with clockwise ring loading and the "road-runner" pinch wheel. If, especially after work on the deck, you get a fixed pattern of dropout blips spread all over the screen of the monitor, check the earthing of the lower drum block. It's linked to the deck by a metal retaining finger at the right of the drum. This finger clamps the lower drum to its plastic mounting and has a long "tail" that's bolted to the deck metalwork.

E.T.

## Hitachi VT530E

The symptom with this new machine was no playback picture, sound o.k. Close examination of the monitor's screen showed that there was a bit of unlocked chroma signal scudding about. An open-circuit low-pass filter, CP202, in the post-demodulator luminance circuit was the cause of the fault. Sometimes these LC assemblies have to be replaced. On this occasion however we were able to dismantle the filter and resolder the termination of the very fine wire from a tiny ferrite-cored coil.

E.T.

## Sony HVC4000P

These early and rather bulky cameras were excellent in good light and many of them are still about, as often as not working with VHS equipment via plug-in adaptors. This one had no picture, but slight noise was perceptible on the monitor's screen, changing as the sensitivity switch was operated. In addition the tint changed as the white balance was altered manually. All these things pointed to a stuck-closed iris, and sure enough the iris drive motor had seized up. A microscopic drop of oil at each end of the spindle restored pictures.

E.T.

## Ferguson 3V53

Play-only machines were never very popular but we've had two examples of this model in for repair recently. Both had the same fault – no go, power supply not operating. There's no write-up on this power supply's operating principle. Its in the form of a module and most

problems seem to stem from failure of the i.c.-based oscillator to start up. If you encounter this, try replacing C23 (47 $\mu$ F, 25V) and zener diode D20. We've found that more reliable operation is obtained by using a 16V, 400mW zener diode in this position. **E.T.**

### **Panasonic NV333**

There were several problems with this machine. First, there was considerable flutter on sound. This was quickly remedied by replacing the capstan motor. All belts, the idler and the reel clutch were then changed. When the machine was tried it went into a state of confusion: the record LED was on all the time, the machine wouldn't switch off and the clock and timer couldn't be set. After a bit of checking we found that the 2.5A fuse associated with the mains transformer's 17V a.c. winding was open-circuit due to overloading on the 5V rail. The cause of this was internal shorts in the MN1405VKK microcomputer control chip. **N.B.**

### **Salora SV8500/Mitsubishi HS304**

This machine was being checked after coming back off rental. The customer had pointed out to the engineer who collected it that the sound was intermittent in E-E and playback. While thinking about getting to the heads to clean them I spotted the cause of the trouble – the r.f. modulator's audio pin had never been soldered. **N.B.**

### **Panasonic NV-F70**

This machine was virtually dead, the characteristic squeal at switch-on being rather muted. We found that rectifier D1111 in the power supply was short-circuit. This surprised us as it's a very large device that looks as if it's capable of carrying several amps. **N.B.**

### **Panasonic NV-M3**

Diagnosis was not particularly difficult but the conditions may be of interest to those not familiar with camcorder servicing. The machine came in from a local factory, owned by a multinational electronics firm, for a routine service. Twaddle I thought, but it genuinely did need attention. Both the power zoom and the auto-focus motors were noisy, mechanically and electrically. As a result there was pick-up by the microphone. The belts and the pinch roller were worn, and the eyepiece rubber surround was, as so often, pretty distressed. On top of this the S4161P pick-up tube was in poor condition. The estimate was thus a high one, and to our surprise was accepted within a week. Excellent results were obtained after carrying out the repairs and setting up the unit. **N.B.**

### **Akai VS1/2/4**

If the problem is poor sync with a single line on the tape about a quarter of an inch (six millimeters to the youngsters) from the bottom edge, look closely at the first tape guide. You'll find that the centre pin has pulled out of the plastic subdeck moulding and that the spring used is reminiscent of that used on the good old pogo stick. The waste bin is the only place for it (the spring). Replace it with something a lot lighter – old retractable pen springs work wonders. Glue the shaft back in place, pressing it well home, then reassemble using the new spring. I've

done lots of these repairs – when you've seen the spring for yourself you'll see why the fault occurs. **E.S.**

### **Akai VS1 and VS4**

These machines have an on-screen display. A fault that can only be described as the space invaders syndrome occurs – a screen full of As that flicker at clock rate. The culprit is the character generator chip IC2 on the operation PCB (front panel). It's an MB88303. I've had this fault on several occasions. **E.S.**

### **Samsung V7 Series**

No erase and no new sound track – yes, it's the bias oscillator. If you dismantle the erase block carefully you can replace the transistor. It's nothing special and usually goes open-circuit emitter-to-collector. **E.S.**

### **Samsung VI611**

Tape left out when the cassette is ejected looks at first sight like a case of poor rewind torque. Usually however it's that biggest blight of our lives the mechanism state switch. You'll find it hidden between the subdeck and case moulding webs. **E.S.**

### **Sanyo VHR3100**

The complaint with this machine was no record sound, playback sound o.k. A prerecorded tape produced a good picture and sound but, as the tape loading and front loading mechanism operated, the verticals in the E-E

picture bent and hum bars appeared on the screen. The E-E picture returned to normal as soon as the mechanism drive motors stopped. With the machine in the record mode, once the tape was fully loaded and the hum bars had gone the E-E sound was lost (muted). Hence the no sound on record problem. As we've had power supply faults with these machines we checked all the regulated rails carefully with a digital meter. They were all within 0.2V of the readings specified in the manual, and no detectable drop occurred in the loading and unloading modes when the hum bars appeared on the screen.

As a working machine was available and the boards can all be removed easily we decided to isolate the cause of the fault by panel swapping. The top signals board seemed to be the most likely source of the problem as most of the

sound processing is carried out here. But changing this then the system control panel and the front function and tuning boards made no difference. We finally swapped the power supply panel. This cured the no sound on record and the hum bars with the motors running problems.

A scope check soon revealed the source of the fault. There was ripple on the 12V and 13V rails. We then found that there was a dry-joint on the reservoir capacitor C5001 (2,200 $\mu$ F, 50V) at the input to the STR7226 regulator chip. As a result the chip could cope under low-load conditions, i.e. in the E-E and playback modes, but on record the extra load produced by the bias oscillator drive to the sound and erase heads caused excessive ripple on the switched 12V line. This upset the sound mute control in IC2001.

**J.H.**

## Philips VR6180

It's rare to come across a VCR with a timer fault that's not due to pilot error. This model is an exception to the rule. If the customer complains of shutting off in the timer mode, the VCR going dead intermittently with the display going haywire, the cassette being spontaneously ejected, etc. and the error memory is empty, suspect a power supply fault.

Before starting with the hairdryer and freezer, disconnect the output plugs P1 and P2. Connect a  $47\Omega$  resistor across the 5V output (pins 7-8 of socket P1) and monitor the 5V line – the reading should be 5.2V! – while heating and cooling the power supply. Likely causes of a varying output voltage are: the BZX79/B5V1 zener diode 6012, the TCDT1101 optocoupler 7103, and transistors 7001 (BC547B) or 7004 (BC548B). **P.B.**

## Grundig VS440

This machine played all right but produced just snow in the E-E and record modes. If the search button was pressed once, the correct channel number could be seen to be stored o.k. but no signals were tuned in. The +A (record) supply was missing as transistor T485 was open-circuit base-to-emitter. **P.B.**

## Philips VR6362

The problem was playback dropouts, just like a worn head, but there was no improvement with a replacement deck. We found that the fault was on the luminance/chroma panel P306, where the dropout offset control (3304) was broken. This can happen if you forget to hinge up panel P306 when removing the front control panel, as the IR receiver can hit it . . . **P.B.**

## Ferguson 3V44/45, JVC HRD140

For intermittent playback colour with these machines, check BPF301 for open-circuit or dry-joints.

If the on LED doesn't light but the capstan runs when the on switch is pressed, check whether the 3.9V zener diode D3 in the power supply is short-circuit. **C.P.**

## Ferguson 3V65

This machine displayed all the symptoms of a defective upper drum but remained the same after a new one had been fitted. When the head pre/rec panel was pressed the fault suddenly cleared. All ten pins of connector CN2 were dry-jointed! **C.P.**

## Hitachi VT130

This was almost certainly a one-off fault. I relate it here to show how careful you have to be when diagnosing VCR faults – even mechanical ones! The machine would intermittently chew the bottom edge of the tape. It was not immediately obvious that the problem stemmed from the fact that the cassette was not going down fully: the tape was fretting on the bottom edge of the plastic housing. This was because the vertical spacing pole

(centre, front of the cassette) was bent, or rather the plate that it's anchored to was buckled. The backward leaning pole rubbed on the inner wall of the cassette shell and stopped it short of its correct position, though a gentle push would force it home. Each cassette inserted into the machine came out with a tell-tale scratch mark on the plastic face behind the tape. Sounds obvious, doesn't it? But it was the devil to find . . . **E.T.**

## Panasonic NV-FS1

The problem with this machine was loss of audio in the E-E mode. In fact when a phono lead was inserted in one audio input socket we found that this input was permanently selected. We also found that the input select switch (S video in/tuner/line) did nothing – the tuner's picture stayed there. The reason for this was soon discovered. The input and simulcast switches on the front panel provide highs and lows to switch between modes. We found that the high levels, which are derived from the 12V line, read only 2.4V. The cause of the problem was in the power supply can: the unswitched regulator transistor Q1004 (2SD638) was open-circuit base-to-emitter and the associated zener diode D1012 connected between its base and chassis was open-circuit. **I.B.**

## Grundig VS200

This machine loaded then unloaded and ejected, with an F3 fault indication. This means that there are no tacho pulses, i.e. there's a deck or electronic fault giving no reel or drum rotation. Thankfully the cause was a simple one. The capstan drive belt was very slack and sometimes slipped under load. When this was put right the machine worked o.k. on test for an hour or so. It then again failed to load. Adjustment of the deck load microswitch finally put matters right, enabling the machine to complete its full play cycle. **S.L.**

## Amstrad VCR6000/6100

We've had some no colour sillies with these machines. As in previous models an HIC101 chip is used and this is often faulty. On many occasions recently the problem has been no colour in the LP mode – the sound has also been distorted. Both faults have been due to missing items. A missing link causes the lack of LP chroma – it's just by the HIC101 chip. A lot of spaces where resistors or capacitors should have been were found on the audio panel. It's easy to spot these as next to each space there's an LP symbol.

Unstable playback with the colour dropping in and out caused some confusion. Hum on the 5V rail to the 14DN300 was responsible due to a diode in the discrete l.t. bridge going open-circuit when warm.

Intermittent or permanent shutdown with the cassette symbol flashing can be caused by several things. The carriage itself is often faulty. Usually the cassette in switch fails to make, the result being ejection and shutdown.

If a VCR6100 accepts a cassette and half loads, then unloads, ejects and shuts down, the usual cause is an intermittent half-load switch. This is situated beneath the audio/control head and is sometimes broken, or the associated gears are stripped. It's not very easy to change.

By far the most common reason for the dreaded cassette symbol flashing is grease on the mode switch contacts. Stripping and cleaning is all that's required, but do it with care, checking the deck timing at the same time. If, afterwards, the machine refuses to play/rewind/fast forward (no tape movement) you've fitted the brake actuation arm incorrectly. It should run on the *outside* of the main gear.

S.L.

### Ferguson 3V22/JVC HR3320

The problem with one of these machines was intermittent loading on play. We found that someone had mixed up the screws when refitting the cassette housing. A large screw that was too long had been put in the back right-hand corner. This put pressure on the two nylon washers (item 77, part no. 668), trapping play lever 3 (item 76, part no. 493) and producing enough friction to make its action intermittent.

J.L.

### Ferguson 3V45/JVC HRD140

You sometimes find the operate LED pulsing on and off with the video head twitching in sympathy with the LED's pulsation rate. The cause is that F2 (2A) at the centre of the power supply board is open-circuit. All rails are still present and measure correctly but the excessive hum causes constant resetting of the microcomputer control chip.

J.H.

### Akai VS55

There was horizontal patterning on the picture in all modes and tearing on the characters of the on-screen display. The cause was C10 (22 $\mu$ F, 50V) in the power supply – it was open-circuit.

J.H.

### Hitachi VT430

Playback was o.k. but there was no E-E sound. When we removed the plug-in tuner/i.f. module we found that the cause of the problem was a stray splash of solder on a surface-mounted resistor to the audio output line.

J.H.

### Hitachi VT120

The trouble with this machine was reduced tuning range – it wouldn't tune up to the h.f. end of the band. In the search mode the varicap tuning line reached only 15V before sweeping back to the low end. The cause of the fault was the tuner/i.f. unit – it was not a synthesiser fault as at first suspected. Excessive current was being drawn when the tuning voltage tried to rise.

J.H.

### Sanyo VRC5000 and VTC5150

It seems that the Sanyo VTC5000 and VTC5150 form a large percentage of the Betamax VCRs in use. I fix more of these than any other single VCR model. They are exceptionally robust machines that go on for ever – apart from their one weakness, reel drive.

Poor or no rewind/fast forward is very common, even

though these operations are done with the tape unlaced (unlike Sony Betamax VCRs). Usually the cause is a worn idler roller: the early ones had only six turns on the springs, but replacements may have many more. Nearly always only the idler roller and springs need to be replaced. This costs about £2 instead of the £5 for the whole idler assembly.

A broken drive belt is fairly obvious and is simple to replace. The other common problem is a worn reel drive motor. This sometimes intermittently fails to run, restarting when the machine is powered down and up, because of the large kick-start at switch on. I have on occasion dismantled a motor to move the brushes slightly to a less worn part of the commutator. This is not recommended, but it can work for years – and the motors are expensive.

A very important point is that there's a bug in the VTC5000's syscon. If it shuts down because it hasn't received reel pulses it proceeds to lace up! If there's no reel drive at this point to take up the tape, the result is a devastated tape. A customer who had put up with this intermittent tape chewing continued to use the tapes: it took a lot of effort to clean the heads so that the machine would work again. The VTC5150 doesn't suffer from this problem.

Sanyo don't seem to have learnt their lesson from these otherwise excellent machines. The Fisher FVHP-905 and FVHP-615 have reel drive mechanisms (they are not compatible) based on heart-shaped assemblies. These use the same principles and suffer from the same problems.

C.McC.

### B and O VHS82

A stock problem with this machine is a cassette jammed inside due to the cassette lift being blocked. The centre pin on bracket 282 blocks the rack slider 278, usually producing a small dent. Extract the jammed cassette by removing the carriage, sliding lever 281 up and down by using a screwdriver inserted through the slotted hole in bracket 282, then switching on and pressing eject. Then clean the back of the rack slider with Freon TMS.

N.B.

### B and O VHS91

A problem with these machines is incorrect positioning of the cassette in the carriage due to the spring-loaded guide pins (parts 202/3) lagging on the hexagonal shafts. The cure is simply to round off the edges of the shafts slightly.

N.B.

### Panasonic NV-G12

A very slight knocking noise was the complaint with this machine. It was slight too, but once you'd picked it up it was annoying. The cause was a dent in the tyre of the reel clutch (VXP0599). Changing this is an involved job.

N.B.

### Sony EVA300

The complaint with this machine was of intermittent flickering and what amounted to line cogging on playback of any material. Cleaning the heads improved matters a bit but not sufficiently, so a new head drum was ordered. When it arrived we fitted it with the aid of the puller supplied and set it up. I then decided to check the back tension as this is so often wrong. With Sony's Video 8 decks you do this by using a dummy reel on the



# Servicing the Panasonic NV2000/2010/3000

Nick Beer

These VCRs are now fairly old. Even when new they were somewhat sparse with respect to features, they looked pretty ordinary and required regular maintenance. So why are they still being sold in large numbers in the reconditioned market, at the same price as say an NV366 which has a much higher specification – and being snapped up as well? Perhaps it's because they are lovely machines to use and to service. They give good results and the head life is good. So they are an excellent choice for budget rental or sale. Since they are still being bought and there are no real reasons to scrap them, it's worth providing an article on servicing to help you to live with them a while longer.

The NV2000 and NV2010 are basic, top-loading machines, silver-grey in colour. The NV3000 is a portable VCR with an NV2000 mechanism, hence its inclusion in this article. This particular machine was not sold in large numbers but we do get them in, so I've provided a brief fault list at the end of this article.

## Dismantling

Dismantling the NV2000/2010 is straightforward and is much the same as with its big brothers the NV7000 (see the September 1985 issue) and the NV7200. The top is held on by two bolts at the back corners: the cassette flap is held by two obvious silver-coloured bolts. With these removed, you'll find that as in the NV7000 series a red screw and a red bolt hold the screening can above the video heads/drum. The top-loading cassette carriage is held by a further four red bolts as in the NV333/NV366. The bottom is secured by six brass-coloured screws: when it has been removed the lower PCB can be hinged backwards after taking out the red screws and bolts and pushing it back and pulling it down from the front. When doing this, watch the tracking control knob – I suspect that you'll get a bit mad if you reassemble the whole thing only to find that there's no tracking knob!

## Mechanical Service

When you get one of these machines it's likely that you will have to carry out a complete mechanical service (the Panasonic maintenance kit is part number VUD4087KIT). I suggest that you remove the top and bottom, unhinge the lower PCB, remove the screening can and the cassette carriage and then work first on the top of the mechanism. It'll save you time – you'll see why later.

With the carriage removed, the reel idler (VXP0329) can be replaced by removing its retaining circlip and guiding its brake arm away while you lift it off the shaft. The reel torque should be in excess of 400g/cm. It's not uncommon to find that this is very low. The brake band is held by its adjusting screw at one end and by a circlip under the back tension post at the other. So the post will have to be removed. Undo its retaining circlip and spring and lift it off. The band can then be released. The back tension should be set at 25-30g half-way through an E120 tape.

I recommend that you remove the bracket on the right-hand side at the top of the mechanism – the one that holds the loading/capstan motors, the dew sensor etc. It's secured by three brass-coloured bolts. Before doing this remove the loading and capstan belts from the motor pulleys on the underside of the mechanism. With this assembly removed you can take off the pinch roller (VXP0330) by removing its single retaining circlip and unhooking its spring. Beneath this you'll find a black plastic cover over the play idler. A single bolt secures the cover – it can be very difficult to undo due to a reaction between the screw and the chassis. Try firmly with a normal screwdriver: if it isn't easy get a very long screwdriver first rather than later – the head burrs very easily.

The play idler is available either as just the idler wheel (VXP0331), as in the VUD kit, in which case it has to be rebuilt on to its arm, or as a complete arm (VXL0763). This arm is of the same design as in the NV333/366 but with the addition of a soft brake for the take-up reel and the associated spring. To remove the arm, the pinch roller and the previously mentioned cover must first be removed. As with the NV333/NV366, when replacing the play arm ensure that it fits at the right side of the main lever underneath – use the same method as with these other machines (see the November-December 1988 issues). The take-up torque should be 130-180g/cm.

Whilst we're on the top side of the mechanism, with machines of this age you'll probably find that the hard brake pads are worn and should be replaced. They aren't in the VUD kit. Part numbers are VXZ0090 (supply) and VXZ0091 (take-up).

Video head replacement is the same as with the NV7000 and NV333/NV366 series, with two bolts and four soldered leads in this case. The discharge angle, which is secured by a single bolt, will have to be removed first of course. To simplify stock holding, the VEH0121 or VEH0103 heads can be used as replacements. The MCES Y series heads are superb replacements and offer a saving on the Panasonic ones. They are brand new, not rebuilds.

And so to the underside of the mechanism. The flat capstan belt (VDV0131) is replaced by removing the plastic cover over the pulley, the flywheel support bracket and the fan wind belt (as Panasonic call it). The latter (VDV0120) drives the reel drive assembly from the capstan flywheel. The loading belts are small and large as with the other machines we've mentioned. To replace them, unbolt the plastic guide beside the bottom of the DD unit then unclip the DD unit loom from the chassis and follow it round to the servo PCB, unplugging it here. The large belt (VDV0135) will have to be pulled up over the loom and the new one threaded over it as the loom goes through the centre of the belt's run. This palava is required because the loom isn't, as with the NV333/NV366, plugged at the DD end. The smaller belt must be replaced before fitting the new large one as it fits on the lower half of their shared loading pulley.

As with the brake band, the idlers, pinch roller etc. these belts are in the VUD kit. Two items that aren't but

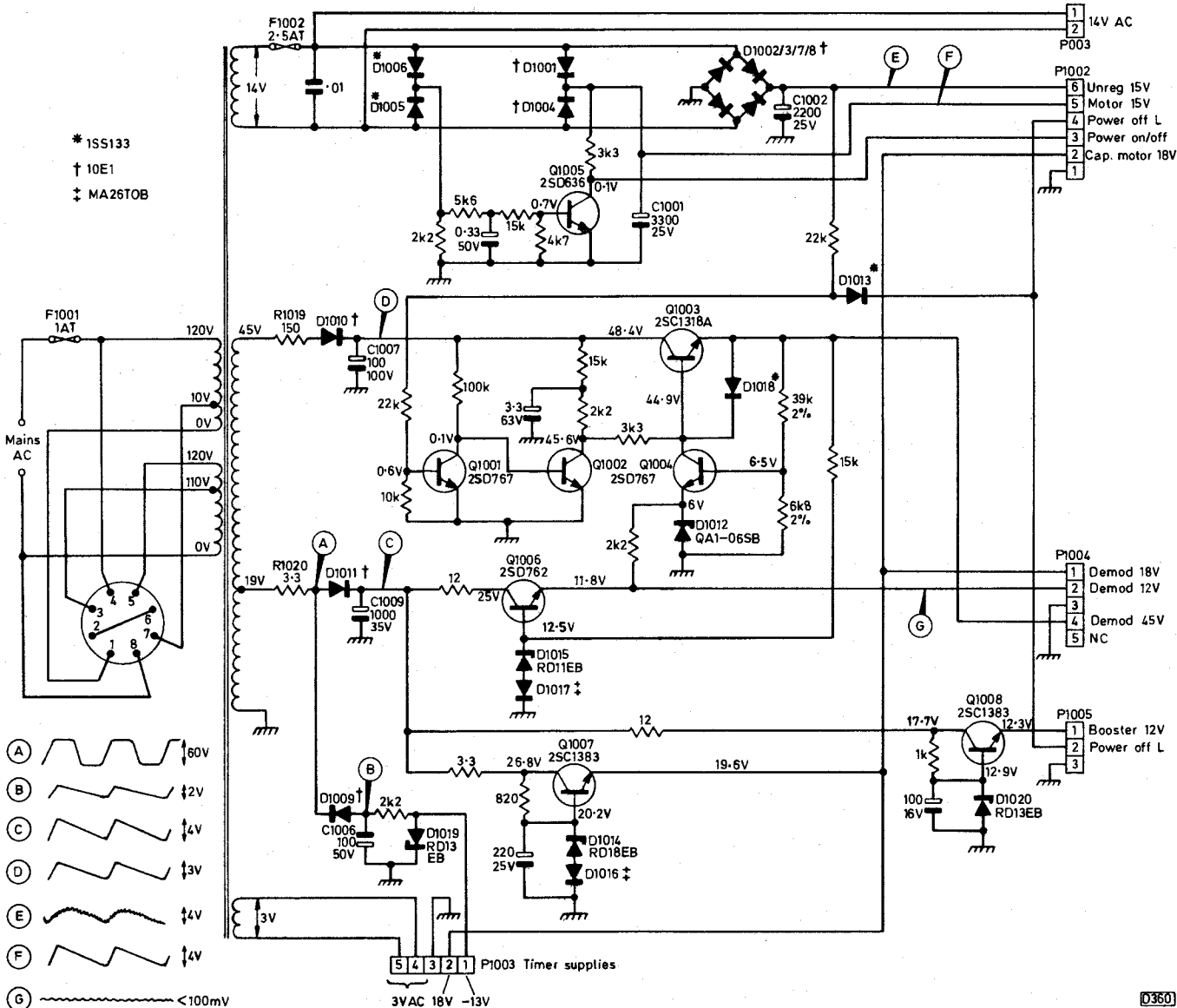

Fig. 1: Power supply circuit used in the Panasonic Model NV2000.

often need replacing are the reel pulley and the secondary pulley (VXP0351/2). These form the drive and clutch system between the belt from the flywheel and the idler itself. The clutch becomes noisy and the pulley wears. The mode switch is exceptionally reliable and thus shouldn't, as it should with more recent Panasonic models, be replaced as a matter of course.

**Faults List**

That sums up the mechanical side. Fig. 1 shows the power supply circuit, with some corrections with respect to the circuit in the manual. The ripple characteristics at various points are included. We'll round off with the usual faults list.

(1) **Will not, or sluggish, rewind or fast forward.** The most likely suspects are the reel idler (VXP0329) and the capstan belt (VDV0131). The clue is usually whether the fault is in both directions: if it is, suspect the idler; if it's in only rewind or fast forward suspect the belt. If the latter is o.k. check the so-called fan belt (VDV0120) and the two-part clutch gear assembly (VXP0351/2). Alternatively for no rewind and/or fast forward relay RY2001 (VSY2026) may have dirty contacts.

(2) **No clock/clock won't set/won't keep correct time.** Usually due to a faulty MN1435VX timer chip (IC7501). Sometimes ancillary components can be at fault. Check X7501, D7501/2/3 and Q7501 (2SD636). See also fault (3).

(3) **No clock, hum on E-E sound and vision, capstan servo incorrect.** All due to C1009 (1,000µF, 35V) being faulty.

(4) **Mechanics stuck in the stop mode, won't eject, otherwise o.k.** D6010 (MA165) faulty, inhibiting the loading motor. Also check the condition of the large loading belt (VDV0135).

(5) **No mechanical operation but will eject.** Cassette sensor lamp (XAMV0019) is probably open-circuit. If it's o.k., check the driver transistors Q6024/7 (2SD636/2SB641). Note that the sensor lamp is pulsed on and off, not lit continuously.

(6) **No go, no E-E, clock o.k.** No 9V as the MN1405VQ syscon microcomputer chip IC6001 is faulty.

(7) **No E-E vision.** Trace the signal path through the demodulator module. If the signal is present at TP3001, suspect IC3004 (AN6332). If not, suspect IC701 (BN5111B).

(8) **Won't switch on, clock flashing.** Fault in the 12V regulated supply. Check transistor Q1008 (2SC1383) and

zener diode D1020 (RD13EB).

(9) **No record or playback colour.** Check the following items and replace as necessary: C8035/6, D8009, IC8003 (AN6371).

(10) **Capstan rotates constantly.** Dry-joint on Q6032.

(11) **Capstan runs at high speed.** Capstan free-run control-1 R2070 open-circuit or no FG output from motor (VEM0133).

(12) **No capstan rotation.** Relay RY1's contacts dirty or coil open-circuit.

(13) **Wow on playback sound.** Check play idler (VXP0331) but usually IC2005 is faulty.

(14) **No drum lock.** Check Q2002, Q2003, IC2001, C2025/6.

(15) **No take-up.** Check play idler (VXP0331), pinch roller (VXP0332) and the loading belts (VDV0122 and VDV0135).

(16) **Snowy picture via r.f. loopthrough – looks like an r.f. amplifier fault.** Check the 12V supply to the booster. If missing check Q1008 for dry-joints on all legs and/or shorts and/or R1008 (12 $\Omega$ , 0.25W fusible) open-circuit.

(17) **No capstan motor rotation.** Q2013 and/or Q2015 faulty.

(18) **Sensor lamp not working, no auto stop but mechanism works.** Q6025/6 in the syscon department faulty.

(19) **High-speed knocking with fast wind.** Replace noisy pulley/clutch VXP0351 and lubricate pinion.

(20) **“WED” partially illuminated on display.** D7513 leaky.

(21) **Cuts out on play as capstan motor stops.** Q2012 faulty.

(22) **No cue.** Q6206 faulty.

(23) **Cassette jammed, tape stuck laced half way.** Faulty loading belts.

(24) **Can't set minutes and hours change with day button.** Reset the blue trimmer R7507 on the timer PCB to give 6 $\mu$ sec pulses measured at the potentiometer.

(25) **No tuner or record operation.** Q1006 (2SD762) faulty.

(26) **No record colour.** Colour-killer preset R8078 noisy.

(27) **Random syscon misoperation/LEDs flashing.** Syscon microcomputer chip IC6001 faulty.

(28) **No functions with capstan motor running continuously.** R6038 (68 $\Omega$ , 2W) in the 5V supply to the microcomputer chip open-circuit.

(29) **Timer microcomputer chip IC7501 fails.** Add a 10 $\mu$ F, 50V capacitor across C7503.

(30) **Squeaking while lacing or unlacing.** Remove reel spools and clean and lubricate the mechanism spindles. The noise usually comes from the supply spool. Be very careful not to spill oil over the drive surfaces. Use Technics RZZ0L02 #56 oil.

(31) **Squeaking in play or record.** Noise comes from drum due to discharge angle. Replace this item with the sturdier VXA1584.

(32) **Corrugated verticals and squeaking noise.** Clean or replace the erase head (VBS0014), the impedance roller (plastic type now in maintenance kit) or the audio/control head (VBR0036).

(33) **Carriage won't stay down.** Check for broken plastic lever (VXA1210) on the latching mechanism.

(34) **No deck functions.** Check the cassette down switch (VES0129) on the latching mechanism beneath the deck.

(35) **Scraping noise in play or record.** Check grease on flywheel bracket.

(36) **Wow on sound with noise bars rolling through the picture.** No capstan servo action due to absence of

control pulses. Clean or replace the audio/control head (VBR0036).

(37) **Grainy picture.** Check the condition of the video heads and, at TP3007 and TP3008 (earth), that the record level isn't in excess of 150mV. Adjust with R3022.

## The NV3000

Finally a short faults list for the NV3000.

(1) **No sound with own recordings, playback o.k.** Faulty microphone socket (VJJ0076).

(2) **No playback or E-E vision.** C3077 or IC3004 (AN6332) faulty.

(3) **No deck functions, power cuts off after a few seconds.** MN1405VQ syscon microcomputer IC6201 faulty.

(4) **Dew light permanently on.** IC6205 (AN6912) faulty.

(5) **Wow on sound, noise bars on picture.** IC2003 (AN6341N) faulty.

---

## CORRECTIONS

Several points in the December issue require correction/amendment.

(1) The Salora J chassis was also used in some 16in. sets. The line driver transistor (last paragraph, page 102) is TB500, not TB501. Item (2) in the faults list, page 104, should have given CB400 and CB410 as being the usual causes of distorted field scan. CB410 is the scan coupling capacitor and is usually 1,000 $\mu$ F. CB412 is innocent!

(2) In CD Player Casebook, page 124, JVC Model XL-V2B, the tracking offset control is adjusted with TTS and TSS earthed (not TTS and TTS!).

(3) VCR Clinic, page 127, mentions the rack slider problem with the B and O VHS82. When this fault is encountered the rack slider should be replaced. It comes as a kit of parts, all of which must be fitted. This is a lengthy job and is tricky until you've done a few. A check on the rear edge of the old rack slider will usually reveal a pit or indentation which will confirm the diagnosis.

The mechanism is a Philips one, so the point is also applicable to many Philips machines, also Tatung and Pioneer models including the VR505 and VR707.

(4) The two electrolytics in the Rediffusion Mk. 3 chassis mentioned in Dave Mackrill's letter (page 108) should have been specified as 6C14 and 6C15 (6C12 does not cause this problem).

## Hitachi VT33

The problem with this machine was intermittent loss of the E-E and playback picture. The video signal was present at IC202's output but was missing at pin 8 of plug PG233. It was being lost at Q210 whose base voltage was low at 1V instead of 6-7V. Tracing back we found that Q224's base voltage was also low. The culprit was C292 which was leaky. **P.B.**

## GEC V4007

This machine and the Philips equivalent can suffer from broken wires to switch COD3. The symptoms are acceptance of the cassette which is then immediately ejected. The wire usually breaks where it connects to the small PCB under the deck. **P.B.**

## Panasonic NV730

The weakness of the worm-wheel unit, part no. VXP0575, fitted to the front-loading mechanism in this machine was mentioned on page 20 of the November issue. A possibly puzzling symptom associated with this and other front-loading assembly faults is that the left-hand side supply spool rotates backwards for several seconds before auto-shutdown of the machine. **E.T.**

## Sanyo VHR3300

The symptoms were no off-air signals, failure to tune, and the orange channel display was both dim and flashed on-off. The rest of the display was also dim, though the machine provided good playback. We found that the -30V supply to the display/key board was low at -12V because R5008 (47Ω, safety type) on power panel PW1 was open-circuit. No overload could be found and the replacement resistor has not failed. **E.T.**

## Hitachi VT88

This was an unusual fault. With certain tapes there was slight horizontal picture instability, especially near the bottom, and the tracking was critical for hi-fi sound. We found that the sealant used in the factory to seal the exit guide screw top had run down and formed a blob on the guide's nylon sleeve. This also prevented the sleeve from rotating. **E.T.**

## Panasonic NV-L20

We've had a couple of these machines with the back-tension arm stiff on its pivot. The effects are failure to erase previous recordings, picture rolling, and virtually unwatchable own-recordings. The machine usually works fine when it's stood on its left-hand side! The cure is to remove the lever, check that the box-section at its pivot end is square, and reassemble with a drop of lubricant. **E.T.**

## Panasonic NV-MS1

Modern full-feature S-VHS camcorders are complex animals. This one had an intermittent problem - failure, sometimes, to display white-balance information in the

viewfinder. The actual white-balance operation, auto or manual, was fine. It took us a long time to find out where these captions come from! There's no separate character generator chip in this machine: the operation is carried out inside the main microcomputer chip IC6001 on the syscon panel. Replacement of this chip, using a mighty magnifier, restored order to the viewfinder readout. **E.T.**

## JVC GRC9, GRC11

If you encounter one of these camcorders with a no-eject problem and the power LED winks at you when you try to eject the cassette, check the dressing of the wire to the full-erase head. If it goes astray it can get caught between the trigger and detent lever on the side of the cassette housing assembly, thus preventing release of the cradle. **E.T.**

## Ferguson 3V32/JVC HR7655

This machine operated at about half speed. Double speed wouldn't work and the slow-speed mode was very slow indeed. After a bit of signal tracing with the oscilloscope we found that the fault was within IC6 - the waveforms at pins 3 and 4 were totally incorrect. **K.R.**

## Ferguson 3V39/JVC HRD110

The problem was intermittent sound muting, recording and E-E depending on the picture content. Dark scenes produced sound muting, bright scenes brought the sound back, while in between the sound fluttered and caused a disturbance to the picture's luminance level. The cause of the fault was traced to L7 on the tuner/i.f. panel. It should be tuned to 15.625kHz but was found to be off frequency. Normal operation was restored when L7 was peaked, using an oscilloscope, but at resonance the core was fully tightened. An un-numbered tuning capacitor within L7's can was thought to be defective. Adding an externally mounted 330pF ceramic capacitor remedied the situation. **K.R.**

## Panasonic NV-G40

We've had a couple of these machines with the following complaint. After about five seconds the machine switches itself off. When we saw the report on the job card our immediate thought was of a dodgy solenoid. In fact this wasn't the case. When the mechanism solenoid sticks, the machine can't move the mechanism into the correct mode. It thus switches back to standby.

The problem was that when the tape was moving in play, fast forward, rewind etc. it would run for only about seven seconds before the machine went into the stop mode. This sounded like a reel rotation problem, so a check was made at pin 27 of the system control chip IC6001 (t.reel input). When play was selected, this input switched correctly between 0V and 5V a few times before sticking at the high level, even though the take-up reel was still moving. There's an operational amplifier, IC6002, between the system control chip and the take-up reel phototransistor. One of its inputs (pin 3) is held at

2.5V by a potential divider while the other input (pin 2) is connected to the sensor. This latter input varies between about 1V to 3V to give a change of voltage at output pin 1. When play was selected we found that the input switched from high to low but the output remained high, proving that the operational amplifier was faulty. **I.B.**

### **Panasonic NV180**

This is a 12V machine and was used in a coach. It was brought to us because a cassette was jammed in. To release, you turn the machine upside down and remove the bottom cover at the front. At the front of the machine, near the colour auto switch, there's a release hole through the PCB to a metal plate on the cassette deck. Press this with a screwdriver and the deck will release. See page 2-3 of the service manual.

When we'd done this we discovered that the machine was dead, due to a Wickman fuse (F10J). You'll find it in the middle of the servo board at the back, near TP1003. It's in the 5V line and is not shown in early circuit diagrams, so you can be puzzled if you don't know it's there. **J.L.**

### **Ferguson 3V23**

This machine played back o.k. but wouldn't record any picture at all, just noise. Someone else had recently fitted a new head. Naturally we assumed that it was o.k. and spent a lot of time making checks and setting up the circuits. When we replaced the head with one obtained from Ferguson normal results were obtained. The head we took out worked all right in a 3V22. **J.L.**

### **Ferguson 3V00/16/22 etc.**

This VCR got me thinking hard – it had a fault I'd not come across before on one of these venerable machines. When play was pressed, nothing happened. No motors turned, there was no loading and no sensor operation. The play key simply stayed down. All supplies were present and the sensor lamp was not open-circuit. If the after-load switch was operated the drum turned – in fact if the pinch roller was engaged the machine loaded and played. The play microswitch on the front key PCB assembly was open-circuit. **S.L.**

### **Schneider SVC245RC**

This VCR's tuning was very unstable. It was just possible to tune something in, but the display soon drifted off. There was also some hum on the picture and sound. A scope check on the tuner rails showed that there was some ripple present. The cause turned out to be C3 (47 $\mu$ F, 50V) on the power supply panel. **S.L.**

### **Akai VS1**

There was not a beep out of this machine. The always 12V and 5V rails were found to be present and a check at pin 9 of the STK5325 chip IC1 revealed that the correct momentary low command came from the microcomputer chip when the power-on switch was operated. This instructs IC1 to switch on provided all is well. A check on its output rails proved that the supplies appeared momentarily then switched off.

Obviously the MB88401 microcomputer chip was detecting a problem. Checks here revealed that the "B

down" signal at pin 5 was permanently low instead of at 5V. As a check the NTSC switching pin 6 was shorted to pin 5. This enabled the power supply, and we were on our way. The fault was traced to TR9 being open-circuit as someone in the past had shorted out the sensor lamp.

A function check on the deck then revealed a further problem. Although the VCR seemed to acknowledge the fast forward command, no motors turned in this mode. All the other functions worked correctly. The switching signal was traced up to the BA6109 reel drive chip IC6 and was found to be normal. There was no output from the chip in the fast forward mode however. I interchanged it with the loading chip as this is of the same type and there was then no tape loading, proving that the chip was faulty. A replacement put matters right. **S.L.**

### **Amstrad VCR4600**

Nothing at all could be tuned in when using the thumbwheels. As all the tuner supplies were correct a replacement was fitted. This enabled all stations to be tuned in but the station selector buttons didn't change channel. The indicator LEDs changed but the picture remained the same. The AN5015K RAM chip on the front panel proved to be at fault. **S.L.**

### **Saisho VRS4000**

This machine had unstable drum servo operation. The clue was a momentary sideways movement of the picture every few seconds or so. When the fault was present, selecting pause didn't change the symptom. A variation in drum speed could be heard and seen. When the connector to the lower motor was touched there were wild drum speed and phase gyrations. Since contact couldn't be improved I removed the plug and socket and soldered the wires directly. After a long soak test however the variations continued. The cause of the problem was eventually found to be a hiccup in the output waveform of IC01 (OEC9009). It's interesting that most of the chips in this machine are labelled IC01! **S.L.**

### **Ferguson 3V59/3V65/FV11 etc.**

A fault that's becoming increasingly common with this range of machines is failure of the STK5481 multiregulator chip. You usually find that the inputs are correct but one of the three outputs is missing. Symptoms include no go with the display coming on but with no on-off LED display, or dead with the cassette being accepted but not coming out. The chips are reasonably priced and are a worthwhile addition to your spares if you see a lot of these machines. **N.B.**

### **Panasonic NV370E**

This machine isn't a UK model but works on the UK standards. It belonged to a doctor who had brought it back with him from an overseas appointment. His complaint was that since a local contractor had fitted a new aerial the vision had been snowy. On test we found that there was severe hum on the E-E and playback sound and picture and that there was no capstan servo lock. A quick check showed that the unregulated 18V supply reservoir capacitor C1102 was severely leaky. In fact it bulged physically. It's on the mains transformer PCB. **N.B.**

# More on VCR Back Tension

Nick Beer

There have been several developments since my article on "The Importance of Back Tension" in the August 1988 issue of *Television*. Despite the fact that incorrect back tension is the root cause of many VCR faults we don't hear much about it from the manufacturers. I shall however continue to emphasise the importance of this adjustment in my articles. In addition many of you will have seen the first results of research carried out by MCES of Manchester on the effects of incorrect back tension, the life of various types of head and the effects of video cleaning cassettes. An article relating to this appeared in the August 1989 issue of *Television* and MCES has published a wall chart that's been distributed to the trade. This article provides an update on the subject and expands on various aspects of it.

## New Measuring Cassette

First, Konig has introduced a combined back tension and take-up torque measurement cassette. I've tested the VHS version in the workshop and a colleague has tested it in the field. We feel that it's excellent value for money. It comes in a hard plastic case which is similar to the type used for very early library tapes.

The scales are marked on labels that are stuck over what would, with an ordinary cassette, be the windows. Back tension is measured on the supply reel, from 0-80g/cm (this is of course actually a torque measurement). Take-up torque is measured on the take-up reel, from 50-250g/cm. A marker within the cassette is viewed against these external scales. The construction may seem to be a bit floppy but the accuracy should be within the specified range of  $\pm 2$  for back tension and  $\pm 5$  for take-up torque. The scales have to be reset to zero manually after each test, by turning the supply spool.

The cassette worked very well on test. The only slight hiccup occurred when it was tested with an old Ferguson 3V00: the VCR's rather crotchety carriage made the spools push up into the cassette and lock off centre, but a quick click returned them to the normal position. This could possibly have been prevented by stronger balance springs within the cassette. Note that back tension (torque) is measured in g/cm, not g as with a Tentelometer.

In view of the cost of the gauges available for measuring back tension most workshops will doubtless have only one type. The very reasonable cost of this Konig cassette gauge makes it a good choice.

## Tension/torque Conversion

While most manufacturers quote back tension in g/cm (torque) some, Panasonic in particular, give Tentelometer readings in g. Many people ask about converting these figures. Conversion depends on several factors however. A cassette gauge measures in g/cm the take-up reel torque and the supply reel torque required to overcome the braking force present while a Tentelometer measures in g the force applied between its prongs (effectively the tautness of the tape) at a position between the exit from the cassette and the entry guide

prior to the drum. The only useful conversion therefore is between g/cm and tension (g) at this particular point, measured half way through a three-hour tape.

The problem in practice is that conversion depends on the mechanical arrangement used in a particular deck. For example, Fig. 1 shows the Tentelometer measuring point and a conversion graph for a typical Panasonic deck (actually an NV7000). As you can see, the tension readings are lower than the torque measurements. This is because with this design the back tension depends more on the supply reel braking than the action of the back-tension arm/post. Fig. 2 shows the same conditions for a JVC (Ferguson 3V55) deck. Here the tension readings are considerably higher than the torque ones, because the tension depends more on the back-tension arm. You will see that in comparison with the Panasonic design there's an extra post between the cassette exit and the back-tension post. The ideal situation of course would be for manufacturers to give figures for both types of measurement.

## Back to the Konig Cassette

The Konig cassette is an excellent purchase for the workshop. It's about half the price of a Tentelometer or, for example, the Sharp cassette gauge, and in addition you have the take-up torque scale. A separate take-up torque gauge may well set you back another £200 or so, but will of course measure the higher fast-wind torques. The Konig cassette's accuracy with back-tension measurements may at first seem to be a little vague, but it falls well within most specifications. Being a combined unit it makes an ideal tool for field servicing, though care should be taken with handling and storage in these conditions. I suggest that for each engineer in a large company to be equipped with one will be an investment that's soon recouped as a result of quicker fault diagnosis and an improved repair throughput – not to mention the benefits that come with correct back-tension adjustment.

The cassette is available from Willow Vale Electronics at £149.95 trade plus VAT under order code 12-400.

## A Philips VHS Deck Design

In the August 1988 article I quoted back tension for various Panasonic machines and showed a typical VHS deck layout. Deck designs vary, as we've seen, but Philips has come up with a mechanism that differs radically from the usual arrangement. It's used in the Philips VR6467 and various clones such as the Pioneer VR707 and the B and O VHS82. Back tension is altered in two ways with this design. First, by what's called "dynamic tape tension", and secondly by supply-reel friction. Both of these should be checked in cases where you'd normally check the back tension.

The tape tension is checked by playing back the Philips test tape and monitoring the phase jump in the white bar at the bottom of the display. It should be 8µsec or less, which equates with one colour bar width. To adjust, move spring 203 along the notches of lever

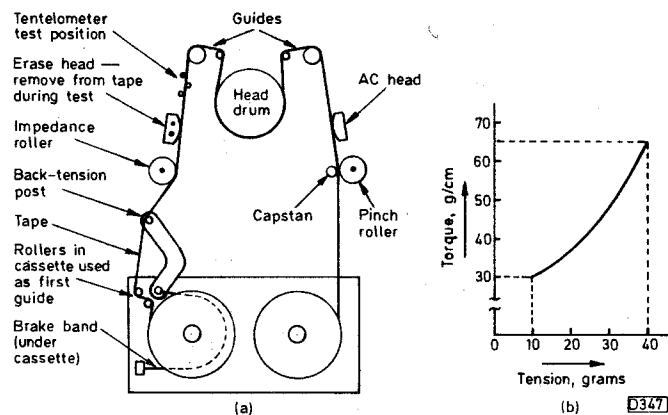

Fig. 1: (a) Typical Panasonic deck mechanism, simplified, showing the back-tension arrangement. (b) Conversion for tension/torque measurements with the D1 deck — 40-45g/cm is the correct back tension (torque).

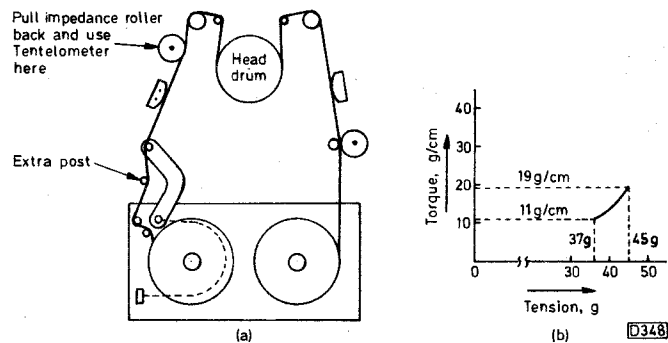

Fig. 2: (a) Typical Ferguson/JVC mechanism. (b) Tension/torque conversion for the 3V55.

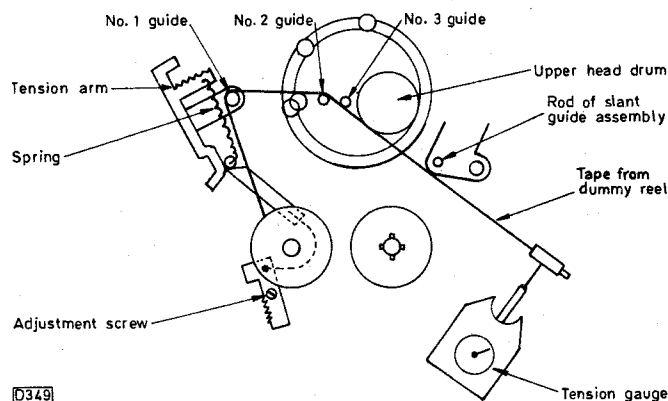

Fig. 3: Video-8 back-tension measurement. You use a fan-type tension gauge and dummy reel.

204. The supply-reel friction is checked by setting the deck in the unthreaded stop position, removing the reel brakes and then, using a hand torque meter, noting the reading in the clockwise direction. It should be 13-16gf/cm (grams force per centimetre). Alternatively use a fan-type tension gauge (see later under Video-8) and a dummy reel. To adjust the friction, set the deck in the threaded stop position, with no cassette in, and alter the position of the spring that's visible through the hole in the mechanism plate, just behind the supply spool — move it to the right to increase the friction.

## VHS-C Decks

With VHS-C decks back tension is measured in different ways depending on the deck's make and age. In

the case of older Panasonic machines such as the portable NV200 a Tentelometer reading in grams is specified. With later machines such as the NV-MC10 camcorder a measurement of the landing position of the back-tension post is specified. Tape tension at the traditional measuring point between the erase head and the entry guide is so low that it doesn't register with a Tentelometer. With JVC/Ferguson machines such as the 3C03 a g/cm reading is specified and this has to be measured using a VHS-C torque cassette. JVC produces such a cassette, part number PUJ50431. It's available from Willow Vale Electronics at £239.50 trade plus VAT, order code 20-300T.

## Betamax Decks

With most Betamax decks the use of a cassette gauge is specified, the reading being quoted in g/cm or gf/cm. Apparently there's a Beta version of the Konig cassette, and of course Sony have such a unit (torque cassette SL-0003C). Taking as an example the Sony SL-F1, the reading should be 45-48g/cm. In this model a preset, RV202 on board LS-8, is used to adjust the back tension. It's in the capstan servo system which provides electronic torque control. Some Betamax machines use the more traditional variable spring position means of adjustment, as with a VHS deck.

## Video-8 Decks

The mechanism used in Video-8 machines is of course very small in comparison with a VHS or Betamax mechanism. As well as the repair problems that this introduces, it also means that a different alignment procedure is required. With Sony machines, to check the back tension you have to remove the mechanism from the machine (camcorder or domestic model), then the cassette carriage from the mechanism. Fig. 3 shows a Video-8 back-tension arrangement. You use a fan-type tension gauge to draw tape through the tape path. The gauge measures up to 30g in either direction, and is used with another reel for take-up torque measurement. The tape is on a dummy reel.

Reel plus tape is part number J-608-083-1A while the gauge is part number J-608-082-4A (Sony part numbers). The gauge costs £77.11 trade plus VAT, the dummy reel with tape £5 trade plus VAT.

You can thus make a practice of checking the back tension with Video-8 decks as well as VHS ones. Here's an example of the benefit of doing this. I recently had to replace a faulty video head in an 18-month old Sony EVA300. I knew that it had had very moderate use. The back tension was found to be over 28g instead of the specified 12g.

## In Conclusion

I shall probably have to return to this subject again later. Meanwhile if anyone has any further information or queries, please write to me via the magazine.

## Addresses

Finally a couple of addresses. MCES is at 15 Lostock Road, Davyhulme, Manchester. Willow Vale Electronics Ltd, can be contacted at 11 Arkwright Road, Reading, Berks RG2 0LU (0734 876 444).

## Grundig VS340

When the tape was ejected there would occasionally be a loop left out of the cassette. This is usually due to a dead spot on the capstan motor, but a scope check on the motor seemed to show that this was not the case. Just then the capstan stopped. Some careful waggling of the wires showed that there was a dry-joint where the capstan motor wires are soldered to the small PCB at the back of the deck. **P.B.**

## Philips VR6660

The magnets on the threading motor sometimes fall out, the result being that the deck doesn't initialise. If you can find the lost magnet, it does matter which way round it goes. You need to have the N pole pointing outside with one magnet and the S pole pointing outside with the other one. **P.B.**

## Philips VR6362

One of the dealers we do work for regularly sends us repairs with no indication as to the fault. Luckily with this range of machines a look at the error memory usually gives a clue. Not this time however – the CMOS RAM battery was flat! The machine played all right but when I tried to tune in a station the picture was overlaid with diagonal black-and-white bars (like a monochrome barber's pole). A panel swap proved that the fault was on the signals panel P306. We found that the play supply switching transistor T7304 was short-circuit. **P.B.**

## Philips VR6660

This machine would intermittently stop playing. If the tape deck test was called up it said that one of the tacho signals was missing – though a visual check showed that the reels, the capstan and the head drum were all rotating when the fault occurred. Scope checks revealed that the wind tacho signal was going missing. When the reel was removed you could see that the reel magnet rubbed on the Hall sensor: as the magnet wasn't glued to the reel it would stop rotating while the reel kept going. The sensor wasn't sitting correctly in its slot as a wire had been trapped underneath it. **P.B.**

## Grundig VS400

I had just fitted a new mode control switch because the machine looped the tape on eject. When play was selected however noise bars ran through the picture as there was no output from the control track. A scope check showed that the control head's earth connection was floating, though the fault would clear if the chassis was disturbed. The cause of the problem was eventually traced to a poor connection at plug A3 on chassis board 1. **P.B.**

## Philips VR6185

After a few minutes' use the E-E signal would fade off, leaving just snow on the screen. A scope check on the

frequency divider signal at pin 13 of the tuner showed that it gradually got smaller and smaller until it reached 0.2V, when the picture went off. The U744 tuner was faulty. **P.B.**

## Toshiba V55

For an intermittently dead machine – even the clock goes off – check for dry-joints at the a.c. input to the power supply module. **P.B.**

## Sanyo VHR1100

If you come across a dead VCR of this type, one which will not eject a tape, perform any deck functions or respond to the remote-control handset, the likelihood is that its on/off key is stuck in. If so it will come up on "operate" (rather than standby) as soon as the machine is plugged into the mains supply. The cause is usually physical, the on/off button being stuck, jammed or gunged up. Check by removing the front cover. **E.T.**

## Akai VS425

I've often found when working on the bench with these machines that the remote control operation is intermittent or doesn't work at all. This is not a fault: if the handset is too close to the machine there's no response. At normal operating distances you'll find that the outfit works perfectly.

The head drum motors in these machines can give trouble ranging from erratic speed and phase to a runaway condition in which the drum continues to whiz at high speed even when the rest of the deck has shut down in the stop mode. **E.T.**

## Sharp VC486 etc

The service manuals for Sharp VCRs of this period don't give a setting up procedure for the mode switch. Though it's more reliable than the ones in Panasonic and some other makes of machine, it can fail and be in need of replacement. Don't pay attention to the notch in the rotary part. With the deck mechanics in the stop or eject mode, carefully turn the pinion (several turns if necessary) until you get a short-circuit reading between the lead-outs. Fix the switch in place in this position. **E.T.**

## Ferguson 3V30/JVC HR7300 etc

The symptoms sometimes found with this range of machines are no E-E signals and no tuning signal though the r.f.-through signal is o.k. and the deck mechanics all work. In these circumstances check for a dry-joint at the always 9V regulator transistor Q101. **E.T.**

## Sanyo VHR1100

We've had more than one of these VCRs with the following fault: while the clock/display works all right the machine won't switch on. Checks have shown that



the power supply and the syscon microcomputer chip were doing their stuff, the cause of the problem being that the 12V switch transistor Q5006 is open-circuit. The equivalent books say that a BC328 can be used as a substitute. In practice we've found that this transistor is not man enough and recommend that the correct type is ordered and fitted.

E.T.

### **Baird 8940/JVC HR7350**

The complaint with this machine was that it had snapped four of the customer's tapes (will some people never learn?!). The cause was a badly fitted cassette lamp. It was so far down its holder that the sensor received no light when the leader appeared. Thus the tape got ripped out of its clip on the supply spool.

Here are a few other faults we've had with this model:

- (1) Intermittent loss of playback picture was caused by the track of the noise-cancelling potentiometer R208 (470 $\Omega$ ) being open-circuit.
- (2) No E-E sound. Q11 was open-circuit.
- (3) No sound erasure. Q10 was short-circuit.
- (4) No capstan motor operation. C62 and Q8 were both short-circuit.

The above component reference numbers were taken from the JVC HR7350 manual.

C.P.

### **Time-saving Tip**

Here's a time-saving tip, even if it seems a bit obvious. To insert those very tight self-tappers that screw into plastic, put a drop of oil on the screw first. It will then go in almost by finger pressure only.

C.P.

### **Grundig VS180**

This machine was dead, with just a momentary twitch of the capstan motor at switch on. The power supply is commendably simple and I soon found that D425 was short-circuit. A BY299 was used as a replacement. This made it possible to play back a tape to check the deck functions. No recording was possible however as there were no signals. The main 33V supply was missing at the relevant power supply pin, a short to chassis being recorded at this point. It was due to the 33V zener diode on the front panel.

S.L.

### **Tatung TVP1311**

This VCR was dead with F2 (2A) very definitely blown. As there was no obvious short-circuit we fitted a new fuse. When we switched on again the machine came to life for several seconds then the fuse once more blew. Several fuses later we found that there was a dead short across the 12V rail. This was pinned down to the servo board, then to the deck connection PCB. By further disconnection we isolated the fault to the reel sensor. When this was examined we found that a blob of solder shorted out the printed track to the metalwork. How the machine could have worked from new we were unable to see.

M.D.

### **Sharp VC381**

The complaint with this machine was that most functions didn't work. A quick check on the power supply showed that the 13V and 12V outputs at pins 1 and 8 were missing. When the power supply was taken apart we

were able to check back through the regulators. This revealed that there was no output from the 2SD1308 14V regulator transistor Q01. I ordered a replacement and fitting this cured the problem. After a few weeks however the machine returned with the complaint that it would load but nothing else worked. This was the case and in addition the loading was very slow. A check on the power supply showed that while the 13V output was correct off load it dropped to 3V when a cassette was being loaded and the motor was running. It turned out that our new 2SD1308 transistor was faulty, though this was not obvious at the time due to the difficulty of taking measurements with the power supply apart.

M.D.

### **Hitachi VT120**

The customer complained that there had been intermittent problems for some time. Now none of the operation keys worked and the clock display was random. We found that there was no 5V supply at pin 32 of the timer control and operation (key scan) chip IC751. This supply follows a very devious route: we eventually found that circuit protector IC805 on the VS tuning PCB was open-circuit.

M.D.

### **Philips VR6467**

The complaint was no playback video. There was a healthy f.m. signal output from the head but no video output from the Y/C processing board. The f.m. signal entered the TDA3730 chip IC7351 at pin 17 but didn't reappear at pin 16 as it should have done. This was not surprising as the supply to this chip was missing. It comes via a BC238 series regulator transistor T7304 which we discovered had gone short-circuit base to collector. This was not the end of the story since there was still no output when we'd replaced this transistor. It turned out that C2329 (330 $\mu$ F, 16V) was also dead short.

M.D.

### **Ferguson 3V57**

The following note could apply to any of the machines in this range. The symptoms were not uncommon - clock alight but the machine wouldn't switch on. This is usually due to the absence of one or more of the switched supplies because of an open-circuit ICP in the power supply. In this case however the ICPs were intact, but the switched lines were missing because the power supply CRTL line at pin 9 of CN3 remained high at 3.2V. This high came from pin 1 of the syscon microcomputer.

The power switch input to pin 17 of the microcomputer chip was very low but was being earthed as the switch was pressed. The same applied to the timer input at pin 20. Separate pull-up resistors are used, so the fault had to be in the supply. In fact the unswitched 5V line was missing. It's obtained from the unswitched 12V supply via a regulator on the main panel (not the PSU). The 12V supply was present here but the regulator transistor Q602 was not being biased on as there was a 90 $\Omega$  leak from its base to chassis. We found that the culprit was not the zener diode, as expected, but the parallel 0.022 $\mu$ F ceramic decoupler C6050. The interesting point was that the fault had been reported as intermittent some days earlier. We'd returned the machine with a "no fault found" note under the assumption that a mains lock-out had occurred, something that's not uncommon with these machines.

N.B.

# Servicing the Mitsubishi HS304

John Coombes

The HS304 was Mitsubishi's first front-loading VCR. It was sold in large quantities during the period 1983-4 and was also released under the Salora brand name as Model V8300.

## Common Faults

One of the most common faults is that the picture has random lines across it, as if the tracking is set incorrectly. The cause is misalignment of the guide poles. You can tackle this fault in the field, using a known good prerecorded tape. Adjust the guide poles so that the lines slowly disappear up and/or down the screen. If the guides are turned incorrectly the number of lines will increase. This adjustment should be done only as a temporary measure however. The correct way to adjust the guide poles is to use a scope to check the f.m. envelope at test point TP2C. Insert a hexagonal key in the top of the guide roller with the set screw in front of the guide slackened off slightly. Adjust for a perfectly shaped f.m. waveform then tighten the set screw. Use a slight amount of locking paint to prevent further misalignment.

The reel motors are another common cause of trouble. For no play, intermittent play and/or very noisy rewind/fast forward or no fast forward check the take-up motor. It should spin freely when removed. The fault is caused by a worn bearing and the only solution is to replace the motor. There are other possibilities however. Check the pinion take-up cog which may have moved down the shaft with the result that it no longer meshes with the take-up spool. Alternatively you may find that it is split or that a few of the slits have been removed, displaced or badly damaged. The best replacement is the type used in Model HS330 as it can be fitted on the shaft with grub screws, preventing further trouble. For no rewind check the supply motor which will have to be replaced if faulty.

## Power Supply Faults

The usual cause of the "no results" symptom is that the 3-15A fuse F901 is open-circuit or blown. If it has blown, check bridge rectifier D906 (M4B51) and the protection capacitors C909/910/911 (all 4,700pF) for shorts. Alternatively the 400mA T fuses F971/2 on the primary side of the mains transformer may be open-circuit or blown. The latter will be due to shorted turns on the mains transformer T971, but this is a very rare occurrence.

If the power on/off switch doesn't operate and all days of the week light faintly check whether the 10 $\Omega$  safety resistor R915 has gone open-circuit. You will sometimes find it necessary to replace the 9V standby transistor Q903 (2SC1983) in this event.

If the machine won't switch off, check whether R908 (1.8k $\Omega$ ) or R910 (56 $\Omega$ ) is open-circuit.

For no clock display check for -27V at the collector of Q902 (2SA715). If this voltage is missing D904 (RM1) is probably open-circuit. If the -27V supply is present check Q902.

If playback is all right but there are no E-E signals

check that the 30V a.c. output is being provided by T971 then check D901 (RM1) and Q901 (2SA673) as necessary for being open-circuit.

## Servo Faults

If the drum doesn't rotate - this problem can be intermittent - check whether R403 (82 $\Omega$ ) on the drum motor drive board is open-circuit. Also check for dry-joints here. If necessary check the LB1620 drum motor drive chip IC401 by replacement and for dry-joints on the drum MDA board.

If, at power switch on, the drum motor speed is excessive, check whether transistor Q4B0 (2SC2603) on the control (mechacon/servo/power) panel is open-circuit. If necessary check the d.c. conditions around Q4B0 and IC4A8 (AN6344). Check Q4B0 and IC4A8 by replacement if necessary.

For excessive drum speed check the voltage at pin 1 of IC4A8. The reading here should be about 9V. If the voltage is low or missing suspect IC4A8 and check whether Q4A2 (2SA1115) is open-circuit.

Slow sound with a noise bar on the picture indicates a capstan servo fault. Check the voltage at pin 16 of IC4A3 (M54896P). It's connected to the switched 9V line. A short in IC4A3 can drag the voltage down.

Excessive capstan speed will give lines on the picture like poor tracking and fast sound. Check that the FG pulses are present at pin 6 of plug and socket CE. If so C4F9 (0.22 $\mu$ F) is probably open-circuit.

If the capstan motor is inoperative, check IC4A0 (M50129P) by replacement or by noting the d.c. conditions.

A faulty capstan motor can result in the machine taking a long time to come out of the visual search mode.

When R4K9 (1.5 $\Omega$ , 2W) in the capstan motor drive circuit goes open-circuit you get snowy vision with a slight picture at the top. If left to run in this condition the VCR will cut out.

For displaced colour/picture jitter check the 9V supply at pin 14 of IC4A1 (TC4066BP). If the reading is low suspect the chip - check it by replacement.

## Mechanical Problems

If the machine half loads then cuts out, check whether the loading belt is dirty or stretched and replace as necessary. If the loading belt is o.k. replace the loading motor.

No record but playback all right could simply be that the cassette tab is missing or fractured. The other likely cause is that the record prevention switch is open-circuit, broken or incorrectly positioned.

For bent verticals/picture skewing check the back tension, which should be 27g/cm. Excessive back tension over a long period of time will result in early failure of the heads. If you find that there's a constant 5g/cm variation, check the springs and spring holder, also that the tension arm is not bent or incorrectly set.

No play or intermittent no play can be caused by a faulty dew sensor or the lead connections to the sensor.

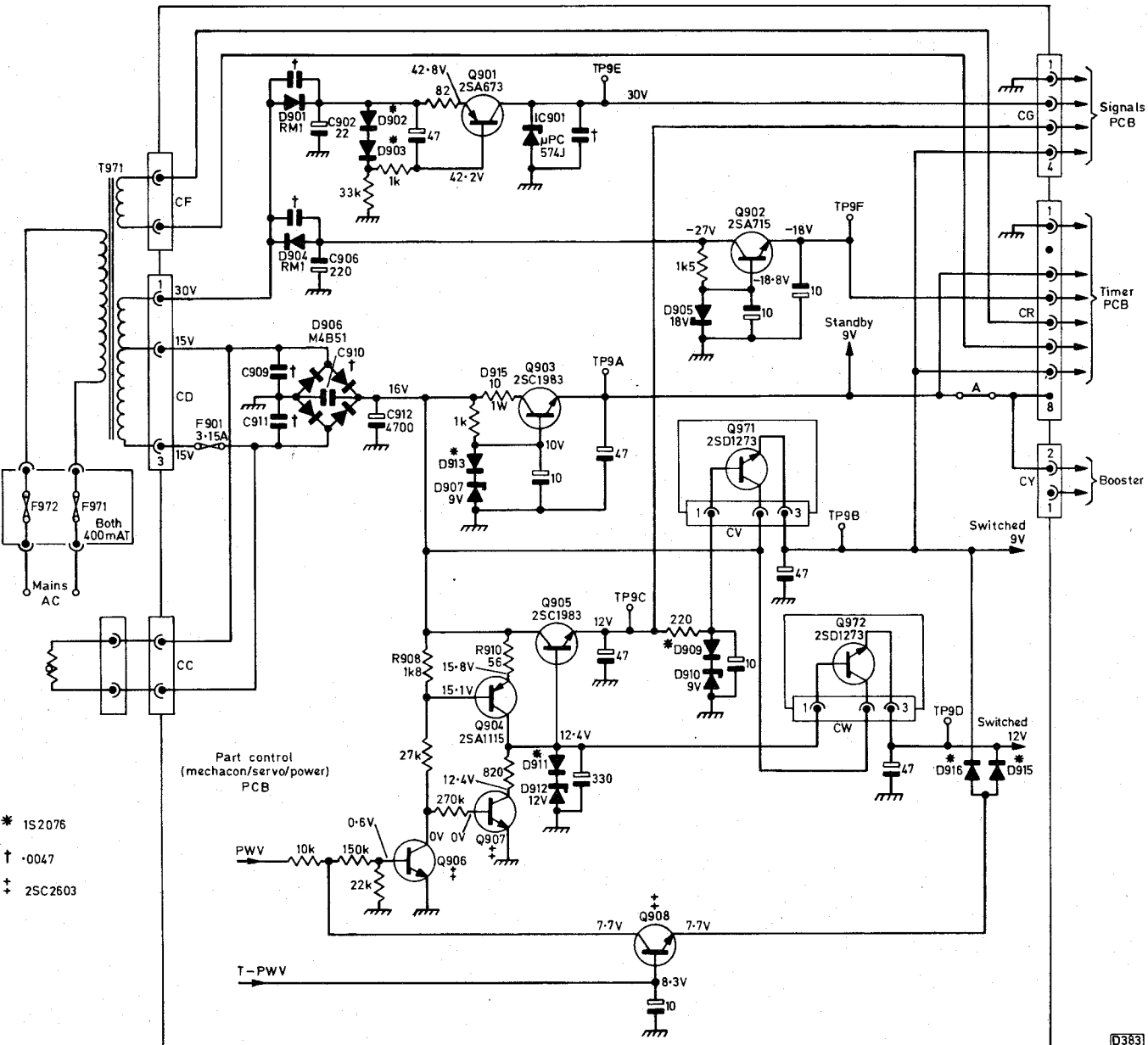

Fig. 1: Power supply circuitry used in the Mitsubishi Model HS304.

If necessary check the plug/socket for poor connections and for dry-joints on the board at the socket end.

If there are no results when a cassette is inserted and the loading motor keeps running, check whether the orange lead or the switch on the loading mechanism is open-circuit. If the VCR won't accept a tape check for an open-circuit at the switch with the yellow lead.

Failure to erase the previous sound track - this may be intermittent - is usually due to dry-joints on the erase head, the PCB and/or the leads being broken. It's best to replace the leads and remove the plug/socket, wiring directly to the PCB. Failure to erase can also be due to a badly contaminated or faulty erase head.

Intermittent sound can be caused by a misaligned audio/control head assembly.

**Signal Circuit Faults**

If you get snowy vision and noisy sound on E-E and also when the TV set is switched to off-air reception suspect a faulty aerial input booster/converter. If the poor results occur only in the 'E-E mode the booster

could still be responsible but the tuner is also suspect. Before condemning the tuner, check the 12V supply to pin BU. If this is missing check back to pin 3 of plug/socket CG on the control PCB and if necessary check Q905 (2SC1983) by replacement. A faulty tuner can give rise to patterning/instability on some channels.

For blurred E-E vision check the d.c. conditions at the 2SC2603 E-E switch transistor Q3A5 on the signals board. This transistor can go open-circuit to give this symptom.

For blank vision/noisy sound check whether the 2SC2724 video amplifier transistor Q103 is open-circuit. If this transistor is o.k. check the associated circuitry and IC101 (M5186P) by replacement.

Weak colour that flickered on and off was traced to Q6A3 (2SC2603) being open-circuit. The most common cause of no colour is Q6A9 (2SC2724) being open-circuit. There are two crystal oscillators in the colour circuitry, the crystals being X6A0 (4-433619MHz) and X6A1 (4-435572MHz), tuned by trimmers VC6A0 and VC6A1 respectively. It's worth using a counter to ensure that these are set to within 50Hz. The main trouble we

have had is with X6A1/VC6A1. If necessary check the crystal(s) and the condition of the trimmers. If still in trouble with no playback colour check IC6A0 (HA11741) by replacement or by checking the d.c. conditions.

Dry-joints around IC2A0 (M51450P) usually result in intermittent playback luminance. They can also cause intermittent failure to record a picture, intermittent colour recording or intermittent speed variation. It's best to resolder all the pins – clean them very well before doing so.

## **Remote Control**

The HS304 has a cable-connected remote control system. If there's no operation, check for poor connection at the remote control socket, which you may find broken. Check also for a broken jack plug and the connections within it for dry-joints or for shorts if twisted. If still in trouble check for a break within the remote control unit – the panel may be cracked or there may be a poor connection or dry-joint between the lead and the PCB. If necessary check whether the lead is open-circuit. Try cleaning if any of the individual buttons give trouble. You may have to replace the unit.

## JVC HRD180

Hello everyone. Sorry you've not heard much from me for a while but the farm and the specialist camera/camcorder servicing operation I run keep me pretty busy. The technology is still advancing, and bringing with it ever more mind-boggling faults. The hotline between myself and Nick Beer has been fairly buzzing of late, for reasons that will be divulged another time. Meanwhile here's a case where the fault symptom and the defective component were not clearly related, the sort of thing that causes us considerable hardship.

The machine was a JVC HRD180 with which Mastercare was having problems. I was asked to help out as a JVC authorised service centre. More often than not the playback picture was very poor. The fault was easy to see: the poor-quality playback picture had lots of very small herringbone squiggles all over it and a grainy look, with black tadpole-like spots trailing across on peak whites.

The first thought that crossed my mind was the obvious one that the outputs from the heads were low. Our local Mastercare branch is very good about supplying engineer's notes however. They showed that the heads and the HA11870NT preamplifier chip had been replaced, also that there had been some problem with the power supply as a regulator had been changed twice along with some circuit protectors. To be on the safe side I spent some time just cross-checking, in case some point had been missed. This included verification of the preamplifier operation, the LP/SP switching and the adjustment of the head tuning circuits. The latter were left temporarily misaligned as it was impossible to determine their correct alignment at this stage.

The head drum seemed to lack power, and gave the impression that it was running on the slow side, but a locked picture was obtained. At one point early one morning a good quality picture came up and then deteriorated before I could check anything. Some recordings were made as a check. They played back reasonably well on another machine. So it was difficult to know exactly what were the fault symptoms and what were red herrings. Scepticism about everything seemed to be the only logical approach to adopt.

Time was spent checking the operation of the luminance playback circuitry. This included changing the PU22282A chip IC101. All to no avail, except that the upper and lower edges of the f.m. waveform at pin 22 of IC101 were seen to be ragged and not smooth as with an HRD170 used for comparison (it's the single-speed version, and happened to be hanging around). I next hijacked the HRD170's preamplifier and tried it in the faulty machine. This move was inconclusive but suggested that the preamplifier was all right. I was still suspicious about the f.m. carrier however: it seemed to contain excessive h.f. content, causing beat patterning. So if the preamplifier was o.k. the problem was possibly due to the filter circuit between the preamplifier and IC101. This was checked, but no evidence was found to suggest that there was a faulty component here. The only likely item left was the lower drum unit with the rotary transformer and motor. This was changed, but the symptoms persisted.

I next tried some panel jockeying to try to isolate the cause of the fault. The preamplifier was again swapped, this time for an HRD180 one. The servo panel was swapped and the power supply rails were again checked for level and ripple. I also checked the r.f. unit, but as the testing was on the video output this was a move of desperation. The HRD180 was then put aside for a while for further thought - actually the further the better . . .

After a week or so the situation was reappraised. So far I'd eliminated the video heads, the lower drum and rotary transformer, the preamplifier, the luminance processing, the power supplies and the servo, also the tuner and r.f. modulator. A helpful suggestion from JVC was that the only thing left was the cabinet. Thanks, Kevin!

Eventually one quiet Saturday morning the HRD180 was put back on the bench. The fault had not gone away. There was still a poor picture and the f.m. waveform had fuzzy edges. That bothered me: you know the feeling in the back of your mind, a nagging "there's the clue". Then it dawned! Clearly the cause of the problem, if it was not the f.m. carrier filters, was that the signal from the video heads was not of the correct frequency. This in turn meant that the drum speed was incorrect.

As the servo and drive amplifier, along with the power supplies, had been checked and cleared, what else was there that could affect the drum motor? Only the stop/start signal from the syscon microcomputer chip, but as the drum stopped and started correctly this must be operational. Pin 7 of the M50965-612SP system control microcomputer chip IC601 should be high for drum "off" and low for drum "on". It sat at 3V and had a sawtooth waveform on it. So that was it, the sawtooth was modulating the speed of the drum motor and the f.m. signal coming off the tape! Once the microcomputer chip had been replaced clear pictures were obtained. Guides, switching points and the head tuning circuits were then set up and the repair completed.

Poor picture quality due to a faulty syscon microcomputer chip, would you believe it? I'm sure that the trade price of a new machine was less than my invoice, despite full time not being charged. S.B.

## Sanyo VHR5200

"New unsold stock, no deck functions, wanted for sale Saturday" the job ticket read. We dismantled the machine, put it on its side, and were surprised to find that it burst into life when we poked and prodded at the underside of the deck.

They didn't get it back for Saturday as we had to order a new capstan motor. The original one had a couple of dead spots in its rotation, which is unusual for an electronic direct-drive motor. Once the motor stopped at a dead spot nothing would happen until it was flicked by hand. E.T.

## Grundig VS500

This machine chewed tapes. When a cassette was inserted the deck went as far as the half-load position then the tape spilt out of the cassette and off the guides.

The cause of the problem was that the left-hand spool wasn't being braked as spring 26 had come off. When the spring was refitted in its hole in the chassis normal operation was restored. **P.B.**

## Philips VR6561

On playback there was no sound and a blank raster. We found that the +10d (record) supply was present at all times as the RE2 line didn't go high in playback. It comes from the P608 board where T7701 (BC328) was open-circuit base-to-emitter. **P.B.**

## Amstrad 4600/4700/6000/6100/TVR2/TVR3

If the machine is apparently dead, with no clock display, see if it will load a cassette. If the deck functions are normal the problem is usually confined to the FIP801 display's heater supply. The cause is an open-circuit here or, very commonly, a faulty mains transformer. Incidentally these mains transformers are not very reliable – when defective they usually run very hot. If the machine won't accept a cassette, check the +28V output from the power supply. If this is low the 14DN332 timer chip is almost certainly faulty.

The timer chip is also usually the cause when display segments that shouldn't be lit up are alight. This fault can however be caused by the zener diode in the power supply between the heaters and the +28V rail. **S.L.**

## Setting up Amstrad VCRs

A few words about setting up Amstrad VCRs. It's a very straightforward process due to the simplicity of these machines.

First, use the scope's trigger channel to monitor the head switching pulses and the other channel to look at the control track pulses. What you should see is shown in Fig. 1. If the conditions aren't as shown, adjust the appropriate potentiometer (test point and potentiometer circuit reference numbers vary from machine to machine – refer to the manual).

Next transfer one input from the control track pulses to the playback f.m. signal. Adjust the audio/control head (large brass adjustment) for maximum f.m., then adjust the customer tracking control. Maximum f.m. has been obtained when the waveform amplitude will only decrease. Finally, trim up the f.m. waveform shape with the relevant guide.

If the switching pulses are incorrect this will show up as a bright-up between head scans. Adjust the switching roughly for no bright-up (two controls, i.e. Ch.1/2, with the VCR4600, only one control with the other models). For precise setting a check can be made on the video waveform.

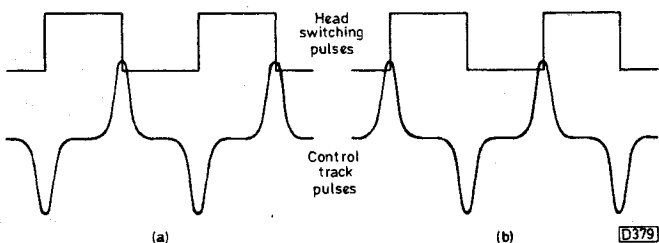

Fig. 1: Setting up waveforms for Amstrad VCRs. (a) Models VCR4700/6000/6100/TVR3 VCR. (b) Model VCR4600 only. In both cases with the tracking control in the centre, detent position.

Adjust the sound for the best frequency response with a known good music recording (this is second best to an azimuth tape of course). White noise is also a good check. **S.L.**

## Hitachi VTM622

This brand new VCR had a healthy appetite for tapes. The damage was not creasing: the tape was being stretched so much that oxide had fallen off in places to reveal the clear backing. A check on the tape back tension sent the scale needle to over 60 grams. The tension pole positioning was correct, and after removing the tension band we found that the supply reel was still very stiff. When the reel had been removed a black circle mark was seen on the tape deck chassis. The spacing washer under the supply reel had never been fitted. **A.D.**

## Philips VR6760

This machine came in with a long list of faults: no hi-fi sound on playback of any tape; no normal sound; and no E-E sound through the TV set, with the picture distorted – the distortion took the form of a black-and-white bar that rolled up and across the screen, similar to sync bars breaking through from an adjacent channel. After chasing several red herrings we found that the culprit was transistor T607 on board P606. It was open-circuit, as a result of which the +11b supply was missing. **A.D.**

## Fisher FVHP615

This machine came in with the usual complaint of chewing tapes and poor rewind. Both idler assemblies were replaced and the machine was returned to the customer. A few weeks later it came back with the symptoms of wow and flutter and tape chewing, but only at the very start of a tape. This had started to happen after replacing the idlers.

When we played a fully rewound tape in the machine we found that the capstan speed varied and that as the tape was being taken back into the cassette it slipped down the guide and was crushed on the lower edge of the housing. This indicated high take-up torque, which was found to be over 200 grams. The cause of the problem was the take-up reel. These reels have a clutch at the bottom and this one had virtually seized. **A.D.**

## Amstrad VCR4600

A very common fault that's recently started to occur is failure of the left-hand sensor. Complaints range from no play or fast forward to intermittent stopping in the record mode. **M.D.**

## Ferguson 3V65

This machine came in for head replacement. When we'd done this we made a recording and found that the picture/colour etc. were normal. The machine was therefore returned to the subscriber who subsequently complained that it played his tapes only in monochrome. When we tested the machine in the workshop with a prerecorded tape, sure enough no colour. The reason for this was that the upper drum had been fitted 180° out of its correct position, something that's very easy to do with this model as the "relay pins" are both made of the same colour plastic. **C.P.**

## Sony CCDV8AF

Many camcorder users complain of lens motor noise on the sound tracks they record, particularly during quiet passages when the audio auto-level control winds up the gain of the sound channel. In most cases little can be done about this short of buying and using an external microphone – we've changed motors on several different models with little or no improvement in the results obtained.

We've found however that the auto-focus drive motor wears in the Sony CCDV8AF, which is now three-four years old, and that fitting a replacement results in a marked decrease in sound-track rumble when the lens is on the move. **E.T.**

## Sanyo VHR3300

This machine had fine E-E sound but instead of a picture there were swirling black-and-white patterns that looked as though they were caused by instability. This led us to investigate the vision i.f. section, but we found that a perfectly good composite video signal emerged from the demodulator. The trouble was caused by IC001 (LA7223) in the video circuit. The instruction entering this route switching chip was correct and the video signal was present at its input pin 7, but all that emerged from the output pin 1 was hash. **E.T.**

## Alba VCR4000X

We didn't have a service manual for this machine, which was a great handicap in view of the fault – intermittent failure to play rented tapes in colour. The machine's own recordings played backed in colour correctly. The problem was solved by replacing the 4.43MHz crystal in the chroma section and setting up the VXO potentiometer R491. **E.T.**

## Grundig VS180

There was an intermittent fault with this machine: when the fault was present the machine wouldn't carry out any deck function. It was very similar to the faulty cassette lamp syndrome with early makes and models. With a cassette in the machine however the stop button would act as an eject control.

The cause of this one was leakage in the CASS (eject) keyswitch. It was upsetting the keyscan system with the result that the action of the other switches was inhibited. Since the front surface of the faulty keyswitch was rather battered and the corresponding plastic "hinge" on the user's front-panel CASS key was in poor condition we replaced both items. **E.T.**

## Mitsubishi HS302

"Reversed tape as sample" said a scribbled note on this machine. What could that mean? Examination of the cassette stuck to the machine's top cover showed that the ribbon was inside out. When we checked the machine's operation we found that the entry guide did not retract fully in the stop mode, so that when a cassette was inserted its ribbon caught the top of the guide and was

twisted round. The cause of the problem was an almost seized bearing at the pivot of the arm that drives the entry guide through the tape-loading process. It's below the head drum, on the left-hand side of the subdeck, and is difficult to get at. Penetrating oil and much toing and froing by hand finally freed it and enabled the spring to pull the guide to the fully-retracted position. **E.T.**

## Toshiba V66/JVC HRD140

The deck used in this machine is similar to the one in a whole range of JVC-based machines – the HRD140, 3V43 etc. Sometimes tapes are damaged in the backwards search (review) mode. This is due to the tape buckling and bubbling between the capstan and pinch roller. The cause is an out of vertical guide arm, the one between the capstan and the TLL reel. It's better to replace this than to bend it – part no. PQ41384A. **E.T.**

## Philips VR6660

When the test pattern was selected it couldn't be removed except by interrupting the mains supply. When playback of a cassette was tried the tape would thread then immediately unthread. The head drum rotated even in the stop mode. I started with this last point as it seemed to be the easiest one to deal with. As the /motor stop line (pin 25) didn't go low in the stop mode a new MAB8420C047 microcomputer chip was fitted. This cleared all the faults. Phew! **P.B.**

## Grundig VS500

This machine blew the mains fuse because the BUZ90A chopper transistor was short-circuit. When d.c. checks were made to find out why we discovered that R1318 (300k $\Omega$ ) was open-circuit. The f.e.t. and resistor were replaced, but the BUZ90A again failed at switch on. We had to fit a new TDA4650 control chip as well. **P.B.**

## Philips VR6562/Pye DV543/Sharp VC750

A pair of these came in one day, both with the same fault. They would very intermittently go to stop a few seconds after play was selected. Sometimes the capstan didn't turn, other times the brake lever didn't move over so that the idler didn't contact the take-up reel and the tape spilt out. A new mecha state switch was tried but made no difference. In desperation I rang the nice man at Sharp. He suggested changing the cam gears, and he was right. I owe him a pint, maybe two . . . **P.B.**

## Ferguson 3V24/JVC HR2200

The complaint with this machine was no picture. On examination I found that there was no drum rotation and, an added symptom, the VCR didn't enter the alarm mode. I decided to tackle the drum fault first. The cause of failure to rotate was that the drum stop signal wasn't being removed when play was selected. Tracing this brought me to IC4 on the audio/CPU board. When play

is selected pin 2 of IC4 should drop to 0V, removing the drum stop signal. But in this machine pin 2 fell to only 4V. The reason for this was eventually traced to leakage across the board to pin 2 of IC4, between two points where the print connection is taken through the board to the component side. Carefully cutting the print prior to the feed-through links and replacing it with a length of insulated wire restored normal results — including operation of the alarm mode when there's no drum rotation. **A.D.**

### **Panasonic NV180**

This machine came in with a cassette inside and the tape still threaded. On applying power the drum motor ran fast and no functions were available. We found that the 5V supply at T1003 on the front system control/power panel was missing. There's a circuit protector connected to the collector of the 5V regulator transistor Q1001. It's not shown in the circuit diagram and had gone open-circuit. Replacing it restored all functions and allowed the tape to unthread correctly — saving a valuable wedding video. **A.D.**

### **Amstrad VCR4700/TVR2/TVR3**

Tuning faults should lead to a check on the DAC output from the timer chip if the display indication in the tuning modes is incorrect. A variable mark-space ratio square-wave should be seen. If this is correct, follow it to pin 8 of the tuning voltage generator chip. This can and does fail, with no 0-30V output at pin 10. No DAC output is of course our old friend the 14DN233A timer chip. **S.L.**

### **Sentra GX8000**

The customer's complaint was of difficulty in tuning channels B and D. I found that on these two channel positions only the tuning voltage wouldn't rise above 26V. There was a leak through selector G. After eliminating the isolating diodes I found that C407 had a 4k $\Omega$  leak. **S.L.**

### **B and O VHS82**

The reported fault was that the machine wouldn't accept tapes. The front loading worked correctly when a cassette was inserted, but if any mechanical function was selected the capstan motor would kick anti-clockwise, clockwise, then anti-clockwise again, after which the cassette was automatically ejected. The reason for this behaviour was loss of tacho pulses from the capstan, the cause being that C2206 (47 $\mu$ F) in the +11V supply to the tacho amplifier circuit had gone short-circuit. No other damage had been caused as the supply comes from the 13V line via a 1k $\Omega$  resistor. **I.B.**

### **Panasonic NV-L28**

This one had three reported faults. There was intermittent operation of the functions via remote control, the VTR power button mounted on the fold-down control panel didn't always work, and lastly the most significant symptom — when the control panel was in the upright position the tracking shifted off to one end of its range. All these problems were caused by one fault. The control matrix PCB is connected to the machine via a

flat, fifteen-way flexible lead that plugs into both the front PCB and the control PCB. The cause of the fault was a very small conductive strand which bridged between connections 14 and 15 of the FPC at the control panel end. As a result tracking minus ("Set Down" in the manual) was selected momentarily, or all the time with the control panel closed up. If any of these keys is held down no other key will be detected, including the VTR power switch, and it will also lock out the remote control input. **I.B.**

### **Samsung SI7220**

The problem with this new machine was loss of E-E sound. It cleared when the bottom cover was removed, but could be made to come and go by slight pressure on the main panel. We soon found the cause. There was a 100 $\mu$ F capacitor mounted on the underside of the panel, a production modification. Its negative lead should be connected to chassis but bridged from where it was soldered to an adjacent land. This land is the audio feed from the tuner/input select area via pin 3 of connector CN401, and was thus shorting out the signal. **I.B.**

### **Logic VR950**

The capstan servo was hunting and the tracking control had no effect. We traced the cause of the fault to the control, which was worn and open-circuit. Because of spares problems with these machines we used a standard horizontal 470k $\Omega$  preset, fitted with a suitable spindle that matched up with the front panel. This arrangement worked well. We then found the cause of the control's failure — a badly worn head drum that produced a poor, unstable picture and gave rise to an overworked tracking control. All was well after fitting a new drum from MCES. **C.A.**

### **Sharp VCA100HM**

This machine accepted a cassette briefly then spat it out again. As one connection tag had broken off the top cassette sensing switch someone had soldered both leads together! The simple answer was a new switch. **C.A.**

### **Saisho VR1200HQ**

This was a NICAM (Nasty Intruder Caused Absolute Mayhem) job. The original complaint was that the machine wouldn't accept a cassette. Its owner had accepted the kind repair offer of a friend at the local Electricity Board. When she retrieved it some time later it was completely dead.

A replacement 12V regulator transistor (Q2502) restored some life, but the machine still refused to accept cassettes. If a tape was wound in manually the start and fast-wind functions worked, but with no end-sensing operation. The left-hand PT361 sensor was open-circuit (the original fault?), but a replacement made no difference. The right-hand sensor is decoupled by a 10nF capacitor (C1012) which had been carefully replaced by a 4.7 $\Omega$  resistor! The correct component restored loading and end-sensing, but with no playback picture. Meterman had removed the head amplifier module and refitted it with the PCB edge connector misaligned. After correcting this we had a working machine, the owner had a large bill, and I suspect that her SWEB friend was about to receive a shock. **C.A.**



# Servicing the Panasonic D1 Deck

Nick Beer

The D1 deck mechanism was used in a large number of Panasonic VCRs released over a period of some years. It was also used in slightly modified form in many other machines. This article deals mainly with the overall mechanism, but also provides notes on electronic faults experienced with some models. VCRs that use the basic deck are as follows: NV230, NV430, NV810, NV870, NV-G7, NV-G10, NV-G12 and NV-G18. They are all front loaders and cover a wide range from the NV230, a basic machine with wired remote control, to models with dual-speed operation and hi-fi sound. We'll deal first with the mechanical operation of the deck.

## Mechanical Operation

As in the NV730, which we dealt with in an earlier article, the cassette is loaded into the carriage by means of a slot-in belt (part no. VDV0151). The front loading motor drives a worm via this belt, the mechanism being located on the right-hand side of the carriage. It's easy to remove the carriage – usually there's a red screw or bolt at each of its four corners. Doing this makes for easier mechanism service. The carriage can be lifted out (see later) and placed upside down on a piece of paper or foam on top of the timer PCB to its right: with the connector refitted, it will load a cassette to enable the mechanism to run for observation purposes.

Reel drive is provided by idler VXP0521, which is of the same type as in the NV370/830/850. It's between the reel turntables and gets its drive from a belt (VDV0149) on the capstan rotor via a clutch (VXP0600). Capstan drive is by means of a direct-drive, fixed-stator motor. Thus the motor is split into two major, replaceable components, the rotor and stator (see faults list).

Tape loading and mechanism mode selection are driven by a loading motor (VEM0211) via a loading belt (VDV0152). As in earlier machines, a cam and lever principle is involved. Mode selection is by means of a linear mode switch which is mounted in parallel to the main lever. In earlier models this was type VSS0110 but in later ones with NV-G numbers it's type VSS0135. Physically the main difference consists of an extra tag, for an earthing lead to the mechanism chassis, below the centre contact. A single retaining bolt (XYE3 + BF10FZ) holds the mode switch. Whenever the switch is replaced this bolt should also be changed (see faults list).

The VXL1371 pinch roller is of the established Panasonic design – a pivoting arm with counterspring arrangement. The brake band (VXZ0165) is mounted in the same way as in the NV730, around the supply reel. Drum drive is via a direct-drive unit: as with the heads, the part numbers vary from model to model depending on the features included. Table 1 provides a list.

The video heads are all mounted in the same way: pins are soldered through the PCB on the head drum. Always remove the head drum carefully – I must repeat the warnings given in previous articles always to ensure that all pins are free from solder before removal and that the correct sequence is observed. The Panasonic head puller can be used.

The audio/control head (VEH0247) is prone to wear, especially in the NV430. As you would expect the symptoms are low and muffled sound. Replacement is straightforward: the three-screw adjustment method is used, with plug-in connections.

## Maintenance Kit

The maintenance kit for this range of models is part number VUD4093KIT. It contains nothing unusual – idler, pinch roller, the three belts, impedance roller, etc. The price is very reasonable, representing a considerable saving on the cost of the individual parts.

## Replacing Mechanical Parts

The video head drum is fixed to the lower drum with the standard two bolts, connection being by pins soldered through the small PCB in the upper drum. This has already been mentioned, along with the precautions to take. The number of connection pins varies depending on the number of heads in the drum, i.e. the features incorporated in particular models.

Replacing parts – other than the heads – on the upper side of the mechanism is much easier when the cassette carriage has been removed. After removing it you can replace the idler, brake band, pinch roller, etc.

The idler is secured by means of a split washer. After removing this and unhooking the spring across the back of the idler arm you can pull the idler up and off its shaft.

The brake band can be removed after undoing the adjustment screw and unclipping the other end from the

Table 1: Models using the D1 deck.

Model	Features	Video head	DD unit
NV230	Cord RCU, two heads, one event timer	VEH0296	VEG0397
NV430	IR RCU, two heads, four event timer	VEH0271/86	VEG0353
NV810	IR RCU, hi-fi audio, four event timer	VEH0294	VEG0396
NV870	IR RCU, hi-fi audio, eight event timer, dual speed	VEH0288	VEG0367
NV-G7	IR RCU, two heads, one event timer	VEH0296	VEG0397
NV-G10	IR RCU, super still, eight event timer	VEH0287	VEG0352
NV-G12	IR RCU (timer prog.) four event timer, optional DBS	VEH0287	VEG0352
NV-G18	IR RCU, dual speed, eight event timer	VEH0330/1	VEG0449

Abbreviations: IR infra-red, RCU remote control unit, DBS digital bar scanner (the Panasonic light pen for timer setting).

back-tension post arm. After replacement, reset the back tension – see later.

The pinch roller is secured by a single circlip that fits over its pivot.

The impedance roller (VDP0908) is held on its shaft by a nut. The replacement must be at exactly the right height otherwise there will be severe disturbance on the picture. Make a note of its approximate position before removing the old one. With non hi-fi machines, fine set the new one by playing a standard tracking tape (not your best one, as it may get marked when you adjust the height of the roller). With hi-fi machines align the roller while viewing the hi-fi audio envelope – the roller's position can have a drastic effect on the hi-fi envelope with minimal effect on the vision. If doing a general service, make impedance roller replacement the last job.

## Underside of Deck

Now for the underside of the deck. The loading belt simply fits over the loading and loading-motor pulleys. The capstan belt fits over the capstan-rotor pulley and the large reel-clutch pulley (VDP0985). You will have to move the flywheel bracket over the rotor to replace the capstan belt. This is best done by removing the belt nearest the front of the machine and loosening the other one, giving you enough clearance to be able to replace the belt.

To replace the reel clutch (VXP0600), remove the capstan belt then the large clutch pulley on to which the belt fits. Beneath this you will have to remove the small gear to the left-hand side as you view from the front of the machine (see Fig. 1). The pulley and gear are secured with split fibre washers. With the gear removed you will have sufficient clearance to be able to lift out the reel clutch. When replacing it take care not to lose the washer. It's usually worth replacing the two slit washers as they become weak. Unfortunately the clutch is not part of the maintenance kit and you will usually find that it's noisy – see faults list.

The mode switch is mounted on the chassis with the arm connected to the main lever. Fig. 2 shows the

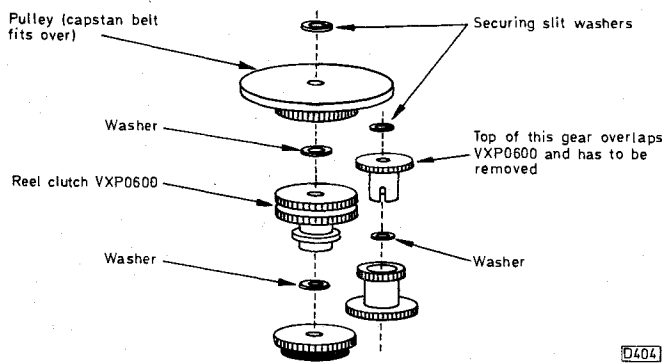

Fig. 1: The reel drive arrangement, viewed from the rear with the machine upside down.

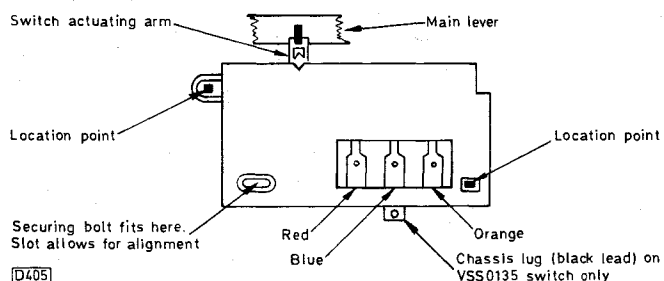

Fig. 2: Connections to and alignment of the mode switch.

connections. For alignment purposes the notches in the arm and body of the switch should be aligned in the stop mode.

## Back Tension

The Tentelometer back tension is specified as 25-30g. For adequate noise suppression in the search modes and good still-frame performance it needs to be at the 29-30g end of the range. As usual, adjustment is by means of the slotted hole in the brake band. If you can't obtain adequate performance in the trick modes don't increase the back tension. Instead, try altering the back-tension post's landing position.

## Reel Torques

The reel torques are over 350g-cm for fast forward and rewind, 105-155g-cm take-up.

## Dismantling

Cabinet dismantling varies from model to model. In general however the following instructions apply. In the earlier machines the lids are secured by four large bolts, one in each corner. In the NV-G series the lid is secured by either two or four smaller screws. If two are used they are at the rear of centre. The bottom flap is either a small metal plate that covers just the bottom of the mechanism (NV-G series) or one that covers the whole bottom (earlier models). In either case the plate is secured by a number of gold-coloured screws.

The fronts are secured by clips around their edges and

red securing screws. The bottom flap must be removed first. With the small flap you'll find that there's a gold screw in the third clip along the bottom of the front, i.e. the clip not covered by the bottom flap. This screw has to be removed.

The cassette carriage is secured by four red bolts, one at each corner, or by just two bolts, one in each rearmost corner. When removing it, first pull out the multi-pin plug on the right-hand side to avoid damage. When it's out the carriage can be laid, upside down on an insulator, on top of the timer PCB. If you then reinsert the plug a cassette can be fed in to allow the mechanism to run without being covered by the cassette.

### Remote Control Units

Quite a number of different remote control units were used by the different models in this series. They are usually pretty expensive to replace. Thus repair, which is usually not difficult, is very often a viable proposition. Notes on this subject were included in my article in the September 1989 issue. Except for the NV230 which uses a wired unit, the rest of the handsets are of the infra-red type.

### Mechanical Faults

We'll deal first with mechanical faults applicable to all models.

- (1) Knocking noise in play. Replace noisy clutch (VXP0600) and sometimes the idler (VXP0521).
- (2) Squeaking noise in play. Replace the pinch roller and clean the complete tape path.
- (3) Tape stuck laced up in deck. Replace the mode switch and bolt.
- (4) No drum rotation, sometimes doesn't unlace as a result. Replace the mode switch.
- (5) Tape loop left in machine when cassette is ejected. Check the condition of the idler and loading belt (VDV0152).
- (5) Monochrome or noisy playback or recording. The video head needs replacement. Check the drum for signs of burring due to excessive back tension – check the back tension anyway.
- (6) Cassette will not go in or comes straight back out. You've guessed it – the cassette up and down switches on the carriage (VSM0049).
- (7) With hi-fi models, random dropouts on hi-fi recordings mean that the upper drum is dirty or worn and needs cleaning or replacement.

### Electronic Faults – All Models

Here are some electronic faults applicable to all machines.

- (1) Fluorescent displays dim but centre of elements remain bright. Replace low-emission digitron.
- (2) No go, no display or timer inoperative. Timer microcomputer chip IC7501 is faulty. The type varies with the model.
- (3) Machine dead, switches off intermittently and won't restart, or dew light permanently on. Syscon microcomputer chip IC6001 faulty. Type varies with model – ensure that you quote the exact part number when ordering a replacement.
- (4) Won't accept or unload a cassette, or no mechanism shuffle at switch on, or switches off after a few seconds – especially after one or more of these symptoms. The loading and front loading drive chip is faulty. In some

models this is IC6003, in others IC6004.

(5) No drum rotation. Check the drives at pins 1, 2 and 23 of IC2006. If abnormal, replace this chip. This has been another common failing with Panasonic VCRs over the years.

### Electronic Faults – Specific Models

The following electronic faults have been experienced with particular models. Most could occur with other machines as well.

- (1) Incorrect capstan speed. IC2001 (AN6359N) or IC2002 (AN3821K) faulty. Which chip is defective can usually be determined by the extent of the error, i.e. speed or phase. Model NV430.
- (2) No capstan rotation or sometimes intermittent rotation depending on the position of the rotor over the stator. If the capstan can be kick started, suspect the stator (VEK2257) – check the continuity of the windings. Otherwise suspect IC2002 (AN3821K). Models NV430 and NV-G12.
- (3) No sound with new recordings. No bias due to instability in IC402. A modified chip, type  $\mu$ PC1519HA, should be fitted in place of the TA7361P. Model NV430.
- (4) No colour, intermittent colour or incorrect colour phasing. The VEFC009 hybrid film chip IC801 faulty. Model NV430.
- (5) No reel drive in rewind, fast forward or cue/review. IC2004 in servo faulty. Model NV810.
- (6) No go at all. Regulated  $-29V$  supply at pin 7 of P1001, the power supply output plug on the main chassis, absent as R1103 ( $8-2\Omega$ ) is open-circuit because Q1101 (2SA684RNC) and also possibly D1105 (MA4300) is short-circuit. Model NV-G7.
- (7) Intermittent or complete loss of field sync on playback of own recordings. Dry-joint at pin 1 of the AN3215 chip on the hybrid assembly IC301 (VEFY014). Replacement of the hybrid assembly is not usually necessary, but be careful when resoldering. Models NV-G7 and NV-G10.
- (8) Hum bar on the picture and colour intermittent. C1002 leaky. Models NV-G7 and NV-G10.
- (9) Loss of colour in standard-play trick modes only. Incorrect head switching as the AN6359N chip IC2001 is faulty. Model NV-G18.
- (10) No tuning, Model NV-G12 with serial numbers commencing E7. This was a very common fault when these machines were new. The primary cause was that R7573's legs, which are bent over, shorted to adjacent print lands. The trouble can sometimes be cured by straightening the legs and cutting them short, but usually one of the following components has failed: IC7551, Q7551, D7555.

### Conclusion

As with most VCRs, the electronic faults are mainly one-offs but there's a definite mechanical fault pattern. That's why I've grouped these models in this way. The mechanism is not significantly different from earlier ones and the faults can easily be predicted. This makes servicing rather routine, but it also means that the machines are ideal for rental purposes and lend themselves to field servicing. The mechanism that followed this, the G, is another matter entirely. More on this in a later issue (some preliminary notes appeared in the September 1988 issue).

# Fred's Fishy Fisher

**Dave Mackrill**

Fred brought in this Fisher FVHP615. "It belongs to my mate at work" he said, "but I don't know what's wrong with it." I gave him a rough idea of the cost of a service plus a replacement idler and belts.

## **Initial Discoveries**

Next day, as I removed the case and cassette holder, I noticed two wood screws that held on the cassette lid. I turned the machine over and shook it. Out came one matchstick, two plastic shop pricing numbers  $\frac{3}{4} \times \frac{5}{8}$ in. and a screw. It's surprising what you find in some of them. Wearing my specs and grabbing a mask I next took the machine out the back to blow out the dirt with a vacuum cleaner. As the plugtop was dangling nearly off, it was reconnected and the 13A fuse was replaced with a more suitable 3A type. A strengthening ring was fitted to the vulnerable aerial socket.

## **First Checks**

Before too much work is carried out I like to check the video heads by getting a picture on the monitor screen. So I cleaned the tape path and warmed the drum with the hairdryer. The machine was powered up and, first

with no cassette inserted, made to load. The loading motor had other ideas. It continued to run after completion of the loading sequence. Just a matter of a dirty mode switch I thought.

The deck was given a thorough clean and lubrication. The belts and reel idler were replaced, and all screws tightened – some missing ones were replaced. I removed, dismantled and cleaned the mode switch, tested its associated diodes, then reassembled and refitted it. Not only did this make no difference but the channel select was stuck on 1. I then had to put the machine to one side to attend to more urgent work. While refitting the case I spotted the label on the side. This proclaimed that the machine had been sold second-hand by Smashem and Bodgem down the road. Oh no! Not them again.

A few days later Fred called and I warned him that his repair could be a problem and was likely to be more expensive than originally expected. Little did I know how bad it was!

## **Let Battle Commence**

After checking components in the loading motor drive and polarity switching circuitry I returned to the mode switch and replaced it with one from a scrap machine. The tape then laced and stayed laced as the loading motor stopped. When the stop mode was selected however the tape was left out instead of being rewound on to the supply reel. Fast forward and rewind didn't work either.

The "bottle-opener" shaped reel idler is responsible for fast forward and rewind. It's driven from a milled wheel at the top of the gear idler assembly, which is belt driven from the capstan flywheel. This gear idler provides reel take-up during play and supply reel reverse rotation during unlacing. To do this its plastic gear meshes with teeth at the bottom of the take-up and supply reel turntables.

As I'd fitted a genuine Fisher reel idler I knew that this was o.k. So I decided to install a new gear idler assembly. It would hardly go on the spindle, as this was bent. The spindle was carefully straightened but the idler still wouldn't rotate freely. I therefore fitted the shaft from the old idler to the new assembly. It could then be seen that while its gear just reached the take-up reel table teeth it was barely far enough on the spindle to meet the teeth on the supply reel table. There was something fishy about this deck . . .

As we had a reconditioned, working machine on display, it was dismantled and measurements were taken. Yes, the distance between the main chassis and the reel subdeck was slightly deeper on the fishy machine. Had it been dropped? And if so, how could it affect this spacing?

## **A Rebuild**

To overcome this disparity the gear idler was dismantled, both shim washers were fitted at the bottom above the belt pulley, the shaft was pushed down the assembly and the washer between the reel subdeck boss and the idler was removed and fitted at the end of the spindle, under the pulley. This bodge did the trick, as it raised the gear part of the idler on its shaft and the spindle sufficiently just to mesh fully with the supply reel turntable teeth. It goes without saying that I was not entirely happy with this arrangement.

So far so good? Not so because when the idler control arm, which keys into the master cam, was refitted the gears still wouldn't meet together during unlacing, leaving the familiar tape loop. I had to retime the loading take-up gear to the master cam and loading rings, then readjust the mode switch. Correct operation was then obtained.

At last we had good fast forward and rewind, proper take-up torque, and the tape was reeled in during the unlacing operation. I was now able to adjust the tape back tension to the correct 30-40 g/cm. Feeling pleased with myself, I reconnected the aerial and monitor, thinking that the struggle was over. I should be so lucky!

The picture was fine but the exit guide arm sometimes seemed to stick in its slot. This didn't happen when the machine was made to load with no cassette however. Probably just needs greasing I thought. Hang on though, there's no sound. Time for lunch.

After the break I decided to tackle the channel change problem first. I soon found that the emitter of regulator transistor Q1307 on the front timer panel was unsoldered. Having attended to that, I hooked the scope to the inside of the audio output socket and played the 3kHz section of the alignment tape. When the audio/control head assembly was wound down with a nut spanner I was rewarded with a nice fat waveform and sound.

I greased both loading arm slots, refitted the cassette holder, inserted a cassette and put the machine in the play mode. What's this then? The cassette was wobbling about in the cassette holder. Both plastic cassette hold-

down clamps and their springs were missing. I replaced them with those from the scrap machine then, monitoring the f.m. at TP221 and triggering the scope's channel 2 from the 25Hz head switching signal at TP205, I played the stair section of the tape. I was able to adjust the entry and exit guides for a nice, flat envelope. Good. But no, not yet, because every third time the tape laced the exit guide arm stuck, leaving the guide 1/16 in. out of its V block with consequent mistracking.

## **Second Rebuild**

To cut part of this very long story short, after changing the guide arms and various other bits I noticed a small dent in the nylon lining to the exit side loading arm slot. I finally changed the chassis with the one from the scrap machine, which had a duff lower drum assembly, and fitted to it the best bits from both decks. This cured all the evils at a stroke and the gear idler was reassembled correctly with its new shaft and all shim washers in their correct places.

After cleaning and lubrication, complete mechanical retiming and adjustment - including some electronic adjustments - the machine laced properly every time and gave very good results. Two nice new flat-top "Panasonic" screws were fitted to the cassette lid. The case was cleaned with foam cleaner. I removed the nasty label spotted earlier and felt justified in attaching one of mine. A timer recording was then made and the machine was run on soak test.

When Fred called in I told him that his mate was "taking the p . . ." as the machine couldn't have run recently and, in my opinion, hadn't worked properly for some time. I suggested that his mate had probably either bought it at a car boot sale or found it somewhere. Using the old deck, I described some of the problems and the time it had taken to rebuild the machine twice. Fred seemed happy with the bill, which was for almost three times the original quote.

## **Final Problems**

Fred disappeared to get more cash, but the machine fought back to the last. I loaded an old library tape when he had gone and, to my horror, got just noise on the screen. I whipped off the case and the head screening plate and cleaned the heads. This restored the picture. To be on the safe side I rechecked the back tension. It was off the clock on my gauge. I quickly adjusted it, but this made no difference. I released the reel brakes and tried to spin each reel table. They were both tight. I suddenly realised what had happened.

The final assault on the machine had taken place late at night. Being absorbed in the struggle I hadn't noticed how cold it was in the workshop. The machine had then been left plugged in, with a piece of cardboard and another VCR on top. This morning I'd turned on the workshop heater for the first time this winter. The increased temperature had taken all the up and down free play of the reel tables. Quick as a flash I removed one thick washer from the top of the supply reel table then took one thin one from the take-up side and fitted in on the supply side. Both stopper washers were refitted and the back tension was readjusted. There was just time to refit the head screen, screw on the case, then make a recording and play it back as Fred came in with the money.

## Ferguson 3V65/JVC HRD170 etc

Failure of the M54644AL or M54644BL motor drive chips on the mechacon panel in these and clone models is not unusual — they control the capstan and reel motors. Recently we had one of these machines in which IC603 had died (all inputs and supplies o.k. but no output), so we confidently quoted for a replacement. When this was fitted the reel motor remained still and the new chip started to overheat. The reel motor was short-circuit through 300° or so of its rotation! It carries a high price tag for a brush motor, and a difficult telephone conversation with the owner prefaced the fitting of a replacement.

E.T.

## Sony SLC20

An unusual one this. The ch. 36 picture from the VCR was heavily overlaid with a herringbone pattern, whether its source was off-air, off-tape or E-E with a test pattern injected into the video input socket. The machine had also been accused of producing pictures that rolled, though they wouldn't roll for me. Experimental decoupling of the switched supply to the r.f. modulator, using a handy electrolytic capacitor, cleared up the trouble. It transpired that decoupler C319 in the power supply section had gone open-circuit. We replaced several others in the power supply for good measure. With that and a head clean the machine was as good as new.

E.T.

## Sharp VL-C73

The unfortunate owners of this little camcorder went through a whole holiday recording monochrome pictures. On the bench we found that the E-E pictures, via the video output port, were in full colour. This narrowed the field of search a lot! Scope checks showed that the 627kHz chroma signal was getting lost en route to the recording heads. We found that low-pass filter FL503 was open-circuit. With the filter shorted out to prove the diagnosis the colour picture recorded on the tape was surprisingly good!

E.T.

## Ferguson 3V43/JVC HRD725

When the fault occurred the only way to shut the machine off was to pull out the mains plug! Whether the machine was off or in standby, the capstan motor and the take-up reel would whiz up to a high speed, with the clock display extinguished. This strange combination of symptoms was due to loss of the unswitched 12V line. The cause was a dry-joint on the lowest wire link between the two PCBs that make up the power regulator section, isolating the base of Q1 from pin 8 of IC1. The other joints are also worth resoldering.

E.T.

## JVC HRD700

If the fluorescent display panel in one of these machines won't light, before delving into the rather inaccessible electronics on the front panel assembly it's worth having a look at R5 on the 01 power transformer panel. It may

have gone open-circuit, deleting the -30V supply. As is common with these safety resistors, there may be no external cause of its failure.

E.T.

## Philips VR6180 (5V Version)

This repair took longer than it should as the machine had two faults — both man made! The eject, power and channel buttons had no effect at all. The play and wind buttons changed the display to play or wind for a second, the deck clicked, but the command wasn't carried out. On removing the display module a crack could be seen by the set clock switch, so the tracks were bridged and the panel was then refitted. All the buttons now worked but the deck still didn't react. Someone had shorted the start/end of tape sensor wires together!! While searching for the cause of this last symptom I was led a wild goose chase around the loom. When checking signals at plug B3 of the family board, just because there's a large one printed at one end of the socket it doesn't mean that pin 1 is at that end — the one is meant for the socket next door, pin 1 being at the other end!

P.B.

## Philips VR6660

The problem with this machine was flutter on sound and a panel swap proved that the cause was on the P604 servo board. In the past I've had the DAC cause this fault. As there was a 1V peak-to-peak squarewave at pin 13 of this chip I fitted a new one. To no avail. As I started to unsolder the servo microcomputer chip I noticed a solder blob that shorted pins 9 and 10 together. When the short was removed and the pins I'd unsoldered were resoldered the sound was fine. The soldering looked original, so why hadn't the customer noticed the fault before?

P.B.

## Matsui VX820

This machine would wind and rewind but when play was selected the loading started then jammed prior to engagement of the pinch roller. We first suspected that the loading belt was slipping, but when we turned the machine upside down to remove the base cover a small metal pin about 5mm long dropped out. On investigation we found that this came from a plastic arm just to the front of the pinch roller. After replacing it, using a dab of Araldite, the loading worked perfectly.

M.D.

## Sharp VC387

This machine led us a merry dance for several weeks. The complaint when it first came into the workshop was failure to record when warm. We soak tested it for a long time but couldn't find anything amiss. In fact it was some weeks before the fault returned. This time we saw the problem: when recording the picture went blank after about a quarter of an hour — the E-E picture and sound had disappeared.

A scope check on the output from the tuner/i.f. panel showed that this was missing when the fault occurred. We checked the 12V supply at pin 1 of plug IB and found

that this also went missing. This supply comes, along with the 31V for the varicap tuning system, from a converter in the PSU. We resoldered some suspect joints in this area but the fault persisted. The next step was to try blanket replacement of semiconductor devices. This still didn't cure the fault, but when transformer T951 was replaced the fault had been cleared. We could find nothing wrong with the old transformer. **M.D.**

### **Panasonic NV2000**

The problem with this machine was that the capstan ran slowly for the first ten minutes. The customer told us that the fault had developed gradually over the last few months. When we hooked up the machine in the workshop we selected the test signal to tune it to our test set and noticed that there was a sizeable hum bar which ran down the picture. Investigation of the power supply showed that the modulator's feed is provided by Q1008 which supplies a regulated 12V output derived from an 18V line. The 18V supply's reservoir capacitor was found to be almost open-circuit. When it was replaced the hum bar had gone and the capstan speed was correct from cold. **M.D.**

### **Ferguson FV10B**

The now infamous power supply chip IC801 (STK5481) had failed, with the 5V line rising to 9V as a result of an internal short-circuit. We replaced this and the clock display returned to normal. When a tape was loaded it would wind and rewind all right but if play was selected the machine would lace and then unlace as soon as the pinch roller engaged. On investigation we found that there were no drum flip-flop pulses at pin 34 of IC601 (M50731-623SP), though the drum rotated normally. When we checked the servo chip IC401 (HD49712NT) there was no pulse output at pin 62. Replacing this i.c. provided a cure. We've had several machines since with similar problems, including a JVC HRD170 which has more or less the same circuit with different chip types. **M.D.**

### **Saisho VR1200**

The problem with this machine was complete lack of sound in the E-E, play and record modes. We traced the incoming sound signal from the tuner/i.f. section through to pin 8 of IC5001 (BA7751LS) with a scope. Thereafter nothing. As this chip does just about everything in the audio department it was replaced. Success! It's fiddly to get at however. The control and bottom PCBs have to be hinged out as otherwise access to the top of the i.c. is limited by the plastic chassis/frame. In addition it's a 24-pin SIL with the pins quilled, so you need a fine-tipped iron. CPC's part no. is HN107T67751L. **J.C.P.**

### **Budget Machines – a Warning!**

When working on budget machines where production costs are a major factor in the design it pays to take care as you open up the VCR for examination. I've come across several machines recently in which the finish of metal pressings used for casings, top and bottom covers and deck components leaves much to be desired. In many cases the sheet metal edges are straight from the metal press without turned-over edges or burnishing. They can take large pieces from unwary fingers. A recent Samsung 710 for example took one of my fingers

down to the bone when I inadvertently ran my fingers along the edges of the top cover while opening up the machine. I've also frequently received painful nicks from bottom cover plates, edges of cassette lifts, etc. So be warned. **J.C.P.**

### **Ferguson 3V59**

The complaint was of intermittently playing fast. This was confirmed by a field engineer who also noted that when pause was selected during play the tape didn't stop but moved forwards very slowly. Another symptom was that the fast-wind functions started off too fast – usually when fast forward or rewind is selected the tape winds for a second or so at a lower speed then steps up to a higher one. With this machine the tape started off fast then increased its speed slightly. A check in the pause mode revealed that there was no capstan drive though the tape was moving. The cause of all these symptoms was high take-up drive, even in the pause mode when there shouldn't be any. In short there was a reel motor drive problem.

The reel motor is driven by IC603. The voltage this chip supplies to the motor, and thus the torque produced, depends on the d.c. voltage at pin 8 of the chip. This is derived from a pulse-width modulated waveform at pin 4 of the mechacon chip IC601. The PWM switches transistors Q604/5 on and off, as a result of which C608 charges to produce the variable d.c level that's fed to the motor driver. In this case the voltage at pin 4 of IC601 didn't rise sufficiently high to switch Q604/5 off. The voltage across C608 was always high therefore, around 10.5V even in the stop mode. The mechacon chip IC601 was at fault, with an internal leak to chassis from pin 4. **I.B.**

### **B and O VHS91-2**

There's a modification for this machine should the drum motor speed increase after a couple of hours' use. Mount a diode in the position occupied by 1C442, with its cathode to 1C402 (on the audio PCB). B and O's part number for the diode is 8300439. **N.B.**

### **Samsung VI616/VI626**

These two machines are virtually the same, so you can expect the same faults to occur on them both. This one had no remote control operation because of a dry-joint at the base of the DTA144 transistor Q0609 on the timer microcomputer PCB. **N.B.**

## Philips VR6462

There was no reel motor rotation in play, though fast forward and rewind were all right. Comparisons with another machine (as usual there were no voltages on this section of the circuit) revealed that the supply to pin 2 of the drive chip was missing. It should be 7.5V in play and comes via the BAX18 diode D6147 which was open-circuit. In the fast-wind modes the supply comes via D6146. **P.B.**

## Philips VR6182

If you get wow on sound, before reaching for the manual check the condition of the capstan drive belt. Rotate the motor by hand while looking at the motor pulley: you'll probably see the belt moving up and down the pulley because it's warped. **P.B.**

## Sharp VC9300

There was no modulator output from this machine. The video/TV LED lit but the modulator's 12V supply was missing. Supply switching is carried out by transistor Q803 on the mechacon board. It was open-circuit base-to-emitter. **P.B.**

## Sharp VC381H

This may seem to be obvious, but for an intermittent blank raster in the play or E-E mode check that the test pattern switch on the modulator isn't dirty. **P.B.**

## Philips VR6462

Intermittently one side of the cassette lift didn't go down as the cassette was taken in. Lever 209 had been bent when the idler had been changed at some time in the past. As a result it didn't locate in the tray very well. Something to bear in mind next time you change one. **P.B.**

## Saisho VR1100/1200/1600

A common fault with these machines is no movement of the tape after threading up in the play mode. Just to the right of the capstan/pressure roller there's a guide pin (limiter post) that should move in an arc away from and to the right of the capstan during the threading-up process. In the fault condition it doesn't move and wedges the pressure roller so that it can't rotate. This limiter post is in its turn controlled by a white nylon lever that's pivoted at its centre, has a fork at one end that engages with the limiter post and at the other end has a steel pin that projects down through a slot in the deck to be operated by the mecha-slide.

This lever splits where the pin is pressed in, as a result of which the pin falls out into the bottom of the cabinet. If you can find it the pin can in an emergency be got back into place by using Araldite. It's best however to fit a new lever, which is available from CPC at Preston under part number MA850A600039. The replacement lever has a slightly enlarged boss to hold the steel pin. This is a

more secure arrangement - certainly I've had no callbacks after fitting this lever.

Replacement can be carried out by removing the cabinet top cover and then the limiter post assembly (one self-locking nut on the pivot). The white nylon lever can then be removed from its pivot after freeing the securing clip. Reassemble in the reverse order, not forgetting the limiter post's return spring and a touch of sealing paint on the locking nut. About a quarter of an hour when you've done it once or twice. **J.C.P.**

## Philips VR6367

The call-out complaint was "no picture". On site we found that all functions worked, the loop-through and E-E signals were fine, but on playback only a locked black raster was displayed. Sound was also absent. After making some basic voltage checks the machine was taken back to the workshop where we found that recordings made on it played back well on another machine but that playback of its own or other recordings just produced the black raster.

Attention was turned to the P310 signal panel. The voltages around IC7351 (TDA3730) and transistors 7305/6/7 were correct. A good f.m. waveform was present at the output from the head amplifier and was traced through to pin 19 of IC7351. Demodulated video was present at pin 24 and was traced through to pin 5 of module 1006 on the noise reduction and dropout compensation panel. There was no output at pin 2 however. The Philips manual doesn't describe this module at component level: it has two chips and a 13.3MHz crystal amongst other things. To confirm that the fault was in this module a 68µF electrolytic was used to bridge across pins 2 and 5 (positive end to pin 2). This produced playback sound and vision, of degraded quality due to loss of any compensation but surprisingly good in the circumstances. Similar steps were made on the module itself to try to localise the fault to component level, but apart from confirming that the 13.3MHz crystal was working we couldn't with certainty pinpoint the cause of the fault to either chip. These chips (TL8704P and TA7741P) are not listed by any of the wholesalers we use and a check via Philips' MOVIES showed that they were both over £12 with VAT. Since the customer was getting impatient we decided to order the complete module, at £26.35 plus VAT. This restored normal operation. I've hung on to the old module however and when I've a little time to spare and another of these machines to hand I'll investigate further and let you know the outcome. **J.C.P.**

## Ferguson 3V35/JVC HRD120

This VCR drifted off tune on BBC-1 only. My first thought was to put BBC-1 on another button and see if this drifted too. It did. The tuning voltage is obtained from a voltage doubler circuit which according to the circuit should produce some 45V at TP6. Ferguson told me that the voltage here should be a bit higher than this but if it gets very high, say 70V, all the components in



the voltage doubler circuit should be changed – D14, D15, C21, C22, C23, C24, C25 and R13. I did this and the machine was o.k. for about four weeks. Then it came back again.

This time I decided to change the HZT33-02 33V stabiliser D10. The machine seems to have worked all right ever since, but I would still recommend that anyone experiencing tuning faults with these machines should look at that doubler circuit. It had gone haywire in this particular machine and no particular component could be blamed.

J.L.

### **Matsui VX820**

A dead machine with not even any clock operation should lead to a check on the 12V regulator transistor Q02. You'll often find that it's short-circuit base-to-emitter. You may also find that the 13V zener diode in its emitter circuit is faulty. Q02 is associated with IC01, the main power supply chip at the rear centre of the main base panel. During normal use a lot of heat is generated here, which no doubt contributes to the failure of Q02. We use a BD131 as a replacement.

S.L.

### **Matsui VX880**

The problem with this machine was low E-E and playback luminance – the chrominance and sound were not affected. PF01, a coil which couples the signal to the r.f. modulator, was faulty. When it was dismantled we found that it was full of green gunge. The machine has a history of spillages and the results are beginning to show up.

S.L.

### **Sharp VC8300**

The customer's complaint was that there was no carriage operation and the T2-5A fuse on the power panel was open-circuit. When we replaced the fuse and loaded a cassette the machine very slowly laced up before blowing the fuse again. The loading motor proved to be the cause. Amongst other things it had also damaged the STA401 loading motor drive chip I805.

S.L.

### **Panasonic NV7200**

This ex-rental machine had been put aside by a junior engineer. The complaint was that it cut out after a couple of seconds in play. At first glance the symptoms on the card suggested that the large loading belt was worn, but on test the machine laced and ran before cutting out. It also cut out in the rewind and fast forward modes. A loss of reel pulses then? Yes indeed. I've had the magnetic base of the supply table fail in these machines and while beginning to check for this I found the cause of the problem – the spool securing circlip was weak and the spool had risen above the brake. Thus the base was too far away from the sensor to be able to produce good pulses. Those not familiar with these machines should note that the pulses come from the supply instead of, more usually, the take-up reel.

N.B.

### **Panasonic NV-M5**

I thought that this was going to be an easy one – there was no EVF picture. The usual cause is a noisy brightness control potentiometer. This time the control

was completely noise-free however, and when it was turned most of the way up a dim, defocused picture appeared. Low c.r.t. voltages were then suspected, but none of any interest are given on the circuit diagram. The focus supply was found to be 170V. Obviously low, but how low? A check on Panasonic's Bristol technical line produced some guidance. Though they hadn't any additional information on the M5's EVF they had some readings for the MC10. This suggested that the line output transformer was defective, but a new one made no difference. The fault was eventually traced to rectifier D803 which had gone high-resistance. When a replacement was fitted the voltage at its cathode was 440V and the picture was restored. All relevant readings were taken and noted on the circuit for future reference. But the c.r.t. was on the poor side and I decided to replace it. It was the second EVF c.r.t. with a burn image in one week. The other was in a Sony CCD-V8AF that was used as a surveillance camera!

N.B.

### **Panasonic NV-G40**

We were sure that fast flutter on the playback sound would be a mechanical problem, due to the capstan shaft or bearing. It turned out to be an electrical problem with the motor stator unit however, part no. VEK2944. Note that the capstan motor is not supplied complete, you have to order the various component parts to change the whole motor.

J.H.

### **Samsung V1611/Logic VR950**

No playback chroma was traced to the coupling capacitor C3103 (0.01 $\mu$ F) being leaky. While searching for the cause of this fault someone had changed just about everything else in the colour section.

J.H.

### **NEC N9015K**

The problems with this machine were poor playback and f.m. inversion (black streaking) on record, similar to what you get with a badly worn head or incorrect adjustment of the head resonance controls. The cause however was that C75 in the head amplifier section on the main signal PCB had gone open-circuit. It's a 1 $\mu$ F, 50V capacitor and when we removed it from the board the telltale white powdery deposit was visible around its leads.

J.H.

### **Panasonic NV-L28**

This machine failed to produce any digital functions. If picture-in-picture was selected, followed by the swap function, in the playback mode the machine would toggle between tape playback and E-E but without the inset screen. We removed the digital box and its covers and made checks around the digital microcomputer IC9007 but couldn't find anything wrong. We then noticed a couple of VCO/phase comparator chips, IC9003 and IC9004 (type MN6790), which are controlled by the microcomputer chip. They both receive line-frequency inputs which are used to lock an internal 21.4MHz VCO. A divided-by-two output derived from this oscillator appears at pin 8. When a digital function is selected, pins 9 and 7 are taken low. This should switch on the oscillators. The output from IC9003 was fine, but only 5V appeared at pin 8 of IC9004. Replacing this chip restored full operation.

I.B.

# The Ferguson FV30's Chopper PSU

J. LeJeune

The FV30 was the first of a new generation of Ferguson VCRs that show a trend away from Japanese design ideas towards a more European approach. Notable amongst these design trends is the use of a switch-mode power supply which is energised as long as the mains supply is connected to the machine. Although servicing the FV30 is not as simple as its predecessors, the power supply need not be a daunting prospect in a fault condition.

You'll find the power supply on the right-hand side of the machine. Take care over physical handling as the live mains and other high voltages are present on the PCB. Use of a mains isolating transformer is strongly recommended. With transistors that are directly connected you can get multiple failures under a fault condition. This is particularly so when the chopper transistor TP37 fails.

The power supply is capable of operating with a mains input over the range 110-240V a.c., either 50 or 60Hz. Consumption is 42VA maximum. There are three operating modes: (1) standby, (2) tuner (E-E) and (3) full operation. In the standby mode the power supply provides outputs for the microcomputer chip, the panel display, the r.f. mixer-booster and for tuning. In the tuner operation or E-E mode (tuner switch at "on") the

power supply energises all the signal processing and control unit circuitry: this enables the machine to be used as a receiver with an output on ch. 36 or a video output via the scart connector. With full operation all the circuits are energised.

As there's no master switch the power supply is constantly on (when the mains supply is connected), providing a standby voltage. The microcomputer chip controls the application of power to the various parts of the machine. Fig. 1. shows the basic power supply circuit.

## Circuit Operation

Three voltages are established when the machine is connected to the mains supply. These are: (1) a 300V supply which is provided by the mains bridge rectifier DP01-4 in conjunction with the reservoir capacitor CP07. (2) A 2.2-5V supply which is produced in under two seconds by DP11, RP12 and CP14. (3) A 3-5V supply which is produced in under two seconds by DP11 with RP11 and CP38.

When the second of these supplies has reached 1.5V the start-up oscillator TP16/17 will run at about 20kHz, driving the chopper transistor TP37 via TP28 and the

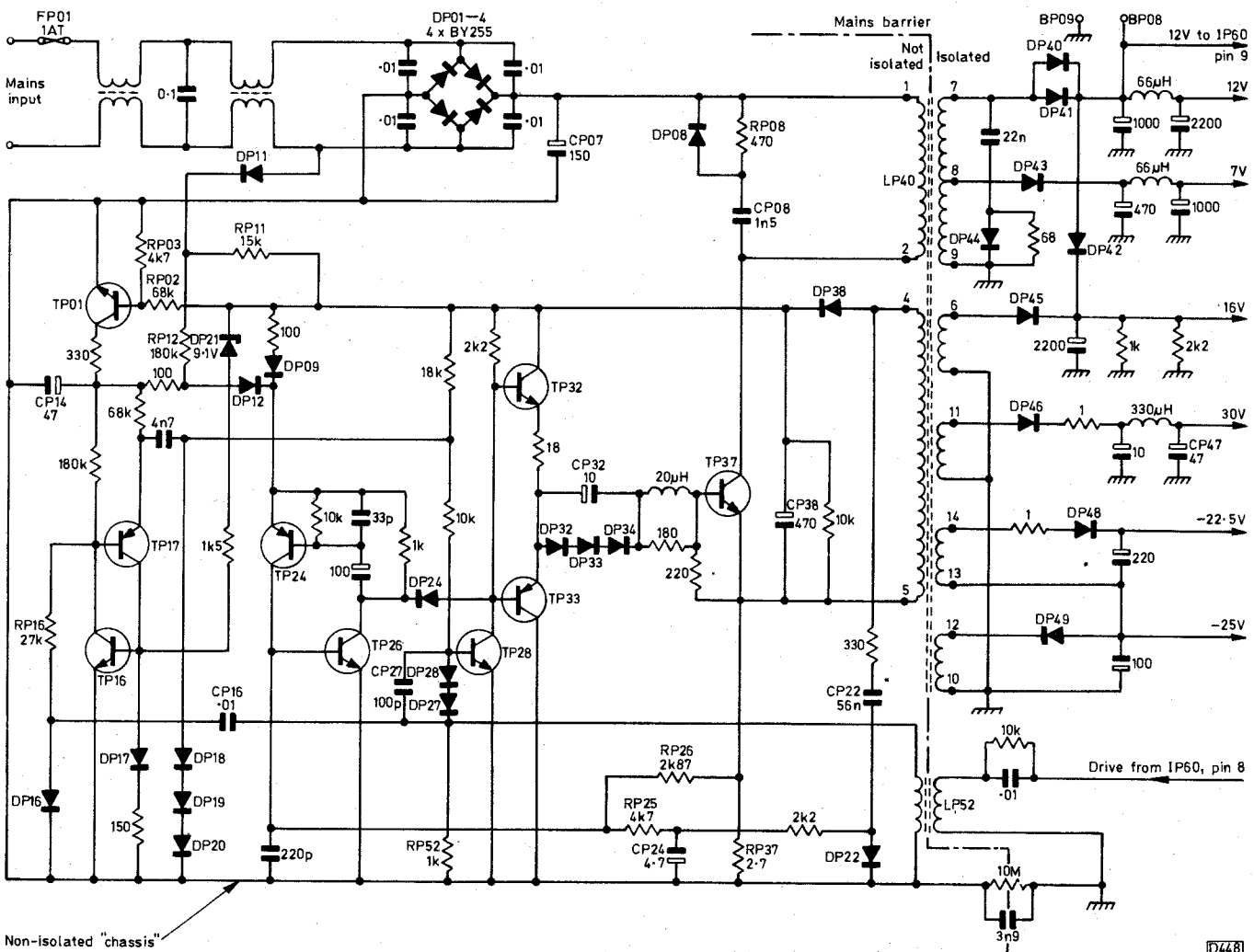

Fig. 1: The Ferguson FV30's chopper power supply circuit.

driver transistors TP32/3. At this time supply (3) powers these latter transistors (TP28/32/33). When the chopper transistor TP37 is switched on, the lower end of the chopper transformer's primary winding (pin 2 of LP40), which is supplied by the mains bridge rectifier, is grounded via RP37. As a result, a rising ramp current flows through the winding. When TP37 is switched off by the drive waveform the flux established by the ramp current collapses, energising the transformer's secondary windings.

Once the circuit has got going the drive for TP28/32/33/37 is provided by the regulator chip IP60 (see Fig. 2) via the isolating transformer LP52. DP40/41 supply 12V to pin 9 of this chip to power the emitter-follower output transistor within IP60. DP46 provides a 30V supply which is fed via RP59 to the 24V zener diode DP59. This is the main supply to the chip, which generates a reference voltage that appears at pin 12 and is then fed to pins 2 and 13. Within the chip the voltage at pin 2 is compared with that at pin 1, tapped from the set 12V control PP57. The error voltage thus produced is added to a sawtooth signal generated within the i.c. This is the classic pulse-width modulator arrangement. Over the whole feedback loop, the on time of the drive pulse applied to the chopper transistor is determined by the sample voltage at pin 1 of IP60.

The pulse-width modulated drive at pin 8 of IP60 is coupled to the base of TP28 via LP52 and DP27/28/CP27. During the start-up period it also synchronises the start-up oscillator via CP16/DP16/RP16.

As the circuit starts up DP38 develops about 13V across CP38. This supply powers TP28/32/33 and also, via the potential divider RP02/3, switches on TP01. As a result the supply to the start-up oscillator is effectively removed and it stops, leaving the chopper transistor under the control of IP60 which, via the PWM feedback, compensates for variations in the mains supply voltage and the VCR's current consumption, keeping the various voltages derived from the chopper transformer's secondary windings constant.

Transistors TP24/26 provide drive limiting in the event of excessive current demand from any of the circuits within the machine. CP22 and DP22 develop about -6V across CP24. This voltage is linked to the base of TP26 via RP25. When the chopper transistor TP37 switches on a positive voltage is developed across RP37. This appears at the base of TP26 via RP26. As a result TP26's base is normally at around -2V. Should the current demand be excessive TP37 will remain on for a longer period during each cycle of the switch-mode power supply's operation and the voltage developed across RP37 will rise. Should the voltage at the junction of RP25/6 swing positively TP24/26 will switch on, interrupting the drive to TP37. TP24/26 form a monostable oscillator which will remain on long enough to allow the circuit to stabilise and resume normal operation.

As voltages (2) and (3) rise slowly due to the time-constants RP12/CP14 and RP11/CP38, the chopper transistor is switched on for only very short periods initially, then for progressively longer periods until IP60 takes over. This constitutes a soft-start system, to ensure that the power is brought up slowly.

We'll next take a closer look at the operation of IP60. The inputs to the voltage comparator stage are at pins 1 (feedback from PP57) and 2 (reference voltage from pin 12). The second comparator (input pins 13 and 14) is so biased that it does not affect the regulation. Pin 3 provides a feedback path to stabilise the comparator,

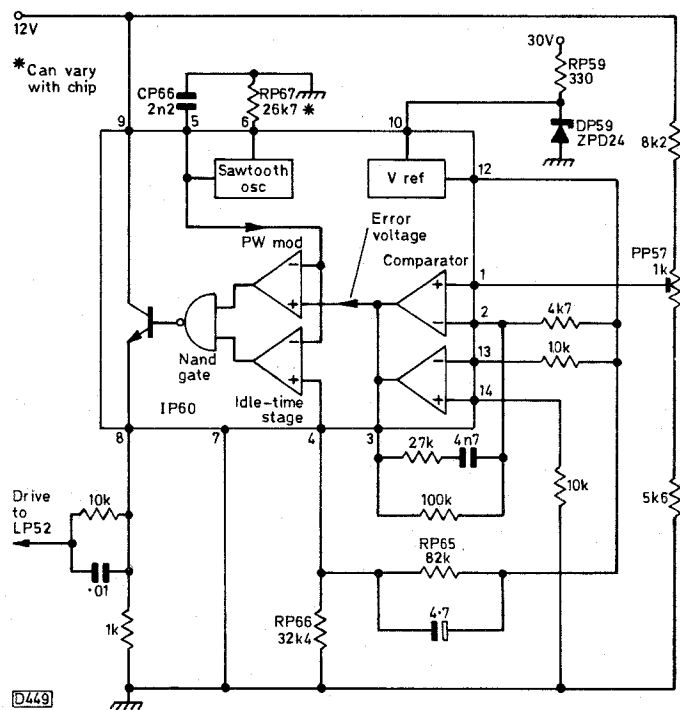

Fig. 2: The MC34060 regulator chip.

whose output at this point is applied to the non-inverting input of the following pulse-width modulator. The other (inverting) input to this stage (pin 5) comes from the internal sawtooth oscillator whose timing components CP66 and RP67 are connected to pins 5 and 6 respectively. The point during the sawtooth when the pulse-width modulator's output changes state depends on the error voltage. In this way a variable pulse-width drive waveform is produced to control the on/off times of the chopper transistor. The oscillator runs at approximately 20kHz.

The pulse-width modulator's output is one input to a NAND gate whose other input comes from the "idle-time" stage. This stage receives the sawtooth waveform at its inverting input and the reference voltage from pin 12 at its non-inverting input (pin 4) via a potential divider (RP65/6). It produces at its output a constant pulse-width 20kHz signal. When both its inputs are positive the NAND gate provides a negative-going output. The maximum pulse-width output from the NAND gate is therefore determined by the output from the idle-time stage. This provides stable limiting of the maximum output pulse width provided by the chip.

The chopper transistor TP37 is driven by a complementary-symmetry driver stage (TP32/33). When TP28 is turned off by the output from IP60 TP32 conducts and TP33 is cut off. CP32 charges until there is sufficient forward bias for diodes DP32/3/4 to turn on. This arrangement provides the correct drive conditions for TP37 which switches on. When TP28 is switched on again by the PWM drive TP32 is turned off and TP33 conducts, discharging CP32 via TP37's base current. As a result TP37 is rapidly switched off. The flow of current in LP40's primary winding is thus interrupted and the magnetic flux it created in the transformer's core collapses rapidly. This produces a high back-e.m.f. in the primary winding and the other windings coupled to the core. These secondary outputs are rectified to produce the various rails required by the VCR.

IP60 monitors the 12V supply and as a result of the tight coupling of the other windings to LP40's core all the

supplies derived from the transformer are stabilised.

The snubber network RP08, DP08, CP08 is included to protect TP37 from the fast-rising transient that would otherwise be present when it switches off.

Many of the supplies derived from the chopper transformer are fed to a switching circuit which consists of a simple transistor logic arrangement controlled by two switching signals – see Fig. 3.

In the standby mode the on/off monitor line is low because of the connection via RP93 to the -25V line. When the machine is set to the tuner (E-E) mode the on/off monitor line goes high, switching on TP77. As a result TP75 switches on and the 12V supply is applied to the signal circuits. TP73 also switches on, allowing 7V to be fed to the low-level servo stages and to the 5V regulator IP73. The latter supplies 5V to the signal circuits and to the collector of TP88. When play is pressed the servo on/off line goes high, switching on transistors TP71 and TP70. Thus 16V is passed to the servo system. In addition TP83 and TP88 are switched on to supply 12V and 5V to the servos. As a result of this arrangement power is applied to the servos in correct sequence.

## Servicing

Switch-mode power supplies are about to become a way of life in the video sector. Though many engineers may hanker after the traditional mains transformer and static regulator designs, the switch-mode power supply operates at higher efficiency and does this at lower cost and less weight. Now to the servicing aspects.

The FV30's power supply, also the similar arrangements used in the FV31 and FV32, have a characteristic which, in human beings, would be described as volatile. Care is therefore required when servicing these power supplies as mistakes like forgetting to change the testmeter to volts from amps when checking a voltage, or

a slight slip of a meter probe, will cause mayhem amongst the directly-connected transistors. Great caution is also necessary because of the high voltages present.

We should point out from the start that the circuit is sensitive to mains-borne transients. This can be the cause of repeated failure in the field. Make sure that the connections to the mains plug are sound and that the wall socket is satisfactory. If a domestic appliance is suspected of creating mains-borne voltage spikes, try fitting a suitably rated VDR to the offending item's mains input – or to the mains input in the VDR. These VDRs provide effective transient limiting.

The most common failure is a dead machine with fuse FP01 blown. In this event the chopper transistor TP37 is suspect number one. If you find that it's short-circuit RP37 will almost certainly have suffered as well. It should be investigated and if necessary replaced. If RP37 has been damaged it's certain that other items will have been affected because the 300V supply from the mains bridge rectifier will have passed via the shorted TP37 to the driver and preceding stages. It's therefore advisable to check TP24/26/28/32/33 plus diodes DP22/24/27/28/32/33/34. The start-up oscillator normally survives, but DP11, DP08 and DP38 could also have been damaged and may need replacement. It's often more economical to replace all the semiconductor devices en masse rather than risk another catastrophe when you switch on.

Say you've replaced all the dead silicon but you're reluctant to switch on before making certain that the same event won't instantly occur. Check the copper tracks around RP08 and the soldering to this resistor. These steps could save further mass destruction. Look for cracks in the print and bridge any you find with hook-up wire between the nearest solder pads.

A stage by stage check can now be made to ensure that all is well. First, if you've fitted a new TP37 take it out again! Remove TP01 and DP21. The start-up oscillator should now run continuously. Look for a sawtooth signal at the emitter of TP17 and check for 3V across CP14. There should also be about 12V across CP38. If there isn't, check that RP37 is o.k. The drive signal is applied to the base of TP28, but under these conditions it may be insufficient to turn TP28 on.

With no drive TP28 is on and TP32 is off. Check this part of the circuit by turning off TP28, using a shorting link between TP28's base and "chassis" – remember that it's live on this side of the chopper transformer. TP28 should switch off, TP32 on and TP33 off.

Checking the trip circuit under these conditions is not easy. A suggestion is to connect a 1.5V dry cell between the base of TP26 and "chassis", positive side to TP26's base, with a 470Ω resistor in series with the cell to limit the base current. This should turn TP26 on and indicate whether the trip circuit is likely to work in the restored power unit.

The regulator chip IP60 can be checked with the aid of a 12V supply. You need to apply this to test point BP08 and the positive side of CP47 as IP60 requires supplies at pins 9 and 10 to get going (the latter supply is normally derived from the 30V line). Connect an oscilloscope to pin 8 of IP60. If the chip is working you should see a pulse output.

You will find that you can work on the power supply more easily if it's removed from the cabinet. Desolder the mains lead and use another one for testing if you've no desire to struggle with the one fitted to the cabinet. Bare live terminals will be all too readily accessible, so

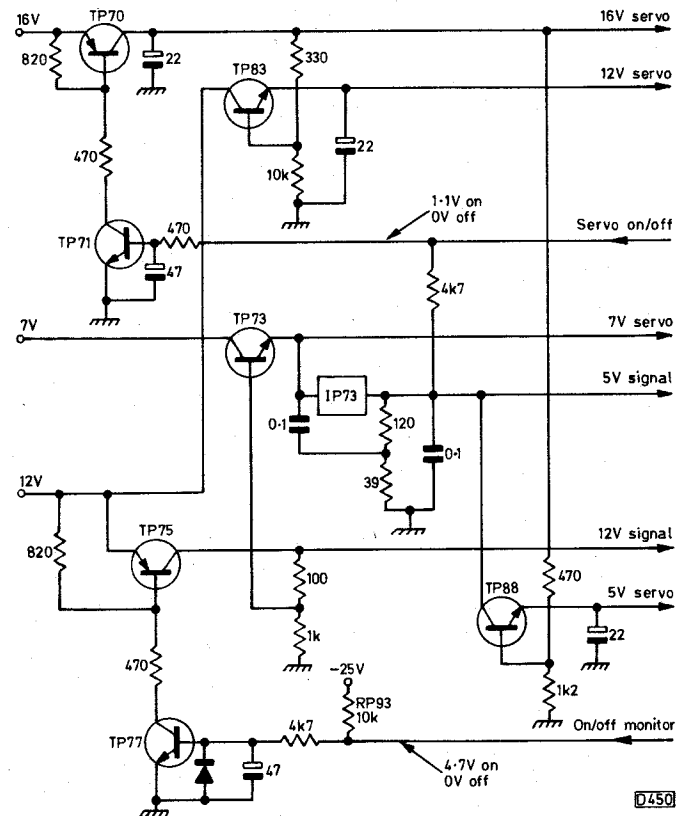

Fig. 3: The power switching circuitry.

great care must be taken.

When you are sure that your checks confirm that the unit will run, replace TP01 and DP21, fit TP37 and switch on. If you have a variac you can be more prudent, using it to set the mains input at 110V before you try the unit. If the power supply works under these conditions,

set the 12V rail correctly (monitor at test point BP08) by adjusting PP57 *slowly*. Then raise the mains input to 240V and check that the 12V setting is maintained. If you've been thorough the power supply should work normally and the machine can be returned to its owner. If you haven't – go back to square one and try again!

---

## Philips DMP Series Decks

When taking the top plate from the mechanism be careful as you remove the erase plug: if you don't release the clips first you can easily break off part of the erase head mounting. This happens to be where the 180° roller adjusting screw operates, the result being that the tape path goes way off adjustment. Usually the engineer glues the erase head back on but leaves the L-shaped lug off, thinking that it has no effect – it comes into use only when threaded up. . . To do the job properly a new scanner ring is required. **P.B.**

## Pye DV464/Philips VR6462

"Goes beserk" said the fault note, which wasn't far wrong. At switch on the deck would initialise then the clock would go off, the deck would go into wind and wouldn't stop. All this was accompanied by clouds of smoke from the i.f. module. The smoke was coming from R3426 as C2422 was short-circuit. It's part of the tuning voltage generator. . . **P.B.**

## Philips VR6468

On occasions the cassette would eject when play or rewind was selected. If the service mode was selected the error was -2 (capstan not rotating). This time it wasn't loss of the tacho signal: the capstan motor had a dud spot. **P.B.**

## Blaupunkt RTV310

The problem was tuning drift, with a hum bar superimposed on the snow. C1103 (47 $\mu$ F, 100V) on the power supply PCB was open-circuit. **P.B.**

## Philips VR6362

The clock display would either go off or only one digit would appear – it was an intermittent fault. When it occurred the machine didn't answer the keyboard. Crystal 1001 on the clock module was dry-jointed. **P.B.**

## JVC HRD320

The problem was very intermittent loss of the playback picture. Days would pass without the fault showing. Sometimes it would tease us for a few minutes at first switch-on from cold. We tried replacing the luminance chip IC101 but this didn't cure the problem. The symptom finally stayed for long enough to enable us to do some scope tests. These proved that low-pass filter LPF102 was the culprit. These filters have many internal joints, which probably explains why they are so often the cause of exasperating intermittent signal problems. **E.T.**

## Samsung VI910

The reported fault was of cutting out intermittently on playback. No cause could at first be found: the most likely suspect, the reel drive idler, appeared to be fine. After the machine had worked correctly for several days it came to a stop – when we noticed it the tape had unlaced and the machine was in the off mode. We restarted it and it ran for only a few seconds before

stopping again. This time we noticed that the power LED went out momentarily just as the machine cut out. We restarted it again, with a meter handy. This time when the fault occurred the machine just stopped dead with the tape still fully laced. We quickly found that the 13V supply, from which all the other supplies are derived, was missing. The cause was the 3132V regulator chip IC1. It could be turned on again by applying just a few drops of freezer to its case. **I.B.**

## Panasonic NV-G21

When we switched the machine on a squealing noise came from it. After removing the top cover we noticed that the capstan rotor was vibrating. A check at the torque control input pin of the BA6430S motor driver chip IC2001 revealed some bursts of 1.8V spikes that sat on a d.c. level of 1.5V. The timing of these bursts seemed to coincide with changes in pitch in the noise coming from the motor. After checking with another machine however we found that these bursts are quite normal. We also discovered that the noise would fade away when the machine had been on for a few moments. A quick spray of freezer on the motor driver chip brought the fault back again, proving that the i.c. itself was the cause of the problem. **I.B.**

## Panasonic NV-L25

This seemed to be a very strange fault at first. The customer said that the two words "write" and "release" would intermittently appear in the display and that when this happened nothing could be done with the machine. Unusually for an intermittent fault it showed up straight away for us, and we found that by lifting the front right corner of the machine slightly it cleared. As soon as the top cover screws had been removed however the fault wouldn't occur, no matter how the machine was flexed. With the top cover removed the cause of the fault was spotted straight away. A flat 14-way connecting cable goes from P7401 on the main PCB to P7501 on the display PCB. It hadn't been bent down far enough and the insulation had been cut through at connection five (serial data line) by the front of the metal top cover. This connection was thus earthed when the cover screws were fitted. **I.B.**

## Panasonic NV-G21

This machine showed very little sign of life. There was no display and no LED indications. In fact all that worked was the r.f. amplifier. The cause was quickly traced to the power supply – there was no 6V and hence no switched 5V output from the STK5338 multi-voltage regulator chip IC1001. It was the second machine we'd had in a single week with the same fault. **I.B.**

## Mitsubishi HS-B30

The owner complained that the counter didn't work correctly. In fact the digital readout didn't change at all. At the same time a noise bar moved through the picture, indicating absence of the CTL pulses. Replacement of

the audio/control head cured both faults. This is rather intriguing: why complain about something as trivial as the counter when the playback picture quality is so poor?

As a footnote I received another VCR with the same complaint/symptoms later the same day. This one was a brand new Akai, but this time all that was necessary was to clean the control head. **A.D.**

### **Ferguson 3V57**

This machine would intermittently stop due to either reduced amplitude or missing take-up reel pulses. The usual causes of this problem with these machines are dry-joints or a defective reel optocoupler. This time however I found that the switched 12V supply to the reel sensor board was low and varying. When the supply and the reel pulse waveform were monitored you could see that the latter disappeared when the supply dropped to 9.5V. The cause of the problem was on the power supply board: D3 was leaky with a reading of approximately 600Ω. **A.D.**

### **Ferguson FV13H**

The job card said "dirty heads". When the machine was tested there was no picture but sound could be heard. So I switched off and set about cleaning the heads. When the test tape was tried again the symptoms were the same. I stopped the tape, ejected it and was about to attempt to clean the heads a second time when I noticed that the drum, which was slowing and about to stop, was actually running backwards! Not really believing my eyes I tried the test tape again and sure enough the drum was rotating backwards. So attention was turned to the servo board. After finding an incorrect voltage I replaced the VC2023B2 servo chip. This restored normal drum rotation. **A.D.**

### **Tashiko VVE922**

Failure to record colour was the complaint with this particular Japanese nightmare. The more I looked for the cause of the fault the more intermittent it became. I tried creeping up on it but this didn't help. How do they know? Anyway, after a long foray into the machine with a hairdryer in one hand and freezer in the other VR303 (627kHz set potentiometer) proved to be the cause. Don't twiddle – the setting is critical. **S.L.**

### **Amstrad VCR4500/9000**

On several occasions we've had no tuning or poor band coverage due to the 43V zener diode D517 on the power supply module. It's type GZA43Y but I always make do with a 33V and 9.1V zener diode together as 43V zeners don't exactly grow on spares cabinets. **S.L.**

### **Panasonic NV370/Philips VR6520**

There was severe hum on both picture and sound in the E-E mode. It also showed very clearly with the test signal displayed. C1102 (2,200μF, 25V) on the power supply panel was bulging out its innards for all to see and was virtually open-circuit. **S.L.**

### **Amstrad VCR7000**

Due to no take up, poor fast wind etc. we had to replace the reel idler in this machine. No surprise here of course,

but we were surprised to find that the symptoms were still present after the replacement. The drive circuitry is very simple and the fault was quickly traced to Q15 (2SD1348) which was short-circuit base-to-collector. For those who may not know this, the idler is the same as the one used in the Sharp VC9300/VC381 range of VCRs. **S.L.**

### **Panasonic NV333**

A case of no tuning voltage was traced to R7019 on the panel mounted vertically at the rear of the deck. Its value is 10Ω and there appeared to be no contributory cause to its failure. **S.L.**

### **B and O VHS80**

Chewing tapes it said. Easy I thought – the idler is faulty for sure. More fool me! I found that the capstan motor didn't move in fast forward and rewind, nor did it move to give take-up in play or record. But it did thread. There was also a loud scratching noise during threading. A check on the circuit revealed that I'd had this problem before, but the resistor was o.k. this time. So time for some proper fault-finding.

There was no output from the capstan drive switching chip IC1151 though it was being switched correctly. This was because there was no motor supply input. There should be a regulated 4.2V input which is obtained from the 16V rail via Q1158. This transistor's collector voltage was high as it had no base bias because R1153, a tiny 1kΩ resistor, was open-circuit. Replacing this resistor restored motor drive. In the fast modes the reel drive was sluggish. A new idler upped the torque, but the deck didn't lace completely and because of this there was no take-up in the play and record modes. The cause was much simpler this time: the loading belts were very worn – as were the pinch roller and the other belts.

The mechanism is very similar to that in the Hitachi VT11. **N.B.**

### **Sony CCD-F340E**

The card listed two faults, a loud screeching sound when rewinding and poor life from the battery – there was no indication as to whether it was the sole battery that had been used. I decided to deal with the noise first as I'd a fair idea of the likely cause, a faulty supply reel table. This had to be ordered and was fitted a couple of days later. I then looked into the battery problem.

The battery sent with the machine wasn't of Sony manufacture. It was a high-capacity (1,400mAh) Maxell one. As it was flat we charged it then tried it out. On continuous play it lasted for just a quarter of an hour. The camcorder was drawing the correct 6.5W in the camera record mode, and when flat the battery voltage had dropped to just over 5V.

We've found that the most common cause of loss of battery capacity is incorrect use/charging. The problem arises when people charge the battery, use it for a short time without "flattening" it, then charge it again. This is commonplace in the shop of course, where camcorders are constantly being demonstrated and the batteries left on charge. We've had some success with continually flattening and recharging batteries for a period to reactivate them. Customer education is the best cure. The fault seems to affect mainly batteries used with Sony camcorders and their clones – not just Sony batteries either. **N.B.**

## Pioneer VR727/Philips/etc

This range of VCRs uses a switch-mode power supply. The one in this machine fluttered audibly all the time the machine was on. We found that the outputs were low and fluttered in sympathy with the sound coming from the chopper transformer – there was a huge, triangular ripple voltage. If the load on the power supply was disconnected by withdrawing P023 the fluttering stopped and the output voltages settled down at the correct levels. Despite this the trouble was within the power supply, where C211 had gone low in value. It says  $10\mu\text{F}$  on the circuit diagram but was actually  $33\mu\text{F}$ . Good old Philips! E.T.

## JVC HR7200/Ferguson 3V29

This machine was fitted with the later PU21235A motor-drive amplifier panel. The problem was with the capstan speed – it was slow. We found that Q210's emitter-base junction was open-circuit while its collector-emitter path was leaky. E.T.

## Philips VR6730/Finlux VR2030/etc

If you get one of these or their several clones with the complaint that it doesn't work but flashes all its function LEDs in sequence, together with the programme indicator and clock displays, look no further than crystal 1001 on the front PCB. It's the 6MHz clock for IC7050 and may be dry-jointed or faulty. E.T.

## Ferguson FV30

If the off-air (E-E) signals go weak or are lost in a snowstorm, check for dry-joints at the pins of the modulator/booster module. It's mounted on the main PCB and it seems that the pins can be strained by plugging and unplugging aerial cables. E.T.

## Hitachi VT11/33/etc

This problem cropped up on a Bang and Olufsen clone, Model VHS80, that uses the same deck. It was the very common one of loss of reel traction. This time replacing the reel idler didn't provide a cure: the reel drive clutch assembly beneath the deck was very stiff on its shaft. Removal, cleaning and a spot of lubrication got things going again and we added another chewed tape to our collection. E.T.

## JVC HRD520

The symptom with this machine was failure to complete the tape-loading cycle. As soon as the guides had gone fully home the loading belt at the top right-hand side of the deck would slip and squeal loudly for some seconds until the machine shut down in standby.

In this half-loading deck design the pinch roller is lowered into place at a late point in the loading cycle, when a peg on the underside of the pinch roller pressure lever drops into a groove on the control cam. This one was getting stuck in the tight double-bend there. We cured the problem by easing the profile of the inner

groove and lubricating the groove and peg with white Molykote grease. E.T.

## Philips VR6485/6585/6880/etc

Intermittent no record colour is beginning to be a common problem with these machines. So far the cause has been a faulty TDA4710 chip. If you do have to change it, don't forget to read the note that comes in the box. This time it's not telling you to remove your nylon pullover before touching the pins but is a modification.

Look at the number beginning with DSD. If it ends with 2Y (the new chip's number ends in 3Y) the following changes will have to be made: increase the value of C2416 from 180pF to 330pF (part no. 4822 122 31353), reduce the value of R3418 from 82k $\Omega$  to 47k $\Omega$  (4822 116 52857) and increase the value of R3459 from 47k $\Omega$  to 470k $\Omega$  (4822 050 14704). P.B.

## Philips VR6585

After about ten seconds the sound would become weak and distorted. The signal was o.k. at the P127 front-end module but faulty at the audio output sockets and of course the modulator. The cause turned out to be on the P524 f.m. audio board where decoupling capacitor C2211 was dry-jointed. For no sound at all check that the 80mA Wickman fuse on this module hasn't blown. P.B.

## Philips VR6462

When play was selected the tape threaded but the head rotated much too fast. So the machine immediately unthreaded. This is usually due to an open-circuit head position sensing optocoupler, but not this time. The opto LED is in series with the tower LED (IR cassette bulb) and it was this that was open-circuit. The clue is that the head optocoupler LED voltages are normally around 3V but in this case were at 12V. P.B.

## Philips VR6362

The E-E picture was smeary but was o.k. on playback. By substitution we narrowed the cause down to the P607 mother board. Voltage checks around the 4053 video switching chip showed that the EXT switching line was at 2V when it should have been at 0V. The chip itself was leaky, a new one (IC7951) restoring normal service. P.B.

## No Picture

Two machines came in with no picture in the E-E or play modes. In both cases I first blamed the modulator then had to start serious fault finding. I'd no circuit diagrams for the first machine, a Sharp VC7300, but managed to track down the fault to the HA11703 chip.

The second machine was a Panasonic NV730 where the chip that carries out the same functions, i.e. head signal amplifier and E-E/video switching, is an AN6337S. It's on the folded luminance-2 panel. Unfortunately this chip seems to be unavailable – and the board is hideously expensive. Worse still my meter



probe slipped whilst I was monitoring the power supply lines. This damaged the tuner and the BN5115 on the demodulator panel, the result being low gain. I was able to replace these items with parts from a scrap NV366, with some modifications. Note that the manual may not correspond with the actual demodulator PCB or the aerial booster/modulator unit. C.McC.

### **Panasonic NV2010**

This machine had noisy drum bearings. They can be changed in the same way as described for the NV333/366 on page 595 of the July 1989 issue. With the NV2010 don't remove the whole drum before dismantling; the stator with most of the wiring can stay in the machine. Fine adjustment of the head switching point can be carried out by means of the slotted screw holes at the back of the drum flywheel, by trial and error if necessary. I actually salvaged the bearings from an NV366. C.McC.

### **Amstrad VCR4600**

No servo action was fixed by replacing the BA718 chip IC302. It's a dual operational amplifier that drives the main servo chip. Note that there's a fault in the information given in the item on page 364 of the March 1988 issue. This seems to be a stock fault. C.McC.

### **Panasonic NV7000**

The customer's complaint was "poor picture - video heads?". On test the playback showed that the CTL pulses, with both its own recordings and pre-recorded tapes, were missing. All checks pointed to the audio/control head but this proved to be innocent when fitting a replacement left the symptoms as before. We then changed the i.c. that contains the CTL amplifier, but again there was no difference. Replacing C2039 and C2040 provided the cure. A.D.

### **Panasonic FS100**

The complaint was no hi-fi audio monitor output and no audio when a signal was applied to the audio input. Both faults were due to the absence of the -27V supply to the input/output pack. I found that a safety resistor in the feed was open-circuit - it's not shown on the circuit diagram. A.D.

### **Sony SL301**

The capstan motor was running at full speed. I found that the capstan frequency generator signal was missing at pin 62 of IC501. Making checks farther back in the circuit I found that there was a sinewave input at the capstan FG amplifier IC404 but no output. Replacing this chip restored normal operation. A.D.

### **Pye DV291**

This machine was new stock and we were told that the problem was no results. So, expecting a dead set, I was surprised to find that the display lit up when it was powered. The VCR accepted a cassette and then sat there, refusing to play, wind, rewind, record etc. It also refused to give us back the cassette. On trying the remote control unit all functions worked normally.

IC101 on the display/timer/operate board accepts the instructions from the IR preamplifier and from the on-board controls. The scan outputs from this chip were all correct, and were being correctly returned to its input port. Replacing IC101 restored normal operation. A.D.

### **Akai VS35**

This VCR refused to accept a cassette. Checks were made on the mechanism timing, which was found to be correct. I then looked for "cassette detect" switches in the cassette housing but couldn't find any. In these machines the cassette is detected by the end-sensing phototransistors. The one on the supply side was open-circuit. A.D.

### **Panasonic NV-MC30**

There was no drum rotation with this camcorder. The drum motor-on signal was correct but the "CYL VM" supply to the servo was at only 1.4V instead of 5V. Replacing IC1004 in the power supply restored normal operation. A.D.

### **Amstrad VCR4600**

The complaint was of two thin lines approximately a third and two thirds of the way down the screen. It affected both record and playback. The fault persisted when a known good recording was tried, but improved as the machine warmed up. In addition varying the back tension changed the look of the fault. After a long search we discovered that a small 10 $\mu$ F, 16V electrolytic on the drum motor assembly was the cause. But how did the effect get into the signal circuits? Who knows with an Amstrad. . . B.McC.

### **Panasonic NV366/777/etc/Hitachi VT17**

If any of these machines appears to have a faulty head, before condemning it check that the relay clicks in the pause mode. If it fails to click the fault is either in the relay (dirty contacts) or its control circuit. It's a good bet that the head is o.k. S.DaC.

### **Panasonic NV830**

The problem with this machine was no colour. We found that the switched 12V line read 10V. The switching transistor Q6013 in the syscon was leaky. S.DaC.

### **Panasonic D1 deck (NV430)**

Here's another fault to add to the list of electronic faults given on page 521 of the May 1990 issue. No clock display but the machine comes on, no cassette functions, the cassette will go in but not come out and no deck functions, Model NV430. IC7502 (AN5033) faulty - the 5V reset missing at pin 12. S.DaC.

### **Sharp VC7300/7800**

White bleeps were visible on all tapes, increasing in number with weaker prints. We tried just about everything, including the entire head assembly. The cause of the fault lay in the drum motor holder unit - there was leakage in the plastic insulating washers. Replacing the unit put matters right. S.DaC.

# Could Some Japanese Gent Explain?

Steve Beeching, T.Eng.

I recently had a bit of bother with a Panasonic camcorder, Model NV-M5. It came to me from a dealer because of a loading mechanism fault. All the loading drive gears were jammed and mistimed and there was a note to the effect that the owner had experienced threading problems from new.

## **Bias Pressure Spring**

There's a bias pressure spring that stabilises the exit guide post when it arrives back at its rest position during unthreading. It's shown as item 228 in the service manual parts list, but there's no part number. The pressure spring is positioned below the threading rings, and for whatever reason the guide can sometimes foul it during the threading operation. I can only speculate on how this happens, but the spring lever gets bent back and prevents threading. The loading mechanism then jams and the drive gears are frequently damaged as there's insufficient protection. In this particular case no damage occurred to the drive gears, so the spring lever was replaced, the mechanism was retimed and, after testing, the camcorder was returned to the dealer.

## **Back it Comes**

Unfortunately when his customer inserted a cassette it again jammed. So the machine came back to me. Initially the tape was suspected. The pressure spring was intact however and was thus not involved this time. So was this a different fault?

Further inspection revealed that this time the loading cam (148), the retaining arm (154), the quadrant gear (157) and the loading gear (153) were damaged and would have to be replaced. Something had held the tape guides back during the threading, and as the drive motor continued the intermediate parts just mentioned had suffered. In addition the quadrant gear had been forced out of its cam slot, damaging the main drive cam slot wall. The only course of action would be to replace the above parts, retime the mechanism, and start again.

The loading mechanism was tested first, on a dry run by powering the motor via an external voltage. It was then tested self-powered but without a cassette. Everything was fine. Testing with a cassette in place was rather different. The quadrant gear could be seen to rise upwards with stress as the threading guides were held back. The reason why was not at first obvious.

After some time had been spent playing with the loading mechanism, both with and without a tape, I was able to deduce that the tape around the loading guide was being stretched and damaged every time during tape loading.

## **The Anomaly**

Now for the anomaly. With no tape inserted I could see that during the threading process the supply spool turntable rotated in reverse for a second or two. Thus while the loading guide system was pulling the tape out of the cassette the supply spool was trying to wind it back in again. No wonder that the loading mechanism and

tape were under quite a lot of stress!

I decided to cross-check this with other models to see if the supply turntable did the same. I checked an NV-M1. No reverse rotation. The same with an NV-M7 and an NV-MS1. So why should the NV-M5 be different? I rang Nick Beer who later called back to say that his NV-M5s had no supply turntable reverse rotation during threading.

I next found that the system control microcomputer chip's R/S/F (reverse/stop/forward) signal goes high for reverse for about one second when the capstan power is 2V. Close inspection of the capstan timing waveforms confirmed this. So the spool idler drives the supply spool in reverse under these conditions. Why shouldn't it? But none of the others do. Nick's don't.

Panic, and as a last resort ring Panasonic. The man there had no idea. They'd not come across this problem.

As I had an NV-MS1 (Super VHS) to hand I decided to cross-check the capstan drive level during threading. Electrical measurements showed that sure enough there was a one-second drive pulse. But the supply spool didn't rotate in the reverse direction, because the idler seemed to be prevented from contacting the supply spool turntable. At last a clue.

Further inspection of the NV-MS1 revealed a thin, flat lever (item 155, the arm kick lever) that's moved slightly during threading and holds the idler assembly off the supply spool turntable, thus preventing reverse rotation. Back to the NV-M5. The arm kick lever had slipped and stuck and was not being operated by the loading mechanism cam lever, thus allowing the idler to drive the supply turntable. Once the arm kick lever had been correctly repositioned perfect operation was obtained.

Maybe some Japanese engineer could let me know why a one-second reverse drive is programmed into the microcomputer and then mechanically inhibited? Incidentally the same pulse is present in the NV-M1 through to the NV-MS1.

## **Another Funny**

Another funny problem that led me a merry dance occurred with the NV-MC10 chassis. After replacing some parts in one that had been dropped the deck unit was tested. It recorded and played back fine, but threading, fast forward and rewind were not smooth. To put it mildly, the capstan motor was very lumpy. It rewound in massive jerks for a short period, then shut off.

Considerable time was spent checking through the main PCB which I thought might have suffered damage, but I couldn't find anything amiss. The only clue was that the servo drive output was abnormally high and was over-driving the d.c./d.c. converter chips. Hence the lumpy drive, as the d.c./d.c. converter was switching on and off.

Previous MC10s had not acted like this. Nick Beer confirmed that he had run the deck section of an NV-MC10 on its own without problems. A man at Panasonic said that the only time he'd had this fault was when the servo reference oscillator signal was missing, and that this was in playthrough. Anyway the machine

was shelved for a while so that we could check whether a new main PCB could be afforded.

Some time later another MC10 came in for intermittent something or other, which meant that the deck had to be removed, and blow me if it didn't have the same lumpy rewind. But half a minute. This machine worked all right didn't it? The deck section was quickly reconnected to the camera and it ran fine. A nice smooth rewind. But when the camera section was disconnected the rewind was once more erratic. Needless to say back to the shelved unit for a retest. The results were the same. If the camera was connected the rewind was smooth. If not the rewind was lumpy.

The key was the colour signal. If it was present all the capstan functions were smooth. If it was absent, play and record were fine but the unthreading, fast forward and rewind drive was lumpy.

The cause was the colour VXO from which the servo obtains a 4.43MHz carrier as its reference signal. It runs in play and record but not during rewind, fast forward and unthreading unless the chroma signal from the camera is present. It then became apparent from the manual that this happens only in later versions with a modified Y/C PCB.

Perhaps that Japanese engineer could explain the design criteria of this circuit to me?!

## Philips VR6290/6291/6390

If you encounter one of these machines that intermittently doesn't play or record check the error memory. You'll need the remote control handset for this. I know the manual says otherwise, but where's the set clock button gone? If the last two digits are E6 (head blocked) the following modification is probably needed. Find C2040 on the family board. If its value is  $0.1\mu\text{F}$ , replace it with an  $0.01\mu\text{F}$  capacitor (part no. 4822 121 51304). The circuit shows it as being  $0.01\mu\text{F}$ . P.B.

## Philips VR6720

This machine produced no sound from the speakers, though the headphones worked all right – it's the one with the  $2 \times 15\text{W}$  stereo amplifier. The supplies and input signals were present, but the signals got lost at the driver chips IC101/2. The delay muting transistor TS120 was leaky. P.B.

## Grundig VS200/220

This machine would intermittently stop playing. When this happened it would unthread and show F2 in the display. It would also sometimes stop during wind or rewind, but the display would then show F6. Both of these fault codes indicate that the microcomputer chip thinks one of the spools has stopped. As there was no tape spillage scope checks were made on the spool optocouplers. With the machine playing or winding the optocouplers' output should consist of a signal of about 9V peak-to-peak. The output from one of them was only 2V pk-pk. A new supply optocoupler was required. P.B.

## Grundig VS310

We've had two of these machines in recently. The problem with the first one was wow on sound. On inspection we found that the capstan belt was hard and covered with cracks. Fit a Grundig replacement if you have the same problem.

The second one was dead – no clock, no booster, nothing at all from the power supply. The chopper transistor was o.k., with 30V across it, but there was no drive. D425 was short-circuit. P.B.

## Ferguson 3V36/JVC HRD225

In the play mode the sound was o.k. but the screen showed nothing but dark grey with occasional flashes of picture content in the background. On tracing the video signal through I discovered that it became a little distorted in the luminance amplifiers (Q106/7) that follow the f.m. demodulator filters. It disappeared completely at the output of amplifier transistor Q103. Meter checks showed that the pre-playback 9V supply was low at only 2.5V. Switching transistor Q501 was the cause of the problem. J.C.

## Grundig 2 × 4 Super

This machine would play back, search and wind/rewind but wouldn't record. It wouldn't initiate record or thread

in. The problem was that the left-hand keyboard didn't respond as button 1 was permanently "on". In fact the push-buttons jammed in when pressed – buttons 4 and 7 exhibited this to a lesser extent. The keyboard is part of a large board that's secured to the front panel by plastic blobs and contains all the other front panel push-buttons. Grundig Service told us that a repair kit is available but that relieving the front panel cutouts around the buttons is usually adequate. This provided a perfectly acceptable cure. B.R.

## Panasonic NV688

Here's an example of confusion caused by an incorrect symbol on the circuit diagram. The problem was no playback, recording or signals – just a buzz and noise bar in the E-E mode. We soon found that the regulated 5V rail was low at only 2V. No excessive load was apparent and transistors Q1003/4 and zener diode D1006 in the regulator circuit all checked out correctly when cold resistance tests were carried out. We decided to check the 2SD1275 series regulator transistor by replacement. It's listed as a Darlington device, though the circuit shows it as a straight npn transistor – which it seemed to be from our meter check. In fact the Darlington bit had shorted out. A replacement solved the mystery, with no thanks to Panasonic's circuit diagram. C.A.

## Hitachi VT8000

This machine would load up and play. It then refused to unload and eject the tape, though the left-hand reel was driven normally to retract it. If the tape was unloaded manually and a fast wind command was given the machine would respond initially but the loading arms would also move forwards slightly. This disturbed the loading switch, thus preventing acceptance of further commands until the loading arms were wound back again manually. The microcomputer's voltages were all correct and the right instructions reached the loading motor control chip IC905. Replacing this TA4194A device did the trick. C.A.

## Saisho VR1200HQ

When we find "HQ" appended to this breed of VCRs we're inclined to take it as meaning highly questionable. "It won't stay on" said the owner, the reason being that fuse F502 had blown. When our adapted Thorn 3500 cutout was connected temporarily the machine wouldn't accept a tape and the BA6239A loading motor chip quickly reached fried egg temperature. After using an external supply to check the loading motor we replaced the chip, fitted the correct fuse, and another Saisho limped off into the sunset. C.A.

## Panasonic NV730

I owe this one to regular reading of *Television* articles! The problem was intermittent stopping in the play mode. The machine had come to us as another local firm had unsuccessfully tried to sort it out. It was obvious that previous work had been done on the deck – the guides

had been cleaned and the take-up idler roughened up. After a long soak test the fault showed up as no take up, with tape spillage into the machine before the system control came to the rescue. Q1504 at the rear right of the machine (from the front) was found to have dry-joints. S.L.

### Saisho VR1200HQ

This machine would very intermittently go to stop while in use. It didn't matter which particular function was asked of it, i.e. rewind, FF, play etc. Although we didn't really suspect the deck sensors they were replaced as strange things do happen. The supply lines were all checked, the mode switch was cleaned and aligned, and a thorough search for dry-joints was carried out. On test however the fault was still present. Eventually we found that the BU2716S (IC01) was the cause. Other Saisho models such as the VR1600 etc. could equally be affected by this problem as similar circuitry is used. S.L.

### Sharp VC651HM

This was another intermittent nasty – tape chewing. After a very long on/off cycling test the fault showed up as intermittent no take-up. The machine had been serviced recently and the reel drum unit had been replaced, so this was assumed to be all right. With the carriage out and the machine on its side it was possible to observe the operation. The fault showed up on about one in every ten or fifteen tries. We noticed that the brake on the take-up reel lagged now and then: the brake driver lever didn't move far enough to disengage this brake and didn't latch on to the little electromagnet. We deduced that the cam switch (mode switch to you and me) must be faulty. The problem was cured by stripping this switch out and cleaning it. As a precaution we also replaced the loading belt. S.L.

### Ferguson 3V44/JVC HRD140

There were several problems with this machine. The clock couldn't be set, there was no tuning and the timer couldn't be set being amongst the most obvious ones. A case of a very large brain failure. After perusal of the circuit diagram we suspected the microcomputer chip IC601. As its 5V supply and clock were o.k. we tried a replacement. This cured all the symptoms. It's type M50730-607. S.L.

### Samsung V510T

The basic problem with this machine was failure to switch on. The take-up reel rotated backwards and the capstan motor intermittently ran slowly. This was all without a tape in. The power supply at the rear of the machine, with an i.c. of the STK variety, produces several rails. There's an always 13V supply from the chip and switched 12V, 50V and -24V supplies from a transformer-fed series regulator. The basic problem was that the switched 12V supply was missing. A check was made on the power-on command from pin 15 of IC1 and this was found to be present, but instead of a nice positive d.c. charge when the operate button was used there were several pulses – see Fig. 1.

We then found that the machine operated normally

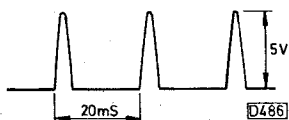

Fig. 1: Incorrect power-on signal discovered in a Samsung V510T.

when the error detector transistors were temporarily shorted across, to simulate full conduction. As soon as power was removed however the machine would of course fail to respond. If nothing else this removed the possibility of a d.c. fault in the 12V series regulator. The power-on command was then checked with the line disconnected from the power supply. Since the pulses disappeared the fault appeared to be generated in the few components in the first transistor's base circuit. So it was, with C6 being open-circuit. We found that an 0.22 $\mu$ F capacitor gave reliable operation. Since then we've had another of these machines with the same problem. S.L.

### Sentra VX8400/Questar V300R

This one caused us some problems due to the random nature of the fault. Basically the machine would occasionally fail to store ch. 2 only, after correctly searching for the channel. Alternatively ch. 2 would search and store but on selecting channels sequentially, both up and down, ch. 2 would be missed in the down direction. Unusual I think you'll agree, and we stored each channel several times before we actually believed what the machine was doing. The culprit turned out to be the M58659P EPROM IC702 on the front panel. S.L.

### JVC HR7700/Ferguson 3V23

Rewind and fast forward were o.k. but when play was selected the machine loaded the tape half way then stopped – the drum also stopped. To unlace the tape you had to use the on/off button. All the sensors and switches were tried, then all the panels, but still no success. We finally tried a new drum assembly, after which the machine worked perfectly. The rotor base unit in this assembly has two magnets opposite each other at the bottom. One of them was missing, so there was no pick-up pulse. S.DaC.

### Panasonic NV-L20

The fault report was that the on/off button didn't work. When the machine was connected to the mains supply the clock display flashed as usual. Key scanning is carried out by IC7501 which is also the timer/display driver chip. It appeared to be working all right since pressing the timer button produced a warning that the clock wasn't set and that there was no tape, i.e. there were beeps and the timer and tape symbols in the display flashed. On a couple of occasions we found that the machine seemed to be on when connected to the mains supply since a channel number appeared in the display – it could be changed up and down with the front keys. A check was made on the serial clock and data lines between IC7501 and the system control chip IC2001 (pins 44 and 45). Both were high (5V) with no pulses. Since IC2001 produces the serial clock signal its reset and clock inputs were checked. There was no clock input from the osc pack CBA, a small PCB beneath the main panel. The single transistor on this PCB was at fault. It's Q6101, type 2SC2206. I.B.

### Panasonic NV-G45

The reason for no play or record with this machine was that the drum didn't start up. It just kicked backwards and forwards. Experience has shown that with the type of motor used here the cause of this condition is usually

something to do with the rotor position sensing, since this controls the current that's switched to the three pairs of drive coils. A single Hall-effect device is used with these drums. The connections are to pins 2 and 6 of plug/socket P2001. With this particular unit we got a reading of 2.7k $\Omega$  between these pins. When we checked a G40 drum the reading was 400 $\Omega$ .

Unfortunately the Hall device is not available as a separate item. You have to order a complete motor assembly which costs around £60. We had a scrapped rental NV430 in the workshop however – it had been written off due to liquid spillage. Its drum motor has two Hall-effect devices, one of which was removed. Before removing the cup-shaped rotor of the G45's motor we marked on it the positions of the centres of the two securing screws in the two adjusting slots. The Hall-effect device was then removed and the replacement from the NV430 was carefully fitted in exactly the same place. The rotor was then refitted, with the two securing screws just tight enough to allow adjustment of the rotor's phase, and the drum was secured back in the

machine. A standard tape was played and the head switching point was adjusted visually before tightening the rotor screws fully and carrying out fine electronic adjustment of the head switching point. **I.B.**

### **Panasonic NV-G45**

The customer complained of a whine from the machine when it was switched on, and that it wouldn't play back correctly. The reason for these symptoms was that the drum motor ran flat out. When tests were made we found that the voltage at the torque control input pin of the drum driver chip IC2901 (pin 7) was incorrect. In the stop mode (machine on) the voltage at this pin should be 3.8V. It was low at 1.4V. With the pin disconnected from the PCB the motor didn't start and the voltage rose to around 3.6V, indicating that there was some loading on the line. It was due to a leaky capacitor, C2117 (0.47 $\mu$ F electrolytic), which filters the speed and phase control voltage from the operational amplifier IC2103. **I.B.**

## Philips VR6760

This machine had come from another dealer. He'd cleaned the tape path because of intermittent hi-fi sound, but when he returned it the customer complained that it wouldn't play any of his previous recordings in hi-fi at all. New recordings were o.k., as were prerecorded tapes. We found that with the old recordings the hi-fi sound faded in and out though the picture remained perfect. On inspection we discovered a lot of tape oxide by the capstan, suggesting tape crinkling at the last guide, 256. Yes, it was another case of a faulty pinch roller. **P.B.**

## Philips DMP Series Decks

There have been a lot of changes during the production of these decks. When ordering parts, look at the paper label on the inside left-hand side of the metal chassis – the label is easier to read with the tray in the lowered position. Note the type number (DMP 2-2) and the week number (WD. .) and check in supplement 4822 726 14564 whether the part you want has been changed – some have been modified twice. The IDM series deck is similar to the DMP type in appearance but many of the lift and threading parts differ and are not interchangeable. There's a different manual for this deck. **P.B.**

## Grundig VS300

This machine would accept a tape but wouldn't initialise and wouldn't play or wind. F7 was flashing in the display. The capstan motor had a dead spot, but before fitting a replacement I turned the motor a few times and tried a test recording. This revealed that the recorded sound was weak and that the colour from the previous picture showed through. The customer had had a quick look, had accidentally pulled off plug L14 and had then fitted it back-to-front. This meant that the erase head wasn't connected and the sound bias was excessive. **P.B.**

## Philips Service Manuals

Philips video and TV manuals can be difficult to store: the paper is too thin to last long in a ring binder and staples tend to rip the next manual in the pile. I've lately been raiding the office for plastic slide binders. As they hold the length of the page they spread the load better – and you can also dismantle the manual to add the inevitable supplements! **P.B.**

## Ferguson 3V56

This play-only machine – a rare breed – refused to come out of standby whether the "on" request came from the front-panel key or the remote control handset. The power supply module was intact but got no PWR CTL command from the syscon control chip IC601. This i.c. was without its supply because the 5.6V zener diode D616 in the voltage regulator that provides it was short-circuited. **E.T.**

## JVC HRD520

The symptom with this machine was no playback sound. We found that the sound system was muted because the /

EE control line was low at 2.6V – it should have been at over 10V during playback. The source of this control line is pin 32 of the microcomputer chip IC601. Leakage inside this chip was pulling the line down – we proved this by disconnecting the pin, whereupon the line rose to 10.4V. Replacing IC601 cured the trouble but the curious thing was that the chrominance, luminance and other sections of the VCR still functioned in the playback mode despite the /EE line being at 2.6V. **E.T.**

## Ferguson FV30B

This machine has a slightly unusual syscon, with responsibility for deck control being shared between the main microcomputer chip and the one on the front panel. The deck shutdown symptom after a few seconds in any mode can be caused by faulty reel-rotation sensors, even though the output pulses may look all right. Use the modified types PU60271 and PU61088 for replacement, changing both these optocouplers at the same time. **E.T.**

## Matsui VX800/Saisho VR1000

Intermittent failure to eject a tape as a result of carriage overshoot is a common fault with these machines. Carry out the following modification to overcome this problem. Remove the blue lead from the cassette loading motor and replace it with a BY127 diode (cathode to the motor), with a 27 $\Omega$ , 0.25W resistor in parallel with the diode. **E.R.**

## Logik VR950

The symptoms were intermittent loss of the signals from the tuner. Investigation revealed that there were several dry-joints on the tuner's pins. Resoldering these restored normal working. We've since had two more of these machines with the same problem. **E.R.**

## Matsui VX820/Saisho VR1200

A faulty mode switch proved to be the cause of no functions with a Matsui VX820. To replace the switch the carriage must first be removed. The switch can then be taken out by releasing the retaining screw and unsoldering the three leads that are attached to it. Reassembly is the reverse of this procedure. Take care to align the two slots on the switch. **E.R.**

## Hitachi VT33

This machine played prerecorded tapes reasonably well but the sound on its own recordings was extremely poor. As cleaning the audio-control head failed to improve matters a replacement head was fitted. This cured the problem. **E.R.**

## Akai VS23

This machine came in with the complaint "not working". On removing the top cover we found that the loading arms were in the fully loaded position but the cassette house was in the eject position. There were comments in the workshop about how the cassette could have been

removed, and that the problem looked like being a difficult one. We removed the loading block, reset the timing and then left the machine to play. Later that day another VS23 came into the workshop in the same state. It responded to the same treatment, working after the loading block had been removed and the mode timing reset. Taking no chances, as both machines were still within the guarantee period, we ordered and fitted new mode switches. Neither machine has been seen since. **A.D.**

### **Panasonic NV370**

In the E-E mode this machine displayed a half black/half white screen. The cause of the fault was traced to C1102 (2,200 $\mu$ F, 25V) being open-circuit. **A.D.**

### **GoldStar GHV1290**

There was no playback: the fault gave the impression that the video heads were dirty, but cleaning them proved that this wasn't the cause of the problem. We traced the playback f.m. signal to pin 3 or IC302 then found that there was no output at pin 15. Replacing IC302 restored normal results. **A.D.**

### **Akai VS4**

There was distorted video in the playback and E-E modes with this machine. The symptoms suggested a fault on the video panel, where most of the signal processing is carried out. On screen the "picture" lacked contrast, with no sync. A scope check showed that the sync pulses were badly crushed. We found that TR31 was short-circuit all ways. The 2SA1115 fitted in this position was replaced with a BC212L. **S.L.**

### **Philips VR6293**

These VCRs have a separate chopper power supply contained in its own tin house at the rear of the machine. In a recent case the BUT11A chopper transistor was short-circuit, the feed resistor R109 was open-circuit and the 2AT mains fuse had blown. At switch-on our replacements went the same way as the originals. The cause of the trouble was the CNX83A optoisolator chip IC124. We understand that it's policy to change this whenever the chopper transistor is found to be defective. **S.L.**

### **Sharp VC383**

The reel motor in this machine ran continuously. As the STA471C reel drive chip had obviously been under stress it was replaced. The new chip also ran hot. We found that the root cause was the 2SA733 transistor Q7754 which was open-circuit. **S.L.**

### **Toshiba V93**

I'm sorry to be vague about this one, but we don't have the manual. The basic fault was no clock or other display, though the deck functions were o.k. ZL62, a Wickman fuse on the bottom panel, was found to be open-circuit, replacement bringing the machine back to life. There's a small can, beneath which an oscillator resides, on this panel (timer-2/i.f. and prescaler). The coil has a little metal top hat as screening, glued into place. This cap falls off. I'm not sure whether a change of inductance occurs to open-circuit the fuse or whether it's simply a matter of a short-circuit due to the metal contacting something in the

circuit. I'm led to believe that the problem is a common one. Perhaps another contributor would care to fill in the details? **S.L.**

### **Ferguson 3V30/JVC HR7300**

We still see a large number of these excellent and on the whole reliable machines. With this particular one the drum would stop after a few minutes and wouldn't restart. An initial check on the supplies (we all do that, don't we?) proved to be a good move as the 12.5V rail read 15V. It's derived from Q1 on the power supply board. This was o.k. but farther back the sensing transistor Q3 and its emitter zener diode D5 were faulty. **S.L.**

### **Panasonic NV-MS50**

The problem we've had with two of these camcorders has been no E-E or recorded sound, playback of good recordings being o.k. It's not difficult to trace the cause – the microphone is faulty. A fair amount of dismantling is required to replace it. **N.B.**

### **Panasonic NV-G21/G25**

A few of these machines have come in recently because of no on-off LED indication, although the switching works – indicated by the appearance of the counter display and the beep. The other problem has been no deck functions. The cause of these symptoms is that the 12V output from pin 6 of the STK5338 regulator chip IC1001 has fallen to about 7V. Replacing the chip puts matters right. **N.B.**

### **Ferguson FV31R/FV32L**

A problem we've had with these machines is ticking over the playback sound. It's due to pick up on the audio/control head loom to the PCB because of insufficient screening. A modified lead with braided instead of spiralled screening is available and this cures the problem.

We've also had a couple of faults in the r.f. converters. The problem with one machine was intermittent low gain. The other intermittently lost the E-E and V-V vision. In both cases the cause was dry-joints – and in both cases the fault could be instigated or cleared by applying minute pressure anywhere on the signals panel on which the converter is mounted. **N.B.**

### **Panasonic NV-GD48**

The symptoms were no deck functions, unable to switch the machine to standby, takes tape in then locks up and won't eject. The MN15283VPY clock chip IC7501 was faulty, though the clock display functions were all normal. **J.H.**

### **Ferguson FV26D and Equivalents**

We've had this fault several times – very low remote handset range due to a dry-joint on the infra-red amplifier subpanel where it's soldered into the clock panel. **J.H.**

### **NEC PX1200K**

There was no drum rotation, also a burning smell. D3 in the power supply was short-circuit. If the drum rotates after replacing this diode but the capstan doesn't run you'll probably find that the UPC324 chip IC605 is faulty as a result of excessive a.c. on the 18V supply line. **J.H.**



# VCR Clinic

Reports from Philip Blundell, AMIEIE, Eugene Trundle, Alfred Damp, Ed Rowland, John C. Priest, Jim Littler, Jeff Herbert, S. Da Costa, Ian Bowden, Mick Dutton and Nick Beer.

## Philips DMP Series Deck

On going from rewind search to playback the take-up spool would sometimes cease to rotate and the machine would then stop. When play is selected the brake magnet normally holds the brakes off, but sometimes the magnet let go and the fault would occur. The cause of the problem was a dry-joint on the brake electromagnet.

P.B.

## Philips VR6290

If you tried to go to stop after this machine had been playing for a few hours it would get stuck in pause and couldn't be restarted, stopped or put into standby. Scope checks around the keyboard processor chip showed that the SDA2 and SCL2 signals changed from blocks of data to continuous signals. Replacing the keyboard module as an initial check made no difference. The SDA2 and SCL2 lines communicate with the tuner, so a new one was fitted. This cured the problem. It seemed an unlikely cause, but fitting the suspect tuner in a working machine took the fault with it.

P.B.

## Philips VR6182

If you have to order a capstan flywheel for later Philips models check whether the tacho head is adjustable from the top of the machine. If so a modified flywheel is needed, part number 4822 535 92909.

P.B.

## Philips VR6760

This machine had the usual jammed rack. So the deck was stripped down and the rack, pinch roller and coupling were replaced. After giving the mechanism a dummy run using a 9V battery we tried the machine out for the first time for real. This showed that the power supply was dead, the cause being the BD436 transistor 7001 which was open-circuit. After replacing this we made another attempt. This time the deck initialised but a burning smell came from the 5V section of the power supply. Someone had replaced the BYV10-20 with a 10V zener diode. As there is normally a 14V squarewave across this diode it was working rather hard. Everything was o.k. when the correct diode had been fitted.

P.B.

## JVC HRD170

If you encounter one of these machines with a channel change fault, be wary! We've now had two in which the channel could not be changed using either the front-panel keys or the remote control unit. Since neither the tuning nor the channel digit display changes you might reasonably suspect the clock/display/key-decoder microcomputer chip on the front panel. Not a bit of it! With both the machines we had in the bug responsible was IC2 on the tuner/i.f. panel. It's type M50440-391SP.

E.T.

## Ferguson 3V41

This camcorder came in with the fault report "no eject". In fact no other function worked: the stop LED would blink then the unit would shut down. On inspection we

found that the mode control motor didn't move. Power was being supplied to the motor, which was drawing a heavy current. The problem was that the loading bracket assembly's worm gear was sticking. Normal operation was restored by removing the worm gear and the grease applied to the spindle (similar to the problems you get with the 3V44 etc.), cleaning and applying new grease.

A.D.

## Amstrad VCR4500

The symptoms with this machine were no clock display and no functions, with the function and pause LEDs permanently lit. Voltage checks around the power supply revealed that the A/T 12V rail at pin 1 (red lead) of plug CL4 was low, the reading being 2.8V. Further investigation brought us to R661 (4.7Ω) which was open-circuit. Fitting a replacement cleared up the trouble.

E.R.

## JVC HRD170

This machine had been to another dealer with the now familiar "intermittent function" fault. In return for a large sum of money a new set of carriage end-sensors had been fitted. This had failed to cure the trouble of course and the machine's owner, being unable to obtain either satisfaction or a refund, brought the machine to us. As usual we found that the small earthing screw on the motor subpanel was loose.

After putting this right we connected the machine to the mains supply and switched on. It immediately went into the fast-forward mode. When a cassette was loaded the machine acted normally. We noticed however that when the tape was ejected the loading motor at the side of the carriage continued to run for a further five seconds. Also the machine went into fast forward every time it was disconnected then reconnected to the mains supply. A quick look at the end sensors showed that the two-pin plug on the left-hand sensor had been left off. Refitting this restored normal operation.

E.R.

## Amstrad VCR6000

The call-out note said "intermittent poor picture and the sound grunts". On playing back a tape in the SP mode it was obvious that the machine was switching randomly between SP and LP. So the tape path was examined and the audio/control head was cleaned and its alignment checked. This didn't clear the fault but I next found that putting the machine into the forward search mode then reverting to play would clear it. After doing this the machine would play normally for several minutes or until stop was pressed. On next pressing play the fault would again be present. I checked the A/C head connections and followed the path back to plug and socket CN-E on the servo board. As this area of the board seemed to be sensitive to pressure some time was spent looking for dry-joints, checking the coupling electrolytics C417 and C419 and bypassing CN-E by wiring a lead direct to the board. As none of this produced a solution the machine was taken back to the workshop.

With the machine on the bench I used a scope to

check the CTL pulses from the A/C head right through to pin 25 of IC402. Everything was o.k. The waveforms at TP401 and TP402 were next checked. RF SW (f) at TP401 was o.k. but the CTL pulses (g) at TP402, although of correct amplitude and in the correct phase relationship with RF SW (f), were accompanied by an awful lot of noise on the base line. Checks on the peripheral components in this area (CTL-Amp) of the chip failed to reveal anything amiss so a new 14DN363 servo chip (IC402) was obtained and fitted. Result, a nice clean waveform at TP402 and fault-free performance.

The apparent dry-joint or board sensitivity to pressure had been a red herring, the cause of this being hand-capacitance effects. In fact it was possible to trigger the machine into and out of the fault condition by applying a finger tip or the end of a screwdriver to the can of C419. The resulting massive squarewave that showed momentarily at TP402 booted the LP/SP switching into the opposite mode in the same way that selecting forward search would also clear the fault for short periods.

**J.C.P.**

### **Samsung VI611**

I came across this machine in a friend's shop. It played all right but wouldn't record off air. The E-E display consisted of a blank raster with a murky bar near the top and the tuning was not precise. I suggested scoping the video detector's output but the scope was broken. So I injected a 39.5MHz signal from a signal generator into the i.f. amplifier. This showed that the i.f. section was all right. The next step was to decouple the various feeds to the tuner. First the a.g.c., then the a.f.c. and finally, using a 22 $\mu$ F capacitor, the tuning voltage at pin 2. This last action restored the picture and sound. When the voltage was traced back to source I found that C4 (47 $\mu$ F, 100V) in the 52V part of the power supply was open-circuit. **J.L.**

### **Panasonic NV-L20**

This machine was dead: after an initial burst at switch-on there was no output from the switch-mode power supply. Diode D1103 on the primary side of the chopper transformer was leaky. **J.H.**

### **Logic VR950**

Playback of prerecorded tapes was normal but as there were no recorded control pulses servo lock was lost with the machine's own recordings. We found that the inverter transistor Q0214 on the main panel PC6 was faulty. **J.H.**

### **Panasonic NV333**

After running for just a split second in the rewind or fast forward mode this machine would stop. Playback was o.k. We thought that the fault was a mechanical one but eventually found that D1003 in the power supply was open-circuit, reducing the relevant voltage to about half. We were surprised by this: since playback was perfect one would have thought that the power supply was o.k. **S.DaC.**

### **Panasonic NV780/480/850**

The problem was no capstan motor rotation. An external 5V supply showed that the motor was all right and we then found that the 5V capstan pulse was missing at pin 38 of the syscon chip IC6001. Replacing this chip failed to

resolve the problem which, after much frustration and head-scratching, turned out to be due to the MN1455BVL chip IC7501 on the timer panel. **S.DaC.**

### **Ferguson FV20**

The reported fault was no colour. We found that the machine played back prerecorded tapes all right but it wouldn't record any chroma. As a first step we scoped the down-converted chroma output at pin 5 of IC201. There was only a very small signal here, about 10mV peak-to-peak. This signal is fed to an emitter-follower buffer stage via a low-pass filter, LPF202, so the input to the filter was disconnected to see if the problem was due to excess loading. There was no change in the signal level. All the inputs to the chip were then checked and found to be correct, suggesting that the chip itself was defective. As we had another FV20 in the workshop we borrowed its main converter chip. Still no improvement. After spending some time going round in circles we decided to replace the low-pass filter with the one in the second machine. To our relief a healthy 900mV peak-to-peak chroma signal then appeared at IC201's output pin. **I.B.**

### **Hinari VXL8**

This machine's problem was that the capstan wouldn't run. We'd no service information but we had a bit of luck: when we touched the ribbon cable to the capstan PCB the motor started to work. There was no further trouble after stripping this back and resoldering it. **M.D.**

### **Tatung VRH8490**

The main complaint was no play. In addition the sound had been slurred for some time. When a tape was inserted it threaded all right but when play was selected there was a squealing noise and the machine shut down. The cause of the problem was that the pinch roller had seized solid on the shaft. Freeing is enabled the machine to play but we had to fit a replacement to cure the wow on sound. **M.D.**

### **Panasonic NV-G40**

This machine uses the later version of the G mechanism, which is much more reliable. It would refuse to keep a tape in however. The machine would load the tape then begin to lace it but the mechanism didn't click and engage half way through to allow lacing to be completed. An additional point is that the fault was intermittent. Experience of the earlier version suggested that the relay was probably faulty. Sure enough a replacement restored normal operation. The replacements now supplied are like those used in the subsequent L model number machines. **N.B.**

### **Panasonic NV-L20/L25/L28**

This range of machines uses a very slightly improved and modified version of the G deck. Noisy rewind was the complaint with an L20B that came in recently. On test it wasn't noticeably noisy but a slight knocking was just discernible. As it causes the problem in the earlier versions I first replaced the main pulley (VXP0917). This time however the cause was the intermediate gear (VDG0546) which transfers the drive from the centre pulley unit. **N.B.**



synthesis tuning system. The output from the precler chip enters the 6805T2 microcomputer chip IC7 at pin 11. Commands from the remote control system arrive at pin 2. The programme tuning data, along with normalised analogue control settings, are stored in the SDA2516 non-volatile memory chip IC13. On receipt of a channel change command the relevant data from the memory enters IC7 at pin 25. A phase-locked loop within IC7 produces a control voltage at pin 7. This is fed to the UAA2001 tuner control chip IC8 which produces the tuning voltage at pin 2. After filtering to control the rate-of-change this voltage is applied to pin 5 of the tuner. The tuning voltage supply is obtained from the 115V h.t. line and is stabilised by the 33V zener diode D33.

IC8 also forms part of the analogue control system – for volume, brightness, contrast and colour saturation control. It receives data from IC7 at pin 14 and supplies a data output at pin 4 which is connected to pin 1 of the MC144111 digital-to-analogue converter chip IC9.

## The TDA4505 Chip

The TDA4505 chip IC2 provides composite video, audio, field and line drive and tuner a.g.c. outputs. It incorporates an a.f.c. circuit but this feature is left unused as the receiver has a frequency-synthesised tuning system. Its a.g.c. output is inverted by TR10 for application to the tuner. The a.g.c. crossover point is set by RV1, which is normally adjusted for 3.5V at pin 1. It's important that the a.g.c. voltage at pin 2 of the SC4 tuner does not exceed 3.5V – if it does the video will be noisy. The tuner's a.g.c. voltage should lie in the range 2.5-3V, set by RV1.

The composite video plus 6MHz sound output appears at pin 17 of the TDA4505 chip. You can expect 1.75-2V peak-to-peak video at this pin, sitting on a d.c. level of 2.25V. The 6MHz intercarrier sound is filtered out and re-enters IC2 at pin 15, the audio output appearing at pin 12. Its level is fixed by a 3.3kΩ resistor connected to pin 11 since volume control is carried out in the following switching chip IC15.

## Signal Switching

The audio and video switching system is shown in Fig. 3 (there's separate switching for the teletext/external RGB signals). Two chips are used for the switching, a TDA5850 (IC14) for the video signals and a TDA8196 (IC15) for the audio signals. They are controlled by the AV output from pin 5 of the tuner control chip IC8.

IC14 receives off-air video at pin 8 and video from pin 20 of the scart socket at pin 4. Its output at pin 5 is filtered to separate the luminance and chrominance signals which are then fed to the TDA3301B colour decoder chip. The output at pin 5 is also fed via emitter-follower TR22 to the teletext decoder/on-screen graphics generator circuitry. Pin 2 provides an output that's taken to pin 19 of the scart socket. The switching control input is at pin 3, which is connected to the AV line via the inverter TR13.

The arrangements around IC15 in the audio channel are somewhat different. Off-air audio enters this chip at pin 2. This feed is also taken to the emitter-follower TR1 whose output is connected to pins 1 and 3 of the scart socket. The audio inputs at pins 2 and 6 of the scart socket are summed and fed to pin 4 of IC15, which receives a d.c. volume control potential from the DA

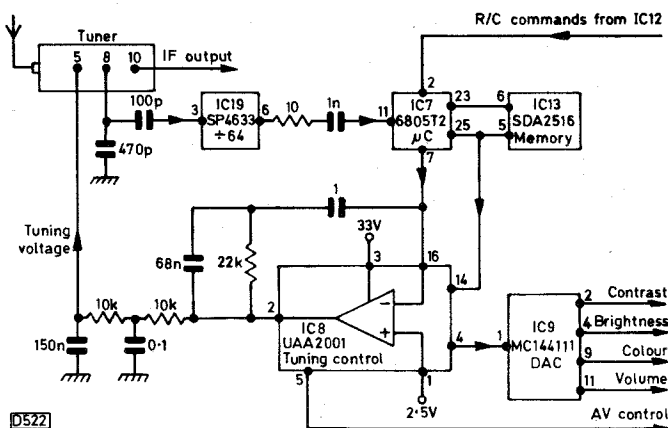

Fig. 2: The tuning and analogue control system.

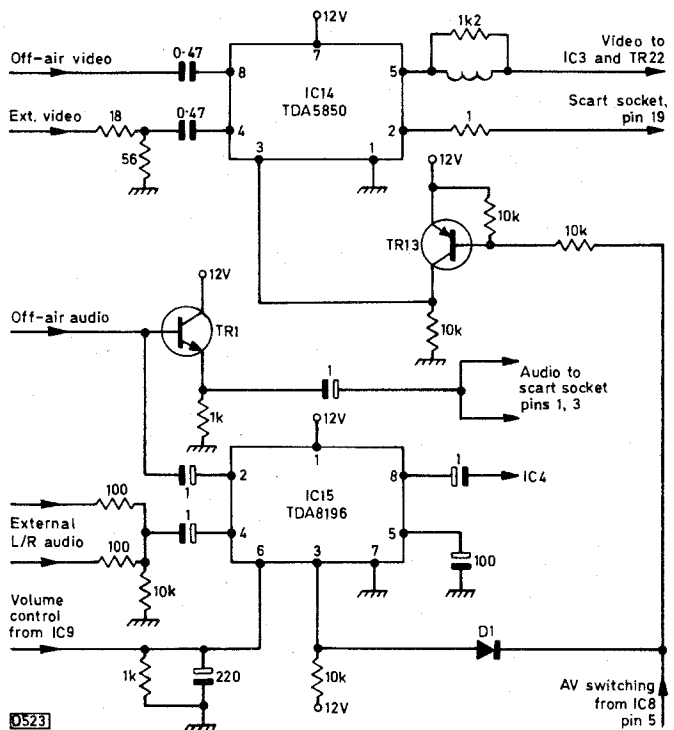

Fig. 3: The video and audio signal switching arrangement.

converter chip IC9 at pin 6. The output to the TDA2611A audio chip IC4 is at pin 8.

When AV is selected the control line takes pin 19 of the TDA4505 chip IC2 low. This input acts on the a.g.c. circuit, muting the i.f. strip so that the off-air sync pulses are deleted. The composite video input is fed via TR22 to a switch in the teletext chip IC12, emerging at pin 2 of this chip from which it's fed back to the sync separator in the TDA4505 chip at pin 25. In the RGB mode the switch in IC12 selects pulses generated within this chip for feeding back to IC2 to synchronise the timebase generators.

## The Colour Decoder Chip

A Motorola TDA3301B chip (IC3) is used as the PAL decoder. This chip also provides auto grey-scale tracking, beam limiting and switching between off-air and teletext/external RGB inputs. The component count in this area is low and the arrangement deceptively simple – a remarkable amount of cunning went into the design of this 40-pin chip. The luminance delay line DL14 is a TDK SEL4680: it resembles a thick-film circuit.

There are separate feedback paths from the RGB output stages to IC3 for grey-scale tracking. The chip generates dark-level pulses which are inserted during the field flyback period to enable the "black current" at each gun to be sampled. A switched sampling system within the chip compares the feedback samples with an internal reference. The error voltages produced are stored as clamp voltages on the 10nF capacitors connected to pins 15, 18 and 21. This system operates at only the low-light drive level of course. RV21 and RV23 on the c.r.t. base panel enable the gain of the green and red output stages respectively to be adjusted for correct highlights. Following current practice, the gain of the blue channel is fixed at close to maximum. Black level is set by selecting aux with no input and using the brightness control on the remote control unit to set the highest of the c.r.t.'s cathode voltages at 160V. This should be the "normal" setting.

## RGB Output Stages

Fig. 4 shows the red output stage. TR25 is a class A amplifier driving the two emitter-followers TR29 and TR26. Under normal drive conditions TR25 forward biases the base of TR26 via D204, the c.r.t.'s red cathode current flowing via R65, R63 (these two resistors are on the main panel), R212, TR26 and the flashover protection resistor R225. The voltage developed across R65 is thus proportional to the cathode current and is used as the feedback. With a sudden transition to black TR25 is cut off and the c.r.t.'s cathode capacitance is discharged via TR29 and D203.

TR20, TR30 and their associated components are common to all three RGB channels. TR20 is a constant-current source, providing a stable bias for the RGB amplifiers. When the set is first switched on TR30 is cut off and D209 is forward biased by the 12V supply. The current drawn through R65 and R63 develops sufficient voltage to bring the beam limiter system in IC3 into operation, overriding the auto grey-scale circuitry. The conduction of TR30 is controlled by the delay circuit R223/R227/C212. At switch on C212 charges via R223. Once TR30's base voltage rises sufficiently it switches on, reverse biasing D209. D210 provides a discharge path for C212 at switch off. The circuit is included to avoid the viewer seeing a peak-white auto grey-scale line during the heater warm-up period.

## Beam Limiting

In addition to providing a sample "black current" feedback voltage R65 also enables the TDA3301B chip to provide beam limiting. When the chip senses that the current in any of the three beams has reached the maximum allowable value the beam limiter system within the chip reduces the drive via the contrast arrangement. The maximum beam current is set at 3mA by the value of R57.

There's a further beam limiter circuit associated with the e.h.t. system, see Fig. 5. It's a conventional circuit based on a diode that cuts off when the total beam current reaches a certain value. The diode concerned, D27, is forward biased from the 115V h.t. line via R127 and R128. In normal operation the beam current flows via this diode. Should the current reach the excess level the voltage at the junction of R128 and D27 will swing negatively, cutting the diode off. The beam current path is now via R127/8. The negative-going voltage switches on the

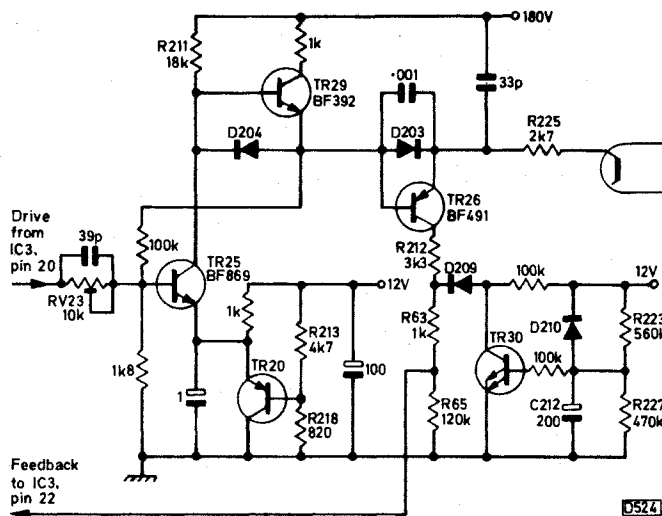

Fig. 4: The red video output stage circuit. The circuitry around stabiliser transistor TR20 and the delay-on transistor TR30 is common to all three RGB output stages.

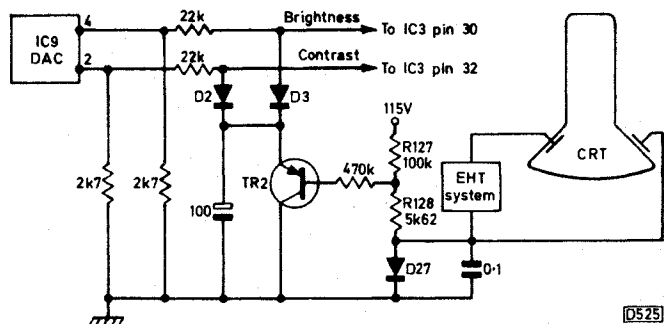

Fig. 5: The static beam limiter circuit.

emitter-follower TR2 so that diodes D2 and D3 also conduct, pulling down the contrast and brightness control voltages to provide static limitation of beam current.

This double-barrelled beam-limiting arrangement is popular in current designs, affording improved c.r.t. protection against excessive dissipation. Along with the stabilised heater voltage this technique helps prolong c.r.t. life, though there's a little sacrifice in terms of picture "punch". It's nowadays commonplace and is preferred to the "leap out and stun you" pictures of the early and mid-eighties.

## Alternative CRT Base Panels

There are two c.r.t. base panels, types PC1311-001 and PC1318-002. The only difference between them appears to be the value of the c.r.t. heater dropper resistor R222 which is 3.3Ω on the former panel and 6.8Ω on the latter.

## Standby Switching

A simple arrangement is used to give standby operation. The 5V and 12V l.t. supplies are derived from the TBA8138 regulator chip IC11, see Fig. 6. In the standby mode a low from the microcomputer chip is applied to pin 4 of IC11, switching off its 12V output. Since the TDA4505 chip receives its supply from the 12V rail the i.f. system and the timebase generators are cut off. In this condition the chopper circuit continues to operate in a low-power, high-frequency mode, as in the TX99. The maintained 5V supply keeps the microcom-

puter chip and the remote control system in operation. Otherwise the power supply and the timebase output stages remain as in the TX99.

## Remote Control

Signals from the infra-red remote-control handset are detected by a photodiode and then amplified by an SL486 chip, IC984. These components are on the front control panel. The output from IC984 is fed via a remote-control interface circuit in the teletext chip IC12 to the microcomputer chip IC7 where the commands are decoded and routed in the appropriate directions. IC7 also drives the LED displays. The control system consists of IC7, the memory chip IC13, the tuner control chip IC8 and the DA converter chip IC9. Decoded data travels from IC7 to the DAC chip via IC8 which inverts it. IC7's 4MHz clock crystal is connected between pins 4 and 5: the clock signal is also used by IC8 and IC9.

Reset for the microcomputer chip is derived from pin 6 of the 5/12V regulator chip IC11. At power-up this pin goes low for 200msec. During normal operation it sits at 5V while in standby the voltage drops to 4.5V. The reset function selects programme 1 and normalises the user controls.

The reason for passing the remote control data to IC7 via the teletext and graphics processor chip IC12 is that this i.c. checks for text commands. These are not passed on, being diverted to the text/graphics system in the chip. The other commands are passed to IC7.

## Teletext

Though the set is described as having a single-chip teletext decoder, the Texas CF70064 teletext decoder chip IC12 works in conjunction with the CF72303 data slicer chip IC16. Video from the switching chip IC14 reaches IC16 via the buffer transistor TR22. Thus teletext signals coming via the scart socket can be decoded. This is useful where a satellite TV receiver is connected to the scart socket. The data slicer chip generates clock, data and sync signals. It has a crystal oscillator that runs at 55.5MHz, eight times the teletext clock frequency: the crystal is connected between pins 11 and 12 – you should see 6V peak-to-peak at pin 12.

The inclusion of nearly all the teletext decoding and display generation circuitry within the 28-pin CF70064 chip is a considerable achievement. This is not a fully-implemented Fastext system however. The coloured buttons do not give instant access to the desired page but, in this version, give one-button selection of the page number. After that the decoder looks for the page in the normal way.

IC12 also provides on-screen graphics which are called up whenever a remote-control command that necessitates their appearance is received. This is organised by the chip's internal logic and is one reason for routing the remote-control commands via this chip. The system timing oscillator runs at 22MHz. It's controlled by the BB531 varicap diode D41 linked to pin 26 – the control voltage comes from pin 28.

## RGB Source Switching

The TEA5114A chip IC17, see Fig. 7, provides switching between the RGB and fast blanking signals from the teletext chip and those from the scart socket. Pin 8 (source switching) of the scart socket is not

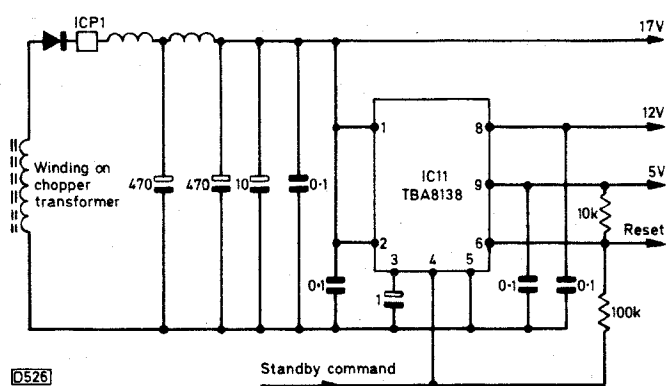

Fig. 6: The 1.2V regulator circuit also provides standby switching. In early production a subpanel with separate 5V and 12V regulators was fitted in place of IC11.

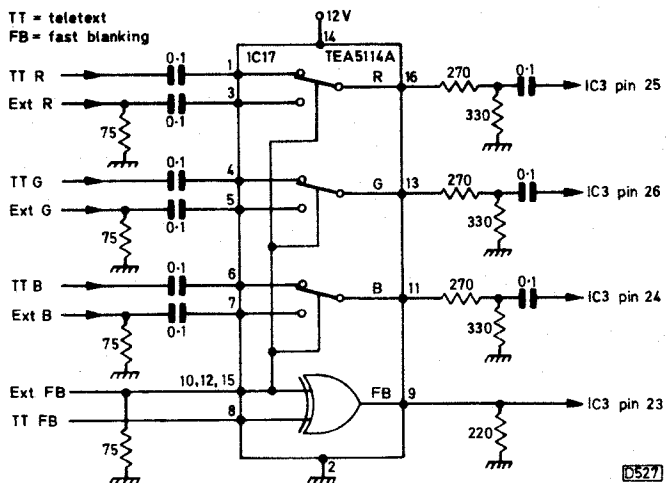

Fig. 7: The RGB source switching chip IC17.

connected. An exclusive-or gate in IC17 selects the fast blanking from either source automatically.

## Summary

The TX98 chassis should earn for itself a place in engineers' hearts for its straightforward design, ease of servicing and performance. Much has been crammed into the chassis, yet the layout is uncluttered. The receiver works well with mediocre signals, is light on mains power – it could well work with a battery adaptor if one is ever made available – and offers all the features of an expensive model at a moderate price. As the nine in its chassis number suggests it's designed to drive 90° tubes.

The set should not present any serious challenges to the service engineer. Remember that the sync pulses and the remote control commands pass via the CF70064 teletext chip, points that could lead to confusion. Failure of the BY500-800 h.t. rectifier D17 can cause damage to the following components: the chopper transistor TR3, its TDA4600-2 control chip IC6, the mains bridge rectifier diodes D6-9 and the degaussing thermistor Z2 which also acts as the surge limiter. With any faults in this area use only direct Ferguson replacements. There have been one or two minor modifications. R35 has been changed from 1kΩ to 560Ω to overcome loss of colour with high beam current; C74 has been changed from 22nF to 15nF to improve the h.f. response with the smaller-screen model; C40 has been deleted with main board PC1410-006 (Model 36K3) to correct a small h.f. video lift because this model doesn't have scart facilities.

# Features of the Sharp VCD-805

Mick Dutton

Sharp's top of the range VCD-805H VCR has some very impressive features. These include digital picture effects such as nine-picture strobe, frame-by-frame advance, picture-in-picture, variable-speed strobe and a nine-channel picture search that enables the user to scan the broadcast band and sample the programmes available. The digital circuitry also provides a superb still-frame picture. Other features include a comprehensive on-screen display, a linear tape counter and index search. Picture quality is excellent in the normal and the trick modes. The machine follows normal Sharp design practice, with everything accessible and the panels laid out logically. Design is up to the minute all round, including a digital servo system.

The sophisticated on-screen display system provides the user with full timer-control information in an easy to understand form. In the absence of a signal it provides a blue screen with the Sharp logo, which doubles as the initial tuning signal.

A data bus links the system control and timer chips along with the servo and digital circuits. The tuning chip is also responsible for the key scan and processing of the remote control information.

The mechanics are new, but appear to be just as solidly built as in previous machines.

## Video System

The digital section is contained in a metal can that's mounted above the other electronics. Fig. 1 shows a simplified block diagram. Incoming off-air, playback or external (from the scart socket) video is applied to selection switches and then follows two paths, called main and sub video. The main video signal is buffered and then passed via a switch and amplifier to the r.f. modulator and the scart socket's video output pin. This switch is used to select either the main or the digitally generated signal. It can switch between the two pictures or one picture can be inserted into the other one.

The sub-video path also starts with a buffer, after which the signal is separated into its luminance and chrominance components. A low-pass filter ensures that there are no luminance signal components above 3MHz, to avoid interference with the 10MHz sampling carried out in the following analogue-to-digital converter. The digitised luminance is then fed into two memory chips each of which stores a complete field. A 4.43MHz bandpass filter selects the chroma signals, B - Y and R - Y, which after demodulation are digitised and stored in a single memory chip.

A sync separator extracts the sync pulses which are passed, as write sync, to the memory control chip to lock its write clock. This chip contains most of the digital signal processing. It provides digital chrominance (R - Y and B - Y) and luminance outputs that pass to three separate DA converters. After filtering the analogue signals are fed to the encoder chip where sync from the main signal path is inserted so that both sets of signals are locked.

Let's consider briefly the way in which a digital picture for insertion in the main one is formed, see Fig. 2. Since they are extracted and reinserted later it's not necessary

to digitise the sync signals. With a 51.2µsec length of line sampled at 10MHz there will be 512 samples per line. In the vertical direction the top 30 lines and the bottom 9.5 aren't sampled, leaving 273 lines that are digitised. After processing, an insertion signal box that's 17µsec wide and 90 lines high is obtained.

The AD converters are conventional. The luminance input is first clamped then fed to 64-bit comparators whose outputs pass to a 64-to-6 bit encoder. A data latch and buffer feeds the signal in serial form to the memories. The reference voltages for the comparators come from an integrated ladder network fed from internal reference sources, giving a 2.8V reference at the bottom of the ladder for black level and 3.5V at the top.

The chroma AD converter operates on similar principles but in this case the incoming R - Y and B - Y signals are multiplexed at 2.5MHz to provide alternate samples. Clamping is somewhat different since the reference position is mid-point, i.e. no chroma means the half-voltage level. Thus the chroma can swing between positive and negative values. This time the sampling rate is 5MHz, with the output to the memory again in serial form.

The three memory chips, two for luminance information and one for chroma, are identical. They are unusual in having separate inputs and outputs to enable them to be filled at the same time that they are being emptied. This gives perfect transitions between successive digital pictures. Each chip can store 320 lines × 270 columns, and a refresh circuit is built in to ensure that the material doesn't deteriorate with time. The heart of the digital circuitry is the memory control chip, a 100-pin monster. Amongst other things it generates all the timing pulses and the sync signals required.

There are two voltage-controlled oscillators, one for writing information into the memories and the other for reading it out. The write clock is synchronised to the sub-video input. It runs at 10MHz. The 5MHz chroma sampling pulses and 2.5MHz R - Y/B - Y multiplex pulses are derived from it.

The read clock also runs at 10MHz. It generates sync pulses and pulses for reading the information out of the memories, and is locked to the main video line sync pulses. As a result the digital video is synchronised with the main video source, giving noise-and jitter-free transitions.

In the digital pause mode the information coming from the video heads contains considerable noise. As this signal would be unsatisfactory for locking a VCO the VCO is switched off. The 10MHz crystal-controlled oscillator is then used instead.

The memory control chip combines the information from the two luminance stores to provide an output to the luminance DA converter. The chroma signals have to be demultiplexed then sent to separate DA converters. DA conversion is simple. The incoming serial data operates a series of switches that place, in turn, the 5V supply across different combinations of an internal resistive ladder network. The outputs are buffered then fed through low-pass filters to remove any residual sampling frequency components. For the luminance signal the filtering cuts off signals above 3MHz. With the

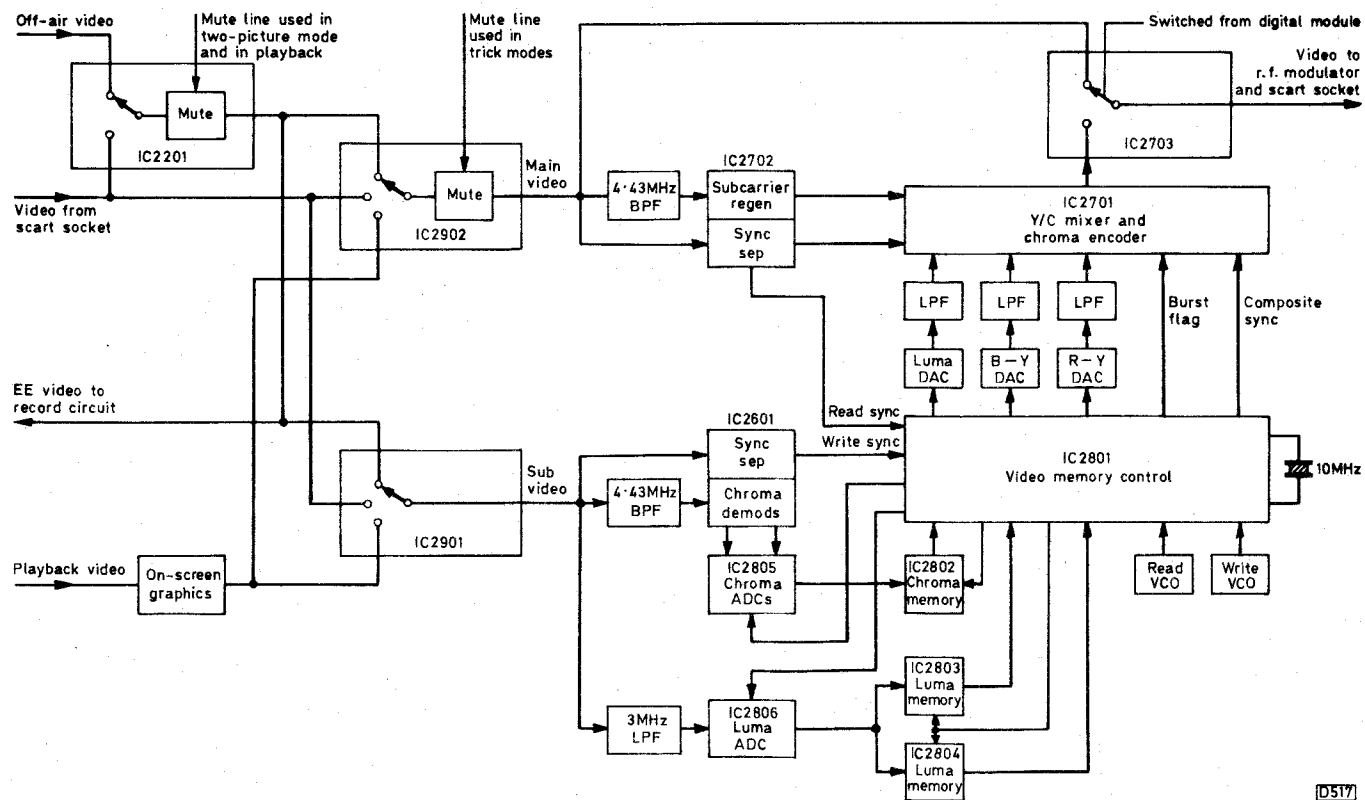

D517

Fig. 1: Simplified block diagram of the digital video processing circuitry.

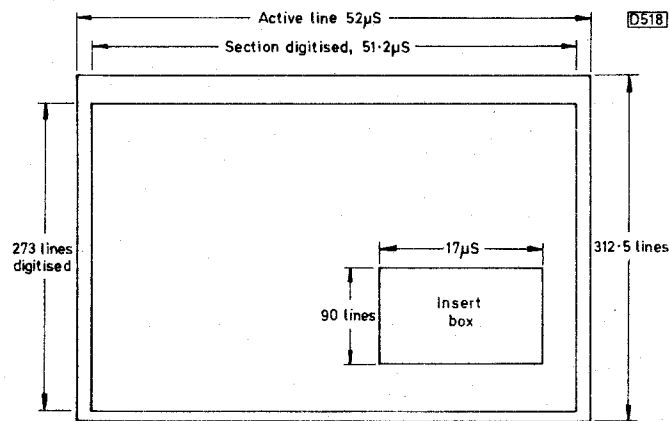

D518

Fig. 2: Sampled area of the picture and the size of the insert box.

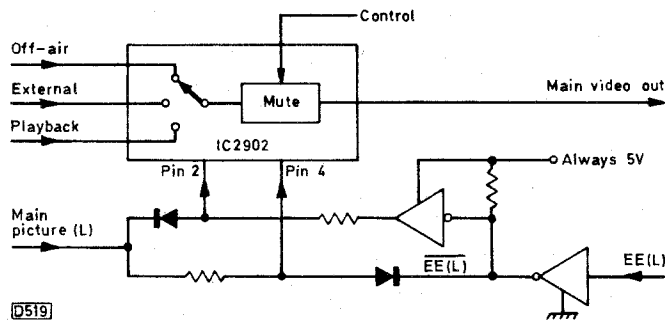

D519

Fig. 3: Main picture selection switching.



D520

Fig. 4: Symbols used to denote digital transistors. (a) NPN type with type number starting DTC. (b) PNP type with type number starting DTA.

chroma signals the cut-off is at 1MHz.

The three signals are finally fed to an encoder chip that produces a composite video output complete with reinserted sync and burst, along with the colour subcarrier.

### Video Switching

As its name suggests, the main video provides the main picture. The sub video is digitised to provide effects and picture-in-picture. To reverse the presentation of the two pictures seen in the picture-in-picture mode all video sources have to be switched in both channels. This is done by electronic switches which are controlled by high and low signals on the playback-high and digital-on control lines. Fig. 3 shows the relevant circuitry and Table 1 the logic conditions. It's also necessary to switch the initial input to the machine from off-air to scart sourced, which is also done by the switching chip. Digital transistors - see Fig. 4 - control the switching. An

interesting point here is that low is represented by a voltage of less than 0.5V while high is 1.8V or greater.

Servicing should be fairly straightforward, and if previous Sharp models are anything to go by the reliability should be high.

Table 1: Picture selection logic.

Mode	EE (L)	EE (L)	Main pic	Pin 2	Pin 4
EE or two-picture	L	H	L	L	L
Play or two-picture	H	L	L	L	L
Two-picture reverse (EE sub video)	L	H	H	L	H
Two-picture reverse (play sub video)	H	L	H	H	L



## Philips VR6542

I recently had to sort out one of these VCRs for another local engineer who had tried to change the cam switch but had lost the gear alignment. The manual shows you how to align the gears using the triangular timing holes – the only snag is that the factory fitted gears don't always have them! Replacement gears do, thank goodness, so I cheated and fitted new ones.

If you have to change the cam switch and the triangular holes aren't present, mark the positions of the main and brake cams by scratching marks on the metal with a jewellers' screwdriver, through the small holes.

If one of these machines comes in with intermittent mechanical problems, to save time I change the loading belt, brake and master cams, and the cam switch. After doing this you should – as long as the reel idler is o.k. and the capstan motor hasn't got a dead spot – have covered the likely failure points. This has been my experience to date anyway.

P.B.

## Philips VR6290/1/3 and Clones

If the BUT11AF chopper transistor repeatedly fails in the customer's home but doesn't in the workshop, try fitting modification kit 4822 310 31817. Power supplies with a green label have already been modified.

P.B.

## Grundig VS200/220

If you look in the front of the service manual for these machines you'll see that there's a special function which allows you to put the machine in play without a tape. I tried this on several occasions and it didn't work. Then, while looking through Grundig's technical tips one day, I found out why – you have to lower the cassette tray first! Do this by pressing the cassette-in switch by hand for a few seconds. It isn't necessary with models such as the VS340 as with these the machine lowers the tray for you.

P.B.

## Grundig VS200

We've had several of these machines with a defective audio/control/erase head. The last one that came in had another problem – tape creasing when "back editing control" was working, prior to a recording being made. It seems to be essential to bend the leading roller on the threading ring backwards or forwards, despite perfect alignment of the ACE head, to ensure that the tape path is exactly central on this roller. Beware of this one.

B.McC.

## Logik VR955/Samsung VI711

No erase bias at all was caused by an internal fault in the bias oscillator coil unit L0504. It's perhaps worth noting that the Samsung unit is much cheaper.

R.J.L.

## Ferguson FV10B

The repair ticket said "dead", and the machine was very dead indeed, with no display and no functions. A check at pin 10 of the voltage regulator chip IC801 showed that the 13.2V which should have been present here was missing. A glance at the circuit diagram showed that there were

several possibilities for this. The culprit turned out to be R1 (10Ω) which had gone open-circuit. A replacement brought the machine back to life.

E.R.

## Matsui VX3000/Saisho VR3400

A fault you sometimes get with these machines is loss of the playback picture, resembling head wear or failure. As often as not however the cause is poor head amplifier earthing, which is achieved via the screening can. The cure is to solder a short length of copper braid from the top of the screening can to the copper static discharge strip on the head drum.

E.R.

## Telefunken VR4935

The function LED wouldn't come on but the machine would accept a cassette. When play was selected the tape would lace up then immediately unlace. In the fast-forward and rewind modes the machine would run for a couple of seconds then stop. Having had this fault before we went straight for the STK5481 voltage regulator chip, which proved to be cause of the problem.

E.R.

## Ferguson 3V31

A recent case of no channel storage in this early search-tune machine was caused by loss of the -23V supply. It should be present at pin 9 of IC205, an MN1218A RAM. Q207 proved to be open-circuit.

S.L.

## Saisho VR1000

The fault with this machine was normal playback but no E-E video. C9, a 470μF, 10V electrolytic that couples the output from the i.f. section to the rest of the circuit, was leaky. As recently reported, this fault also occurs with the Amstrad VCR4600/4700 range.

S.L.

## Ferguson FV13H

This machine had been to two other companies before it was brought to us. The fault was very intermittent tape stopping, sometimes accompanied by some noises, with associated tape damage. We left the machine on test, partially dismantled, with a meter across the reel motor. Eventually we found what was causing the problem – intermittent no take-up. A fortunate guess on my part! The meter said that the supply continued to be present, so this left the motor itself or the idler/clutch assembly. As the motor didn't read open-circuit the whole assembly – the reel motor plus clutch – was removed and the idler was inspected. It appeared to be in almost new condition, but was very rough when turned by hand – particularly at one point. Separation of the unit into its two parts is easy. When this had been done the reason for the roughness was evident – a small piece of magnetic material was loose inside and would periodically jam, preventing movement. The internals were fortunately intact, and once the foreign body had been removed normal operation was restored. The material had presumably been there since the machine had been made, as the customer complained of the fault from new.

The drive system is ingenious – simple and effective. The idler/clutch has only two sections, with none of the usual felt pads, springs, washers, etc. Take up torque would appear to rely on the motor drive plus the magnetic flux/attraction between the two idler sections. Very neat.

Another of these nice machines came in with no capstan drive. The circuit is simple, with the microcomputer chip IC601 delivering capstan on/off commands via pins 52 and 53 to the M54644BL capstan drive chip IC604. IC601's outputs were present but there was no output from IC604. As a cross check IC604 and IC605 were interchanged – the reel drive chip IC605 is the same type. This proved the point by giving us capstan operation but no reel drive. **S.L.**

### **Logik VR950**

The only problem with this machine was that it wouldn't switch off. Because Q3 (2SC815) was short-circuit collector-to-emitter the power supply was always on.

**M.D.**

### **Saisho VR3650**

The complaint with this machine was noise bars on the screen. We found that the right-hand loading arm didn't locate fully in its V block. Further investigation showed that this arm was loose as the tension spring within its operating cog had broken. Incidentally the same mechanism is used in the Matsui VX850.

**M.D.**

### **Philips VR6462**

The customer's complaint was that this machine would play but not record. This proved to be the case: when record was selected you couldn't tune in a station. As another machine was handy we swapped the tuner/i.f. panel P104. The first machine then worked all right. Access to this panel in situ is very poor, but after replacing the machine's own panel we managed to check the voltages at the tuner. This showed that there was no voltage on the tuning line to pin 7. We traced the source back to IC7401 where there was no still output, but connecting the meter to pin 8 of this chip restored the tuning. This pin is the 30V input from the regulator. We let the machine cool down then tried again. This time there was no voltage at pin 8 and on tracing back to the regulator we found that there was a 40V input but nothing from T7601 (BC556A). Replacing this transistor restored normal operation.

The second machine would jam a tape as it loaded. We found that the spring in the right-hand side of the cassette lift had come out. As a result the lift would jam half way down.

**M.D.**

### **Ferguson 3V29**

There was no reel drive and no supply to the motor. We checked back through the junction PCB to the mechacon panel where there was no drive voltage output from the reel drive chip IC12. We soon found that there was no input supply at pin 10. This comes from regulator transistor Q1 via CP-20. The problem was that Q16, which turns Q1 on, was open-circuit.

**M.D.**

### **Panasonic NV333**

The customer's complaint was that the machine would intermittently shut down during play or record. We ran several tapes through before the fault showed up. There was excessive tape tension – even with the back-tension

lever pulled off the tape tension was still high. A check revealed that the supply spool was stiff on its shaft. Stripping this down and greasing it provided a cure. **M.D.**

### **Saisho VR1200**

This machine didn't always start – there would also be no clock display. Q2582 can cause the problem but this time the cause of the fault was dry-joints on the 6V regulator. It's mounted on the chassis, to the rear of the head drum.

**M.D.**

### **Panasonic NV-G40**

This machine would accept a tape and half lace it correctly, but when asked to give the tape back it refused. We found that when the machine began to unlace and the mechanism reached the point where it has to click the solenoid to move to the next stage, i.e. half way between half lace and the entry to the cassette, the mechanism stopped as the solenoid didn't move. Despite the fact that the solenoid worked perfectly on the outward excursion it was the cause of the fault.

**N.B.**

### **Ferguson FV32L**

The job card said "no r.f. output". Now dry-joints in the r.f. amplifier/modulator unit can cause this, and I was thinking about it when I picked up the job. But this time the cause of the trouble was quite different. There was no tuning as the pulse-width modulated drive from IT20 was missing. Furthermore the following BC558 transistor that supplies pin BT of the tuner was short-circuit all ways round. The tuner had a short to earth from pin BT and all three devices had to be replaced.

**N.B.**

### **Ferguson FV31R**

The installer complained that this new machine was dead. On the bench that ever so nice power supply (see J. LeJeune's article in the July 1990 issue) pumped and whistled at me. With the covers removed I switched the machine back on at the mains and it started up correctly. My next fault-finding step may seem odd to those of you who don't know these VCRs: I tapped the tuner/i.f./signals PCB that sits across the top of the machine. It could then be made to stop and start. My experience has been that however strange the symptoms this is very often the area in which the cause of the fault lies. After looking at thousands of perfectly good joints I eventually found that there was an intermittent short in the tuner/r.f. amplifier. I should have looked there first of course.

**N.B.**

### **Logik/Triumph/Saisho**

The problem I've had with various Logik, Triumph, Saisho etc. machines that use an Orion deck is no capstan rotation in play. In each case the cause has been a metal pin dropping out of the plastic arm that feeds through the deck just in front of the capstan. It usually falls out when you remove the bottom cover. You will need to glue it back in – the pin protrudes on the lower side of the arm.

**N.B.**

### **Help Wanted**

Does anyone have a new or serviceable video head for the Philips VR2334? The part number is 4822 691 20195. Please write to Philip Blundell, AMIEIE, c/o the Editor at the editorial office.

# Steve's Camcorner

**Steve Beeching, T. Eng.**

I've commented before on fault symptoms being caused by a component in an apparently unrelated part of the circuitry. Recently I had another classic example, a weird fault with a JVC GRC7 camcorder. In fact I was caught out twice by this one.

The fault report was "no tracking control – possibly dirty heads". On test I found that the picture was o.k. but a bit grainy and noisy because the heads were slightly off track. The tracking control had no effect.

Checks were made around the servo chip IC101. There was a tracking ramp waveform at pin 18, to which the tracking control is connected. When the control was adjusted the ramp's rise-time period varied – this confirmed that the tracking circuit monostable was working. Much time was then spent checking the rest of the capstan servo. I found that nothing else, from the pulse width outputs of the digital servo to the motor drive, varied when the tracking control was adjusted.

Now the only times when the tracking circuit is inoperative are when the camcorder is in the record or assembly edit mode. In these modes switching within the chip controls the tracking, but there's no way of checking the situation externally. The camcorder was clearly not in the record mode. Perhaps it was stuck in assembly edit? Checks on the control logic and various voltages and waveforms confirmed that the machine was in the playback mode. It seemed therefore that the chip was faulty. A replacement was fitted and, as you've probably guessed, there was no change.

More time was spent cross-checking around the chip, but I still couldn't find any reason for the lack of servo control. The switched 5V line was correct so there was nothing wrong with the supply to the chip. There was no ripple on the supply. In fact there was no reason for the fault condition.

The only logical course left was to swap the main PCB temporarily with one from another GRC7. When this had been done the fault was still present. I then found that the main board worked fine in the other machine. So the main PCB, which contains the entire control system, the power supplies, the servo electronics and tracking system was without fault.

There followed a frenzy of uncontrolled board swapping, just to narrow the fault down to one PCB or

the chassis. The breakthrough came when the operation panel was changed. This cleared the fault, with full tracking restored. I then noticed that the LC display on the panel was blank – there was no voltage across it. Now comes the fun bit.

The operation microcomputer chip and serial interface are supplied by an always-5V line, AL5BV. The same line supplies the display, via three small series diodes to provide a voltage drop. C6 decouples the output from the diode droppers. It was short-circuit and as a result the AL5BV line, which comes from a regulator, was low at just over 4V. Strangely, when C6 had been replaced the servo tracking fault had cleared.

So a shorted capacitor that decouples a different 5V supply to the one used by the servo circuitry caused a servo fault! The only explanation I can think of is that the low voltage to the operation microcomputer chip

resulted in it producing serial data which the servo chip interpreted as “assembly edit/play”. As a result the tracking control circuit was disconnected.

I was caught out twice because I went for the obvious possibility of dirty or faulty video heads first and didn't spot the fact that the tiny LC display wasn't working. It won't get me again – or will it?

# Servicing the Ferguson 3V29 VCR

Joe Cieszyński

This popular VCR of early Eighties vintage was designed and built by JVC but was distributed by a number of manufacturers under their own brand names and model numbers. It came on the market at the time of a video boom, and in consequence was sold and rented in large numbers. Ten years later many of these machines are circulating on the secondhand market in excellent order, having stood the test of time. Because of their reliability and a ready supply of cheap spares, these machines are often well worth overhauling. In this article I'll be highlighting some common problems. I'd also point out that these machines are ideal for training purposes: they are basic, easily accessible for servicing, spares are cheap, advice is not difficult to come by and, should you do something silly to them, they are usually very forgiving.

The basic JVC version is Model HR7200, but in the UK the Ferguson 3V29 is more often encountered. Other guises include the Decca/Tatung VHR8300, the Granada VHSWJ1 and the ITT TR3913. It's a basic model with a single-event timer and wired remote control. The 3V30 (JVC HR7300) looks much the same but has a multi-event timer and Dolby sound: it was distributed through Thorn rental outlets as the Baird 8930. The various manufacturers who marketed these machines had their own customised front panels, which enabled the layout of the controls to be varied. They are quickly identifiable however by their characteristic pop-up cassette housing, the large preset tuning cover to the right of this and the three-position standby/on/timer switch at the front left.

## Modifications and Variations

During the two-three years when these machines were in production several major modifications and additions were introduced. This is something that must be taken into account when using circuit/layout diagrams for fault finding and when considering the use of panels from a scrap machine. The main changes are outlined below. Fig. 1 shows the basic panel layout.

The luminance/chroma/audio (YCA) board at the bottom of the machine underwent three major design changes during production, the modifications being confined mainly to the luminance and f.m. circuitry. In the earliest version all the YCA circuits are on the main panel. The second version had a noise-cancelling circuit added using a chip designated IC1 (not to be confused with the audio processor chip which is also labelled IC1): this circuit couldn't be contained on the main panel, so a sub-panel mounted beneath the presetter board was added. Connectors 161-162 and 171-174 were added to the main panel to link it to the sub-panel. The third version has an enlarged sub-panel to accommodate extra noise-cancelling circuitry, while the main panel has extra interconnection sockets. In addition, with this version the f.m. and luminance signal paths on the main panel were altered drastically, making it difficult if not impossible to trace signals using one of the earlier diagrams.

Another major area of change is the motor drive amplifier (MDA) circuit and board. In the earliest machines the drum MDA circuit consists almost entirely of discrete components: the board is mounted vertically in front of the cassette housing. A little afterwards the twenty

nine transistors were replaced by a single HA13008 chip. The modified PCB is mounted in the same position. Subsequently the main servo board on the left-hand side was redesigned to accommodate the drum and capstan MDA circuits – the compartment forward of the housing was left vacant. The servo and MDA circuits remained unchanged, i.e. the same chip set was used, only the board layout being different.

A new microcomputer/system control board was introduced at the same time as the combined servo/MDA panel. The later version has a different plug/socket arrangement. Thus the two boards are not interchangeable, though the individual chips are.

There's also a version (Baird 8940/JVC HR7350) with stereo sound: this has a new servo chip set, the circuitry bearing no resemblance to the earlier versions – not even the i.c. circuit reference numbers are the same. The main change here is the replacement of the 28-pin HA11711 servo chip with a 40-pin BA851A (IC2 on the new board). Two BA6302A chips replace the three VC1029 frequency-voltage converter chips. In the earlier circuits the third VC1029 is used for reel motor control during visual search: in this later version IC8 doubles as capstan speed control for playback/record and reel motor control during search. Another significant change in the 8940 is the accommodation of the Dolby stereo sound PCB in the vacant compartment in front of the cassette housing. This is worth noting as it is not unknown for an unsuspecting engineer to look for an MDA fault on the Dolby stereo sound board! This model was amongst the first of the stereo VCRs, prior to hi-fi sound: it was not a great success because the stereo sound still used the lateral audio tracks and, as a result of the low tape speed (23.39mm/sec), the audio quality was nothing like hi-fi.

The majority of machines have an f.m. test point (TPFM) atop the deck terminal 1 board. In the 8940 the f.m. test point is on the servo panel: it's towards the rear of

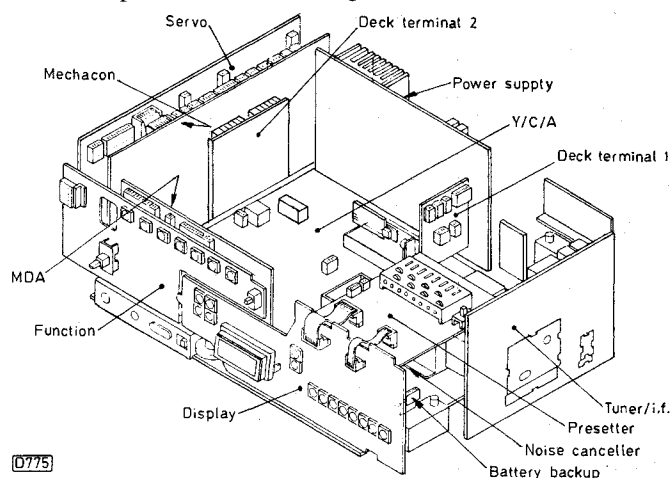

Fig. 1: Panel layout. The earliest versions didn't have the noise-canceller board or battery back-up. On later versions the MDA circuit was put on to the servo board, leaving an empty compartment behind the function board. On the stereo sound version this compartment was used to house the additional audio circuits. The deck terminal 2 board is needed only with the combined servo/MDA board: it was added to accommodate the interconnections between the MDA, the system control and the motors.

the board and is designated TP9.

Another addition with the 8940 is a ni-cad battery and charger circuit to provide clock and timer back-up in the event of mains failure. These items are located next to the noise-canceller sub-panel beneath the presetter board.

In some cases it's possible to interchange panels between different versions of the machine, but this is rarely possible without having to carry out modifications.

### Basic Mechanical Overhaul

In most cases a 3V29 can be restored to normal working order by replacing the pinch roller, the loading belt and the cassette lamp. This should of course be accompanied by thorough cleaning of the tape path. If this basic overhaul has restored normal operation, it simply remains to check the tape path for signs of tape curl, the reel idler operation, the take-up spool torque, the condition of the heads, and the tuning presets. Once these points have been attended to and any repairs required have been carried out the average machine will be ready to give a further four-five years of trouble-free operation. Many other problems arise quite frequently however. A more detailed account of these and how to cope with them follows.

### Mechanical Faults

A pinch roller that has done more than a thousand hours of service generally needs replacement because it becomes concave, see Fig. 2. Thus the tape will slide up or down with respect to the audio/control head. The result is poor quality h.f. audio response or poor tracking due to loss of the CTL pulses. Both symptoms can be intermittent. Creasing of the tape edge may also occur.

The same symptoms can be caused by a distorted pinch-roller mounting bracket. It becomes distorted when excessive pressure is applied whilst removing the pinch roller fixing screw. It's worth checking for this during each routine service. Fig. 3 shows the method of checking the mounting.

The back-tension band is not a source of trouble with these machines. If it appears to be well worn however it should be replaced. According to the service manual the torque should be set at between 30-40g-cm, using a back-tension cassette. The only correct way to set back tension is to use some form of tension gauge. If you are working on only the occasional machine however, out of interest rather than as a repair service, the 3V29 is, unlike many other models, very tolerant and will often allow you to set the tension using the method outlined below (see Fig. 4) – but I must emphasise that you do so at your own risk. Tension is adjusted by moving the foot (A) from left to right. Without a tension gauge, fitting a new band in the same mechanical position as the old one will usually give you approximately the correct tension. Where the original band has been moved (you can tell if the locking glue has been broken), approximately correct tension should be obtained by aligning the slot in the foot with the adjacent hole in the chassis. This forms a good starting point when you do use a tension gauge.

The loading belt in this machine is notorious. When it stretches it will either fail to close the after-load switch, as a result of which the machine will unload after about ten seconds, or it will fail to close the unload switch, with the result that the motors continue to rotate after unloading and the cassette housing won't open. Both symptoms may be intermittent.

To replace the belt, remove the loading motor assembly

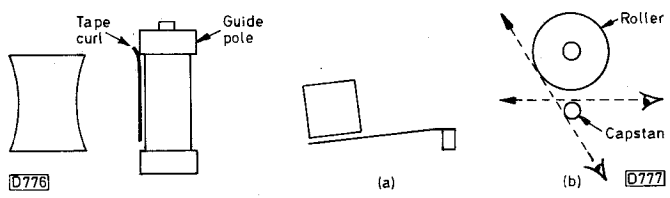

Fig. 2 (left): A concave pinch roller results in uneven pressure on the tape, which will slip up or down on the exit guide pole. It's best to check the pinch roller by removing it.

Fig. 3 (right): It's essential that the pinch roller is vertical. A distorted pinch roller mounting bracket is shown at (a). The pinch roller can be checked, see (b), by pressing the roller towards the capstan with a finger, leaving just a narrow gap through which the roller can be sighted. Use the capstan as a reference. Check from two angles, as shown, for zenith and azimuth distortion.

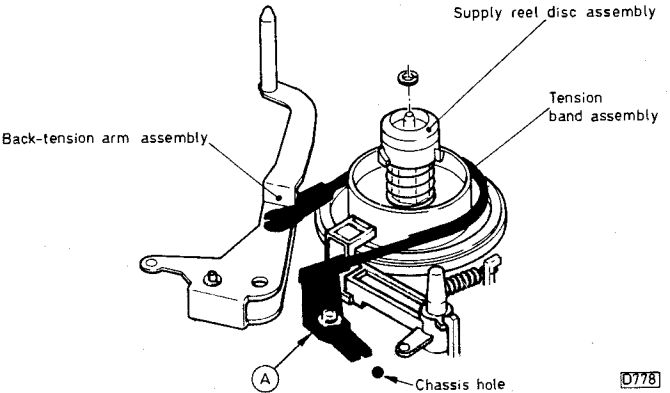

Fig. 4: The back-tension assembly.

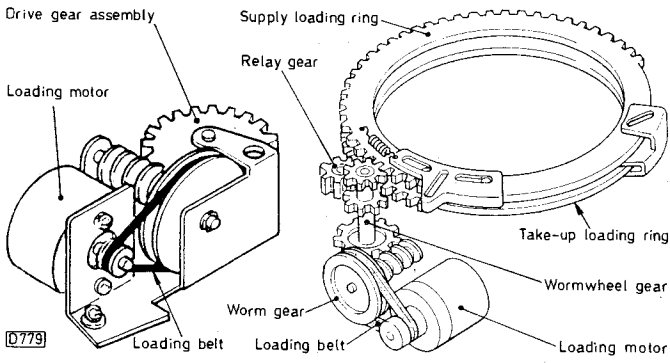

Fig. 5: The loading block and loading rings. The simplest way to replace the belt is to remove the block, but note that the rings are then free to move and can thus become unmeshed.

(see Fig. 5) and release the circlip. But beware: when the motor assembly has been removed the two loading rings are free to move and, after reassembly, may be out of mesh. This problem can occur even when you take great care as you remove and replace the assembly. What usually happens is that the gears on the motor block rotate as you change the belt. Thus when the motor block is reinserted the gear teeth no longer locate with those in the rings. One's natural instinct is to gently juggle the motor block until the teeth are aligned, but this is when the rings move out of mesh. What you should do is to lower the motor block on to the rings and, if the teeth don't engage immediately, gently rotate the motor pulley until they do. The operation isn't difficult: I've managed it successfully in a customer's front room on many occasions.

If the rings do become unmeshed, remove the loading block, fully retract both the slant poles, look to see that the

teeth on both rings are aligned above each other, then reinsert the loading motor block. Now check the loading, ensuring that the guide rollers locate firmly in the V notches.

You may occasionally encounter a machine in which the loading motor has lost its torque, or where a tooth on one of the drive gears has come adrift. These are not common problems with the 3V29 however.

Still connected with the loading belt, another problem you might encounter is the afterload switch actuation bar sticking. This bar is on the top of the deck, running beneath the supply spool, the back-tension arm and the sub-deck. It has a hook at one end – this presses against the switch when loading is complete. The bar sticks because the hook is bent: the latter occurs because many engineers do this in a vain attempt to correct the fault caused by a stretched loading belt (they are usually not aware that the belt is the culprit, and bending the bar seems to be the obvious cure).

It's not possible to straighten the bar from beneath the deck – this will introduce a kink that will cause sticking – and the bar cannot be removed as it's secured to the chassis by rivets. The best thing to do is to remove the back-tension arm, the sub-deck and the loading rings, after which the bar can be straightened from above, using a wide, flat-bladed screwdriver and some gentle percussion.

As with many other VCRs, the take-up clutch is a common cause of trouble. Intermittent tape spillage into the machine, or the machine going into the stop mode during play, are more often than not caused by a defective clutch or the take-up idler which is between the clutch and the take-up spool.

The manual quotes a take-up torque of between 60-150g-cm. A torque gauge is not essential however. Diagnosis of a defective clutch can usually be carried out by playing the latter part of a three-hour tape and watching the spool operation for a brief period: you will see the spool begin to stall.

The reel idler also gives its fair share of trouble. Apart from poor fast winding and failure to reel the tape into the cassette when unloading, the reel idler is also the main cause of poor visual search performance. During search the reel motor comes under the control of a servo that uses the control-track pulses for feedback. If the idler is worn or dirty, the servo will not be able to maintain proper control of the nine times normal tape speed.

Another cause of poor search is a slightly dirty CTL head. The head may provide sufficient output for normal play, but in the search modes the CTL output falls and the servo accelerates the reel motor to the full fast-wind speed.

Occasionally, apparent failure of the reel idler may be due to distortion of the plate spring behind the idler. This spring keeps the idler pressed against the motor pulley when it's jockeying between the two spools. If the spring is distorted the idler won't throw over. You can usually straighten and retension the spring.

Unlike other makes that I could mention, the reel motor rarely gives trouble. Before you condemn it I would recommend that you rule out all other possibilities.

Because of the age of these machines, worn or hardened spool carrier tyres are common. If they need to be renewed it's advisable to replace the clutch and the reel idler at the same time (unless new ones have recently been fitted).

The guide rollers should never fail. But thousands have had to be replaced because they have been adjusted without releasing the locking screw at the rear base. If the top of the roller appears to be chewed, scope the f.m. waveform while a known good tape is being played and

look for signs of dropout. If dropouts are evident it's best to remove both rollers and inspect the shafts. Look for scouring caused by the locking screws. I always replace the guide roller(s) when scouring is evident – experience has shown that a lot of time can be wasted trying to set the rollers when in fact they've become distorted.

Here's a practical hint when adjusting the guide rollers. Holes in the V notches make it possible to release and secure the hexagonal locking nuts with the machine in the play mode. After adjustment it's advisable to secure the screws with the rollers in this position, as otherwise they have a tendency to move out of alignment when unloading.

A number of things can cause poor tracking and a poor f.m. waveform. When you feel that you've tried everything possible to correct this situation the slant pole(s) are suspect. In several machines I've come across a slant pole has worn at the point where the tape runs round. In all cases the wear has been almost unmeasurable and invisible but a replacement pole has cured the problem.

A common problem occurred in the early days when someone would fit the drum rotor back on its shaft in the wrong position. This puts the PG magnets out-of-phase with the video heads, causing all sorts of upsets. Most engineers today are aware of this problem, but do bear it in mind if you have to remove the rotor: the locking screw must locate against the flat on the shaft.

The cassette housing is robust and quite reliable. Occasionally you come across one where fluff or fur have become entangled around the damper fan mechanism, the result being that the housing won't come right up. The main problem with the housing itself is refitting it after service. If it's too far back, i.e. away from the front of the player, the machine may eject the cassette whilst in the play mode. If it's too far forward it will fail to eject at all. There was originally a housing alignment jig, but I doubt whether many people ever used it. In the main, correct operation will be obtained when the housing is fitted loosely, pulled fully forward, then pushed back about one millimetre. Secure the housing then check its operation by playing a tape then pressing eject, preferably with your hand over the housing just in case!

The capstan motor is on the whole reliable but is occasionally responsible for wow and flutter. The main complaint about it however is the noise it produces – the motor tends to hiss constantly when running. Before you spend a large amount of money on a replacement note that they are like this from new.

The drum motor is equally reliable, but you can come across one where a Hall element has failed or where the PCB breaks inside the motor, the result being that it either takes off at full speed or runs at a snail's pace. I also had one machine in which patterning and noisy chroma were caused by a defective rotary transformer. The f.m. waveform in one channel was clearly noisy, and a replacement lower drum assembly (after replacing just about everything else) provided a cure.

## Electronic Faults

In its youth the 3V29 had its fair share of electrical faults. This was quite unlike the earlier 3V00/3V16/3V22 series which mainly suffered from mechanical failure such as distorted loading arms and gears. I should add that many of us were at the time tired of rebuilding those machines and viewed an electrical fault as a relief!

Electrical faults with the 3V29 are rare nowadays. When they do occur, a replacement panel from a scrap machine can usually be quickly found. But many electrical faults are

easy to trace, and repair is often quicker than realigning a replacement panel. Here's a rundown on the more common faults I've had.

Any of the five fuses on the power supply panel can fail due to age – they rarely fail because of a fault condition. With a dead machine it's prudent to start by making a quick check on these fuses. At the start I mentioned that the 3V29 is very forgiving. By this I meant that should a spanner or meter probe fall into the works the only damage suffered is very often a blown fuse on the power board. This cannot be said of certain other VCRs.

Dry-joints can occur anywhere. Some of the more common ones are as follows:

(1) At Q101 on the YCA panel. The result is loss of the "all time 9V" supply and hence all the switched supplies.

(2) At the tuning block assembly or associated transistors (presetter board). The symptoms are won't tune or intermittently jumps off tune.

(3) At the connector terminals on top of the full erase head. The symptoms are as follows: the picture and sound are recorded correctly (the old video tracks are erased by the h.f. f.m. signal while the sound track is erased by the audio dub head) but colour patterning is evident because the f.m. doesn't remove all the l.f. chroma of the previous recording.

(4) At various transistors in the audio stages (YCA panel). The symptom is intermittent sound, perhaps only when recording.

These machines can suffer from breaks in the wiring looms. They occur where a wire enters the plug connector. As the breaks are usually within PVC sleeving they are not obvious. Once you've located a break, the best way of dealing with it is to remove the terminal pin from the plug and remake the connection by soldering the wire to the pin, which can be removed by pressing the barb in gently with a fine screwdriver. When reinserting the pin, be sure to open the barb first otherwise the pin will push out as you reconnect the plug.

Cracks in the servo panel can result in the capstan motor taking off at full speed due to loss of the FG signal. These cracks occur in two places: in the top left-hand corner, by plug 61/62, and along the bottom edge close to Q2. The most effective repair is to hard wire across the print using insulated wire.

With any older VCR failure of the stop sensor lamp is the most common cause of an inoperative machine. Just once in a while however a new lamp doesn't restore operation with a 3V29. Where this is the case the most likely suspect is the feed transistor Q1, which is mounted on the deck terminal 1 board. When replacing this, note that it's a pnp device. A BC307 usually works.

With any electronic equipment, ensuring that all the power supply lines are present and correct is an essential initial check. As with most VCRs the 3V29 has a number of supply lines that are switched to change the mode, i.e. the Play 9V, Rec 9V, E-E 9V etc. lines. Supply switching is carried out by a set of mode-control transistors on the YCA panel. An open-circuit transistor results in loss of the relevant supply. Problems also occur when one of the transistors is leaky, with the result that the supply is permanently present. This can be interesting. With a leaky E-E switch transistor for example the machine will record correctly but operation of the luminance, chroma and servo circuits in the play mode is totally incorrect as the circuits receive both the Play and E-E supplies. Fig. 6 provides an outline of the mode-control circuit.

Small isolating inductors are used to prevent interaction between circuits via the supply lines. Occasionally one of

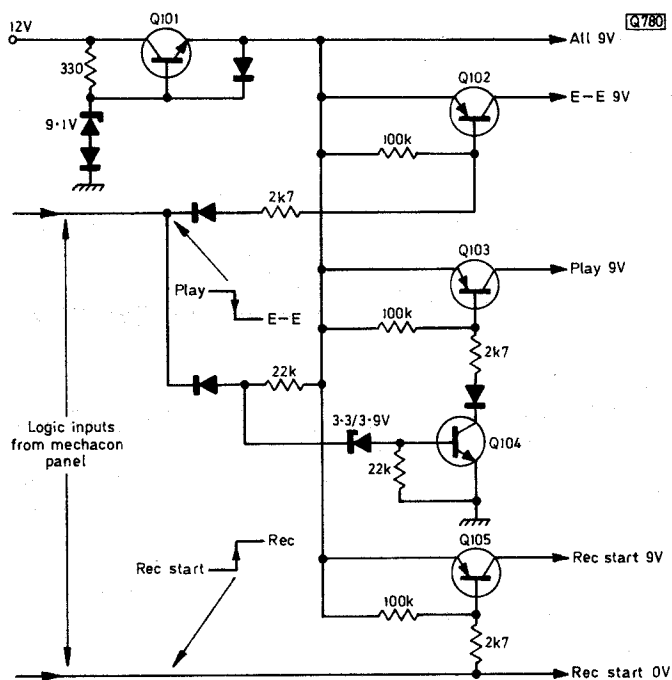

Fig. 6: The mode-control circuit. It's on the YCA board.

these coils goes open-circuit, the result being failure of one small area of the circuit.

Watch out for failure of the 32V tuning supply. The regulator consists of Q8 and IC3, which are on the tuner/i.f. panel. An unregulated 40V supply feeds the circuit. This has its own 315mA fuse (F5) on the power supply panel.

Failure of the reel motor to operate can be due to a defective circuit protector (CP2) on the mechacon panel. It's shown as a 10Ω resistor in some circuit diagrams but in even the earliest machines I've never found anything other than a circuit protector.

IC12 on the mechacon panel tends to be blamed for other reel motor faults. It's a reliable device however and I've found that the cause of the fault usually lies elsewhere. Possibilities include regulator Q2 on the main chassis, behind the drum motor, an inverter in IC8 on the mechacon panel and faults in the wiring looms.

Chip failure is not frequent but does occur. In my experience two of the most troublesome devices are the VC1029 frequency-voltage converter chips and the IR2403 logic inverter chips. The operational amplifiers in the VC1029 chips (servo and MDA panels) fail occasionally. The IR2403 contains seven separate inverters. It's not uncommon for one of the outputs to become permanently short-circuited to the negative side of the supply, a fault that can be confirmed with an ohmmeter. This type of chip is used extensively on the servo and mechacon panels.

If visual search results in loss of line lock with the tape accelerating to the fast wind speed, clean the CTL head and check that it's correctly aligned. During search the reel motor comes under the control of a servo that uses the control track pulses for feedback.

If the front display is dim and patchy forget it! The vacuum fluorescent display is a thermionic device which, as with all such devices, loses emission.

## In Conclusion

Given an overhaul the majority of these machines should be able to provide another four or five years service. They and their clones have proved to be the true workhorses of the video world.



# Steve's Camcorner

**Steve Beeching, T. Eng.**

An increasing number of the new camcorders that are coming on to the market have no camera setting up controls. Instead, they have EVRs – electronically variable resistors. The controls are in fact buried at an address location within an EEPROM (electronically erasable programmable read only memory). The data stored at the relevant location is fed to a digital-to-analogue decoder which produces the appropriate d.c. level for the required control setting. Functions such as luminance level, colour matrixing and even the auto-iris setting are stored in this way. Examples of models with this feature are the Panasonic NV-S1, NV-G1, NV-G2 and the JVC palmcorder range.

To alter an EVR value you require a microprocessor controlled EVR jig. Under the control of a ROM this uses hexadecimal codes to gain access to the EVRs and alter them. The codes allow for 256 control levels to be used.

Be warned: if you carry out camcorder repairs, don't attempt to replace the lens assembly in a Panasonic G series model without measuring the correct reference levels and without access to an EVR jig. Otherwise, believe me, you will be in it deep. My prediction is that EVR control will be increasingly used in camcorders and also VCRs: it makes computerised adjustment on an assembly line in the factory quick and cheap. The problem is that the EVR jigs required for servicing cost between £200 and £400 each. The cost will have to be borne by specialist service centres and charged to dealers (even under guarantee) and to the public. Dealers who expect EVR controlled video equipment to be repaired for the cost of a manufacturer's claimback are going to be in for a nasty surprise quite soon!

## Sharp VLC73

The problem with a Sharp VLC73 was that at power on only a small current, less than 100mA, was drawn before it switched off again. This suspiciously low current suggested a power supply problem, supported by the fact that the 9.4V rail was missing. The power board was removed for checking, with the aid of extension leads from various JVC kits.

We found that pin 10 of IC901 was low while the base of Q909 was high: this was a bit puzzling as they are both

connected (or supposed to be) to a single run of print. What had happened was that C927 had leaked slightly and corroded the print running beneath it – the print that connects Q909 and IC901. A piece of miniature cable was used to link Q909 and IC901, while operation was restored by replacing C927.

## Sony TR55

Two months after I fitted a capstan motor to a Sony TR55 because the FG signal was missing it came back with the complaint "snow outside". After cross-examining the owner I came to the conclusion that the problem was overloading because the iris didn't shut down. Strangely enough, in between the initial telephone call and the customer's arrival with his TR55 I received a Grundig Technical Bulletin that referred to the VS8300, which is not sold in the UK but is a TR55 clone. The note in the bulletin referred to the iris staying closed and described how to strip down the optics to clean the iris blades, which can stick in the closed position. When I stripped down the TR55's optical block I found traces of oil on a tail part of one of the iris vanes. The oil, probably from the zoom drive motor, had made its way around the lens and into the iris assembly via a screw. Cleaning provided an effective cure, but great care was needed.

## Toshiba A1-420

A Toshiba A1-420 caused its owner, myself and the dealer some major upsets. The batteries didn't seem to last very long before "battery low" appeared in the viewfinder, followed by power switch off. The batteries were initially blamed, but the dealer (Fletch) subsequently found, with the owner, that they were not responsible. So we had the camcorder in, stripped it down and tried to adjust the low-battery indicator preset R650. It's mounted on the inside of a mother PCB which has another PCB on top of it. So both PCBs had to be removed, refitted together and then reconnected to the deck assembly, which is not the easiest of tasks. Then the camera head had to be connected to re-establish the power. Unfortunately the lead required to connect the motor drive on the deck to the mother PCB was not included in the lead kit, but I found a JVC one that fitted.

R650 was set for 9.3V in the battery-low condition, not according to the manual which is nonsense. After reassembling the camcorder it was returned, but came back some weeks later with the same complaint. We repeated the adjustment and left the camcorder on soak

test all day. At the end of the day the battery-low indicator came on at 9.6V. R650 and its associated resistors (R601/2) were cleared of suspicion when we found that the voltage from the micro varied between 2.15V (for 9.3V battery low) to 2.2V (for 9.6V). This shouldn't be, as the microcomputer chip should be internally referenced to produce the battery-low indication at a given single voltage level, not one that varies. Toshiba eventually managed to supply a new chip (IC601). When it was fitted and R650 was set so that the battery-low indication came on at 9.3V we found that the variance when hot was only to 9.4V, a much more stable situation.

## **JVC GRC2**

Circuit protector CP1, which feeds a 5V d.c./d.c. converter in the JVC GRC2, kept blowing. Initially the cause was a mystery. Eventually however a high-pitched whistling came from the main PCB, which was lying on the bench all on its own. While checking around I found that IC12, an LC4011 logic chip, had a section which produced a squarewave output for no reason at all. This output went to a small bistable on/off relay which chopped the 9.6V supply and obviously upset the d.c./d.c. converter. Rather like a line output stage, if the triggering is interrupted a large current can flow. Hence the failure of CP1.

## **Ferguson FC08**

There was no fast forward or rewind with a Ferguson FC08. In addition the functions were intermittent. When I stripped it apart I found that the capstan motor stopped when the servo PCB was flexed. Seeing that the d.c./d.c. converter had been replaced, I came to the conclusion that someone else had also attempted to find the cause of the fault.

After checking all the way through the servo only to find that it was operating normally I checked beneath the PCB, which was difficult. A large capacitor, C7, was fouling the capstan motor spool belt pulley – repositioning it cured the problem. As it's next to the d.c./d.c. converter it was difficult to decide whether whoever had changed the converter had moved C7.

## **Tandy Head Cleaning Cassette**

A Tandy Video Care head cleaning cassette in a Panasonic NV-MS1 had reached the end of the tape. As it didn't have a clear section for the machine's end sensor to realise this, it was probably responsible for jamming the mechanism and the demise of the loading motor i.c.

## **Panasonic NV-G45**

We deal with VCRs (and a few TV sets) as well of course. Some problems were being caused by a Panasonic NV-G45. A tape provided by the customer showed that there was no video head drum servo lock in the record mode. The symptom shows as the head crossover point wandering up and down the screen. Additional symptoms were poor capstan servo lock with sound pitch variation. Neither the dealer nor ourselves were able to confirm these symptoms. I'm glad that I was able to phone my friend SG (Super Gerald) at Panasonic. He came up with a circuit upgrade to deal with the problem. A 150kΩ resistor and a 15nF capacitor are added in parallel across R338 on the YC panel – this appears to be part of the sync separator circuit. Closer inspection of the results produced by the owner's tape showed that servo lock was lost when a rapid screen change from very dark to light occurred. This probably made the video signal ride up and down on the d.c. level, affecting the sync slicing.

## **Sony SLV401**

Although playback of tapes recorded by other machines was fine, anything that this machine recorded then played back came out very poorly, with streaks, worms and dots on the picture. The cause was worn video heads. When we found that the trade price of the upper drum assembly is just over £100 we decided to try resetting the luminance record current. In the Sony alignment details the instruction is to set the current for 2.2V at the appropriate test point. We found that the machine recorded perfectly all right when the voltage at this test point was 1.2V, but we had to warn the customer that the pictures would deteriorate sooner or later as the heads wore down further.

E.T.

## **Fisher FVH-P615**

Here was another case where the cost of spares pushed us into mending rather than replacing. The trouble was juddering E-E pictures and a very strange video waveform from the tuner module, which includes the u.h.f. tuner, the i.f. section and the demodulators. The source of the trouble seemed to be in the vision a.f.c. section, but the service manual gives no circuit details – the black-box approach. Sanyo, who handle Fisher spares, quoted us £93.73 plus VAT (trade price) for this mystical module. We went into it with a hairdryer and freezer and found that C12 (0.47µF, 50V) was the cause of the trouble. An 0.47µF, 35V tantalum bead replacement (blue one, Les!) put all to rights.

E.T.

## **Sanyo VMH100P**

If you get one of these camcorders that provides no chrominance signal output to the TV set's (or copy VCR's) S terminal, check the continuity of the S-connecting lead before dismantling the camcorder. We've had two with open-circuits in the chroma wire – it's probably a batch problem.

E.T.

## **Matsui VX820/Saisho VR1200**

According to the customer this machine had been afflicted by a power surge or something similar. All the unswitched supplies from the multiregulator were present but there were no switching signals for the others. This was caused by loss of the 12V supply as the 2SD1207 regulator transistor Q2 was short-circuit base-to-emitter.

N.B.

## **Panasonic NV-G40B Scanner**

This scanner powered up and everything, including the red light, worked. But it wouldn't read codes. The cause of this was that the 1µF, 50V coupling capacitor C02 was open-circuit. It's a surface-mounted, can-type non-polarised electrolytic. Spares are not easy to obtain.

N.B.

## **Salora SV8600/Mitsubishi HS337**

This machine allegedly stopped in the play mode. It ran faultlessly until I got in and provoked it. The pinch roller was distorted, apparently because of spillage that entered courtesy of the tape (the tape path was coated). A good

clean and a new roller were all that was required. For those who don't have an NCS or Mitsubishi account, genuine rollers are available from Willow Vale.

N.B.

## **JVC HRD320**

This machine would accept a tape very slowly, then eject it and switch off. Sometimes it would try lace-up/fast forward/rewind etc., accompanied by unhealthy noises (crunching and groaning) from the mechanism, then shut down. Checks on the STK5481 regulator chip, always a good place to start, showed that pin 3 was at 1V instead of 5V and pin 4 at 0.7V instead of 12V. Replacing the regulator restored normal operation.

J.E.

## **Ferguson FV26D**

This machine accepted a tape but there were no deck functions. When eject was selected the cassette was returned but a loop of tape was left caught around the left-hand roller guide. Quick checks at TP801 and TP802 showed that the 12V and 5V supplies were missing. Circuit protectors CP601 and CP602 were o.k., the culprit being the STK5481 regulator chip. This chip is prone to failure and it pays to check the voltages around it before carrying out any other work on the VCR. As a guide, the following voltage readings were obtained with a working machine, using a 10MΩ/volt DMM. Pin 1 3.4V; pin 2 8.4V; pin 3 5.2V; pin 4 12V; pin 5 0.2V; pin 6 12V; pin 7 13.2V; pin 8 18V; pin 9 11.9V; pin 10 13V; pin 11 18V; pin 12 0V.

J.E.

## **Ferguson 3V30/JVC HR7300**

The cause of this fault eluded us for nearly a year. Very occasionally the customer reported that on pressing play, record or timer record the machine would load then unload. We had tried the usual causes – the belts and pulse inputs to the microcomputer chip. Then finally the fault put in an appearance for us: the pinch-roller solenoid disengaged before our eyes. Transistor Q4 had gone slightly leaky from base to emitter. Happiness is a niggling fault put to rest! Bear in mind that the holding drive transistor is a definite possibility for this sort of trouble.

B.McC.

## **JVC HRD211**

This machine came in dead. The famous STK5481 chip was faulty. Replacing this chip brought the machine to life but it was very confused. The record and pause lights were both on, the loading motor ran continuously in the loading direction and the tray moved in and out. A new microcontroller chip put matters right.

S.DaC.

## **Panasonic NV-D38**

The clock lit but the machine wouldn't work because the regulated 5V supply was missing. Q2006 (2SD1330) on the main PCB was open-circuit base-to-emitter. Tuning in an off-air programme was impossible and as a result the picture-in-picture feature was inoperative. We found that the 45V line was loaded down, reading only 18V. This was

due to the AN5043 chip IC7551 being faulty – it was rather hot. **S.DaC.**

drawing current via TR6 and TR7, overloading the “limit 12V” supply. **A.D.**

### Hitachi VT17

After playing for a few hours this machine would loose speed and eventually stop. When we opened it up we found that all the chips had been replaced and a new capstan motor had been fitted. Someone had been beaten by this one! We found that the flywheel became stiff when the fault occurred. All that was needed was cleaning and lubrication. **S.DaC.**

### Toshiba V210

A vertical black bar moved across the screen in the E-E tuner mode. It didn't appear in the E-E Aux mode, which narrowed the field of search to the off-air circuitry. An oscilloscope check showed that there was ripple on the detected video from the i.f. unit, but replacing this module made no difference. The tuner unit was the next logical suspect, especially as there was no discernible ripple on the supply lines. A replacement tuner put matters right. **A.D.**

### Akai VS15

This machine came in because there was no fluorescent display. When we dismantled it the display worked. We left the machine on test with all the boards accessible. After a time the fault started to come and go. Waveforms were present at all the grids and segments of the display. The cause of the fault was eventually traced to the display filament rectifier going open-circuit intermittently. **A.D.**

### Hitachi VT410

The problem with this machine was intermittent audio recording due to loss of bias. We traced the cause to a switch within IC401 closing. This occurred because the voltage at pin 5 fell below 11.3V, thus activating the switch. C431 was found to have a 2MΩ leak. Note that according to the diagram pin 5 has to go high for the switch to close: in fact it has to go low. **A.D.**

### Akai VS33

After half an hour the E-E mode tuner picture was replaced by a blue screen. We traced the off-air signal on the E-E route from the i.f. unit to the base of transistor TR113 on the main board. It was missing at the emitter of this emitter-follower transistor. This was due to the action of IC201, TR106 and TR109 earthing TR113's emitter. Both the chip's oscillators were working but there was a sync pulse problem. Replacing the LVA519S chip IC801 cured the fault. **A.D.**

### Akai VSF33

When play was selected there was a hum bar on the E-E picture while the playback picture consisted of noise and a hum bar. All the supply lines were correct except for the “limit 12V” rail which was low at 8.5V. A check at the junction of the limit-12V reservoir capacitor C7 and resistor FR4 showed that a large ripple was present, but replacing C7 made no difference. This point is also connected to the collector of TR7, the power-on transistor for the “idle 5V” supply which is derived from TR6. We found that the supply to TR6 was missing because FR2 was open-circuit. The “idle 5V” supply was

### Hitachi VT33

This VCR would shut down after five seconds. The drum and capstan motors both worked but a hunting sound came from the drum. At start up a scope check showed that there were squarewaves on the 9.5V supply to the servo: the supply was also trying to rise to 10.5V. Replacing the STK5421 chip IC151 on the regulator board cured the fault. **A.D.**

### Matsui VX800/Saisho VR1000

Fast forward and rewind worked but there was no drum rotation, also no E-E picture – just a blank, noise-free raster. The cause was F2001 of course. It's an N20 (800mA) ICP. To avoid having to remove the front PCB etc. you can replace it from above by lifting out the power supply. After replacing F2001 everything worked all right until play was selected. The tape then loaded but as soon as it touched the head drum the tape stuck to the drum and the motor stalled, blowing F2001 again. This was due to sticky gunge on the drum. A good clean and polish plus a new ICP put matters right. Normal current through the ICP is 260mA in the E-E mode, 360mA in the play mode. **M.Dr.**

### Hinari VXL9

When play was selected this machine would load then unload straight away. Fast forward and rewind were o.k. After a very unsuccessful search with the scope the machine was put to one side while a manual was obtained. It was not up to the usual Hinari standard: the circuit diagram had to be viewed through a magnifying glass as it's all on a single page. Checks around the TD6364NPAL digital servo controller chip IC102 showed that drum switching pulses were present at pin 18 but there was no head switching squarewave at pin 9. Since the 5V supply was o.k. at pin 38 it seemed that the chip was faulty. As a check a Matsui VX820 that was waiting for a new carriage was pressed into service – its head switching signal was fed to the Hinari VCR, which then played but with the drum rotating too fast. Normal operation was restored after obtaining and fitting a new TD6364NPAL chip. **M.Dr.**

### Sharp VC488

This VCR caused me a bit of a turn. The reported fault was no rewind. Just the usual idler replacement and clean up I thought. After doing this I inserted a test tape, but there was no picture. As the heads appeared to be dirty I gave them a good scrub and tried again. No better. It's an upmarket hi-fi machine so I thought I'd better check on the price of heads with Willow Vale before giving the customer a quote. I'm glad I did. I was told that they are not held in stock and asked if I was sitting down! The trade price is £173 plus VAT. So I decided not to order. I returned to the bench and wondered what to tell the customer. Then I noticed that the playback picture had improved significantly while I'd been on the phone. A quick tweak on the tracking control was all that was needed. The situation was that the machine wouldn't work from cold, so I sprayed some freezer here and there. The cause of the fault was dried up electrolytics in the power supply. After replacing C952/3/4/5, C961 and C963 the machine worked normally at all temperatures. I still can't believe the price of those heads though! **M.L.**

# Fault Guide for the Ferguson 3V29

John Coombes

The following fault-finding list summarises our experiences with the Ferguson 3V29/30 and their JVC equivalents Models HR7200/7300. It supplements Joe Cieszynski's outline of basic overhaul procedures last month.

## Electronic Faults

**No results:** First checks should be on the sensor lamp, the mains switch and the 1-25AT mains fuse F1. The latter may have failed due to age. If it has blown, check the filter capacitor C1 (0.022 $\mu$ F). The mains transformer T001 could have shorted turns or its internal thermal fuse might be open-circuit. Next check F3 (2.5AT) in the feed to bridge rectifier DS1 (D5FB10-1). If this fuse has blown, check the bridge rectifier diodes for shorts, also if necessary the protection capacitors C2-6 (all 0.01 $\mu$ F) and the reservoir capacitor C7 (4,700 $\mu$ F, 35V). If the regulated 12.5V supply is still missing, check the regulator driver transistor Q1 (2SD639R) which tends to go short-circuit.

If the problem is that the front panel buttons and/or the remote control unit, also the timer start, is/are inactive, check that data information is present at pin 39 of the UPD553C-164 microcomputer chip IC2. This chip could be responsible for the lack of response but in practice rarely fails. Check the d.c. conditions carefully before condemning it. The clock oscillator is connected to pins 1 and 42. No clock operation could be due to the crystal CF1 and/or the tuning capacitors C2 (100pF)/C3 (470pF) which can become leaky – IC2 could also be responsible. Check also that the reset pulse is present at pin 26. If not, suspect IC3 (UPC339C).

If the buttons work but there's no remote control operation, check IC3 (UPC339C) which contains a series of comparators.

If there's no mechanical operation through the clock display is present, the play button light is on and the E-E mode is working, check F4 (2.5A). It may simply have gone open-circuit. If it has blown, check bridge rectifier diodes D7-10 (type V03E), the 0.01 $\mu$ F protection capacitors C13-17, the reservoir capacitor C18 (4,700 $\mu$ F) and Q5 (2SD637R) for shorts. Relay RY1 could be responsible for the fault.

**No E-E signals, all mechanical functions operational:** Check fuse F5 (315mAT). If this has not failed due to age, check D11 (V03E), C19, (0.01 $\mu$ F) and C20 (100 $\mu$ F) for shorts. If all is o.k. here, check for shorts at Q8 (2SB644) and IC3 (UPC574J) on the tuner/i.f. panel.

**No clock display:** Check F6 (315mAT). If blown, check D12 (10E2), C21 (0.01 $\mu$ F) and zener diode D13 (HZ22-3L) for shorts. Q7 (2SD880) and Q8 (2SB642Q) can also go short-circuit.

If the -23V supply is present at pin 71 of the power supply/regulator panel, check the following items on the timer/display panel: zener diode D418 (RD6-2EB2); the heater transformer T401 which can be dry-joined or have an open-circuit winding; and the UPD552C-060 chip IC401. If these are all o.k., replace the fluorescent display.

**No mechanical operation, sensor light out, clock display o.k.:** Check F8 (1.25A). If it has blown, check Q4

(2SA10200) on the tuner/i.f. panel for shorts.

**Incorrect drum speed:** A check on the conditions around IC3 (HA11711) will usually reveal the cause of this fault. There should be a trapezoid waveform and a squarewave sampling pulse at TP4. If these waveforms are correct check at the input (pin 3) of IC7 (UPC1458C) where a  $6.2 \pm 0.2$ V d.c. drum phase error signal should be present. If not, return to IC3 and check associated components. If the input to IC7 is correct check its drum phase output at pin 1, where the drum phase error signal should be 6.1V. Replace IC7 if there is no output at pin 1 – but first check that the 12.5V supply is present at pin 8. If necessary check IC202 (UPC1458C) then trace through to the drum motor.

The next thing to check is that the frequency pulses are correct from the drum motor. If so, turn to IC201 (VC1029). If the 12V supply is correct at pin 7, there should be a regulated 6V output at pin 9. If any voltage around IC201 is incorrect, check associated components and if necessary fit a new VC1029 chip.

**Incorrect capstan speed:** The first thing to check is that the supplies to the chips in the capstan servo are correct. Next check for the FG signal at TP1. If missing, check that the signal is entering IC1 (VC1029) at pin 2 and if not trace back to source. An input at pin 2 of IC1 but no output at pin 3 should lead to a replacement check on this device.

If everything is o.k. in this area, check the capstan phase control output at pin 25 of IC3 (HA11711). The voltage here should be  $6.3V \pm 0.2V$ . If it's missing, check that the 32kHz oscillator signal is present at pin 28 and if so replace the chip.

If necessary move on to IC7 (UPC1485C). Check the input at pin 6 and the output at pin 7. If the output is all right, check the input at pin 5 and the output at pin 7 of IC204, another UPC1458C chip. The output at pin 7 goes to pin 2 of the second comparator in this chip which receives the speed error control voltage at pin 3, the combined capstan servo output being at pin 1. If any of these waveforms/outputs are missing, replace IC204. If necessary trace through from pin 1 of IC204 via the drive amplifier Q235/6 to the capstan motor.

**Intermittent noise bars on playback:** A quick servo check is to select the still mode. If this is o.k. the drum servo is operating correctly.

If the capstan servo is at fault, check the waveform at TP5. There should be a trapezoidal waveform and sampling pulses here. If the trapezoid is missing, check that the 32kHz reference signal is present at pin 28 of IC3. If the pulses are missing, trace back to source at the CTL head. If both signals are present at TP5 but the sample pulses won't lock on to the trapezoid, check the setting of the capstan discriminator control R10, also the condition of its track. If R10 won't lock the sampling pulses on the trapezoid, check the capstan speed servo.

Check the operation of the tape transport system if the capstan servo circuits are all right.

**No horizontal sync and/or horizontal sway on playback:** With the VCR in the playback mode, check that the drum trapezoid is present at TP4. There should also be sampling

pulses here: if these are missing check the 32kHz waveform at pin 28 of IC3. If the trapezoid is missing, check that the drum phase control pulses are present at TP6. If both waveforms are present at TP4, adjust R207 to lock the sampling pulses on to the trapezoid. Should this not be possible, check the drum speed servo.

If the problem persists, select the playback still mode. While the machine is in this mode touch the upper cylinder lightly: the d.c. voltage at pin 10 of IC201 should vary. If not, ensure that the FG pulses are correct. Trace back to source if necessary.

If still in trouble, check IC201 (VC1029) by replacement.

If playback of a prerecorded tape is all right but playback of the machine's own recordings is incorrect, check the playback CTL signal. Ensure that the CTL pulses are being recorded – check at pins 41/42 of the plugs/sockets on the servo board. Absence of signal here means that the control head is dirty or faulty – check by replacement.

**Cuts out after short playback:** Failure of the drum to rotate will produce this fault. The cause can be on the servo or mechacon board. Another cause is loss of the unregulated 22V supply to the mechacon board. In this event it's worth checking Q5 (2SD637R) and zener diode D14 (HZ12C3L).

**Failure to record:** Can be caused by failure of Q209 (2SC2021Q) and/or zener diode D208 (RD4-3/5-6EB) on the audio/video board.

**E-E stuck on one channel:** Can be caused by dry-joints on Q207 (2SD637R). Remove it and carefully clean the leads.

**Hum bar on E-E:** Check whether Q8 (2SB644) on the tuner/i.f. board is short-circuit. If it is, IC3 (UPC574J) may have been damaged by excessive current.

**Goes to pause during record:** Can be caused by IC4 (TMS1025N2LL) on the mechacon panel – check the data input and output lines – but is usually caused by failure of IC2 (UPD553C-164).

**Tuning drift:** First check that the unregulated 40V supply at plug/socket 83 of the power supply panel isn't varying. If it is, check back to source (D11/C20). Next check Q8 (2SB644) and/or the UPC574J 33V regulator IC3 by replacement. The other possibility is a faulty tuner.

**Snowy E-E and TV vision:** Check the aerial booster/mixer by replacement.

**Snowy E-E vision:** The aerial booster/mixer can again be responsible. Other causes are a faulty tuner or i.f. amplifier. The latter is in the AN5111 chip IC1. Check the d.c. conditions here, or by signal injection – input at pins 1/28, output at pin 7.

**Loss of luminance:** Make a recording to check whether the problem is in the record or playback circuitry. If the recording plays back satisfactorily on a known good machine, trace the playback signal from the video output socket back to source as a playback f.m. signal.

If there's no record luminance signal, check the video waveform at pin 26 of IC201 (HA11728). Check back to source if this is missing.

If the E-E luminance signal is missing, check through the

a.g.c. feedback path via Q203 and Q204 (both type 2SC2021Q). Check these transistors by replacement.

**No colour or poor colour:** Make a recording and check the tape in a known good machine. If the colour is o.k. the fault is in the a.p.c. loop. First things to check are Q410 (2SC2063Q) and crystal 402. Next check IC403 (AN6371), then Q409 (2SC2063Q), IC401 (AN6360) and that C472 in the subcarrier oscillator circuit is set correctly.

If the recording doesn't play back o.k. on a good machine the fault is in the a.f.c. circuitry. Set the machine in the record mode with no signal – this can be done quickly by placing the AUX/TV switch in the AUX position. Connect a frequency counter to TP402 and adjust R451 for 15.625kHz. Reposition the AUX/TV switch to TV and check that an incoming signal is present. The a.f.c. circuit should now lock to 15.625kHz. If it doesn't, check the luminance input to the sync separator at pin 6 of IC402 (AN6362) and the burst gate output at pin 18. If necessary check that the 5.06MHz signal is present at pin 14 of IC401. If not, check the voltage-controlled crystal oscillator in IC403 (AN6371).

**Colour playback o.k. with own recordings but poor/no colour when recording is played back on another VCR:** Check that the drum flip-flop input is present at pin 11 of IC402 (AN6362). Check IC402 by replacement if necessary. Also check crystal 401 for dry-joints or by replacement. If the frequency (4.43557MHz) is incorrect check IC403 (AN6371) by replacement.

**No reel motor operation:** Check whether the 10Ω fusible resistor R48 is open-circuit. If so, the reel motor or the associated circuitry may be at fault.

## Mechanical Faults

**No play:** First check whether the sensor lamp is open-circuit. If the tape isn't moving check the take-up idler assembly for wear. If the machine only partly loads and the pinch wheel isn't engaged, check for faulty loading belts. The loading motor can be at fault, but this is very rare. Check whether the capstan belt is worn or stretched.

**No play:** If you find that the drum and capstan motors continue to rotate even in the stop mode, it's likely that the after-load switch S002 is faulty. It may be sticking or have faulty contacts. Replacement is the best course.

**No fast forward/rewind:** Check the reel idler assembly, then if necessary the reel motor. Check whether the reel motor pulley is dirty or damaged. Also check that the plate spring is fitted correctly and that the brakes are not clamped on due to a bent or damaged mechanism.

**Bent verticals:** Can be caused by incorrect back tension, which should be between 30 and 40g. Excessive back tension can also lead to early failure of the video heads. If the tension is incorrect, replace the tension band and/or the tension arm.

**Chewed or tangled tape:** Check for a worn or missing brake shoe at the supply spool.

**Reel motor rotates for a short time when the VCR is switched on then stops:** The unload switch S003 is faulty.

**VCR threads up but there's no play:** The usual cause is that

the pinch roller doesn't engage. Check the pin that links the mechanism to the play solenoid. Refit the pin and seal it to prevent further trouble.

**Tape creasing or pleated:** The pinch roller assembly probably needs to be replaced.

**Noise bar on prerecorded tapes:** Check that the tape transport system is operating correctly and that the guide poles are correctly aligned – do this while watching the f.m.

signal envelope. Also ensure that the poles are loading fully at both sides.

**No colour:** Can be caused by the channel set/black/white/colour switch.

## **Component Reference Numbers**

Note that all component reference numbers in the above notes relate to the original version of these machines.

## Sony EVS700

Fortunately audio PCM faults are rare – the circuits are very complex! The right-hand audio channel playback signal was grossly distorted with this Video-8 machine. The f.m. audio playback was fine. Scope checks proved that the trouble was associated with the noise-reduction chip IC601. To cut a very long story short, C417 which is connected to pin 17 was responsible. It had a leakage resistance of 200k $\Omega$  or so. **E.T.**

## Sharp VC9300/9700 and clones

These machines are now quite elderly. It's important to check the reel motor thoroughly when replacing the reel idler. The job will bounce back (our score is two recently) unless the motor is above reproach. To test the motor, hook a scope across it then run it in all modes, particularly in the fast forward and rewind modes with a heavy mechanical load. If you see needle pulses on the screen the motor is duff. **E.T.**

## Ferguson 3V56

The basic fault here was no capstan rotation following tape lace up. Selection of rewind produced the correct result, but when fast forward was selected the result was rewind. I decided to look into the first problem, and went in search of a sloppy loading belt or missing after-load signal. No such luck. As all the supplies were present and correct I decided to monitor the FF/rewind drive output from IC601 (M50730-614SP). All was normal here as well. The drive is applied to the capstan motor via Q603/4. Checks here revealed that while Q603 was switching normally Q604 wasn't. A TIP41 proved to be a suitable replacement. **S.L.**

## Panasonic NV-J35

This machine was dead and checks in the switch-mode power supply showed that D1113 was short-circuit. It's the 20V protection zener diode connected across the 14V line. So it seemed that the 14V line was going way above its normal level, well above 20V in fact. We suspected a fault on the primary side of the circuit and started to check the components here. This paid off: when C1114 was checked it was found to have fallen in value from 47 $\mu$ F to 0.5 $\mu$ F. It's a decoupling capacitor that's connected between the chopper transformer and the regulation control pin of the chopper chip. A new 47 $\mu$ F, 16V capacitor enabled the VCR to breathe again. **S.C.**

## Panasonic NV-L20B

A few of these machines have come in completely dead. They have those nice switch-mode power supplies that are, arguably, neither use nor ornament as far as a domestic VCR is concerned. It's nice to see that some manufacturers, e.g. Ferguson, have returned to good old mains transformers and low-voltage series regulators after making a move to SMPSs. However that may be, this SMPS had to be fixed. A full, rectified mains supply was being delivered to the chopper chip, but no voltages were being generated on the secondary side of the chopper transformer. Back to basics, and back to thinking about

SMPSs in TV sets. This situation can arise when, as in the Ferguson TX100 and Finlux 1000 chassis, one of the rectifier diodes on the secondary side of the transformer is short-circuit. So checks were made here and sure enough the 14V rectifier D1109 was short-circuit. **S.C.**

## Hitachi VTM820

Due to lack of a test signal and a playback picture this machine couldn't be tuned to a TV set. All other functions worked correctly. The test signal is generated by the on-screen character generator chip IC1401. We checked the 17MHz crystal here and found that the clock frequency was missing. A new 17.73MHz crystal restored normal operation. **S.C.**

## Salora SV8710

This machine was accused of chewing tapes, which was not surprising since the reel belt was off. What was interesting was that the rubber had decomposed to form a very sticky substance that was all over both of the pulleys on which the belt sits. There was no evidence of any spillage in the machine. A bad belt, or something in the atmosphere? **N.B.**

## Panasonic NV-MC20B

The viewfinder picture in this C-format camcorder was very dim and defocused. When the output was viewed on a monitor however it was perfect. I've had various Panasonic camcorders in which the diode that feeds the focus and brightness voltages to the viewfinder from the line output transformer has gone virtually open-circuit, producing exactly this symptom. It wasn't the cause this time however. There was over 1,200V at the viewfinder tube's cathode because the 33M $\Omega$  focus potentiometer VR803 was open-circuit. The brightness control in older models suffers from a similar affliction when its rivets become loose. **N.B.**

## Panasonic NV-MC30B

There was intermittent over exposure of the image with this camcorder. The auto iris was on, but when the fault occurred the iris didn't move. When the fault finally showed up after dismantling the unit I found that the drive was working correctly despite the lack of physical activity. To cure the fault we had to replace the iris. I suspect that one of its leaves had become distorted. Maybe the unit had been dropped or subjected to shock. **N.B.**

## Philips VR6180/Pye DV186

A word of warning with this one. The problem was excessive wow and flutter because of a worn capstan bearing, which is not uncommon. But it took us a long time to get the correct replacement because the mechanism is not the same as that referred to in the Willow Vale catalogue. I believe it's called the DMP4: the capstan assembly 262 is neither the 4822 520 10635 nor the 4822 520 10559 but the 4822 535 92909, which Willow Vale supply



under code 164467CP though it's not listed in the catalogue. The problem is that this mechanism has the capstan FG head mounted on the exterior of the flywheel, so the magnetic area has to be on the outside. The other types supplied by Willow Vale have the magnetic area on the inner edge of the flywheel, the result being that there are no FG pulses when they are fitted in this machine. Thus the cassette is ejected whichever deck function is selected. **N.B.**

### **Panasonic NV-L20/5/8**

A fault I've had a couple of times recently has been no vision. The fault tends to be exceptionally intermittent and affects only the r.f. output. This is the big clue, but it takes some time to establish this when the fault occurs for only two-three minutes a week! The exact symptoms are akin to a TV set being off tune – the output seems to move through the tuning point but won't lock. The raster is dark or affected by hum, with exaggerated chroma present and distorted sync. The cause of the trouble is the ENC17952 r.f. modulator. **N.B.**

### **Hitachi VT9300**

Playback was good but there were no E-E signals and no recordings could be made. A colleague told me that soldering any suspect joints in the i.f. unit would provide a cure. This was done and didn't, though there were some really bad joints on the screening plate. Changing the tuner didn't help either. A scope check on the i.f. unit's video output showed that the tuner and i.f. strip were working and that, with a colour-bar u.h.f. input, the i.f. box produced a nice staircase waveform. The video signal arrived at the video board but didn't leave it again. I eventually found that the PB9V line was permanently present – disabling this line got record and E-E working again. The fault was in the TA4349 chip IC909. **P.H.**

### **Sony SLC6**

The job card said "rolling noise bars and sound varies". When play was selected, every two seconds a noise bar filled the screen and the sound slowed down. Obviously a capstan servo fault. The pulses from the control head are amplified to 7V peak-to-peak and should be present at test point 7 on board SS9. A scope check showed that they were o.k. at this point. Voltage checks around the servo chip then suggested that everything was in order here. A cure was provided by slight adjustment of the capstan free-run preset RV001. **J.E.**

### **Amstrad VCR4500**

The job card said "no clock display and weird operation". There was indeed no clock display, although the channel indicators worked. The machine accepted a cassette but when fast forward was selected it entered the stop mode after a few seconds. When rewind was selected the rewind indicator came on and a clunk was heard from the mechanism, but there was no operation and again it went to stop. I decided not to bother about checking the play mode as without any rewind function I would probably have ended up with a chewed tape. Eject worked o.k.

A syscon or power supply fault was suspected. So checks were made on the supply lines. This showed that the 12V supply to the timer board, at pin 5 of plug CN16, was missing. Hence no clock display. This feed is tapped from

pin 1 of plug CN15 via a 27Ω resistor which was open-circuit. As no short to chassis could be measured the resistor, circuit reference R662, was replaced. Normal functioning was then restored.

A long soak test revealed that there was tape chewing. So in went the pinch wheel modification kit and the waste bin received another tape. In future, no matter what the problem, we are going to change the pinch wheel kit before returning the machine to its owner. **J.E.**

### **Matsui VCP500**

This playback only machine would accept a tape. Rewind and fast forward were normal, but when play was selected the picture and sound were at twice the normal speed. Scope checks around the servo chip showed that the capstan FG pulses at pin 36 were missing. We traced back to the capstan motor unit, where the pulses should have been present at pin 5 of plug CD2003. As only noise was present here we ordered a new capstan unit. Fortunately this cured the problem. The new unit produced 2V peak-to-peak sinewave FG pulses. **J.E.**

### **Saisho VR3300X/Matsui VX735A**

As the manual gives no information whatsoever on the mode switch it's important to make a plan of the positions of the old one before fitting a replacement.

One of these machines came in with the loading arms jammed. While we were checking the deck we found that the limiter post arm's pin was missing. When the deck was stripped down we found the pin stuck in the underside of the master cam.

Note that if the carriage is not fitted to the deck it won't accept a cassette and the machine will switch off, i.e. the infra-red end sensor must shine on the carriage end sensors before a cassette can be loaded. **M.Dr.**

### **Ferguson FV21**

This machine came in dead. Now we've had so many of them in with the STK5481 hybrid regulator chip faulty that I didn't bother to carry out any checks, I simply fitted a new STK5481. Guess what? The machine was still dead! Checks around the STK5481 regulator then showed that the voltage at pin 5 of connector CN801 was missing. This voltage is applied via resistors to pins 7 and 10 of the chip. When the source of this voltage was traced back to the mains transformer PCB we found that R4 and D9 were o.k. but the 10Ω surge limiting safety resistor R1 was open-circuit. Replacing this restored full operation. Maybe the STK5481 had been the cause of this, but I wasn't going to find out and left the new one in! **M.Dr.**

### **Panasonic NV7000**

There was a very strange fault with this old machine. The symptoms were no clock display and stuck on channel one. Everything returned to normal when the machine warmed up. It didn't take us long to find out that the 6V regulator chip IC1501 in the power supply was sensitive to freezer. Although it's a 6V regulator the output was found to be 5V. Cooling it down made the clock go off but there was no change in its output voltage. A scope connected to the output also confirmed that there was no difference between the fault and working states. In fact we could find no reason for the clock going off when IC1501 was cooled down, but replacing it cured the fault. **M.Dr.**

# Servicing Philips DMP Series Decks

Philip Blundell, AMIEIE

The aim of this article is to provide insight into the problems commonly encountered with VCRs that use the Philips DMP/IDM series deck. Philips VCR models include the VR202, 203, 6180, 6182, 6185, 6285, 6290, 6291, 6362, 6367, 6390, 6467, 6468, 6470, 6561, 6760, 6761 and 6870. I've seen clones in the Pye, Pioneer, Tatung, Tashiko, GEC, B and O and Finlux ranges.

## Information and Spares

A circuit description for the early models (VR6760) is available from Philips under part number 4822 726 14069. It gives an in-depth description of the electronics and the mechanics. When you order a manual for a Philips model you generally get the electronics and cabinet sections: if you need information on the mechanics you have to quote the deck type number. When ordering parts it's important to look at the label between the left-hand side of the lift and the lift guides. This will tell you the deck model and the production week. Deck types in this series are as follows:

- DMP2/0. Deck has two video heads only.
- DMP2/2. Deck has two video and two hi-fi audio heads.
- DMP3/0. Deck has two video and one perfect still head.
- DMP3/2. Two video, one perfect still and two hi-fi audio heads.
- IDM2/0. Two video heads only.
- IDM3/0. Two video and one perfect still head.

The WD number is the week code.

Certain parts, particularly those in the lift mechanism, have been modified – some three times! Fitting the wrong lift causes problems with the COD3 switch not closing or the cassette door opening too late to miss the cassette on its way out. The IDM decks have strengthened lift mechanics. Although they look similar to the DMP types, not many of the parts are interchangeable.

If any of the moulded parts have broken off the chassis, a new subassembly is available. The half chassis comes complete with rack, coupling, scanner ring etc. ready to accept the original video drum, drum motor and top plate. You'll need to set up the tape path – don't forget the back tension as the assembly comes with this set at minimum. The part number for the half deck is 4822 691 20465.

## Deck Design

The mechanical design of the deck is unlike anything seen before. It was designed for automated production – even the tape path alignment was automated. The deck is very simple and robust.

The chassis consists of a steel plate with the two sides bent square. Moulded guides that control the cassette lift as it is raised or lowered are located in the sides. There are three motors. The drum motor is of the direct-drive type. The combined capstan and wind motor is called the combi motor. The control motor is for threading and lift operation. Deck position is sensed by three switches which Philips call code switches, or COD for short. Switch COD1 is on the left-hand side of the chassis: it senses eject mode and cassette inserted. Switch COD2 is at the rear, by the

head drum: it's closed several times during threading or unthreading. Switch COD3 senses when the lift is down. There are three mechanism states – eject, stop out (threaded out = wind/rewind) and stop in (threaded in = play, record, visual search). The microcomputer control chip monitors deck operation by sensing the inputs from the code switches, the tape beginning and end sensors, the control track output, head, capstan and take-up reel rotation and the presence of the record tab.

Figs. 1-3 illustrate various aspects of the deck.

## Cassette Lift Operation

The following things should happen when the cassette lift is in operation. The cassette should slide easily into the lift, which shouldn't move forward (tripping switch COD1) until the cassette is against the stops. The threading motor is then energised, rotating the gearbox. The rack moves backwards, turning the lift lever and pulling the lift forwards and down.

As we all know however, customers can insert cassettes askew, put stickers in the wrong places and so on. As a result the lift can begin to move before the cassette is fully home. There is then a collision between the cassette and the pinch roller. This means damage to the pinch roller, the lift lever, the rack or all three. In later production the problem was solved by adding a mechanical catch to the lift: it's released only when the cassette is fully home. The parts required are available as spares, but not all chassis have holes drilled where the fixed part should fit.

## Common Faults

Early racks (dated 1986) had a tendency to loose teeth. This causes a jam up, usually in the threaded position. Much used racks of any date tend to develop a wear ridge where the metal blocking lever rubs on the rack. As a result the rack jams, usually in transition from stop to eject.

A perished pinch roller is not uncommon. Problems with tape creasing, the tape path or varying sound volume could well be due to this. No visible signs of rubber cracking may

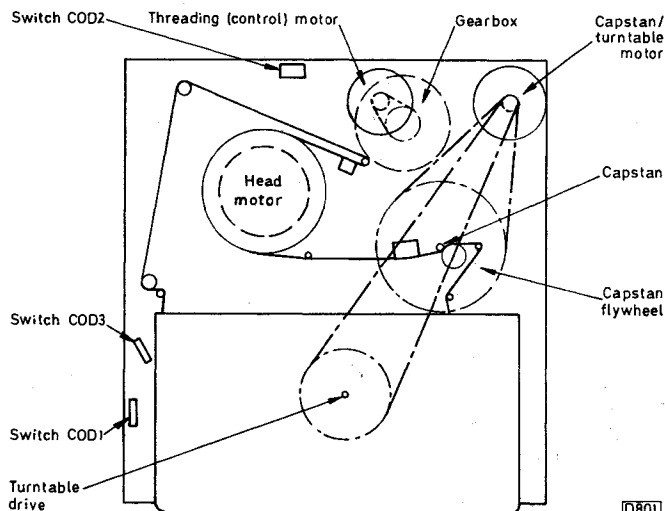

Fig. 1: Outline of the motor drive system.

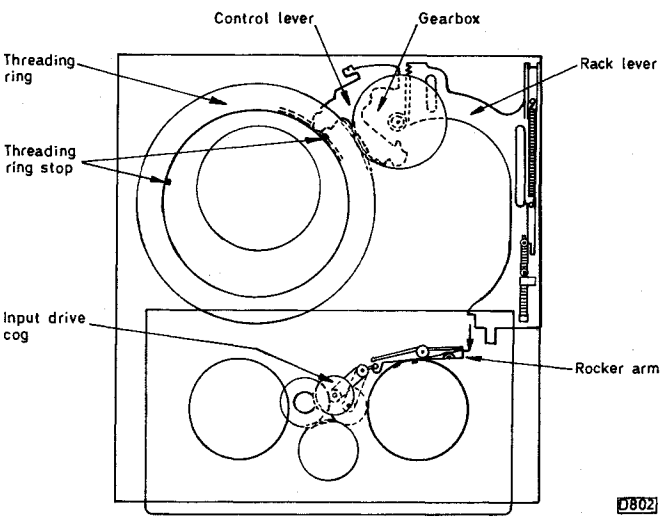

Fig. 2: Outline of the loading/threading system.

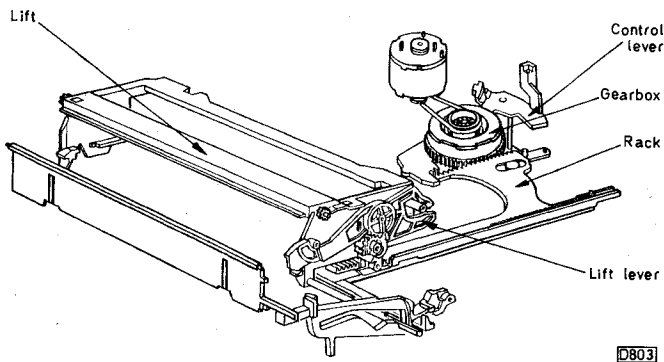

Fig. 3: The cassette lift mechanism.

be seen in the early stages of failure. One cause of a snapped off pinch roller has already been mentioned. Other things to check are that the flap opening lever operation is free and the tension of the return spring.

The wind/rewind coupling can cause problems in the search modes. The usual problems are noisy operation in reverse search or the tape suddenly becoming tight during search operation. The latter may dirty the heads or stall the drum.

If you need to dismantle the deck to replace any of these items, buy a service kit, part no. 4822 310 31803, and fit all the things it contains. It's cheaper to buy the kit than to buy any two of the previously mentioned items, and once the kit has been fitted all the main trouble spots will have been dealt with. The deck will be a lot quieter in operation because of the new gearbox and pulley design. The rack components have also been changed – so don't re-use any of the old parts.

## Dismantling the Deck

The following deck dismantling description applies to Model VR6761. There are only minor differences with the other models.

To work on the deck the threading motor will have to be rotated. As access to the pulley is difficult you can't turn the mechanism by hand as you would with say a Ferguson 3V30. Instead, power the motor by connecting a 9V battery or supply to it. Don't forget to disconnect the motor from the L293 drive chip, either by disconnecting one of the motor wires or unplugging connector L2 on

board P678, to prevent damage to the chip.

Remove the three screws that secure the chassis to the cabinet. Unplug and remove the erase oscillator PCB (if fitted). Very carefully remove the plug from the erase head – use too much force and you can break the head mounting. Unplug the other connectors, take off the cross bar (if fitted) and the cassette flap and remove the chassis from the cabinet.

## Removing the Lift

Next lift removal. The lift should be in the raised position. The gears on the left are under spring tension which can be retained if the plastic catch on the right-hand side is used to lock the gear teeth first.

Carefully lever the left-hand side of the lift inwards so that the projection on the lift is disconnected from the COD1 switch cam. The lift is now free to be moved towards the flap, where there are holes in the gear track to allow it to come free. To retain the spring tension, lock the gear teeth with the catch provided. Raise the left-hand side of the lift free, then the right-hand side. If the spring tension is lost you'll have to turn the gear twenty turns anticlockwise looking from the right-hand side.

## Removing the Top Plate

The deck has to be partly threaded before the top plate can be removed. Power the threading motor while the lift lever goes down and the threading ring moves the tape guide (next to the pinch roller) out of the way. Stop the motor when the pinch roller begins to move. Then reverse the motor so that the pinch roller is back where it started.

The five red screws can now be removed – there are two countersunk ones, two raised-head screws and one TORX 10 screw. Bend the head amplifier's wire bracket to the left, then disconnect the loading belt and the pinch roller's tension spring. The top plate can now be removed, bringing the pinch roller with it. Hold the pinch roller in place to make reassembly easier. With the top plate removed you have access to the rest of the mechanism.

## Reel Idler and Rack Removal

Reel idler and rack removal. If the reel idler gear is unclipped it can be lifted clear. Remove the long spring between the two brakes and the connecting link that goes to the back-tension arm. Unclip the right-hand brake lever and raise the right-hand side of the brake bar. The latter can now be moved to the right, along the slot in the chassis, to where the slot widens. Then lift the bar clear. The coupling can now be lifted off the shaft. The latest type is made of blue plastic – earlier types were white or pink. To test the coupling, rotate the top and bottom gears clockwise and anticlockwise: the resistance should be similar in both directions. Reassemble the coupling and the brake assembly.

To change the rack, the belt pulley and gearbox will first have to be removed. In most models the pulley is held on by plastic clips that must be prised outwards before the pulley can be lifted up. The gearbox is not fixed: provided you've put the threading ring in the correct position the gearbox can be lifted off the shaft. On very early models the pulley was not fixed but the gearbox was – by means of a plastic split ring. In this case the gearbox must be dismantled in situ by unclipping the top cover to get to the retaining ring. Later models have the gearbox and pulley free on the shaft with no fixings. If there's a plastic washer

beneath the gearbox remove this as it's not required with the latest gearbox and pulley.

The rack teeth can now be seen. If the rack is lifted clear of the metal blocking lever it can be moved towards the rear of the chassis till the lift lever is vertical. The latter can now be carefully levered inwards so that it comes off the shaft. The rack is then free to be removed. The metal blocking lever and cover can be undipped. Put the threading ring in the fully threaded position, then remove the spring under the deck. The control lever can now be prised up and removed.

## Reassembly

Next, reassembly. The new parts in the kit can now be fitted. Put a small amount of grease in the control lever's groove. Make sure that the threading ring is in the fully threaded position, then fit the control lever in place. Turn the threading ring back to the dismantling position. Fit the spring under the deck, the metal blocking lever and the plastic cover. The original covers were white, later ones were grey while the latest ones are black. The racks are date coded, with the year in a circle. The replacement can be fitted without modification. There's one exception: some very early racks didn't have the raised triangular piece on the side. With these only, you need to break off the triangular piece on the new rack.

## Rack and Lift Lever Timing

The timing of the rack and the lift levers needs some care. Put the rack on the plastic ridge, but don't at this stage fit it in place at the gearbox end. Offer up the lift lever, with it in the lift down position, so that the wedge-shaped tooth on the lever sits in the space between the spring-loaded bar and the rack's plastic teeth. Push the lift lever on to the shaft. Check the timing of the gears on the lift levers by moving the rack forwards and back. The lift levers should both move through their full travel. If the timing is wrong, the rack and the two levers won't move – so remove the lift lever and try again with it in a slightly different position. When this is satisfactory, press the rack into position next to the metal blocking lever and fit the rivet, gearbox and pulley. The gearbox will be easier to fit if the rack is moved to the right by hand to make more room for the gear teeth. Put the loading belt on to the plastic pulley.

## Refitting the Top Plate

Now to refit the top plate. Fit the new capstan belt, clean the capstan and lodge the new pinch roller in place on the top plate. Offer up the top plate and fit the pinch roller on to the gear (the threading gear should have been left so that the pinch roller gear is in the starting position). To help when fitting the two gears together there's a hole in the top plate so that the gears can be seen. The gears are correctly timed when the pinch roller can be moved diagonally no more than 3-4mm relative to the top plate. If it moves more than this or not at all, try altering it one tooth then try again. Fit the left-hand countersunk screw loosely to hold the pinch roller in place. At the other end of the top plate, fit the tension spring into the hole in the control lever then, using a wire hook, pull the loading belt over the motor pulley. Bend the head amplifier's metal stay back into position and fit the rest of the red screws and the long belt under the deck.

Rotate the combi motor back and forth, checking that the brakes come on and spring off again. Lastly, turn the

combi motor anticlockwise to move the back-tension arm out of the way of the moving tape guide as it returns. Power the threading motor so that the deck threads up fully, then unthread it and leave the deck in the eject position. If all is well so far the lift can now be replaced.

## Refitting the Lift

Fit the right-hand side of the lift then the left, using the slots in the lift guides. Disconnect the catch from the gear while pushing the lift forward into the track. If a mechanical catch is fitted to the right-hand side of the lift this may have to be released to allow the lift to go far enough forward to enable the COD1 switch cam to be aligned with the lug on the lift. Check that the lift gears are parallel, with the same number of teeth showing at each side. Fit the cassette flap and spring, and plug the deck back in. Make sure that the cables are fitted into the plastic guides by the head drum, also that the wires to the erase head are out of the way of the tape in the play position. After fitting the deck retaining screws you should be ready for a trial run.

## Dealing with a Jammed Deck

If the deck is jammed with the lift down you won't be able to dismantle it until the lift is raised. Remove the deck from the machine and look at the rear of the chassis. You'll see a slotted hole in the metal by the threading motor. Push the rack by pressing a small screwdriver through the slot: this will often release the rack, allowing the threading mechanism to turn. In difficult cases the metal blocking lever will have to be removed, though this means that the lift will be raised before unthreading is complete.

## The Scanner Ring

As previously mentioned, if too much force is used when removing the erase head plug you can break off the erase head mounting. The bracket is part of the scanner ring – the plastic moulding on which the lower drum fits. If you remove the scanner ring be careful not to lose the spring beneath it. This spring raises the scanner ring off the chassis at one side, allowing the tilt of the lower drum to be adjusted when the tape path is being set up.

## Lower Drum Earthing

As the lower drum is fitted on a plastic moulding it has to be separately earthed. This is done by means of a metal strap. Any problems that look like bad tracking could well be due to the lower drum not making good contact with this strap.

## Service Mode

For several years now Philips VCRs have had a service mode in which, if there's a deck fault that causes the machine to stop, the front display produces an "error code" to show what the microcomputer control chip has sensed is wrong. With this range the error memory is battery backed so that the fault code is still present when the mains supply is interrupted (so long as the NiCad battery isn't flat of course...).

To call up the service mode in early models, with the video showing E-to-E press store and set clock at the same time. The channel number will go off, being replaced by the error code. The left-hand digit shows which mode the

machine was in when the fault occurred. This varies from model to model. With the VR6761 the code is as follows: 1 record; 2 play; 3 play +3; 4 rewind; 5 wind; 6 play -7; 7 play +7; 8 stop; 9 still; dark eject; C play -1.

The right-hand digit shows a number that indicates the fault, as follows: 1 loading/threading time too long; 2 capstan still; 3 head still; 4 right-hand reel not turning.

Only the last fault to occur is shown – a new fault overwrites any previous one.

On later models the reset button can be used to clear the memory, leaving it at 00. Early models are more difficult to clear. Put the machine into the service mode with a tape inserted, then press rewind or play. This puts the machine into continuous test: it plays a tape to the end, rewinds back to the start, then starts playing again automatically. As the error memory is cleared each time the machine starts to play from the start, if you switch to standby at this point the error memory is set to 00.

Newer models without a set-clock button on the front need the use of a remote control handset to get into the service mode. With these machines you press the remote control stop, then play on the VCR for four seconds or so.

I wish that Japanese manufacturers would incorporate a similar system. How many hours have you spent looking at decks waiting to find out what stops?

## Some Mechanical Faults

For wow on sound, suspect a twisted capstan belt or a faulty capstan motor. The best way to check the motor is by substitution. If you don't have one to hand a rough check can be done by free-running the motor from a 9V supply. Connect a 10 $\Omega$ , 5W resistor in series with the motor and use an oscilloscope to measure the voltage across this resistor. With no load a good motor will produce regular voltage peaks of around 0.5V p-p. A faulty motor will produce pulses of much larger amplitude.

If the cassette is ejected when play or one of the wind modes is selected, the machine probably thinks that the capstan isn't rotating. The capstan tacho signal could well be missing due to a crack by plug L2 on the small P678 PCB on the top plate. To prevent this happening, be gentle when removing plug L2.

If the machine shuffles the tray but won't come on to E-to-E it hasn't initialised properly. The usual cause of this is failure of the COD1 switch to open and close as the tray moves. In this case the service mode is of no help – as you cannot get E-to-E, the machine won't go into the service mode. Often however a visual check will show that the lift isn't connecting with the COD1 switch cam or the cam has fallen off.

## Electronic Faults

As with most modern VCRs, electronic faults are comparatively rare. The VR6290 and VR6291 have a chopper power supply that had a tendency for the BUT11AF chopper transistor to blow if the mains plug arced or the mains supply was faulty. Fitting the SBC7013 kit (part no. 4822 310 31817) should cure this if the power supply can has a red label. If the label is green the modification has already been carried out.

VR6870s can go dead with a clicking noise coming from the power supply. The culprit is usually C2011 (33 $\mu$ F) but to be sure I change all three of the small electrolytics on the stand-up panel.

In the earlier models (VR6362 etc.) C2329 (330 $\mu$ F) on the i.f. panel causes all sorts of trouble when it goes short-

circuit, depending on whether the overloaded supply switching transistors go open- or short-circuit. Likely faults are no test pattern, no E-to-E operation, a blank screen on play or being in record and play at the same time. This last one is tricky as it gives the impression that the video heads have failed though what's really happening is that the tape is being erased! Even more fun occurs if the engineer tries the faulty i.f. panel in another machine which fails in a different way...

## Faults List

Finally, here's a list of various faults we've encountered:

**No display or keyboard operation:** No +13a supply as R3509 is open-circuit.

**Ejects when play or wind is selected:** No capstan tacho signal as R3509 is high-resistance or C2206 is short-circuit.

**Head drum not rotating:** T7113 open-circuit.

**Bad playback dropouts:** DOC offset control 3304 broken or lower drum not earthed.

**Takes in cassette then ejects it again:** Wire to switch COD3 broken.

**Intermittent clock or keyboard stops working:** Dry-joint on crystal 1001.

**Take-up spool stops intermittently in play:** Dry-joint on brake electromagnet.

**Power supply output voltage varies:** Check 6012, the optocoupler, 7001 and 7004 (Model VR6180).

**Low or no power supply output:** 7001 (BD436) open-circuit, D6006 or 2007 short-circuit or 1004 open-circuit.

**Patterning on playback colour:** Power supply screening plate missing.

**No E-to-E colour:** PB 10c supply still present but 7304 on board P306 leaky.

**No record picture but sound o.k.:** +12d supply missing. 7202 open-circuit.

**No sound recorded (hi-fi models):** Record level sliders at minimum!

**Display shows wrong operation:** Language option not set to English (later models only).

**Smeary monochrome picture:** Crack in track on on-screen display board by C2103 (Model VR6468).

**Playback colour crosstalk:** Faulty delay line 5102 (Model VR6180).

**Microcomputer control chip crashes intermittently (timer or clock etc. stops intermittently):** Check whether the 5V supply is low.

**E-to-E fades off:** U744 tuner (Model VR6185).

**Smeary E-to-E picture:** 7951 (4053) faulty (Model VR6362).

**Intermittent failure of head to rotate:** Change C2040 from 100nF to 10nF (VR6290 etc.).

**Noise bar running through picture:** Low control track signal due to internal leak at pin 13 of 7551.

**Wow on sound:** C2326 (4.7 $\mu$ F) open-circuit (Model VR6470).

**BUT11AF chopper transistor keeps blowing:** C2127 open-circuit (Model VR202).

## Ferguson 3V59/JVC HRD180

The fluorescent and LCD displays would go off intermittently though the machine still worked. A look at the Ferguson fault diagnosis pocket book suggested that the timer chip IC101 was suspect in this event, so a replacement was fitted. Unfortunately the fault persisted. Interrupting the mains input would bring back the supplies, so it seemed that something was causing the timer chip to freeze – but what? A scope was left connected to the 5V supply line. This showed that the voltage dropped momentarily. We traced back to the 12V supply and found that this also dropped occasionally. The STK5481 regulator chip was faulty. I suppose I had to come across an intermittent one sometime! **P.B.**

## Philips VR6670

This machine had no colour in either the E-E, play or record modes. The dealer had already changed the TDA3760 and TDA3755 chips. As the play/record switching voltages were correct I used a scope to trace the chroma signal through the TDA3760. It went in at pin 2, came out at pin 27 but was missing at pin 23. The BC548B emitter-follower transistor 7102 was open-circuit. **P.B.**

## GoldStar GHV1246I

With most VCRs poor rewind means a worn idler or slack belts. With this machine however the brakes weren't coming off in the wind modes, though they did in play. They are operated by a shaped steel plate whose hook was worn. A new slide plate (AY) was required – part no. 256-218B. **P.B.**

## Philips VR6870

When play was selected the drum turned only very slowly. Then, after a few attempts, the cassette would eject. The drum drive transistors all tested o.k. and the loom to the motor was intact, so another motor was connected temporarily. The drum motor was faulty. **P.B.**

## JVC HRD520

There were tracking lines when prerecorded tapes were played. On inspection you could see that the tape wasn't riding along the knife edge on the lower drum. As the rotary guide locking screws were loose the guides were adjusting themselves as the tape played. All that was necessary was to reset the guides and tighten the screws. Had the phantom fiddler passed this way? **P.B.**

## Akai VS23

This machine came in with a crunched tape and a rude note – rental customers very often send rude notes with their gear. Inspection showed that the mechanism was at odds: the FL cradle was in the fully-ejected position while the tape guides were in the loading complete positions. Yet they are all driven by the same motor! We rephased the deck mechanics, tested the machine and returned it. With hindsight this was a foolish act...

A week later the machine was back with another chewed

tape and an even ruder note threatening rental termination. The mechanics were in the same contradictory state as before. After much testing and head-scratching we found the cause of the trouble. On the front left-hand side of the deck there's a vertical steel plate which carries the plastic cogs and pinions that drive the FL cradle. The plate had bent to the left, the result being that the FL pinion could – maybe once in fifty loading operations – jump out of phase. **E.T.**

## JVC HRD230/Ferguson FV12L

There's a well known weak spot in certain JVC VCRs. It's cured by fitting a shakeproof washer to the under-deck PCB fixing screw to ensure a good electrical earth connection. This is not relevant to the HRD230, but we had one whose play or record would be suddenly interrupted at random times, reverting to the stop mode. It was because the reel pulses disappeared. To obtain a reliable earth connection for the optocoupler we had to fit a tiny shakeproof washer to the reel sensor PCB assembly's fixing screw. **E.T.**

## Hitachi VT63/64

The problem was failure of the deck functions, though cassette and tape loading worked all right. The drum motor didn't turn at all, and the capstan motor ran only during tape loading and unloading – which at least prevented the tape from being chewed! The cause of the fault was failure of the 12V regulator within the STK5451 power supply chip. Its output was down at 2.7V except when boosted during the motor-start phase (while the tape guides are on the move). **E.T.**

## Ferguson 3V43/JVC HRD725

Tape playback was normal but there was no E-E audio. The cause was traced to circuit protector CP3 on the FMA board being open-circuit. It's in the 12V feed to the f.m. circuit and seems to fail for no apparent reason. **J.E.**

## Osaki VCR31

No E-E, just snow, with the channel indicators working o.k. were the symptoms with this machine. Q755 was open-circuit base-to-emitter. **J.E.**

## Lloyd LV44

The channel indicators were o.k. but there was no picture or sound in the E-E mode. The cause was traced to R21 (1.8k $\Omega$ ) on the tuner/i.f. board being open-circuit. It supplies the 30V tuning voltage. **J.E.**

## Akai VS1

In both the E-E and playback modes the monitor screen displayed a rectangular box that contained rows of letter As. The box flashed on/off at the clock rate. Outside the box there was just a blank raster. The character generator chip is IC2, type MB88303M. It's mounted on the front

clock/timer board. Voltage checks at its pins produced correct readings as per the manual except at pins 12 and 13, which were at 5V instead of 0.1V. Replacing IC2 cured the problem. **J.E.**

### **Panasonic NV-M7B**

The complaint with this camcorder was no drum drive. All the drum drive and power supply chips had been changed by the dealer to no avail. Careful voltage checks revealed nothing unusual except that when play was selected the drum power dropped momentarily to almost nothing. Although the power chips had been changed, suspicion was heading towards them. So a bench power supply was hooked to the drum power line. The drum then sprang to life.

In this camcorder feedback from the drum and capstan drive chips to the power supplies regulates the operation. The drum feedback is applied to the regulator chip via a 150k $\Omega$  resistor which is decoupled by a 1 $\mu$ F capacitor. When I eventually managed to remove this surface-mounted capacitor from beneath a crystal and coil I found that it was leaky, reading about 30k $\Omega$ . A replacement restored normal working. **B.S.**

### **Panasonic NV-FS100/NV-F70**

Just as I was beginning to believe in my VCR repair ability along came this all-singing, all-dancing NV-FS100. The dealer said that the power supply would intermittently shut down, though it wouldn't do so for him! So we put the machine on the soak test bench, where it worked perfectly for days, until I left a tape in it overnight. When I came to switch it on next morning, it wouldn't power up. The timer flashed its zeros as normal, but when the operate button was pressed the channel display appeared briefly, the VU meters didn't light up then the machine shut down. This happened three times, until the VU meter lit, the mechanism shuffled and the unit powered up. It then worked perfectly until next morning when the ritual was repeated. After a few days of fruitless early morning checks I realised that with no tape in it the machine seemed to work when first asked. So the fault was evidently in the sophisticated system and servo circuits, to do with the tape control.

One morning, after my usual fruitless ten minutes' checking the NV-FS100, one of its smaller brothers, an NV-F70, appeared with the comment "no rewind" on the attached label. I cautiously plugged it in, offered it a tape and pressed rewind. The machine powered down and sulkily refused to return my test tape. Though already fairly low, my heart sank. After removing the bottom cover, I wound the tape out. On next inserting the tape I pressed play. So far so good: picture, sound and locked servos. I then tried fast forward. After a few seconds the unit powered down again. Once more to the bottom cover to reclaim my tape.

Now on this more sophisticated version of the G mechanism there's a reel motor which is mounted above the deck mode switch. It's used for the instant jog-shuttle cue/review functions that these machines have. Although the normal capstan driven functions still worked, when the reel motor was called into action the syscon realised that there was a problem and powered down to prevent tape damage. So I disconnected the reel drive plug and applied a small external voltage. The supply spool rotated healthily. Checks were next made around the reel motor drive chip, where a blackened resistor gazed sorrowfully

up at me: R6035 (0.9 $\Omega$ ) was in a state of some distress. Replacing this resistor restored normal operation. But why had it burnt? The unit worked perfectly for a week with R6035 not even getting warm.

On an impulse I stared accusingly at the NV-FS100. Reel drive problems? I lifted the main board and there was R6035, blackened and reading about 5 $\Omega$  on my meter. Needless to say the correct resistor restored normal operation, even first thing in the morning. Both machines were too new to have had a worn reel motor. Perhaps the motor can be intermittently stalled by the mechanism? Perhaps the reel drive chip can fail intermittently? Does anybody out there know? **B.S.**

### **Panasonic NV-G25**

The symptoms were alarming: there was patterning on E-E, sluggish operation of the drum motor and, when the machine did play back, no colour. The dealer who brought it in said that the luminance/chrominance pack, the head amplifier module and the head drum motor had been changed. After that his technician left, suffering from nervous exhaustion... Fortunately the problem was not as bad as it seemed. C1023 (1,000 $\mu$ F), the 14V supply reservoir capacitor in the chopper circuit, was faulty. **B.S.**

### **Panasonic NV-M1**

The request with this vintage camcorder was for an estimate for fitting a new vidicon tube and battery. Out came the dusty old connector to my monitor. On test, the camcorder produced a bright green picture. As it was clear and well focused my attention turned to IC401. It's not uncommon for this chip to fail in these machines - in the NV-M3 it's provided with a heatsink. Replacing this colour-difference matrixing chip produced more normal colours. Quick adjustment of the red/blue gain, electronic focus and beam current controls then produced a good camera picture. A new VWVBM3 battery, still available from Panasonic, completed the repair. **B.S.**

### **Sharp VC400/581/582/583/584**

A fault we've had with a number of these machines is that the mechanics go out of sync, producing all sorts of strange symptoms. It's caused by the white plastic cog on the mode switch cracking around the spindle. As a result the cog still turns but the mode switch doesn't move. Thus the machine gets confused. The switch is part no. QSW-R0014GEZZ. It must be fitted exactly as laid down in the manual. The reason for this is that inside the switch there's a 5-to-1 reduction drive. So the cog on the outside turns five times before the switch has turned once. Although the old cam switch can be glued, a replacement is the best solution. **M.Dr.**

### **Ferguson FV32L**

This machine came in dead. A quick check showed that the mains fuse F1 was open-circuit. As no fault could be found and the fuse wasn't blackened a replacement was fitted. At switch on the new fuse flashed violently. There was still no readable short-circuit, so the chopper transistor was removed from the board and another new fuse was tried. It again blew straight away. The only likely causes of the fuse blowing were the mains rectifier diodes and the 150 $\mu$ F, 385V reservoir capacitor CP07. The latter was our first suspect and when it was removed a new fuse held. When

tested on our capacitance meter the old capacitor seemed to be all right, but a replacement cured the fault. The old one must have been flashing over internally when the mains voltage was applied.

**M.Dr.**

### **JVC HRD400**

A recent case of intermittent record and playback pictures was caused by dry-joints within the luminance module. Although it bristles with surface-mounted components, it's possible, with care, to provide a cure by resoldering.

**S.L.**

### **Samsung VI510**

These are likeable, basic machines. This one was dead with a blown 2.5AT mains fuse. A replacement didn't blow until a cassette was tried in the carriage. As those familiar with these machines will know, the cassette carriage is driven directly by the loading gears, having no separate motor. When turned, the loading motor was found to be very stiff and notchy. It wouldn't operate even from a separate supply. Replacement put matters right. Incidentally, linking pins 1, 2 and 3 of the carriage plug enables the deck to be operated without the hindrance of the carriage.

**S.L.**

### **Ferguson FV11R/JVC HRD170**

This machine would accept tapes and perform deck functions normally but there was no clock and no timer operation. IC1 (UPD75208CW-097) on the front panel seemed to be a logical place at which to start. Supplies arrive at CN1: the -30V and filament supplies were both

correct. Unswitched 12V was present at pin 1 of CN3 and was being converted to unswitched 5V by IC2 to feed pin 64 of IC1. The reset line at pin 39 of this chip twitched normally at switch on, and the clock oscillator across pins 30 and 31 was o.k. There was little to show by way of data output however, despite various requests being made of the chip. A new chip restored normal operation.

**S.L.**

### **Amstrad VC6100/Tashiko VVF934**

The lady customer who brought in this machine said there was no playback colour. She also said "my husband thinks it's just a wire off" – that kind of comment can put a tenner on the bill! On test there was just a slight green haze on the playback picture, but the machine's recordings were o.k. when played back on a good machine. After trying all the usual things that cause this fault, i.e. the 4.43MHz crystal, various filters and the HIC101 chroma module, I retired the scope and engaged the meter. A check on the 9V supply at fuse F602 on the power supply produced a reading of 6.5V. This 9V supply goes to several i.c. regulators on the video/chroma board. Disconnecting various lines brought the voltage up slightly, but the fault wasn't being caused by shorts or leakage. What had happened was that some smart person had fitted a 200mA instead of a 500mA fuse in the F602 position. The internal resistance of a 200mA fuse is higher of course, hence the voltage drop. A new 500mA fuse restored playback in living colour. So next time one of these machines comes in with no playback colour, remember that it's not a wire off but probably just a fuse! For those interested in the charge, it was seven times more than that for the lady's comment!!

**B.D.**



## Philips VR6462

There were E-E signals but when play or the test pattern was selected there was no output from the modulator. The +12b supply was disappearing – check it at R3160. By disconnecting PCBs I was able to establish that the fault was on the P302 signals panel where C2329 (220 $\mu$ F, 16V) was short-circuit. **P.B.**

## Philips VR6180

This machine had a deck problem: when a cassette was inserted the deck couldn't find the stop position. The cassette would go in, the deck would start to lace up, then it would eject the cassette and switch off. Inspection showed that the cassette-down switch COD3 was working correctly. Deck state is also sensed by switch COD2 however – the one at the back by the threading motor. This one was sticking in the closed position. So it was just a question of fitting a new micro switch. **P.B.**

## Philips VR6468

There was a buzzing noise on the sound while a hot smell came from the inside. The hot smell was coming from Tr7108, which is one of the drum motor drive transistors. A check on this transistor's drive waveform (HMC2) showed that there was an oscillation on it. Replacing Tr7108 and its driver transistor Tr7107 made no difference, in fact the oscillation appeared to be coming from the P8051-C21D4 chip. A replacement cured the problem. **P.B.**

## Grundig VS510

There was no teletext – when this mode was selected the page number appeared but there was no clock while the no teletext active message was present at the bottom of the screen. Tests around the SAA5231 chip on the DOS/TEXT board showed that there was no video input at pin 27. The BC848 transistor CT1655 was open-circuit. **P.B.**

## Philips VR6490

This machine kept stopping in play. The reel rotation signal was intermittent, though the reel was turning all right. On investigation we found that the ribbon cable to deck plug P1504 wasn't clamped into the connector. A press on the locking bar was all that was required. **P.B.**

## Philips VR6460

This machine was dead – no clock, no deck activity, nothing. The AT supplies were present but there was no activity on the I2C bus data line. It was shorted to chassis (47 $\Omega$ ), but the short cleared when the keyboard was unplugged. A new TMS3763ANL28 chip was required. **P.B.**

## Philips VR6462

The ticket said that the complaint was no sound – also that the machine had been to another repairer. Playback sound

was o.k. but the E-to-E sound was weak with buzzing. A look at the sound subpanel showed that there had been a lot of soldering activity – also a new 5.5MHz sound filter had been fitted! Fitting the correct 6MHz type cut down the buzz while a tweak on coil S5 brought back the sound. Someone hadn't read the small print on the diagram – 6MHz for /05, i.e. for 6MHz UK use. **P.B.**

## JVC HRD520

The half-loading mechanism in this machine enables the counter and index functions to work in the fast-forward and rewind modes when the tape isn't wrapped around the drum. This machine's owner insisted that it sometimes failed to count in the fast tape transport modes. We found that the counting worked perfectly if fast forward or rewind was entered from stop after play, but if fast forward or rewind was selected immediately after tape insertion the guide pole failed to pull out a tape loop and there was no count. The mode switch was responsible. Since we had none in stock we dismantled and cleaned the original one, which had tiny black spots on its stator contact bars. **E.T.**

## JVC HRD580

This machine's recordings were marred by horizontal black flashes across the screen – the sort of interference you get from a latched aerial plug or an intermittent tuner. The effect could be seen on the E-to-E pictures. Some heating and freezing on i.f. panel 07 revealed that one end of R38, the demodulated video feed, was dry-jointed. **E.T.**

## Sanyo VTC5150

This old Betamax machine led me a dance. Whichever mode was selected it would stop after a few moments. Since the machine would sit there happily in the pause mode the reel sensor system was clearly implicated. There were pulses from the reel sensor optocoupler in the other modes. These pulses were being amplified sufficiently by Q3012 to keep the tape counter working but not sufficiently for the microcontroller chip IC3001. The optocoupler's output pulses were of low amplitude because the LED and photodiode beneath the take-up reel were thick with dust. A good blow-through cured the problem. Shades of Test Case 335! **E.T.**

## Sanyo VHR4350

If eject is sometimes accompanied by tape looping, with consequent tape damage, remove the bottom cover and take a look at the reel drive system. There's a "switched clutch" that slides up and down the gear shaft between the spools. On several occasions we've found the clutch to be tight on the shaft. **E.T.**

## Sharp VC383

This machine wouldn't record in colour. Presented with a tape recorded elsewhere it would play this back with perfectly acceptable colour, which seemed to eliminate all the colour circuitry that's common to record and playback.

One of the exonerated components was the 5.06MHz chroma filter FL503 between the sub- and main colour signal converters though it had, maybe because of an internal open-circuit, become very lossy. The manual provides few clues to the colour-under subcarrier signal levels. The main one is the chroma record current which was found to be about 6dB down. The cause of the trouble was the HA1178NT chip. **E.T.**

### **Samsung SI1240**

We've had the same fault with two brand new SI1240s. The symptom is that the machine performs no functions and switches off after a few seconds, perhaps with the cassette-in symbol showing even when the FL cradle is empty. The cause of the trouble is failure of the KA8301 loading-motor drive chip. An equivalent is the more common BA6209. **E.T.**

### **Sony SLV474**

This machine has digital video circuitry to produce picture-in-picture displays and a useful edit monitor screen that shows as small inset pictures the incoming video signal and the last off-tape image when going from play pause to record pause. The user employs this latter facility when copying from a camcorder, and the fault on this machine was particularly important to him. The fault symptom was as follows. In the edit monitor or picture-in-picture mode the inset display would be very dark at first. It would then lighten slowly until it was almost whited out.

Before being fed to pins 8, 7 and 6 respectively of the AD converter chip IC108 the video signal is split into its Y, R - Y and B - Y components. The chip also has a black-level clamp that operates prior to AD conversion, the clamp pulses being fed in at pin 15. The video signals, in component form, are fed into the chip via 1µF capacitors, so the d.c. voltages at the input pins must come from within the chip. The voltages at the two colour-difference signal input pins were correct at 3.4V. At the Y input pin 8 however the d.c. voltage fell dramatically when the high-impedance voltmeter was connected. As a result the digitised picture became very dark. Because of a fault within the chip the black level at this input wasn't being clamped. **I.B.**

### **Ferguson FV41**

After playing back for a couple of hours a chroma fault would appear. The symptoms were as follows: on the left-hand side of the screen the colour remained correct but farther across to the right its phase changed, e.g. blue changed to orange. The fault would clear if the tape was stopped and then re-started or the cue and review functions were used. As the conditions around the chroma signal processing chip IC08 were correct we decided to swap it with one in another machine. The fault moved with the chip, proving that the latter was defective. **I.B.**

### **Panasonic NV-MS90**

The reported fault was of a dark or no picture from the camera section of this camcorder. What was happening was that the luminance disappeared after a few minutes' use. When we dismantled the machine we found that the slightest pressure applied to the process PCB made the fault come and go. Checks showed that the luminance signal was always present at pin 7 of IC306, which is an

output to switching and one-line delay circuitry: when the fault was present the signal at pin 24, where it should return after the switching and delay operations, was missing. The cause of the problem was within the subpanel delay chip IC302 - the input at pin 11 was always present but the output at pin 22 disappeared in the fault condition. **I.B.**

### **Mitsubishi HS306**

If the machine stops intermittently during play or record check IC5A4 - it's mounted on the metal bracket along the front. **R.J.A.**

### **Hitachi VTM622**

This fairly new machine had no servo pulses on record only, being o.k. with prerecorded tapes. The cure was simply to clean the audio/control head. I wonder if this is going to become a problem, as with the VT410 series? **R.J.A.**

### **Hitachi VT120**

When a tape was inserted this machine would sometimes load it very slowly half way then just sit there and switch off, leaving the tape half laced. On one occasion the machine accepted the tape normally then switched off, again without ejecting the cassette. Suspecting a faulty loading motor, we applied an external 9V supply to its terminals. The carriage operated normally. As the M54649L carriage motor/loading chip IC902 has given trouble in the past we checked the voltages here while trying to load a tape. There was only 2-3V across the motor, measured at pin 10, so we checked the 12V supply at pin 9. This dropped to 2V when the chip was asked to drive the motor. As replacing the chip made no difference attention was turned to the source of the 12V supply, at pin 7 of the STK5471 regulator chip. A new chip restored normal operation. **J.E.**

### **Amstrad VCR4700**

After about an hour in either the play or record mode this machine would give a quiet "squeak" then unlace and switch off. Using a dummy cassette we saw that the take-up spool carrier faltered and stopped: the capstan, belt and clutch drive wheel rotated normally until the system control went into the stop mode due to absence of the reel pulses. Fitting the clutch modification kit provided the cure. It's common for the clutch unit to be responsible for tape creasing: I'd not seen one seize before. **J.E.**

### **Saisho VR705**

The deck functions operated normally but there was no E-E or tape playback signal. The switched 9V supply was missing. It's produced by Q507 (2SD1266) which had 20V at its collector. Fitting a new transistor cured the problem. **J.E.**

### **Matsui VX755A/Saisho VR3600**

This machine wouldn't accept a tape. The standby indicator was on and the clock display was normal. When an attempt was made to insert a tape the standby indicator went off and the machine shut down. The cause of the fault was traced to the supply end sensor on the carriage. **J.E.**

# Fault Notes on the JVC HRD110/Ferguson 3V38

John Coombes

The JVC HRD110 was on sale during the period 1984-5. It appeared in various guises including the Ferguson 3V38/39/49, the ITT VR3605 and the Toshiba V55. The following fault notes summarise our experiences of these machines.

**No results:** First check the 500mA fuse F1 which may simply have gone open-circuit. If a replacement blows check for shorted turns in the mains transformer. The next item to check is the 2.5A fuse F2 which again may simply be open-circuit. If this fuse has blown check for shorts in the 0.01 $\mu$ F filter capacitors C1-5 and the bridge rectifier diodes D3-6 (two type 30D2, two type 10E2). Next ensure that relay RY1 is operating and is not open-circuit. Q2 (2SD637) and/or Q3 (2SD880) could be short-circuit. If the power regulator appears to be working correctly check whether CP2 on the servo/logic/audio panel is open-circuit.

**No clock display:** Check the 315mA fuse F3. If a replacement blows check for shorts in D11 (11E2), Q8 (2SA1020), C20 (33 $\mu$ F) and/or D12 (HZ30-2L). Alternatively C18 (100 $\mu$ F) could be leaky.

If the l.t. supply to the clock display is present the display itself (FDP) could be faulty. Check the voltages around the UPD7538C chip IC1 very carefully: if necessary check the chip by replacement. Other possibilities here are absence of the reset pulse at pin 1 or the voltage at pin 41. If the latter is missing, suspect IC2 (TL077P) and/or Q1 (DTC114). Check these items by replacement. As Q1 is a digital transistor the resistance readings you obtain will not be what you might expect.

**Will not take tape into the cassette housing:** Ensure that the l.t. supply is present at pins 1/2 and 8/9 of the M54544L chip IC204. If not, check whether circuit protector CP1 is open-circuit then if necessary check IC204 by replacement. Alternatively the up/down detector switch could be faulty.

**Cassette housing moves in and out:** First check the voltage at pin 39 of the M50740-602SP chip IC201. If this is unstable the resistive network RA204 could be faulty or dry-jointed. Don't confuse this fault with intermittent loading of the tape into the cassette housing due to a faulty front loading motor or broken or damaged cogs on the cassette housing unit.

**Tape loads but no capstan rotation:** Check the loading belt which may be stretched and/or the loading switches which may be faulty.

**Intermittent stopping in play/record:** This is usually due to a faulty take-up reel sensor or coupler. Check by replacement.

**No fast forward/rewind:** The usual cause is a worn reel idler. Alternatively the reel belt may be stretched or cracked and thus slipping.

**No play/intermittent play:** The usual cause is a worn rubber drive wheel on the idler arm, the result being no tape take up. If necessary check the take-up spool and the capstan belt which may be stretched or cracked, causing slipping

and tape looping around the capstan flywheel spindle. If the tape is creased in pleats and looping, check the pinch roller by replacement.

## Sound Faults

**Intermittent sound on record:** If you get this fault accompanied by coloured patterns on the picture ensure that C27 has been increased in value from 0.0015 $\mu$ F to 0.0082 $\mu$ F – this value can vary with model. Alternatively the cause of the fault could be broken leads at the full erase head.

**Intermittent record sound:** If this fault occurs along with no picture, check the plugs and sockets associated with the audio/control head. Things to look for here are poor connections, dry-joints or even high-resistance connections. Alternatively the cause of the intermittent sound could be a worn audio head.

**Recorded sound at low level, possibly with excessive treble:** Check the audio record signal at pin 1 of connector CN1. If incorrect, L4 could be open-circuit or there could be dry-joints or cracks on the PCB.

## Electronic Faults

**Bent verticals/poor sync with E-E signals:** Check the a.g.c. voltage at pin 3 of the M51316P chip IC1 very carefully. If it's incorrect C7 (0.047 $\mu$ F) is probably faulty. Alternatively you may have to check IC1 by replacement.

**Noise bars on playback:** The capstan servo is unlocked. Check for a trapezoidal waveform at TP403. If this is missing, check crystal X401 by replacement. Otherwise replace IC403 (HA11751NT).

**Playback o.k. but no fast forward or reverse search capstan drive:** You may have to trace through the whole of the capstan servo drive circuit to find an open-circuit component. R605 (100k $\Omega$ ) is a possibility.

**Capstan motor stops intermittently in reverse search:** Check the voltages around IC206 (M54544L) very carefully, especially at pin 6 which should go to zero in the reverse search mode. If this voltage doesn't fall to zero, check Q218 (DTA144F) and/or D229 (1SS133), by replacement if necessary.

**No playback luminance:** Check the voltages around IC101 (M51454L) and/or IC102 (HA11738). If an incorrect voltage is found, check the chip by replacement. Alternatively you may find that R111 (22k $\Omega$ ) is open-circuit. In this event there may be no luminance with chroma flashing.

**No record luminance:** Check the voltages around IC102 (HA11738) and/or IC103 (HA11724). If an incorrect voltage is present check the chip by replacement. An alternative is leakage in D104 (MA27). You may have to check this on the high ohms range.

## Grundig VS340

This machine had a capstan servo fault. In play the capstan would stop, then go too fast, then stop and so on. Checks showed that the capstan tacho signal at pin 2 of IC700 was erratic while there was no input at pins 17 and 18 of this chip. The wire to the tacho coil was dry-jointed where it connects to the threading motor's PCB. **P.B.**

## Mitsubishi HS349

This machine kept stopping in play. The reel tacho signal at the collector of Q5A0 was intermittent because the reel sensor PCB's earthing screws were making poor contact. **P.B.**

## Grundig VCRs with Panasonic G Deck

If you encounter one of these machines with the timing gears out of alignment, check socket P1503 for dry-joints – it's on the right-hand side of the cassette carriage. **P.B.**

## Philips DMP2 and DMP3 Decks

Further to Nick Beer's note (February Clinic, page 272) on the VR6180, a number of changes were made to later versions of these decks, which have the capstan tacho head on the outside of the flywheel. The following parts were changed: top plate item 255, part no. 4822 466 82467; scanner ring item 227, part no. 4822 532 11776; erase head item 247, part no. 4822 249 40252; capstan item 262, part no. 4822 535 92909; tacho head and PCB, part no. 4822 214 32587; threading motor item 252, part no. 4822 361 21242; crank item 259, part no. 4822 528 20593; control lever item 272, part no. 4822 403 53744; in addition a washer and spring were added under item 256, washer part no. 4822 532 11775, spring part no. 4822 492 52095. **P.B.**

## Grundig VS700

The complaint was that this machine wouldn't play. When a cassette was inserted the counter was displayed after ATTS, not the time used on the tape, while if any deck function was tried it would operate for only a second after which stop was selected. Checks showed that the reel tacho signals were present at the optocouplers but were missing at pin 32 of the SDA2087 chip. The TDA8118 chip was faulty with pin 14 short-circuit to chassis. **P.B.**

## Panasonic NV-G45

Erratic capstan was the complaint with this machine. So it proved to be on test, speeding up and slowing down at random. On this machine (G deck) the capstan also drives the mechanism operation, so you have to be careful with capstan speed faults because you can damage the mechanism. The fault would show up when any point in the capstan circuit was touched, but it seemed logical to start by checking the capstan FG waveforms. Sure enough we found that the FG waveforms fluctuated up and down wildly at the capstan FG amplifier IC2104. The key seemed to lie with R2184 at the input to the FG amplifier, as there was no waveform amplitude variation at one end

of this component and a very erratic variation at the other end. We removed this surface-mounted resistor and tacked a conventional 1k $\Omega$  resistor in its place. The capstan circuit then operated perfectly in all modes. **B.S.**

## National NV-H75

This foreign machine had a dead power supply. Power was restored when the 2SC1384 crowbar transistor Q1006 on the secondary side of the switch-mode power supply was replaced. It was leaky. The machine then seemed to work – until the deck solenoid was engaged. The power supply then current limited sharply. Investigation in the primary side feedback circuit brought us to a rather sorry looking capacitor, C1042 (10 $\mu$ F, 25V). It was brown and discoloured. Fitting a replacement restored normal power. **B.S.**

## Hinari VXL6

This machine would stop intermittently and the counter was very erratic in the play mode. We also noticed that the counter continued to count even in the stop mode. Replacing the take-up reel sensor cured the fault. **A.D.**

## Mitsubishi HS330

The problem here was no playback colour. We scoped the video output when a known good tape was tried. This showed that the colour burst was present, so the next step was to check the alignment of the colour playback circuit. The voltage-controlled crystal oscillator was found to be running at 4.4328MHz instead of 4.4336MHz. Adjusting this as laid down in the manual restored the playback colour. **A.D.**

## JVC HRD520

If you get one of these machines with what appears to be a loading-mechanism or mode-switch fault, e.g. the pinch roller drive peg hits the end of its cam, check that the slit washer (item 40 in the mechanical parts list) is present and correct. If it falls off, the sliding plate assembly's teeth can jump across those of the control cam. **E.T.**

## Sony SLV615

This machine wouldn't carry out any reverse functions (rewind, review, reverse slo-mo): within a few seconds of one of these being selected the deck would shut down. The obvious suspect was the right-hand end sensor, but both this and the nearby operational-amplifier buffer chip proved to be innocent. The 100-pin flatpack syscon/servo chip was the cause of the trouble. **E.T.**

## Sanyo VHR4350 (P88 Mechanism)

This machine would intermittently fail to rewind or fast wind the tape because it tried to drive the reels via the clutch instead of directly. The mechanism is in the same position for stop, fast forward and rewind: when the fault was present we saw that the cam slide assembly at the rear right-hand side of the deck had jumped out of cam groove

3. The cure for this problem is to replace the cam slide assembly with a modified one, available under the same part number (613 022 0059), which comes with fitting instructions. Also replace the loading belt.

An occasional problem with this deck is tape snagging when the cassette is ejected. Cure it by cleaning the periphery of the capstan flywheel and the brake pad that bears on it.

E.T.

### **Akai VS967**

This machine worked perfectly in every respect apart from the fact that the fluorescent display panel wasn't lit up. Very low heater drive was the cause of this, and replacement of C446/7 in the voltage-doubler circuit on the main PCB provided a complete cure. The faulty capacitors measured o.k. when removed from the machine... This and several contemporary models can suffer from premature display panel wear unless the circuit in the area of C446/7 is modified – details are available from Akai in modification sheet AV10015.

E.T.

### **Philips VR6290**

This machine half accepted a tape then the carriage made a squealing noise and ejected it. Inspection of the carriage's operation with the top cover removed showed that the carriage attempted to go in all the way but the cassette flap didn't open and thus fouled on the left-hand guide roller. The cause of this was that the tape flap opener spring had become displaced. Simply relocating the spring into the opener cured the problem.

J.E.

### **Panasonic NV7200**

No tape functions and won't eject said the job card. There was a tape in the machine but there was no response from the function selectors and their indicators though the power-on LED and the channel indicator were as normal. Our past experience has often been that this problem is caused by either dirty contacts or a broken cassette-in leaf switch. Not this time however. With a cassette in there should be 12V at each tag of the switch (contacts closed). There was no voltage at either tag, so we had a 12V feed problem. When we traced back to pin 2 of plug/socket P6014 on the system control panel we found that the 12V supply was missing here as well. L6001 was open-circuit.

J.E.

### **Toshiba V57/Ferguson 3V35/JVC HRD120**

"Went haywire, then o.k. except that it wouldn't eject, now no functions" read the report. This is becoming a common fault. CP1 (ICP-F15) goes open-circuit due to failure of the M54544L cassette motor driver chip. Another reason for this can be a defective motor. The same two possibilities apply with the loading motor and its drive chip, which are also fed via the same ICP. When CP1 goes open-circuit the 13V supply to both circuits is removed.

N.B.

### **Panasonic NV7200**

This machine had been serviced by one of our apprentices – he'd fitted the parts in the VUD kit, changed the heads and one or two other items, but there was now no drive. The absence of a familiar sound when ejecting was noted: the solenoids weren't being energised, so the brakes were

on. R6083 (2- $\Omega$  fusible) which feeds the unregulated 20V supply to the solenoid drive circuits was open-circuit because the 2SA768 transistor Q6027 was short-circuit – it had run hot and melted its solder. The reason for this failure was the presence of an extraneous conductor that had fallen on to the syscon board from the mechanism – a circlip that was missing from the brake band under the back-tension post.

N.B.

### **Grundig VS310**

The display said F1. This was because there was no loading motor movement – it wasn't being driven as R2155, the PTC thermistor in series with the output to the motor from pin 3 of IC2150, was dry-jointed at one end.

N.B.

### **Toshiba V109**

This full-face machine was accused of damaging tapes, as a result of which the heads were now clogged. After cleaning these we found that the cause of the problem was very slightly weak reel drive due to a worn drive clutch. It's a delight to change this item from underneath.

N.B.

### **Sanyo VHR2300/Granada VHSDS2**

The complaint was that the sound had been poor and had subsequently disappeared. On inspection we noticed that the 820 $\Omega$  resistor R10 looked a little discoloured. A check then showed that it was open-circuit. Fitting a replacement restored the sound, but it was poor. This was due to a contaminated audio-control head. After cleaning the tape path we had perfect operation.

G.R.

### **Sharp VC780HM**

This machine would eject any cassette that was inserted. We soon found that it could be fooled into accepting a cassette if it was switched off immediately after inserting the cassette then switched on again. Checks at pins 47 and 14 of the IX0234GE system control chip showed that they changed state before the cassette was ejected. The reason for this became clear when we checked at pins 17 and 18: there were no end or start sensor pulses. When attention was turned to the sensors themselves we found that two tiny black squares of tape had been applied. Where had they come from?

G.R.

### **Panasonic NV-G25**

The fault report said that the playback picture was noisy: it was also worse with its own recordings. On test we found that the noise on the screen had a definite pattern and wasn't random. As a start we checked the earth continuity between the video head preamplifier unit and the main PCB and other possible earth paths. All measured o.k. but the strange thing was that the noise was made worse when an extra lead was connected from the head preamplifier to the main PCB. A scope was next used to check the noise on the various supply lines – the main connector from the switch-mode power supply seemed a convenient place to do this. Apart from the -19V supply at pin 10 of P1001 the supplies had very little noise. At pin 10 however there were noise spikes of around 1V amplitude. When the power supply can was removed the cause of the trouble was obvious: smoothing capacitor C1022 had split its top and was open-circuit. A new capacitor greatly reduced the spikes and cured the problem.

I.B.

# Serviceing the Hinari VXL8

Graham Rees and Joe Cieszynski

About six years ago Hinari introduced a budget video range that was aimed at the High Street punter on the lookout for a quick bargain. The relatively low cost of these machines combined with the attraction of many features such as a long-play mode, HQ circuitry and remote control programming made them an instant success in terms of sales. And it was not just the public that made a beeline for them. Some of the large rental organisations considered them to be a good business proposition, renting them out for two or three years and then disposing of them as soon as a major failure occurred, considering it more economical to replace the machine with a new model rather than pay an engineer to carry out a repair and service.

As a result of all this these machines are now around in considerable numbers. In spite of their reputation in the

trade as being something of a bogey to be avoided, they are well worth repairing. We don't deny that fault diagnosis can be difficult. But many "difficult" faults can be traced to specific components, as we shall see.

We shall be referring specifically to the Hinari VXL8 but there are a number of related models. The VXL9 is basically the same with some additional features such as remote control programming. The deck mechanism used in the VXL8 is also used in the VXL12. Variations of the deck mechanism are found in the Sentra Models VX8500LP and VX8600LP, the Amstrad Models VCR6000 and VCR6100 and the Nikkai Model J1, though the PCB layouts in these machines differ somewhat from those in the Hinari models.

Another significant difference between models is the CXP505B microcomputer control chip's programme

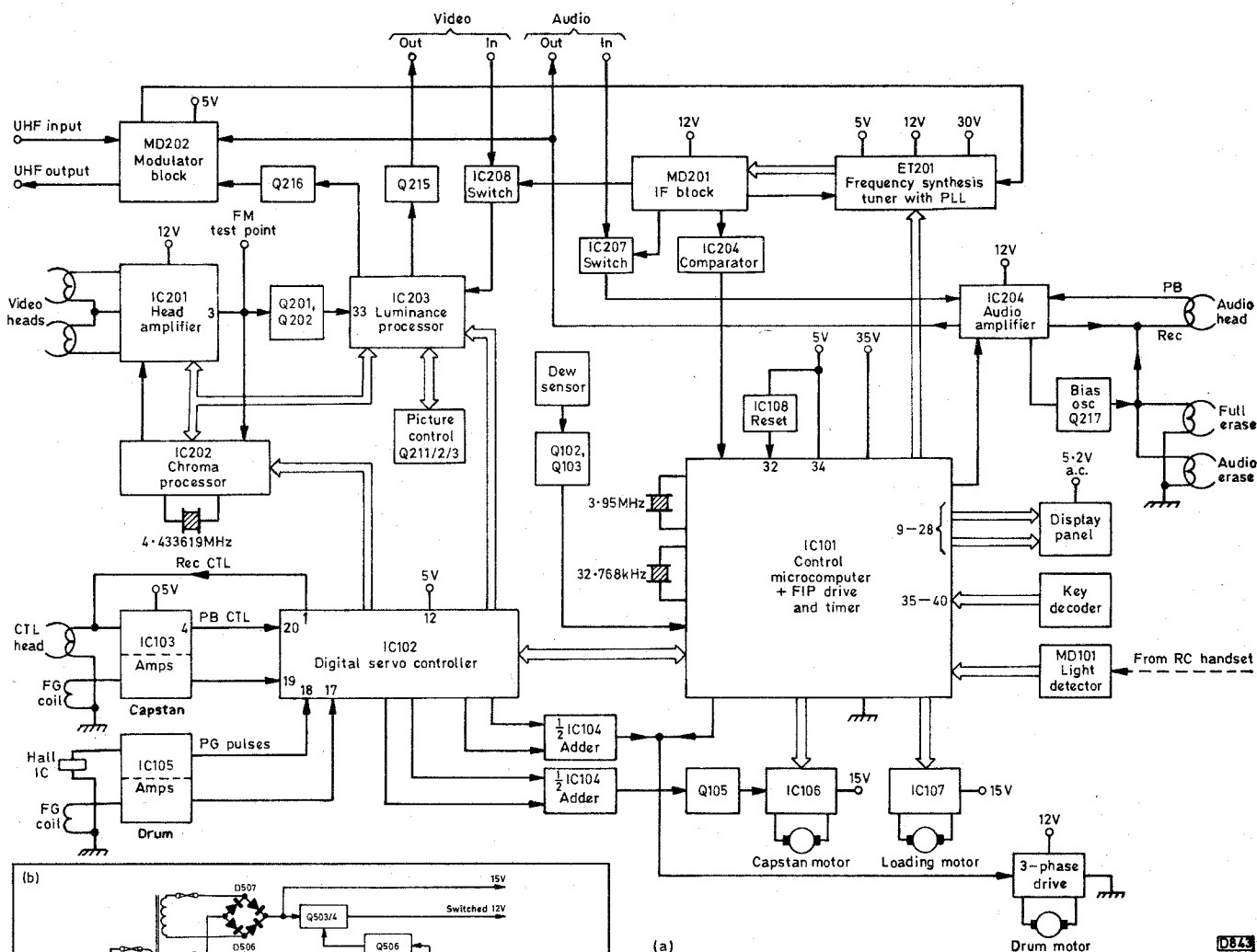

Fig. 1: Block diagram of the Hinari VXL8 and VXL9, showing key voltages, test points and signal paths. (a) Signal processing, servo and control sections; (b) the power supply arrangements.

codes. The VXL8 programme number is 117; with the VXL9 and the Sentra VX8600LP the number is 118; the Sentra VX8500LP uses programme number 143.

## Machine Details

Figs. 1-5 are included to help those who don't have a full service manual. Many of the test points and components shown in these diagrams are referred to in this article. Note the differences between the YC boards in the Hinari and

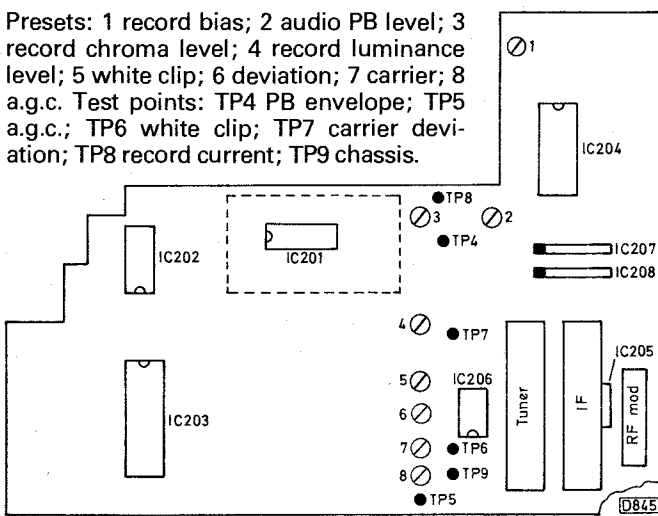

Fig. 2: Luminance-chroma (YC) board layout for the Hinari VXL8/9, viewed from the component side.

Sentra models. Fig. 1 shows an overall block diagram for the VXL8/9; Fig. 2 shows the main items on the Hinari YC (luminance and chroma) board; Fig. 3 shows the same for the Sentra YC board; Fig. 4 shows the servo/CPU board; Fig. 5 shows the board layout in the VXL8/9.

We'll start with electronic faults. On the whole the PCBs are quite reliable, but there are a number of common problems produced by specific components.

### Electronic Faults

The first problem we'll consider occurs frequently. Its cause is extremely difficult to track down – it took us some months to fathom this one out. As these machines began to age we received a number of complaints of jumping into the SP mode momentarily while playing an LP recording. On the first few occasions we couldn't instigate the fault so we did the obvious thing and cleaned the CTL head. (For those not familiar with LP operation, the machine selects the playback speed automatically after sensing the frequency of the pulses on the CTL track. Thus if the CTL head is dirty the machine may select the wrong playback speed.)

On some occasions this cured the problem. On other occasions however the customer was soon back with us, complaining about the same thing. We next considered realigning the CTL head. This taught us an important lesson about CTL head alignment. With the VXL8, servo lock will be lost and the machine will jump between the SP and LP modes if the amplitude of the CTL pulses is less than 0.6V peak-to-peak. So on the next few occasions we realigned the CTL head. Within a short while the same machines were coming back again because of LP/SP jumping. We then began to replace the CTL heads, but the fault persisted.

We finally came across a machine that produced the symptom all the time. Only then were we able to scope the CTL pulses and see what the cause of the trouble was. The pulses were riding on a large 50Hz ripple (see Fig. 6). As a result of this the servo was being triggered at different time intervals. The same ripple was present (see Fig. 7) when we scoped the switched 5.1V supply. We suspected the main reservoir capacitor C105 but the culprit turned out to be bridge rectifier D506.

We've now had this complaint with numerous VXL8s and its clones. The cause has always turned out to be either a dirty CTL head or a defective bridge rectifier (D506). So

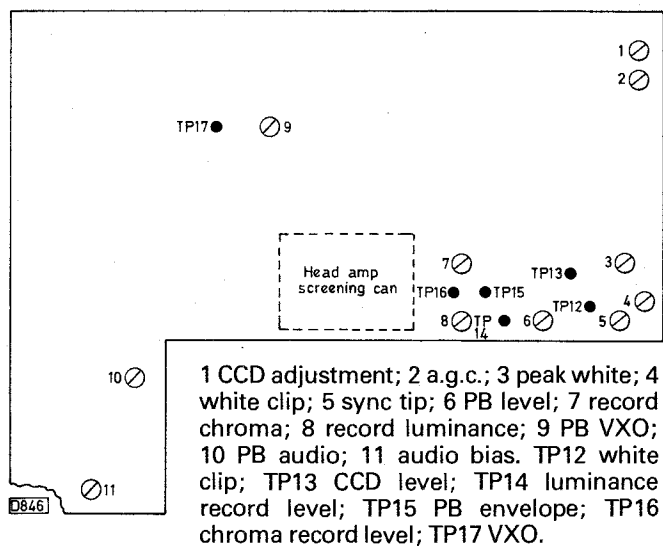

Fig. 3: Luminance-chroma board layout for the Sentra Models VX8500/8600, viewed from the component side.

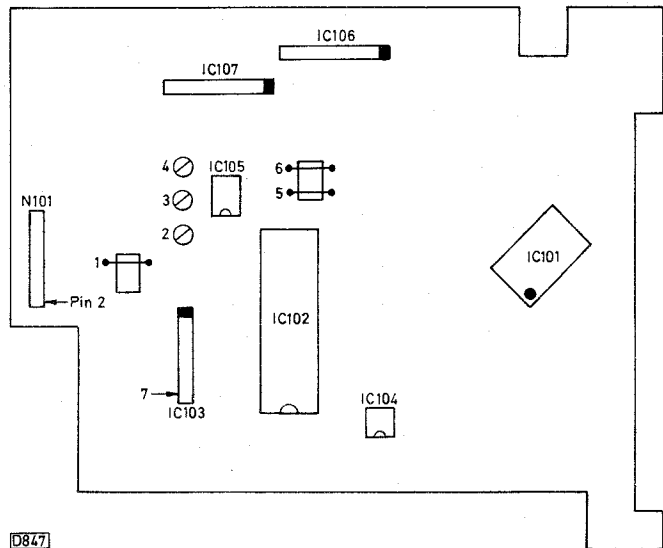

Fig. 4: Layout of the servo/microcomputer control board, Hinari Models VXL8/9. 1 TP3 record CTL; 2 head switching-1; 3 head switching-2; 4 preset tracking; 5 TP1 drum flip-flop; 6 TP2 chassis; 7 IC103 pin 7, playback CTL.

whenever we service one of these machines we clean the head and replace D506 as a matter of course.

Note that D506 has also been responsible for intermittent cutting out due to 50Hz ripple finding its way into the microcomputer control chip.

The most convenient place at which to scope the switched 5.1V supply is at pin 2 of connector N101 at the rear of the servo/control PCB (see Fig. 4). We don't recommend that you place your probe on this pin directly however as there's a possibility of shorting it to pin 3 which carries the unregulated 16V supply. If this occurs the microcomputer control chip IC101 is certain to fail.

Another cause of SP/LP jumping we've come across is interference via the mains supply. The culprit was a flashing fluorescent light in another room.

### Erase Fault

When these machines first went into circulation a fairly common fault was failure of the full erase function due to a trapped ribbon cable. The ribbon cable concerned runs along the top of the cassette housing and is sometimes crimped. Although it was not difficult to trace the cause of

the fault it does have a very surprising symptom. Normally the symptoms when the full erase circuit fails are that the original sound track is left on (assuming that you are over recording), the new picture is recorded and background patterning is present. This is not the case with the VXL8.

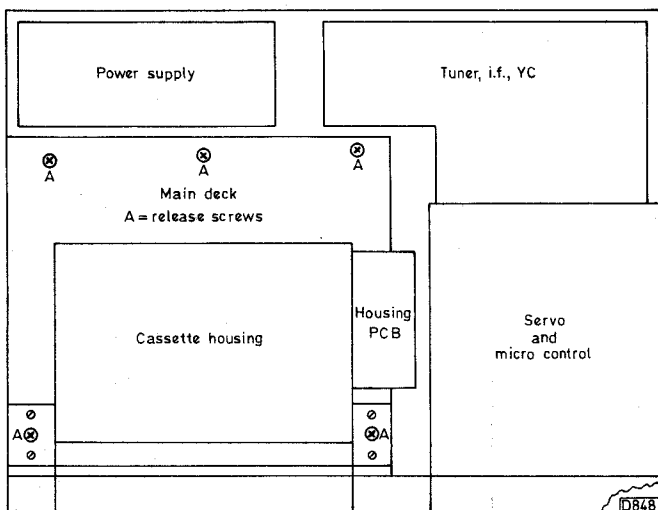

Fig. 5: General layout, Hinari Models VXL8/9.

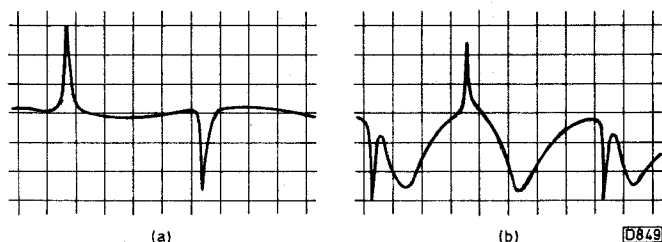

Fig. 6: CTL waveforms. (a) Correct waveform at pin 7 of IC103 (first CTL amplifier output). For reliable operation it should be greater than 1V p-p. (b) Typical CTL waveform when bridge rectifier D506 is defective. Scope settings Y 0.2V/div, X 5msec/div.

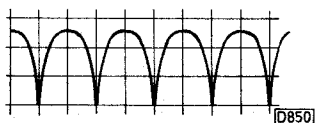

Fig. 7: 50Hz ripple present on the switched 5.1V rail when D506 is defective. Under normal conditions the ripple should be less than 20mV p-p. Waveform taken at pin 2 of connector N101. Scope settings Y 50mV/div, X 10msec/div.

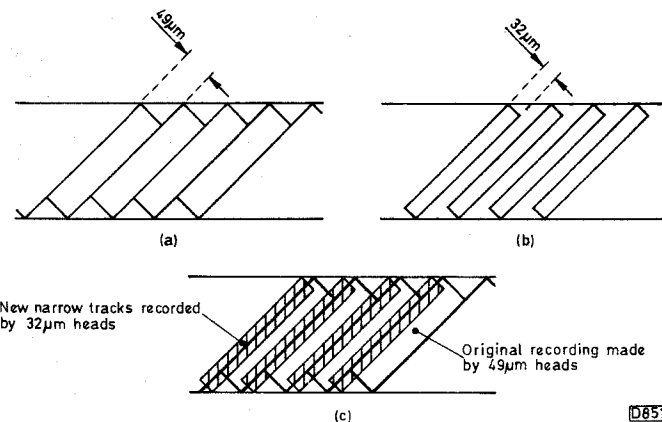

Fig. 8: Standard track pattern for VHS SP recording (a). Track pattern with a machine (e.g. VXL8) that has thinner head cores (b). Effect of over-recording 49µm tracks with thinner heads in the event of failure of the full erase head (c) – the original tracks are only partially removed.

As mentioned earlier, the VXL8 is a budget machine. Thus although it has LP operation there are only two heads. To optimise these for both speeds the cores are 32µm instead of the usual 49µm for VHS. This gives a rather unusual recording pattern on the tape in the SP mode. In effect, a small guard band is left between tracks – see Fig. 8.

When the full erase function fails and a previously recorded tape is re-recorded there's a good chance that the new tracks will be laid down not directly over the original ones but partially in between. When this tape is played back it's actually possible to select which picture you view by using the tracking control! Moving it to the left selects one recording, moving it to the right selects the other one. In some cases the two pictures are of surprising clarity. Some might think this to be impossible. That's what we thought until we saw it for ourselves. For those who can lay their hands on one of these machines to experiment, it's well worth disconnecting the full erase head and over recording a tape just to see the effect. For best results use a tape that has been recorded on a model that has standard thickness heads.

## Head Wear

In connection with head wear, we've noticed that the setting of the recording current has a significant effect on picture quality. The manual specifies a recording current level of 120mV (220mV with Sentra models) measured at test point 8 on the YC board (Fig. 2). Experience has shown that with a new head the quality of recordings improves slightly when the recording current is set at around 150mV. As the heads wear however you will begin to experience black/white inversion (streaking) on sharp vertical edges. This can be eliminated by reducing the record current level. Trial and error is the order of the day, but the level may be taken as low as 90mV. This is naturally only a temporary cure as the symptom will reappear with further head wear.

The head drum is very simple to replace. Remove the two screws and lift off the upper drum – no soldering is necessary.

## Spares

Like most parts for the VXL8/9, video heads are available from CPC or Wizard. MCES can supply retipped heads and we understand that they will, if asked, retip the drum with standard thickness heads. With these the machine would no longer produce acceptable pictures in the LP mode but the SP picture quality would be improved, something that would not go amiss with these machines.

MCES will also service the u.h.f. tuner, the r.f. modulator and the tuning board synthesiser for the Hinari models.

## Microcomputer Faults

As with any VCR the microcomputer control chip, in this case IC101, occasionally causes problems. One in particular we have encountered on a number of occasions. The symptoms are as follows: the power indicator fails to light, the channel indicator works, the machine will accept a cassette and will fast wind forward and backwards but will not play.

A check on the supply rails will reveal that the switched 5.1V and 12V supplies are missing (check at pins 2 and 5



respectively of connector N101 on the servo board). The power-on signal (pin 4 of N101) comes directly from pin 4 of IC101 and to enable the power supply should be low. You will find that this line is floating: shorting pin 4 of N101 to chassis will start up the power supply. Replacing IC101 should be all that's required – as long as you are o.k. at handling surface-mounted devices!

Another problem that can be attributed directly to IC101 is failure to load or unload. Pins 57 and 58 of IC101 control the loading motor via the driver chip IC107. Under the fault condition the logic level at these two pins remains high. Connecting them to chassis should make the motor operate, confirming that the rest of the circuit works.

IC101 was also the cause of no E-to-E signals on one occasion. Playback was correct but in the E-to-E mode the display consisted of a blank grey raster. IC208 on the YC board performs r.f./line video selection in the VXL8: IC207 does the same for audio. We found that pin 3 of these i.c.s didn't go low to select the r.f. input. The logic signal comes from IC101 directly.

## Electronic Faults List

Here's a brief summary of other electronic faults we've encountered:

- (1) No ch. 1 display. Pin 39 of IC101 dry-jointed.
- (2) No E-E or playback video. The LA7305 main processing chip IC203 faulty.
- (3) No E-E sound was corrected by replacing the main i.f. can.
- (4) No picture at all, just snow: the tracking control was at one end!
- (5) Capstan motor running fast: C117 was open-circuit resulting in loss of the FG signal.
- (6) Intermittent operation of the capstan and/or loading motor(s). The cause was dry-joints on IC106 and IC107.
- (7) Noise bars rolling through and LP tapes play in the SP mode. Cause was C115 open-circuit, resulting in loss of the playback control pulses.
- (8) Search tuning taking a long time to lock on to the station once found. Defective crystal (F601) on the subpanel mounted on the cabinet above the i.f. module. This panel forms part of the search tune circuitry, overriding the a.f.c. in the search mode and sensing the presence of an off-air signal.
- (9) Rewind o.k. but no play or fast wind – machine will lace up. Capstan motor driver chip IC106 defective.
- (10) We've had a few leaky end sensors. The symptoms are either no play or fast wind but rewind o.k. or vice versa depending on which sensor is faulty. We have, incidentally, discovered that if a sensor were to go open-circuit the machine will operate perfectly until it comes to the end of a tape in fast wind!
- (11) Patterning on playback can be due to loss of earthing between the head amplifier screening cover and the metal bottom plate. The earth connection is made via a small spring and the contact point can become tarnished. Rather

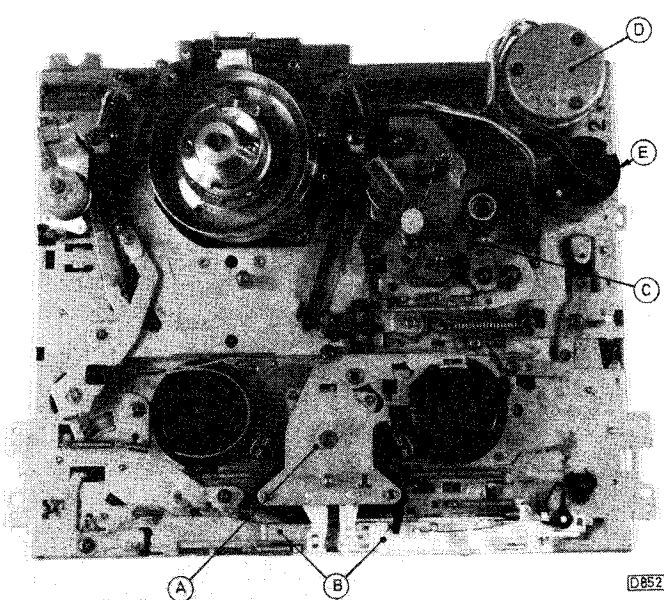

Fig. 9: Upper deck with the cassette housing and head drum removed. The loading arms are in the half-laced position. Key: A forward/reverse drive idler assembly; B slide bars (operating levers); C reverse guide arm; D capstan motor; E loading motor.

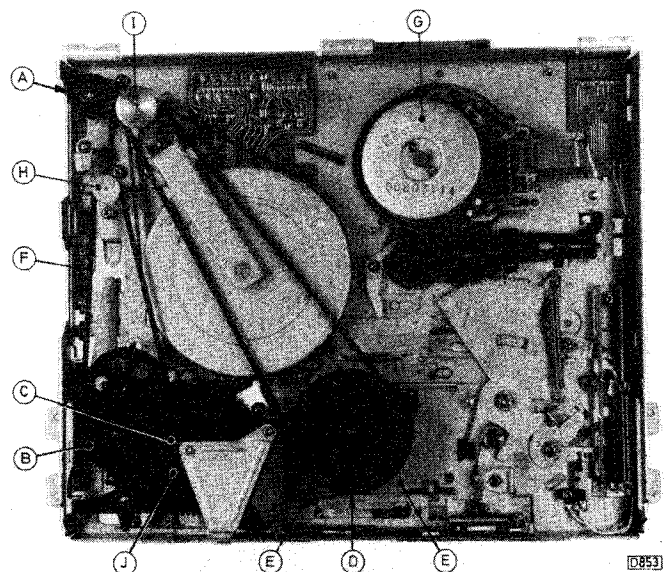

Fig. 10: View of the lower deck. Key: A cassette lift drive pulley; B loading gears; C main cam; D spool drive pulley; E forward/rewind spool drive gears; F loading belt; G drum motor; H loading motor pulley; I capstan motor pulley; J mode switch (beneath cam).

than simply clean the contact we solder a lead from the cover to the copper earth terminal at one of the screw holes for the bottom plate.

## The Mechanics

Figs. 9 and 10 show the deck. These photographs should be helpful in identifying the various items referred to in the following notes.

As with any VCR the cassette housing has to be removed before any work can be carried out on the tape transport mechanism. This is not as simple with the VXL8 as with some other machines because the cassette lift is driven by the capstan from the underside of the deck. The simplest approach is to take the entire deck, including the cassette housing, out of the machine then remove the housing.

Deck removal is straightforward. It's usually secured by three screws (on certain clones there are five) which are easy to locate. Once the deck has been removed the housing can be released by taking out two small screws on either side and removing the cassette lift belt. It's often helpful to keep the cassette housing plugged in as this will enable you to operate all the mechanical functions normally - as long as a cassette is loaded into the housing and the lift is down.

There's a small PCB with three microswitches on its underside at the top right-hand side of the cassette housing. These switches are linked to the microcomputer control chip IC101 for correct operation of the cassette lift. We've found it useful to check the logic conditions at these switches on occasions when we've had a machine with the lift either inoperative or not working correctly. Fig. 11 shows the PCB layout: with an operational housing the conditions at the pins marked are as follows:

Pin	lift up	lift down
1	low	low
2	low	high
3	low	low
4	low	high
5	high	low
6	high	low
7	low	high

If these conditions are incorrect the cause is most likely to be a dirty switch contact.

### Wow on Sound

Wow on sound, perhaps during only the first quarter of an hour of a tape and more pronounced in the LP mode, is one of the most common complaints with these machines. There are several possible causes, e.g. the pinch roller slipping or the capstan motor binding, but experience has shown that excessive take-up torque is the most common cause. Excessive take-up torque can also lead to the tape riding up or down the capstan with the result that one edge of the tape is chewed. As set up by the manufacturer the take-up torque is unusually high, around 200g-cm. It can be reduced to around 100g-cm by dismantling the take-up clutch assembly, taking about one and a half turns off the tension spring then cleaning the assembly, including the two felt pads, with isopropyl fluid.

The clutch is beneath the spool drive pulley (itemised in Fig. 10). To remove it you must first take out the spool drive pulley and the forward and reverse drive gears. Take care not to mix up the two gears when reassembling them as they are different. The clutch can now be extracted. A gentle pull on the smaller black gear will separate the clutch assembly, but take care that the spring doesn't launch itself into orbit at this point! Fig. 12 shows the

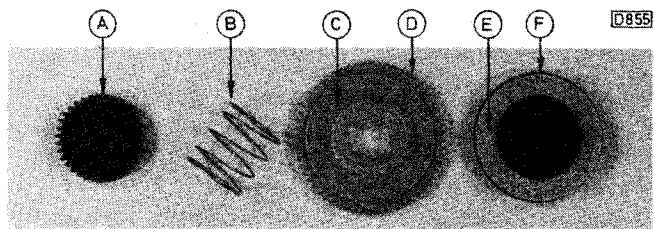

Fig. 12: Dismantled clutch assembly. Key: A upper gear; B tension spring; C clutch plate; D central gear; E friction pad; F lower gear.

dismantled clutch.

We must point out that this is not an official Hinari modification. We've carried it out on a considerable number of these machines however without any comebacks.

Naturally a torque gauge must be used to check the take-up torque. This is simple if you have the cassette type. If however you use, like us, the type that fits over the take-up spool you'll find that the cassette housing frame gets in the way. To save having to remove the housing Graham looked to the resources of his garage to construct an extension shaft for the gauge, see Fig. 13. The idea is simple but is very effective: we've found it to be an invaluable time saver not only with Hinari but with most other VHS machines.

Whilst on the subject of torques, the back tension torque should measure around 40-45g-cm with the VXL8 when checked with a back-tension cassette.

### Miscellaneous Mechanical Faults

Another problem we've had on a number of occasions is where the machine refuses to go into fast wind or rewind after coming out of the play mode though you can hear the motors running. The fault is often intermittent. It's caused by seizure of the operating levers at the front of the deck. Fig. 14 shows these levers in closer detail. There are two white nylon gear levers operated by slide bars located centrally between the supply and take-up spools. These gear levers are slotted to locate on to pins on the slide bars. The fault occurs when the pin in the left-hand gear lever sticks in the slot.

We used to rectify the fault by dismantling the gear assembly and widening the slot on the left-hand lever fractionally, using a needle file. More recently however we've noticed that the pivot on the left-hand gear lever (D in Fig. 14) has a very small amount of play when this fault is experienced. We now feel that filing the slot simply counteracts the effect without removing its cause. So we've taken to replacing the left-hand gear lever which we obtain from CPC under part no. HN62D085909305. Should you encounter this fault condition you should inspect this whole area, looking for signs of wear.

A problem we've had on a couple of occasions is where the reverse guide arm located near the pinch roller (see Fig. 9) is bent, probably due to abuse by the owner. This results in the tape riding up or down the capstan, crinkling

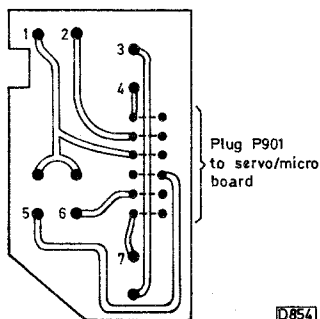

Fig. 11: Cassette lift microswitch PCB. See text for logic conditions at the pins. The pin numbers shown relate to solder joints on the PCB and are included for identification only. The pins on plug P901 are twin terminals, shown here linked by broken lines.

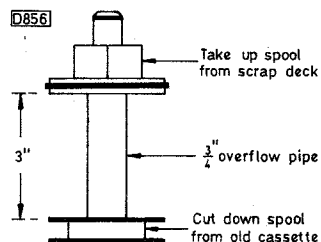
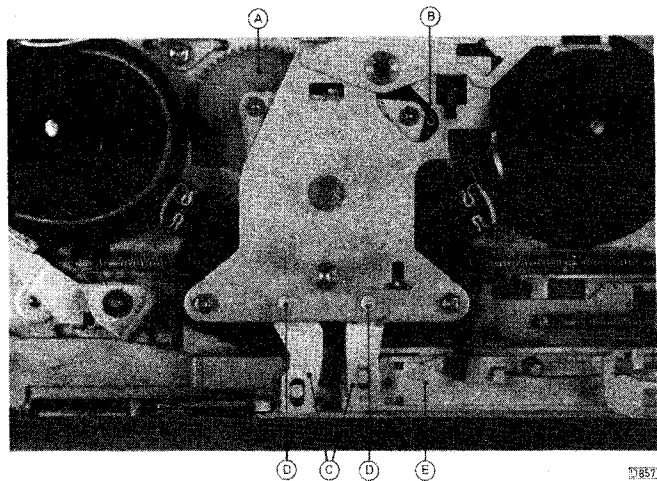

Fig. 13: Torque gauge extension. Glue the plastic pipe to the two spools with Araldite. The diameter of the lower spool has been reduced to allow it to fit through the top of the cassette housing.



*Fig. 14: Operating levers and drive-gear assembly. Key: A reverse drive gear; B forward drive gear; C gear levers; D gear lever pivots; E slide bars/operating levers.*

the tape edge. Straightening this is not a simple task and care must be taken not to score the polished surface as this will impair tape travel. It may be necessary to replace the guide, perhaps with one from a scrap deck.

The mode switch causes very little trouble, unlike some decks. Should you need to get to it you'll find it beneath the large cam in the loading gear assembly. It takes the form of four wiper contacts that are secured to the underside of the cam. As the cam rotates, the contacts move over a PCB with copper segments, making and breaking different switch outputs.

Dismantling the switch is not difficult, but you must ensure that the deck is in the fully unloaded position before you start. First remove the loading belt pulley wheel and the gear next to it, then the metal plate that secures the main cam. This gives less chance of the cam rotating by accident. As you remove the one metal and two plastic brackets that locate on to the upper side of the cam, note carefully which grooves they locate into. Also note the position of the cam.

You may well get away with not having to remove the cam in the event of intermittent problems due to dirty mode switch contacts: a spray of switch cleaner under the cam will penetrate to the wipers and copper segments. This method may avoid the problems that can arise when resetting the timing of the loading gears.

## In Conclusion

As with many of the smaller importers, Hinari was never number one when it came to technical support. Service information is basic and the circuit diagrams are small and difficult to follow unless enlarged using a photocopier. When Hinari went into liquidation all technical support other than spares ceased, leaving the service industry with yet another headache. We are familiar with these Hinari VCRs only because our company sold so many of them. It's hoped that the information in this article will be helpful to others who come across these machines and in particular those who may have shied away from them till now. We would encourage readers who have encountered other faults on Hinari VCRs to write in: one thing Graham and I have learnt is that you never know everything about a particular piece of equipment.

# VCR Clinic

Reports from Philip Blundell, AMIEIE, Eugene Trundle, Brian Storm, Ronnie Boag, Graham Rees, Nick Beer, John Edwards, Michael Dranfield and Gerald Smith

## Ferguson FV32

This machine was confused: it continually tried to unlace, even though it was fully unthreaded. It wouldn't accept or eject a cassette. The clock and signal circuits worked all right and all the supplies were present, though it looked as if work had been carried out on the power supply PCB recently. Metering between the mode select switch and connector BT04 revealed that the ribbon cable from the deck to the system controller was open-circuit. The ribbon cable's part number is 556 555 00. **P.B.**

## Philips VR202

This machine worked perfectly in the play mode but on E-to-E or record two vertical bars were superimposed on the picture. These bars were not present at the output from the i.f. strip but were present at the output from the 4053 video switching chip IC7550. When we removed IC7550 we found that the /PBV (playback switching) line was pulsing in the E-to-E and record modes. The SAD1009 chip was faulty. **P.B.**

## Mitsubishi HSB11

This machine would sometimes fail to carry out a deck command. It would usually fail when asked to play or eject, and would then switch off. A new mode switch was fitted but the fault persisted. One morning the machine wouldn't switch on – the mechanism didn't do its usual shuffle. The loading motor had almost seized solid. A new one solved the problem. **P.B.**

## Philips DMP2/3 decks

If the complaint is of intermittent failure to carry out a timer recording or to playback when the tape is fully rewind, check that the spool brakes are working effectively. The right-hand spool can rotate during the threading process. This activates the end-of-tape sensor, aborting the play or record command. Replacing the brake rollers usually does the trick, but in a well-worn machine the reel spools and counterforce brake will also need to be replaced. Philips recommends that both reel friction settings are checked, following the procedure laid down under sections 2.1 and 2.2 in the deck service manual. **P.B.**

## Sanyo VHR3300

A common fault with this machine – we've had it four times so far – is failure of IC1001, a route-switching chip, on circuit board VD1. The symptoms are no E-to-E vision signal, with wavy lines and patterns on the monitor's screen, the E-to-E sound being unimpaired. You'll find that a video signal enters this LA7223 chip at pin 7 but the output is not present at pin 1. **E.T.**

## Fisher FVHP905/6/7

Failure of the reel idler on these and similar models is very common. The symptoms are: slow, laboured rewind; no fast forward or rewind; failure to wind the tape into the cassette when unloading; or no take-up. These symptoms can also be

caused by the drive pulley (item 4 in the exploded diagram in the manual) being very tight on its shaft. Sometimes you discover this only after you've spent much time replacing the idler assembly. **E.T.**

## Panasonic NVJ40

This machine came in with tuning problems. Sometimes no stations could be tuned in, but more often the mid-band stations were crammed at one end. Attention was focused on the plug-in demodulator pack and IC7652 (AN5043). This provides the tuner unit with the relevant tuning voltages etc. The voltage at pin 3 of IC7652 was low and varying, so I replaced C7666 (0.01 $\mu$ F) which decouples this point. **B.S.**

## Panasonic NVL25

In spring attention turns to clearing my soak test bench. Two residents here were both NVL25s with complaints of intermittent operation. This is often a cue to resolder X6101, the main system control and servo crystal. It didn't help with these two machines however. After a few hours the capstan motor would sometimes cog and judder to a halt. Any attempt at approaching these machines with test gear provided a complete cure until the following day. I decided to remove the main PCB and inspect it for any suspect wiring or soldering. As I came to withdraw the capstan motor plug P2001 I thought that it came out rather easily. When I turned to the other machine I found that, sure enough, the plug wasn't fully inserted. Refitting the plug provided a complete cure with both machines. **B.S.**

## Panasonic NVD80

This all-singing, all-dancing digital machine came in woe-fully quiet. Quite dead in fact. When the mains supply was connected the switch-mode power supply would give a quick whistle then die. There were no apparent shorts or overloads on the secondary side of the PSU. So attention turned to looking for the most singed and discoloured capacitor on the primary side. C1045 (47 $\mu$ F, 35V) won hands down. A replacement got the show back on the road. **B.S.**

## Panasonic NVG21

This machine appeared to be completely dead. There were no mechanical operations, no displays and no noises except for the characteristic power supply start-up squeal. When the PSU can was removed and disconnected all the supplies were found to be present and correct. The regulated 5V and 6V rails were extremely low however when the power supply was connected to the rest of the circuitry. There was no excessive loading on either rail: the STK5338 multiregulator chip was faulty. **N.B.**

## Panasonic NVMS70

This basic S-VHS-C camcorder uses the later Panasonic mechanism with two exit guides that follow each other to and fro like a train and then return to their respective sheds via a set of points which are automatically triggered when the first one passes. All very clever and a delight to watch. In this example however the tape was stuck because the first

guide had returned home to the points hadn't moved, so the second guide was stuck. A new spring (part no. VMB2087) and arm (VML2359) cured the trouble. **N.B.**

### **Panasonic NV370**

This machine worked fine as long as the TV set was on the AV channel, but when you switched to a TV channel the VCR cut off the loopthrough. The cause was loss of the regulated 12V supply to the r.f. amplifier. D1106, a 13V zener diode in the regulator circuit on the power supply panel, was short-circuit. **N.B.**

### **Mitsubishi HS337**

This machine would intermittently go to standby. The cause of the problem was dry-joints on transistor Q942 in the 5V switched supply on the bottom PCB. **R.B.**

### **JVC HRD520/HRD830**

The channels drifting off tune has been a problem with these machines. The cause is Q2 on the tuner panel overheating. Replace it with a 2SD1207ST. **R.B.**

### **Fisher FVHP906**

The problem with this machine was no functions. At switch on the power light lit then, after six seconds, the machine went to standby. In addition there was no loading motor shuffle. If you get these symptoms check for the presence of the 12VSW supply at pin 2 of PA902, and the power control condition at pin 4. If the 12V line is low and pin 4 is at 4.5V, change the STK5466ST chip IC901. **R.B.**

### **Hitachi VT11**

No E-to-E or playback sound and vision was traced to a faulty coil, L2, inside the r.f. converter. **R.B.**

### **Fisher FVHP710**

There were various intermittent symptoms with this machine as follows: failure to accept tapes, the counter zeroing, and no functions. The cause was dry-joints at plug PV903 on the power supply panel. **R.B.**

### **Hitachi VT120**

This machine came in with a threaded up tape stuck inside it. If the power switch was pressed it would power up for about three seconds then revert to standby. The first thing to do was to check the power rails. They were all o.k. After several attempts to switch the machine on we noticed that a slight thud occurred when the power button was pressed. It appeared to come from the underside of the deck. On further examination we found that it came from the capstan motor. When its pulley was touched the capstan motor began to rotate and the tape unlaced. Subsequent checks showed that the capstan motor had a dead spot. **M.Dr.**

### **Saisho VR3400**

This newer-generation machine came in with the symptoms of dirty heads. We cleaned the heads, the drum and the entire tape path then inserted a tape and pressed play. The tape laced up around the drum but the pinch roller failed to pull in on to the capstan. After a lot of messing about I

found by accident the machine has a quick-start function, similar to Akai machines. All that was necessary was to push the play button twice! **M.Dr.**

### **Mitsubishi HSB27**

We've had the following fault on several of these machines. When the tape is inserted it's loaded very fast, i.e. snatched out of one's hand. Then when play is pressed the machine acts as though it's in the search mode. In addition the fast forward and rewind modes operate a lot faster than normally. The cause of the trouble is no capstan FG. Replace the capstan motor and PCB assembly.

We've also had this fault with the more recent Model HSMX1B. **G.R.**

### **Mitsubishi HSB27**

We've had this fault on three occasions: the machine cuts out approximately 45 minutes after the beginning of a tape. The cause of the fault is low-amplitude take-up reel pulses. They can be checked and compared with the supply reel pulses at the collectors of Q5A4 and Q5B4. The cure is to replace the photo-interruptor. It's possible to replace this item without dismantling the bottom PCB. **G.R.**

### **Hitachi VT140**

This machine would accept a tape and carry out all functions correctly except that it wouldn't eject a tape when asked to do so. When eject was selected the capstan spun normally but the belt and the main pulley of the clutch plate assembly appeared to be seized. Slight movement of the carriage was seen as it attempted to rise, then after a few seconds the system control gave up and the tape was lowered back down to the loaded position. All the mechanical operations, including carriage up/down, are driven by the capstan motor and the capstan drive belt via the self-contained clutch plate unit. Replacing this unit (part no. 6896951) and fitting a new belt (part no. 6351554) cured the fault.

The clutch plate unit has also been responsible for symptoms such as very slow rewind and fast forward and scraping noises during play and fast forward. **J.E.**

### **JVC HRD140/Ferguson 3V44**

Here's a nice simple one for a change. In the event of no power indication and no drum rotation check circuit protector CP4 for being open-circuit. **J.E.**

### **Toshiba V300**

There was intermittent bad wow on playback and record. We found that IC501 was thermally sensitive, a replacement providing a complete cure. **G.S.**

### **Fisher FVHP905-FVHP910**

White interference flashes on the playback picture can be cured by fitting a screening plate between the power supply and the drum assembly. The plate is available from Sanyo/Fisher under part no. SM0349. **G.S.**

### **Panasonic NV430**

If the machine won't come back out of the reverse search mode until stop is selected check the AN3821K capstan motor drive chip IC2002 on the servo panel. **G.S.**

## Sanyo VHR3300

We've had three of these machines with the same evil intermittent fault which snaps a tape completely in two – sometimes! This model apart, it's rare for any VCR to break a tape though it often occurs when efforts are made to remove a tangled tape. With the VHR3300 the disaster occurs at the beginning of tape threading, due to a reel brake problem. Look at the feed spool's hard brake arm. On its left there's a metal pin which is, or should be, pushed by an underdeck lever. The pin can work upwards in the plastic arm to the point where it rides over the lever. Its correct position is where it just clears the topmost surface of the underdeck plastic cam. Fix it in position with Superglue or, better, replace the arm assembly. **E.T.**

## Tatung TVR6111

This model is similar to those in the Amstrad range of three or so years ago. A symptom that's becoming common is intermittent ejection of cassettes, either when one is inserted or at random during play. The cause is dry-joints at the tags of the three microswitches (start, in, out) on the horizontal PCB fixed to the right of the front-loading gantry. **E.T.**

## Philips VR6462/Finlux 1010 etc

These machines use the early Philips VHS deck with conventional M loading of the tape. Many of them now suffer from insufficient reel torque in the fast transport modes – fast forward, rewind, cue and review. Typical symptoms are spillage with E180 or E240 tapes in the forward search mode and long rewind times. Some models benefit from the official modification – fit a 22Ω resistor across R3101/3103 in the reel motor drive circuit. Whether or not you do this, check for excessive friction between the reel idler wheel and the guide plate below it, and for gummy shafts on the spool turntables. To cure the latter problem, remove the turntables and thoroughly clean the holes in them, then clean and polish the shafts. Apply a tiny drop of light oil when reassembling. **E.T.**

## JVC GRC11

This record-only camcorder promptly ejected a tape whenever one was inserted. With no cassette present the lid would open only when the power was removed and then restored. A check showed that pin 30 (eject) of the microcomputer chip was permanently low at about 1.1V. This was caused by an electrically leaky eject slide switch. A replacement had to be fitted. **E.T.**

## Panasonic NVL25

A curious set of symptoms greeted me with this machine: no "power on" and the timer flashed zeros, but above these were the words "write" and "erase" – it was not something I'd ever seen before. The machine would accept a tape, but as the controls were inoperative it wouldn't return the tape. This suggested to me that the systems and servo chip IC2001 was probably all right. I'd also no good reason to suspect the timer chip IC7501. Voltage checks between these two chips showed that the serial data and serial clock lines were the source of the trouble. The serial data line was sitting at about

1V while the serial clock line, at around 4V, was closer to the normal condition for these lines.

Disconnecting IC7501's serial data pin removed the "write erase" from the display, but the line's voltage remained low. Disconnecting the other two chips connected to the serial data line, IC2001 and IC6801, also had no effect – the voltage remained low. The only other possibility was the 270pF capacitor C6012 which is connected between the line and chassis. When I eventually found it (it's a small, surface-mounted capacitor tucked away at the edge of the main board) it turned out to be leaky. A normal-sized replacement restored correct operation. **B.S.**

## Panasonic NVG21

The playback sound gave a fair impression of a washing machine and a tumble drier working in unison, drowning the recorded sound with buzzing and spurious oscillation. Voltage checks around IC4001 in the sound section produced no clues except that the noises were reduced when the meter's probe touched the input pin. So attention was turned to the input circuitry, where R4021 (47Ω), a surface-mounted resistor connected to a filter network, was found to be open-circuit. **B.S.**

## National NVG33

A dead power supply was the trouble with this foreign machine. Checks in the switch-mode power supply failed to reveal any shorts in either the primary or the secondary side, so attention was turned to the start-up circuit. We found that C1003 (1μF, 250V) was open-circuit. **B.S.**

## Ferguson 3V44

For once the symptoms displayed agreed with the fault description on the job ticket. This said dirty heads. Cleaning them didn't help however and the reason for this was soon apparent: the drum motor was running backwards at full speed. D408, a 5.1V zener diode, was short-circuit. **A.D.**

## Sony SL615

While this machine was still apart after being serviced we found that no functions could be obtained via the operation board though remote control operation was correct. The "fault" was eventually traced to the fact that there was no earth link to the operation board because the bottom case was open-circuit: normal operation was restored when the bottom case was refitted. **A.D.**

## Amstrad VCR6000/6100

There was neither forward wind nor rewind as the reel brakes were on. They would come off if the brake plate, reference 261, or the brake actuator, reference 262, was operated manually before selecting a wind mode, but when a wind mode

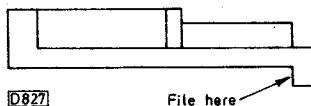

Fig. 1: Cure for Amstrad VCR6000/6100 fault.

was stopped then selected again the reel brakes once more remained on. The cause of the problem was that the brake actuator plate moved but the brake plate didn't. Careful observation showed that the lever trigger, reference 260, didn't return to its correct resting place, thus inhibiting movement of the brake plate. Filing at the point shown in Fig. 1 cured the fault. **A.D.**

### **Panasonic NV333**

The capstan servo wasn't locked, the symptom being a noise bar that floated through the playback picture. This is typical of a no CTL pulse fault, but checks on the CTL section of the circuit showed that it was working correctly. Further checks revealed the fact that the 9V supply to the tracking control was missing. This is the "except Rec 9V" supply. It comes from the syscon panel where Q6003 was found to be open-circuit. **A.D.**

### **Panasonic NVG40**

Fast forward and rewind were o.k. but the machine didn't play. When we checked the operation of the mechanism we found that the P5 unit arm didn't come across fully in the stop mode. This was because the "pull-out sector gear" was broken. We replaced the gear and also the mode switch as it's the most likely thing to have caused the gear to break. **R.B.**

### **Panasonic NVG12**

There was a rather unusual symptom – no sound in any mode, including E-E. A sound signal was going from the TV demodulator PCB to the audio pack, where all the audio goes. It wasn't being switched out of the BA7752LS chip IC410 however. The supplies and the d.c. switching conditions were all correct so it seemed that the i.c. was faulty. A replacement restored the sound. **N.B.**

### **Panasonic NVG12**

This machine would enter the record mode and proceed as if everything was o.k., but when you rewound the tape and replayed it the previous recording was still present. Although the machine entered the record mode it didn't produce the delayed record 12V supply. There was no 12V at the emitter of Q6005 as Q6006 was switched off because its base voltage was high. Q6006's base voltage should be pulled down by the record prevent switch line from the microcomputer chip IC6001. The voltage was correct at IC6001, the cause of the fault being a break in the print between the cathode of D6005 and R6041 as the print winds its way through the pins of the audio pack. **N.B.**

### **Ferguson FV52L**

This machine had been installed only two days previously, yet here I was looking into why it lost about twenty minutes an hour. The cause was fairly simple – reference crystal 01 was dry-jointed on both legs. This was probably due to the fact that the PCB holes are much too large for the legs of this device. **N.B.**

### **Panasonic NVG45**

Steve Beeching mentioned the sync separator modification for this model in his Camcorner feature last January. I reported on the problem a couple of years ago and pointed out that the modification could be improved by adding an

extra 47k $\Omega$  resistor across the components that Panasonic supply. I'd found this to be necessary because users complained about severe drum twitch and HSP running through the picture when recording from early Bush/Alba satellite TV receivers (the ones that used to drift off tune). I had heard that the video output from these units was suspect and that there was a modification for them. But customers who rented G40s and G45s from us preferred us to take action. **N.B.**

### **Samsung VI710**

Playback was fine but there was no E-E sound or vision. Inputs from the line or tuner were missing. There was vision at pin 4 of the TA8605N chip IC303, but only hash at pin 10. The amplifier inside the chip had to be all right as it fed both the playback and E-E video through to pin 10. So the cause of the problem had to be in the switching. The chip was stuck in the playback mode as pin 13 remained high. But the PB 5V was switching correctly – so where was the 5V coming from? Not via the white-clip network but from within the chip itself. We proved this by disconnecting the pin and finding that the 5V was still present here. A new chip restored normal operation. **N.B.**

### **Panasonic NVM7**

A common problem with these and other full-size camcorders is that the unit powers up and then, within a few seconds, shuts down again. The clue is that the mechanism doesn't shuffle as it should, the cause being a faulty M54543L loading motor driver chip. It's easy to check the i.c. If its supply is present and there are correct commands at its logic pins but no output is provided the chip is defective. Another clue is that the chip's supply falls when the load should be on. **N.B.**

### **Panasonic NVJ40**

This machine drifted off tune on any channel above 59. The cause was a faulty tuner. **N.B.**

### **Salora SV6910**

There were no functions and no clock display. FR2 in the power supply was open-circuit. **G.S.**

### **Akai VS33**

This machine kept going to standby. The drum speed was found to be erratic and a check on the drum PG waveform showed that noise was present. Replacement of C6, which was leaky, on the drum motor PCB provided a complete cure. **G.S.**

### **Akai VS35**

The playback picture was marred by numerous white dashes which were similar to the spots produced by e.h.t. arcing in a TV set. The cause of this interference was traced to the fact that the head preamplifier screening plate's chassis earthing screw was loose. Retightening it solved the problem. **J.E.**

### **Ferguson 3V55**

The loading motor continued to run after the cassette had been ejected. As a result the loading belt squealed loudly. We found that the cause of the fault was the mode opto-switch assembly. It's available from CPC at a very reasonable price under part no. TNPU35632A3. **M.Dr.**

## Toshiba V110B

There was no E-to-E output, just a blank raster in play and the clock display showed wrong characters. An initial check around the power supplies revealed that the U8 (5V) line was high at 8.8V. We found that the ZPD2.7V zener diode DT53 was open-circuit. When a replacement was fitted the U8 supply was back at 5V (check it at the collector of TT53) and the faults had cleared. **P.B.**

## ITT VR3918

I expected this machine to be a JVC clone but as soon as I removed the covers I saw that I was wrong (I found out later that it's of Sanyo manufacture). There was a cassette lift fault – the machine was reluctant to accept a cassette. It could take four attempts before a cassette would be taken in, and would only partly eject the cassette once it had been taken down. The cassette lift is operated by a gear off the capstan fly-wheel, so I wound a cassette in manually and pressed play. The machine threaded up but the capstan didn't turn. Luckily I was able to obtain a manual: then battle commenced!

The capstan motor wasn't being turned on in the play mode, and on the rare occasions when the capstan did turn to operate the lift the syscon didn't seem to be able to read the lift's position, even though the limit switches were all o.k. and the signals were reaching the syscon chip. A study of the block diagram showed that a signal should go to the syscon chip from the capstan FG. It was missing. A new LC7412-8017 chip brought it back and restored normal operation. **P.B.**

## Philips VR203

This machine had unlocked servos in play – the symptom was a noise bar running across the screen. The audio/control/erase head was clean but there was no control signal at pin 16 of IC7040. The supplies and control signals to this chip were all found to be o.k. A new SAA1310 chip put matters right. **P.B.**

## Panasonic NVL25

A sullen refusal to power up and the legend "write erase" displayed above the flashing timer display were new symptoms to me. The machine would accept a cassette but wouldn't return it. In fact the only control that operated was the timer on/off button. This persuaded me that the systems and servo chip IC2001 and the operation and timer chip IC7501 were working. Checks on the serial data line showed that the amplitude of the serial data was low at about 1V. Even with all the serial data ports disconnected and only a pull-up resistor and a 270pF decoupling capacitor left in circuit the data line sat at about 1.5V. Sure enough the capacitor (C6012) which is a surface-mounted type was leaky, a replacement providing a complete cure. **B.S.**

## Panasonic NVG21

This machine buzzed and hummed alarmingly when it played back a good tape. The dealer concerned had replaced the audio/control head and the audio chip (IC4001). Nothing was revealed by carrying out careful voltage checks, but the audio input to IC4001 seemed to be abnormally sensitive.

There's a fairly severe input filter between the audio head and IC4001. Resistor R4021, which is a 47Ω surface-mounted device, is part of this filter and was open-circuit. An ordinary 0.25W 47Ω resistor fitted neatly on the board and cured the trouble. **B.S.**

## Panasonic NVMS95

We've had a few of these top-of-the-range camcorders in with no titling or ability to set the clock. In every case the surface-mounted connector P6502 on the operations PCB was dry-jointed. In later versions the plug is glued in place, presumably to stop this happening! **B.S.**

## Panasonic NV850

There were no signals in the E-E mode. The 30V tuning supply is derived from Q7507/8, feeding pin 4 of the AN5033 chip IC7505. The voltage at this point was very low due to leakage: the cause was C7524 (0.01μF disc) which read 8kΩ. **S.L.**

## Fisher FVHP710

Although rewind and fast forward were normal, when play was tried the loading arms began to move forwards then stopped, returning almost at once to rest. A check on the supply lines showed that the 5V rail to the micro/syscon departments was high at 8V. This supply comes from the STK5431ST multiregulator chip in the PSU. As the other sections of the chip were clearly all right I decided to carry out a modification. Pin 1 of the chip was disconnected from the print and taken to the input of a standard three-pin 5V regulator whose output was connected to pin 1 of PV904, the 5V line. The regulator was then screwed to the flat pad at the top of the power supply heatsink. This course was adopted because the customer required the machine in a hurry. I recall being told in my training days that "a bodge is only a bodge if it can be considered unreliable and/or unsafe – otherwise it becomes a modification"! **S.L.**

## Philips VR6460

This machine came in dead and we found that the 10.2V supply was missing. It comes from the L4811 regulator 7110. As this device had no 12V input we moved back to the LM317 regulator 7105 which proved to be open-circuit. Do others find these Philips manuals almost impossible to follow or is it just me?! **S.L.**

## Samsung VI710

No rewind or fast forward was found to be due to absence of the 15V supply at pin 8 of IC206. R244 (3.3Ω, 1W) which feeds this supply to the BA6209 capstan drive chip was open-circuit. After replacing this resistor the machine went into permanent search when play was selected. An open-circuit between the print and pin 3 of CN204 was the cause. This is the "cap drive" input and the fault could conceivably have occurred during the earlier replacement. A final check showed that normal deck operation had been restored but the



E-E signal suffered from a.g.c. overload. The cause of this final fault was a defective tuner. **S.L.**

### **Akai VS5**

This machine was in good condition despite its age. But on switching from channel to channel a popping on sound, bars over the picture and loss of colour indicated that the a.f.c. was hopping about. When the sweep tuning was tried we found that it wouldn't rest on located programmes but swept on. The cause of the fault was tracked down to the AN6362 chip IC8, whose output is evidence to the tuning microcomputer chip that a legitimate signal has been found. **B.McC.**

### **Sharp VCA105HM**

If you find that the back-tension arm has jammed the mechanism it's probably because the arm has missed the tape when loading, due to slackness. There's no underlying problem. But remember that if you load a transparent service cassette without tape you'll jam the machine as it depends on the tape to control the position of the back-tension arm. **B.McC.**

### **Fisher FVHP5000/5100**

There was no playback picture with the machine's own recordings, E-E and playback of prerecorded tapes being o.k. Replacing IC201 cured the fault. **R.B.**

### **Philips VR6462/Finlux VR1010**

No functions and no clock were cured by replacing the MAB8420 chip IC7091 on the back panel. **R.B.**

### **Salora SV6800**

This machine is a Sanyo clone that uses the P90 mechanism. The original complaint was of intermittent operation and poor compatibility with prerecorded tapes. We removed the cassette lift to examine the brakes and the back-tension assembly, but when we'd reassembled the machine it wouldn't accept a cassette. After a lot of mechanical hassle we discovered that it's necessary to pull the toothed slide bar that operates the cassette lift until the last tooth engages in the white nylon cog. If this isn't done the mechanism goes out of sequence. Unfortunately the explanation in the manual is not at all clear. Back to the original fault. We found that the brakes didn't always release correctly because the "act brake lever" tended to stick. A modified part is supplied. **M.D.**

### **Philips VR6520/Panasonic NV370**

This machine came in because of no functions or clock display. On many occasions we've had problems with the small safety resistors on the power supply panel going open-circuit for no apparent reason, but this time the power supply was working normally. A look at the circuit showed that there's a further regulator on the main panel. Checks here revealed that the fusible resistor R1001 was open-circuit, hence no regulated 5V supply. **M.D.**

### **NEC N9033K**

This machine came in because it chewed tapes. Rewind was very poor, and on investigation we found that the idler rubber was well worn. The idler and the clutch assembly were both replaced but both wind and rewind were still weak. Closer

inspection revealed that the brakes were not being released properly because the brake solenoid didn't operate fully. Its driver transistor TR102 had been overheating badly, the board was scorched and the solenoid's coil had become distorted through overheating. We ordered a new solenoid and fitted it along with three new transistors, TR101/2/3, in the driver circuit. A note came with the solenoid recommending a modification to prevent a recurrence of the problem: this consists of fitting a 1SS133 diode between pins 12 and 55 of IC101, with its anode to pin 55. **M.D.**

### **NordMende V1021**

This machine wouldn't accept a tape, the reason for this being the absence of the 17V unregulated supply. The cause was immediately apparent when we removed the power supply panel. At some time the machine had suffered from liquid spillage, as a result of which wire links B30 and B31 had rotted through. Fortunately there was no other damage. **M.D.**

### **Sanyo VHR1300**

We'd only recently fitted a new set of heads in this machine, so we were somewhat put out to receive a call from the customer who said that the machine was still not right. When he made recordings the pictures were very poor. What in fact was happening was that the tuner was drifting. As we had a tuner in stock we fitted it. But the problem persisted. The cause was eventually traced to the LA7913 tuner control chip IC3, a replacement restoring normal quality recordings. The repair was not quite as difficult as trying to extract more money from the customer, who was under the impression that having had new heads fitted entitled him to a life-time guarantee of everything! **E.R.**

### **Ferguson FV43/4/5/6**

A noise best described as a squeal in rewind is caused by incorrect meshing of the drive gears. This can be cured by adding spacer PQX45716. The idler can also jam, causing no drive. I've also experienced this problem in the later FV51. **N.B.**

### **Panasonic G Mechanism**

A problem that's becoming very common with earlier versions of this mechanism is noisy rewind/fast forward and a tape loop being left when ejecting from the half-lace, stop-1 position. The cause is wear of the VXL1490 play gear's teeth. It's beneath the centre pulley. Removing the latter and undoing the screw that secures the kick/limit arm assembly allows the arm/gear to be replaced. **N.B.**

### **Akai VS427**

This VCR was dead. Checks in the power supply revealed that the safety fusible resistor FR1 was open-circuit while the associated IN4007 rectifier diode was short-circuit. Replacing these components, using a new resistor obtained from Akai, completed the repair. This power supply circuit looks a lot more friendly than that in the VS22 series. **N.B.**

### **Samsung SI7220**

Calls to a completely dead machine – no clock or anything – are becoming common with this model. The cause is a locked-up microcomputer chip. Remove the mains supply for a few seconds then reconnect it and all will be well. **N.B.**

# VCR Clinic

*Reports from Philip Blundell, AMIEIE  
Eugene Trundle, Michael Dranfield,  
Alfred Damp, Nick Beer, Brian Storm  
and Joe Cieszynski.*

## Philips VR703/713/813

For intermittently ejecting the tape while in play or record, especially in the LP mode, and E4 or E5 in the error memory, check the amplitude of the reel tacho pulses. If they are low change the value of the opto pull-up resistors R3318/9 from 100k $\Omega$  to 47k $\Omega$ . **P.B.**

## Philips VR6585/Granada VHSGP7

There is usually, but not always, a mechanical cause for mechanical misalignment of the Panasonic G deck. In this case the cause was electrical. After replacing the stripped gears and checking the operation of the mechanism by rotating the drive by hand I connected the power. The mechanism took the cassette in but didn't find the half-load position. After four or five attempts the cassette would be ejected. Sometimes the capstan would run at full speed when the power was connected: as the motor didn't stop at the fully threaded position you would have to repair the gears again if you weren't quick to disconnect the power! We fitted a new mode switch and a new tray position switch, but the fault was still present. Fortunately we had a new stock machine of the same type, so we were able to do some panel swapping to localise the cause of the fault. This proved that the cause of the trouble was in the power supply. The output voltages were correct, but they dropped when the deck was in operation. A new CNX83A optocoupler put matters right. **P.B.**

## Sony SLV373

Sony machines are not given to tape chewing. This one would damage the tape at the end of high-speed rewind however, especially if you went straight to eject. The cause of the trouble was that the take-up reel was being inadequately braked. This was because the felt pad on the brake shoe was skew-whiff. As a result it failed to contact the turntable rim. We restuck it with Superglue. **E.T.**

## Logik VR955/Samsung VI710

If the problem is no erasure (the old sound left on the tape and floating colour blobs on playback of the machine's own recordings) look no farther than L0504, which is a little oscillator module in a screening can. It's prone to staging a mini bonfire inside. Willow Vale can supply replacements under part number 79710CB. **E.T.**

## Sharp VCA140HM

When this machine had been running for about twenty minutes the capstan motor would start to stop for about half a second every few seconds, giving a momentary freeze-frame effect twice a minute. We found that the i.c. incorporated in the capstan motor was too hot to touch, so a new motor was fitted. This cured the problem. Note that a different capstan motor (part no. RM0TN2020GEZZ) is used in machines whose serial number is above 628200, as this one was. **E.T.**

## Hitachi VTM820E

Sometimes – not often! – this machine would record and play with severe mistracking. Playback of a good recording would

give no sound and multiple narrow noise bars across the screen – rather like the effect of cue-mode operation, but at normal speed. If by chance the fault was present during both recording and playback of the same programme the picture and sound came through quite well. Close examination of the deck when the fault was present showed that the tongue of the exit guide pole assembly failed to locate properly in its V block. The cause of this was that the plate assembly's inner slide bar (no. 216 in the exploded diagram in the manual) was bent upwards slightly. We judiciously bent it back downwards slightly. **E.T.**

## Ferguson FV11R

The complaint with this VCR was that it kept stopping after about an hour's use. On test we found that the tape counter stopped counting. The cause of this turned out to be the famous loose deck earthing screw that provides the earth return for the take-up optosensor and the mode switch. What puzzled us was that in every previous case we've dealt with this screw has caused a loading fault when loose. Presumably a high-resistance connection was enough to upset the optosensor but not the input to the microcomputer chip from the mode switch. Incidentally the official cure is to fit a small shake-proof washer beneath the screw, not just tighten it. **M.Dr.**

## Saisho VR3400

The problem was that the take-up reel wasn't being braked when stop was pressed during rewind, causing tape to be spilled into the machine. We've had this fault often enough with the Sharp VC8300, but in this case we were unable to find the brake. On the underside of the deck the take-up reel is obscured by the master cam: it looked like a fair old job stripping the lot down. A check on the supply spool however suggested that the brake was on the inside of the spool. After removing the take-up and supply reel discs the cause of the problem was clear. A small spring was missing. We assumed that it had never been fitted. When we'd found and fitted a suitable spring the machine functioned normally. **M.Dr.**

## Sharp VC9300

This machine came in from another dealer with the suggestion that the 12V supply was missing. Sound was o.k. but there was no E-E or playback vision. Scope checks showed that the video signal was o.k. up to the HA11703 chip IC402 but didn't emerge at pin 16 of this chip. An incorrect d.c. voltage reading (12V) at this pin led us to check Q406 (2SC945) which was short-circuit collector to base. Hence the 12V at pin 16 of IC402. A new transistor put matters right – fortunately the chip hadn't been damaged. **M.Dr.**

## Ferguson FV26D

This machine came from another dealer with the complaint of no playback video. On test we found that the E-E picture seemed to be slightly over-modulated. There was a good f.m. envelope at pin 39 of the PB20166G chip IC101. Further checks on this i.c. showed that the output at pin 10 wasn't passing via LPF102 to reach pin 21. As we didn't have this

filter in stock we had to order one from CPC. It arrived next day. When we'd fitted it the machine was back in good working order.

**M.Dr.**

### **Hitachi VT220**

This machine was dead with no switched 5V or 12V supplies. The display lit up and the operate LED was on continuously. We found that IC901's reset pin 49 was high at 5V instead of being at 0V. The reset pulse is generated within IC802 on the VS tuning PCB. A check at pin 9 of this chip showed that everything was in order. The collector and base of transistor QR804 were both at 5V however – the collector should have been at 0V. Replacing QR804 restored normal operation.**A.D.**

### **Hitachi VT63**

The problem with this machine was overloaded video. A quick scope check revealed that the cause of the fault was at the front end, on the tuner/i.f. board. C832 (470µF) was short-circuit.  
**A.D.**

### **Panasonic NV333**

The reported problem was faulty audio. We found that the VCR also refused to work mechanically. The audio fault was in the E-to-E mode: approximately one second of audio was heard about every five seconds. The audio mute line was high most of the time but dipped low to allow sound to be heard intermittently. The audio mute command comes from the syscon chip IC6001. A check at its reset pin 27 showed that a continuous line of pulses were present here. The reason for this was traced to D6038 which was leaky.  
**A.D.**

### **Panasonic NVMC20**

There was a problem with this camcorder's electronic viewfinder. I replaced the c.r.t. as it had been cracked when the unit had been dropped. On soak test the new c.r.t. fired over and I was left with an overbright raster with flyback lines – vision was discernible. The d.c. conditions around the video output from the chip were low while they were high at the collector of the 2SA1532 video output transistor Q803, a tiny surface-mounted device. There should have been -11.9V here but there was over 1V. As there was -23V at pin 9 of the line output transformer we checked Q803 which turned out to be short-circuit collector-to-base.  
**N.B.**

### **Samsung VI710**

The carriage was out of sync with the rest of the mechanism – there's no separate front-loading motor in these machines, the drive coming from the main mechanism loading motor. Retiming got the machine working but it would snap intermittently as teeth slipped. There was too much lateral play in the front-loading mechanism because of a crack in the right-hand black plastic sidepiece where the cogs mount.  
**N.B.**

### **Panasonic NVL20**

This G mechanism machine refused to load a tape because it had damaged gears. So out came the main cam gears (VDG0343 and VDG0346) which both had damaged teeth. The subloading cam gear (VDG0448) and arm (VXL1857) were also broken. Replacements were fitted, along with a new deck mode switch (VSS0175A) in case this was the source of the problem. In the test mode with the carriage out everything worked correctly. After refitting the carriage how-

ever I managed to jam the cassette across it. Instead of the machine stalling and ejecting the tape there was a raucous clattering of disintegrating nylon teeth, after which the machine sullenly powered down. Once more to the gear drawer.

In these machines the mechanism is driven by the capstan motor via a simple gearing system that's engaged by a solenoid. To prevent the full capstan torque damaging the nylon gears there's a friction clutch on the bottom of the capstan rotor: it's designed to slip before the gears are damaged. In this case the clutch was the cause of the problem – it was too tight. A replacement rotor and another set of gears restored normal operation.  
**B.S.**

### **Panasonic NVJ30**

This machine suffered from very intermittent capstan servo problems. After about three hours' operation the sound would start to wow and tracking bars would flash and flicker across the picture. Unfortunately the symptoms were erratic and couldn't be relied upon, so fault-finding of any sort was fruitless. Convinced that the cause of the fault was in the main systems and servo circuit we changed many i.c.s and capacitors in this area, but the fault continued to recur. After the machine had spent many weeks on the soak test bench the cause proved to be C1122 (330µF, 10V) in the power supply module. It was apparently going open-circuit when hot.  
**B.S.**

### **Panasonic NVF55**

The complaint was of monochrome recordings and an unstable picture. On test however all that this modern Nicam machine would do was to display E9 in the self-diagnosis list. According to the service manual this means no serial data. The MN67431VREH systems and servo flat-pack chip IC6001 was totally inactive. A replacement got the machine working and we were then able to attend to the original complaint. This was dealt with by switching off the NTSC 4-43 switch which is meant for copying NTSC tapes only.  
**B.S.**

### **Ferguson 3V35**

When switched on this machine was mechanically dead – it wouldn't even accept a cassette, though E-E came up. After ruling out such things as the cassette lift and the power supply we turned our attention to the system control section. A cassette was manually loaded and left in the unlaced position. The relevant logic conditions around IC201 were then checked. This showed that when any function was selected the microcomputer control chip would attempt to energise the relevant motors though nothing happened. At this point we discovered that circuit protector CP1 was open-circuit. It's on the servo/mechacon panel and is in series with the 13V supply to all the motors apart from the drum motor. With CP1 replaced the machine would load a cassette and fast wind was restored, but it still wouldn't thread the tape when play was selected. Further tests showed that the mode/lacing motor was open-circuit. A replacement restored full operation.  
**J.C.**

### **Ferguson 3V36**

Sound problems are rare with these machines. One that had no E-E or playback sound came along recently however. We soon found that there was no d.c. supply to any of the sound chips on the main sound panel, which is mounted at the back of the chassis. The cause of the trouble was that the regulator transistor Q4 on the sound panel was short-circuit base-to-collector.  
**J.C.**

## Panasonic NVL28

This machine would intermittently play back a mixture of the E-E and off-tape pictures. Not something I've seen before, but this machine sure did it. Checks on the video and E-E switching showed that there were no problems here, and I couldn't see any other likely cause of the fault. But this machine has an extra digital pack for picture-in-picture effects. This was where the cause of the problem lay. Two wires in this pack were shorting intermittently. Trimming them provided a complete cure. **B.S.**

## Panasonic NVF75

The E-E picture rolled and pulled though video playback was fine. A scope check on the video output from the demodulator pack produced a nice waveform with plenty of sync pulse depth. This went into the luminance processing chip IC301 where it retained its purity. But the output from the M51292FP switching chip IC3901 on the back panel was a sorry picture indeed. Replacing this chip cured the problem. **B.S.**

## Panasonic NVF55

Two of these machines have come in recently with the complaint that they were dead, with no output from the power supply module. Disconnecting the module from the machine then plugging it in again showed that the various supplies were at about twice the correct voltage. Checks around IC1103, which provides a stable reference for the power supply, showed that the earth pin was at about 19V. The print had gone open-circuit around the nearest earthing connection to the screening can. **B.S.**

## Panasonic NVJ40

We've had this fault twice recently. At switch on the cassette carriage tried to load though there was no tape. The machine soon powered down as the system control detected that there was a problem. Checks showed that the capstan drive chip was operating at full tilt all the time, irrespective of the control signal at pin 16. The cure is to replace the BA6435 capstan drive chip. **B.S.**

## Akai VS485

The E-E sound disappeared after a few minutes. After an hour the E-E video disappeared as well, leaving a blank raster. The culprit was the UPD75216A-OA6 timer chip. Pin 37, the tuner mute line, was at an indeterminate state (1.2V) instead of 0V when a signal was detected. The 1.2V was enough to turn on the digital sound and video muting transistors when they had become warm. A new timer chip cured the fault. **J.H.**

## Sony SLV270 Mk II/Grundig equivalent

Once this machine had reached the half-load state no deck operations worked. As the drum didn't rotate, the microcontroller chip wouldn't allow any functions other than eject.

The cause of the problem was the surface-mounted capacitor CC243 which had a 17k $\Omega$  leak. Fitting a replacement restored drum rotation and normal operation. We have found that these brown-coloured surface-mounted capacitors fail quite regularly, causing various faults in Grundig machines – this one is a Grundig clone. **J.H.**

## JVC HRD540

Playback in the reverse direction is a rare fault with any model. But several of these JVC machines have done exactly this. The sound is backwards: the picture is present with some mistracking bands on it, and there's colour. The play mode is entered but the tape runs in the reverse direction. The cause of the problem is the PU61003 capstan motor: due to an internal fault in its drive chip the forward/reverse line is shorted. In all cases so far a new motor has provided a cure. **J.H.**

## Sony SLV615

There was no rewind or reverse picture search, a fault we've had several times with these machines. When rewind was selected the machine rewound the tape for a second then stopped. The same thing happened in the review mode, but every other function was fine. We suspected something optoish, such as an end sensor, reel sensor, etc. So we scoped the outputs from the supply and take-up spool sensors. The low-frequency take-up reel sensor pulses appeared to be perfect, with correct amplitude. Things were different with the output from the supply reel sensor PH001 however. Pulses were present, but at only half the correct amplitude. Switching the scope to d.c. input showed that the pulses were still well above 0V at their lowest level. After fitting a new opto-sensor (part no. 8-759-144-33) the machine was back in good working order. **S.C.**

## Panasonic NVG45

This machine had an intermittent fault. The capstan would start to run fast in all modes, including lacing and unlacing. When the fault was present in the play mode the machine was toggling between SP and LP. We suspected a fault in the capstan FG pulse feedback circuit and sure enough found that the FG signal was going missing at pin 3 of IC2104 on the sub-main servo part of the PCB. The only components in the feed here are R2184 and C2185. Scope checks at the resistor showed that the signal was present at one side but not the other. It's a surface-mounted component, with a value of 1k $\Omega$ . We cured the fault by fitting a standard eighth watt resistor. **S.C.**

## NEC N9055K

This machine would shut down and display the error signal (a flashing square in the fluorescent display). We gave the machine a clean up and changed the idler after which it would record and play back its own tapes. But the recordings were incompatible with another machine: the sound was out of sync and there were multiple noise bars on the screen. The cause of this was that the exit guide didn't locate fully in its V block because the tape guide had slipped out of position in

the guide casting. The entry and exit guides were both replaced. After realignment the machine performed perfectly. I've since learnt that this is a common problem with these machines but it was new to me. **P.H.**

### Hitachi VT520

This machine played its own recordings perfectly but with prerecorded tapes the chroma was at best noisy and at worst non-existent. Checks around the chroma processing chip IC301 showed that the chroma signal was of about the right amplitude but very noisy. Matters weren't helped by several mistakes in the circuit diagram: the playback not the record voltages are the ones in brackets while pin 18, the search switching line, should be at 1.5V or so in play and 0V in search. I felt that the f.m. entering the chroma processing was poor but it looked fine. Luckily I had another head amplifier, but substitution made no difference. And so to the video heads. Strange though it may seem, the cause of the problem was the lower drum assembly/rotary transformer/drum motor. **N.B.**

### Panasonic NV688

This ageing LP VCR was pretty dead: there was no clock display and the machine didn't work, though the LP and power LEDs were permanently on. The cause of the problem was that the regulated 6V supply, from which the 5V supply is also developed, was missing. There was voltage at the emitter of the regulator transistor Q1201 and the correct base bias was present, but there was no output at its collector which was dry-jointed. Q1201 is miles away from the power supply area, being mounted on the back of the DD unit. **N.B.**

### Sharp VCA100H

This VCR was noisy in review, had low sound output and intermittently poor playback sync. The noise was caused by a barrelled pinch roller, which also caused severe tape riding in all modes. The other two faults were caused by a very worn audio-control head. **N.B.**

### Ferguson FV50

This machine wouldn't accept a cassette. Removal of the carriage enabled me to check that the mechanism was working all right and that the problem was due to the carriage itself: the main cam had broken off its mount. **N.B.**

### Hitachi VT130

Intermittent stopping of the capstan and drum motors is a fault we've had on a couple of occasions with these machines. Because of the intermittent nature of the fault it took us some time to get to the bottom of the problem the first time round. We found that tapping the luminance-chroma subpanel would instigate the fault, giving us the clue to its cause – the fact that the 4.43MHz reference oscillator signal is also used by the servo circuits. A scope check at pin 32 of the servo chip IC601 showed that the 4.43MHz signal went missing when the Y/C panel was flexed or tapped. After much searching and soldering we decided to replace the HT4539B chip IC301, which is the source of the 4.43MHz signal. It's a hybrid chip that contains some surface-mounted components and has a crystal stuck on top. We didn't attempt to replace the crystal but think it's the cause of the trouble since no

amount of panel tapping stops the oscillator when the crystal is cooled. Those without an account with Hitachi can obtain the chip from Willow Vale. **M.Dr.**

### Sharp VCA615HM

Many odd, intermittent faults with the Sharp VCA range of VCRs can be cured by replacing the mode switch, which is a very easy job. This particular machine proved to be a real time waster however. After we'd replaced the mode switch everything worked fine until fast forward or rewind was pressed. In these modes the reel idler didn't move far enough towards the reel discs to engage. After much checking we discovered that in addition the brakes were not being released from the reel discs. Both of these operations are controlled by a lever off the master cam. By turning the master cam back a bit the brakes came off and the reel idler engaged with the reel disc. So it seemed that the loading motor was overshooting its correct position. Then the penny dropped. Although the new mode switch looked exactly like the old one in fact the rotating part was a different colour. When we prised open the two switches we found that they had different track patterns. After fitting the right switch – a yellow one for the VCA615 – the machine functioned correctly. **M.Dr.**

### Akai VS23

This machine came in with a power supply fault – hum on sound and unstable vision. The cause was ripple on the 5V line from the chopper power supply. Replacing C7 (100µF, 10V), C6 (220µF, 10V) and C60 (100µF, 25V) which were all low in value cured the trouble. Beware of a misleading indication however. A finger placed across pins 2 and 3 of the NJM2352 chopper chip IC1 may seem to provide a cure and lead you to look elsewhere, as I did. All this does is to increase the chopper frequency, making the electrolytics more effective.

Repeated failure of TR12 (2SD1292) in the voltage doubler circuit that produces the -35V supply for the display digitron is caused by shorted turns in choke L8. When you replace TR12, always replace L8 at the same time. **M.Dr.**

### Ferguson FV30

This machine worked all right with its own recordings and could be set up for near perfect f.m. with an alignment tape, but on all other prerecorded tapes there was rolling as though the TV set was tuned to the wrong channel. If the microcontroller chip IT01 has been changed you will have to follow the instructions in the manual on resetting the head switching pulses. BT08 has to be shorted to chassis for one second: this starts an internal program within IT01 to set up the chip for the deck. It's quite hard to find BT08, which is at the right-hand side of IT01 on the component side. There's a convenient chassis pin next to it. Surprisingly enough doing this cured the fault. **E.S.**

### Akai VS23

The E-E and playback pictures suffered from severe vertical jitter, with line tearing and a ragged hum bar across the centre of the screen. A check on the voltages at the power supply output plug P1 showed that pin 4 was at 17V instead of 9V. The 2SA1286 transistor TR7 turned out to be leaky all round. When this had been replaced the picture was steady but a slight hum bar was still visible. Replacing C4 (47µF, 25V) and C6 (220µF, 10V) cured this final problem. **J.E.**

## Panasonic NVMC5

This little machine has a JVC style mechanism. It came in with a no playback fault. Recording was o.k., with fine results from playback via another machine. This eliminated the heads and most of the head switching circuitry. The culprit turned out to be an open-circuit coil in the head amplifier circuit – the coil that feeds the PB 5V supply to the M51459FP head amplifier chip. As usual with faults in this area, diagnosis was easier than gaining access to the PCB, mounted as it is within its own screening can. **D.C.W.**

## Panasonic NVMS2

The problem here was intermittent closure of the iris. As the symptom could sometimes be brought on by tapping the case a dry-joint was suspected. When the case was removed and the fault area was located we found not one faulty joint but many: connector P001 on the camera operation PCB had never been soldered in! **D.C.W.**

## JVC GRC2

There were no functions apart from fast forward/rewind at about half the normal speed. No E-E pictures or any other results were obtained, except that the emergency mode was entered within a few seconds of pressing the fast forward or rewind button. CP3 was replaced, as suggested by the emergency-mode display. This restored all the deck functions, but there was still no camera picture though YC signals from the YC separator could be recorded. Playback was o.k.

The supplies to the camera head were correct but there wasn't a glimmer of an output. At this point fate gave a helping hand. When the camera head was removed from the case a large screw dropped out – it was one of the deck securing screws. To cut the story short, the offending screw had caused extensive damage to the SSG circuitry. The SSG chip IC3, the blanking chip IC4 and the regulator and switching chip IC1 all had to be replaced, also Q6 (in the 5V supply of IC3) which was open-circuit. One screw did all this – and an estimate had been requested. Estimating can be a nightmare with camcorders! **D.C.W.**

## Sony CCD330

This one had been "looked at" by a large service centre that had charged for a no-fault found repair! According to the customer the problem was occasional tape crinkling. Apparently the camera would sometimes behave itself while on other occasions it would chew the tape immediately, causing the mechanism to jam with the inevitable eventual shutdown. The customer was then left to retrieve what was left of his tape as best he could.

On removing the case and watching the tape load and run it was obvious that all was not well with the tape transport system. The tape was being dragged up the pinch roller and, if left, would eventually jam against the guide. We also noticed that the travel of the tape tension arm was being restricted – in fact it was jamming against guide two (TG2) on the tape supply side of the mechanism. All this was caused by nothing more than misadjustment downwards of TG2. How it had come to be so far away from its correct

position, and why this wasn't spotted by the previous repairer, will never be known! **D.C.W.**

## JVC GFS1000

The symptom was intermittent spots that covered the whole screen in playback. They could have been caused by a capstan servo fault but were actually too random and instantaneous for this diagnosis to apply. In fact the cause was that one of the heads wasn't being switched on. The fault persisted, though with less regularity, after replacing the TA8609P playback f.m. processing and head switching chip IC701. Closer inspection of the r.f. switching signal then showed that it skipped a beat every so often, staying high instead of going low. This signal is derived from the drum PG pulses by the servo chips IC401 and IC403, so checks were carried out in this area. The r.f. switching output at pin 16 of the main servo chip IC401 was first compared with the preamplifier's f.m. output, using the scope's two beams. Nothing conclusive resulted from this and other checks and the problem was getting more difficult as the fault was now more intermittent. Replacing IC401 made no difference so I moved on to the next chip down the line, the drum PG pulse amplifier IC403. This turned out to be the cause of the fault. **S.B.**

## Sanyo VMD3P

A cassette was jammed in this camcorder. Checks showed that there was no loading or capstan motor drive as F4001 (type ICP-F10) on PCB SV1 had blown. This fuse feeds the 2SB1205 5V regulator transistor Q4006. There were no readable shorts but over 1A was being drawn through F4001 which is a 400mA device. Disconnecting the loading and capstan circuits in turn suggested that the fault was in the former, but we couldn't find anything amiss here. When an external 5V supply was used instead of the regulator circuit the peak current demand was 150mA. Q4006 was faulty. **N.B.**

## Panasonic NVM10

This machine, which belonged to a local school, had been dropped. The smashed case was easily replaced, as was the buckled cassette carriage. We then found that there was no play or record as the drum had seized. This is not uncommon when one of these machines has been dropped – the hifi stator jams the drum either because the stator centralising has been knocked off or the supporting bracket has been bent. The latter was the case this time. Next the machine wouldn't record as the record prevent switch was broken. When this had been attended to we put the machine on soak test where it ran well for some days. It then wouldn't switch on.

After checking the power supply I established that the fault was in the power switching logic rather than the supply itself. There was pull-up on the switch line and the switch operated correctly, taking the line low. This takes the common cathode connection of two diodes low. Conditions were correct here. However the common anode connection of the following pair of diodes remained high. Yes, would you believe it, a break in the print?! **N.B.**

# VHS Tape Path Alignment

Joe Cieszynski

Tracking correction by moving the V blocks with which the guide rollers engage seems to be a common practice nowadays, though totally wrong. I've recently come across a number of engineers who did it as a matter of course without realising the damage they were inflicting on the machines. In some cases they were acting on the instructions of others who told them that it was an accepted cure for tracking problems. It isn't. In fact the practice can be more destructive to a machine than pouring the mains supply down low-voltage lines: at least you can repair all the damage done by the mains.

## Back to Basics

I'm concerned mainly with full-size M-wrap decks – see Fig. 1 – though the theory applies to other formats as well. To start off we should examine why it's imperative for the V blocks to be left in their factory preset positions. To do this we must look at the way in which the helical tracks are laid down on the tape and how this is done.

Fig. 2 shows the standard VHS track layout. The critical factor that governs tape tracking is angle  $\alpha$ , which for VHS is  $5.963^\circ$ . If, because of mechanical misalignment, the video heads scan the tape at a slightly different angle the machine will replay its own recordings correctly but tracking problems will be evident with prerecorded tapes. There will also be poor tracking or complete mistracking when the machine's tapes are played via another machine.

## Tolerances

This precise angle of  $5.963^\circ$  is well enough known, but how often do we recall the strict tolerances to which the threading mechanism is manufactured? The tape is wrapped around the drum by something in the order of  $185\text{--}188^\circ$  (more on this in a minute); the drum diameter is precisely 62mm, so that when it rotates at 1,500 r.p.m. the head velocity is 4.87m/sec; the drum is tilted at a precise angle with respect to the tape path; tape speed is a constant 23.39mm/sec; and finally the tape height is set at the entry and exit points, then tilted by the slant poles, so that the tape contacts the drum surface correctly. All these factors ensure that the two  $49\mu\text{m}$  thick heads travel across the tape at the correct angle so that the  $0.3\mu\text{m}$  head gaps, set at a  $12^\circ$  offset angle with respect to each other, retrieve the recorded information. If any one of these parameters is changed by even the smallest amount you no longer have the exact VHS format. It's for this reason that the V block settings are so critical: if either block is misaligned, the wrap angle changes and so does the tracking angle.

At deck assembly plants, where the original alignment is carried out, manufacturers work to tolerances of the order of  $1\mu\text{m}$ . The plants are built on firm rock foundations to reduce the effects of vibration produced by traffic, aircraft etc. The Thomson VCR factory at Yishun, Singapore provides an interesting illustration of the lengths to which manufacturers go to ensure precision production: the head drum facility has a suspended floor to prevent any vibrations that would otherwise upset the production tolerances. If the manufacturers find it necessary to go to such lengths to ensure correct alignment, how can anyone hope to do as

well with a Phillips screwdriver, a pair of pliers and the machine on a wooden bench?

## Mechanical Reference

The two V blocks form a reference for the alignment of the rest of the deck. Moving the blocks may appear to fix a machine that's mistracking, but in fact what's being done is to introduce an error to compensate for the original fault.

Some might argue that since the drum wrap can be anything between  $185^\circ$  and  $188^\circ$  moving the blocks is in order. This is not so. The wrap has to be in excess of  $180^\circ$  to accommodate the playback head switching, the most popular wrap being  $186^\circ$ . But it's the manufacturer who decides on the wrap. He then sets the angle of the slant poles to suit. So the argument for leaving the V blocks alone stands.

The blocks are generally firmly secured to the chassis or subchassis by means of screws that are often fixed with locking compound. It follows that if the tracking is poor the cause of this must lie elsewhere.

When I made further enquiries about the effectiveness of the practice of moving the V blocks amongst those who do this some admitted to a comeback rate in excess of thirty per cent. They couldn't understand why, as the machines appeared to be fine when they left the workshop. Clearly in some cases the original fault may have altered slightly. In

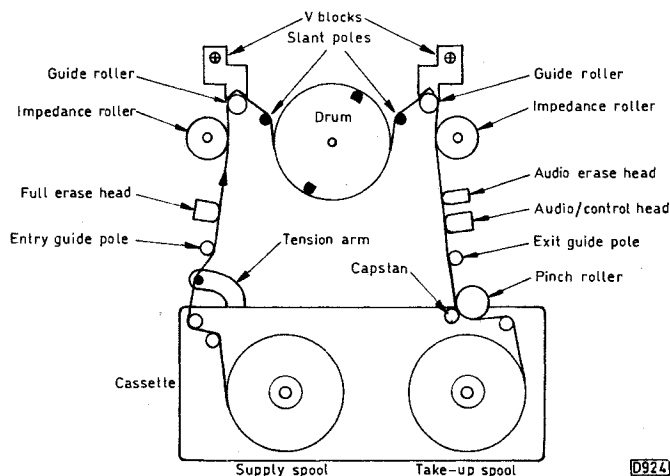

Fig. 1: Basic VHS deck layout with M-format tape wrap, indicating the positions of the main mechanical items. In practice some variations occur: one or both of the impedance rollers, which are included to prevent tape flutter at the entry and exit points, may be omitted; the entry guide pole may simply be a pin; an audio erase head is generally included only with models that have editing facilities.

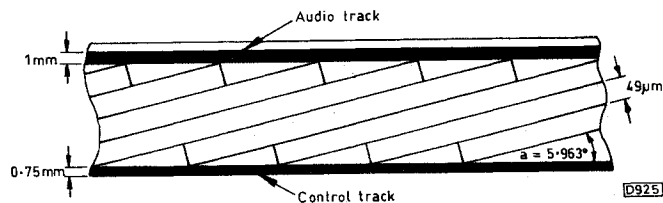
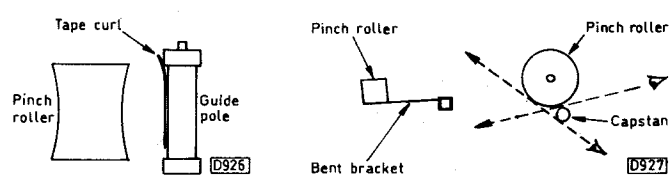
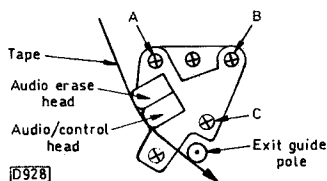

Fig. 2: Way in which the signals are laid down on the tape (standard VHS format).

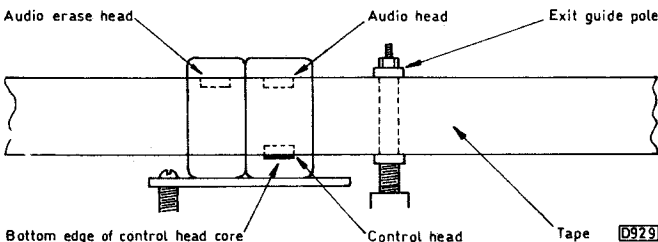

**Fig. 3 (left):** A concave pinch roller can cause creasing at the top or bottom edge of the tape. A hardened pinch roller can have the same effect.

**Fig. 4 (right):** Check for correct vertical alignment if the pinch roller is mounted on a soft metal bracket. A distorted bracket can cause tape edge creasing. Check for both zenith and azimuth distortion.



**Fig. 5:** Typical arrangement of the height, azimuth and zenith adjustment screws for an audio/control head. Adjust screws A, B and C for the correct height, screws A and C for the correct azimuth setting and screw B for the correct zenith setting.



**Fig. 6:** Correct height conditions for the audio/control head.

others the machine may be able to cope with good quality tapes but will struggle to track correctly with tapes that are a little worn but still within specification, e.g. some hired tapes or old recordings.

## How to Deal with Mistracking

Having made the point that you don't move the V blocks to correct tape path problems we'll next consider how mistracking should be tackled. There are several approaches to VHS deck servicing: each engineer adopts his/her own method. The procedure I'm about to describe is presented for the benefit of those still gaining experience. It's not the only way to go about it, but it is a logical approach that will in most cases get you to the root of the trouble.

After carrying out a quick visual check to see whether there are any obvious faults such as foreign bodies, pieces of the mechanism broken off etc., the first thing to do is to inspect the pinch roller.

## Defective Pinch Roller

When the roller is worn the tape will ride up or down the capstan because of the uneven pressure (see Fig. 3). This in turn causes tape curling at the exit guide. One or more of the following symptoms will be present: (1) tape edge creasing, with permanent damage; (2) loss of the CTL pulses, the result being intermittent noise bars; (3) poor h.f. audio response because of poor head/tape contact.

The tape curl shown in Fig. 3 is best observed by looking

at the tape from directly above: if there's no curl the tape should be almost invisible as you are viewing it edge on. Even the slightest curl should be evident when the tape is viewed in this way, but you must carry out the check under good light conditions. I should perhaps point out that when training engineers in this skill I've found that some are unable to see very slight curls that have been introduced artificially though others have no difficulty at all. The danger is that if you don't notice what's happening you'll start to look for the cause of the trouble elsewhere. This check must be carried out carefully.

The way in which the roller deteriorates depends on the composition of the rubber. This varies with different manufacturers. The wear illustrated in Fig. 3 is easy to detect by checking the pinch roller against a straight edge. Roller replacement is not a major job. Alternatively the rubber may become hard – often shiny – the result being poor tape transport. You can get the same symptoms as with a concave roller.

The roller is sometimes mounted on a soft metal bracket which may have bent, see Fig. 4. This usually happens when someone has applied excessive pressure while replacing the roller. As shown in Fig. 4, the capstan provides a convenient line against which to site the roller.

## Back Tension

Back tension is the next thing to check. Incorrect back tension can cause misalignment anywhere along the tape path. The only correct method of checking the back tension is to use an appropriate gauge – a back-tension cassette, tentelometer or spring gauge. Too many service engineers are under the impression that back tension can be set without the use of a gauge. This is not the case. All video workshops should not only have a gauge, they should use it. Nick Beer's articles in the August 1988 and January 1990 issues of *Television* provide further information on back-tension problems.

## The Audio/control Head

Having checked the pinch roller and back tension you know with certainty that the conditions are correct at the tape entry and exit points. In most cases the tracking will now be correct. If it isn't, proceed as follows.

Check the alignment of the audio/control head. Incorrect alignment can produce the same symptoms as a defective pinch roller. In addition the tape may be displaced at the exit guide roller, giving the impression that this roller is misaligned. It's in such circumstances that a VCR deck can end up in a state of complete misalignment.

If the screws that secure the audio/control head are still locked with the manufacturer's locking compound you can be fairly certain that the head alignment is correct. If the compound is broken the alignment must be checked.

In their manuals manufacturers usually tell you what to look for when carrying out head alignment, but they seldom tell you how to do it. The following procedure generally works well. The best alignment order is: height, zenith and finally azimuth.

First set the head so that it's roughly perpendicular, using all the setting screws – see Fig. 5. This gives you a good starting point. Now set the height. This can be done with a jig, but most manufacturers recommend that the height is set up while playing a tape, looking for the conditions shown in Fig. 6: the top of the audio head core is just covered and a fraction of the control head core shows beneath the tape. When adjusting the height rotate each screw in turn by the



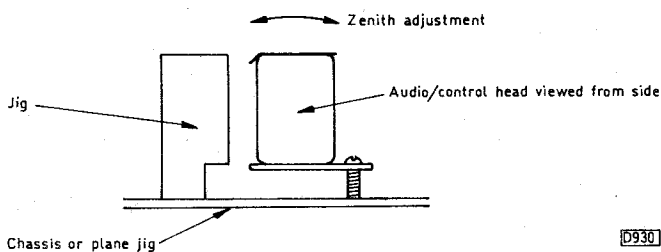

**Fig. 7: Zenith adjustment using a vertical jig.** I use the reel disc height jig from the old Ferguson 3V00 VCR service kit but any suitable straight edge will generally do.

same amount, e.g. by 90° increments, so that the head remains vertical with respect to chassis.

Once the height has been set correctly, carry out the zenith adjustment. Check this by placing a vertical edge – a piece of stiff card will do if nothing else is available – about 1mm from the front face of the head and looking at the gap, see Fig. 7. Any tilt in the zenith plane will be clearly visible. When tilt is evident it's not always easy to know which adjustment screw (where there are two screws), front or rear, should be adjusted. To avoid putting the height adjustment too far out I suggest that each screw is adjusted equally to correct the zenith error.

The correct azimuth alignment method requires the use of an alignment tape. This is not an essential item of test equipment for domestic machines however: tolerances are generally such that a known good test recording can be used. It's not sufficient to set the azimuth for optimum h.f. audio response: scope the control track output as well. It's possible to have good audio with very attenuated control pulses.

To ensure correct adjustment, check the height, zenith and azimuth settings once more.

The lateral (lip sync) adjustment is necessary only when it has been misadjusted by someone else or a new audio/control head has been fitted.

## The Guide Rollers

If there are signs that the guide rollers have been adjusted previously, i.e. they are chewed up, full alignment with a scope is recommended. As a general rule I always replace chewed guide rollers because there's no way of telling whether they have become fractionally distorted – even fractional distortion will affect the machine's tracking ability. Guide rollers get chewed because people don't slacken off the locking screws before attempting adjustment.

## Other Possibilities

There are many occasions when the symptoms displayed on the screen suggest that a guide roller is misaligned but there's no evidence that the machine has received previous attention. Why might the guide(s) have gone out of alignment when they are still locked tight? In all probability the guides are not the cause of the problem: several other things can give the impression that a guide roller is misaligned.

The head drum may have been replaced at an earlier stage in the machine's life. In theory the guide rollers should be reset when a new drum is fitted, but in practice this is rarely done. In most cases this doesn't matter. Sometimes however the f.m. output is compromised slightly when a new head is fitted and, as the drum wears, the entry/exit angles shift farther, resulting in a noticeable loss of f.m. output.

Another possibility is a worn slant pole. The wear may be

almost invisible yet a check on the f.m. output shows serious entry/exit misalignment. Replacement of the offending slant pole is often the only way of confirming this.

A worn lower drum can give the same symptoms.

Adjustment of the guide rollers will sometimes compensate for any of these possibilities. If it proves difficult to adjust a guide roller however the worn item must be replaced – you will otherwise waste many long hours trying, without success, to get the machine to perform correctly. I cannot stress sufficiently the fine tolerances to which we have to work. Too often engineers who happily replace electronic components are reluctant to replace slant poles, guide rollers, the lower drum etc. Admittedly some of these items can be expensive, but the sort of wear we are considering only occurs with older machines for which spares from scrap machines are usually readily available.

## Back to the V Blocks

This brings us back to the subject of the V blocks. A machine with a poor f.m. output at the entry or exit point may be in this condition because someone has moved the blocks. It's easy to see how this arises. The machine has say a worn slant pole but the engineer fails to diagnose this. Having heard that V block adjustment is an accepted cure he goes ahead and adjusts them.

The question that now arises is what can you do about the problem? A precise alignment jig would have been used to set the blocks at the factory, but such jigs are simply not available to the service engineer. Even if they were they would be very expensive. One thing is for sure: unless the blocks are reset full interchangeability performance will never be attained.

You must first confirm that the blocks have been moved. This is usually simple – the screwheads will show signs of wear. They are sometimes secured with locking compound and this seal will have been broken. If the blocks have been moved, you must accept that precise alignment will be impossible without a jig. The tolerances are just too fine. The best that you can hope for is to get them close enough to the correct positions to be able to set the guide rollers for an acceptable though not perfect f.m. output.

If there are marks in the surrounding dust to give an indication of the original settings, use these as a guide. Then set the guide rollers. After doing this the entry point, which is the most critical factor, can be tweaked using the head-switching procedure.

Check first that the head switching controls haven't been got at, i.e. that they are set at approximately their mid positions. Insert the tape that you use for head switching adjustment (this should be an alignment tape) and set up your scope. With the VHS system head switching should occur 6.5 lines before the field sync. This will be the case if the entry V block is set correctly. If the block is offset slightly the tape wrap will result in noise during the field blanking period. Move the block fractionally to reduce this noise, resetting the guide roller as you do so. You can eventually reach a point where slight movement of the block appears to shift the head switching point – in fact you are moving the tape in relation to the head switching time. Adjust the block so that head switching occurs exactly 6.5 lines before the field sync.

The results with machines that I've dealt with in this way have been varied. Some appear to have been restored to correct operation. Others display a slight amount of interlace flicker. This is why at the outset I commented that moving the V blocks can be more destructive than mains

down the supply rail. At least in the latter case the equipment and spares are available to carry out a proper repair.

## **In Conclusion**

Repairing video mechanisms has never been more difficult. Multi-function motors that drive complex gear trains, mode switches that tie the deck to an even greater extent to the microcontroller chip, and layered deck construction all contribute to the problems encountered by the service engineer.

Then there are the tiny mechanisms used in VHS-C and 8mm format camcorders.

The video deck is a piece of precision engineering that must be treated with respect. Mistakes will be made and accidents do happen during servicing. But I personally was disappointed to find that fundamental errors which were being made fifteen years ago are still common today, even in some of the larger workshops. This bodge does nothing for the service industry in terms of customer relations and makes things much more difficult for those who try to do the job properly.

## Philips DMP Series Decks

A lift guide repair kit for the Charlie range of decks is now available from Konig, the part number being VID1534. Damage to the lift guides previously meant either a replacement chassis or a bodge with Araldite, but this kit enables a satisfactory and neat repair to be carried out in only a few minutes. **P.B.**

## Philips VR6185

With this one the keyboard and the syscon didn't talk to one another! The machine would take in a cassette and would change channel in the E-E mode, but there was no sound. When a deck function was tried the display showed that the command had been received but nothing happened. If the operation board was pressed in the right place the fault cleared. On inspecting the print we noticed that there was a crack by the side of the infra-red receiver can. **P.B.**

## Mitsubishi HS347

The customer complained that rewind was poor and that the machine didn't always carry out a timer recording. At first I couldn't see a connection, but the faults did have a common cause. The reel idler was so worn that it could hardly wind forward either. Thus if a tape was inserted with the start leader showing the idler tried to move it along but couldn't. When play or a timer recording was then tried it wasn't carried out. A new gum idler unit was required. **P.B.**

## Philips VR502

In the event of intermittent remote control operation check for dry-joints on the infra-red receiver chip IC121. **P.B.**

## Grundig VS520

For no teletext check the voltage at pin 12 of the SAA5231 chip. If it's between 10-11V you'll probably find that R574 (10 $\Omega$  safety type) is open-circuit. **P.B.**

## Mitsubishi HSB32

This machine played all right but there was no forward wind or rewind as the brakes stayed on. They should be held off by an electromagnetically-controlled plastic lever. The magnet was energised but the lever didn't latch on the brake cam correctly. As the lever is plastic and the brake cam metal it seemed reasonable to assume that the plastic item would wear first, so it was replaced. This made no difference. A replacement brake cam put things right. It's called brake cam C, part no. 591b554010. **P.B.**

## Akai VS25

This machine came from another dealer with a ticket that simply said "won't play". When we tested it there wasn't a no play fault initially but we did notice a slight drum servo twitch. The cause of this couldn't be pinned down as the symptom quickly disappeared. Later, on soak test, the machine intermittently switched to standby, leaving the tape

threaded up. Extensive power supply checks failed to reveal anything amiss here, so we left a meter connected to pin 61 (function off) of the main microcontroller chip IC506. This proved that the chip was intermittently issuing the off command. On test next day another symptom appeared: the head switching point wandered up and down the picture.

This was the last straw, so we referred the problem to Akai Technical. A very nice man suggested that as the machine went into standby only when the tape was playing it would be a good idea to check the continuity of the drum PG pulse feed – the machine will go to standby if these pulses are missing. A scope left connected to pin 7 of the BU2735AS digital servo chip IC503 showed that the drum PG pulses were o.k. here, but the story was very different when the scope was connected to pin 9. The mark-space ratio of the 25Hz head switching squarewave varied intermittently then, a bit later, the waveform started to disappear completely from time to time, the result being that the machine switched to standby. A new BU2735AS chip cured all the faults. Phew! **M.Dr.**

## Logik VR960

The complaint was of buzzing on sound due to a faulty aerial socket. Strange, I thought, but on test this proved to be the case. When the aerial input socket on the modulator was pulled down the E-E sound disappeared, leaving a loud buzzing noise. A scope check on the audio input to the modulator showed that the signal was still present when the fault occurred. No dry-joints could be seen when the modulator was removed but after going over all the connections with a fine-tipped iron the fault had cleared. **M.Dr.**

## Sony SLC9

The fault with this machine was no clock display due to a faulty d.c.-d.c. converter on the rear-mounted power supply PCB. Unfortunately the cost of a replacement unit is over £20 trade. By the time that labour had been added the charge would have been outside the customer's budget. So we decided to open up the old unit to see if it could be repaired. The only difficult job was unsoldering the tin can that surrounds the PCB inside. We did this by applying heat from a miniature blow-torch powered by lighter fuel. Once we'd got inside we found that a 2SD789 transistor had an open-circuit emitter terminal. A 2SD774 made an excellent substitute as we didn't have a 2SD789 in stock. For good measure we replaced the four electrolytics (10 $\mu$ F, 16V; 10 $\mu$ F, 50V; 10 $\mu$ F, 50V; 330 $\mu$ F, 16V) as tests showed that they were well down and possibly the cause of the transistor failure. After reassembling the case we refitted the converter and gave the VCR a two-day soak test. The results were excellent and our charge was within the customer's £50 limit. **M.Dr.**

## Samsung SI1240

In the April issue E.T. mentioned the problem of failure of the KA8301 loading motor drive chip. The latest Samsung technical information book (vol. 3) contains details of a modification to overcome this. **M.Dr.**

## Panasonic NVF75

This all-singing and dancing machine worked perfectly unless you took notice of the function display – the usual display was pause, with no counter display in any mode. Our first checks were on the serial data and clock lines between the syscon chip IC6001 and the timer and display chip IC7501. As data signals go, they appeared to be all right. To eliminate the front panel timer and display circuits the front panel PCB from a nearby NVF70 was borrowed. This showed the same errors, so back to the syscon circuitry.

Comparative checks with the NVF70 showed that identical data left the syscon chip. Only an inverter circuit centred on transistor QR6017 was left to check. It was working as well as I could tell but the culprit turned out to be C6011 at the base of QR6017. It's a tiny surface-mounted type capacitor and was open-circuit, thus apparently corrupting the data signals to IC7501. **B.S.**

## Saisho VR1200

This machine would accept a cassette but no functions, including eject, worked. When the bottom cover was removed we found that the main drive belt was broken. A replacement restored normal operation. **E.R.**

## Panasonic NVG40

This machine made a real mess of tapes by damaging their bottom edge. The cause of the problem was a faulty pinch roller. It was quite an expensive repair as the pinch roller can't be detached from its drive assembly – the whole thing has to be purchased as a unit. **E.R.**

## Saisho VR3600X

This machine blew the 1.6AT fuse F502 at switch on. Fortunately the first component we checked, D504, was found to be short-circuit. A replacement cured the fault. **E.R.**

## Samsung SI1260

This machine recorded the sound but not the video – there was just snow. Playback of prerecorded tapes was correct. Scope checks showed that there was low record f.m. in the vicinity of C3203, which when checked read 68Ω. Strangely, its value is 68pF. We subsequently had the same fault on two other machines. **A.S.**

## Hitachi VTF770

When power on was pressed the machine powered down almost immediately. Checks showed that the 18V supply was missing. The cause was a crack around one of the mains transformer's pins. Some fresh solder restored normal operation. **A.S.**

## Philips DMP Series Decks

We've had two cases where the cassette would be ejected whatever deck function was requested. In both machines the capstan motor had seized due to a build-up of sticky gunge on the capstan shaft in the upper bearing. Dismantling and cleaning provides a cure.

Some older DMP/IDM series decks are developing cracks in the top rails of the plastic racks that guide the cassette lift on its way in and out of the machine. If they

actually break you have to fit a very expensive half-chassis subassembly (but see note elsewhere on the Konig repair kit – Ed.). To guard against having to do this we run a layer of hot-melt glue along the top surface of any cracked racks we find, forcing it tight into the angle between the rack moulding and the metal wall to which it's fixed. **E.T.**

## Tatung TVR6151

The problem was a buzz on the hi-fi sound, present only when the machine had warmed up. A tiny gap could be seen in the f.m. sound playback envelope waveform at the start of the helical scan, the cause being misadjustment of the head switching-point preset VR2 on the top rear PCB. Adjust for zero envelope gap at TP4501, with the scope triggered by the flip-flop waveform at TP2. It seems that this is a batch problem – two machines with similar serial numbers came in with the same symptom, cause and cure. **E.T.**

## Akai VSF200

If one of these machines comes in with the no-go symptom you may well find that fusible resistor FR1 is open-circuit. If so, check zener diodes D13 and D16 in the motor supply stabiliser circuit for leakage or being short-circuit. D13 is a 16V type and D16 a 10V device. **E.T.**

## JVC HRD700

This machine suffered from a rare intermittent fault: about once a week the spool motor would fail to rewind the tape into the cassette when entering the stop mode. The result was tape looping and crushing. A replacement mode switch solved the problem – the original one seemed to be putting hash and noise into the microcomputer control chip whenever the loading motor was on the move. **E.T.**

## Mitsubishi HS318/Luxor 9253-97

After about half an hour in the play mode the speed of the capstan motor would fluctuate wildly, sometimes coming to a complete stop so that the machine entered the stop mode. Whenever this happened however the capstan motor would never fail to perk up and run backwards to drive the take-up spool! The cause of the fault was traced to a hairline crack in the top PCB, between the capstan motor driver chip IC5A2 and the pull-up resistor R5C6. **E.T.**

## JVC HRD530

On rare occasions this machine would stop in the middle of play or record. Luckily we were watching the deck when it had a spasm and saw that the take-up reel stopped. We subsequently found that when the fault occurred the voltage applied to the reel motor dropped but the current through it increased. In fact the motor was going short-circuit intermittently and had to be replaced. To be on the safe side we also replaced the drive chip in case it had been damaged by the increased current flows – more than an amp. **E.T.**

## ITT VR3918

The cassette would be ejected when this machine was set to record. At last a simple one! The erase prevention switch had become disconnected from the frame of the deck. As it didn't open, it didn't tell the control chip that the tab had been removed. I refitted the switch with a tiny spot of glue so that it couldn't fall off again. **C.W.**

## Mitsubishi HSB27

This machine was dead. As it was a Mitsubishi I had a quick look round for open-circuit safety resistors before I got too involved and sure enough R5K3 on the lower board was open-circuit. A short to chassis could be measured from one end of the resistor however. I traced this to the deck where a spring was shorting one end of the latch magnet to the chassis: the reel disc unit had sprung apart and as a result the spring had fallen out.

P.B.

## Grundig VS310

The sound wasn't being muted in search or ATTS. Muting is carried out on the sound (TON) board, where R1351 (10k $\Omega$ ) was found to be dry-jointed.

P.B.

## JVC HRD170/Ferguson FV11R

When this machine was connected to the mains supply the clock flashed as usual but the tape in indicator came on although a tape hadn't been inserted. When the operate button was depressed the indicator remained out and the machine went into the rewind mode for two seconds after which it shut down. An STK5481 chip is used in the power supply. This seemed a good place to start and a replacement restored normal operation.

J.E.

## Akai VS66

The customer's complaint was that fast forward, rewind and record were o.k. but the machine wouldn't play back a tape. The child lock mode was in operation, easily proved by pressing play on the handset for about eight seconds. When the lock mode is selected with this machine, either deliberately or accidentally, by pressing the stop button on the handset for eight seconds the lock symbol in the display lights up only briefly. It's thus easily missed, with the result that the user isn't aware of what has happened.

J.E.

## Ferguson FV26D

When the on button was pressed the deck mechanics shuffled back and forth for a couple of seconds and the channel indicator appeared briefly then the machine shut down. The cause was loss of the 12V and 5V supplies because the STK5481 chip was faulty.

J.E.

## Philips VR6870

The machine was completely dead – no displays and no deck functions. This is a nice stock fault. Go straight for C112 (33 $\mu$ F, 25V) on the stand-up subpanel in the power supply module. It goes open-circuit or changes value.

J.E.

## Ferguson 3V29/JVC HR7200

A loud clanging noise and tape judder during rewind and fast forward were due to the fact that the idler was broken in half – most unusual. When a replacement had been fitted the tape functions worked well except for noise bands and vertical

judder during playback. Out came the carriage again. We then noticed that the back-tension band was crinkled at the tension-lever pivot: it had been adjusted by bending the band with pliers instead of adjusting the screw. The phantom fiddler had struck again – this time it was a "helpful" neighbour.

J.E.

## Panasonic NVF65

The capstan motor ran at full speed in all modes – load, playback and search. Supply choke L2002 on the main PCB was open-circuit. It supplies 5V to the capstan motor's FG stage. Because there were no FG pulses the servo ran the motor at full speed.

J.H.

## Ferguson 3V35/JVC HRD120

No playback or record colour is not uncommon with these machines, due to faults around the crystal oscillators. On this particular machine however the cause was the colour/monochrome/test switch at the back. It had become leaky. As the customer didn't know it was there and obviously never used it I simply removed the connections to the offending portion of the switch. Everything then worked correctly.

C.W.

## Saisho/Matsui VCRs

A number of Saisho and Matsui VCRs use a small plastic item to release the limiter post. It commonly breaks, the usual complaint from the customer being that the machine is stuck in the pause mode though what actually happens is that the pinch roller is jammed by the limiter post. There are various sources for this plastic part. Unfortunately in some cases the pivot hole is too large. As a result the limiter post again jams, because it hasn't been moved far enough from the pinch roller.

C.W.

## Sharp/Orion Decks

Many decks look similar to the Sharp VC381 type and most use a similar reel-drive system. This tends to be unreliable, the symptoms being poor winding and search and poor or no reclaim of tape so that a hanging loop is left. The use of genuine spares is generally best but I've recently been replacing the original nylon hub on the motor shaft with a brass drive hub. I don't know whether this is actually a genuine spare but it certainly works very well and is easy to fit. For example this is how it goes in an Amstrad VCR7000.

Remove the lift, the post that releases the cassette brakes and one screw from the plate that secures the motor and the idler spring. Loosen the other screw until the plate can be moved. Remove the idler spring when loose, then the idler. Retighten the screw in the motor so that it's held steady, but make sure that the plate is clear of the motor shaft. Now, using a medium-sized screwdriver, prise up the nylon drive hub. Pliers can be used, but make sure that you don't bend the motor shaft. The hub comes off quite easily and can be discarded. Next fit the new brass drive hub: some care is called for to make sure that it's in the right place, as the height is important – the idler and hub must contact correctly and the new hub is not as tall as the nylon one. To fit the

brass hub you need a soldering iron and a screwdriver or similar to push it down when the hub is hot. Place the hub on the shaft: it will fit just enough to hold in place. Put the iron on top of the hub. When the hub is hot enough it will slide on to the shaft and, usually, stop at just the right place. When the hub has cooled down the machine can be reassembled and you'll have no more problems.

I don't know whether the major spares firms carry this item but it's advertised in the magazine and is also available from VAS in Derby. C.W.

### Grundig VS500

The voltage at the power supply pin of the sequence-control microcomputer chip CIC230 in this machine was low at 2V instead of 5V. The dealer the machine had come from asked us to replace the chip as he didn't have the tools to complete the task. Fair enough, at least this would save damaging the print. But let's see, is the chip getting hot? It wasn't. So perhaps the 5V regulator was faulty. A replacement made no difference and I then noticed that the 12V supply was also affected. I checked both supplies by powering them from an external source: the 5V rail took 330mA while the 12V rail took 125mA. No shorts then. The power supply was either not regulating or not providing sufficient power.

The power supply was actually switching in bursts, so it could have been working in a heavy-load mode. In fact this was not the case. The cause of the problem was an open-circuit capacitor (C1326) in the regulator control feedback circuit. Grundig tell me that the fault is not unknown to them. S.B.

### Ferguson FV42L

This new machine could be tuned in to the TV set and played back a prerecorded tape, but with record and E-E operation the picture was terrible. Checks showed that there was a very distorted video signal as coil FW11 was open-circuit, in fact physically damaged. M.D.M.

### Panasonic NV730

The complaint was of critical tracking in the LP mode, the SP mode being good. A check showed that one head's output was low in the LP mode. Fitting a new head made no difference, so we quoted for a new lower drum assembly and replacement video heads (they come together when you purchase the lower drum) and a service. Surprisingly, in view of the high cost, the customer gave us the go ahead. Correct operation was restored when the work had been completed. M.D.M.

### Matsui VX850

The top of the picture was jumping and the sound was like listening to chipmonks! The first fault was cured by retuning the VCR to programme 0 on the TV set, the second fault being caused by a faulty bias oscillator – it had been damaged by liquid spillage. The new recordings were made in the SP mode: the old ones, which were not being erased, were in the LP mode – hence the chirpy sound. A new bias coil (T01) put matters right. M.D.M.

### Panasonic NVG45

Prerecorded tapes were played back correctly but the machine wouldn't play back its own recordings properly. A check with another machine proved that the cause of the fault was in the record circuitry – the fault was also intermittent.

The record track wasn't being recorded as pin 1 of IC2102 in the servo section was dry-jointed. M.D.M.

### Akai VSF33

A dead machine with the power supply working should lead to a check on TR408 (2SD1292) on the main PCB. If this is short-circuit check the 4-7Ω safety resistor FB498 and replace the two 56μF, 16V electrolytics C446/7. Failure to replace these two capacitors will result in a very dim clock display with TR408 overheating and leading a short life. It's also a good idea to remove that blob of brown glue near C446/7 – the one with the blue wire running through it – as it absorbs moisture. This results in corrosion of the PCB beneath. M.Dr.

### Saisho VR3300X/Matsui VX735A

The E-E picture appeared to be slightly off tune and the drum motor didn't rotate. Two faults or one? A check showed that the 4.43MHz reference signal at pin 3 of the digital servo chip IC2001 was missing. We checked back to the buffer transistor Q3004 on the YC subpanel where the collector voltage was only 2.5V instead of 4.9V. Further tracing back brought us to Q506 (2SD734) which is labelled "power control 5V switch". Its base and collector voltages were correct but there was only 2.5V at its emitter. A new 2SD734 transistor cured both faults. M.Dr.

### JVC HRS5000

This all-singing, all-dancing machine came in because of intermittent slow playback with some tapes. After watching the tape supplied by the customer we came to the conclusion that the tape transport system was running too fast. As lengthy efforts failed to instigate the fault we left the machine on the soak test bench. About two weeks later the fault finally showed up. The loading cycle hadn't been completed and as a result the pinch roller hadn't been pulled on to the capstan shaft. Thus the reel motor was driving the tape. A replacement mode switch cured the fault. M.Dr.

### Fidelity VTR1000

Although the clock was o.k. this machine wouldn't switch on. A check at the power-in pin 13 of the microcontroller chip IC501 showed that everything was in order here, but pin 2 wasn't producing a low signal to switch on the 15V line. As a test we shorted pin 2 to chassis. This brought the machine to life, but when a tape was inserted there were no deck functions. Further checks around IC501 showed that the reset pin 15 was floating at around 2.5V. Zener diode ZD504 in the reset circuit was leaky. The manual doesn't give its rating, which is 10V. M.Dr.

### Samsung VI510

There was patterning on the E-E picture, similar to that present when the modulator has been tuned too close to a TV station. After eliminating this possibility we carried out checks on the tuner-i.f. panel. The TAA550B tuning voltage stabiliser chip IC2 was found to have about 1V peak-to-peak of ripple across it. When a 150μF, 63V electrolytic was temporarily connected across IC2 the ripple fell to about 20mV and the fault had been cured. The source of the 50V line is a small switching converter within the power supply: we found that the 33μF, 100V smoothing capacitor C7 was leaky, with one leg rotted away. A replacement restored good results. M.Dr.

## Hinari VXL8

This machine was switching between the SP and LP modes in both record and playback. In the past we've found that this has been due to tape wrinkling, usually as a result of a faulty pinch roller or incorrectly adjusted back tension. This causes distortion of the signal from the control track, a problem from which the Amstrad VCR6000/6100 series machines also suffer – they use the same deck. The tape path was carefully examined, but was blameless.

The control track pulses can be monitored at pin 7 of IC103. They were seen to be of reduced amplitude and varying, but adjustment of the control head failed to produce any improvement. This was in no small part due to the large amount of hum on the "µcom +5" rail. You can measure this at pin 1 of the power supply plug. The cause of the trouble was bridge rectifier D506, which had an open-circuit diode. We also replaced the associated 2,200µF, 16V reservoir capacitor C505. S.L.

## Ferguson 3V35/JVC HRD120

This was a straightforward fault though it did involve a chase through three boards to find the cause. In the E-E mode the video signal would fade out or disappear instantly in a very unpredictable manner. A check showed that the i.f. panel's video output was present. Over to the luminance section then. The signal was present at pin 8 of the switching chip IC501 but didn't emerge at pin 4 because the voltage at switching pin 2 was incorrect. This voltage should be zero in the TV mode and 7.5V in the video/aux mode. It was 1.6V and varying. We eventually found that the TV/video switch itself was the cause of the trouble. The sound remained unaffected throughout. S.L.

## Tashiko VVD951/Sharp VC681H

This machine was stuck in the pause mode. The deck would accept a cassette and attempt to play it, but on completion of loading it would enter the pause mode. The pause LED remained lit from cassette acceptance until ejection. During a timer recording however the machine performed faultlessly. This at least eliminated the front operation panel, but to confirm this we disconnected the data input to the panel at HA2. The pause LED then went out, confirming that something upstream was the cause of the indication.

We noticed that the key input at pin 47 of the IX0151 microcontroller chip IC801 changed following selection and cancellation of pause. The chip's 5V supply at pin 58 was clean and correct, and the still output at pin 54 changed state on request. This appeared to exonerate the system control chip.

We next moved to the still panel where we found that disconnecting the still input (pin 29) got the machine running up to a point and extinguished the pause LED. Something was wrong with the syscon's pause output therefore, and replacement of the chip cured the fault. Diagnosis of faults on serial data lines can be very difficult, even when direct comparisons are carried out with a working machine. We find that substitution is a more valid test and that this usually saves time and money. S.L.

## Panasonic NVJ40

This is a tale of two videos, one with no E-E sound, the other with no search tuning lock. No apparent connection – but read on. We tackled the one with no sound first and soon found that no sound left the demodulator pack because

Q713 (audio defeat) had a high at its base. There are two feeds to Q713, a mute from the syscon department and an interstation mute that's generated by IC7651. During search tuning IC7651 receives a video feed: it generates a sync-low signal to stop search tuning when a station is found. With a station already tuned in there should be nothing at IC7651's sync-low pin 9, but there was 5V here. A new AN5421 cured the fault. The problem was the same with the other machine but as there were no previously tuned in stations there was no search lock. A new AN5421 restored full tuning capability. B.S.

## Panasonic NVF55B

I've had a few of these machines that all too readily misload a videocassette, often throwing the tape out three times in four attempts. Check the tension of the cassette gripping flanges: slight readjustment is all that's needed. B.S.

## Sharp VCA5011

The complaint was that a bar moved up the recorded picture. On test this proved to be a hum bar: it was also present when the VCR channel was viewed while recording. What could cause a hum bar in record but not playback? A logical starting point seemed to be the bias control line (record 9V supply) which is derived from Q8801 on the main panel and passes to the YC panel then the head amplifier. A check with the oscilloscope showed that there was 2V of hum on this line.

To try to isolate the source of the fault we disconnected the head amplifier. The hum bar disappeared from the monitor. An ammeter connected in series with the supply to the head amplifier produced a reading of 40mA. We pondered for a long time then decided to check the power supply – but wasn't it common to playback? A check on the always 9V line showed that the voltage was correct but there was about 4V of hum that wasn't present in playback. Checks farther back showed that the input to the 9V regulator chip was low at 10V instead of 15V. There was also a very considerable hum voltage. There was more headscratching when we found that the reservoir capacitor C902 was perfect. We decided to connect the scope across the rectifier diodes. This is a full-wave circuit but the two diodes in each leg are in series. A check on the individual diodes showed that one of them, D904, was partly open-circuit. This was the cause of the excessive ripple: incredible that the extra 40mA drawn by the head amplifier was enough to cause the fault to show up on the display. M.D.

## Philips VR6870

The complaint was of no functions and flashing in the display. On test this turned out to be the case: no operation was possible and there was random flickering within the display. A check showed that the power supply outputs were all slightly low. As we were carrying out checks we noticed that more display segments lit then, after about ten minutes, the machine came into operation with all the supplies correct. When we applied freezer to the VA4006B power supply control chip the machine shut down, but a replacement produced the same results. More careful use of the freezer then showed that C2311 was very sensitive. When a replacement, 33µF as fitted, was installed the machine would start up after about 90 seconds. Reference to the circuit diagram suggested that the correct value for this capacitor is 10µF. Operation was normal when we fitted a 10µF capacitor. M.D.

## Hitachi VM200

The symptoms were no mechanical functions, just a loud whirring noise when any mode was selected. E-E pictures were o.k. The cause of the failure was simply a very worn loading belt. On closer inspection the belt was seen to be rather oily: it transpired that the customer had tried to cure a squeaking noise with a liberal application of oil. A new belt and mechanical service restored normal operation. **D.C.W.**

## Ferguson 3C01

The customer's fault description was "green pictures with purple flashing". To my surprise at switch on the camcorder was o.k. Apart from a small problem with the burst vector position the camcorder seemed to be satisfactory. Some of these older camcorders, especially ex-rental ones, can be rather noisy mechanically but this one was fine. When the case was removed however the cause of the problem was obvious: the focus connection at the tube base was just touching. A quick refit provided a complete cure. **D.C.W.**

## Panasonic NVMS70

Intermittent operation of the auto-focus system with these camcorders is often caused by imperfect ribbon cable connections. **D.C.W.**

## Ferguson 3V46

This unit, used in conjunction with a 3V33 camera, failed to operate. The only thing that happened was that the capstan motor ran in reverse – at speed! The cause was a faulty BA6109U3 mode-control chip, IC5. The loading drive had failed between modes, causing the rather misleading symptoms. **D.C.W.**

## Canon VME1

I don't see many Canon products and have extreme difficulty in getting parts. This rather elderly machine had no E-E camera picture though playback was o.k. Service manuals are hard to get, but the similarity between various Canon and Sony models can be a great help. In this case the tube supplies were correct and the SSG circuits seemed to be o.k., but there was no picture. After various scope and meter checks attention was turned to the preamplifier PCB which, as usual, is housed in its own screening can. The signal-injecting finger was applied but produced none of the noise and patterning one expects. A quick voltage check then showed that the preamplifier's supply was missing. The cause was a short-circuit 220 $\mu$ F, 6-3V decoupling capacitor on the SSG PCB. Replacing this restored the E-E picture. **D.C.W.**

## Panasonic NVM10

This is a simple but common fault nowadays. The report was of no record sound, playback being o.k. The culprit was the external microphone jack socket, which has a built-in switch that opens when an external microphone is connected. It normally needs to be closed. What happens is

that corrosion develops at the switch contacts. It's easy to rectify by cleaning and retensioning. **D.C.W.**

## Panasonic NVMC20

The problem with this camcorder was intermittent zoom operation. Since the fault showed up only occasionally we had to dismantle the machine and watch carefully. When the fault occurred we found that voltage was present at the zoom motor terminals but there was no motor rotation. The motor was defective. **S.DaC.**

## Panasonic NVM1000

There was no record or playback operation for the simple reason that the drum didn't rotate. R1075, a fusible circuit protector, was open-circuit. Thankfully there were no further problems. **S. DaC.**

## Panasonic NVM3

The customer had attempted to use a damp tape, the result being that it jammed around the drum. We had to cut it out and give the mechanism a thorough clean up. When we tried the machine it didn't work. The loading motor drive chip seemed to be a good starting point and we soon found that there was no supply at pins 2 and 8 because the 2-2 $\Omega$  resistor R6020 was open-circuit. A replacement got the machine working normally. **M.D.**

## JVC GRS77

This camcorder had been dropped. As a result there were no functions though the cabinet hadn't been damaged in any way. Surprisingly the main d.c.-d.c. converter had failed. Replacement of this produced normal deck operation – and a very spotty picture. The cause of this was pixel dropout in the CCD image sensing chip. After fitting a new image sensor the spots had gone but the picture was still less than perfect. On further investigation we found that there was an intermittent dry-joint at one end of R9, which is in one of the clock pulse feeds to the CCD sensor. After resoldering this all we had to do was to check and adjust the camera video 1 and 2 PCB settings. But I would still like to know how dropping a camera can cause a d.c.-d.c. converter and a CCD chip to fail! **D.C.W.**

## Canon E50

Poor recording and playback after the use of a head cleaning tape made me wonder. We made the usual scope checks around the signal and a.t.f. circuits then changed the heads. This produced a complete cure. **D.C.W.**

## Ferguson FC27

Playback was o.k. but there was no camera picture. The culprit was the camera d.c.-d.c. converter along with the F20 type circuit protector CP4. **D.C.W.**



## Panasonic NVM7

Intermittent flashing was the complaint with this camcorder. Sure enough after about twenty minutes the colour content of the camera picture started to flash and break up. Scope checks around the camera process board, after first removing multiple screening cans etc., showed that the R – Y and B – Y signal outputs from the Y and C processor chip IC304 were fluctuating severely. Farther back in the signal chain, at the other side of the 1H and 2H delay CCD chip (VCR200), things settled down a bit. Replacing this item cured the fault.

B.S.

## Panasonic NVM7

This M7 was dead: the power supply wouldn't stay on because the 16V and –8V camera supplies were missing, their absence activating a power-off circuit. The root of the problem seemed to be a badly scorched chopper transistor, Q1003, for the 16V and –8V supplies. After fitting a replacement 2SD1293M there was a wisp of smoke from the camera section. Fortunately I was able to switch off before Q1003 expired again. The cause of this latest problem was a charred luminance 1H delay CCD chip (VCR0199) on the camera process board – it had gone short-circuit to chassis.

B.S.

## Philips VKR6820

This is an earlyish Panasonic clone. The report was of no playback sound though I couldn't find anything amiss. A call to the customer provided the answer. There was no sound on holiday in Sweden! He'd not tried it back home. Unfortunately this is one of the very few machines in which the 5.5MHz sound carrier is not a switchable option on the r.f. unit.

D.C.W.

## JVC GRC7E/Ferguson 3C03

The reported fault was no focus: the lens unit was well and truly jammed. It's quite a common fault with these camcorders. As a replacement optical block is expensive it's worth having a go at carrying out a repair, though repair is probably not the right word as the action required is to strip the optical assembly from the camera head and "unscrew" the primary lens. This involves removal of a piece of "sticky tape" that locates the mating edges of the separate lens parts. Mark both surfaces to help with reassembly,

If it's now possible to unscrew the primary lens all is well. If not, apply a minimum of force to the primary lens by holding the camera body and pressing the lens hood against a firm surface. If you're lucky a click will be heard (and felt) as the lens assembly assumes its new position.

Once the primary lens is free, remove it from the rest of the assembly. Check whether the multithread threads of the lens and its housing are damaged (cracked). If all is well, reassemble the primary lens to the main assembly, noting that the correct threading of these parts will allow full rotation of the assembly. Refit the "sticky tape", align the lens sections and check the zoom and focus rings for freedom of operation. Set up as required – back focus, A/F tracking and focal distance.

This procedure can be carried out with certain other JVC

models – indeed with most early models from most manufacturers, including the latest full-size machines with manually adjustable focus and zoom lenses.

D.C.W.

## Panasonic NVMS1

The report said auto-focus sticking. Investigation showed that this full-size camcorder had been dropped on its optical block end. In fact the primary lens was coming away from the rest of the unit, the result being that it jammed in certain positions. Now a new optical unit for one of these machines costs around £200 trade. When you add the labour charge, this repair for what is really not too serious a problem can be quite expensive, at least from the customer's point of view. Can it be done more cheaply? – how often do we hear these words! Well yes it can, but only by dismantling the primary lens and drilling a small (0.8mm!) hole to accommodate a securing screw. Result, a satisfied customer.

But don't do this sort of thing if you have anything better to do! An interest in model building means that I've assembled a range of small hand tools that are occasionally pressed into service for jobs like this. If you do wish to attempt the odd mechanical repair you will need very small drills, taps etc. – model making suppliers are a good source.

D.C.W.

## Sony CCDV88

The fault report with this handycam was of odd coloured lines and patches floating up the picture. The cause was a dirty flying erase head. Nearly fooled me – the video heads were o.k.

D.C.W.

## JVC GRC1

I expect everyone has had the no colour fault with one of these early camcorders. This one was no exception – the culprit was the MCM1068A chip IC8. Good results were obtained after setting up the chroma circuits.

D.C.W.

## Panasonic NVMS70

If the problem with one of these camcorders is intermittent operation and/or intermittent viewfinder and LCD displays replace both clock oscillators on the operation PCB. One runs at 32kHz, the other at 4MHz. This can save much searching and time.

D.C.W.

## Amstrad VMC100

These record-only camcorders can be difficult to service without the special jig that allows a playback mode to be entered. This one reportedly left loops of tape and ejected the cassette at random. It certainly lived up to its reputation! It would run for a while, stop, eject the cassette (complete with a loop of tape) then refuse to do anything.

When I removed the case to see what was going on I discovered that the capstan stopped intermittently, producing the fault symptoms. If pause was selected in the record mode the machine would sit there with the capstan running until record was again selected, when the capstan would cease to rotate. The cause of the problem was a faulty BA6431F capstan drive chip.

D.C.W.

# VCR Clinic

Reports from Philip Blundell AMIEIE, Nick Beer, Chris Hawkins, Steve Cannon, Graham Rees, Basil Davidson, Alfred Damp, John Edwards, and Michael Dranfield

## Philips VR6490

When one of these machines comes in dead check whether R102 (330k $\Omega$ ) in the power supply is open-circuit. It's a safety component, part no. 4822 116 52272. **P.B.**

## Ferguson 3V39/JVC HRD110

I had quite a succession of VCRs and TV sets with damaged tuners and aerial amplifiers after the succession of thunderstorms last summer. This one was different however. When operating with its internal tuner the gain was so low that the signal could hardly be seen. A new tuner was fitted but this made no difference. As the voltages around the tuner were correct attention was turned to the SL1432 SAWF driver chip. Voltage checks at pins 3 and 4 produced 10V instead of 5.3V readings. A new SL1432 restored normal gain. **P.B.**

## Sharp VCT310H

The problem was a hum ripple on the recorded picture. You could see the tipple on the AT9V supply. The value of the 2,200 $\mu$ F reservoir capacitor C905 was low. **P.B.**

## Alba VCR6000X

This machine was dead with an open-circuit mains fuse. After replacing this with the correct semi-delay type we tested the unit and found that the tuning was very erratic – running at high speed through and about the correct point. The tuning voltage was varying of course, the cause of the trouble being leakage between print tracks. We cured this by cutting out the VT line and hardwiring it instead. On test we discovered that after a few hours' use the tuning on all channels would shift by a tiny amount. Use of freezer proved that C134 (0.1 $\mu$ F), which decouples the tuning line, was the cause of the trouble. As C133 and C135 are identical components that perform the same task at various stages of the d.c. line these were also replaced. **N.B.**

## Ferguson FV52L

This machine was dead though the power supply worked, producing all its outputs. The machine started up when the flat lead from the power supply to the main servo-signals PCB was flexed. We soon found that the cause of the trouble was dry-joints on all the legs of TT64, which is mounted on the large, flat heatsink at the right-hand edge of this PCB. **N.B.**

## Panasonic NV730B

This machine had an intermittent fault. Initially a perfect horizontal line would appear exactly two-thirds of the way down the screen during playback. It would then disappear, to be replaced by a line exactly a third of the way down the screen. Then both lines would appear simultaneously, with varying intensity. There was no noise near the lines, which were very fine – only about one or two TV lines deep. They looked like fine switching lines.

The tapes were not being marked, but to prove that the tape path was not responsible we checked and cleaned it

thoroughly. Eventually we traced the cause of the trouble to an intermittently high-resistance connection between the centre of the drum and the discharge angle, which is at the bottom of the mechanism in this model. **N.B.**

## Samsung SI1240/1260

The drum in these full-lace machines should spin as soon as a tape is inserted. This one just pulsed back and forth, making no headway towards achieving 1,500 r.p.m. The lack of drive was caused by the motor connector CN207 – it had tarnished pins all along its length. **N.B.**

## Pioneer VR707/Philips VR6760

This machine was dead with no 5V output from the 5V regulator/reset generator IC7502. Its input was low at 3.8V, so no surprise that there was nothing coming out. The input comes from the collector of the BD136 transistor TR7004, which had a base-emitter leak. When a replacement was fitted IC7502 received its correct 6V or so input. But there were still no other voltages around IC7502, so the machine remained dead. Cold checks soon showed that there was a short to chassis at IC7502's output pin 5. Guess what had shorted – a little blue electrolytic, C2013 (150 $\mu$ F, 10V). There's a change! **N.B.**

## Orion VCRL3

If rewind and fast forward are o.k. but the tape binds in play and/or the drum doesn't turn or turns intermittently, check the edge connector on the direct-drive drum motor and for dry-joints near the connector. **C.H.**

## Daewo 3300FR

For no channels and/or no playback picture check for hair-line cracks around the tuner/i.f. PCB. For poor reception or bad colours check IC105/6/7 by substitution. **C.H.**

## Orion VD800

For intermittent jamming of the mechanism on this quick-start model, with the cassette having been extracted by force by the customer, check whether the left-hand loading arm guide roller is fouling the tape tension arm as well as the state of the three loading belts.

For painfully slow rewind and fast forward, remove, clean and lubricate the spool axles before condemning the capstan motor. **C.H.**

## Akai VS18/19/21/22/35

We've repaired over a hundred of these machines and have found that a BD238 is a viable alternative to the 2SB1010, 2SB891 and 2SB1185 while a BD237 works all right in place of a 2SD1292. In three years we've had only two comebacks where the BD237/8 have blown. It's advisable to change C4 and C20 from 47 $\mu$ F, 25V to 100 $\mu$ F, 35V. For improved reliability change C6 from 100 $\mu$ F, 25V to 220 $\mu$ F,

35V at the same time. Before returning a machine check that the current flowing via fusible resistor FR1 doesn't exceed 250-500mA and that via FR2 150-500mA depending on function. We run these machines for at least three-four days before releasing them. **C.H.**

### **Sony SLV373**

This fault caused an immense amount of head scratching until we made a call to Sony technical in Cumbernauld. Even though I sometimes struggle to understand their broad Scottish accents, "see you Jimmy!" and all that, they certainly came up trumps with this one. The symptom was diagonal dark bands on recordings only: the picture was perfect with E-E operation and playback of a prerecorded tape. Curiously, the fault clears when the top, right-hand PCB is hinged up. The offending component is L252. Apparently an incorrect type that radiates to the erase circuitry was fitted. Part no. for the replacement is 1-412-092-11. **S.C.**

### **Hitachi VTM822**

There was severe warbling on record only, more noticeable in the LP mode. Surprisingly a new pinch roller and capstan motor failed to cure the fault, whose cause was eventually traced to the reel clutch assembly underneath. This item has been responsible for a number of faults we've had - usually no play, chewed tapes, no rewind or no eject. On this occasion however one of its cogs was vibrating. The vibration was travelling along the drive belt, affecting the capstan. That's our theory, anyway, and we're sticking to it! **S.C.**

### **Hitachi VTS80**

The reported fault with this stock machine was no colour through the scart connector. Sure enough the symptom was as reported. To cut a long and embarrassing story short, the SVHS Euroconnector setting can be altered via the on-screen display menu. This selects whether composite video or separate luminance and chroma signals pass via the scart socket. The latter option is provided for TV sets capable of SVHS operation. As you may have guessed, someone had selected it - hence no colour on our non-SVHS receiver. **S.C.**

### **Akura VX100**

We've had a couple of interesting faults recently with this model. Very weak video was cured by replacing Q318. Lines on the playback picture were cured by replacing the TL8819P dropout compensator chip IC304. **G.R.**

### **Hinari VXL8**

No fast forward/rewind though you can hear the motors running was mentioned on page 566 in the June issue, in the servicing article on this model. Another cause is distortion of the rubber grommet on the stop lever. It sits upright next to the slide bars/operating levers which rest against it in the eject mode. Where this is the case a replacement grommet provides a complete cure. **B.D.**

### **Ferguson 3V44/JVC HRD140**

This VCR came in with a jammed cassette, a bent cassette housing and the tape still partially wrapped around the drum, but the machine did its best to eject the cassette. To start with we straightened and retimed the cassette housing, then reset the deck timing. As we didn't trust the VCR

completely we inserted a dummy cassette and watched the operation of the deck very closely. Everything worked well until eject was selected, when it was obvious that the cassette was ejected much too early - had it been a proper cassette the tape would still have been partially wrapped around the drum. My first thought was to replace the mode control switch. This machine uses a LED and sensor assembly however, with the light shining through holes in the cam gear. When this item was replaced the deck mechanics worked correctly. **A.D.**

### **Hitachi VT530**

There appeared to be three separate faults in this machine. First no playback - the condition was described as "dirty heads". Secondly the E-E picture appeared to suffer from a.g.c. overloading. And thirdly the search tuning system didn't stop when a channel was found. All these symptoms were caused by one component however, CP205 (LC delay) on the YC board. **A.D.**

### **Ferguson 3V35/JVC HRD120**

This VCR had developed an expensive taste for prerecorded tapes: because the bias oscillator ran in the playback mode it erased them as they were being watched. The cause of the fault was traced to Q503 on the video PCB. As it was leaky it held the Rec Start Low line at 3V instead of 9V in playback. **A.D.**

### **Sharp VC381H**

Because the carriage left-hand microswitch was broken this machine would accept a cassette only half way. A new switch cured the problem. **J.E.**

### **Hitachi VT63**

There were screaming and clanging noises when the tape was ejected. The machine then switched off. When we checked out the deck functions we noticed that there was no auto-stop at the end of fast forward. Both problems were caused by the fact that the left-hand tape sensor wasn't working. When the voltage at the EST pin on the carriage PCB was checked it hovered at around 4V instead of 9V, but the slightest movement of the carriage produced the correct 9V and normal operation. Careful positioning of the end sensor holder monitoring the EST voltage and securing it with a drop of Superglue solved the problem. **J.E.**

### **Sharp VC9300**

There were no deck functions and the dew indicator was blinking. Pin 19 (dew sensor input) of the microcontroller chip IC801 was high because the sensor was open-circuit. It's mounted on the cassette flap opener bracket, near the pinch wheel. **J.E.**

### **JVC HRD540**

This machine would play, rewind and wind fast forwards for a few seconds then stop, though the tape counter was working. Pressing pause cured the stopping. All was revealed when we consulted the service manual. The supply and take-up reels both have a rotation sensor. One supplies a pulse, the other only a 5V d.c. voltage. A call to our suppliers revealed that this part is in demand and was out of stock. Has it suddenly become a common fault? **M.Dr.**

# VCR Clinic

*Reports from Philip Blundell, AMIEE, Eugene Trundle, Brian Storm, Nick Beer, Stephen Leatherbarrow, Michael Dranfield, John Edwards, Andy Gallagher, Mick Dutton, Mike Leach Richard Newman, Roger Burchett and Alfred Damp*

## Sharp VC651H

This machine was stuck in the pause mode – the pause light came on as soon as a cassette was inserted, preventing play and record though fast forward and rewind operated. I took on the repair because I thought that the machine was the same as the Philips VR6843 for which I have a manual, but although it's similar mechanically the electronics are different. The front controls are connected to a resistor ladder network which is read by the syscon chip. None of the switches were dirty or leaky, and the isolation diodes were all o.k. So suspicion fell on the syscon chip. Fortunately I was right about this, a new chip restoring normal operation. According to Willow Vale's COPS the chip can be an X0161GE, IX0263GE or an IX0174GE. **P.B.**

## Philips VR6870

This machine produced no E-E sound unless the audio select button was pressed. All became clear when the front was removed: the audio level sliders were not located on the controls themselves! Thus although the knobs were set at maximum the controls were at minimum. Fitting the front correctly and resetting the levels cured the trouble. **P.B.**

## Philips VR6870 and Clones

Problems with the power supply, which uses a UA4006 chip, have been reported on a few occasions in recent issues. The circuit diagram shows C2007, C2027 and C2011 as all being 10 $\mu$ F electrolytics. In fact C2011 should be 33 $\mu$ F. In the event of a dead machine with a ticking noise coming from the power supply change all three capacitors. **P.B.**

## Sharp VC482/VC8482

Sometimes – not often – this machine would fail to carry out forward deck functions. The rewind and review modes worked correctly. With the fault present we found that there was 3.5V on the REEL-M-RVS line, which normally toggles between logic levels 0V and 12V. After a long search the cause of the problem was traced to diode D735 being leaky. **E.T.**

## Sharp VC9300

Considering that the symptom was simply no switch on, it took us rather a long time to locate the cause of this fault. The syscon 'on' command turned on Q9008 in the power supply but Q9005 failed to come on. Thus the regulator wasn't being latched on. The culprit was the electrolytic capacitor C9008, which is a decoupler in Q9005's emitter circuit. **E.T.**

## Panasonic NVJ35

The complaint with this machine was that its maximum record time was one hour and twenty minutes. When I tried it the machine just stopped after an hour and twelve minutes. It then resumed and recorded for about half an hour before again stopping. The farther along the tape it got, the shorter its record periods. A scope check showed that the reel pulses

that reached the syscon chip were at about 3.5V. In my experience they are usually more than 4V peak-to-peak. When I checked the opto chip from which these pulses are derived I found that there was a fair covering of fluff on the reflective surface of the reel drive gear. This has alternating black and mirrored portions that generate the reel pulses optically. Needless to say cleaning the surfaces cured the problem. **B.S.**

## Panasonic NVJ45

When this machine was tried out all the displays lit up at once and flashed rhythmically. Checks showed that there were no abnormalities in the filament and dynamic drives from IC7501. But R7504 in the grid supplies had rather a large voltage drop across it for a 100 $\Omega$  resistor. When it was measured out of circuit the reading was about 1k $\Omega$ . A replacement restored normal operation. **B.S.**

## Panasonic NVL28

This machine would record and then play back perfectly but was unable to produce colour with a prerecorded tape. Further checks showed that "super still" was also very poor with prerecorded tapes. My first checks were around the video head and drum assembly to make sure that the head hadn't been fitted out-of-phase – this can cause no chroma playback and still frame problems. But there was nothing amiss here. A look at the servo and colour circuitry suggested that the MN6740VCJK systems and servo main processor chip IC2001 might be responsible for the trouble as it feeds rotary signals to the colour circuits and many other signals to the slow and still servo circuits. Fortunately a replacement cured the fault.

I then had colour and perfect slow and still when playing back prerecorded tapes but any tape with copy guard on it caused pulling at the top of the screen. As a cure for this Panasonic recommend fitting a 22 $\mu$ F non-polarised or tantalum capacitor across C9568 in the digital pack. **B.S.**

## ITT VR3919

One or two faults are being noted with these Mitsubishi clones. Failure to record with the unit always auto playing is caused by the retaining clip on the rather weak record prevent switch being broken. Tape damage, particularly edge creasing and tearing with large amounts of oxide dust appearing around post P4, is usually caused by a worn pinch roller. Intermittent low or no sound and counter plus tracking problems is caused by a worn audio/control head – it seems to wear badly in these half-lace mechanisms. **N.B.**

## Ferguson FV20

This machine would, with or without a cassette inserted, intermittently go into rewind or fast forward then switch to standby. If there was no cassette present when this happened the machine would light the cassette symbol in the display. Checks showed that the end sense condition at pin 43 of the syscon microcontroller chip IC6001 was incorrect. The d.c.

pull-up was low because R628 (120k $\Omega$ ) had gone high in value. **N.B.**

### Hitachi VT11

The drum would intermittently run at very high speed, the picture dissolving into a large number of lines. The cause was a dry-joint on the drum PG head connector. To locate and repair this we had to remove the DD unit. A new cassette housing damper to prevent any more cassettes going into orbit completed the repair. **N.B.**

### Sanyo VHR4350

A loop of tape being left at eject is not uncommon with these full-lace machines. The cause in this case was new to me. As the capstan brake was sticking there was excessive braking and lack of reel drive during the unlacing process. Cleaning proved the point, replacement cured it. **N.B.**

### Logik VR950/Samsung VI611

This machine accepted a cassette but when rewind was selected the tape was rewound for a few seconds after which the machine shut down with the standby LED blinking. When fast forward was selected the reel motor refused to turn – there was just a click, then the machine shut down again. There was also no reel motor rotation in the play mode, so the tape was looped. The fast forward command comes from pin 22 of the syscon chip IC602. We found that the voltage here changed from 0 to 2V when fast forward was selected. This voltage change should have appeared at pin 2 of the BA6209 motor drive chip IC0212. It didn't because of a hairline crack in the print near this pin. When this was linked across all functions worked but there was again shut down after a few seconds. This was caused by the reel optocoupler, which was producing distorted pulses. **J.E.**

### JVC HRD110/Ferguson 3V38

Rewind and fast forward were normal but when play was selected the capstan ran flat out, giving the fast search symptom. Plug CN11 on the servo PCB was dry-jointed and loose. Resoldering didn't cure the problem: soldering the leads direct to the PCB did. **J.E.**

### Hitachi VT130 and VT14

Picture rolling in the E-E and playback modes is a common fault with Model VT130. The cause is C524 (220 $\mu$ F, 16V) which is on the top PCB near the converter module. You usually find that it's swollen and discoloured. The same fault occurs with Model VT14, but in this case the capacitor is C859 (470 $\mu$ F, 16V). It's best to fit a capacitor with a higher voltage rating in both models. **J.E.**

### Ferguson 3V55

We all drop clangers from time to time but this was a beauty. The complaint was that the channel selector couldn't be moved from the auxiliary input position (position 0). As there had been several heavy thunder storms recently we came to the conclusion that either the timer or the mechacon microcontroller chip had succumbed. But substitution checks showed that neither was at fault.

We decided to force the machine into the timer mode by making the auxiliary line go low. This produced snow on the screen in the E-E mode and we were able to tune in stations

in the auxiliary position. We then found that we were also able to tune in the other positions and when the auxiliary line was released everything worked normally. This whole business wasted several hours. What had happened of course was that the electrical storm had wiped the tuning memory clean and it then refused to select any channel other than auxiliary until this position contained information. **M.D.**

### Osaki V20H

The fault with this machine was excessive drum speed followed by shut down. We traced the cause of C145 (100 $\mu$ F, 10V) which was leaky, upsetting the FG processing associated with the BA4558 chip IC104. **S.L.**

### Matsui VCP100

This machine would very randomly fail to play a tape. It would stop and unload. We eventually noticed that this also occurred in rewind and fast forward. Lack of reel pulses seemed to be the obvious diagnosis, and sure enough we found that after the machine had been in use for a while they became low in amplitude and distorted. In this machine the relevant piece of optical wizardry is mounted on a neat PCB beneath the take-up reel. This is available from CPC – buy the GoldStar deck equivalent, it's cheaper. **S.L.**

### Schneider SVC261RC

There were no E-E signals, just a blank screen. We struck lucky with our first check, at the 12V input to the i.f. unit. This supply was missing because R330 (4.7 $\Omega$ ) was open-circuit. It seemed to have failed because the customer had accidentally dropped a 1p piece into the machine. **S.L.**

### Philips VR6870

This VCR came in dead. We soon found that the cause was the usual culprit – C2011 (33 $\mu$ F) was leaky. After replacing this capacitor we left the machine on test for the rest of the day then returned it. Two days later it came back with a note to say "no better, as before, worse". It was in fact dead. Further checks revealed that two more electrolytics were leaky, C2006 and C2007. C2006 is 220 $\mu$ F and is in the power supply on the main PCB. C2007 is 25 $\mu$ F and is on the sub-PCB – the circuit diagram gives the value as 10 $\mu$ F. **A.D.**

### JVC HRD170/Ferguson FV11R

The problem with this machine was loss of capstan servo control – noise bars ran through the picture. The control track pulses were o.k. at pin 20 of the servo chip IC2, and someone had already changed this i.c. So further investigation was required. We eventually found that C25 (4.7 $\mu$ F, 25V) was the cause of the trouble. It tested o.k. but a replacement cured the fault. **M.Dr.**

### Proline 5000XR and Amstrad VCR4600

The Proline 5000XR looks like the Amstrad VCR4600. The one that came to us had the same fault we've experienced with many VCR4600s, no E-E picture, just a blank raster, but the sound o.k. In the Amstrad VCR4600 the 1,000 $\mu$ F, 6.3V video coupling capacitor C817 at the i.f. block's output pin is the cause of the trouble. This capacitor has a different reference number, C710, in the Proline model. On test we found that it wasn't short-circuit, but we replaced it anyway, using a 25V type for good measure. This made no

difference. The cause was actually inside the i.f. block: there was a dry-joint at the earthing pad to can, connected to a small, blue surface-mounted component near TR3, which is presumably the video output buffer transistor. Resoldering the joint put matters right. **M.Dr.**

### **GoldStar GHV1240**

Playback was o.k. with this machine but the E-E pictures were very poor, as though they were slightly off tune. After checking the tuning we connected the scope to the i.f. module's video output pin and found that the waveform was very distorted. So the module was removed for testing. As we've had almost the same fault with Grundig tuner/i.f. modules, caused by a 1 $\mu$ F electrolytic, we weren't surprised to find a very dried up 1 $\mu$ F, 50V capacitor. Its reference number wasn't clear - C71 something - but you shouldn't have any trouble locating it as it's the smallest electrolytic in the can. Replacing it cured the fault. **M.Dr.**

### **Akai VS23**

If you find that TR12 is short-circuit collector-to-emitter and FR1 is open-circuit with power supply V1084B502A the cause is likely to be shorted turns in L8. Replace L8, TR12 and FR1. **A.G.**

### **Sony SLV373**

This new machine had apparently worked for a week. Then it came in with the complaint that there was no colour with playback of prerecorded tapes. I tried making a recording and sure enough the playback produced good colour. But there was no colour when I played back the recording in a known good machine - our old faithful Ferguson 3V29. So the Sony machine was working to its own standard. There was only very slight colour with playback of prerecorded tapes.

I ordered a service manual and hoped that the fault would go away by itself. Well, the manual came but the fault didn't go away. I dived in at the HA118016NT chroma processing chip IC801 on the YC board, checking all the waveforms and d.c. voltages while playing a prerecorded tape. The conditions at pin 19 were very wrong: the d.c. voltage was low and the waveform was completely different from that shown in the manual. Sony calls this waveform C ROT. It should be a squarewave at about 4.5V peak-to-peak. But it didn't look like a squarewave at all. So I traced it back to the head amplifier board where I found that the print at pin 6 of plug CN004 was broken. It was obvious that someone had been at it before, as the soldering around this plug was in an appalling condition for a new machine. After repairing the print and generally tidying up the plug all tapes played back correctly. **M.L.**

### **Philips VR6460**

This machine had an intermittent fault. It would work normally for days or weeks at a time. Then it would 'hang up', going into permanent rewind no matter which button was pressed. Once the tape had been ejected it wouldn't accept another one. We were convinced that it was a mode switch fault and fitted a replacement. The machine worked for two weeks then the same thing happened again. Heating or freezing the servo board had no effect and another engineer had tried the microcontroller chip. We suspected plugs and sockets but couldn't fault them. By now the fault had once more cleared.

When the fault next appeared I was ready to do battle!

Armed with the service manual and a logic probe I set to work checking the input conditions at the servo chip IC7125 from the mode switch. The manual is very helpful, giving the logic conditions for all functions at pins 4, 5 and 6. All three inputs were high, which is incorrect. The reason for this was soon apparent as the earth connection to the mode switch also measured high! This connection goes to a plug and socket on a small PCB (P667) which is mounted on the front deck. The panel is earthed by a single screw and star washer that had worked loose. A screwdriver was all that was needed to provide a complete cure. I now check this on all VR6460s that come in. **R.N.**

### **JVC HRD170/Ferguson FV11R**

Two of these machines came in with the same fault. They would accept a tape and the front controls operated. There were no functions however because the drum wouldn't rotate, and there were no E-E signals. The tape would be ejected after a few seconds. In both cases replacing the STK5481 power supply module cured the trouble. **R.N.**

### **Ferguson 3V44/JVC HRD140**

Because of the extremely intermittent nature of the fault with this machine it unfortunately bounced. Operation with prerecorded tapes was perfect, but with its own recordings there were occasionally tracking errors and an interference bar would roll through the picture. As a complete repair kit had already been fitted I decided that a mechanical cause of the trouble was extremely unlikely. Eventually scope checks revealed that the machine didn't always record a control track on the tape. After some time had been spent checking around I found that C430, which couples the control pulses to the head circuit, was dry-jointed. Resoldering was all that was required. **R.N.**

### **Amstrad VCR6000**

As usual with calls from remote and exposed places the symptoms hadn't been very clearly explained over the phone. A quick glance at the owner's tapes showed a familiar sight however - crinkling of the bottom edge. But this wasn't a 4500 or a 4600. It seems that the fault had been present from new. Recordings made in the LP mode were unwatchable as the machine kept switching cyclically into the SP mode. Easing off the back tension showed that the tape was being pulled down by the pinch roller, which was some way off vertical. So was I as I battled back against the storm. **R.B.**

### **Philips VR6520**

After a full mechanical service this machine displayed a flashing dew warning while the cassette down symbol was permanently lit. The reason for this was simple but could catch anyone out. Link W20 on the operation panel had been replaced with a choke which was shorting to link W21. This had obviously happened when I'd refitted the front panel. W20 is in the regulated 5V supply to the operations panel while W21 is in the serial data line from IC6501. The machine worked all right apart from this, though the functions weren't displayed. **R.B.**

### **Proline 5100XT**

This machine is similar to the Amstrad 4600 Mk. II and suffers from the same tape-creasing problems. **R.B.**

## Hitachi VM200E

The problem with this camcorder was a very liney playback picture. Its cause was traced to an open-circuit 2H chroma delay line. With this item open-circuit the chroma crosstalk cancellation system doesn't operate, producing the symptom described above. This fault could of course happen with any VHS machine, as the cancellation system is part of the VHS format. **D.C.W.**

## Movalarm 614

This is a surveillance camera, not a camcorder. Its 1in. vidicon produced no pictures for the first half hour of operation. Then a picture appeared. When the unit had been switched off for any length of time this same delay occurred after switching on. The cause of the problem was traced to a leaky decoupling electrolytic capacitor at the line oscillator chip's supply pin. It effectively removed the line drive to the tube's scan coils. As a result the beam blanking (tube protection) circuit came into action, removing the video signal. When the faulty capacitor eventually charged it enabled the line oscillator to generate the line drive and the video signal was restored. Although this was a surveillance camera the principle applies to most cameras that use a tube. **D.C.W.**

## Sharp VCC10P

The fault complaint was that the dew indicator appeared in the viewfinder, followed by shut down. We found that the sensor itself was faulty. When damp its resistance should increase, the reverse of what seems logical! The voltage across it should range from 0V (normal operation) to 5V (dew condition). This one produced 0.3V initially, rising quickly to the trigger level. **D.C.W.**

## Philips VKR6850

The owner complained that there was no playback of recorded sound – he said that a friend who knows about videos had had a look at it. . . The original fault, no recorded sound, was the old faithful one – a contaminated microphone socket switch. When this had been attended to there was audio for recording but the machine didn't record the sound or play back prerecorded sound. Once the case had been

removed the cause was obvious: the audio/control head had been screwed down far below its correct position. **D.C.W.**

## Sharp VLMX7

A new model with an old problem, no functions. The cause was simply failure of the fusible link F901. After replacing it we were unable to find any cause of the failure despite a long soak test and much use.

The optical effects are quite amusing with this dual-lens/CCD package. PIP is available, with other digital effects, to encourage the user. On the servicing side a glance at the manual shows that extensive use is made of digital techniques. Our congratulations to Sharp on the ease with which the camcorder can be dismantled and the reduced number of securing screw types! **D.C.W.**

## Panasonic NVG2B

This one had really taken a tumble – from the steps of an aeroplane at Hinari airport, so the lady said. The optics seemed to be o.k. and some functions worked. There were camera E-E pictures, but no mechanical functions. Investigation showed that the 24-pin connector B6003 had sheared from its normal position. It provides connection to the deck MDA drive systems, hence no mechanical functions.

A new main board would cost around £200 trade. With labour and a few case parts there would be a fairly hefty bill. The customer then let out that she had already received an estimate in excess of £500 from a large service centre. Could I do it for less? I looked at the main PCB with its severed B6003 and concluded that it was worth the risk. The customer agreed that if the attempt to rescue the PCB failed I'd be paid for my efforts (no, I don't work for free!).

A new B6003 connector was obtained and fitted. Some repair work to lifted print was required, but the surgery worked! A microscope is needed for this sort of work (by me anyway). The result of all this was a working camera at a lot less than £500, with still enough in it for me to make a decent profit.

I appreciate that this sort of repair is not viable for a large organisation: but my view is that we're in a service environment, and that to provide a good standard of work at a reasonable cost is an achievable goal. **D.C.W.**

# TV Fault Finding

Reports from Philip Blundell, AMIEIE  
Nick Beer, Mike Leach, Steve Cannon,  
Chris Watton, Michael Dranfield,  
G. Bakawala, Alfred Damp,  
Richard Newman, John Edwards,  
and Chris Avis

## Grundig CUC3300 and CUC3400 Chassis

Poor focus or focusing that can't be adjusted is usually a straightforward fault with Grundig TV sets that have the focus control mounted on the tripler – in most cases the control itself is the cause of the trouble. If the set is fitted with one of the above chassis however and the focus is so bad that the picture can hardly be seen – take care! Remove C433 (1,000 $\mu$ F). If it's marked 16V fit a 25V type instead. The 16V type can go short-circuit, as a result of which d.c. flows through the field scan coils. But instead of the symptom being a picture shift upwards or downwards the result is a full, defocused raster that's dim and impure. While you have the set working the deflection coils are getting hot and there's a risk of cracking the neck of the c.r.t. One to watch out for!

**P.B.**

## Sony KVM2121U

This brand new set arced badly – the vision was severely corrupted and the arcing was being picked up by any set within a mile! The cause, which we've come across before with new Sony sets, was that the e.h.t. cap had not been fitted securely.

**N.B.**

## Sanyo CBP2152

The text TV handset with this receiver didn't function. Cause of the fault was a fracture in one of the legs of the ceramic resonator.

**N.B.**

## Tatung 185 Chassis

There were no signals though the display showed the correct channel numbers. In addition the text display consisted simply of an over-bright P100 and channel changing was sluggish. The cause of the fault was no voltage at the cathode of the ZTK33 33V voltage stabiliser as one of the 10k $\Omega$ , 0.5W feed resistors R005/6 was open-circuit. We replaced them both.

**N.B.**

## Salora J Chassis

In the September issue Michael Dranfield reported a familiar fault with this chassis – excessive height with incorrect chroma phasing (green faces). On this occasion the field output chip was faulty. A far more common cause however is that the field hold control RT400 is noisy. Slight readjustment will usually provide a cure as long as the control is cleaned.

**N.B.**

## Samsung CI537V (P55 Chassis)

The complaint with this set was of intermittently low, unadjustable contrast. I managed to instigate the fault and, having previously decided on the checks I wanted to carry out, was able to make good progress while the fault lasted. The beam limiting and blanking circuits were eliminated simply by lifting the diodes in the respective feeds to the d.c. contrast control line to the colour decoder chip. The

cause of the fault was definitely low voltage on the contrast control line. I was able to confirm this by using an external voltage from the bench power supply instead. This enabled complete control of the contrast range to be achieved. The cause of the trouble was then soon traced to the 12k $\Omega$  pull-up resistor for the d.c. line, on the front microcontroller PCB, going open-circuit intermittently.

**N.B.**

## Philips CTX Chassis

When this set was switched on from cold there was no colour. Then, as the set warmed up, the colour level increased gradually. It reached the point where it was barely adequate even with the colour control at maximum, then varied between this level and zero. The cause of the trouble was high-resistance connections to the TDA3560 colour decoder chip's holder.

**N.B.**

## Samsung CI212R

The audio output from this little portable was at maximum and couldn't be turned down. Checks showed that the microcontroller chip was sending the correct volume up/down signals, but they weren't reaching the audio section. The cause of the fault was that Q119 (2SC1685) was leaky between its base and collector, a replacement restoring normal operation.

**M.L.**

## Matsui 1460, 1660 and 2060

If the fault is no luminance check the KTA562 transistor Q201 before suspecting the TA7698 chip. I've had this fault on several occasions now.

**M.L.**

## Sony KVM2131U

This set was dead with no h.t. from the power supply. A resistance check across the h.t. line confirmed our suspicions that a short-circuit was shutting the power supply down, and in fact the BU506 line output transistor was very much short-circuit. When a new one was fitted and the set was switched on the e.h.t. crackled up for an instant then everything was as dead as before. This time the protection diode across the h.t. line, D611, was dead in addition to the line output transistor. So it seemed obvious that the power supply was producing an excessive h.t. output. We suspected the feedback path from the chopper transformer to power supply chip and checks here showed that the 68 $\Omega$  fusible resistor R606 was open-circuit. When this and the other two items had been replaced the set breathed life again.

**S.C.**

## Finlux 3000 Chassis

There was no sound or picture, with just snow on the screen. Channel numbers were accepted and stored, but with no results. Ti4 on the signals panel controls the tuning voltage, and a quick check showed that its collector supply was



missing. There are two feed resistors on the 30V line, Ri37 and Ri39. The latter was open-circuit. Fitting a new 330Ω resistor put matters right. S.C.

### Toshiba 221T3B

This set had a field fault when cold. At switch-on there was foldover at the top of the screen and several teletext lines were visible. As the set warmed up the display improved until the fault eventually cleared. Time to apply the freezer and fry technique. The cause of the fault seemed to be one of the output transistors, but a replacement left us in the same situation as before. More selective use of the freezer and hot-air gun eventually led us to the 10μF, 35V electrolytic C312. S.C.

### Sony KVX2521U

The fault symptom was no picture. I soon found that there was no first anode voltage at the tube. As its heaters were alight and the e.h.t. rustled up the line output stage was clearly working. So I checked back to the source of the first anode voltage. This brought me to D803 and R807 (1kΩ) both of which were faulty. Replacing them restored a good picture. C.W.

### Matsui 2085

This set was dead. The chassis was very difficult to remove – I had to loosen the fixing nuts and shift the tube over to get the control panel past the c.r.t. lug at the bottom. I then found that the 1.6A fuse was open-circuit and the chopper transistor short-circuit. These items along with the 120kΩ and 150kΩ resistors in the charging circuit and the 100μF, 25V chopper transistor base drive coupling capacitor were replaced. The set then came to life, but after a short time it stopped. This time the chopper transistor hadn't failed. A check showed that the voltage across the mains rectifier's reservoir capacitor was low at 205V instead of 320V. As the rectifiers were o.k. it was clear that the capacitor was open-circuit. A new 150μF, 350V capacitor restored normal operation. I presume that it was the cause of the initial transistor failure. C.W.

### Mitsubishi CT2532TX

This set was dead though the mains input and rectifiers were o.k. and there was 320V across the reservoir capacitor. I decided to check the line output transistor in circuit before delving into the power supply. It gave a short-circuit reading, but was o.k. when checked out of circuit. There was little else to cause the short which turned out to be in the line output transformer, between pins 2 (h.t. feed) and 7 (chassis). C.W.

### Grundig GSC100 Chassis

For field collapse first check that the 18V supply is present at pin 6 of the field output module. If this is o.k. check diode Di447 – this may save you trying a replacement TDA1170 chip. We've found that a 1N4007 is a suitable diode. M.Dr.

### Hitachi C21-P818

This set was stuck in the AV mode, displaying AV alongside the channel no. 21 (BBC-1 here at Buxton). A check at the video input switching chip IC301 showed that the voltage at pin 9 was high: pressing the AV/RGB button

didn't change this state. The switching signal here comes from the junction of pin 37 of the main microcontroller chip IC501 and the 10kΩ pull-up resistor R1569: when this pin was connected to chassis normal operation was restored. So it seemed that IC501 might be faulty. But a similar fault in a different model was caused by the associated EEPROM chip. As this is the cheaper device we ordered it first (be careful to fit the correct one, part no. E740004, as it's programmed). Unfortunately the cause of the fault turned out to be IC501 after all. When the replacement came it was a different type. It was accompanied by details of a modification required – the new chip works with a 5V instead of a 6V supply. M.Dr.

### JVC CS2181EKT

This set had a tuning fault: it would display only a snowy raster though a signal fed into the scart socket was o.k. On investigation we found that there was no output at one of the tuner's prescaler sockets. The prescaler chip inside the tuner is an M54477L, which we couldn't find in any of our catalogues. A call was made to MCES to check whether they could repair the tuner, but we were told that they couldn't obtain this particular chip though they did have the prescaler chip used in other JVC tuners. We had to obtain a new tuner from JVC, at some £40 odd. M.Dr.

### Hitachi CPT2060 (Salora J Chassis)

As this set was dead we replaced CB726 and CB712 (both 4.7μF). It remained lifeless however. Checks in the start-up circuit then revealed that diac DB725 (BR100) was short-circuit. M.Dr.

### Nikkai Baby 10

The complaints with this set were that it switched itself off intermittently and suffered from field bounce on a change of scene. On test we found that the picture was oversized, with bent verticals. A check on the potted regulator chip IC402 showed that its output and input were the same. So a new one was ordered. When this came we found that it had been improved for the better, having a diecast case to improve the heat transfer to the heatsink and a fixing hole so that it could be screwed down tightly. M.Dr.

### Matsui 1440A

The usual causes of a dead set are the STR50103A chopper chip, the SR2M protection diode and the 5-6Ω surge limiter resistor. If you find that they are all o.k., check R502 and R503 (both 330kΩ) and Q108 (2SB698). In one set Q108 was short-circuit collector-to-emitter and R503 was open-circuit. These components are in the start-up circuit. M.Dr.

### Hitachi CPT1444

If the set is dead but the power supply is working check the feed resistors R710 (2.7kΩ) and R713 (2.2kΩ) in the supply to the line driver transistor Q702. The chances are that only R710 will be open-circuit, but replace both resistors and stand them clear of the PCB to improve the cooling. M.Dr.

### Salora J Chassis

This set had a teletext fault: the selected teletext lacked field sync, rolling through the screen. A check showed that the field sync pulses were missing at pin 13 of the SAA5030

VIP chip. Fortunately this chip plugs into a socket. A replacement cured the fault. **M.Dr.**

output at pin 8. The chip itself was faulty – this is becoming quite a common fault. **J.E.**

### **Sony KV2020UB**

A two-inch foldover at the top of the screen can be a problem with these sets. The cure is to replace C559 (0.022 $\mu$ F) and C560 (0.015 $\mu$ F). **G.B.**

### **Toshiba 140E4B**

If the set is dead or intermittently dead check the pins of the line output transformer. The cause of the trouble is dry-joints here. **G.B.**

### **Sony KV1412**

This set was dead and a scope check showed that there were no output pulses from the chopper control chip. Pin 4 read 2.5V but the circuit diagram said 2.9V. Was this 0.4V difference enough to stop the power supply working? The answer was yes. R602 (2.2M $\Omega$ ) was open-circuit. **A.D.**

### **Sanyo CBP2145**

The symptom was that one colour would drop out intermittently. Its cause was on the c.r.t. base panel, where the RGB output transistors are mounted in the same well-known way as the field output transistors in older Hitachi sets. The cure is to resolder the transistors and edge connectors on the board. **J.E.**

### **Logik 4298/Ferguson TX100 Chassis**

For fast tripping go straight for the line output transformer. It's quite a common fault now. **J.E.**

### **Amstrad/Fidelity TVR3**

The TV section was dead. There was h.t. across C306, the mains rectifier's reservoir capacitor, but no output from the STK7348 power supply chip IC301. Before condemning the chip I checked the rectifiers on the secondary side of the chopper circuit and found that D306 (FR304) was short-circuit. It provides the 120V supply for the line output stage. A new diode restored normal operation. **J.E.**

### **Ferguson TX10 Chassis**

The complaint was of a "fizzing noise and lines across the screen". In fact the focus unit was arcing. A replacement cured the fizzing but there was still no line sync and the hold control had no effect. Replacing the TDA2576A time-base generator chip IC741 restored normal operation. **J.E.**

### **Philips 2A Chassis**

Very occasionally this set would shut down and the power supply would whine. A slight tap on the PCB in the line output stage area would bring the fault on. Close examination showed that the tuning capacitor C2609 was dry-jointed. Resoldering this and several suspect joints in the same area cured the fault. **J.E.**

### **Ferguson TX98 Chassis**

This set was dead with 17V at the input to the TDA8138 regulator chip IC11 but no 5V output at pin 9 and no 12V

### **Grundig CUC2401 Chassis**

The customer reported that the set would occasionally switch to standby. This went on for several months. All he had to do was to switch the set back on again, and it could be several weeks before there was a repeat performance. Now however the set tripped off only minutes after being switched on. I replaced the tripler and ran the set for two days as a check. It remained on. As a final check I refitted the original tripler, which brought the fault back. **J.E.**

### **Fidelity AVS2000**

The sound was o.k. but there was no raster because of field collapse. The TDA2270 field output chip IC4 was the cause of the problem. **J.E.**

### **Ferguson TX10 Chassis**

This set came in with a shattered mains fuse. It was no surprise to find that the chopper transistor was short-circuit. A replacement brought the set back to life – until I'd put the back on! The new chopper transistor had again failed. After checking around I found that the cause of the trouble was that R724 (1.2k $\Omega$ ) was open-circuit. **R.N.**

### **Philips 3A Chassis**

This was a rather annoying fault as time was wasted due to an error in the manual. The power supply had shut down but was o.k. as it worked with a dummy load (60W bulb) connected across the 140V h.t. line in place of the line output stage. I found that when the line output stage was connected the protection circuit operated, firing thyristor Ty6698. Checks in the line output stage eventually revealed that the 315mA fuse F1601 was open-circuit. It's in the feed to the EW correction circuit. So I removed and checked the BD678 EW driver transistor Tr7599 which measured leaky. When I looked in the equivalents book for a suitable replacement I discovered that it's a Darlington device – the manual shows it as being an ordinary npn transistor. Thus the transistor wasn't faulty. A new fuse cured the problem. **R.N.**

### **Samsung CI537V (P55 Chassis)**

Strange things happen in this business – apart from the customers. The power supply worked but the set didn't show the standby dash in the display and wouldn't come on. A replacement 12MHz crystal (XF001) restored the display, but when a channel button was pressed the set came on with no line timebase operation. Seconds later it returned to standby. D912, the start-up diode in the supply to the line oscillator, was found to have a high forward resistance of 2k $\Omega$ . Now why would two apparently unrelated faults occur simultaneously? **C.A.**

### **Osume CTV1484R/Nikkai TLG88/89**

There was sound but no e.h.t. and only about 1V of drive at the base of the line output transistor Q111. The line driver transistor Q110 had a healthy input but not much came out at the other end. The unexpected cause was the line driver transformer EM115 whose primary winding read high at 80 $\Omega$ . A check on the replacement produced a reading of 50 $\Omega$ . **C.A.**

# VCR Clinic

*Reports from Philip Blundell, AMIEE, Stephen Leatherbarrow, Eugene Trundle, Brian Storm, Nick Beer, Michael Dranfield, Roger Burchett, John Edwards, Chris Avis, Jeff Herbert and Graham Richards.*

## GEC V4007

This Philips clone had the classic one broken/clogged head symptom. A scope check at the f.m. out test point (pin 3 of plug L6) confirmed that there was no f.m. output from video head one. Cleaning the heads a few times produced no improvement so, as a rough check on the head preamplifier, I injected a signal at pins VK1 and 2 and was surprised that there was again no head 1 output. So the heads were blameless this time! A check through the signal path then brought me to C2001 (22nF) which was open-circuit. Ninety nine times out of a hundred it's the heads that are at fault, but beware of the one in a hundred! **P.B.**

## Toshiba DV90

This machine would play a tape but there was no display and no signals were tuned in during E-E operation. The d.c.-d.c. converter was inoperative because ZL62 (ICP-N10) was open-circuit. **P.B.**

## Sharp VC651H

This machine didn't record. I decided to follow the signal path through the AN3215K video signal processor chip IC201 – the signal enters and leaves at several points. All was well up to pin 19, but there was no output at pin 21 (TP203). The chip itself proved to be faulty, but fitting a replacement revealed another problem – the video heads were badly worn. Some days you just can't win.

It's quite common with this and related machines to find that the sound is being recorded only intermittently. The cause is usually dry-joints on the audio board. You have to unsolder this from the main panel in order to work on it. To complete the job we also solder the wires directly to the erase head. **S.L.**

## Akai VS22

We've had our fair share of these nice machines in recently because of no results. The cause is invariably failure of one of the transistors on the power supply panel. I strongly recommend fitting only exact replacements, otherwise problems can arise. The numerous small electrolytics on this panel regularly fail, producing various symptoms such as dead with localised transistor overheating or display o.k. but no power up. We've had C6 causing interference/patterning and C20 (100µF, 16V) causing no power up. Our policy is to remove and test all the electrolytics on this board. It saves time in the long run as you avoid bounces.

After doing this recently with two of these machines and successfully repairing the power supplies we found that they would both load tapes normally but neither the drum nor the capstan motor operated. There was no rewind or fast forward drive either. In both cases the BU2735AS chip IC503 was the cause. **S.L.**

## Hitachi Capstan Bearings

We've had a lot of trouble recently with gunged-up capstan bearings in Hitachi VCRs. A VTM720 would squeal on

rewind and would intermittently unlatch at odd intervals: the upper capstan bearing was dirty and tight. The same thing with the same effects occurred with a VTM622E. It's not difficult to dismantle the motor to clean and lubricate the upper bearing. Use very thin oil – as much as a gnat might put in his chamber pot. **E.T.**

## Sanyo VHR4350

A couple of these machines developed intermittent loss of drum servo phase lock – the effect is similar to that of dirty heads, but it drifts in and out of the picture. Check the internal jointing and plug/socket connections to the drum motor's PG coil. You have to dismantle the upper and lower drum assemblies to get at the stator PCB. **E.T.**

## Philips VR502

After running for about fifteen minutes this machine lost all TV programmes – it was as if the aerial lead had been pulled out. We found that the voltage at pin 11 of the tuner was being pulled down from within the tuner. A suitable voltage fed to pin 11 from a bench power supply showed that 22mA was being sunk inside the tuner. A new tuner restored normal operation. **E.T.**

## Sanyo VHR3300

The audio/control head stack used in this and similar models wears at a relatively fast rate – we've replaced many of them. Signs of failure are: sound level fluctuation; tape fussiness with respect to servo lock with a machine's own recordings; and intermittent miscounting by the tape counter. The only cure is a replacement ACE head assembly. **E.T.**

## Pioneer VR727/Philips VR6870

Failure of C2011 in the chopper power supply has been mentioned on a number of occasions. Another, nastier failure in the same area occurs when the 6.8V reservoir capacitors C2032 and C2033 dry up. They are both 680µF, 16V. The symptoms are several: the machine may take minutes or hours to come to life after being switched on; all segments in the fluorescent display may light up; or there may be intermittent or no sound in the E-E and playback modes. **E.T.**

## Sharp VC681

When this machine finds a blank portion of tape it switches into the video search mode and quickly skips through until it comes to the next recording. It then reverts to the play mode. We had one of these machines that would remain in the search mode however: the only way to stop it was to press the play button.

The blank detector circuit is centred around the µPC393C chip IC701. It works by detecting the off-tape line sync pulses. All was well at Q701's collector, but although the signal at pin 3 of IC701 changed when a recording was found the signal at pin 1 didn't change. As replacing IC701

made no difference it seemed that R7106 and R7107 at pin 2, the operational amplifier's non-inverting input, were faulty. But their values were spot on. With no faulty component present we could only conclude that the circuit had gone out of tolerance, perhaps due to age. So a modification was called for. After some consideration we decided that the fault could be cured by reducing the voltage at pin 2 by 0.2V. The modification consisted of adding a 470k $\Omega$  resistor in parallel with R7107. A good soak test showed that this had cured the fault.

**M.Dr.**

### **Amstrad VCR9000**

This machine had no E-E or playback sound. A check at pin 6 of IC701 showed that its 8V supply was missing, though there was voltage at the other end of R735. This resistor was o.k., the cause of the problem being that C721 (100 $\mu$ F, 10V) was short-circuit. We fitted a replacement rated at 16V.

**M.Dr.**

### **Samsung VI730**

As the 1.2 $\Omega$ , 0.5W protection resistor (FR101) for the STK5333 voltage regulator was open-circuit the machine was dead. The cause of the failure was a loose fuse clip in the mains plug. The machine had stopped in the partially laced condition.

**R.B.**

### **Philips VR6542**

This machine has a Panasonic deck and suffers from the same mode-switch problems as Panasonic models.

**R.B.**

### **Panasonic NVF65**

This Nicam stereo hi-fi deck wouldn't stop when search tuning, though if you tried tuning in the opposite direction the machine would usually (but not always) lock on a station. So checks were made for sync low and a.f.c. defeat switching at the pins of the demodulator pack. Normally when tuning the a.f.c. defeat voltage changes from 4.5V to 0V. In this case it remained at 2.5V all the time. The MN12C261D front panel memory chip IC7502 is directly responsible for this and proved to be the culprit, a replacement curing the fault.

**B.S.**

### **Panasonic NVJ47**

The mechanism was erratic to say the least: a lot of movement but rarely reaching the play position without sighing to a halt and shutting down. The cause of the problem seemed to be the capstan stator. It had very little torque and emitted strange whistling noises intermittently. When the capstan rotor was removed to gain access to the stator we found that the soldering to the stator coils could have been better. In fact resoldering the stator coils and the Hall i.c.s cured the trouble.

**B.S.**

### **Panasonic NVJ42**

The search tuning fault with this machine was no lock in either direction. Sync low and a.f.c. defeat were normal but because there was no a.f.c. feed from pin 6 of the plug-in demodulator pack the front panel microcontroller chip had no information to work on. Pin 6 of the demodulator pack proved to be the cause of the problem: it was open-circuit to the demodulator pack plug itself. Fitting a new socket cured the problem.

**B.S.**

### **JVC HRD110/Ferguson 3V38/9**

This machine would shut down after attempting to lace up. A new loading belt was fitted but made no difference. The cause of the fault was traced to the after-load leaf switch unit which is mounted close to the loading motor – one of the contacts had broken off.

**J.E.**

### **Ferguson 3V35/JVC HRD120**

As the thermal fuse in the mains transformer's primary winding was open-circuit this machine was dead. Fortunately the pin-outs on the PCB are accessible. So to avoid the cost of a new transformer we added a 250mA fuse externally, soldering it across the pins in place of the internal fuse. The machine then worked well.

**J.E.**

### **Hitachi VT17**

Motorboating on sound during playback was caused by relay RL401 on the audio PCB. Removing the plastic cover and cleaning the contacts provided a cure.

**J.E.**

### **Sharp VCA113HM**

When play was selected the picture appeared for a few seconds in the pause mode then the machine went into the stop mode. The pinch wheel had fallen down its shaft because its internal grip had broken. A new pinch wheel assembly (part no. MLEVF0281GEZZ) cured the problem.

**J.E.**

### **GEC V4005**

This Hitachi clone (VT63/4) suffered from an intermittent very loud knocking noise when playing or recording. Not the capstan bearing this time – too loud anyway – but a worn reel pulley on its pinion. A new clutch base assembly provided a complete cure.

**N.B.**

### **Fisher FVHP520**

The cause of low reel torque can be difficult to find on these machines. We've found that it's usually due to reel spool tyre wear. Cleaning with alcohol and drying will prove the point.

**N.B.**

### **Susumu XR1**

The cause of tape chewing in this Clydesdale supplied machine was a faulty reel idler. It's Panasonic part no. VXP0521. Willow Vale list it and a number of other spares for this model – the mechanism is similar to that used in the Panasonic Model NV370.

There was a second fault however – very poor playback picture quality because of poor screening around the head amplifier. The cause was that some idiot hadn't secured the upper PCB behind the mechanism – the screws were nowhere to be seen and the board was being held down by the lid! It has a spring contact to earth the plate.

**N.B.**

### **Logic VR950/Samsung VI611**

This machine wouldn't play or record – the arms didn't lace up because the pin had dropped out of the sector gear. As a result it didn't move when the main cam did. A new sector gear was installed and the pin, found loose in the mechanism, was fitted into it. The old gear was faulty – the hole for the pin had become enlarged.

**N.B.**

## JVC HR7200/Ferguson 3V29

This oldie had no colour playback with known good recordings and no drum lock or chroma with its own recordings – no prizes for spotting the connection. The fault could be instigated and cleared by touching anywhere on the bottom PCB. We eventually found the dry-joint on one leg of C347, which is connected to one leg of IC402. The leg had a very fine ring around it. **N.B.**

## Osaki VCR33

It didn't take long to find the cause of the fault in this machine – tape chewing due to a faulty reel idler. But the fact that the Panasonic mechanism it uses is similar to that in the NV370 may be of interest since the appropriate VUD kit or individual components are easy to obtain. Don't use the Panasonic pinch roller though – a Sharp unit from Willow Vale will do. The rest of the machine is not of Panasonic origin. The whole lot looks very similar to the Susumu XR1 which was marketed by Clydesdale. **N.B.**

## JVC HRD565

There was intermittent loss of r.f. vision, the symptom being a black raster with weak vision floating through. Wiggling either r.f. lead would instigate the fault or cure it. When I'd dismantled the r.f. modulator/amplifier I found that there was a break in the print between the input plug's vision pin (screened lead) and its first connection about 1.5in. away inside the modulator. **N.B.**

## Panasonic NV870

The only sign of life was an occasional flicker from the display. There was less than 1V on the Reg 5V rail due to a 10 $\Omega$  short to chassis. Several plugs, sockets and links later I reached the operation display board and found that the earthed leg of C6512, which decouples the supply to IC6503, was pushed against the positive leg of the Reg 5V decoupler C6502, behind the digitron. With the leads apart life was restored to the machine. But no channels could be tuned or memorised for several minutes, after which this fault would suddenly clear. The AN5033 tuning chip was temperature-sensitive. **C.A.**

## Panasonic NV370

The E-E picture was marred by fine horizontal lines that varied with the tuning. A.G.C. decoupler C702 on the tuner/i.f. panel was open-circuit. **C.A.**

## Baird 8940/JVC HR7350

No erase or recorded sound prompted a gleeful leap on to the erase head connector, only to find that it had already been bypassed and removed. The cause of the problem was that the bias oscillator was receiving no supply voltage in the record mode because switching transistor Q10 was not being turned on. Its base bias resistor had risen in value from 5.6k $\Omega$  to 53k $\Omega$ . **C.A.**

## Panasonic NVG40

The playback and E-E pictures were intermittent, but the owner said that the machine worked fine on its side! Tapping anywhere on the top main board affected the fault, so I scoped the video signal at input pin 3 of the

luma/chroma subpanel. It was constant here, but at output pin 1 it fluctuated as the panel was flexed. When the subpanel was removed I saw that there were cracks around pins 1 and 2. Resoldering them provided a more permanent remedy that gravity! **C.A.**

## Panasonic NVL25

Very intermittent servo lock caused us a few problems with this machine. It would play all right for hours then, suddenly, the capstan motor would rapidly speed up, causing sound distortion. At the same time the drum speed would go way off lock, the result on the picture being like loss of line hold. The fault would last for about ten seconds after which everything returned to normal as suddenly as the fault had appeared. After much head scratching and component changing we found that the cause of the fault was the STK5392 regulator chip in the power supply. When the fault condition was present the regulated 5V rail rose to 6.2V and became unsmoothed with h.f. pulses on it. Because of the very intermittent nature of the fault it took several days of testing and probing to find the cause. **J.H.**

## Panasonic NVJ35

Playback was perfect, but when record was selected the machine would run for a few seconds then return to the stop mode. L4002, the choke in the l.t. feed to the audio bias oscillator, had gone open-circuit because a solder blob inside the oscillator transformer T001 had provided a short to chassis. When L4002 had been replaced and the solder blob had been removed the record function worked normally. A microcontroller chip pin monitors the bias oscillator: if no oscillation is detected the deck is returned to the stop mode. **J.H.**

## Panasonic NVJ40

No full tape width erase was the trouble with this machine. The symptom was blue and red patterns with new recordings because the chroma from the previous recording wasn't being erased. The cause of the fault was simple. The full width erase head plugs in. During manufacture one pin had bent over when the plug was inserted and thus failed to make contact. With these later type G decks the erase voltage is fed via a ribbon cable across the top of the cassette housing, along with the end sensor supply. **J.H.**

## Sentra VX8400HQ/Alba VCR5000X

Tuning drift is a common problem with these machines. Change D101, preferably to a TAA550 i.c. If you still have problems, remove the glue/gunge from around C133/4/5, also around R158/9/60. The glue becomes slightly conductive, causing erratic drifting – sometimes on one or two channels only! **G.R.**

## Hitachi VT430

The mains input PCB had to be repaired because of damage caused by mains-borne lightning. This got the machine working, but in the play and E-E modes there was a blank raster. Replacing Q3301 – we used a BC640 – restored the playback luminance but we now had weak E-E. Scope checks proved that the i.f./demodulator and p-in-p modules were o.k. The video was traced to pin 7 of the LA7016 chip IC1501, but there was very little output at pin 4. Replacing this chip cleared the final fault. **G.R.**

## Panasonic NVM3B

This one was o.k. until you switched it off! All the normal functions worked: play, record etc. were fine. But at switch off things went seriously wrong. It would eventually switch off, but after several attempts R20 (2.2Ω, 1W) would burn out. This resistor is in the 12V supply to the loading motor drive chip IC6004. By connecting an ammeter in series with the supply we found that at switch off the current drawn by the loading motor was greatly in excess of the normal value. Hence the burn out of R20.

The clue was the fact that the excess current was the cause of the unit shutting down: it triggered the excess-current circuit in the power supply. The cause of the problem was an open-circuit link-through from one side of the PCB to the other. As a result the syscon micro was robbed of its supply when switch off was attempted. It reacted by driving the loading motor hard in the unload direction. The moral is that when extraordinary symptoms are present, look for all possible clues. In this particular case the clue was provided by monitoring the micro's 5V supply. D.C.W.

## Sharp VCC10P

The colour was erratic in the camera mode, with bent verticals and intermittent picture roll. Playback was o.k. The customer said that if you hit the camera the fault cleared. And it did! The cause of the trouble was a dry-joint on the camera video board, where the sync subpanel is connected. It took rather longer than it should have done to find the dry-joint, because a touch almost anywhere produced the fault. D.C.W.

## Philips VKR6830/JVC GRC7E

The customer complained of no functions, and indeed absolutely nothing worked. An internal inspection showed that the cause of the problem was a common one – water! Why don't they tell us they got it wet? Carefully cleaning the operation PCB restored most of the functions, but after a short period they ceased. There was a further contaminated area on the MDA PCB. Except for these two areas everything else had been spared the flood effect.

I always give equipment that has suffered in this way an extended test run. This hopefully avoids the possibility of a further failure. As a general rule, if the fault produces various unexplained symptoms look for an ingress of liquid. When asked, the customer invariably "remembers" the circumstances of the accident! D.C.W.

## Canon VME70E

This camcorder had been dropped. There was only slight cabinet damage, the complaint being of tape chewing. The cassette housing had suffered slightly, but this responded to some metal work. The mechanism seemed to work all right, at least without a tape. When a tape was inserted and the play button was pressed pictures were obtained. No incorrect tape path effects were apparent. The record mode also worked correctly.

I left the machine running in the LP play mode and got

on with some other work. Shortly afterwards a scrunching sound from the direction of the VME70E drew my attention. The tape had ridden up the capstan shaft and was about to jam against the guides – I managed to get to the stop button just in time. After some observation it became clear that the fault occurred only at the start of transport when a rewind cassette was laced up and moving. I subsequently found that the cause was the fact that both helical-wrap guide pole securing screws were loose. Tightening them and checking the tape path for correct operation cured the fault. Both screws loosened by a fall? Well I never! D.C.W.

## Ferguson 3C03/JVC GRC7E

The reported fault was no record or playback colour. E-E colour was o.k. The customer said that it happened after "winter storage". Unfortunately the fault is quite common with this model: it's unfortunate because of the high cost of IC10, which is almost always the cause of the problem. Check carefully around IC10 on the YC PCB for other possible causes, but be prepared to replace IC10. After replacing it a complete chroma set-up is advisable. D.C.W.

## Sony ACP88

This worldwide camcorder charger/power supply unit is quite expensive to replace but is eminently serviceable. This one was dead, with fuse F101 (1.25A) black. Not surprisingly the 2SC3457 chopper transistor Q101 was short-circuit all ways round, but the cause was a dry-joint on the reservoir capacitor C105 – the big black one. Its positive connection had obviously been arcing. N.B.

## Sanyo VMD3P

You may recall that I wrote about failure of the silver-can, surface-mounted electrolytic capacitor in position C4011 in the system control circuit in this model. More recently this type of capacitor has been failing everywhere. With this particular machine there was loss of vision in the pause/cue and review modes because C1095 (10μF) had fallen in value. When all the other capacitors of the same type were checked I found that the vast majority of them were physically leaking. I ended up replacing the lot in the VCR section. Imagine the problems that this will cause if the trouble is widespread, with electrolyte leaking all over the densely packed PCBs. And they smell awful when you heat the area with an iron! N.B.

## Sanyo VMD6P

This camcorder came to me from Australia (some reputation, eh?). The problem was that a cassette was jammed inside and the loading motor could be heard running. When I dismantled the unit (watch the plugs and sockets which connect the assemblies to the cases) I found that two out of the four loading gears mounted on the loading motor bracket had damaged or missing teeth. A new set of four gears was fitted. I've since had several others in with the same problem. N.B.

# Battle with a Solavox VCR

Dave Mackrill

"It won't play at all now" complained the lady owner, "and it had been going so well." The machine was a Solavox Model NCVR5000. When I unscrewed the case the machine looked like certain Sentra and Alba models, and I noticed a familiar Panasonic 777-type reel idler.

I loaded a cassette and, guess what? – the machine played perfectly. So I left it playing while I sorted out another machine. When I returned to it the test tape was almost at the end. I pressed rewind and left it running, but it stopped sooner than I expected. This time the tape was right at the end. Thinking that I must have selected fast forward by mistake, I pressed rewind again. Nothing happened. I ejected the cassette, loaded a different one and pressed the fast forward button. As the tape wound forwards normally I stopped it and once more selected rewind. The machine had other ideas however: it still wound forwards!

## Fault Finding

I managed to borrow a service manual from Vic down the road. It bore the model number VCR-30DAP but no brand name. The "servo-logic" PCB is under the PIF (tuner/i.f.) PCB on the right-hand side. After consulting the "U501 logic circuit" I eyed with suspicion the PU4310 reel motor drive chip IC606, which is near the rear heatsink. I decided to start at the other end however and stuck my digi meter across pins 7 and 8 (see Fig. 1) of the large MN1522-0231 microcontroller chip IC601.

As expected, in fast forward I got a positive voltage at pin 8 with respect to pin 7. In rewind however there was a positive voltage at pin 7 with respect to pin 8 but it was only about 2V instead of the 3-8V shown on the circuit diagram. When I checked from pin 8 to chassis in this mode the reading was over 1V instead of zero or 0.1V.

I disconnected the 10k $\Omega$  resistors R636 and R641 that apply bias to the KTC1815 polarity switching transistors Q609 and Q610 and checked the voltages again in both

modes. This time the voltages at pins 7 and 8 were normal, the appropriate pin being pulled up to the positive supply line voltage by R663 or R664 when the other one is taken to zero or 0.1V by the switching action of the chip.

Q609 is obviously leaky I thought as I unsoldered and removed it. But no, it was o.k. Maybe something was wrong with Q610 then. It tested o.k. however. I refitted the transistors, reconnected R636 and R641 and then unsoldered the control pins 2, 4, 6 and 8 of the reel motor drive chip IC606. This made no difference. Lots of other tests on components and sections of the circuitry were then carried out, proving conclusively that IC606 was blameless. I finally removed C606 (0.01 $\mu$ F). Bingo! It had a 7k $\Omega$  leak. I then checked C607 which read 17nF instead of 0.01 $\mu$ F on the capacitance meter.

To be on the safe side both capacitors were replaced with nice new 0.01 $\mu$ F, 350V types. Fast forward and rewind were then o.k. but a bit sluggish. So a new reel idler was fitted. A deck service completed the repair.

## Chewed Tapes

This was not to be the end of the story however. A fortnight later the machine was back with two damaged tapes. Why always two? I checked fast forward and rewind, and the take-up torque in the play mode. As the latter seemed slightly weak the idler was again changed. This improved matters a bit, but I was still not happy.

Suspecting the reel motor, I noticed that it was a special "fat-looking" type. The day was saved however when I discovered that the manual mentions a "reel motor current" (torque) adjustment. So I connected the meter's positive lead to TP601 and its negative lead to TP602, i.e. across the 1 $\Omega$ , 1W reel motor and drive circuitry current sampling resistor R644 on the servo-logic PCB, put the machine in the still mode and adjusted R649 for a reading of 190mV.

This must be a sort of "quiescent current" state. At last I

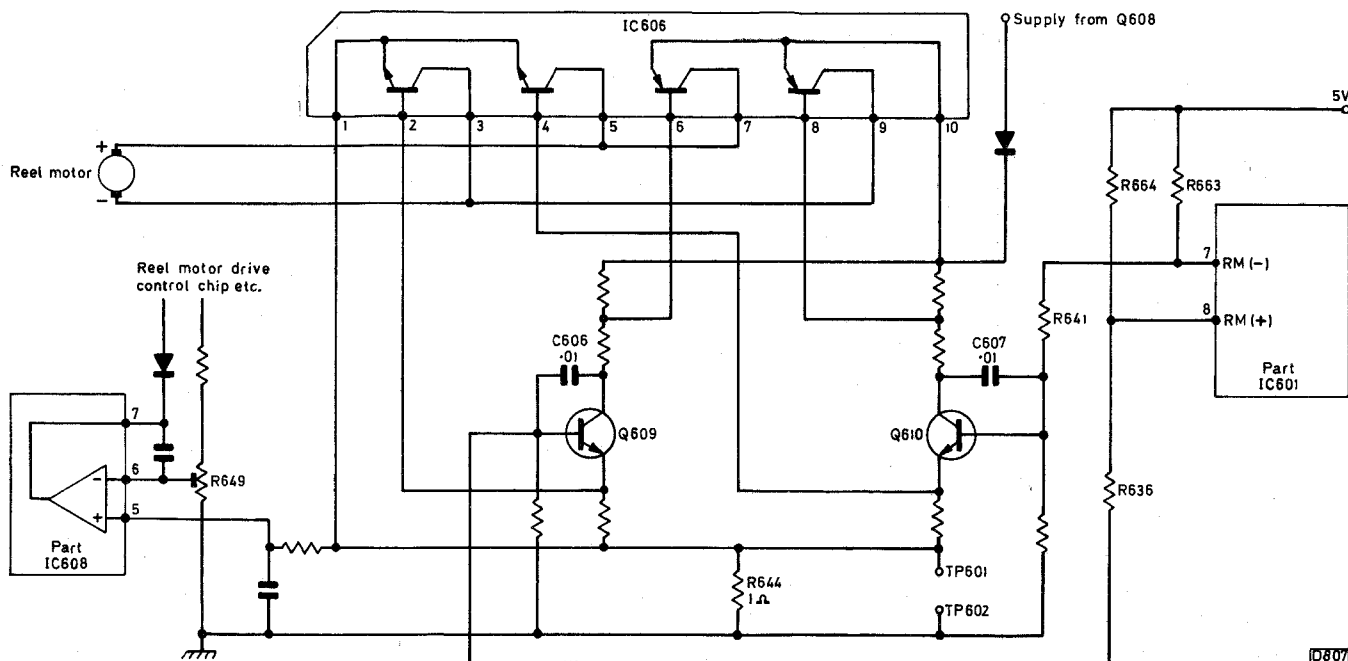

Fig. 1: Reel drive circuitry used in the Solavox Model NCVR5000.

was rewarded with good take-up torque plus powerful fast forward and rewind. Potentiometer R649 is at the right-hand edge of the board and can be tweaked without removing the tuner/i.f. panel.

Presumably the reel motor had been a bit tired after all the excitement, though its spindle seemed free enough. Or perhaps its commutator had become sooty. So I made a note to warn the owner that a replacement motor might be needed before very much longer.

As the two damaged tapes were new I cut out the mangled

sections, unwound the tape back to the take-up spool leaders and respliced them. The lady was pleasantly surprised to get them back, albeit with labels attached warning that they were no longer three-hour cassettes.

**Editorial note:** The Mauritron Technical Publications *Video Recorder and Camcorder Equivalents* book MTP-143 lists the following equivalents of the Solavox NCVR-5000: Nikkai NVR-500RC; Sentra GX8000; Alba VCR3000X, VCR4000X and SVC7414.



## GoldStar GHV1240I

This machine produced an unstable E-E picture, with poor sync, white crushing and bright psychedelic colours. The cause, as is usually the case, was the 1 $\mu$ F a.g.c. reservoir/decoupling capacitor, in this case C715. It was open-circuit. **E.T.**

## Akai VS23

This machine has a rather complex power supply, with a mains transformer, chopper circuits and voltage doublers. One of the more obscure faults that arises in this area is partial failure of C6 (220 $\mu$ F, 10V). The symptoms are wavy horizontal bars (like r.f. interference) across the picture and on-screen captions and intermittent colour in the E-E and playback modes.

It's worth noting that if the audio/preamplifier PCB behind the drum isn't earthed the syscon shuts the deck down within a few seconds in all modes. Beware of this! **E.T.**

## Tatung TVR6111

We do a lot of Tatung servicing and have on several occasions come across the following fault: the reel drive intermittently fails to engage when fast forward or rewind is selected. If you get this symptom, check that lever trigger 260 is free to slide along brake plate 261. If it's stiff, the metal stop for the brake plate (formed from the deck plate) needs to be bent very slightly to the right as you view the underside of the deck from the front. The numbers quoted above are taken from the exploded deck diagram in the service manual. This machine also appears under the Amstrad banner. **E.T.**

## JVC HRD150/Ferguson 3V45

The play symbol, a dotted triangle, was lit up the whole time the machine was switched on, whether or not the play mode was engaged. It was caused by leakage between pins 4 and 5 of the fluorescent display PCB. Someone must have managed to spill liquid through the cassette loading slot! Thorough scrubbing with surgical spirit removed the conductive deposit in this very high-impedance circuit. **E.T.**

## Sharp VC381

Misalignment is becoming a common problem with older VCRs. Realignment usually provides a lasting cure, making repairs justifiable. This particular example suffered from intermittent playback chroma. When the colour was present there was patterning on it. The cure was to reset the carrier peak adjustment slightly. In the record mode there was no picture because the dark clip was misadjusted. **N.B.**

## Granada VSHX3/Hitachi VT8700

This old timer had been bought for £50 at a sale. There are still plenty of them about! The customer said that it

wouldn't play. On test there was no vision in the E-E mode – that's right, there were dry-joints in the i.f. can. It was the first time in years I've had that one. Next the supply guide post was missing, then the loading belt and the spool tyres were duff. After sorting that lot out and setting the machine up I found that it worked very well. An interesting point was that it had a large safety test label on the side from the previous day – presumably all electrical items in the sale had been tested. **N.B.**

## Mitsubishi HS330

The complaint with this machine was that the sound would vibrate when the machine had warmed up. Having tested the machine for ages and heard no "vibration" I questioned the customer to find out whether she meant wow and flutter, which is not uncommon with this model. Not so. It seemed to be a buzz. So I had a poke around and had success – a buzz appeared on the playback sound. Its cause was traced to a dirty connection between the copper-coloured spring metal that earths the top of the cassette housing and the regulator heatsink. A clean and retension cured the problem. **N.B.**

## Ferguson 3V54/55/57

Here's a trap for the unwary, like me. The VCR owner's house mains supply earth leakage trip had operated for some reason. When it was reset, the VCR was stuck in the aux mode. Embarrassment prevents a description of our efforts to restore sanity to the confused microcontroller chip and ourselves until a wiser colleague advised us to press the recessed "ch set" button. **C.A.**

## Hinari VXL5

Two non-working, ex-rental machines we'd purchased had the same fault – when play was selected the tape laced, the drum ran very fast then the tape unlaced. The cause of the trouble was that the 6V supply to the drum feedback amplifier IC104 was very low as C145 (100 $\mu$ F, 10V) was short-circuit. We used a replacement rated at 16V. **C.A.**

## Ferguson 3V54/55

We purchased a quantity of 3V54 non-remote control machines for reconditioning as the preferred 3V55 remote control version wasn't available at the time. It surprised us to find that infra-red receivers were fitted, though the machines would respond only to manual operation. When we traced the signal path from the IR receiver's output we came to a link, which had been cut, next to connector CN402 on the small eject-tracking PCB PC1614/1626. When the broken link is replaced the 3V54 becomes a fully remote-controlled 3V55! **C.A.**

## Hitachi VT64

Playback was all right but when record was selected the drum and capstan failed to rotate though the record indicator

lit and the tape laced up briefly before unlacing again. We found that the record/play switching voltage double-diode block D626 was open-circuit on the record side. By coincidence we found a similar faulty device recently in the sound section of an older Hitachi machine. In both cases a couple of good old 1N4148 diodes wired in back-to-back proved to be a suitable replacement.

C.A.

### Sentra VX8100HQ/Samsung VI710

For no erase replace transistor Q0501. It's a 2SD261 and no other transistor will work in this position! The cause of its failure is the erase head going open-circuit intermittently because of the plug/socket arrangement. Remove this and solder the lead on directly. How many more types of VCR will need this modification?

G.R.

### Hinari VXL8

The problem, because of mains-borne transients, was no E-E operation, no channel changing, cannot program etc. with just the letter E in the display. Unsolder the back-up capacitor for thirty seconds then reconnect it. Switch on and the microcontroller chip should recover from its crash. We've had this more than once and the routine has worked each time!

G.R.

### GoldStar GHV1248I

The E-E pictures were pulling, with ragged edges, more so on some channels than others. Attenuating the input signal (via the aerial lead) established that it was an i.f./a.g.c. type fault – in fact the symptoms were identical to those you get with some CUC series Grundig TV sets. Replacing C715 (1 $\mu$ F, 63V) put matters right. We assume that it provides a.g.c. smoothing but as we don't have the manual we can't be sure.

G.R.

### Alba VCR6000X/Sentra VX8400

As mentioned by Nick Beer in the January Clinic these machines very often suffer from tuning drift. Decoupling capacitors C133/4/5 for the VT line are prone to being leaky. In addition hardwiring the VT line to cure leakage will indeed provide a cure. But the reason for this tuning drift isn't leakage between the print tracks: it's caused by leakage on the component legs themselves! – around C134. The problem is caused by the quantity of glue that's put around the components in this area of the PCB during manufacture (top upper left-hand side with the board hinged up). I suspect that this glue absorbs moisture and then slowly becomes conductive. Thus rather than hardwiring it's easier and quicker to remove this glue and replace C134 (0.1 $\mu$ F). The  $\mu$ 574 33V regulator on this board can also be the reason for tuning drift.

G.R.

### Panasonic NVJ42

Although this machine would accept a cassette it was difficult to get the cassette back and the mechanism spooled backwards and forwards a great deal, rarely performing any function correctly. Checks soon showed that the solenoid which engages the mechanism was operating erratically. Instead of a satisfyingly solid clunk when the operation buttons were pressed only an anaemic click was heard. The solenoid drive system has two parts, a kick and a hold circuit. D603 in the kick section was open-circuit, a replacement restoring normal operation.

B.S.

### Panasonic NVF55

I seem to get more than my fair share of search-tuning faults. This machine would search but wouldn't lock on to stations. Checks on the sync low, a.f.c. defeat and a.f.c. feeds showed that there was nothing amiss to and from the demodulator pack, so out came this plug-in pack, revealing a surface-mounted diode (D6701, type MA151WK) with one end missing. A replacement cured the problem.

B.S.

### Ferguson FV31R

This machine had a nasty habit of breaking its back-tension arm as the deck mechanics mistimed themselves, no matter how carefully the instructions in the manual were followed. We noticed that when the machine set off in play the drum motor didn't rotate. This turned out to be a vital clue. The drum stood still because the 5V supply to pin 2 of chip IM02 was missing. From a look at the circuit diagram this appears to be totally unrelated. The PCB layout holds the clue: the link that supplies 5V to IM02 also supplies the pull-up resistor RT67 in the mode-sensing circuit, the cause of the trouble being a dry-joint on this link. With the dry-joint resoldered and the deck mechanics realigned yet again everything worked correctly. All that was left to do was to fit a new back-tension arm.

A.D.

### Ferguson 3V44/JVC HRD140

The drum and the capstan were both running slowly. A check on the servo reference signal, using a frequency counter, showed that it was running at only 2.5MHz. The cure was to replace the 4.433MHz crystal in the chroma circuit.

A.D.

### Matsui VX3000

The complaint was of loss of tuning overnight. On the bench however no channels could be tuned in. R6045 (33k $\Omega$ ) was open-circuit.

A.D.

### Akai VS22

The problem with this machine was a bad hum bar on the E-E pictures. We found that C4 (47 $\mu$ F, 25V) on the power supply PCB was leaky.

A.D.

### Hitachi VTM722

The E-E audio was low and distorted while playback of a prerecorded tape produced only a cyclic chirping sound. We found that the always 9V supply to IC401 was low at only 4.9V because zener diode ZD854 on the power board was short-circuit.

A.D.

### Toshiba V83

The capstan motor was clearly running too fast. A check on the drive voltage showed that it was high at about 10-11V instead of 6.7V. Checks around the servo chip IC501 showed that although the voltage at pin 14 (capstan a.p.c.) was correct at 3.3V the voltage at pin 15 was only 0.9V instead of 3.3V. Scope checks at pins 19 and 20 (CTL in and out) showed that the control pulses were of correct amplitude though the frequency was of course high because of the excessive tape speed. The tracking input at pin 28 varied the length of the waveform, so all seemed to be correct here.

The next check was on the FG pulses at TP518. The waveform here had gaps in it and varied a little in amplitude. Unfortunately I ignored this, putting the irregularity down to the motor's increased and wowing speed. Wrong decision! So after replacing IC501 and finding that the fault remained as before I had a closer look at the FG pulses. When I dismantled the capstan assembly I found that the coil which forms the stator of the pulse generator was dry-jointed at the point where the enamelled copper wire is connected to the terminal. **C.W.**

### **Amstrad VCR4600**

This machine was dead with the 2A fuse F603 open-circuit. I checked the rectifiers in the main power supply and as they all read o.k. a new fuse was fitted. It blew only a few seconds after switching the machine on again. The cause of the fault turned out to be C836 (3.3 $\mu$ F, 35V) which is in one of the voltage regulator circuits on the main servo/system control panel. **C.W.**

### **Logik VR950/Samsung VI611**

This machine came to us with the infra-red sensor broken and the loading arms flopping about all over the place. The owner said that she'd tried to remove a jammed cassette and had damaged it in the process. What in fact appeared to have happened was that the nylon gear sector – it's the fan-shaped bit on the loading mechanism – had split where the steel pin is located, allowing the pin to slip out. Hence the looseness of the loading arms. A spot of Superglue was all that was required to repair the infra-red assembly. A new gear sector and pin – they are separate items – had to be ordered from Mastercare.

Imagine our surprise when, a few days later, the postman delivered two packages from Mastercare, one a box containing the gear sector, the other a jiffy bag containing the pin! Anyway fitting the parts and removing a thick ring of oxide from the capstan restored normal operation. **E.R.**

### **Saisho VR1200HQ/Matsui VX820/Hinari VXL35**

Failure of Q02, type 2SD1207, is common with these machines. We find that a TIP41C with a heatsink is a reliable replacement. **J.R.C.**

### **Hitachi VT150**

This machine is almost the same as the VT130 but has long play. The problem was a tape stuck inside, no functions and no eject. Whilst checking around we found that the M54649L loading motor and cassette lift motor control chip IC902 was very hot. As both motors ran when powered from a separate d.c. supply we replaced IC902. Unfortunately this made no difference. Voltage checks then showed that the 12V supply at pin 9 was very low at 0.5V. It's worth noting that this chip has two 12V supplies, one at pin 7 for the internal logic and one at pin 9 for the high-current motor drive.

Tracing back from pin 9 brought us to the power supply where IC851 had 18V at its input but no 12V output. Although the power supply panel looks the same as that in the VT130 the regulator chip is different – type STK5476. This is a 12-pin device with only pins 1-10 used. We didn't have one in stock though we did have the STK5471 as used in the VT130. When we removed the STK5476 we

found that the heatsink was drilled with two sets of holes. The smaller 10-pin STK5471 was quickly fitted to the heatsink, restoring full operation. Could the STK5476 have been fitted because of a shortage of the other type of regulator? **M.Dr.**

### **Hitachi VT7000**

This two-part tuner-timer/VCR came in with the symptoms of a dirty head. Cleaning this appeared to cure the fault but when a recording was made and played back nothing but snow and sound had been recorded. After borrowing a service manual we found that the record 9V supply at pin 8 of the TA4190 chip IC205 was very low at only 1V in the record mode. The source of this supply was traced to a small relay, RL402, on the bottom PCB. There was 9V at the input to this relay but no output. As we couldn't find a relay with the same pin connections amongst our scrap panels we decided to try cleaning the contacts of the old one. We used an Electrolube contact cleaning strip that's specially made for this type of job. It provided a complete cure and after a long soak test the machine was pronounced fit again. **M.Dr.**

### **Toshiba V71**

As a new reel motor failed to restore reel operation we started to make checks in the drive circuit. The conditions at the fast forward and rewind selection pins of the TA7267P motor drive chip IC603 were correct but there was no motor supply at pin 3. Replacing this i.c. cured the problem.

For reference purposes note that in the rewind mode pin 7 is at 12V, pin 6 drops from 12V to 5V then returns to 12V, pin 5 changes from zero to 0.7V, pin 4 is the chassis pin, pin 3 changes from zero to 5V for a couple of seconds then rises to 10V, pin 2 changes from 5V to zero and pin 1 stays at 5V. In the fast forward mode the voltages are the same except that pin 2 remains at 5V and pin 1 changes from 5V to zero. It's not uncommon for the reel motor or IC603 to fail, so the above readings may be of help in deciding which item to blame if you don't have the manual. **J.E.**

### **Akai VS105**

Everything worked correctly except eject, the problem here being that the cassette came out flush with the front panel and couldn't be gripped. All the mechanical functions are set in motion by a motor which drives the main rotary cam beneath the deck via a plastic toothed belt and worm pulley. The carriage up/down lever is driven by a groove in the rotary cam. It was not travelling far enough to push the carriage all the way up, i.e. to eject. When the metal plate that covers the rotary cam was removed we saw that there was a split across half the width of the cam. Replacing the cam and retiming the mechanism cured the problem. Only the eject mode was affected because the other modes used the good portion of the cam. **J.E.**

### **Ferguson 3V44/JVC HRD140**

This machine wouldn't accept a cassette. As the power supply circuit protectors were intact we turned our attention to the carriage assembly. The cassette could be loaded manually, after which all functions such as fast forward, rewind and play worked normally and the cassette was ejected correctly. We found that the cause of the problem was the leaf switch at the right-hand side of the carriage assembly. All was well after fitting a replacement. **J.E.**

## Panasonic NVMS2B

This camcorder would play back a tape quite normally if the record tab was removed but a virgin tape would be greeted with high-pitched whistling that drowned out the sound track. In these machines the tab switch enables Q6003, which then feeds 9V to various places including the 2SB1219 transistor Q4005 that produces the delayed 9V record voltage. The problem was that Q4005 was passing about 2.5V to the record circuits even when no switching voltage was applied to it. A replacement cured the fault – it's a surface-mounted device. **B.S.**

## Panasonic NVMC5

This rather elderly camcorder came in with a request for an estimate for head replacement and a service. Despite the machine's apparent age the mechanism was clean and sparkling, with no signs of wear and tear. When our test 'C' cassette was played back however we found that the output from one head was missing. As I suspected, replacement heads produced no improvement. So attention was turned to the head amplifier pack and the flexible connector from the drum to the pack. Removing and resoldering the connecting pins cured the fault completely. **B.S.**

## Panasonic NVMC20

This camcorder was accused of bloody-mindedness: it would sometimes refuse a tape, just ejecting it then leaving the cassette door open! It performed beautifully on test of course, showing no inclination at all to misbehave. After a call to Panasonic a nice man called Phil assured me that a replacement mode switch would cure the problem. It's part no. VES0416 and did the trick. **B.S.**

## Sony CCDF340E

The symptoms were no sound and intermittent VTR functions. Neither fault was difficult to cure. The no sound fault was cured by replacing the microphone preamplifier chip IC585. A damaged flexi board was the cause of the intermittent VTR functions (how do they get damaged?). **D.C.W.**

## Ferguson FC28

The fault report said "won't always switch on and, when working, won't always switch off". I thought that this was probably a mechacon reset problem but inspection revealed nothing more than a faulty power switch (SW617). Note that with these machines the response to a selected mode, e.g. power on/off, play etc. is not always instant – a sort of "soft" response to commands is often evident (or is it me?). **D.C.W.**

## JVC GR65E

No autofocus was the problem with this one. The motor assembly proved to be at fault, with a jammed gearbox. The initial drive from the motor is via a belt that's connected to a reduction gear (a sealed unit). It was this item that had failed, possibly because the slipping clutch assembly, which

is the final part of the autofocus drive to the lens assembly, was locked tight and was unable to slip when required. Manual focus adjustment probably caused the gearbox failure. **D.C.W.**

## Sony CCDF450E

I suppose we all get caught out sometimes by diving in too deeply. The symptom with this machine was intermittent playback functions, including fast-forward/rewind search. Recording was o.k. After some abortive in-depth investigations I discovered that the power switch (camera/player) made intermittently poor contact in the play mode. A replacement put matters right. **D.C.W.**

## Panasonic NVMS1

Sound recording via the microphone was o.k. when listened to using the headphones but there was no output from the A/V out connector (the picture was o.k.). Playback sound was also available only via the headphone socket. The cause of the trouble was that the 2SD1328 audio mute transistor Q4013 was short-circuit emitter-to-base. Note that it's mounted at the opposite end of the main PCB to most of the audio circuitry. **D.C.W.**

## JVC GRA30E

Two of these came in at the same time from the same source with the same fault – no functions, with the emergency mode indication E01 in the viewfinder. This means that the 8V supply is missing. Amongst other uses it appears as the r.f. unit supply at the AV output socket. The cause of the trouble was a faulty AV lead, which had been tried with both cameras. Unfortunately there's no fuse in this line to protect the main d.c.-d.c. converter. So two converters had to be replaced, which was a costly exercise. In view of the fact that it's an easily produced fault it is surprising that better protection wasn't incorporated. **D.C.W.**

## Sony CCDV88E

This machine would shut down intermittently in the play mode and just sit there looking at you. Careful inspection at the instant of failure revealed that just before the shut down occurred the capstan motor's speed rapidly increased. We decided to investigate the capstan FG circuit and found a dry-joint at pin 16 of IC503, the capstan FG waveform shaper. **D.C.W.**

## Fugix M890

This machine is a clone of the Sony CCDTR75E. The problem was an intermittent trigger button – the sub-trigger button worked all right. Unfortunately the trigger button switch is available only as part of the complete control assembly, which includes wide/telephoto toggle, play, record, pause etc. and all the operation keys. A replacement is costly, especially when only one key function has failed. **D.C.W.**

## Panasonic NVG101

This camcorder was reported to be dead. When it was switched on or eject was pressed nothing happened. The cause of the problem was soon traced to the fact that the reset at pin 20 of the system control chip IC6007 was low at 1.5V instead of momentarily dropping to zero then rising to 5V. We suspected the small reset generator chip IC6003 and confirmed that the fault was in this area by removing it from the PCB then, shortly after connecting the battery, connecting pin 20 of IC6007 to the 5V line via a suitable resistor. The machine then attempted to work, but as the PCBs weren't connected to the mechanism it just flashed the power on LED as a warning signal.

A new reset generator chip was fitted but the fault was still present. A check on the resistance between the reset line and chassis produced a reading of 1.5k $\Omega$ . When pin 20 of IC6007 was disconnected from the PCB the resistance reading remained the same. The only other component connected to this point is the 0.1 $\mu$ F capacitor C6017 which had developed a leak. With this capacitor loading it down the reset chip couldn't pull the line high enough. **I.B.**

## Sony CCDV8

The fault with this machine was loss of playback ATF servo action: the picture would appear then disappear into noise cyclically. A check at output pin 25 of the ATF servo chip IC106 showed a movement of only 200mV from the nominal d.c. level of 2.6V. When we checked around the input and low-pass filter areas of this chip we found that an h.f. signal was present up to pin 8, which appears to be an input to an amplifier stage. But there was only a very low output at pin 12, which feeds the two bandpass filters. An identical signal to that at pin 8 was present at pin 9, which is connected to chassis via the 6.8 $\mu$ F surface-mounted tantalum capacitor C200. This capacitor was open-circuit, a replacement restoring normal operation with a 40mV peak-to-peak input signal at pin 8 of the chip and a 2V peak-to-peak output at pin 12. **I.B.**

## Panasonic NVMS4

This was my first glimpse of the new all-singing, all-dancing full-size Panasonic Super VHS camcorder, an imposing beast. But it appeared to have dirty heads. In my experience the cause of a fault like this with a new camcorder is always a duff direct-drive motor assembly. Nevertheless I did try to clean the heads, but to no avail. I also tried replacing the heads, then placed on order a VEG0889 DD motor while I played with all the new and exciting buttons on the camera section! **B.S.**

## JVC GR323E

This camcorder had been dropped and wasn't the better for it. The reported fault was 'no functions with a scraping noise'. The cause of the scraping noise could be seen when the case had been removed: the impedance roller/guide assembly was in contact with the upper drum. Once this had been sorted out all functions seemed to work correctly. After the usual checks we reboxed the camcorder and put it on soak test.

All was fine until stop was selected whilst in the play

mode: the mechanism then decided to shut down. After several attempts to resume operation had failed, the casing was once more removed. Then, at switch on, all functions had been restored! We noticed that there was a slight nick in the ribbon cable that connects the lower drum to the main PCB. Only one connection was damaged – drum motor Hall effect to the motor drive amplifier. If this connection goes open-circuit whilst in the play mode there is no effect, but when stop is then selected it's impossible to return to the play mode because the drum motor won't rotate. The nick in the ribbon cable had been caused by the fact that the impedance roller assembly tension spring had become detached and had punctured it. To avoid the cost of a replacement lower drum and all the extra work involved the cable was repaired. **D.C.W.**

## Sony CCDV88E

The report with this one said that it played and recorded all right but would go into the caution mode after rewinding a tape to its end. All functions remained available if the tape was only partially rewound. Now the caution mode is effectively a shut-down situation, with the caution LED flashing and no user functions available. To restore the functions to the previous state the camcorder has to be switched off then on.

The cause of the problem was an open-circuit cassette LED, D991, which is normally required only for tape-end detection. The fact that it's open-circuit won't be evident until the missing tape-end signal is detected. This differs from the effect that a similar failure would produce in a mains operated machine. **D.C.W.**

## Mitsubishi HSC40B

This C format machine has a full-sized drum, with results to match. The fault report was of wow on sound. Sure enough a wow was discernible when we played the relevant JVC test-tape section. A scope check on the audio signal showed that the problem was more of a random change than a regular change of frequency. As a first step we removed and inspected the capstan motor: everything seemed to be in order here – the bearings were o.k. and no sticking or slackness was discernible. After refitting this we cleaned the tape path as a precaution and checked the tape path tensions. It was immediately clear that something was wrong in the back-tension department – in fact there wasn't any back tension at all! The tension adjusting screw had become slack, causing the rather unusual symptom. Resetting it to provide the correct tension completely cleared the trouble. We locked the screw with a suitable sealant. **D.C.W.**

## Sony CCDTR55E

Playback was fine but there were no camera pictures. This was because the iris return spring had become detached and the vanes were stuck in the closed position. Dismantling the lens unit is quite straightforward, and cleaning and refitting the iris parts is not too time consuming. There are only two vanes to refit: this makes it rather easier than with the three-vane variety whose washers and retaining plate always seem to move out of place at the slightest touch. **D.C.W.**

anything was amiss I decided to replace the 14DN363 servo chip IC402. This cured the problem and cleaned up the waveform. **R.N.**

### **Ferguson 3V54**

If the capstan motor appears to run through with no control pulses present at the control amplifier, check the condition of C405 on the main PCB. You will probably find that it's either dry-jointed or open-circuit. **M.L.**

### **Sanyo VHR1100E**

This machine chewed tapes whenever stop or eject was selected. The tape was not being wound back into the cassette. We replaced the idler and checked the condition of the loading motor, but the VCR came back into the workshop two or three times before we finally traced the cause of the fault. When stop or eject was selected the loading guides would occasionally return from the loaded to the stop position extremely fast. The reel motor then didn't have a chance to load the tape back into the cassette. The cause of the problem was simply dirty mode select switch contacts. We should probably have replaced the mode switch, but the job was an urgent one and a good strip down and clean seemed to work just as well as a new switch would have done.

Panasonic and JVC switches can also be cleaned quite successfully provided care is taken when reassembling the switch. **M.L.**

### **Ferguson 3V57**

The cause of no playback colour was traced to IC301 on the main PCB. Part no. is PU22046A. Chroma was present at pin 24 of the chip but there was no output at pin 22. **M.L.**

### **Hitachi VTM722**

The P50116 microcontroller chip in this model deals with a wide range of functions. It's responsible for deck control, tuning, the timer clock functions etc. Deck control problems can easily lead one astray.

A VTM722 came in recently with what looked like a power supply fault. The machine appeared to be completely dead, with no clock and no loading motor movement. As the power supply checked out all right we came to the conclusion that the microcontroller chip was faulty. It's on the top of the main panel, in close proximity to the front escutcheon. A replacement was therefore fitted, which is not easy as the print is very fine, but the fault remained as before.

I then remembered a conversation with Jim from Hitachi some time ago. He told us that these machines can easily become confused if the deck is out of sync. The microcontroller chip has to deal with so many functions that a wrong signal from the mode control switch can produce total lock up. This is in fact what had happened. With the loading motor and the mode switch removed I was able to re-sync the mechanism and could then reset the mode switch to position one (eject). Up came the clock and all functions worked correctly. The eject mode is quite easy to find when winding the mechanism by hand. After removing the loading block simply turn the main cam until the eject gear beneath the deck – it drives the carriage – turns when the capstan motor is rotated. This is the eject mode. Then set the mode control switch to position one and replace the loading assembly. It's important that the cam and the mode switch are correctly aligned. When the

capstan motor rotates the eject gear, as described above, you will usually find that by turning the cam to one end then backing it off until it clicks into its first position it is in the correct eject position. Be sure always to replace the mode switch. **M.L.**

### **Ferguson FV31R**

The problem with this machine was very intermittent loss of drum sync, the symptoms being picture disturbance and momentary loss of sound. After an extensive investigation of the motor drive and servo circuits a chance brush against the ribbon cable connector immediately behind the upper drum produced the fault. Remaking the ribbon cable connection to the free socket cured the trouble. **J.LeJ.**

### **Philips VR6463**

There was no E-E or playback sound. We eventually discovered that an 11.6V supply was missing because C2023 (330µF, 16V) was short-circuit. The 220Ω series resistor was none the worse for its experience. **S.L.**

### **Osaki VCR33/GoldStar GHV1232I**

A recent case of channel-dependent cogging and pulling from cold, clearing after an hour or so, was cured by replacing the a.g.c. reservoir capacitor. The offending item is C704 (1µF, 50V). **S.L.**

### **Panasonic NVG21**

This nice machine was dead. We quickly found that a 5V supply was missing. We removed the power supply can and then, with some difficulty, took off its covers. After this it was a simple matter to discover that IC1001 (STK5338) was faulty. Why do manufacturers fit the wire-ended/push-in type connectors when a plug/socket would surely be a more practical solution? We've had many of this type of connector produce intermittent results in various machines. **S.L.**

### **Sharp VC381**

This old front-loader would only intermittently allow you to set the clock and timer information. On the odd occasion when this was possible the machine would begin to load under the control of the timer, then unload with the clock resetting to zero. Severe patterning was evident on playback of a tape, to the extent that the picture was almost obliterated. The E-E pictures remained normal.

Scope checks showed that some very bad hash was present on the supply rails. The following capacitors were found to be open-circuit: C12 (100µF, 16V); C17 (100µF, 16V); and C16 (10µF, 50V). As a precaution all other capacitors of this type – there aren't many – were removed and tested. **S.L.**

### **Ferguson FV11**

There was very bad hum in both the E-E and the playback modes. A scope check proved that this was being caused by the 5V supply from the STK5481 regulator chip. The input at pin 2 of this regulator is smoothed by C4 (2,200µF). A replacement capacitor cured the initial problem but on test F3 (1AT) failed. It took us some time (and some fuses) to establish that the STK5481 chip had an intermittent fault. **S.L.**

## Panasonic NVS5

Intermittent zoom operation was the problem with this palmcorder. So it was left on test with the side casings removed. When the fault did put in an appearance, touching the main or the process PCB immediately cured it for the day! Many days later the flexi-cable between the main and the process PCBs was declared guilty. Part no. VWJ0495. **B.S.**

## Panasonic NVMS1B

This S-VHS camcorder produced a nice sepia monochrome camera picture. Checks on the various power supply lines didn't reveal anything amiss so, as things became more technical, out came the scope. Checks around the CCD 1H and 2H delay line chip IC308 revealed some abnormalities so a replacement was fitted. This put matters right – part no. VCR0256. **B.S.**

## Panasonic NVS5

We've had no auto-focus or zoom operation a couple of times with this model. On both occasions the focus motor was faulty. Part no. VEM0314. **B.S.**

## Fisher FVHP701

There was no mechanical operation, even eject. We found that the 5V supply to the capstan and loading drive circuits was missing because ICP F4001 (type ICPF10) was open-circuit. This was in turn due to the fact that the surface-mounted reservoir capacitor C4011 (10 $\mu$ F, 16V) was leaky both electrically and physically – I had to remove many surface-mounted components to clean under them. **N.B.**

## Sony CCDTR55E

The problem with this Handycam type camcorder was lack of date/time and title retention when the battery pack or d.c. supply was removed despite the fact that a perfectly good 3V lithium back-up cell was permanently in place. The unit display flashed, also the viewfinder display, for the first few seconds, suggesting that the lithium battery was low or faulty. A new one had been fitted.

The lithium pre-end detection circuit is based on two dual-transistor devices, Q565 (XN6401) and Q566 (XN6501). I found that the d.c. conditions here were haywire despite the fact that the 3V from the lithium battery reached the UPD7503 graphics chip. The cause of the problem was a short-circuit between the two transistor collectors in Q565. **N.B.**

## Sony CCDTR55E

This one caused us some headscratching. Not because of an electronic fault but because it is difficult to see what's going on in the compact mechanism. The fault note said that it was impossible to insert a cassette and that 'a mechanical scrunching noise' accompanied a rather tortured loading sequence. . . On inspection we immediately noticed that the

back-tension guide (arm assembly TG1) was in the wrong position – it was permanently in the play or record mode condition.

When the LS deck assembly had been removed we saw that there was heavy wear on the plastic guide base (base TG1 cam) because, in turn, of wear on arm assembly 314. Now this arm has a peg (cam follower) that sits in the related cam gear. It was very worn, allowing the back-tension arm assembly to go its own way. What would we do without Sony's excellent mode-selector fitment? **D.C.W.**

## Canon A10E

There were no functions with this camcorder. It's shaped more like a Polaroid instant camera than a camcorder but is comfortable to use. On inspection we found that the 2A Wickman-type fuse was open-circuit. Now anything that blows a fuse with this rating has to be a pretty hefty short-circuit. There are three other lower-rated circuit protectors, none of which had failed. Unusual – especially as no short-circuits could be found!

With some trepidation we fitted a lower-rated fuse and connected an analogue ammeter to show quickly (we hoped!) whether there was a destructive overload – before any damage could be done. When we switched on all functions worked. In fact no fault showed up during a long soak test.

Before refitting the case we decided to dismantle and carefully inspect the sections where a fault of this sort would be likely to occur. To cut a very long story short, the culprit turned out to be a tiny screw that normally secures the deck to the plastic frame. It had fallen out and lodged inside the main d.c.-d.c. converter can, where it intermittently shorted the d.c. input to chassis. If it had lodged elsewhere – well, that doesn't bear thinking about! **D.C.W.**

## Sony VO4800PS (U-Matic)

This is not a camcorder but is part of a kit with a separate camera. There were no functions at all: button pushing produced no response and no LEDs were alight. The machine just sat there. Some quick checks showed that the power supply was o.k. We then noticed that the loading mechanism was in the loaded position despite the fact that a cassette hadn't been inserted. What had happened was that the mechanism had stalled between modes and was thus unable to operate. A mechanical service, belt replacement etc. restored normal operation. **D.C.W.**

## Ferguson FC28

This full-sized VHS camcorder suffered from intermittent capstan speed changes accompanied by a shift to the right of the colour information in the picture. The problem was caused by the fact that the value of C240 (0.0033 $\mu$ F) in the video section was varying. It feeds the 4.43MHz subcarrier signal to the servo/mechacon section where it's used as the reference for the digital servo circuitry. You could see the level of this signal varying widely. A replacement capacitor restored stable operation. **D.C.W.**

## Mitsubishi HSB11/31/41

The cause of failure to play or record (doesn't lace up fully), either permanently or intermittently, can be the fact that the loading motor is being stalled because the pinch roller has jammed against the top of the capstan tower. The pinch roller arm assembly slides up and down a vertical pole which can become sticky. Clean and lubricate it, and use Philips' Molykote lubricant to grease the spiral cam that drives it. **E.T.**

## Tatung TVR6122

This quite new model suffers from a tendency to sound flutter – it's a longitudinal sound track machine. The trouble is usually worst during playback of its own recordings, and sometimes gets worse as the machine warms up. Don't be misled into checking the pinch roller or capstan department: replace the reel drive clutch, part no. 250814. **E.T.**

## Hitachi VT520

We've had the direct-drive capstan motor fail in a very misleading way in a couple of these machines: the on-board drive chip gets too hot to touch after running for a few minutes. You might find that the unstabilised 16V line is as high as 23V. Even so the motor itself is the cause of the fault, which often shows up as intermittent stopping and starting of the capstan. **E.T.**

## Sanyo VHR3300

Now that these machines have a few years under their belts they are beginning to produce a new fault – the loading mechanism jammed, with the half-load pole failing to get out of the way of the entry guide on its way back towards the cassette during the unthreading process. Replace the lever assembly – no. 79 in the mechanical parts (2) diagram. You'll find that its metal pin has become loose or strained. **E.T.**

## NEC N9033K

A common fault with this machine is failure of the reel brakes to disengage. The resulting drag either stops the tape moving or slows it, depending on the condition of the brake pads and the deck generally. A common symptom is slurred sound and cyclic mistracking. The cause of the fault is shorting turns in the 'pull' coil section of the brake solenoid – you'll often find that the coil-drive transistor has been wrecked. SEME has a repair kit which is available at about £20. It contains the solenoid, a transistor, a diode and modification details. **E.T.**

## Panasonic NVF65

In the E-E mode, and also with the customer's own recordings, the sound would intermittently go off. We've had a few faults on the TV demodulator pack in this range of VCRs, so our suspicions were immediately directed to this area. Fault finding on the upright panels, especially with an

intermittent fault, can be nigh on impossible. Our suspicions were soon proved to be correct: we found another NVF65 and swapped the TV demodulator packs over, the fault transferring with the pack.

No obvious cracks or dry-joints could be seen on the defective pack, but when the copper side was attacked with freezer we found that we could instigate the fault. The audio defeat transistor Q713 was being turned on in the fault condition, connecting the normal audio output line to chassis. We traced the reason for this to IC7651: voltage checks here showed that the 12V supply to pin 3 disappeared. This was due to a faulty surface-mounted device, in fact a link. It's not shown on the circuit diagram and was going open-circuit intermittently. Once a proper wire link had been fitted in its place the machine worked normally. **S.C.**

## Panasonic NV7200

This quite ancient machine would unlace about a second after lacing up in either the play or the record mode. After we'd checked various bits and pieces we came to suspect the supply Hall-effect sensor. I was about to find a scrap machine to rob it of its sensor when Pobs had the bright idea of checking with a magnet. His idea was to take the supply spool off, select play and move the magnet back and forth to the sensor. Why? Because he'd had exactly the same fault with an Hitachi machine and had found that the magnet on the underside of the spool rather than the sensor was the cause of the trouble. When the magnet was used the machine played happily. So we 'borrowed' a supply spool from a scrap machine. Pobs became Workshop Sage for the day. **S.C.**

## Amstrad VCR6100

This machine had been in storage and now chewed tapes. We found that the larger of the two half-loading belts had decomposed, causing erratic drive – particularly when unloading. A new pair of belts, fitted in the rather clumsy way made necessary by the ridiculous design of this part of the mechanism, cured the problem. **N.B.**

## Panasonic NV370

According to the job card there were lines across the picture – it was right. Tracking bars that the control couldn't remove were present. The cause of the trouble was insufficient back tension because the pad had dropped off the brake band. Watch out for this with all Panasonic machines that use the metallic band. **N.B.**

## Sony SLV373

This machine would play back prerecorded tapes perfectly in either the SP or LP mode but with one of its own recordings only the blue mute raster was present – there was no vision signal on the tape. Scope checks showed that the f.m. luminance plus chroma signal was present at pin 18 of the



head amplifier/switching chip IC001, but there was no output to any of the heads. The d.c. switching conditions around the chip were correct but at whichever outputs were selected the d.c. voltage was high - 3.5V instead of 2.2V. There were also incorrect (low) voltages at pins 16 (head select) and 26 (25Hz pulse input). The chip was faulty. **N.B.**

### **Samsung SI7220**

There was no r.f. output because the supply to the modulator was missing. This comes from the regulator transistor Q105 which was without its 15V input. A choke and diode deliver this supply. The latter (D114), which is in the power supply section of the main PCB, was open-circuit. A new 1N4002 restored the signals. **N.B.**

### **Panasonic NVF70B**

We've mentioned before that these machines can switch off when the review motor is called upon to do any work. You find that the 0.9Ω resistor R6035 has gone high in value or open-circuit because the motor drive chip and/or the motor itself is faulty. In this case however exactly the same symptom occurred when the tape was unloaded from stop-2 to stop-1. The cause of the trouble was that release lever 160 (part no. VML2200) was stuck on its pivot because of deteriorated plastic. A new lever cured the problem. **N.B.**

### **Panasonic NVF65B**

No signals was the complaint with this Nicam/hi-fi machine. On the bench we found that although a test signal could be obtained and the record/playback/search functions operated correctly it was impossible to tune in any local channels. There was a lively E-E raster and as we had already confirmed that there was an r.f. output from the combined r.f. amplifier-tuner module attention was turned to the tuner voltages.

The 12V regulated supply was present at pin 2 (BM) and the tuning voltage at pin 7 (BT) cycled nicely through its range in the preset/tuning mode. But no pictures appeared on the screen. What was missing was the u.h.f. enable at pin 8 (BU). This should be at 11.5V, the supply coming from pin 12 of the AN5043 chip IC7652. When pin 12 of this chip was isolated and 12V from a separate source was fed to pin 8 of the tuner signals could be tuned in though the machine wouldn't lock on to them when set to scan through the band. A replacement AN5043 was obtained and fitted but made not one jot of difference.

Feeling somewhat miffed, we delved further into the circuit and eventually followed the Band-U feed to pin 10 of IC7652 back via the audio board to the timer panel, where IC7502 (MN12C261D) was found burried under the display. Amongst its other functions this chip passes the v.h.f./u.h.f. switching from the timer/control microcomputer chip IC7501 to the TV demodulator. Although the voltage at pin 5 (U out) was correct at 2.1V, as there is nothing else between IC7501 and IC7502 we decided to obtain a replacement MN12C261D. Fitting this restored correct tuning.

It's a pity that the manual for this machine is rather vague regarding the functions of some of the control chips. **J.C.P.**

### **Sharp VC386**

There was intermittent colour in both the record and playback modes. IC501 proved to be defective, but its replacement cleared only the no playback colour fault. Because of chip tolerances the a.f.c. adjustment was wrong. There's no

setting-up procedure in the manual but we found that rotating the a.f.c. adjustment control to give 4.7V at pin 29 of IC501 provided a complete cure. **R.J.A.**

### **NEC N9077**

The reported fault was that a tape was stuck in the machine. Checks showed that the supplies from IC1 (PQ12R04) were missing. A replacement was obtained from SEME under part no. 37101407. **R.J.A.**

### **NEC N9077**

In the May 1991 issue reference was made to the following fault with this machine: fast forward and rewind very slow and the machine shuts down in the playback and record modes. In addition to replacing the reel braking solenoid it's necessary to obtain and fit a kit of three transistors and one diode. This is available from SEME. Part nos. are 35543418 (2SC1741A), 355D1931 (2SC2785), 35S62518 (2SD1227) and 36001026 (1S133). **R.J.A.**

### **Alba VCR4000**

'Occasional streaky pictures' it said on the job card. When the covers were removed the innards looked like new. It was obvious that the tape path was incorrectly aligned, and a general re-tweak as per the manual soon had everything working correctly. So out with the cassette, reload it and check again. The problem was back. "Oh drat" I said and looked for any loose mechanical bits. None.

I'll spare you the agony of what happened next. Eventually I spotted an eighth of an inch of thin plastic sleeving lodged in the end of the fixed part of the tape loading guide (the right-hand side one): it was held in firmly by the grease used to lubricate the loading runners. Swift removal with a pair of tweezers plus one final mechanical realignment restored a reliable, grade one picture. **H.A.**

### **Hitachi VT86**

There was no play mode with this machine because the drum wouldn't rotate. Another dealer had asked us to look at it as he'd run out of ideas. The machine would accept a cassette and lace up when play was selected, but because the drum remained stationary it then unlaced and went to stop. The STK5451 regulator chip and the drum stator PCB had been renewed. While checking through all the functions, on the basis that it's important to find out what does work as well as what doesn't, I found that the machine worked normally when record was selected. So it was a playback only fault.

When playback is selected Q608 (2SA673C) in the servo section of the main PCB should switch on to provide the PB12V supply to various parts of the servo circuit. A check showed that its collector remained at 0V, which is correct for the record mode. The cause of the problem was a dry-joint at the base of Q608. **J.E.**

### **Hitachi VTM830**

It was sometimes difficult to see the fault symptom on this machine: the customer's complaint was of poor colour playback. It could best be seen with a dark picture, where coloured snow was present. Much of the colour processing is done on a subpanel. As luck would have it we had another of these machines in, for drum replacement. I therefore swapped over the subpanels, proving that this is

# Servicing the Philips VR6462 and Clones

Chris Watton

The Philips VR6462 was released during the mid-Eighties. Clones include the Finlux VR1010, Pye DV464, Tatung VRH8490 and GEC V4006. It was quite different from the mainstream, Japanese-based machines with which we'd become familiar, including for example auto-tracking and the ability to revert to a function if the mains supply is interrupted – this is unlike most machines which assume the standby condition when this happens. There are also some in-built test programmes that can be used to check the machine's condition in the event of a failure – various codes are displayed on the clock display. To call them up, press two buttons on the operating panel whilst connecting the power supply (this is known as power-on reset, or POR).

One of these functions reveals the number of hours' use the machine has had, which can be useful in assessing wear etc. since the last service. To call up this feature you disconnect the machine from the mains supply then press and hold in the forward search and ITR keys whilst reconnecting the mains supply. The clock then shows the machine's use in hours. To leave this function, disconnect the machine from the mains.

Another point to note is that the machine reverts to standby if not operated for eight minutes. This obviously rules out long-term E-E use. Thus customers with manual control TV sets cannot use the VCR's remote control as an upgrade.

## The Mechanical Side

As with most VCRs, the problems that commonly occur arise in the mechanical section, where the lubrication applied to the moving parts dries out and the surfaces of rubber drive components wear down or become hard and

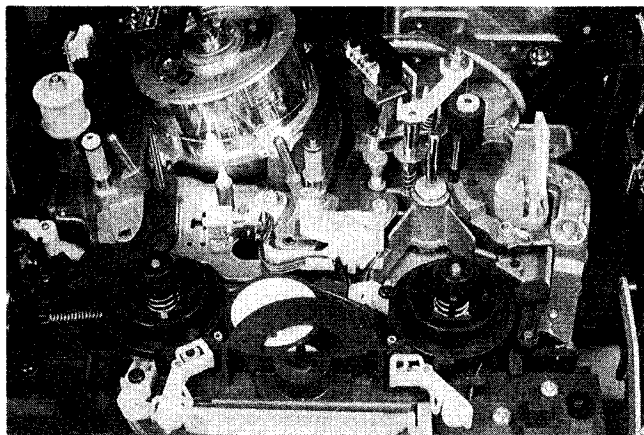

View of the deck mechanism.

misshapen. The cleanliness of the tape path and the condition of the pinch roller and back-tension band are very important.

Servicing is reasonably straightforward once you know certain things about this type of machine. When the unit is first plugged in the deck goes through a cycle known as initialisation: the lift goes down, then the take-up and supply reels spin and finally the lift returns to the upper position. The machine is then ready to accept a cassette. You can test it in all modes with the top cover removed and no cassette inserted. For the record mode the protection switch must first be opened. This can be done by inserting a piece of paper between the contacts. The condition of the deck can thus be assessed without the possibility of tape damage. You can for example see if the reel drive is in order and whether the guide blocks move smoothly and reach their destinations.

## Mechanical Service

The reel discs and idler parts can be serviced after removing the lift mechanism. To do this take off the front operating panel, which is secured by three plastic snap-fit clips, unclip the cassette flap then set the deck to the eject position. To remove the lift, bend slightly outwards the sides of the frame around the deck, at the same time raising the lift about half an inch. Then use a medium-sized screwdriver to press in gently the two operating levers which are engaged in the holes at the bottom of the lift. Once these levers have been freed the lift can be withdrawn. The deck is still operational, which can be helpful when dealing with such faults as noisy reel movement. A twin lead is connected to the lift's cassette-in switch: be careful not to damage it when removing the lift.

The reel discs can now be removed for cleaning and lubrication. They are held on their spindles by three locking tabs that drop into a groove at the top. There's a special tool for removing these, but with care you can do it using a small screwdriver, pulling the disc up as each tab is prised out of the groove. The important thing here is to be careful, as the tabs can easily be broken when removed in this manner. A soft brake fits under the reel disc on the take-up side: take care not to lose or damage it. Hold it in place with small pliers when refitting the disc. The back-tension band is beneath the supply disc.

It's common to find that both spindles are like glue, as the old lubricant has dried. I clean it all off using a cloth moistened with methylated spirit, then polish with chamois leather. Don't forget to clean out the bore in the discs as well. Apply new lubricant then refit the reels. Simply push them down on to the shafts, but ensure that the brakes are held clear when you do this.

The idler/swivelling wheel should next be replaced, along with the omega spring. A replacement comes with the new idler. It's secured by two small plastic sleeves which are also supplied. Take care when fitting these sleeves as it's possible to break off the pin that secures the spring. The spring locates in a groove beneath the idler wheel. Once this has been fitted, check for freedom of movement side-to-side. If the spring is located incorrectly this movement will be impaired.

The runners for the blocks that carry the guides and slant poles should be cleaned and lubricated. Finally the entire tape path must be cleaned and a new pinch roller fitted. This should have completed the upper deck service, and the lift can now be refitted.

Turn over the machine, remove three screws from the bottom and take off the metal cover. Be careful as the deck

is now loose in the cabinet. A worm drive is connected to the end of the threading motor shaft. Its spindle becomes dry. As a result there's an awful noise when the lift is moving or a cassette is being loaded. A little light oil will cure this – just a spot on both ends. Except where there's a fault, most of the other items under this cover seldom require attention. Replace the cover and the machine is ready for testing. All should be well. If not, the following fault list may be of help.

## Fault List

**(1) Machine dead, no clock operation:** Check the BZX79-C30 zener diode D6103. If necessary check transistor Tr7125 in the reset circuit and the microcontroller chip IC7091.

**(2) Test signal present during play:** Check the BC548 transistor Tr7508.

**(3) No drum rotation:** Check the L272 chip IC7001.

**(4) Drum spins too fast:** Check the optocoupler on the drum and the IR cassette LED.

**(5) Cassette lift doesn't rise:** Pin of lever 242 lost. Replace lever.

**(6) Won't tune:** Check transistors Tr7601 (BC556A) and Tr7420 (BC547).

**(7) Function faults, e.g. no fast forward/rewind, intermittent play, tape tangling:** The brake solenoid sticking can cause such troubles. It's best to fit a replacement. Slug-

gish brake solenoid operation can be caused by dry-joints in the power supply.

**(8) Insufficient reel torque in fast forward/rewind, cue/review:** There's an official modification – add a 22 $\Omega$  resistor in parallel with R3101/R3103. Make sure there's no friction between the reel idler and the guide plate below and that the reel disc spindles are clean (see mechanical service).

**(9) Unstable r.f. output or r.f. output only up to channel 23:** Check the ZTK18 stabiliser D6601.

**(10) Poor sound:** Check the pinch roller and for dry-joints on the audio head.

**(11) No reel drive in play:** Check the BA317 diode D6147.

**(12) Failure of IC7201 (L272M):** The loading motor probably has shorted turns.

**(13) Squeals during loading:** Dry shaft on worm gear from motor.

**(14) Knocking in fast wind:** Idler is worn.

**(15) Exit side of tape guide block doesn't reach the V block:** Dry shaft on take-up reel disc.

**(16) No functions or clock, drum spinning too fast:** Check fuse F1109.

**(17) No rewind:** The photodiode on board P672 at the right-hand side of the deck could be leaky.

## Panasonic MS50

If this little treasure is dropped, the pin can jump out of its groove in the loading mechanism's main cam. This immobilises the deck but leaves some telltale play in the loading guide poles. **E.T.**

## Panasonic MS50

This machine came in with the audio hi-fi indicator (green LED on the top surface) lit up whenever a battery or external power supply was connected: in this state it drew 45mA with the power switched off. The culprit was transistor Q4521, an 8-4V stabiliser on the hi-fi audio PCB – it had developed internal leakage. **E.T.**

## JVC GR45E

'A colour problem' the job ticket said. That was true, but there were two separate faults in different parts of the circuitry. The first one was a distinct lack of B – Y, producing a picture with only red and cyan casts. The vectorscope showed this quite clearly. But where to start looking? After much searching I discovered an intermittent dry-joint at pin 24 of IC4 on the Video 1 PCB. With this corrected the camera was put on test – only to discover that after a short period the playback colour disappeared. The cause was failure of IC4 on the Y/C PCB when warm. This chip is the THE045A that's used (and fails) in other JVC models. Replacement and setting up completed the repair. **D.C.W.**

## Sony CCDV8AF

The cause of no viewfinder picture is generally a break in the print on the viewfinder socket PCB. **D.C.W.**

## JVC GRC1E

We've had two of these early machines in recently with a failed lower drum motor. Instead of running the drum twitches. Replacement cures the problem – coincidence, or are these camcorders just getting old? **D.C.W.**

## Sony CCDV800E

This Hi-8 camcorder had me puzzled for a while. It worked all right in the standard-8 mode in both record and playback, but when switched to Hi-8 only the record function operated correctly. Playback of one of its own recordings or a known good tape in this mode produced the effect of one head giving little output. The playback equalising circuits were checked but everything here was in order. There was nothing for it but to change the upper drum. This solved the problem. **D.C.W.**

## Ferguson 3C03

Don't get caught as I have (twice!) when working on the camera section of this model using patch leads. If you leave the audio lead connector between the camera and deck sections unplugged you'll find the camera operation controls acting very strangely: the fader and WB controls are inoperative while the BLC button fades the picture! The

reason for this is that the controls are earthed via the audio lead's screen connection (CN14 on the main PCB). **D.C.W.**

## Amstrad PSI AC Adaptor

The cause of failure to charge with the power on LED flashing was a defective NE555 timer chip (IC2). Other types of 555 chip may produce different fault symptoms if used as a replacement. **D.C.W.**

## JVC GR45

There was flickering on the picture, more noticeable during playback of the camcorder's own recordings than in the E-E mode. Two separate faults contributed to the problem. First a d.c.-d.c. converter was not to specification – it produced ripple on the camera signal processing supply, as a result of which the amplitude of the luminance signal fluctuated. Secondly the a.g.c. circuit in the luminance recording chip seemed to over-react to the signal variations. Replacing the d.c.-d.c. converter and the chip cleared the problem. **S.B.**

## Ferguson 3C03

The problem was no auto-focus operation: a new auto-focus sensor assembly plus resetting the focal plane put matters right. **S.B.**

## Panasonic NVM5B

There was no zoom and no power-up reset on the deck – only a sort of soft-shoe shuffle. We found that the zoom controls had been unplugged, which indicated that our local Jessie James had been at it. A new loading motor drive chip restored the deck reset and loading drive but there was no capstan drive. Two further i.c.s (MN6170 and MN3805) cured that problem and I now found that I had playback but no camera pictures. I suspected that this was the original fault. Its cause was quickly traced to a BA6149LS CCD delay line in the camera signal processing circuitry. **S.B.**

## Ferguson FC06

The cassette housing opened when power was first applied but not thereafter, which obviously affected cassette removal after filming. I found that there was some slight corrosion on the main PCB. Cleaning it off with ammonia and relacquering cured the fault. **S.B.**

## JVC GRAX5

The loading mechanism was inclined to jam when unthreading the tape. More seriously, during threading the top of the entry guide caught on the upper drum. Both loading rings and the entry guide had to be replaced, then aligned. Not a job for the faint-hearted. **S.B.**

## Panasonic NVM7B

The colours from the camera head were incorrect – very bluey/greeny/yellowy. The cause was a dry-joint on the R – Y level control VR316. **S.B.**

## Philips VR6490

There was intermittent sound on the tape that was brought in with this machine. It came on and went off suddenly, as if the muting circuit was operating. When we tried the customer's tape in another machine there was a different symptom – the sound stayed on but there was a warble. I put the cassette back in the customer's machine and checked the control track pulses. They were weak and varied in amplitude. When the pulses were large the sound remained on: when they were small the sound was muted. All that was wrong was that the control track head was dirty. Cleaning its face and making a test recording proved that the problem had been cured. **P.B.**

## Grundig VS300

The customer complained of tape damage. He brought two cassettes along with the machine, both of which were creased towards the end of the tape. When I tried fast forward then stop, tape spilled out as the brakes didn't come on. The cause of the problem was that the BC876 brake solenoid driver transistor T2141 was short-circuit. **P.B.**

## Fisher FVHP715

There was a loud, 50Hz hum in the E-E and playback modes. Slight flexing of the mains transformer's PCB would make the hum come and go. Resoldering the transformer's nine pins and every other soldered joint didn't cure the problem but linking across the three PCB-mounted fuses in turn proved that F904 was responsible. It had gone high-resistance. **J.E.**

## Hitachi VT120

The mode switch in this VCR has given us trouble in the past. The symptoms are numerous and varied. Should you suspect the mode switch, check the following voltages at pins 47, 48 and 49 of the HD614042SD37 system control chip IC901:

Mode	47	48	49
Rec/play/forward search	0	0	0
Fast forward/rewind	0	5	0
Stop (carriage up or down)	5	5	0
Rewind search	5	0	0

**J.E.**

## Triumph VR9500

This machine would switch on and the clock/channel indicators worked normally. But there were no functions when a cassette was inserted. A check in the power supply showed that the 5V output at pin 5 of the STK5326 regulator chip IC501 was missing. A new regulator got the machine working and we also fitted a new idler in case the machine came back with the same symptoms (what's the point of getting older if you don't get wiser?). **J.E.**

## Ferguson 3V45/JVC HRD150

Rewind and fast forward were o.k. but during playback or record the machine would enter the stop mode. It would sometimes play almost to the end of a tape before shutting down: at other times it wouldn't even enter the play mode after lacing up. We noticed that slight pressure anywhere on the main PCB would make the machine shut down. Voltage checks were of no use in this situation, so we used a magnifying glass to carry out a careful scan of the board. This revealed that R501 (680Ω, 0.5W) was dry-jointed at one end. IC404 in the servo section receives its 17V supply from R501. Resoldering provided a complete cure. **J.E.**

## Hitachi VT33

It's quite common with many Hitachi models to find that the tape threads up then almost immediately unthreads. What happens is that the drum slows down because the servo reference signal is missing. It comes from the 4.43MHz chroma subcarrier oscillator section of the HT4539B hybrid chip IC203. I changed IC203 on this machine as a matter of course, but this time the fault was still present. Doing what I should have done to start off with, I then checked the voltages around IC203. The 9V supply was missing at pin 9 because choke L216 was open-circuit. The questions now were whether IC203 had been faulty and whether L216 had burnt out? I broke L216 open and found that it wasn't obviously burnt: I guess that one day I'll fit the old HT4539B to another machine to see what happens. It's the unpredictability of it all that keeps me going! **R.B.**

## Hitachi VT120

Very intermittent vision overloading in the E-E and record modes was traced to the HT4757 hybrid chip. **R.B.**

## Hinari VTV100

During play, record or any other mode this machine would intermittently refuse all commands. Spraying the microcontroller chip with freezer proved that this was the culprit. It's a Sony type CXP5058H-118. Fitting a replacement and cleaning the tape path put the machine back in working order. **G.R.**

## Ferguson 3V29/JVC HR7200

Sound was o.k. but there was no E-E video. We traced the luminance signal right up to the HA11738 chip IC201 on the bottom PCB where the E-E video was present at pin 26 but no output appeared at pin 5. Voltage checks around this chip showed that there was only 0.4V at pin 8 instead of 2.9V. C243 (220μF, 6.3V) which is connected to this pin via R244/5 was leaky. **G.R.**

## Amstrad D8900 Double Decker

There was no display from the digitron – this includes the clock, timer, counter, channel information etc. – because the -28V supply, measured at pin 11 of connector CN2,

was missing. Investigation showed that D24 was short-circuit and the 15Ω safety resistor R29 was open-circuit. Replacing these restored the display. We used a 1N4005 in position D24.

G.R.

### Hitachi VT11/33/64/120/520 etc

The capstan motor slowing down, usually intermittently, is a problem with these machines. In this event replace the VDR in the capstan servo circuit – it's marked CH4R7-20V. In an emergency a 4-7Ω resistor will work. Note that some machines have a second VDR in the drum servo circuit, so make sure that you replace the correct one!

G.R.

### Samsung VI710

There was no display. A few checks in the power supply soon revealed that the 6-8V zener diode ZD102 was faulty, a replacement putting matters right.

C.W.

### Amstrad VCR4600

The job card said "crinkled pictures". And crinkled they were – almost like a Thorn 3000 chassis when the 140μF electrolytic had failed (those were the days!). I first checked the tape path for anything that might make the tape shudder. But everything seemed to be running nicely and evenly and looked clean. The lower drum wasn't damaged and didn't look at all worn. As I had one available however I decided to change it. To my pleasure this cured the fault – except for one thing. The head switching point now appeared at the top of the picture. The lower drum had been taken from a new full deck assembly that we'd recently purchased for about £25. It must have been for a different model however, as the magnet assembly at the bottom had the pulse magnets in a different position with respect to the drum's position of rotation. Taking off this assembly and fitting the one from the old drum allowed the switching point to be set up perfectly.

C.W.

### Matsui VX1000Y

I have had the following problem several times now. The symptoms can appear as poor drum servo lock, a head switching type fault or as if one head has failed – the fault can also be intermittent. To ensure a permanent cure remove the FG pick-up on the drum, clean the two pins and the PCB connections thoroughly, then resolder.

I would add that with a lot of the faults experienced with Matsui/Saisho VCRs it pays to look for bad soldering or poor connections. Doing this will probably cure many of the faults that come your way.

T.L.

### Philips VR202

When any key on the control panel was used it would lock up totally and the command that was entered would be totally ignored. On investigation we found that the main data line became continuously busy. After trying the obvious chips we moved to the on-screen display i.c. When this was replaced the machine was back in full working order.

T.L.

### Sony SLV625

No output from one head almost caused me to order a new drum – after the normal cleaning and checks had been carried out. But I decided to take off the drum and use a

magnifier to see whether I could find anything amiss. A non-soldered connection was found on the lower drum, and when this had been resoldered the whole machine worked perfectly. This goes to show how important it is always to check around, even when the fault appears to be such an obvious one.

T.L.

### Toshiba V83

I've had various intermittent speed faults with this and similar models due to defective mode switches. A complete cure is usually possible by removing and cleaning the switch. Recently however I had a machine that suffered from intermittent capstan rotation. It was no better after replacing the loading belt and cleaning the mode switch. It transpired that the capstan motor had a dead spot, a replacement putting everything right.

R.N.

### Matsui VX820/Saisho VR1200HQ

This machine was dead when it came in. Voltage checks showed that the STK5332 power supply module was faulty, so a new one was fitted. The machine then powered up, but there was no drum or capstan rotation. Voltage checks around the servo chip IC2001 were inconclusive, but scope checks showed that there was a distinct lack of activity in this area. Replacing this i.c. restored normal operation. Presumably the faulty STK5332 had destroyed the servo chip.

This machine also appears as the *Hinari* VXL35 and the *Orion* VHML.

R.N.

### Philips VR6920

In the February issue (page 254) I wrote about a problem I'd had with a VR6460. The VR6920 is a Panasonic clone with hi-fi stereo sound, using the same deck. This one came in dead and we soon found that the 0-39Ω safety resistor R1001 was open-circuit. It's a fairly common fault, so we were not surprised. After fitting a new resistor, replacing the loading belt and giving the machine a good clean up it gave excellent results. But as it was getting late I left casing up until the following day.

When the machine was checked from cold next morning it didn't work, or rather it was permanently in the rewind mode, stopping after a few seconds and not accepting a cassette. This straight away rang bells, and a check on the little subpanel at the front of the deck revealed that it was loose. Removing the deck and tightening the screw cured the problem, so it seems that this happens on all these decks. It thus pays to make this a part of the standard service procedure.

R.N.

### Amstrad VCR6000

I had two of these machine in recently, both with the same complaint but with different faults. Both machines would switch between the SP and LP modes at random. The cause on the first machine was easy to see: the tape was being pulled down across the audio/sync head because the pinch roller bracket was bent. A new bracket and pinch roller put matters right.

Tracing the cause of the problem with the second machine was more difficult. The tape path was perfect, and the heads were clean. A scope check at test point HP1 (TP402) however showed that the sync pulses were of very low and varying amplitude, with a lot of noise present. As checks on components in this area failed to show that

where the cause of the fault lay. A check on the waveforms at R326 (270Ω) proved to be useful as the waveform at the end connected to the 2H delay line CP303 did a nose dive, being hardly visible. When we replaced CP303 we were rewarded with a very good picture. **K.E.F.**

### **Hinari/Orion VXL35**

This machine was dead with no clock display. Replacing Q02 (2SD1207) restored normal operation. **K.E.F.**

### **ITT VR3929**

If the display appears at switch on but goes out as soon as a deck function is selected, after which there is no further operation, replace the two 47μF capacitors on the subpanel in the power supply unit. **K.E.F.**

### **Samsung VI1260**

We've had a number of these machines in for repair. The usual fault is that the machine laces up then switches back to standby. The cure is to replace D109 or D110, but as both can give trouble I now replace the two of them. Note that the fault can be and often is intermittent. **K.E.F.**

### **JVC HRD610**

This machine worked well in play until a trick function (search or pause) was selected. The picture then had lines about every 3mm across it. Wet finger checks soon established that the cause of the fault was IC301 – it's a small subpanel. When a replacement was fitted all was well again. **K.E.F.**

### **Proline DX3300**

There was a tape stuck inside this machine. When a function was selected the display would give the appropriate indication but nothing else happened. I hadn't seen one of these machines before, though the deck looks like an Amstrad one. A check on the two fuses in the power supply came up trumps: Z502 (1AT) was open-circuit. That saved the cost of a service manual! A long soak test proved that Z502 had failed of its own accord. **M.Dr.**

### **Akai VS22**

If the problem with one of these machines is that TR10 and TR11 in the power supply are either overheating or short-circuit, replace the following electrolytics: C7 (100μF, 10V); C6 (220μF, 10V); and C21 (47μF, 16V). We use replacements rated at 25V or above. It seems that excessive ripple upsets things and results in TR10 and TR11 conducting when they shouldn't. **M.Dr.**

### **JVC HRD540**

The customer told us that a cassette had got stuck in this machine and that he'd removed it himself. When we plugged the machine in we found that the cassette loading motor would start to run with no cassette inserted. Then, after a few seconds, the machine would switch to standby. If a cassette was inserted and the machine was switched on the cassette would load down then immediately be ejected: the housing motor would continue to run.

We decided to load a tape manually and thread it up. The result was some operation but the capstan motor didn't

rotate and there was thus no reel drive. The machine sat happily in pause however. Attention was turned to the capstan motor, which was found to be without its 12V supply. Tracing the source of this back we came to an open-circuit circuit protector (CP5, type ICPN38) on the main PCB. A replacement was fitted and the machine was given a good soak test. This proved that there was no underlying cause for the failure of CP5. **M.Dr.**

### **Ferguson FV42L**

The complaint was of a noisy picture during playback of the machine's own recordings. After many hours we saw the fault. White dots washed across the picture, at times looking almost like a test pattern of vertical lines of dots. The symptom was also present in the E-E mode whilst a recording was being made. We noticed that there was a slight delay between the machine starting to record and the appearance of the dots. The cause of the problem was spikes produced by the audio bias/erase oscillator appearing on the 12V supply to the tuner etc. The culprit was CS29 (10nF) which is connected between the base of the oscillator transistor (TS26) and chassis. **I.B.**

### **Panasonic NVD80**

This machine came in for service with various complaints, the main ones being of a poor playback picture and noisy hi-fi sound. A new upper drum put that right. We then noticed that with SP recordings there were noise bars across the picture in the cue and review modes instead of noise-free horizontal 'cuts' – the LP results looked fine. The cause was discovered after some searching around the signal paths in the video preamplifier area. There was a break in the print on the underside of the main PCB between pin 8 of connector BP3001 and pin 17 of the servo pack connector. This is a feed from the preamplifier called 'enve. select'. During normal playback there should be a voltage high here, becoming a square-wave in SP cue/review. The squarewave is used by the servo PCB to produce an output called 'h.amp switch' at pin 16. It returns to the video preamplifier PCB. **I.B.**

### **Philips VR6870**

There were no displays while the power supply produced stressful noises. Scope checks on its outputs showed that there was enough mush present for us to wonder about possible damage to the rest of the machine. The machine was therefore disconnected and cold checks were started. We soon found that D4, a 10V zener diode, was leaky. **S.L.**

### **Ferguson FV30**

A recent case of intermittent shutdown, with the tape remaining laced up and all the motors stopped, was cured by fitting a new reel optocoupler and mode switch. **S.L.**

### **Panasonic NV333**

This machine was dead because the STR1096 power supply chip didn't produce a 6V output at pin 5. There was a normal 15V input at pin 1 and a 9V output at pin 4, thus switching problems were ruled out. A new STR1096 provided a complete cure. As the customer wanted the machine serviced we fitted one of the excellent full refurbishment kits available from SEME and others. Fit only original Panasonic parts, clean, grease and lubricate as per the manual and no problems will arise. **S.L.**

# VCR Clinic

*Reports from Philip Blundell, AMIEE, Brian Storm, Ronald Aranha, J.C. Priest, Simon Bodgett, Michael Dranfield, Hugh Allison, Geoff Fardon, Nick Williams, Chris Watton, Ronnie Boag and Nick Beer*

## Ferguson 3V55

There was an intermittent fault with this VCR: the drum would begin to go too fast, then the machine would shut down. In the fault condition the drum FG signal at TP414 went missing, though it was present at pin 6 of IC404. The supply to this chip was intermittent because R501 was dry-jointed. **P.B.**

## Philips VR322

The problem here was that the remote control system didn't work. Nice squarewaves from the remote control receiver i.c. arrived at pin 41 of the operating panel microcontroller chip, but it ignored them. As the signal conditions at all the other inputs seemed to be o.k. we decided, with crossed fingers, to fit a new TMP47C1670N. This restored the remote control operation. **P.B.**

## Ferguson 3V36/JVC HRD225

For weak E-E video check whether the 1k $\Omega$  E-E level control is open-circuit. **P.B.**

## Panasonic NVJ35

This machine refused to accept tapes, throwing them out immediately. We found that the cassette housing was misaligned with the main deck. Realigning the housing rack gear with the main deck metal drive gear provided only a temporary cure – the machine relapsed into its previous state with a clattering of slipping gears. Inspection of the right-side section of the cassette housing showed that there were two broken plastic retaining lugs. The result was too much play on the rack gears. A new right-side assembly (part no. VXA3153) cured the problem. **B.S.**

## Panasonic NV200

These VHS-C portable recorders sold well in our area. They are now coming back to us for repair. The most common fault symptom is perfect recording but intermittent playback. Tapping the middle of the top of the recorder, with the top on, normally aggravates the intermittency.

After removing the case, which is no easy task, up-end the unit with the front facing you. You are looking at the print side of PCB 600. Half a dozen components are tacked on to this side of the board. At the rear of the board there's a choke which is connected to two capacitors, the joins also being laid-on connections to the PCB. These two joints become intermittent. If you simply reflow them the unit will be back within six months. To make a reliable repair take an inch of thin, flexible insulated wire, bend it back on itself to make a narrow, half-inch long U, solder one end to the choke/capacitor joints and use the other as a soldered lay-on to the board. The U acts as a shock absorber between the heavy choke/capacitor and the board, preventing them tearing themselves off in the future. **H.A.**

## Ferguson 3V29/JVC HR7200

This machine had an intermittent drum servo problem. There were no abnormalities in the waveforms on the servo

boards but the tracking control had no effect. Transistor Q9 had 5.5V at its base, implying that it was in the search mode. This switching transistor is controlled by the voltage at pin 12 of the IR2403 chip IC4, where the reading was 0V. Pin 5 is the relevant input, which receives the search command from system control. The reading here was 6V. When pin 5 was disconnected it was clear that this voltage was coming from within IC4. A replacement chip (M54519P) restored Q9's base voltage to 12.5V. R10 and R207 were then readjusted as per the instructions in the manual. **R.A.**

## Ferguson FV31R

The complaint with this machine was that it wouldn't tune to the local channels. On test we found that although all other functions worked correctly there were problems when the machine was put in the channel preset mode. The tuning display counted up through the channels numbers, but the monitor didn't display any sound or vision and the tuner wouldn't lock on to any of the channels as it passed through them.

After removing the case and raising the top PCB we took the screening cans from above and below the tuner/i.f. section and examined the area carefully for print cracks, dry-joints etc., something that's common in this range of machines. Everything seemed to be o.k. this time however. So checks were made at the tuner's base pins where we found that the tuning voltage (pin 11) was missing. We moved back to the tuning control transistor TT12, whose collector voltage was at 0V, then to pin 9 of the TD6316AP tuning control chip IT20 where the voltage was 3.2V. This was turning TT12 fully on, hence the absence of its collector voltage. A new TD6316AP chip restored correct tuning. **J.C.P.**

## Sanyo VHR135

The complaint with this machine was that it wouldn't do more than two or three timed recordings in sequence. I called at the house and set it up to do five two-minute recordings at two-minute intervals. It went through the sequence without error, so I came to the conclusion that the problem was caused by operator error. I set up a further sequence of half-hour recordings and left to make other calls.

When I returned in the late afternoon the machine should have been half way through its last recording period. Instead it was off and the cassette had been ejected. On questioning the customer I discovered that on occasions when a blank cassette was inserted the machine would go into automatic play as though it was a protected cassette. Light dawned. The record protection switch looked o.k. and produced a good continuity reading when operated, but I fitted a temporary link across it and asked the customer what programs he wanted to record that night. I set up a full six timed recordings and warned the customer that the protection circuit wouldn't operate until I came back.

The following day I found that all six items had been recorded without problem. Obviously dodgy switch contacts persuaded the machine, when it had been in operation for



## Grundig VS440

There were no E-E signals, only snow. By using the direct tuning method rather than search tuning the channels could be set in the tuner preset positions but there were still no signals. Checks on the tuner module showed that all voltages were present and correct. The other thing to check here is the I2C data and clock lines. These were at the correct d.c. levels, and pulses were present. Inside the can there's an SDA3202-2 PLL chip. We found that it had no output at pin 18. A replacement restored correct tuning. **C.W.**

## Hinari VTV100

There was no playback colour. I checked the VCR section with another TV set and everything was fine. I then connected another VCR and found that the fault was present. After a lot of component replacement and adjustment checks I replaced the 4.43MHz crystal XTL301. This provided a complete cure. **C.W.**

## ITT VR3918

The tape was thrown out when record was selected. At last a simple one! The erase prevention switch had become dislocated from the frame of the deck and thus failed to open. This told the microcontroller chip that the tab had been removed. I refitted the switch, using a tiny spot of glue so that it wouldn't fall off again. **C.W.**

## Samsung SI1240

In the play mode the video level was fine. In the E-E mode however the picture was negative. A check at test point TP3202 (video output) produced a reading about twice the correct value (over 5V) while the top of the waveform was cut off. Adjustment of the E-E level control VR3205 made no difference. This potentiometer sets the d.c. level at pin 19 of the LA7323 video chip IC3201, but the voltage here didn't change when VR3205 was adjusted. The cause of the trouble was R3218 (2.7k $\Omega$ ) which was open-circuit. When a replacement had been fitted and the E-E level had been set to 2V peak-to-peak at TP3202 we had normal results in both the E-E and the playback modes. **C.W.**

## Finlux VR3300

The fault was an intermittent video rasp on playback of prerecorded tapes. The r.f. modulator couldn't handle high-content video. **R.B.**

## Fisher FVHP5000

There was no playback or E-E picture, the r.f. picture being o.k. We found that there was a dry-joint on D203 which is near the green disc capacitor on the solder side of the bottom PCB. **R.B.**

## Sanyo VHR4350/7250

A problem you can sometimes get with these machines is wear of the sub-reel brakes. The cure is to replace the old reels with new modified ones – part nos. 613 126 6148 and 613 126 6155. **R.B.**

## Samsung VI710

This unit was dead. A check on the 30V supply at pin 10 of

CN101 showed that the voltage here was low. The cause was that R109 (4.7k $\Omega$ ) which biases the base of transistor Q102 was open-circuit. **R.B.**

## Hitachi VT35

There was no clock display because R2711 (22 $\Omega$ ) on the back-up supply PCB was open-circuit. **R.B.**

## Fisher VHFP5100

If there are no remote-control functions try fitting a three-core mains cable. If this doesn't cure the fault replace IC151. **R.B.**

## Hitachi VT11

There was no E-E picture – but if playback was pressed the E-E instead of the playback picture came up. Voltage checks showed that the PB 9V supply was missing. We found that transistor Q905 was short-circuit base-to-collector, a replacement restoring normal operation. **R.B.**

## Sharp VCA105HM

This machine badly damaged tapes because the loading arms/guide poles didn't return to their correct rest position when unlacing was complete – they sat directly below where the tape emerged from the cassette's flap. The timing between them and the sector gear was one tooth out. Retiming provided a cure but the gear had to be replaced as it was damaged. Following advice in a letter in the December issue I also replaced the back-tension post lever and gear – it's conceivable that this was the root cause of the problem. **N.B.**

## Panasonic NVJ30B

This machine, which uses the G mechanism, refused to accept a cassette because the capstan motor didn't move – with this deck front loading is performed via a rack that's driven by the capstan motor. Checks around IC2101 showed that the 12V supply was present but the 5V Hall bias supply was missing. In fact there was no 5V supply throughout the system control circuit. It comes from the 2SD1330 regulator transistor Q1102 which read perfectly when tested cold but went open-circuit under load. **N.B.**

## Panasonic NVJ42/7/F55

Failure to transmit is a very common problem with the remote handset/scanner unit. The cause is a very high-resistance IR emitting diode. Another point is that the front flap is weak – it's easy to replace.

An interesting point is that the VideoPlus handset supplied with the brand new NVSD30 will work in the VideoPlus mode with all modern machines that use a scanner handset – while the scanner handsets will work with the NVSD30. **N.B.**

## Sharp VC651HM

A cassette was jammed inside with the machine fully laced. This was unlike the more usual case where the deck can't shuffle because the reel idler is faulty. The cause of the trouble was a faulty loading belt. This would normally prevent completion of loading rather than prevent unloading. **N.B.**

Scope checks showed that there was significant ripple on the IDL 10V supply. There was a smaller amount of ripple on the IDL 5V line. As the ripple was at 50Hz it seemed that there was an open-circuit rectifier diode somewhere in the supply, but investigation showed that D9 was short-circuit while the fusible resistor FR6 (0.1Ω) was open-circuit. Aren't these resistors expensive?!

R.F.

### **Panasonic NVF70**

As these machines age, particularly the mechanics (G mechanism with review motor), various squeaks and rattles can arise. This is particularly the case with models, such as this one, that have jog shuttle dials. A delightful series of shrieks, whines, rattles and buzzes can be demonstrated. Replacement of the tension unit (part no. VXA3516) and the soft brake (VXL1873) usually restores relatively quiet operation.

B.S.

### **Panasonic NVFS90**

The complaint, a very unusual one with these machines, was of poor picture quality. An abundance of faint, flickering lines were present in the background of the playback picture. The condition was even worse in the LP mode. I decided to check on the HQ pack. As I removed the screening can X3301, the crystal associated with the 1H delay CCD chip IC3302, came out of the board. Resoldering it back into the board restored the normally excellent playback picture.

B.S.

### **Matsui VX6600Y**

No E-E picture with normal sound is becoming a very common fault with this model. Check inductor L4801 which goes open-circuit.

T.L.

### **Akai VS427**

No playback sound caused us some problems. The sound circuits were being switched off because the main microcontroller chip was sending out the wrong signal. Must be the chip we thought, but to be on the safe side we tried a new front operations panel. This cured the fault. The μPD75216A-268 timer microcontroller chip IC1 was the culprit, a replacement restoring the sound.

T.L.

### **Hitachi VT410**

The problem was poor or very noisy eject. In this model the cassette carriage is driven by the capstan motor via a series of cogs and gears. The cause of the fault was the worm on the right-hand side of the carriage, part no. 6435571. As a precaution I also replaced the worm wheel assembly, part no. 6896971.

R.J.A.

### **Akai VSF33**

Low or no clock display was caused by the fact that the power supply wasn't oscillating. Akai has a modification sheet and kit, AV10015, part no. EX744015JOAP, to correct this.

R.J.A.

### **Philips VR6293**

This machine had a tendency to eject tapes at odd intervals. The customer had put up with this for some time, complaining only when the machine failed completely. Total

failure was caused by a power supply fault – a new 3.3Ω resistor was all that was required to put this right. I then called up the service test program, which indicated that the drum motor had stopped although the machine was working perfectly. I was able to catch the machine in the fault condition just once, when it was switched on from cold one morning: the drum gave a little kick then refused to turn again, after which the machine shut down. Various component replacements in the drum motor driver stages failed to cure the fault, so a new lower drum was eventually tried. This provided a complete cure. I'm finding that motors which cause this sort of fault are becoming very common.

R.N.

### **Sharp VC581**

This machine had been looked at by a dealer who had decided that it was not worth repair. It eventually came to me via a neighbour. As there was no take up I looked at the idler wheel. This had been changed, but was not making contact with the take-up spool or the reel motor. There was too much clearance between the idler and the motor, and the idler was fouling the motor fixing screws. After removing the motor I realised that it could be fitted in either of two ways. When it was turned through 180° and refitted the machine worked. A good clean up and a new set of belts completed the repair, saving what turned out to be a very good machine from the scrap heap.

R.N.

### **Panasonic NVL20**

This machine produced very poor E-E pictures that could be cleared by tapping the tuner and r.f. converter. As MCES were on holiday I removed the tuner and converter and had a look inside. I found a large number of dry-joints along the output pins in both units and very carefully resoldered them. When the units had been refitted the machine worked perfectly and didn't even need to be retuned.

R.N.

### **Ferguson 3V53/JVC HRD755**

This hi-fi machine wouldn't switch on. It would accept a cassette but wouldn't eject it. The clock was flashing away and could be set, but basically the machine was dead. No faults could be found when initial checks were carried out in the power supply. I then found that the on line didn't go low when the on button was pressed. The switch itself was o.k., but the power-on output from the microcontroller chip IC202 didn't change. If a shorting lead was used to take the line low the machine made an attempt to start and various supply lines became active. A replacement microcontroller chip, type M50742-621, put matters right.

R.N.

### **Hinari VXL5**

The video signal was low, smeary and contained crushed sync pulses in the playback and E-E modes. Sound was not affected. As we didn't have a manual we carried out scope checks back from the r.f. modulator. Things were clearly wrong around Q306, where we found that C353 (47μF, 16V) was short-circuit. It appears to be a video signal coupling capacitor.

S.L.

### **Sharp VCA5011HM**

The cause of failure to accept a cassette was incorrect voltages around the BA6238AM chip IC803. D805, type HZS12EB3, was short-circuit. A standard 12V zener diode in this position restored normal operation.

S.L.

## Ferguson FC06

There was intermittent sound because the tape shifted in height as it ran across the audio head: the cause of the problem was the pinch roller. **S.B.**

## Sony CCDTR55

This 790g wonder had a cassette stuck in it. Pressing the eject button had no effect, though motor noise and mechanical movement could be heard for a while, followed by shut-down and then the caution indicator blinking. When we opened the unit we found that the camera block could be separated from the VTR section. The machine unloaded without problem when an external d.c. voltage was applied to the loading motor, so the load/unload mechanism seemed to be all right.

We next checked for reel pulses at the syscon chip IC601 on board VS37. These and the head switching pulses were present, but in comparison with another machine the capstan motor movement seemed to be much too fast. A check showed that the capstan FG pulses at pin 62 of IC601 were missing. They come from the CX20115A chip IC503, which produced no output pulses at pin 12. The d.c. voltage here was also incorrect. A new CX20115A chip restored normal operation. It's an SMD, so special care is required. **R.A.**

## Sony CCDV90E

We had to attend to this camcorder on three occasions. It showed the no power symptom, i.e. no display in the LCD window. On the first two occasions the LCD appeared and all other functions were restored when the lithium battery, which is used to store day and date information, was removed then replaced. On the third occasion manipulating the lithium battery made no difference. So voltage checks were carried out around IC151 ( $\mu$ PD7503G) and reset transistors Q156/8/9 on board FD4P. No abnormal readings were found, but when C153 ( $1\mu$ F) was momentarily shorted the LC display came on. Shorting C153 makes Q159's collector, which is connected to IC151's reset pin, go high. On the assumption that IC151 was not able to reset internally we fitted a replacement. Everything then functioned normally. **R.A.**

## Sony CCDTR75E

The reported fault was that there were no functions and a tape was stuck in the mechanism. After removing the tape and checking for any obvious mechanical problems we inserted a cassette. It seemed to load correctly but when we tried there were no functions and the tape was once more stuck. After several more attempts at loading it became clear that the cause of the problem was a capstan fault. In fact the capstan motor didn't turn – it merely twitched. A new CXA1127AM capstan drive chip restored normal operation: one of its three-phase drive outputs had failed. **D.C.W.**

## Bauer VCC526AF

The complaint with this full-size VHS Panasonic clone was that it produced noise on the sound with recordings. We

soon found that the noise was there during playback as well – the lower capstan motor bearing was worn to the extent that the rotor scraped against the motor's windings. When the capstan shaft was rotated by hand the noise was not evident: the symptom occurred only when sideways pressure from the pinch roller was present. A new set of bearings cured the problem. **D.C.W.**

## Sony CCDF375E

There was no playback sound. A check with another machine proved that sound was being recorded. The playback audio f.m. signal from the video heads passes via the servo/syscon PCB, where there are a buffer stage and a stage of amplification. The  $0.01\mu$ F coupling capacitor between the two stages, C401, was open-circuit. **D.C.W.**

## Panasonic NVS5B

The complaint was of a 'cinemascope viewfinder'. On inspection we found that the fault was lack of height in the electronic viewfinder display. Recordings made and then played back on another machine proved that the camera operation was o.k., and an AV link to a monitor to display the live picture proved that the fault was within the EVF unit.

The EVF PCB is fitted inside the camcorder's right-hand side casing. Viewfinder brightness and focus controls are accessible through a small oval hole sealed with a rubber cap. There's also a height control on this PCB, but it's not within reach of the adjustment hole. A little judicious pressure on the PCB, using a plastic probe inserted through the hole, cured the fault intermittently however. There was obviously a dry-joint somewhere.

The palmgrip casing was dismantled to gain access to the EVF PCB, which was then removed and examined. The cause of the fault would probably lie in the area of pins 1 and 5 of IC801 and resistors VR801 (height) and R802/R827. But despite a close examination, using a x10 headband magnifier, no fault could be seen. We decided to apply a small bead of rework flux to each suspect joint in the area, using a sharpened matchstick, and then use a Weller hot-air soldering tool to heat each joint in turn until the solder flowed. During this operation the surface-mounted components were held in place with fine tweezers, to prevent them moving while the solder was fluid.

When we reassembled the camcorder and tested it we found that the fault had been cleared completely. This was confirmed by several periods of recording and playback with 'rough' handling and vibration to try to recreate the fault. Everything was o.k.

A week later another NVS5 arrived in the workshop with exactly the same fault. It also responded to the reflow treatment. **J.C.P.**

## Panasonic NVS5B

Intermittent no zoom was the complaint with this palm-corder. When we stripped it down we found that simply touching the flexicable between the process CBA and the main CBA produced the fault. A new flexicable (VWJ049S) cured the fault. **B.S.**

# VCR Clinic

Reports from Michael Dranfield,  
Ed Rowland, Nick Beer, Chris Watton  
Stephen Leatherbarrow, Mike Leach,  
Michael D. Maurice, Savio Da Costa  
and John Edwards

## Ferguson FV26D

Because the brakes didn't come on in the rewind and fast forward modes there was tape spillage. A check with an identical machine showed that in the faulty machine the windmill, item 54 in the exploded view, turned both ways while in the good machine it turned only one way. The cause of the fault turned out to be a broken clutch spring, item 55 part no. PQ42002. Note that in this machine the capstan motor has to be removed before the loading block assembly can be lifted out.

M.Dr.

## Saisho VR3300X/Matsui VX735

The customer's complaint was that there was no picture. When we carried out checks we found that the video signal entered the modulator but didn't emerge at the r.f. output socket. It was evident, when we took the modulator out, that someone had been having a go. The aerial input socket was held by solder in a manner that resembled bird droppings, and there were solder splashes on the PCB inside. We cleared the shorts, resoldered the socket and refitted the modulator. Everything worked all right – until record was selected. In this mode the E-E sound disappeared.

After spending a lot of time searching and checking along signal paths we eventually found that the fault cleared when the supply to the bias/erase oscillator was disconnected. The cause of the fault was that the bias level potentiometer VR5002 had been set at maximum. Somehow this excessive level of bias current swamped the audio. We have had this fault since in another machine that had been got at by the customer.

M.Dr.

## Aiwa HVG71K

Should there be no capstan motor rotation, check R266 (3.3 $\Omega$ ) before, if necessary, replacing the motor drive chip IC206.

M.Dr.

## Amstrad VCR4500

This machine wouldn't accept a cassette and the function LED was permanently alight. Voltage checks in the power supply showed that the all-time 12V line was low at just over 2V. As application of 12V d.c. from an external source restored all functions, checks were carried out around the 12V regulator Q651. Although resistance readings failed to reveal anything amiss, when Q651 and D655 were replaced normal operation was restored.

E.R.

## Panasonic NVJ35B

The problem was no record chroma. Scope checks showed that everything was in order up to the 1.6MHz LPF section of the multi-filter package FL801 (ELB4W002). It was open-circuit.

N.B.

## Amstrad VCR6100

A loop of tape would be left after fast-forward operation. As a result there would be chewed tape if eject was then selected. The cause of the problem was inefficient braking

of the supply spool – little wonder as the brake pad had been removed! When a replacement had been fitted there was permanent supply spool braking in fast forward and rewind, as the supply brake arm wasn't being released. In these modes it should be released by the take-up arm, which is moved by the brake actuating lever, being released by the lever on its own in the play and record modes. The cause of the problem was that the take-up arm was the wrong shape. A new arm of the type used in the VCR6000 put matters right. One wonders whether the wrong arm had been fitted during production or whether it was simply incorrectly moulded, also who had removed the pad instead of dealing with the problem properly!

N.B.

## Sharp VC780HM

This machine would intermittently go into play from cold then unlace because the capstan didn't rotate. The fault occurred about once a day. Because of the fault's unpredictable nature, and the fact that the machine would revert to stop whenever the fault occurred, it was virtually impossible to do any fault finding. A new cam switch seemed to provide a cure.

N.B.

## Ferguson FV31R

This machine was dead but the fuse was o.k. and the characteristic squeal was heard as the power supply started up. Failure to operate was due to loss of the 5V supply to the timer microcontroller chip. Fusible resistor RK44 (1 $\Omega$ ) was open-circuit.

N.B.

## Panasonic NV7000

Apart from the clock this old-stager was dead. Fuse F1002 (4AT) was open-circuit because one half of the full-wave encapsulated rectifier D1006 was short-circuit. Once the machine had been got going it required a bit of mechanical work, which was hardly surprising.

N.B.

## Samsung SI1240/1260

A cassette was stuck in this full-lace machine because there was no loading motor drive. The KA8301 chip IC206 had obviously been getting hot as the solder on its legs had melted and was now crystalline and dry. A replacement chip, type BA6209K, got things going again after we'd made sure that there was no excess loading on its output (shorted motor etc.). A long soak test proved that the machine was now all right.

N.B.

## Hitachi VT520

This machine would load. Then the drum would stop – the capstan never started – and the deck would remain still until the mains supply was switched off and on again. The deck would then unload and the machine would switch off. When the voltages at the mode control inputs (pins 11, 12 and 13) of IC901 were checked I found that 3.3V was present at pin 11 whatever the position of the deck. The cause was a leaky

mode switch. A new switch restored normal operation – note its position before you remove it. C.W.

### Saisho/Matsui VCRs

A number of these VCRs have a little plastic item to release the limiter post. It tends to break, the usual complaint being that the machine is stuck in pause. Actually the pinch roller is jammed by the limiter post. There are various sources for this item. Unfortunately the pivot hole is sometimes too large, the result being that the limiter post again jams as it doesn't move far enough from the pinch roller. C.W.

### Ferguson 3V35/JVC HRD120

No playback or record colour is not uncommon with these machines, due to faults around the crystal oscillators. On this one however the cause of the trouble turned out to be the colour/monochrome/test pattern switch at the back. It had become leaky. C.W.

### Samsung VI710

This machine had no clock display. We found that the 6-8V zener diode ZD102 in the 30V regulator circuit on the power supply panel was short-circuit. C.W.

### Ferguson FV32L

When this machine was first switched on the drum motor hunted, the picture tore and line slip developed. The picture began to stabilise as the machine warmed up, but it never became stationary. Since the fault was worse when the machine was cold I got out the freezer and hairdryer and began my attack. Any heat in the servo area lessened the effect of the fault, but no amount of freezer made it worse. So I removed the bottom cover and applied gentle heat to the drum motor PCB. The fault then disappeared. When a shot of freezer hit C6 (3-3 $\mu$ F) the drum almost span off the deck. After replacing this sub-miniature capacitor perfect control at all temperatures was restored. C.W.

### Amstrad VCR4600

This machine produced a corrugated picture with both its own recordings and prerecorded tapes. There was obviously something amiss around the head drum. I checked the guides and the tape path for cleanliness. All was well here, so suspicion fell on the lower drum/motor assembly. As we had one in stock it was quickly fitted. This cured the ragged picture, but the head switching point was about two inches from the top of the screen and couldn't be adjusted. Inspection of the motor then revealed that it had a different magnet assembly. So off with the one from the old motor – only a couple of screws. When this was fitted to the new unit and everything was set up the machine worked as it should. C.W.

### Samsung VI710/Logik VR955

There was no E-E picture and no playback colour. Both symptoms were caused by D102 (1N4002) in the power supply. It's the source of the always 12V supply, which was low at only about 7.5V. C.W.

### Samsung VI710

When the power switch was pressed the channel indicator in the clock display lit up but not the indicator at the

bottom. The deck was dead. The output from the power unit has a PC15 that didn't come on with the power control command, which was present. We found that the 15V section of the STK5333 power regulator chip was open-circuit. C.W.

### Hinari VXL8

This machine had virtually no capstan drive, i.e. there was no play, rewind or fast forward. Control of the capstan motor centres around the BA6219 chip IC106. Its supply at pins 7 and 8 was o.k. at about 15V, but pin 4 was at 0V. This could have been because Q105 was short-circuit or biased fully on, but what we actually found was that the 9-1V zener diode D110, which is connected to pin 4 of IC107 (another BA6219), was the cause of the fault. As IC107 is the loading motor drive chip this calls for some further explanation! D110 straddles the print run from pin 4 of IC106. It's glued down, with just the PCB varnish for insulation. Lifting the diode clear and insulating it provided a complete cure. Just to add to the fun, the fault was initially intermittent. S.L.

### JVC HRD660

The deck functions were normal but there was no front panel display. Absence of the -30V supply at pin 2 of CN1 was the cause. We found that the safety resistor R2 (47 $\Omega$ ) had gone open-circuit. A long soak test proved that there was no contributory cause for the failure of R2. S.L.

### Samsung VI730

There was a blank raster with no sound though playback was normal. The supply voltages were correct at the tuner and i.f. cans, but no video emerged from the latter. When pin 1 of IC404 (TA7348) was lifted the video returned on the scope's screen. IC404 had a crack down its centre. The video signal was now being weakly displayed but there was still no sound. This was because the TA7348 audio switching chip IC403 was also faulty. The video coupling capacitor C415 (10 $\mu$ F, 25V) was short-circuit and the video input socket's terminating resistor R416 (75 $\Omega$ ) was open-circuit. We feel that the customer knows more than he is prepared to reveal about the causes! S.L.

### Ferguson 3V29/JVC HR7200

Two of these machines have been in our workshop recently with audio faults. The first machine would record the sound, albeit almost inaudibly, but failed to erase the previously recorded sound. There was plenty of bias at T1, but it wasn't reaching the erase head. In the record mode the bottom end of RY1 wasn't being switched via pin 89 (audio dub line). In fact the voltage here varied between 5V and 12V. The cause of the problem was the  $\mu$ PA81C chip IC5 on the mechacon PCB.

The second machine also failed to erase the sound, but for more bread-and-butter reasons – the erase head plug/socket was intermittent. We cut it off and rewired directly. S.L.

### Hitachi VTF770

This machine would shut down about two or three seconds after being switched on. The display came up, but no tape functions seemed to work. The cause of the problem was no loading motor drive because the BA6209 drive chip had

failed. Unfortunately the failure of this chip had resulted in the mechanics going badly out of sync. The mode switch had to be replaced and the mechanics realigned. **M.L.**

### **Hitachi VTM710**

When this machine came in there were no functions and no display. It was kept for about a week before we got around to it. We then found that it worked, though it didn't produce a picture. The display came up, the tape loaded and play could be selected. We assumed that the machine had locked up and that the week's rest had done it a bit of good. The no picture symptom was caused by the fact that the modulator didn't produce an output – the switched 12V supply was missing. This comes from the power supply, the switching being controlled by the power control line from the main microcontroller chip. The line was high at 2.3V instead of being at 0V. When the  $\mu$ PD75516-108 microcontroller chip (IC901) had been replaced the switched 12V line was present and the machine worked perfectly. We checked the mode switch and mechanism as a precaution. **M.L.**

### **Hitachi VT120/VT220**

Intermittent loss of colour has been the fault with several of these machines we've had in for repair. In each case replacement of the HT4539B chip IC301 on the Y/chroma PCB has cured the trouble. **M.D.M.**

### **Ferguson 3V29/JVC HR7200**

We were asked to quote for fitting a new capstan motor and suggested that we should inspect the machine first. When we opened it up the cause of the problem turned out to be a loose capstan belt – it was just about ready to fall off. A set of new belts and a clean up made the customer very happy. **M.D.M.**

### **Panasonic NV430**

The rewind, stop and eject keys worked but the others didn't. All functions worked when the remote control unit was used. The cause of the fault was that R6554 (2.7k $\Omega$ ) on the operation PCB was open-circuit. **S.DaC.**

### **Panasonic NVG30**

The clock lit but the VTR switch wouldn't. If a tape was inserted the machine would switch on but wouldn't go off. There were no deck functions, with either manual or remote control. All this was caused by a faulty M50395V4AB clock chip (IC7501).

With another of these machines the squelch characteristic at switch-on was muted and the machine would remain dead. D18 was short-circuit.

A third machine that came in was dead with a blackened fuse. The STR1806E chip was short-circuit all ways. We replaced the 2.2 $\Omega$  feed resistor R1002 as well as a precaution. **S.DaC.**

### **Panasonic G Deck**

We recently had in a couple of Grundig machines, Models VS500 and VS540, that use this deck. As the tape wouldn't lace up to the capstan the pinch roller touched it with no tape in between. The P5 unit wouldn't come into position fully, failing to sit in position in the pinch cam

rift. The P5 pull-out sector gear which controls this was slightly cracked at the corner. A replacement restored normal operation. We've also had several Panasonic machines with this fault. **S.DaC.**

### **Panasonic NVL10**

This machine would load a tape to just about the stop point, then eject it. The cause of the problem was a faulty take-up sensor. **S.DaC.**

### **Panasonic NVG12**

The symptoms were as follows: there was no rewind, forward wind or play; the capstan motor was shunting; and the drum motor ran at full speed. A quick check showed that the 4.43MHz clock signal from the video pack was missing. This signal is produced by IC8001 which on inspection was cracked. A replacement restored normal operation.

We find that this fault is now quite a common one with several Panasonic models, in particular the NV830/NV870 series. **S.DaC.**

### **JVC HRD455**

This machine actually wore Saba livery. The complaint was of periodic tracking bars, the tracking knob having no effect. We found that when play was selected the machine seemed to be in fast search for two seconds, then stabilised. Replacement chips in the servo section had no effect. When an off-air recording was tried we noticed that the channel number wouldn't change and the memory couldn't be used. The drum and capstan speeds were erratic and there was slight hum, the picture flicking about. A check on the switched 12V line produced a reading of 19.5V. All these problems were being caused by Q2 in the power supply: it was leaky all ways. **S.DaC.**

### **Samsung VI710**

Every couple of days this machine would fail to produce an E-E or playback picture. As there was no r.f. output the monitor just displayed noise. When the fault finally showed up in the workshop I noticed that the deck functions worked but there was no test signal and the channels wouldn't search. As a start I checked the power supply outputs at connector CN104. They were all correct. But something seemed to be amiss in the power supply system. The 15V line feeds the 12V regulator transistor Q105. A voltage check at Q105's collector produced a reading of 0V. The cause was a dry-joint at L105. Relief all round: when this coil was prodded the machine came to life. Resoldering L105, also D114 and Q105 to be on the safe side, restored reliable operation. **J.E.**

### **Ferguson 3V36/JVC HRD225**

The playback picture and sound were in slow motion, with tracking lines. Occasionally correct pictures and sound would appear, followed by a screeching noise then a return to the fault condition. When the capstan motor was removed I found that its shaft was very tight. A new motor cured the problem. **J.E.**

### **Toshiba V71**

No reel rotation and thus chewed tapes was the complaint with this machine. The cause was the TA7267P reel drive chip IC603. **J.E.**

## **Panasonic NVM7**

The customer's complaint was that this camcorder would fail after twenty minutes or so. In fact the battery was defective. Strange, as the battery low warning didn't show and the current consumption was o.k. **S.DaC.**

## **Panasonic NVM7**

There was no camera picture, just a blank screen. We found that the camera 16V supply was missing at pin 5 of connector P3003 though it was present at TP1001. Obviously there was a break somewhere but a jumper wire restored a good picture. **S.DaC.**

## **Telefunken 890 (VHS-C)**

This camcorder wouldn't play or record because the drum ran at full speed. When we opened the unit the screw that secures the cassette lid jumped out and we found that the three cassette deck mounting poles had broken away from the main housing – the deck was virtually falling off. We fixed the poles with superglue, securing the deck, and all was well when the unit had been reassembled. Presumably the camcorder had been subjected to shock and that screw had shorted somewhere without causing a massive fault. **S.DaC.**

## **Panasonic NVM1**

We recently had three of these camcorders with different faults. The first had no EVF picture in any mode, just a blank screen. Q3004 on the luminance PCB was open-circuit all ways.

The second machine would record but had no playback picture or sound. We found that the except Rec 5V line was at 0.86V because Q6004 on the syscon panel was open-circuit base-to-emitter.

The third one had a tape jammed inside. When we powered the machine it switched on then went off after a few seconds. The loading motor didn't operate and its driver chip IC6004 was decidedly hot. A replacement i.c. restored motor operation and the tape unloaded but didn't wind back into the cassette. There was no capstan rotation because its driver chip IC2006 was faulty. **S.DaC.**

## **Panasonic NVMS4B**

This machine was totally dead – no lights, action or anything. Voltage checks around the main systems micro-controller chip, which has a frightening number of legs, showed that the systems 5V supply was missing. The S81350HG-KD 5V regulator IC6010 and the associated 2SD1328 switching transistor Q6010 were both faulty. **B.S.**

## **Panasonic NVM10B**

There was a most surprising fault with this full-size camcorder. The electronic zoom operated slowly at switch on, going to full telephoto. After this the lens would usually work normally. Sometimes on auto-focus however it would move slowly to full telephoto: this occurred only when the picture was out of focus. I

vaguely recalled a feature of this model. If you leave the unit in macro, switched to auto-focus, at switch on it will zoom out of macro before attempting auto-focus. I immediately began to search through my box of used lenses. Digging out an old NVM10 lens, I removed the optical position sensors then fitted them to the faulty camera. Much to my relief this provided a complete cure. The defective sensors measured all right and the reflective strips were cleaned, but new sensors had to be fitted. Since my first experience I've had this fault with another NVM10B, so beware. **B.S.**

## **National VWAM7BA**

This is the power supply/charger/r.f.-av adaptor for the NVM7 camcorder. It has a switch-mode power supply with an f.e.t. as the chopper device. The unit was dead because there was no chopper drive, though the start-up voltage was present at the control chip. The cause of the fault was lack of feedback from the secondary side of the supply because rectifier D1001 was dry-jointed on all three legs. **N.B.**

## **Panasonic NVS6B**

When this camcorder powered up, the picture from the camera head flashed like mad. The iris was opening and closing at an alarming rate, with no apparent damping. A new iris assembly put matters right. **S.B.**

## **Panasonic NVM40**

In both record and playback a clicking noise could be heard coming from the mechanism. The cure consisted of removing a foreign body from the capstan motor area followed by motor rotor/stator clearance adjustment. **S.B.**

## **Fuji F610/Sony CCDF330**

This one came in with a damaged lens. I tried to fix it with sticky-backed tape but this didn't hold very well. After fitting a replacement lens deep depression set it: there was an unreported fault, intermittent loss of playback colour. We traced the cause to the colour a.f.c. filter capacitor C461. **S.B.**

## **Telefunken 4300**

The customer had two complaints with this machine: noise bars on the picture and cassette eject failure. Retiming the loading mechanism restored correct mechanical operation. The noise bars were being caused by a faulty video head preamplifier. **S.B.**

## **JVC GRAX2**

The reported faults were no camera operation and the viewfinder blank when recording. This camcorder had suffered from rough handling, as a result of which the camera PCBs had sprung apart. Reassembly was all that was required. **S.B.**

# VCR Clinic

*Reports from John Edwards, Nick Beer, Michael Dranfield, Stephen Leatherbarrow, Hugh Allison, Philip Blundell, AMIEE, Terry Lamoon, Eugene Trundle, Brian Storm, Chris Watton and Bob McClenning*

## Ferguson 3V35/JVC HRD120

This machine would go dead after a few minutes or sometimes days. There would be no functions and no displays – nothing. We found that slight movement of the rear, vertically-mounted power supply board would initiate the fault. So we removed the board and examined it with a magnifying glass. This showed that pin 4 of CN1, which supplies the board via the mains transformer, was dry-jointed – a slight ring was just noticeable around the solder joint on the PCB. Resoldering cured the fault but for good measure we went over the whole board as some other joints looked a bit dodgy. **J.E.**

## JVC HRD720/640/860 etc

We've had the following problem with several of these machines. When the machine is plugged into the mains supply the loading motor attempts to lower the carriage then, after a few seconds, gives up and attempts to return the carriage to the eject position. This is accompanied by buzzing, clanging and crunching noises. We can't be sure of the cause, but the cure is always the same.

Remove the carriage housing and note the position of the alignment hole in the large rotary cam beneath the pinch roller. The hole should be at approximately the 12 o'clock position and over the hole in the deck chassis. If this is not the case, which is likely, rotate the worm drive that runs alongside the cam until the holes line up. When the carriage has been refitted normal operation will in all likelihood have been restored. If not the carriage is suspect – check for faulty end sensors or the mechanics being broken or out of alignment. **J.E.**

## Akai VS2

The problem was intermittent sound in the playback and E-E modes. Its cause was an open-circuit screened lead connected to socket J8. As there was plenty of slack we were able to cut back beyond the break, redress the lead then resolder it to the socket pin. Our fault-finding was aided by the fact that movement of the lead made the sound come and go. **J.E.**

## Samsung VI1260

The following fault is beginning to show up regularly on these machines: after a few seconds the VCR returns to standby, with no capstan motor rotation. The cause of the fault is always diodes D109, D110, D212, D213. Always check by measuring the voltage across the diode – with a good diode the cathode voltage will be 0.7V less than the voltage at the anode. We have found that with some diodes there is as much as 4V or more across the device, though the diode reads correctly when checked with a meter. Any diode from 1N4001 to 1N4007 will work all right in these positions. It's best to replace all four diodes to prevent comebacks. **M.Dr.**

## Ferguson FV33H

When a recording was made and played back the sound switched between Nicam and mono at a cyclic rate. The

changes were accompanied by a servo twitch on the picture. A colleague suggested that cleaning the audio/control head might be a good idea. Doing this provided a complete cure. **M.Dr.**

## Sharp VCA105HM

Two of these machines have been regular visitors to the workshop over the past couple of months, both with the same intermittent fault: during ejection the tape would get stuck before the process was completed. If the tape was wound out manually everything would be all right until some weeks later when the customer would return the machine with another tape jammed inside.

We approached Sharp Technical on several occasions, as a result of which various parts were replaced, including some kind of modification PCB on the cassette housing, but the fault persisted. As we'd never seen the fault occur it was difficult to know what to do. Finally both machines arrived at the shop together. A careful examination with the machines side by side, one with the tape ejected and the other with the tape stuck, showed that both main decks were in the same position mechanically. This could mean only one thing, that the cause of the fault was the cassette carriage. Very careful investigation of the housing showed that just before the cassette lift arm, item 308, came to the vertical position the clutch could jump out, disengaging the drive to the lift assembly. It seemed certain that the clutch latching bar, item 319, was the cause of the trouble but to be on the safe side and avoid further comebacks we ordered two new cassette housings. Examination of the new housings showed that the latching bar and clutch operating lever (item 321) have been redesigned. We have subsequently fitted just these two items, with no further problems. Part nos. are latching bar MLEVP0140GEZZ (item 319); operating lever MLEVP0139GEZZ (item 321). The new latching bar has a rectangular cutout, the cutout in the old latching bar being angled at one side. **M.Dr.**

## Samsung VI611

Here's a quickie on this range of models. For no signals check R6 (3.9k $\Omega$ ) on the power supply PCB – it feeds the 33V regulator. We've had this resistor go open-circuit on a number of occasions. **S.L.**

## Ferguson 3V30/JVC HR7300

Because the optical reel sensor produced no reel pulses this machine would stop in any mode. The 11V supply that should be present at pin 3 of the sensor PCB was missing. It comes via pin 63 on the small subpanel that's mounted to the right of the deck (viewed from above). The track between pins 25 and 63 on this PCB was open-circuit. On another of these machines the same fault was caused by the fact that the lead from pin 63 to the sensor PCB was open-circuit. **S.L.**

## Amstrad TVR1

Two well-defined lines, approximately half and two-thirds of the way down the screen, were present during playback.



They looked very much like head switching point signals. Initial panic was followed by recollection that we'd come across this one before: C2 (10 $\mu$ F, 16V) on the lower drum PCB assembly was open-circuit. This fault could well occur with the similar drums fitted to other TVR models. **S.L.**

### **Ferguson 3V35/JVC HRD120**

This machine didn't play back audio because the playback level potentiometer was open-circuit. The result was no audio signal but a very noisy output of crackles, pops and white noise. **S.L.**

### **Sharp VC9300**

I thought everyone knew this dodge, but when a friend rang up and said that he'd undone the screws but couldn't remove the head I thought I'd better pass it on. In this machine there's a little cover over the wires that connect the heads and the rotating transformer. To change the drum you have to remove this cover, which is held by quarter-inch long screws. You can then get to and undo the half-inch long head securing screws. If the head won't budge, simply put the longer screws down the screening cover holes. The thread is the same but as the head screws are longer they bottom on the housing and thus force the head off. I suggest tightening the screws to the bottom by hand, then a further quarter of a turn to them alternately with a screwdriver until the head breaks free. **H.A.**

### **Toshiba V312**

This machine was jammed. On investigation we found that the main cam gear was damaged. The new one came with a modified soft-brake lever enclosed, so it would seem that this is a common problem. **T.L.**

### **Philips VR522**

When a tape was loaded a very nasty noise came from the vicinity of the video heads. I stopped the machine and inspected the heads. There was a very nasty groove in the upper drum. Wondering what could have caused such damage, I looked at the rest of the mechanism and noticed that the left guide arm was at a peculiar angle, pointing into the drum. It locked back into position with a push. I then saw that the impedance roller was loose. After tracing the holding spring and rebuilding the assembly the machine worked normally – except for the need for new heads as they were by now totally useless. I assume that the damage had been done by someone using extreme force to extract a jammed tape. **T.L.**

### **Akai VS485**

When this machine was switched on we found that it was in limbo, with a tape stuck inside. When the tape was released and the machine was once more powered up it worked perfectly. But it's wise with these machines to check the loading gear on the cassette carriage. We found that the half-moon gear was in poor condition while the metal running gear that operates it was very sloppy. A replacement gear cured the first problem, but the other fault required a simple modification that comes from Akai. It consists of a small U-shaped piece of plastic which you glue into position just beneath the metal gear retaining clip. This has the effect of tightening up the gears and preventing damage to the plastic ones. Once it

was dry we replaced the carriage and the machine worked perfectly. **T.L.**

### **JVC HRD640**

Don't get caught out like I did with this machine! It came in with a faulty mode switch. We fitted a replacement but the machine bounced back with all these symptoms: momentary formation of a tape loop while unlacing; failure to come out of the pause mode, followed by shutdown; and intermittent tape spillage during eject. What we'd fitted was slide switch PU60973 which looks right and fits perfectly but is intended for an earlier model. The correct part number for the HRD640's mode switch is PU61247. **E.T.**

### **Panasonic NV730**

These machines are now old but since we've had a couple in recently both with the same nasty intermittent fault the following note may be useful to others. The symptom is that the machine suddenly stops during record or playback: when the cassette is ejected you find that there's a crumpled loop of tape hanging from it. The cause of the fault is dry-joints at the connections to the reel-motor voltage-regulator transistor Q1504 which is mounted on an L-shaped heatsink in the rear right-hand corner of the machine. **E.T.**

### **Philips VR6670**

This machine was dead: the 3.3 $\Omega$  resistor R3024 was open-circuit and the BUT11AF chopper transistor was short-circuit. Cold checks on the rest of the circuit showed that the BC547 transistor Tr7001 was open-circuit. Replacing all three items restored normal operation. **P.B.**

### **Ferguson FV33**

This machine worked normally in the SP mode. In the LP mode however there was a blank screen, though the sound was normal. Embarrassment prevents me from disclosing the full extent of the testing that ensued. Suffice it to say that in the LP mode the FV33 is an audio only machine. If Ferguson manuals included the details in the customers' instruction book I'd have realised this sooner. **P.B.**

### **Panasonic NVJ47**

The complaint we've had with some of these VCRs has been of whistling or buzzing when the machine is switched off. Although I'm unable to confirm the exact nature of the sound, perhaps because of deafness to line and field scan noise as a result of length of time spent in this trade, I can report that a squirt of sealant on T1101 in the power supply puts an end to the trouble. **B.S.**

### **Hitachi VT33**

The ticket said that this one worked for only a few seconds. Simple idler replacement and service I thought. But when I inserted a cassette the lift moved so quickly that it almost pulled me in. Then the power LED went off. When I switched on again and ejected the cassette it came out very fast. I decided to check the power supply to the cassette lift motor and found that the voltage was high. A check around the STK5421 power supply chip then showed that the 9.5VA and 9.5VB lines were both at 17V. A new STK5421 restored normal operation but a new idler and deck service were required. **C.W.**

## Hitachi VT17/B and O VHS80

This early Hitachi machine suffered from intermittent capstan motor drive. As it's not uncommon I expected to find a dead spot in the capstan motor. The cause of the fault turned out to be diode D511 on the top panel however. It responded to the hairdryer and freezer every time. **C.W.**

## Sharp VC9700

When this machine was first plugged in the clock came on but went off again after about thirty seconds. A large red thing on the print side of the audio panel was getting very hot: a shot of freezer here would bring back the clock for a few seconds after which it would fade away again. A check on the resistance of this positive-temperature coefficient thermistor, which is marked 4R7, produced a reading of 50Ω when cold and a few hundred ohms when hot. A replacement obtained from a scrap machine restored the correct display brightness. **C.W.**

## ITT VR3918

Rewind and fast forward were perfect, but when play was selected the machine would instantly unload. The drum didn't rotate, hence no pulses to the microcontroller chip. During play pin 14 of IC4001 was low at only 0.8V instead of 2.5V. Fitting a new LC7142-8017 chip (very expensive) restored the correct voltage and drum rotation. **C.W.**

## Matsui VX3000

The cassette went in then came straight back out again. Checks on the switching at the lift and on the end sensors were fruitless. A new OEC0017B system control chip had to be fitted. **C.W.**

## Tashiko VVE921/GoldStar GHV12211

Play and fast forward were o.k., but when rewind was selected the machine would run for about thirty seconds then stop. If rewind was pressed again you got another thirty seconds of operation. I followed the usual procedures – changed the reel drive parts such as the idler and belt, and cleaned and lubricated the various parts – but the fault remained the same. Turning attention to the electrical side, I checked the voltage feed to the capstan motor which also drives the reel system. Nothing wrong here, even during rewind. So suspicion fell on the capstan motor itself. When I'd removed it and taken it to pieces I found that the bearings were as dry and tight as could be. Lubrication gave new life to the motor: rewind now worked, and fast forward was much faster. **C.W.**

## Philips VR6462

This machine wouldn't accept a cassette. If the cassette was placed in the slot however and a key such as play or stop was pressed, the tape went in and the machine worked normally. The cause of the problem was a shorted switch in the lift housing – as a result the machine thought that a cassette had already been inserted. **C.W.**

## ITT VR3907

This machine wouldn't switch off. The channel indicator was lit, so was the power-on LED. If the machine was playing and the power button was pressed the tape would unload but the lights remained on and the E-E voltages

remained. We found that a transistor, TR2, in the power supply was leaky. A TIP42 is a suitable replacement. **C.W.**

## Panasonic NVG40

There was sporadic loss of sound with this machine's own recordings. The recordings themselves were o.k., as a check with another machine proved, and playback of prerecorded tapes was all right. The answer to the problem lay in realigning the audio/control head assembly in order to provide the microcontroller chip with better pulses. It was muting the sound at pin 18 of IC4001. **B.McC.**

## Tashiko VVE922/GoldStar GHV21401

The problem with this machine was occasional wobbly pictures. The cause was found to be the 1μF, 50V decoupling capacitor C712 in the i.f. unit. Curiously, this changes the action of the a.g.c. potentiometer. **B.McC.**

## Grundig VS200

The problem here was occasional tape damage and loading problems. With a little perseverance we found that the switch behind the brake solenoid didn't make contact every time. Thus the machine locked up. Cleaning cured the problem. **B.McC.**

## Sharp VC780HM

A colleague had been looking at this one but couldn't work out why it would jam when unlacing. On dismantling the mechanism and carrying out a closer examination I found that one of the two cams – not the cam-switch one – had a broken wall on its hidden side. Replacement and retiming got the mechanism working properly again. **N.B.**

## Salora SV8600/Mitsubishi HS337

There was no reel drive as the brakes weren't being released in the fast forward and rewind modes – playback was o.k. The cause of the trouble was that the brake release bar latching lever spring beneath the mode motor assembly was disconnected at one end. **N.B.**

## Sharp VC781HM

It's not uncommon to get tape riding in these machines because the pinch roller is worn and deformed or the arm is bent. With this one however the problem was bad riding in the cue mode because of excessive friction prior to the exit guide. Reducing the back tension alleviated the problem, but the cause was the surface of the lower drum. **N.B.**

## Salora SV8600/Mitsubishi HS337

This one came in from another dealer who was having difficulty with it – the cassette carriage was up, the guide poles were forward and the pinch roller wasn't engaged! I stripped down the mechanism, cleaned and regreased everything, put the lot back together again in the correct timing sequence and replaced the mode switch. The result: a working machine. **N.B.**

## Logik VR960A

A common problem with these small machines is poor/low sound. The cause is simply a worn audio/control head. **N.B.**

## Panasonic NVS5B

The fault with this palmcorder was no focus or zoom operation. With a camcorder I always suspect the worst and check for any signs of lens damage due to misuse. This time the user was not guilty. The cause was a faulty zoom motor, part no. VEM0314. **B.S.**

## Sony CCDTR45

There was either very poor rewind or no rewind at all. The fault also affected the cassette eject operation as a loop of tape was left. Replacing both turntables and the intermediate gear restored correct operation. **S.B.**

## Hitachi VM200

The complaint with this one was of viewfinder flicker. A new connecting cable put matters right. **S.B.**

## Grundig VSC45

This machine is a Panasonic clone: the cassette door wouldn't close because the mechanism was in the eject mode. A new loading motor and mode switch restored normal operation. **S.B.**

## JVC GRS77

The problem was picture break-up, but only with S-VHS recordings. We traced the cause of the fault to a THE326A non-linear pre-emphasis chip. **S.B.**

## JVC GR65

Following impact there was no viewfinder operation – fortunately the problem was confined to the viewfinder. There's a scan-correction capacitor attached to the PCB by long legs that tend to fracture. Careful repair by scraping away the varnish in the winding and resoldering the connection provides a cure. The capacitor can be secured by tape or by use of a hot-glue gun. **S.B.**

## Grundig VS8250/Sony CCDF375

There were no camera functions. Tests soon showed that the camera d.c.-d.c. converter wasn't being switched on by the microcontroller chip. The camera/off/play switch was o.k. as the machine would play back, and the switch was being scanned by the microcontroller chip. We eventually isolated the cause of the fault to the circuit that scans the record lock switch on the side case. As the K out line from the microcontroller chip had no scanning pulses on it we fitted a replacement. This was not a good decision: the conditions were the same with the new chip installed. What we found after further investigation was open-circuit print beneath the audio and video output connectors, due to minor corrosion. The scanning pulses were absent because the pull-up resistor for the output port was on the input side of the K in 6 line, the open-circuit giving the impression that the chip wasn't working. Microsurgery was used to repair the damaged

print: the alternative would have been a new PCB and a lot of software setting up! **S.B.**

## Ferguson FC31

Because of a damaged record switch there were no record functions. I managed to replace the switch and secure it with glue – otherwise the whole cable would have had to be replaced, at great expense to the customer. **S.B.**

## JVC GRS70

The fault report said “no recordings and nothing on the viewfinder”. Checks showed that the camera power supply circuits were all working correctly, but there was no output from the CCD image sensor because of a bias problem. R24 failed to make contact at one end. **S.B.**

## Panasonic NVS5

The complaint with this machine was that it was “stuck in the cue mode”. This was not the case. The problem was that the capstan motor was running at a very high speed because of loss of FG control pulses to the servo control circuits. A replacement capstan motor, part no. VEM0384, put matters right. **B.S.**

## Panasonic NVMC6

We've had a few of these camcorders in recently with various capstan faults. Symptoms have been wowing, grating noises and, in bad cases, an unlocked capstan. In all cases the cause has been the capstan motor itself. Apparently the metallic coating on the rotor flakes off and rubs on the stator coils. I've found that it is best to replace the complete motor assembly (part no. VEM0284). **B.S.**

## Panasonic NVS5

This machine had two intermittent faults. First on occasions the drum wouldn't start to rotate from cold. Secondly there was sometimes bad playback picture disturbance, as if one head was faulty. Fitting a new drum and motor assembly, part no. VEG0927, cured both faults. **B.S.**

## Panasonic NVS6

We've had a few of these in with no electronic viewfinder display. In each case the cause has been an open-circuit in the EVF connecting cable, part no. VEE8055. **B.S.**

## Panasonic NVS5

A fault we've had several times with these palmcorders is no zoom. The cause of the problem is that an earthing clip on the process PCB slips out of position: as a result its three ‘fingers’ short out various points beneath the process board. Presumably onset of the fault is helped by a sharp knock in use. Refitting the clip cures the fault. **B.S.**

# VCR Clinic

*Reports from Nick Beer, Richard Newman, Brian Storm, Ian Bowden, Eugene Trundle, Mike Leach, Fauz Ahmed Sumar, John Coombes, Chris Watton, John Hepworth and John Edwards*

## Panasonic NVG40

This machine had been in several times with the complaint of intermittent loss of sound and counter operation in the playback mode, but the fault wouldn't put in an appearance in the workshop. As the picture apparently remained perfectly o.k., loss of control pulses, at least to the servo, was not the cause. This time however the fault was present, and the customer had been perfectly correct about the symptoms.

There was loss of control pulses at the microcontroller chip IC6001 – in fact there was no activity at the relevant pin. The pulses come from the servo section on the sub main PCB via connection 11, where the pulses were present. The soldering on the wire hoop, so often dry, was fine. From here the pulses pass, via both sides of the PCB, to the base of transistor Q2003. We found that there was no output at the collector of Q2003, though it was not open-circuit. In addition the d.c. conditions around Q2003 and the following transistor Q2004 were correct. Careful checks showed that the pulses at the base of Q2003 were of about 35 per cent lower amplitude than those at pin 11 of the sub main PCB. This disparity was detected across the 10 $\mu$ F, 16V coupling capacitor C2022 which turned out to be low in value. **N.B.**

## Panasonic NVJ40

The job card said "no playback for the first half hour, then bad patterning". It turned out to be an accurate description. Checks showed that from cold transistor Q3204, which provides the 'except record 5V' supply to the head amplifier playback circuits, wasn't fully conductive. The supply would gradually increase from about 2V (no picture) to 3V (poor picture with lines across) then 4V (reasonable picture with patterning). After much investigation in the switching and biasing circuits, all to no avail, I finally found that C1127 (330 $\mu$ F) in the power supply was the cause of the trouble. It decouples the 5V feed to the system circuit. **B.S.**

## Panasonic NVFS90

This all-singing, all-dancing editing machine would refuse to play back S-VHS recordings after about half an hour. Checks in the S signal channel brought me to IC303 (part no. VEFH05BT) which proved to be heat sensitive. A replacement restored the excellent picture. **B.S.**

## Philips VR6760

Distorted sound was the complaint with this machine. When we tried it out we found that the sound was very distorted – it was rather like an output stage with no bias. There was perfect sound however when we checked at the scart socket. This simple test saved us a lot of time. Both linear and hi-fi audio are fed to pins 1 and 3 of the scart socket via a couple of 470 $\Omega$  resistors. As the sound was o.k. here everything up to this point, including the switching chip IC7061, could be ruled out.

The sound feed to the modulator is via a couple of 100k $\Omega$  resistors and a buffer stage with a single transistor, Tr7904. Checks showed that there was a clean signal at one side of the two resistors R3925/6 but a very distorted one at the

base of Tr7904. The transistor was o.k. but its 3.3 $\mu$ F coupling capacitor C2917 had a 2k $\Omega$  leak. A replacement cured the distortion. **R.N.**

## Panasonic NVL20

This fault had been very intermittent and didn't show up in the workshop until it was provoked. The complaint was that the machine would stop during playback or record then power off. We found that pins 14 and 15 of connector P2001 were dry-jointed. These are connections to the capstan motor: when we flexed the joints during playback the capstan motor started to make a knocking noise then stopped, after which the machine tried to unlatch then powered off. **I.B.**

## Ferguson FV51R

This machine produced no results at all and the BD202 12V regulator transistor TP03 overheated mightily. As the 12V line feeds many circuits it took us a time to find that the u.h.f. tuner was responsible for the trouble, with an internal short-circuit across its 12V supply pin. Meanwhile the BC327 switching transistor TW41 had overheated and gone short-circuit. **E.T.**

## Panasonic G Deck

This mechanism often seems to throw up new faults – new to us, anyway! The trouble this time was a very intermittent raucous squeal at the completion of tape threading or during unthreading. It came from the brake pad that operates on the capstan flywheel. Clean the pad or replace the arm. **E.T.**

## Sharp VCA140HM

If the complaint with one of these machines is that it scrunches the tape once in a while – you're unlikely to see this actually happening – check whether the movement of the half-load arm is free. It can stick on dry grease. **E.T.**

## Nikkai NVR3/Cathay VCR7110

This machine displayed a number of fault symptoms: the front loading, drum rotation and eject were slow and there was no play. We did very little before we obtained a service manual, then found that all the voltages at plug P801 in the power supply were low – this included the ever 5V, ever 12V, ever 5.8V and MTR 12V lines. The cause was a leaky 5.1V zener diode, D812, in the power supply. A replacement restored normal operation. **M.L.**

## Samsung VI710

When this machine ejected a cassette it chewed the tape, which of course was not being wound back in. We assumed that the cause of the fault was mechanical and replaced the idler/clutch assembly, then checked the brake and soft-brake assemblies. None of this made any difference. As the

subpanel at the back of the deck is prone to dry-joints, causing various symptoms, this was next removed and checked. Once again we drew a blank. Eventually the cause of the trouble turned out to be the BA6209 capstan motor drive chip IC206 – it's on the subpanel we'd just soldered up. A replacement cleared the fault. **M.L.**

### **Hitachi VT120**

The complaint with this machine was low E-E sound. We traced the cause to a leaky 4.7 $\mu$ F, 35V capacitor, C08, in the i.f. block. **M.L.**

### **Sharp VC585H**

There were very smeary, low-gain E-E and recorded pictures. It could have taken some time to get to the bottom of this, but I'd had much the same symptom with a Sharp TV set a couple of years previously and the i.f. units looked alike. When the i.f. module in the VCR was heated with a hairdryer, the fault almost cleared and normal pictures were obtained. The cause of the trouble in the TV set had been a dried up 10 $\mu$ F, 16V electrolytic capacitor. When this same component in the VCR was replaced the fault again cleared. As there are no component reference numbers on the board I can't identify the component in this way. It's easy to find however, being the only red one on the board – all the other ones are blue. **M.L.**

### **JVC HRDX22**

The cause of no E-E and playback sound was traced to dry-joints at several of IC301's pins. A good solder up is all that's required. **M.L.**

### **Panasonic NVG10**

There was no playback colour with this machine. We traced the chroma signal as far as C8002 (0.01 $\mu$ F) which couples the signal to pin 31 (playback chroma input) of the luminance/chrominance pack. There was a signal at one end of C8002 but not at the other. A new capacitor restored the colour. **F.A.S.**

### **JVC HRD171**

Fast forward and rewind were all right but when playback was selected the tape laced up then, within a few seconds, unlaced because there was no drum rotation. After wasting a lot of time we found that the voltage at pin 20 (drum start/stop) of the VC2025 chip IC1 didn't go high when play was selected. Pin 20 was internally shorted to chassis. A complete stator/MDA unit cured the problem. **F.A.S.**

### **Panasonic NV8600**

This old tank sometimes wouldn't complete the threading process and on occasions the functions couldn't be selected as the keys were stiff. We'd have wasted a lot of time if we hadn't noticed the changing intensity of the light from the cassette lamp. The cause of the problem was that the cassette lamp leadouts were intermittently shorting in the holder. Straightening the leadouts provided a complete cure. **F.A.S.**

### **JVC HRD171**

This machine worked in all modes except play, when a

cyclical tracking bar would travel from the bottom to the top of the screen with a slur on the sound as the bar passed. A check on the control pulse at pin 6 of IC2 (M51796P) showed that a nice 5.2V peak-to-peak squarewave was present here. It should be passed to pin 20 of the V2023A servo chip IC2 via a 10k $\Omega$  resistor but was missing at this point. A voltage check here produced a reading of 5.2V instead of 3.4V; pin 20 had shorted internally to the 5V line. A new chip cured the fault. **F.A.S.**

### **Panasonic NV333**

There were severe tracking bars that couldn't be removed by adjustment of the tracking control – though the control was effective with some tapes. After wasting time cleaning the tape path and adjusting the tape guides we found that the tracking shifter control R2035 was at one end of its travel. Adjusting it with the tracking control at its centre 'click' position provided compatibility with all tapes. **F.A.S.**

### **JVC HRD171**

The complaint with this machine was no functions. It took some time before we realised that the four circuit protectors in the power supply were going open-circuit intermittently – sometimes you would get a voltage reading, sometimes not. **F.A.S.**

### **Panasonic NVJ45**

This machine would cut out after a few seconds in the record mode. A check on the main PCB showed that the delay record 12V (D Rec 12V) supply was missing. The 2SB1321AR transistor Q6203 turned out to be faulty. **J.C.**

### **Toshiba V83**

A faulty cam switch can cause various problems such as fast in play, fast in record/slow in playback, review changes to pause or maybe the arms stop in the half-loaded position. If however the tape loads around the drum at switch on but the machine then returns to standby check for dry-joints at the cam switch sockets on the main PCB, at the cam switch itself and at the pull-up resistors. **J.C.**

### **Panasonic NVL25**

The complaint with this machine was no results. Because of its cause the fault had been present for some time, unnoticed. C1109 (1 $\mu$ F) was open-circuit. As long as the machine remained plugged into the mains supply it was all right. When the mains supply was disconnected then reconnected the power supply wouldn't start up. **J.C.**

### **Mitsubishi HSB27**

This machine worked correctly in all modes except the higher times-nine speed cue mode. We noticed that in this mode the capstan motor was stopping and starting. The cause of the trouble was a worn lower drum assembly – this was making the tape drag. **J.C.**

### **Hitachi VTM753**

There was a cassette jammed in this machine which at switch on just switched off again. We found that the 1.6A fuse F852 was open-circuit. A replacement restored operation but the capstan flywheel made a loud screeching noise

and caused considerable tape drag. Lubricating the capstan flywheel spindle put this right. J.C.

### **Mitsubishi HSB27**

A worn lower drum assembly can cause many problems such as poor cue and review, picture jumping, poor tracking and no picture. The diagnosis can be confirmed by monitoring the f.m. waveform envelope, which will usually be impossible to set correctly. The fault can give trouble in the SP and LP modes. J.C.

### **Toshiba V312**

The complaint was of no results and no display. We were surprised to find that all the voltages in the power supply were at half the correct level. The ZPD3V9 zener diode DP15, which is not shown in the circuit diagram, was short-circuit. It's located beneath the 1-5Ω wirewound resistor RP33. J.C.

### **Matsui VX2000Y**

There was no remote control operation. As the handset worked all right with another machine I connected a scope to the output from the IR receiver can. This showed a healthy waveform. I followed the signal along the print and found that it disappeared when it passed (or should have passed) through the hinge-type edge connector. C.W.

### **Grundig VS440**

Playback was o.k. but there was no vision in the E-E mode. The tuning worked in that the channel numbers were right, but one of the 12V supplies was missing. Transistor T685 (BC548) was open-circuit. C.W.

### **Matsui VX770/Saisho VR3700**

More often than not the deck would load then stop. It wouldn't unload until switched on again. The loading seemed to operate correctly and the drum rotated at the right speed. But when the capstan should have started the machine went into the standby state and didn't unload. This was all caused by the mode switch, which had poor contacts. Replacement is quite easy in these machines. C.W.

### **Hitachi VT120**

All functions except play and stop worked perfectly. The play and stop buttons had to be held or pressed repeatedly before they would operate – sometimes. Suspicions that there was something sinister in the system control or timer microcontroller circuit turned out to be unfounded: both switches were faulty. I wonder why? C.W.

### **Samsung SI1260**

This machine powered up and the clock and E-E system worked, but there were no motor functions at all. The always 15V rail supplies the motor drive circuits via the 1N4001 diode D212 on the main PCB. It was open-circuit. C.W.

### **Toshiba V209**

This machine was dead with the tape still fully loaded. The power supply was in trouble: the switched 9V supply was missing at pin 2 of the power regulator chip, there was around 20V at input pins 1 and 15, and when an on/off

signal was received at pin 4 there was still only 2.7V at the output (pin 2). A replacement chip restored the 9V line and full operation. C.W.

### **Hitachi VT120**

There were no functions at all, only a clock display that randomly changed from bright to dim and light from the operate LED. Checks in the power supply indicated that the STK5471 regulator chip was faulty. A replacement restored the machine to life. C.W.

### **Amstrad VCR6000**

The complaint was of poor playback pictures. It turned out that the heads were faulty, but the symptoms were misleading. Playback of a test tape with colour bars produced a display that was clear but with violently juddering verticals, as though there was a shuddering drum motor or a bent drum motor shaft, while a recording made by the machine could be played back on another good machine at an acceptable level. Quite some time was spent before we got round to trying a new drum: why don't we invest in a head-checking machine? C.W.

### **Hitachi VT130**

During playback of this machine's own recordings or prerecorded tapes the picture was covered with a fish-net type of interference irrespective of picture content. The cause of the fault was the HT4757 chip/module on the YC panel. A replacement and a deck service brought a smile to the customer's face – until he received the bill. C.W.

### **Ferguson 3V58/JVC HRD370**

This machine wouldn't respond to remote control commands. We found that D501 on the infra-red receiver panel was open-circuit. J.H.

### **Orion VCP150**

The cause of no colour was eventually traced to the fact that the low-pass filter PF4003 was open-circuit. It took us longer than it should to discover this because the filter is shown as PF4002 in the manual. J.H.

### **Ferguson 3V59/JVC HRD180**

This machine's drum rotated in the reverse direction. Replacing the VC2023A chip IC2 cured the fault. J.H.

### **Mitsubishi HS306**

Poor sound with intermittent failure to record the sound was cured by replacing the REC bias preset VR3A1 J.H.

### **Toshiba V73**

The cause of no rewind was traced to the TMP4746 chip IC601. J.H.

### **JVC HRD210**

When this machine was plugged in the left-hand spool carrier would rotate for a few seconds then the machine would shut down, with the mode motor running. The cause of the problem was that the mode-motor drive belt was slipping. A new belt cured it. J.E.

## Philips VR6548

Over the past couple of months I've had two of these machines in with the same fault – failure to accept a cassette. The cassette lift is operated from the main deck via a complicated clutch arrangement and the locking lever appears to jam. Philips now supply a modification kit, part number 4822 214 32583. This seems to cure the problem.

P.B.

## Blaupunkt RTV740

This machine was dead – at switch on just a click came from the power supply. Resistance checks across the power supply outputs showed that there was a short-circuit across the 45V line. Q1006 (2SC1384) was found to be short-circuit. When this was replaced the machine worked but the display, which should have been blanked, showed dimly. Zener diode D7503 (MA4068) on the timer board was short-circuit.

P.B.

## Grundig VS340

Early versions of this model tend to produce black spaghetti after white when playing prerecorded tapes. The cure is to get an exchange panel from Grundig. It will have the following changes: C1406 220pF; L1406 will have two green and one blue paint spot; R1501 100kΩ; a 560Ω resistor will be added in series with C1420.

If you modify an early module the DOK control will need to be reset. Make a recording then play it back. Connect your scope to pin 16 of IC1430 and set the Y amplitude so that the waveform takes up six vertical divisions. Then adjust the DOK control so that the waveform occupies eight vertical divisions.

P.B.

## Hitachi VT150

The problem with this machine was intermittent severe overloading in the record and E-E modes, with the picture crushed into white. As with the best intermittent faults it would lie dormant for long periods, fooling you into thinking that either you'd cured it or that it had gone away. At length we found that although the signal entering the HT4757A hybrid chip IC203 on the YC panel was o.k. in the fault condition it was much too large at pins 8 and 27. The chip itself was defective, with intermittent failure of the internal a.g.c. system.

E.T.

## Mitsubishi HS347

Here's a new one for you – chewed tape due to failure of a crystal! From time to time crystal X6A0, the chroma reference crystal on the YC panel, would go open-circuit, deleting the colour and with it most of the urge of the drum and capstan motors – the crystal is also used as a servo reference. When the crystal stopped the head drum slowed, the capstan motor pulsed and, since the capstan motor powers the reel drive, a loop of crushed tape was left hanging from the front of the ejected cassette.

E.T.

## Sharp VC9500/Rediffusion 620

Tape chewing is probably the most common offence committed by this range of models. The usual cause is the

reel idler. A less common cause is the reel drive motor. To our dismay replacement of both these items failed to cure the drive problem with this particular machine. Very little torque, insufficient to turn the take-up spool at all during play in fact, was the cause this time. It's very unusual for these machines to develop electronic faults, but failure of the 2SD882 reel motor load switching transistor Q7754 was the root cause of the problem. It had an open-circuit base-emitter junction.

E.T.

## JVC HRD150

There was no response when the operate key was depressed though the clock display was present. The main power supply section was o.k. but the microcomputer chip IC601 had no 5V supply. This comes from the unswitched stabiliser transistor Q602 which in this case had zero voltage at its base and emitter. We expected the fault to be in zener diode D604 but in fact the parallel 22nF capacitor C605 was short-circuit.

E.T.

## Philips VR6367/Tatung VHR8495 etc

The no-go symptom with this much-cloned range of models can be misleading. There's a little chopper power supply on panel 009, based on a BD436 switching transistor Tr7001 with catching diode D6006 and choke L5002. If there's no drive from pin 7 of the 7051-2A operational amplifier chip you might suspect this item. But change the BD436 first. This usually cures the problem.

E.T.

## Samsung SI8220

This fairly new machine would sometimes fail to record the sound. The fact that it also failed to erase the sound when making new recordings indicated that the fault was in the bias oscillator circuit. Visual inspection around Q501 showed that one of its legs was dry-jointed. Resoldering cleared the fault.

E.R.

## Sharp VC482H

"Not playing, damages tapes" said the ticket attached to this machine. So we changed the idler, loaded a cassette and pressed play. The tape threaded but there was no capstan rotation and the machine promptly switched off. We then discovered that the capstan had seized solid on its bearing. Good working order was restored by removing and cleaning the capstan and applying a tiny spot of oil.

E.R.

## Toshiba V71B

In the play mode this machine would function normally for about half an hour from cold. It would then stop and unthread. Fast forward would fail shortly after this and the tape would be randomly ejected. The only mode then still working was rewind. Experience of this problem with other machines suggested that the carriage end sensors were probably faulty. We replaced them but the fault remained: so much for experience! As we didn't have a service manual our next step was to freeze the

TMP47465759 microcomputer chip IC601 while the machine was in the fault state. Immediately all functions reverted to normal. When a new chip had been obtained from Toshiba and fitted we'd yet another satisfied customer! **E.R.**

### **Panasonic NV250/450**

Cassette ejects instantly after being inserted is generally due to a worn out front loading motor belt. With one of these machines we then found that although the function display gave the appropriate indications there was no tape movement when functions other than play were selected. When play was selected the tape laced up but with no tape take-up the supply sensor triggered the syscon chip and the stop mode was entered. On occasions the machine worked perfectly. The cause of all this trouble was dry-joints on the AN3821K capstan drive chip. We've had this on several of these machines. **H.M.**

### **Hitachi VT5000E**

Here are a couple of faults we've had with these machines. The problem with the first one was that the playback mode picture was as if the machine was in the search mode (cue), with Mickey Mouse sound. Q505 was open-circuit collector-to-base. With the second machine the tape threaded but there was no take-up, after which it went into the stop mode. We noticed that the capstan motor didn't rotate after tape threading. D525 was open-circuit. **H.M.**

### **Samsung SI7220**

This fault was a little disconcerting. When a good recording was played back the picture was in black and white with severe distortion in the form of horizontal pulling - like hum. The fault cleared when the YC panel was lifted to make measurements, and I soon found that messing about with connector CN3201 could provoke and clear the symptom. The cause of the trouble was a high-resistance connection to pin 5, via which the playback f.m. from the head amplifier passes to the YC processing section. A cure was achieved by soldering the lead to the board. This step was necessary because Samsung tell us that they don't stock as spares any leads/looms/connectors, and this one couldn't be repaired successfully. We've had similar problems with other Samsung models, but nothing that can be noted as a stock fault. **N.B.**

### **Ferguson FV31R**

I'm not impressed by the mechanism in these machines. Extensive use is made of plastic components and this can lead to trouble. The initial problem with this one was that a cassette had stuck in it. It was the owner's fault - he'd stuck stickers all over the cassette rather than in only the specified positions. Our field engineer managed to extract the tape but then found that the mechanism was out of sync, something that afflicts these machines. Because of the design, in the event of even a small snarl-up there's a chain reaction of breakage in the rest of the mechanism. This machine required a new pair of loading rings and retiming. **N.B.**

### **B and O VHS80**

The mechanism and most of the electronics in this machine are the same as the Hitachi VT11. This one had come to us about eighteen months previously when it required the

usual belts and idler. It had also needed a new front flap escutcheon as the record button had disappeared inside. The controls are robust enough, so we thought it was a one-off failure. But here it was back again with the complaints that the button had once again broken and that it intermittently failed to lace. The customer admitted that the broken buttons were due to ham-fistedness, and having been in the trade he was able to give us a very accurate description of the lacing problem. This was just as well, as the fault wouldn't show up for us initially.

As the machine had obviously seen a lot of use I suspected that the loading belts were worn. When the fault did finally show up replacing them was the obvious course of action. One thing to remember is to get the similarly sized belts the right way round. I once spent ages looking for this intermittent fault only to find that another engineer had fitted the belts the wrong way round.

After we'd replaced the belts the machine performed faultlessly on soak test for several days. Then it started to play up again. The motor or mode switch were the next suspects. Voltage checks in the syscon circuit ruled out the mode switch, so a motor was ordered. Fitting this cured the fault - now all that remains is to replace that control flap again. **N.B.**

### **Sony SLC9**

Cassette lift problems with this machine are usually guaranteed to give me nightmares. This one was no exception. The customer had tried to remove a jammed cassette and in doing so had put everything out of sequence. I got the lift working after replacing the broken cogs, then the fun started. When I switched the machine on the rewind motor started to run then the eject light flashed. If a cassette was loaded manually it would thread and play, but when eject was pressed it would unthread but not unload. A cold check on the operation of all the switches failed to reveal anything amiss, but after a lot of searching the cause of the problem turned out to be the unthreading switch which had gone high-resistance. It's mounted alongside the loading rings. **M.D.**

### **Sanyo VHR3100**

The cassette lift would load half way then come part of the way back out again. After this the machine would shut down. If the tape was put into the stop position by hand, rewind and fast forward worked normally. But when play was selected the tape would load, the capstan would start to run very fast, then the tape would unlace and the machine would shut down. The voltages all seemed to be o.k. We then checked the mode switch by substitution. Next we suspected the system control microcomputer chip, but the fault was still present when a replacement had been fitted. In the end the cause of the fault turned out to be the LC7412 digital servo chip IC4001 **M.D.**

### **Mitsubishi HS306**

The problem with this machine was very intermittent tuning drift. It would run all right for days with the top cover off. Heat and freezer had no effect. So we left a meter connected to the stabilised 30V line and covered the machine with a blanket. When the fault appeared the voltage dropped. Careful inspection of the 30V regulator on the main panel showed that there was some brown, foreign matter at the connections to D913 and D914. The problem didn't recur when this had been removed. **M.D.**



some time, that a protected cassette was loaded – hence the eject. Removing the link and cleaning the switch contacts restored normal operation, but to be on the safe side a new switch was ordered and fitted.

**J.C.P.**

## **JVC HRS5800**

The remote control system worked all right but the on-deck controls didn't operate. There was also no change when the audio/mix switch was operated. IC1 was at fault – one of its scanning ports was down.

**S.B.**

## **JVC HRD4700**

This machine produced noisy pictures intermittently. The symptom looked like head clogging, but this wasn't the cause of the fault. I had to replace the lower drum assembly because of a problem with the ribbon cable that carries the signals to and from the heads.

**S.B.**

## **Ferguson 3V42/JVC HRD455**

“Won't accept a tape” the note said. The cause was failure of one or both of the cassette detect microswitches on the cassette housing. I decided to replace them both.

**S.B.**

## **Sentra VX8400/Alba VCR5000/6000X**

For no drum rotation check IC506 (BA6411) by substitution, especially if the print is discoloured and it looks as if the chip has been overheating.

**M.Dr.**

## **Sharp VC9300**

After fitting a new switch on the cassette housing and servicing the deck we found that the capstan motor would slow down intermittently. The cause was eventually traced to a dry-joint on the f.e.t. Q705.

**M.Dr.**

## **Sharp VC9300**

When we plugged this machine in the capstan motor ran for a couple of seconds then stopped. In the past we've had problems with the STK5725 power supply regulator I9002, so this is where we started. Its 13V and 18V outputs were o.k., but the 11V output at pin 1 was missing although the 12.7V input was present at pin 2. We next found that the power control input at pin 3 was permanently high: it should be low for power on. Shorting the base of Q9003 to chassis via R9021 brought some life back to the VCR. The power-on low signal comes from pin 24 of the main microcontroller chip I5002. Checks here showed that the 5V supply at pin 64 was missing. This comes from regulator transistor Q5002, whose 13V collector supply was missing. Yet the 13V rail was o.k. at the power supply end.

The syscon PCB in this model uses double-sided print. The track to Q5002's collector is on the component side, where the fault lay. Q5002 and the surrounding components were covered in brown glue that holds a passing bunch of wires. When we'd removed the glue we found that the track to Q5002's collector had been eaten away. A fine-wire link restored normal operation.

Now how's this for coincidence? A week later the same dealer brought in another of these machines, this time with a clock fault. The time could be set but the colons didn't flash and the clock didn't count. A check at pins 2-3 of I5002 showed that the 32.768kHz clock oscillator had stopped. We confidently fitted a new crystal but the clock still didn't

work. Further checks in this area showed that R5047 (56k $\Omega$ ) was open-circuit. Guess what? It's underneath the same blob of glue around Q5002! When we removed the glue we found that R5047 was without its leadout wires. A replacement put matters right.

It seems that this moisture-absorbing, corrosive glue is like a time bomb ticking away in these old machines.

**M.Dr.**

## **Hitachi VT11**

There was no response from front panel commands, i.e. no play/fast forward/rewind etc., though the machine worked normally when asked to make a timed recording. The remedy was to replace the BA6304 chip that interfaces the front panel to the microcontroller chip.

**G.F.**

## **Samsung VI611/Logik VR950**

The problem was no play, with no drum or capstan rotation. We found that there was no 12V supply to the servo panel. Transistor Q2 (2SA634) wasn't switching on because R7 (1.5k $\Omega$ ) in its bias network was open-circuit.

**N.W.**

## **Samsung S11260**

Failure to record when warm is becoming a common fault. The first report you may get is of poor recording in the LP mode, progressing to no LP or SP recording. It looks as if no signal is being recorded, just noise – as though the machine is off tune. In fact the cause of the fault is lack of the luminance record signal: a scope check at TR3201 will show that it is almost non-existent. Replace C3203 (68pF) which goes open-circuit.

**N.W.**

## **Amstrad VCR4600**

There was severe patterning on the TV channels, present only when the VCR was switched off. I suspected the booster module but a replacement made no difference and when the original one was tested out of the machine with a bench supply it proved to be o.k. As the only supply that's present when the machine is switched off is the always 12V line I checked the source of this. C508 (100 $\mu$ F, 16V) on the main panel was low in value.

**C.W.**

## **Philips VR6520**

The complaint with this machine was no colour. There was also a hum bar in the E-E mode. Replacing C1103 (1,000 $\mu$ F, 63V) provided a complete cure.

**C.W.**

## **Akai VS22**

The power supply in these machines can be a little trying to say the least. This one wasn't too bad however. The complaint was that the clock was out of sync: there were also hum bars on the picture in the E-E mode. I would normally expect to find some leaky transistors and over-heated print, but the cause was simply C6 (220 $\mu$ F, 10V).

**C.W.**

## **Matsui VX820/Saisho VR1200HQ**

When the mains supply was connected to this machine the motors gave a twitch and the operate LED came on for half a second. Checks showed that the 12V rail was low at only 3V. It's provided by the series regulator transistor Q02 whose base is biased by R06 (1.5k $\Omega$ ) and the 13V zener diode D07. The zener diode proved to be leaky.

**C.W.**

## **Ferguson 3V30/JVC HR7300**

The problem was no reel drive. I found that CP2 in the supply to the 10VT05 reel driver chip IC12 was open-circuit while the chip itself, a hybrid device, had burnt up. The cause of all this was an intermittently short-circuit reel motor. **N.B.**

## **NEC9033**

The fault symptom I've had with a couple of these machines has been low, varying sound. The sound is low because the audio/control head wears out: it varies because the pinch roller is barrelled, as a result of which the tape moves out of position. **N.B.**

## **Panasonic NV2000**

The customer's complaint was that there were no deck functions. This was because the cassette didn't sit right down on the left-hand side when the carriage closed. The cause of the problem was that the cassette balance spring on this side was very weak – part no. VMB0730. **N.B.**

## **Ferguson FV61LV**

There were a number of faults with this brand new, centre-mechanism machine, some of them intermittent. Here's the list: excessive fast-wind torque (to the extent that once-wound tapes were too tight to play!), no tape end sensing, failure to accept a cassette, failure to eject a cassette, no capstan operation and switching off with no mechanical movement. Just about every operation is controlled by the ST90T30-QFP80 servo microcontroller chip IT01. It's a many-legged, four-sided flatpack device mounted on the lower PCB. We found that it was thermally faulty. **N.B.**

## **GoldStar GSE1891I**

The customer said that this machine had for some time refused to eject cassettes. On the last occasion he'd used a breadknife to force it to release the cassette. As a result, the right-hand mount for the synchronisation bar and gears had broken. Obtaining replacement parts turned out to be a bit of a problem. In the process I learnt that the usual cause of the problem is broken gears. Not this time though! I eventually obtained the part number for the side piece required from GoldStar technical. CPC then supplied both sides as a kit. They were easy to fit – unlike many carriages, this one is very simple and easy to reassemble. **N.B.**

## **Akai VS425EK**

There were two faults on this machine. First, the customer complained that very intermittently it would chew a tape on eject. A new belt, clutch and mode switch cured that. I also noticed that there was a nasty graunching when the cassette was ejected, the blinder moving very urgently. Investigation showed that the graunching came from the mechanism only when the front was fitted – to be more

specific when the blinder was lifted to eject the cassette.

I carried out the eject spacer modification – fitting the spacer under the front rack lug on the left-hand side – and noticed that the synchronising gear (arm loading BLK, item 43) that links the drive from one side of the carriage to the other was buckled on the right-hand side, where the blinder lifting lever sits. When this had been replaced everything ran as smooth as silk. **N.B.**

## **Panasonic NVJ30**

This machine couldn't be tuned in the E-E mode. Because of an instruction from the timer microcontroller chip IC7501, which handles tuning, it was locked in the Band I mode. The instruction comes via IC7502 (MN12C261D5) which was faulty – it provides parallel switching lines from the serial data fed to it. **N.B.**

## **Samsung VI710**

There was no go at all. While plenty of unregulated voltage reached the STK5333 multiregulator chip no supplies left it. A replacement restored normal operation. **N.B.**

## **Philips DMP Series Decks**

A common failure with these decks is the rather unusual pinch roller assembly. The rubber roller seems to decompose rather alarmingly. Symptoms vary – poor or varying sound or tracking for example or tape damage. **N.B.**

## **Alba VCR3000X**

There were no functions and no displays. This is not unusual – replace C821. When this had been done the machine came to life but wouldn't accept a cassette. Fortunately I've had this one before. It's usually due to microcontroller lock-out. Load the tape by rotating the carriage motor by hand, then press the power on/off button followed by the eject button. The cassette will then be ejected and future instructions will be obeyed. **J.E.**

## **JVC HRD610**

The playback picture had five thin tracking lines spaced equally apart across the picture and the sound was muted. The cause was that the exit guide was loose. Slight adjustment of the guide's height, followed by tightening the grub screw, corrected the fault. It's worth noting that a defective mechacon chip can produce almost identical symptoms – but in this case the audio track will be erased whilst you are looking at the symptom. **J.E.**

## **Panasonic NVG7**

There was vertical rolling when a known good tape or a self-recorded one was played back. In addition the tape would be crinkled along its bottom edge. The pinch roller

was glossy and tape ridges were evident. A new roller cured both problems. **J.E.**

### **Akai VS35**

This machine would stop at random in the record mode. The tape would remain threaded and the pinch wheel would be engaged on the capstan shaft. To try to simulate the fault we disconnected the take-up reel pulses while the machine was working correctly. The machine stopped, but the pinch wheel was disengaged and the tape was released from the drum. So absence of the reel pulses was not the cause of the problem. We next tried stopping the capstan motor physically, whereupon the normal stop mode was entered. So the capstan department was not the cause of the fault. When the drum was stopped physically the symptoms matched those of the fault condition. So we had a drum servo fault.

We replaced the BU2735S servo chip IC503 but after recording for two hours the fault reappeared. Voltage and waveform checks were of no use because of the intermittent nature of the fault. So we replaced the motor circuit board on the lower drum assembly. Numerous test recordings proved that the fault had been cured. **J.E.**

### **Akai VS55**

As there was no record colour, checks were carried out around the LA7330 chroma processing chip IC400. The video input, filter input and output, sync signals and d.c. levels appeared to be o.k. but there was no record output signal at pin 9. We then found that the frequency of the 4.433MHz voltage-controlled oscillator was erratic – about 1.2kHz low on average. Because of failure of the oscillator to lock, the colour-killer was active. Careful monitoring of the oscillator's control voltage (nominally 2.2V) at pin 15 showed that it was about 100mV low. After some further checks we found that steering diode D401 had a reverse leakage of 50kΩ. A replacement restored normal operation. **N.E.E.**

### **Sony SLVX10**

"No sound" it said on the job card that accompanied one of these machines. When we inserted a cassette and pressed the play button there was a snowy picture and of course no sound. There was little improvement when the tracking control was adjusted – capstan servo symptoms appeared on the screen instead. The audio circuit is centred on the LA7294 chip IC201, pin 12 being the mute input. We found that the mute action, which is controlled by the syscon chip, was in operation. As there was a servo problem we checked for CTL pulses at pin 10 of the servo processing chip IC351: they were missing. This took us back to pin 4 of the LA7123 CTL pulse amplifier chip IC352, where the pulses were also missing. After carrying out voltage checks we decided to replace IC352. This restored a beautiful picture along with sound as the mute was released by the syscon chip.

Another of these machines was brought in because of intermittent failure to record the sound. We set it to record and connected a scope to the bias oscillator's output point. After an hour or so oscillation suddenly stopped. The switched supply for the 2SD734 bias oscillator transistor Q2001 comes from pin 1 of the LA7294 chip IC201. A voltage check here produced a reading of only 0.6V. When Q2001's collector was disconnected the voltage at pin 1 of IC201 rose to the correct figure. We found that Q2001 had a 40Ω leak between its collector and emitter, though it behaved perfectly at times, especially when cold. When a

new transistor was fitted the machine worked without any further problems – because of stock shortages we used a 2SD774. **R.A.**

### **Amstrad VCR4600**

When a function was selected the mechanics would start but the machine would almost instantaneously power down. Scope checks on the supply lines showed that there was a large negative-going pulse on the 5V rail. As a result, the supply to the microcontroller chip was being regularly removed. Thus functions wouldn't latch on. Our first suspect, the 5V regulator, proved to be o.k. The culprit was eventually found to be the bridge rectifier. **A.D.**

### **Samsung SI1260**

This machine came in with a fully laced tape inside. When it was powered it refused to unlace the tape. We eventually found that the cause of the problem was D212, which was open-circuit. It provides IC206 with a -15V supply. **A.D.**

### **Ferguson 3V42/JVC HRD455**

This one could apply to other models which use the same deck. We found that during the last part of the loading cycle, as the pinch roller starts to pull in, the loading motor would slow down and struggle to complete the loading sequence. The cause was traced to the grease on the lower drum casting – the bit with the V blocks. Though it wasn't as hard as in some models it was nevertheless very sticky, impeding the slant pole base. To cure the problem clean the grease off with solvent then apply a smear of graphite grease. **M.Dr.**

### **Akai VSF410**

There was no clock display and no manual or remote functions would operate. The machine would accept and play a prerecorded tape however. The supplies to the operation PCB were all o.k., and the timer microcontroller chip's two clock oscillators were running. But there was no activity at any other pin. Voltage checks showed that the 'not power down' input at pin 5 was low, putting the chip into its idle mode as though the mains supply had failed. Tracing back to the power-down detector circuit brought us to transistor TR203 which had an open-circuit collector. A replacement restored normal operation. **R.F.**

### **Samsung SI1260**

As soon as the machine was powered the loading motor would run in the eject direction, stopping only when the syscon microcontroller chip decided that a fault condition was present and shut down the switched supplies. Attention was eventually turned to the mode switch, where the voltage at pin D never rose above 1.8V regardless of the position of the mechanism. This pin is effectively the cassette-up switch – so the machine must have thought the cassette housing was down even though it wasn't. A new mode switch (part no. 63579-101-026) provided a complete cure. **R.F.**

### **Akai VS485**

Apart from a hum bar, and picture disturbance that appeared only when the loading motor ran, i.e. when ejecting or inserting a cassette, this machine performed normally.

## Panasonic NVMS90

We've had a few of these come in with intermittent colour and/or luminance, maybe with flickering in the electronic viewfinder, all caused by damage to the ribbon cable between the hi-fi sound head amplifier CBA and the main board. It rubs on the corner of the chassis, with the result that a black burn mark eventually shows on the ribbon lead. Replace the cable, part no. VWJ0394, and to prevent further damage insulate the chassis corner with tape. **B.S.**

## Sony CCDF250

This machine had a damaged cassette carrier: the customer must have forced it open, breaking the carrier locking mechanism in the process. When the carrier had been replaced the machine appeared to work well, but when it was powered for the first time after being fully reassembled the machine laced up without a cassette being inserted, the mode motor could be heard to shunt backwards and forwards, then the machine switched off. With the cases removed the machine again worked correctly. Back on with the cases and the fault condition was restored.

We removed the cover screws and after much careful flexing and prodding discovered that the small, flexible PCB (FP89) that connects the mechanism and mode switch to the CC15P PCB was bent in a S shape. As a result it touched the aluminium mechanism base. The mode problems were caused by the fact that the PCB covering had worn through, connection 4 (mode switch 2) shorting to chassis. **I.B.**

## Panasonic NVMC6

The cassette carrier was damaged: because it was bent out of shape it wouldn't close. We replaced the carrier and tested the unit. When playback was selected the machine started to pull the tape from the cassette then stopped and unlaced. When record was selected the machine went into the rewind mode. It seemed that the unit was detecting the end of the tape.

There's only one photodetector on the supply reel side of the tape path. This detector is exposed to the infra-red emitter before tape lace-up, its view being blocked when the tape is pulled out. The emitter should be switched off before the tape starts to move, so that the detector isn't activated. The top loading ring that's attached to the supply side guide assembly was found to be one tooth too far anticlockwise however. Thus when the emitter was switched on the tape hadn't moved far enough to block the beam. With the ring aligned correctly all was well. **I.B.**

## Sony CCDF355

There was no sound output when this machine's own recordings or known good ones were played back, though audio was produced when the camera's output was monitored. We checked the r.f. playback signal at pin 11 of IC401 on the f.m. modulator/demodulator sub-PCB. A signal was present here but as no level is specified we were not sure whether it was sufficient. We took a feed from pin 15 of IC401 – this is after the f.m. demodulator – to an external audio amplifier and obtained correct audio. But there was no output from either

pin 29 (line audio) or pin 27 (earphone audio). The fault was cured by replacing the chip. **I.B.**

## Sony CCDTR55

The camera section wouldn't turn on properly. You got a blank screen with increasingly scrambled lines that turned into a misty picture which became magenta and was then o.k. It took us some time to trace the cause. We suspected missing clamp pulses at the colour encoder and discovered that L302 was dry-jointed.

Another of these machines wouldn't wind the tape into the cassette fully when ejecting it. We replaced both spool carriers and the idler gear as a kit. This was perhaps a bit over the top, but when these mechanisms are in bits it's not worth taking a chance. **S.B.**

## Ferguson 3C03

The owner complained that the picture twitched and flashed and there was no colour recording. A vectorscope check showed that the colour carrier frequency was miles out. After replacing the SSG circuit's clock crystal without putting matters right I came to the conclusion that the SSG chip was faulty. Replacing it is not an easy job. I was pleased that the results looked perfect. **S.B.**

## Akai PVC4

This camcorder had a white-balance fault – the camera picture was pink. It turned out to be a bit of a job. Poor red/blue separation was producing a magenta bias. This is normally caused by a faulty delay line, and one had to be fitted before the real culprit could be tracked down – the R/B separation control. **S.B.**

## Panasonic NVS1E

The symptoms with this machine were intermittent colour from the video output and a blue line down the centre of the picture. They had started after the customer had dropped the camera. I phoned Panasonic to check on the price of a new side panel for the camera and the availability of replacement PCBs. As these are no longer available we carried out a careful visual check and found that delay line DL8001 was cracked. A replacement provided a complete cure. **B.D.**

## Panasonic NVM7

The owner was furious with this unit – it shut off while he was changing tapes when filming Niagara Falls. The tape was stuck: it wouldn't unwind from the loading point. IC6004 was the cause of the fault. All inputs were present but there was no output to the loading motor. **S.DaC.**

## Panasonic NVM5

The VCR/camera select door switch was inoperative, so you couldn't record. A new switch restored full operation – the old one had cracked in half. **S.DaC.**

# Introduction to the Panasonic K Deck

Simon Nash\*

Over the past six years Panasonic VCRs have used the G deck. When this was launched it was the first VCR mechanism to use the capstan motor for two purposes: the major one was for tape transport, the secondary one being to move the mechanism between the various mode positions. Because of this dual capstan-motor use, mode selection between certain operations was considered to be rather slow. Later versions (the G2 deck) have an additional review motor to improve the mode-switching time, but this deck is used in only top-of-the-range models. What was needed was a new mechanism with the following features: faster mode switching; easy alignment of the gears; and less gearing.

As a result of advances in the technology, the K deck has been introduced as a replacement for the G deck in the latest series of Panasonic VCRs. UK VCRs that use this new deck, which is sometimes referred to as the Super Drive mechanism, include the NV-SD30/40B and the NV-HD100B.

## Improvements

K deck VCRs incorporate many improvements. Amongst other things these make servicing much easier. Some of

them can be seen in Figs. 1 and 2, which show top and bottom views of the mechanism respectively. The main ones are as follows:

- (1) There's an overall reduction of 51 per cent in the number of mechanical parts. This makes alignment easier. Since fewer spares have to be held in stock, servicing costs are reduced.
- (2) A new loading motor moves only the mechanism, leaving the capstan to move the tape.
- (3) The main lever assembly is responsible for moving the main mechanical items, i.e. the loading arms, the brakes and the back-tension lever.
- (4) Because of the added loading motor the solenoid is no longer required. As a result the mechanism is quieter and quicker.
- (5) Circlips are no longer used. Instead, self-locking tabs are used on some gears, e.g. the reel turntables.
- (6) There are fewer wire connections: all the sensors are on

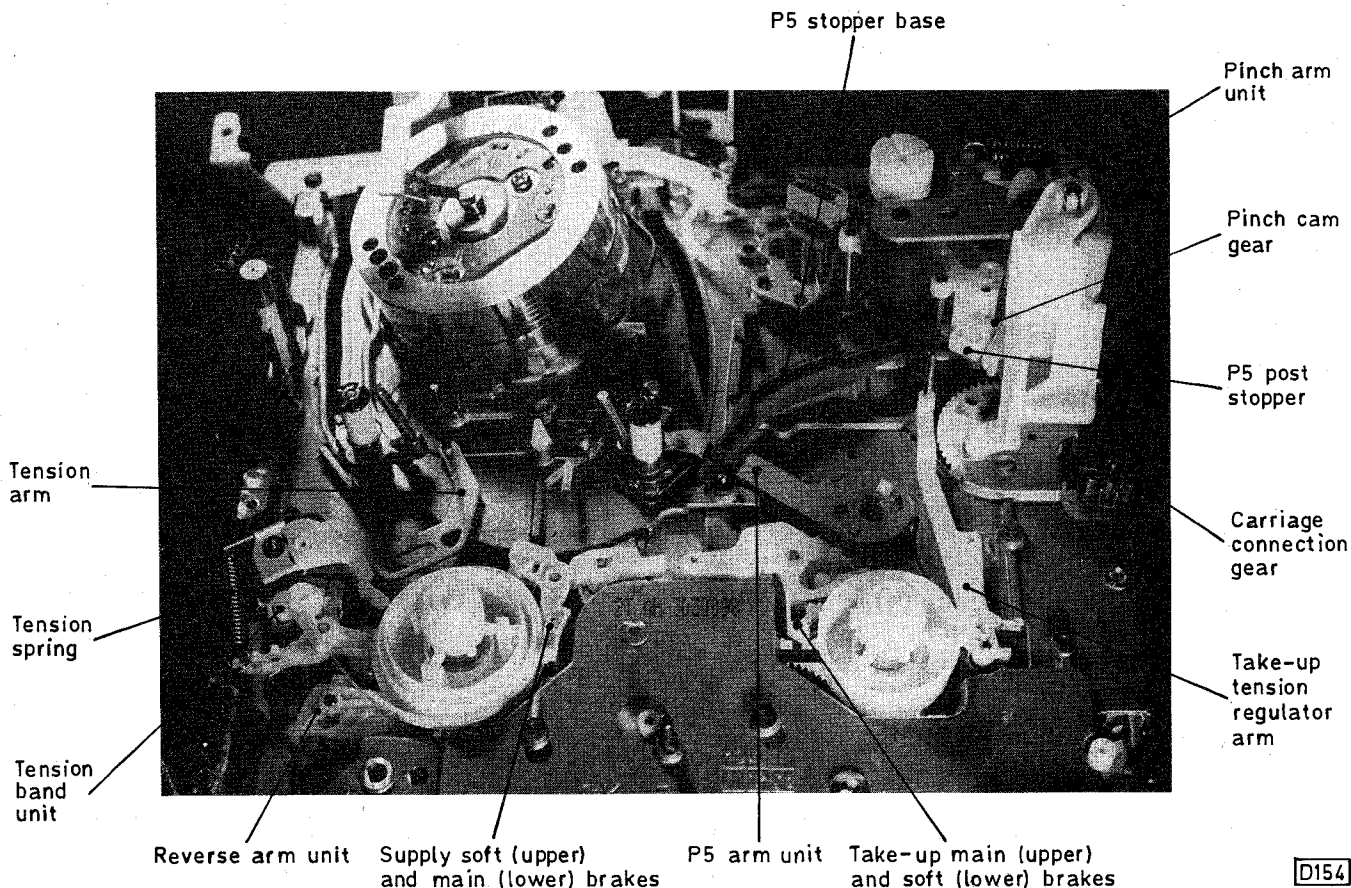

Fig. 1: Top view of the K mechanism.

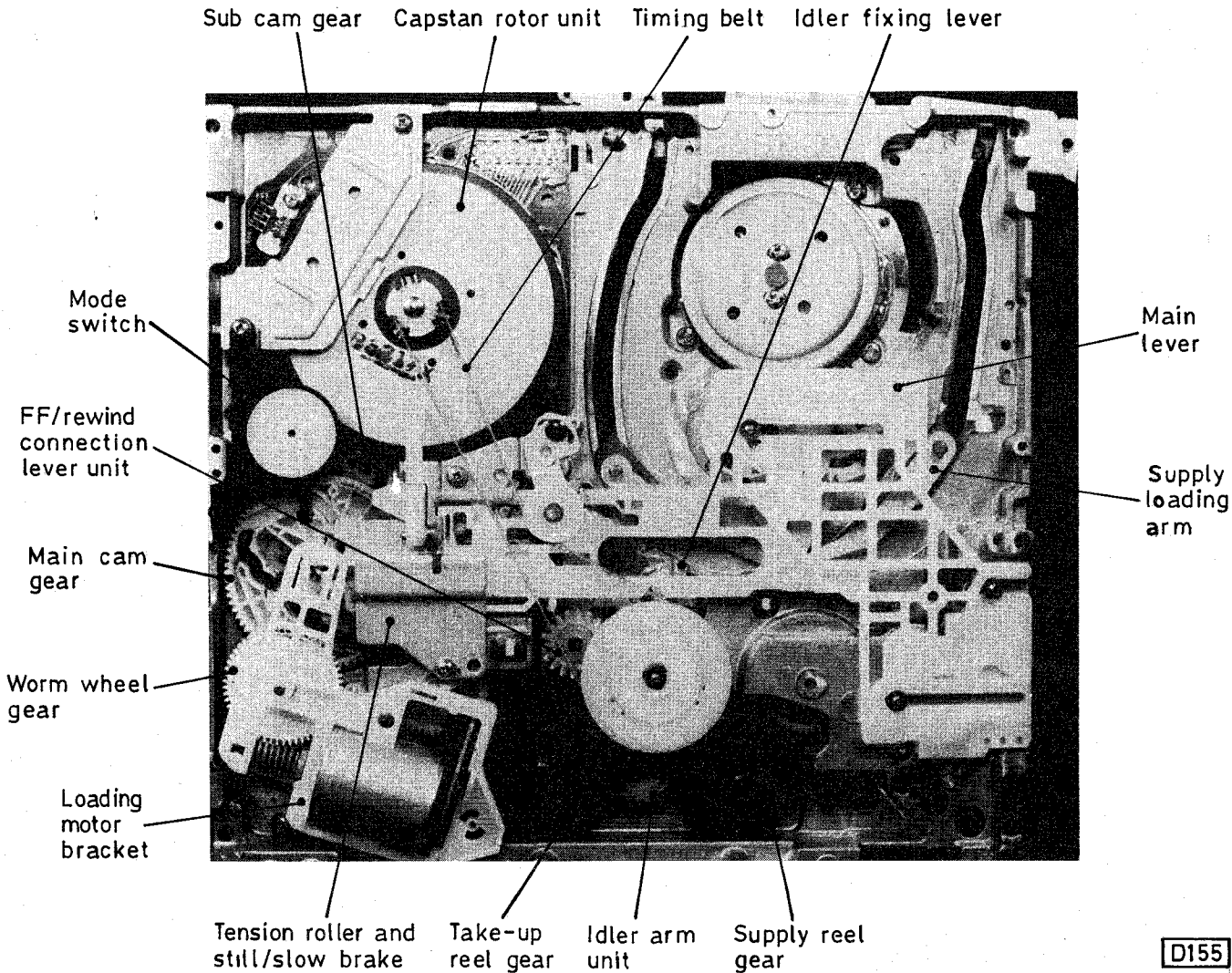

Fig. 2: Bottom view of the K mechanism.

the mechanism-connection PCB, i.e. in one location.

(7) Fewer alignment points. While the G deck has twelve phase alignment points the K deck has only six.

(8) There is no longer need for P5 post height adjustment as it auto-locates at the correct height.

(9) For easy phase alignment a diagram is stamped on the mechanism's plastic chassis.

(10) Seven service modes give the service engineer ready information on a faulty machine. More on these later.

### Gearing

The type of gearing used differs from that in the G deck. Fig. 3 illustrates the new tooth arrangement, which is known as 'helical gearing'. It has two advantages. First, as the gear

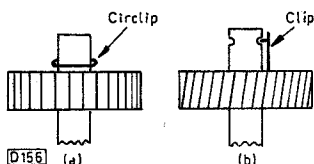

Fig. 3: Difference between the type of gear used in the G mechanism (a) and the helical gears used in the K mechanism (b).

teeth are longer the gears can withstand a greater applied force. Secondly, because the teeth engage and disengage gradually the meshing noise is significantly reduced. These helical gears are used extensively in the area of the play idlers, reel turntables etc.

Fig. 3 also shows the new method of gear fixing. Use of fixing clips instead of circlips makes servicing easier. Care must however be taken not to apply too much force to the clips: when one of them breaks the gear has to be replaced. Two clips, one at either side, are used to fix some of the gears. Should one of these be damaged it's best, in the interests of long-term reliability, to replace the gear.

### Servicing

The K deck is not fully serviceable when fitted in the VCR. A servicing position is provided however to enable engineers to gain easy access to carry out repair or alignment as required. To take the deck out, simply remove three large brass screws and disconnect seven connectors. The deck can then be fixed in the service position – see Fig. 4.

Although removal of the deck is simple, if a cassette is jammed in the mechanism access to one of the three screws mentioned above is not possible. The jammed cassette must first be removed therefore. There are two ways of doing this.

The first method involves loading motor rotation, either by hand or by using an external supply – you can connect 4.5V to the motor while it's in circuit without damaging the

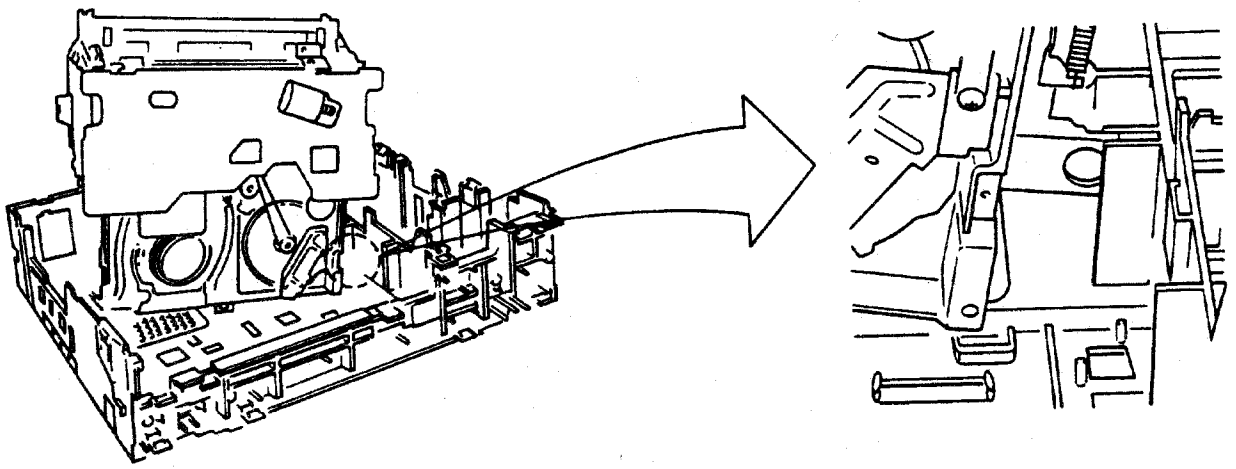

Fig. 4: Service position for the K deck. The mechanism can be easily fixed by standing it up in the main frame as shown.

drive chip. Once the mechanism is in the unloaded state, rotate the capstan motor so that the slack tape is taken up. See Fig. 5.

The second method is to use service mode seven. This mode gives you manual loading-motor drive, using the play and stop keys to control the loading motor. Once the machine is in service mode seven there is also a drive to the capstan motor. This is very useful as the slack tape is automatically taken up. An explanation of the service modes is given below.

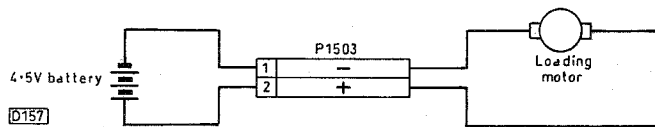
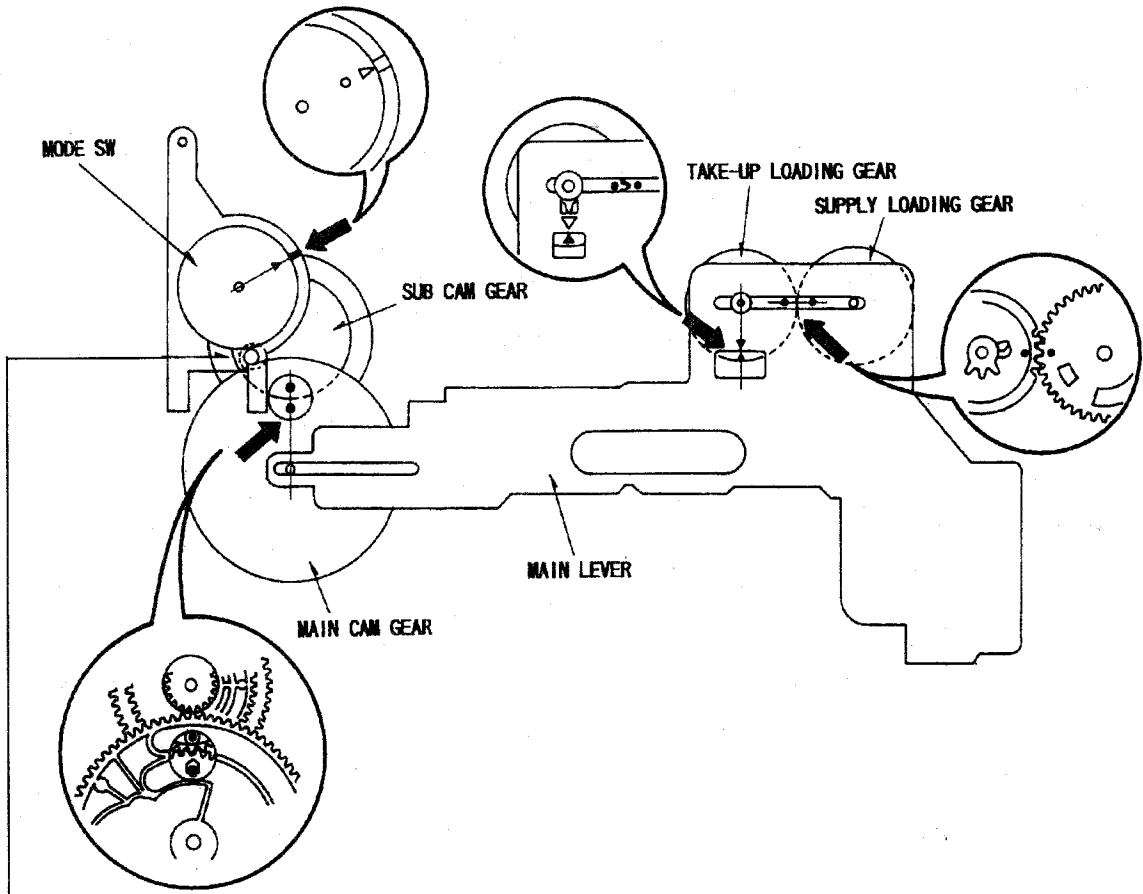

Fig. 5: Battery operation of the loading motor.



( There is a hole on the Sub-Cam Gear and a hole on the chassis that are used for alignment reference. )

Fig. 6: Gear phase alignment, top view.

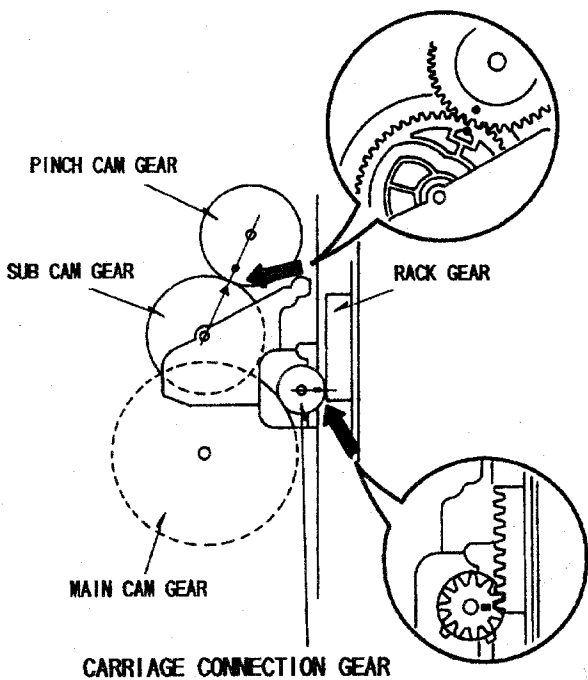

Fig. 7: Gear phase alignment, bottom view.

## Alignment

There are two main aspects of alignment: (1) gear phase alignment and (2) main-lever assembly positioning.

Phase alignment of the gears is much easier than with the G mechanism, there being only six points instead of twelve. Figs. 6 and 7 show the phase alignment.

## The Main-lever Assembly

Correct positioning of the main-lever assembly is critical for proper operation of the mechanism. Phase alignment of the lever is not difficult but must be correct for the tension posts to locate in their appropriate positions. Fig. 8 shows the post positions for different modes of operation.

As a basic rule when replacing/aligning the main-lever assembly, ensure that the lever is positioned so that it sits as flatly as possible and doesn't feel springy. Poor post positioning is the main cause of incorrect alignment.

One final point on the main lever. When the mechanism is powered for testing, either from an external supply or in service mode seven, the main lever will flex under load. The reason for this is that under microcontroller chip and mode-switch control the mechanism never reaches the extreme positions that occur with manual operation. To prevent misalignment, make sure that you install the loading-motor bracket and the belt-tension assembly: both of these act as fixing points to hold the main lever in position.

## The Service Modes

To make servicing easier with the latest range of Panasonic VCRs the number of service modes has been increased. For access to the service modes turn the shuttle ring to the fast-forward mode then select the eject mode simultaneously. The service mode information will then be displayed for sixty seconds. If you require a continuous service mode, connect a shorting link between TP GROUND and TP SERVICE on the main PCB. Fig. 9

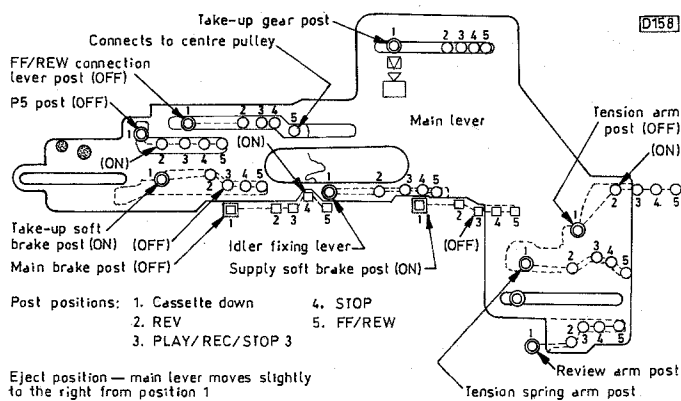

Fig. 8: Post and main-lever position in each mode.

shows a typical service-mode display. The seven modes are as follows:

**Mode 1:** This checks the sensor LED, the supply and take-up phototransistors and the connections to IC6001.

**Mode 2:** This mode indicates the mechanical position, with a corresponding display.

**Mode 3:** This checks the mode-switch operation. When the switch is in a position, e.g. play, the display will show '00' irrespective of the mode.

**Mode 4:** This checks the operation of the key scanning on the front panel, also the data being transmitted from the remote-control unit. A corresponding display is given on the front panel.

**Mode 5:** This checks and shows whether IC6001 has received a capstan-motor start request.

**Mode 6:** This checks and shows whether IC6001 has received a drum-motor start request.



Fig. 9: A typical service mode display. The left-hand digit is the service mode number, indicating the operation being checked. The next two digits (03 here) indicate the circuit condition and/or the position of the mechanism.

**Mode 7:** This mode is used for manual loading-motor drive, as explained earlier, using the stop and play keys. It can be entered in two ways, depending on whether the machine is an early or later production version – refer to the service manual for full details.

As mentioned above, selection between the various service modes can be achieved by selecting fast forward and eject simultaneously.

## Dealer Support

A video tape that shows the dismantling/reassembling procedure is being prepared as an aid to dealers' service departments. There's also a training manual for the K mechanism, part no. VRD9302D101.

**\* Simon Nash is with Panasonic Technical Support.**



# Service Briefs from Toshiba

As a follow-up to last month's briefs, the notes below provide additional information on various Toshiba TV models and a section on VCRs, again based on information published in Toshiba's *Technical Bulletins*.

## TELEVISION

### Models 2505DBT/2805DBT

**Motorboating noise can be heard from all speakers in the standby mode – this fault is very intermittent:** Cause is poor earth contact of the black anodised heatsink for IC609 and IC610 (which is incorrectly identified as IC601 on the underside of the PCB). The heatsink is earthed only by the location pin at the opposite end to the earth tag. Move the green earth wire fitted between socket M002A pin C and M002B pin C to fit between M002A pin C and the adjacent, surrounding area of already tinned earth print, after shortening the wire to approximately 3cm.

**Low level of hum in the left-hand surround speaker in all modes, noticeable when Dolby Surround is selected and the volume is set low (two segments of the volume scale):** Cause of the problem is that earth loops induce hum in the surround sound amplifier IC610. Carry out the action described above in connection with motorboating. Then add a PVC covered wire between pin C of M002A and pin C of M001A. In the unlikely event that the hum is still present, remove link JP403 adjacent to the Dolby PCB (near R676).

**Very quiet ticking noise comes from the right-hand surround speaker. Present only when using Dolby Surround and noticeable only when the surround speakers go quiet with no signal:** Cause is pick-up from the I2C data bus at pin 1 of IC611. Remove R610 (68k $\Omega$ ) and jumper link J109 which is under the heatsink for IC611/IC608. Refit R610 in the J109 position. Fit a wire link in the position previously occupied by R610. To gain access to jumper J109 it's advisable to remove the heatsink and chips.

**Blank raster and no sound. No response to remote control commands. No SDA and SCL outputs from the CX80424 microcontroller chip ICA01, both lines being stuck at 2V d.c.:** The TA78L009AP 9V regulator QV22 for the TA8777N AV switch chip ICV01 on the back terminal PCB has become unsoldered. Resolder and ensure that the back terminal cover plate isn't pressing on QV22.

If failure of the TDA2030A chips (part no. 23319009) used in positions IC608/609/610/611 is experienced, check the speaker wiring as shorts here will damage them. A short-circuited TDA2030A will in some cases damage the chopper transformer T803, giving the dead set (current trip) condition.

### Models 2527DB/2927BB/3327DB

**Stuck in standby:** The SFRN5A circuit protector ZP82 is open-circuit, possibly because the surround sound output chip ICS01 is faulty. Replace ZP82 (part no. 23144450) and if necessary ICS01 (part no. B0376856). If ICS01 has failed

it's very important to replace the following four diodes (all type 1N4148, part no. 23115599) which may well have been damaged: DS01/2/3/7.

### Model 215T8B

**Low brilliance/contrast/poor focus – looks as if the c.r.t. has lost emission:** The 3 $\Omega$  resistor R920 in the c.r.t.'s heater supply tends to go high in value (may rise to 6 $\Omega$ ).

## VCRs

### Model V77B

**Tuning drift or no tuning at all:** Replace the 0.1 $\mu$ F capacitor connected across C025 in the VT line to the tuner. It tends to become leaky. Note that it's not shown in the circuit diagram (use the V83B service manual).

### Model V83B

**No playback colour:** Can be caused by IC401, type BA72675, part no. 70119508.

### Model V93B

**Fuses F802 (1.25A) and F803 (1.6A) blow intermittently when the unit is switched from standby to on:** Replace the ERC04-02F bridge rectifier diode D802, part no. 23118485, which can go open-circuit intermittently.

### Models V110B and V210B

**Mains transformer is noisy in standby:** Fit a self-adhesive spacer, part no. 70050434, to the transformer so that it projects from the coil former through the plastic inner case to the cabinet. The cause of the problem is that the transformer's magnetic field resonates the VCR's cabinet: pressure on the right-hand side of the cabinet reduces the noise.

**Fuse FP01 (630mA) fails for no apparent reason:** Replace the 0.1 $\mu$ F mains filter capacitor CP01 with a 4,700pF capacitor that has a working voltage rating of 275V a.c. Quote RIFACAP as the part number. Cause of the problem is spikes on the mains supply or a poor quality wall socket.

**Patterning on the screen in the standby mode/distorted playback and E-E pictures/no playback colour/an off-tune effect with playback and E-E signals/static interference even in standby (Model V210B)/no functions, machine laced up, crazy display – no data at IW18 from the KDB microcomputer chip:** Replace the 2.7V zener diode DT53, part no. 70010160, in the Video +5V supply regulator circuit. The diode goes leaky, the fault symptoms varying with the output voltage from the regulator. Note that the circuit was altered in later production: refer to the service data for Models V211B/V411B for the later version.

**Tuning drift or failure to tune in the higher channels:** Replace the ZTK33B 33V regulator DP04, part no. 70010628, in the power supply.

**Failure of the r.f. modulator:** This is usually caused by customer misuse, the result being broken channel adjustment resistors.

For some faults with these models a full micro reset may be necessary to remove information memorised under the fault condition, otherwise the repaired unit may not operate correctly. Full reset is achieved by pressing and holding the timer and '-' buttons while applying a.c. power.

Note that two different drum assemblies have been used in Model V210B. Complete assemblies are interchangeable but parts of them, i.e. the upper drum, are not. If the letter M follows the model number on the rear label and the upper drum carries the letters MF, use complete drum assembly part no. 70030922 (upper drum part no. 70030918, lower drum part no. 70030921). If there are no extra letters use complete drum assembly part no. 70050148 (upper drum part no. 70030006, lower drum part no. 70030618).

### **Models V212B, V312B and V412B**

**Dead with no display, all power supply output voltages being at about half the correct figure, e.g. the 14V line being at 6-7V:** Replace the ZPD3V9 zener diode DP15 which is short-circuit. Note that this zener diode is not shown on the circuit diagram. It's located under the 1-5Ω cement wire-wound resistor RP33 (difficult to see) on the component side of the power supply PCB.

**No mechanical operation:** Cam gear ref. B710, part no. 70011070, is probably jammed with stripped teeth. Replace this item (see pages 2-22 and 2-23 in the service manual for the correct assembly and alignment) and also the supply soft brake lever (an improved type, coloured black, comes with the replacement cam gear).

**Failure to erase the previous sound track and slight coloured patterning on recorded pictures:** The bias oscillator is inoperative – the symptom can be very intermittent. Improving the connection between the full-width erase head and its connecting cable will usually provide a cure.

**Erasement of sound on prerecorded tapes and own recordings:** Though the erase off command from the microcomputer chip is o.k. the bias oscillator continues to run in the playback mode because CL05 (0.01μF) in the oscillator stage is open-circuit. Replace it.

**The cassette loads and the drum rotates but the machine won't play, going to standby. The cassette is then ejected but without the tape being reloaded into it:** Resolder dry-joints at pins 8, 9 and 10 of connector BT06 – the +5V supply to the logic/servo chip IT01 is missing.

**Slow rewind and fast forward:** The MPS750 transistors TP81 and TP83, part no. 70010939, in the power supply are both leaky base-to-collector. As a result the power supply is not providing the capstan +14V and +18V supplies at pin 3 (UCAPST) of connector BP03. Replace TP81 and TP83, which are surface-mounted devices.

**Intermittent poor playback (loss of output from one head) in the SP mode. Tapping the head preamplifier unit may clear the fault:** Replace the surface-mounted capacitors CQ05 and/or CQ06, part no. 70040991. They go open-circuit (normally cracked). The wire-ended type can be used.

### **Model V300B**

**Dew sensor operates mistakenly, '- d -' appearing in the display:** Resolder dry-joints at the connections on the loading-motor PCB.

### **Models V300B and V500B**

**Warble on sound:** Replace the TD6361N servo chip IC501. Part no. is B0272617 with the V300B and B0272616 with the V500B.

**Intermittent audio recording:** Replace the lead between the ACE head and the full-erase head with new type, part no. 70160889.

### **Model V411B**

**Drum fails to rotate, just twitching when the tape is being loaded:** Check that the capstan CTL drive is present at pin 3 of plug 152 on the capstan motor PCB. If this is o.k., replace the whole drum assembly, part no. 70050435.

**The machine goes into a lock-up condition or ejects the tape if rewind or fast forward is used for approximately one minute or more in the LP mode only and play instead of stop is then pressed:** An improvement is needed in the logic/servo chip circuit – add an extra transistor between pins 8 and 12 of IT01. Details are available from Technical Advice on 0276 694 555.

### **Model V610B**

**Faint white flashing lines are present across the screen with E-E pictures, playback of prerecorded tapes being o.k. Symptom is like that produced by poor aerial connections and is present only on channels above 45:** Data bus noise is being picked in the Matsushita tuner. Replace with an Alps tuner, part no. 70121102.

**Machine is dead with no Ever +6.5V supply:** IC811's load coil L814 has shorted turns and is overheating. Replace coil, part no. 23103961, or the PCB if this has burnt.

### **Model V711B**

**Intermittently snowy picture, symptom looks like that produced by faulty heads:** Resolder dry-joints at the lower end of the head connections on the lower drum.

**Popping noise with Nicam reception:** Replace the 6MHz filter ZD02, type TCF1073, with improved type TCF1083 (part no. 23303054).

**Noises (popping, crackling) with hi-fi playback:** F.M. envelope is poor because of incorrect entry S-guide setting or incorrect head switching position. Adjust as necessary using an alignment tape.

### **Servo Chip IC501**

In Model DV90B this is type TD6361-C5, part no. B0272638; in Model V93B it's type TD6361-D5, part no. B0272628; in Model V300B it's type TD6361N-E5, part no. B0272617; in Model V500B it's type TD6361N-A6, part no. B0272616. It is not possible to interchange these chips.

# Fault Notes on Toshiba's VHS VCRs

John Coombes

The following notes summarise our experience with the V55B/V57B, the V65B/V66B and the V71B/V73B/V81B/V83B series.

## MODELS V55B/V57B

We'll start with common faults experienced with the V55B/V57B.

**No play/record:** The most likely culprit is the loading belt. The loading motor is another possibility.

**No rewind/fast forward:** Check the reel idler assembly by replacement.

**Snowy vision with own recordings:** Suspect a faulty video head. Check by replacing the drum.

**Original sound left on tape:** Probably due to a faulty plug/socket on the full erase head. For a complete cure remove the plug/socket and make soldered connections directly to the head.

**Ejects tape:** Probably a cassette housing fault. Check the switches for incorrect operation and if necessary check for broken cogs. The cassette loading motor could be defective.

## Miscellaneous Faults

The following notes detail less common faults.

**Unit inoperative/no clock or function lights:** Check that the 9V supply from the regulator panel is present. If missing at pin 2 of plug/socket CN2 check transistors Q5 (2SD1128) and Q6 (2SD637). If the 9V supply is present at pin 2 of CN2 check whether protector CP2 or coil L201 is open-circuit.

**Intermittent loss of sound with own recordings:** There are three likely causes of this fault. The first is faulty connections to the audio/control head. It's best to remove the plug and socket and make soldered connections to the head and PCB directly. The second possibility is failure of the oscillator to start. If this is the case and you get colour patterns on the screen increase the value of C27 to 0.0082 $\mu$ F. The third thing to check is for an open-circuit in the leads to the full erase head.

**Snowy playback:** The obvious possibility is faulty heads. If the heads are o.k., ensure that the head amplifier chip is receiving about 2.5V on playback. For incorrect voltage here check Q504 (2SB641S) which can become leaky.

**Intermittent stopping in the record and/or playback modes:** Check the take-up reel sensor optocoupler by replacement.

**Intermittent stopping and going into the rewind mode:** The first suspect is the M50790SA expander chip IC202. Check it by replacement or check the d.c. conditions at its pins.

The other strong possibility is that C1 (0.001 $\mu$ F) across the end sensor is short-circuit.

**Intermittent stopping in the review mode:** The main possibilities are again IC202 and C1, see previous fault.

**Distorted verticals:** This symptom is often associated with poor picture sync, the symptoms varying with picture content. Suspect that C7 (0.047 $\mu$ F) in the i.f. a.g.c. circuit is open-circuit.

**Playback speed slow:** Check the voltage at pin 6 of the BA6302A chip IC401. If the voltage is low D206 (1SS133) could well be leaky.

## MODELS V65B/V66B

The following notes apply to the V65B/V66B.

**No results, channels lit:** There are two things to check for this one. First check for 5V at pin 6 of plug/socket CN3. Its absence will probably mean that CP4 (ICP-N10) is open-circuit. The other likelihood is that the 5V and 12V outputs from the power supply are low because zener diode D3 (RD3.9EB) is faulty. Check it by replacement. If the diode is simply leaky the VCR will work but the counter will continue to be operational in the stop mode.

**No clock display:** Check whether the -30V supply is present at pin 3 of plug/socket CN2. If this voltage is absent fusible resistor R2 (560 $\Omega$ ) could be open-circuit or regulator transistor Q1 (2SB644) faulty. The cause could be in the timer section however. In this case check the clock display FDP (PU57345-2), IC301 (MN1250BJA) and IC401 (HD614042SB27) as necessary.

**No video/luminance:** Check whether the switched 5V supply is present at pin 1 of CN3. If not CP2 (ICP-F10) is probably open-circuit.

**Machine plays for a short time then goes to stop:** If the counter doesn't work, suspect a faulty take-up reel sensor.

**No manual record, o.k. with timed recordings and remote control:** Check the d.c. conditions around IC101 (HA11839NT) on the main PCB. If you find incorrect voltages check IC101 by replacement.

**Ejects tape and shuts down:** A faulty loading mode sensor is the usual cause of this.

**Machine half loads then unloads:** Watch the drum. If it runs backwards, or simply moves back and forwards slightly, zener diode D408 (RD5.1\*) is probably leaky. Check it by replacement.

**Intermittent drum rotation:** Dry-joints on Q1 (2SB1052) are the usual cause. Resoldering will usually put matters right. If the transistor's leads are discoloured however it's best to fit a replacement to prevent further trouble.

**Incorrect loading/no play:** The first thing to check is the loading belt, which may be badly stretched. Check by comparison with a new one or by replacement. If the loading belt is o.k. it may be necessary to check the loading gear and cam gear assembly. Dismantle the assembly then clean off the old grease, which causes friction when it becomes hard. When reassembled the assembly must be in the correct position as indicated in the service manual.

**Previous sound recording left on tape:** As with the V55B/V57B the usual cause is the plug/socket connections to the erase head. Solder the leads to the head directly. Be sure not to apply excessive heat to the head, i.e. don't apply the iron for too long.

## **V71B/V73B/V81B/V83B SERIES**

There are some common fault patterns with the V71B/V73B/V81B/V83B. You very often get intermittent faults like going into the search mode with fast sound, or stops in pause when review is pressed in the play mode, or stops loading when only half loaded. These problems can all be caused by a faulty cam switch. When this is replaced it's important to ensure that there's an earthing screw to the reel motor bracket. This screw also prevents static discharge from the reel assembly. Such discharges can ruin the servo/logic chips.

### **Faulty Chips**

If the TD6360N servo chip IC501 has been damaged by static discharge you may find that the problem in the record mode is no servo lock. The unlocked head switching produces picture disturbance, jitter or roll. On playback the problem is usually loss of servo control, i.e. varying speed and poor tracking.

If the static has ruined the TMP4746N5759 logic chip IC601 the usual problem is no reel rotation due to wrong voltage levels at pins 19 and 20. If there's no motor drive, or the power disappears after ten seconds due to the TA7288P chip IC602 drawing excessive current, this i.c. will have to be replaced.

If there's no reel rotation in any mode, suspect the TA6267P chip IC603. It may have been getting hot because the 2SB101SY drive transistor Q625 is defective. If necessary check it by replacement.

If the tape counter is inoperative and the machine goes into the stop mode when play is selected, replace the TA75393P reel sensor chip IC604.

### **Incorrect Speed**

A faulty cam switch often results in the machine running fast in the play mode, with fast sound, the pinch roller not being engaged. If the machine is used to record with this fault it may run fast, giving slow replay.

### **Blown Fuse**

Fuse F803 (1.25AT) will blow if there's a short of course, but you may find that D801/3 are open-circuit or that there's a dry-joint at the connection of D801/2.

## **MODEL V93B**

A problem we've had on several occasions with the V93B is no clock display due to circuit protector 2L62 (ICP-N10) on the Timer-2 board being open-circuit.

## Mitsubishi HS400

The job card said "keeps pausing". Sure enough a soak test showed that the tape stopped moving for a second or so at rare intervals. It would sometimes stop long enough for the system control to shut down the deck. With the top cover of the capstan motor removed it took us some time to establish that the motor itself stopped when the fault occurred. The culprit was the STK6962 motor drive chip IC5A4. It's similar in shape and size to the motor-drive chips that gave a lot of trouble in earlier models. E.T.

## Hitachi VT9500

This is a veteran machine. The unusual symptom was complete failure – no clock display, no indication lights and no functions. Mains current was flowing into it however, and the several rectifiers were doing their stuff. The system control/regulator panel along the back of the machine is no fun to deal with physically. We found that the trouble was due to one of the 10V dropper diodes here – D904 was open-circuit. E.T.

## Toshiba V93

This machine's owner, or rather her two small children of two and four, were very upset. It had chewed a couple of their tapes. The reason for this was obvious when the fault developed: the take-up reel stopped but the capstan continued to run, thus making a right mess of Noddy and Big Ears. As we've had problems with it on earlier models suspicion fell on the reel motor. Sure enough if it was given a sharp knock with the handle of a screwdriver it stopped. A replacement put matters right, but unfortunately Rod, Jane and Freddie were no more. S.C.

## Hitachi VT35

No clock display with the machine otherwise working correctly is a fault we've had on a number of occasions with this model. The cause is a defective d.c.-to-d.c. converter chip, IC711, which burns out L701. Hitachi supply a new d.c.-to-d.c. converter and a modification kit that includes L701. Its part number is 7026181. S.C.

## Hitachi VT130

The problem with this machine was no tape transport. Suspicion fell on the A5V supply to the syscon section of the circuitry. Sure enough it was missing. We traced the circuit back to the 9V circuit protector which was open-circuit. Before fitting a new one a resistance check was made between the 9V line and the deck. The reading was only a few ohms. Further checks showed that there was a short-circuit inside the A5V regulator IC802 on the VST board. Replacing this restored normal operation. S.C.

## Hitachi VT520

This quite new machine had an unusual fault: the playback picture was very poor and was rolling while the sound was low and very muffled. With a fault like this the audio/control head is the first thing that springs to mind, but in fact the symptoms were caused by insufficient back tension. A check on the back-tension post showed that it

was about half an inch away from the tape. The reason for this was not at all obvious. Nothing was jamming it. The mechanism that controls the arm looked o.k., but it didn't move the arm far enough. Curiously, if the loading motor was given a few more turns the mechanism and back-tension post moved to their correct positions and normal operation was obtained. Of course when the machine was stopped and play was again selected the fault was back.

We made a note of the number at which the arrow on the mode switch pointed. In play or record it should normally be 6, but the arrow pointed to 5. This is the position for reverse play, in which no back tension is needed. A new mode switch from Hitachi, part no. 5610702, cured the problem. S.C.

## Ferguson FV30

This machine went into the stop mode after a few seconds of play, record, rewind, etc. The fault was very nearly the same as the one with the GoldStar machine featured in Test Case 335. We followed the same test procedure, but rather than gunged up reflectors the fault in this machine was caused by the supply spool optosensor. S.C.

## Hinari VXL6

There was no drum rotation though all the other functions were in order. Voltage checks in the power supply disclosed that the P-on 5V rail was low at 2.8V. The culprit turned out to be Q504, though the device read o.k. when checked on a transistor tester. As we didn't have a direct replacement we fitted a TIP42C. This restored normal operation. E.R.

## Panasonic NV2000

This repair served as a reminder of the usefulness of the servicing articles in this magazine. The symptoms were no E-E signals with the channel LEDs out. As we hadn't had this problem before we referred to Nick Beer's article on the machine in the January 1990 issue. This enabled us to go straight to Q1006 which was open-circuit base-to-emitter. Thanks Nick. E.R.

## Panasonic G Series

Intermittently going to stop during play and sometimes not winding the tape back into the cassette is due to dry-joints on the AN3821K DD capstan drive chip. Make a point of resoldering this i.c. whenever any VCR that uses it comes in for repair. It will save you a call-back. H.M.

## Panasonic NV7000

The picture was intermittently smeary – as if it was out of focus. Flexing or patting the bottom PCB, one half of which carries the chrominance and luminance circuitry, would instigate the fault. Sometimes the machine would behave itself for a day or two, then we were back to square one. The problem was that there was no time to scope any signals when the fault appeared. So I went on tapping the board until I came to the luminance playback level preset which seemed to be the cause of the fault. After changing it

I gave the machine a soak test then returned it to its owner. Five days later it was back with the same fault. To cut a long story short I eventually found that filter FL3002 had a dry-joint at one end.

H.M.

### **Panasonic NV7000**

Sound was o.k. but there was no picture. In fact there was a blank white raster on playback. As the E-E picture and sound were o.k. we suspected either a blanking or recording fault. It turned out that the record-on switch transistor Q3013 was short-circuit, a replacement restoring the picture.

H.M.

### **Panasonic NV340**

Apart from the clock display nothing worked. The power supply rails were all as specified however. When the machine was plugged in the capstan motor rotated slowly and wouldn't stop until the machine was disconnected. Now when VTR is pressed pin 8 of the MN1405VKF syscon chip should go low. It didn't change state. Replacing this chip restored all functions.

H.M.

### **Panasonic NV8600**

Playback produced a blank white raster with normal sound. There was no E-E picture and we couldn't get the test signal. I suspected the r.f. converter but as we didn't have one to hand I decided to start fault finding. The first step was to check the supply to the r.f. converter. It was correct at 9V. Next the converter's video input was checked. The manual says there should be a 1V p-p signal here but there was a 10V d.c. reading. This 10V was traced to the buffer transistor Q313 which was short-circuit all ways. A replacement put matters right.

H.M.

### **Panasonic NV7000**

For snowy playback pictures, as if the heads are worn out, check the continuity of the rotary transformer's windings before changing the drum. I've had three machines with this fault and in each case one winding was found to be open-circuit.

H.M.

### **Panasonic NV-G12/G21 Series**

We've had several cases of a broken safety tab switch with these machines. The symptom is that the cassette is ejected when record is selected.

H.M.

### **Panasonic NV250/NV450**

In cases of intermittently going to stop during playback then rewinding, in fact with all sorts of confusing conditions, check for a leaky supply phototransistor. There should be 3-2V at pins 20 and 21 of the syscon chip IC6001. If not change both sensors.

H.M.

### **Panasonic NV-M7**

The complaint with this camcorder was that it wouldn't eject. It came from a teaching hospital and we were asked to carry out a "general service". So we replaced worn belts, the pinch roller and idler, and the main loading pulley. The latter had caused a lot of knocking while the threading operation was being carried out - like what you get with the NV730. But we never saw the eject fault! The

very dry grease was replaced with some nice new Moritone and we then powered the unit (still disassembled). There were no deck functions. I've had this before but it took me a few minutes to remember the cause. If the earthing lead from the top bolt hole of the battery compartment is undone you won't get anything. This lead earths the main PCB to the deck. Another reminder to stick above the bench!

N.B.

### **Toshiba V55**

E-E operation was o.k. but this machine wouldn't load a cassette. My first check was on the power supply outputs, which were all o.k. A scope check was then made on the inputs to the microcomputer chip. It was receiving instructions but was it carrying them out? I scoped the outputs but these didn't make much sense. Try a different approach: maybe no power is going to the motors? Three changeover switch chips feed 13V to the motors. Check and find that there's nothing at IC204/5 because circuit protector CP1 is open-circuit. As there were no shorts I replaced CP1. At switch on 13V appeared at the switches.

A cassette could now be inserted and the drum and capstan motors rotated, but there was no lace up. Feel each switch chip and find that one is too hot. Is it faulty? Switch off and remove the chip to check it. Checks not conclusive. Decide to try feeding each switch output with 10V from an external power supply - with the VCR switched off of course. Find that all the motors except the mode one run. Remove leads from mode motor and connect to power supply. Motor still doesn't run even with the drive belt removed. Replace motor and i.c. switches and find that all is now well.

R.C.

### **Hitachi VT33**

The complaint was that tapes remained looped in the machine on eject. Whilst removing the covers I noticed a label on the base plate saying that another company had repaired the machine some months earlier. Considering this fact I was amazed at the amount of dust inside it. On running the machine with an old "test" tape I found that there was no fast forward or rewind action because the rubber drive wheels and the clutch assembly had all been coated with a layer of oil, which appeared to be due to over-generous application to bearings during the previous service. This meant a complete mechanical strip down, clean and rebuild, something that could have been avoided if the previous "service engineer" had been more careful in cleaning the machine properly and had not been so generous with the oil.

A.W.

### **Sony SLC6**

This machine suffered from lack of capstan servo lock, the problem being worse in play than record. The cause was C7 (0.22 $\mu$ F). Sony say that this is a common problem and in addition recommend changing C8 which is also 0.22 $\mu$ F.

M.D.

### **Sharp VC7300**

The playback picture showed increasing interference as the machine warmed up - the effect was similar to that produced by an arcing tripler in a colour TV set. The E-E picture was normal and the sound was not affected. We found that the problem was caused by the HA11703 chip I403 in which the playback f.m. signal is detected.

M.D.

removed prior to this in the case of the right-hand side piece.

## Mechanical Servicing

We'll consider first replacement procedures for some of the items that occasionally need to be renewed.

The pinch roller can be taken out after removing the plastic pinch cam cap then pulling it gently up and free. The cap has a modified part number, VMX1353, this being the skeleton type. The problem with the older solid type was that removing the cap with the cassette carriage fitted meant that the pinch cam shaft had to be bent. The pinch roller has been modified from the original with its brass-coloured insert to an aluminium-coloured one which is slightly longer (part no. VXL1743).

## Centre Pulley Replacement

The centre pulley's 'tail' sits under the main lever, so this has to be moved out of the way during replacement. The main lever can be removed but some may prefer to take the less involved route if they aren't familiar with the positioning of the pins around the lever. Remove the slit washer on the right-hand side of the lever, taking careful note of the positions of the pins around and through the various slots in the lever, then gently lift up the lever from the right-hand end and pull it slightly towards the front of the machine. It will then sit on one of the pins. After doing this the centre pulley can be removed by taking off its slit washer and lifting it up as far as it will go then turning it about 45° anticlockwise, viewed from the front of the machine. This allows the tail to come out from under the lever. When removing the pulley take care not to lose the washer underneath it, on the shaft. It can be caught by bending the pulley's trajectory as you pull it off its shaft – the oil on the shaft will then hold the washer at the top of the shaft. When fitting the replacement pulley reverse the above procedure. Take care to get the tail into the kick gear and to get the pins in and around the main lever as before. If the mechanism is being rebuilt the main lever will of course be off and fitting a new pulley will be a minor job.

## Capstan Rotor Replacement

Replacing the capstan rotor is another job that can be fiddly if you don't follow the appropriate procedure. Remove the belt, which just slips over the rotor pulley, the centre gear/pulley and the jockey pulley. The bracket that holds this pulley and the capstan brake will have to be removed. It's usually secured by one cross-headed bolt but sometimes a circlip on another shaft is also used. Access to the rotor will then be impeded by a bent bracket which is secured by one cross-headed screw at the back of the mechanism. Remove it. On later machines, the G40 for example, you will have to remove a nut on a threaded pillar in the opposite corner of the stator. To make access to the capstan easier, remove the pinch roller. Do not put the deck upside down with the pinch roller removed however: keep it on its end otherwise the pinch cam will disengage from the connection gear and the mode switch – if this is not noticed the mechanism may go out of sync, especially if the cam falls back into place in the wrong position. Now simply pull the rotor out from the bottom of the machine. Do this gently and smoothly – you will have to overcome the magnetic effect.

There are two spacers on the capstan shaft. If the rotor is

removed carefully they will accommodate themselves on top of the capstan bearing on the top of the machine. You will also notice a rattle from a plate under the stator – it centres itself when the magnetic rotor is replaced, so don't be alarmed about this.

When fitting the new rotor start by inserting the very end of the capstan shaft into the bearing opening with the machine stood on its side. Place the end of your index finger on the top of the machine, holding down the top of the two spacers firmly so that when the rotor is inserted they are impaled on the capstan shaft. As the shaft appears through the top spacer let go and push the rotor in a little farther. Now insert a small screwdriver between the two spacers, forcing the second one down on to the capstan bearing while pushing the rotor in fully so that the first spacer goes to the top of the holder. Clean the capstan to remove oil and refit the pinch roller, the cap, then the hardware underneath.

## Capstan Brake Arm Replacement

To replace the capstan brake arm remove the brake/pulley bracket and belt (to make it easier to refit the bracket). Then remove the split washer holding the arm and pull it and its spring off. Fit the spring to the new arm then reassemble everything.

## Video Head Replacement

Replacement of the video head is largely a matter of common sense. Suffice it to say that the pins on the video head PCB should be desoldered thoroughly before the drum is removed to prevent damage to the rotary transformer. Note that the Panasonic head puller will fit all drums fitted to G mechanism machines.

## Alignment on Underside

We'll deal now with alignment of the gears and other mechanism components where inaccuracies can lead to problems. A rebuild of the extent common under normal servicing conditions, i.e. where there are timing problems, is assumed. Part numbers refer to earlier models: consult the service manual for the relevant model for the correct part numbers. The following alignment instructions leave the deck in the stop mode, so the carriage should be refitted in the down position when the job is finished. Fig. 1 shows the underside of the standard G deck, Fig. 2 shows the alignment order of the parts beneath the deck and Fig.

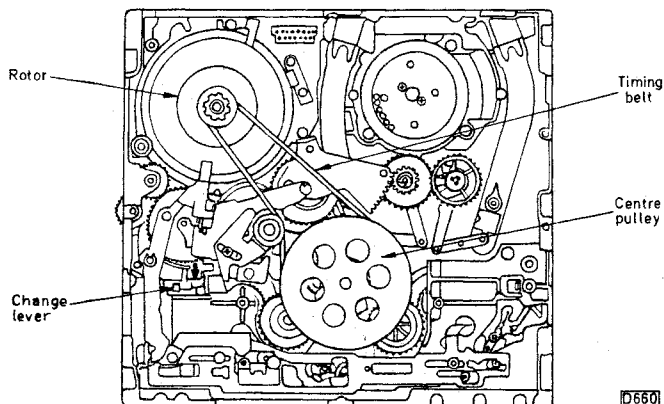

Fig. 1: View of the standard G mechanism from underneath. The arrow beside the change lever indicates the direction in which to click it during manual operation of the mechanism (see text).

3 the alignment order above the deck.

Start by inserting ring gear A, part no. VDG0342, so that its hole aligns in the hole in the mechanism beneath it. A needle or something similar is useful to maintain alignment because when further gears are inserted others can move slightly (something that must be avoided or corrected) with the result that sight of the mechanism holes is lost. Then insert sub-cam gear B, part no. VDG0343, to the left of the ring gear with its two holes in line with the one in the ring gear. At this point the indentation in the circumference of the sub-cam gear should face south, viewed from the front of the machine.

Locate detent arm C, part no. VML1861, on to its shaft and into the indentation in the sub-cam gear. You may need to jiggle the arm to clear the machine's plastic case if the mechanism hasn't been removed. The main cam gear D, part no. VDG0346, is then fitted on the same shaft on top of sub-cam gear B. The double holes in these two cam gears should coincide. Despite Fig. 2 and the manual however some main cam gears have two single holes instead of three holes, so the gear could be fitted in two ways: the correct way is with the holes at ten to and just after ten past. The right-hand hole will then align with the sub-cam gear and the left-hand hole will align with the pinch-speed down gear to be inserted later.

Insert retainer gear E, part no. VDG0344, into ring gear A. This gear has three smaller gears attached to its three arms. They don't come with the new retainer gear and have to be ordered under part no. VDG0345 – or they can be easily unclipped from the old retainer gear. When fitting the retainer gear plenty of Moriton grease should be applied to it and the inside of the ring gear. Fit it with the two holes about 170° apart at the top half, with the left-hand hole aligned with the right-hand hole in the main cam gear and the hole in the ring gear beneath it. The right-hand hole should align with the hole in loading-cam gear F, part no. VDG0347, which is fitted next. When fitting this gear ensure that the black sub-loading arm (part no. VXL1480) is moved around to the side of the audio/control head on the top of the deck, so that its spring stretches and the lug on the base of the arm engages with the indentation in the gear being fitted. Note that when the loading-cam gear, sector gear or either loading arm gear is ordered a kit of all four items (VUA4100KIT) will be supplied as they have been modified. The sector gear has been strengthened by putting a step in it: the other gears have been altered to accommodate this.

Centre gear G, part no. VDG0348, is next fitted over the retainer and ring gears, with the left-hand holes aligned. The right-hand hole should be at twenty past, aligned with the hole in the clutch disc that resides under the centre pulley unit (part no. VXP0917). You will usually have to rotate the clutch disc to align it prior to fitting the centre gear. Sector gear H should be positioned as shown. The main lever can now be refitted. Refit the cam follower arm into the main lever and main cam and the centre pulley unit over its shaft – if the main lever has been removed however this is best done before refitting the main lever and the belt. The main lever is simply slotted over the poles and pins that it actuates: take care to get it right.

## Top Alignment

The next steps are on top of the deck. Before turning it over ensure that all circlips and slit washers have been refitted to avoid things falling off. On top the first step is to fit the pinch-speed down gear I, part no. VDG0344, with

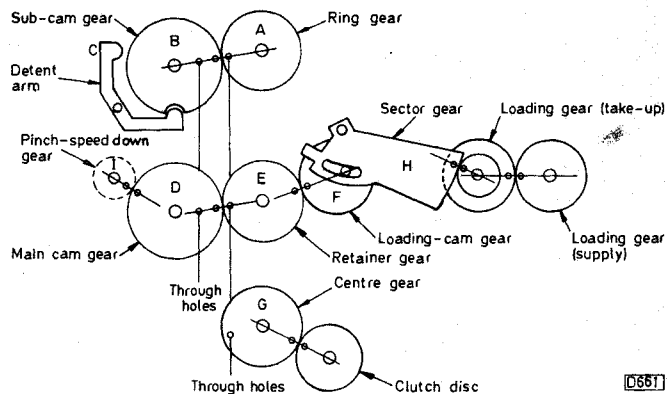

Fig. 2: Assembly/alignment order for the gears on the underside of the mechanism.

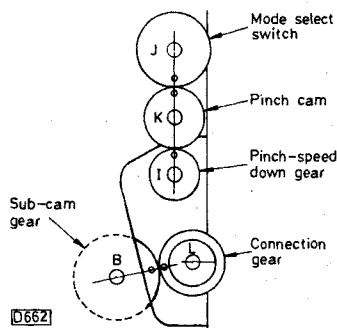

Fig. 3: Assembly/alignment of the items on the top of the mechanism.

its hole aligned with the left-hand hole in the main cam gear as previously mentioned. This obviously needs to be viewed from the underside. The hole in the top gear should then face north. Mode select switch J, part no. VSS0175A, is next located so that its hole faces south. Pinch cam K, part no. VDG0356, is then inserted between them: its hole aligns with the hole in the mode switch and its arrow-head projection 180° opposite aligns with the hole in the pinch-speed down gear.

Finally on top fit connection gear L, part no. VDG0332, so that its hole is aligned with the upper hole in the edge of sub-cam gear B, seen to the left.

Take great care over all this: it's vital that alignment is single-tooth accurate if timing problems are to be avoided.

## Refitting the Carriage

The mechanism is now in the stop mode (stop mode 1 with the G2 version). Thus if the carriage were fitted in the eject position the unit would go out of step. The carriage must therefore be fitted in its lowered position. This is done by mounting the two side pieces only – no carrier or lid – with the white lever on the outer side of the black, right-hand carriage side piece pushed down flat to the bottom before it's fitted. Take care not to push the lever too hard or far as it might jam. The first tooth of the rack on the right-hand side should engage with the connection gear's slot, which is marked with an adjacent indented line. You may need to jiggle the carriage side slightly to align this.

Now manually unlace and eject the mechanism – this is described below – and refit the carriage and lid.

## Manual Operation

The mechanism works on a process method of mode selection: as it reaches the end of one process the solenoid has to be energised to pull a lever which then re-engages the mode-selection mechanism and the drive from the



capstan motor. So if you need to move the mechanism through its modes with the machine unpowered, for example to release a damaged cassette, this can be done by turning the capstan rotor. It's much more easily done however, with the belt fitted or not, by turning the centre pulley and, at the required points (when the mechanism stops moving between modes), clicking the solenoid lever on the underside (see Fig. 1) then resuming the rotation. This is best done with a normal cassette inserted – dummy cassettes don't always agree with the front loading mechanism, but as long as they have a blinder flap they should work.

The problems occur with the action of the white jamming lever at the front right-hand side of the front loading mechanism. This mechanism has an effective jamming system to prevent cassettes of dubious construction or entry angle being loaded. It's also possible, by flicking the jamming lever at the correct point, to load the carrier with no cassette.

Though it may have sounded tedious, aligning these mechanisms isn't that bad in practice. If I've made it sound easy, maybe you've been doing it differently – give these methods a try.

## Mechanical Faults List

We will conclude this instalment with a mechanical faults list. The electrical aspects of the Panasonic machines will be dealt with in Part 2 next month.

**(1) Knocking noise, particularly when lacing:** Noisy capstan rotor (VXP0777).

**(2) Scraping noise, particularly in play:** Worn capstan brake pad (VXL1500).

**(3) Cassette goes in but doesn't reach the half-lace position:** Check that the play arm VXL1480 is intact. It often snaps in two, particularly at the base where it enters the cam on the underside of the mechanism. This can be caused by a timing error. A sticky or open-circuit solenoid (VXA2693) is another cause.

**(4) Low or muffled sound:** Invariably due to a worn audio/control head. With the G21/G25 ensure that the replacement is type VBR0125. With later models the head is supplied minus its PCB, so this will have to be transferred from the old one – it involves only half a dozen or so connections and is soon done. Check the audio bias (see next month) every time you replace or adjust the head. This is very important.

**(5) Won't accept a cassette/carrier askew:** Return the carrier manually (see above) to the eject position, remove and replace. Check the mechanism carefully for broken pieces of plastic from the carrier – these can often fall off and impede the operation of the mechanism. Also check the alignment of the pinch cam and connection gears (see above).

**(6) Tape crinkling over post P4:** Check the pinch roller. If it has a gold/brass coloured insert replace it with one that has a silver/aluminium coloured insert. If it has a silver insert it could still be the cause of the fault – check it carefully for a bowed roller. Ideally the pinch roller should be checked by substitution.

If the pinch roller isn't the cause of the problem check the back-forth tilt of the audio/control head. If it's set too

far one way it will still produce perfectly adequate sound (with the azimuth set to compensate) but will cause the tape to ride up or down over post P4. Readjust and lock with Unibond or Screwlock.

**(7) Picture pulling at top in review, particularly at the beginning of a tape:** Faulty video head. Replace and check the back tension.

**(8) Picture disappears intermittently on playback – looks like intermittently clogged video heads:** Cause is breaks in the leadouts or coils of the rotary transformer. If break cannot be located replace whole DD unit. In rare cases the break may be accessible and repairable, but I wouldn't recommend repair in a customer's machine.

**(9) Poor still frame, noisy picture and/or poor vertical lock:** Usually due to a worn or poorly aligned audio/control head if the video heads are o.k. Clean all heads and align the tape path exactly. Pay particular attention to the height and H position of the audio/control head. Regular checks should be made on the audio level and still frame performance. Check the audio bias during alignment.

**(10) Cyclic clicking, ticking or rubbing noise:** These symptoms suggest a noisy centre gear unit (VXP0767 G, VXP0917 G') rather than a faulty capstan rotor (VXP0777) which tends to result in a knocking noise. Note that you cannot interchange the two types of pulley without changing the belt type as the belt (VDV0169) used in the G' is thinner than the earlier G type (VDV0159). In order to rationalise spare parts stocking, Panasonic supply the later type of pulley complete with the new type of belt and new slit washers under part no. VXP0917K.

**(11) Intermittent failure to accept a cassette, lace, unlace, rewind, wind fast forwards etc.:** This fault usually affects rewind or eject and can be exceptionally intermittent. The cause is often a dodgy solenoid (VXA2693/3735), i.e. failure of the solenoid action to click the gears into the drive from the capstan/belt. See also (18) and (19).

**(12) Cuts out in review, all other deck functions work:** Mode switch set one tooth out. Turn it one tooth anti-clockwise relative to the pinch cam.

**(13) No take-up:** This fault often occurs after replacing parts on the underside of the deck. It's due to the pin adjacent to the spike on the end of the main lever assembly. This area is at the front right-hand side with the machine upside down, viewed from the front. The pin is probably below the lever, i.e. to the front of the mechanism. It should be behind the lever. In certain circumstances this can badly damage the sector gear/guide pole gears as it prevents the back-tension arm getting out of the way of the guide pole bases during unlacing.

**(14) Cassette goes in, half laces very quickly and is then ejected. Process is repeated automatically then the machine switches off:** Another problem caused by mislocation of the pins in the main lever assembly. Check the pins of the left-hand side of the lever with the machine upside down and viewed from the front. For this fault the relevant pin is the one locating above the swinging arm part of the main lever.

**(15) Rattling noise, particularly during lacing:** Usually due to a noisy jockey pulley (VXA2674) on the belt

tioner/capstan brake bracket. To replace it undo the black screw. Fit replacement with the bracket already located over its two pins so that the black screw locates at the centre of the travel of the slot in the pulley arm.

**(16) Chewing tapes/odd mechanical behaviour during half lace:** This is usually due to a fractured P5 post arm unit. As a result the P5 post drops out. A replacement is easy to fit but one or two points should be mentioned. First, before removing the 5.5mm nut carefully note the height of the old unit. Install the new one at the same height then fine set it for good tape path travel, i.e. no buckling over posts P4/5 in any mode. Check the review mode especially. A jig (VFK0191) is available for use in conjunction with the height gauge VFK0190, but these are not normally required. Prior to removing the post try to establish that there is no buckling over post P4, otherwise you may be trying to set the height of post P5 to overcome a problem caused by the audio/control head being set incorrectly (see above). Secondly you will need to remove the P5 pull-out sector gear — the plastic gear that drives the post from the pinch cam. This is secured on its shaft (remove the pinch cam cap and pinch roller first to make life easier) by a sprung plastic retainer which is almost impossible to remove without being weakened or broken. It's therefore best to replace this as well. Finally ensure that the washer is refitted with the post arm.

**(17) Failure to accept or reject a cassette:** This is usually due

to breakages on the right-hand side piece of the carriage mechanism. Prove the point by removing the carriage component parts and engaging the mechanism in the stop mode manually, then check that the timing is correct. The complete right-hand side piece is available preassembled and is often the most economical way of carrying out a repair.

**(18) Odd mechanical behaviour, especially of an intermittent nature:** Examples of this are tapes half lacing then immediately ejected, won't review, stops laced up whilst playing and machine then switches off, etc. The cause is the mode switch (VSS0175A). There are two designs, a black and white plastic version and a white wheel on a green/brown coloured base.

**(19) Intermittent problems:** Examples are refusing to accept a cassette, ejecting cassettes and loss of deck functions, particularly rewind, especially after making a fair length recording. Suspect a faulty mode switch (VSS0175A) and/or solenoid (VXA2693/3735). The mode switch is the more likely cause, especially if it's of the green/white/brown variety. You probably won't be able to experience the symptoms complained about by the customer as they can be extremely intermittent. When changing the solenoid and resoldering the flexi print take care not to get a short between the two connections: the soldering should be nice, neat and quick!

## Philips DMP3-0 Deck

This machine recorded colour all right but there was no playback colour. When we scoped the input to the modulator we could see that alternate fields of bursts and chroma were missing. A chroma panel swap proved that the fault wasn't there. It wasn't on any of the other likely panels either. But when the deck was changed the colour returned. A scope check on the off-tape f.m. signal showed that the output from one head was low, but new heads didn't restore the playback colour. Use of a signal generator then showed that the picture was being made up from the signals from one video head and one hi-fi audio head. The f.m. from VK2 was missing at pin 3 of the LA7018 chip as transistor 7004 was switched on in the play mode – it should conduct only in still frame and record. Transistor 7014 was also switched on as there was a crack in the print to the stop motion line (pin 1 of plug L6). This particular machine was fitted with the P404 head amplifier.

**P.B.**

## Philips VR6460

Playback was o.k. but there was a very poor picture in the E-E mode. There was no sync and the picture was pulling and shaking. C22 (1 $\mu$ F) on the i.f. panel was open-circuit.

**P.B.**

## Philips VR6467

A noise bar ran through the picture every ten seconds or so. Scope checks showed that the amplitude of the control track pulse at pin 13 of 7551 was low at 2V instead of 5V. This chip (8051) was defective, with an internal pull-up open-circuit.

**P.B.**

## Philips DMP3-0 Deck/VR6561

When play was selected the take-up spool didn't rotate – in fact if a dummy cassette was tried it was the supply spool that was being driven! Normally in play the rack pushes lever 237 which reverses the rotation of the coupling and changes the gearing. This wasn't happening as the leaf spring on lever 237 had come off. The VCR was a VR6561.

**P.B.**

## GEC V4005

Intermittent failure to play was the problem with this machine. When it was tried first thing in the morning it laced up but line slip showed that the drum speed was incorrect. Then, after a few seconds, it would go to stop. Selecting play-pause had no effect. Probing around in the power supply would instigate the fault and voltage checks then showed that the 12V/16V supply was disappearing. The cause of the trouble was a dry-joint at pin 6 of the STK5451 chip.

**P.B.**

## Ferguson 3V54

The job card said "dead" but the supply lines were o.k. The actual symptoms were no timer display and no operation, with a cassette still in the machine. Checks showed that the display grid drive was correct but there was no segment drive. We then found that the

microcontroller chip was not receiving the a.c. clock reference pulse though it was arriving at the timer board. C214 was found to be faulty with a resistance of 330 $\Omega$ .

**A.D.**

## Hitachi VT220

Poor colour was the report. In fact on playback the chroma produced a diamond pattern. A scope check at pin 16 of IC301 (playback main converter output) showed that the signal was virtually the same as that at pin 8 (4.43MHz chroma input). Replacing the bandpass filter CP302 seemed to be the logical thing to do but the fault remained. After pursuing several other red herrings we cured the fault by changing the chip.

**A.D.**

## Hitachi VT17

There was very bad interference on playback, with two thick bands of noise that moved up or down the picture. A scope check on the playback f.m. signal showed that there was an h.f. signal superimposed on it. The h.f. signal wasn't locked to either the f.m. signal or the drum FF pulses. A scope check was then made on the 9V PB line. This showed that an 0.5V peak-to-peak ripple at approximately 2.7MHz was present. It cleared when C1159 on the servo/reg board was replaced. A meter check showed that this electrolytic charged correctly. It also produced the correct display with the component tester built into our Hameg scope. Unfortunately these testers work at 50Hz and don't show up h.f. faults.

**A.D.**

## JVC HRS5000

The problem was overloaded video and crushed sync in the E-E mode. Its cause was traced to C14 on the signal processing panel being short-circuit. As a result the relevant pin of IC1 was at 5V instead of 1.4V, upsetting the clamp detector stage.

**J.H.**

## JVC HRS5000

The E-E signals were normal but on playback there was sound only, the monitor displaying a blank raster. Scope checks in the playback signal path showed that composite playback video was present at pin 15 of IC3 but was missing at pin 16. This was due to about 3V at pin 13, bringing on the muting within the chip. Open-circuiting pin 13 restored the playback video and left 3V on the print. The source of this voltage was traced to leakage in C121 (10 $\mu$ F, 16V), replacement providing a cure.

**J.H.**

## Toshiba V66

This JVC clone came in with complaints about poor tracking and poor quality recording. This was not surprising as there was no back tension – the adjustment screw had been set up to give no tension.

**M.D.**

## ITT VR3916

There was an audio fault with this machine: the customer said that he couldn't record the sound. When we opened it

up we found that the audio stages had been got at. If a hand was placed near the machine there was a lot of hum pick up in record. We repaired the print and replaced the AN3991K amplifier chip IC1 and the TA7361AP switching chip IC2 but the problem persisted. The only thing left seemed to be the head. When a replacement was fitted the problem had been cured but we couldn't find anything wrong with the old one.

M.D.

### Ferguson 3V48/JVC HRD565

This machine nearly drove us to desperation and certainly had us all questioning its parentage. On the fourth visit to the workshop the fault showed up as no take-up: the capstan motor would stop after an indeterminate time. The merest suggestion of heat or cold on IC202 (M50742-614SP) had the desired effect so we replaced it. But the fault was still present. A scope was connected to pins 8 and 7 to monitor the capstan drive while a meter was connected to the unswitched 5V supply at pin 9. We waited, and waited! Eventually the fault showed up as a distortion, reduction and final disappearance of the capstan drive. IC403 (BU2710) proved to be faulty, again in a thermal manner.

S.L.

### Fisher FVH-P615

There was a no record fault with this machine. The switching signal at pin 16 of the LM6416E-239 chip IC503 goes low in the record mode, turning on the REC 9V switching transistor Q513. The REC 9V line was low because Q513 was faulty. A BC640 gave good results.

S.L.

### Samsung VI8220

Bias oscillator problems with earlier Samsung VCRs are common. The oscillator circuit in this later model was redesigned and taken out of its can. It still fails, though for different reasons. The sequence of events is usually as follows. Service call one, no fault found. Call two, dry-joints found and resoldered, usually on the oscillator transistor Q501. Call three, hole in the PCB where Q501 used to live. What happens is that you get shorted turns in the REC 9V smoothing choke L0503. As a result there's enough ripple on the rail eventually to upset the oscillator coil and the transistor. The answer is to order and replace all three items at the same time, i.e. L0503, L0504 and Q501. The parts are inexpensive and Samsung is courteous and efficient. This looks like the fault reported by Ed Rowland in the January 1991 VCR Clinic.

S.L.

### Panasonic NV-F65

This machine failed when it was being installed. It would go completely dead, with no display etc. When it was powered in the workshop it ran all right for many hours before it failed. Failure eventually occurred during play: the tape remained laced up and it was just as if the mains plug had been pulled out. If the mains supply was disconnected then quickly reconnected a short buzzing noise was heard from the power supply. If the mains supply was disconnected for a couple of minutes before reconnection however the power supply would start up and the machine would work without any problems for perhaps an hour or two before it stopped again.

Because of the disorderly shut down a power supply problem seemed likely. A careful examination of the PCB revealed no suspect joints or breaks, but there was an

interesting pointer. If the mains supply was connected to the power unit with no connection made to the rest of the machine the power supply wouldn't run: it just buzzed for a couple of seconds (unlike the G21 etc. which will work in this condition). As a check we fitted the power supply from another new machine and connected it up. The machine faulted again after several hours, so the fault wasn't in the power supply itself. We then found that the fault could be brought on by flexing the main PCB. Careful pressure in different parts revealed a sensitive point, down the left edge near the mechanism. As the fault occurred when the board was pressed down a break on the underside print was suspected. Ohmmeter checks on the print then revealed the cause of the trouble: a break in the print that connects R6036 to the base of the motor regulator transistor Q6004 near the front of the machine. To put matters right we connected a link across the faulty section of print. Presumably the loss of loading on the one power supply output caused the complete shut down.

I.B.

### Logik VR950

The poor, low-contrast pictures produced by this machine led us to suspect that the playback luminance amplifier Q0310 was faulty. We've had this transistor fail on other occasions. This time however the culprit was its collector resistor R0364 (3.3k $\Omega$ ) which had gone high in value.

E.R.

### A Fairy Tale

How about this one for a bodge? The owner of a Sharp VC381H brought it to us saying that a friend of his had looked at it but had failed to repair it, and would we like to try? After removing the top cover we connected the mains supply and pressed the operate button. To our amazement the interior of the machine was bathed in a warm, pink glow. Raising the top PCB revealed the source of this wondrous phenomenon. There, nestling among the components on the bottom panel, was of all things a Christmas-tree fairy light. There was no sign of the original cassette lamp or its holder, so new ones were fitted and the makeshift lamp was consigned to the bin. After doing this all that was required was a new idler and a general clean up. Whatever next?

E.R.

### Ferguson 3V45/JVC HRD150

Although this machine would accept a cassette and the fast-forward and rewind modes were o.k. there was no drum rotation and the function LED wouldn't come on. The cause of the problem was an open-circuit fusible link, B3, which is located in the power supply.

E.R.

### NEC 9077

We had had to clean the heads on this new machine several times, which seemed odd. So we brought it in for a check over. The customer's tapes were new and of good quality, and apparently he never used hired or rented ones. After several days' testing the fault showed up. Fast forward and rewind became very slow, and in the playback and record modes the machine shut down because the take-up reel had stopped, the tape being laced tight enough across the upper drum eventually to stall it. Attention was turned to the reel braking mechanism where the cause of the problem was found to be an intermittent brake solenoid. It energises to take off the reel brakes and occasionally didn't do so. Fitting a replacement put matters right.

R.F.

## JVC GR-C7

This little machine gave only monochrome playback. Its recordings were in black and white too when checked with another VCR, though there was a confetti effect on both. Since the E-E colour was fine the implication was that the VCR section was faulty in a stage common to both record and playback. We found that there was no 5.06MHz input to the main converter because bandpass filter BPF2 had gone open-circuit. E.T.

## Matsui VX800A

All functions worked except eject. When the eject button was pressed the carriage would jam and the power supply would then shut down. The cause of the trouble was eventually traced to the castellated coupling on the motor: it had slipped down the spindle, and was fouling the motor housing. Gently easing the coupling back along the spindle allowed the motor to turn freely again, and after doing this the machine ejected without trouble. E.R.

## Amstrad VCR4600

The capstan speed varied, the result being wow on the playback sound. Replacing IC302 (BA718) provided a complete cure. E.R.

## Amstrad TVR1

A fault we've had on several occasions with these TV/video combinations is intermittent operation of the various VCR mechanical functions – fast forward, rewind, etc. The usual cause of this trouble is malfunction of the mode switch. A cure can usually be effected by dismantling the switch assembly, cleaning and retensioning the contacts and applying a small amount of Servisol before reassembling. It's essential to use the correct size of Phillips screwdriver when doing all this as the small retaining screws are usually quite tight and their heads are easily damaged. If cleaning fails to the cure problem, as is sometimes the case, the switch must be replaced. E.R.

## Fisher FVHP710

This machine worked to an extent but lacked any trace of a display or channel indication. Checks at IC101 (LC6502B-633) showed that the supplies were present and the clock oscillator worked, but the reset line (pin 19) was in a permanently low state. The reset pulse is produced by Q009/Q010 on the preset/tuning board. The transistors were healthy but C017 (0.01µF), a disc ceramic capacitor across the reset line, measured 5kΩ. Replacing this cured the problems as the chip could now initialise. S.L.

## Amstrad VCR4600 and VCR4700

A VCR4600 came in with no video in the E-E mode though the sound was normal. Playback pictures and sound weren't affected. After checking the various supply lines I hooked a scope to the video output socket. Nothing resembling a normal signal was present here. As many things could have been responsible I decided to apply an external video signal. This produced normal results and exonerated most of the signal circuitry, i.e. the

video/sound switching chip, the luminance chip etc., at one go. Attention was thus turned to the front end. As the tuner was unlikely to be responsible and the supplies to the i.f. can were normal this latter unit was replaced. Again no luck. When pin 8 (video output) was lifted however the video returned, so the fault wasn't far away. In fact the output coupling capacitor C817 (1,000µF, 6.3V) was leaky. In the VCR4600 Mk. II and VCR4700 the circuit reference is C710. S.L.

## Hitachi VT17

The tape would sometimes stop moving. This intermittency made diagnosis a long and difficult job. Eventually the fault continued long enough for me to see that the capstan motor stopped. Further investigation showed that the cause was dry-joints within the five-pin plug and socket at the nearby control panel. Resoldering and cleaning put an end to this elusive and time-consuming fault. D.B.

## JVC HRD230/Ferguson FV12L

Another easy job I thought – the customer complained that the machine's operation was haywire and my tests confirmed this. I replaced the STK5841 chip and the machine seemed to be all right, but on soak test it went haywire again. This time attention was directed to the mechanics, which were found to be dry and stiff. After removing the mechanism baseplate and cleaning and lubricating the mechanism the machine worked well. D.B.

## Ferguson 3V55/JVC HRD120

This machine came in because of dirty heads. It was given the usual wash and brush up, but after reassembly it didn't work. At switch on the left-hand spool and the capstan rotated for five seconds then the machine shut down. After a good deal of exploration I found that CP1 on the main panel was open-circuit. A few days later I had another of these machines with exactly the same trouble. It seems that we need protection from these circuit protectors! D.B.

## Fisher FVHP905

We're gathering experience of the mechanical troubles that occur with these machines. With this one it seemed that the idler was the cause of tape transport troubles, but after fitting a replacement rewind and fast forward were still a little erratic and in the play mode the machine sometimes squealed and stalled.

I found it necessary to fit new loading and capstan belts and to lubricate the cog and worm system and the spool spindles. Incidentally, before embarking on this type of repair, remove and save the little idler tension spring on the cassette side of the deck. It's easy to lose this, particularly if you don't know it's there, and you may never guess why the machine refuses to play while rewinding and fast forwarding perfectly. D.B.

## Ferguson 3V57 etc.

For some time now we've experienced problems associated with dried and hardened grease around the mode cam,

guide bases, etc. In recent cases of mode problems – usually showing up as the mechanism being out of sync and the motor and belt running (and usually squealing) against the clutch – it has been necessary to replace the motor in addition to carrying out the grease treatment. It tends to become lazy. It's best to replace the motor as an assembly, with the cam and bracket pregreased. This saves a lot of time and mess and the assemblies are reasonably priced.

**N.B.**

### **Ferguson 3V31/JVC HR7650**

The problem with this machine was noise in the bottom inch of the picture – though there were a couple of clear lines below the noise. The tracking control, and adjustment of the guides, had no effect. It looked more like head switching point trouble. Judicious adjustment of the ch. 1/2 switching positions showed that the ch. 2 adjustment had no effect. The drum magnets were all present, the head hadn't been moved, nor had the drum flywheel. When I carried out checks around the drum servo I found that C53 in the pulse amplifier circuit was dry-jointed. A new set of loading rollers was also required.

**N.B.**

### **Hitachi VT64**

This machine intermittently thought that eject had been pressed when in fact the operate button had been selected. There's nothing very complicated about the switch matrixing circuit. Most of the switches go to the syscon chip via the matrixing resistive ladder network RA9001, which is on the function switch PCB along with the switches themselves. When a switch is pressed a series of resistors is connected to chassis and the syscon chip and its decoding i.c. work out which key has been selected. The faulty item was in fact the operate switch, which had gone resistive. This fooled the syscon by in effect altering the resistance in the matrix ladder. Come back the piano-key Ferguson 3V00!

**S.C.**

### **Panasonic NV-G21B**

The capstan speed was very slow and the tape counter was permanently counting or, as you could call it, free-running. The symptoms were present in both the record and playback modes while in pause the tape counter still incremented at ten to the dozen. We carried out a scope check on the control pulses at the audio/control head during record and found that they were missing. After a lot of head scratching we eventually discovered that the servo pack was shorting to chassis a link in the control pulse path. Normal operation was restored after relocating the servo pack and insulating the link.

**S.C.**

### **Toshiba V83**

The sound was being recorded but not the video. It wasn't just a matter of head cleaning as we initially thought. Checks showed that the REC 7V supply at pin 6 of P202 on the head amplifier pack was missing. The regulated 12V supply was correct but there was no output from the record buffer transistor Q131 because its feed resistor R165 (22 $\Omega$ , fusible) was open-circuit. Replacing this item restored normal operation.

**S.C.**

### **Panasonic NV-L20B**

The customer's complaint was of distorted sound. It was a highly intermittent fault but we found that the E-E sound

became distorted and that the distortion could be recorded. Many things were replaced, including the tuner and the r.f. converter, all to no avail. When the machine had been in the workshop for a while the fault seemed to occur more often and we noticed that the luminance was shaded when it was present. This showed up more with the grey-scale bars from the pattern generator. On the hunch that the two faults were related we replaced IC701 (M51366SP) on the TV demodulator pack. This cured both problems.

**S.C.**

### **Hitachi VT64**

This machine kept stopping in play or record, but the problem was extremely intermittent. Various mechanical items had already been changed, including a faulty capstan motor which we've known to cause this problem, but the fault persisted. The cause of the problem turned out to be totally electronic – that plague of all electronic equipment, dry-joints. Several were found around the 9V regulator Q605 on the servo board, also on R699. After resoldering these the problem had been cured permanently.

**S.C.**

### **Toshiba V85**

Incorrect line sync in the cue and review modes is a fault we've had on several occasions with these machines. Each time we've found that replacing the TD6360N servo chip IC501 has provided a cure.

**S.C.**

### **Panasonic NV-G40B**

This machine worked perfectly until its owner moved and tried to tune to another transmitter. It would search, and the stations could be seen as they passed, but the machine wouldn't lock. A look at the circuit suggested to us that the timer chip was responsible for channel search and wasn't receiving sync pulses back to say that a station had been found. We confirmed this when we carried out a check on the sync detect line at pin 11 of plug 7501 and found that it didn't alter. We then moved back to the sync detect chip where the voltage at pin 9 went low when a signal was detected. The route from this chip to the front panel is a devious one right around the board via several chip resistors. One of these had never been soldered at one end.

**M.D.**

### **Sharp VC681**

The customer had for some time complained about intermittent operation – the machine would occasionally refuse to eject a tape. We'd soaked tested it on a couple of occasions but had not been able to find anything wrong. Now the machine was back in the workshop with a note to say that the tape couldn't be ejected. After releasing the tape manually the machine worked perfectly. We suspected problems with the mode switch but decided to check out the mechanics. When we stripped down the master cam we found that there was considerable wear on the inner surface. As a result the mechanism would occasionally stick. We had no further problems after replacing the master cam. Alignment is critical and has to be followed exactly.

**M.D.**

### **Sentra GX8000**

A common problem with these machines is failure to initialise. It can be cured by replacement of C821 (0-1F) in the reset circuit.

**M.D.**

## Philips VR6463

This machine was dead with no 5V output from the power supply because of a short to chassis. If plug P12 was removed the short disappeared, so the search continued on the P603 module. There are quite a lot of decoupling capacitors here. Fortunately the second one I tried was the cause of the short – C2919 (47 $\mu$ F, 16V). **P.B.**

## JVC HRD520

For mechanical malfunctions such as the tape being ejected while still laced up try changing the control cam, part no. PQ32413. The latest type is made of grey plastic instead of white. **P.B.**

## Philips VR2022

For a dead machine with a rattling deck solenoid check for dry-joints on bridge rectifier 6005 in the power supply. **P.B.**

## Grundig VS200/220

If the machine is completely dead check whether D410 (ZD16) is short-circuit. While you have the panel out look at the centre pin of C407. When this electrolytic capacitor begins to swell it pushes the positive pin through the board, cracking the solder. **P.B.**

## Osaki VCR31

There were no E-E signals with this machine as the 12V supply to the tuner/i.f. section was absent. The cause of the trouble was failure of the 2SA966A transistor Q410 which is on the bottom PCB. As we didn't have this type of transistor in stock we fitted a TIP32. This restored normal operation. **E.R.**

## Ferguson 3V23/JVC HR7700

Destruction of F3 (1-6AT) at switch on proved to be the result of a faulty d.c.-d.c. converter on the display control PCB. **E.R.**

## Alba VCR4000X

As reported by others in these pages, the Nikkai chassis used in this and similar models can cause confusion when the reset fails to work. In this one the machine appeared to be in the timer record mode, with the operate and record LEDs on and no display. When a cassette was inserted the machine set itself to record. To stop it the plug had to be pulled out. When this was refitted the cassette was ejected. All very confusing! **R.B.**

## Panasonic NV-L25B

This unit was inoperative with just the timer flashing zeros. There was no power up. When offered a tape the machine loaded it and kept it. The dealer who had brought this one in had changed the systems and servo control chip IC2001 and the operation and timer chip IC7501.

I started by carefully checking all the supply lines.

Everything here was fine. Something was inhibiting IC2001 and IC7501 however, but what? I decided to scope the serial clock and data lines between these two chips – this can sometimes show up problems. To my surprise there was 5V on both lines. I disconnected the serial clock and data feeds to the front panel. The 5V remained on the main PCB. Where else do the clock and data lines go? Well on this model there's an additional subsystems circuit for control of the audio dub and insert edit operations. It's undertaken by the MN15522VMS chip IC6801. A quick check showed that it was short-circuit between the 5V line and the data and clock lines. When these lines were disconnected the machine powered up and returned my test tape. Replacing IC6801 restored normal operation. **B.S.**

## Ferguson FV41R

This new machine was pretty inactive. The clock display showed "3:7" but otherwise it wouldn't do anything. Checks on the power supply showed that everything was all right here. Next step was over to the system microcomputer chip on the front panel. The supplies were o.k., as were the reset line and the main oscillator. SCL wasn't being generated however. As there was no excessive loading on this line it seemed that the micro chip was at fault, which proved to be the case. The circuit for these machines isn't very good – there are few voltages, the connection notation is confusing and a high or low chip reset both have the simple label "reset". **N.B.**

## Panasonic NV7200

There was a very loud knock from the mechanism when lacing or entering the cue mode – but not review. It suggested noisy loading motor bearings, but in fact the cause was a very worn capstan bearing. **N.B.**

## Philips VR6180/6185/6285, Pye DV186

No fluorescent display was the complaint. I found that there was no –28V supply to the operation panel though it was present at the power supply output plug. The supply goes via the P90 panel, where it's fused by ICP1001 (80mA). This fuse was open-circuit, but no cause for its failure could be found. **N.B.**

## Luxor 9272

The problem with this machine was tape path distortion: as the tape went around the entry guide it buckled cyclically. The frequency of the effect was the same as the rotational frequency of the guide pole sleeve, which provided a clue. When the pole was removed we saw that the sleeve had a very slight dig in it. This dig seemed quite disproportionate to the effect it created, but was the cause of the trouble. **N.B.**

## Ferguson 3V53/5/7, JVC HRD755

The red LED was lit but there were no functions and no clock display. Integrated circuit protector CP3 in the power supply had failed, causing loss of the unswitched 12V

supply. Failure of one or other of the four ICPs in the power supply circuit for no apparent reason is not uncommon. The engineer can be responsible however when the screening can is removed from the mechanism with the unit powered – switch off first. **N.B.**

### **Ferguson FV31R**

The card said that this machine was dead. When checked on the bench the power supply was pumping and whistled at me. With the covers removed I switched back on at the mains to find that the machine started up all right. Now for a bit of highly technical fault-finding: I tapped the tuner/i.f./signals PCB that sits across the top of the machine. Doing this would stop and start the machine. In my experience this is very often the area in which the fault lies, however strange the symptoms. After looking at thousands of perfectly good joints I found an intermittent short in the tuner/r.f. amplifier. **N.B.**

### **Telefunken 1930i/Ferguson 3V35**

No playback colour was quickly traced to the usual XB401 oscillator block. One was ordered and fitted, whereupon the machine refused to turn on! A gremlin in the waiting room had struck at the SW9V rail on the video board, shorting it out. As we expected, the cause was a short-circuit in the 4-7 $\mu$ F decoupling capacitor C419, which is of the dreaded blue tant variety. In the Ferguson version it's a 100 $\mu$ F, 10V type. **C.A.**

### **Saisho VR1200/Matsui VX820**

"Recording problems" said the ticket. "Worn head" said the pictures on the monitor. So a replacement was ordered and fitted. This seemed to put matters right, and the machine was duly collected and paid for. Next day it was back again. "It's just the same" protested the owner, "it records for only five minutes, then nothing." As I'd given the machine a full three hour record/playback test this seemed unlikely, but I checked it again. After five minutes the f.m. luminance record signal disappeared in a snow storm.

I found that the signal could be restored or killed by flexing the luminance subpanel on the YC board. As the print side of the panel is inaccessible when in situ I solderwicked all 29 pins, removed the sub-panel then wired it temporarily to the print side of the YC board for detailed inspection. There are printed pads along the edges of several subassemblies on the luminance panel. These assemblies are inserted into the panel at right angles, then soldered. It's rather like a microscopic version of the old IIT CVC5 i.f. module. The assemblies suffer from the same problem too – hairline cracks across the thinly soldered junctions. When I'd resoldered actual and suspect cracks, using a fine tip, I found that the panel could be flexed without any faults arising. So it was refitted in the normal manner. This wire-looping technique may sound lengthy and laborious, but it's a useful aid to diagnosis with an inaccessible board. This particular job took less than an hour to complete. **C.A.**

### **Ferguson FV31R**

It seemed that this machine had damaged heads, but a new drum produced no improvement. A look at the circuit showed that the outputs from the heads enter the TA7772P preamplifier chip IQ80 at pins 2 and 6, the output

appearing at pin 10 where there should be an 0.3V peak-to-peak f.m. waveform. In fact the output from only one head was present, a straight line being displayed where the other head's output should have appeared. So we had a head switching problem or a lower drum fault.

The head drum flip-flop signal from the servo panel is connected to the signals panel at pin 8 of connector BW04. There's a test point, BW11, and the amplitude should be 3-6V peak-to-peak. The waveform was missing however. So it was back to the servo panel, where the drum FF squarewave is generated by the microcomputer chip IT01. The output, at pin 14, depends on pin 8 receiving a pulse from the drum optocoupler via IM01. As there was a signal at pin 8 but not at pin 14 we replaced IT01. To our relief this cured the trouble. Unfortunately the manual provides no details of the voltages or waveforms around this chip. Note also that two types have been fitted in these machines. If, as in this one, there are two small subpanels mounted vertically on the servo/power supply panel, use type ZC93168P. The other type is EF6801U4DTD243.

Conclusion: if a badly damaged head is suspected, check the drum FF signal. **J.E.**

### **Hinari VLX5**

The E-E and playback pictures were unstable with very poor contrast. There was hardly any vertical or horizontal lock and no colour. A scope check at the video input pin on the r.f. in/out converter module showed that whilst the luminance signal was normal there were no field or line sync pulses. Tracing back from this point – we'd no manual – we came to a 47 $\mu$ F, 16V electrolytic capacitor (C354) which is connected to the collector of a transistor. At this transistor's base the video signal was correct. It was also correct at the collector once C354 had been disconnected. The capacitor checked out all right with our scope tester but we decided to fit a replacement. This restored normal operation. **J.E.**

### **Akai VS1**

This machine would lace up but not run. The head drum rotated but the capstan motor didn't start. It's driven by the BA6209 chip IC7 which contains a logic circuit, preamplifier and the motor drive stage. Checks on the driver stage, after finding that the logic inputs were o.k., showed that the servo input was high at 24V instead of 1.4V. This input comes via an operational amplifier in IC11 which seemed to be o.k. when checked. We concluded that there was a short-circuit in IC7 and a replacement provided the cure. **M.D.**

### **Logik VR950/Samsung VI611**

The complaint was of tape chewing. I thought I had an easy idler job, but when I ran the machine up it laced all right and started to play. Then the tape looped around the pinch wheel and stopped. In wind and rewind the tape moved, but very slowly. Further investigation showed that the operation of the reel motor was sluggish. Checks around the BA6209 driver chip IC0212 revealed that the supply at pin 8 was low at 9.2V instead of 12V. Also the chip was running warm. The 13V supply was correct and regulator Q0221 was o.k., but there was nearly 3V across R0282. The circuit gives the value of this resistor as 3-3 $\Omega$ , but it read 12.6 $\Omega$  when checked. A replacement of the correct value cured the problem. Incidentally this machine is of Samsung manufacture. **M.D.**



# Servicing the Saisho VR1200/Matsui VX820

Ed Rowland

The Saisho VR1200 and its Matsui equivalent, Model VX820, were released during the latter part of 1986. The Saisho VCR was sold through Dixons outlets and the Matsui version through Currys stores. They are identical units and the following notes therefore apply to both.

Although these machines were manufactured down to a price they have proved to be reasonably reliable apart from a few problems that can by now be classified as stock faults and some others that, though not as common, will no doubt be encountered by engineers who deal with these VCRs fairly regularly.

The power supply, see Fig. 1, is straightforward and in general doesn't give much trouble. There are a couple of fairly common faults however, not least of which is failure of the 2SD1207 12V regulator transistor Q2502. It lives

directly in front of the STK5332 regulator chip. Note that this transistor is a safety component: although other types will work in this position, it's important that the correct replacement is used in order to comply with safety requirements. When Q2502 fails the result is no functions, often with the red "operate" LED lighting momentarily when the function button is pressed. A new transistor is usually all that's required to restore normal operation.

Another cause of no functions is failure of the STK5332 chip IC2501, in which case the display will usually be o.k. and the machine will accept a cassette, though no other functions are possible.

Failure of the machine to power up, with the display strobing, should lead to a check on diodes D501 and D502. Replace them both.

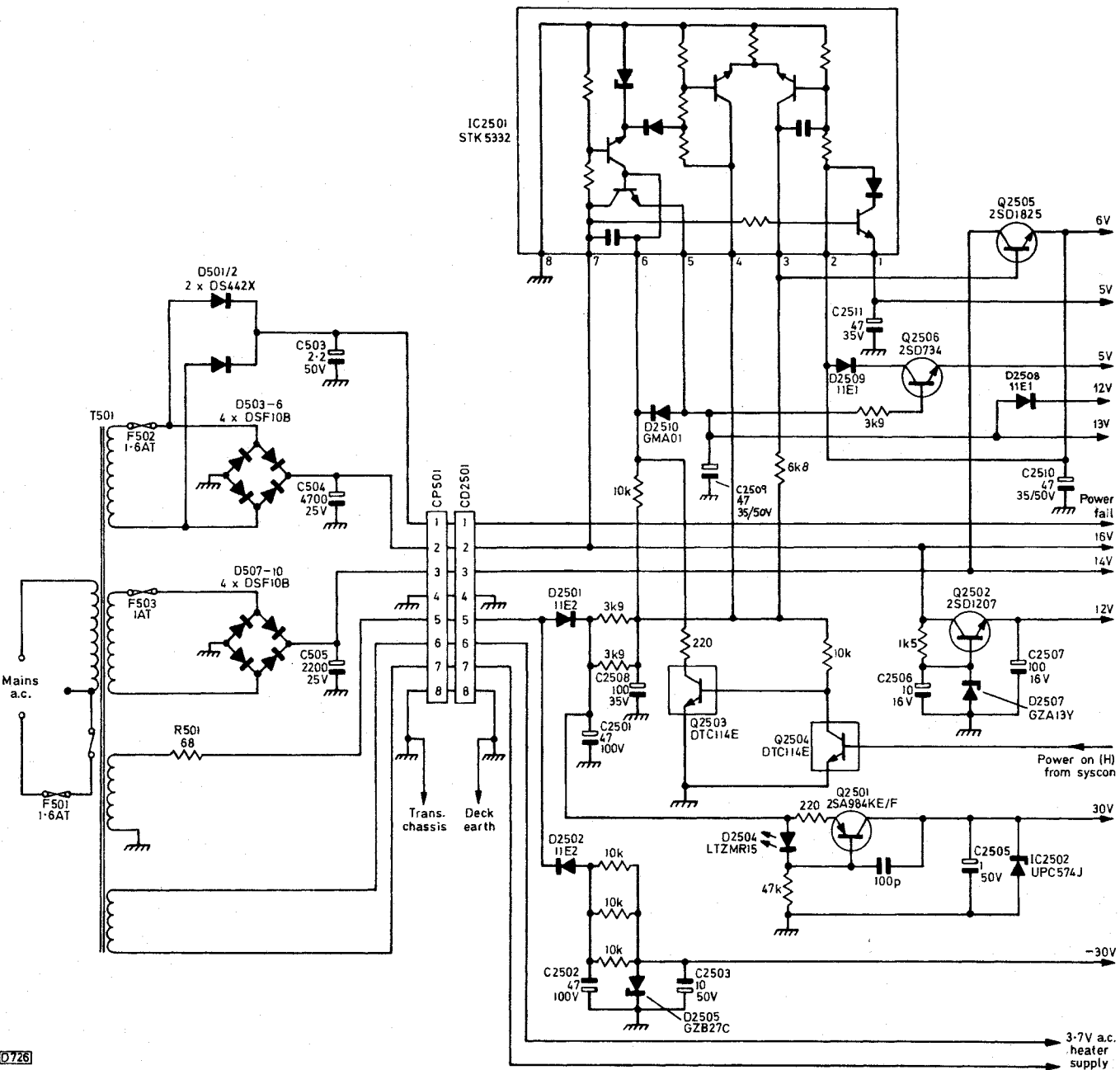

Fig. 1: Power supply circuit used in the Saisho VR1200/Matsui VX820.

# Servicing the Panasonic NV777/788

Nick Beer

Amongst the various VCRs that have been marketed by Panasonic in the UK these two are a bit special. They are very similar, though by no means identical, top-of-the-range models dating from 1983-4. The NV777 was the first to appear: its features include front loading, an eight-event timer, infra-red remote control, reverse play and variable-speed slow motion. The later NV788 has the additional benefit of two-speed operation. While the LP quality is not as good as that with the NV730, a later machine that was on the market simultaneously for a short while, it's certainly better than that with the NV688, Panasonic's first consumer dual-speed model in the UK.

The mechanisms are a cross between the NV366 and the NV7200 series, with slight modifications. Anyone familiar with these mechanisms will soon find themselves at home with the NV777 and NV788.

## Points to note

The NV788 has index searching, which means that there's an extra head at the front centre of the direct-drive unit. It inserts itself in the cassette cutout at this point when a cassette is loaded and is known as the MR head. The annoying thing is that the lead to the head, which is plugged at only the system control PCB end, is fed to the top of the mechanism through the large loading belt. Thus belt replacement involves undoing the PCB and all the lead retainers, then unplugging the lead, passing it through the old belt and threading it through the new one before this is fitted.

The still/slow performance is good. The still lock controls are accessible without removing covers. There's a small rubber strip on the right-hand side of the machine (viewed from the front): when this is removed the controls can be adjusted through the exposed hole.

At this stage of their life these machines, particularly the NV788s, will have begun to get a bit noisy. The reel motors tend to tick and buzz and the mains transformer can also buzz loudly when old. The power supply circuits are straightforward and, in our experience, have been very reliable.

## Dismantling

The top cover is held on by four screws, one at each corner. With this removed you can take out the screening can by slackening the red screws and sliding it off. The heads can then be cleaned.

The front of the machine is clipped as well as being held by screws across the top. To remove the front you first have to take off the metal bottom plate, which is held by brass-coloured screws. Doing this allows the clips across the bottom of the front to be undone.

After removing these three items the cassette carriage can be taken out. Undo the four red securing bolts, one at each top corner, taking care of the earthing leads that will now be free. The small PCB mounted in the right-hand corner, over the mechanism, will also have to be removed – it's secured by three red screws. Lay it on the adjacent PCBs, with foam or something similar between for safe operation. If you want to remove the carriage completely, for example to replace mechanical parts, undo the multipin

connector at the rear right-hand side. To run the mechanism with no tape or carriage, leave this plug connected, lift the carriage out and tip it upside down on to a piece of foam placed over the adjacent timer/presetter PCB. If you now insert a cassette into the carriage, bottom side up of course, the machine will run as the photosensors are on the side of the carriage and the emitter is in the machine. Note that in the rewind mode the machine will cut out if the take-up reel is not spun by hand, as this is where the reel-rotation sensor is situated.

One uncommon feature of these machines is that when the cassette carriage is removed you see a metal plate that's mounted over the reel drive and brake mechanisms beneath, with only the two reel turntables protruding. To replace the idler, brake band etc. this plate has to be removed. It's secured by two circlips, one large and one small one. The latter is usually damaged when it's removed, so it is useful to stock some spares. If you use the Panasonic VUD kit you'll find that all relevant circlips are included. Use of small circlip pliers helps to avoid damage. Remember to refit this plate before refitting the carriage.

## Mechanical Servicing

Mechanical servicing follows the procedures for the NV333/366/7000/7200. We'll deal here with replacement of the parts included in the Panasonic 1,000-hour maintenance kit, which was reviewed by Ian Bowden in the October 1988 issue, and some other commonly required replacements. The kit is type VUD4090KIT.

## Video Head Replacement

To replace the video heads, part no. VEH0201 for the NV788 and VEH0177 for the NV777, remove the single bolt that secures the discharge angle on top of the drum, then the two bolts that hold the upper and lower drum together. The drum connections are via flying leads from the lower drum to a PCB on the upper drum. There are quite a lot of leads in the NV788: although the colours are marked to show where the leads go, it's wise to draw a diagram before you start – the letters, K for black etc., are not all obvious. Take care when soldering the leads, which vary in length, as they are easy to damage and there are no spares – a new DD unit will be the unfortunate consequence of broken leads, unless you dare trying to take the unit apart and run in a new lead!

The heads are quite expensive and do fail. Very good rebuilds are available from MCES Ltd, 15 Lostock Road, Davyhulme, Manchester M31 1SU. Unfortunately however there's a tendency for the drum to become burred, which means that it's not suitable for rebuilding. This is caused by excessive back tension or poor tapes. These factors also cause excessive audio/control head wear, which has been a problem with some of these machines. The back tension should be checked and, if necessary, reset whenever one of these machines comes into the workshop.

## Back Tension

The back-tension specification is the usual 25-30g, measured with a Tentelometer half way through a three-

hour tape. For good noise suppression and quality in the trick modes the back tension should be set near the top of the specified range, i.e. typically at 28-30g. Don't fall into the trap of setting it higher than this in order to get better results. Doing this is quite unnecessary: the trick is to adjust the back-tension post landing position carefully then compensate by adjusting the soft-brake band. This will give you correct back tension and trick-mode operation.

## The Audio/control Head

Audio/control head wear is comparatively common, especially with the NV788, and as just mentioned is made much worse if the back tension is excessive. The deck needs to be fairly clear for head replacement. Though it's not essential to remove the cassette carriage, life is made a lot easier if you do – and anyway you'll probably be replacing the idler etc. at the same time. The head has the usual three-screw mount. The centre screw is threaded into the base of the head assembly and so needn't be removed until the head is taken out. The rearmost screw (left-hand side viewed from the front) is the counterspring holder: it's best to remove this one last. The foremost, right-hand side screw is threaded into the mechanism and thus has to be removed – it's best to do this before the counterspring one.

After removing it the tilt screw can be fitted to the new head. First note the approximate protrusion into the head so that the new head will be roughly aligned when fitted. Then fit the new head, ensuring that the indentation at the front fits over the pip, about which it pivots, on the mechanism. Fit the azimuth screw, roughly in place, then fit the counterspring screw to the correct tension, i.e. don't over compress the spring. Finally align the head using a standards tape. Align the tilt carefully in order to prevent tape-path crinkling – watch the tape travel around the adjacent guides and posts.

## Idler Replacement

Idler replacement is a bit more involved and tricky than one would like. Remove the top and bottom covers, then the front and the cassette carriage. The metal plate has to come out next. Remove the retaining circlip at the top of the take-up spool, after which the spool can be pulled off – take care not to lose any washers underneath it. Next remove the reel motor underneath in its plastic frame. This is done by taking out the three brass reel bolts/screws that hold it. At this point take a careful look at the idler from underneath: note the position of the spring at the rear of its arm. Use a screwdriver blade to move the nylon lever to

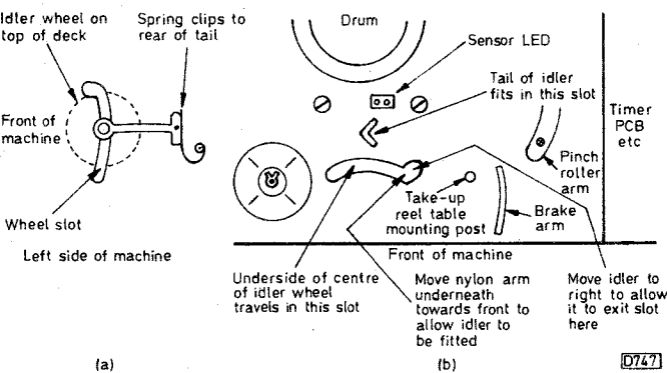

Fig. 1: Replacing the idler. (a) Underside of the mechanism (simplified) showing the nylon arm and spring positions when fitting the idler. Machine is on its left-hand side. (b) A simplified view of the upper side of the mechanism, with the take-up reel table and the idler removed.

# VCR Clinic

*Reports from Philip Blundell, AMIEE, Ed Rowland, John Edwards, Mick Dutton, Graham Richards, S. Da Costa, E.M. Beddow, Roger Burchett and Nick Beer*

## Philips VR6185 (later 5V version)

How's this for a saga! The machine came in from another dealer with the complaint that it was dead. There was no clock, no signals were present and there was no deck activity. But the power supply was working. A check showed that the Wickman fuse on the family board was open-circuit, but replacing it didn't change any of the symptoms. Checks were carried out around the P8051A-H1-2-D2 syscon chip. Its supplies were present, the reset worked and the clock oscillator was o.k., but it gave no output. So a replacement was ordered. With this fitted the deck initialised but there was gibberish on the display and none of the keys worked. A new TMP47C870N chip cured that. We'd no playback colour however. As the paint seals on the H-PLL control had been broken it was reset as per the manual. Finally all was well! I kept the machine for a few days on test however, just to be on the safe side. **P.B.**

## Grundig VS310

The symptoms here were that F1 flashed on the display and the machine wouldn't take in a cassette. A check can be made on the cassette-in switches at connection 3 of plug L12. The voltage here should be 5V until the switches close, when it should drop to zero. But the voltage never rose above 1V. A new M722AB1 chip was required. **P.B.**

## Philips VR2334

I've had this fault on three of these machines now. The deck doesn't initialise and there's no clock display. With the first one that came along I temporarily fitted a new A630 panel. This proved that the fault was here. Scope checks showed that pin 38 (bus data in/out) of the 8050 chip was being held down. The chip had an internal leak. **P.B.**

## NEC N831

When the covers of this NEC machine were removed I found a JVC HRD120 (Ferguson 3V35). Lucky that. The problem was no record or playback colour. A quick run round with the frequency counter showed that all the oscillators were running at the correct frequency. So why was the colour-killer operating? The colour/monochrome switching line was at mono because the colour/mono/test switch was leaky! **P.B.**

## Philips VR6548

This model is a Sharp clone. Until this one came in the only problem I've had with these VCRs has been with the cassette tray – the symptom is intermittent failure to accept a cassette. Fitting the modified tray switch kit, part number 4822 214 32583, usually puts matters right. This particular machine also seemed to stall the loading motor at odd times. The cause was a faulty mode control switch, part no. 4822 276 12482. **P.B.**

## Sanyo VTC5150

Fast forward and rewind were o.k., but when play was selected the tape would lace up then, after a few seconds,

unlace. The fact that the loading motor continued to run after the tape was fully laced drew attention to the after-load switch. It closed but the contacts were oxidised. A squirt of Electrolube cleared the trouble. **E.R.**

## Mitsubishi HS307

We don't know whether this trade has a patron saint. If so he wasn't in a very benign mood when this machine came along. The complaint was that it sometimes failed to record the sound. We removed the plugs on the audio/control head and hard-wired the leads to the panel. This cured the problem and we thought that was it. Two days later however the customer rang to say that although the sound was now being recorded it became distorted after an hour. The machine would then stop playing. A check showed that after an hour the capstan speed became erratic. The capstan motor would then stop altogether, after which the machine would work only in the rewind mode. Freezing the MN6168MBB chip IC4A1 got the capstan motor running again and a replacement chip restored normal operation. Luckily we obtained one from a scrap machine, as the customer made it plain that he wouldn't pay for attending to a fault that wasn't present when the machine came in initially. Now how do you argue with that? **E.R.**

## Matsui VX800

The symptoms were slow rewind and fast forward, also tape chewing in the play mode. We initially suspected the clutch/idler assembly, but while running through the mechanical operations without a tape in we noticed that in the play mode the reel motor didn't rotate. A check showed that there was only 0.5V across its terminals. The culprit turned out to be the 2SD1246 transistor Q2022 which was short-circuit base-to-emitter. It forms a low-resistance chassis return for the motor, which instead was relying on a couple of low-value resistors that are in parallel with the transistor. **J.E.**

## Mitsubishi HS-B20

Playback and the tape functions were o.k. but there was no E-E picture or sound. Channel selection was shown on the display and the tuning indicator searched normally for a station to lock to, but as none was found the search continued in vain, the monitor's screen remaining blank. A check on the voltages around IC101 in the i.f./a.g.c. can showed that pin 2 was at a much lower voltage than its normal 5V. So the a.g.c. wasn't working and the signal was cut off. The cause was the 0.1 $\mu$ F, 35V tantalum capacitor C105 which was leaky. **J.E.**

## Matsui VX880

This machine would accept a cassette then almost immediately eject it, after which it would switch off. We noticed that during the attempt to load the tape the cassette-in symbol flickered on then, as the tape was ejected, off. The after-load leaf switch mounted on the carriage was o.k. We then made a careful study of the action of the mechanism during the cassette loading

operation. This showed that the leaf switch is activated by a lever driven by the side-mounted rotary cam, which is in turn driven directly by the loading motor. The lever pressed the leaf switch home all right but immediately returned back a small way so that the switch went open-circuit again. During the loading process the motor spun normally, but as soon as the cassette reached the bottom the motor reversed by about three revolutions. A meter connected across its terminals showed no reverse voltage when this occurred, thank goodness. A new loading motor cured the problem. **J.E.**

### **Saisho VR3600/Orion VCR-MD3**

This machine cut out after a short while, i.e. it returned to standby, and wouldn't accept a cassette. I noticed that there was no sign of any jog from the loading mechanism, and when I tried to advance it by hand it was as solid as a rock. When the gearing on the tape transport was stripped down I saw that the master cam gear had disintegrated. After fitting a replacement and rebuilding the mechanism the machine ran smoothly. **G.R.**

### **Panasonic NV370**

The E-E picture was half white and half black, i.e. there was hum on vision. C1102 (2,200 $\mu$ F) in the power supply was open-circuit. The playback picture was only slightly affected. **G.R.**

### **Hitachi VT410**

The complaint was of vertical black and white bars instead of a picture during the first fifteen minutes of playback. On test we found that a tap on the panel would clear the fault. The signal appeared to be getting lost within IC202, but a replacement made no difference. We then found that connecting a scope probe to pin 14 of IC203 would remove the black and white bars, leaving snow on the screen. It seemed that the f.m. demodulator wasn't operating correctly and that as a result the dropout compensator was working overtime, causing instability in the form of the bars. Replacing IC201 cured the fault but it was impossible to prove which part of the chip was defective. **M.D.**

### **Philips VR6467**

When a tape was being played there was no sound or vision, just a blank screen. This was due to absence of the 10V supply at the head amplifier panel. Transistor 7607 (BC328) was open-circuit. **M.D.**

### **Panasonic NV370**

The picture was o.k. with some tapes but with others there was rolling and a small white bar was visible at the bottom of the screen. Playback of the machine's own recordings was o.k. except for the white bar. After a lot of deck realignment we established that the fault was being caused by the drum assembly. The rotor base at the bottom had shifted slightly out of position, so that the pole switching was incorrect. Slight adjustment by loosening the hex nut in the base and realigning it put matters right.

All was now o.k. except for cue. When this was selected the machine ran in the cue mode but when the button was released it still ran in the cue mode though the cue sign disappeared from the display. The AN3822 capstan chip was faulty, pin 17 being virtually open-circuit when a check

was made between here and chassis.

A common problem with these machines is a dew indication. Touching the dew sensor on the deck with the tip of a hot soldering iron for about 20-30 seconds usually provides a lasting cure. If the dew indication is erratic however the sensor is at fault. **S.DaC.**

### **Amstrad VCR4600 Mk II**

The report over the telephone was "not rewinding". In due course I took the top off and saw a spotless mechanism – would that they all were! The machine worked perfectly when it had warmed up. It was left overnight then sometimes failed to respond to any deck command, including eject, though the display changed to show the appropriate symbol.

On this machine the mode switch is operated via a bell crank and levers. Cleaning and greasing cleared the fault. A linkage like this is asking for trouble as there are too many points of friction and potential wear.

A few months later the mode switch itself started to play up, giving no rewind or fast forward. **R.B.**

### **Grundig VS310**

Warble on sound was the complaint with this machine, which had already been somewhere else for repair. When we tested it the sound was indeed poor. We were told that the capstan belt and motor had been replaced. After checking that the power supply voltages and ripple levels were o.k. we removed the chassis screws and hinged it out so that we could watch the flywheel and belt running. There was a noticeable vibration with the belt, which looked new but didn't seem to be as tight as one would expect. When a new, original Grundig belt was fitted everything was all right. The old belt had a lot more stretch than the new one and was obviously not a proper Grundig spare. The usual fault with these belts is that they split and break, maybe due to the hard rubber of which they are made. **E.M.B.**

### **Mitsubishi HS-B30**

This machine had been playing around for some time. A couple of calls had been made but nothing amiss had been found. Eventually we saw what was happening. The drum motor would slow to the point where line lock was lost on the TV set. When the wires that connect the drum motor to the servo panel were moved normality was restored. We removed the drum motor and found that the connector plug hadn't been pushed home fully. Refitting it restored normal operation. **E.M.B.**

### **Panasonic NV-M10**

This camcorder was accused of not focusing. Indeed on test the image from the camera head was very strange. The centre could be focused fairly well manually, but it was as if a special-effects filter was fitted – the edge of the image was severely defocused. In addition the unit made no attempt to auto-focus. The cause of the auto-focus fault was that the lens focus ring moved much too freely: the bracket that holds the auto-focus motor and its gearing to the side of the lens was bent, so the gear wasn't contacting the focus ring. The bracket is made of very thin aluminium. A faulty lens was the cause of the focus fault. Putting two and two together I came to the conclusion that the unit had been dropped. **N.B.**

# More on the Panasonic G Deck

**M.P. Prakash R. Lewis**

In the May-June issues Nick Beer wrote about servicing VCRs fitted with the Panasonic G deck. One point he didn't mention was the voracious appetite of Panasonic models for the chopper chip Q1001. We've handled hundreds of these machines over the last couple of years. Commonly we start by finding that the mains fuse has blown, then we find that Q1001 has gone short-circuit. In some cases the  $0.39\Omega$ , 2W resistor between pins 4 and 5 of Q1001 will have been damaged or the  $2.2\Omega$ , 2W surge limiting resistor in series with the bridge rectifier, on the earthy side, may have taken the plunge. While at it, check the zener diodes present with some circuits on the primary side of the chopper transformer for shorts or leakage. The cause of failure to start when a new chopper chip has been fitted, or a short-lived chopper, invariably has its roots here.

Some models such as the G9-12, G15, G30 and NV280 have a similar power supply. In the event of Q1101's failure, replace D1120 as well. Ensure that Q1101 is fitted with a smear of heatsink compound and the plastic part (VG00922) which meshes Q1101's heatsink to the isolated metal shield body - the heatsink is at mains potential as the chopper transistor's collector (pin 3) is connected to the metal tab. The grey-coloured plastic is between the heatsink and body. If the power supply works intermittently take a closer look at the subassembly (VJB01211) where D1117, D1104 and R1105 can become leaky or open-circuit.

On the secondary side, the axial electrolytics tend to lose capacitance. This results in obscure symptoms.

Failure of the luminance module, part no. VEFH03D, is common with some of these machines. The symptom varies from no playback with E-E normal to playback with streaking lines.

## Mechanical Faults

The deck itself causes few problems. The subloading arm tends to break at the bottom however if the timing goes haywire. Incidentally, this arm pivots the tape into contact with the audio/control head in the semi-loaded

position in order to read the off-tape control pulses for the real-time counter. If the machine often mistimes or changes mode with an accompanying noise that sets your teeth on edge, a new set of teeth/gears is probably required. When the sub-cam gear or ring gear wears mode-switch alignment will be required daily: the cure is to change them even if they don't look worn.

For routine service this deck, unlike the previous D1, doesn't require removal of the cassette compartment to gain access. You simply remove the two small, gold-coloured screws that hold the top of the compartment and lift out the metal lid. To set the timing, remove the two red-coloured screws at the right-hand side of the compartment and lift this side. Saves time and further complications.

## A National G12

A National G12 had us baffled for some time. The symptom was a medium-level hum on playback and record. If the input was shorted out in the record mode the hum vanished, only to reappear as soon as the input was restored. We changed IC403, then the associated transistors and electrolytics, all to no avail. One item we suspected was the audio/control head, but this was cleared by substitution. Eventually we cleared the trouble by adding a 7812 regulator in the supply to the audio module. Scope checks carried out earlier in the fault-finding process showed that the ripple was normal compared with a working machine. Now there's no trace of any hum at all.

## Sharp VC9300

Talking of audio problems, we had considerable difficulty with a Sharp VC9300. The symptom was intermittent crackling. When the scope's probe was connected however the machine worked impeccably. The switching chip and all the electrolytics were checked by substitution to no effect. We eventually found that Q607 and Q608 were responsible, though they gave correct displays when checked with a component tester.

# Servicing the Fisher FVH-P520 VCR

John Coombes

The Fisher FVH-P520 is a VHS machine dating from 1982-3. The following is a list of the main fault symptoms we've encountered and the steps to take when fault-finding. The basic power supply circuitry is shown in Fig. 1.

## Timer LED Out

If the timer LED doesn't light though the a.c. mains supply is applied, check that the PSU is supplying -48V to the timer panel - this voltage should be present at pin 4 of plug/socket PV903. If this voltage is present, suspect a fault on the timer board: if it's not present, check whether rectifier diode D907 is open-circuit then if necessary check by replacement the protection capacitor C914 and reservoir capacitor C915. Next check for 16V across C931. Absence of this voltage should lead to a check on D908/9, C916/7 which could be leaky, and C931 - check by replacement. If the 16V supply is present, carry out checks on the 9.8V regulator circuit (ZD902, Q904/5 etc.). There should be 11V across ZD902. If this voltage is low or absent, check ZD902 by replacement, check D905 and R906 for being open-circuit and C918 by replacement. If the conditions at the zener diode are o.k., check Q904/5 then C919/920 as necessary. There should be 9.8V at pin 2 of plug/socket PV903.

## Function LED Out

The no results with the function LED not alight symptom calls for a detailed check on the power supply system. For the function LED to light, the 18V, 5V, 15V and 9.5V lines must all be present. If the 18V supply at pin 3 of PV902 is missing, check fuse F902. It can go open-circuit on its own account (check by replacement). If the replacement blows, check for shorts in D901-4, C906 and C902-5. If F902 is o.k., T901 could have shorted turns.

The regulated 15V supply is switched by IC501 which is on the syscon panel. IC501 receives its supply (at pin 21) from a 5V regulator on the syscon panel. If this supply is missing, check ZD503 and Q505. The regulator is fed from the 18V line. For the regulated 15V supply to be present pin 2 of IC501 should be low. This in turn requires pin 13 (power in) to be high and pin 15 (reset) to be low. If pin 15 is high, check ZD504, Q506 and Q507 in the reset circuit as necessary. If pin 15 is low and pin 2 is high or pin 13 low, check IC501 (HD44801A19) by replacement. If the 15V supply switching is o.k. but the regulated 15V output is not present at pin 4 of PV902, check Q901, Q902, Q903 and ZD901. If the 15V supply is correct, check the 9.5V regulator (fed from the 15V line) on the syscon panel - Q501 (2SC2274), Q502 (2SD536NP), ZD501 (GZA6.2) and Q891 (2SD3131).

The function LED might not light because the setting of the timer switch in the off position is incorrect.

## Dew Fault

If the function LED lights but there's no operation and the stop light won't flash, suspect a dew fault. If dampness is present leave the machine switched on for twenty minutes or dry carefully with a hairdryer. If there's no dampness, ensure that the end lamp isn't disconnected.

Also check whether there's a fault in the dew sensor circuitry.

## Channel LEDs Out

If the channel LEDs don't light, check for 12V at pin 9 of plug/socket PH004 on the tuner/r.f. converter panel. Check whether Q512 (2SC2274) is short-circuit should this voltage be missing. If it's present and correct check the voltages around Q005 (2SA984). Replace it if necessary. If the transistor is operating correctly, check the channel LEDs and replace as necessary. R012 (820Ω) being open-circuit will also cause failure of the LEDs to light.

## No Picture or Sound

If a channel indicator lights but there's no picture or sound, first check for 12V at pin 9 of PH005. Absence of this voltage should lead to a check on Q512 (2SC2274). If the supply is present check for 7V at pin 3 of PH006. Check Q007 and/or Q004 (both type 2SC536) should this voltage be missing. If still without signals, check for a fault condition on the tuner/i.f. panel. Check the tuner/aerial input connections, then that the voltage at pin 2 of PH005 varies when the channel is changed. If not, check for 45V at pin 2 of PH003. Should this voltage be missing check that it's present at pin 2 of PV904. Presence of 45V here means that there's a broken, dry-jointed or disconnected lead from the power supply to the tuner/r.f. converter board. No voltage at pin 2 of PV904 should lead to a check on D906 and C913.

If the voltage at pin 2 of PH003 is correct, check D001 and D008 (both type DS442), then the channel selector, Q001/2/3 (all type 2SC2274) and ZD001 ( $\mu$ PC574J) as necessary.

## Various Faults

In the event of no rewind/fast forward operation, check the idler. If this is o.k., check the following items in this order: the reel motor; the main brake assembly for incorrect operation; the supply reel/take-up reel rubber for no rewind/fast forward respectively; and finally the roller wind assembly that links the drive idler to the reel motor.

For no mechanical play operation check the take-up idler by replacement and for wear on the take-up reel rubber. Check that the brake solenoid has not seized.

The main cause of bent verticals or even picture pulling is incorrect back tension. The correct tension is between 30 and 35g-cm. Incorrect tension can be caused by a slightly stretched tension arm spring or a broken/damaged tension band. Check also that the tension arm hasn't been bent. Remember that excessive back tension will shorten the life of the video heads.

For mechanical noise on playback, check and regrease the drum spindle under the drum bush.

Cutting out for no apparent reason is very often caused by a faulty capstan motor. Check by replacement.

Noise bars across the screen are often first noticed with prerecorded tapes. If the f.m. envelope is examined you will find that it's badly out of shape. To correct this, set up the alignment of the guide poles.

# Servicing the Panasonic G Deck

Part 1

Nick Beer

In the September 1988 issue I covered initial procedures for servicing the Panasonic G deck. The machines were then relatively new, though the second generation (G40/G45/D48) was just being introduced. There are now many more machines that use the mechanism and its variants and consequently a number of new mechanical faults have appeared. There are also electronic fault patterns that we can report. Many engineers have had considerable difficulty in aligning the mechanism and in fault finding. This has been recognised by Panasonic and the company's recent VCR seminars have included practical work on the G deck, a very helpful move. In this article we will provide an updated account of the mechanical situation, information on setting up, and also cover electronic faults in various Panasonic models that use the G deck. The G mechanism is also used in models in other manufacturers' ranges, for example Grundig, Philips, Pioneer, Pye and Sony.

## Overview

The capstan motor drives everything except the drum. As only one belt is used a fairly complicated system with a rack and gears is required. Drive has also to be transferred from the bottom of the mechanism, where the motor drives via the belt, to the top where drive is needed for front loading of the cassette and for the mode switch and pinch roller, which descends from above and then contacts the capstan on a cam. Also driven on the top side of the mechanism are the play arm (driven by a cam on the underside of the mechanism) and the tension post P5. The design is very clever.

There are four versions of the G mechanism. After the original G came the G' which had mechanical improvements – it's used in the G40/G45 series. The G-Rev (G revised) came next, used in the L20/L25/J30/J35 series machines. Finally there's the G2, known in sales circles as the 'Turbo Intelligent' mechanism. This is used in the NV-F65, F70, F75, FS95 and FS100 top-end machines.

The first three versions are very similar, the later ones incorporating improved mechanical parts. Reliability has increased to the extent that the L and J series models come in more often because of electronic than mechanical faults – and you don't get many electronic faults.

The G2 is an enhanced design. It has an extra motor, known as the review motor, which is mounted behind the mode switch at the rear right-hand side of the mechanism. Increased capstan torque gives much faster wind times. The final difference with the G2 mechanism is a dual loading system. In common with many mechanisms the G deck has a half-lace position when a cassette is loaded: it keeps the tape in contact with the audio/control head in order to provide pulses for the real-time counter. With the G2 deck there is also a full-lace stop position (stop 2). When a cassette is inserted the unit rapidly laces fully then slackens off the tape – this operation is discussed later. The unit remains in this position for about ten minutes, after which it returns to stop 1 (half lace) if no suitable function has been selected.

Modified parts have been introduced throughout the evolution of the mechanism. Very often the modified parts fitted to later versions are supplied as replacements for

earlier ones, but not always, so do check part numbers. In addition the method of fixing certain items can be different in later machines. For example in earlier versions the play arm was fixed with a circlip: in later machines such as the L20 series the arm incorporates its own plastic spring retainer.

## Dismantling

The exact procedure for removing the top and bottom varies slightly depending on the model. However there are standard Phillips screws in the usual positions – as with other Panasonic models. Once you are inside, the arrangements with the various models are very similar.

In many cases the main PCB has to be moved out of the way in order to remove such things as the cassette carriage cover. As this suggests, the design of the PCB varies with different models and ranges. Follow the rule that red screws, usually four or five, retain the PCB from above (in some models such as the G21/G25 however there's a gold-coloured screw above the power supply can) and that further support comes from two or four black screws fitted across the back of the machine, around the r.f. and video sockets. With earlier models the small PCB in the rear left-hand corner will also have to be removed to allow the main PCB to move very far. Finally, you'll usually find one or two white compression clips, which need to be undone, across the front edge of the main PCB. They should always be refitted when the board is replaced, but can easily be forgotten. Locate them correctly, not only in the holes in the PCB but also in the case moulding, otherwise the PCBs or the lid will not sit correctly. After freeing it the PCB will lift up and sit on its right-hand edge. In some cases, e.g. the G40, there are also clips along this right-hand edge, holding the PCB to the plastic side frame of the cabinet.

There's no screening can over the standard G mechanism head drum. The cassette carriage is not of the type in older Panasonic machines, i.e. a substantial single unit made up from component parts. Instead it consists of two side pieces, a holder and a cage type cover across the top. To remove this cover the front of the machine will usually need to be taken off. Some of the fronts are in two pieces, upper and lower, as in the NV730 (see the November 1989 issue of *Television*) – the same removal procedures apply. Take care not to damage or lose the metal earthing strip at the inside centre of some of the top halves of the cabinet front. With the front removed, the carriage top can be taken out after undoing the two small gold screws in the centre of each side and the red and gold screws on up to three of its four corners. The rear right-hand screw often secures a black earthing lead to the main PCB, a point that should be remembered during reassembly. The cover lifts off after disconnecting the supply photosensor lead that runs across the cover from its plug on the right-hand side of the carriage.

The carrier can be removed by grabbing the centre of the holder, in the eject position, and gently moving it forwards until the rear pegs in their runners line up with the slots in the side pieces, then moving it upwards. After this the black side pieces can be removed by undoing the two red screws that hold them to the main mechanism chassis at each side. The main PCB will often have to be



# Servicing the Panasonic G Deck

Part 2

Nick Beer

Last month we dealt with basic servicing procedures for the Panasonic G deck and provided a mechanical faults list. This month we'll deal with the electronics used in Panasonic VCRs that use the G deck. First however a point about reassembly.

When refitting the top cage-style lid to the cassette carriage in older models it's important to fit the very short brass screw that also secures the black earth lead in its correct location at the back right when viewed from the front of the machine. Fit the longer brass screw diagonally opposite, at the front left. If these two screws are crossed over the carrier will jam on its way down as the end of the longer screw impedes its travel. We've had this problem on a number of occasions. Even removing the screw won't always correct the problem as plastic flack created by the overlong screw penetrating the moulding will still be present. File flat and fit the correct screw.

## Electronic Circuitry

As a whole the electronic circuitry used in the Panasonic models is extremely reliable. The only section that produces any regular service work is the power supply. Two different versions have been used. Fig. 4 shows the circuit in the original NV-G21/G25/D80 series. Models since the NV-G40 series have used a circuit similar to that shown in Fig. 5. Both consist of a chopper arrangement with linear regulation on the secondary side of the transformer.

The earlier power supply tends to suffer from fuse blowing and failure of the linear regulator chip IC1001, type STK5338. In the event of intermittent fuse failure look for dry-joints on the primary side of the circuit. Also check the mains lead and socket for arcing. To check the linear regulator chip, confirm that the unregulated inputs are present at pins 4 and 8 and that the power switching signal from the system control circuit, at pin 6 of P1001, isn't turning its outputs off. If all is well in these respects suspect the chip. As with many machines that use similar chips failure is not uncommon.

There are no real stock faults with the later circuit. Shorts in the mains bridge rectifier D1004 will result in a blown mains fuse (F1001) of course. D1014 going short-circuit will give the no results symptom - this tends to be associated with shorts in D1004. Failure of Q1004 will result in a low voltage on the non-switched 12V line, the symptom being no r.f. loopthrough. The key to successful fault-finding is to use standard TV techniques: confirm that there's no excess loading on any of the secondary rails, check the rectifiers on the secondary side of the circuit, check the start-up resistor network R1002 (82k $\Omega$ , 1W), R1003 (82k $\Omega$ , 2W), R1005 and R1006 (both 56k $\Omega$ ), check for a switch-on pulse at pin 2 of Q1001 (C1003, 1 $\mu$ F, gives trouble), etc.

One or two other points should be made about the electronic circuitry. First, as with many other Panasonic machines, a lot of these models incorporate r.f. loopthrough cut-off when the machine is in the play mode. Some customers, particularly those who use the machine to feed more than one set, prefer not to have this feature. The appropriate line ("VTR ON") from the system controller can be disabled, for example by disconnecting the collector

of Q6006 in Model NV-G21. Other models can be modified by disconnecting the appropriate pin at the r.f. amplifier. Note that later machines use separate converters and amplifiers.

The solenoid drive circuit in the system control section sometimes gives trouble in the G21/25. Short-circuit driver transistors can be the result of a short across the solenoid coil due to a short in the flexiboard used for the connections.

## Audio Bias Adjustment

There are few electrical adjustments. One that is critical for correct operation is the audio bias. The procedure for setting this is the same for all models, though the bias level varies (see Table 1). Fit a short-circuiting phono plug into the audio input socket and set the machine to the record mode. Connect a voltmeter across TP4002 (positive lead) and TP4003 (negative lead). Then adjust VR4002 for the reading shown in Table 1, to within 0.1mV. You don't need to remove the chassis as this preset is accessible through a hole in the PCB, from above. The bias setting has a drastic effect on the sound: it should be checked whenever a machine is serviced, and aligned carefully whenever the audio/control head is changed. The level can drift, causing degradation of the sound quality over a period that may be weeks or months. This can be cured by replacing the head and realigning the bias - the setting will differ with the new head.

## Electrical Fault List

Here's a list of electrical faults we've had with these machines.

(1) **VU meter levels don't tally with a mono signal (NV-D80 only):** Replace the display unit and realign the meter ranges.

(2) **No video input from the BNC socket:** Check the switch within the socket. It often becomes defective when the

Table 1: Models and audio bias settings.

Model	Mechanism	Audio bias
NV-G21B	G	3.2mV
NV-G25B	G	2.7mV
NV-G40B	G'	2.2mV
NV-G45B	G'	2.2mV
NV-D48B	G'	2.2mV
NV-D80B	G	2.5mV
NV-F65B	G2	2.4mV
NV-F70B	G2	2.4mV
NV-F75B	G2	2.4mV
NV-FS1B	G'	2.5mV
NV-FS90B	G2	2.9mV
NV-FS100B	G2	2.6mV
NV-L20B	G REV	2.4mV
NV-L25B	G REV	2.7mV
NV-L28B	G REV	2.7mV
NV-J30B	G REV	2.7mV
NV-J35B	G REV	2.7mV

Note that Model NV-FS95 mentioned under the heading "Overview" last month should have read Model NV-FS90.



the tuner. To do this the TV demodulator pack has to be unsoldered from the main PCB, which has to be removed from the machine. The tuner can then be unsoldered from the demodulator pack. P3001 has to be unplugged to remove the demodulator pack: it's very easy to forget to plug it back, the result being no playback f.m.

**(8) R.F. amplifier socket problems, Models NV-G40/45:** The r.f. amplifier input and output sockets in these models tend to break. They can often be repaired using a big iron and plenty of solder, but sometimes the PCB in the unit is cracked.

**(9) Cutting out on all functions after a few revolutions:** Check for loss of the reel tacho pulses. Even if they are present the cause of the trouble is likely to be the opto-interrupter (IC1501) under the take-up spool.

**(10) Drum runaway or failure to start:** This isn't a common problem but sometimes occurs with the G40 series which uses the cheaper direct-drive units. The Hall-effect devices tend to fail, and you get breaks in the coil PCB, especially around the plug on the DD unit. The Hall-effect devices are not available separately but you could do a transplant if you have an old unit with a different fault.

## Remote Control Units

Most early machines came with a fairly standard remote-control handset. The digital bar scanner was introduced with this range of models, and subsequent versions include LCD displays. Later models have combined scanner/handsets. The only common problem is clogging of the small scanner hole through which the red light shines. The nozzle can be twisted off for cleaning. Some models came with a small brush for this purpose, but customers seem to be unable to manage this. The combined units with LCD displays tend to suffer from dirty, carbonised rubber contact mats, the result being dim or missing digits.

The scanner wallets tend to split if roughly handled. The scanner cards can wear, causing loss of codes, again if roughly used.

## Spares Sources

Account holders can obviously obtain spares direct from Panasonic. Non-account holders are directed to SEME. Those who have accounts with Willow Vale can obtain many spares as Grundig parts. If this is your chosen source, use the exploded diagram in WVE's loose-leaf catalogue to establish what you want.

## Matters Arising

One or two points on the mechanical side, dealt with last month, are worth making. First the underside rebuild because of timing problems is by no means an everyday occurrence. Secondly in later versions (G-Rev/G2) the capstan brake differs slightly and has no retaining slit washer. Thirdly the review motor used in the G2 version can be disconcertingly noisy, but this seems to be normal. A very useful guide that lists characteristics, including part numbers, for the four variants of the G mechanism is now available from Panasonic (part no. VRD8906T101).

Finally here's a correction. In the fault note on the NV-G40 in VCR Clinic, November 1990, the cause should have read the solenoid (VXA2693/VXA3735) not the relay.

socket is used regularly. If the switch is o.k., trace the signal path through the input selector pack, where you will probably find that a buffer transistor is open-circuit.

**(3) No vision in any mode via r.f. input, BNC input o.k.:** Q3501 and D3502 on the input selector pack open-circuit (many would immediately condemn the r.f. amplifier/modulator).

**(4) Switches on but no on/off light display and won't accept a cassette:** This applies with the earlier power supply. Cause is no regulated 5V line because the STK5338 chip IC1001 is faulty. If other regulated lines are missing (check at the pins of P1001) this chip could be responsible.

**(5) No go:** With the later power supply, check for shorts in the chopper chip Q1001. Also check D1014 and D1004. If the mains fuse has blown, check D1004 and the diac D1001 across the mains input – the latter will sometimes be found blackened following a mains surge or a storm.

With models that use the earlier power supply, check the mains fuse F1001 which may have simply died instead of blowing. Check for dry-joints on the power supply PCB and for poor plug-in mains lead connections.

**(6) No r.f. loopthrough, later power supply:** As mentioned earlier, this can be due to failure of Q1004 in the power supply. It tends to go open-circuit base-to-emitter. As a result, the voltage at pin 2 of P1001 falls to about 5V.

**(7) Low r.f. gain, Models NV-L20/J30 etc.:** In these machines the r.f. amplifier is incorporated in the tuner, the modulator being separate. We've had quite a few machines with a low-gain r.f. amplifier, necessitating replacement of

We've never known the 6V regulator transistor Q2505 to fail. In general, as previously mentioned, we've found that the power supply is pretty reliable.

### **Fault Round-up**

No functions can be the result of things other than the power supply going wrong. We've had trouble with the mode switch for example. It's located beneath the right-side of the carriage and can give rise to several symptoms, some of which are quite perplexing. They include switching off after the machine has ejected a cassette, intermittent stopping in the record or play mode, and no functions after accepting a cassette. The only sure way of providing a cure is to replace the switch – cleaning it usually doesn't produce any improvement.

Loss of functions can also occur when the BU2176S chip IC2001 fails. It's located on the main PCB and is fairly easy to replace. We've had this fault only once however, though we have had drum speed problems due to this i.c. on a few occasions.

We've had a number of these machine come into the workshop with a cracked front operations PCB, though goodness knows how users manage to do it! Depending on the severity of the damage the job can be a more or a less arduous undertaking, as there are literally dozens of fine tracks. These require very delicate microsurgery to effect a repair. In situations like this we find that the fibre pencils sold by SEME can be extremely useful for removing the etch-resist from the damaged print in order to expose the copper track.

One of the faults most frequently encountered is loss of the steel activating pin from the limiter post lever assembly, which is situated next to the pinch roller. What

happens is that the nylon bush that holds the pin splits, with the result that it falls into the machine. The outcome is that when play is selected the machine laces up and then, after displaying for a few seconds a picture that looks as though the machine is in the pause mode, it unlaces. The pin can be refitted using Superglue, but a replacement lever is a better option.

To remove the old lever assembly simply ease back the nylon clip that holds it in place and, using long-nosed pliers, raise it above the clip. Then rotate the lever assembly anticlockwise and the limiter post arm clockwise until the pin on the arm disengages from the slot in the lever assembly, which can now be lifted clear. Don't forget to recover the old pin from within the machine: it could cause problems, though it quite often drops out through the ventilation holes when the machine is being transported.

Other faults that you could meet are as follows: failure to accept a cassette due to faulty end sensors or alternatively the BA6329A chip IC1003; no drum rotation because circuit protector CP209 is open-circuit; no E-E signals because C6017 (1,000pF) between pin 5 of IC6001 and chassis is leaky; and varying capstan speed accompanied by wide noise bars on the screen because of failure of the BA6305 chip IC2004.

In the event of there being no clock display, with everything else o.k., remove the back-up battery BT601 from the main PCB and refit it after 20-30 seconds.

Tape edge damage is usually caused by a faulty clutch and/or pinch roller. If in doubt replace them both.

If you find that it's necessary to replace the loading belt it is advisable to obtain the service manual before undertaking the operation. Its replacement involves dismantling the loading gear mechanism, a rather complex

undertaking that's not too easy even with the manufacturer's instructions to hand. Fortunately very little trouble is experienced in this section of the machine.

Two tuners have been used in these machines, types TEEB1X032A and UE30-B03. They are interchangeable.

Spares for the Matsui/Saisho range are available from CPC, Chas. Hyde, HRS Electronics and Mastercare.

---

# A Video Nasty

**Nick Beer**

A VCR fault I had recently could contend with some of Steve Beeching's and no doubt many others' for the video fault of the year title. The machine involved was a Panasonic NV-FS1B. It's a first-generation S-VHS VCR that uses the G mechanism, not that the mechanism had anything to do with the fault.

## Symptoms

As the customer was an AV technician at a local school he had enough technical background to be able to give a fairly accurate description of the symptoms. The main symptom was a vertical bar about a inch wide at each side of the playback picture, approximately one and a quarter inches in from the side of the screen. When the playback picture had dark areas, falling to black level, at the edge the bars took the form of a blue cast. As the video level in these areas increased, the colour of the bars changed, becoming orange/yellow at white level. In addition, at or near black level a third bar could be seen about an inch from the left-hand one. This bar had no chroma content – it looked more like a parasitic oscillation. The fault was present on playback only: recordings made on the machine and played back via another one were perfect.

But this was only one of the symptoms! When a tape with high chroma content was played chroma phase inversion occurred, e.g. highly saturated reds/oranges became green. The saturation had to be high for this to happen: when the colour-bar section of the Panasonic test tape was played only slight errors were present – the chroma was smeary, shifted and weak but no inversion occurred. I used a known good machine to record the colour bars, with a high level of chroma, from our colour-bar generator. When these were played back there was chroma inversion.

The symptoms were worse when the machine was in the LP mode and worse still in S-VHS.

## Fault Tracing

The cause of the fault was likely to lie in a common playback area, so large chunks of the circuitry could be ruled out as being unlikely to be involved. This done, there was still a large area for investigation. I decided that the symptoms probably had a common cause, and also that I would find it much more easily by concentrating on the first symptom. The luminance/chrominance signal processing circuitry in this model is extremely complex in block diagram form, let alone by reference to the circuit diagram. As a start, I played back a blank raster and scoped the chroma output from the head amplifier. The output was as expected: pretty inert and, most significantly, flat across the line period. The signal is

buffered on the main PCB and is then fed to pin 32 of the YC module, where it goes to pin 13 of the hybrid chip IC801. Scope checks showed that the signal was o.k. up to this point.

The chroma signal output from the hybrid chip is at pin 11. At this point spikes could be seen on the line-frequency chroma display, corresponding with the bars on the picture. The circuit here becomes common to the record and playback signals – the record chroma passes through a 1k $\Omega$  resistor on the hybrid chip, leaving at pin 9. I disconnected pin 9 to eliminate any possible problems here. Now an optimist would check for such things as a noisy supply to the chip, then try a new chip. Being one I did just this, and of course it didn't make the slightest difference.

Checks around the hybrid chip failed to reveal anything new, so I came to the conclusion that a fault upstream was introducing an incorrect impedance in the chroma signal's path. One interesting factor I discovered, purely by chance, was that very slight pressure just behind the exit guide, effectively increasing the tape wrap length, removed the symptoms from the screen. This was presumably due to altered chroma signal level.

I was left pondering theoretical possibilities, and was also considering the second symptom – the phase problem. Before I wasted too many more hours I decided that consultation with Panasonic was a sensible step. The local branch hadn't experienced such a problem, but the engineer I spoke to was intrigued by the symptoms and offered to take the machine off my hands. That would have meant that I couldn't write about the fault when I did find its cause, so I declined the offer, at least temporarily!

Further thought led me to suspect delay line trouble, or a capacitor or inductor fault. Bridging or checking suspects proved only that they weren't at fault. A call was then made to Bracknell to enquire whether this fault had been experienced. The answer was no, but the engineer went away for ten minutes to consult with his colleagues. When he got back he confirmed my first suspicion, that the 2H delay line DL802 could be responsible.

Panasonic viewdata said that there was no such part number (EFDHR124A13S). Our storeman consulted Panasonic spares who consulted Japan. A delivery time in weeks was being talked about. While all this was going on I discovered that the same device is used in the Panasonic NV-G25. One was swiftly removed from a stock machine and fitted in the faulty one. Lo and behold, a complete cure! When the cover was removed from the faulty delay line a quarter inch crack could be seen in the glass. Very strange, as the device is mounted in a fairly central position and there was no suggestion that any shock had been applied.

## Panasonic Comment

Shortly after this incident I attended a Panasonic seminar on camcorders. A point made was that one of two nasty problems with video equipment had been traced to damaged delay lines . . .

## Salora J Chassis

On a different subject, Steve Cannon in his article "Gremlins and Gurus" in the July issue mentioned DB712 in the Salora J series chassis' power supply. In a previous article I mentioned that it can go short-circuit, which is the usual thing that happens. But like Steve I too have had it go open-circuit on occasion.

the front of the machine, carefully unhook the spring then, from above, move the idler towards the space vacated by the take-up spool along its slot. The idler's tail can now come through the expanded slot and the idler will come out.

Fit the replacement in the reverse order, ensuring that you place the spring correctly on the idler's tail. See Fig. 1.

### Capstan Motor

The capstan motor is a direct-drive unit. Note that the part number is given incorrectly as VEM0165 in the mechanism photograph in the manual for the NV777. The correct part no. is VEM0164. The capstan motor is quite pricey but rarely fails. Capstan servo problems can be caused by dry-joints or breaks on the small PCB for the FG circuit at the base of the capstan motor.

### Mode Switches

The mode switches are very reliable and align in the standard manner, notch to notch in the eject mode.

### Belt Replacement

Apart from the previously mentioned problem with the large loading belt in the NV788, belt replacement is straightforward. The kick-pulley belt (part no. VDV0138) simply fits over pulleys at either end and should be removed first and fitted last. To replace the large loading belt (part no. VDV0135) you have to remove the DD unit connector at the drum end (unlike the NV7000/7200/7800 where you have to ferret around the loom, tracing it back

## FAULTS LIST

The following is a list of the main troubles we've had with these machines.

**(1) Low sound level or poor h.f. response.** The audio/control head in these machines tends to wear out. Part nos. are VBR0061 for the NV777, VBR0067 for the NV788. The fault is particularly noticeable with the NV788 in the LP mode, since the head-to-tape speed is slower. After replacing the head, check the back tension and audio bias.

**(2) Poor or noisy rewind/fast forward.** This is usually due to a faulty idler (VXP0463) or reel motor (KFN56FB8A).

**(3) Tape remaining counter reads four hours with certain three-hour tapes.** You can't correct this fault – it's a design quirk!

**(4) Squeaks in play. The squeak stops when pause is selected.** This is usually due to a noisy pinch roller. Replace it and clean the tape path. Also lubricate the reel shafts with a very small amount of thin oil.

**(5) As (4) but continues in pause.** Suspect a noisy discharge angle (VXA1584).

**(6) Goes into play then immediately returns to stop.** Large loading belt (VDV0135) faulty. It's worth replacing all three belts at the same time.

**(7) Noisy picture during or following trick-mode operation.** Check the head switching relay(s) by substitution.

to the PCB end) and the small plastic belt cover which is secured by a single bolt. This belt has to be taken off the intermediate loading pulley before the small loading belt (VDV0122) can be replaced. Therefore the best policy is to remove all three belts and fit them in the following order: small loading, large loading and kick pulley.

### Pinch Roller

To replace the pinch-roller arm (roller only part no. VXP0518), first remove the cassette carriage, then the cassette blinder release bracket. The arm is held by a single circlip about the centre pivot. Take care not to over-stretch and damage the spring.

### Impedance Roller

A single nut secures the impedance roller in the usual manner. Take care to ensure smooth travel of the tape over it when it's aligned. Also take care not to lose the roller's inner sleeve when removing the old one. The replacement will usually be plastic, unlike the original metallic version.

### Brake Band

The brake band clips into the back-tension lever at one end and is bolted through its slot at the other end. See the previous notes about adjustment. For correct back tension the right-hand edge of the washer under the head of the bolt usually needs to just cover the inner edge of the right-hand side of the slot in the band – anyway this is a good starting position for adjustment.

**(8) Loses timer and clock information during a power interruption.** Replace the back-up battery (VSB0004). When this is fully charged it should give a reading of approximately 4.25V, falling to 4.07V after 48 hours' discharge. An eight-hour charge should allow a 48-hour discharge. When fully charged the battery will last for 72 hours on average. The battery, usually consisting of three NiCd cells, is on the timer PCB.

**(9) Doesn't accept a cassette/other loading problems.** Replace broken or dirty cassette up and down switches on the side of the cassette carriage.

**(10) Machine is affected by mains-borne noise, e.g. when a fluorescent light is switched on or off. The unit then for example enters the stop mode.** If this hasn't been done during production, add a 1 $\mu$ F, 50V electrolytic capacitor between pin 9 of IC7505 (positive lead) and chassis (negative lead), on the print side of the board. The component is C7552, part no. ECEA1HS010.

**(11) Remote control unit doesn't work.** The remote control units are straightforward and all the usual advice applies, i.e. check batteries, LEDs etc. as necessary. The only stock fault is failure due to the legs of the ceramic resonator (CSB420) fracturing, usually as a result of the unit being dropped once too often.

**(12) Various Y/C faults, e.g. unlocked colour.** As these machines have aged, dry-joints have become quite common on the Y/C board (the lower PCB, beside the bottom of the mechanism). Try resoldering suspect chassis connections, the flying leads and the large hybrid chips on this board. Also check relay contacts.

while a tape was being loaded the pulley moved from side to side. When the top deck was dismantled we found that the shaft on which the differential gear sits was loose in its chassis mount. We got over the problem by fitting a chassis from a scrap machine – otherwise the machine would have been beyond economic repair. **A.D.**

### **NEC DX100K**

This machine was brought in for a new idler and service. When we obtained and fitted the necessary parts we found that the E-E video was overloaded – there was a gradual improvement as the machine warmed up. This machine has a digital still TV picture mode. When this was selected we got a good still E-E picture. The cause of the fault was traced to pin 3 of IC207, where the voltage didn't go low enough for E-E video. There was leakage here, due to the glue that had been applied to the PCB to secure cables. **A.D.**

### **Panasonic NVG21**

There was no audio playback. We found that the audio mute line was high, the cause of this being absence of the CTL pulses. We checked back to the servo pack where C240 in the 'AGC CTL' circuit was defective. **A.D.**

### **Saisho VR1000/Matsui VX800**

The complaint was that the 2.5AT fuse F502 would blow intermittently. While the machine sat on the bench it behaved normally, but as soon as it was moved the fuse blew. We found that the bottom PCB had warped beneath the power supply. As a result the fuse blew every time the PCB came into contact with the metal bottom case. **A.D.**

### **Crown VRS200/Alba VCR7000/8000**

The capstan speed would slow and the machine would switch from the SP to the LP mode. Scope checks showed that the control pulses were curved and that there were 1V negative-going pulses on the 6V line. The bridge rectifier was the cause of the fault. **A.D.**

### **Samsung SI1260**

There was a blank raster and no playback. After removing the top cover we saw that there was neither drum nor capstan rotation: the blank raster gave the impression that the machine was stuck in the AV mode, though it wasn't. Voltage checks showed that the switched 5V supply was missing at D109 (1N4001) which had gone open-circuit. A replacement restored normal operation. **M.L.**

### **Ferguson 3V54**

The clock worked but there was no other operation. None of the front controls had any effect. As the circuit protectors in the main body of the power supply were all in order we turned our attention to the main PCB where we found that the switched 5V supply was missing. The cause of the fault was C605 on the top panel – it was leaky, a replacement restoring normal operation. **M.L.**

### **Akai VSC200**

If there's no playback check that the video lock is not in the on position. To unlock, press the remote control unit's play button and hold it down for ten seconds then do the same

with the stop button. If this fails to restore playback check that the cassette is accepted correctly. If not, check or replace the cassette loading block. **J.C.**

### **Mitsubishi HS337**

For no rewind or fast forward operation and failure to record check the record inhibit switch. It may be misaligned, broken or damaged as the result of use of a C format cassette. **J.C.**

### **JVC HRD540**

There was no E-E sound. The cause was failure of the 4.7 $\Omega$  safety resistor R47 in the l.t. feed to the audio circuit. **J.C.**

### **JVC HRD520**

For muted sound with lines on the picture check the f.m. waveform. This will show that the guide poles are misaligned. Under these conditions the VCR may record and play back its own tapes all right but it won't play back prerecorded tapes. **J.C.**

### **Toshiba V110**

If the tuning is off, check the 2.7V zener diode DT53 in the video 5V supply regulator circuit. It tends to become leaky. Other possible symptoms when this diode is leaky are no playback colour or distorted playback and E-E pictures. **J.C.**

### **Amstrad TVR2**

It's difficult to decide whether to list this fault in the TV or VCR section. The symptom was severe 100Hz hum on the TV picture and sound, though tape playback was o.k. Its cause was in the video power supply however, where the 2,200 $\mu$ F, 25V capacitor C606 was almost open-circuit. It smooths the 20V supply to the 12V regulator chip IC601. **C.A.**

### **Hitachi VT410**

An obscure fault caused this machine to lace up, play briefly, then unlace. The counter was working, and the waveforms around the syscon chip IC901 were all o.k. except for the 25Hz signal at pin 23 which was found to be of low amplitude when a comparison check was carried out with a working machine. The signal comes from the servo chip IC601, where a comparative resistance reading to chassis revealed that the faulty machine had a 400 $\Omega$  leak. The cause of this was C23, a surface-mounted capacitor on the video head preamplifier PCB! **C.A.**

### **JVC HRD540**

The problem was intermittent E-E and playback sound. Application of freezer anywhere around Q5 and Q6 on the tuner/i.f. PCB instigated the fault, as did any attempt to measure the voltages around Q6 (FMS2) which proved to be the culprit. This tiny, five-legged surface-mounted device is not listed by any of our usual suppliers, but a replacement was obtained from JVC without difficulty. **C.A.**

### **Philips VR422**

There was intermittent mistracking and generally very poor playback. As there were no obvious mechanical faults and

the deck had been realigned a few times we suspected an electronic fault. A scope check on the drum PG/FG pulses at the head amplifier showed, when a comparison was made with the oscillogram, that there was no synchronising pulse. The oscillogram shows this as a gap in the drum pulse waveform. After replacing the TDA5140 drum motor driver chip IC7301 and carrying out slight realignment of the deck we obtained an excellent picture. S.C.

### **Bush VCR185**

There were no E-E signals. Checks showed that the u.h.f. tuner received a 0-30V ramp voltage while search tuning but, as voltage UB was missing, no signals were selected. R132 (10k $\Omega$ ) in the band-switching system was open-circuit. C.W.

### **Logik VR950/Samsung VI611**

This machine wouldn't play. We found that the drum didn't rotate and the operate LED didn't light up. Although some of the power controlled circuits were working, the PC12 line was low. The cause of the trouble was D4 (1N4002) on the power supply PCB. C.W.

### **Akai VSF33**

When any operation was selected, via either the machine's own controls or the remote control unit, the power went off leaving just the clock. When the machine was switched on again it would stay on until a tape was inserted or the channel was changed. It would then power down again. The cause of the fault lay in the 23.5V regulator circuit, where R221 (120 $\Omega$ ) had gone high in value. C.W.

### **Hitachi VTM740**

The customer complained that there were lines on the picture and that the tracking light flashed, mostly at the start of a tape. When we ran a test tape the symptoms were as described: the tape speed varied, being mostly slow. Checks on the pinch roller, the back tension and the tape path led us to the capstan motor, whose upper bush was bone dry. Dismantling the motor, lubricating the bush then reassembling the unit provided a complete cure. C.W.

### **Pye 65VR20/Philips VR6520**

This machine sometimes stopped after only a few minutes, but only in the record mode. It turned out to be a nice easy job for a change: the recording tab switch was as black as your hat! A new switch restored normal operation. C.W.

### **Amstrad VCR8600**

There was no drum rotation. The cause was traced to tiny cracks on the signal panel, where the YC subpanel is joined. This is a very flimsy area, and the print is quite tricky to repair. I applied a few blobs of glue to help support the subpanel. C.W.

### **Panasonic NVG21**

The lift was jammed half way in and the machine was dead – no clock display or power-on LED indication. A check in the power supply showed that the 1 $\Omega$  safety resistor R15 was open-circuit. This was the cause of the dead machine, and I assume that the jammed lift was responsible for its

failure. Once the lift had been extracted I found that various plastic tabs had broken off, so a new side plate (part no. VXA2677) was obtained from SEME. If you have to fit one of these I recommend that you read Nick Beer's article (May 1991) on servicing this model: without his advice I'm sure that I would still be trying to align the gears. C.W.

### **Hitachi VT430**

This machine was stuck in pause. When a cassette was inserted the pause indicator lit up. Other functions could be selected, e.g. play, but this produced only a still picture. A check at pin 56 of IC901 produced a reading of 3.2V instead of 0V. This led us to I1581, a 100 $\mu$ H choke that's in series with the camera pause socket. C.W.

### **JVC HRD880**

A tape was stuck in the cassette housing and there were no functions. We found that a key scan port associated with IC1 was stuck high. Everything worked correctly when the chip had been replaced. S.B.

### **S-VHS Instability**

The complaint with a JVC HRD4700 was that it wouldn't record via the S-VHS sockets while the S-VHS output signals were inherently unstable. We found that it recorded and played back very well in the S-VHS mode. The playback instability occurred with titles that had been added by the amateur film maker who owned the VCR. We told him that the black-level clamping in his titling machine wasn't up to much – if indeed it had such a thing. S.B.

### **JVC HRD560**

One of these machines wouldn't tune. We replaced the tuner, the tuning memory chip, then the tuner/timer chip for key scan control, all to no avail. Finally we replaced the system control chip. That did it!

Another of these machines came in dead. We replaced circuit protector CP1 in the power supply then, on final test, noticed that the capstan motor was inclined to act erratically – in fact at one time it went into reverse. A new motor had to be fitted. S.B.

### **Panasonic WJMX12 Mixer**

This mixer caused us a lot of trouble. The alleged fault was loss of channel 2 colour after some time – a tape was supplied as proof. We were unable to confirm the fault and got a second opinion from Panasonic who ran the machine on test for a week then concluded that it wasn't faulty. The report said that the VXOs and VCOs were all set up correctly and that full genlock was consistently obtained. We eventually discovered that the fault did exist when the mixer got hot. The cause of the fault was a crystal in the channel 2 input colour decoder. It went off frequency when hot, i.e. very hot. S.B.

### **Grundig 2 x 4 Super**

I rarely see one of these machines. This one came in with a power supply fault. After removing the 25A car fuse and replacing the intermittent on/off switch I eventually found the real cause of the fault – the coupling capacitor between the TDA4600 chopper control chip and the chopper transistor. S.B.



## Ferguson FC31

The complaint with one of these camcorders was of intermittent no functions with a drip showing in the viewfinder: a dodgy dew sensor was the cause of the problem.

Another FC31 suffered from random operation, a permanent dew indication and a warped cassette housing, the latter probably because of forced cassette extraction. As first steps we fitted a new dew sensor and cassette housing. The cause of the random operation was a noisy record safety switch. **S.B.**

## Sony CCDF380

There was a cassette stuck in this camcorder. At least the customer hadn't used too much force in trying to get it out: the damage was restricted to a poor eject damper, while the cause of the trouble was failure of a circuit fuse buried deep inside, on the main deck PCB. **S.B.**

## Ferguson FC06

This machine had suffered at the hands of an incompetent. As a result of previous 'repairs' all the circuit protectors had blown and there was some print damage. After replacing the circuit protectors and tidying things up a bit we found that the loading motor drive chip was the cause of the original fault. **S.B.**

## JVC GRS70

The cause of very intermittent luminance was traced to R339 in the camera encoder section. A second machine came in with the complaint that the picture went green, red then black-and-white. This was not as serious as it sounds: all that was required was to set up the camera phase-locked loop. **S.B.**

## Panasonic NVMS2

We had two of these camcorders in recently from the same customer. Both had the same fault symptom: no functions. The cause was also the same – reversed battery supply connections. You know what happens: this one doesn't work so we'll try the other one! Naturally the cure was the same in both cases, replacement of the fusible link (VSF0059) and the M54543L loading motor control chip. This restored normal operation though further checks were carried out to ensure that no other damage had been sustained. **D.C.W.**

## Sanyo VMD6P

There was no viewfinder picture because the viewfinder focus control was open-circuit. Its lower end feeds the brightness circuits. **D.C.W.**

## Panasonic NVMC6

The complaint was of a loud 'shrieking' noise from the mechanism, with picture wobble and warbling sound. When we inspected the capstan motor's rotor we found that the plating material which covers the magnetic disc had almost completely lifted. The remaining material scraped against

the motor's windings, causing the noise and damage to the varnish. Motor drive signals in the windings were being conducted to chassis via the plating material. A new motor restored normal operation. **D.C.W.**

## Sanyo VMD3P

There were no viewfinder pictures. The cause was yet another electrolytic capacitor, this time C9911. Maybe it's best to replace all the electrolytics in these camcorders. Nearly every day seems to bring a 'new one'. **D.C.W.**

## Sharp VLC690

The cause of intermittent operation, cutting out and various other symptoms was traced to broken connections at the junction of the main PCB and the operation PCB. If there's a shock at the rear end because one of these cameras has been dropped, as this one had, the connectors at this point are easily detached from their respective print points. **D.C.W.**

## Panasonic NVM7

This camcorder would intermittently go into the pause mode, with 'tape' showing in the viewfinder, when recording. The cause was a corroded contact on the 'rec. prevent tab switch'. **D.C.W.**

## Sony CCDTR55

There was a cassette stuck in the mechanism and the 'caution' warning was being displayed. No functions were available. The cause of the trouble was a short-circuit loading motor (the short was to chassis). There was also an open-circuit circuit protector (type PS602-N25). **D.C.W.**

## Panasonic NVMS2

The customer's complaint was that batteries lasted for only a very short time. We checked the charger and batteries and found that they were o.k. On test a fully-charged battery gave a recording time of about two hours. Nothing wrong then – except that the viewfinder display said that the battery was low after only a very short period of operation! We checked and set up the supply rails and R6002 (battery low detect). This provided a complete cure. **D.C.W.**

## Sony CCDTR50

Playback was o.k. but there was no camera picture. We found that Q501 on the main camera PCB was open-circuit all ways. **D.C.W.**

## Panasonic NVMC6

The complaint was that this camcorder cut out after a few seconds in both the record and playback modes. Checks on the sensor inputs to the syscon microcontroller chip showed that the supply-reel pulses were intermittent. This was because R6075 had gone open-circuit. **D.C.W.**

connect cog on the right-hand side of the lift had a broken pin and spring. A replacement cog and spring assembly and alignment of the lift cogs cured the problem. **G.S.**

### **Nokia 3722/42**

There were no functions and the machine wouldn't accept a tape or power up. The clock display showed four small zeros. A check showed that the back-up 5V supply was low. D7001 was found to be open-circuit while the back-up capacitor C7001 was gradually discharging and not being recharged via D7001. Replacing D7001 cured the problem. You get the same fault when C7001 is leaky. **G.S.**

### **JVC HRD400**

There was no play, fast forward, rewind or eject, the machine going to standby after a few seconds. We found that the reel brakes were jammed on hard and the idler was jammed on the brake mechanism. The clutch spring, which is used along with the 'windmill' to release the reel brakes, was broken and when the mechanism had been stripped down I found that the main cam was also damaged. The slide encoder, the main cam and the clutch spring were replaced and after realignment of the mechanism everything worked correctly. **G.S.**

### **Nokia 3722/42**

A fault we've had with a number of these machines is loops of tape left hanging out when the cassette is ejected. There are two common causes. First a stiff capstan motor. As a result there's no take-up on eject. The cure is to replace the capstan motor. The second cause is a faulty mode switch. This switch can also be responsible for erratic functions, failure to accept tapes and failure to eject them. **G.S.**

### **Sanyo VHR3100**

The cassette would go in only about a quarter of an inch then come out again. On investigation we found that the capstan to idler belt had become very soggy: it had glued itself to the capstan pulley which couldn't turn. A good clean up and some new belts made the machine as good as new. **C.W.**

### **Ferguson 3V44/JVC HRD140/NordMende V1001**

This machine was brought to us because of loss of colour. A tap on the top panel would restore it temporarily, but even after a mass soldering operation the colour was still tap-sensitive. So methodical checks had to be carried out. This brought me to filter BP301, which must have had a poor internal contact. Anyway a replacement restored reliable colour. **C.W.**

### **Sanyo VHR1100**

For tracking errors check both the supply and take-up guide rollers which tend to become loose at the pole base. In the past we've tried to glue them back but this is not a good idea. Replacement of the pole base assemblies gives a reliable cure. **M.Dr.**

### **Akai VS967**

If the capstan motor works in the fast forward and rewind

modes but won't turn in the play mode check the fusible resistor FR4 in the power supply. It will almost certainly be open-circuit. **M.Dr.**

### **Saisho VR3600/Matsui VX755**

When this machine had been running for about an hour the capstan motor would momentarily stop for about a second then start to turn, repeating the sequence about every six revolutions to give a play/pause symptom. We've had this fault on many occasions, also with Sharp/Philips machines that use the same (M51782ASP) capstan motor drive chip. Cooling the chip will cure the fault for a while, but beware: on the first occasion we spent some £18 on a new chip only to find that the replacement didn't provide a cure – despite the fact that cooling it restored normal operation. We now replace the motor, which is not much dearer than the chip. **M.Dr.**

### **Samsung VI910**

Field roll was the complaint with this playback-only machine. The cause was insufficient back tension because of sticky grease on the back-tension post bearing. Cleaning and relubrication provides a cure – the cleaning needs to be thorough. **N.B.**

### **Panasonic NVJ35B**

This machine came in dead. That there was no operation on the primary side of the power supply was indicated by absence of the squeal at switch on. We found that diode D1104 (type AP01C) in the snubber network was short-circuit. **N.B.**

### **Sony SLC30**

These machines now suffer from a common affliction that's often not mentioned by the customer. When the machine is repowered after being unplugged the E-E and playback vision are sometimes marred by severe diagonal patterning, at both r.f. and baseband, the latter usually being better. The cause is C319 (22µF, 16V) in the power supply. It goes low in value or open-circuit. **N.B.**

### **Philips VR6180/Pye DV186**

There was no playback f.m., just noise. The cause of this was the fact that the lower drum earthing bracket's securing screw was very loose. When this was tightened there was a nice clean picture but no colour. Recordings were fine when played back on another machine. I found that the f.m. from the head amplifier was about fifty per cent down and rather noisy: this was triggering the colour killer, though the luminance seemed to be perfectly all right. After much searching around I found the cause of the problem. Someone had soldered the leads from pins 1 and 2 of L6 to the print side of the PCB. Fitting them to the connector itself restored the colour. Perhaps a previous attempt to cure the loss of f.m. had gone awry? **N.B.**

### **Toshiba V209**

There was no mechanical action. Checks showed that the 9V output from the power supply was very low. Disconnecting this supply restored the voltage, but there was no excessive load. A replacement STK7253 multiregulator chip cured the fault. **N.B.**

## **Panasonic NVJ40/42/45/47**

In this range of machines a drum motor that appears to be lazy or is mechanically noisy is rarely due to the drum itself. The cause of the fault usually lies in the drive circuit on the small PCB behind the mechanism. You will probably find that one of the three electrolytic capacitors C204/5/6 (0.1 $\mu$ F, 50V) is faulty. **N.B.**

## **JVC HRD820**

This machine suffered from an intermittent loading fault: it would also stop dead in play for no obvious reason. We suspected the syscon sensors but it was the microcontroller chip itself that was faulty. **S.B.**

## **Panasonic NVJ40**

This machine came in with a tape stuck inside. The cause of the trouble turned out to be the capstan motor. Tape loading was o.k., driven by the capstan motor, but once loading was complete and play commenced the motor wouldn't run at the slower speed. **S.B.**

## **Panasonic NVL25HQ**

If there is no output from this machine's power supply it's as well to go straight to C9 (1 $\mu$ F, 350V). It's positioned between two high-wattage resistors that cook it gently, drying it out. **J.K.P.**

## **Hitachi VT410**

There was sound but only a blank white raster. I inserted our colour-bar test tape and checked at the video output socket with a scope. Only a chroma signal was present. This was strange, as one would have expected to see flickering colour on the monitor's screen. The scope was next used to check the luminance signal path. The signal was present at pin 7 of the HT4848B chip IC202 but didn't emerge at pin 1. After confirming that its supply was present we replaced the chip. This restored normal operation. **F.A.S.**

## **Hitachi VT9500**

Fast forward and rewind were o.k. but when play was selected the tape loaded to the heads then unloaded as there was no drum rotation. A check on the supply at pin 4 of the drum chip IC503 produced a reading of 0V instead of 9V. The cause of the fault was the STK5720 regulator chip IC901 on the syscon PCB. **F.A.S.**

## **JVC HRD211**

There was a fast forward/rewind fault with this machine. These modes could be selected and worked, but when stop was selected the tape would thread to the drum and no tape end was sensed - the loading motor would start to screech, then the machine would switch off. The cure was to replace the M50731-626SP mechacon chip. **F.A.S.**

## **Ferguson FV12L/JVC HRD230**

In the E-E and playback modes a single, large hum bar travelled from the bottom to the top of the display on the monitor's screen. A check on the switched 5V line showed that a distorted 500mV, 50Hz squarewave was present. We initially suspected C14 which decouples the switched 5V

output at pin 3 of the STK5481 chip IC1. It was o.k. however, the cause of the fault being the chip itself. **J.E.**

## **Panasonic NV830B**

There were snowy E-E and loop-through pictures. This time the cause wasn't the r.f. booster module itself but absence of the 12V supply at its ANT BS input because the RD13EB3 zener diode D1110 was short-circuit. Note that there are two 12V supplies to the module, the always 12V supply and the ANT BS supply which is switched - this is why the fault didn't affect tape playback. **J.E.**

## **Sanyo VHR3100**

The fault with this machine was no rewind. I tackled it the hard way. First I checked the idler assembly and all the parts around it, then I ordered the service manual. This isn't exactly comprehensive, so it took quite a lot of observation to discover what was wrong.

On the underside of the mechanism there's an assembly that consists of a main slide on top of which (with the unit upside down) there's a sub-slide. This has an elongated hole and is held in place by a pin, washer and plastic retaining clip. In the fault condition the sub-slide rode over the pin because the space between the washer and the sub-slide was too great. I carried out a temporary repair by fitting a compression spring between the washer and the plate to hold the sub-slide tighter against the main slide. This worked very well.

I then sent a fax to Sanyo to ask what I should have done. A short time later I received a phone call from Sanyo's Technical Department to tell me that the fault was not an unusual one and that all that was necessary was to push the retaining pin back against the sub-slide and fit a circlip on the other side of the deck to hold it in place. Many thanks Sanyo for a prompt, efficient and polite service. **J.H.**

## **Mitsubishi HS337**

The customer's complaint was that while the sound was o.k. the picture had slowly "evaporated". There was no E-E or playback output though there was a signal at the scart connector. So we knew that the signal was there but wasn't getting to the modulator. The cause of the fault was C2E5 (100 $\mu$ F, 25V). Being close to a power transistor it had slowly and surely baked dry! **B.McC.**

## **Ferguson 3V48/JVC HRD565**

The following fault caused us some sleepless nights. The machine came in with a damaged timer door and PCB. Putting this right was quite easy but when we tested the machine we found that while instant and normal recording worked fine all we got with a timer recording was garbage. The mechanism sprang into action correctly, and checks showed that all the record voltages were the same as with an instant or normal recording. A clue was that when coming out of the timer record mode the E-E display had swirling interference on it: this cleared when the machine was set for another function.

We eventually traced the cause of the fault to C10 which is connected to the switched 5V rail. It allowed parasitic oscillation to get into the f.m. modulator with a timed recording only, destroying any chance of a successful recording. The display gave the impression that there were the remnants of a picture behind the scrambled garbage. **B.McC.**

## JVC HRD750

The trouble with this machine was intermittent failure of circuit protector CP802 in the motor 12V line. When failure had occurred the machine would perform no deck functions, switching itself off after eight seconds. The cause was an expensive one: an intermittent short-circuit within the capstan motor.

E.T.

## Sony SLV353

If you get one of these machines with the complaint that it damages or snags the tape, often intermittently, during the eject operation feel the half-loading arm: it will probably be very stiff on its shaft, as a result of which it will be slow to retract. If it doesn't get there by the time the cassette moves up, it's bad news for the tape! The cure is to clean and lubricate the arm's shaft and bearing.

E.T.

## Philips DMP Deck (VR6362 etc)

If the cassette sometimes gets caught and jammed on its way into the machine, don't change the carriage ('lift' in Philips' language) until you've checked for loss of strength in the tension spring associated with the lift-operating rack at the right of the deck – it's no. 275 in the exploded view of the deck shown in the manual.

E.T.

## Sony SLV625

The spool-rotation sensors are a weak spot in this and similar Sony VCRs. This particular machine would play or record for about half an hour then shut down with the letter L displayed in the place where the hours digits normally live. Thereafter it would shut down as soon as any tape forward mode was selected, though it was quite happy to run in the reverse modes. The cure was to replace both the optocouplers, HP001 and HP002, under the deck. Type number is PS6002.

E.T.

## Audio/Control Heads

Have you noticed the increased failure rate of AC heads in more modern machines? I have and know of several machines that are ten or more years old and still carry on operating reliably with their original AC heads which show little visible sign of wear. It is becoming necessary to replace AC heads in a growing number of newer machines however, because of wear to either the linear audio head or the sync head – or both.

If you have problems with intermittent loss of capstan sync or trouble with low or muffled sound, especially with playback of a machine's own recordings, take a good look at the face of the AC head. Visible wear, curvature of the surface of the polepieces etc., is enough to condemn the head. With some heads you find that the whole face shows a vertical bronze stripe where the original chromium surface has worn away.

The common denominator with these machines is that they nearly all feature index search. Consequently the tape remains fully laced during wind and rewind as well as during record, play and search. Thus during any

record/rewind/play sequence the amount of AC head wear is increased by fifty per cent: much use of the index search/shuttle features only adds to the problem. The incorporation of a half-load or reverse back-tension arm increases the wrap around the head and contributes to increased head wear.

When you remove a faulty head prior to replacement, examine the top and bottom polepieces to see if there's been uneven wear, i.e. the audio head is more worn than the sync head or vice versa. This indicates incorrect alignment of either the head's vertical setting or the half-load/reverse-tension arm. When fitting the replacement head/assembly it's essential to take extra care with the alignment. Note the manufacturer's recommended back-tension setting and the alignment of the AC head and half-load arm – as well as carrying out the usual checks on the entry and exit guides etc. The tape path arrangement during rewind or reverse search is particularly important. Tape tension in these modes can be measured accurately only by using a tentelometer – if you can afford one! The usual back-tension cassette works only in the forward play mode.

Another side effect of index-search machines being fully laced in all modes is increased lower drum assembly wear. This eventually imposes additional friction on tape movement, showing up first as poor tracking in reverse search and/or throwing loops of tape during extended periods in this mode. When the lower drum needs to be replaced it's usually best to replace the whole unit, including the upper drum. Check the condition of the soft-brake band and the back-tension arm at the same time. Give a realistic estimate for this sort of job as the customer, when faced with a bill for a full drum assembly together with AC head replacement, new soft brake, idlers, clutch, belts plus cleaning and lubrication etc. and all the work involved in such an extensive overhaul, will often decide to trade in the machine in favour of the latest model with Nicam sound and VideoPlus.

J.C.P.

## Orion D4500A/GSC

A common fault with these machines and several other Orion VCRs that have a similar power supply module is no functions and no display. The machine will probably come in with a cassette loaded but will neither eject it or lace up, and no keyboard or remote control commands will operate. Check the switched 5V and 12V supplies (the manual calls them p.con 5V/12V) at pins 4 and 5 of CP502 on the power supply panel. If they are absent check for 13V at pin 6 of the STK5342 regulator chip. If this voltage is low or zero, before condemning the chip check R508 (10kΩ). It will probably have gone high in value or open-circuit.

Other models that have a similar power supply module and suffer from the same fault are the D1000/D1100/D2000X/D5000/VXL12. Model VL is prone to the same fault but in this one the regulator is type STK5332 and the suspect resistor is R2508.

J.C.P.

## Hitachi VT63

With a prerecorded tape the picture was unwatchable when the tracking control was in its centre position. If it was

moved to either end there was a stable, watchable picture. We found that the f.m. envelope varied and couldn't be corrected by operation of the tracking control. Replacing the audio/control head provided a complete cure. **J.C.**

### **Panasonic NVG21**

Intermittent tape take-up, or the tape being caught in the carriage during eject, can be caused by a faulty play arm. It can also be caused by a stiff mounting post. The remedy is to replace the play arm unit and lightly oil the play arm's mounting post. **J.C.**

### **Sharp VCA105HM**

If there's a jammed tape check for foreign bodies in the machine then check whether the tension arm assembly is bent, preventing the loading arms moving to the unloaded positions. If the latter is the cause of the problem, replace the tension arm assembly, band brake and spring. **J.C.**

### **Panasonic NVG45**

Failure to accept tapes is often caused by a faulty timing belt. In one case recently however the flywheel was at fault: the collar that provides the belt drive had become detached. Check the flywheel by replacement. **J.C.**

### **Toshiba DV80**

If F803 has gone open-circuit you will often find that the machine works normally for some time after fuse replacement. The cause however may well be dry-joints at the junction of diodes D801/2 (the earthy end). **J.C.**

### **Tashiko VVE921/GoldStar GHV1221**

Problems in the i.f. department are becoming all too common with these machines. This one was no exception. The E-E and recorded pictures were both very poor: tearing was evident at the top, and the luminance content was very low. The cause of the trouble turned out to be a leaky capacitor, C704. It's a 1 $\mu$ F, 50V type that's mounted close to the LA7530 i.f. chip. **M.L.**

### **Hitachi VT17**

As with all machines that have a few years of service behind them head wear is becoming a problem with this model. This particular machine's symptoms were poor playback with a lot of tracking noise evident with prerecorded tapes: reproduction of the machine's own recordings was poor, but not quite as bad as with prerecorded tapes. We tried fitting some second-hand heads from a scrap machine but the fault persisted. Replacement of the relay behind the head drum assembly also made no difference. The clue to sorting out the problem was the fact that the tracking control seemed to be loose while we couldn't find its centre position. The control turned out to be open-circuit, a replacement restoring normal results. **M.L.**

### **Amstrad VCR6100**

The complaint with this machine was of wow on sound. We replaced the take-up clutch and pinch wheel but the problem persisted. So we ordered an HIC401 hybrid servo chip from CPC. On inspecting the faulty chip we saw that C3 (33 $\mu$ F, 10V) was leaking and thus of low capacitance value. It's not

visible until the chip is removed from the PCB: next time a cheaper repair will be possible. **M.P.**

### **Saisho VR1200HQ/Matsui VX820**

In the play and record modes this machine would lace up and then run for only three seconds. Since the machine would start to operate normally we suspected a false end-of-tape message from the left-hand end sensor. For once we were right first time! **J.P.F.**

### **Toshiba V109B**

A cassette stuck in the machine and no loading motor life took us back to the power supply regulator, where we found that the 12V supply was missing. A temporary bypass, using a 78012 chip, proved the point. Replacing the STK7248 chip completed the repair. **J.P.F.**

### **Matsui VX880/Saisho VR1600/Hinari VXL4**

There was intermittent poor lift operation. It was sometimes dead, and appeared to overshoot the end stop during the eject cycle. Both leaf switches were tested and found to be o.k. Fortunately another similar machine came in – we tried its lift and got the same results. This led us to the mode control switch which, when checked with a component tester and scope, produced some very ragged on-to-off changeovers. A replacement put matters right. **C.W.**

### **Philips VR6462**

Lift problems said the card, and the tape wouldn't go in. We found that with a cassette inserted and then a key pressed it went down and everything worked correctly. The switch on the lift assembly has to be pressed and released before the lift will go down. If the cassette is put in and doesn't come out a little the lift will stand still. It all depends on the cassette being pushed out after being pushed in by the user. If you look at item 2421 on the lower side of the deck you'll see that there's an eccentric nut with a locking screw. Adjustment of this determines how far out the cassette is ejected after being inserted, and hence the action of switch 204 (lift switch tape in). The adjustment enables a small amount of mechanism wear to be taken up. **C.W.**

### **JVC HRD640**

This machine worked correctly until play was selected after pause or reverse search. It would then unlace and enter the stop mode. The cause turned out to be the mode control switch. **J.E.**

### **Amstrad VCR4600**

When play was selected the machine went straight into forward picture search. Replacing IC302 (BA718) cured the problem. **J.E.**

### **Toshiba V93**

There was a normal tape playback picture but no front display and only snow in the E-E mode. The cause was traced to circuit protector 2L62 (ICP-N10) on the timer-2 PCB being open-circuit. A long soak test after fitting a replacement proved that all was well, with no other cause apparently being present to make the CP go open-circuit. **J.E.**

## JVC GR45

Irrespective of the position of the on/off switch this camcorder's viewfinder produced a blank white raster whenever power was connected. In fact operating the on/off switch had no effect: a blank raster was still present, with no functions available. The cause of the problem was the fact that the switch's contacts were permanently made, thus inhibiting any function. **D.C.W.**

## Canon VME1E

There was no output from this camcorder's a.c. adaptor. The cause was C22 (2,200 $\mu$ F) being open-circuit. **D.C.W.**

## JVC GRAX10

The complaint was of an intermittent viewfinder picture. In fact in the record mode the camera section of this camcorder switched on and off at random. I suspected the d.c.-d.c. converter, which in fact proved to be the cause of the trouble. The unit is replaceable only as a complete assembly, but in this case a quick reflow session with the hot-air tool provided a complete cure. **D.C.W.**

## Canon E60E

The cause of white flashes and a generally flickering picture was traced to a noisy resistor (R1055) on the main camera PCB. It biases Q1007, a buffer stage in the signal path between the sample-and-hold and processing stages. Not a nice one to get at! **D.C.W.**

## Sony CCDV30E

The complaints with this old timer were that it occasionally chewed tapes and that it produced a rolling picture for the first half minute of a playback. When checked in the workshop it worked all right, with no fault showing up – until it had been left on the bench overnight. When play was selected the following day the rolling picture fault symptom was seen. After a short period the picture stabilised and efforts to instigate the fault were ineffective. The cause of the trouble was that because of contamination the back-tension guide pivot was sticking: it was o.k. when warm, but when cold it took several seconds to reach its correct working position. Once we'd removed the assembly and cleaned the pivot bearing we had no further problems. **D.C.W.**

## Sony CCDF330E

Loss of playback chroma was the complaint. The fault was intermittent with the camcorder's own recordings and seemed to be thermal, as indeed it was. Replacement of DL360 cleared the fault. **N.B.**

## Panasonic VWAM7B

This is the a.c. power supply/charger/AV unit for use with the NVM7B camcorder. The complaint was of no baseband or r.f. output, though the unit did power a camcorder admirably. Checks showed that there was no SW12V supply

at the terminal CBA, where it should appear via the yellow lead that's paired with a pink lead. Between the terminal CBA and the front switch CBA this pair of leads passes via an in-line plug and socket which is not shown in the circuit diagram. The cause of the fault was simply that the plug wasn't fully home – the unit had been dropped, and some case parts had to be replaced.

It's interesting that although the unit came from a state school where technicians look at equipment before it is sent to us the mains plug was in a lethal condition – a 13A fuse was fitted, there were long tails, the cord grip was faulty and undone and a piece of the plug body was missing, exposing the live fuseholder. **N.B.**

## Sony TR45

This machine is very similar to the TR55, for which servicing notes were published in a separate article in the March 1994 issue of *Television*. It suffers from similar faults: the following are ones that were not included in the TR55 article. Note that the front section of the lens on this unit sometimes falls off. This is not because of damage caused by the user but because the glue that was used was not strong enough. Simply reglue it back on, noting the correct position for accurate focusing.

(1) No E-E picture luminance, playback o.k.: Checks showed that there was an input at pin 2 of the low-pass filter FL181 but no output at pin 11. Pin 6 was open-circuit. Fault was cured by replacing FL181, part no. 123626611 (board VC84).

(2) No E-E picture, playback o.k. Checks showed that the V1 and V2 pulses to the CCD image sensor were low. Pulses V3 and V4 were o.k. Cause of the fault was a defective pin-through on board CD48P. Cure is to replace the board or hard wire.

(3) No E-E picture, black screen, intermittent noisy white lines may be seen. Oscillator X101 on board VC84 was not running at the correct frequency because C112 was faulty.

(4) No E-E luminance though titles and playback o.k. A scope check at pin 41 of IC301 (board VC84) restored the picture. C305 (0.01 $\mu$ F, part no. 116297411) was faulty.

(5) Recording produces a black screen: the E-E and playback pictures o.k. Scope checks brought us to filter FL503 on board VC60. We have on occasions found this filter to be either open-circuit or dry-jointed. Replace or resolder as necessary.

(6) When the door was closed with no cassette in, the mechanism loaded halfway, rewound for about three seconds then stopped. Cause was failure of the LED in the centre of the mechanism. Replace LED (GL453, part no. 871995103).

(7) Lines on playback picture (smeared picture). Heads didn't seem to lock because the PG pulse wasn't locking them. C515 (2.2 $\mu$ F, 10V) on board VS72P was open-circuit. **K.T.K.**

## Sony V50

We've had two faults recently with this one, as follows:

(1) No E-E colour, no date/time, superimpose intermittent. The cause of the fault was on board RZ1P which was not providing a 5V supply for board DS24P. Transistor Q118 was faulty.

(2) The E-E display had pink colouring at the top left-hand corner. Prior to the appearance of the fault the lens had been replaced. Because its earth lead had been laid near the CCD's output pin the signal was being distorted. The cure was to move the earth lead away from the output pin. **K.T.K.**

## Sony CCDF555

This camcorder produced a grainy E-E image. Checks on board VC96P showed that the EVR didn't change the voltage at pin 5 of IC301 (type M62352GP, part no. 875963527). Replacing IC301 cured the fault. **K.T.K.**

## Sony ACV30

(1) This unit produced no output and the LEDs weren't lit. A voltage check at pin 4 of board CT produced a reading of 13.5V. R104 had gone high in value, a replacement curing the fault.

(2) The output was o.k. but no LEDs were lit. There was zero voltage at pin 3 of IC251 which was faulty. Board CH had to be replaced as IC251 is not available separately.

(3) This one failed to charge. The power light was out and the d.c. output was low. We found that the d.c. output socket was faulty. The cabinet top had to be replaced as the socket is not available separately.

(4) The power light was on but the unit failed to charge, its d.c. output being low. PS201 on board MA had gone high-resistance. Replacing PS201 restored normal operation. **K.T.K.**

## Akai PVC40E

This palmcorder produced camera pictures but little else: no mechanical functions operated. The cause of this was damage to part of the mechanism that positions the pinch-roller assembly. We replaced cam T and lever cam T and retimed the mechanism. Then, using the Sony mode box, we found that the original cause of the damage was still present. If the audio/control head stack is set slightly too high the 'assembly stopper - TG' will mess up the loading/unloading sequence. The cure was to set things up as per the manufacturer's instructions. **D.C.W.**

## JVC GR323E

This camcorder produced very poor camera pictures. Playback etc. was fine. The picture was dark and pulled to the right-hand side of the display, with colour smearing. We found that the picture signals leaving the SSG PCB were

incorrect. Dry-joints around IC3 were suspected, but none could be found. During their path from source to further processing stages the signals pass through intermediate PCB layers: once again, application of hot-air rework methods in the IC3 area cured the problem. **D.C.W.**

## Philips 22AV5150 Adaptor

This adaptor failed to charge: the 2A, 115°C thermal fuse TF2 had failed and switch SW2 was faulty. **D.C.W.**

## JVC GRS505E

The rather unusual symptom with this S-VHS model was that the viewfinder picture became blurred, with a noticeable lack of width, after a period of use. Monitor pictures remained normal however, with no noticeable degradation. The fault condition would be followed by shut-down to power off. A 9.6V battery powers this model.

When we tried the camcorder out with a variable power supply we found that the voltage could be reduced to about 8V, at which point shut-down occurred. We also noticed that there was no battery-low indication on either the rear LCD operation display or the viewfinder when the fault occurred. The cause of all this turned out to be something quite simple. Pin 5 of the mechacon microcontroller chip IC301 is used to monitor the battery voltage, the feed being from a potential divider network across the supply. R325, a 68kΩ chip resistor in this network, was open-circuit - neither damaged nor dry-jointed. **D.C.W.**

## Philips VKR6847

This camcorder is based on the Panasonic NVG1. The fault we had was no record or playback sound, though E-E was o.k. R4001 turned out to be open-circuit. **D.C.W.**

## Sony CCDF355

Playback was o.k. but there was no camera picture nor were graphics available. The cause was that the trigger/standby PCB RC04 was broken. We often find that this assembly has been damaged because of excessive pressure on the trigger button. **D.C.W.**

## Sanyo VMD90P

The E-E and playback colour were o.k. but there was no record colour. We found that L1361, a low-pass filter in the record chroma path via Q1361 to the head amplifier chip, was open-circuit. A replacement fixed it good and proper! This little machine is around with other brand badges on it. **D.C.W.**

## JVC GR323E

Problems with the dew sensor seem to be the flavour of the month with this and similar models at present. If a replacement sensor fails to provide a cure, check the plug/socket connection to the main PCB. **D.C.W.**

# VCR Clinic

*Reports from Philip Blundell, AMIEE, Eugene Trundle, John Edwards, Richard Newman, Mike Leach, Michael Dranfield, Dave Mackrill and Keith Evans*

## Toshiba V110B

If the machine won't take in a cassette (no capstan rotation) check whether transistor TT68, type BC557, is open-circuit. **P.B.**

## JVC HRD640

If the machine is dead with 'Set Clock \*' in the display the child lock is set. To clear it use the remote control handset to send a power-on command – the customer did send you the remote control unit, didn't he? **P.B.**

## Sharp VCH84

This is a newish machine that boasts a single-chip (TB1204F) Nicam decoder. Unfortunately for most of the time the output from the right-hand channel was lost in a sea of crackle and hiss. Resoldering a bad joint at pin 24 of the TB1204F wonder-chip IC1701 restored good sound. **E.T.**

## Mitsubishi HSB31/41

This machine would be brought into the workshop about once a month with its mechanism jammed in the fully-laced position. One touch was sufficient to release it, after which the machine would be o.k. for another month. The mode switch can cause this but had already been replaced. Cleaning, degreasing and then lightly lubricating the loading mechanics, including the half-loading arm pivot, joint gear, main cam and the vertical shafts that carry the pinch roller and pinch roller spiral cam, provided a permanent cure. **E.T.**

## JVC HRD830

This was a strange and unusual fault! The capstan motor would rattle and roar in the play mode, the playback picture showing that there was no capstan phase lock (noise bars cycled over the picture at a rate of about three a second). If the CTL pulses were removed – by playing a blank tape, lifting the tape from the ACE head or shorting out the CTL head winding – the motor would settle down. After a long search we found that C405 in the servo circuit was leaky – it read about 800Ω. **E.T.**

## Akai VS22

The design of the power supply section of this machine is not of the best. As they age, we are getting lots of these VCRs in for repair with symptoms that range from ripple, hum and interference on the picture to intermittent and 'weary' deck operation or complete loss of functions. Akai can supply a reasonably-priced replacement PSU board, part no. 99002209, but I find it less trouble to replace all the electrolytics on the board. There are lots of them, but they are small, inexpensive ones. No machines have bounced after this treatment. **E.T.**

## Hitachi VT520

Printed flexible ribbons are used to link the tape-end sensors to the main PCB in this model. A common cause of prob-

lems, mainly concerning the end sensors, is poor contact with the edge connector at one end or other of a ribbon. The usual symptom is failure to accept a cassette or retraction of the cassette after ejection; or alternatively deck shutdown a few seconds after entering the forward mode. The cure is to clean the connectors and ribbon ends.

We are now starting to find worn audio/control heads in these machines. The first indication of this is loss of capstan servo lock with a machine's own recordings. **E.T.**

## Philips VR6470

There was no i.f. output from the tuner. Checks showed that the tuner and SAB3036 CITAC chip supply voltages were o.k. but the tuning voltage remained at zero. 33V was present at pin 9 of the CITAC chip but there was no output at pin 8. As the I2C bus lines were o.k. we changed the chip. That did the trick, and the tuning points were still stored in the memory – all four channels were available straight away. **E.T.**

## Amstrad VCR6000

If the complaint is that the machine keeps changing from SP to LP at random, replace the 14DN363 chip IC402. It's the control pulse amplifier. If the customer complains that the sound is also poor, suspect the audio/control head. Mind you, it could be both! **J.E.**

## Panasonic NVJ35/G Deck

This G deck machine came in with a jammed mechanism. Thanks to Nick Beer's excellent article on the deck (May 1991) I now rebuild them with confidence. It's important to check the rack assembly on the right-hand cassette housing side. With the arm in the down (horizontal) position, the arrow on the nylon gear should line up with the one on the rack. If it's out by just one tooth you can get nasty crunching noises when ejecting the cassette because the switch on the side piece is in the wrong position and the capstan motor isn't switched off in time. As a result it tries to force the housing beyond its stop, crunching the gears. This occurs with any machine that uses the G deck.

With this particular machine the rack was two teeth out. This is the reason why a complete rebuild was required. The right-hand side piece is also prone to damage: it's available as a complete assembly. **R.N.**

## Philips VR6542

This Sharp based machine was in permanent rewind. After checking the light sensors I removed the cam assembly to get at the mode switch and found that it had fallen apart. When a new mode switch had been fitted the machine would wind and rewind but wouldn't play as the capstan refused to turn in this mode. I made various checks and was beginning to suspect the system control chip IC801, though I've never known one of these to fail.

There were some peculiar voltages around pins 25-28 – they were varying slightly up and down. A look at the print



side of the board showed that these pins are covered with a piece of sticky foam that's used to isolate a couple of capacitors from the PCB. I decided to remove the foam to check whether the chip's pins were dry-jointed. They weren't, but when I checked the voltages at pins 25-28 they were now correct. Not only that, but the machine now worked. I looked at the piece of foam and checked it with a meter: it had a resistance of a few k $\Omega$ !

There was another fault with the machine: the counter didn't work (though pulses were present) and it wouldn't change channels. The cause? You've guessed it! A similar piece of foam fitted to the back of the front control panel. Once this had been removed the machine worked perfectly. **R.N.**

### **Samsung SI1260**

This machine could be switched on and produced normal displays. It wouldn't respond to any key operation or accept a tape however. IC206 has given trouble in these machines, so voltage checks were made here. A low supply voltage led us back to D212 (1N4001) which was open-circuit. Normal operation was restored after fitting a replacement. **R.N.**

### **Saisho VR905S**

This ageing machine produced very poor E-E and recorded pictures. It gave the impression that there was an a.g.c. fault somewhere in the i.f. strip. This turned out to be the case: when heat was applied to C10 (0.47 $\mu$ F, 50V) on the i.f. panel the E-E and record pictures were o.k. All was well after fitting a replacement capacitor. **M.L.**

### **Philips VR6460**

The display lit but there was no other operation. If the machine was powered up it would immediately shut down. There was also no capstan motor shuffle when the mains voltage was applied. As a tape couldn't be inserted, I started by making some cold checks in the power supply. Basically the 12V supply was missing, or rather it was being dragged down to approximately 1.2V, because of a short on the audio board. The cause turned out to be C2024 (330 $\mu$ F, 16V) which was very leaky. Replacement of this item cured the power supply problem and restored normal operation. **M.L.**

### **Hitachi VTM830E**

The customer's complaint was of not being able to get a tape out and poor pictures. As an aside, why is it that when a customer complains about failure to eject tapes there's hardly ever a cassette inside the machine? I think we all know the answer to that one! Anyway, back to the fault. The loading was very slow, and when the cassette had reached its down position in the carriage the machine immediately started a slow rewind. We connected it to a monitor and found that a very bad hum bar was present in all modes. The cause was traced to C857 (4,700 $\mu$ F, 25V) on the power supply panel. It had become very leaky. A replacement restored normal eject operation without having to dig the cassette out with a screwdriver or whatever else it is that customers use! **M.L.**

### **Ferguson FV43H**

There was intermittent loss of the signals from the tuner, leaving only snow. As fitting a replacement tuner (very expensive) failed to provide a cure further investigation was carried

out. This showed that during the fault condition the 5V supply to the tuner's internal prescaler dropped to 2.5V. No single component in the 5V regulator circuit seemed to be responsible for this, so to be on the safe side we replaced the lot – Q2, R7, D4, C16, D3 and C15. This cured the fault. **M.Dr.**

### **Toshiba V110**

This machine was dead with no 12V standby supply. We found that resistor RP14 in the power supply was hot: well it would be with a dead short across the 12V rail. The cause was the 15V zener diode DP011, which is connected across the 12V line to provide protection in the event of TP03 going short-circuit. A check showed that TP03 was all right, and a long soak test brought no other possible cause of DP011's failure to light. **M.Dr.**

### **Ferguson 3V29/30/JVC HR7200/7300**

One of these machines intermittently refused to load. All the usual things – the load switches, sliding plate under the supply reel and of course the loading motor and belt – were checked and it was only when, in desperation, I was about to replace the complete loading block that I noticed several broken strands on one of the motor leads. Presumably it had become fatigued over the years, during successive belt changes, reducing the motor current.

I find that with these machines it pays to remove and inspect, with a magnifying glass, the mechacon panel: you will usually find several ringed and crystallised joints. Resoldering these will prevent a number of confusing, intermittent fault symptoms. **D.M.**

### **Sharp VC750HM**

Our friend Malcolm reported that the playback picture would sometimes disappear, leaving a fuzzy display. He said that initially the picture would return to normal when he tapped the top, front left-hand side of the machine. More recently he'd found it necessary to place a house brick on the right-hand side of the metal case, with a 3lb club hammer on top of that! As this no longer restored normal operation and no amount of banging, thumping or leaning on the case would do the trick he decided that it was perhaps time to seek professional assistance.

When I checked the machine with a test tape it worked normally for some time. Then, during an assault on the right-hand corner of the case, the display suddenly disappeared behind a sheet of noise. I whipped off the top and tapped the f.m. preamplifier can at the rear of the lower drum assembly. As this brought the picture back I removed the module and found that all the connections to plug ZA, which fits on to the lower drum, were fatigued. The soldered joints had fractured, leaving a ring between the pins and the print. After resoldering these and the connections, which appeared to be almost as bad, to plug XA none of Malcolm's efforts would bring the fault back. He departed happily with the poor old machine tucked under his arm. **D.M.**

### **Sony EVA300**

We don't see many of these very nicely engineered Video 8 machines so there was some headscratching when this one appeared with an inoperative cassette compartment door. On a hunch, and without the aid of a service manual, we checked a couple of the more obvious circuit protectors (PS101 and PS102) mounted at the rear of the top PCB. The N5 value protector was open-circuit. **K.E.**

## Panasonic NVFV1

When powered up this laptop model would just spool and switch off. It's basically an NVM10 in a different box, with a 5in. LCD screen tacked on top. This led us to conclude that the M54543AL loading motor drive chip IC6005 was faulty. When a replacement was obtained and fitted the mechanism shuffled, the laptop stayed on and all things were bright and beautiful. **B.S.**

## Sony TR75

This model is very similar to the TR45 and TR55 and is subject to similar faults. The following faults are additional to those listed on Model TR55 (see *Television* March 1994).

**No E-E colour, playback o.k.:** Replace IC201 on board VS72.

**No playback, head rotating in reverse direction – all fuses may be blown:** Replace d.c.-d.c. converter and fuses.

**No playback or record colour:** Signal o.k. at IC203 on board VS67, no voltage at pin 14 of IC204 (colour killer). Caused by faulty capacitor(s) – C352/3/4 – usually only one. Replace capacitors one at a time to find faulty one(s). **K.T.K.**

## Mitsubishi HSC35B

The report with this S-VHS machine said "dead with no functions". The customer thought that it may have been connected to an "unsuitable power source"! Investigation showed that there had been a severe overload in the power supply, with IC902, Q904/5, Z800 etc. the worse for wear. Fortunately the power supply is not the usual unrepairable d.c.-d.c. converter. Also at the time of the repair Mitsubishi had available a replacement power supply at little more than the cost of the chip! One was obtained, fitted and set up as per the note that comes with the assembly. One other item had to be replaced, the CCP2E-25 circuit protector on the main VTR PCB. No other fault was evident, the power supply having taken the brunt of the overload. **D.C.W.**

## Sanyo VMD6P

There were no functions and a tape was jammed in the mechanism. It's common for one or more of the loading drive gears to loose a tooth. Usually a replacement gear is all that's required. It's a straightforward job as gear failure doesn't upset the timing of the mechanism. **D.C.W.**

## Fujix P600AF/Sony CCDV50

Playback was o.k. but there was no camera picture. The cause of the fault was the camera d.c.-d.c. converter being inoperative and fuselink PS901 open-circuit. **D.C.W.**

## Panasonic NVMS90

When play or record was selected there was a 'wobbling' picture accompanied by a 'screeching' noise from within.

Thoughts of capstan motor failure (a flaking rotor) came to mind but the cure was much simpler. The cassette lid safety lever assembly had been fitted incorrectly and was fouling the top edge of the upper drum. Fortunately the drum hadn't been damaged, a quick refit of the offending part saving the day. **D.C.W.**

## Canon E110E

Everything worked apart from the fact that the viewfinder picture disappeared almost before it arrived! Checks in the relevant circuitry proved inconclusive, though the problem was persistent. A new tube cured it. Just what was going on inside the old tube remains a mystery. **D.C.W.**

## Sony CCDV50E

This middle-aged machine had lost its ability to record sound from the microphone or provide E-E sound. Playback audio was fine. The UPC4522 chip IC451 on the microphone amplifier PCB was faulty. A straightforward repair: the worst bit was getting to the PCB! **D.C.W.**

## Hi-8 Tapes

The reported symptoms with a Sony CCDTR705E Hi-8 palmcorder were "intermittent 'screeching' noises from the mechanism and 'wobble' on the playback picture". We've noticed these symptoms on several occasions with certain brands of Hi-8 tapes. Only ME tapes produce this effect, MP tapes performing correctly in both the Hi-8 and the 8 mode. The fact that the machine was a Sony model was not relevant to the condition. **D.C.W.**

## Panasonic NVM10

Complete failure of these full-sized VHS machines to operate is often caused by a loading drive problem. Not this time! The main 2A fuse was open-circuit, indicating that a heavy overload had occurred. Indeed a near short-circuit could be measured across the main 12V line. The only thing for it was an unplugging session to try to establish the location of the fault. Eventually (it's always the last one you try, isn't it?) we arrived at the hi-fi audio PCB, where C4542, a 68µF, 16V electrolytic, had leaked. As a result there had been arcing between its pins. After removing the faulty item and cleaning the electrolyte from the PCB we had to carry out a little surgery to save the slightly charred board. A replacement capacitor and fuse (VSF6059) completed the repair, restoring the machine to its former glory. **D.C.W.**

## Sony CCDTR705E

The viewfinder picture was intermittent because the cable was damaged. Abrasion had been caused by the bracket assembly that swivels as the viewfinder is moved. A new cable and removal of a burr at the edge of the bracket put matters right. It might be worth checking this when one of these models comes in for service. **D.C.W.**

# VCR Clinic

**Reports from Eugene Trundle,  
Colin McCormick, Ian Rees, Della Verita,  
Gerald Smith, Keith Evans,  
Graham Richards, Ronnie Boag  
and David Belmont**

## JVC HRD560

Fast forward and rewind were painfully slow – an E180 tape took over thirty minutes! Throughout this time the tape remained fully laced with the drum rotating. The cause of the fault was failure of the supply reel spool rotation sensing optocoupler, circuit reference PS2. In addition it's a good idea to change the slider mode switch and ensure that the new type of main cam is fitted – this can be identified by its black colour. **E.T.**

## Hitachi VT520

We've recently had three of these VCRs in which the capstan motor would stop momentarily every few seconds when the machine had been in operation for between thirty minutes and an hour. In each case the motor-mounted coil-drive chip was too hot to touch and a new capstan motor had to be fitted. **E.T.**

## Sanyo VHR4350

Unreliable cassette front loading has been the trouble with several of these VCRs we've had in. With an afflicted machine there's an even chance that a proffered tape will be drawn in then spat out again. The usual cause is simple: loss of tension in the two finger springs that hold the cassette firmly in the front-loading cradle. **E.T.**

## Tatung VR8530

About every third time this Akai-based machine was asked to play or record it would lace up then shut down, with the head drum trembling and throbbing on the spot instead of rotating. There were very strange waveforms at pins 8 and 9 of the on-board drive chip (type BA6413) at all times, and even when it did get started the drum motor took a long time to run up to speed. The chip may or may not have been faulty. Since it's not listed separately as a spare a new stator assembly, including the coils, chip, Hall sensors, etc., had to be obtained and fitted. **E.T.**

## Saisho VR1100

Intermittent E-E audio was the problem with this very tatty example of the VR1100. When I connected an external audio input I found that the machine switched the audio source to external while leaving the tuner as the video source. In the camera position the tuner-camera switch provides a high output to the audio switching chip: in the tuner position it provides a high output to the video circuitry. It was actually supplying a drifting voltage to the audio circuit as a result of liquid spillage on the front PCB. **C.McC.**

## Sony SLC20

This smart Beta machine intermittently destroyed the tape when ejecting a cassette. A chattering noise accompanied this. Once a tape has been loaded, the machine stays laced: so it was clear that when the fault occurred unlacing was not being completed before cassette ejection. The first suspect for this sort of thing is, with many machines, the reel idler.

But as the reel idler in the SLC20 is of the gear type, the friction to swing it from side to side being provided by internal magnets, I did not initially suspect it. Repeated operation of the mechanism however showed that very occasionally the idler failed to meet the supply spool for rewind during the unlance operation. Presumably the magnets had become weak – a new reel idler cured the fault. As the one supplied was different from the original, I added a spacer on the shaft so that it wouldn't collide with other deck parts. Strangely, Sony call the reel idler an 'arm block assembly pendulum'! **C.McC.**

## Ferguson FV31R

For no or unstable playback check whether the insulating washer beneath the head of the screw that secures the top PCB is missing. If it is, tracks short-circuit to chassis. **I.R.**

## JVC HRD700EK

If one of these machines comes in dead, check whether R1 (10Ω fusible) beneath the mains transformer is open-circuit. **I.R.**

## Ferguson FV32L

There was irregular jumping between the LP and SP modes and finally the machine creased a tape. It had already received attention from someone who had resoldered several connections on the servo PCB. After a bit more resoldering around the capstan chips the machine seemed to work all right. But after an hour I gave the board a push and the fault returned. This time I was able to localise the source of the fault to the area around the LM393 capstan speed comparator chip IT45. Checks here showed that there was a jumping voltage at pin 2. When a spotlight was trained on the area I found a very small crack in the print between pin 2 of IT45 and CT48 (1μF). Repairing this finally cleared the fault. So you not only have to look out for soldering problems with this range of VCRs but also keep a watch out for cracked tracks. **D.V.**

## Samsung SI3240

There was no clock display though the machine worked correctly in every other respect. Checks showed that the 3-4V a.c. supply across the end pins of the fluorescent display was missing. The cause of this was defective pads (10 and 11) at the mains transformer. Hardwiring these connections cured the fault. **G.S.**

## Mitsubishi HS347

Intermittent failure to make a timer recording was the complaint with this machine. We found that this would happen when the tape was at the beginning after a rewind: after full-speed rewind the tape leader was left showing and the low-speed forward take-up didn't take the tape back in. Thus when the timer recording started the tape leader showed at the take-up end sensor and the unit stopped.

Although the take-up torque and the fast forward/rewind torque were o.k. the low-speed take-up torque was very low. A new reel idler cured the problem. **G.S.**

### **Toshiba V611**

This machine was dead (no functions). Replacing the 400mA fuse F801 and resoldering dry-joints around Q821 got it going again. **G.S.**

### **GoldStar GHV1296I**

The complaint with this machine was that it damaged tapes. As the capstan was inoperative there was no play, fast forward or rewind. Checks showed that the regulated 12V supply was low at around 6V. The DTC124ES transistor Q103, which is part of the power control arrangement, turned out to be faulty, a replacement restoring normal operation. **G.S.**

### **Grundig VS440**

This machine had lost its ability to tune in stations. A defective tuner was the first thought that occurred to us, but a closer study of the circuit diagram revealed a cheaper possibility – the SDA3202-3 PLL chip. It's housed within the tuner assembly, and is fairly easy to replace. After doing this normal operation was restored. **K.E.**

### **Hinari VXL8**

Although this machine was several years old it had hardly been used. The complaint was that the playback speed was faster than the search mode – in fact selecting fast search slowed the capstan down. There was obviously something wrong in the servo department. Several chips can influence the capstan speed, but voltage checks in this area were inconclusive in relation to the figures given in the manual. The Gods must have been smiling at us on that day however as an identical Orion machine came in for service. After making some comparison voltage checks with both machines in the playback mode we replaced the digital servo chip IC102. All was then well. **K.E.**

### **Akai VS422/VS425**

If one of these machines won't accept a cassette or there's a cassette jammed in the mechanism, check the condition of the 'arm damper' assembly. When its spring retainer spigot breaks off you get jamming etc. The part number is ML-391745J1 – it's on the left-hand side of the cassette housing. **G.R.**

### **Samsung SI3260**

The tuning had disappeared. When search tuning was tried it took a long time to search and when a signal was found it was very unstable with what looked like hum bars across the picture. In addition the tuning drifted. A check on the 30V tuning supply produced a reading of only 16V. The 30V regulator is fed from a 40V rail via R108 (1k $\Omega$ ) and was zenering at 16V! A new 30V regulator put matters right – we replaced R108 as well as it had become discoloured. **G.R.**

### **Sony SLF30**

There was fast, erratic tape movement and no E-E video or sound. After some time checking around we found that the

800mA fuse PS001 on the bottom video board was open-circuit. No shorts were present and the fault occurred when the customer was removing a jammed cassette.

If one of these machines doesn't switch on, check the alignment of the cassette housing – where the switch is situated. **G.R.**

### **Toshiba V109**

A laced-up tape was jammed in this machine. Checks showed that the on/off 9V supply was missing. The repair consisted of replacing IC811 in the power supply and, as a precaution, the mode switch. **R.B.**

### **JVC HRD830**

There were no timer recordings with this machine. It went through the motions then, after loading up, ejected the cassette. Manual recording was o.k. A replacement record inhibit switch cured the fault. **R.B.**

### **GoldStar GHV1296I**

There were erratic functions with < > showing in the display. A replacement mode switch restored normal operation. **R.B.**

### **Panasonic NV333**

There was a snowy r.f.-r.f. signal, no E-E output and no reception. The cause of all this turned out to be a dry-joint at pin 1 of plug P7003 on the TV demodulator PCB. **R.B.**

### **Amstrad VCR4600**

When a deck function was selected the mechanism started to operate then shut down. This happened whichever function was selected. A clue was that the clock would also reset. Whenever a function was selected the 5V supply went low. Replacing the bridge rectifier and the fuse to the 5V supply cured the fault. **D.B.**

### **Sony SLV425**

This machine failed to record sound. The cause was the bias oscillator, which in these machines is separate from the erase oscillator. CY1255 (47 $\mu$ F, 63V) was open-circuit. **D.B.**

### **Aiwa VXT1010**

Very intermittently this machine would shut down while playing a tape. Lack of the drum flip-flop pulses was the cause. The drum produced a good pulse output, the culprit being IC2001. **D.B.**

### **Hitachi VTM830**

This machine would go into some rather odd modes at random. We found that the microcontroller chip IC751 was dry-jointed. After resoldering all the connections and a long soak test all functions worked correctly. **D.B.**

### **Saisho VR905**

There was intermittent loss of reel drive. For once the reel idler and motor were blameless: Q2101 was going open-circuit intermittently. **D.B.**

# Service Briefs from Toshiba

*Continued from the April issue: further TV items and notes on older and newer Toshiba VCRs*

## TELEVISION

### Model 289T6B

**Brightness flicker at the top of the screen:** Reduce the value of C205 from 0.47 $\mu$ F to 0.027 $\mu$ F.

### Model 1400TBT

**Intermittent field collapse (h.t. voltage fluctuates when set is warm):** Replace Q803 (2SC3425) in the power supply. Part no. A6361601.

**Low h.t. voltage or stuck in standby:** Q803 faulty (see above).

### Model 1510RB

**Dead set with buzzing noise:** Replace Q803 (2SC3425), part no. A6361601.

### Model 1721TB

**Set stuck in standby:** Replace transistors Q803 (type 2SC2023, part no. 23314246) and Q804 (2SA1321, part no. A6547303).

### Models 2100RBT/2100TBT

**Set dead, chopper transistor Q802 fails repeatedly at switch on:** R810 (330k $\Omega$ ) is either open-circuit or high in value.

**Hum on chroma (varies with setting of colour control):** Replace C515 (22 $\mu$ F, 50V, part no. 24636220).

### Models 2112DB/2512DB/2812DB

**Power supply trips in any mode:** Replace D807 (BYD33J, part no. 23118479) which is open-circuit.

**Power supply trips in normal operation, o.k. in standby:** Replace the 13V zener diode D812 (part no. 23316337) which is leaky or short-circuit, reducing the voltage at pin 5 of IC801 below the standby threshold.

**Set won't go into standby:** Replace transistor Q845 (2SC2023, part no. 23314246) which is short-circuit.

**Field jitter and picture breathing:** Replace transistor Q833, type S1854, part no. A6907751.

**Loud crack from both speakers when set is turned off (Model 2112DB only):** C639 (100 $\mu$ F, 25V) in the audio mute circuit is open-circuit. Fit a replacement.

### Models 2505DB/2805DB

**Set won't come out of standby:** Replace memory chip

ICA07, part no. 23319016. At power on voltage at pin 37 of the microcontroller chip drops low then reverts to 5V.

### Models 2527DB/2927DB/3327DB

**Set dead, power and timer LEDs flashing, h.t. at 40V and varying:** Replace transistor Q828 (type 2SC2230A-Y, part no. A6325067).

**Set stuck in standby:** Replace circuit protector ZP82 (part no. 23144450) which is open-circuit, removing the supply to pin 40 of IC501 and thus the line drive.

**Crackle on Nicam, f.m. and external audio:** Replace the TA8776N audio processor chip ICG07 on the back terminal PCB. Part no. B0383935).

**No audio from the rear speakers in the DSP, Dolby Surround or pseudo-surround modes:** Replace CG25 (10 $\mu$ F, 16V).

## VCRs

Information on some of the following machines will also be found on pages 52-3 of our November 1993 issue.

### Models V55B/57B

**Intermittent recorded sound:** Check for poor plug/socket contact at the audio-control-erase head assembly.

**Intermittent recorded sound with coloured patterns on the picture:** Check for open-circuit leads at the full erase head. If the bias/erase oscillator doesn't start, increase the value of C27 to 8,200pF.

**Noisy playback – looks like worn heads:** Q504 in the E-E supply is leaky, allowing about 3V to reach the head amplifier chip during playback.

**Distorted verticals/poor sync, changes with E-E picture content:** The i.f. a.g.c. decoupling capacitor C7 (0.047 $\mu$ F) is open-circuit.

**Playback speed slow:** Check whether the voltage at pin 6 of IC401 is low – this won't show with use of a DMM. If so D206 is leaky.

**Drum servo slow to lock:** Drum discriminator adjustment potentiometer R463 is noisy.

**Intermittent stopping in rewind/review:** C1 across the start sensor is short-circuit.

**Intermittent stopping and reverting to rewind in play/fast forward:** C1 across the end sensor is short-circuit.

**Machine dead with no clock display or function lights:** Check whether circuit protector CP2 on the servo/logic PCB is open-circuit.

**Stops intermittently in play or record:** Replace the take-up reel sensor (optocoupler).

## Models V65B/66B

**Machine won't switch on – channel lights only:** If the switched 5V and 12V supplies are low, check D3. Note that when this diode is only slightly leaky the machine will work but the counter runs in stop. If there's no switched 5V supply at pin 6 of CN3, CP4 is open-circuit.

**No standby mode with the take-up spool and capstan running:** If there are no switched 5V and 12V supplies and pin 9 of CN3 (CTL in) is at 3.2V instead of 1.8V, IC602 is faulty.

**Intermittent drum rotation:** Check for a dry-joint at Q1.

**No clock display:** If the –30V supply is missing, fusible resistor R2 in the power supply is open-circuit.

**Half loads then unloads:** D408 leaky.

**Drum doesn't rotate but twitches backwards and forwards:** D408 leaky.

**Intermittently ejects and switches off:** Replace loading mode sensor part no. 70673470.

**Remote control unit doesn't work when near an ordinary light:** Add an extra IR filter. Details available from Toshiba Technical

**No record, o.k. on OTR and remote:** IC101 faulty.

**Intermittent stopping in rewind/review/play/fast forward:** See notes on these faults under Models V55B/V57B.

**Drum runs backwards:** R501 open-circuit and D408 leaky.

**No CTL pulse amplification (TP401):** C405 is open-circuit.

**Plays for three seconds then stops, with counter not working:** Replace the take-up reel sensor.

**Intermittent recorded sound:** See notes under Models V55B/V57B.

## Models V71B/73B

**Earthing screw problem:** Always ensure that an earthing screw is fitted to the reel motor plate to prevent static charge from the reel pulley. This charge can damage the following i.c.s on the logic/servo PCB.

**Servo chip IC501:** Symptoms no servo lock in record (unlocked head switching point) and no playback servo control (varying speed and poor tracking).

**Logic chip IC601:** Symptoms no fast forward or reverse reel rotation because of incorrect logic levels at pins 19 and 20. Note: When replacing a TMP4746N5758 chip with a TMP4746N5759, remove and discard the logic-2 unit fitted to the i.c.

**Loading drive chip IC602:** Symptoms no motor functions, the power supply shuts down after ten seconds and IC602 draws excessive current (the motor +B and switched 12V supplies are over-current sensed).

**Reel switching chip IC603:** Symptoms no reel rotation in any mode. The i.c. may show signs of overheating, and drive transistor Q625 should be checked.

**Reel sensor chip IC604:** Symptoms no fast forward/rewind tape count, returns to the stop mode; no play/record tape count, returns to the stop mode and the power supply shuts down.

**Cam switch faults:** The following very intermittent faults can be caused by a defective cam switch. (1) Fast play operation with pinch roller not engaged (sound is fast). (2) Runs fast in the record mode, hence playback is slow. (3) When review is selected the machine goes to pause. (4) Arms stop in the half-loaded position. The switch is part no. 70901769.

**Reel motor fault:** A defective reel motor can be the cause of intermittent stopping in play or record. In the play mode a new reel motor should take a current of 90mA (350mV across R643). The take-up torque will then be correct.

**Servicing note:** If a machine is operated with the cassette housing removed and not earthed, (1) the auto switch won't work, (2) power on inserts a tape but the power supply then shuts down, (3) power on ejects a tape then reinserts it and the power supply shuts down.

## Models V71B/73B/81B/83B/85B/86B/93B, DV80B/90B

To reduce mechanical noise a new head drum earth brush, part no. 70903022, was introduced.

To overcome reel idler stop post damage, a new stop post assembly, part no. 70901865, was introduced. Fitting instructions are available from Toshiba Technical.

## Models V81B/83B/85B/86B/DV80B

**Intermittent stopping in the play/record modes:** Faulty reel motor – this is more common with Model V83B.

**Intermittent cam switch problems:** A modified cam switch was introduced.

**Low-gain E-E signals in weak reception areas:** Readjust the r.f. a.g.c. control R51.

**Won't accept a cassette and returns to standby after ten seconds with the cassette indicator flashing:** Replace timer chip ICX01.

**Failure of F803:** Cause is probably poor F802 fuseholder contact or a dry-joint at the junction of D801/2/chassis.

**When the machine is switched on tape is immediately loaded around the drum then the machine returns to standby:** Check for dry-joints at the cam switch socket on the main PCB and at the cam switch pull-up resistors.

## Models V93B/DV90B

**No display, no E-E operation (power on/off o.k.):** Circuit

protector ZL62 on the timer-2 PCB is open-circuit. Check the inside of the d.c./d.c. converter Z802 as the small metal cap on the transformer can become unglued and fall off, causing a short-circuit.

**Intermittent stopping in play/record:** Replace the reel motor.

**Patterning with E-E signals and recordings:** Check the adjustment of the r.f. a.g.c. control.

**No cassette insertion, no test signal:** F804 (1-6A) is open-circuit.

### Models V110B/210B

**Picture pulses in the E-E mode:** Replace the 2-4V back-up battery XK03 on the key display PCB (part no. 70010166).

### Model V211B

**Won't accept tapes:** Replace faulty U2561B FG/CTL pulse amplifier chip IT18, part no. 70010166.

### Models V212B/312B/412B

**Failure to erase the previous sound track and slight coloured patterning on recorded pictures:** This is a fairly common condition that may be permanent or intermittent. If the fault is permanent, you might find that RL02 (10 $\Omega$ ) is open-circuit and that transistor TL01 (BC337) is short-circuit. Whether the fault is permanent or intermittent, the following steps should be taken: fit replacement kit part no. 70903796, change the value of RT102 from 56k $\Omega$  to 39k $\Omega$  (part no. 24872393), and improve the connections at the full erase head plug and socket by soldering the wires directly to the terminals at the back of the head.

**No E-E or playback pictures:** Replace the MC14094BD shift register chip IW20, part no. 70010981.

**Slow, jerky tape ejection. Tape reaches front flap, stops then reloads, or may stop during the unloading cycle:** Loading motor has dead spots on its commutator. Test by removing the belt. Motor part no. is 70011062.

**No playback colour, record colour o.k.:** Standby 12V supply is low at 9-6V because the 10V zener diode DP86 is faulty and the 27 $\Omega$  resistor RP86 is open-circuit. Replace these items, part nos. 70010959 (DP86) and 70041074 (RP86).

**No E-E or playback sound and will not stop on station when search tuning:** Audio mute is activated because of no field sync pulses at pin 31 of IA40. Replace the TDA8128 field sync pulse processing chip IA01, part no. 70010967.

**No functions, goes to standby after two minutes:** Replace cam 1 photosensor GT22, part no. 70010960.

**Power supply tripping after half an hour:** Replace the 6-2V zener diode DP08, part no. 70010958.

**Snaps tape in rewind/fast forward, with no counter operation in these modes:** No FG output at pin 15 of the U2565B CTL/FG pulse amplifier chip IT40 in fast forward and rewind. Replace IT40, part no. 70010979.

### Model V300B

**No display, no E-E outputs, playback o.k.:** Circuit protector Z803 is open-circuit. D.C.-d.c. converter Z801 (logic PCB) may be shorted because of high output from IC820 (power 2). If the +6.5V supply is o.k., check whether the small metal cap on the transformer in Z802 has become unglued and fallen off, causing a short (see same symptoms under Models V93B/DV90B).

**Intermittent audio erasure:** The two-wire lead at either the full erase head PCB or the audio-control-erase head PCB has poor plug-socket connections.

### Model V312B

**Picture continually switches between play and E-E in the playback mode:** Cause is corrupt control data from the servo chip IT01 to the shift register chip IW85. Replace IT01, part no. 70011398.

### Model V411B

**Intermittent random switching between SP and LP in the play mode:** Replace the U2561B FG/CTL pulse amplifier chip IT10, part no. 70010166 (PG waveform at pin 11 has superimposed hum).

### Model V703B

**No test signal and no playback:** Replace the ICP-N5 circuit protector ZP681, part no. 23118122. When this goes open-circuit the ever 5V supply is missing at Q688 and Q685.

### Models V703B/813B

**Installation problem with the Amstrad SRD400 satellite receiver:** Under the following conditions it's not possible to make recordings from the receiver: (1) full scart connection using the VCR for loop-through; (2) record mode selected using line input LI; (3) TV/VTR switch is in the VTR position; (4) the sound and picture are being monitored. All you get is black and white lines with no sound. This is because, when pin 8 is enabled, the SRD400's scart socket can be used to connect a decoder: with the TV/VTR switch set to VTR the VCR supplies a +12V control voltage to both scart sockets. The remedy is to disconnect pin 8 of the scart lead between the VCR and the SRD400 or leave the TV/VTR switch in the TV position and, if you want to monitor the recording, do so by using the input select button on the TV handset.

## Panasonic NVFS100

In both the S-VHS and standard VHS modes the playback picture was just a dark, blurred mess. After much chasing of signals around this complex machine attention was focused on the sub-luminance pack, in particular the 1H delay system. Checks showed that the video output waveform at pin 1 of IC3504 was badly distorted. The culprit was eventually found to be C3510, which decouples pin 5 of this chip. It was open-circuit, a new 3.3 $\mu$ F, 25V capacitor curing the problem. **B.S.**

## Panasonic NVL20

The complaint was of intermittent flashing on the E-E pictures. As I was unable to tune in any of the local channels I first checked the tuner's BT supply, which was low. It eventually transpired that C706 (0.01 $\mu$ F) was leaky, compressing the tuning band at one end and probably causing some instability from cold. **B.S.**

## Panasonic NVHD100

This machine's recordings were spoilt by an intermittent twitching, as though there was a 'glitch' on the drum drive. The cause of the fault turned out to be the impedance roller next to the full-erase head. A replacement, part no. VXP1402, restored flicker-free operation. **B.S.**

## Panasonic NVL28

There was no power supply operation, the set being totally dead. Checks on the primary side of the power supply revealed that C1109 (1 $\mu$ F, 400V) was open-circuit. **B.S.**

## Panasonic NVW1E

This standards-conversion machine has only line in and line out facilities. It played back, or would monitor, sound but in any mode the picture was just blank. Some quick scope checks showed that video was almost everywhere it should have been inside the machine. We eventually found that the 2SD601 video buffer transistor Q3908 was faulty. It feeds video to the output jacks. **B.S.**

## Matsui VX1000

The complaint with this machine was of severe sound wow, getting worse towards the middle and end of a tape. We found that the reel brakes weren't being released during playback because the operating lever had come adrift. A broken plastic lug on the main chassis was the cause of this. Unfortunately the only cure is to replace the deck chassis. **D.B.**

## Amstrad UF20

No fast forward or rewind has been the fault with several of these machines, whose design leaves a lot to be desired. If you insert a dummy cassette the reels turn but the torque is low because the clutch is engaged. The culprit is the M lever (part no. 2549601), which is under the cam gear. The

clutch here loses its grip. Replacement restores normal operation. **D.B.**

## Ingersol VR965

This machine wouldn't tune in any off-air signals – the tuning voltage was stuck at 12V. We found that IC6101 had an internal short-circuit, a replacement clearing the problem. **D.B.**

## JVC HRD750

This machine was dead apart from a hissing noise. On investigation we found that there was arcing between the 350V line and the chopper transistor's heatsink. Cutting the track and fitting an insulated wire link as a replacement restored normal operation. **D.B.**

## Ferguson FV21R

When play was selected fuse F2 blew. Another engineer thought that the loading chip was the cause of the fault but the fuse blew only when the loading cycle had been completed. The culprit turned out to be the capstan drive chip. **D.B.**

## Saishi VP3000 Video Player

This machine would turn itself off after varying lengths of time. Replacing both end-of-tape sensors cured the fault. **D.B.**

## Aiwa VXT1000

There was no audio output from this TV-video combination. At switch on the volume is at minimum: we found that the volume-up button was dry-jointed, resoldering this restoring the sound. **D.B.**

## Hitachi VTM598

There was no servo lock with this multistandard machine. After replacing IC601 and setting up the tape path the results obtained were excellent. **D.B.**

## Sony SLV425

The reported fault was that the playback picture was poor and reverted intermittently to a blue screen. There's a Sony technical tip for a similar fault, to replace the EPROM ICY270 (part no. G79801093), but doing this made no difference. Good job the machine was under guarantee – the chip costs around £30 trade.

The usual reason for reversion to a blue screen is a noisy signal. So we checked the video playback output at pin 7 of CIC2160. It was a good, clean signal. From here the signal is passed to CIC2520, which provides signal delay and is part of the dropout compensation circuit. The input at pin 6 was o.k., but there was a severely distorted output at pin 4: it should have been delayed video but looked more like high-amplitude (4V peak-to-peak) digital



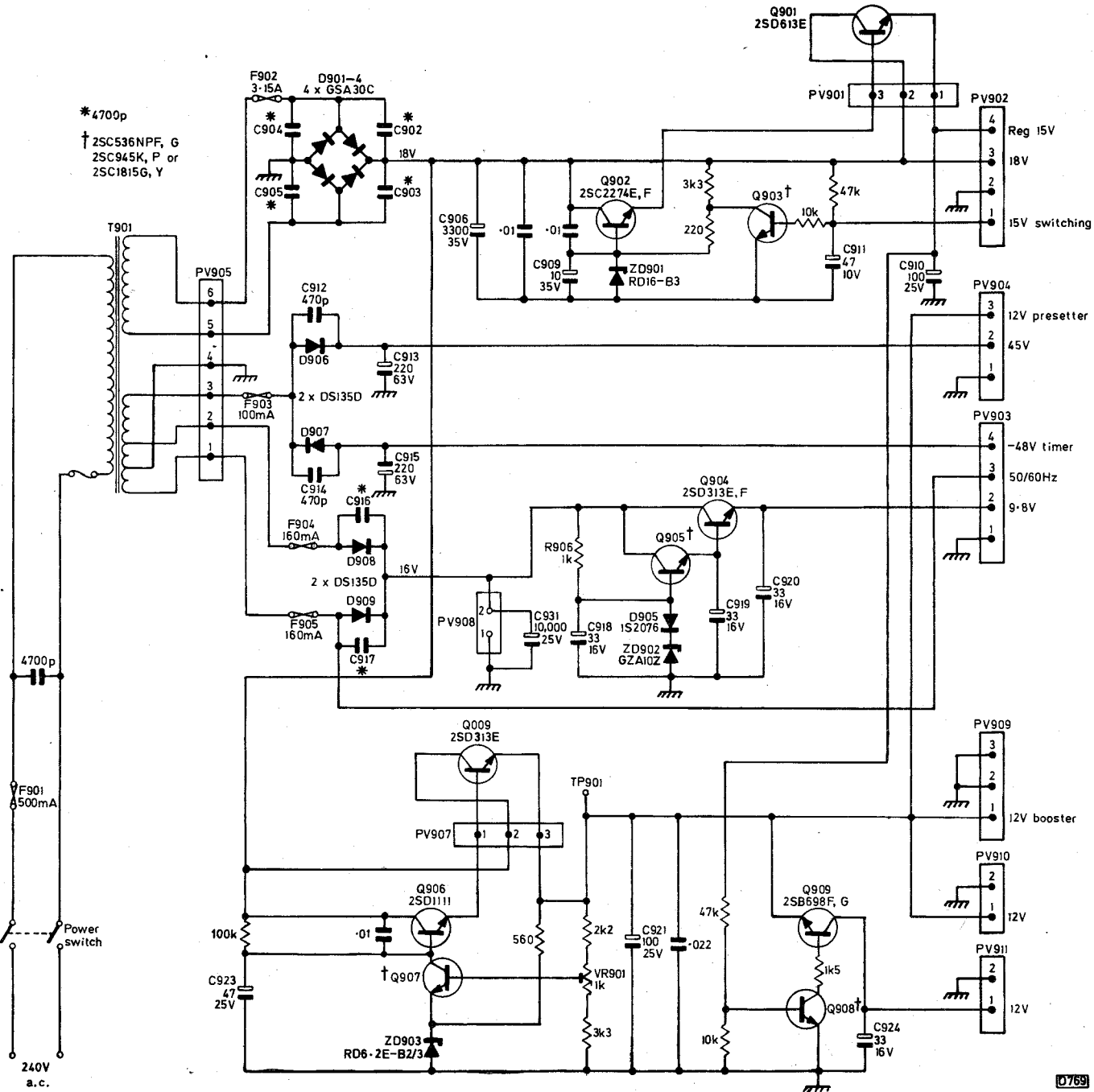

Fig. 1: Basic power supply circuit in the Fisher VVH-P520 VCR. There are additional regulators on other panels.

The picture and sound being out of sync means that the tape path between the video and the audio/control heads is incorrect. Check for mechanical faults such as a bent loading arm.

For no colour check the d.c. conditions around the HA11741 chip IC203. If incorrect voltages are found check IC203 by replacement. If the fault persists, check for dry-joints or cracks on the PCB. Crystal X202 can also be responsible for this fault.

**No Tape Action**

For no tape action first check whether the cassette has completely unloaded when eject is pressed. If it has, check that the mechanism is functioning correctly. If the cassette has not unloaded completely, check that pin 6 of the microcomputer chip IC501 (HD44801A19) is low. If not, check whether pins 24 (forward end sense), 32 (cassette

holder) and 33 (dew) are high. If any of these are high, check the end sensor, the stage switch (WH203) and the dew sensor respectively. If these pins are not in the high state replace the chip.

If the fault persists with pin 6 of IC501 low, check for 9V at pin 3 of plug/socket PV522. If this voltage is missing, check at pin 1. If the voltage here is less than 15V, check Q901 in the power supply and its associated components as necessary. Should the voltage be higher than 15V, check ZD501 (GZA6.2), ZD502 (GZA10) and Q893 (2SD313) in the motor supply circuitry.

If the voltage at pin 3 of PV522 is correct, check that pin 3 of plug/socket PV881 is in the low state. If this is correct, check at pin 1 for a high state. If this is also correct, check the condition of the loading belt and for a faulty loading motor. If pin 1 is not in the high state, check for a fault in the system control drive circuitry – items to check are Q868 (2SD612), IC863 (003) and IC864 (004).

## Panasonic NV-G40

The fault note read "noise like a machine gun". Sure enough the deck solenoid was firing continually. Quick checks in the power supply showed that the Reg. 12V, Reg. 6V, Reg. 5V and power-off lines were all pulsing. I was about to look at the system control chip when I noticed from the i.c. block diagram that the Reg. 6V supply isn't controlled by the power-off line. A new STK5340 chip was required. **P.B.**

## Grundig VS540

For a dead machine with no output from the power supply, check whether C420 is open-circuit. **P.B.**

## Panasonic NV730

I've had a few of these machines with the following complaints: intermittent fast forward or rewind, intermittent tape damage when ejecting a cassette, intermittent play, etc. In all cases the cause was ageing of the solder connections to Q1504. This power transistor is mounted on the right-hand heatsink: it gets rather hot, the result being dry-joints on all three legs. Removing the old solder then resoldering with high melting-point solder restores reliable supplies to the reel motor. **B.S.**

## Panasonic NV370/NV830

A problem with these now rather elderly machines is intermittent lapsing into the dew mode – even when the dew sensor is disabled. Panasonic used to recommend fitting a 560Ω resistor in series with an 0.01μF capacitor between pin 22 of IC6001 and chassis. By decoupling the power on/off line from the operate switch on the front panel this modification prevents the syscon microcomputer chip from misoperation, avoiding "chatter". Because of the age of the machines the only cure now is to replace the switch – part no. VSP0145. **B.S.**

## Alba VCR6000X

This machine would accept a cassette but after that there were no further functions, including eject. The cause of the trouble was the DMB5208VT chip IC701 on the front panel. **E.R.**

## Matsui VX755/Saisho VR3600

The complaint with this machine was that it wouldn't play tapes and left a loop of tape inside when the cassette was ejected. We removed the cover and inserted a cassette. When play was selected the machine laced up but there was neither drum nor capstan rotation. Thus after a couple of seconds the machine unlaced, without taking the tape back into the cassette. The cause of the trouble was the OEC9005 chip IC2001: fitting a replacement restored normal operation. **E.R.**

## GEC 4006/05

This machine, which is a Marantz clone, operated all right in the rewind and fast forward modes. When play

was selected however it laced up then immediately unlaced, ejected the cassette and switched off. The cause was no capstan rotation. Quite a bit of time was spent checking the capstan motor and its supply voltages before we discovered that the pinch roller had seized on its mounting – it was so tight that it had to be prised free. A clean up and a new pinch roller restored normal operation. **E.R.**

## Akai VS1

The complaint with this machine was that playback and E-E were o.k. but it wouldn't record. On test all modes worked fine except when record was selected. The machine's record indicator then blinked on and off a few times after which the cassette was ejected. The anti-record safety leaf switch mounted on the carriage turned out to be the culprit. Its plastic mounting hooks had broken and were hanging loose. Part no. 11906SW from Chas Hyde Ltd. **J.E.**

## Sanyo VHR2300

Replace the STK5482 regulator chip if the symptoms are as follows: no E-E picture or sound; accepts a tape; fast forward and rewind are very slow; shuts off when play is selected. **J.E.**

## Sanyo VHR3100

The complaints were of no sound in the E-E mode and failure to record sound. The picture was fine and playback of prerecorded tapes was normal. My first thoughts were of a fault in the tuner/i.f. area, but a glance at the rear of the machine revealed all: the external link that couples the tuner audio out to audio in was missing. A temporary wire link produced good sound in all modes. When our field engineer returned the machine he found the link under the base of the TV/video stand. It took him a while to live that one down. **J.E.**

## Orion VH200 and Clones

When the machine was switched on the record light stayed on permanently and there were no deck functions. If you get this situation, check that the regulated 12V supply is present before delving into the syscon department. It's derived from the STK5326 chip which you will probably have to replace. The record light stays on even when the syscon chip is removed! **S.DaC.**

## Panasonic NV-G20/NV-G21

There are only minor differences in the power supply circuitry used in these two models. We've had the following faults:

- (1) No power. Usually the fuse is blown and blackened. The mains rectifier fails and the STR11006 chip usually reads short-circuit between pins 2, 3 and 5. At times Q1011 goes short-circuit collector-to-emitter. L1001 sometimes melts.
- (2) No power with the fuse o.k. The STR11006 chip is short-circuit between pins 2 and 4.

(3) Intermittent power failure. Check for dry-joints at pins 1, 2 and 3 on the sub-power PCB.

(4) Machine dead but all supplies are present except at pins 3, 4 and 5 of P1001. The voltages at these pins are restored when they are isolated, but when the connector is fitted they fall to zero. The STK5338 chip is faulty.

(5) The r.f. booster doesn't work. Q1004 is open-circuit and D1012 is short-circuit. **S.DaC.**

### **Panasonic NV-G12**

The picture was o.k. with some tapes but on others there were tracking lines. No amount of tracking control adjustment would cure this. We found that playback of the machine's own recordings was perfect, and that these were o.k. with other machines. Someone had a go and tried almost everything – head cleaning, drum assembly, guides etc. After much resetting and realignment the fault was still present. Fortunately another one of these machines then turned up. It had a broken display although it worked well. We decided to sort this out by swapping over the timer panels. The first machine then worked perfectly with all tapes. So it was the timer panel! In fact the (–) tracking control was permanently shorted and as a result the tracking was set at its most negative end. **S.DaC.**

### **Ferguson 3V24/JVC HR2200**

The complaint with this portable was that it wouldn't load a tape. On test we found that the capstan ran all the time while the operation switch didn't work. After much searching we discovered that the 2SC1881 10V regulator transistor on the mechanism panel had gone open-circuit. **M.D.**

### **Salora SV8600/Mitsubishi HS337**

The complaint with this machine was that it would shut down intermittently or sometimes fail to power up from cold. After some searching we found that in the fault condition the switched 5V supply was missing. We traced the cause to the regulator transistor Q9A2 which was dry-jointed on all three legs. **M.D.**

### **Sharp VC-A140**

The customer complained that this machine creased the bottom edge of the tape. We suspected the pinch roller, but the pinch roller arm turned out to be the cause of the problem. **M.D.**

### **Hinari VXL5**

There was no E-E or playback audio. A scope check at pin 9 of the i.f. module showed that the audio signal was present here and wasn't being muted by Q301. Audio was present at two of the pins of IC309, an electronic switch, so this device was ruled out – it's a one-pole, two-way switch, though the manual doesn't say so. The audio signal was then traced to the servo board. It was present at pin 13 of the LA7096 audio chip IC103 but there was no output at pin 18. We got low-level E-E audio by connecting a 47 $\mu$ F electrolytic capacitor between pins 13 and 18 of this chip, thus ruling out anything that followed it. A new chip failed to cure the fault (Sod's Law), so further checks had to be made on the components around it. The 12V supply was present at pin 27, but there was no voltage at pin 3. A small 47 $\mu$ F decoupling electrolytic capacitor between this pin

and chassis was short-circuit. Fitting a replacement cured the fault.

This is not the first time we've had capacitor troubles with this particular model. A fault we've had many times is that the machine loads then immediately unthreads. This is caused by loss of the drum PG pulses. In every case we've found that C145 (100 $\mu$ F 10V) in the PG amplifier circuit had gone short-circuit. **M.Dr.**

### **Saisho VR605/VR1000, Matsui VX500/VX800**

To overcome slight loss of torque when unloading, possibly due to a worn reel motor, change zener diode D27 (D2027 in the VR1000/VX800) from a 7.5V to a 10V type. **M.Dr.**

### **Philips VR6870**

There was a loud buzzing noise in the power supply when this machine was plugged in. The clock display segments lit at random and flashed on/off. Another dealer mentioned to us that he'd had a similar problem which was caused by a faulty capacitor. We removed a small subpanel from the power supply can and used a digital capacitance meter to test the three electrolytic capacitors on it – C7, C11 and C27. All were very low in value. After fitting replacements the machine worked normally. **M.Dr.**

### **Sharp VC387**

Signals from the tuner disappeared about five minutes after switch-on. On test I found that the 12V tuner BU line dropped to about 3V when the fault occurred. After completing the difficult job of getting the power supply out of the machine I used the hairdryer to check for a thermal fault and found that the problem occurred when the small 2-2 $\Omega$  disc thermistor in the supply to the switching converter was heated. But a replacement didn't cure the fault. Silly me! The thermistor was doing its job, heating up and restricting the current flow because the converter was drawing excess current.

Further checks showed that the cause of the fault was on the primary side of the converter circuit. It was eventually traced to the 10 $\mu$ F damping capacitor C954 which was low in value at about 2 $\mu$ F. In view of the difficulty in getting the power supply out, and not wanting a bouncer, I checked the other electrolytics in this complex power supply. Several had to be replaced as they were drying up. It seems that sealing hot-running circuitry in a can is a recipe for failure. **M.Dr.**

### **Granada DS2/Sanyo VHR2300**

This machine was dead with very little coming from the STK5482 regulator IC1. There was no change however when a replacement was fitted. After obtaining a manual we realised that the reason for no 5V and 12V outputs from the chip was no switching voltage at pins 5 and 10. This comes from the collector Q5002. There should be 31.4V at the collector but this voltage was missing – the correct 50V was present at the emitter. A resistance check showed that there was a short across this line. It was traced to the presetter board where the UPC574J 33V regulator IC6204 had gone short-circuit. When a replacement was fitted the machine worked but there was no clock. The –30V supply at pin 5 of connector CN5002 was missing because the 27V and 4.3V zener diodes D5006 and D5005 were both short-circuit. No further problems were noted during a soak test. **G.R.**

## JVC GRAX55

This camcorder wouldn't play or record and there was no fast forward or rewind operation. E01 and E02 were displayed in the viewfinder. The problem lay in the drive to the loading motor: the 'sensor PCB cable' on the underside of the mechanism was open-circuit where the loading motor cable plugs in. Replacing this sensor PCB cable got the camera up and running again.. G.S.

## Finlux CR4700

There were lines on the playback picture and recordings and the machine damaged tapes. The fault was caused by the fact that the cassette holder didn't sit down far enough. A new cassette holder cured the problems. G.S.

## JVC GRSX9

The camera section failed to produce a picture because the iris jammed shut from cold. As the iris is not available separately you have to replace the 'optical block assembly' to cure the problem. G.S.

## Sanyo VMD3P

We've had two of these camcorders with foldover on the right-hand side of the picture produced by the viewfinder. In both cases the fault was cured by replacing C9911 (10 $\mu$ F, 16V), the line drive coupling capacitor in the didy little horizontal scan stage. E.T.

## Sony V90

We've had the following faults with this model:

- (1) Intermittent rewind. Cause was a dry-joint at IC001.
- (2) No fast forward/rewind/playback/record. The capstan wasn't being powered because the flexi connector FP53 was faulty. Part no. A7060693A.
- (3) No playback colour or sound was caused by absence of a 5V supply because transistor Q952 was faulty.
- (4) We've had a couple with this fault, the symptom being playback picture shake. The cause was the fact that the supply reel didn't turn smoothly because of a missing washer (part no. 370144101) beneath it. Where does it go to?!

Note that when the camcorder is dismantled there will be no playback sound or colour if CN501 is not connected to W953. K.T.K.

## Sony CCDF330

Faulty playback colour was the complaint, and it certainly was! Flashes of colour were visible amongst a jumble of wavy lines. A check along the chroma playback signal path brought me to IC363 (jog chroma processing) where something very nasty appeared to be happening. The signal

waveforms were distorted and the HD pulses at pin 10 were missing. I came to the conclusion that the chip had to be faulty but decided to check its supply at pin 1 before ordering a replacement. It was fortunate that I did because there was appreciable ripple. The culprit turned out to be the decoupling capacitor C455 (0.01 $\mu$ F) which was completely open-circuit. D.C.W.

## Sony F Range with U and U' Mechanisms

I've recently had three of these machines with similar problems. During the loading process either guide pole base can hesitate or jam at a particular point in the sequence, the result being anything from a mere click from the mechanism to a caution situation with no functions available to the user. In each case the cause was a slight deformation of the main chassis in the area of the guide slots. I was able to overcome the problem in each case by dismantling the deck mechanism and carrying out careful realignment. D.C.W.

## Ferguson FC07

The cause of no autofocus or zoom operation was the fact that the 10 $\Omega$  safety resistor R81 had gone open-circuit. It's in a supply that goes to autofocus and zoom drives on the AF PCB. D.C.W.

## Sanyo VMD6P

Although a tape could be loaded successfully no functions were then available and 'cassette' flashed in the viewfinder. Checks showed that all the deck sensors were functioning correctly while mode-switch information was being received correctly by the syscon chip. When eject was selected unloading took place correctly – or did it? Wasn't the capstan motor revolving a little too fast? Yes, it was! As no capstan FG signals reached the syscon chip it thought there wasn't a tape present. The motor itself was the cause of the problem, a replacement providing a complete cure. D.C.W.

## Canon A10E

The grip strap on early versions of this model often becomes detached from the rear-end mountings. It's secured by two screws that hold it to the right-hand side case. What happens is that the internal moulded screw securing point breaks away from the case. A replacement we obtained from Canon shows the later method of securing the grip. Moulded securing points and screws are no longer used. Instead, a short length of steel rod is linked through the holes previously occupied by the screws. This is glued to the inside of the case. So it's not necessary to obtain a new case to repair a detached strap – merely a short steel rod and some glue! D.C.W.

## Amstrad VMC100

A dead machine was rescued by replacement of CP401 and CP402 (main board) and Q402. D.C.W.

## Hitachi VTM620E

If the cassette lift doesn't work check that the capstan motor is free to rotate easily – in this model the capstan motor operates the lift. A stiff motor can be cured by dismantling it and cleaning the capstan spindle bearing. **P.B.**

## Grundig 2 X 4 Super

This old-timer had a servo fault – there were tracking bars in play and still frame. Module swapping proved that the cause of the fault was on the DTF board. Comparison checks with a working board then soon showed that the signal at pin 1 of IC2630 was missing. A new MC14066 chip in position IC2605 brought the signal back: the still-frame picture was now o.k. but there were still tracking bars in the play mode. There was a lot of ripple on the waveform at pin 7 of IC2710 because the sampling gate in IC2708 was leaky. It's another MC14066 – good job I had two of them on the shelf! **P.B.**

## Panasonic NVG500

If the power supply is dead replace the 10 $\mu$ F electrolytic capacitor C15. **P.B.**

## Ferguson FV67HV

Suspect a faulty loading motor if cassette loading/unloading is slow. Good motors usually have a current consumption of about 30mA with a 6V test supply and the belt removed: I've had faulty motors that take 2A! **P.B.**

## General VGX520/Panasonic NV430

There was a slight hum bar in the E-E mode and a stronger hum bar with colour reversal in it in the playback mode. Electrolytics C1002 (4.7 $\mu$ F, 40V) and C1003 (47 $\mu$ F, 40V) in the power supply section were the cause. As the panel is difficult to get at, replace both capacitors – either can cause this fault, and it would be annoying to have to take the panel out again. **C.W.**

## Toshiba V211

Playback of a test tape produced a good picture but there was a cyclic wow, about every four seconds, when the tape speed varied. This was a simple one: cleaning the control head cured the fault, but why was there no picture disturbance when control was lost? **C.W.**

## Ferguson 3V55

The problem was that this machine would stop in play. Watching the tape counter in the fast-wind mode led me to the reel sensor – the counter worked in fits and starts instead of providing a steady count. As cleaning the underside of the reel disc and the faces of the opto device made no difference, a new sensor was fitted. But the fault was still present. A scope check on the sensor's output showed that it was intermittent: so a new reel disc was tried. The results were no better. The cause of the trouble was actually down to me: when I first removed the reel disc to clean it one of the height setting

washers had been lost. Thus when the disc was refitted it was too close to the sensor. Matters were put right when a new washer was fitted beneath the reel disc. So the cause of all the trouble had been a dirty reel disc, but carelessness had resulted in lost time. I should be shot at dawn! **C.W.**

## Panasonic NVG21B/25B

The following power supply fault is becoming quite common in these machines. Symptoms vary, but there are usually striations and interference on the E-E and playback vision, and the drum servo can be disturbed. The cause is excessive ripple on the unregulated 8V input to the multi-regulator chip, caused by C1023 (1,000 $\mu$ F, 10V, 105°C) going low in value or open-circuit. Check the 6V supply which will usually be on the low side. Note that the physical size of this capacitor is critical, being a high-temperature type. **N.B.**

## Panasonic NVF55

In the E-E mode this machine produced a blank, grey raster, with no VU meter display on the display tube. The M66006FP chip IC1701 enables the VU display and switches the AV1 and AV2 circuits: fitting a replacement cured the fault. **B.S.**

## Panasonic NVSD40

This machine would accept a tape then keep it: lapsing into sullen silence, it would power down then after a few minutes the power supply would cut out. The machine was brought back to life when I connected a battery to the loading motor to extract the tape. Checks in the loading motor drive circuit showed that the BA6219B chip IC6501 was badly overheating – presumably it was making the power supply cut out. Fitting a replacement cured the fault. **B.S.**

## Mitsubishi HSB12 etc

The following problem can occur with most Mitsubishi VCRs in the HSB11/21/31 and HSB12/27/32 series and later. The symptoms are that the machine will accept a tape and lace up but won't play, won't wind properly, damages tapes and the tape counter doesn't work.

Insert a cassette and watch the action of the guides during lace-up. Then eject the tape and observe the at-rest position of arm TU-G (C-033) which is sometimes referred to as the half-load arm. You'll see that it has been prevented from going all the way back by arm TENS-REG-T (C-031) which has moved too far to its left. It should not move behind arm TU-G but should stay to the right of it. The consequence of this is that when a cassette is loaded arm TU-G is outside the cassette and as a result can't carry a loop of tape towards the capstan and pinch roller during lace-up. Thus when play is selected the tape doesn't move and during wind the counter cannot operate as the tape isn't held against the audio/control head.

As with most machines which incorporate a real-time counter, indexing and jog/shuttle/reverse play functions

there are several guides and tension arms that are not found in more basic models. In this design arm TU-G has to carry the tape through the gap between the capstan and the pinch roller during the lace-up so that it passes across the face of the audio/control head during both forward and reverse play. Arm TENS-REG-T operates as a reverse back-tension arm during reverse play and search. It also has, at its pivot end, a small brake arm that bears on the take-up reel turntable. If this brake's friction pad becomes dislodged, arm TENS-REG-T can move an extra five degrees or so to the left. This in turn means that when arm TU-G moves back during the unlacing process it's obstructed by arm TENS-REG-T and comes to rest outside the front edge of the cassette, producing the symptoms mentioned above when the next cassette is inserted.

If the missing brake pad is still inside the machine it can be refitted using a touch of Evostick. Otherwise, replace the complete arm assembly, part no. 591B551010. Note that there are two tension springs at the pivot end of the arm – omit one of them at your peril!

J.C.P.

### **Toshiba V309**

The complaint was that this machine would neither eject or play a tape – there was one in it. It would try to rewind. The timing of the loading gear was a mile out. After setting it up the machine worked correctly. A week later it came back with the same fault however. This happened again after a further week. A new loading motor assembly finally cured the problem.

J.H.

### **Toshiba V93**

I've had a few of these machines that would play but had no clock display. This means that the tuning doesn't work either. The cause of the fault is the d.c.-d.c. converter unit, which develops an internal short. As a result its circuit protector goes open-circuit.

J.H.

### **Baird 8940/JVC HR7350**

There was no rewind or fast forward operation. Checks showed that CP2 on the mechacon panel was open-circuit. So I changed IC12 (10VT05) for good measure. After this the machine functioned perfectly. This is my favourite VCR.

J.H.

### **Hinari VXL5**

This problem will probably be experienced with any VCR that uses the same deck, for example the Amstrad VCR4600. The machine worked perfectly with some tapes, but with others the recorded sound was very low. After much searching, soldering and component checking I soldered all the connections on the audio/control head. This provided a complete cure.

J.H.

### **Hitachi VT9500**

Apart from clock operation there were no functions. After checking the supplies on the rectifier PCB and finding that they were as given in the manual we next checked the voltage at the syscon chip's supply pin 21. The reading here was 0V instead of 10V. This supply is obtained from the 12V regulator chip IC903, the feed being via two 1SS133 diodes, D904 and D905. When they were checked we found that D904 was open-circuit while D905 was leaky. After fitting new diodes the machine worked normally.

F.A.S.

### **Matsui VX735/Saisho VR3300**

When the machine had been working for about two hours the capstan would start to stop for about a second at regular intervals. Application of freezer to the control chip on the capstan motor subpanel would restore normal operation for a short period, implying that the i.c. was faulty. Unfortunately it's not available as a separate item, so a complete motor assembly is required.

E.R.

### **Philips VR6520/Panasonic NV370**

This machine was dead with no display: the function LED lit continuously though dimly. The cause of the fault was absence of the 5V supply because R1001 (0.39Ω) had gone open-circuit for no apparent reason. It's shown as R1 on the PCB, which is a bit confusing if you are not familiar with this model. Sometimes failure of the 3.9V zener diode D1002 can be the cause of R1001's demise. On this occasion however simple resistor replacement restored normal operation.

E.R.

### **Akai VS5**

There was no colour in either the playback or the record mode. As the machine was getting on it years repair might not have been economic if we'd had to spend time on fault finding. We'd come across the fault in the past however and as we note such things in the relevant manual we were able to restore the colour by going straight to C60 (0.01μF) and replacing it. The capacitor had become leaky.

E.R.

### **Sharp VC583H**

The fault, which was very intermittent at first, was no playback/record/E-E picture. Its cause was traced to dry-joints at plug/socket CC on the video/chroma PCB. Resoldering restored normal operation.

J.C.

### **JVC HRD750EK**

Poor recorded sound can be a problem with this model. It's usually accompanied by a slight crackle. In one case recently the cause turned out to be a worn audio/control head, but in some cases the tape path guides are incorrectly set. The result is a low f.m. and/or audio waveform.

J.C.

### **JVC HRD225/Ferguson 3V36**

If the machine won't accept a tape, check whether the supply spool rotates for a short time. If it does, check the l.t. supply to IC204. Should this be missing circuit protector CP1 (F15) is probably open-circuit. If it doesn't, check the voltage at pin 37 of IC201: this should be in the low state without a tape in the cassette housing. If it isn't low, check the up/down detector switches by replacement.

J.C.

### **Hitachi VT410**

We found that slow rewind and fast forward with one of these machines was being caused by a power supply fault: the 12V output from IC851 (STK5372) was low.

J.C.

### **Sharp VC583H**

Incorrect or no functions can be caused by a faulty mode switch. But check whether it might be misaligned because of a jammed tape, causing cog jumping.

J.C.

# VCR Clinic

Reports from Philip Blundell, AMIEE, Eugene Trundle, Richard J. Avis, Adrian Farnborough, John Edwards, Alfred Damp, Mike Leach, John Coombes, Chris Avis, Steve Cannon, Chris Watton and Simon Bodgett

## Philips VR6761

In the E-E and playback modes there was sound but just a blank raster. Checks on the record/playback switching voltages showed that there was only 2V instead of 12V at D6403 on signals board P306 in the E-E and playback modes. This voltage comes from mother board P606, where the BC328/40 transistor Tr7607 was found to be open-circuit base-to-emitter. P.B.

## Ferguson 3V35/JVC HRD120

Check for h.f. ripple on the 12V supply, at pin 1 of connector CN4, if the playback picture suffers from herringbone patterning. A ripple voltage of 0.5V here should lead to a check on C16 (47 $\mu$ F) which you will probably find is open-circuit. P.B.

## Samsung SI/SX7220/Goodmans VCR2500

If one of these machines fails to eject the tape or dies as it completes the tape loading process it's likely that the loading motor is weak. On a couple of occasions recently however we've found that poor regulation by the STK5333 chip on the power regulator PCB was the cause. E.T.

## Tatung TVR6111/Amstrad VCR9410/etc

There are doubtless other Amstrad VCRs and more makes and models that use this mechanism. A very common fault with it now is intermittent failure to rewind or wind fast forwards. The motor whirrs but the reel-drive gears don't

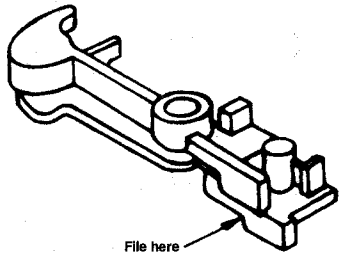

Fig. 1: Where to file the trigger lever - see Tatung TVR6111/Amstrad VCR9410/etc.

move into engagement. The cause of the problem is failure of the trigger lever (item 260 in the exploded view of the deck) to flip back into position in the stop mode. Cure it by filing a fraction of a millimetre off the end of its skirt, as shown in Fig. 1. E.T.

## JVC HRD520

This machine had been to several service departments, always with the complaint of intermittent tape looping. After a great deal of time we traced the cause of the fault to the mode switch, which is available from CPC under part no. TNPU60622-1-1. R.J.A.

## Ferguson 3V32/JVC HR7655

The 3V32 is not a common visitor to our workshop. In view of this and its complex circuitry we tend to be apprehensive when one comes along. The fault with this one was complete

absence of the fluorescent display. Not surprisingly we found that the filament supply voltage was missing. It comes from a 37kHz oscillator which is mounted on a small subpanel behind the main display, the main items here being T201 and Q205. There should be 3V p-p at the centre-tapped secondary winding but a scope check showed that the oscillator had stopped. It turned out that the oscillator transistor's 22k $\Omega$  base bias resistor R281 was open-circuit. A.F.

## Akai VS22

The tape loaded correctly but there was no drum or capstan rotation in either direction because the BU2735AS chip IC503 was faulty. We've had failure of this chip on a number of occasions. J.E.

## Ferguson 3V23/JVC HR7700

A tape was stuck in this machine: the eject button had no effect because there was no voltage across the carriage loading motor. We found that fuse F5 had blown because C36 was short-circuit. Replacing these items put matters right. J.E.

## Panasonic NV370/830/850

If you get one of these machines that's dead with no displays and no functions check the 0.39 $\Omega$  resistor R1001 in the small power area on the main board. It will probably be open-circuit with no contributory cause - it feeds the 5V regulator. A new resistor should provide a cure. J.E.

## Hitachi VT8000

All functions worked in this old machine, but only for about five seconds. It would then shut down. The cause was a stretched take-up spool carrier to counter belt - so the counter and the take-up spool rotation pulses stopped. A new belt solved the problem. J.E.

## Philips VR6362

In rewind or fast forward this machine would stop and eject the tape after a few seconds. In the play mode it would lace up then unlace and eject the tape. All this was because the drum didn't rotate as the 3.3 $\Omega$  resistor R3142, which is in the 13V feed to the drum drive circuit, had failed. J.E.

## Philips DMP2 Deck

Shortly after we'd fitted a service kit to one of these machines the customer returned it with the complaint that although it now worked it would occasionally refuse to load a tape. The machine worked all right for several days before the fault showed up. When we called up the fault status from the machine's software we got an indication that tape loading was too long, heavy loading, etc., in other words a service kit was required. In an attempt to see what was happening we examined the machine from all angles. Nothing was obvious until I peered into the loading motor and pulley housing:

# VCR Clinic

*Reports from Eugene Trundle, Terry Lamoon, Brian Storm, Gerald Smith, Chris Watton, Michael Dranfield, Nick Beer, Simon Bodgett, J.K. Potts, Fauz Ahmed Sumar, John Edwards, John Hopkins and Bob McClenning*

## Mitsubishi HSB21

The same deck is used in a wide range of Mitsubishi HSB models, so the following problem could probably happen with any of them. When the machine was set to play it would lace up then produce a broken-up still picture (tape stationary) before shutting down again. Sometimes the tape would struggle forwards, producing a very mistracked picture with no sound and no tape-counter action. It didn't touch the capstan or the audio-control head. The cause of all this was that the half-loading arm (C033 in the exploded diagram of the deck) didn't retract fully at eject, so that it was unable to catch and pull the tape when a cassette was next loaded. It was caught behind the take-up tension regulator arm (C031) which moved too far to the left because its brake pad had come adrift, allowing the metal shoe to bear on the rim of the take-up turntable. **E.T.**

## Hitachi VTM820

A long search for the cause of a very intermittent squealing noise from this machine's deck, accompanied by a rippled picture, led us to the shaft of the white plastic impedance roller just upstream from the entry tape guide. Giving it a clean, a polish and a single tiny drop of light oil cured the problem. **E.T.**

## JVC HRD520

This machine produced off-tape pictures that were marred by multiple thin mistracking bars spaced progressively closer towards the top of the screen. The cause was failure of the entry guide to go fully home – its base jammed in the plastic guide rails that had become distorted or warped. Some careful paring with a file or a very sharp knife gets things moving again. **E.T.**

## Samsung SI/SX7220

It took us weeks to find the cause of this machine's very intermittent fault: the tape would run at very high speed to give a search-forward effect, with the sound still present – fast and high-pitched. A dry-joint in the capstan FG feed-back line on the 'deck-joint' PCB which sits behind the capstan motor was responsible. It wasn't obvious to the eye: re-make the joints between the board and motor connector CN213. **E.T.**

## Hitachi VT63/64

Two other firms had attempted to repair this old-timer, which would sometimes fail to play or record when asked. Between them they had replaced all the belts, the reel idler, the capstan motor drive chip and the thermistor that feeds power to this chip. The real culprit was the capstan motor, which when put on test drew over 1A from a 4V supply! **E.T.**

## Panasonic K Deck

The first machine fitted with this new deck came into the workshop recently. It was damaging tapes. When we opened

it up and watched the loading we saw that the loading arm pulled the tape up to the control head but didn't lock into place fully. On careful examination it could be seen that the arm was slightly bent over. Realigning it provided a complete cure. It wouldn't surprise us if this became a regular problem with the deck, especially if users try to retrieve tapes from semi-loaded machines as some do. The construction of this arm (P5) is not rigid. **T.L.**

## JVC HRD860

The problem with this machine was no E-E sound while the recorded sound buzzed. I checked the sound along to IC6 where it disappeared. Further checks showed that the supply here was low at only 2V. Following this back I found that the full voltage appeared at the connector to the panel. The plug was covered with a gluey substance, presumably to stop it moving. When this had been cleaned off the fault was no longer present. What amazes me is how the machine could work for months before the substance decided to foul up the sound completely. Funny business! **T.L.**

## Panasonic NVL20

There was a very poor picture in the review mode while, more seriously, the machine would sometimes throw out tape into the mechanism, much to the detriment of the tape. A careful check on the tape's progress along its path failed to reveal any obstructions or resistance: all the brakes and soft brakes were working faultlessly. The culprit was eventually found to be the head drum entry guide, which had seized. As the guide didn't rotate, the tape's progress was somewhat unstable as it stuck and jumped randomly over the guide. A replacement guide, part no. VXP0863, restored correct operation. **B.S.**

## Panasonic NVJ40

This machine intermittently powered down when a tape was inserted. Preliminary checks showed that the head drum didn't start as the tape was loaded – in this machine the tape is fully loaded round the head in the stop mode. Inserting the tape a couple of times would get the machine to work.

As the condition and alignment of the mode switches seemed to be o.k. suspicion fell on the systems and servo control, in particular the microcontroller chip IC6001, but again the verdict was not guilty. I still felt that there had to be a problem with the mode switches. A look at the carriage mode switch, which I'd already replaced, showed that it seemed to be less securely mounted than usual. Holding it securely with my finger as I loaded a tape proved the point: the machine worked faultlessly. A replacement right side cassette housing, part no. VXA4468, cured the problem. The cause of the trouble was the excessive play in the mode switch mounting. **B.S.**

## GoldStar GHV1244

This machine wouldn't accept tapes and kept going into the standby mode. An examination showed that the shaft-



## Amstrad VMC100

For no colour check the 2SC3929 transistor Q517 on the camera PCB. It buffers the chroma signal feed to the deck section. **D.C.W.**

## Ferguson FC07

This JVC-designed camcorder had no camera E-E picture. A common cause of this symptom (a blank white viewfinder screen) is lock-up of the microcontroller chip: removing then refitting the clock battery normally provides a cure. Not so this time! On inspection we found that the iris remained closed – pictures were obtained when the iris mechanism was manually operated. The cause of the fault was traced to D4 on the IMG SSG panel. It was open-circuit. In fact this glass-type diode was literally shattered. An interesting point is that it's shown in the manual as a chip component.

No cause for the failure of this component could be found and a replacement provided a complete cure. The diode's physical position on the PCB puts it in contact with the rear edge of the deck mechanism. It seems possible that a knock to the optical block could produce a mechanical shock that was transferred to the D4 area, cracking the glass. **D.C.W.**

## Panasonic NVMS2

The problem with this camcorder was incorrect white balance. We traced the cause to poor soldering at P001 on the camera operation PCB. **D.C.W.**

## Sony CCDF250

The reported fault was "viewfinder and E-E camera pictures disappear after a few minutes' use". Sure enough they did! We traced the camera picture signals, both Y and C, through to the output pins of the encoder chip IC606 on board CV9. At this point they are applied to a Y/C mixing and buffering circuit consisting of Q602, Q617 and Q619, a composite video signal appearing at the emitter of Q619. This signal disappeared intermittently, causing the fault symptom.

The Y/C mixer stages are direct coupled, and voltage checks here showed that the d.c. conditions varied wildly. Static checks and the replacement of several components in this area didn't help. The voltages at the pin connections varied even when the three transistors were removed from the board! Sabotage was suspected. . . The cause of the problem turned out to be a 120µF, 6.3V electrolytic capacitor (C704) that decouples the 5V rail. It had leaked over part of the print in the Y/C mixer section. I suppose the moral is that if odd symptoms that defy logic persist, look for a leaky capacitor. **D.C.W.**

## Amstrad VMC100

The fault report with this point-and-shoot model said "no functions with the cassette housing open". We found that CP403 and the 9.6V regulator transistor Q402 on the main PCB were both open-circuit. We

checked for shorts then fitted replacement components. This provided a cure – until eject was pressed. CP403 then failed, but this time Q402 was all right. As no likely cause could be discovered CP403 was replaced, a tape was loaded and a recording was started. Everything was o.k., even when eject was pressed: the recordings were found to be o.k. when checked in a playback machine. But after much soak testing CP403 again failed while the machine was in the eject mode.

In sheer desperation I dismantled the unit once more and connected an analogue ammeter in series with CP403. Tape loading was achieved without mishap, but when the eject button was pressed the ammeter showed that there was an excessively heavy overload, far in excess of normal. The cause of the trouble was finally traced to the loading motor, which was going short-circuit to chassis intermittently, thus explaining why the fault occurred only in the eject mode. **D.C.W.**

## Sony V900

These camcorders are very reliable and are easy to fix once they are opened up, but a very large number of patch leads are required. Once you are able to power the machine the assembly looks like spaghetti. Repair is not a job for the beginner. We've had the following faults:

(1) There was playback/recording for a few seconds, then a warning symbol appeared. We found that in fast forward the take-up reel didn't move while the clutch was slipping. A new take-up reel restored correct operation.

(2) There were horizontal stripes on the playback picture. We found that the tape path couldn't be adjusted. There was a faulty tape guide, a new roller assembly putting matters right.

(3) The LCD was o.k. but there was no power to the camera/VCR section, with the electronic viewfinder dead. Checks around IC101 on board FD10P showed that the 5V supply was present at pin 54, there was oscillation at pins 55/58 but the VTR power-on output didn't go low. IC101 was faulty, a replacement restoring normal operation. This is a fairly common fault. **K.T.K.**

## Sony V700

Here are a couple of faults we've had with this model:

(1) There was no playback picture (black screen) and no sound. Checks showed that the 5V PB supply was low at 1.5V. The cause was transistor Q280 (type 2SC4081R, part no. 872990535).

(2) No playback picture (black screen) but this time the sound was o.k. Checks showed that there was an input signal at pin 41 of IC650, which turned out to be faulty. It's type CXA1207R (part no. 875203619). **K.T.K.**

noise of some kind.

A check showed that the clock pulse input at pin 7 was fine. What next? Fortunately we had another of these machines in for a different fault. So we hoisted it over in order to compare the voltages and waveforms around CIC2520. With this second machine the signal that emerged at pin 4 was indeed normal, delayed video. Before condemning the chip we decided to check the conditions at the other three pins (excluding the supply and chassis pins) – pins 1, 5 and 8. In the faulty machine there was a 5V clock-frequency sinewave at pin 8, the other machine having just a d.c. voltage here. The only component connected to this pin is a 10nF surface-mounted capacitor, CC2527. To my relief when a 10nF capacitor was bridged across it the problem cleared. Fitting a replacement restored the machine to good health. **S.C.**

## JVC HRD540

It's very common for the deck to jam, leaving the loading motor whirring away. The cause of this is the half-loading arm/gear, JVC part no. PQ43570B: the teeth wear and the gear then jumps a tooth or two, jamming the deck. Sometimes the first tooth breaks off the master cam, JVC part no. PQ20822-2-7. Both items are available from Willow Vale. It's best to replace them both regardless.

When you've removed the old half-loading arm, don't discard it immediately – it can be useful for realigning the deck. You'll see that there's a hole just above the cassette lamp: if you push the half-loading arm into this hole it will hold the slider plate beneath in exactly the right position ready for fitting the master cam. Don't forget to align the audio/control head, which has to be removed to fit the half-loading arm. **M.Dr.**

## Sony SLV415

The symptoms with this machine were odd. A tape could be loaded but the machine then went into fast-forward video search with no other functions available – though twisting the jog-shuttle control backwards and forwards would sometimes give the pause mode. The tape couldn't be ejected: it had to be wound out manually after disconnection from the mains supply. Another symptom was that none of the buttons on the remote control unit had any effect, though an IR test showed that the device was working.

With very little experience of this model and no manual, we decided to go straight to the deck mechanical position (mode) switch. But after giving this a good clean the faults remained the same. Then a thought came to mind: the jog-shuttle control at the front of the machine is more or less just a big mode switch and could be faulty. Fortunately it plugs in. Disconnecting it brought the machine back to life – the remote control unit now worked, and all functions were available. When we opened the jog-shuttle control up we found that it was very tarnished inside. Cleaning it failed to cure the problem, a replacement from Sony (part no. 1-572-662-11) being required. It costs less than £10. After a good clean the machine performed excellently. **M.Dr.**

## GoldStar P5001

We've had a number of these playback-only machines in recently, all with the same fault – throwing loops of tape in the rewind mode. In every case the cause has been a faulty soft-brake lever on the take-up spool. All the machines have been fairly new. On examination we've

found no friction surface on the soft-brake lever, no trace of a loose felt pad inside the machine and no sign of adhesive on the face of the brake lever. So it would seem that a brake pad had never been fitted. Without one there's insufficient friction when the brake is applied during rewind. As a result the spool is allowed to overrun, spilling tape as it does.

Correction for this is easy. The lever can be lifted out of the mechanism without any need for dismantling other than to remove the machine's top cover. The lever is held on its pivot by a small plastic catch. After removing it, a small piece of felt from an old back-tension band can be attached with a small dab of Evostick or similar impact adhesive. Make sure that the adhesive is dry before refitting the lever and testing.

The lever illustration in the service manual for this mechanism seems to show a brake pad attached. The parts list shows it as 'Item 049 – Brake – pt. no. 338-083A (Assy T-Soft)' and also denotes it 'NSP' (non service part). **J.C.P.**

## Sanyo VHR291E

When you've uncased this VCR you have to lift the main PCB CP1 before work can be carried out on the deck mechanism. The board can be mounted vertically at the rear of the chassis, and to facilitate this a long ribbon cable at the right-hand side is connected to the operation/display board TM1 on the front panel, being long enough when unfolded to allow board CP1 to stand upright. The ribbon cable at the left-hand side of board CP1, connected to the audio level meter board AD2, is shorter and must be disconnected. If audio tests are not involved you can operate the deck with this cable disconnected – alternatively if it's necessary to work on panel AD2 use extension cable 'relay jig' VHJ-0088 which is available from Sanyo.

It's common, when deck maintenance or cleaning has been carried out, to find that on test after reassembly there's an audio problem. It shows up as a whine at about 3kHz, usually in the right-hand channel only, with both recordings and playback. The cause is that board CP1 has been refitted with the long, right-hand side ribbon cable stowed, as seems to be natural, with a single fold in the clear space in the chassis to the right of the deck mechanism. As a result of this however the folded end of the cable towards the rear of the case can become sandwiched between Nicam board TM5 at the bottom of the case and the tuner/VIF/RF modulator modules on the underside of board CP1. The problem is that signals from the ribbon cable's clock/data lines are then picked up by the other circuit modules, producing the audio whine. Make sure that when board CP1 is refitted the long ribbon cable is rolled up and stowed in the front section of the case, well away from the other circuit modules. There doesn't seem to be any cautionary note about this in the manual, and the first time we came across the problem there was a lot of head scratching before we solved it. **J.C.P.**

## Samsung SI1260

This machine produced a blank display. We connected a scope to the modulator/booster can's input, with the machine operating in the playback mode, and found that there was no signal. A check on the play mode supply line DLPB5V at pin 4 of CN3201, the 11-pin plug to the preamplifier module, produced a reading of only 3.6V. We traced the source of this back to D110 (1N4001) which turned out to be faulty. It provides the PB5 supply from 'always 5' via switch transistor Q105. **C.W.**

## Samsung SI621

The customer's note said that this machine would play some tapes but not others. This was because of loss of the control pulses from the audio/control head. Cleaning the head thoroughly and lubricating it failed to clear the fault, though the face of the head appeared to be perfect. A new head had to be fitted.

C.W.

## Toshiba V110

The job ticket said "clock went first, now dead". A check on the power supply showed that all voltages were present and correct however. When the main board was lifted we saw that there's a large heatsink on the left-hand side. Two transistors here, TT52 and TT53, and i.c. IT14 were dry-jointed.

A.J.F.

## Ferguson 3V42/JVC HRD455 range

These machines are now becoming slow at lacing up for play or record. Cleaning the drive gear loading cog assembly provides only a temporary cure. The permanent cure is to obtain a complete assembly, ready lubricated and including the motor and new plastic circlips, from SEME (part no. DECKR5). The motor can also be faulty. Don't forget to clean the spindles of the two small white cogs (connect gear 1 and 2) and the two larger cogs (loading gear 1 and 2) at the bottom of the deck.

A.J.F.

## ITT VR3620 and Clones (Twin Speed)

Replacement power supplies can be obtained from NCS and from Akai. You'll find it a lot cheaper to order from Akai (part no. BAV1084D500B)!

A.J.F.

## Toshiba V210

These machines can do strange things. Measure the voltage between the cathode of DT53 and chassis. If the reading is not exactly 5V, replace DT53 with a 2.7V zener diode. You'll find DT53 at the bottom right-hand corner of the top panel.

A.J.F.

## Panasonic NVG21

The complaint was of tuning drift. We found that a tape could be played but when stop was selected the machine would shut down, tripping. On examining the power supply we found that C12 and C39, both 47 $\mu$ F, 16V, were faulty. After replacing them the machine remained dead! Other capacitors in the power supply were then found to be either open-circuit or of incorrect value - C18, C22 and C25, all 47 $\mu$ F, 50V and C2, 1,000 $\mu$ F, 6.3V. (Power supply type VEK3254-2.)

A.J.F.

## Saisho VR805S

This machine would intermittently stop when playing a tape. The usual standard Sharp idler was replaced but the fault persisted. This time the cause turned out to be the cassette-in switch on the main deck. Cleaning it cured the problem.

A.J.F.

## Salora SV9900

The cause of a dim clock display was found to be capacitors C446 and C447, both 56 $\mu$ F, 16V - a strange value. The

replacements supplied by the manufacturer were 120 $\mu$ F, 35V high-temperature (105°C) types. When we fitted them the display seemed to be no different from that with the 47 $\mu$ F capacitors fitted as a temporary cure!

A.J.F.

## Sony SLV373

This machine displayed P6 and rewind didn't work. The cure was to replace the two reel turntable photosensors PH001 and PH002 (part no. 8-759-144-33) on board MD40 beneath the deck mechanism. It's best to replace the two as the cost is minimal and any further trouble in this area is prevented. They are easier than it may at first seem to replace.

A.J.F.

## Sony GV8E

**No LC display, VTR section o.k.:** Replace the d.c.-a.c. converter (internally shorted) and fuse F103 on boards PS181/RG5.

**No LC display, no sound, sound/vision o.k. at line outputs. Q114 keeps blowing, no output from T101:** The 5V line is being earthed on PCB TT20. Replace D310 (short-circuit), which is connected to pin 58 of IC301, and Q114. Fault area boards PS181/TT20.

**No power to TV section, mechanism and line outputs o.k.:** Replace fuse F103 on board PS181.

**No playback colour, TV o.k.:** Replace faulty delay line on board SV35.

**Playback picture jumps:** Symptom is similar to that with dirty heads but cleaning doesn't clear fault. Replace head drum.

**Low brightness:** Back light in reflector assembly not working. Replace fluorescent tube.

**Click on rewind/fast forward:** Replace worn mechanism pulley relay assembly.

K.T.K.

## Goodmans SX2700

The customer complained that he couldn't copy tapes to this machine. Normally this is down to the customer's wiring, but not this time. A check showed that there was no video from the socket. As I didn't have a manual I thought I'd try and trace the signal back. Fortunately I soon came across a dry-joint at C381. When this was resoldered and the machine was switched back on the results were perfect.

T.L.

## Akai VSG43

This brand-new machine chewed tapes. When the top had been removed I noticed that the take-up spool wasn't moving. Investigation at the underside of the mechanism showed that the clutch drive was disengaged and the circlip was missing. When I pushed the clutch together and fitted a new circlip everything worked perfectly. How simple some faults can be!

T.L.

## Philips VR6585

When this Nicam VCR was switched on there was just a blank screen in either E-E or playback. The cause was failure of the 315mA wickman fuse T501. It's on the luminance/chroma panel, not in the power supply.

T.L.

## Toshiba SK60P/JVC GRC7EK

This machine would record only when the wired remote control unit was connected, the trigger switch being inoperative. The cause of the problem was the remote jack: its normally-closed contact remained open, disabling the trigger switch. **D.C.W.**

## Canon E200E

Failure of the mechanism in the eject position was caused by a faulty tape (jammed supply reel). Circuit protector RR1934 was open-circuit. **D.C.W.**

## JVC GR65E

A common cause of no operation is a faulty AV lead short-circuiting the 8V supply at pin 3 of the 8-pin mini socket to an earthed pin. As a result CP3 (N15) on the main PCB goes open-circuit. Note that when the camcorder is working correctly the voltage at pin 3 of the AV socket is 9.6V, not 8V as shown in the circuit diagrams: it falls to 8V when an r.f. unit is fitted as it then becomes this unit's supply. A look at the circuit shows the reason for this apparent inconsistency. **D.C.W.**

## Sanyo VMD9P

Playback of a prerecorded tape was o.k. but no a.t.f. signals were being laid down in the record mode. As a result there was mistracking with playback of the machine's own recordings. The a.t.f. chip IC361 has two operational amplifiers in the record a.t.f. signal path: the signals were going missing between these two stages. We found that R3602 and R3603 had been fitted to the PCB incorrectly. Fitting them in the correct positions restored normal operation. **D.C.W.**

## JVC HRC3EK

This is a mini C VTR that's used with a separate camera. At switch on all the display LEDs flashed and there was an almost instant return to the power-off mode. Sometimes however the machine would work for a while before returning to the off condition.

The cause of the trouble was traced to a leaky capacitor, C3 (22 $\mu$ F, 16V), in the battery-low detection circuit. This capacitor is at the non-inverting input of a comparator chip, IC3, that monitors the 12V battery supply. As it prevented the correct potential being reached, the circuit signalled a battery-low condition to the microcontroller chip IC1 (pin 15). **D.C.W.**

## Mitsubishi CX7

This S-VHS palmcorder came in because its battery contacts required attention. A simple matter to put right. On test, VHS and S-VHS recordings and playback were fine. But when, to check compatibility, one of this machine's recordings was played back by another machine there was audio but no picture. The cause of this puzzling symptom was the fact that the VHS/S-VHS tape detect switch toggle was missing. Thus S-VHS recordings were being made even

when a VHS tape was inserted. A new switch cured the problem. **D.C.W.**

## Panasonic NVM10

This camcorder was dead. Preliminary checks showed that the power supply was working, but the 5V supply's integrated-circuit protector had gone open-circuit. This was not surprising: the line was at over 9V. This is always a cue to replace IC1001 and IC1002. So a new BA6149LS and UN1002 were fitted, along with an ICP. The machine now powered up and produced a good camera picture but the capstan motor just sat there, edging backwards and forwards. Checks around the servo chips showed that the servo 5V supply was way down at only 1.7V. It comes from Q1004, a new 2SD1238 transistor restoring normal service. **B.S.**

## JVC GRAX5

This camcorder intermittently showed E-04 in the viewfinder. When I stripped it down I found a screw from the bottom left area of the PCB rattling around the drum chip IC201. Refitting the screw cured the problem. I've since had two more of these camcorders with this screw very loose, just waiting to fall out. If you get one of these camcorders it would be worth checking the tightness of the screw. **G.S.**

## Finlux VR4700

This camcorder charger was dead, with no lights lit and no d.c. output. Bridge rectifier D101 was faulty and resistor R102 open-circuit. Replacing these items got it going again. **G.S.**

## Sony V88

This was the first camcorder I came across that used the EVR chip set. Electrically it's quite reliable. The mechanism suffers from similar faults to the TR55 which followed it (see *Television* March 1994). The following are additional to those previously listed.

**Failure to load tapes (sometimes won't rewind). The mechanism half loads then slowly tries to finish but fails:** Cause of the fault is a slightly bent supply-reel pole. Because of this the reel is stiff. The LS chassis has to be replaced. I don't know how this fault occurs, but I've come across it several times.

**Intermittent playback colour:** Replace C134 on board VA39.

**E-E picture slightly green, playback o.k.:** Replace IC616 on board VC32P.

**No focus/zoom. E-E, playback and record o.k.:** Cause was PS403 on board SS82P having gone high resistance. As a result there was no AF unregulated supply to FC13P/AF36P. Replacing PS403 restored normal operation. **K.T.K.**

# The Sony CCDF335 Camcorder

Keith T. Keeton

We've had the following faults with this camcorder.

**Black E-E picture, playback o.k.:** The iris was closed. C904 on board L110 was open-circuit. On another occasion the same condition arose because the track between R861 and Q818 on board CV9 was open-circuit. Hard-wiring cured this. Replacement of a faulty 4MHz crystal (X601) on board CV9 cured the fault on another occasion.

**Black E-E picture, playback o.k.:** Q602 on board CV9 was faulty. We replaced Q602, Q617 and Q619.

**Black E-E picture, RC jig shows line:** IC601 (MC68HC05N4) on panel CV9 was faulty.

**Colour noise on fine detail, E-E display in monochrome:** Wrong filter had been fitted (lens may have been changed previously). Replace filter or complete CCD assembly.

**Intermittent focus, zoom and E-E o.k.:** IC601 (MC68HC05N4) on panel CV9 faulty. On other occasions we've had dry-joints around IC803/5/7/8 on this panel. Resolder as necessary.

**No E-E colour, titles grey, playback o.k.:** 17MHz crystal X602 on panel CV9 faulty.

**No focus, zoom intermittent:** Focus diode on the lens focus PCB short-circuit. Replace the lens assembly as the diode/board is not available separately. Note that there are two types (screw and nut and self-tapping).

**No record, tape protected symbol appears:** Switch S302 or flexiconnector FP90 in mechanism faulty. Replace as necessary.

**No red in E-E display, titles wrong colours, playback o.k.:** IC605 (CXA1339R) on panel CV9 faulty.

**No E-E sound, playback o.k.:** IC451 (LA7293) on panel MC24 faulty. On another occasion the lead between boards MC24 and VA41 was damaged.

**No time/date, titles see through on E-E, playback o.k.:** Dry-joint at IC606 (CXA1072R) on board CV9.

**Noise lines across E-E picture:** C704 on board CV9 faulty.

**E-E picture flickers like old-time movie:** Flicker was caused by the iris. Cured by refitting connector CN801 on panel CV9.

**E-E picture has pink tinge, playback o.k.:** IC601 (MC68HC05N4) on board CV9 faulty.

**Pixel down:** Replace faulty CCD imager.

**Intermittent red on titles, E-E o.k.:** Resolder dry-joints on board LI10.

**Solid red or green E-E picture, titles wrong colours:** IC605 (CXA1339R) on panel CV9 faulty.

**Solid red E-E picture, RC not functioning:** Burst data set incorrectly on RC (CV9 board). Reprogram EVR or replace IC601 (MC68HC05N4).

**Capstan runs in FF on playback:** Replace faulty capstan assembly (part no. 883533101).

**Fault symbol appears when play or record is selected:** Tape slack not being taken up. Replace faulty take-up reel/clutch assembly (part no. X37268254).

**Failure to eject cassette:** In one case the capstan and drum operated but not the loading motor, and the RC said 01. Replacing fuse PS503 (ICP N20) on board CO2P cured this fault. On another occasion the capstan ran all the time, then an error signal appeared. Resynchronising the mechanism cured this.

**Failure to eject with PS503 blown:** The capstan motor was faulty – not clear why this stopped the loading motor. RC said no fault. New capstan motor (883533101) cured fault.

**Failure to eject – half ejects then goes back. RC says FG error (02):** Break in flexicable FP89.

**No playback/record/FF/rewind. Tape spooling out of head, pinch roller not turning:** Replace arm block, part no. A7040163B.

**No playback/record, loading arms pulse then stop:** Worn worm gear on loading motor. Replace worm (258), part no. X37268071.

**Plays back/records for a few seconds then no functions. Capstan rotates but take-up reel doesn't:** Washer had come off gear assembly. Replace washer (part no. 332139311) and if necessary gear (part no. X3726812).

**Plays back/records for only a few seconds then error symbol appears:** Take-up reel slipping on toothed cam because take-up reel teeth worn. Replace take-up reel (part no. X3726825A).

**Plays back in monochrome. E-E and recordings o.k.:** Q251 on board CV9 faulty.

**Playback pictures unstable. Take-up reel judders in the playback and FF modes:** Sand had got into the capstan motor. Replace motor (part no. 883533101).

# Fisher FVHP710 Reel Idler Replacement

*Ed Rowland*

If a list of the jobs that engineers most dislike doing were to be compiled, replacing the reel idler in the Fisher FVHP710 VCR would definitely be somewhere near the top. Most of the engineers with whom I've discussed this tend to regard the task as a punishment visited upon them for past sins.

Many engineers may be familiar with the method about to be described, but there are doubtless plenty of poor, unenlightened souls out there who still spend too much time – up to two hours – on what can be quite a simple operation.

The problem arises because the nylon gear on the idler gear assembly is captive beneath the metal plate known as the reel bracket: it appears to be impossible to remove the idler without dismantling a major portion of the mechanics – and, according to the service manual, this is indeed the case. When you use the method shown in the manual the following items have to be removed: the capstan motor, protective plate, drive assembly, reel bracket (along with the main cam and the supply and take-up reels), idler gear, loading gear and loading motor assembly. Hence the lengthy time factor. By using the method described below the operation can be completed in under half an hour – with practice, even less.

On later models in this series a semicircular cutout is provided in the reel bracket to facilitate removal of the

idler gear. One wonders why the problem wasn't anticipated at the design stage?

## **Procedure**

First remove the top and bottom covers, the front fascia and the cassette housing. Next comes the take-up reel – make sure you don't lose the plastic spacer beneath it – and the idler spring.

Turn the machine upside down, remove the drive belt and take the brass screw out of the plastic protector. Free the wiring that's loomed beneath clips on the protector: also take off the idler arm spring. The protector can now be removed. This gives access to the idler arm and idler gear. The idler arm can be lifted clear after removing the washer.

Prise off the neoprene washer that secures the idler gear. While holding down the main body of the idler gear with one hand, firmly grasp the pulley with the other hand and pull it upwards. The pulley, a press-on fit, should then come away, revealing the top of the brass bush on which the assembly rotates.

Using two fingers of one hand, press down very firmly on the outer edge of the gear assembly: use the other hand to grasp the shaft of the idler gear and slide the assembly up the brass bush. It's now possible, by bending the nylon body downwards, to slide the toothed gear from under the reel bracket. This enables the idler gear assembly to be removed, then the reel idler.

## **Reassembly**

Reverse the above procedure to reassemble the mechanism. Note the following points however. Before replacing the take-up reel, apply a tiny spot of lubricant to the spindle. Clean the working edges of the supply and take-up reels with isopropyl alcohol or something similar. When refitting the idler gear pulley, ensure that its top is flush with the end of the brass bush and that the idler arm is positioned correctly in relation to the idler. Check that all the springs are in place, and replace all earth leads. It's sometimes a good idea to shorten the reel idler spring by a couple of turns to improve the performance.

## Panasonic NVMS2

This camcorder had an unnerving habit of powering up on its own. Inevitably, removing the side cover provided a temporary cure. I was presently aware of being watched, as the autofocus lens followed by every move. Creeping up on the machine, I started to check the power supply switching. But any work done on the camcorder would make the fault lie low for hours at a time. It was a great relief when, a few weeks later, D6004 in the elaborate power on/off circuitry was found to be leaky. It's part of a six-pin diode combination, part no. MA141WA. When this had been replaced the machine would power up only when asked. **B.S.**

## JVC GRAX2

A fault you sometimes get is E03 appearing in the EVF intermittently. The usual cause is that the take-up sensor is spaced too far from the reel. Fit a new sensor flexi connector or a new sensor slightly raised to provide better pick-up. Alternatively the take-up reel may be slipping. In this case the cure is to replace the guide pin.

For failure to record the sound (previous sound not being erased), with the playback and E-E sound o.k., check whether L401 in the oscillator stage is open-circuit.

The cause of no E-E picture was the fact that connector CN33 was broken. The camera may have taken a knock.

Failure to eject, with no power to the heads/capstan and CP1 blowing repeatedly, was caused by the fact that Q11 on the main board was short-circuit. **K.T.K.**

## Sanyo VMD3P

A number of faults on this model have been reported in Camcorner. Most have been caused by various electrolytic capacitors being leaky or of low value. Here are some more! For smeary playback pictures, check C1038 and C1107. If the recorded luminance is poor, with poor playback field sync, but the E-E pictures are o.k. change C1100, C1115 and C1166. These capacitors are all on the VD1 PCB. C1166 is 22 $\mu$ F, 6-3V. The others are all 10 $\mu$ F, 16V electrolytics. **D.C.W.**

## Ferguson FC37

The presence of stationary vertical lines on the E-E picture, playback being o.k., suggested that the CCD imager had failed. Fortunately dry-joints on the SSG PCB proved to be the rather less expensive cause of the fault. **D.C.W.**

## JVC GR65E

Incorrect back-tension setting can be the cause of various effects with camcorders that have a small head drum. This camcorder would play tapes with no noticeable horizontal jitter, usually the most obvious effect with back-tension related problems. When the machine played back one of its own recordings however the picture would roll a few frames at the start of each recorded sequence, then be o.k. until the

next 'pause'. Replacing the supply spool and tension belt cured the problem. **D.C.W.**

## Sony CCDF330E

No functions, not even eject, were available though the E-E pictures were o.k. The cause of the fault was a damaged flexicable, FP124. It had been punctured by the viewfinder bracket assembly. **D.C.W.**

## Sanyo VEMS1P

This camcorder arrived with the cassette housing half way out and no functions selectable. The E-E pictures were o.k. however. We've had this type of fault with the VMES88P, which uses the same mechanism. The cause of the problem was broken guide rails that attach the LS assembly to the main deck (bracket 636 019 3758, cam 636 019 4311). Deck timing has to be carried out after replacing these items. This can be a tricky operation to get right – having the service manual helps. **D.C.W.**

## Sony CCDTR705E

The problem with this Hi8 Handicam was intermittent loss of both the left and right audio channels. When a faulty recording was played back there would be only a noisy 'scratching' which varied in level. Fortunately the fault was also present in the E-E mode, which made fault-finding considerably easier. The fault couldn't be instigated by carrying out disturbance tests on the AFM stereo PCB (AU121), but a dry-joint still seemed to be a likely cause. After a long session of inconclusive checking around the matrix chip IC803 we decided to reflow the connections in this area. This put an end to the trouble. Problems of this type seem to be getting more common – or is it just me? **D.C.W.**

## Panasonic NVM7B

There was no E-E colour with this full-sized oldie – playback colour was o.k. When we carried out checks on the encoder subassembly on the main camera signals processing PCB we found that there were no R – Y and B – Y subcarrier inputs at pins 13 and 14. We traced back to the subcarrier generator chip IC309 and found that its supply was missing at pin 6. L313, which provides the 5V feed, was open-circuit. **D.C.W.**

## Canon E6E (Sony Q deck)

This stereo camcorder suffered from the same fault as other models that use the Sony Q deck mechanism – noises from the deck in all modes, especially rewind and fast forward. The cause is damaged teeth on the conversion gear which mates with the capstan motor's outer edge gear. Be careful to ensure that no small pieces of teeth are left stuck to the capstan motor gear when you replace the conversion gear. It's best to remove the capstan motor to check – even a small piece of tooth can cause knocking noises. **D.C.W.**

# VCR Clinic

*Reports from Philip Blundell, AMIEIE, Brian Storm, Richard Newman, Ronnie Boag, Denis Parsons, Terry Lamoon, David Belmont, Gerald Smith, John C. Priest and Graham Richards*

## Ferguson FV30

Playback was o.k. but there were no E-E or record signals – just snow. Checks showed that the 12V u.h.f. band switching voltage at pin 8 of the tuner was missing. TT06 (BC558) was open-circuit. **P.B.**

## Philips 2SB11

This machine wouldn't accept a tape. Although the cassette-in switch worked, there was no voltage change at pin 38 of IC7140. Fuse 1005 (250mA – looks like a diode) was open-circuit. **P.B.**

## Ferguson 3V44/JVC HRD140

The E-E picture and sound were present but on playback there was just a blank raster, the sound being o.k. Scope checks showed that there was no video output at pin 9 of IC102 and no sync output at pin 2. Voltage checks on the chip were inconclusive, the voltages at pins 2, 24, 27 and 33 being incorrect. I finally had to change the chip, thus proving that it was the cause of the fault. It's a small 'end-on' PCB, part no. PU22031A. **P.B.**

## Mitsubishi HS306

There was a problem with this old-timer's loading arms: when play was selected the left-hand moving guide didn't go into the V block fully unless you gave it a push with a pencil. I suspected wear in the plastic gear cams, but a new pair made no difference. Finally, to cut a long story short, changing the cast-alloy shuttle block itself (part no. 32 in the exploded view) restored normal operation. **P.B.**

## Ferguson FV30

There had been a power supply blow up. When the kit of parts had been fitted the 12V line could be set up correctly, so the the power supply was connected to the rest of the circuitry. But there was no clock or mechanism activity. Checks showed that the voltage on the 7V line was low, the other supply voltages being correct. The chopper transformer LP40 was faulty. **P.B.**

## Panasonic NVSD40

This machine would accept a cassette but refused to retain it. Everything seemed to be normal when the tape was being loaded, but after a pause it was ejected. My first checks were around the mode switch and the systems circuits, but nothing seemed to be amiss. After much hair tearing and grinding of teeth I discovered that the BA6439P capstan drive chip was faulty. Presumably the system control section checks for capstan operation before lacing up, to prevent tape damage. **B.S.**

## Panasonic NVG21B

About once every three months the mains fuse would part, apologetically, but no amount of testing enabled the cause to be established in the workshop. Our first clue came when

we noticed that the power supply whistled intermittently while the machine was on test. The switch-mode power supply normally operates at about 35kHz. A check on the ripple on the 45V line showed that it was operating at nearer to 25kHz. We eventually found that D1002 was slightly leaky, a replacement ERA22-08 diode restoring the life expectancy of the mains fuse. **B.S.**

## Panasonic NVV8000

The problem with this all-singing, all-dancing machine looked like dirty heads, but no amount of cleaning would restore the picture. Because of the price of the heads for these machines I checked for life around the head amplifier module, where the 5V supply was found to be missing because of a loose plug on the chroma/luminacne board. Refitting P3001 restored a perfect picture. **B.S.**

## Panasonic NVD80

This machine would lose control over its mechanism, lapse into a sulk and power down. Moments later the fault would clear and everything operated normally again. The clue with this machine and indeed with most G mechanisms is that you should get a nice, satisfying 'clack' when a key is pressed – as the mechanism solenoid engages and the capstan motor moves the mechanism to the selected mode. With this machine the solenoid was intermittently sticking. The system control then became confused and powered down. A new solenoid, part no. VXA3735, cured the fault. **B.S.**

## Sanyo VHR350A

This newish machine suffered from bad horizontal jitter. A noise in sympathy with it came from the head drum motor. It was obvious that the drum servo wasn't quite locking. Unless you have extension leads, which we don't, it's not easy to work on this machine: you have to remove the deck to work on the main panel, which carries everything. After doing as many checks as we could we came to the conclusion that either the drum motor or the BU2890BK digital servo chip IC351 was the cause of the trouble. Neither prospect was attractive: the motor costs around £100 while the chip is a 44-pin surface-mounted device. As the chip is the cheaper item we ordered one and fitted it. This gave us a perfect, working machine. The replacement chip was suffixed DK, so it's presumably a later software version. **R.N.**

## Ferguson 3V24

There can't be many of these portable machines still around. The main problem with this one was the lamp, which we replaced. The machine then powered up and accepted a tape, but when play was selected the machine laced up then, after a few seconds, shut down with all the lights on the front panel strobing through. After this nothing would work until the machine was powered down and restarted. The cycle would then be repeated.



As the LCD counter wasn't working I checked for pulses at the right-hand turntable sensor. They were o.k. here and were also present at input pin 10 of the NJM2901M chip IC5 on the front panel. This chip produced no output at pin 13 however. A replacement cured the problem. **R.N.**

### **Philips VR6585**

This machine, which uses the Panasonic G deck, came in with a jammed mechanism. I fitted a new gear set then tested the mechanism by turning the capstan motor by hand. As it went through the various motions without a hitch I powered the machine. It went into turbo drive, accompanied by some nasty crunching noises, then promptly seized solid again (I hadn't inserted a cassette). Clearly there was a power supply fault that had caused the original failure.

I retimed the mechanism (fortunately no damage had been done) then borrowed the power supply from a known good machine. The result was perfect operation. I have to admit that I fitted a new power supply from stock. One day I may feel brave enough to repair the old one! **R.N.**

### **Ferguson FV22L**

The STK5490 chip in the power supply had failed. When a new one was fitted the machine worked for an hour then the picture and sound disappeared. A plain white screen with a faint field sync bar running up it was displayed. By tapping in the vicinity of the scart socket the picture and sound could be made to appear intermittently. IC103 (BX6385), which controls the video and audio switching and is like a small PCB with surface-mounted components on it, was very touchy. But no amount of resoldering with a small iron helped. A replacement restored normal operation. **R.N.**

### **Baird 8930/JVC HR7359**

You sometimes find that the loading arms fail to load up properly when the belt has been replaced. The cause is nearly always the fact that the mechanism which contacts with the loading motor gears has missed a couple of gear teeth. Thus the arms move forwards. Use elastic bands to pull the arms back (or use a Phillips 0 size screwdriver pushed through the service hole behind the PCB to the right of the motor, directly beneath the drum). This will stop the mechanism turning while the loading motor assembly is being replaced.

If you run out of belts or can't obtain one a trick is to use a file to elongate one of the holes that support the motor mounting, then shift the motor upwards by an eighth of an inch. This will tighten the loading belt slightly. Cover with Loctite. This shouldn't be regarded as a permanent cure – unless you can't get belts any more. Why don't they provide an adjustment? **D.P.**

### **Matsui VX1100**

No power was the problem with this new mid-mounted machine. A check on the voltages around IC501 showed that the operate voltage was missing. This comes from IC601 on the timer board. A replacement, which took quite a while to obtain, restored normal operation. **T.L.**

### **Matsui VX2500**

I thought that this would be a nice, simple repair. The customer said he could hear the sound of a previous recording and that there were coloured blobs on the picture.

I made a test recording and sure enough there was no erasure. This usually means a dodgy connection at the full erase head. But there was nothing wrong here, so more detailed checks were required. The voltage at the base of the bias oscillator transistor Q5002 was found to be incorrect, the result being that it was cut off. I then found that the 5.6k $\Omega$  bias resistor R5001 was open-circuit. A replacement restored normal operation: not so bad after all! **T.L.**

### **Amstrad UF20**

This is one of those centre-load machines. Whoever thought of the idea doesn't like repair technicians. The problems were no E-E or test signals and no playback. As the supply to the r.f. modulator was present it was a fair bet that the modulator had failed. It was replaced with some difficulty, but the fault remained. I then noticed that there's a power-on 12V line to this module. When checked it was found to be low. Tracing the source back brought me to Q01 which was leaky – it's in the power supply. A replacement restored normal results.

There's a lot of heat stress in this area of the UF20, so the fault could become a common one. **T.L.**

### **Panasonic NVSD40**

There were lines across the screen in the play mode. It looked as though the loading arms were misaligned but inspection in this area showed that there was a circlip stuck in the way of one loading arm. When it was removed the machine worked all right. It didn't take long to discover where the circlip had come from and fit a new one. **T.L.**

### **Grundig VS450**

This machine would switch off after a few seconds, with F1 flashing. Investigation showed that neither of the reel sensors produced a pulse output. The LED parts of the reel sensors are connected in series, together with the end-of-tape sensor LED, and are fed with a 12V supply that was missing. The cause was transistor Q537 which was open-circuit. A BC640 proved to be a suitable replacement. **D.B.**

### **Matsui VX1000/VX2000/VX2500**

If the complaint with one of these machines is that it won't go into the timer-record mode it could be that the customer has the wrong remote control unit. There are two. One has a power on/timer RFC and the other a separate timer-record button. **D.B.**

### **Akai VSF510**

The customer complained of a generally poor picture. I found that there was smearing on peak whites. Good results were obtained by playing back a known good recording of colour bars and adjusting the playback luminance level, then adjusting the carrier and deviation levels in the record mode. **D.B.**

### **Ferguson FV22**

Very intermittently the picture would go dark, with colour, as though the luminance signal had dropped out. When I could get the fault to remain for some time I found that a good video signal went into IC301 but very little came out. IC301 is a thick-film circuit. On removing it I found that a 390 $\Omega$  surface-mounted resistor was dry-jointed. Resoldering

this then reassembling IC301 provided a complete cure. But the machine came back with a deck mechanism fault: this time the screw on the deck PCB needed tightening. **D.B.**

### **Matsui VX1000/VX2000/VX2500**

Tuning drift can occur with these machines when R6045 (33k $\Omega$ ) has gone high in value. **D.B.**

### **Sony SLV353**

The tape went in but would only partially lace up because the post limiter had seized on its pivot. Dismantling it and relubrication cured the fault. **D.B.**

### **Panasonic NVL20**

This machine played back and recorded all right but in the forward search mode the picture broke into lines. The cause was a worn lower drum assembly. **G.S.**

### **Nokia 3783**

The complaint with this machine was that the sound was o.k. with its own recordings but when the recordings were played back via a friend's machine (not hi-fi) the sound didn't match the picture. We found that the linear sound on these recordings was from an old sound track. There was no erasure because the bias oscillator transformer T2001 was short-circuit. A replacement cured the problem. **G.S.**

### **Bang and Olufsen VHS66**

We don't get much B&O equipment passing through our hands and this machine in fact came from an engineer who gets even less! Its recordings played back all right on any other machine, but playback of its own and other recordings suffered from intermittent loss of colour, poor colour and patterning. On removing the case we saw that there was a definite Hitachi touch: apart from an extra audio panel and some differences on the main PCB, it looked very much like the Hitachi VT65.

As we were now on familiar ground we turned our attention to the Y/Chroma PCB. This has three Hitachi hybrid i.c. modules that are all frequent causes of trouble. We found that ICC203 (HT4509C) was very sensitive to disturbance testing, and after confirming that there were no dry-joints in the area we obtained and fitted a replacement (part no. 5374594). This cured the problem.

Incidentally Hitachi manuals dating from the mid-Eighties can cause some distractions. Apart from howlers like 'blightness', why would a Japanese company producing manuals for the UK choose to use Gothic script on the cover – and get it wrong?! In my copy of the VT65 manual the parts lists proclaims itself to be the 'tarts edition'. **J.C.P.**

### **Sanyo VHR3300**

The complaints with this machine were "picture jumping and tape damage". The first thing we noticed was that someone who shouldn't had been inside it – there were damaged screw heads and the audio/control head was way out of alignment. This was mainly because one of its levelling screws, the one that retains the coil spring, had been sheared off.

After rummaging through our box of worn heads to find replacement screws we carried out a rough realignment then tried powering up. Playback was fair, but there was no E-E

picture and no recording. At this point we phoned the customer, who told us that a friend had adjusted the machine to improve the sound! The lack of E-E hadn't been noticed as the machine was mainly used to play hired videos. After some discussion about cost we returned to the machine and carried out some scope checks. These confirmed that the tuner and i.f. sections were in good order: composite video was present at the output of tuner block VD1, and was traced around the board until it disappeared into the LA7223 chip IC001 at pin 7. It didn't reappear at pin 1. This is a video/audio switching chip that doesn't seem to be in any wholesaler's list. A replacement was obtained from Sanyo however (part no. 409-114-4407). Fitting it restored normal operation and a general clean, lubrication and realignment completed the repair. **J.C.P.**

### **Toshiba V65**

There was no playback or record colour. Checks around IC301 showed that there was a video input but no chroma output. Replacing the IC301 module cured the fault. **R.B.**

### **JVC HRD455**

This machine was dead because of a dry-joint at CN1 in the power supply. **R.B.**

### **Panasonic NVJ30**

There were no E-E, playback or test signals. After carrying out waveform and voltage checks we came to the conclusion that the r.f. converter module was faulty. A replacement restored the signals. **R.B.**

### **Akura VX140**

Failure to eject tapes and no functions was cured by replacing the BA209N chip IC601 and the 2.2 $\Omega$  resistor R601. **R.B.**

### **Sanyo VHR315**

This dead machine kept on blowing the N38 fuse PR511. By disconnecting the various 5V rails we discovered that there was an internal short-circuit in the tuner/i.f. unit. A replacement module restored normal operation. **R.B.**

### **Akai VS485**

There was no clock display because the d.c.-d.c. converter was faulty. If you get inside this and find that TR408, TR409 etc. are o.k. an economy repair can be achieved by replacing the electrolytic capacitors – all eight of them! They are C432, C434, C446, C447, C448, C449, C450 and C451. The problem is that they dry up because of the heat. **G.R.**

### **Philips VR6467**

After refurbishing the mechanism (rack slider kit etc., part no. 4822 403 53377) the machine displayed only a test signal, i.e. there was no playback or E-E video. The 10V supply was missing because the BC328-40 transistor 7607 was short-circuit base-to-emitter. A replacement restored the signals. Transistor 7304 on the chroma/video processor board causes a similar fault – it's also a BC328-40. Also check the electrolytic capacitor C2329. If transistor 7304 is faulty this capacitor will almost certainly be short-circuit. **G.R.**

# Service Notes on the Sony CCDF350 Camcorder

Keith T. Keeton

This camcorder is very similar to the CCDF335, for which servicing notes were published last month. It's a very sturdy and reliable unit that can take quite a few knocks. The U mechanism it uses is very easy to repair.

## Fault Diagnosis

In these servicing notes I sometimes refer to the EE picture. This is the signal from the CCD image sensor to the output socket or electronic viewfinder (EVF), not the feed to the record heads. As it doesn't, usually, go through any of the record circuitry a large section of the camera can be eliminated for fault diagnostic purposes.

Knowing that the playback signal is also unaffected enables you to eliminate from suspicion those sections of circuitry common to the EE and playback signals.

If the playback and EE signals are both affected the cause of the fault will probably lie in their common circuitry.

When record and playback are both at fault, the EE circuitry can be eliminated.

The more circuitry you can eliminate, the easier fault finding becomes.

Now to specific faults experienced with this camcorder.

## Camera Section Faults

**Camera won't turn on; flashes then goes dead:** The cause of this was a dry-joint at C946 on board PS263.

**Bottom of the EE picture dark, top has mixed colours. Playback o.k.:** All the control pulses were being applied to the CCD but the output was faulty. A new CCD cured the fault.

**The EE picture was distorted at the left-hand side only, the picture otherwise being o.k.:** When the CCD board was disconnected the EE display was, as expected, black – but with a light band down the left-hand side. The cause was easily traced back to HIC602 (MX7) whose board had a small crack. This chip is on panel CV9. A new MX7 cured the fault. On another occasion the same symptoms were present but the cause was dry-joints at pins 16-22 of HIC602.

**The EE picture goes dark and may flash black lines. The faults was sometimes intermittent:** C704 on panel CV9 was faulty.

**The EE picture was blue but playback was o.k.:** IC606 (CXA1072R) on board CV9 was the cause.

**There was no EE picture and white characters scrolled sideways on the data screen:** Q617 and Q619 (type 2SC1623) on panel CV9 were faulty.

**No power to the camera section and the EVF dead in the camera mode:** Cause of the troubles seemed to be low output from panel PS263P. Removing L939 restored the voltage however. C216 (10 $\mu$ F, 16V) on panel CV9 was defective, earthing the 5V video line.

**No power to the camera section, the VCR section being o.k.:** The voltages around Q939 on panel PS263P were wrong. Replacing Q939 and Q937 restored normal operation. IC935 sometimes causes this fault.

## Mechanism Faults

**No playback, stops in the playback mode. Mechanism tries to unload but stops before it gets half way:** A faulty encoder or broken flexiconnector (FP89) to the encoder can be responsible for this.

**Failure to load/eject. Arms move in and out continuously until the fault sign appears:** The take-up reel was jammed. Repair or if necessary replace it.

## VCR Section Faults

**No playback picture, EE o.k.:** IC203 (CXA1200BQ) on panel CV9 was faulty with no output at pin 45 (signal o.k. at pins 22/23). On another occasion IC201 (CXA1201Q) on the same panel was faulty with no output at pin 11 (input o.k. at pin 2).

**White screen in the PB mode, sound and EE o.k.:** We have come across several causes of this symptom. C451 (1 $\mu$ F, 16V) may be faulty, removing the bias at pin 11 of IC202. The same conditions can be caused by C235 being faulty. Another cause is IC202 (CXL1502M) – check the output at pin 11. All these items are mounted on panel CV9.

**Playback picture shakes, EE picture o.k.:** The capstan was juddering because the pulses to the capstan motor were wrong. IC510 on panel CO2P was faulty.

**Playback picture wavy, EE picture o.k.:** Sync signal is o.k. at pin 56 of IC203 but of low amplitude at Q216. Cause is C212 being open-circuit. Resolder or replace C212 as necessary. These items are on panel CV9.

## VCR/camera Faults

**Faint, coloured vertical line on the EE picture. The line can also appear on the playback picture:** The delay line on panel PJ20 was faulty.

**No characters in the EVF, playback and EE o.k.:** There was a dry-joint at connector CN802 on panel CV9.

**No playback, EE picture smeared:** There was no sync output at pin 11 of IC201 though the input was o.k. at pins 2 and 31. Disconnecting pin 11 restored the signal. The 1 $\mu$ F, 16V ceramic capacitor C218 was faulty. These items are on panel CV9.

# VCR Clinic

*Reports from Graham Richards, Mike Leach, Terry Lamoon, Andrew J. Finn, Steve Cannon, Keith Evans, Chris Avis, Chris Watton Michael Dranfield and John Edwards*

## **Amstrad VCR8800 (4 x 8 Nicam)**

"Nothing" was the complaint. And that was all it did! The machine was dead because the 5V regulator IC651 had gone open-circuit. A replacement restored normal operation. **G.R.**

## **Akai VSF200**

The customer thought that this machine was faulty. In fact it was in the child-lock mode. Nothing then works, with just 'L' showing in the display. Press the handset's play button for ten seconds to return to normal operation. **G.R.**

## **Panasonic NVG21**

This machine had come into the workshop on several occasions, each time with a report of a different, niggly fault, none of which were ever really cured. Very rarely could we get the machine to show one of these faults. This time the complaint was of no playback colour and lines on the screen. We confirmed that there was no playback colour and found that the drum speed was varying slightly, as a result of which the picture shifted a little on the screen. The cause was easily found with the aid of a hairdryer and freezer: C23 (1,000µF, 10V) in the power supply was leaky. Replacing this cured the latest problem and all the other ones that plagued the customer seem to have gone away. **M.L.**

## **Pioneer VR727/Philips VR6870**

This machine had given trouble for some months. The first complaints were of intermittent functions and going into play and rewind by itself. On that occasion we were unable to find anything wrong, and after a long soak test returned the machine to its owner. It came back the following day with the complaint of no results at all. We switched it on and after half an hour it sprang to life and carried on working. So we replaced various components in the start-up circuit and returned it, once more with a nominal charge. It was recently back with the same complaint.

This time there was a tape in the machine, in the stop position. So we plugged in and waited. As the machine sprang to life half an hour later it started to do some strange things. The clock display came on first, then the carriage tried to lift the tape about an inch or so then plonked it down again. It did this several times before going into rewind by itself. Then it was all right for the rest of the day.

We switched it off for a few days and pretended that it wasn't there, like you do. Unfortunately it didn't go away. The next time I switched it on I monitored all the supply lines. Except for the 6V and 5.1V supplies they were all correct. The 6V supply was low at 4.2V while the 5.1V supply was down at 4V. A look at the circuit diagram showed that three 680µF capacitors smooth the input to the BD434 transistor Q7008. They had dried up. Replacements rated at 25V rather than 16V were fitted. After this the machine worked perfectly. **M.L.**

## **Amstrad UF20**

When a cassette was loaded this machine would power down with the display flashing erratically. Checks on the

supplies showed that the voltage on the 12V rail was low. The cause of the trouble was the 12V regulator IC01 which was breaking down. A replacement restored normal operation. **T.L.**

## **JVC HRJ205**

The customer said that when he inserted a tape and pushed play the machine would stop working and the display would "go peculiar and disappear". I'd seen this one before and went straight to the ICP fuse in the power supply. Sure enough it was open-circuit, a replacement restoring normal operation. This is becoming a common fault. When I phoned JVC Technical for advice I was told that the cause is being looked into. Until they come up with something, keep a good supply of these ICPs handy in your kit. **T.L.**

## **Hitachi VTM770**

There was a tape jammed inside this machine. When switched on it powered down within seconds. Investigation showed that the 1.6AT fuse had blown. When this had been replaced and the tape had been wound out manually the machine remained on. A cassette was then loaded, but it was noisy and sluggish because the capstan was stiff. When the shaft had been cleaned and lubricated the machine was as smooth as silk. **T.L.**

## **ITT Nokia VR5720**

These machines tend to suffer from a very poorly lit display. The cure is to replace C447 (47µF, 6.3V) on the main board. It needs to go down by only 9µF to cause the problem. **A.J.F.**

## **Sharp VC8581H**

This may sound silly but it caught one of us out. The machine would accept and eject a cassette but there were no deck functions. Although the lights on the front panel lit up correctly for the operation selected nothing else happened. The cause of the trouble was the small 2.5A fuse protector IP901 in the power supply – not the wrongly diagnosed microcontroller chip! **A.J.F.**

## **Mitsubishi HSM16**

"Warble on music" it said on the ticket. Sure enough this was the case. A look around the servo section showed that one leg of the 1µF capacitor C4D3 had failed to pass through its hole and was bent back on itself. This had obviously missed quality control. **A.J.F.**

## **Logic VR950/Samsung VI611**

This machine worked well for about a quarter of an hour. The drum would then speed up and nearly take off! The capstan motor would run flat out and the machine would shut down. As both motors were affected we decided to check the power supply. In the fault condition pin 6 of plug

F02 (5V output to the servo) was at 2.4V. When this pin was removed the voltage returned to 5V. As there were no shorts across this supply a 6V battery was connected. This restored normal operation, so the 2SC1008 5V regulator transistor Q5 was replaced. After a long soak test the machine was returned to its owner. **A.J.F.**

### Philips VR6462

This machine appeared to be dead, with no clock display or deck functions. But the customer had noticed that it worked perfectly with remote control. A new TMS1934 clock display/function chip on the front panel put matters right. **A.J.F.**

### Sanyo VHR135E

"No operation" it said on the ticket. Although the drum was stationary, all the lines to the motor said go. A replacement stator winding board from Chas Hyde got the drum going. But although the machine laced up it wouldn't play and there was no rewind/fast forward. Checks were made around the microcontroller chip but there was nothing obviously wrong. Stalling the head motor failed to shut the machine down however. The conditions at pin 85 of the chip appeared to change with the head stalling, but the chip did nothing about it. So we changed the micro (a one inch square surface-mounted device with 94 pins).

Although the machine now played, the pictures were virtually non-existent. We checked the whole head amplifier and changed the chip. Hair pulling started! Then it suddenly dawned: the heads were mistracking by 180°. As the head rotor had been replaced, we turned the rotor magnet by 180° and refitted it. Success at last! **A.J.F.**

### Sony SLV425

This machine would sometimes fail to power up and play correctly. If the power switch was pressed when the fault was present the fluorescent display would light, giving the impression that the machine was powered up, but the power LED would remain red rather than glowing green.

The green power LED is controlled by the +5VF line, which comes up only when the +12VF line is active. This line is controlled by T108, CT110, CIC130 and the syscon chip CIC200. Basically, when the +12VF line goes high this feeds to the power supply and brings up the +5VF line which powers the rest of the machine. T108 and CT110 are controlled by pin 7 of CIC130: the conditions at this pin didn't alter when the power switch was pressed. A check was then made on the inputs to this chip from CIC200. These did seem to alter when the power switch was pressed. As CIC130's supply and chassis lines were intact, we found and fitted a replacement. It's a surface-mounted chip, and care has to be taken as there are quite a few surrounding components – hot-air soldering guns are becoming essential for successfully and safely removing such devices. With the new chip fitted the machine worked perfectly. After spending the afternoon on test, it was pronounced fit. **S.C.**

### Samsung VI710

We had two of these machines in the workshop recently. The first one wouldn't work in the record mode. Investigation showed that the REC 9V supply to the preamplifier on the luminance/chrominance panel (at the top) was missing. The reason for this was that diode DO305 at the front left of this panel was open-circuit.

The second machine displayed all the symptoms of a defective video head, but fitting a replacement made no difference. It was beginning to look as though the lower drum may have been the culprit – until we learnt about the machine's history. It had spent a lengthy period at another workshop and had eventually been retrieved by its disgruntled owner who had brought it to us for assessment. We put off changing the lower drum and concentrated on the head amplifier module. When we unplugged the unit to check the rotary transformer connections and continuity we soon realised that the module could easily be reconnected in the wrong position. A sigh of relief was breathed when this proved to be the case. After a clean and service, the machine was returned to its grateful owner. **K.E.**

### Sharp VC582

The complaint with this elderly machine was that it wouldn't play tapes. When a blank test cassette was inserted we saw that the capstan didn't rotate. After eliminating the motor we turned our attention to the servo and motor drive amplifier section. As the voltages around the motor polarity switching chip IC701 didn't look right we fitted a replacement. It sits on the main PCB, under the deck mechanism, so it's not easy to get at. Lifting the deck is probably better than trying to hinge up the main PCB.

Fortunately the replacement restored capstan rotation, but we then found that there was hum on playback and the recorded sound and picture – the E-E signal didn't seem to be affected. Checks in the power supply showed that the 15V feed to the 9V regulator was low at 11V. A replacement reservoir capacitor (2,200µF) produced only a marginal improvement, so resistance checks were carried out on the bridge rectifier diodes (be warned – they are buried beneath the mains transformer). They appeared to be normal but as the transformer's secondary winding provides about 12V a.c. we decided to replace them anyway. This provided a complete cure, restoring all voltages to the correct levels. **K.E.**

### JVC HRD620

Playback suffered from four equally-spaced horizontal noise bars, and there was poor or no sound. Having had this problem with several of these machines recently we checked the tape wrap alignment around the drum. Sure enough the tape was sitting high near the exit slant post, indicating that the guide roller had moved. The small locking grub screws beneath the guide posts tend to work loose. Then each tape loading turns the roller minutely out of alignment. Adjustment of the roller and tightening the grub screw did the trick. It's worth checking both the entry and exit roller screws. **K.E.**

### Ferguson FV42L

This machine seemed to be dead but was all right when the top cover was removed. All then seemed to be well – until our trusty PCB whacking tool was brought to bear on the main board. We soon established that the regulated 5V supply would go missing. This comes from TT64 (BD435), which is fed with a 7V supply. TT64's three legs were all dry-jointed. **K.E.**

### NEC N9120K

If the drum motor runs very slowly during play and the capstan motor 'chugs' lazily, check the 4.43MHz subcarrier

signal at pin 1 of the servo chip IC601 – its amplitude should be 3-4V p-p. If it's present, replace IC601. If it's missing, replace crystal X1401 adjacent to the chroma chip IC1401. The correct crystal, part no. 64004143 from SEME, must be used. A standard 4.43MHz crystal will oscillate but there will be no colour. **C.A.**

### **Samsung SI1240**

The owner complained that recording was very intermittent – just the fault for Monday morning! Fortunately he supplied a sample tape, which showed an apparent loss of signal rather than recording. The suspect tuner was eventually persuaded to go intermittent in the E-E mode by being tapped. So we removed it and wired it back to the PCB temporarily for easier access and checking. The cause of the fault was then found to be a hairline crack around one of the SAWF's pins in the tuner/i.f. section. **C.A.**

### **Hitachi VTM822**

The rewind action was very poor because the rewind gear actuating slide didn't travel far enough to engage with the gear correctly. It took us a while to discover that the mecha-state switch was responsible for this. Although this would be an easy part to remove and replace, it's supplied only as part of the whole 'loading block assembly'. Good old Hitachi! **C.A.**

### **Panasonic NVG12**

When this machine was brought in the loading arms were out. Then it unloaded, leaving the supply reel turning slowly – all this with no cassette inserted. Replacing the deck mode-control switch restored normal operation. **C.W.**

### **Amstrad VCR6100**

When eject was requested a small loop of tape was left outside the cassette. This caught on the lift and broke. Tape reclaim works in two ways in these decks. From the play to the stop mode the tape is drawn back into the cassette by reverse rotation of the supply reel turntable, driven by the rewind drive gear assembly. The drive for the final reclaim is at the take-up reel, operated by the half-loading wind gear. If this is either loose or sticks on the pillar the tape won't be drawn back in: it turns only about twice, and unless it engages instantly a small amount of tape is left hanging out of the cassette. The item to replace is no. 613 in the service manual. **C.W.**

### **Akai VS2**

There was loss of both the E-E and playback pictures. The on-screen display was working however and the sound was o.k. The cause of the loss was the 2SC536 transistor TR15, which had a collector-to-emitter short-circuit. A BC547 with its legs crossed makes a suitable replacement. **C.W.**

### **JVC HRD720**

This machine was dead with a fully-loaded tape inside. There was no clock display, no nothing, though there were outputs from the power supply. We didn't have the manual, but did find one for the Ferguson FV45X which seems to have the same power supply. Armed with this we soon found that the unswitched 12V supply was missing because circuit protector CP2 (N20) was open-circuit. A meter check

showed that the maximum current being drawn was 400mA. A replacement CP cured the fault. **M.Dr.**

### **Samsung SI3240/3260**

This machine would load a tape but when play was selected it would unlace, leaving the tape hanging out of the cassette. Fast forward and rewind were o.k. however. Very low capstan motor torque was the cause of the trouble. The torque control circuit consists of Q102, D108, D109 and D110. In the play mode power is fed to the motor via the three diodes. In the fast forward and rewind modes the three diodes are switched out by Q102. The cause of the trouble was D109, which introduced a voltage drop of about 4V though it tested o.k. on an ohmmeter. All three diodes are type 1N4001, and I suspect that they came from the same bad batch that affects Models SI1240/1260. Replace all three to avoid comebacks. **M.Dr.**

### **GoldStar GSE1290IQ**

The customer complained about a poor playback picture and tape chewing. We replaced the pinch roller and arm assembly and gave the deck a good clean/service. After a soak test the machine was returned to its owner. A couple of days later it came back, again because the playback picture was poor. After several tries at loading and unloading we found that the back-tension arm sometimes stopped before it reached the play position. As it is mechanically linked to the main cam we decided to replace the mode switch. This cured the fault for good. **M.Dr.**

### **Philips VR201**

This machine wouldn't erase the previous sound when a new recording was made. A check on the BC337 erase bias oscillator transistor Tr7252 showed that it had base-collector leakage, a replacement curing the fault. **J.E.**

### **Aiwa G700GPS**

This model uses the same deck as the **Amstrad VCR4600**. The one we had would accept a cassette but nothing else worked because the belt between the capstan motor and the intermediate idler had fallen off. A new belt kit cured that, but while the machine was on test it began to crinkle the tape. So in went the modified clutch/pinch roller kit. When the machine was put back on test there was a reasonable playback picture for about half an hour after which the colour suddenly flickered on and off a few times then disappeared. I didn't panic, honest! Memory took over: the colour was restored when I'd resoldered all the pins of the chroma module HCI201. Unfortunately the customer had been quoted for only a belt. Oh well, what's new!? **J.E.**

### **Hitachi VT33**

The complaint with this machine was that it wouldn't eject a tape – there was a cassette in the machine to prove the point. No matter what mode the machine was in, pressing the eject button wouldn't release the cassette. In fact pressing the button would sometimes change the function, for example if the machine was in the play mode pressing eject might put it into the fast forward or some other mode. Usually however pressing the button had no effect at all. The cause of the trouble was the eject switch itself. It measured all right out of circuit when checked with an ohmmeter, but a replacement from a scrap machine cured the fault. **J.E.**

## Panasonic NVG1

The complaint was of intermittent loss of colour. According to the owner the loss would occur after filming for ten minutes. Inspection on the bench revealed two significant factors. First the loss didn't affect the burst vectors. Secondly the luminance had a high contrast level and was clipped. If the camera PCB was moved the fault came and went. Then it stayed.

During the period when the fault was intermittent, I noticed that the luminance level at pin 11 of IC314 dropped when the fault occurred. The output at pin 5 was overloaded and clipped: there was no overloading at pins 7 and 3. I couldn't verify these changes now however as the fault was permanent. There was only one thing to do, to follow the colour signal path. IC314 had a colour signal at output pin 33, but the following buffer transistor Q311 didn't produce an output. In fact it seemed to be cut off. Q311 feeds a hybrid delay line chip, IC318, so it seemed that this was loading down Q311. But the fault did once respond to PCB movement. When I checked around IC318 I found that it has more than one supply line – in fact it has four! Pin 18 was without any voltage because L303 was dry-jointed. Phew!

S.B.

## Sony CCDF250

This camcorder is very similar to the F335, which I covered in the July issue (page 667), but doesn't have a digital titler. The auto-focus is sometimes slow. Otherwise, these camcorders are very sturdy and reliable. They use the easy-to-repair U mechanism. We've had the following faults.

**Black E-E picture, playback o.k.:** DT73, which is a hybrid i.c. on board CV9, was faulty. A replacement (part no. A7068150A) restored normal operation.

**No zoom. Focus and E-E operation o.k.:** IC801 (TK10500M) on board CV9 can cause this fault. Part no. 875923123. We've also had to replace the zoom motor. Part no. 370756201.

**Interference at bottom edge of playback picture:** C161 (47µF) on board CO2P was faulty. Part no. 112620411.

**Playback picture jumps:** IC501 (CXP80116099Q) on board CO2P was faulty. Part no. 875280908.

**E-E o.k., playback produces white screen:** The usual cause is dirty or worn heads – the picture is blanked when the signal is very poor. Part no. A7049215A.

**The E-E and playback pictures were very dark though the EVF display was o.k.:** A check at IC201 on board CV9 showed that the output (pin 8) was clipped. C214 was faulty.

K.T.K.

## Sanyo VMD9P

The record and playback pictures were fine but the playback sound was intermittent. The effect was random sound cut-out for a fraction of a second at a time. We found that the

problem was worse with some tapes than others, and was most noticeable where picture dropouts were visible. The audio chip is IC201, on the main board. C2001 (0.01µF) is connected between pin 2 and chassis: it forms part of the mute detect system and was open-circuit. Because of this the mute threshold operated incorrectly. A replacement cured the fault.

D.C.W.

## Sony CCDF380E

The cause of no camera picture with playback o.k. was traced to IC3651 on board CK19P being faulty. A camera picture was available with the back-up battery removed. When it was fitted the picture remained until the camera was de-powered. On power-up the fault returned.

D.C.W.

## Sony CCDTR105E

This camcorder had two faults: it wouldn't accept a tape, and the picture disappeared intermittently. The cause of the tape problem was incorrect positioning of the back-tension guide pole – the pole was in the play position when the cassette housing was fully open. Normal operation was restored when cam and guide arm TG1 were replaced. A dry-joint at connector CN801 on the camera PCB was the cause of the intermittent picture.

D.C.W.

## Sanyo VMD6P

Poor battery contacts seem to be a problem with this model. Recent experience suggests that when you have the case off for servicing it's worthwhile checking the soldering to the main PCB – saves having to remove it all again later!

D.C.W.

## Sony CCDF500E

There was a noise band across the bottom of the playback picture. Tape path fault we thought, and we were right. On examination we found that the supply side roller guide (TG2) was missing! A replacement cured the fault of course, but where had it gone?

D.C.W.

## JVC GRC7E

Intermittent playback luminance was the problem with this camcorder. The luminance playback signal path (YC PCB) is via Q3, at the junction of R44 and R45. On investigation we found that one end of R44 had a crack across it. A replacement cured the fault, but unfortunately these components are all under a large blob of JVC glue!

D.C.W.

## JVC GRS77E

When record or play was selected the machine would lace up normally until tape transport began: the capstan motor would then take off at full speed! The cause of the problem was a faulty Hall effect chip on the motor assembly – it produced a capstan FG signal of reduced amplitude. The motor has to be replaced as the chip is not available separately.

D.C.W.

## Panasonic NVMS4

This camcorder was accused of being unreliable when recording. Apparently it would sometimes stick in pause and sometimes shuffle and back space erratically. After some hours had been spent testing the machine sure enough when record pause was selected it unlaced, spooled backwards, laced up again and then finally, after back-spacing unsteadily, it obeyed the original command. Heating and cooling the various systems and servo chips had no effect on the fault condition. After another spasmodic display suspicion fell on the mechanism mode switch. A replacement, part no. VSS0193, cured the problem. **B.S.**

## JVC GRA1

The symptoms produced by this machine gave the impression that the playback control pulses were missing: there were cyclic noise bars on the picture, and use of the tracking control wouldn't alter them. The machine's recordings played back all right in another machine.

We monitored the playback control pulse input to the digital servo chip IC101. This only confused us as the pulses were present, stable, of the correct amplitude and frequency etc. – at least as far as we could discern. We then recalled that these machines were amongst the first to have a 'reverse-tracking' feature. This is intended to ensure that the correct video head (A, A', B or B') reads the track being played back. Without this feature picture wobble effects can occur, when for example head A reads a track recorded by head A'. The system modifies the duty cycle of the recorded control pulses, thereby enabling the tracks to be identified during playback.

The servo chip, in conjunction with the mechacon chip, checks the duty cycle of the control pulses and adjusts the capstan phase to achieve correct tracking. In this case there was a control pulse input to IC101, as mentioned above, but no playback control output at pin 29 to the mechacon chip. IC101 was faulty, a replacement putting matters right – thank heavens! **D.C.W.**

## Ferguson FC27/JVC GRA1/Telefunken VM4300

The reported fault was no tape transport. As with many of these JVC based machines, the loading rings had become misaligned. In addition – another common fault – the middle guide pole assembly had broken off. A damaged intermediate gear, which had to be replaced, was the cause of the misaligned loading rings. This is quite a job. The drum assembly and most of the deck guide rails etc. have to be removed, and the loading rings have to be lifted off the main deck to give access to the gear. Refitting involves complete mechanism alignment and timing. As with all mechanisms, the Sony Mode Box is invaluable when checking for correct operation. **D.C.W.**

## Sanyo VMD9P

The complaint was of "intermittent and unwanted deck functions". This recent model uses the Sony A mechanism and required a new mode switch to settle down. The Sony

mode box and leads help with this type of problem as incorrect mode-switch functions are indicated visually with LEDs. **D.C.W.**

## Mitsubishi HSC35B

This is the model with the colour viewfinder known as the 'Truefinder'. The display is produced by a colour-filter disc that revolves in front of a monochrome c.r.t., not by an LCD panel. The disc is driven by a small motor and is synchronised to provide correct colour registration. A great deal of digital processing is involved: the circuitry used for this occupies most of the interior of the viewfinder case. The digital PCB sits above the monochrome c.r.t. and its scanning and video circuits.

The problem with this one was that the viewfinder picture occasionally shifted sideways and jittered. The E-E picture displayed on a monitor was unaffected: only the viewfinder picture 'twitched'. Various checks were carried out on the scanning and video PCB, to no avail. All the viewfinder circuits are supplied by a 5V line that comes from the main VTR power supply. This rail has to provide quite a heavy current, around 350mA. A check here showed that under the fault condition the voltage varied from its normal 5V by about 0.2V. So was the viewfinder overloading the supply, or was the supply faulty?

The answer was obtained by using a separate supply for the viewfinder. This proved that the cause of the trouble was in the power supply in the camcorder body. The main items in the regulator are IC901 and a large transistor, Q901. As the fault was intermittent I decided to replace all the components in this circuit. This put an end to the trouble. **D.C.W.**

## Sanyo VAR30B

This adaptor is used with Model VMH100P. It had no output and wouldn't charge a battery. The faulty items that had to be replaced were F102, the 85°C thermal fuse RR201 (4A) and T1 (1.25A glass). Strangely the chopper transistor was all right. **D.C.W.**

## Sharp VLC690

Playback was all right with this C-format camcorder but the E-E pictures were very weak – in fact there was an image only when the camcorder was used outdoors. A vectorscope check showed that colour information was present, but a scope display didn't show any luminance signal. So we checked through the luminance signal path and found that IC203 (MSM6850M) was the cause of the problem. This 1H delay line type of chip, like similar ones in other makes, seems to be a common cause of loss of signal. **D.C.W.**

## Toshiba SK60P/JVC GRC7

There was no viewfinder picture, just field collapse. We found that the height control VR3 was open-circuit. **D.C.W.**



# VCR Clinic

*Reports from Philip Blundell, AMIEIE,  
Nick Beer, Gerald Smith, David Belmont,  
Ronnie Boag, Graham Richards  
and John Edwards*

## Sony SLV777

For intermittent tape damage when a cassette is ejected, or failure to play because the tape is not taken across to the capstan, check whether the half loading arm is stiff in operation. **P.B.**

## Grundig VS500

For inoperative tape start and end sensors check the drive to the tower LED. R285 (47Ω safety) can go open-circuit, as can CT285 (BC848C).

If the clock display flickers (the flicker gets worse if you put your hand near the display) change the fluorescent display itself. **P.B.**

## JVC HRD180

This machine wouldn't record new video signals. Sound was recorded and the previous video was erased, but the new video information was missing (if the full erase head was disconnected temporarily, the previous video was left). A check on the pre-rec board showed that the /REC line didn't go low. The cause was a dry-joint at the ribbon cable link (CN2) between the mechacon board and the video board. **P.B.**

## Philips VR231

When a known good tape was inserted and play was selected the display consisted of a monochrome picture with field jitter. If forward search was tried the fault cleared and the display remained o.k. when you went back to play. Scope checks around the LA7191 luminance/chroma chip IC7051 showed that the video signal was being corrupted by the CCD delay line chip IC7504. The video input at pin 6 was all right but the output at pin 4 was 'chopped up'. The CCD clocking signal at pin 7 was similarly chopped up. It comes from IC7051, where the VXO crystal 1601 wasn't producing a clean oscillation. A new crystal solved the problem. **P.B.**

## Hinari VXL9

This machine wouldn't tune. The BT line was permanently high, and altering the channel number (FS tuning) had no effect. The clock and data lines at pins 53 and 52 respectively of the flat-pack, surface-mounted microcontroller chip IC601 seemed to be o.k. but the supply 'load' at pin 51 was low as it was dry-jointed. **N.B.**

## Hinari VXL9

This machine caused us a series of problems, one after another. I finally got down to the last two faults, which seemed to be linked. The machine would intermittently go into the external input mode of its own accord - replacing the channel number with an E. Even more intermittently it would for no apparent reason go into pause. This happened only in the play mode, never during record. As scope checks showed that the spurious commands weren't coming from the local keys, checks were carried out around

the IR amplifier. The supply was found to be slightly low at 4.7V and had a 1V p-p ripple on it. This supply also powers the microcontroller chip. So over to the power supply where both C505 (2,200μF) and C507 (220μF) were low in value. Replacements restored a clean supply at the correct level and the mysterious happenings ceased. **N.B.**

## Samsung SI3240/3260

Cassette loading problems are quite common with these machines. There's a modified side plate for the carriage as well as a different connect gear (the front loading drive comes from the main mechanism loading motor). These parts are available from a number of sources - but beware, they are sometimes up to 400 per cent more expensive than from Samsung, which charges just over a pound for the side plate! **N.B.**

## Panasonic NVL20EG

This Continental machine wouldn't tune. It wouldn't search, let alone find anything. The tuning system is far more involved than that in the equivalent UK model, as there's a multi-band facility as well as switchable a.f.c. and fine tuning. A d.c. check showed that the 5V supply to pin 11 of the TV demodulator PCB was low at 1.08V. But it was not being loaded excessively. It was present at source, and most of the way to this destination. The cause of the fault was a faulty through-the-board link between C7407 and L7405. When this was linked across we could tune limitlessly. **N.B.**

## Samsung VI611/621

There was intermittent hum on the E-E and playback sound and vision. We initially suspected defective capacitors in the power supply, but the fact that the fault occurred when the machine was hot suggested otherwise. The cause of the trouble was a superb dry-joint at the positive leg of C8 in the power supply. **N.B.**

## Grundig VS400

There was no tuning: the BT supply at pins 15 and 16 of the tuner was permanently high at 32V. The bus lines to the tuner appeared to be o.k., and disconnecting the link between pins 15 and 16 then injecting a varying d.c. voltage proved that the tuner itself worked. So there was a fault in the tuner's PLL/synthesis circuit. We sent the tuner to MCES who speedily put matters right. Incidentally this machine uses the Panasonic D1 mechanism. **N.B.**

## Panasonic NVG21/25

One of these machines came in dead save for the fact that the cassette-in LED was on. Checks in the power supply showed that the unregulated 45V line was low at around 25V. The 47μF, 50V reservoir capacitor C1018 was open-circuit.

As many of you will know, C1023 (1,000μF, 10V) in the

power supply commonly fails, causing various servo and chroma faults. These are sufficiently severe to lead to a service call, but if the capacitor is left to deteriorate the display and other features will be lost and regained rhythmically. **N.B.**

### **Panasonic NV788**

This machine's remote control system didn't work. The IR commands were being inhibited because the machine thought that the timer was on. Timer inhibit is introduced by the MA165 diode D7554 on the timer PCB. A check showed that the diode was leaky. **N.B.**

### **Nokia VR3722**

This machine had no stored channels and wouldn't tune any in. I found that the pulse-width modulation at pin 52 of IC301 was of low amplitude. C6003 was short-circuit and had damaged IC301. Everything was all right when these two items had been replaced. **G.S.**

### **Sharp VC481HM**

"Tape stuck" it said on the note attached to this machine. On test rewind, fast forward and eject all failed intermittently. A new mode state switch cured the problem. **G.S.**

### **Matsui VX2000Y**

This machine appeared to be dead although the power supply was working. The culprit turned out to be TC01, the orange trimmer capacitor that sits near the microcontroller chip in part of the clock circuit. A replacement trimmer restored the machine to life. **D.B.**

### **Akai VS75EK**

The cause of very intermittent failure of the drum to rotate was traced to dry-joints on the power supply PCB. **D.B.**

### **JVC HRD660**

Tape playback in the SP mode was good but the pause, search and LP modes were poor. I found that the LP heads were not being switched on because one end of R19, a chip component on the head amplifier PCB, had never been soldered. **D.B.**

### **Matsui VX755A**

There were two faults with this machine: no display and no remote control operation. The former was caused by D1005 in the 5V supply to the timer chip going open-circuit, the latter by a faulty remote-control sensor. **D.B.**

### **JVC HRD750**

When this machine was switched on from cold it appeared to work, but after a few minutes the display would dim and then go out. A check showed that the -30V supply dropped to -10V. The cause was soon traced to IC3 on the tuner board. **D.B.**

### **Philips 31DV3**

This machine caused a lot of problems for the customer and the local video hire shop: it would intermittently erase the

tape, sometimes for a fraction of a second. I monitored the record 12V supply and found that it occasionally switched on during playback. The service manual is a little unclear, but tracing the print back brought me to T141 which was going leaky. A replacement cured the fault and, I guess, brought relief to all concerned. **D.B.**

### **Matsui VX6000A**

This machine wouldn't accept a tape, the carriage moving only very slowly. The loading motor had to be replaced as it had partially seized. **D.B.**

### **JVC HRS6800**

This top-of-the-range JVC S-VHS machine has a full range of features including PDC control. But it would record only one minute of the programme. The cause of the fault was the MV1820 PDC chip IC201. **D.B.**

### **JVC HRD880**

This machine would sometimes fail to accept a tape. The cause was a broken tooth on the lift gear. We had to replace the lift assembly as lift parts are not available separately. **R.B.**

### **Toshiba V309**

A problem we've had with this model is the drum running too fast intermittently. Check for dry-joints at P509 on the main video PCB, also IC501 for bad connections. **R.B.**

### **Sanyo VHR7250**

Failure to accept a tape and the drum not turning at switch on has in our experience always been because the 13V supply is low. Check for dry-joints at D5105, D5106 and D5107. **R.B.**

### **Toshiba V110**

There was no fast forward or rewind operation. We found that the pin had broken off the white lever in the loading block. The complete loading block had to be replaced as the part is not available separately. **R.B.**

### **Sanyo VHR235**

This machine wouldn't accept a tape and there was no drum rotation at switch on. A check on the voltages at pins 6 and 8 of CN541 showed that the voltage on the always 13V line was low. The fault was cured by replacing the STK5446 chip IC521. **R.B.**

### **Sharp VC481H**

This machine caused us many headaches. When it first appeared in the workshop it needed a new upper drum assembly. Not long afterwards it came back because of an intermittent low gain tuner. A replacement cured that. The next complaint, not long after we'd returned the machine, was that the E-E picture would vanish or go milky, with poor sync. But we saw this fault only once. We decided to change IC402 (HA11745NT). As it does nearly all the video processing, why not!

A week later it was back with the same complaint, but at least the fault was there most of the time. Freezing and

heating got us nowhere, but scope checks showed that the video signal was going missing at pin 5 of IC402. I phoned Sharp Technical who, after a lengthy examination of the circuit, suggested that we replace Q403 (2SC2308) – we were told that a BC546 would be suitable. Spot on and thanks Sharp Technical! The fault returned when the original transistor was put back. We were later told by the customer that the fault had been present, on and off, since the machine had been bought new! **G.R.**

### **JVC HRD520/HRD560/Ferguson FV42L etc**

You sometimes get strange mechanism behaviour with these machines, for example the pressure roller not engaging properly or too soon, or the half loading arm positioning itself wrongly. The cause is likely to be that the cam assembly is misaligned or has a tooth missing at its outer edge – check carefully, as this can be overlooked!

If the machine tries to load without a cassette being inserted, or there's a cassette already jammed in the housing assembly, the optical switch at the right side of the housing is faulty. You can usually prove this by removing the housing assembly and linking pins 2 and 3 of connector CN601 on the main PCB. This enables the machine to be run without the housing, which is handy when servicing the mechanism. When refitting the housing make sure that the small wheel which drives the housing – it's on the mechanism floor – is engaged, i.e. flick it closer to the mechanism wall. Also remember to remove the service link at CN601.

To remove a jammed cassette disconnect the belt drive then turn the housing cam clockwise until the cassette is ejected.

The part number for the optical switch (phototransistor) assembly is PN268V1. The complete housing PCB part no. is PB40061. These part numbers are for the JVC HRD560EK.

Finally a word of warning. When checking for the cause of a tape transport fault don't connect an external power supply to the transport motor. The drive chip is mounted with the motor on the same PCB and will be destroyed. If you have to test the mechanism with an external power supply, isolate the drive chip from the motor connections. Better still, operate manually by hand! **G.R.**

### **Hitachi VT520**

This machine tried to load a cassette without one being inserted and the wording "Code 1" appeared in the clock display. We suspected the start and end sensors: fortunately both pins of the rewind sensor were dry-jointed. After soldering this up the machine worked perfectly – and the wording "Code 1" disappeared as well. Phew! **G.R.**

### **Logik VR950/Samsung VI611**

For tuning drift with the 33V line being low and unstable, replace C2 (47µF, 63V) in the power supply and the 33V regulator IC901 which is on the PCB behind the clock. **G.R.**

### **Toshiba DV90B**

There was no clock and no tuning. The cause of the trouble was the d.c.-d.c. converter circuit reference Z802. **G.R.**

### **Amstrad TVR1**

This unit played tapes but wouldn't record. The record

button had no effect because the switch was leaky between pins. A replacement from a scrap panel cured the fault. The customer had been using the timer override instant record button for ages to delay repair, but had finally got fed up with having to press the button every half hour to continue recording! **J.E.**

### **Hitachi VTF770**

This machine was lifeless apart from the clock display, and had a fully laced up tape inside. When the power button was pressed the channel indicator came on but the machine shut down again two seconds later. Fuse F852 (1-6A) in the supply to the 14V bridge rectifier on the power supply PCB was open-circuit. As it hadn't blown, a replacement went in. This restored normal operation. **J.E.**

### **Sharp VC9300**

Rewind and fast forward were o.k. When either play or record was selected however there was motor noise but the tape remained unlaced, the machine entering the forward mode at a slightly faster speed than normal playback. Fortunately the cause of the fault was nothing more than a stretched lace-up belt. It's under the deck assembly, at the front left-hand side. **J.E.**

### **Sharp VCA105HM**

Playback was o.k. but there was just snow in the E-E mode. When the up/down channel search button was pressed there was a normal pulse-width modulated squarewave at the base of Q1451, but there was no voltage at its collector (or the tuner's VT pin) because the 33V regulator chip IC951 was short-circuit. **J.E.**

### **Logic VR960**

Rewind and fast forward were o.k. When play was selected however the machine laced up then, after a few seconds, unlaced and shut down. It wasn't the limiter post this time but the loading belt, which was slipping. Normal operation was restored when a new belt had been fitted. We noticed that a slight crack was developing in the limiter post so this was replaced as well – we didn't want a "same symptom as before" situation. **J.E.**

### **Matsui VX880/Saisho VR1600/Hinari VXL4**

One of these machines would accept a tape and its display showed the functions selected, but it wouldn't carry out any of the functions and refused to give the tape back. We found that circuit protector ICP201 in the 18V supply was open-circuit. A replacement plus resoldering of Q02's connections restored normal operation. **J.E.**

### **Sharp VC381**

There was an intermittent loading fault. Sometimes the cassette would be lowered only half way and remain there. If the eject button was then pressed the cassette would be returned. A meter connected across the carriage motor during the loading process showed that the voltage at the earthed terminal would fluctuate then rise to 12V, thus stopping the motor. The cause of this was soiled contacts in relay RY802 on the main panel. We carefully prised off the cover and gave it a squirt of switch cleaner. This cured the problem. **J.E.**

# Camcorner

## **Panasonic NVMS2**

There were two problems with one of these full-size S-VHS machines. First it produced a 'glitch' between recording sequences, giving a noisy edit. Secondly when going from record to pause it would sometimes back-wind the tape far beyond the normal point, thus losing the end of the previous sequence. The first problem was cured by replacement of the pinch-roller assembly, the second by replacement of the mode encoder switch.

Since this repair we've had two similar machines that displayed the same fault symptoms and were put right in the same way. **D.C.W.**

## **Sony TR Range**

Failure of the flexible membrane that connects the VTR function keys and the zoom and trigger buttons is becoming a problem with some of the earlier models in this range. Unfortunately the membrane cannot be repaired. It's part of the complete switch block control assembly, which costs around £55 trade - a high price to pay for the loss of maybe just one function.

The membrane can become intermittent. As it's part of the key-scan control matrix this can result in various unrelated fault symptoms.

Later TR models have a replaceable membrane. **D.C.W.**

## **Canon E230E**

The repair ticket said that this camcorder showed a picture outdoors only when the 1/4,000th sec shutter was used. At this speed there are of course no indoor pictures! The cause of the problem was seen once the casing had been removed: the iris assembly had 'fallen out' of the lens unit and jammed open.

With these lens assemblies the iris unit is removeable from the rest of the lens in one section without need to dismantle the whole assembly. Very nice for us! This one hadn't been seated properly and had literally fallen out. It's normally held in position by a retaining clip on the main lens moulding. **D.C.W.**

## **Sharp VLC750H**

This one gave us some headaches. The playback pictures would sometimes be o.k. On other occasions there would be a noise bar either at the bottom or through the centre of the picture. If the drum was slowed momentarily the noise bar would shift, locking randomly at either one of the previously mentioned positions.

The servo section circuit diagram gives little away about its operation or the waveforms to expect at key points. We found that the drum FG and PG signals seemed to vary little wherever the noise bar appeared. With symptoms of this type one would expect there to be some problem with the PG signal, but with no guidance on waveforms etc. it's difficult to be certain.

A Sharp service bulletin told us that a likely cause of the problem is failure of the main servo chip IC701, but a replacement didn't provide a cure. What did put matters

right was replacement of IC702. This chip's main job is to generate the four-phase head switching pulse train: it also combines the drum PG and FG signals into a form that's acceptable to the main servo chip IC701.

When we'd got the machine working properly we were unable to discern any difference between the waveforms obtained and those previously seen. **D.C.W.**

## **Sanyo VMD6P**

Tape chewing and irregular mechanical functions were the rather obvious symptoms with this machine. The cause was a worn drive belt. The capstan motor drives two belts. Both are 'toothed' types and connect with the assembly bracket unit (part no. 636 023 8756). Several teeth were missing from the belt that's driven directly by the capstan. The belts are supplied as part of the assembly bracket. **D.C.W.**

## **Panasonic NVMS50B**

There were some strange symptoms with this S-VHS, hi-fi sound, C-format machine. When, without operating the power switch, power was supplied via the d.c. lead the capstan motor would run for a short time then stop. No other signs of life were obvious, apart from the fact that the viewfinder would occasionally flicker into life for a few seconds.

The cause of these strange goings on was failure of Q1006 and Q1007 in the power supply. Both were leaky and even when 'off' they passed sufficient current to cause the symptoms described above. They are parallel-wired regulators that supply the main 5V rail. **D.C.W.**

## **Sony CCDTR305E**

There were no mechanical functions with this young TR model. Inspection showed that a tooth was missing from the rotating part (mode control gear) of the mode switch. A pin had also broken off the Arm 1 assembly, a cam follower. We replaced these items and also cam TG1 as this is inclined to fail with the result that the back-tension pole assembly (arm assembly TG1) takes up the wrong position. This is easily seen in the eject mode as arm assembly TG1 then sits in the play position. After replacing these items we carried out the timing necessary to produce a working unit. **D.C.W.**

## **Sony CCDTR303E**

I've had one or two of these camcorders with the complaint that the standby/lock switch is broken. In fact only one section of this multi-part knob fails, item 5. The part number is 394298501. **N.B.**

## **Panasonic NVMS50 - Correction**

A transcription error occurred in my note on this model in the October issue (page 855). The excess friction was between the tape and the upper and lower drums, not between the two drums. **N.B.**

## Akai VS23EK

If one of these machines has no display and a buzz comes from the power supply *unplug quickly* – the power supply is just about to self-destruct! Then replace C6 (220µF, 10V) under the metal can on the power supply. This will save you the cost of a replacement power supply. **A.J.F.**

## Mitsubishi HSM57

A fault you can get with these machines is a half to three-quarter inch pattern at the bottom of the picture, worse with prerecorded tapes. Mitsubishi has come up with an answer. The cause of the fault is the fact that both video heads are in contact with the tape at the same time. As a result there's crosstalk between the heads, hence the patterning. Mitsubishi will, if requested, supply a new, specially-selected head drum (upper and lower). This doesn't cure the problem completely but does make a big improvement. **A.J.F.**

## Finlux VR2040/05G

This Philips clone (DMP2 deck) came in to have its carriage refitted. Two days later it came back because there was no channel-change operation. The channel up and down buttons appeared to change the channels occasionally but there were no TV pictures. We then spotted that the infra-red sensor was visible. The dark blue infra-red plate that covers the receiver had slipped and dropped in front of the single channel number display, so that only above ten could be seen. **A.J.F.**

## Amstrad VCR6200

If the cassette jams in the down position, with the belt screaming underneath, release the tape then clean the three switches on the side of the cassette housing. When the switch contact becomes poor the housing loads too far and jams. **A.J.F.**

## Pioneer VR737

If there's no clock display check the 315mAT Wickman fuse in the power supply metal box. **A.J.F.**

## Philips VR6180/DMP2 deck

The customer complained that there was no play at the beginning of a tape. On test an E240 cassette wound back to the beginning wouldn't play. The deck shuffled, then went back to the stop mode. The same thing happened in the fast forward mode.

It seemed that the brakes weren't operating correctly. We compared the operation with another machine. When play was selected this machine took up the tension briefly, by winding the supply reel slightly, then went into play. The faulty machine seemed to take up the tension too much, winding the tape back slightly so that the leader passed the end sensor and the machine shut down.

Brakes, reel table and belts were all swapped but this made no difference. After swapping further bits we consulted Philips, who told us to replace all the bits that

had been swapped plus some more. So the following items were ordered: one bracket part no. 4822 403 1025; one lever arm, part no. 4822 403 52488; two disc reels part no. 4822 528 10523; two rollers part no. 4822 528 70638. The machine worked properly when the new bits had been fitted. **A.J.F.**

## JVC HRD830

For no or intermittent tuner signals check the 2SD1863 transistor Q13 on the tuner board. It's easy to find this transistor: the board around it becomes discoloured as the transistor overheats and becomes defective. A 2SD1207 seems to be a more manly transistor for the job. **A.J.F.**

## JVC HRD580

The complaint with one of these machines was that it made a "knocking noise". We found that the drive belt bush at the back of the capstan motor had split. A replacement capstan motor had to be fitted – this is becoming quite a common fault. **D.B.**

## Saisho VR1000/Matsui VX800/Hinari VXL3

The customer complained about intermittent squeaking noises in the play and record modes. Cleaning and lubricating the bottom flywheel bearing silenced the squeaks. **D.B.**

## JVC HRD560

The cause of no drum or capstan operation was traced to CP1 in the power supply being open-circuit. **D.B.**

## Matsui VX1000Y

One of these machines couldn't be tuned in. We found that the tuner had no tuning voltage because R6045 was open-circuit. This resistor can also go high in value – the result is tuning drift. **D.B.**

## JVC HRJ205

A rice-pattern effect on the playback picture can be caused by excess grease on the drum discharge brushes. The head drum motor and drive are on the top of the drum assembly in these machines.

To repair, remove the two screws that hold the drum drive board to the drum. Then loosen the grub screw that holds the bush to the shaft, noting its position carefully. Remove the upper drum and clean the grease off the brush assembly. Reverse this procedure to reassemble the unit. Remember to check/adjust the head switching point. **D.B.**

## Toshiba V211

This Thomson based machine produced very noisy pictures. We found that the noise was on the 5V line and that it came from TT53. A replacement restored clear pictures. **D.B.**

## Sony SLV225

This Sanyo based machine would intermittently stop in play, fast forward or rewind. The cause was a faulty reel sensor, part no. 1 808 723 11. **D.B.**

## Matsui VX6600

There was no E-E or playback picture. We found that the cause was L01 in the on-screen display circuit. It had gone open-circuit. **D.B.**

## Ferguson FV68

For very intermittent, poor or no Nicam, replace capacitors CM50 and CM51 using 5.6pF types (part no. 50876240). **D.B.**

## Nokia VR3743VP

The playback sound and picture were faulty because the back-tension arm didn't come across fully. Replacing a broken lever, part no. 613-022-2015, cured the problem. **R.B.**

## Sharp VCT310

The tape had jammed in the half-loaded position. On removing the tape manually and checking the alignment of the control cam and mode switch I found that the control cam was damaged. Replacing the control cam and mode switch and aligning them both cured the problem. **R.B.**

## Nokia VR3722

There was a noisy squeak, mainly during rewind. The capstan motor, reels and gears were checked and found to be o.k. I then greased the reels, but this again made no difference. The squeak was found to be coming from the supply guide pole. Replacing this item cured the fault. **R.B.**

## Samsung VIK320

The lift would shuffle back and forth with no cassette inserted. On inspection I found that the tape-start sensor was dry-jointed. Resoldering this cured the problem. We've since had the same symptom caused by dry-joints on the LED tower and tape-stop sensor. **G.S.**

## Nokia VR3783VP

There was interference on the TV channels with the machine in the record mode. After much time had been spent checking around we found that the cause of the interference was chroma spray at r.f. from the head amplifier. Replacing IC181 in the head amplifier cleared the interference. **G.S.**

## Samsung SI3240

There were various intermittent problems: no functions, tapes jamming, no or a flashing display and sticking in standby. We found that the all 5V rail was intermittently low or missing. It took some time to discover that the print track below the metal plate which covers the mode switch had been sparking across to the plate (earth). Some PCB sealant was applied and the machine was then given a good test run. After this it was declared to be o.k. **G.S.**

## JVC HRS5800

The remote control system worked but there was no response from the on-board deck controls. There was also no function change when the audio-mix switch was operated. IC1 was the cause of the fault: one of its scanning outputs had failed. **S.B.**

## JVC HRD4700

There was an intermittently noisy picture. It looked like head clogging, but this wasn't the cause of the fault. The lower drum assembly had to be replaced because of a problem with the ribbon cable that carries the r.f. signals to and from the heads. **S.B.**

## GoldStar GHV1290

When this machine was tested we found that the drum and the capstan motor were running too fast. The thing to check in this event is the 4.43MHz signal that comes from the chroma circuit and is fed to the servo section. Follow it around, soldering and making good any bad connections. This should cure the fault – it certainly did with this one. **T.L.**

## Samsung SI1260

This machine wouldn't load. So I got my meter and went to the loading drive i.c. to check the voltages, but it wasn't there! When the panel was lifted it was found at the bottom of the machine. Replacing it restored normal operation. Apparently a cassette had got jammed: it seems that the chip had so overheated while trying to load the cassette that the solder had melted. I fitted a new chip to be on the safe side. **T.L.**

## Matsui VX1100

If you have any servo, sound erase etc. faults with these machines remove the mechanism and check the connections between it and the main panel. Resoldering the connections will clear many problems. **T.L.**

## JVC HRD860

This machine worked perfectly except for fast forward and rewind. When these modes were selected they would start but fast operation, which should commence after about ten seconds, didn't take place. Fortunately I've had this problem many times before. So I changed the reel sensors. It's quite a common fault with these machines. **T.L.**

## Matsui VP9301

This machine would load a cassette but then shut down. When I watched it I found that the drum sped up just before the fault occurred. By careful manipulation of leads I narrowed the fault area to the heads. So I removed the stator PCB that sits on the top of the video heads and found a nice little crack in part of the print. Careful repair got the machine working perfectly again. **T.L.**

## B and O V6000

This machine makes extensive use of on-screen menus and displays. In the stop mode these displays were perfectly o.k., but in the playback mode the colours would gradually change phase, for example from the correct cyan lettering at

the left of a text line to orange at the right-hand side. A look at the circuit showed that there's a reference line, marked F H/2, that comes from the video/chroma area of the main board. A scope connected to this line showed that only noise was present. We traced back to transistors 7560 and 7513 and still found just noise. We then noticed that a surface-mounted capacitor in this area had a flattened blob of solder at one end. When this was heated with an iron to remove it the capacitor's end cap came away with the solder. The capacitor concerned is C2514 (10nF): it couples the signal to the transistor circuit mentioned above. A replacement capacitor restored normal operation. **I.B.**

### **Mitsubishi HS320**

This machine laced up and played, with one head apparently clogged, then after about five seconds it stopped. The FG signal was not getting through because Q404, which is part of the FG pulse amplifier, had become very noisy. **R.F.W.**

### **Ferguson 3V35/JVC HRD120**

The symptom gave the impression that one head was clogged, but the cause of the trouble was the fact that the SW25 signal was of very low amplitude. We found that the 9V supply was low at only 5V because the 9V adjustment potentiometer on the power supply board was faulty. **R.F.W.**

### **Ferguson FV11**

The capstan motor was very slow and its drive chip was very hot. Unlike more modern DD motors, the chip is not part of the motor and doesn't cut out when it overheats. A new chip got the motor running but was getting hot. It's not an easy motor to dismantle, but once the bearings had been cleaned in alcohol and reassembled with fresh oil the motor ran at full speed without the chip overheating. **R.F.W.**

### **Akai VS485EK**

The display didn't work because its heater supply was missing. The cause of this was capacitors C446 and C447 on the main board. **R.F.W.**

### **Panasonic NVL20/NVL28**

After a mains supply fluctuation caused by a storm the machine's power supply wouldn't start. C1109 (1µF, 400V), which provides a start-up pulse, had gone low in value. The 12V supply was also missing because Q1102 was open-circuit. **R.F.W.**

### **JVC HRD230**

There was no capstan rotation, so the machine would cut out in play or record as soon as it had finished lacing up. The M54644BL drive chip IC604 was found to be faulty, a new one restoring activity. But the wow and flutter were atrocious. No wonder since the motor was extremely tight. A new one prevented another drive chip biting the dust. **N.B.**

### **Ferguson FV44L**

There was a buzz that couldn't be ignored on the playback sound. Checks around the audio circuit led me to conclude that the audio head's record side wasn't being earthed in the playback mode, confirmed by the fact that the relevant pin of IC1 was high, as it is in the record mode. Further checks

showed that the 'record start low' line was low at about 9V. Thus Q6, a digital transistor that's connected to pin 25 of IC1, produced a high output as in the record mode. The record start low line comes from pin 34 of the M37418M6-263SP microcontroller chip IC601, which proved to be faulty. Interestingly, none of IC601's other ports were incorrect. **N.B.**

### **Sharp VCA30HM**

Rewind and fast forward sometimes failed to operate. The capstan motor would rotate, but the idler gearing wasn't being engaged. Play, cue and review were fine. A new mode switch cured the problem. **N.B.**

### **Samsung SI1240**

Cutting out during rewind was the complaint with this machine. On test we found that when a three-hour cassette was rewound the tape would slow after the one-hour point, the capstan would start to labour and the machine would then cut out. When the belt was removed from the capstan motor there was still plenty of torque. This was confirmed by the fact that fast forward was fine. As it's a full-lace machine I removed the tape from around the guides manually and let it run straight across the front of the cassette, to eliminate excessive friction in the tape path. This helped, but by no means cured the symptom. The cause of the trouble was excessive friction in the spools. Removing them then cleaning and lubricating the shafts cured it.

All the diodes were changed as they were the original ones. The FL motor chip was also replaced: this had been done previously, but the earth link modification in the power supply hadn't been carried out. **N.B.**

### **Akai VS23EK**

This machine cut off in play, fast forward and rewind after a few seconds. The reel pulse input to IC505 was o.k. but the output at pin 7 was faulty. Replacing IC505 restored normal operation. **R.B.**

### **Sanyo VHR4350**

At switch on the machine went into the fast forward mode automatically. We first checked the mechanism's alignment, which was o.k. A replacement capstan motor cured the problem. **R.B.**

### **Finlux VR2040**

This machine would cut out in play. Fast forward and rewind were o.k. The cause of the problem was no play take-up: replacing the clutch cured it. **R.B.**

### **Toshiba V55**

Although the display segments all lit, the machine didn't switch on. On investigation we found that there was a dry-joint at pin 1 of connector CN1 on the regulator PCB. Resoldering the plug connection cured the fault. **R.B.**

### **Mitsubishi HSB12**

This machine would cut out after a few seconds in play, because the arm guide and arm tension lever didn't take up the tape. The arm tension post lever has a felt pad that rests against the take-up reel: the pad was missing. A replacement lever, part no. 591B551010, cured the problem. **R.B.**

# Sony Camcorder Fault Notes

Keith T. Keeton

The following is a short list of some faults we've had with various Sony Camcorders.

## Model TR50

**Camera focuses once at start then won't focus again:** Q621 (XN650) on board VC81P faulty. Part no. 872940219.

**No E-E (black screen), no zoom and no focusing:** IC361 (MC68HC05N4SC406667) on board VC81P faulty. Part no. 875903760. There were no signals on the check pin array.

**No E-E luminance:** C305 on board VC81P open-circuit.

**E-E picture half white and half solid black:** IC141 (CXD1209Q) on board VC81P faulty. Part no. 875233585.

**No viewfinder picture, direct output o.k.:** Flyback transformer T901 on board VF14P faulty. Part no. 143943111.

**No camera/VTR power:** IC601 (CXP80116) on board VS69P faulty. Part no. 875281858. There were no output pulses at pin 43 of the chip.

**No power to camcorder:** IC601 (CXP80116) on board VS69P faulty. Part no. 875281858. There was no VTR DD on signal from IC601.

**Mechanism loads up with no tape in:** Replace encoder, part no. 157217311. Mechanism arms moved in and out erratically.

**Noisy eject:** Replaced slightly bent worm gear shaft. Part no. X37288681.

**Tape riding up pinch roller:** Adjust incorrectly set back tension.

**Excessive playback dropouts. Flashing white lines sometimes present:** IC203 (CX1200BQ) on board VS69 faulty. Part no. 875203440. Dropout pulses o.k. at pin 2 of chip but no correction.

**No playback – mechanism loads up slowly without tape:** Flexiconnector FP313 slightly away from PCB (CC52). Resolder or replace as necessary. Part no. 163649611.

## Model TR105

**Smeared E-E picture:** CN801 on board VC104 open-circuit, with possible board print damage. Lens may have been knocked. Resolder CN801 or replace board if tracks damaged.

**No E-E colour, playback o.k.:** L721 (68µH) on board VC104 open-circuit or dry-jointed. Resolder/replace L721 as necessary. Part no. 141039111. Signal is o.k. at Q704 but no signal at Q706.

**No E-E colour, record and playback o.k.:** IC707

(CXD2100Q) on board VC104 faulty. Part no. 875233732. No output signal at pin 30.

**No zoom. Focus and E-E o.k.:** Sponge on lens pushing against zoom motor. Reposition sponge.

**Viewfinder picture shakes:** Dry-joint at R521 on board VF42.

**Lines on top part of viewfinder display, data display corrupted:** Dry-joint at C516 on board VF42.

**FF/REW/PB/REC for few seconds then flashes fault present:** Sensor board faulty. Replace MD chassis, part no. A7010369A – sensor not separate item.

**Loads a tape but no FF/REW/PB/REC. Will not eject a loaded tape:** Capstan faulty (no rotation). Replace, part no. 883532912.

**Failure to eject. FF/REW very fast:** No capstan feedback. Pins 17 and 18 of flexi W203 dry-jointed (board VS83). Resolder flexi.

**Failure to load/eject. Guides only partly loading, with intake guide jamming against railbase assembly:** Replace railbase assembly, part no. A7040289A.

## Model TR705

This camcorder is very similar to the TR105 and has similar faults. We've had the following additional faults.

**Failure to load a tape. Loads o.k. without a tape. Drum doesn't rotate:** Replace faulty drum assembly (machine will not load fully until drum rotates).

**Unstable playback picture when using Hi-8 tapes:** Replace faulty guide rails. Part no. A7040251F/X39410272.

## Model F500

**No E-E colour, playback o.k.:** Crystal X621 faulty. No 4fsc to encoder chip IC701.

**No E-E sound, playback o.k.:** MC36P (small PCB) faulty. Replace.

**Intermittent playback sound, E-E o.k.:** Hybrid chip IC580 on board VA43 faulty. Sound comes and goes when pressure is applied to IC580.

**No colour with playback of own recordings. E-E o.k. Plays back prerecorded tapes with colour:** IC364 on board VA43 faulty. Signal low at input to IC364, no output from it.

**No playback picture, E-E o.k.:** Input to IC362 low because metal shielding can is shorting to track. Bend can out of way.



**No playback picture (black screen), E-E o.k.:** IC360 faulty (no output at pin 56).

**Playback for only fifteen minutes with battery operation:** Unit consuming excessive current because Q001 and IC005 faulty.

**No playback/E-E pictures:** IC001 on board SS100P faulty. Input to bus decoder IC362 was found to be high instead of low.

**No camera/mechanism power:** Replace F991.

## **Model F550**

**Manual white balance and focus switches not working. LCD doesn't change when buttons pressed:** Macro/auto-focus button jammed on by case (board CK20P). Free button or replace case.

**No E-E picture (black screen). Data scrolling:** Q509 defective. Fault area FU100.

**No E-E picture (black screen), playback o.k.:** IC501 on board VC67P faulty.

**Dropout on playback, E-E o.k.:** C224 on board VA46P was leaky.

**Noisy playback – looks like dirty heads. Picture may be o.k. in pause mode:** Head amplifier RP17 faulty.

**Jumping picture. Noise bars at top/bottom:** Impedance roller set too high. Reset and carry out complete tape path retrack.

**EVF shows just line. Picture o.k. via AV output:** C919 on board VF26P faulty.

**No playback or E-E colour:** IC203 on board VA46P faulty.

**No operation after replacing IC501:** Wrong version used – requires updated version. Fault area SS100P.

**No EVF picture (blank screen). Picture o.k. via AV output. TX whining:** C918 on board VF26P faulty.

**Thick vertical line on EVF. TV picture o.k.:** L903 on board VF26P open-circuit.

**No playback or E-E sound:** Q409/Q410 on board VA46P both short-circuit collector-to-emitter. (Sound present at pin 7 of IC403).

## **Model F355**

This camcorder is very similar to the F350 for which fault notes were published in the August 1994 issue (see page 735).

**Lines on E-E picture to start with, then fading away:** C704 on board CV9 faulty.

**Intermittent E-E luminance, playback o.k.:** Dry-joint at FL601 on board CV9 (signal input but no output).

**No E-E luminance, playback o.k.:** IC501 (UPD6145G601) on board CV9 faulty.

**No E-E picture but reappears after a short time:** Leakage from C704 (120 $\mu$ F) on board CV9. Can cause damage to PCB beneath it.

**EVF picture too bright with lines:** Poor contact at c.r.t. yoke (no signal here though video o.k. at pin 1 of W901). Refit pin correctly.

**Failure to record sound. Playback and E-E o.k.:** Q401 (2SC1623) on board CO2P faulty.

**Record and playback pictures very bright:** IC203 (CXA1200BQ) on board CV9 faulty (black level wrong at output pin 47).

**Recordings noisy, like dropout. Fault intermittent:** C704 on board CV9 faulty.

**EVF display has symbols flashing all over:** IC501 (UPD6145G601) on board CV9 faulty.

**Drum doesn't rotate. Vibrates slightly:** IC507 (CX20114) on board CO2P faulty. Drive pulses from pin 24 incorrect.

**Playback suffers from interference, E-E o.k.:** Replace 5-17MHz filter FL203 on board CV9. Signal o.k. at pin 3 of IC203 but noisy at pin 4.

**Garbled symbols on screen when data pressed:** IC501 on board CV9 faulty (peaks on output signals at pins 13 and 15).

## Sanyo VEMS1P

Known in some parts as the LEMSIP model, this one had its cassette mechanism in the half-ejected position. Removal of the LS mechanism revealed that the two plastic guide rails had fractured. So they and the ribbon cable that connects the two halves of the mechanism had to be replaced. When fitting a new ribbon attach it to the main mechanism first, leaving the other end free. When the mechanism has been refitted, solder the other end of the ribbon to the LS deck. This will avoid any tendency for the ribbon to twist. As mentioned before, realigning these mechanisms can be fun! **D.C.W.**

## JVC GRAX5E

This camcorder had been dropped. As a result there was no camera E-E picture, though the machine worked correctly in all other respects. With this range of camcorders it's quite common for the camera section to detach itself from the main PCB after such treatment. In this case connector CN33 was damaged and had to be replaced. **D.C.W.**

## Panasonic VWF15E Camera

This S-VHS camera didn't operate. Replacing the 1.5A ceramic fuse F1 on the audio PCB restored the input to the power supply PCB, with the standby LED alight, but there were still no video or audio output signals. Attention was focused on the power supply PCB which, like all the other subassemblies, can be detached from the mother PCB. The 5V and 9V outputs were present, but the 17V and 27V outputs were missing. The 27V supply is generated from the 9V supply, with Q7 operating as the driver for a d.c.-d.c. converter. Checks here showed that Q7 was leaky base-to-emitter while L6 had short-circuit turns. Other components that had to be replaced were C14 (180 $\mu$ F) in the 9V supply, R24 (24k $\Omega$ ) which had increased in value to 68k $\Omega$ , D5 (27V supply) which was short-circuit and the control chip IC1.

Note that this power supply runs rather warm, and that the correct replacement components must be used. **D.C.W.**

## Ferguson FC05/JVC GR45

This machine produced no pictures, either from the EVF or the AV connector. There was an audio output however. The playback f.m. signal was present at the input to the YC board, via the main board, but didn't appear at the outputs. We then found that the video mute line on the YC board was permanently high. The source of this signal is pin 51 of the mechacon controller chip, where it was correct. Failure of the buffer/inverter transistor Q409 was the cause of the permanently high mute signal. **D.C.W.**

## Mitsubishi HSC40B

This well-engineered S-VHSC machine would remain powered up for only a few seconds. It's not an easy model to work on, as ribbon cables abound. Gently tapping the main PCB seemed to affect the fault – on occasions this would produce a period of operation. We eventually traced the cause of the trouble to Q409 and IC401, which were both dry-jointed at all pins. The only thing that was keeping

them in contact appeared to be the large helping of goo beneath which they were burried. Beware! **D.C.W.**

## Sony CCDTR60E

The reported fault was no camera E-E picture. In fact the chroma component of the E-E signal was present, but there was no luminance contribution. The cause was C305 which was disconnected at one end. Refitting it cured the problem – it's on the camera PCB. **D.C.W.**

## Fujix-8 FF120SW

Intermittent colour dropout was the problem with this camcorder, a clean mono picture remaining when the colour was lost. Absence of a manual sent us in search of dry-joints on the main video processing board. Fortunately it's the top section of a layered structure. Flexing around the screened part of the board would instigate the fault: a closer inspection here showed that one of the pads for a surface-mounted resonator package had failed to flow solder. **N.E.**

## Ferguson F801

We've had the following faults with this model:

**No titler operation:** Cause was a dry-joint at IC901.

**No power:** This can be caused by a faulty d.c.-d.c. converter. On occasions we've found that the 5V supply is o.k. at pin 72 of IC901 but not at the function switch block chip IC912 because pins 3 and 4 are shorted together. This error can result in failure of IC901.

**Will not memorise title when powered down fully:** Pins 5 and 6 of PG052 on the fuse PCB soldered together, so no voltage at pin 6. Lithium battery drains slowly.

**Tape loads then unloads after a few seconds:** As arms don't load fully the mode switch doesn't complete its cycle. Supply guide roller two bent at its base. Replace arm assembly (item 268).

**Mechanism jams when loaded:** Head support catches cylinder. Adjust or replace.

**No power to mechanism:** CP open-circuit.

**Ejects partly then stops. Reloads after a few seconds:** Arm operation pressure roller drive spring bent. Replace arm or pressure roller.

**Pinch roller spools tape out:** Washer on central gear idler missing. Replace.

**Batteries don't charge – charge light flashes slowly:** Faulty d.c. jack (SW101) fails to provide power.

**Distorted sound and noise bars on playback picture:** Faulty capstan. Replace. **K.T.K.**

# Fault Notes for the Sony CCDF380

Keith K. Keeton

*The following is a summary of the fault experiences we've had with this camcorder.*

## Camera

**E-E picture smears vertically when camera is pointed at a bright light:** DT79A hybrid i.c. on panel CV9 faulty. The substrate voltage appears to be out and the picture is slightly grainy.

**E-E picture dark under low-light conditions, playback o.k.:** DT79A hybrid i.c. on panel CV9 faulty. Gain was not changing to compensate for light level.

**E-E picture dark, playback o.k.:** Iris was fully open. Cause of the trouble was a dry-joint on panel CD17P.

**E-E picture flickers like an old movie:** Iris motor not damped because damping coil open-circuit. Lens section had to be replaced.

**E-E titles will not memorise or change colour:** D655 on panel CK19P faulty. Titler worked correctly with buttons to D656 shorted.

**No E-E sound, playback o.k.:** LA7293 chip IC451 on panel MA37P faulty (signal input but no output).

**Record picture white. E-E and playback o.k.:** Dry-joint at IC101 on panel CO2P. IC101 had an input signal but no output.

**E-E picture red:** IC605 on board CV9 faulty.

## Camera/VTR

**No record sound, E-E and playback o.k.:** Hybrid chip IC401 on panel CO2P faulty.

**Record/playback picture very bright, E-E picture o.k.:** CX1200BQ chip IC203 on panel CV9 faulty.

## Mechanism Faults

**Grating noise with fast forward/eject/load:** The LB gear block assembly rattled. Cause was a spring missing from

the LB gear assembly.

**Intermittent failure to eject:** LB1631M chip IC504 on panel CO2P faulty. Tape would load half way then stop.

**Failure to eject/load:** Reel sensor on panel CC26P faulty. Remote commander said fault code 2. Loading arms came out half way then stopped. On another occasion the cassette assembly was slightly bent and had to be replaced.

**When eject is selected the mechanism goes to fast forward before ejecting. Mechanism only half loads:** No FG output from capstan sensor which was faulty – replace capstan.

**Take-up reel spins fast during eject:** Replace capstan motor – feedback faulty.

## VTR

**When a function is selected, i.e. playback, the screen goes black then the eject sign appears:** The CXP80116 chip IC501 on panel CO2P was faulty. Pin 3 (VTR DD on) went low when the fault occurred, shutting down the VTR and camera DD on.

**No video playback, sound o.k. E-E operation o.k.:** C287 on panel CV9 faulty.

**VTR picture smeary with grey lines. Playback and E-E o.k.:** The sync pulses at pin 8 of IC201 occurred at 61µsec instead of 64µsec because the VCO was running slowly. Remedy was to adjust CV502 for the correct frequency.

**Playback picture whites out. Melts sideways with h.f. playback:** Replace faulty drum.

**Black streaks on picture with own recordings. Playback otherwise o.k.:** Deviation adjustment R204 on panel CV9 incorrect.

**Excessive playback dropout; sometimes flashing white lines:** The CX1200BQ chip IC203 on panel CV9 was faulty. Dropout pulses at pin 2 were detected, but no correction followed.

## VTR/Camera

**No playback colour, E-E o.k.:** The CXA1200BQ chip IC203 on panel CV9 was faulty. Signal input at pin 3 was o.k. but no output.

**No power to camcorder:** We have experienced several causes of this condition, as follows.

(1) PS902/3 on panel PS225P open-circuit. Still no go when they were replaced. No output from the d.c.-d.c. converter which was faulty.

(2) PS902/3 on panel PS225P open-circuit. Still no go when they were replaced. Cause of the fault was the 2SA1385 transistor Q941 whose output was low.

(3) Pin 2 of W901 was shorted-circuit to chassis because the plastic earthing sheet behind the camera was shorting the capstan motor. Remedy is to insulate the pins from the sheet. Area of fault mechanism/panel CO2P.

## JVC HRD580

This machine had a sound fault. Operation in the E-E and record modes was o.k., but playback produced only a loud hum. Checks around the BA7765 sound chip showed that there was a problem with the switching lines – Q6's collector didn't go low for playback. The command comes from pin 34 of the main microcontroller chip IC601, where we found that the voltage rose to only 9V instead of 12V for playback. IC601 (JPC2002B-263) was faulty. **P.B.**

## GEC V4100/Hitachi VT11

Although the take-up reel rotated this machine thought that it didn't. By removing the Hall-effect reel sensor and using a magnet to test for an output change I was able to prove that the sensor was o.k. All was revealed when the reel was removed: the magnetic ring had come loose and moved out of position. A blob of glue soon had it back in its rightful place. **P.B.**

## Toshiba V110B

For no E-E tuning, just snow on the screen, check for 30V at power supply test point BP08. If it's missing the items to check are DP04 (ZTK33B) and RP03 (2.2k $\Omega$ ). **P.B.**

## Philips VR502

This machine had an intermittent fault: the capstan would occasionally start to rotate uncontrollably. If this happened when a tape was threaded it would be moved though the drum didn't rotate and the rest of the circuitry would be shut down. If it happened without a cassette the lift mechanism would lock and the capstan clutch would slip. The fault condition would last for five minutes or so after which it would clear and the machine would be fine for days.

Board swapping enabled me to prove that the cause of the fault was on the family board. With the machine in the service mode while the fault was present I found that the microcontroller chip read the deck state correctly but seemed unable to control the capstan motor. New tape servo and interfacing chips made no difference.

Two signals, CAP and CREV, control the tape servo chip. Resistor/capacitor integrating networks are used to DA convert these signals. C2316, a 22nF surface-mounted capacitor, was found to be intermittently leaky – it read 6k $\Omega$  when faulty. **P.B.**

## Akai VSF280

This machine came into the workshop to have the drum replaced. On test however we found that there was a substantial hum bar on the screen in the playback mode: it was much less noticeable in the E-E mode. Scope checks on the supply lines showed that the problem related to the IDL9/12V line (pin 6 of power supply plug 1). Bridge rectifier diodes D5-8 and D10, 12, 17, 18 were all o.k., as were capacitors C3, C8 and the 2SD2061 series regulator transistor TR3. We then noticed that the regulation control comes from the main (A) PCB via pin 5 of plug 1. The operational amplifiers in IC201a/b (type NJM455BL) are involved with this.

Replacing IC201, also the 5.3V zener diode D204, restored correct voltages and removed the hum bar.

Note that the lead/pin numbering (1-12) of plug P1 on the power supply panel is the reverse of that at the corresponding connector WF201 on the main (A) PCB. This can be confusing when checking voltages at both ends of the harness. Another point is that individual leads of the harness can rub against the lower edge of the aluminium heatsink that carries TR2/4, causing possible damage to IC201. As a precaution, put a couple of turns of vinyl tape around the harness to act as a sleeve. **J.C.P.**

## Toshiba V213B

This machine led us quite a dance. The complaint was of intermittent loss of sound during playback. On test we found that the sound was lost a few minutes after the start of playback, then returned for random periods of time till the end of the tape. We started by confirming that the fault occurred with both prerecorded tapes and the machine's own recordings, a check with another machine showing that the fault occurred in only the playback mode.

As this is not a Nicam or hi-fi stereo machine we were concerned with normal linear audio circuits. Voltage checks on the audio PCB didn't provide any clues. Fortunately there was a Toshiba V212B, with an identical audio PCB, in the workshop. Swapping over the audio PCBs proved that the cause of the fault was not in this area. A similar step cleared the audio/control head.

We refitted the original audio board and monitored pin 3 of connector B002 – the mute line. This proved that the loss of audio was being caused by operation of the mute circuit. Tracing the source back brought us to the TDA8128 chip IA01, the muting chip which monitors the video playback signal at pin 1 and the power on at pin 4. Pins 3 and 6 feed field and line sync to the on-screen display chip IA40, while pin 5 supplies the mute control output to various other circuits. The composite video signal at pin 1 looked all right, but as there's no waveform in the manual we couldn't be sure. We checked the buffer transistor TN01 then ordered a new TDA8128.

During our wait for this chip we checked and rechecked the tape path in case playback f.m. variations, masked by the digital tracking, were the cause of the mute circuit operation. No luck. But we also noticed that the E-E signal varied a bit sometimes – white areas of some programmes tended to go a bit negative. Adjustment of the E-E level control PN39 didn't help matters: in fact at one end the contrast would start to fluctuate with picture content. Other things we noticed were that the amount of dropout increased the longer the machine was left on, while the sound sometimes dropped out within thirty seconds of the start of playback and didn't return. Also if the upper drum rotation was momentarily impeded during a period of sound muting this would trigger sound restoration for a few seconds, and that if the picture displayed at that time had a mainly dark content the sound would remain on until the scene changed or the luminance level rose, when the sound would again be muted.

By the time that the TDA8128 arrived – it made no

difference when fitted – suspicion had already turned to the AN3248NK luminance processor chip IN01. A scope check on the composite sync output at pin 1 showed that there were wide amplitude variations as the picture contrast varied. We replaced the chip along with CN37 (22 $\mu$ F) and CN43 (3.3 $\mu$ F) which provide coupling and decoupling around the a.g.c. detector/amplifier area of the chip. This cured all the symptoms, with no more sound dropouts, consistent and adjustable E-E and improved video record/playback quality.

The Toshiba part number for this chip is 70010966. If you order the service manual you'll also need the one for Model V212, as the former gives only the variations from the basic model. Part numbers are 780-050 and 783-050. Incidentally freezing IN01 had no effect on the symptoms. The customer, who is also in electronics, was highly intrigued to learn that a fault in the video processing could cause loss of sound without any noticeable loss of picture quality. So was I!

**J.C.P.**

## Sharp VCA105

We get quite a few of these machines in the workshop with the complaint that either the mechanical functions are faulty or, as with this machine, a tape is jammed inside. Dirty mode switch contacts are the usual cause. The best cure is to remove the switch assembly, dismantle the switch, then clean the contacts using a fibre pen or a cotton bud moistened with methylated spirit. Simply squirting cleaner into the switch does not always provide a permanent remedy. The markers on the rotary centre piece must be aligned when the assembly is refitted – otherwise the assembly will not go back into place.

When we'd done all this we connected the machine to the mains supply and inserted a cassette. Everything seemed to be fine until play was selected. We then found that the capstan ran far too fast. The control chip had failed. This meant a new capstan motor, more than doubling the cost of the repair.

**E.R.**

## JVC HRJ205/400/600

White static spots are becoming a common problem with these machines. The JVC cure is to replace the drum brush assembly: if the fault persists you can fit a special cap. The most important thing is to remove all grease in the contact area and clean thoroughly.

**T.L.**

## General VGX520/Panasonic NV430

The playback picture had a moving band, like a hum bar, in which the colour was missing. The cause was traced to C1003 and C1007 on the power supply PCB.

**R.F.W.**

## Goodmans TX1100

The capstan motor ran slow intermittently, as though there was a problem with the control pulses. I eventually traced the cause to C509 on the power board. It decouples the 5V supply.

**R.F.W.**

## Ferguson FV12/JVC HRD230

The capstan motor was free-running. It would lock only occasionally, when the machine had warmed up (after five minutes). Use of freezer in the servo area was inconclusive. Replacing C25 and C26, both 4.7 $\mu$ F, finally cleared the fault.

**R.F.W.**

## Finlux VR5250/Philips VR212/3 (IDM2/3 deck)

This machine came in with an unlaced tape stuck in it. I disconnected the loading motor and then used a battery to power it, winding the mechanism through its modes to eject (with a few turns on the capstan motor flywheel at the right point to take up the loop of tape). This confirmed that there was no mechanical problem.

A cassette could be inserted, but no other functions were possible. The drum failed to spin and the display, consisting of only the time and the symbol shown in Fig. 1, flashed when any function was tried – even install. The

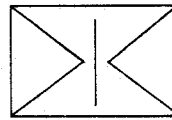

*Fig. 1: The flashing display symbol in the Finlux VR5250/Philips VR212 fault report.*

drum was clearly not being turned on: its switched 8V supply was missing, the cause being traced back to incorrect communication on the I2C bus. In fact the cause of the fault turned out to be the TMP47C1670N timer microcontroller chip IC7101. During the bus fault-finding process I replaced the syscon microcontroller chip first though! A point to note is that the service mode couldn't be entered: maybe this should have suggested trying IC7101 first.

**N.B.**

## Sharp VC381HM

This old-timer apparently cut out intermittently. The customer said that it often happened, usually preceded in play by a still frame/pause. This suggested that the capstan was stopping. The first fault I found however was that the cassette-down switch was defective, causing all deck functions to cut out. After replacing this the machine was put on soak test. It was ages before the capstan fault showed up. Its cause turned out to be a dry-joint at pin 1 of IC7006. I resoldered all the connections as they were going the same way.

**N.B.**

## Pye 2SB11

There were two faults with this machine. First the r.f. loop-through signals were severely attenuated, and secondly the playback audio level was very low. The second fault was an easy one: the audio/control head was dirty. The first fault was not difficult either, but the failure was quite interesting. There was no 5V supply to the amplifier section of the r.f. amplifier/modulator because the series choke L510 on the main board was open-circuit.

**N.B.**

## Panasonic NV7200

As the operation of the capstan motor was not stable the pictures in both the playback and record modes were unstable. When I opened the machine up I found that all the chips in the servo department had been replaced. As a first step I checked the supplies and found that the voltage on the 45V line read low at 35V, falling to 25V. C1010 and C1013 had dried out, replacements restoring normal operation.

**S.DaC.**

## JVC HRD1520

The picture was unstable because the exit guide was loose.

As the plastic boss that holds the guide unit and the arm drive was loose the guide wouldn't sit in the slot. A new boss cured the problem. **S.DaC.**

### **Panasonic NVG21**

This machine was dead because C1018 (47 $\mu$ F, 50V) which provides the supply for IC1001 was open-circuit. It's best to replace C1022 and C1025 as well. C1022 can be responsible for patterning on the screen. **S.DaC.**

### **Sony SLVX20/30/50 series**

If one of these machines comes in with a blue screen problem, i.e. when playing a tape all you get is a blue screen, clean the audio/control head. The cause of the problem is that the CTL pulses are of low amplitude. I've recently had the problem with five of these machines. A worn AC head will produce the same symptom. **S.DaC.**

### **Saisho VR605/Matsui VX500/Hinari VXL3**

When the power button was pressed the timer mode flashed and the standby light came on. Connector 6D2 on the front panel had dry-jointed connections. **S.DaC.**

### **JVC HRD520/540/1540 series**

Failure of the tape to be wound back into the cassette when stop/eject is pressed, leaving a loop in the machine, is becoming a common problem with these VCRs. The cause is the mode switch. **S.DaC.**

### **Amstrad DD8900**

There were no functions with this double-decker VCR, though both decks would accept a cassette. The display showed only the cassette-in indicators and a row of flashing dashes in the clock section. The display board has a 19-way ribbon connector. I had a spare board with a 21-way connector so I tried this, fitting the ribbon between pins 1-19. There were now no display functions at all, but when I looked at the display closely I saw that all the segments were lit very dimly. This suggested that there was a power supply fault. C27 (33 $\mu$ F) in the power supply module was open-circuit, a replacement putting matters right. **J.H.**

### **Baird 8942/Ferguson 3V32**

After watching this machine operate for a bit I realised that it was loading, unloading and ejecting too fast. So I checked regulator Q16's output which should be 14V, with 12V across zener diode D34. Instead of 14V there was 25V! Replacing D34 put that right. The end sensors also had to be replaced, and there was yet another fault: the machine ejected tapes in the timer mode. The cause of this final fault was that pin 32 of IC3 was open-circuit (the reading was 9V). When IC3 had been replaced the machine worked normally in every respect. **D.P.**

### **Goodmans VCR1000**

This machine ruined tapes. On inspecting the tape path I saw that there was some oxide lodged in the groove of the tape guide that runs around the head drum. This was cleaned off, and the heads and tape path were also given a clean. When I pressed my finger lightly on the right-hand spool there wasn't a lot of torque, so I cleaned the pinch

roller and rewind pulley. Everything then seemed to be o.k. during a soak test, with no tape snagging. **D.P.**

### **Baird 8930/40/Ferguson 3V29/30**

There were no clock functions and the machine was stuck on channel 1. Disconnecting the machine from the mains supply didn't do any good, so off came the top cover. This revealed that there had been some spillage on the tuner/timer board, around IC201. One of the chip's pins almost disintegrated when touched. I cleaned the area with alcohol and repaired the pin connection with a piece of wire. This brought success, though a guarantee couldn't be given of course. **D.P.**

### **Saisho VR2000/Matsui VX900/Orion VHX**

If there are no E-E signals – it looks as if the VCR is in the camera mode but the channel LEDs light up – replace circuit protector ICP201 (N20). **M.Dr.**

### **Hinari VXL5**

If the machine is dead with no clock display and no power-on signal to the power supply, check whether the 33V zener diode D504 in the power supply is short-circuit. **M.Dr.**

### **Hitachi VTM740**

If there's a loud squealing in the fast forward and rewind modes, dismantle the capstan motor, clean the capstan shaft and bearing and lubricate with one drop of Castrol DWF. We've had this fault a few times now. **M.Dr.**

### **Philips VR6462**

E-E sound o.k. but no playback sound should lead to a check on C2027 (330 $\mu$ F, 16V) on the audio PCB. You will probably find that it's short-circuit. To avoid further trouble replace it with a 25V type. **M.Dr.**

### **Panasonic NVG40**

As there was no always 12V supply this machine produced no signals, not even via the r.f. loop-through. Q04 in the power supply was open-circuit. **D.B.**

### **Ferguson FV68**

There was intermittent right-hand channel distortion during a Nicam transmission. The cure for this is to fit 5-6pF capacitors (part no. 50876240) in positions CM50 and CM51. **D.B.**

### **Samsung VIK310**

When this machine came in the mechanism was out of alignment. After realigning it I found that the carriage would go back and forth on its own. The BOT sensor, which is mounted on the main PCB, also acts as a tape inserted sensor. It was dry-jointed. **D.B.**

### **Matsui VX888**

There was an intermittent fault with this machine: if a completely rewound tape was inserted the machine would sometimes eject it. The end sensors were both found to be leaky, replacement curing the trouble. **D.B.**

## Panasonic NVR10 and Others

We've had a few Panasonic camcorders in recently with faults similar to the one with this machine. It would shut down during record or playback: sometimes an error code would appear in the EVF display. Once we gained access to the innards the cause of the trouble was soon evident. The plug to the head cylinder motor was badly fitted to the main board.

You can sometimes get away with resoldering the connections to the print, but in this particular case the connector had to be replaced. It can be a difficult job, and an expensive one if the fine and delicate print is damaged during the replacement. **B.S.**

## Panasonic NVS1

The problem with this compact camcorder was vertical coloured bands on the left-hand side of the playback picture. On dismantling the machine we noticed some evidence of impact damage – some casing fixtures were bent. In view of this we decided to examine the delay lines along the edges of the board. Sure enough DL8001 was cracked, its replacement restoring a clean picture. **B.S.**

## Panasonic NVMS4

A jerking capstan motor was the fault with this machine. Something caused a ragged spike to appear on the capstan drive voltage. With faults of this type it can be difficult to prove whether the cause is in the drive, output or error correction circuitry.

Our first checks were in the power supply, as the fault was reflected on all the supply lines. But this proved to be a red herring. After much testing, measuring and tail chasing we found that the cause of the fault was within the main system and servo microcontroller chip IC6001, which was generating the defective control voltage. A new MN6755243V6E chip, fitted with care, restored normal operation. **B.S.**

## Panasonic NVM7B

This camcorder's zoom control buttons were inoperative: all other functions worked correctly. The lens was undamaged and was free to rotate, and when the zoom motor was removed and checked with a bench power supply it seemed to work. The motor drive circuit was found to be o.k., but it wouldn't power the motor. Fitting a replacement motor assembly cured the problem. So why did the original one work with the bench supply? It would revolve, but in doing so it drew approximately three times the normal current. **D.C.W.**

## Sharp VLC680H

A knock to the optical assembly caused the autofocus to stick. The cure was easy: to remove, clean and refit the optical assembly elements. What was not so easy to cure was the fact that the viewfinder display showed XCAS-SETTEX at the upper left-hand side. The camcorder's functions all worked correctly, but the viewfinder failed to show the correct function details. When we removed the camera

section for inspection we noticed that one of the connections to P701 appeared to be slightly farther out than the rest of them. The offending connection was to pin 1, the 'ready' line between the camera microcontroller and the syscon controller. Refitting cleared the problem. **D.C.W.**

## Canon E200E

Two of these camcorders came in on the same day with the same fault. They would cut out after a few seconds in either fast forward or rewind, entering the caution mode (eject flashing). If play or record was selected there was normal operation for maybe ten minutes, then failure. We found that the capstan motor FG signal disappeared when the failures occurred. Both camcorders had to have new capstan motors fitted. **D.C.W.**

## JVC GRSX9E

Because of a faulty record tab switch this S-VHSC machine would suddenly stop recording. Unfortunately the switch is available only as part of the complete sensor board assembly, greatly increasing its cost. **D.C.W.**

## Canon E60E

More and more camcorders are suffering from what at first seemed to afflict mainly the Sanyo VMD3P, leakage of electrolyte from capacitors of the round-can, PCB-mounting type. The symptom that led to this machine being brought in was loss of the video output signal from the AV phono socket – the EVF picture was o.k., as were all other functions. C104 and C108 on the main PCB were leaky.

Since we encountered this problem for the first time, two other machines with the same fault have come in for attention. Doubtless there are other potential failures to look forward to. **D.C.W.**

## Sony CCDTR105E

Everything seemed to be o.k. except for rewind. When this was selected the tape would spill out, because the supply spool failed to rewind correctly. The cause of the trouble was the fact that the relay belt which couples the midway gear assembly to the capstan motor drive had 'flipped' over at one end. As a result the non-toothed side ran against the driving gear. There was still enough torque for most functions – except rewind. A new belt cured the fault (a Sony kit that includes the parts mentioned above is available). **D.C.W.**

## Canon E850E

The reported fault was failure to eject. In fact this meant failure to do anything mechanical at all! The cause of the fault was loss of the FG output from the capstan motor. With this design the syscon microcontroller chip immediately senses the absence of the FG pulses and brings about a remarkably fast shut-down sequence – so fast that the capstan motor hardly has time to rotate! **D.C.W.**

# Fault Notes for the Sony CCDF450

Keith T. Keeton

**We've encountered the following faults with this camcorder.**

## Camera

**Black screen in E-E mode, playback o.k.:** Iris shut. No output at pin 1 of IC651 on board VC67P. Replacement chip cured fault.

**Dark E-E picture:** In one case FP268 on board CD20P was cracked. In another case the shutter was constantly on because IC902 on board CT21P was faulty.

**No E-E colour:** IC708 (NJM2233BM) on board CT21P was faulty, failing to switch the camera colour through.

**No E-E colour, playback o.k.:** In one case IC203 (CXA1208R) on board VA46P was faulty. In another case there was no 4fsc signal to the encoder board. X122 on board CD20P was faulty.

**Intermittent loss of E-E colour:** Cause was a dry-joint at pin 4 of CN202 on board VS72

**No E-E colour, recorded colour slightly low:** Track was broken between pin 4 of CN202 and C219 on board VS72. Cured by hardwiring between pin 4 of CN202 and C219.

**No E-E picture, playback o.k.:** Iris was closed, because Q126 on board CD20P was faulty.

**No E-E picture, screen scrambled:** Crystal X121 on board CD20P was faulty.

**No E-E picture, playback picture garbled in pause:** FL204 (LC delay) on board VA46P was faulty.

**No record colour, playback o.k.:** Signal o.k. at pin 1 of CN202 but not present at C325 because of a faulty PCB pin-through link (board VS72). Hardwire or replace board.

**No red on titler, E-E and playback pictures o.k.:** Caused by a dry-joint at pin 40 of IC704 on board CT21P (incorrect signal output from IC704).

**No titler red or green, E-E o.k.:** C745 (0.01 $\mu$ F) on board CT21P open-circuit (signal o.k. at pin 13 of IC703, no signal at pin 31 of IC704).

**Noisy coloured lines on E-E picture, playback o.k.:** Dry-joint at pin 22 of IC401 on board VC67P.

**No E-E or record sound:** Faulty microphone. Note that there are two types of microphone with this model.

**No right channel E-E sound, playback o.k.:** Dry-joint at pin 40 of IC400 on board VA46P.

**Failure to focus:** FP268 on board CD20P cracked. Replace FP268.

**No zoom; focus, E-E and playback o.k.:** Lens motor faulty. Replace lens assembly as motor is not available separately.

**Zoom causes iris to close, E-E picture o.k.:** Pin 17 of IC501 on board VC67P shorted to pin 18 via solder link (same varying voltage at pins 17 and 18). Resolder pins.

**E-E power down to no raster, very intermittent:** Repair/replace camera/off/VTR switch S514 on board VK10P because of poor contact (no raster when top board touched hard).

**Patterning on E-E picture:** Open-circuit at Q126 (XN4601) on board CD20P. Resolder/replace Q126 as necessary.

**E-E picture goes black intermittently:** C418 on board VA46P open-circuit.

**E-E picture too bright:** Iris sticking when nearly closed. Replace lens.

**Powers down to no raster, sometimes intermittent:** IC501 (CXP801166790) on board SS100P faulty.

**Records black screen, E-E and playback o.k.:** Dry-joint at pin 43 of IC201 on board VA46P (no input at Q115/7).

## Camera/VTR

**Flashes low battery then powers down:** This was a really odd fault. We had to replace IC501 on boards SS100, FU72 and VC67 because they failed one after the other for reasons unknown. Probably a one-off fault.

**Intermittent power down:** We've experienced various causes of this fault, as follows:

(1) Switch S514 (VTR/camera power) on board VK10P faulty.

(2) IC901 (MB3783PFV) on panel SS136 faulty. There was a VTR DD on signal at pin 21 but no output at pin 41.

(3) Powers down to a black raster because IC501 (UPD75316GF0643B9) on board FU72P is faulty. A replacement PCB is cheaper than the chip.

**Function buttons didn't work:** There was also no remote commander operation because the data lines were earthed. Corrosion adjoining CN508 (it's next to the video output socket) on board VA46P was the cause. Board was replaced.

**No EVF picture:** L903 on board VF26P faulty (vertical pulse notched).



**No power to camera/VTR:** L901 on board SS100P dry-jointed.

**No power to camcorder:** C518 (4.7 $\mu$ F, 18V) on board FU72P short-circuit (high current drawn from the power supply).

**No power to camcorder, EVF o.k.:** PS501 (N10) on board SS100P high-resistance, so no power to the loading motor.

**No power to camcorder, EVF display present but scrambled:** PS990 (1250) on board FU72P high-resistance

**Unit dead:** Replace X301 on panel VA67P.

**No playback/record sound, E-E o.k.:** C401 on board SS100P broken – was knocked by C703 on board CT21P.

**Interference lines on record picture, E-E and playback o.k.:** IC203 (CX1208) on board VA46P faulty.

## ***Mechanism***

**Capstan rotates very fast on eject:** No feedback from capstan motor (check FG and Hall). New capstan motor cured fault.

**Eject symbol shows when play/record selected, then mechanism stops after four seconds:** No eject, half unloads then stops. Power down to complete eject. Take-up reel sensor (photocoupler) D303 faulty.

**Mechanism loads without tape:** Replace C529 (15pF) and C711 (470pF) on board SS100 (on eject the FF reel spins then the arms load whilst still ejected).

**At power up the drum rotates and the mechanism operates in the fast forwards mode, but no eject:** The mechanism was in the load position because IC501 on board SS100 was faulty.

**Tape rides up pinch roller:** Various causes, as follows:

- (1) Incorrect back tension – adjust.
- (2) Pinch roller not straight because support pole bent. Chassis had to be replaced.
- (3) Worn capstan motor (moves up and down in bracket).

## ***VTR***

**No playback picture (black screen):** Pin 3 of CN507 on board VA46P open-circuit. Resolder or link.

**No playback picture (black screen), sound and E-E o.k.:** IC201 (CXA1207R) on board VA46P faulty (no output at pin 38).

**Snowy playback picture, E-E o.k.:** HIC board RP77 (SBX150951) faulty. Replace.

**No playback sound, E-E o.k.:** FL402 on board VA46P open-circuit. The signal was o.k. at Q400 but missing at Q401.

## Tatung VRH8350

This model uses an Akai deck, so the same fault could occur with its Akai contemporaries. The symptom was loss of field lock, with a very poor playback f.m. envelope shape at the start of each head scan. This was because the tape rode very high (round the top of the adjusting nut in fact!) at the first stationary guide upstream from the full-erase head. We found that the back-tension arm was bent to the extent that its tape-feeler pin listed heavily to starboard. As bending the arm back with sufficient precision is difficult we fitted a new one.

E.T.

## JVC HRD520

It's not uncommon for this and similar models to leave a loop of tape dangling from the cassette occasionally on eject. The well-known cure for this and various other mechanical problems is to replace the mode switch – we change the main cam as well.

One machine we repaired in this way bounced straight back with the same fault – and a very irate customer waving a damaged *Snow White* tape! We found that there was some toffee-like substance on the felt strip of the back-tension band and the corresponding periphery of the supply spool turntable. As a result the turntable 'picked up' the band now and again during eject and jammed, preventing tape take-up during the unthreading process.

E.T.

## Panasonic NVH65

This machine had two faults, both of which were intermittent. The cause of occasional loss of colour in the record mode only was tracked down to dry-joints on the YC pack at the point where the mother board connection pins are soldered. You have to remove the pack to deal with this one. Then at odd intervals, depending on temperature, the machine would lose servo lock, the result being wobbly sound and cyclic mistracking. The cause was C1023 (1,000 $\mu$ F, 10V) in the power supply. It had gone low in value – and was very responsive to heat and freeze treatment.

E.T.

## Sony SLV415

This was a nasty one! When the machine was connected to the mains supply one of two things would happen: there would be either no sign of life or a very bright MON – and nothing else at all – would appear in the fluorescent display panel. In neither case would the front-panel keys or the remote control system do anything at all. We found that the power supply worked but didn't get an on command from the system control department. It transpired that the 4.19MHz crystal X1, which is mounted alongside the micro-controller chip on the front panel, was responsible: its oscillation was intermittent, in fact 'ragged' when viewed with an oscilloscope.

E.T.

## Panasonic NVHD100

This machine had an intermittent problem: after operating for a few hours it would shut down and sulk. Any attempt to

get the tape out would be frustrated until the machine had been left disconnected from the mains supply for a few hours. After many hours had been spent head scratching we eventually found that the mechanism loading motor, part no. VEM0427, was the culprit. A replacement restored the machine's good nature.

B.S.

## Panasonic NVSD44

We've had this fault, not stopping on station when search tuning, on two occasions now. The basic cause is that the a.f.c. defeat signal fails to reach the demodulator panel. In these machines the sub-panels plug into the main board. The trouble has been that the first pin on the demodulator board plug is bent. As a result it doesn't engage properly with the socket, hence the tuning problem. Straightening the pin and refitting the socket cures the problem.

B.S.

## Panasonic NVJ30

This machine had a dead power supply. The usual culprit is C1109, but not this time. Checks showed that the power supply worked initially but swiftly cut out. We eventually found that D1110 on the secondary side of the power supply was leaky. A new MA185 diode was all that was required to restore full operation.

B.S.

## Panasonic NVJ35

My report (February, page 254) on a capstan servo fault caused by a defective component in the power supply led to a couple of queries. The symptoms were bad sound wow with spasmodic tracking bars on the screen. The report was correct for the machine in question – C1118 was the cause of the fault. C1122 is the more usual cause however, as several readers pointed out. Both capacitors had deteriorated in the machine on which the report was based.

B.S.

## Panasonic NVG21

This machine's playback picture had an attractive swirling pattern superimposed on it. The cause, not unusually for a machine that's as long in the tooth as this one, was a capacitor in the power supply. C1022 (47 $\mu$ F, 50V) was the culprit. For good measure C1118 and C1023 were also replaced.

B.S.

## Mitsubishi M20V

The cause of the fault with this machine appeared to be simply dirty heads. I should be so lucky! The symptom consisted of very severe noise on the playback picture – in fact you might have thought that the machine was in the picture search mode. The tracking control didn't seem to have much effect and, knowing that the machine had recently been transported by not the smoothest of means, I suspected that there might be print damage in the vicinity of the control. When I turned the machine on its side to dismantle it further a small metal shaft fell out: it was the slant pole from the entry guide. When this had been refitted

the picture was restored to its former glory.

This had been a field call, and unfortunately the customer's problems were not at an end. While I was still there a rather nasty hail storm passed, bringing with it a huge puddle of water down the aerial lead. Oh well, such is life!

**A.T.**

## **Grundig VS200**

The owner of this machine bought a second-hand satellite unit to add to his existing two VCR and three TV set-up. As all the signals had to travel around the house the connections were made at u.h.f. This, together with our local group A transmissions, didn't leave much room for another modulator! My solution was a small modification to the only varicap modulator in the set-up, the one in this VCR. The 9V zener diode that regulates the supply to the tuning preset was replaced with two zener diodes, providing 5.1V and 5.6V, connected in series. This increased the tuning voltage sufficiently to provide an extra three channels, releasing enough room for the satellite receiver.

I've since modified several Grundig modulators in this way, in each case obtaining enough room for pattern-free reception.

**R.P.**

## **Philips VR6760 and Clones**

A very simple modification to these machines will extend the modulator tuning range to channel 43 or 44. This will often give pattern-free reception where band space is limited. Simply short out one of the resistors in series with the feed to the tuning supply. The values of these resistors seem to vary at the whim of the designers. You'll find them outside the can, right by the potentiometer. Short out the resistor with the lowest value. In some models released abroad there's only one resistor.

**R.P.**

## **Grundig VS200**

The owner of this machine had only recently arrived in our area and called me in to retune it to the local transmissions. Would I set the clock while I was about it? The tuning memorised all right, until the power was disconnected when all memory was lost. It then emerged that the clock hadn't worked for a long time. So a quick tune-in turned into a workshop repair.

The fact that the clock could be set but wouldn't run led me to the power supply, where I found that the 50Hz pulses were weak and distorted. This was a complete red herring however. The memory and clock functions were both restored by replacement of the 1.2V power pack. It had shorted internally, one result being an excessive load on the circuit which buffers the 50Hz pulses that trigger the battery-powered crystal oscillator when the mains supply is available. This battery is quite hard to find: it's on the board immediately to the left of the deck. A Philips type memory cell worked all right when the mounting had been 'fine tuned'.

**R.P.**

## **Matsui VX2700**

This machine wouldn't load or unload: the load motor drive chip IC1003 had failed.

**D.B.**

## **Saisho VRS4200**

No LP-mode sound was the complaint with this machine. It didn't matter whether you were in E-E, LP playback or LP

record, the sound was muted. Checks around the syscon microcontroller chip IC1001 showed that pin 61 (audio mute) went high in the LP mode. LP/SP switching is controlled by the logic level at pins 16 and 17, which receive inputs from the servo chip. These levels were correct.

A new OEC0015 microcontroller chip (IC1001) seemed to be the answer but made no difference. Pin 61 goes high in the search mode, its output going to IC4202 (audio switching) and to IC5001 and IC5002 on the audio subpanel. Further checks showed that in the LP mode pin 61 of IC1001 went to approximately 3.8V while in the search mode it went to 5.4V. So as a temporary measure I connected a 4.7kΩ resistor between pin 61 and earth. Bingo: sound o.k. I was tempted to add this resistor on the audio subpanel permanently, but removal of this panel revealed the true culprit – a bit of liquid corrosion between pins 17 and 18 of IC5001. Cleaning this off cured the fault.

**D.B.**

## **JVC HRJ200/205/400/600**

In a previous report I mentioned that excess grease causes white spots on the picture. JVC has issued a modification for implementation where removal of the grease doesn't cure the trouble. This is as follows: replace the brush assembly with a new brush, part number PDM4343A, and fit a capacitor (part number PD4328-2) to the upper drum's lower bearing. If the machine is an HRS5900 the part number for the brush is PDM4343B.

**D.B.**

## **Panasonic NVG25**

Intermittent shut down was the complaint with this VCR. We found that capacitors C18-21 were all low in value. Replacement cured all the faults.

**D.B.**

## **Saisho VR805S/Hinari VXL2**

Intermittent colour was the complaint with this machine, which had been back to us several times with the same fault. Replacing crystals X3001 and X3002 and realigning the colour circuit usually provides a cure, but not this time. A new colour board, type PCB 301, put matters right.

**D.B.**

## **Sanyo VHR291**

Sound slurring and tape creasing were the reported faults with this machine. At some previous stage it had been stripped to fit a new reel sensor and had not been reassembled correctly. Dismantling it and reassembling it correctly put matters right.

**D.B.**

## **Matsui VP9401**

I've had two of these machines with the same symptoms but different faults. The symptoms were that the machine would accept a tape, play it if the tab is missing, but there's no display and the front panel buttons don't work. In one case the control chip IC601 was the cause of the fault. In the other case we found that a digital waveform was superimposed on the oscillator signal: because of a dry-joint at CN601's earth connector, the oscillator's earthing was open-circuit.

**D.B.**

## **Amstrad TVR2**

This TV/VCR combination originally came in because it wouldn't play tapes. Realigning the carriage and cleaning

the heads sorted that out. But when an aerial was connected to the TV section the signal was poor, as though the tuner's gain was low. A new tuner didn't solve the problem and, to cut a long story short, we eventually got a clear picture by replacing the SAW filter. **D.B.**

### **Ferguson FV71LV**

The picture was fuzzy, giving the appearance that there was no output from one head. Cleaning the drum made no difference, nor did a replacement preamplifier chip (IR01). We finally found that CR05 was leaky. **D.B.**

### **Amstrad UF40**

This machine was dead. Fortunately the power supply hadn't blown up – R1018 was dry-jointed. When this had been attended to we had no E-E or record sound. The r.f. block, which consists of an r.f. converter, a tuner and i.f. strip all in one can, had to be replaced. **D.B.**

### **Sanyo VHR315**

This machine had a cassette jammed inside it. The usual cause is a faulty mode switch, which jams the mechanism. After fitting a replacement we put the machine on test and found that it would sometimes leave tape out on eject. A sticky capstan brake was the cause. Replacing the brake pad and cleaning the capstan cured the problem. **G.S.**

### **Hinari VXL8**

There was no rewind or fast forward operation, though play and record were fine. We soon spotted that the brakes didn't come off in the rewind and fast forward modes, but it took a lot longer to find the cause.

The brake trigger mechanism, items 259-262 in the exploded view in the manual, was suspected. Trigger lever 260 didn't latch properly. The cause of this was traced to a square rubber pad that sits over a pin on the mechanism. In the stop mode it rests against brake plate 261. This rubber bumper holds brake plate 261 to the right, enabling trigger lever 260 to latch. As the rubber bumper wears down, the trigger stops latching and the brakes stay on in fast forward/rewind.

As this rubber bumper isn't shown on the diagram you can't get it. You can either get one from a scrap machine or turn it round by 180°, which will cure the problem. **G.S.**

### **Panasonic NVJ42**

There was no record or E-E video, though the sound was o.k. (use the test signal switch to get sound with self-muting TV sets). This machine is very hard to work on, with limited access to the luminance/chroma PCB. Replacing IC302 cured the problem. **G.S.**

### **JVC HRD880**

This machine was dead, with no clock and no functions. Checks in the power supply showed that the 12V supply was missing. CP2 was open-circuit. **G.S.**

### **Nokia 3782**

This machine lost around thirty seconds a day, the clock time gradually drifting off. The problem was cured by replacing the 32kHz 'crystal oscillator' X7101. **G.S.**

### **Akura VX140**

This machine kept going to standby and ejected any tape that was inserted. To be more precise, the motor that drives the lift ran continuously then the machine went to standby. I stripped down the lift assembly and refitted a spring on the switch-arm assembly (item 244). This triggers the lift eject stop switch 'C-OUT'. The machine was then up and running. **G.S.**

### **Akai VS427**

This machine came in because it required the usual pinch roller replacement and general clean up. We also noticed a secondary fault. A hum bar would appear briefly when a cassette was ejected and sometimes during rewind. The symptom was worse when pressure was applied to the capstan motor, with the hum bar permanent. Various smoothing capacitors in the power supply were tried, but the cause of the fault was eventually traced to D2 (1N4002) which was leaky – it's also in the power supply. **M.L.**

### **Ferguson 3V29/JVC HRD110**

Regardless of which button was pressed all you got was fast forward. Normal operation was restored by replacement of the right-hand carriage end sensor (viewed from the front). Fine. But can anyone explain why the loading belts in these machines invariably fail the minute they arrive in the workshop? While we're on this subject, when refitting the motor after belt replacement anchor the motor assembly with one screw then stand the machine on end and push both loading arms forward into the V blocks. The motor can then be located with the gears meshed correctly and the remaining screw fitted. **E.R.**

### **Samsung VI710**

This machine was totally dead, with a tape stuck in it. We're not familiar with this particular model but, fortunately, noticed that R109 in the power supply had disintegrated. After fitting a replacement the machine powered up. We then discovered, not surprisingly, that the idler was worn. Changing it didn't look too easy, as the carriage has to be removed. We overcame the problem by turning the machine upside down, removing the idler pulley from its assembly then, after replacing the tyre, refitting it. **E.R.**

### **Toshiba V57**

The capstan rotated for a few seconds when this machine was switched on, then it shut down. We found that the circuit protector CP1 for the switched 12V supply was open-circuit, a replacement restoring normal operation. The current through CP1 peaked at only 110mA during lace-up, so there didn't seem to be any overload. After soak testing it for a day we pronounced the machine fit. **J.E.**

### **Panasonic NV730**

This machine wouldn't accept a tape. We measured 10V at both terminals of the carriage motor, indicating that there was an open-circuit somewhere. Checks on the BA6209 loading motor drive chip IC6004 showed that all pins were at 10-12V. The cause of the trouble was a hairline crack in the print connected to pin 1 of IC6004. Soldering a link across this restored normal operation. **J.E.**

## Sanyo VMD66P

Failure to eject cassettes was the fault with this machine. It uses a Sony U mechanism, which is where the cause of the trouble lay: the supply coaster was detached from its correct position and flopped about as it wished. Some deck dismantling was required to enable the loading gear (part no. 374410901) and the gear assembly drive (X37288421) to be replaced. We also replaced the coaster leaf spring (373648501). **D.C.W.**

## Sony CCDV100E

This old-timer came in dead. A check on the power supply PCB revealed that the main fuse was shattered. As it's a glass, 3-15A type this suggested the presence of a serious overload. Things were not as bad as they might have been however as the other fuses (CPs) in the power supply were all intact. So the cause of the trouble wasn't far off. In fact the composition block assembly was short-circuit to chassis at pin 2. This is the only section that could cause failure of the main fuse while leaving the CPs intact. A new composition block assembly and service restored the machine to good health. **D.C.W.**

## Panasonic NVMS70

This nice S-VHS-C, hi-fi unit had been dropped on its rear end, causing damage to the VCR function PCB. Thus no functions were available to the user. Repairs to the print on this board restored some functions: record was available, also fast forward and rewind, but there was no playback picture, just snow. Audio, both linear and hi-fi, was o.k. Checks showed that the playback 5V supply was missing at the head amplifier circuit: L5007 had broken from the PCB and Q5009 was defective. Replacing these items restored the playback picture, but we were not quite out of the woods yet!

While the unit was on test after being re-cased we noticed that during playback of its own recordings a faint pattern would sometimes drift across the picture. This didn't happen with a test tape. Autotracking on playback, with a switch to provide manual tracking if required, is a feature of this machine. With the machine switched to manual tracking while playing one of its own recordings we found that adjustment of the tracking control produced an almost perfect second picture that had been previously recorded by another machine. So two playback pictures were available simply by adjusting the tracking control!

The reason for this unusual symptom was simply that the ribbon cable which supplies the drive to the full erase head had been damaged. So the erase head didn't function. As this machine uses its LP heads for SP mode recordings, a guard-band is left between recorded tracks. Thus with the full erase head inoperative a new recording over a previous one made with normal track width left bands of the original recording. A new ribbon cable restored normal operation. **D.C.W.**

## Canon E60E

The E-E colour was o.k. but there was no colour with playback pictures. This was another case of a leaky electrolytic,

the culprit being C313, a 10 $\mu$ F, 16V can type (aren't they always?!) on the main PCB. It had leaked over the track to pin 13 of IC301. **D.C.W.**

## Sony CCDTR55E

There were two reported faults with this handycam. During the first few minutes of operation there was no E-E or recorded sound, though the playback sound was o.k. All was well after this initial problem until the unit had been left for a while, when the symptom would return. Its cause was the CXA1237AR chip IC401 on the audio PCB.

The second fault was that although all functions worked normally, with good recording and playback, if the tape was wound to either end 'caution' would be displayed in the EVF and the functions would then shut down. This was cured by replacing the GL453S cassette LED. **D.C.W.**

## Canon E70E

The mechanism would sometimes jam when loading or unloading was attempted. Being put under a severe strain, the loading motor would stall and initiate a shut-down sequence. A Sony O type mechanism, which does not normally suffer from this type of problem, is used in the E70E.

With the mechanism removed and the mode box connected it seemed at first that the coaster assemblies were sticking. But this proved to be the symptom rather than the cause of the trouble. In this mechanism the LS assembly is attached to the main deck by four brass pillar fixings, with slots to allow the loading/unloading movement. These brass fixings are rivetted to the main deck. One of them had become loose and was moving in the direction of travel of the LS assembly. As a result there was a tightening of the sliding section clearance. The only remedy was to replace the main deck, which of course entails the transfer of all the motors, gears, guide rails etc. All was well when this had been done, with no deck operation jamming. **D.C.W.**

## Samsung VPE405

This neat handycam-type unit had a Sony look about it – until it was opened up. There the similarity stopped dead! The reason for its visit to the workshop was loss of the E-E picture, although clock data etc. was present. The cause of the fault was simply that a small screw had become lodged in the iris mechanism. All was well when it had been removed and returned to its proper home. **D.C.W.**

## Canon E110E

This camcorder had been dropped. All the functions worked but there was no viewfinder picture because the c.r.t. had fractured. When a replacement was fitted there was still no picture. We checked the video signal path and found that the MA110 diode D2902 was faulty, a replacement putting matters right. The diode in this position in Canon units always seems to fail when the viewfinder c.r.t. is fractured. **D.C.W.**

## Philips Turbodeck VCRs

For poor tracking or slow autotracking operation check that the control head is clean. These and other half-loading decks seem to be prone to dirt build up at this point. **P.B.**

## Ferguson 3V43/JVC HRD725

One of these machines failed to read the reel tacho pulses. The amplitude of the TU FG signal was low at pin 41 of IC202 because D248 (1N4148) was leaky. It's fitted on the sub-board, by IC202. **P.B.**

## Hinari VXL4/Matsui VX880/Saisho VR1600

Playback was perfect for the first few minutes. Then, as the machine warmed up, the top of the picture began to flicker. This gradually became worse as time went by until the top of the picture became folded over and the colour was lost. We removed and checked the capstan, but it was shiny and clean and didn't appear to be running tight. Nevertheless we lightly oiled the bearing before refitting it. A soak test proved that the fault had been cleared. **D.A.C.**

## Hitachi VTM722E

Intermittent play, rewind etc. was the complaint with this machine. We'd lubricated the capstan motor a few months previously, so this wasn't responsible. What we did notice was that the reel drive gear didn't mesh correctly with the teeth on the tape reels. When the clutch assembly had been dismantled we found that a retaining ring had come out of its groove. As a result the pressure spring was free to push the reel drive gear upwards. A new retaining ring restored correct operation. **D.A.C.**

## Samsung VI910

The r.f. output from this portable VCR was very weak. A damaged r.f. converter was the cause. The VI920 is sold complete with a cloth carry bag and shoulder strap. The owner was in the habit of leaving the r.f. lead connected to the machine when he carried it. When he lowered the bag to the floor the plug would land first, transferring the force to the r.f. socket which as a result had been pushed in. The PCB was damaged, but a repair was possible using a small iron and fine wire. **D.A.C.**

## Ferguson 3V31/JVC HR7650

The cause of intermittent playback, record and E-E colour was traced to the 4-435571MHz crystal X401 being dry-jointed. It's on the colour PWB assembly board. **D.A.C.**

## Mitsubishi HSM45

Playback pictures were unstable and appeared to be mistracking. The video heads, control head and tape path were cleaned but this had no effect. As the tape guides were still securely fixed they hadn't moved out of adjustment. We then noticed that the cassette didn't quite load fully on the take-up side. The cassette carriage was disman-

ted and the old grease was cleaned off, then the guide runners were checked, a couple of small burrs were eased and some fresh grease was applied. On test the cassette loaded with a satisfying, positive click and the picture was back to normal. **D.A.C.**

## Ferguson 3V30/JVC HR7300 (early models)

If the drum runs at full speed in the wrong direction, i.e. clockwise, check the plug-socket connections to the MDA (motor drive amplifier) panel and the print continuity on the panel itself, especially around Q216. This transistor tends to run quite hot. The MDA panel was mounted vertically behind the function PCB in early models: in later models the MDA circuitry was moved on to the servo panel. **D.A.C.**

## Ferguson FV32

This machine would load a tape and both rewind and fast forward were all right. But when play was selected the machine would start to thread then suddenly stop in its tracks, leaving the tape partially loaded. We found that the timer i.c. was supplying a servo stop signal to pin 26 of the system control/servo chip IT01. So a new HD614080S chip was ordered, but when fitted made no difference.

Maybe the machine was entering an alarm/stop mode, though the drum and capstan motors still rotated. We decided to get out the scope to check waveforms and found that there were no drum PG pulses at test point BK02. So we replaced TK25, still to no avail. At this point we decided that it had to be the drum motor. But have you seen the price?!

We carefully dismantled the direct-drive drum motor and found that the PG pick-up consists of two single printed-circuit coils, with a small surface-mounted electrolytic capacitor (C6) connecting one end to the driver chip. This capacitor was open-circuit. Its value is 3.3 $\mu$ F, rating 50V. We used a 10 $\mu$ F subminiature type from an Amstrad 4600 i.f. can as a replacement. The result was perfect – and a fraction of the cost of a new DD unit. **M.Dr.**

## JVC HRD230/Ferguson FV12L

The customer asked us to fit a new drum in this four-head machine. He'd cleaned the heads himself, then come to the conclusion that they were faulty. What he'd actually done was to break all four head tips.

When we'd replaced the upper drum the original fault was apparent. Every time that play was selected, with a known good tape, a portion of the f.m. playback carrier was missing, giving the impression that the heads were clogged. At one point there was so little f.m. signal that the tape might as well not have been wrapped around the drum. Thus a mechanical fault was ruled out. In this model the drum PG and FG signals are combined and leave the drum together at pin 3 of connector CN3. A scope check here showed that the PG pulses were missing. After some careful testing we removed the PG pick-up and found that it was open-circuit. Unfortunately parts for the drum are not available individually. But we found an identical pick-

up in a scrap HRD170, though the motor is different. Fitting it cured the fault. **M.Dr.**

### **JVC HRD170/Ferguson FV11R**

This machine worked normally except for the fact that there was no clock display. We found that R4 (220Ω) on the power supply PCB had gone open-circuit. A long soak test after fitting a replacement failed to bring to light any reason for its failure. **M.Dr.**

### **Sharp VCA105**

This machine would power on and initialise, then shut down with no functions and no display. We couldn't find any incorrect voltages. Replacing the timer chip IC5001 cured the fault.

A useful tip with a fault like this is to remove all plugs from the front timer PCB and insert a prerecorded tape with the safety tab removed. The machine will accept, load and play this tape, proving that the deck and syscon are o.k. **R.J.L.**

### **Matsui VX755/Saisho VR3600**

For intermittent stopping during play, replace the take-up reel sensor. **R.J.L.**

### **Mitsubishi HSB27**

Rewind and fast forward were intermittent when this machine was hot, the other functions being o.k. A new mode switch didn't cure the fault: a new loading motor assembly did. **R.J.L.**

### **Samsung VI611**

There was a hum bar in the E-E mode only. We found that C4 (47μF, 100V) was open-circuit. As a result the voltage at pin 18 'PRST VTG' was low. It should be 33V (this voltage is not shown in the service manual). **R.J.L.**

### **Ferguson FV11R/JVC HRD170**

E-E was o.k. On playback there was sound but only a blank screen (no video). Checks showed that the E-E 5V line was always at 5V. The DTC144W digital transistor Q503 was faulty. **R.J.L.**

### **Panasonic NVG21**

There were no functions and no display, just a ticking noise from the power supply. Replacing the STR1006 chip in the power supply restored normal operation. **R.J.L.**

### **Panasonic NV370**

The clock and counter displays were very dim. All the other functions worked all right and good pictures were produced. Checks on the outputs from the power supply showed that the voltage on the -50V rail was low at -30V. Replacing C1104 (100μF, 63V) restored the correct voltage and display. **C.W.**

### **Saisho VR3800 with Teletext**

The customer complained about an intermittent yellow picture when on the video channel. We brought the machine

in and ran it for some time in the E-E mode. Eventually we got a blank screen – not yellow, but blank. The sound remained o.k., and the channels could be changed. If play was selected the picture would sometimes appear, but not always. Then the picture might reappear in all modes, the machine working all right for some time.

I scoped the video signal at the input to the teletext panel while the machine was faulty in the E-E mode. The signal was present here but didn't come out of the board again. Although the fault couldn't be instigated by heating, cooling or thrashing, I still decided on a good solder up around the various chips and the through-the-board links. This didn't provide a cure. We were fortunate to have a circuit of the text unit in our U-View set of manuals. I found that the voltage at pin 17 of IC8502 was slightly high. The pin is labelled 'brank' (surely blank?). After much searching and checking I noticed that the 1kΩ surface-mounted pull-up resistor R8524 had a scummy film on it. When this was cleaned off the picture returned. It was obviously pulling the blanking line high. **C.W.**

### **Ferguson FV37H**

Although the tuning mode could be set and the channel numbers appeared correctly the channels couldn't be tuned in. A look at the tuner PCB revealed that Q2 had obviously been struggling – the board around it was discoloured and the solder had a very shabby look. On test Q2 was found to be open-circuit. Various checks were made, but no other fault could be found. A replacement transistor restored the tuning but was pretty warm after only a few seconds. A long soak test proved that the transistor was all right, so maybe it just does run warm. **C.W.**

### **Akai VS25**

There were horizontal dark lines across the entire screen, more noticeable during playback and in the E-E mode with the aerial disconnected, i.e. the picture muted. C6 (220μF, 10V) and C7 (100μF, 10V) on the power supply board were responsible for this. Over 300mV of spikey noise was measured across C6. Both capacitors measured o.k. when checked with a capacitance meter, but when they were compared with a known good capacitor using the scope's component tester function a marked difference was displayed. I'm very impressed with this facility on the scope, and find it much more accurate and trustworthy than the majority of separate component testers. **J.E.**

### **Hitachi VT33**

The display and the E-E mode were o.k., but this machine wouldn't accept a tape. When a tape had been inserted manually there were still no deck functions. Checks showed that the switched 9V supply was missing, because the SKT5421 regulator had failed. A replacement restored normal operation. **J.E.**

### **Ferguson 3V35/JVC HRD120**

The deck modes would all go to stop after a few seconds. All was well when the take-up reel optocoupler had been replaced. **J.E.**

### **Ferguson 3V65/JVC HRD170**

There was no reel motor operation, the cause being failure of the M54644AL drive chip. As I've had this fault before, I

gave an estimate based on replacing the chip. Unfortunately for me when the replacement was obtained and fitted the reel motor still refused to do anything and the chip burnt up. Yes, you've guessed it, the reel motor was the cause of the fault. There were then some problems with the customer, but that's another story! **J.E.**

### **Samsung SI1260**

This machine made a loud noise in the rewind mode and would shut down in play. The cure is to remove the take-up spool and push the two halves together. **D.B.**

### **Ferguson FV71LV**

This machine was dead. Fortunately replacing IP01, TP01, RP18 and RP21 in the power supply restored operation without the blow-ups you usually get with switch-mode power supplies of this type. **D.B.**

### **Hitachi VTM822**

This machine wouldn't accept tapes, and when you could manage to load one the tape would be chewed. Checks around the microcontroller chip IC901 revealed evidence of liquid spillage. A clean up here restored normal operation. **D.B.**

### **Amstrad UF40**

This machine would eject tapes, but not when it was in the service mode. By blanking off the sensors (not easy) we found that when a cassette was inserted the tape would be wound forwards slowly then stop, followed by ejection. Checks showed that the voltage at the take-up sensor was permanently low. The cause was a 3k $\Omega$  leak to chassis at pin 46 of the microcontroller chip IC6001. Replacing IC6001 restored normal operation. **D.B.**

### **Panasonic NVJ35**

The capstan jerked round, the picture wobbled and the sound had lots of wow on it. So we checked at pin 13 of the capstan drive chip and found that there was 2V of ripple on the 5V supply. There was ripple on the other supplies as well. Replacing most of the capacitors in the power supply restored normal operation. **D.B.**

### **Amstrad DD8900**

The top deck would stop after a couple of seconds. The cause of this was the reel sensor, which is not available separately. It comes with the plate sensor, part no. 250827. **D.B.**

### **Hitachi VTF860**

No go or intermittent failure to perk up from cold is generally caused by the kick-start capacitor C6 (1 $\mu$ F, 250V) in the power supply having dried out or being partially open-circuit. The fault doesn't put in an appearance with normal use in the home – unless the machine is deprived of mains power for any reason. It crops up when the machine is on the bench for diagnosis of the cause of some other fault – or when the customer gets it back home again! **E.T.**

### **Philips VR6462**

We've had a couple of cases of loss of sound (E-E and play-back) with this model. Both times the cause was C2007

going short-circuit. It's a 330 $\mu$ F, 16V electrolytic mounted on panel P502. **E.T.**

### **Sony SLV315**

This fault is usually intermittent to start with, then becomes permanent to aid diagnosis! The symptoms are no sound, multiple mistracking bars on the picture and tape damage when the cassette is ejected. Look no farther than the half-loading arm, which becomes tight on its shaft. The cure is to give the shaft and the arm bearing a good clean followed by a small drop of thin oil. **E.T.**

### **Panasonic NVSD40B**

Intermittent loss of r.f. loop-through was the complaint with this machine. The cause was loss of the unswitched 12V supply to the amplifier section of the tuner because L7005, a surface-mounted 47 $\mu$ H choke, was going open-circuit intermittently. It's fitted in the UK version only. **N.B.**

### **Samsung VIK346**

This brand new machine worked perfectly apart from the fact that there was no display. Checks showed that the voltages at G1-10 were all low because of a leak within the digitron display (DT701). When it was removed a crack was seen in the back. **N.B.**

### **Panasonic NVSD25B**

There was no full erase with this brand new budget VCR simply because P4001, the feed to the full-erase head, had never been plugged in! **N.B.**

### **Salora SV8400/Mitsubishi HS308**

We've had two of these machines in recently. With the first one there was severe patterning over the r.f. through the machine because C912 (330 $\mu$ F) was open-circuit. The second one was dead except for the clock, which flashed on when the switch was closed from standby but then went off again. The cause was C911 (47 $\mu$ F) in the 12V power supply – it had gone very low in value. **N.B.**

### **Matsui VX1000Y**

This machine wouldn't tune in signals. I found that the voltage at tuner pin BT was virtually zero wherever the unit was tuned. The voltage at the 33V regulator was correct but R45, a tiny 33k $\Omega$  resistor, was open-circuit. **N.B.**

### **Sharp VCH88HM**

This machine wouldn't accept remote control commands. Scope checks showed that the IR receiver was sending rubbish to the microcontroller chip. A new infra-red receiver put matters right. **C.N.**

### **Hitachi VT530**

This machine kept coming back to the workshop because the cassette housing needed to be retimed to the main deck. When this had been done it would work perfectly, but it would return with the same problem about three months later. We finally traced the cause of the trouble to the start and end sensors on the cassette housing and replaced the IR emitter. **C.N.**



# JVC HRD530 Fault Guide

John Coombes

This popular SP/LP VCR, with hi-fi sound, was launched in 1988. It also appeared in the UK in the Ferguson and Telefunken ranges, as the FV14T and VR3975 respectively. We'll group the fault conditions we've experienced under the headings mechanical, power supply, electronic and remote control.

## Mechanical Faults

The deck is used in a number of JVC models. Some of the mechanical problems can be very intermittent.

**Intermittent problems:** The mode select switch can be responsible for the no play symptom when this is intermittent. This switch can also be responsible for failure to eject the tape, no loading or unloading, no servo control or no tape slackness operation. In the timer mode the machine may stop then power down.

The machine going into the stop mode is another intermittent problem you can get. Its cause is poor earthing of the PCB beneath the deck. This PCB is earthed by two or sometimes three screws. Remove the screws, resolder the PCB, fit lock-tight washers then replace the screws tightly – but not too tight or the PCB may crack.

**No play or chewing tapes:** This can be caused by a worn idler assembly. Check that there is drive from the reel motor: if not, check the motor and if necessary its drive circuit. Another cause of this fault is the pole base assemblies, both take-up and supply. The pole base screws can become loose, the results being incorrect loading and tape chewing.

**Intermittent loading:** Check whether the cam control gear is damaged. If this is o.k., check that the worm gear assembly is free running. The grease can become hard, preventing rotation. Other things to check if necessary are the loading belt and the loading motor.

**Take-up spool does not rotate correctly:** The spindle should be slightly lubricated. If necessary, lubricate to restore free running. If the problem persists, check that the main take-up brake is operating correctly. It may be worn. If the brake seems to be in good condition, ensure that the plate assembly slides freely and that the grease hasn't gone hard. Remove the plate and clean it to restore normal operation.

**Low sound or picture jumping:** The audio/control head may be misaligned. Check for wear and ensure that the tape path is set up correctly.

**Drum problems:** The upper drum can cause lower drum wear. This will result in poor playback/picture jumping and may also affect recordings made by the machine. The lower drum can cause problems when the upper drum has been replaced: it may be impossible to set up the tape path to produce a good f.m. waveform shape.

Before condemning the upper drum, try cleaning the heads and leaving them for a short period. This will enable the fluid to soak in and break down the oxides – this is necessary only when the heads are very dirty.

Another approach is to remove the upper drum and clean all its surfaces. Clean out oxide from the lower drum and under the upper drum surface. Reassemble and check operation.

**Half-loading arms unable to eject/remove tape:** This fault causes tape chewing and prevents free tape ejection. The cassette becomes statically charged, so that the tape sticks to the cassette lid when it is removed. A new lid guide (PRD43315) cures the problem.

## Power Supply Faults

**No results:** First check whether the 800mA mains input fuse F1 is blown or open-circuit. If it has blown, the 4,700pF mains filter fuse C101 is probably short-circuit. Then check the fuses on the secondary side of the mains transformer. If F2 (2.5A) has blown, check whether D1 or D2 (both type 10E2) or the 0.047 $\mu$ F protection capacitor C1 is short-circuit. If F3 (1.6A) has blown, check bridge rectifier DS2 (D5SB10) and if necessary its 3,300 $\mu$ F, 16V reservoir capacitor C4 for shorts. If there is no 8V input at the collector of the 2SD1761 switched 5V supply series regulator transistor Q8, check whether DS2 is open-circuit.

**No tuning voltage supply:** If the 45V supply to the 30V tuning voltage regulator is missing, check whether C5 (47 $\mu$ F) is short-circuit or D3 (11E2) or the 10 $\Omega$  fusible safety resistor R1 is open-circuit.

**No 12V motor supply:** Check whether Q7 (2SD1785) is open-circuit and for dry-joints here.

**No unswitched 12V supply:** If there is no unswitched 12V supply at pin 1 of plug/socket CN1, check whether power transistor Q9 and/or Q10 (both type 2SD1785) is open-circuit and for dry-joints, then if necessary check whether circuit protector CP1 (F25) is open-circuit.

**Switched 12V supply:** This is derived from the unswitched 12V supply via switching transistor Q5 (2SB1068). It will be missing if Q5 is not switched on at its base by the M50965-351SP microcontroller chip IC601 (pin 6). So IC601 could be the cause. First make sure that the 5V supply is correct. If the switched 12V supply is low, check whether C13 (47 $\mu$ F, 16V) is leaky or open-circuit.

**Display not aight:** The display unit may be faulty but if the 5V a.c. supply at pins 1/2 and 57/58 is missing suspect that the relevant winding on the mains transformer T101 is open-circuit.

**Connectors:** Plugs/sockets CN1, CN2, CN3, CN4 and

CN5 should be checked for dry-joints or poor connections when power supply faults are experienced.

## **Electronic Faults**

**Poor/snowy picture:** If the E-E signals and the TV channels are affected the r.f. converter/aerial booster is likely to be faulty. If only the E-E signals are affected the booster or tuner unit could be faulty. Ensure that the tuner is receiving its 12V supply – check whether L13 is open-circuit.

**Loss of channels:** The M58655P channel memory chip IC3 could be faulty. Before trying a replacement, check its supplies. There should be 5V at pin 1 and –30V at pin 2. If the latter supply is missing, check Q1 (2SB1005O/Y) on the regulator board by replacement then, if necessary, check whether Q23 (2SC1740S) on the tuner/i.f. panel is open-circuit.

**No signal from the tuner:** The cause could be the M50440-394SP tuning chip IC2. Check its d.c. conditions carefully or check it by replacement. If IC2 is faulty Q17 and Q18 may not switch on with the result that the tuner unit doesn't receive its 12V supply. Check L13 if necessary.

**I.F. faults:** If there is just a blank raster, check the operation of the M51365SP i.f. chip IC1. There should be 8.8V at pins 5 and 21. If this supply is missing, check whether Q15 (2SD1468S) is open-circuit. Alternatively the MTZ10B zener diode D7 could be short-circuit.

If the picture is ringing or there are double images, check around the SAW filter SAW1 for dry-joints. If necessary try a replacement SAWF.

**No colour:** Ensure that IC301's 5V supply is present at pin 25. Next check crystal X301 which may be dry-jointed or faulty. Check that the VXO preset R328 is set up correctly and the condition of its track. IC301 (PU22046A) could be faulty – check by replacement. A less common cause is IC401 (AN3592K).

If the playback colour is not present at TP304, check whether low-pass filter LPF301 is open-circuit. Alternatively Q301 or Q302 (both type 2SC1740S) could be open-circuit.

**Servo faults:** These can vary from just stopping to intermittent playback or noise bars on the screen. There may even be tape speed variation. The main cause of these problems is the HD49712ANT servo chip IC1, but check for dry-jointed connections. There will be no operation if the internal clock (pins 58, 59) isn't working. Crystal X1 could be faulty or dry-jointed.

**Display faults:** Check first that the –30V supply is present. If so, the first suspect is the UPD7538ACU-214 display driver chip IC1. If particular segments don't light up, the display unit FDP1 could be faulty or alternatively IC1 could be the cause.

**Stereo L/R normal indicators don't light:** Check for dry-joints on the display PCB or a fault in plug/socket CN5 – resolder or remake to restore correct operation.

**LH channel level display at full deflection, RH display normal – or the opposite:** It's not easy to check for this because IC101's output is scan pulses. Replacing IC101 (MSC1124BRS) should restore normal operation.

**RH channel record level full on, no control over the level:** Check at pin 4 of CN3 on the f.m. audio PCB. The voltage here should vary as the E-E level potentiometer R34 is adjusted. Check for dry-jointed connections to R34 and the condition of its carbon track.

**LH channel record level full on, no control over level:** Same as above but check at pin 3 of CN3, the relevant potentiometer being R33.

**No hi-fi sound playback:** Check for 5V at pin 16 of IC201 on the f.m. audio PCB. If this supply is low, C227 (0.01 $\mu$ F) is probably short-circuit and L203 will be warm, providing a clue. Alternatively IC201 (HA11752) could be faulty. Check by replacement.

## **Remote Control Unit**

With all remote control units the first check must be on the batteries and their connections. No IR output can be caused by crystal X1 (CSB400BIT): it may be dry-jointed or have broken legs. If part segments only light, the display unit and/or IC1 (M50565-016FP) is faulty. If individual channels cannot be obtained, suspect a faulty rubber sheet. A temporary cure may be achieved by cleaning the contacts. If all channels and/or functions are inoperative, IC1 is suspect.

## Panasonic NVS20B

This camcorder refused to do very much in the deck mode, basically because there was no capstan rotation. Voltage checks in the driver circuit revealed the cause: when a load was applied the voltage on the CAP.SW. line fell severely. Moving back to the power supply we found that Q1007, a surface-mounted 2SB798 transistor, was short-circuit base-to-collector. It's the 'capstan power generator' – a switching transistor. **N.B.**

## Panasonic NVR30B

This slimcorder came back shortly after it had been sold, the complaint being that the zoom didn't work. There's only a power zoom in these modern units, which don't have a lens that you can manipulate. Although there was drive to the zoom motor section the lens didn't move because connector FP701 had been fitted incorrectly. **N.B.**

## Canon E30E

The list of fault symptoms made it sound as if this was going to be a rather expensive repair. There was no viewfinder picture, no playback picture, no zoom button operation and no clock/title function. Apart from this everything else was o.k.! Autofocusing worked, as did record, with E-E vision and sound via a monitor. We found that playback of a recording in another machine showed a colour flicker problem however. Where to start?

A collection of almost random symptoms like this can of course be due to liquid getting into the works, but in this case no tell-tale signs of spillage were visible. To reduce a long story to readable length, the cause of all this mayhem was once more a leaky electrolytic capacitor. Incredibly it was in this instance in the grip case section, which includes the viewfinder circuitry. The culprit was C2931, a 47 $\mu$ F, 16V electrolytic that had leaked and corroded the print running between its pins. This track carries the EVF ON line, which should normally be low. As it was at 6V, there was no viewfinder picture. In addition the EVF 5V regulated supply, which is used to power the zoom button control circuit, was turned off. The date and title functions are tied up with this supply, and because of the way in which the corrosion had occurred the other diverse symptoms were all related. **D.C.W.**

## Sony CCDTR105E

This handycam was with us for a long time. Not because of what it came in for, a stuck iris, but because of something that showed up only while it was on soak test.

Very occasionally in the playback mode, sometimes from cold and sometimes not, the machine would produce a picture with very bad dropouts and slight distortion – similar to the effect of an incorrectly terminated AV link. A scope check on the video signal in the fault condition showed a tendency to overshoot and sync pulse train distortion. Most of the time the unit played back perfectly however. When the fault was present, pressing the stop button then going back to play would sometimes clear the symptom. It tended to occur mostly with the case fitted.

Various heating and freezing sessions didn't help. Then

one day the fault occurred when the camcorder was out of its case. We transferred it to the bench with great care, and positioned it so that we could investigate the problem. The cause of the trouble was found to be an open-circuit capacitor, C088 (0.01 $\mu$ F) – not an electrolytic this time! It feeds the playback f.m. signal to pin 1 of IC005 on the syscon/servo/video PCB.

One of IC005's functions is to check for Hi8 tape in the playback mode. To aid detection, IC005 disables the DOC circuitry in the main playback signal path. With C088 open-circuit, the detection switching was random, with the results described. This was a nasty one! To add to the confusion, I didn't appreciate that although the CCDTR105 is not a Hi8 machine it does have the facility to play back Hi8 tapes. We live and learn! **D.C.W.**

## Hitachi VMC1E

This twist-and-shoot model came in because it was dead. We found that the two ceramic fusible links F971 and F972 were open-circuit. They are both rated at 2A and feed separate circuits. The fault was noticed after the unit had been dropped. But there was no sign of impact anywhere, either on the case or internally, so the reason for their failure is a mystery. A long soak test while monitoring the current flowing through the fuses didn't enlighten us either! We have however had the same symptom, some time ago, with at least one other of these units. There again fitting new fuses provided a complete cure. Does anyone know the reason for this fuse failure? **D.C.W.**

## Panasonic NVG2B

This machine produced a bright blue picture – very bright blue, with no other colour showing. The iris was also fully open at all times. The playback pictures were fine, also the audio.

A vectorscope display showed a distorted burst signal near the U axis, with no V (R – Y) signal present. Most of the YC signal processing is carried out by IC314 on the camera PCB. The signals around this chip suggested that it was faulty, further confirmation coming from the fact that it also incorporates the iris drive circuitry. But there's always the possibility these days that the cause of the fault might be wrong set-up levels being applied because of failure of a controlling EEPROM chip. In this case, fortunately, IC314 was the cause, a replacement restoring all the colours and normal iris operation. **D.C.W.**

## Panasonic NVS1E

A "whirring" noise from within was the reported fault with this camcorder. In fact once it had been switched on the loading arms continuously moved in and out of position. With any attempt to power off, the fault would continue and all circuits remained on. We weren't told that the camcorder had been dropped. One of the results of this was that the eject switch was permanently on. Thus the machine continuously tried to eject with the outer cassette door closed. With any other camcorder the fault would have been obvious as the cassette lid would have opened! **D.C.W.**

# VCR Clinic

Reports from Eugene Trundle, Andrew Tebbutt, Nick Beer, David Belmont, Christopher Nunn, Bob McClenning, V.W. Cox, Graham Thompson, Ronnie Boag, Gerald Smith, Roger F. White and Terry Lamoon

## JVC HRFC100

The real-time tape counter in this VHS/VHS-C compatible machine worked in the record and playback but not in the fast-forward and rewind modes. This was because the left-hand half-loading arm (item 25 in the exploded deck diagram in the manual) was bent, diverting the tape path past the control track head. **E.T.**

## Sanyo VHR3300

Very intermittent failure to accept a cassette has been the problem with an increasing number of these middle-aged machines. The tape goes in, half laces, half ejects, goes back down and is then fully ejected! The culprit is the mode switch, which is more accessible in this than in some Sanyo models. **E.T.**

## JVC HRFC100

Towards the end of rewind a VHS-C tape, but not an ordinary VHS one, would be cruelly chewed. When small cassettes are being fast rewound the tape guides are extended a little from the cassette shell. The tape was riding up and over the upper collar of the entry guide because it was loose and able to vibrate and lean backwards. We cured the problem by pushing home the entry guide's retaining stopper on the underside of the deck. It's item 11 in the exploded deck diagram on page 4-6 of the manual. **E.T.**

## Ferguson FV31

If you come across this type of machine with a no-go, no light-up condition, check the supply voltage at pin 32 of the microcontroller chip IK60. The chances are that you'll find little or no voltage here because the BC337 regulator transistor TK44 has failed. Also check its  $1\Omega$ , fusible series feed resistor RK44, which is a safety component. **E.T.**

## JVC HRJ200

If the problem with one of these newish machines is no action and failure to eject the tape, check CP1 in the power supply. It's an N20 type, rated at 800mA, and often fails. You will probably find that the current through the replacement is normal, at about 550mA, but to prevent further failure earth the cassette cradle with a bracket, JVC part no. PQ46086. It seems that static discharges can produce current surges through the protector. **E.T.**

## Ferguson FV81LV

If one of these machines seems to be completely dead though the mains fuse is intact and the power supply is producing outputs that pulsate at low levels, take a look at CP008 (100 $\mu$ F, 50V) in the power supply. If it looks unhealthy, replace it and the machine should burst into life. **A.T.**

## Mitsubishi HSB11/32 and similar models

A common fault as these machines begin to age is no

rewind/fast forward/take-up. The cure is to replace unit gear idler part no. 522C077020, pulley gear part no. 641C789020 and thrust washer part no. 552C010040. If you still have the same or similar symptoms after replacing these items replace the loading motor as well. This will in most cases solve the problem. **A.T.**

## Sanyo VAR512 Battery charger/power pack

We've had two of these units in recently because they were completely dead. In both cases the cause was R5104 (0-33 $\Omega$ ) being open-circuit. **A.T.**

## GoldStar 2031

Be warned if one of these machines won't play back an LP tape recorded by another VCR. Although the LP indicator in the display lights up this is not an LP model! I wasted some time in a customer's house before I found this out. **A.T.**

## Panasonic NVFS200B

The complaint with this highly-specified S-VHS edit deck was that the front AV inputs (AV4) didn't work. There was no display though the audio was o.k. Tests showed that one of the scart sockets, AV2, was similarly afflicted. The address lines to the audio switching array were clearly o.k. They were similarly correct at the M52474P video switching chip IC3901, which was faulty. **N.B.**

## Panasonic NVHD90B

The playback pictures produced by this brand-new budget hi-fi machine were spoiled by a faint blue vertical bar about a third of the way in from the right-hand side. Scope checks while a black level was being played back showed that the noise appeared at pin 16 of IC301 in the CNR circuit. The cause of the trouble was that the chroma recursive adjustment VR801 was set incorrectly. Realignment as per the manual cleared the problem. **N.B.**

## Saisho VR805S

This machine would accept a tape but wouldn't accept any other tape command. A new cassette lamp put matters right. **D.B.**

## Matsui VX2700

This machine wouldn't give the customer his tape back. The cause of the fault was in the power supply, where the switched 5V feed was missing. A new STK5342 chip (IC501) restored the 5V supply and gave us back the tape. **D.B.**

## JVC HRFC100EK

This machine was dead, which is not uncommon. Replacing Q1 and Q2 usually cures the fault, but not this time. When Q1 and Q2 had been replaced the machine squealed. D15 was short-circuit. After replacing this diode and switching

on again the machine went bang. So Q1, Q2 and the photo-coupler PHS1 were replaced. This time the fuse didn't blow, but all the voltages were low – approximately half what they should have been. This was cured by replacing IC1. Then FR23 went up in smoke. D33 was short-circuit. Replacing D33 and R33 finally restored normal operation. **D.B.**

### **Panasonic NVF65B**

Very noisy rewind was the complaint with this machine. We found that the supply and take-up spindles were as dry as a bone. Lubrication silenced the noise. **D.B.**

### **Panasonic NVJ40**

This machine wouldn't eject tapes because the release spring had parted company with the release lever. Refitting the spring and retiming the mechanism cleared the fault. We fitted a new mode switch for good measure. **D.B.**

### **Mitsubishi HSM48V**

This machine wouldn't rewind or wind the tape fully and at speed. We found that the idler assembly had popped out of its locating clip. Refitting it cured the problem. **D.B.**

### **Hinari VXL8**

If the complaint with one of these machines is that the channel display goes to E, or pause or record lights up, or the machine jumps between the LP and SP modes, before carrying out any checks replace C509 (220µF, 10V) in the 5V supply. A scope check on this supply will probably show that a 50Hz ripple is present. These problems tend to be very intermittent. So give the machine a long test before returning it. **C.N.**

### **Sharp VCH81H**

This machine would try to load the cassette housing without a cassette being inserted. The IR emitter was short-circuit. **C.N.**

### **Ferguson FV50B**

The symptoms were sound muting and lines on recordings. Playback of a known good tape was o.k. The mute circuit was firing up and not only muting the E-E sound but also causing mistiming of the head amplifier flip-flops because of V pulse suppression and thus loss of sync. Replacing the BC548B transistor TN74 put the machine back in the pink. **B.McC.**

### **Samsung VI621**

There was no colour with timer recordings only. I thought we'd a really difficult one here but all it took to put matters right was to set up the colour lock adjustment. Why the problem occurred only with timer recordings is beyond me! **B.McC.**

### **Sharp VCA100**

On rare occasions this machine would refuse to play or record, with the capstan and drum both motionless though the machine had loaded and the display showed the play symbol. The cause of the fault turned out to be poor riveting on the print that connects pin 10 of IC801 to AE4 en route to the cam switch, which modulates the voltage supplied to IC801 and thus confirms the mode position. At least it

wasn't the mode switch again! The problem was cured by fitting a bridging wire over the defective print. **V.W.C.**

### **JVC HRD455**

If one of these machines comes in dead check for a dry-joint at CN1 in the power supply. **R.B.**

### **Sanyo VHR291**

Intermittent loss of colour in the record mode was the problem with one of these VCRs. The fault could be instigated by going to pause and changing channels. When checking around IC101 (LA7395) we found that all its inputs were correct but when changing channels in the record mode the colour killer would trip. A new LA7395 chip cured the problem. **G.S.**

### **JVC HRD960**

There were no functions, a tape was jammed inside and the display was very, very dull. After many checks I found that the machine wasn't coming out of standby. The power supply rails were o.k., the secondary side supplies coming up when the machine was first plugged in, only to return to standby shortly after. As I could find nothing actually wrong I phoned the customer who said that the display had been dull for some time. Looking at it closely I noticed a small bar lit up at the top. I kicked myself and went in hunt of a remote control unit so that I could bring the machine out of the child-lock mode. After pressing the remote control unit's power button for a couple of seconds the machine sprang to life and is now working normally – after replacing the display. **G.S.**

### **Panasonic NVG40**

Playback was o.k. but when the machine was asked to record the tape counter stopped after about seven seconds and neither sound nor the control pulses were recorded. IC2101 was faulty. **G.S.**

### **Toshiba V711**

This machine would sometimes go to standby when eject was selected. There was also intermittent failure to change mode, e.g. from play to stop, unless the power was switched off then back on again. The cause was a faulty mode state switch. **G.S.**

### **Sanyo VHR315**

This VCR was dead, with no clock and no functions and the power supply tripping. We found that IC511, a zener regulator on the secondary side of the power supply, was short-circuit. **G.S.**

### **Toshiba V110**

There was no play, fast forward, rewind etc. The machine would try to go into a mode then, after a few seconds, it would revert to standby. When hand-winding the loading block I found that it would jam. On stripping it down I discovered that the main cam was damaged. To put this right you have to replace the full loading block assembly. **G.S.**

### **Akura VX140**

There was no on-screen display. If the PCB was tapped,

OSD letters would jumble or flash. The problem was cured by resoldering ICC101 and LC01, the voltage feed coil to the OSD section. G.S.

### JVC HRD830

The playback picture would jump, and the sound would jump from hi-fi to linear. A check on the off-tape f.m. signal envelope showed that a slice was missing. To cure this the drum motor (available only as a lower drum assembly) had to be replaced. G.S.

### Akura VX150

Failure to accept a tape was the complaint with one of these machines. Everything was o.k. around the microcontroller chip, but there was no drive from pin 12 of IC702. R762 in the feed to pin 11 was open-circuit. G.S.

### Mitsubishi HSB30

A blue, muted screen in the E-E mode signified loss of the signal. Sure enough nothing discernible emerged from the M51496P i.f. chip IC101. The voltages around this chip were reasonable except for those at pins 1 and 2, where the expected 4.9V was much reduced because C104 (0.22 $\mu$ F, 50V) was leaky. It's of the much maligned tantalum variety. S.L.

### Ferguson FV31R

This machine was dead: no functions worked and there were no displays. Checks showed that the switched 5V supply was missing – all the unswitched supplies were present and correct. The culprit was TP73, which was open-circuit. It's on the timer/display board. S.L.

### Hinari VXL8/Amstrad VCR6000 etc

There have been several references to the no rewind/fast forward problem you get with these and similar machines. In the May issue (page 504) Gerald Smith mentioned that the rubber pad which causes the trouble is not available as a spare. He and others will be pleased to know that it's available from SEME under part no. VPAR6833 (rubber damper). S.L.

### Ferguson FV71 (R3000 Chassis)

Failure to erase the old sound track was the problem with this machine, the bias oscillator being responsible. Its circuit, consisting largely of surface-mounted components, is on the small PCB to the right of the deck. We found that the transistor, IT001, was short-circuit and its 18 $\Omega$  feed resistor RL02 was open-circuit. A bell began to ring about a modification in this area. Solder up the oscillator coil LL01, and change the value of C002 from 1nF to 2.7nF (part no. 20136340). This modification improves the oscillator's ability to start. We also soldered the erase head wires directly, as failure in this area is common with other machines we've had in. S.L.

### Ferguson FV21

There was an interesting fault with this machine: intermittently part of the playback picture, sometimes all of it, would be missing. The fault was different each time the machine was put into the playback mode. A scope check showed that during part of each field there was a complete absence of signal. When we looked at the FG signal from

the lower drum we found that FG was there but no PG. The cause of the fault was a 3.3 $\mu$ F capacitor on the lower drum PCB. R.F.W.

### Samsung SI1240

There were random functions, as if the end sensors were faulty. With a cassette loaded we found that the voltage at one end sensor was 0.6V and at the other 5V. R6203 (4.7k $\Omega$ ) on the deck joint PCB was open-circuit. This is the small board beside the loading motor. R.F.W.

### Ferguson FV30

After we'd replaced all the usual items that fail when the switch-mode power supply dies the voltages were pulsing and the machine was still dead. Replacing CP38 (470 $\mu$ F) cured the fault. R.F.W.

### Akura VX160

The loading motor drive chip IC601 was short-circuit. The chip had overheated to such an extent that the solder had melted and it had fallen off the PCB. The same thing had happened to the associated current-limiting resistor R601. This is becoming a common fault – we've had it on a number of occasions. A different chip, type BA6219B, is now being supplied by Akura. G.T.

### Samsung SI1260

There was no 15V supply to the loading motor drive chip in this machine. After a few checks we found that D212 was open-circuit. G.T.

### Orion D1094

We've had various faults, usually intermittent, with this model. Symptoms have been no audio playback or record, no control pulses, no erase etc. Check for dry-joints at the vertical PCB to the rear of the deck. It connects the deck to the main PCB. G.T.

### Sony SLV280

This machine was brought in because it wouldn't load a tape. When I tried to load a tape manually I found that the loading motor was very tight. A replacement loading motor restored normal operation. T.L.

### Ferguson FV71

This is one to watch out for. Ferguson recommends changing the value of C002 from 1.4nF to 2.7nF if one of these machines fails to erase the previous sound. Part no. of the new capacitor is 20136340. The fault can be intermittent. T.L.

### Matsui VP9401

This machine came in dead. Once we'd opened it up we found that fuse F502 was open-circuit. A replacement got the machine working, but there were no mechanical functions and it went into the standby mode after three seconds. This is a mid-mount machine, so I took it all apart and removed the PCB from the casing. The loading motor chip IC1004 had obviously been getting very hot: on closer examination I noticed that there was a small eruption on its plastic encapsulation. A new i.c. cured the problem. T.L.

## Panasonic NVMS70

The symptom with this camcorder was intermittent colour from the camera head. On examination I found that the fault could be instigated or cleared by applying a tiny amount of pressure to the titler PCB above the lens. This pressure was in turn flexing the process PCB where IC317, a surface-mounted chip, had a couple of dry-jointed connections. Resoldering cured the problem. **N.B.**

## JVC GR45, 60 etc

We've had several of these camcorders in recently with symptoms that suggested worn or contaminated video heads. The cause however was poor connection of the ribbon cable between the lower drum and the head amplifier PCB. The action required is to tighten the contacts of the connector on the head amplifier PCB. **D.C.W.**

## Sony CCDV800E etc

We were recently asked to check the autofocus action with one of these Hi-8 models. The point to note is that at the wide-angle end of the zoom range the focus lens assumes a mid-position (approximately 7ft) and will not alter from this state even when an object is positioned closer (4ft minimum). This doesn't affect the quality of the picture, but can be misleading as some models operate differently – the focus lens moves to a closer setting when the zoom is moved towards the telephoto end of its range. **D.C.W.**

## JVC GRAX7E

This camcorder had been dropped and as a result was inoperative, the emergency code E04 showing in the viewfinder. We found that the mechanism was jammed in the half-loaded position, with no drum rotation. The mechanism problem was simply due to a piece of cassette lid that had broken off and become stuck in the supply-side guide rail base. Fortunately we were able to put this right without any need to realign the loading rings etc. But the drum still refused to rotate.

The cause of this second fault condition was a 'nick' in the drum-motor ribbon cable, which is dressed around the underside of the loading motor. Because of its position between the motor and the lower case this cable is often a casualty when one of these camcorders has been dropped. In our experience the cable can usually be saved by carefully removing the insulation and linking across the damaged print. The damaged area can then be insulated and the cable refitted – saving the cost of a replacement drum assembly. **D.C.W.**

## Sanyo VMD6P

The cause of flickering camera E-E pictures with several of these camcorders has been traced to poor soldering of the CCD imager's pins, on board CA1. **D.C.W.**

## Minolta 8100E

We don't see many of these camcorders. But those we do see seem to suffer from the same problem – a very loud

'screeching' sound when loading and unloading. To the customer this probably sounds like an expensive matter. In fact it can usually be cured by lubricating the loading motor bearings suitably. Unfortunately it isn't the easiest of camcorders to take apart, but once you know the method it's not too bad. Don't forget to refit the sliding cover over the AV socket! **D.C.W.**

## Canon E300E

This camcorder recorded and played back all right but there were only lines in the viewfinder display. The cause of this was traced to C468 (4.7µF, 25V) which had leaked over the track to pin 1 of IC462 on the grip PCB. **D.C.W.**

## Sanyo VEMS1P

White flashes on the playback picture was the complaint with this camcorder. C1005 (10µF, 16V) on board VD1 was the culprit: it had leaked over the print directly around its connections. **D.C.W.**

## Canon E50E

Yet another leaky electrolytic problem! This time the symptoms were no playback and no EVF pictures, also no zoom operation and no clock or data information. The cause was C2931 (47µF, 16V) on the grip PCB. It had leaked over and severely corroded the EVF 'on' L signal print between pin 7 of CN2901 and pin 2 of IC2931. Cleaning up the PCB, replacing the capacitor and fitting a link between the two points mentioned provided a complete cure for this curiously varied set of fault symptoms. **D.C.W.**

## Sony CCDV8AF

Because it had been dropped on its rear end this old-timer was, except for E-E pictures, inoperative. Fortunately the VTR operation PCB had survived without damage, needing only to be refitted in its correct position. The cause of the failure was the fact that PS601 (board HS5) and PS602 (board MC8) were both open-circuit. Why they had both failed is difficult to say, but their replacement restored the unit to working order. **D.C.W.**

## Sanyo VMD6P

There are some common faults with these popular camcorders, but they seldom fail completely as this one had. There was no response to power-up or eject, and a cassette was stuck in the machine. The cause of the fault was traced to an incorrect reset condition at IC301 on board SY1 (VTR operation). A discrete-component circuit produces the reset pulse. Transistor Q3014 in this circuit was found to be leaky, the result being a permanent low at IC301's reset pin. Replacing the transistor cured the fault.

When fault finding it's helpful to know that the camera section can be disconnected for work on the VTR unit – but the SY2 board must be connected to the SY1 board. **D.C.W.**

# VCR Clinic

Reports from Eugene Trundle, Brian Storm, David Belmont, Chris Watton, R.J. Longhurst, Mike Rathbone, Jeff Herbert, Richard Newman, Nick Beer, Gerald White and Michael Dranfield

## Panasonic NVJ42

This was a true video nasty! The machine would run for days without misbehaving, then suddenly shut down to stop, giving us a diagnosis time of perhaps two seconds. But we solved it! The waveform produced by the supply spool rotation-detector optocoupler was of low amplitude, just borderline for tripping the operational amplifier switch that's connected between it and the microcontroller chip. A new optocoupler solved the problem. **E.T.**

## Sony VHS Models

This note applies to a large number of Sony domestic VCRs in the SLV model range. How many times have you replaced the pinch roller to cure tape edge damage (scalping, crinkling) only to find that the job bounces shortly after? Very often the cause is a warped capstan motor housing. To avoid the high cost of a new motor, a repair kit, part no. A6759-567-A, is available from Sony. It includes four surface-mounted capacitors that must also be fitted to certain types of motor. **E.T.**

## Tatung TVR7121

Intermittent failure to operate in the fast forward or rewind modes seems to be an increasingly common complaint with these machines. Sometimes the cause is a faulty clutch solenoid under the deck, but far more often the mode switch is responsible. It's mounted under the loading motor and is quite easy to change. At a pinch it can be cleaned, but replacement is far better. **E.T.**

## Akai VSS99

A dead machine, with all the fuses intact and current flowing in the primary winding of the mains transformer, may well be the result of the fusible resistor in position R902 going open-circuit. This 6.8 $\Omega$ , 0.25W safety component seems to fail for internal reasons. We've never seen a failed one with signs of overheating, and have never had a bounce back after fitting a replacement. **E.T.**

## Sanyo VHR135E

Intermittent failure to operate in the fast forward or rewind modes has been the problem with a number of these machines that have come into the workshop. In every case the cause has been failure of the cam slide assembly, item 29 in the exploded diagram. The part no. is 613 094 9240. What happens is that its claw sometimes fails to engage. Replacement involves a lot of dismantling and reassembly: when you put everything back together, ensure that the mechanical phasing of the mechanism and the mode switch is correct. **E.T.**

## Akai VS765

After a very involved, costly and time consuming job elsewhere in this machine we were dismayed to find that the u.h.f. tuning drifted and dithered when the machine warmed up. The cure was to replace all the capacitors –

C11-14 – in the low-pass RC filter that produces the tuning voltage. **E.T.**

## JVC HRD180/Ferguson 3V59

If the fault with one of these machines is permanent or intermittent failure of some of the front-panel keys (station selection etc.) to operate, look for dry-joints at CN1, where it's soldered to timer PWB no. 15, before getting involved with the front panel. **E.T.**

## Akai VS765

A very puzzling no-go situation, with the main power supply section working correctly, can be caused by loss of the BU (back-up) 5V supply to the microcomputer chip on the front control panel. The usual cause is R221 (15 $\Omega$ ) on the main PCB going high-resistance or open-circuit. **E.T.**

## Panasonic NVL25

This machine suffered from intermittent operation. After a few hours' use the mechanism would just shuffle, cut out then power down. A replacement deck mode switch, part no. VSS0175A, cured the problem. **B.S.**

## Panasonic NVG18

The reason why this machine was dead seemed to be a corrupted reset voltage at the front display microcontroller chip IC7501. Adjusting the TH.ADJ control on the main board restored operation: the real cause of the problem then became apparent, as there was a bad ripple on the E-E picture. Replacing C1104 (100 $\mu$ F, 63V) on the power supply panel restored correct operation. **B.S.**

## Panasonic NVF55B

When a tape was inserted, the capstan motor would judder around very slowly. If you were lucky, the tape might load. We checked the voltages around the capstan motor drive chip. They all appeared to be correct. So we tried a new stator, which made no difference. Time for some drastic action! We earthed pin 16 of the chip. This time the motor rotated, but fast. Pin 16 is controlled by the syscon/servo chip IC6001. Replacing this cured the fault. **D.B.**

## Ferguson FV62

This machine appeared to be dead. There was no display, no nothing. The cause of the trouble was in the r.f. converter/tuner, where the SDA and SCK lines were shorted. A replacement module cleared the trouble. **D.B.**

## Matsui VX1000Y

This machine didn't record sound and there was no output from the bias oscillator. We found that there was liquid spillage in the vicinity of T5001 and the surrounding components. After removing them we cleaned the board



thoroughly. Then T5001, I5002 and C5031 were replaced. This restored sound recording. **D.B.**

### **JVC HRD910**

A tape was stuck in this machine. It couldn't be ejected nor could any other function be selected. This wasn't surprising, as the loading motor drive chip IC1 had a large hole in it, probably caused by the motor. Replacing IC1, the loading motor and the circuit protector restored normal operation. **D.B.**

### **Logik VR950/Samsung VI611**

These machines have never been favourites of mine. The customer's complaint was that there was no record picture or sound. It transpired that someone had had a good twiddle. The f.m. record level, carrier and deviation controls had to be set up correctly. Good results were obtained after doing this. **D.B.**

### **Panasonic NVL25**

The customer complained that the counter would stop when the machine was in forward search. On inspection we found that the tape was riding up the audio/control head. As the pinch roller was worn we fitted a replacement, but this made little difference. Next comes post P5, which will produce the condition if even only very slightly bent. But it was o.k. Attention was next turned to the AC head, which was worn. Replacing this and realigning the machine cured the fault. The upper drum was also worn. The customer accepted a further estimate, and once a new upper drum had been fitted the machine worked faultlessly. **D.B.**

### **Sanyo VHR135**

This machine worked only intermittently. We found that most of the pins at connectors CN301 and CN302 were dry-jointed. **D.B.**

### **Grundig VS510**

When this machine was powered all that could be heard from it was a clicking noise. It was otherwise dead. Whenever you get an odd fault like this with one of these VCRs head straight for the electrolytic coupling capacitor in the chopper transistor's base circuit (usual value 47µF). In this case replacing it stopped the clicking and restored the power to the rest of the circuitry. **D.B.**

### **Sony SLV270**

This Grundig clone was dead. Replacing C1325 and C1326 in the power supply brought it back to life. **D.B.**

### **Philips VR6462**

No picture was the complaint with this machine. Bench tests showed that the fault was no loop-through and no test signal. When checks were carried out in the power supply we found that there was a short-circuit across the 12V line. The cause was traced to C2404 (330µF, 16V) on the audio panel. **C.W.**

### **Hinari VXL90**

We were told that there was intermittent slow playback. On test we soon noticed that the tape was travelling at the

LP speed when an SP cassette was being played. The tape speed indicator showed SP however. The tape speed was constant but slow. Checks in the servo section were fruitless. The supply was at the correct voltage, but a scope checked showed that noise was present. This was upsetting the action of the CTL amplifier. Replacing the bridge rectifier (D506) in the power supply restored normal operation. **C.W.**

### **Alba VCR5000X**

This machine had a tuning problem. When search tuning was tried it generally wouldn't stop. On some occasions it would stop at a station and when this was stored it would be remembered, but when the channel was changed the previous one would remain for anything up to five seconds before the correct station appeared. All this was caused by wire link C on the tuner/i.f. board not being soldered at one end. **C.W.**

### **Panasonic NVL20**

This machine was completely dead. There was rectified mains voltage at the bridge rectifier's reservoir capacitor but no start-up ripple for the power supply because C1109 (1µF, 400V, 105°C) was open-circuit. **C.W.**

### **Hinari VTV100**

No playback colour was the complaint with this VCR/TV combi machine. The cause of the fault turned out to be in the TV section. We noticed that unless the off-air signal was perfect the colour lock was poor (good job we've some dodgy flyleads to help with tests!). So attention was turned to the chip that seems to do almost everything, including colour decoding. A check at pin 38 showed that the line pulse input was incorrect. C481, an 0.47µF, 50V electrolytic, was low in value. A replacement restored good lock with both off-air and off-tape signals. **C.W.**

### **GoldStar RQ504I**

There were white spots and lines across the playback picture. The static discharge brush had obviously fallen off. Wrong again! As numerous checks on the earthing failed to bring anything to light, attention was turned to the bottom of the machine. I temporarily connected another earth wire to the shaft of the drum spindle. This made a difference to the spots, but only for an instant. So I took the motor apart and found that one of the stator turns was loose and had been rubbing on the rotor/magnetic flywheel. Redressing and fixing it with some superglue kept it away from the flywheel, clearing the discharge effect. **C.W.**

### **Sanyo VHRD4890E**

The complaint with this machine was crackling on sound. The cause was dry-joints at filter XF02 on the Nicam PCB. **R.J.L.**

### **Panasonic NVG500EM**

This machine was dead following a power cut. We found that C3 (4.7µF, 250V) was the cause. **R.J.L.**

### **Matsui VX820/880/Saisho VR1200**

During playback the colour drifted in and out and there was

a gurgle on sound. E-E operation was o.k. The cause of the trouble was the 100µF capacitor C2508.

**R.J.L.**

### **Sony SLV270**

There was no display and you could hear the deck solenoid clicking. Checks showed that all the outputs from the power supply were varying. C1326 (47µF, 25V) was the cause of the trouble.

**R.J.L.**

### **Matsui VX6600**

There was a blue screen in the E-E mode and recordings showed i.f. pulling and a.g.c. overloading. C17 was responsible. It's an 0.1µF tantalum capacitor.

**R.J.L.**

### **Panasonic Bar-code Remotes**

Panasonic combined remote control/bar-code readers such as the VEQ1107, VEQ1119 etc. sometimes fail to respond when the scanner on/off button is pressed. This usually happens after the customer has replaced the batteries. If you get this problem, remove the batteries and short the power terminals together for ten seconds or so. After replacing the batteries the display should come alive when the button is pressed. Don't ask me why this works, but I've used this trick successfully about a dozen times over the past few years.

**M.R.**

### **Mitsubishi HSM20V**

There was no playback colour, though a recording made by the machine produced colour when played back on another VCR. This suggested that there was a fault in the chroma playback processing circuitry, but in fact Q289, a surface-mounted buffer transistor in the record signal path, was responsible. It was leaky, causing the no playback colour fault by upsetting the d.c. bias at the input to the main chroma processing chip. The record signal passed through the faulty stage without being affected.

**J.H.**

### **Matsui VX2500**

The problem with this machine was very intermittent shut-down to standby after several hours' use in the play or record mode. The cause turned out to be intermittent loss of the FG pulses from the drum motor because C18, which couples the pulses to the servo chip, was dry-jointed. The drum would suddenly run at full speed: as the head-switching squarewave was then so far off frequency, the microcontroller chip would switch the machine to standby.

**J.H.**

### **Panasonic Power Supplies**

I've had a run of Panasonic machines recently, all with power supply faults. Dried out electrolytics have been the cause. They run quite hot, and the only reliable way of dealing with the problem is to fit 105°C types. When tackling dry-joints around transformers and chokes it's best to remove the device and clean the tags before resoldering. Otherwise you may get trouble later on.

**R.N.**

### **Panasonic NVG25**

This machine's head was clogged when it was first brought in. No other problems were evident. A few days later however the customer said that it had gone dead. When it was back on the bench I found that the mains fuse had

blown. A closer look at the power supply revealed the cause. The STR11006 chip had overheated so badly that its plastic clamp had melted, allowing it to fall free of the metalwork and thus run without a heatsink. D02 and Q11 were short-circuit, also D05 on the little subpanel. R1009 on the subpanel was dry-jointed. I used a BYD33J in position D02, a BC640 in position Q11 and a 1N4148 in position D05. A new STR11006 and a 1.6A fuse completed the repair.

**R.N.**

### **Ferguson FV31R**

This machine was completely dead with no clock display. Checks on the supply voltages revealed that the on/off monitor wasn't working. We traced back to the timer display board and found that RK44 (1Ω fusible) was open-circuit. A replacement restored normal operation.

**G.W.**

### **GoldStar GHV94001**

If the E-E sound is low, remove R460 and fit a wire link in its place.

**G.W.**

### **GoldStar GSE12901Q**

If the machine won't accept or eject a tape, remove diode D521 and fit a wire link in its place.

**G.W.**

### **Hitachi VT150**

Though intermittent the fault was present most of the time. The symptom – snow over the playback picture – gave the impression that a head had failed or was clogged. It could be instigated by touching the YC board almost anywhere. The HT4757A luminance processing hybrid chip was the cause. When this item fails the symptom is often patterning on the playback and E-E pictures. Not on this occasion however.

**N.B.**

### **Sony SLV280**

This machine uses a Sanyo mechanism and suffers from the same tape chewing on eject problem – the capstan brake pad becomes sticky. For a lasting cure replace it.

**N.B.**

### **Hitachi VT410**

Very intermittently when play or record was selected the drum would just kick rather than rotate. The cause was traced to failure of the thick-film chroma processing chip IC301.

**N.B.**

### **Matsui VX3000**

If the capstan motor appears to have lost its torque, operating slowly with some tapes, try cleaning and lubricating the bearing. This may enable you to avoid having to replace the motor.

**M.Dr.**

### **Panasonic NVJ40**

There was no recorded chroma though playback was o.k. After carrying out scope checks around the VEFH14D hybrid chroma chip we came to the conclusion that it was faulty. But in view of its price, about £42 plus VAT, we decided to give Panasonic technical a call before ordering a replacement. A nice man agreed with our diagnosis, and a new chip cured the fault. Phew!

**M.Dr.**

# Service Briefs from Toshiba

The following information is based on Toshiba Technical Bulletins CDH50-CDH54 issued between October 1994 and June 1995. This month we cover VCRs.

## Models V110B/V210B

**Erases prerecorded tapes:** Replace leaky BC548B transistor in position TW56 (REC supply), part no. 70010134.

**Drum speed varies in play, eject operation is slow:** Replace BD435 5V regulator transistor in position TT52 on the main PCB, part no. 70010149.

**Machine locks up when going from fast forward to play or play to stop:** Replace the U2559B servo control reset chip IT46, part no. 70010170

**Playback picture has striation lines, E-E and playback sound is distorted:** Replace the 2.2 $\mu$ F, 50V capacitor CN77 at the base of TN81 (+5V switch).

## Models V204B V254B V404B V454B V804B V854B

Note that these VCRs come with a double-shielded r.f. lead which should be used, otherwise interference patterning may be experienced.

All previous versions of the main microcontroller chip IT001 (CAT1 models) have been superseded by type TMP90CR74DF-7356, part no. 70012290.

**Buzz on sound with only some channels and some transmitters/relays:** Cause is excessive video modulation at the r.f. modulator's output. Adjust the orange potentiometer inside the tuner/modulator.

**Machine dead with pulsating power supply:** Capstan motor B560 could be presenting a short-circuit across the 14V supply. If so replace it – part no. 70031498.

**Tape chewing or erratic capstan motor operation:** Can be caused by poor contact at capstan motor connector BT006 (CAT1) or P502 (CAT2). Replace connector, part no. 70011830. When fitting the motor, ensure that the hole in the motor PCB is aligned with the hole in the mechanism deck.

**Satellite control signal too slow for Pace receivers, i.e. selects only single-digit channels 1-9:** Replace KDB microcontroller chip ICK01 (CAT1) or ICX01 (CAT2) with latest version, TMP87CK70AF-6251, part no. 70012260.

**No eject (CAT1 and 2):** T loading assembly B470 has worn out gear. Replace with improved part kit 70903974.

**Tape damage – cassette may be stuck in unit (CAT1):** Caused by the fact that the capstan motor doesn't stop immediately after rewind or fast forward, hence a loop of tape spills into the machine. Capstan FG not detected. Cure is to add a 100 $\mu$ F, 6.3V capacitor across the Cap +5V supply, on the component side of the PCB with the positive lead to the cathode of DT107 and the negative lead to chassis at jumper JT035.

## Model V210B

**No playback colour, black lines running down screen:**

Replace the 47nF, 63V capacitor in position CV13, connected to pin 12 of IV08.

## Models V211B V411B

**Machine dead with FP01 (630mA) open-circuit, no other fault found:** Replace the fuse and change the value of the r.f. filter capacitor CP01 from 0.1 $\mu$ F to 0.0047 $\mu$ F, part no. 24094916.

## Models V212B V213B V312B V412B V423B V513B

**Field jitter and rolling playback picture; can also go to the play mode with the E-E picture and sound remaining:** Cause is dust build up between the drum flywheel veins – clean.

**Playback picture has interference spots in an almost triangular waveform pattern:** Cause is poor drum spindle static discharge under the plastic flywheel. Clean the brush.

**Tape loop formed when a cassette is ejected:** Replace spring K188, part no. 70050638.

**E-E picture has slight white overloading, playback picture has distorted white with no colour:** Replace leaky 220nF chip capacitor in position CN13, between pins 21 and 22 of IN01.

**Erratic mechanism operation and clock:** Replace CP81 (1,000 $\mu$ F, 16V) in the power supply.

**Machine dead but drum rotating:** Replace leaky MPS750 14V switch transistor TP83 in the power supply, part no. 70010939.

**Machine dead, power supply buzzing:** The L2726 loading motor drive chip IT60 could be faulty. If so, replace it – part no. 70010975.

## Models V213B V423B V513B

**E-E picture and sound pulse on and off:** Replace the TDA5930 video i.f. chip II40 on the main PCB, part no. 70010531.

**Tape loads around the drum but no cue or review action so tape unloads, leaving a loop:** Replace cam sensor (photo-coupler) GT23, part no. 70010961.

## Models V300B V309B V500B V509B

**Patterning on E-E pictures:** Replace L811, part no. 23221817, in the power supply because of shorted turns.

## Models V212B V312B V412B

**Correction:** In the final note under this heading on page 53 of our November 1993 issue the two capacitors should have been

specified as CQ06 and/or CQ07 (both 4-7nF), not CQ05 and/or CQ06.

## Model V411B

**Poor or no playback colour:** Can be caused by the BC558 transistor in position TV37, part no. 70010137.

**Weak video and bent verticals:** Can be caused by CA09 (10 $\mu$ F) on the OSD PCB. Replace with a 35V type.

**Bent verticals and poor field sync:** Can be caused by CA02 (100 $\mu$ F) on the OSD PCB. Replace with a 16V type.

## Models V703B V813B

**Tape loads, drum twitches then machine goes to standby:** Replace loading motor B630, part no. 70322489. Spikes from the motor get on to the supply and corrupt the logic at the microcontroller chip.

**Tape loads around drum, tape guides unload half way leaving tape around drum, then the machine shuts down:** Replace Z111 mode sensor ABS (photocoupler), part no. 70128691.

**Intermittent linear mono audio track recording and failure to erase old track:** Caused by poor connections to the full-width erase head (FE). Solder the wires directly to the head connections.

**No display:** D.c.-d.c. converter Z832 (DK2A, part no. 23107555) has failed. ICPN10 Z831 (part no. 23118132) will

probably be open-circuit.

**Machine is dead with reset at pin 68 of IC501 low and the 8MHz timer clock not running:** Cause is loss of a.c. pulses from the power supply because the TLP721 photocoupler IC801 has failed. Part no. is A8645130.

## Models V804B V854B

Note that all previous versions of the main microcontroller chip IC501 have been superseded by type TMP90CR74DF-7329, part no. 70903981. When replacing this chip also replace C539 with the 8pF capacitor supplied.

**Warning:** The initial surge can cause failure of IC803 (STR-D6802) when the machine is connected to the power supply. In this event a piece of its encapsulation can be discharged. When servicing the machine, take care if you plug it in with the cover removed. The part no. is 70903964: fit the modification kit that comes with it. The chip does not fail during normal operation.

**Intermittent poor playback picture with no colour:** Cause is probably missed solder connections at pins 1 to 15 of the TA8894AF chip IC101, which is a surface-mounted device. Resolder as necessary.

**No video, blank screen:** Refit rear terminal PCB connector PF01 if this has separated from the main PCB connector P201. In later production this end of the terminal PCB is glued to the main PCB. This prevents the fault but means that care is required when removing the terminal PCB for other repairs.

# CAMCORNER

Reports from David C. Woodnott

## Panasonic NVG202B

This is a later version of the popular G1/2. The complaint was that it played back at high speed, producing pictures as if fast-forward search had been selected. The cause was failure of the capstan motor FG sensor, which is available separately for these models. It's interesting that the machine continued to operate with this fault present: most would quickly go to emergency shut-down. In fact we have been surprised in the past at how quickly some machines shut down when an FG malfunction is detected. **D.C.W.**

## Chinon VC1600

This and certain Orion and some Hitachi E series models use a similar lens block with an infra-red auto-focus system that generally works well. This one didn't however. The focusing lens had jammed, though the zoom lever operated normally. The main focusing lens in these optical assemblies is held in position with adhesive – there are no screws or sticky tape, as is usually the case. So to refit the lens correctly the old adhesive has to be removed. The assembly can then be adjusted. A quick-drying epoxy resin is the best adhesive to use – definitely no superglue! **D.C.W.**

## Sony CCDV50E

The zoom buttons failed to rotate the lens. Otherwise all functions worked normally. We found that Q120 on board RZ1 was open-circuit. A replacement put matters right. **D.C.W.**

## Hitachi VM3280

This full-size VHS machine came in for a general service and a check on the playback colour, which was thought to be "not quite right". Indeed it wasn't! The vectorscope display looked distinctly odd. The cause of the trouble was spotted when the underside case screws were being removed: a switch, labelled PAL/MESECAM, was incorrectly set. It's in the position normally occupied by the mic/mix switch – in Model VM2300 for example. The customer later told us that the camcorder had been purchased abroad. **D.C.W.**

## Sony CCDF330E

The customer complained that there were no functions except for the camera picture and that the dew symbol was present in the viewfinder. Failure of the capstan motor to operate, because of lack of drive, was the cause. We found that the ribbon cable connection between the motor and the VS PCB had been punctured by one edge of the tripod bush plate, which was bent inwards. A new cable and attention to the tripod plate restored normal service. **D.C.W.**

## JVC GRC11

These early record-only units can catch you out if you are not aware of their foibles. For example they won't power up unless a tape is loaded: it's worth remembering this when looking for the cause of certain types of fault. This machine's cassette door was permanently open, and it didn't

seem to power up or provide any functions.

A quick check on the circuit protectors and power supplies failed to reveal anything amiss, but when a tape was inserted the machine would attempt to eject it and the power LED would come on briefly – the cassette compartment remained stubbornly open. We then realised that the machine was in a state of permanent eject! The cause of the fault was traced to a leaky eject switch. This was removed, cleaned and refitted, after which the rather confusing fault symptom had cleared. **D.C.W.**

## Canon UC10

The report that came with this machine said that the tape would jam and shut down the mechanism, and that when it was working the picture would fluctuate. The mechanism problem is becoming quite common with Canon units that use this deck. The trouble occurs when a cassette is inserted in the housing and the lid is closed: if any force is applied it's likely that either one or both of the reel spindles will be bent, thus jamming the mechanism. The problem can usually be overcome by removing the LS assembly and carefully straightening the spindles. In a severe case however a replacement LS unit may be required.

The second fault, playback picture fluctuations, was caused by dry-joints on the connectors between the main camera and the digital title PCBs. **D.C.W.**

## Sony CCDV50E

A 'pink' tinge to highlights on outdoor shots, sometimes, was the reported fault with this machine. Fortunately the tape provided by the customer showed the effect. It seemed that under the conditions described – certain views, usually with a bright sky background – the iris would malfunction, remaining slightly more open than required. Under similar test conditions the effect could be seen and corrected temporarily by means of a gentle tap on the lens unit. An inspection of the lens unit was called for.

As anyone who has worked on any of these models knows, getting to the interior of the lens is a bit of a challenge – it's surrounded by a metal frame and various PCBs. They all fit together quite snugly, at least until you've had them apart! To curtail a rather long story, after inspecting and cleaning the iris assembly we came to the conclusion that it was not the cause of the trouble. This proved, after further tests and much reassembling, to be the case. So we had to dismantle everything again to get to the iris drive circuitry.

As checks on PCB 1A-1 were inconclusive we ordered a replacement iris drive chip (IC721). This wasn't the cause of the fault either! The problem was an elusive one because it was intermittent and hard to simulate. Cold tests on the components on panel 1A-1 eventually revealed the cause of the trouble – a PCB through link was making intermittent and high resistance contact. The connection concerned was between the slider of the iris set control and the junction of R752 and R760, a composite unit that feeds pins 12 and 10 of IC721. We fitted a wire link, set up the controls on the panel and then, after final reassembly of the camera head unit, gave the camcorder a long soak test. This proved that at last everything was in order. **D.C.W.**

## Correction

**Panasonic Model NVMS4:** In the May camcorder column we referred to the systems and servo chip in this machine as IC6001. It should of course have been referred to as IC6004. Sorry. **B.S.**

## Philips VR422

Plyback produced only a blank screen though the sound came through all right. Checks with the scope showed that the video was being lost in IC7501 (LA7391A). The off-tape f.m. entered at pin 39, came out at pin 3, re-entered at pin 4 but then got lost internally. As voltage checks on the supplies and the record/playback switching didn't come up with anything we fitted a new LA7391A chip. This solved the problem. **P.B.**

## Sharp VCA615

There was an on-screen display problem: all you got was a screen full of zeros. Tests on the OSD generator chip IC5901 showed that pin 7 (CS) didn't go high. The command comes from pin 12 of the RHIX0581 timer chip IC5001. A new RHIX0581 chip restored normal operation. **P.B.**

## Panasonic NVSD25

This machine had no E-E picture. Checks showed that the 12.3V supply was low at about 7V. When the power supply was disconnected from the main board the voltage returned to normal. We eventually found that the UN2211 transistor QR1001, which buffers the power on-off switching, was leaky. A replacement transistor cured the trouble. **B.S.**

## Panasonic NVFS100

There were problems with this S-VHS machine's mechanism, but nothing that you could really put your finger on. The machine would play a tape all right, but when going from play to rewind or fast forward there would sometimes be problems: after briefly spooling backwards and forwards the machine would lapse into standby.

Our first move, more in hope than the expectation that this would work, was to replace the mode switch. We then carried out a full check on the mechanical alignment. All to no avail. The G mechanism in this machine is operated by the capstan motor, through a gear train which is switched in and out by a solenoid. Kick and hold circuits control the solenoid. What was happening was that the kick circuit was operating weakly, sometimes not at all, because C6017 had gone low in value. As a result the pulse to the kick circuit was of low amplitude. **B.S.**

## Panasonic NVHD90

This Nicam machine had no E-E picture. Checks showed that the voltage on the 12.3V line was low at about 5V. As disconnecting the power supply made no difference to the voltage the cause of the fault was clearly in the power supply itself. C1130 (1,000pF) was eventually found to be leaky. **B.S.**

## Panasonic NVJ42

This is one of those Panasonic models that can increase its wind/rewind speed as it spools through the tape, slowing down before the transparent leader that activates the end stop is reached. This machine did not slow down when it

rewound a tape, though it did when it wound one. Thus a tape that was being rewound had to stop very suddenly: sometimes this would tear the leader off the tape. . .

The systems and servo microcontroller chip has to monitor the two reel sensors to determine the type of tape and thus calculate when it should speed up and when it should slow down. If the tape is not recognised, usually because it has a non-standard length and/or hub size, or cannot be spooled evenly, it will not be wound or rewound at top speed. Now back to the fault. The amplitude of the output from the take-up reel sensor was lower than that from the supply reel sensor: perhaps more importantly, there was also a glitch at the bottom of the waveform. A replacement take-up reel sensor, part no. ON2170, cured the unfortunate tendency to separate leaders from tapes. **B.S.**

## Logik VR955/Samsung VI710

The cause of loss of the test signal and the supply to the r.f. modulator was traced to L105, a 33µH choke on the bottom PCB. A replacement from a scrap machine put matters right. **M.Dr.**

## Ferguson FV31

If the mains input fuse is blackened but the chopper transistor is o.k., replace the mains rectifier's 150µF, 385V reservoir capacitor. It tends to flash over when the mains voltage is applied. A cold test will suggest that it is o.k. **M.Dr.**

## Sharp VCT72H etc

Don't immediately replace the reel idler/clutch assembly if the take-up torque is poor and the tape spills out. The cause of the trouble is more likely to be the take-up reel's soft brake. It becomes contaminated, and as a result introduces more friction than the idler can cope with. The part number in the exploded view in the service manual is 112. This applies to all machines that use the same deck, but quote the part number shown in the relevant manual as different part numbers are used. **M.Dr.**

## Sony SLV415

The drum servo was unstable. It hunted, especially when the machine was cold. When I applied a puff of freezer to the AN3814K drum motor drive chip the drum virtually stopped – it was left just twitching backwards and forwards, even with no tape inserted in the machine. A replacement drive chip, part no. 8-759-420-83, cured the problem. **M.Dr.**

## Philips DMP2 Deck

If the complaint is about intermittent timer recordings and failure to play back a fully rewound tape, fit a Philips brake modification kit. It's part no. 4822-466-40181, contains six different parts and costs about £4. During the tape threading process the take-up spool can rotate

slightly, activating the end sensor with the result that the machine shuts down. **M.Dr.**

multimeter, but the scope component tester displayed the tell-tale waveform. This is a very useful device! **J.E.**

### Salora SV6500/Sanyo VHR1100

The customer had previously taken this machine to a local cowboy who said that the capstan motor needed replacement and that this would cost over £100. On inspection we noticed that several chips had been changed. The capstan speed was certainly varying, but careful scope checks around the servo chip IC4002 showed that the tracking control was open-circuit. The NCS part no. for this 100kΩ slider potentiometer is 6130010278. If you don't have an account with NCS, Willow Vale can obtain it for you - quote the same part no. **M.Dr.**

### Sanyo VHR4350

The fault we had with this machine is more common with Hitachi than Sanyo VCRs! After running for one-two hours the sound would be affected by a lot of wow: soon after that the capstan would start to stop at intervals of a few seconds. Under the fault condition we found that the drive chip, which is mounted on the capstan motor, was too hot to touch. The entire motor assembly had to be replaced. **E.T.**

### Sanyo VHR150

This was a simple enough fault, but the cure was very expensive. The machine would sometimes mangle tapes when in the reverse search (review) mode. When we finally got to see what happened, we found that the tape was piling up on the right-hand side of the drum. The cause was excessive friction on the lower drum periphery. We had to replace the lower drum assembly. **E.T.**

### Sony SLV353

If you get tape creasing with one of these machines the first item to check is the pinch roller. Replace it if worn. The other thing to check if necessary is that arm assembly RVS is well lubricated, clean and moving freely so that the tape is removed from the cassette smoothly. **J.C.**

### Sony SLV373

Intermittent drum motor rotation can also show up as picture hunting in a recording. Although the drum motor would appear to be faulty the usual cause of the trouble is one or more of four capacitors, CO13,4,5 (all 0.1μF) and/or CO19 (0.15μF). It's best to replace all four capacitors. **J.C.**

### Hitachi VT150

This machine wouldn't play tapes. On inspection we found that there was no drum or capstan rotation. We also found that the SP/LP tape speed switch didn't operate. The cause was soon tracked down to failure of the STK5476 power regulator IC851 to provide a 5V output. A new chip restored normal operation. **J.C.**

### Hitachi VT63

This machine wouldn't accept a cassette. The tape-in indicator was permanently lit and the carriage loading motor was trying to eject the carriage from the machine! This was all because the carriage-mounted tape end sensors were slightly leaky. The leak couldn't be measured with a

### Panasonic NV730

The job card read "tape chewing when tape ejected". It failed to mention that no tape transport modes worked, except tape lace/unlace when play was selected. We found that all three legs of the reel motor driver transistor Q1504 were badly dry-jointed. Cleaning and resoldering them provided a complete cure. **J.E.**

### Samsung SI7230

When play was selected the drum rotated and the tape laced up. It then unlaced and the machine shut down. There was no rewind and no fast forward operation. The basic cause of all this was no capstan movement. R244 (3.3Ω) in the 15V feed to the BA6209 capstan drive chip was open-circuit. A replacement immediately burnt up because the chip itself was faulty. A new chip and feed resistor restored normal operation. **J.E.**

### Ferguson 3V29/JVC HR7200

There were no deck functions. A routine check on the tape-end sensor bulb, by depressing the tape-in switch, confirmed that there was no illumination. After fitting a new bulb there was still no light! That'll teach me to be so optimistic. With the tape-in switch depressed the voltage across the lamp was found to be only 1.4V instead of 12V. The supply comes via the collector of the 2SB643 transistor Q1, a pnp device which is on the little PCB that holds the two-pin lamp socket. 12V was present at the emitter of this transistor, but its collector was open-circuit. A new transistor restored the glow and the deck functions then worked normally. **J.E.**

### Samsung VI710

This machine was completely dead, with no displays. A replacement STK5333 power supply regulator chip restored normal operation. **J.E.**

### Akai FS200

The job card said "won't accept a tape, but works all right if a tape is placed in position". The tape loading tray (cassette load block as Akai calls it) was in its correct position but loose, as if it wasn't connected to anything. The customer was quite right: if a tape was placed on the tray and simply pushed down gently into position the machine would work perfectly.

The tray is raised and lowered by a half-moon shaped gear called the eject gear (part no. MZ-387335J). This is driven by a metal-toothed shaft, which is aptly called the eject slider. The gear had severely worn and chipped teeth, while the moulded grip that attaches it to the machine's frame was broken. So there was little or no contact between it and the slider.

After fitting a new gear and reassembling the tray holder and tray it was time for a test run. Fortunately I was able to unplug the machine before the tray had lowered fully, because the reason for the damage was now obvious. There's a spring-loaded piece of plastic, called a torsion arm damper (part no. ML-391745J2), to the left of the carriage. The spring is held in place by a small moulded pip which had broken off. So the spring was left protruding into the tray's path. As the tray was lowered it would jam against the spring, but the tray drive would try to keep it moving.

The weakest point will give, in this case the gear/lever parts.

A new torsion arm and spring finally restored normal operation. Incidentally while I was waiting for these items I found that the machine worked perfectly during numerous test runs. So I'm not sure of their purpose. No doubt someone will write in to enlighten us. **J.E.**

### **Samsung VI375**

This machine was completely dead with a tape loaded in the mechanism. A check in the power supply showed that the 2.7Ω surge limiter resistor R901 was open-circuit. The usual cause of this is failure of the STR11006 power regulator chip. When this chip and the 2.7Ω resistor had been replaced the power supply squeaked loudly. Cold checks revealed that the 22V zener diode ZD101 was short-circuit. A replacement immediately failed.

When we removed the power supply from the rest of the machine and lifted ZD101 from the board we found that the 16V supply had risen to 29V. There was obviously another fault. The culprit turned out to be the 100μF, 25V, 110° electrolytic capacitor C110, which was leaky. If you have difficulty locating it, you'll find that it has a small rubber cap glued to the top. When this item had been replaced the 16V line returned to its normal voltage. After replacing the zener diode and refitting the power supply the machine worked perfectly. **M.L.**

### **Mitsubishi HSM55**

Since there was no 5V supply to the microcontroller chip nothing worked. The STBY 5V supply is obtained from the power supply sub-board which in turn requires a 30V input. This was missing. It's derived from Q901, which had 30V at its collector with plug PZ disconnected. So the 30V supply was being dragged down somewhere else in the machine.

The 30V line also supplies the front panel, via plug PZ, for tuning etc. Checks here showed that the uPC574J-KL regulator IC8A2 was short-circuit. When this item was replaced the supply lines all came up and the machine worked normally. **M.L.**

### **Philips VR2574**

The symptoms suggested that the heads were dirty. But cleaning them made no difference. When the tape path was examined I saw that the entry guide didn't move home fully into the V block. While looking for the reason for this I suddenly realised that the deck bears more than a passing resemblance to that used in the JVC HRD540. In this deck the pin that holds the guide arm in place has a tendency to come adrift. The same thing had happened with this Philips machine. Fortunately the deck is much easier to remove. You don't have to take out the cassette housing, as you do with the JVC deck, to gain access to various fixing screws. **A.T.**

### **Samsung SI1260/Sticky Labels**

The playback picture produced by this VCR had a slight tracking error at the top, as if the back tension needed adjustment. When the top cover was removed and the tape path was examined we found that a sticky label, of the type used to index cassettes, was stuck to the entry guide. Removing it restored normal playback.

I seem to recall having a similar fault with a

Ferguson 3V55 some years ago. On that occasion however the label was stuck to the underside of the take-up spool. As a result the machine shut down, because there were no reel pulses. In addition the label was not as obvious and not as easy to remove – the bottom of the machine and the reel sensor assembly had to be withdrawn in order to gain access to it. **A.T.**

### **Sanyo VHR190**

After being recorded for about twenty minutes the f.m. signal would disappear. The bad news is that fault finding in this area is almost impossible, as you can't lift the board out of its can and operate the machine. The good news is that Sanyo can supply a replacement PCB at a reasonable cost. The part no. is 613 123 6110. Fitting a replacement cured the fault. **D.B.**

### **JVC HRD910**

There was intermittent loss of colour in the LP mode. SP was o.k. Our prime suspect was the main video processor chip on the video subpanel, but a replacement made no difference. By coincidence I found that moving the head amplifier brought the colour back. All that was required was to tighten the screws which secure the head amplifier's can to the deck chassis. **D.B.**

### **Hitachi VT65**

This machine would very intermittently fail to record video information. After soak testing it for a week we found that the amplitude of the record f.m. signal input to the head switching chip was occasionally low. Our problems were made much worse by the fact that even the slightest movement would restore the amplitude of the f.m. signal. The cause of the trouble was eventually tracked down to IC202, which is a hybrid thick-film chip. **D.B.**

### **Amstrad UF40**

The spring associated with the cassette flap opener had come out of the carriage and landed in the power supply section of the PCB, where it had done major damage that included blowing the optocoupler in half! All the semiconductor devices on the primary side of the power supply were short-circuit, with the fusible resistors open-circuit. When these items had been replaced the power supply worked but we found that the main microcontrolled chip IC6001 had also failed. Replacing this got the machine going again. **D.B.**

### **Sony SLVE80**

The playback picture produced by this six-month old machine was very poor. The cause was a worn upper drum. I don't know how it came to wear so quickly, but it did. A new one cured the fault. **D.B.**

### **Panasonic G Deck**

If the carriage has jammed but when you remove it you find that the rest of the mechanism is correctly aligned the cause of the problem is a worn right-side plate and its corresponding connection gear. Inspection will show that the gear teeth are severely worn. Both items must be replaced or the machine will bounce. This has become such a common problem that I now replace these items automatically. **D.B.**



# Servicing Matsui/Saisho VCRs

## Part 1

Jack Barclay

This article deals with Matsui and Saisho VCRs that were introduced after 1990. They are fitted with a new mechanism which has one loading motor that drives both the front loading assembly (carriage) and the main mechanism. You can recognise this mechanism by the fact that the loading motor is mounted on top of the mechanism, at the rear right-hand side, and is coupled to the front loading assembly by means of a belt. Models in the range include the following:

**Matsui:** VX1000, VX1100, VX2000, VX2500, VX2700, VX3000, VX6400, VX6600, VP9301, VP9401 and VP9501.

**Saisho:** VR3400, VR6000A, VRS5000A and VXL12A.

### Model Guide

The first machines to be fitted with this mechanism were the Saisho models listed above and the Matsui VX3000, VX6000, VX6400 and VX6600. They have a large 64-pin microcontroller chip for system control and a second 64-pin microcontroller chip for the front panel operation and display. A manual rotary tracking control is provided. Features such as teletext, Nicam sound, linear stereo recording, on-screen displays and audio power amplifiers depend on model specification.

The Matsui VX1000, VX2000 and VX2500 came next. The VX1000 is a basic two-speed, two-head VCR with remote control; the VX2000 is the same with linear stereo sound (not Nicam); while the VX2500 is a four-head version of the VX1000. These models have a single 80-pin flatpack microcontroller chip that drives the display and monitors the operation keys directly, without the need for a second microcontroller chip.

Matsui then got the centre-loading bug. The first machines of this type were the VX2700 and VP9301, the latter being Matsui's first VideoPlus model. The mechanism is mounted centrally: to accommodate this the power supply, which had previously been mounted at the rear of the machine, was moved to the space at the left-hand side of the unit, the main PCB being fitted above the mechanism, at its rear.

Accessibility is good. The various PCBs are linked by large ribbon cables with plenty of slack to enable the unit to be operated in the service position.

The latest models in the range are the VX1000, the VP9401 and more recently the VP9501. In these the main PCB is beneath the mechanism. The power supply plugs into this board directly. An 84-pin flatpack microcontroller chip carries out the syscon, servo and timer functions, a separate display driver chip being fitted on

the front PCB. These machines have different electronics, with little in common with their predecessors. The VP9501 has an auto set-up facility: simply connect the machine to the mains supply, plug in an aerial and the channels will be tuned in automatically with the correct time and date being set – this information is provided by the teletext service. The VP9501 is also a four-head machine, producing perfect still and good trick pictures.

### Mechanism Details

Although the deck layout is conventional, all tape functions are carried out with the tape fully laced up around the drum. There are three motors, as follows: a direct-drive drum motor; a capstan motor which also drives the spools via a belt, clutch and idler; and the loading motor which as mentioned earlier drives the front loading assembly and the deck loading, via three belts.

Mechanism servicing usually calls for removal of the front loading assembly. To do this, remove the belt that connects it to the loading motor pulley, remove two screws at the bottom rear of the assembly, then remove (if fitted) the screw at the top, front right-hand side of the

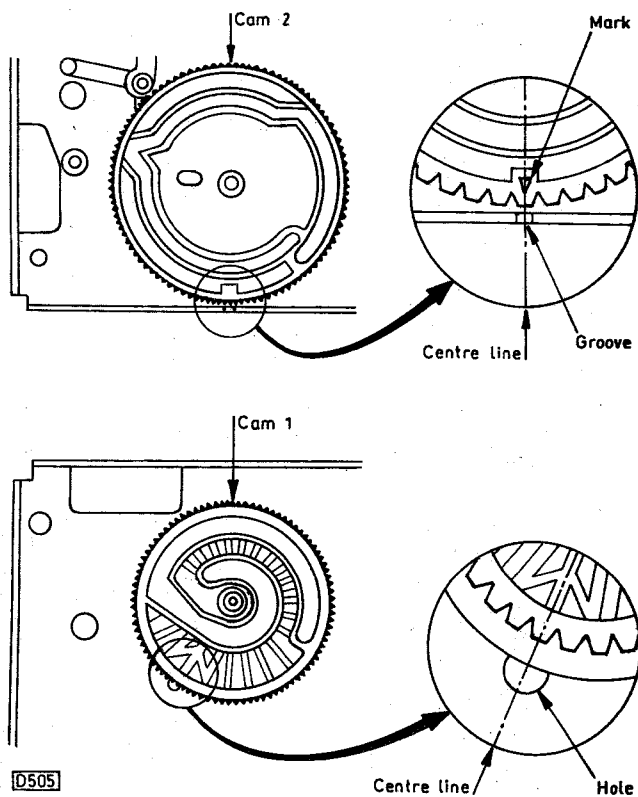

Fig. 1: Correct alignment of Cam 1 and Cam 2.

unit. After removing the cabinet front, the loading unit can be lifted out.

Most of the mechanics are on the underside of the deck. There are two cams. The smaller one (Cam 1) drives a toothed bracket which, in turn, drives the loading arm gears. The larger cam (Cam 2) operates the clutch, brakes, back-tension arm and the rotary mode switch. This cam is partly concealed by the mechanism PCB, which carries the beginning and end of tape sensors, the rotary mode switch, the front load switch, the connections to the electromagnet and the loading motor, the LED tower and the

reel sensor. A ribbon cable connects it to the main PCB – in the VX1100, VP9401 and VP9501 however the mechanism panel plugs into the main PCB directly.

A worm assembly links the two cams. This is in turn driven by the loading motor, via a belt that passes through the mechanism. As there's a timing relationship between these two cams and the front loading unit, the timing should be checked whenever any work has been carried out on the mechanism.

## Servicing

The mechanism PCB has to be removed to gain access to the underside of the mechanism. It's best to slacken the

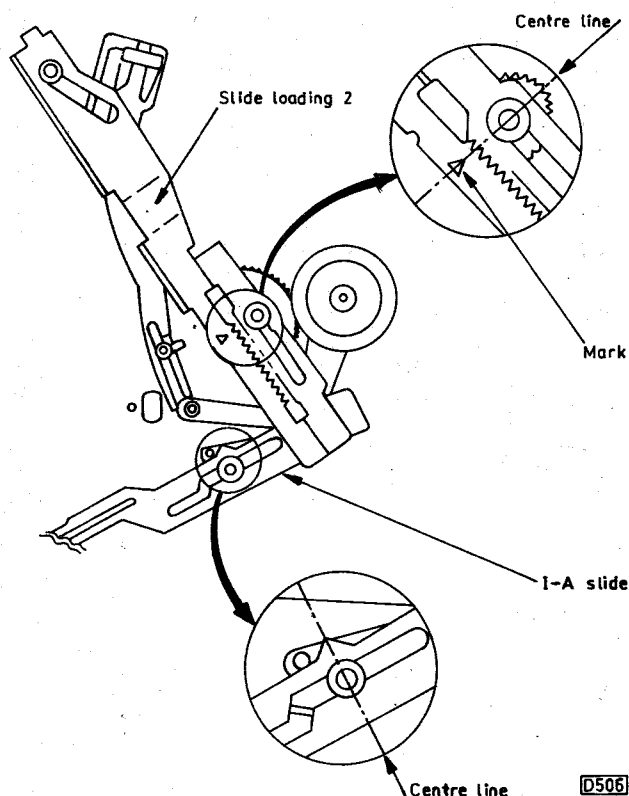

**Fig. 2: Correct alignment of the supply and take-up loading gears.**

wires to the loading motor then, after removing the three screws, withdraw the capstan motor plug, unsolder the wires to the electromagnet and lift out the board.

It's unusual to find that the timing relationship between the two cams is incorrect. But, see Fig. 1, check that the moulded arrow in Cam 1 is aligned with the hole in the deck and that the arrow in Cam 2 is pointing at the groove cut-out in the deck. If adjustment is required, remove the worm assembly: take out the screw and bracket near the pulley, slip off the belt then lift out the assembly. The worm assembly also has to be removed to get the capstan motor out. With the cams in the position described above the mechanism is in the eject mode.

When you replace the mechanism PCB ensure that the mode switch is located correctly. A small peg in the switch fits into the hole in Cam 2. Also check the supply and take-up loading gears – see Fig. 2.

One fault you can get with these machines is wow and flutter on the sound. It can be caused by excessive back tension. You might find that the back tension is as high as

60-70g. Resetting the back tension to between 25 and 35g will clear the fault and still provide good pictures and sound.

A worn pinch roller is another cause of the fault. It can also be responsible for creasing along the edge of the tape. Replacement is simple enough.

Fortunately these decks don't seem to suffer from clutch wear, which was a problem with their predecessors. I've only ever had to replace one clutch unit.

## Drums

With all except for the most recent models (VX1000, VX1100, VX2500, VX2700 and the VP ones) the upper drum can be separated from the lower drum and replaced. You may occasionally find a faulty lower drum. Removal and replacement is simple. Unplug the drum motor connector on the underside of the deck; above the deck, disconnect the head amplifier plug, remove the 5V regulator transistor, take out three screws and lift the drum unit from the machine. When replacing the drum, note the two grey wires that go to the full erase head. They can get trapped beneath the drum, giving rise to tracking errors.

Later drums have the stator and rotor unit fitted above the heads. As the upper and lower drum sections cannot be separated, the complete unit has to be replaced. There are several different types, which are not interchangeable. It's thus important to quote the correct model number and version when ordering replacements. A fault you can get with these later drums produces a rice pattern effect. This is caused by static build up: drum replacement is the only cure.

## AC Heads

There are two types of audio-control head, stereo and mono. The stereo heads are prone to wear, the usual symptom being poor sound on one or both channels.

The control head section can go open-circuit with later machines, the result being no control pulses. Nine times out of ten it's the control head winding that fails, though the audio section does occasionally fail. I've not had this fault with stereo heads.

## The Mode Switch

We've already mentioned the rotary mode switch, which is mounted on the mechanism PCB. It can cause a number of elusive faults. The most common one is loops of tape being left out of the cassette when this is ejected. Another fault I've had is that the mechanism loads up when a cassette is inserted: it then jams in the fully laced-up position. Check by substitution.

## The Capstan Motor

The direct-drive capstan motor can cause some peculiar faults. Problems I've come across include slow rotation when there is no tape in the machine, wow and flutter, and of course no go. Replacement is simple, but requires removal of the mechanism PCB and the worm shaft to gain access.

## The Front Loading Assembly

Customer misuse has been the cause of most of the faults I've had with the front loading unit. Replacement is

often simpler than repair, but note that there are different types of flap opener – this depends on whether the flap is on the cabinet front or the carriage. You may have to use the original flap opener. The units are available from Mastercare, CPC and other distributors at around £16.

## **Belts**

My recommendation is to replace all four belts when one of these machines comes in for service. Failure to do so can result in bouncers. Slipping belts can cause timing problems. In later models a slightly thicker belt is used to drive the carriage. If the front loading belt slips, the loading tray may not seat correctly. As a result the tape will be looped when the cassette is ejected.

## **Loading, Run and Eject Sequences**

Before we go on to the electronics used in these machines the sequence of events that occurs when a cassette is loaded, run or ejected should be noted.

Insertion of a cassette into the carriage activates the front load switch on the mechanism PCB. The loading motor starts, the cassette is taken in and lowered, the clutch lever on the housing moves to disengage the carriage drive, the drum motor starts then the capstan motor does a shuffle. If all these things operate correctly, the tape is laced around the drum. This is what happens in the stop, fast forward and rewind modes.

In play or fast-forward search the back-tension arm and pinch roller then move to their respective positions. In the rewind search mode the back-tension arm is moved back in.

When eject is selected the tape is unlaced, the capstan motor shuffles, and if all is correct the tape is ejected.

In the standby mode the tape is wound back into the cassette. This will also happen when the machine is left in the stop position for more than a few minutes.

## **System Control and Timer Operation**

As previously mentioned in earlier models there are two 64-pin microcontroller chips, one on the main PCB for syscon operation and one on the front PCB for the timer and function operations.

The front PCB also accommodates the channel data memory chip IC603 and the circuitry that produces the tuning voltage. This has proved to be reliable. For tuning drift suspect either the active filter chip or the 33kΩ resistor that feeds the collector of the voltage-converter transistor. In the manual I'm looking at these items are IC6201, R6201 and Q6201 respectively, but the component reference numbers can vary from model to model. Note that the Matsui VX6600 has no front panel display, information being shown on the TV set's screen.

If you get a dead machine with the power supplies in order, check the orange trimmer TC601.

The main microcontroller chip IC6001 is extremely

reliable. It communicates with the front panel microcontroller chip via four ports, strobe, serial clock, serial data in and serial data out.

The motor loading drive chip IC6003 is type BA6247. It fails quite often for no apparent reason, sometimes leaving a big hole in the front. Its replacement will usually restore normal operation.

## **Servo Control**

IC2001, type OEC9011, carries out servo control. It's not too reliable, a common fault being no capstan or drum operation. When you remove the chip you will probably find it burnt, with a small crack on its underside and the PCB beneath scorched. Replacing it will restore capstan and drum operation.

Failure of this chip can produce the following situation. When a cassette is inserted it will be lowered but the tape will not lace. The machine will then refuse to return the cassette and go to standby.

## **The Power Supply**

These machines all use similar, conventional power supplies, with an STK5342 as the main regulator device. A transistor fitted to the drum block provides the AT6V (All Time 6V) supply. When you remove this transistor from the drum block or refit it, make sure that you don't lose the copper spring. To leave the transistor in with dollops of heatsink compound but no copper spring will not do!

The mains transformer has four secondary windings. After rectification and regulation, 30V, -30V, switched 12V and 5V lines are produced. There are also unregulated 18V and 12V lines, and a 4V a.c. supply for the display filament.

Machines that incorporate audio power amplifiers have a heavier mains transformer: it has an extra winding to supply the amplifiers with an unregulated 16V supply.

As with most power supplies that use this type of regulator chip, the STK5342 i.c. is the usual cause of power supply failure.

## **On-screen Display – Model VX6600**

Model VX6600 is fitted with an on-screen display system, the front panel fluorescent display being omitted. An OEC7007 chip, IC4801, provides the on-screen display. Video goes into the chip, where it's processed to produce the display. If there's no video input, a blue screen will appear. If there's a blank raster, check coils L4801 and L4802. They tend to go open-circuit.

## **Next Month**

In Part 2 next month we'll continue with the electronic circuitry used in these machines. The articles will end with a faults list and some useful parts numbers.

# VCR Clinic

**Reports from Philip Blundell, AMIEEIE, Eugene Trundle, Gerald White, Gerald Smith, Chris Avis, Stephen Leatherbarrow, Terry Lamoon, David A. Chaplin, David Belmont, John Edwards and Ronnie Boag**

## Ferguson 3V38/JVC HRD110

Playback of this machine's own recordings produced very spotty, weak pictures, though playback of a known good prerecorded tape was o.k. A scope check on the f.m. record signal (at TP122 and TP124) showed that it was very low. The record level preset R213 (1k $\Omega$ ) was found to be open-circuit. **P.B.**

## Grundig VS510

If you get a blank raster in the play and E-E modes, with the sound, the display and the deck all o.k., inspect the DOS (display on screen) board visually for damage. The place to look is just behind where the front, right-hand side top retaining screw goes. If the wrong length of screw has been fitted, CR1550 can be damaged, producing the above symptom. **P.B.**

## Hitachi VT420

Each time we thought we'd repaired this machine it would reappear, three or four weeks later, with the same fault: a second or two after switching the machine on it would revert to standby.

We eventually found that when the machine was in the fault condition its syscon microcontroller chip IC901 was being reset (pin 49) at two-second intervals. Reset pulses were being generated by IC801 on the VS tuning board because its A12V supply had negative blips riding on it. These dipped to 6.5V. The culprit was the STK5372H regulator chip IC851 in the power supply: the 12V section was flipping its top, as it were. **E.T.**

## Mitsubishi B11/B12/B16/B21/B27/B31 etc

Various symptoms, as follows, can have a common cause: dead with no clock display and no functions; the tape symbol running as though a tape is rewinding though there's no tape in the machine; cutting out in picture search. Check the standby 5V supply, which comes from regulator Q971. This is on the underside of the machine, on the PCB deck, not in the power supply. The voltage has to be precise (5V  $\pm$ 1V). If it drops below this figure the microcontroller chips IC5A0 and IC8A0 can cause the symptoms described above. **G.W.**

## JVC HRD830

This machine was dead with no clock, no functions and the chopper transformer buzzing. We found that zener diode D28 on the secondary side of the power supply was short-circuit while the mains rectifier's reservoir capacitor C12 on the primary side was open-circuit. Replacing these items restored normal operation. **G.S.**

## Nokia VR3783

There was no clock display and no functions worked. A check at CN511 in the power supply showed that the output voltages were all o.k. So we moved on to the secondary rails on the main PCB, where PR541 was found to be open-

circuit. Replacing this item restored the always 5V supply and normal operation of the machine. **G.S.**

## Nokia VR3615

This machine was dead with no clock display and no functions. Checks showed that Q803 was short-circuit, removing Q801's gate bias. Replacing Q803 restored normal operation. **G.S.**

## Toshiba V309

There were no functions and the dew symbol was present in the display. A check on the dew line input to microcontroller chip IC601 showed the voltage to be correct at 4.6V. Replacing the chip put matters right. **G.S.**

## Samsung SI3260

This one made us long for the gift of hindsight. It was dead, with no AL5V supply at pin 5 of CN601. This is derived from the AL6V (or AL5.8V, depending on which page of the manual you look at) line via the 1N4148 diode D602, which was faulty.

But the repair bounced. When the machine came back it shut down after loading a tape. There was also the strange symptom that operating the on/off button removed the channel number from the display but not E-E reception! Checks showed that power control pin 11 of the TC4094 expander chip IC606 was stuck at 1.8V. A new TC4094 restored correct power supply switching, but the shutdown after loading still occurred. We eventually found that there was a hairline crack near a plastic locating peg hole on the top PCB. **C.A.**

## Fidelity VR910/Amstrad VCR9140

After staying on for a few seconds this machine would turn itself off. The power supply outputs were all o.k., but we found that there was no 5V output from the 7805 regulator IC01 on the main PCB. A new 7805 chip put that right. **C.A.**

## Ferguson FV31R

This machine was dead but didn't appear to have destroyed its power supply. We then found that it would power up via a variac at 235V or less. For the machine to get going, a start-up supply must be developed across CP14 before the 12V supply is developed across CP38. If not, the start-up oscillator TL16/17 quickly dies. Zener diode DP21 had changed its zener point from 9.1V to 11V. As a result the voltage across CP38 was incorrect, locking up the power supply. As a replacement we used the heftier BZX61 1.3W type. **C.A.**

## Akai VS967 etc

We have replaced many failed fluorescent displays in this series of VCRs, and have carried out Akai's modifications to the display power supply circuit, around L404. After

carrying out these repairs this machine's display was almost invisible. A check on the display filament voltage produced a reading of only 1.3V d.c: the modification usually reduces this voltage from 5V to about 3.5V. So what had gone wrong? We eventually discovered that with this particular coil (L404) the 'centre tap' was not at the centre of the winding but at an approximately 2:1 ratio. Correct operation was obtained when the cut connection to C447 was restored and the connection to the opposite end of L404 was cut and linked to the middle pin. Was this just a freak case caused by an incorrectly wound coil? Perhaps, but it might be worth noting for future reference. **C.A.**

### **Ferguson FV22**

No E-E sound was the unusual fault with this machine. The relevant signal processing chip is IC1 (M51496P). Voltage checks showed that pin 9 was at 9V instead of 2.1V. We eliminated mute line problems by removing Q2, which carries out muting by linking the signal at pin 6 to chassis. The cause of the fault lay elsewhere however: the 6MHz filter CF2 was the culprit. **S.L.**

### **Philips VR6585**

This machine bounced back on me after I'd rebuilt the deck, which is the Panasonic G type. The customer complained of sideways picture movement. Small displacements were apparent, just about discernible on my 14in. monitor. The effect was very much more noticeable on the customer's large-screen set.

I checked the previous work, then investigated the drum circuit. Well, to be truthful I started off here. This didn't get me anywhere and, having woken from my stupor, I then noticed that the fault was worse from cold. So I reached for the freezer. This led me to the non-polarised, 4.7µF electrolytic capacitor C255, which turned out to be low in value. Two 10µF electrolytics in parallel improved the situation but didn't cure the fault completely. As the lower drum was a little noisy I removed it and applied a drop of penetrating oil to the bottom bearing. This finally cured the problem. **S.L.**

### **Panasonic NVJ35B**

This machine gave every indication of capstan motor failure. There was very noisy operation and sluggishness whilst loading, and if loading was completed there was severe warble in play. Operation even sounded 'metallic', as if bearing failure had occurred.

A colleague had fitted a new motor, but to his dismay this had no effect on the symptoms. Now electrolytics are often a problem with Panasonic equipment, so we carried out some checks in the power supply and discovered that C22 (330µF, 10V) was very low in value. Several other capacitors were checked as well and found to be wanting. **S.L.**

### **Mitsubishi HSM57**

If the problem with one of these machines is that the fast forward/rewind brake stays on, clean all the graphite grease off the plate beneath, using solvent cleaner. Do not regrease it. **T.L.**

### **Ferguson FV74**

If you get a power supply burn up, especially involving RP18 and RP21, the following components must be replaced: IP01 (U4614B); TP01 (TE02537F); RP18 (1.5Ω

safety type); and RP21 (2.2kΩ safety type). Check whether any of the following diodes on the secondary side of the supply are short-circuit: DP41, DP51, DP61, DP62, DP71. They are all type BA157. This should cure the problem. **T.L.**

### **Akai VSG64EK**

You sometimes get a paused picture when you put one of these machines into play. If you inspect the mechanics you will probably find that the tape is on the wrong side of the capstan shaft. If this is the case, replace item 49 on the cassette lift. When ordering this item use part no. ZG387348J2, not the part number given in the manual. **T.L.**

### **Hitachi VT33**

The cassette would be ejected a few seconds after being loaded. On investigation I found that the supply side was being loaded but the take-up side wasn't going down. The cassette flap wasn't opening because the flap lock release arm had lost its tension. I was able to retension the arm after removing the cassette holder, saving the cost of a new carriage. **D.A.C.**

### **Panasonic NVF77B**

This top-of-the-range Nicam machine came along without any fault description. When I switched it on, the drum spun until the machine switched itself off. On investigation I found that several deck parts were damaged and the timing of the cassette carriage and associated parts had slipped. The following items had to be replaced: the pinch roller down gear (part no. VDG0483); the pinch cam (VDG0421); the pinch lift arm (VML1874); the pinch cam cap (VMX1353); and the pull-out sector gear P5 (VDG0597).

This model is fitted with the G2 deck. For mechanical adjustments and assembly work the G2/G-REV service manual (order no. VRD8901M101) is required, the NVF77B manual being almost totally devoted to the electrical side.

Normal operation was obtained on reassembling the machine, but I hadn't found the cause of the breakdown. I was eventually told that a cassette had failed to load correctly. So I tried every cassette I could lay my hands on, a total of 45. They all loaded correctly. Then I managed to obtain the original cassette that hadn't loaded, a brand new Scotch E240.

It looked o.k., so I tried loading it. The take-up side loaded, but the supply side stuck on the bend before its vertical descent. I isolated the mains like lightning! I then removed the cassette loading assembly, but couldn't find anything wrong with it – or the cassette. It seemed sensible to obtain and fit a new L side plate (VMD1787) and cassette holder unit (VXA3840). When this had been done the rogue cassette loaded as smooth as silk!

The manual and parts were obtained from SEME. The parts were surprisingly cheap: everything except the cassette holder cost less than £1 per item. **D.A.C.**

### **Saisho VCP100**

This playback only machine had no fast forward or rewind operation – the play mode was o.k. On inspection I found that the idler was trying to turn the spool carriers but the brakes were not being released. Further investigation showed that the mode motor was stopping prematurely. I looked at the mode switch suspiciously and, while selecting rewind, gave its sliding contact a helpful prod. Off came the

brakes as the cam rotated fully. This ruse worked twice more, so I removed the mode switch and gave it a squirt of spray cleaner. Operation was faultless when I reinstalled it, but to be on the safe side I fitted a replacement. **J.E.**

### **Akai VS23**

This machine had had previous unsuccessful treatment elsewhere. The tape speed in the play mode was too fast, the symptoms being no line lock and muted sound. Our first check was to see whether capstan FG pulses were present at pin 21 of the BU2735AS chip IC503. They weren't. On tracing the path of the pulses from the capstan motor to IC503 we found that they were present at pin 2 of IC502 but not at pin 3 of IC507. As the resistor in between, R625, was o.k. it seemed that IC507 was faulty at its input. Closer examination showed that its pins had all been freshly soldered. All was then clear – it had been fitted the wrong way round! Putting this right produced the correct playback speed – and a sigh of relief! **J.E.**

### **Toshiba V109B**

The clock display was normal and the machine had a fully laced up tape inside. When any tape function was selected the correct symbol appeared in the display but the mechanism remained lifeless. There was a power supply fault, which was cured by replacing the STK7253 regulator chip. Once this had been done the machine unlaced and ejected the tape normally.

While I was checking the tape functions the capstan suddenly made such a whirring and grating noise that I immediately pressed the stop button. This problem was cured by removing the capstan then cleaning and lightly lubricating the shaft. I wondered whether the capstan had seized, causing the demise of the regulator. We'll never know! **J.E.**

### **Matsui VX1100**

The bias oscillator worked intermittently. If you went straight into record after switching on it worked, but if you came out of record then went back after a few minutes it didn't. The problem was that C5017 wasn't being fully discharged, so that when the oscillator tried to start up again the change in voltage wasn't enough to get it to run. I replaced most of the components in the circuit to no avail then, in desperation, connected a 3.3k $\Omega$  resistor across C5017. This provided a complete cure. **D.B.**

### **Ferguson FV71L**

This machine was dead. Fortunately the only thing that was wrong was that RP18 had failed. A replacement restored the power. **D.B.**

### **Mitsubishi HSB52**

The report said that this machine wouldn't play and chewed tapes. On investigation I found that the idler assembly didn't move far enough for take-up drive. The idler should have a spring which is held in by a circlip. It was missing. A new idler cured the fault. **D.B.**

### **Ferguson FV41R**

This machine was dead with no clock display. Checks showed that there were problems around the microcomputer

chip IT01 – and that one of our less qualified friends had got his paws on the machine. The crystal associated with IT01 had been replaced with a 17MHz instead of a 4MHz type. Fitting the correct type still didn't bring the machine to life, but unplugging the on-screen display panel did. Replacing IA21 finally got the machine running correctly. **D.B.**

### **Ferguson FV68TX**

There was no hi-fi recording, though playback of pre-recorded hi-fi tapes was o.k. We suspected the TEA5712 chip in the head amplifier, but fitting a replacement made no difference. Luckily another VCR of the same type was in the workshop. Swapping the drum assembly over proved that this item was the cause of the trouble. **D.B.**

### **JVC HRJ205**

There was no E-E tuner operation, with just a blank raster. Unfortunately the construction of this unit makes fault diagnosis in this area very difficult. Replacing the tuner and i.f. strip restored normal pictures and sound. **D.B.**

### **Akai VSG64**

This machine had been to the workshop on several occasions because of a jammed mechanism. As we'd already carried out the usual modifications we decided to plump for a complete mechanism block. Akai appears to be the only manufacturer that supplies a block like this, complete except for the drum and audio-control head assemblies. We fitted this and set up the head alignment – and haven't seen the machine since. **D.B.**

### **Nokia VR3784**

There were no E-E or playback signals at the scart 1 connector. A check on the waveforms at the scart PCB showed that the VD OUT AV signal was not present at pin 9 of CN861. On tracing back I found that the print at one side of C1602 had lifted. **R.B.**

### **JVC HRD540**

When the rewind or fast forward button was pressed the tape loaded up fully and went into the selected mode, but at the visual search speed. Replacing the end sensors cured the problem. **R.B.**

### **Nokia VR3783**

This machine wouldn't slow down and stop in rewind, breaking tapes. Refitting the LED tower plug to the sensor PCB cured the fault. **R.B.**

### **Samsung VIK310**

This machine spilled tape out in play. In addition fast forward operation was noisy. On investigation we found that a piece of paper had jammed in the teeth of the take-up reel. Removing it restored correct operation. **R.B.**

### **Nokia VR3761**

When this machine powered up it would switch off instantly to standby. Normal operation was restored when we replaced the 2SC4484S transistor Q5402 on the PWA board. It was short-circuit all ways round. **R.B.**

# Toshiba Service Briefs

The following update notes from Toshiba Technical are based on bulletin CDH55, which was issued in August.

## CTV RECEIVERS

### Model 210T6B

**Distorted sound:** If the unregulated 12V supply at pin 9 of M582 has risen to 27V, replace Q809 (BC557B). Part no. is 23114546.

### Model 215T8B

**Set is stuck in standby:** If the voltage at pin 7 (reset) of the M34300N583SP microcontroller chip QA01 is low at 2-4V and the reset chip Q805 is o.k., replace QA01 – part no. 23318387.

### Models 285T8B/BU

**Stuck in standby very intermittently. The Nicam and bilingual LEDs may just glow:** The power supply is in the over-current trip mode, with the h.t. at less than 20V. Increase the value of C845 from 22 $\mu$ F to 100 $\mu$ F (50V).

Note that a similar symptom, intermittent start-up, has previously been reported. The remedy for this is as follows: change R818 to 15k $\Omega$ , 3W; replace the 22 $\mu$ F, 16V capacitor in parallel with diode DF80, but mounted on the print side of the panel, with a 100 $\mu$ F, 16V type; add a 5.1k $\Omega$  1/8W resistor in parallel with D812, on the print side of the panel. The three components required are available as kit 23305114.

### Models 2100RB 2100TB 2101/2/3TB

**Intermittent partial field collapse with black bands on the picture:** The output from the  $\mu$ PC7812H 12V regulator IC408 is falling to 8V. Replace IC408, part no. 23318218.

## VCRs

### Models V204B V254B V404B V454B (Cat 1)

**No colour, video streaking in playback:** CV21 (0.015 $\mu$ F) at pin 21 of IV001 is leaky or, if an additional 27pF capacitor is fitted between pins 21 and 25, it may be touching an earthed section of the print. Replace CV21 or reposition the extra capacitor as necessary.

**Machine is dead with the power supplies o.k.:** Replace the ST24C04/CB1 EEPROM chip IT003, part no. 70011892. Clues are no data at pin 6 with the d.c. voltage incorrect at 0.8V instead of 4.8V.

### Models V204B V254B V404B V454B V804B V854B

**Clock is inaccurate:** The main microcontroller's 8.000020MHz oscillator is out of specification (the timer and clock are inside the main not the display micro). Adjust

C552, using a non-metallic tool. Refer to the service data for Models V804B/V854B, page 2-47. In Cat 1 models there is no test pin TP501: use pin 63 of IT001 (it's best to connect a piece of wire to this pin to link with a frequency counter probe) and remove the mechanism to gain access to C552.

### Models V212B V213B V312B V412B V423B V513B

**No display, won't turn on, capstan runs continuously:** Replace the U2559B regulator IT25 which is holding the 5V supply low. Part no. 70010977.

**Tape speed slow:** The capstan motor bearings are seizing up. Replace the motor, part no. 70011046.

### Model V411B

**Audio buzz in playback:** Cause is a poor earth connection from the ACE head at connector BS01 on the main signal PCB. The connection can be repaired.

### Model V703B

**Dead with no display:** This can happen when the a.c. clock generator IC801 in the power supply has stopped. You will probably find that the chip is o.k., the 75k $\Omega$ , 0.5W feed resistor R802 being open-circuit.

### Models V804B V854B

**Machine is dead:** The STRD6802 chip IC803 is probably short-circuit. D803, type S1WBA60, may also be short-circuit. Replace IC803 with kit part no. 70903970. If D803 has to be replaced the part no. is 70011880.

## CAMCORDER

### Model AI420BK

**The machine appears to be in the cue (forward search) mode intermittently, but the drum runs too fast and the picture is lost:** There are two possible causes. Either C519 (10 $\mu$ F, 16V) is faulty or pins 11 and 12 of the FG/CTL amplifier Q502 are dry-jointed. Replace the capacitor or resolder the pins.

## SATELLITE RECEIVER

### Model TS540

**VideoCrypt channels remain scrambled:** This can happen if the picture contrast has been set too low via the customer menu, reducing the video input to the decoder. The cure is to reset to factory default 4. Advise the customer.

## NEW PUBLICATION

A pocket-sized version of the *Toshiba Technical Repair Data Book*, designed for the field service engineer, is available from Toshiba (U.K.) Ltd. at £5, part no. TTRD95.

# Servicing Matsui and Saisho VCRs

## Part 2

Jack Barclay

In this concluding part we'll take a look at the electronics used in later models, then at the new centre-loading machines, and end with a short faults guide and a useful parts list.

### Models VX1000, VX2000 and VX2500

These machines are similar electrically. The power supply is conventional, again using an STK5342 main regulator chip. Last month's comments on the basic power supply also apply to these models therefore.

### Syscon and Timer

These models were the first in the Matsui range to use surface-mount technology. The syscon/timer circuit employs an 80-pin flatpack microcontroller chip (IC1001) that's superglued to the board! Fortunately it has proved to be reliable, but take good care if you have to remove it.

You will find either an OEC0020 or an OEC0026 in the IC1001 position. They are not interchangeable. The latter uses the off-tape control pulses to provide a real-time counter. It also requires a different remote control unit, which has a separate timer rec. button.

If the machine is dead but the power supply is working normally, check by substitution the orange trimmer capacitor in IC1001's oscillator circuit – note that there are actually two oscillators.

This chip feeds the fluorescent display on the front PCB directly. It also scans the keys on this board and takes in information from the infra-red remote control receiver. The supplies to the chip are +5V and -30V. The former is derived from the AT6V line via diode D1002. When this diode goes open-circuit, the result is a dead machine.

The outputs from the mode switch, the rec. tab switch and the FL switch are fed to IC1001 via a resistor network. Very odd faults occur when these resistors fail. The reason for the use of this strange circuit appears to be to reduce six control lines to two to feed IC1001. Fault finding in this area is tedious and difficult. Fortunately I've had only one failure here, when one of the resistors was physically broken.

Pin 75 of IC1001 is the standby/power on switching output. It goes to the power supply via Q1007. When this transistor goes open-circuit the machine appears to be on (indication in the display) but there are no functions, the switched outputs from the power supply remaining off. Q1007 is a digital transistor: replace it with the same or a suitable equivalent type.

Pins 14 and 15 of IC1001 control the BA6247 loading motor drive chip IC1003, which can fail. It usually self-destructs, the result being a large hole in its front. Replace-

ment will normally restore correct operation. Its failure can also be caused by the loading motor.

Tuning data is stored in the memory chip IC1005. I've never had to replace this item. The tuning voltage is derived from the pulse-width modulated output at pin 55 of IC1001. An active filter produces the voltage to control the tuner. More on this later.

### Servo Control

The servo circuitry is mostly contained in the OEC6014C chip IC2001, which is more reliable than its OEC9011 predecessor. It does fail on occasions however.

If there's no motor operation, check IC2001's supplies first then for 4-43MHz at pin 22. This signal comes from the YC board.

Pin 39 is a good point at which to check the control pulses in the playback mode. If the capstan or drum motor is running at the wrong speed, check C2008/9 in the former case and C2010/1 in the latter. An odd condition occurs when either C2023 or C2024 fails. There appears to be a lack of control pulses. A check at pin 39 will show whether the control pulses are low or missing. Disconnecting the plug from the control head will alter the rate of the displayed bars.

Outputs from IC2001 feed the capstan and drum motors directly.

A fault I've had is no switching pulses from the lower drum. Replacement of the lower drum is the only solution.

### Tuner, RF Converter and IF Strip

The r.f. and i.f. sections are conventional. An r.f. booster/converter provides the tuner's r.f. input. Its supplies are AT5V for the booster section and switched 5V for the converter section. Note that the video signal passes through a filter before it reaches the r.f. converter. I've had this filter fail, the result being weak video through the converter.

The microcontroller chip IC1001 produces a pulse-width modulated tuning output which is passed via active filter IC6002 to the tuner's BT pin. Tuning drift is a common fault. Check R6045 (33kΩ) which can go high in value or open-circuit – in the latter condition there's no tuning voltage at all. Before condemning R6045 as the cause of tuning drift, check that the a.f.t. is switched on for the channels that drift – it has to be actively selected, whilst presetting the tuner.

The tuner is the usual cause of low gain or no tuning (but first check the voltage at its BT pin). The i.f. strip, which is on the YC board, has proved to be reliable, the only faults being caused by IC6001. In the event of intermittent faults, it pays to check for dry-joints at the connections to the main PCB.

### Video Processing

This is carried out on the YC board, which has a lot of surface-mounted resistors and capacitors. These are again glued to the board prior to being soldered.

The main video processing chip, IC4001, is a standard 36-pin DIL LA7390 type. There is no pin that determines whether this chip is in the E-E or play mode: the circuit relies on subtle d.c. voltage differences. I've had little cause to delve into this circuit. The cause of intermittent luminance recording was traced to failure of a chip resistor, and I once had to set up the carrier and deviation controls after a phantom twiddler had got at them.



One complaint you may get is inability to play certain prerecorded Disney and other tapes. The cause is the anti-copying signals included on the tape. To overcome this problem, change IC4001 to type LA7390N.

With very tricky faults the best course is to obtain a replacement PCB from Mastercare. They come pre-aligned.

The video processing board is connected to the pre-rec head amplifier PCB which is mounted on the drum assembly. This PCB usually comes with a new drum. Before replacing it or the drum, check that the PCB is the correct type. If the original had no Y and C record level presets, the replacement shouldn't have them either (see later versions). I've had one i.c. failure on this board. The type varies with the model.

With the exception of the stereo machines, the external inputs are selected by switches in the relevant rear-mounted phono sockets. For poor or no E-E audio or video it pays to check these sockets.

## Audio Processing

The audio processing and the bias and erase oscillator circuitry in the VX1000 and VX2500 are mounted on the main PCB. The circuitry is straightforward: the only problems I've had have been caused by liquid spillage.

Model VX2000 has linear stereo. The entire audio circuitry is on a separate board, along with the bias and erase oscillator.

The earlier Model VX6600 has Nicam as well as linear stereo sound. This section has proved to be trouble free: the entire audio department – the Nicam circuitry, amplifiers and the bias oscillator – is on a single plug-in PCB.

The audio/control head can wear, giving poor sound on one or both channels.

Stereo models have extra switches at the front to enable either or both channels to be selected for playback, and another switch for selection of internal, external or simul-cast sources for recording.

As there are so many variations in this area, if problems do arise it's almost essential to obtain the relevant service manual.

With later VX1000 and VX2500 machines there's a tendency for the audio section of the audio/control head to go open-circuit.

## Later Versions

There are several versions of Models VX1000, VX2000 and VX2500, with differences that make certain PCBs (and circuit diagrams of course) incompatible. Models VX1000 and VX2500 were upgraded, with new PCBs, scart sockets and a new type of drum which has the motor's rotor and stator mounted on the assembly. These later boards are not interchangeable with the earlier ones. The front operation board and head amplifier board were also changed.

You should find a little white sticker on the back of all these machines. It bears the manufacturer's version and a letter. Quote this letter when ordering spares. Hopefully the sticker won't be missing.

## Models VX2700 and VP9301

The VP9301 was Matsui's first Video Plus model. Apart from this feature it's identical to the VX2700. Both models introduced the change to centre loading with Matsui machines. Otherwise they are very similar to the VX1000, the deck and the electronics having much in common. In the VX2700 the syscon/timer microcontroller chip IC1001 is

an OEC0026. In the VP9301 it's changed to type OEC0037 to take into account the Video Plus feature.

## Models VX1100, VP9401 and VP9501

These models are totally different from the earlier ones covered in these articles. Their construction doesn't make for easy servicing. A jig is available, but servicing can be carried out without it. The jig consists of extension leads that enable the power supply and the deck to be separated from the main PCB. I find it easier to work on the main PCB when it's plugged into the deck directly however. The jig part numbers are JG104, JG105 and JG106.

The power supply in these machines is conventional. These are the major differences: the main regulator chip is now an STK5343; the AT12V line becomes AT10V; and the 6V and 12V regulator transistors, along with IC501, are mounted on a common heatsink.

The syscon, servo and timer circuits are contained in an 84-pin flatpack chip, IC1001. I've not had a failure here so far. The circuitry has been simplified: there are no resistor networks between the deck switches and the chip, single 10kΩ resistors connecting each switch contact to the chip directly.

The loading motor drive chip IC1004 is changed to type BA6886-V1. Like its predecessor, it can self-destruct.

The r.f. converter, tuner and i.f. strip are contained in a single r.f. block. The test switch is external to this can: in normal operation it earths pin 3. There are no circuits for this r.f. block, which should be replaced as a complete unit.

The head preamplifier section is now on the main PCB. Most of the video processing is carried out by an LA9397 chip. The presets are on the main PCB, at the rear left behind the mechanism. There's access to the head switching point preset through a hole in the operation board. In theory these controls should never require adjustment. Should you get a blank raster in the E-E mode however, check the setting of the video a.g.c. preset VR4002 before delving into the video circuits. I've found this adjustment to be incorrect on a couple of occasions, possibly as a result of board mishandling as it is removed from the case.

Since the new syscon/servo/timer chip can't handle the fluorescent display drive directly, an MN12510 chip (IC601) is used as a drive interface. It also scans the front key pad. This chip also receives the output from the infra-red remote control receiver chip. Communication between IC1001 and IC601 is via four clock and data lines.

IC601 has its own oscillator circuit, with X601, C602 and C603. Failure of this circuit can give the impression that the machine is dead, but it will take in a tape (preferably a prerecorded one) and play it, thus ruling out the power supply, IC1001 and associated circuits. I've had a few problems with IC601, but check first for oscillation at pins 2 and 3. If there is a digital signal superimposed on the oscillation, check for dry-joints on the earthy side of the oscillator circuit. If the oscillator is running correctly, IC601 is suspect.

## Model VP9501 Differences

Model VP9501 is similar to the VP9401 but has four heads and an auto set-up facility. This works by using teletext data to identify the channels. The identification is fed, in the form of converted data, to IC1001. Connect an aerial to the machine, then connect it to the mains supply. If you have a satellite receiver, switch it on and tune to Sky 1. The machine will then preset all channels in the correct order,

and display the correct time. In poor-signal areas the setting up can be done manually.

The circuitry for this facility is on a sub-panel that's soldered to the main PCB vertically. It's to the right of the main PCB. IC851 and IC852 take care of most of the text processing, with just a few peripheral components. Clock and data lines feed the information to IC1001.

## In Conclusion

So there you have it! This completes our servicing notes on these machines, which were on sale until quite recently. Though basic, the machines give reasonably good results when working well. Servicing shouldn't give the competent service engineer too many problems.

## FAULTS LIST

The following list is based on my experience of these machines to date. Others may well be able to add to it. If so, write in.

### Mechanical Faults

**Tape looping on eject:** Replace the mode switch.

**Tape chewing at the bottom edge:** Check the pinch roller and clutch.

**Wow and flutter:** Check the back tension, pinch roller and capstan motor.

**Carriage fails to lower fully:** Check the loading belts and the link gear on the right-hand side of the carriage.

**Jammed mechanism:** Check the loading belts first then, if necessary, the mode switch.

**Tracking errors:** Check the erase head wiring. Ensure that it isn't trapped beneath the drum.

**Mechanism fails to load or unload fully:** Check the timing relationship between cam 1 and cam 2, also the mode switch.

### Electronic Faults

**Dead machine:** Check the power supply outputs. If there's no power, check the STK5342 regulator chip and the AT6V regulator. If the power supply is o.k., check the orange trimmer associated with the timer or main syscon chip.

**No capstan drive, no drum drive or both:** Check IC2001, type OEC9001 in earlier machines, OEC6014 in later models.

**Picture unable to track, control pulses missing:** Check the control head for continuity.

**Inability to go into the timer record mode:** You may be using the wrong type of handset. Check this.

**No sound:** Check the audio section of the AC head.

**One half of the playback picture is missing:** Check for PG pulses from the drum motor.

**Slow running capstan motor:** Check the back tension then

suspect the capstan motor.

**No video output, or weak video from the r.f. modulator:** Check the filter network PF4201.

**No tuning, or tuning drift:** Suspect R6045 in the voltage converter circuit. Check the tuner if necessary.

**No on-screen display:** Check L4801 and L4802.

**No erase/bias oscillator output:** Check the leads to the erase head and the continuity of coil T5001.

**No colour:** Check whether X4001 on the YC board is dry-jointed. If necessary check IC4001.

**Failure to play prerecorded tapes:** Replace IC4001 with new version (suffix N).

**No switched supplies (Models VX1000, VX2000 and VX2500):** Check Q1007.

**Poor picture and/or sound in the E-E or record modes:** Check the switched phono auxiliary input sockets at the rear.

## USEFUL PART NUMBERS

The following are Mastercare part numbers.

Front loading unit	89000200
Capstan motor	1510S98021
Front loading belt	850P600313
Front loading belt (VX2700 on)	850P600438
Loading motor belt	850P600317
Reel belt	850P600316
Mode switch	0520U44002
Pinch roller assembly	850A400073
Gear loading S assembly	850A30035
Gear loading R assembly	850A30036
Clutch assembly	850A20027
Reel sensor	0002300140
OEC9011 chip	197D49011A
OEC6014 chip	195D46014B
OEC0020 chip	154F50020D
BA6247 chip	107S06247V
STK5342 regulator	123S953420
Orange trimmer capacitor	0100614T08
Audio-control head (stereo)	1523D91011
Audio-control head (mono)	1523D91010

## Hitachi VM1200E

This full-size VHS machine would load a tape then, shortly afterwards, return to the stop mode. Investigation showed that the capstan motor didn't rotate. When a clear service cassette was loaded everything appeared to be o.k., with the capstan turning normally. With an ordinary tape loaded however the fault was back. A check on the capstan motor revealed that it was quite happy to work off load, but didn't provide sufficient torque when a tape was loaded. A new motor cured the problem. **D.C.W.**

## Canon A10E (Sony FL Mechanism)

This neat model, which uses the Sony FL mechanism, naturally from time to time suffers from similar faults to those experienced with Sony camcorders. This one produced a symptom we'd not seen before however. A tape would load half way, stick, then be ejected. We checked the mechanism with the mode box, but it appeared to be faultless.

If loading was attempted with a tape inserted the fault would occur: the tape would become taught across the head then cease to move. The cause was simply that the brakes within the cassette were not being released. We found that the release pin was missing from the base assembly (L) RL. Its part no. is X39406751. A replacement cured the fault – but it took a while to decontaminate the video heads! **D.C.W.**

## Panasonic NVMS90B

The cause of intermittent loss of the camera picture or hi-fi sound or any other odd complaints from customers could be abrasion of the flexible cable between the main CBA and the hi-fi head amplifier module, near the main CBA end. In a recent case the edge of the chassis had a rough casting flash on it. This had worn into the insulation, shorting several tracks together. We were lucky: only Q3507 (2SB970X) and the flexible cable (part no. VWJ0394) had to be replaced. It could have been a lot worse. **T.B.**

## Panasonic NVMS40B

If the complaint is that the camcorder intermittently stops and the cassette door opens, or the door flies open by itself when there is no tape in the machine, you will probably find that the eject switch SW6516 has almost collapsed. A new switch will put matters right (part no. EVQQ-FR2K). Since the switch costs only 44p, it might be worth replacing this item each time one of these machines comes in for attention. In every MVM40B we've seen the switch shows signs of imminent failure. Any mods, Panasonic? **T.B.**

## JVC GRAX5

The fault report said "damaged in raid, repair if viable". Obviously this one was just short of a car boot sale. I replaced some cabinet parts and it worked fine. **S.B.**

## Panasonic NVMS90B etc

This note applies to the NVMS90B and other machines that use a similar deck. If the mechanism fails to shuffle at

power up, with the drum running and everything else apparently o.k., check that the screws which hold the VTR section into the case are in the right holes. Our Ordinary Assistant Fixer (OAF. . .) had by mistake put the one with the soft plastic spacer in the top hole, seizing the loading motor worm gear. **T.B.**

## JVC GRS70

There was no viewfinder display in either play or record. In fact there was no E-E signal from the camera, playback of a known good tape being o.k. We found that R24 on the camera processing board was open-circuit. That was an unusual one. **S.B.**

## Ferguson FC23

"No record picture unless you bash it" the customer said. The iris was sticking because oil from the zoom motor had trickled down on to the iris vanes while the machine had been in storage. With this model I can strip the lens and clean the iris vanes: a bit of a bodge, but it doesn't upset the lens alignment. **S.B.**

## JVC GRC1

This one wouldn't eject a cassette, which was not surprising as the loading motor was knackered. **S.B.**

## Grundig VSC45

We were asked to check out the unit, the complaint being picture disturbance when the capstan motor runs. Replacing the idler drive pulley and the power regulator transistors restored normal operation. **S.B.**

## Sony CCDTR55

There was no picture from the camera section. Another iris vane strip down and clean job. Sony had put too much oil in the zoom motor. This is not uncommon. **S.B.**

## JVC GRAX5

Code A04 would appear in the viewfinder. This suggested that the drum was jamming intermittently. Not so however: pin 9 of IC102 was dry-jointed. So I resoldered it and tidied up some joints on i.c.s that M. Oron had previously replaced in a failed attempt to rectify the fault. **S.B.**

## JVC GRS70

A strobing pattern of horizontal lines appeared in the viewfinder in both the record and VCR modes, and was being recorded on the tape. This was an easy one: we replaced the deck d.c.-d.c. converter. **S.B.**

## Sony TR105E

There was a tape stuck inside, with no functions and no eject. No capstan motor operation either. A new motor restored normal operation. **S.B.**

## Sony CCDF555E

The customer had complained about the viewfinder picture: it could almost be focused, but wasn't quite up to standard. After checks in the relevant circuitry proved fruitless we decided to replace the line output transformer. This did the trick. Note that some Sony viewfinder tubes are electrostatically and others magnetically focused. **D.C.W.**

## JVC GRC1E

This oldie would power up for a few seconds then power down. There were no noises from the mechanism or other clues. As a start we checked the various power supply circuit protectors. They were all in order. We then noticed that one of the tape guides was positioned incorrectly, the unit being in the stop mode. As a result the loading motor had jammed and the mechacon decided to abort the start-up sequence. Loading gear realignment restored the unit to working order. **D.C.W.**

## Orion CMV392

This VHS-C model wouldn't function, the message "EMG. CYL" being present in the viewfinder. A quick look showed that the middle guide pole had broken off, something that's not uncommon with this type of mechanism, which is based on a JVC model. Simply fitting a replacement guide didn't cure the problem of course. Further investigation revealed several dry-joints in the drum-drive PWM circuit, around the 37.5Hz filter. The circuitry here is very similar to that in JVC models of the same period. After carrying out the resoldering required we gave the machine a long soak test. All was well. **D.C.W.**

## Sanyo VMD6P

Intermittent autofocus operation was the problem with this one. Board TC1 receives a 4fsc input at pin 1 of CN952. It was missing, because of a faulty connector at board CA1 (the source of the 4fsc signal). Remaking the connection put matters right. **D.C.W.**

## Canon A10E (Sony FL Mechanism)

A tape would load until the LS deck moved to the point where the tape comes into contact with the head drum. At this instant the tape would be ejected. It wasn't immediately obvious that the brakes within the cassette weren't being released. When we realised that this was the situation it took only an instant to see the cause – the cassette brake release pin was missing from the mechanism. A replacement put matters right. **D.C.W.**

## Sony TR105E

The cause of the reported fault, cutting out after a few seconds in any mode, was lack of the capstan FG signal. It's not uncommon for the capstan waveshaping/amplifier/etc. chip IC159 in this model to fail, producing this symptom. But it had already been replaced! The FG signal from the capstan motor was correct at IC159's input pins, but was

missing at pin 25. As the chip had been replaced we decided to carry out some cold checks around pin 25.

The resistance between pin 25 and chassis was 350Ω, which was patently incorrect. But what was the cause? Pin 25 feeds the FG signal to the syscon and servo chips: checks at the relevant pins confirmed the low resistance reading. We then noticed that the capstan FG signal takes one other path, to the check pin of socket CN002. An inspection at this socket revealed a solder bridge between pins 2 and 4. When this was cleared all was well with the capstan FG signal. **D.C.W.**

## JVC GRS99

There was no output from the camera section, playback was in mono only, there was no viewfinder display and noise on playback. Very few will touch this camcorder, as you can't operate it with the cover removed – unless you have the Bodgett set of special extension leads. Action: replaced an open-circuit protector in the camera head, sussed out that mono meant no colour and not mono as opposed to stereo, and set the YC switch to CVBS. **S.B.**

## JVC GRS707

This machine powered up but there was no picture in the viewfinder or via any of the outputs. The 8V regulator transistor had failed and, by the looks of the soldering, someone had replaced it before. I'll bet it fails only when the owner is copying. Make phone call to owner to check. He's astounded that Bodgett knew what had happened. Owner told in no uncertain terms to get a new JVC AV lead and stop using crap pattern accessories. Write out large bill to include AV lead. **S.B.**

## JVC GRAX2

"Cracked and a smell of burning" it said. I think you have to be psychic to be able to decipher some of these fault reports. We replaced the burnt out d.c.-d.c. converter and associated circuit fuse (the cause of the 'crack' when it blew up), then the loading motor which had been the cause of it all. Added psycho levy charge to the bill – for a new crystal ball. **S.B.**

## JVC GRAX5

The picture was negative and out of focus. This meant that there was little or no luminance, just chroma and syncs. The usual cause is the CCD delay line chip in the camera head. Replacing it cured the trouble. **S.B.**

## JVC GFS1000

The record on/off button was broken, the lens and PCBs were pushed back, the lens frame was warped, there was no iris control, a PCB support pillar had broken and the camera operation PCB connector was also broken. Had it been dropped? "Understatement" is probably the word to use here, along with "pillock" to describe the owner. Anyway we were able to put matters right. We replaced the camera frame, the iris amplifier's drive transistor and the PCB connector, then glued the damaged stop/start switch. **S.B.**

## Philips VR231

If the power supply is dead and the start-up voltage for the control chip is low, check whether diode 6115 is leaky. The type fitted in this position depends on the model. If it's a UG06B, the part no. is 4822 130 83307. **P.B.**

## Panasonic NVG21

When replacing post P5, make sure that you use the correct part for the machine on which you are working. After fitting a new post we found that it caught on the securing screws for the capstan motor. This resulted in a tape loop on eject. The new post looked identical to the old one but was about 1mm thicker. It would seem that different ones are used in the deck. **M.Dr.**

## Panasonic NVG7

Stations could be tuned in and stored, but on channel change they disappeared. We suspected the MN1220 memory chip, but checks took us to the -30V supply which was rather high at -57V! Q1101 and D11 in the power supply were found to be short-circuit. Despite this high voltage the memory chip was perfectly o.k. **M.Dr.**

## Sanyo VHR3300

The effect produced by this fault suggested that its cause lay in the i.f. or a.g.c. circuits. Symptoms were a grossly distorted, soot-and-whitewash E-E picture with patterning and loss of sync. In fact the signal that emerged from the vision detector was perfectly good! The cause of the trouble was a faulty vision switching chip, IC1001 (LA7223). **E.T.**

## Sanyo VHR190

To all intents and purposes this machine was completely dead. When we checked around in the power supply section with an oscilloscope however we found that there were needle pulses at the chopper transformer. The cause of the failure was the 14V rectifier D5101 which was short-circuit. **E.T.**

## Panasonic NVG21

This machine originally came in for a service. In addition to replacing all the gears, the pinch roller and the mode switch we had to replace the side plate and connection gear. Two months later the machine came back, the complaint being that when it was switched on the carriage moved forwards then ejected, repeating this until the machine went back to standby. You often get this fault when there's a worn carriage mode switch or a bent lever. Not this time however. The cause of the trouble was that all the joints of the new carriage's connector were dry-jointed. Resoldering put matters right. **D.B.**

## Sanyo VHR135

There was intermittent failure to take up in play or rewind. The cause of the problem was that the idler was sticking on

its shaft. A drop of oil on the pivot shaft was all that was required to restore correct operation. **D.B.**

## Matsui VX730/Saisho VR3200

This machine appeared to be dead. The power supply was working, but there was no AT6V supply because of a break in the ribbon cable that connects Q505 to the power supply. A new cable loom put matters right. **D.B.**

## Ferguson FV70

This machine had a tape stuck in it. As the loading motor had partially seized, its drive chip had a large hole in it. Replacing the chip and the loading motor enabled us to retrieve the tape. **D.B.**

## JVC HRD580

We seem to be getting quite a few of these machines in which a previous engineer has replaced the mode switch but fitted the wrong type. The symptoms are that the tape laces up and the machine then plays for a few seconds before shutting down. The part number for the mode switch, which has a black body, is PU60973. Don't fit the red type. **D.B.**

## Sanyo VHR251

The E-E and playback pictures were poor, with what appeared to be hum bars and a rolling effect. A check via the scart lead showed that the video signal was good. When we opened the r.f. converter we saw two small 1µF capacitors. Replacing them restored a good picture. **D.B.**

## Aiwa HVG110K

This machine went dead intermittently. When we examined the power transformer we found that pins 15, 16 and 17 were dry-jointed. Resoldering them restored reliable operation. **D.B.**

## JVC HRD910

This tip could save you a lot of heartache – as well as money! The symptom we had was an unstable picture in the top half of the screen and just snow in the bottom half. Scope checks showed that the output from one head was greatly reduced. Replacing the upper drum marginally improved the top half of the picture, but had no effect on the snow. . . . Logically, the cause of the problem had to be the lower drum. But before we frightened the customer with the price of a new one we rung JVC Technical. We were told that there's a 3-3µF capacitor, which is not shown in the service manual, on the lower drum PCB. Replacing this cured the fault. **S.H.**

## Ferguson 3V23/JVC HR7700

It's not often that one of these venerable machines turns up, but this one was extremely clean. Its noisy picture was

simply the result of worn out heads, which the owner thought it worth replacing. He also said that the machine didn't always load, especially with a timed recording. A new loading belt cured that. We also replaced the cassette lamp as it appeared to be the original one. **M.H.**

### **Fisher FVH715**

A nice easy one: this machine produced a picture with two hum bars that tripped the field lock each time they arrived at the bottom of the screen. Two bars indicates 100Hz hum, so we had a quick look around the main electrolytics. C906 (1,000µF, 35V) turned out to be almost open-circuit. It took longer to take the cover off the machine and find the power supply than to do the repair! **M.H.**

### **Saisho VR1200/Matsui VX800A**

This machine had no eject, fast forward or rewind operation, though it would load. We noticed that there was no capstan rotation, and a quick check showed that there was no 16V feed from the power supply. This led us to the good old circuit protector ICP201 which was open-circuit. Replacing this and giving the machine a good clean up completed the repair. I love the easy ones! **T.L.**

### **JVC HRFC100F**

This model is unusual in that it will work with both normal VHS and VHS-C camcorder tapes. Its loading mechanism is therefore slightly more complicated, and this is where you get most of the problems. The machine I had in recently was no exception – there was a tape jammed in it.

I managed to extract the tape, and on inspection noticed that the half-load arm was quite badly twisted and in need of replacement. It is always worth checking that the carriage is not sloppy in its down position: it might also need to be replaced, and is an expensive item. Fortunately in this case the carriage was o.k. and replacement of the half-load arm and the gear assembly was all that was required. **T.L.**

### **Matsui VX1100**

There was intermittent E-E sound. Getting out my faithful old screwdriver, I did some highly technical fault tracing by tapping around the boards. This soon led me to a very sensitive scart panel, and on closer examination I noticed that C4513 was dry-jointed. Resoldering it cured the fault. **T.L.**

### **Hinari VXL6**

In both the E-E and playback modes the video signal was very crushed and distorted, and of low amplitude. Not having a manual, I was forced to follow the print. This brought me to Q306 (2SC1740), whose base voltage was too low for it to switch on properly. The cause of the trouble was C353 (47µF, 16V) which was short-circuit. We've had problems with other 16V electrolytics in these machines. Symptoms have included no drum rotation and excessive capstan speed. **S.L.**

### **Amstrad VCR4600**

There seemed to be two problems with this machine, but they proved to have the same cause. If any deck mode was selected while the machine was in the E-E mode, the sound would be either muted or its level would vary momentarily. Deck mode changes also produced video signal level varia-

tions. The obvious thing to do seemed to be to check the supply voltages. When I did this I found that the AL12V supply was at 18V and varying. This supply is produced by Q802, along with the 5V regulator IC801 and the 8.2V zener diode D810. The culprit was Q802. **S.L.**

### **Sharp VCA46 – Video Plus Handset**

There was a problem with this machine's Video Plus remote control handset. If a Video Plus code for any previous day was entered, the LCD would display the correct start/stop day/month. If a code for the current or any subsequent day was entered, the wrong start/stop day etc. would be displayed. The cure was to remove the handset's batteries then discharge the internal capacitor by shorting the battery terminals together for a few seconds. The problem had arisen after fitting replacement batteries. **M.Dr.**

### **Ferguson 3V36/JVC HRD225**

Playback of a prerecorded tape was o.k., but when a recording made by the machine was played back the capstan speed was slow. Checks showed that the capstan FG comparison signal was missing at pin 6 of IC408 (BA6305) though the input to this section, at pin 5, was o.k. The obvious thing seemed to be to replace the chip, but this made no difference. After checking the chip's peripheral components I did what I should have done in the first place – check the amplitude of the pulses at pin 5. It was low of course (200mV). When I checked back to pin 1 I found that the signal from the capstan flywheel FG coil was also low.

An inspection of the flywheel revealed that the two screws which hold the bracket were chewed up, and that someone had already fitted a new set of belts. The cause of the trouble was excessive clearance between the flywheel and the FG coil. I think that whoever had fitted the belts was unable to undo the screws and bent the flywheel bracket to get the new belt on. **M.Dr.**

### **Philips VR6462**

There was no playback sound though the E-E sound was normal. I like to use a signal tracer. So I lifted out audio panel P502 to make checks. There was plenty of signal from the head, at the base of transistor 7010, but nothing at its collector. A few further quick checks showed that although there was 11V at the top end of R3037 (3.3kΩ) there were no voltages around transistors 7010 and 7009. The decoupling electrolytic C2027 (330µF, 16V) was dead short, a replacement restoring full sound. **R.N.**

### **Philips VR6585**

There was neither E-E nor playback sound with this Nicam machine. Initial checks were carried out around the audio switching panel, but everything seemed to be o.k. here. What I did notice was that the level indicator on the front panel barely moved. It's driven by the f.m. audio panel, where there was no supply to the audio processor chip because the 80mA Wickman fuse F1201 was open-circuit. All that was required to restore the sound was a new fuse. **R.N.**

### **Sharp VCA113HM**

This machine belonged to a heavy smoker and needed a good clean up. I was told that it had failed quite suddenly while playing back one of the soaps. On test it was found to be reluctant to thread, with the arms going only about half

way; the half-load arm moved in odd jerks, and the machine wouldn't wind tape back into the cassette. The mode switch was the cause of all this. When I removed it and took it apart the contacts were seen to be suffering badly from nicotine poisoning. They cleaned up all right, and the machine worked when reassembled, but I decided to change the switch to be on the safe side. **R.N.**

## Philips VR6462

There were no signals, either E-E or playback, nor was it possible to obtain a test signal as there seemed to be no output from the modulator. Mechanically the machine was o.k. A substitute i.f. panel failed to restore the signals, so I checked the voltages at pins 4 and 6 of socket P5 on interface panel P005: these are the supplies to the modulator. The switched 12V supply (12b) at pin 4 was missing. It comes from transistor 7002, which had correct voltages at its base and emitter but nothing at its collector. The 'on' line to IC7150 seemed to be working correctly.

Component replacement on panel P005 can be carried out only after removing it. Remove the i.f. and chroma panels, then the three screws that secure the mains transformer. After unplugging the transformer, release the plastic clips that hold the panel, raising it gently as you do so. The panel can be worked on by resting it on its side, and you can plug the transformer back in. All deck functions will then remain operational. Once transistor 7002 had been replaced normal operation was restored. It's a BD678 Darlington type transistor. **R.N.**

## Toshiba V309B etc

This machine would stop in playback or record after anything from twenty minutes to two hours. The cause was high reel motor current, though the motor rewound very fast and wasn't particularly noisy. We've also had the fault with the V109B and V209B. **J.P.-F.**

## Panasonic NVG20

No power up with this machine was caused by C39 in the power supply. It had gone low in value. **J.P.-F.**

## Ferguson 3V35/JVC HRD120

The tuning department wouldn't light up, behaving as though it was in the camera mode. The tuner/camera switch was o.k. however. Replacing the HD552-088C chip cured the fault. **J.P.-F.**

## JVC HRD580/Ferguson FV43H/44L/46T

This machine stopped intermittently, usually at start up. As a replacement clutch unit failed to restore reliable operation I removed the deck terminal PCB and cassette housing in order to give the deck a thorough inspection. While looking for a foreign object I noticed that the brake pad on the sub-brake assembly was dislocated. A replacement, part no. PQ43583A, cleared the fault. **J.P.-F.**

## Hinari VXL90 etc

No fast forward or rewind, everything else working normally, is becoming a stock fault with the deck used in this machine (and many others, see note at end). The cause is unreliable trigger lever action (item 260, see Fig. 1). In order to engage the fast forward/rewind action after a

command, this lever must have returned to its rest position. Instead, it tends to remain protruding about 1mm towards the front of the deck. To improve reliability:

(1) Carefully round off the sharp edges of the trigger lever and brake plate mouldings in the areas indicated by an X in Fig. 1, using a sharp knife in a scraping action.

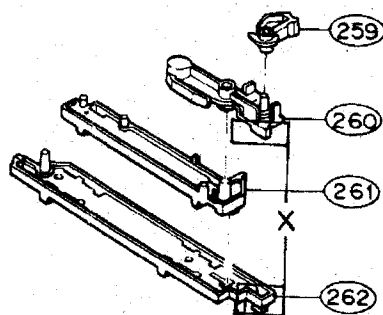

**Fig. 1: Trigger/brake components, 259 trigger hook, 260 trigger lever, 261 brake plate, 262 brake actuate base. Round off the edges of items 260 and 262 in the areas marked X.**

(2) Increase the spring torque by bending the bottom end of the spring an extra 60°.

(3) Clean off all dirt and reassemble, lubricating the rubber parts with a *small* amount of *plastic* grease such as Electrolube or Mycote.

**Note:** Other machines that use the deck include the Hinari VXL8/9, Sentra VX8500/8600, Amstrad VCR6000/6100, Tashiko VVF933/934, Proline VCR9100, Goodmans TX1100, Osaki VCR35 and many more. **J.P.-F.**

## JVC HRS5800

This machine came in with a list of faults: intermittent sound; picture not stable; and the left VU meter not working. There was no sample tape, and I had little to go on as the machine had come from another dealer. I checked the tape path and set it up. This cured most of the problems. I then braced myself for a complicated VU meter drive problem. There was relief when I discovered that it had been selected as a tracking indicator. **S.B.**

## Grundig VS340

Sound warble was the complaint. It was caused by tight capstan motor bearings, a new motor curing the trouble. Unlike some who would strip the motor down and lubricate it, "to save the customer some money", I prefer to work to manufacturers' standards. **S.B.**

## JVC HRS4700

Faulty functions. What a brilliant fault report! Says it all, doesn't it? Normal operation was restored by replacing the CAT chip. To non-JVC types, that's the memory i.c. **S.B.**

## JVC HRS5800

Loading difficulties was the complaint with this machine. Its cause was a broken spring in the idler/brake control. All suspect gears and cams were replaced to restore reliable operation. **S.B.**

## Panasonic NVG21

The symptoms were badly distorted sound and diagonal lines across the picture. Anyone optimistic enough to try to play a tape would see that the drum and capstan speeds were incorrect. In a machine of this age the initial checks should be carried out in the switch-mode power supply. We found that C1019 (1,000µF, 25V) had died of old age. **B.S.**

## Panasonic NVG10

An intermittent mechanical fit was the complaint with this machine – the mechanism would shuffle around, the machine then powering down. Selecting rewind or fast forward would sometimes produce a quick shuffle, then the command would be ignored. A machine of this age is usually in dire need of maintenance kit VUD4103KIT, but the part needed to cure the symptoms just mentioned, the mode switch, is not included. Its part number is VSS0135. **B.S.**

## Panasonic NVJ40

The machines in this range and subsequent ones incorporate an internal fault diagnosis system. Pressing eject, fast forward and rewind puts the machine in the fault diagnosis mode (with shuttle search machines press eject and hold shuttle forward). The VCR will then recall from its memory the last registered fault – unless it has been unplugged from the mains supply since the last fault occurred.

The fault with this machine was intermittent stopping. Unfortunately it occurred once every two weeks. But the machine said E2, which according to the manual means reel stop problems. So we turfed out the two ON2170 reel sensors and cleaned the reflector surfaces. Our sincere thanks to the diagnostic system – the machine hasn't darkened our doorway since! **B.S.**

## Akai VS765

This machine wouldn't respond to any function requests. There was also no clock display. A start was made in the power supply, to see whether there was anything obvious amiss, but the voltages at plug WP201 were all correct. Attention was next turned to the microcontroller chip IC403 and the front control panel. We found that the 5V supply to the chip and the panel were o.k., but the 5V reset voltage to the clock microcontroller chip was very slow in coming up while there was no reset voltage at all at the microcontroller chip on the main board.

The reset pulse is derived from the BU5V supply, which was very low. It comes from TR205 on the main panel. This transistor should receive a 23V input, but the voltage had fallen to only 5-6V. The cause was the 15Ω safety resistor R221, which had gone high in value. A replacement produced normal operation. **M.L.**

## Akura VX90

The customer said that this machine would shut down when play or record was selected. Fast forward and rewind were o.k. Once the top cover had been removed I saw that there was no drum rotation. Although I didn't have the circuit

diagram, I decided to strip out the main PCB and investigate. Unfortunately first-line checks proved to be inconclusive. As no resistors or safety components had failed, I felt that a manual would be required.

While I was trying to relocate the top board however my hand brushed against the r.f. booster/modulator. It was very warm. I then noticed that the r.f. channel output adjustment was chewed and possibly damaged. When the modulator was disconnected from the PCB the drum rotated and playback was achieved. A new modulator put matters right. The job might have been easier had there been a few more safety components. **M.L.**

## Samsung VIK320

Watch out for this one: if the machine starts to do weird things by itself, e.g. trying to load with no cassette inserted, or the cassette flap 'flapping' with no tape in, check for dry-joints at the lighthouse. **M.L.**

## Matsui VP9401

This machine wouldn't load. As there was no drive to the loading motor I pulled the machine apart to gain access to the loading drive chip. This was very hot and its casing was damaged. The machine worked when a replacement chip had been fitted, but the chip was still overheating. A new loading motor put that right. The machine then worked fine. **T.L.**

## Matsui VX1100 etc

Intermittent mechanism faults are now common with this range of machines, e.g. failure to eject, not playing, etc. If you get this problem you can clear it by cleaning the mode switch. For a permanent cure however replace the switch with the improved type. **T.L.**

## Matsui VP9401, VP9501

For problems with sound recording or playback, or any other intermittent deck problems, check the jump connection board at the rear of the mechanism. You will probably find dry-joints. Resolder all connections and give the machine a good test. **T.L.**

## Sony SLVE40

This machine wouldn't eject tapes. The mechanics didn't jam: the mechanism would go to the point where it was ready to eject, then just sit there. The culprit was the mode switch, a replacement restoring normal operation. The mechanism bears an uncanny resemblance to the deck used in the Amstrad double-deckers, budget Aiwa machines, etc. **D.B.**

## Hitachi VT65

Intermittent failure to record the picture was the complaint with this machine. When a sample tape provided by the customer was tried we found that no f.m. had been recorded. When the fault eventually put in an appearance in the work-



shop we found that little f.m. came from the modulator chip. A replacement thick-film unit cured the trouble. **D.B.**

### Panasonic NVF65

This machine was dead with just a squeal from the power supply. When the main PCB was disconnected the power supply worked perfectly. So it was time to start disconnecting the loads to find out which one was imposing the excessive load. The 45V line turned out to be the culprit. Now there's a rather unusual shunt stabiliser across this rail, based around transistor Q6021 which was being turned on hard. A fault in its base drive circuit was therefore suspected. But checks here proved fruitless. The cause of the problem was the fuse on the main PCB. It was dry-jointed. Resoldering it cured the problem. **D.B.**

### Sanyo VHR7700

This machine was dead, with only the clock display showing. There was no switched 5V supply because Q5402 was open-circuit. **D.B.**

### Amstrad UF20

There was buzz on the E-E sound and tuner signal recordings: recordings via the scart socket were fine. In this and later Amstrad models the tuner, i.f. section and r.f. converter are housed in one can, part no. 254873. A replacement cured the fault. **D.B.**

### Ferguson FV31R

This machine would jam intermittently then turn itself off. It uses optocouplers as mode switches. A sub-panel mounted on the power supply/servo PCB feeds the pull-up resistors associated with these optocouplers. The cause of the fault was a dry-joint on this panel. **D.B.**

### Matsui VX800/Saisho VR1000

This machine's mechanics failed to complete the loading cycle in either play or record. On inspection we found that the cam gear was bone dry. A replacement together with some grease restored normal operation. **D.B.**

### Panasonic NVFS90

This machine's playback picture was certainly below par. We suspected the heads but the drum is very expensive. So some checks were carried out. We found that the source of the trouble was on the delay PCB, which sits on its own at the bottom of the machine, being connected to the main PCB via various cables. A clean signal arrived at this board, but a very poor signal left it. On further investigation we found that capacitors C3501 and C3506 had dried out. Replacing them restored the excellent pictures that this superb SVHS machine produces. **D.B.**

### JVC HRD660

The pulley ring on the capstan motor in these machines tends to split, the result being either cyclic interference to playback accompanied by a ticking noise or complete failure if the pulley and belt actually come off. The pulley is

a toothed gear. JVC can supply a replacement, part number PTU96031-678C, to eliminate the need to replace the capstan motor. **P.J.C.**

### Amstrad DD8900 Twin Deck

The problem with this machine was no fluorescent display. R29 (15Ω, fusible) in the power supply was open-circuit. Replace D29 (BA157) as well, or the repair will probably bounce. It's wise to mount these two components off the board to increase the air circulation around them. **P.J.C.**

### Mitsubishi HSM34

This machine had a cassette stuck inside it. We found that the eject sequence couldn't be carried out because the main reel belt was off its pulley at the capstan motor. The pulley ring was off the capstan too – a split had appeared in the pulley. This would normally call for replacement of the capstan motor. We've had success however by simply fixing the split pulley back on its shaft. The small split doesn't impair performance. **P.J.C.**

### Akai VSF30EK

Fluorescent display failure is common with these machines. A kit is available from Akai, part number BX744015J. It consists of replacements for C446/7 and D416/7 together with details of a small modification to extend tube life. **P.J.C.**

### Mitsubishi HSM54 and Variants

This machine seemed to load the cassette correctly until either play or record was selected. It would then cut off, after approximately three seconds. The cause of the fault was the cam pinch lever (L016) which had become misshapen where it contacts the pinch cam, preventing completion of the loading sequence. I've also known this part to break completely, the symptom then being either failure to accept a cassette or tape damage on load/eject. **P.J.C.**

### Hitachi VTM830

This machine didn't record sound and there was no E-E sound whilst recording. When the record button was pressed there was a noise as if the sound was being strangled: sad, really! The sound feed to the modulator and the scart socket is from pin 30 of the LA7297 record/playback processor chip IC401, which also switches on the 9V supply to the bias oscillator. The bias oscillator transistor Q401 had died. **R.M.**

### Goodmans TX1101 etc

The deck used in this machine is the same as that in the Amstrad VCR6000 and many other, often obscure, models. There are many similarities in the electrical/electronic systems as well. The following fault, which has become common, applies to them all.

The usual symptom is switching from the LP to the SP mode without being asked. Ripple on the 'mcom +5V' supply is the usual cause – it's at the rightmost power supply plug pin. The component that's responsible is either the bridge rectifier or C509 (220μF, 25V). We replace them

both, also the pinch roller, then set up the control head. There have been no comebacks after doing this.

It's also common to find that the audio/control head tilt adjustment was incorrect from new (as it was with the Amstrad machines), to the extent that there is insufficient tension at the top edge of the tape. This produces rippling at the top edge and thus poor tape/head contact.

C509 can deteriorate further. As a result the 5V supply is so poor that the microcontroller chip fails to reset. The deck continues to carry out its initial shuffle however. **S.L.**

### **Samsung VI711**

Intermittent play was the customer's complaint. I assumed to start with that the cause was of the usual idler or belt kit variety. Not so. Another symptom I noticed was patterning on the E-E pictures. So I checked for hum on the supply rails. This was in fact the cause of the trouble: C102 (3,300µF, 35V) had fallen to a very low value. **S.L.**

### **Sharp VC390H**

After carrying out a deck service I did a full function check and was surprised to find that there was a no record fault. Playback was o.k., but the machine would neither record pictures and sound nor erase previously recorded material. The Rec12V line seemed to be an obvious thing to check. Bingo – the voltage was missing. It comes from the 2SA950 transistor Q807 on the bottom 'servo' board. As we didn't have a 2SA950 a BC640 was tried instead. It provided a complete cure. **S.L.**

### **Matsui VX735A/Saisho VR3300**

The customer complained that the aerial socket was too hot to touch! When we tested the machine we found that the r.f. modulator's metal case was indeed extremely hot. A check on its supplies showed that one read 18V while the other was correct at 12V. These voltages were measured at CP501. Further checks in the power supply revealed that Q502 (2SD1207) was short-circuit all ways round. **S.L.**

### **Orion D4500**

No playback was the customer's complaint. In fact the machine's r.f. output lacked video modulation because of an intermittent dry-joint on the wire link next to R4203, which is near the LA7282 chip and the r.f. modulator can.

The innards of this machine bear a close resemblance to the Matsui VX1000/2000. **R.P.**

### **Fisher FVH5100**

Failure to play was the original symptom, with auto-ejection of the cassette. A new idler assembly cured that. But there was occasional colour dropout when playing a known good tape, leaving a white-spotted monochrome picture. Scope checks showed that one head's f.m. signal was missing at the output from the BA7253S three-head amplifier and switching chip. By the time the head-switching signal at pin 1 could be measured, the fault had cleared and didn't return for a month – in the customer's home, of course. Replacing the upper drum assembly cured the fault.

The original head assembly appeared to be in perfect

condition. There must have been an intermittent break in a head winding or head ferrite, possibly caused by the tape brought along by the customer – it had been spliced using Sellotape. **R.P.**

### **Matsui VX800A/Saisho VR1200**

This machine had been in several times because of the same fault: intermittent switching off. I changed the mode switch but this made no difference. Then, quite by chance, I discovered that the spring action of the play and stop switches had been lost. As a result they were not making when required. New switches cleared the trouble, but two weeks later the machine was back. This time the cam had seized. After replacing this item we'd finally seen the back of the machine. **M.M.**

### **Ferguson FV62L**

Capstan wobble was the trouble with this machine – the picture broke up in both rewind and forward search. The culprit was IT25. After replacing it the machine behaved normally. **M.M.**

### **Matsui VX1100**

There was no LP playback colour with this machine, though recording was normal. The cause was eventually traced to C4316. One of its legs was dry-jointed. **M.M.**

### **Telefunken VR4940**

This machine is similar to the Ferguson FV32. The one we had would load up, start to play, then stop. I suspected the reel sensors, but replacing them made no difference. Replacing the mode switch put matters right. **M.M.**

### **Matsui VX2700**

Intermittently reverting to standby, after long periods of varying duration, was the complaint with this machine. Resoldering a number of dry-joints around the microcontroller chip IC1101 cured the trouble. **M.M.**

### **Philips VR727**

This machine's threading motor had seized and its drive chip had burnt out. Unfortunately the chip is not listed separately in the manual: you have to replace the capstan drive board. Replacing this and the motor restored normal operation. **M.M.**

### **Ferguson FV62L**

The customer described the symptom as "a vibration on verticals when a tape is being played". The fault was intermittent as well. A call to Ferguson Technical produced the suggestion that IT25 was responsible. Replacing it cleared the trouble. **M.M.**

### **Hitachi VT430**

This machine wouldn't eject tapes. The cause was simply a slack reel drive belt – in the eject mode the belt drives the carriage. A new belt put matters right. **M.M.**

## Panasonic NVM40

Tape playback was marred by a noise bar across the picture, as if the tape path was misadjusted. So this was the first thing we checked, only to find that it was all right. We next found that the PG adjustments had no effect on the head switching point. The cause of this was eventually traced to C6219 (0.027 $\mu$ F), which is connected across the PG adjustment control VR6201. It had gone open-circuit. A replacement capacitor closed the gap in the f.m. waveform. **B.S.**

## Panasonic NVMS50

This oldish S-VHS machine would intermittently power down by itself, usually after working for hours on the soak test bench. The only thing we could do was to carry out a blanket replacement of the TL1453CNS power supply control chip (IC1001) and the 2SB956 transistors Q1001/2/6/7. After doing this we gave the machine a long soak test and declared it fit for return to service. **B.S.**

## JVC AA-V3EK

This is the power supply for the GRAX5. It wouldn't charge, the power LED display being dull and pulsing. On investigation I found that D2 on the primary side of the supply was open-circuit. **G.S.**

## JVC GRS70

This one wouldn't record colour. It's a not uncommon fault, caused by the failure of capacitors in the a.p.c. loop on the hybrid chip. You have to replace the chip. **S.B.**

## JVC GR303

"Playback picture interference, see tape" it said. Yippee! With this one we got a sample tape. We had to clean the clogged flying erase head. **S.B.**

## Sony CCDF340E

The E-E pictures were o.k. but there were no mechanical functions. Failure of the drum to rotate was the basic cause. Investigation brought us to an open-circuit lead-through between the sides of board SS86, specifically between Q053 (drum drive inverter) and Q052 (PWM amplifier).

When we'd restored the drum motor drive another problem showed up: playback was marred by coloured lines that flickered across the screen. The cause of this was C456 (22 $\mu$ F, 16V) which was open-circuit. It decouples pin 1 of IC363 (jog chroma processing) on board VA41. This fault has been reported previously but is now becoming quite common. **D.C.W.**

## Mitsubishi CX1B

When we received this VHS-C camcorder a cassette was stuck in the mechanism and a "no tape" message showed in the viewfinder! No functions worked. Once you've removed the forty or so screws, access to the mechanism is quite good. We then removed the tape by using the Sony mode box to power the loading motor.

The cause of the trouble was damaged parts around the

back-tension lever. Compared with some decks, this part of the mechanism is actually quite complex. The parts that had to be replaced were: spring push 2; set arm S; and lever tension off.

An excellent training tape from Akai covers all you need to know about aligning the mechanism, which is used in the Akai Model PVC20. **D.C.W.**

## Sony CCDV800E

A knocking noise was being recorded on the tape. The cause was a faulty capstan motor bearing. Unfortunately the bearings are not available separately, so a new motor is required. We've had the same problem with other camcorders that use the same mechanism (U and U'), e.g. Canon, Sanyo etc. models. **D.C.W.**

## Sanyo VMD9P

Noise bars on the playback picture is quite a common problem with this model. The effect is of no a.f.t. control. The fault sometimes affects the recorded picture as well, but more often it affects only playback. There seems to have been a batch problem with IC361: a replacement invariably cures the symptom. **D.C.W.**

## JVC GRAX2

The E-E picture was o.k. but there were no mechanical functions. A quick check showed that CP1 (N38) was open-circuit. When this had been replaced the problem appeared to have been cured, with all functions restored, but on test the symptom returned when we pressed the record button. With this model there is a high current demand when the drum motor starts up and is then slowed as the tape wrap occurs. Even when the machine is working normally some 2A (total current) can be measured if the drum is slowed slightly in the record mode. The cause of the trouble turned out to be Q13 (2SB1302-SB) which was leaky. It acts as a switch-mode regulator for the drum 5V MDA supply. **D.C.W.**

## Sanyo VMD3P

Three more capacitors to add to the list of those that should be replaced in this model. First C2009 (33 $\mu$ F) which is connected to pin 9 of the audio chip IC2001. It's in the audio level control circuit, and when faulty the result is continuous maximum audio sensitivity in the record mode. The other two capacitors are C1098 and C1124, which can leak producing a symptom that's identical to failure of one head in playback. The electrolyte leakage causes loss of the drum FF pulses to the head amplifier chip, hence the 'one head only working' symptom. **D.C.W.**

## Canon E200E

The problem was lack of playback audio – the E-E and recorded sound were both o.k. Only a rough, rasping sound could be heard during playback. The culprit turned out to be the LA7454W a.f.m. demodulator etc. chip IC802, which is on the A-V out sub PCB. After fitting a replacement the relevant controls (deviation etc.) have to be set up as laid down in the manual. **D.C.W.**

# Toshiba's V3 Series VCRs

The V3 series deck has a third fewer parts than its predecessor while the VCRs have user-friendly features and improved performance.

Philip Blundell looks at some of the technology used

The V3 range of VCRs is produced at the International Video Product (IVP) factory, which is jointly owned by Toshiba and Thomson, in Singapore. The designers of the V3 range set out to make the machines easy to use, with the features people really want, and to have better performance than the previous range. The mechanism has a faster winding speed and a third fewer parts than the previous deck. The current V3 range is as follows:

**V204B** with two video heads, mono sound and standard-play speed.

**V254B** with two video heads, mono sound and standard/long play.



**V404B** with four video heads, mono sound and standard/long play.

**V454B** with four video heads, mono sound and standard/long play.

**V804B** with four video heads, two hi-fi sound heads, standard/long play, Nicam sound and jog shuttle control.

**V854B** with four video heads, hi-fi sound heads, a flying erase head, standard/long play, PDC, Nicam sound and jog shuttle control.

## Features

All models have Video Plus programming, on-screen programming and on-screen error messages for the seven most common operator errors. These include trying to record on a

Fig. 1: Simplified circuit of the power supply used in mono sound models.

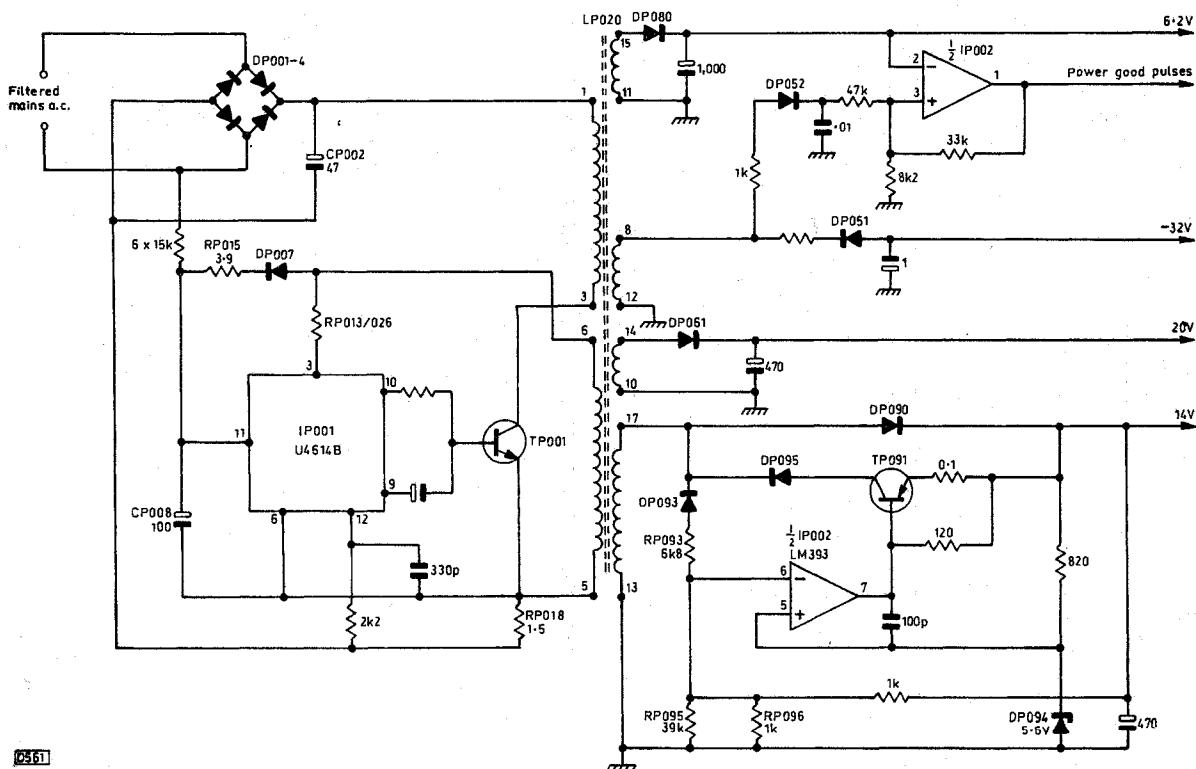

0561

cassette with the safety tab removed, mistakes in setting up for a timed recording, trying to change channels while a recording is in progress and setting the timer without a cassette inserted.

The VCRs in the V3 range use the new PRO head drum. With mono sound models the head preamplifier is fitted in the lower drum. In hi-fi sound models a flying preamplifier is fitted in the upper drum. More about this later.

All two-speed models have Auto Speed Adjust – this means that the machine switches to the LP mode automatically if the timer is set to SP but the event is too long to fit on the tape available.

If a wide-screen (16:9 aspect ratio) programme is recorded, this is identified by the changed duty cycle of the pulses on the control track. A change in the start status voltage occurs, enabling a suitable TV set to switch to the 16:9 mode.

All models have a satellite monitor facility: when the sat moni button on the remote control handset is pressed the AV signal is looped between the two video scart sockets, even when the VCR is in standby.

Those who wish to feed the aerial signal on to other rooms will be glad

to know that the aerial mixer can be switched to on or off during play as required. The u.h.f. modulator's output can be tuned from ch. 53 to ch. 67.

All models have satellite receiver control. This enables the VCR to change the satellite receiver's channel when a timed satellite recording is made. For this purpose an infra-red LED is fitted towards the top of the machine, in the display window, to transmit channel commands to the satellite receiver. Most satellite receivers will have to be brought out of standby for this feature to work. An LED pyramid on a short cable can be obtained from Toshiba to avoid problems where the signal might be obscured by a shelf. It plugs into a jack socket on the front panel. Not all satellite brands or models can be controlled however.

Depending on the model, one of three remote control handsets may be supplied. These are as follows:

- (1) A basic (normal) remote control unit.
- (2) A multi-brand remote control unit. This enables the basic adjustments to be carried out with a number of TV brands. In addition, by routing the command signal through the VCR a

satellite receiver's channel can be changed – subject to the qualification already noted.

(3) A CS (Customer Satisfaction) remote control unit. This can also be used for basic TV set adjustments. If the set is controllable, linked functions are possible: for example, if you press the handset's programming screen button the TV will switch out of standby and the VCR will come on showing the VideoPlus screen.

Hi-fi models have front audio sockets and allow audio dubbing on the mono (longitudinal) sound track.

As long as the TV set can cope with a 60Hz field frequency, the current models will play NTSC 4-43 and 3-56MHz NTSC tapes of the correct speed format – extended play tapes won't play back via a PAL TV set.

## **Power Supplies**

There are different power supply circuits in the mono sound and hi-fi sound models. Fig. 1 shows in simplified form the power supply used in Models V204B, V254B, V404B and V454B. There are two chips, a U4614B (IP001) for chopper transistor control on the primary side and an LM393 dual voltage comparator (IP002) on the

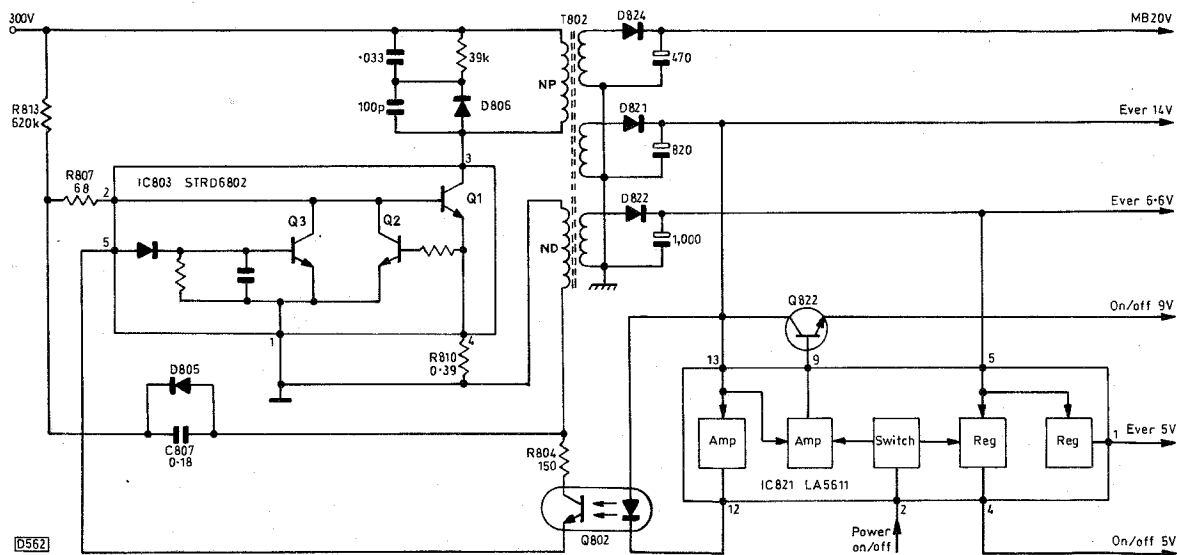

**Fig. 2: Simplified circuit of the power supply used in hi-fi sound models.**

secondary side. One of the comparators provides a 'power good' pulse signal which is fed to the microcontroller chip. The other comparator forms part of the voltage control system. This is rather unusual – see the circuit description below.

The outputs obtained on the secondary side of the chopper transformer LP020 (not all are shown in Fig. 1) are as follows:

- (1) A fluorescent display filament supply from rectifier DP041.
- (2) A 20V motor supply from rectifier DP061.

(3) A 33V varicap tuner tuning supply from rectifier DP071.

(4) A -32V fluorescent display cathode bias supply from rectifier DP051.

(5) A pulse input for the LM393 comparator that produces the 'power good' pulses for the microcontroller chip. The input pulses arrive via diode DP052.

(6) A 6.2V supply from rectifier diode DP080 for the servo/logic board. This supply becomes 5V. The 6.2V supply is also the second input to the LM393 comparator that produces the power-good pulses.

(7) The main 14V supply, which is derived from rectifier diode DP090.

At switch on the six series-connected 15kΩ resistors feed a start-up voltage to pin 11 of IP001. The chip begins to oscillate at approximately 30kHz, delivering base drive to the chopper transistor TP001 from pins 9 and 10. When running, IP001 produces a 3.5V reference voltage at pin 5.

The chopper transistor's emitter current flows through RP018 (1.5Ω), the voltage developed across this resistor appearing between pins 12 and 6 of IP001. Should TP001's emitter current exceed 0.4A, IP001 will cease to produce a drive output for TP001.

Voltage control is centred on one comparator section of IP002 and transistor TP091 on the secondary side of the circuit. The principle is to pass a current pulse, whose amplitude is directly proportional to the voltage on the 14V line, back to the primary side of the circuit via the transformer.

Pin 5 of IP002 is held at 5.6V by zener diode DP094. Negative-going pulses are fed to the comparator's other, non-inverting input, at pin 6, via diode D093. The pulse output produced at pin 7 drives the base of the pnp transistor TP091, which in turn feeds pulses to pin 17 of the transformer via DP095. The amplitude of these pulses is determined by the bias at TP091's emitter, which is connected to the 14V supply. The current pulses in the transformer are stepped up by the turns ratio of winding 13/17 to 5/6 and are fed back to pin 3 of IP001 via RP013/RP026 to control the on/off time of TP001.

During normal running the voltage at pin 11 of IP001, produced by the rectifier circuit DP007/CP008, is 9.4V.

## The PRO Drum

This range of models uses two types of PRO video drum. Both have the head amplifier fitted inside the drum: putting it there improves the signal-to-noise ratio and reduces the crosstalk. Mono sound models have the preamplifier in the lower drum, the drum assembly being available only as a complete unit.

With hi-fi models the preamplifier is in the upper drum, which introduces the problem of how to get power and switching signals to a rotating mechanism. Power is supplied via a slip ring, while the r.f. switching signals are passed via the hi-fi transformer to the preamplifier section. An envelope comparator is contained in the preamplifier. During trick-mode playback, i.e. search or still, this produces either a high or a low voltage depending on which head (LP or SP) has the greatest output. This information is passed back via the rotary transformer as the 1.2MHz envelope comparator signal, then acted on by changing the r.f. switching signal. The r.f. switching signal is a composite one with both amplitude and frequency modulation. The timing of the head switching signal is critical: to minimise any switching noise, it occurs during the line flyback.

The frequencies used for r.f. switching (see Fig. 3) are between 9.4MHz and 11.4MHz. These are sufficiently high to avoid crosstalk with the video f.m. signal. Similarly the 1.2MHz envelope comparator signal falls between the 627kHz chroma signal and the 1.4MHz and 1.8MHz hi-fi audio carriers.

In the still mode, if the tape stops on a ch. 1 track the heads will repeatedly scan the same track. To give the smallest noise band on the picture, the switching signal selects the SP and LP ch. 1 heads alternately.

For normal play the LP/SP switching will stay in one state depending on the speed.

In the search mode the LP/SP switching signal changes state at the same rate as the heads cross the tracks, thus maximising the output at all times.

To optimise the LP picture quality the video heads are narrower than usual (24µm).

**Fig. 3: V3 series head switching waveforms and carrier frequencies (a), frequency spectrum for the various signals (b).**

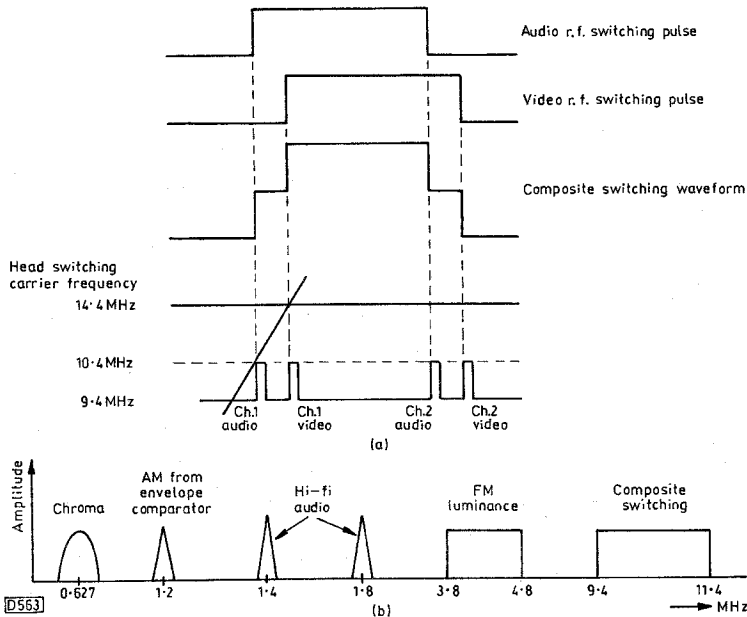

**Fig. 4: A typical error display.**

OF E03 OF

**Fig. 4: A typical error display.**

It will be higher if the chip is in the over-voltage mode.

Fig. 2 shows in simplified form the power supply used in Models V804B and V854B. It's based on an STRD6802 chopper chip, with regulation from the secondary side of the circuit via optocoupler Q802. The LA5611 chip IC821 on the secondary side of the circuit senses the chopper circuit's output voltages, drives the optocoupler and generates the ever 5V and other supplies. A d.c.-to-d.c. converter that takes its feed from the ever 6.6V supply generates filament and cathode bias supplies for the fluorescent display, also the tuning voltage.

The secondary side supplies (not all shown) are as follows:

(1) Ever 14V from rectifier diode D821. IC821 generates the on/off 12V, on/off 9V, on/off 5V and ever 5V supplies from the ever 14V line.

(2) 20V from D824 for the drum, loading and capstan motors.

(3) Ever 6.6V, from D822, to feed the d.c.-d.c. converter.

(4) On/off 12V from Q823 for the tuner, i.f. and Nicam circuits. This source also provides the fluorescent display heater supply.

The primary side circuit acts as a blocking oscillator. At switch on Q1 is turned on by the bias provided by resistors R813 and R807. Current flows via winding NP on the chopper transformer, with feedback to the base of Q1 from winding ND so that Q1 rapidly saturates. The voltage across winding ND then reverses, switching Q1 off for a period that depends on the charge on C807. When this capacitor has discharged sufficiently, Q1 turns on again. The conditions at the base of Q1 and thus the discharge of C807 are determined by Q3 under the control of Q802 and IC821. Two zener diodes D807/8 (not shown) connected across winding ND limit Q1's drive waveform, keeping the drive constant irrespective of mains input voltage variations.

This is a variable-frequency power supply. When the load is light, the chopper transistor conducts only briefly and the oscillation frequency is high - it's 160kHz in standby. When the load is heavier, the chopper transistor conducts for longer periods. In normal operation the oscillation frequency is 75kHz. IC821 monitors the 14V supply, in turn controlling Q802. When the phototransistor in Q802 conducts more heavily, the voltage at the base of

Q3 is increased and C807 discharges more rapidly.

Q1's emitter current flows via R810 (0.39Ω). The voltage across this resistor is monitored by Q2. If it reaches 0.6V Q2 switches on, removing the chopper drive. Thus in the event of a fault condition Q1's on time is limited.

### Self-diagnosis

If the VCR has a mechanical problem that results in the machine shutting down, a code is stored in the EEPROM. This code can be recalled and displayed by putting the machine into the self-diagnosis mode.

To recall the error message, press the VCR's ch. up and ch. down buttons simultaneously, holding them down for five seconds or more. Then, within two seconds, press the remote control unit's still button. The front display will then show the error message.

Fig. 4 shows an error display. The first two digits/letters show the mode in which the fault occurred, the code being as follows:

00	standby
01	stop
02	rewind
03	review
04	fast forward
05	cue
06	playback
07	still/slow playback
08	x2 playback
09	stop - dew (moisture) sensed
0A	reverse playback
0B	still/slow reverse playback
0C	recording
0D	record pause
0E	power-off eject
0F	eject
10	short FF
11	short rewind

13	audio dub
14	audio dub pause

The middle section shows the error found, as follows:

E01	drum stopped
E02	take-up reel stopped
E03	supply reel stopped
E04	cassette load/unload fault
E05	tape threading fault

The final two digits/letters indicate the mechanism position error:

00	front loading in progress
01	front loading out
02	front loading in progress
03	front loading down
04	tape lacing
05	tape lacing
07	reverse rotation with pinch roller on
08	between playback and review
09	playback with pinch roller on
0B	stop with main brake on
0D	fast forward/rewind
0F	position detection not possible

The error message must be erased after the repair. Press the counter reset button while the VCR is displaying the self-diagnosis message: the display will then show '-'. ■

### Acknowledgement

I would like to thank the Training Department of Toshiba UK for help in the preparation of this article.

# Camcorner

## A selection of recent camcorder servicing problems

### Panasonic NVS20

A 'whining' noise was being recorded on the sound. The cure was to clean and lubricate the drum earthing brush. This is a common problem, once encountered with early JVC designs. **D.C.W.**

### Sanyo VAR30B Adaptor

This unit charged batteries very slowly – it took about four hours for a normal one and a half hour type – and would power a camcorder for only a short time before ceasing to operate. We found that the value of R201 had increased from 0.1Ω to 0.3Ω! It's in the excess current detect circuit on the secondary side of the supply. A check on this resistor is worthwhile whenever one of these units comes in for repair. **D.C.W.**

### Sharp VLC790H

The 5V regulator transistor Q920 in the power supply had failed. As a result there were no E-E or viewfinder pictures. The cause of the failure was C011 (220μF, 6.3V) on the EVF PCB. It had leaked and carbonised the area between its wire connections – no, it's not a can type this time! The effect was to place a near short-circuit across the 5V rail. We were able to revive the unit by scraping the affected area, giving it a general clean up and replacing the failed components. **D.C.W.**

### Chinnon VCI500

The viewfinder had fallen off, which is normal with one of these camcorders! We were also asked to check the batteries and the adaptor, as only a short (fifteen-minute) recording could be made before 'BATT' showed in the viewfinder. The unit worked all right when powered via the adaptor. Further checks then showed that the battery down adjustment (R1001) had been set incorrectly. As no fault could be found in this area, we set the unit up as specified in the manual and gave it a long soak test. It seemed to be

perfectly satisfactory – but don't these machines make a noise when loading and unloading! **D.C.W.**

### Panasonic NVMC20

Incorrect capstan control was the problem here. The capstan speed was about right, but the phase wasn't being controlled correctly. Because of this a noise bar rolled through the picture slowly, at a consistent rate. After much testing and probing we found that the voltages around the AN3798NS chip IC2003 were incorrect. Replacing this chip restored accurate capstan control. **B.S.**

### Panasonic NVMI

The camera picture colours produced by this vintage camcorder were incorrect – blue and red predominated. The tube was still o.k., the culprit eventually being identified as IC401 (AN2431LF) in the colour-difference signal processing circuitry. After replacing this item we adjusted the electronic focusing and the beam current. The outcome was a very acceptable picture. **B.S.**

### Panasonic NVS90

There was no playback picture, though recordings were fine. No playback luminance was the basic problem. Checks around the hybrid luminance chip IC3001 showed that the playback luminance signal was o.k. as far as pin 42, where it leaves via buffer transistor Q3014 to go to the timebase corrector (TBC). On its return it should appear at pin 2 of IC3001. It didn't.

Checks in the TBC circuit showed that everything was fine as far as the output pin (36) of the chip (IC3501). The luminance signal then passes to discrete-component amplifying stages, where it was being lost at Q3511. This transistor's d.c. base voltage was high, upsetting its operation. Further checks brought us to pin 2 of the sync reinsertion chip IC3504, where the voltage was also incorrect, in turn because of the loss of the composite sync input at

pin 4. The pulses were being lost farther back in the circuit, at the 120pF chip capacitor C3562 which was cracked. It's on the back of the main PCB – the side that faces the back of the mechanism. **N.B.**

### Canon A2HiE

Hi8 recordings were marred by phenomenal amounts of dropouts and over-modulation. I wondered whether the fault had occurred suddenly or developed over a period of time. The problem was not present when the machine was used for low-band V8 recording. Obviously such a fault will show first with hi-band recordings, but what a difference! The cause of the problem was the heads, which are Sony DGR62s. If you have a Sony account, you'll probably find that a cheaper source. **N.B.**

### Canon E50E

Playback was o.k. but there was no camera E-E picture. Once again the cause was traced to a leaky electrolytic, this time C2651 (47μF) on the camera process PCB. It had leaked over a print run that connects the CAM ON L signal to the PWR ON pin of the camera d.c.-d.c. converter. This meant that the pin was permanently high, thus no E-E picture. A link had to be fitted as the print had been almost completely corroded away.

At switch on we were surprised to find that we still had no E-E picture, though a healthy burst signal was now present. This time we found that the iris remained closed. Gentle movement of the iris mechanism revealed that the camera circuits worked in general, but when the mechanism was released the iris closed automatically. After a long search in the iris drive circuitry we found that the 0.047μF chip capacitor C2224 on the SUB PCB was open-circuit. It appears to act as a reservoir for the iris drive circuit. After replacing it we at last had a good picture. **D.C.W.** ■

*Reports from*  
**David C.**  
**Woodnott**  
**Brian Storm**  
**Nick Beer**



# VCRCLINIC

## Reports from

Eugene Trundle

Philip Blundell

Gerald Smith

David Belmont

Bob McClenning

V.W. Cox

Brian Storm

John Pitt-Francis

Glyn Dickinson

Christopher Nunn

Chris Watton

Nigel Burton

E.J. Edwards

Michael Maurice

John Edwards

## Ferguson FV77

The cause of the problem took us a long time to track down, the fault being very intermittent. When it did appear the machine wouldn't perform any deck functions, even eject, though the clock, E-E operation and channel selection were all o.k. If one was requested, the machine would present a flashing cassette symbol for a few seconds then go back to sleep. The culprit was the cassette-down (FL) switch ST71, which was noisy and sometimes failed to make contact at all. E.T.

## Mitsubishi HSB12

Failure to wind or rewind the tape can be caused by the machine trying to operate through the reel-drive clutch, slide-bar B having failed to latch. We've never had the fault stay long enough to be able to confirm a diagnosis, but have found that replacing the latch magnet coil (part no. 299P124010) and its driver transistor Q5B5 has, along with a check on their interconnections, provided a cure. E.T.

## Toshiba V110/210

Intermittent loss of playback capstan servo lock was the problem here. We thought that a replacement ACE head had cured the fault but the machine bounced. Further tests showed that the pulses at pin 6 of the U2561B FG/CTL control pulse amplifier chip IT18 were very weak and noisy. In fact the chip itself was the culprit, as repeated attacks on it with a freezer aerosol and a hairdryer proved. E.T.

## Toshiba V423

This machine lives in a house where all the residents smoke like chimneys – the contents of the living room are all nicotine brown, especially the TV set and the VCR. The complaint was that the picture had a horizontal shift which was worse in the record mode. Expecting a sticky guide roller, I marked them all with a fine felt-tip pen. Sure enough the no. 1 guide was

not turning smoothly. A new one improved matters, but the problem was still present.

I pressed pause while playing a known good tape. The shift could be seen. A drum servo problem? All was revealed when the bottom PCB was removed. The drum PG/FG photo-sensor was contaminated while the plastic interrupter blades were caked with fluff. Cleaning the optical faces with a cotton bud soaked in foam cleaner and removing the fluff from the interrupter restored the picture stability. P.B.

## Toshiba V703

Playback was o.k. but there was no E-E picture and no baseband video from the scart sockets. The on-screen graphics and the E-E sound were o.k. Scope checks along the video path showed that the signal was present at pin 8 of ICF01 on the terminal board and TP201 but not at TP203. A visual check revealed a crack in the print to pin 1 of plug 201 on the mother-board. P.B.

## Panasonic NVJ47

There was a colour phase fault with playback, which would intermittently become black and white. It looked like a delay line fault, but the cause was IC302. G.S.

## Sanyo VHR274

The playback picture had lines on it, because the drum to capstan sync drifted off cyclically. IC351 was the cause of the fault. G.S.

## Panasonic NVFS1

There was intermittent colour with this machine's recordings. We found the cause to be dry-joints around the luminance/chroma pack, at pin 34 in particular. G.S.

## Nokia VR3615

This machine worked but the power supply buzzed and ran hot. We found that the voltages on the secondary side of the power supply were too

high, and the over-voltage protection diodes were conductive. The cause of the problem was D804, which was short-circuit. G.S.

## Nokia VR3615

Rewind and fast forward were intermittent, and when eject was operated the machine would sometimes leave the tape hanging out. A replacement mode state assembly cured the problem. G.S.

## Finlux VR3400

Distorted Nicam stereo sound was the problem with this machine. Checks revealed that one channel was over-modulated at the input to IC1808. The cause was the TDA1543 DA converter chip IC1803. G.S.

## Nokia VR3615

There were hum bars and the E-E picture was too bright (playback was normal). I found dry-joints at various components in the i.f. unit, i.e. Q102, Q101, Z103, Z102 and L104. After resoldering these the machine performed correctly. G.S.

## Akura VX140

This machine would intermittently leave tape out on eject or not play or record, with the mechanism over-loading and the loading belt slipping. A faulty mode switch was the cause of all these symptoms. G.S.

## Panasonic NVSD30

Intermittent tape damage was the complaint. There was also a clicking noise between modes. On close examination I found that the slide cam was damaged. As a precaution I replaced the mode switch as well. G.S.

## Samsung VIK306

There was no playback picture, with the drum rotating at excessive speed. The drum FG and PG pulses were present but too fast. When the drum drive from pin 7 of IC201 was checked it was found to be too high, at a full 5V, and didn't vary when the

drum was cleaned by hand. Replacing IC201 cured the fault. **G.S.**

### Sharp VCA55HM

This machine was totally dead. The cause turned out to be R905 in the power supply. **D.B.**

### ITT VR3938

There was a waving pattern on the E-E and playback pictures – it looked as if waves were moving from right to left on the screen. Quite pretty, really! The cause was C3 in the power supply. **B.McC.**

### Panasonic NV333

A thick hum bar appeared when play or record was pressed. The cause was failure of one of the diodes in the bridge rectifier circuit that provides the 15V motor supply. **V.W.C.**

### Panasonic NVSD30

There was a problem in the cue mode: any attempt to cue forward resulted in loss of line lock because the drum speed changed incorrectly. Checks in the system control circuit showed that IC6001 was changing to the NTSC default condition, despite this machine not being fully equipped for NTSC playback.

The cause of the problem was poor head-to-tape contact. Further checks showed that the performance in the review mode was very poor, the top half of the picture being covered with noise. A badly worn and very shiny pressure roller confirmed the diagnosis. The drum was badly worn: because of the relative newness of the machine this was something we hadn't considered initially. **B.S.**

### Toshiba V309

This machine would stop during playback or record, after anything from twenty minutes to two hours. The cause was high reel motor drain current, though the motor provided very fast rewind and wasn't particularly noisy. A new motor cleared the fault, which can also occur with the **V109** and **V209**. **J.P-F.**

### Ferguson 3V35/JVC HRD120

The tuning department wouldn't light up: in fact this VCR behaved as if it was in the camera mode, though the camera/tuner switch was o.k. Replacing the HD552 088C chip put matters right. **J.P-F.**

### Grundig VS500

This VCR produced the dead machine symptom initially, with very low voltages at the secondary side of the

chopper transformer. Over the course of half an hour however the voltages gradually increased, creating a chatter from the deck solenoid and eventually normal operation. The cause of all this was C1409 (33µF) in the primary side of the chopper circuit. It had gone low in value. The replacement must be a 105° type. **J.P-F.**

### JVC HRD540

There was a severe tracking error with this machine – about four tracking bars were present towards the top of the screen. On investigation we found that the left-hand guide pole didn't engage with the end stop. A thorough check for a foreign body, i.e. something that might have caused the problem by blocking its path, was carried out. As we couldn't find anything we came to the conclusion that pole was just a bit too loose, snagging before it entered the end stop. The cause of this was stopper 2 (item 17). Because it was a poor fit, it had worked loose. A replacement (part number PQ43525) cured the problem.

An improved pole kit is available to deal with severe cases – part numbers PTU96102E (supply) and PTU96103E (take-up). **J.P-F.**

### Sharp VCA105

The mode switch and master cam assembly cause various problems with this model. The suspect cam is black, replacements being white. Unlike earlier models, replacement is not too difficult. To confuse matters, a modified assembly was introduced after serial number 659812 and in later models that have a mode switch with a yellow centre. These require a different cam and switch. They are not interchangeable. **G.D.**

### Samsung SI3260

Rewind and fast forward were both o.k., but in play and record there was no capstan drive. A check on the 12V feed to the capstan motor in play, at pin 15 of CN201, produced a reading of only 2-3V. Replacing L201 and D110 (1N4001) cured the fault. **C.N.**

### GoldStar RQ5041

There was no drum rotation. It was soon apparent that the motor was faulty, as the chip on the motor PCB had a hole in it. This is the second faulty motor we've had in these comparatively new machines. When the cause of the fault is not as obvious as in this case, the important motor connector pins to check are 4 earth, 5 always 12V and 6 where the control voltage should be present. When this reaches 1V the motor should be

turning. The other pins are for the PG and FG pulses, playing no part in starting the motor. Pin 1 of the connector is identifiable by the black wire. The part no. for the lower drum/motor assembly is 413-220A. **C.W.**

### Samsung SI3260

The E-E signal produced by this machine consisted of the blue mute raster. It refused to tune in any stations. A check at the collector of Q401, which supplies the tuner's VT (voltage tuning) pin, produced a reading of zero volts. There was no 33V feed because D105 (1N4001) was open-circuit. **C.N.**

### Philips VR6462

There was no sound in any mode. The cause was traced to C2007 (330µF, 16V) on the audio panel. We've had a number of these blue Philips capacitors on the audio panel fail, causing a number of symptoms. They usually go dead short, so a faulty one is not too hard to find. **C.W.**

### Hitachi VT220

This machine was almost dead, with no clock and no deck functions. But the power supply voltages were all present at the output connector. Circuit protector IC405 (N5) was open-circuit. It's not easy to find, as it hides close to the side of PG604. There was no apparent cause for its failure, and the machine worked perfectly after fitting a replacement. **C.W.**

### Amstrad VCR6000

The loading belt is suspect if the machine goes to standby when a tape function is selected. Often however the control cam's brush assembly is the cause. This fits into the cam. When fitting a replacement, clean the static part of the mode switch and smear a small amount of silicone grease on it.

Another fault you get with these machines is failure to rewind or wind fast forward because the trigger lever sticks. This has been a common problem for several years, and has been mentioned before in these pages. The cause is the rubber damper which becomes soggy with age (like Hitachi drive belts), preventing the trigger from going far enough.

The CPC part no. for the brush is AM153114 and for the damper AM153091. **C.W.**

### Hitachi VT150

There were no playback or E-E pictures, though the sound was o.k. On several occasions we've found

that the cause has been the HT4757 chip IC203 on the YC subpanel. So we carried out a check at pin 1 in the E-E mode. The scope displayed a nice composite video signal, but there was no output at pin 27. Before replacing this very expensive chip I checked for 5V at pin 6. The reading here was 0V. Checks in the power supply revealed that there was no 5V output at pin 1 of the STK5476 multi-regulator chip IC881. Replacing this item cleared the playback and E-E mode faults. **C.W.**

### **Samsung VI710**

Playback was in monochrome only and there was no vision in the E-E mode. Power supply checks showed that there was no supply to the three-pin regulator fixed to the lower drum assembly. The cause was the 2Ω safety resistor FR02 being open-circuit. No cause for its failure could be found. **C.W.**

### **Panasonic NV430**

The E-E picture was o.k. but there was no colour at the top and bottom of the playback picture. After initially suspecting a fault in the chroma circuitry we turned our attention to the electrolytics in the power supply. Replacing C1001-C1004 and C1101-C1104 cured the fault. **N.Bu.**

### **Panasonic NV870 (DI Deck)**

When review was selected this machine would sometimes unlace, with the play symbol appearing in the display. Then, after realising its mistake, the machine would lace up again, usually successfully but sometimes with tape chewing. Replacing the mode switch cured the fault. **N.Bu.**

### **Hitachi VT11/13**

There was no playback picture though E-E operation was o.k. We traced the cause of the fault to Q905, a replacement restoring the picture. **E.J.E.**

### **Panasonic NV366**

There was no rewind and only 2V at the motor plug. The cause of the fault was traced to Q6022, a replacement putting matters right. **E.J.E.**

### **Philips VR6362**

The original complaint with this machine was of sound warble. When it arrived on my bench it would eject the tape whenever a deck function was selected. Now before it will allow any functions, the microcontroller chip requires sample capstan FG pulses. When a tape is inserted, the

capstan does a shuffle for about half a second. In this machine the capstan turned for about five seconds.

The capstan FG pulses are picked up by a tacho coil that's mounted close to the capstan flywheel. They are amplified by the tacho amplifier, which is mounted under the sub-plate. It receives an 11V supply that's derived from the +13a rail via a 1kΩ resistor with a 47μF, 16V decoupling capacitor, C2206. This last item was short-circuit. When a replacement had been fitted we had some FG pulses, but they were too low in amplitude for the micro to recognise them. After replacing the tacho amplifier PCB and the tacho head the machine worked normally – with no trace of any sound warble. **M.M.**

### **Sony SLVE25UY**

Tape chewing was the complaint with this machine. On investigation I found that the exit guide had parted company with the load arm. Refitting this guide provided a complete cure. **M.M.**

### **Matsui VP9401**

The customer's complaints were of failure to load a tape and a burning smell. A previous engineer had diagnosed "incorrect data from IC1001": he obviously hadn't noticed the large hole in the loading motor drive chip. Replacing this item cured the trouble. **M.M.**

### **Akai VS485**

This machine would very intermittently leave a loop of tape hanging out when the cassette was ejected. The cause was the capstan motor, which wasn't turning freely. A replacement motor cured the fault. **M.M.**

### **Ferguson FV42**

Intermittent cutting out was the reported fault with this machine. On test we found that there was no mechanical fault. When playback was selected however the tape laced up and the play symbol appeared in the display but the machine stayed in the E-E mode. The PB12V supply is derived from pin 4 of the MC14094 chip IW27, via a couple of transistors. There was no voltage at pin 4 of IW27, so we swapped it over with IW18. This restored the playback signals. Replacing IW18 and IW27 cured the trouble. **M.M.**

### **Amstrad UF20**

This machine wouldn't play pre-recorded tapes. Playback of its own SP recordings was o.k., but LP recordings were unwatchable. The upper drum had already been replaced

without producing any improvement. Replacing the lower drum cured the fault. **M.M.**

### **Sony SLV373**

The customer complained about intermittent tape chewing. He provided three samples that showed they were looping on eject. The cause was the capstan motor, whose base plate had warped. A new motor solved the problem. I understand that Sony is aware of this problem and that replacement base parts are available. **M.M.**

### **Hitachi VTM930**

An intermittent buzzing noise, especially when the machine was hot, was the complaint with this machine. The mains transformer proved to be the culprit, a replacement ensuring silent operation. **M.M.**

### **NEC PX1200K**

Playback was o.k., but if a timed or a manual recording was attempted "error" would be displayed followed by either tape eject and/or the machine going into the standby mode. The anti-record inhibit switch mounted on the carriage had come adrift. Its plastic support legs were weak but not broken, so a drop of modelling glue provided the answer to the problem. **J.E.**

### **Hitachi VT120**

This machine wouldn't record or play back in colour. The playback picture also had what can best be described as an "orange peel" effect which was more noticeable in light grey to white areas. In addition white flaring occurred when the picture contained sudden light to dark areas, this symptom being more pronounced when the sharpness control setting was advanced. Slight finger pressure on the HT4539 hybrid decoder module would restore normal colour for an indefinite period. We wasted a lot of time soldering in the area around the module and the module's pins, but in the end it was a new module that restored the colour. The part is available from Charles Hyde but is expensive, the trade price at the time of the fault being nearly £40. **J.E.**

### **Mitsubishi HSM59**

Slow rewind and eject was the customer's complaint. When we turned the machine upside down and removed the bottom cover to inspect the mechanism the plastic capstan belt pulley fell on to the bench. After fitting a new pulley (Mitsubishi part no. 999D126010) the machine worked normally. **J.E.**

# Camcorner

Reports from  
David C. Woodnott

## Sony EVS550

The complaint was no mechanical operation. In fact loading was partially o.k., but the take-up coaster assembly was detached from its linkage. After dismantling the unit to reach the assembly we refitted the coaster, using Loctite to replace the linkage pin which had fallen out. **D.C.W.**

## Sony CCDF500

This F series unit had no mechanical functions and there was no EVF picture. The E-E pictures were o.k. The cause of these problems was a chafed EVF connecting cable, which had shorted the supply rail to the earthed metal bracket. As a result PS990 (1-6A) on the power supply PCB (PA-24P) had failed.

Unfortunately the EVF connecting lead is only available with a new EVF PCB (VS41). Rather a high price to pay for a damaged lead! It was not possible to repair the lead as this had been done before. We got round the problem by fitting a lead from a scrap EVF. The customer was happy to accept the lower cost! **D.C.W.**

## JVC GRAX2

The symptoms were confusing to say the least. When a battery was connected the PWR ON LED lit, as usual, but then stayed on despite operation of the on/off button. Everything appeared to be o.k. in the playback mode, but when the machine was switched to the camera mode a picture with noise lines that moved around in the background was displayed. If the record trigger was pressed, the noise lines would disappear and recording would continue normally. But playback of the recording would be marred by

incorrect drum speed (no servo lock). The main d.c.-d.c. converter was the cause of these diverse symptoms. It provides several outputs, including switched 8V and 5V supplies. The latter was permanently on and not regulated (it would read about 5V with a 6V battery connected, rising to 8V or so when the camcorder was run from an adaptor or power supply). A replacement converter restored normal operation. We've since had another GRAX2 with a similar d.c.-d.c. converter problem. **D.C.W.**

## Sanyo VMD6P

This camcorder would power up then do nothing. On inspection we found that another party had had a go and had fitted connector CN312 on the SYSCON 2 PCB incorrectly. CN312 is a two-pin plug that connects the trigger switch to the syscon circuit's key-scan matrix. By reversing the plug CN312's live pin was effectively earthed, thus locking up the micro-controller chip. Remember the effect – it might happen to you! **D.C.W.**

## Panasonic NVR50B

No mechanical functions and shut down was the problem with this machine. The cause was a detached pinch roller assembly. The roller arm is, on earlier models, made of plastic and can break off. A replacement restored normal operation. **D.C.W.**

## Sharp VLC6400E

This camcorder produced distorted pictures, with the white areas of the picture crushed and loss of sync. There was also pulling of the highlights and rolling, in both the E-E and playback

modes. As the chroma signal seemed to be o.k. we investigated the luminance signal path. As usual, the signal processing circuitry is largely common to both record and playback operation, IC201 being at the heart of things.

Various capacitors that we felt might be suspect were replaced, to no avail. After a lot more checking we decided that IC201 itself was probably the cause of the trouble. So a replacement was ordered. When it arrived we found that instead of a single i.c. there was a kit of parts: it consisted of a replacement i.c. (not the original type, which is no longer available) and about twenty chip components that had to be fitted to enable the new i.c. to function. Who estimated for this one?! To be fair to Sharp the kit was well marked, with each component individually bagged and a circuit diagram showing the modifications required. Unfortunately there was no PCB layout.

Thoughts about the likely time required to fit this little lot led us to make some further checks in case the chip wasn't the cause of the trouble. In the event we didn't have to replace the i.c. The cause of the fault was C211 (8,200pF) which was open-circuit. It acts as a reservoir capacitor in the composite sync separator stage, being connected to pin 4 of IC201. **D.C.W.**

## Sony CCDTR50

The electronic viewfinder display consisted of a blank white raster, all other functions being o.k. The cause of the trouble was on board VF41, where C965 (2.2µF, 35V) was open-circuit. **D.C.W.**

## JVC GRAX7

No pictures were being recorded, though the E-E pictures and playback of prerecorded tapes were fine. The sound was also o.k. We found that the REC 8V supply was not being switched by Q524 because R599 (1.5kΩ) was open-circuit. **D.C.W.**

## Canon E640E

There was no viewfinder picture. We found that C2931 (47µF) and C2933 (100µF) had failed. They are both 16V can type electrolytics. **D.C.W.**

## Sony CCDTR805

There was a rather worrying symptom in the E-E mode: the screen was covered with white spots (CCD failure?). Over the course of a minute or so however the spots would gradually disappear, leaving a normal picture. Playback and all other functions were o.k. If the machine was switched off then on again, the spots would reappear.

When a bench power supply was used instead of a battery the symptom was slightly different: any adjustment of the supply voltage around 6V either increased or decreased the picture's 'spottiness' and the length of time the spots remained. This led us to the power supply PCB, where the MC4600FU switch-mode drive chip IC231 was failing to regulate its output and produced severe hash on the camera supplies – hence the variable white spots. A replacement chip and power supply set up cured the trouble. **D.C.W.**

# VCR CLINIC

**Reports from**  
**Philip Blundell**  
**Chris Watton**  
**Nick Beer**  
**Stephen**  
**Leatherbarrow**  
**Eugene Trundle**  
**Gerald Smith**  
**Ronnie Boag**  
**Richard Newman**  
**John Edwards**  
**Michael Maurice**

## Ferguson FV72

If the machine takes in a tape but the threading poles move only slightly then stop, suspect that the main cam has lost a tooth. The Ferguson part number is 20086520. **P.B.**

## Grundig VS340

For intermittent or complete loss of the control track signals, check for dry-joints where the cables connect to the audio/control/erase head. **P.B.**

## Mitsubishi HSB12

There was no play, and no counting in the fast-wind modes. A look at the deck showed that the tape wasn't being loaded correctly: the half-loading arm was jammed by the soft-brake arm on the take-up side, and as a result didn't take the tape around the audio/control head – hence no counter. The pad on the end of the soft-brake arm had fallen off, leaving the arm in the wrong place all the time. As the arm was o.k. and the pad was lying by the take-up reel disc we decided to stick it back on. The machine then worked perfectly. **C.W.**

## Amstrad TVR3

The strange report with this VCR/TV set combination read "plays films in green though the TV pictures are all right". Sure enough, this was so. After some contemplation we decided to replace HIC101 (1812421), which restored normal colour in all modes. The CPC part code is AM152030. **C.W.**

## Ferguson FV31

This machine carried out all functions except stop. Playback and record were fine, but when stop was selected the machine might carry out any function. It would sometimes switch off, and at other times perhaps go into reverse picture search. If a cassette was loaded and the machine was left in the stop mode, it might set off by itself after a while. A replacement HD614081S microcontroller chip cured the fault. We later learnt that

the fault had started after a storm during which the power supply to the house had been struck. **C.W.**

## Samsung SI1260

There were no deck functions. The usual cause of this is loss of the power supply to the motor and servo sections because D112 (1N4001) has failed. Experience has shown that to ensure reliability it's wise to replace D108, D109, D110 and D123 as well. They are all type 1N4001 and are on the main, not the power supply, panel. **C.W.**

## General VGX520

This machine worked well in the E-E mode, but when playback was tried the colour was present for only about five seconds after which the picture became black-and-white. Call it intuition if you will, but I suspected the power supply and was rewarded when the colour returned for a few seconds after a shot of freezer on capacitors C1002 and C1003. Replacing these two 47µF capacitors restored good pictures in all modes, but as I was in the mood I decided to replace all the electrolytics on the board. Perhaps the machine will still be going in the next century! **C.W.**

## Matsui VX2000Y

As these machines have no fast wind buttons you need the handset for servicing. This one came in without the handset. The faults were noisy fast winding and an intermittently wobbly playback picture. The fast wind groaning was caused by a noisy capstan motor. Dismantling it then cleaning and lubricating the bearing cured that – there was a huge amount of sticky mess in there. Back-tension arm oscillation was the cause of the wobbly playback. This was in turn caused by dirt on the tension band pad. Cleaning sufficed. **N.B.**

## Sanyo VHR3100

This machine had been elsewhere. Its power and eject buttons didn't work.

Everything else did – there's a power button on the remote control handset. But there was no remote eject.

The two buttons are on a separate PCB from the timer and all the other buttons. They share it with the tracking control, which worked. The cause of the problem was lack of an earth connection to the two switches: the print was intact, but the lead that should have earthed the area to the mechanism was loose inside the unit. It should have been screwed to the top of the cassette carriage. **N.B.**

## Panasonic NVJ40/2/5/7/F55

No output is a very common problem with the handsets that come with these machines. The display lights up, the bar scanner works but there are no IR commands. The cause is simple: the IR output LED goes open-circuit or high resistance (causing poor range). Spares for the units are available, despite the absence of a list in most of the service manuals. The part number for the LED is SE303ACY: it costs about a pound. Being complex, replacement handsets are extremely expensive. So repair is by far the best idea. **N.B.**

## Ferguson 3V57

This machine was completely dead: no functions, no clock, no nothing! When we measured the power supply outputs at CN3 we found that the unswitched 12V and 17V outputs were o.k. at pins 7 and 8. But there were no switched output voltages – pins 1 and 2 should be at 5V and 12V respectively. As a check, take pin 9 (labelled P CTL IN) of CN3 low: the switched voltages should then appear.

In this case they did. So over to the microcontroller board, where the 5V supply was missing at pin 32 of the chip. This is derived from the unswitched 12V rail via TR201 (BC337), which was open-circuit.

After replacing it the clock worked but the machine still wouldn't power

up when asked. Over next to the servo/MDA section, where IC607 (M50730-610SP) had no 5V supply at pin 52. This time Q602 (2SD638 – use a BC639) was open-circuit. The machine worked normally when this had been replaced.

The common denominator was the unswitched 12V supply, but a check on the components here proved fruitless. No further problems arose during the soak test. S.L.

### **Amstrad VCR9140**

Intermittent mains fuse failure was the complaint with this recent machine. We failed to find any contributory cause. As its F200mA value seemed to be very low, we checked with Amstrad technical who told us that it has been updated to T500mA. S.L.

### **Hitachi VTF770**

A defective capstan motor is usually the cause of failure of the 1-6A delay fuse in the power supply at intervals varying from days to weeks. There may be other symptoms, perhaps a screech or roar during loading, eject or fast tape transport. E.T.

### **Goodmans GVR4500**

Although these machines are relative strangers to us, we've recently had two with the same puzzling symptom: intermittent failure to load a tape, followed by reversion to the standby mode. In both cases we found that the loading motor spindle was turning inside the hollow worm shaft, which had cracked and thus loosened its grip on the spindle. E.T.

### **Akura VX140**

This machine wouldn't accept tapes fully: they would go in partially then come back out again. The cassette flap releaser was missing. The cure was to replace the 'lift slide holder assembly'. G.S.

### **Nokia VR3615**

The picture was intermittently too bright. On checking the video waveform at the input to the modulator I found that it was producing over-modulation. The cause of the fault was traced to a damaged solder pad at the bias feed resistor R189, which is connected to the video buffer transistor Q181. Normal operation was restored by repairing a small piece of print. G.S.

### **Samsung VIK326**

This machine wouldn't tune in any channels: it searched for stations but wouldn't find any. When I checked the i.f. output from the tuner during

search I found a reasonable signal as the tuner passed through the station, but there was no output from pin 13 of IC401. Replacing this chip cured the fault. G.S.

### **Panasonic NVG21**

This machine was dead with no functions. When I checked the power supply outputs I found that the regulated 5V and 6V supplies were far too low. Replacing the STR5338 regulator chip restored normal operation. G.S.

### **Nokia VR3615**

This machine wouldn't come out of standby and wouldn't accept tapes. At switch on the drum and capstan started but the loading motor didn't shuffle. The power supply outputs were all present and correct, but when a check was made at pin 8 (V ref) of the loading motor drive chip IC602 the reading was very low. It should be around 8V. Zener diode D607 was found to be virtually short-circuit, a replacement restoring normal operation. G.S.

### **Samsung VI375**

This machine was dead with no clock and no functions. Checks in the power supply showed that IC101 (STR11006) was short-circuit, R101 open-circuit and ZD101 short-circuit. As ZD101 provides over-voltage protection, it seemed that the power supply outputs had gone high before these various items failed. The culprit was C110 (100µF) which had fallen in value to around 10µF. G.S.

### **Nokia VR3615**

This machine wouldn't tune in any channels. When the tuner's VT input was checked during search a ripple was seen to be present – and the search wouldn't go below 12V. A check on the PWM output from the microcontroller chip showed that this was noisy, irregular and erratic. I then noticed the presence of discoloured manufacturer's flux in this area. After treating the area with PCB cleaner the machine worked normally. G.S.

### **Samsung VIK326**

There were no functions with this machine, which wouldn't come out of standby. A check in the power supply showed that the ALL 5-8V supply wasn't being smoothed. Replacing C35 and C36 cured this smoothing problem, after which the machine worked normally. G.S.

### **Samsung SI3240**

When the power button was pressed the channel number failed to light up and the machine wouldn't accept a

tape. The cure is to replace the lift right-hand side and align the mechanism. R.B.

### **Sanyo VHR7250**

At switch on this machine wouldn't accept a tape and the drum failed to turn. Checks in the power supply showed that the always 13V output was low. The cause was a dry-joint at D5107. R.B.

### **Nokia VR3761**

This machine wouldn't come out of standby. When the switched power supplies were checked we found that there was no switched 5V output. Q5402 (2SC4484S) was found to be short-circuit base-to-emitter, a replacement restoring normal operation. R.B.

### **Panasonic NVFS100**

There were snowy E-E and r.f.-r.f. outputs and no reel counter operation. Voltage checks at plug P1101 in the power supply showed that the non-switched 12V output at pin 1 was missing. Q1102 was found to be open-circuit base-to-emitter. R.B.

### **Nokia VR3783**

There was a loud tone during playback and an intermittent tone was recorded. The cure was to refit the full erase head to the audio/control head PCB. R.B.

### **Sanyo VHR244**

There was no record colour with this machine. A check on oscillator X1001 showed that it wasn't running. Replacing the crystal cured the fault. R.B.

### **Philips VR7225 Turbo**

This machine's lift didn't work. Tests showed that the gear which operates the lift was slipping on its shaft. The assembly forms part of the worm gear on top of the deck, and is driven from the main cam. Order kit A and you get a worm gear plus cassette drive gear and main cam. Fitting these parts and retiming the lift in accordance with the instructions in the manual produced perfect results. R.N.

### **Philips VR6185**

The customer had got a tape stuck in this machine. Instead of calling me first, he took the top off and used a knife to get the cassette out. When I looked at the machine the lift was lying loose inside together with the remains of lever arm 238. According to the customer there had been intermittent picture rolling for some time, then the machine had continuously ejected tapes. The problem tape got

stuck when I tried to physically blocked the cassette opening by holding the cassette down while the machine was trying to eject it. In spite of all this mistreatment, the rest of the mechanism seemed to be in reasonable order.

The cause of the rolling picture was a disintegrated pinch roller. After splitting the deck and fitting a replacement and a new lever arm, then reassembling everything, I found that the deck seemed to work when run with a d.c. supply to the loading motor. But when a tape was tried it was immediately ejected. The service mode indicated that there were no capstan pulses. As the capstan was turning, I decided to check the sensor. Once again the deck was split, and when the sensor panel was removed one of the sensor's leads was seen to be adrift. On putting this right and reassembling the deck I found that the machine now worked mechanically.

My problems were not over however, as the customer had fiddled with the sync head. In fact he'd tightened the screws to the extent that the base of the head was bent. I had to fit a new head and set it up.

So the original faults had been a worn pinch roller and a lead off the capstan sensor. What should have been a half-hour job had taken almost three hours. R.N.

### **Philips VR6462**

The 330µF, 16V capacitors used extensively in this and other Philips VCRs seem to fail quite often, usually going short-circuit. The complaint I had with one machine that came in recently was no sound. C2007 on the audio panel had gone short-circuit. R.N.

### **Hitachi VT19**

During playback the capstan would, after a while, gradually slow down, with slurred sound and cyclic tracking bars. The symptoms were similar to those produced by lack of control pulses because of a worn or dirty ACE head. Eventually the capstan would stop, followed by the tape unloading into the stop mode. In the fault condition there was a healthy 12V at one side of the posistor (PH1151 - 4R7) that supplies the capstan drive chip, but the voltage at the output side dropped rapidly. When it reached 4V the capstan stopped. The PTC was very hot to touch. Fortunately a replacement cured the fault. J.E.

### **Matsui VCP550**

This machine is actually made by GoldStar, the same mechanism being

used in that company's models, in particular the RC703L. The half-load arm can cause several faults. This particular machine failed to load the tape to the audio/control head and the capstan shaft. A previous engineer had thought that the capstan motor was faulty and had replaced it. The cause of the fault was much simpler: the half-load arm had gone out of mesh with the lever gear. Realignment put matters right. M.M.

### **Toshiba V213**

The power and rewind buttons on the front of this machine didn't work, though these functions could be controlled by the remote control handset. I found that pins 1 and 3 of BK05 on the front panel PCB were bridged. Resoldering them cured the fault. M.M.

### **Logic VR955/Samsung VI710**

This machine wouldn't record. Checks showed that there was no record 9V supply because Q110 was open-circuit. This was in turn caused by bias coil L504 having gone short-circuit. Replacing these items, also an idler and the pinch roller, restored correct operation of the machine. M.M.

### **JVC HRD830**

The mechanism would jam when loading. On investigation we found that the brass shaft on which the control cam rotates had risen slightly. As a result the cam rose and jammed on the half-load gear. The solution is to push the shaft back down, using the back of a screwdriver. A click will often be heard as the shaft goes back into place. M.M.

### **Sharp VC750**

This machine's mechanism kept jamming. The cause was the loading gears which were worn. They would jump a tooth, particularly when unlacing. As a result the back-tension arm fouled the movement of the supply guides. Fitting replacement gears cured the trouble. M.M.

### **Philips VR522**

This machine was jammed. A field engineer had removed the tape, only to find that the entry guide had parted company with the load arm. Refitting was all that was necessary - a quick and easy repair for a change. M.M.

### **Sanyo VHR190E**

A common fault with this Sanyo model and its clones is mechanism lock-up, i.e. intermittent failure to

advance a tape. The cause is usually the mode switch, Sanyo part number 613 1100 374. Note that carriage replacement should be done in the down position. M.M.

### **Ferguson FV74L**

A buzz on sound was the complaint with this machine - but only during playback of its own recordings. E-E and prerecorded tape playback were fine. The cause of the fault was that the recorded video level was too high: slight adjustment of the deviation control PV04 cured the buzz. M.M.

### **Matsui VX990**

This old timer had two faults that initially appeared to be unrelated: there was loss of playback colour and wow and flutter on the sound. Investigation revealed that there was excessive ripple across C08 in the power supply. A replacement cured both symptoms. M.M.

### **B and O VHS63\***

Playback with this Philips clone was marred by the fact that all vertical lines were affected by what appeared to be a hum bar. But it wasn't a hum bar: there were approximately six cycles per frame! Neither the f.m. envelope nor the video signal provided a clue, but a check on the drum motor's connection revealed massive spikes. The fault was cured by replacing the lower drum. M.M.

### **Ferguson FV32L**

The reported fault was incorrect tracking. When we tested the machine we found that playback of its own recordings was poor. Replacement of the upper drum produced little improvement, but replacing the lower drum cured the fault. M.M.

### **Sanyo VHR350E**

This machine had an intermittently low gain tuner. Fortunately all that was wrong was some dry-joints in the tuner can. We dealt with these then gave the machine a long soak test. This proved that the fault had been cured. M.M.

### **Panasonic NVL28**

Intermittent failure to record or play and tape chewing were the complaints with this machine. On inspection I found that arm P5 was sticking on its post. It would sometimes fail to go into the fully eject position, thereby catching the tape. At other times it wouldn't pick up the tape and take it past the capstan shaft. Lubricating the shaft and arm cured the trouble. M.M.

\* = Philips  
VR6462

# VCR CLINIC

Reports from  
**Mike Leach**  
**Brian Storm**  
**Ronnie Boag**  
**Gerald Smith**  
**Eugene Trundle**  
**E.J. Edwards**  
**Michael Maurice**  
**Jeff Herbert**  
**Michael**  
**Dranfield**  
**Nick Beer**  
**John Coombes**

## Hitachi VTF860

This machine would sometimes shut down when loading in the record mode. The tape guides would reach about half way towards the full loading position, after which the display would go out briefly and the loading motor would shut down. This would last for about a second. The machine would then start up again and revert to standby. I suspected a fault in the power supply, and my diagnosis turned out to be correct. Q7 (2SC1741) was the culprit – it was breaking down when warm. I replaced the 2SK1611 chopper transistor (f.e.t. type) as well. **M.L.**

## Samsung SI1260

If there's no drum and capstan rotation and the tapes get severely chewed you'll probably find that D109 on the main panel is open-circuit. This diode is in the 5V supply. **M.L.**

## Sharp VCA100

If you pressed fast forward when this machine was in the stop mode it would automatically go into fast forward search. The loading belt was in very poor condition, but the cause of the problem turned out to be the mode switch. After stripping, cleaning and re-timing, normal results were obtained. **M.L.**

## Panasonic NVJ30

There were display problems with this machine. Although it worked perfectly, it was difficult to operate because the channel information and cassette functions were not shown on the front display panel. As the deck functions were not affected, it seemed logical to assume that the system control chip IC2001 and the timer and front display control chip IC7501 were both o.k. So a thorough check was carried out on the serial data connections between these

chips. This revealed that R6044 had risen in value from 220Ω to over 900Ω. The problem was cured by fitting the correct value resistor in this position. **B.S.**

## Panasonic NVSD200

This machine would sometimes shut down while accepting or ejecting a tape. A check on the built-in error codes told us that the mechanism was jamming whilst loading or unloading. As the tapes used for testing were known good ones, we turned our attention to the loading motor drive and the gearing from the loading motor. Checks at the loading motor connection PCB, which is on the back of the loading motor, revealed cold soldering at all four connections. After resoldering these the machine worked faultlessly. **B.S.**

## Panasonic NVFS200

This machine wouldn't record, though every other function worked perfectly. A few seconds after pressing the record button the machine would go back to the stop mode. Checks on the various record switching lines showed that the delayed record 12V supply was missing. A check back through the various switching transistors then revealed that the Q4004 (2SB790) was faulty. A replacement restored the missing function. **B.S.**

## Panasonic NVSD25

The complaints with this machine were of poor recorded sound and slow rewind or tape wind. We decided to concentrate on the sound fault initially. There was some bottom edge damage with the tapes supplied: they seemed to play all right in the workshop, but when the tape was cued forwards it would run down the guide next to the audio/control head. We first suspected that arm P5 was slightly bent, as can happen with the K

mechanism. But a replacement made no difference. We then tried AC head tilt adjustment, again to no avail.

The cause of the trouble was eventually traced to excessive back tension. We found that the supply spool brake was permanently engaged because the brake lever assembly (VXZ0313) had a broken lever. After replacing this the machine worked perfectly, even in the wind and rewind modes.

The worrying thing about this fault was that the tape remains threaded around the drum in the wind and rewind modes. With the tape tension so dramatically increased, how much wear had been imposed on the drum while the fault was present? **B.S.**

## Panasonic NVHD100

"Bad picture" was the complaint with this machine. Sure enough the playback picture had very bad drop-outs, with lots of black flashes and glitches. Clearly the drop-out compensation circuit wasn't working. Checks in the video processing circuitry showed that there was no 5V feed at pin 44 of IC301 – this pin supplies the drop-out compensation part of the chip. The cause was coil L304, which was open-circuit. A much cleaner playback picture was produced when a replacement coil had been fitted. **B.S.**

## Panasonic NVJ35

This machine's mechanism operated very erratically: the mechanism solenoid would sometimes chatter and often disengage before an operation was complete. Our first step was to check the supply to the solenoid for ripple – we suspected a faulty decoupling capacitor. As the supply was o.k. we replaced the solenoid, but the fault was still present. We subsequently discovered that R6022



in the solenoid drive circuit was dry-jointed. A bit of resoldering was all that was required. **B.S.**

### **Mitsubishi HSM37**

Noisy rewind was the complaint with this machine. The cure was to replace gear idler and gear reel S (part numbers 522C077020 and 522C083010) as their edges were chewed. **R.B.**

### **JVC HRD720**

This machine wouldn't play or record and cut off in the fast forward and rewind modes. In addition the drum didn't rotate when a tape was inserted. Voltage checks showed that the motor 13V supply was missing at plug CN401. The cause was CP401 (ICP-F15) which was open-circuit. A replacement restored normal operation. **R.B.**

### **Hitachi VTM722**

The power up and cassette lights were on all the time and the machine wouldn't accept a tape. The cause of the trouble was dry-joints at the end sensors. **R.B.**

### **JVC HRFC100**

This machine wouldn't accept tapes: the guides would half load then the machine would cut off to standby. The cure was to replace the cont plate assembly. This controls the alignment of the mechanism – part of the plate was broken. **R.B.**

### **Nokia VR3761**

This machine wouldn't come out of standby properly and would occasionally pulse on and off. Checks while the voltages on the secondary side of the supply were pulsing on and off showed that noise was present on the main data lines associated with IC301. Replacing IC301 cured the problem. **G.S.**

### **Nokia VR3615**

Bands of colour flashed on the playback picture – this happened only with prerecorded tapes with colour guard etc. Replacing IC301 cured the fault. **G.S.**

### **Nokia VR3761**

The customer said that the sound was faulty when he gave a tape to a friend to play. On checking we discovered that the linear sound was the old sound track while the hi-fi sound was the new sound, i.e. the machine didn't erase the linear sound when it made a recording. The cause was dry-joints at C2019 and CN202 on the linear audio PCB. **G.S.**

### **Sanyo VHR3300**

If the symptoms with one of these machines are that the programme indicator is flashing and the tuning system is unable to memorise tuning instructions, it's likely that the –30V supply to its EPROM section has increased to about –55V. The culprit will be the GZS33X zener chip D5102 in the power supply – it goes open-circuit. We find that a ZTK33B is an acceptable replacement. **E.T.**

### **Ferguson 3V31**

This machine wouldn't accept a tape. As the cassette loading belt was slack a replacement was fitted, but this made no difference. The next step was to check the motor voltage during the loading cycle. It was low, because transistor Q8 was faulty. A replacement restored normal operation. **E.J.E.**

### **Panasonic NV333/366**

Rewind was normal to start with but it would then slow and subsequently shut down. All other functions were o.k. The cause of the fault was transistor Q17 (Q6017), a replacement restoring correct rewind operation. **E.J.E.**

### **Amstrad UF20**

There was no digit display or E-E operation. The deck functions were o.k., but the playback picture was just lines. We traced the cause of the trouble to R1024 (10 $\Omega$ ) in the power supply. Replacing it restored normal operation. **E.J.E.**

### **Ferguson FV13R**

There were no E-E signals. The cause was LT03 which had gone open-circuit, removing the tuner's 12V supply. A new coil cured the fault. **M.M.**

### **JVC HRS5500**

This machine had been looked at by another engineer. The problem was that although it would respond to simple remote control commands such as play, stop, rewind etc. it wouldn't respond to either clock setting or programming by remote control. I eventually discovered that the cause of the fault was in the remote control receiver section: the IR detector diode had been bent over and didn't face the cut-out in the metal box. Bending it back cured the trouble.

When replacing the front panel unit you have to take care that the operation button's peg doesn't go into the receiver, bending the IR detector diode over. In other words,

ensure that the front panel unit is offered up to the machine squarely. **M.M.**

### **JVC HRJ205**

The customer thought that this machine needed a new head drum. In fact the cause of the trouble was an incorrectly set head switching point. This had possibly been misadjusted by the engineer who tried to cure the static problem! **M.M.**

### **Ferguson FV81L**

The customer complained that the eject button didn't work. On investigation we found that the cabinet button didn't contact the switch. The cure was to remove the front panel and refit. **M.M.**

### **Matsui VS888**

There was no through r.f. and no E-E operation. On investigation we found that there was no AT12V supply to the modulator because the print to Q502 in the power supply had disintegrated. Remaking the connections to Q502 restored normal operation. **M.M.**

### **Ferguson 3V32**

There were two faults with this old timer. One was that the motors didn't work – because there was no 12V output from the regulator circuit on the bottom PCB. We found that ZD34 had gone open-circuit and Q16, on the mechacon board, had literally blown up. When this had been repaired the machine worked normally. It came back three days later, this time with no functions and no display.

We found that CP1 on the tuner/timer control board was open-circuit. After replacing it the machine worked for a few minutes then failed again. To cut a long story short, and three CPs later, we discovered that there's a capacitor connected between pins 5 and 10 of IC205. It's glued to the back of the PCB and is not shown on the circuit diagram. What had happened was that the leg connected to pin 5 (chassis) of IC205 was almost touching pin 4 (supply). We moved the capacitor and secured it with hot-melt. This finally cleared the trouble. **M.M.**

### **JVC HRD610**

Picture rolling was the complaint with this VCR. When we examined the video f.m. waveform we saw that there was a gap in the envelope: the head switching point was out. It's set up using the

presetter remote control unit from JVC. M.M.

### GoldStar RDD01

The capstan motor in the VHS section of this VHS/Video 8 deck ran slowly in reverse, even without a tape. The motor itself was faulty. A replacement put matters right. M.M.

### Matsui VSR1500

This combined satellite receiver/VCR has many similarities with the Amstrad Model VS1000. This one wouldn't record. On investigation we found that there was no signal to the head amplifier because of a broken track between Q4013 and pin 6 of the head amplifier connector. Fitting an insulated wire link between these points restored the f.m. input to the head amplifier, curing the fault. M.M.

### Akai VSG64

This machine bounced in and out of the workshop like a yo-yo. Each time the mechanism was out of alignment. In the end we decided that it was easiest to replace the mechanism block complete.

Akai is the only manufacturer, as far as I know, that will supply a mechanism which is complete apart from the drum and audio/control head assembly. After fitting this and setting it up we returned the machine to the customer and haven't heard from him since. The part number for the mechanism is BBV1172A020A. It can be used with all models that use this deck. M.M.

### Saisho VR3400

When a tape was inserted it would be laced up then ejected. The cause of the trouble was no capstan drive because the OEC9011 chip IC2001 had failed. M.M.

### Samsung VIK326

There was no playback picture, just a blank raster. Resoldering all the joints on the head amplifier connector CN302 cured the fault. M.M.

### Sanyo VHR135

There were large hum bars on the E-E picture and the drum was rotating flat out all the time. Scope checks showed that there was 2V of ripple on the 5V supply and 4V of ripple on the 13V supply. The cause was eventually traced to an open-circuit secondary winding on the mains transformer, between pins 7-8. As a result, only half of this

centre-tapped winding was in circuit.

When we removed the transformer we saw that one end of the heavy-gauge, enamel-coated wire was only wrapped, not soldered, to the terminal. Scraping off the insulating enamel and soldering the pin cured the hum and drum faults. J.H.

### Sharp VCBS97HM

In the E-E mode there was poor sync (ragged verticals and occasional field roll) with both satellite and terrestrial TV signals. Playback was fine, ruling out a fault in the r.f. modulator.

Scope checks through the complicated signal switching stages on the bottom PCB brought us to C2527, a coupling capacitor to the record source select chip. There was a good video waveform at one side, but at the other side the line sync pulses were rounded. When we tested this 10µF, 16V capacitor we found that its value had fallen to zero. A replacement restored the E-E signals and the record signal quality. J.H.

### Akai VS23

There was no fluorescent clock display and none of the function buttons worked. The auto-play function worked when a prerecorded tape was inserted. Playback picture quality was good, but there was no sound. The tape had to be removed from the machine manually, as the stop button had no effect.

I found that pin 5 of the clock microcontroller chip IC901 was at 0V instead of 5V. This is the power-down detect line, which senses loss of mains power by monitoring the always 12V supply. This supply was low at 4.2V and was the cause of the problem. TR7 (2SA1286) and TR15 (2SB1010) on the power supply PCB were both found to be leaky. When they were replaced, the 12V supply was restored along with the clock display and playback sound. I wonder how many machines can load up and play a tape with an always 12V supply virtually missing?! J.H.

### Philips VR6870

This machine had previously been in for replacement of the loading belt, which was worn and slipped. It was now back because the clock gained approximately one hour a day. We had to put up with the old story that "it was all right before". The cause of the trouble turned out

to be a faulty 1.2V nicad battery. Strangely, the tuning data had been retained. M.Dr.

### Samsung SI3240/3260

For poor E-E picture stability, especially when the machine has just been plugged in from cold, replace C4112 (0.47µF, 50V), C4110 (47µF, 16V) and C4120 (2.2µF, 50V), which are all in the i.f. can. The cause of the problem is that the i.f. chip runs very hot. Hence the three electrolytics dry out. M.Dr.

### Samsung VIK326

This machine wouldn't come out of standby. The clock display (unset) was present, but when the power-on key was pressed nothing happened. When a cassette was inserted the unit tried to power up then returned to standby. One clue as to the cause of the fault was present – a low-level but raucous noise from the power supply can. Voltage checks here showed that the ever 5.9V supply was low at about 4.8V. As a result, the 5V supplies were too low to be of use. A scope check showed that there was a lot of hash on the supply. C35 (470µF, 16V) was open-circuit. N.B.

### Toshiba V212B

The cause of field jitter/picture rolling can be difficult to find. Sometimes the fault is intermittent. The cure is very easy however. Dust build up on the drum flywheel slats is the cause. Carefully brush off all the dust. J.C.

### Mitsubishi HSM45

A jammed tape is a problem you sometimes get with these machines – the fault can be intermittent. The cause is a broken capstan pulley. It can be obtained as a separate part from Mitsubishi, i.e. you don't have to order the complete flywheel. J.C.

### Toshiba V110B

There were no results and no display. The cause of the fault was obviously in the power supply, and it didn't take us long to find that the ZPD6V8 zener diode DP09 was open-circuit. In addition DP011 (ZPY15) was short-circuit. J.C.

### Panasonic NVL25

The symptoms were wow on sound and picture flicker. Our first steps were to replace the pinch roller and stator unit, but the fault persisted. It was cured by replacing the XRA6435S capstan drive chip IC2101. J.C.

# More on the

# Toshiba V3 range

The Toshiba V3 VCR model range is split into two categories, Cat 1 which includes all mono sound models and Cat 2 which includes the models with Nicam stereo and hi-fi sound. Manufacture is at the joint Thomson/Toshiba plant in Singapore. Cat 1 machines are mainly Thomson designed while Cat 2 machines have mainly Toshiba design. This explains, amongst other things, the different

mechanism is fitted into this while the plastic carriage guides are moulded in. The loading motor, together with its control cam and the mode switch, are fitted on top of the deck. The mode motor is held in by clips. It can be easily and quickly removed, giving access to the pinch roller. Refitting is simple. This assembly includes a method of lacing/unlacing by hand so that a jammed tape in a dead machine can be released.

The drum with its integral preamplifier is of course mounted on the deck. The rotor is fitted to the underside of this assembly while the stator is on the main PCB. When the main PCB is fitted to the deck, the stator sits inside the rotor. This means that the mechanics cannot be operated separately from the main PCB, which could make fault finding more difficult – especially when there's an intermittent mechanism fault. It could also, I presume, make life more difficult in the event of an intermittent or heat-sensitive fault with the electronics in this area.

The deck makes extensive use of plastic assemblies, far more than in previous models, though this appears to be the way all manufacturers are going. The entry/exit guides are plastic for example, relying on friction between the plastic and the metal rollers to maintain the guide height alignment. This can work – the Philips Turbo decks use the technique – but I've had a couple of these guides go out of alignment.

The cog that drives the carriage seems to be a weak spot. It's driven by a metal rack slider and can be damaged if subjected to excessive force when a cassette is inserted incorrectly.

For most repairs the deck will have to be removed from the machine. This involves removal of the main PCB, which can be awkward. An exception is the pinch roller. Once the mode motor assembly has been removed this can be replaced without the need to remove the deck.

Most parts, such as the guides and cogs, fit in through cut-outs in the chassis. In the normal working modes

they don't come out. This dispenses with the need for circlips etc.

## The Drum Assembly

The head drum assembly is the interesting bit. It's a well-known fact that the closer an amplifier is to the source of the signal to be amplified, the better the signal-to-noise ratio will be. In the past, manufacturers have had to use cables to couple the video (and audio) heads to the preamplifiers. In early machines the cables could be several inches long. More recently the preamplifier has been positioned at the back of the drum assembly, usually with a flexible coupler about an inch long. Thomson/Toshiba have taken this one step farther, fitting the preamplifier inside the drum. This is a feature previously found only in professional decks, hence Toshiba's name for the new arrangement – the PRO drum.

In Cat 1 machines the preamplifier is part of the lower drum. The usual rotary transformer arrangement is used to provide coupling between the lower and upper drum. In Cat 2 machines (hi-fi stereo) the preamplifier is part of the upper drum. Rotary transformers couple the preamplifier to the lower drum, but the transformers also have to be capable of carrying the head switching, LP/SP, record/playback, envelope comparator and other signals.

Cat 2 machines, on which we will concentrate here, have three rotary transformers, with a slip ring assembly to provide the 9V d.c. supply for the preamplifier. The assemblies also include the earthing brush.

The lower drum consists of a plastic rotor assembly that houses a 23-pole magnet. This produces, via sensors on the main PCB, the FG and PG pulses. The lower drum also contains the rotary transformers.

In addition to the f.m. video, the chroma and the f.m. hi-fi audio signals, an r.f. switching pulse (25Hz or SW25), an r.f. audio switching pulse and LP/SP switching have to pass through the rotary transformer. The audio and video switching

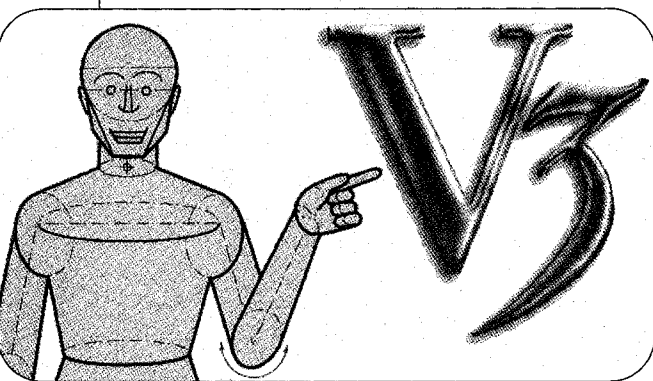

power supply circuits used in models with mono sound only and those with hi-fi stereo sound.

Toshiba claims that in comparison with its previous range there has been a thirty per cent component reduction in the electronics used and a fifty per cent reduction in the number of mechanical components. The former has been achieved by increased electronic integration, the latter by designing the mechanics so that items such as guide locking screws, spool retention circlips etc. are no longer required.

## The Mechanics

The new and in my view simpler mechanism is based on a U-shaped pressed steel chassis. The carriage

The technical features of the new Toshiba V3 range of VCRs were outlined in Philip Blundell's article in the January issue (pages 176-179).

Michael Maurice provides some additional notes



**The Toshiba V855B**

signals are combined into a composite switching signal. This frequency modulates a carrier over the range 9.4-11.4MHz. The frequency band is high enough to avoid crosstalk with the other signals.

During playback an envelope comparator produces an output that varies between high and low depending on which dual-azimuth head is producing the largest signal output. This high/low output is digitally processed within the preamplifier to produce a 1.2MHz a.m. signal that, after passing through the rotary transformer, is reprocessed for SP/LP head selection. This head select signal sets the amplitude of the composite AV/FM head selection control signal. As the 1.2MHz output from the envelope comparator lies between the 627kHz chroma signal and the 1.4-1.8MHz hi-fi audio, there is again no interference.

Cat 2 machines also incorporate a flying erase head. This ensures that clean pictures with no chroma content from the previous recording are produced from the start of a new recording. A flying erase head comes into its own with insert editing, where a precise section of the tape needs to be erased prior to insertion of the new recording.

### The RF Block

The RF block, as Thomson/Toshiba call it, combines an RF converter (modulator) and a tuner/IF strip. Both sections are controlled by an I2C bus, which enables the user to set the RF output between channels 53 and 67 – it's set to ch. 60 at the factory.

The aerial booster can be set to either off or mix during playback. This is done via menus, the factory default setting being the mix mode. Those who have an aerial system that includes video wired throughout the house will find this a benefit – previously the RF booster was switched off during playback.

The RF block otherwise follows conventional practice. In Cat 1 machines the video output is at pin 6 and the demodulated audio output at pin 7. In Cat 2 machines, which have Nicam capability, the audio output from the IF strip is an SIF signal (sound IF) which is fed to the MPX unit. This contains an MSP3410 digital multi sound processor chip that can process all TV sound systems available, including 5.5MHz and 6MHz f.m. sound and Nicam sound. If this chip fails it means that you will get no sound, either Nicam or f.m. According to Toshiba these modules are designed to be replaced in the event of failure, not repaired.

### Microcontrollers

As you would expect, microcomputer chips are used for system control, a main one and a second one for the display. The display microcontroller chip is connected to the main one via four lines – system data in, system data out, system clock and start code (strobe).

There are two I2C bus networks. Bus 1 controls the signal processing - hi-fi sound, video, pre-record control and the multi-sound processor (Cat 2 models). Bus 2 controls the RF block, PDC where fitted, video in/out and the EEPROM.

The EEPROM enables the machines to be set for use in different countries with different languages. It also stores tuning data, RF output data and the playback head switching phase. When the EEPROM is replaced the correct data must be entered and stored. Consult the relevant service manual – each model is different in this respect.

### Satellite Control

A rather neat feature is the ability to use the VCR to control a satellite TV receiver in the Video Plus timer recording mode. An infra-red LED inside the front top of the case transmits the relevant data to the satellite receiver. Thomson/Toshiba provide a comprehensive list of receivers that can be operated in this way, with clear instructions on how to set up the machine for this use.

### Power Supplies

In Cat 2 machines the power supply is on the main PCB. In Cat 1 machines the power supply is separate, in a metal can. Basic circuit operation was described in the earlier article (January).

In Cat 1 models the power supply provides a "power good" output. This tells the microcontroller chip whether there's a power failure. The idea is let the microcontroller know of the failure before the capacitors in the 6.2V supply have had a chance to discharge, so that it can ensure the back-up clock is running correctly.

The Cat 1 power supply has been used in previous Thomson/Toshiba

VCRs. In the event of failure, check the diodes on the secondary side for short-circuits then replace the chopper control chip IP001, the chopper transistor TP001, RP021 and RP018 as required. With the exception of RP021 these items were shown in Fig. 1, page 176 (January). RP021 (2.2k $\Omega$ ) is connected to pin 12 (current sensing) of IP001.

As previously mentioned, the Cat 2 power supply is on the main PCB – so care is required when servicing, or you'll be in for a nasty surprise!

### In Conclusion

The models in the V3 range give excellent results. They should prove reliable, but only time will tell.

The main source of my information is the excellent courses run by Toshiba. ■

# Camcorner

Reports from  
David C.  
Woodnott

## Samsung VCE805P

We initially thought that the cause of the two faults with this camcorder might be the same. There were no camera E-E or electronic viewfinder pictures, just a white screen. In the playback mode the AV picture was o.k. but there was still no EVF picture, just the white raster. Loss of the E-E picture was caused by the camera control chip being locked up – remove and replace the back-up battery. The viewfinder problem was caused by VR701, which was open-circuit. It's part of a composite resistor assembly.

## Sony CCDTR105E

Intermittent recording and playback was the complaint with this smallest of small (so far!) camcorders. When we tried it out in the playback mode we noticed that the drum speed varied, producing the symptom. The cause was simply an ill-fitting connector between the drum motor and the main PCB. On subsequent test however the unit failed completely! The capstan drive chip had given up. Ah well, a replacement chip is not too expensive. It was a good job we'd given a reasonably high estimate.

A few days later the unit was brought back because "it failed to operate at all". Although it had been checked and found to be o.k. as part of the service, the take-up guide assembly had fallen apart. Fortunately it was possible to re-attach the detached roller guide with Loctite without dismantling the unit. After a long test it went back to its owner again. I am now

working with my fingers permanently crossed, which is not easy!

## Ferguson F801/Hitachi E10E

When an attempt was made to rewind a tape this machine would shut down after a few seconds. If rewind search was requested in the play mode however all was well. Every other function worked normally.

Checks on the supply and take-up reel sensor signals showed that the output from the supply sensor was at only half the correct amplitude. In addition the leading edges of the squarewave pulses were rounded off. The mechanism has to be dismantled to replace a reel sensor. While the operation is not too difficult with this model it's still time consuming. And of course the replacement didn't alter either the amplitude or shape of the supply-reel sensor signal. Oh well!

Various checks were then carried out around the 'trouble-detect' chip IC907, all to no avail – even cold tests brought us to a dead end. We decided to compare the supply and take-up sensor input circuits at PG905 on the main board, and found that there was a measurable capacitance to chassis at pin 9 (supply input) but no such capacitance at pin 6 (take-up input). It was then a simple (?) matter of tracking down the cause of the pulse level reduction and rounding. The culprit turned out to be C101 (220µF, 6.3V), which of course is not connected to the sensor circuits in any way: it merely bridges the

print that carries the sensor signal.

## Sony CCDF380

There was no E-E picture and the playback picture disappeared when the DATA button was pressed. The cause of the failure was traced to the camera function microcontroller chip IC651 on board CK19P

## JVC GRC7E

This oldie lost its E-E picture intermittently. The cause of the fault was not in the camera section but on the YC board, where R49 was dry-jointed. As a result there was intermittent video muting. The resistor was under one of those large lumps of JVCgoo.

## Panasonic NVG202

The electronic viewfinder pictures were dark. The cure was to replace the scan transformer assembly.

## Sony CCDTR750E

This Hi8 unit came in with a list of faults. They included an intermittent viewfinder picture, eject sticks, and no record or playback colour. All these symptoms were caused by the fact that the unit had at some time been dropped. As a result, various connectors had parted company with their respective PCBs. This included the separate chroma processing PCB, which had become completely detached from the main board. Carefully refitting the connectors cured the various faults – fortunately there was no damage to the PCBs.

## Panasonic NVR50A

This camcorder powered down almost immediately after powering up. Previously to this it had apparently lost its digital functions, which are controlled by a rotary knob below the lens assembly. Both symptoms were caused by dry-joints at connectors on the main and MDA boards. We had to refit the connectors that link the two PCBs – the digital function connector had in fact become completely detached from the PCB.

## Sony CCDTR45E

The E-E picture would occasionally disappear and then return. All other functions were o.k. After a look around for dry-joints we decided to check the iris mechanism, as there have been problems in this area with these camcorders. When we opened the iris manually there was an E-E picture, but it was not up to the normal standard. In addition there was no autofocus or zoom operation in this condition.

We checked for a missing supply, but they were all present. Checks around the camera control chips then revealed that the signal on the SCKL line was present but of low amplitude. This line links IC611/2/3. A resistance check to chassis produced a reading of 213Ω. We eventually traced the cause of the trouble to C648 (100µF, 10V) which had leaked over CN304, tracking between the GRND and SCKL pins. A replacement capacitor along with a clean up of the area around CN304, which had to be removed, restored normal operation.

# VCR CLINIC

**Reports from Philip Blundell, AMIEEIE,  
Simon Bodgett, Eugene Trundle, Brian Storm,  
Richard Flowerday, Ray Porter, Chris Avis,  
R.J. Longhurst, Christopher Nunn,  
Michael Maurice and Gerald Smith**

## **JVC HR-D540 etc**

The cause of tracking problems with this range of machines can usually be traced to defects with the pole bases. You may find that the rotary guides are loose, the result being that they adjust themselves as the tape passes. The brass insert can become dislodged, so that the pole base does not go fully into the V block. Finally, the inclined guide can become loose, so that its alignment changes – or it can even fall out! **P.B.**

## **Philips VR2547**

This machine would not operate for more than a few seconds in the play, wind or rewind modes. Scope checks at connector CN1 showed that while supply reel pulses were present at pin 17 there were no take-up reel pulses at pin 5. The cause of the fault was photointerrupter PS1 (part no. 4822 130 82705). **P.B.**

## **JVC Heads**

During the period just before Christmas Darron had fitted new video heads in a JVC HR-J420. When he tested the machine he had difficulty with LP recording and playback – standard play operation was fine. We went through the usual checks, including another set of heads and a replacement lower drum. A comparison was then made between the new heads and the ones that had been removed. Our conclusion was that two of the rotary transformer windings between the LP heads were swapped over.

JVC has now confirmed that any of three different and non-interchangeable drum units may be fitted to this range of VCRs, depending on geographical production batches. The models involved are the HR-J220, HR-J225, HR-J420, HR-J425, HR-J620, HR-J625, HR-J725 and HR-J825.

Before any major part of a drum unit is changed – the upper or lower section or static components – JVC bulletin DKC322, dated February 1996, should be referred to. Non JVC account holders can obtain the information from the Willow Vale technical line (0891 615 915). Calls cost 49p/min. To save costs, write down the model and serial number before making the call. **S.B.**

## **JVC HR-J200**

Failure of the under-deck mode switch is quite common with JVC machines. This is the first time we've had the fault with a 'mid-mount' model however. The symptoms – both very shy and spasmodic – were failure to rewind and tape looping at eject. **E.T.**

## **Panasonic NVG25**

You sometimes find that the head drum motor in one of these machines won't start up – it twitches instead. The cause of the trouble may well lie in the power supply, where the electrolytic capacitors C18/22/23 are suspect. If replacing them doesn't cure the fault, try replacing all nine miniature electrolytic capacitors on the drum drive CBA under the drum motor – ensure that the types used in positions C1, C2 and C3 are non-polarised.

This note probably applies to many models that use the Panasonic G deck. **E.T.**

## **Tatung TVR6151/Decca DVR6151**

We've encountered intermittent ghosting – and multiple ghosting – in the record and E-E modes with three of these machines. The cause is dry-joints at the legs of the SAW filter in the IF module. Retin and solder them all, whether or not the tell-tale 'rings' are visible. **E.T.**

## **Panasonic NVJ47**

This machine's E-E picture was covered with wide, dark flashing bars that seemed to vary with the sound signal. After a quick check on the power supply lines to confirm that they were all up to specification we moved to the luminance/chrominance subpanel. The main item here is IC302, which processes the luminance and chroma playback, record and E-E signals – and is expensive! Fortunately C318, a small 22µF capacitor connected to pin 9 of the chip, turned out to be the culprit. When this had been replaced we had clear E-E pictures. **B.S.**

## **Panasonic NVSD200**

This machine played back tapes at cue forward speed. The cause of the trouble was the BA6871S capstan motor drive chip IC2501. **B.S.**

## **Panasonic NVG21**

This machine worked all right for a ten-year old VCR, but there was no illumination from the multi-function display on the timer board. The cause of most faults with these machines can usually be traced to world-

wearly capacitors in the power supply, but in this case the chopper transformer T1001 was defective – windings S7 and S8, which should supply the filament voltage, didn't. **B.S.**

### **Panasonic NVHS800**

This S-VHS machine would try to load the cassette carriage then power down and sulk. The mechanism is activated by blocking the take-up spool tape end sensor when a cassette is inserted. In this case the transmitter diode D1501 was open-circuit. A replacement LN59P infra-red transmitter diode restored normal operation. **B.S.**

### **Sanyo VHR775E**

The customer complained that one of these normally reliable machines "kept switching off". On test we discovered that when the machine powered up the drum and capstan motors would run at top speed for a few seconds, the machine then shutting down. The cause of the fault turned out to be the BU2896K servo chip IC351, whose capstan and drum servo outputs were continuously high at 5V. A replacement cured the problem. **R.F.**

### **Akai VS22**

This machine was to all intents and purposes dead, with all five outputs from the power supply either missing or very low. The obvious split present in TR12 suggested that there was worse to come, and that a replacement power supply board would be the ideal solution. But that would have written off the machine.

We were able to restore the machine to working order by replacing TR1, TR7, TR12, L8 and C6 however. A mains surge could have led to TR7 and TR1 going short-circuit. This would have split TR12 and burnt out L8, but why should C6 have gone open-circuit at the same time? **R.P.**

### **Panasonic NVSD44**

This machine would take in a tape but would then immediately eject it. The usual cause of this symptom is a stalled capstan motor: the drive chip may be faulty, or the capstan stator unit. In this case however the cause of the fault was the MN67434VRSG main microcontroller chip IC6001. **B.S.**

### **Panasonic NVHS1000**

This top-of-the-range machine was inoperative, with no illumination of any kind from the front display panel. Fortunately the cause of the trouble was a minor one. Transistor Q1102 in the power supply was open-circuit, with the result that there was no unswitched 5V supply. A new 2SD1996STTA transistor restored life to the beast. **B.S.**

### **Samsung SV82IK**

These elegant, neatly-designed machines have proved to be a popular choice with our customers. The dozen or so we've sold recently have produced no serious problems, though there has been one irritating niggle: some won't produce a paused picture in the SP mode without a noise bar at the top. This is more apparent on some machines than on others. A check on the FM envelope produced by our Philips test signal tape showed a slight dip at each end. This was easily corrected by slight anticlockwise adjustment of the input and exit guides. Then, with a fresh recording, we obtained a near-perfect still frame – as you would expect with a four-head machine.

One machine we tested also had no lip sync with our prerecorded Dudley Moore tape – the notes on his piano were in the wrong place! The Philips test tape has a useful 'flash/click' section for checking the phase alignment of the audio/control head. This revealed that the head's lateral adjustment was one FM envelope peak too far from the head drum.

Samsung seem to be unaware of these problems, but if this is the worst trouble we get I for one will excuse the company for the odd off day on the assembly line! **C.A.**

### **Ferguson 3V29/JVC HR7200**

After fitting a service kit to this venerable machine we found that we had no playback picture. Scope checks along the luminance signal path brought us to the playback Y level preset R201, which was open-circuit at the top end. **C.A.**

### **Akai VSF33EK**

If the machine is dead with no display though the power supply is o.k., go to the 120Ω fusible resistor FR221 which is situated near the i.f. module under a left-to-right cross plate. When it goes open-circuit the 'power-down' voltage at pin 5 of the syscon chip IC1 remains high at 5V. The result is complete shut-down of the machine. **R.J.L.**

### **Ferguson 3V35/6/8/JVC HRD120 etc**

There was intermittent flashing/pulling in the E-E mode and the playback picture consisted of horizontal bars. Checks in the power supply revealed that the 9.3V supply was fluctuating quite wildly. The fault came and went when the set-up preset R8 was tapped. Everything was o.k. when a replacement had been fitted and set up. **R.J.L.**

### **GoldStar GSE1296I**

A hum bar in the E-E mode also affected playback etc. Checks in the power supply showed that all the outputs seemed to be affected, but scope checks were inconclusive. After further investigation got us nowhere we resorted to careful electrolytic bridging. Healthy conditions were obtained when C118, a 100μF, 16V electrolytic, was bridged. Replacing it restored correct operation. **R.J.L.**

### **Akai VSF55EK**

Lines flashed across the E-E picture and the machine wouldn't play tapes properly. These symptoms usually mean that C15 is open-circuit. This time it wasn't! The power supply was quietly ticking, and checks at connector WF1 showed that the unregulated 10/13V supply (pin 9) was the cause of the trouble. This led us to C6, whose replacement cured the fault. It's a 100μF electrolytic. **R.J.L.**

### **JVC HRD530/Ferguson FV14T**

There was a hum bar in the E-E mode. It's not the easiest power supply to work on, but scope and meter tests revealed that the 40V supply was low at 30V, with a lovely ripple. Even better, the offending capacitor C5, a 47μF, 63V electrolytic, was sitting above the mains transformer winding, next to C6 which was also suffering from heat stress. This is a 100μF, 63V electrolytic. Two new electrolytics solved this one. **R.J.L.**

### **Roadstar VCR7200**

This VCR kept blowing its 1.25A fuse (F803). Current checks at the fuseholder revealed wild fluctuations

depending on which function was selected. The cause of the fault was traced to C807 (4.7 $\mu$ F, 100V). Once this had been replaced the current measurements returned to an acceptable level. C.N.

### **GoldStar GSE1290IQ**

There were a couple of intermittent problems with this machine: it would sometimes refuse to accept a cassette, and it would sometimes switch from SP to LP. I suspected the mode switch but decided to replace the whole loading block, which includes the mode switch and loading motor. A speed fault was cured by replacing the pinch roller. M.M.

### **Toshiba V513B**

The customer complained of a snowy picture on his other TV sets when he was using this machine. This wasn't a fault condition: the aerial amplifier within the VCR is turned off during playback. As you can't switch it back on in these Thomson machines, if the customer has his aerial system wired so that he can watch tapes throughout the house he can't watch normal off-air TV. Fortunately the shop where the machine was purchased took a sympathetic attitude and exchanged it for another machine. M.M.

### **Sanyo VHR390E**

The customer's complaint was of snowy TV and VCR E-E pictures. We found that liquid spillage had corroded the supply track to the signal booster section of the RF converter module. Cleaning the PCB and adding a link restored the signals. M.M.

### **GoldStar RC703I**

This machine would intermittently loop the tape and would also switch from SP to LP. Originally, when eject was selected the half-load arm would spring back to a position next to the capstan motor, sometimes catching the tape. There's a modification kit to overcome this problem: you replace the cam and gear so that during eject the guide arm stays under the carriage. In addition, check whether the felt that forms the take-up spool's soft brake has come away from the lever: if so, glue it back. This can also be a cause of tape looping on eject. The speed change was cured by replacing the pinch roller.

Part numbers are: modified cam and gear lever 435-450A; mode switch if required 556-133A; pinch roller 333-209C. M.M.

### **Ferguson FV68TX**

This machine was dead with the chopper transistor short-circuit and the mains fuse open-circuit. The cause of the failure was attributed to diodes DP91 and DP92, which are wired in parallel. When they'd been replaced the chopper control chip IP01 still didn't work



### **Matsui VP9401**

This machine wouldn't rewind tapes and would stop when rewind search was selected. The beginning of tape sensor Q1002 was found to be dry-jointed. M.M.

however. To cut a long story short, we had to replace FP01, TP34, TP35, DP16, DP11, RP27 and, again, IP01. To my relief the machine then worked. M.M.

### **Akai VSF15**

Intermittent shutting down and ejecting was the complaint with this machine. When it came to me it would only eject: the loading motor ran in reverse and stalled when it got to the fully eject position. The cause of the trouble was a tiny sliver of solder across two pins of the loading chip - removing this cleared the fault. M.M.

### **Akai VS66EK**

The original fault with this machine was that the mechanism was mistimed. After resetting it we found that there was a lot of interference on the playback and E-E pictures. This was caused by noise from the power supply. It was cured by replacing C15 (100 $\mu$ F, 25V). M.M.

### **Toshiba V804B**

The mechanism was jammed, and the carriage drive lever gear had broken. After replacing this item and retiming the machine I found that the entry guide wasn't going fully home. The guides are made of plastic, and the lugs that keep this one on track had broken. A new guide cured the fault. M.M.

### **Finlux VR3724**

The complaint with this machine was that it wouldn't play and/or damaged tapes. On inspection I found that the capstan motor was not turning. The cause was Q5102 which was open-circuit. G.S.

### **Sanyo VHR190**

Intermittent failure to work with the remote control unit was the complaint with this VCR. I stripped the machine down and removed the remote control receiver, but there were no dry-joints here. On investigating further I found a collection of dry-joints at CN712, which connects the two front panels. Resoldering these dry-joints cured the problem. G.S.

### **Nokia VR3784**

No functions was the complaint with this one - it wouldn't come out of standby. All the outputs from the power supply were present, but the secondary switched supplies were missing. This was because the power-up output from IC301 remained low. Replacing IC301 cured the problem. G.S.

### **Finlux VR3724**

The playback picture had lots of heavy, black horizontal lines across it. When we carried out scope checks around IC101 we found that the waveform at pin 41 was OK but the waveform that returned to the chip at pin 42 was noticeably faulty. The cause of the fault was traced to the 1k $\Omega$  resistor R1007, which biases buffer transistor Q1003, having gone high in value. A new resistor cured the fault. G.S.

### **Sanyo VHR150**

This machine played and searched correctly but there was no or very slow rewind and fast forward operation. Tests showed that the rewind/FF torque was very low.

The clutch seemed to be operating in the wrong mode, supplying play-level torque in the rewind and FF modes. The cause of this was a missing plastic end stop, against which the clutch mode select arm should rest. I inserted a screw in the plastic hole behind the clutch arm to act as an end stop. This restored normal rewind/FF torque. G.S.



# Camcorner

Reports from David C. Woodnott and Nick Beer

## Sony CCDFX500

Although this camcorder powered up all right it wouldn't load a tape. The E-E pictures were fine, but there was no autofocus or zoom operation. These symptoms were all caused by the failure of PS501, an 0-8A circuit protector on board CS35. It protects regulator transistor Q509, which provides the MT5V supply for the loading and zoom/autofocus motors. **D.C.W.**

## Sanyo VMD6P

Complete loss of power is unusual with this camcorder. But here we were, confronted with a blown 3-15A ceramic fuse – doubtless because the DC-DC converter unit B1001 had failed. We fitted replacements, carried out cold checks for shorts etc., then applied power. It was distressing to find that there was no response to our request for activity! The cause of this problem was traced to connector CN304, where pin 3 (VTR PWR UP) was open-circuit.

Once this minor hiccup had been dealt with, all was well in the power-up department. But when a tape was loaded there were no functions. The cause of this final problem was traced to connector CN355 being dry-jointed. It conveys the cassette-down signal to the syscon microcontroller chip. At last all was well! **D.C.W.**

## Sony CCDV88

The customer's complaint had been that this camcorder wouldn't load a tape. When we inserted one however it was accepted and loaded and the machine worked correctly in all modes. We had the machine on test for some time before it decided to exhibit its fault state by going into the caution mode. Switching off then on again showed that the trouble was being caused by absence of the drum FG signals.

We quickly traced the cause to the pick-up device on the top of the drum assembly – the FG section

was failing intermittently. The unit is available only as part of a complete drum assembly, which means an expensive repair when the motor and heads are OK.

Fortunately we had a spare unit from a faulty drum. This saved the day. **D.C.W.**

## Sanyo VMD3P

The JU0336 hybrid chip IC201 was the cause of no sound with this camcorder. After fitting a replacement we changed the dozen or so leaky electrolytics we've mentioned before in this column. This restored the machine to good order. **D.C.W.**

## Hitachi VME10E

The cause of wavy lines that drifted up the E-E picture was traced to C1218, a 10 $\mu$ F, 16V electrolytic on the main camera processing PCB. We cleaned the PCB before fitting a replacement, then finally checked the adjustment of the subcarrier VCO's lock and PLL. **D.C.W.**

## Sony CCDTR8

We removed, cleaned and refitted a stuck iris assembly in one of these miniature machines only to have the problem recur a couple of months later, after little use. An inspection showed that further amounts of excess lubricant were present on the iris vane assembly. We decided to fit a new unit – this is a relatively easy job, as it slides out of the optical block without too much dismantling. The main work involved is to remove the camera's case assemblies. Because of the construction and the method of ribbon cable fitment, this is not as easy as with earlier Sony designs. The moral seems to be to fit a replacement unit the first time. **D.C.W.**

## Panasonic NVR50

Powering up then off is a common symptom with this range of otherwise excellent camcorders.

You will find that the cause is almost always dry-jointed connections at the main and MDA PCB ribbon connectors FP6005, FP302, FP6007 and FP2003. All that's usually required is some resoldering. But access to the connector pins calls for care – with some, screening cans have to be removed to ease the soldering operation. **D.C.W.**

## Canon 850HiE

This unit would power up then go off within ten seconds. Our experience, particularly with Model A10E, suggested trouble with the clock battery. We removed and refitted it, then gave the machine a long soak test. All was well.

Canon has issued a modification when similar symptoms are experienced with Model A10E. It involves fitting a new microcontroller chip. But we don't know of a modification for this model. **D.C.W.**

## Sanyo VMEX22P

The tape couldn't be ejected, though all the other functions operated correctly. The unloading sequence would start when the eject button was pressed, but would stop short of the point where the housing should release the tape. Loading would then restart. The cause of the trouble was that the contacts of the cassette-down switch were permanently made. A new switch put matters right. **D.C.W.**

## Panasonic NVS90

The playback picture's video level varied and the field sync was very weak at best. Scope checks on the luminance playback signal's connections to IC3001 showed that the DC level at pin 2 was excessive. This is the luminance re-entry point for timebase-correction processing. The cause of the trouble was a short between pins 1 and 2 of this hybrid chip, caused by a tiny blob of solder. **N.B.**

# Self-diagnostic SYSTEMS

**T**he move to using microcomputer control via a data bus has made it possible to incorporate self-diagnostic systems in many VCRs and TV sets. This can cut down the amount of time spent during a field call. But because of surface mounting and component miniaturisation, with the need for specialist tools to carry out replacements, it can be impractical to complete repairs

in the field. As a result we might have to go back to the practice of panel swapping, with faulty panels taken back to the workshop for attention. This could in turn lead to decreased reliability, with plugs and sockets giving rise to poor contact and dry-joint problems.

The data bus, which links most of the ICs used in a microcomputer-controlled TV set, enables service adjustments such as height, linearity etc. to be carried out using an 'electronic screwdriver', i.e. a remote control unit that contains the necessary codes. With this type of arrangement it is usually possible to reprogram the set's EEPROM so that different standards, tuning arrangements etc. can be selected.

Another helpful feature is the ability to enter an ideal set up in the remote control unit. This makes installation very easy. If

there is a problem or fault, this can be shown via a remote control unit display. So you can get clues even when there's no tube display.

## Philips GFL Series

With the new Philips GFL series receivers, numbers displayed by the dealer service tool (DST - a remote

control unit) provide error codes that indicate the nature of the fault present. There is also a default mode: this tunes the receiver to 475.25MHz, with the sound and picture settings in a predefined state. Two service pins provide an alternative way of entering the default mode. An error memory can store the last ten errors to occur, which is an advantage when dealing with intermittent faults.

DST operation is simple. The relevant circuit diagram has a flow chart which interprets the error code, telling you which area or even component to check or change. I have been pleasantly surprised by the DST. Initially I thought that an experienced engineer should be able to make a diagnosis after a quick look. While this is true, the DST does speed things up and helps you to get to the cause of a fault with the minimum of hassle. It is of particular help with intermittent faults.

## Toshiba V3 VCRs

The current Toshiba V3 range of VCRs, which has been the subject of previous articles (see January and March issues), incorporates automatic fault self-diagnosis. When a tape transport or power fault occurs, a special chip detects this and produces an error code display. With the top-of-the-range Models V804B/V854B the code is shown visually, using the display at the front of the machine.

When the machine powers down or the tape stops running, the fault is noted by the EEPROM for display. The VCR buttons and the remote control unit buttons have to be used to produce the error code display. Code details are as follows.

First two numbers/letters: these indicate the mode in which the fault occurred, as follows:

00	Standby
01	Stop
02	Rewind
03	Review
04	Fast forward
05	Cue
06	Playback
07	Still, slow playback
08	x2 playback
09	Stop (moisture detected)
0A	Reverse playback
0B	Reverse playback still/slow
0C	Record
0D	Record pause
0E	Power off eject
0F	Eject
10	Short FF
11	Short REW
13	Audio dub

**Many VCRs and TV sets now incorporate self-diagnostic systems, which have advantages and disadvantages. John Coombes on the new approach to servicing**

**Our picture shows the Philips Professional dealer service tool.**



The centre section of the display indicates the basic fault, as follows:

- 01 Drum stopped
- 02 Take-up reel fault
- 03 Supply reel fault
- 04 Cassette in/out fault
- 05 Threading fault

The right-hand numbers/letters indicate the mechanism state when the fault occurred:

- 01 Front loading out
- 03 Loading down
- 05 Tape threading
- 07 Reverse rotation, pinch roller on
- 09 Playback, pinch roller off
- 0B Stop, main brake on
- 0D Fast forward/rewind
- 0F Position not certain

**Panasonic NVSD200B/400B**

Panasonic uses self-diagnostic codes in its NVSD200B and NVSD400B VCRs. When the machine detects a fault during installation or normal use it automatically shows an error code on the display screen.

This consists of five digits. The first indicates the area where checks are required (service mode), the second and third indicate the basic nature of the fault (service data) while the fourth and fifth indicate the the circuit that senses the malfunction (service information).

The engineer can obtain service information displays by pressing FF (fast forward), REW (rewind) and eject at the same time or by short-circuiting the service test point (TP SERV) to chassis.

Service mode checks are as follows:

- 1 Tape protection circuit
- 2 Tape transport mechanism
- 3 Mode switch operation
- 4 Control buttons
- 5 Capstan motor
- 6 Drum motor
- 7 Load/unload operation
- 8 See below

The mode 8 display occurs only when connecting TP SERV to chassis.

Service data codes are as follows:

- 00 No problem (operation is normal)
- 01 Drum has stopped
- 02 Tape reel has stopped
- 03 Stop other than 04 or 06
- 04 Stop during unloading
- 05 Capstan rotation fault
- 06 Stop during cassette in/eject
- 07 Voltage error in record mode
- 08 Voltage error except in record mode
- 09 Data communication error between system control and timer

Mode 1 means check the sensor LED supply and the take-up sensors. The latter can be checked by blocking the light from the LED. If all is well, the service data numbers will show 00. When the light to an end sensor is blocked the data indication will be 01, meaning that the drum has

**Table 1: Self-test checking**

Code	Fault	Check
H01	Drum stops and doesn't start even after tape unloading.	Drum motor drive circuit.
H02	Tape not wound up during unloading, except eject.	Capstan motor drive circuit.
F03	Mechanism stops during mode transition, except eject.	(1) Loading motor drive circuit. (2) Mechanism phase alignment. (3) Mode switch.
F04	Mechanism stops during tape unloading.	(1) Loading motor drive circuit. (2) Mechanism phase alignment.
F05	Tape not wound up during unloading/eject.	(1) Capstan motor drive circuit. (2) Supply/take-up reel pulses.
F06	Mechanism stops after unloading in eject mode.	(1) Loading motor drive circuit. (2) Phase alignment of cassette holder unit.
F07	Record mode supply voltage missing.	Record power supply.
F08	Record supply voltage present but not in record mode.	Record power supply.
F09	No clock pulses between IC6001 and IC7501.	Serial clock data circuit.

stopped. To carry on, press FF, REW and eject together to obtain mode 2.

In this mode the mode switch circuit is checked and the mechanism position indicated. The data numbers provide the indication.

The next mode, 3, checks that the mode switch circuitry has completed its operations. After each of its mechanism movements has been completed, the data number 00 should be shown if correct.

Mode 4 makes sure that the operation circuit is working correctly. This checks whether system control/servo chip IC6001 is receiving data from the buttons and/or remote control unit.

Mode 5 checks the capstan motor circuitry and whether IC6001 has received information to drive the capstan motor.

Mode 6 does the same for the drum drive.

Mode 7 checks the loading and unloading operation. To check the loading function press the play button. Press the stop button to check the unloading. This mode will be displayed indefinitely until the power button is pressed.

There is some additional service data for mode 4. This is obtained when an operating button is pressed, giving a service data number shown in the complete service manual for the Panasonic Model NVSD200B.

The self-test display code consists of a single letter and two numbers. Table 1 provides details.

**In Conclusion**

The developments outlined here show how servicing is changing. Such aids should help us to complete jobs more quickly and increase daily throughput, thus keeping down costs. The problem remains that if the price of new equipment remains low, repairs may still be uneconomical. ■

Reports from Eugene Trundle Philip Blundell AMIEEIE

Simon Bodgett John Coombes Brian Storm

Gerald Smith Mike Leach Robert Marshall

Stephen Leatherbarrow Terry Lamoon

Michael Maurice Keith Evans

## Daewoo V415 etc

Tuning drift is an increasingly common fault with this series of models. While other things can be responsible, the usual cause lies with the three 100nF capacitors C140/1/2 in the tuning voltage integrator/filter circuit. **E.T.**

## Finlux VR2030/Philips

If there is no tacho feedback from the capstan FG to the control system the machine will shut down almost instantaneously. This particular VCR would accept and load a cassette but then ejected it as soon as any deck function was selected. Checks showed that there was no +11a supply to the tacho amplifier on the deck because the decoupling capacitor C2206, at the front of the main PCB, was short-circuit. **E.T.**

## Panasonic NVG25

The customer may not be aware of this fault unless the machine is, for any reason, disconnected from the mains supply – it generally crops up when the machine is on the repair bench for attention to some other fault. The symptom is complete lack of action, the cause being a dried-up kick-start capacitor in the power supply. Look for C1109 (1µF, 400V). **E.T.**

## GoldStar GHV1296PQ

The playback picture would sometimes roll vertically because of poor head/tape contact at the start of the drum wrap. We found that the back-tension lever was not always moving fully to the left, because of a faulty mode switch. It's much

easier to replace than with many other types of VCR. **E.T.**

## Hitachi VTM822/922 etc

We've had three of these machines in recently with front-loading problems. The trouble starts during eject, when the cassette may jam when half way up or collide with the back of the still closed cassette flap.

The cause is a loose metal side plate at the right of the FL assembly. It's labelled the 'RHS bracket gear 411' in the parts diagram. What happens is that the plastic claws that should retain it become fatigued and bent. One cure is to replace bracket 403, but I fit a suitable (that's important!) self-tapping screw into the hollow end of FL shaft assembly 424 – in the hole marked F in the drawing of bracket 411. I then wedge the plastic clickers back into position, and warm the plate with a hairdryer to set them properly. Remove the wedges only when everything has fully cooled (leave the self-tapping screw in place). **E.T.**

## Hitachi VTM720

For low take-up torque (should be 80-170g) check the clutch base assembly for wear. The gear train in the assembly can become stiff because of wear under the take-up gear. **P.B.**

## JVC HRJ420

This fault note could apply to other models. The problem was intermittent E-E picture blanking/video recording, playback of a known good tape being OK. A

scope check showed that in the E-E mode there was a healthy input at pin 62 of the video processor chip IC201, and that it didn't drop out. The output at pin 64 was being disrupted intermittently however, with compressed sync pulses, or half the signal or no signal. What do you do – replace IC201? Wrong!

The signal is probably being disrupted because Q207/212 in the following stage are being switched on by control line 'P. mute', which is going low at random. Having discovered this, some people have changed the microcontroller chip since there are no other obvious problems. But problems there are! One of its input lines, 'sync. det.', is instructing the micro to mute the picture.

The guilty components have been found to be the sync ringing coil T901 and/or the IF module. There should be a distorted sinewave of at least 4V peak-to-peak amplitude at C905, otherwise Q905 will remain off and 'P. mute' is then on. If the sinewave is of lower amplitude and the positive potential above earth is varying by less than 3V, check Q904's input signal.

Another culprit is IF unit TNR2. The 'sync sep' output should be at a DC level of almost 9V, with a 3V negative-going triangular waveform on it. If there is any video signal content here, the IF unit is faulty.

Follow this advice and save JVC the cost of video processing and microcontroller chips. **S.B.**

## GoldStar RF900i

These machines have a fully-enclosed chopper power supply

which is therefore inclined to heat up. Failure of the chopper transistor can be caused by a  $1\mu\text{F}$ , 50V electrolytic drying up and thus going low in value. The best way to tackle this is to replace the transistor, the control chip, rectifier, fusible resistor and the two electrolytics in the feedback supplies around the optocoupler. **S.B.**

### Ferguson FV62

This machine wouldn't accept tapes. The cause was simply dust in the timing slots at the bottom of the drum assembly. A thorough clean restored normal operation. **J.C.**

### Toshiba V110B

When the mains supply was switched on this machine went into the stop mode. After a lot of tests we discovered that replacing the end and supply sensors restored normal operation. **J.C.**

### Akai VSF33

The complaint with this machine was that the tape stuck. When we checked it we found that the tape was sticking in the cassette housing. A replacement damper arm restored normal operation. **J.C.**

### Panasonic NVJ30

When this machine was switched on from cold the top half of the E-E picture would show bad distortion. The distortion would gradually decrease until, a few minutes later, the picture was fine. As with all such ephemeral faults, it took many days of soak bench testing to find the culprit, which turned out to be C768. This  $10\mu\text{F}$  capacitor decouples the 12V supply on the demodulator board. **B.S.**

### Panasonic NVHD90

Reception was consistently disturbed by a 'glitch' – a transient flash that muted the sound momentarily and made the stereo indicator flicker. Since this looked a bit like tuner flashing we tried fitting a replacement. The glitch returned almost immediately. After much scoping and measuring we traced the cause of the fault to C1130, a leaky  $1,000\text{pF}$  ceramic capacitor in the power supply. A replacement restored the tranquility of the 12V supply. **B.S.**

### Panasonic NVSD25

This machine played back all right but any attempt to cue forwards or backwards would result in loss of line lock as the machine tried to default to the NTSC mode. A

number of defects, e.g. worn video heads, poor tape path alignment, incorrect back tension etc., can cause this problem. In this case the cause turned out to be the capstan motor's top bearing, which was almost seized because of a build up of dirt. Once the capstan spindle and bearing had been cleaned and lubricated line lock was maintained in all modes. **B.S.**

### Panasonic NVF55

There was no normal sound or Nicam sound in the E-E mode. After making a few voltage checks we found that the audio defeat line to the Nicam pack was permanently high. The audio defeat line is produced by the M66006FP chip IC7001. A replacement removed the silence. **B.S.**

### Panasonic NVL20

Because the VL and VU lines were wrong we were unable to tune in any channels. These two signals are set by the front panel microcontroller chip IC7501, determining the tuning bands. A replacement M37422V4AF microcontroller chip produced the correct band. **B.S.**

### Panasonic NVJ45

There was an unusual complaint with this machine. When the record mode was selected, some channels on the TV set were affected by heavy diagonal patterning. On a hunch we checked the luminance and chrominance pack carefully for ageing capacitors. Sure enough when C831 ( $4\text{-}7\mu\text{F}$ ) had been turfed out and a replacement fitted the problem had gone. **B.S.**

### Nokia VR3784

This machine had faulty hi-fi sound, the left channel output being very low – in fact virtually missing. Checks carried out around the AN3961NFBP-A hi-fi processing chip IC231 showed that the input side was OK but the left channel output was very low. Replacing this chip cured the fault. **G.S.**

### Samsung VIK316

This machine was completely dead, with no functions whatsoever. Checks in the power supply revealed that the always 5.8V supply at pin 6 of connector CN02 was missing. The rectifier diode in this supply (D34) was OK, but its  $470\mu\text{F}$ , 16V reservoir capacitor C35 had dried up.

When a replacement had been fitted the machine sprang to life, but

the display was rather dimly lit. The cause of this was another dried up capacitor, this time C38 ( $100\mu\text{F}$ , 10V). **M.L.**

### Akai VSF310

This machine wouldn't front load a tape. All the usual checks were carried out: the mechanism timing was checked and a new mode select switch was fitted, all to no avail. I have to admit that it took a lot of investigation before the cause of the fault was found – a dry-joint on the machine's bottom board.

Although the machine wouldn't front load, if a tape was wound in by hand to the stop position all functions would work. In the end I assumed that an end sensor problem had to be the cause of my woes. The dry-joint was where the leads from the left-hand end sensor join the panel, near the mode switch. It couldn't be seen with the naked eye.

Basically, the logic levels at the microcontroller chip weren't quite right when a tape was pushed into the housing. This is what led me to the end sensors. It's one that I would rather forget! **M.L.**

### Samsung VI710

The display produced random flashes and there were no other functions. When one of these machines comes in with the no operation symptom you can usually bet that the STK5333 regulator chip is faulty. On this occasion it was OK, the cause of the rather unusual symptom being the  $3,300\mu\text{F}$ , 16V smoothing capacitor C103. **M.L.**

### Matsui VX2500

No picture was the complaint with this machine. When attempts to clean the video heads didn't help we found that there was no drum servo lock. This was put right by replacing IC2001 (OEC6014B).

With the machine running on its side the drum assembly made a noise. We found that the collar under the dome-shaped flywheel was coming loose. If this collar is not in the correct position relative to the video heads the flywheel, which contains the magnet for the PG head to detect, will also be incorrectly positioned. As a result only a part of the picture will be seen on the screen, the rest of the display consisting of noise. **R.M.**

### Ferguson FV31R

Although this VCR was dead the fuse was OK and so were all the transistors in the power supply. The start-up oscillator signal could be

seen at the junction of RP28/29 but not at the base of TP28. The diodes were all OK except for one – DP16 was very leaky! Incidentally, never leave the base of TP28 disconnected when power is applied. **R.M.**

### **Ferguson FV41**

The complaint was rolling pictures with some tapes. A look at the FM waveform at BF14/6 revealed all – the switching points were incorrect. Adjustment does not involve presets and an oscilloscope with these machines. You simply play back an alignment tape and press and hold 0 and 8 simultaneously. Then, after about two seconds, press stop. This completes the alignment. A tweak on the left-hand guide to straighten up the FM waveform completed the 'repair'. **S.L.**

### **Mitsubishi HSM Series**

We still get a lot of these machines with a cracked plastic capstan motor belt pulley. The pulley and belt jump off the motor, with obvious results. A quick cure, with which we've had a 100 per cent success rate, is to use a pulley from a JVC HRD series motor. It's a perfect fit and the replacement takes just a few minutes. **S.L.**

### **Ferguson FV11R/JVC HRD170**

The cause of a recent case of intermittent signals proved to be extremely difficult to track down at component level, because of its irritating habit of clearing itself as soon as fault finding commenced. Tuning seemed to be normal when the fault was present, with ch. 55 (our local BBC-1) appearing on cue during search tune. But no signals were evident, because there was no output from the BC182 transistor TR15. The input to its base comes from IC4 (TD6359N), which receives data for tuning etc. from the front panel.

After an extended period of testing, TR15's emitter capacitor succumbed to an attack with freezer. It's a 22nF disc capacitor – but the value had fallen to about 3-4nF. **S.L.**

### **Mitsubishi HSMS9**

This machine was completely dead – there was not even a clock display. With the ever-increasing use of switch-mode power supplies in VCRs we were not surprised to find one here. A recent cold spell led me to suspect the electrolytics in the primary side of the supply. I was quickly rewarded: C912 (220µF, 16V) had gone low in value. It

seemed as well to replace the other two electrolytics on the primary side of the circuit, C906 (2-2µF, 200V) and C911 (100µF, 50V). **S.L.**

### **Amstrad VCR4600**

Sound warble was the complaint with this dual-speed machine, the symptom being more apparent in the LP mode. A previous engineer had replaced the capstan motor, the belts, the pinch roller and the capstan drive chip.

A check showed that the capstan control waveform at TP22 was incorrect, with a couple of extra negative-going pulses present. These drifted and, when coincident with the control pulse, reduced its effective amplitude. The capstan control loop then failed. We eventually found that the extra pulses were being produced by the BA718 dual op-amp chip IC302. **S.L.**

### **Matsui VP9501OP**

This machine came in with mechanical problems such as not loading correctly. Someone had already fitted the usual replacement mode switch. I checked the alignment, which was OK underneath. When I inspected the top area however I noticed that the idler lever was disengaged from the idler wheel. The machine worked correctly when this item had been put back in its correct position. **T.L.**

### **Philips VR712**

There was no front display although all the functions worked. The display was receiving data and its main LT supply was present, but there was no heater voltage. When I traced the source of this back to the power supply I found an open-circuit Wickman fuse, 1216. A replacement restored the display. **T.L.**

### **Matsui VP9401 etc**

A warning about this and similar models: when you put the deck back into position after replacing the mode switch, make sure that you do not crush the central LED tower as you can short the two unprotected leads together, causing strange mechanical symptoms. It's easy to do this, not so easy to find the cause of the resultant faults. **T.L.**

### **Sanyo VHR390**

Whatever function was selected, the tape would stop after a few seconds. This can be caused by dirt on the take-up spool or its sensor, or a faulty sensor. The first thing to do is to remove the take-up spool and examine the black and silver

sectors. Check whether the black sectors are really black. If in doubt, replace the take-up spool and sensor.

When cleaning the spool use a clean, dry cloth. Don't apply much pressure, otherwise the black paint will come off. **M.M.**

### **Ferguson FV33H**

This VCR was dead. When it was switched on at the mains, a small arc could be seen near the chopper transistor's heatsink. We cured the problem by cutting the track near the heatsink lug and replacing it with a small length of insulated wire. **M.M.**

### **Ferguson FV80L**

I'm not sure how this machine, which came from another dealer, came to be so badly misaligned. The carriage was in the eject position, the pinch roller was approximately 3mm from the capstan shaft and the guides were a quarter of the way into their travel! Fortunately nothing was broken or damaged and deck realignment put matters right. **M.M.**

### **Fisher FVHP716**

This machine would occasionally drop into the timer mode and refuse to come out. During our investigation, the LT fuse F902 failed for no apparent reason – but maybe this was a clue. When the fault finally reappeared, the LT voltages were all very low. The main 22V feed to the power chip had dropped to just 9V. On checking back to the transformer we found that there was a dry-joint at connector PV903, which links the 18V AC supply to the regulator board. **K.E.**

### **Sanyo VHR291**

This hi-fi stereo machine would occasionally fail to eject the cassette. The problem could usually be cured by briefly disconnecting the mains power, thus resetting the microcontroller chip. This didn't always work however, and was causing the user some frustration. This not uncommon symptom pointed to our old friend the mode select switch. But beware! It's buried under the loading motor block. Thus a service manual is almost essential, to be able to reset the timing marks on the cam gears and sprockets.

It's worth checking the condition of the loading motor belt while the loading block is out and you have easy access to it. **K.E.**



## Ferguson FC28

We've had intermittent power-up faults before with this model. The usual cause is a leaky capacitor that decouples the power-on line to the mechacon chip. This time there was a different cause. R302-304 in the same power-on circuit were dry-jointed.

## JVC GRAX400E

This unit would switch between the SP and LP modes and back during play. In addition the clock data was intermittent. The cause of both symptoms was at the connection of the VTR operation assembly ribbon to the main PCB socket. Cleaning and refitting cleared the troubles.

## Sanyo VMD1P

There was no operation with this oldie. When it was shaken, something could be heard rattling around inside. A screw had become detached and had fallen into 'the words', causing failure of the 3.15A ceramic fuse. We fitted a replacement then checked for possible short-circuits etc. A soak test proved that even old machines can produce good results.

## Panasonic NVS20B

Intermittent operation was the complaint with this unit. On test we found that it worked for long periods at a time with no problems. While observing its operation we noticed that failure usually occurred at the end of tape loading. If this operation was performed correctly all was well. If not, a second attempt would usually also fail.

The final mechanical loading movement was the problem area. We first thought that the guide assembly was sticking. As checks here proved to be inconclusive, we decided to replace the mode encoder switch. This restored normal operation. The job is quite understandably left until last, as the switch is buried deep within the mechanism.

## Canon A2H.E (Sony U Mechanism)

If you get one of these in with the common fault, which you also get with Sony models, of a detached coaster assembly, give a slightly higher estimate. Because of the amount of dismantling required to gain access, the time taken is likely to be considerably longer. If possible, before dismantling the unit check that the capstan motor bearing isn't noisy – this may avoid a repeat strip down.

## Sony ACV25 Adaptor

There was no operation: after replacing Q301, R110 and R104/5/6 we modified the unit as laid down in the Sony bulletin.

## Canon E230E

We had previously replaced most of the small can electrolytics, mentioned in other Canon reports, in this camcorder. Here it was back again, just within its guarantee. It wouldn't operate in any mode, being to all intents and purposes dead. The cause was simply failure of the VTR operation PCB assembly, which is stuck to the internal case moulding. A replacement restored normal operation.

When fitting a new unit, take care over its positioning – you don't get two goes! – and the dressing of the ribbon cable to the main PCB connector. Note that it's as well to disconnect this unit when working on the main PCB. On/off and eject can be achieved by earthing the appropriate connection to the operation PCB socket, all other functions being available via the remote control unit. Very clever to have a remote control unit that

doubles as a means of operating the service modes. Even better, it can be used with most if not all Canon models.

## Canon UC16E

This is a version of the UC15 with a colour viewfinder. The fault report said "picture disappears when warmed up", and so it did: after about five minutes the E-E picture gradually darkened until it disappeared completely. So we carried out checks around the camera processing circuitry, including the iris section. We found that C2115 (1µF) was temperature sensitive: it's part of a clamp circuit at pin 26 of the sample-and-hold and AGC chip IC2101. Once a replacement capacitor had been fitted the picture behaved itself.

## JVC GR303

Failure to record, playback OK was the complaint with this one. We found that connectors CN5 on the A-V PCB and CN14 on the main PCB had become detached from their locations: resoldering cured the problem. Reassembling the unit into its case parts can be a tricky operation – whoever designed it?

## Sony CCDV30

Incorrect auto-focusing action was caused by a faulty limit switch: because of metal fatigue, one switch leaf had become detached.

## Ferguson FC27

Intermittent power up and intermittent eject were the reported faults. The unit would sometimes run continuously without any trouble, only to fail when tried next day. We carried out cold checks on the mode switch and the buffer circuit to the mechacon chip and noted the usual readings. To cut a long story short, we eventually found that the electrolytic capacitor C317 (47µF) had leaked over much of the relevant circuitry. A new capacitor and a PCB clean up put matters right. Needless to say C317 was not itself involved with the circuitry that produced the fault symptoms! ■

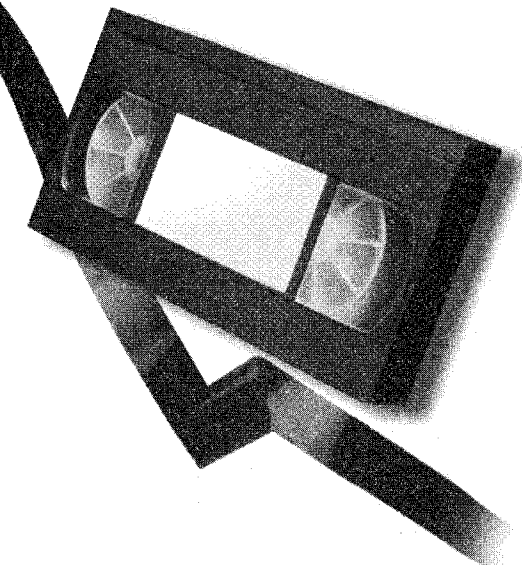

# VCR Clinic

Reports from Philip Blundell, AMIEEIE, Richard Flowerday, Paul Hardy, Justin Smith, John Pitt-Francis, Brian Storm, Michael Dranfield, Michael Maurice, Graham Richards and Roger White

## Philips VR6470

"Chews tapes" was the complaint with this VCR. When we tested the machine the tape played for a while then the take-up spool stopped. With the clear cassette in place we saw that the brake magnet released, the brakes then coming on. Transistor 7053 on the servo board operates the brake magnet. The transistor was OK, but the wire between it and the magnet was open-circuit: there was a dry-joint where the wire is connected to the magnet. **P.B.**

## Toshiba V509B

Usually when play was tried the drum didn't rotate. Sometimes however it ran much too fast. Checks around the TD6361 servo chip showed that the voltage at pin 35 was incorrect. The Toshiba stock fault book suggests that C516 (0.01 $\mu$ F) can be responsible for this. It was OK however. A new TD6361-A6 chip was required. **P.B.**

## Grundig VS600/700/800/900 Series

If the start and end sensors don't work, check that the LED tower is receiving drive pulses. Loss of these pulses can be caused by failure of transistor CT275 or CT285 (circuit reference depends on the model). It was originally type BC848B. Uprate it to type BC818A or B. **P.B.**

## Hitachi VTM722E

A cassette had got stuck in this machine and had been removed by the customer (why do they do it?).

When we'd reassembled the housing the machine wouldn't accept a cassette. Checks at the loading motor drive chip IC753 showed that its 14V supply was missing. The cause of this was failure of the 2SD1765 series regulator transistor Q601, which had gone open-circuit. It's mounted on the main PCB. When we'd fitted a replacement the machine still wouldn't accept a tape, reverting to standby after a short time.

We eventually found that the loading motor was trying to run in the unload direction, despite the fact that the cassette lift was fully up. The reason for this was that the unload pin (42) of the system microcontroller chip IC751 (type CXP50116-116Q) was permanently high. Replacing this 80-pin chip restored normal operation. **R.F.**

## Mitsubishi HSM54

A cassette was stuck in this machine, with a large loop of tape in the works. When I removed the bottom cover to operate the wind mechanism manually I found that the pulley on the capstan motor was split. My manual doesn't show this as a separate item, but Willow Vale stock it (reference no. 77054P). It's not cheap for a bit of plastic but is a lot cheaper than a new motor. **P.H.**

## Toshiba V57/JVC HRD225/ Ferguson 3V36

This machine needed new heads. We fitted a new drum and carried out a full mechanical service. After

a couple of weeks however the customer reported that there was a problem with the sound – any sustained note suffered from wow. As a new pinch roller made no difference, I took the machine back to the workshop.

A scope check showed that the capstan servo would periodically hunt. The control pulses and signals from the capstan motor were present, and servo alignment failed to improve matters. So a new motor was tried. This again made no difference. The culprit turned out to be the capstan belt. The one I'd fitted as part of the service obviously had a tight spot, though it felt all right and there were no obvious signs of poor manufacture. **P.H.**

## Hitachi VT8000

After carrying out a mechanical service there was still intermittent fast-forward operation. The cause was traced to the rear-most microswitch on the deck. It had a loose fitting case, which resulted in premature operation. A replacement cured the trouble. **P.H.**

## Ferguson 3V42/JVC HRD455

Poor audio was the complaint with this machine. A piece of sticky label was found attached to the AC head. I removed this and cleaned the head but the fault persisted. Audio was fine at the AV socket and was present at the input to the modulator, which was the cause of the trouble. I sent it to MCES for attention. The returned unit fixed



the problem. Full marks to MCES, as usual. **P.H.**

### **Panasonic NVJ35**

The complaint was that this machine wouldn't eject a cassette. On test it wouldn't power up. C9 in the power supply was open-circuit. After replacing this I found that the capstan speed was erratic and there were tracking problems on the picture. C18 and C22 in the power supply were low in value. **P.H.**

### **Sharp VC681HM**

After replacing the belts, pinch roller and reel drive unit this machine seemed to be all right. Several weeks later it was back on the bench, with the complaint that the audio was poor. This turned out to be intermittent, so we asked the customer for a tape that showed the symptom. Sure enough it sounded as if the capstan was running slow – but only at the start of a tape. The sound was fine a few minutes later.

I eventually traced the cause of the trouble to the tape guide between the audio/control head and the pinch roller. It showed signs of wear on its lower edge and was slightly out of alignment. Slight readjustment cured the problem. **P.H.**

### **Ferguson FV31R**

The original fault was failure to load. This was cured by removing the debris that jammed the entry guide. I then gave the machine a good clean up and tested it. Playback produced normal sound but no picture: the display consisted of white diamond shapes, about the size of a large postage stamp, on a black background. Using the AV connector output produced the same result.

I hinged out the top board and attached the scope probe to test point BW10. Normal video was present. Refitting the board produced the same fault symptom. The cause of the trouble was traced to the board fixing screw at the right-hand side, where it screws into the cassette housing. It was shorting an adjacent PCB track. An insulating washer beneath the screw cured the problem.

You could get the same trouble with Models **FV30** and **FV32**. **P.H.**

### **Sharp VC750**

The customer's complaint was that this machine would sometimes jam and now had a tape firmly stuck in it. I found that loading gear A had a broken tooth and that the master cam was worn. Replacing these

items and the mode switch put matters right. **P.H.**

### **Grundig VS310**

This machine was reluctant to accept a tape and showed F9 in the display. Once many dry-joints had been resoldered and subpanel mounting pins cleaned the machine seemed to be more keen on the idea of working, but it still wasn't very co-operative. I then noticed that there was no tuning memory. After replacing the back-up battery the F9 indication disappeared and full operation was restored. The battery is mounted on the main panel and is heavily disguised.

Unfortunately however the E-E vision was very poor, especially from cold. Faults that appear before equipment has warmed up are usually caused by either dry-joints or defective capacitors. When all three capacitors (C2251, C2254 and C2261) on the video board, next to the tuner, had been replaced the customer was able to resume his endless taping of *Neighbours* and other such anodyne examples of antipodian culture. . . **J.S.**

### **Hitachi VT520**

Low sound and intermittent jumping/critical tracking indicated that the audio/control head was faulty. At last we seem to be getting some sensibly priced alternatives. **J.P-F.**

### **Amstrad VCR4700**

Fast forward and rewind were OK but when play was selected all we got was about two seconds of freeze frame. Surprisingly, the cause was simply the pinch lever arm action being too stiff. The 'grease' was more akin to glue that has nearly set. A good clean up with alcohol and a smear of Molyslip put the machine to rights.

We've had the same problem with other decks. **J.P-F.**

### **Sony SLV315**

The cause of power failure was traced to C111 which had gone low in value **J.P-F.**

### **Panasonic NVG21**

This machine suffered from unreliable tape unlacing action. The cure was to replace the play arm unit, part no. VXL1490. **J.P-F.**

### **Matsui VR805**

The fast forward and rewind operations were poor and the machine chewed tapes. Although cleaning the idler helped with

rewind, the reel motor wouldn't work at the low voltages supplied in the take-up mode. After ten years or so this VCR deserved and got a new motor. **J.P-F.**

### **Samsung SI7230**

Unreliable eject was the problem with this machine. After fitting a new loading belt and release belt I received a recall. The final solution was a new motor, CPC code no. SS64769-052-140. **J.P-F.**

### **Panasonic NVHD100**

The owner of this machine had included a recording to illustrate the fault: about once every half hour there was an interruption – a missing word, a flick of the picture or a jump in the scene. We came to the conclusion that the fault was probably caused by the capstan motor stopping briefly or slowing down every so often. Inspection of the XRA6439P capstan drive chip showed that its heatsink was very loose. For good measure we replaced the chip and refitted the heatsink securely. So far there have been no further interruptions. **B.S.**

### **Panasonic NVJ47**

The head drum was very reluctant to rotate. It would eventually do so on about the third attempt. The result however was a picture that readily smeared across the screen as the drum servo struggled to maintain lock. Checks around the drum drive chip showed that C206, which is connected to pin 12, was defective. A new 0.1µF electrolytic capacitor cured the fault. **B.S.**

### **Panasonic NVFS100**

The playback picture was marred by faint diagonal patterning. C3311 in the HQ pack is the usual suspect when this symptom is present. On this occasion it was OK. Deep in the bowels of the machine you will find the 1H CCD delay line pack – on the sub-luminance and chrominance board. Several small capacitors here can die: C3501, C3506 and C3516 often fail. This time C3509 (3.3µF) had expired. After replacing it we had a very good, clean picture. **B.S.**

### **Matsui VP9501**

This machine's deck was jammed up solid: it would move neither forwards nor backwards. The cause of the problem turned out to be the reel drive clutch shift quadrant, which had jumped out of its track on the master cam. As a precaution we replaced the mode switch, in case it

allowed the deck to ever run. We've not seen the machine since. **M.Dr.**

### **Matsui VP9301**

Poor IF stability and streaking can be cured by replacing the three 0.47µF, 50V capacitors in the IF module. We use 1µF replacements. **M.Dr.**

### **Panasonic NVJ35**

The reported fault was that the counter had gone berserk. On inspection I found that in the search mode the tape moved up the head. The cause was post assembly P5 which was bent. Replacement restored normal operation. **M.M.**

### **Matsui VX2000Y**

This machine would cut out intermittently and would snap the tape at the end of rewind. The cause of the trouble was a dry-joint at D01, the sensor LED on the deck PCB. **M.M.**

### **Panasonic NVJ47**

This machine kept on coming back to the workshop because it would intermittently switch itself on or off. The cause was simple: the VCR button on the front panel was gummed up. As a result it randomly switched on the power. A good clean up cleared the fault. **M.M.**

### **Akai VSF510**

This machine wouldn't play tapes – the screen went green. The cause of the fault was absence of the playback 5V line because of a damaged port at IC504. A new chip cured the trouble. **M.M.**

### **Matsui VP9301**

The playback picture suffered from static interference which was caused by the drum assembly. Unfortunately the upper and lower drums cannot be separated for cleaning, so a complete new unit had to be fitted. **M.M.**

### **Hitachi VTM822**

There were intermittent problems with this machine: it would stop playing or go into other modes – in fact it seemed to have a mind of its own. Resoldering the micro-controller chip seemed to put matters right, but the repair bounced. The cause of the trouble was that the connectors between the main PCB and the operating PCB were dry-jointed. Resoldering them put an end to the playing about. **M.M.**

### **Panasonic NVL25**

There were two faults with this VCR. The first was mechanical – it required a new carriage RHS,

connection gear and retiming of the gears. Secondly the booster circuit in the tuner block had low gain. We usually have to fit a new tuner, but these are expensive. On inspection however we found that there were several dry-joints in the booster section. Resoldering cured the fault. **M.M.**

### **Toshiba V711B**

There was no power and we found that Z613 on the sub-PCB was open-circuit. Traces of liquid spillage were present in the vicinity of connector P603. Replacing Z613 and P603 and giving the machine a good clean up brought it back to life. **M.M.**

### **Panasonic NVF65**

This machine would turn itself off when any function was selected. The cause of the fault was the reel optocouplers, part no. ON2170. **M.M.**

### **Sharp VC105HM/VCA111HM**

Replace the belt if cassettes are ejected immediately. For erratic mechanical functions, remove and clean the mode switch or, better still, replace it. The cure for poor rewind is to remove the spools and clean both shafts. The up/down movement of the clutch reel mechanism can sometimes stick, causing search and wind problems. In most cases this problem can be cured by cleaning the shaft and lubricating with silicone grease spray. **G.R.**

### **Toshiba V312B**

The complaint was no functions. Voltage checks showed that the 14V supply was missing. A resistance measurement at pin 1 of the L2726 loading motor drive chip IC760 produced a short-circuit reading. The cause of the problem was the loading motor, which produced a reading of 4Ω. The chip and motor were replaced, also the cassette door lever, restoring the machine to rights. **G.R.**

### **Amstrad DD8900**

This is the double decker. The problem we had with one of them was intermittent recording. We found that the cause was dry-joints at IC53 (78M05) on the lower video PCB. Another of these devices, on the upper PCB, was OK. **G.R.**

### **Samsung SI1260**

This machine wouldn't respond when a cassette was inserted. A scope check on the logic condition at input pin 5 of the KA8301/BA6209 loading motor drive chip

IC206 showed that it changed state. So we replaced the chip, fitting a BA6209 as it seems to be much more reliable. This brought the machine back to life. The BA6219 is also a suitable replacement – it's higher rated than the BA6209. **G.R.**

### **ITT VR3907/Samsung VI611**

If there are hum bars on the E-E picture, check the 100µF, 100V smoothing electrolytic capacitor C4 connected to the 33V line. **G.R.**

### **Alba VCR6700/Bush VCR185**

There was no playback FM – though we'd cleaned the heads first! Careful checks on the record and playback 12V supplies to the head amplifier showed that in both modes the rec 12V line was stuck at 2.5V. Although it read OK, we replaced the rec supply switching transistor Q505. This cleared the fault. We used a BC546. **G.R.**

### **Saisho VR1200**

There was very poor take-up. Rewind and fast forward were OK, and the clutch seemed to be working. When I removed the idler it was obviously too stiff. So I dismantled it and cleaned the spindle. On reassembly all was well. **R.W.**

### **Sony SVL625**

Some cassettes, but only a few, would go in but wouldn't go all the way down. After a few seconds they would come back up. After inserting one of these cassettes many times and watching what happened I noticed that the left-hand carriage release lever was bent back towards the cassette. Straightening it cured the fault. **R.W.**

### **Alba VTV10**

There was no playback picture. It was as though the heads were dirty. The cause of the trouble was that the record high supply to the head amplifier was present in the playback mode. Q10 was short-circuit. **R.W.**

### **Samsung VI1860**

This machine wouldn't accept a tape. The tape-in light was on, and when the power button was pressed the head rotated and the supply reel wound back. This lasted for about five seconds, then everything stopped with the power light flashing. It looked very much like an end sensor fault. In fact the 5V supply to the deck PCB was only 0.5V. D601, a 1N4148 diode on the print side of the syscon PCB, was faulty. **R.W.** ■

# Servicing the Hitachi VTM720/722

**John Coombes on dealing with the problems you may encounter with these VCRs**

**T**he VTM720 and VTM722 were Hitachi's basic models during the period 1990-2, the 722 being a two-speed version. We've had the following fault conditions with them.

## **Mechanical Faults**

**Failure to accept or eject a cassette:** The cassette side holders can jam in the runners. If these are not jammed, check whether the base holder is bent – this will also result in jammed side holders. Another possibility is the shaft assemblies: if force is used to insert a cassette the plastic ends break off. Should you have to replace the shaft assembly, be sure to lubricate the ends with Sonic Slidas oil (#1600).

If the gear bracket has to be removed because of a jammed tape, ensure that the worm shaft and worm are lubricated, the former with Slidas oil and the latter with Froil (G31SAY). The worm wheel assembly should be lubricated with Froil.

If a cassette is accepted but won't come back out because the door fails to open, you will find that the bracket which fits into the cassette door assembly to lift it is broken.

**Noisy rewind and/or fast forward:** Check the capstan motor – it may be necessary to remove the flywheel to clean and relubricate the shaft and bearing. If the capstan motor is at fault it will usually also be noisy when ejecting a tape. See below.

Alternatively the clutch base assembly could be at fault. Either replace or dismantle and clean all the cogs, removing any hard grease that could be causing friction and noise.

Change the reel belt if this has stretched.

**Lines across the picture:** If the off-tape FM waveform is incorrect, check that the guide poles are correctly set up. Reset as necessary, then lock the Allen screw tight and seal.

**Loading problems:** The loading motor block may be faulty. If the block is OK, check the worm gear and mode gear – the latter could have damaged teeth.

**Tape looping:** This can be caused by a worn pinch roller. Alternatively the take-up spool may not be running freely – clean and relubricate the spindle.

**Noisy operation:** The capstan motor could be faulty. In most cases however the cure is a spot of grease on the drum brush. The lower drum motor may be noisy.

**Poor sound and possible poor picture:** The audio/control head may be misaligned. If there is tape creasing at the bottom, check that the azimuth tilt is correct. Alternatively the head may be clogged – bad clogging will result in

muffled sound and/or a broken up picture, and the sound may be slow. If cleaning doesn't cure this, replace the head.

**Picture tearing or jumping:** If the tearing is mainly at the top of the picture, the audio-control head is probably faulty. The basic fault can be caused by incorrect back tension because the tension band is misadjusted or damaged. Don't confuse this fault with the TV set not being on an AV channel – this will cause hooking.

**Poor playback picture, sound OK:** The cause may simply be dirty video heads. When the VTM722 is used in the LP mode the picture may jump, roll or just be very unstable because the lower drum is worn. This may also make it look as if only one head is working. If you are unsure, check the off-tape FM waveform.

**Failure to erase the previous sound track:** If cleaning the erase head doesn't provide a cure, check the erase head connections.

**Guides not loading correctly:** Check that the guide rollers are tight and correctly positioned. If still in trouble check the plate for a bent piece of metal that prevents the guide reaching the stop position.

**Capstan motor faults:** The capstan motor requires regular servicing. There can be various symptoms: noisy rewind and/or fast forward operation, also very noisy eject, or sometimes you may get intermittent pauses during playback. Cleaning and relubricating the spindle will usually put matters right. If the spindle has a ridge on it and/or a heat mark however the capstan motor will have to be replaced. The motor can also stop and jam the tape. The result may be tape chewing or the VCR coming to a halt. With all these problems it is as well to replace the reel belt.

**Colour beating:** Possible causes are an excessively dirty erase head, poor connections to the head, also broken leads because of incorrect positioning.

## **Incorrect Loading**

This can be caused by electrical or mechanical (see previous note) faults. It's often very intermittent and can usually be cured by replacing the loading motor block complete. You may get intermittent loading, half loading or half loading then eject, with the tape chewed or left half in/out. The VCR may fail to lace the tape and just eject it. These things can all be caused by the mode selector switch.

Alternatively the CXP50116-116Q microcontroller chip IC751 can cause the same problems when faulty.

When faulty the XRA6209U4 loading motor drive chip IC753 can be responsible for failure to load, intermittent

loading or slow eject. Check that its 14V supply is present at pin 7. If this is missing, check back to source. Before replacing IC753 check whether the HZS9A-2 zener diode D753 is short-circuit.

## Electrical Faults

**Incorrect capstan motor speed:** The capstan motor can be the cause of this but, apart from the previous note under mechanical faults, it has proved to be reliable. Check that the FG pulses are reaching pin 2 of the BA6993 FG amplifier chip IC602. If they are missing, trace the path back to the capstan motor and FG pickup. If they are present, check for output pulses at pin 1. Replace IC602 if there are no pulses here. If IC602 is OK, check for pulses at pin 21 of the HD49747NT servo control chip IC601. No pulses here could mean that IC601 is faulty or perhaps C622 (0.47 $\mu$ F, 50V) is short-circuit. Next check for pulses at pin 27 of IC601. If there's no output, replace IC601. If IC601 is OK, trace through to the SA2007A capstan motor drive chip IC1M.

**Drum motor not locked:** The symptoms may be intermittent noise over the picture then normal lock for a short time. If there are no drum FG pulses, check the BA6459P1 drum motor drive chip IC1651. If this is OK, the FG coils could be at fault. They are in the lower drum unit. If this is all OK, suspect IC601 (HD49747NT) – check its output at pin 12. If this is present, trace back to the drum motor drive chip. If not, C603 (1 $\mu$ F, 50V) could be open-circuit. If C603 is OK, replace IC601.

**No colour:** Ensure that the DC conditions are correct around the M52057FP chip IC301. If all is OK here, X301 (4.433MHz) could be dry-jointed or faulty.

## Power Supply Faults

The most common fault with these VCRs is no results. The cause might be an open-circuit mains feed, open-circuit input fuses or faulty bridge rectifier diodes. If these items are all OK, check the regulator chips. The 5V regulator is IC851 (RC78M05E), the 12V regulator IC852 (RC78M12FA). They can go open- or short-circuit. If necessary check whether C860 (10 $\mu$ F, 16V) in the 12V supply is short-circuit.

## No Display

Ensure that the -30V supply is reaching the system control PCB. This powers the display unit's filament. If the supply is missing, check back to its source on the power supply PCB. If the supply is present, the display unit could be faulty. Check that the CXP50116-116Q chip IC751 is receiving the -30V supply at pin 76, and that its 5V supply is present. If so but the display is not being driven, crystal X751 (4.19MHz) could be dry-jointed or faulty or IC751 defective. Check by replacement.

If various segments are not lit or are partly lit, IC751 or the display could be faulty. Again check by replacement.

## Remote Control Faults

If the remote control unit provides no functions or display, check that the battery connections are soldered correctly with no dry-joints and that the spring is pulled out far enough to make contact, also that the batteries themselves are OK. If the display is lit up but there are no commands, check the connections to the LED. The connections to the crystals could be broken, damaged or dry-jointed. If necessary replace the crystals. If the remote control unit is producing an infra-red output but there is no remote control operation, check whether the TV/VTR2/VTR1 switch SW01 is correctly set. There will be no operation if it's in

the TV position, or if the VCR is set to VTR1 and the handset to VTR2 or vice versa.

If various buttons don't work, check the rubber sheet for wear or clean the pad and buttons. Alternatively the M50933-102FP chip IC01 could be faulty. IC01 can also be responsible for no display, a dim display and/or various segments not lighting up.

The handset could have been damaged by rough use. If it has been dropped the PCB could be broken, giving total failure or intermittent operation. Spillage is another possible cause of intermittent operation.

## Regular Maintenance

Regular replacement of the head cleaning roller is important. It can get very dirty: this can result in ruined heads. Check the complete tape transport system. Dirty video heads can cause loss of colour and/or field jitter, even horizontal jitter.

Replace the reel belt if fast forward/rewind don't work. If these operations are slow, the belt could be dirty. Clean the belt and all pulleys.

Check the pinch roller. If this is worn, the tape might not run or be slack.

If the back tension is excessive the result can be bent verticals or hooking at the top of the picture. Check that the spring is set in position A. It may be necessary to check the tension pole position – refer to the service manual.

Always ensure that the plug top pins are insulated and that the correct (3A) fuse is fitted. Inspect the mains lead for cuts, damage or insulation breakdown. ■

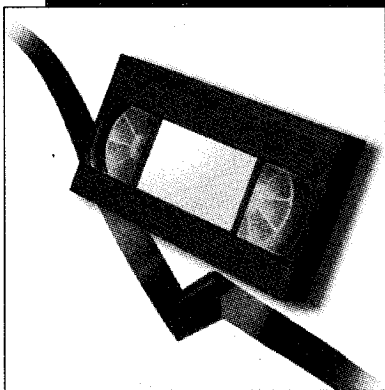

# VCR Clinic

**Reports from Philip Blundell, AMIEEIE, Michael Dranfield, Eugene Trundle, Paul Hardy, Keith Evans, Chris Watton, Simon Bodgett, Robert C. Meade, Graham Thompson and Michael Maurice**

## **Philips VR6761 etc**

If the symptoms displayed by one of these machines look as if a video head has failed, check for the presence of the head switching pulses (HP) at pin 7 of plug L6 on the head amplifier module before ordering new heads. The HP pulses can go missing because of a broken wire from plug B15 on the lower logic/servo board P606 to plug S2 on the top signals board P303. The solid-cored wire takes exception to being flexed too often. **P.B.**

## **Toshiba V404**

If the machine plays all right but there's no front display, check whether RP051 (39 $\Omega$ , safety) in the power supply is open-circuit. A possible cause of its failure is that the ribbon cable to connector PK02 on the front panel is incorrectly routed, with the ribbon chafing on the cabinet top. The resistor's part no. is 70041116. **P.B.**

## **Samsung VIK310, 320, 350, 375 Series**

These VCRs suffer from a serious problem in the fully-enclosed chopper power supply. C110

(100 $\mu$ F, 25), which provides negative bias for the error amplifier within the STR11006 chip IC101 to control the regulation, dries up. When it loses capacitance, the negative feedback at pin 1 of IC101 falls. As a result the chip thinks that the output voltages have fallen and attempts to increase them, causing a lot of damage.

When a customer brings in one of these machines never, whatever the complaint, plug it in without first replacing C110. If a machine goes off during say a power cut and is left off for any length of time the power supply can blow up (if you are lucky!) when power is restored. If you are unlucky, you can find yourself replacing endless components. In some cases the burnt up components can damage the main PCB.

In addition to replacing C110 it's advisable to replace C122 (2.2 $\mu$ F, 250V) and C109 (47 $\mu$ F, 100V). **M.Dr.**

## **Sharp VCA615 etc**

In this range of VCRs the tape should shuffle backwards and forwards after loading. If this doesn't happen, the capstan motor is usually faulty. The small 10 $\mu$ F, 25V capacitor leaks electrolyte that eats the print away. Don't despair: the damage can easily be mended with some fine wire. **M.Dr.**

## **Ferguson FV71**

This machine had failed to come back on after a power cut. There were no dried up capacitors this time: TP91 (2SA1020) was short-circuit collector-to-emitter. A replacement restored normal operation. **M.Dr.**

## **Memorex VR2150**

Apart from fast forward/rewind this

machine worked normally. In the fast wind modes the torque was very low – the same as the play torque in fact. We suspected the mode switch, and managed to match it up with a Sanyo one stocked by Chas Hyde and Son Ltd. (part no. 11600CF). The only problems were that a fair amount of dismantling was required and to reassemble/align the mechanism we had to obtain a service manual from Tandy at £21. The new switch cured the trouble however. **M.Dr.**

## **JVC HRD750**

These excellent machines are six or seven years old now. Thus some are suffering from dried up electrolytics in the power supply. If the problem is total loss of action, check C14 (1 $\mu$ F, 50V) and C13 (180 $\mu$ F, 16V) in the chopper circuit. **E.T.**

## **Panasonic NVG21**

The fault with this machine was very intermittent and it took us a long time to track down the culprit. When the fault was present there was complete loss of action: even the clock display went out, leaving only the green cassette-in indicator (near the standby switch) alight to indicate that power was reaching the machine. The culprit turned out to be the STK5338 regulator chip IC1001 in the power supply can. **E.T.**

## **Toshiba V611B**

This machine's fault would put in an appearance about once every three months. When it did appear the symptoms were no eject, no deck functions and a seemingly jammed tape-loading mechanism, culminating in shut down. Loading motor M003 was the culprit. In the fault condition it drew 600mA from the 5V supply with no mechanical load. So we also replaced its driver chip IC603. There

was a clue, had we realised it: picture interference when the faulty motor was running. **E.T.**

### Hitachi VTM112E

This machine wouldn't accept a cassette – the half-load lever would not retract. I partially stripped the mode gear assembly, half expecting to find the gear damaged. What I actually found was a split washer jammed in one of the cam-gear grooves. As no split washer seemed to be missing from the mechanism, I assume that it had fallen in during manufacture. I managed to get it out without having to dismantle the mechanism completely. **P.H.**

### Hitachi VT5890E

I had no information on this machine and the customer was extremely vague about what the problem was. After some testing I found that a still picture would sometimes be displayed although the still command hadn't been used. This usually happened after a reverse search then going back to play. A tight capstan motor was the cause of the trouble. I took it to bits, cleaned and greased the bearings then reassembled it. This fixed the fault. **P.H.**

### Sharp VCH81H

A cassette was jammed in the mechanism. After extracting it manually and confirming that there was no mechanical damage I inserted another cassette, but it wouldn't play and there was no capstan rotation. The supply voltages and control signals on the motor board were correct. A new motor assembly got the machine working again. Fortunately the assembly is not expensive and is easy to change. **P.H.**

### Philips Charlie Deck

There was usually no forward motion (play, record or fast forward) once a cassette had been fully rewound. No apparent error showed up when the on-board diagnostic program was tried. A phone call to Philips technical produced the solution. As the brakes were inefficient, the entire length of the clear leader was drawn towards the supply spool. The slight forward tape movement after rewind was insufficient to wind the leader on to the take-up spool fully. As a result the leader was exposed during loading.

The solution is to replace the reel discs and brake parts as follows: counter force brake, item 209, part

no. 4822 403 52488; brake arm assembly, item 213, part no. 4822 403 10257; reel discs (two), item 207, part no. 4822 528 10523; brake rollers (two), item 232, part no. 4822 528 70638. The item numbers refer to the numbers shown on the exploded view of the mechanism in the manual. Replacing the reel discs is a fiddly job: the special removal tool part no. 4822 395 30243 helps. **P.H.**

### Panasonic NVD48

This machine was dead. Checks in the power supply showed that Q3 and D12 were short-circuit. After replacing them D12 failed at power up. Another replacement was fitted, then the machine was powered up via the variac. This revealed that the power supply outputs were not being regulated properly. The cause was C12, which had fallen in value. In addition C19 was open-circuit. Once these two capacitors had been replaced the machine worked normally. **P.H.**

### GoldStar RQ5041

After fitting a new drum we found that there was poor colour with prerecorded tapes. So we set the machine up as per the book, but the results were the same – the colour in the playback picture was still out-of-phase. Advice was sought from GoldStar technical, who are very helpful. "Try another drum" was their recommendation, but again the results were the same.

Time for some head scratching. We had already checked the chroma signal path and had found no faults. The only thing that didn't match up with the measurements given in the manual was the FM envelope, which was smaller than specified though beautifully formed. Fortunately a similar machine came in for repair, so we were able to carry out comparison checks. With the good machine the FM was not appreciably larger and wasn't as well formed as with the faulty machine. So we decided to change all the subassemblies, again without any improvement.

When a third new drum was fitted the machine worked perfectly. So was this two faulty new drum assemblies? Well, not actually faulty but incorrectly assembled. The upper drums were on the wrong way round. Correcting this produced perfect results. Should you get this sort of problem, note that the upper drum is coloured green on one side and white on the other. The upper face of the lower

drum is coloured green. White goes to green, not green to green as with the faulty drums. **C.W.**

### Goodmans GVR3000

If you have trouble tuning in one of these machines, or you get a number of the same channels grouped together, remove the front panel then look beneath the clock where you should find four holes in the board, marked TP4 and 5 and TP6 and 7. Short out 4 and 5 to empty the memory then short 6 and 7 to start full auto-tuning. **C.W.**

### Grundig VS500

This machine was dead with no outputs from the power supply unit. The mains side was OK, but the primary side wasn't oscillating. A check at pin 6 of the chip produced a reading of 10V, which should have started the drive but didn't. So we replaced the chip. This was the wrong thing to do, as it made no difference. The cause of the problem turned out to be C1326 (47µF, 25V), which was low in value. It's the reservoir capacitor for the chip's DC supply. **C.W.**

### Matsui VX755/Saisho VR3600

This machine would run all right for a couple of hours. It would then appear to go into the pause mode for about a quarter of a second, run normally for a few seconds then pause again. When we looked in at the top we saw that the capstan motor was pausing, with the tape not stopping long enough to switch off the machine. Checks at the motor drive and supply pins showed no reason for the pauses, so we assumed that the motor was duff. In fact all that was required was a spot of oil in the motor's upper bush. **C.W.**

### Akai VSF10

This machine was doing some nasty things to our customer's tapes. On examination we found that the cassette tray didn't go down fully because the left-hand coupling cam and operating rack had slipped by one tooth. Willow Vale supply a modification kit, part no. 57550E, to cure the possibility of slippage. **K.E.**

### NEC N9053K

Coloured noise on the picture and failure to erase previously recorded audio were the complaints with this machine. When you get this it's a safe bet that the cause of the problem is around the full erase head. On this machine a plug and

socket arrangement is used here. When the plug was removed we found a fractured wire. It's best to remove the plug and hard wire the connections directly on to the head pins. **K.E.**

### **Samsung SI7220**

The causes of intermittent servo faults can be frustrating and time-consuming to trace. This machine was no exception. It came in with the complaint that the sound suffered from wow and flutter while tracking noise bars moved up the picture. After resoldering numerous suspect joints on the motor control/servo subpanel to no effect we decided to check back to the audio/control head. The screen on the connector plug from the head to the main PCB proved to be loose. **K.E.**

### **JVC HRS4700**

There were no functions at all. No power up, no nothing. Voltage checks showed that the display chip's reset port was at 2V, which is not a good thing. The fault persisted when this chip had been replaced. Doesn't it make you mad! Replacing the timer chip and, for good measure, the CAT chip got the machine going. **S.B.**

### **JVC HRS880**

There was no front-control operation because the tuner/timer chip was faulty. A replacement restored normal control. **S.B.**

### **Amstrad VS1000**

Fuse F01 in this combined satellite/VCR unit had ruptured violently and we found that IC7001, which is type STRD6008, was short-circuit. Amstrad Technical recommended that we also replace the main smoothing block C7510 to prevent further problems. **G.T.**

### **Samsung VI520T**

This machine provided a choice of symptoms. Sometimes it worked. At other times it either locked up with an odd segment of the display lit, or various segments flashed along with random flashing of the function LEDs and the mechanism shuffling.

The power supply in this VCR consists of an STR type chip that provides a 13V output and a discrete-component chopper circuit that provides a 5V output. The normal cause of the sort of fault described above is that C3, which smooths the 13V supply, dries up – being covered with a screening can, the power supply runs warm.

Access is also a test of patience.

After replacing C3 we carried out some checks around the microcontroller chip on the front PCB. When its 5V supply was scoped we found that a 1V peak-to-peak squarewave was sitting on it. Back to the power supply, where C13 and C14 had dried out. A check on the rest of the capacitors in the power supply revealed that many of them were showing signs of stress. A blanket replacement of the capacitors in the power supply and the removal of carbonised glue from the PCB completed the repair. **G.T.**

### **Sanyo VHR3300E**

This machine was dead. Replacing R1, which was open-circuit, in the power supply restored normal operation. **G.T.**

### **Philips VR6185/DMP decks**

The symptom was very intermittent jamming when laced up in the play/record modes. After much investigation I found that a pivot lever (Philips ref. 260) hidden under the threading ring at the rear of the deck was worn/broken.

Replacement with one from a scrap machine provided a cure. **R.C.M.**

### **Panasonic NV430**

If the tape loops after going from play to stop then eject, i.e. not after fast forward or rewind, the mode switch requires cleaning or replacement. **R.C.M.**

### **Ferguson FV62**

The job card said "no E-E sound", but on test there seemed to be plenty. After a while the sound disappeared. The repair shop engineer had replaced the tuner, and was surprised that this hadn't cured the fault.

I traced the sound path from the main board to the little PCB that has the audio record/playback amplifiers on it. There was sound at the input to this board, but not at the input to the chip. C017 had never been soldered at one end. Resoldering it restored permanent sound. **M.M.**

### **Roadstar VCR7200PV**

When a cassette was inserted the machine whirred a bit then ejected it. The customer had already had two quotes: one repairer told her that the lower drum had failed, the other that a new carriage was required. Now I had the machine

and there was another fault: a loop of tape was left when the cassette was ejected.

I checked the machine in front of the customer. The capstan wouldn't rotate because the wrong screw had been fitted to the carriage, distorting the motor plate; wires to the carriage had been cut and twisted together; and it was clear that the machine had been thrown back together when the estimate had been refused. A replacement screw in the carriage got the capstan motor going again, and a new piece of wire replaced the lead that had been cut.

Now to the original fault. When a cassette was inserted the machine went into the rewind mode for a couple of seconds, laced up, went into rewind again, unlaced and ejected the tape. The culprit was the end-of-tape sensor, a replacement restoring normal operation. **M.M.**

### **Toshiba V110B**

We were called to clean the heads but found that we couldn't tune the machine in to the TV set. It appeared that the cable installers had been a bit rough. The centre pin of the RF modulator/converter had been pushed in, and the preset for the RF tuning range was loose – the print around it had been cracked. When all this had been put right we were able to tune in the VCR and cable system. What should have been a twenty minute job (head cleaning) ended up taking an hour and a half! **M.M.**

### **Panasonic NVJ40**

The customer's original complaint was about interference. She also complained that occasionally, during playback, the machine would stop and come back on again. As it looked as if the cause of trouble was ripple from the power supply, I took the machine back to the workshop – where it performed faultlessly. When it was returned to the customer both faults showed up almost immediately.

The switching on and off was a power supply fault: IC1102 was dry-jointed. The interference seemed to be caused by some form of interaction between the TV set and the VCR. Disconnecting the aerial from the VCR failed to cure it. Adding an attenuator made it worse. Slight adjustment of the RF converter frequency plus retuning the TV set eliminated the problem. **M.M.**



Reports from  
David C. Woodnott  
and Brian Storm

### Panasonic NVS7

This model is an S-VHSC palmcorder. The problem was that in the S-VHS mode a noise bar, about an inch from the top of the screen, would appear across the picture. It varied in intensity, almost cyclically, coming and going at will. The effect was more prominent with some tapes than with others. A JVC tape was worst, a Philips one best! The tape path alignment, tensions etc. were carefully checked, all to no avail. We eventually cured the fault by fitting a complete replacement drum assembly. Standard VHS pictures were at all times OK. **D.C.W.**

### Siemens FA244G4/ Panasonic NVG1

"Cuts out in playback" was the reported fault. Record was OK. We checked the connectors around the main PCB and looked for dry-joints, all to no avail. Why playback

# Camcorner

only? This wasn't so surprising when we'd realised how the cam/VTR switching works.

The slider on the VTR operation unit (top of camera) closes the cam/VTR switch contacts in the VTR mode. All that was wrong was a faulty switch. The contacts are open in the camera mode, thus no problem. In the VTR mode, intermittent contacts resulted in the unit defaulting to the camera mode. **D.C.W.**

### Sanyo VMRZ1P

Playback and the VTR functions were OK, but there were no E-E pictures and no zoom/focus operation. The cause of the fault was the camera DC-DC converter, a replacement restoring normal operation. **D.C.W.**

### Panasonic NVG3

As a result of a fall the cassette compartment wouldn't stay closed. We had been asked for an estimate for insurance, but this wasn't needed. All that had happened was that the cassette housing lock lever had become displaced. It was easily returned to its correct position. **D.C.W.**

### Panasonic NVM10

This HiFi VHS camcorder was completely dead – the internal fuse R1701 had blown. A replacement (part no. VSF0059) was fitted, but the result was a brief puff of smoke and another blown fuse. The smoke had come from the HiFi audio PCB, where the 68µF capacitor C4524 had died of old age. A new fuse and

capacitor restored life to the camcorder. **B.S.**

### JVC GR65

There was no sound at all, in either the record or the playback mode. After much checking we decided to replace the BA7757BK audio chip IC30. This cured the fault. **D.C.W.**

### Sanyo VMD6P

The complaint, which is not common with this popular camcorder, was of tape chewing. It was obvious that the capstan motor was the cause of the problem. It turned very slowly, and in fact was almost seized. As cleaning and lubricating the bearing proved to be ineffective we had to fit a replacement. **D.C.W.**

### Sony EVA300

Switching from LP to SP operation and back was the complaint with this camcorder. The cause was broken teeth on the supply and take-up reel assemblies. After fitting replacements we noticed that tape crinkling was evident in the rewind search mode. A new pinch roller put that right. **D.C.W.**

### Canon E100E

There was no operation. We found that D409, which is part of the SS 5V supply to the syscon microcontroller chip, was short-circuit. In this condition the always 5V supply at regulator IC406 was low – the reading was approximately 3V. **D.C.W.** ■

### Panasonic NVG2

The reported fault symptom sounded innocuous enough – "powers up then off". Nothing unusual there. A check in the power supply section of the main board showed that the 2SD2210 transistor Q1008 had overheated and was open-circuit. We fitted a replacement and checked for shorts on the supply rails. As nothing showed up we switched on. The camcorder powered up for about a minute, then our new transistor succumbed.

Q1008 supplies various circuits, including the camera head section. When the latter was disconnected and a second 2SD2210 transistor had been fitted the VTR section worked, with all functions available. So clearly the cause of the fault was in the camera head section.

Again no shorts could be measured. To try to isolate the faulty PCB we decided to disconnect the various sections of the camera

head in turn. A start was made by disconnecting the image sensor PCB. With the rest of the circuitry connected, we applied power. To our surprise power-up was achieved, with the camera unit producing CCD drive pulses and a sync pulse train with burst vectors. When the image sensor PCB was reconnected the original fault condition returned.

So the CCD image sensor was the cause of the fault, though cold checks failed to produce a measurable short-circuit reading. A replacement CCD unit from a scrap unit confirmed our diagnosis by providing E-E pictures. Unfortunately the customer declined, on cost grounds, to have the repair done. This would have been a disappointment in view of the time already spent on the camcorder, but by way of recompense the customer gave us the unit to avoid paying our estimate charge. **D.C.W.**



# Camcorner



Reports from  
David C. Woodnott

## Sharp VLC73H

A common fault with this model, reported previously, is power up then almost instantaneous power down. The cause is leakage from C921 (56 $\mu$ F, 16V), with resultant corrosion of the print beneath its pins. The remedy is to replace the capacitor and link the missing print. This particular one had already had the link fitted when we received it, but the capacitor was the original one! Replacing it failed to cure the problem. Q914 also had to be replaced.

## Sony CCDF330

This model often suffers from intermittent or no autofocus operation. The nice Sony people have introduced a sensor kit that overcomes the problem at modest cost. Refer to information sheet part no. 9972880012 for details of whether the kit is appropriate for a particular symptom. The sheet also gives details of various replacement lens assemblies.

## Ultrasonic Cleaning Tank

A month or two ago I mentioned that I was looking for a reasonably priced ultrasonic cleaning tank for cleaning PCBs that have suffered from capacitor leakage. The one I have since obtained from Langford Electronics Ltd. (01214 334 343), the Sonomatic SO175, fits the bill admirably. I no longer have to use nasty cleaning chemicals etc. It copes well with capacitor leakage and similar problems, using de-ionised water as the cleaning agent. Highly recommended. Various sizes are available to cope with PCBs of different dimensions.

The point to bear in mind is that considerable time may be needed to fit the kit, as all the lens PCBs etc. have to be removed to gain access to the slave lens assembly and sensor fitments. Setting up the autofocus unit is also time consuming, and has to be done before refitting the PCBs. The good news is that it always works – so far!

## Sharp VLC650H

Poor sound was the complaint with this one. Checks in the audio circuitry suggested that the main IC, which is on a ceramic substrate, was faulty. We noticed that an electrolytic capacitor on this unit had been leaking. Careful removal of this item and its replacement cured the problem without need for a new chip.

## Sanyo VMD6P

This machine powered up all right and produced an E-E picture, but it wouldn't eject the tape. Play and rewind/fast forward worked for only a short period, then the unit went into the emergency mode. It's not uncommon for the loading gear train in this model to fail (the plastic gear teeth break). This causes a similar no tape eject symptom. With this camcorder the symptom was different however. When eject was pressed the tape would unload to the stop position, pause – then reload! When the tape was removed manually and the unit was then powered up eject was possible, but when a tape was loaded the previous symptom recurred. The cause of the trouble was traced – after some thinking time! – to a faulty take-up reel sensor. Most mechanisms would allow tape eject when this sensor fails, but some bug in the syscon micro confused the issue.

## Canon E6E

We've had two of these in recently with similar faults. The symptom is vertical lines, which may appear intermittently, on the E-E picture. The trouble can be caused by a defective CCD image sensor or by SSG drive problems, which was in

fact the case here. Unfortunately it was not possible to carry out an economic repair. Once again the cause was our old friend the leaky electrolytic capacitor. The ones that were responsible are mounted on the sensor PCB. This is a ceramic substrate structure that doesn't allow easy component replacement. Because of the corrosion, the printed lands had disappeared. They cannot be bridged.

The problem is also affecting later Canon models, in particular the UC10 series that use the same type of sensor PCB construction. This is not good news for the customer!

## Panasonic NVS85B

There was no capstan rotation. As with other models in this range, symptoms like this can be caused by intermittent connection of the ribbon cable plugs/sockets between the main and the MDA PCBs. We cured the fault by resoldering one such connector: as the unit then worked normally, we reassembled it and put it on test. This is where everything went wrong for us!

We found that in the record mode autofocusing and the viewfinder picture were intermittent. Anyone familiar with this model will know what's coming! We spent some time investigating the intermittent autofocusing. This included complete dismantling of the unit and a check on the ribbon cables, connectors etc. – all to no avail. As we were getting nowhere fast, we decided to look at the viewfinder problem. This proved to be our salvation. The picture came and went when the connecting leads were flexed. But careful checks on the connections drew a blank. It then dawned on us that moving the viewfinder didn't cause the problem – getting physically close did! Yes, this camcorder is fitted with a switchable power-save function that disables the autofocusing and the viewfinder picture when you are in record pause and are not looking through the viewfinder. The function is controlled by a small switch beneath the viewfinder. We won't get caught again! ■

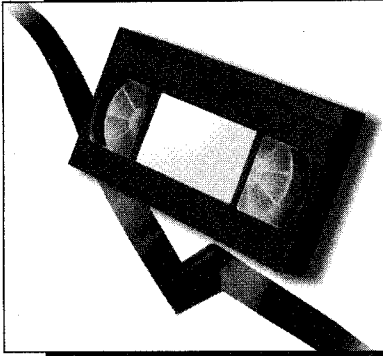

**Reports from  
Eugene Trundle,  
Jeff Herbert,  
Christopher Nunn,  
Ronnie Boag,  
Brian Storm,  
Terry Lamoon,  
Mike Leach,  
Owen Green,  
Michael Maurice,  
John Coombes,  
Bob Longhurst and  
Robert C. Meade**

### **Sanyo VHR4350**

Tape crunching – a loop of tape left hanging from the cassette flap on eject – is an increasing problem with these machines. Capstan brake binding is the cause. Cleaning the brake pad and the periphery of the flywheel solves the problem, but it's perhaps better to clean the flywheel and replace the brake arm. E.T.

### **Akai VSF10**

The cause of intermittent deck shut down took us a long time to find – the fault would occur at intervals of hours or days. We eventually discovered that the take-up reel rotation sensing optocoupler was responsible. It comes as two separate components, a LED and a photodiode.

We had a clue in the fact that the tape remained threaded after shut down – with most other faults, including power supply interruptions, the deck unthreads the tape in an 'emergency' mode. E.T.

### **Sanyo VHR150**

There was a continuous crackle on sound – like an old telephone system. It was present in record and

# VCR Clinic

playback, but only in the LP mode. The cure was replacement of the audio chip IC210 – pin 14 had been pulling the LP/SP switching line to 1.2V (should be 4.9V). E.T.

### **JVC HRD750**

If one of these machines has no deck functions, perhaps with a cassette stuck inside, you may well find that circuit protector CP802 has failed. A replacement generally gets the machine going – until CP802 opens again. The root cause of the problem is the capstan motor. E.T.

### **Tatung TVR6122**

These VCRs have much in common with contemporary models from the Amstrad stable. A common problem is flutter on sound. The way to cure it is as follows: replace the pinch roller; get the take-up tension down to about 80g/cm by fair means or foul; lubricate both spool spindles and the back-tension pole pivot; fit a new back-tension band and reset the back tension; and clean the entire tape path. E.T.

### **B & O VHS90**

Complete loss of audio output from the rear-mounted phono sockets was the problem with one of these machines. Not shown on the circuit diagram, but very much present in the VCR, are a couple of muting transistors at the sockets. They are fed from the /PB12V line, which was high at all times because of a short-circuit between pins 13 and 14 of the EXB341 thick-film module IC1154. E.T.

### **Mitsubishi HS306B**

There was no playback or record colour. Virtually all the chroma processing is carried out by the M51452G 39-pin chip IC6A0. I played back a colour-bar tape to

provide a stable chroma signal, and traced this to where it's separated from the luminance signal and fed into IC6A0 at pin 34. A recognisable 626kHz modulated envelope was present here, but the signal that emerged at pin 35 was grossly distorted and of low amplitude. As the supplies were all present, the crystal oscillators were working and the head switching and composite sync pulses were present I pronounced IC6A0 faulty and fitted a replacement. No change! If the input or output pin of the bandpass filter BPF6A1 was lifted (open-circuited), a healthy converted 4.43MHz signal appeared at pin 35 of IC6A0. So the filter was condemned as being internally leaky. Once more a replacement made no difference.

Fortunately another working machine was available, enabling us to carry out comparisons. While checking IC6A0 pin by pin with a scope I found that there was a ragged 150mV field-rate sinewave at pin 26, which is the 9V supply pin. There was no such waveform in the machine that was working correctly. The supplies to the chip's pins are decoupled separately, by a series choke and an electrolytic capacitor. 6C6C (33µF, 16V) had dried up and lost value. When we checked its value the reading was 12µF. A replacement restored the colour.

Though small and easy to miss, the spurious 150mV field-rate signal on the supply had been enough to stop the circuitry within the chroma chip working correctly. The moral to this story is to wind up the Y gain and flick through the timebase steps when checking supply lines with a scope. There may be something lurking there. If, like me, you miss it, you could be in

for several hours of fruitless searching before you return for a recheck. **J.H.**

### Panasonic NVJ30

This machine was dead but was restored to life when its power supply was heated with a hairdryer. When it cooled down it returned to the dead condition. There was obviously a faulty reservoir/smoothing capacitor somewhere. It turned out to be C9 (1 $\mu$ F, 400V) which, when checked, produced a reading of about 0.03 $\mu$ F. Where would we be without tins of freezer and a hairdryer?! **C.N.**

### Sanyo VHR5240

When play was pressed the drum failed to rotate and the machine switched off. A check on the SW5V rail showed that it was very low. The 2SC3807 transistor Q5402 was short-circuit base-to-emitter. **R.B.**

### Nokia VR3785

This machine left tape out of the spool when the cassette was ejected. A replacement capstan brake (part no. 8681-4167) cured the fault. **R.B.**

### Toshiba V611

Noisy fast forward, rewind and play were the complaints with this machine. There was no noise when we checked with a transparent service tape. A replacement take-up guide pole cured the fault. **R.B.**

### Sanyo VHR291

Intermittent failure to power up or down and to eject was the complaint with this machine. The cause of the trouble was dry-joints at plug CN712. **R.B.**

### Nokia VR3785

In the play, record and fast forward modes this machine would stop after a few seconds. Rewind was OK. Normal operation was restored once we'd cleaned the take-up reel and reel sensor. **R.B.**

### Panasonic NV430

This vintage machine didn't produce a clear E-E picture – there were wide black bands and bad distortion. Not surprisingly, we found that one of the capacitors in the power supply had died of old age. The culprit was C1002 (47 $\mu$ F) in the 45V supply. **B.S.**

### Panasonic NVFS88

This S-VHS machine was totally inoperative. The only signs of life were provided by the timer clock, which flashed three zeros. Except

for the switched ones, all the power supplies were present and correct. Our next move was to check the serial clock and data lines: the serial data line was found to be low. The reason for this was eventually traced to the M34255V1AH microcontroller chip IC7507, which generates the VU display. It had an internal leak. A replacement restored normal operation – it's mounted on the front panel. **B.S.**

### Panasonic NVFS1

Intermittent operation was the complaint with this vintage machine. Sure enough we found that it failed to function mechanically when cold. Unfortunately any attempt to take the top off the machine cured the fault! We had it on soak test for many days before discovering that the multi-voltage regulator in the power supply was the cause of the trouble. There were several dry-joints at its pins. **B.S.**

### Panasonic NVHD650

Apart from the fact that the drum rotated at high speed this machine was dead. Checks showed that there was a dead short across the system control 5V line. The cause was eventually traced to the BU1201-02 chip IC3904 on the input/output pack. It was short-circuit. **B.S.**

### Panasonic NVFS1

When a cassette was inserted it would be accepted, taken into the depths of the machine then quickly spat out again. We checked the mechanism and mode switches for correct alignment, but everything was OK. Attention was next turned to the systems microcontroller chip, where we found that only one of the mode-switch tristate position signals changed state with the mechanism. The other one remained at 5V all the time. R1501 (47k $\Omega$ ), which is across the mode switch, was open-circuit. **B.S.**

### Matsui VX2500

This machine chewed tapes. The pinch roller was OK, but while checking the take-up I noticed that the limiter arm didn't move – the spring had slipped off. I put it back, secured it and gave the machine a good clean. It worked well. **T.L.**

### Toshiba V711

The mechanism of this centre-loading machine was jammed. When I stripped it down I found that the main cam and the loading arms were well mauled. After

fitting replacements, also a new mode switch, and realigning the mechanism everything was OK. Alignment is quite straightforward. **T.L.**

### Samsung S11240

This machine would go to standby shortly after a function had been selected. It would shut down in play, rewind, record etc., but the fault seemed to go away when pause was selected. This suggested that the cause of the trouble was to do with the reel pulse sensor or the reel turntable itself. Scope checks at the 2SC945 reel pulse amplifier transistor Q2601 showed that the pulses at its collector were only marginally greater in amplitude than those at its base. A new transistor increased the amplitude of the pulses significantly, but the fault persisted. The output from Q2601 is fed to the TC4021BP chip IC6201, which also had to be replaced. The two faulty components are mounted on a subpanel next to the loading motor. **M.L.**

### Hitachi VT120

There was low E-E and record sound. We traced the cause to C08 (4.7 $\mu$ F, 35V) in the IF unit. The fault seems to be turning up quite often now that these machines have seen a fair bit of use. **M.L.**

### Toshiba V880MS

This beast of a multi-system machine, for which we didn't have a manual, would power up then go completely off. The clock display would flicker for a second before it went out. When an attempt was made to load a tape the capstan motor would start to turn, extremely slowly, before stopping at shut down. I put the machine to one side and returned to it later.

When I did so I found that it had powered up by itself and was working. I'd left it plugged in. The cause of the trouble was obviously in the power supply, and after a good old spray around with freezer the culprit turned out to be C809 (10 $\mu$ F, 50V). It's on the power supply's small subpanel, inside the can. A replacement brought a sigh of relief! **M.L.**

### Akai VS8

This machine had stopped working with a cassette inside. Operation of any of the controls made the buzzer sound: nothing worked – though the main power rails appeared to be OK. As the power and syscon circuit is quite complicated, we had to obtain

a manual. We then found that the STK5325 regulator chip wasn't producing the 12V AL supply. To add to the confusion, the cassette lamp was open-circuit. **O.G.**

### **Hitachi VT33 + Rediffusion Mk 4 Chassis**

Perhaps this one should have been in the TV section. The customer's complaint was about "white spots on VCR playback". Over the phone this sounded like a head cleaning job. When we called we found that the playback picture consisted of white lines all over the screen. The E-E and normal TV pictures were fine. So we took the VCR back to the workshop, where it performed faultlessly.

The cause of the trouble was in the TV set, where 4C16 (3,300pF) was dry-jointed. It forms part of a snubber network across the chopper transistor. At least the customer agreed to have his VCR serviced, which it desperately needed – the belts were about to fall off! **M.M.**

### **Saisho VR2000**

This one was a right pig – and had been got at by someone! Fuse F502 (2.5A) kept on blowing at switch on. It didn't take long to discover that there was a dead short across the AT13 rail. The short was in the drum motor, so I removed its PCB for inspection. There was nothing obviously amiss, and I eventually discovered that the short was between the 13V supply and the body of the motor – but the exact location of the short was impossible to determine.

I was able to get over the problem with some thick insulating plastic, which I cut to size and fitted between the drum motor's PCB and its chassis. This removed the short-circuit, and all was well when I applied power to the machine – until I selected rewind. I then found that in addition to an obvious pattern idler a different screw had been fitted to the bracket over the reel motor's pulley. Fitting the correct screw fixed that, and a soak test proved that everything was now OK. **M.M.**

### **Philips VR323**

This machine produced scrambled text. The cause was the SAA5231 teletext processing chip. **M.M.**

### **JVC HRDX22**

This centre-loading machine jammed when it went into play. I stripped it down and replaced the half-load gear and control cam, but

it still jammed. The cause of the problem was the fact that the control cam's spindle was not seated properly in its plastic moulding. Pushing this down until there was a click provided a complete cure. **M.M.**

### **Hitachi VT220**

Creasing tapes and noisy operation were the complaints with this machine. The problems were caused by a worn pinch roller and a very worn capstan shaft and bearing. They were so worn that there was substantial play in the bearings. Fortunately these parts are available from Hitachi. Replacing them cleared the faults. **M.M.**

### **Philips VR727**

There was no playback or E-E sound. It's not easy to trace the cause of this sort of thing where there is hi-fi, Nicam and linear sound. We eventually found that there was faulty switching within the TDA2518 chip IC7205. **J.C.**

### **Samsung VI375**

No results was the complaint with this one. The 2.7Ω surge limiter resistor R101 was open-circuit and the STR11006 regulator chip IC101 short-circuit. In addition the 22V zener diode ZD101 on the secondary side of the chopper transformer was short-circuit. When these items were replaced and the machine was powered up they all failed again. Further investigation led us to C110 (100μF) which was open-circuit. **J.C.**

### **Panasonic NVG21**

There are several possible causes of the no-results symptom with these VCRs. In this one the STK5338 regulator chip IC1001 failed to produce a 5V output. **J.C.**

### **JVC HRJ200**

Intermittent rewind and tape chewing were the complaints with one of these machines. We noticed that when rewind was selected the VCR would sometimes load then unload slowly, leaving a loop of tape. We also found that this could happen in the play mode.

Replacement of the mode select switch (part no. PU60622-1-2) put matters right. We have had this fault several times now. **J.C.**

### **Toshiba V254B**

Because of a faulty cassette holder assembly this machine wouldn't accept a tape. The plastic piece on the side of the cassette holder had

broken – the bit that releases the cassette flap to enable the tape to drop on to the spools. **J.C.**

### **Panasonic NVJ35**

No results is a very common fault when the mains input has for one reason or another been removed from this model. The auto-selector or power regulator chip can be responsible. Alternatively C1109 (1μF) can, as here, fall in value or go open-circuit. **J.C.**

### **Panasonic NVJ47**

The customer complained about a high-pitched noise in the standby mode. The problem occurs only where the mains voltage is very high – 250V or above. Transformer T1101 then buzzes. During a chat with Panasonic I was told to add an 0.01μF, 50V capacitor across pins 3 and 4 of optocoupler Q1103 in the power supply. There's a part number for this capacitor: ECUM1M103KBN. **J.C.**

### **Amstrad VCR4600**

There was no display and no functions could be selected. The machine would load a tape but not eject it. The cause of the trouble was X502 in the syscon department. **B.L.**

### **Matsui VX750/Saisho VR3500**

This machine would accept a tape but powered down as soon as any function was selected. The N10 circuit protector ICP201 in the 19V supply to the capstan motor was open-circuit. **B.L.**

### **Ferguson 3V38/JVC HRD110**

All sections of the fluorescent display lit but the machine wouldn't power up and there was loss of the loop-through to the TV set. Checks in the power supply produced readings of 0V at pin 1 (ALL 12V) and pins 3 and 4 (16.5V AC) of CN1. The pins had arced and gone open-circuit. Cleaning and resoldering put matters right.

Another of these machines was totally dead because pin 4 of CN1 had failed in the same way. **B.L.**

### **Ferguson 3V38/JVC HRD110**

No recorded picture, the E-E picture being OK, was the complaint with one of these machines. We found that C197 was short-circuit.

Intermittent lockout with a dim operation LED is the symptom when the relay on the power supply board is faulty. Clean or replace it. **R.C.M.**



Reports from  
**David C. Woodnott  
and Eugene Trundle**

### **Sanyo VMD3P**

There was no viewfinder picture though the machine was otherwise OK. We traced the cause of the fault to leakage in the line drive coupling capacitor C9911. This was a very misleading fault, because the waveform at the base of the line output transistor seemed to be good while the waveform at its collector was ragged. This could lead one to suspect the line output transformer and its peripheral components. **E.T.**

### **Canon E200E**

This one came in because there was playback picture mistracking. The cause was a loose slant pole, something that's not uncommon with this model. It was easy enough to put right: we reset the pole's position, then secured it with a Loctite product. After this the machine seemed to work fine.

When we tested it however there was a problem at tape end. The machine entered the caution mode, with a flashing symbol in the viewfinder. No functions were available until the tape had been ejected and reinserted. At the end of rewind the same fault recurred.

This prompted a suspicion that the cassette LED had failed – rare perhaps, but not impossible. The lamp and the connecting ribbon cable were both OK however. Use of another camcorder to view the LED confirmed that it was working. What next? – there were still no outputs from the tape-end sensors. The only other item in the chain, the gooseneck baseplate which carries a clear plastic lens assembly to direct

# Camcorner

the light from the LED into the cassette, turned out to be the cause of the trouble. The plastic light-bending unit was deformed, probably because of heat during a previous soldering operation. Beware! **D.C.W.**

### **JVC GRM3F**

There was no camera operation. This was simply because the camera head section had become detached from the deck section, no doubt as a result of an impact. Refitting the connector restored all functions. **D.C.W.**

### **Canon UC10E**

Playback was OK with this 'upright' model, but there was no camera E-E picture. The cause of the fault lay with the sensor PCB assembly which, having a ceramic-based substrate, is unfortunately not repairable. Capacitor failure had caused print damage. The problem is becoming a serious one with models that use this form of construction. We've had similar faults with **Model E6E** and others. A new board is required, at around £120 trade! **D.C.W.**

### **Panasonic NV5500**

All functions except for zoom and autofocus worked correctly. The cause of the fault was a damaged ribbon cable at the connection to the zoom motor, possibly the result of impact damage. A new cable put matters right. **D.C.W.**

### **Sanyo VEM51P**

As with several models these days, electrolyte leakage can cause various fault symptoms, necessitating replacement of all the surface-mounted can electrolytics on the main PCB. A quick check on the situation, without need to remove the case, is to examine the video signal waveform while playing back a previously recorded tape: note especially any rounding off or crushing in the sync pulse area – this is a sure sign that all is not well.

It's easy to get confused when replacing the capacitors in this model as there is an extra, marked space for a capacitor that's not

fitted. Note this position before you start removing the old capacitors – the layout detail in the manual is not too clear (both sides of the PCB are shown as seen from the same side, requiring some mental agility in getting things right when you turn the board over). **D.C.W.**

### **Sanyo VMD90P**

The reported fault was that the camera E-E picture flashed on and off erratically, and that an E-E picture was seen dimly even in the playback 'stop' mode, which is normally blank. Tape playback was OK. Internal inspection showed that the iris motor had moved from its normal position, doubtless because of an impact – it sits only a few millimetres behind the front of the case. We had to fit a new lens assembly, as the motor is not available separately. The result was a fairly expensive repair.

Note that the lens assembly for **Model VMD90R** has a different iris motor. A few days after this repair another Sanyo came in with an E-E picture showing in the VTR mode! Another lens unit was required. **D.C.W.**

### **Chinon VC1500**

Mechanical failures are common with this mechanism, which is very similar to the Amstrad VMC100 and various JVC decks. One we had in recently had failed during eject, and as a result had damaged the intermediate gear. The cause of the failure had been the spring plate beneath the take-up guide becoming loose. The mechanism had then jammed, causing the fault and the damage to the intermediate gear. Although the gear costs only a few pounds, you have to dismantle most of the loading ring gear and head drum assembly to fit it. Retiming is straightforward – in comparison with some later mechanisms! **D.C.W.**

### **Sony FX Series**

For no power up, check the connections between the DC-DC converter and the main PCB. Impact damage can detach the socket pins from the PCB. **D.C.W.** ■

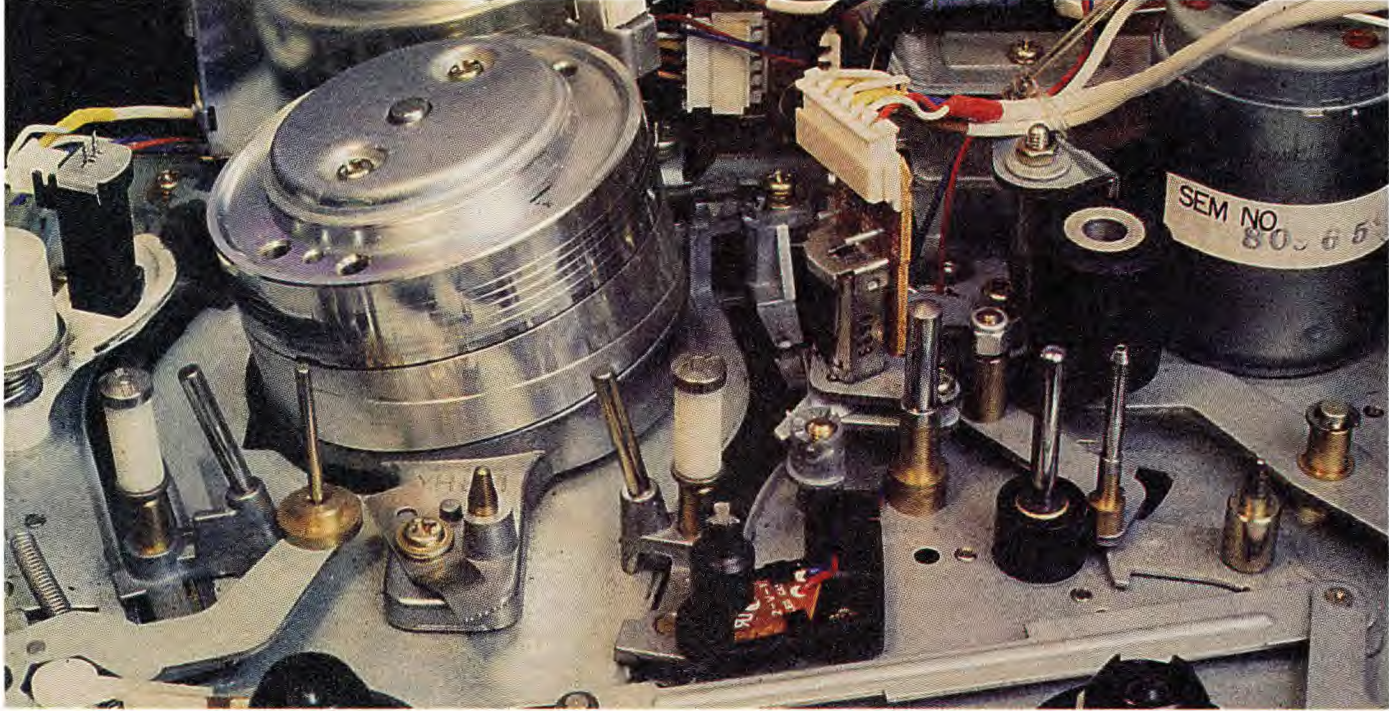

# Servicing the Samsung VI710

**John Coombes** on what to check when electronic or mechanical problems are encountered with these popular VCRs

**T**he Samsung VI710 is a basic model, with HQ, that was on sale during the 1988-90 period. A badged version was sold as the Logik VR955.

## **Power Failure Faults**

If the clock display is lit up, the power switch is on but the power indicator light is not illuminated, check that the always 6V supply is present at pin 32 of the UPD75104CW-087 microcontroller chip IC601. If this supply is missing, check whether D601 and/or D602 is open-circuit. Both diodes are type 1N4148. If the voltage at pin 32 is present and correct, check at the power control output pin (56) of IC601 where the reading should be 0V. If this voltage is incorrect, check IC601 by replacement.

If there is no clock display, check whether the always 6V supply is present at pin 5 of connector CN101 on the power supply/regulator panel. Check the following items should this voltage be missing: the mains transformer PT101, the RBV-402 mains bridge rectifier D101 and fuses F101 (500mA) and F102 (2.5A). If F101 has blown, check the mains filter capacitor C101 which is probably short-circuit.

Should the always 6V supply be present and correct, check for 30V at pin 10 of CN101. When this voltage is missing, the following items should be checked: the 1N4002 rectifier diode D104, the KSC945 30V regulator transistor Q102, its 2.7k $\Omega$  collector feed resistor R108 and zener diodes ZD101 (24V) and ZD102 (6.8V).

The next thing to check is that the display device is receiving its 5.1V AC supply. Check back to source (at PT101) if this is missing.

There must be a 50Hz signal at pin 8 of connector CN101. If this is missing, Q101 (KSC945) could be open-circuit, D103 (1N4148) could be short-circuit or leaky or R101 (10k $\Omega$ ) open-circuit.

The STK5333 regulator chip IC101 could be faulty – check it by replacement. If necessary check the fusible resistors FR101 (1.2 $\Omega$ ) and FR102 (2 $\Omega$ ) which could be open-circuit.

Fig. 1 shows the circuitry on the power supply/regulator panel.

## **No Play**

Incorrect or no tape loading is the first possibility here. Check for a high state voltage (4.8V) at pin 53 of the microcontroller chip IC601 and a low-state voltage at pin 52. If these conditions are not present, check IC601 by replacement. If they are correct, check the BA6209 loading motor drive chip IC205 by replacement and then if necessary the loading motor itself, again by replacement.

If tape loading is OK, check the operation of the tape-end sensor. Its output is fed to pin 18 of IC601, where the reading should be 0V. If the voltage is high, suspect the tape. If it is correct, check that the drum is rotating. The first things to check when the drum fails to rotate are that the 15V supply is present at pin 1 of connector CN101 and the 5V supply at pin 4. If these voltages are

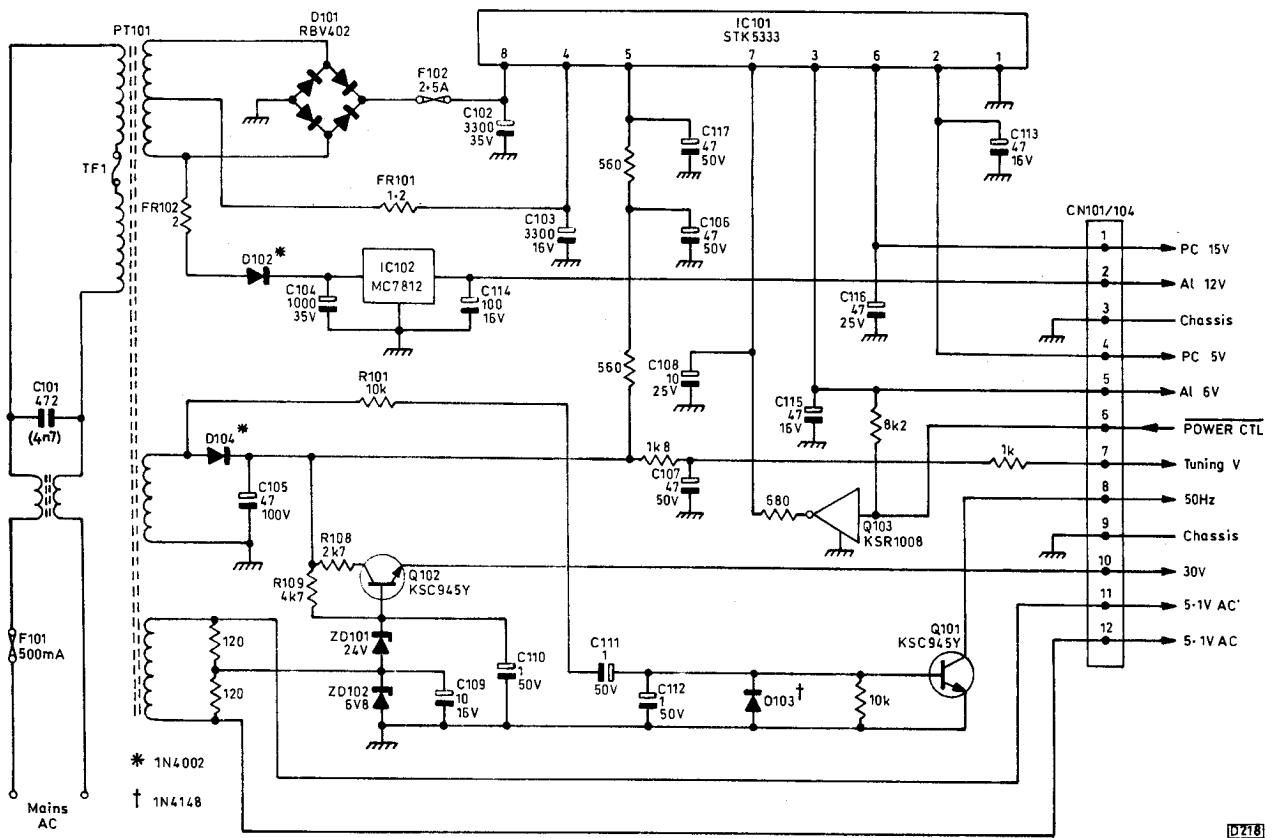

**Fig. 1:** The power supply/regulator circuitry used in the Samsung Model VI710. Supply line switching is carried out on the main PCB.

present and correct, suspect the microcontroller chip IC601, the BA718 chip IC202 or the drum motor assembly. Check these items by replacement.

If drum rotation is normal but the machine cuts out quickly, check for the presence of the 25Hz switching pulse waveform at pin 1 of IC601. It comes from pin 9 of the SD3624A servo chip IC201. If the 25Hz waveform is not present here, check that the drum PG signal is present at pin 17. Check it back to source if missing (via C211, CN201, CN204, CN214).

If the 25Hz waveform is OK, does the capstan motor rotate? If not and the 15V and 5V supplies are correct, IC601, IC201 and/or IC202 (BA718) and the capstan motor are suspect.

Another check to make if necessary is that turntable reel pulses are present at pin 2 of IC601. If these are missing, Q209 (KSC945) or R251 (470k $\Omega$ ) could be open-circuit or the reel sensor Q005 (NJL5141EA) faulty – check it by replacement. If the pulses are present at pin 2, check IC601 by replacement.

### Failure to Record

If the complaint is failure to record, first check that the machine will play – see previous section.

Insert a tape and press record. Does the record mode symbol appear in the display? If not, check whether the record safety input at pin 9 of IC601 is correct (5V). If this is incorrect, check IC601 and/or the safety tab switch by replacement.

If the record mode symbol is present, check pin 51

(rec) of IC601 where the voltage should be 5V. If it's low, replace IC601.

If these control arrangements are OK, check the video and audio circuitry as necessary.

### No E-E Video

Check with the VCR in the stop mode. If the video signal is missing, check the following items: IC0303 (TA8605), C0353 (4.7 $\mu$ F), IC0302 (TA8606), Q0304 (KSA733) and low-pass filter FL0302. C0353, Q034 and FL0302 can go open-circuit. Make sure that the DC conditions around IC0303 and IC0302 are correct. C0366 (100pF) and R0359 (82k $\Omega$ ), which are connected to pin 28 of IC0303, are possible suspects.

### Loss of Playback Video

For playback, the PB5V supply must be present at pin 10 of IC0301, pin 4 of IC0302, pin 13 of IC0303 and pin 7 of IC0307. If this supply is missing, check Q112 (KSA928), Q113 and/or Q114 (both type KSR1004), by replacement if necessary.

If still in trouble use a scope to trace the signal path through IC0303, IC0302 and IC0301. By a process of elimination you'll locate the faulty chip or associated component.

Other possibilities are the TA7772 video preamplifier chip IC0307 and the heads.

### Tuning Faults

First check that all channels can be selected. If not,

L218

check that the strobe, clock and data pulses are present at pins 11, 12 and 13 of IC601. Suspect IC601 if they are missing – check by replacement.

Ensure that the data track between IC601 and the tuner is intact. If so, suspect the tuner.

In general, if the IF section is at fault there will be a blank screen, whereas if the tuner is faulty there will be either no picture or a snowstorm.

### Deck Faults

The most common deck fault is tape chewing or creasing because the pinch roller is worn or faulty.

If there's no picture, just snow or bent verticals, or hooking over the top third of the screen, check the tension band assembly for wear or damage.

If playback of prerecorded tapes is marred by lines, check that the guide poles are correctly set up, using the FM waveform as a guide.

Tape slowing down or not being taken up by the spools is very often caused by lack of lubrication on the take-up and/or supply spool spindles. Only a spot of oil is required to give freedom of movement.

Wear on the lower drum assembly, though not common with this machine, can be responsible for a rolling picture, picture jitter, intermittent loss of the picture and poor or jerky visual search (usually only in the reverse direction). A scope check will generally show this: loss of contact between the tape and the heads will leave gaps between the sections of the FM waveform.

If there is no play, rewind or fast forward, check the

idler clutch assembly for wear. Also the idler belt for wear or stretching.

Check the capstan belt if the picture quality varies. To prevent noisy play or record, ensure that the capstan flywheel spindle is lubricated. Sound variation can be caused by a faulty capstan motor.

If there is a loading fault that's purely mechanical, replace the loading motor assembly, which comes complete.

A worn audio/control head will cause poor/no/low amplitude sound.

Check the front-loading cassette unit if there is no fast forward and/or rewind.

Phototransistors Q003 and/or Q004 (both type PN202S) should be checked if the tape will not start or stop after fast forward or rewind.

Should the VCR fail to function when record is pressed, ensure that the record safety switch is OK.

If the machine won't accept a cassette, check the cassette switch. Failure to accept a tape, with possible grinding of the mechanics, should lead to a check on the side arm gears, the timing gear and the arm gear. Any one of these items may have stripped teeth or broken or cracked cogs. Another cause of failure to accept a tape is a bent or misaligned lid opener. If the loading operates correctly in the manual mode, check IC601 and the loading motor drive chip IC205 – by replacement. If the cassette doesn't drop down straight, or jams, check the cassette holder assembly. It may be bent, or the guide pins may be broken or out of position. ■



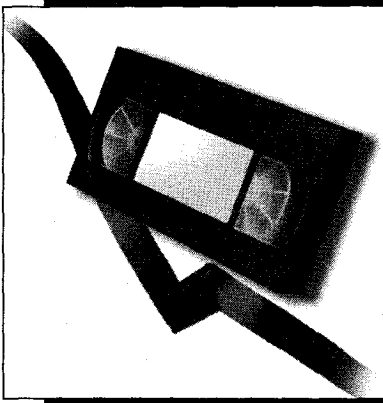

**Reports from  
Philip Blundell, AMIEEIE,  
Edward Branch,  
David Corcoran,  
Chris Hawkins,  
Michael Maurice,  
Michael Dranfield,  
Chris Watton,  
Adrian Farnborough  
and Nick Beer**

### **Toshiba V254**

This machine produced some odd symptoms. There was no E-E sound, and with its own recordings the head switching line floated up and down the screen. The playback picture and sound with a known good tape were OK.

A check at the audio mute test point BS004 showed that the mute line was active (the reading was 5V). So attention was directed to the main microcontroller chip IT001. As expected, the voltage at the audio mute pin 16 was high. Checks on the video inputs to the chip showed that there was no signal at pin 70, the composite sync detect pin. This input comes from pin 42 of IV001 on the other side of the board, where the signal was present. When we traced along the track we found that the signal was lost after the wire jumper above RV139 (by the cut out in the PCB for the drum motor). Bridging the break with fine wire restored normal operation. **P.B.**

### **JVC HRD540**

This VCR was apparently dead with no clock display. Checks

# VCR Clinic

showed that the unswitched 12V and 5V supplies were present but not the switched 12V and 5V supplies, and there was no power-on signal to the main micro IC601. If the power-on line was taken low manually, the switched supplies appeared but there was still no go. The microcontroller chips seemed to be getting all their supplies, but there were no strobe pulses from micro IC1 to the clock display. I took a chance and ordered a UPD725216ACW-A35 from JVC. Fitting it restored normal operation. **E.B.**

### **Panasonic NVJ30**

If the problem is dark/pulling E-E and playback pictures, check for dry-joints at the RF converter. **E.B.**

### **Samsung V1711**

There was no sign of life – no display or operate light. All the power supply output voltages were present, but the /power control signal at pin 5 of CN101 was, at 2.4V, in neither the high nor the low state. I tried replacing the STK5333 power chip and digital transistor Q103 before delving into the microcontroller circuitry.

IC601's supply was present, but there was no oscillation at pins 46 and 47. It was possible to instigate oscillation, sometimes briefly and sometimes for a longer period, by holding crystal X601 with one's fingers. When oscillation was present the machine worked normally.

I assumed that the crystal was faulty and fitted a replacement. A soak test suggested that everything was now OK, but a few days later the machine was back with the same symptom – dead. It could still be coaxed back to life by touching the crystal, or by briefly shorting

the 5V supply (Vdd) to chassis.

This led me to suspect that the cause of the trouble was in the reset switch stage. Transistor Q601 wasn't faulty, but C612 (22 $\mu$ F, 35V) certainly was! A further soak test proved that this time my diagnosis was correct. **E.B.**

### **JVC HRD540**

This VCR was completely dead: no LED display, no clock, nothing! Full HT was present at C12, but there were no outputs on the secondary side of the chopper transformer. Q1 (2SC4517) was open-circuit. Replacing this item restored the machine to life. **D.C.**

### **Akai VS248, 249, 250**

If the complaint is poor quality recording and playback, before you change the drum check that the small earthing screw in the middle of the PCB, under the metal screen that covers the video preamplifier, is fully tightened. **C.H.**

### **Samsung VB920**

This machine would sometimes cut out after a couple of minutes for no apparent reason. On other occasions it would run perfectly for hours. Replacing the 12V and 5V regulator chips, IC1 (S3122) and IC2 (AN7805) respectively, put an end to the trouble. **C.H.**

### **Akai VS18, 19, 22, 23, 24, 34, 35**

If the drum motor takes off at high speed, or play stops after a few seconds, suspect the BU2375 digital servo chip IC503. It tends to be damaged when the voltage at pin 28 (5V) goes high because of a power supply fault. As this chip is expensive, it's a sensible precaution to add a 6.2V, 1.3W zener diode across C9 (100 $\mu$ F, 6.3V) in the

supply to pin 28. There's room on the reverse side of the power supply PCB, near connector P1. C.H.

### **JVC HRD600, 620, 650/ Ferguson FV37H, FV43H**

There was no problem about getting the tape around the heads, but the machine refused to give the tape back unless it was disconnected from the mains supply. It seemed that either the mode switch or the servo chip was the cause of the trouble, but before we dived in at the deep end we sent a search party to look at the lower deck during tape loading. The cause of the problem became apparent after several attempts at loading. Because the toothed part of the plastic sliding bar (item 39) didn't engage correctly at the end of its run, the full loading sequence could not be completed. Plastic circlip item 40 was the cause of the trouble: it had gone on holiday. C.H.

### **Matsui VX1000**

The customer complained that "half the old programme showed". We found that the tape failed to make proper contact with the full erase head because the back-tension arm didn't move to its correct position. The cure was to grease the operating lever that contacts the back-tension arm and check the back tension. M.M.

### **Panasonic NVJ35**

There was a display problem with this machine. Several segments were permanently lit up. Our experience has been that this fault is usually caused by the display itself or one of the diodes connected to it. Not on this occasion however: the microcontroller chip IC7501 was faulty. M.M.

### **Sanyo VHR350E**

This unit was dead. We found that the two 560k $\Omega$  start-up resistors R5005 and R5006 were both open-circuit. Replacements restored the machine to life. M.M.

### **Akai VSG64**

The customer's complaint was that most tapes wouldn't play properly – the off-tape pictures rolled. Her husband, who is a computer engineer, mentioned that if he twiddled the left-hand guide this would sometimes temporarily stop the rolling. My rule is that if the guides are tight, why should they have moved from the manufacturer's settings? In fact the cause of the fault was poor head-to-tape

contact. The user confessed that the machine led a hard life, being constantly in use. A new upper drum, together with slight realignment of the entry guide, restored normal working. M.M.

### **Mitsubishi HSB20**

This machine had been to another dealer who, despite replacing the loading belts, had failed to cure the fault – intermittent failure to accept a tape. The cause of the trouble was the cassette-in switches on the front of the loading unit. A replacement, part no. 439C021010, cured the fault. M.M.

### **Osaki VCR33**

The following note illustrates what can happen when incorrect parts are fitted. Intermittent tape chewing and going into the fault mode was the complaint. Now this model is a GoldStar clone and uses a deck that bears an uncanny resemblance to the Panasonic D mechanism. On inspection we found that the gear which is part of the plate assembly A10 had split. So we ordered one and fitted it. The machine then appeared to work correctly – until the bottom cover was fitted, when the fault returned.

To cut a long story short, we discovered that the loading motor from a Panasonic deck had been fitted. Its pulley fouled the bottom cover, which was minus some of its screws, thereby stalling the motor. All was well when the correct GoldStar loading motor was obtained and fitted. M.M.

### **JVC HRD230/Ferguson FV12L**

Intermittent failure to play or record was the complaint with this machine: the tape would lace up, but the drum wouldn't rotate. Voltage checks showed that the Motor 12V supply and the motor drive and motor run voltages were all present. When I removed and dismantled the lower drum I found that the ICP on the drum motor's PCB was dry-jointed. Resoldering provided a complete cure. M.M.

### **Hitachi VTF770**

This machine wouldn't eject tapes. Fortunately the cause was simply a slipping belt. M.M.

### **JVC HRD230/Ferguson FV12L**

This machine would intermittently stop while in the play or record mode. On test it appeared that the capstan motor was stalling. As there

was no stiffness in the motor I came to the conclusion that it had a dead spot. A new motor cured the trouble. M.M.

### **Samsung SI3560**

This machine's carriage didn't sit properly when a cassette was loaded and ejected the tape with the force of a bullet! When faced with this problem the usual procedure is to replace the eject gear and the right-hand side carriage bracket, which has been modified. All was revealed when we stripped the machine down. Another 'engineer' had tried to repair the bracket by using a large self-tapping bolt to mount the side plate's drive gear! A new eject gear and bracket restored normal operation. M.M.

### **JVC HRD150/Ferguson 3V45**

This machine would sometimes fail to go into the record or playback mode, switching itself off in the loaded state. The cause of this is usually hardened grease and a worn belt on the loading block, but a replacement block failed to cure the fault. An optosensor that's fitted to the underside of the deck was the cause of the trouble. M.M.

### **Samsung VI730**

Dropouts were the problem with this machine – the symptom was long, black streaks that ran across the picture. As a start we decided to set up the CCD level control as laid down in the manual. Connect a scope to TP3303 and adjust VR3301 for a video level of 0.6V peak-to-peak it said. In fact the video signal was missing at TP3303, though it was present at pin 4 of the 1H delay chip IC3302. The only item in between is a 3MHz low-pass filter, FL3303, which was open-circuit. We took one from a scrap machine and after setting up the dropout compensation operation was back to normal. M.Dr.

### **Sharp VCA33**

If tape spills out during play, i.e. there's no take up, try a spot of fine oil on the idler shaft, where the idler gear slides up and down. It tends to become a bit sticky and fails to reach the bottom. This note applies to all machines that use this deck. M.Dr.

### **Akai VS77**

This machine stopped after five seconds, indicating a take-up rotation fault. We cleaned the underside of the reel disc, but the fault remained. A scope check at the

take-up sensor showed that the amplitude of the pulses was only 3V peak-to-peak – it should be 5V p-p. Presumably the LED part of the sensor had lost emission. A new sensor restored the amplitude and correct operation. **M.Dr.**

### **Samsung VIK310, 320, 350, 375**

Further to my note on power supply failure with these machines (see page 658, July), a 100µF, 25V capacitor rated at 125° can be obtained from Farnell Electronic Components of Leeds (01132 636 311) for use in position C110. It's made by Philips and the part no. is 286-709. **M.Dr.**

### **Saisho VRS5000**

This machine appeared to be dead, as there was no clock display. But if a tape was inserted it would half load then stop. Still no display however, and eject didn't work – the tape had to be wound out. The drum would sometimes rotate when a tape was inserted, and would continue for four-five minutes. The power supply seemed to be OK, though the switched outputs couldn't be checked.

Checks at the tuner/timer chip IC601 showed that the 5V supply was present. All the display drives were at -28V. No key scan pulses could be found. We then discovered that there was no activity at crystal oscillator X601. A new crystal restored normal operation. **C.W.**

### **Amstrad DD8900**

Various display segments flickered and the control keys were either very slow to act or produced the wrong function. The stop-eject key initiated forward wind for example. A look at the circuit diagram showed that the display drivers operate with a -27V supply. The display outputs are also connected to the key lines. So a supply problem was suspected. A check showed that the voltage was low at only -15V. Replacing C27 (47µF, 50V, 105°C) cured both problems. **C.W.**

### **Bush VCR190**

This double-deck machine came to us with a list of intermittent faults. They included won't accept a tape, won't eject, won't play, sometimes stops during rewind and sometimes switches off – all with the bottom deck, as is usual with twin decks. I pounced on the mode switch like wildfire, but this was a waste of

time. By watching what happened when a fault symptom occurred I saw that the capstan motor seized. Stripping it down then cleaning the bushes and oiling them cured the fault. I then lubricated all the moving bits on the bottom deck and, to be on the safe side, did the same with the top one. **C.W.**

### **Mitsubishi HSM50**

Rows of white spots marred the playback picture. We removed the deck and checked the static discharge arrangement, which appeared to be OK. The large screened PCB along the back of the deck was loose however. Three screws secure it and provide earthing. Tightening the screws solved this one. **C.W.**

### **Samsung VI611**

In any mode the tape would run for only about a second. The machine would then go into the 'emergency state', with the standby LED flashing. The cause of the fault was in the rotation sensor section. As cleaning made no difference, we checked at pin 3 of the sensor – you can see it when the bottom cover is removed. A squarewave was present when the disc was rotated, but its amplitude was only 2V. A new sensor (part no. 62309110243) produced pulses of greater than 4V amplitude, the signal now reaching pin 55 of the syscon chip. This restored normal operation. **C.W.**

### **Mitsubishi HS551B**

This machine would run for only a few seconds in any mode then stop. A check showed that the take-up reel pulses were missing at pin 92 of the microcontroller chip. When we examined the connections to the reel sensor (Q5E4) we saw that three of its legs were broken. **A.F.**

### **Mitsubishi HSM20V (J Deck)**

We've had two of these machines, both rental models, with broken loading gears. Although the fault is reasonably easy to put right, provided you are not interrupted, be careful that item C 053 plate cam B has its full complement of teeth. Is it the machines, or are the customers too rough? Time will tell. **A.F.**

### **Ferguson FV30B**

This was another machine that would run for only a few seconds in any mode. A check at test point BT15 showed that the supply reel pulses were of low amplitude and

tended to be erratic. A complete clean of the clutch assembly and the sensor cleared the fault. **A.F.**

### **Panasonic NVSD200**

Very low E-E audio was the complaint with this machine. I found that one end of C0729 in the VIF pack was dry-jointed – it's the detector audio output coupling capacitor. Interesting that the other end had clearly been soldered manually! **N.B.**

### **GoldStar GS11290I**

The E-E sound and vision were affected by severe hum. There was slightly less hum in the playback mode. The culprit turned out to be C118 (470µF, 25V). It took a while to find, as I didn't have a circuit diagram. **N.B.**

### **Panasonic NVJ30**

As the combined remote control/bar scanner handset (part no. VEQ1107) for these machines is an expensive item, repair is usually economic. This one seemed to be dead, though the chips were being supplied. There was no clock signal at pins 15 and 16 of the microcontroller chip IC1 however. Crystal X1 (3.52MHz) was faulty. **N.B.**

### **Fisher FVHP445VK**

This non-UK machine is similar to the Sanyo VHR5200E. The one brought in by a customer wouldn't come out of standby. Checks revealed that the switched 5V supply was missing. Q5402 (2SC3070) turned out to be short-circuit base-to-emitter. **N.B.**

### **Panasonic NVFS90**

The complaint was no S-VHS playback or record – standard VHS was fine. When I traced the luminance path through I found that the signal entered the hybrid chip IC303 (VEFH05BT) at pin 2 but nothing came out at pins 7 and 8. The cause of the trouble appeared to be that one of the aluminium can, surface-mount electrolytics in the module had leaked. A replacement IC cured the problem. **N.B.**

### **Panasonic NVL25**

When this machine was put into the standby mode the vision remained and the red LED stayed alight! The cause of these interesting symptoms was a splash of solder that shorted the cathode of D1002 to an adjacent wire link. As a result the switch line to the power supply didn't change state. **N.B.**



**Reports from  
Adrian Spriddell and  
David C. Woodnott**

### **Panasonic NVMC20B**

The cause of intermittent zoom operation has been traced to excessive drag in the zoom motor gearbox. Several weeks ago we tried lubricating one with Tri-flow as an alternative to replacing the unit. Correct operation was restored, with no adverse side effects noted so far. **A.S.**

### **Sony CCDF500**

The complaint with this camcorder was "no eject". In fact it wouldn't perform any mechanical functions. We noticed that when eject was requested the head failed to rotate: it twitched, then the unit went into the caution mode and shut down.

We suspected the drum drive chip IC004 on board SS93P, but a replacement made no difference. The culprits were C069, C070, C071, C072, C073 and C074, which were all either leaky or of changed value. Replacing them restored normal operation.

Interesting to note that in the fault condition the head could be made to rotate by giving it a prod, with normal operation until the head was stopped. **D.C.W.**

### **Canon E90E**

This elderly unit suffered from erratic drum rotation, which led to no operation. We cured the fault by replacing C439, C440 and C441 (all 10 $\mu$ F, 16V) on the main PCB. They form part of the head drum commutation unit.

On test we then found that normal shut down was marred by failure of the viewfinder picture to extinguish

# Camcorner

itself for at least five seconds. The cause of this was C2931 (47 $\mu$ F, 16V) on the grip PCB – it was leaky. The viewfinder behaved correctly when a replacement had been fitted. **D.C.W.**

### **Sanyo VMD3P**

This model is well known for leaky capacitor problems, mainly on the video and syscon PCBs. The symptom with this one was absence of the camera E-E picture. We traced the cause to C9146, a 3.3 $\mu$ F capacitor on board CA1. It's not an electrolytic, and was short-circuit! No other damage had occurred, and a replacement cured the fault. We also replaced the usual twenty or so capacitors previously mentioned in this column. **D.C.W.**

### **Sony CCDFX300**

The usual cause of intermittent operation in either the VTR or the camera mode is a faulty CAM/VTR switch. This comes as no surprise, as it's the same one that is used in most of the F range. **D.C.W.**

### **Canon UC1000E**

There was no E-E or record sound. Otherwise the unit worked normally. A faulty microphone was the slightly unexpected cause of the fault. **D.C.W.**

### **JVC AA-V2EK (AC Adaptor)**

Failure of the 150°C 3A thermal fuse TF4 is a common failure with this unit. A replacement is available from RS (part no. 417-076). **D.C.W.**

### **Sony EVA300UB**

This camcorder tended to chew tapes in the rewind search mode. Rewind itself was OK, and the unit worked correctly in every other respect. A slightly worn pinch roller assembly was the cause of the trouble. As this item is expensive, we tried cleaning it. Unfortunately this didn't work and a replacement had to be fitted. **D.C.W.**

### **Canon E50E**

When the lens assembly in these camcorders is subject to impact an

internal mounting bracket is often damaged and a few electrolytic capacitors can be detached from the main PCB, adjacent to the lens.

After repairs and capacitor replacement you may find that the unit powers down almost instantly after powering up. This is nothing to do with the impact: the cause is leakage from the capacitors just mentioned (C605, C616 etc.). But the area of the board affected is at the opposite side, where the electrolyte will have seeped around IC605, IC606 etc. These are regulator and reset devices associated with the main micro-controller chip IC601. Cleaning the PCB in this area should cure the fault. **D.C.W.**

### **JVC GRAX2**

All functions were OK but there was no viewfinder picture. We found that a circuit protector (SOC250) had failed. On test no other circuit fault or excessive current demand was apparent and a replacement CP put matters right. The trade price of £8 plus VAT comes as a bit of a shock – other SOC type fuses normally cost around £2. **D.C.W.**

### **Canon A1HiE**

We'd not seen one of these camcorders previously. So it came as a surprise when we received three of them within a week from different sources. All suffered from similar problems, which ranged from uncontrollable drum speed to knocking noises from the drum motor and intermittent operation. As service information is no longer available, an educated guess seemed to be in order. We replaced all twenty two electrolytic capacitors on the MDA board.

The reason for this possible 'overkill' was our previous experience with leaky capacitors generally – and the fact that the MDA board takes some getting at in this model! All three machines are now happily back with their owners. Our only slight worry is that there are several other similar capacitors on other PCBs. **D.C.W.**

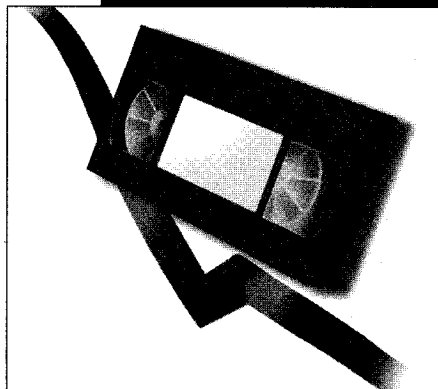

# VCR Clinic

Reports from  
**Eugene Trundle,**  
**Philip Blundell, AMIEIE,**  
**John Edwards,**  
**Roger Burchett,**  
**Brian Storm,**  
**Robert C. Meade,**  
**Terry Lamoon,**  
**Bob McClenning,**  
**Richard Newman,**  
**Phil Marrison and**  
**Michael Maurice**

## **Panasonic NVL25**

Severe wow on sound was the complaint with this machine. It was terrible with prerecorded tapes, even worse with playback of its own recordings. The wow rate was 3-4Hz, and there were strange corresponding waveforms at pins 2 and 20 of the BA6435S capstan drive chip IC2101. A new BA6435S cleared the trouble. **E.T.**

## **Akai VS467**

Intermittent deck shutdown and intermittent refusal to accept a cassette have been the symptoms with two of these machines we've had in. On both occasions we found that the cassette LED on the underdeck sensor PCB was dry-jointed. In fact there are two LEDs, one facing each way. They are connected in series with R1 (62Ω) and fed from the IDL5V line. **E.T.**

## **Panasonic NVSD40**

At very rare and erratic intervals this machine would fail to record the picture. The effect on playback was a screenful of snow, with the sound continuing normally. Surface-mounted transistor Q3007

turned out to be the culprit: it had an intermittently open-circuit base-emitter junction. Its job is to switch the operating voltage to the video record amplifier. **E.T.**

## **Amstrad VCR9500**

We hadn't encountered this model before, and as a result made fools of ourselves! If a fully rewound tape was inserted it would be ejected. If a part-wound tape was inserted the machine would rewind then eject it. The light pipe was missing from the start sensor optics at the left of the cassette cradle. **E.T.**

## **Grundig VS400**

When fast forward was selected the FF symbol showed in the display but rewind was what you got. Play, rewind and forward search were all OK. This ruled out problems with the end sensors. A new mode switch was tried, solving the problem. **P.B.**

## **Hitachi VT428**

There was a faint, stationary hum bar on the screen in the E-E mode while playback of a known good recording was marred by random horizontal black streaks. Playback of the machine's own recordings gave the impression that the heads were worn. In addition there was line tearing, as if the head speed was wrong – though it wasn't! The smell of something hot drew me to the IF module, where the chip was cooking nicely. Its 12V supply was at just under 20V – as were the 12V outputs at pins 1 and 3 of the STK5372H regulator chip. A replacement regulator chip put matters right. **J.E.**

## **Philips VR1541**

This machine chewed the tape when play was selected and wouldn't wind fast forwards or rewind. As

the circlip that holds the swinging idler parts together had fallen off there was no reel rotation. The circlip was nowhere to be seen. The idler assembly is cheap and is easy to fit once the carriage has been removed. So we ordered a replacement – a lot less bother than trying to obtain and fit a circlip with the idler assembly in situ. **J.E.**

## **Samsung SI7230**

Although there wasn't a tape in this machine it continuously tried to eject the carriage, which would have spent the rest of its life going in and out if it hadn't been for the carriage lock hook. This kept the carriage in the eject position. All deck functions worked normally when a tape was inserted and loaded by hand – until eject was selected. We then had a repeat performance.

The cause of the trouble was the tape-in leaf switch that's mounted on top of the carriage. There was 5V at both connections irrespective of the position of the contacts. Closer inspection revealed that one of the contacts was slightly twisted and was thus permanently closed. We were able to untwist the contact, using small, long-nose pliers. This restored correct switch and machine operation. **J.E.**

## **JVC HRD820**

Tape damage was the complaint with this machine. When a dummy tape was inserted and play was selected the take-up spool carrier was seen to rotate in a jerky stop-go manner. Rewind and fast forward were sluggish and noisy. Suspecting a clutch problem, I removed the bottom cover. A small toothed pulley mounted on the capstan flywheel drives the clutch via a toothed belt. It had become loose,

and a crack was evident down its side. Non-JVC account holders can obtain the pulley from Willow Vale – part no. 87660PG. **J.E.**

### **Matsui VX900**

If the heads seem to be faulty don't immediately order and fit a new drum, as I did. Instead, lower the bottom main board to gain access to the head amplifier screening can. Then use a switch cleaning aerosol to clean the contacts of the head switching relay. The chances are that this will save you a lot of money! **J.E.**

### **Ferguson 3V42/JVC HRD455**

This machine came in for the routine job of fitting a new carriage assembly. It didn't take long to do this, but my heart sank when I tested the machine and saw the playback picture. It was a complete mess, consisting of two very wide horizontal dark bands that resembled hum bars, with a colourless, spotty picture in between – and not a straight vertical line in sight. The display was so ragged that I had to check the tape's label to find out what I was supposed to be looking at.

"Don't panic" I told myself, "go for the power supply". As the E-E picture was normal, a scope check on the switched playback 6V rail (test point TP2 on the regulator board) seemed to be a good idea. The display consisted of a 2V squarewave sitting on 4V DC. The likely culprit was C23 (2,200µF, 16V), which measured open-circuit. A replacement restored normal playback. Naturally as far as the customer was concerned playback had been perfect before the carriage broke! **J.E.**

### **Lloyd LV400/Amstrad VCR7000**

This Orion machine had a partly laced-up tape in it. No functions worked. The cause of the trouble was an open-circuit N20 circuit protector on the power board. It doesn't seem to have a circuit reference number. The only other problem was a loose (slipping) loading belt. **R.B.**

### **Ferguson FV26D**

The half loading arm was very sticky, to the extent that most of the time during play it was outside the tape path. At other times the loading sequence would be aborted because the arm jammed with the guide poles. When the cam gears were

stripped down I found that the grease was hardening. So a complete clean and relubrication was carried out. After this the machine played faultlessly. Unfortunately the audio/control head was so badly adjusted that the machine would play only its own recordings. It's OK now, but there's a pile of tapes that are of no use! **R.B.**

### **Grundig VS200**

The owner of this machine said that it wouldn't record. He was more used to Far Eastern models. All that was wrong was that he didn't select an input before pressing record. **R.B.**

### **Ferguson 3V29 etc**

Repairing broken 'hinges' on the front panel function switch operating pads has probably taxed the ingenuity and patience of us all. This latest machine to come my way had obviously led a hard life. The fast forward pad was completely detached, with very little left of the hinges following earlier repairs. I was therefore forced to try a new approach.

What I eventually did was to cut thin strips from a washing-up liquid bottle, then superglue them in place to form new hinges. When set, I cut V-shaped grooves across the strips so that they would flex rather than attempt to become detached under pressure. So far the repair has proved to be satisfactory. **R.B.**

### **Panasonic NVFS90**

Dark smearing to the right of any black image during playback was the complaint with this machine. The main cause of picture distortion in these S-VHS machines is the 1H delay CCD pack on the sub-luminance and chrominance board. Scope checks in this area led me to C3506, in the 9V supply to IC3504. It was open-circuit. A new 10µF capacitor restored an excellent picture. **B.S.**

### **Panasonic NVFS90**

This machine produced bad drop-outs: when any tape was played back there were excessive flashing black and white lines. We eventually traced the cause of the fault to C3311 (10µF) in the HQ pack – it was open-circuit. After fitting a replacement the picture was clear. **B.S.**

### **Samsung VI611**

This machine would stop intermittently. On investigation we

found that the take-up reel pulses were weak or absent. A new reel sensor cleared the fault. **R.C.M.**

### **GoldStar GSEQ201**

This machine would sometimes eject the tape of its own accord. The cause was found to be a dirty mode switch. Cleaning it cured the problem. **R.C.M.**

### **Philips VR727**

If the problem with one of these machines is poor load or eject, it's worth checking the long pulley shaft that drives the main cam. The small end cog splits then slips when torque is applied. Replace it and check the other gears for damage: this should cure the problem. The pulley shaft doesn't seem to be up to the job. **T.L.**

### **Ferguson FV61LV**

Because the strength of the erase bias varied, bits of the previous track were left superimposed on bits of fresh recordings. The cause of the fault was the BC337-40 transistor TL01, which is mounted on the PCB beneath the deck. Replacement set everything to rights. We discovered that the transistor's gain was varying – it was in fact heat sensitive. **B.McC.**

### **Bush VCR161**

Field roll and apparent picture overloading were the symptoms with this machine. They could be cured by tapping the modulator. When this was opened up we found that the earth joints were poor. A good solder up put an end to the problem. **R.N.**

### **Matsui VCP100**

This old playback-only machine chewed tapes. The cause was not difficult to see: the reel idler's rubber tyre had split and was lying in the bottom of the deck! As the customer was short of cash, I used a suitable tyre from a bag of assorted sizes. When this had been fitted the machine produced very good pictures, but there was no wind and no rewind. Dirty mode switch contacts turned out to be the cause. Cleaning and adjusting put matters right. **R.N.**

### **Samsung SI3260**

The customer had levered a tape out of this machine. Fortunately the carriage was intact, but its timing was wrong. When this had been corrected the machine wouldn't thread up. An external DC voltage fed to the loading motor with the

carriage removed proved that the mechanism was partly jammed. The only solution was to retune the machine – the main cam was almost 180° out. Once the timing had been reset everything worked well. **R.N.**

### Saisho VR54400

This teletext machine suffered from what looked like severe video overloading. It could run perfectly for hours then, with no warning, the picture would almost go negative. As I didn't have a circuit diagram, I spent a bit of time working my way around the machine. With the VCR displaying a faulty picture, I scoped the waveform at the video output socket and found that it was very crushed. Working my way back along the print, I next found myself at pin 6 of socket CT8503 which connects with the teletext PCB. The video was again crushed. Obviously there had to be a video input to the panel. This turned out to be at pin 6 of CT8502, the other socket linked to the text PCB, where the video was perfect. When the text board was removed the crushed waveform disappeared, the perfect waveform remaining at pin 6 of CT8502. So I left the text PCB out and linked pin 6 of CT8502 to pin 6 of CT8503. The machine now worked perfectly.

So the cause of the fault was on the text PCB. A few days later a friend sent me a photocopy of the text board circuit. The video input goes to a clamp in the BA7606 chip IC8507. Scope checks confirmed that this chip was the cause of the trouble, a replacement putting matters right. I was somewhat puzzled by the signal fed to pin 7: it's marked "brank". This is connected to pin 17 of the SAA5243 CCT chip, where it says "branking" ... A branking pulse?! **R.N.**

### Philips VR6185

This machine came in with a cassette loaded but the tape not threaded up, the complaint being that the cassette couldn't be ejected and the machine would shut down. It seemed to initialise when reconnected to the mains supply, then the cassette ejected all right. I thought that the deck microcontroller had become corrupted, but the machine then again failed to eject. The problem was that the fault would occur only every so often, while in all other respects the machine worked perfectly.

The service mode suggested that the threading mechanism might be too heavy. As I've had threading motor failure quite often with these

machines I fitted a replacement. Unfortunately this made no difference. I eventually cured the fault by replacing the L293 loading motor driver chip IC7001, after discovering that pins 11 and 14 were sometimes both at 4.5V in the eject mode (alternate pins should go low during threading or unthreading). Oddly, the cassette loading was never affected. **R.N.**

### JVC HR7300/Ferg 3V30

This machine's recordings were marred by a black flashing line. The cause was traced to the 12.5V supply being too high: we found that the 1kΩ set-up potentiometer R5 was open-circuit. A replacement enabled the 12.5V supply to be set up correctly, restoring normal operation. **P.M.**

### Panasonic NVFS200

This S-VHS machine suffered from very intermittent picture break up with its own recordings, but only for the first ten minutes after switch on. While checking the supplies associated with the TV demodulator module we noticed that it was microphonic. This was the cause of the symptoms. When we removed the module for inspection we found that there were several suspect joints. After resoldering these and reassembling the unit the microphonic effects has gone and the machine worked correctly from switch on. **P.M.**

### Sony SLVE8

The complaint was no rewind. Previous repair shop engineers had replaced the beginning and end of tape sensors and had ordered a microcontroller chip. The machine came to me because they didn't have the equipment to deal with flatpack chips.

I thought it unlikely that the chip was responsible. On test the machine worked faultlessly in play and fast forward, but when either rewind or reverse search was selected the tape would start to rewind then, within a fraction of a second, stop. This was the clue. I put the machine in fast forward and scoped the output from the two sensors. One was clearly low. These sensors are a common cause of trouble with this series of VCRs. I replaced them both for good measure, clearing the fault. **M.M.**

### Toshiba V813

The power supply had been dead with the STRD6202 chopper chip IC803 split in two. After fitting a

new STRD6202 without success the first dealer had replaced both optocouplers, had changed R802 from 75kΩ to 39Ω, had fitted a BY133 diode in position D802 and had replaced the the mains bridge rectifier D804 with a standard 800V type! When this didn't work he gave up and the machine came to me.

A label stuck on the power supply said check the value of R802 (75kΩ was right). Toshiba's excellent technical advice service then told me that the following should be replaced: IC803 (STRD6202); the optocoupler IC804 (TLP721); the adjustable zener IC821 (μPC1093J); the small power control PCB U803 and R805 (0.56Ω). When these had been replaced, along with IC801 (the other optocoupler), R802 (correct value), D802 and D804, the machine powered up, bringing a sigh of relief from me. A full function check then showed that all was well.

According to Toshiba it's no use replacing parts one by one in the power supply to find out which is the culprit. Replace the those listed in one go. **M.M.**

### Akai VS767

In this and a number of other Akai machines the display filament supply is obtained from a small transformer and a couple of diodes and capacitors. There's a modification kit. You replace the diodes and capacitors and alter a connection to the coil. This had already been done, but there was still no display. The transformer itself had burnt out. **M.M.**

### JVC HRJ205

The complaint with this machine was of a double image. Playback of a tape with vertical lines in the display showed this up. The fault was also intermittent. We traced the cause to dry-joints at the delay line. When this item was removed from the video processing board we found that there was a crack in the print to its earth pin. Remaking the print and resoldering cured the fault. **M.M.**

### Matsui VX6600

This machine would tune in but not store channels. The cause of the fault was the little UPD6525C memory chip on the operation/display PCB. Take care when ordering: it's advisable to quote the Matsui part no. or obtain it from Partmaster. **M.M.**

# Customer Reliability

One thing will keep us busy for the foreseeable future – the customers themselves. Brian Storm presents the case

Continual design improvement and technical development are features to which we have become accustomed with the equipment we sell and service. Add to this its increased reliability and you have three good reasons why the number of electronic units that arrive in our workshops should decrease year by year. There's a good reason to expect many more years of employment in our trade however – the little matter of customer competence.

Very little of the development work being done today is aimed at improving Homo sapiens. This has various consequences. For instance all the technology in the world will fail to give a camcorder a soft landing when its owner neglects to put the shoulder strap around his neck and the machine falls through his grasp. Here are some recent examples.

## Exhibit A

The first is a Panasonic palmcorder, Model NVS1. According to my computer records this is its third appearance on my workbench. Not because of a design fault, inferior technology or poor construction, but simply because for the third time it has mimicked Newton's apple and succumbed to the force of gravity – despite the fact that a serviceable safety strap lies neglected in its carrying case.

The angry owner told me that it was dead when he

wanted to use it after it had spent a few weeks dormant in its bag. But there was sufficient evidence within the camcorder to suggest that sudden impact had been the cause of the problem.

The main connecting plug had broken off the operation panel. So a new operation panel assembly (part no. VES0603) had to be fitted. This restored some life, but when a tape was offered there was a grunting noise as the unit powered down and sulked. When a bent piece of chassis frame had been removed from the top of the head drum, the camcorder was able to play the tape. This wasn't the end of the story however. Although there was good tape playback via my monitor, there was no viewfinder picture – just some characters that went across a grey screen.

An hour later, after repairing the print to the viewfinder plug, I was able to present the camcorder to its owner. He was somewhat miffed about the bill, complaining that I had repaired the unit for him a year ago, since when he'd hardly used it.

Tact and diplomacy have never been my strong points, but I've always been at my diplomatic best when presenting a bill. I printed out a copy of his previous invoice. "Replaced cassette housing and side casing assembly, broken because of impact damage. . ." He turned away from the printer and hurriedly wrote out his cheque.

I did suggest that he practise using the strap, but he was away before the ink was dry on his signature. I made a mental reservation for the same time next year.

## The Next One

Exhibit B is a Panasonic NVHD100 VCR that came back last month. Its owner was irate and abusive, demanding that I contact Panasonic immediately to get him a replacement. Not only had it refused to play tapes only six months after he'd bought the machine, it had also damaged some brand-new Disney tapes.

As the machine uses the newer K mechanism, which to date has been utterly reliable, I removed the top cover in front of him. I've never seen the wind removed from someone's sails so quickly. A child's eraser was nestling comfortably against the drum. I quickly removed this intruder and tested the machine. Fortunately no lasting damage had been done.

Feeling unfairly wronged, I took up the challenge and told the becalmed owner he was fortunate that the object

*That's odd! it was working perfectly when I phoned Margo from home five minutes ago.*

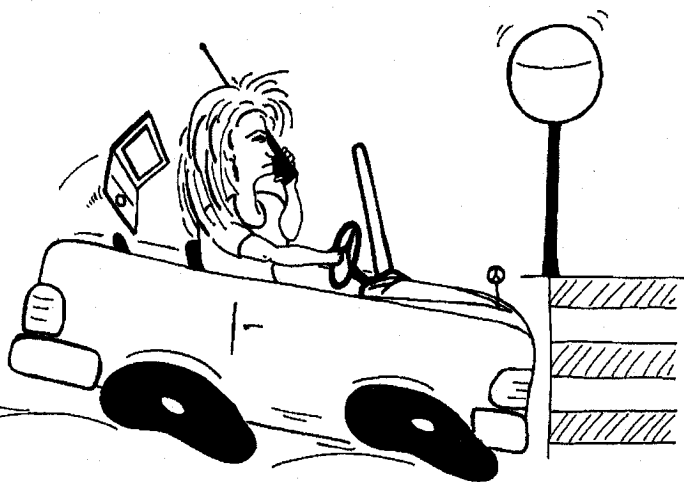



had been a soft one. Otherwise he would have needed a new video head drum and, even more expensively, a head drum motor complete. I should really have charged him, and of course the guarantee was in danger of being invalid. But I said I was willing to overlook it this time. He left with the machine, silently.

### **A Knife**

I reached for the morning post, in which some parts for exhibit C had arrived. This was a Panasonic NVJ35 VCR that was on the awaiting spares rack. Its owner had used a large kitchen knife to remove the tape! The knife was of unquestionably strong constitution – in fact it was a glowing tribute to the art of knife making, and was without any signs of damage after prising the cassette holder from the depths of the machine. Unlike the mangled cassette holder, which was bent and buckled and beyond repair.

I'd already tested the VCR without the cassette holder fitted. Miraculously, it had gone through its various mechanical functions without any problems. So all I had to do was to assemble the contents of the bag of spare parts to produce a cassette holder and fit it in the machine, which fortunately worked fine a bit later on.

I couldn't help but wonder why it had been so important to remove that tape. What had been on it, why had been it so urgent – and why risk damaging a perfectly good kitchen knife? Suggestions on a post card, please. . .

### **A Computer**

I get very few computer repairs in my neck of the woods. But the problem with exhibit D was again entirely the

owner's fault. This neat little Panasonic CF1000 notebook computer (a 386SX25 80MB DD for the technically minded) had been lying serenely on the back seat of its owner's car. Until she braked sharply, that is, throwing the computer into the front instrument console and cracking its display panel.

I checked it out with a colour monitor to see if anything else had been damaged. It worked perfectly, but unfortunately for the owner the display panel costs over six hundred pounds trade. As a result, I had a rather expensive estimate to present to her when she returned. She put it in her handbag. While she had it undone I couldn't help noticing a cordless phone handset in there. So I asked her if she'd brought it in for repair? She said she always carried it around in case her husband wanted to get in touch, but hadn't found it to be very good. She handed it to me for inspection and invited me to make a call on it.

I reflected on the fact that it had been a long day, then settled down to explain to her the fundamental principles of the cordless phone and the inherent advantages of the cell phone.

### **In Summary**

So there we have it m'lud. Add to these exhibits frequent dropped and damaged personal stereos and ghetto blasters, cordless phone handsets with damaged internal or external aerials, camcorders with sand or water damage (if they haven't been dropped), and remote control units of all shapes and sizes in various states of decay. With customers like these, who needs faulty products? I'm sure no jury would sentence me for contempt. ■

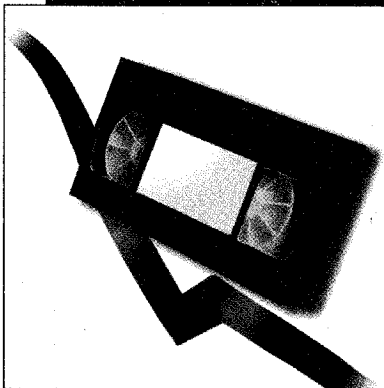

**Reports from Philip Blundell, AMIEEIE, Eugene Trundle, Mike Leach, Terry Lamoon, Andrew Tebbutt, Gerald Smith, Steve Hague, John Coombes, George Whiteside, Chris Watton and Michael Dranfield**

### **Mitsubishi HSB31**

No rewind was the complaint. The brakes failed to come off as the latch magnet was open-circuit (it should have a DC resistance of approximately 600Ω). The part number for the latch magnet is 299P124010. **P.B.**

### **JVC HRDX22**

This one caused me to scratch my head for a few minutes before I realised that the Phantom Fiddler had been at work. The symptom was faulty cassette lift operation: the machine would accept a cassette, but something prevented it going fully down.

I noticed that the pin was broken off the guide arm (exploded view reference 47) and was wondering whether the gears had jumped some teeth when I saw that the half-loading arm (reference 49) had two pins! Yes, someone had glued the broken pin on to the wrong arm. **P.B.**

### **Hitachi VT150**

This machine was nearly ten years old and still going strong – except that its E-E and recorded sound

# VCR Clinic

were quiet and 'buzzy'. Playback of a known good tape was fine. A check on the audio output from the IF module showed that it was weak and noisy. The culprit was a 4.7μF, 35V coupling capacitor (C08) in the module. There's a circuit diagram of this in the manual but no layout picture. **E.T.**

### **JVC HRJ210**

Intermittent picture jumping was the problem with this machine – for the very good reason that the playback video FM envelope was very ragged at the start of a scan. A check showed that the supply guide was a little sloppy in the V block. The cause of this turned out to be a latching loading arm assembly on the underside of the deck. Its part number is PQ43537B. **E.T.**

### **Samsung VIK316**

This machine was to all intents and purposes dead. The obvious power supply checks were carried out – fuses etc. – but everything appeared to be in order. Time to get the circuit and check some voltages. This revealed that the always 5.8V supply was low at 3.5V. I decided to replace C35 (400μF, 16V) and C36 (330μF, 16V), after which the machine fired up and worked perfectly. **M.L.**

### **Mitsubishi HSB41**

This machine came in because of mechanical problems: it needed a new pinch roller assembly and a good grease up. After doing this I tested the machine and found that there was no E-E or record sound. Perhaps a plug had come adrift? No, all the plugs were in place and no dry-joints were evident on the main panel. When I used the scope to trace the path of the audio output from the IF section I found that it

went to the front panel for the headphone take-off. The cause of the trouble turned out to be a dry-joint at transistor Q8B0 on this panel. After resoldering this transistor the machine performed correctly with good audio. **M.L.**

### **Hitachi VTF770**

If one of these machines shows "CODE -1" in the display when you press the operate button, try replacing C711 (33μF, 6.3V) and C771 (220μF, 6.3V). They are both on the front panel, beneath the display.

I've also had to replace the EEPROM (IC702) when the machine wouldn't change channels after replacing the two capacitors just mentioned. **M.L.**

### **Matsui VX1000**

According to the customer this machine intermittently chewed tapes and forward search was slow. When we put the machine on test it slowed down after a while. Application of freezer to the capstan motor got the machine going normally again, while warming the motor with a hairdryer shut it down altogether. A new capstan motor was the costly answer. **T.L.**

### **Mitsubishi HSB12**

The complaint with this machine was that it played at the wrong speed and produced Mickey Mouse sound. Sure enough, that's exactly what it did. When we removed the top we saw that the loading arm was sticking and in the wrong position. This was because the brake pad lining had come adrift from its lever. A replacement brake lever cured the fault. **T.L.**

### **Akai VSF33**

This machine suffered from the

usual problem: the display was missing. After fitting a modification kit the display was there but was so low that a new display tube had to be fitted to give normal viewing. The machine also needed a new pinch roller. **T.L.**

### **Matsui VP570**

This machine would intermittently shut down because the drum stopped rotating. Careful examination of the connector board that runs between the mechanism and the mother board revealed a dry-joint at pin 1. Resoldering this stopped the playing up. **T.L.**

### **Sony SLVE25**

There was no playback, just a blue screen. When the machine was put in the visual search mode a picture appeared. On checking out the mechanism I saw that the pinch roller wasn't engaging correctly. I then realised that the pinch roller was too high, because the circlip that should hold it in position was missing. Where it had gone remains a mystery, but a new one cured the fault. Perhaps it had never been fitted in the first place? Strange. **T.L.**

### **Bush VCR802**

As the cassette flap had come adrift this machine wouldn't accept a tape. After refitting the lever we inserted a cassette and found that it couldn't be ejected. The tactile eject switch had fallen to pieces. A new switch restored normal operation. Incidentally the deck looks very similar to the one in some Akai models I've seen. **A.T.**

### **Ferguson 3V48, JVC HRD140**

These two machines, which have similar mechanisms, had the same fault – they required new loading belts (remember the 3V30?). The 3V48 came back however with the complaint that it would only rewind/wind fast forward in the picture search modes. A plastic lever on the loading block had come adrift – it's used to free the brakes for rewind/fast forward. I can't quote a reference/part number for it as it's not listed as being separate from the loading block. **A.T.**

### **Aiwa VXT1420K**

This combined TV/VCR would eject a tape as soon as the loading cycle had been completed (tape fully around the head drum). The cause was failure of the drum to rotate. A new motor restored

normal operation. The mechanism in these units is the same as that used in some Orion VCRs. **A.T.**

### **JVC HRD520**

This machine damaged tapes on eject. I replaced the mode switch as usual, but the tape was still a little loose and sometimes caught on eject. The cure was to replace the capstan belt and clean the capstan brake. **G.S.**

### **Finlux VR3724**

This machine wouldn't memorise or change channels or tune in properly. A replacement memory chip (IC602) put matters right. **G.S.**

### **Nokia VR3615**

Intermittent failure to rewind or leaving tape out on eject was the complaint with this machine. When the fault showed up I noticed that the reel gear didn't come over far enough to touch the reels. Thus no take-up on eject or rewind. A replacement reel gear assembly cured the fault. **G.S.**

### **Samsung SI3240**

There was a tape stuck in this machine and the quarter load arm was out of sync with the mechanism. If you get this problem, check the gears and arm for damage, replace any defective parts and align the mechanism. The most likely cause of the fault however is a broken brake trigger spring on the loading motor spindle. So check this as well! **G.S.**

### **Nokia VR3615**

The customer complained that there was intermittent loss of the playback or E-E picture. We found that the on/off 5V output from the power supply occasionally disappeared. The cause was dry-joints at Q854. **G.S.**

### **Sharp VCH81HM**

There was no play, fast forward or rewind with this machine, which also damaged tapes on eject. A faulty capstan motor was the cause. On closer inspection however I found that C6 (10 $\mu$ F, 25V) was open-circuit and that the leakage from it had corroded the print that links the 12V supply to the motor. I was able to get the motor going again by repairing the print and replacing the capacitor. **G.S.**

### **Sanyo VHR190**

There was an odd fault with this centre-deck machine. When rewind was selected it would wind the tape

forwards, though the display said that the machine was in the rewind mode. As we didn't have a service manual, we gave Sanyo a quick call and were told that a forward-reverse switching voltage is applied to pin 1 of the capstan motor drive unit connector. A meter check showed that this was happening. So we were left with the LB1688 motor drive chip as the only possible culprit. Unfortunately it's not available as a separate item. You have to replace the complete motor unit (ouch!). Anyway, this cured the fault. **S.H.**

### **Mitsubishi HSB20**

This one gave us a hard time. It was reputed to run slow, refuse to accept commands, eat tapes and in general exhibit some pretty expensive sounding symptoms. After many hours of soak testing the capstan motor seized up. So we fitted a replacement, gave the machine a soak test for several hours then returned it to the customer.

Two days later it came back with the same complaints. After several more hours of soak testing the fault put in an appearance. It transpired that the microcontroller chip was applying a gradually increasing braking voltage to the capstan drive chip. A new micro was the answer. **S.H.**

### **Panasonic NVJ30/35**

Poor (noisy) playback, which gives the impression that the video heads are dirty or faulty, can be caused by a poor connection on the lower drum. The solution is to remove the heads and resolder the connections to the lower drum assembly. **J.C.**

### **Toshiba V212**

Intermittently poor playback was the complaint with this machine. The fault could be instigated by tapping the head preamplifier. We found that CQ05 was faulty but have also had CQ06 go open-circuit. **J.C.**

### **Panasonic NVJ45**

If there's no colour with the machine's own recordings and the drum servo is hunting, check whether the 4.43MHz NTSC switch on the front panel is switched to on. It should be in the off position – the switch should be in the on position only in the dubbing mode. **J.C.**

### **Akai VSF30**

Tape chewing with this model is usually caused by failure of the loading block mechanism to seat properly. Replacement of the

loading block unit may be necessary. If it's all right, check the retaining clip. If this is loose the eject gear will jump a cog. The only way round this one is to insert a piece of plastic of the correct size to prevent it happening. **J.C.**

### **Panasonic NVSD40**

This machine wouldn't accept tapes. On checking it we were perhaps lucky to find the cause of the problem first time: there were dry-joints at plug/socket P1506. It's connected to Q1503 (2SB941), which is mounted on the diecast chassis. **J.C.**

### **Akai VSF200**

To cure tape creasing at the top only, replace the pinch roller with the modified type. If the old type with a U-shaped insert and the spring tension on the side is fitted, replace it with the new type. Make sure that you read the modification sheet carefully and set the machine up correctly for an even FM video envelope. **J.C.**

### **Sony SLV415**

There was no picture and a smell of burning. When we took the top off we saw that the drum motor wasn't rotating. It was pulsing instead, but if spun would build up speed. After finding that the motor drive chip was OK (by replacing it) we suspected the Hall chip within the lower drum and, taking the easy course, replaced the lot. The fault was still present however. The cause of the trouble was actually C014 (0.1 $\mu$ F). Failure of C013 or C015 would have had the same effect. It's best to check all three capacitors by replacement. **J.C.**

### **Panasonic NVG21/25**

For intermittent loss of playback colour, check C1023 (1,000 $\mu$ F, 10V) in the power supply. It may be open-circuit or just dried up. **J.C.**

### **JVC HRD580**

There was a line, about 1.5in. wide, across the picture. It looked like a very wide noise bar, the sort of thing you get with poor back tension or a badly worn lower drum. The cause turned out to be a faulty 3.3 $\mu$ F, 50V chip capacitor (C6) on the drum motor PCB. **J.C.**

### **Panasonic NVSD40**

One of these machines gave us a lot of trouble. Sometimes the symptom was tuning drift on one or all channels. Alternatively there could be a flashing or flickering picture

that varied when the tuner/IF panel was tapped. We eventually cured the fault by removing the 0.1 $\mu$ F chip capacitor C706, cleaning the paint mark off the PCB and then refitting it. **J.C.**

### **Sony SLV353/373 Series**

This one comes under the heading "how could I have missed that?" The machine couldn't be switched off and would only play, rewind or wind fast forwards. As disconnecting it from the mains supply and waiting a few seconds had no effect, I started to dismantle the machine to check whether any of the front-panel buttons were jammed on. When I went to remove the rotary control I noticed that the play arrow pointed down instead of to the right. Gently pressing it and rotating it counter-clockwise enabled me to gain full control of the machine.

The culprit turned out to be the customer's granddaughter. This 'fault' could be an ideal way of keeping a toddler amused: by inserting a favourite tape and selecting continuous play. **G.W.**

### **Toshiba V110**

The tape would load but the pinch roller wouldn't engage. The machine would then go to standby. When the tape was ejected we noticed that the drum was rotating too fast. A check at BT33 (drum PG/FG in) showed that the waveform was missing. This is the drum tacho – a squarewave should be present here. The optocoupler on the drum motor PCB had failed. **C.W.**

### **Panasonic NVJ40**

The customer complained that when he used this machine in the visual search mode all he got was a blank screen. Various checks were made, which brought us to the lower drum. This seemed to be worn. If the tape tension in the search mode was increased the picture reappeared. As the drum unit is so expensive we tried to revive it by polishing with Brasso and Duraglit. Needless to say, the lower drum soon found its way to the bin. A new drum restored perfect operation. **C.W.**

### **Samsung VI7220**

This machine did everything it should but the pictures were poor. So something was amiss. As the machine was loading I noticed that a kink appeared in the picture. This gave me a clue as to where the cause of the trouble lay. A check on the power supply's outputs quickly

took me to C102, which had dried up. **C.W.**

### **Hinari VLX10**

This machine worked in the E-E mode, but when any tape function was tried it started up then reverted to standby. The cause of the trouble was traced to bridge rectifier D502 on the power supply PCB. **C.W.**

### **Philips VR727**

Failure to load, with mechanical noises, should lead to a check on the pulley shaft that transfers the loading motor drive to the deck. The small plastic cog at the end splits and just spins on its shaft. To replace it you have to remove the capstan motor, the loading block, the deck and the cassette housing. The part number is 4822 528 81462 – it's item 47 in the exploded view. This is the only item that's available on its own. All other deck components are supplied in kits. This applies with all Turbo deck VCRs. **M.Dr.**

### **Hitachi VTM722**

Fuse F852 in the power supply had blown. Checks showed that there was a dead short across the 12V rail. Many items were disconnected before we found that the RF booster was the culprit. A splash of solder was shorting out two pins. **M.Dr.**

### **Sharp VCM60**

We'd sold this top-of-the-range model some ten months previously. It came back dead, and on inspection we found that the 4.7 $\Omega$  surge limiting resistor R904 was open-circuit and the 2SC4231 chopper transistor Q901 short-circuit. Replacements brought the machine back to life, but we noticed that heat had discoloured the PCB below Q901. So we decided to fit a small heatsink to it. An old Ferguson 9000 chassis sound output transistor heatsink proved to be an ideal fit. **M.Dr.**

### **Samsung VIK326**

This machine would power up then return to standby. In fact it did this so quickly that we didn't have time to carry out any checks in the power supply. So we placed a short-circuit across the collector and emitter of the power control transistor Q158, thereby keeping the supply lines switched on. In this condition we found that the 5V supply was low at 3.5V. The culprit was the 8V supply's smoothing capacitor C35, which had dried up. It's a 470 $\mu$ F, 16V 105°C electrolytic. **M.Dr.**

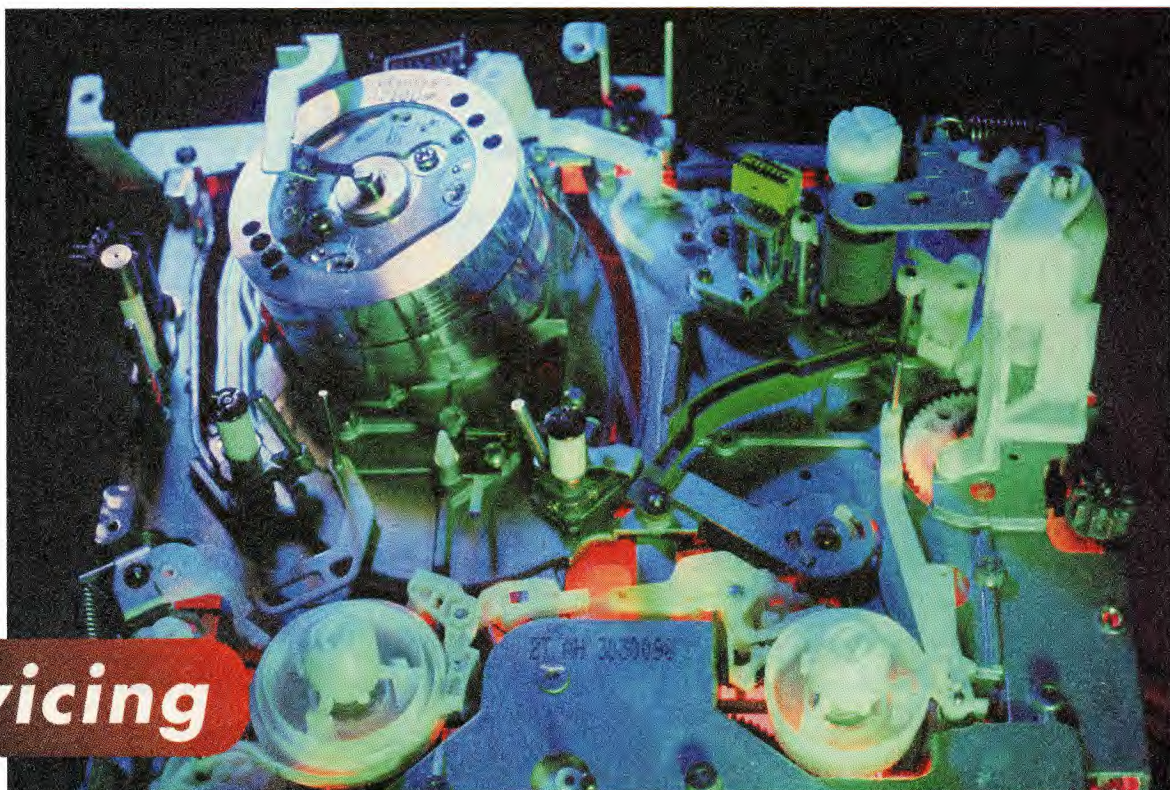

## Servicing

# The Panasonic K Deck

**It's three years since Panasonic VCRs started to use the K deck, long enough for a service history to be prepared. John Coombes describes the various fault conditions he has encountered**

**T**he design of the Panasonic K deck, used in NVHD and NVSD series models, follows the line adopted by all VCR manufacturers in recent years, with a substantially reduced number of parts in the drive mechanism.

### Design Features

A separate motor is used for loading and mechanism control, with the brakes and loading gears directly driven via a multi-function lever. There are no sub-levers or solenoids. A tape end/beginning detector LED is used instead of a slide switch: this reduces the wiring required. There are fewer joint parts, and a smaller and thinner top plate and rack.

There is no longer any take-up reel incline position or P5 post height adjustment. Gear phase position alignment is also reduced. The K deck has only six gear phase alignment positions in comparison with the G deck's twelve positions.

The VCRs that use the deck are easy to dismantle, with the deck coming away from the main PCB. This enables mechanical parts to be replaced very easily. To help with fault finding, the VCR software has a built-in self-diagnostic test system.

### The Servicing Position

The K mechanism can be removed from the main circuit board assembly, but an extension cable (part no. VFK0889) between the loading motor and PCB socket P2001 has to be used to maintain operation. With the deck in the service position, its condition and the gear phase alignment can be checked. The loading/unloading operation can also be checked. This can be done by connecting a 4-5V battery across the loading motor pins, or by manually turning the worm gear or worm wheel gear.

If eject occurs when the cassette carriage has been removed, on reinserting it after repair the main cam gear will not engage with the carriage connection gear and will not rotate. To set up the eject operation with the cassette carriage disconnected you have to rotate the carriage connection gear by hand in the anti-clockwise direction.

### Faults Encountered

As with so many decks, the most common problem is tape damage because of a faulty pinch roller (part no. VXA2246). The symptom can be tape creasing or chewing. There may also be tape looping, which can cause damage in playback or when the tape is ejected –

you can get looping around the guide poles or the pinch roller itself. The tape can ride up and down a well polished pinch roller, the result being creasing at the bottom and/or top of the tape and possible damage. This problem can also affect the sound and/or picture quality. If there is wow on sound, or picture jitter with missing control pulses, but no tape damage the cause can again be incorrect tape drive because of a polished pinch roller.

If playback of a machine's own recordings produces a noisy picture (poor sound and picture), check whether the audio/control head is dirty. The cause of the problem is missing control pulses. Cleaning the audio/control head usually suffices, but on a few occasions we have had to replace it. Although we have not had any electronic faults in this respect, the control pulses come from pins 34 and 35 of the MN6743VRTB chip IC6001. If there is no sound with a machine's own recordings and the output at pins 34 and 35 of IC6001 is correct, replace the AC head.

A worn lower drum can also affect the sound, and we've had this with a few machines. Because of the wear, the tape wanders up and down the AC head.

Mechanical noise in the fast forward mode can be caused by the tape itself or a faulty idler arm unit. If the VCR won't load correctly after replacing the idler arm unit, check that the idler control lever is correctly fitted and is not broken – replace it if you are not sure.

If the tape becomes stuck when eject is selected, check whether the take-up brake arm unit has come off or broken – this will mean that the take-up reel is unable to rotate.

If the playback picture is noisy, check the lead connections to the lower drum. Be sure to check the RF envelope. If the lead is broken, there will be no FM output from the video heads or upper drum.

On a few occasions we have had a machine whose playback has been spoiled by noise bars. They have been very noticeable with prerecorded tapes, though the machine's own recordings have been free of the fault. The cause has been dust or dirt on the inclined base assembly (guide poles).

Always check whether anything is obstructing the inclined base assembly. If this is OK but the VCR goes into the cue mode when the play button is pressed, check whether the inclined base units (supply and take-up) are completely locking. Ensure that the V stopper and inclined base assembly is well greased.

If the machine won't accept a cassette, check the cassette holder plate unit. The cause may be just a broken release lever at the side of the unit.

If the video head cleaner arm unit is broken or incorrectly positioned, the head cleaner can be left in contact with the head all the time. This can result in a very badly worn upper drum.

There are several possible causes of chewed tape, including the pinch roller (see previous note). If necessary check the P5 arm unit, which may be bent. This can prevent tape ejection, with damage to the tape. Also check P5's stopper base, which can crack. Visual inspection will show whether either of these faults is present. If the P5

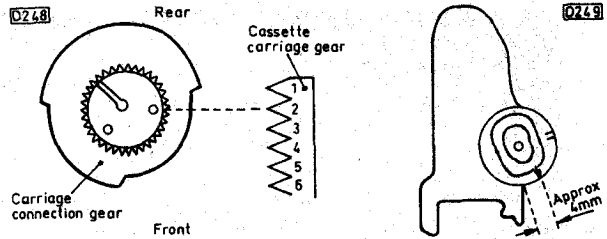

**Fig. 1 (left): Carriage connection gear phase alignment.**

**Fig. 2 (right): Mode switch alignment.**

post stopper retaining clip is broken there can be incorrect mechanical functions.

If the cassette blinder flap doesn't close, check the operation of the carriage connection gear with the side plate unit (right-hand side). There may be a phase error between the two assemblies. Remove the cassette unit and ensure that the tape will go in and out of the housing freely by hand. If this is OK, set up the carriage connection gear as laid down in the service manual. If the two side plate units and the carriage connection gear are incorrectly set, the tape may be ejected immediately after it's inserted. For smooth loading and unloading, the carriage connection gear must be set up to fit into the cassette carriage gear as shown in Fig. 1.

For correct operation of all mechanical functions the mode switch must be set correctly. Set it as shown in Fig. 2, in the eject mode, so that there is a 4mm gap between the edge of the switch and the arrow marked on the dial.

Note that if eject is selected when the cassette carriage is not in position, when it's refitted the main cam gear will not engage with the carriage connection gear which will not rotate. To reset, rotate the carriage connection gear by hand so that, as shown in Fig. 1, it's in alignment with the cassette carriage gear.

The mode switch causes its share of problems, many of which are intermittent. No play, fast forward in play and no rewind for example. If any of these operations works intermittently, try cleaning the contacts on the switch and the PCB before resorting to mode switch replacement.

For noisy rewind and/or fast forward operation, check that the take-up and/or supply reels are lubricated so that their rotation is free.

## Earlier Models

We've had forward visual search problems with some earlier models, such as the NVSD30 and NVSD40. Because of a worn lower drum unit, line lock is lost during search. The fault has been experienced with three- and four-hour tapes. Playback and cue have remained stable.

The cause of the excessive wear has been a broken take-up brake arm unit. As a result the back tension is increased. A new unit may cure the fault, but the drum assembly will need replacement in the near future. ■

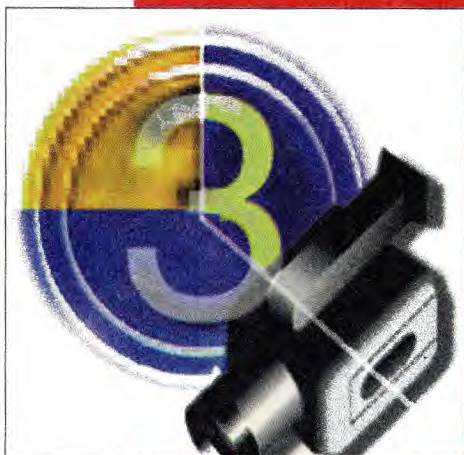

Reports from  
**David C. Woodnott,**  
**David Corcoran**  
**and Simon Bodgett**

### **Panasonic NVS20**

The reported symptom was no zoom or autofocus operation. Our first step was to check the relevant ribbon cables carefully. Everything seemed to be OK. Checks around the autofocus processor IC702 were not helpful, but we decided to replace it as other tests were equally inconclusive. Thankfully this cured the fault. **D.C.W.**

### **Sony CCDTR45**

The complaint was of noise lines that rolled down the picture. Playback was OK with one of our own tapes, so we checked the customer's tape and found that it had diagonal crease lines across it. As the tape path alignment appeared to be all right, we checked the mechanism in the fast forward and rewind modes and found that in the latter the supply reel stopped rotating intermittently. A new back-tension string assembly and supply reel base cured the problem. **D.C.W.**

### **Canon E30E/E50E etc**

Colour balance problems with this range of camcorders can usually be cured by replacing the six surface-mounted electrolytic capacitors on the Process PCB. It's advisable to clean the PCB ultrasonically. **D.C.W.**

### **JVC GRS707**

This middle-aged S-VHS model's camera E-E pictures were OK but there were no mechanical functions. The cause was simply that CP203 (F20) on the main PCB was open-circuit. Inspection showed that it had been replaced on a previous

# Camcorner

occasion. As no cause of its failure could be found we replaced it, reassembled the unit then tested it. When we discussed the matter with the customer he said that it had been bought new and had never been repaired. Oh well! **D.C.W.**

### **Sanyo VMD6P**

The report which came with this camcorder said that playback was marred by a colour fault and flashing white lines, the E-E pictures being OK. X9101 on board CA-1 was the cause of the colour fault. Because of its failure the phase locked loop couldn't be set up correctly, the result being several no-colour bands on the picture. C1210 (10 $\mu$ F) on the main VTR PCB was the cause of the white flashing. It had gone low in value. **D.C.W.**

### **Canon E60E**

One of these camcorders came in with the usual faults you get with this range, i.e. intermittent power up, no playback colour etc. When we'd replaced the 31 capacitors previously mentioned in these pages, playback and all mechanical operations were OK. But there was a further fault we'd not had before – no E-E pictures. Yet another electrolytic capacitor was leaky, this time C1036 (33 $\mu$ F, 25V) on the camera process PCB. **D.C.W.**

### **Ferguson FC27**

This unit was permanently powered up and there were no functions. The cause was electrolyte leakage from C317 on the main PCB. When it's leaky this capacitor can be the cause of various diverse symptoms, such as erratic tape ejection during play or record – this is quite a frightening occurrence! Another symptom is failure of the mechacon chip to carry out deck functions in accordance with the position of the mode encoder. The mechanism can lock-up in the laced state and become jammed. A new capacitor and a PCB clean up in the ultrasonic tank usually provide a lasting cure. **D.C.W.**

### **Panasonic NVM10**

All functions apart from zoom worked correctly. The cause of the fault was traced to R763 (27 $\Omega$ ) on the autofocus board being open-circuit. When you get this fault, the first thing to do is to check connectors P705 (to the lens unit) and P706 (to the zoom switch). **D.C.**

### **JVC GR303**

Failure to record because of loss of one of the power supplies is a fairly common fault with this model. What happens is that connectors CN5 and CN14 break their bond to the print when the PCBs mounted on the deck assembly are subjected to stress as a result of an impact. It's good practice to remove these two connectors, resolder them, then bond them with a hot-glue gun. Also check CN9 and CN3's connections. I place small pieces of bonding around the connectors then melt them with a fine hot-air jet. **S.B.**

### **JVC GRAX5**

According to the fault report this camcorder produced negative pictures. They were not really negative however: loss of a substantial portion of the luminance signal, leaving mainly the chroma component, produced the effect. The cause of the fault was the MSM6819MS luminance delay line chip IC4. It's used in a wide range of models and the fault can occur with any of them.

In one case we thought we'd cured the fault by replacing the chip, but it returned when the camcorder had been left for a while. This time the cause was the decoupling capacitor C49, which is connected to pin 5 of the chip. To save time and prevent subsequent problems, it's as well to replace both components. **S.B.**

### **Grundig VSC70**

After eject the cassette housing would sometimes fail to close. The cause was the loading motor, which had a dead spot. **S.B.**

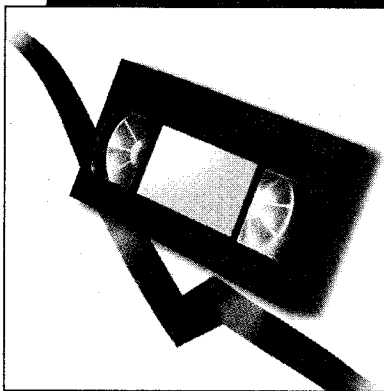

# VCR Clinic

**Reports from**  
**Eugene Trundle,**  
**Brian Storm,**  
**Nick Beer**  
**Michael Maurice,**  
**Adrian Spriddell,**  
**John Coombes,**  
**Graham Thompson**  
**and**  
**Graham Richards**

## **Sanyo VHR291E**

After service work and reassembly you may find that Nicam sound reception is accompanied by a whining noise which disappears when you switch to mono-FM TV reception. The cause is incorrect dressing of the long, white flat ribbon cable that comes from the right-hand side of the front control panel. Fold and dress it clear of the Nicam decoder board. **E.T.**

## **Tatung TVR7121**

This note is likely to be relevant to other VCRs that use the same Sharp manufactured deck. The problem is occasional deck shut down when the reverse search (review) mode is selected. Its cause is the mode switch, part no. QSW-R0026 GEZZ. The same part number can be used when ordering from Tatung, Sharp or Willow Vale. **E.T.**

## **Sharp VCA49HM**

The deck used in this machine is also used in some Tatung and other models. We have sometimes found that the pinch roller has seized solid on its shaft. The symptoms you get are deck shut down after a few

seconds, during which there is a squealing noise and, if play is selected, a torn-up still picture. The part no. for the pinch roller/lever assembly is MLEV0281GEZZ. **E.T.**

## **Panasonic NVF55**

This machine's mechanism operated at a frighteningly fast speed. Checks showed that there were no FG signals from the capstan motor to the systems control chip IC6001. The cause of the trouble was soon traced to L2001, which was open-circuit. It filters the 12V supply to the capstan stator. **B.S.**

## **Panasonic NVFS100**

There was a problem when recording with this machine. Although the recordings were good, the real-time counter didn't work and, when it appeared, the 'write' signal was frozen on the display. The real-time counter worked in the playback mode, but the index function didn't. After some checking around in the servo circuitry I found a section of open-circuit print between D2306 and pin 12 of IC2201. The cause of the print problem was corrosion because C2311 had leaked on to the adjacent copper track. **B.S.**

## **Panasonic NVF75**

This machine's operation was very unreliable. It would power-down frequently and ignore all operational requests. When the machine could be induced to show some life the multi-function display produced all kinds of random indications. After much hair tearing I eventually discovered that the 1,000pF capacitor C6011 at the base of the serial data inverter transistor QR6017 was open-circuit. Replacing this surface-mounted capacitor cured all the problems. **B.S.**

## **Panasonic NVHD100**

This machine's mechanism kept jamming. Usually the tape would stick in the half-loaded position, with the machine powering down. As everything seemed to work normally when the mechanism was manually operated I suspected the loading motor. A replacement restored correct operation. The cause of the trouble was evident when I inspected the faulty loading motor – a plastic drive shaft pushed on the motor's metal shaft had split, with the result that it slipped under pressure. Unfortunately these drive shafts are not available separately from the loading motor assembly, which is part no. VEM0427. **B.S.**

## **Sanyo VHR274E**

I'd not seen one of these machines before. It was dead with the mains fuse blown and the chopper transistor short-circuit. For good measure I replaced the three other transistors in the power supply as well as the chopper transistor and the fuse, and resoldered the dry-joints on the chopper transformer. At switch on everything was fine. **N.B.**

## **Panasonic NVFS90**

I've had several of these VCRs with varying degrees of no playback luminance and weak record luminance. The cause of the problem is signal loss within the thick-film hybrid chip IC303, which incorporates surface-mounted can electrolytics. They leak – as they do in Sanyo camcorders. **N.B.**

## **Matsui VX2500**

The complaint with this machine was that it didn't respond to remote control commands. I found that the handset was transmitting, while labels showed that the machine had recently been to another repair



centre! A scope check showed that data appeared to be reaching the timer microcontroller chip. When I took another look at the handset I noticed a reset button beneath the battery cover. After actuating this and fitting new batteries everything worked correctly. **N.B.**

### Panasonic NVJ35

A common symptom now is noisy (lumpy) capstan motor operation when it's running slow, i.e. during play/record and loading. The cause is loss of capacitance in C1122 (330µF). As a result the supply is affected by noise. **N.B.**

### Sanyo VHR7200

Severe wow and flutter on sound was the problem with this machine. The customer didn't appear to have noticed the awful din it made while rewinding. The cause of both these conditions was a very dry capstan bearing. It had been getting so hot that the capstan itself was discoloured. Without too much hope I decided to strip the motor then clean and lubricate it. After reassembly I checked with the wow and flutter meter and to my delight the results were pretty good. A soak test confirmed that everything was OK. A lot cheaper than a new motor! **N.B.**

### Panasonic NVFS90

This S-VHS machine produced a very poor playback picture in both the S and VHS modes. Its recordings were fine when checked with another machine. Many readers will be aware of the luminance problems that arise when the hybrid chip IC301 fails, but visual inspection showed that there were no signs of leakage from the aluminium can surface-mounted electrolytics in the module.

The luminance varied with temperature, from being virtually non-existent through no field sync to being almost OK but with tearing on highlights. When I traced through the playback path everything was fine up to the sub-YC pack. Everything was OK within it up to the luminance feed to the 1H delay pack, at pin 12 of P3504. But there was complete loss of the sync pulses at the output. The incoming luminance signal passed through FL3504 within the 1H delay pack, but was being lost at the 1µF, 50V electrolytic C3501. **N.B.**

### Panasonic AG7500

This is an industrial S-VHS edit deck, the sort of thing most home

movie and amateur wedding filmers would die for! There was a very intermittent fault with the audio on longitudinal track one. Hi-Fi was fine, longitudinal track two fine, but the sound on longitudinal track one would intermittently be recorded at low amplitude, distorted or not at all. When the fault occurred, a scope check on the output to the head showed that the bias level fell dramatically. The cause was oscillator transistor Q10 (2SD639) going open-circuit.

An interesting point is that there are separate oscillators for full erase and for channel one and channel two bias. Dry-joints are a common problem with these transistors. **N.B.**

### Sony SLVE40

This VCR had a very intermittent fault. The customer's complaint was that at times it wouldn't go into play, would make a funny noise, would show 'L' in the display and leave loops of tape in the machine when ejecting the cassette.

Although I couldn't instigate the fault, I suspected that the mode switch was responsible. Fitting a replacement and checking with the customer three weeks later confirmed the diagnosis. The part no. is 3-946-958-01. **M.M.**

### JVC HRFC100

Occasionally you will find that the power supply in these dual VHS/VHS-C machines blows up. The usual cause is the chopper transistor Q1 going short-circuit. I replace Q1 with a BUT11AF and Q2 with a BC637. After that the power supply runs normally. **M.M.**

### Toshiba/Ferguson VCRs

The latest machines from the IVC factory in Singapore often cause confusion with customers, especially over setting the timer – whether using Video Plus or not. It's not enough to tune the VCR to the stations on installation. You also have to set the 'channel mapping'. Otherwise the machine won't accept timer commands. **M.M.**

### Panasonic NVJ30

I bought this ex-rental machine untested from a wholesaler. It came with a bag of bits that contained the pinch roller, a new unwrapped tuner/booster and the demodulator PCB. The tuner was fitted to the PCB which was then fitted to the main board. On switching on however the machine was dead. A new 1µF, 400V capacitor in the power supply cured that. When a

tape was inserted the solenoid clicked but the capstan wouldn't rotate. The cause was excessive clearance between the capstan's rotor and stator. After setting this up I had a working machine. **M.M.**

### Ferguson 3V55

This machine came from another dealer who said that the drum rotated very fast. This was an understatement. It not only ran fast, it also ran backwards! Checks in the servo circuit brought me to the 5·1V zener diode D408 which was short-circuit. This is where things went wrong.

After removing the diode the machine was tried again: the drum rotated in the right direction but at the wrong speed. While more checks were being carried out the power supply died. Q3 and F2 had failed. Replacing these two items cured the power supply fault while replacing D408 made the drum rotate at the correct speed, though a tweak on the drum discriminator was required.

The final test was to record something. But nothing could be tuned in – the TD6359P PLL tuning chip was roasting. Replacing this restored tuning control and a new back-up battery enabled us to store the channels. The machine now worked correctly. **M.M.**

### Memorex VR1950

This Sanyo-based machine wouldn't rewind or wind fast forward unless you tried it several times. When it didn't work the motors whirred but the clutch wouldn't engage. A replacement mode switch restored normal operation. **M.M.**

### Goodmans SD1600

The problem with this machine was that it failed to load fully in the play mode. With older machines this can be caused by a stretched loading belt, but this is a fairly recent model. Removing the bottom cover revealed all: the loading motor's pulley had split in half and the belt was sitting on its shaft. A new pulley put matters right. **M.M.**

### Hitachi VT64

There was no display, no channel changing and very erratic tape transport. Sometimes the machine would load, sometimes it wouldn't. The wind functions were not available, though play could sometimes be selected. The tape could be ejected all right nine times out of ten. After spending hours

looking for a logic/mecha-state type fault we stumbled across C609 (47 $\mu$ F) which was leaky. It decouples the 5-6V supply to the drum servo. **A.S.**

### Tatung TVR7211

Fast forward and rewind were intermittent. The cause was traced to erratic operation of the wind solenoid. Replacing the cam switch provided a complete cure. **A.S.**

### Toshiba V703

If the machine is dead or operates intermittently, replace all the small electrolytics in the power supply with 105°C types.

Now here's a real puzzle. The last one of these machines we had in for repair with the above symptoms had another fault in addition to the power supply problem. The system would crash when a new E180 cassette was loaded with the record protection tab intact. If the tab had been removed, the tape would go into auto-play and all would be well until a wind function (fast forward, rewind, cue or review) was selected. The system would then crash. If the tape was wound in another machine until only thirty minutes or so of tape was left on the supply reel, and this cassette was then inserted, the machine would behave normally with all functions selectable. Once it was accepted, the tape could be rewound to the start and played normally. C60 tapes would not play regardless of how little tape remained. The rotation sensors were OK, and the tape-remaining readout was always correct.

Here's the solution. The customer had decided to help the flagging mechanics along by removing the top and bottom covers – "to give it a bit of a push". In doing so he had broken off the master cam's first opto blind. Fitting a new cam cleared all the symptoms. Is there anyone out there who can explain why the machine reacts in this way? **A.S.**

### JVC HRD520

The cause of tape ejection when in the half-loaded position is usually the mode select switch. It can also be responsible for no play or no reverse search. **J.C.**

### Panasonic NVSD30

Tape chewing was the complaint with this VCR. With the machine in the playback mode we saw that the tape was being chewed at its bottom edge. The back tension was very high, while the supply reel was very

stiff. A careful deck inspection showed that the end of the take-up brake arm unit was broken. A replacement restored normal operation. **J.C.**

### Toshiba V55

The cause of intermittent rewind/review turned out to be the capacitor across the start sensor. It was short-circuit. **J.C.**

### Panasonic NVSD40

Poor playback/visual search was the complaint. When we checked the machine in the playback mode the performance was very poor. A further check showed that the upper and lower drum assemblies were both badly worn. There were just lines in the forward search mode, as if the scanning wasn't locked. The cause of all this was excessive back tension because the take-up brake arm unit (part no. VXZ0313) was broken. To restore good playback we had to replace this item and the complete drum assembly. **J.C.**

### Logic VR960

This machine wasn't completely dead – the display was alight, and standby was operational. But it wouldn't work. Circuit protector ICP201 was open-circuit. **J.C.**

### Panasonic NVG7

The cause of the capstan motor running at the wrong speed was faulty CTL pulses. C248 (1 $\mu$ F) had failed. **J.C.**

### Akai VSF30

If there's no display and no operation, check whether the 0-72 $\Omega$  safety resistor FR4 is open-circuit. If a new one fails, suspect D5 and/or D10 – check them by replacement. **J.C.**

### Akai VSF440

This machine wouldn't accept tapes. On investigation we found that the lead to the supply side end sensor had snapped off the PCB underneath the deck. **G.T.**

### Fidelity VCR4000

There was an awful grinding noise in the fast forward and rewind modes. A replacement capstan motor cured the problem. **G.T.**

### Samsung VIK326

There were power supply problems with this machine. It would start up, then trip. If any load on the secondary side of the circuit was disconnected the power supply would run. The cause of the trouble

was C35. Thank you Samsung Technical for help with this one. **G.T.**

### JVC HRJ600

Very occasionally this machine would lock up totally. If it was switched off then back on it would work normally for quite some time. We eventually traced the cause of the trouble to the back-up capacitor C608 which was dry-jointed at one end. **G.T.**

### Alba VCR7000

Tuning drift was the complaint with this machine. We noticed that there was a hum bar rolling through the picture. The cause was C501, which was dry-jointed. Resoldering restored normal operation. C501 is the smoothing capacitor for the 12V regulator Q503. **G.T.**

### Goodmans 3400

Channels could be changed only by remote control. Trying to change channels using the on-board controls had no effect. The cause of the fault was the non-volatile memory chip IC702. We've had this fault on several occasions. **G.T.**

### Grundig VS510

This machine was totally dead. I removed the power supply and soon found that there was just 2V at the 12V output. Moving to the primary side of the circuit, I connected the scope to C1326 (47 $\mu$ F, 25V) and found that excessive noise was present. C1326, which decouples the 10V feed to the TDA4605 chopper control chip, was in fact open-circuit. A replacement brought the power supply back to life. I also replaced C1325 (1 $\mu$ F, 100V). After refitting the power supply the VCR worked perfectly. **G.R.**

### GoldStar D17 Mechanism

For tape creasing/snapping tapes, caused by the take-up lever not catching the tape, fit modified take-up lever and cam assembly part no. 333-206A. The cam is modified so that the tape take-up arm is left in the parked position when inserting a cassette. The mechanism is used in the Matsui VCP550 player and Soundwave VCRs. **G.R.**

### Goodmans TX1200

This machine would intermittently die because of loss of the 6V supply. Checks showed that when the fault was present RD00's base voltage was missing. There was a hairline crack between the base of RD00 and R808 (220 $\Omega$ ). **G.R.**



# Camcorner

**Reports from  
Simon Bodgett  
Brian Storm  
Nick Beer and  
David C. Woodnott**

## Sharp VLC73

There was no power. On investigation we discovered that C927 had leaked and corroded the print beneath it. After print repairs and replacement of C927 we found that the chopper control chip IC901 and transistors Q909, Q910 and Q914 had also been damaged. Everything worked correctly once they had been replaced. **S.B.**

## JVC GRAX10

This camcorder produced an over-exposed picture. Our initial diagnosis was a stuck iris. This turned out to be wrong, very wrong. Checks showed that the video waveform was clipped: the peak white level at pin 38 of the HA118618MA chip IC3 was flat and compressed, though it was OK at pin 34. After fitting a new chip, using the correct soldering equipment as it has 58 legs, we set up the various levels. **S.B.**

## Ferguson 3C03

This one had a retailer's service department worried. Circuit protector CP3 kept blowing and the DC-DC converter was suspected. Fortunately the cause of the problem was cables shorting to the camera head screening can. They needed insulating. **S.B.**

## JVC GR323

The dew light was permanently on. We have been told that the cause of this fault is a connector problem and that the dew sensor wires

should be soldered to the board. This is not good practice. The dew sensor should be replaced. This also applies with **Models GRAX7, 9 and 10. S.B.**

## JVC GR303

The cause of intermittent capstan motor operation with this camcorder proved to be particularly difficult to locate. Filter FT101 had a faulty connection. **S.B.**

## JVC GR45

Intermittent AV audio output and a poor picture were amongst the many complaints with this camcorder. All were caused by dried up electrolytics. C306 was leaky, and there were dry-joints at the CCD image sensor HD drive sub-assembly. C203 and IC5 were replaced to remove ghosting on the camera pictures, though C203 was the main culprit. **S.B.**

## Panasonic NVS20

There were two fault symptoms with this VHS-C machine. It would sometimes power down when a cassette was inserted. And it would sometimes refuse to play a tape that it had accepted. Nearly all such problems with this model are caused by the mechanism mode switch, which is part no. VXG0029. Unfortunately it's located in the depths of the mechanism, a partial strip down being required to replace it. **B.S.**

## Panasonic NVMC20

There was no capstan motor operation with this VHS-C camcorder. Checks showed that the supply to the capstan drive chip was missing. The cause was the 2SB956 regulator transistor Q1101 in the power supply – it was open-circuit. **B.S.**

## Sony CCDTRV30

This camcorder has a built-in colour LCD monitor as well as an electronic viewfinder. As it had been dropped, there was some cabinet damage. There were also some faults: no playback sound, no remote control operation, and no playback chroma. The cause of the

first two symptoms was dislocation of the audio PCB at its plug-socket connection to the main VCR PCB. Similar trouble caused the third symptom, this time with the little PAL jog PCB PJ70, which is positioned across the front of the camcorder beneath the lens – I suspect that the plug and socket will give rise to dry-joint problems in the years to come. **N.B.**

## Sharp VLC650

Playback was OK but there were no E-E pictures – just a white screen, as the customer said. The cause was absence of the camera 9V supply, which is produced by the main DC-DC converter. Although the circuit is shown in the manual, it is difficult to remove the PCB from its metal screening can. Refitting the PCB can be even more difficult – some bending is usually unavoidable. I find it best to obtain and fit a new unit. When we did this we found that there was no excessive load on the previously missing 9V supply. **D.C.W.**

## Panasonic NVS5B

All functions worked but there was no colour in either the E-E or the playback mode. The cause of this was traced to the chroma processing and encoder chip IC8001 on the main VTR PCB. As this IC is on the underside of the board, we could have had problems – we don't have the extension lead kit for this model. But for checking purposes it's possible to work on this area of the PCB if the edge-connected ribbon cables to the deck are left attached. **D.C.W.**

## Sony ACV60 Adaptor

We had to replace the 1-25A mains fuse, the opto-isolator IC101 and PCB assembly CT31, which houses the chopper drive chip and associated circuitry, to get this unit to work. Strangely, the chopper transistor itself was OK. **D.C.W.**

## Sony ACV30 Adaptor

There was no operation. The 2A ceramic fuse PS201 was open-circuit while Q205 was open-circuit base-to-emitter. **D.C.W.**

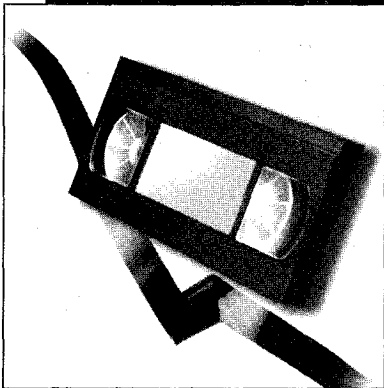

**Reports from**  
**Philip Blundell,**  
**AMIEEIE**  
**Michael Maurice**  
**Graham Richards**  
**Terry Lamoon**  
**Shane Humphrey**  
**Steven Johnstone**  
**Steven Leatherbarrow**  
**Brian Storm and**  
**Nigel Burton**

### **Toshiba V204**

This VCR was dead. Checks on the power supply outputs showed that they were all low and pulsing. The situation was the same when the power supply was removed for testing. Resistance checks on the secondary side of the circuit failed to reveal any shorts, but when the chopper transformer was removed a 1M $\Omega$  leak was measured across the 1N5822 rectifier DP080 in the +6VE supply. A new 1N5822 diode restored normal operation. **P.B.**

### **JVC HRD790**

This was another dead VCR. Checks on the power supply outputs showed that the unswitched 5.8V supply was missing at the emitter of Q802 (2SC1740S). When this transistor was checked it was found to be open-circuit base-to-emitter. **P.B.**

### **Panasonic NVFS100B**

This machine came from another dealer, who is a main Panasonic service centre. It arrived in pieces. Once the deck had been rebuilt and the connection gear and side carriage had been replaced the machine would power up, accept a

# VCR Clinic

tape and carry out the normal mechanical functions. Playback was unwatchable however.

I found that the entry and exit guides had been twiddled, and that the base of the audio/control head was bent. It was impossible, however carefully the guides were adjusted, to obtain the correct FM envelope. After many fruitless attempts at alignment I decided to replace both entry and exit guides (items 57, 58, 61 and 62 in the mechanism diagram in the manual), the entry and exit stoppers (60) and the AC head assembly (34). It was then possible to set up the tape path correctly.

But the pictures were still not right. The upper drum was worn, with one of the LP heads chipped, and the capacitors in the 1H CCD unit required replacement. The dealer wouldn't agree to replace the upper drum, but when the rest of the work was completed the machine worked correctly. In all the years that I have been repairing Panasonic G mechanisms I've never before had to realign the entry/exit guides let alone replace them. **M.M.**

### **JVC HRD637HM**

This multistandard machine came in because a tape had jammed. The owner had removed it, causing additional damage. On investigation I found that the original problem had been caused by a tape guide, which had come apart and jammed the mechanism. The customer's efforts had damaged the plate assembly. Rebuilding the guides and replacing the plate assembly cured the fault. **M.M.**

### **Sony SLV270 Mk 2**

This machine, a Grundig clone, suffered from buzz on the E-E and record sound. I suspected the RF

block then noticed the TBA120T sound demodulator chip on the main board. There are two filters associated with this chip. Replacing the F385SFE6.0 filter banished the buzzes. **M.M.**

### **Mitsubishi HSB32**

"Stuck in pause" it said on the job card. On inspection I found that the tape wasn't being loaded up to the capstan shaft because the half-load arm didn't return to its eject position. It fouled on the tension lever. The reason for this was that the tension lever's brake pad had come off, allowing the lever to move too far to the left. A replacement tension arm cured the fault. **M.M.**

### **Panasonic NV230**

This machine had been serviced about eight months ago. It now required an upper drum, for which a quote was submitted. The customer decided to take the machine away to think about it. A few weeks later he brought it back.

A quick check revealed that it had been elsewhere, and that the saboteurs had been active. The drum's flywheel had been moved, its phase now being way out. The entry and exit guides were loose and out of alignment, and the entry guide's lock screw was missing. When all this had been put right and a new drum had been fitted we got a good picture. But when we made a recording and played it back there was nothing on the screen. The luminance record level preset had been set so that there was no record FM signal at the head amplifier. Readjusting this completed the repairs. **M.M.**

### **Goodmans TX1100**

There was no capstan servo lock -

transistor Q082 restored the machine to life. **S.J.**

### Hitachi VTF630

There were some very puzzling symptoms with this Nicam VCR. It would sometimes power up without producing a display; if a display did appear, any one of the function indicators would light when the standby button was pressed. The standby, green on LED and record lights were sometimes on – without a tape in the machine! Although a tape was accepted, no functions could be selected.

After checking the power supply outputs I cast a jaundiced eye in the direction of the main micro-controller chip. When I checked on its price however I decided to consult a local engineer with experience of odd Hitachi faults. He told me to rewire the three-pin link lead from the front, drop-down panel. When I checked here I found that one wire was indeed open-circuit.

The particularly misleading thing about this fault is that I had earlier disconnected the front membrane to eliminate it from the search. So beware: these machines will not respond to remote control commands with the front panel removed. **S.L.**

### Sharp VCA30

The problem with this VCR was poor rewind. It would occasionally fail to complete a tape rewind, with consequent shut down. This is a common problem with these machines. The cause is dirt on the take-up reel's soft brake. Clean and lubricate both spool spindles and clean the brake pad – or preferably replace it (it's not expensive).

We are seeing more and more of these machines and others (in particular Saisho/Matsui VCRs) with failed capstan motor bearings/bushes. The cause is contamination from above, i.e. tape or pinch roller debris. This acts as a very efficient grinding paste. We now strip, clean and lubricate (with bearing oil) the bearings whatever the reported fault. **S.L.**

### Matsui VX3000

This machine would power up and accept a tape. But it would't accept any deck commands and would then shut down with a short capstan motor run. These machines are designed to load the tape around the drum on accepting a cassette. The one we had failed at this initial point.

Checks in the power supply

showed that the PC12V supply was missing at pin 2 of CP501. We had no circuit diagram, but the supply appeared to be derived directly from pin 6 of the STK5342 chip. So we replaced this chip, and were rather disappointed to find that the situation was the same as before. But we felt that the cause of the fault couldn't be far away. This was so: R508 (10k $\Omega$ ), which is connected between pins 4 and 6 of the STK5342 chip, was open-circuit. After replacing this resistor we found that the working voltages at pins 4 and 6 are 24.5V and 13.5V respectively.

To prevent unnecessary callbacks, we stripped out and cleaned the mode switch assembly and replaced all the belts. **S.L.**

### Matsui VX2500

The customer complained that there was no sound with his recordings. In fact the previous sound was present, which is a characteristic of bias oscillator failure. What we actually found however was that the amplitude of the oscillator's output was only about a quarter of what it should have been – 50V or so peak-to-peak is normal. The 2SB698 transistor Q02 was short-circuit. **S.L.**

### Panasonic NVF75

This machine worked perfectly except for one small detail. While editing tapes, which the machine's owner was inclined to do, there was some flickering blue disturbance in the background with super still or super fine slow. Fortunately the cause of the problem was not as obscure as it first seemed. Replacing C1022 (47 $\mu$ F) in the power supply cleared the fault. **B.S.**

### Panasonic NVJ35

There are days when it doesn't pay to get out of bed. This machine was the cause of such a day. The E-E picture was blank, and the erase symbol flickered on and off intermittently in the fluorescent display. In addition the mechanism (type G) had shed a few gear teeth and refused to accept a tape. While puzzling over the former symptoms I realigned the mechanism, replacing the usual gears (VDG0343, VDG0346 and VDG0448). Once this had been done the machine accepted and loaded a tape – but wouldn't stop loading. I hastily unplugged the machine and replaced the mode switch (VSS0175A). This failed to cure the fault as the print to one of its pins was open-circuit. A good,

clear playback picture appeared when this had been repaired.

I started to check around the fluorescent display and timer circuitry. IC7501 was replaced and a new display was fitted, but the erase symbol still flickered on and off erratically. As all the diodes, resistors and capacitors on the timer board checked out OK I decided that I should be looking for the cause of the other fault.

When I checked through the E-E picture circuitry I found that the E-E video stopped at the input/output AV switching chip IC3901. Checks in this area failed to reveal any obvious problems, but one of the switching lines was permanently high. As the signal on this line comes from the MN15522VMS subsystems control chip IC6801, I started to carry out checks here. It seemed odd that nearly every pin of this chip was at about 5V. When I removed the supply and the reset to this chip, the E-E picture came up. Inexplicably, the display problem had also been cured. Replacing IC6801 completed the marathon job. **B.S.**

### Panasonic NV870 (D1 Mechanism)

The hi-fi sound would be lost intermittently while a tape was being played. The longer the machine was in use the worse the symptom became, suggesting that there was a thermal fault. Use of a hairdryer on the electronics failed to instigate the fault however.

Following a hunch, I decided to check on the mechanics and found that minute changes in the back tension coincided with the loss of sound. Back tension is applied via the tension arm 1 unit (VXL1157) which engages, on the underside of the mechanism, with the main cam gear (VDG0200). Close examination of this gear revealed that the Moriton grease used here for lubrication had become lumpy with age. This would occasionally prevent the back tension arm engaging fully. The 'thermal fault' I had suspected must have been caused by the grease's characteristics altering with the temperature of the machine.

Cleaning the cam and applying fresh grease cured the problem. **N.B.**

### Panasonic NV370

We've had several dead NV370s in recently because the mains transformer's primary winding has been open-circuit. **N.B.**

in fact the capstan motor was running slow. Checks in the servo circuit were inconclusive, but checks in the power supply showed that the UCOM 5V rail had 2V of noise on it. Replacing C509 cleared the noise and cured the servo fault. **M.M.**

### **Samsung VIK316/326/346**

If one of these machines is dead, check for 5V across C33 (330 $\mu$ F). Replace it if the voltage is low. C34 (470 $\mu$ F) can also cause problems. These electrolytics can lose capacitance slowly, causing capstan warble and patterning on RF loop through. Replace them with 105 $^{\circ}$ C types. **G.R.**

### **Fisher FVHP5100**

This machine had two faults. First, it would shut down after six seconds because the loading mechanism was jammed. I found that the flat of the mode switch spindle had turned 180 $^{\circ}$  then presumably jammed. Securing the switch and clearing the jam was all that was required.

Secondly there was no capstan rotation. This was caused by a leaking electrolytic capacitor (C1) on the motor plate. It had leaked electrolyte, removing the supply to the SA3001 motor drive chip. Replacing C1 and fitting a wire link (after cleaning) saved the cost of a new motor. **G.R.**

### **Salora SV6600/Sanyo VHR1300**

The symptoms were intermittent stopping in playback, capstan servo warble and poor channel tuning (i.e. drifting and hum in the E-E mode). We soon found that the voltage at the 33V regulator transistor Q5004 was 47V. Zener diode D5004, type GZA32, was zenering at 47V! A replacement put everything to rights.

The 33V line is also used as a reference by the STK5482 regulator, hence the various fault symptoms. **G.R.**

### **Philips VR6467**

For rolling pictures in all modes – record, playback and E-E – check the 220nF, 100V capacitor that decouples pin 2 of the TDA3755 chip IC7451. You will probably find that it is dry-jointed at both ends. **G.R.**

### **Decca DVR6641/Tatung TVR6141**

If one of these machines is totally dead, go straight to the mains bridge

rectifier diodes D801-4. They should produce a 30V DC output (off load). If not, replace all four diodes. We fit the beefier 1N5392 or 1N5401. The 1N4006 type usually fitted is not up to the job. **G.R.**

### **Panasonic NV430**

This rather complicated two-speed machine was dead, though the clock flashed on for a second. Almost always the cause of this fault is the two 100 $\mu$ F, 63V electrolytics in the power supply. Check the condition of the 3,300 $\mu$ F and 47 $\mu$ F, 63V electrolytics if there are signs of hum on the picture. **G.R.**

### **Mitsubishi HSM55**

This machine had a tape jammed in it. The cause of the trouble was obvious once the tape had been removed – the capstan motor belt had come off because the capstan pulley was cracked. This is becoming a very common fault. Fortunately you can now obtain the pulley from Mitsubishi – you don't have to replace the capstan motor, which is rather expensive. A new pulley and belt restored the machine to full working order. **T.L.**

### **Ferguson FV95**

Be warned. If you get one of these machines from a customer who says he cannot get anything from it on his TV receiver, check that it's being used with a smart TV set. These machines are not designed for RF connection. The instruction booklet is not that clear, and customers do move the machines around to other TV sets in the house. You could end up wasting a lot of time for nothing! **T.L.**

### **Samsung VIK350**

Two of these machines came in recently with the same fault – "went bang then dead". R1011, IC101 and C110 in the power supply had all failed, which is not unusual. In these two cases however IC602 and the capstan IC were showing signs of severe overheating while R630 and R631 were both open-circuit.

These items, including the capstan motor assembly, had to be replaced to get the VCRs working. **S.H.**

### **Toshiba V254B/Ferguson FV90LV**

Failure to accept tapes was the complaint with one of these machines, though the lift shuffled in and out when we switched it on. Initial checks were carried out around the loading motor drive chip IT002. We then moved over to the

main microcontroller chip IT001, where we discovered that pin 26 had not been soldered. This is the chassis line, and is connected to pin 9 of IT002. When pin 26 of IT001 had been soldered the machine worked normally. **S.J.**

### **Hitachi VTF860**

A number of these machines have come in dead. The main causes are D11, D12 or D13, RF1 (a 68 $\Omega$  resistor) or PR2 (ICP-N38). They are all on the secondary side of the power supply. **S.J.**

### **Goodmans TX3950**

This machine produced rolling E-E pictures. We replaced several items before finding the culprit, which was C183 (10 $\mu$ F, 50V). It's on the main PCB, near the RF converter. **S.J.**

### **Mitsubishi HS550V**

No playback colour was the complaint with this machine. On test we found that when making a recording there was a colour signal at TP2N, which is just behind the head amplifier on the main PCB. As the head amplifier is almost impossible to get at when the machine is working I took a guess and replaced IC201 (BA7184). This restored the playback colour. **S.J.**

### **Akai VS967**

When the sound was switched to Nicam it would almost completely disappear. Replacing the SAA7320GP chip IC4 restored the Nicam sound. **S.J.**

### **Toshiba V705**

There was no playback or E-E sound. A quick check showed that the 9V supply to the sound chip IN007 was low at approximately 2.5V. Replacing zener diode DW011 cleared the fault. **S.J.**

### **Sanyo VHR274**

There was a playback fault with this machine – it switched between a picture and a blue screen. A quick check at the audio/control head showed that the control pulses were missing. They were also missing when we traced back to the BU2896K chip IC351. A new BU2896K chip restored correct playback. **S.J.**

### **Toshiba V109**

The customer complained that he couldn't eject the tape. When I tried the machine out I found that there were no mechanical functions at all. Replacing the 2SA1297Y



**Reports from**  
**David C. Woodnott**  
**Simon Bodgett**  
**Brian Storm and**  
**Eugene Trundle**

### **Sanyo VMD90R**

When the eject button was pressed the cassette housing would open then close automatically. It's not an unusual fault with models that use this deck. The trouble occurs when the mechanism, which is of very light construction and liable to bend under stress conditions, has been forced/dropped etc. The cassette latch and down switch are particularly vulnerable, but can normally be reset (bent!) to overcome the problem. A warning to the customer about the consequences of repeat damage, i.e. the cost of a new cassette housing, is not out of place and is generally heeded. **D.C.W.**

### **Sharp VLV690H**

The VTR functions were OK but there were no E-E pictures. Checks showed that the 15V camera supply was low at 10V. The guilty components were R116 (2.2k $\Omega$ ) which had gone high in value (3k $\Omega$ ), C138 (10 $\mu$ F) and C137 (1 $\mu$ F). Normal service was resumed when they had been replaced. **D.C.W.**

### **Panasonic NVG3B**

The customer phoned to ask how much we would charge to replace the CCD imager. We asked why he thought this was necessary? Apparently he had been told that this was the only thing that could cause the symptom – vertical lines in the background of the picture. While agreeing that the imager could be the cause, we suggested that an inspection would probably be worthwhile before such an

# Camcorner

expensive item was replaced. The cause turned out to be a dry-joint at the CCD connector. Result – one happy customer! **D.C.W.**

### **Sanyo VMRZIP**

The customer complained about "lines across the playback picture". In fact because of an ATF fault there was incorrect tracking and LP/SP switching. The cause of the trouble was failure of IC361 on the main PCB.

This was a common problem with an early batch of these camcorders. Hopefully most of the faulty chips have now been replaced. **D.C.W.**

### **JVC GRS707**

"No camera power" was the complaint. On test we found that after a while the blank screen changed to a very discoloured picture, with red in the centre and a green line across the top. Then, as the camcorder warmed up, a good picture appeared. As freezer failed to reveal the culprit(s), patience was required. It paid off after several days. C37 and C38 on the imager PCB were both leaky – C37 was well out of specification. **S.B.**

### **JVC GRSZ1**

The fault report said that this camcorder wouldn't record sound. When I checked it I found that there was no power. Previous repair attempts had resulted in the failure of several circuit protectors. The cause of the trouble was the audio/control head cable. We had to replace the head assembly. **S.B.**

### **JVC GRS707**

This camcorder wouldn't record colour. We found that C445 was open-circuit. It's mounted on the edge of the PCB and can be damaged as a result of an impact – you sometimes find that it's missing altogether. **S.B.**

### **JVC GRAX10**

The fault report said that this unit recorded in monochrome for the first two minutes, then in colour. What it didn't say was that previous

repair attempts had left IC601 and its surrounding components in pretty poor condition. After a clean-up operation we found that the cause of the original fault was R605 and that the VCO (320fh) resistor R666 needed setting up. **S.B.**

### **JVC GR570/GR577**

Poor S-VHS playback, VHS OK, occurs when the THE326A non-linear de-emphasis module IC2 fails. Record as well as playback is affected, leaving the customer with defective recordings. The chip usually becomes intermittent in operation, and can reduce or limit its output without failing completely. **S.B.**

### **JVC GFS1000**

This camcorder produced very poor playback pictures. It had been to another service organisation, which had replaced many components but not the defective one. The culprit turned out to be C47, in the comb filter return path. **S.B.**

### **Panasonic NVM40**

This full-sized machine behaved as if it had faulty video heads: when a known good tape was played back there was just a screenful of noise. Initial checks showed that there was no playback 5V supply at the head amplifier circuitry. As the correct switching sense was present at the systems control chip IC6004, we followed the switching lines through to the various buffer transistors. The switching terminated prematurely at the 2SB970X transistor Q3022. **B.S.**

### **Sony CCDTR55**

The E-E luminance signal would disappear a few minutes after this camcorder was switched on, leaving just the chroma and syncs. We found that there was no luminance output from the encoder chip IC301, though it was receiving a luminance feed, blanking and sync pulses and the correct control voltages from the EVR chip. IC301 itself, type CXA1072R, was faulty. **E.T.**

# Servicing the

# Samsung VIK310/320/350

**Mike Leach on how to tackle the various faults you could encounter with these popular VCRs**

**T**hese VCRs are good from both the user's and the technician's point of view, though there are a few common fault conditions that we will look at in this article. They are reasonably easy to operate, and can be quickly dismantled for servicing as and when required. The VIK310/320/350 have been around for two to three years now, and a definite fault pattern seems to have emerged. Those who are familiar with them will be fully aware of the faults and remedies described in this article. It should however be of benefit to the technician who sees one for the first time. The range is as follows:

**Model VIK310:** This is a simple two-head machine with standard play only.

**Model VIK320:** This is a two-head machine with standard and long-play modes.

**Model VIK350:** This is a four-head machine with standard and long-play modes.

The most common failure occurs in the power supply. It can often lead to faults developing in other areas of the machine. I'll start off with the 'regulator' section of the power supply (the chopper circuit), as faults here must be cleared before any other checks can be made.

## The Power Supply

The power supply can be divided into two sections. First the chopper circuit (see Fig. 1), which is housed inside the large metal can towards the right-hand side of the machine. This produces permanent outputs for the power switching/distribution section on the main mother board. We'll concentrate on the chopper circuit, since nearly all the power supply faults occur here.

The most common symptom is a completely dead machine. The customer will often say that the machine had been disconnected and moved, but wouldn't come back on when connected to the mains supply some time later. This is very common and brings us straight to the crux of most of the problems from which these machines suffer. The reason that they may fail to come on again after a rest is capacitor C110, a 100 $\mu$ F, 25V, 105°C electrolytic. You may find it difficult to find: it's protected by a plastic shroud, which is brown in colour. Look between the STR11006 chopper chip IC101 and the chopper transformer T101. C109 is protected by a similar plastic

shroud, but this capacitor should not require replacement.

My rule these days is to replace C110 before I even plug the machine in on the bench. Even when the VCR has come in for only a minor fault such as a head clean, I always replace C110 first. C110 dries up because of excessive heat. It can destroy IC101 and the 2.7 $\Omega$ , 2W surge limiter resistor R101, thus producing the dead machine condition. The first time I came across this situation I replaced only R101 and the chip. I did that only once!

## Dead Machine

Thus when faced with a dead machine the first thing to do is to replace C110. You'll find that in nine cases out of ten the surge limiter R101 will also have failed, which means that the STR11006 chip will require replacement as well. This chip doesn't always fail, but as there's no way of checking it the best course is to replace it to be sure.

When these three items have been replaced there are several other things to check in the power supply before trying the machine. Check F102 (2A) in the 6.5V supply. It may have blown. Another item that causes problems is the 22V zener diode ZD101, which is buried amongst other components. It protects the 16.5V supply. Well, sometimes it provides protection and sometimes it doesn't. I've known it to go short-circuit or open-circuit, so it must be checked and replaced as necessary. Then take a look at R113 (1.5k $\Omega$ , 0.25W), which may be a little charred. If so, replace it.

To summarise: always replace C110; replace IC101 if the machine is dead; check and replace as necessary R101, ZD101, R113 and F102.

This covers most of the common power supply ailments. I've known very bad cases where a complete new power supply has had to be ordered, but this is a rare occurrence and the above checks will in most cases provide a complete cure. If there are no other burn ups in the power supply, you can assume that the unit is now OK and that it's safe to power the rest of the machine.

In my experience the power supply will run on its own and doesn't have to be plugged into the main PCB. It's best to plug it in however, as the voltages on the supply lines can be rather high off load. It is obviously not a good idea to run the power supply in this way if you are not sure whether everything is OK. So the rule is to plug it in.

All things being equal, the machine should now work. But the chances are that it won't. Let's look at some of the other faults you may encounter.



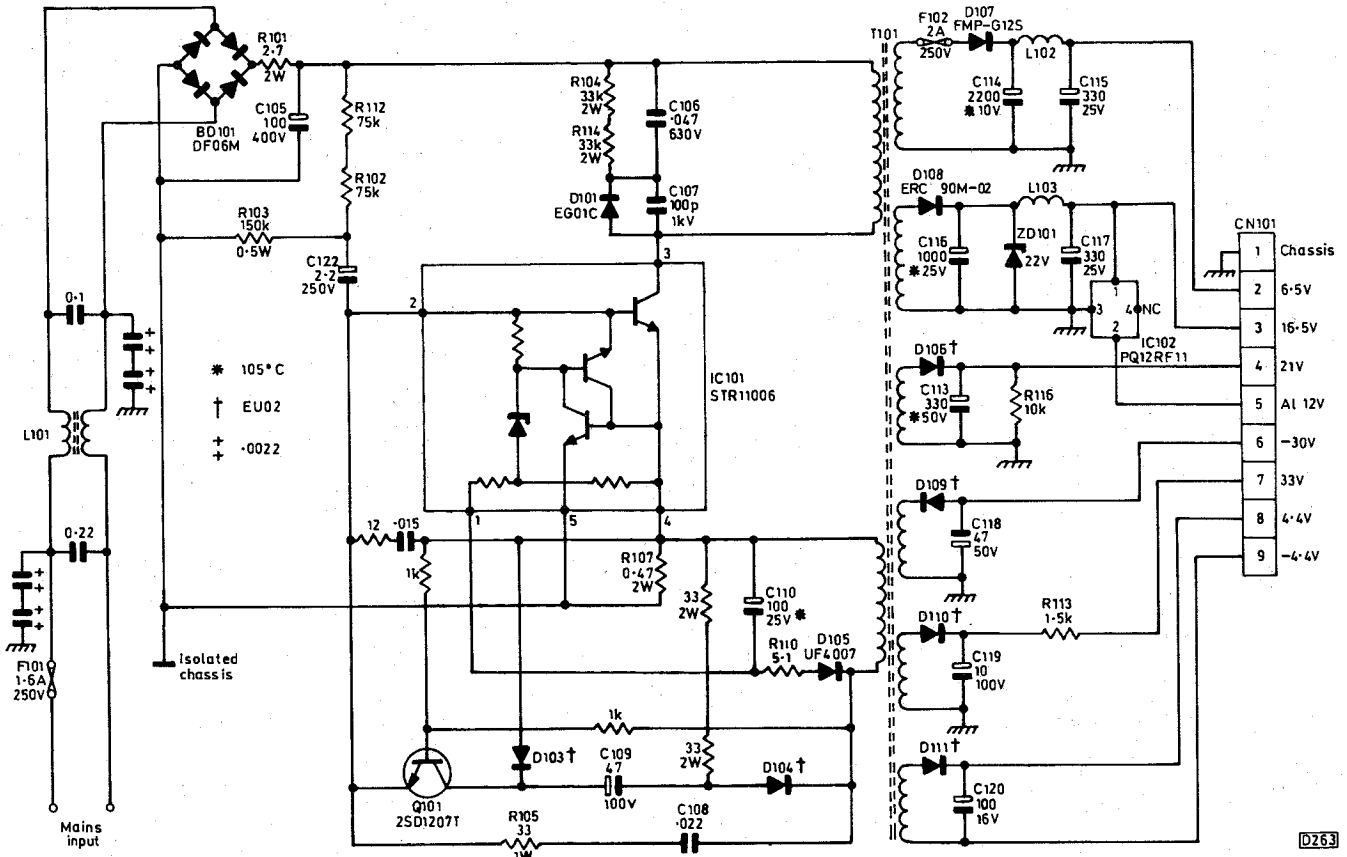

**Fig. 1:** Circuit diagram of the chopper power supply used in the Samsung Models VIK310, VIK320 and VIK350. Model VIK375 uses an almost identical circuit, the difference being that a single 68k $\Omega$ , 5W resistor is used in the R104/R114 position.

## Clock/display Problems

After a major power supply repair you will often find that the clock is either dimly lit or there's no display at all. The fault is easy to rectify, but it's a good idea to know a bit about the source of the digitron display's power supply and also to be able to identify which type of main panel is fitted to the machine.

A good working power supply provides -30V at pin 6 of plug CN151 on the main panel. This voltage is fed to the two 100 $\Omega$  chip resistors R638 and R664, which are mounted on the underside of the main panel. They are connected in parallel, presenting an effective resistance of 50 $\Omega$ . After the resistors, a chunky 27V zener diode stabilises the supply. It's then applied to the digitron (DT701) and the microcontroller chip. The zener diode and the two resistors are the main cause of display problems. The diode may be in one of two places, depending on which type of main panel was fitted during manufacture of the machine.

If you've got a problem the chances are that the zener diode is D606, which is mounted just to the left of the power supply plug/socket CN151. You may find that the board is a little charred in this area. If you can't find a D606 in this area the diode will be ZD702 instead. It's mounted on the front panel, just to the right of the digitron.

In either case a quick check should be made on the value of the two resistors. If the zener diode has gone short-circuit or leaky, one or both of the resistors will probably have failed. If only one of them has gone open-circuit the effective resistance will have risen to 100 $\Omega$ . So the clock display will be dim.

It's easy to check the resistors. Remove the power supply can and find CN151 on the main panel. Switch your bench meter to the 200 $\Omega$  range and connect one

probe to pin 6 of CN151, the other probe to jumper wire W691. This jumper wire is immediately to the right of the larger of the two ribbon cables that connect the main and the front panel. It's a good idea to disconnect this ribbon cable whilst carrying out the resistance check. The reading obtained should be 50 $\Omega$ . If you get a higher or an open-circuit reading, you will have to remove the main panel and replace the resistors.

Access to the PCB is simple. Remove the complete deck assembly (see mechanical section later) and the front timer board, also the power supply if you haven't already done so. Then remove the two screws at the back end of the machine, above the scart socket. The main PCB will now come out of the cabinet freely. Turn it over and look for CN151's soldered connections. R638 and R664 are just above it.

Always replace them both, even if only one of them is faulty. You must use chip components in these positions. It may be tempting to use a couple of 0.25W resistors if the original type is not to hand. They will work of course, but if the 27V zener diode were to go short-circuit at a later date the 0.25W resistors would fire up big time and produce much smoke and burning. Two chip resistors will just give off a minor 'phut' and go open-circuit. I would regard them as safety components, so the original type must be used.

This brings us to the heat generated by the 27V zener diode. When the diode is D606 on the main PCB you are likely to find that the board is somewhat charred or even burnt through. If the board is in a bad way, it could well be that damage to the very fine print that runs in this area has occurred. This means replacing the whole board. Samsung can supply one, minus the tuner etc., for a reasonable price.

If the board around D606 is just slightly darkened and

the print hasn't been damaged you can prevent further damage by replacing the diode, not necessarily in its original position. As a better alternative you can mount a new 27V zener diode in the ZD702 position on the front panel. Fortunately where the diode is D606 on the main PCB there is also a vacant position marked ZD702 on the front panel, just to the right of the digitron display. A new diode can be mounted here – on the component side of course – without fear of any further heat damage occurring. There are no extra leads to run, just fit the new diode in this position. Make sure that you solder it well as it will still get rather warm.

Be careful when removing the old D606 diode. Wagging it about while trying to remove it can cause print damage – be very careful when working in this area, and always use a new diode. I've known of cases where excessive heat from a soldering iron has damaged the old diode, with the result that R638 and R664 were knocked out when the machine was switched on again.

Where the diode was mounted on the front panel during manufacture, just check it for dry-joints. It's likely that the solder will have dried up a little.

If the display is still dim after carrying out these checks and any necessary replacements, you'll have to replace the digitron. I've had to replace several of them over the past year or so. The symptoms are the usual ones: some segments brighter than others rather than the whole display being uniformly dim.

### Loading Motor Drive

Another problem you may get after a major power supply failure is a blown loading motor drive chip (IC602, type KA8301). The damage can vary from a disintegrated chip that has blown itself in half and burnt its feed resistors (R630 and R631) to a chip that has simply packed up. The chip is mounted between the two ribbon cables on the main panel, to the left of the power supply.

Problems with this chip are becoming quite common. After a power supply repair a machine will often power up then either refuse to load a tape or, if the tape is already in the machine, it will remain in the fully-loaded position and refuse to eject the cassette. Don't despair. When you remove the bottom cover you will find that the loading motor drive chip and its two feed resistors are accessible from beneath. This is one of the few things you can get at without having to remove the deck assembly. The 7.5Ω feed resistors R630 and R631 are of the safety type, rated at 1W. I always replace them both as they are connected in parallel. Once again the original type must be used.

### Less Common Problems

If the machine keeps trying to front load of its own accord, without a tape being inserted, strip it down and check for dry-joints at the lighthouse (LD601) and the two end sensors. Also check the two plugs and sockets that connect the deck assembly to the main panel. They are usually OK, but bear in mind that one of these plugs is connected directly to the mode-select switch – you obviously don't want any intermittent connections here.

The cause of intermittent patterning, poor E-E and record pictures etc. is usually the tuner. The IF and mixer/booster assemblies are reliable.

A few weeks ago I repaired a machine that had died after a power cut. Apart from power supply failure, the capstan motor drive chip, which is mounted on the capstan motor, had blown itself apart and the servo and main microcontroller chips had failed. This was interesting. After replacing the 27V zener diode the machine continued to destroy the previously mentioned resistors R638/R664 in the -27V supply. It did so because of the

shorted microcontroller chip. Definitely one to watch out for in future.

### Summary – Electronics

Apart from the 'one off' failures we all get, that's about it with regard to electrical problems with these machines. If you are now in the fortunate position of being able to box up the machine and return it to the customer, there are just two small things that are worth attention.

First, when you replace the power supply in the machine for the last time check the condition of the small insulating pad between the power supply and the main board. The space between the power supply and the main panel is only a couple of millimetres: the white and green looking pad provides insulation between the two. It can deteriorate over a period of time because of heat, and obviously needs to be checked. I've found that the double-sided sticky Pritt Pads make an ideal replacement should the original pad be too far gone.

Secondly, make sure that the ribbon cables between the front panel and the main board are dressed clear of the loading motor drive chip. We have noted that this chip can be distressed, so don't ask for trouble!

### Deck Basics

The deck used in these machines is very similar to that used in the earlier SI3260 and subsequent models. But it's more reliable. Two motors are used for tape transport. The loading motor drives the cassette housing and tape guides, while the capstan motor also provides wind/rewind drive. As with most modern machines, a pinch roller cam drives the pinch roller assembly up and down and a review arm guides the tape up to the capstan motor spindle. A sliding rack driven by the main cam provides tape guide operation.

### Removing a Tape

Removing a tape from a dead machine looks difficult at first because in the loaded position one of the main deck-retaining screws is obscured by the cassette housing. OK, you can remove the cassette housing by taking off the front panel to gain access to the two screws that hold it at the front, then remove the screws that hold it at the top. But if you do this you will still have difficulty if the tape is in the fully-loaded position, because the pinch roller will prevent the tape from coming out easily.

The best way to remove a tape is to take off the bottom metal cover to gain access to the previously mentioned loading motor drive chip. Then unsolder the chip and apply a few volts from the bench power supply to the loading motor via the print. Apply about 5-7V, positive to pin 10 and negative to pin 2, *with the chip removed*. This will unload the tape. Do it slowly, stopping every second or so. You will have to turn the capstan motor spindle from the top of the machine to wind in the loop of tape caused by this unloading.

You probably won't have to do this very often because, as we all know, the customer usually finds a far better way of removing a tape!

### Cassette Housing and Eject Gear

The cassette housing is driven by the white or black eject gear that protrudes slightly above the metal chassis at the right-hand side of the deck. If a white one is fitted, you will probably find that the teeth which drive the cassette housing have worn away. Obviously the eject gear must be replaced. It's a good idea to replace the right-hand plate of the cassette housing at the same time, as the problem might otherwise recur.

To replace the eject gear, proceed as follows. Remove

the six screws that hold the cassette housing in place. Remove the housing, then undo from underneath the three screws that hold the main deck. There are three more larger screws that have to come out from the top of the deck, after which it should be free. Don't forget to unplug the connecting leads from above. One of them is the flexy print to the lower drum. It can easily be damaged. You can now lift out the deck and turn it over to replace the eject gear. The loading motor and cam should be on the left-hand side as you look at the deck. Remove the three screws that hold them in position. From now on we will refer to this as the loading block.

Fig. 2 shows the loading block and eject gear in the eject position, correctly timed. If the mechanism has gone out of sync because of a worn eject gear, you will usually find that turning the loading motor a few times will resync the mechanism to the correct position. If the loading motor is stiff, it's likely that the nylon worm wheel will need to be replaced along with the eject gear. This worm wheel's teeth can be distressed if the loading assembly seizes. I've never known the main cam to suffer. The mode select switch, which is beneath the main cam, is also usually reliable.

The arrow on the relay pinch gear can be difficult to see. Make sure, by looking from the top of the deck, that the review arm is in the unloaded position (in line with the tape guides). It should now be easier to see the arrow for retiming. With the new eject gear in position, its arrow aligned with the main cam as shown in Fig. 2, double check the alignment of the relay pinch gear then screw the loading block firmly back into position. Also ensure that the sliding rack which loads the tape guides is pushed firmly to the right before tightening the loading block.

All that now remains is to reseat the cassette housing in line with the eject gear from above. Fig. 3 shows the timing of the eject gear and the cassette housing in the eject mode. Notice that the first tooth of the cassette housing rack goes into the first slot of the eject gear. As with most machines, if the timing is only one tooth out there will be problems.

The deck can now be replaced in the cabinet, with the cassette housing in place. The deck retaining screws are all accessible without a tape in.

## Tape Damage

No take-up is a common symptom with these machines. The usual cause is a faulty clutch unit, which has to be replaced. I've known several cases however where the cause was the small idler, which can be seen immediately below the cassette housing. It swings to and fro, and often becomes stiff on its pivot. I have had to replace it, but sometimes a small drop of light oil on the pivot is all that's required to get it swinging again.

In fact with the cassette housing removed you can see a whole series of small gears that drive the two reel turntables in the various modes. Each one can be removed and cleaned, which is a good idea when carrying out a service. If some of these gears seize up the result can be a severe tape loop on eject, though take-up in the play mode may be OK.

Tape wrinkling can also be a problem. As with any machine, a good test for tape wrinkling is to put it into fast-forward search then review search then back into play. The obvious cause is the pinch roller. When replacing this item, be sure to use the complete unit available from Samsung. I've tried using a plain pattern roller and have still had problems because the shaft on which the roller sits was slightly out of true (bent!). This will wrinkle the tape.

The review arm is critical. If in doubt, replace it. At least you know that a new one will be right. I say this because

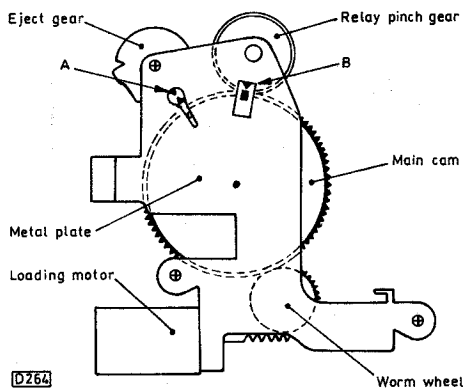

**Fig. 2: The loading block assembly, shown in the correct position for the eject mode. Broken lines indicate the cam and worm wheel hidden beneath the metal chassis plate. A and B: the timing arrows on the eject gear, relay pinch gear and main cam, also the hole in the latter, should line up as shown for correct mechanical synchronisation.**

there's no review arm height adjustment, and if the old one is only slightly bent there will be tape wrinkling problems.

If the pinch roller and review arm are OK but the machine still wrinkles tape, it's possible that the audio/control head requires fine adjustment. This is also

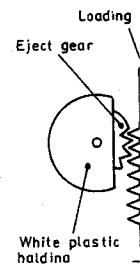

**Fig. 3: Correct timing of the eject gear and the loading rack attached to the cassette housing. The first tooth of the rack goes into the first slot of the gear.**

critical. If the head is only marginally out of alignment it will cause tape wrinkling, but check the other items first.

## Summary - Mechanical

So much for the general run of mechanical problems I've had with these machines. There is one other problem. I've spoken to Samsung about it on a couple of occasions and have also discussed it with other engineers, but no one has come up with the answer. On possibly seven or eight occasions now a machine has come into the workshop with a tape wrapped perfectly around the back of the drum, with no apparent tape damage. After removing the tape the machines have worked perfectly, showing no signs of any mechanical fault.

Now it's worth noting that as these machines load the tape to the drum they produce a little kick just at the time when the guides reach the fully-loaded position. This kick leaves, briefly, a very small loop of tape around the head and then tightens up again. It's very small and isn't really a problem. But suppose that a contaminated tape is inserted and the contaminated part reaches the head at the time when the kick occurs: it might be just enough to throw the tape over the drum to cause the problem. This is only a theory however, as I've never seen it happen. Has anyone else seen it? It's probably just one of those inexplicable quirks we encounter every day in this trade. ■

## Useful part numbers

### Power supply

C110	A1104-0364
IC101	B4010-0015
R101	A1014-0011
ZD101	62169-423-096

### Main panel

D606 or ZD702	A4106-0065
IC602	62119-401-300
R630/R631	B1004-0229
R638/R664	61079-917-101

**Front panel** DT701 (digitron) A4153-0018

### Mechanical parts

Cassette housing complete	62052-0004-00
Cassette housing RH plate	62203-0025-01
Eject gear	61473-0051-01
Review arm	61544-0032-00
Pinch roller complete	61523-0021-01
Clutch unit	61453-0001-01

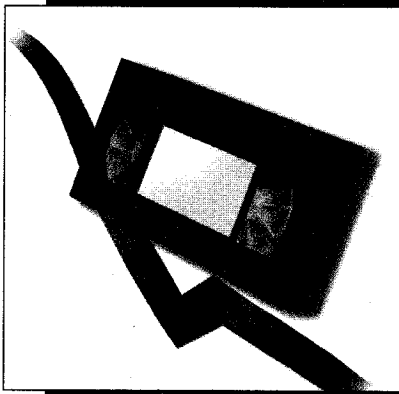

**Reports from**  
**Chris Watton**  
**John Edwards**  
**John Pitt-Francis**  
**Keith Evans**  
**Michael Maurice**  
**Brian Storm**  
**Gerald Smith**  
**Mike Orr**  
**Michael Brett**  
**Graham Richards**  
**and John Coombes**

### **Samsung VI375**

This machine was dead. There's a repair kit for the power supply, called the 6 WINNER1 kit – it's available from Samsung or CPC. When we fitted one the machine worked but the brightness of the clock display varied. In fact it sometimes almost went out. Replacing D109 and C118 in the power supply cured this problem. C.W.

### **Akai VS425**

This machine was brought in because the display was dim. As usual, the cause was the 56 $\mu$ F capacitors C446 and C447. Once these had been replaced however the machine was dead. Great! The power supply connector 201 had correct voltages, but the power-down detector was operating because the 15 $\Omega$  23V feed resistor R221 was open-circuit. It supplies TR205. C.W.

### **Ferguson FV61B**

This machine was dead. A check at pin 1 of connector BW06, where -25V should be present, produced a reading of only about -2V. As this

# VCR Clinic

is an unswitched rail, this suggested that there was a fault in the power supply. Checks at the output rectifiers showed that there was a short-circuit across the 14V line. Transistor TP91 (BCP53-16 or 2SA2010) was found to be short-circuit and RP91 (1.5 $\Omega$  safety) open-circuit. Once these two items had been replaced the machine powered up normally. C.W.

### **Sony SLV270**

This machine was dead with no display. Checks in the power supply showed that C1325 (1 $\mu$ F, 100V) measured only 0.7 $\mu$ F while C1326 (47 $\mu$ F, 63V) measured 19 $\mu$ F and was very leaky. J.E.

### **Sharp VC9300**

This machine refused to accept a tape because the 'tape-in detect' leaf switch, which is mounted on top of the carriage, was buckled. A new switch restored normal operation. It's available from Willow Vale under part no. 27354BT. J.E.

### **Samsung VI710**

There were no functions and no display because the STK5333 regulator chip didn't provide any switched voltages. The 25V input from the bridge rectifier was correct at pin 8, but there was no 30V input at pin 5. This comes from a separate winding on the mains transformer, via a rectifier diode and 560 $\Omega$  resistor (R104). The resistor had gone open-circuit. J.E.

### **Amstrad UF30**

This machine produced no channels or E-E signals – not even a test signal. When the standby switch was operated, the switched 5V supply at pin 2 of the tuner/modulator/IF module TU01 rose to

only 0.4V. The cause was traced to Q7005, which provides the switched 10V supply. It was short-circuit base-to-emitter. A BD131 was well able to carry out the task of the original 2SC3246 – and fitted nicely as well! J.P-F.

### **Sharp VC8300**

The cassette lift would jam because the lift arms were out of sync, i.e. the left side was higher than the right. On investigation we discovered that the reciprocating collar (item 23) within the worm wheel had fractured. The part no. is LANGJ0009GEZZ – it's still available from Sharp! J.P-F.

### **JVC HRD230/Ferguson FV22L**

The channels were slightly off tune. But when fine tuning was carried out and the channel was stored in memory it reverted to the original mistuned condition. The culprit was the MN1220 EPROM chip IC101, which is conveniently plugged in piggyback fashion at the rear of the front control panel. J.P-F.

### **Amstrad VCR9000**

"Won't play tapes" is a common enough complaint from our customers. On this occasion the cause wasn't a mechanism fault. When we inserted our trusty blank cassette we saw that the drum wasn't rotating. Checks on the various voltage rails showed that there was no 5V supply. The 78M05 regulator chip IC1 on the main panel had failed. K.E.

### **Matsui VX2700**

The customer complained about "tracking problems". In fact the playback picture was badly broken up. When we examined the operation of the mechanism in the

playback mode it was apparent that someone had been fiddling with the back-tension arm. As a result, it jammed. After readjusting it and checking for correct tension we were able to see the original fault symptom – the capstan was running at the wrong speed. If the back tension, and hence the load on the capstan motor, was reduced manually the tape speed altered noticeably. A new DD motor assembly was required. **K.E.**

### Panasonic NVJ35

This machine would go into the tuning search mode but wouldn't stop when a channel was reached. The cause of the fault was cracked print leading to pin 2 of the tuner/demodulator pack. A link across the crack solved the problem. **M.M.**

### JVC HRD700/Ferguson FV26D

The reported fault was field roll in the playback mode. It's becoming quite common to find that the entry and exit guides in these machines are starting to work loose, so I set up the tape path. Then, while playing back a tape, I noticed a severe hum bar on the picture. It seemed to be intermittent. Checks showed that there was ripple on the switched 5V supply when the fault was present. A replacement STK5481 power regulator chip restored normal operation. **M.M.**

### Toshiba V813B

This machine's capstan motor was running slow. All that was required was to dismantle the motor and slightly lubricate its bearings. After that the machine worked correctly. **M.M.**

### Matsui VX2500

The playback and E-E pictures were very poor. As this is one of the later versions with a scart socket, I tried a scart connection to the TV set. The picture was then OK. A replacement RF converter cured the fault. **M.M.**

### Osaki VR300

Tape chewing was the complaint with this machine, which had come via another dealer. As the bottom edge of the tape was being crinkled, the dealer had replaced the pinch roller. This appeared to stop the creasing, but the sound was muffled and there was a lack of control pulses. On inspection I found that when the tape was loaded it was at the correct height with respect to

the audio/control head, but when the pinch roller moved into position the tape rode up the AC head by about 1mm. The dealer had fitted a pattern pinch roller. Fitting the original type and arm assembly cured the fault, a new clutch completing the repair. **M.M.**

### JVC HRD540

The clutch wouldn't engage correctly in the fast-forward mode. Instead, there was a grinding noise and virtually no torque at the tape spool. I found that the plate assembly was worn, a replacement restoring correct operation. **M.M.**

### Panasonic NVHD90

This machine recorded the head switching point two thirds of the way up the screen. Suspicion naturally fell on the integrity of the field sync signal that's used to lock the phase of the head drum in the record mode. It was completely missing, the cause being a defective video processor chip (IC301, part no. VEFH29H). **B.S.**

### Panasonic NVSD40

This machine rejected any video cassette it was offered. When it took the cassette in it would pause briefly then throw the cassette back out. This is a classic result of no capstan motor operation. But in this case the capstan motor was going too fast, as there was no 12V supply to the capstan motor's stator. The 2SD601 voltage regulator transistor Q2505 was found to be open-circuit. **B.S.**

### Panasonic NVSD200

If one of these machines intermittently shows F04 or F05 or sometimes F06, check for dry-joints on the loading motor. In this particular case however the cause of the problem was a deformed contact on the mode switch plug-in connector, which stands up off the main board. **B.S.**

### Panasonic NVHD650

This is the third of these machines we've had in with the remote control unit apparently failing to operate it. The reason is that the owner has selected the VTR2 mode from the on-screen graphics menu. When this is done, the VCR ignores all further commands from the remote control unit unless this is also changed to the VTR2 mode. Open the remote control unit's flap and press 'TV select' while also pressing 'cursor up' or 'cursor down'. This changes the data to

match the VCR, and all in the garden is then rosy again. **B.S.**

### Samsung SI3260

As the capstan didn't turn, this machine was damaging tapes. We found that D108 was going open-circuit under load. As a precaution we also replaced D109 and D110. **G.S.**

### Nokia VR3722

There was no channel display and the machine wouldn't tune in. A quick check showed that the 33V supply was missing. The 33V regulator was OK, but C6010 nearby was going short-circuit. A replacement capacitor restored normal operation. **G.S.**

### Samsung VIK320

Dead, no power and no clock display – an all too common set of symptoms with these machines. After fitting the power supply repair kit the power came up but the servo was drifting in both playback and record, as though there were no control pulses. A new servo chip (IC201) cured the problem. **G.S.**

### Sharp VCM20

There was no clock display and no functions. When you encounter these symptoms in this model you will probably find that Q901 is short-circuit and R904 open-circuit. To prevent a recurrence of the fault Sharp has introduced a heatsink for Q901. The part no. for this is PRDAF1065UMFW. **G.S.**

### JVC HRD830

This machine's power supply was buzzing badly. The cure was to replace C12 and remove the darkened glue from the Q1 heatsink area. **G.S.**

### Nokia VR3716

After a while the sound produced by this machine was marred by wow. The cause was a faulty main clutch. **G.S.**

### Panasonic NVJ40

The deck was jammed, with the tape wrapped around the head. There was nothing unusual about this, so the upper and lower deck service kits were fitted and aligned. I find the G deck alignment instruction video that's available from Charles Hyde and Son very helpful: it takes you through the procedure step-by-step – you simply use playback pause while carrying out the task described, then continue.

When the service kits had been

fitted everything worked normally apart from the fact that there was no auto stop at the end of rewind, play and fast forward. The micro-controller chip was calculating the speeds of the spool carriers accurately, because the tape speed was being reduced as the tape neared its end. But when the tape ran out the mechanism struggled to keep it going for a few seconds then the VCR entered the stop mode. This would not do the mechanism any good, and was probably the cause of the misalignment in the first place.

A scope check across the infra-red 'lighthouse' transmitter produced a 2.5V peak-to-peak pulse at 25msecs. When we fitted a replacement the reading was 0.8V peak-to-peak and the auto stop worked correctly. **J.E.**

### JVC HRD660

There was no play: the tape would be pulled out of the cassette in the normal way, but would not be positioned between the capstan and the pinch roller. As a result there was no forward tape motion. The pin that was responsible for this problem had parted from its plastic holder and was nowhere to be seen (the deck reference number is 47). It's reminiscent of the infamous limiter post used in some Matsui machines, and could also become a stock fault. **J.E.**

### Panasonic NVSD40

This VCR was brought in because the tuner/booster pack produced a low-gain E-E output. This is not unusual. After fitting a replacement however the machine wouldn't tune in any stations. A check on the tuning voltage showed that the sweep was normal, so we assumed that the new tuner was faulty. It wasn't.

This model has a band-switching circuit, which is controlled by IC6710 on the syscon board. It should supply a low output to the band-switching chip, but the output was high. Replacing IC6710 restored correct operation.

A quick check for this is to short the relevant pin of IC6710 to chassis and see whether you can then tune in stations. **M.O.**

### JVC HRD580

The customer complained about a rattling noise in the fast forward and rewind modes. I replaced the idler gear unit and clutch, but this didn't fix the problem. When I examined the small toothed gear at

the rear of the capstan motor closely I noticed a small, hair-line crack in it. As this gear is not shown as a separate part in the manual I considered a replacement capstan motor assembly. But the cost is quite high. So I spoke to a very helpful person at JVC Technical and was advised to order part no. PTU96031-678C – it's a gear kit. Installing this cured the fault. **M.B.**

### Ferguson 3V54

The customer complained that this machine damaged tapes when it ejected them. It seemed that the slant poles didn't fully retract. Replacement of the loading sensor assembly, part no. PU35632A3 fixed the problem. I've also had this failure with **Model 3V55**, which uses the same part. **M.B.**

### Hitachi VT65

Intermittent failure to record in colour was the complaint with this machine. Initial tests showed that the tape-in light was permanently illuminated. Further tests revealed a bad tape-end sensor. The cause of the "intermittent colour" was an extremely dirty video head drum. This was cleaned – the customer declined the quote for a replacement. **M.B.**

### Amstrad VCR3000

Intermittent loss of stations and failure to store channels was the complaint with this machine. After exhaustive tests we condemned the X24C01P memory chip IC05. A replacement confirmed the diagnosis.

If you have a non-mechanical fault with one of these machines, linking pins 10 and 13 of CN601 will enable the entire mechanism to be removed so that checks can be carried out on the PCB. **G.R.**

### Sharp VCH81H/ VCA113HM

Failure of the capstan motor is a common fault with these models and those from other manufacturers that use the same deck. So I asked myself why? If you have a dead capstan motor, look carefully at C6 (10µF, 25V). Early motors were not fitted with a leakproof capacitor. As a result, electrolyte gets on to the print between pin 12 of the motor IC (usually an M52440ASP) and the motor's input socket (where the ribbon is inserted). The print goes open-circuit, removing the chip's 12V supply.

With a good hot soldering iron and calm nerves the track can be linked and C6 replaced. But first remove any gunge. I've repaired several of these motors in this way.

One motor ran slow after the repair – it still did after cleaning and greasing the shaft and capstan. I found that R3, an 0-47Ω surface-mounted resistor, had gone high in value. Its replacement cured the fault. These motors are very similar to those used in Matsui and other machines.

Proper cleaning and lubrication of the capstan and shaft is very important. **G.R.**

### Sharp VC9300

This old timer had been in for replacement of the reel motor and idler. It bounced, with the same fault description – intermittently shredding tapes. I soon found that when the fault occurred the supply to the reel motor went missing. But the machine would then run correctly for days! Fortunately I was able to spot the microscopic dry-joints at a couple of the pins of the reel drive chip IC7751. **G.R.**

### Mitsubishi HSM40V

If the machine doesn't accept tapes, check the front-loading cassette housing. The item called JUT J (L-031, part no. 622D231010) can break or become disconnected because of excessive force when inserting a tape. If JUT J has broken, make sure that spring JUT is also fitted. When JUT J is faulty the tape flap won't open. Hence no loading and the tape being ejected. **J.C.**

### Aiwa HVGX150

Failure to accept or eject a tape is generally caused by a faulty loading belt. In this case however the loading motor had seized. **J.C.**

### Panasonic NVG7

Check the drum servo chip IC6387 if the drum motor hunts or runs fast in the forward direction.

If the tape laces up but the capstan motor doesn't rotate, just vibrating, check the AN3821K chip IC2001 by replacement. **J.C.**

### JVC HRD530

You sometimes find that the half-loading arm is not able to extract tape from the cassette. The problem is caused by static. As a result of this, the tape sticks to the lid of the cassette. The cure is to replace the housing lid guide, part no. PRD43315. **J.C.**

# Camcorner



Reports from  
**David C. Woodnott**  
**Simon Bodgett and**  
**David Corcoran**

## Canon UCX1HiE

All functions worked but the customer said that the colour viewfinder picture had 'bits missing'. In fact several areas of the LCD failed to operate correctly, giving the missing pixels effect. Inspection revealed that the mask which surrounds the LCD was pit-marked in several places. This indicated that the problem had been caused by the sun's rays being focused on to the LCD and its mask, probably while the camcorder was being transported. A new LCD was required. We warned the owner to take care when out on sunny days. The rays also affect monochrome CRT viewfinders, but the only damage is usually to the CRT mask, which will show this tell-tale pitting. **D.C.W.**

## Ferguson FC54

The reported fault was no operation. There was a tape stuck in the mechanism, which made removal of the deck section difficult. Fortunately the loading motor's contacts are accessible, and after removing the connections to the drive circuits power could be applied to get the cassette out.

With the deck removed, an inspection revealed that the main cam gear was damaged. We replaced this along with the mode switch, which is usually the cause of such problems with these mechanisms. The switch fails to tell the mechacon to stop driving the

loading motor when the fully laced condition is reached. Hence the damage to the cam gear etc. It's best to check all the plastic gears for damage while you have the unit dismantled. Retiming is straightforward.

The deck was still inoperative when we'd reassembled and reconnected it, because CP1 (N20) on the main PCB had failed. Replacing this item restored the unit to active service. **D.C.W.**

## Hitachi VME21E

This and other Hitachi models seem to appear, often with various clone badges, on a fairly regular basis. The reported fault with this one was that the AV socket was faulty. In fact the socket was OK, but the pins in the miniconnector were severely bent. Once we'd overcome this problem, a quick check on the camcorder's operation revealed two previously unmentioned faults. There was no autofocus operation, because the lens was completely jammed. And there was a noise band at the bottom of the playback picture.

The lens problem was resolved by dismantling the unit then reassembling it correctly. This is not easy, as the sections are glued together – the unit is not designed to be repaired. Fortunately there was no damage to the unit's parts. The noise band problem was cured by refitting the take-up tape guide assembly to the coaster base. It's common for this guide to become loose, or even detached, with this mechanism. Once refitted the guide needs to be secured with a suitable adhesive. **D.C.W.**

## JVC GRC1

This camcorder would record only if the record button was pressed in quick succession. No, I didn't understand the fault report either! The capstan flywheel FG signal was missing, and there was intermittent slow rewind. A dark cloud of gloom spread overhead, as is usual with this sort of fault. Anyway, we discovered that there was a break in

the 8V supply to the capstan motor, at connector CN11. Replacing IC4 and C24 in the servo department stabilised the operation of the capstan, restoring order. **S.B.**

## JVC GRAX5

This camcorder's viewfinder had poor focusing. The cause was a defective EHT transformer. Note that if the EVF tube is broken it's cheaper to order the complete viewfinder. The tube tends to be more expensive. **S.B.**

## JVC GRAX40

"Films in black and white" the report said. Checks showed that there was no chroma in the E-E signal. It was a camera head fault of course. The chroma encoder is IC801, whose subcarrier feed was missing. This comes from the EHD-GA1451 hybrid subcarrier oscillator chip, which was faulty. **S.B.**

## JVC GRS505

This camcorder had come from Mastercare, so it was going to be a difficult fault. There was no playback colour, and the Mastercare engineer had noted that there was no E-E colour though the burst was present. A quick vectorscope check showed that the subcarrier frequency was incorrect. The main subcarrier oscillator is in IC110, type MC8181D. Replacing this item restored the colour. An updated IC is now available, type EHD-GA1389A. **S.B.**

## JVC GR45

The cause of intermittent camera pictures is often dry-joints on the bit of flexiprint (horizontal drive pulse circuit) over the CCD imager, particularly at diode D2. **S.B.**

## Panasonic NVMS4 and NVM40

No power when used with the battery but OK with the AC adaptor seems to be a common fault with these models. The cause is open-circuit print on the AV jack (B) PCB, between pin 1 of P1604 and pin 4 of P1602. **D.C.**

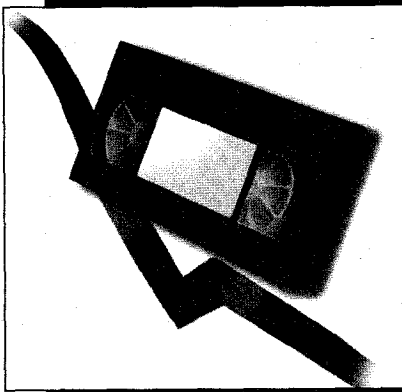

# VCR Clinic

**Reports from**  
**Philip Blundell,**  
**AMIEE**  
**John Coombes**  
**Graham Thompson**  
**Nick Beer**  
**Keith Evans**  
**Chris Watton and**  
**Gerald Smith**

## **Philips VR323 (Charlie Deck)**

Tape damage because it rides up or down the capstan is a routine fault with the older Charlie range of VCRs. The cause is often a defective pinch roller, but lately I've had several cases where this has not been the cause. The take-up torque has been excessive because the coupling (item 214 in the exploded view of the deck) is faulty. This item and the pinch roller are included in service kit 4822 310 31803.

Take care with the back-tension band when fitting a service kit to a Charlie deck. Make sure that it is clipped into its holder. I've come across cases where this has not been done. The resultant low back tension produces spotty playback pictures with the tape running up or down the capstan. **P.B.**

## **Ferguson 3V65**

This machine thought it had a tape inside and was trying to rewind it, though there was no cassette present. When I've encountered this fault on previous occasions the cause has been loss of the switched

outputs from the STK5481 chip. But in this case the supplies were all OK. There was no voltage at the cassette lift however. On inspection the motherboard was found to be suffering from dry-joints at the connectors, especially at CN1. **P.B.**

## **Pioneer VR737**

This machine worked all right but there was no display. I was able to use the Philips VR6484 manual to find that fuse 1216 in the power supply was open-circuit. **P.B.**

## **Mitsubishi HSM57**

"Noise on Nicam" was the complaint. Sure enough when stereo was selected in the E-E mode there was a loud rushing noise that swamped the audio signal. Mono E-E sound, also hi-fi record and playback sound, were OK.

A problem in the area of the digital-to-analogue converters seemed likely – otherwise I would have expected the internal muting to have been in operation. Checks around the TD6710AN chip soon bore fruit: the 16.93MHz resonator X7A2 wasn't oscillating. A replacement restored the Nicam sound to normal. **P.B.**

## **Logic VR960**

If the problem is no operation light and no functions, the STK5332 power regulator chip is probably faulty. **J.C.**

## **Toshiba V215B**

If there's no fast-forward movement because the main brake has not released, being in the on position, reset its mechanical position. **J.C.**

## **Panasonic NVL20**

There was no display or operation. C1109 (1µF) in the power supply is the usual cause of this – it goes open-circuit. But this time the mains input fuse had blown because

the bridge rectifier D1102 (S1WBAGO) was short-circuit. Note that the STRD1816 auto voltage-selector chip IC1101 can go short-circuit between pins 2, 3 and 4. **J.C.**

## **GoldStar RQ2931**

It's becoming quite common to get a dead machine, the cause being failure of the KIA7806 6V regulator chip IC101 in the power supply. **G.T.**

## **Toshiba V404B**

There were no results. Power supply checks showed that the outputs were all low by about 50 per cent. The U4614B control chip IP001 in the primary side of the power supply was faulty. **G.T.**

## **Ferguson FV26D**

A check in the power supply of this dead machine revealed that R1 was open-circuit. It's a safety resistor which is mounted near the mains transformer. **G.T.**

## **Panasonic NVJ45**

There was no E-E tuning, though loopthrough and playback were fine. The tuner used in these VCRs is known for problems, but not of this sort. Checks showed that its 12V BU supply was missing. This comes from the adjacent band-switching chip, which is largely redundant in the UK version. Pin 12 of this chip produced a low reading of 0.2V, though its supplies and controls were all fine. A resistance check here produced a reading of 1kΩ to chassis. So I tried, to no avail, a replacement chip from a scrap unit.

I then noticed that the tuner had been replaced, and that one lug of its case is soldered very close to the print to the BU pin. There are a couple of surface-mounted links on this print. One was touching the



rather bulbous joint on the tuner's lug – or was it? The resistance check had produced a reading of  $1k\Omega$ : it now read short-circuit! Tidying up the joint restored the  $1k\Omega$  reading and the tuning. But I didn't trust the original chip. **N.B.**

### Samsung VIK316

This machine produced a very dim display. It was invisible in standby, and barely visible when powered up. Otherwise the unit worked fine. The filament supply was at 2.5V, with 6V peak-to-peak of hash on it. This pointed to capacitor trouble, and we duly found that C38 ( $100\mu\text{F}$ , 10V) was open-circuit. The correct filament supply voltage is not quoted in the manual: with the machine working correctly I found that the reading was 5.72V. **N.B.**

### Panasonic NVG10

This elderly VCR's playback vision was dull and there was no field sync. When a recording was played back on another machine it was fine. It seemed likely that there was a faulty electrolytic in the playback luminance path, and a search for a suitable candidate brought me to C306 ( $10\mu\text{F}$ ). A scope check across this capacitor proved its guilt, while a warm iron on its top cleared the fault. A replacement restored the playback vision. **N.B.**

### Mitsubishi HS337

This machine came in because it had mechanical problems, and did need a good service. On test from cold however it was found to produce very weak playback vision – a check on a recording with another machine proved that the fault was with playback only. We found that a small resistor had been tacked across C2C1 ( $10\mu\text{F}$ ) on the print side of the PCB, to which it was glued. This glue was now conductive when cold. Removing it and cleaning up the area cured the fault. **N.B.**

### Panasonic NVL25 Remote

As the remote control handset that goes with this model is expensive to replace I decided to try to repair it. The problem was that the scanner section wouldn't switch off – the red beam stayed on all the time, with the result that battery life was very short. Pin 13 of IC2, the scanner control chip, was stuck at 1.5V – this is the power-on line. The switching signal comes from a microcontroller chip via QR2, which is a UN2211 digital transistor (internal biasing). As the base of

this transistor toggled correctly while its collector voltage remained at 1.5V it was obviously open-circuit. A replacement restored normal operation – it's a surface-mounted device. **N.B.**

### Panasonic NVG40

There was no capstan phase lock in the playback mode though record was OK. Checks around IC2101 on the servo sub-pack produced the following results: the capstan speed duty cycle at pin 16 was correct at 50:50, though the DC voltage was high at 5V instead of 2.5V; the capstan phase duty cycle at pin 17 was wrong at 1:99, with the DC voltage at 0V instead of 2.5V; the DC voltage at pin 2 (tracking MMV) was low at 0.3V. The latter seemed odd, as this is a simple DC control voltage obtained from the 5V supply via the tracking control. Herein lay the simple answer: there was no 5V at the top end of the tracking control as the grey single wire to the control sub-PCB from the timer PCB (pin 4 of P7503) had broken off. It had never been secured by tape or glue. **N.B.**

### Panasonic NVJ35 etc

The dead machine symptom with any model that uses this power supply can be caused by C1119 ( $680\mu\text{F}$ ) on the secondary side of the supply being short-circuit. This is unusual however: the usual cause is C1109 ( $1\mu\text{F}$ ) on the primary side of the supply. The difference is that with C1119 short-circuit you get a slight chirp at switch on. **N.B.**

### Ferguson FV11R/JVC HRD170

There was heavy patterning on the playback picture. One could have been forgiven for suspecting the heads, but this was not the cause. A 4MHz signal was being superimposed on the playback FM.

We scoped every conceivable circuit to try to find the source of the interference. It was only when the short interconnecting lead between the tuner/IF and the mother board was disturbed that there was a noticeable change in the interference signal. When the lead was disconnected, removing the power to the tuner/IF board, there was no interference.

As our scope checks showed that there was a substantial amount of the offending interference signal on the power supply rails, we looked questioningly at the 5V regulator chip on the tuner/IF board. It seemed to be running very hot, and

when a quick burst of freezer was applied the patterning disappeared. It seems that as the 7805 regulator's temperature rose it began to behave as an effective signal generator. **K.E.**

### Matsui VX2500

Our customer complained that this machine wouldn't record. On test it soon became apparent that the cause of the fault lay in the receiver section, where it was possible to select stations but the signals were badly broken up. As the problem looked like poor demodulation, we decided to replace the LA7577 chip IC01. This restored normal operation. **K.E.**

### Samsung VI611

This machine's clock display was intermittent. There should be -24V at pin 17 of the power supply's output socket: when the display was out there was only -1V here. The -24V supply is derived from the mains transformer by rectifier D1 (1N4002) and its reservoir capacitor C3 ( $47\mu\text{F}$ ), with stabilisation by Q1 and ZD2. As you often find in Samsung machines, some of the components are glued to the PCB. The trouble is that the glue becomes conductive. This was the cause of the problem – when the fault was present Q1 was bottomed. Removing the glue cured the fault. **C.W.**

### Sharp VCA55

When this machine had been used in the search mode, particularly in the forward search mode, it would sometimes continue to move the tape at search speed after play had been selected – with the play symbol showing in the display. The cause of the fault was traced to the capstan motor. Although its control voltage would change to the play level, the motor would continue to run at the higher speed. **C.W.**

### Sharp VCM20

Even after fitting a heatsink Q901 blew intermittently. In addition the chopper transformer would buzz. The cause of the problem was dry-joints on the optocoupler IC901. **G.S.**

### JVC HRJ565

There were various erratic faults, for example the power light not lighting, the capstan going into the rewind mode by itself, the machine cutting off to standby and failure to accept tapes. The cause was oxidised glue in the power supply. **G.S.**



# Camcorner

Reports from  
Simon Bodgett and  
D.C. Woodnott

## JVC GFS1000

The complaint was that this camcorder would shut down intermittently in the record mode. It did so in the playback mode as well, because the cause of the trouble was dry-joints at R15 in the drum motor drive circuit. The board concerned is mounted above the tripod base and is subject to stress. **S.B.**

## JVC GRAX10

The scribbled fault report said that the picture was out of focus and the sound was too quick. When we tested the machine there was severe capstan motor warble in the playback mode. We decided to tackle this first, and it took some time to narrow the cause of the problem down to a defective capacitor, C116, which decouples the servo non-linear filter to a reference source. Adjusting the viewfinder's optical focus control cured the out of focus picture. **S.B.**

## JVC GRS707

The customer couldn't eject tapes and said that the rewind button was slow to respond. This camcorder's eject function is routed through the main operations panel, and as this is a single unit it had to be replaced. Both faults were then cleared. **S.B.**

## JVC GRM3

There was no camera operation though playback was OK. Obviously a camera head fault. The head has a DC-DC converter module/IC, DD1. Fusible resistor R85 in the feed to this

IC was open-circuit. So it seemed that the chip was faulty. Did it die or was it killed? We shall never know: a replacement IC and resistor restored normal operation. The repair was not an easy one.

There's an interesting anomaly with this model. To operate the autofocus and zoom while service testing, the EVF and the T/W zoom switch must be connected at power up – otherwise the functions don't operate. **S.B.**

## JVC GRS707

Circuit protector CP204 had failed. The replacement held OK until the camera head was reconnected. We eventually traced the cause of the failure to C122 on the YC board – it was leaky. **S.B.**

## Sharp VLE31

A clicking sound from within when the mechanism was operating was the complaint with this camcorder. The offending noise came from the head drum. My first thought was that a foreign body might be lodged between the upper and low drum, but on investigation I found that one of the small screws on the upper drum was loose and was fouling against the lower drum. All was well when the offending part had been adjusted and secured. **D.C.W.**

## Panasonic NVS6B

The reported fault was no digital functions, all other operations being OK. The cause turned out to be a faulty switch on the camera operation assembly (part no. ESU39013).

It's not unusual for one function only to fail with this type of assembly. You get similar problems with other Panasonic models that use similar membrane-type units. **D.C.W.**

## Samsung VPE807

No camera E-E picture with playback OK is a common fault with this model. It can usually be cured by removing and replacing the lithium clock battery. We've never had one come back for a more serious repair after doing this. **D.C.W.**

## Ferguson FC08

We don't see many of these camcorders nowadays. This one had a fault that was always common with them, a poor viewfinder picture. For some reason JVC, which had always provided good viewfinder pictures with previous models, slipped up with this one.

The thing to do is to remove the 'blue' substance around the CRT base and pins. This will usually brighten up the picture to an at least acceptable level. It may still not be considered up to scratch however. The later Model FC28 didn't suffer from this problem despite the fact that its EVF is very similar. **D.C.W.**

## Sanyo VARS12B Adaptor

If one of these units fails to operate, check whether limit resistor R5104 is open-circuit. As yet we have found no external cause for this resistor's failure, nor have any units been returned after its replacement. **D.C.W.**

## Panasonic WVCL350 Camera

These cameras often fail to produce a picture because C52 (100µF, 16V) on the power supply PCB has dried out and fallen in value. In this situation you'll find that the voltage on the 5V line is slightly low.

Although this is the only electrolytic capacitor that normally fails on PSU board, we usually replace the others as well. They all run rather 'warm'. **D.C.W.**

## Canon UC15E

We were told that this camcorder's cassette housing was permanently open. When we powered it the housing closed, but when a cassette was inserted the housing again refused to close. The cause was failure of the drum to rotate. An inspection showed that there were dry-joints at the upper drum commutation PCB's connections. It's always worth checking for faulty connections on this board: we've had other faults – for example no FG pulses etc. – that were caused by this problem. **D.C.W.**

**These VCRs are well worth renovating. With the faults list and recommendations provided by **Brian Storm** you should be able to clear any incipient troubles**

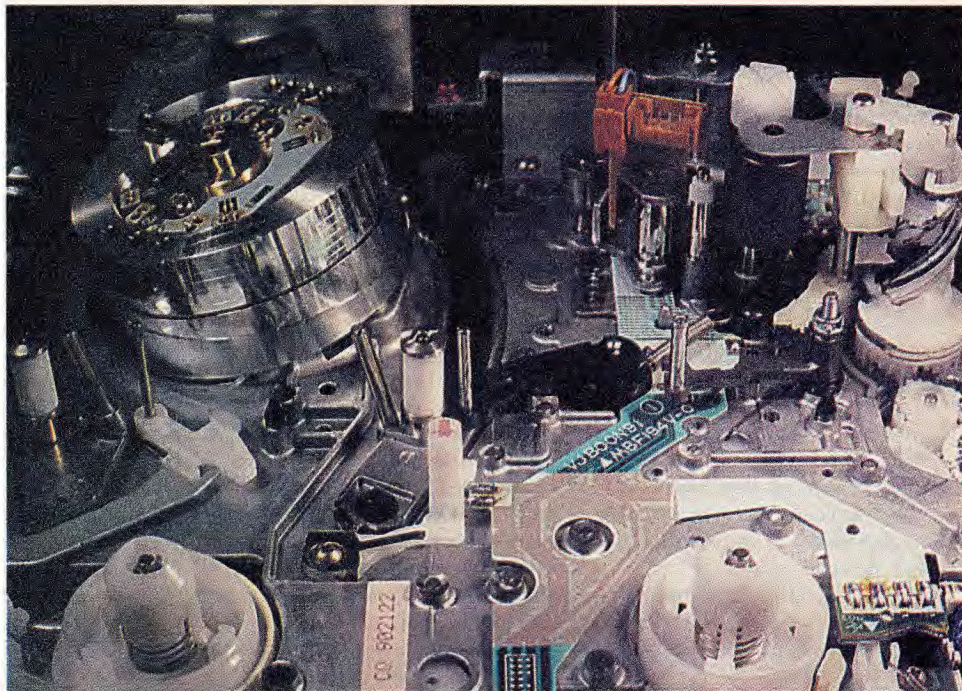

# Renovating the Panasonic NVG21 /25

**T**hese now elderly VCRs are well worth renovating, particularly as the picture quality they provide is exceptional. The NVG21 and NVG25, along with their up-market relative the NVH65, were the first models to appear with the compact G mechanism. This helped to reduce considerably the size and weight of Panasonic VCRs. Another contributory factor to this was the introduction of a much smaller switch-mode power supply module. Other features of these models are real-time counter functions and bar-code scanners for timer and clock functions.

## Power Supply

Fig. 1 shows the power supply circuit used in these models. The electrolytic capacitors in the switch-mode power supply of any machine that's about ten years old are likely to be reaching retirement age. Always replace the electrolytics in the primary side of the circuit because, as they decrease in value, the voltages on the secondary side of the circuit can increase, with possible damage to the items supplied.

Always resolder the legs of the STR10006C chopper chip Q1001 and the STK5338 series regulator

chip IC1001. With both, the solder ages and eventually becomes dry.

On the secondary side of the circuit, electrolytic capacitors C1023, C1018 and C1022 should be replaced.

Here are some fairly common power supply faults:

**Bad patterning, no colour and maybe drum servo problems:** Replace C1023 (1,000 $\mu$ F, 10V).

**White patterning, varies with the setting of the tracking control:** Replace C1022 (47 $\mu$ F, 50V).

**Loses the E-E picture when a tape is inserted:** Replace C1018 (47 $\mu$ F, 50V).

**Intermittent mains fuse blowing:** D1002 (type ERA22-08) in the snubber network is probably leaky.

**Clock display goes off intermittently:** Replace C1018 (47 $\mu$ F, 50V).

**Red power LED remains on when the machine is**

**switched off:** Cause is open-circuit print between IC6001 and the base of QR6014

## The Mechanism

After attending to the power supply, the next area most likely to require attention is the now familiar G mechanism. In these machines the capstan motor also carries out the functions of a front-loading motor and main loading motor. Because of this the mechanism is driven by a gear train that engages with the capstan motor via a solenoid at the appropriate times. The phasing and integrity of the gears are critical. Faults here can cause numerous symptoms. Here is a list of fairly common mechanism faults:

**Cassette housing keeps going out of line with the main mechanism:** Replace the cassette mechanism right-side housing assembly (part no. VXA2677) which is probably worn or broken.

**Tape damage at bottom edge:** The pinch roller is worn or the audio/control head is tilted down.

**Tape damage at top edge:** Arm P5 is bent or the A/C head is tilted up.

**No rewind or fast forward:** The centre pulley assembly (part no. VXP0769) is faulty (split).

**Intermittent horizontal twitching:** The impedance roller is sticking.

**Intermittent tape damage (looping):** Replace the play

arm unit, part no. VXL1490.

**Squeaking noise from the mechanism:** Replace worn capstan rotor pressure pad, part no. VXL1500.

**Rattling noise in rewind or fast forward:** The belt tension roller is worn. Replace it, part no. VXA2674.

**Intermittent solenoid operation:** Connector loose in plug 1504.

**Tape loads but plays fast for a few seconds then the machine cuts out:** The mode switch is out of phase with the mechanism by one gear tooth.

**Machine cuts out in the review mode:** The mode switch is out of phase with the mechanism by one tooth in the opposite direction to fault above.

**A tape is accepted then ejected almost immediately:** There's a phase error between the cassette housing rack gear and the drive gear.

**Arm P4 broken:** This occurs when there's a phase error between the planet and cam gears.

With older G mechanisms it always pays to check the tape path carefully, especially between the audio/control head and arm P5 via the pressure roller.

I recommend checking the A/C head for wear whenever the video head is replaced. A grid of white parallel lines is printed on the flexi-cable beneath the head. This is convenient. The pattern is reflected by the video tape as it passes across the A/C head. Thus any tape

**Fig. 1: Power supply circuit used in the Panasonic Models NVG21 and NVG25. D1029 is type ENB461D-05A.**

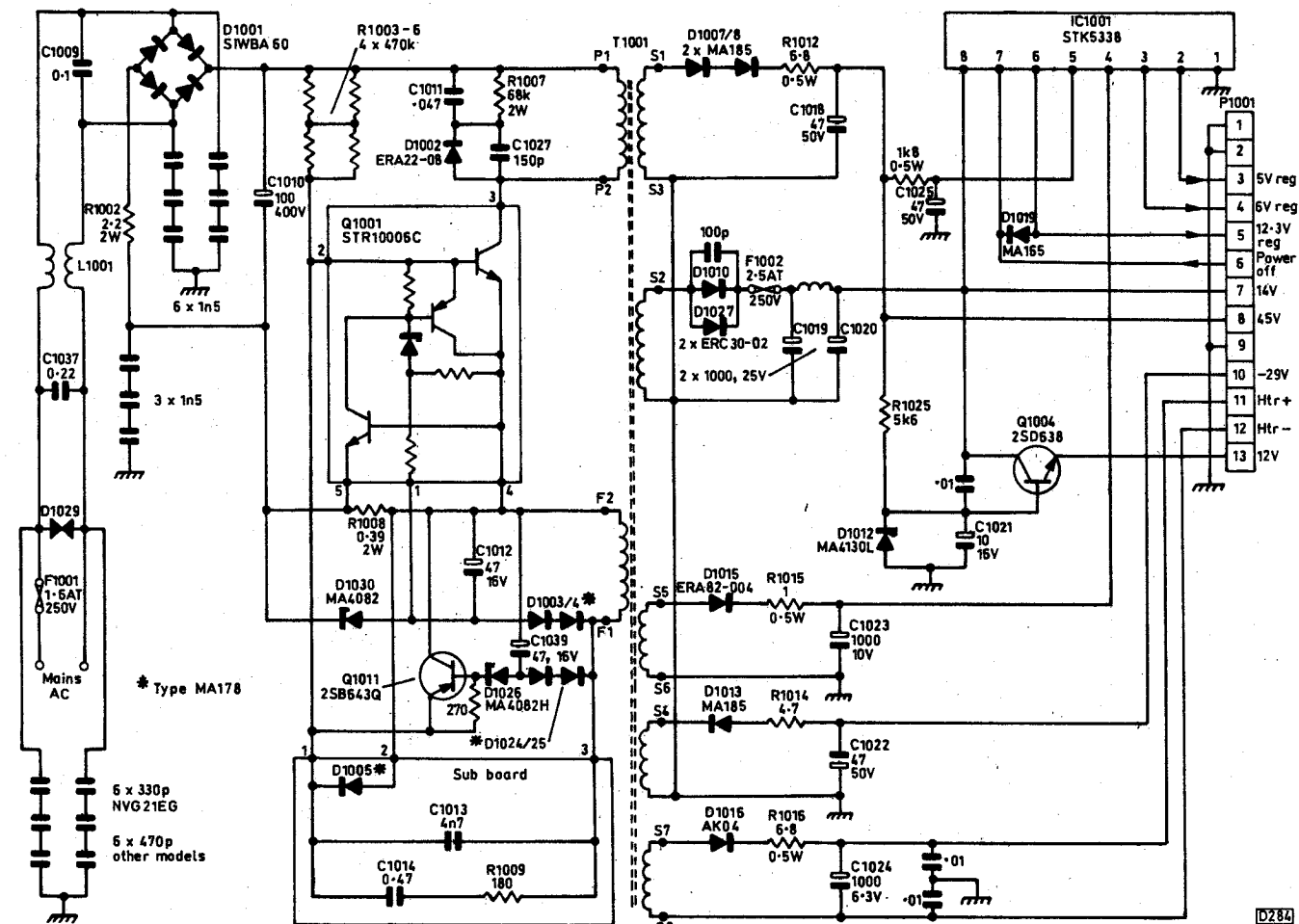

curling or deviation is easily observed.

For tape curling or flagging, also check arm P5. It can be twisted or bent by a tight cassette.

The impedance roller should be removed and cleaned and the lower drum cylinder cleaned as necessary, also the entry and exit guides.

### Sound Faults

Here's a list of sound faults you could encounter:

**No sound and counter not working:** C240 (10 $\mu$ F, 16V) open-circuit.

**Muffled or low playback sound:** Audio/control head (part no. VBR0125) is worn.

**Recorded sound is of low amplitude with lack of HF content:** Can be caused by excessive record bias. Check the adjustment potentiometer, which can be intermittent.

**Noisy and distorted sound:** Check whether R4021 (47 $\Omega$ ) is open-circuit.

### Video Faults

Most intermittent video faults are caused by dry-joints on the luminance and chrominance sub PCB, where it's joined to the main PCB.

Permanent or intermittent loss of the E-E video, with the sound all right, is usually caused by poor connection at the switch on the video input socket.

## The Panasonic G Deck

**J**ohn Coombes adds: G deck alignment is very important. Any replacements/resetting should be carried out as laid down in the service manual. This includes refitting the cassette housing, where alignment should be done very carefully.

Pinch roller wear is a common problem. The result can be tape creasing or chewing at the top and bottom, or the tape can loop out causing damage when it's ejected.

A lot of upper drum wear is caused by excessive back tension. The correct setting is around 25g. Check the back-tension band and replace it if necessary. Excessive back tension can also cause line pulling at the top of the picture. If resetting fails to cure this problem, replace the upper drum.

The video heads can cause various problems such as a snowy picture, streaking on peak whites, or possibly poor quality playback because the picture is covered in lines. Sometimes playback of prerecorded tapes is OK but recordings are very poor. The heads can be damaged or even badly marked because a cleaning tape has been used.

The mode switch causes various problems. Examples are incorrect loading/unloading; the tape being ejected after insertion; no fast forward, or rewind, or visual search in either direction; fast forward visual search instead of playback; tape ejection before rewind is complete. The mode switch has five soldered tags: dry-joints here can cause all sorts of strange faults. Several types of mode switch have been used in the G deck over the years. If you come across one with a metal centre, replace it immediately – this type is prone to trouble.

If the tape doesn't lace up correctly, check the play control arm which may be broken.

Noise in the rewind and/or fast forward mode can be caused by lack of take-up and/or rewind turntable lubrication. Other possible causes are a faulty centre pulley unit and/or the intermediate gear – check by replacement.

The G deck can be noisy. This can be a real problem should the SS brake arm unit (VXL1500) become worn at the bottom of the capstan motor. It can break into pieces here when badly worn. If there is a knocking noise, mostly in the playback mode, check the clutch disc and/or the play arm unit. If these are OK, suspect the main pulley and/or intermediate gear. Check that they are clean and free running, and then if

necessary by replacement.

A grating noise from beneath the deck is caused by worn or stripped gears, e.g. the ring gear, retainer gear, the three planet gears, the centre gear, sub-cam gear and disc drive along with the main cam gear. The sub-cam and ring gears will have to be replaced if the mode switch is incorrectly aligned and constantly becomes misaligned. Set all the gears and the mode switch very carefully, as laid down in the manual.

A sticking or bent P5 arm can cause tape chewing or damage at the top or bottom edge.

The cassette housing can cause troubles, i.e. a jammed cassette or failure to accept a cassette. First ensure that the wiper arms haven't gone out of alignment, failing to return to the correct position. Check that the main shaft is in the correct position, and that the cog on the side has not been damaged.

Check for a broken opening lever if the tape won't come out of the housing because the blinder panel doesn't open. Then if necessary check that the left/right side panels and slide switch unit operate correctly. If a cassette can't be inserted, check whether the opening lever is broken or whether its spring has stretched or dropped off.

Lower drum assembly wear may not be noticeable in the SP mode. If the machine has an LP mode, wear here can cause picture jitter, field roll or even an intermittently snowy picture on one 'channel'.

Some models have rotary heads for hi-fi sound. If the upper and/or lower drum is worn, the playback sound may give the impression of a helicopter whirling around.

If the top third of the picture is snowy in the review mode, suspect the upper drum.

Ensure that the back tension is set correctly before replacing the upper drum.

If the drum motor keeps running but the VCR won't play, check for a faulty Hall IC in the drum assembly. If this item is faulty, complete drum assembly replacement instead of repair is strongly recommended. But it may be worth checking for dry-joints in and around the direct drive assembly.

I have had very few problems with the capstan motor. On a couple of occasions it has been responsible for the no functions symptom. All inputs and outputs were OK, also the supply to the motor, but the machine refused to operate. The cause of the mechanism jamming intermittently can be failure of the friction clutch on the capstan motor to slip free – this occurs with some of the earlier models. The cure is to replace the capstan motor.

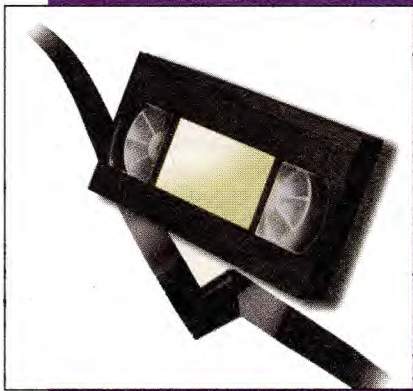

Reports from  
**Philip Blundell, AMIEEIE**  
**Gerald Smith**  
**Terry Lamoon**  
**Roger Burchett**  
**Michael Maurice**  
**Eugene Trundle**  
**David Corcoran and**  
**Michael Dranfield**

### **Philips VR422**

The mechanism was OK but there was no picture or sound (just a blank raster) in any mode. While tracing the video path back from the modulator, I soon discovered that the +12a supply was missing. Safety resistors R3151 and R3147 (both 6-8Ω, part no. 4822 050 26808) were open-circuit. No reason for their failure could be found, and the replacements didn't fail during a soak test. **P.B.**

### **Toshiba V110**

This VCR would only receive channels below 43. Channels above 43 could be stored correctly, but only snow was displayed. Checks in the power supply showed that the voltage at test point BP08 was low at 13V instead of 33V. A new ZTK33B voltage regulator (DP04) restored normal operation. **P.B.**

### **Philips VR727**

Take care when ordering deck parts for VCRs that use the Philips Turbo deck. Although they look similar, there have been changes in later versions – mainly in the braking system. Instead of using a trigger-operated brake, the main cam operates the brake directly. To do this, the design of the main cam has been changed (the cam has a sun or star shape moulded in to its top surface), the worm shaft is simplified and the trigger components are omitted.

Unknown to me, the machine that

# VCR Clinic

caused me problems had had the wrong cam fitted. The deck wouldn't initialise. When a cassette was inserted, the tape threaded up and unthreaded twice, then the machine powered down. A check on the error memory in the service mode showed that the microcontroller chip sensed a threading error, though visually the deck appeared to be operating correctly.

The microcontroller chip senses the threading position by counting the pulses from the 'windmill' optosensor on the threading worm in relation to the moment when the INIT switch closes. Because the wrong cam had been fitted, the INIT switch closed later than it should have done. The microcontroller chip sensed this.

A cam from the N kit instead of the A kit had been fitted. If you find that the marks on the main cam are different, or the threading worm is a different shape from the one originally fitted, check that you've got the correct part no. **P.B.**

### **JVC HRJ215**

This machine had no functions and an erratic display. On checking we found that the 5V supply was low at 2.5V. The cause was a faulty circuit protector (CP1). **G.S.**

### **Toshiba V204**

This machine was dead. The primary side of the power supply was pulsing but wouldn't run. The cause of the fault was the U4614B chopper control chip IP001. **G.S.**

### **Mitsubishi HSB330**

A rolling E-E picture from cold was the complaint with this machine. The cause was C111, which had fallen in value. **G.S.**

### **Toshiba V212**

This machine would try to accept a

tape then eject it after a few seconds. The usual cause of this is the loading motor. On this occasion however the cause was tinfoil that had been jammed in the loading area.

There was also a squeal on rewind. We found that the take-up reel was dry – a little oil silenced the squeal.

Next, the playback picture pulled from side to side, as though there was a drum fault. The cause was dust on the plastic cap beneath the drum – it provides information on the drum speed and position, via an optical pickup.

Finally the audio head and pinch roller had to be replaced. **G.S.**

### **Sharp VCM20**

If there is intermittent loss of response to jog shuttle, or functions are erratic, check for dry-joints at plug and socket AO and OA. **G.S.**

### **Saisho VR1600**

These machines are now quite old, but still produce good results. This one had the common fault of going into play, the picture freezing, then shutting down. The cause of the problem is usually the limiter post near the take-up reel. When you remove it you'll find that the pin is missing. A replacement will restore full working order. **T.L.**

### **Matsui VPA9601**

A common problem has appeared with this relatively new model: when the machine goes into the review mode the tape is not taken in and loops. The cause is wear on the plastic slide plate underneath. For a complete repair replace this plate and the idler. **T.L.**

### **JVC HRD560**

Snowy bars at the top of the picture was the complaint with this

machine. If you get this problem, the thing to check is the loading arms. They usually become loose, or become disengaged altogether. You can tighten them, but for a good repair it's best to replace them. **T.L.**

### **Akai VSG815**

This model differs from most VCRs in that the front display is in the cassette flap and there's a quite complicated loading mechanism. This seems to be causing problems. Levers at the top of the cassette housing run along the cassette as it's being ejected. Normally there is no problem, but if the cassette has a loose plastic window the lever's downward pressure can push the window out. The lever then gets caught in the cassette, the result being shut down.

It's quite easy to remove the lever and faulty cassette. The real problem comes when the customer tries to remove the cassette himself. If he pulls too hard, there's a danger of damage to the gears and mechanism misalignment, which is not so easy. I feel that Akai should be looking into this. **T.L.**

### **Ferguson FV81**

Our customer complained that the clock reset itself to 3:00 a.m. every night. These machines use a signal to set the clock each night, but there's a set-up sequence when the machine is first powered. This was odd, as the customer had owned the VCR for two years. What had happened was that he'd switched the machine off when he went away on holiday.

The correct sequence from first power up is:

- (1) Do not set the clock.
- (2) Tune in to BBC-1 and leave the machine on this channel.
- (3) Switch to standby.
- (4) At 3:00 a.m. the clock will set itself. It will remain OK while still powered. **T.L.**

### **Matsui VX990/Saisho VR2500**

It's common to find that there is no output from the 12V regulator circuit. Not so common to find that the transistor is OK but the zener diode is short-circuit, as was the case with this machine. **R.B.**

### **Ferguson FV26D**

There was no display, though commands were accepted and the relevant LEDs lit up. The cause of this was traced to IC1 (type UPD75212ACW-015) on the

memory PCB. The owner had had a go - there were odd screws everywhere. **R.B.**

### **Ferguson 3V45**

Odd symptoms occur when the 5-1V zener diode D408 is leaky. In this machine the drum immediately took off backwards at high speed, and there was just a quick burst from the capstan motor. A replacement put that right.

But the remains of the back-tension band were jammed in the carriage. This prevented the arm coming into contact with the tape. I know that the machine had been used like this. What had the owner been watching?! **R.B.**

### **Hitachi VT120**

This machine showed the cassette-in symbol at all times and the carriage wouldn't stay up. All functions were normal, including eject. But you had to be quick about getting the cassette out before the carriage took it back in again. For once the sensors were OK. I followed the wiring from the plug (socket on the main board) and found a dry-joint at R906. Resoldering this cured the problem. **R.B.**

### **Panasonic NVG12**

This machine would sometimes unlace immediately because the drum failed to rotate. The reason for this was a dry-joint at the motor drive plug/socket. **R.B.**

### **Ferguson FV70B**

The customer complained that there was a flickering picture and intermittent loss of sound. I found that the tape path was slightly out of alignment. Resetting this cured the fault. **M.M.**

### **Ferguson 3V32/JVC HR7655**

I had serviced this machine about three months previously, and had been called back because of what looked like dirty heads. Cleaning them seemed to cure the problem. I was then called back again. The heads appeared to be dirty once more, but if the machine was left to cool down the picture would be restored. The fault could be induced by going into the search mode.

I took the machine back to the workshop and left it running until the fault appeared. I then scoped the drum flip-flop waveform which, instead of being a square wave, was a series of pulses. As the amplified drum pick-up pulses were OK, I froze the BA853 chip IC7 and found

that the fault cleared. So a new BA853 chip was obtained from JVC and fitted.

Imagine my horror when the machine produced exactly the same symptoms (the chip costs over £40 trade). I subsequently tweaked R57, which sets the drum pick-up pulse level at IC7. Fortunately this cured the problem. A long soak test proved that everything was OK.

It's possible that the drum pick-up pulse head may be starting to fail. Only time will tell. **M.M.**

### **Ferguson 3V32/JVC HR7655**

After carrying out a service I found that the display wasn't working. Checks showed that its -28V supply was missing. This is derived from the timer/tuner board, where zener diode D233 was found to be short-circuit. A replacement brought the display to life. **M.M.**

### **JVC HRJ205**

A loop of tape was left when you tried to eject a cassette. The cause of this can be a faulty mode switch or capstan motor. As the mode switch is cheap and readily available I decided to change it first. Fortunately this cured the fault. **M.M.**

### **Ferguson FV71LV**

We were told that this machine was found to be dead after a thunderstorm. When I tested it the power supply was tripping. The cause of this was RP18 (1.5Ω), which had risen in value to approximately 8.8Ω. A replacement stopped the tripping and brought the machine back to life. **M.M.**

### **JVC HRD610**

When a tape was inserted this machine would start to lace up then stop and switch off. I tried this several times: each time the point at which the machine stopped varied. When I removed the mode switch I found that it was starting to break up. A replacement put matters right. **M.M.**

### **Sanyo VHR7700E**

If the machine goes off within a split second of being switched on and there are no functions, check transistor Q5402 on the main PCB (CP1). You'll probably find that its base-emitter junction is leaky. From the dissipation point of view the device seems to be hard pressed. I've found that the higher-rated 2SD1207 is a more reliable replacement. **E.T.**

### **Sony SLVE200/250**

We've had intermittent tape looping at eject with a couple of these machines. The cause is excessive capstan brake friction, something that also affects certain Sanyo models. With the Sony machines this is best dealt with by replacing the brake-lever assembly complete and cleaning the periphery of the capstan flywheel. **E.T.**

### **Orion D1094**

This note applies to the above VCR, to the **Tatung** Models DVR634VN, DVR832V, TVR734VN, TVR932V, and probably others – the problem is with the Orion deck. Symptoms are intermittently stopping short of full cassette eject or when the cassette is half way in, and intermittent deck functions like load and play. The cause is a dirty or tarnished mode switch. You can clean it, but replacement is better. **E.T.**

### **Panasonic NVL20/25**

An intermittent fault that's difficult to diagnose is spasmodic deck shut down because the capstan motor stops during play or record. The cause is usually dry-joints where P2001 is soldered to the main PCB – they are not obvious to the naked eye, but a times eight magnifier shows them well enough. It's a good idea to replace C1122 (330µF, 10V) in the power supply while you are about it – use a 105°C type. **E.T.**

### **Tatung TVR6122**

The reported fault was tuning drift. In addition we found that when a new channel was selected it took several seconds to arrive. The stabilised tuning voltage supply was low because the 2SA1038 transistor Q1001 in the 50V supply line was faulty. It's mounted at the top edge of the PSU-stabiliser board. **E.T.**

### **Samsung S1124**

The symptoms were no RF output from the modulator and no video from the scart socket, though RF-through was OK, the deck worked and its functions were displayed on the fluorescent panel. We found that the 1N4001 diode D110 in the 5V supply on the main PCB was open-circuit. The nearby diode D109 can also fail, producing various puzzling function and servo faults. **E.T.**

### **Thorn VR182LV**

This machine was dead, with no outputs from the power supply. Full

HT was present across C5003 on the primary side of the circuit. Resistance checks showed that regulator IC5003 on the secondary side was short-circuit, though a replacement failed to cure the fault. D5004 (1SS244) on the primary side was then found to be leaky. A new diode restored the machine to working order. **D.C.**

### **Matsui VX6600**

If the E-E sound is OK but the picture goes to blue mute when the channel is changed, the problem being worse from cold, replace C17 (0.1µF, 50V) on the IF PCB. **M.Dr.**

### **Panasonic NVJ30**

Playing slow was the complaint with this machine. On inspection we found that the real-time tape counter was counting up on its own, even with no tape in the machine! It must have been counting pulses from the power supply. Replacing C22 (330µF, 10V) in the power supply cured both symptoms. It had dried out. **M.Dr.**

### **GoldStar GSE2000IQ**

This machine wouldn't accept a tape. If a tape was held in the cassette housing, the loading motor would shuffle backwards and forwards. The culprit turned out to be R537 (100kΩ), which was open-circuit. We discovered this thanks to the low input impedance (20kΩ) of our analogue meter – while taking voltage measurements the tape loaded. **M.Dr.**

### **Alba VCR6200 etc**

We've seen a number of these machines under different names, for example the **Akura VX150**, all with the same fault – the BA6209N loading motor chip burnt out. Sometimes the PCB is badly scorched. The cause of the fault is the loading motor going short-circuit intermittently. Sometimes the bearing seizes up.

Replace the motor with a different type, part no. MOTOR4305, from SEME. But note that you have to reverse the leads, as it's wired in the opposite polarity. Replace the BA6209N chip with the uprated BA6209, which has a small heatsink tab. **M.Dr.**

### **Sanyo VHR390E**

The symptom with this mid-mount machine was cyclic noise bars, which is caused by a capstan phase problem. As a start we cleaned the audio/control head, but this made no difference. So we scoped the control amplifier output at pin 26 of

the BU2890DK chip IC351. No problem here. There is also a control pulse output to the microcontroller chip, at pin 15. This was also OK. When we scoped the pulse-width modulator output at pin 44 however we could, by changing the scope's timebase speed, resolve two waveforms. One looked like serial data. A replacement BU2890DK chip – it's a 44-pin flatpack type – cured the fault. **M.Dr.**

### **Fisher FVHP725**

This VCR produced an over-modulated picture, with inversion on the whites. Playback of a prerecorded tape was OK, so this ruled out the modulator. The video coupling capacitor C050 (1,000µF, 6.3V) turned out to be dead short. This item is on the video in/out jack socket PCB at the rear of the machine. I seem to recall having had a similar problem with an Amstrad machine. **M.Dr.**

### **Akai VSF600**

This Nicam machine was brought in because playback of prerecorded tapes was bad. Its own recordings were satisfactory. I decided to realign the mechanism and, going to the ACE head to adjust its X setting, I found that it was loose. Playback of all tapes was perfect once it had been reset.

When I queried this the customer said that someone else had replaced the ACE head some months previously. Whoever had done this must have forgotten to tighten up the screws, and really should have applied some Locktite paint. Still, we all make mistakes occasionally. **T.L.**

### **Matsui VXA1100**

This VCR chewed tapes, usually when they were being rewound. Once we'd opened it and inserted a test tape we soon saw what was wrong. When the machine was stopped in the rewind mode the brakes failed to come on. The best thing to do when you get troubles with these machines is to replace the mode switch. I did this and lo and behold the VCR had been cured. **T.L.**

### **Matsui VP9401**

Odd mechanical functions is something we've had with several of these machines. The thing to do is to carry out a visual check on the little brake lever coupling that sits under the cassette housing. When its securing clip wears or breaks, it becomes loose. The result is half actions etc. Replace it if it has come adrift. **T.L.**





Reports from  
**Simon Bodgett**  
and  
**David C. Woodnott**

# Camcorner

ing, the one used by the VITC unit. There was an open-circuit earth connection at pin 5 of connector CN803 on the camera operations panel. I doubt whether anyone will get this fault again! **S.B.**

## JVC GRC7

This old-timer suffered from EVF picture flicker in the E-E mode. The obvious diagnosis would have been lack of EVF field lock, but the output signal was also affected. Close examination of the video waveform showed that the field period was not 20msec. The master oscillator crystal X101 was the culprit. **S.B.**

## Canon A9E

No autofocus was the complaint. Internal inspection showed that the unit had been dropped. As a result, the infra-red autofocus lens assembly had become detached from the main lens unit.

A single screw secures the AF assembly to the underside of the main lens unit, and part of the moulding had broken away. As a complete new lens unit is an expensive item, we decided to try to rescue the original units. This proved to be possible. With this type of problem, the broken moulding can often be redrilled – there's a section of undrilled plastic at the mounting point.

Use a small drill (a pin vice is helpful) to cut into the previously undrilled section. A slightly longer screw than originally used is required to refit the AF lens unit.

We've carried out the repair with several Canon models that use this type of IR AF assembly. So far, none have failed. A warning to the customer that further impact damage will result in an expensive bill probably encourages greater care than is customary!

Note that this type of unit is used in other makes and models. **D.C.W.**

## Sharp VLC73H

It's unusual with this model to find faults other than the common corroded PSU print problem. But this one was different! The playback picture was marred by an overall

effect that was similar to the black inversion symptom produced by a worn or incorrectly set up video head. The camcorder's recordings were OK when played back via another machine. It seemed unlikely that the heads were the cause of the fault, but they couldn't be ruled out completely.

After much checking I discovered that an 0.01 $\mu$ F chip capacitor, C427, was open-circuit. It connects pin 5 of the skew jump PCB connector AG to pin 7 of IC402 (3fC signal). A replacement cured this rather misleading fault. **D.C.W.**

## Minolta 406E

Rewind would fail after running for a few seconds. All other functions worked, and rewind search was OK. The cause of the fault was leakage from the 220 $\mu$ F capacitor on the main PCB. A replacement capacitor and PCB clean up restored the unit to normal operation.

The machine is an **Hitachi** clone. **D.C.W.**

## Sony CCDF375E

The playback fault symptom gave the impression of a defective video head. But the drum was OK. So was the head amplifier assembly, which commonly fails in this and similar models.

After much checking I discovered that the supply to pin 27 of the ATF process chip IC506 was missing (the supply to pin 28 was OK). The cause was C562 and C563 (both 10 $\mu$ F, 16V), neither of which are surface-mounted types. They had leaked and corroded the PCB, effectively disconnecting the supply to pin 27. After cleaning and repairing the PCB, replacement capacitors restored normal operation. **D.C.W.**

## Sony CCDFX500E

If the symptom is no playback after one of this series of models has been dropped, check whether the head amplifier connector on the main PCB has become detached from the print. We've had this fault three times recently. **D.C.W.**

## JVC GRS707

If the symptoms are no functions or some missing, with no E-E camera pictures, the power regulator transistor Q203 is defective. Great care is required when replacing it and reassembling the camera. The usual cause of the trouble is a defective AV lead. **S.B.**

## JVC GRS77

No playback colour, E-E OK was the complaint with this unit. It's a common fault that calls for replacement of the H8B7101 colour processing chip IC8. This is not easy to accomplish, as the main PCB may be covered by two or more flexiprints that have to be removed. After replacing IC8, a 47k $\Omega$  preset must be fitted in position R423 and the 320FH VCO set up. **S.B.**

## JVC GRS707

This was a particularly difficult problem that involved a Philips-made VITC unit which was connected between the camcorder and the viewfinder. The camcorder itself operated normally. So did the VITC unit when it was checked with another GRS707! But when the two were connected and the stop-start button was pressed the pictures went off. This impeded recordings!

I won't go into the amount of time it took to get a circuit diagram for the VITC unit, or the time spent cross-checking. What it came down to was earth paths. One was miss-

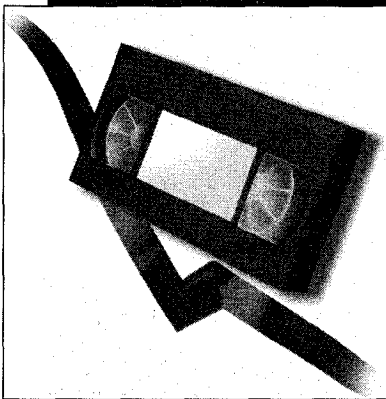

Reports from  
**Philip Blundell, AMIEEIE**  
**Terry Lamoon**  
**Roger Burchett**  
**Richard Newman**  
**Bob Longhurst and**  
**Martin Cleaver**

### **Grundig VS920**

If the power supply is dead, check C1626 (47 $\mu$ F, 25V) by substitution.

If the sound is wowy, with the capstan tending to run slow, try replacing the capstan brake lever before spending time testing the servo circuit. **P.B.**

### **Toshiba V404**

If the machine is dead, with the power supply outputs low and pulsing, replace CP008 (100 $\mu$ F, 25V) and CP007 (10 $\mu$ F, 50V). **P.B.**

### **Matsui TVR151**

This is a combined TV/VCR unit, and for a change an easy one to get at and work on. The fault was no tape playing. When the video section was removed it was found to be a standard Matsui unit. After replacing the troublesome mode switch and realigning the mechanism, which is very simple, it worked perfectly. **T.L.**

### **JVC HRD860**

This VCR's alignment was all out. According to the customer it had happened after he'd rewound a tape. Once the mechanism had been realigned it worked perfectly, but I replaced the reel and tape sensors to be on the safe side – they often cause problems. I've not seen the machine since, so presumably it has been cured. **T.L.**

### **Matsui VPA9401 etc**

If you get problems on the primary

# VCR Clinic

side of the power supply with this and similar models, it's advisable to replace every semiconductor device and check all the passive components. This should guarantee a long-lasting repair. **T.L.**

### **Panasonic NVF65B**

If the problem with one of these VCRs is low E-E output, don't assume that the cause is the RF converter. It's more likely to be the M51292FP switching chip IC1300. Replacement should cure the problem. **T.L.**

### **Matsui VP Range**

If there's no E-E audio, check C5015 for dry-joints. This is becoming quite a common problem. **T.L.**

### **Ferguson 3V29/JVC HR7200**

After replacing the cassette bulb, which was open-circuit, there was still no illumination. Checks around the circuit produced 12.5V readings everywhere, including the earthy end of the cassette switch. Odd, to say the least. The penny dropped after much checking around the mechacon board: sockets 11-13 (supplies from the regulator board) and 71-73 (main solenoid) had been transposed.

Fitting them correctly produced a lit bulb, but there was no capstan drive. The driver transistor, on the separate motor drive board, was dry-jointed.

Finally circuit protector CP2 was open-circuit, hence no reel drive. Any idea which fault occurred first?! **R.B.**

### **Philips VR6860**

A number of ex-rental VR6860s came my way recently. The BD678 Darlington transistor was faulty in most of the repairable ones. This removes the 12b supply (switched 12V supply to the modulator).

Hence no E-E or playback signals – no test signal either.

This one appeared to be another such case, but a quick check on all the symptoms revealed that there was no display either. The PCF 8571P memory chip 7501 was shorting the data and clock lines to chassis. **R.B.**

### **Ferguson FV31R**

There were no E-E or V-V signals. I found that LW03 (22 $\mu$ H) was open-circuit, removing the 12V standby supply (U4) to the power splitter. Unfortunately the owner had 'looked at it' and had neglected to refit the insulating washer under the right-hand PCB's mounting screw. The TA8607P FM amplifier chip IQ40 had objected and died. **R.B.**

### **Sharp VC750**

The complaint with this machine was that it "would sometimes go straight to still in playback or record, then quickly shut down". On inspection I noticed that the idler didn't always reach the take-up reel. A more detailed look at the operation revealed that a lever which is directly driven by a cam didn't go over far enough. The cause was broken plastic in the grease on the cam. The debris hadn't come from the machine. **R.B.**

### **Hinari VXL6**

This machine started to dislike the 47 $\mu$ F, 16V capacitors that are sprinkled throughout its circuitry. The cause of no erase was C160 short-circuit, with R164 (22 $\Omega$  fusible) open-circuit. There was no record because C212 in the head preamplifier can was short-circuit (record 12V line). Just for variety C145 (100 $\mu$ F, 10V) went short-circuit, with the result that the 6V supply to IC104 (drum feedback amplifier) was very low. The symp-

tom this time was that the machine unthreaded immediately after threading. **R.B.**

### Philips Turbo Deck

There have been reports that in VCRs which use this deck the new-style head doesn't fit the lower drum spindle. In severe cases, dealers have been replacing the lower drum as well. Here's a tip that may save some money.

When the old head has been removed, try using some rubbing compound on the lower drum spindle. Duraglit or some other metal polish may even work. It's possible that the cause of the problem is slight corrosion because of migration from the old head. If you are careful, the new head should now slide on to the shaft easily, using the special tool. **R.N.**

### Ferguson 3V32/JVC HR7655

This old-timer had been running for years with no problems. Then the ravages of time took their toll. First the record function failed, then the machine refused to play a tape. The second fault was easily cured: a new loading belt was required. I fitted a new economy repair kit, which included the turntable rubbers. The machine then worked extremely well mechanically, and the playback picture was of excellent quality. But there was no E-E signal.

Scope checks showed that video was present at the output from the IF board, and that it arrived at the video processing board. The signal entered pin 7 of the BA7001 chip IC201, but it didn't emerge at pin 4. Voltage checks didn't tell me much, and the control switching was OK. A new chip restored normal results. **R.N.**

### Philips VR838

This VCR wouldn't accept a tape. When a cassette was inserted there was no resistance and the housing flopped about. The coupling gears driven by the main cam and the worm had sprung apart, because the claws of the red plastic lever were weak and wouldn't hold the gears together.

A new L kit was fitted. This cured the main fault, but a new housing was also required – the original one was bent. **R.N.**

### Matsui VX730/Saisho VR3200

The complaint with this machine was intermittent E-E signals. Some careful tapping around the main PCB brought me to the area of the

phono input/output sockets. As there were no obvious dry-joints here, waveform checks were necessary. It soon became apparent that the cause of the trouble was the video input socket. Rather than cleaning it and risking a comeback I fitted a new socket. **B.L.**

### Mitsubishi HSB82

E-E and playback suffered from pulling and low contrast. The scart output was also faulty. A scope check on the power supply outputs proved that the cause of the pulling wasn't ripple. Without a circuit diagram, the next step was careful heating of components in the video areas. This produced some improvement. The cause of the trouble was eventually traced to C232 (10 $\mu$ F, 15V), which is just behind the video 1 socket. It's a small, metal-cased, surface-mounted electrolytic capacitor. **B.L.**

### Saisho VR1600/Matsui VX880

After a straightforward service I found that there was no playback colour. E-E was OK. Mindful of Panasonic power supply faults, I started off in this area. Bingo! C08 (100 $\mu$ F) looked stressed. When it was replaced the playback picture had good colour. **B.L.**

### Ferguson 3V35/JVC HRD120

The channel selector LEDs lit up but not the red power LED. Checks in the power supply showed that the switched 9V output was low. The always 9V output was OK. Although the relay produced a healthy click when power-on was operated, the contacts for this line were not very healthy. Carefully cleaning them with fine emery paper and slight bending cured the problem. **B.L.**

### Panasonic NVHD610

This VCR came in with a dead power supply. The field engineer had replaced the 1A fuse F1, which had soft-blown. After doing this the power supply was still dead but various resistors were glowing hot!

On inspection I found that C1117 (0.1 $\mu$ F, 50V) in the slow-start circuit had blasted in two, Q1101 (STP3N60FI-M) and IC1101 (TDA4605-3) were short-circuit while R1114 (0.75 $\Omega$ ) and R1119 (220 $\Omega$ ) were open-circuit. R1114 is the primary current sensing resistor – R1119 is connected from pin 1 of IC1101 to chassis. Having had this fault before with

## Philips VR231 and clones

There has been comment in the magazine about poor picture quality with these machines. While the cause can be worn video heads, there are other possibilities. Here are a few things to check first:

- (1) That the tape guides, all heads and the lower drum knife edge are clean.
- (2) That the back tension is correct.
- (3) That nothing in the tape path causes tape creasing. Check especially the fixed guide between the ACE head and the pinch roller.
- (4) That the tape moves across the CTL head correctly and is not riding up or down. Test by selecting reverse search then play. If in doubt, scope the CTL pulses.

If the power supply is the type that uses an SPH4690 IC, add a 33 $\mu$ H coil (part no. 4822 157 53006) in series with inductor 5204. This should reduce the dots in the dark areas of the picture, and help the auto-tracking system to find the off-tape FM amongst the power supply hash. Watch out for poor electrolytic capacitors as these machines age.

Put the machine in the service mode (method varies with the make and model) and check the X position of the ACE head as laid down in the manual.

If the drum has already been replaced, use the Mylar shims supplied with the new head as a feeler gauge to check that the upper drum to lower drum gap is correct.

When replacing the drum, beware if the old one is tight on the shaft. If the securing screw has been overtightened, the motor shaft can be scored with the result that the new head jams as it is fitted. Make sure that the shaft is clean and undamaged. If there is slight damage, careful application of fine abrasive paper may remove the scoring. Otherwise a new lower drum/motor will be needed. Later video heads have a triangular circlip at the top and bottom of the drum instead of the single-screw fixing. A special tool (part no. 4822 395 90977) is required to release this type of drum.

If the tracking is OK at the top and bottom of the picture but the FM dips at the centre of the screen, the lower drum is probably worn.

As long as the machine is picking up the CTL pulses all right, the auto-tracking should search three times then go into play in the best position it has found. If the off-tape FM is low or the CTL pulses are intermittent, the tracking comes to the wrong conclusion. If it goes past the best position, pressing play when the best place is found during auto-tracking will result in play continuing at that tracking value.

Remember that these VCRs use narrow video heads that are optimised for LP use, not SP. **P.B.**

these modern machines we had the parts in stock. Service departments wishing to be prepared may wish to order the following: C1117 part no. ECQV1H104JM; R1114 part no. ERX12SJR75; R1119 part no. ERDS2FJ221; IC1101 type TDA4605-3; Q1101 now type STP3N60. **M.C.**

# Servicing

## the Mitsubishi HSMX1

John Coombes presents a servicing guide that deals with the mechanical and electronic sections of this VCR

**M**ost of the mechanical faults you get with this VCR can be cured with the aid of the Mitsubishi service kit part no. 789C014010. Unfortunately it doesn't include a capstan pulley. When faulty this item can be responsible for no eject, the tape being jammed in the machine or even no rewind/fast forward. When they first occur these faults may be intermittent – until the pulley breaks completely. Other symptoms are tape chewing and half loading.

### The Service Kit

The item you are most likely to need in the service kit is the pinch roller. It can break, with the result that the tape is jammed in the machine or won't go in. If the roller's surface becomes highly polished, you may get tape creasing at the top and/or bottom.

To replace the pinch roller you have to remove the cam pinching, on which the pinch roller travels. Clean this, removing all the thick, black grease.

Clean the spindles and loading motor, and regrease with PG641 (part no. 859D55030). This will prevent intermittent play – cutting out for no apparent reason.

If the machine won't load and go into play the cause may be the grease on the pinch or a faulty loading motor. The latter can be checked by slightly rotating with a finger. If the motor is free with no resistance, it's OK. If there's slight resistance, replace the motor.

The next item in the kit to replace is the tape tension regulator arm. It can be responsible for the tape stopping just after the start of playback. Alternatively tape movement may continue but because of the loss of the pad there's no playback. Check this by reseating the pad. This should restore normal playback.

The capstan brake can wear. The result will be poor still pictures, or there may be a squeak at the start of recording. These faults can also be caused by a defective reel belt, which can also be the cause of a jammed tape.

The tape tension brake band can cause bent verticals, hooking at the top of the picture or up and down movement of the playback picture.

If the supply/take-up brakes wear they won't work in the rewind and/or fast forward modes.

The final item in the kit is a lever brake. Replace it to

prevent picture noise at the start in the slow rewind mode. This item is not present in all models.

### Mechanical Faults

**Noisy rewind/fast forward:** Check that the take-up and supply turntable reel spindles are lubricated and free running. If necessary check the gear reel units. Remove, clean and relubricate them. This usually cures the problem.

**Poor playback/lines on the picture:** Misaligned guide poles can cause this. Reset and seal the screw with Loctite paint. Also ensure that the guide pole arms aren't bent. If so, replace the complete guide pole.

**Noisy playback/stills:** On rare occasions the cause can be a faulty drum motor bearing. In this case replace the complete drum assembly. Alternatively the cause may be the earthing brush on the drum spindle. To prevent any further noise, ensure that it's greased.

**Intermittent clicking noise during playback:** This can be a very intermittent fault. Its cause is the spring in the gear idler unit. Check by replacement. Clean all the mechanical components here and lubricate the spindles.

**Poor sound/muffled sound:** Ensure that the audio/control head is clean and not clogged with oxide. If the AC head is OK in this respect, check whether the pinch roller is worn – if it is, the tape will slide and slip. The audio/control head could be faulty.

**No erase:** We've always found that the head is dirty. When worn it may keep on getting dirty. Only replacement will cure this.

**Mechanism jams:** We've had this fault on rare occasions because the gear arm TU-G2 has cracked or lost its teeth.

**Mode switch faults:** The mode switch S570 can be responsible for many problems – no play, no eject or no fast forward and rewind. The condition may be very intermittent. Be sure that the VCR is in the eject mode when you replace the mode switch.

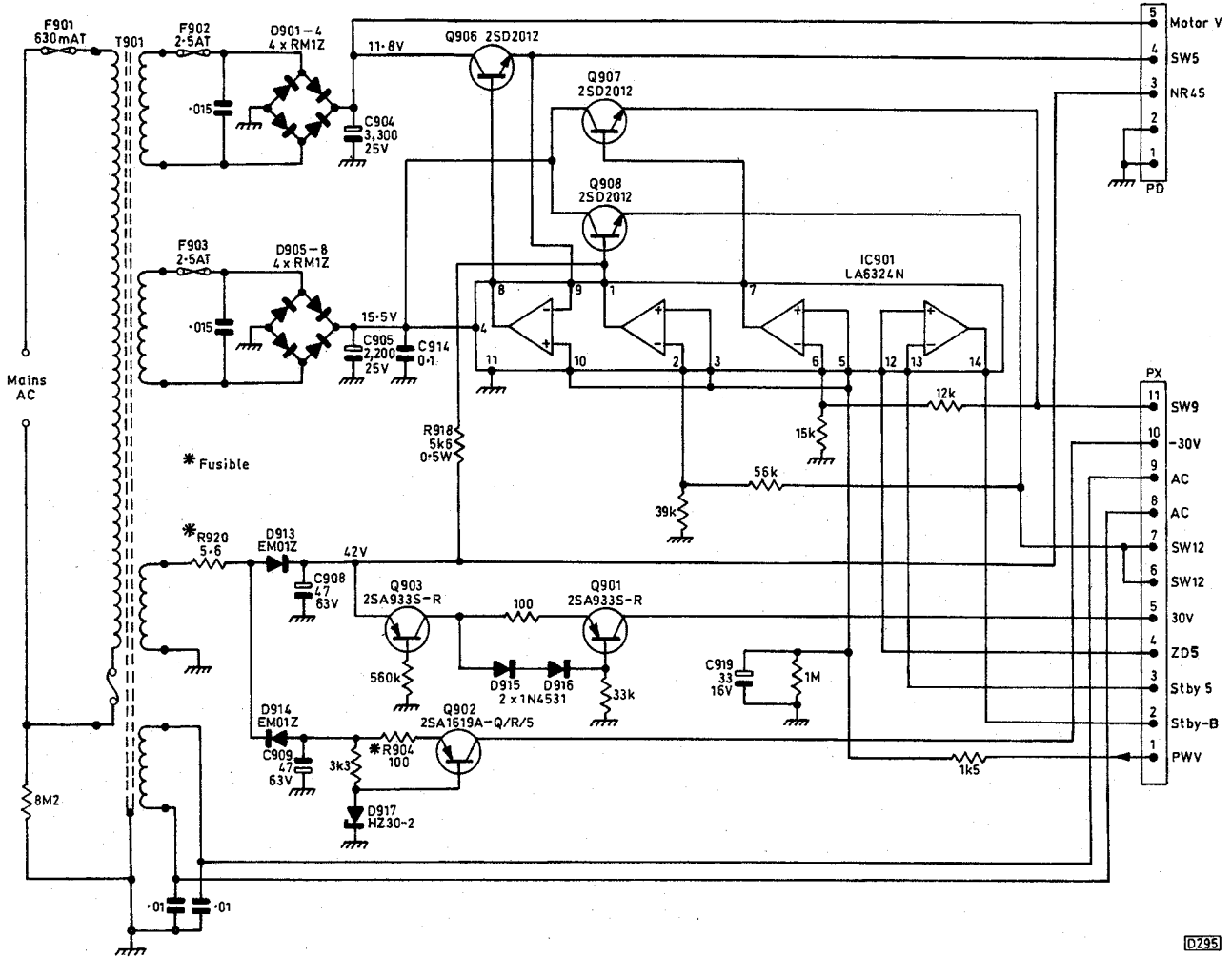

Fig. 1: The power supply circuit used in the Mitsubishi Model HSMX1B VCR.

**Intermittent pause in playback:** This can be a very intermittent fault. We've found that the capstan motor is usually the cause.

**Cassette housing faults:** If the front loading door arm A or B jams and breaks, the front door won't open and the tape will be trapped inside the VCR.

The cause of the cassette tape not seating correctly on the take-up/supply spools can be a bent or damaged bottom cassette plate.

If the cassette housing doesn't load or unload the tape, check the front loading gear for wear, and the gear and/or drive gear for cog damage or being split.

If the tape is jammed in the cassette housing or fails to

load, check the front loading arms for a break or displacement.

**Picture jitter:** A worn lower drum or a faulty audio/control head can cause this. Another thing to check is for a faulty tape tension band brake or maybe a bent tension arm.

**Tape looping out because a reel disc doesn't rotate:** We've had this fault with many different Mitsubishi VCRs. It's caused by the pulley gear being incorrectly seated, because the split washer has been pushed down past the slot on the shaft that holds the reel gear unit. If you wish to prove the point, swap with the washer on top of the belt pulley.

**Video head faults:** The most common problem is a snowy picture because the heads are dirty (clean them) or faulty. One head may be clogged, with the result that there is a picture on part of the screen, the rest being snowy. Check also for poor connections at plug/socket GB. If the lower drum is badly worn, the video heads can clog prematurely.

If the heads are OK, check back through the video head amplifier. The first step is to ensure that the XRA7254S

### Transistor voltages

Transistor	C	B	E
Q901	32	41	41.6
Q902	-30	-30.7	-40.6
Q903	42	41.6	42
Q906	11.8	5.8	5.1
Q907	15.5	9.9	9.3
Q908	15.5	13.2	12.6

### IC901 Voltages

Pin	V
1	13.2
2	5.1
3	5.1
4	15.4
5	5.1
6	5.1
7	9.9
8	5.8
9	5.1
10	5.1
11	0
12	5.1
13	5.1
14	5.8

chip IC201 is receiving its 5V supply – if not, check back to source. IC201 could be faulty: check the DC conditions before trying a replacement.

This of course brings us to the electronic side of the machine.

### Electronic Faults

**No results:** The first thing to check is the 630mA mains input fuse F901, see Fig. 1. If this has blown, the power transformer T901 could have shorted turns.

The next thing to check is whether either of the 2.5AT fuses F902 or F903 is open-circuit.

If F902 has blown, check the four RM1Z bridge rectifier diodes D901-904, transistor Q906 (2SD2012) and C904 (3,300 $\mu$ F) for shorts.

If F903 has blown, check the RM1Z bridge rectifier diodes D905-908, transistor Q907 (2SD2012) and C905 (2,200 $\mu$ F) for shorts. Q907 could be dry-jointed. If necessary, go on to check Q908 (2SD2012) and C914 (0.1 $\mu$ F), then the LA6324N chip IC901 (check its DC conditions or by replacement).

**No display – power supply fault:** Check for –30V at pin 10 of plug/socket PX. If this voltage is missing, the first things to check are whether Q902 (2SA1619A) is open-circuit, D917 (HZ30-2) is short-circuit or R904 (100 $\Omega$  safety) open-circuit. It's possible that Q902 or D917 is leaky. D914 (EM01Z) could be open-circuit or C909 (47 $\mu$ F) short-circuit.

**Tuner/IF faults:** A broken RF input or output socket is a common problem with all VCRs. The sockets can be physically damaged as a result of plug removal and replacement, or may become dry-jointed. The symptom may be a snowy picture, a flickering picture or just a complete snow storm. Don't try to repair a damaged socket, fit a replacement. See also converter/booster faults below.

If the sockets are OK and the picture is snowy the tuner (TU01) could be faulty. Check its LT and tuning supplies. If there is no tuning voltage, R08 and/or R09 (both 10k $\Omega$ ) could be open-circuit.

Check for poor or dry-jointed connections within and external to the tuner. Take great care not to use too much solder or too hot an iron inside the tuner – otherwise you may create shorts.

**Tuning drift:** Check IC8A2 (type  $\mu$ PC574J) which could be faulty.

**Colour/luminance faults:** Luminance faults are generally caused by a defective BA7255BS chip (IC2A0) and/or associated components. The low-pass filter LPF2A0 (part no. ELB-4M089N) could be open-circuit. Check for dry-joints in this area.

For loss of colour the LA7333 chip IC6A0 is suspect. First check that its DC supply is present. If not, check back to source. The 4.43MHz crystal X6A0 could be faulty or dry-jointed. Check for dry-joints around IC6A0 and the chroma delay line DL6A0 (type CF873). Also check all relevant connections and plugs/sockets.

**No or low playback sound:** Check the audio/control head which could be worn or dirty. Clean the head then try a test recording/playback. If the sound is still low or muffled, replace the head. Use an alignment tape to set up the new head, and seal the screws with Loctite paint to prevent movement.

If the head is OK, the LA7295 audio processor chip IC310 is suspect. Make sure that its 12V supply is present at pin 8, then check the DC conditions around the chip. If

incorrect voltages are present, replace it.

**No E-E sound:** Check whether the audio signal is present at the RF converter and the NJM2233BL chip IC311. If IC311's 5V supply is missing (pin 2), check back to source. IC311 or IC310 (LA7295) could be faulty – check by replacement.

It may be necessary to check the M51496P IF chip IC101 and its associated components. If all is OK here, check the signal path through the NT/VPS/SIF PCB. The 6MHz crystal filters CF51 and/or CF53 could be faulty, or Q51 (2SC2058S) open-circuit.

**Timer faults:** The cause of no timer display is usually in the power supply, but D8Z1 (RD4-7EB) could be leaky or the display's filament open-circuit.

If this is all OK the 64-pin microcontroller chip IC8A0 (type  $\mu$ PD75216AGF663-3BE) is suspect. Before trying a replacement, ensure that the 4.19MHz crystal X8A0 is operating correctly and that IC8A0's supply is present. If this is missing, check Z8A0 (GPIU72RM).

IC8A0 can be responsible for no display, intermittent display operation, some segments not being alight or the display being very dim. The display may be flickering or giving wrong information.

**Loading faults:** The TA7291S loading motor drive chip IC4A2 can be the cause of no loading or incorrect operation.

**Servo faults:** If the drum or capstan speed is incorrect the usual cause is the associated drive or control chip. The capstan and drum servos are within the BU2820S chip IC4A0. Check the DC conditions around this chip. If necessary check it by replacement. When the drum speed is excessive because IC4A0 is faulty it may be impossible to lock the picture on the TV screen. When the capstan speed is incorrect because IC4A0 is faulty there will be noise bars on the screen.

If the drum and capstan are operating greatly out of tolerance the VCR may just cut out and power down.

The drum motor is very reliable, the main problem being a worn lower drum.

A faulty capstan motor can cause noise bars and there may also be poor sound (wow). If the capstan spindle is seizing because of lack of lubrication there will be poor or no operation. The capstan drive chip could be faulty – it's part of the capstan motor assembly.

Low amplitude or no control pulses from the AC head will produce a jittery or rolling picture. The first thing to do is to clean the head. If the head is OK, check IC4A0.

**RF converter/booster faults:** Physical damage is the main problem with the booster-converter CU01. The usual problem is a snowy picture because the sockets are broken or dry-jointed to the PCB. If water reaches the booster via the downlead the result can be corrosion and a snowy picture. The only solution to this is to replace CU01. If there is also corrosion on the main PCB repair may not be worthwhile. See also tuner/IF faults.

**Remote control unit faults:** The most likely cause of failure is poor battery connections or low output from the batteries. LED1 could be dry-jointed. The leads to the CSB393PB crystal X1 could be dry-jointed or broken. If these items are all OK, suspect the M50560-248FP chip IC1 – check it by replacement.

If any one function fails to work, suspect a faulty button assembly. This is not listed as a spare in the service manual.

# Coincidences

The saying “lightning never strikes in the same place twice” is common enough, but in this trade I feel it should be “lightning never strikes in the same place once”. We’re all familiar with stock faults. But how often have you replaced a component in one type of set, say a field timebase chip or a mains switch, only to have the same fault in a different set at your next call or soon afterwards? Here are a few examples of what I mean.

## Tape Ejection

My first call one day was to a **Sanyo VHR244E**, the complaint being that it would not eject the tape. On inspection it was easy to see why. The eject button had come off its mounting and was not contacting the tactile switch on the main board. You used to get a similar problem with the Baird/DER clones of the Ferguson 3V30.

If you are dexterous enough with a hot iron you may be able to remount the button in the Sanyo machine, but a replacement front panel provides a more lasting repair.

## Different Symptom, Similar Cause

At the next call the cause of the trouble was similar but the symptom was different. The VCR was a **Goodmans GVR3400 (Bush VCR185)**. It would accept a tape but then immediately ejected it. After a detailed inspection I discovered that the eject button was resting on the switch on the panel behind it. I presume that as a result of constant use the plastic hinge had lost its springiness – I’ve seen this fault in quite a few of these machines (and their clones) that have had odd symptoms

(intermittently going off etc.) because either the eject or the power button is stuck.

## No Record

Then off to another town, to two different VCRs with very similar faults. The first was an **Orion D1094** whose mode switch had recently been replaced to prevent the usual jiggery-pokery you get with these machines. Since the replacement however the machine wouldn’t record – it would immediately go into the play mode, whether the tape inserted was with or without its safety tab. It transpired that when the mechanism had been removed to replace the mode switch the lever that operates the record safety switch had not been positioned correctly.

While on the subject of these machines, here’s another point to note. If, after replacing the mechanism, you have no sound, a playback picture that looks as if the heads need cleaning, or another obscure fault, check that the plugs and sockets which connect the mechanism to the main board are seated correctly. I’ve had faults caused by plug and socket problems with new machines.

The final coincidental call was to a **Philips VR2574**, the one with the JVC deck. It had recently been returned from the workshop and had identical symptoms to the Orion machine. When it had been in the workshop its reel sensor had been replaced. To do this, you have to remove a PCB on the underside of the mechanism. When he’d replaced it the engineer had not resoldered the record safety switch tags.

I could go on about such coincidences, and am sure that other readers will have had similar experiences. **Andrew Tebbutt**



**Reports from  
Simon Bodgett  
and  
David C. Woodnott**

### **JVC GR60/65/70/77**

A horizontal rolling green and magenta colour change is a not uncommon complaint with these camcorders. The cause of this peculiar effect is a faulty phase-lock loop in IC2 on the video PCB in the camera head. Crystal X101 is the usual culprit. The loop is locked by two lines, HD and CFMO, from IC303 (MC8181D, replaced by type EHD-GA1389A) on the encoder board. Once any faulty components have been replaced, the loop is set up by locking a vectorscope to an external reference then adjusting C3 until the displayed burst stops rotating. **S.B.**

### **JVC GRAX2 and GRAX5**

Intermittent take-up reel stopping, with E03 showing in the viewfinder, is a complaint we sometimes get with the GRAX2. The problem arises when the customer supports the camcorder by holding the cassette housing door as well as using the strap. The force projected inwards and upwards pushes the cassette housing up, jamming the take-up gears.

An upgrade that consists of a replacement cassette support guide and a spacer for the upper inside lip of the door is available. It can also be fitted to the GRAX5, though the problem is less often experienced with this model.

Two problems arise if one of these camcorders is tested with the viewfinder disconnected. First, the manual tracking doesn't function.

# Camcorner

Secondly and more importantly, the rewind end stop doesn't work. Thus if the camcorder is left in the rewind mode the ICP-N38 circuit protector CP1 will fail, sometimes exploding. **S.B.**

### **Ferguson FC07**

A vertical white line (striation) on the camera E-E picture is a common fault with this model. A scope check on the video output signal with the lens capped usually shows this quite clearly as a leading edge. The culprit is C19 on the IMG/SSG PCB.

Various other capacitors on this PCB can be faulty, causing similar symptoms. Beware when replacing these components – the print is an exceptionally good conductor of heat, making the job more difficult than with boards that use thinner copper. **D.C.W.**

### **Sanyo VMEX20P**

As this camcorder had been dropped, it was no great surprise to find that there was no camera E-E picture. Playback and all other functions were OK.

An internal inspection showed that the twelve-way connector between the CCD PCB and the camera process PCB had become detached from the latter. Only minimal print damage had been done, but unfortunately the connector couldn't be reused. It's not available from Sanyo as a spare part – you have to order the complete board. This makes it an expensive repair. Fortunately I was able to find a replacement connector in a Canon Model UC10 – the one that couples the A-V and main PCBs. **D.C.W.**

### **Sony CCDTR370E**

Poor focus at the wide-angle setting was the reported fault – closeups were OK. Use of the Sony Lanlink (PC-based) interface enabled us to read the autofocus data easily. It was seen to be correct. Set up of the flange back adjustment cured the problem. When the new data was checked after the set up, the original data was found to have been corrupted.

Note that these set ups can be done using the RM95 remote control unit, following the method outlined in the service manual. No reason for the corrupted data was found – and the camcorder is still working correctly. **D.C.W.**

### **Sanyo VAR66D**

This adaptor would power the camcorder via its DC socket but would not charge the battery. D0404 was found to be short-circuit and Q0303 open-circuit. Replacing these items cured the fault. **D.C.W.**

### **Canon UC8HiE**

Playback picture shaking was the reported fault symptom. It did this more effectively with its own recordings – playback with a known good recording was almost normal. The brand or length of the tape seemed to affect the amount of 'shake'.

This model uses the Sony A mechanism, which is normally very reliable. We found that the back-tension 'string' was the cause of the problem. This and the supply reel were changed, then the back tension was set up. We've since had this problem with two other models that use the same mechanism. **D.C.W.**

### **Hitachi VME10E**

This camcorder came in with an audio fault. In both the record and the playback mode the sound would crackle and change level intermittently. As luck would have it we had another of these camcorders in, and were thus able to make a quick audio PCB swap over to prove that the cause of the trouble was on this PCB. Unfortunately there are no circuit details in the Hitachi manual, just a replacement PCB part number.

The ICs on the board are standard Sony devices however, used in various models. Also present are various surface-mounted electrolytic capacitors of the type known to fail almost everywhere they are found! So we replaced these and cleaned the PCB. At power up all was well. The customer was happy, not having to buy a new PCB. **D.C.W.**



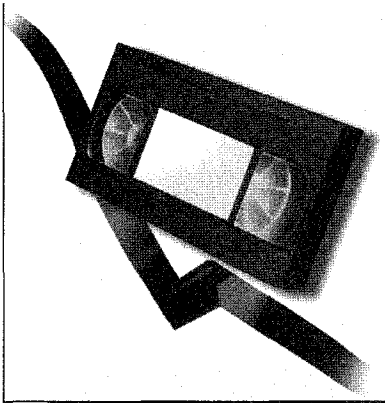

# VCR Clinic

Reports from  
**Philip Blundell AMIEEIE**  
**Simon Bodgett**  
**Christopher Nunn**  
**Steven Leatherbarrow**  
**Joe Cieszynski**  
**Shane Humphrey**  
**Graham Thompson**  
**Eugene Trundle**  
**Mervyn Deeley and**  
**Michael Dranfield**

## JVC HRS4700

Although this is a high-specification VCR, we've had a number of complaints about poor pictures with S-VHS recordings. A sample tape was brought along with one machine that came our way recently.

The fact is that off-air recordings look worse in S-VHS than they do in standard VHS. Because the S-VHS bandwidth is wider than that of the received signal, the difference is filled with HF noise. With standard VHS this noise does not arise. Thus S-VHS playback of an off-air recording looks worse, because of the extra noise.

The customer was given back his tape, with some high-grade camcorder recordings (of our dogs running around). These did justice to the machine's excellent S-VHS capabilities. **S.B.**

## Orion D3000SC

This VCR was at least alive, but there was no loading and no capstan or drum rotation. I found that the 13V zener diode D09 was short-circuit. It's next to the loading motor drive chip IC03. **C.N.**

## Mitsubishi HSM48V

There was no picture, just a blue screen. In addition the sound war-

bled and the counter didn't work. The reason for all this was lack of CTL pulses. I checked the AC head and cleaned the machine but this made no difference.

Scope checks showed that there was no CTL pulse output at pin 2 of the MN67492MSV5 chip IC4A0 on the main board. Replacing this IC cured the fault. **C.N.**

## Ferguson FV31R

This VCR wouldn't store any channels. The cause was traced to the BC337 transistor TK44, which showed signs of distress (it had bubbled out). Standby battery XK59 was responsible for TK44's distress. There should be 2.4V across it but the reading was 1.2V. **C.N.**

## Toshiba V703B

This machine's power supply was pulsing and it wouldn't accept a tape. The cause turned out to be C813 (47 $\mu$ F, 16V, 105°C) in the power supply. It was low in value. We fitted a replacement rated at 63V, 105°C. Hopefully it will last a little longer than the original one. **S.L.**

## Samsung SV801K

The deck tried but failed in its attempt to load a tape. It's a remarkably simple deck – one can only wonder why some manufacturers insist on using a multitude of cogs, pulleys, levers etc. to achieve the same result. But I digress.

On investigation I found that the main slider and master gear both had chewed teeth. Part nos. are 61641-0023-00 for the slider and 61472-0104-00 for the gear. Non Samsung account holders can order both parts, with an SS suffix, from CPC. The parts are B251 and B255 in the exploded view and parts list in the service manual.

Fitting them was straightforward and didn't, as so often, require reference to the manual for timing etc. **S.L.**

## Hinari VXL9

A fault we've had on a few occasions popped up again recently. The symptoms are no E-E video or audio, with playback OK. You will find that there is no or very little video output from the machine's IF can, because C312 (470 $\mu$ F, 16V) is short-circuit or leaky. It couples the video signal to the switching chip IC208. **S.L.**

## Ferguson FV10B

This machine's playback picture was marred by what appeared to be three or four lines missing every inch or so. The effect consisted of thin, horizontal black lines that varied in intensity with adjustment of the tracking control. We found that C801 (47 $\mu$ F, 25V) in the Motor 12V supply had gone low in value. The problem was not present in the record mode.

The relevant capacitor in JVC HRD170 series machines is C10. **S.L.**

## JVC HRD230

The playback picture was marred by bent verticals which extended from the bottom to the top. Clearly the head drum was hunting, but why? I've come across various causes of this in the past, including a defective drum motor, dried up electrolytics in the power supply, and drag because of loss of nickel plating on the upper drum. This time the cause was very simple. A squeal came from the earthing brush on top of the head drum. When the slightest pressure was applied to it the squeal and the hunting stopped. Cleaning the brush and applying light lubrication cured the fault. **J.Ci.**

### **Panasonic NVSD40**

There was no E-E or playback sound from the modulator – the sound was OK at the AV connector. We found that the 1k $\Omega$  chip resistor R7005 was open-circuit. It couples the sound signal to pin 4 of the RF converter. **S.H.**

### **Samsung SV301K**

The E-E and playback sound were distorted. Checks showed that the 9V supply was missing at pin 9 of IC4303, the cause being a print crack between links W052 and W067. Print repair restored normal sound. **S.H.**

### **Panasonic NVSD40**

This machine had been to another 'repairer'. When it came to us the fault was loss of the E-E and playback signals. The TV demodulator pack is connected to the main PCB by several plugs and sockets, PS701, PS702 etc. Their contacts can break internally if care is not taken when the panel is removed. Replacing PS701 and resoldering the other sockets where they are connected to the main PCB restored normal operation. **S.H.**

### **Amstrad VCR400**

There was intermittent loss of sound in both the record and playback modes. The cause was a splash of solder, from manufacture, lodged at the bottom of the socket on the ACE head. It was intermittently shorting out the pins to the audio section of the head. **G.T.**

### **Samsung SV1401**

No E-E operation was the complaint with this machine. The cause turned out to be failure of clock crystal XT901 associated with the on-screen display chip IC901. A new crystal restored the signals. **G.T.**

### **Sanyo VHR3100**

This machine was dead. Checks in the power supply brought me to the GZB16C zener diode D5009 which was short-circuit. It's connected to the always 13V line. **G.T.**

### **Samsung VIK316**

When these VCRs are switched to standby, the display should dim. In this case it disappeared. Capacitors C37 and C38 in the power supply were faulty. We also replaced C35, since this tends to give trouble. For those of you who have not come across failure of C35, the symptom is that the machine starts up then shuts down. **G.T.**

### **Quickies**

**Alba VCR7200:** Intermittent loss of

the clock display was the fault with this machine. Crystal X6002 was dry-jointed.

**Toshiba V404:** Apart from a ticking power supply there were no signs of life. The cause was CP008 (100 $\mu$ F, 25V).

**Daewoo V60:** Tuning drift was the problem with this machine. The cause was the 33V stabiliser D851, which is type KA33V. **G.T.**

### **JVC HRD750**

Complete loss of action was the symptom, with no output voltages at all from the power supply module. For once the culprit was not the kick-start capacitor C14, though we replaced this as a matter of course. It was the STR10006 chopper chip. **E.T.**

### **Sony SLVE250**

This machine had a very intermittent fault: maybe once a month it would chew a tape badly. We saw this happen once in the workshop. The cassette went in and down then, immediately after completion of tape threading, the loading arms retracted. Back came the cassette, with a large tape loop hanging from it. The mode switch was the cause of the problem. **E.T.**

### **Panasonic K Deck**

The K deck is less troublesome and easier to deal with than its predecessor, the G deck. This one crunched the tape under the descending pinch roller however, because arm P5 did not move far enough fast enough. The main lever (a plastic moulding, part no. VXL2307) was found to be cracked in the region of the P5 arm's driving notch. **E.T.**

### **GoldStar GSE1293IQ**

Intermittent picture rolling was the complaint with this machine. We traced the cause to failure of the back-tension arm to move into the correct tensioning position in the play/record modes, because the mode-switch contacts were tarnished. Cleaning the switch cured the fault. **M.D.**

### **Grundig VS920**

The symptoms were no clock display and clicking noises from the mechanism. We traced the cause to a 47 $\mu$ F, 25V capacitor in the power supply, on the primary side of the circuit. Use a 105 $^{\circ}$ C high-temperature replacement. **M.D.**

### **Samsung VI720**

The complaint was that this machine was running slow. We traced the

### **Philips Turbodeck Models**

Plastic lugs that break off have been a difficult problem to deal with – until now! The lugs that break hold down the record-protection switch spring, pivot the brake pulse lever, and pivot the brake pulse roller. You no longer have to practice your modelling skills with Araldite. Just order kit part no. 4822 256 92316 and you get the parts to repair all three trouble spots. **P.B.**

cause to the 3-3 $\Omega$ , 1W resistor R244, which had gone high in value. **M.D.**

### **Ferguson FV77**

If the power supply is dead or tripping, the first thing to do is to replace CP11 (220 $\mu$ F, 25) which is on the primary side of the power supply circuit. Use a 105 $^{\circ}$ C type. If the machine remains dead, check the 0-47 $\Omega$  safety resistor RP91 and replace the little 100 $\mu$ F, 10V yellow capacitor CP60. This capacitor is next to IP02, the four-pin regulator. **M.Dr.**

### **Matsui VP9401**

Tape spilling out during reverse search was the problem. With this deck the usual cause is the mode switch. A drop of bearing oil should also be applied to the capstan motor. This time however these measures didn't work.

We found that the fast forward/rewind clutch assembly was slipping, though the clutch itself wasn't faulty. In reverse search the back-tension band doubles up as a soft brake. This is where the cause of the trouble lay. There was too much braking pressure. A replacement lever sub brake, part no. 850P600311 (item 334 in the exploded view of the VP9301 deck), cured the problem. It's driven from the master cam. Because a small plastic leg had broken off, it rode up and didn't release the brakes properly.

This problem could become as common as the limiter post failure in earlier Matsui machines.

Get the replacement from Willow Vale – it's nearly £1 cheaper than from other sources. **M.Dr.**

### **Matsui VP9501**

The E-E picture had venetian blinds, though the playback picture was OK. In fact the symptom was identical to what you get with certain Pace satellite receivers when the 2-2 $\mu$ F capacitor in the tuner dries up. With this in mind, we removed the combined tuner, modulator and IF can. Inside the IF section there was a tiny 3-3 $\mu$ F, 50V capacitor, C227, which had gone open-circuit. A replacement cured the problem which, incidentally, disappeared when the signal from the aerial was attenuated. **M.Dr.**

## the Sony SLV757UB

**John Coombes on the things to check when faults are encountered with these VCRs**

This is a two-speed HQ machine with Nicam sound facilities. Features include a picture-in-picture function that enables a small TV picture to be displayed during tape playback and vice versa.

In this article I'll summarise the various fault symptoms we've experienced and list what to check. Some faults have an electronic and others a mechanical cause, while some can be caused by either mechanical or electronic failure. For convenience, I'll list faults under these headings, with separate sections on the power supply (see Fig. 1), cassette housing and remote control unit.

If the keys don't work, observation is required to gain as much information as possible on what is and what isn't working. If there is no display, there could be a timer/display problem or a power supply fault. Does the VCR load when a cassette is inserted? If so, does the tape thread up? Is the system control functioning, or the mode switch faulty? If there's a power supply fault, the VCR will usually be completely dead. This is not always the case however – only one LT supply may be missing.

In many cases a check on the CXP80116 servo/system microcontroller chip IC501 on board MA29 is required. Check the DC conditions very carefully, as replacement of this 80-pin chip is not recommended unless it is essential. If necessary, remove it very carefully – otherwise the print may be ruined. It is possible to cut IC501 out, but the best way of removing it is to use a gas-operated soldering iron. With practice this will enable you to desolder all the pins together and melt the glue that holds the chip to the PCB.

### Power Supply Faults

**Blown mains fuse (F101):** If the 2AT mains fuse F101 has blown check whether the 0.22 $\mu$ F mains filter capacitor C101, the S1WBA60 bridge rectifier D101 or the protection capacitor C104 (3 x 4,700pF) is short-circuit. Less likely is that the MA2830 hybrid chopper chip HIC101 has shorted internally. Check it by replacement if necessary.

**No outputs:** Check whether the 4.7 $\Omega$ , 3W surge limiter resistor R101 is open-circuit. If so, HIC101 could be faulty. If necessary check the chopper transformer T101 which could have an open-circuit primary winding.

**No 12V motor supply:** Check for 13.6V at pin 5 of the SI3120CA 12V regulator chip IC201. If this voltage is missing, D201 (S3LA20) is probably open-circuit. There should be 12V at pin 3 of IC201. Check IC201 by replacement if this voltage is missing.

**12V motor supply low:** Check IC201 (SI3120CA) by replacement. Alternatively C202 (100 $\mu$ F, 25V) could be open-circuit.

**No switched 12V supply:** Check for 13.6V at pin 5 of the SI3120CA 12V regulator chip IC202. If this voltage is missing, D205 (S3LA20) is likely to be open-circuit. Also check C204 (1,000 $\mu$ F, 16V) which could be short-circuit. If there is no 12V output at pin 3 of IC202, check this device by replacement.

**No 35V supply:** This line supplies the servo/system control PCB. Check whether the 56 $\Omega$ , 0.5W resistor R201 is open-circuit or zener diode D203 (RD51FB) is short-circuit. These are safety components. If R201 is open-circuit, C216 (100 $\mu$ F, 50V) and/or zener diode D209 (RD39FB) may be short-circuit. Alternatively D202 (D1NL20) could be open-circuit.

**No -29V supply:** Check whether zener diode D210 (RD30FB) is short-circuit. Also check D207 (D1NL20) and R203 (22 $\Omega$ ) which could be open-circuit.

**No 5V Supply:** Check for 5.9V at pin 5 of the SI3050CA 5V regulator chip IC204. If this voltage is missing, rectifier D206 (S3S4M) is likely to be open-circuit. If it's present, check for 5.3V at pin 3 of IC204. Should this voltage be missing, check IC204 by replacement then, if necessary, C207 (100 $\mu$ F, 10V) which could be short-circuit.



**rotating:** Check the mode switch by replacement. If this fails to correct the fault, trace back to the CXP80116 syscon chip IC501. Check the DC conditions at its pins, then if necessary by replacement.

**Threads up but won't run, possibly intermittent:** The front loading unit may be faulty – check that threading is completed. The mode switch is the next suspect. If necessary trace back to the CXP80116 syscon chip IC501.

**Drum rotates too fast:** If the drum motor inputs are OK, check the drum motor. Ensure that FG pulses are produced by the pick-up coil. They should be present at pins 19/20 of the TA8424F chip IC001 on the motor drive PCB (MD22), emerging at pin 17. After this they pass to board MA29, where they are fed via the 1SS119 protection diode D503 to pin 61 of the CXP80116 syscon chip IC501. D503 may be open-circuit or IC501 faulty.

**All functions missing, power supply OK:** Check the capstan motor and all motor inputs. Check the belt and the rack and gear system. Finally check the DC conditions around the CXP80116 syscon chip IC501. A defect in this chip can result in the absence of many or all deck functions, or faulty deck functions, while the clock display remains all right. If necessary check the chip by replacement.

**Tape speeds up erratically:** Clean and check the capstan motor. Check that the capstan FG pulses are present and correct at pin 62 of IC501 (CXP80116). IC501 could be faulty. Alternatively suspect the MJM45560 FG pulse amplifier chip IC404 (check by replacement) or the following DTA144ES digital transistor Q410 which could be open-circuit.

**Periodic noise appears on the screen:** Check whether the capstan FG and playback control pulses are present at pins 62 and 59 respectively of IC501 (CXP80116). The playback control pulses pass via IC401 (MC14066BCP), IC402 (M52435P) and Q412 (DTC144ES). If they are missing at IC501, check these items. If IC501 is receiving its pulse inputs, check it by replacement.

**Machine will not record, otherwise OK:** Since all other operations are OK, a stop or pause signal must be interrupting the record program. The mode switch could be faulty and IC501 (CXP80116) is suspect. Check the the conditions at the relevant pins of IC501, then by replacement if necessary.

**No timer recordings:** Assuming that a cassette with the end tab knocked out is not being used, the operation of the MB89793B timer control chip IC001 (board MF48) is suspect. Check its working conditions. Also that the VCR is correctly loaded and IC501 (CXP80116) is operating correctly. The mode switch is another possibility.

**Machine switches itself off:** There can be many causes from loss of a power supply to an incorrectly operating CXP80116 microcontroller chip (IC501). First, ensure that the cassette housing operates correctly. If this is OK, check that the cam motor is working correctly. If the cam motor and the mode switch are all right, check the

conditions around IC501.

**Machine switches to record during playback:** This fault may occur only during the first few seconds of operation. The most likely cause is the mode switch. If this item is OK, check the operation of the CXP80116 microcontroller chip IC501.

**Search is faulty:** This occurs when the cam motor is operating incorrectly. Check that loading is complete, and that the mode switch is OK. If so, check that the CXP80116 microcontroller chip IC501 is receiving correct information. If it is, check IC501 by replacement.

If still in trouble, check that the pendulum arm assembly is operating correctly. It could be broken or there could be missing teeth. Ensure that the pendulum slide plate is free and operates correctly. Hardened grease between the plates and chassis will prevent free movement.

If the search is too fast, check the points just mentioned. The capstan motor control could be faulty. IC501 (CXP80116) is the usual culprit in this case, but check for dry-joints and faulty components in the path from this IC to the capstan motor.

**Machine goes into rewind without being asked/rewinds when any key is pressed:** Check the end-sensor phototransistor by replacement

**Won't rewind automatically:** Check the supplies to the end sensors. If these are OK, replace them. If not, trace back to source. IC501 (CXP80116) could be faulty, but check for open-circuit or dry-joints along the sensor line.

**Machine won't rewind to end, has trouble starting to rewind or leaves a loop of loose tape when it stops rewinding:** Worn or misaligned belts are a common cause of this trouble. Check the belts and belt tension, then check the clutches for wear. If necessary check as specified under "won't rewind automatically" (previous section). Check that the capstan motor is operating correctly, and not incorrectly operating the cam motor to give a false loading position.

**Will not rewind and/or wind fast forward:** Check that the cam motor rotates the mode selector switch correctly. If not, check the mode switch alignment. If the mechanical side is OK, check the DC conditions around the CXP80116 microcontroller chip IC501. If necessary, check as described under "won't rewind automatically".

**Any single function not working:** Check the mode switch, by replacement if necessary. Alternatively the CXP80116 microcontroller chip IC501 is suspect. Check it by replacement.

## Mechanical Faults

**Tape threads then sticks or fails to unlace:** Failure of the drum to rotate or a faulty mode select switch are the likely causes.

**Machine keeps tangling or damaging tapes:** Check whether the pinch roller is worn, showing signs of being very shiny. If this item is OK, check the elevator cam which could be incorrectly positioned or cracked. Check

the tape path, clean the heads and tape path. Check tape path adjustments and pressures. Look for parts that don't move freely. Check that the mode select switch is operating correctly.

**Shaky sound:** Check mechanical parts – belts, takeups, clutches etc. – for wear. If replacement of any worn items fails to cure the problem, check the capstan motor drive and, if necessary, the capstan motor itself by replacement.

**Picture pulling at top:** Check and reset the back tension. If this doesn't resolve the problem, check/replace the band assembly (tension regulator) before suspecting faulty video heads. Incorrect back tension can lead to premature head failure.

**Poor recordings/fuzzy picture:** This suggests worn heads. Check for visual signs, or better still by replacement. If there is interference on the picture rather than overall poor quality, the cause is more likely to be dirt on the drum or somewhere along the tape path. A fuzzy picture indicates a worn head.

**Interference on picture:** If the input signal and the TV set being used as the monitor are OK, the cause of interference is likely to be dust, dirt or faulty/worn video heads. Clean the heads and tape path. Check that the threading is correct. If necessary replace the video head drum.

**Sound and picture out-of-sync:** There is a fault in the tape path between the two heads. The usual cause is a damaged loading arm. If the path is shortened the sound precedes the picture, and vice versa.

**Irregular noise bars on picture:** If this is a tracking fault, realign the tape path. The cause could however be dirt on the heads or along the tape path.

**Squeaks:** There are many possible causes. You'll find that mechanical parts are rubbing. Check that items like the head spring are centred properly and not touching the sides. Check the flywheels and tape-operation mechanisms. A little grease on the finger tip can sometimes work wonders! Check for rubbing plastic and moving parts that stick.

## Electronic Faults

**No record/playback colour:** Check the conditions around the HA118016NT chroma processing chip IC801 on board YC65, particularly the chroma in and out. Bandpass filter FL801 could be open-circuit. Dry-joints are a possibility, especially if the fault is intermittent. Check all connections along the chroma path.

**No playback colour:** There should be a chroma input at pin 5 of the HA118016NT chip IC801 on board YC65, and a chroma output at pin 25. Buffer transistor Q805 (2SA812), comb filter DL801 or bandpass filter FL801 could be open-circuit. If necessary check IC801 by replacement.

**No record colour:** Check the conditions around the HA118016NT chroma processing chip IC801 on board YC65. If necessary, check it by replacement. Other

possibilities are bandpass filter FL801 which could be open-circuit, or buffer transistor Q801 (2SC1623) which could be open-circuit or dry-jointed. Further testing is best done with an oscilloscope to check through the record colour signal path.

**Poor record and/or playback colour:** Check the conditions around the HA118016NT chip IC801 on board YC65. If a known good recording of a colour-bar signal plays back correctly, the AFC section will be confirmed as OK. If the colour image isn't normal, the fault will lie in the APC section.

**Poor playback colour:** This is again a matter of checking around IC801 on board YC65, as above, and the chroma path. IC801 (HA118016NT) is the main suspect. When the fault is in playback only, the picture may break up.

**Tuning problems:** The symptoms when there is tuning drift are usually no sound and no colour with a timed recording. Retune. If trouble is experienced with tuning these machines, check the AFT output at pin 6 of the IF unit IF001. If this is OK, check the MB89793B microcontroller chip IC001 on board MF48 – the DC conditions here then, if necessary, the chip by replacement.

**Luminance faults:** When a luminance fault is present the first step is to check the conditions at the pins of the AN3231K luminance processing chip IC701 on board YC65. If this chip has to be replaced, alignment will be required. This calls for an oscilloscope, a frequency counter, a DC power supply and the full service manual.

**No sound or picture, all mechanical functions working:** Check for damaged aerial and TV sockets. Then check whether the tuner is receiving signals and power. If the inputs and supplies are OK, the tuner unit (TU001) is suspect. Check the IF path from pin 1 of the tuner to pin 2 of the IF unit IF001. Possibilities here are open-circuit components, dry-joints and broken print or connections.

**No playback picture:** This assumes that the machine will record tapes that can be played back on another machine, but will not play back its own recordings or prerecorded tapes. An open-circuit is obviously present in the video playback circuit. Check the DC conditions around the AN3231K luminance processing chip IC701 on board YC65, and the chip itself by replacement if necessary. Check all LPF and bandpass filters, and for open-circuits in and around IC701. If this doesn't solve the problem, check back from the output socket.

**Records blank screen, sound OK:** Either the drum is faulty or there's an open-circuit in the video record signal path. Establish whether the signal is reaching the heads by checking at plug/socket CN801 then at the head terminals. Replace the drum if it's receiving signal inputs. If there is no signal at CN801, suspect the HA118019NT record/playback amplifier chip IC801 on board RP63. Check the DC conditions at its pins, or just check it by replacement.

**Records visual gibberish in colour:** Check the DC conditions around the HA118016NT chroma processing chip IC801 on board YC65. Check this IC by

replacement if necessary. If this chip is OK, check that the LA7213 sync separator chip IC802 on board YC65 is providing a composite sync output at 2 and that the following DTA144EK buffer transistor Q810 is OK. If these checks fail to detect the cause of the fault, check whether bandpass filter FL801 (on board YC65) is open-circuit. Also ensure that the skew-on input to board YC65 from the syscon board, at pin 4 of connector CN703, turns on at the correct point – when the line sync goes low during a high peak.

Check that the erase heads are OK, and trace their input back to source if this is missing.

**Picture or colour shakes from side to side:** Check around the drum or capstan servo section of the CXP80116 microcontroller chip IC501. The capstan speed error output can be checked at pin 65, the drum speed error output at pin 66. If IC501 is OK, check and clean the motors. Replacement may be required.

**Regular noise bar on the picture:** Check the DC conditions around the CXP80116 microcontroller chip IC501. Ensure that the drum FG pulses are arriving at pin 61. If so, IC501 could be faulty.

**TV display has no line sync or excessive horizontal sway:** Faults of this type are usually caused by the CXP80116 servo/syscon chip IC501 or an associated peripheral component. Check the DC conditions around the chip. Then check any suspect peripheral components. Finally replace IC501 if necessary.

**Hum bar on E-E picture:** Check the DC conditions on the tuner/IF panel TU01, particularly the 30V tuning voltage supply at pin 11 of the tuner. This voltage is smoothed by C031 (4.7µF, 50V) and comes from the 30V regulator which consists of Q016 (2SD774-3) and the RD33EB2 zener diode D003. If all these items are OK, check back to the supply source.

**No E-E sound:** Check the conditions at the IF module IF001, which may have to be replaced. Check for dry-joints and continuity of the E-E sound path.

**No playback sound:** Trace the playback audio path via IC002 (AN3932S) and IC001 (AN3972FC) on panel HF9. The inputs to IC002 are at pins 19 and 21. Pins 5 and 28 supply the outputs to IC001. If the DC conditions at either chip are incorrect, check the chip by replacement. Look for dry-joints, which can easily cause loss of sound.

**Interference on E-E sound:** Attempt to remove interference by adjusting the vision detector circuit in the IF module (IF001 on board TU01). If this has some effect but doesn't remove the interference, check relevant capacitors in the IF circuitry. The IF output is at pin 9.

A faint buzz may be the best that can be achieved. Even fitting an attenuator or carefully adjusting the vision detector circuit seldom completely eliminates a faint buzz.

**Machine won't change channels:** Check that the tuner is receiving serial clock and data inputs at pins 16 and 17 respectively, also an enable input at pin 18. Check that the tuner's LT supplies are correct and not too low – 30V (tuning) at pin 11, 12V at pin 3 and 5V at pin 12. The tuner itself could be faulty. This fault can be intermittent.

**Any single channel will not tune in:** Check the operation of the MB89793B tuner/timer control chip IC001 on panel MF48, and that it's supplying the correct serial data. Ensure

that the AFT system is operating correctly – the AFT control voltage comes from pin 6 of the IF module IF001 on panel TU01, via buffer transistor Q007.

**TV cannot be received via the VCR, possibly on one channel only:** Check the aerial socket and the switching in this area. If only one channel is affected, the likely cause is the MB89793B microcontroller chip IC001 (panel MF48) which might need to be replaced because of incorrect serial data. Check for open-circuit or dry joints throughout the channel data path. If all channels are affected, it's almost certain that the machine has been moved around and as a result the aerial socket has been damaged.

**Drum doesn't rotate:** Check whether power is reaching the drum motor. If not, trace back to the TA8424F chip IC001 on the motor drive board MD22. DC checks on this IC will normally sort out the problem – the chip itself is the most likely component to fail. Also check whether R009 (0.47Ω) is open-circuit.

A full check in this area requires the use of an oscilloscope. Check the coil waveforms and the outputs from the Hall elements. If there is a substantial difference in these, i.e. one output is much lower than the others, replace the lower drum assembly and realign the tape path.

If two coils are not correctly phased the drum won't rotate. This is most likely to be because of failure of IC001, but check the associated components as well. Check all connections and continuity to and from IC001.

**Clock faults:** First check for dry-joints in the clock circuit on board MF48. Check that only the clock, not other functions, is affected. This will prove that the cause is in the timer/display circuit.

If there is no clock display, check the DC conditions around the BA6800AF display driver chip IC007 or check it by replacement. If IC007 is OK, check the clock crystals X001 (32kHz) and X002 (8MHz). They may be dry-jointed or have broken connections to the PCB. If these are OK, check the DC conditions around the MB89793B tuner/timer chip IC001. This chip may have to be checked by replacement.

An incorrect IC pin reading should lead to the cause of the fault without difficulty. Note that the tuner/timer chip can be affected by weather conditions, see below.

If the clock is losing or gaining time, check crystals X001 and X002 for dry-joints/faulty connections and the DC conditions around IC001. Make sure that all inputs and outputs are correct before replacing it.

**Clock plus other functions inoperative:** Check the DC conditions around IC007 (BA6800AF) and IC001 (MB89793B). If necessary check these ICs by replacement. Before contemplating replacement of IC001, note that this type of chip can produce fault symptoms because of external influences, e.g. lightning and some electronic equipment. Thus before assuming the worst, it's advisable to check whether the clock can be started by switching off at the mains then starting again from scratch.

## Remote Control Unit Faults

Battery contacts can be a problem. They can be corroded, broken or dry-jointed at the PCB. Check the spring tension – if this is poor operation may be intermittent.

Check for dry-joints or broken legs at the crystals, also for dry-jointed or open-circuit LEDs.

The other common problem is a faulty rubber sheet. Replacement is the only way of dealing with this.

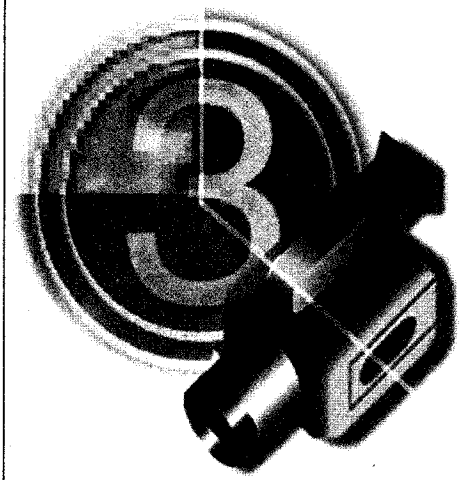

## Reports from David C. Woodnott

### **Sony CCDTRV30E**

This model has an LCD screen as well as a standard viewfinder. The viewfinder picture and all the camera and playback functions were OK, the only inoperative feature being the LCD display.

Various checks in the relevant circuitry revealed little except that something odd had possibly occurred. As no circuit fault could be found, we decided to use the EVR to check the relevant data at page D. This was found to be reasonably correct (near to standard values) in all but one address location – address BB, which read 00. The manual shows this location as data 92. When it was set to this figure the LCD picture appeared! We then switched the unit off, and were pleased to find that the LCD still operated at switch on.

We finally set up the LCD adjustments as per the manual. All was now well. It seems that the data had become corrupted, but no reason for this could be found. An interesting point is that the function of the offending address, BB, is not listed in the manual. **D.C.W.**

### **Sharp VLM4H**

The iris behaved erratically when the camera was pointed at a strong light source – all other functions worked correctly. The cause was a dry-joint at connector P8 on the main PCB. **D.C.W.**

### **Sony CCDTR75E**

The complaint with this camcorder was failure to eject the cassette. When the eject button was pressed,

# Camcorner

all that happened was that the caution LED flashed. The E-E pictures were OK.

Once the cassette had been removed we found that the capstan motor wasn't working. The motor does sometimes fail, but not this time. Another quite common problem is poor joints at the capstan motor edge connector (this is also a problem with other connectors, i.e. the drum motor, deck sensors, etc.). In fact however the culprit was the CXA1127AM capstan motor drive chip. A replacement restored the unit to its former happy state. **D.C.W.**

### **Ferguson Pro 8/220**

This one is a bit of an oddity! It bears the Thomson as well as the Ferguson name and is a clone (or very much like) the Samsung VPE807, a model for which certain spares are no longer available.

This one required a replacement head drum assembly, which is available from Ferguson only as a complete unit. The replacement restored the machine to working order, though its price is rather high for a 'low-end' camcorder. The drum is not available from Samsung, but you may find that Ferguson still have some stock. **D.C.W.**

### **Sharp VLC690H**

No operation was the complaint with one of these popular camcorders. As with many of its contemporaries, leaky capacitors are a problem. This time C946 was the culprit.

It's probably wise to inspect and/or replace all the electrolytics used in this and similar models, as a preventative measure – leakage has become the number one common fault in recent times. PCB cleaning is also required of course. **D.C.W.**

### **Hitachi VM2300E**

This full-sized camcorder produced good playback pictures and sound, but the camera mode E-E pictures were covered with horizontal lines. These disappeared (almost) when the unit had been left running for

some time. A replacement camera DC-DC converter cured the fault. **D.C.W.**

### **Canon E400E**

There were lines on the playback picture. Replacement of the BT string assembly cleared the fault. This model uses the Sony A mechanism, and can suffer from similar fault symptoms to Sony models. Generally the unit is very reliable. **D.C.W.**

### **Sharp VLC690H**

There were severe striations on the camera E-E pictures. Playback of a known good tape was OK. The cause of the trouble was C210 (33 $\mu$ F, 16V) on the YC PCB (Y DET). It's becoming a common fault with this model. **D.C.W.**

### **Canon E110E**

This model, being based on the E60E, suffers from the same leaky capacitor problem. As little else seems to fail, these camcorders are generally worth repairing. They do however have a considerable number of extra electrolytics on the enlarged audio-video panel CBA. To overcome audio problems, seventeen or so electrolytics on this PCB should be replaced. The symptoms can be no E-E record sound, no playback sound or a mixture of both. The symptoms can also change with use – as can most problems due to this cause.

To ensure a long working life with no returns under your guarantee a total of around 48 components should be replaced. **D.C.W.**

### **Ferguson FC28**

This full-sized, ex-rental camcorder was brought in because it was dead. We'd seen several of them when they were new (around nine years ago) but few recently. The cause of the trouble had not been common at that earlier stage. Circuit protectors CP3 on the main PCB and CP601 on the camera operation PCB had both failed. (CP601 is not shown in some circuit diagrams!) No cause of the CP failures could be found. **D.C.W.**



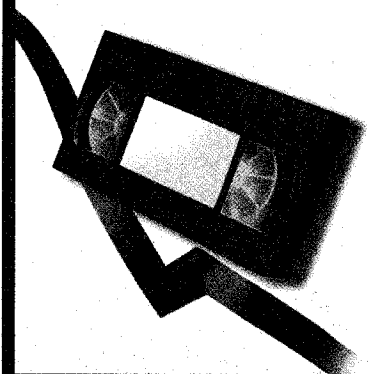

Reports from  
**Philip Blundell, AMIEEIE**  
**Michael Dranfield**  
**David Corcoran**  
**Mike Leach**  
**Shane Humphrey, LCGI**  
**John Pitt-Francis**  
**Martin Cleaver and**  
**John Edwards**

### Philips VR757

There was no E-E or record sound – the playback sound was normal. The scart sockets produced no sound output, and if an external input was tried the vision came through but not the sound.

Audio went into IC7010 at pins 1, 2 and 3 but wasn't seen again. Internal signal switching is controlled via the I2C bus, so a half hour was spent with the instruction book and remote control unit checking whether there were any options or modes that could account for the problem. Then a RAM clear was tried. This erased all the channels, the time etc. When they were set up again the fault was still present. Incidentally when setting up the RAM I found that if you set the REC TV option to ON (so that the machine records from the TV set only via the scart connector) the station cannot be stored when you tune in using the manual method.

When checked, the voltages at all 64 pins of the TDA9614 chip were found to be correct. A replacement chip was then tried but made no difference.

It seemed that the TDA9614 chip was being muted via the I2C bus. According to the circuit description this chip is muted when there is a servo fault and during all operations other than record, playback and E-E. Checks on the record and playback control lines didn't reveal any problems, neither did a check

# VCR Clinic

on the AFC signals in case there was a tuning fault. Maybe the deck controller chip (IC7100) was muting the sound, but why should it do so in the E-E mode?

Scope checks around IC7100 showed that the field sync pulses were missing at pin 6. When I traced back to the sync separator (transistor Tr7810 etc.) I found that there was no pulse output here. The sync separator itself was OK, but the pulses fed to it from the OSD board were of low amplitude – 1V instead of 3V peak-to-peak. The cause of the trouble was transistor Tr7918 on the OSD board.

The machine was an early production model whose OSD board had a BA7046 chip on it. A replacement OSD board restored the sound. Why had the transistor failed? The screened cable that connects the video signal from the OSD board to the motherboard hadn't been trimmed properly. A stray piece of wire stood proud of the board and had shorted to the earthed metal case. **P.B.**

### Akai VS650

The owner of this top-of-the-range Dolby Surround sound machine brought it in to us when one of the local cowboys had failed to cure a tracking fault. When we removed the top we were horrified to see the trail of destruction that had been left behind. Every single potentiometer in the machine had been twiddled – even the L-R hi-fi level meter adjustments. Could it be that this person hadn't a clue about what he was doing?

After replacing the AC head and the base, because all the screws had been churned up and the base bent, we had to reset the deck and guides, replace the worn video head (the original cause of the tracking problem), and reset all the potentiometers in accordance with the instructions in the service manual.

When this had been done we had one remaining problem, severe chroma patterning. It was worse

with SP than LP recordings. We worked on the problem for weeks on and off. Finally, drawing a blank, we decided to phone Akai's Technical Department. The man on the end of the phone diagnosed the cause of the trouble immediately. "With the top off, turn the machine upside down and see what drops out" he said. Nothing, I replied. "Go back to the person who looked at the machine last and ask for the plastic-coated tinfoil shield that should be between the head amplifier and the power supply" he continued, "because it's not available as a separate item from Akai. To prove the point, lift out the power supply and position it 90° to the head amplifier."

As this cured the fault, we made up a shield from some material from the base of a scrap Video-Crypt decoder. The power supply, which is partly a switching regulator, uses large inductors that radiate. Hence the importance of good shielding.

Although the customer was not too happy with the charge of £150, he was glad to get his machine back in working order. **M.Dr.**

### Ferguson FV74

The power supply was tripping and a clonking noise came from the capacitor motor. The cause of the trouble was eventually traced to CP71 (10µF, 50V) which is mounted on the print side of the power supply. It was slightly low in value, and must have become resistive as the power supply fired up when it was disconnected. It's in circuit between the 12V and 33V rails. **M.Dr.**

### Panasonic NVJ35

This machine was OK when used with the AV connectors, but provided no RF output. The +B voltage for the RF converter comes from Q1102 in the power supply, via the demodulator pack. This is the N.SW12V supply. We found that Q1102 (type 2SD1330) was open-circuit. **D.C.**

### JVC HRD860EK

There were no functions at all and the display consisted of an occasional random flashing of various segments. I checked the power supply and found that its outputs were all correct. When I moved over to the microcontroller chip IC601 I found that pin 28 (reset) was at 12-15V, which was obviously high. The cause of the trouble was a leaky 7.5V zener diode, D601, which is connected to the unswitched 12V supply. A replacement restored normal operation. **M.L.**

### Panasonic NVL28

No rewind was the problem with this machine. We eventually traced the cause to the mode switch. **S.H.**

### Panasonic NVSD400

There was no playback or E-E sound. We were surprised to find that instead of being in the audio circuitry the cause of the problem was on the timer PCB, where pin 30 of IC7501 was not properly connected to the PCB. **S.H.**

### Ferguson 3V45/JVC HRD150

This VCR couldn't be tuned. I found that the 30V supply was missing at pin 5 of CN1, though 45V was present at pin 3 of CN2. Nor was there 13V at the collector of Q13. Lifting the tuner panel revealed all. Water had come down the aerial lead into the RF converter/booster and flooded under the nearby tuner/IF panel, corroding away the link between the emitter of Q12 and the collector of Q13. Hence the fault – the booster was undamaged. **J.P.-F.**

### Mitsubishi HS421B

The customer complained that rewind/fast forward hadn't worked for some time – he had to use review to wind his tapes back! After explaining to him that this would double the head wear, I started to look for the cause of the trouble. It didn't lie with the idler or its surrounding mechanics. When link C (item 94) was pulled – it's towards the back of the deck, see Fig. 1 – the idler gripped properly and there was normal rewind.

After removing the loading motor assembly I found that the spring (item 45) beneath the trigger lever (item 44) was dislocated. It was also upside down. Once you've got it the right way up, a parking post on the underside of the lever enables the lever and spring to be put in position. The spring is then released for normal

operation by pushing downwards as the loading assembly is replaced. Magic! I've explained this in some detail as I had to learn it the hard way. I wonder who turned the spring round? **J.P.-F.**

### Panasonic NVHD610B

In the E-E mode the left-hand channel produced no sound, just a roaring noise. Playback of a prerecorded tape was OK. After I'd spent some time carrying out voltage checks, another machine came in with the same fault. So it seemed that a quick phone call to Panasonic might prove helpful. I was told to check the 5V supply (at Q7301) and the 8V supply (at Q7302) in the Nicam section and, if these were OK (they were), to replace the MSP3410-15 chip IC7301.

I persuaded Rob, a fellow technician who can see the connections around this 68-pin flat-pack device, to fit replacements using the pyro pen. Both machines then worked all right. **M.C.**

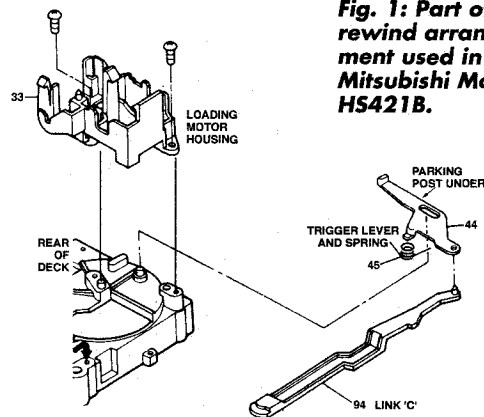

**Fig. 1: Part of the rewind arrangement used in the Mitsubishi Model HS421B.**

### GoldStar GSEQ121

A loud scraping noise accompanied all tape functions. It was caused by the fact that all three capstan motor securing screws had become loose. The cure was simply to tighten the screws and then apply locking paint. **J.E.**

## Panasonic K Deck

As with many modern mechanisms that are otherwise reliable, the K deck can suffer when a faulty tape or the brakes within a cassette jam and the customer tries to remove it himself. You realign the deck and return the machine to the customer in good working condition. It then jams again for no apparent reason. In this event it's worth checking the following items:

- (1) The side plate (right-hand side). It can cause problems, but check that the spring which gives tension to a lever has not fallen off (difficult to describe, but easy to see if it has come off).
- (2) The main shaft drive arm (VXP1339) that drives the cassette lift. It tends to sprain outwards and slip. If you look down the right-hand side of the carriage you will see that it is driving the lever down on its edge, not the whole cam.
- (3) The loading motor drive cog. It can be replaced without upsetting the alignment of the mechanism. You may find that the small, underside cog has some stripped teeth. The part supplied by Panasonic (VDG0868) seems to have been made stronger.
- (4) The P5 arm unit (sub-loading arm VXL2306) can get bent when the tape is ejected. It can sometimes be bent back, but it's well worth keeping some in stock.

For odd operation, check the tape sensors and IR sender. To do this you have to lift the deck off the mother board then lift the board out. This is a quick operation with later models that have fewer screws. If care is taken, the mode switch (VSS0365) is easy to replace and align.

The loading motor's supply comes via a plug which is connected to the mother board. It can produce odd problems and is worth replacement if you are in any doubt.

Some odd faults I've had have been as follows. A broken take-up arm unit (VXZ0313). The metal arm on the loading post had fallen out, jamming the mechanism. The pressure roller has a nylon peg that engages with a drive cam: it has been known to snap off.

Those who have not worked on this deck before should note that the cassette lift loading drive relies on the lift assembly to tension the drive cog. The operation of this is not very easy to see. You'll find that a service manual or the K deck video tape is a great help. **M.C.**

# A True Story for Telly Folk

The saga of Johnny and his mum's VCRs. By Peter Graves

Tonight's true story for Telly Folk everywhere starts at a time long before the G deck rebuild kit was even a twinkle in its designer's eye and when SMDs could be found only on the top shelf of local newsagents.

Young Johnny Buoy had recently failed his maths exams and should have been spending the afternoon concentrating on his Media Studies, though his Mummy was convinced that he would one day turn out to be a much respected doctor.

## Anatomy

It was with the study of anatomy in mind that, on this particular afternoon, while Mummy was out at work teaching, he pushed a tape firmly into the cassette housing of her lovingly cared for Panasonic NV333, switched on the television, sunk into the armchair and, before long, was engrossed in the pursuit of his own higher education.

Little Johnny was very appreciative of the accurate flesh tones provided by Mummy's brand new, large-screen TX100. He had just noticed the condensation forming on the lounge windows when a terrible thing happened.

## Disaster

All of a sudden a snowstorm erupted on the screen. Johnny looked down at the VCR and saw that the little red play light had gone out. Horrified, he leapt from the armchair, executed a perfect nosedive, and on his descent sustained two very sore knees from the carpet.

Face to face with the VCR, Johnny pressed the play button. Nothing happened. Nothing continued to happen the next hundred times he pressed the button. In fact he pressed the button so hard that it became very floppy and wouldn't press any more. He did the same with the eject button until, tiring of the attention, it disappeared forever.

Poor Johnny stared at the machine, then peered into the lid. He could see the tape label plainly,

with the words "starring Mary Hinge" screaming at him. He would have to get the tape out before Mummy got home, or she would be very cross and would probably beat him all shades of red, green and blue. This, he pondered, would probably make a very good subject for a programme if only he could afford one of those new camcorder things.

Suddenly he had a brainwave. In a flash he returned to the lounge with his toolbox and quickly found just the thing he needed. He didn't know the name of it, but it was as big as a samurai sword and had a nice lever at the end. It was bound to do the job! With a satisfying 'clunk', the lid was open. But Johnny still had to deal with the problem of the threaded tape.

## The friendly Video Store

The following day Mrs Buoy appeared in Mr Busto's friendly video repair shop.

"There's nothing much wrong with it" she declared. "It's just the lid. It won't stay down. My son said it was all right one minute then just went funny!"

Mr Busto soon had the poor machine on his workbench. Although he managed to find the remains of the cassette lock lever, the eject button was nowhere to be found. Neither were the tips of the video heads, nor the other half of the pinch roller.

Friendly Mr Busto soon found the cause of the original problem - an open-circuit mains fuse. He could barely see the break under his huge magnifying glass.

Mrs Buoy was slightly annoyed when told of the number of items that would have to be replaced, especially when Mr Busto added that it would probably need some drive belts and idlers as well.

"That's the last time I buy one of those flimsy Panasonics" she said. "You can

keep it for spares."

Mr Busto placed the VCR gently in a safe corner of his workshop. It looked up at him in the sad way that neglected videos do, and he vowed that he would make her better. He was in need of a video machine himself but, as he was only a lowly video mechanic, he would have to purchase the spares one by one as he couldn't afford them all in one go.

## Big John

Many moons have passed and Mrs Buoy has long since retired. Big John, as he likes to be called these days, works in an office operating a huge machine that calculates everyone's Council Tax.

His mother occasionally sends him to Mr Busto's shop with the video she bought from "those awfully nice Sony people". Friendly Mr Busto hasn't the heart to tell her the truth any more as he replaces all the smashed bits and realigns her G deck mechanism for the umpteenth time.

The rebuilt NV333 continues to give sterling service in Mr Busto's house, but is nowadays referred to affectionately as Polly Panna.

Goodnight Telly People everywhere!



*Oh please God, please God, don't let it get jammed.*



## Reports from David C. Woodnott and Nick Beer

### Canon E60/110/230 etc

A common problem with many camcorders in this range, which uses infra-red autofocus, is inability to focus correctly at infinity. Things are usually OK at lesser distances, but at infinity the malfunctioning occurs.

The problem can often be overcome by carefully washing the infra-red optical unit in an ultrasonic cleaning tank. It seems that fogging of the lens occurs with age. It's best not to dismantle the unit and clean it manually, as doing this disturbs the set-up integrity. It's a much cheaper option than a replacement at around £60 trade. **D.C.W.**

### Sharp VLC73H

No operation was the complaint. This camcorder didn't even power up then down, as some of them do. The cause was soon found to be failure of the ceramic fuse link F901. Replacing it didn't restore full operation however, as IC802 (the loading motor drive chip) was also faulty. Once this item had been replaced all was well. **D.C.W.**

### Samsung VPU10

No camera E-E picture, all playback functions being OK, is a common problem with this model. The cause is usually failure of the autofocus or zoom motor.

If the microcontroller chip detects a problem with the lens unit

# Camcorner

during the switch-on initialisation, the result is no E-E pictures. The lens position sensors can cause similar faults, but this is less common.

The faulty motor(s) stick because of insufficient torque. Replace them and carry out autofocus setting up as laid down in the manual. **D.C.W.**

### Sony CCDF150E

After a short period of use there would be no E-E or playback sound. When the camcorder was switched on the sound was OK: the sound gradually faded off. Pictures were OK.

The cause of the trouble was a leaky capacitor (C420, 1µF) in the audio mute circuit. We've had failure of this capacitor in several other Sony models that use the same or similar circuitry.

Note also that failure of the HIC audio chip (SBX-1505-2) is becoming very common in any model that uses it. The chip usually becomes temperature sensitive, and can be made to fail or work at will by the application of heat or freezer. **D.C.W.**

### Sony CCDV7AF

This old timer was inoperative mechanically. Normal operation was restored by replacement of PS601 (N20) and the mode motor. It's a common failure with models of this period, and also with the contemporary EV series VTR units.

As with all units that use the K mechanism, it's likely that both reel turntables and possibly the pinch roller will require replacement. Also check the idler assembly for a loose and incorrectly positioned pivot. **D.C.W.**

### Sony CCDTR505E

This newish Handycam had two seemingly unconnected faults with a common cause. The symptoms were no autofocus and no trigger (record/pause) button operation. All other functions were OK.

If the RM95 remote control unit was used, recordings could be

made but the autofocus remained inoperative.

The cause of the trouble was an internal failure in the switch block control (camera operation unit, ref. 59). This type of failure is often difficult to pinpoint quickly – there are usually several other items to eliminate first. The unit is expensive if ordered in error – yes, we have done it! **D.C.W.**

### Hitachi VMC1E

This camcorder was brought to us because it was dead. Except for failed circuit protectors, it's an uncommon symptom with this model. The cause of the trouble was capacitor leakage, which again is unusual in this model (shall I live to regret saying that?!).

The culprit was C824 (22µF, 6-3V) on the main PCB. It had corroded the print, thereby disconnecting the 5-3V supply from regulator IC804 to pin 8 of the syscon chip IC802. A replacement capacitor, PCB clean up and a wire link restored normal operation. **D.C.W.**

### Panasonic NV55B

This camcorder was dead – there was just a flash of red LED when an attempt was made to power it. The cause of the problem was traced to the tiny, 1kΩ surface-mounted resistor R6028, which was open-circuit. It's in the battery-level circuit, connected to pin 102 of the system microcontroller chip IC6001. **N.B.**

### Sony CCDTR75E

There was no playback luminance, just very dark, almost non-existent vision. A check through the luminance playback signal processing path brought me to the CCD comb filter circuitry on board VS67. There was an input here but no output. The reference level at pin 12 of IC202 was found to be very low, and a resistance check to chassis produced a reading of 800Ω. C237, a 1µF surface-mounted capacitor (part no. 1-162-638-11), was leaky. **N.B.**

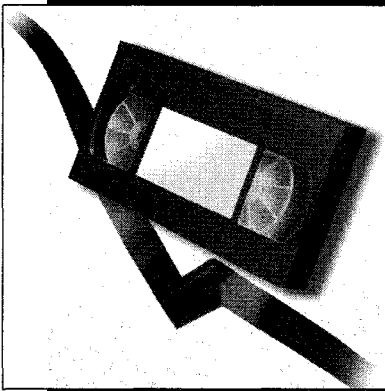

**Reports from**  
**Philip Blundell, AMIEEIE**  
**Eugene Trundle**  
**Steve Stamford**  
**Gerald Smith**  
**Terry Lamoon**  
**Brian Storm**  
**John Edwards**  
**Ronnie Boag and**  
**Michael Maurice**

### **Grundig VS340**

"Buzz on sound" was the complaint with this machine: there was a loud, 25Hz beating noise during playback of any hi-fi tape. This is usually caused by worn hi-fi heads, but a scope check at the hi-fi FM test point (pin 35 of the hi-fi sound module) showed that the signal here was fine. So we started to check through the signal path. Everything was OK up to the output (pins 9 and 3) of IC1135, where the audio signal had 20msec chunks cut out of it.

IC1135 is part of the extrapolator circuit. It should be switched on for 12µsec periods, but was being switched on for 20msec ones instead. The timing is set by the 4070 quad exclusive-or chip IC1140, which was faulty. A new 4070 chip restored normal sound. **P.B.**

### **Philips VR6557**

This machine kept ejecting the cassette because the pin that presses the cassette-in switch down was broken. You won't find the part number for this item in the manual. The nice man at Philips Technical told me that it's 4822 535 10316. **P.B.**

### **Matsui VP9601N/Tatung TVR634N and TVR734N**

Intermittent mechanical deck functions with these machines are often caused by failure of the mode

# VCR Clinic

switch. Cleaning it will provide a cure, but replacing it is better. The most common symptom is sporadic failure to accept or eject a cassette. **E.T.**

### **JVC HRD540/580/910 etc**

These models have a similar drum motor that can cause trouble when it fails to produce a PG pulse output – the pulses should be superimposed on the FG waveform. Before fitting a very expensive lower drum assembly or writing off the machine, try replacing the 3.3µF, 30V electrolytic capacitor on the stator PCB. There's no component reference number, but it's the only can-type capacitor – about the size of a match head – on the board. **E.T.**

### **Hitachi VTM410E**

Here's a fault that you could spend for ever trying to sort out without getting near the solution! The symptom is an irregular 'snicking' noise – a bit like the sound of a gas ring spark-igniter – on the playback sound. The cause is static discharge, and the cure is to replace the toothed reel-drive belt. The specially-treated replacement will be supplied when the original part number is used. **E.T.**

### **JVC HRD860**

If the problem with one of these VCRs is complete or intermittent power supply failure, in addition to replacing the start-up capacitor etc. check for a dry-joint at the emitter connection of the chopper transistor Q1. A section of the solder pad seems to detach itself from the rest of the print land. To be sure of the repair, use a tiny length of tinned copper wire to bypass the immediate printed land area. **E.T.**

### **Sony SLV200UX**

This VCR's unusual symptom was

the presence, in the record mode only, of a head-switching bar about two-thirds of the way down the screen. During playback the switching point was correct – at 6.5 lines before the field sync pulse, adjustable with VR351. The cause was a faulty servo chip (IC351). It's a 44-pin, surface-mounted device that costs a staggering £39.64 net trade plus VAT... **E.T.**

### **JVC HRD320**

This VCR reset its clock with annoying irregularity. Otherwise it was perfectly OK. Once in a while the display said "video" and it locked up. I decided, after the usual fruitless search that occurs when a machine develops a mind of its own, to phone JVC and was told that the back-up capacitor C3 (0.1F, 5.5V) had given up the ghost. A replacement restored normal operation – it's mounted on the display panel. My thanks to JVC for help with this one.

The **Ferguson FV21R** seems to be very similar, so the fault might also be experienced with this model. **S.S.**

### **Nokia VR3615**

This machine wouldn't rewind. Close inspection of the "relay plate" revealed that the pin below the main cam was bent. Straightening it restored the rewind function. **G.S.**

### **JVC HRA630**

When this machine was switched on the lift would sometimes shuffle back and forth. The machine would then revert to standby. The cause was a faulty mode switch. **G.S.**

### **Daewoo V215**

There was no manual or auto tracking. As a result, playback of prerecorded tapes produced poor pictures. A check at pin 22 (TRK

DLY) of IC601 showed that the voltage was low and didn't vary with tracking control adjustment. The cause of the trouble was C520 (10µF), which had fallen in value. **G.S.**

### **Sony SLV625**

This machine would try to load then revert to the unlaced position. Even if the machine did manage to go into the record or playback mode it would intermittently revert to stop. The cause of the trouble was bad connections at both ends of the drum motor plugs. **G.S.**

### **Samsung VIK316**

This machine worked all right but the display was dull. A check on the VF+/- supply produced a reading of 5V AC instead of about 4V DC with 1V AC. The fault was caused by C38 (100µF, 10V). **G.S.**

### **Nokia VR3615**

This machine would sometimes revert to standby when a cassette was inserted. A replacement mode switch assembly cured the fault. **G.S.**

### **Matsui VP9301**

There was a serious wow and flutter problem with the sound. As I had a spare capstan motor in the workshop I fitted it. This cured the fault - sometimes you have a bit of luck! **T.L.**

### **JVC HRD560**

This machine had a playback fault - part of the picture was missing. As it appeared to be a tape path problem I checked the loading arms. Sure enough, the supply arm was loose. This is becoming quite common now with these machines. You can reset the arm with a little glue to hold it, but I would recommend replacement to ensure a reliable repair. **T.L.**

### **Matsui VP9401**

If you get a low sound complaint with one of these machines, check C3606 (10µF, 16V) by replacement. **T.L.**

### **Panasonic NVHD100**

The complaint with this machine was that it would sometimes lose drum lock in the cue and review modes. Although the fault was intermittent, operating the machine from cold would instigate it. Examination of the capstan rotor top bearing showed that there was quite a build up of dirt and debris here. After cleaning this away, the

wear on the capstan spindle caused by the partial seizure could be clearly seen. A replacement spindle (VXP1350) and a new top bearing (VXD0140) cured the fault. **B.S.**

### **Panasonic NVF65**

The symptom complained about was "strange speckling on the playback picture". On test we found that there were white flecks at regular intervals all over the picture. The cause was C1018 (100µF, 63V) in the power supply. As it was open-circuit, there was HF noise on the 45V line. If the machine had not been used with line inputs exclusively there would have been bad patterning on the E-E picture as well. **B.S.**

### **Panasonic NVD80**

This elderly digital machine had an intermittent E-E problem: it would sometimes display a ragged dark raster, usually after changing channels a few times. To obtain a clear channel you would then have to unplug the machine and start up again. Fortunately the fault was easy to cure. The outputs from the superannuated power supply module were all too high because C1012 and C1039 (both 47µF, 16V) on the primary side were low in value. Replacements cured the fault. **B.S.**

### **JVC HRJ400**

There was a half-loaded tape in this machine. The only other sign of life was the word "eject" in the display, whose segments were being illuminated sequentially to give a clockwise cyclic rotation effect. No functions were possible. Replacing CP1 on the power supply board brought the machine back to life. **J.E.**

### **Fisher FVHP716**

Tape playback was normal but the E-E picture was severely distorted, with line tearing and vertical judder and rolling. The cure was to replace C8 (1µF), C9 (0.47µF), C16 (10µF) and C17 (1µF) in the IF module. I have to admit that I achieved this more by guesswork than detailed fault analysis. **J.E.**

### **Samsung SI1240**

Tape playback was at about the same speed as fast forward. I did not have a manual, but luckily spotted print corrosion at pins 5-11 of socket CN206. It's at the front right-hand side of the top main board, and can just be seen with

the front fascia in position. A good scrape followed by resoldering restored normal operation. **J.E.**

### **Panasonic NVJ45**

This machine would eject a cassette as soon as it had been inserted. Removing and refitting the carriage unit cured the problem. The usual lower deck strip down and alignment weren't necessary. **J.E.**

### **Nokia VR3723**

Intermittent failure to rewind can be a problem with these machines. The first thing to do is to replace the mode switch. If this has already been done, replace the slide cam (part no. 613 094 9240) and the loading belt. **R.B.**

### **Finlux VR3724**

A problem we've had with these machines is colour flashing with some prerecorded tapes. The cure is to replace the video processing chip IC101. **R.B.**

### **Nokia VR3716**

The symptoms with one of these machines were no display, the drum motor running and the capstan driving the supply reel. The cause of the problem was dry-joints at oscillator crystal X702. **R.B.**

### **Sanyo VHR276**

If one of these machines won't accept a tape, the lift shuffling in and out, replace the rotary switch. **R.B.**

### **Panasonic NVF55**

There were coloured speckles throughout the picture in the E-E mode only. The cause was dry-joints in the tuner unit. **R.B.**

### **Mitsubishi HSM48**

This machine had two faults. First its mechanism was jammed, with the exit guide halfway towards the loaded position. The cause of this was a rubber that the customer's daughter had put inside. When the exit guide's gear and the control plate had been replaced the mechanics worked. The second fault was intermittent failure to record sound. This was caused by C932 being dry-jointed at one end. **M.M.**

### **Alba VCR7800**

There was no E-E video. A previous engineer had replaced the RF converter, and in doing so had cut one of the fine tracks that pass near it. Linking this break restored the pictures. **M.M.**



## Reports from David C. Woodnott

### **Sony CCDF500E**

The reported symptom was no operation. We found that the cassette housing would open and close without a tape, but wouldn't close with a tape inserted. The reason for this was the fact that the drum did not rotate. It would twitch, but failed to operate correctly. We replaced five leaky electrolytic capacitors in the drum commutation circuitry. This restored normal operation. **D.C.W.**

### **Hitachi VM600E**

This full-size VHS oldie behaved erratically. It would sometimes operate reasonably well, and at other times not. With this model we generally replace the pinch roller assembly, the mode encoder switch assembly and fit a new set of belts (three). You have to replace the complete pinch roller assembly, with operating arm – replacing the pinch roller only is often ineffective, as the riveted pivot comes loose. It's also worth checking the CAM/VTR switch, which can give trouble.

These measures plus a service will usually restore the unit to good health. **D.C.W.**

### **Sharp VLC790H**

One of these units arrived with the cassette housing open and the mechanism in the eject mode. It would power up, and the E-E pictures were OK. We began by checking the mechanism alignment, which proved to be correct. We then set the mechanism to the stop mode manually and powered up. The cassette housing instantly

# Camcorner

opened and refused to close!

We now realised that this wasn't going to be as simple as we had at first thought. So we decided to check the syscon and mode motor circuits, and found that the A/D 5V supply to the mode control circuitry was missing. C802 (22 $\mu$ F, 16V) had leaked and corroded the print, thereby rendering the supply open-circuit between D804, pin 2, and Q810 (switch).

We replaced C802 then cleaned the damaged print and fitted a link across it. This time the cassette housing behaved as it should when the unit was powered up. **D.C.W.**

### **Sanyo VMD5P**

This uncommon model (to us, anyway!) had an E-E picture with striations and a low luminance signal level. Playback was similarly affected. The cause was (surprise, surprise!) a number of leaky capacitors on the main PCB. In all we had to replace 23 – after the usual washing session etc. with the PCB. This restored the unit to full working order.

The VMD5P seems to have been based on the earlier Model VMD3P, about which we've written before regarding its capacitor problems. **D.C.W.**

### **Canon E6E**

This is a hybrid model – part Sony (TR55 mechanism and main PCB). It was brought in because of a sound problem: the recorded sound would disappear and reappear at will, making life a little tiring for the owner (and me!).

There are two audio PCBs in this model. The fault was on audio PCB 2. After replacing C1215, C1216, C1219, C1223 and C1224 the unit provided a consistent audio level. **D.C.W.**

### **Sony CCDF340E**

We had to chuckle over this one. It arrived with striations on the E-E and playback pictures – the AV and EVF pictures were both affected. As usual, the cause was leaky capacitors. After replacing C494, C497 and C499 on the main PCB (VA41) we had clear pictures at the

AV connector, but the EVF picture was still covered with striations. The cause this time was C909 on the EVF PCB (good job we checked the viewfinder!). **D.C.W.**

### **Sanyo VMD9P**

No power up the report said. It's an unusual situation with this model – except for broken battery contacts! The cause was simply the 3A ceramic fuse F3001, which was open-circuit. We could find no cause for its failure. **D.C.W.**

### **Panasonic NVMC6B**

This VHS-C model wouldn't power up. We found that the fusible link (R1037) on the main PCB was open-circuit because zener diode D1003 was short-circuit. Replacing these two items restored normal operation.

To avoid further problems later we usually replace the mode encoder switch when servicing these machines. **D.C.W.**

### **Sharp VLC690H**

An E-E picture with striations is commonly caused by the failure of C210 (33 $\mu$ F, 16V) on the YC PCB. We recommend that all the electrolytics are inspected for leakage, as age is now taking its toll with these camcorders. **D.C.W.**

### **Sanyo VMEX220P**

Playback was OK, but there was no E-E picture: only vertical lines were visible at both the AV connector and the EVF in the E-E mode. It's not uncommon to experience connection problems between the CCD and the camera main (CA-2) PCBs when one of these popular machines has been dropped – the connector on panel CA-2 can become detached from the print. We checked on this first, and found that the connections were intact.

Checks around the CCD drive chip (SSG) then showed that two of the V drives were missing. The CXD1257AR timing chip IC916 was faulty, all other outputs being OK. A replacement chip restored the E-E picture, and a service completed the repair. **D.C.W.**

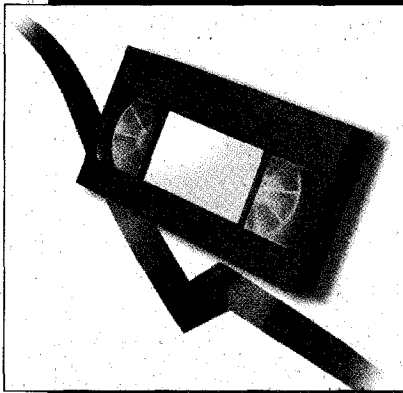

**Reports from**  
**Eugene Trundle**  
**Adrian Spriddell**  
**Paul Hardy**  
**Michael Maurice**  
**Nick Beer**  
**Chris Watton**  
**Terry Lamoon and**  
**Gerald Smith**

### **TDK Tapes**

A JVC HRD520 was brought in with the complaint that it would rewind only fifteen per cent of the tape, after which it would stop. Further goes with the rewind button had no effect. On test we found that the start-sensor photodiode voltage, which is normally 5V in darkness, fell to 3.8V as rewinding progressed. At this point the machine shut down.

The tapes were the cause of the problem. Four TDK ones, which were semi-translucent. When we shone torchlight through them we could see more light than with four other brands we tried. Hopefully this is a one-off batch problem. Has anyone else encountered this problem with TDK VHS tapes? **E.T.**

### **Akai VSG225**

One rare occasions the cassette cradle would oscillate to and fro when a tape had been ejected. It wasn't possible to make a definite diagnosis, but a new mode switch and start tape-end sensor (righthand side) cured the fault. **E.T.**

### **Amstrad DD8900**

There was no tape slack removal and the wind operations were erratic. As an alternative to a clutch arrangement, these decks have a limited drag lubricant applied to the reel arms during manufacture. With this machine the lubricant

# VCR Clinic

appeared to have become runny. As a result, it didn't apply sufficient torque to make or retain secure reel drive cog engagement. To resolve the problem we cleaned off the old lubricant and applied a coating of 'Kilopoise' which is available from Farnell. **A.S.**

### **Goodmans GVR3450**

Tape chewing is a problem we've had with several of these machines, because of a warped play idler arm which has fouled the cassette tray baseplate. The arm is actually a Daewoo part, from the G1 mechanism. It's readily available from SEME as deck YC item no. 33. **A.S.**

### **Amstrad TVR3**

Loss of the -27V supply from the VCR section prevented the TV section from working. We replaced zener diode D603 and the timer chip IC803, which was dragging down the -27V supply, fitting a 14DN487 in place of the 14DN332A, also the unnumbered 1N4148 protection diode that feeds it. After testing the unit for two days it was returned to the customer.

Two weeks later it was back again, with apparently the same fault. Couldn't be, we thought. But it was. All the same components had failed for the same reasons and were replaced FOC, this time together with the real culprit – the fluorescent display. **A.S.**

### **Sharp VCH81H**

This machine would sometimes fail to make a timed recording. It had been seen by two of my colleagues during the previous couple of months for the same reason. The power supply had been checked thoroughly and the machine had been given a service, yet here it was again on the bench with the same problem.

Bearing in mind all that had been done, I wondered where to start. In the end I decided to replace the mode switch, even though the other modes all seemed to be OK. The machine then tested OK – but it always did! We returned it and asked the customer to report back if any more problems were encountered. A phone call to him some months later proved that all was well. **P.H.**

### **Goodmans GVR5500**

Wind and rewind were very noisy – the reel idler kept jumping away from the reel turntables. The problem had been caused by a previous repairer, who had fitted an incorrect idler. I found that a refurbishment kit for the Sentra VX8500 had been used – because I attempted to use the same kit! It's the same superficially, but the reel idlers are slightly different when viewed from underneath. The Sentra idler has a larger diameter retainer disc, which fouls on the underside of the chassis as the idler reaches the end of its travel in the guide slot.

Spares for this model are available from Daewoo Electronics UK Ltd., Rathernraw Industrial Estate, 62-82 Greystone Road, Antrim, N. Ireland BT41 1NU (01849 469 696). **P.H.**

### **Akai VS55**

This machine was dead. As there was ripple on all the major supply lines I replaced C6, C10, C15 and C17 – they all measured low value when checked with a capacitance bridge. At power up the machine still refused to do anything and there was no clock display. There was no response to front panel or remote control commands, and the machine wouldn't accept a cassette.

Both the oscillators associated



with IC900 were running, but there was no serial clock or data and there were no pulses on the switch strobe lines.

As I was working on it the deck started to shuffle and finally initialised. Everything except the clock then worked. If the power was disconnected from the machine and it was left for half an hour, the above process would be repeated.

I suspected IC900. When I went to remove the fluorescent display to get at the chip one of the end legs fell off. Someone had obviously had a go, and had broken the display while trying to get at IC900 – which hadn't been replaced. Whoever it was had even attempted to solder the broken ends back on to the bits of leg that were still visible at the edge of the display!

I replaced both items, then confidently powered up. But there were still no functions. After half an hour everything started to work. The cause of the trouble was eventually traced to transistor TR104 on the main board – it was dry-jointed. I had to remove the board to solder the joints, which are hidden beneath a couple of cables. TR104 provides the BU5V supply for the operations panel. **P.H.**

### **Roadstar 7272**

This machine wouldn't drive the spools. The cause of the problem was the reel idler assembly. One of the pulleys incorporates a clutch assembly that makes it swing from the supply to the take-up spool. A new clutch assembly cured the fault. **M.M.**

### **Hitachi VTM640**

There was loss of capstan lock because the control pulses were missing. They were not low in amplitude but completely absent, though the AC head didn't appear to be worn. Scope checks showed that the gain of the control pulse amplifier was low. C631 (47µF, 16V) was responsible for this, a replacement curing the problem. It's in the feedback loop.

I subsequently had another machine with exactly the same fault. **M.M.**

### **JVC HRD820**

When a tape was inserted it would be loaded to the half-load position. If play was then selected the pinch roller would move down but the guides would stay where they were. On examining the underside of the mechanism I found that the pin and

circlip which held the plate assembly in position with the guide arm gears had come out. So I refitted it. Then, when play was selected, the machine jammed.

What had happened was that the machine had received attention elsewhere. The previous engineer had glued up the brass part of the entry and exit guides – and managed to glue the guides to the deck! I had to strip the guides from the deck, remove all traces of Superglue from the guides and the runners in the deck, then relubricate the runners and reassemble. This cured the problem.

If the brass part parts company with the guide, remove the guide, use one drop of Superglue and refit the brass part. Wipe any excess from the guide quickly. I normally remove the head drum assembly to refit the guides. Use the stoppers to attach them to the guide arm. Before returning the machine to the customer, check several times that the guides go to the play position fully. **M.M.**

### **Hitachi VTM830**

This machine was dead, with fuse F852 blown. When a replacement had been fitted the machine accepted a tape but wouldn't lace up. The XRA6209 (BA6209) loading motor drive chip had failed. After fitting a replacement I found that the machine loaded very slowly. The cause was the loading motor, which was taking amps off load! A new loading block, which incorporates the motor and mode switch, cured the fault. **M.M.**

### **Toshiba V705**

I've had a couple of brand new machines with no hi-fi sound. The cause of the problem has been that the lid earthing spring plate on the AV connection PCB across the back, behind the mechanism, is fitted incorrectly. The spigot is not located in the hole in the PCB, with the result that when it's fitted the earthing plate shorts out pin 1 of connector BN003 (the audio FF signal) to the lid. This means that the fault often clears when the lid is removed! **N.B.**

### **Akura VX150**

This machine gave the impression that its heads had failed. As a replacement upper drum was in stock we fitted it, but there was no improvement to the picture. Further checks, around the head amplifier, revealed the cause of the fault: the snap-fit connector that joins the foil wire from the lower drum was loose. Effectively, only one half of the drum was connected. All that was

required to restore the machine to full working order was to refit the connector. **C.W.**

### **Akai VS25**

The playback picture was marred by thin lines that looked like the result of RF interference. I'd had a similar problem before, caused by defective capacitors in the power supply, but the symptom remained as bad after replacing all the electrolytics. To cut rather a long story short, the cause of the trouble was the MSM9565-3 chip IC202. **C.W.**

### **Toshiba Core Deck VCRs**

If the problem with one of these VCRs is low gain or tuner drift, replace the tuner/modulator module. **T.L.**

### **JVC HRD860**

The complaint with one of these machines was that playback was sometimes OK, sometimes there was only half a picture and sometimes none at all. The cure is easy: replace the 4.7µF, 63V capacitor on the head drum PCB. This is becoming quite a common fault with these machines. **T.L.**

### **Toshiba V703**

There was no power and no display, no functions could be selected and a very slight whistle came from the power supply. A check on the supply lines showed that the Ever 14V supply was missing. The simple cause was that protector Z821 was open-circuit. **T.L.**

### **JVC HRD22**

Intermittent tape damage was the complaint with one of these machines. On investigation we found that when the machine stopped from rewind the brakes didn't come on. As a result, tape was spilled out inside the machine. The mode switch was the cause of the trouble. **G.S.**

### **Samsung VIK310**

When a tape was inserted this machine would sometimes jam and go to standby. Alternatively, when a cassette was ejected the indicator would sometimes keep flashing and the capstan motor would continue to turn. The mode switch was faulty. **G.S.**

### **Hitachi VT530**

There was sound wow in both the record and playback modes. The capstan and pinch roller were both fine. I traced the source of the wow to the clutch assembly. **G.S.**

# Camcorner

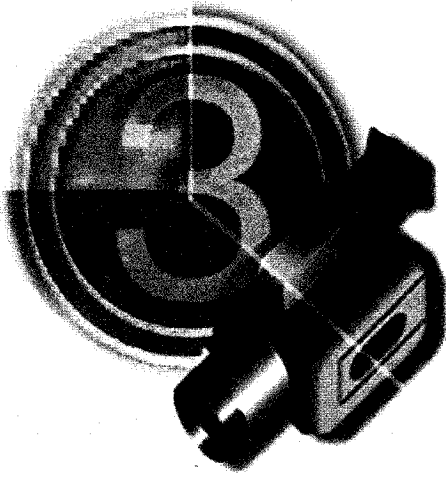

Reports from  
David C. Woodnott

## Sharp VLC690H

Although the E-E picture and playback of existing tapes were OK, there was no video recording. Sound was OK in both the record and playback modes. The cause of the fault was traced to the two 22 $\mu$ F, 35V surface-mounted electrolytics C945 and C946 on the main PCB. They had leaked and corroded the print beneath their contacts. After cleaning up, a link was fitted between pin 72 of IC801 (syscon) and pin 5 of Q935 (rec H SW). This restored normal operation. **D.C.W.**

## JVC GRAX5E

There was no power-up, nor were there any signs of life. The customer had mentioned a "burning smell" at the time of the failure. An inspection showed that D14 (DAN202U) on the main PCB had disintegrated, leaving only some charred remains to indicate its previous whereabouts. The main DC-DC converter had also been damaged – there was no regulated 8V output at pin 5. D14 feeds this supply to pin 3 of an 8-pin DIN socket to power the plug-in RF unit. The line is not fuse protected. A replacement DC-DC converter and diode restored normal working.

The cause of the problem is not uncommon, and can occur with other makes and models. At the time of the failure, the customer was about to transfer a recording to his new VHS machine via a DIN-scart lead. The fault occurred as

he connected this, because it earthed the 8V supply via the wiring to the VHS machine's scart socket. As we didn't have the VHS machine, we decided to disconnect the 8V supply at the scart end of the lead. The customer could still use his RF unit if required, but would hopefully not damage his camcorder again – in this way at any rate! **D.C.W.**

## Samsung VP10

There was a tape stuck in this machine, which was active electrically though eject was not possible. After extracting the tape manually, I dismantled the mechanism to allow an internal inspection. The mode switch had a missing tooth, and various parts were either 'bent' or misplaced. A replacement mode switch, slide plate assembly, supply and take-up arm pole assemblies and main roller cam restored normal operation. The deck is reasonably easy to work on but, like most current 8mm units, is rather flimsy and prone to bending if it becomes jammed for any reason. **D.C.W.**

## Canon A2HiE

This nice Hi-8 machine gave us a few headaches before it revealed its secret! It would power up and operate mechanically in both the record and play modes, but there were no output signals. Correction: in the E-E mode unlocked chroma would occasionally glide across the monitor's screen. In playback even this small sign of life was missing. As anyone familiar with these units knows, they are not all that friendly to work on – the three PCBs at the rear of the mechanism are mounted closely together one above the other. After gaining sufficient access to the video PCB to be able to carry out some checks, we soon found ourselves a little confused (nothing unusual here!).

Video from the camera section arrived at the processing chip IC201, but failed to emerge from it. At first we suspected the chip, as most measurable inputs, supplies etc. seemed to be in order. We then noticed that one input wasn't right. Pin 23 of IC201 is a clock input

that comes directly from the main syscon chip on the syscon PCB. The data signals on the same bus appeared to be OK, but the clock signal was absent.

We traced the line back to pin 16 of the main syscon microcontroller chip IC1601, where the correct signal (CGO/V clock) was present. After this it didn't take long to find the culprit, as only one component was involved: R1659 (1k $\Omega$ ) was open-circuit. It's on the main syscon PCB, on the reverse side of and directly behind IC1601. A replacement restored the pictures and correct operation. **D.C.W.**

## Hitachi E10E

No record picture was the complaint with this camcorder. Playback and E-E operation were OK. I found that C337 (47 $\mu$ F, 6.3V) on the main PCB had leaked. The affected area was cleaned and a replacement capacitor was fitted. On test the machine recorded the video signal, but when rewind commenced it stopped after a few seconds and the machine ceased to operate. The cause was leakage from the 220 $\mu$ F capacitor on the main PCB. **D.C.W.**

## Canon UC30HiE

This recent Hi8 model's playback was OK, but in the camera mode the picture gradually became darker then disappeared. A clue to the cause of the trouble was provided by the fact that if the machine was switched off then allowed to cool the same situation was repeated at power-up. This reminded us of a similar problem we'd had with a Canon camcorder about a year previously.

A quick check in our Camcorder Faults List (pages cut from the magazine!) led us to the culprit. Capacitor C2115 (1 $\mu$ F) on the camera processing PCB was found to be heat-sensitive. The original fault report related to **Model UC16**: the same component had failed in the same way. It just goes to show that keeping notes of fault symptoms and cures is a worthwhile exercise! **D.C.W.**

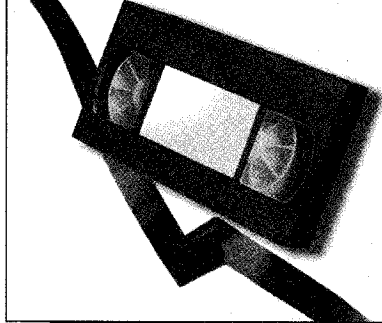

# VCR Clinic

Reports from  
**Philip Blundell AMIEEIE**  
**Alan Travers**  
**Bob Longhurst**  
**Brian Storm**  
**Gerald Smith**  
**Pete Gurney**  
**David Corcoran**  
**Roger F. White and**  
**Stephen Leatherbarrow**

## **Mitsubishi HSM58V**

This VCR had no on-screen menu. When menu was selected, all that appeared was a mass of lines. Tests on the plug-in OSD board soon revealed that the 17.73MHz crystal X501 was faulty. The part no. is 285P084010. P.B.

## **Grundig VS340**

A neighbouring dealer had recently given this machine a deck service. It now damaged the tape as the cassette was ejected. Tape guide 112 failed to return to the eject position because it caught on the pinch roller: the pinch roller return spring 48 had been fitted upside down. P.B.

## **Sony SLC9**

My latest restoration – it took so long that I could hardly call it a repair! – was to the local school's last Betamax VCR. The school has a lot of programmes on Betamax tape: now that the last working machine had lost its heads these couldn't even be copied over to VHS.

As you often find with an old machine, this one had another, intermittent fault. But the school had been living with it. Nevertheless before buying new heads I thought it best to find the cause of the fault, as the part responsible might no longer be available (the heads are available to order from CHS).

When the machine was switched on from cold, no deck function

would continue for more than three seconds: play, fast forward and rewind all terminated after a few seconds. Once the machine had been on for a few minutes the fault would clear and not reappear until next day.

A look through back issues of *Television* brought the suggestion that the deck state switches can give trouble. But a week spent monitoring them proved that they were without blame. I then checked the reel tach pulses. Sure enough the take-up reel tach pulses (the TFG signal at test point TP001) were missing in the fault condition. The voltages at the take-up pulse op-amp were found to be lower than those at the supply pulse op-amp. C004 (10µF, 16V) turned out to be leaky. The heads are now on order! A.T.

## **JVC HRJ235**

The cassette had jammed inside one of these machines, and the owner had somehow yanked it out. As it was my first encounter with this new mechanism, I obtained a service manual. A subsequent call to JVC Technical made me realise that this was not going to be an easy job. I was told to replace the guide-arm assembly, the pinch-roller assembly, the control cam, the pinch plate and, if it's not the uprated metal type, the lever assembly. Then realign the mechanism. Time to draw the curtains and take the phone off the hook. The job was successfully completed, some hours later, by following the instructions in the manual. Dry runs were also successful. Time to refit and power up. Great! Everything functioned – until the tape was ejected then pushed in again to play. A gear-grating noise came from the right-hand side of the housing. Then everything ground to a halt.

When I removed and dismantled

the cassette housing gears I found that one gear had mangled teeth. A telephone call produced the news that only the complete housing assembly is available. So I wrote to JVC. In response, I received a phone call giving me the part numbers for the damaged black and white gears. The 'drive gear' is part no. PQ35040, the 'helical gear' part no. PQ35039-1-2.

I have just had in another of these machines with identical faults, so maybe this is going to become a common problem. Anyway, ten out of ten to JVC for the company's invaluable help. B.L.

## **Toshiba V854B**

There was intermittent loss of the E-E sound with screeching noises at times. It didn't take long to discover that the MPX module was microphonic. Establishing the cause was not so easy. To work on the unit I had to solder some fifteen flyleads between its pins and the relevant PCB solder points. This provided 'live' working.

After much flexing etc. I discovered that crystal XD01 was dry-jointed. Resoldering restored correct operation. B.L.

## **Panasonic NVHD90**

This machine would sometimes accept a tape, try to load it, fail then eject it. My first suspect was the mode switch, but it proved to be innocent. Eventually arm P5 was found to be the culprit. Because it was slightly distorted, it would sometimes jam as it attempted to load. A replacement (part no. VXL2306) provided a reliable cure. B.S.

## **Panasonic NVV8000**

One of these machines had a mechanism fault. Unfortunately they have a dual VHS-C and standard-VHS cassette loading mechanism,

which means that the cassette carriage assembly is fairly complicated. It would jam – it seemed to stop between the two modes, after which the machine would power down. The main mechanism within the machine stayed in the VHS-C mode.

The cassette carriage was removed after a long struggle. I then realigned the many gears and levers. After that the machine worked consistently. I was unable to find any damaged gears or bent levers that could have been the cause of the misalignment, and was just grateful that the machine now worked. **B.S.**

### **Panasonic NVSD40**

This machine wouldn't record. Although it entered the appropriate mode, the expected recording didn't take place. A previous recording would not be affected, which proved that the full erase circuitry wasn't being activated either. Some basic checks in the record switching circuitry revealed that the 2SB710 surface-mounted transistor Q3007 was faulty, a replacement curing the trouble. **B.S.**

### **Nokia VR3716**

This machine would sometimes cut off in the record mode. The cause was excessive noise on the key-scan lines. To reduce this, fit two 330pF capacitors on the function PCB, at plug OA, between pins 4 and 6 and 3 and 6. Also check plug/socket OA/AO for bad connections. **G.S.**

### **Daewoo V22**

One of these machines was dead, the cause being low drive at the base of the chopper transistor. Replacing IC801 and Q802 cured the fault. **G.S.**

### **Samsung VIK326**

In the E-E mode this machine would sometimes produce a blue screen. The tuner and the 33V stabiliser were both OK. I traced the cause of the problem to bad contacts at the pins of the power supply plug and socket. **G.S.**

### **Daewoo V22**

There was sound wow in both the record and playback modes. The capstan and pinch roller were both OK. The cause of the trouble turned out to be the clutch assembly. **G.S.**

### **Sharp VCA105/615/60**

No operation because of a dead DD capstan motor is a problem I've had

on quite a number of occasions with these machines – the deck is of the type that requires a quick motor shuffle before initialisation is complete, hence the no operation. But before you replace the motor, it can pay to look a bit further. All references in the following note are to the DD motor PCB itself.

The M52440ASP DD motor drive chip is supplied with 12V (at pin 17) via the ribbon connector socket MC. Check the 10 $\mu$ F, 25V electrolytic capacitor next to this plug carefully. It's marked C6. On many occasions I have found that this capacitor has leaked electrolyte, which has rotted away the print between the connector and the capacitor, removing the supply to the drive chip. This is not obvious, as the print still appears to be intact. A check for 12V at the connector and at the positive end of C6 will usually prove the point.

The cure is to remove C6, clean the board thoroughly and, with care, fit a wire link to replace the open-circuit print. Then fit a sub-miniature replacement electrolytic. While I'm in this area I usually strip, clean and relubricate the capstan shaft.

The motor is used in several other Sharp decks and in quite a few Granada and Pye/Philips clone machines. **P.G.**

### **Panasonic NVF55**

The customer reported that one of these machines had "gone dead" after a local power cut. There was HT across C1103 in the primary side of the chopper power supply, but there were no outputs on the secondary side. The cause was traced to R1103, which was open-circuit. It provides IC1101 with a start-up feed. Replace R1103 and R1133 (both 220k $\Omega$ ). **D.C.**

### **Philips VR6290**

This machine came in with a cassette stuck inside. When I switched it on the tape wouldn't eject, and if any function was selected the clock display flashed on and off. I found that the power supply was pulsing because the CNX83A optocoupler IC7124 was faulty. A new CNX83A restored normal operation. **R.F.W.**

### **Logik VR950**

The E-E picture was very distorted, and part of it was blanked out. The cause was hum on the preset tuning voltage supply, which is identified as PRST VTG. Replacing C4 (47 $\mu$ F, 100V) cured the fault. **R.F.W.**

### **Hitachi VTM720**

Intermittent stopping was the complaint with this machine. It would sometimes go into play for only a few seconds then switch off. The cause of the fault seemed to be to do with the take-up rotation sensor. I inspected the deck PCB, looking for dry-joints, and thought that I had found the solution to the problem. But the machine was back a few days later with the same complaint. A new Hall effect chip, IC141, restored normal operation. **R.F.W.**

### **Ferguson FV32**

Tape chewing was the complaint with this machine. When I tried it none of the functions worked. The cause was a wire broken off the loading motor, which made me think that someone had been there before me. After reconnecting the wire I selected play. A strained sound came from the tape, so I removed it and inserted an empty cassette. When play was selected I could then see that the take-up spool was rotating at the full fast-forward speed. The faulty component was the MC14094 chip IT62. **R.F.W.**

### **Sanyo VHR291**

This machine would stop when in play. Although the take-up sensor was working, it wasn't producing a regular series of pulses. The strange thing was that when the machine was turned on its side or upside down it played all right. The increased space between the bottom of the reel and the faulty sensor somehow improved its response. A new sensor cured the fault. **R.F.W.**

### **Granada VSHS5**

This Sanyo-based text machine had a tape stuck inside and wouldn't respond to any button pressing. Without a manual it was with some difficulty that we arrived at the 2SD1207 transistor Q5402, which was short-circuit. It appears to provide a switched 12V supply. A nearby 47 $\mu$ F electrolytic was open-circuit.

After replacing these items we gave the machine a soak test then returned it to the customer. It was back a week later, again with Q5402 faulty. This time however there was a short-circuit across the supply. We traced the cause to the RF modulator – the short came and went when pressure was applied to its case. To be sure, we replaced this unit. **S.L.**



## Reports from David C. Woodnott

### Sony CCDF550E

The E-E picture was marred by striations and scrolling clock/date information. The cause of this was traced to C717 (22 $\mu$ F, 16V) on PCB CT21. A replacement capacitor and service restored normal operation. **D.C.W.**

### Sony AC88P and BCA80

This AC adaptor and separate charger plate combination was brought in to be checked because of poor charging. The AC88P was OK, but the adaptor unit wouldn't charge a battery. It has provision to charge from one to three batteries in sequence automatically. The usual cause of such failure is that the three protection thermal link fuses are open-circuit, as they were in this case. Replacing them restored normal charging. It's as well to check the customer's batteries, as the most likely cause of the problem is a short-circuit battery. **D.C.W.**

### Hitachi VM500E

These full-size camcorders often arrive with complaints about intermittent mechanical operation. As previously reported, they respond well to replacement of the mode switch, belts and pinch roller assembly. This particular one required slightly more attention, for which we'd not estimated because of the "I know what that will be" attitude – we never learn, do we?

A tape was stuck in the mechanism, and no functions were available. Internal inspection revealed that the mechanism retaining plate, which holds all the gearing etc. together, had become almost

# Camcorner

detached from its normal site because the three screws that hold it in place had become loose. After removing the tape manually we had to replace the loading motor holder and worm-gear assembly, which had suffered badly from its experience. The M45454B loading motor drive chip also had to be replaced. This is the same chip that's used in the Panasonic NVM7 etc. – so we had one in stock! These measures restored normal operation, though at a somewhat lower profit margin than we'd anticipated. **D.C.W.**

### Sony CCDTR305E

This model seems to suffer more than most from corrupted or missing memory data. The symptoms could be very confusing if a means of checking the data was not available. In this case the symptoms were monochrome E-E pictures with reduced height (NTSC mode?) and no playback signals. The mechanism performed normally. The cause of the problem was that the page D data was missing from the memory. All was well when this data had been reprogrammed.

We've had similar though not always exactly the same symptoms with this model before. The cause of the failure has never been found. The camcorders have all continued to operate after reprogramming. **D.C.W.**

### Hitachi VME31E

This handycam style unit didn't power up and there were no functions. The ceramic fuses (F551 and F553, both 1.6A) on the power supply PCB had failed. The cause of the failure was the fact that the mechanism had become jammed, damaging the loading drive chip IC909. Once this chip had been replaced and the mechanism had been repaired all was well – the supply loading arm had become detached from the coaster assembly, which is a common fault previously mentioned in this column. **D.C.W.**

### Hitachi VME1E

In a previous report a while back I said that capacitor leakage prob-

lems are uncommon with this model. The report related to a capacitor in the power supply. At the time I wrote "we hope not to regret having said that the fault was unusual". Well I do now regret saying that, having had several of these units in since then with leakage-caused faults.

Several 47 $\mu$ F capacitors on the camera head (sensor) PCB are prone to leakage. So are several others on the main VCR PCB. C406 (100 $\mu$ F) in particular causes problems – E-E and playback picture disturbances (pulling on whites, sync cramping – you name it!).

Will this model follow the Canon E60? With the E60 you need to replace all the electrolytics to achieve a viable, long-lasting repair. **D.C.W.**

### Canon UC1000E

We received two of these camcorders from the same source and with the same fault symptoms – neither would power up or show any semblance of life. One of them had stopped recording the sound prior to its complete failure, but had been OK otherwise. Internal inspection showed that in both units the 2A ceramic fuse had failed.

As no short-circuits could be detected, new fuses were fitted and the machines were then tried. They both powered up and worked in all modes, except that one of them did not record the sound. The cause of this turned out to be a faulty microphone, a problem we've had previously with similar models. The fuse failure couldn't be explained initially, as the units continued to operate on extended test. We were using our bench power supplies.

The camcorders had come in their cartons, with one AC adaptor and DC connector between the two of them. The charger was OK, but when we checked the connector assembly we discovered the cause of the fuse failure. It had been assembled with the polarity of its contacts reversed! As it's a sealed unit, a replacement was required. We informed Canon in case other units are affected. A good job the unit was in the box! **D.C.W.**

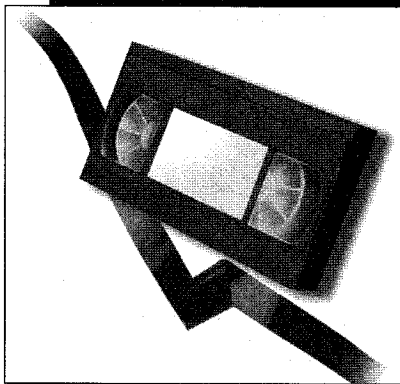

**Reports from**  
**Richard Flowerday**  
**Shane Humphrey**  
**Eugene Trundle**  
**Michael J. Cousins**  
**Stephen Webster**  
**Terry Lamoon**  
**Michael Maurice and**  
**Adrian Farnborough**

### **Panasonic NVHS1000**

The customer complained about poor results from the AV1 scart socket – the machine was used extensively for tape copying. He also mentioned that the standby light didn't come on when the VCR was switched off using the handset.

On test we found that AV2 operation worked perfectly, but the E-E signal via socket AV1 was very weak and grainy with loss of sync. The cause of the trouble was the input switching chip IC3901, whose AV1 input pin had developed a leak to chassis. Replacing this chip also restored normal operation of the standby LED – the chip has an always 12V supply and a switched 12V supply and had developed an internal leak of some 20Ω between the two.

As we've experienced the problem previously, it occurs to us that static from an external source can damage the chip. **R.F.**

### **Panasonic NVG21**

Occasional picture rolling was the complaint with this machine. When the fault occurred a band of noise would move slowly down the picture, which suggested that the control pulses were missing. This was confirmed by a scope check at TP2002 on the main PCB. So we turned our attention to the servo pack. The fault came and went when this was alternately heated and frozen. We eventually traced

# VCR Clinic

the cause of the trouble to the 10μF, 16V coupling capacitor C240. What would we do without freezer?! **R.F.**

### **Panasonic NVHD605**

There was a tape stuck in this machine and the error message H02 was present in the front display. This indicates a capstan drive problem. Replacing the capstan motor's stator unit (part no. VEK5927) restored normal operation. **S.H.**

### **Samsung VI611**

One of these machines produced a blank, black screen when you tried to either play a tape or view a TV channel via the VCR's tuner, the symptom being present with both RF and AV outputs. We found that the PC 12V supply from the regulator had massive ripple on it. C6 (2,200μF, 35V) and C7 (47μF, 16V) both looked very unhappy. They had dried out because of the heat from a nearby large heatsink. Two new capacitors restored the pictures.

Here are a couple of other faults we've had with these machines:

(1) Channel indicator and/or power light stays on when the machine is switched to standby. Transistor Q2 (KSA634H) short-circuit emitter-to-collector.

(2) Lines across the picture and distorted sound when using the machine's tuner. The PC 12V supply had risen to about 17V because the 12V regulator IC1 was faulty. **S.H.**

### **Panasonic NVSD200 (K Deck)**

We've seen the following symptoms several times since the warmer weather arrived: a stuck tape, sometimes with the error message F06 present in the front display. In almost every case the cause has been a 'warped' right-hand side

arm on the main shaft unit (part of the cassette housing mechanism). There is a tendency for this to warp, particularly when the machine is used in high ambient temperatures. Replacing the main shaft unit (part no. VXP1339) usually restores normal operation. Apparently an improved part is now used in the K deck. **S.H.**

### **Sanyo VHR135E**

We've had several of these machines in with the same problem: intermittent loss of front-panel power and eject key operation. In every case the cause has been poor soldered joints at the pins of the connector (CN702) between the two front PCBs, TM1 and TM2. **E.T.**

### **Broken Flaps**

Although this hint relates specifically to the **Amstrad Model VCR4700**, it could apply to many other models in various brand ranges. When the control flap/door's latching spigot breaks off, the door keeps falling open. More often than not you find that the spigot is no longer available as a spare part.

I have overcome the problem by removing the flap and inserting one, two or three split plastic washers (of the type commonly used on decks) as necessary on the hinge shafts. They increase the friction, so that the flap is stiff enough to stay up when closed.

This hint is presented with pride: it won our "workshop badge of the year"! competition for 1997. **E.T.**

### **Tatung TVR634/734, Matsui VP9301 etc**

When the little plastic spigot in the front left-hand corner of the deck becomes worn or broken there is excessive tape back tension. Various symptoms can arise. It's

part of the brake-release mechanism. E.T.

### **JVC HRS5800**

This S-VHS machine came via another dealer. It had a tape jammed inside. After extracting this and carrying out a timing reset I stripped down the mode switch and cleaned it. But when the machine was switched on again with no tape inserted it tried to eject then shut down. The machine wouldn't power up from the front control, but would come to life when the mains supply was switched off then on, with pulses briefly resetting the microcontroller chips.

The cause of the trouble was eventually traced to ribbon cable CN601, which connects the mechanism control to the deck board. There was lack of continuity at pins 15, 17 and 18, with the data connections to the mode switch affected. Once good connections had been established the machine powered up normally.

When a signal was connected however there was no E-E sound (no, the machine was not set to simultaneous). The audio board is underneath, and when the bottom cover complete with 'power bulge' is removed it is very vulnerable. Resoldering a few dry-joints here finally restored normal operation. M.J.C.

### **Amstrad VS1000**

This machine was dead. Unfortunately I don't have a circuit diagram, which made fault finding difficult. An investigation inside the power supply can revealed a blown mains fuse and a short-circuit STRD6008X chopper/regulator chip. On the secondary side of the chopper power supply there was a short-circuit 20V zener diode.

If you are not familiar with a particular circuit, a comparison with a similar one and its faults can be helpful. With the Panasonic NVJ35, failure of the 20V zener diode D1113 is usually caused by a 47µF capacitor (C1114) going low in value. The Amstrad machine has two 47µF capacitors on the primary side of the chopper circuit. They were both low in value. Replacements restored the machine to life.

This was not the end of the story however. When a satellite signal was connected the results were appalling, with weak sync and failure to decode encrypted channels. Inside the caged satellite board I found a number of blue-grey electrolytic capacitors which were all

either open-circuit or low in value. One of the offending capacitors was CA05 (100µF), which was mentioned in the January 1996 Satellite Notebook. M.J.C.

### **Hitachi VTM840**

There was a tape stuck in this machine. Its control panel buttons had little effect, and the standby and operate LEDs were illuminated at the same time. In addition the word 'test' was present in the clock display. One of the three keyboard leads to the LED panel was open-circuit, probably because of fatigue from the hinged control panel arrangement, and there were dry-joints at more than one ribbon connector socket to the main PCB. Fitting a new lead and reflowing the PCB connector joints restored normal operation. S.W.

### **Matsui VP9401**

The customer complained about occasional ripples on the playback picture. When the machine was tested, the symptom appeared after several hours' operation. On investigating the mechanism I noticed that the tension arm was bouncing. A slight touch settled it, and the ripples then disappeared. As the tension arm looked a little mucky I replaced it and reset the tension. This cured the problem. T.L.

### **Sony SLV373**

This machine would stop in rewind or fast forward. A check on the waveform in the reel sensor circuit showed that its amplitude was very low. New sensors restored the waveform to normal and cleared the fault. T.L.

### **Toshiba V703B**

There was no display though everything else worked correctly. I initially suspected the display itself, but then found that the -24.5V supply was missing. A ZX10 device provides protection: it had gone open-circuit. T.L.

### **Matsui VCP5601**

This machine wouldn't accept a tape and the front LED was very dull. A check on the LT lines showed that the NO 6V supply was missing. Regulator IC111 was faulty - a replacement restored normal operation. T.L.

### **Aiwa HVG150**

There were tape speed problems. You could see that the reels rotated sluggishly and were dragging. A check on the braking system

revealed that the sub-brake assembly was broken. It's situated under the cassette housing assembly. The replacement was inexpensive and restored normal operation. T.L.

### **Ferguson FV68TX**

This machine appeared to be dead but was actually tripping. The cause was CP11 (220µF, 25V) which had dried up. A replacement restored normal power supply operation. M.M.

### **JVC HRJ205**

The customer complained about tape chewing. On inspection I found that although the idler turned when the capstan motor was rotated it didn't swing between the spools. The idler's retaining circlip had come off and the various bits were lying in the machine. I didn't want to chance refitting the parts to the old idler as new ones are readily available. A replacement restored normal operation. M.M.

### **Panasonic NVG12**

As this machine required a service the Panasonic VUD4103 maintenance kit was fitted. After doing this I found that there was a grinding noise and no drive when either rewind or fast forward was selected. So I stripped the gears on the underside. When the sliding gear was removed there was a lot of dirt and hair on the shaft. This prevented the gear from making contact with the idler gear. Cleaning out the muck, lubricating and reassembly cured the problem. M.M.

### **Mitsubishi M16**

This machine would occasionally refuse to accept a cassette. It would also, again very intermittently, go into standby after ejecting a cassette.

A new mode switch made no difference, but removing and then refitting the cassette housing cured the fault for quite a long time, providing a clue to the cause of the trouble. The start sensor Q571 lurks under the deck, just to the left of the mode switch. It was clearly dry-jointed. A.F.

### **Mitsubishi HSB10/20**

The symptom with one of these machines was severe playback colour dropouts. Fortunately for us an item we checked and replaced at an early stage in our proposed diagnostic investigation was the LA7331 chip IC6A0. This cleared the fault. A.F.

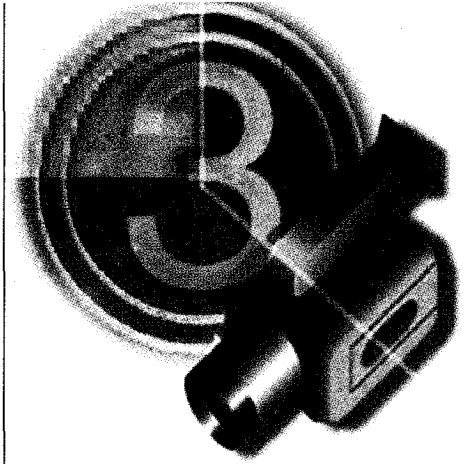

**Reports from  
Brian Storm and  
David C. Woodnott**

**Panasonic NVR50**

This C-cassette model incorporates a colour viewfinder. The problem was erratic colours, sometimes all red and sometimes covered with lines. On test we found that the fault could be cured by moving the viewfinder. The cause of the trouble was eventually traced to a hair-line crack across the ribbon cable between the viewfinder and the main PCB. Its part no. is VWJ0739. **B.S.**

**Sony CCDF555E**

The complaint with one of these camcorders was "striations on the viewfinder picture". Replacement of C909 (1µF) on the electronic viewfinder PCB cured the fault. A general service completed the repair. **D.C.W.**

**Canon UC40HiE**

No eject was the complaint with this recent slimline model. There was a tape in the mechanism. When the eject button was pressed the mechanism shuffled then returned to its initial state. With units that use this mechanism it's fairly common for the supply reel spindle to become bent. This leads to various mechanical faults such as no tape eject, stopping in any mode with "eject" flashing in the viewfinder, and excessive back tension (because the underside of the reel is in continuous contact with the chassis). In this case however the reel spindle was OK.

The cause of the trouble was a faulty capstan motor FG sensor.

# Camcorner

The point worth noting is the apparent reason for its failure. When we removed the motor and inspected it under a microscope we could see that the surface of the sensor was scored across in the direction of motor rotation. Grains of sand were evident: they were stuck to the sensor – and everywhere else! A new motor cured the problem.

Since that first one we have had two similar models in with failed capstan FG sensors, both with score marks across the surface and evidence that sand/grit was the cause. One of them had come in because of a detached grip strap and worked all right until it failed during a soak test! Life isn't fair, is it?! We had to replace this one FOC, but have now learnt to inspect and clean the sensor unit whenever we get one of these units in for repair. This avoids similar, expensive problems. **D.C.W.**

**Sony CCDTR305E**

The customer thought that his handycam's on/off switch was faulty and was pleased when we agreed with his diagnosis. He wasn't quite so pleased at the cost! The complete operation assembly (switch block control), which includes the aforementioned switch, was required. The fault symptoms were as follows: no camera power up; power up in the VTR mode OK but no functions available. **D.C.W.**

**Canon E600E**

This fairly recent model (July 1992) displayed the all too familiar capacitor leakage symptoms we have experienced with earlier Canon models (E60E etc.), i.e. intermittent playback colour and so on. Internal inspection revealed that we would have to replace a total of 48 capacitors to avoid subsequent failure – they were all showing signs of imminent leakage. The estimate was accepted, and we completed the work successfully. It's worrying when such relatively new units suffer from this type of problem.

We have since had others in the

range (E200 etc.) with significant capacitor failures. **D.C.W.**

**Sony CCDV900E**

This early Hi8 machine came in because it was "dead", which it certainly was! As I had not seen many of these camcorders I thought I'd try to save a bit of time by looking through my collection of fault reports from previous issues. I was not let down. A previous report (no on command to the DC-DC converter etc.) mentioned IC101 on board FP10P. A replacement chip cured the fault. Thank you whoever contributed that report!

I have since come across the same fault in other Sony camcorders (Model V600E) which use this chip in the same way, so it's worth noting.

Another V900E came in recently because of intermittent iris operation, no autofocus and intermittent E-E pictures (vertical lines only, of the type you get when there is CCD or SSG drive failure). As anyone who has worked on the camera section of an early Sony camcorder will know, it can take a considerable time to get at the innards – because various screening cans have to be unsoldered etc. When I was finally able to inspect the relevant PCBs I found that there was severe capacitor leakage.

A quick look at the mass of similar capacitors on the deck PCBs revealed the same state of affairs. We advised the customer that in our opinion repair was not worthwhile, because of the high risk of subsequent failure in almost any circuit area. Thankfully our advice was taken.

More and more models of all makes of this vintage are falling victim to the leakage problems so often reported in these pages. Because of the high cost of replacing maybe 80 or more components, and the risk of finding severely corroded print etc., we are reluctantly advising customers that to repair their 'old friends' is in no one's interest. Comments on this would be welcome. **D.C.W.**



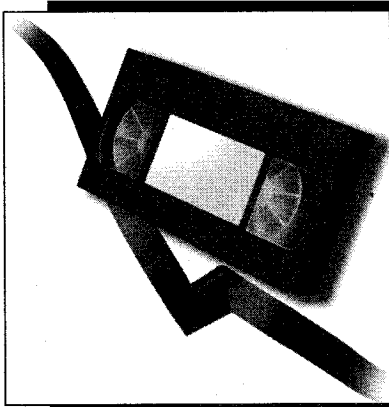

Reports from  
**Philip Blundell, AMIEIE**  
**Robert Marshall**  
**Ronnie Boag**  
**Pete Gurney, LCGI**  
**Adrian Farnborough**  
**Brian Storm and**  
**Maurice Kerry**

### **Toshiba V423**

The sound would mute and field sync would be lost when there was a lot of white in the picture being played back. A scope check at pin 1 of the mute chip showed that with the pictures concerned the video signal had no sync pulses. When I traced back along the circuit to find the source of this input I came to an AN3248 luminance processing chip. To cut a long story short, I eventually found that the associated 3.3 $\mu$ F electrolytic capacitor CN09 had fallen in value. **P.B.**

### **Philips VR727**

A tape would sometimes jam in this machine, with the loading motor in operation but unable to fulfil its purpose. A replacement drive belt seemed to cure the problem, but the fault recurred. With the power off, the loading cycle could be performed without any problems, but insert a cassette and there was lock up.

The cause of the trouble was eventually traced to a wonderful Philips innovation, the 'intermediate lever'. It sits under the arm mechanism, controlling the tape in the capstan and audio/control head area. You see it as a flat bit of plastic (item 32 in the Philips diagram) that goes over part of the main timing gear. Take it out and look at its underside. There's but a

# VCR Clinic

single tooth – in this machine half a tooth. Philips, which is always "Years Ahead", is ready for you with Service Kit F. It contains parts 29 to 32. **R.M.**

### **Sony SLV425**

This machine was playing dead – it couldn't be switched on. The operate switch had no LED indication, but the drum was twitching. Suspicion fell on the power supply, where C5030 had fallen in value. It should be 47 $\mu$ F but read only 2 $\mu$ F. **R.M.**

### **Ferguson 3V43/JVC HRD725**

Playback picture dropouts appeared on the screen in exaggerated form instead of being filled by the dropout compensator. IC8 in the dropout compensator circuit switches between the main (pin 12) and delayed (pin 6) signals. When a dropout is recognised, IC4 generates a switching command (at pin 15) which is sent to pin 14 of IC8. The delayed signal is produced by IC9 (type TL8704P), using charge-coupling techniques. There was an input at pin 11 of this chip but no output at pin 7. So IC8 had been switching to nothing instead of the delayed dropout fill-in signal. A new TL8704P chip from Willow Vale cured the problem. **R.M.**

### **Samsung VIK350**

When this VCR was powered the supply reel would turn for a few seconds, the lift would shuffle then the machine would go to standby. The problem was cured by replacing the lift side chassis and attending to dry-joints on the LED tower. **R.B.**

### **JVC HRD820**

Tape spilled from the spool in the reverse search mode. There was no

further trouble once we'd replaced the mode state switch. **R.B.**

### **Daewoo V2000**

The customer complained about wow with the playback sound. A new back-tension band cured the wow. **R.B.**

### **Nikkai J2**

The 800mA fuse in the power supply had blown and there was a hum bar in the E-E mode. Normal operation was restored by replacing the fuse and the 100 $\mu$ F, 50V electrolytic capacitor in the power supply. **R.B.**

### **Philips VR2547**

This machine would shut down after three seconds in play. It uses a permutation of the deck mechanics originally designed for JVC 540/560 series VCRs. In this case the cause of the trouble was a faulty take-up sensor, something that's quite common with the earlier JVC machines.

Note that in this machine the tape-end stop sensors are mounted on the deck PCB, not on the cassette lift, with two plastic light guides for coupling. To prevent the sensors operating and causing additional, misleading symptoms, shield the deck from strong light while working with the lid off. **P.G.**

### **Mitsubishi HS621V**

It was not possible to load a cassette and, under certain lighting conditions, the cassette housing (more correctly the 'bottom unit') would shuttle forwards and back – reminiscent of something useful in the cotton industry a couple of hundred years ago!

After a time spent delving amongst the many optical devices used on this deck I found that D5B5 was faulty. It's a LED-type

device, part no. SLR-932C-20-AB-TI. A.F.

### **Mitsubishi M16**

This machine would accept a cassette but the loading arms would arrive at the V blocks with the tape left behind. In addition the pinch roller didn't engage with the capstan. Feeling fairly perplexed, I replaced the mode switch. This didn't make any difference. Checks were then carried out around the M37420M6-490SP microcontroller chip IC5A0. It appeared to be at fault and a replacement cured the problem. A.F.

### **Panasonic NVHS1000**

Poor slow-tracking performance was the complaint with this machine: random noise bars would appear in the pause and slow jog modes. Everything else worked perfectly. Having had trouble with the capstan motor in other K mechanism machines I tried a new capstan stator (part no. VEK5927). Fortunately this cured the fault. B.S.

### **Panasonic NVHD605**

There was no loading motor operation. Even when the test modes were accessed the motor stubbornly refused to rotate. Checks around the loading motor drive chip IC2001 showed that there was no voltage at pin 7, where the loading motor drive torque is controlled. The cause of this was C6002 which was short-circuit. It's an 0.22 $\mu$ F surface-mounted electrolytic.

I subsequently had a similar machine with weak loading motor drive. C6002 was again the cause, but this time it had developed an unhealthy leak. B.S.

### **Panasonic NVSD200**

One of these VCRs permanently displayed fault code F06 at the front. On investigation I found that the main right-hand side carriage loading arm had bent away from the carriage and become jammed against a metal guard. The reason for the distortion became apparent when a new loading shaft assembly (part no. VXP1339-1L) had been installed.

When a cassette is inserted, Q7 lurks beneath the nylon loading arm. In fact it almost touches the arm – and it gets very, very hot! The replacement loading shaft assembly is an improved version, but it is still made of nylon and Q7

still gets very, very hot. I judiciously tilted Q7 away from its original position and hoped for the best. B.S.

### **Panasonic NVHD605**

There was no display and the drum was rotating at a very high speed. The 2SD1330 transistor Q1004 in the power supply had failed. B.S.

### **Panasonic NVFS100**

In the S-VHS mode this machine recorded a blank picture, though playback was perfectly good. I hooked up an oscilloscope to trace the signal through the congested luminance and chrominance pack and found that it faltered at the ceramic module IC303, where a corroded capacitor told its own sorry tale. The module is available under part no. VCR0389. A replacement restored the S-VHS recording facility. B.S.

### **Panasonic NVHD660**

This machine's on-screen menus and tuning signal were incorrectly coloured and rolled down the screen. I suspected IC7705, which is the PAL encoder for the OSD information. But the culprit turned out to be the surface-mounted capacitor C7703 (0.22 $\mu$ F), which is connected to pin 12 of IC7705. It was badly leaky. B.S.

### **Panasonic NVHD605**

This machine would accept a cassette then eject it almost immediately. The cause of the rejection was a problem in the capstan motor circuit. The motor rotated at high speed but failed to tell the system control circuitry that it was working: at this point the tape was ejected. C2043 (0.47 $\mu$ F), a surface-mounted capacitor in the FG feed circuitry, was eventually found to be short-circuit. B.S.

### **Panasonic NVSD410**

This VCR wouldn't complete the auto-tune operation, though stations could be tuned in by using the manual method. After much tearing of hair and grinding of teeth I eventually found that C7708 (0.1 $\mu$ F), which is connected to pin 7 of the teletext processor chip IC7708, was leaky. It's a surface-mounted capacitor. B.S.

### **Panasonic NVJ35**

Standard-speed recordings were played back as though they had been recorded in the long-play mode – with no colour in the trick modes and wide noise bars in cue

and review. After much chasing around in the servo circuitry I found that the surface-mounted, 1.5k $\Omega$  resistor R2302 was open-circuit. It had developed a hairline crack at one end. B.S.

### **Panasonic NVHD660**

The E-E picture was too light and crushed while the playback picture had no colour. The TDA9725 luminance and chrominance signal processor chip IC302 was faulty. B.S.

### **Daewoo V50**

The customer had complained about a "poor picture". We found that the drum speed was erratic and that when it did manage to lock the picture the colour was noisy and the picture jittered from side to side. In the stop mode the drum ran but was unstable: this could be heard as a pulsating buzz on E-E sound.

A scope check on the 12V motor supply showed that bursts of HF were superimposed on it. Replacement of C853 (47 $\mu$ F, 25V) cured the fault. It's as well to check C855 in the same area. M.K.

### **Maxell VR2100 (Sanyo deck)**

Tapes were being chewed because the supply brake was on in the playback mode. The brake pivot shaft had broken at its base. To repair it we inserted a thin screw from below through the base into the pivot shaft, thus securing it. This cured the fault. M.K.

### **Ferguson FV71LV (R3000 Chassis)**

Two power supply faults took us a little time to track down. When the VCR first came in it had a tape stuck inside and there were no functions. Checks in the power supply showed that it was tripping. The power supply can be run outside the machine. When we tried this it was still tripping. The over-current sensing resistor RP18 (1.5 $\Omega$ , safety type) was eventually found to be the cause. It tested OK, but a replacement cured the fault.

The machine came back again later with the complaint that it was dead. This was not true. The display went out when the VCR was put into standby. When it was brought out of standby the display came on. The cause of this was CP41 (220 $\mu$ F, 10V) which supplies the display filament. It had gone low in value. M.K.

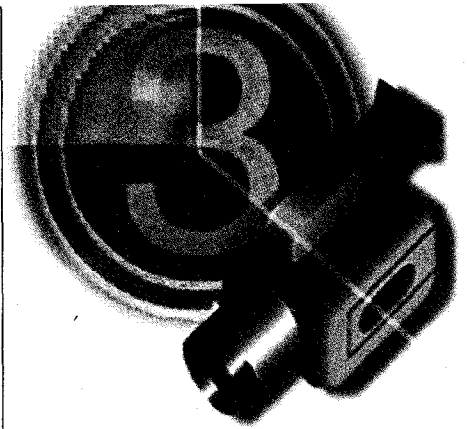

# Camcorner

Reports from  
David. C. Woodnott

## Samsung VPU12

We were told that the tape would "run on" all the time when the unit had been switched on. The cure was a replacement capstan motor – the FG sensor had failed. It's becoming a common problem with units that use this mechanism. D.C.W.

## Sony CCDTR55E

Intermittent monochrome playback was the complaint with this machine. The loss of colour appeared to be related to the length of time the machine had been in operation. Capacitors C203, C204 and C206 on PCB VS37 were the culprits. They were all leaky, and

had contaminated the print with electrolyte. A clean up and three new capacitors cured the fault. The luminance signal level had also been affected, but the customer had apparently not noticed this. D.C.W.

## Sony CCDTR50E

No viewfinder picture was the fault with this early Handycam model. The cause was C924 on the EVF PCB. Not a surface-mounted type this time: it's a 68µF, 16V radial electrolytic capacitor. A service completed the repair. D.C.W.

## Canon UC15E

This camcorder would power up and produce E-E pictures, but wouldn't operate mechanically. Loading/unloading was possible when the loading motor was powered from an external source. The MPC1720 loading drive chip IC1006 was faulty. It's on the power supply PCB at the rear of the unit and is thus unusually easy to get at. A replacement restored normal operation. D.C.W.

## Sanyo VMD6P

The fault report said "playback marred by a noise band at the bottom of the picture and flashing white lines". Tracking faults are

generally very rare with this Sanyo mechanism – except when there has been an impact of one sort or another. The drum assembly is sprung, and if knocked can assume a curious 'angled' position that gives rise to the noise-band symptom.

A small amount of corrective pressure will usually release the assembly so that it returns to its normal position. The 'flashing lines' were dropouts caused by failure of C2106 (10µF, 16V) on the main PCB. D.C.W.

## Panasonic NVM7B

This old timer worked in all modes but wouldn't record pictures on tape (sound was OK). Everything seemed to be all right when record was selected – the mechanism operated correctly and 'REC' appeared in the EVF – but nothing was recorded. The cause of the trouble was open-circuit print, as a result of which there was no 9V REC supply at the emitter of Q026 from the collector of Q6003 (9V switch) in the syscon PCB area.

A wire link cured the trouble. The PCB was cleaned in case there had been capacitor leakage problems – the exact location of the break couldn't be determined. D.C.W.

## JVC GRAX7E

There was a mechanism problem with this unit. It had failed because the supply side guide rail base was broken. After fitting a replacement assembly I checked the mechanism by powering the loading motor from an external source. It seemed to work all right, but when the unit was powered up normally and a tape was inserted it loaded half way then a clicking noise came from the mode motor. I dismantled the motor and found that there was a damaged plastic gear in its attached gearbox. So, with growing confidence (misplaced!) that all would be well, a new motor unit was fitted.

When an attempt was made to load a tape it once more stuck at the half-way position, then unlaced – this time, thankfully, without the gearbox noise. The cause of the trouble was this time found to be the M54543 loading drive chip, which behaved in a very unusual way. It would drive the mechanism correctly until the point of maximum torque was reached (as the pinch roller assembly began to move). It would then fail to produce the drive current required and abort the

sequence. Once a new chip had been fitted all was well – except for the estimate, but you can't always get it right!

The unit was finally serviced, tested and returned to the customer, who immediately took in on holiday with him. A few weeks later he called to say that the unit had worked well on his holiday and that he was pleased with the repair. Good, I thought – but?! Well the only problem was that the tape remaining display and counter occasionally "did funny things".

On test I found that the counter would intermittently stop, miss a few counts then continue. The tape remaining data was also erratic. The cause of this problem was the supply reel which, during the previous trouble, had scraped the deck, damaging its alternate reflective/black surfaces. There was a circular scratch that exposed more reflective surface than was required. This was a bit confusing, as the mechacon didn't register a faulty reel pulse train and stop the normal tape transport operation. A new reel cured this final (I hope!) problem. D.C.W.

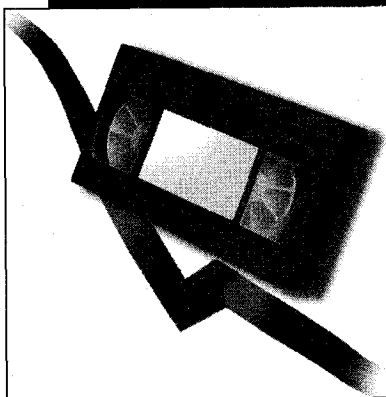

**Reports from**  
**Alan J. Roberts**  
**Roger Burchett**  
**John Coombes**  
**Terry Lamoon**  
**Stephen Leatherbarrow**  
**and Pete Gurney, LCGI**

### **Philips VR813 etc**

No display with all the functions working has been the fault with several of these machines I've had in recently. In each case the cause has been failure of the 315mA fuse that feeds the fluorescent display. No other fault has been found and a replacement Wickman fuse puts things right. **A.J.R.**

### **Sharp VCR8300**

This very old machine was still in excellent condition. It would switch on but did nothing else. The drum drive belt had perished, and the loading arms were halfway up. I replaced the belt, but when I tried to wind the arms down manually I found that the loading motor had seized solid. It's not in the most accessible of places, but by careful manoeuvring I managed to extract the loading motor assembly. A search in my junk box produced an almost identical motor from an old lift assembly. It fitted perfectly, and when the assembly was replaced the machine came to life and worked surprisingly well. **A.J.R.**

### **Goodmans TX3950**

The customer had tried to retune the modulator to avoid Channel 5 interference. I don't know what he had used, but the modulator was in a very sorry state. I removed it and sent it to MCES who, as usual, did a superb job and returned it within a couple of days.

After refitting the modulator I found that everything worked

# VCR Clinic

except wind and rewind. In these modes the brakes were not being released. The brake lever is driven by the master cam, and was clearly operating incorrectly. When I removed the loading motor block to gain access to the cam, then the cam itself, I expected to find that one of the grooves was damaged. Instead I found that the lever itself was bent down slightly – enough for it to slip out of the guide groove. A slight upwards bend was enough, and when the cam had been refitted everything worked correctly. Adjusting the modulator to provide an output on ch. 40 (Channel 5 is on ch. 37 here in London) completed the repair. **A.J.R.**

### **Philips VR2547**

I had to be careful with this one as it belonged to the dentist! The main problem was damage to the top edge of the tape – this was obviously the cause of sound drop-out. A new pinch roller cured that. He had also complained about an intermittent knocking noise. The machine now seemed to be faultless, but I left it running with a four-hour tape. After some time I was aware of a regular knock, which came from the area of the capstan. Once the noise started it got much louder very quickly. I removed and examined the capstan motor, and found that when the rotor was turned by hand it felt a little stiff at one point. A new motor cured this second fault. **A.J.R.**

### **Panasonic NVJ35**

The owner of this machine, which was in excellent condition generally, used it only for dubbing from S-VHS masters. After a while a squeak had developed and the copies had begun to exhibit signs of

capstan servo problems. No, it was not the capstan bearings, though I tried relubricating them. The capstan flywheel 'soft brake' pad had become a very hard brake pad! **R.B.**

### **Saisho VR1000**

The owner's complaint was that this machine wouldn't load a cassette. For once this was 100 per cent correct. All functions worked correctly when a cassette was loaded manually. The supply to the carriage motor was missing because of dry-joints at connector CD1009 on the carriage PCB.

This machine was also sold as the **Matsui VX800** and the **Hinari VXL3**. **R.B.**

### **JVC HR7700/Ferguson 3V23**

Failure of the tape to lace up was, as usual, the result of transistor X7 (2SA1020) being open-circuit. This was something of a red herring however. When it was replaced the loading arms moved but reached only half way then stopped. The drum was rotating but nothing else happened. I unlaced the tape by manual operation of the micro-switches and then found that the 'tape-guard' circuit was coming into operation because the drum pick-up head was open-circuit. A replacement was obtained from a scrap Ferguson machine. **R.B.**

### **Ferguson 3V31**

This machine had been 'looked at' by its owner before he brought it to me. He'd covered his tracks so neatly however that this was not immediately obvious. The original fault had been a failed cassette lamp. When the owner had removed and refitted the right-hand panel (tuning and microcontroller) the 2SC1983 transistor Q204 had

become entangled with a wiring loom. As a result it had twisted and one leg had broken. The machine appeared to be dead, but actually there were no switched supplies. **R.B.**

### **Ferguson FV31R**

No results and no display were the symptoms with one of these machines. We found that there was no 5V supply because the TIP120 transistor TP73 was open-circuit. **J.C.**

### **Panasonic NVHD200**

Intermittent tape loading was the complaint with one of these machines. The cause of the fault can be tracked down by noting the diagnostic code display. F03 and F04 mean incorrect mode operation or incorrect phase alignment respectively. If the display is F06, check the loading motor. **J.C.**

### **JVC HRD660EK**

We sometimes get these machines in because of no results/no display. Q1 going short-circuit or the opto-coupler and IC1 being faulty are common causes. Check whether R2 or R3 (both 330k $\Omega$ ) is open-circuit. The other thing to check is the 2SC3616 transistor Q2, which may be open-circuit or even blown apart, with the 0.33 $\Omega$  resistor R9 open-circuit. **J.C.**

### **Panasonic NVSD40**

Intermittent loss of one channel/tuning drift are problems you sometimes get with these machines. In this event the items to check are the tuner unit and/or the AFC chip IC7653. **J.C.**

### **Matsui VP9601**

There was good E-E but when this machine was put into the playback mode the E-E picture remained, with the playback sound coming through clearly. Nearly all the relevant circuitry is in the tuner module (MRF7 UB32), and fortunately I had a spare one available from an old panel. Fitting this cured the problem, but I then had weak E-E. A new tuner module restored correct operation. **T.L.**

### **Toshiba V705**

This centre-deck machine came in because of a tape chewing problem. When I tried it there was no reel rotation. I stripped the machine down and found that the reel belt was off the capstan because the pulley had broken. Unfortunately the pulley is not listed separately,

so the capstan motor assembly (part no. 70125660) had to be replaced. Luckily the machine was still under guarantee. **T.L.**

### **Matsui VP9501OP**

Slow rewind and mechanical noises were the complaints with this machine. Sure enough it didn't want to go into fast rewind. When I dismantled the deck I found that the spool assembly had sprung apart, with no sign of the circlip. A rebuild was possible, so I obtained a replacement circlip. This cured the fault. Apparently clutch gear assembly problems are quite common with these machines. **T.L.**

### **Philips 14TVCR240**

This combination TV and VCR was brought into the workshop with the complaint that the video section would jam inside intermittently. I stripped the machine down and powered it – fortunately these machines can be run while out of the cabinet. I found that the slightest pressure on the cassette when it was being ejected was enough to jam it. The eject mechanism depends on a long pulley shaft which looks as if it is not up to the job. When I examined it this one certainly wasn't – I could see a split in the plastic gear. This made it slip on the plastic shaft. After replacing this item and the cam gear the machine behaved itself. **T.L.**

### **Ferguson FV11**

Intermittent signals when hot was the complaint with this nice old machine. I've seen a lot of them over the years, but have never had this fault before. Voltage checks showed that the supply to the 5V regulator IC1 on the tuner/IF panel would fall from the correct 8.5V to 4.3V. The cause was R2, which when heated rose in value to around 430 $\Omega$ . It's a 10 $\Omega$  thermistor. **S.L.**

### **Toshiba V204B**

This machine was very dead. As there were no blown fuses, and no short-circuits could be detected, I decided to check the electrolytics on the primary side of the power supply. CP008 (100 $\mu$ F, 25V) and CP007 (10 $\mu$ F, 50V) had both gone low in value. **S.L.**

### **JVC HRJ225**

The cassette carriage was loaded and any attempt to power the machine resulted in shutdown after just one second. The supplies were all fine except for the switched

+5V line, which measured 1.2V during the machine's very brief period of operation. This supply is derived from Q851 and Q852. Checks showed that the print between the base of Q851 and the collector of Q852 was open-circuit. The print run is only about 1cm long, but is straddled by R860 (470 $\Omega$ ) about half way along its length. As no crack or other fault could be seen, I assumed that this was another case of corrosive glue. R860 is a surface-mounted component. **S.L.**

### **Matsui VX3000/Saisho VR3400**

Intermittent tape chewing was the complaint with this machine. I eventually saw the machine fail to unload the tape then eject. The mode switch was faulty. A new belt kit (always necessary) and pinch roller completed the repair. **S.L.**

### **Ferguson FV71**

The note that came with this VCR said that it had gone dead overnight. Although it appeared to be dead it had not suffered the usual chopper power supply failure. In fact if you listened to the power supply carefully you could hear that it was tripping very quietly. I've found that the usual culprits for this are CP07 (10 $\mu$ F) and CP08 (100 $\mu$ F). Both were replaced, using components rated at 105 $^{\circ}$ C, but the fault remained.

Substitution checks on the secondary side of the supply then revealed that the culprit was CP71, which was leaky. It's mounted on the print side of the PCB, not in the position marked on the board, and is between the 13V and 33V rails instead of between the 33V supply and chassis, as marked – the circuit diagram is correct however.

Note that this power supply will run correctly only when it is connected to the main chassis. Resistive loads for test purposes will not give any meaningful results. **P.G.**

### **Toshiba V109B**

This machine worked all right until the mechanism carried out any function or a tape was loaded. The E-E picture then became unstable, and hum bars appeared with some functions. It was obvious that the fault was in the power supply and was load dependent. The culprit was eventually found to be the STK7253 regulator chip, which was unable to supply sufficient current from its switched 9V output. **P.G.**

## Panasonic NVL20/25/28 series VCRs

**These well-made machines are relatively easy to service, having an established fault pattern. Brian Storm provides a quick-check guide to servicing**

**T**hese middle-aged Panasonic VCRs incorporate the G mechanism, super-still video heads, barcode scanning for clock and timer and have a barcode scanner integrated in the remote control unit. They have a modern-looking rounded design with hidden control panels.

### The Power Supply

The most obvious place for faults to develop is in the ageing chopper power supply. Fig. 1 shows the circuit. To ensure reliable power supply start-up, C1109 should be replaced as a matter of course whenever one of these machines is brought into the workshop. To protect the semiconductor devices from damage, it's a good idea to replace the small electrolytic capacitor C1114; also to remake any ageing solder connections, especially at power components.

The electrolytic capacitors on the secondary side of the chopper transformer (T1101) should be checked with an oscilloscope. A quick check on the ripple level on all the supplies will prevent unnecessary investigation in the video and servo circuits when obscure faults are present.

Here are some common power supply faults.

**Power supply dead:** C1109 (1 $\mu$ F, 400V) is probably open-circuit. Alternatively D1118 (MA180) could be leaky.

**Power supply dead with D1113 (20V zener diode) short-circuit:** Check whether C1114 (47 $\mu$ F, 16V) has fallen in value.

**Servo problems:** Check whether C1122 (330 $\mu$ F, 10V) is open-circuit.

### The Mechanism

The deck has been well documented in previous arti-

cles. Here are some faults that are particularly common with these models.

**Intermittent damage to cam gears and arm P:** The capstan rotor clutch torque is too high. Part no. for the complete rotor is VXP1113.

**Alignment between the cassette housing and the bottom mechanism keeps being lost:** The right-hand cassette housing is broken or worn. Part no. is VXA4078.

**Intermittent picture rolling or poor tracking:** Cause is the back-tension arm sticking off. Clean and regrease it.

**Intermittent drum 'twitching':** The impedance roller is sticking.

**Intermittent solenoid operation:** Tighten plug P1504.

**Noisy rewind or fast forward:** Belt tension roller is worn. Part no. is VXA3516.

### System Control

The system control circuitry is generally very reliable. It uses two microcontroller chips, IC7501 and IC2001, that rarely give any trouble.

Cutting out can be caused by a build-up of dirt and fluff on the reflective surface beneath the take-up spool, where the reel pulses are generated.

It's not uncommon for problems to occur with the connectors between the main PCB and the timer PCB. An intermittent fluorescent display is probably the most common fault of this type.

Here are some other fairly common faults.

**Operation intermittently 'freezes':** Check for dry-joints at X6101.

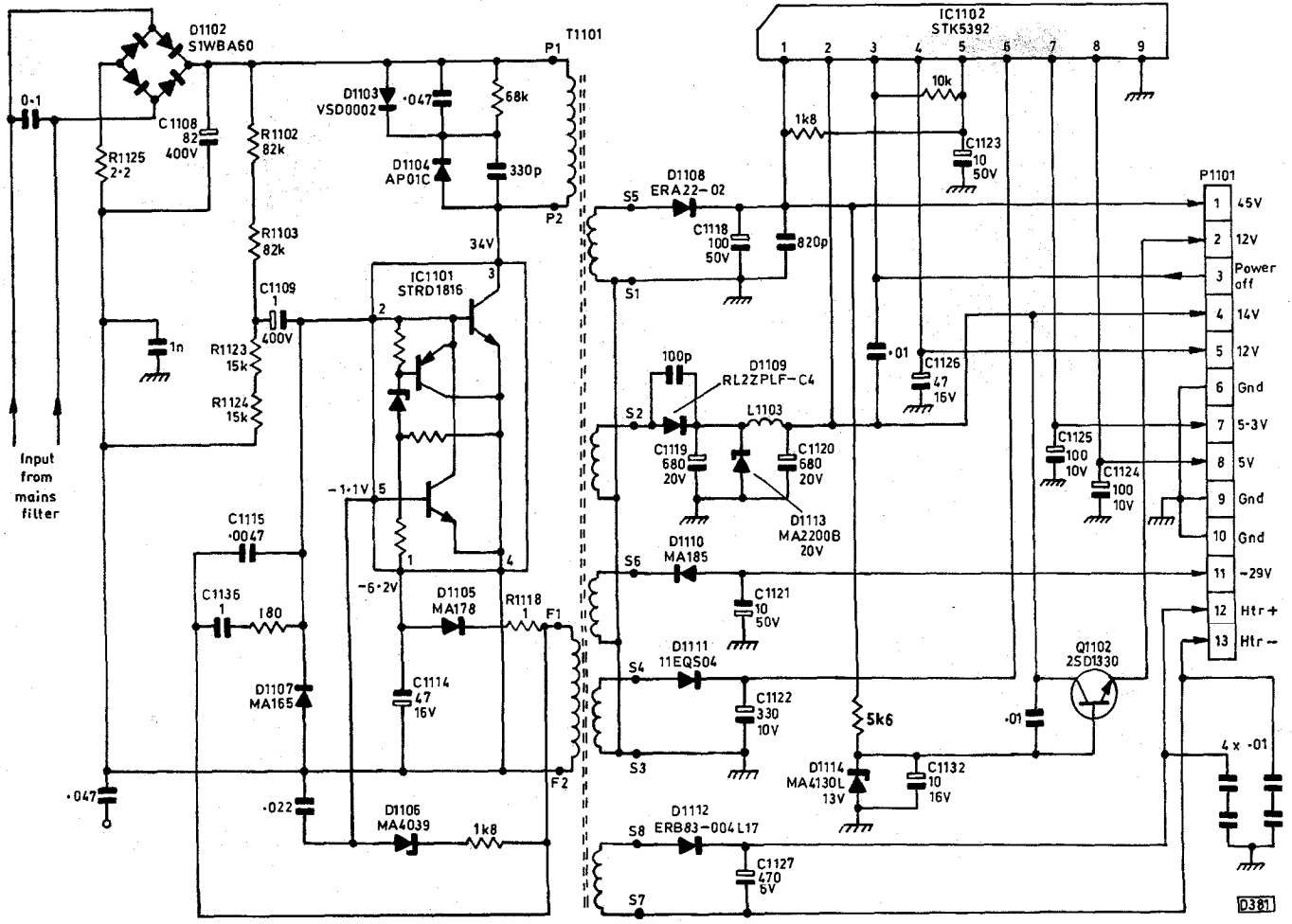

**Intermittent stopping:** The reel sensor is faulty. Part no. is ON2170.

**Capstan motor stops intermittently:** P2001 is dry-jointed.

**Audio dub cuts out after five minutes (Model NVL25):** Change IC6001 to type MN6740VCQK.

**Intermittent cutting out and powering down:** P2001 is loose or dry-jointed.

**No operation:** Q6101 (2SC2206) is probably faulty.

**Dead, unable to power up:** C6011 or C6012 is probably leaky.

**Dead with "write" illuminated in display:** The MN15522VMS chip IC6801 is faulty.

**Servo Control**

Most of the servo control circuitry is within IC2001. The capstan FG amplifiers IC2301 and IC2302 can cause problems by amplifying noise from the power supply or from an out-of-line FG pickup head.

Failure of the capstan drive chip is usually caused by intermittent connections at the capstan plug P2001.

The following are some fairly common servo faults.

**Capstan motor grinding and cogging:** C1122 in the power supply is faulty.

**Capstan motor is unstable in the play mode:** Check the FG head to capstan rotor gap.

**Capstan motor torque poor or motor is inoperative:** Capstan drive chip IC2101 is faulty.

**Poor tracking:** Back-tension arm is not engaged.

**Other Faults**

The following are some other fairly common problems you get with these machines.

**Poor E-E gain:** Tuner unit (type ENV87823H3A) is faulty.

**Poor feed-through gain:** Tuner unit (type ENV87823H3A) is faulty.

**Intermittent playback and E-E distortion:** RF converter (type ENC17952A) is faulty.

**No sound or no picture:** AV input jack switches faulty. Part no. VEJ0777.

**E-E picture smeared:** C7678 or C730 and C731 faulty.

**Barcode scanner inoperative:** Short the battery contacts together for thirty seconds then clean and tighten the contacts.

**Macro problems (Model NVL28):** Fit a 22µF tantalum capacitor across C9568.

**Fig. 1: The basic power supply circuit used in Panasonic VCR Models NVL20, NVL25 and NVL28.**

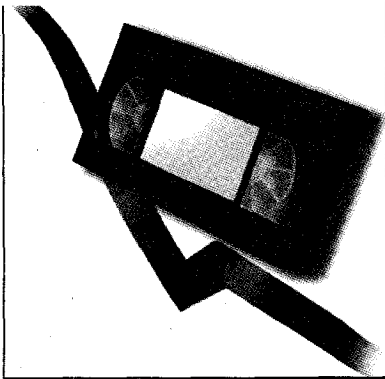

Reports from  
**Pete Gurney, LCGI**  
**Stephen Leatherbarrow**  
**Bob McClenning**  
**V.W. Cox**  
**Brian Storm**  
**Michael J. Cousins**  
**Michael Dranfield**  
**P.J. Roberts and**  
**Chris Watton**

### **JVC HRD820**

The original fault had been no playback picture. So someone had fitted new heads. This hadn't cured the fault and in addition there was now no colour with prerecorded tapes. The colour problem was the easiest one to deal with – the heads had been fitted 180° out. These drums have an index hole in both the head and the lower cylinder boss. They don't align next to each other. If in doubt, look at the mounting surface when the head is removed: there is usually a ring of dust where the index hole had been.

I was now back to square one, with what admittedly looked like a head problem at first glance. The picture sometimes returned however, and when it did the head switching varied between its correct point and somewhere half way up the picture. I've had similar problems before, caused by the lower drum – specifically C6, which is a 3.3µF surface-mounted capacitor. A dose of freezer proved its guilt. Once a replacement had been fitted and the head switching had been set up the machine produced a good picture.

Note that the lower drum drive PCB is common to quite a few JVC Models. **P.G.**

### **Alba VTV10**

This little TV/VCR combination kept on trying to load a tape that wasn't there, then shut down. It looked like a mode switch problem,

# VCR Clinic

which is becoming increasingly common with the type of deck this model uses. As the deck is not the easiest to work on without an extension lead set I replaced the mode switch on spec. No luck. After a lot of searching about I eventually discovered that there was an end-stop sensor fault – no illumination because of a hairline crack around the IR-emitting diode D01. Resoldering cured the problem.

Note that any faults which result in deck shut down will also switch the TV to standby.

I've also had several loading motors go open- or short-circuit, with the result that the TV switches off after ten seconds or so because the deck is unable to initialise. The same deck is used in the Matsui VX735A/Saisho VR3300 and related models. **P.G.**

### **Sharp VCH841**

This machine came in several times over a period of a month or so with the complaint that it would shut down, refuse to respond to the controls and trap a cassette inside. But each time it appeared in the workshop it would reset then work faultlessly.

Clutching at straws, I replaced the mode switch. This made no difference. Eventually the machine came to a complete halt: the cause was immediately traced to a seized capstan motor. A strip down and clean cured the problem. **P.G.**

### **Ferguson FV82**

This dead machine had no functions or clock display. There were no shorts or obvious open-circuits in the power supply, so I decided to check the two electrolytics on the primary side. As is so often the case, the cause of the problem lay here. CP007 (10µF, 50V) had gone very low in value. I decided to replace CP008 (100µF, 25V) for good measure. Capacitors rated at 105°C were used. They are asso-

ciated with pins 9 and 11 respectively of the power supply chip IP001 (U4616B). **S.L.**

### **Baird 8940/JVC HR7350**

Following a service this venerable machine produced no E-E or playback sound. After checking for any obvious switch position sillies I traced the audio output from the IF strip to the AN6394 chip IC2. The signal was present here but got no farther because this chip's supply at pin 14 was missing. It's derived from Q11 (2SC2673). There was no 11V supply at its emitter because of an open-circuit junction. **S.L.**

### **Hitachi VTF860E**

This VCR failed to start up after disconnection from the mains supply. I found that C6 (1µF, 250V) which supplies the kick-start to Q1 in the power supply was low in value. **B.McC.**

### **Grundig VS510**

If the machine is dead with the solenoid clicking, replace C1325 (1µF) in the start-up circuit. **B.McC.**

### **Aiwa FX1500**

There were no record problems but occasionally the playback disappeared, as though the head amplifiers had failed. The fault would come and go with the slightest movement but, despite this, the cause was tricky to find. There are some straggling wired-on extras close to the LA7449 video processor chip. One, a resistor, was only in contact and had never been soldered. **V.W.C.**

### **Panasonic NVHD605**

This machine would accept a tape then go straight into the rewind mode. Apart from tape ejection that's all it would do. Suspecting a faulty end sensor I removed the main PCB and found that the 0.1µF capacitor fitted across the end-sen-



tor transistor Q6003 was leaky. **B.S.**

### **Panasonic NVF590**

This S-VHS machine's E-E pictures were over-white and distorted. Oscilloscope checks brought me to the ceramic module IC303, which had become damaged by capacitor leakage. A new module, part no. VCR0389, cleared the fault. **B.S.**

### **Panasonic NVHD650**

This machine produced neither menus nor a test signal. When a tape was inserted F05 was displayed, indicating loss of reel drive. The 2SD1996STTA 5V regulator transistor Q1002 in the power supply had failed. A replacement restored the missing functions. **B.S.**

### **Panasonic NVHS1000**

This machine was completely dead. There was no display – nothing at all. Fearing extensive component failure in the power supply, I gloomily removed the module. Fortunately all that had failed was the 2SD1996STTA transistor Q1102 in the 5V regulator circuit. **B.S.**

### **Ferguson FV67/77HV**

This Nicam VCR was dead, with no display and no functions. Power supply checks revealed that the voltages on the secondary side of the circuit were very low. So the capacitors on the primary side were checked. CP11 in the start-up supply to the chip, IP01, was low in value at 90µF instead of 220µF. A replacement restored normal operation. **M.J.C.**

### **Daewoo DVR5172P**

This machine wouldn't come out of standby. As the 5V supply to the microcontroller chip was OK I checked the power control pin 41, which was stuck high – it should go low at switch on. The 12MHz clock (pins 31-32) was running, but a check at the reset pin 29 produced a low-voltage reading of 2.5V instead of 5V. Replacing the three-pin reset chip IC603 made no difference however.

This left only two items that could be faulty, either the microcontroller chip itself or C515 (10nF) which decouples its reset pin. C515, which is a small brown disc capacitor, turned out to have a 1.6kΩ leak. **M.Dr.**

### **Samsung VI621**

This machine wouldn't switch on. The clock was OK, but pressing the power button did nothing. As a first

step I removed the front panel – a stuck-down button can cause this fault. Not this time however. The cause was R7 (1.5kΩ), which was open-circuit. It's in the power supply and is part of the power control circuit. **M.Dr.**

### **Ferguson FV10**

There was low playback sound. The E-E sound was also low, though it was OK via the scart socket. Checks revealed that the modulator was at fault: the 0.1µF non-polarised audio coupling electrolytic capacitor C3 had failed. **M.Dr.**

### **Panasonic NVG10**

There was a chroma fault – the symptom varied between flashing colours and no colour. Luckily I remembered a similar fault we'd had with a Matsui VCR. The item to replace is C2 (100µF, 35V) in the power supply. It's next to the power regulator chip on the main board – no wonder it dries out. **M.Dr.**

### **Aiwa HVGX350**

This VCR wouldn't play tapes. While testing it on the bench I noticed that it would occasionally lock up. After this it would work only when the mains supply had been disconnected then reconnected. As the cause of the trouble seemed to be a reset fault, I replaced the KIA7033P reset chip IC504. The machine then worked normally.

Next day it failed again. This time the machine was dead with no outputs from the power supply. The fuse was intact, and there was 320V across the mains bridge rectifier's reservoir capacitor and at pin 7 of the chopper transformer. A scope check on the drive waveform at the gate of the chopper transistor FEP01 showed that its frequency was very low (50Hz). At this point I noticed a very fine break in the PCB track between RP04 (0.47Ω) and FEP01. Once this had been repaired the machine sprang back to life. After a good soak test it was returned to the customer. **P.J.R.**

### **Aiwa VXT1420**

This tele-video wouldn't play tapes. I stripped the unit down and noticed that once a tape had been threaded up the machine would shuffle it back and forth then eject it – I was using a prerecorded tape. While this was going on the drum and the capstan rotated. So a new mode switch was fitted and the deck alignments were checked. This failed to cure the problem.

The power supplies and reset etc. were next checked and found to be OK, and replacing the reel sensor made no difference. As the syscon chip's drum, capstan and reel sensor inputs were fine, the chip itself (IC1001) seemed to be the culprit. When a replacement (part no. SEC90-28B-8BO, type OEC6025A) was obtained and fitted the machine worked normally. **P.J.R.**

### **Amstrad TVR2**

The VCR section appeared to be stuck in the forward search mode, but was actually in the play mode with the capstan motor running too fast. A check showed that there was no capstan motor FG signal at pin 1 of connector CL-FG on the main PCB. There should be a 250Hz (approximately) sinewave at about 0.5V p-p here. As a new motor is expensive, I prised the lid off and checked the coil. The enamelled wire inside wasn't connected, so a repair was possible. **C.W.**

### **Ferguson FV30**

"Can't set the clock" was the complaint with this elderly VCR. All other functions were fine, and the playback picture and sound were good. They don't make them like that now! The cause of the fault was glue beneath the tuner/timer PCB, where a disc capacitor is fixed to the foil side. Correct operation was restored when the glue had been removed. Manufacturers should surely know about the effects of this type of glue, so why do they still use it? Who knows?! **C.W.**

### **Panasonic NVJ40**

The card said that this machine was dead. In fact it came on for about a minute, and during this time a tape could be played. There was no picture however, though the sound was all right. The E-E picture was also OK. I noticed that the drum was running slowly, and when I tried the machine again the E-E picture was covered with swirling lines of white dots. Then the machine went dead.

The power supply seemed to be the obvious place to look. C1110 (10µF, 400V) and C1127 (330µF, 10V) were both found to be low in value. After replacing them the machine seemed to work all right, but further checks revealed that C1131 (330µF), C1126 (10µF) and C1125 (680µF) were faulty – they all read about half the correct value. After replacing them I put the machine on test for a day. The symptoms had all been cured. **C.W.**

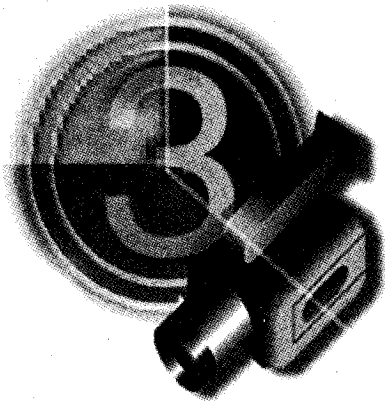

**Reports from  
Nick Beer  
David C. Woodnott  
and Brian Storm**

### **Ferguson F801**

This unit had a dead camera head: the VCR section was OK. Checks showed that there was an open-circuit track between D903 and pin 8 of connector CN909/PG909. This is the camera on (low) line. The cause of the open-circuit was leakage from adjacent surface-mounted electrolytics, which all had to be replaced. **N.B.**

### **Panasonic VW-AMC2B (NVMS50B etc)**

There was an odd fault with this commonly-used camcorder mains unit/battery charger. Charge LED1 was permanently on, and there was no battery charging in position 2. Transistor Q3 (2SB952P) in the switching section was short-circuit. **N.B.**

### **Panasonic NVRX1**

This is one of the newer 'slimline' models. The fault was ability to focus but not to zoom, which rather restricted use of the camcorder. As a result of the lens design in modern units, with everything internal, the fault condition meant that there was only one point on the focus scale where a reasonably good picture could be obtained. The zoom motor drive was present and correct, but it didn't move. A new motor, part number VEM0451, cured the fault.

We've had similar problems, caused by the gear inside the lens, with various Panasonic models that use this design. The plastic gear

# Camcorner

cracks and then slips on its shaft. **N.B.**

### **Sony CCDTR75E**

There was a "no picture" note attached to this Handycam. Chroma only was present at the AV sockets – customers don't count this as much of a signal I suppose! The cause of the fault was C318 (120µF, 6-3V) on board VS67. A replacement capacitor and service restored the unit to good working order. **D.C.W.**

### **Canon UC16**

Playback picture intermittent was the complaint with this fairly recent model. The cause was a detached connector between the mic/jack PCB and the main VTR PCB. It's becoming quite a common failure, usually because of too vigorous fitting/removal of the AV leads. The connector is available from Canon if required – it's CN001, part number VS1-5469-016-000. **D.C.W.**

### **Panasonic NVRX1**

This newish camcorder would neither focus nor zoom – its E-E picture consisted of an unfocused 'blob'. Playback was OK. Error code F52 was displayed in the EVF: the manual tells us that this means "zoom motor lock". When I inspected the motor I found a surplus of hardened grease on the actuating shaft. All was well once this had been removed and new lubricant applied.

To avoid having to reset operating data etc. it's important to refit drive assemblies to current types of lens units very accurately. Although these set-ups are easier than ever now, using automatic programming via a PC interface, life can be very frustrating if you don't have such facilities. **D.C.W.**

### **Sony CCDV600E**

The problem with this nice (I have one!) Hi-8 model was described as "no operation". The only sign of life was a flashing DEW symbol in the camera LC display. As there was no other activity, the dew sensor was clearly not to blame.

The cause of the trouble turned out to be IC201 on the mode control PCB (FD44). Don't confuse this with the more usual syscon mode control functions carried out by PCB SS134. A replacement IC and a general service restored good operation. **D.C.W.**

### **Canon UC10E**

There were no EVF pictures: operation was otherwise normal. The cause of the trouble was failure of C2911 (10µF, 16V) on the EVF PCB. I have since had two more of these camcorders with the same fault. **D.C.W.**

### **Panasonic NVR50**

This VHS-C camcorder would display, very intermittently, coloured lines down the EVF's colour picture. The symptom would often be present only once a day, which made fault finding rather difficult. I have previously had to replace the viewfinder flexi-connector to cure a number of different EVF faults produced by these camcorders. So one was ordered (part number VWJ0739) and fitted, clearing the fault. When the original one was examined, the start of a split across the middle of the connector, where it bends quite sharply beneath the viewfinder, was discovered. **B.S.**

### **Sanyo VMD6P**

These 8mm camcorders tend to have problems with their battery contacts, which are easy enough to replace. But after doing this there seemed to be some intermittent problems with the mechanism. When a cassette was inserted, the tape would sometimes not be loaded around the drum. The cause turned out to be the cassette-down switch, which was loose. There was still a problem when this item had been cleaned and retensioned: the mechanism would sometimes just whirl, then the camcorder would power down and sulk. The cause was a damaged gear in the rather eccentric loading mechanism. Part number is 11915RQ. Once this item had been replaced the camcorder worked normally. **B.S.**

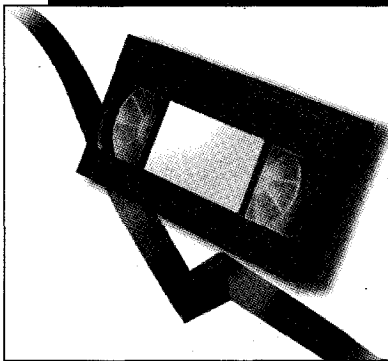

Reports from  
**Philip Blundell, AMIEEIE**  
**Richard Flowerday**  
**Eugene Trundle**  
**David Smith**  
**Maurice Kerry**  
**Roger Burchett and**  
**Pete Gurney, LCGI**

### **Goodmans VN6000**

If one of these machines comes in dead with no blown fuses, check the E 5-8V line at plug P801 in the power supply – the PCB has the voltages marked on it. If the voltage is low, check C822 (330 $\mu$ F) by replacement. **P.B.**

### **Philips VR268**

This machine was faulty from new. When a recording was made then played back, the picture would fade to snow – as if the heads were becoming dirty. The picture would return when the tape was rewound.

All became clear when an LP recording was tried. The machine didn't sense that it was an LP recording, playback being in the SP mode. A problem with the control track? Yes, the machine was intermittently failing to record the control track. Link 9604, which is by the threading belt pulley, was broken. A new wire link restored normal operation. **P.B.**

### **JVC HRJ610EK**

For a dead power supply with no blown fuses, check C12 (2.2 $\mu$ F) by replacement. **P.B.**

### **Grundig GV540**

This machine worked all right mechanically, but with playback and E-E operation there was no sound or video (just a blank screen) from the modulator. Scope checks showed that the TDA8540 video switching chip IC7770 was

# VCR Clinic

not switching the signal to the modulator.

A look through the on-screen menus and the special features revealed no reason for this, so a new TDA8540 was fitted. It made no difference. Fortunately by this time we had a new GV540 in stock, so comparisons could be made. By using both traces of a double-beam scope, I found that the I2C bus signals to IC7770 differed between the two machines. But why? I was about to swap the main boards over when I spotted an IC with a socket. Replacing it restored the signals. The chip was IC7250, the operating system EPROM. **P.B.**

### **JVC HRD580EK**

The only thing this machine would do was to display a flashing clock and a hyphen where the channel indicator should be. Checks showed that the standby voltages were all present, correct and clean. Scope checks on the clock oscillators proved that they were all working normally. With this in mind I decided to replace the memory chip IC602, which cured the problem.

Note that the machine will play without IC602 being present – a useful test if you suspect it. **R.F.**

### **Daewoo V21 (V215, V415)**

'Extreme tiredness' would best sum up the trouble with this machine. The cassette was stuck inside because there was not enough 'urge' to eject it. Tape threading was very slow. Unthreading was equally slow, after which the deck would go back to sleep. This was all because the voltage on the ever-14V line had fallen to 7V. The 14V supply reservoir capacitor C818 in the

power supply section was open-circuit. **E.T.**

### **Panasonic NVL28**

We've had two cases recently of the fluorescent display panel dimming or extinguishing intermittently. The cause was traced to dry-joints, in one case at pin 7 of the chopper transformer T1101, and in the other at the component-side jointing of the links connected to pins 12 and 13 of P1001 on the main PCB. **E.T.**

### **JVC HRJ200**

At random times in the E-E and record modes the picture and sound would be lost, with a coarse whistle on sound and patterning on the vision. Playback was OK at all times. Prolonged scope checks – because of the intermittent nature of the fault – proved that the IF module TNR2 was going unstable. A new module cured the problem. **E.T.**

### **Philips VR813**

The intermittent fault with one of these machines took the form of cassette ejection, deck shutdown, clock readout pulsing and many other symptoms. The interval between the symptoms appearing would sometimes be several days. Someone had apparently already replaced the microcontroller chip. We traced the cause to dry-joints between P1 and the power supply PCB. The mode switch on the Panasonic G deck used in this machine was also changed. **E.T.**

### **Hitachi VTF860E**

There had been a mains power failure: when the power was restored this machine remained dead. Replacing C6 (1 $\mu$ F, 250V, 105°C) restored normal operation. To ensure reliability we also replaced

the 180k $\Omega$  start-up resistors R3 and R4. **D.S.**

### **Mitsubishi HSB27**

When this machine was powered it worked perfectly except for the fact that in the play mode loops of tape were left. There was no take-up. Once I'd got the tape out I noticed that the felt pad had fallen off the half-loading arm. Don't be tempted to refix it without removing the arm, as the rubber washer beneath it may be decomposed, leaving a sticky mess – I've had this with the last two of these machines that came in.

Once the gunge had been removed, a little grease applied, a new washer fitted and everything reassembled the machine produced immaculate pictures. **D.S.**

### **Aiwa FX2500/FX3500**

These two machines both had clock update problems. The time could be set correctly in the evening. The next day it would be one hour fast or slow.

While observing one machine in the workshop I noticed that at 12:00 noon there was no change but at 12:01 the PDC flashed off and on and the time changed to 13:01. By 12:02 it was at 13:03.

The microcontroller chip uses teletext data to set the clock at certain times during the day and night. The PDC and time signals are decoded by the SDA5649 chip IC106. Replacing this item in both machines cured the timer problems. **M.K.**

### **Soundwave VCR961**

This machine is identical to the **Alba VCR7310** and the **Orion D1096**. Very low playback audio was the symptom. As a buzz could be induced in the speaker by touching the back of the ACE head, a new head was fitted. This failed to cure the fault. Neither did replacing the LA7286 chip IC5001. After much checking the culprit turned out to be C5028 (1 $\mu$ F, 50V), which was very low in value and leaky. It's connected to pin 8 of IC5001. A replacement restored the sound level. **M.K.**

### **Aiwa HVF3500**

There was a tape stuck in this machine, but it would still lace up. To sort out the cause of the problem I had to dismantle the machine to get at the underside of the main PCB – you have to do this with machines from more and more manufacturers nowadays. A careful

examination of the power supply area then revealed a bad dry-joint at the emitter of Q601. Once this and other suspect joints had been resoldered and the machine had been reassembled it worked perfectly.

We've had intermittent mechanical and electrical faults, such as no drum rotation, because of poor contact with the flexible PCB links that connect the drum and capstan motors to the base PCB. Modified parts are available from Aiwa: DM lead CB part no. 58 065 130 120 and CM lead CB part no. 58 065 130 111.

I also clean the base PCB spring contact pads with a pencil eraser and the spring contact on the main board, finishing off with alcohol. This mechanism (TN6500) is used by other manufacturers. **M.K.**

### **Toshiba V209**

The symptoms were as follows: the carriage would shuffle in and out; the cassette symbol was permanently lit; and no functions would operate though the correct symbols would light up in the display. The cause of all this was the front loading switch S122, which was permanently closed. It should open when eject is completed. The lever that operates it moved correctly, but the clear plastic cover-cum-operating block was missing. A new switch restored correct operation. **R.B.**

### **Ferguson 3V48**

A quickie on this machine: the cause of intermittent drum rotation was found to be a dry-joint at the 2SB1052 transistor Q1. **R.B.**

### **Sony SLV625**

Rewind and fast forward were particularly noisy, and there was a slight but noticeable rhythmic knock during playback. When I watched the toothed drive belt in the play mode it was obvious that the tension was varying. The machine was considerably quieter in all modes when the belt has been removed and cleaned, also the drive gear on the capstan shaft.

There's a temptation to strip out the reel drive gears and look for problems here when the fault is more fundamental and easier to cure. **R.B.**

### **Goodmans VP2300**

This machine uses the Philips Turbo deck. It was unable to load a cassette – and for good measure a coin was rattling around inside it.

There was only 1.2V at the loading/mode motor, also at its drive chip IC7402. R3483, a 2.2 $\Omega$  safety resistor which is connected to the 15V rail and is next to the chip, was open-circuit. A replacement cured the fault. **P.G.**

### **Amstrad TVR3**

There was no take-up. The usual belts, also the soft brake on the take-up reel, had fallen off. In addition, this time the take-up brake rubber had decomposed and coated the reel turntable with a ring of sticky gum which had eventually seized up the whole assembly. A new take-up reel table and brake assembly restored normal operation.

Another of these machines came to us from a local dealer. It would shut down after six seconds of play. The machine had been stripped and cleaned, after which the present fault had appeared. My first thought was the take-up rotation sensor, as the counter was erratic to say the least – when it worked at all. But I was told that it had already been replaced. After a lot of head scratching I discovered that the spacer washer had been left off the take-up spool. As a result the sensor was almost saturated. A replacement washer cured the fault – it had obviously fallen off when the machine had been stripped. **P.G.**

### **Goodmans GVR4500**

I've had a number of these machines, which use a Daewoo deck, with no tape take-up because of a bent idler unit. This time the idler unit was straight, the cause of the problem being the cassette tray which was bent down slightly. As a result the idler couldn't move. Straightening the tray cured the fault. **P.G.**

### **Goodmans PD1700**

Patterning on the playback picture, more noticeable with a dark background, is a problem I've had with several of these machines. It seems to affect only some of them however. If the screws are left out of the rear of the upper case, or the upper case is removed, there's no earth connection to the bottom cover plate. This picks up radiation from the power supply and transfers it to the lower drum and head amplifier. To prove the point, remove the plate. My cure is to add a soldered lead between the power supply can and the plate instead of relying on multiple screws to make good contact. **P.G.**

# Camcorner



Reports from  
**David C. Woodnott**  
and **Adrian Spriddell**

## Sony CCDTR305E

No playback was the complaint with this camcorder. Inspection revealed that there were other problems, like a rolling black-and-white E-E picture. Although there was no playback, as far as could be ascertained the mechanism operated normally in all modes.

I've had problems with this particular model before because of incorrect or scrambled data in the EEPROMS (pages D and F). So I did a quick reading. This was a good move – page D was empty! All was well after reprogramming.

Checks were carried out to determine the cause of the memory loss, but none was found. After a long soak test the unit was returned to the customer. That was eight months ago, and all seems to be well so far. Of course he probably hasn't used it yet! **D.C.W.**

## Panasonic NVMS2B

The complaint with this full-size unit was "weak camera pictures". All playback etc. functions were OK. On test I found that the camera E-E picture signal was of low amplitude at only some 0.5V – checked at the AV connector with 75Ω termination. Since the signal level remained the same under all lighting conditions it seemed that the iris assembly might be at fault. This turned out to be the case.

The iris motor had leaked oil which had contaminated the iris vane assembly. From past experience I have found that it's unwise to try to clean these units to save expense – the cost of a complete new assembly is modest. Bear in mind the considerable amount of

time required for dismantling, cleaning, setting up etc. Having to do the whole thing twice is not recommended! **D.C.W.**

## Sony CCDV5000E

This top-of-the-range (in its day) camcorder was brought in because it was inoperative, with only the DEW symbol flashing – in the EVF and LC displays. The cause was simply a bad connection at CN002 on the main syscon PCB. I cleaned and refitted the connector pins then carried out a service to complete the repair. **D.C.W.**

## Canon UC10E

I've on several occasions mentioned the common types of mechanical fault that you get with units which use this mechanism – they are often caused by excessive pressure being applied to the cassette when it's inserted. This can bend the supply reel spindle etc. (or worse). So when this one arrived with a note that said "noise band on picture and intermittent shut down" I was not unduly worried. Quite normal I thought, and estimated accordingly.

After straightening the supply reel spindle and checking for correct back tension I realigned the tape path. OK so far. A tape was inserted (fortunately not an 8mm test tape) and playback was selected. The monitor produced a picture, which looked to be OK. After thirty seconds of play however a noise band appeared at the bottom of the picture then disappeared, only to reappear after a short while. This state of affairs continued until I stopped the tape.

The other mechanical functions were then tried. Fast forward was OK, also rewind apart from a cyclic rattle and vibration that came from the back-tension assembly. I also found that the lower edge of the tape was being severely chewed.

Play was once again tried, which confirmed the previous symptoms. I also noticed that the tape was being stretched and chewed at the

point between the take-up guide and the pinch roller. In fact the tape was under so much tension at this point that it would sometimes 'sing' like a violin string! Yet the back-tension was OK. The tape would ride up and down around the drum, and was also under excessive tension here.

I eventually found that the supply roller guide sleeve had seized on its spindle. It looked OK and was correctly positioned, but it wouldn't revolve. A new guide cured the problem.

Since that first experience I've had other units with 'sticky', erratically revolving guides. If the guide has not totally seized, cleaning usually clears the trouble. We live and learn! **D.C.W.**

## Chinnon VC1700

I was told that this handy-cam style unit wouldn't record or play back. The cause was lack of the capstan FG signal. This was immediately obvious, not only from observing the action of the mechanism but from the fact that the motor ribbon cable was damaged! The damage was satisfactorily repaired by linking across the area affected. Just as well, as the motor is now no longer available. **D.C.W.**

## JVC GRS505E

All functions worked but there was no output to the monitor when the RF unit was used – when an AV lead was used the picture and sound were OK. Diode D2 on the jack PCB had failed, removing the 8V RF supply. A faulty AV lead, which had previously shorted out the 8V supply, was the cause of D2's failure. **D.C.W.**

## Canon E50E

If there is no viewfinder picture, check for around 1V or so of luminance at the input pin (11) of the AN2514 viewfinder driver IC. Then see if it comes out at pin 13. If there's luminance at pin 11 but nothing comes out, replacing C2901 (100μF, 6V) will probably put matters right. **A.S.**

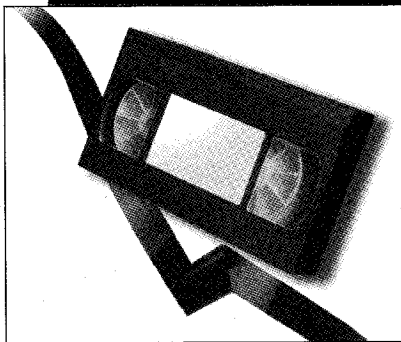

Reports from  
**Michael Dranfield**  
**Brian Storm**  
**Chris Watton**  
**John Trimmer**  
**Gerald Smith**  
**Roy Gaddas**  
**Terry Lamoon**  
**Adrian Spriddell**  
**Ronnie Boag and**  
**Michael Maurice**

### **Samsung S11240/1260**

To disable the auto-tracking when carrying out deck adjustments, solder together pins 4 and 6 of IC202. This is not mentioned in the service manual. **M.Dr.**

### **Sharp VC9300**

These well-built VCRs from the Eighties video boom seem to go on and on, with very few problems apart from failure of the reel idler and cassette lamp. Something that's becoming more common however is failure of the tape to be wound back fully into the cassette. The cause is a weak reel motor. It's a great pity that this is no longer available from Sharp. You can increase the reel motor's unloading torque by adding a 12Ω, 0.5W resistor across the emitter and collector of transistor Q7754. **M.Dr.**

### **Ferguson 3V36/JVC HRD225**

If the cassette housing refuses to accept a tape and the reel motor is turning, you will find that a circuit protector on the bottom PCB, at the back next to the word 'Elna', is open-circuit. In every machine I've come across where this N15 protector has failed the cause has been a shorted loading motor.

If you're stuck, a motor from an old cassette housing can be fitted – by swapping the pulley over. **M.Dr.**

# VCR Clinic

### **Amstrad DD8900**

If you have tuning problems with one of these double-decker machines, i.e. some stations can't be stored, try replacing C7, C9 and C15 in the IF block first. They are all 1μF, 50V: the 105°C type should be used. **M.Dr.**

### **Panasonic NVHD100**

Slow rewind with four-hour tapes was the complaint with this machine. On test, rewind was indeed very poor with the sample four-hour tape provided. After extensive checking and testing I replaced the end sensor diodes Q1501 and Q1502, more in hope than anything else. But this cured the fault! The part number for both of them is PN205L. **B.S.**

### **Panasonic NVJ45**

The E-E picture had jagged verticals and the playback picture was non-existent. For video problems with these machines IC302, which is expensive, is the first suspect. Fortunately on this occasion the cause of the trouble was C1127 (330μF, 10V), which smooths the unregulated 6V feed to the series regulator in the power supply. **B.S.**

### **Saisho VR3000X**

There was no sound recording. Playback sound was OK with pre-recorded tapes, and the E-E sound was also OK. A healthy sinewave erase bias, about 60V p-p, was present and bulk erase worked. There was a good audio signal at pin 19 of the audio processor chip IC5001 on the audio/IF module, but no audio signal at pin 2 of the BA7755 audio record/play switching chip on the same board. It had an internal short. **C.W.**

### **Matsui VX755/Saisho VR3600**

The UHF output was intermittent

because of loss of the supply to the modulator. A check at pin 5 of CN501 in the power supply showed that there were no problems up to this point. The voltage here is applied to the 2SC2274 ripple filter transistor Q507, which was going open-circuit. We didn't have one in stock, but a BC639 proved to be a suitable replacement. **C.W.**

### **Panasonic K Mechanism**

If you have a VCR that shows F03 or F04 in the front display, remove the loading motor and examine the white plastic coupling fitted to it. The coupling sometimes splits. You can either replace the whole motor assembly or, alternatively, the coupling is available separately from Panasonic as part number VDP1434 – a jig, part number VFK1322, is required to fit it on the motor shaft correctly. **J.T.**

### **Hitachi VTM502EUK**

This machine had no display. A voltage check at pin 80 of the deck controller IC7400, which is also the display driver, showed that the 3V supply was missing. It's labelled HEST. When I traced back to the source I came to a faulty BC848B surface-mounted transistor, 7409, on the main PCB. Replacing this item restored the display. **J.T.**

### **Panasonic NVG50PX**

This VCR's power supply didn't start up. Once I'd replaced C3 on the power board everything seemed to be fine initially. Then I noticed that the real-time counter didn't move and that playback was marred by tracking bars. The machine was OK in the rewind and fast-forward modes and also, strangely enough, in reverse search.

I first thought that there must be an alignment error, but close examination showed that the tape remained in the same position in all

modes. As this is a foreign model we didn't have a circuit diagram. After a lot of heating and freezing I discovered that C29 on board ref. 6500 series was low in value. The correct value is 10 $\mu$ F, 16V. I fitted a high-temperature type. **J.T.**

### **Panasonic NVSD30 (K Mechanism)**

The customer complained of tracking bars and slurred speech. The machine also damaged my test tape. Tests showed that there was excessive back tension, but no amount of adjustment would correct it. Then I noticed that the reel brake didn't release. Part of the brake release mechanism was broken. The part number is VX20313. **J.T.**

### **Daewoo V200**

There was intermittent loss of the playback picture – just snow. Checks showed that in the fault condition the PB5V supply to the head amplifiers was missing. It comes from Q304, which was dry-jointed. **G.S.**

### **Nokia 3716**

The fluorescent display had failed. Checks showed that there was no -25V supply at either the display or the driver chip. Further checks showed that R927 (10 $\Omega$ , 0.25W) was open-circuit. A replacement restored the display. **G.S.**

### **Daewoo V435**

This machine would accept a tape, but there was no play/record/FF or rewind. The drum motor wasn't turning properly. Once this had been replaced all functions were back to normal. **G.S.**

### **Akai VSG245**

This machine could be tuned in but wouldn't memorise Ch. 4. When the EPROM presettings were checked they were found to be wrong and couldn't be adjusted. When a new EPROM (IC404) had been fitted and set up and the switching points had been adjusted the machine would memorise Ch. 4. **G.S.**

### **Sharp VCM20**

This machine's owner complained that the LP symbol on the front display was always alight. A new microcontroller chip restored correct operation. **G.S.**

### **Daewoo V21**

This VCR wouldn't tune. A check on the tuning voltage showed that it didn't change. The PMW signal at the timer chip varied, and on fur-

ther investigation I found that there was a small crack in the print at the back of the PCB. Hard-wiring here restored the tuning. **G.S.**

### **Nokia VR3615/Daewoo V200**

If stop was pressed during play the tape would wrap around the guides. It would then get chewed when the customer tried to eject the cassette. The cause of the trouble was traced to the idler assembly FM mechanism. The moulding can become distorted: as a result, the assembly fails to kick the take-up motor into reverse.

The solution is to fit the upgraded assembly that's available from SEME under order code VDC7456. In fact it's best to replace this assembly as a matter of course whenever one of these machines comes into the workshop.

Another problem is that the pin tends to snap off the metal lever below the idler assembly. So the lever should be replaced as well. **R.G.**

### **Matsui VP9501OP**

If the complaint with one of these machines is slowish, noisy rewind, do check the reel spools. They are clutches and have a tendency to fall apart when you remove the retaining clip. A new one will cure the fault. It's probably safest to replace both spools while you are carrying out the repair. It is also advisable at least to clean the mode switch: better to replace it, as the switch oxidises quite badly, giving rise to all sorts of strange symptoms. **T.L.**

### **Hitachi VT860**

Poor and/or noisy loading and occasionally jamming were the complaints with one of these machines. Close inspection revealed that the capstan motor was struggling. So a replacement was fitted, along with the clutch base assembly, belt and pinch roller, which was very shiny. These items got the machine to work perfectly, but the repair proved to be a bit expensive. **T.L.**

### **Hitachi VT150**

The E-E picture was subject to pulling and overloading. Playback of prerecorded tapes was OK, also operation with a video feed via the scart socket. The cause of the trouble was C07 (1 $\mu$ F) in the IF unit. **A.S.**

### **Matsui VX3000**

The problem we had with one of

these machines was tuning drift. Replacing Q6006 (BC182L) and R6045 (33k $\Omega$ ) cured the fault. **A.S.**

### **Sharp VCA111HM etc**

If the drum speed is excessive, the amplitude of the FG pulses could be low. Check the printed FG coil on the motor PCB. You should get an almost short-circuit reading: if the reading is several ohms, the motor PCB will have to be replaced – it's available separately.

This fault can occur with any machine that uses the M series chassis. **A.S.**

### **Akura VX150**

There was no E-E or playback video. Scope checks showed that the video waveform at pin 28 of IC201 was missing. It reappeared when pin 14 of ICC01 (type LC7475) was desoldered. A new LC7475 chip cured the fault. **R.B.**

### **Toshiba V711**

This VCR was dead with no outputs from the STK5383 chip IC802 in the power supply. A new STK5383 chip restored normal operation. **R.B.**

### **Sharp VCM721**

There was no tape take-up with one of these machines. The cause was dry-joints at plug AC on the capstan motor. **R.B.**

### **Daewoo V435**

The symptoms with this machine were intermittent failure to come out of standby and no functions when a tape was inserted. The cause was C822 (330 $\mu$ F, 10V). This capacitor should be upgraded to 1,000 $\mu$ F, 10V. **R.B.**

### **Granada VHSHP7/Philips VR6185**

When review was selected this machine would start to search then switch off. All other functions worked faultlessly. The cause of the fault was the mode switch – a replacement restored correct operation.

These models are fitted with the **Panasonic G** deck. **M.M.**

### **Akai VSS99**

This S-VHS machine turned out to be a Mitsubishi clone. The symptoms were intermittent or no off-air signals. The tuner/IF pack is the same as that in the Mitsubishi CT2564STX range of TV models which can exhibit the same faults. Resoldering the dry-joints in the IF can restore normal operation. **M.M.**

## Panasonic Models

# NVJ30/J35/F65/F70

**These oldish models can still provide excellent results. Fortunately the faults are reasonably predictable. Brian Storm on what to check when a faulty machine comes in**

**A**lthough these VCRs are now well into middle age they are still capable of providing superb picture quality and performance. The NVJ30 and NVJ35 are improved versions of the NVL20 and NVL25. The NVF65 and NVF70 are hi-fi stereo versions with Nicam reception and editing facilities such as jog and shuttle.

These VCRs were all supplied with a bar-code scanning, multi-function remote control unit. A jog and shuttle remote control unit, Model VWRM65E, was available as an optional extra.

### The Power Supply

Fig. 1 shows the power supply circuit. As with all older AV equipment, this is the place to look for the causes of obvious and not so obvious faults. It has become almost second nature with me to measure the 45V output from the power supply module in any Panasonic VCR, as this tells you so much about the machine's operation.

If the 45V supply is high, check C1114 on the primary side of the chopper circuit. If the voltage is low, check the reservoir capacitor C1118. A clue that the 45V supply was high is failure of the 20V zener diode D1113. It goes short-circuit when the 14V supply rises above 20V, killing the power supply completely.

Whatever the fault, it's always worth scoping the power supply outputs for hash noise. Replace any capacitors that are suspect. It's also wise to renew the soldering around the power components. It can become dry after passing high currents for eight or so years.

The most common power supply faults are as follows:

**Dead power supply:** Check C1109 (1 $\mu$ F, 400V), D1110 (10ELS2) which could be leaky, and whether D1113 (MA2200 20V zener diode) is short-circuit. In the latter event, check whether C1114 (47 $\mu$ F, 16V) is open-circuit. Check the crowbar circuit which was added in Model NVF65 (see below).

**Capstan servo problems:** Check C1122 (330 $\mu$ F, 10V).

### Mechanism

Panasonic mechanisms became very much more reliable as the G deck evolved — there were four versions in all. With the addition of a review motor in Models NVF65/F70, placed cunningly above the deck mode switch, the machines became suitable for serious domestic editing, with seamless control of pause, cue and review. This was not previously possible with the G deck.

Here are the common mechanism faults:

**Intermittent squeaking:** Replace the capstan brake, part no. VXL1873/VXL2088.

**Noisy rewind or fast forward:** Replace the tension roller, part no. VXA3516.

**Cassette housing keeps going out of line with the mechanism:** Replace the side plate, part no. VXA4076.

**Intermittent deck solenoid operation, Models NVJ30/35:** Check whether plug P1504 is loose.

After the addition of the DC-controlled review motor, which first appeared in Model NVF70, Model NVF65 was provided with a crowbar transistor (Q6021) plus control circuitry (Q6020 and IC6004) as a precaution against incorrect operation and possible tape damage. Should the supply rails deviate far from their correct voltages the crowbar circuit will cut in, killing the power supply. Check this additional circuit, in the systems control area, if the power supply in Model NVF65 doesn't work when it's connected to the main PCB.

### System Control

The syscon circuitry in all these models is generally reliable, though the MN15522VMS sub-systems microcontroller chip IC6801 in Model NVJ35 can be responsible for a number of different symptoms when it fails, ranging from 'write' shown in the timer display and refusal to power up to no E-E video and no systems operation.

Intermittent or permanent failure of the MN188166VHI chip IC6001 can occur with Model NVF70. The result is no operation, with a pause or play symbol in the fluorescent display or the tracking LED pulsing.

The NVF65/F70 and their bigger brother the NVFS100 can produce misleading symptoms when the 0-9 $\Omega$  resistor R6035 in the feed to the review motor goes open-circuit. If a tape is inserted it may be played, but any attempt to rewind or operate in the fast-forward mode will result in power-down.

### Servo Circuitry

The servo circuitry is also reliable. With Models NVJ30/J35 the most common problem is C1122 (330 $\mu$ F, 10V) in the power supply going open-circuit. This can produce several symptoms, ranging from wow on sound to an unstable capstan then drum motor drive problems.



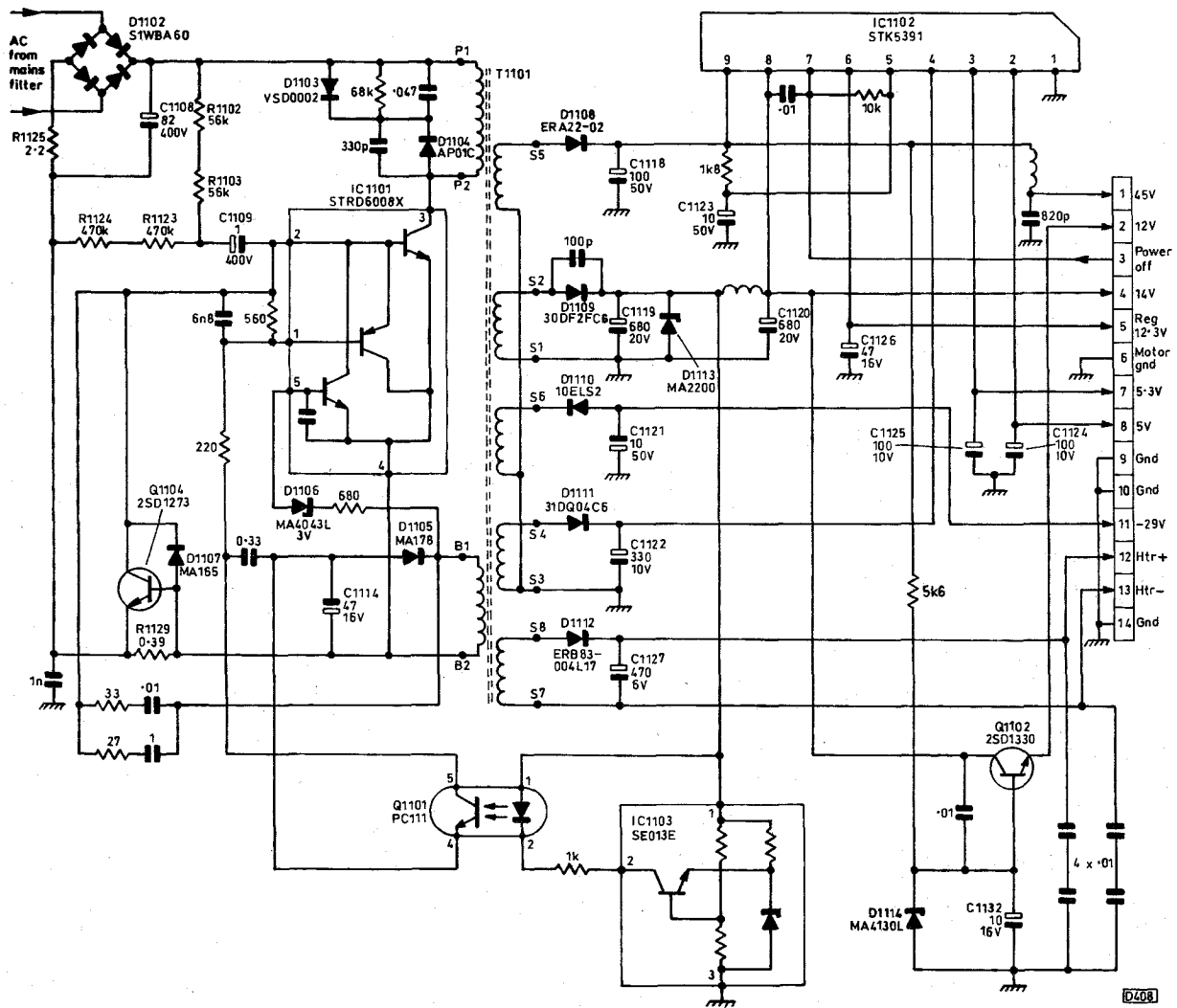

**Fig. 1: Power supply circuit used in the Panasonic Models NVJ30/J35/F65/F70.**

Another cause of capstan speed instability is the gap between the capstan stator FG head and the rotor. If this gap is too wide, the FG amplifiers will start to amplify noise. The result is intermittent playback speed faults.

A less common problem occurs when the capstan motor plug has been inserted in connector P2001 incorrectly. The result can be intermittent capstan cogging or capstan motor cut-out. It's a good idea to check this whenever a machine comes in, also to remake the solder connections to P2001 as dry-joints are another possible cause of intermittent stopping.

A particularly nasty fault with the NVJ35 occurs when the 1.5kΩ resistor R2302 in the FG circuit cracks. This can result in SP recordings being played back as if they are LP recordings, with no colour in the trick modes and wide noise bars in cue and review.

### Miscellaneous Faults

The video circuitry, demodulator pack and timer board give very few problems. Don't be fooled by no E-E video with the NVF65: this machine has an audio only facility in the LP mode, with the video muted.

There will be no tuning when the tuner is stuck in the VHF mode because the memory chip IC7502 is faulty.

This chip can also be responsible for problems with the AFC defeat switching, which should be high or low and not somewhere in between – the symptom is failure to lock to stations when search tuning.

Finally, a general common faults summary:

**No or distorted video, Models NVJ30/J35:** The LA7150 chip IC3901 has probably failed.

**No E-E picture (NVF65):** Machine is in the LP mode.

**No scart socket output, Model NVF70:** R4908 and R4910 missing.

**E-E picture patterning in the top corner:** Replace C7678 (10µF, 16V).

**Smeary E-E picture:** Check C730 and C731 (10µF, 16V).

**Low E-E or feedthrough gain:** Replace the tuner unit, type ENV87837H3Y.

**No tuning, stuck in the VHF mode:** Replace the MN12C261 chip IC7502.

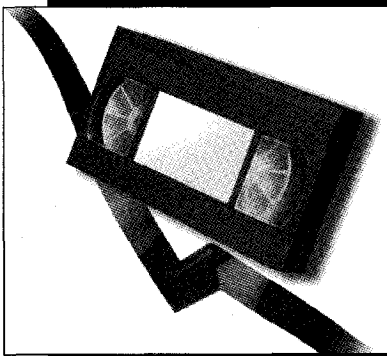

Reports from  
**Philip Blundell, AMIEEIE**  
**Eugene Trundle**  
**D. Evans**  
**Michael Dranfield**  
**Chris Watton**  
**Pete Gurney, LCGI**  
**Gerald Smith**  
**Michael Maurice and**  
**Ronnie Boag**

### **Philips Turbo Decks**

Stuck tapes have been a common problem recently. You find that the tape is still laced around the drum, and that a grinding noise comes from the mechanism when it tries to unlace. The cause is that either the gear on the threading shaft or the gear on the worm shaft has moved out of alignment. The two shafts are available as a pair, part no. 4822 310 10657. To prevent a bounce, replace them both.

The problem is that the cassette covers the deck retaining screws and the tape is still threaded around the capstan. If you are careful, the tape can be removed from the capstan without the need to cut it. When the spring on the top of the pinch roller arm has been disconnected you should find it possible to remove the pinch roller and its arm. The tape can then be eased over the guides and, by turning the reel-belt pulley, wound back into the cassette.

If you are lucky, you will now be able to turn the gears on the side of the lift and eject the cassette. If this is not possible, disconnect the red plastic strap that holds the lift gears together and remove the lift by undoing the four screws underneath the deck. **P.B.**

### **Mitsubishi HSM58V**

This machine would play for just a few seconds then return to the stop mode. Suspecting a reel tacho prob-

# VCR Clinic

lem, I scoped the tacho pulses at the collectors of transistors Q5A0 and Q5A4 on the main PCB. The pulses at the collector of Q5A4 were of low amplitude. As cleaning the window on the sensor had no effect, a new take-up reel sensor (part no. 268P044010) had to be fitted to cure the fault. **P.B.**

### **Ferguson FV77H**

We've had three of these machines in recently with the same complaint: no response to the remote-control unit. In each case the microcontroller chip (IK01) on the front panel was responsible. Take care when you replace it – the device seems to be very vulnerable to attack by electrostatic charges. **E.T.**

### **Akai VSG740/760/770 Series**

If you have to remove and replace the deck or front-loading parts for service, you may then find that the machine won't load a cassette fully or that the spools are scraping. If so, it's likely that you have bent the pressed-steel plate that runs across the bottom of the cassette cradle. It synchronises the two sides of the cassette loading mechanism and is very fragile. **E.T.**

### **Toshiba V411**

Playback was marred by sparklies – the effect you get with a satellite receiver and a weak signal. This is usually caused by poor drum shaft earthing. When I phoned Toshiba I was told to replace the lower drum unit, which is expensive. I got round the problem by fitting an external earthing brush.

It's easiest to fit one underneath the tape deck. If you look at the underside of the drum you will see a hole in the chassis, to the rear, already tapped. I used a brush from a scrap Sharp VC381. The arm had

to be rebent and a small piece sawn off the end of its cranked arm as this was in the way of fitting it to the chassis. I used the original Sharp screw. The modification was a complete success. **D.E.**

### **Matsui VX1000Y**

The usual cause of tape damage, with the tape looping out on eject – sometimes intermittently – is a split capstan motor rotor. Superglue or Araldite provide a lasting solution. **M.Dr.**

### **Goodmans GRV3450**

There were four dashes in the display but the machine wouldn't power up. In addition the tape was fully laced and the loading motor was twitching backwards and forwards. Voltage checks showed that the 5V supply at the emitter of Q801 was pulsing up and down. I initially suspected a heavy load on this supply. Wrong! F803 (1-25AT) on the power PCB was open-circuit. A replacement restored normal operation. **M.Dr.**

### **Sharp VCA63HM**

This machine had a very interesting fault. There were tracking errors and the capstan speed was slightly slow, with poor colour. Checks in the capstan circuit failed to reveal anything amiss, then I found that if the pause button was pressed the machine went into fast forward search and locked up. The only way to stop the machine was to unplug it from the mains supply.

A very useful feature is that if a prerecorded tape (no safety tab) is inserted the machine can be operated with the front panel, which contains the timer microcontroller chip and memory, completely disconnected. This enabled the front panel to be eliminated. When I made further checks in the servo section I

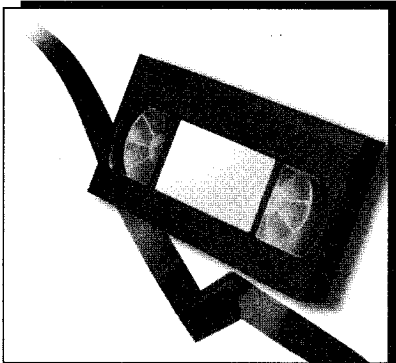

# VCR Clinic

**Reports from**  
**Philip Blundell, AMIE**  
**Pete Gurney, LCGI**  
**Mike Leach**  
**Martyn Davis**  
**Ronnie Boag**  
**Christopher D. Nunn**  
**Graham Richards and**  
**Keith Evans**

## **Matsui TVR141**

This TV-VCR unit had a playback fault: the symptoms were tracking bars and slurred sound, which indicated that the capstan was running slow. The cause of the fault was ripple on the AT5-6V line. It was cured by replacing C523 (100 $\mu$ F, 16V) on the TV chassis.

Replacing C523 cures these symptoms with the Aiwa Model VXT1410K as well, but I'm not sure to what extent these models are the same. **P.B.**

## **Ferguson FV81**

There was no remote control operation. In every other respect the VCR worked perfectly. The handset was checked and found to be OK, so attention was turned to the IR receiver block. This had the correct 5V at its supply pin, and produced a healthy 5V pulse train output. But the output didn't appear to be reaching the microcontroller chip. A check along the path showed that the pulses disappeared at link JK01, which is at the top left of the panel, viewed from the print side. There was a barely visible crack at one end of this SMT link: resoldering cured the problem. **P.G.**

## **Toshiba V711B**

This hi-fi VCR seemed to be dead: there was no display and the machine had a half-laced tape stuck in it. Quick checks on the power supply confirmed that it was work-

ing, but there was a problem with the power on/off signal at pin 6 of plug 806. It should be at either 0V or 5V but was stuck at about 3-3V. Its source is pin 25 of the timer microcontroller chip. Checks around this chip revealed that the -33V supply at pin 66 was missing. The source is a DC-DC converter, Z801, on the logic servo panel U601.

Circuit protector Z802 in the feed to it from the 6-6V rail had failed, and the converter had a very low-resistance reading at its input pin. When the fuse and the converter had been replaced the display reappeared and the mechanism initialised correctly. So the machine was left on soak test.

After several hours the voltage on the 6-6V rail rose to 8V and the STK5383 chopper chip IC802 was excessively hot. An audible rattle came from the power supply. A scope check confirmed that C808 (330 $\mu$ F, 25V) at the input to IC802 was open-circuit.

The excessive voltage on the 6-6V rail had obviously been the cause of the DC-DC converter's failure. Note that this is a 105°C capacitor. To prevent further problems I fitted a low-ESR, 105° type. **P.G.**

## **Samsung VI611**

The E-E signals were severely distorted - playback was OK. In addition the customer complained that he had had to retune the channels almost weekly, until eventually the picture had become unwatchable. A scope check on the tuning supply voltage showed that a considerable amount of AC was present. The cause was the 33V supply's reservoir capacitor C4 (47 $\mu$ F). It had gradually dried up during previous weeks: as the voltage had dropped, the customer had retuned the machine to compensate. **P.G.**

## **Matsui VX2000**

The complaint with this machine was that it wouldn't tune in. In fact it was on channel and worked all

right with a video output. Although the test signal appeared, there was no other video output from the RF modulator. Further checks showed that there was no video input to the modulator. There's not a lot to check here. The cause of the problem was filter PF4201, which was open-circuit. It's in the feed to the base of the buffer transistor which, in turn, feeds the modulator. **P.G.**

## **Panasonic NVG25**

If there's no capstan lock and no sound, check C240 (10 $\mu$ F, 16V) on the servo board. When there are no control pulses the microcontroller chip mutes the sound. **M.L.**

## **Hitachi VTM720**

If the cassette housing tries to load by itself with no tape inserted and the cassette-loaded light comes on, the most likely cause is a dry-joint at link K2546, which is almost next to pin 11 of plug PG1504 on the main PCB. You may not be able to see the dry-joint, but the chances are that there will be one here.

When one of these machines comes in for service it's worth applying a small blob of solder to the end-sensor connections underneath the deck. On many occasions I've found that the cause of various intermittent loading problems is a broken end-sensor lead just beneath the soldered connection. Remove the old solder first to check the lead length. **M.L.**

## **Hitachi VTF770**

If the problem is intermittent poor playback/worn-head symptoms, check for dry-joints at the head amplifier plug. There could be several there. **M.L.**

## **B&O 4539**

The symptom produced by one of these machines gave the impression that the condition of the hi-fi heads was poor: the sound was very noisy with dropouts. New heads failed to cure the fault, which was caused by the capstan motor. The surface-mounted capacitors in the motor had

dried up and some had leaked. As a result the motor ran erratically. Repair kits are available from B&O, but I think the success rate is only about fifty per cent. It's best to replace the motor. **M.L.**

### **Orion D1094**

The tape would spool out inside the machine in the picture review mode. In this mode only the take-up and supply brakes are both applied. The trouble was caused by the supply-spool brake spring, item 309, which was somewhat over tight. This meant that the clutch had to work harder to drive the spool. The problem was cured by fitting a more elastic spring obtained from a scrap deck. **M.D.**

### **Panasonic NVSD260**

This machine's recorded audio was intermittently low. The cause was traced to C4014 (3,300pF, 100V), which is connected to pins 5 and 6 of T4001. **M.D.**

### **Hitachi VTF540**

Tape was left out of the spools on eject and there was no take-up, fast forward or rewind. Pulley part no. 6823333 had sprung open – a replacement cured the problem. **R.B.**

### **Toshiba V855B**

Grainy pictures were produced in the RF-RF and playback modes. We found that there were dry-joints on the tuner's earths. **R.B.**

### **Samsung VIK350**

This machine produced a grinding noise in play. We had to replace the loading motor block to cure the fault – there were damaged teeth on the gear. **R.B.**

### **Ferguson 3V31/32**

The problem with this machine was persistent white horizontal flecks in the playback mode – a new head didn't make any difference. The cause of the trouble was the video head rotary transformer's windings, which become loose in their channels. You can glue the loose windings back, but make sure that no glue sits proud as this will result in the drum motor binding.

This action cures the fault with no need to replace the expensive drum motor! The **JVC** equivalents are Models HR7650 and HR7655. **C.D.N.**

### **Ferguson FV61LV**

The power supply in this 'dead' machine was working but its outputs

were about 30 per cent of what they should have been. I found that all three legs of the 2SA1020 transistor TP91 on the power supply PCB were dry-jointed. Resoldering them cured the fault. **G.R.**

### **Panasonic NVJ35B**

If the problem with one of these machines is wow and flutter on sound, lines on the picture in the playback mode and a scratchy-type noise from the capstan motor, don't start investigating the mechanics. Check C22 (330µF, 10V, 110°C) in the power supply. A hairdryer helped us with the diagnosis of this one! **G.R.**

### **Hitachi VTF860**

This machine's power supply was inactive. The chopper transistor was OK, and the correct voltage was present across the mains rectifier's reservoir capacitor. Right next to it there's another electrolytic capacitor, C6 (1µF, 250V). It was staring right back at me! So I replaced it. Success! Note that you can replace C6 without removing the power supply assembly. **G.R.**

### **Philips VR231**

This machine is fitted with the Turbo deck. Fast forward and rewind were intermittent, and there was tape looping at eject. A look under the mechanism revealed that a spring was missing. It's normally attached to the brake slider assembly and is the larger of the two springs. A replacement obtained from a scrap machine put matters right. Where did the original one go? We'll never know! **G.R.**

### **Samsung VIK316/346**

When one of these machines is brought in as being dead it's extremely common to find that the outputs on the secondary side of the power supply are low or pulsing. The thing to do is to replace C35 (100µF, 25V) and C38 (470µF, 16V), using types rated at 110°C. **G.R.**

### **Sony SLV625**

The complaint with this Nicam hi-fi machine was that its E-E sound was missing. In fact the audio was present but at a very low level. After wading through the numerous foldable diagrams in the very substantial service manual we came to the hi-fi audio subpanel (HF-22), then found that the processing chip seemed to be running rather hot. Because of the position of the board, taking measurements in situ is virtually

impossible without an extension connector.

The IC in question is a 64-pin beast, so its replacement was carried out with some trepidation. On refitting the subpanel and powering up our fears melted away: we were rewarded with clean, crisp, full-level audio. **K.E.**

### **Philips VR727**

An increasing number of Turbo deck mechanisms have appeared in the workshop of late. They seem to be taking over from the old Panasonic G decks. The complaint with this one was no fast forward or rewind.

When we removed the complete deck assembly we found that the 'pulse roller' was adrift and floating around in the works. A close inspection for any breakages failed to reveal anything amiss, so we clipped the roller back into position and reassembled the machine. A long soak test proved that all was now well. **K.E.**

### **JVC HRD230EK**

"Will record only in black and white" was the customer's plaintive cry. As electronic faults of this nature are quite rare, we set about tracing the cause with some relish! So out with the scope and circuit diagram. Before long we had traced the missing signal as far as bandpass filter BPF302 in the video feed to the decoder chip. It was open-circuit. A suitable replacement was found in a scrap machine.

There's a **Ferguson** equivalent, Model FV12L. **K.E.**

### **Samsung SI3240**

A hum-bar type of disturbance on the colour content of the E-E and recorded signals was the symptom this machine produced. Scope checks on the power supplies soon revealed the culprit: the 33V regulator chip IC101. **K.E.**

### **Hitachi VTM830**

This machine burst into life as soon as the operate button was depressed. It would perform the lacing operation without a cassette, while the cassette lift tray would just shuffle back and forth. The problem looked like one you might get with a defective mode switch.

It's always worth checking the tape-end sensors however before you dive in too deep. In this case the take-up end sensor on the subpanel was dry-jointed. While in this area, it's worth resoldering the supply end sensor and the cassette up/down switch connections. **K.E.**

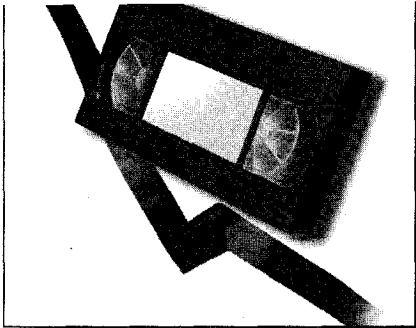

**Reports from**  
**Philip Blundell, AMIElec**  
**Eugene Trundle**  
**Chris Watton**  
**Gerald Smith**  
**Colin J. Guy**  
**Pete Gurney, LCGI**  
**Terry Lamoon**  
**Denis Foley and**  
**Ronnie Boag**

### **Panasonic NVFS100B**

For the first half hour or so the playback picture was ragged with low contrast. This suggested a dried-up electrolytic capacitor, but the hairdryer seemed to have no effect. My thanks to Steve at Merrivale who suggested checking for faulty electrolytics in the two metal screening cans on the small PCBs in the base of the machine. C1 (1 $\mu$ F) on the small piggyback board VJB03680 was the main culprit, though C9, C10 and C16 produced faulty readings when checked with a capacitor bridge. Fit 110°C replacements. **P.B.**

### **Grundig VS540**

A locked-up machine with AO showing in the display usually means that the security lock is set. If you clear the lock by connecting together for a moment the two test pins on the front PCB, then find that the timer and station tables are filled with gibberish, the back-up battery is probably flat – but not always.

Sometimes the battery is fine but the RAM has somehow lost its contents. Check the soldering around IC190, IC120 and IC119 on the sequence-control (lower) PCB. If there are no dry-joints here, replacing the PCF8583 clock/RAM IC and the back-up battery as a

# VCR Clinic

pair should cure the problem.

To avoid having to change the Nicad battery every few years, the manufacturer suggests removing the charging diode MD612 and fitting a lithium battery (27400-220-97) instead. **P.B.**

### **Hitachi VTF550E**

If you have problems with cassette lift operation or tape threading, remove the deck and see what falls out! You could well find that the clutch assembly has come apart (manual reference number 229 231 239). The Hitachi part number is KX17581. **P.B.**

### **Ferguson FV82LV**

The E-E picture was snowy though aerial loophrough and playback of a known good tape were fine. Continuity checks on the main PCB revealed that the track from the tuner's output to the IF module's input was open-circuit. **P.B.**

### **Philips VR6557**

If one of these machines comes in dead, check whether the N20 Wickman circuit protector CP801 is open-circuit. **P.B.**

### **Tatung TVR912/914**

These machines were made by Sharp. This one would jump between SP and LP during playback of its own LP recordings. The cause of the fault was within IC801, which combines the functions of system and servo control and the CTL amplifier. It's quite an expensive chip. **E.T.**

### **Matsui VX1100**

This model's Orion deck is also used in the Tatung DVR634/832, TVR734/932 etc., the Orion VLBF and no doubt other machines. It's becoming common for them to suffer from intermittent front-loading problems, in which case the machine may shut down at some

point during the cassette-loading cycle or eject as soon as front-loading is complete.

The cause is usually the mode switch, which is available as part of a small, cheap PCB assembly. Alternatively the centre-cassette LED can be responsible. **E.T.**

### **Amstrad TVR3**

This combi unit's VCR section didn't produce colour. The cause was the AN3331K chip IC1 in the head amplifier module. You may not spot this item in the service manual, as the IC reference doesn't appear. To check it, play back a test tape while monitoring the video waveform at test point 9. No waveform or only noise usually means that the IC has failed.

An alternative symptom is sometimes seen: the picture is in monochrome for a second when the tape starts to play, then takes on a greenish hue. **C.W.**

### **Aiwa HVF125**

The card said that this machine rewound all the time. Prior to removing the cover I suspected an end sensor fault. I then discovered that the tape didn't lace up fully and that the pinch roller was stuck at the top of its shaft. It had seized up because the grease had turned into glue. A clean up and relubrication restored normal operation. **C.W.**

### **Daewoo V225**

The cause of a dead machine can be failure of the chopper transistor's base drive coupling capacitor C53 (1 $\mu$ F, 100V). It's inside the power supply can. **C.W.**

### **Sharp VCMH60HM**

This machine wouldn't record video – the old picture was still present. Checks showed that there was no drive at the full erase head: the bias oscillator wasn't in opera-

tion, because the 8V bias line voltage was missing. The cure was to replace Q950. **G.S.**

### **Grundig GV6401**

There was no E-E sound output from this VCR. Playback was normal, and the machine's recordings were OK when played back via another VCR. Audio from the tuner arrived at the sound processing PCB, but there was no RF or scart output from it. IC7100 had audio signals through to the noise-reduction section at pins 44-48, but there was no output at pins 17-22. A replacement chip restored normal operation. **G.S.**

### **Panasonic NVG40**

The E-E and looped-through signals were very weak. The cause was not a faulty aerial amplifier this time. Because Q1004 in the power supply was open-circuit there was no 12V supply to the aerial amplifier. **C.J.G.**

### **Sanyo VHR287E**

It took me a long time to be convinced that this machine had a fault. The customer insisted that it would stop after half an hour, but it wouldn't stop for me – with my tape, the customer's tape or even when wrapped up in a blanket. When it came back for the third time, the customer mentioned that the fault occurred in the record mode only, never during playback. Some time would have been saved if I had been told this in the first place. Sure enough it did stop.

While discussing the fault in the pub with a friend who works for a national rental company I discovered that the fault is a common one in this range of machines. The cure is to replace fusible resistor PR512. It's a safety component – the correct type is available from CHS. **C.J.G.**

### **Matsui VP9301**

There were no E-E signals, just snow. I found that R6035 (33kΩ) in the tuning voltage filter was open-circuit. **C.J.G.**

### **Panasonic NVHD100**

This machine would shut down a few seconds after powering up. Its capstan motor couldn't rotate because the brake pad was stuck solid to the flywheel. A clean up and a new brake unit, part no. VXA5138, cured the fault. **C.J.G.**

### **Sharp VCA140HM**

The complaints with this old

machine were that it chewed tapes intermittently, that lines sometimes appeared on the picture, and that the sound sometimes disappeared. After a long soak test I discovered that the fault symptoms put in an appearance only after a function change or when a new tape was inserted. The cause was the half-loading arm, which would intermittently stick because the grease had become quite viscous. When the arm jammed, the tape was lifted from the AC head to a varying extent.

The cure was to remove, clean and realign the arm. The pinch roller was replaced as a matter of course. **P.G.**

### **Sony SLV270UB/Grundig VS600**

This machine had failed when it was disconnected from the mains supply to be moved from one room to another. When it was reconnected the clock display remained out and an audible squealing came from the drum as it tried to rotate to initialise. Suspecting a power supply fault, I checked the various supply lines with an oscilloscope. There were large amounts of ripple on most of them. The main causes were C1736 and C1737, which are both 220μF, 25V. When checked with an ESR meter they were found to be virtually open-circuit. For reliability I replaced all the electrolytic capacitors on the secondary side of the power supply, using low-ESR types. **P.G.**

### **Hitachi VTF860E**

This VCR was dead with no clock display and no output from the power supply. Quick checks on the primary side of the power supply confirmed that there was 320V across the mains bridge rectifier's reservoir capacitor, and that all the fuses and safety resistors were intact. As I didn't have a circuit diagram, I then set about finding out how the start-up supply is obtained. It appeared to be derived from three series-connected resistors across the 320V DC supply, with a kick-start capacitor (C6) connected two-thirds of the way down this network. When I checked C6 I found that it was open-circuit. A replacement (1μF, 250V, 105°C) restored normal operation. **P.G.**

### **Toshiba V218**

The customer complained that this machine wouldn't start up from switch on at the mains – he didn't

leave it plugged in overnight. I found that the start up voltage at TW020 was very low. Tracing back through the circuit I came to RP024 which should read 47kΩ but read very much higher. A replacement cleared the fault. **T.L.**

### **JVC HR255**

There was no drum rotation. Voltage checks showed that there was no LT supply to the drum. The N15 circuit protector CP4001 was open-circuit. Once this had been replaced there was normal operation. **T.L.**

### **Sanyo VHR798**

This machine chewed tapes. When I inspected the deck I found that the tension band had come away from its metal band and got stuck in the gears. A new band and a new mode switch were fitted, then the machine was given a good clean. After that it worked well. **T.L.**

### **Toshiba V856**

Intermittent failure to record in colour was the complaint with this machine. It can be a tricky fault to trace, so I decided to consult Toshiba Technical. Their suggestion was to replace CV30, which tends to develop leakage. A new 0.047μF capacitor, part no. 70041704, did the trick. **T.L.**

### **Ferguson FV62LV**

The playback picture flickered from side to side with loss of line sync and no colour. When I placed a finger gently on the top edge of the drum to slow it down there was a near normal picture. It appeared that the servo control was defective, but there was nothing technical about the cure. Inspection of the head motor and the photosensor on the motor panel showed that an extraordinary amount of dust was present. Use of a soft brush to remove it was all that was required to restore normal pictures. **D.F.**

### **Sanyo VHR775**

This machine sometimes failed to accept a cassette. There was also noisy loading and unloading. Replacement of the mode switch and the loading motor cured the faults. **R.B.**

### **Ferguson FV95V**

This VCR wouldn't accept cassettes: the loading motor ran all the time. The cam lever was broken. I replaced the mode switch as well as a precaution. **R.B.**



# VCR Clinic

Reports from  
**Philip Blundell, AMIElec**  
**Eugene Trundle**  
**Ronnie Boag**  
**Roger F. White**  
**Bob Longhurst**  
**Gerald Smith**  
**John Coombes and**  
**Colin J. Guy**

## Philips VR838

The problem with this top-of-the-range machine was no tape movement in play or wind/rewind. When the tape was fully laced the supply spool wouldn't turn, though the brakes were seen to be off when a clear service cassette was tried.

An inspection under the deck soon revealed the cause of the problem: the kicker gear (item 129 in the exploded view in the manual) was wrongly timed. This gear is not present in basic models that use the Turbo deck. **P.B.**

## JVC HRJ225 and others

The deck used in this and other JVC models can jam in the fully-laced position. When this happens you will see that the pinch roller hasn't fully closed on the capstan shaft. The cause is a broken capstan lever assembly (item 50 in the exploded view in the manual), which is under tremendous stress from its spring. The replacement for this plastic part is made of cast metal. **E.T.**

## Akai VSG240 and others

Here's another common deck fault, which once again is not confined to this particular model. The symptoms are intermittent deck shut down, with ERR2 showing in the display panel. It usually happens when the machine changes mode: from stop to play or rewind, from rewind to stop, etc. The cause is

the mode switch, which is readily accessible on the underside of the deck after removing the deck's five securing screws. **E.T.**

## Akai VSG295

These machines can cut out intermittently in the LP record mode. The cure is to fit TR413 and TR414 (both DTC144TK), R520 and R521 (both 47k $\Omega$ ), C505 and C506 (both 10nF) and remove links JS401 and JS402. **R.B.**

## Sanyo VHR778

The fault with this machine was intermittent loss of sound when a Nicam broadcast was being recorded. The cause was dry-joints at oscillator X6701. **R.B.**

## Finlux VR3724

If the problem with one of these machines is intermittent no rewind or fast forward, replace the cam slide assembly – part no. 8681 4927. **R.B.**

## Ferguson 3V32

Some people think that these VCRs are better than new ones. The fault with this machine was failure to come out of standby. Q22 on the mecha board was short-circuit: as a result the voltage at the cathode of D29 was high, preventing the data pulses passing through. Once Q22 had been replaced and a service kit had been fitted the machine worked as well as many new ones. **R.F.W.**

## Hitachi VTM620E

The switching point varied in both the play and record modes. The cause of the trouble was C616 and C617. **R.F.W.**

## Sharp VCH81

There was no capstan rotation. Before ordering a new motor I examined the old one carefully and

found that the 12V supply was present at the connector but didn't reach the IC. A small electrolytic capacitor had become leaky, and the leakage had eaten through the copper print. **R.F.W.**

## Ferguson FV77

This machine was dead because the UC3842 chopper control chip IP01 had failed. As it's not a common failure, I looked for a reason and found that CP1 (220 $\mu$ F) was faulty. As a result the voltage at pin 7 of IP01 was low. **R.F.W.**

## Samsung SV80IK

This VCR was dead apart from four dashes on the clock display. It didn't respond to the standby switch or attempts to insert a cassette. If a cassette was inserted when the power was off, it would be ejected when the power was switched on again. The booster worked, but there was no test signal and no E-E operation.

My first thought was to clean the mode switch, but when I removed the deck I found that it doesn't have one. So I removed the PCB to check the power supply and noticed that one of the end sensors was unsoldered. After resoldering it I looked around for any other dry-joints then reassembled the machine. It now worked. Must have been one of my lucky days. **R.F.W.**

## GoldStar P131

"Dead" was the customer's complaint. As through-RF was fine I removed the power supply and concentrated on the secondary-side electrolytics. CP19 (1,000 $\mu$ F) proved to be useless when checked with a bridge. Once it had been replaced everything worked though the display was very dull. The cause turned out to be CP25 (100 $\mu$ F). **B.L.**

### **Akai VS66**

The capstan motor was stalling. I held the spindle, with a dummy cassette inserted, and found that it quivered all the time. Not very technical this, but I deduced that there was a power supply fault. In fact the outputs from the power supply were all unstable, with ripple on them. The culprit was C15 (220µF). **B.L.**

### **Panasonic NVL28**

The customer had somehow discovered that intermittent loss of video and sound while recording could be cured by tweaking the input selector switch. Needless to say this switch now had to be replaced. Once this had been done the original fault was apparent when the same PCB was flexed. The cause was dry-joints at the jumper ribbon-cable connections between the front sub-PCBs. What did concern me was that without the customer's hint I certainly wouldn't have started looking for the cause of the trouble in this section of the VCR! **B.L.**

### **Thorn VR172L**

There was no display and no deck functions worked. But the modulator was obviously powered. The customer also mentioned that prior to the present situation recordings played back in monochrome. It was very helpful to find that the power module's output connector was marked with the supply voltages that should be present. The 6V output was low at 2V, but increased to 6V when disconnected from the main PCB. As the 6V regulator wasn't running hot, I decided to connect an external 6V supply to the machine. It then worked normally. A replacement KIA78006A regulator, obtained from Chas Hyde & Son, cured the trouble. **B.L.**

### **Matsui VP9405**

This machine was dead with the mains fuse intact. I had an Orion D1096 circuit, which is almost identical. It didn't take long to discover that the 470kΩ start-up resistor R519 was open-circuit, and I was thankful there hadn't been a power supply blow up as there had with the Orion VCR. After a deck service everything was fine. **B.L.**

### **Akai VSG745**

There was no E-E sound but playback was OK. Checks showed that there was no audio input to the sound processing PCB and no out-

put from the Nicam PCB. The sound would come and go when the Nicam PCB was tapped. Crystal X1 was so dry-jointed that it was hanging out of the PCB. Resoldering this item restored normal sound. **G.S.**

### **Sharp VCM27**

There were heavy interference lines on E-E via the scart output and virtually no E-E picture or playback at RF. A new RF modulator restored normal pictures. **G.S.**

### **Toshiba V404B**

The tape speed was incorrect and the back-tension lever was vibrating. The fault gave the impression that the capstan motor speed was varying, with wow on the sound. In fact the cause of the trouble was incorrect seating of the cam slider, giving incorrect operation of the tension-drive lever. When you get this problem, replace all these components, including the hook levers. **J.C.**

### **Hitachi VTF450**

The complaint with this machine was no results. I soon found that the N5 (250mA) circuit protector QF901 was open-circuit. It protects the supplies to the mode switch (A5.4V), the EPROM (A5V) and the IC902 reset (B5V). **J.C.**

### **Toshiba V705B**

A problem we've had with these machines is intermittent failure to accept a cassette – the fault can be very intermittent. The cause is a faulty cam switch (B432), part number 70031401. **J.C.**

### **Sony SLV625U**

If the RVS arm assembly is creased or jammed because the grease has hardened around the spindle, the tape can loop and jam up on the guide poles, preventing tape ejection. To overcome this problem clean the spindle, lightly oil it and reset the height to restore normal operation.

Other causes of failure to eject the tape are a faulty mode switch or a faulty BA6238A loading motor drive chip (IC204). **J.C.**

### **Panasonic NVSD400**

There were lines on the playback picture and sound variations. A check on the FM waveform showed that it seemed to be distorted. The cause of the trouble was arm unit P5 (part number VXL2306), which was bent. It should be replaced, but as a tempo-

rary measure it can be bent back to the correct position. **J.C.**

### **Toshiba V212B**

The E-E picture was snowy. Reception via the aerial booster was also snowy. We found that the 12V supply to the booster was missing because the BCP53-16 14V regulator transistor TP91 was short-circuit emitter-to-collector. **J.C.**

### **Samsung VIK326**

A faulty right-hand side plate is the usual cause of failure to accept a tape. The plastic mount which holds the cog that drives the lift mechanism in and out becomes cracked. It may break off completely. **J.C.**

### **Ferguson FV61LV**

Although this machine was supposed to be dead there was a shuffle from the deck when I plugged it in. A quick check showed that RP86 (27Ω) was open-circuit. The replacement got very hot, and an audible whistling came from the power supply. Further checks showed that the supply line voltages were all high. Instead of 14V at TP86E there was 18V. The cause was TP01 (BC858) which was leaky. **C.J.G.**

### **Panasonic NVSD40**

A tape was stuck in this machine and the display read H02, which means failure to retract the tape into the cassette. Inspection showed that this was the case, though the loading arms had retracted. At power up there was no movement from any of the motors, but I could wind the tape back into the cassette by turning the capstan with my fingers, so there was no jamming here.

To get to the electronics you have to remove the deck. The clever designer of these machines put a deck fixing screw under the tape carriage: it's inaccessible when there is a tape in the machine. The trick I use is to ease outwards the loading arms at each side of the cassette holder. It's then possible to lift the holder and remove the tape without breaking anything.

The cause of the fault turned out to be dry-joints at the BA6887 loading-motor driver chip IC1, which is right at the front of the PCB. Why the result was failure of the capstan motor to rotate I don't know, but it rotated once IC1 had been resoldered. **C.J.G.**



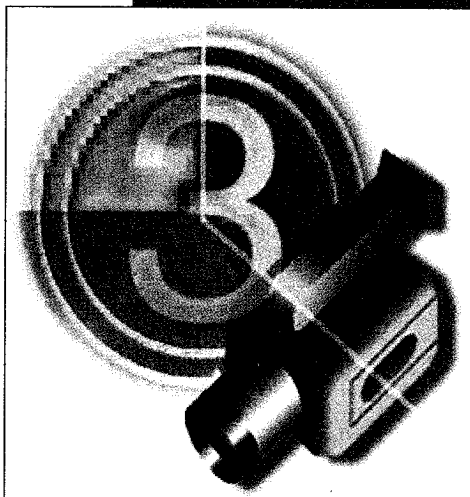

## Reports from David C. Woodnott

### Sony CCD-TR760E

The camera/VTR power switch was extremely stiff. As with other similar models, this switch also operates the internal lens cover mechanism. These parts can often be dismantled then cleaned and lubricated, using a suitable plastic lubricant, before reassembly. With some models they are available as replacements; with other models a complete front case has to be obtained, which makes an expensive repair out of what must seem to the customer to be a rather minor problem.

With this particular unit the dismantling and cleaning procedure worked and all was then well. I did however warn the customer that any further similar trouble would be more expensive to rectify.

### Nikon VN9000

This Sony clone (similar to the CCD-V88) produced a green camera picture. I found that the problem was intermittent, and that the unit would revert to a no-picture condition. Playback was acceptable, but required some 'tidying up'. The camera picture symptom varied between a greenish shade and complete loss of picture into a mass of lines. The sync and burst signals remained constant at all times.

I decided to check the camera head PCBs for signs of leaked electrolyte – widespread capacitor failure on the video and syscon boards is becoming common with these units. Any severe problems here could mean the end of the camcorder, as not being worth repair. In

# Camcorner

this case however both these boards were OK. So on to the camera section.

I removed and inspected all the boards. Board VC32P (process and SSG) was found to be in trouble. Several capacitors had leaked, and some minor print repair was required. After washing, drying and repairing the PCB, and fitting new capacitors, I reassembled the unit for testing – minus, at this stage, the many screening cans/screws etc. that make these camcorders a joy to work on!

At power up the green picture had disappeared. But only the lines were present, as previously! I next investigated the SSG section, and found that the VSUB driver transistor Q629 was faulty. Once this item had been replaced a correctly coloured E-E picture appeared on the monitor's screen.

The VSUB voltage was then reset as laid down in the manual. Having restored the camera head to health, I gave the deck a service and reassembled the units. With a camcorder of this age and known propensity to capacitor failure, I always warn the customer about the risks involved in undertaking a repair.

### Sony CCD-FX500E

The note attached to this unit said it was dead. It certainly was – there was no power up in either the camera or the playback mode.

When the cam/VTR switch fails it usually does so for one or other mode, rarely for both. I released the switch from the case to check it, then saw the cause of the problem. The cam/VTR button had fractured internally: it appeared to move correctly from side to side, but didn't operate the switch. A new button assembly was all that was required.

### Sony CCD-TR780E

When I checked this dead camcorder I found that PS501 had failed. As the usual checks for short-circuits etc. failed to reveal anything amiss, I fitted a replacement and put the unit on soak test. It worked for several days without giving any trouble.

PS501 supplies an unregulated input to IC502 on the servo/syscon PCB VS125. This IC is labelled "reg. battery detect" and, amongst other things, provides separate 5V and 3.7V supplies for the mode control master chip IC503. It was difficult to see how PS501 could have failed without any tell-tale signs in this area, but there weren't any. The unit continued to work during several more days of soak testing, and was then returned to the customer.

A few months later the unit reappeared with exactly the same symptom. PS501 had again failed, and as before no reason for its failure could be found. As electrolytic capacitors are always suspect, though they are usually OK in such a new unit, I replaced C503 and C506 which decouple the two supply lines. They looked and tested OK in all respects – value and ESR. Six months later the unit has not returned, and we know it has been well used.

### Samsung VPK70

This camcorder arrived with a note to say that there was a tracking fault and that it had been checked, unsuccessfully, elsewhere. Their looseness made it fairly obvious that the tape guides had been adjusted in an attempt to achieve stable pictures. During playback the tracking was 'almost OK', with occasional vertical picture jumping, especially after rewind search. Careful realignment of the tape path with a Sony test tape failed to improve matters, and I couldn't see any obvious damage to the deck, guides etc. Everything seemed to be all right, but the machine wouldn't set up properly.

As a last resort I checked the deck against another one that was in the workshop. This almost immediately revealed what was wrong: a slant pole was missing on the take-up guide coaster! This deck has two slant poles on the take-up coaster, and one had sheared off. The break was not detectable unless you knew that the pole should be there. A replacement assembly cured the problem.



# VCR Clinic

Reports from  
**Philip Blundell, AMIElec**  
**Eugene Trundle**  
**Giles Pilbrow**  
**Paul Hardy**  
**Kevin J. Green, TMIE**  
**Bob Longhurst**  
**Michael Maurice**  
**Terry Lamoon**  
**M. Della Verita and**  
**Martyn Davis, MIElec**

## JVC HRJ220

There was no E-E or playback picture or sound, though the mechanical functions and the display worked normally. Checks in the power supply showed that there were no AL12V or SWD5V outputs. The cause was Q859 (2SD1302S) which had an open-circuit base-emitter junction. I didn't have the JVC circuit diagram, but the **Philips VR6557** circuit diagram seemed to be very similar. **P.B.**

## Grundig GV540GB

The complaint with this machine was lack of contrast. There was weak video at RF or via the scart connector, in either the E-E or playback modes, and the on-screen menu display was weak. I used a scope to trace back through the circuit. At connector 1545 I found that a normal signal was entering the OSD module at pin 5 but the output at pin 7 was low. Checks on the module showed that transistor 7905 (BC858B) was open-circuit base-to-emitter.

This particular machine had the OOSGD6-OSD type subpanel fitted on the motherboard. **P.B.**

## Sony SLVE720UX

There was intermittent loss of the E-E sound and picture – not necessarily at the same time! Whenever

the sound went then came back the 'stereo' caption appeared on the screen. The cause of the fault was in the IF module, where the earth lands around the edges of the PCB were dry-jointed to the screening can. **E.T.**

## Sony SLVE280 and others

This machine operated correctly in all modes except for record. In this mode it would loose display (for a second), unlace then go to standby. The cause of the problem was circuit protector PR512 in the power supply: it had gone high-resistance. PR512 can also be responsible for an increased level of audio buzz on playback, because motor noise gets on to the audio supply. You get the same problem with the **SLVE220**, **SLVE520** and several **Sanyo** machines. **G.P.**

## Hitachi VT450

There were slight hum bars on the picture – E-E, playback and record. Checks showed that the regulator pack was producing just over 13V instead of 12V, with slight ripple. A new STK5372H chip cured the fault. **P.H.**

## JVC HRD660EK

The mechanism was jammed. When it had been cleared I found that one of the slit washers that hold the rack slider had fallen off. As a result it had lost engagement. The guide arm, load gear and master cam were replaced as they showed signs of damage. As a precaution the mode switch was also replaced. **P.H.**

## Panasonic AG5700B

This is an S-VHS broadcast-type VCR. There is no tuner but the deck is the G type used in domestic models. As a result these machines suffer from the same mechanical problems with which most of us

are familiar. There are a few minor mechanical part differences, for example the release lever unit, so you need the manual to ensure that you order the correct part. I've encountered very few electronic faults. The following is a run down of those found to date:

(1) The power supply connector P1001 is frequently dry-jointed and should always be checked. As these machines age, the capacitor problems experienced with domestic models may appear.

(2) The cause of no audio can be Q2 in the power supply. It provides the non-switched 12V supply.

(3) Poor colour and resolution with a humming noise that comes from the drum should lead to a check on the lower drum's PCB. You will probably find signs of overheating. A complete new upper and lower drum assembly will be required. **P.H.**

## Akai VSF480

The playback picture was very unstable, as if the tape path was misadjusted. But the FM waveform was OK. Checks in the video processing section brought the cause of the trouble to light: the charge-coupled delay line IC401 was feeling unwell! **K.J.G.**

## Samsung SV140I

This machine would load a tape and would go into the playback mode, but the tape didn't lace around the drum. I removed the mechanism and used an external supply to power the motor to see what was going wrong. As the motor moved, the main plastic slide-plate became cockeyed – because its retaining cut washer had sprung off. I found this item stuck to the base PCB and was able

to refit it. A blob of Evostick was added for good measure.

Retiming the slide-plate is fortunately a straightforward job with no need to refer to the service manual. I could find no reason for this fault: the washer was a good, strong fit. **B.L.**

### VCR Quickies

**Ferguson FV33:** If the machine is totally dead, replace C14 in the power supply.

**Toshiba V711B:** A sluggish loading motor can jam the mechanism. Replace the loading motor block.

**Mitsubishi HS520V:** If the problem is erratic tape acceptance or not fully ejecting the tape, replace the mode select switch. **B.L.**

### Hitachi VTF150E

The playback sound was wowy and when a tape was loaded or ejected the E-E picture flickered and the Nicam stereo LED flashed. Scope checks in the power supply showed that there was ripple on the V-Capst output, with voltage variations when different modes were selected. The smoothing capacitors for this supply are C12 and C13. Checks on these capacitors confirmed that C13 (470 $\mu$ F) was the culprit. **B.L.**

### JVC HRS7000

As this machine wouldn't accept remote control commands the customer unplugged it. After that it remained dead. Some quick checks on the primary side of the power supply revealed that C2 (2.2 $\mu$ F, 63V) was open-circuit. A replacement restored normal operation – and the remote control unit worked. **M.M.**

### Matsui VXA1100A

Initially there had been an intermittent loading fault which was cured by replacing the mode switch. This time the customer complained that a tape was stuck in the machine. Inspection showed that the back-tension lever didn't move out of the way of the entry guide. As a result, the guide jammed on the back-tension arm. The cause was the plastic plate assembly under the deck: it had cracked, and the metal peg that sits in the groove of the cam had come out. Unfortunately the customer decided to buy a new machine. **M.M.**

### Sony SLVE225

The customer complained about a high-pitched squeal from this machine. It came from the drum

assembly. The most likely cause was the static discharge brush, which is beneath the drum. Fortunately the construction of this centre-deck machine is such that you can remove the drum without taking the deck out of the cabinet. Slight adjustment of the brush and a dab of grease silenced the squealing. **M.M.**

### Panasonic NVSD100

This machine had died following a storm. A new mains fuse and STRS6545 regulator chip restored it to life. **M.M.**

### Ferguson FV71LV

The take-up spool intermittently failed to rotate during play. The machine would then shut down. There were other intermittent mechanical faults, such as tape ejection when a function was selected, but failure of the take-up spool to rotate was the most frequent one.

I selected play, switched off the power, removed the carriage and tape, and separated the deck from the main PCB. This revealed that the cam had been driven past the play position and was near the reverse search position, in which the idler cannot go to the tape drive. Mode sensing in this deck is carried out by two optocouplers that detect the signal from slots in the master cam. Replacement of the optocouplers cured the problem. If you look at the cam carefully you can see markings for stop, play and reverse. **M.M.**

### Toshiba V804

This machine came in because it wouldn't load. The mechanism worked perfectly in all the other modes, but didn't load or unload. I found that cam lever K470, which operates the main cam, had broken. This seems to be an increasingly common fault. The machine worked perfectly once the cam lever and pinch roller had been replaced. **T.L.**

### JVC HRD610

This machine was lifeless. A few checks on the primary side of the power supply showed that the voltages were rising and falling. I noticed a capacitor that looked quite stressed and replaced it. Hey presto, the machine then fired up and worked perfectly. The culprit was C12 (2.2 $\mu$ F, 50V). **T.L.**

### Toshiba V703

If you get one of these machines with a dim display, check C810

(15 $\mu$ F, 10V) and C813 (47 $\mu$ F, 16V) in the power supply. Replacing them will usually produce a normal, readable display. **T.L.**

### Akai VSG815

The customer complained that the machine intermittently chewed tapes, but only when it was in the timer record mode. This symptom can be a sign of a dodgy mode switch, so I fitted a replacement. After that all was well. **T.L.**

### Alba VCP3000

We have on occasion had complaints about tape chewing with these machines. The solution is to clean the mode switch (or replace it if necessary), replace the idler spring, and straighten the idler – this can be done using a hairdryer. **M.DV.**

### Panasonic NVL26B

This machine came in because it was dead, which often means a power supply rebuild. I was about to order the two chips when I decided to take a look first. All that was required was to replace C9 (1 $\mu$ F, 400V). **M.DV.**

### Sanyo VHR277

This machine performed all functions correctly but would intermittently shut down while recording, the display showing blanks. A quick call to Sanyo's excellent technical department soon sorted this one out. The value of circuit protector PR512 (0.1 $\Omega$ ) in the power supply can go high, affecting the 5V output. As a result the deck micro is upset. **M.D.**

### Ferguson FV100

There was a whirr on sound and noise bars were present on the picture. Something was obviously causing tape drag. The entry and exit tape guides were carefully examined and the back-tension was checked, but everything here seemed to be OK. I eventually discovered that the loading motor's plastic housing was catching on the top of the pinch roller. But it was difficult to see why: everything seemed to be in its correct place.

After spending far too long staring at the assembly I realised that I was looking at a fault I'd never seen before: the pinch roller itself had come apart! The outer rubber sheath had become detached from its inner metal shaft and had slid upwards, catching on the loading motor's housing. A new pinch roller cured the fault. **M.D.**

found that the drum PG signal at pin 52 of IC801 was missing. The drum PG amplifier is within IC702, but this chip had no input at pin 28 from the sensor on the head drum motor. As the sensor is part of the drum motor I decided to try resolving it. This provided a complete cure. The PG sensor's DC resistance is about 200Ω. **M.Dr.**

### Sharp VCM271

There were two problems with this newish machine: the capstan motor ran in reverse intermittently, and the fluorescent display was out. It must have received a bang at some time. Socket P702, where the capstan motor is plugged in, was dry-jointed. The display had no filament supply because of a cracked print land at the chopper transformer. **M.Dr.**

### Amstrad VC9140

Intermittent loss of the record colour was the complaint – always a tricky fault. Fortunately I noticed that the E-E picture was lost when the tape was ejected, which suggested a fault in the power supply. When some checks were carried out while the tape was being loaded and ejected I noticed that the 'P.ON50V' supply fluctuated quite a lot – in fact it varied when there was any deck mode change. The cause was traced to R06 (100kΩ).

Having cured this fault I put the VCR on soak test to wait for the intermittent record colour problem to show up. It didn't. I assume that the power supply fault had also been the cause of this symptom. The tuning voltage is derived from the 50V supply, so it's likely that the machine drifted off tune to the extent that the colour was lost. **C.W.**

### Ferguson FV32L

The power supply had blown up. I fitted the SP3881 kit, which is a bag full of bits – loads of diodes, transistors etc. Once this job had been completed I tried the machine and found that it was still dead. But at least it didn't blow the mains fuse, and there was 320V across the bridge rectifier's reservoir capacitor. Checks on the secondary side of the chopper transformer then revealed that DP48 (BA158) was short-circuit. A replacement restored normal operation. **C.W.**

### Mitsubishi MX1

Playback was OK but there was no E-E video - the sound was not affected. There was video at pin 16 of the IF processor chip IC101 but

not at the drum PG signal from Q102. The cause of the fault was traced to coil L108, which was open-circuit. It's in parallel with CF101, which is part of the filter network just after the signal for the sound detector is extracted. **P.G.**

### Daewoo DVF502P

There were no functions and no display. The cause of the problem was C703, which had changed value. It's linked to IC701's reset line. **G.S.**

### Samsung VIK310

The complaints were picture flicker and wow on sound. I found that the back-tension arm was oscillating and the take-up reel was jerky. After a thorough tape path clean and fitting a replacement back-tension band the back-tension arm had stabilised but the take-up reel remained jerky, producing wow on sound. A replacement clutch assembly cleared up the wow. I then replaced the worn audio head and pinch roller, and as a precaution the now infamous C110 in the power supply. **G.S.**

### Sharp VCM27

This machine failed to erase in the record mode. Tests showed that the erase bias oscillator wasn't running. After checking for shorts etc. I found that the microcontroller chip IC701 didn't switch the bias on. All was well when the microcontroller chip had been replaced. **G.S.**

### Nokia VR3615

The faults with this machine were intermittent loss of the E-E picture and intermittent going to standby. Both were caused by dry-joints at Q853. **G.S.**

### Samsung VIK310

This machine would sometimes damage a tape: at the end of rewind it would eject too quickly, leaving tape out. It would also intermittently eject the tape when stop was pressed. The cause of these problems was a faulty mode switch. **G.S.**

### Aiwa FX55S

This machine would accept a tape. But when any mode was selected it would operate for a fraction of a second then eject the tape and shut down. It seemed to be a reel sensor problem. The PCB on which this item is mounted is connected to another PCB via an exposed four-way connector, which appeared to be incorrectly located. I loosened the fastening screw and moved the

reel-sensor PCB slightly so that the connector was centrally aligned. This cured the fault. **M.M.**

### Philips VR6291

After running for about one and a half hours this machine would start to behave erratically and then shut down. A quick glance in the power supply section revealed that R247 (270Ω) had cooked. It's in the optocoupler circuit. So I replaced R247, using an 0.25W type, T246 (BC547) and the CNX83A optocoupler. After a prolonged test I decided that the machine was now OK. **M.M.**

### Matsui VP9501

This machine didn't wind the tape into the cassette during eject. When the mechanism had been removed it was clear that the take-up clutch had disintegrated. The cause of this was the plastic circlip, which couldn't take the force of the clutch spring. I first reassembled the clutch using the original circlip: as it sprang open two seconds later I used a metal E circlip. This solved the problem, which I understand is quite common. **M.M.**

### Nokia VR3785

The rather unusual symptom was that the characters in the on-screen display wouldn't remain stationary. It occurred when the machine had been on for some time. Application of freezer to the LC74760 on-screen control chip IC162 stopped the characters moving and a replacement cured the fault. **R.B.**

### Sanyo VHR287

This machine would cut out intermittently in the play/record modes. The fault was cured by replacing protector PR512. **R.B.**

### Hitachi VTF150

There were noise bars in the E-E mode. The capstan was noisy in play and tended to cut out in the record mode. Checks in the power supply revealed that there was a lot of ripple across C12. A replacement cleared all the symptoms. **R.B.**

### Nokia VR3716

There was intermittent loss of the E-E picture. The cause turned out to be dry-joints at filter FL2401. **R.B.**

### Samsung VIK326

The guides wouldn't load up around the drum assembly. The cure was to replace the mode-state switch and the slide main assembly. **R.B.**



**Reports from  
David C. Woodnott  
and Adrian Spriddell**

**Sony CCDTRV70E**

This modern unit had been dropped. As a result there were no viewfinder pictures. The LCD and all other functions worked. A broken EVF CRT was, I thought, the most likely cause, but on opening the EVF case I found that inductor L903 was damaged and had been 'uprooted' from the PCB. As it couldn't be repaired a replacement had to be obtained and fitted. When this had been done the viewfinder worked but there was a severe line linearity problem.

A small magnet is glued to the top end of the inductor, placed off-centre. If fitted incorrectly, as I had done, the magnet will be too close to the CRT, causing geometry errors. The problem was resolved by reversing the position of the magnet. **D.C.W.**

**Sony CCDTR60E**

No viewfinder picture was the complaint, which was cured by replacing C924 (68µF, 16V) on the EVF PCB. This is becoming quite a common fault. The usual symptom is a bright, blank raster with fly-back lines. **D.C.W.**

**Canon UC100E**

The customer told us that new heads were required, that he had been phoning around for the best (lowest) price, and that we were "best on this score" (not intentionally!). So the unit was brought in for inspection. The customer was pleased to learn that new heads were not required, merely refitting

# Camcorner

the head drum connector. We have found this to be a problem with other models: poor connection can give the impression that one head has failed. **D.C.W.**

**Sony CCDTR750E**

Intermittent failure to accept a tape was the complaint with this camcorder. A check, using the Lanlink interface, showed that there was a head drum error during loading. The connections to the drum (CN500) were checked, cleaned and treated with Sony Fluid grease. A long soak test then proved that all was well. We have found it advisable to remove all such deck connectors, especially those associated with the various sensors, and service them in the manner described above. **D.C.W.**

**JVC GRAX7**

There was a tape stuck in this machine. An accompanying note said that the problem had occurred before, and that the unit had been 'fixed' by an undisclosed repairer. It's not uncommon for the mechanism to fail because of wear or broken plastic guides, cams etc. The mechanism has been generally reliable, but these units are now about seven years old.

I removed the tape and checked the mechanism for signs of wear or damage, but couldn't see any. The take-up and supply guides were out of sync however. So the drum was removed to gain access to the loading rings, which needed resetting. When the Sony mode box was used to power the loading motor, the loading and unloading cycles seemed to be OK, with no unusual noises or drive sticking. So the PCBs were reconnected and the machine was powered.

Tape loading was OK up to the point at which the pinch arm starts to move. A click was then heard, after which loading ceased and the emergency unload mode was entered. On investigation I found that the mechanism was again out of alignment. So the unit was dismantled, but no reason for the failure was immediately obvious. I did

however notice that the loading rings had perhaps more play than is normal.

The fault was cured by replacing the three sets of loading guides and the washers that control the amount of free play (items 7 and 12). The guide slackness had allowed the upper loading ring to ride up and 'hop a tooth' at the point of failure, because of the increased stress required to operate the pinch roller assembly. **D.C.W.**

**Sony CCDF375E**

One of these camcorders arrived with a note to say that it wouldn't accept a tape but was otherwise OK. On test we found that the drum didn't rotate: it just twitched instead. Failure and leakage of capacitors C502 and C904 on the main syscon PCB was the cause of the trouble.

The fault has become quite common with models that use this PCB layout, i.e. the **F450** etc. Other capacitors in the same area can fail, causing this or other symptoms. They are wire-ended components. **D.C.W.**

**JVC TK885E**

Hot-air rework facilities and a scalpel are useful when the fault is intermittent luminance and/or chrominance. Remove the encoder card and carefully desolder the CX20053 chip IC1. Scrape off all the glue that secures the 'flying' electrolytics to the PCB. You will find that this glue has trickled beneath the flatpack IC, hardened and forced the IC's legs off the pads.

Clean the tracks and pads, coat with reflow flux and resolder the platethroughs beneath the IC. Clean the IC's legs, then refit it. Check the encoder and leadout wires for dry-joints. Finally clean off and refit the card. Fingers crossed! But it should be OK now. **A.S.**

**Sony CCDF555E**

The customer complained that the viewfinder picture was streaky. C909 (1µF) on the EVF PCB was the cause. **D.C.W.**

more on the

# Panasonic K Deck

**Adrian Williams describes some common faults experienced with this widely used VCR mechanism**

**T**he K deck has been around for several years now. It's used in a large number of Panasonic VCRs, ranging from basic mono sound models to S-VHS editing machines with hi-fi stereo and Nicam sound. There are a number of common problems. The following list of symptoms and cures may be helpful to those not familiar with the deck.

**Refusal to load a tape or lace up:** The loading motor, part no. VEM0427, is faulty. The shaft has a plastic collar on it: this spits, the result being loss of drive to the mechanism. Also check worm wheel gear part no. VDG0868 – remove the gear and inspect it for loose or missing teeth.

**Refusal to eject tape or load (tape gets stuck in housing):** Replace shaft assembly part no. VXP1339. It tends to bend outwards, away from the side plate. As a result, the housing gets stuck. You will also notice that the top plate of the carriage assembly is bent on the right-hand side.

**Tape is pulled very tight in the play mode. As a result there is damage to the tape and the guide bases:** Replace the take-up brake lever, part no. VXZ0313. It snaps at the end, where it's in contact with the supply brake arm, part no. VXZ0312, which it holds off during play (in the fault condition the supply brake is on).

**Line at top of screen during pause or forward/rewind search:** Replace the supply guide assembly, part no. VXA5245 KIT. As mentioned above, the brake lever may be faulty. The take-up guide, part no. VXA5427 KIT, may also be damaged.

**Lower edge of tape is damaged, or pinch roller assembly doesn't go down fully:** The P5 arm unit is distorted, part no. VXL2306. Also check the pinch roller, part no. VXL2246.

**Ticking noise from the mechanism during play:** There are three possible cures for this one, as follows.

(1) Strip out the capstan rotor unit and regrease it (not too much).

(2) It may be necessary to replace the flywheel, part no. VXP1519. You will find that the new one has a more solid base where the rotor and capstan shaft meet.

(3) The tension roller unit, part no. VXA4799, may be worn, rubbing on its bracket.

**VCR goes to standby when a tape is pushed in (no forward operation of the loading motor) or ejected (no reverse operation of the loading motor):** Replace the loading motor drive chip. It's usually a BA6887, part no. BA6887-V3. Check the loading motor which may have a dead spot or a broken shaft (see above).

**Capstan speed problems:** The capstan drive chip is probably faulty.

## Service Notes

All new Panasonic VCRs have a service mode. No. 7 drives the loading motor forward when the play key is held on, and reverses the loading motor when the stop key is held on (the capstan is also reversed to prevent a loop of tape being formed). This is very useful, enabling most of these mechanical problems to be diagnosed very quickly without dismantling the VCR – the top must of course be removed. As far as I know older machines such as the NVHD100/NVSD44 don't have this feature.

The timing doesn't usually need to be altered.

For further information refer to John Coombe's article in the November 1996 issue.

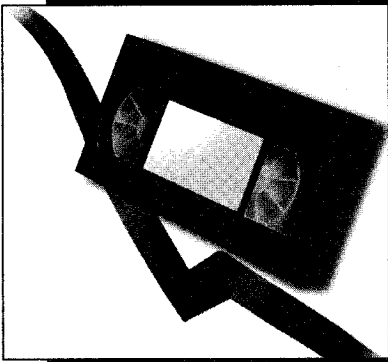

# VCR Clinic

**Reports from**  
**Michael Maurice**  
**John Coombes**  
**M. J. Cousins, MIEEIE**  
**Pete Gurney, LCGI**  
**Russ Phillips and**  
**Owen Green**

## **Panasonic NVJ30B**

This machine would intermittently load or unload, sometimes stopping at various modes. I replaced the rather worn and blackened mode switch, but this failed to cure the problem. A replacement solenoid was the solution, proved by a prolonged soak test. **M.M.**

## **Toshiba V411B**

This machine wouldn't accept a tape. The belt that connects the cassette housing to the eject gear next to the capstan motor had fallen off. Replacing it wasn't the end of the story however. The machine still wouldn't load, because the motor 14V supply was low. TR201 (BD202) was found to be open-circuit. It had failed because the loading motor was faulty: when I tested it with a 12V supply it became hot and drew 3A! A replacement loading motor finally completed the repair. **M.M.**

## **Sony SLVE40**

When play or record was selected there was a clicking noise from the mechanism and, in play, an unsteady picture would appear with wow on the sound. I found that in these modes the clutch wasn't slipping. In this mechanism there's a gear that engages with the clutch in the rewind, fast-forward and unlace modes: it engages with both sections of the clutch to give full torque in these modes. In play and record it should disengage, but didn't.

The cause of the problem was on the top side of the mechanism, where the arm assembly trigger gear (item no. 932) that engages with the top plate was missing. Fortunately I was able to obtain one from a scrap Alba machine. This provided a complete cure. The part number is 3-946-920-01. **M.M.**

## **Osaki VCR34**

The cause of intermittent playback with these machines can usually be traced to dry-joints at the plug-socket connections on the top side of the deck. **J.C.**

## **GoldStar GSE1290IQ**

If one of these machines won't accept a tape, check whether diode D521 is open-circuit. **J.C.**

## **Akai VSF410**

The cause of intermittent no results was traced to dry-joints at transistor TR3. Resoldering restored normal operation. **J.C.**

## **Samsung SV421K**

There was no rewind or fast-forward operation. After the usual checks to ensure that the brakes were not jammed on and the spools were free to move I found that the lever pinch cam (T228) was incorrectly seated. Once its position had been corrected I had rewind and fast forward. **J.C.**

## **Matsui VX1100**

The problem was intermittent cutting out in the playback, rewind and fast-forward modes. After a lot of checking, the mode switch was found to be the cause. **J.C.**

## **Sony SLV353**

This fault occurs only after very fast rewind: when play is pressed at the end of the rewind, the cassette is ejected. The cause is the end-of-tape leader overlapping the sensor, thus preventing correct operation. In this

case however I found that the PH001 supply-reel sensor Q001 was open-circuit. **J.C.**

## **Tatung TVR6111**

A fault you sometimes get is intermittent operation/display. The mechanical operation can also be intermittent. Check crystal X801 which may be faulty or dry-jointed.

The cause of no rewind/fast forward is usually the rubber damper, part no. U153091. **J.C.**

## **Matsui VP9402**

It said no rewind on the ticket, but fast forward didn't function correctly either – it consisted of a series of very violent, erratic jerks. The deck mechanism, which is the same as in the VXA1100, lifts off the mother PCB. To start with I checked the mode switch, timing and idler, which were all OK.

I then turned to items 31 and 34, the clutch-gear supply and take-up assemblies respectively. They can be inspected by removing the polyslider washers. The assemblies flew apart to reveal that the shafts, which should have been hexagonal, were completely rounded on the supply assembly and partly worn on the take-up assembly. This explained the loss of rewind and erratic fast forward, as the shafts would just slip to varying extents. Replacement assemblies restored correct operation.

The only other problem I've had with these decks has been intermittent stopping and shut down, caused by the two reel sensors. **M.J.C.**

## **Ferguson FV80B (R4000 Series)**

There was cassette loading failure: when a cassette was inserted it flopped in rather than being drawn in, and the mode motor laced up without the cassette even being seated.

Tape loading should take place as

follows. When a cassette is inserted it activates a microswitch to power the loading/mode motor which drives the master cam. This is linked to the 'lever cam gear casting', which is in turn connected to the cassette rack.

Because of metal fatigue the lever cam gear casting had failed. It's positioned under the master cam. The replacement was easy to fit and restored normal operation. **M.J.C.**

### **GoldStar GHV1240I**

Tape damage was the main complaint. An initial check revealed a worn reel idler: once this had been replaced the sluggish rewind/fast forward speeded up. So far so good. But there was an extra fault comment, that the tape wouldn't rewind fully. This was a more troublesome problem.

When I watched the tape in the rewind mode it would just stop, with no sign of slowing down, struggling etc. A new reel sensor optocoupler made no difference.

A scope check showed that reel pulses were present at pin 23 of the syson chip IC501, but they were of low amplitude. The only components between the reel sensor and the chip form a digital transistor circuit on the deck junction board. The culprit was the 8.2k $\Omega$  resistor R601. It feeds Q6D0, which amplifies and sharpens the reel pulses. **M.J.C.**

### **JVC HRJ220**

The customer complained about tape damage. Tests showed that when rewinding and stopping there was much spillage from the take-up spool. I cleaned the brake pads – they are of the black-material type that seems to disintegrate on touch – but this made no difference. So replacement brakes were ordered, also a mode switch as a preventative measure. The brake part nos. are PQ46308A-2 (main brake) and PQ46309A-4 (sub-brake).

Mode switch replacement is quite complex, as it's buried beneath the control cam. Once the mechanism has been removed, along with the cassette housing, the machine can be put into the "mechanism assembling mode". This is done by turning the mode motor belt towards the front until a hole in the cam aligns with a hole in the deck: at this point the various holes in components line up with holes in the deck. Thus alignment is easy.

The replacement brakes completely cured the tape damage problem. **M.J.C.**

### **Sanyo VHR4890E**

The complaint with this S-VHS machine was poor sound/picture in the standard VHS mode, S-VHS operation being OK. When I plugged it in however the power supply was tripping and failed to start. A quick check on the capacitors on the primary side of the power supply revealed that C5013 (22 $\mu$ F, 10V) was leaking electrolyte. When this and C5010 (1 $\mu$ F, 25V) had been replaced – they are both rated at 105°C – the VCR powered up.

Before the power supply was recased, I checked the capacitors on the secondary side for ripple with a scope. C1 (47 $\mu$ F, 50V) and C10 (330 $\mu$ F, 6.3V) were low in value and, on removal, were found to be leaking electrolyte. At this point all the other electrolytics on the secondary side were replaced as a precaution.

Finally to the original fault, which turned out to be severe patterning and hiss on sound. They were not present in the S-VHS mode or at the scart socket. The UHF modulator was the cause. **P.G.**

### **Sharp VCA63**

This centre-deck machine frequently died then returned to life again. In view of the customer's report I suspected dry-joints, and a good look around revealed that plug PA in the power supply was virtually unsoldered. But after resoldering it the fault was still present. A further check around the power supply, with a magnifier, brought to light the fact that one leg of C9 had a hairline crack around the joint. This turned out to be the actual cause of the fault. **P.G.**

### **Mitsubishi HSB32**

This VCR came in with a partially laced-up tape stuck inside. At switch on the machine returned to standby after five seconds or so. Checks in the power supply produced correct voltage readings during the brief period before shutdown, so attention was turned to the loading motor where a voltage check confirmed the lack of any drive.

I disconnected the motor at the plug and socket on the servo deck and, to unlance the tape, applied to its contacts 9V from a variable-voltage power supply. I find that this is usually the best way, before proceeding further, of checking the deck for correct operation – customers have a nasty habit of attempting tape removal by force, which results in additional problems once the origi-

nal fault has been put right. While the tape was unlancing I noticed that the motor had a bad spot on its commutator. As a result the motor frequently stopped and drew excessive current.

After replacing the motor I checked the TA72915 drive chip IC4A2 and found that this had also died – in fact it had split in two! Once this item had been replaced the machine worked correctly. **P.G.**

### **Ferguson FV72**

The mechanism was jammed and there was a tape in the fully loaded position. At power up the capstan motor could be heard to run just before the machine shut down. Removal of the base plate gives only limited access, but enough in this case to be able to see that the plastic pulley on the capstan motor had fallen off. It hadn't split, and could be reattached soundly with a small amount of Araldite. After that the machine worked correctly. **P.G.**

### **Panasonic NVSD260**

This reasonably new K-deck machine intermittently failed to load a tape. The cause was dry-joints at the end sensors. To be on the safe side, and because the mechanism had to be removed to get at the offending items, I also resoldered the sensor LED. **R.P.**

### **Panasonic NVD80**

This machine worked all right but the display didn't light up. There was no 33V feed from the power supply because R1016 (2.2 $\Omega$ , 0.5W) was open-circuit. **R.P.**

### **Hitachi VC102**

The power-on indicator switched off after about ten seconds because the microcontroller chip sent an 'off' signal to the power supply. There was a tape inside the machine. After chasing a few red herrings I found that the STK5471 regulator chip was the cause of the fault. **O.G.**

### **Ferguson FV105HV**

Tape loading problems were caused not only by broken gears on the cassette housing but also by a tiny microswitch on the main circuit board, underneath the mechanism assembly. **O.G.**

### **Samsung SI7220**

There were no mechanical functions and the loaded tape wouldn't eject. Checks showed that the 12V supply was low at only 2V. The cause of the problem was the STK5333S power regulator chip. **O.G.**



# A Hi-8 Video Problem

One of our customers asked us to look at his Sony EVS1000E Hi-8 VCR, which he used for editing camcorder tapes and for transfer to VHS. It had suffered from an unusual fault from new. When he used it to play back a standard-play (SP) Hi-8 recording made by his camcorder, the picture was covered with white spots – similar to the effect produced by a poorly earthed head drum. Playback of the VCR's own recordings was reasonably good. LP camcorder recordings were also played back with little problem. The EVS1000E is a well-specified machine, with good slow-playback modes via a jog/shuttle feature, Nicam off-air sound, PCM and hi-fi stereo etc.

Our first checks were on the anti-static brush and the earthing of the head drum and head amplifier sections. Everything was OK. We next checked and set up the tape path alignment, tape tension etc. The FM signal was checked, also the supplies and the signals to the head amplifier assembly. No problems. After finding that the DOC adjustment was correct, we decided to check the head  $Q$  (playback frequency) adjustments, using the relevant test tape.

There are two SP-mode adjustments, one for each head. Both could be set up all right, but the ch. 1 adjustment also altered the picture's spottiness. Unfortunately we didn't appreciate the significance of this at the time! Our next step was to replace the upper drum assembly. This was not a good move – it's expensive, and made only a small difference to the symptom.

What was going on? The important points were that only SP

camcorder recordings produced the fault symptom, and that the EVS1000E has an unusual head drum configuration. It has separate SP and LP heads, unlike the customer's CCDV800E and most 8mm camcorders which use LP heads for both tape speeds. LP heads have a narrower gap than SP ones of course.

As the camcorder has only LP heads, its SP-mode recordings have guard bands between the tracks (the VCR has full track-width SP heads that don't produce guard bands). The cause of the trouble was that one of the VCR's LP heads was permanently switched on. During playback of the machine's own SP recordings some off-tape information was picked up. This did not degrade the picture significantly – after all, the two LP heads are active in the trick-playback modes, providing good still pictures etc. But when an SP camcorder tape was being played back the active LP head was looking at either the guard band or was completely off-tape, thus producing the 'static' type interference. It took us a while to figure out what was happening!

Why was one LP head permanently active? Because of a manufacturing error: C102 (1.5 $\mu$ F electrolytic) had been fitted the wrong way round. It's part of the head switching circuit, which normally shorts out the ch. 1 LP head in the SP mode.

You are unlikely to come across exactly the same component problem, but the effect on the picture produced by different head types and thus different track layouts may be worth bearing in mind.

D.C.W.



Reports from  
Nick Beer and  
David Woodnott

### Hitachi VCM1E

I'd not had one of these twist-and-shoot models for repair before. They clearly suffer from the surface-mounted electrolytic capacitor problem. This particular one recorded perfectly when twisted into the camera mode. In the untwisted VCR mode however it would intermittently either refuse to carry out any deck functions, or the buttons would select the wrong functions, or the machine would permanently be in the rewind or another mode.

The control switches appear to be connected to a resistive ladder network. An examination revealed that some of the through-the-board links in front of the connector (PG802) to the switches had become corroded. The answer lay on the other side of the PCB: C234 (100 $\mu$ F, 6.3V) and C244 (47 $\mu$ F, 6V) were leaking.

There were leaky electrolytics in other areas as well. **N.B.**

### Panasonic NVM10B

This full-sized camcorder was dead. It was no surprise to find that the 0-025 $\Omega$  fusible resistor R1051 (part no. VSF0059) was open-circuit, but the short that could be measured between its business end and chassis had a rather unusual cause. Much lifting of chokes to isolate circuit areas confirmed that the cause of the problem was somewhere in the middle of the power supply. The chopper transistor was OK, but the transformer had a short-circuit between its primary winding and chassis. It's T1001, part no. ELL10R010. A

# Camcorner

replacement transformer and fusible resistor restored normal operation. **N.B.**

### Panasonic NVMC30B

This one arrived with a tape stuck in the mechanism and a note to say that it would remain powered up for only a few seconds. It's not an uncommon fault with this model, the cause usually being faulty regulator transistors in the power supply. In this case however the power supply was OK. Inspection of the unit at power up, with the tape still loaded, revealed that the drum didn't rotate. In fact it was completely jammed! We removed, cleaned and refitted the drum, after which all was well. Dirt of some sort must have made the drum stick. **D.C.W.**

### Sanyo VMD6P

A faulty AV socket is quite a common problem with these popular, middle-aged camcorders. The socket is available at modest cost from CHS. Sometimes however you find that the printed circuit has been damaged by excessive AV connector wiggling. So a new PCB has to be obtained. This is also available from CHS, though not at quite such a modest price.

We've on occasions found that some audio circuit setting up is required after fitting a replacement board. The usual symptom is low or distorted sound. Information on this is included in the relevant service manual. **D.C.W.**

### Sony CCDTR305E

The customer said that this newish camcorder had operated intermittently for some time but had now ceased to do anything at all. There was a tape, which couldn't be ejected, in the mechanism. An initial inspection showed that the unit would power up in the VTR mode but not in the camera mode. No functions worked however.

When the RM95 remote unit was connected the VTR functions could be operated by the buttons, but there was no camera mode as the CAM/VTR switch is in the main body of the camcorder. A replace-

ment Switch Block Control, as Sony call the complete control-button assembly, was required. This cured all the symptoms – albeit at a price. **D.C.W.**

### Sharp VLE30H

This early Viewcam model has been generally reliable. Until recently we've not seen many of them. This one came in for a general service. There is nothing much to report, except for something that those with little experience of these machines (like us!) should note.

After its service the unit was put on test and performed well. As we didn't have the customer's AV connector, we were able to check the results only by looking at the LCD screen and by using another camcorder to play back a tape, which was OK.

The unit soon came back however, with a report to say that while it now worked well there were no outputs via the AV connector. We had failed to notice a peculiarity with the connectors used in this model. The ribbon cable connectors used by most manufacturers have a grip system that, when released, enables the cable to be removed. Refitting is the reverse procedure. With the Sharp version, as used in this model, it's possible for the whole section to come away at the cable end when the grip is released. This is of no consequence if the grip is not removed from the cable. If it should fall off, as it must have done in this case, it can be refitted incorrectly. This might not be noticed – the connector can appear to be correctly recoupled to the PCB socket. When it's incorrectly fitted however a section of the plastic grip part-insulates the ribbon cable end from the connecting pins on the PCB.

This was where we had made our mistake with the AV connector. It was simple to rectify once we realised that this reversed connection is possible. It can obviously occur with any of the other similar connectors, causing various symptoms – thankfully none fatal, as the worst that can happen is an open-circuit. We live and learn! **D.C.W.**



# Camcorner

Reports from  
David C. Woodnott

## Electrolytics

The extremely useful **Capacitor Wizard** was reviewed in these pages recently (June). One of them now has a permanent place on my workbench. I agree with all that was said in the review, but would like to add a note on its use.

Anyone who is familiar with the Camcorner page will realise that I have to replace a lot of electrolytic capacitors, especially the small types used in the Canon E60 range etc. When using the Wizard to check these capacitors the readings obtained could lead to misunderstanding. The Wizard's display is divided into three sections, Good, Compare and Bad. The instructions supplied emphasise that a degree of judgement is required in interpreting readings in the Compare area. This is fine. But note that these small electrolytics show up as Bad even when new! I checked several dozen from a reel. All measured Bad but were perfectly OK. A really bad capacitor of this type (10µF, 16V) won't even move the pointer off the end stop!

So beware of misinterpreting the readout. Always compare and everything will be OK. It's a truly excellent and much-needed piece of equipment.

## Sony CCDTR805E

Intermittent operation was the complaint with this Hi-8 unit. On test everything at first seemed to be OK, but after a while the unit powered down. It wouldn't switch on again

until the supply had been removed then reapplied.

When it was working again (in the play mode) I noticed that if the bench power supply's output voltage was slightly altered – by only about 1V from nominal – there were picture disturbances. These took the form of horizontal bands that moved in the background of the picture, or white spots that covered it completely. I also noticed – nothing much gets by me! – that the unit didn't always power down correctly. Even when the supply voltage was reduced below the nominal cut-off level, to about 4.5V, it would still hang on.

The cause of the trouble was a faulty MC141600FU DC-DC driver chip, IC231, in the power supply. When a replacement has been fitted the unit needs to be set up correctly as per the manual.

The chip is used in various models and is suspect whenever this type of fault occurs.

## Sony GVS50E (Video Walkman)

This particular unit is used as part of a mobile surveillance system. It came in for repair because there was no AV input operation. Playback worked correctly via the LCD, and there were AV output signals. But there were no LCD pictures, or monitor pictures via the AV connectors, in the record mode.

The cause of the trouble was failure of circuit protector PS402 on the audio PCB (AU147), on which the AV connectors are fitted. This CP is at the earth connection side of the video input socket. Another CP (PS401) provides similar protection for the audio input. No cause of the failure could be found – it's likely that an incorrectly earthed input had been connected, producing a voltage across the CP.

## Samsung VPJ52

Intermittent record colour was the reported symptom. The effect could be readily seen in the E-E mode. Playback of a previous recording was OK. The cause of the trouble was

simply dry-joints on the multipin connector between the camera head and the main PCB.

We've had other intermittent faults caused by these connections. Impact damage is probably the basic cause: the connections are very close to the case internally.

## Sony CCDTR350E

No operation was the complaint with this newish Handycam. In fact there was no power up, and an inspection revealed that circuit protector PS901 was open-circuit. As no shorts could be found, a replacement was fitted. The unit was then switched on.

A check on the various outputs from the power supply showed that they were all missing. The DC-DC driver chip IC901 was suspect and was replaced, curing the fault.

With all functions now working, the final step was to set up the power supply circuits as laid down in the manual.

## Sanyo VMEX280P

We recently replaced the complete lens assembly in one of these camcorders because the iris vanes had become contaminated with oil that had leaked from the motor unit. As cleaning is seldom successful, and the iris assembly is not available separately, the complete unit usually has to be replaced.

Focusing may not work correctly when a new assembly has been fitted. The unit really needs to be set up, for which operation an interface is required. The EEPROM chip that holds the focus data etc. is mounted on the lens unit on a small, flexible PCB that connects all the sensors and motors etc. to the main PCB. If the old EEPROM is transplanted on to the new lens unit you will probably find that, as in this case, all will be well. There's no servicing information for the components mounted on the lens assembly, so setting up is at best an educated guess!

When we subsequently replaced a lens unit in a similar Sanyo model we found that transplanting the old EEPROM was again successful.

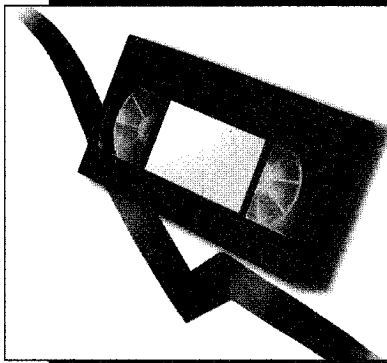

**Reports from  
Eugene Trundle  
Gerald Smith  
Maurice Kerry  
Ronnie Boag  
Paul Hardy and  
C.J. Guy**

### **Hitachi VTM720**

This machine had suffered from a very intermittent fault – for years! It would sometimes eject a cassette immediately after insertion, or try to pull the empty cradle back in after eject. It would often behave itself for months. We finally tracked the cause of the fault down. When it occurred, the voltage at pin 65 of the syscon chip rose to about 1V instead of 5V. There was an ‘invisible’ dry-joint at one of the wire links that supply the pull-up resistor R759. **E.T.**

### **Hitachi VTF641**

This machine appeared to be dead, with no deck operation and no front-panel display. The power supply seemed to be working all right, but neither microcontroller chip had a reset pulse. We found that the +5D line voltage was low at 4.6V, because of heavy electrical leakage in the capstan motor. When the deck was unplugged, the display lit up and the control system responded to commands. A new capstan motor restored normal operation.

VTM6XX series models are similar, so you could get the same problem with them. **E.T.**

### **Hitachi VTF550**

Another intermittent front-loading fault! We had fitted new end sensors and a mode switch, but this machine continued, at rare intervals, to try to kick the FL cradle outwards at switch-on with no tape

# VCR Clinic

present, or eject the cassette at the completion of front loading. It transpired that the front-loading switch S2102 would sometimes stick in its in position. A replacement switch cured the fault forever! **E.T.**

### **Sharp VCM271**

This machine wouldn’t accept a tape. But if you took the top cover off it started to work. A new LED restored normal operation. **G.S.**

### **JVC HRD820**

Playback was marred by lines on the picture while the sound was a little too fast. If the capstan was slowed by hand the speed and picture would lock and stay OK until you went to search or stop. Replacing IC401 cured the fault. **G.S.**

### **Sharp VCM27**

This machine didn’t erase the previous sound and failed to record the new sound. A check on the erase bias showed that its frequency and amplitude were too high and the waveform was generally unclean. The fault was cured by repairing the print at C623, which is connected to the base of the bias oscillator transistor. **G.S.**

### **Daewoo V225**

This machine came in dead. Checks showed that the primary side of the chopper power supply wasn’t working. The cause was the 1µF, 100V start-up capacitor C53 – a replacement restored normal operation. **G.S.**

### **Sharp VCM271**

This machine would accept a tape then promptly eject it. Replacing the start and end sensors cured the fault. **G.S.**

### **GoldStar T2631**

This machine didn’t record the audio signal and failed to erase the previous sound track. The bias/erase oscillator wasn’t running, but

started up when the full erase head was disconnected. A replacement head, part no. 523-833A, cured the fault. **M.K.**

### **Sharp VCM271**

This machine was brought in because it was dead. Checks in the power supply showed that the output voltages were low and pulsing. Further checks revealed that Q921, a 2SB709 surface-mounted transistor, was leaky. I replaced it with a 2SB710 which cured the fault. **M.K.**

### **Mitsubishi HS761V/641V**

One of these machines was brought in with a fully-laced tape in it. When eject was pressed the guides came back half way then returned to the fully laced position. I removed the tape manually then inserted it in the cassette housing; this produced only a forwards-backwards movement.

These machines have an optical mode control system. The cause of the trouble was the LED D5B5, whose output was low. Replacement cured the fault. We’ve had this fault on a number of occasions now. The part no. of the LED is 264P696010. **M.K.**

### **Sanyo VHR286**

The customer complained that this machine lost time intermittently and that timer recordings were unreliable. I eventually found that crystal X3002, next to IC302, had a dry-joint at one lead. **M.K.**

### **GoldStar T161/T1631**

There was no capstan servo lock. Playback of prerecorded tapes was OK, but with the machine’s own recordings the picture ran through. Replacement of the audio/control head, part no. 225-371A, cured the fault. **M.K.**

### **Sharp VCH84**

The complaint with this machine was intermittent loss of functions.

The cure was to replace the faulty gear assembly part no. NGERH1128GEZZ. **R.B.**

### **Toshiba V204**

There was no playback or E-E picture. The cause was found to be loss of the supply to the RF modulator. Checks showed that CW001 (100µF) was faulty, a replacement curing the problem. **R.B.**

### **JVC HRJ246**

The loading motor would run for a few seconds then the machine would switch to standby. The cause of the trouble was dry-joints at the end sensors. **R.B.**

### **Sanyo VHR275**

This machine chewed tapes in play. Replacing the arm lever load, part no. 613-164-4762, cured the trouble. **R.B.**

### **Toshiba V204**

This machine was dead though the power supply was ticking. Capacitor CP007 (10µF, 50V) had fallen in value – a replacement restored normal operation. **R.B.**

### **Panasonic NVJ35B**

The main complaint, low gain via the tuner/booster unit, was cured by resoldering a number of bad joints in this module. But there was still a problem – severe patterning with the output from the modulator. This disappeared gradually when the machine had been on for a while. C9 in the power supply had fallen in value. **P.H.**

### **NEC PX1200R**

The customer said that this machine would sometimes fail to record and, when setting timed recordings, would show "error" in the display. I also found that it would sometimes auto play a tape even though the record tab was present on the cassette. The cause of the trouble was that the contacts of the record protection switch had gone high-resistance. Replacing this item and giving the machine a 'rubber' overhaul completed the repair. **P.H.**

### **Nokia VR3783**

This centre-deck Hi-Fi VCR would not accept a cassette. The lift was mistimed, and it looked as if someone had already had a go. I retimed the lift and replaced the front loading gear – the tension of its retaining lever had been lost, with the result that the gear moved up the shaft. The timing of the main gears was checked and found to be fine.

There were no damaged teeth. But when the VCR was powered the deck went berserk. I retimed it and operated it manually. As everything seemed to work all right the most likely suspect was the mode switch, which is buried inside the loading block. It was, with a great deal of effort, replaced. Fortunately this cured the problem. **P.H.**

### **Mitsubishi HSM18V (J Deck)**

The mechanism had jammed. I removed the cassette and checked the deck mechanism, which was fine. The problem was being caused by the sense and drive gears on the cassette lift – they had both lost some teeth. Willow Vale do a service kit (77048KT) which cured the fault. **P.H.**

### **GoldStar KI14V20 (D17 deck)**

A cassette was jammed in this combined TV/VCR. When it had been removed and the lift had been refitted a cassette could be inserted. But when play was selected the tape was damaged by the pinch roller as it made its way down the guide.

After watching the operation of the mechanism a few times, using a dummy cassette, I realised that the take-up arm was bent and didn't clear the pinch roller when in its correct position. A service kit (88021FA) from Willow Vale was fitted – it has the take-up arm assembly, the take-up lever and the pinch tower. There is also a kit (88100L) which has only the pinch tower and the take-up lever. A modified pinch roller assembly (88100F) was fitted to complete the repair. **P.H.**

### **Mitsubishi HSM54**

The sound was being played back at slow speed. On investigation I found that the pinch roller wasn't engaging fully because the grease on its guide pin had gone hard. Cleaning and regreasing the guide was the only action required.

I always clean and regrease the guide pin when I get a VCR fitted with this deck. Failure to do so will lead to the pinch-roller assembly sticking on the guide pin and the cam pinch lever breaking. This item can be obtained from Willow Vale – the order code is 77890L. **P.H.**

### **Panasonic NVSD200**

The report said that this machine intermittently locked up and displayed F03. Now the usual cause of

this is the mode switch or its connector, but not this time! Eventually the fault did put in an appearance – after changing from reverse search to play. There was a whirring from the loading motor, but nothing happened. Then the machine shut down. When repowered it unthreaded normally. An examination of the loading motor revealed that the plastic coupling on its shaft had split. Replacement cured the problem. **C.J.G.**

### **Hitachi VT11/GEC V4005**

The problem was intermittent loss of drum and capstan servo lock. Its cause was traced to intermittent loss of the 4.43MHz input at the servo chip. It comes from the HT3509 thick-film module on the Y/C board. A tap on this chip would instigate the fault – the 4.43MHz output at pin 27 disappeared. But the oscillator in the module didn't stop. We cured the problem by soldering a 1nF capacitor between pin 27 and the side of the crystal farthest from the pin. The owner was saved the cost of this expensive module. **C.J.G.**

### **GoldStar GSE1290**

This machine worked perfectly but its owner complained about a very loud whistle. It came from the piezo 'buzzer' P8501, which proved to have DC leakage. As a result, the oscillator transistor Q502 was permanently biased on. **C.J.G.**

### **Auto Head Cleaners**

Whenever you replace the head in a VCR that has one of these abortions in it, replace the cleaning roller as well. I had one ruin a new head in a very short time, because it had become hard and abrasive. Better still, remove the thing altogether – I reckon the heads will last a whole lot longer! **C.J.G.**

### **Ferguson FV91L**

There was no drum rotation, only a slight twitch when it attempted to start. The rotor had been pushed too far on to the shaft. If it's pushed all the way down to the bearings, it is too far away from the PCB-mounted stator when the deck is assembled to the PCB. **C.J.G.**

### **Philips VR203**

The sound produced by this Charlie deck VCR suffered from severe wow. None of the usual problems was the cause. Idler 216 turned out to be the culprit. The bearing in this item had seized up. **C.J.G.**

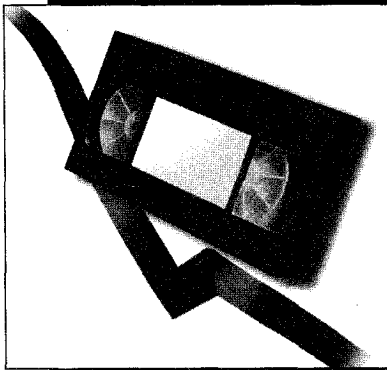

**Reports from**  
**Nick Beer**  
**Terry Lamoon**  
**Michael Dranfield**  
**Philip Blundell, AMIE**  
**Chris Watton**  
**Ronnie Boag and**  
**Christopher D. Nunn**

### **JVC HRJ225**

Drive for the front loading mechanism was not present because the lever (part no. PQ4635A-2) behind the reels was not being counter-sprung into position: the lever's lug, to which the counter spring is attached, had broken off. A new lever cured the fault. But, looking at the size of the lug and considering the tension on the spring, I feel that it's likely to break again. **N.B.**

### **Philips VR6547**

This machine did nothing. The dealer who sent it to me had discovered that the ICP for the 5V supply was open-circuit. A replacement made no difference, but at least it didn't fail. When the power supply was run without load the outputs seemed to be OK, though the voltages across the 12V, 6V and -30V rails were slightly low. On load, every output fell to about half the correct level.

The biasing of the optocoupler PCI was excessive because the 2SC1740S error detector transistor Q31 was leaky. **N.B.**

### **Panasonic NVL28B**

This machine was dead. No, it was not C9 this time! Tests on the secondary side of the power supply revealed that the 20V over-voltage protection zener diode D1113 was short-circuit. It had clearly been replaced before, apparently quite recently. When I removed it and ran the power supply without load I dis-

# VCR Clinic

covered why – the 20V line was at 35V. All the other voltages on the secondary side of the circuit were proportionately high. The cause of the trouble was C1114 (47 $\mu$ F, 16V) in the feedback network on the primary side of the circuit. **N.B.**

### **Matsui VP9601**

Intermittent tape chewing was the complaint. So I took the top off the machine and put it on test. It worked happily all day. What to do? I decided to make it work harder by putting it into rewind then stopping it half way through. As the brakes didn't act immediately, the tape looped. The cure was a new mode switch – it's a common cause of problems with this model. **T.L.**

### **Philips Turbo Deck**

If the problem with a machine fitted with this deck is failure to load or intermittent failure to do so, check whether the loading motor's pulley shaft is damaged or split. If it is, order the kit from Philips – part no. 4822 310 10657. **T.L.**

### **Sony SLVE7**

Tape damage is a common problem with these machines. Always check that the load arm moves freely. If it doesn't, take it off, clean it thoroughly, lubricate the contact points and replace it in the correct position. The machine should then be OK. **T.L.**

### **Matsui VP9405**

The complaints were that this machine didn't always eject, loaded badly or the tape jammed. I went straight for the mode switch, but it had already been changed. Time to put the machine through its paces. Loading was very slow, but manual load with no cassette was perfectly free. When I inserted another cassette for loading I put the slightest

pressure on the loading belt, which stopped. It started again when gently pushed. The loading motor was faulty and was unable to take much resistance. A replacement cured the problems. **T.L.**

### **Toshiba V254**

Looping on rewind was the problem, because the capstan didn't stop quickly enough. I spoke to the Toshiba boffins about this. They suggested adding a 100 $\mu$ F, 6.3V capacitor across the Cap +5V supply, positive lead to the cathode of DT107 and the negative lead to jumper wire JT035. It worked. **T.L.**

### **Sanyo VHR390**

This machine played all right but shut off in rewind. Fast forward was OK. I was suspicious of the reel sensor which, when I checked it, was full of dirt and hair. This was removed and the area was thoroughly cleaned. The machine then worked perfectly. **T.L.**

### **Matsui VXA1100**

This relatively new machine was dead. The cause was simply that R534 (470k $\Omega$ ) in the primary side of the power supply had gone open-circuit. **M.Dr.**

### **Akai VSF410**

This machine had gone off after a power surge during an electrical storm. The clock lit up and, when the power button was pressed, the machine powered up. But it immediately powered down again. The 13V zener diode D13 had gone short-circuit, leaving Tr1 without base bias. **M.Dr.**

### **Tatung TVR912**

There were several symptoms with this Sharp clone. Play stopped after about one second; the counter read six minutes when an E180 tape had

been fully rewound; and if the ACE head was unplugged during a rewind the tape counter continued to count. Very strange! The cause of these symptoms was about 0.8V of ripple at pin 22 of the microcontroller chip.

A check in the power supply showed that there was about 4V peak-to-peak of 50Hz ripple on the UR 6.5V line. The 0.27Ω safety resistor R904 in the feed to the bridge rectifier was open-circuit, hence the 50Hz ripple. A replacement failed at switch on: D907 (1N4003) in the bridge was short-circuit. Replacing these two items restored normal operation. **M.Dr.**

### **Grundig VS520/540**

We've had a number of these machines with a dead power supply: once the mains feed has been disconnected the power supply won't restart. If the mains fuse is intact, replacing C407 (220μF, 25V), C420 (100μF, 25V) and C443 (100μF, 10V) usually solves the problem. **P.B.**

### **Philips VR258/05**

If there's no front keyboard or remote control operation (the machine will accept a tape but won't eject or play it), check whether the Wickman fuse F1403 (315mA) is open-circuit. **P.B.**

### **Ferguson FV62 (R2000 Cat 1 Chassis)**

This machine was dead with a blown mains fuse and a short-circuit chopper transistor (TP08). After fitting a Thomson repair kit I found that the power supply worked but the output voltage was high – check for 14.2V across test points BP04 and BP05, with a 220V AC mains input. The correct voltage was obtained when CP10 (10μF) had been replaced.

One component that's not included in the kit is the ZPD3.9V zener diode DP15 – it's not shown on the circuit diagram, but is connected in parallel with RP33 (1.5Ω). It can go short-circuit when TP08 fails. The result is low output voltages. **P.B.**

### **Baird 8945**

The customer said that this two-speed machine kept jumping to LP. After testing it for several days we returned it as the fault hadn't put in an appearance. It came back a few days later with a post-it note that pointed to the LP LED and the comment that this would light when the fault occurred.

We plugged it in and left it. After a while we heard a faint relay ticking sound every thirty seconds or so. Sure enough the LP LED was coming on. This was in the E-E mode, with no tape inserted. A check at the active pin of the switch produced a DC reading that wavered between 2.5-5.5V. The reading should be 0V for LP and 8.5V for SP. Dismantling and cleaning out the switch cured the fault.

This Model was also sold as the **Ferguson 3V42** and the **JVC HRD455EK**. **C.W.**

### **Saisho VR2500/Matsui VX990**

There was a warble on the sound and poor playback chroma lock. The cause was traced to C08 in the power supply. It's near the STK5332 multi-voltage regulator chip. **C.W.**

### **Ferguson FV22L**

There's a modification to deal with various timer faults such as ignoring the stop time or stopping prematurely in the OTR mode: fit an 0.047μF capacitor between pins 3 and 8 of connector CN603, on the print side of the PCB. A kit is available, part no. 01P1-500-001 – or Willow Vale 20122MT. **C.W.**

### **GoldStar RQ5041**

The customer complained that this machine sometimes failed to start. The buttons worked and the display symbols lit, but the machine didn't respond. On test we found that the drum didn't rotate because its supply was missing. There was a 12V output at the power supply, but it didn't reach the motor because L202 (100μH) was open-circuit. **C.W.**

### **Daewoo V435**

The symptoms were cutting out in play and record, and noisy in play, fast forward and record. The solution was to replace the reel gear total assembly, part no. 97SB382410. **R.B.**

### **Samsung P130R**

IC702 (KA8301) had blown in half because the outputs from the power supply were twice what they should be! The culprit was C104 (33μF, 35V), whose value had decreased by about a half. Obvious enough, but don't leave the power supply connected for any length of time while testing or C017 will be sent into orbit (yes, it happened!). It's rated at 25V and, under the fault

condition, receives some 50V.

As there are only a few electrolytics in the power supply I replaced them all. The machine then worked very well. **C.D.N.**

### **Amstrad DD8900**

This monster's lower deck had a fault: intermittent eject. I decided to remove the bottom plate rather than the top deck. After about a million attempts to get the deck to refuse to eject, the fault suddenly appeared. The cassette housing drive spindle was being overdriven, and thus jamming, because the down switch was dirty. **C.D.N.**

### **Toshiba V703B**

This VCR's display had become dim. The machine then died completely. Heating the power supply brought it back to life, and with the aid of a can of freezer I found that C813 (47μF, 16V) in the power control circuit was the cause of the trouble. **C.D.N.**

### **Sanyo VHR3100**

When a cassette was inserted the carriage would move backwards and forwards then the machine would switch off. If a tape was loaded manually, fast forward and rewind were OK but in the play mode the capstan motor ran very fast while the drum motor sometimes wouldn't rotate at all. The cure was to replace IC4001 (LC7412-8017). Shop around, because the price tends to vary quite a lot. **C.D.N.**

### **Aiwa HVG75K**

The playback sound disappeared when this machine had been working for one to two hours. It came back when IC701 (BA7767AS) was frozen, but a replacement failed to cure the fault. After more heating and freezing I found that C732 (0.1μF) was the culprit. It sits just under IC701. **C.D.N.**

### **Ferguson 3V32/JVC HR7655EK**

This machine sometimes failed to unload and eject, though the stop light flashed – as if it was waiting for the mechanism to unwind.

The loading belt and timing were OK. When I disconnected the motor I found that 12V was present in the unload mode. The voltage dropped to 3-6V when the loading motor was reconnected. But a new loading motor made no difference! Q5 was OK but D19 produced a high reading. Thankfully a replacement cured the fault. **C.D.N.**



**Reports from  
David C. Woodnott  
and  
Eugene Trundle**

### **Sony CCDF150E**

The complaint was that previously recorded tapes played back all right but new recordings wouldn't play back correctly. The cause was traced to failure of C206 and C216 on board CV9. Replacement of these two surface-mounted capacitors and a service restored the unit to good health. **D.C.W.**

### **Sony CCDTR305E**

This small handycam didn't produce any E-E pictures – playback was OK. An internal inspection revealed that L852 had become detached from its normal position. As a result there was no HT supply to the camera section. Refitting L852 restored normal operation – the customer denied any knowledge of possible impact! **D.C.W.**

### **Canon UC2000E**

The note that came with this camcorder said that it wouldn't accept a tape but would close the housing if a tape wasn't fitted. When we checked it we heard the capstan motor rotating at high speed. Further checks proved that the FG sensor was faulty. A new motor restored the unit to normal working order.

This model is very similar to a **Samsung** one that uses the same or a very similar mechanism! **D.C.W.**

### **Sony CCDTR810E**

The complaint was "no operation" but in fact the unit was dead – there was no power-up. The cause was

# Camcorner

easy to spot: PS1502, a surface-mounted protector, was open-circuit. Despite various checks and a long soak test no reason for its failure could be established. **D.C.W.**

### **Sony CCDTR75E**

This camcorder's mechanism wouldn't accept a tape but closed satisfactorily without one. A common cause of this is failure of the drum to rotate, possibly because of a ribbon-cable connection problem. But the drum could be seen to start, at which point the mechanism ejected the tape.

A check on the cassette brake-release mechanism showed that it was working correctly. When the take-up and supply reel spools were rotated manually however the supply reel was almost completely jammed. Further examination revealed the cause: the spindle was bent.

All was well once the spindle had been straightened and the reel had been refitted. No other damage had been sustained. It's an uncommon fault with this mechanism. You more often get it with the **Canon UC** mechanism (Models UC10 etc.). Someone must have been a bit heavy-handed I suppose. **D.C.W.**

### **Chinnon VC1500 etc**

This and similar **Orion** models now often damage the tape when used in the play revue mode. The usual cause is a worn capstan drive belt. If a Chinnon replacement isn't available, a JVC type for a similar mechanism will work all right – Willow Vale part no. 20406NA. **D.C.W.**

### **Canon E600E**

The report with this camcorder listed a couple of seemingly unrelated symptoms. First there was intermittent zoom operation with the W/T buttons. Then the fade button worked only occasionally, with the fade sometimes staying on after the button was released. This model

has a direct-acting fade: hold the button in to fade, release it to restore the picture.

They are not common faults with this model. In fact during initial tests it was difficult to get the unit to misbehave for long enough to be able to carry out any meaningful checks. As the various connectors on the camera head are sometimes damaged by side-case impact I decided to check them. They looked to be OK, but I resoldered them as a precaution. All to no avail: although the unit worked for long periods with its case removed, as soon as the case was refitted the faults reappeared – intermittently of course!

Further internal inspection revealed that the short ribbon cable (EF20) between the camera head and the main VTR PCBs was slightly fractured. A replacement cured the problems. Doubtless refitting the case had moved the cable sufficiently to cause the fracture to become intermittent. **D.C.W.**

### **Sharp VLE30H**

Intermittent operation was the complaint with this early Viewcam. It would shut down, sometimes after being moved or the camera section being tilted. An internal inspection revealed that one of the two ribbon cables which connect the camera unit to the main recorder section was fractured. It's best to replace them as a pair – they are identical. The cables allow independent movement of the two sections of the unit, and are generally reliable. A replacement cable pair (Tilt FPC) restored the unit to good health. **D.C.W.**

### **JVC AA-V35**

This dual-battery charger appeared to be quite dead, with no LEDs alight and no output voltages. It did draw current from the mains supply however. We found that the double-wound toroidal choke L23 was short-circuit between windings. **E.T.**



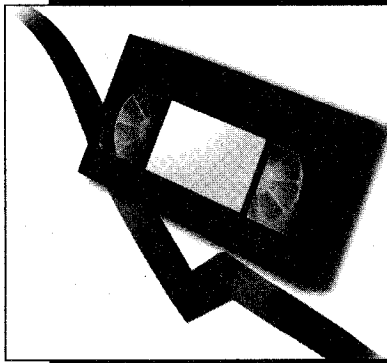

**Reports from**  
**Eugene Trundle**  
**C.J. Guy**  
**Andy Barkley**  
**Ronnie Boag**  
**David A. Chaplin**  
**Paul Hardy**  
**Mike Orr and**  
**Chris Watton**

### **Hitachi VTF645E**

The picture was intermittently corrugated, with a whine or squeal that came from within the machine. This could happen in either the record or the play mode, in the former case leaving a permanent record of the fault symptom on the tape. The usual cause of this is a vibrating sleeve on one of the tape guides, but in this case the back-tension pole was responsible. Its part no. is KX11531. **E.T.**

### **Daewoo V22**

If the cassette intermittently jams while front loading it is likely that the little tension spring has disappeared from the flap-opener trigger in the FL cradle. It's item 11 in the exploded view diagram in the manual, part no. 97S 3001 700. It is vital to ensure that the escaped spring is not lying loose on the PCB, where it could cause havoc – especially in the power supply section! **E.T.**

### **Philips VR312**

The fault report read "failure to record sound". As the machine worked all right on test we returned it to the customer and asked him to provide us with a tape that showed the fault next time it occurred. In due course the machine came back with a tape whose sound track was completely silent, suggesting failure of the bias/erase oscillator. In addition there was an odd 'hunting' effect on the picture. Our recording

# VCR Clinic

over it didn't produce this effect, and the sound was OK.

We then discovered that changing channel produced the fault effect on the E-E picture, while the sound muted until the machine was switched off then on again, after which the fault cleared. The cause of the trouble turned out to be an open-circuit track along the right-hand edge of the PCB. It carries the AFC signal from the IF chip to the processor. **C.J.G.**

### **Daewoo V22**

There were almost no signs of life except for a brief head spin at power up. Checks showed that the reset pin of the front-panel mounted micro-controller chip was at about 1V. The cause was C703 (0.01 $\mu$ F), which was leaky. It appears to be the same infamous type of capacitor used by Panasonic, so watch for this one! **C.J.G.**

### **Matsui VX1100**

This machine appeared to be dead, but there was 3V on the 5V line. Where it came from I never fathomed out, since ICP501 in the 5V feed on the secondary side of the power supply was open-circuit. A replacement restored normal operation. **C.J.G.**

### **Amstrad VCR6100**

This machine had wow sound. The phantom 'repairman' had fitted the flywheel belt so that it ran on the wrong part of the motor pulley. **C.J.G.**

### **Sharp VCA39**

Our customer returned this machine a few days after we'd fitted a new upper drum. He complained that the machine behaved erratically – it would stop at random for example. We had forgotten to replace the small (5mm x 2mm) spring that provides earth continuity to the drum. Replacing it cured the problem. It fits in the untapped hole in the brass bush on the drum assembly. Before

you drop it in, make sure that the equally small carbon brush is already there. **A.B.**

### **Sharp F360E**

This machine would drop out after a few seconds in the play/record modes. The cause was a layer of grease on the take-up reel optical sensor. As a result, the control system thought the reel wasn't rotating. This particular machine seemed to have been well endowed with grease, either during manufacture or a previous repair. **A.B.**

### **Sharp VCM29**

There was no E-E picture and the playback picture was in black and white. We found that crystal X501 wasn't oscillating. Resoldering it cured the fault. **R.B.**

### **Akai VSG745**

Tape was intermittently left out of the cassette on eject. There was also intermittently no fast forward or rewind. A new mode switch cured the problem. **R.B.**

### **Toshiba V854**

This machine wouldn't accept tapes. We found that the cam lever beneath the main cam was broken. A replacement lever and mode switch cured the fault. **R.B.**

### **Sharp VCMH64**

Playback was marred by intermittent background hiss. The cause was a dry-joint at pin 4 of plug AU on the main PCB. **R.B.**

### **Ssangyong SVR101**

This VCR is very like the Amstrad VCR6000 etc. The initial fault was no E-E or playback output. On investigation I discovered that the test pattern switch in the RF converter had been mutilated. I removed the RF unit, took out the damaged switch and wired across it to omit the test pattern. Once the RF unit had been refitted there was normal reception most of the time, but the

signals disappeared intermittently. After much testing I found that a track to the RF unit, on the main PCB, occasionally went open-circuit. This was discovered by using a scope – I couldn't see the break, even with a magnifying glass after narrowing its position down to a half inch of track. **D.A.C.**

### **Ferguson 3V35/39 etc**

One of these machines wouldn't accept a cassette. On investigation I found that protector CP1 (0-6A) was open-circuit. So I removed the cassette carriage and tested the loading motor, which drew about 850mA off load. Under the same conditions a new motor draws about 25mA. Once the motor and fuse had been replaced cassettes loaded normally. **D.A.C.**

### **Hitachi VT120E**

There was a cassette that couldn't be ejected in this machine, and none of the other deck functions worked. Checks in the power supply showed that the 12V output at pin 7 of the STK5471 chip IC851 was missing. A replacement chip restored normal operation. **D.A.C.**

### **Panasonic NVG40**

The cause of severe patterning on the E-E and playback pictures turned out to be C19 (330µF, 10V) in the power supply. It had fallen in value and in addition had been leaking physically. **D.A.C.**

### **JVC HRJ400**

When this machine was switched on a slight squeak came from the power supply then it shut down. Zener diode D40 (5.1V) in the power supply was short-circuit. It had failed because Q2 was dry-jointed. After resoldering the transistor and replacing the diode I gave the machine a good soak test. This proved that the fault had been cured. **D.A.C.**

### **Sony SLV270UB**

This machine failed to work. The customer said that it had been all right until the local electricity company had done some work – he thought this had caused damage. Fortunately this was not the case. All that was necessary was to replace C1325 and C1326 in the power supply. **P.H.**

### **Goodmans GVR3450**

There was a fully loaded tape in this machine and the loading motor had jammed – it seemed that the motor had failed to stop on completion of the loading sequence. As there was

no obvious break in the gear train and the timing was correct, the mode switch was suspect. This can be obtained from Daewoo, and comes complete with the loading motor, its loading bracket and a connection PCB. Unfortunately the connectors on the PCB were not compatible with the ones in the machine, so I had to transfer the mode switch on its own. This solved the problem. **P.H.**

### **Panasonic FS88B**

This S-VHS Nicam stereo machine wouldn't accept a cassette. When a cassette was inserted it would immediately be ejected. The mechanism was found to be correctly timed, and worked when driven manually. The cause of the trouble was a sticking eject button on the control door. **P.H.**

### **Ferguson FV81LV**

This machine was supposed to be dead. In fact if it was left on long enough the display would appear. Then, some time later, the machine would initialise. All this took about half an hour, after which the machine worked normally. Capacitors CP007 and CP008 in the power supply were both low in value. **P.H.**

### **Philips VR6290**

This VCR needed a mechanical rebuild, which had been declined by the customer initially as he thought he could do it himself. He made a start then thought better of it. I found that a Philips service kit had been fitted, but at power up the deck immediately tried to take in the cassette housing even though there was no tape present. It accepted a cassette when operated from an external 9V supply, and worked when tried in another machine. So the deck was OK. As the power supply is easy to change I tried another one, but the mechanism continued to misbehave.

I then found that the microcontroller IC7140 was very hot, with only 2.5V at pin 40 though there was 5V at the other side of L5002. When a replacement chip had been fitted the machine accepted a tape but the threading operation was intermittent and, when the tape was fully loaded, there was only temporary capstan rotation. A scope check at the L293B motor control chip's supply pin revealed that significant hash was present. The cause of the trouble was traced to C2003, which was open-circuit – it decouples the supply to the chip.

This was not the end of the matter. Playback was very snowy, though the machine's recordings played back all right via another one. The playback head amplifier board was faulty. One from a scrap machine completed the repair. **P.H.**

### **Hitachi VTF150E**

There was a slightly misleading symptom with this machine. The capstan motor was noisy, and the noise could be stopped by touching the motor. But a replacement motor made no difference. Checks on the various rails showed that the 12V supply dropped to 10V when the capstan motor was turning. The cause of the problem was C12. **M.O.**

### **Toshiba V110B**

There was no display and none of the functions worked. This can be caused by a faulty microcontroller chip, but its 5V supply was missing. It's not easy to find the source of this supply. 12V is fed to pin 11 of IT46, whose 5.58V output at pin 10 is fed to the 5V switch transistor TT52. The cause of the trouble was dry-jointed connections to this transistor. We've had the fault on several occasions, so it could be a common problem. **M.O.**

### **Mitsubishi HSB27**

There was poor video response, with a jumping picture, in the E-E mode. Playback was OK. The video signal at the PCB output and at pin 8 of IC2A1 was normal. At pin 6 of IC2X1 it was crushed. The cause was C2X2 (10µF, 50V), a replacement curing the problem. **M.O.**

### **JVC HRJ600**

The mains supply had been disconnected for a few hours, after which the machine wouldn't start. C12 (2.2µF) in the power supply had deteriorated. **C.W.**

### **Matsui VX2000**

There was no record colour, though playback colour was fine when a test tape was tried. Fortunately we had a circuit diagram, which made matters easier. A scope check at the head amplifier module pin marked REC-C produced a good waveform. We then traced along to the IC and found that the waveform was lost at the wiper of potentiometer REC-C, which was open-circuit. As we had no electrical adjustment guide we set the replacement by trial and error, ensuring that while the colour locked it didn't overload in heavily saturated areas of the picture. **C.W.**

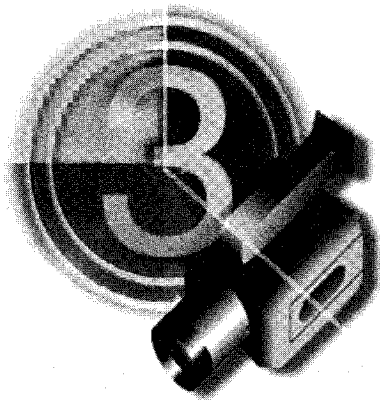

**Reports from  
Steve Beeching  
and  
David Woodnott**

### Auto-focus Lenses

The subject of auto-focus lenses came up in this column recently (Sanyo VMEX280P, August). There's rather more to it than was suggested.

The lenses used in early video cameras and camcorders were quite long, with the focus elements at the front and the zoom elements at the rear. Zoom/focus tracking, which determines the quality of the lens, was set optically during manufacture.

To achieve a wider zoom range and faster auto-focus operation with a small overall length, more modern camcorders use an 'optical block' with the focus elements at the rear and the zoom elements at the front. Optical zoom/focus tracking is not possible, and is therefore set by a microcontroller/EEPROM arrangement. For this to work, the optical block includes encoders that sense the position of the zoom and focus elements. The zoom encoder must *never* be undone: the focus encoder should not be undone

# CamCorner

unless you have the software to set it again. These encoders usually consist of variable resistors, but LED/optical or Hall-effect devices may be used. The latest digital camcorders have a linear focus motor that moves along two shafts: its position is sensed by a Hall-effect variable resistor.

The zoom encoder sends information on the position of the zoom elements to the microcontroller chip, which then adjusts the focusing in accordance with a zoom/focus tracking curve (see Fig. 1) that's held in the EEPROM.

There's a set-up facility for correct tracking in the manual mode. It has nothing to do with auto-focusing. The set-up involves obtaining correct focus at each end of the zoom/focus curve, wide and tele, plus some adjustment along the curve. The latter (centre tracking) can be adjusted either by moving the focus encoder then readjusting the values at the wide and tele ends, or by storing software data values – by testing the tracking against a reference curve. What all this means is that no two optical blocks are the same, nor is the data stored in the EEPROM.

To check the manual tracking the auto-focus must be turned off. Select an object at infinity, say a tree 20m or more away, though across the room is OK for test purposes. Zoom in to tele, focus on the object manually, then zoom out. The chosen object should remain in focus throughout the zoom. Small focus corrections can sometimes be

seen as the microcontroller chip adjusts the focusing to correspond with the zoom/focus curve stored in the EEPROM. The curve is much steeper at the tele end, so the errors will be greater here – an error will show up if there is one. At the wide-angle end the back focus may in particular be incorrect, the whole scene going out of focus.

If the auto-focus is on, it will try to correct for tracking errors. If these are present it will work much harder than it should do. You might think that the optical block is OK, as focusing is maintained. But this may not be so. In such a case the zoom/focus tracking errors will cause auto-focus delays – with some scenes the system will struggle and take longer than normal to settle. If the back focus is too far out, the correction may never be right at the extreme wide-angle end of the curve.

As zoom ranges increase (we are not talking about digital zoom of course), alignment becomes more critical, particularly the x10 and x16 ranges. Auto-focus won't cover up for swapped EEPROMs.

Some camcorders are difficult and fiddly to set up. With other models I fit a collimator with an infinity Siemens star, hit the computer's start button and have a cup of coffee while the software sets up the optical block and stores the values in the EEPROM. **S.B.**

### Panasonic NVM7B

This machine would play back only in black-and-white: the E-E camera picture was OK. The cause of the fault was traced to the chroma amplifier transistor Q8006. A replacement and service restored the unit to normal working order. **D.C.W.**

### Sony CCDF450E

One of these popular camcorders arrived with a report that said "poor playback colour; intermittent, weak E-E colour". The cause of the problem was four faulty capacitors, C310, C311 and C263 on board VA46P and C411 on board VS67. Unusually, there were no other faulty capacitors. **D.C.W.**

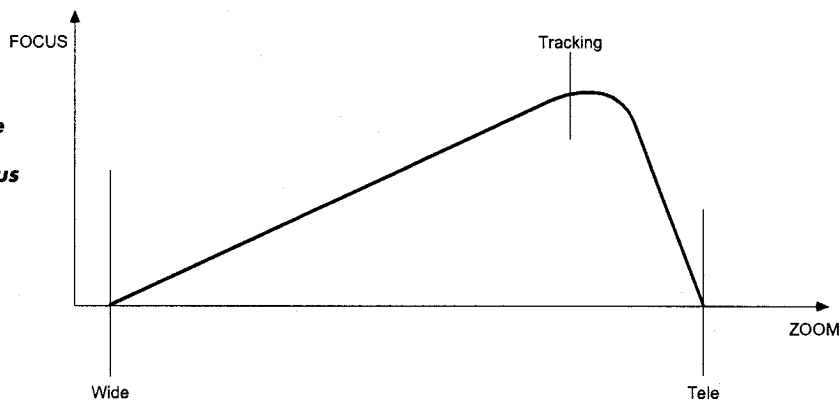

**Fig. 1: The basic zoom/focus tracking curve.**

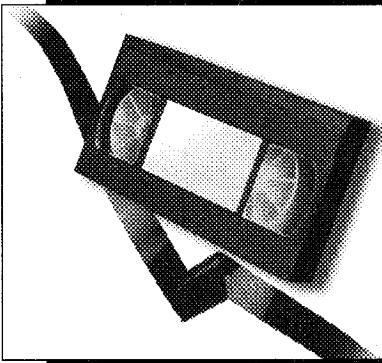

**Reports from**  
**Philip Blundell, AMIEelec**  
**Eugene Trundle**  
**Michael Dranfield**  
**Michael Maurice**  
**Richard Flowerday**  
**Gerald Smith and**  
**Pete Gurney, LCGI**

### **Samsung VI375**

The power supply had previously failed, no doubt after its outputs had risen, and a new one had been bought and fitted. Now the machine was dead again. When the main PCB was removed R638 and R664, both 100Ω surface-mounted resistors, were found to be open-circuit while the case of the KA8301 loading motor drive chip had split.

Once these three items had been replaced the machine was found to be none the worse for its ordeal. Note that in later production a 27V, 1W zener diode is connected across R116 in the power supply to provide improved overvoltage protection. **P.B.**

### **Philips VR522**

If the power supply is 'chirping' and its output voltages are low and pulsing, suspect that C2112 (100μF, 385V) has lost capacitance. The voltage across C2112 may still be correct even though the capacitor is faulty. Its part no. is 4822 124 41556. **P.B.**

### **Samsung SI3240 Series**

The cassette lift drive gears sometimes go out of alignment. A modified cassette lift right-hand side is now supplied. The part no. is 62203-0025-01 (Willow Vale code 79030CR). Also check the gear eject drive for wear – part no. 61473-0051-01 (Willow Vale code 79326J).

# VCR Clinic

The above applies to Models SI3240, SI3260, SI3560, PI30R and VI30R. **P.B.**

### **Daewoo 5172 and 7372**

These machines are now about five years old and the F mechanism they use is beginning to wear. One effect of this is bad sound wow and/or flutter because of a problem in the reel-drive clutch that's incorporated in the reel-drive gear assembly (part no. 97SA46900). It is possible to dismantle the assembly and doctor the clutch, but it's better to replace the whole thing. **E.T.**

### **Panasonic NVHD610**

This newish machine had a fully-laced tape in it. When it was switched on the drum ran at a million miles an hour and the front display showed the error code F09. This means that there's no serial clock signal transmission between IC6001 and IC7501. In fact the cause of the problem turned out to be IC6001's 6MHz crystal X6001. If you touched it with a finger, the machine came to life and continued to work all day. But next day, when the machine had been standing overnight, the fault would be back. A new 6MHz crystal put an end to the trouble. **M.Dr.**

### **Aiwa HVGX750**

This new machine wouldn't come out of standby. Checks around the main microcontroller chip showed that the power-on line (pin 60) remained low. There was a 10MHz clock signal at pins 72/73, and the real-time clock crystal at pins 69/70 was also active. But the serial clock/data lines, at pins 90-91, remained inactive. The reset pin 16 was low at 2V: to reset the microcontroller chip correctly, this pin must be above 3.3V.

Multimeter checks failed to reveal the cause of the problem, but when we disconnected all the com-

ponents connected to pin 16 we came to a small decoupling capacitor, C565 (0.1μF), which was holding the reset pin low. A check on C565 produced a reading of 200kΩ. Replacing it cured the fault. **M.Dr.**

### **JVC HRJ425**

Failure to eject was the complaint with this machine. The carriage is driven by the capstan motor in this deck. In the eject and tape loading mode, the 'gear-change' drives the carriage via the 'belt-change'. The gear-change is engaged/disengaged by the arm-change assembly, item 74 in the diagram in the manual. A spring, item 76, holds the arm in position in this mode.

The plastic lug on the arm-change assembly had broken, the result being that the gear-change didn't engage with the pulley. A new arm-change assembly cured the fault. Its replacement required a fair amount of dismantling. **M.M.**

### **Aiwa VXT1410**

This TV/VCR combination's fault was in the video section. When the unit was cold, the servos would hunt and there were gross tracking errors. After a while the servos would stabilise and a picture would appear – with severe patterning. The cause of the trouble was C523 (100μF, 16V). Although my tester produced a reading of 88μF, the capacitor responded to heating and freezing when in circuit. A new capacitor cured the fault. **M.M.**

### **Toshiba V204**

There was a tape stuck in this machine. The customer said that cassette insertion had been difficult before. It was easy to remove the tape: the cause of the problem was simply that the cassette-flap opener on the right-hand side of the carriage had become unclipped. Refitting it and reassembly should have been the end of the matter, but

the customer had been the opinion that a liberal spraying of WD40 through the cassette flap would cure the problem. So a further half hour had to be spent cleaning it up. Fortunately it hadn't ruined the heads. **M.M.**

### **Ferguson FV71LV**

This machine was dead apart from the power supply which was ticking. The cause of the problem was eventually traced to a 10 $\mu$ F, 63V capacitor that's mounted on the print side of the power supply PCB. Note that the power supply ticks when unloaded, i.e. not connected to the main PCB. **M.M.**

### **Matsui VP9501**

This machine failed to wind the tape into the cassette on eject. The capstan motor didn't even turn. There were no problems once the mode switch had been replaced. **M.M.**

### **Sharp VCA49**

This machine had been brought in about six months previously because the upper drum had failed. It was now back, the complaints this time being low sound and noise bars through the picture. When I tested the machine I found that there was also poor rewind.

The cause of the trouble was excessive friction between the tape and the AC head, because of excessive wear. Once a new AC head had been fitted and aligned the symptoms had cleared. **M.M.**

### **Toshiba V226B**

No playback or E-E sound was the customer's complaint with this almost new machine, which was still under warranty. It recorded sound however, proved by playing a test recording on another machine. The cause of the fault was easily traced to the BA7795LS audio record/playback chip IS001, from which there was no audio output. It's not the first time we've had this problem with these Toshiba machines and their Ferguson-badged equivalents. **R.F.**

### **Akai VSG855**

When a tape was inserted the clock display went out and the machine 'died'. Some checks in the power supply revealed that the 14V output wasn't smoothed. Replacing C222 cured the fault. **G.S.**

### **Toshiba V726**

When this machine was switched on there were no functions and auto

paths and switching ICs showed that the common source of the video signal is at the buffer transistors Q208/7/6. Q208 feeds the scart connector and the RF modulator. The Y output from the YC S-VHS socket J204 was similarly crushed and distorted. Its source is prior to Q208, at the emitter of Q206. The cause of the problem was C232, a 10 $\mu$ F, 16V surface-mounted capacitor that couples the video signal to the base of Q206. On closer inspection, visible leakage could be seen on the PCB. A clean-up and new capacitor cured the fault. **P.G.**

### **Daewoo V215**

There were intermittent symptoms with this machine: no mode functions and the clock becoming blank. I had to wait patiently for the fault to appear, then found that crystal X701 wasn't running. A new crystal cured the fault. **G.S.**

### **Tatung TVR933**

This machine produced very snowy E-E pictures with low luminance. Checks revealed that the AGC output at pin 2 of IC4001 was low and cramped. A replacement chip restored good E-E pictures. **G.S.**

### **Aiwa HVFX2500**

This machine had a picture fault in both the E-E and playback modes. In the E-E mode the left-hand side of the picture was too dark while the rest of the picture was too bright. In the playback mode the picture had dark streaks. The problem was cured by resoldering the pins of the Y/C processor chip IC301. **G.S.**

### **Philips VR6490**

This machine had failed when it was unplugged: when the mains supply was restored it remained dead. The power supply is not the easiest section of the machine to reach, being buried under the main PCB. But you can remove it then reconnect it outside the machine, the harness being just long enough to permit this.

I found that the power supply worked and that its outputs were correct, except for the 5V line which was low at 3V. Quick scope checks at the relevant reservoir and smoothing capacitors C119 and C120 (both 1,000 $\mu$ F, 16V, 105 $^{\circ}$  types) revealed that they were virtually open-circuit. As the ventilation in these machines is poor, I decided to replace all the electrolytic capacitors on the secondary side of the power supply, using the correct low-ESR types. **P.G.**

### **Mitsubishi HSB82**

This S-VHS machine's video output was very poor: there was rolling, and the video was extremely crushed. In fact the output was poor from the scart and phono sockets and the RF modulator, which helped to narrow the field of search a bit.

A look at the myriad signal

The 30V supply was found to be low, and a scope check showed that a large AC component was present. The cause of the trouble was traced to C803 (100 $\mu$ F, 50V) which was open-circuit. When a replacement had been fitted the channels had to be retuned back to their correct channel numbers - the customer had altered them over a period of several months to compensate as the capacitor dried up. **P.G.**

### **Goodmans TX1200**

There was severe patterning in the E-E mode, but the severity of the symptom decreased the longer the VCR was left on. A check on the tuning revealed that the channels didn't correspond with the selected channel numbers. This suggested that there was a tuning voltage fault.

The 30V supply was found to be low, and a scope check showed that a large AC component was present. The cause of the trouble was traced to C803 (100 $\mu$ F, 50V) which was open-circuit. When a replacement had been fitted the channels had to be retuned back to their correct channel numbers - the customer had altered them over a period of several months to compensate as the capacitor dried up. **P.G.**

### **Samsung SII260**

Tape chewing was the complaint with this machine. Everything seemed to be OK when a dummy tape was loaded, but after a few minutes the capstan motor refused to work in the play mode and wouldn't spool the tape back when unthreading. Fast forward and rewind were not affected initially, but eventually failed.

A quick check at the supply plug (CN201) to the motor on the main PCB showed that the voltages were mostly correct. The exception was the permanent 15V motor feed voltage, which varied erratically depending on which function was selected. The feed comes from the always 15V rail via two series-connected 1N4001 diodes, D212/3. What was happening was that D213 went open-circuit under load. A replacement diode cured the problem.

In the past I've had D212 cause similar problems, but in addition intermittent/poor loading - the junction of D212/3 feeds the loading motor drive chip IC206. **P.G.**

## SERVICING

# the Aiwa HVFX1500 VCR

**John Coombes provides fault-finding know-how on this machine. The notes on deck faults are applicable to a number of models in different ranges**

This VCR uses the same deck as a number of other VCRs. The list includes the following models:

**Aiwa:** HVFX150 and HVFX1500.

**Alba:** VCR6800 and VCR6900.

**Amstrad:** VS1000 and VS1140.

**Bush:** VCR161 and VCR162.

**Matsui:** VP9401, VP9501, VX2700 and VX6000A.

**Orion:** D4500 and D5000.

**Saisho:** VR3400.

**Tatung:** DVR634UN.

The following notes on the deck apply to all these models. The electronics may differ however.

### Deck Faults

If the machine won't accept a cassette and the worm gear on the front loading doesn't activate, check the front loading gears. There may be broken or worn teeth on the cogs. The next thing to check is the pack springs on the cassette loading unit – for damage or being bent. Next check the voltage across pins 1 and 2 of connector CX5002. If 12V is present, suspect the loading motor. Another possibility is a faulty front loading switch. Ensure that the loading motor hasn't seized, and check the loading belts which could be stretched or cracked.

If rewind and fast forward operate correctly but playback is at twice the normal speed, the capstan motor is suspect. The capstan motor can also run slow, with wow and flutter as symptoms. Check it by replacement.

When the deck stops in playback, check for reel-sensor pulses at pin 11 of connector CX1003. If they are

missing, first check that 5V is present at pin 10 of CX1003. Then if necessary replace the reel sensor.

If the capstan doesn't rotate at all, check the DC conditions at CX1003 and/or IC1001. IC1002 is suspect if the voltages are OK: check it by replacement. Alternatively the capstan motor may have failed.

If the capstan flywheel spindle rubs on the motor bearing there will be jitter on the playback picture. Should this occur, strip the flywheel spindle from the unit then clean and re-lubricate it. Reassemble and soak test the machine. If the fault is still present, replace the capstan motor.

If there is intermittent tape chewing, ensure that the capstan motor is free running and that the tape isn't creasing. Check the pinch roller which could be worn or have a highly-polished surface. A faulty pinch roller will cause tape slipping or creasing at the top or bottom. If necessary, check the back-tension band assembly which could be broken or incorrectly aligned. Alternatively the idler unit could be operating incorrectly. Ensure that no teeth are missing. This fault will cause lack of drive and thus tape spillage. Alternatively the limit-post arm assembly could be damaged, causing lack of tape movement and damage.

If the tape is being chewed and the reel drive doesn't rotate, check the capstan pulley which could be cracked and the reel belt which could be broken or badly stretched – check it by replacement. Tape chewing will also occur when the pinch roller arm spring is slack, since the pinch roller won't load properly and lock against the flywheel spindle.

If the tape is chewed when first inserted, with the VCR only partly loading and the sound of the loading motor racing at high speed, check the joint pulley (item 431) and/or worm assembly, which could be cracked or broken. If loading is not completed and the mechanism becomes very tight, check cam 1 and/or cam 2 for stripped or worn teeth. Also check the mode switch.

The mode switch can be the cause of many different



lower drum wear may be very noticeable in the visual search modes, with the picture going into lines.

If only one head works, giving a partly visible picture, the other one producing a snowy or grainy picture, try cleaning the heads. If this doesn't work the upper drum will have to be replaced.

After replacing the drum assembly, ensure that the back tension is set correctly. Excessive tension will cause premature upper and lower drum wear.

The machine will often provide normal playback but, in the Hi-Fi mode, the sound is very noisy – like helicopter rotors going round. A replacement upper drum should cure this, but if the lower drum is badly worn the whole assembly will have to be replaced.

### Power Supply Faults

Fig. 1 shows the power supply circuit used in Model HVFX1500. It's a straightforward linear arrangement.

If the machine is dead with no display, check fuses F502 (2AT) and F503 (3-15AT). If F502 has blown, check diodes D501-4 (4 x DSA12TB) for shorts. If F503 has blown check D505-8 (4 x DSA26C) for shorts.

If F502-3 are OK, check for -30V at pin 1 of connector CX511. Absence of this voltage probably means that zener diode D512 is short-circuit. Alternatively circuit protector ICP501 could be open-circuit. Check for 3-8V AC between pins 5 and 6 of CX511: if this voltage is missing, check for dry-joints at T501.

If these supplies are present, check for 6V at pin 14 of CX511. Trace back to pin 2 of the PQ05RF21 6V regulator IC502 if this voltage is low or missing. There should be 7-6V at the input to IC502 (pin 1). Check C502 (6,800µF) which could be short-circuit if this voltage is missing or open-circuit if the voltage is low.

If the display is lit but the machine doesn't turn on, check that pin 7 of IC1001 (OEC8057C) is in the low state. If not replace IC1001. Care is required when doing this: use a hot-air soldering unit and make sure that the heat setting is not too high, otherwise associated components may be damaged.

If IC1001 is OK, check the voltages at IC501 (PQ30RV21). Check IC501 and the associated components as necessary.

If there is no playback or E-E video but mechanical operation is OK, suspect IC502 (PQ05RF21). Check for dry-joints here and if necessary replace IC502.

### No E-E Signals

Check that the following voltages are present at the terminals of the tuner/RF unit TU6001: B+ (9V), BB (5V), TU (30V) and MB (5V). There could be dry-joints here. If any voltages are missing, check back to the source in the power supply. If there is no video signal (IF) at pin 18, replace the tuner unit. If necessary go on to check whether IC6303 (µPC574J-T) is short-circuit and the DC conditions around IC6302 (LA6358ST). If IC6303 is short-circuit R6314 (10Ω) will probably be open-circuit.

If the 9V supply (B+) is missing at pin 13 of TU6001 check back to IC503 (TA7810S) in the power supply. There should be 16V at its input. Check whether bridge rectifier diodes D501-4 (4 x DSA12TB) are open-circuit if this voltage is missing. There should be 10V at pin 3 of IC503. If not, check for dry-joints then if necessary replace IC503.

### Whistle from the RF Modulator

There have been complaints of a whistle from the RF modulator. To overcome this Aiwa has issued a modi-

fication: add a 470pF capacitor between pin 5 of the tuner and chassis.

### No Playback Audio

If the E-E audio is OK, check whether there's 9V at pins 53-55 of the LA7252M hi-fi audio processor chip IC5500. Check back to source or the peripheral circuitry if this voltage is missing. The next check should be for audio at pins 62 and 64 of IC5500. If there's no audio here, check the chip by replacement. If audio is present, check the voltage at pin 23 of the LA7286 audio amplifier chip IC5001. If this isn't low, check the DC conditions around the OEC8057C chip IC1001. Replace it if they are incorrect. If the voltage at pin 23 of IC5001 is low, check for audio at pin 8. Should the audio signal be missing or incorrect, check that the playback audio level control VR5001 is correctly set. If there is an audio signal at pin 8 of IC5001, check whether the audio/control head is dirty. If, after cleaning, there is still a problem and the connections to the audio head are correctly seated, replace IC5001.

### No Record Audio

First check whether there's a bias signal at the oscillator transformer T5001. If not, check the voltage at pin 19 of IC5001 (LA7286). There should be 9V here. This voltage comes from Q502 (2SB926) in the power supply. If the 9V supply is missing, Q502 could be dry-jointed or open-circuit. Check the DC conditions around IC5001, and that 9V is present at the collector of the bias oscillator transistor Q5001 (2SC1317). If this voltage is OK, T5001 could have shorted turns. Check it by replacement. If the bias signal is present, check for an audio input at pin 10 of IC5001. There should be audio outputs at pins 13 and 15. If not, replace IC5001. Check the connections to the audio/control head if necessary.

### No Playback

If there's no playback, check the FM envelope at test point TP4003. If it's missing, check for dry-joints on the head amplifier PCB and/or the DC conditions around the LA7416 chip IC4101. Replace it if they are incorrect.

The cause of the fault could be at IC4001 (LA7439). Check for 5V at pins 14 and 39. Check back to the power supply if this voltage is missing. Otherwise replace IC4001.

Should everything be OK up to this point, check the DC conditions around the LC89970 delay line chip IC4002. If there's an error here replace the chip.

## Corrections

**Satellite TV:** The Fidelity equivalent of the Amstrad Model SRD700 is Model SR950+, not SR920+ (August issue, page 681)

**Indiana 100 chassis:** The Alba Models CTV704T and CTV744 were included in error in the list of models fitted with this chassis (May issue, page 494).

**Tesco Tellys:** A connection blob is missing in Fig. 1. Q1's source, and the other components connected to this point, should also be connected to the line that links pin 4 of IC1, pin 5 of TR1 and the 'earthy' side of the mains bridge rectifier D1-4 (August issue, page 675).



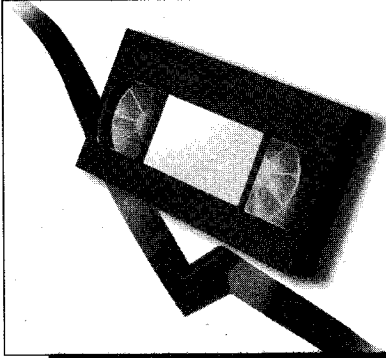

# VCR Clinic

Reports from  
**Philip Blundell, AMIIElec**  
**Eugene Trundle**  
**Kevin J. Green, TMIIE**  
**Derek Bogiscin**  
**M. Della Verita**  
**John Edwards**  
**Adrian Williams and**  
**Ronnie Boag**

## **Mitsubishi HSM40V**

If the machine won't thread up though the rest of the mechanism seems to be OK, the drive gears to the loading arms have probably lost some teeth. When the mechanism has been dismantled you will be able to see which of the following need to be replaced:

arm load T (take-up side)

592B047010

arm load S (supply side)

592B048010

plate cam B 641A311010. **P.B.**

## **Daewoo V235**

We've had two of these machines in with a very obscure intermittent fault: the video and RF outputs were lost and all deck functions had failed, but the front display remained normal. In both cases the cause of the fault was a dry-joint at Q856, which is part of the switch for the 'on-off 5V' line. When the fault was present this voltage dropped to 1.25V. **E.T.**

## **Akai VSG770 etc**

The machine we had in for repair was a Model VSG770, but the fault could no doubt arise with other models in this range. The symptom was comet-tail blips over the playback picture, sometimes in clearly-defined horizontal lines and sometimes disappearing after say half an hour's playing time. The cure is to remove the PCB atop the drum

assembly (motor stator) to reveal the drum-earthing brush. Then clean and retension the brush and spring. If this is properly done there will be no interference on the playback picture even when you touch the rotating upper drum gently with your finger. **E.T.**

## **LG/GoldStar N3091**

There was intermittent failure of fuse F107, the result being loss of the deck functions. The cause turned out to be a faulty loading motor: when tested it drew a high and irregular current from a fixed-voltage source. **E.T.**

## **Samsung VIK316**

The 'dead' symptom was cured by replacing C35 in the power supply – it was virtually open-circuit. Although the machine then worked all right its fluorescent display panel was dim. Checks showed that the heater voltage was low. Full brightness was restored by replacing C38 (100µF, 10V). **E.T.**

## **Daewoo DVR7372, 5172**

The F mechanism used in these models, now six years old, is beginning to show its age. A new (to us) fault is beginning to appear: the mechanism jams because of a broken plastic wall on the underside of the main drive cam. It's item 6-7, part no. 97S2707400. **E.T.**

## **Hitachi VTFX770E**

This quite new model has much in common with the VTFX550 etc. The one we had in for repair was still under guarantee and was dead. It sprang to life when the deck was removed. On test I found that there was a heavy load on the 5V supply. A faulty capstan motor (part no. GP10254) was the cause. **E.T.**

## **Amstrad DD9900, UF20 etc**

No rewind or fast forward are the symptoms when, in these modes, the machine attempts to drive the reels via the clutch. The root cause of the trouble is the M-lever holder assembly underneath the main cam. Its part no. is 255034 – you can get it from CPC under code no. AM255034. **E.T.**

## **Panasonic NVHD90**

When this machine had been in operation for about half an hour the picture would become very poor – lines would appear across the recorded picture. The cause of the fault was IC301, part no. VEFH29H. **K.J.G.**

## **Aiwa HVFX1500**

There was no drum rotation. Checks showed that the supplies to the drum were all OK. The cause of the fault turned out to be the stator motor (M2003), part no. S5895110070. **K.J.G.**

## **Sharp VCM311HM**

This fault produced very deceptive symptoms. When a prerecorded tape was inserted only a few seconds of very snowy-looking picture were played back, with the counter running much too fast. It seemed to me that the control pulses were low or missing. Not so. The cause of the fault was Q652, a small DTC323 'digital' transistor. It had gone short-circuit, leaving the oscillator running all the time and thus upsetting my prerecorded tape. **K.J.G.**

## **Mitsubishi HS651V**

This machine would come on then, after several seconds, power down and revert to standby. The cause of the problem was Q903. **K.J.G.**

### **Sony SLVE520**

The customer complained about a permanent droning noise on the playback audio. I checked what I could around the audio playback amplifier section of IC101 and found that a cyclic noise could be seen at the output, even with the feed from the audio head shorted to chassis. So it seemed that the IC was introducing the noise. A check on the IC's supply showed that it was a little low, with a similar cyclic noise present. This led me back to the troublesome fusible link PR512 in the power supply section. It had the tell-tale brown line around it. When a higher-rated replacement was fitted the fault had been cured. **D.B.**

### **Osaki VR410**

There was low or fluctuating sound with playback of this machine's own recordings: pre-recorded tapes were OK. I traced the cause of the fault to C227 (1 $\mu$ F, 63V), which is connected to pin 11 of the pre-amplifier chip IC201 on the audio/video preamplifier PCB. The fault is probably caused by excessive heat from the nearby power supply radiator. **M.D.V.**

### **Toshiba V300**

The sound in both the playback and E-E modes was fine, but the E-E picture was a mess. It could best be described as having poor interlace with constant vertical rolling. The playback picture was also affected by what seemed to be poor interlace, i.e. every other line darker or missing; and although it was locked, it had a 'dirty', low-gain look to it. The culprits were on the power supply-2 PCB. C826 (1,200 $\mu$ F, 16V) and C822 (47 $\mu$ F, 16V) were leaky; C823 (1 $\mu$ F, 50V) was very leaky; and C824 (220 $\mu$ F, 16V) was almost open-circuit. **J.E.**

### **Samsung SI1260**

When a cassette was inserted the tape loaded half way, as usual, but thereafter no other functions could be selected – whether via the remote control unit or the on-board controls. There was no drum or capstan rotation. When eject was selected the tape guides would unload but the tape remained laced up round the drum and the carriage remained down. The only way in which I could eject the tape was by rotating the loading-motor pulley manually. The next time I tried to insert a cassette the machine wouldn't let me.

Checks showed that the 15V

supply to the loading motor control chip IC206 was very low at only 1.2V. D212 was found to be faulty by substitution – it checked OK with a meter. Once D212 had been replaced the machine accepted a cassette, but there was still no drum or capstan rotation. The eject mode now worked, but the tape looped on the way out. This time I found that the 5V supply at the cathode of D109 was low at only 0.5V. Once more the diode checked OK but was proved to be faulty by substitution.

At last I had a machine that worked normally. I remain surprised by the fact that the two diodes seemed to be OK when checked with a multimeter (diode test function) and an oscilloscope component tester but were nevertheless faulty. **J.E.**

### **Panasonic NVSD200 (K deck)**

It's becoming quite common to find that the plastic pulley attached to the loading motor has cracked. This item is quite cheap and is readily available from the major suppliers. But the symptoms you get can vary. When I have mechanical problems with these machines I now inspect the pulley first – I could strike lucky! With this particular machine the tape functions all worked until eject was selected. It would then unlace and shut down, leaving the cassette in the down position – code F06 would sometimes be displayed. **J.E.**

### **Matsui VPA9401A**

This machine appeared to be totally dead: there were no functions and no displays. But the power supply was in fact working. The cause of the trouble was protector ICP501 which was open-circuit. **J.E.**

### **JVC HRJ235**

This machine refused to work after a thunderstorm. The mains fuse had shattered and, not surprisingly, the chopper FET Q901 was short-circuit. I replaced it, using the readily available 2SK1275. The driver transistor Q902, which is a high base-to-emitter voltage type, was also short-circuit. A BC4204 was fitted in this position. The only other failed component was the mains bridge rectifier. Once this was replaced everything worked well.

I had been asked to investigate pending an insurance claim. Although the power supply had clearly suffered, I was reluctant to

commit myself to a quotation in case there was further damage. Hence the repairwork just described. The customer agreed that the cost of this didn't warrant losing his no-claim bonus and excess. **J.E.**

### **Hitachi VTM620**

There was poor capstan servo lock in the play mode and, intermittently, the capstan would run away (fast). Using my Alan Willcox ESR meter I discovered that C901 (47 $\mu$ F, 16V) and C622 (10 $\mu$ F, 63V) both produced higher than normal readings. C622 was also leaking – this was not visible with the capacitor in situ. Replacements restored correct operation. Someone else had previously replaced the servo ICs. **A.W.**

### **Daewoo V200**

If one of these machines comes in dead, replace the 1 $\mu$ F, 100V capacitor on the primary side in the power supply module and the two 22 $\mu$ F, 63V capacitors on the secondary side. **A.W.**

### **Toshiba V728**

The fault with this machine was intermittent loss of the E-E sound. Scope checks revealed that oscillator QN201 was dry-jointed. Resoldering cured the problem. **R.B.**

### **Goodmans VN6000**

This machine would intermittently fail to power up. The cure was to upgrade C822 in the power supply. A 1,000 $\mu$ F, 10V capacitor in this position cures the problem. **R.B.**

### **GoldStar RE703**

This machine wouldn't play tapes because the final take-up arm did not pull the tape over to the capstan spindle. Fitting kit RK205G from SEME cured the problem. **R.B.**

### **Akai VSG245**

When this machine's recordings were played back parts of the sound and picture were missing and the display said E03. The fault was cured by replacing the mode switch. **R.B.**

### **JVC HRJ265**

There was no E-E or playback picture via either the modulator output or the scart connector. When I carried out video waveform checks I found that there was no output at pin 23 of IC7151. A new chip cured the fault. **R.B.**

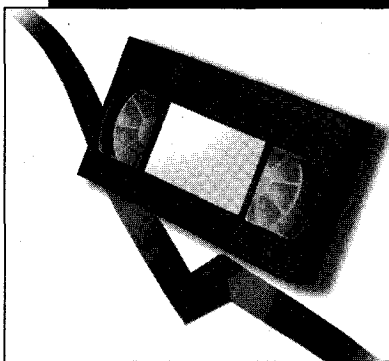

Reports from  
**Derek Bogiscin**  
**John Poulton**  
**Michael Dranfield**  
**Pete Gurney, LCGI**  
**Brian Wright**  
**Dave Hewitt**  
**M.R. Sabir and**  
**Michael Maurice**

### **Panasonic NVHD605**

The complaint with this VCR was that it couldn't be tuned in. I tested it and discovered that it didn't find any channels when auto-tuning, but if the channel number was dialled in manually a dark picture could be seen, with both line and field slip, suggesting poor sync. The menu displays were fine, and the symptoms were the same with the output at RF or via the scart connector.

Scope checks showed that the detector module's output was OK, but once the signal had passed through a 150Ω resistor the sync amplitude was greatly reduced. There are only three components through which the signal passes on its way to the input/output PCB at the rear of the machine: they were all OK.

Checks on the supplies to the audio and video switching ICs on this board revealed that the VE 5-4V supply at pin 7 of five of these ICs was low – it was only 0.8V. By lifting IC pins in turn I established that the cause of the trouble was the surface-mounted 4053 switching chip IC3902. Once this IC had been replaced everything seemed to be OK – except when a signal was fed in at scart connector 2. This signal path goes straight to pin 15 of the 4051 chip IC3906. There was no video output at pin 3, though the tuner's video output, which also goes via this IC,

was OK. A replacement 4051 chip restored full operation. **D.B.**

### **Toshiba V856**

Intermittent failure to record or play back was the complaint with this VCR. It was put on test and worked for many hours before the fault appeared – the playback picture went blank. At this point I made a quick recording: when it was played back via another machine there was no picture.

The mechanism and main PCB were removed from the lower case. As feared, the fault was no longer present. The complete assembly was then run upside down. When the main PCB was gently flexed the fault came back. Checks around the main YC processing chip IV001 showed that the luminance signal emerged at pin 46, to pass through two transistor stages, but failed to return at pin 47. The cause of the fault turned out to be a surface-mounted shorting link, ref. RV048, which is near the tuner/modulator unit. **D.B.**

### **Panasonic NVHD620**

Severe patterning on the E-E video was present only when record was selected ("interference" had been the complaint). It started just after the machine finished its back-space operation, prior to the start of recording. I found that one of the two wires to the full erase head had been caught under a metal bracket at the rear of the mechanism. It was shorting the head to chassis. **D.B.**

### **Panasonic NVHD90**

The customer complained that the machine made a noise all the time when there was a tape in it. It sounded to me like the capstan motor bearings, but when I took the lid off I realised that the capstan motor wasn't running and that the drum motor was making the noise.

# VCR Clinic

It's quite easy to remove the upper drum assembly complete – undo the three small torx screws that hold the plate in the centre and lift out the circlip inside. The bearings can then be cleaned and oiled before reassembly. I gather from CHS that this problem is not uncommon. **J.P.**

### **Sharp VCM26**

This machine was dead with a tripping power supply. The customer's son had inserted a metal object through the cassette flap. As the customer had removed it, we didn't know what it had shorted out. I narrowed the cause of the problem to the area around the power supply optocoupler. The -25V line used to supply the fluorescent display is also used as a source of bias for the optocoupler, and was found to be missing between power supply trips. The cause of the fault was R995 (10Ω), a surface-mount resistor, which was open-circuit.

The clock display tube stands up from the PCB on tall legs in these VCRs. This must have been shorted out, causing the demise of R995. **M.Dr.**

### **Sharp VCM27**

Although the power supply was tripping none of its output voltages rose. The cause of the fault was the feedback optocoupler IC901, type FX0007GE. **M.Dr.**

### **Toshiba V854**

A 'jumping picture' was the complaint with this machine. There was obviously a tape-path fault. When the wrap was observed while a tape was being played I could see, viewing it from above, that there was a distinct bend on the supply side. The cause was the back-tension lever, which was slightly bent. Straightening it so that it was vertical cured the problem. It remains a

mystery how the lever became distorted. **P.G.**

### **JVC HRD750**

This machine was dead following a power cut. Most voltages on the primary side of the chopper power supply were present, but there were no outputs. In a case like this the usual cause is a failed electrolytic capacitor. The culprit was C14 (1 $\mu$ F, 50V), which was open-circuit. It's on the primary side of the power supply. Replacement with a 105° type restored normal operation. **P.G.**

### **JVC HRDX22**

There was poor capstan lock and colour flashing on the playback picture. Checks showed that the switched 5V supply was high at 5.9V. Adjustment cured the fault. R805 should be set for 5.3V at TP803. **B.W.**

### **Hitachi VTM620**

When play was selected there was no sound for about five minutes. The cause was C411, which was low in value and leaking electrolyte. It's best to replace C407 as well. They are both 47 $\mu$ F, 16V capacitors. **B.W.**

### **JVC HRJ625**

There was no RF output from the modulator. It can be a very misleading symptom with this model, which has a rear switch marked 'RF out'. It appears to be a test signal on/off switch, but is a three-way switch marked 'on-test-off'. The indentations are so slight that the user wrongly thinks the off position is for the test signal. In fact it switches off the RF output. This is a case of bad ergonomics: it's very difficult to set the switch in its centre position. **B.W.**

### **Akai VSG2DPL**

This machine wouldn't accept a cassette and displayed 'error 2' in the window. The cure was to replace the mode switch, which lifts out with the mode motor. Take care to remove the ribbon cable from the lower head drum before you lift out the deck for access to the switch – it's hidden by a small screening can. **D.H.**

### **Panasonic NVSD600**

There was no capstan rotation. The cause turned out to be failure of the BA6871 servo chip IC2501. The self-test mode and direct address procedure to the microcontroller and servo control chips, outlined in

the service manual, helped greatly in diagnosing the cause of this fault. It's the first capstan servo chip I've had to replace in a machine with the K deck. **D.H.**

### **Ferguson FVB9**

This machine was completely dead. I've come across the same one branded **Daewoo** and **Roadstar**. The power supply unit has to be unsoldered from beneath the PCB to gain access, so you have to take the mechanism out first. C53 (1 $\mu$ F, 100V) was found to be open-circuit. C63 and C65 (22 $\mu$ F, 50V) were also replaced as they didn't look too good.

If one of these machines leaves a loop of tape behind on eject, replace the mode switch. **M.R.S.**

### **GoldStar T2631**

I've had two of these machines in recently. The first one had a tape stuck in it and there were no functions. CP25 (100 $\mu$ F, 10V) in the power supply was open-circuit.

The other one would load a tape then the front display would play tricks and a clicking noise would come from the mechanism, like capstan shuffling. This machine had been to another dealer who had replaced all the electrolytics in the power supply. I had a spare power supply, which enabled me to carry out some comparison checks. This led to the discovery that RP09 measured 93 $\Omega$  instead of 22 $\Omega$ . So I removed it for a further check: the reading jumped from around 22 $\Omega$  to 2.3M $\Omega$ ! A replacement restored normal operation. **M.R.S.**

### **Ferguson FV21R**

This machine required new video heads. After replacing them the tape wouldn't go in. If a tape was loaded manually, play etc. worked but there was no eject. When I've had this fault on previous occasions the STK5482 IC has been faulty. Not this time. After much head-scratching I found that the wires on the carriage motor were loose. **M.R.S.**

### **Panasonic NVSD220 (K deck)**

This machine had a cassette in it and wouldn't unload – F4 appeared in the display. The cause of the problem was one that's become quite common. The plastic collar shaft on the loading motor splits. As a result the motor turns but the mechanism doesn't. You used to have to order a new loading motor complete, but the plastic collar can

now be obtained on its own – the part no. is VDP1434. **M.M.**

### **Toshiba V212/V213**

This machine appeared to be dead. Checks in the power supply revealed that DP71 (BA158), one of the rectifiers on the secondary side, was leaky. It provides the 33V supply. A replacement brought the machine back to life. **M.M.**

### **Aiwa FX11**

The customer said that the trouble started with failure to eject a cassette. When he disconnected then reconnected the mains supply the tape unlaced and the fault appeared to have gone. Subsequently he had intermittent problems with getting the tape to stay in: the machine would accept a cassette then, after a few seconds, eject it. The cause of the trouble was the mode switch: a replacement restored reliable operation. **M.M.**

### **Toshiba V804**

The original fault with this machine, which came to me from another dealer, was that it wouldn't accept tapes. When I plugged it in it was dead! Quick checks showed that the power supply was in fact working. The cause of the original problem was the cassette lid opener on the carriage: it had come adrift, together with a couple of springs. This was easily put right. When I checked around the main microcontroller chip I found that its 5V supply was missing. This comes from a 5V regulator. R591 which feeds this regulator was open-circuit. Once a new resistor had been fitted the machine was OK. **M.M.**

### **Matsui TVR141**

When this combi unit was used for tape playback it was very slow. The cause was excessive back tension. To cure the problem, remove the back-tension band and the supply-reel table. Clean both thoroughly with isopropyl alcohol or Servisol head cleaning fluid. Allow the alcohol to evaporate, then reassemble. Finally, check and adjust the back tension. **M.M.**

### **Akai VSG270**

I've had two of these machines with the same problem: the cassette carriage is floppy and won't accept a tape. In both cases the cause of the trouble was the right-hand loading arm. When a replacement is fitted the tension in the carriage mechanism is restored and a cassette can be loaded. **M.M.**

# Servicing

John Coombes on how to tackle the various fault symptoms you could encounter with this VCR

## the JVC HRD720

**T**he JVC Model HRD720 was introduced in 1991. It's a well-made, two-speed VCR that's worth repair. The following is a summary of the faults I've encountered with it. The deck is the JVC M3.

### Mechanical Faults

**Poor recording/fuzzy picture:** Head wear is likely to be the cause. If the picture is marred by interference rather than being of overall poor quality, the cause is more likely to be dirt on the drum or somewhere in the tape path. If the drum has to be replaced, ensure that the correct one is ordered – different models in the range use different heads.

**Picture marred by interference:** Provided the input signal is OK, also the TV set being used for the display, the cause is likely to be dust, dirt or faulty/worn heads. Clean the heads and tape path. Check that the threading is OK. If necessary replace the drum.

**Irregular noise bars on picture:** Check and adjust the tape path and that the heads and tape path are clean.

**Loss of sound-picture sync:** This is caused by the tape path between the sound and video heads being incorrect. The most common cause is a damaged loading arm. If the path is too short, the sound precedes the picture and vice versa.

**Squeaks:** Check mechanical drive conditions and that items such as the head spring are centred correctly and not touching the sides. Check flywheels and tape drive mechanisms. A little grease on the finger tip will often work wonders. Check for plastic rubbing, and look for stickiness in moving parts.

**Machine goes to rewind or rewinds when any key is pressed:** The end sensor unit is probably faulty.

**No rewind and/or fast forward:** Check the reel belt then, if necessary, the switch assembly by replacement.

### Mechanical/electronic faults

This section deals with symptoms that could have either a mechanical or an electronic cause.

**One function not working:** Check that the VCR is loading correctly. If not, check the mode switch which could be faulty or incorrectly positioned. If necessary check that the mechacon chip IC601 is operating correctly.

**Tape threads but won't play, possibly intermittent:** Check that the pinch roller engages after threading, then if necessary for some other mechanical cause – there could be a broken nylon gear or faulty drive to loading gear.

The cause of the fault could lie in the mechacon circuit. Check that IC601's supply (5V at pin 1) is correct, then its inputs and outputs. If necessary check IC601 (M37524M3-151SP) by replacement.

**No drum rotation:** Check that power is reaching the drum. If not check CP401 (ICP-F15). Check the drum drive assembly, which is usually replaced with the motor.

A full investigation in this area is requires the use of an oscilloscope to check the coil drive waveforms and the outputs from the Hall elements. This is all part of the drum motor assembly, which comes as a complete unit.

**Tape damage/tangling:** Check whether the reel and/or loading belts are broken or stretched, then whether the pinch roller is worn. Check the tape path: clean if necessary then check adjustments and pressures – look for sticky moving parts. The brake shoes might need to be replaced.

**Drum rotates too fast:** Check whether the motor drive is correct. If OK, check the motor. The cause is most likely to be in the electronic circuitry however. Check the conditions at the pins of the HD49733NT servo chip IC401. If these are OK the chip must also be OK. In this case check the brake drive.

**Shaky sound:** Check mechanical parts such as belts, take-ups, clutches etc. for wear. If replacement of any worn items fails to cure the fault, check the capstan motor drive. If the connections and driver chip are OK, check the motor by replacement.

**Periodic noise on TV display:** The audio-control head could be dirty or worn. If it's OK, check at pins 29 and 30 of the HD49733NT servo chip IC401. No voltage or incorrect conditions here could mean that the chip is faulty. Check the tape transport path if the capstan servo is OK.

**Failure to record:** If mechanical operation is OK, check the conditions around the video record/playback processor chip IC1 (JCP0016-2) then if necessary the mechacon chip IC601.

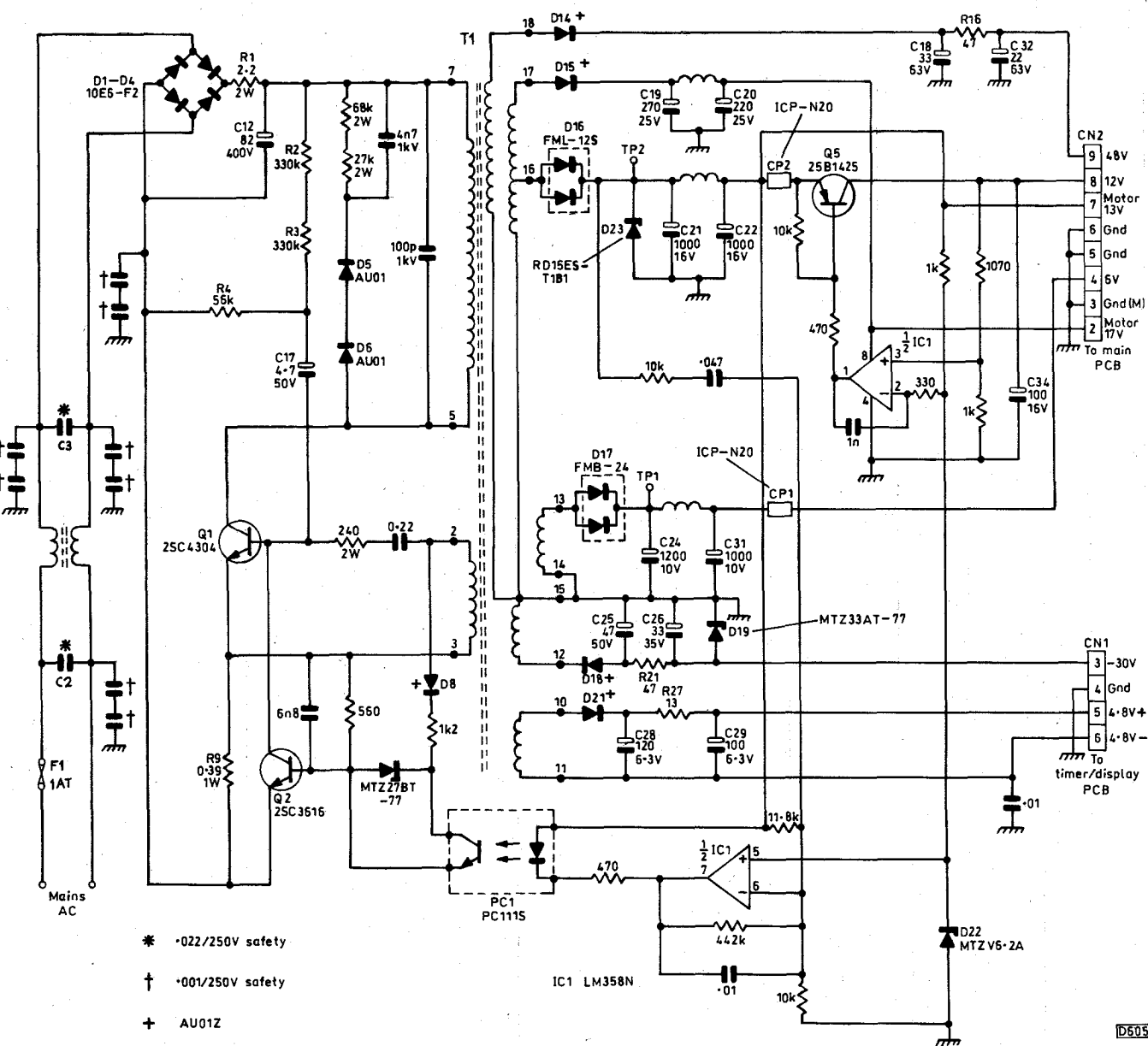

**Machine switches itself off:** Check that the mechacon chip IC601 is receiving correct information from all sources and that its supply and the clock/data lines are OK. A mechanical fault could be the cause of the shut-down.

**Rewind faults:** If the machine won't rewind to the end, has trouble starting or leaves a loop or loose tape when rewind stops, check the belts which could be worn or misaligned, then the clutches for wear. For any of these faults or failure to rewind automatically, check the supply to the end sensors, then check from the sensors to the mechacon chip IC601. If the output from this chip is incorrect, replace it.

**Faulty search:** This usually means incorrect operation of the reel belt driven by the capstan motor. If its rotation is too fast there will be only lines on the TV screen, if it's too slow the search will be slowed, if stopped the picture will stop. Check the belt then the clutch assembly and the supply/take-up spools – lubricate the spindles if they are noisy or sticky, preventing free movement. The mechacon circuit could be responsible for the

fault. Check the conditions at the pins of IC601. If necessary check it by replacement.  
If the search is too fast, check the above points then the conditions around the servo chip IC401. Check for dry-joints, and check the components in the path from this IC.

### The Power Supply

Fig. 1 shows the chopper power supply circuit. Further regulators and the power on/off switching arrangement are on the main panel, see Fig. 2. The main items here are Q802 which produces an unswitched 5.8V supply, Q803 which produces a switched 5V supply and IC801 which produces the unswitched 5V supply for the mechacon and other circuitry. On/off switching is carried out by Q801 which produces a switched 12V supply: the on/off switching signal from pin 47 of the mechacon chip IC601 is applied to its base.

**No results, mains fuse F1 (1AT) blown:** Check the mains bridge rectifier diodes D1-4 (4 x 10E6-F2) and the mains filter capacitors C2 and C3 (both 0.022µF).

**No 48V supply:** If the 48V supply is missing at pin 9 of

**Fig. 1: The chopper power supply circuit used in the JVC Model HRD720 VCR.**

CN2 check D14 (AU01Z), C18 (33 $\mu$ F, 63V), R16 (47 $\Omega$ ) safety) and C32 (22 $\mu$ F, 63V).

**No 12V supply:** There should be 12V at pin 8 of CN2. If not, check CP2 (ICP-N20). If it's open-circuit and a replacement fails, check zener diode D23 (RD15ES-T1B1) and C21 (1,000 $\mu$ F, 16V). If CP2 is OK, check D16 (FML12S) and if necessary the DC conditions around the regulator transistor Q5 (2SB1425-EU).

**No 6V supply:** There should be 6V at pin 4 of CN2. If this supply is missing, check CP1 (ICP-N20), D17 (FMB24), C24 (1,200 $\mu$ F, 10V) and C31 (1,000 $\mu$ F, 10V).

### Electronic Faults

**No functions:** Check that the mechacon chip IC601 (M37524M3-151SP) is receiving its 5V supply at pin 1. This comes from the UPC24M0HF 5V regulator IC801. Check that the conditions at IC601's reset pin 28 are correct. If not, check zener diode D602 (HZS8.2EB2TJ), C603 (1 $\mu$ F, 50V), R603 (4-7k $\Omega$ ) and R604 (10k $\Omega$ ). Check the voltages at the pins of IC601, then if necessary the chip itself by replacement. The CAT35C104P-023 memory chip IC602 is also suspect. Check that the on/off switching works. IC601 produces the on/off output at pin 47. It's applied to the base of Q801 (2SB1425EU) in the regulation section of the main panel

**Switches to record during playback:** This could be a remote control unit fault. The most likely cause within the VCR is the mechacon chip IC601.

**No loophrough signals, maybe one channel only:** Check the aerial connection and the switching in this area. The mechacon chip IC601 is suspect but check for dry-joints in this area. If all channels are affected the aerial socket has almost certainly been damaged.

**Noise bar on picture:** Once the supply lines have been cleared, check the DC conditions at the pins of the HD49733NT servo chip IC401.

**Tape speeds up erratically:** Clean and check the capstan motor. Check that the capstan FG signal is present at pin 37 of IC401. If missing, trace back. Check for hairline cracks in the capstan servo circuitry.

**Playback faults:** If there is no playback picture check the DC conditions at the pins of IC1 (JCP0016-2) on the video board. Otherwise check back from the output.

If the picture or colour shakes from side-to-side, check the motor connections, that the supplies are stable and the servo adjustments, then the conditions around the servo chip IC401 – check voltages and if necessary the chip be replacement.

If the display has no line sync or excessive horizontal sway, check the drum FG/PG waveform (4-2V p-p) at pin 9 of IC401. If this is OK, check the voltages at pins 5-9 of IC401 then suspect the chip.

If there's no playback sound, look for short- or open-circuits and dry-joints in the audio playback circuit.

See also colour faults.

**Record faults:** If the machine's recordings consist of a blank screen with the sound all right, check the video head terminals. Presence of signals here indicates that the heads are faulty. Otherwise trace back through the video circuitry to IC1 (JCP0016-2). If the recording

consists of gibberish in colour, check the DC conditions at the pins of IC1. Otherwise check the erase heads and the drive to them. This also applies when recordings are partial, with some of the original recording left.

If the recorder will not make timed recordings, check the DC conditions at the pins of IC1 (UPD75217CW-073) on the timer/display panel then if necessary at the pins of the mechacon chip IC601 on the main panel. Either chip could be faulty.

See also colour faults.

**E-E faults:** If there's a hum bar on the E-E picture check the DC conditions at the pins of IC1 (LA7575) in the tuner section. D1 (E452-2) could be faulty. If necessary carry out a systematic check on the diodes and capacitors in this area.

For no E-E sound check the DC conditions at IC1 and for dry-joints and open-circuit components in the signal path.

Interference on the E-E sound is sometimes experienced. First try to adjust it out. Then if necessary check the capacitors in the IF circuitry. Note that adjustments to the coils in this area can be tricky. If adjustment has no effect and the interference is fairly constant irrespective of picture content, check IC1 by replacement. For a faint buzz the official recommendation is to try fitting an attenuator and adjustment of the vision detector circuit. Even this will rarely eliminate a faint buzz altogether.

**No record/E-E vision or sound:** Check the aerial and TV sockets, and that the tuner is receiving power and a signal input. If so the tuner is suspect, but it's best to carry out scope checks along the signal path – tuner, SAWF and IC1 (LA7575). This IC could be faulty, but first check for 10V at pin 9 – the supply comes via Q3 and Q1. Check the VCO coil T1. Look for dry-joints and broken print/connections in this area. Video muting is carried out by Q18 (DTC144EU) and Q5 (2SK381C), audio muting by Q16 (DTC144EU).

**Luminance faults:** Check the DC conditions around IC1 (JCP0016-2) on the main panel. If this chip has to be replaced, adjustments will be necessary. This requires an oscilloscope, frequency counter and a DC power supply. It's advisable only in the workshop, with the full service manual.

Nearly all electrical adjustments require workshop equipment and the full service manual for the necessary instructions.

**Colour faults:** IC1 (JCP0016-2) can be responsible for various faults such as no playback and/or record colour, intermittent colour and poor playback and/or record colour. Check the DC conditions around this chip, also for dry-joints in this area. Make sure that there is 5V at pin 15 of IC1.

Either C71 (0-0027 $\mu$ F) or LPF3 open-circuit will remove the playback colour.

If the above points are OK, a scope is required for signal tracing in the relevant path.

For record colour faults trace the signal back from TP205. Tuning drift will remove the colour in the record mode.

**Tuner faults:** For drift, try retuning then suspect the 33V stabiliser D2 (HZT33-02). Alternatively the tuner could be faulty. Tuner drift will result in loss of recorded colour and sound. For signal/intermittent signal problems, check the aerial input through to the tuner, then its

power supplies. If incorrect tuning voltage is the fault, first check the unswitched 48V supply then D1 (E452-2), D2 and C8 (10 $\mu$ F, 50V). Intermittent operation suggests the presence of dry-joints or cracks in this area. Failure to change channels, possibly intermittent, also points to dry-joints and D2.

**Clock faults:** Check for dry-joints on the timer/display panel. If timer/clock data is missing at CN2, IC1 (UPD75217CW-073) is suspect though crystal X1 could be faulty or dry-jointed. First check that IC1's 5V supply is present at pin 64. It comes from regulator IC101 (GPIU541X) via D7. Note that IC1 can be affected by interference, lightning and other influences. It is thus advisable to check whether the clock can be restarted, by switching off at the mains then restarting, before condemning the chip.

The display unit FDP101 can be responsible for no display, loss of digits or loss of complete numbers. First check that data is reaching it from IC1.

Check X1 and IC1 if the clock gains or loses time.

### Remote Control Unit

The first, obvious, check when operation is faulty is the batteries and their connections. The contacts could be dry-jointed to the PCB. If necessary check for dry-joints at LED1, LED2, X1 (32.768kHz) and CF1 (400kHz). If the processor chip is faulty it's best to replace the hand-set.

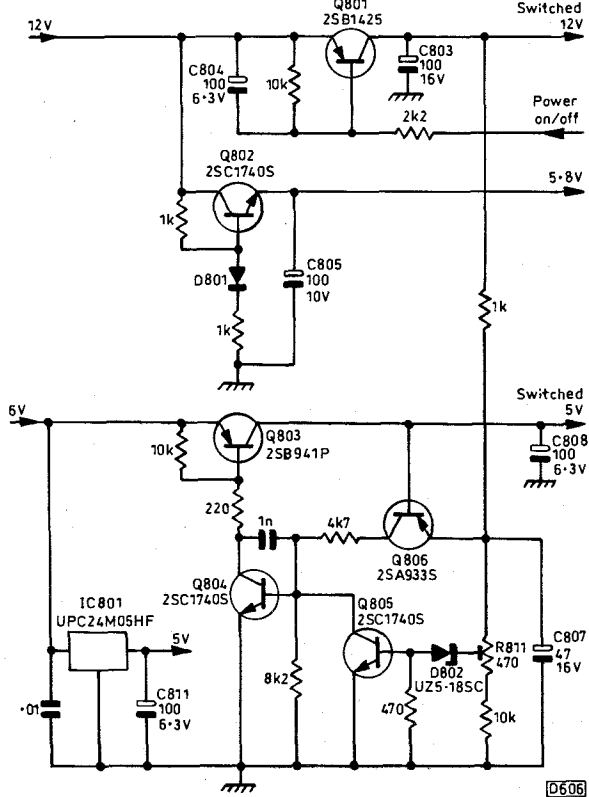

**Fig. 2: Regulator and power switching circuitry on the main PCB.**

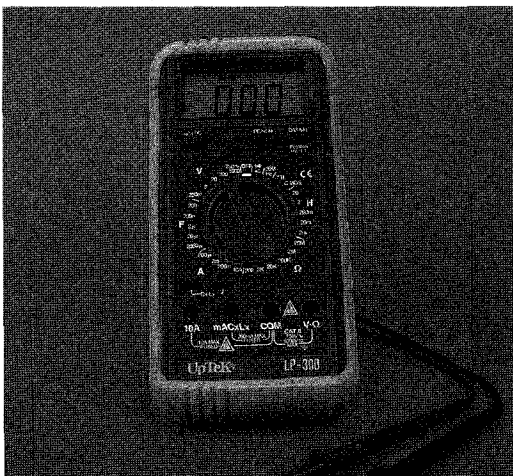

Vann Draper is offering the professional quality LP300 digital multimeter to readers of *Television* at a 30% discount. The LP300 normally sells at an already low price of £81.08 but is available to readers for only **£59** fully inclusive of vat & delivery.

The meter is supplied ready to use complete with test leads, rubber holster, battery, operating instructions and a 12 month guarantee.

Data sheets for all products are published on our web site at [www.vanndraper.co.uk](http://www.vanndraper.co.uk) including the new pc based 20MHz 40Ms/s digital scope & spectrum analyser for <£200

To order your meter simply post the coupon to :

**Vann Draper Electronics Ltd, Stenson House, Stenson, Derby DE73 1HL.**  
Or Tel 01283 704706 Fax 01283 704707 Email [sales@vanndraper.co.uk](mailto:sales@vanndraper.co.uk)

### Key Specifications

DC volts	:	200m, 2V, 20V, 200V, 1000V - basic accuracy 0.25%
AC volts	:	200m, 2V, 20V, 200V, 750V - basic accuracy 1.0%
DC current	:	200uA, 2mA, 200mA, 10A - 200mA & 10A fuse protection
AC current	:	200uA, 2mA, 200mA, 10A - 200mA & 10A fuse protection
Resistance	:	200ohm, 2k, 20k, 200k, 2M, 20M - protection to 500Vrms
Capacitance	:	20nF, 200nF, 2uF, 20uF, 2000uF - by test leads or socket
Inductance	:	2mH, 20mH, 200mH, 2H, 20H - by test leads or socket
Frequency	:	2kHz, 20kHz, 200kHz, 2MHz, 20MHz - auto ranging
Size and weight	:	200 x 95 x 55mm, 500g (with holster)

**30% discount for TV readers**  
on dmm with frequency, capacitance & inductance



**Vann Draper Electronics Ltd**  
The test & measurement specialists

[www.vanndraper.co.uk](http://www.vanndraper.co.uk)

Equipment from Grundig, Kenwood, Hameg, Tektronix, Hitachi, Fluke, Avo and many more.

**Use this coupon for your order**

Please supply me:

..... LP300 multimeter(s) at £59.00 inc vat & del

Name:

Address:

Tel No:

Total £

Cheques payable to Vann Draper Electronics Ltd or debit my visa, mastercard or switch card:

Card type:

Card No:

Expiry date:

Switch iss No:

Signature:

Overseas readers can still obtain this discount but carriage charges vary according to country. Please telephone, fax, email or write to Vann Draper.



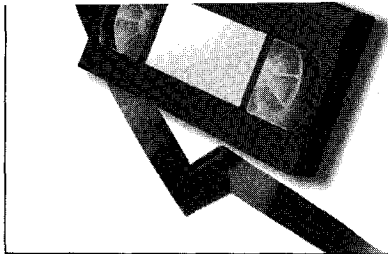

# VCR Clinic

**Reports from**  
**Eugene Trundle**  
**Kevin Green, TMIIE**  
**Steven Leatherbarrow**  
**Tim Edwards**  
**John Coombes**  
**Paul Hardy and**  
**Michael Maurice**

## **Akai VSG770**

'Error 1' usually appeared in the display at switch on. When this didn't happen the machine worked normally for a while then shut itself down, with error 1 again appearing. The cause turned out to be switch transistor TR215, which was leaky. I've been told that zener diodes D236 and D237 can cause the same symptom with this and similar models. **E.T.**

## **Sony SLVE720**

Two of these machines have been brought to us because of a low-gain tuner. The RF through and playback pictures were good, but E-E and off-tape pictures via the tuner were poor and grainy. In both cases the cause was a dry-joint inside the tuner/receiver module – at the front, bottom corner, farthest from the aerial socket. The PCB's earth-land solder link to the screening can tends to crack at this point. **E.T.**

## **JVC HRJ625**

If the problem is failure to eject the cassette, with the capstan motor whirring, the cause will probably be that the spring anchorage has broken off the change arm (item 74 in the exploded view of the deck). When this happens the inject mechanism doesn't engage. In its confusion the deck laces the tape up again then shuts down. **E.T.**

## **Toshiba V204B**

The symptom with this machine

was complete lack of action and display – nothing was coming from the power supply. Only very brief pulses, at a rate of about two per second, were seen when an oscilloscope probe was connected to the collector of the chopper transistor. Normal operation was restored when capacitors CP007 (10 $\mu$ F, 50V) and CP008 (100 $\mu$ F, 25V) on the primary side of the power supply were replaced. **E.T.**

## **JVC HRJ665**

The only response this machine produced was a very faint ticking that came from the chopper power supply. A 15V zener diode, D5301, turned out to be the cause of the trouble. It had gone short-circuit. **K.G.**

## **Sharp VCM301HM**

The tape would load and then play for a maximum of about four minutes, after which the machine would cut out. Investigation showed that in the fault condition the drum motor stopped rotating. The cause of the trouble was the BA6977S drum driver chip IC702. **K.G.**

## **Sharp VCM26**

There was extremely bad patterning, of the type you generally come across only with co-channel interference. But it was also present in the playback mode and with the aerial disconnected. The colour would drop out, and when present differed in hue across the screen. X501, which is associated with IC201, was the culprit. **S.L.**

## **Orion D9600**

The upper deck of this double-deck VCR produced pictures that rolled/jumped. Adjustment seemed to be the answer, but as usual nowadays there were no presets to adjust. What you have to do is this: set the display to deck A, play back an alignment or known good tape

and, while the machine is playing back, press 'tracking auto' on the handset and 'play' at the machine. If the ATR flag disappears, adjustment is complete. I found that several attempts had to be made.

If the ATR flag remains, a different procedure is required and a 'service handset' (JG155) has to be obtained. Fortunately I didn't have to go that far with this machine. The manufacturer could of course have fitted a potentiometer or two, saving the cost of a manual (about £20) and a two-week wait. **S.L.**

## **Daewoo V200**

This supermarket special uses a Sony power supply module that's in a neat little can. It is common for C53 (1 $\mu$ F, 100V) to dry out, the result being a dead machine. **S.L.**

## **Akura VX160**

There was a very intermittent fault with this machine: the playback FM signal would disappear at random, but never for long enough to enable fault tracing to be undertaken. I eventually found that the LA7376 FM amplifier chip in the can behind the drum was heat sensitive. A replacement cured the fault. **S.L.**

## **Ferguson FV71LV**

The customer complained about poor start-up, intermittent play and jumping to rewind etc. of its own accord. This looked like power supply trouble. So I replaced CP07 (10 $\mu$ F, 50V) and CP08 (100 $\mu$ F, 50V). When DP06 (BYV10-20) was tested I obtained a reading of 300 $\Omega$ . I replaced it with a BYD33D. On the secondary side of the circuit I noticed that there was an 85°C axial capacitor in position CP41 (220 $\mu$ F, 25V). So this was replaced with the correct radial 105°C type. I also replaced CP71 (10 $\mu$ F, 50V) on the print side as

this can also cause problems.

When I refitted the power supply and switched on I found that a cassette could be loaded but would not play properly, and there was no eject. To cut a long story short, by running the machine out of its case I found that everything was working correctly. So where were the strange commands coming from? The base screws were too long. The one on the side of the play button was touching the soldered pins (track side) of connector BC06. T.E.

### **Hitachi VTM230**

The complaint with this machine was about tape chewing, which to start with was very intermittent. After a long soak test however it was obvious what was responsible for the tape damage. The pinch roller was faulty, not because of wear but because the retainer plastic insert that holds the roller to the arm assembly had split. As a result the pinch roller slowly moved down the shaft and the tape was then incorrectly positioned. J.C.

### **Toshiba V212**

There was an unusual fault with this machine. When it was in the playback mode it produced an E-E picture! The cause was the MC1409 shift register chip IW20. The only reliable check is by substitution. J.C.

### **Samsung SV421K**

If there is tape damage when the tape is running, check the pinch roller for wear. If there is damage when the tape is ejected, check the left-hand brake assembly. It can wear to cause this trouble. J.C.

### **Akai VSG745**

We've had two different faults with this model recently, both caused by a defective mode switch. The problem with the first machine was intermittent fast forward and rewind. With the second machine there was tape damage at eject, because a loop of tape was being left out of the cassette. J.C.

### **Philips VR522**

A number of power supply capacitors can cause the no results symptom with this machine. In this case the culprit was C2112 (100µF), which had fallen in value to just 7µF. J.C.

### **Sony SLV625**

The original problem was tape damage because of a sticking limit

post. As the grease had hardened, the post didn't return to its correct position. The arm had to be removed, cleaned and regreased. I gave the machine a good clean and replaced the head-cleaning roller. One problem remained after this: there was a slight, very strange knocking noise. The cause was traced to the timing belt, which had stretched. P.H.

### **Mitsubishi HSM40V (J deck)**

A tape was jammed in this machine. I unloaded it manually then removed the cassette lift assembly for inspection. The cause of the problem was that the peg was out of engagement with the spring at the right-hand side of the cassette. As no other damage was apparent, I retimed the mechanism and tried it with another tape. Everything was fine, but the machine failed when the customer's tape was tried. I had to retime it again. The cause of the problem was the customer's cassette. P.H.

### **Panasonic NVF65**

"Poor signals" it said on the job card. When I tested the machine I found that it would search for channels but wouldn't stop at a signal. In addition interference could be seen on the received picture as the transmission was tuned through. The cause of the trouble was hash on the 45V supply because C1118 was open-circuit. The other power supply lines were OK. P.H.

### **Ferguson FV81LV**

This machine wouldn't accept a cassette. The cause of the trouble was the small lever that actuates the cassette flap lock - it was missing. I couldn't find it in the machine, and it's not available separately. Although the Willow Vale catalogue has an exploded view of the L mechanism, the cassette holder (item 16) is not shown in the parts list. It is however available under WVE order code 20081HC. P.H.

### **Mitsubishi HSM37B**

This machine was jammed in the fully-loaded state. I released it by turning the loading motor, after which the fault wouldn't recur. So I stripped out the pinch roller and pinch cam helter-skelter gear and then thoroughly regreased all the moving parts. A few weeks later I was called back. This time eject was difficult, also going into play and record. The cause was the

grease around the idler: it had gone hard and sticky. I had to strip down both plates on the underside of the mechanism and regrease all the bearings and pivots. If you fit the pinch-roller kit, new grease comes with it. This information will apply to other models that use the same mechanism. M.M.

### **Sanyo VHR190E**

There was either intermittent or no remote control operation. The cause was dry-joints at the connectors that link the two front-panel PCBs. Resoldering provided a complete cure. M.M.

### **Sony SLV625**

A couple of weeks after replacing the pinch roller and regreasing the half-load arm I was called back because there was no record/E-E sound. Connector CN0306 on the Nicam module was dry-jointed at nearly every pin that links it to the main PCB. M.M.

### **Sharp VCA55HM**

Rewind and fast forward were OK, but play was either very slow or not at all. For a change the capstan motor was running freely. It had failed electrically, a replacement restoring normal operation. M.M.

### **JVC HRJ600**

This machine wouldn't eject a cassette fully. JVC's excellent technical department told me the cause is the pin, on the main deck, that acts as a bearing for the relay arm and gear, and that the only cure is to replace the main deck chassis, part no. PQ11473B-4. The main deck comes as a bare chassis, so every part from the old one has to be removed and transferred to the new one - 105 parts excluding the drum assembly. Be prepared to spend a few hours doing this.

After reassembly and testing I found that there was a fault with the brakes. They didn't come on when stop or play was selected after rewind or fast forward. The cause was misalignment between the sliding base (item no. 151) and the control cam. So I replaced this, the slide plate and main brakes. But the brakes still didn't come on after fast forward. To cut a long story short, I found the cause to be lack of grease on the new slide plate. I also had to replace the slide plate's spring. The machine then worked correctly.

Next time I'll make sure I charge a lot more for my time! M.M.

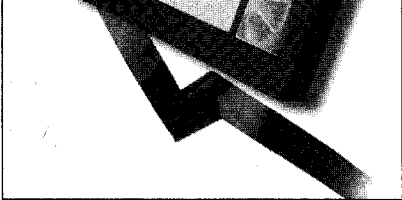

# VCR Clinic

Reports from  
**Philip Blundell, AMIIElec**  
**Dave Hewitt**  
**Gerry Mumford**  
**M. Della Verita**  
**Paul Smith and**  
**Michael Maurice**

## Sharp VCT510HM

This machine wouldn't play or record tapes. A cassette would be accepted, but when play was selected the loading process would stop part way then go back to the stop mode. Scope checks showed that the capstan and drum FG pulses were present but the drum PG pulses were missing. The PG coil was found to be open-circuit.

Fortunately continuity was restored by resoldering the lead-outs: the pulses were then back. If the coil cannot be repaired the motor PCB is available as a spare part at a reasonable price. **P.B.**

## Panasonic NVHD100B

Because of the cost of a new lower drum assembly, a noisy drum bearing often means that the machine has to be written off. Before you assume the worst however try this. Remove the earthing brush then the three Torx screws that hold the earthing disc in place. Remove the disc then put a drop of thin oil down the side of the shaft. Leave for a couple of hours then reassemble. It worked for me! **P.B.**

## Mitsubishi HSB30

A neighbouring dealer had fitted new video heads to this machine because of loss of playback. When he tested it however he found that the recordings were marred by black spaghetti streaks on peak-white areas of the picture. Fortunately he had lent the customer a replacement

machine and had noticed, when he installed it, that the customer's tapes recorded prior to the head failure also suffered from black streaking. A slight tweak on the white-clip control VR2A2 put an end to the streaking. **P.B.**

## Philips VR6542

This machine's threading mechanism had jammed. The cause of the trouble was evident once the plate on the underside had been removed: a piece of plastic had broken off the master cam. A new cam, mode switch and belts restored normal operation. **P.B.**

## ITT VR3916

The take-up reel tacho pulses at the collector of Q1 on the deck terminal board were intermittent. As a new 2SD636 transistor in position Q1 had no effect the reel optosensor became suspect. Three suppliers I tried said his item is no longer available. Fortunately I was able to salvage one from a scrap machine. Equivalent models in the **JVC** and **Ferguson** ranges are the HRD150 and 3V45 respectively. **P.B.**

## Panasonic NVF65

There was bad patterning on the E-E video, the result being poor recordings. Checks in the power supply with a Genie ESR meter soon revealed that C1118 (100µF, 50V) on the secondary side was faulty. A replacement cured the patterning. I also replaced C1109 (1µF, 400V) on the primary side as it is often the cause of a dead power supply. **D.H.**

## Sony SLVE700

There were two faults with this Nicam VCR. First tape chewing and terrible tracking. The cause of this was the take-up tape guide buckling over as it entered the V block at the end of its travel. When I split the deck from the PCB – a

complex operation to say the least – I discovered that the tape guide slider is held tight to the slide path under the deck by only a bronze-coloured spring arrangement (not unlike some Matsui and Aiwa budget-priced models). A new spring assembly, which is attached to the body of the tape guide by a tiny screw, cured the problem. The part numbers for these rather flimsy bronze spring units are 3960-68801 (take-up side) and 3960-68701 (supply side).

The second fault was to do with sound: the customer said that the E-E sound was distorted and that the input from his camcorder at position L2 was similarly distorted. Having spent a considerable time tracing through the sound path I discovered that audio-wise nothing much was getting past the BA7632AF-E2 scart switching chip IC102, which is a surface-mounted device on the smaller scart board at the back left-hand side, above the main PCB. Its part no. is 8759 44569 and it is not exactly cheap. For test purposes the E-E sound can be linked across at the ribbon cable connections to the scart board.

The replacement chip I fitted cured the problem. For good measure I also replaced the 12V regulator chip IC1404 for the supply to the scart switching chip. **D.H.**

## JVC HRJ400

A tape was stuck in the deck, there were odd symbols in the display and there was no action. The cause was CP1 in the power supply – it was open-circuit. As there seemed to be no reason for the failure of this N20 800mA circuit protector and everything seemed to be fine once it had been replaced, I decided to ask JVC's excellent technical department whether there might be any known cause of its random failure. I was told that static discharge between the case and the mecha-

nism could sometimes account for it blowing, and was advised to make up a leaf-type earthing spring to fit between the cassette housing and the top cover, as in older machines.

The customer subsequently told me that he had been inserting a tape when the machine failed. On reflection, if you brush against the TV set's screen while touching the VCR quite a large charge can be passed to the VCR's case – especially if you are kneeling on a nylon carpet at the time! **D.H.**

### **GoldStar W201**

This machine powered up but there was only a clock display, which reverted to  $\diamond$  after a few seconds – as if the deck timing was out. In fact the timing was OK. Checks revealed that the 12V supply was missing at the loading motor drive IC. It's switched by a fairly complicated transistor arrangement, where I found that Q132 (KSA709C) didn't switch on when asked to do so. A replacement transistor cured the fault, though the original tested OK with a meter – it must have had very slight base-emitter leakage. **G.M.**

### **Matsui VX6600**

This machine's recordings played back as a mass of coloured lines, though the stereo sound was perfect. I couldn't find any faulty components but, fortunately, slight adjustment of the FM carrier preset (VR4001) on the YC subpanel completely cured the fault. **G.M.**

### **Mitsubishi HS740V**

The power supply would start up then shut down very quickly. Cold checks showed that the AP01C diode D903 was leaky – about 390 $\Omega$ . It's part of the snubber/efficiency network connected across the primary winding of the chopper transformer. **G.M.**

### **Philips VR422**

The customer said that a cassette was jammed in the machine, the display flashed and he could hear a faint ticking noise from inside. When I put the machine on the bench and plugged it in there was no life at all. Checks in the power supply revealed that C2114 (47 $\mu$ F, 25V) was faulty. When a replacement had been fitted the machine came on and all functions operated correctly. **P.S.**

### **Aiwa HVFX2800K**

During playback of prerecorded

tapes there was a noise bar at the bottom of the picture. When the machine's own recordings were played back the picture continually jumped. The alignment of the guides, back tension and take-up torque were all checked and found to be OK. What cured the fault was slight adjustment of the position of the drum motor on top of the video heads. To realign, loosen the two Allen screws on the upper brass bush and turn the whole unit (in this case anti-clockwise) while monitoring the picture. Once operation is correct, relock the screws. **P.S.**

### **Daewoo V200**

The customer couldn't tune his TV in to this VCR and neither could we! The RF converter wasn't functioning because the 12V line was at 1.3V. It didn't take long to trace the cause of the trouble to the 13V zener diode D654, which was leaky. **P.S.**

### **Goodmans RC7051 (LG D17 chassis)**

There were two faults with this machine. The RF aerial input socket had snapped, and there was intermittent loss of colour or the tape would go faster on playback (looked like a capstan motor fault). Instead of buying a new RF-through booster I modified the one in the machine, adding an RF socket between the scart connector and the actual booster.

The second fault was a bit more tricky. The machine had apparently been dropped, so I hit it with the back of my giant screwdriver. As the intermittent fault was still present I lifted the main PCB and hit it again. Something dropped off. It was crystal X301, which is next to the LA7390 PAL/Secam chip IC301. Resoldering it cleared the fault. **M.D.V.**

### **LG N309i**

The complaint with this new machine was that it didn't always make a timed Video Plus recording. It was returned after a week with a 'no fault found' letter. A few days later it came back with a note to say that the clock didn't always show the correct time. We put it on the test rack and, sure enough, after a short while the clock was two hours fast. Later that same day the clock was correct again.

A call to the LG technical department revealed that the type of PDC (Programme Delivery Control) signal transmitted by some broadcasters can upset the micro-

controller chip. The advice was to disable the PDC by adding a signal diode in position D622 on the front PCB. When this had been done the clock kept perfect time. **P.S.**

### **Sanyo VHR245**

This machine would take in a cassette partially then eject it. Inspection revealed that the tape-flap lever, item 040C, was missing from the carriage, which fell out in two pieces when the mechanism was inverted. A new lever and spring (item 040B) restored normal loading. **P.S.**

### **Panasonic NVJ45**

This machine wouldn't do timer recordings and many attempts were usually required to get it to go into play or record. When I checked its operation I found that the loading guides would move about half way then stop. As there was no obstruction when I tried manual loading I decided to replace the mode switch. This cleared the trouble and a new pinch roller completed the repair. **M.M.**

### **Toshiba V703B**

There were no functions and the display was dim. When this happens, tell the customer to disconnect the machine from the mains supply and not reconnect it before bringing it to you for repair. The cause of the fault is the two capacitors, 15 $\mu$ F/50V and 47 $\mu$ F/16V, in the power supply. Note that they are os-con (organic semiconductor) electrolytics: correct replacements obtained from Toshiba must be used. **M.M.**

### **Samsung VIK310**

After fitting an upgrade kit and checking through the power supply I retested this machine. It started up but died after a few minutes. Checks showed that the voltages on the secondary side of the power supply were very low, though no obvious reason could be found for this. I eventually cured the fault by replacing the STR11006 chopper chip. **M.M.**

### **Bush BTV10**

This combi VCR/TV unit produced neither sound nor a picture and wouldn't play back or record. There was a raster or sorts however, and the VCR section operated mechanically. The cause of all these symptoms was R24, a 1 $\Omega$  fusible resistor in the video section's power supply. It was open-circuit, a replacement restoring normal results. **M.M.**

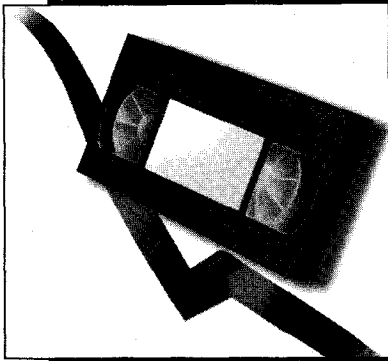

**Reports from**  
**Andy Barkley**  
**Michael Maurice**  
**Kevin Green, TMIIE**  
**Colin J. Guy**  
**Michael Dranfield**  
**Pete Gurney, LCGI and**  
**Adrian Spriddell**

### **Saisho VR1000 etc**

The capstan motor in these machines is no longer available. Unfortunately it's prone to failure. We have found that the SEME motor type MOTOR4156 at about £4.50 is a good replacement. Although it's physically larger, it is a comfortable fit.

Remove the old motor by undoing the three screws that hold its mounting plate to the main deck, then remove the motor from the mounting plate by sawing through its shaft (you will need to re-use the plate). Fit the replacement motor on the mounting plate – you will need to find three suitable screws, as the ones from the old motor are too small. Connect the wires and slip the belt over the shaft.

Once you've done a few you will find it a twenty-minute job. We have found that these machines, which are otherwise reliable, are much favoured by customers who prefer a nice, simple VCR. Equivalents in other ranges include the **Hinari VXL3**, the **Matsui VX800** and the **Orion VHL**. **A.B.**

### **Daewoo DVF932P**

You could insert a cassette but the machine then shut down. It also shut down when a function was selected. Checks in the workshop revealed that the 12V and 14V outputs from the power supply were high: the 6V output was slightly low, but there was no ripple.

# VCR Clinic

Further checks revealed that when a function was selected the 5V supply to the microcontroller chip dipped – only slightly, but it was enough to trigger the reset ICs.

The power supply consists of a pack that's soldered to the main PCB. The idea is that 330V DC goes in and low DC voltages come out. I didn't have a circuit diagram, but it was obvious that the cause of the problem was within this pack. The 6V line decoupling capacitor looked suspect. A 470µF, 16V replacement cured the fault. **M.M.**

### **Philips VR1541**

A thunderstorm had killed this VCR. When I checked it I found that the power supply was dead with the chopper transistor short-circuit. Once the optocoupler, Q1 (2SC4517A), Q2 (2SC3616) and the mains fuse had been replaced the machine worked normally. **M.M.**

### **Mitsubishi HSMX1**

The initial complaint was that the tape would stop after a few seconds then the machine would switch off. When I got it the machine was dead. Cold checks showed that there was an open-circuit resistor in the power supply and that the resistor that feeds the 5V regulator on the main PCB had also failed. There was power when these resistors had been replaced, but the machine wouldn't lace up fully. This was because the grease on the pinch roller and helter-skelter gear shafts had hardened. So these were stripped, cleaned and regreased.

After that the machine powered up and laced up, then promptly unlaced and switched off. The cause was loss of the drum flip-flop pulse input at the microcontroller chip. Further checks showed that pulses were coming from the drum but there was no output from the BU2820S servo chip. Replacement

of this item finally restored correct operation. **M.M.**

### **Hitachi VTF150**

If the tape appears to be running slow and you hear a grumbling sound from the capstan motor, replace C12 and C13 in the power supply. They are both 470µF, 16V electrolytic capacitors. **M.M.**

### **Panasonic NVJ35**

This VCR came in because it was dead. The power supply worked once C909 (1µF, 400V) had been replaced, but the machine remained dead apart from a ticking noise. Microcontroller chip IC7501 on the front panel PCB was the cause, a replacement restoring normal operation. **M.M.**

### **JVC HRJ655**

This machine's power supply made a very faint whistle for a split second then went into a slumber. The cause of the problem was found to be the 15V zener diode D5301, which was short-circuit. **K.G.**

### **Panasonic NVHD630**

The complaint with this machine was very intermittent failure to record colour, for some strange reason only in the LP mode. I had to leave it recording for many hours before the fault showed up. Replacement of IC3001 was tried, but the fault was still present. I then tried replacing three surface-mounted capacitors, C3075, C3076 and C3078. After a soak test that lasted for several days it was time to celebrate. **K.G.**

### **Sharp VCA36HM/ VCA46HM**

This was an odd problem. When the machine was put in the visual search forward mode, then the play button was pressed to release this mode, the machine just carried on in search forward but with some

garbled sound from our monitor TV. After checking many things I found that the capstan motor was the cause of the fault. **K.G.**

### **JVC HRFC100**

This is one of those dual-mode machines that will accept both VHS and VHS-C cassettes. Only this one didn't. If a cassette was inserted it went in but not down. If play was selected it came back out again. The cause of the problem was one of the sensors, PS2, on the top of the housing. It was dry-jointed. **C.J.G.**

### **Sharp VCM21etc**

The owner complained that this machine chewed tapes. I inserted my dummy cassette and looked to see what happened. The capstan motor rotated in reverse whatever mode was selected. So I removed the deck, then the PCB and reconnected the two. The capstan motor now failed to rotate at all! I then noticed that all the connections to the capstan motor socket were dry-jointed. Resoldering them cured the fault completely.

I've since had a similar fault on a couple of other models in this range, so it looks as if there's a stock fault here. **C.J.G.**

### **Daewoo V31**

There was no playback colour with this machine. It was recording colour, proved by playing back a recording on another machine. The cause of the fault was eventually traced to C409, a tiny surface-mounted 0.022 $\mu$ F capacitor on the YC daughter board. It had a leak that measured about 30k $\Omega$ . **C.J.G.**

### **Panasonic NVSD200**

This machine was brought to the workshop several times before the fault put in an appearance. The machine's owner complained that it would switch itself on at random, make all manner of mechanical noises, then switch itself off again – without any action on her part. She was not impressed with my theory that some people emit radiation that affects electronic equipment, and I had already suggested that she cover the machine to rule out the possibility of interference from fluorescent lights etc.

I eventually discovered that the sensor LED in the middle of the deck was going open-circuit very intermittently. As a result, the machine thought that someone was inserting a cassette. A replacement LED cured the problem and

restored the owner's and my sanity. **C.J.G.**

### **Bush BTV14**

This TV-VCR combi unit was dead apart from a plopping noise that came from the speaker. Voltage checks revealed that there was a low 5V supply on the video deck PCB. The cause was the KIA7805 regulator chip IC661. It was given away by the fact that the PCB was scorched. **M.Dr.**

### **Philips VR727**

This machine was dead with no outputs from the power supply, though voltages were present on the primary side of the circuit and scope checks revealed some bursts of life in the secondary windings. Most problems with this switch-mode power supply result in multiple component failure and a blown mains fuse. A service kit, part no. ES7051, is available. It contains all the parts required when this occurs.

In this case however the fuse was intact. I noticed that all the electrolytic capacitors on the secondary side of the circuit were leaking electrolyte. When I'd replaced them the power supply still refused to start, though the voltages on the primary side of the circuit were not far from those expected. At this stage I decided to fit the service kit, as it contains all the semiconductor devices likely to fail, but the fault was still present.

After extensive component checking I eventually found that the cause of the trouble was the mains bridge rectifier's reservoir capacitor C2117 (100 $\mu$ F, 375V). Although it was still able to hold a charge, and the voltage you would expect was developed across it, an ESR meter check produced a reading of 58 $\Omega$ . Once this capacitor had been replaced the power supply started up. **P.G.**

### **Hitachi VTF540**

This machine intermittently looped tapes on eject, and occasionally chewed them. When I checked it the machine appeared to work normally, with no evidence of anything amiss apart from a loud mechanical noise during wind/rewind. When the deck was removed for examination of the lower mechanism all became clear. The clutch unit, which is secured on its shaft by two small moulded pins, had fallen apart. How the machine had worked at all is a mystery: I can only assume that the unit had been partly held together

by the proximity of the main PCB.

A replacement unit is available from Chas Hyde under part no. 12017AX. **P.G.**

### **Sony SLVE220 etc**

This machine refused to power up. When it was plugged in the clock appeared briefly then faded out as the deck attempted to initialise. The cycle repeated itself, as if the power supply was in the trip mode, but the voltages on the secondary side of the supply were correct.

When faced with strange happenings in this series of VCRs my first suspect is usually the 1A fuselink J5130 in the 5V supply. It has a habit of going open-circuit progressively, causing all manner of symptoms depending on the voltage drop across it. In this case I found that the fuse read 2.5 $\Omega$ . A replacement restored normal operation. **P.G.**

### **JVC HRD180**

There was a high-pitched whistle on sound and a Venetian-blind effect on the E-E picture and on playback of the machine's own recordings. Playback of prerecorded tapes was OK. The cause was C5 (47 $\mu$ F) in the power supply: its value had fallen to 4 $\mu$ F. **A.S.**

### **Toshiba V213**

There was poor E-E and playback video, with low contrast, tearing and pulling. The cause of the problem was in the playback video path where coupling capacitor CW97 (10 $\mu$ F) had fallen in value. **A.S.**

### **Samsung VIK310**

When faced with a blown mains fuse we used to replace just the STR11006 chopper chip, R101 and C110. We've now widened the net to include C109, C122 (a low-impedance type) and the X2 capacitor C101. **A.S.**

### **Ferguson FV10B**

This machine was dead with the mains fuse open-circuit. The customer had replaced the fuse several times before finally bringing the VCR to us for attention. A complete cure was achieved by resoldering IC801. **A.S.**

### **Toshiba V204**

There was erratic operation, with tapes being ejected and/or the machine shutting down at odd times. The faults were cured by replacing all the electrolytic capacitors in the power supply, using low-impedance types. **A.S.**

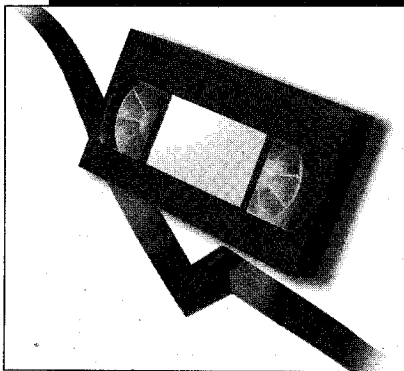

**Reports from  
Eugene Trundle  
Ronnie Boag  
Mike Leach  
Paul Hardy  
Michael Dranfield  
Chris Watton and  
Michael Maurice**

### **Toshiba V703**

This was an unusual fault: the tape was chewed immediately after the cassette had been taken on to the deck. This machine 'shuffles' the tape on receipt. During the first (backwards) phase of this shuffle the tape rode upwards and out from between the capstan and the pinch roller. The cause of the trouble was the pinch roller, which was worn. Part number is 70322504. **E.T.**

### **Tatung DVR744N**

There was no E-E sound with this machine. The cure was to replace the non-volatile memory chip and carry out reprogramming. **R.B.**

### **JVC HRJ600**

The complaint with this machine was intermittent failure to eject a tape. When I checked the mechanism I found that there were damaged teeth on the relay gear and drive arm assembly. The cause of this would have been a faulty mode state switch. Replacement of these three items cured the fault. **R.B.**

### **Panasonic NVFS100**

This machine left a loop of tape out when eject was selected. The cure was to remove, clean and refit the quarter-load arm. Part number is VXL1857. **R.B.**

### **Sanyo VHR279**

The complaint with this machine was failure to erase previously recorded sound. Scope checks

# VCR Clinic

brought me to the audio/control head which was open-circuit. **R.B.**

### **Nokia VR3786**

There was no scart switching when a tape was inserted and play was selected. The cause of the fault was the MM1117XF video switching chip IC2202 on the back PCB. A replacement cured the fault. **R.B.**

### **Samsung VI611**

Intermittent loss of the clock display was the complaint with this machine. The cure was to remove glue in the C3, Q1 area. This had become conductive, and as a result the -24V supply was low. **R.B.**

### **Sony SLVE70**

There was no RF audio in the E-E and playback modes. The scart sound was OK. I initially suspected a modulator fault, but this possibility was quickly ruled out as a buzz was obtained when the modulator's audio input pin was touched. Scope checks then showed that there was no output from the XLH7776K audio processor chip IC101 on board HF34. A replacement chip cured the fault. **M.L.**

### **Hitachi VTM510E**

If the problem is low, buzzy E-E sound, replace C2727 (22 $\mu$ F). This capacitor causes various audio symptoms when faulty. Use of heat and freezer usually confirms the diagnosis. **M.L.**

### **Samsung SV603B**

When the right-hand start sensor becomes dry-jointed the symptoms are no front loading or the cassette housing permanently trying to eject the tape in the housing. I've had the fault with several of these and other similar machines. It's a quick fault to repair as the mechanism assembly comes out easily, also the main

PCB on which the sensors are mounted. A quick solder up usually cures these symptoms. **M.L.**

### **Hitachi VTM740**

There was no sound recording, though the sound from the previous recording was erased. All that was present with a new recording was tape hiss – and a picture. Scope checks around the XRA7767A audio processor chip IC401 revealed that audio was present at pin 20 but not at pin 25, the record amplifier. The chip was out in no time, and a replacement from a scrap machine was fitted. This made no difference! A record detector stage within the chip is externally decoupled by C408 (4.7 $\mu$ F, 35V) which proved to be the culprit. It had leaked – the smell was a sure clue. **M.L.**

### **Toshiba V228**

The drum speed varied intermittently. When the machine was cold it worked all right. When it was warm, or when the tape was changed, the drum speed would take off at a phenomenal rate. The machine would have to be left to cool down for a while before the drum speed returned to normal.

I found that tapping around the lower drum, and pressure on the main PCB, would instigate the fault. This suggested dry-joint problems on the PCB, but this was not the cause of the fault. It took a while to establish that the cause was the drum stator coil, which is mounted on and soldered to the main PCB. The leads from the coils were not soldered to the pins that are soldered to the PCB: they seemed to be just twisted clumsily around the pins and made very intermittent contact.

A good clean up and soldering secured the connections. Then,

when the coil assembly was remounted on the main PCB, the machine worked normally. **M.L.**

### **Hitachi VTF660**

The blue mute would come on in the E-E mode because the video signal was of low amplitude. In addition the playback picture was very poor. As with most modern VCRs, the video signal path is complicated. But scope checks revealed that the video signal at pin 57 of the HA118203F video/audio processor chip IC201 was poor and crushed. A new chip cured the fault.

It's worth noting that the machine can be run with the deck mechanics removed when there's an E-E fault. As the mode switch is mounted on the main PCB instead of the deck, the VCR won't shut off to standby. Just make sure that the mode switch is in the eject position before you switch on. **M.L.**

### **Panasonic NVFS88**

This S-VHS machine wouldn't accept a cassette. When a tape was inserted it went in but was immediately ejected. Moving the mechanism manually proved that there wasn't a deck problem. I eventually found that the eject button on the control door was stuck down. It was freed by cleaning around the edge of the button. **P.H.**

### **Ferguson FV72LV**

This machine damaged tapes and a check showed that there was no take-up or supply reel rotation. The cause was the pulley, which had split, on the capstan motor. It's not available as a separate item, which makes repair quite expensive. Fortunately most FV6X/FV7X models use the same motor, so I was able to use a pulley from a scrap machine. **P.H.**

### **JVC HRJ715**

This machine was found to be dead after a power cut. The power supply wouldn't start until C12 had been replaced. I used a replacement rated at 105°C. **P.H.**

### **Panasonic NVSD44**

Tapes would sometimes get jammed in this machine. As they wouldn't eject, the customer had tried to 'fix' the problem himself. Fortunately he hadn't done any damage. The coupling on the mechanism motor was in good condition, and the mechanism worked reliably when driven by hand. The cause of the trouble was the mode switch,

which was heavily contaminated with oil. A replacement switch cured this intermittent problem. **P.H.**

### **JVC HRS6800**

This S-VHS machine produced a snowy display, with a crease line sometimes present in the picture. I was told that cleaning improved matters, but found that with both VHS and S-VHS playback there was no output from one video head. A new upper drum was fitted but didn't cure the fault. I then realised my mistake and replaced the 3.3µF surface-mounted capacitor on the drum motor. This cleared the fault. **P.H.**

### **Panasonic NVFS88**

I've found it necessary to replace the complete upper and lower drum assembly in a number of these machines. The symptom has been a loud hum after the machine has been in use for a few minutes. It's intermittent, and usually happens only from cold. The noise gradually gets worse and also affects the picture. The hum can sometimes be stopped or started by gently tapping the deck near the drum.

When the drum comes to rest it's clear that there's something amiss with the bearings, because the drum slows down prematurely with a pronounced rubbing sound. A complete replacement drum unit cures the fault, but it does mean an expensive repair. Don't throw the old unit away, as the motor PCB is not available separately. This does fail and is easy to replace. The upper drum is also useful as a cheap alternative to a new one. **P.H.**

### **Sharp VCM321**

This machine didn't erase the previous sound track. Investigation showed that the cause of the fault was the DTC323TK transistor Q652, which was open-circuit. It's a surface-mounted digital transistor that turns on the bias oscillator transistor Q651 by connecting its emitter to chassis. **M.Dr.**

### **Mitsubishi HSB12**

The playback picture was good but the E-E picture was very poor, with weak sync. The cause of the fault was C2X2 (10µF) which is located near the booster module, right in the corner of the PCB. **C.W.**

### **Bush VCR8150**

This VCR had an intermittent fault that eventually became permanent, loss of erase bias. The machine had

sometimes recorded the sound with gaps in it, leaving the previous sound in the gaps. This situation had become worse, until there was no sound recording and the picture was marred by flickering colour produced by previous video information that should have been erased.

Checks on these mid-mount units are not easy, as the deck is not secured to the PCB when it's removed from the case. I decided to remove the deck and the supply to the erase bias circuit. I then fed this circuit from a 12V bench supply. A scope check showed that the oscillator ran for a second then stopped. The culprit was C410 (47µF, 16V). Normal operation was obtained once this capacitor had been replaced. **C.W.**

### **Ferguson FV201LV**

This VCR would sometimes work. At other times it would accept a tape then make a few odd noises. On inspection I found that the head drum didn't rotate when the fault was present – it just jerked a few times. The cause was not stiffness but the fact that the tachometer detector GT001 was dry-jointed. **C.W.**

### **LG P434I**

There were various peculiar faults with this machine. In particular when play was selected the E-E picture was still present but was dim and rolled. If another function was tried, such as search or still, the off-tape picture appeared briefly then the E-E picture returned. When stop was pressed the E-E picture became clear again. If you get this problem, replace CP19 (1,000µF, 10V) in the power supply. **C.W.**

### **Panasonic NVG21**

This machine would occasionally switch itself on, then not switch off. In addition the stations were sometimes not there. Normal operation was restored by replacing all the electrolytic capacitors on the secondary side of the power supply. **C.W.**

### **Salora SV601**

This VCR was suffering from the effects of liquid spillage. I cleaned the board thoroughly then replaced the M5218L chip, which was badly corroded. After that the machine worked, but there was no audio erase bias. This fault was cured by replacing the audio erase coil. A new damper arm and mode switch completed the repair. **M.M.**



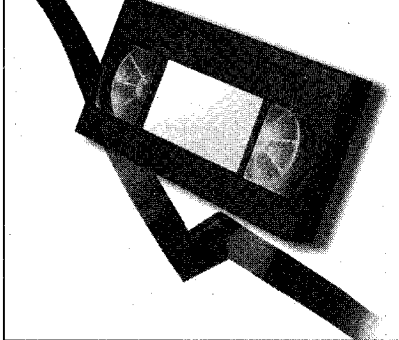

# VCR Clinic

**Reports from**  
**Eugene Trundle**  
**Maurice Kerry**  
**John Edwards**  
**Michael Maurice**  
**Gerry Mumford**  
**Nigel Burton**  
**Bob McClenning**  
**Paul Smith and**  
**Adrian Spriddell**

## **Hitachi VTF550E etc**

Other Hitachi models that use this deck could suffer from the same fault, which can produce several symptoms: groaning or squealing in the play, record and fast-transport modes; and intermittent shut-down at any time, often trapping a cassette in the machine. The culprit is the capstan motor. It's best to fit a new one, though you may find that careful dismantling and lubrication is successful. E.T.

## **Aiwa VXT1420**

A broad noise bar could be seen during playback, even with a known good recording, and tracking adjustment wouldn't move it. The cure was to replace IC102, an XL24C04 EPROM that had to be obtained from Aiwa. Auto head switching set-up could then be carried out as follows: in the play mode, press volume down and channel 5 on the remote control unit to set tracking centre, then press volume down and channel 3 to set the head switching.

This is of course a TV/VCR combi unit. M.K.

## **Mitsubishi HSB10**

Tape playback was OK, but in the E-E mode there was a blank screen and no sound – as if the machine was in the external or AV mode, which it wasn't. The tuner's 12V supply was present, and setting the VCR to channel search produced the correct ramp voltage at the tuning pin. A scope check at pin 18

(video output) of the M51496 vision and sound IF chip while scanning through the channels produced very brief bursts of composite video. It seemed that something was wrong with the control of the tuner, and a check at pin 17 (AGC output) of the M51496 chip produced the clue. The reading was 0V – the tuner's gain was being switched off. As a further check I connected the tuner's AGC pin to a 6V DC source instead. Up came a picture – not a good one, and in monochrome, but a picture nevertheless.

I decided to replace all the components that would affect control of the tuner by the chip: the 4.7 $\mu$ F AGC reservoir capacitor C02, the 4.7k $\Omega$  AGC feed resistor R02, the 12k $\Omega$  resistor (R105) that connects the AGC preset to the 9V supply and the preset itself. As preliminary checks had indicated that the fault was tap-sensitive, I resoldered the chip's pins then scraped and tinned the numerous very fine print tracks to them. When I switched on again sound and a good, stable picture were present. No amount of tapping interfered with it, and a two-day soak test confirmed that all was now OK. J.E.

## **ITT VR3907/Samsung VI611**

The problem with this machine was that it couldn't be switched off. The standby LED remained on all the time, as did the channel indicator. Q2 (2SA634) in the power supply was short-circuit. It's a pnp device and a TIP42A proved to be a suitable replacement. J.E.

## **Panasonic NVSD100**

There were two faults with this machine: first intermittent failure to accept and/or load an accepted cassette; secondly very poor E-E and record pictures. The first was dealt with by replacing the loading motor's plastic coupling, the worm wheel (most of its inner teeth were chewed), and the main unit which

was cracked in two places – it's sometimes called a plate assembly.

The cause of the poor pictures was the chrominance/luminance module, in which the video signal was being distorted (the sync pulses were being crushed). Most of the processing is carried out within a thick-film unit, which is usually not repairable and is also expensive. The service manual does not give component reference numbers within this unit but does provide a circuit diagram. Replacement of a 3.3 $\mu$ F, 50V surface-mounted capacitor within this unit cured the fault. The replacement was not easy. M.M.

## **Pye DV291/Philips VR6290**

It didn't take too much to restore this dead machine to life. I had to replace the chopper transistor, optocoupler and the surge-limiter resistor. M.M.

## **JVC HRJ610**

The complaint with this machine was that the E-E and record video would blank out intermittently. When I got it back to the workshop it was dead. Once C12 (2.2 $\mu$ F, 63V) in the power supply had been replaced the machine worked and I was able to tackle the original fault.

Video muting is carried out in these machines by feeding a video signal from the IF module to a 15.625kHz tuned circuit, rectifying the output and using the DC thus obtained to switch a transistor on or off. As the transistor wasn't getting enough drive, it was switching on and off at random. A comparison check with another machine that uses a similar IF module revealed that the video output to the muting circuit was low. The manual for the HRJ610 doesn't show the circuit of the IF module. But I had a circuit for a similar, discrete component module that's used in Model HRD910. Reference to this suggested a check on C206 (0.1 $\mu$ F, 50V), which proved to have gone low in

value (0.03 $\mu$ F). A replacement restored correct operation of the muting circuit. **M.M.**

### **Ferguson FV32L**

This machine performed faultlessly during my first call, much to the embarrassment of its owner. On my second visit she told me that she had to reset the clock, which was a very helpful clue. The back-up battery was dead. A replacement cured the various complaints – after reprogramming the relevant data. **M.M.**

### **Sony SLVE280UX**

The original complaint had been intermittent stopping while in play or record. By the time the machine reached me it was dead. I found that fuse PR512 was open-circuit, but couldn't find any cause for its failure. A new fuse restored normal operation, and a long soak test proved that the intermittent stopping had been cured. **M.M.**

### **Panasonic NVJ700AM**

This multi-standard VCR was dead – there was just a squeal from the power supply. The usual cause of this is the 1 $\mu$ F, 400V start-up capacitor, which goes open-circuit. Not this time however. There was a dead short on the secondary side of the power supply, the cause being C49 (0.1 $\mu$ F, 100V). A replacement cleared the short and restored normal operation. **M.M.**

### **Matsui VP9506**

The owner complained that there was a wide grey band at the bottom of the picture. For some strange reason the head switching point was way out. Resetting it cured the fault. **M.M.**

### **Sanyo VHR335E**

There was no playback colour, though recordings made by the machine were played back in colour by another VCR. Most of the video processing is carried out within the LA7345M chip IC101, but the playback chroma signal path can be checked by connecting an oscilloscope to pins 20 and 22. Between these pins the signal passes through comb filter DL101 and a 5.7MHz trap that consists of L1010, C1058, L1008 and a couple of resistors. The output at pin 3 of the comb filter was being pulled low by L1008. This 15 $\mu$ H choke produced a short reading of 0.5 $\Omega$  – a new choke should read 1.7 $\Omega$ . A replacement cured the fault. **G.M.**

### **Philips VR675**

This machine would accept a cas-

sette, lace up but then immediately unlace and eject the cassette. The cause of the trouble was obvious once the deck had been removed. The INIT microswitch 1460 on the right-hand side of the PCB under the deck was jammed in the on position – its tongue had become pushed back and down. Freeing it cured the fault. **G.M.**

### **Philips VR6591/75**

If the complaint is noisy E-E audio, replace C16 (0.47 $\mu$ F, 50V), C23 (2.2 $\mu$ F, 50V), C29 (47 $\mu$ F, 16V) and C42 (1 $\mu$ F, 50V) on the IF PCB. Also check for dry-joints at the 5V regulator IC75. **N.B.**

### **Sony SLV353**

This machine wouldn't erase tapes despite a healthy bias being present at the full-erase head, which was OK. I cured the problem by removing the connectors and hard wiring instead. **N.B.**

### **Toshiba V321B**

It looked very much as if the drum motor was useless, as it was very unstable. Cleaning the dust off the optocoupler and the 'windows' on the head disc restored normal operation however. **B.McC.**

### **Akura VX110**

This VCR wouldn't accept a cassette. If one was loaded manually however it could be ejected. A series of function tests showed that the loading motor would turn in only one direction. Voltage checks at the mode switch revealed that the highest reading was only 1.7V. When I traced the 5V rail back to the power supply I came to D702 which was open-circuit.

This diode is about 3cm behind the surface-mounted system control IC. **P.S.**

### **LG T263i**

On eject, a loop of tape would be left protruding from the cassette. The supply spool didn't rotate during the unload sequence because the idler-arm assembly (item 072) didn't swing across to it. A new idler cured the fault.

As a temporary measure, or to prove that the idler is faulty, press in the brass pin at the centre of the assembly. This increases the resistance of the cogs in relation to each other. **P.S.**

### **Daewoo DVK985P**

This machine wouldn't accept a cassette until the loading motor was tweaked by hand. After doing this all

functions operated normally until the cassette was ejected, when the mechanism would again jam. The cause of the problem was the master cam gear, which had rough grooves on its underside.

When a replacement had been fitted I noticed that the loading motor turns back slightly at the end of the unload sequence, thus resetting the mechanism ready for the next cassette. **P.S.**

### **Goodmans GVR3400**

This machine came in for a head clean but had a more serious fault. One head seemed to drop out half way through every test recording. Freezing two of the disc capacitors in the head amplifier module cured the fault for several minutes, but fitting replacements had no lasting effect. I eventually traced the cause of the fault to a dodgy AN331YK IC. **A.S.**

### **Ferguson FV62LV**

This machine was dead because of trouble in the power supply. The following items had to be replaced to get the machine working again: CP05/6/7 (all 1 $\mu$ F, 50V); CP10 (10 $\mu$ F, 50V); TP91 (2SA1020); and RP91 (1.5 $\Omega$ ). **A.S.**

### **Panasonic NVFS90B**

The complaint was no playback sound. This was not quite accurate: there was sound, but only for a second or so; and, after failing, it could be restored by putting the deck into reverse search then back into play. The counter was also erratic, working in fast wind but tending to freeze during standard play.

Having waded through much of the sound and system control circuitry I eventually found that C2311 on the servo card had fallen in value from 1 $\mu$ F to 10nF. As a result the microcontroller chip IC6001 pulled down the mute lines from pins 12 and 14 to the main audio chip IC4501, via pin 65. **A.S.**

### **Ferguson FV50**

This VCR was brought to us to have the pause button disconnected. When we questioned the customer he said "the pause light always comes on when you try to record". We tried this and found that it did. But it's supposed to – it's a cue function.

We were also asked to supply a new remote control unit as the original one "had failed". The VCR was first tried with our programmable workshop remote control unit. We got no results until a new U2505 chip had been fitted on the timer card. **A.S.**

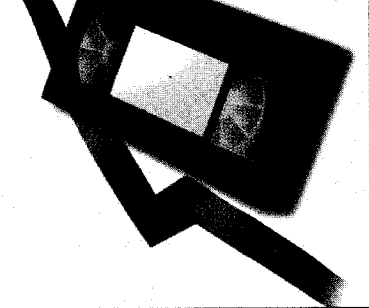

# VCR Clinic

Reports from  
**Pete Gurney, LCGI**  
**Kevin Green, TMIE**  
**Roger F. White, TMIE**  
and **John Coombes**

## **Sony SLV720B**

This centre-deck machine refused to accept a tape and powered down when an attempt was made to load one. A check on the supply rails revealed that the MTR 12V supply was missing. The 2SB733 regulator transistor Q602 had a visible crack through it, and the surrounding board was discoloured. As a check on the resistance of the motor supply showed that everything seemed to be OK, I assumed that the transistor had suffered over a period of time before it died, hence the board discoloration.

I fitted a replacement transistor and powered the VCR. The MTR 12V supply was now present, but when a tape was inserted it immediately died with the transistor again splitting in half. It was difficult to locate the cause of the trouble, as no low-resistance paths were present. The 12V rail has a convenient link however, next to Q602. I removed it and fitted a 10Ω resistor to reduce the current flow. Q602 was again replaced and a tape was inserted.

The voltage on the motor side of the added resistor immediately fell to nearly zero, but this time the regulator transistor survived. Unfortunately the MTR 12V rail feeds three motors, capstan, drum and loading. They are all inaccessible when the deck is mated to the PCB. To establish which motor was causing the trouble I had to disconnect each one in turn, reassemble the deck, and load a tape to check for the presence

of the 12V supply. The culprit was eventually found to be the capstan motor. Although it showed no measurable shorts, a replacement cured the fault.

It's advisable to shop around for these motors, as the price seems to vary by as much as £30. P.G.

## **Sanyo TLS924**

Intermittent shut-down was the complaint with this time-lapse machine. It has a built-in self-diagnosis system, which at least gives a clue as to the probable area in which the fault lies. In this case the error code was E3, which indicates failure of the capstan motor to rotate. These motors rarely give trouble because of an electrical problem, and the cause of the fault was quickly traced to the upper capstan bearings. These have a habit of seizing up intermittently as they disintegrate.

A good check on the state of the upper bearings is to attempt to move the capstan motor shaft from side to side. In this case I found that there was about an eighth of an inch of movement. Replacement bearings are available from Sanyo agents Charles Hyde and Son, under part no. 11930HP. Fitting replacements and a 1,000 hour service kit completed the repair. P.G.

## **Panasonic NVSD400**

There was no video or audio at either the scart connector or the RF output. When I took the machine apart I found coins of the realm rolling around under the PCB. After many checks the cause of the trouble was found to be the failure of a couple of surface-mounted components, Q3003 and R3028. K.G.

## **Akai VS485**

The capstan motor wouldn't rotate in play but was OK in the fast forward and search modes. It's fed from the 12V supply for normal playback/

record but has a higher supply for FF and rewind. The cause of the fault was traced to diode D206, which is by socket WP201 on the main PCB. R.F.W.

## **Hitachi VTF250**

I had two of these machines with the same fault in a single week. Capstan motor operation was very weak. The 14V supply was low because C12 and C13 were faulty. R.F.W.

## **Sanyo VHR774**

The complaint was poor rewind, so I ordered and fitted new belts and a mecha state switch. The fault was still present of course. I eventually discovered that a small piece of plastic was massing from the chassis moulding under the take-up spool. It's part of the mechanism that selects clutch or direct drive to the spools – so the machine was trying to rewind via the take-up clutch. As a full repair would have been uneconomic, I glued a small piece of plastic in place with epoxy. Fortunately this worked. R.F.W.

## **Sony SLVE220UB**

Intermittent cutting out is a complaint you can get with this machine. It can be very intermittent indeed. The cause is circuit protector PR501, which goes high-resistance. A replacement will restore normal operation. J.C.

## **Toshiba V729B**

If the playback picture is marred by dots and dashes, check the brass earth spring at the back of the deck. To prove the point, clean the spring and increase its tension. This should restore correct playback.

Toshiba has a modification kit however. This involves soldering a link from deck earth to the spring (see page 411, May issue of *Television*). It eliminates the fault completely. J.C.

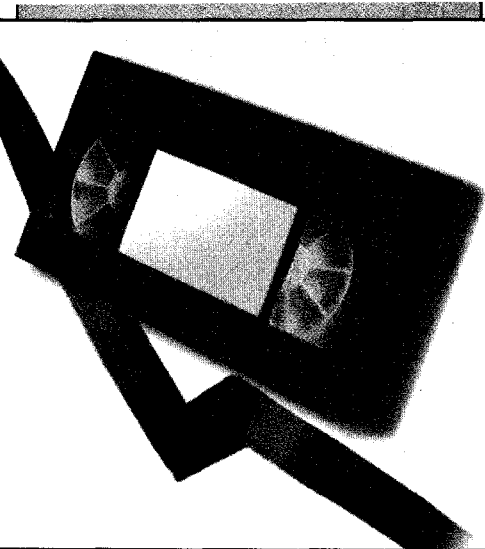

## VCR CLINIC

Reports from

Ian Bowden

Denis Foley

John Coombes

John Edwards

P.J. Roberts and

Michael Maurice

### Panasonic NVHD640

The complaint was that this machine cut out when it went into rewind or review. When I checked it there were no problems for many hours. Then I noticed that there was loss of reel drive shortly after going into the review mode. Watching the large mode cam as the mechanism changed from play to review, I saw that when the fault occurred the cam didn't move as far in the clockwise direction as it should have done before moving back anti-clockwise.

I had a look at the mode switch, which in these Z mechanism machines is soldered to the main PCB. When I unsoldered it one end leg that had been bent over during production fell off.

Once a new mode switch had been fitted the machine worked perfectly. Either the mode switch had been faulty or the leg had separated as a result of slight switch movement when driven by the mechanism. This is the first Panasonic deck I've come across in which the switch isn't screwed securely to the mechanism. I.B.

### Hitachi VTM620E

There was no playback audio. No hum or buzz was produced when the audio head leads were touched, but there was hum when I probed around pins 21 and 23 of the audio record/playback chip IC401. These pins are after the playback equalising amplifier section. A DC check at the IC's input pin 15 produced a reading of about 0V instead of the correct 2.3V. The cause was the 560pF capacitor C480, which produced a resistance reading of about 100Ω. It had been corroded by leakage from C402, a 1μF, 50V electrolytic that's mounted next to it on the PCB. A clean up and new capacitors restored the playback sound. I.B.

### Aiwa HVGX500K

The complaint with this machine was failure to rewind. It worked fine for several hours, but then started to fail fairly frequently, normally when going from play to the review modes. The machine would power off, after which the mains supply had to be disconnected then reconnected to get it going again. It also failed when going from stop to rewind, as reported.

As the fault appeared to be mode related I had a look at the mode switch, which is part of the mechanism connection PCB on the underside of the deck. It looked like new, with no sign of tarnishing of the PCB part or the moving

fingers inside the plastic holder. I cleaned it anyway, after which the machine appeared to work all right.

During a soak test however it failed again, just once as before. When I called Aiwa technical I was told that the switch should be replaced even though it looked fine. A new switch cured the problem. I.B.

### Hitachi VTM640E and VTM622E

If the capstan motor operates in the fast forward and rewind modes but not during playback or record, try replacing C626 and C627 which are both 47μF, 16V electrolytics. They are reference voltage components for the pulse amplifier chip IC602. D.F.

### Sanyo VHR4350

The cause of damaged tapes can be a faulty mode switch. If not and there's a tape loop when the cassette is ejected, check the brake pads and capstan flywheel. Also replace the brake arm. J.C.

### Toshiba V726B/V727B

No results can be caused by faulty capacitors. Check CP007 (10μF, 50V) and/or CP008 (100μF, 25V) by replacement.

If the display is dim check CP041 (220μF, 10V) in the power supply. It can go low in value. J.C.

### Akai VSG745E

Failure to accept tapes can be caused by a misaligned or faulty mode switch. Another possible cause is the arm loading block, which may be broken or bent. Check it by replacement. J.C.

### Toshiba V204B

Sound variation is a complaint you sometimes get with these machines. The cause is usually worn take-up or supply spools, which cause intermittent tape speed variation. Check by replacing them both. J.C.

### Hitachi VTM622E

A high-pitched whistle could be heard in the E-E mode, along with normal sound. The off-tape picture appeared when playback was selected, but the E-E sound was still present. So was the whistle. When a finger was placed in close proximity to the case of the LA7295 audio chip IC401 the intensity of the whistle increased.

Scope checks at the output pins of the chip revealed that the audio waveform was riding on an HF oscillation. Normal

sound and mode switching were restored when a new IC had been fitted. **J.E.**

### Grundig GV469M

This machine was brought in because it was dead. I inspected the power supply and found that the majority of components were dry-jointed. But the machine still wouldn't come on after attending to the dry-joints. The cause of the trouble was C136 (1µF, 400V). **P.J.R.**

### LG N311

There was no record or playback colour. It didn't take long to find the cause – someone had removed the 4.43MHz crystal X301. A replacement restored the colour. You would get the same symptoms with a defective or dry-jointed crystal, so it's worth checking this item.

Unfortunately it is not listed in the manual. A suitable replacement is available from CPC however, order code SCC4103. **P.J.R.**

### Ferguson FV62LV

This VCR was completely dead with the fuse intact. We don't see many of these

Thomson-based machines, so I'm not familiar with the power supply layout. It's a chopper circuit with a load of electrolytic capacitors waiting to dry up and fail. I decided to replace all those on the primary side of the circuit: CP05, CP06 and CP07, all 1µF, 50V, and CP10 which is 10µF, 50V. They are all 105°C types. Once this had been done and several dry-joints had been attended to all was well. **P.J.R.**

### Panasonic NVFS90B

There was no RF through to the TV set. The cause was not a loose RF output socket as the customer suggested but dry-joints at the sub-PCB's connector to the motherboard. **M.M.**

### Toshiba V804

This VCR had received attention from the local rip-off merchant, who had charged £100 for changing the heads. In fact he had cleaned them and removed the head cleaner. The machine was now jammed, because the supply guide's gear was out of sync with the load bar. Toshiba has a kit that consists of the gear, bar and a split

washer. The repair consisted of fitting these items, a new head cleaner and some missing screws. **M.M.**

### Hitachi VTM930

When this machine was powered up the cassette carriage would immediately try to move forward even without a tape. If a cassette was inserted before powering up, the tape would fully lace but no other functions worked – except eject. The BOT sensor doubles as a tape-in sensor. When I removed it I found that one leg was broken near the PCB. Repairing this lead cured the fault. **M.M.**

### Mitsubishi HS651V

Very occasionally this machine would leave a loop of tape when the cassette was ejected. The cure was to fit a new mode switch. **M.M.**

### JVC HRJ625EK

This machine was jammed. I couldn't see any damage but decided to replace the control cam, control plate and mode switch. Once the deck had been realigned all was well. **M.M.**

### How to pay

(VCR Fault Finding Guide) paperback

I enclose a cheque/bank draft for £ \_\_\_\_\_  
(payable to Reed Business Information)

Please charge my credit/charge card

Mastercard  American Express  Visa  Diners Club

Credit Card No: \_\_\_\_\_ Expiry Date: \_\_\_\_\_

Signature of Cardholder: \_\_\_\_\_

Cardholder's statement address: (please use capitals)

Name \_\_\_\_\_

Address \_\_\_\_\_  
\_\_\_\_\_  
\_\_\_\_\_

Post Code \_\_\_\_\_ Tel: \_\_\_\_\_

Television magazine's VCR Clinic column is a unique forum for practical servicing tips, with the UK's leading service engineers and servicing writers contributing their observations and recommendations month by month. But try finding those faults reports for the Amstrad XYZ123 that's on your bench. Even with an index you will be chasing through a pile of magazines... until now. Peter Marlow's VCR Fault Finding Guide is a distillation of the most used fault reports from 11 years of Television magazine. Arranged by make and model the information is extremely easy to access, and the book is a convenient size for the bench or to carry with you. This will undoubtedly become one of the service engineer's most useful tools. Unlike other fault guides, this one is based on top quality information from leading authorities, and genuine repair case studies. This is real-life servicing information, not just a compilation of manufacturers' manuals.

Approximately 2,000 reports on 193 models from 35 different manufacturers Instant on-the-spot diagnosis and repair advice Television magazine's leading writers' wit and wisdom available for the first time in book form

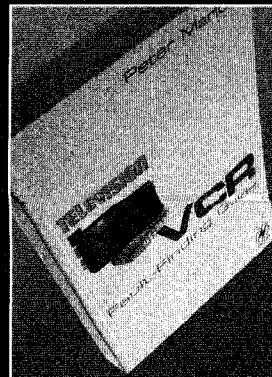

### VCR Fault Finding Guide

Peter Marlow

This book is an essential repair tool, not just another volume for the shelf

Pages: 464pp

Price: £22.50



## VCR CLINIC

Reports from  
**Eugene Trundle**  
**Mike Leach**  
**Ronnie Boag**  
**Paul Smith**  
**Derek Bogicin**  
**P.J. Roberts and**  
**Pete Gurney, LCGI**

### **Sony SLVSE70 etc**

If you find that there's a tape chewed or jammed in the fully loaded position with the loading motor stalled, followed by machine shut down, check the 'press block assembly, pinch' whose cam-follower shaft has probably snapped off. The part number is A6759-615-A.

This note applies to all Sony VCRs that use the S mechanism. **E.T.**

### **Mitsubishi HS550V**

Playback pictures were fine, but recordings made by this machine played back in black and white – the record colour-under signal was missing. The cause turned out to be a hairline crack on the PCB between TP2N and R2D1. **E.T.**

### **Sharp VCMH711**

The complaint was no results with no display. It turned out to be an interesting fault. The cause was Q704, a surface-mounted transistor. One of its legs had never been soldered. **M.L.**

### **Toshiba V854B**

This machine was dead with no front display and no motor functions. Voltage checks showed that the 12.5V input at pin 1 of the AN7805F 5V regulator IC598 was missing. The 18Ω safety resistor R591 in the supply line was open-circuit. I expected the replacement to blow at switch on, but all was OK: the old resistor had simply failed. **M.L.**

### **Samsung SV213**

The complaint with this machine was that it would intermittently revert to standby. The cause was found to be dry-joints at the end sensors. **R.B.**

### **Tatung TVR844N**

This machine wouldn't load properly and left tape out of the cassette on eject. The cure was to replace the back-tension band. **R.B.**

### **Akai VSG878**

This VCR was dead and I found that TR1 in the power supply was short-circuit. The other items that had to be replaced were D1-4, R2, R3, C13 and TR2. **R.B.**

### **Sony SLVE720**

This VCR wouldn't accept tapes. The cure was to replace the mode-state switch. **R.B.**

### **JVC HRS9500**

There was tape spilling when stop was pressed in the fast-forward or rewind mode. The items I had to replace to cure the fault were: the main brake (S) assem-

bly, part no. LP40110.002H; and the main brake (T), part no. LP40111-002C. **R.B.**

### **Ferguson FV61LV**

The complaint with this VCR was intermittent shut down during record or playback. We tested it for several days before the fault put in an appearance. When it did I noticed that the drum slowed and eventually stopped. The fault was cured by resoldering BT02 on the lower PCB.

If you need to alter the output frequency of the RF modulator in one of these machines, the procedure is as follows. Hold down the remote control unit's green or B button for eight seconds. The display will then show the current channel used for the output, usually ch. 60. Press the + button to select a new channel, then press the exit or E button to store the channel. If you need to fine tune the new frequency, use the tracking + or – while the machine is in the RF mode. **P.S.**

### **Samsung VI710**

There were two faults with this machine: a blank screen during E-E operation, as if the machine was in auxiliary mode, and no playback sound. Voltage checks at connector CN101 proved that the power supply was OK. When I moved on to CN301 I discovered that the PC 9V supply at pin 2 was low at only 4.3V. This voltage originates from the KSC2328Y transistor Q109, which was open-circuit. A replacement cured both faults. **P.S.**

### **Amstrad UF30**

This VCR was dead with the internal 1.6A fuse blown. Meter checks showed that Q1002 (2SC4517) was short-circuit and Q1001 (2SC4204) open-circuit. No other faults could be found. Two replacement transistors and a new fuse restored normal operation. **P.S.**

### **Akai VSG24EK**

The reported fault with this machine was "not taking a cassette". I loaded one manually and checked the functions. Almost everything worked well, but during rewind the sensor failed to recognise that tape end had been reached. Once the take-up photo-sensor D2 on the PCB under the deck had been replaced the VCR accepted tapes and worked normally. **P.S.**

### **Panasonic NVDA1**

This camcorder's manual focusing didn't work. It's done by turning a focus ring at the front of the lens, movement being detected by two photo-interrupters. I soon found that while one phototransistor switched on and off as the ring was turned

the other one didn't. There was a 10kΩ leak across its collector and emitter, so the output was always high. The opto-interrupter itself was fine.

The leak between the feed to the collector of the non-operative phototransistor and the sensing output back from its emitter was in the FPC between the camera operation unit and the front CBA. It's one of those opaque blue ones, and a visible black spot could be seen between the two adjacent lines. Correct operation was restored once a new FPC had been fitted. **D.B.**

### Panasonic NVJ45

All functions operated correctly except rewind search. If this was selected the machine would stop, unthread the tape and select the rewind mode. The reel sensors and reel table encoders were checked and found to be OK. The cause of the trouble was found to be the mode switch. I went for this item last as it had been replaced recently during a full service. The part number of the mode switch is VSS0175A. **P.J.R.**

### Sony SLV715UB

There was no power though the fuse was OK. When I inspected the power supply I

found a mass of dry-joints and capacitor leakage. If you get this problem it's necessary to replace all the electrolytic capacitors on the secondary side of the power supply: Sony has a kit of the capacitors required (part no. A-675-957-4A).

Once the electrolyte had been cleaned from the PCB, the new capacitors had been fitted and the dry-joints had been attended to the machine worked. A new pinch roller and general service completed the repair. **P.J.R.**

### Hitachi VTF150E

This machine appeared to be dead, with no display and a laced-up tape stuck inside. I made some quick checks at the power supply connector PG1. It's quite common for the power supply in these machines to shut down because of faulty capacitors on the primary side of the circuit. In this case however the power supply was working but there was no -30V output at pin 3 of the connector. This supply feeds the display unit and has to be present for other functions to work.

There are only a few components in the -30V supply. Rectifier diode D11 and the fusible resistor R36 were both OK, and

there was a waveform at the diode. The cause of the trouble was eventually found to be the chopper transformer, which had developed high resistance between pins 11 and 12. This is the end of a large winding that also provides feeds for the 14V and 44V rails. When I removed the transformer and examined the connections to the pins I found that almost all of them were dry. Some looked as if they had never been soldered.

Resoldering the pins cured the fault, restoring the -30V supply and enabling the machine to initialise again. In the interests of reliability I replaced all the electrolytic capacitors in the power supply. **P.G.**

### Fidelity VCR4000

This problem is becoming quite common with these budget-price machines. The symptoms are tape chewing with no rotation of the take-up spool. When the deck is removed you will usually find that the capstan belt pulley has parted company with the flywheel. Careful application of Araldite provides a permanent cure. I dread to think of the cost of a motor assembly in comparison with the price of the machine. **P.G.**

### How to pay

(VCR Fault Finding Guide) paperback

I enclose a cheque/bank draft for £ \_\_\_\_\_  
(payable to Reed Business Information)

Please charge my credit/charge card

Mastercard  American Express  Visa  Diners Club

Credit Card No: \_\_\_\_\_ Expiry Date: \_\_\_\_\_

Signature of Cardholder \_\_\_\_\_

Cardholder's statement address: (please use capitals)

Name \_\_\_\_\_

Address \_\_\_\_\_  
\_\_\_\_\_  
\_\_\_\_\_

Post Code \_\_\_\_\_ Tel: \_\_\_\_\_

Television magazine's VCR Clinic column is a unique forum for practical servicing tips, with the UK's leading service engineers and servicing writers contributing their observations and recommendations month by month. But try finding those faults reports for the Amstrad XYZ123 that's on your bench. Even with an index you will be chasing through a pile of magazines... until now. Peter Marlow's VCR Fault Finding Guide is a distillation of the most used fault reports from 11 years of Television magazine. Arranged by make and model the information is extremely easy to access, and the book is a convenient size for the bench or to carry with you. This will undoubtedly become one of the service engineer's most useful tools. Unlike other fault guides, this one is based on top quality information from leading authorities, and genuine repair case studies. This is real-life servicing information, not just a compilation of manufacturers' manuals.

Approximately 2,000 reports on 193 models from 35 different manufacturers Instant on-the-spot diagnosis and repair advice Television magazine's leading writers' wit and wisdom available for the first time in book form

**Post your completed order form to:  
Jackie Lowe, Room L514, Quadrant  
House, The Quadrant, Sutton, Surrey,  
SM2 5AS**

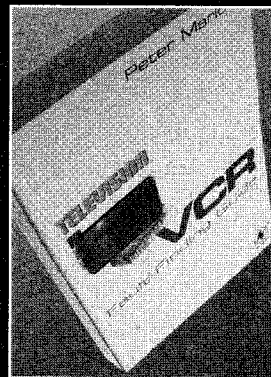

### VCR Fault Finding Guide

Peter Marlow

**This book is an essential repair tool, not just another volume for the shelf**

Pages: 464pp

Price: £22.50

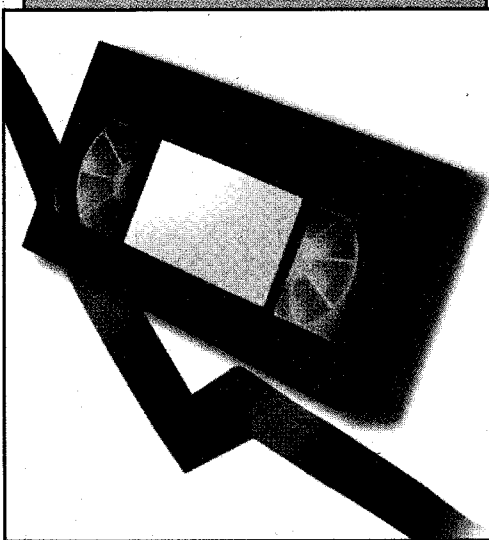

## VCR CLINIC

Reports from  
**Eugene Trundle**  
**Ian Bowden**  
**Pete Gurney, LCGI**  
**Michael Maurice**  
**Steven Leatherbarrow**  
**Paul Smith and**  
**Giles Pilbrow**

### **Philips VR241 etc (Turbo deck)**

This machine, badged **Bang & Olufsen**, was fitted with the Philips Turbo deck. It wouldn't eject the tape. Nor, when the cassette had been wound out by hand, would it accept one. If the tape was wound in by hand all the way however the machine would play and record. The plastic lens/prism above the central cassette LED had broken off. It's available only as part of Kit G, which is part no. 4822 310 31961. **E.T.**

### **Sony SLVE250**

This machine was accused of damaging tapes because it left a loop out during eject. It behaved itself for two days, then caught a loop of tape as described. I found that the supply reel was intermittently sticking to the back-tension regulator band, whose felt strip had come unstuck from its plastic backing. **E.T.**

### **Thorn VR426NVA**

We've had two of these VCRs in recently, both with the same fault: a fully-laced tape was stuck inside and the machine went back to standby a few seconds after being switched on. In both cases the always +13V supply was missing because one end of D5110, in the power supply section, had not been soldered properly in production. You could well get this fault on an intermittent basis.

The machines are made by **Sanyo** and are similar to the VHR275E, also the **Sony SLVE200/250**. **E.T.**

### **Sony SLVE200UX**

The reported symptom was no picture or menus. When playback was tried with a scart connection there was sound but no picture. The machine produced an RF output, but my sweep-tune monitor TV would not stop at it. All the mechanical functions worked, but the tuner channel couldn't be changed from preset 1. Checks in the power supply area revealed that there was no +36V supply for the tuner section. Rectifier diode D5103 was found to be leaky, and as a result fusible resistor R5110 was open-circuit. Once these two components had been replaced, the reason why you couldn't change channel numbers was seen: the machine was waiting for the user to press execute on the handset to start the auto-tuning procedure. **I.B.**

### **Goodmans VCP650**

The customer said that this machine would not accept tapes. It worked all right for me until I removed the top cover. After that it failed to recognise that a tape was being

inserted. This turned out to be a red herring however. Too much light was reaching the rear of the take-up side tape sensor which, as in many machines, is used – in conjunction with a shutter – to signal tape insertion.

With the sensor covered, the machine worked perfectly for many days until it was heard to shuffle the cassette carrier in and out of its own accord. I then discovered that the output from the supply-side sensor was going high. The voltage at its 0V pin had risen because of a high-resistance connection at the crimp connector between the main and the mech-connection PCB. This is PJ601, pin 1 – the blue wire. It's also the 0V connection to the mode switch. **I.B.**

### **Akai VSA650EK**

The complaint was that any recordings made by this machine produced noise, mainly from the right-hand channel, when played back by another hi-fi VCR. I checked the hi-fi FM envelope with an alignment tape and found that it was perfectly flat. The two carrier frequencies were also correct. When I compared the amplitude of the hi-fi FM envelope during playback of a prerecorded tape with that produced during playback of one of the machine's own recordings I found that it was twice as high.

I tried increasing the hi-fi record current but this made no difference. The cause of the problem was that the luminance record current was too high. I assume that it was partially erasing the hi-fi signal, which is recorded beneath it on the tape. Once the luminance record current had been reduced, the amplitude of the hi-fi playback signal was the same with prerecorded tapes and the machine's own recordings. **I.B.**

### **Sony SLVE520**

The problem with this machine occurred in the record mode only, when it would shut down after a while. Playback was OK. At first the fault took a considerable time to show up. It later became much more frequent. The cause was an old favourite with these machines: the fuse link PR512 had gone high-resistance.

It seems that while the supply rail voltage is adequate for playback the additional current required for the bias oscillator in the record mode increases the voltage drop across PR512 sufficiently to shut the machine down. **P.G.**

### **Panasonic NV850**

The lights flashed and buzzing noises came from the mechanics of this old but well-made machine. There are two 3,300µF



capacitors in the power supply: both were in need of replacement. After that the machine worked and a service completed the repair. **M.M.**

### **Sony SLVE280**

The N25 circuit protector PR512 is a common cause of trouble with these VCRs. In this case the machine would go to standby if either record or timer operation was selected. The customer also complained about poor sound. A new CP cured both faults. **M.M.**

### **JVC HRD910 etc**

If there's poor tracking, usually varying in degree each time a tape is inserted, replace the 3.3 $\mu$ F aluminium electrolytic capacitor on the lower drum PCB assembly. A common fault is that the take-up and supply guides part company with the deck.

These points apply with many HRD series machines. **S.L.**

### **Hitachi VTF150**

The capstan motor operated intermittently and was noisy. This sometimes meant shut down of the VCR. I've had to strip, clean

or replace many bearings in Hitachi and other VCRs, and was a little surprised to find that in this case they were perfect, particularly as the noises suggested otherwise. The cause of the problem was C12 (470 $\mu$ F, 16V) in the power supply. **S.L.**

### **Mitsubishi HS740**

Shut down, caused by failure of the capstan motor to operate (sometimes intermittently), can be caused by dry-joints at the capstan motor connector. **S.L.**

### **Sanyo VHR874E**

If the machine seems to be dead, check the IC protector PR541 which is rated at 1A. I've also had normal playback but failure to record, with the machine shutting down, when this CP's resistance has increased slightly. **S.L.**

### **Goodmans TX1100**

Playback was slow – similar to a standard-play tape moving at the LP speed. A scope check at pin 1 of P501 showed that there was ripple on the 5V supply. The cause was C509 (220 $\mu$ F, 10V), which was low at approximately half its correct value. **P.S.**

### **Matsui VP9405**

This machine was brought in with a tape stuck inside. I had to remove it manually. The machine then accepted a cassette, but played it back at the fast-forward speed for a few seconds then shut down. The tape once again had to be ejected manually. The cause of the trouble was a faulty capstan motor. **P.S.**

### **GoldStar/LG RQ121**

There was no display and the machine wouldn't accept a cassette. Voltage checks around the microcontroller chip IC505 showed that the 5V supply was missing. I traced the source back to D508, which was open-circuit. It's at the centre front of the top PCB. A new 1N4148 diode restored the voltage and normal operation. **P.S.**

### **Sony SLVE920UX**

This machine had no display. All other functions worked normally. The cause of the fault was traced to transistor Q612 in the power supply. It forms part of a power-saving circuit that switches the display off in the standby mode, and was dry-jointed. **G.P.**

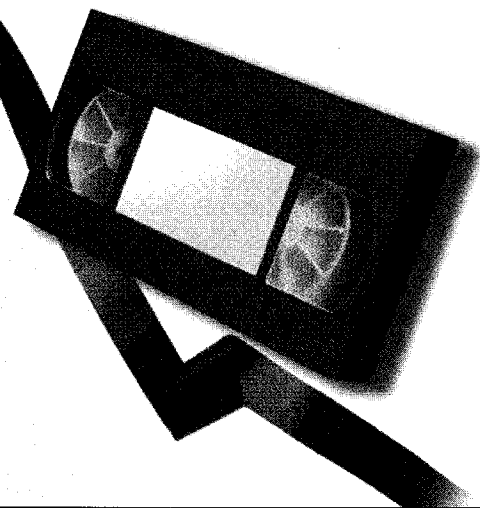

## VCR CLINIC

Reports from  
**Eugene Trundle**  
**Steve Leatherbarrow**  
**Denis Foley**  
**Graham Richards**  
**Paul Smith and**  
**Ronnie Boag**

We welcome fault reports from readers – payment for each report is made on publication. See page 106 for where and how to send reports.

### **Tatung TVR7121**

These machines are fitted with a deck produced by Sharp. It can give capstan-speed problems, including 'pulsing' once per motor revolution. Before you condemn the motor (and hence probably the machine itself!), ensure that the little FG generator block, a four-pin device, is very close to the rim of the flywheel. **E.T.**

### **Mitsubishi HSM54B/59B**

The cause of refusal to fast-forward or rewind a tape can be dry-soldered joints on tarnished connection pins at the brake latching solenoid L570, which is beneath the deck at the front. The fault can be intermittent. **E.T.**

### **Sony SLV757UB**

This machine's playback picture gave the impression that its video heads were dirty or blocked, but I found that a picture of sorts was obtained when the drum was slowed by hand. The symptom was intermittent, generally appearing when the VCR was first switched on. The cause of the trouble turned out to be dry-joints at the drum motor stator's plug/socket. **E.T.**

### **Toshiba V703B**

If there's a dim display, with possibly sluggish operation or tape chewing etc., replace the electrolytic capacitors on the primary side of the power supply unit. The usual cause of trouble is C813 (47 $\mu$ F, 63V) **S.L.**

### **Sharp VCM26**

If the machine is stuck in the child-lock mode and you don't know the pin number, proceed as follows:

- (1) Press and hold the remote-control unit's lock key. The lock symbol appears in the display.
- (2) Press and hold for more than three seconds the remote-control unit's standby key and the standby key at the front of the VCR.

The VCR should shut down and clear the child-lock entry. **S.L.**

### **Philips VR4557/05 (JVC clone)**

The cassette loading mechanism was 'floppy' – it would move in and out with very little effort. The customer's son insisted that it went like this suddenly when he was loading a tape. This part of the mechanism gets its drive from the capstan motor via an intermediate gear (item 74) that JVC calls the change-arm assembly. The arm is held in place by a spring that hides beneath the sliding plate (item 56). The problem was that the small nylon pin on the arm had broken off.

I cheated by fixing the end of the spring

into the nylon arm by application of heat from a hot soldering iron – and an extra dollop of hot nylon. This seems to me to be more secure than the original miserable pin.

Cheats never prosper however. When everything had been reassembled I had no front display and no E-E signals. The switched 5V supply had been removed by the leaf spring beneath the power supply. It's there for connection to the bottom screening plate – and to catch out unsuspecting technicians! I had pushed it into the power supply, but fortunately only CP801, a CN20 circuit protector, had been damaged. A new CP and more careful reassembly left me with a fully working machine.

I'm not sure which is the equivalent JVC model, possibly the HRJ220. **D.F.**

### **Panasonic NVHD600B**

A continual tripping could be heard when this VCR was powered. Cold checks in the power supply led me to the MA185 rectifier diode D1124, which produces the -28V output. Once a replacement had been fitted there was normal operation. The BYD33D or BYD33J is suitable in this position. **G.R.**

### **JVC HRJ610EK**

This VCR was dead. Checks with our Wizard capacitor tester revealed that C12 (2.2 $\mu$ F, 50V) on the primary side of the power supply was open-circuit. The following capacitors on the secondary side were replaced because they produced poor readings: C31 (22 $\mu$ F, 50V), C34 (22 $\mu$ F, 63V), C36 (470 $\mu$ F, 10V) and C38 (0.47 $\mu$ F, 50V). **G.R.**

### **Sanyo VHR766E**

The tape would load but there were no functions. Checks showed that the 12V and 5V (switched) supplies were missing. The culprit was Q513 (2SC4483). A 2SD1207 is a more substantial replacement.

Q1501 can cause the same symptoms. When it fails only the switched 5V supply is removed. It's also a 2SC4483. **G.R.**

### **Orion D1096/D2096**

This machine would intermittently stop, eject the cassette and revert to standby. I thought that the cause of the problem was poor soldered connections to the supply-reel sensor Q1001. The fault was in fact cured by replacing both reel sensors, Q1001 and Q1006. **G.R.**

### **Matsui VP9405**

There was very slow rewind with a clunking sound. It was caused by a defective supply-side clutch assembly. The square-

sided centre shaft starts to slip, then wears down until it becomes almost cylindrical. You can get the same problem with forward wind, when the take-up clutch assembly is defective.

Replacement is the only cure. As this was an economy repair, I used a replacement from a scrap mechanism.

The RF modulator frequency also had to be retuned. The procedure is as follows:

- (1) Switch on the VCR.
- (2) Keep the standby button pressed until the display alters and a test signal appears.
- (3) Use the + or - buttons to set the RF output frequency, as displayed on the clock.
- (4) Press standby again until the display reverts back to the clock. **G.R.**

### **Ferguson FV41R/Toshiba V110B**

There was severe pulling (similar to overloaded video) with E-E pictures and no playback video. Checks around the BA7258AS video processor chip showed that there was perfect video at pin 27 in the play mode but nothing at pin 24. A low-pass filter, circuit reference FN54, is connected between these pins. As a check I bypassed it with a 1 $\mu$ F, 63V electrolytic

capacitor, which restored the video signal. A replacement filter unit, type SEL4230, cured both symptoms. **G.R.**

### **Sharp VCA50**

There was intermittent buzz on playback sound. On investigation I saw that C603 was pressing against the mechanism. Slight repositioning cured the fault. **G.R.**

### **Akai VSF33EK**

The display showed four bars but the machine couldn't be turned on or persuaded to take a cassette. Visual inspection of the bottom PCB revealed dry-joints at TR408, which is near the back-up capacitor. As a result the safety resistor R425 (0.47 $\Omega$ ) had gone open-circuit. A replacement resistor and some resoldering brought the VCR back to life.

Another of these machines had a picture with noise bars on it. The cause was C7 (1,000 $\mu$ F, 16V) in the power supply. Its value was low. **P.S.**

### **Matsui VP9405**

This machine would shut down after about five seconds in any mode. Scope checks revealed that there was no output from the

reel sensor beneath the take-up spool. A replacement cured the fault. **P.S.**

### **Toshiba V726**

This machine came in with the complaint that it was dead. Operation was restored by replacing CP007 (10 $\mu$ F, 50V) and CP008 (100 $\mu$ F, 25V), but the display was dull. This was corrected by replacing CP041 (220 $\mu$ F, 10V). **R.B.**

### **Akai VSG271**

This machine refused to accept tapes. The cause was found to be dry-joints at D402 (LED tower). **R.B.**

### **Samsung SV222**

This machine was dead. When voltage checks were carried out in the power supply I found that capacitor C1SS33 and diode D1SS33 were both faulty. Replacements restored normal operation. **R.B.**

### **Nokia VR3786**

There was no rewind and tape wasn't taken up on eject. The cure was to replace the back-tension band. The old one had come off and the band had stuck to the supply reel. **R.B.**

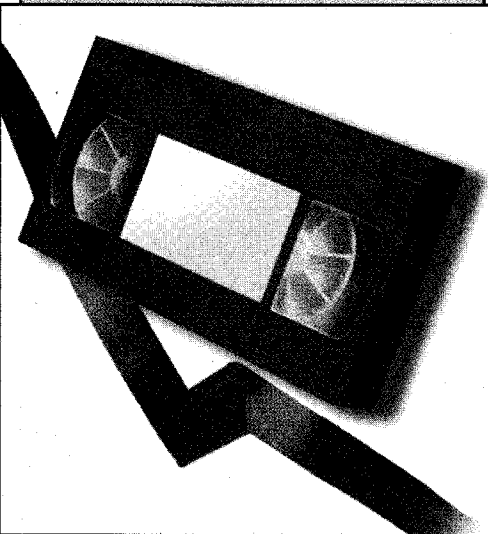

## VCR CLINIC

Reports from  
**Eugene Trundle**  
**Ronnie Boag**  
**David Smith**  
**Paul J. Roberts**  
**Roger Burchett**  
**John Coombes**  
**R.A.F. (Ace TV and Video)**  
**Dave Dulson and**  
**Ian White**

### **Daewoo DVR7372P**

The fault symptom, which was very intermittent, was that of dirty heads during playback, with slow and 'slurred' sound reproduction, even though the front panel proclaimed that the machine was operating in the SP mode. In fact the pinch roller was barely in contact with the tape, because of a faulty mode switch. **E.T.**

### **Panasonic NVSD40**

No-go was the symptom with this machine: the only sign of life was a faint ticking that came from the power supply, at a rate of about one tick per second. Checks showed that there were no shorts or excessive loading. We also found that the power supply

was of the FET chopper type, which is not covered in the main manual. R1120 had risen in value from 560k $\Omega$  to 900k $\Omega$  and R1121 from 820k $\Omega$  to 1M $\Omega$ . To ensure reliability we also replaced C1111 and C1136. **E.T.**

### **Tatung TVR933V etc**

The deck and the electronics used in this and many contemporary Tatung VCRs are made by **Orion**. There is a tendency to erratic mechanical action, one aspect of which is refusal to eject the tape or respond to deck commands. The culprit is the tape-centre LED, which is mounted on the main PCB. I always replace the mode switch at the same time as it can be the cause of similar problems. **E.T.**

### **JVC HRJ220**

This machine refused to accept tapes. The usual cure for this problem is to replace the mode state switch. In this case however the change-arm assembly (part no. PQ46353A-1) also had to be replaced. **R.B.**

### **Finlux VR163NX**

This machine was dead. A new mains bridge-rectifier reservoir capacitor (100 $\mu$ F, 385V) got it going again with no further problems. **R.B.**

### **Sony SLVE280UK**

This machine had been taken two dealers who had said "sorry, can't repair". It played perfectly, but when record was selected it would go into this mode for about fifteen seconds then shut down completely with the display going out. After a second or two it would try to reset and would then behave impeccably until record was again selected.

The cause was that infamous fuse PR512 (1A) in the 5V supply. A resistance check on it produced a reading of about 0.5 $\Omega$ . As a telltale sign the fuse had a slightly discoloured band around the centre. Should PR512 fail completely there will be no operation or display. **D.S.**

### **Grundig GV496M**

This VCR was dead after being unplugged by the customer. With the machine opened up it was just a matter of replacing C136 (1 $\mu$ F, 400V, 105°C) in the power supply and a general resoldering of dry-joints. **P.J.R.**

### **Sharp VCM20**

This machine damaged the top of the tape. The pinch roller was well worn, but a replacement failed to cure the trouble – the tape continued to ride up the fixed guide. Sharp has issued a technical bulletin on set-

ting up the audio/control head on the VCM23 etc. After going through the procedure I found that the problem was no longer present in the play mode but remained in forward search. Further checks revealed that the take-up torque was excessive. A new pulley reel cured that. **R.Bu.**

### **Hitachi VTM740E**

This machine would accept a tape and the playback, record, rewind and fast-forward functions were OK. When eject was pressed however the machine would try to eject then reload. The cause of the problem was traced to the clutch base assembly. The top of the front-loading gear was damaged and there was a loose spring, which prevented movement of the cogs to the correct position for tape ejection. **J.C.**

### **Ferguson FV71LV (R3000 chassis)**

No results with no display usually means faulty capacitors in the power supply. The first items to check are CP007 (100 $\mu$ F, 25V) and CP008 (10 $\mu$ F, 50V). Further possibilities are CP81 (1,200 $\mu$ F, 16V) and CP82 (1,000 $\mu$ F, 16V). Check them all by replacement.

If the capstan doesn't rotate, check whether the plastic pulley on the capstan spindle has fallen off. **J.C.**

### **Hitachi VTF450E**

For an intermittently snowy picture, as if there are low-amplitude or missing CTL pulses, check the condition of the tension band. With this machine the felt had become unstuck, so that only the plastic rested on the supply spool. A replacement restored reliable operation. **J.C.**

### **Toshiba V254B**

You can get very intermittent no results and a dim display with these machines. The item to check is CP041 (220 $\mu$ F), which tends to fall in value. The last time I had the fault CP041 measured 70 $\mu$ F. **J.C.**

### **Panasonic NVSD200**

We've had several complaints about noisy rewind with these machines. First, ensure that the take-up and supply spools rotate freely and are well lubricated. Then, if necessary, check for a broken loading motor bracket and worm wheel gear. Replace as necessary. **J.C.**

### **Akai VSF510**

If there is no playback picture but the sound appears to be OK, check the 5V reference supply at IC201. When D204 is leaky or short-circuit the supply can drop to 4.8V. There is a modification in this

area: a revised diode type and added 750Ω (1/6W) resistor. **J.C.**

### **Daewoo V60**

For failure to start up, check capacitor C53 (1μF) which goes open-circuit. Then if necessary check resistors R51 and R52 (both 390kΩ) which tend to go high in value. **J.C.**

### **Thomson V321**

If there is a loop of tape when a cassette is ejected, check diode D229 (1N4148) by replacement. **J.C.**

### **Goodmans TX4000**

This machine was dead, so I replaced the usual capacitors in the Sony-made power supply. As this failed to cure the problem I had to take the machine apart again. There are two 390kΩ resistors in the power supply, R21 and R22. One of them was open-circuit, but it seemed wise to replace them both. In fact I suggest that this is done whenever one of these machines comes in – I have since had a two more failures. Use resistors rated at 0.5Ω. **R.A.F.**

### **Alba VCR7200**

This machine would switch off because the drum speed was excessive. Checks showed that the drum servo was very unstable. A couple of freezer cans later I found that C6031 (10μF) near the reel sensor was heat-sensitive and in fact open-circuit.

**R.A.F.**

### **JVC HRD610**

The problem was lines across the picture, like mistracking. They were sometimes present when a tape was loaded but not on other occasions. I found that the left guide sometimes failed to reach the V block, because the brass bush beneath was loose. Remove and repair or replace it. **D.D.**

### **Philips Turbo deck**

A fault you can get with these machines (Model VR285 etc.) is intermittent cutting out in play or record, showing error 2. Check the clutch unit underneath the deck. The spring inside cuts a groove in the inner bush and then, instead of gripping, just rotates. So the clutch has no grip. Replace item 115 (manual identification). **D.D.**

### **Sony SLVE220UB**

The chassis used in this machine is used in a number of other models, including some **Sanyo** ones. Circuit protector PR512 is the root of many evils and is worth checking whenever you see any of these machines. If there is any sign of discoloration, replace it.

The faults it causes depend on the extent to which its resistance value has increased. Common ones I have come across are:

- (1) Cuts out in record only.
- (2) Cuts out in timer record only.
- (3) The recorded audio is microphonic and echoey, playback being OK.
- (4) Slow to change modes, especially from play to rewind.
- (5) Intermittent capstan motor start-up.

So beware and watch this item carefully. **I.W.**

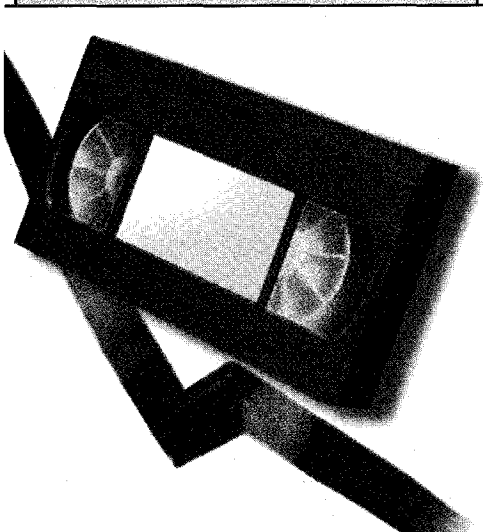

# VCR CLINIC

Reports from  
**Philip Blundell, AMIIE**  
**Graham Richards**  
**Michael Dranfield**  
**Kevin Green, TMIIE**  
**Geoff Butcher**  
**John Poulton and**  
**M. Della Verita**

We welcome fault reports from readers – payment for each fault is made shortly after publication. See page 246 for where and how to send reports.

## Panasonic NVL25

For a smeary picture with poor sync and intermittently muting sound check C7651 (10 $\mu$ F, 16V). It's a bipolar electrolytic. **P.B.**

## Toshiba V109B

If there's no lift or deck operation though the clock is working, check the STK7253 chip in the power supply for missing outputs. **P.B.**

## Panasonic NVFS100B

If there's no S-VHS playback, check for video at pin 7 of the hybrid chip IC303 on the luminance/chrominance pack. The IC is suspect if the video signal is present at pin 2 but not at pin 7. Its part number is VEFH05. But first replace the surface-mounted capacitors on the hybrid and check the tracks around them for corrosion. It worked for me! **P.B.**

## Mitsubishi HS721-V-B (U deck)

We've had several of these machines in which the lift levers have broken. The part numbers are as follows: F/L arm L 515C001030 (WVE code 77641BA), F/L arm R 515C001040 (WVE code 77641AA). **P.B.**

## Mitsubishi HSB29

The playback pictures lacked detail and the contrast was low. In addition picture mute would intermittently operate, going to a blue raster. Use of heat and freezer indicated that the cause of the fault was near the BA7255BS chip IC2A0 on the top PCB. In fact C204 and C284 (both 10 $\mu$ F, 50V) were leaking electrolyte. Replacements cured the faults. **G.R.**

## Sanyo VHR276E

No picture playback and no E-E, just a blank screen, are the symptoms when the 12V supply is missing. The usual cause is that R5110, a 27 $\Omega$  Sanyo safety component, is open-circuit.

Dry-joints at the chopper transformer can be the cause of its demise. **G.R.**

## Hitachi VTF860

Intermittent appearance of the on-screen display during playback etc. was the complaint with this machine. The cause was found to be the M50458 OSD generator chip IC1401. **G.R.**

## Daewoo V50

If the power supply is completely dead, check C53 (1 $\mu$ F, 100V) on the power supply sub-PCB. The replacement must be a 105 $^{\circ}$ C type. **G.R.**

## Goodmans VN6000

If the machine won't switch on and the clock flashes on or off, go straight for

C822 (330 $\mu$ F, 10V). The voltage reading across this capacitor should be 5-8V. If the voltage is slightly low, the capacitor is faulty. **G.R.**

## Akai VSA650

This top-of-the-range VCR had already been to two other dealers. The first one had made the problem worse while the second one said that a new power supply would be required, at a cost of £140.

These VCRs have a quite complicated chopper power supply. I found that the machine was dead and that the 2.2 $\Omega$  thermistor TH1 had been replaced with a 3W wirewound resistor, which was smoking. In addition lots of electrolytic capacitors had been replaced and the print was damaged.

A check at the base of TR20 suggested that its on time was too long. The cause was C24 (22 $\mu$ F, 50V) in the error amplifier circuit. It had dried out, with the result that TR17 was on for too long.

This wasn't the end of the story however. The 40V supply was low at 20V because the 1.5mH storage inductor L6 had shorted turns. A replacement was required.

And finally the screening plate from behind the power supply was missing. This machine will not function correctly without it, as switching radiation from the inductors is picked up by the head amplifier. A plastic coated screening plate from an old satellite decoder was cut to size and pressed into service. **M.D.**

## Hitachi VTF860

There was a disturbance on the screen when this machine loaded or unloaded a tape. The cause was traced to C12 (470 $\mu$ F, 16V) in the power supply. It was open-circuit. **M.D.**

## Toshiba V213B

This machine's power supply had blown up. The cause was failure of the three electrolytic capacitors on the primary side of the chopper circuit. Once the power supply was up and running I found that the machine had difficulty loading a tape, either in or out. The tape would jerk violently. More capacitors I thought, as the motor supply voltage bounced up and down with the jerking. I was wrong however: the loading motor was faulty. It read only 10 $\Omega$ . A new motor produced a reading of over 200 $\Omega$  and rotated when connected to an ohmmeter. **M.D.**

## Panasonic NVSD44

This machine was brought to us because of a power supply problem. The cause was quickly traced to D14 and D15, both of which were open-circuit. As a result there was no 12V supply. There was more to it than that however, as the tuner/RF booster was found to have an internal short. I was

lucky: the cause was simply a solder bridge in the tuner. **K.G.**

### **Panasonic NVF588**

We had many hours of fun with this machine before finding the cause of the problem. The VCR would run for some five-six seconds then stop, but this happened only in the record mode. The cause was failure of transistor Q4004. **K.G.**

### **Samsung SV421K**

This machine would chew the tape very nicely when rewind was selected – it would emit a very loud crunch as it reached the start of the tape. After many checks the cause of the fault was found to be C240, which is a small surface-mounted capacitor. **K.G.**

### **Ferguson FV77HV**

This VCR behaved very strangely. When a tape was inserted it would thread up, go into a fast play mode for a few seconds then stop. After that no functions worked. If the machine was switched off at the mains then switched on again, with a tape already inserted, it would fast wind in either direction and the channels could be changed normally. If play was selected however the tape would start to run much too fast for a

few seconds, with a bit of a straining noise from the mechanism. It would then gradually slow down and stop, with all the functions locked up as before. If the machine was stood on its end it worked normally!

To cut a long story short, I found that the retaining circlip on the capstan spindle was missing. As a result the capstan rotor dropped down slightly. This presumably upset the capstan pulse generators. **G.B.**

### **Hitachi VTF770E**

The customer complained about poor playback and recording. These turned out to be separate faults.

I decided to tackle the playback problem first. The machine would sometimes play back perfectly, but the picture was sometimes barely recognisable. On other occasions it was evident that the problem was to do with the head switching. When this was checked I found that the switching point varied each time a tape was loaded. The tacho pulse at pin 7 of IC601 was found to be low in amplitude at 1V p-p instead of 3.3V p-p. The cause was C1656, which read 2 $\mu$ F instead of 10 $\mu$ F (16V). A replacement capacitor plus head switching-point adjustment restored perfect playback.

The cause of the record problem was the

AGC capacitor C5F (0.47 $\mu$ F) in the IF module. **J.P.**

### **Panasonic NVHD625B**

The complaint with this machine was that it ejected the tapes. I had to replace the worm wheel, which had a few cracked teeth, the master main cam gear, the loading motor shaft and the mode switch.

The worm wheel had cracked teeth because the plastic loading motor PCB holder had snapped, so the PCB kept falling down. The worm wheel intermittently caught the main gear and snapped a few of its teeth. **M.D.V.**

### **JVC HRD960EK**

This machine had apparently died while in use. Replacement of the following items brought it back to life: C28 (100 $\mu$ F, 63V, 105°C), C25 (47 $\mu$ F, 50V) and CP2 (N20). **M.D.V.**

### **Toshiba V813B**

The complaint with this machine was tape chewing. I traced the cause to the capstan flywheel, which was cracked. This item is not available separately, so the capstan had to be replaced. Wilts Grove seemed to offer the best price. I also replaced the usual belts and the pinch roller. **M.D.V.**

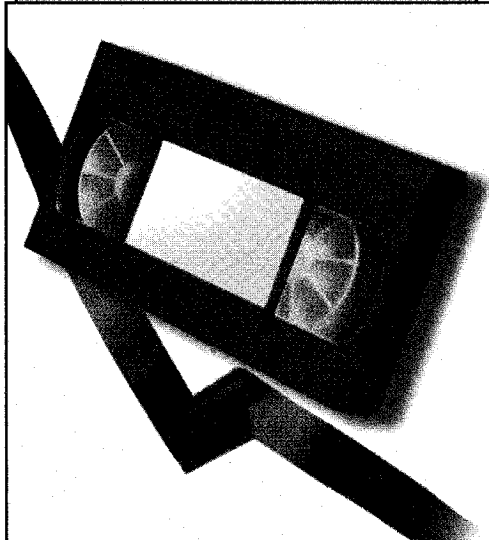

## VCR CLINIC

Reports from  
**Eugene Trundle**  
**Michael Dranfield**  
**Graham Richards**  
**Mike Leach**  
**Keith Brown**  
**C.M. Crook and**  
**Geoff Butcher**

We welcome fault reports from readers – payment for each fault is made shortly after publication. See page 298 for details of where and how to send reports.

### Ferguson FV305HV

Playback was marred by wow on sound and random mistracking because of erratic tape speed. Some quick checks showed that the output voltages from the power supply section were all fluctuating, while a strange noise came from the little chopper transformer. The cause of the trouble was the mains bridge rectifier's reservoir capacitor CP010 (47 $\mu$ F, 385V), which was virtually open-circuit – it was betrayed by bulging and splitting at the top of the can. **E.T.**

### Hitachi VTF550E

This machine had a horribly intermittent fault – spasmodic, random loss of functions. Sometimes the on/off key didn't work. Every connection at socket PG2701 on the front shuttle-switch panel was dry-jointed. **E.T.**

### Daewoo V435

Two of these machines have come in with the same problem: intermittent or permanent failure to record in colour, with E-E and playback (from a known good recording) OK. In both cases the surface-mounted capacitor C402 (0.022 $\mu$ F) at pin 15 of IC301 was responsible – probably with a hairline crack. **E.T.**

### Tatung TVR7121

There was a tape stuck inside this VCR, and reversion to standby took place within a few seconds of switch-on. It didn't take long to discover that the BA6209 loading-motor driver chip IC802 was faulty. But a replacement failed after about three seconds! The loading motor produced a reading of about 2 $\Omega$ : when it was fed with 6V from a bench power supply smoke poured from it. A new loading motor and another BA6209 chip solved the problem. **E.T.**

### Hitachi VTMX810E

There was intermittent loss of the E-E and playback sound via the RF output: a coarse buzz replaced it. The cause was poor soldering in the tuner/modulator unit, where a metal earthing 'finger' was dry-jointed to an earth land near the RF socket end of the unit. Incidentally this machine is made by Philips. **E.T.**

### Tatung TVR2121

As these machines, of Sharp manufacture, age their capstan motors are beginning to fail. The most common symptom is limited operation of the loading motor, with a cassette stuck in the lowered cradle and the capstan, though free to rotate, not moving at all. **E.T.**

### Daewoo V235

It's quite common for these machines to develop the 'dead' symptom, usually after a period without mains power. The usual

cause of failure is C53 (1 $\mu$ F, 100V) in the power supply module. Recently however we've found that one or other of the two 390k $\Omega$  resistors R51 or R52 can be the cause. They go high in value. It's best to replace all three components while the module is dismantled. **E.T.**

### Tatung TVR933V

If the problem is that the deck shuts down after running for three seconds in any mode, key 'play' then, quickly, 'pause'. So long as the tape remains laced up with the drum rotating, the likelihood is that R1013 is open-circuit. It feeds the LED section of the take-up reel sensor optocoupler. **E.T.**

### Samsung SV615B

There was a horrible fault with this machine. The symptoms were random deck functions, typically cycling between play and rewind, while the front fluorescent panel erratically displayed symbols and parts of characters in a sort of slow-motion flickering sequence. The culprit was IC701, a 52-pin flatpack chip on the vertical front PCB. **E.T.**

### Sony SLVE220

This machine is a Sanyo clone. The customer complained that when record was selected it would start off then power down to standby. Playback and fast forward/rewind were OK. An easy job, I thought: probably a faulty record tab switch. Not so however. The cause of the problem was eventually traced to circuit protector PR512 in the power supply. In the record mode it had 6V at one end and 5V at the other. A new one measured 0.1 $\Omega$  when checked with a meter while the faulty one produced a reading of 0.4 $\Omega$ . The CHS part number is 11929YE.

Note that when this item goes open-circuit the result is a dead machine with no clock display. **M.D.**

### Thorn VR194LV

This Sanyo clone was dead. As there were no shorts on the secondary side of the power supply, attention was turned to the primary side. Cold checks revealed that D504, which rectifies the feedback winding supply, was leaky. A 1N4148 proved to be a suitable replacement. **M.D.**

### Samsung SV213B

The job card said that this machine wouldn't accept a tape. I found that the 'cass in and tape start sensor' SP602, also the end sensor SP601, were badly soldered. Resoldering cured the fault. **G.R.**

### Hitachi VTM620

The symptom with this machine was slow capstan speed. I tried inducing a 50Hz hum by touching the connections to the



audio/control head, but this had no effect on the capstan servo. The electrolytic coupling capacitor C610 (10 $\mu$ F, 16V) for the control track pulses from the tape had dried up. **G.R.**

### **Logik VR950**

This robust old-timer suffered from severe power supply hum with playback, recording and E-E operation. The cause was C7 (2,200 $\mu$ F, 63V). When it was removed one of its legs fell off! **G.R.**

### **Sanyo VHR390E**

The complaint was no functions, so I took a look at the power supply and found that a couple of capacitors, C5104 (1,000 $\mu$ F, 10V) and C5101 (1,000 $\mu$ F, 16V), had leaked quite badly. The board needed a good clean up before replacements could be fitted. After that the machine worked normally. **M.L.**

### **Mitsubishi HS5424E**

This time-lapse machine's display was alight, but when a tape was inserted it immediately shut down. No other functions worked. I first wondered about the mechanism – it seemed as if the loading motor had seized or become very tight. But the cause of the trouble was in the power supply, where a 47 $\mu$ F, 50V capacitor was in

poor condition. Because of leakage it was impossible to read the circuit reference number – it's mounted fairly near the mains transformer. A replacement restored normal operation. **M.L.**

### **Hitachi VTM610E**

This machine would stop intermittently, spilling tape. I began to suspect microprocessor trouble, but luck helped when I noticed that the take-up spool had stopped turning. A replacement clutch cured the fault.

This machine is fitted with the **Philips Turbo deck**. **K.B.**

### **Toshiba V705B**

This machine was dead with no display. The cause was obviously in the power supply, and turned out to be C808 (100 $\mu$ F, 25V). The correct type must be used, otherwise it will fail again. I found that out by experience! **K.B.**

### **Sanyo VHR335E**

The complaint with this machine was slow and jumpy playback. The always 13V supply was found to be low at 10.5V. C5101 (1,000 $\mu$ F, 16V) had exploded, and the electrolyte had damaged D5114 (1SS244) which was open-circuit. As a result there

was no –23V supply. Once these two components had been replaced the machine worked normally. **C.M.C.**

### **Panasonic NVF55B**

It's surprising how many jobs turn out to involve two faults: the one the customer complained about and the one that wasn't mentioned. This job was no exception, the complaint being very poor recording and playback. Thorough video head cleaning cured this, but I then noticed that the tape counter didn't function in fast forward or rewind. The problem was caused by the half-load arm, which didn't operate at all because of a broken gear. Replacement restored normal service. **G.B.**

### **Goodmans VP2400PDC**

"Loss of tracking" was the complaint. The symptoms didn't show up in the workshop for quite a while. Eventually the problem appeared, as described but with loss of sound at the same time. It seemed more likely to occur in the long-play mode.

Examination of the tape path revealed that the tape was riding up the capstan by about a millimetre or so. A replacement pinch wheel and arm cured the fault.

This machine is fitted with the **Philips turbo deck**. **G.B.**

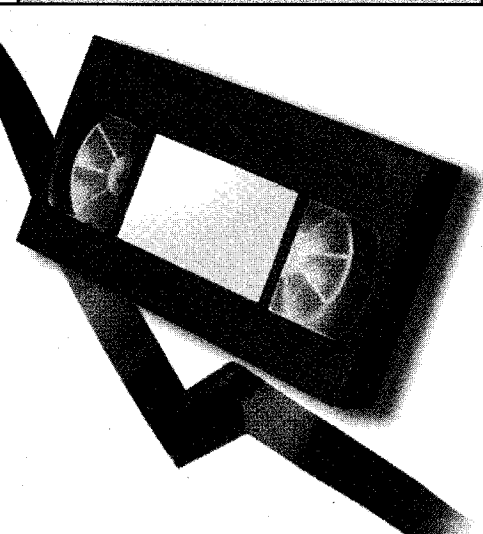

## VCR CLINIC

Reports from  
**Geoff Butcher**  
**Ian Bowden**  
**Eugene Trundle**  
and  
**Michael Dranfield**

We welcome fault reports from readers – payment for each fault is made shortly after publication. See page 362 for details of where and how to send reports.

### Mitsubishi HSB27

The E-E and playback sound were fine but there was no recorded sound. Various checks on the signals around the record/playback audio amplifier chip IC310 were carried out but failed to reveal anything amiss. So another test recording was made.

Annoyingly, the sound had returned! It seemed to be slightly distorted however. I decided, without much enthusiasm, to check the electrolytic capacitors in this area with my ever-useful ESR meter. My reward came when I found that C327 (33 $\mu$ F, 16V) was almost open-circuit. It decouples the supply to the bias oscillator. After fitting a replacement there were no further sound problems. **G.B.**

### Goodmans TVC1400

There was a problem with the VCR section of this unit. Recording was OK, but when any tape was played back the capstan and drum both ran much too fast. I obtained a service manual, then decided to replace the control chip IC601. To my dismay the fault was still present. To my even greater dismay and embarrassment I eventually found that the front panel PAL/NTSC switch was in the NTSC position! This had apparently happened by accident, as the customer doesn't have any NTSC tapes.

I've since had exactly the same problem with a different machine that can also be switched between PAL and NTSC playback. I wasn't caught out the second time! **G.B.**

### Hitachi VTM740

The customer complained that playback was marred by flashing colours. When a check was carried out with a prerecorded tape everything was OK, but the problem was obvious when one of the machine's own recordings was played back. So too was the clean edit back to a previous recording under the new one, i.e. full erase wasn't in operation. The cause of the problem was the 2SA952 switching transistor Q1542 that supplies the erase oscillator in the record mode. **I.B.**

### Panasonic NVJ40

The customer's complaint was poor playback colour. When I tuned the VCR to a monitor I noticed that there was a lot of flashing on E-E vision. The results were the same on playback with, as reported, the colour dropping in and out. When recording was tried the tape was erased but nothing was recorded.

A check at the connections to the video head preamplifier unit revealed that the E.Record 5V (i.e. playback 5V) supply was low at 3V. When scoped, HF oscillations were seen on it. Back in the power supply

section the voltage at pin 6 of P1001 (regulated 5V) was found to be high at 6.2V, occasionally dropping back to the correct level. The cause of the trouble was the regulator chip IC1103, part no. VEFH24A. There was normal operation once a replacement had been fitted. **I.B.**

### Sharp VCH92HM

There was no rewind: the machine would go into the review or rewind mode but cut out after a few seconds. The cause of the problem was a faulty reel rotation optosensor, on the supply side. The optotransistor's collector voltage varied between 5V and 2.7V instead of 5V and 0V.

I also found that when the machine was powered up from cold there was severe line noise across the E-E picture. After about twenty minutes this was barely noticeable. Use of a spot of freezer inside the combined RF/detector can revealed two suspect miniature capacitors, CQ601 (0.47 $\mu$ F, 50V, 105°C) and CQ602 (2.2 $\mu$ F, 50V, 85°C). Once these had been replaced the unit was fine, even from cold. **I.B.**

### Sony SLVE200

This machine was supposed to be dead. When I connected it to the mains supply the drum didn't spin for a second or so, as normally happens, and the tape inserted symbol was displayed though the machine was in the eject mode.

Checks in the power supply revealed that Q5101 (2SC4483) was open-circuit base-to-emitter. When the VCR is in the on state Q5101's base should be at 5.8V. There was only 1.2V at its emitter. A new 2SC4483 restored normal operation. **I.B.**

### Aiwa HVFX2500

Poor playback colour was the complaint with this machine. When I first tried it there was no colour at all then, after a few minutes, areas of chroma patterning rolled through the playback picture with normal colour between them.

Thermal tests in the power supply area led me to C618 (10 $\mu$ F, 50V), which is connected to pin 7 of IC601. When this capacitor was cold there was a normal 500mV of 100Hz ripple across it and, in addition, HF ripple. A replacement capacitor removed this HF component and restored normal playback colour. **I.B.**

### JVC HRJ610EK

The complaint with this machine was 'intermittent picture': most of the time there was a blank screen in the E-E mode, with just occasionally a burst of picture. These symptoms have been reported before in VCR Clinic, for a similar machine. In

the previous fault report (May 1996) the output from the IF/detector was being muted by the system control micro because of lack of sync detection.

I found that the signal at pin 3 of transformer T901 was at about 4V peak-to-peak, which pointed to a problem in the IF/detector unit. When this was fitted on the other side of the PCB I soon found that the problem was thermal – heating the unit cleared the fault. A few squirts of freezer revealed that C206 (0.1 $\mu$ F, 50V) was the cause of the trouble. When a replacement had been fitted there was a 6.5V peak-to-peak signal at pin 3 of T901 with no muting. **I.B.**

### **Sony KV21FV1U**

This was a brand new TV-VCR combi unit. At random intervals the deck stopped, regardless of which mode it was in. After much dismantling I discovered that one of the leadouts from the take-up spool's rotation-detector optocoupler (PH452) was dry-jointed. **E.T.**

### **Sony SLVE710**

The symptom with this machine was very intermittent refusal to accept a cassette,

because it thought one had already been inserted – indicated by the cassette symbol on the front panel being alight. The cure was a 'blanket' job: I replaced the centre (cassette) LED, both end-sensor photodiodes, the record-safety tabswitch (which also acts as tape-in indicator), and the two 39k $\Omega$  surface-mounted resistors R264/5. The latter is recommended in a Sony service bulletin. **E.T.**

### **Daewoo DVF932P**

This machine behaved itself most of the time. Occasionally however it would eject a cassette immediately after taking it in and down, while the fluorescent display was incomplete and there were no E-E signals. The cause was trouble with the 6V supply. The 470 $\mu$ F, 10V reservoir capacitor C23 produced a high reading when checked with an ESR meter. **E.T.**

### **Sony SLV825UB**

When this machine was connected to the mains supply it alternated between the standby and on modes, with its indicator flashing from red to green. After a while it would settle at standby, but any attempt to switch it on produced only a momentary

green light before reversion to standby. The cause of the trouble was C207 (2,200 $\mu$ F, 16V) in the power supply – there's no power supply circuit in the service manual! **E.T.**

### **Alba VCR7340T**

Manual control worked, but this machine didn't respond to commands from the remote-control unit. When I checked the unit with my tester it sounded all right. I then scoped the output from the IR receiver, and found that there was a serial data train at approximately 5V peak-to-peak. So the receiver appeared to be OK, but I replaced it nevertheless – to no avail.

As remote control data entered the microcontroller chip at pin 14, it seemed that either the micro or the EEPROM chip was faulty. A new EEPROM made no difference. While I was thinking about fitting a new OEC7035A microcontroller chip another dealer came into the shop. He suggested opening the remote control unit and reflowing all the pins of the IC.

I did this and pointed the unit at my tester. The sound it produced was no different, but it now worked the VCR with no trouble. **M.D.**

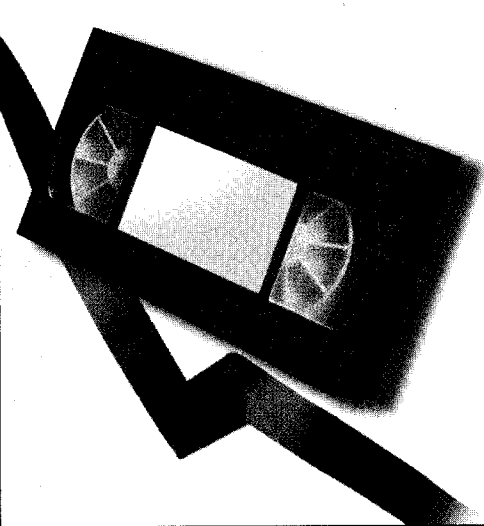

## VCR CLINIC

Reports from  
**Eugene Trundle**  
**Mike Leach**  
**D.M. Thomas**  
**Michael Maurice**  
**Ronnie Boag and**  
**Paul Sargent, LCGI**

We welcome fault reports from readers – payment for each fault is made shortly after publication. See page 426 for details of where and how to send reports.

### **Sony SLVE295UX etc**

This machine sometimes refused to eject a cassette and would go to sleep a few seconds later. The clue to the cause of the trouble was a whirring sound. It came from the loading motor, whose worm was cracked. As a result, when loaded the motor shaft rotated inside the worm. Shades of the Panasonic K deck, but in this case the little plastic bit is available separately.

I guess this fault could occur with any Sony model that uses the **S tape deck**.  
**E.T.**

### **Hitachi VTF660E**

Playback via the RF modulator was fine but the picture that came via the scart socket was marred by lines of interference – similar to the effect of co-channel interference with analogue terrestrial TV reception. The culprit turned out to be the BH7633AS signal-routeing chip IC4501 on the rear jack PCB. It contains amplifiers and clamps as well as switches. **E.T.**

### **Sony SLVE730**

This machine was to all intents and purposes dead, but when listening closely in the power supply area I heard a single squawk shortly after switch on. There was normal operation once C153 (47µF, 50V) and C154 (1µF, 50V) on the primary side of the power supply had been replaced.

A similar power supply module is used in Models **SLVSE35/50/60/70/80** and **SLV SX60/70/80**. **E.T.**

### **Philips 14VP200/07**

This TV/video combi unit was still under guarantee. The fault symptom was a tinny buzz during tape playback only. It came and went when the ribbon cable from the audio/control/erase head was flexed at the PCB end. Because of access problems and difficulty getting the unit to work when it was dismantled, I decided to replace the ribbon cable and resolder the socket to the main (VCR) PCB. This cured the fault. **E.T.**

### **Aiwa HVGX350K**

The fluorescent display panel was very dimly lit – in fact the display was only just discernible. Checks showed that its heater voltage was low. The cause was failure of CP25 (100µF, 10V) in the power supply section. **E.T.**

### **JVC HRJ225**

Because of a broken gear on the upper side of the deck there was no eject. This is becoming quite a common fault, which is easy to cure by removing the carriage and

unclipping the sliding-brake assembly. There's just enough room to replace the gear without the need for a major strip-down.

Once this had been done however there was a strange problem. When the machine was connected to the mains supply the mechanism would shuffle and the capstan motor would spin quickly, trying to eject a tape that wasn't there. The machine would then shut down. I initially suspected the mode switch, which is difficult and very fiddly to change, but the switch turned out to be OK. A faulty start sensor eventually proved to be the cause – a replacement cured the problem. It's worth noting that when a tape was wound into the machine manually in the fault condition everything worked fine, including fast forward, rewind etc. The fault symptom showed only when the machine was first powered up from the mains. **M.L.**

### **Sony SLV825UB**

E-E operation was very poor and there were bent verticals. The cause of the trouble was traced to C13 (1µF, 63V) in the IF assembly. **M.L.**

### **Goodmans PD1700**

There was playback but no record. The cause was the BC848B transistor 7605. **D.M.T.**

### **Panasonic NVHD620**

This machine was dead. Checks showed that the problem was caused by QR1101 (UN6114) and Q1102 (2SD1991A) in the voltage-control section. **D.M.T.**

### **Samsung/Goodmans TVP5050IST**

This unit was stuck in the pause mode. I found that the slider supply gear (item G520) was cracked – a replacement restored normal operation. The part no. is SAMSAC6680142A. **D.M.T.**

### **Goodmans/Daewoo VP2500**

In the E-E mode there was just a blue screen. With playback there was no picture but the sound was OK. The menu was OK. The cause was traced to R350 in the video processor circuit. It's a 270Ω surface-mounted resistor. **D.M.T.**

### **Sanyo VHR276**

This machine caused me a lot of grief. The customer complained that it would switch off when going into record. Easy I thought, replace PR512. So I fitted an N25 circuit protector, printed out an invoice and left. A couple of days later the customer com-

plained that the fault was still present, and added that it usually occurred after a rewind. So I replaced the mode switch. After that the machine acted strangely. I took it back to the workshop and found that the machine would accept a tape but when any function was selected it would lace up, unlace then switch to standby. I started off by carrying out checks in the power supply, but there was nothing wrong there. Then I checked and double checked the alignment, which was correct. In desperation I fitted another mode switch. After that the machine worked correctly. **M.M.**

### **Hitachi VTF360**

This machine would intermittently fail to record or play the control track and creased the edge of a couple of tapes. The cause was found to be the back-tension band: the felt had parted company with the plastic band. A replacement restored normal operation. **M.M.**

### **Sony SLVE280**

The customer complained about very poor recorded sound and intermittent failure to record. The circuit protector looked in a bit

of a sorry state, so I replaced it with a CP N25. After that the record and playback sound were both good, and I was able to assure the customer that his machine wouldn't cut out again. **M.M.**

### **JVC HRJ425**

This machine wouldn't go into play because the pinch roller failed to contact the capstan shaft. The cause was lever assembly item 50, which was cracked. **M.M.**

### **Sharp VCMH60**

To start with there was motor pulsing and no display, but after a few minutes the VCR worked normally. When the outputs from the power supply were checked the 5V rail was found to be low. The fault was cured by replacing C925 (470 $\mu$ F, 10V) and C929 (330 $\mu$ F, 10V). **R.B.**

### **Daewoo V200**

There was no display, so some voltage checks were carried out. I found that the -24V supply was missing. All that was required was to replace R62 (18 $\Omega$ , 0.25W). **R.B.**

### **Samsung SV222B**

This machine was dead. To restore normal operation several items in the power supply had to be replaced: transistors Q1SR01 and Q1SR12, diode D1SR11, zener diode ZD1SS1, capacitor C1SR12 and resistor R1SR11. **R.B.**

### **Akai VSG295**

This machine's recorded pictures were intermittently snowy. The cause was dry-joints at capacitor C609 (10 $\mu$ F, 50V), which is part of the TU +B supply. **R.B.**

### **LG T163I**

There was very low E-E and playback sound. The cause was a dry-joint at L402, which is in the supply to pin 11 of the BA7797 chip IC401. **R.B.**

### **Hitachi VT530E**

"Poor tracking" it said on the job card. I nearly missed this one! When the machine had been playing for about an hour the picture paused every second or so. The culprit was a faulty and very hot capstan motor. Within a week I had another identical failure. **P.S.**

Though the price of many VHS VCRs has fallen to the point where repair may not be economically viable, nevertheless most of the problems that crop up are relatively simple mechanical ones. These are economic to fix.

Eugene Trundle provides a diagnosis and repair guide that's based on many years' practical experience

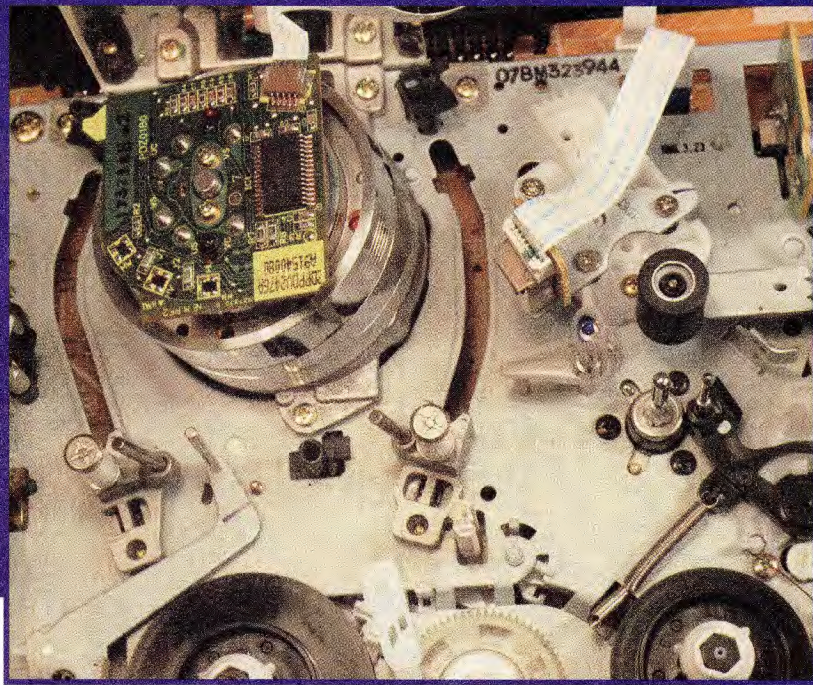

## Servicing

# VHS decks

**S**afely away from the high voltages, heavy currents and thermal cycling that are associated with TV sets, the electronics in today's VCRs give relatively little trouble. Most of the VCR problems you get are associated with the moving and wearing parts of the mechanical deck. In fact a video technician can spend whole days without recourse to a test meter or soldering iron, except perhaps when it's necessary to replace a mode switch. Motors and head assemblies excepted, deck components are not expensive and, with a knowledge of what commonly goes wrong (and why), fault diagnosis and repair can in most cases be quick and profitable – whatever the make, price or quality of the machine.

In this guide we will follow the tape on its journey around the deck, looking at each mechanical part in turn and the effect it has, when faulty, worn or misaligned, on the tape running and the sound and vision. We'll consider not only fault symptoms that are present whenever the tape is in motion, but also the horrible intermittent faults that can arise. Fig. 1 shows a typical modern centre-mount tape deck layout.

### Cassette-in

Failure of the cassette to be drawn into the machine, which is on and lit up, is a common problem. Check that the cassette-in signal is reaching the syscon (system controller) chip from the sensor, which may be a mechanical switch or a photocoupler. If it is present at the syscon chip, use a DC-coupled oscilloscope, which will reveal much more than any sort of meter, to look at the drive to the motor (loading or capstan, depending on design). There may be no power to the drive chip or motor, or a mechanical jam-up, indicated by the presence of electrical power for a few seconds only.

An attempt to turn the motor/mechanics by hand will confirm whether it's jammed, perhaps because a deck component is broken, there's incorrect mechanical phasing, or a 'spanner in the works' – a foreign body. Sometimes the cassette moves some way in then jams. If it's floppy in the tray, check the sprung fingers above that hold it in place. If the whole cradle/tray is skew-whiff, it's likely that one side of the front-load mechanism is loose because of a broken arm or pinion. Sometimes the cassette goes all the way down

to the deck then comes straight back up and out. The cause will be failure of a tape-end sensor, failure of the cassette-down/in sensor, or because their signals don't arrive at the syscon chip. Check at the appropriate pin of the chip, if it's accessible.

### Threading the tape

With most modern decks the tape is threaded as soon as the cassette goes down. Whether or not this is the case, if tape threading is a laboured business or the movement stalls, it's likely that the supply spool is not free to turn and, as a result, the tape is stretched taut. See if the reel brake is on, because of a misphased or broken mechanism, and if necessary check the back-tension band whose felt strip may have parted company with the plastic band and is now stuck fast to the periphery of the turntable.

The tape guides act as threading poles initially. They can become jammed at some point in their travel because of hard grease in their guiding slots. The solution is to clean with solvent and relubricate with light grease. The guides might stop short of their precision end-stops: this causes tracking problems. Particularly in older JVC

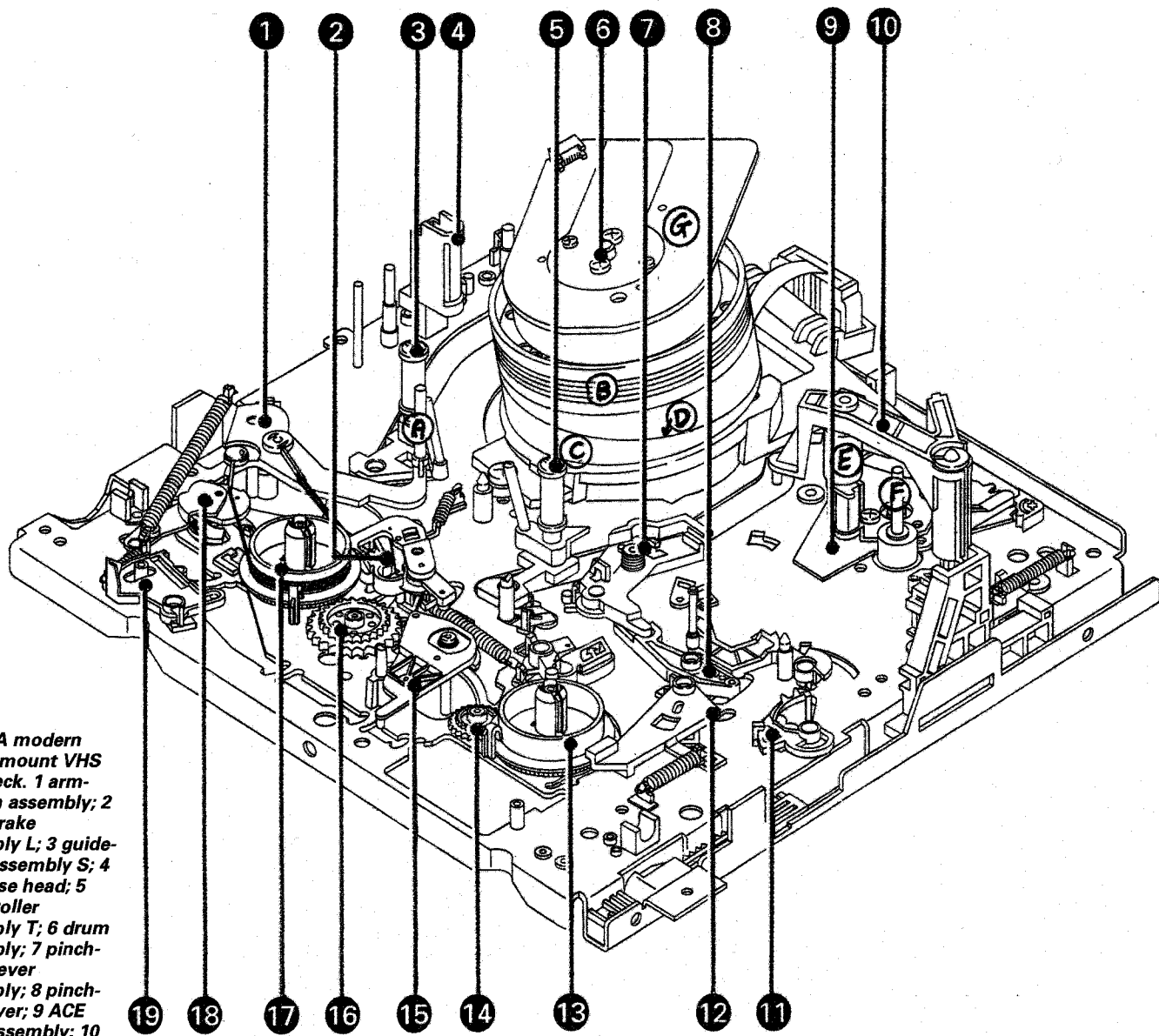

**Fig. 1: A modern centre-mount VHS tape deck. 1 arm-tension assembly; 2 main brake assembly L; 3 guide-roller assembly S; 4 full erase head; 5 guide-roller assembly T; 6 drum assembly; 7 pinch-comp lever assembly; 8 pinch-cam lever; 9 ACE head assembly; 10 pinch-roller assembly; 11 review lever; 12 brake sub-assembly R; 13 reel-disc assembly R; 14 gear-relay assembly T; 15 idler assembly; 16 gear-relay assembly S; 17 reel-disc assembly L; 18 jog-lever assembly; A back-tension pole; B upper drum; C lower drum; D rabbit; E pinch roller; F capstan; G drum motor.**

decks, the cause of this can be slackness in the joint between the articulated loading drive arms and the pole bases. Slackness and wear in arm-joints or drive pinions can result in the guides being 'floppy' at the loading end: the result is poor or erratic tracking. If you pull backwards a tape-guide which is in the fully-loaded position and then let it go, it should snap back into place under spring pressure: only when this is so can you be sure that the tape path around the head drum will be consistently reliable.

All this assumes that threading takes place. If it doesn't, or the tape is smartly returned to the cassette after the completion of threading, check that the head drum is rotating and that the loading belt, if used, isn't slipping. Then suspect the mode switch.

### Tape outward journey

Fig. 2 shows the path the tape takes

around the deck furniture. A certain amount of variation in the details is to be expected with different deck designs. Fig. 3 is a 'straightened-out' diagram, showing the movers, shakers and transducers the tape meets along the way.

The first item that the moving tape encounters on its passage away from the cassette is usually the back-tension pole, which pulls on the friction band around the supply-spool turntable. Examine the band itself first. The felt strip may have broken up or become partially or wholly disengaged from its strap. This will play havoc with the tape tension. Check that the tension pole is free to move, and that it takes up the correct position when the tape is running – this is usually indicated by an engraving on the deck surface, or you may have to refer to a diagram in the service manual. Fig. 4 shows the basic arrangement, with a cam for tape-tension

adjustment. There is generally a setting screw. A typical back-tension figure for a modern deck is 35g/cm, measured at the beginning of SP tape playback using a cassette-type torque meter. It's easier however to use an on-screen indication, of the type provided by a test tape such as the MB Swiss-4, to check the back tension – see Fig. 5.

The most common symptoms produced by insufficient back tension are noise on the picture and/or picture judder/roll because of poor head-tape contact at the beginning of the head's tape scan. The effect is worse with a recording made by the same machine. Too much back tension can cause hooking and bending in the picture, and excessive tape and video head wear: in extreme cases the capstan and pinch roller skid on the tape, which becomes taut then stops moving or slows, with mistracking and wow on sound in the latter case.

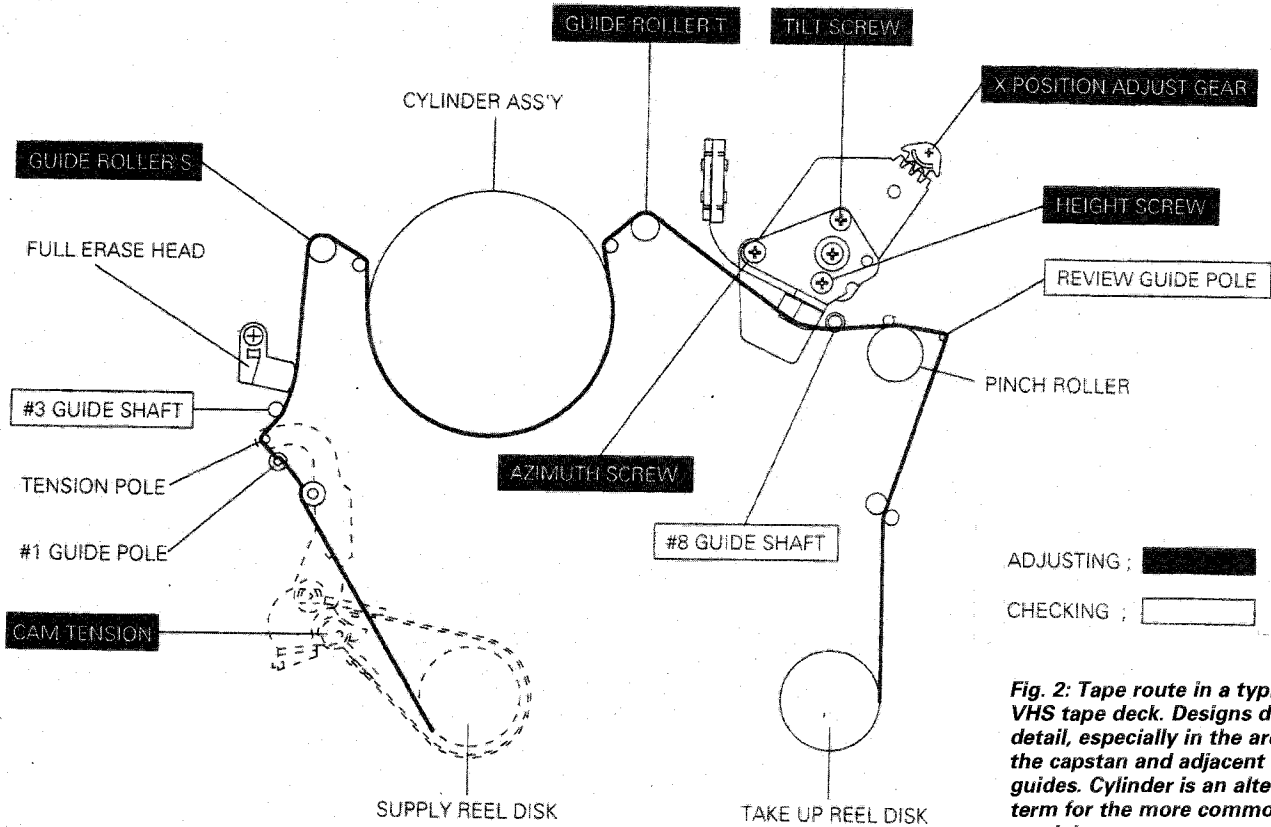

**Fig. 2: Tape route in a typical VHS tape deck. Designs differ in detail, especially in the area of the capstan and adjacent tape guides. Cylinder is an alternative term for the more commonly used drum.**

If the back-tension pole is not perfectly vertical the tape will ride up or down it. The result is tape crinkling or an incorrect tape path across the full-erase head to the drum-entry guide. The only effective way of dealing with this is to fit a new lever assembly.

The next major item the tape encounters is the full-erase (FE) head. As its magnetic gap is longer than the tape width it doesn't require adjustment. The important things here are to ensure that the head is able to move freely on any swing-pivot it may have, and that the electrical connections to the head are good. It's often recommended that any plugs and sockets used here are replaced with soldered connections to the PCB. Attention to these points ensures that tape erasure takes place before a new recording is made, and that the new sound track goes on to the tape as it should. If the tape is not being erased properly the effect, with a tape that has been previously recorded on, is blobs and clouds of vague floating colour when the new recording is played back.

Some VCRs, especially older ones, have an impedance roller (not shown in Figs. 1-3) downstream from the FE head. Its function is to damp and thus smooth the tape motion, helping to iron out any timing jitter. It can do this only if it rotates. A drop of fine lubricating

oil on its shaft will also silence the tortured squeal or groan you can get in the fast-forward and rewind modes with a dry one.

### The guides and drum

The tape next passes round the drum-entry (S) guide, a crucial component that's changed its role from pull-out/threading pole to precision tape positioner. In conjunction with the adjacent slant pole it ensures that the tape sits correctly on the rabbet, the spiral shoulder machined into the periphery of the lower drum, so that the rotating video heads on the upper drum are aligned with the tape's magnetic tracks.

Guide alignment should not normally be necessary except after replacement. Slacken the lock-screw at the bottom of the guide shaft then, using the correct (forked) driving tool, slowly adjust the guide downwards until the tape

can be seen to start to 'bubble' on the rabbet. Observe the RF envelope pattern from the heads during playback of an alignment tape, using an oscilloscope that's synchronised with the head flip-flop (SW25) pulses. Screw the guide up until the bubbling just stops, then finely adjust for a good entry-side waveform, see Fig. 6.

If it's not possible to achieve a good entry-side waveform, ensure that the back tension is correctly set, that the guide base has gone fully home, and that the heads and drum are perfectly clean. If these points are all in order, it's likely that the video heads are worn.

A couple of physical problems can occur with the tape guides. First the lower shaft (normally made of brass in older machines) sometimes becomes loose in its mounting. This is curable with locking compound, not superglue. Secondly the rotating plastic sleeve can vibrate on the

**Fig. 3: Linear tape path illustration, corresponding to the layout shown in Fig. 2.**

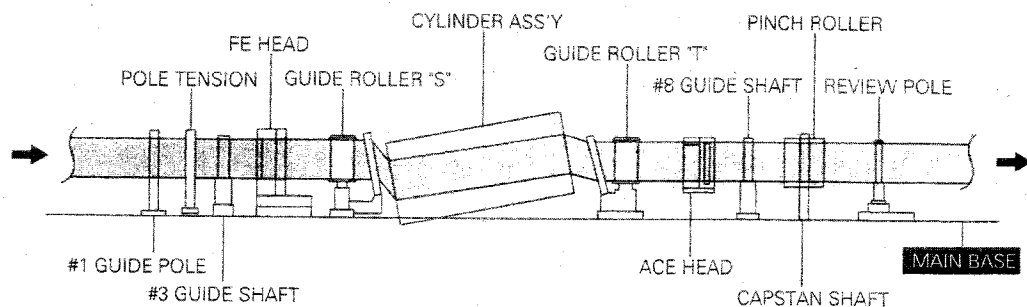



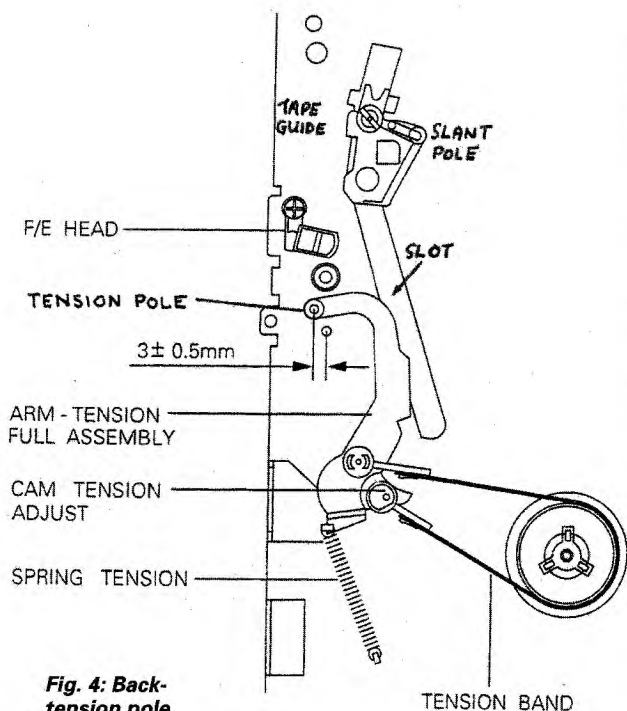
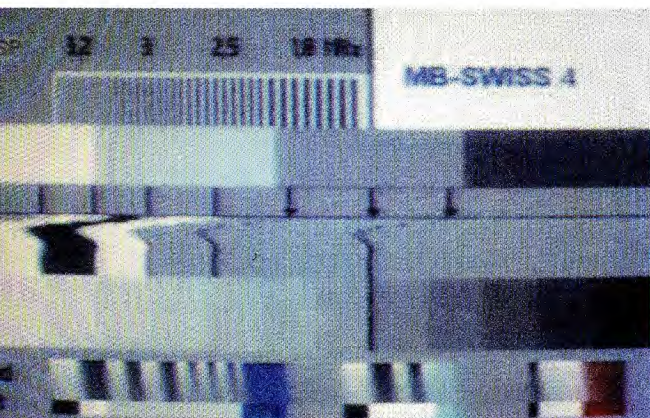

**Fig. 4: Back-tension pole, band and setting arrangement (cam tension adjust). Note the setting indication by the pole.**

shaft. This produces a corrugated effect on the picture, and sometimes a squeal in one or more of the operating modes. The cure for this is replacement: don't try lubrication.

The lower drum and its rabbet act as tape positioner and guide while the tape is being scanned by the heads in the upper drum. Any dirt or deposit on the lower drum will give rise to some form of horizontal interference band or noise bar in the picture. As they age some lower drums develop excessive surface friction. This is indicated by much greater tape tension upstream from the tape wrap than at the input side. If this gets very bad the capstan may not be able to pull the tape around the head. More often the tape piles up on the deck in the review (search backwards) mode. This happens because the backwards-rotating supply spool

**Fig. 5: Use of a test tape to check the back tension. Pulling to the right in the middle of this off-screen TV shot shows that the tape tension needs to be increased.**



has insufficient torque to overcome the tape friction around the drum wrap while the capstan continues to feed tape to the 'sticky' drum. In such a case cleaning and polishing the lower drum can be tried, but probably won't help. The cure, a new lower drum assembly, is expensive.

The comments above about the entry guide apply equally to the exit (T) guide on the other side of the drum. This should be adjusted for a good square envelope waveform at the end of the head scan, see Fig. 6. Once again, before you try adjustment check the guide's physical conditions and its positioning at the end stop, and ensure that the tape just touches the rabbet while running.

Here are some possibilities for poor tracking, which shows as inability to achieve a good RF envelope pattern at any point during adjustment. Head wear is a strong possibility if everything is clean, and can even be responsible for a dip in the waveform at some intermediate point during the head scan. Misalignment of a component prior to the entry guide or after the exit guide can also cause tracking problems: examples are a bent back-tension lever or an excessively tilted ACE (audio/control/erase) head assembly.

If tracking is erratic and the envelope waveform sags at or near the middle of the head scans it could be that both tape guides are set fractionally too high, with the result that the tape is poised slightly above the rabbet on its way around. A gap in the waveform at either end of the scans can be caused by incorrect adjustment of the head-switch timing. A gap at the start of the scans, in the record mode only, is caused by the ACE head assembly being too high. As a result the CTL head takes 'bites' out of the start of new video tracks.

Anything that prevents good tape/head contact or tracking at the very beginning of the scans will impair the field sync part of the video output signal and thus cause vertical judder and/or picture rolling.

### The video heads

Dirty video heads cause the familiar coarse-snow effect on the playback picture, see Fig. 7; also, unless both heads are equally affected, a 25Hz flickering effect. Worn heads can produce the same effects but more often give rise to black and/or white

streaking from vertical edges in the picture. Fig. 8 illustrates this effect. When this occurs with only the machine's own recordings, some temporary relief can be obtained by reducing the luminance signal writing current. But head drum replacement is the only lasting cure.

You sometimes find that for optimum output with a known-good recording the two video heads require different tracking-control settings. This indicates that the head chips are running at different levels, more often because of a speck of something or other under a newly-fitted upper drum than faulty drum manufacture. Anyone who can get a foreign body under the drum may also be capable of fitting it 180° out of phase. The result will be colour playback with the machine's own recordings but not with playback of any others.

Worn or dirty VHS hi-fi heads can cause audio drop-out, buzz, and critical tracking adjustment for sound. When it gets too bad the sound reverts to the linear/longitudinal mono sound track. Incorrect head switch-point setting can also cause buzz on hi-fi sound, so check this before suspecting head wear.

If the video heads wear out quickly it's likely that the cause is either excessive tape tension or over-frequent use of a head-cleaning tape. Heads that frequently get dirty or blocked are probably being soiled by the tape: after all nothing else (except those dreadful head-cleaning rollers!) ever touches them. Get the customer to check by using a new batch of tapes over a period. In over two decades of VCR servicing I've only ever encountered two heads that self-soiled, probably because they were abrasive.

To clean the rotary heads use a soft cloth or buckskin or a proprietary cleaning stick, stroking only in the heads' normal direction of travel, see Fig. 9. In stubborn cases, and with care (and perhaps nothing to lose!), try the effect of a piece of card, similar in thickness and finish to a business card, soaked in isopropyl alcohol: press it hard against the upper drum's periphery while you rotate the drum anti-clockwise by hand. Make sure that the drum surface is dry before testing with a tape.

Static blips on the playback picture, looking like little white-tailed comets that occur at random points, are usually caused by poor earthing of the upper drum. As a

result static electricity builds up on the drum and discharges itself several times during the period of a TV frame. The earthing brush, when external to the drum assembly, can also squeal or whine despite the rubber damper that's stuck to its sprung arm. A dab of lubricant on the nose of the carbon tip cures this one. Some drum assemblies, notably middle-aged JVC ones, have internal earthing brushes. These can be replaced with an improved type when static-discharge problems are experienced. Some models have no visible earthing arrangement at all. I've had a couple of these that have produced static-discharge effects, probably because of a faulty drum or motor. They were cured by adapting an earthing brush from a scrap deck of a different type.

**Head replacement**

The relevant service manual will provide instructions for upper drum replacement. Afterwards, the most important setting-up adjustments are tape path (guide) alignment, head switch-point setting and tracking. The latter is carried out at the ACE head, which we'll come to next month. With many modern VCR designs the need for adjustment of the FM writing current has been eliminated. Head preamplifier setting-up presets disappeared many years ago.

Some perfectly good head drums have been replaced to no effect, because of faults elsewhere. The rotary transformer occasionally fails, as do FM preamplifier chips. A faulty drum motor can cause the 'dirty-head' effect - that small surface-mounted electrolytic capacitor in old JVC motors comes to mind. Another red-herring occurs when there is poor earthing of the shielding for the playback RF preamplifier, usually because of a

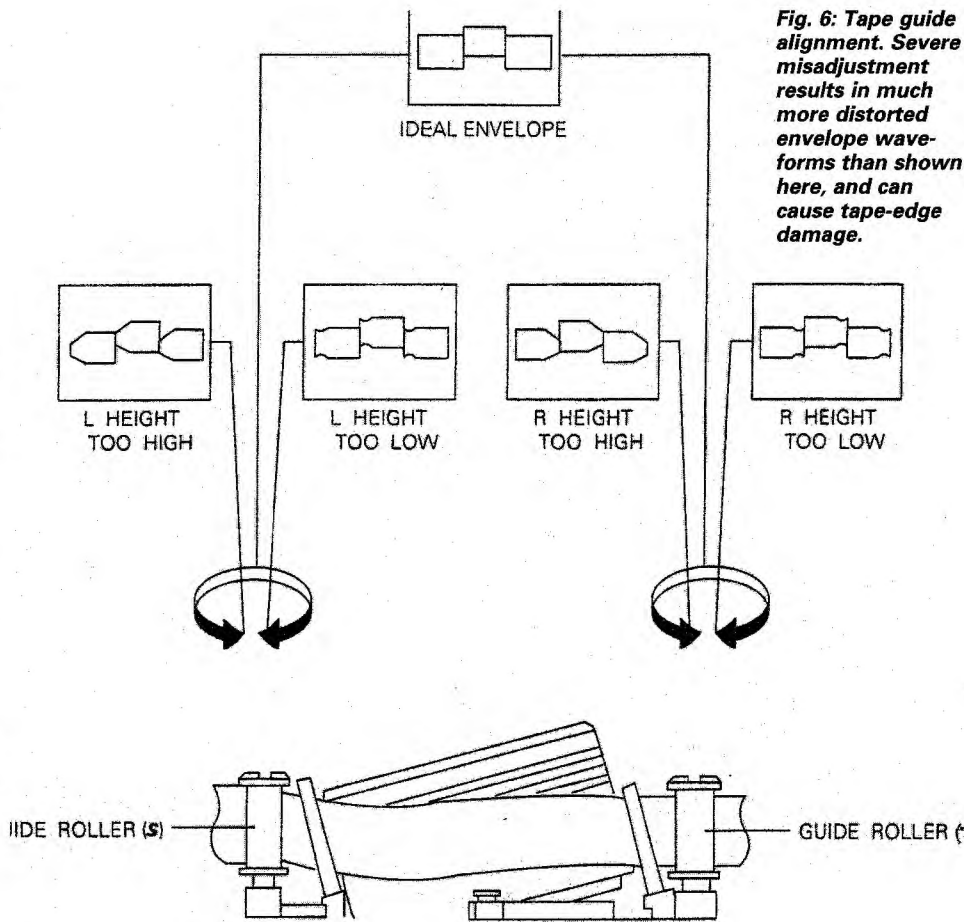

**Fig. 6: Tape guide alignment. Severe misadjustment results in much more distorted envelope wave-forms than shown here, and can cause tape-edge damage.**

missing or loose fixing screw: in some decks of Philips' manufacture it's a Torx-type screw with access through a hole in the machine's plastic rear cover.

Pattern heads available from companies such as Philex and TW Electronics are now very good and their prices are low. While they may not have quite the performance or longevity of original manufacturers' drums, they will usually outlast the well-used machine in which they are fitted, and anything that reduces repair costs is welcome in the present situation. ■

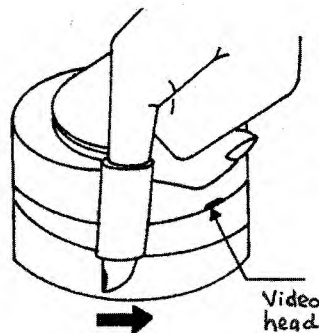

**Fig. 9: Video head cleaning by hand. Keep the forefinger, wrapped in fine chamois leather, still while using the other hand to rotate the drum anticlockwise.**

**Next month**

In the concluding instalment next month we'll follow the tape on its downstream path from the drum, consider tape damage and other general deck problems, outline the causes of intermittent faults, and take a look at the auto-diagnostic systems incorporated in many modern VCR designs.

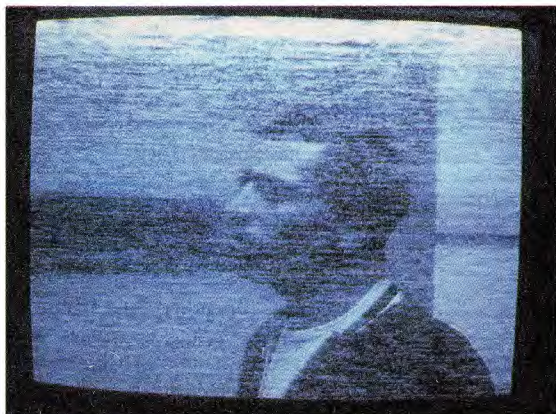

**Fig. 7: Effect produced by dirty video heads.**

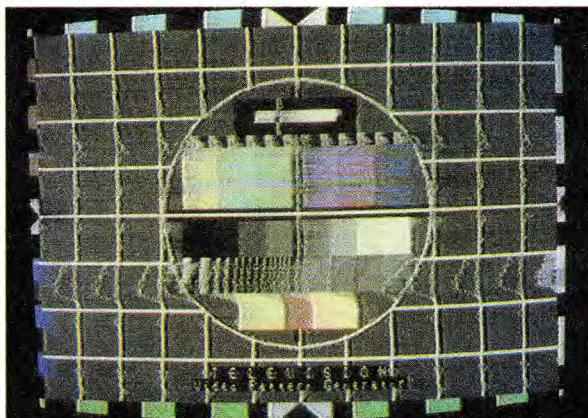

**Fig. 8: The ragged picture, image pulling and 'worms-and-dots' streaking effects shown in this off-screen shot are caused by worn video heads.**

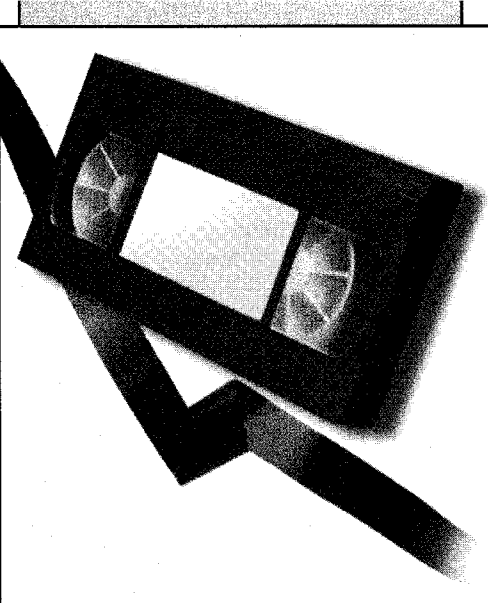

## VCR CLINIC

Reports from  
**Eugene Trundle**  
**Geoff Butcher**  
**Nick Beer**  
**Dean Ratcliffe**  
**Denis Foley**  
**Chris Watton and**  
**Michael Dranfield**

We welcome fault reports from readers – payment for each fault is made shortly after publication. See page 490 for details of where and how to send reports.

### Sony SLVE230

Intermittent failure to eject the cassette was the elusive symptom with this machine. When I finally got it to misbehave a whirring sound came from the region of the loading motor, followed by shutdown shortly after. The culprit was a split worm (part no. 3-977-436-01) on the loading-motor shaft. Shades of the Panasonic K deck! **E.T.**

### Bang and Olufsen 4500/5000

These machines, which are now about twelve years old, seem to be cherished by their owners. They work with the Link system and are controlled via B&O TV sets. Two have come in recently with fault symptoms such as tape stuck in, tape running too fast, strange 'control' faults etc. In both cases the culprit was the capstan motor, with gungy black corrosion on the pins of the built-in control/drive chip. This part is still available at a surprisingly low price, so both jobs went ahead. **E.T.**

### JVC HRJ225

This machine wouldn't eject tapes, though the motor could be heard to run. The eject mechanism failed to engage because the spring anchor had broken off the change-arm assembly, part no. PQ46353A-2. I also found that the spring anchor had broken away from the take-up lever assembly. This is item 58, part no. PQ21686-1-3. **E.T.**

### Sony SLVE280

Failure of fusible resistor PR512 is well-known in this and other budget Sony and Sanyo VCRs. In latter production the component is uprated to 2A to forestall trouble. Despite this I've found one of these uprated fuses completely open-circuit, the result being a dead machine. **E.T.**

### Panasonic NVHS950

As often as not the deck would shut down when the review mode was selected, with the left-hand spool stationary and tape piling up between the pinch roller and the drum. In addition rewind was sometimes 'snatchy'. The cause was excessive friction on the lower drum surface. Remedial work was not sanctioned: the lower-drum assembly costs a three-figure sum, even at the net trade price. **E.T.**

### Akai VS-G2DPL

The cassette loading carriage was all askew and jammed. This machine's deck is used in a number of other Akai models. When trouble with the cassette lift is experienced, the usual cause is the right-hand loading block, part no. BL-433561N4. I replaced the block but the loading mechanism was still very floppy in the ejected position. A projecting pin on the loading slide had bro-

ken off – it should engage with the spring on the loading block. The part no. of the slide is ML-433567N1. **G.B.**

### JVC HRD660

A cassette was stuck in this machine, with a large amount of the tape wrapped around the pinch wheel. After unwinding it the cause of the entanglement was discovered. The idler gear, which swings between the supply and take-up spools, was very sluggish in operation. As a result, the take-up spool didn't start promptly when play was selected.

A new idler assembly cured the fault. It was of different design, with two gears instead of one. Maybe this has happened before! **G.B.**

### Panasonic NVHD605B

Panasonic VCRs have tended to suffer from tuner problems, low gain and drift being common. More recent models have not been affected to the same extent. The symptom with this 1996 model was that the tuning had shifted. I initially thought that it had been lost, but discovered that the tuning points had all been shifted up the band uniformly. R7612/6 (330Ω) had obviously been getting pretty warm. The cause was the 0.01μF surface-mounted capacitor C7605, which was very leaky. **N.B.**

### Bang and Olufsen VX7000

This not too old model is based on an Hitachi machine, but with substantial additions and modifications. The complaint was "poor pictures", and was extremely intermittent. I initially found that the symptom could be instigated by gently manipulating one of the two connectors on the top of the head amplifier PCB. Once the pins of the connector had been recrimped the problem seemed to have been cured, but it returned when the machine had been on soak test for a few days. The cause was actually dry-joints at the connector at the base of the head amplifier PCB. It's connected to the rotary transformer in the drum assembly. Resoldering produced a lasting cure. **N.B.**

### Hitachi VTF860

There was crosstalk between E-E and playback audio. The cause was traced to C514R (4.7μF, 35V). **D.R.**

### Ferguson FV77HV

If there's defective or no rewind, check for 13.6V at pin 1 of BP03 and 21.8V at pin 2. Also check whether the 120Ω resistors RP75, RP83, RP84 and RP85 are open-circuit or poorly soldered. **D.R.**

### Sanyo VHR274E

This machine was dead with no display. Checks on the power supply proved that on

this occasion the machine was working. The supplies to the LED display were normal, but further checks showed that the always 5V supply was missing. Once this had been discovered it was easy to find the cause, which was the 2SC22747F series regulator transistor Q5101. **D.F.**

### **Sony SLVE720UX**

If speech sounds as though people are speaking through a long, hollow tube and there's a background noise, which varies with picture content, like the sea breaking on a beach, this is not a fault, just misadjustment. Use the remote control unit to enter the settings menu, then reset 'Hi-Fi - Mix' to off. **D.F.**

### **GoldStar P234i**

When play was selected the picture went off then returned. The E-E picture and its sound were OK, and the sound from the tape not affected. The cause of the trouble was in the power supply, where replacement of C19 (1,000 $\mu$ F, 10V) cured the fault. To be on the safe side I replaced all the electrolytic capacitors in the power supply. **C.W.**

### **LG PW904i**

The owner of this machine complained that the playback sound was distorted and there was a lot of background noise - but only with some tapes. He also mentioned that

the occasion the display was corrupted for a few seconds when the machine was powered from cold. I ignored the display fault to start with and spent much time in the hi-fi audio department. Getting nowhere, I decided to concentrate on the display fault. All the electrolytic capacitors in the power supply were replaced. This cleared the display fault and, you guessed it, the audio fault as well. The moral seems to be: if there are two faults, tackle the easy one first. **C.W.**

### **Hitachi VTF250**

This machine's capstan motor was very noisy. As a test I replaced it with one from another machine. Fortunately I hadn't ordered a replacement, as the fault was still present. A check on the supply showed that it was low with ripple. The cause was C12 (470 $\mu$ F), which is the reservoir capacitor for the A14V supply. **C.W.**

### **Panasonic NVF55**

There was no sound in any mode because the -8V supply to the audio pack was missing. D1108 (MA165) and C1112 (56 $\mu$ F) in the power supply section were both faulty. **C.W.**

### **Tatung TVC563**

Two of these TV-video combi units came to us from another dealer. They were almost new. The first one was stuck in

standby. The power-on command comes from the video PCB. A check at pin 35 of microcontroller chip here showed that it didn't produce a power-on output. There was a 10MHz clock signal at pins 67-69, and the reset pin 66 was OK at the high level. So it seemed that either the microcontroller chip or the EEPROM was faulty. The other unit worked, but search didn't stop when a station was found.

I compared the serial data from the EEPROM, pin 5, to the microcontroller chip in the two machines and found that there was a big difference. When I fitted the EEPROM from the working machine in the one that was stuck in standby it came on - but the tuning wouldn't stop at a station! The cause of the fault in both units had been found, EEPROM IC1099.

The EEPROM is supplied blank, and you will need the service manual to program in the 40 odd hex codes. The set that would sweep tune but not stop just needed reprogramming - the cure was to change the data at location OD from 00 to B3.

A very useful feature of these machines is the service display of running time. Neither machine had had more than eight hours' use from new. Note that the running time is shown in hexadecimal form.

I've since come across the same machine with the brand names **Bush, Alba** and **Goodmans. M.D.**

In this concluding instalment Eugene Trundle deals with problems that arise along the tape path after the tape has passed the drum, tape damage, the mode switch, how to deal with a jammed deck, intermittent faults and auto-diagnosis

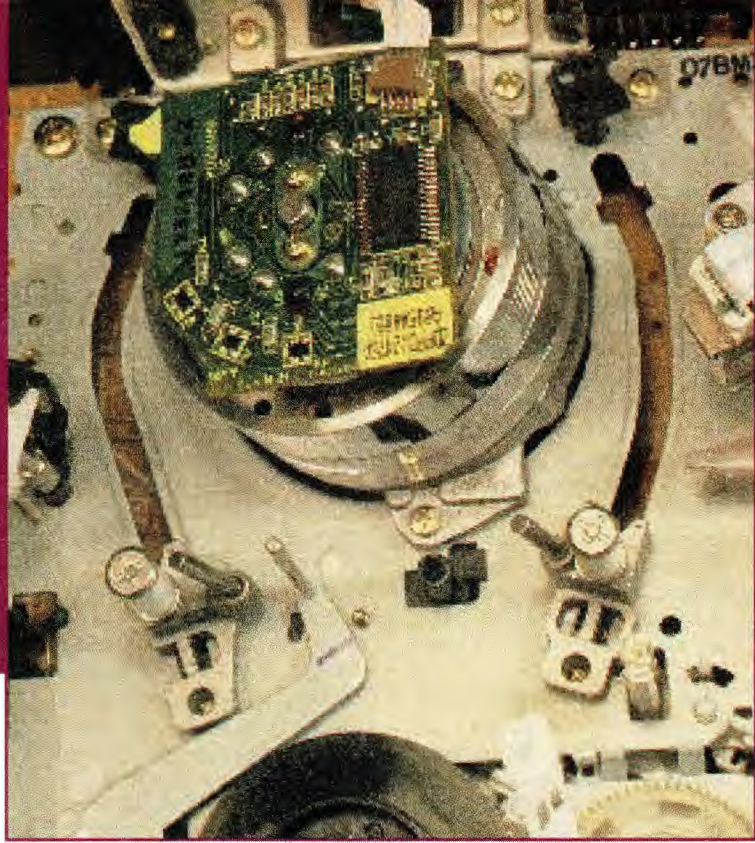

## Servicing

# VHS decks

Last month we covered the path of the slow-moving tape to the point where it parts company with the whizzing drum. Its next few centimetres of travel contain many potential trouble spots!

The first item it encounters is sometimes a moving ('half-load') guide pole that swings out from the cassette to route the tape past the ACE (audio/control/erase) head when the deck is in a fast-transport mode: it enables the control track to be read with the tape unthreaded. If the guide-pole arm is stiff on its bearing, the tape will catch in the works at eject. This occurs particularly with some old Sony decks. If the vertical pole or

its arm is bent, this will upset the tape's path across the ACE head, preventing readout and probably crinkling one edge of the tape.

### The ACE head assembly

The tape next passes across the face of the ACE head assembly, see Fig. 10. It must at this point be running perfectly parallel with the surface of the deck, and the head assembly must be truly vertical. An error here will have little effect on playback of the deck's own recordings, but those made elsewhere will produce very muffled and 'woolly' audio from the mono/longitudinal sound track because of azimuth error.

The head's azimuth (sideways tilt) is carried out to obtain optimum response from an alignment tape's 6kHz audio edge-track signal while the head is being rocked with the azimuth adjustment screw shown at the top left of Fig. 1 last month. The photo in Fig. 11 shows the adjustment being carried out.

ACE head height is set initially by visual inspection of the tape path (Fig. 10), then by adjustment for maximum audio head output as seen on an oscilloscope screen.

There are two other aspects to alignment of the critical ACE head assembly. The tilt screw, see Fig. 2, adjusts the assembly's 'lean forward': it's generally set so that the top (audio) section is slightly inclined towards the tape, to optimise sound transfer while not noticeably impairing the less critical writing and reading of the control track at the bottom edge of the tape. Too much tilt can lead to unreliable control-track pulse transfer and a tendency for the lower edge of the tape to bubble or scrunch on the lower flange of

Fig. 10: Tape path across the ACE head assembly and its vertical adjustment.

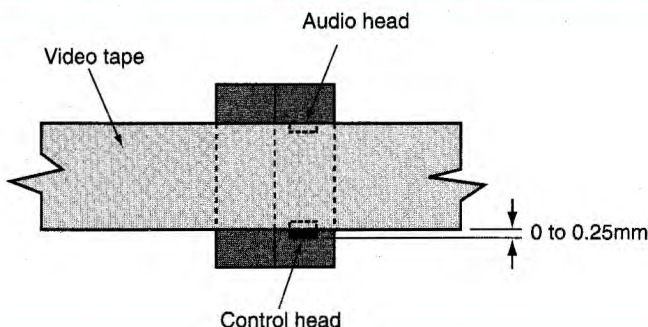

nearby tape guides.

Lateral positioning of the ACE head assembly is critical. Large errors cause bad sound/vision synchronisation ('lip-sync'); small errors upset the tracking. There's no effect when a maladjusted machine is playing back one of its own recordings. The trouble occurs when different machines are used for record and playback. The tracking error will however be corrected in modern designs that incorporate automatic tracking. But even with an auto-tracking model there will be instructions in the manual for lateral (sometimes called X) adjustment of the ACE assembly. This may involve the use of an oscilloscope to check relative pulse timings, see Fig. 12.

The usual problem with an ACE head is surface wear. This is most easily seen by reflection of a bright light from the face, using a dental mirror to check when the head is in situ. A ridge can be seen where the tape runs past the head. It's often more pronounced at one edge, either the top (audio head) or the bottom (control head).

The effect of a worn audio head is weak and muffled sound, especially with the machine's own recordings, together with hiss when the setting of the TV receiver's volume control is advanced to compensate. Control-track head wear leads to erratic servo control: the symptoms may be cycling noise bars on the screen during playback; wobbly sound with wow; or intermittent muting of the picture. With some models, notably older Panasonic ones, a worn, faulty or misaligned control (CTL) head produces the unexpected effect of speeding up the head drum, which returns to normal speed when the multiway plug at the ACE head is disconnected.

After the ACE head assembly the tape encounters a flanged tape guide – the most common one for a tape edge to crinkle on when there are tape-level problems in this area. As with the other guides, it's vital that this one is perfectly vertical and in the right place. If it's bent or damaged, replace it. If it's misplaced, check the mechanism phasing and the pinion, arm and/or cam that positions it.

### The pinch roller

The tape is pulled around the deck by the pinch roller, not the capstan. The roller, forced against the

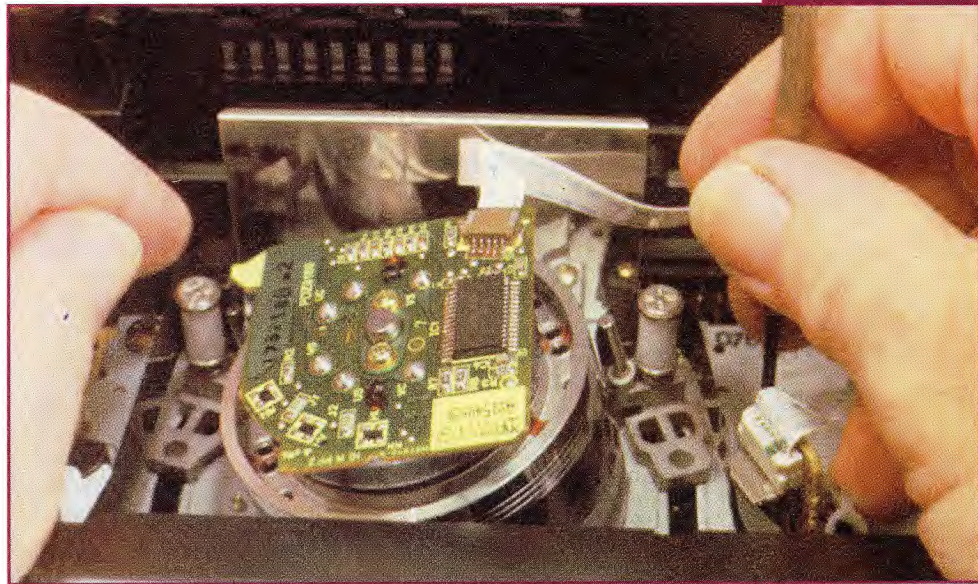

capstan by spring pressure of about 1.6kg, is driven by friction against the highly-polished capstan shaft, then grips and pulls the tape.

It's very common for the pinch roller to become worn, acquiring an almost mirror surface in some designs and getting to look like a lump of dry toffee in the old Philips Charlie decks. A worn or faulty pinch roller may lose its grip on the tape, especially when the lower drum is worn and sticky. The result is deck shutdown. More often the effect of pinch-roller wear is to bias the tape up or down as it passes, the result being poor or no transfer of the sound and control-track pulses. From the beginning of play (or after momentarily pulling the roller away by hand during play) you will see the tape slowly ride up or down the ACE head face and hear the sound fade down, while servo control becomes erratic or is lost. At this point the tape will probably begin to crinkle or scallop its edge on the adjacent tape-guide flange, as shown in Fig. 13. Should a worn roller work all right in the play and record modes it may have the effects described above in the cue and/or review modes, when it's driving the tape faster.

Never try to refurbish or treat the surface of a duff pinch roller. Replace it, preferably with one from the manufacturer rather than a 'pattern' type. Take particular care over removal and fitting when the roller is on a pivoted arm stamped out of sheet metal: this is easily bent by vertical force in either direction, leading to a repeat of the tape-path troubles described

above.

The pinch roller can also cause wow and flutter with reproduction of mono sound, and can be responsible for graunching noises that come from its internal bearing. When its surface is polluted or damaged it can impress little repeating patterns on the tape surface: these show, when the tape

**Fig. 11:** Adjustment of the audio head azimuth angle. Tune for maximum treble response with an alignment tape.

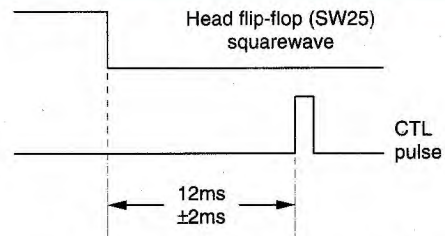

**Fig. 12:** One method of ACE head lateral adjustment with an auto-tracking VCR. Setting is carried out with an oscilloscope to check the timing difference between the SW25 and CTL pulses during playback of an alignment tape.

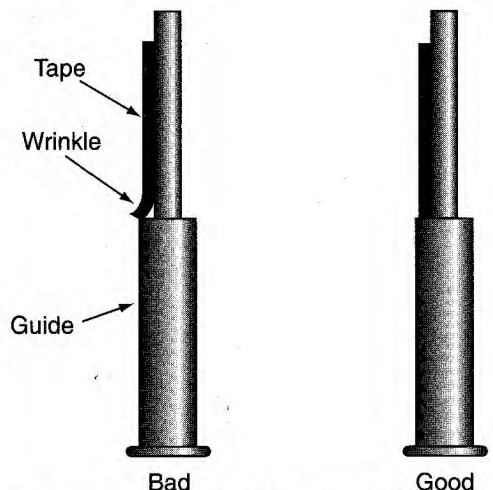

**Fig. 13:** Tape damage at the flange of a guide: the same can happen at the top edge if the tape rides upwards and a flange is present there.

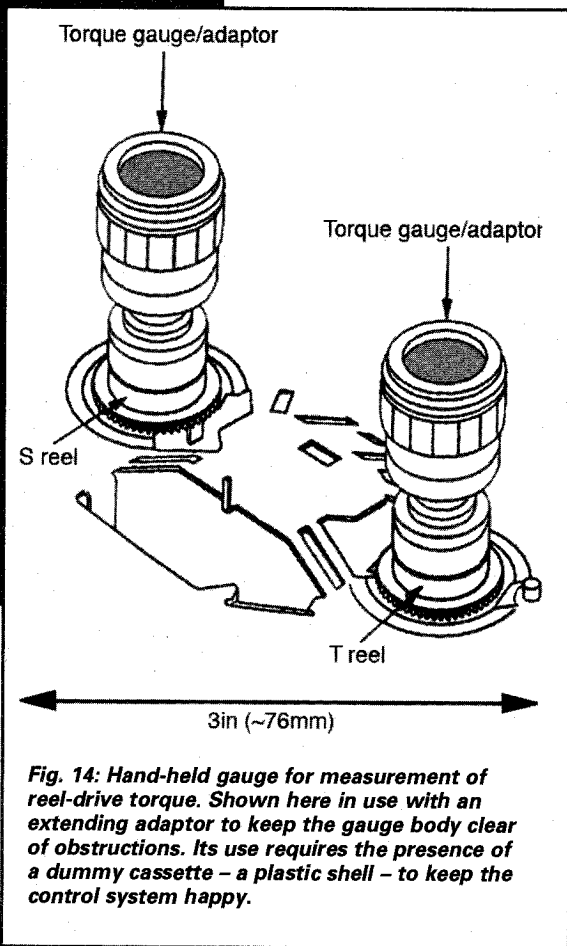

**Fig. 14: Hand-held gauge for measurement of reel-drive torque. Shown here in use with an extending adaptor to keep the gauge body clear of obstructions. Its use requires the presence of a dummy cassette – a plastic shell – to keep the control system happy.**

is next played, as regularly-cycling horizontal lines on the picture. So much for the pinch roller, a troublesome item indeed.

### The capstan

The capstan itself seldom gets into deeper trouble than the need for a good shaft clean. Stubborn dirt can be removed with a fibre pen, which will cause no damage to the hard, polished-steel finish. The capstan motor, which is almost always a direct-drive type, can and does give problems however. The symptoms can be failure to turn or insufficient torque; wow and flutter; irregular rotation, with effects on the sound and the picture tracking; and tape chewing because the supply spool fails to take up the tape during the unthreading process, leaving a loop of tape out of the cassette at eject.

Some types of capstan motor, for example older Hitachi ones, develop a fault that causes the on-board drive chip to become progressively hotter while running, with the torque steadily decreasing. A good indication of this is obtained by placing a finger on the chip. If your finger gets too hot for comfort, the motor is in trouble.

Capstan motors can seldom be

repaired, because their individual components are not available separately. The bearings can become tight or sticky – it's a common problem with old Hitachi and Sanyo decks. To cure this, dismantle the motor by releasing the clip or ring at the bottom of the shaft, remove the flywheel, then thoroughly clean the shaft and bearings. Add a tiny drop of light lubricating oil before reassembly.

Many deck designs have a flanged tape guide, sometimes called the review pole, see Figs. 2 and 3, downstream from the capstan. It again tends to damage the tape edge when the pinch roller is faulty or worn. But ensure that this guide is vertical, undamaged and correctly placed before looking elsewhere for the cause of this trouble.

### Take-up

The tape is next spooled on to the right-hand (TU, take-up) cassette reel. The spool turntable is driven by a clutch designed for a torque of about 60 or 80g/cm. This can be measured using a hand-held torque gauge, see Fig. 14.

Insufficient torque can be caused by a faulty clutch, a slipping drive belt, a tight clutch on the swinging reel-drive idler, or excessive reel braking. Don't mess with a faulty clutch assembly: replace it! With insufficient torque there's erratic take-up, the result being intermittent deck shutdown and/or tape looping at eject, the latter because the supply spool is turned backwards by the same clutch to retract tape during the unthreading process.

With excessive take-up torque, which is invariably caused by a faulty clutch, there can be wow and flutter with reproduction of mono sound and tape damage – the latter was very common with yesteryear's Amstrad decks. Some reel-drive clutches, notably those used on certain Daewoo decks, develop a 'snatching' action. As a result the tape is relaxed then tightened in very short cycles. This causes wow or flutter with sound from the mono track and, in severe cases, the back-tension pole at the other side of the deck oscillates.

### Fast transport

This means fast-forward and rewind. With these functions the reel-drive clutch is mechanically short-circuited, as it were. This should be checked when rewind/fast-forward is slow, or doesn't work with the machine

shutting down within a few seconds of the mode being selected. Clutch-switching is generally carried out by a mechanical slider or lever that's operated by the deck's main cam, driven by the loading motor, or by a 'grab' solenoid.

Other causes of slow or laboured fast-forward/rewind are slipping belts, reel brakes dragging, low capstan-motor torque or, when rewind takes place with the tape fully threaded, a 'sticky' lower drum (see previous notes and compare the tautness of the tape at each side of the drum).

### Tape damage

Mention has already been made of several causes of tape chewing. When a loop is caught in the works or left hanging from the cassette at eject this will be because the supply reel failed to take it up during the unthreading process. Check the points mentioned above, also that the reel idler pivots freely between the spool turntables; that the brakes on the latter or (if fitted) on the capstan-motor flywheel are operating correctly; and that the mode switch (see next section) is in good condition.

If the tape has been snapped at its end or pulled off the spool, the first thing to check is that the optical end-sensor is working correctly. If it is, it may be that the reel brakes are worn or not being applied fully, or that the reels are still rotating at full speed until the end of the tape – in this case the reel-rotation sensor(s) is the usual cause. These can also be responsible for deck shutdown within a few seconds of entering a mode. To distinguish between this and other causes of the same symptom, key play followed quickly by pause. If the tape now stays put, a reel sensor will be to blame – or its link to the control chip.

### The mode switch

The mode switch, which is also known as the cam switch, rotary encoder and slide encoder, is the most unreliable part of a video deck and a prolific source of fault symptoms – and repair jobs! Its internal contacts become dirty or oxidised, with the result that it sends unreliable data – or downright porky pies – to the control chip. The resulting fault symptoms range from tape scrunching and damage to mechanical deck components to deck shutdown, mechanical oscillation, loss of some functions

**Table 1: 'Emergency' data readout for a modern JVC deck.**

Emergency	Symptom	Detecting mode	Subsequent mode
E:01	Loading motor rotates for more than 8 secs without shift to next mode	Loading	Power off
E:02	Loading motor rotates for more than 8 secs without shift to next mode	Unloading	Power off
E:03	TU reel FG absent for more than 4 secs	Rec/play/FF/rew/ search FF/search rew	Stop then power off
E:04	Drum FF input absent for more than 3 secs	Rec/play/FF/rew/ search FF/search rew	Stop then power off
E:06	Capstan FG input absent for more than 4 secs	Rec/play/FF/rew searchFF/search rew	Stop then power off
E:07	No SWD5V/12V	Power on	Power off

The last two events are held in memory and can be called up as required.

and intermittent operation generally. If in doubt, replace it. You can get away with servicing it: dismantle it, thoroughly clean the contacts and rotary brush, retention the latter, then reassemble it with a squirt of switch cleaner/lubricant. But replacement is best where possible – it's cheap enough!

A good idea of the condition of a mode switch can be obtained by connecting a DC-coupled oscilloscope to each of its active pins in turn and watching on screen the effects of selecting the various deck functions. A bad switch will be betrayed by noise and hash on the control lines – sufficient to confuse the control chip totally.

It's vital that the mode switch is correctly phased to the deck mechanics. Diagrams are provided in service manuals. The correct position is indicated by a notch, hole or mark on the switch rotor and a corresponding one on the bar, slider pinion or whatever drives it. Ensure that the deck mechanism is in the 'reference' position at the time: this may be stop (tape in and unthreaded) or eject.

A few deck designs have dispensed with a mechanical mode switch, most notably some Philips types in which a rotating 'butterfly' is used instead, in conjunction with an optocoupler. They are more reliable for it!

### Jammed deck

A tape sometimes gets stuck in a jammed or non-operational machine and prevents dismantling for investigation and repair because it masks one or more of the deck fixing screws. Instructions

for dealing with this difficult situation are sometimes given in the service manual or, as in recent JVC designs, there's a means of release by removing the cassette cradle's top plate and then the cassette.

In other cases, particularly where access is possible to the underside of the deck, you can often drive the mechanics by hand or by applying an externally-derived 6-10V supply to the loading motor. If you do the latter, be sure to disconnect the motor from the VCR's electronics, otherwise you will wreck the motor-drive chip. While the tape is being unthreaded in this way, it may be possible to prevent tape damage by turning the capstan flywheel by hand to take up the slack.

Another approach, usable only where its fixing screws are accessible, is to remove the front-load cradle assembly and lift it out, complete with the cassette.

### Intermittent faults

The most common causes of intermittent or spasmodic deck faults are: the mode switch; slipping drive belts; wear and slippage at other friction surfaces, for example at reel idlers and brake pads; and the unpredictable effects of hard, dried grease on moving parts, for example in older Mitsubishi decks where, amongst other things, it can cause breakage of part of the capstan assembly.

In later Orion decks, used by Tatung and others, the centre LED (used for cassette-in and tape-end detection) can be responsible for intermittent operation.

### Auto-diagnosis

Many modern VCRs have an auto fault-diagnostic system built into their control processor. It produces an alphanumerically-coded indication of why the system instigated deck shutdown during an 'emergency routine'. This is useful when investigating a deck fault, particularly an intermittent one, if fault data is stored even when deck operation subsequently returns to normal. The feature is not always obvious. Look in the service manual for instructions on calling it up and interpreting the codes.

An example of data readout, for a JVC HRJ-series machine, is shown in Table 1. This particular model requires the use of a special presetting unit (technician's remote-control unit): to bring up the diagnostic display, hold down the N key for more than two seconds.

### In conclusion

It has not been possible in this article to cover all the problems that may crop up in all deck designs. For specific faults by model and deck type there are various sources of information – the technical advice lines of the manufacturers concerned, the disc index to the wide-ranging coverage of *Television* magazine's VCR Clinic feature, and the CD-ROM Euras guide to faults. Before you turn to any of these however take a good, analytical look at the deck concerned in operation. It might well save you having to use the phone or boot up the computer. ■



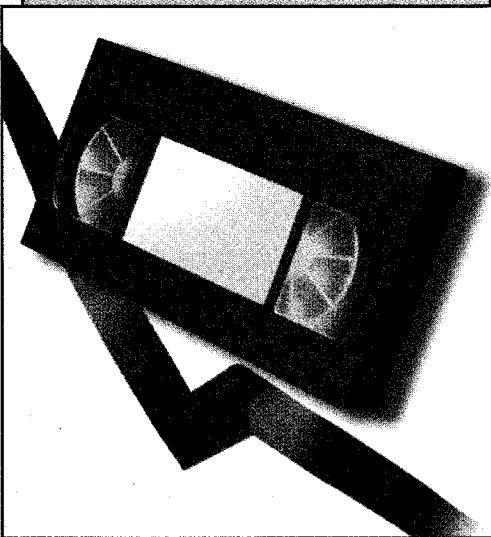

## VCR CLINIC

Reports from  
Eugene Trundle  
Chris Watton  
J.C. Sebastian  
Roger Burchett  
Denis Foley  
Nick Beer  
Stephen Leatherbarrow  
Shane Humphrey  
Nicholas Arnold and  
D.M. Thomas

We welcome fault reports from readers – payment for each fault is made shortly after publication. See page 554 for details of where and how to send reports.

### Sony SLV373UB

These decks may be ten years old, but many are still in use and working well. A common problem is tape looping at eject, because of a stiff pivot-bearing on the RVS arm. We've now found that another cause of this symptom is a worn brake on the take-up reel turntable. E.T.

### Aiwa HVF125

There was no RF output from this machine. Not having a circuit diagram, all I could do was to check that there was a supply to the modulator. Pin 5 was at 5V, but all the other pins were at 0V. I assumed that this was OK, but as I was about to start unsoldering the modulator I spotted that IC307, which is an N10 circuit protector, was open-circuit. A replacement restored the RF output – at much less cost than a modulator repair. C.W.

### LG BC969i

This new VCR had apparently died while recording. I carried out some checks on the outputs from the power supply and soon discovered that the 1N5822 Schottky diode D106 was short-circuit. C.W.

### Sanyo VHR251E

The customer said that the picture and sound disappeared after a few minutes, leaving just a blue screen, when the machine's own recordings were played back. Playback of prerecorded tapes was OK. Voltage and current checks in the record/playback paths failed to reveal anything amiss. The cause of the trouble turned out to be mechanical: the tension-band lever was out of position. The cure was to adjust the tension band as laid down in the manual. J.C.S.

### Sony CCD-F335

The E-E and playback sound had gradually faded away until it was non-existent. On investigation I found that the surface-mounted electrolytic C420 (1 $\mu$ F, 50V) had leaked. Because the fault had been left so long, the copper had been eroded at one point. Fortunately it was repairable. After that the camcorder worked normally but, to avoid bounces, I obtained the owner's permission to replace all suspect electrolytics. R.B.

### Sony CCD-F330

This well-used camcorder suffered from surface-mounted electrolytic capacitor problems. The playback pictures were, as usual, affected by the five 22 $\mu$ F, 6V capacitors C317, C320, C330, C348 and C353 on board SS86. The E-E and thus the recorded pictures were severely broken up.

To be on the safe side I replaced C790 and C791 (both 33 $\mu$ F, 4V) on board VC50 and C808 (4.7 $\mu$ F, 35V), C812 (22 $\mu$ F, 6.3V), C810 and C816 (both 10 $\mu$ F, 16V) on board VC51.

As usual, it was the 22 $\mu$ F capacitors that were causing the problems and, as usual, the boards were undamaged.

Another CCD-F330 was brought in because there were striations on the E-E and playback pictures. The culprits were C494 (10 $\mu$ F, 16V) and C497 (22 $\mu$ F, 6.3V). To be safe, I did a blanket electrolytic capacitor replacement job. R.B.

### Granada/Finlandia VHS-LH7G (Hitachi VTF250E)

This machine would accept a cassette. But when eject was pressed it would unlatch, the capstan motor would 'grumble', then it would latch up again. A clue was provided by the fact that the LED display dimmed slightly during the 'grumble' period. So attention was turned to the power supply.

I found that an LT smoothing capacitor, C12 (470 $\mu$ F, 16V, 105°C), was faulty. A replacement restored normal operation. This model seems to be similar to the Hitachi VTF350E. D.F.

### Aiwa HVGX770K

The complaint was dead with no display. I found that the 5V rectifier D517 was short-circuit. It's a Schottky-GL diode, type SB340L. Type 1N5822 seems to be a cheaper equivalent. D.F.

### Sharp VLE66

This Viewcam unit was dead. On investigation I found that CP901 was open-circuit because the display DC-DC converter can was faulty. N.B.

### Toshiba V711B

This machine had a general reluctance to return the tape to its owner. All other functions were all right, including acceptance of tapes. I stripped the carriage right-hand side, then cleaned and refitted the switch. After that all was well. S.L.

### JVC HRD610

The cause of a recent case of the machine being dead when the family returned from a short break was traced to C12 in the power supply unit. S.L.

### Panasonic NVDH600B

There was a tricky problem with this machine. The tuning wasn't 'positive', with occasional tuner drift – usually only slight. The cause was eventually traced to C7605. It's an 0.1 $\mu$ F, 50V capacitor, part no. ECUM1H1042FN. Come to think of it

we've had failure of this type of capacitor in many Panasonic colour TV sets and VCRs over the years. **S.L.**

### **Sharp VCM20HM**

Intermittent failure to accept a tape or intermittent stopping can be caused by faulty start or end sensors. They can be obtained from WVE under part no. 0233GEZZ. **S.L.**

### **Sony SLVAV100**

Echo on the playback sound is a complaint we still get with these machines. Don't waste your time looking for the cause of a fault however – it doesn't exist! Go to the audio menu and deselect the audio mix mode. **S.L.**

### **Mitsubishi HSM50**

The symptom looked like that produced by dirty heads. We've been fooled by this before however. A sharp tap on the deck removed the symptom. The cure is to remove the head amplifier and resolder the connector connections. Redo all the panel earths at the same time. The fault can be very intermittent. **S.L.**

### **Toshiba V213B**

This machine was dead with a slight whistling sound from the power supply unit. Z821 turned out to be the cause. It's in the always 14V supply. The part no. is 23144480. **S.L.**

### **Samsung SV231BV**

There was no record sound, though prerecorded tapes played back OK. The cause was traced to resistor R3A19, which feeds the record signal to the audio/control head assembly. It had not been soldered in place correctly during assembly, and made only intermittent contact with the PCB print. Resoldering cured the fault.

We've had another of these machines in the workshop recently, this time with no record or playback audio. The audio/control head assembly had to be replaced. **S.H.**

### **Matsui VP9601N Mk 2**

The cause of weak sound and cyclical mistracking turned out to be a faulty pinch roller. Although the original pinch roller didn't appear to be at all misshapen and was unusually clean, it made the tape ride fractionally high over the audio/control

head assembly. Turning the roller upside down proved the point, and a replacement cured the problem.

The sound problem was obviously not present when a tape with hi-fi sound was being played but, oddly, the mistracking was also much less pronounced.

I gather that this machine uses a **Tatung** deck. **N.A.**

### **Panasonic NVHD600**

There was no record picture. Playback and the recorded sound were OK. The cause was Q3002 (BC856B) which was short-circuit. As a result there was no 5V record supply at pin 2 of the head amplifier.

**D.M.T.**

### **JVC HRJ265**

This machine was dead with no display and no functions. The cause was zener diode D5301, type MTZJ15A, which was short-circuit. **D.M.T.**

### **Goodmans/Daewoo VP2500**

There was no playback – it looked as if one head was faulty. The cause was C408, which is connected to pin 89 or IC301. **D.M.T. ■**

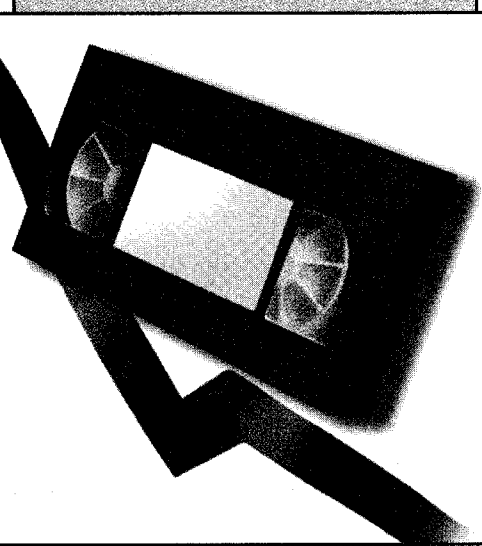

## VCR CLINIC

Reports from  
**Eugene Trundle**  
**Roger Burchett**  
**Robin Beaumont**  
**Ronnie Boag**  
**John Coombes**  
**Peter Tennant**  
**Chris MacRae and**  
**Glyn Dickinson**

We welcome fault reports from readers – payment is made for each fault published. See page 682 for details of where and how to send reports.

### **Sony SLV-ER7UY**

We've had a couple of these machines in the workshop with the same symptom: the deck shuts down a few seconds after a function is selected, or at a random time during any form of tape motion. In both cases the cause was dry-joints at drum motor plug CN1 on the under-deck of the MD56 PCB. **E.T.**

### **Hitachi VTF645E etc**

The VTF645E shares with various other Hitachi models the **US deck**. A problem that's now becoming common with this deck is no spool rotation, with tape spillage during eject. Usually you will find that the reel-drive pulley/clutch assembly (part no. KX11443) has slid down its shaft and is out of engagement.

If the same symptom is present intermittently, the possibilities are: a damaged back-tension band; faulty change and/or gear drives KF10513 and KF10501; or even a faulty capstan motor. **E.T.**

### **Daewoo DVF502**

This machine spent many days on the soak-test bench before it revealed the cause of intermittent deck failure. We finally saw that the cause was very simple – the loading belt occasionally slipped. SEME stocks it under part no. BELT4154. **E.T.**

### **Ferguson FV95HV**

Since this machine had died during a thunderstorm and simultaneous power cut, we feared the worst. No short-circuit semiconductor devices were found in the power supply, but a scope check showed that it was pumping at a rate of about 1Hz. I was relieved to find that replacement of the electrolytic capacitors CP007 (10 $\mu$ F, 50V) and CP008 (100 $\mu$ F, 25V) on the primary side of the power supply cured the fault. **E.T.**

### **Aiwa HVFX1500**

This VCR would sometimes stop during loading or eject and shut down. A mode switch problem of course. It's easy enough to dismantle and clean the switch once the deck has been removed. **R.Bu.**

### **Philips VR600/05 (Apollo 11 chassis)**

The dealer who sent this machine to us said that the recorded pictures were poor. He thought that playback was OK, but our test-pattern tape revealed line jitter and low luminance level. The fault was present when using the scart output, thus eliminating the RF modulator. Oscilloscope checks showed that the video waveform was poor,

with low-amplitude sync pulses, severe ringing on syncs and LF video loss. The E-E signal was normal.

Most of the video processing in this machine is carried out by the LA71527M chip IC7007. It can be difficult carrying out measurements on the underside of the board while the machine is playing back, but I was able to establish that the video output waveform at pin 25 was good while the return video waveform at pin 26 was distorted. The only components between these two pins are a de-emphasis network, the emitter-follower transistor Tr7002, and capacitor C2012.

C2012 is a 4.7 $\mu$ F electrolytic. The fault cleared when I bypassed it, so I fitted a replacement. On test the original capacitor read completely open-circuit. **R.Be.**

### **JVC HRJ625**

If the symptom is failure to accept tapes, replace the change arm assembly and the mode switch. **R.B.**

### **Akai VSJ217**

There was no rewind and tape was left out on eject. The cure was to replace the broken clutch assembly. **R.B.**

### **Sanyo VHR278**

This machine would cut out in the fast forward and rewind modes and leave tape out on eject. The cure is to replace the complete mounting clutch, part no. 613-175-0661. **R.B.**

### **Tatung TVR774N**

If the fault is no E-E sound, try replacing the NV memory chip. This usually provides a cure. **R.B.**

### **Ferguson FV67**

The complaint was no results. On investigation I found that there was no voltage at the base of TT26 though there was 6.5V at its collector. The cause was IT25 (U2559B). Check it by replacement. **J.C.**

### **Panasonic NVFS1**

If the complaint with one of these VCRs is no results, check C1045 (47 $\mu$ F, 10V). It tends to loose capacitance or develop a high ESR. Another symptom caused by this capacitor is intermittent operation. **J.C.**

### **Philips VR676**

This model is fitted with the **Queen deck**. If one of these machines won't accept a cassette, remove the lift assembly and check the long metal bar with a cog at each end. These can crack, with the result that the cassette jams when inserted.

Unfortunately they are not available separately. You have to order a complete lift assembly, item 150, part no. 4822 443 64112. **J.C.**

### **Ferguson FV33H**

In many cases the cause of no results is the fact that the STR10006 chopper chip IC1 is short-circuit. Sometimes the 39V zener diode D25 doesn't go short-circuit quickly enough to protect IC1. When you find that IC1/D25 are short-circuit, check whether R9 has gone open-circuit. **J.C.**

### **Samsung SV421K**

If there is no display or a dim one, the item to check is C37 (100 $\mu$ F, 16V). In one recent case I found that the capacitance had fallen to 25 $\mu$ F while the ESR reading was very high at 20 $\Omega$ . **J.C.**

### **Panasonic NVHD660**

There was a cassette stuck in this machine, with no eject action. The diagnostic display showed H02, which means no capstan drive. But, after dismantling the cassette housing, I found that the 2SD25440PQA 12V regulator transistor Q1007 in the

power supply section was the cause of the trouble. It's mounted on the main PCB and, if incorrectly positioned, the action of the shaft unit can rip its legs off. **J.C.**

### **Hitachi VTF645**

If there are no outputs from the power supply check whether C6 (1 $\mu$ F, 250V) is open-circuit. **J.C.**

### **Sanyo VHR277**

If the complaint is no results, check the power supply to ensure that there are no capacitors with their jackets shrunk or dried up. If there are no problems of this sort, check whether circuit protector PF512 (1A) is open-circuit. **J.C.**

### **Hitachi VTM720**

Any number of faults in the power supply could cause the no results with no display symptoms. In this case however the cause turned out to be a faulty mode switch. **J.C.**

### **Toshiba V813B**

This VCR wouldn't record – all other functions were OK. The actual symptom was repeated recording for two seconds with

two-second pauses in between. If the VCR was left, this would continue for as long as it was on timer or straight recording.

It took some time to discover the cause. After stripping out the deck and PCB I found that there was a hairline crack in the PCB, at the left bottom edge near the lower drum assembly. **P.T.**

### **Matsui VP9407A**

A customer gave me this almost new VCR. He thought it was faulty and had bought another one. All that was wrong was that the RF output had been disabled. To set the RF output or enable it, hold the on button on the VCR down until the display flashes off, then select RF output with the VCR's channel down button. **C.MacR.**

### **Hitachi VTM722 and 822 series**

These VCRs can suffer from odd faults such as unstable audio, sticking in the LP mode, servo hunting and so on. Once the fault area has been isolated, replace the 4.7 $\mu$ F capacitors there and the fault will be cured. These capacitors usually leak. Oddly, it only seems to happen with the 4.7 $\mu$ F capacitors. **G.D.**

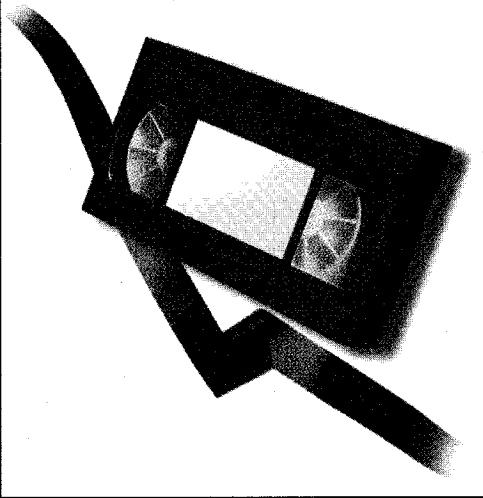

## VCR CLINIC

Reports from  
**Eugene Trundle**  
**John Coombes**  
**Martyn Davis**  
**Roger F. White**  
**Ronnie Boag**  
**Geoff Butcher and**  
**Nick Beer**

We welcome fault reports from readers – payment for each fault is made after publication. See page 746 for details of where and how to send reports.

### **Toshiba V312B**

The front panel didn't light up and there was no action or response – except that the head drum was whizzing around faster than normal! Checks showed that there was low-frequency ripple on the outputs from the power supply. The culprit turned out to be DP15, a 3.9V zener diode that's wired across RP33 on the primary side of the power supply. It was short-circuit. This item is not shown in the circuit diagram, and was not fitted in all production batches. **E.T.**

### **LG KE14U43**

This TV/VCR combi unit had a nasty buzz on sound, but only with tape playback. Consultation with LG revealed that replacement of three capacitors helps with early production units like this one. Change the value of C358 on the video panel from 0.022 $\mu$ F to 0.033 $\mu$ F. It's connected to pin 65 of IC300. On the TV board, change the value of C607 to 100 $\mu$ F and C603 to 56nF. With this particular machine there was also cyclic variation of the off-tape sound volume. It was cured by giving the ACE head assembly a little more 'lean-forward' into the tape. **E.T.**

### **Aiwa VX-T1450K**

Access is good with this TV/VCR combi unit, and the deck can be got going for test while it's out of the cabinet. There was little sign of life with this one until fuse F90 had been replaced. The capstan motor rotation was then intermittent, the result being shut-down, chewed tapes etc. The motor itself was responsible. It's available from CPC under part number AWS6-003-030-600 at a little over £40 net. **E.T.**

### **Hitachi VTF450**

Noisy playback, rewind and fast forward can be caused by the cassette housing's failure to drop the cassette low enough for correct drive. In this case however the cause proved to be a faulty tooth-type drive belt, which stretches and knocks on the chassis. To prevent stretching of the new belt, replace the take-up pulley as well. **J.C.**

### **Mitsubishi HS721 etc**

The mode operation diodes can fail, causing a number of symptoms. In this case the machine cut out in playback after a few seconds because D5A9 and D5A1 were faulty. Other symptoms caused by faulty mode operation diodes include failure to accept a tape in the standby mode, no tape-remaining indication, and no tape autplay only without its tab (in this case tape ejection may not work).

There is a modification kit which consists of all these diodes. It applies to the HS600 mono series and the HS700 mono and hi-fi series. **J.C.**

### **Toshiba V404B**

No results because of a power supply problem can be caused by CP007 and/or

CP008. Check them by replacement. **J.C.**

### **Mitsubishi HS621**

The customer complained that this machine was either dead or ran erratically. There was no trouble once the following electrolytic capacitors had been replaced: C910 (4.7 $\mu$ F, 5V), C915 (2.2 $\mu$ F, 50V) and C9A3 (1,000 $\mu$ F, 10V). **M.D.**

### **Sharp VCM301**

This machine was brought in because there was no deck operation. Curiously, the power supply was OK. After much hunting around I discovered a dry-joint at Q9903, on the secondary side of the power supply. **M.D.**

### **Mitsubishi HS750V**

This machine came in with the complaint "dead – won't accept tapes". Checks showed that the power supply was working and that all the main voltages on the secondary side were apparently correct. But the 6.5V that should be present at D9AZ was low at only about 1V. Once C9A3 (1,000 $\mu$ F, 10V) had been replaced this voltage was correct and the machine ran normally. **M.D.**

### **GoldStar PW904I, T1631**

If the fluorescent display is dim, replace C25 (100 $\mu$ F, 10V) in the power supply. **M.D.**

### **Sharp VCH81H**

There was no capstan rotation. After checking the supplies to the motor I took a closer look at the motor itself and found that a 10 $\mu$ F, 25V capacitor had leaked on to the motor's PCB. As a result the print was open-circuit. A fairly neat repair was possible, and after fitting a replacement capacitor everything was OK. **R.F.W.**

### **Lloyds L444**

The display had just two zeros, with occasional flicker, and there were no functions. It was the first time I'd ever seen a Lloyds VCR, but the Sharp deck was familiar. The fault was in the power supply however, where a 3,300 $\mu$ F, 25V radial electrolytic capacitor had a slight bulge in its top. When I unsoldered it one leg fell off. A replacement restored normal operation. **R.F.W.**

### **JVC HRJ665**

This machine went dead intermittently. The cause was dry-joints at DS207. **R.B.**

### **Sanyo VHR789**

This machine wouldn't accept tapes. A check showed that there was no voltage across the loading motor, which was short-circuit. **R.B.**

### **Akai VSJ717**

There was no playback or E-E sound. Replacement of the TDA9605 chip IC801 cured the fault. **R.B.**

## **Matsui VP9505**

This machine would sometimes eject a cassette immediately after insertion. At other times it would thread up and work normally. A new mode switch made no difference.

Some cassettes seemed to be more troublesome than others. Having found one that never seemed to work, I discovered that the left-hand end of the lift didn't go home fully. As a result, the cassette-down switch didn't operate and the machine ejected the tape.

I found that a new lift assembly, part no. HOUS471, is available from SEME at a surprisingly low cost, so it wasn't worth messing about with the original one. Once the new lift assembly had been installed the machine worked correctly at all times.

**G.B.**

## **Panasonic NVA3B**

A colleague was having problems with this VHS-C Slimcorder. When power was

applied the chopper circuit started up but was pulsing. A raster appeared in the EVF then disappeared, and there was no video at the AV outputs. He had disconnected the camera head to eliminate the effect of a fault in this area – we occasionally get jammed iris motors for example – but this had made no difference to the symptoms. There didn't seem to be any shorts across the outputs from the power supply, and hot checks were inconclusive because of the speed of the pulsing.

I was able to establish that when the power supply started up its three main outputs appeared. Not all three feedbacks were present however. The camera 18V and -8V supplies provided via T1001 came up momentarily, like the others, but feedback at pin 22 of IC1001 was nil. I then found, by carrying out DC checks, that the 22k $\Omega$  surface-mounted resistor R1008 was open-circuit. When I inserted a temporary replacement, from a scrap PCB, the unit seemed to be working

properly but the camera section was still disconnected. When it was plugged in the fault returned!

Disconnecting the camera section cleared the pulsing. So there had been two faults. It's relatively easy to establish the nature of a fault in the camera head as there are only two connectors, one for the lens motors and sensors and the other for the imager. In fact the imager was the cause of the problem. No shorts could be detected, and none of the few surface-mounted components on the flexiprint was the cause. A new imager restored order – and sanity.

Note that the imager's part number changed during production. The part number in the manual, VEK7146, applies to earlier models with a shorter FPC. The later part number, VEK7375, applies with the longer FPC. **N.B.**

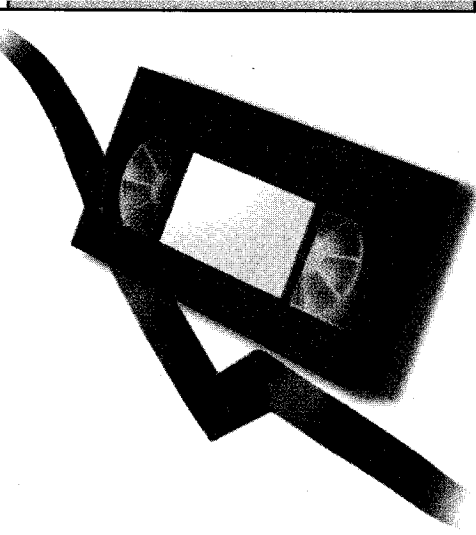

## VCR CLINIC

Reports from  
**Michael Dranfield**  
**Eugene Trundle**  
**Michael Maurice**  
**John Coombes**  
and  
**Bob Flynn**

We welcome fault reports from readers – payment for each fault is made after publication. See page 42 for details of where and how to send reports.

### **Samsung SI1240**

There was no capstan motor rotation. On investigation I found that the tiny 10 $\mu$ F, 25V electrolytic capacitor on the motor PCB had leaked electrolyte which had eaten away the 12V supply track. This is a very common fault with Sharp machines, but I've never previously come across it with any other make of video. **M.D.**

### **Crown CRV97**

This Daewoo VCR failed to come back on after a thunderstorm and power cut. Simple I thought: just replace the 1 $\mu$ F capacitor in the power supply. When I did this the VCR came back on but wouldn't rewind or fast-forward very well, while the drum ran too slowly and hunted.

After ruling out the power supply I scoped the drum speed control signal at pin 3 of IC501. Its mark-space ratio was all over the place. Perhaps the EEPROM, IC503, had been corrupted. But when I scoped its serial clock line I found that the clock frequency was drifting erratically. Now the EEPROM data is clocked by the microcontroller chip, which has an external 16MHz clock crystal, X501. When I connected a frequency counter, via a  $\times 10$  probe, across X501 the VCR's fluorescent display went off. This suggested that the crystal was faulty, and indeed a replacement provided a complete cure. I obtained it from Farnell Electronic Components – part no. 485-093. **M.D.**

### **Sony SLV-SE700**

There was a cassette trapped inside this machine and the mechanism was jammed. At switch on the loading motor pulsed once only. Investigation showed that the main loading cam was at an angle with respect to the deck plane. When it was removed the plastic spigot on slider B was seen to be bent and distorted – it had escaped from the cam groove. A new slider, part no. 3-053-878-01, restored normal operation. **E.T.**

### **Sony SLV-E720UX**

This machine's front-panel display operated intermittently. The cause was several dry-joints at connector CN601 on the power supply board. **E.T.**

### **Sony SLV-F900B**

This quite new machine was completely immobilised – in fact there was no sign of life at all. The mains fuse was found to be intact, and a check showed that charging current was drawn from the mains supply at switch on. Normal operation was restored once C153 (47 $\mu$ F, 50V) and C154 (1 $\mu$ F,

50V) in the power supply had been replaced. **E.T.**

### **Amstrad DD8900**

The E-E picture produced by this machine was very poor. It didn't look like a power supply fault, and in fact the cause was in the IF module. I decided to replace all the electrolytic capacitors in this module. This cleared the fault. **M.M.**

### **Panasonic K mechanism**

The cause of failure to accept a tape and no tape eject with F03 shown in the display is often, but not always, a cracked loading motor coupling. Sometimes a faulty mode switch gives the same symptoms. It's advisable to replace both items. **M.M.**

### **Hitachi VTF360E**

The symptoms were poor mono sound and picture flickering, with noise bars going through the picture. Observation revealed that the tape was riding up the audio/control head. I initially suspected the pinch roller, but the cause of the trouble was the back-tension band – the pad had parted company with it. A new back-tension band restored correct operation. **M.M.**

### **Sony SLC5**

The customer's instructions were to repair this machine whatever the cost! There was no play or fast-forward operation, though rewind was possible. The cause of the trouble was the BOT sensor, which was short-circuit. Even after seventeen years it was still available from Sony. So were all the belts and the rewind modification kit. The machine worked extremely well after these items had been fitted. I wonder how many of today's VCRs will be working in seventeen years' time?! **M.M.**

### **Hitachi VTF150**

This machine wouldn't play tapes because the half-load arm failed to pull the tape up to the capstan shaft. The reason for this was that the spring on the half-load arm had broken. It's supplied only with the half-load arm assembly, but once this had been fitted the VCR worked perfectly. **M.M.**

### **Toshiba V703B**

The sound was very poor with a definite wow. I had to replace the capstan motor and the pinch-roller assembly. **M.M.**

### **JVC HRS5900**

The customer said that this machine would sometimes switch itself off. It had received previous attention – the mode switch, pinch roller and control plate had been replaced.

In view of the symptoms I decided to replace both end-of-tape sensors and both reel sensors. A check with the customer a few days later confirmed that all was now well. **M.M.**

### **Toshiba V854**

There was no audio from this machine and the record indicators were flat out. The cause of the trouble was the multi-standard MSP3410 sound processor chip ICD03. It's on the MPX board. **J.C.**

### **Sony SLVE520U**

There are several power supply causes of the no results symptom, but a common one is circuit protector PR512. Note that it has been uprated to 1.25A from 1A. **J.C.**

### **GoldStar GSEQ210 (D17 series deck)**

Tape damage is usually caused by a faulty pinch gear and take-up lever. The damage occurs when a cassette is ejected. If the old-type parts are fitted, the take-up guide will be in a forward position after replacement of the pinch gear and the take-up lever will position the guide so that it faces to the left

of the deck. When first installing the unit remember that the guide may look as if it's in the wrong position but is actually set correctly. **J.C.**

### **Ferguson FV11**

There was no mechanical operation and checks soon revealed that there were no 5V and 12V outputs from the STK5481 chip IC1. A replacement restored the voltages but there was still no reel motor operation. The cause was traced to Q605 (2SC2560). **J.C.**

### **Aiwa HVFX1500**

This machine wouldn't eject tapes. The cause was a cassette housing fault. When I dismantled the unit I found that the slide lever was broken. It's item 429 in the parts layout in the service manual. **J.C.**

### **Sony SLV625**

A problem you can get with these machines is cutting out in playback or record. The VCR may work in playback or record for several minutes, then just stop. The cause is faulty sensors, HP001 and HP002. Check them by replacement. **J.C.**

### **Sanyo VHR776E**

This machine was dead and a quick check revealed that the 2.5A mains fuse F5001 had blown. The cause turned out to be the BC10 mains bridge rectifier D5001, which was short-circuit between the positive pin and one mains input pin. **J.C.**

### **Mitsubishi HSM40V**

This machine would leave a loop of tape when a cassette was ejected, especially after rewind. The usual cause is the mode switch, but not this time. Replacement of the idler reel assembly, item C035 in the diagram, cured the problem. Rewind operation was still a bit noisy however. This was cured by cleaning and lubricating the shaft of the take-up gear spool, item C031. **B.F.**

### **Hitachi VT410**

This old-timer showed no signs of life. On investigation I found that there were no switched voltage outputs from the power chip because it wasn't getting a power-on signal. The fault was eventually cured by replacing the LA7935 chip on the VST tuning panel. Hardly an obvious cause! **B.F.**



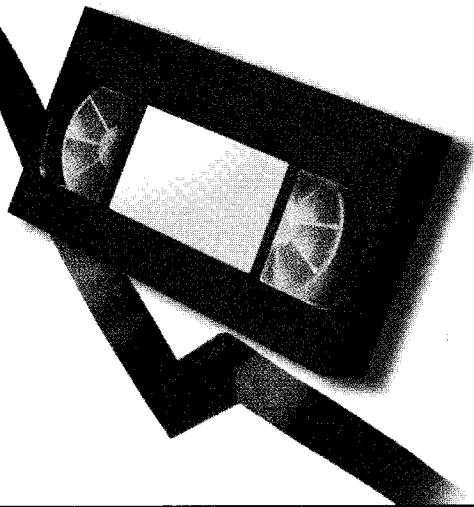

## VCR CLINIC

Reports from  
**Eugene Trundle**  
**David Gough**  
**Chris Avis**  
**Ronnie Boag**  
**John Coombes**  
**Bob Flynn**  
**Gary Laidler and**  
**Graham Boor**

We welcome fault reports from readers – payment for each fault is made after publication. See page 106 for details of where and how to send reports.

### Sony SLVE720

There was no trouble with the RF-through path but the E-E and record pictures would intermittently become grainy. At the same time the sound disappeared, being replaced by a low-level buzz. The cause was bad soldered joints inside the tuner module, where the earth print is connected to the metal frame.

To ensure a good bond in cases like this we now bypass the original joint with a short wire link between the print and the wall of the tuner can, using lots of liquid flux before the soldering. **E.T.**

### JVC HRJ670

On rare occasions a loop of tape would be left hanging from the flap when the cassette was ejected. The problem was solved (we assume, as we've not heard anything since!) by replacing the idler-arm assembly and idler lever B. The part numbers are LP40114-008A and LP30236-002B respectively. **E.T.**

### Daewoo V50

This VCR came in dead with no display. I suspected electrolytic capacitor problems in the power supply, and some ESR meter checks soon confirmed this. The following were all faulty: C53 (1 $\mu$ F, 100V); C66 (33 $\mu$ F, 6.3V); C63 and C65 (both 22 $\mu$ F, 50V). It's also worthwhile removing the power supply can and resoldering all the dry-joints. Replacement capacitors and some resoldering restored normal operation. **D.G.**

### Panasonic NV-A3

The customer complained that this palmcorder wouldn't zoom. When I operated the zoom control with the machine on the bench I got what seemed to be a momentary movement from the lens motor. My suspicions about the cause were confirmed when I stripped the camera down: one of the three wires to the zoom control had broken away from its solder pad. Full operation was restored once the connection had been remade. **D.G.**

### Matsui VX820

This VCR was dead with no display. Checks on the outputs at the secondary side of the power supply showed that everything was OK up to this point. I then carried out a visual inspection of the power connection area on the main PCB. There was an area that appeared to be quite badly affected by heat. Cold checks here showed that Q02 (2SD1207) was open-circuit. This little transistor runs very hot. When it was removed some solder pads came off with it, so a certain amount of making good was required. I

decided to fit a more robust TIP31C as the replacement. Once this had been done the machine worked perfectly. **D.G.**

### Sanyo VHR789, 899 etc

The customer's complaint was "no eject", but by the time the machine reached my bench it did eject the tape. When the tape was reloaded it played and wound all right initially, then the deck shut down. Eject was tried but there was no response – and the display dimmed.

I looked for the infamous PR512 in the power supply, but it measured OK and a replacement made no difference. Eventually I checked the loading motor, which produced resistance readings between 15 $\Omega$  and zero! A replacement was ordered from CHS (order code 11935WM) and was quick to arrive. When checked it provided a resistance reading of 40 $\Omega$ , and my meter's internal battery was enough to produce shaft rotation. Fortunately there had been no damage to the supply, and the easy clip-in replacement motor cured the fault.

A colleague has had this problem with a similar model, so it may be becoming a stock fault. **C.A.**

### Philips VR676

This machine came in with a "dead" report. The cure was to replace capacitors C2361 (47 $\mu$ F, 100V) and C2356 (1 $\mu$ F, 50V) in the power supply. **R.B.**

### Sanyo VHR778

The complaint was intermittent failure to record Nicam sound. I traced the cause to dry-joints at X6701. **R.B.**

### Goodmans VN6000

No results can be caused by a number of things, from an open-circuit input fuse to a short-circuit power regulator transistor. In this case however the cause was a faulty capacitor, C822 (330 $\mu$ F, 10V). When it was checked with a capacitance meter its value was found to be low at 286 $\mu$ F. **J.C.**

### LG PW9041

If you find that all the symbols in the display are lit, check the value of CP19 (1,000 $\mu$ F, 10V) in the power supply. In one case recently I found that its value had fallen to 750 $\mu$ F. **J.C.**

### Ferguson FV42L

There was no operation – the display didn't light and none of the mechanical functions worked. The cause turned out to be dry-joints at transistors TT64 (BD435) and TT71 (BD676), which are in the servo section of the signals/servo PCB. **J.C.**

### **Aiwa HVFX1500X**

The complaint with this machine was very intermittent tape chewing. I replaced the obvious items (the pinch roller and the mode switch) but the problem persisted. It was cured by replacing the sub-brake lever. **J.C.**

### **Akai VSG745**

Intermittent stopping while in play, or even switching off, was the complaint with this machine. It didn't sound like the usual mode-switch problems, and in fact the cause turned out to be poor connections to L203 in the power-supply section of the main board. Resoldering cured the fault. **B.F.**

### **Toshiba V854**

There was no take-up spool rotation because the idler didn't get over to it. When I removed the mechanism I found that the idle kick lever, item K440 in the exploded view diagram in the manual, had come loose. Refitting it was all that was needed. **B.F.**

### **Hitachi VTM610E**

If there is no power with R3357 burnt out,

check/replace the following items: IC7354 (MC44603P); T7350 (STP3NA60); D6351 (BAT185); D6352/3 (both BYD33D); R3357 (4.7k $\Omega$ , 0.1W); and R3361 (47 $\Omega$ , 0.33W). **B.F.**

### **Sharp VCMH67**

There were no signs of life with this machine. I checked the various supplies and found that the regulated 5V output was missing. The cause was Q961 (2SC2001LK). A replacement restored normal operation. **B.F.**

### **Philips VR170-05**

The customer said that this machine didn't come back on after being unplugged from the mains supply. It was totally dead when I checked it. Power supply capacitors I thought, but the cause of the trouble was that R3369 and R3370 (both 39k $\Omega$ ) were open-circuit. R3369 had a clearly visible burn mark on it. **G.L.**

### **Mitsubishi HS750**

The job sheet said that this machine took a long time to come back on after doing a timed recording. I found that the

display didn't light up. Once C9A3 and C9A4 in the power supply had been replaced the display was back and, after a long soak test, the timer circuit was also given the OK. **G.B.**

### **Crown CV93V**

The owner of this budget-priced machine said it was reluctant to eject tapes. The fault was intermittent. It was cured by replacing the mode switch and the loading belt. **G.B.**

### **Philips VR502**

The complaint with this machine was no playback colour. So out with the scope and the service manual. I eventually found that there was no waveform at pin 1 of IC7151. Tracing back from this point I came to T7109 which was open-circuit. A replacement restored normal playback. **G.B.**

### **GoldStar T161**

This machine was dead and the owner didn't want to spend too much on the repair. It was up and running once the optocoupler ICP02 and capacitors CP19, CP21 and CP25 had been replaced. **G.B. ■**

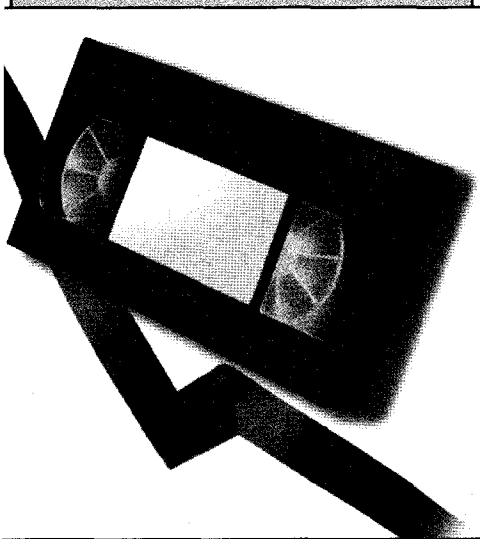

## VCR CLINIC

Reports from  
**Eugene Trundle**  
**Ronnie Boag**  
**Geoff Butcher**  
**J.S. Ogilvie**  
**Bob Flynn**  
**Graham Boor and**  
**John Coombes**

We welcome fault reports from readers – payment for each fault is made after publication. See page 170 for details of where and how to send reports.

### JVC HRJ600

This VCR was labelled “dead”. It showed no signs of life. Having checked that the mains fuses were intact, I replaced C12 on the primary side of the power supply. The result was a bird-like squawk at switch-on but nothing more. Cold checks revealed that zener diode D35 (16V) was short-circuit, for no apparent reason. A replacement restored normal operation. **E.T.**

### LG AF999NI

The problem with this VCR was deck shutdown when fast forward or rewind was selected. On investigation I found that the reel-drive clutch failed to lock because its internal retaining claws were broken. The part number for this assembly is 4265R-0002A. **E.T.**

### JVC HRJ665

This machine came in dead. The cause turned out to be the 15V zener diode D5301 on the secondary side of the power supply. **R.B.**

### Toshiba V226

There was no playback or E-E sound, though record was OK. The cure was to replace IS001 (type BA7795LS). **R.B.**

### Sanyo VHR776

Replacement of Q5001 (2SK1460) restored this dead machine to life. **R.B.**

### Goodmans VN9000

This machine suffered from various intermittent faults such as not accepting a tape, failure to thread up, failure to eject a tape, intermittent display, etc. On inspection I noticed that D820, near the power-supply module, had obviously been running hot – the PCB was discoloured. It’s a 16V zener diode which is connected across the 12.4V supply, presumably for protection, so it shouldn’t normally pass any current at all. When I opened the screened PSU module I found that C23 (100µF, 10V) had also overheated, and was open-circuit.

I replaced these items and also C13 (47µF, 16V), on the primary side of the power supply, and C26 (22µF, 50V), both of which tested poor. The power supply then produced the correct output voltages, and normal operation was restored. **G.Bu.**

### Philips 14PV170/05

This teletext unit would load a tape, but when any function was selected it would run normally for a second or two then stop and eject the tape. This suggested reel sensor trouble. So, as it was difficult to operate the deck and carry out measurements at the same time, I crossed

my fingers and replaced the sensor. Unfortunately the fault was still present, but I was convinced that missing reel pulses were the cause. I eventually found that the 10nF ceramic surface-mounted capacitor C2458, which is connected to the reel-pulse line on the main PCB, was leaky – it measured 500Ω. A replacement solved the problem. **G.Bu.**

### Goodmans SD7700

If the complaint with one of these machines is intermittent sound, check or replace the 6MHz filters in the IF can. **J.S.O.**

### Orion D1000

If the complaint is odd functions, unplug the cassette housing connector. If the machine then works correctly, check/replace as necessary the sensors on the cassette housing. **J.S.O.**

### Goodmans PX2400/TX1200

I’ve had several cases where the tuner has been unsteady. In this event check the 30V supply. If it’s low at 25V, replace C803 (100µF, 50V). **J.S.O.**

### Sony SLVE210 etc

If the machine jams when it laces up, check the tape-tension band. It usually sticks to the supply reel, which therefore doesn’t operate correctly. The cure is to replace the band. **J.S.O.**

### Toshiba V229B

If the complaint is spooling out tape, remove the deck and check the centre clutch assembly. The top gear can split and jam up against the reel-drive gear assembly. **J.S.O.**

### Sony SLV615

This VCR carried out all functions correctly except when it was asked to pause in playback. Having paused, it would refuse to resume play. A new mode switch assembly cured the problem – presumably it had a dead spot.

Incidentally if, while you are working on one of these VCRs, you find that none of the front controls work don’t panic – put the bottom cover back on! **B.F.**

### Philips VR422

This Turbo deck machine was OK mechanically but there was nothing in the way of playback or E-E pictures, or even the test words. The cause was traced to resistors R3147 and R3151, which are both 6.8Ω, 0.6W (part number 4822 050 26808).

The cause of their failure was rather obscure: because there was too much equipment on top of the machine the top cover had shorted out to the main board! **B.F.**

### **Akai VS425**

The symptoms were a hum bar on the E-E picture, a noisy capstan motor, and stopping after a few seconds in play. Sounds like a power supply problem, and so it is. Replace C2 (2,200 $\mu$ F, 25V). **B.F.**

### **Ferguson FV22L**

When this machine ejected a cassette there would sometimes be a small loop of tape hanging from it. Although it appeared to be OK, the take-up main brake was sufficiently worn to be the cause of the problem. Replacing it and the take-up sub brake assembly cured the tape looping. **B.F.**

### **Goodmans GVR3450**

There were no functions and no display. It wasn't a power supply fault but a system control problem. The cure was to replace crystal X701 (4.19MHz). **B.F.**

### **Ferguson C3615UT (type 441B)**

This teletext unit wouldn't accept a tape. All was well when I tried loading a tape manually however. I didn't have a service manual, but the obvious thing seemed to be to look at the voltage

supplies to the mechanics. A check on RW002 (1 $\Omega$  safety resistor) on the VCR PCB showed that it was open-circuit. It was not discoloured. A replacement followed by a long test proved that the unit was now operating correctly. **B.F.**

### **Bush VCR3402**

There was a hum bar on the E-E picture and the E-E gain seemed to be low. Correct operation was restored by replacing C803 (100 $\mu$ F, 50V). **B.F.**

### **Philips Turbo Decks**

A problem I've had with several of these decks is a tape locking up without warning – usually after the machine has been asked to wind or rewind. The cure is to replace the pressure roller assembly. **B.F.**

### **JVC HRJ610**

The owner of this machine found that it was dead when he returned from holiday – there had been a power cut while he was away. The cure was to replace C12 (2.2 $\mu$ F) in the power supply. **G.Bo.**

### **Panasonic NVG21**

This old-timer was dead with only the tape LED alight. The machine was in

pristine condition and had obviously seen little use. Capacitor checks in the power supply showed that C18 and C23 were faulty. Replacements restored normal operation. **G.Bo.**

### **Toshiba V426**

The owner of this VCR complained that the display was very dim. If the lights were all switched off you could just see the clock. The cure is to replace CP041 in the power supply. For reliability, replace CP007 and CP008 as well. **G.Bo.**

### **Ferguson FV67HV**

The cause of no results was traced to CP11 (220 $\mu$ F, 25V) in the power supply. It had a high ESR reading – 28 $\Omega$ . **J.C.**

### **Philips VR668**

The display was very hard to see but all the machine's functions worked correctly. A check on the negative supply to the filament showed that it was very low. The cause was zener diode D6070 (BZX79-B10). **J.C.**

### **Mitsubishi HS841V**

If there are no functions and no display, check whether C9A3 (1,000 $\mu$ F, 16V) in the power supply is open-circuit. **J.C. ■**

# Repairing VCR mode switches

**The mode switch is the most troublesome item in a VCR deck, and when suspect should preferably be replaced. This is not always feasible however. Eugene Trundle describes a reliable repair method – also a repair tip for broken flaps**

**T**he mode switch, which is also known as the rotary- or slide-encoder or cam switch, is the most unreliable item in a VCR deck. A few decks use optocouplers to indicate to the microcontroller chip the status of the mechanics, but the vast majority employ a mode switch in one form or another. When it fails, the symptoms can be many and various and are often intermittent. They include scrunched tape, a jammed mechanism, failure to achieve one or more functions, shutdown, mistracking, mechanical oscillation, slow rewind and other problems.

## Checking and faults

A DC-coupled oscilloscope connected to the mode-switch contact leadouts can give a clear indication of its condition. A defective mode switch is revealed by hash and glitches in the waveform as the deck is cycled through the different functions. The basic cause of the trouble is seldom wear: it arises because of old grease, dirt and

oxides on the surfaces of the switch segments and the multi-contact wiper that brushes over them.

Before you reach for the phone, keyboard or pen to shower the editorial department with protests, I know perfectly well that mode switches should be replaced rather than refurbished and would not advocate repair when a replacement is available. It's not an expensive part. There are, on the other hand, times when repair may be necessary. The switch may no longer be available or be hard to obtain; it may be part of a much larger and more expensive assembly; the job might need to be done at minimum cost and delay; or, as with some old Sanyo and other decks, it could be that gaining access to the top of the switch and its solder joints is simply uneconomic in terms of labour time.

## How to go about it

It's not difficult, with experience and practice, to overhaul a mode switch. Provided the job is done properly, I've

found it to be 100 per cent successful. The first step is to dismantle the switch, separating its rotor (or slide) and contact surface. With the rotary type this involves carefully pulling away the rotor plate, which is 'clicked in' at its centre. Slide switches, for example those used in earlier JVC decks, have plastic click-latches at the sides: these break easily if care is not taken. The wipers and contact base are then revealed. Fig. 1 shows a typical example.

The base will often be found to contain a gooey, yellow grease. Remove this, using a small piece of soft toilet tissue rotated by your fingertip. Do it twice or thrice, changing the paper each time. At this stage you will probably see dirt or oxides on the contacts. Clean it off with a cotton bud soaked in isopropyl alcohol, rubbing hard. In stubborn cases it may be necessary to use a fibre pen to get the contacts really clean and shiny – if you have to do this, ensure that the switch is thoroughly washed through with alcohol afterwards.

Attention can then be turned to the rotor's wiper fingers. They are very fragile, so great care is needed here. Wash off any grease, using a small, fine paintbrush and alcohol. Then clean them with more alcohol and a cotton bud, supporting them from below while wiping from their anchored ends towards the tips. Turn or change the bud often. The wiper tips usually have tiny domes on them: it's here that the surface must be clean.

The next action is to retension the sprung fingers. Fig. 2 shows how this is best done. Use a finger nail, screwdriver or whatever to prevent strain on the plastic rivet heads that anchor the wiper to its disc, while bending the fingers upwards with a penknife blade or something similar. Make sure that you keep the blade parallel and at right-angles to the wiper's fingers. Don't push them too far: an additional 10° or 15° is usually about right to ensure good contact without excessive wear.

I avoid the use of any sort of grease before reassembly, and use a squirt of

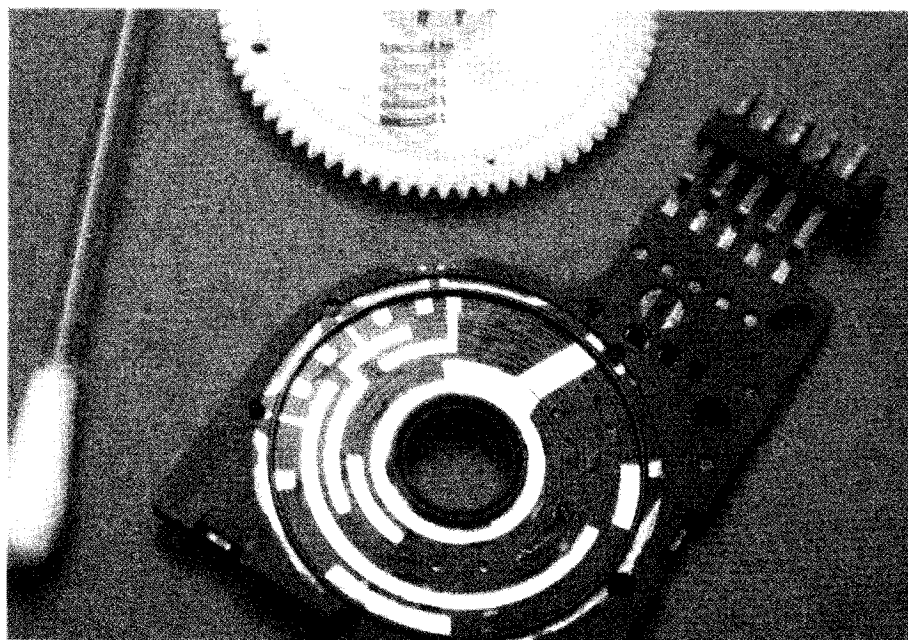

**Fig. 1: Inside a typical rotary mode switch.**

Philips switch cleaner from an aerosol as a parting shot, so to speak.

The switch can then be clicked together with assurance that it will work reliably. I've not had any comebacks.

## Broken flaps

Having got into what some readers might regard as bodgery, I'll follow up with a tip on repairing cassette flaps. Clumsy or abusive users very often break off one of the plastic shafts on which the flap swings. Even more than with mode switches, a replacement may not be easy to obtain. I've repaired flaps successfully on many occasions by melting in a new metal spigot.

Place the damaged flap in a mini-vice, between soft surfaces to prevent further damage. Use a tiny drill (<1mm) or, sometimes better, an 0.75 or 1mm jeweller's flat-bladed screwdriver rotated between your fingers to bore a pilot hole into the end of the top edge of the flap, in the centre of the scar where the shaft has broken. Take a piece of stout copper wire from, for example, a 30A mains cooker cable and push it gently, held by pliers,

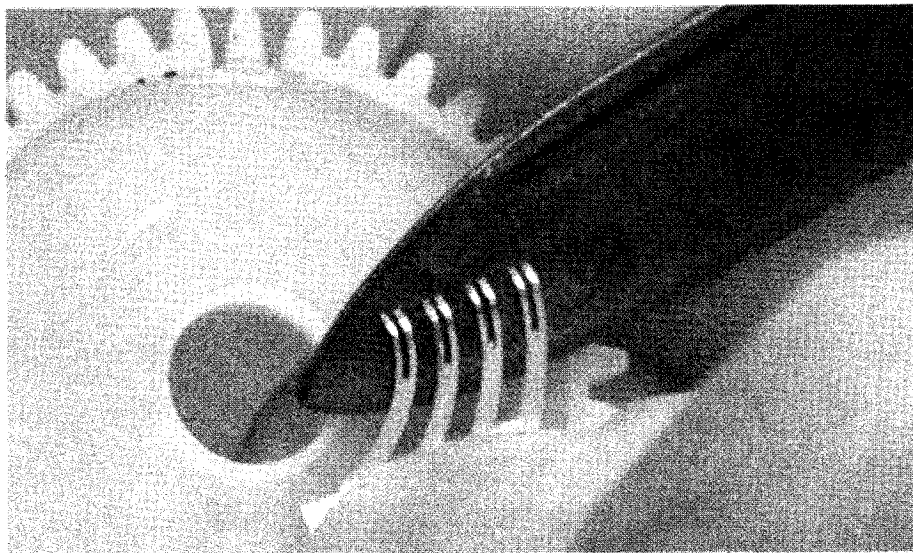
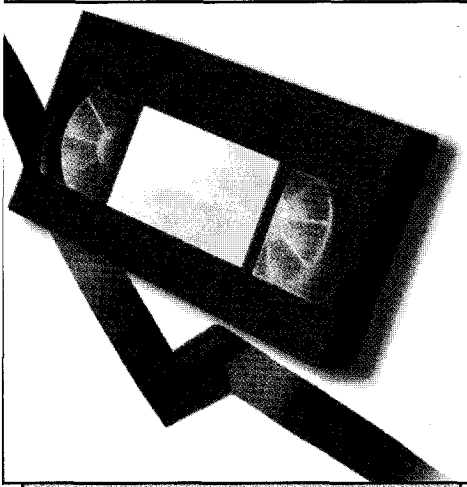

**Fig. 2: Retensioning the wiper blades – take great care over this.**

into the hole while heating it with a soldering iron near the point of entry. Remove the heat as soon as possible, then cut the new shaft to the correct length. With some VCRs it may be necessary to increase the diameter of the new shaft to make it fit well into the eye of the plastic front-cover moulding. Use ordinary plastic

sleeving to do this – oil it first if necessary.

It's much better to replace the flap if possible. With a rental VCR, a broken flap can make the difference between having to scrap the machine or putting it back to further profitable hire, so repair may well be worthwhile. Again, I've yet to have this type of job bounce back on me. ■



## VCR CLINIC

Reports from  
**Eugene Trundle**  
**J.S. Ogilvie**  
**Dave Gough**  
**John Hepworth**  
**David I Scott**  
**Ian Bowden**  
and **Michael Dranfield**

We welcome fault reports from readers – payment for each fault is made after publication. See page 234 for details of where and how to send reports.

### **Matsui VP9601N**

Under the skin this inexpensive machine is the same as some contemporary **Tatung** VCRs. There were various intermittent faults: failure to lace up; ejecting a cassette soon after its insertion; no picture, but the sound OK; shutdown at some stage while loading or threading. All these symptoms were cleared by replacing the half dozen or so electrolytic capacitors on the secondary side of the power supply. **E.T.**

### **Daewoo V215**

The erase oscillator had failed: recordings made on any but a blank tape had the sound from the previous recording. I found that the oscillator transistor Q201 was short-circuit and R200 burnt. These two components were replaced, along with C204 in case it was responsible for the problem. After that everything was OK. **E.T.**

### **JVC HRD540, 560 etc**

A fault you sometimes get with these and other models that use the same deck gives the impression of drum failure or misalignment of the guide poles. It's usually cured by replacing the 3.3 $\mu$ F, 50V capacitor associated with the drum motor. Also check the brass bushes on the guide poles. **J.S.O.**

### **GoldStar RC7031**

This Nicam stereo VCR produced a dark picture. The cause was traced to C707 (4.7 $\mu$ F, 50V) on the main PCB. It's near connector P7003 in the tuner section. **J.S.O.**

### **Panasonic NVFS series**

I've had a few of these S-VHS VCRs that have come in from other shops with reported drum failure. Before ordering and replacing a drum, check for dry-joints on the drum motor PCB. **J.S.O.**

### **Sony SLV625UB**

The complaint was dead with no display. Checks in the power supply showed that the cause of the trouble was C202 (3,300 $\mu$ F). In fact it had leaked electrolyte on to the board.

When carrying out a repair of this sort I always, as a matter of good practice, check the ESR of all the electrolytic capacitors in the power supply and replace any that are even remotely suspect. **D.G.**

### **Daewoo DVK985PI**

The machine was dead. Internal inspection suggested that the cause of the

problem was within the chopper power supply can. This was removed and the usual culprit, C23 (1,000 $\mu$ F), was found to be faulty. But the machine was still dead when C23 had been replaced and the can had been refitted. Back to the PCB. Checks on all the small capacitors near the chopper can revealed that C823, C816, C825 and C826 were all faulty. Replacement of these capacitors restored full operation. **D.G.**

### **Matsui VX1100**

The customer said that this VCR would chew tapes, with a length of tape not rewound into the cassette. Mechanical checks with our transparent test cassette soon showed the cause. Some of the felt on the brake band had been lost, and as a result the supply reel didn't work correctly. A new brake band restored normal operation. **D.G.**

### **Hitachi VTM212E**

The customer said that this VCR made a terrible clicking noise in any mode. She was right – it sounded awful! I removed the base, inserted a test cassette and selected play. The cause of the trouble was soon evident: the nylon drive cog at the base of the capstan motor was split. Even though this item is replaceable (it pulls off) I was unable to obtain one. But Wiltsgrove supplied a complete capstan motor assembly for only £9.95. Who needs a cog at that price?! **D.G.**

### **Sharp VC787H**

There was no sound or picture in the E-E mode, but the sound appeared when the test pattern was switched on. When a tape was played the picture from it appeared on the screen but the sound wasn't from the tape – it was the E-E sound. A scope check at pin 3 of IC2201 showed that video was present, but there was no supply at pin 9 because zener diode D2201 was short-circuit. A replacement restored normal operation. **J.H.**

### **Panasonic NVHD605**

Failure to accept a cassette was accompanied by an 'F03' indication in the display. The motor-drive coupling had split, causing loss of drive to the cassette-loading mechanism. I've had this problem before with these machines. No wonder the spares stockists supply the couplings in packs of ten! **D.I.S.**

### **Sony SLVE70UY**

Tapes were being tangled during ejection. I noticed that the half-loading arm wasn't being retracted during unlacing, and felt

certain that it and the pivot shaft merely needed degreasing and re-oiling. On this occasion however something else was wrong: the return spring had broken. A replacement spring plus cleaning, oiling and adjustment of the half-loading mechanism restored correct operation.

**D.I.S.**

### **Sony SLV715**

This machine was dead with no activity on the secondary side of the chopper power supply. A pity, since the power-supply module is no friend of mine: its soldered-on metal cover and cramped component layout don't lend themselves to good-tempered repairs! Sony's Kit 777 was confidently fitted however, replacing all thirteen capacitors on the secondary side of the power supply, then the module and machine were reassembled. The mechanism and display now worked, but the signal sections didn't and there was no remote-control operation.

Checks on the rebuilt power module revealed that there was no 12V output. So the whole lot had to come apart again! The cause of the trouble was eventually traced to resistive leakage on the

component side of the power module PCB. It was at its worst beneath capacitors C208 and C209, whose leads were badly corroded. The cause of this corrosion was undoubtedly leaked electrolyte from the larger electrolytic capacitors. Fortunately thorough cleaning of the PCB with isopropanol, replacement of C208 and C209 and a repeat replacement of Kit 777 finally restored correct operation. **D.I.S.**

### **Mitsubishi HS750V**

The report said that this machine was dead. In fact when it was connected to the mains supply the front panel display would flash then go blank, after which the machine failed to respond in any way. The cause of the trouble was found to be C9A3 (1,000 $\mu$ F, 10V), which is in the power supply area. It had fallen in value. **I.B.**

### **Thorn VR414LVA**

This VCR worked fine mechanically, and playback was OK. But when a tape was inserted all tuning was lost. Checks showed that the 32.5V supply, at the collector of Q406 (2SA1266), was low at

only 18V. The voltage fell even farther when the mechanism was being driven. The cause of the trouble was Q406 itself – it was almost short-circuit base-to-emitter. A correctly-regulated supply was present once a new 2SA1266 transistor had been fitted. **I.B.**

### **Sony SLVE700UX**

The report said poot/noisy E-E sound. In fact there was an intermittent crackle on the left Nicam channel output – if right channel only or mono sound was selected there was no problem. The cause of the trouble turned out to be the surface-mounted audio switching chip IC102 (BA7632F). It's on the small PCB which has the line-in two scart socket on it. This PCB is at the top left of the machine. There was no noise on the input signal at pin 7 of the IC, but grass-type spikes of noise were present on the output at pin 1. **I.B.**

### **Goodmans VN6000**

This machine was dead. Checks showed that the Ever 5V supply was low, because C822 (330 $\mu$ F, 10V) had dried out. Use a low-ESR capacitor as the replacement. **M.D. ■**



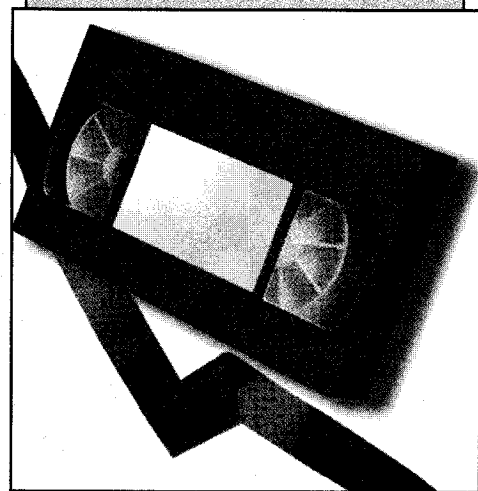

## VCR CLINIC

Reports from  
**Eugene Trundle**  
**Stephen Dixon**  
**John Coombes**  
**Geoff Butcher**  
**Bob Flynn**  
**Dean Ratcliffe**  
and **Michael Maurice**

We welcome fault reports from readers – payment for each fault is made after publication. See page 298 for details of where and how to send reports.

### **Samsung SV213B**

The following symptoms, which are usually intermittent, are caused by dry-joints at the tape-end sensor photodiodes S601 and S602: refusal to accept a cassette; re-entry of the cassette which then jams after eject; and tape damage at rewind end. While the PCB is out it's also worth checking the soldering of the centre LED LD601. **E.T.**

### **Samsung VIK346**

The job card with this one said "white lines across the picture". But when I got the machine to my bench it was barely alive, with just the smallest glimmer in the fluorescent display panel and a motor that just about stirred when a cassette was offered. The cure was to replace several capacitors in the power supply, in particular C35 (470µF, 16V). **E.T.**

### **Sony SLVE720UX**

I've recently had two of these machines whose RF gain went low intermittently, producing grainy pictures in the E-E and record modes. The tuner used in this model is expensive. A cheaper solution is to flux and resolder the connections between the PCB earth lands and the lugs on the screening can. **E.T.**

### **Samsung SV615B**

We have a number of these machines out on rental. A couple have been returned to the workshop with the intermittent jammed deck symptom – in the fully-loaded position. In both cases the cause was a faulty mode switch assembly (SW601), part no. AC34 22001E. **E.T.**

### **ITT/Nokia VR3761**

This VCR would cut out after a few seconds. The cause was the spool sensors.

With this machine the tape counter is operated via the ACE head. **S.D.**

### **GoldStar GHV1290I**

There was intermittent poor wind and rewind with this machine. The digitron display would eventually go out while the power LED remained on.

Checks on the outputs from the power supply showed that it was OK, but the 5V supply at the syscon chip IC501 and the digitron chip IC601 read 3-4V. The cause of the fault was traced to high-resistance print between pin 11 of P5101 (reg. 6V supply) and C502, on the system control PCB. The offending print was beneath glue. **S.D.**

### **Aiwa HVGX150K**

This machine would cut out after nine seconds. The cause was traced to a faulty take-up photosensor. **S.D.**

### **Aiwa HVGX150**

If the problem with one of these machines is poor video with the sound all right, check the surface-mounted video driver transistor Q553 (2SA1037). It tends to go short-circuit. In some cases you will find signs of transistor and/or PCB overheating. **J.C.**

### **Sony SLV625**

The usual cause of tape chewing with these machines is a faulty pinch roller. In this case however transistor Q203 (2SA943Q) in the 9V supply was the cause. **J.C.**

### **Panasonic NV200B**

A problem you can get with these machines is failure to accept a tape. When a cassette is inserted the machine switches itself off, with F03 in the display. This indication means that the mechanism locks during mode transition, except for eject. The cause can be the loading motor, but in this case the loading-motor coupling was faulty. The part no. is VDP1434. **J.C.**

### **Hitachi VT450E**

Playback of prerecorded tapes was fine, but there was very poor sound with the machine's own recordings – the level was low, and there was a lot of background hiss and hum. I worked my way back to the IF module, where I found the cause of the problem. C20 (100µF, 16V), inside the module, had leaked electrolyte which had found its way on to the copper side of the board. As a result here was a partial short-circuit of the audio signal, which passes underneath C20. **G.B.**

### **Ferguson FV62**

When this machine was asked to play a tape everything was correct mechanically but the E-E picture remained on the screen. As a quick move I cleaned the vanes under the drum motor, having had some weird effects before because of problems here. Once the dust had been removed the playback picture had returned. **B.F.**

### **Akai VSF280EK**

If one of these machines turns off when asked to move from one mode to another, replace the mode switch assembly. **B.F.**

### **Hitachi VTM502E**

The playback picture kept clearing and breaking up, as though there were no off-tape control pulses. Voices sounded as if they were under water! A check through the control-pulse path revealed the cause of the trouble, which was the BC848B surface-mounted transistor Q7469. **B.F.**

## **Akai VS422**

Poor rewind, especially near the start of a tape, can be caused by wear on the review brake spigot, where it runs along the main lever under the deck. It wears to a flat edge. Because of this it brakes the take-up spool when it should be off. While replacing the review brake (item 4 in the exploded deck diagram) it's a good idea to clean and lubricate the take-up spool shaft. **B.F.**

## **Philips VR806**

This VCR had blown the fuse in the plug but not the internal one. I found that the STP3NA60FI chopper FET was short-circuit, but there was no obvious reason for its failure. D6160 (1N4006) looked as if it had been getting warm. It measured OK however. There was also a possible poor connection at R3159.

I replaced the FET, the MC44603P control chip and D6160, resoldered R3159, then gave the machine a very long soak test. This proved that everything was now OK. **B.F.**

## **Panasonic NVHD685B (Z mechanism)**

This VCR had a tape that wouldn't eject inside it, though the machine would do everything else. The deck would jam when it moved to the eject position. The only obvious clue was the multiple

tracking errors all over the picture when play was selected, because the tape arms weren't locating fully.

As this chassis was a new one to me I ordered a Z mechanism manual from SEME, part no. VRD9802005C2. It includes a section on removing a jammed tape. Once I had done this I was able to examine the mechanics and found the cause of the jamming: the plastic teeth of the take-up loading arm (part no. VXL2670) had broken where they fit into the loading rack. Replacement of the loading arm was simple and cured the fault. **B.F.**

## **JVC HRJ435**

There was no power because Q902, type 2SC3616(ML), was short-circuit base-to-emitter. A replacement restored normal operation. **B.F.**

## **Philips 20PV164**

The VCR section of this TV/VCR combi unit intermittently failed to follow commands: mechanical movement could be heard, followed by tape ejection. When the deck has been removed the leads are long enough to operate it and be able to observe the mechanics.

In the fault condition the tape went down OK, then went into the play position, but the drum motor was struggling to rotate. The cause was poor

connections at plug-socket 1930 which is on a PCB that's mounted behind the heads. Resoldering cured the problem. **B.F.**

## **Matsui VP9401**

This machine was dead with F502 open-circuit. A replacement restored life to the machine, but there were no mechanical functions and it went to standby after about three seconds. On investigation I found that the loading-motor drive chip IC1004 was getting very hot. After fitting a replacement I checked ICP051 in the power supply and D16 in case it was short-circuit. The machine was now OK. **D.R.**

## **Hitachi VTM930**

This machine wouldn't accept a tape and occasionally loaded up on its own. I initially thought that the cause would be the mode switch, but in fact one lead of the end-of-tape sensor had broken. A new sensor restored normal operation. **M.M.**

## **JVC HRJ635EK**

After being switched on this machine would try to eject the carriage, even when it was already in the eject mode. If you tried to install a tape manually it would be immediately ejected. The cause of the problem was the mode switch. A replacement restored normal operation. **M.M. ■**

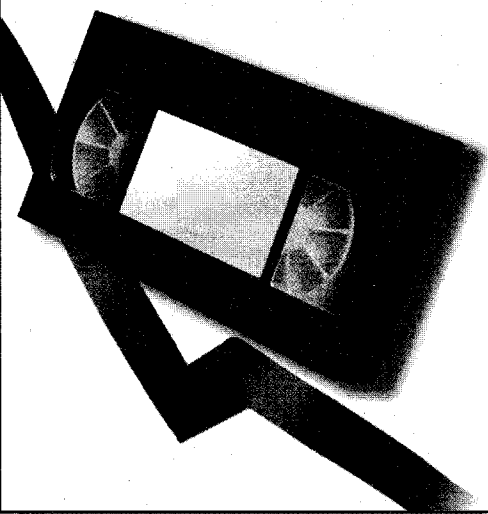

## VCR CLINIC

Reports from  
**Eugene Trundle**  
**Michael Dranfield**  
**John Coombes**  
**Michael Maurice**  
**Gary Laidler**  
**and**  
**Bob Flynn**

We welcome fault reports from readers – payment for each fault is made after publication. See page 358 for details of where and how to send reports.

### **Sony SLVE230**

The problem with this machine was that the RF output from the UHF modulator seemed to disappear intermittently. In fact it was reverting to about ch. 22 from its presetting at ch. 33. The cause was loss of the UNREG 30V feed. Coil L600 (68 $\mu$ H) at pin 8 of the power supply module, or its soldered jointing, was going open-circuit. **E.T.**

### **Akai VSG270**

The fault with this machine showed up when going from fast-forward to play: a rough, mistracked picture would appear for a couple of seconds, then the deck would shut down. It occurred because the supply-spool brake failed to engage. The slack tape produced the picture then, as the reel lost momentum, stopped and failed to rotate in the play mode, shutdown was triggered. The basic cause of the problem was very dirty mode-switch contacts. This machine is unusual amongst the cheaper models nowadays in having a supply-reel sensor. **E.T.**

### **Sharp VCMH711**

At switch on the cassette housing would try to load a tape even without one being pushed in. I thought the cause was going to be nice and easy, a dry-joint at the end sensor or cassette LED. Quite wrong! The voltage at the right-hand sensor was low, but the sensor was OK. Pin 79 of IC701, the microcontroller chip's end-sensor input, was dragging the voltage down. A new IX1420UMN8 micro chip was required, and with a trade price of £27 plus VAT I couldn't see the customer agreeing to have this job done. Wrong again! The estimate was accepted. **M.D.**

### **JVC HRJ625**

This VCR wouldn't eject the tape. The cause was the change-arm assembly, SEME part no. VPAR7178 – the small plastic peg had broken off, releasing the spring. At first I thought that the spring was missing, but it had retracted beneath the sliding brake plate. **M.D.**

### **Sony SLVE275**

Damage to the slide crescent and a broken soft brake can cause the following symptoms: very poor or no rewind, and no picture in the reverse-search mode with all other functions operating correctly. Replacements will restore normal operation. **J.C.**

### **JVC HRJ220**

The cause of a dead machine is usually three capacitors in the power supply. Check and replace C860 (22 $\mu$ F, 50V), C868 (47 $\mu$ F, 16V) and C806 (2.2 $\mu$ F, 50V).

If the machine won't accept or eject tapes, i.e. a tape will not go into the VCR, replace the arm assembly. The cause of the problem is that a lug breaks off, which prevents the spring from pulling the arm across to the drive cog. **J.C.**

### **Panasonic NVFS100**

There was normal E-E and standard/extended play operation but no playback S-video picture. The cause was traced to module IC303, part no. VEFH05B). A replacement cured the problem. **J.C.**

### **Toshiba V727B**

A complaint you can sometimes get is whistling in the E-E mode. The sound may be poor, as if the detector coil is misaligned. The cause of the trouble is faulty decoupling capacitors: C102, C103, C104 and C105 can develop leakage. 2,200pF, 50V chip capacitors should be fitted in positions C102 and C105. **J.C.**

### **Samsung SV224B**

If one of these machines will not accept a tape, or the tape has to be pushed in a long way before it's accepted, the start sensor PT602 (9PT493F) is probably the cause. It is difficult to remove the deck when a tape is jammed inside. The tape can be unwound mechanically after removing the worm holder (B446). **J.C.**

### **Hitachi VTF360**

Intermittent tape looping on eject was the complaint with this machine. It was another mode-switch fault. Once a replacement had been fitted the machine behaved itself. **M.M.**

### **Grundig GV6001V+**

This machine wouldn't play tapes because the drum wouldn't rotate. The cause was lower drum seizure because the lubricant had dried out. Relubrication isn't simple, as you have to remove the upper drum first, but this cured the fault. **M.M.**

### **Hitachi VTM212E**

The complaints with this machine were that it didn't respond to remote-control commands and that the front-panel buttons were sluggish. Both faults were cured by resoldering several dry-joints at the connector on the front-panel operation PCB. **M.M.**

### **Mitsubishi HS550V**

This machine was dead. I traced the cause to TR8 in the power supply. **M.M.**

### **Mitsubishi HSM16**

This VCR worked except for the fact that the clock display was missing. Checks in the power supply revealed that C905, C908 and C909 were all leaking electrolyte, but

replacements failed to cure the fault. R904 was then found to be open-circuit and D917 (HZ30-2) short-circuit. **G.L.**

### **Sanyo VHR279E**

The recorded sound would vary between being OK and including samples of the previously recorded sound. I cleaned the full-erase head, but this made no difference. I then noticed quite a bit of bare copper wire at the two connections at the rear of the head. A check on the resistance at these connections produced a reading of 28Ω. After resoldering, the resistance had fallen to 1Ω and the machine now recorded perfectly. **B.F.**

### **JVC HRS7500**

An annoying squeak while in play or record was cured by removing the deck, taking out the clutch unit and the small gear next to it, then cleaning and relubricating the shafts. Operation was then silent. **B.F.**

### **Sanyo VHR390E**

This VCR struggled to wind or rewind, especially near the ends of a tape. The usual cause of this is that a white piece of plastic breaks from the underside of the deck. It sits between item 9 and items 3

and 7 shown in the deck diagram, and can be refitted using a screw or glue. In this case however it was still in place, but I noticed that the nearby plastic fixing which secures the underside of the supply spool shaft to the deck was badly cracked and loose.

The cure was to glue the fixing back in place and lubricate all the drive gears and their shafts, also both tape spools and their shafts. **B.F.**

### **Panasonic NVSD200B (K deck)**

This VCR didn't know that it had a tape inside: it made no attempt to eject, play or wind the tape. When I called up the fault codes, by pressing FF, rewind and eject simultaneously, no error codes appeared.

To extract the tape to allow deck removal I took off the top plate and gently separated the arms at the sides of the cassette holder. While doing so I noticed that the right-hand arm had warped badly away from the housing, and was not holding the right-hand side of the cassette fully down. Once the mechanism had been removed the deck was found to be in the full eject position, with the cassette holder in the down position. I presume that because of the warped arm the

cassette holder had failed to lift.

All was OK on test when a new main shaft unit, part no. VXP1330-1L, had been fitted. **B.F.**

### **JVC HRJ225**

There was an intermittent fault with this VCR: sometimes a tape would play for a few seconds then the machine would turn off. When I removed the top I found that in the fault condition the take-up spool didn't rotate. As a result there was a tape build up at the pinch roller, then the machine turned off.

I could see no mechanical reason for this from the top, so I removed the deck. There were no signs of trouble except that the external contacts on the mode switch were badly tarnished. The problem was cured by cleaning these and the contacts on the main board. **B.F.**

### **Philips 14PV184**

The TV section of this combi unit's remote-control handset worked correctly but none of the VCR buttons had any effect, though the LED at the front of the unit would flash to indicate that commands had been received. I assumed that the handset had to be the cause, and was relieved when a new one proved the case. **B.F. ■**

# Hitachi VTF645 fault-finding guide

**T**his is one of a group of popular VCRs, introduced in about 1996, that incorporate the US mechanism. In the following run down on fault conditions you could encounter I'll start with mechanical problems.

## Mechanical faults

The most common cause of chewed tapes is a worn pinch roller. In some cases the bearing may warp or be distorted: the incorrect balance causes tape chewing.

If the pinch roller is OK, check the clutch pulley assembly – items 229 (pulley, part no. KX11443) and 239 (gear, part no. KF10551) in the exploded view (bottom) in the manual. Look for damage or broken plastic retaining lugs. Problems here can cause many different faults, including tape looping during eject, which can be very intermittent. There may be no take-up or drive in the play mode. No fast forward/rewind can be the result when the pulley has broken.

If these items are all OK, check the operation of the capstan motor. You may have to remove the motor, dismantle the flywheel spindle, clean and relubricate the shaft and bearing, reassemble and set up. A faulty bearing can cause tape looping/creasing at the top and bottom. If the bearing is badly contaminated the capstan motor may have to be replaced, because the hole in the bearing has become oval. In this event, even if the tape drive is OK after cleaning, the sound can suffer from wow and flutter, with poor music.

In some cases there may be no tape damage but the VCR makes a groaning noise in playback, record, fast forward or rewind. This also requires the capstan motor bearing to be cleaned and the spindle set up. Follow with a soak test.

If there is very intermittent tape chewing or looping check the two small moulded pins, which secure the clutch unit, on the shaft.

If the tape is not being wound back into

the cassette check that the reel spools (supply item 248, take-up item 250) are rotating correctly. The spools should be lightly lubricated. If not friction can, over a period of time, result in elongated holes. The spools then slow down and stick, with the result that the tape drags or spills out over the drive mechanism.

If these items are all in order, it may be worth checking through the tape path to ensure that there are no sticky patches on the guide poles, the audio/control head or drum assembly. If the tape sticks it can be damaged.

Tape damage can also be caused by incorrect operation of the brakes, item 254 left and/or item 255 right. They can break or, very often, one of the lugs that holds the brake spring can crack. The spring then drops off and the brakes don't operate correctly.

Another cause of tape damage is when the VCR timing is badly out because the mode switch (S2101) is faulty. Check by cleaning or by replacement.

If the VCR sometimes tries to load without a tape, or ejects immediately after loading, replace the front-loading switch (S2102).

A problem I've come across on a number of occasions is an intermittent corrugated effect on the playback picture, with a loud whine or squeal. It can also occur in the record mode, with the symptom being recorded. Very often the cause is a vibrating sleeve on one of the guide poles. Another cause is a faulty back-tension arm (part no. KX11531).

If the VCR powers down intermittently, check the capstan motor. It may be possible to cure this by dismantling, cleaning and relubricating the motor. If not, check the motor by replacement.

In a few rare cases there has been no reset pulse to the microcontroller IC, with the voltage on the B5V line low at 4-6V. The cause has been heavy electrical leakage in the capstan motor, which must be replaced.

If the VCR can't thread the tape or lift it

up and down in the cassette housing, replace the pulley (part no. KX11443) and gear (part no. KF10551) in the clutch pulley assembly.

## Diagnostic fault finding

This VCR produces diagnostic malfunction codes in the LC display as an aid to fault finding. To display the fault code, press the channel down button with the power turned off and hold it. The code is displayed as long as the button is held. Various possibilities are as follows.

If **code 01** is displayed there's a problem with the front-loading (FL) mechanism. If the mechanism is jammed, check the unit for broken cogs or levers and ensure that it moves freely along the tracks. If the FL unit isn't jammed, check whether the capstan motor rotates. If it does there's a mechanism fault.

If the capstan motor doesn't rotate, check the FG output from the motor. This is fed to pin 40 of the HD6433977SB54 microcontroller chip IC901 via pin 5 of PG001/PG601, C601 (2.2µF, 50V) and R636 (3.3kΩ). Servo control from pins 25 and 75 of IC901 is fed to the capstan motor via pin 1 of PG601/PG001. Checks here should show whether the motor or IC901 is at fault.

If **code 16** (servo fault) is displayed, check for 5V at pin 41 of IC901 with the power on. If the supply is present, replace IC901. If the 5V supply is missing, check the M5278L05 5V regulator IC905 which should have 9V at its input and 5V at its output.

If **code 04** (reel lock) is displayed and the capstan motor rotates, does the supply reel turn in reverse? The reverse signal comes from pin 60 of IC901 and is supplied to the capstan motor via pin 7 of PG601/PG001. If pin 60 is high, check for a mechanical fault – the gears and drive belt. If pin 60 is not high, replace IC901.

If the supply reel is OK, check whether the take-up reel rotates during playback. If it doesn't, check for a mechanical fault. If it does rotate, check for pulses at the base of Q2104 (DTC144K) on the mechanism sensor board. No pulses here suggests that the SG236 take-up reel sensor chip IC2101 is faulty. If Q2104 is receiving pulses, check whether they arrive at pin 88 of IC901. If not, suspect Q2104 and its associated components. If they do, check IC901 by replacement.

The SG237 supply reel sensor feeds pulses to Q2103 (DTC144K). These should arrive at pin 89 of IC901. Carry out the same checks to ensure correct operation in this path.

If **code 07** is displayed there's a loading problem. The loading motor could be faulty, but the first thing to check is the 12V supply at pins 7 and 8 of the BA6209 loading motor drive chip IC904. If this supply is missing, check whether R976 (2.2Ω fusible) is open-circuit or C914 (33μF, 25V) is short-circuit. IC904 provides drive outputs at pins 2 and 10 – there should be 0.6V at these pins. If IC904 is providing drive outputs the motor is suspect. If there is loss of the outputs replace IC904. If tape loading or unloading is intermittent, check for dry-joints at the pins of IC904.

## Electronic faults

If there are no outputs from the power supply, check whether the 1.6A mains fuse F851 is open-circuit. If it is, check the S1WBA60 mains bridge rectifier D851 for shorts and, if necessary, the FS3KM-18A chopper MOSFET Q851. If Q851 has failed R856 (0.33Ω, 1W) which is in series with its source will probably be open-circuit. On rare occasions shorted turns in the chopper transformer T851 are the cause of F851 being open-circuit. If F851 is OK, check whether circuit protector QF851 (ICP-N38, 1.5A) is open-circuit.

If the VCR works but there are no E-E pictures the 33V tuning supply is missing. The main suspects are the HZS30-3 zener diode ZD2501 which could be short-circuit or Q2506 (2SA844CD) which could be open-circuit or leaky.

Loss or intermittent loss of colour is very often caused by IC201 (HA118203F), but check for dry-joints first. Another cause is the 4.43MHz crystal X202, which could also be dry-jointed.

If there is no sound, distorted sound or crackles on sound, check for dry-joints at the SAA7283GP Nicam decoder chip IC1810 and if necessary replace the chip. If there is only one channel, left or right, with Nicam sound, IC1810 or the dual op-amp

chip IC1802 (NJM4558M) could be faulty.

If the display is poor or doesn't function, check the BU9716K LCD driver chip IC1701. If only part of the segments show, check the display (LCD1701) by replacement. IC1701 receives inputs from pins 98, 99 and 100 of IC901: if necessary check that these outputs are present.

If there is loss of information to the microcontroller IC901, the ST24C02 EEPROM chip IC903 is suspect. Before replacing it, confirm that the 5.1V supply at pin 8 is present and correct. It comes from D861 in the power supply.

If remote control doesn't operate though the handset is providing an IR output, check for dry-jointed or high-resistance connections at the TFMS5380B IR receiver IR1701. Its output at pin 1 is fed via pin 5 of PG1703/PG703 to pin 82 of IC901, which could also be dry-jointed. Alternatively either device could be faulty.

If the handset is the cause of the problem, check for poor battery connections – make sure that there are no dry-joints at the connector. If necessary check for dry-joints at the LED and the crystal. Sometimes the legs on the crystal break off, giving loss of operation. The handset may have been damaged by being dropped etc. In many cases such damage is beyond economic repair. ■

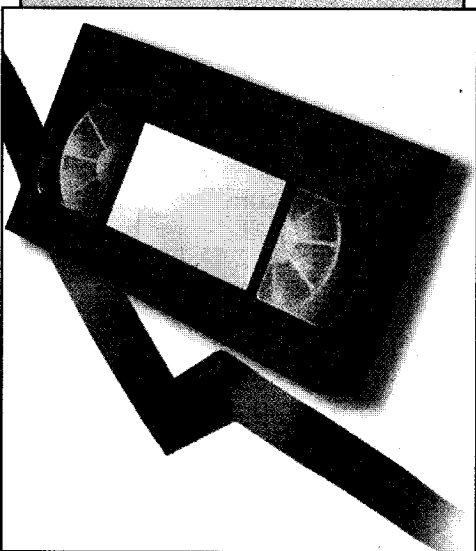

## VCR CLINIC

Reports from  
**Eugene Trundle**  
**Kevin Green**  
**Bob Flynn**  
**Steve Barlow**  
**Ivan Levy, LCGI**  
**Michael Maurice**  
**Dean Ratcliffe and**  
**Graham Bond**

We welcome fault reports from readers – payment for each fault is made after publication. See page 424 for details of where and how to send reports.

### **Sony SLV-SE710G**

This very new machine chewed tapes because the supply spool didn't reel in the tape at eject. I found that the capstan didn't turn backwards in rewind or reverse-search either. The capstan motor was the cause of the trouble. **E.T.**

### **Panasonic NVG21**

This machine had no display. Some checks in the power supply revealed that C1018 (47 $\mu$ F, 63V) was faulty. A replacement cured the display fault, but when a cassette was inserted the machine switched off. Some further capacitor checks proved that C1023 was the cause. Thank goodness for the ESR capacitor tester. It comes into its own with this type of fault. **K.G.**

### **Sony SLV-E720 (H mechanism)**

This VCR became very noisy in play or record, especially after running for a while. A scraping type of noise could be heard, the same as with previous Sony models when the capstan motor is faulty. Although this model uses a different type of motor, it was the cause of the trouble. After removal it felt very warm. A new motor and pinch roller cured the problem. **B.F.**

### **Saisho VR3400**

If the cassette won't eject because the tape is caught up under it, or a loop of tape catches up as the cassette is ejected, take a look at the limiter post arm – item 328 in the diagram in the manual. It should move freely. If it's stiff, remove it and clean off all the grease from its shaft and on the deck where it goes through. Refit it, with a small amount of new grease, and check that it springs back into position. **B.F.**

### **GoldStar P234I (D27 mechanism)**

This VCR had a tape stuck in it. When it was plugged in, the mechanism unlaced towards the eject position, returned to the play position and then remained lifeless until it was unplugged and plugged in again. You then got the same shuffle. There was also no display at the front.

When I replaced CP19 (1,000 $\mu$ F, 10V), CP21 (47 $\mu$ F, 50V) and CP25 (100 $\mu$ F, 10V) in the power supply – they all give trouble – I was rewarded with the same shuffle of the mechanics but there was now a display. This revealed all. It said "lock on" – the machine was in the child-lock mode. Pressing 'C lock' on the remote control unit released it, giving normal operation. **B.F.**

### **Toshiba V720UK (DX-9R deck)**

The take-up spool didn't turn in play, so the tape looped up inside the cassette.

The reason why it didn't turn was that the centre gear (item K221) had a split in its side. The parts connected to it are all known to crack, usually giving rewind problems. The centre gear can be obtained from Charles Hyde, under part number 15005GA. **B.F.**

### **Aiwa FX3500**

The complaint with this VCR was that "wait" appeared in the display and no other operation was possible. When I switched the machine on it burst into life with no sign of a fault. I then inserted a tape and selected play. The machine played back without any problems, so I left it on test while attending to other jobs.

When the tape came to the end the forward drive ceased and rewind began. Almost immediately the machine stopped and "wait" appeared in the display. At this point no further operation was possible – unless the mains supply was disconnected and the machine was restarted. When I did this and tried rewind again the same symptoms appeared. I inspected the deck, but couldn't find any defect with the mechanics or the deck sensors. It seemed that the system control was detecting a deck fault and shutting the machine down. After replacing a couple of items without success I changed the lower drum, using one obtained from a scrap machine. I was surprised when I found that this cured the fault, restoring normal operation.

I now know why I refuse to throw away that huge pile of scrap VCRs in the corner of my workshop! **S.B.**

### **JVC HRJ220**

The report with this VCR said no play, wind or rewind. On test this was found to be correct, though the machine did seem to load a tape and made an attempt to play. But there was no tape movement.

On close inspection I found that the pinch roller didn't quite touch the capstan. It is not easy to spot but there's a piece of black plastic, with a spring moulded into it, that acts as the pinch-roller cam. Because this plastic cam was cracked, it didn't apply any pressure to the roller. Normal operation was restored once a new plastic cam with spring had been fitted. **S.B.**

### **Sanyo VH335e**

This machine played slow and cut out, with wowing sound and no drum sync. I initially thought that there was a mechanical fault, but after a general service I found that the machine would switch between the LP and SP modes. The cause was reservoir capacitor C501, which was open-circuit. **I.L.**

### **Panasonic AG7350**

This industrial VCR had no S-VHS playback: there was just an unsynchronised picture, with the stereo sound present. The VHS picture was OK. I found that the S-VHS signal was present at pin 5 of IC6 (the sub-emphasis board), but there was no output from IC6. A replacement sub-emphasis board cured the fault. **I.L.**

### **Hitachi VTF860**

The complaint with this machine was noisy fast forward and rewind. I found that the capstan had partially seized. A replacement capstan assembly cured the problem. **I.L.**

### **Sony SLV-E730**

There was a tape stuck in this machine, because the slider assembly was broken. A replacement, part no. 3-977-442-03, restored normal operation. **M.M.**

### **JVC HRD755**

When play or record was selected the tape would start to load up then unload. The cause could be a worn loading belt or loading block of course, but not this time. The drum failed to rotate because it was partially seizing. I dismantled the motor, but couldn't find the cause. It would

appear that the upper drum's mountings had dropped slightly, with the result that it was seizing on the lower drum. I dismantled the drum and added a very thin shim, then reassembled it. The motor then turned freely. Once I had reset the tracking and checked the tape path this lovely old VCR was finally restored to life.

Although JVC would not have approved of the repair, it was either this or writing the machine off – a new lower drum is prohibitively expensive. **M.M.**

### **Panasonic NVHD90B**

There was no UHF output from this machine, the cause being a dry-joint within the RF modulator assembly. **M.M.**

### **Panasonic NVHD605**

The complaint with this machine was no tuning. The on-screen display menu was OK, but when a channel number was dialled manually the picture was dark with line and field slip. The cause of the problem turned out to be the surface-mounted 4053 switching chip IC3902. **D.R.**

### **Ferguson FV405HV**

This machine was dead with the BUZ91 chopper transistor running hot. I replaced the following items: the chain of 180k $\Omega$

resistors between pin 8 of the chopper transformer and CP011; RP04-RP09; and the two ZPD10 (10V) zener diodes in series with PD020 and DP044. **D.R.**

### **Panasonic NVSD230B**

The customer complained that the playback sound speeded up and slowed down. There's an official modification for this: change C2519 to 0.18 $\mu$ F, part no. ECUMIC184KBN. **D.R.**

### **Toshiba V312B**

The complaint was no functions, though a cassette was accepted and laced up normally. In this event, check the data and clock pins 2 and 3 of the SDA5642 chip IW31 – this applies to machines without OSDs. If the signal is OK, unsolder pins 2 and 3 of IW31. If the machine then functions, IW31 is defective and must be replaced. The part no. is 276TX4341. **D.R.**

### **Mitsubishi HSB12**

A problem you can get with these machines is failure to erase the sound and picture and record new programmes. It's sometimes intermittent. The usual cause is failure of C333 (10 $\mu$ F, 50V) on the top panel. As a result, the voltage at pin 1 of IC310 reads about 0.5V instead of 11V in the record mode. This prevents the bias/erase oscillator working. **G.B. ■**



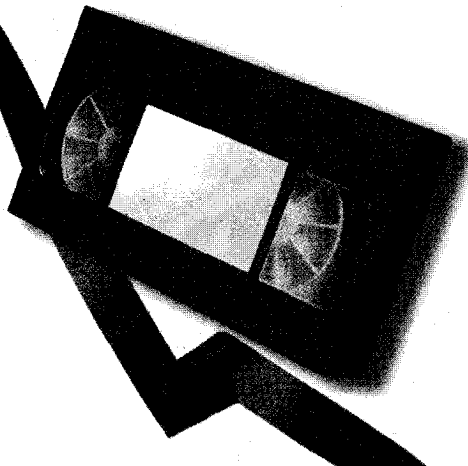

## VCR CLINIC

Reports from  
**Eugene Trundle**  
**Ronnie Boag**  
**John Coombes**  
**Mike Leach**  
**David I. Scott**  
**Dave Gough**  
and  
**Nick Beer**

We welcome fault reports from readers – payment for each fault is made after publication. See page 552 for details of where and how to send reports.

### **Panasonic NVHD660**

There was a very elusive fault with this machine: it took two visits to the workshop to find the cure. Very intermittently the cassette cradle would pull back in and jam after eject, then the machine would switch off. A new mode switch was tried, but this didn't help. I eventually discovered that the cassette-centre LED was dry-jointed to the PCB. The tape-end photosensor diodes were also resoldered. **E.T.**

### **Samsung SV23B**

This fault was cured without us ever seeing or hearing the symptoms! The complaint was about an intermittent crackle on E-E and recorded sound, apparently from a stray digital transmission. Samsung has available an improved UHF tuner that's more resistant to digital co-channel interference. Fitting one cleared the problem. **E.T.**

### **Panasonic G deck**

Machines that are fitted with this deck are now quite old, but many of them are still in use. We increasingly find that they turn up with intermittent faults like no play, tape chewing etc. because pole P5 is stiff on its shaft. Remove and lubricate it, then carefully reset its height. **E.T.**

### **Toshiba V856B**

The fault was no playback sound or picture, E-E operation being OK. The cure was to replace the LA7447BM chip IV001 – a scope check showed that there was no video output at pin 11. **R.B.**

### **Sanyo VHR899**

This machine was brought in because it was dead. The power supply worked normally once D5012 on the primary side had been replaced, but I then found that the machine was slow to accept tapes. A new loading motor cured that. **R.B.**

### **Toshiba V710**

There was intermittent loss of the E-E sound. The cause was traced to a dry-joint at crystal XT4N01 on the sub-board. **R.B.**

### **JVC HRJ270**

Intermittent cutting out and a tape dragging noise were the complaints. The problem was cured by replacing the idler arm assembly. **R.B.**

### **JVC HRJ205**

The initial complaint had been about a jammed tape. But when I tried the unit the display was odd. The customer said there had been a slight bang when it had gone off. A check in the power supply revealed that circuit protector CP1 (N20) had blown in half, because C36 (470 $\mu$ F) was short-cir-

cuit. C33 (470 $\mu$ F) should also be checked, for leakage. **J.C.**

### **Sony SLV715**

This machine had been brought in with the complaint no results. A look at the power supply revealed that several of the electrolytic capacitors had split and leaked their contents over the PCB. There's a Service Kit to deal with this problem, part no. A-6759-574-A, with twelve electrolytic capacitors. Clean both sides of the PCB before fitting the replacements. **J.C.**

### **LG K1-20U72X**

There was no playback sound with this combi unit. The E-E and TV sound were OK. The cause of the trouble was IC401 (BA7797) which had to be checked by replacement. **J.C.**

### **Philips VR6490**

The complaint with this machine was no results. I checked C638 (1 $\mu$ F) first as it causes many problems when open-circuit. The items to check for this fault if C638 is OK are R534 (3.3 $\Omega$ ) and the start-up resistor R102 (330k $\Omega$ ), both of which can go open-circuit. **J.C.**

### **NEC N895**

Fuse F6 blew when play was selected. I found that C3 (33 $\mu$ F, 6.3V) on the video board O3 was short-circuit. It smooths the 5V supply. **J.C.**

### **Akai VSF33**

The cassette jammed on insertion or eject. The usual cause is a faulty cassette lifting unit, but not this time. The retainer ring that holds the pinch roller in place was incorrectly positioned. **J.C.**

### **Sony SLV-AV100UX**

This monster of a machine produced no video output from either the RF or the scart socket. Video from the tuner reached the switching/scart PCB I056, but the  $\pm$ 5V supplies that should have been present here were missing. I spent over half an hour chasing voltages and supplies to and from various different panels before I realised that the source of these supplies is board T012 on the secondary side of the mains transformer. It had been staring me in the face all along! There are two 0.47 $\Omega$  safety resistors here, and both were open-circuit. Check them first! **M.L.**

### **GoldStar RC7051**

The symptom with this machine was very poor E-E with playback OK. For this fault check C707 (4.7 $\mu$ F, 50V) on the top panel. It's almost at the centre of the board. **M.L.**

C+5V supply at pin 39 was low – it was only 2.1V. The source of this supply is Q607 on the main PCB. I found that this transistor's collector connection hadn't been soldered properly and was high-resistance. A touch with the soldering iron put matters right. **M.L.**

### **Akai VSA650EK**

“Sort of working” was the unhelpful though fairly typical report that accompanied this impressive-looking VCR. On initial inspection it seemed to me that the machine was completely dead. But I was wrong. Although there was no display, all the deck functions worked correctly. Voltage checks revealed that the 20V supply was very low, suggesting electrolytic capacitor trouble. As there were clear signs of leakage, I decided to play safe and replace all those in the power supply. This restored the display and the 20V supply, but there was still work to be done before the machine could be returned to the customer.

Sluggish rewind/fast-forward operation and a tendency to snag tapes during eject called for a belt change. **D.I.S.**

### **Panasonic NVG40**

When the owner of this machine had disconnected the RF link cable he'd pulled off the output socket as well. The RF booster had to be removed to reconnect the socket, a straightforward though tedious task. Replacement of the worn pinch roller and back-tension band, followed by a clean up of the mechanics and readjustment, restored normal operation.

The machines in this series have long been favourites of mine, but it's not the first time I've had to refit a broken-off RF output socket. This does seem to be a weakness of the design. **D.I.S.**

### **Sony SLV-E730UX**

I'd not come across one of these machines before. It was inoperative, though the mains fuse on the power board was intact. The fault was likely to be on the primary side of the power supply, where I found that C153 (47 $\mu$ F) and, in particular, C154 (1 $\mu$ F) had dried up.

Replacements restored correct operation, but the job was complicated by difficult access to the components. In addition to

removing the power supply board from the VCR, the screening can and the power module have to be unsoldered from the mother board. As testing can be carried out only when this lot has been reassembled, I was relieved to find that everything then worked correctly. **D.I.S.**

### **Aiwa VSG240EK**

This machine came in dead with no display. Cold checks in the power supply soon revealed the cause of the fault: R204 (270k $\Omega$ ) was open-circuit. **D.G.**

### **Sony CCDF455E**

The problem with this elderly camcorder was vertical bars over the viewfinder image and a graduated brightness change from left to right. Otherwise it worked well. The cause of the viewfinder fault was a couple of surface-mounted electrolytic capacitors, C904 and C915 (both 1 $\mu$ F, 50V). Unfortunately most of the capacitors of this type in the rest of the unit were starting to leak, but at least the two replacements fitted cured the viewfinder fault. **N.B.** ■

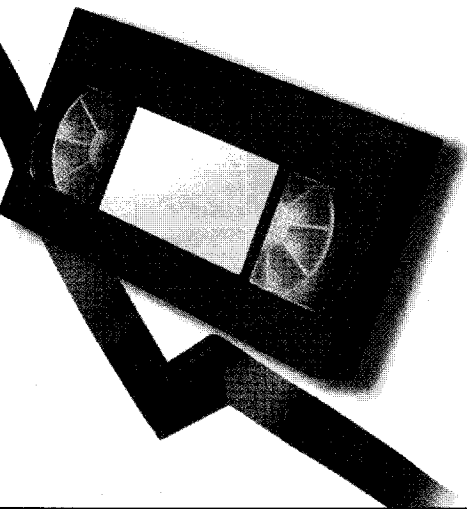

## VCR CLINIC

Reports from  
**G.W. Roper**  
**Steve Barlow**  
**Ivan Levy, LCGI**  
**Michael Maurice**  
and **Bob Flynn**

We welcome fault reports from readers – payment for each fault is made after publication. See page 488 for details of where and how to send reports.

### Amstrad TVR3

With tape playback there were, in the top third of the picture, two or three solid white lines about 3/4in. apart followed by a blanked out line, with the same symptom repeated in the bottom third of the picture. Applying slight pressure to the drum earthing brush made no difference, so I decided to try replacing the electrolytic capacitors in the head amplifier. This didn't improve matters either. I recalled an early Ferguson mechanical VCR that produced a solid white line on the picture because of a faulty video head, but a replacement didn't alter the display.

Wondering whether bonding the head amplifier's case to the earthing brush might help, I held a piece of wire on them. Then fate gave a helping hand: the wire slipped off the brush on to the drum shaft, clearing the fault.

There was no improvement when I cleaned the brush and the drum shaft. Then, looking for a suitable brush in my box of useful bits, I found one of the caps that early JVC machines and their clones used on the drum shaft for contact with the earthing brush. Once I had fitted this the fault cleared. The cap was slightly too long but, rather than risk ruining it by trying to cut it down, I decided to put a set into the brush and, with the slotted mounting, centre it on the shaft cap. The drum bearings felt OK. A very big sigh of relief – and another happy customer! **G.W.R.**

### Mitsubishi HS621V

This machine was dead with no display. Checks showed that there were some voltages on the secondary side of the power supply. As always these days, the ESR meter was brought out to check the electrolytics in the power supply. Before long C9A3 was found to be faulty. Once this capacitor had been replaced the VCR sprang back to life. What did we do before the advent of the ESR meter? **S.B.**

### Panasonic NVSD40

When an unprotected tape was used this machine went into play but wouldn't go into record. Easy I thought, quickly removing the deck to inspect the record protect switch. It was OK however. So I dug out the manual to trace the path from this switch. It was not long before I found that the track on the main PCB was black by the side of the back-up cell, which had leaked and damaged the print, preventing the record-protect signal reaching the microcontroller chip.

This seems to be a common fault – I've now had it three times. **S.B.**

### Mitsubishi HS821

This machine had a tape stuck in it and

error code 1 in the display. I removed the tape manually and reset the EPROM. This removed the error code, but the VCR wouldn't lace up tapes. When I checked the mechanism I discovered a piece of plastic in the loading worn gear slots. Removing it cleared the fault and a soak test confirmed that everything was now OK. **I.L.**

### Panasonic AG526

This machine would accept a tape but not lace up. On investigation I found that the drum didn't rotate and the capstan was pulsating. Checks on the light sensor signals to the system control chip showed that these were normal. The IC was sending the correct drive signal to the drum, but the drum-drive circuit wasn't responding. The cause was inductor L2301, which was open-circuit. It's on the main board. **I.L.**

### Sony SLV401

Intermittent loss of colour was cured by replacing CV801 on the YC board. The type is similar to that used in some Grundig sets. I used a replacement from RS Components. **M.M.**

### JVC HRJ645

When an attempt was made to load a tape there would be a squealing noise from the loading belt then the machine would revert to standby. The cause of the trouble was dry-joints at the beginning-of-tape sensor. **M.M.**

### Sony SLVE920

There was no display. A quick inspection of the power supply PCB revealed that Q612 had never been soldered. Resoldering restored the display. **M.M.**

### Hitachi VTF150E

There appeared to be several faults with this machine: it wouldn't go into the record mode, the Nicam lights were flashing, and the playback picture produced with known-good tapes was poor with a graunching noise from the capstan motor. I dismantled the power supply and replaced all the electrolytic capacitors on the secondary side of the circuit. The machine then worked correctly. **M.M.**

### Philips VR686/07

This machine would very intermittently stop and eject the tape, in either the play or the record mode. The cause was the clutch assembly, which sprang apart when I removed it. **M.M.**

### Mitsubishi HS640V

The right-hand carriage lever had broken. This fault is not uncommon, but was made worse by the fact that the plastic guides, which are part of the chassis, had cracked.

When this happens the only remedy is a new mechanism. Fortunately Mitsubishi has recognised this and supplies new decks, minus the head-drum assembly, at a reasonable cost. **M.M.**

### **Samsung TVP5050IST**

This TV/VCR combi unit was stuck in standby with a tape stuck inside. The cause was a faulty pinch cam lever. I obtained a replacement from Chas. Hyde, part no. 15003BL. **M.M.**

### **Matsui VX1105**

Intermittent tape chewing, in play or record, was caused by the back-tension band. As so often with modern VCRs, the felt had parted company with its plastic backing, exposing the supply spool to its glue. A replacement back-tension band and spool surface clean cured the problem.

When you replace the band you will find that there's a metal plate in the way. Remove the cassette housing, then loosen two of the plate's screws just enough to get the band into place. **B.F.**

### **Toshiba V854B**

A tape had been stuck in this machine and, as usual, the customer had forced it

out. The cause of the trouble was found to be the cam lever, item K470, which had broken – it's a very common failure.

When I reassembled the main cam gear I found that it wouldn't sit down in position. The reason for this was that the loading slider assembly, item B490, which is underneath the deck, had jumped one tooth out of alignment where it engages with the take-up loading arm, item B470. This was obviously the result of the tape having been forced out. Although these two items appeared to be undamaged I fitted replacements obtained from a scrap machine. Everything worked well after reassembly. **B.F.**

### **Philips 14TVCR240 (Turbo deck)**

The faults listed here were: leaving a loop of tape out when the cassette was ejected, noisy wind and rewind, and damaging tapes while playing. A new pressure roller cured the tape damage in play, but the cause of the other faults was less obvious. I inserted a dummy cassette and tried wind and rewind. This seemed to prove that the tape spools were OK – they wouldn't both be noisy. As the clutch, item 115, can be troublesome I replaced this, and also cleaned

and lubricated its shaft and that of the large pulley which fits over the top of it. A very long test proved that all faults had been cleared. **B.F.**

### **JVC HRFC100EK**

This model's cassette drawer takes VHS and VHS-C cassettes. With rough treatment, it's easy for problems to arise. Because of a child's mishandling, one side of the drawer had come adrift. The reason for this was clear when the front had been removed and the machine had been turned upside down. A metal spigot on the underside of the drawer had come out of its runner. All that was required was to push it back into place, but I had wasted a lot of time looking around the top of the mechanism. **B.F.**

### **Sharp VCM311HM**

When a tape was inserted this machine would go into rewind, then wind, and finally just sit there. It would eject the tape all right, but no other function was possible when requested. The only clue while all this winding and rewinding was going on was that the drum was pulsing, not rotating. A replacement drum drive chip, IC702 (BA6977S), cured the fault. **B.F.**

# Tom Baker's tales

**A warning about security-coded machines, a dead Matsui TV and cheapo VCRs**

**H**ave you ever noticed how, just as you feel you are winning a race, someone always seems to catch up and overtake you? That's exactly how I felt last week when I was fixing, or so I thought, a Matsui VX1108 VCR.

## The VX1108 saga

The day had started well enough, and I was feeling great. Then Mr Jenkins from across the road came in with his video recorder. "Morning Doctor" he said.

He always calls me doctor, as in Dr Who, my name being the same as one of the actors who played him in that TV show. "Morning squire" I replied, "what can I do for you today?"

"It's me video" he continued, "very poorly I think. Might be near death's door."

"Quite possibly" I said, "but what's the matter with it?"

"Dead" he replied.

"Then it's already gone" I replied, "but I'll try and work a miracle for you. Give me a ring later."

After those comforting words he left with a spring in his step.

I put the machine, a Matsui VX1108, on the bench and switched it on. It was indeed dead. Not being one to allow that to bother me, I took the cover off and checked the mains fuse. It had blown, but wasn't black. So, before fitting a replacement, I carried out some checks in the mains input department and found that one of the bridge rectifier diodes had gone short-circuit. The machine had a laced-up video stuck inside and, as it's of the type with a centre-mounted deck on a single PCB, this had to be removed before I could get to the diode to unsolder it. Fortunately the only screw that was difficult to get at was accessible, albeit difficult to remove with the tape still in, but I managed it. Once the tape had been removed it was fairly easy to strip the rest down. Then, after fitting a new rectifier and checking to see if anything else had gone, I reassembled the machine, minus the awkward screw, replaced the fuse, switched on and waited for the bang and the smoke.

It worked all right, or so I thought, because it ejected the tape that had been stuck inside and, once reinserted, accepted the tape and laced up. Then the dark clouds started to appear. There was no play, fast forward or rewind operation. So I called half time, with the score VCR 1

Tom 0, put the kettle on and tried to refresh the old grey cells.

This seemed to work. While I was drinking my coffee something started to nag at the back of my mind. I recalled an article I'd seen recently about this same type of fault. Yes, Test Case 469 last January. So I reread it and then looked to see if the spool release post was broken. Yes, you've guessed right, it wasn't.

Feeling dejected, I decided to put it aside and leave it for another day. But at this point I noticed something on the front of the machine, the words "security coded". I hadn't paid any attention to this as lots of machines have this on them and it's not caused me any problems before. Why should it now?

At this stage I hadn't connected the VCR to a monitor, as I was mainly interested in getting it to work mechanically. But I thought I would see if there was anything wrong with the E-E picture. A bright blue screen appeared with, flashing, the word "pin" on it. So I phoned Mr Jenkins and asked him for his pin number and remote-control handset.

He turned up almost immediately and put in his year of birth. Then, as if by magic, the machine allowed me to play, rewind, etc.

I'm not sure about the moral of this story but, in future, I won't accept a VCR with "security coded" on it unless I have the remote-control unit and the customer's guidance as to whether it has been activated or not and, if it has, the pin number.

Final score VCR 1, Tom 2.

## A Matsui 2109NS

Later that day old Tom from the camp site turned up with his TV. "Morning young Tom" he said, "can you have a look at me telly? It's just out of guarantee with Currys and they want £45 to come out and look at it."

I like it when he comes to see me, because not many people call me young any more. So I asked him to bring the set along.

It turned out to be a Matsui 2109NS. I have to say that in recent times more of my customers seem to be unhappy about the after-sales service they get from the big multiples, who want an arm and a leg just to look at something. But don't get me wrong, I think this is great – it's more work for me.

I put the set on the bench and switched

it on. There seemed to be no life in it at all. After doing the usual things like checking the fuses and diodes etc. and finding nothing amiss I started to look for dry-joints. Still no luck. So I switched it on again and started to carry out voltage checks. There was voltage across the mains bridge rectifier's reservoir capacitor, but nothing much else. I switched off and waited a few seconds then checked the main reservoir capacitor before going any further. To my surprise it was still charged to 245V. So I discharged it properly and started to look for open-circuit resistors.

This proved successful, as R504 (2.2M $\Omega$ , 1/8W) was open-circuit. There are two of these tiny resistors, of the same value, in series. After fitting a replacement I switched the set on and waited for maximum smoke. Fortunately it worked well enough and, after a bit of setting up, I couldn't fault it.

I phoned Tom and gave him the good news, that I had found the cause of the trouble and repaired it. He turned up a short while later, paid me and thanked me for the wonderful same-day service.

## A cheap VCR

I had to write off a VCR the other day. It was one of those awkward occasions, because the customer said she couldn't afford a new one. As she had been recently widowed I felt I should try and help and said I would see what I could get a new one for.

So out came the catalogues and flyers, but the cheapest was still nearly £100 including the dreaded VAT. I spent a long time making enquiries, then my wife asked whether I'd looked in the Argos catalogue. I hadn't thought to do so, and when I did I was gobsmacked to find a Bush VCR905 for sale at £64.99. I rang the customer and said I could supply one for £70 – after all there was time and petrol to pay for. As she was happy with this price I went off, joined the queues and came back with a cheap and cheerful VCR.

Somewhere along the line this machine had been manufactured, packaged, stored, shipped, transported and delivered to the depots – and VAT added. Assuming that all these processes had involved costs, one's mind boggles at how low the initial cost of the unit must have been. And everyone along the line must have been making a bit of profit.

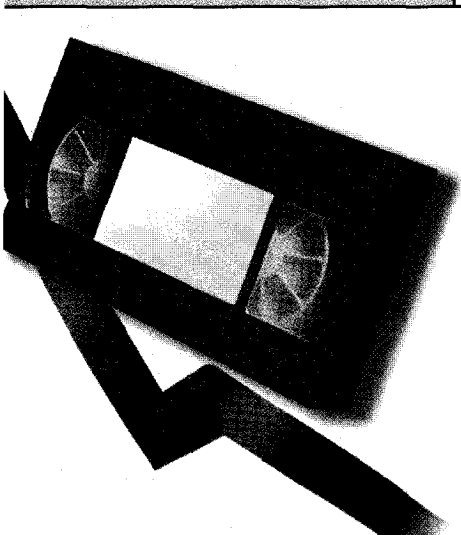

## VCR CLINIC

Reports from  
Eugene Trundle

J.S. Ogilvie

Robin Beaumont

Ronnie Boag

and

Bob Flynn

We welcome fault reports from readers – payment for each fault is made after publication. See page 616 for details of where and how to send reports.

### Sanyo VHR777E

The only way to describe this fault is “erratic behaviour”. The deck would shut down intermittently, the lights would go out when a function was selected, and so on. These problems were all caused by the loading motor, which drew over 50mA from a 5V supply with no mechanical load. Replacements are available from SEME as MOTOR4363 at £13.95 net. **E.T.**

### Hitachi VTF540E

The problem with this machine was intermittent tape looping at eject. Various causes can cause this fault. In this case the cause was simple and obvious: the back-tension band’s felt strip was partially adrift and sometimes stuck to the supply-spool turntable. Its part no. is KX11631. **E.T.**

### Daewoo V2235

The cause of noisy, ‘snatchy’ rewind with this machine was a badly worn brake pad on the take-up (right-hand side) spool turntable. Strangely it didn’t cause tape tangling or spillage, as far as I could see. **E.T.**

### Sony SLVSE70UX

As with many other Sony models, this one uses the SR deck mechanism. We’ve recently had two of these machines whose deck became jammed because the cam-follower spigot broke off the press block assembly pinch, part no. A6759 863B. As a result it caught below the flap-opener moulding. **E.T.**

### Hitachi VTFX765E

The lightning season is here again! A bolt via the mains supply had disabled this machine, which was dead. It came back to life when I replaced the STRF6653 chopper chip I085 and optocouplers PC0851 and PC0852. **E.T.**

### Mitsubishi HS651

The cassette cradle tended to jam towards the end of the eject phase. The cause was FL arm/lever 621C2500010, which had warped sufficiently to catch the cradle slider.

This fault could also occur with the **Tatung Model TVR952** and other machines that use the same deck. **E.T.**

### Philips VR6547 (JVC deck)

If the machine shuts off on rewind and goes to standby, check the reel sensors for dry-joints. **J.S.O.**

### Goodmans SD1600

The complaint was “tape stuck”. When the machine was switched on you could hear the motor running, then it shut down. If

you get this fault, remove the bottom cover carefully and look for the loading motor pulley. It falls off. I find that a spot of Evostick prevents a recurrence. **J.S.O.**

### Sony SLV625

The display flashed wildly and there were no functions. After a few minutes everything was OK. For this fault check C202 (3,300µF, 16V), which tends to leak, and C208 (2,200µF, 10V). It also pays to check the following electrolytics: C111 (1µF, 100V), C204 (1µF, 50V) and C212 (100µF, 50V).

In addition remove the FF/rewind/play control then strip and clean it. It can be the cause of all segments of the display lighting up when FF/rewind is selected. **J.S.O.**

### Toshiba V804B

When FF or rewind was selected this machine would stay in that mode. The cure is to remove and clean the FF/rewind control. **J.S.O.**

### Grundig GV411

This Philips manufactured machine produced a very low contrast picture via the RF output. The feed via the scart output connector was OK. I found that the fault became worse as the machine warmed up. The video signal is fed to the RF modulator via a BC858B emitter-follower transistor, which was the cause of the trouble. It was leaky. It’s a common problem with this and similar surface-mounted devices. **R.B.**

### Panasonic NVSD410B

All functions worked correctly but the timer display was very dim. The cause was diode D7532, which sets the bias conditions for the display tube. It was leaky. A replacement 22V zener diode restored full brightness to the display. **R.B.**

### JVC HRA631EK

The dealer who brought this machine to us had done some work on it but, after reassembling it, found that the cassette was ejected immediately after it reached the loading down position. The nylon pin that operates the cassette-down switch was missing and had to be replaced. Presumably it had fallen out during the previous repair. **R.B.**

### Sony SLVSE800G

This VCR’s power supply was dead. Sony has available a modification kit to overcome a problem with the start-up resistors, but fitting this didn’t cure the fault. The TDA16846 power-control chip, IC151, had an internal fault between its supply pin and ground and had to be replaced. For good

measure I also replaced the feedback optocoupler (PC151). **R.B.**

### **Toshiba V726**

This VCR produced a snowy E-E picture. The cure was to replace capacitor CP051 (1 $\mu$ F, 50V) which is associated with the -32V rail. **R.Bo.**

### **Sanyo VHRH791**

There was no tape take-up with this machine. The cure was to replace the clutch assembly and the arm assembly. **R.Bo.**

### **Samsung SV637B**

This machine was dead. It returned to life once capacitors CISS35 and CISS36 in the power supply had been replaced. **R.Bo**

### **Hitachi VTF350E**

There was no front display and the mechanism would go straight into play after which there was nothing. If it was turned on again there would be a brief movement then nothing, with still no display.

I happily replaced C12 and C13 which are usually responsible for this sort of thing, also C11, C16 and C6 which cause

trouble. My smile vanished when, on plugging the machine back in again, nothing had changed. A more scientific approach was required. So I measured the outputs from the power supply and found that the -30V feed at pin 3 of the connector was missing. Further checks revealed that the tiny 68 $\Omega$ , 1/6W fusible resistor R36 was open-circuit. Just in case, I replaced C15 (10 $\mu$ F, 50V) as well. My smile returned when I plugged the machine in again. **B.F.**

### **LG BC999NI**

There was poor playback of some tapes while others were OK, the cause being a worn pressure roller. I couldn't find this model listed anywhere, but SEME can supply the complete arm under order code PW6151 (the LG part no. is 4261R-0011A). It's easy to fit the replacement, the arm being held in place by a twist-off piece of plastic. **B.F.**

### **Toshiba V857B (V3 CAT 2)**

According to the customer this machine "went pop then dead". Mysteriously, neither the fuse in the mains plug nor the one inside the power supply had blown. What was even more mysterious was that the heatsink for power transistor TP001

had lifted away from the board at its anchor end and forced the legs of the transistor loose at the other end. It's the second time I've seen this, and I still can't understand how it happens.

A repair kit with all the parts required to restore power supply operation is available - **Ferguson** part no. 20343140 or **Thomson** part no. 35065920. **B.F.**

### **Philips 14TVCR240/05 (Turbo deck)**

The customer had removed a cassette from this combi unit as it wouldn't eject normally. An examination of the deck revealed that the tape-loading arms were jamming the mechanics. The cam wheel tension (item 113B) and the tension lever (item 112M) under the deck were found to be adrift. The metal shaft that the cam wheel clips on to had come loose from its plastic base on the chassis, because of a hairline crack in the plastic.

I couldn't find a repair kit listed, so supergluing the shaft at the correct height was the only option. The height at which it's glued is important, so that the gear will click into the shaft slot and align with the surrounding gears.

A very long soak test proved that all was now OK. **B.F.**

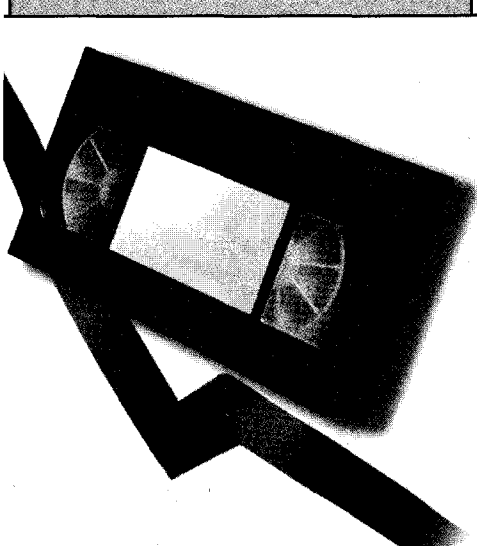

## VCR CLINIC

Reports from  
**Bob Flynn**  
**Carl Owen**  
**Martin Cole**  
**J.S. Ogilvie**  
and **David I. Scott**

We welcome fault reports from readers – payment for each fault is made after publication. See page 680 for details of where and how to send reports.

### **Akai VSG781EK**

This VCR wouldn't accept a tape. Motors could be heard spinning, but no attempt was made to draw the cassette in. No broken parts were seen when the mechanism was removed, and manually loading a tape was OK. Nothing amiss was found when the connections to the end sensors and the centre LED were examined, but they were resoldered anyway.

I removed the mode-switch assembly and found that it was far from clean inside. Once it had been cleaned and lubricated the machine accepted tapes. **B.F.**

### **Panasonic NVHD605B (K deck)**

A cassette that wouldn't eject was stuck in this VCR. The machine would just go into rewind for a while then switch off, with F03 in the display. After a few attempts the cassette did eject on its own, avoiding the need for a delicate removal operation.

The loading-motor coupling was OK, and there was nothing obviously wrong with the other gears. While looking at the main board for possible dry-joints at sensors I noticed that one of the four copper contacts on the mode switch connector had come out of its casing. This would give poor contact with the mode switch of course, and cause intermittent operation. Once the contact had been refitted in its casing and the contacts had been cleaned the machine worked correctly – a long soak test proved that all was now well. **B.F.**

### **Sharp VCA43HM**

Sometimes this machine wouldn't start up – it would just produce a high-pitched whistle from the power supply. Removal of the power supply didn't reveal anything that was obviously wrong, but when C907 was moved it was found to have an unsoldered leg. Reliable operation was obtained by resoldering C907, C906 and the plug connections at PA, and replacing C913 (47µF, 16V) on the primary side of the power supply. **B.F.**

### **Ferguson FV61**

This machine was lifeless apart from the loading motor, which was pulsating. The power supply output voltages were correct except for those at pins 1, 2 and 3 of BP03. The voltages at pins 1 and 2, which should be 13.6V and 21.8V respectively, were both missing. The voltage at pin 3 was high at 20V instead of 5.9V. The cause of the fault was IT25 (U2559BFP), a small IC on the large servo board. All was well once it had been replaced. **B.F.**

### **JVC HRD960**

When this machine went into fast wind or rewind it would switch off. The brief slow

wind or rewind before it unlaced and speeded up was OK. As no mechanical faults could be found, attention was turned to the power supply where C19 proved to be the culprit. **B.F.**

### **Sharp VCH84/86**

If the tape plays back at high speed, check the amplitude of the waveform at pin 3 of the capstan motor. It should be 2V peak-to-peak. If it isn't, try moving the sensor on the motor closer to the edge of the pulley. In this machine the sensor was loose. Alternatively you could replace the motor, but the cost would probably mean that the VCR was not worth repairing. **C.O.**

### **Samsung C15A chassis (tele-video)**

There was a cassette stuck in the VCR section of this combi unit. After releasing the cassette and cleaning the mode switch the unit no longer remained in standby. **C.O.**

### **Philips VR948**

This top-of-the range S-VHS machine had a cassette stuck inside. At power up a whirring sound was heard, which indicated that the gear was loose on either the loading shaft or its associated worm gear. A kit is available to deal with this, part no. 4822 310 10657. Replacing the shaft and worm gear did indeed cure the fault.

But other strange faults were found to be present when the machine was tested. Playback was OK, but when fast search was selected the capstan took several seconds to reach the normal "scanning + 9" speed, and when play was pressed to return to the normal speed the capstan took about ten seconds to gradually slow down to normal. When reverse search was selected, the capstan stopped and the picture froze – despite the fact that the display showed "scanning – 9". And when the audio was switched to mono the display bargraphs went to maximum with no sound. During playback of any tape, including prerecorded films, the mono soundtrack was erased.

I decided to tackle the speed fault first, which was a wrong move! A replacement capstan motor made no difference. Then I thought that the UPD78134 microcontroller chip IC7060 might be faulty, as it controls the capstan motor directly. It's a difficult chip to replace, so I had to be pretty certain that a replacement would clear the problems. I went ahead, but the faults remained exactly the same.

I left the machine for a day, then spent ages checking the reset circuitry. After that I decided to tackle the sound fault. As I suspected, the mono linear sound bias/erase oscillator was on all the time. The cause was the BC848B surface-mounted transistor Tr7242, which had collector-emitter



leakage. After fitting a replacement I tested the machine again, and was surprised to find that the faults had all been cured!

The only link between the two circuits is the reset line, which is connected to the emitter of Tr7242. It must have been corrupted somehow, affecting the micro-controller chip.

After reassembly and a final test I had to work out what to charge. Fortunately the customer was very understanding and very fond of the machine! **M.C.**

### **Goodmans VN6000**

If the display is flashing, the power supply produces a slight buzz and the machine loads but doesn't play, replace the main reservoir capacitor (82 $\mu$ F, 400V) in the power supply. Also clean the mode switch – a loop of tape may be left if this is not done. **J.S.O.**

### **Matsui VX1105/VXA1100**

I've had several of these machines recently with the tape creasing complaint. Check the retainer clips on the take-up and supply guide poles – they can slip down, with the result that the guides don't locate in the V blocks. Refit

and add a small spot of Evostick to prevent the fault recurring. It pays to check both clutches and clean the mode switch while the deck is out. **J.S.O.**

### **HTC TVR402**

I've repaired several of these 10in. TV/VCR combi units for a local caravan hire firm. All have had the same fault – no functions when the tape has loaded. The cure is to remove and clean grease from the mode switch. The deck is similar to that usually found in Daewoo models and other budget machines. It's a straightforward job with this deck. **J.S.O.**

### **Thorn VR202LV**

The owner of this machine complained that the picture was intermittently unstable, with tracking noise at the top of the screen. When I removed the cover I saw that the back-tension band's felt pad had parted company with its backing, so I was fairly confident that a replacement and adjustment would cure the fault. But although there was an undoubted improvement when this had been done, the picture stability still left a lot to be desired. A look at one of the owner's tapes provided the vital clue – there was

slight crinkling along its edges. Correct operation was restored by cleaning the capstan and replacing the pinch roller. **D.I.S.**

### **Panasonic NVHD620B**

There had been a gradual deterioration of playback of tapes recorded by this well-used VCR. The owner had tolerated this until tape-loading problems arose. He then asked me to look at both problems. Although I was rather concerned about the very evident head-drum surface wear, I had to tackle the loading problem first. I suspected yet another split loading-motor coupling, but this proved to be OK. The cause of the trouble was slow operation of the loading mechanism, which prevented full loading. Much time was spent cleaning and lubricating the mechanism before suspicion fell on the loading motor itself. Substitution of a known good loading motor proved the point.

Unfortunately the poor picture quality was down to excessive head-drum wear. At this point the owner declined the repair and bought a new VCR from Tesco – for slightly less than the cost of the head drum and loading motor from Panasonic. **D.I.S.** ■

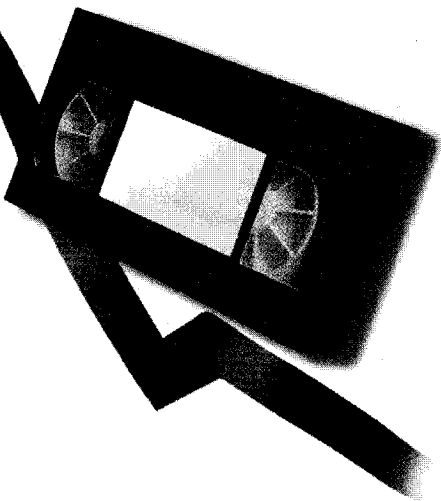

## VCR CLINIC

Reports from  
Robin Beaumont  
Neil Sleeman-Smith  
Ron Mitchell  
Martyn S. Davis  
Ivan Levy, LCGI  
Dave Gough  
Dean Ratcliffe and  
Keith Cummins

We welcome fault reports from readers – payment for each fault is made after publication. See page 744 for details of where and how to send reports.

### Philips VR510/07 (Apollo 12 chassis)

This machine's E-E picture kept disappearing, as if it was switching to the AV input. The clue was that there was no sound in any mode. I found that the TDA9605H audio processing chip's 9V supply was low, with excessive voltage drop across the 100mA fuse F1509. While I was carrying out checks the fuse failed completely, and I was able to confirm that the IC was faulty. A new fuse and IC restored normal operation. **R.B.**

### Panasonic NVHD640B (Z mechanism)

This machine would shut down at random during play or record. I initially tried replacing the reel sensors, but the cause of the trouble was loss of take-up tension. A new clutch assembly (part no. VXP1732) and drive gear (part no. VDG1221) were required. **R.B.**

### Sharp VCM26HM

This machine's stop/eject button was broken and the tape couldn't be ejected. Not a real problem, but when I checked the Sharp website I found that a modification is available – an additional plastic bracket that restricts the travel of the buttons and thus reduces the likelihood of breakage. There are two versions of the bracket, depending on the particular model being repaired. **R.B.**

### Philips 14PV200/07

This combi unit was stuck in standby with no bus-line activity. The fault can sometimes be caused by a memory problem, but in this case the TMP93C071 microcontroller chip IC7900 was faulty. Replacement is not a job for the faint-hearted: the IC has 120 pins!

The same microcontroller chip is used in the Philips **Apollo 20** VCR chassis, in which it can cause similar problems. **R.B.**

### Sanyo VHR776E

We had a pig of a fault with this machine. The tape loaded, but there were no functions and the drum was spinning far too fast. IC351 and the stator motor were replaced without curing the trouble, the cause of which turned out to be C3525 (0.47µF, 50V). It's connected to pin 29 of IC351. The capacitor read all right when checked with our test gear. **N.S.-S.**

### GoldStar P134I

This VCR seemed to be completely dead. But when the power supply was removed the fuse was found to be intact, and on test all outputs were present and were clean when checked with a scope. When

the power supply was plugged back into the main PCB the +6V supply showed terrible noise on load. C19 (1,000µF, 10V) had dried up. For improved reliability I used a 1,000µF, 16V 105°C type as the replacement. This got the machine going again – all the other supplies were clean when checked. **R.M.**

### LG S909

This rather nice VCR was dead. Its power supply can be removed and run, up to a point, as a separate unit. Cold checks failed to reveal any problems with circuit protectors or start-up resistors, but CP06 (33µF, 25V) on the primary side of the circuit read low and was replaced. On power-up I had, as expected, some secondary voltages. Some of the secondary voltages will always be present, others will be switched by the microcontroller chip on the main board. So, was there a fault in the power supply or on the main board?

The clue was the voltage at pin 8 of PP501. This is shown on the circuit as 5.3V, but in fact should be nearer 6V. The reading I obtained was 5.1V. Now there isn't a great difference between 5.3V and 5.1V, but there is between 6V and 5.1V! This voltage is provided by two 1,000µF capacitors, CP12 and CP13. Both read low in value, and replacements restored the VCR to life. **M.S.D.**

### JVC HRJ660

This machine was brought in because it had chewed a couple of tapes. It behaved itself on my bench however. I've found that with machines that use this deck the mode switch and a couple of idler items, as follows, should be replaced: item 102, idler lever, part no. LP30236-002B; item 89, idler arm assembly, part no. LP40114-006B; and item 106, rotary encoder, part no. QSW0554-003. It seems that the main culprit is item 102, which occasionally sticks. **M.S.D.**

### Sanyo VHR279E

The fault report said "tape jammed". On investigation I found that the cassette loading operation was lazy, sometimes loading and sometimes stopping half way. According to the fine men at Sanyo Technical, if the loading motor draws more than 30mA it should be replaced. I haven't discovered how to measure this, since the motor sits beneath the deck in what is a now standard mid-mount mechanism. A replacement motor cured the fault however. The part no. is 645 029 7014. **M.S.D.**

### Panasonic AG5260

This VCR showed error 5 in its display.

When I checked its mechanical operation I found that the tape was being accepted and laced up but the pinch roller didn't engage, because the plastic locating pin on the assembly had broken off. A new pinch-roller assembly and general clean restored normal operation. **I.L.**

### **Panasonic NVHD90**

There was a tape stuck in this VCR's mechanism. I had to strip the mechanism down completely and retime it. After fitting a new clutch, idler and roller and cleaning the very dirty deck I found that there was no test signal. The cause was dry-joints in the RF modulator. **I.L.**

### **Panasonic AG5260**

This VCR produced a blank screen with normal sound. Checks showed that there was no video at pin 28 of IC3001 and that the IC's supply (SW5V) at pin 6 was low – only 2.5V. The cause of this low voltage was Q6101, which was open-circuit. **I.L.**

### **Ferguson FV71LV**

A tape was jammed inside this machine. Removal of the top revealed a Toshiba deck that suffers from a common fault:

the plastic pulley at the base of the capstan motor splits and drops off. Deck removal confirmed my suspicions. Normal operation was restored once a new pulley had been fitted. **D.G.**

### **Akai VSG240EK**

When asked to rewind or fast-forward this machine would display "error" and stop. The fault can be cured by removing, stripping and cleaning the mode switch. **D.G.**

### **Samsung VIK306**

This machine would power up for a few seconds then die, with no display or anything. Checks in the power supply revealed that, as expected, the electrolytic capacitors were to blame. One in particular, C35 (470 $\mu$ F, 16V), had leaked. I replaced this and, as a precaution, all the other electrolytics. The result was a fully-restored machine. **D.G.**

### **Panasonic NVHD660**

This machine sometimes displayed F3 or F4 in the display when rewind or fast-forward was selected. It might work for two-three days before the fault put in an appearance again. This sort of thing is

caused by a defective mode switch or a defective loading-motor coupling. **D.R.**

### **Toshiba V856B**

There was no E-E or playback picture. Scope checks showed that the video output at pin 11 of the video processor chip IV001 didn't reach the buffer transistor TV011 because RV011 (100 $\Omega$ ) was open-circuit. The part no. for this resistor is 24872101. **D.R.**

### **Sony SLV715**

There was no reverse operation and no rewind function. The cause was R003 (5.6k $\Omega$ ) on board MD49. Its part no. is 124942 611. **D.R.**

### **Hitachi VTF700E**

This elderly Nicam machine had run faultlessly for over ten years but had now developed a capstan servo fault. The servo ran in and out of lock cyclically for the first fifteen minutes of playback, during which time the off-tape time display was permanently stalled. The cause of the fault was C613 (47 $\mu$ F, 16V), which was open-circuit when cool. Recording was not affected by the fault. **K.C.** ■

Ralph Buckstone describes the beginning and the end of a major consumer video system

# RIP

## Betamax video: 1975-2002



The photograph above shows an early Sony Betamax VCR, with cassette and remote-control unit.

The Sony Corporation has announced that it will make only 2,000 more Betamax video recorders for the consumer market: its 27-year old VCR format will be discontinued later this year. The advent of new digital recording formats was specified as being the official killer of the system. In particular the recordable DVD seems to have precipitated a final decline in demand, and has made it “difficult to secure parts” for Betamax machines. But Sony has given assurance that it will continue to repair Beta recorders and manufacture blank Beta tapes, and stresses that the announcement is totally unrelated to its popular Betacam products for the broadcast and video production markets.

### History

Sony had some success with its CV2000 open-reel video recorders in the late Sixties, though these were primarily intended for the commercial and educational markets. Then, in 1972, Philips launched the first video-cassette system aimed at the consumer market. It wasn't very successful, for three main reasons: it was quite expensive, the recording time was limited (one hour maximum), and the cassette, with its reels mounted one above the other, led to reliability problems.

In 1975 Sony launched its Betamax video-cassette recorder system, two years before JVC's Video Home System (VHS), with the slogan “Now you don't have to miss Kojak because you're watching Columbo” (and vice versa). It had the great advantages of a longer playing time and a neat cassette with the reels side-by-side. With its invention, Sony could claim to have changed the way we watch TV, the way we look at movies and the way in which we schedule our evening hours.

### Beta vs VHS

But the video system war followed and, although Betamax survived, VHS ended up as the dominant system. Sony made one fatal error: it was late to license its VCR technology to other manufacturers. JVC vigorously marketed its technology, and quite soon VHS machines were appearing under all sorts of brand names, with many major consumer electronics manufacturers licensed to use it.

There was another reason for the success of the VHS system in the UK market. At the time when VCRs first appeared in the UK the domestic electronic rental market was totally dominated by Thorn Rentals. Nearly every high street in the country seemed to have one or more branches of Radio Rentals, DER or Focus. If Thorn selected something as number one choice, that's what it became. Thorn selected VHS, and these machines started to appear in viewers' living rooms in vast quantities. They were backed by good provision of software, which also had an adverse effect on Betamax: software manufacturers didn't like the idea of having to produce their products in two different formats, and VHS was obviously number one choice.

But Betamax survived, and was judged by many to be the superior format technically. After conceding defeat in the infamous format war, Sony continued to market Betamax machines as a niche item. Production of Betamax VCRs peaked in 1984, at 2.3m units. By 1998 Betamax VCRs were available only in Japan. Sony reported shipment of 2,800 machines in its 2001 fiscal year, which ended in March. The total number of machines produced during the format's lifetime will have topped 18m.

It's sad that, after many years of slow decline, the Betamax format is about to disappear into the attic of history. Sony was to some extent itself to blame for the failure, as previously mentioned. Furthermore the company cut back on promotion once the machines were selling reasonably well. Subsequently Sony launched a new VCR format, the tiny 8mm system, another excellent product. But the company cancelled nearly all Beta advertising, and the result was a weak 8mm market and a dead Beta one.

Sony also failed to appreciate that consumers are not choosy about where they buy items such as VCRs, and often do so on impulse. VHS manufacturers made sure that their recorders were available in many different types of stores – even, eventually, supermarkets.

### The end

It is easy to imagine a different outcome. Beta had at least four solid advantages in comparison with VHS: the picture was sharper, the tape-transport mechanism was more controllable, the cassettes were small enough to carry in a coat pocket or purse, and the hi-fi did not cause any problems for high-speed duplication. Yet only one of these advantages was regularly mentioned in Sony advertisements – when they appeared. The company fell back on word-of-mouth promotion, which was not enough to keep Betamax afloat. So the eject button has been pressed for the last time: RIP, Betamax. ■

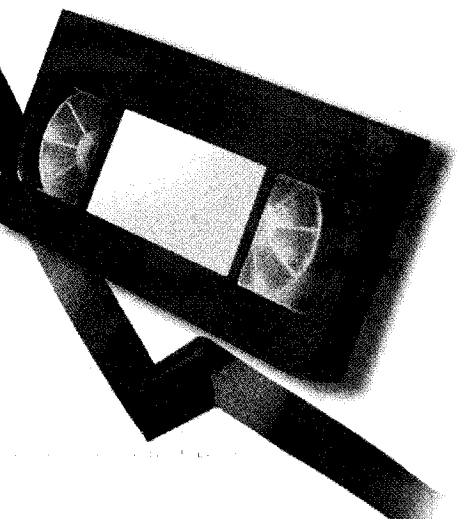

## VCR CLINIC

Reports from  
**Eugene Trundle**  
**Chris Avis**  
**Glyn Dickinson**  
**John Coombes**  
**Bob Flynn and**  
**J.S. Ogilvie**

We welcome fault reports from readers – payment for each fault is made after publication. See page 40 for details of where and how to send reports.

### Hitachi VTF350E

Sometimes the remote-control unit would work and sometimes it wouldn't, though it never failed to produce IR emission when a key was pressed. The cure was to resolder the joints on the VCR's main PCB at PG951, the link to the front panel. **E.T.**

### Sony SLVE730UX

There were no functions and the front display didn't light up. The machine did however produce a fluttering/squealing noise from the little chopper transformer in the power supply section. The culprit was C153, which produced a high ESR reading. **E.T.**

### Samsung SV213B

This machine came in with a couple of severed tapes to illustrate the fault. Very intermittently, it would badly damage the tape when this was ejected. The cure (touch wood, it hasn't come back!) was to replace the loading switch assembly S601 and the reel idler, which is item T236 in the deck parts diagram. **E.T.**

### JVC HRJ420/425

The problem with this machine was no playback sound, E-E sound OK – a simple symptom hiding a far from simple diagnosis. Sound was entering the surface-mounted BA7797F chip IC1, but nothing came out and several pin voltages were wrong. After carrying out ESR checks on and clearing all suspect electrolytics in this area a £10 replacement chip was ordered and fitted. It made no difference (the more costly the part, the more likely misdiagnosis!).

C1 (22µF, 10V) in the equalisation feedback circuit associated with the op-amp between pins 16 and 17 of IC1 had, when initially checked, produced a healthy 3Ω ESR reading. Unfortunately this reading was produced by a 3Ω leak in the component. A replacement restored normal sound. The ESR meter is a great aid to servicing, but is not infallible! **C.A.**

### Bush 190TA

Just in case you get caught out by this Orion double-decker, as I did, one of the four case screws is shorter than the others. It belongs at the front left. If you use a longer screw it will foul the loading gear – occasionally! The machine performs faultlessly on test of course, until you case it up and return it to the customer. **G.D.**

### Philips VR700/07

When a cassette was inserted in this machine it would just be ejected. Occasionally however the machine would accept a tape, half load then jam up. The sensors were checked, and the gear pulley

for cracks, but everything seemed to be OK. I decided to fit a new capstan motor, which cured the fault. **J.C.**

### JVC HRS7000EK

If one of these machines comes in dead, check C2 (2.2µF, 50V) and C58 (10µF, 50V) on the primary side of the chopper power supply. C2 tends to go open-circuit and C58 tends to develop a high ESR (12Ω). If new capacitors fail to restore normal operation, replace C59 and C60 on the secondary side of the circuit. These 22µF, 63V capacitors tend to go open-circuit. **J.C.**

### Samsung SV221B

This machine was dead with a tape stuck inside. On investigation I found that the 1-6A fuse was open-circuit and various items in the power supply were faulty, as follows: Q1SR01 (2SC4517A) short-circuit, R1SR10 (2.7Ω) open-circuit, Q1SR12 (2SC3203) short-circuit, R1SR11 (0.68Ω) open-circuit, D1SR11 (1N4148) leaky and zener diode ZD1SR1 short-circuit. At this point I decided to contact Samsung technical and was advised to carry out the following modifications:

(1) Remove the 47µF, 35V capacitors C642 and C643. Replace them with 10kΩ resistors. Fit these on the print side of the PCB, and don't allow the leads to go through the PCB.

(2) Remove wire link W029 and refit it on the print side of the PCB – again no leads through the board.

(3) Locate pin 21 of IC601 and trace back about 1.5in. to a print dead end. Fit a link from here to chassis at the bottom of the PCB. **J.C.**

### Ferguson FV77HV

No results is usually a simple matter with this model. Check CP11 (220µF, 25V), CP19 (22µF, 63V) and CP26 (1µF, 50V). These capacitors all tend to go open-circuit. **J.C.**

### Goodmans VN6000 (Daewoo G deck)

With any power-related problems, four capacitors should be replaced. These are C822 (330µF, 10V), C823 (1,000µF, 10V), C824 (100µF, 19V) and C826 (3.3µF, 50V). **B.F.**

### Ferguson FV67HV

Rewind was weak when this was requested near the start of a tape. I cleaned and lubricated the take-up spool and shaft and cleaned the take-up brake pad but this made no difference. The cause of the trouble was

the capstan motor pulley, which had a split in it and must have been slipping with the extra effort. Normally it falls off the motor. I glued it back with superglue and on test everything then seemed to be OK. **B.F.**

### **Goodmans VN9600B (Daewoo K deck)**

The symptoms with this machine were intermittent no rewind or play, with loops of tape on eject and the word ERR in the display. The cause was a faulty mode switch. Access is easy. One screw holds the loading mechanism in place. Remove the screw and lift the mechanism off. All that was required was to clean the contacts inside the mode switch. Timing is to align two diamond shapes on the mode switch itself, and a small hole in the main cam gear aligns with a small hole in the deck. **B.F.**

### **Aiwa HVFX5100K**

Recordings made on some tapes were fine. With others playback gave the impression that there were no off-tape control pulses, the picture continually breaking up and clearing again, with no sound.

Nothing seemed to be amiss except for the pinch roller, which had a slightly

curved edge. SEME can supply the complete arm (order code PW6150), which is held in place by a white plastic moulding. Before you remove this moulding, take care to remove a small spring that's attached, noting its position, and pull back a post which has a foot that goes under the deck. I was rewarded with perfect recordings once the replacement had been fitted. **B.F.**

### **Ferguson FV71**

The cause of no power was transistor TP01, which was very leaky, and the fact that RP18 (1.5Ω) and RP21 (2.2kΩ) were both open-circuit. When you get this type of fault, fit the R3000 power repair kit. It has all the parts required and moreover is reasonably priced. **B.F.**

### **Sony SLVE700 (H mechanism)**

There were two faults with this machine. First the tape would build up in play etc. because of no spool rotation – the capstan motor was running all right. The second fault occurred during eject: the tape would start to eject, then stick, then be ejected at an alarming speed.

No spool rotation was caused by the capstan motor pulley, which had broken away. Supergluing it back cured the problem.

The 100 MPH eject was caused by a broken damper arm at the right-hand side of the housing. A totally inadequate plastic hook that secures a torsion spring had broken off. The arm is easy to change but is not available as a spare part, so I rescued one from a write-off machine. Later housings don't have this arm.

I feel that the capstan motor pulley may have broken away because of the initial resistance to eject followed by the sudden rapid movement. **B.F.**

### **Panasonic NVHD600/605**

The customer complained that tapes were being snagged when loaded. On investigation I noticed that the tape was being caught by the pinch-roller assembly. When this was removed I found that the small plastic collar had cracked and slipped down slightly. A replacement collar cured the problem, preventing further damage. **J.S.O.**

### **JVC HRJ625**

If the power supply is squealing, replace the main reservoir capacitor (68μF, 400V). It can go open-circuit. Check most of the other electrolytics while you are at it – they tend to go low in value. **J.S.O.** ■

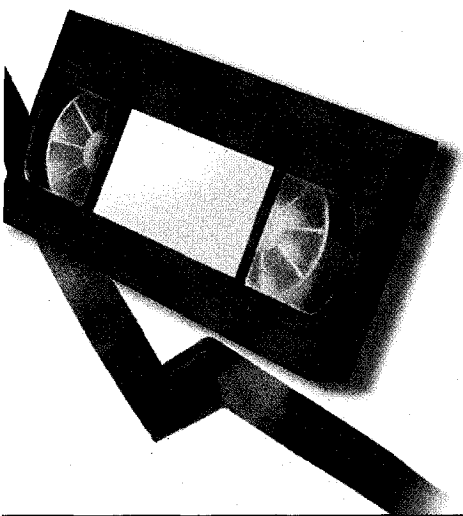

## VCR CLINIC

Reports from  
**Eugene Trundle**  
**C.A. Jackson**  
**Robin Beaumont**  
**Roger Burchett**  
**J.S. Ogilvie**  
**Michael Dranfield**  
and  
**Bob Flynn**

We welcome fault reports from readers – payment for each fault is made after publication. See page 108 for details of where and how to send reports.

### **LG KE14U73**

Sometimes a recording made by this TV/VCR combi unit would play back with the sound from a previous recording and coloured blobs all over the picture. The cause of this was the bias/erase oscillator, which was lazy in starting up. Diagnosis is very difficult here, because of access problems. So we checked that the supply voltage was present during the fault, then replaced Q304, T300 and capacitors C302/5/6/7. That fixed it! **E.T.**

### **Toshiba V726/727B**

The fluorescent display was almost out – it was just discernible in the dark. Once capacitors CP041 (220 $\mu$ F, 10V) and CP051 (1 $\mu$ F, 50V) in the power supply had been replaced full brightness was back. **E.T.**

### **Sony SLV815UB**

Was this one too old to repair? Maybe, with hindsight! As there was little visible head wear, a quote was given and accepted for replacement of the weeping, smelly electrolytic capacitors in the power supply section and a clean-up of the PCB there. The job was done, paid for and the VCR went on its way. A week later it was back, the complaint being intermittent hi-fi sound playback despite the fact that the stereo indicator lit up. I had to replace all the purple electrolytic capacitors on audio board HF9 – at no charge! – to restore correct operation. **E.T.**

### **Philips VR6547**

Two of these came in at the same time after a power cut, both dead with no display, one with a blown mains fuse. Normal operation was restored once C12 (2.2 $\mu$ F, 63V), C31 (22 $\mu$ F, 63V) and C41 (22 $\mu$ F, 50V) in the power supply had been replaced – plus one fuse of course! **C.A.J.**

### **Panasonic NVFJ620B (Z mechanism)**

This machine would not accept a tape because the loading motor didn't run. With this mechanism the loading motor driver is integrated into the capstan motor IC, so a new capstan motor was required. But when I'd fitted the motor and reassembled the deck the loading motor still wouldn't run. Resisting the temptation to panic, I checked through the circuit again and found that repeated dismantling during diagnosis had resulted in joint problems at the loading-motor connector on the main board. Some resoldering here cured the problem. **R.B.**

### **Philips 14PV163/05 (TVCR Beta range)**

A common fault with this and similar TV/VCR combi models is that the unit

goes to standby after running normally for a few minutes. Any problem that triggers the protection circuit can cause this, but I've found that D6513 (BAV21), the flyback boost diode in the field output stage, is often responsible. I usually uprate the diode, using a BYD33J or similar type. This provides a permanent cure. **R.B.**

### **Sanyo VHR279E**

I had a couple of these machines in recently with similar problems: either the cassette would refuse to load or eject, or the mechanism would stick in the fully-threaded mode. In both cases the loading motor had to be replaced because it had a dead spot. Be careful to order the correct part, as there's a similar model with a wired-in loading motor. The VHR279E's motor has an integral plug connector. The motors are not interchangeable. **R.B.**

### **Philips 14PV164/05 (TVCR Beta range)**

This unit was dead with the line output transistor short-circuit. It worked for half an hour after a replacement had been fitted, then stopped with no line drive – the new line output transistor was OK. Scope checks showed that the line-drive waveform that left the TDA8361 chip on the VCR board was of low-amplitude, the cause of this being the BC848B transistor Tr7205, which was leaky. A new BC848B cleared the fault. **R.B.**

### **Sony KV21V5U**

The TV section of this combi unit worked normally, but the video section wouldn't accept a tape or respond to operation of any of the controls. I checked for power-supply problems and obvious mechanical faults, then decided to replace the system-control micro IC402. There was no change, so I had to look harder! One of the IC bus lines between the main microcontroller chip and the system-control micro had leakage which reduced the signal amplitude. The cause was traced to a faulty 6.2V protection zener diode. Everything was OK once this had been replaced. **R.B.**

### **Ferguson FV205**

This was a case of making incorrect assumptions. The call came late one Sunday evening. It was about a TV set that seemed to have AFC or AGC problems. I didn't ask the make, as the house was only a few minutes' walk away. As I gathered some tools together, I suspected a Sony set – I'd had a run of them with problems in the IF unit. The set was indeed a Sony, and I had the IF module out and the soldering iron on before the customer mentioned a cassette stuck in the VCR. A quick look revealed that it was a Ferguson FV205,

with a cassette visible (almost ejected) and no display. Hang on, but there was loop-through. Then the penny dropped. The TV set was OK but the VCR's power supply was in trouble.

Then I remembered the power cut on Saturday night. The TV set's IF unit was in fact OK, though I resoldered it nevertheless. I took the VCR back to the workshop and repaired it the following day. It's the same cased unit as in the FV80/1 etc, and the culprit was CP008 (100 $\mu$ F, 25V) which read just under 60 $\mu$ F when checked.

The moral is not to jump to conclusions. The customer got her IF unit checked over for free, but had to pay a premium for a Sunday evening call! **R.Bu.**

### **GoldStar GHV12961**

According to the customer all that happened was that the FF and rewind symbols in the display flashed. When I opened the machine I found that the loading mechanism was jammed by a steel pin which had worked its way from its mounting on the deck, next to the light tower. Removal of the pin and resetting the mechanism usually clears this fault. Best thing to do with the pin is

to bin it. I can't see that it serves any useful purpose. **J.S.O.**

### **Matsui VP9605**

If one of these machines damages tapes, check the back-tension band. It's usually stuck to the supply reel. A replacement band will restore normal operation.

**J.S.O.**

### **Sanyo VHR777E**

This VCR was dead, with the mains input choke melted and both windings open-circuit. It's not an item you would normally expect to find faulty. But in addition the surface-mounted mains bridge rectifier was short-circuit and the 2.5A fuse had blown. According to the customer this had occurred about ten minutes after reconnecting the machine to the mains supply after moving house. **M.D.**

### **Ferguson FV77HV**

There was just a faint noise from the power supply and all the voltages on the secondary side were low. As there were no faulty fusible resistors, I decided to replace all the known troublesome capacitors – CP11 (220 $\mu$ F, 25V), CP19 (22 $\mu$ F, 63V), CP26 (1 $\mu$ F, 50V), CP28

(47 $\mu$ F, 50V) and CP35 (100 $\mu$ F, 25V). After that the power supply worked normally. **B.F.**

### **Mitsubishi HSM37**

This VCR came back every couple of weeks with a tape stuck in the fully-loaded position. The normal cause of this is hardened grease around the pressure-roller mechanism or on the two sliding plates underneath the deck, but these points had been attended to. The only clue was that the loading motor had to be rotated a few times to released the mechanics rather than, when grease is the cause, giving it a slight touch. I assumed that the mode switch was faulty and replaced it. The machine has not been back these last six months. **B.F.**

### **Aiwa HVGX350K**

The customer reported that this VCR stopped playing then all the display symbols lit up. When I tried it out in the workshop it was dead. Four capacitors in the power supply give problems, CP11 (33 $\mu$ F, 25V), CP19 (1,000 $\mu$ F, 10V), CP21 (47 $\mu$ F, 50V) and CP25 (100 $\mu$ F, 10V). Once these had been replaced all was well. **B.F.** ■



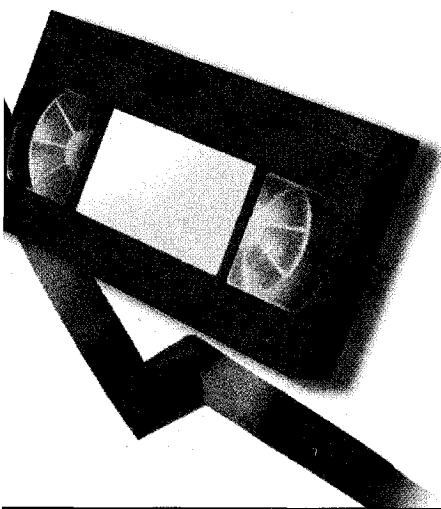

## VCR CLINIC

Reports from  
**Eugene Trundle**  
**Dave Gough**  
**Bob Flynn**  
**Peter Tennant**  
**Bob McClenning**  
**Bob Longhurst**  
**Paul Flower**  
and  
**Jerry Fedorak**

We welcome fault reports from readers — payment for each fault is made after publication. See page 172 for details of where and how to send reports.

### **Panasonic NVFJ610**

We've had several of these and similar models with the complaint of static 'blips' on the playback picture. In some cases the cure has been to clean the PCB land that earths the metal bottom panel. Some however can be dealt with properly only by replacing the earthing brush that's buried under the upper drum. Panasonic has available a rather expensive conductive oil with which to anoint the shaft. **E.T.**

### **Goodmans VN9600B**

Functions were intermittent or, as the customer said, the machine "had a mind of its own", with "error" shown in the display. Once I had removed the lid I recognised the mechanism and knew exactly what to do. Remove the white plastic frame that holds the mode switch, unsolder the switch, open it up and deal with the dreaded green gunge. Clean and replace the switch and you will have normal operation. **D.G.**

### **Panasonic NV870**

Once a tape had been inserted this old-timer would refuse to release it. As I suspected, the loading belt was the cause. But inspection showed that further work was required. SEME has a service kit at a very reasonable price. Once I'd fitted this and given the machine a good clean it worked very well. These are well-made machines that provide excellent pictures and sound. It's a pleasure to work on them. In addition I had a happy customer! **D.G.**

### **Bush BTV14**

I'm not too keen on these cheaply-made combi units. This one was ticking and did nothing else. Fortunately the cause was simple, a dry-joint at the ceramic insulated wire link next to the line output transformer, on the LOPT panel. Once this had been resoldered there was normal operation. **D.G.**

### **JVC HRJ755EK (1998 deck)**

Tapes couldn't be inserted because the top plate, item 274, had come adrift. It's held in place by two flimsy plastic clips, one at each side, on the side holders. Both had become weak. Charles Hyde can supply the left-side holder under order code 22007MZ and the right-side holder under order code 22007PA.

The manual tells you to remove all the gears on the side, but this isn't necessary. Unclip the two plastic assemblies at the left of the deck, move the mechanism so that the drive arms are upright, and lift the holder out. **B.F.**

### **Hitachi VTF150E**

Sometimes a loop of tape would be left inside the VCR when a tape was ejected.

The cause appeared to be erratic movement of the half-loading arm. In fact it was because the back-tension band had come apart, exposing the sticky part to the supply spool. **B.F.**

### **Panasonic NVF55B (G deck)**

When this machine was asked to play or record it would lace up, freeze then turn off. The cause of the trouble was the plastic retainer for the pinch roller. It had split, allowing the roller to slip down and jam the mechanism. **B.F.**

### **JVC HRS7500EK (1998 deck)**

This VCR tried but failed to unload the tape from the play position. It's the third time I've had the problem with this deck. Each time the cause has been a piece of white plastic about 1.5in. long that jammed the tape arms. It looks as if it might have come from the large control plate, but comparison with another deck failed to show where it had come from. As with the previous cases, removing this piece of plastic restored full working order.

Does anyone know where the plastic comes from and why it's not needed for the deck to work? **B.F.**

### **JVC HRJ670 (1998 deck)**

There was no power with the 1.6A mains input fuse F5001 blown. Visual inspection revealed that Q5102 (2SD2144S) had blown apart. Further checks revealed that the chopper FET Q5101 (2SK2632-CB14) was short-circuit and R5106 (0.39Ω, 1W) was open-circuit. No reason for the failures could be found so, in addition to these items, I replaced the optocoupler PC5101 (ON3171) and C5104 (1μF, 50V). A long soak test proved that the machine was now OK **B.F.**

### **Panasonic NVHD620B (K deck)**

A tape would sometimes jam in the play position with F03 shown in the display. It's not possible to unload the tape manually with the deck removed, but this can be done if the cassette housing is removed. On inspection there was no visible physical damage, and the loading motor coupling was OK.

I've had a similar problem with a Mitsubishi VCR that would continue to load past the correct position and jam up. As in that case, replacement of the mode switch cleared the fault. **B.F.**

### **Goodmans TX4000 (Daewoo FM)**

This machine would accept a tape and go to the laced-up position, but the drum motor wouldn't turn. The VCR would then unlace, with the drum motor now turning though

the capstan motor didn't. So a loop of tape was left out as the tape was ejected. This unusual sequence of events was cured by cleaning the mode switch. **B.F.**

### **Sony SLVE40UX**

This machine would intermittently die with no display at the front. If there was a tape inside it would be jammed, even if the power subsequently returned. It took a long time to trace the cause, but the cure was simple: resolder pin 1 of connector CN1 on the front display panel. **P.T.**

### **Toshiba V813C**

Dead symptoms can usually be cured by replacing the 47nF, 250V capacitor next to the STRD6202 chopper chip. In some cases you may have to retune all the stations. **P.T.**

### **JVC HRD610**

This VCR was dead because C12 (2.2 $\mu$ F, 50V) in the power supply had failed.

Another fault that's very common with these machines is recording only one programme in the timer mode. Any attempt to record further programmes (on timer) shuts the machine down. The cure is to replace the mode switch (care-

fully). Cleaning it does not usually provide a lasting cure. **P.T.**

### **Hitachi VTF550K**

The usual cause of intermittent stopping and a cassette jam up is a clutch assembly that's parted company. Don't try to repair it as this will not last. The only cure is replacement **P.T.**

### **Ferguson FV91LV**

The fault with this machine was no display. CP041 (220 $\mu$ F, 10V) in the 'boxed' power supply had failed. **B.McC.**

### **Sony SLVE700UX**

As this machine was completely dead I had to unsolder the self-contained power supply from the main PCB. ESR checks then revealed that C204 (1 $\mu$ F, 50V) and C103 (1 $\mu$ F, 100V) were faulty. Once they had been replaced and the unit had been soldered back in place the VCR powered up OK. **B.L.**

### **Sanyo TLS942P (P90 mechanism)**

The problem with this time-lapse machine was that tapes snagged as they were ejected. I soon discovered the

cause: the supply spool was just wobbling around inside the back-tension band. On closer investigation I found that its centre shaft's retaining plastic 'socket', which is held in place by four plastic spokes, had broken away from the mechanism's chassis. I could find no repair kits, which meant that in theory this was a dustbin job. The same plastic parts on the take-up spool were cracked.

I used epoxy resin glue to carry out repair, the result being much stronger than the original fixings. I couldn't decide whether the damage had occurred as a result of misuse or not. Over the years I've repaired dozens of P90 mechanisms but have never before had this problem. **B.L.**

### **Sanyo VHR289**

The fault with this terror was leaving old audio on new recordings. After many hours checking around I found the cause to be a small capacitor under the head drum, circuit reference C2015 (47 $\mu$ F, 6.3V). A replacement solved the problem. **P.F.**

### **Toshiba V709B**

If there is only a flashing red LED with the power supply pulsing, replace C15535 (2,200 $\mu$ F, 10V). **J.F.**

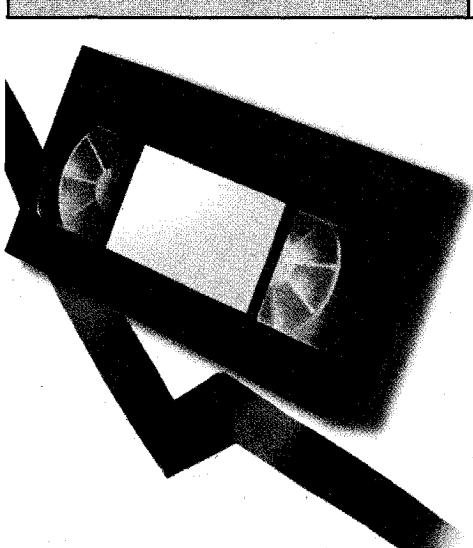

### **Toshiba V725K**

This machine would accept a cassette, but with one exception none of the front-panel keys had any effect. The eject key had an effect – it brought up 'test' on the front-panel display. Play mode could be entered by using the remote-control unit, but the picture was snowy and had bad tracking. Nor was there any sound from the tape or the tuner! All these symptoms stemmed from corrupt data in the EEPROM chip. We had to reset all the option bytes. A table listing them is available from Toshiba's technical department. **E.T.**

### **JVC HRJ665**

This was a strange one! The machine wouldn't accept a cassette but if one was wound in manually the deck worked correctly in every respect. There would be a problem only during eject, when the cassette stopped while it was still well inside the machine. The cause was that the record tab switch, which also acts momentarily as a cassette in/out sensor, wasn't being triggered. Its little plastic operating lever had somehow become 'unclicked' at the left-hand side. All that was needed was to press it back into place. **E.T.**

### **Philips VR6547**

The customer complained that after a minute the picture would break up with no sound, and the counter would stop. But when I plugged the machine in to test it nothing came to life. This VCR is identical to the **JVC HRJ200** range and, as with these machines, C12 (2.2 $\mu$ F, 50V) was the cause.

Then, before I had a chance to insert a tape, I noticed that the E-E picture and sound were constantly blanking out and returning. The situation improved as the machine warmed up. The cure was to replace C206 (0.1 $\mu$ F, 50V) in the IF module, which is the smaller of the three cans.

At last to the original fault, whose cause turned out to be a worn pressure roller. As a result of the wear the tape rode up off the control head.

When I ejected the cassette a big loop of tape was left inside the machine. A new mode switch, part no. PU60622, sorted out this final problem.

What a life indeed! **B.F.**

### **GoldStar GHV1240I**

This old-timer wouldn't accept tapes. As usual, the arm assembly gear R on the side of the housing had parted company with its spring because of a broken lug. Tapes were accepted when a new gear (435-148R) was fitted, but as I wired up the machine to test it I found that the TV channels via the VCR

were wandering in and out of tune.

I replaced C715 in the IF module as it often causes similar problems, but this made no difference. I then spotted some old brown glue under a coil connected to the tuner unit's TU pin. Removing this glue cured the fault. **B.F.**

### **Sanyo VHR790**

This machine was dead following a power cut. It has two 150k $\Omega$  start-up resistors which, curiously, are fed from the mains bridge rectifier's reservoir capacitor via two 1.5M $\Omega$  resistors. One of these was open-circuit. I decided to replace them both, after which everything was fine. **M.S.D.**

### **Samsung SV630B**

This machine came in dead with a tape stuck inside it. Some quick checks revealed a power-supply meltdown: D1SR11, Q1SR02, Q1SR01, R1SR11 and R1SS10 had all failed. A quick call to Samsung Technical produced the suggestion that the cause could have been the 43V zener diode ZD1SS1 associated with the 33V line, on the secondary side of the power supply. Not this time!

After a full rebuild and reassembly I sat and watched as R1SR11 went up like a firecracker while everything else went short-circuit.

Second time round I replaced the failed components, removed and checked every capacitor, measured every resistor, checked every diode then powered the main board via a variac. With an input of about 50V AC the VCR's display bars lit up, and stayed lit as I increased the input to the full mains voltage. I refitted the deck and repeated the variac power-up procedure. This time the power supply failed to come to life. The fault had to be on the deck!

In fact the cause of the fault was to do with the capstan-motor assembly: its on-board IC had blown a hole and was leaking fine sand! It seems that with this power supply design the 15V rail will, when a short is present, continue to supply current until the chopper transistor has had enough and breaks down. **M.S.D.**

### **Panasonic NVSD40B**

There were two complaints with this immaculately kept machine, intermittent sound drop-out and picture instability. They sometimes occurred together, but often happened independently. Fortunately for me the fault put in an appearance straight away. The cause was fairly quickly traced to poor soldered joints at the audio/sync head.

Playback of prerecorded tapes was satisfactory once these dry-joints had been attended to, but playback of the machine's own recordings wasn't. I was fairly

## **VCR CLINIC**

**Reports from  
Eugene Trundle  
Bob Flynn  
Martyn S. Davis  
David I. Scott  
and  
Dave Husband**

**We welcome fault reports from readers – payment for each fault is made after publication. See page 236 for details of where and how to send reports.**

confident that a general mechanism overhaul would improve matters, and this turned out to be the case. The guilty items were a very loose pinch roller and a back-tension band with virtually no friction material left. After replacing them and carrying out adjustments perfect results were obtained. **D.I.S.**

### **Goodmans TX3650**

This well-used machine was given to its new owner who simply wanted to be able to play prerecorded tapes. Unfortunately when he tried to use it he was unable to find the test signal so that he could tune his TV set to the VCR's output. On top of this, when he tried to play a tape it tangled within a few seconds. The test-signal problem was caused by a faulty modulator, which it would not have been economic to replace. I suggested to the owner that he should use the scart connector for playback, which he was prepared to do.

The other problem was cured by replacing the pinch roller and back-tension band and cleaning and adjusting the mechanism. An acceptable though compromise repair was thus achieved.

**D.I.S.**

### **Panasonic NVFJ610B-K**

This fairly new machine wouldn't respond to the remote-control unit. The limited number of functions that could be controlled at the machine itself worked correctly, while the remote-control unit worked the owner's matching Panasonic TV set.

Correct operation could be restored by applying slight pressure to the IR receiver, so I suspected poor joints on the main PCB. This was not the case however. The cause of the problem was that one of the IR receiver's three leads had fractured where it enters the body. The leads are bent by 90°, so it's possible that the damage could have happened during the lead-forming process or when the component was attached to the PCB.

As with most modern machines, access to the solder side of either PCB is not good, and requires deck removal. After removing the deck I was able to loosen both PCBs from their fixings. This provided sufficient room to be able to solder the new component without having to strip everything out of the case. **D.I.S.**

### **Ferguson FV10**

Another repairer had fitted a new head

drum and had overhauled the mechanics. Shortly afterwards a sound problem arose, but my now he had had enough and wouldn't look at the machine!

The symptoms, low and distorted sound in the E-E and playback modes, suggested trouble in the modulator. I would have preferred to fit a replacement, but was pretty sure that the owner wouldn't agree to this after his recent expenditure on the machine. So repair at component level was called for. When I removed and examined the modulator I found two capacitors that appeared to have dried out, C2 and C3. Replacements provided a cost-effective repair – to everyone's relief! **D.I.S.**

### **Hitachi VTMX110E**

This Hitachi-badged VCR with the Philips Turbo deck was dead. I found that the LT fuse MP160 was open-circuit. A total strip down was required to replace it, but after doing this and inserting a tape the fuse blew a few seconds later. Before its demise I noticed that the heads rotated but the capstan motor hadn't even twitched. A new motor cured the fault – or rather one from a scrap machine, to make the repair economical! **D.H.** ■

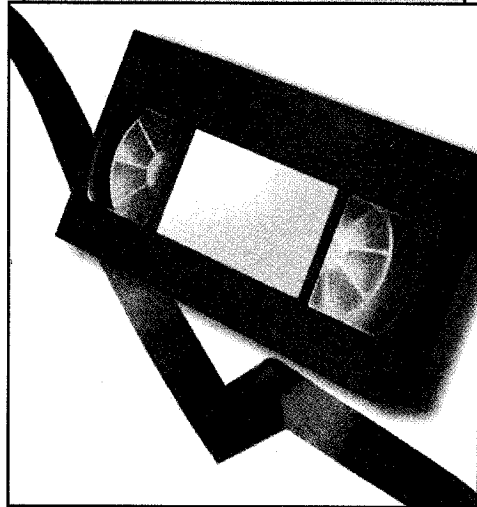

## VCR CLINIC

Reports from  
**Eugene Trundle**  
**Dean Ratcliffe**  
**Garry Laidler**  
**K.V. Cunliffe**  
**Bob Flynn**  
 and  
**J.S. Ogilvie**

We welcome fault reports from readers – payment for each fault is made after publication. See page 300 for details of where and how to send reports.

### Sony SLV-E710UX

This and many other contemporary Sony VHS machines use the H deck. Two of them I've had recently chewed tapes because of lack of reel drive: the toothed pulley had fallen off the capstan flywheel. Sticking the pulleys back on with epoxy resin worked for me, with no bounce-backs. **E.T.**

### Hitachi VTF360

This machine produced no signs of life at all, but an ear close to the power section detected a faint whistle, indicating that the mains fuse at least was intact. The cause of the trouble turned out to be failure of the electrolytic capacitors C865 and C866 – no surprise in such a hot spot! The electrolytics on the secondary side of the power supply were also tired, so I fitted replacements. Access to the components inside this module is frustratingly difficult. **E.T.**

### Sony SLV-E80UX

This machine's deck did nothing because fuse PS201 had blown. Inside there was a tape stuck in the fully-laced position. When I connected an ammeter in place of the fuse and switched on the reading was 1.3A. The culprit was the loading motor. When I sniffed it I detected a pong that replicated something quite unmentionable! **E.T.**

### Sony SLV-SE710

This machine was completely dead because R156 in the power supply was open-circuit. It's best to replace R156 and R157, which are both 2.2M $\Omega$ .

A service kit is available from Sony, spares, part no. A6705-263-A, for this and similar models (SLV-SE600/700/800) that tend to suffer from the fault. **E.T.**

### Panasonic G deck

There was low/muffled sound because of a worn audio/control head. Ensure that the replacement is type VBR0125 with the G21/25 models. With later models the head is supplied without its PCB, so this will have to be transferred from the old one. Check the audio bias each time a head is replaced or adjusted. **D.R.**

### JVC HRJ205

This machine was dead. ICP failure is a common cause. If the display shows an arrow or three dashes, check CP1, replace control cam part no. PQ32413-1-6 and the half-loading arm part no. PQ48570B then realign. **D.R.**

### Toshiba V710

This machine was dead with the standby

LED pulsing. A faint, fast tripping noise could be heard coming from the power supply. The cure was to replace D15531 (F1T4) and C15535 (1,000 $\mu$ F, 10V). **D.R.**

### Philips VR6490

There were no functions because of a faulty power supply. The items to check/replace are as follows: T7101 (BC548C), T7102 (BC558C), T7103 (BC635), T7104 (BUT11AF), D6101-4 (all type IN5062), zener diode D6108 (BZV85- C5V1) and resistors R3118/3104. **D.R.**

### NEC N895

When a cassette was inserted this machine went to playback for one second then the capstan speed increased as in fast-forward. The tape continued to be loaded around the video heads. The rewind, fast-forward, pause and slow functions were all OK. The cause was found to be the BA6305 mechacon servo chip IC415 on the motherboard.

Watch out for open-circuits on this board, for example between pin 7 of IC410 and the jumper J64. **D.R.**

### Thomson VTH6021U

This machine was dead after the customer unplugged her VCR instead of her Sky digibox. For once the cause of the trouble wasn't capacitors or high-value resistors on the primary side of the power supply. Cold checks showed that DP066 (1N5822) on the secondary side of the chopper transformer was short-circuit. **G.L.**

### Samsung SV245B and others

I have had a few of these VCRs with the power supply blown up, possibly because of varying mains supply voltages after storms. Before you replace the defective items on the hot side of the power supply it's as well to check for shorts on the cold side, where you will almost always find that the 43V zener diode ZD1SS1 is short-circuit. In this event the machine will not work after repairing the hot side.

When this power supply failure occurs, the items that have to be replaced are Q1SR01 (2SC4517A), Q1SR02 (KTC3203), D1SR11 (1N4148), D1SD11 (F1T4), R1SR11 (0.68 $\Omega$ , 2W), R1SS10 (2.7 $\Omega$ , 2W) and C1SR12 (22 $\mu$ F, 16V). Note that this is not a polarised electrolytic: it's a special non-polarised type, part no. 2401-000905.

This fault also occurs with derivative models SV643 and SV647 and the earlier SV230, SV233 and SV630/3/7. **K.V.C.**

### Sharp VCA63HM

When this machine had been on for

twenty minutes or more its power supply would usually shut down, with just a whistling noise. Power could be restored once the machine had cooled down. The power supply is easy to remove and work on. I eventually found that the cause of the trouble was C913 (47 $\mu$ F, 16V). **B.F.**

### **Panasonic NVSD230 (Z deck)**

There were various fault symptoms with this machine. Amongst them the tape would go down then eject; or go into the play position then unlatch and eject; or, if the tape did stay in, when the machine was asked to wind or rewind it would do so at only a slow speed. The fault was eventually cured by replacing the two reel sensors IC1501 and IC1502. They are both type RPI354N. **B.F.**

### **Matsui VP9405**

The tape would go into the play position and then just sit there, with the play symbol at the front still lit. A few seconds later the machine would turn off. When the machine was asked to eject the tape this would get to the eject position then, again, the machine would turn off.

Although the mode switch looked to be OK, cleaning the contacts inside and out cured the fault. **B.F.**

### **Sharp VCA72HM**

A tape was stuck in the cassette housing because the rack sliders at the right-hand side had broken away. They are held in place by three plastic spigots, one of which had broken off.

Fortunately I had a scrap housing but, if you need to order the side piece, it's item 302, frame R, part no. LHLDX1025AJ00. **B.F.**

### **Hitachi VTFX980**

This machine was brought in because it was wrecking tapes. When the deck was removed the answer was in bits on the main PCB. It was the clutch assembly, which had fallen apart because the plastic locating lugs had worn away. A replacement clutch is the cure for this one. As these are quite new machines, I think this could become quite a common fault. **J.S.O.**

### **Philips VP28/55**

This multi-standard machine would load a tape then shut down. When it was switched on again it would eject the tape, leaving a loop of tape out of the cassette. On examination I found that the pinch roller assembly was jamming. Its spring guide had jumped out of the

groove on the main cam.

When you relocate it, bend the spring down slightly to prevent a recurrence. **J.S.O.**

### **Matsui VP9601N**

If the power supply is dead or squeaky, check C514 (330 $\mu$ F, 16V). **J.S.O.**

### **Goodmans VP2500/2500A**

This machine would load a tape then eject it and go to standby, leaving out a loop of tape. The cure is to remove the loading-motor assembly to gain access to the mode switch, clean it and refit. It's a quick job to do. **J.S.O.**

### **Nokia VCR3785UK**

The symptom with this Nicam stereo machine was a venetian-blind effect on E-E video. Playback was fine. When you get this problem open up the tuner/IF module then remove and check C205 (1 $\mu$ F, 50V). It's in the top corner of the IF section, by the 6MHz filters. You will usually find that it's open-circuit. A replacement clears the fault. **J.S.O.** ■

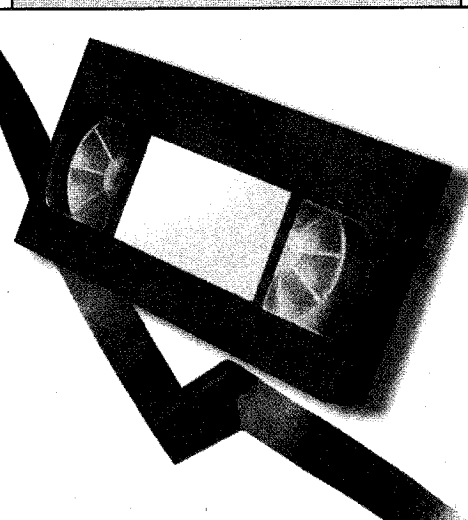

## VCR CLINIC

Reports from  
**Eugene Trundle**  
**John Coombes**  
**Dave Gough**  
**Bob Flynn**  
**Dean Ratcliffe**  
and  
**Martin McCluskey**

We welcome fault reports from readers – payment for each fault is made after publication. See page 364 for details of where and how to send reports.

### **Hitachi VTFX940**

The symptom with this machine was a complete lack of everything. I found that the 3A plug fuse and the internal AC mains fuse had both blown. One of the four diodes in the mains bridge rectifier, D6310, was short-circuit. This fault is less common in VCRs than in TV sets. **E.T.**

### **Sony SLVE80**

When a cassette was inserted its tape began to lace but then rapidly retracted, smartly followed by cassette ejection. The cause was that the take-up side cantilever loading arm, under the deck, was jamming in a cracked and warped plastic loading-slot liner. Had the machine not been a rented one it would have been a write-off. I got it to work by bending the arm and 'elbow' slightly away from the deck and thus clear of the obstruction. The travel of the guide-pole bases was unimpaired by the poor condition of their path-liners. **E.T.**

### **Ferguson FV62LV, Toshiba V312B/V513B**

Failure to accept a tape usually means that the front cassette housing is at fault. In this case however the drive-shaft assembly on the deck, which loads the cassette unit, had split. As a result it didn't rotate correctly to load/unload. A replacement restored normal operation. **J.C.**

### **Sony SLVE700UX**

When one of these machines is dead the first action to take is to check all the electrolytic capacitors in the power supply. If they are OK, suspect the DC-DC converter. Check it by replacement. **J.C.**

### **Samsung SV301**

This VCR wouldn't accept a tape. When I checked it I found that the master gear has a small plastic lug which had broken off. As a result the slide rack couldn't engage and connect to the master gear. A replacement restored normal operation. **J.C.**

### **Samsung SV241K**

This fault – the symptom is a dead machine – seems to occur only when there is a surge in the mains voltage, causing transient spikes, or in some cases when there is lightning in the air. Varistor VA1 goes short-circuit. Check it by replacement. It's usually blown apart or badly damaged. **J.C.**

### **Panasonic NV530B**

Dead with no display was the complaint with this machine. At power up I heard a single chirp from the power supply.

Checks with the ESR meter showed that electrolytic capacitor C9 was the cause of the trouble. As a precaution I also replaced C21/22/27. After that the machine worked well. **D.G.**

### **Daewoo V60**

This machine was brought in with "not working" written on it. When I powered it up and inserted a tape the functions were erratic and the machine finally ejected the tape with a large unwound portion. A check on the mechanism showed that the loading belt was worn and the mode switch was faulty. Replacement of these items restored correct operation. **D.G.**

### **Panasonic NVSD200**

The customer complained that this VCR had a mind of its own. As I suspected, and bench tests proved, the problem was in the loading section. The plastic drive-shaft coupler on the loading-motor spindle had split. Everything was OK once this item had been replaced. **D.G.**

### **Toshiba V726B**

This machine was dead. Cold checks in the power supply revealed that electrolytic capacitor CP0007B had a detached, dry-jointed leg. A resolder restored normal operation. **D.G.**

### **Panasonic NVHD660B (K deck)**

The sleeve that holds the pressure roller had cracked and the two parts had fallen into the mechanics. The roller jammed the back-tension arm, preventing the tape supply arm from going to the play position. I fitted a new sleeve and roller then found that the two tape arms couldn't make it to the play position. On the underside of the deck the large main-lever unit, item 144, was cracked near the main cam gear. I also suspected that both tape arms would have to be replaced.

Items taken from a scrap VCR were surprisingly straightforward to fit. When fitting the main lever unit note that the tension-arm spigot on the right-hand side fits underneath. It needs to be moved slightly, with a handy piece of attached plastic, to allow the lever to sit down properly and keep the back-tension arm in place. **B.F.**

### **Sharp VCA50HM**

When this machine was switched on the cassette mechanism shuffled rapidly in and out. The machine would then shut down. This usually means end-sensor problems, but in this case the cassette mechanism was faulty. A spring-loaded 'sensor lever', item 322 and part no. MLEVP0248AJ00, should cover the start sensor as the tape is

inserted. In this machine the lever was bent, with the result that it covered the sensor all the time. Replacement is the only cure. **B.F.**

### **Philips VR2547 (JVC deck)**

The cause of a very poor playback picture was failure of the supply pole base to go home fully in the V block. This was because the black-plastic stopper (item 120) that connects the loading arm to the pole base had come adrift. Although it's not obvious, because it is probably no longer there, the stopper is held in place by a split washer (item 121). What causes the problem is not clear. The stopper is part no. T43525 from CHS or 4822 462 71866 from Philips. The Philips part no. for the split washer is 4822 532 52533. **B.F.**

### **JVC HRJ635 (1996 deck)**

No power after a supply cut was cured by replacing C906 (2·2 $\mu$ F, 50V). To get to this item remove the front panel, then seven screws to enable the complete PCB and deck to be taken out, and finally unsolder the screening shield. **B.F.**

### **Samsung SV401K**

The customer complained about tapes

being chewed after being rewound. On test I couldn't find anything wrong, but this was because I was rewinding the tape back to the start. The problem occurred when the tape was stopped before it got that far back. A large loop of tape would then be left around the pinch roller. The cause was inadequate braking of the take-up spool. 'Brake main right', item T208, was ineffective as it was worn. **B.F.**

### **Akai VSF33**

When one of these machines is dead with the power supply working, check TR408 (2SD1292) on the main PCB. If this transistor is short-circuit, check safety resistor FB498 (4·7 $\Omega$ ) and replace the two 56 $\mu$ F, 16V electrolytic capacitors C446/7. It's also a good idea to remove the blob of brown glue near C446/7 – the one with the blue wiring running through it – as this absorbs moisture which corrodes the PCB.

Another item that may need to be checked is the 120 $\Omega$  resistor FR221 near the IF module. **D.R.**

### **GoldStar RC705I**

The symptom with this machine was no sound in the E-E mode. The cure was to

replace IC703, part no. 0IIT241000A. **D.R.**

### **Akai VSA650EK**

There was poor playback of this VCR's own recordings. The cause was failure of the full erase to operate. When this occurs check C212 (0·001 $\mu$ F) which goes short-circuit. TR211 then goes open-circuit. **D.R.**

### **GoldStar RC703I**

The complaint with this machine was that it wouldn't record. In fact there was either no or very weak video in the E-E mode. Things improved slightly the longer the machine was left switched on. Heat and freezer treatment proved that C707 (47 $\mu$ F, 50V) was the culprit. **M.McC.**

### **JMB D1020**

Whether the scart or RF output was used, the playback and E-E picture produced by this Orion-based machine was marred by thick, horizontal black bands across the screen. The fault disappeared when a hairdryer was used to blast the PCB for a few minutes. Replacing C4084 (2·2 $\mu$ F, 50V) cured the problem. **M.McC.** ■



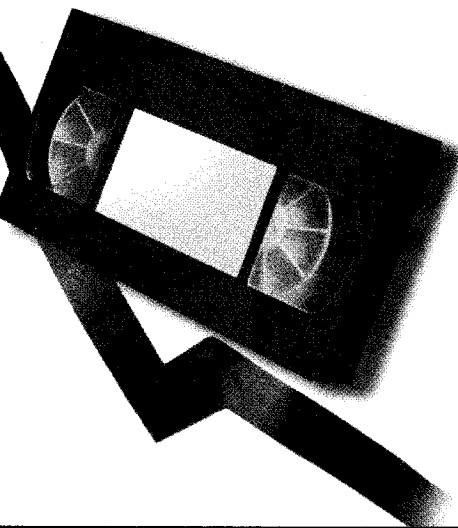

## VCR CLINIC

Reports from  
**Bob Flynn**  
**Gary Laidler**  
**Philip Blundell, MIEE**  
**Ivan Levy**  
**Dean Ratcliffe**  
**J.C Sebastian**  
**J.S. Ogilvie**  
and  
**Nick Beer**

We welcome fault reports from readers – payment for each fault is made after publication. See page 428 for details of where and how to send reports.

### Saisho VR3400

This VCR would usually wind or rewind but would struggle when towards either end, sometimes with a very jerky motion. At other times it wouldn't wind or rewind at all, leaving a loop of tape out when it stopped. The cause of the trouble was the reel idler. When the part in the centre of the gear (underside), that holds it all together, has a split in it the idler starts to come apart. **B.F.**

### Akai VSG280

When this machine was asked to play a tape there was very weak forward drive, resulting in a tape build up. Forward wind was also weak, but rewind was OK. Once the take-up spool had been unclipped the felt brake pad could be seen to be dirty and hardened. Giving it a good clean, also the surface of the spool, was all that was required. **B.F.**

### Ferguson FV44L

All functions worked but there was an extremely dim clock display. This model has the same power supply as the **JVC HRD860**. A check with the circuit diagram in my service manual for this model suggested that the items to replace would be C28 (120µF, 6.3V) and C29 (100µF, 6.3V) in the + and -3.8V DC supplies to the display. Once this had been done the display was back to normal. **B.F.**

### Panasonic NVG25 (G deck)

The customer asked if anything could be done about setting this VCR's clock: the year would only go up to 2001, so he couldn't set up the timer recordings properly. Nothing can be done to the VCR but there's a thing called a perpetual calendar, which is a list of years that exactly match the days and months of other years. For 2003 the matching year is 1997. Setting the clock to 1997 will give the correct days throughout this year. Unfortunately 2004 is 1976, but 2005 is 1994 and 2006 is 1995. **B.F.**

### Philips VC522 (Turbo deck)

The mains bridge rectifier's 100µF, 385V reservoir capacitor was replaced to restore power. Everything was then OK except for background interference on E-E pictures. This varied with mechanical operation. Suspecting further problems in the power supply I replaced C2280 and C2281 (both 47µF, 50V). This cleared the interference. **B.F.**

### Toshiba V709B

The problem with this machine was tape chewing. It's fairly straightforward to cure. Replace the 'gear centre assembly', which can be ordered from SEME under part number VDC7720. The price is very

reasonable and it's quite simple to fit. The old part looks OK until flexed: you can then see the cracks. The same deck is used in the **Fidelity VCR1600F** – I had three in one week. So it looks as if this is a common fault. **G.L.**

### Goodmans VN9600B

This machine was dead. Fortunately the game was given away by a slight bulge in C805 (47µF, 400V). As a precaution I also replaced C806 (1µF, 160V). **G.L.**

### JVC HRD790EK

We still get these old-timers in. Usually the pictures they produce are better than with new machines. This VCR was dead. Cold checks in the power supply showed that R2 (330kΩ) was high in value, reading 950kΩ, while R3 (330kΩ) had gone slightly high. Once replacements had been fitted the results were excellent. **G.L.**

### Grundig VS720

The fault symptom was weak sound with playback of prerecorded and own-recorded tapes. The sound was rather 'tinny', which suggested that the audio head was clean. This was the first thing I checked however, to no avail.

In this model the audio/video PCB is mounted above the power supply and is subjected to a certain amount of heat. So a dried-up electrolytic capacitor seemed to be the next possibility. I replaced C425 (4.7µF), C423 (47µF) and C415 (4.7µF), which cured the fault.

When these capacitors were checked out-of-circuit the culprit was found to be C423. It was leaky. **P.B.**

### Panasonic AG5260 (K mechanism)

This machine produced error code E5 in its display. On investigation I found that tension post P5 was bent. When I replaced this and checked the loading motor pulley the VCR worked but produced only mono sound. A check on the audio RF carrier showed that only one of the hi-fi heads was in operation. A replacement drum and alignment cured this fault. **I.L.**

### Sanyo VHR777E

This machine was dead with circuit protector PR512 (1.25A, 125V) in the power supply blown. The item to check in this situation is the surface-mounted servo chip IC351, which goes short-circuit. It's visible through one of the holes in the plastic chassis when the metal base is removed. **D.R.**

### Hitachi VTF540E

There was no take-up, fast forward or rewind with this machine, and tape was left

out of the spool on eject. The item to replace is pulley part number 6823333.  
**D.R.**

### **Sony SLVSE70**

This machine chewed tapes when it got to the fully-loaded position, then powered down. For this fault check whether the cam-follower shaft associated with the press block assembly pinch has snapped off. If so, replace. The part number is A6759615A. **D.R.**

### **Hitachi VTFX765E**

This machine was dead with 320V present at the chopper transistor. A check on the voltage at the start-up resistor R856 (220k $\Omega$ ) produced a low reading of 2.5V. It must be about 12-14V for the machine to work. The cause of the low voltage is usually the PC123FY optocoupler PC851, which becomes leaky between pins 3 and 4.  
**D.R.**

### **Panasonic NV45**

There was a tape stuck inside this very old machine, which was dead. The customer wanted it repaired because of its sentimental value. It's quite common knowledge that the high-voltage capacitor in the power supply in these older models tends to fail. In this case the capacitor is

C1003. It had become leaky. A replacement restored normal operation.  
**J.C.S.**

### **Sanyo VHR279**

This machine had a tape stuck in it and failed to eject the tape when the cassette housing was removed. When you get this situation, check the right-hand side of the housing. I usually find that the right-hand side arm assembly is broken. If the broken off piece can be found repair can be carried out with a small screw and a spot of glue. If not, replacement is necessary. **J.S.O.**

### **Hitachi VTF650E**

This VCR would struggle to load a tape then shut down, leaving a loop of tape. In this event take a look at the tape-tension band, which will probably be stuck to the supply reel. A replacement will cure the fault. **J.S.O.**

### **Hitachi VTF350**

This VCR ran slow, giving the impression that the capstan motor was faulty. I tried one from another machine but there was no difference. So I checked for dodgy capacitors in the power supply. C12 and C13 (470 $\mu$ F, 16V) read OK with our meter, but the fault was cured when replacements were fitted. **J.S.O.**

### **Sony SLV-SE30UX**

The problem was intermittent tape damage. When I removed the cassette housing I found that the take-up brake assembly had broken and its spring, which links the supply and take-up brakes together, had fallen off. If you are careful you can repair this without having to fit a replacement.  
**J.S.O.**

### **Sony SLF30UB**

No you are not dreaming: this is a Betamax machine, and no way could I put the owner off having it repaired! The machine was dead, apparently following a power cut. In the UK version there's a linear power supply, so electrolytic capacitor problems are less likely than in newer units that use a switch-mode power supply. The only sign of life was that the power LED in the centre of the power button lit up green. There was no display, and no mechanism activity. Checks showed that the unswitched 6V and 5V supplies were missing, because Q106 was open-circuit base-to-emitter. A 2SC1740 transistor had been fitted, though the circuit diagram shows a different type in this position. A replacement got the machine working, but the ACE assembly was heavily worn, also the drum's surfaces. **N.B.** ■

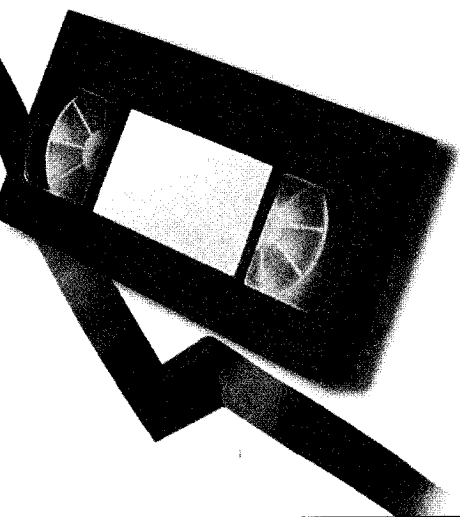

## VCR CLINIC

Reports from  
**Eugene Trundle**  
**Michael Dranfield**  
**Bob Flynn**  
**Dean Ratcliffe**  
**Roger Burchett**  
**Peter Dolman**  
**Robert Marshall**  
**Jerry Fedorak and**  
**James Grant**

We welcome fault reports from readers – payment for each fault is made after publication. See page 489 for details of where and how to send reports.

### Hitachi VTF150

The only sign of life that this machine produced was a just-audible squawk at switch on. I found that zener diode D9 had gone short-circuit, the failure being triggered by C16 nearby. The latter had developed a high ESR with age, thus reducing the sampling voltage and pushing up the other output levels. **E.T.**

### Toshiba V701UK

The reel drive was 'snatchy' in all modes – play, search, fast forward and rewind. The cause was the centre-gear assembly, part no. BY730111, which was cracked.

You can also get this fault with some Sony VCRs that use the same deck. **E.T.**

### Toshiba V631UK

This VCR appears to be of Samsung manufacture. The complaint was no scart or RF video output – the customer mentioned that the fault had occurred after connecting a TV set to the scart socket. I spotted the cause of the trouble straight away. The 44-pin, surface-mounted LA73024 chip IC801, which is right behind the scart sockets, was not properly soldered to the PCB. On closer inspection I saw that the chip had become very hot, the solder had melted and the SRBP board had blistered, pushing the chip off the board.

A new IC cured the fault, but it was difficult to get it to sit flat as the board had blistered quite badly. I advised the customer to unplug his equipment before reconnecting the leads. **M.D.**

### Philips VR600 (Turbo deck)

If the only response to remote-control commands is for VCR1 to appear in the display, as with TV/VCR combi units the remote-control unit has to be reset to VCR1 to match the VCR. Unlike the combi units, with this model you press select and 1 together and then the OK button. **B.F.**

### Sony EVS550E

This Video-8 machine appeared to be dead, but in fact the power supply was producing very low outputs. Normal operation was restored when the following capacitors, which were all faulty, had been replaced: C11 (2,200 $\mu$ F, 16V), C12 (330 $\mu$ F, 16V), C14, C15 (both 1,000 $\mu$ F, 16V), C16, C18 (both 470 $\mu$ F, 10V) and C36 (1,000 $\mu$ F, 16V). **B.F.**

### Philips VR675 (Turbo deck)

If you tried to play after rewinding back to the start all you got was the top half of the screen blanked out and the bottom half all snow. Then, after a couple of seconds, the machine would turn off. The cause of the problem was poor braking action, which led to a large build up of tape on the supply spool. As a result the supply spool didn't turn in play and the VCR switched off.

The usual cause of braking problems with the Turbo deck is broken plastic holders, under the deck, for the pulse roller or brake levers. But this model uses a later version of the deck. While removing it to discover this a spring fell on to the workbench. It had come from the top of the deck, and should be fitted to the supply-spool brake arm. No reason for its displacement could be found, and refitting it cured the problem. **B.F.**

### Mitsubishi HS651

When record was selected the take-up spool stayed still for three seconds then caught up. The tape tangled on eject, with a tape loop. Check the play/rewind/FF idler clutch assembly for a damaged spring. In this event the assembly will have to be replaced. **D.R.**

### Panasonic NVSD220 (K mechanism)

Moisture down the coaxial cable had caused havoc in the tuner/modulator unit. So the unit was sent to those fine people at MCES. In the meantime, after thoroughly cleaning the PCB, I tried the machine out. There was no display, and the head drum took off at high speed. Checks in the servo system brought me to the 2SD1996 5V regulator transistor Q1005 which was open-circuit base-to-emitter. **R.B.**

### JVC HRD960

This machine intermittently ejected the tape when play or fast forward was selected. I never saw this, but the owner is not someone who imagines things. So I delved into the power supply and found that C19 (470 $\mu$ F, 25V) was leaking badly. I've had this failure before, but on previous occasions fast forward and reverse have been affected. **R.B.**

### Panasonic NVSD220

Water had got into this machine and the demodulator pack had to be replaced. Coils L7601-3 on top of the main board had also suffered and had to be replaced – the legs fell from the bodies when these coils were removed. I then switched on, but the demodulator's output couldn't be found. After much head scratching and supply line checking I came to K7605, a choke in the SCL/TSG input at pin 13. It's a surface-mounted device that's located under the main board, and was missing – it must have dropped off when I unsoldered the faulty pack. The part number is VLP0153. **R.B.**

### Philips VR700/800 series

The repair note with this machine said "no signal processing". Its mechanics worked, and the fluorescent display reacted correctly to commands, but there were no scart or RF outputs. With these machines it's possible to remove the mechanism and motherboard (or MoBo as Philips calls it) complete. The

ribbon leads to the power supply and the front panel are long enough for the machine to be operated in this state and for fault diagnosis to be carried out.

I found that the switched 5V supplies were both missing, because the FET switch Tr7323 was incorrectly biased. This in turn was because the 33V supply was missing. It comes from a series regulator on the plug-in power supply unit. The cause of the problem was that R3193 (68k $\Omega$ ) was open-circuit. It provides the current for the 33V reference zener diode in this regulator. So there had been no need to remove the works after all! **P.D.**

### **JVC HRS7000**

This machine displayed a confusing mixture of patterning, unstable sync and loss of colour/colour banding (similar in appearance to the effect of an unlocked chroma reference oscillator). This occurred in both the playback and E-E modes.

As this is an S-VHS machine there's a good deal of signal processing. But scope checks showed that noise was superimposed on the relevant output from the Y/C panel, which is a separate board mounted to the left of the motherboard. The following capacitors contributed to

the effects: C37 (10 $\mu$ F, 16V) produced sync crushing while C5 (4.7 $\mu$ F, 25V) and C26 (1 $\mu$ F, 50V) were responsible for the patterning. These electrolytics are of the same type, red in colour.

Two others of the same type are employed on this board, C91 and C92 (both 0.47 $\mu$ F, 50V), so these were also replaced as a precaution. I have found that these very small-value electrolytic capacitors (i.e. less than 1 $\mu$ F) are rather unreliable. RS Components stocks a useful range of polyester capacitors that are compact and ideal as replacements. I suggest fitting the stock code 118-016 type (0.47 $\mu$ F, 50V) here. **P.D.**

### **Philips VR572 (and many others)**

The power supply was dead though 320V was present across C2318. I replaced items 7302 (2SK2750), 7303 (MC44608) and 7300 (TCET1101G) but the power supply still didn't work. When I read a description of the power supply's operation I was given a clue to the cause of the trouble. The voltage across C2310 (22 $\mu$ F, 50V) should rise to 13V, at which point the IC should start up. In this case the voltage actually fell, from an initial 4.5V. The cause was my favourite, a leaky diode, D6307 (BAV21). **R.M.**

### **Philips VR231/05**

This machine was dead following a power cut. Checks in the power supply showed that C2114 (47 $\mu$ F, 25V) and C2201 (47 $\mu$ F, 50V) had both failed. The machine came to life, with good results, when replacements had been fitted. **J.F.**

### **Ferguson FV305V**

This VCR had very poor picture search, deteriorating as the search speed was increased. In addition the machine tended to shut down momentarily when loading or unloading.

The capacitors on the secondary side of the power supply all proved to be OK, but the outputs fluctuated wildly when loading and during picture search. I carried out scope checks, which were inconclusive, in the power supply – then the machine shut down completely. The voltages on the secondary side of the power supply were now all very low, and the oscillation on the primary side was of very low amplitude.

Cold checks on the primary side of the power supply revealed that RP027 (5.6k $\Omega$ ) had risen in value to 20k $\Omega$ . I don't have a circuit diagram for this machine, so can't say what this resistor does. But a replacement brought the machine back to perfect working order. **J.G.** ■

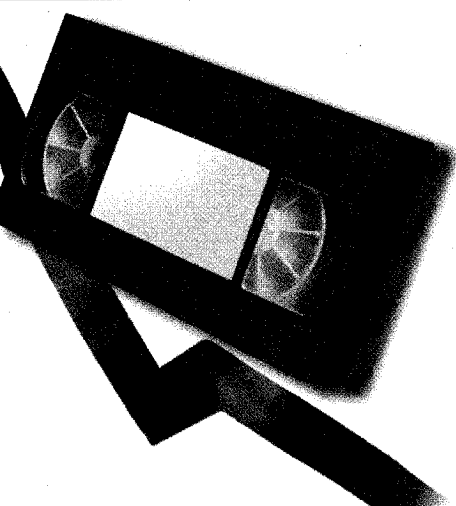

## VCR CLINIC

Reports from  
**J.S. Ogilvie**  
**Denis Foley**  
**Martin McCluskey**  
**David I. Scott**  
and  
**Andrew Duggan**

We welcome fault reports from readers – payment for each fault is made after publication. See page 553 for details of where and how to send reports.

### JVC HRD910

“Wrecking tapes” the ticket said. Sure enough the machine did exactly that. When I removed the reel drive assembly I found that it was very tight on its shaft. A quick strip down, a tiny drop of oil and a clean up cured the fault. **J.S.O.**

### Sony SLV715UB

There was no drum or capstan motor rotation. The machine would load then unload, leaving a loop of tape. The cure for this fault is to replace all the capacitors in the power supply. They are available as a repair kit from SEME, order code CAPKIT7. You may also have to repair badly corroded tracking on the PCB. **J.S.O.**

### Alba VCR8900

This machine powered up and the display was fine, but there were no deck functions. A check on fuse Z902 (1.25AT) showed that it had blown. The cause of this was the BA6209 chip IC001, which had a hole burnt through it. There was no obvious cause for this, so I fitted a replacement and another fuse. After that the machine worked normally. **J.S.O.**

### Panasonic AG5700B

This unusual S-VHS machine jammed up when loading. The remedy was to remove and clean the pinch roller shaft – the original grease on it had dried up. Relubricate with a spot of light oil. It also pays to clean the mode switch while the machine is apart. **J.S.O.**

### Sharp VCM29HM

The fault ticket said “chews tapes or jams up”. For this fault check the back-tension band, which usually sticks to the supply spool. A replacement cures the fault. **J.S.O.**

### GoldStar GSE1290IQ

A nice quick one for a change. The complaint was bad E-E operation. The cure is to replace C726 (1 $\mu$ F, 50V). **J.S.O.**

### Panasonic NVG40

This was another case of dried grease causing problems, like damaged tapes. Remove and clean the P5 arm unit and sub-loading arm, and the pinch roller assembly. Then reassemble and test. **J.S.O.**

### Sanyo VHR274E

This machine seemed to be dead, with no display. But checks showed that the power supply was working, and that the supplies to the LED display were normal. Further checks showed that the always 5V supply was missing. Having got this far I found it easy to find the cause, which was the

2SC2274F series regulator transistor Q5101. A replacement restored normal operation. **D.F.**

### Toshiba V219B

White and black spots (sparklies?) were present during playback. They were slightly worse with the machine’s own recordings. The symptom gave the impression of a faulty video head or poor head earthing. When I removed the deck mechanism I discovered a copper earthing clip. Cleaning and retensioning this cured the problem. **D.F.**

### Aiwa HV-FX7700

This machine was dead with no display. The green ‘one-touch playback’ LED was illuminated however. As the power supply seemed to be working, I began to suspect the microcontroller chip. But scope checks showed that there were huge spikes on the always 5V supply. Normal operation was restored by replacing the relevant reservoir capacitor, C116 (1,000 $\mu$ F, 16V, 105°C).

This fault could also occur with Models FX8200, FX710, GX930, GX935 and GX955. **D.F.**

### Hitachi VTFX860

This VCR’s power supply was ‘dead’ with low, pulsating output voltages. Much time was wasted checking around the circuitry on the primary side before I found that circuit protector QF0873 was open-circuit. This is on the secondary side of the circuit but, amongst other things, its output feeds the optocoupler.

Forget all the theory you learnt at college: with much of this modern equipment the bicycle repair man could find the cause of a fault quicker than a trained engineer! **M.McC.**

### Daewoo DVT14F4P

“Won’t erase or record sound” was the customer’s complaint with this combi unit. When I checked it on the bench it powered up but cut out after a few seconds. The deck functions operated while the unit worked, but were very slow. I noticed that R817 (1 $\Omega$ ) on the back of the TV main PCB looked distressed. It feeds +14V to the video deck, and its value had risen considerably. A replacement restored life to the unit and, when checked, erase and record were OK. All this was several months ago, and the machine hasn’t been back to us. **M.McC.**

### Goodmans TVC1400

If this combi unit plays tapes with the drum and capstan speeds way out, check the position of the PAL/NTSC switch on the front panel! **M.McC.**

### **Sony SLV715UB**

I had repaired this VCR's power supply about a year ago when the machine was brought in because it was dead. On that occasion I had fitted the Sony 777 capacitor kit. The machine was now back again, once more dead.

My initial reaction was to suspect a repeat failure of one of the capacitors in the service kit – the reliability of modern capacitors is not, in my opinion, all that good. But, having once again done battle with the power supply's solder-on covers, it didn't take me long to find that the surge-limiting resistor R101 was open-circuit. It's connected between the output from the mains bridge rectifier D101 and the reservoir capacitor C105. Checks on the circuitry down stream from C105 didn't yield any clues as to why R101 should have failed, so a replacement was fitted. A lengthy soak test proved that all was now well. I came to the conclusion that the resistor had simply failed from old age. **D.I.S.**

### **Hitachi VTM722E**

This elderly but well kept VCR came with a cassette inside and the complaint that it sometimes wouldn't rewind. Fortunately the fault was present when I first tried the machine, and I was able to

trace the cause fairly quickly to an intermittent mode switch. Once a replacement had been fitted the tape transport functions all worked correctly, but I then found that I had another problem on my hands – the cassette wouldn't eject.

As I could hear the capstan motor responding to eject button operation I was concerned that there might be damage to the cassette mechanism. But the cause was simply a stretched drive belt. Correct eject operation was restored once a replacement had been fitted. It seems that the belt's condition must have been borderline, since eject was the only function that was affected. **D.I.S.**

### **Ferguson 3V36**

These machines seem to go on for ever! We have a similar but more basic JVC HRD110 that's taken all the punishment our three children could offer and still come out on top virtually unscathed. Although this 3V36 appeared to be in almost as-new condition, the tell-tale *Thomas the Tank Engine* stuck inside gave the game away: it had probably suffered at the hands of its owner's children.

When the tape had been fully rewound into the cassette it was clear that the

problem had occurred in the eject mode. Removal of the cassette assembly, a dream with these machines, revealed damaged cogs that had allowed the ejecting cassette to jam against the mechanism flaps, neither of which had opened. I was curious to know what had caused this, and didn't have to look far: a paper clip was jammed in the mechanism.

In this case it wasn't necessary to go in search of a cost-effective second-hand carriage assembly, as the cogs are available separately. Once the carriage had been rebuilt, taking care over correct alignment (I used my HRD110's carriage as a template), and the mechanism had been cleaned there was correct operation.

These machines are from another era, when design and build quality weren't compromised by clever and often unwanted features, and there was no need to sell at minimal cost. They are a pleasure to repair. **D.I.S.**

### **LG BC969NI**

This fairly new machine was dead with a tape stuck inside. After removing the tape and the deck I investigated the power supply. C116's solder joints appeared to be a little dry. The best course seemed to be to fit a replacement (1,000 $\mu$ F, 16V). This restored normal operation. **A.T.D. ■**

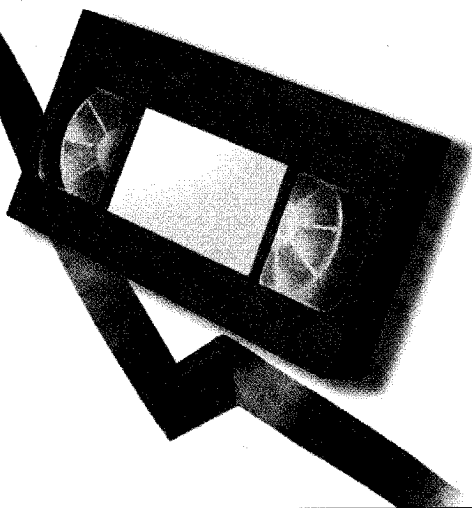

## VCR CLINIC

Reports from

Bob Flynn

Dave Gough

Gary Laidler

Martyn S. Davis

Matthew Biddlecombe

Graham Richards

and

Michael Smallwood

We welcome fault reports from readers – payment for each fault is made after publication. See page 617 for details of where and how to send reports.

### Akai VSG796EK

The brakes didn't work correctly when a tape was stopped after wind or rewind, and as a result a lot of loose tape would build up. This can be caused by the mode switch, which was found to be very mucky inside when removed. But cleaning it didn't cure the problem. The cause was on the take-up spool brake assembly, where the felt of the hard brake had become dirty and hard. I cleared the fault by cleaning the felt and the surface of the spool. **B.F.**

### Panasonic NVHD620 (K deck)

The mechanism would stop intermittently with F06 in the display. This problem can be caused by the white plastic loading arm, which was warped away from the carriage, but a replacement made no difference. The cause was traced to poor solder joints at the centre LED, D1. **B.F.**

### Sony SLVE230UY

When it was asked this machine tended to load/unload intermittently. Checks in the loading mechanism showed that the coupling on the motor was cracked (just like with Panasonic machines). A replacement cured the fault. **D.G.**

### Philips VR165

The problem with this VCR was lack of tracking-control pulses – for once it wasn't the pinch roller! Fortunately I had the circuit diagram, which made matters much easier, and soon traced the cause of the fault to transistor Tr7469 (BC848). **G.L.**

### Daewoo V435

The complaint with this VCR was no playback or record colour. Careful use of the hairdryer and freezer led me to C402 (0.022 $\mu$ F) which went open-circuit when cold. **G.L.**

### Aiwa HV-FX7700K

This VCR was dead. Once I had managed to get the PCB out I noticed that C116 (1,000 $\mu$ F, 16V) had a dry-joint at its negative pin. As it was also a bit discoloured and read low when checked with my capacitance meter I decided to fit a replacement. Fortunately everything then worked correctly. **G.L.**

### Philips VR765

This machine appeared to be totally dead. When you lift the lid you see a metal-encased standalone power-supply unit at the right of the chassis. A quick meter check revealed that the fuse was intact and that there were no obvious output voltages, though one of them appeared to be pulsing up and down. This suggested the presence of a short-circuit somewhere on the secondary side.

When I removed the ribbon cable to isolate the power supply I discovered that the short was on the power-supply panel itself. I decided to check the rectifier diodes and found that D6165 (BYW98-200) was dead short. The part number is 4822 130 11584. **M.S.D.**

### Toshiba V230K

This machine arrived with a Harry Potter tape loaded but not laced up. When play was pressed the machine immediately powered off, as the mechanism was out of sync. The cause of the fault was a small, white triangular piece of plastic that sits on top of a pillar. Its job is to lift up the cassette flap as the tape descends. It had split and twisted round on its post: a spot of superglue fixed this.

Realignment of the mechanism is fairly simple, as all the main parts are well marked with timing indications – dots and arrows etc. The difficult part was removal of the tape without causing further damage, as the mechanism is held in place by a screw that's hidden right beneath a fully-loaded tape. I eventually achieved this by 'crowbarring' the cassette slightly and forcing a small, flat-bladed screwdriver to rotate a two-point Phillips screw at an angle of about 20°.

Crowbarring VCR decks that have been ingeniously designed to make them impossible to dismantle without causing damage makes me feel like a true engineer! **M.S.D.**

### Bush VCR880NVP

According to the customer this VCR played back in black-and-white with both prerecorded tapes and its own recordings. When I tried my test tape in it the E-E was in colour but the playback was switching between colour and monochrome. It wasn't a job I fancied doing sat on the floor cross-legged, so I took it back to the workshop.

When I tried the machine out in the workshop what little colour there had been in the house had gone, the hi-fi sound was now poor – as if the heads were worn – and the head switching point was way out. I removed the deck and was about to release the clip to take out the main PCB when my hand brushed against one of the electrolytics on the secondary side of the power supply. It felt remarkably warm considering that the machine had been in operation for only about three minutes. Tests showed that C016 (470 $\mu$ F) and C019 (330 $\mu$ F) were both low in value at about 180 $\mu$ F. The adjacent electrolytic C021 (100 $\mu$ F) read correctly but was also warm. So I decided to replace all three. Fortunately this cured all three problems. You just get lucky sometimes!!

Incidentally the bright spark who designed this machine considered it necessary to fit three screws to the screening

cover over the heads. Two of them can be reached from the top of the VCR, but the third is located at the rear. Yes, you've guessed it, the whole deck has to be removed to get at this screw, just so that you can clean the heads. Much though I hate leaving screws out of VCRs, I returned this one to the customer minus one stupidly placed screw! **M.B.**

### **LG N311**

I suspect that this may become a common problem. When play or rewind was selected the machine would revert to stop after a few seconds. The cause of the problem was grease that had become detached from the cam gear and blocked the supply-reel sensor. A good clean was all that was required. **G.R.**

### **Sanyo VTC5000**

This Betamax old-timer made me feel quite nostalgic. It had two problems: tape looping, and hum bars in playback and E-E. The first was caused by a broken reel-supply belt, between the take-up and supply spools. These tiny belts are still available, in packs of two, from CHS.

The hum was caused by two electrolytics in the power supply, C5101

(2,200 $\mu$ F, 35V) which was open-circuit, and C5203 (100 $\mu$ F, 100V) which was leaking electrolyte. After fitting replacements I made a test recording – and was surprised how good the playback was. **G.R.**

### **Orion D2000**

The customer had broken the cassette lift when removing a cassette, so I fitted a housing from a scrap D1094. It then started to eject a cassette only to take it back in before eject was completed! I realised that I had fitted a cassette housing with a differently sized drive pulley. All was well once I had swapped over the drive pulleys. Cleaning the mode switch completed the repair. **G.R.**

### **Philips 14PV165/20PV165**

I've had a number of these machines with the following faults. (1) No sound with the volume OSD stuck at minimum. (2) No text. (3) Won't record pictures, only noise, but playback OK. (4) Certain OSD functions not working, e.g. tuning/install menu. (5) Mechanism stopping intermittently and tape transport behaving erratically.

In every case the cause has been the 24C02 memory IC. The faults may be present individually or some, e.g. (2)

and (3), may appear together. **G.R.**

### **Matsui VP9405**

This VCR was dead apart from a squealing noise that came from the power supply. I also noticed that the chopper transistor Q506 was getting very hot. The cause of all this was a short-circuit on the secondary side, the culprit being D512. I fitted a BA157, but the machine then wouldn't eject the customer's tape. So I stripped, cleaned and aligned the mode switch. After that the machine was back in working order. **G.R.**

### **Toshiba V711UK**

There was either no stereo sound or it was very faint and distorted. Mono sound was OK. I found that there was no 12V supply at IC801 because of a crack in the PCB where there's a hole through it, next to the loading-motor power socket CN601. The board is stressed here when the capstan-motor connector plug is being pushed home during assembly.

Several other tracks were cracked, the most difficult to repair being the audio right out and audio left out. These were dealt with by stringing wires across the PCB, from C801 (R)/C802 (L) to C524 (R)/C525 (L) at IC501. **M.S.**



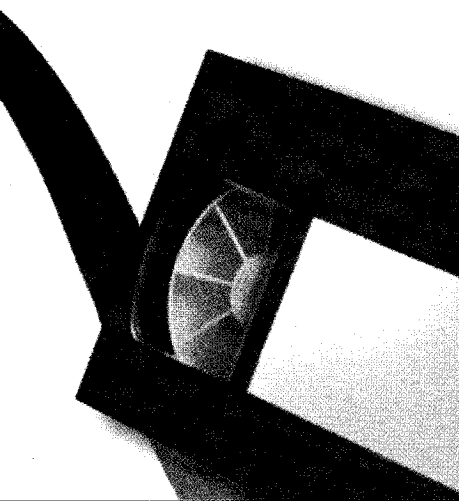

## VCR CLINIC

Reports from

**Bob Flynn**

**Martin McCluskey**

**Michael Dranfield**

**Brian Mumford**

**John Young**

**Martin Cole and**

**Dave Gough**

**We welcome fault reports from readers – payment for each fault is made after publication. See page 681 for details of where and how to send reports.**

### **Aiwa HV-FX2800K**

A cassette would occasionally be ejected after insertion. The usual cause of this is the centre LED or the mode switch, but in this case it was the two metal tension springs that grip the cassette. Both needed retensioning.

The mechanism is the same as in the **Matsui VXA1100** etc. **B.F.**

### **Hitachi VT520E**

There was a noise bar across the screen, a few inches up from the bottom, with playback of prerecorded tapes. Playback of the machine's own recordings was OK. The take-up arm didn't seem as locked in position as it should be. Slight downwards retensioning of the metal runner behind the guide pole cured the problem. **B.F.**

### **JVC HRJ411EK**

The cause of no power was Q2 (2SC3616), which was very leaky. I also replaced C12 (2·2 $\mu$ F, 50V) as it tends to cause problems. **B.F.**

### **Sony SLV-SE70UX**

Playback was slow and jerky, with severe wow on sound. There was no fast forward or rewind, though the capstan motor turned normally to take in slack tape before ejecting a cassette. Fortunately I had an identical machine in the workshop, with worn video heads. Substitution proved that the capstan motor was the cause of the fault. **M.McC.**

### **JVC HRD540**

The playback picture was very poor, with bands of mistracking and no colour. These symptoms were present with the machine's own recordings and a known good tape. New video heads made no difference. The culprit was the surface-mounted 3·3 $\mu$ F electrolytic capacitor on the drum motor. With care, a normal-sized capacitor can be fitted. **M.McC.**

### **Sharp VCMH60**

The playback picture was broken up by bands of mistracking, and there was no sound. The cause was obvious once I had removed the top from the machine. The tape was riding up the capstan spindle because the pinch-roller bearing had disintegrated. Once a new roller had been fitted the results were first class. **M.McC.**

### **JVC HRD180EK**

This old-timer was in showroom condition. But the tape would stop after a few seconds whichever mode was selected. In addition the tape counter didn't work and the front on/off LED was out. The cause of all these symptoms was very simple: fuse F3 (1A) was open-circuit. A replacement restored normal operation, and a soak test proved

that no other faults were present.

How many of today's supermarket machines will still be working in fifteen years' time? **M.McC.**

### **Akai VSG240EK**

Once a cassette had been accepted the drum rotated and the loading arms moved to their full travel. Then the machine unloaded and switched off. There was normal operation when the state switch had been removed and cleaned/lubricated.

The customer had been given this machine, which had come from another area. He found that he couldn't tune and store any stations in positions 1-5. With these and other Akai machines you have to cancel existing channel data before anything else can be stored in any program position. **M.McC.**

### **JVC HRJ410EK**

This machine was dead following a power cut. The usual cause is C12 (2·2 $\mu$ F, 50V) in the power supply unit, but in this case one of the two 220k $\Omega$  series-connected start-up resistors R4/5 was open-circuit. Watch out for a fully charged reservoir capacitor! **M.McC.**

### **Daewoo DV-F832P**

When this machine was plugged in it came on in standby with the display bars illuminated. When it was switched on, using either the remote-control unit or the front-panel button, the display would go out for three seconds then the machine would come back on in standby. The problem was to do with the +5V supply and was cleared by replacing its reservoir capacitor C23 (470 $\mu$ F, 10V). **M.McC.**

### **Ferguson FV305HV**

The complaint with this machine was "tape stuck inside". The front LEDs lit up (the machine doesn't have a clock display) but when it was switched on the only sign of life was a twitch from the drum motor, and the function keys had no effect. I noticed that CP064 (1,000 $\mu$ F, 25V) in the power supply had a slight bulge at the top. A replacement cured the fault. **M.McC.**

### **Amstrad DD8900**

This is the double-decker machine. All the digits in the fluorescent display lit up and flickered. The cause was a dud capacitor in the power supply, C27 (47 $\mu$ F, 50V) – it was open-circuit. The top deck and front PCB have to be removed to gain access to the power supply. **M.D.**

### **Aiwa HV-FX7700K**

There was a tape stuck inside this VCR, which appeared to be dead with no clock. But after a couple of minutes the one-touch playback light came on, flickering. There

was a low voltage at the 5V supply rectifier D106. When I replaced the associated reservoir capacitor C116 (100 $\mu$ F) the voltage increased and the machine worked normally. **B.M.**

### **Matsui TVR141**

This combi unit had a swirling pattern on the screen and tape playback was slow with mistracking. The problem was cured by replacing C522 (2.2 $\mu$ F) and C523 (100 $\mu$ F) in the power supply. **B.M.**

### **Goodmans TVC202TS**

The complaint with this combi unit was that it would eject the tape on timer recording only. Unlikely though it sounds, this really was the case. There's a modification to cure the problem. Fit a 1k $\Omega$ , 6W resistor between pins 1 and 2 of the optocoupler. There's a place in the PCB for this resistor, which is R820. **B.M.**

### **Grundig 2x4 Super**

Total loss of playback video looked like head clogging initially, but the cause was traced to the TDA2740A trick-mode compensation chip IC731, which switches a delay line in and out of circuit in fast picture search, slow-motion etc. A replacement IC cured the fault.

Note that there are two glass delay lines on this board. One is the trick-mode compensation delay line GV11, the other

the dropout compensation delay line GV8. The plug-in module arrangement in this model is quite difficult to work on without an extender card – and where does one get these nowadays? **J.Y.**

### **Grundig 2x4 Super**

The cause of no audio recording with colour patterning behind the new video was traced to a dry-joint at the erase/bias oscillator coil L1161 on the sound plug-in board. Remaking the joint cured the problem. **J.Y.**

### **Grundig VS540**

During a recording the audio cut off abruptly, as if switched off, the video not being affected. Audio was absent in the E-E mode. The cause was failure of the U2829B audio discriminator IC. **J.Y.**

### **Philips VR630-07**

This machine accepted cassettes but wouldn't eject them properly. A very loud clicking noise, of gears being chewed up, accompanied the fault. After removing the machine from the case and looking at the poor build quality I was about to put it back together and give up. The machine certainly hadn't been made by Philips. As it was under guarantee however I persevered with the repair.

The rack assembly bracket (item B555) on the right-hand side of the chas-

sis was badly deformed and the main cam gear (B491) looked distressed. To separate the deck from the PCB you have to unsolder the ribbon cables, including a flat one that would normally push into a socket. You can imagine the state this cable was in after doing this just a couple of times!

The machine still jammed on eject when these items had been replaced, but I managed to remove the power before any damage was done. The cause of the trouble was finally tracked down to rough edges on the cut-outs on the chassis sides. Careful use of a small round file enabled the lift to eject smoothly.

On reassembly into the case I found that the machine wouldn't rewind or fast forward properly. This was because I hadn't fitted the deck exactly on the PCB, so the reel pulses were weak. I don't think I'll be repairing any of these again! **M.C.**

### **Matsui TVR161**

This TV/VCR combi unit had a cassette jammed inside. The customer said there had previously been a tendency for the cassette to be ejected with a large loop of tape left unwound. The cause was obvious once the tape and carriage had been removed: one side of the clutch mechanism had fallen off. The unit worked perfectly once a new clutch and, as a precaution, mode switch had been fitted. **D.G.** ■

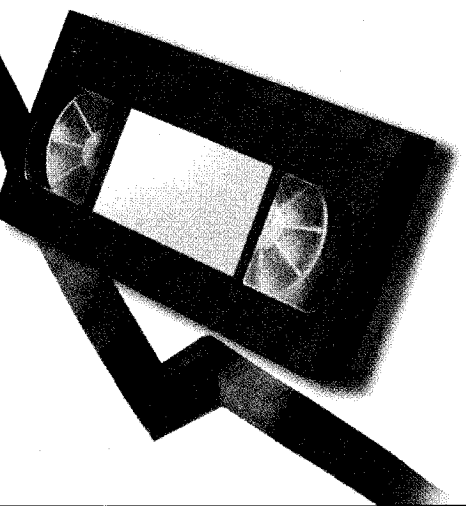

## VCR CLINIC

Reports from  
**J.S. Ogilvie**  
**Chris Bowers**  
**Graham Richards**  
**David I. Scott**  
**Gary Laidler**  
and  
**John Young**

We welcome fault reports from readers – payment for each fault is made after publication. See page 745 for details of where and how to send reports.

### **Panasonic NVL28**

The fault report said “pauses then switches off”. When I tried the machine on the bench it worked fine for a while – until I moved it, when it did what the card said. On closer inspection I found that connector P1 on the main PCB was dry-jointed. IC101 should also be checked for dry-joints. **J.S.O.**

### **Philips VR453**

This machine uses a JVC deck. The fault was leaving a loop of tape hanging out or chewing tapes on eject. The remedy for this is to strip and clean the idler gear assembly, which tends to seize up partially. Apply a spot of oil then reassemble. It’s starting to become a common problem with these ageing machines, but they are usually worth repair. **J.S.O.**

### **GoldStar GSEQ201i**

This machine was wrecking tapes. The fault is usually cured by replacing bracket assembly F/R A06, which is available from SEME. The part no. is VPAR6962. **J.S.O.**

### **LG 221**

This machine was jammed up. The cause was the small plastic collar that holds the pinch roller on. It had split and slipped down the shaft. As a result the pinch roller had dropped and jammed the sub-loading arm. Replace the collar and the machine will be back in normal working order.

We seem to be getting a lot of machines that use this type of roller assembly – the same thing happens. **J.S.O.**

### **Goodmans VN9500S**

Dead and chews tapes it said on the card. For the former fault go to the power supply section and check C822 and C823 (both 680 $\mu$ F, 25V). On this occasion they read about 500 $\mu$ F on our capacitance meter. Replacements will get the machine running again.

The tape chewing was caused by the felt part of the back-tension band parting company with the rest. It had stuck itself around the supply spool. Replacement cured this one too. **J.S.O.**

### **Thomson VTH7090U**

The sound was poor and the machine creased tapes. For this fault replace the pinch roller. The problem is cheap rollers with nasty plastic rollers instead of bearings. **J.S.O.**

### **Sony SLV-SF99UX**

There was no loading or playback. Inspection inside revealed that the ‘arm driving’ (TG8) and the ‘gear pinch pressing’ were damaged. Sony now supplies improved parts, which restored normal loading and playback operation. The part

nos. are 3-977-445-02 and 3-977-441-03. **C.B.**

### **Sony SLV-SF99UX**

During playback of an E180 tape there was intermittent picture noise towards the end. A look inside the machine revealed the cause of the problem. The guide roller assembly of TG3 and TG6, part no. X-3949-704-1, had to be replaced followed by tape path adjustment. **C.B.**

### **Sharp VCM321**

The playback sound consisted of an awful screeching noise. The fault cleared, restoring normal playback sound, when freezer was applied to Q651 (2SC3203). Warming it up again brought the fault back. A replacement transistor cured the fault – I used type BC639. **G.R.**

### **GoldStar 5121**

A common problem with this model is intermittently accepting or ejecting tapes or just shutting down. The cure is to fit a modified central LED tower unit, part no. G871R-1080F. It comes with a few resistors and the LED. **G.R.**

### **Mitsubishi HS-MB32**

Picture pulling during playback (weak video/poor sync) was caused by failure of two electrolytic capacitors, C2B4 and C2B7 (both 4.7 $\mu$ F, 35V). They both produced a horrible smell when heat was applied. **G.R.**

### **Nokia VCR3716**

The complaint with this Sharp clone was very poor playback pictures. When I tried it all I could get was intermittent rewind. I was told to set the clock first, which produced normal operation (thanks Genserve for this information). The poor pictures were caused by a worn upper drum (whatever happened to the good old Sharp drums that lasted forever?). As a new drum costs more than the machine it was returned to the customer. **G.R.**

### **JVC HRD880EK**

This Nicam VCR produced good playback pictures only very intermittently. At other times the effect was like a worn upper drum assembly. I’ve had this effect before, when the PG pulses are low or missing. But I then spotted a 3.3 $\mu$ F, 50V surface-mounted electrolytic capacitor on the lower drum. When it was checked with a Wizard tester it turned out to be open-circuit. A replacement restored good pictures. **G.R.**

### **Mitsubishi HS561V**

This VCR was dead with the standby 5V supply missing. It comes from the emitter of Q904, whose collector voltage was also missing because R917 (2.7 $\Omega$ , 0.5W fusible)

was open-circuit. As no shorts could be detected I fitted a replacement resistor, which restored normal operation. Incidentally R917 is mounted on the main PCB, hidden behind a subpanel that's marked 'power sub 2', and is next to a heatsink. **G.R.**

### **Sharp VCM321HM**

This machine wouldn't erase or record sound. The following items had to be replaced to restore normal operation: Q651 2SC3203Y; Q652 DTC323TK; IC651 BA7755A; and R6518, 47 $\Omega$ , 0.5W. **G.R.**

### **Sanyo VHR335E**

If the symptoms are a pulsing playback picture and noise from the capstan motor, go straight to C510 (1,000 $\mu$ F, 16V). It's next to D510. If it has leaked, the PCB may need to be cleaned. **G.R.**

### **Sony SLV757UB**

This machine was a real nightmare. The cause of the trouble was easy to diagnose: the upper drum assembly was so badly worn that one of the head tips appeared to be missing altogether. This was a very impressive – and expensive – machine in its day, but there was no getting away from the fact that it was now

quite old. The owner was aware of this and although he wanted it fixed a realistic budget had been set. This ruled out the use of a genuine Sony upper drum. So a 'replacement' head drum had to be obtained, together with the normal replacement items – pinch roller, back-tension band, etc.

The problems then started. Quite a lot of pins pass through and are soldered to the upper drum PCB. Even when they were all desoldered and clear of the PCB holes, heat had to be applied to the drive flange before the old drum could be removed. But this was easy in comparison with trying to fit the replacement. It just wouldn't go on. Some pins appeared to be in line with the PCB holes while others weren't. I battled for over an hour, carefully trying to adjust the pin positioning, before I had to admit defeat and return the upper drum to the suppliers. Understandably, they were somewhat sceptical about my complaint – until they tried to fit it, again without success. A second replacement also wouldn't fit, so we had to conclude that the whole batch was out of tolerance.

Fortunately the VCR's owner then came to the rescue. One of his relatives had a scrap SLV715UB that had been fitted with a replacement head drum a cou-

ple of years ago. The two models use the same head drum. Transplanting this used head drum to the SLV757UB solved the problem. Once a new pinch roller and back-tension band had been fitted and the mechanism had been set up there was perfect operation. **D.I.S.**

### **Sanyo VHR290E**

This machine was dead and for once it wasn't PR512. After removal of the smoothing block checks were carried out on the primary side of the power supply. Resistors R5002 and R5003 (1.5M $\Omega$ ) were both faulty. One was open-circuit and the other high in value. **G.L.**

### **Grundig 2x4 Super**

This golden oldie had stopped dead. Investigation showed that C401 (100 $\mu$ F, 25V), which couples the drive to the BU208A chopper transistor T402, had gone low in value. Normal operation was restored by replacing the capacitor and the transistor. **J.Y.**

### **Grundig 2x4 Super**

Failure of the keyboard was caused by breaks in the conductors of the flat Mylar cable that goes to the main board. I was able to repair it successfully with silver-loaded paint, applied carefully. **J.Y.**

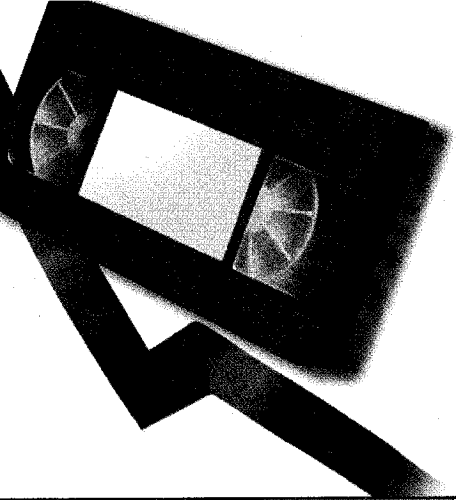

## VCR CLINIC

Reports from  
**Bob Flynn**  
**Graham Richards**  
**Andrew Duggan**  
**Gary Laidler**  
**John Coombes**  
**J.S. Ogilvie**  
**M.J. Abbott**  
and  
**Mark Tyerman**

We welcome fault reports from readers – payment for each fault is made after publication. See page 40 for details of where and how to send reports.

### **Ferguson FV62 (R2000 mechanism)**

There was no wind or rewind, though sometimes these functions would start then stop. All other functions were OK. The cause was traced to wear on the main brake lever (item K156) – it was worn underneath, where it contacts the clutch unit. Replacement cured the fault. The Ferguson part no. is 70420433. **B.F.**

### **Sony SLV-SE700 (S mechanism)**

This VCR was dead with the input fuse blown. The cure was to replace the four 1N4005L bridge-rectifier diodes and the 2SK3047 chopper FET, which was very leaky. The TDA16846 chopper control IC was OK. **B.F.**

### **Hitachi VTM230E**

The half-loading arm (item 256) was sticking on the cam gear underneath it. The reason for this was not obvious, but was found to be that the pinch roller was not secure on its shaft because the plastic sleeve had a split in it. **B.F.**

### **Toshiba V856B**

The playback picture had spots in the background, the same as you get when the deck earthing is poor. Replacing CP051 (1 $\mu$ F, 50V) in the power supply cured this fault and also improved the display brightness. While I had the power supply out I also replaced CP041 (220 $\mu$ F, 10V) which causes dim displays, and CP007 (10 $\mu$ F, 50V) and CP008 (100 $\mu$ F, 25V) which cause no-power problems. **B.F.**

### **Saisho VR1200HQ/Matsui VX820**

If the machine is dead with no clock display, though the standby LED lights briefly, go straight to the clock PCB and remove the five or six blobs of brownish glue, especially the one near the reset chip IC602. For no tuning check whether D2584 is open-circuit. **G.R.**

### **Sony SLV315**

For full display illumination that's possibly intermittent, with maybe a whistling sound, remove the rewind/forward wind rotary-control assembly and dismantle it carefully. Clean the tracks and pins and reassemble. **G.R.**

### **GoldStar RC7031**

This Nicam/VideoPlus VCR produced just a blue screen, with an occasional negative-looking picture appearing in the E-E mode. A check on the electrolytics C707 (4.7 $\mu$ F) and C727 (220 $\mu$ F) proved that they were faulty. The repair was completed by replacing the video coupling capacitor C710

(47 $\mu$ F) and the 12V supply decoupling capacitor C711 (47 $\mu$ F). **G.R.**

### **Sony SLV-SE70**

There was no RF output/loop-through and no AV output. The cause was traced to Q607, which was dry-jointed. It's mounted on the print side of the PCB, near the power supply plug/socket CN600. **G.R.**

### **Ferguson FV81LV**

The clock display could hardly be seen and dimmed even more when a function was selected. CP041 (220 $\mu$ F, 10V) in the display heater feed circuit was virtually open-circuit. While I had the power supply out I replaced the 10 $\mu$ F and 100 $\mu$ F electrolytics on the primary side as a precaution. **G.R.**

### **Akai VS66EK**

The complaint was tape jammed with the loading motor running, also patterning in the E-E mode. After clearing the mechanism jam I scoped the 6V supply and found that there was lots of noise present. Replacement of the following electrolytic capacitors restored normal life to this machine: C1 (2,200 $\mu$ F, 35V), C6 (100 $\mu$ F, 25V), C15 (220 $\mu$ F, 35V), C24 and C25 (both 47 $\mu$ F, 25V). **G.R.**

### **Sanyo VHRH900E**

This VCR was brought in with a tape partially loaded. When the tape had been removed the machine appeared to work normally. It was put on soak test, and after some time failed again. The tape was once more removed but this time, while the deck was finishing the loading cycle, it seemed to slow down. A new loading motor cured the problem. As a precaution, a new mode switch was also fitted. **A.D.**

### **Samsung SV209B**

This machine chewed tapes and was very noisy in the FF/rewind modes. Removal of the gearing and idler assembly required some care. I then found that the centre gear was cracked.

This VCR uses the same deck as the **Toshiba V209UK** and other models. The centre gear is part no. BY730111. It's available from SEME. **A.D.**

### **Toshiba V703**

This VCR's display was very dim. The customer wanted it fixed for sentimental reasons. Fortunately the state of C810/C813 gave the game away. They were leaking badly but hadn't damaged the print. **G.L.**

### **Hitachi VTM620**

The complaint with this machine was that the E-E sound was missing at switch on.

The owner explained that it used to come on after a minute but now took ten minutes. So out with the hairdryer and freezer, which led me to the culprits – C407 and C411. **G.L.**

### **Philips Turbo deck**

If tape playback is very jittery and the take-up spool is very jerky, fit service kit 1. It contains the changing gear, double gear and gear pulley. **J.C.**

### **Panasonic NVSD200 (K deck)**

If one of these machines won't accept a tape, or intermittently won't do so, check the take-up sensor for dry-joints. **J.C.**

### **Samsung SV421**

Tape chewing can be caused by a worn pinch roller or faulty mode switch. In this case however the idler assembly was tight. **J.C.**

### **Toshiba V631UK**

A 'clicking noise' was the complaint with this machine. It seems to be quite a common problem with a number of Toshiba VCRs or, in some cases, the symptom may be a jammed mechanism that prevents loading. The cause of all this is a

guide post that breaks off – the symptom depends on where the post lands. Its part no. is AC61-00122A. **J.C.**

### **Panasonic NVHD625 (K deck)**

If there are loading problems or no FF/rewind etc. check the main lever unit, part no. VXL2307. It has a habit of cracking at one end. While you have the machine apart, check the loading-motor coupler (part no. VDP1434 or SEME VDC7540) for any signs of cracking. If in doubt, replace it. Also clean the mode switch. This will sort the machine out. **J.S.O.**

### **Sharp VCM27HM**

This machine produced a blue screen in the playback mode, but the picture was OK in the FF/rewind search modes. On close inspection I could see that the top edge of the tape was being creased, as a result of which it rode up on the audio/control head. A replacement pinch roller put this machine back in working order. **J.S.O.**

### **Panasonic NVHD100**

If there is no display check Q1701 (2SD973A-R) on the front display PCB. It tends to burn out. A BC337 can be

used as a replacement. **J.S.O.**

### **Sharp VCA63HM**

If the power supply is squealing replace C913 (47 $\mu$ F). **J.S.O.**

### **Philips VR6547/05**

The complaint with this VCR, which is fitted with a JVC deck, was tape chewing. The cause was a faulty clutch assembly. This can be obtained from CPC under order code VSID469. The Konig 1493 will fit, but the pulleys have to be swapped. **M.J.A.**

### **Toshiba V720UK**

This machine wouldn't play tapes because there was no take-up. The boss on the gear centre assembly was cracked. Part no. is BY730111. **M.J.A.**

### **Goodmans TVC146**

The fault with this TV/VCR combi unit was no power. I found that the power switch SW08 was dry-jointed, ready in fact to fall off the board. **M.T.**

### **Ferguson FV44**

This VCR had a very dim display. Replacement of C28 cured the fault. **M.T.**

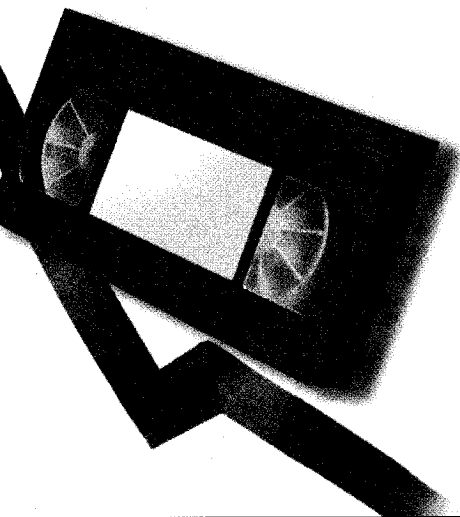

## VCR CLINIC

Reports from  
**Eugene Trundle**  
**Martin McCluskey**  
**Mike Adye**  
**Michael Dranfield**  
**Steve Hague**  
**John Coombes**  
**Colin McCormick and**  
**Dean Ratcliffe**

We welcome fault reports from readers  
– payment for each fault is made after  
publication.

Reports can be sent by post to:

Television Magazine Fault Reports,  
Highbury Business Communications  
Nexus House,  
Azalea Drive, Swanley, Kent BR8 8HU

or e-mailed to:  
t.winford@highburybiz.com

### JVC HRJ690

A complete lack of everything was the symptom with this machine, but the mains fuse was intact and a very quiet, very brief squawk could be heard from the chopper transformer when power was applied. We discovered that a 15V protection zener diode, D5301, was short-circuit. It must have failed for reasons of its own, because no external cause could be found. **E.T.**

### Tatung TVR934

This old-timer's deck and display functions worked normally but there were no E-E signals and there was no output from the RF modulator. The cause was an open-circuit regulator chip, IC502. Three-leg 10V regulators are rare, but we found one in a similar machine on the scrap pile. **E.T.**

### Toshiba V727B

This V3 series machine had a very dim fluorescent display. As is usually the case, the cause was low heater current in the display tube. The culprit was CP041 (220 $\mu$ F, 10V) in the power supply. **E.T.**

### JVC HRJ610EK

There was no spool drive when the tape was being unlaced. As a result a loop of tape would be caught in the deck during eject. The cause was a faulty idler gear unit, whose friction clutch had lost its grip. The part no. is PU60618-1-3. **E.T.**

### Amstrad UF30

After tape rewind or fast forward this machine would shut down with 'tape prob' shown in the display. The cause of the trouble was in the auto-stop circuit. The cure was to replace the infra-red LED D6001. **M.McC.**

### Panasonic NVHD600

There was no clock display. Otherwise this VCR was OK. Unusually for a modern machine, the filament supply for the display is obtained from a DC-DC converter on the front panel. I found that Q1701 (a BC639 is a suitable replacement) was short-circuit. But there was still no display when the replacement had been fitted. Further checks revealed that a tiny coil, L7, on the top panel was open-circuit. It's in the supply to the circuitry on the front panel. Normal operation was restored by fitting a similar coil from a scrap machine. **M.McC.**

### Toshiba V720

This machine wouldn't take up tape in the play and eject modes. There was also a clicking noise from the deck. The problem was to do with the centre clutch/gear assembly – because of a tiny crack in the plastic, the upper pair of cogs had separated from each other.

As the owner didn't want to spend much

on having the machine repaired, a familiar story these days, I decided to try supergluing the cogs together. This cured the fault and, several months later, we have not seen the machine back in the workshop. **M.McC.**

### Daewoo DVF522P

This machine would accept a tape but there was no drum rotation. When the loading arms had tried to thread the tape around the stationary drum the VCR would shut down. Normal operation was restored by cleaning and lubricating the mode switch. **M.McC.**

### Panasonic NVSD230B (Z mechanism)

This machine's deck mechanism was jammed solid and there was a cassette stuck inside. The cause of the problem was clear once the deck fixing screws had been removed – I had to drill two holes in the trapped cassette to get at the front ones. The 'arm loading take up' plastic cog had been chewed up by the teeth in the metal rack. This cog's part no. is VXL2670. Everything worked normally once a replacement had been fitted.

The build quality of these decks is nowhere as good as that of the earlier K mechanism. **M.McC.**

### JVC HRD540/660/770

The display panel was unreadable because C131 (47 $\mu$ F, 16V) and C238 (10 $\mu$ F, 16V) had both failed with high ESR readings. If there's a tracking bar at the top of the picture, check the loading-arm ferrules beneath the deck and replace the 3.3 $\mu$ F, 50V surface-mounted capacitor on the drum motor. **M.A.**

### Goodmans TVC14VP

Tuning drift was the problem with this TV/VCR combi unit. So we took the back off, put it to one side and monitored the tuning voltage (VT) at the tuner. Result: no tuning drift at all! Once we had the manual we checked the tuning-voltage regulator IV05. It was a  $\mu$ PC547J that drifted. Correct operation was restored by fitting a TAA550B as a replacement and a 105 $^{\circ}$ C capacitor in position C837 (47 $\mu$ F, 50V). **M.A.**

### Sony SLVX9G

It's not very often that I repair VCRs now that the average price of a basic machine is £49, or less if you watch out for special offers at Safeway – about five months ago they were selling two-head LG machines at £34.99. But this was a top-of-the-range VCR, and the customer agreed to a minimum repair cost of £35. The machine was dead with a fully laced-up tape in it.

Fortunately the cause was a simple power-supply fault. R156 (2.2M $\Omega$ ) was open-circuit and the resistor in series with it, R157 (also 2.2M $\Omega$ ), had gone high in value. Replacement with 0.75W, 350V metal-film

resistors ensured a lasting cure. **M.D.**

### **Samsung SV651B**

The symptoms with this machine were no display and no deck functions. There was HT at the primary side of the chopper circuit but no switching action. It's a refreshingly simple power supply. Cold checks showed that transistor Q15R02, type 2SC3203, was leaky base-to-emitter. A replacement restored normal operation – a BC639 does the job. **S.H.**

### **Goodmans VN9000**

E-E operation was affected by a hum bar though playback via the scart socket was OK. The cause was traced to two capacitors in the power supply. C26 (22 $\mu$ F, 50V) had fallen in value to 17.2 $\mu$ F while C23 (1,000 $\mu$ F, 10V) was low at 151.1 $\mu$ F. **J.C.**

### **Panasonic K mechanism**

Failure of the drum servo to lock is usually caused by high tape tension across the video head, because the brake (part no. VXZ0313) is broken.

A line twitch on the picture, often very intermittent, is caused by a faulty impedance roller (part no. VXP1402).

If the tape edge is being damaged, check whether arm P5 (part no. VXL2306) is bent/ distorted. This arm

can also be the cause of the mechanism jamming intermittently when loading.

If the tape jams intermittently with the error code F06 shown in the display, the main shaft unit (part no. VXP1339-1L) is damaged/bent/distorted. **J.C.**

### **JVC HRJ625**

Failure to eject the tape can be caused by several things, such as a faulty cassette housing or a broken guide pole that causes a mechanical obstruction. In this case however the lug on the change-arm assembly (item 74) was broken. It holds the spring and provides the correct tension on the main slider bar. **J.C.**

### **Mitsubishi HS641V**

This machine was dead with no display. The cause was traced to C910 (4.7 $\mu$ F, 50V) in the power supply. It was open-circuit. **J.C.**

### **Portland DV-K2AOP (Daewoo)**

This quite new machine is used as a video security recorder in a local memorial park. It came to us because it was dead. I found that there was 330V at the mains bridge rectifier's reservoir capacitor but no other life. Worryingly, the 330V remained long after the source of power was removed. Investigation inside

the power supply can revealed a very fine gap in the tracks between the 300V supply. This had arced as a result of damp conditions, blowing some of the tracks off the board. I cut away the remainder of the very close supply tracks, patched out with wiring and sealed the PCB with lacquer. **C.McC.**

### **Hitachi VT150E**

There was slow fast forward/rewind. The cause was found to be paint that was peeling off the supply reel, interfering with the reel pulses. The cure was to replace the supply reel, part no. 6416631, also the take-up reel, part no. 6416651. **D.R.**

### **Toshiba V710UK**

There was no clock display, just a flashing red LED. The cause was the D1SS31 diode on the secondary side of the power supply. It could of course have been any of the rectifier diodes here. **D.R.**

### **Philips VR6761**

This machine was dead. I found that the thermal cutout in the power supply, next to Q7001, was faulty. **D.R.**

### **Mitsubishi HS651V**

This machine reverted to standby after a few seconds. Q903 was faulty. **D.R.**



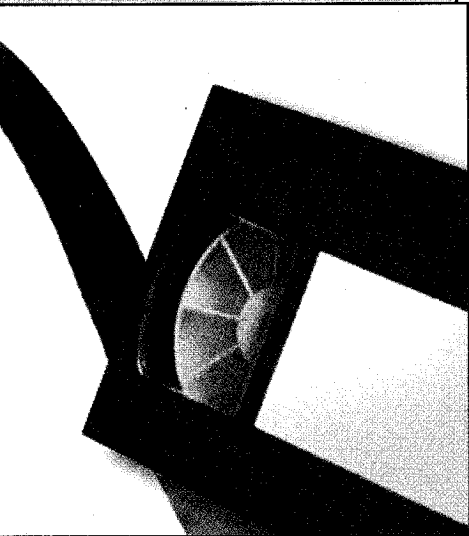

# VCR CLINIC

Reports from  
**Eugene Trundle**  
**Bob Dewis**  
**Bob Flynn**  
and  
**Chris Avis**

We welcome fault reports from readers  
– payment for each fault is made after  
publication.

Reports can be sent by post to:

Television Magazine Fault Reports,  
Highbury Business Communications,  
Nexus House,  
Azalea Drive, Swanley, Kent BR8 8HU

or e-mailed to:  
[twinford@highburybiz.com](mailto:twinford@highburybiz.com)

## Samsung SV213B

Intermittent failure to eject, or leaving a tape loop at eject, is not uncommon with this model. I've found that replacement of the mode switch S601 (part no. AC34-22001E) and the reel idler (part no. AC66-10010A) cures the fault. These are not expensive items. **E.T.**

## Philips VR530/07

The problem with this VCR was intermittent failure to accept or eject a cassette, with the deck getting out of phase mechanically. I found that the tiny FL drive rack was bent out of alignment and that the rotary mode switch needed cleaning. **E.T.**

## Samsung SV613B

A roaring noise came from within this machine and when the cassette was ejected the tape was looped. The cure was to replace the broken reel-drive belt and clean and lubricate the capstan motor's bearings. **E.T.**

## JVC HRJ435

The deck mechanism in this machine was jammed, with a cassette trapped inside. Inspection revealed that the back-tension regulator arm had collided with the retracting tape-entry guide. The cause was not the usual take-up lever assembly but tension-arm lever no. 3 in the exploded diagram, part no. PQ35012-1-3. A plastic spigot had broken off it. **E.T.**

## Sony SLV625UB

As soon as the tape had laced around the drum this machine would unlace and shut down. The cause was lack of FG feedback from the head drum motor, which rotated properly. A replacement stator assembly from a scrap machine cured the problem, despite the fact that there was no discernible fault with the FG coil or its connections to the discarded motor part. **E.T.**

## Sony SLV-SE720G

Manufacturers who won't talk to non-account holders can give their products a bad name. At times repairs may have to be sent miles away to the nearest repair centre. Here's a typical example. We had given up with this machine, then a second one came in with the same fault.

The symptoms were no clock display, no E-E sound, no playback picture and the front buttons doing weird things. Not being Sony repair agents we were unable to phone for advice. But, while having a pint with a friend, I was given an account number. As a result I was able to phone Sony technical and spoke to a nice chap who told me to check whether C701 was fitted the right way round, then change the value of R668

and R669 to 4-k7Ω and reset the EEPROM – he kindly faxed me the option data settings. As a result we had two working machines and two happy customers. The nearest Sony agent is 23 miles away.

I would not normally look for capacitors fitted the wrong way round, or change resistor values. **B.D.**

## Bush VCR924NVPSIL

Weird mechanical behaviour, with ERR showing in the display, was as usual cured by dismantling the mode switch and cleaning the inside. The mode switch is mounted on the main PCB, under the deck, which is the same as that used in the **Thomson Model VTH6210U**, though I suspect that it's a new type of Daewoo manufacture. SEME can supply the mode switch for the Thomson model at 27 pence, part no. 35155800 – this won't last! **B.F.**

## GoldStar P131 (D27 mechanism)

The cassette wouldn't eject – it would make a feeble attempt then the machine would switch off. Normal operation was restored by replacing CP22 (47μF, 25V) in the power supply. It could also be the cause of sluggish mechanical movement. **B.F.**

## Hitachi VTM530E (Philips Turbo deck)

The tape wouldn't eject because the mechanics stopped when unloading towards the eject position. The reason for this was that the left loading arm was one tooth out of phase with the loading gear (item 27). This cannot be seen, because the back-tension arm is in the way. The cause of the trouble was that the plastic shaft on which the loading gear rotates had come adrift from the chassis. The only remedy is to glue the shaft back to the chassis securely and leave overnight. Replacing the loading gear and both tape arms completed the repair. **B.F.**

## Sharp VC-MH54HM

After one and a half to two hours this machine would stop and unlace, while playing or recording. If started again it would do so, but only for a while. As I could see no mechanical reason for this I made a guess and replaced both reel sensors, D854 and D855. The machine then ran for days with no problems. **B.F.**

## Panasonic TX14-GV1 (Daewoo CP421 chassis)

This combi unit produced very warbly sound when playing tapes, particularly in the LP mode. Control pulses were present but were not very clean. I found that disturbing the board would clear the fault intermittently. The cause of the trouble was a dry-joint at the decoupling capacitor CN34 in the control circuit. **C.A.**

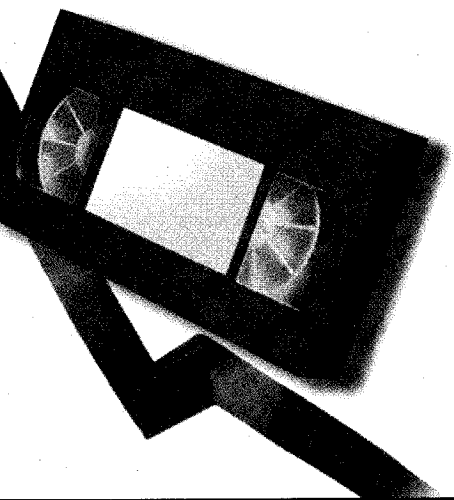

## VCR CLINIC

Reports from  
**Eugene Trundle**  
**Roy Blaber**  
**Dean Ratcliffe**  
**Peter Tennant**  
and  
**Martin McCluskey**

We welcome fault reports from readers – payment for each fault is made after publication.

Reports can be sent by post to:

Television Magazine Fault Reports,  
Highbury Business Communications,  
Nexus House,  
Azalea Drive, Swanley, Kent BR8 8HU

or e-mailed to:  
t.winford@highburybiz.com

### JVC HRJ665

This relatively modern VCR appeared to be completely dead. In fact it had gone into the overload protection mode because the 5V zener diode D5301 was short-circuit. It must have failed for internal reasons, because the 12V rail to which it is connected was, and remains, steady and correct. **E.T.**

### Toshiba V711B

This solidly-built and easy-to-service machine is over ten years old and has served its owner well. It continues to do so after its first, minor, repair: it wouldn't accept a cassette because the contacts of the cassette-in leaf switch had become oxidised. I cleaned them thoroughly and also replaced the FL drive belt, which was slack though not yet slipping. **E.T.**

### Samsung SV633B

This was a bit of a horror story as the VCR was less than four years old and, the customer assured me, had not had heavy use. A sound crackle, on its own recordings only, was caused by worn hi-fi heads on the drum. Repair was not viable economically, so the machine had to be scrapped. **E.T.**

### Toshiba V429

The complaint was stops in the play mode. The tape was in fact looping out because of poor take-up spool rotation. So a new clutch was fitted. I then had poor rewind with a clicking noise. Closer inspection revealed a crack in the rewind gear assembly. A replacement assembly completed the repair. **R.B.**

### Ferguson FV32

This oldie was owned by an elderly lady who insisted that I repair it. Dead with no display was the complaint. Fortunately I had the manual, and found that TK41 on the display panel was open-circuit. **R.B.**

### Sony SLVE710

If one of these machines comes in with eject/loading problems because FL gear 261 is damaged, don't bother to fit a replacement on its own. Sony produces a kit, which is the best way to go as the gear supplied by the usual distributors won't work on its own. **R.B.**

### GoldStar GSE1290IQ

If one of these machines won't accept or eject a tape, remove diode D521 and fit a link in its place. **D.R.**

### Alba VCR7900

This VCR would load tape around the drum as normal then unload and switch off. The problem was worst when the machine was cold, but was intermittent. If

the drum flip-flop pulses at pin 3 of IC101 (head preamplifier) are missing, check the 4.8V supply at pin 1 of this chip. If it's low at about 4.2V, check the capacitors in the power supply, particularly C801 (2,200µF, 16V) and C301/303 (100µF, 50V). They tend to have high ESR readings. **D.R.**

### JVC HRS7000

This machine was dead after having been unplugged. I found that C2 (2.2µF, 63V) in the power supply was open-circuit. **D.R.**

### Daewoo V235

This VCR was dead. After a lot of time had been spent searching in the power supply I found that R52 was open-circuit. I decided to replace R51 as well though it measured OK. The value of both resistors is 390kΩ. It's always a good idea to check the electrolytics as well, as they can go low in value. **P.T.**

### Aiwa HVGX35

A very dim display is a common fault with these machines. The cause is normally CP25 (1,000µF, 10V) in the power supply but, if you are unlucky, it can be the fluorescent display itself. **P.T.**

### Akura VX150

This VCR seemed to be completely dead. Checks around the regulator panel at the front revealed that the 6V supply was low at 3.7V. Replacing the reservoir capacitor C801 (2,200µF, 16V) brought the machine back to life but the drum and capstan speeds were way out. This was cured by replacing C802 (47µF, 16V) which is also on the regulator panel. **M.McC.**

### Toshiba V703B

This machine had gone 'bang' when its owner had returned from holiday and plugged it in. There's a separate power supply can in this model, and the STRD6202 chopper IC had blown apart. I replaced it, along with the three electrolytics on the primary side of the power supply – C817 (0.47µF, 200V), C813 (47µF, 16V) and C810 (15µF, 10V) – and the current sensing resistor R805 (0.56Ω). This restored life to the VCR, but the clock display was very dim. This last problem was solved by replacing C825 (220µF, 10V) which is also in the power supply can. **M.McC.**

### Sharp VCMH60HM

This machine had no display and no functions – the only sign of life was a twitching from the drum motor. Voltage checks revealed that there was only 3.7V at the cathode of rectifier diode D924 instead of 5V. Once its reservoir capacitor C925 (470µF, 10V) had been replaced everything worked normally. **M.McC.**

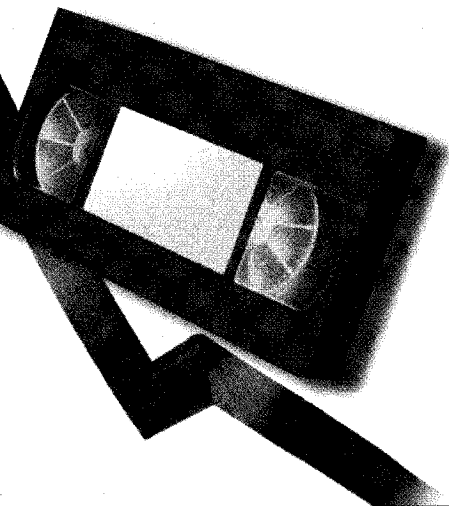

## VCR CLINIC

Reports from  
**Bob Flynn**  
**Gary Laidler**  
**Peter Tennant**  
**George Cooper**  
and  
**Dean Ratcliffe**

We welcome fault reports from readers  
— payment for each fault is made after  
publication.

Reports can be sent by post to:

Television Magazine Fault Reports,  
Highbury Business Communications,  
Nexus House,  
Azalea Drive, Swanley, Kent BR8 8HU

or e-mailed to:  
t.winford@highburybiz.com

### Panasonic NVF70 (G deck)

Although this machine played perfectly there was an annoying clunk every few seconds. When I looked at the underneath of the deck while it was playing I saw that the clutch disc (item 116) was vibrating in coincidence with the noise. It shouldn't move at all in the play mode. The cause was revealed when I removed the centre pulley unit (item 137): its lowest small gear had come adrift as a result of a crack in the main body. A new centre pulley unit cured the fault. **B.F.**

### Bush VCR840VP (Aiwa TN6500 mechanism)

When a tape was played the sound was OK but the TV picture remained on! The only possible clue to the cause of this weird fault was that there would be slight interference on the E-to-E picture when a tape was inserted. As getting to the power circuit is a lengthy process I decided to replace all nine capacitors on the secondary side. This cured the fault. When I checked them afterwards it seemed that C821 (1,000 $\mu$ F, 16V) had probably been the cause. **B.F.**

### Panasonic NVF70 (G deck)

The E-to-E picture had severe patterning. The playback picture also had severe patterning but in addition was in black and white. Replacing C22 (680 $\mu$ F, 10V) inside the power supply cured the fault. It's a problem I have not had before. **B.F.**

### Bush VCR906SIL-T5

When a tape was inserted this machine went into a sluggish fast-forward. After about five seconds it would power down with ERR in the clock display. Puzzling symptoms, but the cure was simple: give the mode switch a good clean. It's mounted on the bottom panel. **G.L.**

### Toshiba V703

The problem with this VCR was tape chewing, the cause being the rotor. Once this had been dealt with the picture had a flicker and was mistracking. I decided to scope the outputs from the power supply and, sure enough, ripple was present. The culprits were the 15 $\mu$ F and 47 $\mu$ F electrolytics on the stand-up subpanel. **G.L.**

### Panasonic NVSD200

This VCR wouldn't accept a tape and a chattering noise came from the loading motor area. It was not the loading coupling or the main lever this time but the gear worm wheel, part no. VDC7466, which was a bit toothless. It's available from SEME at 55p. **G.L.**

### Proline VR515

This fairly new VCR suffered from intermittent loss of tracking and would speed

up from time to time. The cause of the fault was easily traced to connector PJ201, which connects the CTL head to the main board. The poor joints looked as though they had been present from new. **G.L.**

### JVC HRD455

If you get one of these old machines that won't accept tapes, replace both cassette switches to cure the problem. **P.T.**

### Sanyo VHR899

This VCR was dead with the fuse in the plug open-circuit. I thought it was going to be an easy job, but not so. When I tested the machine I found that it was very slow at loading tapes. It turned out that the loading motor was the cause. All was well after fitting a replacement followed by a general clean and test. **P.T.**

### Hitachi VTM930E

This machine was completely dead. I discovered that R851 (1 $\Omega$ , 0.5W fusible) in the power supply was open-circuit. It's not shown on my circuit diagram. **G.C.**

### Sanyo VHR244E

The complaint with this machine was that it would cut off seconds after going into the record mode. Playback was OK. PR512 again I thought, but couldn't have been more wrong: when I removed the top cover I found that it's an earlier model that does not have PR512. As I powered up the machine to take voltage readings I detected a horrid smell that came from the power supply section. You have to remove the main PCB and take off a large metal screening can just to be able to see the power supply. A quick visual inspection revealed that C5107 (47 $\mu$ F, 25V) had leaked badly. It was the source of the smell and had corroded the following adjacent components: C5106 (47 $\mu$ F, 50V), C1501 1,000 $\mu$ F, 16V) and D5114 (1SS244). I removed the damaged components, cleaned the board and fitted replacements. After that the machine worked flawlessly. **G.C.**

### Toshiba V825B

This machine was dead with no signs of life. The cause was C835 (820 $\mu$ F, 16V) in the power supply. **G.C.**

### Panasonic NVSD220

There were no functions with this machine, a tape was stuck in it and there was no E-E operation. The cause was loss of the 5V supply at Q1003. A 2SD1330 or 2SD1996 is used in this position. **D.R.**

### JVC HRD960

If the display is dim, check or replace C28 and C29. **D.R.**

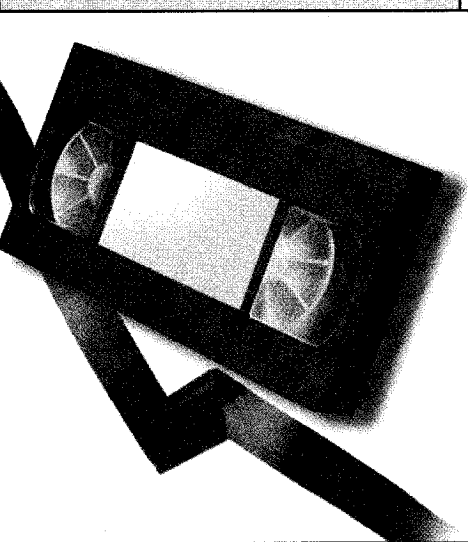

## VCR CLINIC

Reports from  
**Eugene Trundle**  
**Roy Blaber**  
**Dean Ratcliffe**  
**David Kerrod**  
**Mike Leach**  
and  
**Michael Dranfield**

We welcome fault reports from readers  
— payment for each fault is made after  
publication.

Reports can be sent by post to:

Television Magazine Fault Reports,  
Highbury Business,  
Media House,  
Azalea Drive, Swanley, Kent BR8 8HU

or e-mailed to:  
twinford@highburybiz.com

### Wharfedale NV6

There was a very elusive intermittent fault with this machine, which was barely a year old. When selecting or changing a deck mode it would sometimes shut down with an ERROR caption in its display. The cause is the grease used in the rotary mode switch. The cure is to dismantle and degrease the switch, clean the stator and rotor fingers with a fibre pen, retension the fingers then reassemble it with a whiff of switch cleaner. My thanks to Key Electronics for this tip.

Incidentally this is the first VCR I've come across with no cassette LED and no end sensors. It's got a very clever microcontroller instead. **E.T.**

### Hitachi VT-M610EUK

With an RF output the E-E and playback sound were spasmodic, sometimes drowned by a vision-type buzz. Sound from the scart socket was consistently good. I found that the symptom could be made to come and go by wiggling the aerial input plug and socket. There was a dry-joint inside the tuner/modulator assembly, at one of the earthing lugs between the sockets and the first IC.

This VCR is similar inside to many Philips models. **E.T.**

### Toshiba V632

The complaint with this VCR was that the picture rolled when it played back its own recordings. There were also obvious head-switching problems with prerecorded tapes. The cure is to play back a test tape, wait for the machine to finish auto-tracking, press SW703 then the SP/LP button on the remote-control unit. Switch off to store. SW703 is hidden behind the front of the machine. **R.B.**

### Sanyo VHR3100

This old machine had lines across the screen in the E-E mode, similar to co-channel interference. Checks in the power supply led me to C11 (1 $\mu$ F) which was the cause. **R.B.**

### Hitachi VTFX860

The front display was OK in standby but went out when the machine was turned on. This seemed odd until I realised that the machine uses an LC display. Three LEDs are used to light the display dimly in standby. Conventional lamps are used when the machine is brought out of standby. All three were open-circuit. Old cassette lamps proved to be OK. **R.B.**

### Ferguson FV33H

This old Nicam machine wouldn't restart after a power cut. I used my ESR meter to carry out some checks on the primary side of the power supply and found that C13

(180 $\mu$ F) and C14 (1 $\mu$ F) were virtually open-circuit. As 180 $\mu$ F is an unusual value I fitted a 220 $\mu$ F capacitor in this position. **R.B.**

### Sharp VCM27HM

There was no playback colour. The cause was dry-joints at crystal X501 on the main PCB. **D.R.**

### Panasonic NVHV60

This VCR was completely dead. I found that the start-up feed resistor R1150 (1M $\Omega$ ) was open-circuit. **D.K.**

### Akai VSJ719EK-N

For no functions, no display and the standby light flashing, try replacing C116 (1,000 $\mu$ F, 16V) in the power supply. I fitted a capacitor rated at 25V to be on the safe side. **M.L.**

### Panasonic NVSJ220B-S

The tape would be ejected immediately after loading. It's becoming a common symptom with various different machines nowadays. In this case the fault was cured by replacing the capstan motor. The problems didn't end there however. The machine subsequently came back with a report that said "erratic play". It would sometimes unlace then lace up again, sometimes fast rewind wouldn't operate properly, and sometimes the machine would just shut down. These problems were eventually cleared by replacing the two take-up sensors IC1501 and IC1502 on the main PCB.

How can a machine develop two different, genuine faults at the same time, such as a duff capstan motor and faulty sensors as in this case? I'll just file it under 'one of those things', where most stuff seems to end up nowadays! **M.L.**

### Sony SLVSE720

This machine is made by Samsung and is fitted with the Scorpio II chassis. The silk-screen printing is incorrect in one position and because of this C701 (470 $\mu$ F, 16V) in the AL5V supply is inserted the wrong way round. Sony seems to think that fitting a new capacitor the right way round will prevent corruption of the EEPROM — typical symptoms are display not lit, no video playback picture, incorrect head switching or incorrect front-panel button operation. This is not the case however. If you simply replace C701 and reprogram the EEPROM the machine will fail again later. The true cause is the surface-mounted microcontroller chip.

You may, depending on how corrupt the EEPROM has become, have difficulty using the hidden switch to enter the service mode. In this case press any button on the front panel. This will provide access to the EEPROM map. **M.D.**

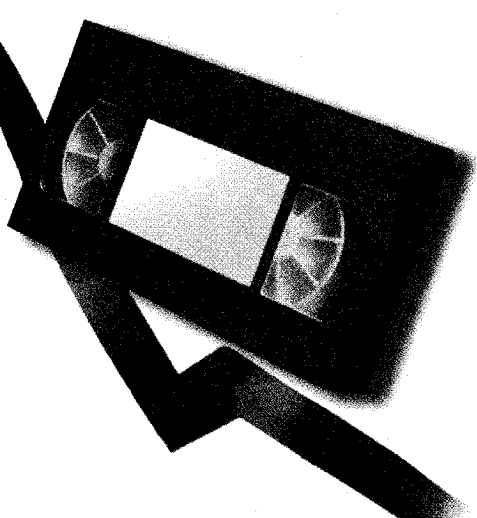

### **Panasonic NV-SD220B**

A cassette was trapped inside this machine, while the front panel displayed the caption H02. It didn't take long to discover that the capstan wasn't turning. It took rather longer to establish that the BA6187S capstan-drive chip IC2501 was the cause. **E.T.**

### **Philips VR437**

This VCR produced no signs of life, but the mains fuse was intact and there was 320V at the chopper transformer's primary winding. My trusty ESR meter showed – after discharging the mains bridge rectifier's reservoir capacitor! – that C2114 and C2201 had both dried out. C2114 (47 $\mu$ F, 25V) is on the primary side of the power supply, while C2201 (47 $\mu$ F, 50V) is on the secondary side. **E.T.**

### **Daewoo V235**

This VCR was dead. After a lot of searching in the power supply I found that R52 (390k $\Omega$ ) was open-circuit. I also replaced R51, which has the same value, though this one produced the correct resistance reading. In addition it's best to check the electrolytics in the power supply. A couple of them were low in value. **P.T.**

### **Sanyo VHR899**

This VCR was dead with the fuse in the plug open-circuit. I thought it was going to be an easy job, but not so. When I tested the machine I found that it was very slow at loading tapes. It turned out that the loading motor had to be replaced. All was well after a general clean and test. **P.T.**

### **JVC HRD455**

If one of these good old machines won't accept tapes, replace both cassette switches to cure the problem. **P.T.**

### **Aiwa HV-GX35**

A very dim display is a common fault with this model. The cause is usually CP25 (1,000 $\mu$ F, 10V) in the power supply but, if you are unlucky, it can be fluorescent display itself. **P.T.**

### **Sony SLV750HF**

This VCR produced snowy playback pictures, though the sound was OK. As a first step I checked the drum for possible dirty or bad heads, but everything was OK in this respect. I then checked the head amplifier assembly and found that IC801 was the cause. A new IC restored clean pictures. **C.B.**

### **Sony SLV825**

The display disappeared when the PAL/NTSC switch was in the PAL position but was OK in the NTSC position. Capacitance meter checks on board MF167

revealed that C604 was the cause of the fault. This double-layer 0.22 $\mu$ F memory capacitor had started to leak on to the board. A quick board clean up and a replacement capacitor restored normal operation. **C.B.**

### **Aiwa VX-G143K**

This VCR was dead. I found that the STRF6707 chip IC501 in the power supply was faulty. Nothing else had failed. **B.L.**

### **Akai VS105**

Failure of the brakes to release in fast forward/rewind was cured by cleaning the mode switch. The fault with another of these machines was no RF or video output and no supply to the tuner. FR3 (0.3 $\Omega$ ) in the 18V supply was high in value. **L.G.**

### **Amstrad UF30**

This VCR wouldn't store channels. The cause was the X24C02P EEPROM IC6004. **L.G.**

### **Alba VCR7300**

According to its frustrated owner this budget VCR did all sorts of strange things. As usual, removal of the mode switch and a check inside showed what was wrong. Once it had been cleaned and retensioned, then refitted, the machine behaved normally. **D.G.**

### **GoldStar T2631**

This VCR was dead with no display. I removed the power supply can and checked the ESR of the electrolytics. True to form, they were all faulty. Once all eight had been replaced the machine sprang to life. To avoid comebacks, it's good workshop policy to replace every electrolytic capacitor in this power supply. **D.G.**

### **Panasonic NVSD40**

The complaint with this VCR was that it produced bad pictures. This was confirmed when I connected it to my monitor on the bench. Head cleaning proved fruitless, but I had in stock a replacement drum unit. Once this had been fitted the machine produced stunning pictures. **D.G.**

### **Sanyo VHRH790E**

This VCR remained dead after a power cut and no amount of blasting with a hairdryer produced any signs of life. When I removed the deck and PCB I found that one of the start-up resistors in the power supply, R60001 (270k $\Omega$ ), was open-circuit. A replacement brought the machine back to life. Beware of a fully-charged mains-rectifier reservoir capacitor. The other series-connected start-up resistor, R60007 (68k $\Omega$ ), is less likely to cause problems. **M.McC.**

## **VCR CLINIC**

**Reports from**  
**Eugene Trundle**  
**Peter Tennant**  
**Chris Bowers**  
**Bob Longhurst**  
**L. Gare**  
**Dave Gough**  
**and**  
**Martin McCluskey**

**We welcome fault reports from readers**  
– payment for each fault is made after  
publication.

**Reports can be sent by post to:**

**Television Magazine Fault Reports,**  
**Highbury Business,**  
**Media House,**  
**Azalea Drive, Swanley, Kent BR8 8HU**

**or e-mailed to:**  
**twinford@highburybiz.com**

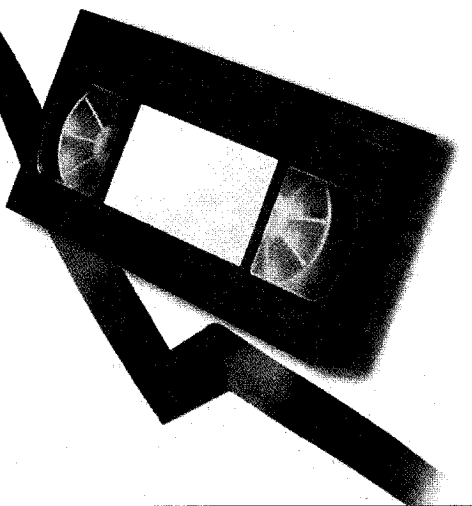

### **Matsui VC9601N**

The customer said that the tape would load then the machine would shut down. A visual check showed that the brake band had snapped. I suspected that this was not all that was wrong and, when I removed the deck, I found that the left supply reel had fallen apart. Once it had been reassembled and the machine had been put back together it produced a fine picture.

I've had this fault with numerous Matsui VCRs. **D.G.**

### **Daewoo V50**

This machine was dead with no display. I removed the power supply can and checked the ESR of the electrolytic capacitors. C53, C63, C65 and C66 all produced high readings. Once replacements had been fitted and some resoldering had been carried out in the power supply the VCR sprang to life and worked well. **D.G.**

### **JVC HR-DVS1EK**

This expensive-looking VCR also has a mini DV deck. Fortunately the problem was with the VCR deck. It was half way through the loading cycle and, when the machine was powered, all that happened was that a clicking noise came from the gearing. I fitted a new mode switch (it lives under the main cam) then carried out a check on all the gears. Realignment is straightforward, as the gears are aligned with holes in the main deck. A soak test confirmed that all was then OK. **A.T.D.**

### **Sanyo VHR190E**

If the complaint is no eject, remove the top cover then the front fascia. Before you replace the eject switch, check for poor joints at the middle connector. **A.T.D.**

### **LG BC999NI**

I tuned in this six-head Nicam VCR a year ago. The customer complained that it subsequently started to go dead intermittently and was now totally dead. He gave me the machine for spares, and I tuned in his new £50 supermarket cheapie. Back in the workshop, cold checks showed that D106 (1N5822) was leaky. A replacement cured the fault, and the results were excellent.

So all that was required was a 20p diode. I'm worried about the future of the TV/video trade, but am never going to be short of decent machines if people keep throwing them away! **G.L.**

### **Aiwa HV-FX7500**

The fault card said "ejects tapes". When I opened the machine up and removed the deck I found that the centre gear assembly was in bits. This VCR uses a Toshiba deck, as in the **Toshiba Model V709B**. A replacement gear assembly and clutch assembly cured the fault.

They are both available from SEME, under part nos. VDC7718 and VDC7720. **J.S.O.**

### **LG BC989NI**

This was a straightforward job: the VCR was dead after a power cut. The cause turned out to be C116 (1,000µF). **J.S.O.**

### **Panasonic NVF70**

This VCR had no RF output but was fine with an AV scart output. I found that IC1 (LA7051) in the RF converter was faulty. **J.S.O.**

### **Mitsubishi HS841V**

It's common to find that the front loading arm unit is broken in these machines. It's available from SEME under part no. VDC7847. **J.S.O.**

### **Panasonic NVFJ610 and NVSJ410**

These machines came in shortly after each other, both with the same fault. The problem was no remote-control operation, though the machines worked correctly when their on-board controls were used. In both cases I found that, after removing the PCB from the cases, the IR sensor IC3 was dry-jointed. Resoldering cured the fault. **J.S.O.**

### **Philips 14PV203/07**

The fault report that came with this TV/VCR combi unit said "no eject". When I checked I found that the mechanism at the side of the cassette housing was dodgy. A replacement restored normal operation. It's called the rack assembly, the part no. being 9965 000 12234, and is available from SEME. **J.S.O.**

### **Toshiba V705B**

This VCR seemed to be dead. But I found that there were fluctuating voltages on the secondary side of the chopper transformer. The cause of the problem was C007 and C008, which were both low in value. **A.H.**

### **Hitachi VT430**

This oldish machine was in surprisingly good condition, but had developed an annoying fault: when any function was selected it would occasionally go into rewind instead of the function selected. The condition was now permanent.

"End sensors" I hear you say. Well, nearly, though I admit that I replaced the supply-side end sensor as a first check before getting out the scope. I then found that the buffer chip IC903, between the end sensors and the micro-controller chip IC901, was faulty. Pin 1 should go low when the supply side end sensor has no light falling on it, but instead was 'floating' at about 1.5V.

IC903 is a BA6993 dual op-amp chip, and had to be obtained from Charles Hyde as a special order. **R.B.**

## **VCR CLINIC**

**Reports from**  
**Dave Gough**  
**Andrew T. Duggan**  
**Gary Laidler**  
**J.S. Ogilvie**  
**A. Haq**  
**and**  
**Roger Burchett**

**We welcome fault reports from readers – payment for each fault is made after publication.**

**Reports can be sent by post to:**

**Television Magazine Fault Reports,  
Highbury Business,  
Media House,  
Azalea Drive, Swanley, Kent BR8 8HU**

**or e-mailed to:  
twinford@highburybiz.com**

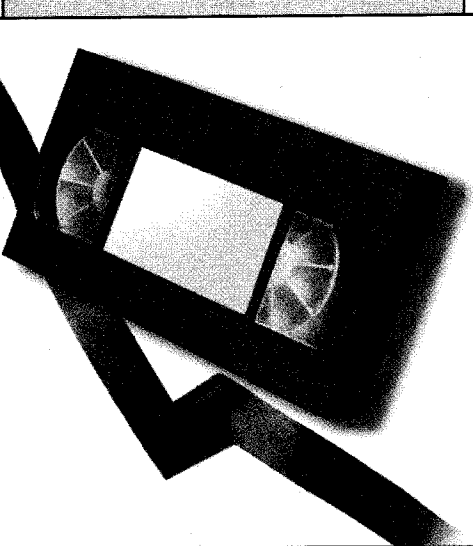

### **Panasonic NVSD200 and similar VCRs**

I have found a simple way of removing an almost fully laced-up tape where the loading motor struggles to provide enough power to engage the pinch roller fully and F03 appears in the display. Remove the pinch-roller tension spring, then press the power button. The machine will continue into the play or stop mode. Immediately press eject.

With the tape removed, unscrew the deck in the normal manner and replace the loading-motor coupling, which you will find has split. Clean the mode-switch touch-contacts at the same time.

This procedure avoids creasing a good tape and saves a lot of time that would be required to dismantle and retape the mechanism.

Don't forget to reconnect the pinch-roller spring. I did on one occasion and ended up with a mangled tape, which completely defeated the object of the exercise! **B.B.**

### **Philips VR6547**

This machine produced the symptoms of an AGC fault, with the contrast level too high in the record mode. I cured it by replacing all the low-value capacitors in the RF module. Some of the 0.1 $\mu$ F capacitors were completely open-circuit. **B.B.**

### **Panasonic NVHD630**

The loading mechanism was jammed with a tape stuck inside. When I finally got the tape out and removed the deck I found that a couple of teeth on the take-up gear arm assembly were missing. A replacement, part no. VDC7880 from SEME, cured the fault. **J.S.O.**

### **B&O V6000 (Turbo deck)**

The complaints with this machine were "damages tapes and bad sound". When I opened it up I found that it was fitted with the **Philips Turbo deck**. A replacement pinch-roller assembly cured the faults. **J.S.O.**

### **Samsung Ti14BS**

This TV/VCR combi unit uses the same deck as several **Toshiba** and **Aiwa** machines. The complaint was that the video section was wrecking tapes. A replacement centre gear assembly from SEME, part no. VDC7720, cured the fault. **J.S.O.**

### **Sharp VCMH64HM**

Here's a quickie on this VCR. If the power supply is pulsing, replace C925 (470 $\mu$ F, 10V). **J.S.O.**

### **Ferguson FV77HV**

Dead after a power cut normally means that the electrolytics on the primary side of the power supply need to be replaced. With this

machine however the cause was on the secondary side, where TP91 (2SA1020Y) was short-circuit and RP91 (1.5 $\Omega$ , 0.3W fusible) was open-circuit. You may also find that RP86 has overheated. If it needs to be replaced, it's a 27 $\Omega$ , 0.3W fusible resistor. **B.F.**

### **Hitachi VTM720E**

Tape ejection was incomplete, with a grating sound of unmeshed gears. I suspected the clutch base but the cause was in fact the worm gear (item 405) on the cassette housing. There's a small piece of plastic at the top of this gear: it had worn away, allowing the gear to rise upwards and unmesh itself from the drive gear on the clutch base. **B.F.**

### **JVC HRJ755EK**

This VCR was dead with the 1.6A input fuse FC5001 blown. I found that Q5102 (2SD2144S) had blown apart and Q5101 (2SK2632-CB14) was short-circuit. Other items that had to be replaced were Q5305 (2SC1740S), R5106 (0.39 $\Omega$ , 1W), PC5101 (PC123F2) and C5104 (1 $\mu$ F, 50V). **B.F.**

### **Panasonic TX14GV1**

This TV/VCR combi unit was brought in because a tape had jammed and couldn't be ejected. When I applied power the only response I got was a 'chattering' relay in the TV section power supply. Time was wasted because I thought the jammed tape was the cause. But, after winding out the tape manually, I found that the relay still clicked away as soon as power was applied.

Suspecting a short of some sort in the line output stage, I wasted more time carrying out fruitless checks. After a bit more thought I came to the conclusion that the chattering relay was not an indication of excess current etc., in fact the opposite. The prime suspect was a suspicious-looking electrolytic, C840 (47 $\mu$ F), whose value proved to be very low. Once a replacement had been fitted the unit powered up normally.

This capacitor fault had shown up only because the unit had been unplugged and had therefore cooled down. If the unit is left in standby everything works normally.

A sticky tape was the cause of the jam-up.

You get the same relay-clicking fault with the **Goodmans TVC14GT** and **Daewoo GB20F8T2** combi units. **B.L.**

### **JVC HR-S8700EK**

This high-specification S-VHS machine appeared to be dead, though a very faint ticking from the power supply could be heard. The cause was not hard to trace - C1502 (27 $\mu$ F, 35V) on the primary side of the power supply. Yes, that unusual value is correct! **G.C.**

## **VCR CLINIC**

Reports from

**Brian Battams**

**J.S. Ogilvie**

**Bob Flynn**

**Bob Longhurst**

and

**George Cooper**

We welcome fault reports from readers - payment for each fault is made after publication.

Reports can be sent by post to:

Television Magazine Fault Reports,  
Highbury Business,  
Media House,  
Azalea Drive, Swanley, Kent BR8 8HU

or e-mailed to:  
t.winford@highburybiz.com

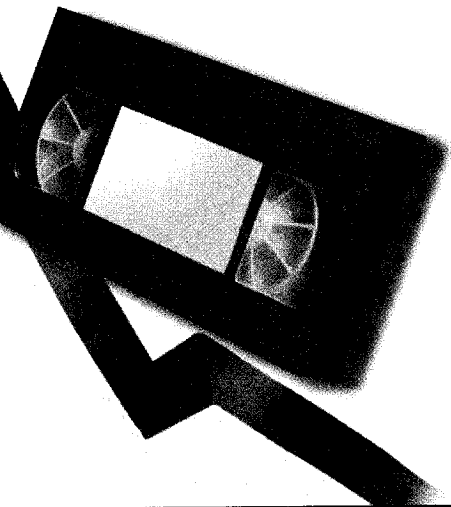

## VCR CLINIC

Reports from  
**Eugene Trundle**  
**Chris Bowers**  
**Steve Roberts**  
**David I. Scott**  
**Mike Leach**  
**Roy Blaber**  
and  
**Andrew Duggan**

We welcome fault reports from readers  
— payment for each fault is made after  
publication.

Reports can be sent by post to:

Television Magazine Fault Reports,  
Highbury Business,  
Media House,  
Azalea Drive, Swanley, Kent BR8 8HU

or e-mailed to:  
[Lwinford@highburybiz.com](mailto:Lwinford@highburybiz.com)

### JVC HRV605

This machine, still under guarantee, was brought in with the complaint that pictures from its own recordings played back with vertical juddering. On test we found that the symptom was confined to the LP mode, in which the off-tape carrier envelope was 'bottle-necked' at the beginning of the head scan. The cause was low back tension. It was cured by fitting a new tension band and adjusting its regulator. **E.T.**

### Sony SLV-SE830G

Mode-switch problems usually occur when a machine has been in use for some years, as the contacts become oxidised or the wiper fingers lose their spring tension. Sometimes, in relatively new machines, problems are caused by grease that's packed into the switch assembly during manufacture. And so it was in this case, the result being odd misbehaviour of the deck mechanics. A typical symptom was failure to eject the cassette fully. **E.T.**

### Sony SLV-SE730G

The complaint with this VCR was poor playback and record. A visual inspection of the cassette mechanism base assembly revealed the cause: the straight guide pole that leads on to the capstan had snapped. All that was required was to bond the guide pole back in place. This restored normal playback and record operation. **C.B.**

### LG N301

I have experienced a couple of faults with these machines. First, intermittent deck operation and weird symbols in the display can be caused by the 31DQ04 diode DP08, which forms part of the 5V sys arrangement. Don't be tempted to fit any old diode in its place. If you can't obtain a 31DQ04, use a BY329-800. This is a fast-recovery type and is rated at 8A. Fitting a BY229-800 will result in a loud explosion after about a minute, as I discovered!

The second fault is failure of the tuning voltage because the 33V zener diode ZD701 and the associated 470Ω resistor R701 is faulty. For some strange reason the diode goes short-circuit and the resistor low in value, not open-circuit.

I've had both of these faults, which have developed at the same time, in some of these models. Strange! **S.R.**

### Ferguson FV71

There was no operation because the power supply was dead. This fault was cured by replacing CP07 (10μF), CP08 (100μF) and CP71 (10μF). But I wasn't happy with the display, which was almost invisible in standby and only marginally brighter when the machine was switched on. I suspected further capacitor problems and, for once, was right: CP41 (220μF) had dried up and lost most of

its capacitance. A replacement restored normal display brightness in both the standby and live modes. **D.I.S.**

### GoldStar RQ2931

This fault was easy to diagnose but not so easy to repair. The owner complained that TV reception and the recordings made by this VCR weren't very good, though it played back recordings made by other machines without any problems. When he connected the aerial lead to his TV set directly reception was OK. So it had to be the VCR.

Its aerial socket was broken of course, though this wasn't immediately obvious. The outer and inner conductors appeared to be solid physically, but the insulator between them had cracked and there was a resistive path across them, possibly because water had travelled down the cable from the roof-mounted aerial. This was the cause of the severe signal degradation.

Unfortunately a complete strip-down was required to replace the socket. **D.I.S.**

### Sony SLV-SF90UX

There was no colour with this VCR's own recordings while good prerecorded tapes produced poor, grainy colour. As with all modern machines, it's difficult to do serious work while they are running. I took a stab in the dark and plumped for the LA1561 YC processor chip IC200, which is a surface-mounted device. Fortunately the replacement provided a complete cure. **M.L.**

### Panasonic NVHD600

This machine was dead with the STP3N60F1 chopper FET Q1101 short-circuit. In addition I had to replace IC1101 (TDA4505-03), C1115 (47μF), C1116 (47μF) and C1134 (680μF). C1134 is on the secondary side of the power supply and was leaking. **R.B.**

### Ferguson FV21 etc

A problem you can get with these oldies is that the cassette doesn't load properly and is a loose fit in the carriage. Ferguson added 3mm strips of felt or chamois leather, sticking them with double-sided tape to the two springs in the top of the carriage. This holds the cassette firmly in place while loading.

I've used this modification with other VCRs as well. **R.B.**

### Grundig TVR3815

The problem with this combi unit was with the tape section. It would accept a tape, lace up then power down. After removing the back cover I could see that there was no drum rotation while it was lacing. I removed the TV section to get at the tape deck, then replaced the drum motor — obtaining one from a unit in our scrap yard department. A good soak test showed that the unit then worked without any problems. **A.D.**



# Servicing JVC HRJ200 series VCRs

**John Coombes provides a detailed fault-finding guide for these popular VCRs**

**T**hese VCRs were released in about 1994. The range includes Models HRJ200, HRJ205 and HRJ400. They are good-quality machines, capable of excellent performance, and are worth repair if in reasonable condition.

## Power supply faults

Fig. 1 shows the chopper power circuit used in these VCRs, and Fig. 2 the regulator and power-switching circuits on board 03.

If the machine is dead with the 1.25A mains fuse F1 open-circuit, check for shorts in the mains bridge rectifier circuit. The diodes are D1-4 (4 x 10E6-F2) and the reservoir capacitor C10 (68 $\mu$ F, 400V). Alternatively the 2SC4517A chopper transistor Q1 could be short-circuit. When Q1 fails R8 (0.39 $\Omega$ , 1W) usually goes open-circuit. Q1, R8 and the optocoupler PC1 (PS2561L-1WL) should all be replaced in the event of failure of Q1. On rare occasions the cause of F1 going open-circuit is shorted turns in the chopper transformer T1.

If the power supply doesn't work and F1 is OK, check C12 (2.2 $\mu$ F, 50V). It may give a high-ESR or low-capacitance reading.

If the symptom is no results with circuit protector CP1 (ICP-N20) in the 6V supply blown for no apparent reason, an earth bracket (part no. 46086) and screw (SDST2604ZY) should be fitted to prevent a static charge build up. It has to be fitted to the front loading mechanism, at the top right, to earth the mechanism to the outer case. If the earth bracket modification has already been fitted, check that the modification in the servo chip (IC401) circuit has been carried out. This is as follows. R401 (originally 1.2k $\Omega$ ) is replaced with a 560 $\Omega$  resistor, part no. QRSA08J-

561YN. An extra resistor, R440 (560 $\Omega$ , part QRD162J-561), is added in series with pin 29 of IC401. Cut the print near pin 29 of IC401 and use the legs of the resistor to connect pin 29 to the junction of C401 and pin 2 of CN401. A spacer (part no. PU59915-105) was supplied to prevent the added resistor (R440) shorting to the PCB. Fig. 3 shows the modification.

If the display is dim or not alight, check C34 (22 $\mu$ F, 50V) which goes low in value and the condition of R32 (47 $\Omega$ ).

## Mechanical faults

One of the most common problems is a faulty mode switch (S3). Symptoms can include random rewind failure, with tape looping on eject, or intermittent no play, fast forward and/or rewind. The tape may simply be ejected from the cassette housing. In many cases the switch can be removed, cleaned and refitted – ensure that the timing is set up correctly.

If the tape is chewed when play is selected, check that the take-up and supply reel disc assemblies run freely. If the reel discs are jerky or stop completely, the holes may be packed with grease or the spindles may be dry with little lubrication. Alternatively the capstan motor may not be operating correctly.

If there is jerky movement or noise comes from the capstan motor, remove and dismantle it, clean the spindle shaft, relubricate at the ends and refit. If there is no noise, the capstan motor is working normally. If noise is still present, check the capstan motor (part no. PU61285) by replacement. If the capstan motor squeals or makes a groaning noise in operation, the cause could be poor lubrication of the capstan motor bearings.

The sound can slur because the capstan slows down. The capstan motor may be faulty or the cause could simply be a stretched capstan belt.

If the tape is chewed when ejected and the idler unit remains between the two tables, replace the capstan belt, the loading belt and the plate assembly (item 145 in the exploded view in the manual). In extreme cases the plate assembly may be cracked.

If the cassette is ejected after insertion, start sensor S1 may be faulty. Remove and add sensor PS3, part no. PU60629.

Tape damage after rewinding is caused by spillage from the take-up spool. This usually means that the brake assembly is faulty. If the main brake (part no. PQ46308A-2) and sub-brake (part no. PQ46309A-4) are not too badly worn cleaning the brake pads may cure the fault, otherwise the brakes will have to be replaced.

If the VCR won't play a tape, check the operation of the reel drive. The clutch can drop out of position because the circlip has come off. A replacement circlip will restore normal operation.

A crack in the capstan gear will result in failure of a tape to play, tape ejection or making a ticking noise. There's a replacement gear kit.

If the tape is jammed in the machine, check the loading arms. The lug on an arm can break, releasing the spring with the result that the arms jam. Alternatively the gears on the cassette housing may be damaged. These are not available as spare parts: the cassette housing (part no. PUS29672A) has to be replaced.

Erratic faults can be caused by oxidised glue on the PCB. Examples are the power LED not

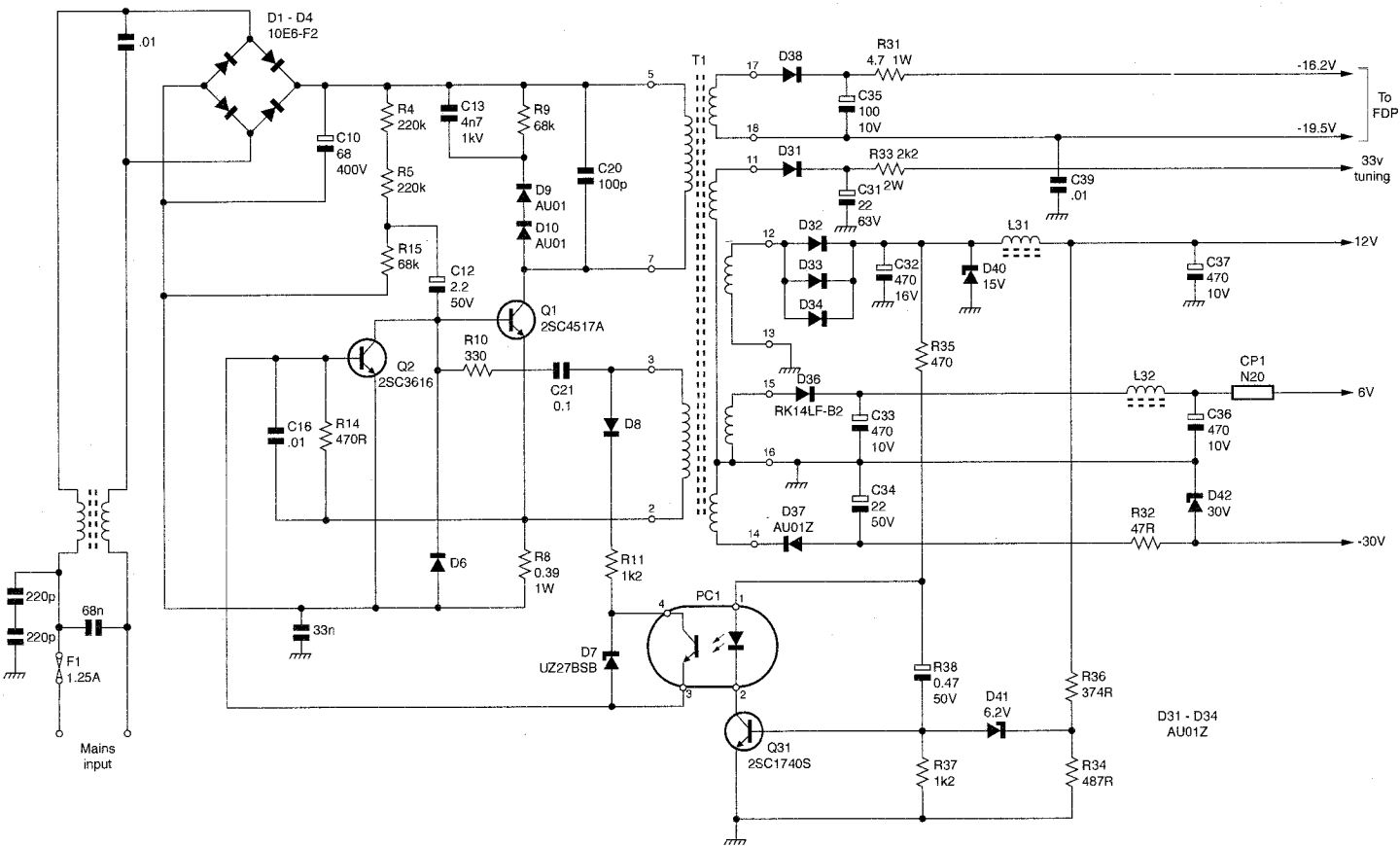

Figure 1: Circuit diagram of the chopper power supply in JVC HRJ200 series VCRs (board 01).

lit, the VCR going to standby and not accepting a tape, or the capstan motor going into the rewind mode of its own accord.

For noisy rewind/fast forward, check the capstan-motor bearings for wear or, more often, lack of lubrication. Also, to ensure that the capstan motor runs freely, clean the capstan flywheel's spindle.

### Video problems

The most common fault is white dots on the picture (static noise). The cure is to replace the brush assembly (part no. PDM4343A) and cap (part no. PDM4328-2) in the drum assembly. If the static noise is very bad, the symptom can look like a faulty upper drum. When replacing the brush assembly, make sure that the spindle is clean and free of grease. If the picture is still very poor after replacing the brush assembly, ensure that the head switching is set up correctly.

If there is incorrect record/playback in the LP mode but SP is OK, check whether the rotary transformer coils on the drum motor are damaged.

Check for dirty video heads if

there is sound but poor playback. If the picture is still snowy after cleaning the heads, check the FM envelope at TP506 on pre/rec board 43. If the output from both or maybe just one head is low the upper drum may be in need of replacement. First however check that the guide poles are set correctly, also the head switching. Check that there is a 5V supply at pin 12 of the BA7182S preamplifier chip IC501. If there is no output at pin 18 of IC501, the IC is probably faulty. If the output is present here but not at TP506, check the emitter-follower transistor Q504 (2SA1740S) by replacement.

An occasional complaint is double images, particularly noticeable when there are vertical lines in the picture. The fault can be very intermittent. The cause is a faulty connection at the earth pin of the delay line.

A very intermittent fault we have had is loss of EE/rec video and sound, which may be accompanied by a very coarse whistle on sound and patterning on the vision, playback being OK. The cause has been a faulty IF module (TNR2). It becomes unstable, the only cure

being replacement.

Snowy pictures and noisy sound can be caused by a low-gain tuner (TNR1) or broken aerial sockets at the RF converter/switch. Make sure that the earthing is not dry-jointed and that the centre pins are correctly soldered.

If the picture drifts off tune, check the 33V zener diode D1 (MTZ33CT-77) which could be leaky. If a replacement fails to cure the problem, replace the tuner unit.

### Sound faults

A faulty audio/control head can be the cause of no or low sound. Make sure that the head is clean before condemning it, as a badly contaminated head will provide poor performance. If the head is OK, check the DC conditions at the pins of the BA7790LS audio chip IC301. If any voltages are incorrect, check back to source or check IC301 by replacement. There should be a 10.3V supply at pin 7: this is derived from the switched 12V supply via R353 (220Ω), with C347 (10μF, 16V) for smoothing.

If a scart lead is in use, ensure that it is pushed into the VCR's

**Figure 2: The regulator and power-switching circuits on board 03.**

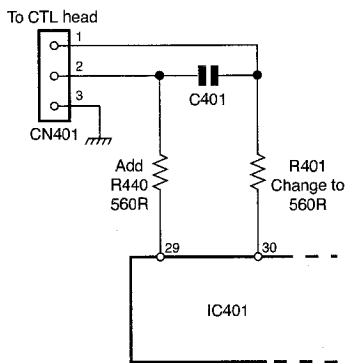
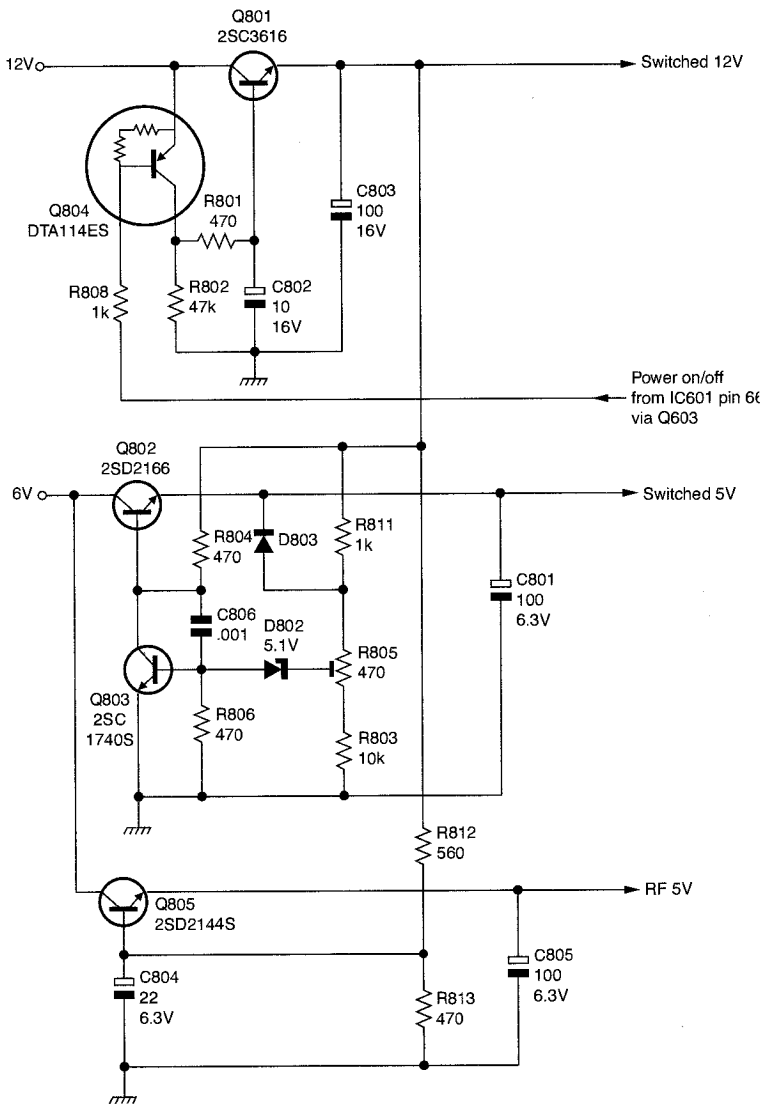

**Figure 3: Modification to the control head circuit to prevent intermittent failure of CP1.**

socket properly. Faulty connection can be the cause of no sound, loss of picture or sometimes both.

If these points are in order, check that there is an audio output at pin 7 of the IF unit TNR2. If not, check for dry-joints then check the IF unit by replacement.

### Syscon and servo faults

If the machine doesn't accept tapes,

check the loading motor. Replace if faulty. If the loading motor is OK, check that there is 12V at pin 6 of the loading-motor drive chip IC1 (BA6418N). If this supply is missing, check back to source via the deck terminal board etc. If the supply is present, check IC1 by replacement. The fault could be caused by the syscon chip IC601 (type HD6433926A13F). Check the DC conditions here and if necessary the IC by replacement.

The capstan motor (part no. PU61285) can be the cause of syscon/servo problems. It can be responsible for intermittent operation with shut down half way through a mode change. If the motor is OK, check the DC conditions around the syscon chip IC601 and the servo chip IC401 (JCP0039). There should be a 5V supply at pin 39 of IC401. If this is missing, check back to source: if it is low, suspect IC401. If the DC

conditions at the two ICs are correct, check the relevant IC by replacement. Mode switch S3 can be the cause of incorrect operation. It can sometimes be dismantled, cleaned and relubricated. Then reassemble and soak test.

Start switch S1 on the cassette housing can cause problems. Check that it is producing a start pulse at pin 39 of IC601. If not, check it by replacement.

If the machine plays up on rewind or fast forward, or cuts out after a short operation, check the take-up reel sensor PS1 and/or the end sensor Q3 by replacement

### Display faults

If the display unit FDP1 produces odd effects, for example loss of a segment, a dim display or the display keeps varying, carry out checks around the display-driver chip IC1 (type UPD16311GCK) before condemning FDP1. There should be a 5.2V supply at pins 33 and 45 of IC1, and a -28.5V supply at pin 34. If the 5.2V supply is missing or low, check back to source. If the -28.5V is incorrect, check the condition of R32 (47Ω) in the chopper power supply and C34 (22μF, 50V) for high ESR. A high ESR reading usually means that C34 is low in value.

If the supplies to IC1 are correct, check for dry-joints at FDP1 and IC1. If everything is in order in this respect, check FDP1 by replacement.

### Remote-control faults

If there is no remote-control operation, the first step is to establish whether the handset or the infra-red receiver is faulty. A remote-control unit tester will check whether the handset is producing an output, but not whether the output is correct to change channels, volume etc. If there's intermittent operation or only some channels work, the cause could be poor batteries or bad battery contacts.

If the handset appears to be working, check for dry-joints at all three connections to the infra-red receiver IC2 (type GPIU581X). There should be a 5.2V supply at pin 2 of IC2. If this voltage is missing, check for dry-joints at plug/socket CN1. If the voltage is OK, use an oscilloscope to check that IC2 is producing a pulse output at pin 1, and that this is reaching pin 50 of the syscon chip IC601 (type HD6433926A13F). If pulses are present here, replace IC601. ■

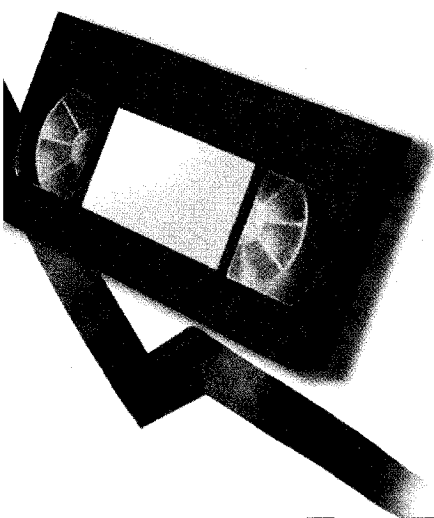

## VCR CLINIC

Reports from  
**Eugene Trundle**  
**Bob Flynn**  
**Martin McCluskey**  
**J.S. Ogilvie**  
and  
**John Coombes**

We welcome fault reports from readers – payment for each fault is made after publication.

Reports can be sent by post to:

Television Magazine Fault Reports,  
Highbury Business,  
Media House,  
Azalea Drive, Swanley, Kent BR8 8HU

or e-mailed to:  
t.winford@highburybiz.com

### Panasonic NV-FJ620

Playback was erratic because readout of the control-track pulses was being upset by crinkling along the lower edge of the tape. The cause was a faulty pinch roller. We often get the problem with the deck used in this and contemporary Panasonic VHS VCRs, and now keep the part in stock. **E.T.**

### Hitachi VTFX940E (later Philips Turbo deck)

Cassettes were ejected with a small loop of tape hanging out. The brakes were OK, and wind and rewind were faultless. The only clues were a jerky tape movement at the start of rewind, before it went to high speed, and a faltering take-up spool movement in play. The cure was to replace the clutch (item 115). **B.F.**

### Sony SLV-SE20UX (S mechanism)

This machine would either refuse to accept a cassette or, when asked to eject it, would do so and then take it back in again. When a cassette was in the VCR, all the other functions seemed to be OK. The cure was to replace the centre LED for the two end-sensors. **B.F.**

### Philips 14PV170 (Turbo deck)

Although the power LED went to green, this TV/VCR combi unit would not power up except for the loading motor trying to eject a non-existent cassette – even though the mechanics were in a fully-ejected state. Various things were tried with no result. In desperation I replaced the complete mechanism, but the situation remained the same.

With only the main board under the deck to check, I carried out a visual inspection and found some corrosion under C2802, which is an 0.22 $\mu$ F memory back-up capacitor. The two tracks that run between its legs were then found to be open-circuit. Repairing them cured the problem. **B.F.**

### Sanyo VHRH900

This expensive (by today's standards) up-market VCR, with picture-in-picture, came in dead. There were no functions and no clock display. Checks showed that the power supply was running, but the +5V output was very low. The cure was to replace the relevant reservoir capacitor, C5101 (1,000 $\mu$ F, 16). **M.McC.**

### Samsung TI205C-DF

A problem you can get with these TV/VCR combi units is interference dashes on the playback picture. The cause is poor connection between a metal earthing 'spring' and the VCR deck plate. The best solution is to bypass this arrangement by soldering one end of a piece of wire to the 'spring' and

securing the other end to the deck with a screw. Some Samsung VCRs suffer from the same problem.

Be careful, when working on the combi units, not to plug the pink and blue cables into the wrong positions on the TV PCB. **M.McC.**

### JVC HRD455EK

This elderly machine was in showroom condition, but the playback picture consisted of distorted video with poor sync. In addition there was a hum bar on EE pictures. I removed the sub-panel with the mains transformer and DC regulator and used a digital meter set to AC voltage to check the various smoothing capacitors. There was over 3V of ripple across C23. Replacement of this 2,200 $\mu$ F, 16V electrolytic capacitor cured the problems. **M.McC.**

### Toshiba V856B

There was very bad interference on the playback picture. It wasn't so bad when I took the top cover off, so I checked all the earthing on the deck. This was OK. The cause of the trouble eventually turned out to be CP051 (1 $\mu$ F, 50V) in the power supply – a replacement cleared the interference. **J.S.O.**

### JVC HRS7000EK

This machine was dead following a power cut. So the obvious thing to check was the capacitors in the power supply. I found that C2 (2.2 $\mu$ F, 50V) was open-circuit. C59 and C60 were also open-circuit. The machine came to life once three new capacitors had been fitted. **J.S.O.**

### Panasonic NVSD200

If the mechanism ticks when in the playback mode, replace the capstan flywheel (part no. VXP1519) and check and regrease the capstan motor. If this doesn't clear the problem, check the tension roller unit (part no. VXA4799) for wear. **J.C.**

### Philips VR765

This VCR was dead. All the obvious things, like fuses and capacitors, were checked without any faults being found. The cause of the trouble turned out to be diode D6156 (type BYW98-200) which was short-circuit. **J.C.**

### Panasonic NVSD200

There was low audio in the EE mode. The cause can be difficult to trace but is usually in the vision IF unit. Check for dry-joints at capacitor CO729. **J.C.**

### Panasonic NVSD220

There was a warble on the audio. The cure was to replace C1, C2, C23 (all 22 $\mu$ F), C6 (47 $\mu$ F) and C22 (220 $\mu$ F). **J.C.**

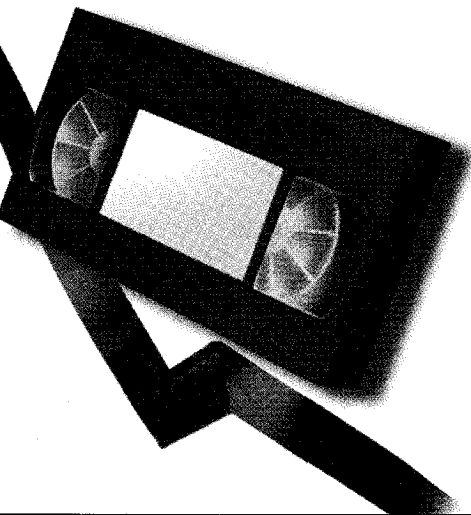

### **Parasonic NV-FJ620B (Z mechanism)**

There were dozens of mistracking lines on the off-tape pictures. On investigation I saw that at lace-up the loading arms didn't push the tape guides fully home. Two teeth had sheared off the inner pinion of the take-up loading arm assembly. It's item 43 in the exploded diagram in the manual, and is part no. VXL2670. I believe the cause of the trouble was that the assembly had not been tight on its shaft. **E.T.**

### **Toshiba V711UK (DX9R chassis)**

The cassette would go down but, after some spinning of motors, it would be ejected. The cause was the take-up loading arm, which consists of a plastic arm (item B500) and a metal arm (item B501). The metal arm had broken loose from the loading arm and the pole base because of a broken clip on the plastic arm. To replace item B500 is easy, as alignment is clearly marked.

The design of both tape arms differs from that in earlier models such as the V229B and V709B. **B.F.**

### **Sanyo VHR-H792E**

A cassette was jammed in this VCR because a large amount of tape was stuck to the wrong side of the video head drum. After removing the cassette I tested the machine and found that during rewind or wind, which is very fast, it would suddenly jerk or stop and throw tape into the deck. The cause was the lever that moves the clutch up and down for different speeds. It had come adrift because of a broken clasp.

This VCR is of GoldStar manufacture and is the same mechanically as the **LG Model LV713**. Order the lever (item 060) using part no. 4510R-0040A. **B.F.**

### **LG S909NI**

This machine appeared to be dead although there were some voltages on the secondary side of the power supply. I decided to carry out electrolytic capacitor checks with my ESR meter and found that CP12 (1,000 $\mu$ F, 16V) produced a high reading. A replacement brought the machine back to life. **R.B.**

### **Goodmans TVC146TWS**

This VCR/TV combi unit was dead though the green LED lit up. It has two separate power supplies, a standby one that was working and the main one which was producing very low outputs. It's based on an STRS5707 chopper chip, IC1801. A replacement cured the fault. **R.B.**

### **Toshiba SD22VB**

"Cassette won't eject" was the complaint with this combined VCR/DVD player. In fact the carriage and videocassette could be lifted up to the eject position without turning the mechanism, because a piece of plas-

tic had broken from the right-hand carriage loading arm. The part is called "loading arm cassette housing" and is available from Charles Hyde and Son under the code no. ALB1448. **M.McC.**

### **Goodmans SD1600**

When a cassette was inserted the E-E picture muted and the tape was played back with the drum and capstan speeds way out. Heat and freezer treatment revealed that the cause of the trouble was C802 (47 $\mu$ F, 16V), which is on the regulator panel. Once a new capacitor had been fitted this elderly VCR produced first-class results. **M.McC.**

### **Aiwa HVGX935K**

This machine was dead with a tape stuck inside. I removed the deck carefully, loosening the carriage to get at the deck-fixing screws underneath the trapped cassette, and carried out some checks on the main circuit board. The power supply was running, but there was no +5V output at the cathode of rectifier diode D106 because the reservoir capacitor C116 (1,000 $\mu$ F, 16V) was open-circuit. A replacement capacitor restored normal operation. **M.McC.**

### **JVC HRJ420**

This machine would accept a cassette then, after a few seconds, eject it. The cassette-down microswitch is on a little sub-panel and is operated by a white plastic 'plunger' on the carriage. The bottom part of this plunger is made of very thin, flexible plastic, and this had broken away completely. If a complete new carriage had been required the repair would have been uneconomical (from the customer's point of view anyway). But the rest of the machine appeared to be in showroom condition, so I decided to have a go at repairing the broken part.

Two large blocks of thick foam rubber material are stuck to the screening cans. I cut away a small square, 7mm thick, and glued it to the underside of the plunger (see Fig. 1). This provided a complete cure and, six months later, the machine has not been back to me again. **M.McC.**

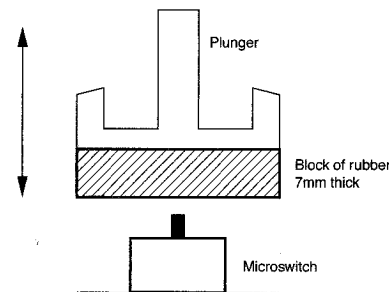

**Fig. 1: Repair to the carriage-down microswitch operating system in the JVC HRJ420.**

## **VCR CLINIC**

**Reports from  
Eugene Trundle  
Bob Flynn  
Roy Blaber  
and  
Martin McCluskey**

**We welcome fault reports from readers – payment for each fault is made after publication.**

**Reports can be sent by post to:**

**Television Magazine Fault Reports,  
Highbury Business,  
Media House,  
Azalea Drive, Swanley, Kent BR8 8HU**

**or e-mailed to:  
t.winford@highburybiz.com**

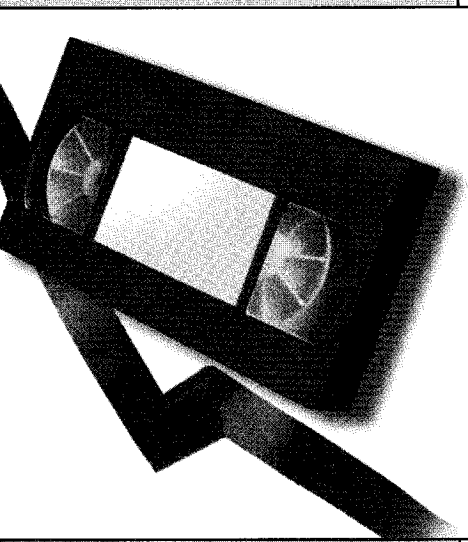

## VCR CLINIC

Reports from  
**Eugene Trundle**  
**Nick Beer**  
**Martin McCluskey**  
**Chris Bowers**  
**Bob Flynn**  
**Roy Blaber**  
**and**  
**Alan Stubbins**

We welcome fault reports from readers  
– payment for each fault is made after  
publication.

Reports can be sent by post to:

Television Magazine Fault Reports,  
Nexus Media Communications,  
Media House,  
Azalea Drive, Swanley, Kent BR8 8HU

or e-mailed to:  
t.winford@highburybiz.com

### JVC HRJ670

There was a horrific set of symptoms with this machine: intermittent operation; erratic deck functions; the display spasmodically flashing and producing random indications; vertical white lines superimposed on the output picture; and so on. The cause of the trouble was in the power supply, where the mains bridge rectifier's reservoir capacitor C5006 (68 $\mu$ F, 400V) was open-circuit. **E.T.**

### B&O VX4500

The customer said that this machine "wouldn't record". In fact there was no real E-E video – there was clearly no sync, so the vision looked negative. The fault was obviously thermal, so I decided to check the electrolytic capacitors in the tuner-video path. When I scoped the output at pin 16 of the IF unit I could see that there was trouble here. By now the symptom had changed to weak field sync.

The cause of the trouble was C14 (1 $\mu$ F, 50V), which is inside the IF pack. I replaced all the electrolytics in the pack to make a reliable job of it. Normally the IF pack is considered to be a replacement item. **N.B.**

### Philips 14VP162

If the audio output from one of these TV/VCR combi units cannot be turned above a certain level it's probably in the hotel mode. Select ch. 38 then press 'stop' on the front panel and on the remote-control unit simultaneously. This toggles the hotel mode on and off. H+ on the screen in on, H- is off. **M.McC.**

### Goodmans TVC142C/Daewoo DVT14F6P

This TV/VCR combi unit was dead apart from a clicking from one of the relays on the separate power/line output panel. I had no circuit diagram, but found that the Ever 6V supply was present and correct at one of the power board's plug connectors. As the standby LED was out, investigation turned to the main VCR board. A piece of print near the microcontroller chip was labelled E5-3V, but a meter check here produced a 0V reading. When I followed the track back I came to a small diode that's marked on the print as a link, J155. It reduces the Ever 6V supply to E5-3V, and was open-circuit. A replacement (1N4148) restored normal operation. **M.McC.**

### Sony SLV-SE820G

The symptoms with this machine were no fluorescent display, erratic operation of the panel buttons, no sound, and a just suggestion of pictures. The cure was as follows. Replace the 100-pin servo/system control chip IC601 and the EEPROM chip IC605, then carry out option settings for the EEPROM. To do this, obtain the adjustment

mode by pressing and holding for five seconds the record button on the VCR and the menu button on the remote-control unit. Numbers 1-72 appear.

Select each number for this model, using the remote-control unit's FF, REW, pause and stop buttons. Turn the required numbers black with the RC unit's select button. The numbers to select, with the SE820G, are 3-15 inclusive, 19, 23, 27, 29, 32, 33, 34, 35, 40, 41, 45, 47, 48, 49, 50, 60, 61, 63, 64, 69 and 72. When the numbers have been selected, press the RC unit's menu button. The VCR's RF output switches to ch. 21, then OK.

Also set the tracking, using the RC unit's test and 5 buttons; and the head switching, using the RC unit's test and SP/LP buttons.

### Sony SLV-SE730G

A tape, which was the wrong way round, was stuck in this unit's flap. When I checked inside I found that a slight press on the carriage mechanism's lower bar would release the tape. It could then be pushed back through the front, allowing normal operation of the machine. **C.B.**

### JVC HRJ670 (1998 deck)

Heavier tapes, i.e. three- and four-hour ones, would go in crooked, with the right-hand side not going down properly. The cause was not the cassette holder but its metal drive arm (item 211 in the manual). **B.F.**

### Panasonic NVFJ625

There was no rewind/fast forward and the tape looped out of the cassette when ejected. I tried cleaning the mode switch, which didn't help, then suspected the capstan motor. When I inspected its PCB closely I found several dry-joints. Once these had been dealt with and the machine had been reassembled it worked fine. **R.B.**

### Sony SL-C30 etc

The customer said this Betamax machine had shut down after being in operation for about an hour. There was a repeat performance the following day, with the tape snagging on eject.

When I had the machine on the bench I noticed that there was tape bunching between the capstan and the take-up spool, indicating inadequate take-up torque. The cause of this fault is the temperature-compensation thermistor TH304 on servo board SS16, beneath the modulator. Unfortunately this item is no longer available. Stable and reliable operation can however be achieved by replacing it with a 5-1k $\Omega$  metal-film resistor and resetting the torque control RV309 for optimum results.

I've also had this fault with Models SL-C20, SL-C40, SL-HF100 and SL-HF950, but not with Models SLF30 and SLF60 in which the thermistor is omitted. **A.S.**

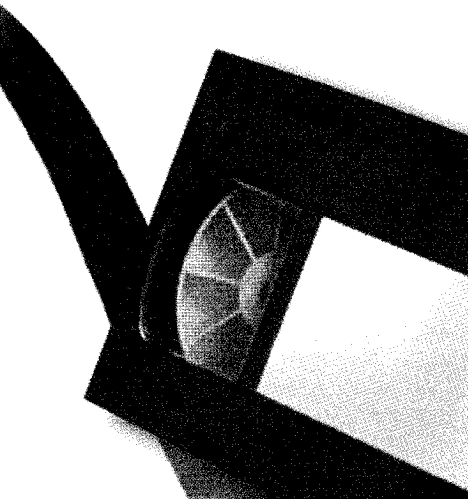

## VCR CLINIC

Reports from  
Brian Battams  
and  
Peter Graves

We welcome fault reports from readers  
— payment for each fault is made after  
publication.

Reports can be sent by post to:

Television Magazine Fault Reports,  
Nexus Media Communications,  
Media House,  
Azalea Drive, Swanley, Kent BR8 8HU

or e-mailed to:  
TVeditor@nexusmedia.com

### JVC HRA230

This machine was brought in for repair after the customer complained that a power surge had destroyed his beloved video recorder. Checks revealed that the only faulty item was a low-value capacitor in the power supply, C906 (2.2 $\mu$ F, 50V). All was well once a replacement had been fitted. **B.B.**

### Daewoo V60

This VCR was dead. When I opened it up I found a Sony SOPS-2021 power supply. Checks inside this unit revealed that C53 (1 $\mu$ F, 100V) was open-circuit. Replacement of this electrolytic capacitor brought the machine back to life. **P.G.**

### Sony SLV725

"Machine cuts out and shows 20,01 or 30.01" said my friend, who owns this VCR. These are error codes that are supposed to tell you what was happening at the time of failure. 20 means that the machine was recording while 30 tells you that it was playing back. So far so good. The 01 part indicates that the take-up reel has stopped. So, assuming that tape take-up had stopped during play and record, a full mechanical service seemed reasonable. Service kits appear to be thin on the ground these days, so the likely troublemakers were ordered individually.

My friend and I have a thing about electrolytic capacitors. He insisted that every one in the power supply be replaced, which is not a bad idea at this stage in the life of one of these VCRs. After doing this I fitted a nice new chassis block assembly and idler-arm pendulum, along with a back-tension band and pinch roller. By request, and against my own judgement, also a new head-cleaning roller. A new timing belt was fitted on the underside. The lot was then reassembled and tested.

It's a good thing I was doing it for a friend as, five minutes after he arrived home with it, he phoned with the good news: "it's still doing it".

"But I tested it all evening!"

He brought it back and we both watched *Toy Story* without interruption — twice!

Five minutes after he got it home again he phoned. "It's done it again!"

"What code are you getting?" I asked. "30.01."

"But everything to do with the take up has been changed!"

My friend works with computers for a living, so I was happy to let him perform the next step. While he was still on the phone he opened the machine and stared at the mechanism until it failed. Within a minute or so I heard the thing cut out. "There, 30.01" he said.

"Are there any loops of tape hanging out on the take-up side?" I asked.

"No" he replied.

The penny then dropped, or so I thought. "It's all done with mirrors" I said, "bring it back."

After removing most of the new bits previously fitted and a few more I had access to the take-up and feed gears, which have alternating mirrored and black segments on the underside. The purpose of these, as we all know, is to reflect light back to the sensor when it hits a mirror-part of the gear and not when it hits a black part. Pulses are thus created, and the machine knows that the take-up reel is rotating. Cleaning the mirror sections while carefully avoiding the black areas (which can clean up a bit too well) produced good reflections once more.

I put it all together again and we watched another video. My friend then took the machine home.

Three minutes later, "it's still doing it!" "Any loops of tape hanging?"

"No, but I'll watch it more carefully this time." One minute later he reported that there seemed to be a knocking sound. Then "30.01 again!"

He tried once more and noticed that a moment before the error code appeared the motor stopped.

"It must be the motor" I said, "there's virtually nothing else left!"

"Couldn't it be anything else?" he asked, with the intonation of a man who was open to any suggestion as long as it didn't involve a faulty motor.

"It might, but we've done the power supply and been through every mechanical part by now. That leaves only the motor, the drive chip or the bearing."

"If we change the bearing, it might stop the knocking at least!" he said, quite reasonably.

"Well, as the whole lot now comes as a as a motor assembly it doesn't really make much difference" I replied.

He tried again, and reluctantly concluded that the knocking was indeed coming from the motor, as touching the top of the bearing stopped it. The trouble was that the motor would stop completely without provocation, and we had now established that this definitely happened a split second before the error code was generated.

So in went a new motor. The knocking had then gone. My friend took the machine away, and it hasn't cut out or produced any error codes since. How come a faulty motor produces error codes that say "take-up failure during play or record"? Who cares anyway? The machine now works!

"Why repair this oldie when a supermarket model can be obtained for less than the cost of the parts required?" I hear someone asking. Well, this VCR has manual audio-level record controls. For those who really care, this is an important facility to have.

**P.G.**