

NELSON HEAT TRACE



NELSON™ CM-2201/CM-2202 HEAT TRACE CONTROLLERS Installation and Operating Instructions

1.0	Introduction	4
	1.1 Getting Started	
2.0	General Application Information	4
3.0	Installation	5
	3.1 Selecting Installation Location	
	3.2 Mounting	
	3.3 Wiring	
4.0	Initial Set-up	5
	4.1 Display Modes	
	4.2 Password Protection	
	4.3 Security Levels	
5.0	General Operation	6
	5.1 Display	
	5.2 Keypad	
	5.3 LED Functions	
	5.4 Monitoring	
	5.5 Alarm Management	
	5.6 Current-Limiting Feature	
	5.7 Ground Faults	
	5.8 Soft Start Feature	
6.0	Control Modes	8
	6.1 On-Off Control	
	6.2 Proportional Control	
	6.3 Forced Control Feature	
7.0	Programming	9
	7.1 Setpoints	
	7.2 Heater Setup	
	7.3 System Setup	
8.0	Communications	15

9.0 Troubleshooting	16
9.1 Operator Checks	
9.2 Ground Faults	
9.3 RTDs	
9.4 Common Warnings/Alarms	
10.0 Maintenance	20
Appendix A – Specifications	21
Appendix B – Wiring Diagrams	22
Appendix C – Typical Installation Diagram	24
Appendix D – Mounting Details	25
Appendix E – Modbus Address List	26
Appendix F – ASCII Table	38
Appendix G – RTD Tables	39
Appendix H – Warranty	48

1.0 Introduction

The Nelson Heat Trace CM-2201 is designed to monitor and control one heating circuit in ordinary and Class I, Division 2, Class I, Zone 2, and Zone 2 hazardous locations.

The CM-2202 can monitor/control two heating circuits in those same locations.

This manual provides information pertaining to the installation, operation, testing, communications and maintenance of these controllers. See Appendix A for detailed specifications

1.1 Getting Started

The CM-2201/CM-2202 is typically connected to external RTDs, power or communication based on Appendix B and C. Detailed set-up of the operating/control/monitoring program is entered throughout the following sections.

For additional help, call Nelson technical support or follow the Troubleshooting section.

General Application Information

CM-2201/CM-2202

2.0 General Application Information

The CM-2201/CM-2202 are designed to operate on input voltages between 100 and 277 Vac and 50/60 Hz. Load switching is handled by a 2-Pole solid-state relay and can control resistive loads of 30A continuous @ 40°C ambient.

The CM-2201/CM-2202 are designed to control heating circuits by monitoring one or two temperature inputs for each circuit via industry standard 3-wire, 100Ω, Platinum RTDs. The two separate RTDs for each circuit may be utilized to customize the temperature control inputs. Several different modes are user selectable as well as the sensor failure operational mode.

The CM-2201 and CM-2202 can be operated in temperatures of -40°F to +104°F (-40°C to +40°C).

3.0 Installation

The CM-2201/CM-2202 must be installed only in areas for which it has been approved and in accordance with all applicable electrical codes and ordinances. All conduit entry holes must be appropriately installed and sealed to maintain ingress protection rating.

Do not install this unit prior to functional testing if shipping container or internal packaging shows signs of damage. Notify the appropriate individuals immediately if damage is suspected.

3.1 Selecting Installation Location

The CM-2201/CM-2202 should be installed in an area protected from the elements as much as possible. It is possible to install the unit in unprotected areas but such often limits maintenance/access. Further, installation in unprotected areas must be carefully considered to ensure it is always in operating conditions consistent with specifications. See Appendix A for additional details.

3.2 Mounting

The CM-2201/CM-2202 should be mounted at a convenient height to suit operator interaction.

(See Appendix D for mounting details.)

Conduit entries should be made in the bottom of the enclosure to prevent damage to the internal electronics from moisture intrusion. Conduit entries should be drilled and the use of suitable bushings is required to maintain the environmental ratings.

3.3 Wiring

Electrical wiring diagrams and schematics are provided in Appendix B and C of this manual. Ensure that all wiring and connections are in accordance with applicable wiring codes. Enclosure grounding must be in accordance with applicable wiring codes for non-metallic devices.

The power supply for the CM-2201 is derived from the power provided for the load. However, the power supply for the CM-2202 can be provided independent of the power supply for the loads being controlled. For example, the power supply for the CM-2202 can be 120 VAC while the loads being controlled can be 277 VAC. Further, the power supply for the CM-2202 may also be derived from either of the loads being controlled – this is implemented by connecting appropriate jumpers.

4.0 Initial Set-Up

Upon initial power-up, the CM-2201/CM-2202 display will run self-check, display the software version and then start the main program. Default settings are set to disable heating cables, (See 7.0 Programming to enable heaters and program set points.)

4.1 Display Modes

This feature determines what messages and functions are displayed during normal operations. If set to “normal user,” only basic information is displayed. If set to “advanced user,” all controller information is displayed. Each parameter shown in this manual will list the Display Mode required to view information and access each function during programming.

4.2 Password Protection

The CM-2201/CM-2202 may have password protection enabled to ensure that sensitive operating parameters are not inadvertently adjusted. If password protection is enabled, the user will be prompted to enter a valid value to access any protected features. The user may also replace the default password value (1234) with their own unique value for greater protection of operational parameters.

4.3 Security Levels

CM-2201/CM-2202 has two levels of security. The high level (Advanced Display) requires password protection. Disabling the password from the Password Enable/Disable menu will keep the password disabled indefinitely – any parameter can be changed without the use of a password. At this level all the functions and monitoring parameters are open.

The low level (Normal Level) does not give access to parameters settings, but certain parameters (such as temperature, current, GFI, etc.) are open for monitoring. If the password is “Enabled”, going directly to the parameter to be changed, and pressing the ‘up’ or ‘down’ arrow, will cause the controller to ask for the password. If correctly entered then the parameter can be changed and saved. The password will stay disabled for 15 min, then be automatically re-enabled. When disabled the password does not need to be entered to change and save parameters.

5.1 Display

The CM-2201/CM-2202 utilizes a 2-line x 16-character alphanumeric display viewable from the front keypad. The top line is reserved for the function or operation and the bottom line displays the value range.

5.1.1 Navigation for CM2201

The CM2201 monitors one heating circuit consisting of load (typically a heating cable) and controls the load based on the temperature of the item being heated (typically a pipe) as provided via one or two RTD's attached to the pipe and connected to the controller. To monitor the load, press **Actual** until "Operating Values" is displayed, then press **Right** or **Left** arrow to scroll through the various values. To review the statistics that have been collected, press **Actual** until "Statistics" is displayed then press **Right** or **Left** arrow to scroll through the various statistics.

To change the control and monitoring settings (including alarm settings), press the **Program** key and then **Right** or **Left** arrow to scroll through the various settings. Any setting can be altered by pressing the **Up** or **Down** arrow. Note that a 4-digit password may be required to change certain settings – when required, the cursor will flash on the leftmost digit – use the **Up** arrow to increase this digit value or the **Down** arrow to decrease it. Move the cursor to the second leftmost digit using the **Right** or **Left** arrow and it will flash until adjusted using **Up/Down** arrows. When the last digit has been selected, press **Enter** and then changes will be allowed to the setting. Once the setting is adjusted, press the **Enter** key to store it.

To view alarms, press the **Alarms** key and then **Right** or **Left** arrow to scroll through the various alarms. Alarms that are not active can be erased by pressing the **Reset** key.

5.1.2 Navigation for CM2202

The CM2202 can monitor/control two separate heating circuits (channels). The controller defaults to Channel 1 upon first start-up. All parameters for Channel 1 can be displayed and modified using standard techniques as described for the CM2201 in Section 5.2.1.

To change to Channel 2, simply press the "Actual" key and then Right arrow – the active channel will be displayed. To change the channel, press the Up arrow.

In general, when the active channel is displayed (e.g. "CH.2"), the channel can be changed by pressing the Up or Down arrow.

5.2 Keypad

The keypad is “capacitive” touch sensitive and keys are activated by simply touching the area of the desired key with a finger, even when wearing gloves. Note that a stylus or other item used to touch the keypad will usually not activate the keys.

5.4 LED Functions

LED indicators will show the status of the respective functions. The power LED will be illuminated when the controller is connected to a source voltage. The heater LED will be illuminated when voltage is applied to any heater. The system LED will illuminate if there is an internal hardware issue with the controller. The comm LED will illuminate when the controller is sending data through external communication. The alarm LED will flash when there is a current active alarm condition or any circuit; the alarm LED will illuminate solid when an alarm was previously present but is not currently active.

5.5 Monitoring

By touching the “**Actual**” button follow the arrow and the controller will scroll through all the active parameters.

5.6 Alarm Management

All alarm(s) will be saved in the alarm log. If no alarms are active (alarm LED solid red) the Alarm LED can be turned off by touching “Reset” once for every alarm that previously occurred. If any alarm is active (alarm LED flashing red) the user cannot reset the alarm. The two alarm relays are SSR type. To set the contacts of the relays go to Settings – Heater Setup – Alarm contact. By choosing up/down arrow, the contacts can be selected to function as Normally Open or Normally Closed. Press “Enter” to save the selection. (See 7.2.12 for further information on the Alarm contacts setting).

Power-Limiting Feature

The Power-Limiting feature operates similarly to the Soft-Start in that it restricts the amount of time the cable is energized during any given period thereby reducing the average current draw of the cable during that period.

For example, if a cable normally draws 8 Amps, but current limit is set to 6 Amps, then the cable would be energized only 75% of the time.

5.7 Ground Faults

Ground faults typically are the result of damaged or improperly installed cables which allow current-carrying conductors/ surfaces/parts to be in contact with grounded objects.

For example, if a heating cable has been secured to a pipe with a clamp, and if the clamp has been overtightened, then the ground braid and/or the pipe may come in contact with current carrying parts within the cable. This would result in current leakage to ground through the ground braid of the cable and/or the pipe itself. This type of fault can eventually become serious, resulting in overheating/fire/shock hazards. Current leakage to ground can be monitored by electronic circuitry and the SPC/DPC can be programmed to either alarm or trip when leakage current exceeds the specified maximum allowable amount.

5.9 Soft-Start Feature

The Soft-Start feature enables self-regulating cables to be energized at low temperatures without causing excessive load on the electrical system and extending cable life by reducing cable internal heating due to inrush currents. The resistance of self-regulating cables decreases as the cables get colder, which results in higher current and can result in breaker trips if temperatures are very cold and the installed length of cable is long. The Soft-Start feature operates by initially only energizing the cable for a very short period of time – while the current draw may be high during this period, the period is usually short enough to reduce average load on the electrical system.

This short energization period is repeated and eventually increased; after a few minutes, the cable is usually warm enough such that the resistance has increased and the current decreased to the point where it can be continuously energized.

6.0 Control Modes

The CM-2201/CM-2202 allows the user to select different control modes based on their individual process control parameters.

6.1 On-Off Control

This control method simply energizes the cable until the actual monitored temperature rises to the setpoint value plus half the deadband value (upper limit). The cable is then de-energized until the actual monitored temperature drops to the setpoint value minus half the deadband value. Note that this type of control can result in some temperature "overshoot;" this is because the cable is de-energized when the monitored temperature reaches the upper limit. However, the residual heat in the cable continues to transfer to the pipe, and this will cause the pipe temperature to increase slightly above the upper limit. Similarly, there can be some temperature "undershoot."

6.2 Proportional Control

This control method uses the typical proportional control algorithm wherein the cable is cycled on and off at a rate proportional to the difference between the setpoint value and the actual monitored temperature. As the difference between the setpoint value and the actual monitored temperature increases, the amount of time the cable is energized increases proportionately. This helps reduce the "overshoot" and "undershoot" commonly associated with On/Off control.

6.4 Forced Control Feature

This control method simply allows the user to force the cable on or off as desired using an external signal (e.g. +5 VDC or 24 VAC) applied to the IN and G terminals or an external dry contact across the +5V and IN terminals. The External Disable must be set to "ON" to allow for external control, at which point the controller operates as follows:

- A) If the Temperature setpoint is "OFF" or "None", then the heater gets energized by applying the external signal or closing the external contact.
- B) If the Temperature setpoint is a specific value (ex. 55C), then the setpoint will be maintained as per normal operation ONLY when the external signal is present, or the external contact is closed – otherwise, the heater will be disabled.

7.1 Program-Setpoints

7.1.1 Setpoint Value

This message displays the name of the sub-menu when entered.

1. Display Mode: All
2. Range: N/A
3. Default: N/A

7.1.2 Maintain Temp

This value sets the control setpoint temperature for all operating modes. For On-Off control, the circuit is energized if the control temperature is less than the maintain temperature minus the deadband. The circuit is de-energized if the control temperature is greater than the maintain temperature plus the deadband. If maintain temp is set to None then the heater circuit will have temperature monitoring with no control temperature. If the maintain temp is set to Off then the heater circuit will have no temperature monitoring or control.

1. Display Mode: All
2. Range: -50 to 500°C, none or -58°F to 932°F, none, Off
3. Default: 10° or 50°F

7.1.3 Low Temp Alarm

This value sets the Low Temperature Alarm setpoint. It must be less than the maintain temperature minus the Deadband. To disable this alarm set the value to "Off". When the measured temperature of either RTDA or RTD B (if activated) is less than or equal to this setpoint, the Low Temperature Alarm is activated and a "LOW TEMP ALARM" message is added to the alarm stack. This alarm deactivates when the temperature rises above the alarm setpoint value.

1. Display Mode: All
2. Range: -50C to Maintain Temperature, Off, -58°F to Maintain Temperature, Off
3. Default: 5°C or 41°F
4. Restrictions: Message does not exist if Maintain Temperature is set to Off.

7.1.4 High Temp Alarm

This value sets the High Temperature Alarm setpoint. It must be greater than the maintain temperature plus deadband. To disable this alarm set the value to "Off"

When the measured temperature of either RTDA or RTD B (if activated) is greater than or equal to this setpoint, the High Temperature Alarm is activated and a "HIGH TEMP ALARM" message is added to the alarm stack. The alarm deactivates when the temperature falls below this alarm setpoint.

1. Display Mode: All
2. Range: Maintain Temperature to +500°C, Off, Maintain Temperature to +932°F, Off
3. Default: Off
4. Restrictions: Message does not exist if Maintain Temperature is set to Off.

7.1.5 Low Current Alarm

This value sets the Low Current Alarm setpoint. It must be less than the high current alarm setpoint. To disable this alarm set the value to "Off". When the heater current is less than or equal to this setpoint, the Low Current Alarm is activated and a "LOW CURRENT ALARM" message is added to the alarm stack. The alarm deactivates when the Heater Current rises above this alarm setpoint. Note: This setpoint is based on the heater at 100% power. If Proportional Control or Current Limiting is enabled, all current measurements will be scaled to 100% power, based on a constant resistive load, before being compared to the alarm setpoint.

1. Display Mode: All
2. Range: 0.1A to High Current Alarm value, Off
3. Default: Off

7.1.6 High Current Alarm

This value sets the High Current Alarm setpoint. It must be greater than the low current alarm setpoint. To disable this alarm set the value to "Off". When the heater current is greater than or equal to this setpoint, the High Current Alarm is activated and a "HIGH CURRENT ALARM" message is added to the alarm stack. The alarm deactivates when the heater current falls below this alarm setpoint. This setpoint is based on the heater at 100% power.

If Proportional Control or Current Limiting is enabled, all current measurements will be scaled to 100% power, based on a constant resistive load, before being compared to the alarm setpoint.

1. Display Mode: All
2. Range: Low Current Alarm value to 30.0A, Off
3. Default: Off

7.1.7 Ground Fault Alarm

This value sets the Ground Fault Alarm setpoint. It must be less than the ground fault trip setpoint. To disable this alarm set the value to "Off". When the Ground Fault Current is greater than or equal to this setpoint, the Ground Fault Alarm is activated and a "GROUND FAULT ALARM" message is added to the alarm stack. The alarm deactivates when the Ground Fault Current falls below this alarm setpoint.

1. Display Mode: All
2. Range: 10 to Ground Fault Trip, Off
3. Default: 30mA

7.1.8 Ground Fault Trip

This value sets the Ground Fault Trip setpoint. It must be greater than the ground fault alarm setpoint. To disable this trip alarm set the value to "Off". When the Ground Fault Current is greater than or equal to this setpoint, the heater circuit is de-energized, the Ground Fault Trip Alarm is activated and a "GROUND FAULT TRIP" message is added to the alarm stack. This is a latching alarm and trip. When the cause of the alarm has been corrected, the circuit may be energized by the manual reset function.

1. Display Mode: All
2. Range: Ground Fault Alarm to 500mA, Off
3. Default: 50mA

7.1.9 Low Voltage Alarm

This value sets the Low Voltage Alarm setpoint. It must be less than the high voltage alarm setpoint. To disable this alarm set the value to "Off". When the Line Voltage is less than or equal to this setpoint, the Low Voltage Alarm is activated and a "LOW VOLTAGE ALARM" message is added to the alarm stack. The alarm deactivates when the Line Voltage rises above this alarm setpoint.

Low Voltage Alarm Continued

1. Display Mode: All
2. Range: 85VAC to High Voltage Alarm, Off
3. Default: Off

7.1.10 High Voltage Alarm

This value sets the High Voltage Alarm setpoint. It must be greater than the Low Voltage Alarm setpoint. To disable this alarm set the value to "Off". When the Heater Voltage is greater than or equal to this setpoint, the High Voltage Alarm is activated and a "HIGH VOLTAGE ALARM" Message is added to the alarm stack messages. The alarm deactivates when the Heater Voltage drops below this alarm setpoint.

1. Display Mode: All
2. Range: Low Voltage Alarm to 280VAC, Off
3. Default: Off

7.2 Program-Heater Setup

7.2.1 Heater Setup

This message displays the name of the sub-menu when entered.

1. Display Mode: Advanced
2. Range: N/A
3. Default: N/A

7.2.2 Heater Enable

This selection enables control and monitoring of the heater circuit. Setpoints and measured value messages cannot be accessed unless the heater is enabled. Select "No" if the circuit is not used.

1. Display Mode: All
2. Range: Yes, No
3. Default: No

7.2.3 Heater ID

This selection allows for user defined Heater Identification. It provides a unique, identifiable tag or label for each heater circuit. The Heater Name allows up to 16 alphanumeric characters which are entered one at a time from left to right. The cursor indicates which character is being selected. Press the [SELECT UP/DOWN] arrow keys to change the character. Move to the next character by pressing [NEXT] arrow. Press [ENTER] in the last character position to save the Heater ID.

1. DisplayMode: Advanced
2. Range: 16 Characters (CM-2201)
12 Characters (CM-2202)
3. Default: Blank

7.2.4 Heater Type

This selection allows the user to set which type of heating cable is being used. Self regulating heating cable should not be used with proportional control, soft-start mode, or Power limiting; for this reason these options are unavailable when heater type is set to self regulating. When heater type is set to fixed resistance all control options are available. DisplayMode: Advanced

1. DisplayMode: Advanced
2. Range: Self Regulating, Fixed Resistance
3. Default: Fixed Resistance

7.2.5 External Disable

This selection sets the response of the heater circuit to the Override inputs. The Override inputs respond to contact closure. If the Override is set to "Disable", the override inputs are ignored, and control of the heater circuit operates normally based on the measured temperature and maintain temperature setpoint. If the Override is set to "Enable", an open contact on the override inputs forces the heater Off. When the contact on the override input is closed, the heater control resumes in normal manner.

1. DisplayMode: Advanced
2. Range: Enable, Disable
3. Default: Disable

7.2.6 Deadband

The Deadband is defined as the difference between the set point temperature and the actual maximum temperature that is ideally allowed in excess of the setpoint temperature. Decreasing the deadband increases the temperature control accuracy but also increases the heater switching frequency.

1. DisplayMode: Advanced
2. Range: 1C° to 5C°, 1F° to 10F°
3. Default: 2C° or 5F°
4. Note: Deadband is disabled for Proportional Control mode.

7.2.7 Control Type

This selection determines the type of control method used by the controller, either On-Off (Deadband) or Proportional Control. The On-Off control mode is available for all heating devices. Proportional Control mode is only available for series type heating devices.

1. DisplayMode: Advanced
2. Range: On-Off, Proportional
3. Default: On-Off
4. Selection does not exist if Heater type is set to Self regulating.
5. Selection does not exist if Maintain Temperature is set to Off.

7.2.8 Power Limit

This selection sets the maximum average current limit allowed for the heater circuit. It is useful for reducing the power output of fixed resistance heaters. The load will be turned on for a period of time and then turned off for a period of time to maintain the average current draw to the value set.

1. DisplayMode: Advanced
2. Range: 20% - 100%, Off
3. Default: Off
4. Note: The value range is in 10% increments.

7.2.9 Soft Start Mode

This function ramps the heater output from Off to nominal current of the heater over the set soft start cycle time. It is useful for reducing inrush currents of self-regulating heaters. At the end of the soft start cycle time, the load will no longer be controlled by the soft start function.

1. Display: Advanced
2. Range: 10 to 999 seconds, Off
3. Default: Off

7.2.10 RTD Operation

This selection determines how the control temperature is utilized by the RTD inputs.

- In One RTD Mode, the temperature is based on the measured temperature from RTD-A.
- In Backup Mode, control temperature is based on RTD-A. If for any reason RTD-A fails, then RTD-B takes over.
- In Average Mode, the control temperature is based on the average of RTD-A and RTD-B measured temperatures.
- In Lowest Mode, control temperature is based on the lowest of the two temperature measurements.
- In Highest Mode, control temperature is based on the highest of the two temperature measurements.
- In High Temperature Cut off Mode, control temperature is based on RTD-A, but if the temperature from RTD-B exceeds the high temperature alarm, the heater is turned Off and a high temperature alarm is activated. The High Temperature cut off mode will operate in one RTD mode if the high temperature alarm is turned Off.

Functions requiring two RTDs to operate, such as Average, Lowest, Highest and High Temperature Cut off, will operate in One RTD mode if one of the two RTDs fail.

1. Display Mode: Advanced
2. Range: One RTD, Backup, Average, Lowest, Highest, High Temperature Cut off
3. Default: One RTD

Restrictions: Message does not exist if Maintain Temperature is set to Off.

7.2.11 Auto Test Cycle

This value sets the frequency at which the Auto Test Cycle is activated. Auto Test is a feature that exercises the system by automatically applying power to the heater at specified time intervals. If an alarm condition is detected

during this period, the Auto Test Alarm is activated and an "ALARM DURING AUTO TEST" message is added to the System Status messages. This is a latching alarm. To clear the alarm, locate the alarm message in the Alarm menu and press [ENTER]. To disable this feature, set the value to "Off". The Auto Test Cycle does not operate if heater is forced off for any reason, including ground fault trip. Auto Test decreases maintenance by providing an early warning of problems that would otherwise go undetected until the heater was needed.

1. Display Mode: Advanced
2. Range: 1 to 720 hours, Off
3. Default: 24 hours

7.2.11 RTD Failure Mode

This selection sets the controller's fail-safe mode. The controller detects if RTD-A has failed and will use RTD-B if available. If RTD-B is not installed or has also failed, the heater will be set to its fail-safe state as selected in this mode. For freeze protection where there is no hazard from overheating, you may select "On" to operate the heater continuously and prevent freeze up. For processes where there is a potential hazard from overheating, you may select "Off", to de-energize the circuit until one of the RTD's becomes available.

1. Display Mode: Advanced
2. Range: On, Off
3. Default: Off

Restrictions: Message does not exist if Maintain Temperature is set to Off.

7.2.12 Alarm Contact

This selection sets the operating mode of the external alarm indicator. By setting the contacts to NC, these contacts will be open when there is no power applied to the unit (this can be useful for signaling loss of power to the unit) OR there is an active alarm OR there previously was an active alarm that has not been acknowledged.

The alarm contacts function as follows:

Position	NC	NO
Power Off	Open	Open
Power On	Closed	Open
Alarm	Open	Closed

1. Display Mode: Advanced
2. Range: Normally Open, Normally Closed
3. Default: Normally Open

7.3 Program–SystemSetup

7.3.1 System Setup

This message displays the name of the sub-menu when entered.

1. DisplayMode: Advanced
2. Range: N/A
3. Default: N/A

7.3.2 Password

This selection determines if password protection is required for programming changes. The display will show “disable” if program access is currently enabled and show “enable” if program access is currently disabled.

1. DisplayMode: All
2. Range: Enable or Disable
3. Default: Enable

7.3.3 Change Password

This selection allows the user to change the default password. The user is prompt to re-enter the old password, press [ENTER]. If correct, the user is prompt to enter the new password, press [ENTER]. The user is then prompt to re-enter the new password. If the user does not enter the new password and press [ENTER] then the password does not change.

1. DisplayMode: All
2. Range: Yes, No
3. Default: No

7.3.4 Units

This selection determines the unit of measure for temperature values. All temperatures are displayed in the selected units of either Celsius degrees (C°) or Fahrenheit degrees (F°).

1. DisplayMode: Advance
2. Range: Celsius, Fahrenheit
3. Default: Celsius

7.3.5 Operational Costs

This value sets the cost per kWh of electrical power. This is used to calculate energy costs for operating this control circuit.

1. DisplayMode: Advance
2. Range: \$0.01 to 1.00
3. Default: \$0.05

7.3.6 Display Mode

This selection determines what messages are displayed by the controller for operations personnel. If set to “advanced user”, all messages are displayed. If set to “normal user”, only the basic messages are displayed. Each message listed throughout this manual shows the Display Mode required to see the message. “Advanced only” indicates that the display mode must be set to “advanced user” to view the message.

1. DisplayMode: All
2. Range: Normal, Advance
3. Default: Advance

7.3.7 Default Display

This function specifies the information that will be displayed when no key has been pressed for the Display Timeout interval as described below.

1. Range: System Status, Heater Status, Heater Temp
2. Default: system status
3. Restrictions: Temperature messages are not displayed if Maintain Temperature is set to Off.

VALUE	INFORMATION DISPLAYED
System status	Alarm status of all the heaters
Heater status	Alarm status of the heater
Heater temp	Temperature of the heater

7.3.8 Display Timeout

This function sets the length of time from the last key press, to automatically return to the Default Display information. Selecting "Off" disables this function.

1. DisplayMode: Advance
2. Range: 5 to 600 seconds, Off
3. Default: 120seconds

7.3.9 Modbus Address

This selection sets a unique address to ensure only one CM- 2201 attempts communications with the master unit at any time. See Section 8.0 for complete information on Modbus communications.

1. DisplayMode: Advance
2. Range: 1 to 255 to accommodate multiple devices on same network.
3. Default: 1

7.3.10 Baud Rate

Sets the communication baud rate for the RS485 serial port. All controllers connected to the same data highway must operate on the same baud rate.

1. DisplayMode: Advance
2. Range: 2400, 4800, 9600, 19200
3. Default: 9600

7.3.11 Reset Module

This selection resets controller memory parameters to factory default values. If the controller's memory becomes corrupt, resetting the module will force the controller to overwrite each register and may correct any problems that exist.

1. DisplayMode: Advance
2. Range: yes, no
3. Default: no

7.4 Program-System Test

7.4.1 System Test

This message displays the name of the sub-menu when entered.

1. DisplayMode: Advanced
2. Range: N/A
3. Default: N/A

7.4.2 Alarm Output Test

This function is used for testing and commissioning purposes allowing the alarm output to be forced On either for a short period of time or continuously. At the end of the specified time duration, the testing option is automatically disabled. The alarm test function will not operate if the alarm configuration is set to disable and the message "ALARM DISABLED" will appear.

1. DisplayMode: Advanced
2. Range: 1-24 hours, Disabled, Continuously
3. Default: disabled

7.4.3 Heater Test

This function overrides heater control for maintenance purposes. For normal operation, set to "disable". If a period of time is selected, the heater is forced On or Off for the selected interval. If "continuous" is selected the heater is forced On until "disable" is selected.

1. Display Mode: Advanced
2. Range: 1-24 hours, Disabled, On Continuously
3. Default: disabled

7.4.4 Ground Fault Test

This function will test the ground fault trip function of the controller to ensure proper operation. When selected, the controller will generate an artificial ground fault current; if the ground fault current is sensed as being greater than 30 mA, the test passes. The GF test function will verify actual ground fault current and heater trip. Status of the test will be displayed as pass or fail. If this test has been invoked by the "Now" option and it passes, the user is prompted to reset the ground fault trip, at which time the load is capable of being re-energized as required. If this test has been invoked by the "Autotest" option and it passes, the load is allowed to be reenergized as required. If this test has been invoked by the Autotest cycle and it fails, an Autotest alarm is generated but the load is allowed to be re-energized as required.

1. DisplayMode: Advanced
2. Range: Autotest cycle, Now, Disabled
3. Default: Disabled

8.0 Communications

The Nelson Heat Trace CM-2201 supports a subset of the Modbus® RTU protocol format that provides monitoring, programming, and control functions using Read (03) and Write (05-06) register commands.

General Information

Serial Port:	Select the serial port that corresponds to your RS-485 adapter. USB to Serial adapter may be used for devices without serial connections.
Baud Rate:	User Defined at 2400, 4800, 9600 or 19200
Data Bits:	8
Stop Bits:	1
Parity:	None
Device Address:	User Defined between 1 and 255

Modbus Registers

For all Modbus register addresses, see *Appendix E*.

Example of checking alarms via Modbus from a remote terminal.

Controller SETTINGS and Status used on this example:

- a. Modbus address 04
- b. Baud rate 19200; non-parity; Stop bit 1.
- c. High Temperature alarm active

1. To check if any alarm is activated, send the following instruction:

```
04 03 0046 0026 2590
04 = controller Modbus number
03 = Modbus function code 3
0046 = start reading from data address 70
0026 = the next 38 addresses
2590 = CRC
```

2. The controller will answer with value 0x02 (High Temperature Alarm) active Alarm

3. Once the alarm condition has been resolved, the alarm can be cleared by sending the following instruction: "04 05 0045 FF00 9C4C"

```
04 = controller Modbus number
05 = Modbus function code 5
0045 = writing to data address 165
FF00 = erase command
9C4C = CRC
```

At this point the controller enters the alarm into the alarm log memory and clears the active alarm. To check the alarm log memory, see below.

4. If the command to check if any alarm is activated (as shown in (1) above) is now sent to the controller, and assuming no other alarms have since been activated, the controller will answer with 0x0000 (no active alarms).

5. To check the alarm log memory, issue the following instructions:

```
04 03 006E 0026 A598
04 = controller Modbus number
03 = Modbus function code 3
006E = start reading from data address 110
0026 = the next 38 addresses
A598 = CRC
```

6. The High Temperature Alarm will be listed here, so the controller will answer 0x02. The Alarm log can hold 20 alarms. After 20 alarms the oldest alarm will be erased to allow for storage of the new alarm. To erase all alarms on alarm log, see below.

7. To erase all alarms on the Alarm log from the remote terminal, send the following instruction:

```
04 05 0097 FF00 3D83
04 = controller Modbus number
05 = Modbus function code
0097 = data address 151 to write
FF00 = command to erase all memory log
3D83 = CRC
```

Note: *The DPC can read up to 45 addresses per command*

9.1 Operator Checks

Upon receipt of the controller, or to check the controller for an indication of normal operation, follow the operational procedures shown below. These procedures are designed to familiarize the operator with the controller and to provide an understanding of its operation.

To determine if a fault is associated with the heat tracing, wiring or the controller, it will be necessary to troubleshoot the wiring and tracer circuit. If the fault remains, remove power from the controller and exchange it with another controller. This may require some reprogramming of the new CM2201/CM-2202. Refer to the following sections for the appropriate topic.

9.2 Ground Fault

Ground fault warning /alarms can be caused by incorrect installation as well as current leakage resulting from wet system components or damaged cables.

The CM2201/CM2202 Controller detects ground faults by summing the outgoing and return trace currents through an internal current transformer. Under normal operating conditions (no ground fault condition) this current will be zero. When there is a flow of current from one of the trace supply wires to ground, a ground fault condition occurs.

If a ground fault alarm is present on start-up of a new installation it is likely due to a wiring error or damaged cable.

To verify this condition:

- a) Check that the heating circuit neutrals return to the controller and are not connected directly to the distribution panel. This can be a common problem if the installation is a retrofit situation.
- b) On paralleled circuits, be certain that ALL neutrals return. The late addition of a circuit may not be obvious.

Note: The controller monitors the integrity of the ground fault (GF) detection. If a fault is detected, the controller will generate a GFI warning/alarm depend of the settings.

9.3 RTDs

RTD failures after installation can generally be attributed to incorrect wiring or improper installation of the sensor. Troubleshooting of these failures is a very simple procedure if the proper steps are undertaken in the correct order. Some specific RTD problems and the correct methods for troubleshooting are outlined as follows.

1. RTD Failure Alarm(s)

If the CM2201/CM-2202 controller indicates a failure of an RTD:

- a) Ensure that the RTD is a 3-wire 100 (Platinum Type).
TURN THE POWER TO THE CONTROLLER OFF BEFORE PROCEEDING!
- b) Disconnect the RTD wiring from the input terminals.
- c) Measure the RTD's resistance between the source (RED) and sense (RED) leads at the controller (it should not exceed 40 Ω). Excessive lead resistance will cause a RTD FAILURE ALARM and must be corrected. Look for loose terminals, excessive lead length, or insufficient wire gauge and correct as necessary.
- d) Measures the RTD's resistance between the source (RED) or sense (RED) lead and the common (WHT) lead of the RTD at the controller (should be between 60 and 330 Ω depending on the temperature and the lead resistance. Verify that the RTD is wired correctly—the heat tracing controllers will always be terminated in the order: source (RED), common (WHT), sense (RED).

When wiring to the CM2201/CM2202, the terminals are marked as follows:

Terminal No.	Description
GNDBus	Shield
RA	RTD A Source (RED)
WA	RTD A Common (WHT)
RA	RTD A Sense (RED)
GNDBus	Shield
RB	RTD B Source (RED)
WB	RTD B Common (WHT)
RB	RTD B Sense (RED)

The RTD manufacturer will typically color code the leads with the source and sense being the same color, and the common a different color. Ensure that the RTD extension wire shield is terminated at one end only, normally using the terminal block provided at the terminal board.

Note: Some manufacturers use the common Black-White-Red triad color code for the RTD connections. Usually, the RED lead is the common connection (same as the White-White-Red color scheme) and the White and Black connections may be used interchangeably.

2. Temperature Verification

If you consider that the indicated or displayed temperature is not correct, the controller and the RTD can be quickly checked for correct operation. To verify the RTD:

TURN THE POWER TO THE CONTROLLER OFF BEFORE PROCEEDING!

- a) Disconnect the RTD wiring from the input terminals.
- b) To calculate the temperature indicated by the RTD, measure the resistance from source (red wire) or sense (red wire) to common (white wire) and subtract the resistance measured between source and sense. This will give a compensated resistance value that can be cross-referenced to one of the RTD tables found in Appendix E or Appendix F. Compare the measured resistance and cross-referenced temperature value obtained from the RTD table to the indicated or displayed value. These should agree to within the accuracy standards of the CM2201/CM2202 and the RTD.

Note: Ensure you refer to the correct RTD table for the type of RTD you are using

To verify the Controller:

TURN THE POWER TO THE CONTROLLER OFF BEFORE PROCEEDING!

- a) Disconnect the RTD wiring from the input terminals.
- b) Connect a 100Ω resistor across the source or sense terminal and common. Insert a jumper between the source and sense terminals.
- c) Apply power to the controller. The indicated or displayed temperature should be about 32°F (0°C) depending on the actual resistance of the test resistor if RTD TYPE is set to 100Ω Platinum. Any resistor may have a +/- 10% tolerance.

3. Unstable Temperature

An erratic indication of temperature can be caused by several factors external to the controller. The controller's accuracy and resolution will result in an indicated temperature change of a couple of degrees if the measured resistance temperature falls between two discrete values (this is sometimes referred to as quantization error).

If the instability is excessive, check:

- a) Wire used for extension of the RTD should be three-wire, twisted and shielded with the shield grounded at the controller only. Each of the three lead wires must be of the same gauge.
- b) The ideal installation has a separate conduit for the RTD leads (if they have been extended). It is not usually a problem to run low signal levels in the same conduit as the power leads even in high power applications, as long as the RTD wire is a twisted, shielded type with an insulation rating equal to or greater than the highest voltage in the conduit. Follow the proper Electrical Code requirements for your particular installation.
- c) Check the specifications for the particular cable being used to ensure that it does not have excessive Capacitance when used in long lengths. This can cause a temperature offset between what the controller reads and what the RTD actually measures. This again is normally not a problem since the controller compensates for all but the worst cases of this.
- d) Check one by one if the all RTD leads are connected to the connector.
- e) Lastly, it is possible for the RTD itself to fail on an intermittent basis, but this failure mode should be considered unusual. This kind of failure is probably the most difficult to find but fortunately it is also the least likely as a failure mechanism.

9.4 Common Warnings/Alarms - What to Look for

The CM-2201/CM-2202 has a wide range of warning and alarming features that may be selectively enabled or disabled to allow the monitoring and indication of trouble conditions. Described below are the different warning and alarm conditions available on the CM-2201/CM-2202, their meanings, and possible causes. The warning settings must be below alarm settings. If an alarm will be activated the two SSR low power will be activated.

9.4.1 Continuity Failure

The "Continuity Failure" alarm indicates that the current being drawn by the load is less than about 0.5 Amps and hence the load is assumed to be disconnected

9.4.2 High Current Warning/Alarm

This Warning/alarms current levels that are greater than the HIGH CURRENT WARNING/ALARM setting for the application.

Cause of Warning/Alarm:

- *Warning/Alarm setting too close to normal operating current*
- *High in-rush current from "cold start" of self regulating cable*
- *Damaged or partially shorted heating cable*
- *"As built" cable length is greater than design value*

9.4.3 Low Current Warning/Alarm

This alarms current levels which are less than the LOW CURRENT WARNING/ALARM setting.

Cause of Warnings/Alarm:

- *Warning/Alarm setting too close to normal operating current*
- *Low source voltage*
- *Damaged or inoperative heating cable*
- *Open connection—wiring problem*
- *SSR or contactor failed open*

9.4.4 Overcurrent Trip

If the controller is unable to start the cable due to high current or after attempting to soft start it, the controller will trip its output switch off.

Cause of Alarm:

- *Excessive in-rush current*
- *Incorrect CM-2201/CM2202 settings*
- *Incorrect wiring*
- *Damaged cable*

9.4.5 Power Limiting (Current Limiting)

This alarm indicates that the solid-state relay is limiting the average amount of power that is applied to the trace circuit as defined by the MAXIMUM POWER setting.

Cause of Alarm:

- *Power applied to trace circuit is being limited to the MAXIMUM POWER setting*

9.4.6 High GFI Warning

This warning ground fault current levels which are greater than the HIGH GFI WARNING setting.

Cause of Warning:

- *Warning setting too close to normal leakage current*
- *Damaged cable insulation and/or moisture present*
- *Moisture in junction box*
- *Poor splice or termination*
- *Moisture provides conductive ground path which allows ground fault current*

9.4.7 GFI Alarm

This value sets the upper limit of allowable ground fault leakage. Exceeding this limit will result in the output switch being latched off and the alarm activated to indicate a ground fault condition.

Cause of Alarm:

- *Trip setting too close to normal leakage current*
- *Damaged cable insulation and/or moisture present*
- *Moisture in junction box*
- *Poor splice or termination*
- *Moisture provides conductive ground path which allows ground fault current*

9.4.8 Switch Failure

This alarm indicates that the controller senses current flow when the output switch should be off.

Cause of Alarm

- *Some other device energized heat trace*
- *Output switch has failed "closed"*

9.4.9 High RTD A/ RTD B Temperature Reading

This warning/alarm appear when the temperature exceeds the HIGH RTD WARNING/ALARM temperature setting.

Cause of Warning/Alarm:

- *Warning/Alarm temperature setting too close to maintain temperature*
- *Flow of hot product*
- *Steaming out lines*
- *Incorrect tracer wiring*

9.4.10 Low RTD A/ RTD B Temperature Reading

This warning/alarm appears when the temperature decreases below the LOW RTD WARNING/ALARM temperature setting.

Cause of Warning/Alarm:

- *Warning/Alarm temperature setting too close to maintain temperature*
- *Flow of cold product*
- *Empty pipe*
- *Damaged, wet, or missing insulation*
- *Heating cable not sized properly for the application*

9.4.11 RTD A/ RTD B Failure

This alarm indicates a sensor is not operating properly. The temperature sensor may fail due to an "open" or "shorted" condition.

Cause of Alarm:

- *Incorrect or damaged field wiring - open leads or excess resistance (either intermittent or continuous) may be due to broken or damaged wires or loose terminals.*
- *Damaged or inoperative temperature sensors*

9.4.12 EEPROM Data Failure

This alarm indicates that the controller has detected a failure in its non-volatile memory (this is where all of the controller's configuration and calibration settings are stored). This indicates an internal problem and the CM2201/CM2202 should be replaced and returned to the factory for repair.

Cause of Alarm:

- *The CM-2201/CM2202 cannot bypass the failed area of its memory and has loaded factory defaults into this failed area.*

9.4.13 High Voltage Warning/Alarm

This warning/alarms voltage levels that are greater than the HIGH VOLTAGE WARNING/ALARM setting.

Cause of Warning/Alarm:

- *Warning/Alarm setting too close to normal operating voltage*
- *Incorrect wiring*
- *Power surge*

9.4.14 Low Voltage Warning/Alarm

This warning/alarms voltage levels are less than the LOW VOLTAGE WARNING/ALARM setting.

Cause of Warning/Alarm:

- *Warning/Alarm setting too close to normal operating voltage*
- *Damaged power cable*
- *Incorrect VOLTAGE TURNS RATIO*
- *"Brown-out" conditions*
- *Loss of power to the circuit*

10.0 Maintenance

The CM-2201/CM-2202 should be regularly maintained as follows:

- a) Check fit of door gasket and adjust as required. Clean door gasket.
- b) Verify that moisture is not entering enclosure; repair as required.
- c) Check terminals to ensure connections are secure.
- d) Check wiring for any signs of overheating.
- e) Clean front panel with mild soap on damp cloth.

Warning: Do not use any cloth from synthetic material or similar. The cleaning process may cause the front label to charge electrostatically and touching the front panel may generate sparks.

Model: Rating:

Maximum Current: Frequency: Switching:

Enclosure:

CM-2201/CM-2202

110-277Vac, 30Amps (Solid StateRelays)

30Amps per Channel 50or 60Hz

SolidStateRelay (DPST) Normally Open (NO) NEMA

4X

Alarm Outputs: 1. 24 VAC to 277 VAC @Max. 0.5Amps (Solid State Relay - requires Min. 100mA load)
 2. 30VDC @Max. 0.1 Amps (SolidStateRelay -requiresMin. 50mA load)

Agency Approval for Hazardous Locations:

cCSAus

Class1, DIV.2, Groups A, B, C, D Class 1, Zone 2: IIC

TemperatureCode: T4(135 °C)

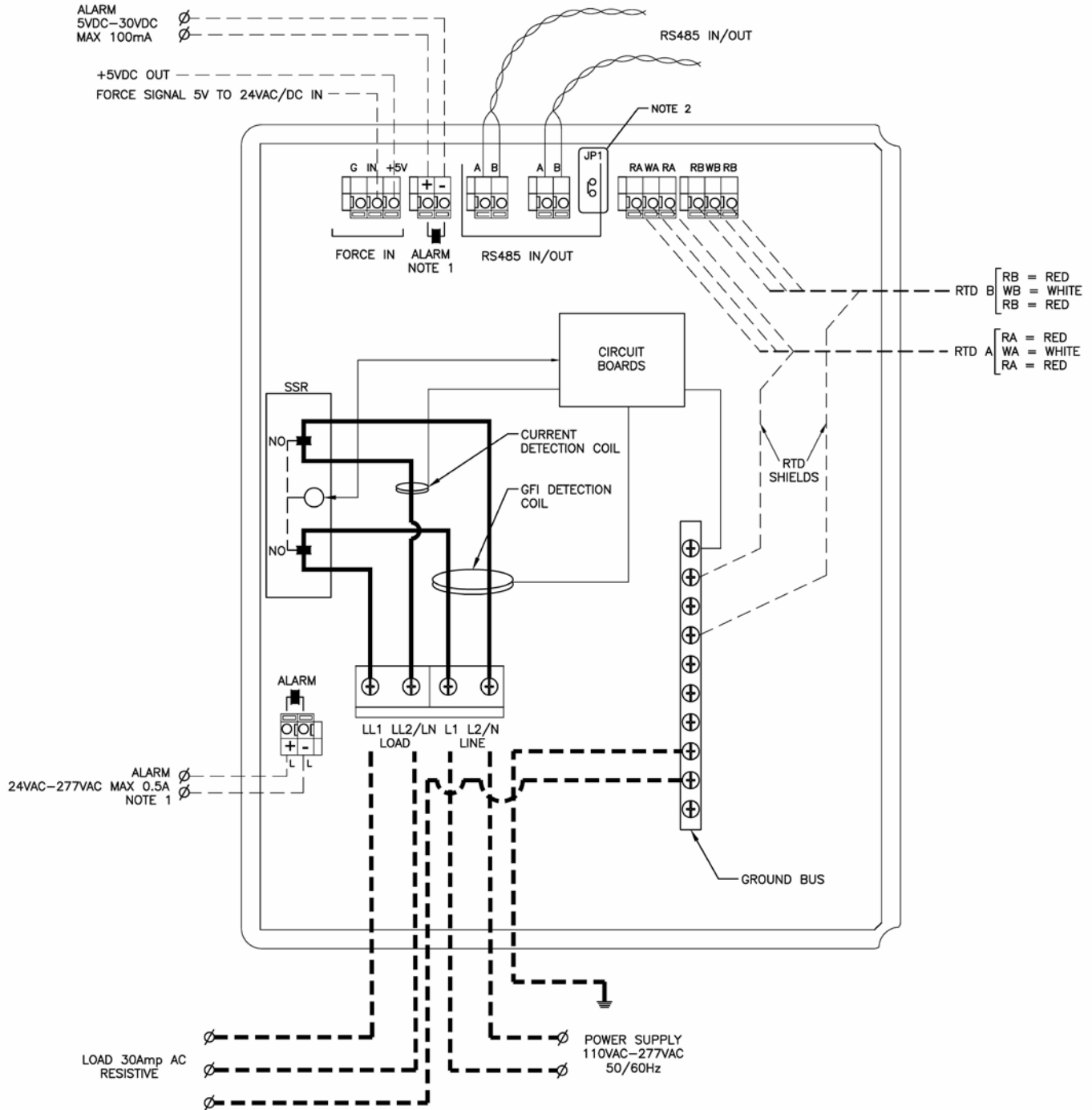

Notes:

1. Solid State Contact
2. Install Jumper at JP1 (120 OHM Resistor) on both terminals if CM-2201 is last device on network. Else install jumper on one terminal only of JP1.
3. If "Force" feature is activated by external "dry contact", use "+5V" and "IN" terminals; Ground connection is not required. If activated by external voltage signal, use "IN" and "G" (Ground) terminals as noted.

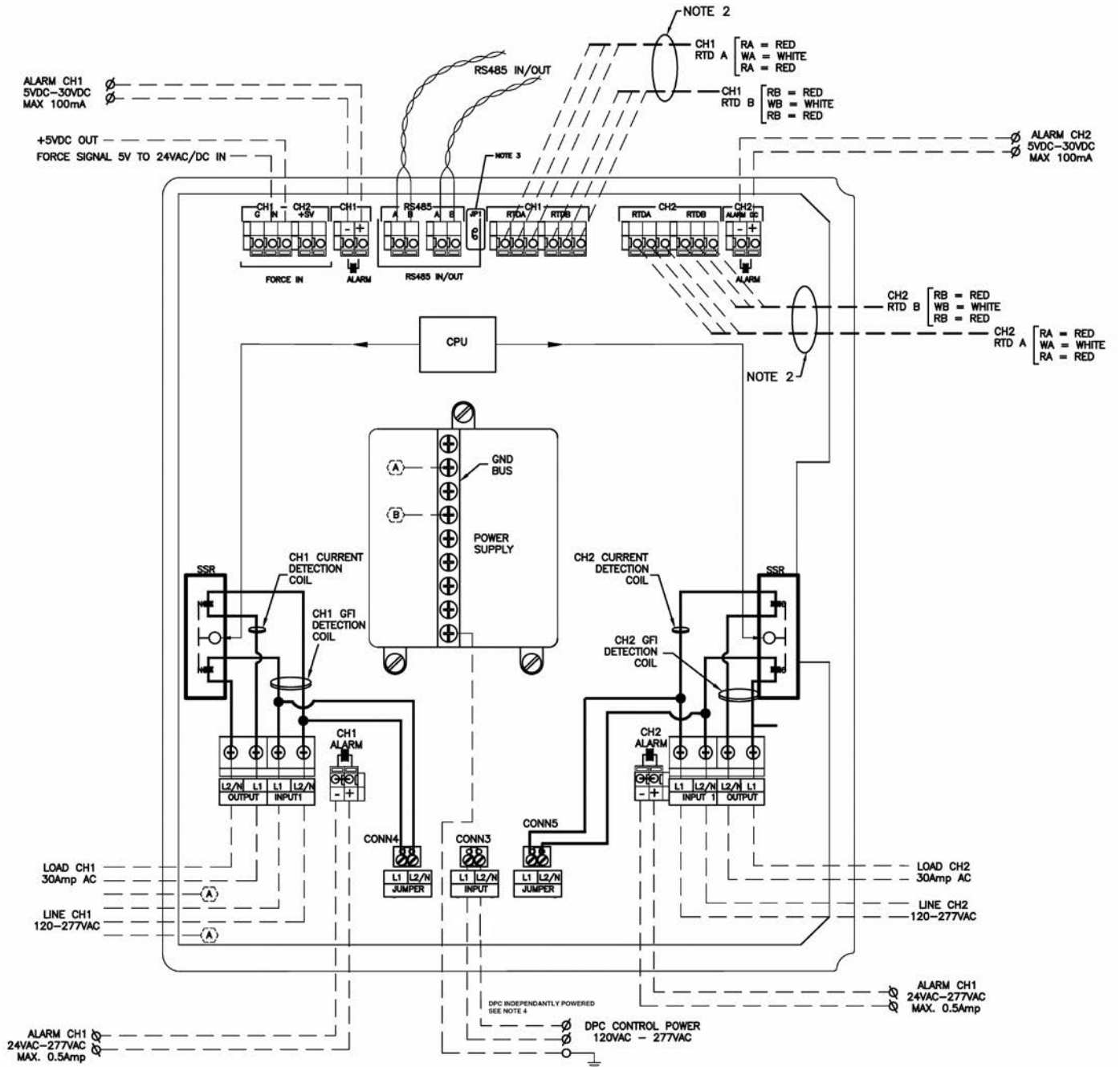

Notes:

1. All Alarms Output are SSR N.O.
2. All RTD's must have the Shield connected to Ground Bus.
3. Remove Jumper JP1 only if the controller is in RS485 Network AND is not the last unit on the Network.
4. Connect Controller Power Supply as follows;

Controller Independently Powered	Controller powered in parallel with CH.1	Controller powered in parallel with CH.2
Connect power supply directly to conn3	Jumper CONN4-L1 to CONN3-L1 & CONN4-L2/N to CONN3-L2/N	Jumper CONN5-L1 to CONN3-L1 & CONN5-L2/N to CONN3-L2/N

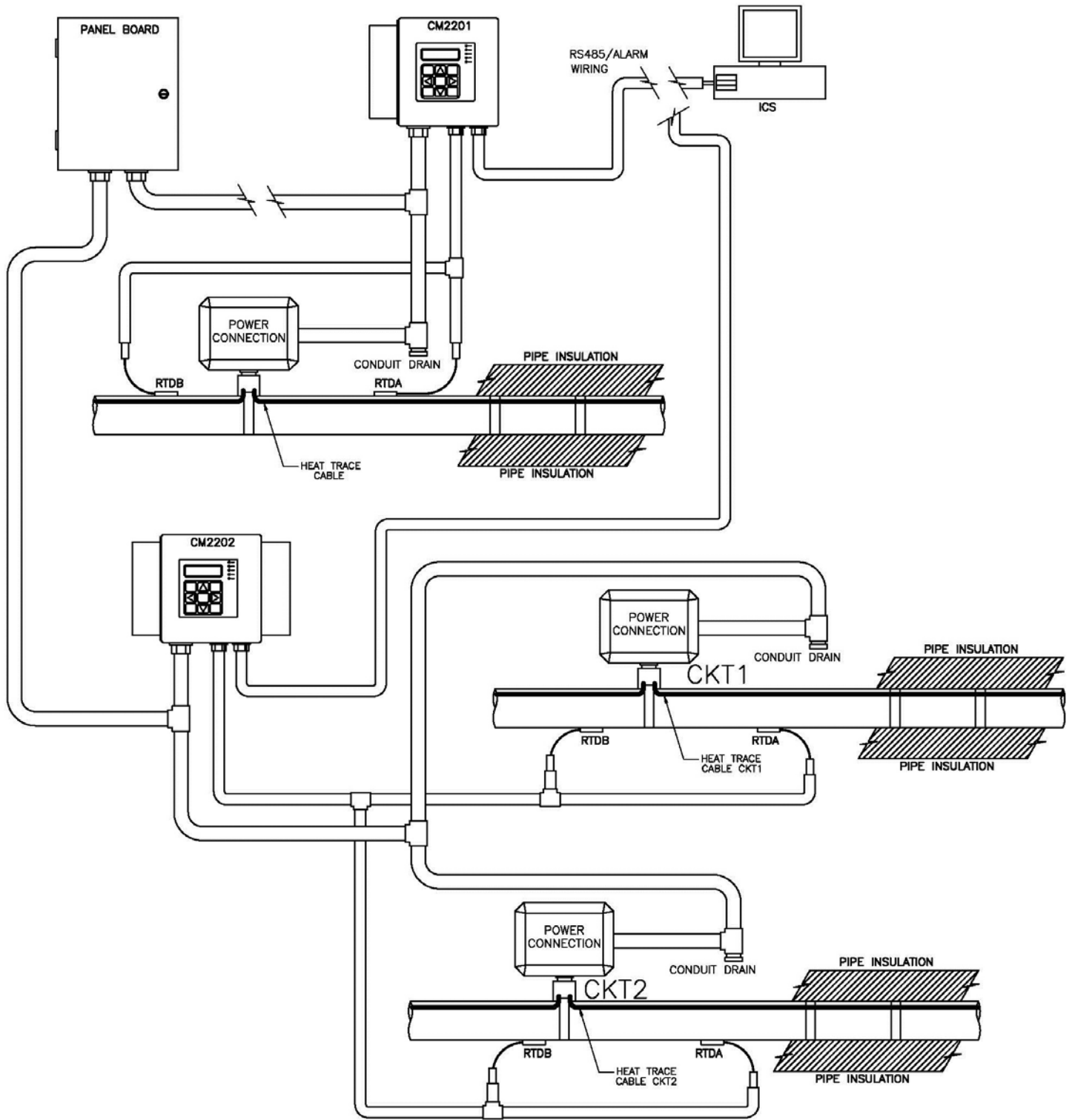

CM-2201 Mounting Details

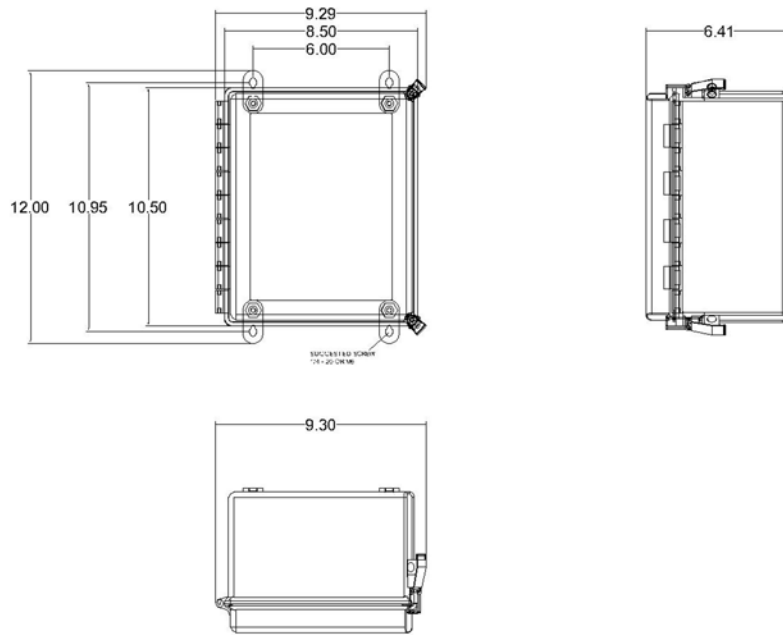

CM-2202 Mounting Details

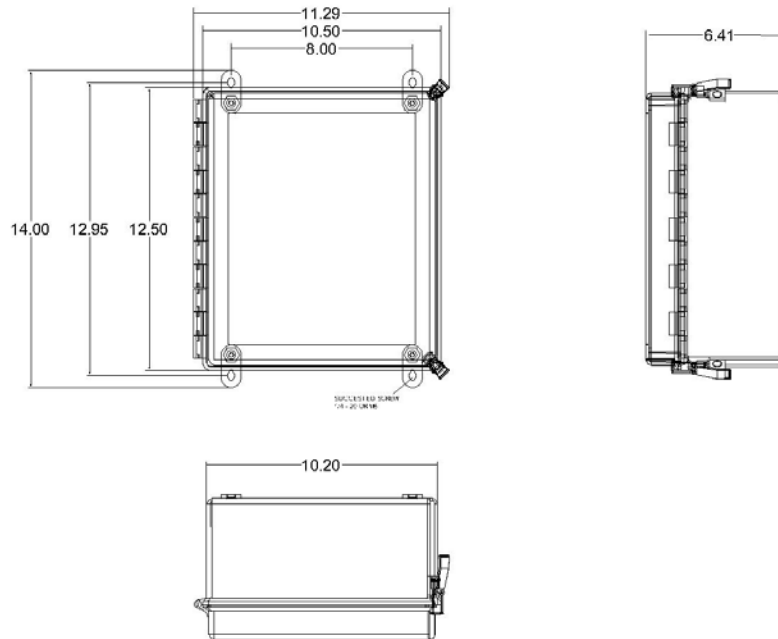

D.1 Module Setup Group (Read/Write)				
Modbus Register	Data Address	Length Bytes	Variable Name	Description/Value Range
40001	0	2	Maintain Temp in °F	= x per 1°F (-58 to +932) = 32766 if Set to None = 32767 if Set to Off
40002	1	2	Maintain Temp in °C	= x per 1°C (-50 to +500) = 32766 if Set to None = 32767 if Set to Off
40003	2	2	Low Temp Alarm in °F	= x per 1°F (-58 to +932) = 32767 if Set to Off
40004	3	2	Low Temp Alarm in °C	= x per 1°C (-50 to +500) = 32767 if Set to Off
40005	4	2	High Temp Alarm in °F	= x per 1°F (-58 to +932) = 32767 if Set to Off
40006	5	2	High Temp Alarm in °C	= x per 1°C (-50 to +500) = 32767 if Set to Off
40007	6	2	Deadband in °F	= x per 1°F (1 to 10)
40008	7	2	Deadband in °C	= x per 1°C (1 to 5)
40009	8	2	Low Current Alarm	= x per 0.1A (1 to 300) = 32767 if Set to Off
40010	9	2	High Current Alarm	= x per 0.1A (1 to 300) = 32767 if Set to Off
40011	10	2	Ground Fault Alarm	= x per 1mA (10 to 500) = 32767 if Set to Off
40012	11	2	Ground Fault Trip	= x per 1mA (10 to 500) = 32767 if Set to Off
40013	12	2	Low Voltage Alarm	= x per 1V (85 to 280) = 32767 if Set to Off
40014	13	2	High Voltage Alarm	= x per 1V (85 to 280) = 32767 if Set to Off
40015	14	2	Power Limit	= x per 10% (1 to 10) = 32767 if Set to Off
40016	15	2	Soft-Start	= x per 1 Second (10 to 999) = 32767 if Set to Off
40017	16	2	Auto Test Cycle	= x per 1 Hour (1 to 720) = 32767 if Set to Off
40018	17	2	Display Time	= x per 1 Second (5 to 600) = 32767 if Set to Off

Modbus Address List

Appendix E

40019	18	2	Cost per kwh	= x per \$0.01 (1 to 100)	
40020	19	2	Reserved		
40021	20	2	Reserved		
40022	21	2	Reserved		
40023	22	2	Alarm Test	= x per 1 Hour (1 to 24) = 32764 if Set to Disable =32765 if Set to Continuously	
40024	23	2	Heater Test	= x per 1 Hour (1 to 24) = 32764 if Set to Disable =32765 if Set to Continuously	
40025	24	2	Reserved		
40026-40033	25 - 32	16	Heater Name	16-Character limit (CM-2201) 12-character limit (CM-2202). See Appendix E for ASCII chart	
40034-40042	33 - 41	16	Reserved		
40043	42	2	bits	Variable name	
			0	GF Test CH.1	00 = Auto Test Cycle 01 = Now 10 = Disable
			1		
			2	Reserved	
			3	Alarm Contact CH.1	0 = Normally Open 1 = Normally Closed
			4	Enable Heater CH.2	0 = No 1 = Yes
			5	External Disable CH.2	0 = Disable 1 = Enable
			6	Control Type (CH.2)	0 = On/Off 1 = Proportional
			7	RTD Operation (CH.2)	000 = Single RTD Mode 001 = Backup 010 = Average 011 = Lowest 100 = Highest 101 = High Temp Cut-out
			8		
			9		
			10	RTD Failure Mode (CH.2)	0 = Off 1 = On
			11	GF Test (CH.2)	00 = Auto Test Cycle 01 = Now 10 = Disable
			12		
			13	Heater Type (CH.2)	0 = Fixed Resistance 1 = Self Regulating
14	Alarm Contact (CH.2)	0 = Normally Open 1 = Normally Closed			
15	Reserved				

Appendix E

Modbus Address List

Modbus Register	Data Address	Length Bytes	bits	Variable name	Description/ Value Range
40044	43	2	0	Units	0 = °F 1 = °C
			1	Enable Heater (CH.1)	0 = No 1 = Yes
			2	External Disable (CH.1)	0 = Disable 1 = Enable
			3	Control Type (CH.1)	0 = On/Off 1 = Proportional
			4	RTD Operation (CH.1)	000 = Single RTD Mode 001 = Backup 010 = Average 011 = Lowest 100 = Highest 101 = High Temp Cut-out
			5		
			6		
			7	RTD Failure Mode (CH.1)	0 = Off 1 = On
			8	Enable Password	0 = Disable 1 = Enable
			9	Display Mode	0 = Normal 1 = Advanced
			10	Default Display	00 = System Status 01 = Heater Status 10 = Heater Temp
			11		
			12	Baud Rate	001 = 2400 bps 010 = 4800 bps 011 = 9600 bps 100 = 19200 bps
			13		
			14		
15	Heater Type (CH.1)	0 = Fixed resistance 1 = Self-regulating			
40201	200	2	Maintain Temp in °F (ch2)		= x per 1°F (-58 to +932) = 32766 if Set to None = 32767 if Set to Off
40202	201	2	Maintain Temp in °C (ch2)		= x per 1°C (-50 to +500) = 32766 if Set to None = 32767 if Set to Off
40203	202	2	Low Temp Alarm in °F (ch2)		= x per 1°F (-58 to +932) = 32767 if Set to Off
40204	203	2	Low Temp Alarm in °C (ch2)		= x per 1°C (-50 to +500) = 32767 if Set to Off
40205	204	2	High Temp Alarm in °F (ch2)		= x per 1°F (-58 to +932) = 32767 if Set to Off
40206	205	2	High Temp Alarm in °C (ch2)		= x per 1°C (-50 to +500) = 32767 if Set to Off
40207	206	2	Deadband in °F (ch2)		= x per 1°F (1 to 10)
40208	207	2	Deadband in °C (ch2)		= x per 1°C (1 to 5)

Modbus Address List

Appendix E

40209	208	2	Low Current Alarm (ch2)	= x per 0.1A (1 to 300) = 32767 if Set to Off
40210	209	2	High Current Alarm (ch2)	= x per 0.1A (1 to 300) = 32767 if Set to Off
40211	210	2	Ground Fault Alarm (ch2)	= x per 1mA (10 to 500) = 32767 if Set to Off
40212	211	2	Ground Fault Trip (ch2)	= x per 1mA (10 to 500) = 32767 if Set to Off
40213	212	2	Low Voltage Alarm (ch2)	= x per 1V (85 to 280) = 32767 if Set to Off
40214	213	2	High Voltage Alarm (ch2)	= x per 1V (85 to 280) = 32767 if Set to Off
40215	214	2	Power Limit (ch2)	= x per 10% (1 to 10) = 32767 if Set to Off
40216	215	2	SoftStart (ch2)	= x per 1 Second (10 to 999) = 32767 if Set to Off
40217	216	2	Auto Test Cycle (ch2)	= x per 1 Hour (1 to 720) = 32767 if Set to Off
40218	217	2	Display Time	= x per 1 Second (5 to 600) = 32767 if Set to Off
40219	218	2	Cost per kwh	= x per \$0.01 (1 to 100)
40220	219	2	Reserved	
40221	220	2	Reserved	
40222	221	2	Reserved	
40223	222	2	Alarm Test (ch2)	= x per 1 Hour (1 to 24) = 32764 if Set to Disable =32765 if Set to Continuously
40224	223	2	Heater Test (ch2)	= x per 1 Hour (1 to 24) = 32764 if Set to Disable =32765 if Set to Continuously
40225	224	2	Reserved	
40191-40198	190-197	16	Heater Name (ch2)	12-character limit. See Appendix E for ASCII chart.

D.2 Module Monitoring Group (Read Only)				
40045	44	2	System Temp in °F	= x per °F = 32765 if RTD Fail = 32763 if Undetected *
40046	45	2	System Temp in °C	= x per °C = 32765 if RTD Fail = 32763 if Undetected *
40047	46	2	RTD-A Temp in °F	= x per °F = 32765 if RTD Fail = 32763 if Undetected *
40048	47	2	RTD-A Temp in °C	= x per °C = 32765 if RTD Fail = 32763 if Undetected *
40049	48	2	RTD-B Temp in °F	= x per °F = 32765 if RTD Fail = 32763 if Undetected *
40050	49	2	RTD-B Temp in °C	= x per °C = 32765 if RTD Fail = 32763 if Undetected *
40051	50	2	Heater Power	= x per 10%
40052	51	2	Current	= x per 0.1A = 32766 if Out of Range
40053	52	2	Reserved	
40054	53	2	GF Current	= x per 1mA= 32766 if Out of Range
40055	54	2	Voltage	= x per 1V = 32766 if Out of Range
40056	55	2	Heater status	= 1 on = 0 off
40057	56	2	Max Temp in °F	= x per °F = 32765 if RTD Fail = 32763 if Undetected *
40058	57	2	Max Temp in °C	= x per °C = 32765 if RTD Fail = 32763 if Undetected *
40059	58	2	Min Temp in °F	= x per °F = 32765 if RTD Fail = 32763 if Undetected *

40060	59	2	Min Temp in °C	= x per E256°C = 32765 if RTD Fail = 32763 if Undetected *
40061	60	2	Max Current	= x per 0.1A = 32766 if Out of Range
40062	61	2	Max GF Current	= x per 1mA = 32766 if Out of Range
40063	62	2	Max Volt	= x per 1V = 32766 if Out of Range
40064	63	2	Min Volt	= x per 1V = 32766 if Out of Range
40065	64	2	Energy	= x per 1MWh = 32766 if Out of Range
40066-40067	65 - 66	4	Cost	= x per \$0.01 = 0x7FFFFFFF Out of Range
40068-40069	67 - 68	4	Heater On Time	= x per 1 Hour = 1500000 Out of Range
40070	69	2	Heater on %	= x per 1%
40071-40072	70 - 71	4	Alarm Stack 01	0 = No Alarm
40073-40074	72 - 73	4	Alarm Stack 02	1 = Low Temp Alarm
40075-40076	74 - 75	4	Alarm Stack 03	2 = High Temp Alarm
40077-40078	76 - 77	4	Alarm Stack 04	4 = Low Current Alarm
40079-40080	78 - 79	4	Alarm Stack 05	8 = High Current Alarm
40081-40082	80 - 81	4	Alarm Stack 06	16 = GF Alarm
40083-40084	82 - 83	4	Alarm Stack 07	32 = GF Trip
40085-40086	84 - 85	4	Alarm Stack 08	64 = Low Voltage Alarm
40087-40088	86 - 87	4	Alarm Stack 09	128 = High Voltage Alarm
40089-40090	88 - 89	4	Alarm Stack 10	256 = Auto Test Alarm
40091-40092	90 - 91	4	Alarm Stack 11	512 = Continuity Failure Alarm
40093-40094	92 - 93	4	Alarm Stack 12	1024 = SSR Failed Shorted Alarm
40095-40096	94 - 95	4	Alarm Stack 13	2048 = RTD-A Fail Alarm
40097-40098	96 - 97	4	Alarm Stack 14	4096 = Reserved
40099-40100	98 - 99	4	Alarm Stack 15	8192 = RTD-B Fail Alarm
40101-40102	100 - 101	4	Alarm Stack 16	16384 = Reserved
40103-40104	102 - 103	4	Alarm Stack 17	32768 = Self Check Failure
40105-40106	104 - 105	4	Alarm Stack 18	65536 = GFI test failure
40107-40108	106 - 107	4	Alarm Stack 19	

Appendices

CM-2201/CM-2202

Appendix E

Modbus Address List

40109-40110	108 – 109	4	Alarm Stack 20	
40111-40112	110 - 111	4	Log Stack 1	0 = No Alarm
40113-40114	112 – 113	4	Log Stack 2	1 = Low Temp Alarm
40115-40116	114 – 115	4	Log Stack 3	2 = High Temp Alarm
40117-40118	116 – 117	4	Log Stack 4	4 = Low Current Alarm
40119-40120	118 – 119	4	Log Stack 5	8 = High Current Alarm
40121-40122	120 – 121	4	Log Stack 6	16 = GF Alarm
40123-40124	122 – 123	4	Log Stack 7	32 = GF Trip
40125-40126	124 – 125	4	Log Stack 8	64 = Low Voltage Alarm
40127-40128	126 – 127	4	Log Stack 9	128 = High Voltage Alarm
40129-40130	128 – 129	4	Log Stack 10	256 = Auto Test Alarm
40131-40132	130 – 131	4	Log Stack 11	512 = Continuity Failure Alarm
40133-40134	132 – 133	4	Log Stack 12	1024 = SSR Failed Shorted Alarm
40135-40136	134 – 135	4	Log Stack 13	2048 = RTD-A Fail Alarm
40137-40138	136 – 137	4	Log Stack 14	4096 = Reserved
40139-40140	138 – 139	4	Log Stack 15	8192 = RTD-B Fail Alarm
40141-40142	140 – 141	4	Log Stack 16	16384 = Reserved
40143-40144	142 – 143	4	Log Stack 17	32768 = Self Check Failure
40145-40146	144 – 145	4	Log Stack 18	65536 = GFI test failure
40147-40148	146 – 147	4	Log Stack 19	
40149-40150	148 – 149	4	Log Stack 20	
40227	226	2	System Temp in °F (ch2)	= x per °F = 32765 if RTD Fail = 32763 if Undetected *
40228	227	2	System Temp in °C (ch2)	= x per °C = 32765 if RTD Fail = 32763 if Undetected *
40229	228	2	RTD-A Temp in °F (ch2)	= x per °F = 32765 if RTD Fail = 32763 if Undetected *
40230	229	2	RTD-A Temp in °C (ch2)	= x per °C = 32765 if RTD Fail = 32763 if Undetected *
40231	230	2	RTD-B Temp in °F (ch2)	= x per °F = 32765 if RTD Fail = 32763 if Undetected *
40232	231	2	RTD-B Temp in °C	= x per °C

			(ch2)	= 32765 if RTD Fail = 32763 if Undetected *
40233	232	2	Heater Power (ch2)	= x per 10%
40234	233	2	Current (ch2)	= x per 0.1A = 32766 if Out of Range
40235	234	2	GF Current (ch2)	= x per 1 mA = 32766 if Out of Range
40236	235	2	Voltage (ch2)	= x per 1V = 32766 if Out of Range
40237	236	1	Heater status (ch2)	= 1 on = 0 off
40238	237	2	Max Temp in °F (ch2)	= x per °F = 32765 if RTD Fail = 32763 if Undetected *
40239	238	2	Max Temp in °C (ch2)	= x per °C = 32765 if RTD Fail = 32763 if Undetected *
40240	239	2	Min Temp in °F (ch2)	= x per °F = 32765 if RTD Fail = 32763 if Undetected *
40241	240	2	Min Temp in °C (ch2)	= x per °C = 32765 if RTD Fail = 32763 if Undetected *
40242	241	2	Max Current (ch2)	= x per 0.1A = 32766 if Out of Range
40243	242	2	Max GF Current (ch2)	= x per 1mA = 32766 if Out of Range
40244	243	2	Max Volt (ch2)	= x per 1V = 32766 if Out of Range
40245	244	2	Min Volt (ch2)	= x per 1V = 32766 if Out of Range
40246	245	2	Energy (ch2)	= x per 1MWh = 32766 if Out of Range
40247-40248	246-247	4	Cost (ch2)	= x per \$0.01 = 0x7FFFFFFF Out of Range
40249-40250	248-249	4	Heater On Time (ch2)	= x per 1 Hour = 1500000 Out of Range
40251	250	2	Heater on % (ch2)	= x per 1%

Appendix E

Modbus Address List

40252-40253	251-252	4	Alarm Stack 01 (ch2)	0 = No Alarm 1 = Low Temp Alarm 2 = High Temp Alarm 4 = Low Current Alarm 8 = High Current Alarm 16 = GF Alarm 32 = GF Trip 64 = Low Voltage Alarm 128 = High Voltage Alarm 256 = Auto Test Alarm 512 = Continuity Failure Alarm 1024 = SSR Failed Shorted Alarm 2048 = RTD-A Fail Alarm 4096 = Reserved 8192 = RTD-B Fail Alarm 16384 = Reserved 32768 = Self Check Failure 65536 = GFI test failure
40254-40255	253 – 254	4	Alarm Stack 02 (ch2)	
40256-40257	255 – 256	4	Alarm Stack 03 (ch2)	
40258-40259	257 - 258	4	Alarm Stack 04 (ch2)	
40260-40261	259 - 260	4	Alarm Stack 05 (ch2)	
40262-40263	261 – 262	4	Alarm Stack 06 (ch2)	
40264-40265	263 – 264	4	Alarm Stack 07 (ch2)	
40266-40267	265 – 266	4	Alarm Stack 08 (ch2)	
40268-40269	267 – 268	4	Alarm Stack 09 (ch2)	
40270-40271	269 – 270	4	Alarm Stack 10 (ch2)	
40272-40273	271 – 272	4	Alarm Stack 11 (ch2)	
40274-40275	273 – 274	4	Alarm Stack 12 (ch2)	
40276-40277	275 – 276	4	Alarm Stack 13 (ch2)	
40278-40279	277 – 278	4	Alarm Stack 14 (ch2)	
40280-40281	279 – 280	4	Alarm Stack 15 (ch2)	
40282-40283	281 – 282	4	Alarm Stack 16 (ch2)	
40284-40285	283 – 284	4	Alarm Stack 17 (ch2)	
40286-40287	285 – 286	4	Alarm Stack 18 (ch2)	
40288-40289	287 – 288	4	Alarm Stack 19 (ch2)	
40290-40291	289 – 290	4	Alarm Stack 20 (ch2)	

40292-40293	291 – 292	4	Log Stack 1 (ch2)	0 = No Alarm 1 = Low Temp Alarm 2 = High Temp Alarm 4 = Low Current Alarm 8 = High Current Alarm 16 = GF Alarm 32 = GF Trip 64 = Low Voltage Alarm 128 = High Voltage Alarm 256 = Auto Test Alarm 512 = Continuity Failure Alarm 1024 = SSR Failed Shorted Alarm 2048 = RTD-A Fail Alarm 4096 = Reserved 8192 = RTD-B Fail Alarm 16384 = Reserved 32768 = Self Check Failure 65536 = GFI test failure
40294-40295	293 – 294	4	Log Stack 2 (ch2)	
40296-40297	295 – 296	4	Log Stack 3 (ch2)	
40298-40299	297 – 298	4	Log Stack 4 (ch2)	
40300-40301	299- 300	4	Log Stack 5 (ch2)	
40302-40303	301 = 302	4	Log Stack 6 (ch2)	
40304-40305	303 – 304	4	Log Stack 7 (ch2)	
40306-40307	305 - 306	4	Log Stack 8 (ch2)	
40308-40309	307 – 308	4	Log Stack 9 (ch2)	
40310-40311	309 – 310	4	Log Stack 10 (ch2)	
40312-40313	311 - 312	4	Log Stack 11 (ch2)	
40314-40315	313 – 314	4	Log Stack 12 (ch2)	
40316-40317	315 – 316	4	Log Stack 13 (ch2)	
40318-40319	317 – 318	4	Log Stack 14 (ch2)	
40320-40321	319 – 320	4	Log Stack 15 (ch2)	
40322-40323	321 – 322	4	Log Stack 16 (ch2)	
40324-40325	323 – 324	4	Log Stack 17 (ch2)	
40326-40327	325 - 326	4	Log Stack 18 (ch2)	
40328-40329	327 – 328	4	Log Stack 19 (ch2)	
40330-40331	329 - 330	4	Log Stack 20 (ch2)	

D.3 Module Reset Group (Write Only)				
00151	150	2	Clear All Alarms	= Set "On (0xFF00)" to Reset
00152	151	2	Clear All Logs	= Set "On (0xFF00)" to Reset
00153	152	2	Reset Max Temp in statistics	= Set "On (0xFF00)" to Reset
00154	153	2	Reset Min Temp in statistics	= Set "On (0xFF00)" to Reset
00155	154	2	Reset Max Current in statistics	= Set "On (0xFF00)" to Reset
00156	155	2	Reset Max GF in statistics	= Set "On (0xFF00)" to Reset
00157	156	2	Reset Max Voltage in statistics	= Set "On (0xFF00)" to Reset
00158	157	2	Reset Min Voltage in statistics	= Set "On (0xFF00)" to Reset
00159	158	2	Reset Energy in statistics	= Set "On (0xFF00)" to Reset
00160	159	2	Reset Cost in statistics	= Set "On (0xFF00)" to Reset
00161	160	2	Reset Heater On Time (Hours) in statistics	= Set "On (0xFF00)" to Reset
00162	161	2	Reset Heater On Percentage in statistics	= Set "On (0xFF00)" to Reset
00163	162	2	Reset All Statistics	= Set "On (0xFF00)" to Reset
00164	163	2	Shut Off Alarm Output	= Set "On (0xFF00)" to Reset
00165	164	2	Reset Low Temperature Alarm	= Set "On (0xFF00)" to Reset
00166	165	2	Reset High Temperature Alarm	= Set "On (0xFF00)" to Reset
00167	166	2	Reset Low Current Alarm	= Set "On (0xFF00)" to Reset
00168	167	2	Reset High Current Alarm	= Set "On (0xFF00)" to Reset
00169	168	2	Reset Ground Fault Alarm	= Set "On (0xFF00)" to Reset
00170	169	2	Reset Ground Fault Trip	= Set "On (0xFF00)" to Reset
00171	170	2	Reset Low Voltage Alarm	= Set "On (0xFF00)" to Reset
00172	171	2	Reset High Voltage Alarm	= Set "On (0xFF00)" to Reset
00173	172	2	Reset Auto Test Alarm	= Set "On (0xFF00)" to Reset
00174	173	2	Reset Continuity Fail Alarm	= Set "On (0xFF00)" to Reset
00175	174	2	Reset Switch Fail Alarm	= Set "On (0xFF00)" to Reset
00176	175	2	Reset RTDA Fail Alarm	= Set "On (0xFF00)" to Reset
00177	176	2	Reset RTDB Fail Alarm	= Set "On (0xFF00)" to Reset
00178	177	2	Reset Self Check Fail Alarm	= Set "On (0xFF00)" to Reset
00179	178	2	Reset GFI Test Alarm	= Set "On (0xFF00)" to Reset
00180-00184	179-183	8	Reserved	

00185	184	2	Clear All Alarms (Ch2)	= Set "On (0xFF00)" to Reset
00186	185	2	Clear All Logs (Ch2)	= Set "On (0xFF00)" to Reset
00187	186	2	Reset Max Temp in statistics (Ch2)	= Set "On (0xFF00)" to Reset
00188	187	2	Reset Min Temp in statistics (Ch2)	= Set "On (0xFF00)" to Reset
00189	188	2	Reset Max Current in statistics (Ch2)	= Set "On (0xFF00)" to Reset
00190	189	2	Reset Max GF in statistics (Ch2)	= Set "On (0xFF00)" to Reset
00191	190	2	Reset Max Voltage in statistics (Ch2)	= Set "On (0xFF00)" to Reset
00192	191	2	Reset Min Voltage in statistics (Ch2)	= Set "On (0xFF00)" to Reset
00193	192	2	Reset Energy in statistics (Ch2)	= Set "On (0xFF00)" to Reset
00194	193	2	Reset Cost in statistics (Ch2)	= Set "On (0xFF00)" to Reset
00195	194	2	Reset Heater On Time in statistics (Hours) (Ch2)	= Set "On (0xFF00)" to Reset
00196	195	2	Reset Heater On Percentage in statistics (Ch2)	= Set "On (0xFF00)" to Reset
00197	196	2	Reset Statistics (Ch2)	= Set "On (0xFF00)" to Reset
00198	197	2	Shut Off Alarm Output (Ch2)	= Set "On (0xFF00)" to Reset
00199	198	2	Reset Low Temperature Alarm (Ch2)	= Set "On (0xFF00)" to Reset
00200	199	2	Reset High Temperature Alarm (Ch2)	= Set "On (0xFF00)" to Reset
00201	200	2	Reset Low Current Alarm (Ch2)	= Set "On (0xFF00)" to Reset
00202	201	2	Reset High Current Alarm (Ch2)	= Set "On (0xFF00)" to Reset
00203	202	2	Reset Ground Fault Alarm (Ch2)	= Set "On (0xFF00)" to Reset
00204	203	2	Reset Ground Fault Trip (Ch2)	= Set "On (0xFF00)" to Reset
00205	204	2	Reset Low Voltage Alarm (Ch2)	= Set "On (0xFF00)" to Reset
00206	205	2	Reset High Voltage Alarm (Ch2)	= Set "On (0xFF00)" to Reset
00207	206	2	Reset Auto Test Alarm (Ch2)	= Set "On (0xFF00)" to Reset
00208	207	2	Reset Continuity Fail Alarm (Ch2)	= Set "On (0xFF00)" to Reset
00209	208	2	Reset Switch Fail Alarm (Ch2)	= Set "On (0xFF00)" to Reset
00210	209	2	Reset RTDA Fail Alarm (Ch2)	= Set "On (0xFF00)" to Reset
00211	210	2	Reset RTDB Fail Alarm (Ch2)	= Set "On (0xFF00)" to Reset
00212	211	2	Reset Self Check Fail Alarm (Ch2)	= Set "On (0xFF00)" to Reset
00213	212	2	Reset GFI Test Alarm (Ch2)	= Set "On (0xFF00)" to Reset

Decimal	Hexidecimal	Binary	Character
0	00	00000000	(NULL)
32	20	00100000 (Space)	
33	21	00100001	!
34	22	00100010	"
35	23	00100011	#
36	24	00100100	\$
37	25	00100101	%
38	26	00100110	&
39	27	00100111	'
40	28	00101000	(
41	29	00101001)
42	2A	00101010	*
43	2B	00101011	+
44	2C	00101100	,
45	2D	00101101	-
46	2E	00101110	.
47	2F	00101111	/
48	30	00110000	0
49	31	00110001	1
50	32	00110010	2
51	33	00110011	3
52	34	00110100	4
53	35	00110101	5
54	36	00110110	6
55	37	00110111	7
56	38	00111000	8
57	39	00111001	9
58	3A	00111010	:
59	3B	00111011	;
60	3C	00111100	<
61	3D	00111101	=
62	3E	00111110	>
63	3F	00111111	?
64	40	01000000	@
91	5B	01011011	[
92	5C	01011100	\
93	5D	01011101]
94	5E	01011110	^
95	5F	01011111	_
96	60	01100000	`
123	7B	01111011	{
124	7C	01111100	
125	7D	01111101	}
65	41	01000001	A
66	42	01000010	B
67	43	01000011	C
68	44	01000100	D
69	45	01000101	E
70	46	01000110	F
71	47	01000111	G
72	48	01001000	H
73	49	01001001	I
74	4A	01001010	J
75	4B	01001011	K
76	4C	01001100	L
77	4D	01001101	M
78	4E	01001110	N
79	4F	01001111	O
80	50	01010000	P
81	51	01010001	Q
82	52	01010010	R
83	53	01010011	S
84	54	01010100	T
85	55	01010101	U
86	56	01010110	V
87	57	01010111	W
88	58	01011000	X
89	59	01011001	Y
90	5A	01011010	Z
97	61	01100001	a
98	62	01100010	b
99	63	01100011	c
100	64	01100100	d
101	65	01100101	e
102	66	01100110	f
103	67	01100111	g
104	68	01101000	h
105	69	01101001	i
106	6A	01101010	j
107	6B	01101011	k
108	6C	01101100	l
109	6D	01101101	m
110	6E	01101110	n
111	6F	01101111	o
112	70	01110000	p
113	71	01110001	q
114	72	01110010	r
115	73	01110011	s
116	74	01110100	t
117	75	01110101	u
118	76	01110110	v
119	77	01110111	w
120	78	01111000	x
121	79	01111001	y
122	7A	01111010	z

Temperature Conversion Platinum Resistance (-200°C to 239°C) Temperature Coefficient - 0.00385 Ohms/Ohm/OC											
°C	Ohms	°C	Ohms	°C	Ohms	°C	Ohms	°C	Ohms	°C	Ohms
-200	18.49	-137	45.11	-74	70.73	-11	95.69	51	119.78	114	143.80
-199	18.93	-136	45.52	-73	71.13			52	120.16	115	144.17
-198	19.36	-135	45.94	-72	71.53	-10	96.09	53	120.55	116	144.55
-197	19.79	-134	46.35	-71	71.93	-9	96.48	54	120.93	117	144.93
-196	20.22	-133	46.76			-8	96.87	55	121.32	118	145.31
-195	20.65	-132	47.18	-70	72.33	-7	97.26	56	121.70	119	145.68
-194	21.08	-131	47.59	-69	72.73	-6	97.65	57	122.09		
-193	21.51			-68	73.13	-5	98.04	58	122.47	120	146.06
-192	21.94	-130	48.00	-67	73.53	-4	98.44	59	122.86	121	146.44
-191	22.37	-129	48.41	-66	73.93	-3	98.83			122	146.81
		-128	48.82	-65	74.33	-2	99.22	60	123.24	123	147.19
-190	22.80	-127	49.23	-64	74.73	-1	99.61	61	123.62	124	147.57
-189	23.23	-126	49.64	-63	75.13			62	124.01	125	147.94
-188	23.66	-125	50.06	-62	75.53	0	100.00	63	124.39	126	148.32
-187	24.09	-124	50.47	-61	75.93	1	100.39	64	124.77	127	148.70
-186	24.52	-123	50.88			2	100.78	65	125.16	128	149.07
-185	24.94	-122	51.29	-60	76.33	3	101.17	66	125.54	129	149.45
-184	25.37	-121	51.70	-59	76.73	4	101.56	67	125.92		
-183	25.80			-58	77.13	5	101.95	68	126.31	130	149.82
-182	26.23	-120	52.11	-57	77.52	6	102.34	69	126.69	131	150.20
-181	26.65	-119	52.52	-56	77.92	7	102.73			132	150.57
		-118	52.92	-55	78.32	8	103.12	70	127.07	133	150.95
-180	27.08	-117	53.33	-54	78.72	9	103.51	71	127.45	134	151.33
-179	27.50	-116	53.74	-53	79.11			72	127.84	135	151.70
-178	27.93	-115	54.15	-52	79.51	10	103.90	73	128.22	136	152.08
-177	28.35	-114	54.56	-51	79.91	11	104.29	74	128.60	137	152.45
-176	28.78	-113	54.97			12	104.68	75	128.98	138	152.83
-175	29.20	-112	55.38	-50	80.31	13	105.07	76	129.37	139	153.20
-174	29.63	-111	55.78	-49	80.70	14	105.46	77	129.75		
-173	30.05			-48	81.10	15	105.85	78	130.13	140	153.58
-172	30.47	-110	56.19	-47	81.50	16	106.24	79	130.51	141	153.95
-171	30.90	-109	56.60	-46	81.89	17	106.63			142	154.32
		-108	57.00	-45	82.29	18	107.02	80	130.89	143	154.70
-170	31.32	-107	57.41	-44	82.69	19	107.40	81	131.27	144	155.07
-169	31.74	-106	57.82	-43	83.08			82	131.66	145	155.45
-168	32.16	-105	58.22	-42	83.48	20	107.79	83	132.04	146	155.82
-167	32.59	-104	58.63	-41	83.88	21	108.18	84	132.42	147	156.19
-166	33.01	-103	59.04			22	108.57	85	132.80	148	156.57
-165	33.43	-102	59.44	-40	84.27	23	108.96	86	133.18	149	156.94
-164	33.85	-101	59.85	-39	84.67	24	109.35	87	133.56		

Temperature Conversion Platinum Resistance (-200°C to 239°C) Temperature Coefficient - 0.00385 Ohms/Ohm/OC											
-163	34.27			-38	85.06	25	109.73	88	133.94	150	157.31
-162	34.69	-100	60.25	-37	85.46	26	110.12	89	134.32	151	157.69
-161	35.11	-99	60.66	-36	85.85	27	110.51			152	158.06
		-98	61.06	-35	86.25	28	110.90	90	134.70	153	158.43
-160	35.53	-97	61.47	-34	86.64	29	111.28	91	135.08	154	158.81
-159	35.95	-96	61.87	-33	87.04			92	135.46	155	159.18
-158	36.37	-95	62.28	-32	87.43	30	111.67	93	135.84	156	159.55
-157	36.79	-94	62.68	-31	87.83	31	112.06	94	136.22	157	159.93
-156	37.21	-93	63.09			32	112.45	95	136.60	158	160.30
-155	37.63	-92	63.49	-30	88.22	33	112.83	96	136.98	159	160.67
-154	38.04	-91	63.90	-29	88.62	34	113.22	97	137.36		
-153	38.46			-28	89.01	35	113.61	98	137.74	160	161.04
-152	38.88	90	64.30	-27	89.40	36	113.99	99	138.12	161	161.42
-151	39.30	-89	64.70	-26	89.80	37	114.38			162	161.79
		-88	65.11	-25	90.19	38	114.77	100	138.50	163	162.16
-150	39.71	-87	65.51	-24	90.59	39	115.15	101	138.88	164	162.53
-149	40.13	-86	65.91	-23	90.98			102	139.26	165	162.90
-148	40.55	-85	66.31	-22	91.37	40	115.54	103	139.64	166	163.27
-147	40.96	-84	66.72	-21	91.77	41	115.93	104	140.02	167	163.65
-146	41.38	-83	67.12			42	116.31	105	140.39	168	164.02
-145	41.79	-82	67.52	-20	92.16	43	116.70	106	140.77	169	164.39
-144	42.21	-81	67.92	-19	92.55	44	117.08	107	141.15		
-143	42.63			-18	92.95	45	117.47	108	141.53	170	164.76
-142	43.04	-80	68.33	-17	93.34	46	117.85	109	141.91	171	165.13
-141	43.45	-79	68.73	-16	93.73	47	118.24			172	165.50
		-78	69.13	-15	94.12	48	118.62	110	142.29	173	165.87
-140	43.87	-77	69.53	-14	94.52	49	119.01	111	142.66	174	166.24
-139	44.28	-76	69.93	-13	94.91			112	143.04	175	166.61
-138	44.70	-75	70.33	-12	95.30	50	119.40	113	143.42	176	166.98
Temperature Conversion Platinum Resistance (240°C to 629°C) Temperature Coefficient - 0.00385 Ohms/Ohm/OC											
°C	Ohms	°C	Ohms	°C	Ohms	°C	Ohms	°C	Ohms	°C	Ohms
240	190.45	301	212.37	362	233.87	423	254.93	484	275.56	545	295.75
241	190.81	302	212.73	363	234.22	424	255.27	485	275.89	546	296.08
242	191.18	303	213.09	364	234.56	425	255.61	486	276.23	547	296.41
243	191.54	304	213.44	365	234.91	426	255.95	487	276.56	548	296.74
244	191.90	305	213.80	366	235.26	427	256.29	488	276.89	549	297.06
245	192.26	306	214.15	367	235.61	428	256.63	489	277.23		
246	192.63	307	214.51	368	235.96	429	258.98			550	297.39

Temperature Conversion Platinum Resistance (240°C to 629°C) Temperature Coefficient - 0.00385 Ohms/Ohm/OC											
247	192.99	308	214.86	369	236.31			490	277.56	551	297.72
248	193.35	309	215.22			430	257.32	491	277.90	552	298.04
249	193.71			370	236.65	431	257.66	492	278.23	553	298.37
		310	215.57	371	237.00	432	258.00	493	278.56	554	298.70
250	194.07	311	215.93	372	237.35	433	258.34	494	278.90	555	299.02
251	194.44	312	216.28	373	237.70	434	258.68	495	279.23	556	299.35
252	194.80	313	216.64	374	238.04	435	259.02	496	279.56	557	299.68
253	195.16	314	216.99	375	238.39	436	259.36	497	279.90	558	300.00
254	195.52	315	217.35	376	238.74	437	259.70	498	280.23	559	300.33
255	195.88	316	217.70	377	239.09	438	260.04	499	280.56		
256	196.24	317	218.05	378	239.43	439	260.38			560	300.65
257	196.60	318	218.41	379	239.78			500	280.90	561	300.98
258	196.96	319	218.76			440	260.72	501	281.23	562	301.31
259	197.33			380	240.13	441	261.06	502	281.56	563	301.63
		320	219.12	381	240.47	442	261.40	503	281.89	564	301.96
260	197.69	321	219.47	382	240.82	443	261.74	504	282.23	565	302.28
261	198.05	322	219.82	383	241.17	444	262.08	505	282.56	566	302.61
262	198.41	323	220.18	384	241.51	445	262.42	506	282.89	567	302.93
263	198.77	324	220.53	385	241.86	446	262.76	507	283.22	568	303.26
264	199.13	325	220.88	386	242.20	447	263.10	508	283.55	569	303.58
265	199.49	326	221.24	387	242.55	448	263.43	509	283.89		
266	199.85	327	221.59	388	242.90	449	236.77			570	303.91
267	200.21	328	221.94	389	243.24			510	284.22	571	304.23
268	200.57	329	222.29			450	264.11	511	284.55	572	304.56
269	200.93			390	243.59	451	264.45	512	284.88	573	304.88
		330	222.65	391	243.93	452	264.79	513	285.21	574	305.20
270	201.29	331	223.00	392	244.28	453	265.13	514	285.54	575	305.53
271	201.65	332	223.35	393	244.62	454	265.46	515	285.87	576	305.85
272	202.01	333	223.70	394	244.97	455	265.80	516	286.21	577	306.18
273	202.36	334	224.06	395	245.31	456	266.14	517	286.54	578	306.50
274	202.72	335	224.41	396	245.66	457	266.48	518	286.87	579	306.82
275	203.08	336	224.76	397	246.00	458	266.82	519	287.20		
276	203.44	337	225.11	398	246.35	459	267.15			580	307.15
277	203.80	338	225.46	399	246.69			520	287.53	581	307.47
278	204.16	339	225.81			460	267.49	521	287.86	582	307.79
279	204.52			400	247.04	461	267.83	522	288.19	583	308.12

Temperature Conversion Platinum Resistance (240°C to 629°C) Temperature Coefficient - 0.00385 Ohms/Ohm/OC											
		340	226.17	401	247.38	462	268.17	523	288.52	584	308.44
280	204.88	341	226.52	402	247.72	463	268.50	524	288.85	585	308.76
281	205.23	342	226.87	403	248.07	464	268.84	525	289.18	586	309.09
282	205.59	343	227.22	404	248.41	465	269.18	526	289.51	587	309.41
283	205.95	344	227.57	405	248.76	466	269.51	527	289.84	588	309.73
284	206.31	345	227.92	406	249.10	467	269.85	528	290.17	589	310.05
285	206.67	346	228.27	407	249.45	468	270.19	529	290.50		
286	207.02	347	228.62	408	249.79	469	270.52			590	310.38
287	207.38	348	228.97	409	250.13			530	290.83	591	310.70
288	207.74	349	229.32			470	270.86	531	291.16	592	311.02
289	208.10			410	250.48	471	271.20	532	291.49	593	311.34
		350	229.67	411	250.82	472	271.53	533	291.81	594	311.66
290	208.45	351	230.02	412	251.16	473	271.87	534	292.14	595	311.99
291	208.81	352	230.37	413	251.50	474	272.20	535	292.47	596	312.31
292	209.17	353	230.72	414	251.85	475	272.54	536	292.80	597	312.63
293	209.52	354	231.07	415	252.19	476	272.88	537	293.13	598	312.95
294	209.88	355	231.42	416	252.53	477	273.21	538	293.46	599	313.27
295	210.24	356	231.77	417	252.87	478	273.55	539	293.79		
296	210.59	357	232.12	418	253.22	479	273.88			600	313.59
297	210.95	358	232.47	419	253.56			540	294.11	601	313.91
298	211.31	359	232.82			480	274.22	541	294.44	602	314.24
299	211.66			420	253.90	481	274.55	542	294.77	603	314.56
		360	233.17	421	254.24	482	274.89	543	295.10	604	314.88
300	212.02	361	233.52	422	254.59	483	275.22	544	295.43	605	315.20

100W Platinum RTD Ω - 0.00385 coefficient												
°F	0	1	2	3	4	5	6	7	8	9	10	°F
Resistance in Ohms												
-320	20.44	20.20	19.96	19.72	19.48	19.24	19.00	18.76	18.52			-320
-310	22.83	22.59	22.35	22.11	21.87	21.63	21.39	21.16	20.92	20.68	20.44	-310
-300	25.20	24.97	24.73	24.49	24.25	24.02	23.78	23.54	23.30	23.06	22.83	-300
-290	27.57	27.33	27.10	26.86	26.62	26.39	26.15	25.91	25.68	25.44	25.20	-290
-280	29.93	29.69	29.46	29.22	28.98	28.75	28.51	28.28	28.04	27.81	27.57	-280
-270	32.27	32.04	31.80	31.57	31.34	31.10	30.87	30.63	30.40	30.16	29.93	-270
-260	34.61	34.38	34.14	33.91	33.68	33.44	33.21	32.98	32.74	32.51	32.27	-260
-250	36.94	36.71	36.47	36.24	36.01	35.78	35.54	35.31	35.08	34.84	34.61	-250
-240	39.26	39.03	38.80	38.56	38.33	38.10	37.87	37.64	37.40	37.17	36.94	-240
-230	41.57	41.34	41.11	40.88	40.65	40.42	40.19	39.95	39.72	39.49	39.26	-230
-220	43.88	43.65	43.42	43.19	42.96	42.73	42.49	42.26	42.03	41.80	41.57	-220
-210	46.17	45.94	45.71	45.48	45.26	45.03	44.80	44.57	44.34	44.11	43.88	-210
-200	48.46	48.23	48.00	47.78	47.55	47.32	47.09	46.86	46.63	46.40	46.17	-200
-190	50.74	50.52	50.29	50.06	49.83	49.60	49.38	49.15	48.92	48.69	48.46	-190
-180	53.02	52.79	52.56	52.34	52.11	51.88	51.65	51.43	51.20	50.97	50.74	-180
-170	55.29	55.06	54.83	54.61	54.38	54.15	53.93	53.70	53.47	53.25	53.02	-170
-160	57.55	57.32	57.10	56.87	56.65	56.42	56.19	55.97	55.74	55.51	55.29	-160
-150	59.81	59.58	59.35	59.13	58.90	58.68	58.45	58.23	58.00	57.78	57.55	-150
-140	62.06	61.83	61.61	61.38	61.16	60.93	60.71	60.48	60.26	60.03	59.81	-140
-130	64.30	64.08	63.85	63.63	63.40	63.18	62.95	62.73	62.50	62.28	62.06	-130
-120	66.54	66.31	66.09	65.87	65.64	65.42	65.20	64.97	64.75	64.52	64.30	-120
-110	68.77	68.55	68.33	68.10	67.88	67.66	67.43	67.21	66.99	66.76	66.54	-110
-100	71.00	70.78	70.55	70.33	70.11	69.89	69.66	69.44	69.22	68.99	68.77	-100
-90	73.22	73.00	72.78	72.56	72.33	72.11	71.89	71.67	71.45	71.22	71.00	-90
-80	75.44	75.22	75.00	74.78	74.55	74.33	74.11	73.89	73.67	73.45	73.22	-80
-70	77.66	77.43	77.21	76.99	76.77	76.55	76.33	76.11	75.88	75.66	75.44	-70
-60	79.86	79.64	79.42	79.20	78.98	78.76	78.54	78.32	78.10	77.88	77.66	-60
-50	82.07	81.85	81.63	81.41	81.19	80.97	80.75	80.53	80.31	80.09	79.86	-50
-40	84.27	84.05	83.83	83.61	83.39	83.17	82.95	82.73	82.51	82.29	82.07	-40
-30	86.47	86.25	86.03	85.81	85.59	85.37	85.15	84.93	84.71	84.49	84.27	-30
-20	88.66	88.44	88.22	88.00	87.78	87.56	87.34	87.13	86.91	86.69	86.47	-20
-10	90.85	90.63	90.41	90.19	89.97	89.75	89.54	89.32	89.10	88.88	88.66	-10

100W Platinum RTD Ω - 0.00385 coefficient												
°F	0	1	2	3	4	5	6	7	8	9	10	°F
Resistance in Ohms												
0	93.03	92.82	92.60	92.38	92.16	91.94	91.72	91.50	91.29	91.07	90.85	0
0	93.03	93.25	93.47	93.69	93.91	94.12	94.34	94.56	94.78	95.00	95.21	0
10	95.21	95.43	95.65	95.87	96.09	96.30	96.52	96.74	96.96	97.17	97.39	10
20	97.39	97.61	97.83	98.04	98.26	98.48	98.70	98.91	99.13	99.35	99.57	20
30	99.57	99.78	100.00	100.22	100.43	100.65	100.87	101.09	101.30	101.52	101.74	30
40	101.74	101.95	102.17	102.39	102.60	102.82	103.04	103.25	103.47	103.69	103.90	40
50	103.90	104.12	104.34	104.55	104.77	104.98	105.20	105.42	105.63	105.85	106.07	50
60	106.07	106.28	106.50	106.71	106.93	107.15	107.36	107.58	107.79	108.01	108.23	60
70	108.23	108.44	108.66	108.87	109.09	109.30	109.52	109.73	109.95	110.17	110.38	70
80	110.38	110.60	110.81	111.03	111.24	111.46	111.67	111.89	112.10	112.32	112.53	80
90	112.53	112.75	112.96	113.18	113.39	113.61	113.82	114.04	114.25	114.47	114.68	90
100	114.68	114.90	115.11	115.33	115.54	115.76	115.97	116.18	116.40	116.61	116.83	100
110	116.83	117.04	117.26	117.47	117.68	117.90	118.11	118.33	118.54	118.76	118.97	110
120	118.97	119.18	119.40	119.61	119.82	120.04	120.25	120.47	120.68	120.89	121.11	120
130	121.11	121.32	121.53	121.75	121.96	122.18	122.39	122.60	122.82	123.03	123.24	130
140	123.24	123.46	123.67	123.88	124.09	124.31	124.52	124.73	124.95	125.16	125.37	140
150	125.37	125.59	125.80		126.22	126.44	126.65	126.86	127.08	127.29	127.50	150
160	127.50	127.71	127.93		128.35	128.56	128.78	128.99	129.20	129.41	129.62	160
170	129.62	129.84	130.05		130.47	130.68	130.90	131.11	131.32	131.53	131.74	170
180	131.74	131.96	132.17		132.59	132.80	133.01	133.23	133.44	133.65	133.86	180
190	133.86	134.07	134.28		134.71	134.92	135.13	135.34	135.55	135.76	135.97	190
200	135.97	136.19	136.40		136.82	137.03	137.24	137.45	137.66	137.87	138.08	200
210	138.08	138.29	138.51		138.93	139.14	139.35	139.56	139.77	139.98	140.19	210
220	140.19	140.40	140.61		141.03	141.24	141.45	141.66	141.87	142.08	142.29	220
230	142.29	142.50	142.71		143.13	143.34	143.55	143.76	143.97	144.18	144.39	230
240	144.39	144.60	144.81		145.23	145.44	145.65	145.86	146.07	146.28	146.49	240
250	146.49	146.70	146.91		147.32	147.53	147.74	147.95	148.16	148.37	148.58	250
260	148.58	148.79	149.00		149.41	149.62	149.83	150.04	150.25	150.46	150.67	260
270	150.67	150.88	151.08		151.50	151.71	151.92	152.13	152.33	152.54	152.75	270
280	152.75	152.96	153.17		153.58	153.79	154.00	154.21	154.42	154.62	154.83	280
290	154.83	155.04	155.25		155.66	155.87	156.08	156.29	156.49	156.70	156.91	290
300	156.91	157.12	157.33		157.74	157.95	158.15	158.36	158.57	158.78	158.98	300
310	158.98	159.19	159.40		159.81	160.02	160.23	160.43	160.64	160.85	161.05	310
320	161.05	161.26	161.47		161.88	162.09	162.29	162.50	162.71	162.91	163.12	320

100W Platinum RTD Ω - 0.00385 coefficient												
°F	0	1	2	3	4	5	6	7	8	9	10	°F
Resistance in Ohms												
330	163.12	163.33	163.53	163.74	163.95	164.15	164.36	164.57	164.77	164.98	165.18	330
340	165.18	165.39	165.60	165.80	166.01	166.21	166.42	166.63	166.83	167.04	167.24	340
350	167.24	167.45	167.66	167.86	168.07	168.27	168.48	168.68	168.89	169.09	169.30	350
360	169.30	169.51	169.71	169.92	170.12	170.33	170.53	170.74	170.94	171.15	171.35	360
370	171.35	171.56	171.76	171.97	172.17	172.38	172.58	172.79	172.99	173.20	173.40	370
380	173.40	173.61	173.81	174.02	174.22	174.43	174.63	174.83	175.04	175.24	175.45	380
390	175.45	175.65	175.86	176.06	176.26	176.47	176.67	176.88	177.08	177.29	177.49	390
400	177.49	177.69	177.90	178.10	178.30	178.51	178.71	178.92	179.12	179.32	179.53	400
410	179.53	179.73	179.93	180.14	180.34	180.55	180.75	180.95	181.16	181.36	181.56	410
420	181.56	181.77	181.97	182.17	182.38	182.58	182.78	182.98	183.19	183.39	183.59	420
430	183.59	183.80	184.00	184.20	184.40	184.61	184.81	185.01	185.22	185.42	185.62	430
440	185.62	185.82	186.03	186.23	186.43	186.63	186.84	187.04	187.24	187.44	187.65	440
450	187.65	187.85	188.05	188.25	188.45	188.66	188.86	189.06	189.26	189.46	189.67	450
460	189.67	189.87	190.07	190.27	190.47	190.67	190.88	191.08	191.28	191.48	191.68	460
470	191.68	191.88	192.09	192.29	192.49	192.69	192.89	193.09	193.29	193.49	193.70	470
480	193.70	193.90	194.10	194.30	194.50	194.70	194.90	195.10	195.30	195.50	195.71	480
490	195.71	195.91	196.11	196.31	196.51	196.71	196.91	197.11	197.31	197.51	197.71	490
500	197.71	197.91	198.11	198.31	198.51	198.71	198.91	199.11	199.31	199.51	199.71	500
510	199.71	199.91	200.11	200.31	200.51	200.71	200.91	201.11	201.31	201.51	201.71	510
520	201.71	201.91	202.11	202.31	202.51	202.71	202.91	203.11	203.31	203.51	203.71	520
530	203.71	203.91	204.11	204.31	204.51	204.71	204.90	205.10	205.30	205.50	205.70	530
540	205.70	205.90	206.10	206.30	206.50	206.70	206.89	207.09	207.29	207.49	207.69	540
550	207.69	207.89	208.09	208.29	208.48	208.68	208.88	209.08	209.28	209.48	209.67	550
560	209.67	209.87	210.07	210.27	210.47	210.67	210.86	211.06	211.26	211.46	211.66	560
570	211.66	211.85	212.05	212.25	212.45	212.64	212.84	213.04	213.24	213.44	213.63	570
580	213.63	213.83	214.03	214.23	214.42	214.62	214.82	215.02	215.21	215.41	215.61	580
590	215.61	215.80	216.00	216.20	216.40	216.59	216.79	216.99	217.18	217.38	217.58	590
600	217.58	217.77	217.97	218.17	218.37	218.56	218.76	218.96	219.15	219.35	219.55	600
610	219.55	219.74	219.94	220.13	220.33	220.53	220.72	220.92	221.12	221.31	221.51	610
620	221.51	221.70	221.90	222.10	222.29	222.49	222.68	222.88	223.08	223.27	223.47	620
630	223.47	223.66	223.86	224.06	224.25	224.45	224.64	224.84	225.03	225.23	225.42	630
640	225.42	225.62	225.82	226.01	226.21	226.40	226.60	226.79	226.99	227.18	227.38	640
650	227.38	227.57	227.77	227.96	228.16	228.35	228.55	228.74	228.94	229.13	229.33	650
660	229.33	229.52	229.72	229.91	230.11	230.30	230.49	230.69	230.88	231.08	231.27	660

Appendices

CM-2201/CM-2202

Appendix G

RTD Tables (°F)

100W Platinum RTD Ω - 0.00385 coefficient												
°F	0	1	2	3	4	5	6	7	8	9	10	°F
Resistance in Ohms												
670	231.27	231.47	231.66	231.86	232.05	232.24	232.44	232.63	232.83	233.02	233.21	670
680	233.21	233.41	233.60	233.80	233.99	234.18	234.38	234.57	234.77	234.96	235.15	680
690	235.15	235.35	235.54	235.73	235.93	236.12	236.31	236.51	236.70	236.89	237.09	690
700	237.09	237.28	237.47	237.67	237.86	238.05	238.25	238.44	238.63	238.83	239.02	700
710	239.02	239.21	239.41	239.60	239.79	239.98	240.18	240.37	240.56	240.75	240.95	710
720	240.95	241.14	241.33	241.52	241.72	241.91	242.10	242.29	242.49	242.68	242.87	720
730	242.87	243.06	243.26	243.45	243.64	243.83	244.02	244.22	244.41	244.60	244.79	730
740	244.79	244.98	245.18	245.37	245.56	245.75	245.94	246.13	246.33	246.52	246.71	740
750	246.71	246.90	247.09	247.28	247.47	247.67	247.86	248.05	248.24	248.43	248.62	750
760	248.62	248.81	249.00	249.20	249.39	249.58	249.77	249.96	250.15	250.34	250.53	760
770	250.53	250.72	250.91	251.10	251.30	251.49	251.68	251.87	252.06	252.25	252.44	770
780	252.44	252.63	252.82	253.01	253.20	253.39	253.58	253.77	253.96	254.15	254.34	780
790	254.34	254.53	254.72	254.91	255.10	255.29	255.48	255.67	255.86	256.05	256.24	790
800	256.24	256.43	256.62	256.81	257.00	257.19	257.38	257.57	257.76	257.95	258.14	800
810	258.14	258.33	258.52	258.70	258.89	259.08	259.27	259.46	259.65	259.84	260.03	810
820	260.03	260.22	260.41	260.60	260.78	260.97	261.16	261.35	261.54	261.73	261.92	820
830	261.92	262.11	262.29	262.48	262.67	262.86	263.05	263.24	263.43	263.61	263.80	830
840	263.80	263.99	264.18	264.37	264.56	264.74	264.93	265.12	265.31	265.50	265.68	840
850	265.68	265.87	266.06	266.25	266.44	266.62	266.81	267.00	267.19	267.37	267.56	850
860	267.56	267.75	267.94	268.12	268.31	268.50	268.69	268.87	269.06	269.25	269.44	860
870	269.44	269.62	269.81	270.00	270.18	270.37	270.56	270.75	270.93	271.12	271.31	870
880	271.31	271.49	271.68	271.87	272.05	272.24	272.43	272.61	272.80	272.99	273.17	880
890	273.17	273.36	273.55	273.73	273.92	274.11	274.29	274.48	274.67	274.85	275.04	890
900	275.04	275.22	275.41	275.60	275.78	275.97	276.15	276.34	276.53	276.71	276.90	900
910	276.90	277.08	277.27	277.46	277.64	277.83	278.01	278.20	278.38	278.57	278.75	910
920	278.75	278.94	279.13	279.31	279.50	279.68	279.87	280.05	280.24	280.42	280.61	920
930	280.61	280.79	280.98	281.16	281.35	281.53	281.72	281.90	282.09	282.27	282.46	930
940	282.46	282.64	282.83	283.01	283.20	283.38	283.56	283.75	283.93	284.12	284.30	940
950	284.30	284.49	284.67	284.86	285.04	285.22	285.41	285.59	285.78	285.96	286.14	950
960	286.14	286.33	286.51	286.70	286.88	287.06	287.25	287.43	287.62	287.80	287.98	960
970	287.98	288.17	288.35	288.53	288.72	288.90	289.08	289.27	289.45	289.64	289.82	970
980	289.82	290.00	290.19	290.37	290.55	290.73	290.92	291.10	291.28	291.47	291.65	980
990	291.65	291.83	292.02	292.20	292.38	292.56	292.75	292.93	293.11	293.30	293.48	990

100W Platinum RTD Ω - 0.00385 coefficient												
°F	0	1	2	3	4	5	6	7	8	9	10	°F
Resistance in Ohms												
1000	293.48	293.66	293.84	294.03	294.21	294.39	294.57	294.76	294.94	295.12	295.30	1000
1010	295.30	295.48	295.67	295.85	296.03	296.21	296.40	296.58	296.76	296.94	297.12	1010
1020	297.12	297.31	297.49	297.67	297.85	298.03	298.21	298.40	298.58	298.76	298.94	1020
1030	298.94	299.12	299.30	299.49	299.67	299.85	300.03	300.21	300.39	300.57	300.75	1030
1040	300.75	300.94	301.12	301.30	301.48	301.66	301.84	302.02	302.20	302.38	302.56	1040
1050	302.56	302.75	302.93	303.11	303.29	303.47	303.65	303.83	304.01	304.19	304.37	1050
1060	304.37	304.55	304.73	304.91	305.09	305.27	305.45	305.63	305.81	305.99	306.17	1060
1070	306.17	306.35	306.53	306.71	306.89	307.07	307.25	307.43	307.61	307.79	307.97	1070
1080	307.97	308.15	308.33	308.51	308.69	308.87	309.05	309.23	309.41	309.59	309.77	1080
1090	309.77	309.95	310.13	310.31	310.49	310.67	310.85	311.02	311.20	311.38	311.56	1090
1100	311.56	311.74	311.92	312.10	312.28	312.46	312.64	312.81	312.99	313.17	313.35	1100
1110	313.35	313.53	313.71	313.89	314.07	314.24	314.42	314.60	314.78	314.96	315.14	1110
1120	315.14	315.31	315.49	315.67	315.85	316.03	316.21	316.38	316.56	316.74	316.92	1120
1130	316.92	317.10	317.27	317.45	317.63	317.81	317.98	318.16	318.34	318.52	318.70	1130
1140	318.70	318.87	319.05	319.23	319.41	319.58	319.76	319.94	320.12	320.29	320.47	1140
1150	320.47	320.65	320.82	321.00	321.18	321.36	321.53	321.71	321.89	322.06	322.24	1150
1160	322.24	322.42	322.59	322.77	322.95	323.13	323.30	323.48	323.66	323.83	324.01	1160
1170	324.01	324.18	324.36	324.54	324.71	324.89	325.07	325.24	325.42	325.60	325.77	1170
1180	325.77	325.95	326.12	326.30	326.48	326.65	326.83	327.00	327.18	327.36	327.53	1180
1190	327.53	327.71	327.88	328.06	328.24	328.41	328.59	328.76	328.94	329.11	329.29	1190
1200	329.29	329.46	329.64	329.82	329.99	330.17	330.34	330.52	330.69	330.87	331.04	1200
1210	331.04	331.22	331.39	331.57	331.74	331.92	332.09	332.27	332.44	332.62	332.79	1210
1220	332.79											1220

Appendix H

Warranty

Nelson Heat Trace Products LIMITED WARRANTY AND LIABILITY

Appleton Grp LLC - d/b/a Appleton Group warrants that if there are any defects in material or workmanship in any heating cable or accessory during the first year after the date of purchase, we will provide new products or replace any defective items, or we will refund the purchase price paid for the accessory or cable, not including any labor or other installation costs. As an alternate, we may elect to repair the cable or accessory at our factory with all shipping and other removal costs borne by the purchaser.

We further warrant that, for a period of twelve (12) months after the date of performance, any services performed here under will be in a good and skillful manner, based on our understanding of pertinent technical data as of the date of performance of such services. Appleton Group's sole responsibility and liability in the event of any defect, error, omission, or failure in the services rendered hereunder shall be to provide corrected services of the type provided for herein, designed to correct such defect, error, omissions, or failure, and in no event shall Appleton Group's liability with respect to such warranty exceed the amount received by it from the Buyer on account of such services.

Our obligation to provide corrected services, new products, refund the purchase price, or perform the repair described above is conditioned upon (a) the installation of the accessory or cable conforming to the directions set forth in our installation instructions and (b) the accessory or cable not having been damaged by mechanical or electrical activities unrelated to the operation of the accessory or cable.

A refund of your purchase price, provision of replacement products, repair of the accessory or cable or provision of corrected services as described above, shall be your sole and exclusive remedy for a breach of this warranty. THESE ARE THE SOLE AND EXCLUSIVE WARRANTIES GIVEN BY APPLETON GROUP WITH RESPECT TO THE GOODS AND SERVICES AND ARE IN LIEU OF AND EXCLUDE ALL OTHER WARRANTIES, EXPRESS OR IMPLIED, ARISING BY OPERATION OF LAW OR OTHERWISE, INCLUDING WITHOUT LIMITATION, MERCHANTABILITY AND FITNESS FOR A PARTICULAR PURPOSE WHETHER OR NOT THE PURPOSE OR USE HAS BEEN DISCLOSED TO NELSON IN SPECIFICATIONS, DRAWINGS OR OTHERWISE, AND WHETHER OR NOT APPLETON GROUP'S PRODUCTS ARE SPECIFICALLY DESIGNED AND/OR MANUFACTURED BY NELSON FOR YOUR USE OR PURPOSE.

This warranty does not extend to any losses or damages due to misuse, accident, abuse, neglect, normal wear and tear, negligence, unauthorized modification or alteration, use beyond rated capacity, or improper installation, maintenance or application. To the extent that you or your agents have supplied specifications, information, representation of operating conditions or other data to Appleton Group in the selection or design of the Goods and the preparation of Appleton Group's quotation, and in the event that actual operating conditions or other conditions differ from those represented by you, any warranties or other provisions contained herein which are affected by such conditions shall be null and void.

If within thirty (30) days after your discovery of any warranty defects within the warranty period, you notify Appleton Group thereof in writing. Appleton Group shall, at its option, repair, correct or replace F.O.B. point of manufacture, or refund the purchase price for, that portion of the Goods found by Appleton Group to be defective. Failure by you to give such written notice within the applicable time period shall be deemed an absolute and unconditional waiver of your claim for such defects. Goods repaired or replaced during the warranty period shall be covered by the foregoing warranty for the remainder of the original warranty period or ninety (90) days from the date of shipment of the repaired or replaced goods, whichever is longer.

This limited warranty does not cover any costs relating to the repair or replacement of any accessory or cable at the installation site. Our accessories and cables are not easily accessible. A failed accessory or cable usually cannot be easily repaired. Replacement of a failed accessory or cable will require that the materials under which it is installed be removed to permit replacement of the accessory or cable. We will not reimburse any costs relating to the repair or replacement of any accessory or cable at the installation site.

IN NO EVENT, REGARDLESS OF THE FORM OF THE CLAIM OR CAUSE OF ACTION (WHETHER BASED IN CONTRACT, INFRINGEMENT, NEGLIGENCE, STRICT LIABILITY, OTHER OR OTHERWISE), SHALL APPLETON GROUP'S LIABILITY TO YOU AND/OR YOUR CUSTOMERS EXCEED THE PRICE PAID BY YOU FOR THE SPECIFIC GOODS PROVIDED BY APPLETON GROUP GIVING RISE TO THE CLAIM OR CAUSE OF ACTION. YOU AGREE THAT WE SHALL NOT BE LIABLE TO YOU OR YOUR CUSTOMERS FOR ANY INCIDENTAL, SPECIAL OR CONSEQUENTIAL OR PUNITIVE DAMAGES.

No agent, employee or representative of ours has authority to bind us to any affirmation, representation of warranty concerning the goods sold unless such affirmation, representation or warranty is specifically incorporated by written agreement.

To obtain new products, arrange repair of existing product, or a refund under this warranty, please contact Appleton Group (800-621-1506) with a description of the defect and proof of purchase at the address noted herein.

Appleton Grp LLC-d/b/a Appleton Group 9377W. Higgins Rd.
Rosemont, IL 60018