



SLOT CAR TRACK SET - INSTRUCTION MANUAL

CHALLENGE LEVEL - 660CM / 21.6FT

LAYOUT

#83151 BATTERY REQUIREMENTS



OR



#83161 BATTERY REQUIREMENTS

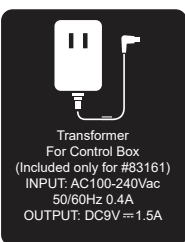

Recommend to play by adaptor

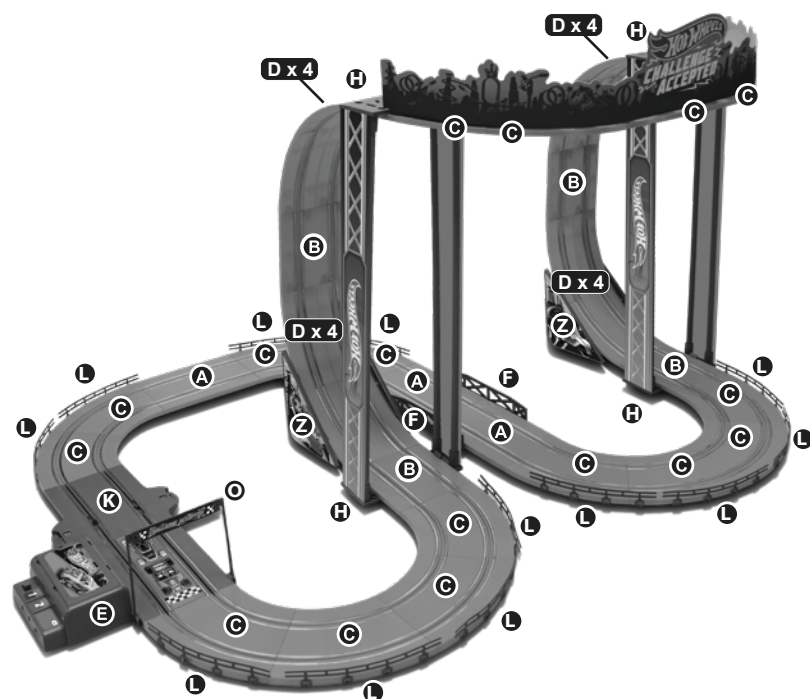

ASSEMBLY

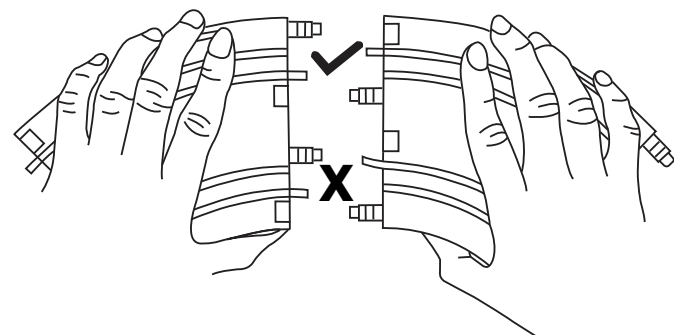

Adjust the distorted joints before joining tracks.
Do not join the tracks together if the joints are distorted.

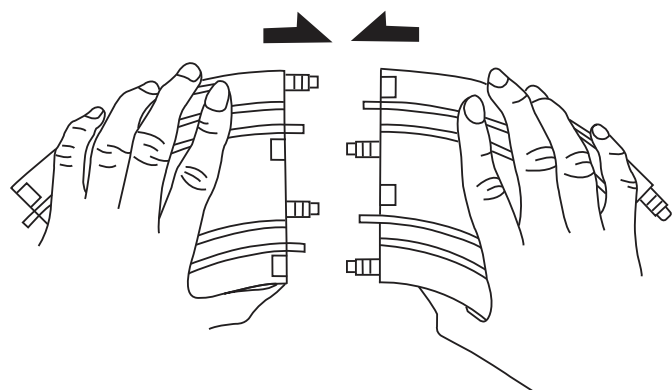

Hold and join tracks together as shown.

CONTENTS

TOTAL: 85 PIECES

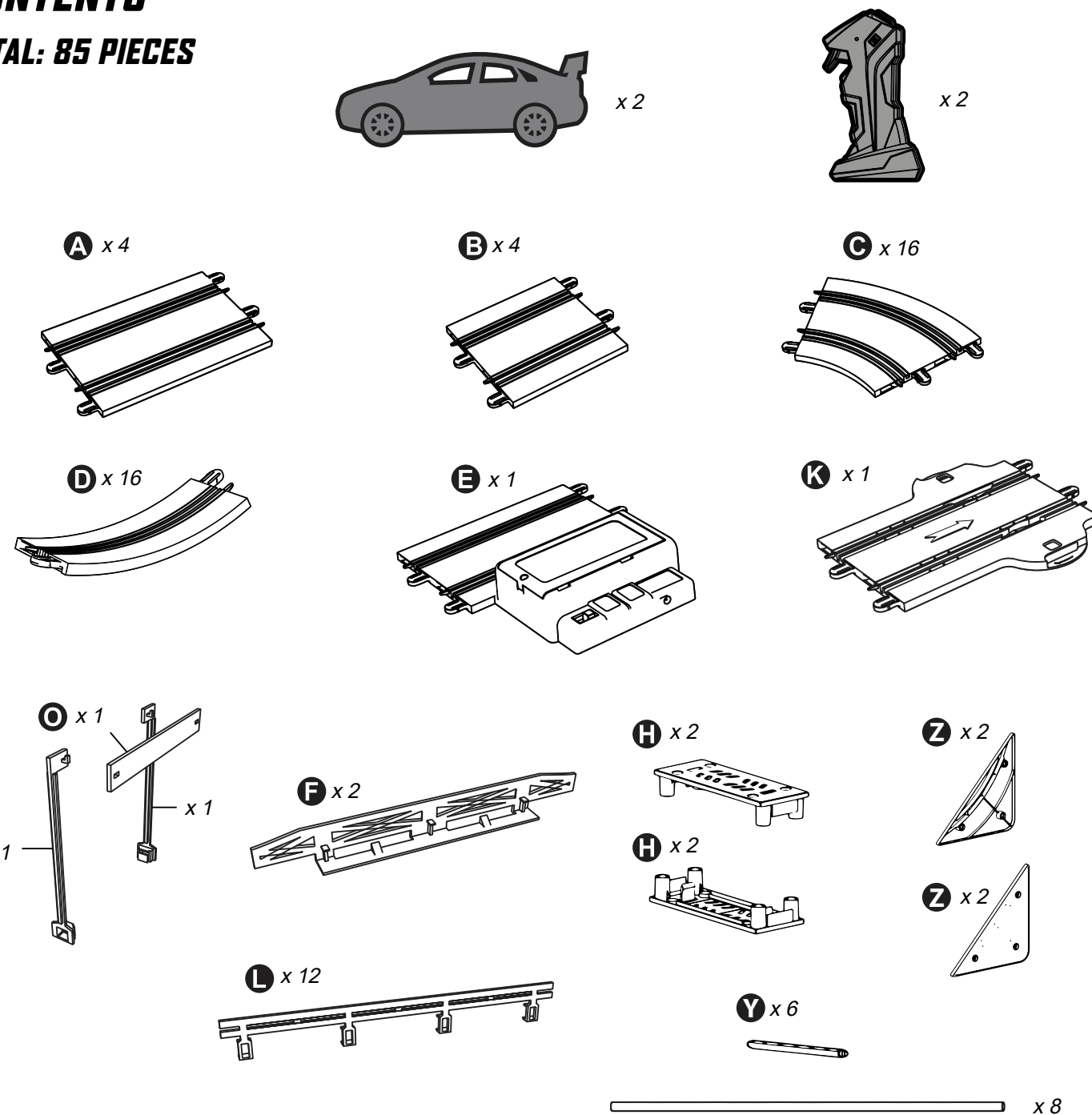

ASSEMBLY

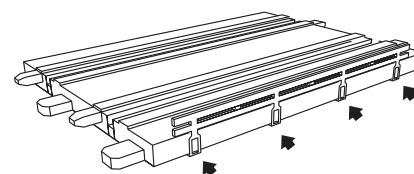

Attach the guardrail to the side of the track as shown.

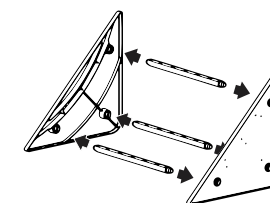
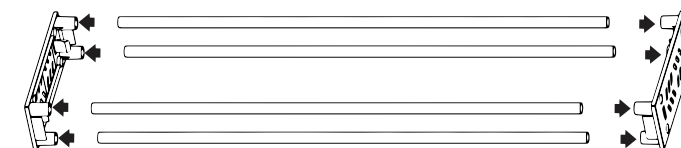

Assemble the track support

TO PLAY

Control box - Battery installation (For B/O Version)

2. Open the battery cover.

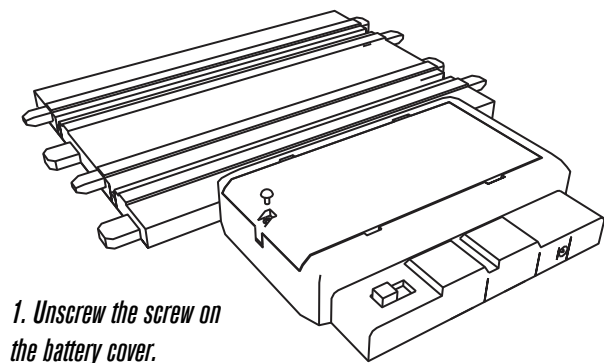

1. Unscrew the screw on the battery cover.

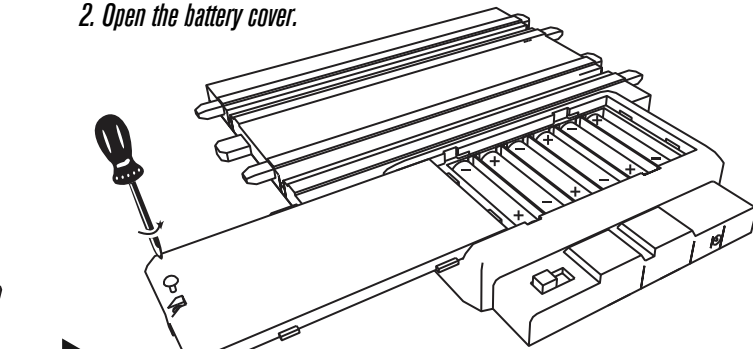

3. Insert new 6 x AA (1.5V) batteries into the battery compartment of the control box with the correct polarity (+/-).

4. Close the battery cover.

5. Tighten the screw on the battery cover.

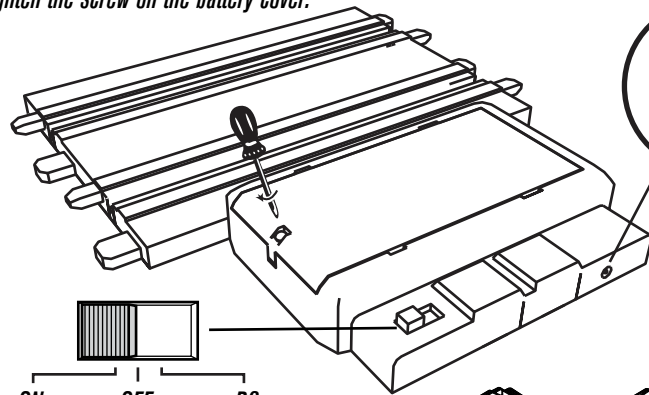

Transformer For Control Box (Included only for #83161)

ON OFF DC
(USE AA BATTERIES) (USE Transformer)

Speed Control

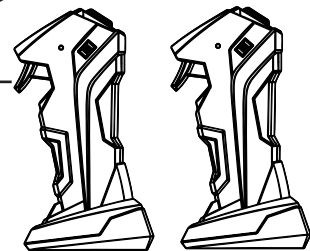

Transmitter - Battery installation

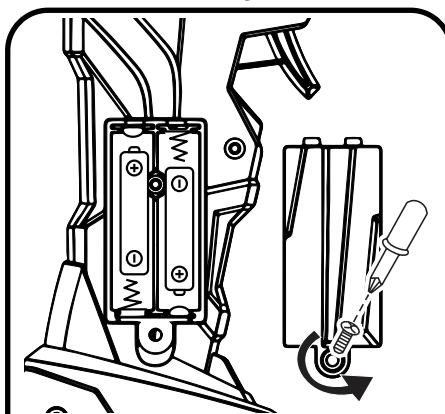

1. Unscrew the screw on the battery cover.

2. Open the battery cover.

3. Insert new 2 x AAA (1.5V) batteries into the battery compartment of each transmitter with the correct polarity (+/-).

4. Close the battery cover.

5. Tighten the screw on the battery cover.



The packaging and instruction manual contain important information. Please keep them for future reference. We reserve the right to improve/amend specifications and colors without notice.

SAFETY

- Alkaline batteries are recommended to be used (For B/O Version)
- Only batteries of the same or equivalent type as recommended are to be used
- Do not mix alkaline, standard or rechargeable batteries
- Do not mix old and new batteries or different type of batteries
- Non-rechargeable batteries are not to be charged
- Rechargeable batteries for adult charging only
- Rechargeable batteries are to be removed from the product before they are charged
- Be sure to insert batteries with correct polarities and always follow the battery manufacturer's instructions
- Remove all batteries when not in use
- Exhausted batteries are to be removed from the product
- The supply terminals are not to be short-circuited
- Dispose of batteries properly. Do not dispose the batteries in fire – it may cause them to explode or leak causing injury or damage
- Battery installation and removal must only be done by adult

FCC label compliance statement:

This device complies with part 15 of the FCC rules. Operation is subject to the following two conditions:

- This device may not cause harmful interference, and
- This device must accept any interference received, including interference that may cause undesired operation. Note: This equipment has been tested and found to comply with the limits for a Class B digital device, pursuant to Part 15 of the FCC Rules. These limits are designed to provide reasonable protection against harmful interference in a residential installation. This equipment generates, uses and can radiate radio frequency energy and, if not installed and used in accordance with the instructions, may cause harmful interference to radio communications. However, there is no guarantee that interference will not occur in a particular installation. If this equipment does cause harmful interference to radio or television reception, which can be determined by turning the equipment off and on, the user is encouraged to try to correct the interference by one or more of the following measures:
 - Reorient or relocate the receiving antenna
 - Increase the separation between the equipment and receiver
 - Connect the equipment into an outlet on a circuit different from that to which the receiver is connected
 - Consult the dealer or an experienced radio/TV technician for help

Warning: Changes or modifications to this unit not expressly approved by the party responsible for compliance could void the user's authority to operate the equipment.

RSS-210 Compliance Statement:

This device contains licence-exempt transmitter(s)/receiver(s) that comply with Innovation, Science and Economic Development Canada's licence-exempt RSS(s).

Operation is subject to the following two conditions:

- This device may not cause interference.
- This device must accept any interference, including interference that may cause undesired operation of the device.

Declaration of Conformity

The product is in conformity with the requirement of EU Directive 2014/53/EU

The instructions for battery toys with replaceable batteries shall contain the substance of the following, as applicable:

Control box : AA batteries x 6 should be used. **Transmitter** : AAA batteries x 4 (2 for each Transmitter) should be used.

Frequency band : 2450 - 2460 MHz

Maximum radio frequency power transmitted : <0 dBm



Environmental notes:

The whole product also does not belong to household waste at the end of the product life.

You can return it at collection points for the recycling of electronic and electrical instruments

The symbol on the item, instruction manual, hangtag or packing is showing this clearly.

Materials should be recycled according to their respective markings.

Recycling of old devices or other re-use of materials contained therein represents an important contribution to environmental protection.

Please ask at your local community for the correct collection point.



Disposal of batteries

Batteries should not be disposed of in the household waste. As the consumer you are legally obliged to return batteries containing harmful substances and all other used batteries. You can hand in your old batteries at public collection points in your area or wherever batteries are sold. You will find these chemical abbreviations along with a crossed-out refuse bin on batteries containing harmful substances:

Pb=Battery contains lead

Cd=Battery contains cadmium

Hg=Battery contains mercury



Conforms to the safety requirements of ASTM F963



PRODUCT MUST BE ASSEMBLED BY ADULT ONLY.

Kidztech Toys Manufacturing Ltd., Hong Kong.
MADE IN CHINA.
HOT WHEELS and associated trademarks and trade dress are owned by, and used under license from Mattel. ©2019 Mattel. All Rights Reserved.

HOTWHEELS.COM

CONSUMER INFORMATION

KIDZTECH TOYS MANUFACTURING LTD.
Room 802, 8/F, Inter-Continental Plaza,
94 Granville Road, TST East, Hong Kong.
Tel: (852) 27218868 info@kidztech.net
http://www.kidztech.net

PRODUCT: SLOT CAR TRACK SET
AGE GRADE: For ages over 5 years.
CONTENTS: All contents listed here.



www.kidztech.net

MAINTENANCE

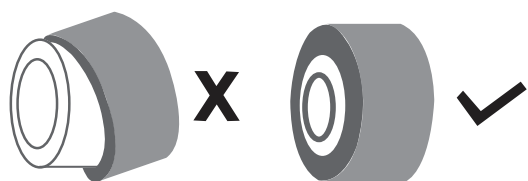

Make sure that the wheel tyres are located as shown.

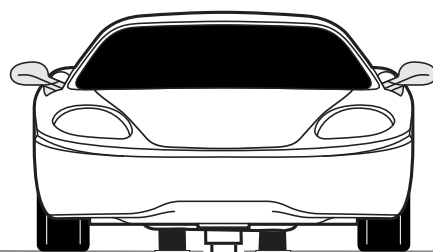

BRUSHES

Guide pin

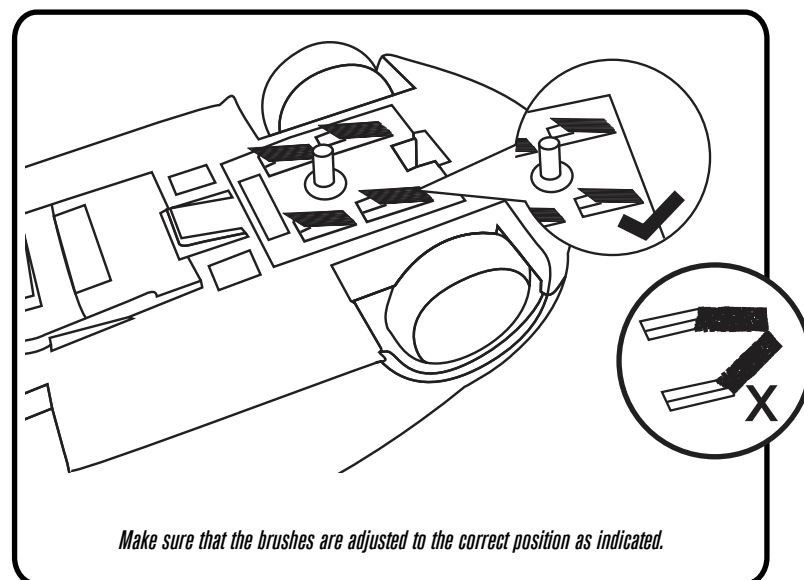

Make sure that the brushes are adjusted to the correct position as indicated.

Guide pin must be in the slot as shown. Check the brushes of the car are in the correct position. Place the car on the track and make sure it has good contacts with the track.