

SIEMENS

SIMATIC

S7-400

Point-to-point Link CP 441 Installation and Parameter Assignment

Manual

Preface

Product Description

1

Basic Principles of Serial Data Transmission

2

Commissioning the CP 441

3

Mounting the CP 441

4

Configuring and Assigning Parameters for the CP 441

5

Communication via System Function Blocks

6

Start-up Characteristics and Operating Mode Transitions of the CP 441

7

Diagnostics Functions of the CP 441

8

Programming Example for System Function Blocks

9

Technical Specifications

A

Cables

B

SFB Parameters

C

Accessories and Order Numbers

D

Literature on SIMATIC S7

E

Legal information

Warning notice system

This manual contains notices you have to observe in order to ensure your personal safety, as well as to prevent damage to property. The notices referring to your personal safety are highlighted in the manual by a safety alert symbol, notices referring only to property damage have no safety alert symbol. These notices shown below are graded according to the degree of danger.

⚠ DANGER
indicates that death or severe personal injury will result if proper precautions are not taken.
⚠ WARNING
indicates that death or severe personal injury may result if proper precautions are not taken.
⚠ CAUTION
with a safety alert symbol, indicates that minor personal injury can result if proper precautions are not taken.
CAUTION
without a safety alert symbol, indicates that property damage can result if proper precautions are not taken.
NOTICE
indicates that an unintended result or situation can occur if the relevant information is not taken into account.

If more than one degree of danger is present, the warning notice representing the highest degree of danger will be used. A notice warning of injury to persons with a safety alert symbol may also include a warning relating to property damage.

Qualified Personnel

The product/system described in this documentation may be operated only by **personnel qualified** for the specific task in accordance with the relevant documentation, in particular its warning notices and safety instructions. Qualified personnel are those who, based on their training and experience, are capable of identifying risks and avoiding potential hazards when working with these products/systems.

Proper use of Siemens products

Note the following:

⚠ WARNING
Siemens products may only be used for the applications described in the catalog and in the relevant technical documentation. If products and components from other manufacturers are used, these must be recommended or approved by Siemens. Proper transport, storage, installation, assembly, commissioning, operation and maintenance are required to ensure that the products operate safely and without any problems. The permissible ambient conditions must be complied with. The information in the relevant documentation must be observed.

Trademarks

All names identified by ® are registered trademarks of Siemens AG. The remaining trademarks in this publication may be trademarks whose use by third parties for their own purposes could violate the rights of the owner.

Disclaimer of Liability

We have reviewed the contents of this publication to ensure consistency with the hardware and software described. Since variance cannot be precluded entirely, we cannot guarantee full consistency. However, the information in this publication is reviewed regularly and any necessary corrections are included in subsequent editions.

Preface

Purpose of This Manual

This manual explains how to establish and operate a point-to-point link.

Contents of the manual

The manual describes the hardware and software of the CP 441 communication processor and its integration in an S7-400 automation system.

The following subjects are covered:

- The basics of point-to-point link with the CP 441
- Commissioning the CP 441
- Mounting the CP 441
- Communication via the CP 441
- Troubleshooting
- Application examples
- Properties and technical specifications

Scope of the manual

The manual is relevant to the following CPs and interface modules:

Product	Order number	As of Release
CP 441-1	6ES7 441-1AA04-0AE0	01
	6ES7 441-1AA05-0AE0	01
CP 441-2	6ES7 441-2AA04-0AE0	01
	6ES7 441-2AA05-0AE0	01
RS232 module	6ES7 963-1AA00-0AA0	01
	6ES7 963-1AA10-0AA0	01
20 mA TTY module	6ES7 963-2AA00-0AA0	01
	6ES7 963-2AA10-0AA0	01
X27 (RS422/485) module	6ES7 963-3AA00-0AA0	01
	6ES7 963-3AA10-0AA0	01

NOTICE

For CP 441 up to order number 6ES7 441-xAA04-0AE0, IF 963 interface modules with order number 6ES7 963-xAA00-0AA0 are used.

For CP 441 as of order number 6ES7 441-xAA05-0AE0, the IF 963 interface modules with order number 6ES7 963-xAA10-0AA0 must be used.

Note

The descriptions of the CP 441 communication processor and the interface modules in this manual were correct at the time of publication. We reserve the right to describe modifications to the functionality of the modules in a separate Product Information.

Changes compared to the previous version (04/2011)

Compared to edition 04/2011 of this manual, this edition describes the additional functions of the CP 441 (as of order number 6ES7441-xAA05-AE0; x=1,2).

This includes:

- Firmware update via HW Config
- Identification data (I&M functions)
- Elimination of limitations (depending on the type of interface) for the data transmission rate
 - CP441-1: Additional data transmission rates 57.6, 76.8 and 115.2 kbps
 - CP441-2: Both interfaces can be operated with 115.2 kbps
- Lowest character delay time at 9600 bps: 2 ms
- Lowest character delay time at data transmission rates ≥ 19.2 kbps: 1 ms
- The dependency of the waiting times on the data transmission rate can be set with RK512.

Approvals

You can find detailed information about certificates, approvals and standards in the manual *S7-400 Programmable Controller; Module Specifications*.

Structure of This Manual

To help you to quickly find the information you require, this manual offers the following:

- A heading indicating the contents of each section is provided in the left-hand column on each page of each chapter.
- Following the appendices, a glossary defines important technical terms used in the manual.
- Finally, a comprehensive index allows quick access to information on specific subjects.

Additional assistance

Please contact your local Siemens representative if you have any queries about the products described in this manual.

- Find your contact partner at:
<http://www.siemens.de/automation/partner> (<http://www.siemens.com/automation/partner>)
- You can find the guide to the technical documentation for the individual SIMATIC products and systems at:
<http://www.siemens.de/simatic-doku> (<http://www.siemens.com/simatic-doku>)
- The online catalog and the online ordering system are available at:
<http://www.siemens.de/automation/mall> (<http://www.siemens.com/automation/mall>)

Conventions

This manual uses the generic term CP 441. This information in the manual applies to the CP 441-1 and CP 441-2 communication processors, unless otherwise specified.

Training Center

We offer a range of courses to help get you started with the S7 automation system. Please contact your local training center or the central training center in Nuremberg, D-90327 Germany.

Internet: <http://www.siemens.com/sitrain> (<http://www.siemens.com/sitrain>)

Technical support

You can reach the technical support for all A&D products

- Use the Web form for the support request

<http://www.siemens.com/automation/support-request>
(<http://www.siemens.com/automation/support-request>)

Additional information about Siemens Technical Support is available on the Internet at
<http://www.siemens.de/automation/service&support>
(<http://www.siemens.com/automation/service&support>)

Service & Support on the Internet

In addition to our documentation, we offer a comprehensive knowledge base online on the Internet.

<http://www.siemens.de/automation/service&support>
(<http://www.siemens.com/automation/service&support>)

There you will find:

- The newsletter, which provides the latest information on your products.
- The documents you require, using our Service & Support search engine.
- A forum where users and specialists exchange information worldwide.
- Your local service partner for Automation & Drives in our contact database.
- Information about on-site service, repairs and spare parts. And much more is available under "Services".

Table of contents

	Preface	3
1	Product Description	11
1.1	Applications for the Communication Processor	11
1.2	Transmission Procedure with a Point-to-Point Connection	14
1.3	Structure of the CP 441	16
1.4	Properties of the Serial Interface	18
1.4.1	Properties of the RS232 interface module	18
1.4.2	Attributes of the 20mA TTY interface submodule	19
1.4.3	Properties of the X27 (RS422/485) interface module	20
1.5	Installation Guidelines	21
2	Basic Principles of Serial Data Transmission.....	23
2.1	Serial transmission of a character	23
2.2	Transmission Procedure with a Point-to-Point Connection	27
2.3	Transmission integrity	29
2.4	Data Transmission with the 3964(R) Procedure.....	32
2.4.1	Control characters.....	33
2.4.2	Block Checksum	34
2.4.3	Sending data with 3964(R)	35
2.4.4	Receiving data with 3964(R).....	39
2.4.5	Handling Erroneous Data.....	43
2.5	Data transmission with the RK512 computer link	46
2.5.1	Sending data with RK512	49
2.5.2	Fetching data with RK512.....	52
2.6	Data Transmission with the ASCII Driver	58
2.6.1	Sending Data with the ASCII Driver.....	58
2.6.2	Receiving Data with the ASCII Driver	61
2.6.3	RS485 mode	67
2.6.4	RS232 mode	68
2.7	Data Transmission with the Printer Driver	72
2.8	Parameter Assignment Data of the Protocols.....	74
2.8.1	Parameter assignment data of the 3964(R) procedure	74
2.8.2	Parameter assignment data of the RK512 computer link	80
2.8.3	Parameter assignment data of the ASCII driver	80
2.8.4	Parameter Assignment Data of the Printer Driver	87
2.8.4.1	Parameter assignment data	87
2.8.4.2	Conversion and control statements for printer output.....	97

3	Commissioning the CP 441	107
4	Mounting the CP 441	109
4.1	CP 441 slots	109
4.2	Mounting and Dismounting the CP 441	110
4.2.1	Installation steps	110
4.2.2	Removal steps	110
4.3	Installing and Removing the Interface Submodules of the CP 441	111
5	Configuring and Assigning Parameters for the CP 441	113
5.1	Parameters for the communications protocols.....	115
5.2	Managing the Parameter Data	117
5.3	Multiprocessor communication.....	118
5.4	Identification data	119
5.5	Subsequent Loading of Drivers (Transmission Protocols).....	120
5.6	Connection Configuration.....	122
5.6.1	Simplified Connection Configuration	123
5.6.2	Complete Connection Configuration	124
5.6.3	Enter a connection in the connection table	125
5.7	Procedure in the "Properties - PtP Connection" dialog	126
5.7.1	"Properties - PtP Connection" dialog, procedures for the ASCII driver, printer driver and 3964(R) procedure	126
5.7.2	"Properties - PtP Connection" dialog, procedure with RK512 computer link.....	129
5.8	Firmware Updates	133
5.8.1	Subsequent Loading of Firmware Updates.....	133
5.8.2	Viewing the Firmware Version	136
6	Communication via System Function Blocks	137
6.1	Overview of the System Function Blocks.....	138
6.2	Using the System Function Blocks	139
6.3	Using the System Function Blocks with the 3964(R) Procedure	144
6.3.1	Applications	144
6.3.2	Data Transmission with 3964(R) Using BSEND and BRCV.....	146
6.3.3	Data transmission with 3964(R) using BSEND and a receive mailbox	149
6.4	Using the system function blocks with the RK512 computer link.....	151
6.4.1	Send data with a static destination definition with RK512	151
6.4.2	Sending data with RK512 to the CP 441 communication partner with static destination definition, use of BSEND and BRCV	153
6.4.3	Sending data with RK512 to the communication partner CP 441 with static destination definition, using BSEND.....	157
6.4.4	Sending data with RK512 to the S5 communication partner or third-party device with static destination definition	161
6.4.5	Sending data with RK512 to a communication partner with dynamic destination definition.....	167
6.4.6	Fetching data with RK512 from a communication partner.....	171

6.5	Using the System Function Blocks with the ASCII Driver.....	175
6.5.1	Reading the RS232 accompanying signals	176
6.5.2	Controlling the RS232 accompanying signals	179
6.6	Using the system function blocks with the printer driver.....	181
6.7	Summary.....	183
7	Start-up Characteristics and Operating Mode Transitions of the CP 441	185
7.1	Startup Characteristics of the CP 441	185
7.2	Operating Mode Transitions of the CP 441	186
8	Diagnostics Functions of the CP 441	187
8.1	Diagnostics via the display elements of the CP 441.....	189
8.2	Diagnostics Messages of the System Function Blocks	190
8.3	Diagnostics via the error signaling area SYSTAT.....	195
8.4	Error Numbers in the Response Message Frame	209
8.5	Diagnostics via the diagnostic buffer of the CP 441	211
8.6	Diagnostic interrupt.....	213
9	Programming Example for System Function Blocks	217
9.1	General Information	217
9.2	Device Configuration.....	219
9.3	Configuring the Controller Setup.....	220
9.4	Parameterizing the CP 441.....	221
9.5	Configuring the Connection to the Communication Partner	222
9.6	Programming an ASCII/3964(R) User Program	223
9.7	Programming an RK512 user program.....	224
9.7.1	Program CP 441 RK512 Send/Recv	224
9.7.2	Blocks Used in the Sample Program	226
9.8	Programming a Printer User Program	227
9.8.1	Cyclic Program.....	228
9.8.2	Blocks Used in the Sample Program	229
9.9	Installation, Error Messages	230

A	Technical Specifications	231
A.1	Technical data of the CP 441 and the interface modules	231
B	Cables	233
B.1	RS232 interface module.....	233
B.2	20mA TTY interface submodule	240
B.3	X27 (RS422/485) interface module.....	247
C	SFB Parameters	251
D	Accessories and Order Numbers	255
E	Literature on SIMATIC S7	257
	Glossary	259
	Index.....	265

Product Description

1.1 Applications for the Communication Processor

Introduction

The communication processor allows you to exchange data between programmable controllers or computers by means of a point-to-point link.

Functionality of the CP 441

The CP 441 communication processor provides the following functionality:

- A choice of two models with either one (the CP 441-1) or two (CP 441-2) serial device interfaces, which can be adjusted to suit the properties of the communication partners by means of plug-in interface modules. There are three interface modules available:
 - RS232 interface module
 - 20mA TTY interface module
 - X27 (RS422/485) interface module
- Transmission rate:
 - CP 441-1 (6ES7 441-1AA04-0AE0): Max. 38.4 kbps
 - CP 441-1 (6ES7 441-1AA05-0AE0): Max. 115.2 kbps
 - CP 441-2 (6ES7 441-2AA04-0AE0): Max. 115.2 kbps (sum data transmission rate)
 - CP 441-2 (6ES7 441-2AA05-0AE0): Max. 115.2 kbps per interface
- Integration of the most important transmission protocols in the module firmware.
- Custom parameter assignment of the transmission protocols with the **CP441: Configuration Package for Point to Point Communication** parameter assignment interface
- For CP 441-2 from order number 6ES7 441-2AA02-0AE0 to order number 6ES7 441-2AA04-0AE0 is the reloading of customer-specific driver (transmission protocols) with the **CP 441: Configuration Package for Point to Point Communication** possible.

Note

Modbus

The firmware of the CP 441-2 with order number 6ES7 441-2AA05-0AE0 already includes drivers for Modbus master, Modbus slave and Data Highway that can be used with a dongle.

Configuration of the reloadable drivers requires the installation of the packages for Modbus master and Modbus slave.

Combination options for CP with interface module

NOTICE
For CP 441 up to order number 6ES7 441-xAA04-0AE0, IF 963 interface modules with order number 6ES7 963-xAA00-0AA0 are used.
For CP 441 as of order number 6ES7 441-xAA05-0AE0, the IF 963 interface modules with order number 6ES7 963-xAA10-0AA0 must be used.

Interface module	CP			
	CP 441-x (6ES7 441-xAA04-0AE0)		CP 441-x (6ES7 441-xAA05-0AE0)	
	CP 441-1 (x=1)	CP 441-2 (x=2)	CP 441-1 (x=1)	CP 441-2 (x=2)
IF963 module RS232 6ES7 963-1AA00-0AA0	•	•	-	-
IF963 module TTY 6ES7 963-2AA00-0AA0	•	•	-	-
IF963 module RS422/RS485 6ES7 963-3AA00-0AA0	•	•	-	-
IF963 module RS232 6ES7 963-1AA10-0AA0	-	-	•	•
IF963 module TTY 6ES7 963-2AA10-0AA0	-	-	•	•
IF963 module RS422/RS485 6ES7 963-3AA10-0AA0	-	-	•	•

Integrated Transmission Protocols

The following transmission protocols are integrated in the module firmware of the CP 441:

Table 1- 1 Transmission Protocols in the Module Firmware

Product	Integrated drivers
CP 441-1	3964(R) procedure, ASCII driver, printer driver
CP 441-2	3964(R) procedure, ASCII driver, RK512 computer link, printer driver

Applications for the Communication Processor

The communication processor allows point-to-point link with SIMATIC modules and with third-party products.

Supported interface module functions

Different driver functions can be used depending on the interface module used:

Table 1- 2 Functions of the CP 441 depending on the interface module used







Function	RS232	20mA TTY	X27 (RS422/485) *	
			RS422	RS485
3964(R) procedure	Yes	Yes	Yes	No
RK512 computer link	Yes	Yes	Yes	No
ASCII driver:	Yes	Yes	Yes	Yes
• Automatic operation of the RS232 accompanying signals	Yes	No	No	No
• Controlling/reading the RS232 accompanying signals with FBs	Yes	No	No	No
• RTS/CTS data flow control	Yes	No	No	No
• XON/XOFF data flow control	Yes	Yes	Yes	No
Printer driver:	Yes	Yes	Yes	Yes
• RTS/CTS data flow control	Yes	No	No	No
• XON/XOFF data flow control	Yes	Yes	Yes	No
* The difference between RS422 and RS485 is defined by configuration.				

1.2 Transmission Procedure with a Point-to-Point Connection

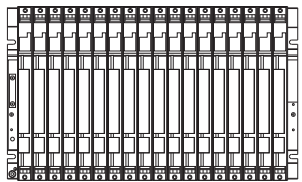
Hardware Components

For a point-to-point link using the CP 441, you require certain hardware components.

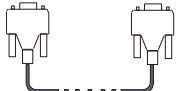



Table 1-3 Hardware Components for a Point-to-Point Link with the CP 441

Components	Function	Diagram
Rack	... provides the mechanical and electrical connections of the S7-400.	
Power supply module (PS)	... converts the line voltage (120/230 V AC or 24 V DC) into the operating voltage of 24 V and 5 V DC required to supply the S7-400.	
Central processor unit (CPU) Accessories: <ul style="list-style-type: none"> • Memory card • Backup battery 	... executes the user program; communicates via the PROFINET or MPI interface with other CPUs or with a programming device.	
CP 441 communication processor Interface modules	... communicates via the interface with one or more communication partners. ... enable the CP 441 to be adapted to suit the communication partner.	
Standard cable	... connects the CP 441 communication processor to the communication partner.	
Programming device cable	... connects a CPU to a programming device/PC.	
Programming device (PG) or PC	... communicates with the CPU of the S7-400.	

Software components

The following table lists the software components required for establishing a point-to-point link with the CP 441.

Table 1- 4 Software components for a point-to-point link with the CP 441

Components	Function	Diagram
STEP 7 software package	... configures, assigns parameters, programs and tests the S7-400.	 + 
Parameter assignment interface: Configuration Package for Point to Point Communication	... assigns parameters for the interfaces of the CP 441.	
Function blocks	... for reading and controlling the RS232 accompanying signals.	
Programming example	... with user programs for printer output and data transfer by means of the ASCII driver, RK512 computer link and the 3964(R) procedure.	
Loadable drivers	... with transmission protocols that can be loaded on the CP 441-2 in addition to the standard protocols in the module firmware.	 + 

1.3 Structure of the CP 441

Setup

The CP 441-1 communication processor has one slot and the CP 441-2 has two slots for plug-in interface modules. The operator control and display elements are in the same position on both the CP 441-1 and the CP 441-2. Identical elements have the same functions on both models.

Position of Operator Control and Display Elements

The figure shows the positions of the operator control and display elements on the front panel of the CP 441-1 and the CP 441-2 communication processors.

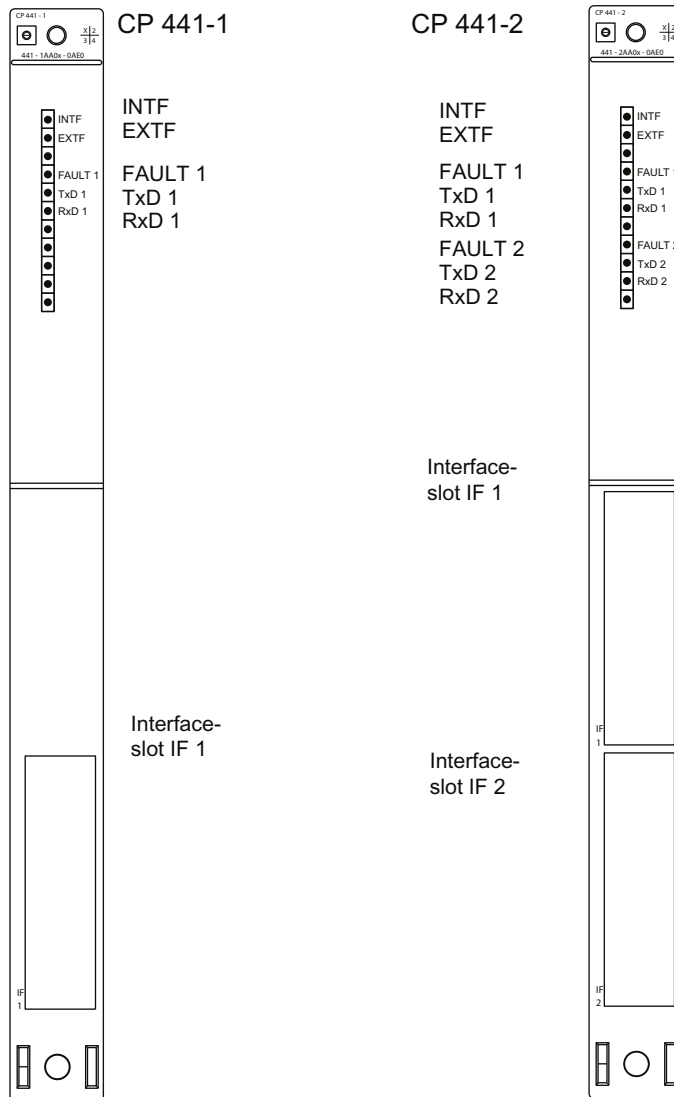

Figure 1-1 Position of the operator control and display elements on the CP 441-1 and CP 441-2 communication processors

LEDs

The following LEDs are located on the front panel of the CP 441:

- INTF (red) CP 441 signals internal fault
- EXFT (red) CP 441 signals external fault
- FAULT 1 (red) Fault display for Interface IF 1
- TXD 1 (green) Interface IF 1 is sending
- RXD 1 (green) Interface IF 1 is receiving
- FAULT 2 (red) Fault display for Interface IF 2 (CP 441-2)
- TXD 2 (green) Interface IF 2 is sending (CP 441-2)
- RXD 2 (green) Interface IF 2 is receiving (CP 441-2)

Slot for Interface Modules

The CP 441-1 contains one slot and the CP 441-2 has two slots for plug-in interface modules. By exchanging the interface modules, you can adapt the CP 441 to suit the properties of the communication partners.

There are three types of interface modules:

- RS232 (see section "Properties of the RS232 interface module (Page 18)")
- 20 mA TTY (see section "Attributes of the 20mA TTY interface submodule (Page 19)")
- X27 (RS422/485) (see section "Properties of the X27 (RS422/485) interface module (Page 20)")

Note

The design of the interface modules for the CP 441 as of order number 6ES7 441-xAA05-OAE0 is different mechanically from earlier interface modules.

Base Connector for S7 Rear Panel Bus

On the back panel of the CP 441 you will find the base connector for the S7-400 rear panel bus.

The S7-400 rear panel bus is a serial data bus via which the CP 441 communicates with the modules of the programmable controller and is supplied with the necessary voltage.

1.4 Properties of the Serial Interface

Introduction

Two module variants of the communication processor are available with three different interface modules for adapting to the properties of communication partners.

Standard Cables

Siemens offers standard cables in various lengths for point-to-point link between the communication processor and a communication partner.

1.4.1 Properties of the RS232 interface module

Definition

The RS232 interface is a voltage interface used for serial data transmission in compliance with the RS232 standard.

Properties

The RS232 interface module has the following properties and fulfills the following requirements:

- Type: Voltage interface
- Front connector: 9-pin sub D male connector with screw-locking
- Max. data transmission rate: 115.2 kbps
- Max. cable length: 15 m
- Standard: DIN 66020, DIN 66259, EIA-RS232, CCITT V.24/V.28
- Degree of protection: IP 00

Please observe the maximum permitted data transmission rates for the modules.

See also

RS232 interface module (Page 233)

1.4.2 Attributes of the 20mA TTY interface submodule

Definition

The 20mA TTY interface module is a current-loop interface used for serial data transmission.

Properties

The 20mA TTY interface module has the following attributes and fulfills the following requirements:

- Type: Linear current interface
- Front connector: 9-pin subminiature D female with screw interlock
- Max. data transmission rate: 19.2 kbps
- Max. cable length: 1000 m at 9600 bps
- Standard: DIN 66258 Part 1
- Degree of protection: IP 00

Please observe the maximum permitted data transmission rates for the modules.

See also

20mA TTY interface submodule (Page 240)

1.4.3 Properties of the X27 (RS422/485) interface module

Definition

The X27 (RS 422/485) interface is a differential voltage interface for serial data transmission in compliance with the X27 standard.

Properties

The X27 (RS422/485) interface module has the following properties and fulfills the following requirements:

- Type: Differential voltage interface
- Front connector: 15-pin sub-D female, with screwed interlock
- Max. data transmission rate: 115.2 kbps
- Max. cable length: 1200 m at 19200 bps
- Standard: DIN 66259 Parts 1 and 3, EIA-RS 422/485, CCITT V.11
- Degree of protection: IP 00

Please observe the maximum permitted data transmission rates for the modules.

Note

With the RK512 and 3964(R) protocols, the X27 (RS422/485) interface module can only be used in 4-wire mode.

See also

X27 (RS422/485) interface module (Page 247)

1.5 Installation Guidelines

Considerations

The general installation guidelines for S7-400 must be followed (see the *S7-400 Automation System, Installation* manual).

To meet the EMC (electromagnetic compatibility) values, the cable shield must be connected to a shield bus.

Basic Principles of Serial Data Transmission

2.1 Serial transmission of a character

Introduction

The system provides various networking options for the exchange of data between two or more communication partners. The simplest form of data interchange is via a point-to-point link between two communication partners.

Point-to-point link

In point-to-point link the communication processor forms the interface between a programmable controller and a communication partner. In PtP link with communication processor, data are transferred via serial interface.

Serial Transmission

In serial transmission, the individual bits of each byte of information are transmitted one after the other in a fixed order.

Unidirectional/Bidirectional Data Traffic

The CP 441 itself handles data transmission with communication partners via its serial interface. The CP 441 is equipped with three different drivers for this purpose.

- Unidirectional data traffic:
 - Printer Driver
- Bidirectional data traffic:
 - ASCII driver
 - 3964(R) procedure
 - RK512 computer link

The CP 441 handles data transmission via the serial interface in accordance with the interface type and the selected driver.

Unidirectional Data Traffic - Printer Output

In the case of printer output (printer driver), n bytes of user data are output to a printer. No characters are received. The only exception to this are data flow control characters (e.g. XON/XOFF).

Bidirectional Data Traffic - Operating Modes

The communication processor has two operating modes for bidirectional data traffic:

- Half-duplex operation (3964(R) procedure, ASCII driver, RK512)

The data is exchanged between the communication partners in both directions alternately. In half-duplex operation, therefore, at any one time data is being either sent or received. The exception to this may be individual control characters for data flow control (e.g. XON/XOFF), which can also be sent during a receive operation or received during a send operation.

- Full-duplex operation (ASCII driver)

The data is exchanged between the communication partners in both directions simultaneously, it can both send and receive at the same time. Every communication partner must be able to operate a send and a receive facility simultaneously.

Only half-duplex mode can be used with an X27 interface module (RS422/485) set to RS485 (2-wire).

Asynchronous Data Transmission

With the communication processor, serial transmission occurs asynchronously. The so-called time base synchronism (a fixed timing code used in the transmission of a fixed character string) is only upheld during transmission of a character. Each character to be sent is preceded by a synchronization impulse, or start bit. The length of the start-bit transmission determines the clock pulse. The end of the character transmission is signaled by the stop bit.

Declarations

As well as the start and stop bits, further declarations must be made between the sending and receiving partners before serial transmission can take place. These include:

- The data transmission rate
- Character and acknowledgment delay times
- Parity
- Number of data bits
- Number of stop bits

Character frame

Data is transmitted between the communication processor and a communication partner via the serial interface in a character frame. Various data formats are available for the character frame. You can set the format for data transmission with the **CP 441: Configuration Package for Point to Point Communication** parameter assignment interface.

The figure below shows examples of different data formats for a 10-bit character frame.

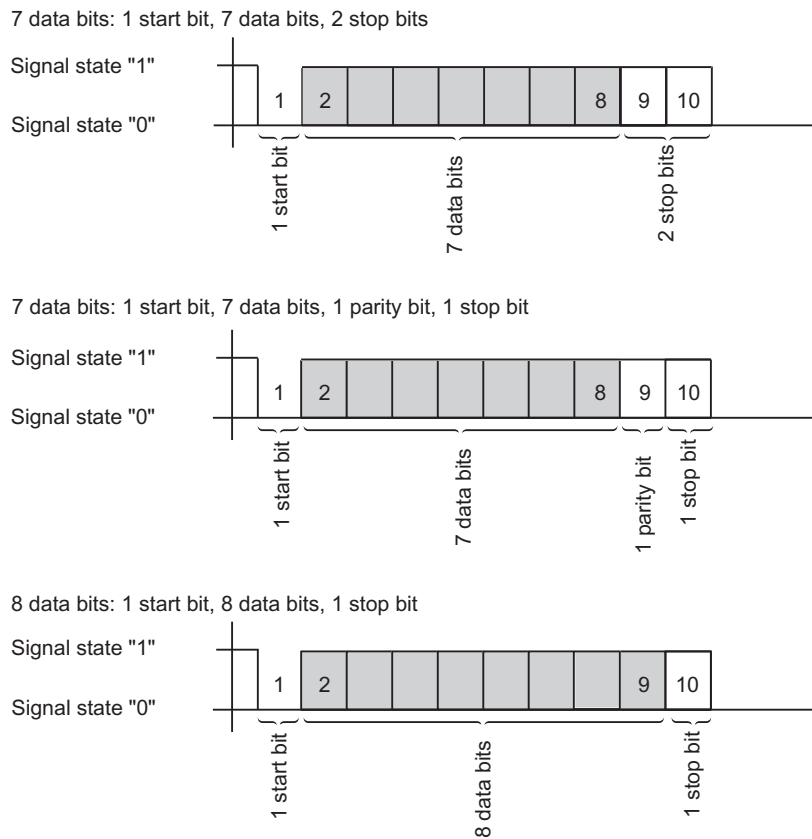

Figure 2-1 10-Bit Character Frame

Character Delay Time

The figure below shows the maximum time permitted between two characters received within a frame. This is known as the character delay time.

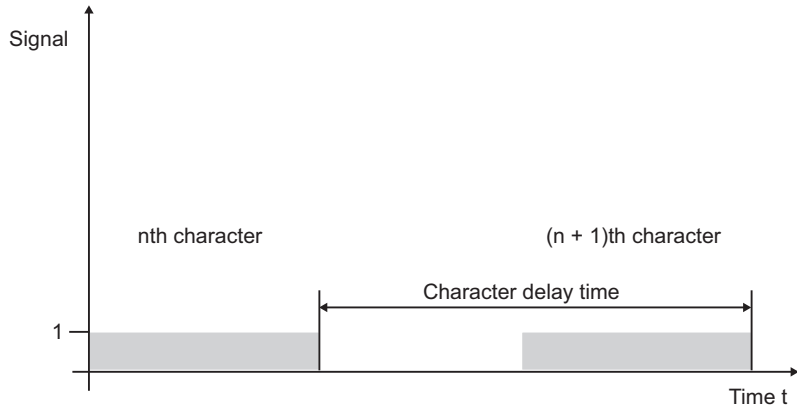

Figure 2-2 Character Delay Time

2.2 Transmission Procedure with a Point-to-Point Connection

Introduction

When data are transmitted, all communication partners must adhere to a fixed set of rules for handling and implementing data traffic. The ISO has defined a 7-layer model, which is recognized as the basis for a worldwide standardization of transmission protocols for computer-to-computer communication.

ISO 7-Layer Reference Model for Data Transmission

All communication partners must adhere to a fixed set of rules for handling and implementing data traffic. Such rules are called protocols.

A protocol defines the following:

- Operating mode
Half-duplex or full-duplex operation
- Initiative
Specifies which communication partners can initiate the transmission and under what conditions.
- Control characters
Specifies the control characters to be used for data transmission.
- Character frame
Specifies which character frames are to be used for data transmission.
- Data backup
Specifies the data backup procedure to be used.
- Character delay time
Specifies the time period within which an incoming character must be received.
- The data transmission rate
Specified in bps.

Procedure

This is the specific process according to which the data is transmitted.

ISO 7-Layer Reference Model

The reference model defines the external behavior of the communication partners. Each protocol layer, except for the lowest one, is embedded in the next one down.

The individual layers are as follows:

1. Physical layer
 - Physical conditions for data transmission, e.g. transmission medium, data transmission rate
2. Data-link layer
 - Security procedure for the transmission
 - Access modes
3. Network layer
 - Network connections
 - Specifies the addresses for communication between two partners.
4. Transport layer
 - Error-recognition procedure
 - Debugging
 - Handshaking
5. Session layer
 - Establishing communication
 - Communication control
 - Terminating communication
6. Presentation layer
 - Conversion of the standard form of data representation of the communication system into a device-specific form (data interpretation rules)
7. Application layer
 - Defining the communication task and the functions it requires

Processing the Protocols

The sending communication partner runs through the protocols from the highest layer (no. 7 - application layer) to the lowest (no. 1 - physical layer), while the receiving partner processes the protocols in the reverse order, i.e. starting with layer 1.

Not all protocols have to take all 7 layers into account. If the sending and receiving partners both use the same protocol, layer 6 can be omitted.

2.3 Transmission integrity

Introduction

Transmission integrity plays an important role in the transmission of data and in selection of the transmission procedure. Generally speaking, the more layers of the reference model are applied, the greater the transmission integrity.

Classifying the Supplied Protocols

The CP 441 can use the following protocols:

- 3964(R) procedure
- RK512 computer link
- ASCII driver
- Printer Driver

The figure below illustrates how these protocols of the CP 441 fit into the reference model:

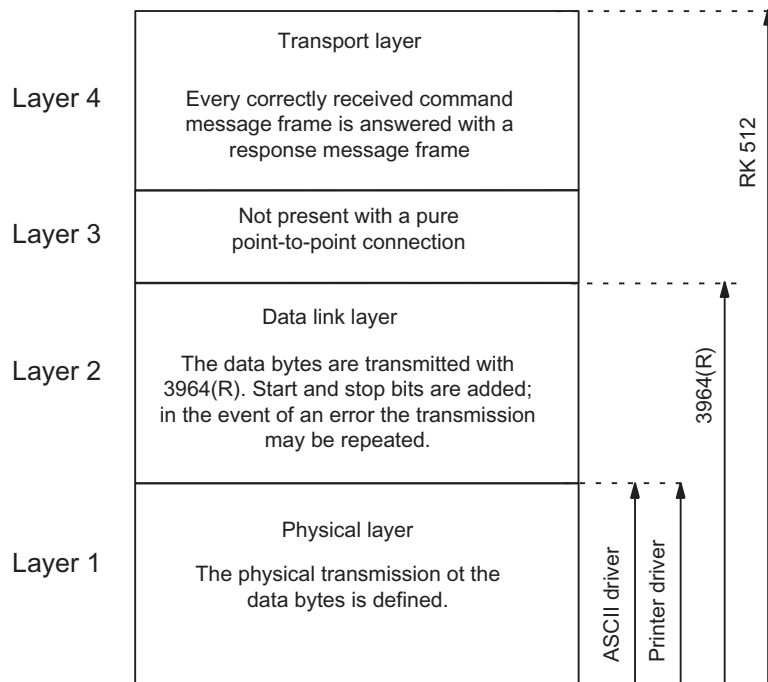

Figure 2-3 Position of the supplied protocols of the CP 441 in the reference model

Transmission Integrity with the Printer Driver

Data Integrity When Using the Printer Driver:

- No data integrity precautions are taken for data transmission with the printer driver.
- To prevent data from being lost in the event of the printer receive buffer overflowing, you can work with data flow control (XON/XOFF, RTS/CTS).
- When data is output to the printer, the printer's BUSY signal is evaluated. The CP 441 receives the BUSY signal as a CTS signal and evaluates it in the same way (see ASCII driver). Note when using CTS/RTS data flow control, that you must set the polarity of the BUSY signal to CTS = "OFF" on the printer (only with the RS232C interface).

Transmission Integrity with the ASCII Driver

Data Integrity When Using the ASCII Driver:

- When data is transmitted via the ASCII driver, there are no data integrity precautions other than the use of a parity bit (can also be canceled, depending on how the character frame is set). This means that, although this type of data transport has a very efficient throughput rate, security is not guaranteed.
- Using the parity bit ensures that the inversion of a bit in a character to be transmitted can be recognized. If two or more bits of a character are inverted, this error can no longer be detected.
- To increase transmission integrity, a checksum and length specification for a frame can be employed. These measures must be implemented by the user.
- A further increase in data integrity can be achieved by means of acknowledgment frames in response to send or receive frames. This is the case with high-level protocols for data communication (see ISO 7-layer reference model).

Transmission Integrity with 3964R

Enhanced Data Integrity with the 3964R Procedure:

- The hamming distance with the 3964R is 3. This measures the integrity of data transmission.
- The 3964R procedure ensures high transmission integrity on the data line. This high integrity is achieved by means of a fixed frame set-up and clear-down as well as the use of a block check character (BCC).

Two different procedures for data transmission can be used, either with or without a block check character:

- data transmission without a block check character: 3964
- data transmission with a block check character: 3964R

In this manual, the designation 3964(R) is used when descriptions and notes refer to both data transmission procedures.

Performance Limits with 3964R

- Further processing of the send/receive data by the PLC program in the communication partner is not guaranteed. You can only ensure this by using a programmable acknowledgment mechanism.
- The block check of the 3964R procedure (EXOR operation) cannot detect missing zeros (as a whole character) because a zero in the EXOR operation does not affect the result of the calculation.

Although the loss of an entire character (this character has to be a zero!) is highly unlikely, it could possibly occur under very bad transmission conditions.

You can protect a transmission against such errors by sending the length of the data frame along with the data itself, and having the length checked at the other end.

- Such transmission errors are ruled out when the RK512 computer link is used for data transmission, because here (unlike the 3964(R) procedure) further processing is acknowledged via response frames (e.g. stored in the destination data block) and the send data length is recorded in the frame header. This enables the RK512 to achieve a higher Hamming distance (of 4) than that with 3964R.

Transmission integrity with RK512

Very high data security using RK512:

- The Hamming distance with the RK512 and 3964R is 4. The Hamming distance is a measure of the integrity for a data transmission.
- Using the RK512 computer link ensures high transmission integrity on the transmission line (because RK512 uses the 3964R procedure for data transport).
- Further processing at the communication partner is ensured (because the RK512 interpreter checks the additional length specification in the header and, after storing the data in the destination data area of the communication partner, generates a frame acknowledging the success or failure of the data transport).
- The RK512 computer link independently guarantees the correct use of the 3964R procedure and the analysis/addition of the length specification as well as the generation of the response frames. There is no user handling! All you need to do is evaluate the positive/negative final acknowledgment.

Performance limits with RK512

- Using the RK512 computer link provides maximum data security! Another advantage, for example, is the use of other block check mechanisms (such as CRC checks).

2.4 Data Transmission with the 3964(R) Procedure

Introduction

The 3964(R) procedure controls point-to-point data exchange between the communication processor and a communication partner. As well as the physical layer (layer 1), the 3964(R) procedure also incorporates the data-link layer (layer 2).

Startup

The figure below illustrates the start-up of the 3964(R) procedure.

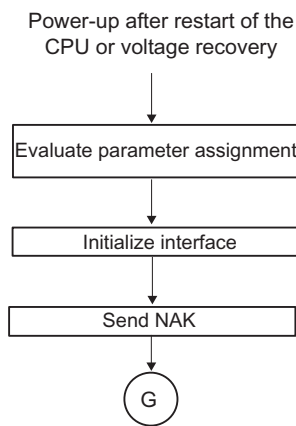

Figure 2-4 Flow diagram of the start-up of the 3964(R) procedure

2.4.1 Control characters

Introduction

The RK 512 computer connection provides a very high degree of data integrity. During data transmission, the 3964(R) procedure adds control characters to the information data (data-connection layer). These control characters allow the communication partner to check whether the data has arrived complete and without errors.

The Control Characters of the 3964(R) Procedure

The 3964(R) procedure analyzes the following control codes:

- **STX**Start of Text; start of character string for transfer
- **DLE**Data Link Escape; data connection escape
- **ETX**End of Text; end of character string for transfer
- **BCC**Block Check Character (3964R only)
- **NAK**Negative Acknowledge

Note

If DLE is transmitted as an information string, it is sent twice so that it can be distinguished from the control code DLE during connection setup and release on the send line (DLE duplication). The receiver then reverses the DLE duplication.

Priority

With the 3964(R) procedure, one communication partner must be assigned a higher priority and the other partner a lower priority. If both partners begin connection setup at the same time, the partner with the lower priority will defer its send request.

2.4.2 Block Checksum

Block Checksum

With the 3964R transmission protocol, data integrity is increased by the additional sending of a block check character (BCC).

Message frame:

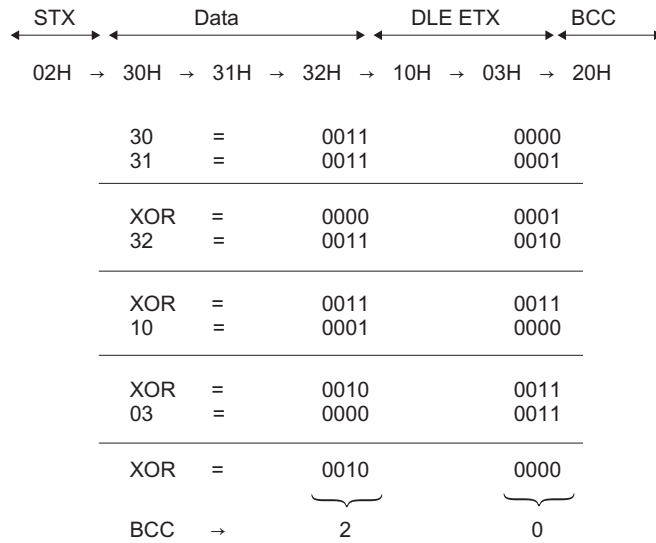

Figure 2-5 Block Checksum

The block checksum is the even longitudinal parity (EXOR operation on all data bytes) of a sent or received block. Its calculation begins with the first byte of user data (first byte of the message frame) after the connection setup, and ends after the DLE ETX code on connection release.

Note

If DLE duplication occurs, the DLE code is accounted for twice in the BCC calculation.

2.4.3 Sending data with 3964(R)

Process of Data Transmission when Sending

The figure below illustrates the transmission sequence when data is sent with the 3964(R) procedure.

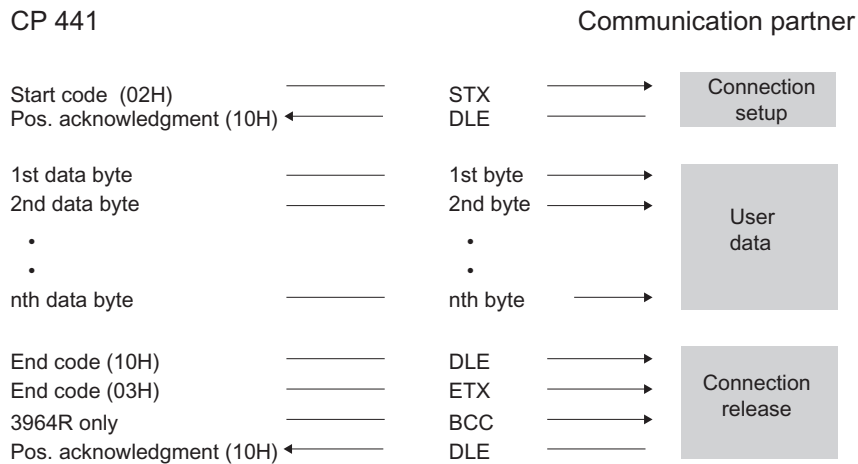

Figure 2-6 Data traffic when sending with the 3964(R) procedure

Establishing a Send Connection

To establish the connection, the 3964(R) procedure sends the control character STX. If the communication partner responds with the DLE code before the acknowledgment delay time expires, the procedure switches to send mode.

If the communication partner answers with NAK or with any other control code (except for DLE or STX), or the acknowledgment delay time expires without a response, the procedure repeats the connection setup. After the defined number of unsuccessful connection attempts, the procedure aborts the connection setup and sends the NAK code to the communication partner. The CP 441 enters an appropriate error number in its SYSTAT area.

Sending Data

If a connection is successfully established, the user data contained in the output buffer of the communication processor is sent to the communication partner with the chosen transmission parameters. The partner monitors the times between incoming characters. The interval between two characters must not exceed the character delay time.

If the communication partner sends the NAK control code during an active send operation, the procedure aborts its transmission of the block and tries again as described above, beginning with connection setup. If a different code is sent, the procedure first waits for the character delay time to expire and then sends the NAK code to change the mode of the communication partner to idle. Then the procedure starts to send the data again with the connection setup STX.

Releasing a Send Connection

Once the contents of the buffer have been sent, the procedure adds the codes DLE, ETX and with the 3964R only the block checksum BCC as the end identifier, and waits for an acknowledgment code. If the communication partner sends the DLE code within the acknowledgment delay time, the data block has been received without errors. If the communication partner responds with NAK, any other code (except DLE), or a damaged code, or if the acknowledgment delay time expires without a response, the procedure starts to send the data again with the connection setup STX.

After the defined number of attempts to send the data block, the procedure stops trying and sends an NAK to the communication partner. The CP 441 reports the error in the SYSTAT error-signaling area.

Sending with the 3964(R) Procedure

The figure below illustrates sending with the 3964(R) procedure.

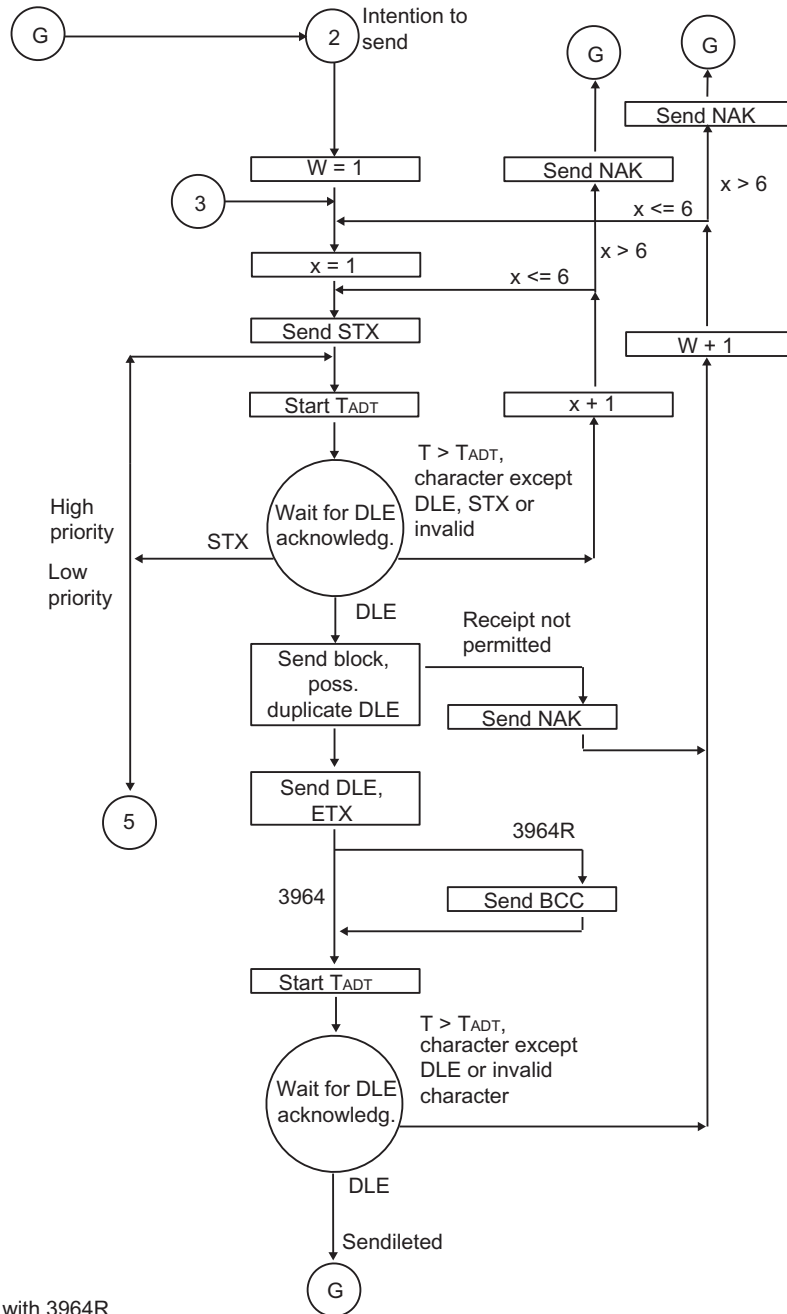

BCC only with 3964R
 x = setup attempt count
 $T_{ADT} = 500 \text{ ms}$ (3964R $T_{ADT} = 2\text{s}$)
 W = transmission attempt count
 Immediate return to initial state at line break (BREAK)

Figure 2-7 Flow diagram of sending with the 3964(R) procedure

C: Counter for connection attempts

R: Counter for retries

D: Default state

W: Waiting for character reception

2.4.4 Receiving data with 3964(R)

Process of Data Transmission when Receiving

The figure below illustrates the transmission sequence when data is received with the 3964(R) procedure.

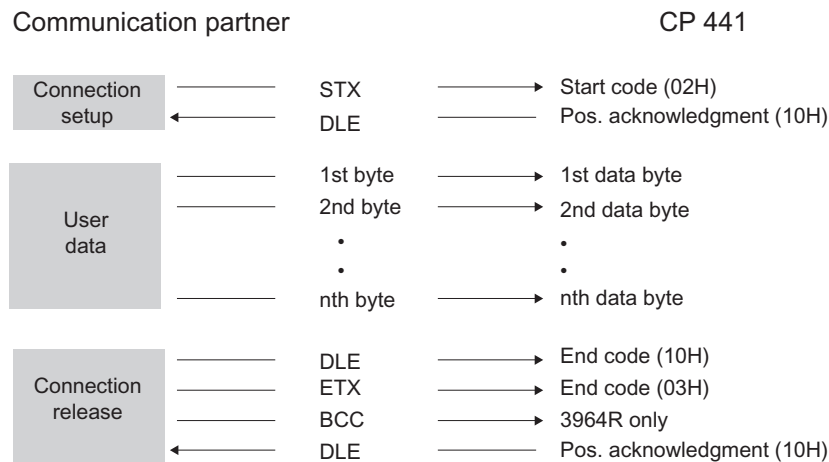

Figure 2-8 Data traffic when receiving with the 3964(R) procedure

Note

As soon as it is ready, the 3964(R) procedure sends a single NAK to the communication partner to set the latter to idle.

Establishing a Receive Connection

In idle mode, when there is no send request to be processed, the procedure waits for the communication partner to establish the connection.

If no empty receive buffer is available during a connection setup with STX, a wait time of 400 ms is started. If there is still no empty receive buffer after this time has expired, the system program reports the error (error number in SYSTAT), and the procedure sends a NAK and returns to idle mode. Otherwise, the procedure sends a DLE and receives the data as described above.

If the idle procedure receives any control code except for STX or NAK, it waits for the character delay time to expire, then sends the code NAK. The CP 441 reports the error in the SYSTAT error-signaling area.

Receiving data

After a successful connection setup, the receive characters that arrive are stored in the receive buffer. If two consecutive DLE codes are received, only one of these is stored in the receive buffer.

After each receive character, the procedure waits out the character delay time for the next character. If this period expires before another character is received, a NAK is sent to the communication partner. The CP 441 reports the error in the SYSTAT error-signaling area. The 3964(R) procedure does not initiate a repetition.

If transmission errors occur during receiving (lost character, frame error, parity error, etc.), the procedure continues to receive until the connection is shut down, then a NAK is sent to the communication partner. A repetition is then expected. If the undamaged block still cannot be received after the number of transmission attempts defined in the static parameter set, or if the communication partner does not start the repetition within a block wait time of 4 seconds, the procedure aborts the receive operation. The CP 441 reports the first erroneous transmission and the final abortion in the SYSTAT error-signaling area.

Releasing a Receive Connection

When the 3964 procedure detects a DLE ETX character string, it ends the receiving operation and confirms the successfully received block by sending a DLE signal to the communication partner. When errors are found in the received data, it outputs a NAK signal to the communication partner. A repetition is then expected.

If the 3964R procedure recognizes the string DLE ETX BCC, it stops receiving and compares the received block check character with the longitudinal parity calculated internally. If the BCC is correct and no other receive errors have occurred, the CP sends the code DLE to the communication partner. If the BCC is correct and no other receive errors have occurred, the 3964R procedure sends a DLE and returns to idle mode. If the BCC is faulty or a different receiving error occurs, a NAK is sent to the communication partner. A repetition is then expected.

Receiving with the 3964(R) Procedure

The figure below illustrates receiving with the 3964(R) procedure.

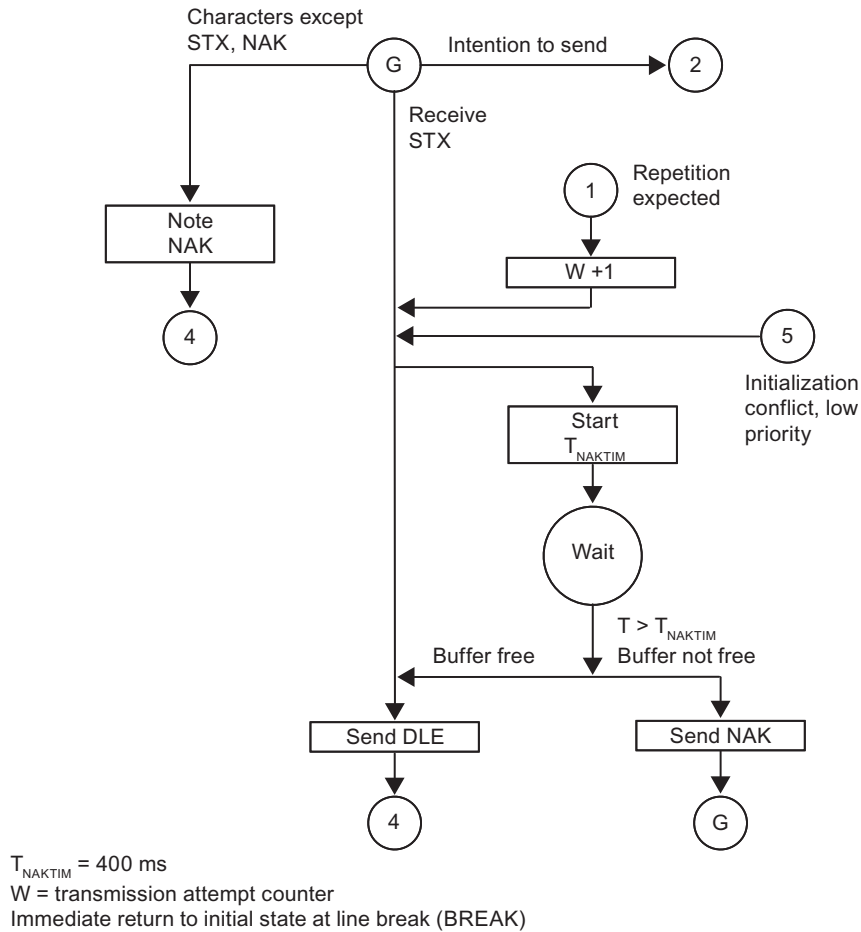

Figure 2-9 Flow chart of receiving with the 3964(R) procedure (part 1)

R: Counter for retries

D: Default state

Receiving with the 3964(R) Procedure

The figure below illustrates receiving with the 3964(R) procedure.

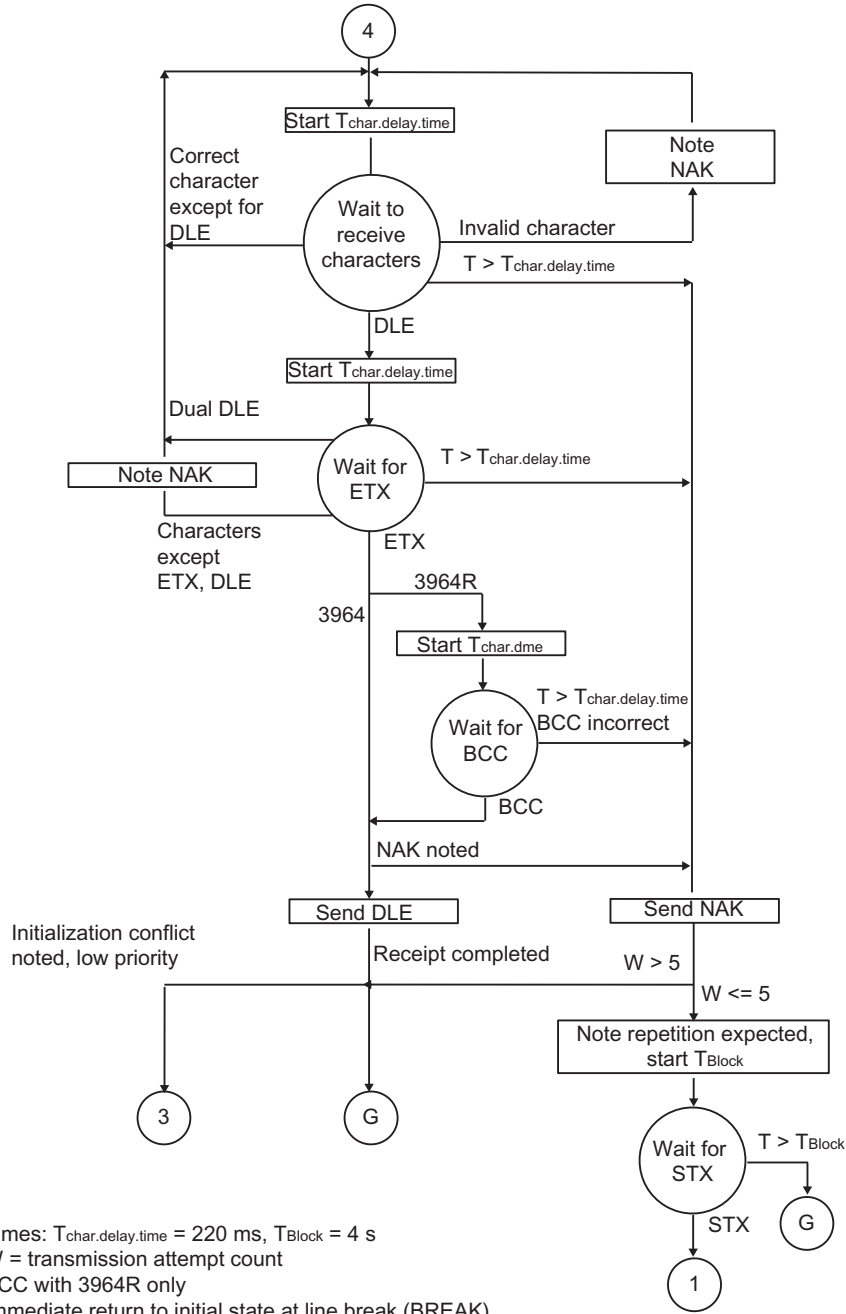

Figure 2-10 Flow chart of receiving with the 3964(R) procedure (part 2)

- R: Counter for retries
- D: Default state
- W: Waiting for character reception

2.4.5 Handling Erroneous Data

Handling Erroneous Data

The figure below illustrates how erroneous data is handled with the 3964(R) procedure.

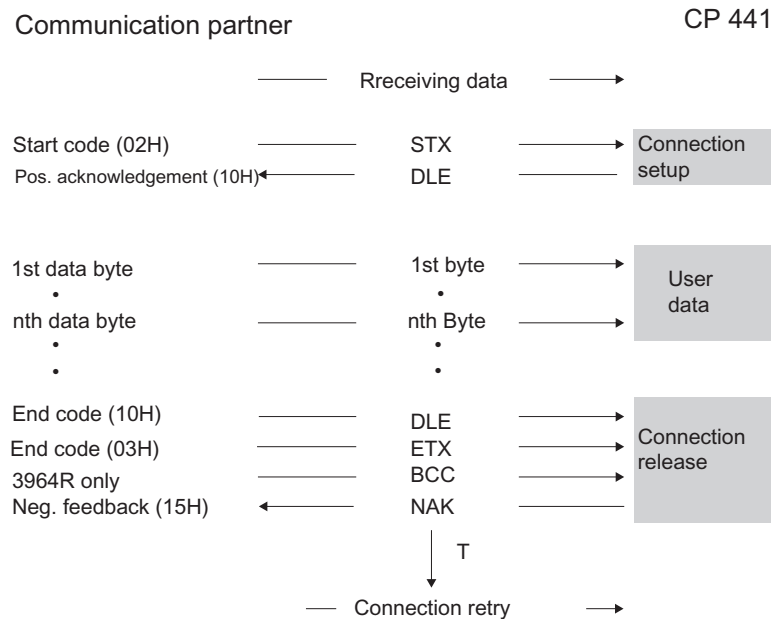

Figure 2-11 Data traffic when receiving erroneous data

When the string DLE ETX BCC is received, the CP 441 compares the BCC of the communication partner with its own internally calculated value. If the BCC is correct and no other receive errors occur, the CP 441 responds with DLE.

Otherwise, the CP 441 responds with an NAK and waits the block wait time (T) of 4 seconds for a new attempt. If after the defined number of transmission attempts the block cannot be received, or if no further attempt is made within the block wait time, the CP 441 aborts the receive operation.

initialization conflict

The figure below illustrates the transmission sequence during an initialization conflict.

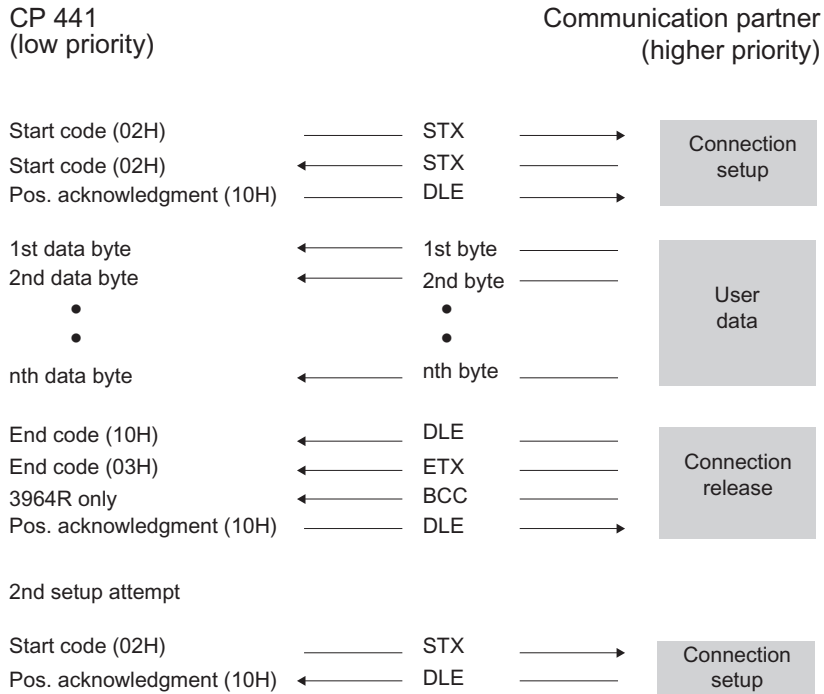

Figure 2-12 Data traffic during an initialization conflict

If a device responds to the communication partner's send request (code STX) within the acknowledgment delay time by sending the code STX instead of the acknowledgment DLE or NAK, an initialization conflict occurs. Both devices want to execute a send request. The device with the lower priority withdraws its send request and responds with the code DLE. The device with the higher priority sends its data in the manner described above. Once the connection has been released, the lower-priority device can execute its send request.

To be able to resolve initialization conflicts you must set different priorities for the communication partners.

Procedure errors

The procedure recognizes both errors which are caused by the communication partner and errors caused by faults on the line.

In both cases, the procedure makes repeated attempts to send/receive the data block correctly. If this is not possible within the maximum number of transmission attempts set (or if a new error status occurs), the procedure aborts the send or receive process. It reports the error number of the first recognized error and returns to idle mode. The CP 441 reports the error in the SYSTAT error-signaling area.

If the CP 441 frequently reports the error number in the SYSTAT for send and receive repetitions, this implies occasional disturbances in the data traffic. The large number of transmission attempts compensates for this, however. In this case you are advised to check the transmission link for possible sources of interference, because frequent repetitions reduce the user-data rate and integrity of the transmission. The disturbance could also be caused, however, by a malfunction on the part of the communication partner.

If the receive connection is interrupted, the system program reports a BREAK status (in SYSTAT). No repeat is started. The BREAK status in the SYSTAT is automatically reset as soon as the connection is restored on the line.

For every recognized transmission error (lost character, frame or parity error), a standard number is reported, regardless of whether the error was detected during sending or receiving of a data block. The error is only reported, however, following unsuccessful repetitions.

If the damaged character is received when the procedure is idle, the system program reports the error (error number in the SYSTAT) to inform you of major interference in the data transmission circuit.

See also

Diagnostics via the error signaling area SYSTAT (Page 195)

2.5 Data transmission with the RK512 computer link

Introduction

The RK512 computer link controls data transmission via a point-to-point link between the CP 441 and a communication partner.

Unlike the 3964(R) procedure, the RK512 computer link includes not only the physical layer (layer 1), and the data link layer (layer 2), but also the transport layer (layer 4) of the ISO reference model. The RK512 computer link also offers greater data security and better addressing options.

Response frame

The RK512 computer link answers each correctly received command frame with a response frame to the CPU (transport layer). This allows senders to check whether their data has arrived undamaged at the CPU or whether the data they require is available on the CPU.

Command frame

Command frames are either SEND/PUT or GET frames.

SEND/PUT frame

A SEND/PUT frame is created when the CP 441 sends a command frame with user data, and the communication partner replies with a response frame without user data.

GET frame

A GET frame is created when the CP 441 sends a command frame without user data, and the communication partner replies with a response frame with user data.

Continuation frame

If the volume of data exceeds 128 bytes, SEND/PUT and GET frames are automatically accompanied by continuation frames.

Frame header

With RK512, each frame begins with a frame header. It contains frame IDs, information on the data destination and source and an error number.

Structure of the frame header

The table below indicates the structure of the header of the command frame.

Table 2- 1 Format of the frame header for the command frame (RK512)

byte	Meaning
1	The frame ID in command frames (00H), in continuation command frames (FFH)
2	Frame ID (00H)
3	'A' (41H) for SEND/PUT request with destination DB or 'O' (4FH) for SEND request with destination DX or 'E' (45H) for GET request
4	Data to be transmitted consists of: 'D' (44H)=data block 'I' (45H) = Input bytes 'O' (41H) = Output bytes 'M' (4DH)=flag bytes 'C' (5AH)=counter cells 'T' (54H) = Time cells (The entry for send requests with BSEND and PUT is always "D", irrespective of the areas from which the data come.)
5 and 6	Data destination of SEND/PUT request or data source of GET request e.g. byte 5 = DB no., byte 6 = DW no. (RK512 addressing describes data source and destination with word limits. Conversion to byte addresses in SIMATIC S7 is automatic.)
7 and 8	Length of high byte Length of data to be transmitted according to type in bytes or Length of low byte words
9	Byte number of the interprocessor communication flag (You can specify interprocessor communication flags for send requests with "BSEND". In the block of the partner you cannot specify interprocessor communication flags, because the CP itself does not support them.) FFH is displayed if you have not specified an interprocessor communication flag.
10	Bit 0 to 3: Bit number of the interprocessor communication flag (You can specify interprocessor communication flags for send requests with "BSEND". You cannot specify interprocessor communication flags in the block of the partner because the CP itself does not support them.) The protocol enters FH here if you have not specified an interprocessor communication flag. Bit 4 to 7: CPU number (number from 1 to 4) (The CPU number 0 is supported as of STEP 7, Version 4.0.); If you have not specified a CPU number but you have specified an interprocessor communication flag, OH is displayed here; if you specified neither a CPU number nor an interprocessor communication flag, FH is shown here.

The letters in bytes 3 and 4 are ASCII characters.

The header of the continuation command frame consists of bytes 1 to 4 only.

Response frame

Once the command frame has been transmitted, the RK512 waits for a response frame from the communication partner within the monitoring time. The length of the monitoring time amounts to 20 s regardless of the data transmission rate.

This monitoring time can be reduced by setting the parameters in the "RK512" registry dialog of the parameter assignment interface. By selecting the "dependent on data transmission rate" option, monitoring is performed with the following maximum waiting times.

Data transmission rate	Time monitoring
300 bps	10 s
600 bps	7 sec
1200 bps	5 sec
as of 38 400 bps	3 sec

The "grayed" "Maximum wait time" field is used only for showing the configured monitoring time and cannot be edited!

Structure and contents of the response frame

The response frame consists of 4 bytes and contains information on the progress of the request.

byte	Meaning
1	Frame ID in response frames (00H), in continuation response frames (FFH)
2	Frame ID (00H)
3	Displays 00H
4	Error number of the communication partner in the response frame: <ul style="list-style-type: none">• 00H if transmission was error-free• > 00H error number The error number in the response frame automatically causes an error number to be entered in the SYSTAT.

See also

Communication via System Function Blocks (Page 137)

Diagnostics via the error signaling area SYSTAT (Page 195)

Error Numbers in the Response Message Frame (Page 209)

2.5.1 Sending data with RK512

Process of Data Transmission when Sending

The figure below shows the transmission sequence when sending data with a response frame using the RK512 computer link.

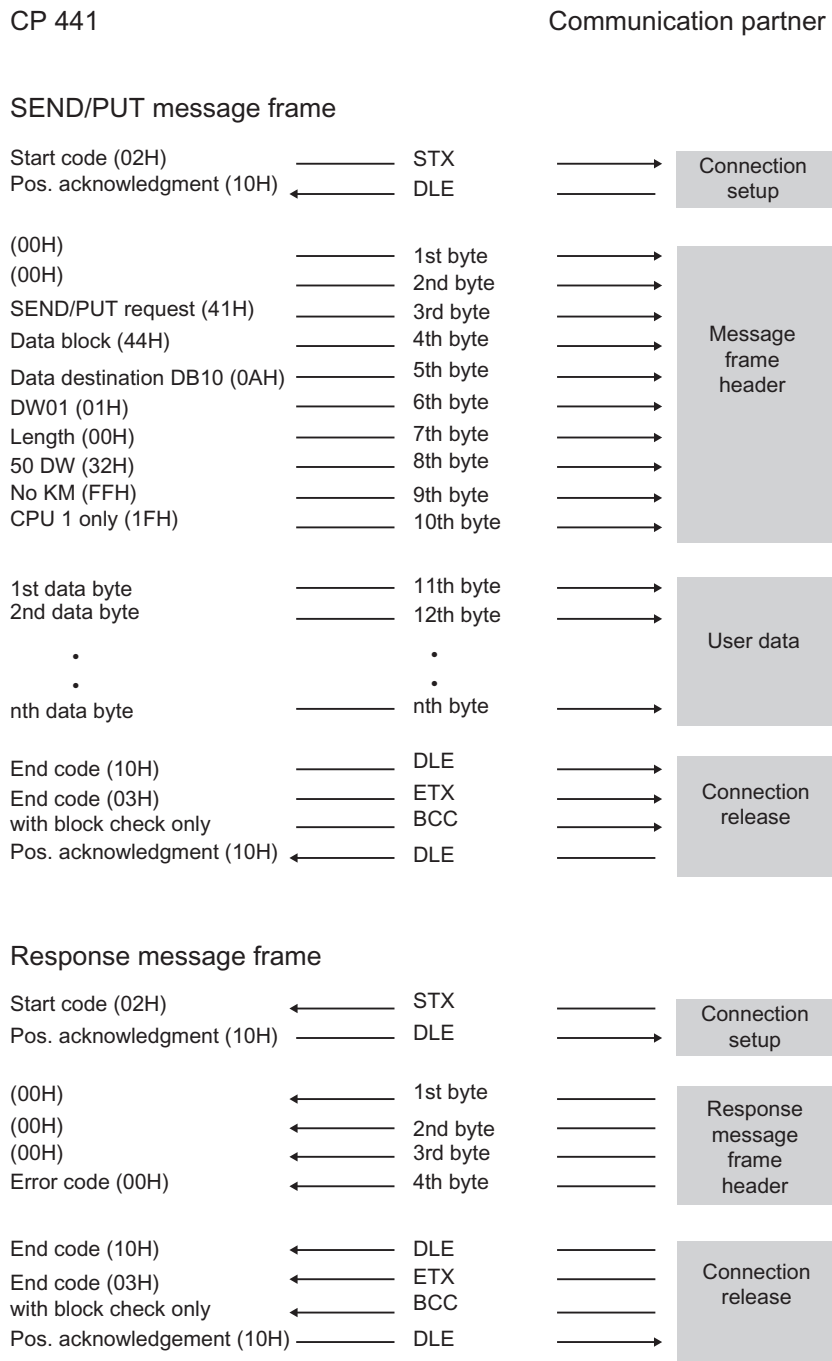

Figure 2-13 Data traffic when sending with a response frame

Sending data

The SEND/PUT request is executed in the following sequence:

- Active partner
Sends a SEND/PUT frame. This contains a frame header and data.
- Passive partner
Receives the frame, checks the header and the data, and acknowledges it with a response frame after passing the data on to the CPU.
- Active partner
Receives the response frame.
If the volume of user data exceeds 128 bytes, the active partner sends a continuation SEND/PUT frame. This contains byte 1 to 4 of the frame header.
- Passive partner
Receives the continuation SEND/PUT frame, checks the header and the data, and acknowledges it with a continuation response frame after passing the data on to the CPU.

Note

If the CPU receives an error SEND/PUT frame or if an error has occurred in the frame header, the communication partner enters an error number in the 4th byte of the response frame. This does not apply when protocol errors occur.

Continuation SEND/PUT frames

A continuation SEND/PUT frame is started if the volume of data exceeds 128 bytes. The process is the same as for SEND/PUT frames.

If more than 128 bytes are sent, the extra bytes are automatically transmitted in one or more continuation frames.

The figure below shows the data transmission sequence when sending a continuation SEND/PUT frame with a continuation response frame.

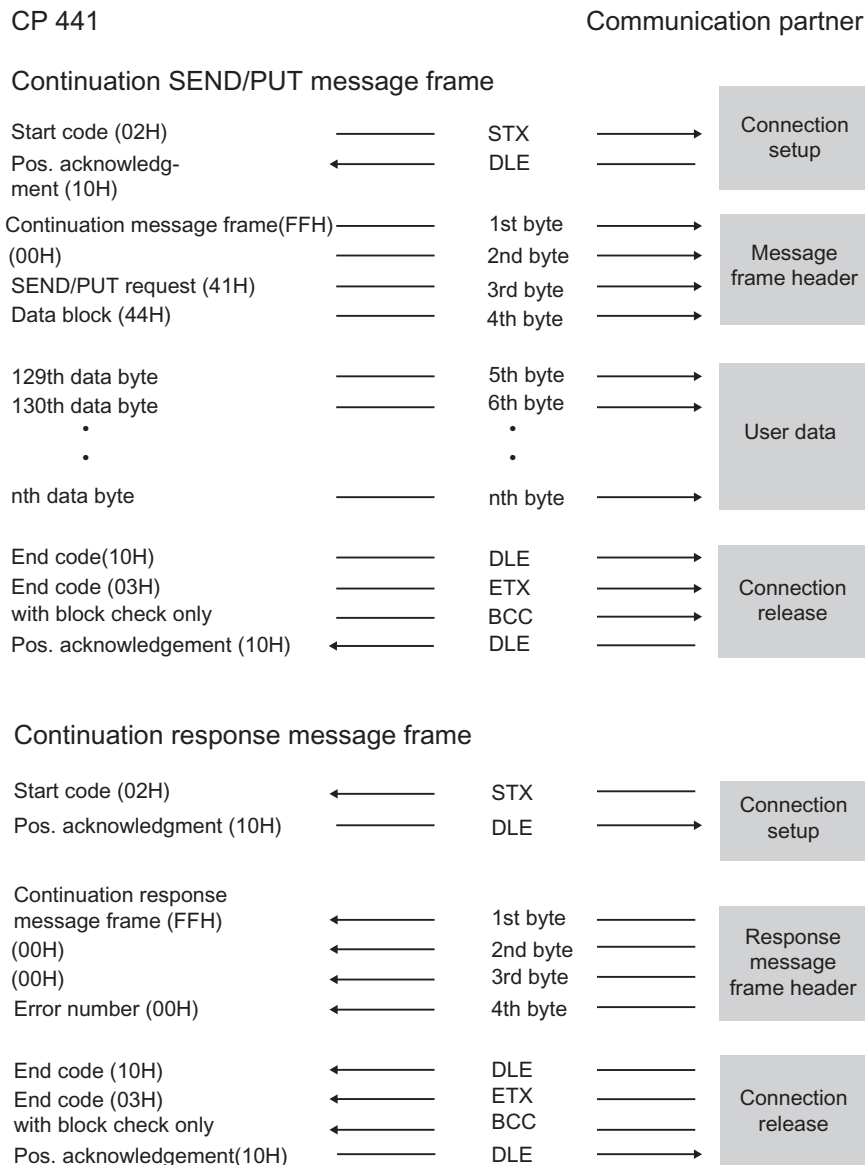

Figure 2-14 Sequence of a continuation SEND/PUT frame with a continuation response frame

2.5.2 Fetching data with RK512

Procedure for fetching data with RK512

The figure below shows the transmission sequence when fetching data with a response frame using the RK512 computer link.

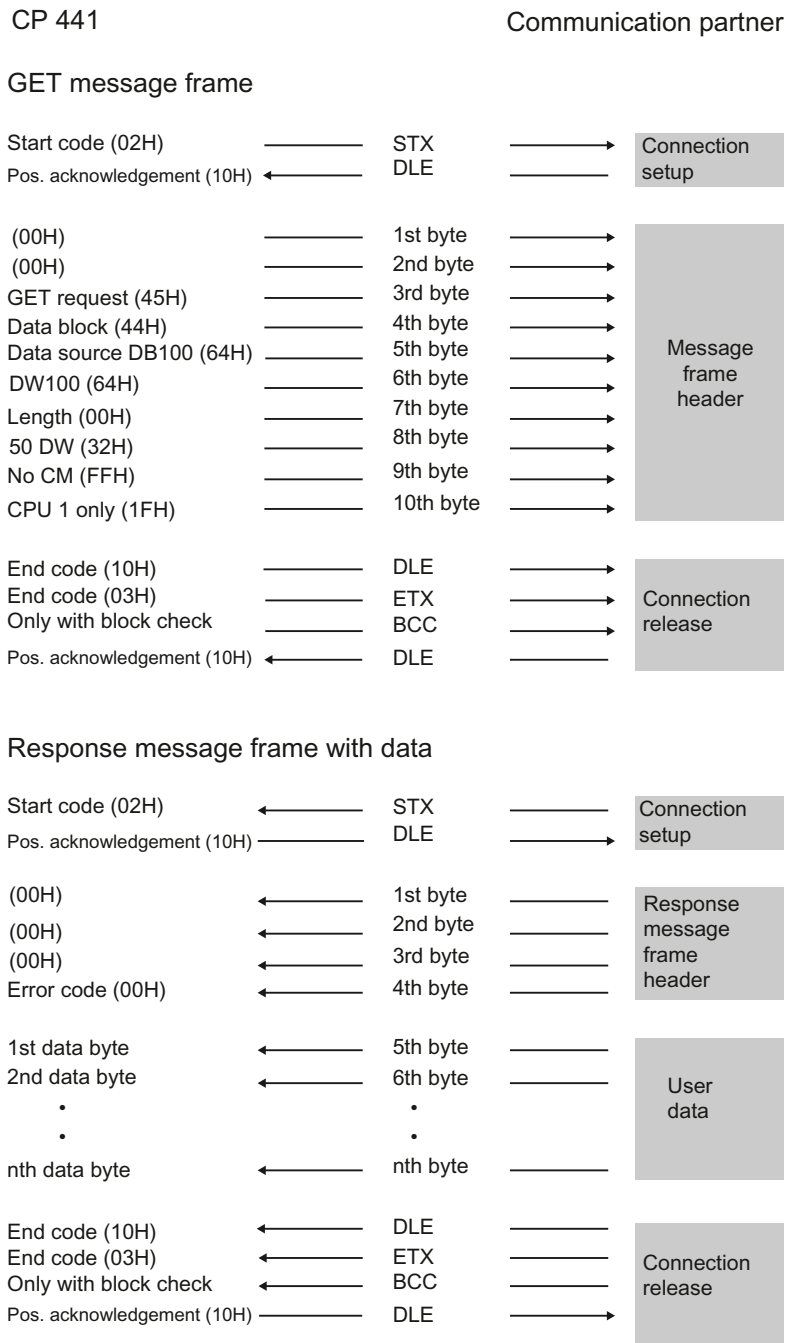

Figure 2-15 Data traffic when fetching with a response frame

Fetching data

The GET request is executed in the following sequence:

- Active partner
Sends a GET frame. This contains a frame header.
- Passive partner
Receives the frame, checks the header, fetches the data from the CPU, and acknowledges this with a response frame containing the data. This contains the data.
- Active partner
Receives the response frame.
If the volume of user data exceeds 128 bytes, the active partner sends a continuation GET frame. This contains byte 1 to 4 of the frame header.
- Passive partner
Receives the continuation GET frame, checks the frame header and acknowledges this with a continuation response frame containing further data.

If there is an error number (not equal to 0) in the 4th byte, the response frame does not contain any data.

If more than 128 bytes are requested, the extra bytes are automatically fetched in one or more continuation frames.

Note

If the CPU receives an error GET frame or if an error has occurred in the frame header, the communication partner enters an error number in the 4th byte of the response frame. This does not apply when protocol errors occur.

Continuation GET frame

The figure below shows the transmission sequence when fetching data with a continuation response frame.

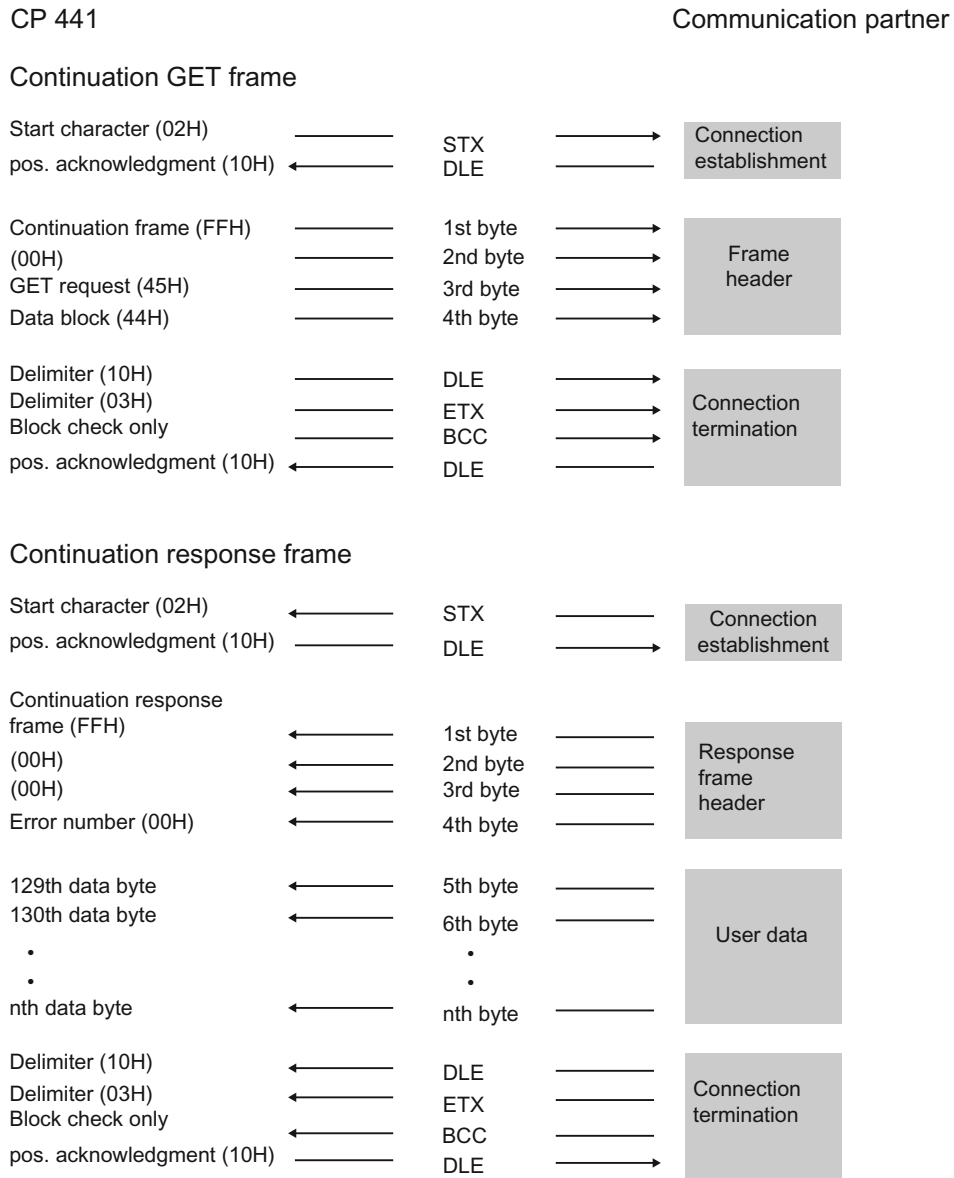

Figure 2-16 Sequence of a continuation GET frame with a continuation response frame

Quasi full-duplex operation

Quasi full-duplex operation means: the partners can send command and response frames at any time as long as the other partner is not sending. The maximum nesting depth for command and response frames is "1". The next command frame, therefore, cannot be processed until the previous one has been answered with a response frame.

It is possible under certain circumstances - if both partners want to send - to transmit a SEND/PUT frame from the partner before the response frame. For example, if a SEND/PUT frame from the partner was entered in the output buffer of the CP 441 before the response frame.

In the following figure the continuation response frame to the first SEND/PUT frame is not sent until after the partner's SEND/PUT frame.

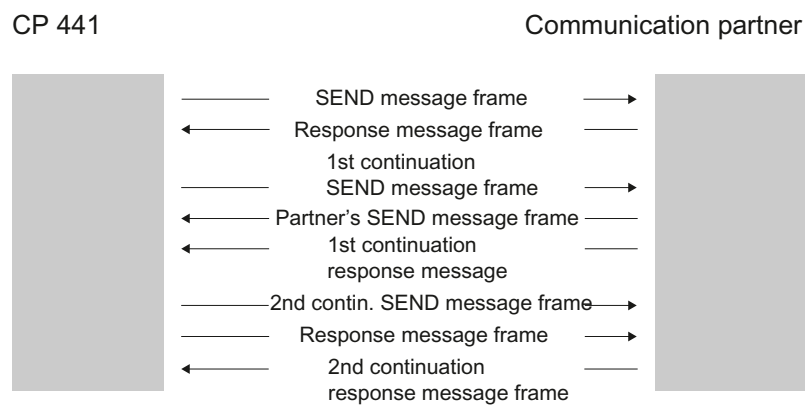

Figure 2-17 Quasi full-duplex operation

RK512 CPU requests

The figure below shows the sequences involved in the RK512 computer link when CPU requests are made.

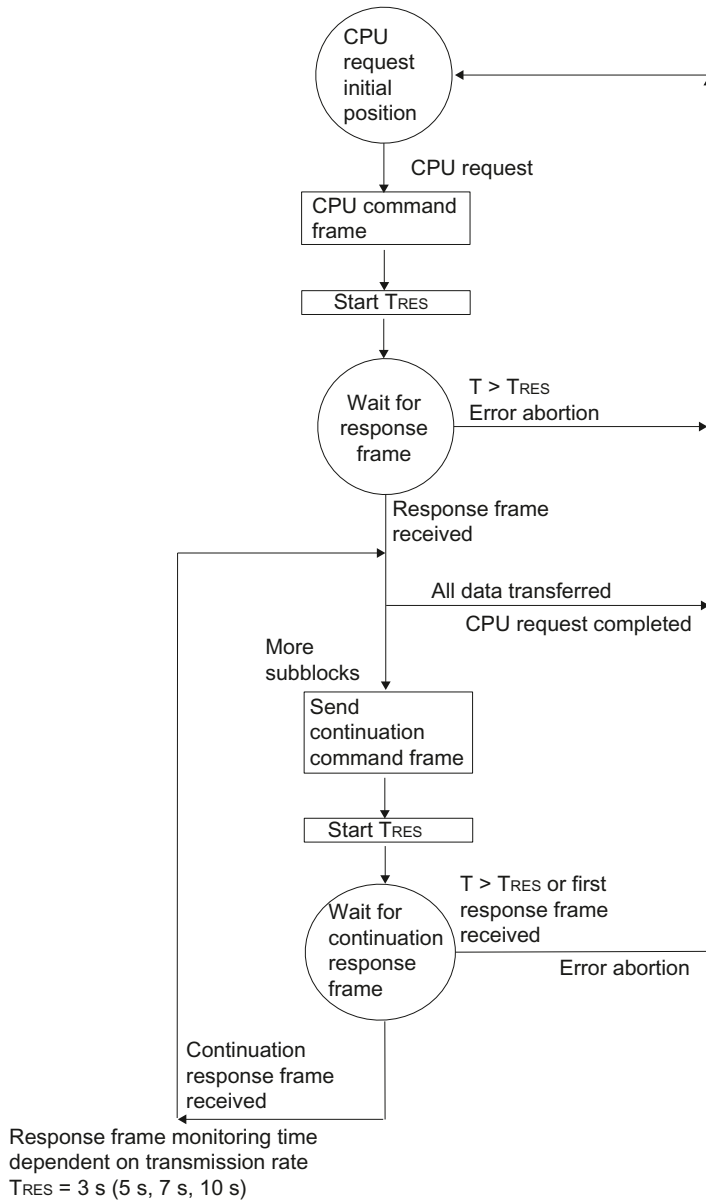
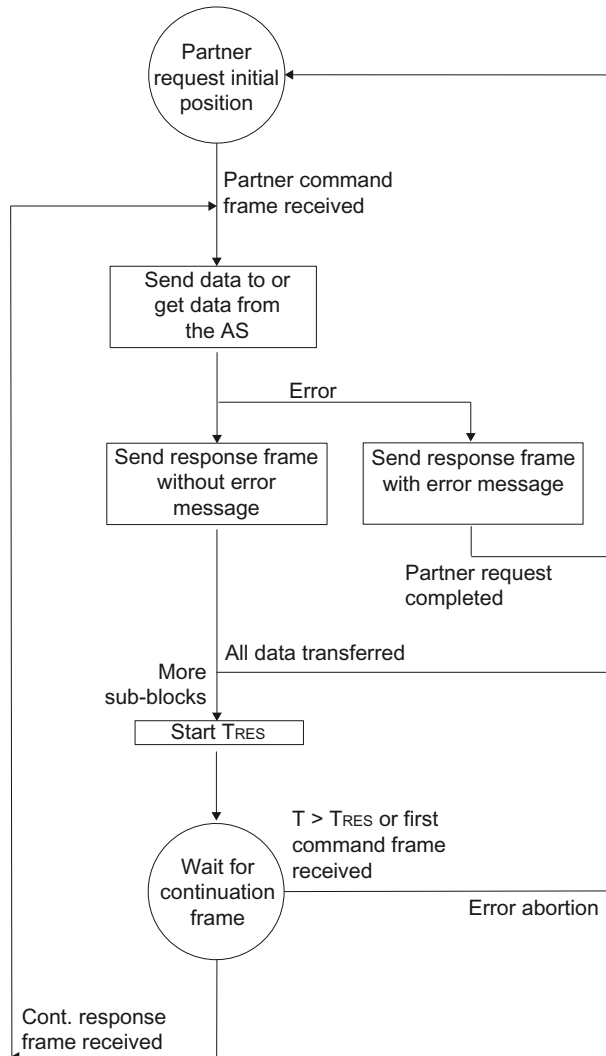

Figure 2-18 Sequence for data transmission from CPU requests with RK512

RK512 partner requests

The figure below shows the sequences involved in the RK512 computer link when partner requests are made.



Response frame monitoring time dependent on transmission rate
 TRES = 3 s (5 s, 7 s, 10 s)
 AS = automation system

Figure 2-19 Flow chart for data transmission from partner requests with RK512

2.6 Data Transmission with the ASCII Driver

Introduction

The ASCII driver controls data transmission via a point-to-point connection between the communication processor and a communication partner. This driver contains the physical layer (layer 1).

The structure of the message frames is left open through the S7 user passing on the complete send message frame to the communication processor. For the receive direction, the end criterion of a message must be configured. The structure of the send message frames may differ from that of the receive message frames.

The ASCII driver allows data of any structure (all printable ASCII characters as well as all other characters from 00 through FFH (with 8 data bit character frames) or from 00 through 7FH (with 7 data bit character frames) to be sent and received.

2.6.1 Sending Data with the ASCII Driver

Sending data

When you send data, you specify the number of user data bytes to be transferred in the "LEN" parameter of the call for the BSEND system function block.

When you work with the end criterion "**After expiration of character delay time**", the ASCII driver pauses between two frames when sending. You can call the BSEND SFB at any time, but the ASCII driver does not begin with output until a time greater than the configured character delay time has passed since the last frame was sent.

If you work with the "**Delimiter**" end criterion, you have 3 options:

- Send up to and including the end-of-text character

The delimiter must be included in the data to be sent. Data is sent only up to and including the delimiter, even if the data length specified in the FB is longer.

- Send up to length configured at the FB

Data is sent up to the length configured at the FB. The last character must be the delimiter.

- Send up to the length configured at the FB and automatically append the delimiter or characters

Data is sent up to the length configured at the FB. The delimiter is automatically appended, in other words the delimiters must not be included in the data to be sent. 1 or 2 characters more than the number specified at the FB are sent to the partner, depending on the number of delimiters.

When you work with the end criterion "**Fixed frame Length**", the amount of data transferred in the send direction is as specified for the "LEN" parameter of the BSEND. The amount of data transferred in the receive direction, i.e. in the receive DB, is specified at the receiver using the "fixed frame length" parameter in the parameter assignment interface. The two parameter settings must be identical, in order to ensure correct data traffic. A pause equal to the length of the character delay time (CDT) is inserted between two frames when sending, to allow the partner to synchronize (recognize start of frame).

If some other method of synchronization is used, the pause in sending can be deactivated by means of the parameter assignment interface.

Note

During parameter assignment of the XON/XOFF data flow control, user data may not contain any of the configured XON or XOFF characters. The default settings are DC1 = 11H for XON and DC3 = 13H for XOFF.

Send Operation

The figure below illustrates a send operation.

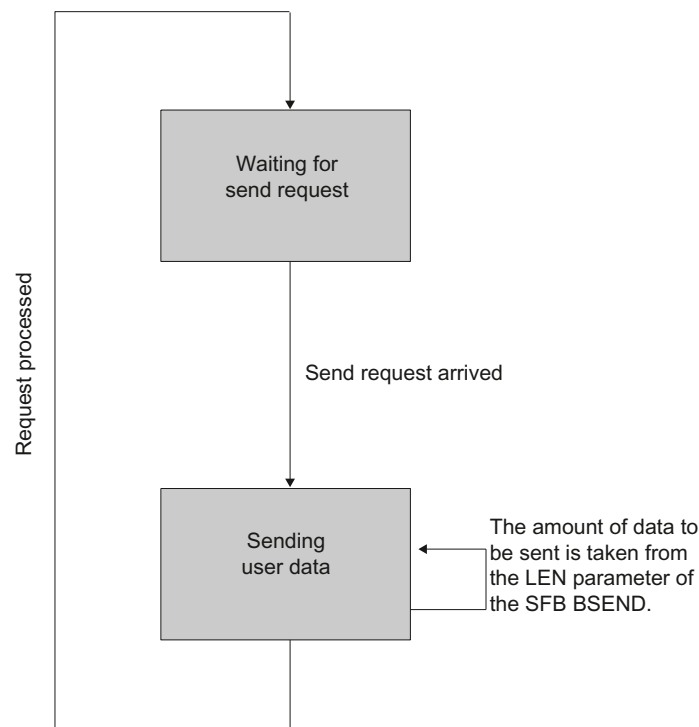

Figure 2-20 Sequence of a send operation

Note

The amount transmitted data can deviate from the length specified in the "LEN" parameter when you "Send with delimiter" (see above).

2.6.2 Receiving Data with the ASCII Driver

Selectable End Criteria

For data transmission using the ASCII driver you can choose between three different end criteria. The end criterion defines when a complete frame is received. The possible end criteria are as follows:

- After expiration of character delay time
The frame has neither a fixed length nor a defined delimiter; the end of the message is defined by a pause on the line (expiration of character delay time).
- On receipt of delimiter(s)
The end of the frame is marked by one or two defined delimiters.
- On receipt of fixed number of characters
The length of the receive frames is always identical.

Code Transparency

The code transparency of the procedure depends on the choice of the configured end criterion and data flow control:

- With one or two delimiters
 - not code-transparent
- When end criterion is character delay time or fixed frame length
 - code-transparent
- Code-transparent operation is not possible when the data flow control XON/XOFF is used.

Code-transparent means that any character combinations can occur in the user data without the end criterion being recognized.

End Criterion "Expiration of Character Delay Time"

When data is received, the end of the frame is recognized when the character delay time expires. The received data is accepted from the CPU.

In this case the character delay time must be set such that it easily expires between two consecutive frames. But it should be long enough so that the end of the frame is not falsely identified whenever the partner in the link takes a send pause within a frame.

The figure below illustrates a receive operation with the end criterion "expiration of character delay time".

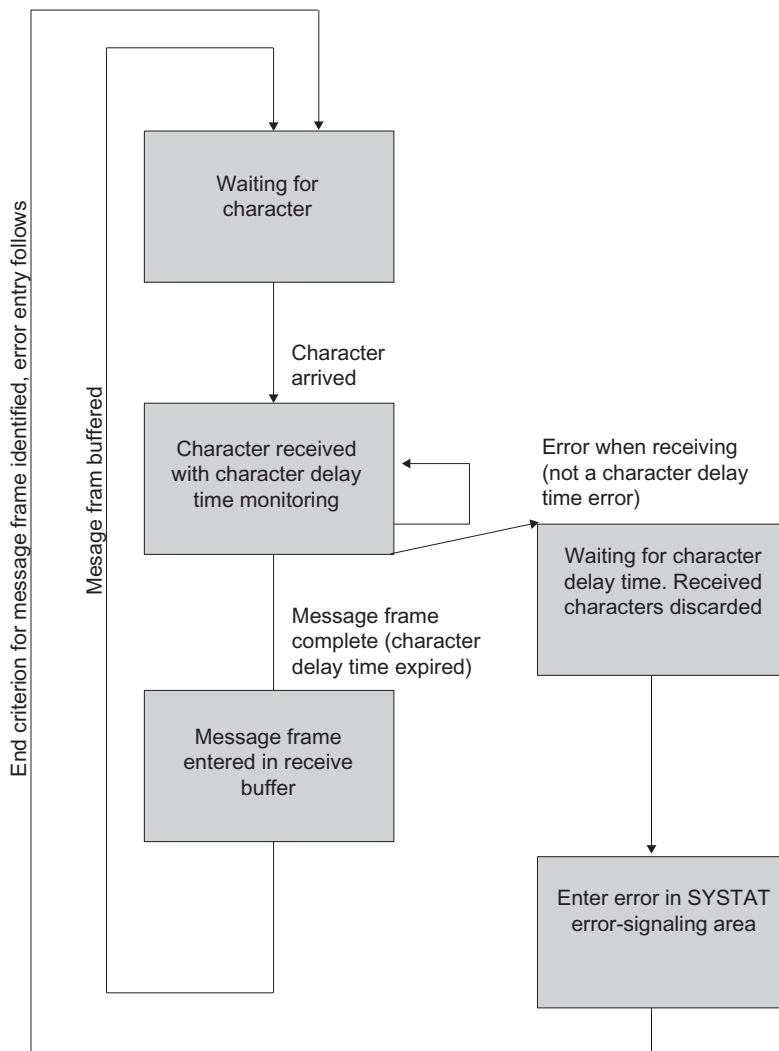

Figure 2-21 Sequence of receive operation with "Expiration of Character Delay Time" end criterion

End criterion delimiter

When data is received, the end of the frame is recognized when the configured delimiter(s) arrive. The received data including the delimiter(s) is accepted from the CPU.

If the character delay time expires while the frame is being received, the receive operation is terminated. An error message is issued and the frame fragment is discarded.

If you are working with delimiters, transmission is not code-transparent, and you must make sure that the end code(s) are not in the user data of the user.

Note the following when the last character in the received frame is not the delimiter.

- End delimiter elsewhere in the frame:

All characters including the delimiter are entered in the receive DB. The characters following the delimiter

- is discarded if the character delay time (CDT) expires at the end of the frame.
- is merged with the next frame if a new frame is received before the character delay time expires.

- End delimiter not included in frame:

The frame

- is discarded if the character delay time (CDT) expires at the end of the frame.
- is merged with the next frame if a new frame is received before the character delay time expires.

The figure below illustrates a receive operation with the end criterion "delimiter".

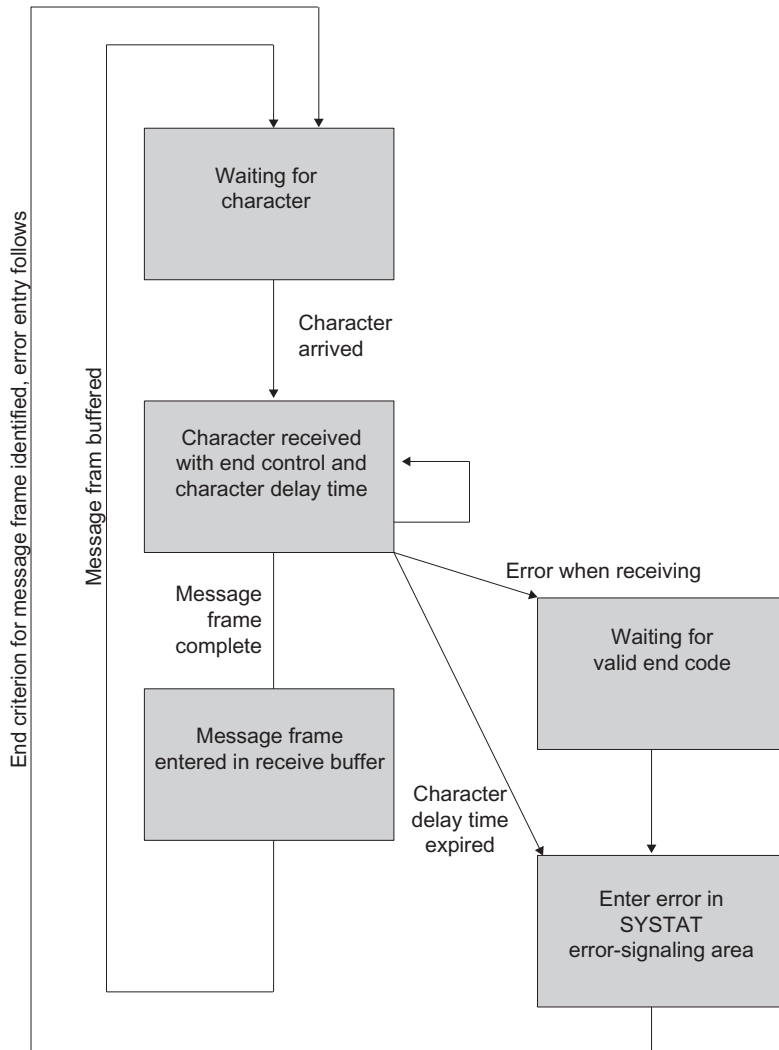

Figure 2-22 Sequence of receive operation with "delimiter" end criterion

End Criterion Fixed Message Frame Length

When data is received, the end of the frame is recognized when the configured number of characters has arrived. The received data is accepted from the CPU.

If the character delay time expires before the configured number of characters has been reached, the receive operation is terminated. An error message is issued and the frame fragment is discarded.

Note the following if the frame length of the received characters does not match the configured fixed frame length:

- Message frame length of received characters greater than configured fixed frame length:
 - All characters received after the parametered fixed frame length is reached
 - is discarded if the character delay time (CDT) expires at the end of the frame.
 - is merged with the next frame if a new frame is received before the character delay time expires.
- Message frame length of received characters less than parametered fixed frame length:
 - The frame
 - is discarded if the character delay time (CDT) expires at the end of the frame.
 - is merged with the next frame if a new frame is received before the character delay time expires.

The figure below illustrates a receive operation with the end criterion "fixed frame length".

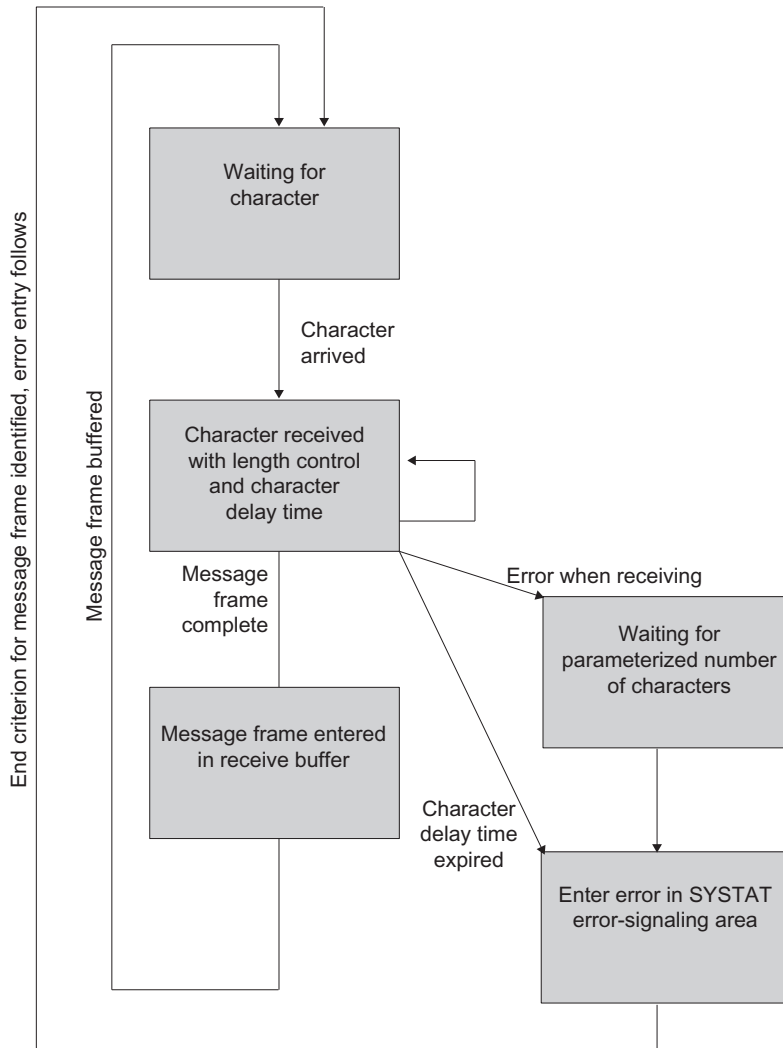

Figure 2-23 Sequence of receive operation with "Fixed Message Frame Length" end criterion

Receive Buffer on CP 441

The CP 441 receive buffer accommodates 4096 bytes. During the parameter assignment, you can specify whether overwriting of data in the receive buffer should be prevented. You can also specify the value range (1 to 250) for the number of buffered receive frames.

The receive buffer on the CP 441 is a ring buffer:

- If several frames are entered in the receive buffer of the CP 441, the following applies: it is always the oldest one that is sent from the CP 441 to the CPU.
- If you only ever want to send the most recent frame to the CPU, you must set the value "1" for the number of buffered frames and deactivate the overwrite protection.

Note

If continuous reading of the received data in the user program is interrupted for a certain time, you may find when the receive data is requested again, that the CP 441 first sends older frames before the CPU receives the most recent one. At the time of interruption, the old frame had already been transferred from the receive buffer of the communication module and prepared for transmission to the CPU.

2.6.3 RS485 mode

Introduction

When you run the ASCII driver in RS485 mode (half-duplex, two-wire mode), you must take steps in the user program to ensure that only one user sends data at any one time. If two users send data simultaneously, the frame is corrupted.

Switch-over Times for RS485 Module in Half-Duplex Mode

The maximum switch-over time between sending and receiving is 1 ms.

This value is applicable to modules as of order number 6ES7 441-xAA03-0AE0 (x=1, 2).

2.6.4 RS232 mode

RS232 accompanying signals

The following RS232C accompanying signals are available on the CP 441 with the use of the RS232 interface module:

- DCD (Input) Data carrier detect
- DTR (Output) Data terminal ready, CP 441 ready to receive
- DSR (Input) Data set ready; communication partner ready for operation
- RTS (Output) Request to send, CP 441 ready to send
- CTS (Input) Clear to send; communication partner can receive data from the CP 441 (response to RTS = ON of the CP 441)
- RI (Input) Ring indicator,

When the CP 441 is switched on, the output signals are in the OFF state (inactive).

You can configure the use of the DTR/DSR and RTS/CTS control signals by means of the **CP 441: Configuration Package for Point to Point Communication** parameter assignment interface or control them using the function blocks (FBs) in the user program.

Operate RS232 accompanying signals

The RS232 accompanying signals can be used as follows:

- When automatic operation of all RS232 accompanying signals is configured
- When data flow control (RTS/CTS) is configured
- By means of the V24_STAT and V24_SET functions (FBs)

Note

When automatic operation of the RS232 accompanying signals is configured, neither RTS/CTS data flow control nor RTS and DTR control by means of the V24_SET FB are possible. When RTS/CTS data flow control is configured, RTS control by means of the V24_SET FB is not possible. On the other hand, it is always possible to read all RS232 accompanying signals using the FB V24_STAT function.

The following sections describe the basic procedures for control and evaluation of the RS232 accompanying signals.

Automatic operation of the accompanying signals

Automatic operation of the RS232 accompanying signals on the CP 441 is implemented as follows:

- As soon as the parameter configuration puts the CP 441 into an operating mode with automatic operation of the RS232 accompanying signals, it sets the RTS line to OFF and the DTR line to ON (CP 441 ready for operation).

Sending and receiving of frames is only possible after the DTR line has been set to ON. As long as DTR remains set to OFF, no data is received via the RS232 interface. A send job is canceled and a corresponding error message is generated.

- When a send request is made, RTS is set to ON and the configured data output waiting time starts. When the data output time elapses and CTS = ON, the data is sent via the RS232 interface.
- If the CTS line is not set to ON within the data output time so that data can be sent, or if CTS changes to OFF during transmission, the send request is aborted and an error message generated.
- After the data is sent, the RTS line is set to OFF after the configured time to RTS OFF has elapsed. The CP does not wait for CTS to change to OFF.
- It is always possible to receive data via the RS232 interface. If the receive buffer of the CP 441 threatens to overflow, the CP 441 does not respond.
- A send request or data receipt is aborted with an error message if DSR changes from ON to OFF. The message "DSR = OFF (automatic operation of V24 signals)" is entered in the SYSTAT error message area of the CP 441 .

Note

When automatic operation of the RS232 accompanying signals is configured, neither RTS/CTS data flow control nor RTS and DTR control by means of the V24_SET FB are possible.

The "time to RTS OFF" must be set in the parameter assignment interface so that the communication partner can receive the last characters of the frame in their entirety before RTS, and thus the send request, is taken away. The "data output waiting time" must be set so that the communication partner can be ready to receive before the time elapses.

Time Diagram

The figure illustrates the chronological sequence of a send request.

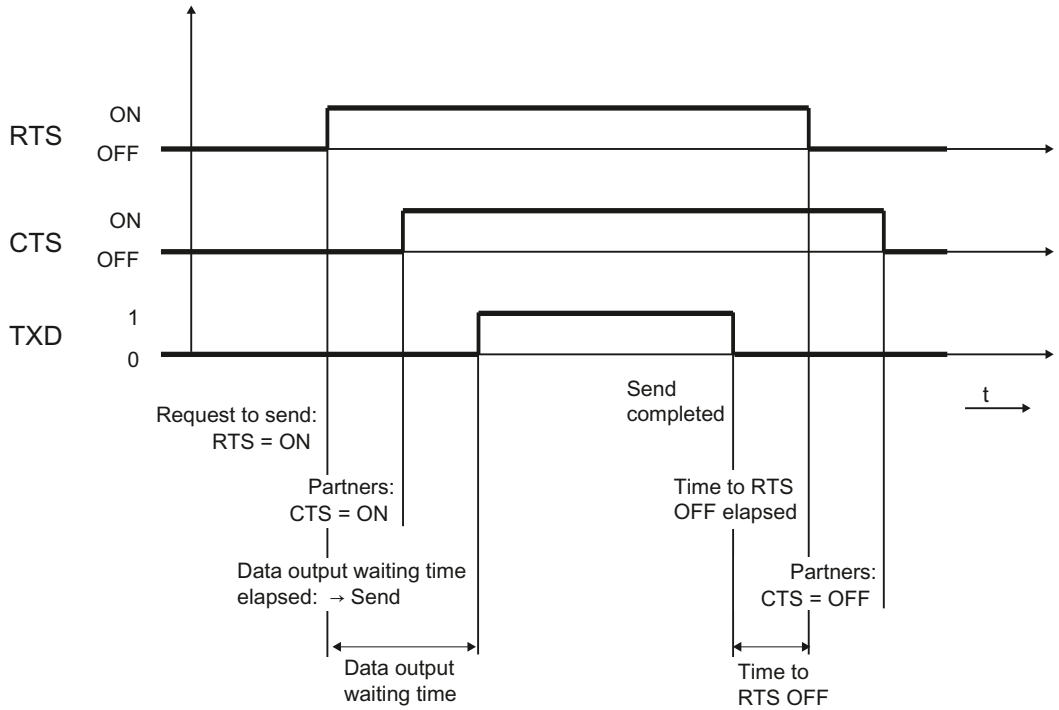

Figure 2-24 Time diagram of automatic operation of the RS232 accompanying signals

Software Handshake / Hardware Handshake

Handshaking controls the data flow between two communication partners. Handshaking ensures that data is not lost in transmissions between devices that work at different speeds. There are essentially two types of handshaking:

- Software handshake (e.g. XON/XOFF)
- Hardware handshake (e.g. RTS/CTS)

Data flow control is implemented as follows on the CP 441:

- As soon as the CP 441 is switched by the parameter configuration to an operating mode with data flow control, it sends the XON character or sets the RTS line to ON.
- When the configured number of frames is reached, or alternatively 50 characters before the receive buffer overflows (size of the receive buffer: 4096 bytes), the CP 441 sends the XOFF character or sets the RTS line to OFF. If the communication partner continues to send data regardless of this, the receive buffer overflows and an error message is generated. The data received in the last frame is discarded.
- As soon as a frame is fetched by the S7 CPU and the receive buffer is ready to receive, the CP 441 sends the XON character or sets the RTS line to ON.
- If the CP 441 receives the XOFF character, or the CTS control signal is set to OFF, the CP 441 interrupts the transmission. If neither an XON character is received nor CTS is set to ON before a configured time has elapsed, the transmission is aborted and an appropriate error message (0708H) is entered in the SYSTAT error-signaling area of the CP 441.

Note

You can configure the characters for XON and XOFF (any ASCII character). During parameter assignment of the XON/XOFF software data flow control, user data may not contain any of the configured XON or XOFF characters.

Note

When RTS/CTS data flow control is configured, you must wire the interface signals in the plug connection accordingly. When RTS/CTS data flow control is configured, RTS control by means of the V24_SET FB is not possible.

Tasks of the V24_STAT/SET FB

The V24_STAT FB function allows the status of each RS232 accompanying signal to be determined. The V24_SET FB allows the DTR and RTS output signals to be controlled (see section "Using the System Function Blocks with the ASCII Driver (Page 175)").

2.7 Data Transmission with the Printer Driver

Introduction

The printer driver allows you to output message texts with the date and time to a printer. This enables you to monitor simple processes, print error or fault messages or issue instructions to the operating personnel, for example.

The printer driver contains the physical layer (layer 1).

Message Texts and Parameters for Printer Output

With the **CP 441: Configuration Package for Point to Point Communication** parameter assignment interface, you can configure the message texts and set the parameters (page layout, character set, control characters) for printer output. Message texts and printer output parameters are transmitted to the CP 441 together with the module parameters when it starts up.

- **Message texts:**

You can configure message texts with variables and control statements (e.g. for bold, condensed, expanded or italic type and underlining). Each message text is assigned a number during parameter assignment. You print out a specific message text by specifying a reference (to the memory cell containing the message text number) for send parameters SD_1 to SD_4 of the PRINT system function block.

- **Page layout:**

You can configure the margins, possible line breaks and headers and footers.

- **Character set:**

The ANSI character set is converted to the printer character set by STEP 7 by means of a character conversion table. You can change a character conversion table suggested for a printer type in order to include special characters required for a particular language, for example.

- **Control characters:**

By means of a control character table you can change the control statements in the message text for the printer emulation for switching on and off bold, condensed, expanded or italic type and underlining and to add control characters.

Printer Output

To output n bytes of user data to a printer, the format string and the variables of the message text must be specified as parameters when the PRINT system function block is called.

During output the data is edited for printing. The print editing is performed as configured in the **CP 441: Configuration Package for Point to Point Communication** parameter assignment interface (page layout, character set, control characters, etc.).

Characters are not received during printer output. An exception to this are any data flow control characters that have been configured. Any characters received are not adopted.

Message Text Output

The figure below illustrates the sequence of operations at printer output.

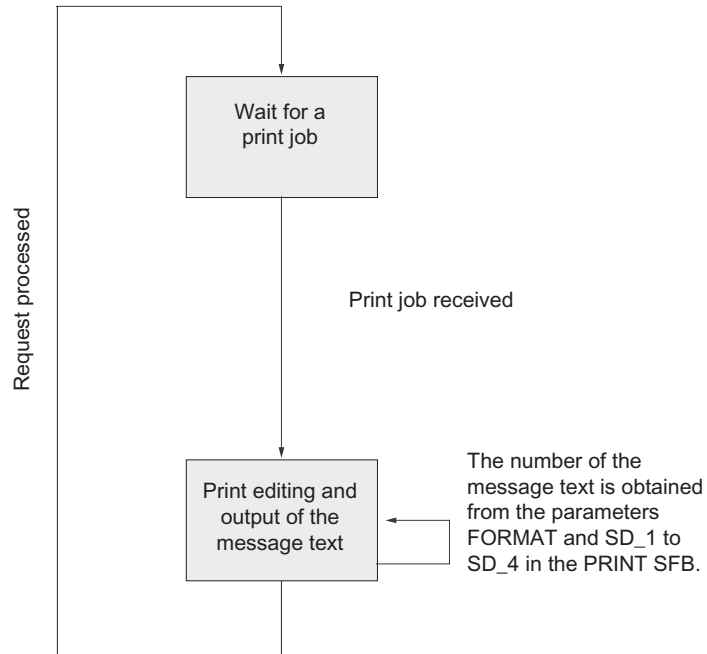

Figure 2-25 Flow chart of printer output

See also

Parameters for the communications protocols (Page 115)

2.8 Parameter Assignment Data of the Protocols

Introduction

By selecting different protocols, you can adjust your CP 441 communication processor to suit the properties of the communication partner.

The sections that follow describe the parameter assignment data of the 3964(R) procedure, RK512 computer link, ASCII driver and printer driver.

2.8.1 Parameter assignment data of the 3964(R) procedure

Parameter Assignment Data of the 3964(R) Procedure

Using the parameter assignment data of the 3964(R) procedure, you can adjust the CP 441 to suit the properties of its communication partner.

With the **CP 441: Configuration Package for Point to Point Communication** parameter assignment interface, you can specify the parameters for the physical layer (layer 1) and for the data connection (layer 2) of the 3964(R) procedure. You will find a detailed description of the parameters below.

X27 (RS422/485) interface module

Please note the following with reference to the X27 (RS422/485) interface module:

Note

When the X27 (RS422/485) interface module is used, the 3964(R) procedure can only be used in four-wire mode.

Protocol

The following table describes the protocol.

Table 2- 2 3964(R) Protocol

Parameter	Description	Default value
3964 with default values and no block check	<ul style="list-style-type: none"> The protocol parameters are set to default values. If the CP 441 recognizes the string DLE ETX, it stops receiving and sends a DLE to the communication partner if the block was received undamaged, or an NAK if it was damaged. 	3964R with default values and block [^] check: CDT = 220 ms ADT = 2000 ms Connection attempts = 6 Transmission attempts = 6
3964R with default values and block check	<ul style="list-style-type: none"> The protocol parameters are set to default values. If the CP 441 recognizes the string DLE ETX BCC, it stops receiving. The CP 441 compares the block check character (BCC) received with the length parity calculated internally. If the BCC is correct and no other receive errors have occurred, the CP 441 sends the code DLE to the communication partner (the NAK code is sent if an error occurs). 	
3964 programmable without block check	<ul style="list-style-type: none"> The protocol parameters are programmable. If the CP 441 recognizes the string DLE ETX, it stops receiving and sends a DLE to the communication partner if the block was received undamaged, or an NAK if it was damaged. 	
3964R programmable with block check	<ul style="list-style-type: none"> The protocol parameters are programmable. If the CP 441 recognizes the string DLE ETX BCC, it stops receiving. The CP 441 compares the block check character (BCC) received with the length parity calculated internally. If the BCC is correct and no other receive errors have occurred, the CP 441 sends the code DLE to the communication partner (the NAK code is sent if an error occurs). 	

Protocol parameters

You can only set the protocol parameters if you have not set the default values in the protocol.

Table 2- 3 Protocol Parameters (3964(R) Procedure)

Parameter	Description	Value range	Default value
Character delay time	The character delay time defines the permitted maximum interval between two incoming characters in a frame.	20 ms to 65530 ms in 10 ms increments The shortest character delay time depends on the data transmission rate: 300 bps: 60 ms 600 bps: 40 ms 1200 bps: 30 ms 2400 to 115200 bps: 20 ms	220 ms
Acknowledgement delay time (ADT)	The acknowledgment delay time defines the maximum amount of time permitted for the partner's acknowledgment to arrive during connection setup (time between STX and partner's DLE acknowledgment) or release (time between DLE ETX and partner's DLE acknowledgment).	20 ms to 65530 ms in 10 ms increments The shortest acknowledgment delay time depends on the data transmission rate: 300 bps: 60 ms 600 bps: 40 ms 1200 bps: 30 ms 2400 to 115200 bps: 20 ms	2000 ms (550 ms with 3964 without block check)
Connection attempts	This parameter defines the maximum number of attempts the CP 441 is allowed in order to establish a connection.	1 to 255	6
Transmission attempts	This parameter defines the maximum number of attempts to transfer a frame (including the first one) in the event of an error.	1 to 255	6

Data transmission rate/character frame

The following table describes the data transmission rate/character frame.

Table 2- 4 Data transmission rate/character frame (3964(R) procedure)

Parameter	Description	Value range	Default value
Data transmission rate	Data transmission rate in bps Note: A maximum of 19200 bps is possible for the 20mA TTY interface module.	<ul style="list-style-type: none"> • 300 • 600 • 1200 • 2400 • 4800 • 9600 • 19200 • 38400 • 57600 • 76800 • 115200 	9600
Start bit	During transmission, a start bit is prefixed to each character to be sent.	1 (fixed value)	1
Data bits	Number of bits onto which a character is mapped.	<ul style="list-style-type: none"> • 7 • 8 	8
Stop bits	During transmission, stop bits are appended to every character to be sent, indicating the end of the character.	<ul style="list-style-type: none"> • 1 • 2 	1
Parity	A sequence of information bits can be extended to include another bit, the parity bit. The addition of its value ("0" or "1") brings the value of all the bits up to a defined status. This improves data integrity. A parity of "none" means that no parity bit is transmitted.	<ul style="list-style-type: none"> • None • Odd • Even 	Even
Priority	A partner has high priority if its send request takes precedence over the send request of the other partner. A partner has low priority if its send request must wait until the send request of the other partner has been dealt with. With the 3964(R) procedure, you must configure both communication partners with different priorities, i.e. one partner is assigned high priority, the other low.	<ul style="list-style-type: none"> • Low • High 	High

Receive buffer on CP

The following table describes the parameters for the CP receive buffer.

Table 2- 5 Receive buffer on CP (3964(R) procedure)

Parameter	Description	Value range	Default value
Delete CP receive buffer at start-up	The CP receive buffer of the CP 441 is not deleted at CPU start-up (STOP RUN transition).	No (fixed)	No
Use CPU receive mailbox	Here you can specify whether a receive mailbox is to be set up on the CPU. You must set up a receive mailbox if you have not programmed a BRCV system function block for the CP 441 in the user program of the CPU. If you have programmed a BRCV, you must deactivate this parameter, otherwise data will be stored in the receive mailbox defined here instead of being processed by the BRCV.	<ul style="list-style-type: none"> • Yes • No 	No
DB number (Only when "use receive mailbox on CPU" = "yes".)	Number of the data block for the receive mailbox on the CPU.	1 to 65535 (depending on the CPU)	1

X27 (RS422) interface

You can find the description of the parameters for the X27 (RS422) interface in the following table. RS485 operation is not possible in conjunction with the 3964(R) procedure.

Table 2- 6 X27 (RS422) interface (3964(R) procedure)

Parameter	Description	Value range	Default value
Initial state of receive line	None: This setting only makes sense with bus-capable special drivers.	None	R(A) 5V / R(B) 0V
	R(A) 5V / R(B) 0V: Break detection is possible with this initial state.	R(A) 5V / R(B) 0V	
	R(A) 0V / R(B) 5V: Break detection is not possible with this initial state.	R(A) 0V / R(B) 5V	

Initial state of receive line

The figure illustrates the wiring of the receiver at the X27 (RS422) interface:

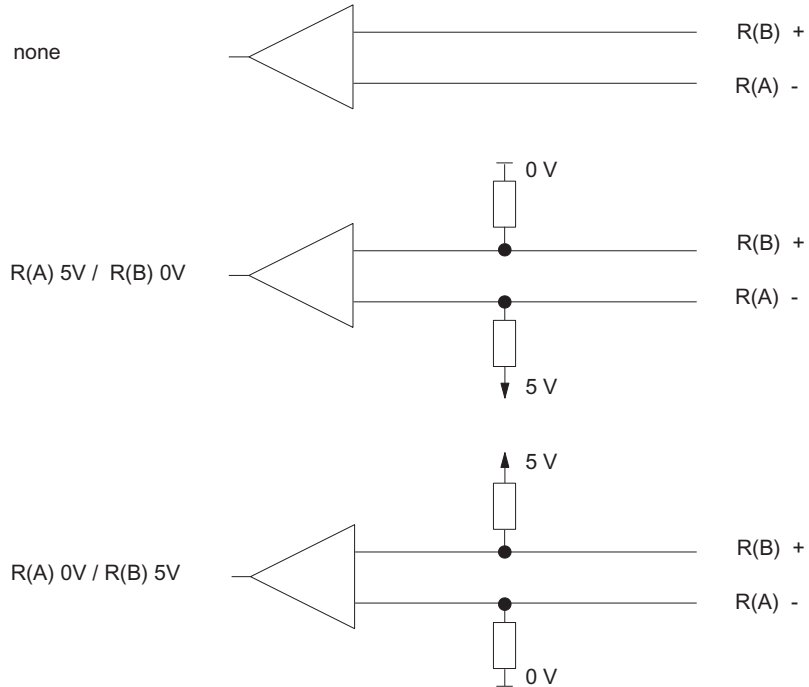

Figure 2-26 Wiring of the receiver at the X27 (RS422) interface (3964(R) procedure)

See also

Parameters for the communications protocols (Page 115)

2.8.2 Parameter assignment data of the RK512 computer link

Introduction

You can use the parameter assignment data of the RK512 computer link to adjust the CP 441 to the properties of a communication partner.

Parameter assignment data of the RK512 computer link

The parameters are identical to those of the 3964(R) procedure because the 3964(R) procedure is a subset of the RK512 computer link in the ISO-7 layer reference model (see section "Parameter assignment data of the 3964(R) procedure (Page 74)").

Note

Exception: The number of data bits per character is set permanently to 8 with the RK512 computer link.

The parameters of the transport layer (layer 4) must be specified in the system function blocks (SFB) used.

2.8.3 Parameter assignment data of the ASCII driver

Introduction

Using the parameter assignment data of the ASCII driver, you can adjust the communication processor to suit the properties of the communication partner.

Parameter Assignment Data of the ASCII Driver

For the **CP 441: Configuration Package for Point to Point Communication** parameter assignment interface, specify the parameters for the physical layer (layer 1) of the ASCII driver. You will find a detailed description of the parameters below.

X27 (RS422/485) interface module

Please note the following with reference to the X27 (RS422/485) interface module:

Note

When the X27 (RS422/485) interface module is used, the ASCII driver can be used in four-wire mode (RS422) and two-wire mode (RS485). During parameter assignment, you specify the type of interface (RS422 or RS485).

Protocol parameters

The table below describes the protocol parameters.

Table 2- 7 Protocol Parameters (ASCII driver)

Parameter	Description	Value range	Default value																								
Indicator for end of receive frame	Defines which criterion signals the end of each frame.	<ul style="list-style-type: none"> • After character delay time expires • On receipt of delimiter • After receipt of a fixed number of characters 	After character delay time expires																								
Character delay time (CDT)	as of 6ES7 441-xAA05-0AE0 The character delay time defines the maximum permitted time between 2 consecutively received characters.	1 to 65530 ms The shortest character delay time depends on the data transmission rate. <table border="1" style="width: 100%; border-collapse: collapse;"> <thead> <tr> <th style="text-align: left;">bps</th> <th style="text-align: left;">CDT</th> </tr> </thead> <tbody> <tr><td>• 300</td><td>• 130</td></tr> <tr><td>• 600</td><td>• 65</td></tr> <tr><td>• 1200</td><td>• 32</td></tr> <tr><td>• 2400</td><td>• 16</td></tr> <tr><td>• 4800</td><td>• 8</td></tr> <tr><td>• 9600</td><td>• 2</td></tr> <tr><td>• 19200</td><td>• 1</td></tr> <tr><td>• 38400</td><td>• 1</td></tr> <tr><td>• 57600</td><td>• 1</td></tr> <tr><td>• 76800</td><td>• 1</td></tr> <tr><td>• 115200</td><td>• 1</td></tr> </tbody> </table>	bps	CDT	• 300	• 130	• 600	• 65	• 1200	• 32	• 2400	• 16	• 4800	• 8	• 9600	• 2	• 19200	• 1	• 38400	• 1	• 57600	• 1	• 76800	• 1	• 115200	• 1	2 ms
bps	CDT																										
• 300	• 130																										
• 600	• 65																										
• 1200	• 32																										
• 2400	• 16																										
• 4800	• 8																										
• 9600	• 2																										
• 19200	• 1																										
• 38400	• 1																										
• 57600	• 1																										
• 76800	• 1																										
• 115200	• 1																										
Character delay time (CDT)	up to 6ES7 441-xAA04-0AE0 The character delay time defines the maximum permitted time between 2 consecutively received characters.	2 to 65530 ms The shortest character delay time depends on the data transmission rate. <table border="1" style="width: 100%; border-collapse: collapse;"> <thead> <tr> <th style="text-align: left;">bps</th> <th style="text-align: left;">CDT</th> </tr> </thead> <tbody> <tr><td>• 300</td><td>• 130</td></tr> <tr><td>• 600</td><td>• 65</td></tr> <tr><td>• 1200</td><td>• 32</td></tr> <tr><td>• 2400</td><td>• 16</td></tr> <tr><td>• 4800</td><td>• 8</td></tr> <tr><td>• 9600</td><td>• 4</td></tr> <tr><td>• 19200</td><td>• 2</td></tr> <tr><td>• 38400</td><td>• 2</td></tr> <tr><td>• 57600</td><td>• 2</td></tr> <tr><td>• 76800</td><td>• 2</td></tr> <tr><td>• 115200</td><td>• 2</td></tr> </tbody> </table>	bps	CDT	• 300	• 130	• 600	• 65	• 1200	• 32	• 2400	• 16	• 4800	• 8	• 9600	• 4	• 19200	• 2	• 38400	• 2	• 57600	• 2	• 76800	• 2	• 115200	• 2	4 ms
bps	CDT																										
• 300	• 130																										
• 600	• 65																										
• 1200	• 32																										
• 2400	• 16																										
• 4800	• 8																										
• 9600	• 4																										
• 19200	• 2																										
• 38400	• 2																										
• 57600	• 2																										
• 76800	• 2																										
• 115200	• 2																										

2.8 Parameter Assignment Data of the Protocols

Parameter	Description	Value range	Default value
End delimiter 1 ⁽¹⁾	First end code.	<ul style="list-style-type: none"> At 7 data bits: 0 to 7FH (Hex)⁽²⁾ At 8 data bits: 0 to FFH (Hex)⁽²⁾ 	3 (03H = ETX)
End-of-text character 2 ⁽¹⁾	Second end code, if specified.	<ul style="list-style-type: none"> At 7 data bits: 0 to 7FH (Hex)⁽²⁾ At 8 data bits: 0 to FFH (hex)⁽²⁾ 	0
Message frame length when received ⁽³⁾	When the end criterion is "fixed frame length", the number of bytes making up a frame is defined.	1 to 4096 (bytes)	240
<p>⁽¹⁾ Can only be set if the end criterion is an delimiter.</p> <p>⁽²⁾ Depending on whether you set 7 or 8 data bits for the character frame</p> <p>⁽³⁾ Can only be set if the end criterion is fixed frame length.</p>			

Data transmission rate/character frame

The table below contains descriptions of and specifies the value ranges of the relevant parameters.

Table 2- 8 Data transmission rate/character frame (ASCII driver)

Parameter	Description	Value range	Default value
Data transmission rate	Data transmission rate in bps Note: The maximum transmission rate for the 20 mA TTY interface module is 19200 bps.	<ul style="list-style-type: none"> 300 600 1200 2400 4800 9600 19200 38400 57600 76800 115200 	9600
Start bit	During transmission, a start bit is prefixed to each character to be sent.	1 (fixed value)	1
Data bits	Number of bits onto which a character is mapped.	<ul style="list-style-type: none"> 7 8 	8

Parameter	Description	Value range	Default value
Stop bits	During transmission, stop bits are appended to every character to be sent, indicating the end of the character.	<ul style="list-style-type: none"> • 1 • 2 	1
Parity	A sequence of information bits can be extended to include another bit, the parity bit. The addition of its value ("0" or "1") brings the value of all the bits up to a defined status. This improves data integrity. A parity of "none" means that no parity bit is transmitted.	<ul style="list-style-type: none"> • None • Odd • Even 	Even

Data flow control

The table below contains descriptions of the parameters for data flow control.

Data flow control is not possible with the RS485 interface. Flow control with "RTS/CTS" and "automatic operation of V24 signals" is only supported when using the RS232 interface module.

Table 2- 9 Data flow control (ASCII driver)

Parameter	Description	Value range	Default value
Data flow control	Defines which data flow control procedure is used.	<ul style="list-style-type: none"> • None • XON/XOFF • RTS/CTS • Automat. operation of the V24 signals 	None
XON character ⁽¹⁾	Code for XON character	<ul style="list-style-type: none"> • At 7 data bits⁽²⁾: 0 to 7FH (Hex) • At 8 data bits⁽²⁾: 0 to FFH (Hex) 	11 (DC1)
XOFF character ⁽¹⁾	Code for XOFF character	<ul style="list-style-type: none"> • At 7 data bits⁽²⁾: 0 to 7FH (Hex) • At 8 data bits⁽²⁾: 0 to FFH (Hex) 	13 (DC3)
Waiting for XON after XOFF (wait time for CTS=ON) ⁽³⁾	Period of time for which the communication processor should wait for the XON code or for CTS="ON" of the communication partner when sending.	20 ms to 65530 ms in 10 ms increments	20000 ms
Time to RTS OFF ⁽⁴⁾	Time to elapse after the transmission before the communication processor sets the RTS line to OFF.	0 ms to 65530 ms in 10 ms increments	10 ms

Parameter	Description	Value range	Default value
Data output waiting time ⁽⁴⁾	Time that the communication processor should wait for the communication partner to set CTS to ON after setting the RTS line to ON and before starting the transmission.	0 ms to 65530 ms in 10 ms increments	10 ms
<p>⁽¹⁾ Only for data flow control with XON/XOFF.</p> <p>⁽²⁾ Depending on whether you set 7 or 8 data bits for the character frame.</p> <p>⁽³⁾ Only for data flow control with XON/XOFF or RTS/CTS.</p> <p>⁽⁴⁾ Only for automatic operation of the RS232 accompanying signals.</p>			

Receive buffer on CP

The following table describes the parameters for the CP receive buffer.

Table 2- 10 Receive buffer on CP (ASCII driver)

Parameter	Description	Value range	Default value
Delete CP receive buffer at start-up	The CP receive buffer of the CP 441 is not deleted at CPU start-up (STOP → RUN transition).	No (fixed)	No
Buffered receive frames	Here you can specify the number of receive frames to be buffered in the CP receive buffer. If you specify "1" here and deactivate the following parameter "prevent overwrite" and cyclically read the received data from the user program, a current frame will always be sent to the CPU.	1 to 250	250
Prevent overwrite	You can deactivate this parameter if the parameter "buffered receive frames" is set to "1". This authorizes the buffered receive frame to be overwritten.	<ul style="list-style-type: none"> • Yes • no ⁽²⁾ 	Yes
Use CPU receive mailbox	Here you can specify whether a receive mailbox is to be set up on the CPU. You must set up a receive mailbox if you have not programmed a BRCV system function block for the CP 441 in the user program of the CPU. If you have programmed a BRCV, you must deactivate this parameter, otherwise data will be stored in the receive mailbox defined here instead of being processed by the BRCV.	<ul style="list-style-type: none"> • Yes • No 	No
DB number ⁽¹⁾	Number of the data block for the receive mailbox on the CPU.	1 to 65535 (depending on the CPU)	1
<p>⁽¹⁾ Only when "Use CPU Receive Mailbox" = "Yes"</p> <p>⁽²⁾ Only when "Buffered receive frames" = "1"</p>			

X27 (RS422/485) interface

The table below contains descriptions of the parameters for the X27 (RS422/485) interface module. RS485 operation is not possible in conjunction with the printer.

Table 2- 11 X27 (RS422/485) interface module (ASCII driver)

Parameter	Description	Value range	Default value
Operating mode	Specifies whether the X27 (RS422/485) interface is to be run in full-duplex mode (RS422) or half-duplex mode (RS485) (see section "Serial transmission of a character (Page 23)").	<ul style="list-style-type: none"> • Full-duplex (RS422), four-wire mode • Half duplex (RS485), two-wire mode 	Full-duplex (RS422), four-wire mode
Initial state of receive line	None: This setting only makes sense with bus-capable special drivers.	None	R(A) 5V / R(B) 0V ⁽²⁾
	R(A) 5V / R(B) 0V: Break detection is possible with this initial state in conjunction with "Full duplex (RS 422), four-wire mode".	R(A) 5V / R(B) 0V ⁽¹⁾	
	R(A) 0V / R(B) 5V: This initial state corresponds to idle (no sender active) in "Half duplex (RS 485), two-wire mode". Break detection is not possible with this initial state.	R(A) 0V / R(B) 5V	
⁽¹⁾ Only with "Full-duplex (RS422), four-wire mode" ⁽²⁾ Only with "Full-duplex (RS422), four-wire mode", with "Half-duplex (RS485), two-wire mode" the default setting is R(A) 0V, R(B) 5V			

Initial state of receive line

The figure illustrates the wiring of the receiver at the X27 (RS422/485) interface:

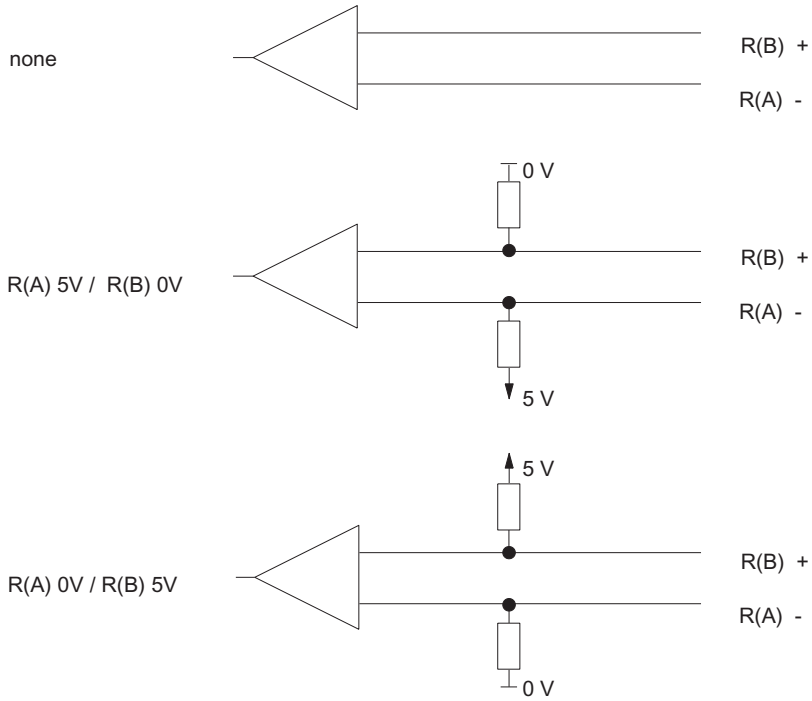

Figure 2-27 Wiring of the receiver at the X27 (RS422/485) interface (ASCII driver)

See also

- Parameters for the communications protocols (Page 115)
- Data Transmission with the ASCII Driver (Page 58)

2.8.4 Parameter Assignment Data of the Printer Driver

2.8.4.1 Parameter assignment data

Introduction

You can use the parameter assignment data of the printer driver to set the transmission-specific parameters and the message texts for printer output.

Parameter assignment data of the printer driver

With the **CP 441: Configuration Package for Point to Point Communication** parameter assignment interface, specify the following:

- The parameters for the physical layer (layer 1) of the printer driver
- The message texts for printer output
- The page layout, character set and control characters for the message texts

You will find a detailed description of the parameters below.

Note

Please note the following:

- The message texts are stored in the CPU's load memory together with the parameter assignment data and loaded automatically onto the CP 441 during the loading operation. You must therefore reserve the corresponding memory space (up to 55 kByte per interface) in the load memory of the CPU for every interface for which you have created message texts.
- Before you transfer the message texts to the CP 441 you must increase the value of the parameter for transferring parameters to modules for the relevant CPU. You should plan in approximately 20 s per interface.

Data transmission rate/character frame

The table below contains descriptions of and specifies the value ranges of the relevant parameters.

Note

Increasing the max. number of signal numbers from 1000 to 4000

As of CP 441, 6ES7 441-XAA04-0AE0 or Parameter assignment interface **CP 441: Configuration Package for Point to Point Communication** V5.1 incl. SP6 you can configure up to 4000 message text numbers (0-3999).

Table 2- 12 Data transmission rate/character frame (printer driver)

Parameter	Description	Value range	Default value
Baud rate	Data transmission rate in bps Note: A maximum of 19200 bps is possible for the 20mA TTY interface module.	<ul style="list-style-type: none"> • 300 • 600 • 1200 • 2400 • 4800 • 9600 • 19200 • 38400 • 57600 • 76800 • 115200 	9600
Start bit	During transmission, a start bit is prefixed to each character to be sent.	1 (fixed value)	1
Data bits	Number of bits onto which a character is mapped.	<ul style="list-style-type: none"> • 7 • 8 	8
Stop bits	During transmission, stop bits are appended to every character to be sent, indicating the end of the character.	<ul style="list-style-type: none"> • 1 • 2 	1
Parity	A sequence of information bits can be extended to include another bit, the parity bit. The addition of its value ("0" or "1") brings the value of all the bits up to a defined status. This improves data integrity. A parity of "none" means that no parity bit is sent.	<ul style="list-style-type: none"> • None • Odd • Even 	Even

X27 (RS422) interface

The table below contains descriptions of the parameters for the X27 (RS422) interface module. RS485 operation is not possible in conjunction with the printer.

Table 2- 13 X27 (RS422) interface module (printer)

Parameter	Description	Value range	Default value
Initial state of receive line	None: This setting only makes sense with bus-capable special drivers.	None	R(A) 5V / R(B) 0V
	R(A) 5V / R(B) 0V: Break detection is possible with this initial state.	R(A) 5V / R(B) 0V	
	R(A) 0V / R(B) 5V: Break detection is not possible with this initial state.	R(A) 0V / R(B) 5V	

Initial state of receive line

The figure illustrates the wiring of the receiver at the X27 (RS422) interface:

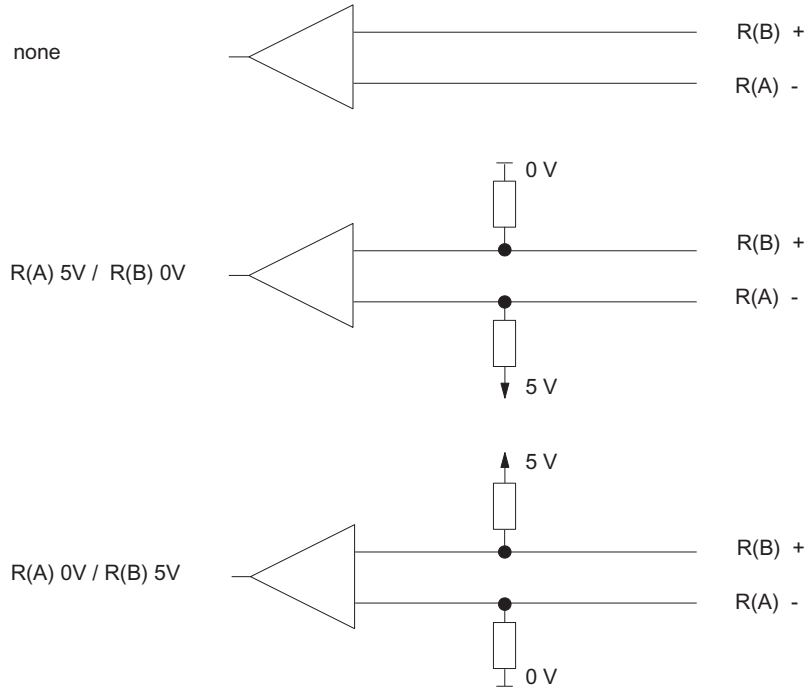

Figure 2-28 Wiring of the receiver at the X27 (RS422) interface

Data flow control/ handshaking

Handshaking controls the data flow between two communication partners. Handshaking ensures that data is not lost in transmissions between devices that work at different speeds.

You can also send message texts with data flow control during printer output. There are essentially two types of handshaking:

- Software handshake (e.g., XON/XOFF)
- Hardware handshake (e.g., RTS/CTS)

Data flow control is implemented as follows on the CP 441 during printer output:

- As soon as the CP 441 is switched by the parameter configuration to the operating mode with data flow control, it sends the XON character or sets the RTS line to ON.
- If the CP 441 receives the XOFF character, or the CTS control signal is set to OFF, the CP 441 interrupts the output of characters. If neither an XON character is received nor CTS is set to ON before a configured time has elapsed, the printer output is aborted and an appropriate error message (0708H) is entered in the SYSTAT error-signaling area of the CP 441.

Note

"RTS/CTS" data flow control is only possible when the RS232 interface module is used. To do this, you must wire the used interface signals in the plug connection accordingly.

BUSY Signal

The CP 441 evaluates the printer's "BUSY" control signal. The printer indicates to the CP 441 that it is ready to receive:

- In the case of the CP 441 with the 20mA TTY interface module: current on RxD line
- In the case of the CP 441 with the RS232 interface module: signal CTS = "ON"

Note

When you configure with RTS/CTS data flow control, you must set the polarity of the BUSY signal on the printer as follows:

- BUSY signal: CTS = "OFF"

Please note that some printers use the DTR signal to display the BUSY signal. In such cases you must wire the cable to the CP 441 appropriately.

Parameters for data flow control

The table below contains descriptions of the parameters for data flow control.

Data flow control is not possible with the RS485 interface. "RTS/CTS" data flow control is only possible when the RS232 interface module is used.

Table 2- 14 Data flow control (printer driver)

Parameter	Description	Value range	Default value
Data flow control	Defines which data flow control procedure is used.	<ul style="list-style-type: none"> • None • XON/XOFF • RTS/CTS 	None
XON character ⁽¹⁾	Code for XON character	<ul style="list-style-type: none"> • At 7 data bits: 0 to 7FH (Hex)⁽²⁾ • At 8 data bits: 0 to FFH (Hex)⁽²⁾ 	11 (DC1)
XOFF character ⁽¹⁾	Code for XOFF character	<ul style="list-style-type: none"> • At 7 data bits: 0 to 7FH (Hex)⁽²⁾ • At 8 data bits: 0 to FFH (Hex)⁽²⁾ 	13 (DC3)
Waiting for XON after XOFF (wait time for CTS=ON) ⁽³⁾	Period of time for which the CP 441 should wait for the XON code or for CTS="ON" of the communication partner when sending.	20 to 65530 ms in 10 ms increments	2000 ms
⁽¹⁾ Only for data flow control with XON/XOFF. ⁽²⁾ Depending on whether you set 7 or 8 data bits for the character frame. ⁽³⁾ Only for data flow control with XON/XOFF or RTS/CTS.			

Page layout

The table below contains descriptions of the parameters for the page layout.

Table 2- 15 Page layout (printer driver)

Parameter	Description	Value range	Default value
Left margin (number of characters)	Number of spaces to precede each line in the body of the text, header or footer. You yourself must ensure that a line is not too long for the printer.	<ul style="list-style-type: none"> 0 to 255 	3
Lines per page (with header and footer)	Number of lines to be printed on each page. The number of printed lines is determined on the basis of the separators output, which means that all header and footer lines must be included in the count.	<ul style="list-style-type: none"> 1 to 255 0 (continuous printing) 	50
Separators/line end	Characters concluding text, header and footer lines. The output text, header and footer must contain the defined separator. If the header does not contain a separator, the text begins right at the top of the page.	<ul style="list-style-type: none"> CR (carriage return) LF (line feed) CR LF (carriage return and line feed) LF CR (line feed and carriage return) 	CR LF (carriage return and line feed)
Header lines / Footer lines	Text for up to max. 2 header and footer lines; a header or footer line is output when the entry field in the parameter assignment software contains a text or at least a blank. If a text is specified only for the 2nd header or footer line, the 1st header or footer line is automatically padded with a blank and printed. A blank line is output before and after the headers/footers.	<ul style="list-style-type: none"> ASCII characters (text) %P (conversion statement for outputting page numbers) (max. 60 characters) 	-

Character set

The table below contains descriptions of the parameters for the character set.

Table 2- 16 Character set (printer driver)

Parameter	Description	Value range	Default value
Printer character set	<p>If you set "IBM", the system character set that is set in Windows is used (conversion of the ANSI character set to the printer character set).</p> <p>If you set "User-Defined", you can adapt the character set to include special characters for a particular language.</p>	<ul style="list-style-type: none"> • IBM • User-defined 	IBM

Control characters

The table below contains a description of the parameter for control characters.

Table 2- 17 Control characters (printer driver)

Parameter	Description	Value range	Default value
Printer emulation	<p>Sets the printer emulation (printer commands for the following control characters: bold, condensed, expanded and italic type and underlining).</p> <p>If you set "User-defined", you can modify the printer emulation and include additional control characters of the printer. The characters A to Z and a to z are permissible as control characters.</p>	<ul style="list-style-type: none"> • HP DeskJet • HP LaserJet • IBM Proprinter • User-defined 	HP DeskJet

Message texts

You can configure message texts with variables and control statements (e.g. for bold, condensed, expanded or italic type and underlining). Each message text is assigned a number during parameter assignment. You print out a specific message text by specifying a reference (to the memory cell containing the message text number) for send parameters SD_1 to SD_4 of the PRINT system function block.

Performance features

Conditions for configuring message texts:

- Max. size of the text SDB: 55 KB
- Max. length of a message text without variables: 150 characters
- Max. length of a message text with variables displayed: 4000 characters
- Max. number of variables per message text: 4 (3 + message text number)
- Max. number of message text numbers: 4000 (0 to 3999)

The net amount of memory space available for the message texts is dependent on the smallest and largest message text number **actually used**. You can calculate the net memory space available for message texts as follows:

Net memory space for message texts *effectively* =

$56,400 - 2 \times (\text{the largest message text number used} - \text{the smallest message text number used} + 1)$

variables

Up to 4 variables (3 + a message text number) can be displayed in a message text. The following can be displayed as variables: values calculated by the user program (e.g. levels), date and time, strings (string variables) or other message texts. The variables are configured as the send parameters SD_1 to SD_4 of the PRINT system function block.

A conversion statement must be specified in the configured message text or in the format string for each variable, and the meaning and output format of the variable value must be encoded in this statement.

Format string

The format string allows you to define the format and composition of a message text. The format string can consist of:

- Text (all printable characters, for example: The level ... was reached at ... hours.)
- Conversion statements for variables (e.g. %N = expression of a message text stored on the CP CP 441; the desired message text number is configured by means of the reference (ANYPOINTER addressed to the memory cell in which the message text number is stored) in the send variables SD_1 to SD_4).

For each variable there must be one conversion statement in the format string. The conversion statements are applied to the variables in the sequence in which they occur in the format string.

- Control statements with control characters for bold, condensed or italic type and underlining (e.g. \B = bold type on) or with additional control characters you have defined.

You can use other control characters supported by your printer if you enter them in the control characters table of the **CP 441: Configuration Package for Point to Point Communication** parameter assignment interface and then make new parameter assignments for the CP 441.

Please note that a line feed is carried out by default after each output.

Message texts

The following table contains descriptions of the parameters for configuring message texts (using the **CP 441: Configuration Package for Point to Point Communication** parameter assignment interface).

Table 2- 18 Message texts (printer driver)

Parameter	Description	Value range	Default value
Name of text SDB/text file	The message texts for a CP 441 (serial interface) must be stored in a text SDB for parameter assignment. You can also store configured message texts in an external text file.	ASCII characters (max. 8 characters)	-
Version number	Version number of the text SDB/text file	0.1 to 99.9	-
Message texts	All the message texts stored in the text block are displayed here together with their message text numbers; you can change a selected message text line by means of the "Edit Message" parameter.	ASCII characters (unchangeable)	-
Edit message	You can transfer message texts edited here to the "Message Texts" list by clicking the "Enter" button.	Message text number: 0 to 3999 Message text (max. 150 characters): <ul style="list-style-type: none"> • ASCII characters (text) • Conversion statements (for variables) • Control characters (all those defined in the control character table) 	-
Font style	You can easily assign control characters to text selected in the "Edit Message" entry box by using buttons B to U.	<ul style="list-style-type: none"> • B (bold) • C (condensed) • E (expanded type) • I (italic type) • U (underline) 	-

Examples

Here are some examples of message texts. The variables (SD_1, SD_2) in the examples must be configured at the PRINT SFB.

Example 1: The level "200" l was reached at "17:30" hours.

Format string = The level %i l was reached at %Z hours!
Variable (SD_1) = Time of day
Variable (SD_2) = State

Example 2: The pressure in the chamber "is falling"

Format string = %N %S
Variable (SD_1) = Reference to memory cell containing "17"
(Text no. 17: The pressure in the chamber ...)
Variable (SD_2) = Reference to string (string variable: ... is falling)
The reference to the string is a symbolic address that specifies where the string is stored (DB).

Example 3: (Setting the page number to 10)

Format string = %P
Variable (SD_1) = 10 (page number: 10)

2.8.4.2 Conversion and control statements for printer output

Introduction

The output of a message text with variables and control statements (e.g. for bold, condensed, expanded or italic type and underlining) is defined by means of a format string.

In the format string you can also define statements to execute other useful functions for printer output (e.g. to set a page number or begin a new page).

All the permissible characters and representation modes for the format string are described below. You can also configure all the control statements for variables (except for \F "begin new page" and \x "printing without a line break") and the conversion statements for variables (except for %P "set page number" and) in the message texts using the parameter assignment interface for the **CP 441: Configuration Package for Point to Point Communication** parameter assignment interface.

Format string

The figure illustrates the structure of the format string schematically.

A format string can contain normal text and/or conversion statements for variables and/or control statements. Normal text, conversion statements and control statements can occur in any sequence in the format string.

There must be a conversion statement (and only one) for each variable in the format string or message text. The conversion statements are applied to the variables in the sequence in which they occur.

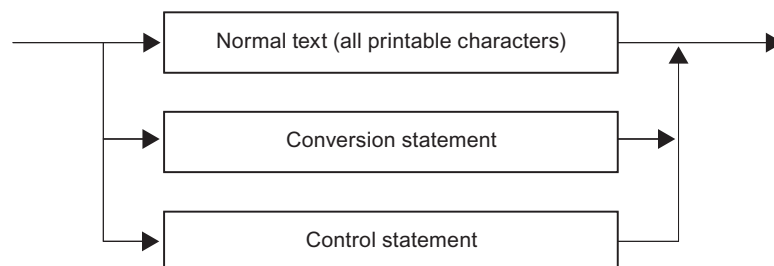

Figure 2-29 Schematic Structure of the Format String

Permissible Characters for Text

The following can be specified as normal text:

- All printable characters
- All characters preceded by \$ on the language interface (ICE 1131–3). The language compilers convert these characters to the corresponding hex code. **Exception:** The character \$N is not permitted.

Example: Carriage return ODH = \$R in the format string

Conversion Statement

The figure illustrates the structure of a conversion statement.

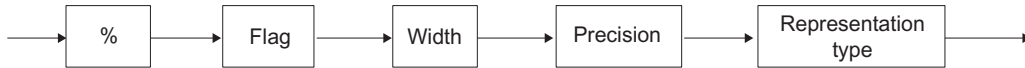

Figure 2-30 Schematic Structure of a Conversion Statement

Flag

- Without = Right-justified output
- = Left-justified output

Width

- Without = Output in the standard representation
- n = Exactly n characters are output
(up to a maximum of 255 characters are possible); blanks may be added before (right-justified) or after (left-justified output)

Precision

Precision is only relevant to representation types A, D, F and R. It is ignored otherwise.

- Without = Output in the standard representation
- .0 = No output of decimal points and decimals in real (R) and floating point (F) format.
- .n = Output of decimal point and n (1 to 99) significant places after the decimal point in the Real (R) and Floating point (F) representation types. In the case of dates (= representation types A and D), precision relates to the number of digits used for the year. Only 2 and 4 are permitted for dates.

Note that the precision is always preceded by a period. The period serves to identify it and separate it from the width.

Representation type

The table below describes the possible representation types of the values of the variables. Representation types N and P are exceptions. They are explained below the table.

Uppercase and lowercase letters are permissible for the representation.

Table 2- 19 Representation types in the conversion statement

Representation type	Associated data type	Standard Representation	Width of the Standard Representation	Description
A	DATE, WORD	10.06.1992 (German)	10	German date format
C	CHAR, BYTE WORD DWORD ARRAY OF CHAR ARRAY OF BYTE	A B AB ABCD ABCDE ...	1 1 2 4 -	Alphanumeric characters
D	DATE, WORD	1996-06-10 (American)	10	Date format according to ICE 61131-3
F	REAL, DWORD	0.123456	8	Floating point, without exponent
H	All data types incl. ARRAY OF BYTE	In accordance with the data type	In accordance with the data type	Hexadecimal format
I	INT, WORD DINT, DWORD	-32767 -2147483647	Max. 6 Max. 11	Integer range
N ⁽¹⁾	WORD (text number)	Message text output	-	Integer 0 to 3999
P ⁽²⁾	INT, WORD	Page number, setting	5	-
R	REAL, DWORD	0.12E-04	8	Floating point, without exponent
S	STRING	Text output	-	Text strings
T ⁽¹⁾	TIME, DWORD	2d_3h_10m_5s_250ms	Max. 21	Duration
U	BYTE WORD DWORD	255 65535 4294967295	Max. 3 Max. 5 Max. 10	Integer range, unsigned
X	BOOL BYTE WORD DWORD	1 11101100 11001... (16) 11001... (32)	1 8 16 32	Binary format

Representation type	Associated data type	Standard Representation	Width of the Standard Representation	Description
Y ⁽³⁾	DATE_AND_TIME_OF_DAY, DT	10.06.1992 - 15:42:59.723	25	Date and time
Z	TIME_OF_DAY DWORD	15:42:59.723	12	Time

(1) If there is no message text number or system time in these representation types, 6 * characters appear in the printout instead (the CP 441 does not keep the time).

(2) The P representation type is only permitted in the format string. P is not permitted in the configured message texts.

(3) The current time and date must be read first by means of the "READ_CLOCK" system function (SFC 1) and stored in the user memory (flag, data).

Output by Means of Message Text Number (%N)

You use the N representation type when you want to start printing message texts stored on the CP 441.

ANYPOINTER is the only data type permissible for the PRINT SFB send variables (SD_1 to SD_4). The variable thus points to the memory cell in which the desired message text number is entered. Please note that the message text number must be specified in the WORD data format.

The flag, width and precision do not affect the printer output in the case of the N representation type. The message text configured beforehand with the **CP 441: Configuration Package for Point to Point Communication** parameter assignment interface is always output completely.

Example: The pressure in the chamber "is falling"

Format string = %N %S

Variable (SD_1) = Reference to memory cell containing "17"
(Text no. 17: The pressure in the chamber ...)

Variable (SD_2) = Reference to string (string variable: ... is falling)

The reference to the string is a symbolic address that specifies where the string is stored (DB).

Note

Within a message text, all conversion statements except for %N and all control statements except for "\F" and "\x" are allowed! An explicit width setting of %N limits the printed length of the referenced message text to the width indicated.

Setting the Page Number (%P)

You use the P representation type to change the page number in the printout.

The CP 441 always begins a printout at page 1. This conversion statement allows you to set the page number to a specific value. The conversion statement variable contains the number to be set.

Example:(Setting the page number to 10)

Format string = %P
Variable (SD_1) = 10 (page number: 10)

Note

In the case of the P representation type, there must be no further text, conversion or control statements in the format string. The P representation type is not permitted in configured message texts.

Notes on the Conversion Statement

Please note the following in relation to conversion statements:

- Whenever a maximum length is specified for the standard representation, the actual output can also be shorter. Example: The output of the integer 10 consists of only 2 characters.
- The length of the data to be printed depends on the length of the variables. For example, in the case of the I representation type a maximum of 6 characters can be output for the INT data type and a maximum of 11 characters for the DINT data type.
- A width of "0" is not permissible in conversion statements. This is printed out as "*****" with the valid conversion statement.
- If the specified width is too small, in the case of text-based output (representation types A, C, D, S, T, Y and Z), only the number of characters corresponding to the specified width are output (the output is truncated). In all other cases, * characters are output corresponding to the width.
- Undefined or invalid conversion statements are not executed. This is printed out as "*****" (e.g. representation type missing: %2.2).

The rest of the conversion statement (e.g. everything after the character identified as incorrect) is output. This allows the exact cause of the error to be determined. If this is not possible, you can use the CP 441 STATUS system function block to find out the cause of the error (see Chapter "Communication via System Function Blocks (Page 137)").
- Conversion statements without associated variables (send variables SD_1 to SD_4 for the PRINT SFB) are ignored. Variables for which there is no conversion statement are not output.

- Conversion statements that are not supported in a header or footer are not executed. Instead, they are forwarded to the printer transparently.
- You have to use control statements to specify formatting (line feed, tabs, etc.) in a message text or in the printer output of a long conversion statement.

Examples of faulty conversion statements

Here are several examples of incorrect conversion statements.

Example 1: *****.2R

Format string = %303.2R
Variable (SD_1) = 1.2345E6

Error: Invalid width in the R representation type. The maximum permitted value for all representation types is 255.

Example 2: ****

Format string = %4.1I
Variable (SD_1) = 12345 DEC

Error: The selected width was too small for the variable value to be output. The precision is not relevant to representation type I.

Example 3: 96-10-3

Format string = %7.2D
Variable (SD_1) = D#1996-10-31

Error: The format string is formally correct, but the selected width was too small to print the date out fully.

Example 4: *****

Format string = %.3A
Variable (SD_1) = D#1996-10-31

Error: The standard width of representation type A was selected but with invalid precision. The possible values here are 2 and 4!

Example 5: *****

Format string = %3.3
Variable (SD_1) = 12345 HEX

Error: A representation type was not specified.

Examples of Correct Conversion Statements

Below are some examples of correct conversion statements.

Example 1:31.10.1996

Format string = %15.4A
Variable (SD_1) = D#1996-10-31

A width of 15 with a precision of 4 (width of the year) and right-justified formatting were selected.

Example 2: 12345.

Format string = %-6l
Variable (SD_1) = 12345 DEC

The selected width was one character greater than the variable value to be output; left-justified formatting.

Example 3: 12d_0h_0m_23s_348ms

Format string = %T
Variable (SD_1) = T#12D23S348MS

The IEC time is in the standard format; unspecified time units are inserted with zeros.

Example 4: 1.234560E+02

Format string = %12.6R
Variable (SD_1) = 1.23456E+002

A width of 10 is available to display the whole variable, with the precision (number of places after the decimal point) taking up 6 characters.

Example 5: TEST..

Format string = %-6C
Variable (SD_1) = TEST

Left-aligned formatting of the text variable

Control statements

Control statements are used to achieve specific results in the printout (e.g. underlining). In addition to the standard control statements (for bold, condensed, expanded or italic type and underlining), you can also use other control characters if you enter them in the control character table of the **CP 441: Configuration Package for Point to Point Communication** parameter assignment interface (e.g., K for "small caps").

The figure illustrates the structure of the control statement schematically.

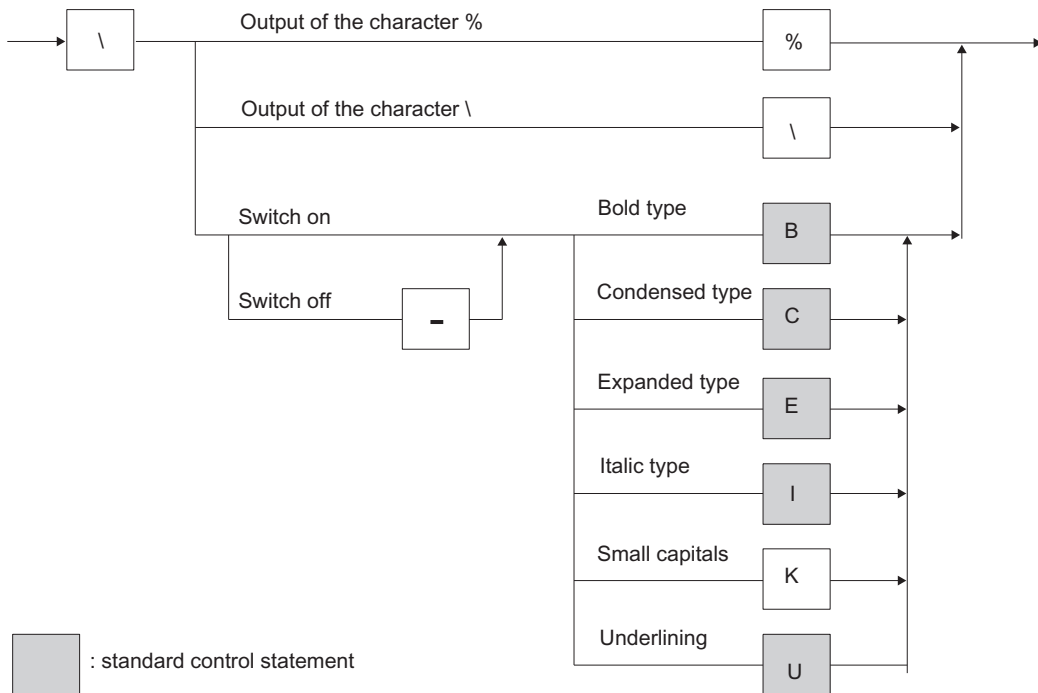

Figure 2-31 Schematic structure of a control statement

Examples

Here are some examples with control statements:

- **Example 1:**

To print the text **Bold type** and underlining are ways of highlighting a text", you have to enter the following:

```
\BBold type\B and \Uunderlining\U are ways of highlighting a text
```

- **Example 2:**

To output the format string with the conversion statement "Message text no. %i of %8.2A" transparently on the printer, you have to enter the following:

```
'Message text no. \%i of \%8.2A'
```

Beginning a New Page (\F)

Given the configured page layout, i.e. the configured headers and footers and the number of lines per page, the \F control statement can be used to begin a new page. This differs from a pure form feed on the printer.

Example: (Beginning a new page)

Format string = \F

Note

In the case of the \F control statement, there must be no further text, conversion or control statements in the format string. The variables remain unassigned.

Printing Without a Line Break (\x)

The CP 441 normally appends the configured end-of-line character (CR, LF, CR LF, LF CR) when when it sends a message text. The \x control statement cancels the line break after a message text. This means that you can print several messages in a single line in order, for example, to display more variables in a line. The \x control statement is appended at the end of the format string.

Example: The level "200" I was reached at "17:30" hours. ...

Format string = The level %i I was reached at %Z hours.\x

Variable SD_1 = Time of day

Variable SD_2 = State

Note

Note that when you use the \x control instruction, the new line always begins without a left margin.

Notes on Control Statements

Please note the following in relation to control statements:

- If the deactivation of an effect is specified without it previously having been activated, or if the output device is incapable of producing the effect, the control statement is ignored.
- The % and \ characters required to define the format string can be printed by means of the control statement.
- Undefined or incorrect control statements are not executed.

Commissioning the CP 441

Step sequence

Before starting up the CP 441 you will need to perform the following operations in the order given.

1. Install the communication processor
2. Configuring the Communication Processor
3. Assigning the Communication Processor Parameters
4. Connection configuration of the communication processor
5. Creating a User Program for the Communication Processor

Mounting the CP 441

Mounting the CP 441 involves inserting it into the mounting rack of your programmable controller and plugging in the interface submodules.

You can find a detailed description in Chapter "Mounting the CP 441 (Page 109)" of this manual.

Configuring the Communication Processor

The CP configuration includes its entry in the configuration table. Configure your communication processor using the STEP 7 software.

You can find a detailed description in Chapter "Configuring and Assigning Parameters for the CP 441 (Page 113)" of this manual.

Assigning the Communication Processor Parameters

Parameter assignment for the communication processor involves creating the specific parameters of the protocols and configuring message texts for printer output. You set the parameters of the CP 441 with the **CP 441: Configuration Package for Point to Point Communication** parameter assignment interface.

You can find a detailed description in Chapter "Configuring and Assigning Parameters for the CP 441 (Page 113)" of this manual.

Backing up Configuration Data

A backup of CP parameter data includes the storage of parameters, their download to the CPU and transfer to the CP. Backup your CP configuration using the STEP 7 software.

You can find a detailed description in Chapter "Managing the Parameter Data (Page 117)" of this manual.

Configuring the Connections for the CP 441

Configuring the connections for the CP 441 means connecting the communication end points within a point-to-point network in the project of your programmable controller. Connections are configured using the STEP 7 software (connection configuration table).

You can find a detailed description in Chapter "Connection Configuration (Page 122)" of this manual.

Creating a User Program for the Communication Processor

CP programming includes the implementation of the CP in the STEP 7 user program of your CPU. Program your CP using the language editors of the STEP 7 software.

You can find a detailed description in Chapter "Communication via System Function Blocks (Page 137)" of this manual and in the *Programming with STEP 7* manual.

A comprehensive programming example is available in the chapter "Programming Example for System Function Blocks (Page 217)".

Mounting the CP 441

4.1 CP 441 slots

Introduction

There are no specific slots reserved for communication modules in the rack of the S7-400 automation system.

Positioning the CP in the Rack

The communication processor can be plugged into any slot in the rack, with the following exception:

In all racks the power supply module occupies slots 1 to 3 depending on the width.

Further Information

Additional information about the topic of racks is available in the installation manual *S7-400, Automation Systems, Installation*.

4.2 Mounting and Dismounting the CP 441

Introduction

When mounting and removing the CP 441, you must observe certain rules.

Tool

You will need a 3.5 mm cylindrical screwdriver to mount or dismount the communication processor.

Note

The CP 441 can be hot-plugged and hot-pulled, in other words with voltage applied. This means that the CP 441 can be replaced while the programmable logic controller is in operation. The CP 441 is configured automatically when it is plugged in. It then operates as before.

4.2.1 Installation steps

Mounting the CP 441

To mount the communication processor in a rack, proceed as follows:

1. Remove the filler panel from the slot you want to use by gripping it where marked and pulling it toward you. Insert the CP 441 module and tilt it downward.
2. Hang the communication processor in the rack and swing it down.
3. Screw down the module at the top and bottom with a torque of 0.8 to 1.1 Nm.

4.2.2 Removal steps

Removing the CP 441

To remove the communication processor from the rack, proceed as follows:

1. Undo the screws at the top and bottom of the module.
2. Tilt the module upward and remove it.
3. Replace the filler panel over the empty slot.

4.3 Installing and Removing the Interface Submodules of the CP 441

Introduction

When installing and removing the interface modules of the CP 441, you must observe certain rules.

CAUTION

Before installing/removing the interface module, unplug the power supply module or dismount the CP 441 from the rack; otherwise the interface module could be permanently damaged.

Note

It is absolutely necessary to apply the shield of the connected plug-in cable to a shield rail for reasons of interference suppression. Only then can the relevant EMC (electromagnetic compatibility) standards be complied with.

Combination options CP with interface module

NOTICE

For CP 441 up to order number 6ES7 441-xAA04-0AE0, IF 963 interface modules with order number 6ES7 963-xAA00-0AA0 are used.

For CP 441 as of order number 6ES7 441-xAA05-0AE0, the IF 963 interface modules with order number 6ES7 963-xAA10-0AA0 must be used.

Installation sequence

To install an interface module in the CP 441, proceed as follows:

1. First unplug the power supply module or dismount the CP 441 from the rack.
2. The installation of an interface module depends on the version of the CP 441.
 - 6ES7 441-xAA04-0AE0
Insert the interface module carefully into the module bay of the CP 441 and fasten the interface module with screws on the top and bottom with a torque of 0.8 to 1.1 Nm.
 - 6ES7 441 xAA05 0AE0
Insert the interface module carefully into the module bay of the CP 441 until the locking mechanism latches into place.

Removal sequence

To remove an interface module from the CP 441, proceed as follows:

1. First unplug the power supply module or dismount the CP 441 from the rack.
2. The removal of an interface module depends on the version of the CP 441.
 - 6ES7 441-xAA04-0AE0
Loosen the screws on the top and bottom on the interface module and remove the interface module carefully from the module bay of the CP 441.
 - 6ES7 441-xAA05-0AE0
Loosen the locking mechanism by pressing it on the sides of the interface module and carefully pull the interface module from the module bay of the CP 441.

Configuring and Assigning Parameters for the CP 441

5

Introduction

Once you have mounted the communication processor, you must inform the programmable controller that it is there. This process is known as "configuration".

Parameter Assignment Options

You configure and set the parameters for the module variants of the CP 441 using STEP 7 or the **CP 441: Configuration Package for Point to Point Communication** parameter assignment interface.

Table 5- 1 Configuration Options for the CP 441

Product	Order Number	Configurable using the parameter assignment tool	under STEP 7	under STEP 7 (TIA Portal)
CP 441-1	6ES7 441-1AA04-0AE0	as of version V5.1.6	as of version V5.3	as of version V11
CP 441-2	6ES7 441-2AA04-0AE0			
CP 441-1	6ES7 441-1AA05-0AE0	as of version V5.1.13	as of version V5.3 using HSP0225	in version V11 SP2 Update 3 using HSP0025
CP 441-2	6ES7 441-2AA05-0AE0			

Requirements

The **CP 441: Configuration Package for Point to Point Communication** parameter assignment interface is installed on the PG/PC under STEP 7 or STEP 7 V11 (SP2). The parameter assignment interface for the CP 441 is included in STEP 7 (TIA Portal) as of V11.

Before you can enter the communication processor in the configuration table of the STEP 7 software, you must have created a project and a terminal with STEP 7.

Configuration

In the following, "configuration" refers to the entry of the communication processor in the configuration table of the STEP 7 software. In the configuration table, enter the rack, the slot and the order number of the communication processor. STEP 7 then automatically assigns an address to the CP.

The CPU is now able to find the communication processor in its slot in the rack by way of its address.

Further Information

The procedure for configuring S7-400 modules is described in detail in the STEP 7 manual. In addition, the STEP 7 online help system will provide you with all the assistance you need when configuring an S7-400 module.

Installing the Parameter Assignment Interface

The **CP 441: Configuration Package for Point to Point Communication** parameter assignment interface together with the programming example can be found on the CD.

To install the engineering tool:

1. Insert the CD into the CD drive of your programming device/PC.
2. To open the dialog for installing software under Windows, double-click the **Add and Remove Programs** icon in the **Control Panel**.
3. In the dialog, select the CD drive and the **Setup.exe** file and start installation.
4. Follow the step-by-step instructions of the Setup program.

Parameter assignment with STEP 7 (TIA Portal) V11

The parameter assignment interface has already been integrated STEP 7 (TIA Portal) as of V11 (no installation required). You can download the respective example projects from the Service and Support pages.

<http://support.automation.siemens.com/WW/view/de/59585200>
(<http://support.automation.siemens.com/WW/view/en/59585200>)

5.1 Parameters for the communications protocols

Introduction

Once you have entered the CP in the configuration table, you must supply its interface with parameters. In the case of the printer driver, you can also configure message texts for printer output. This process is known as "Parameter Assignment".

Parameter assignment

The expression "Parameter Assignment" is used in the following to describe the setting of interface-specific parameters and the configuration of message texts. This is done using the **CP 441: Configuration Package for Point to Point Communication** parameter assignment interface.

You start the parameter assignment interface by double-clicking the order number (CP 441) in the configuration table or by selecting the CP 441 and then calling the **Edit > Object Properties** menu command.

You do not have to specify any settings for the CP 441 on the "General" and "Addresses" tabs.

Select the "Basic parameters" tab and enter the interface number and the type of interface. Click on the "Parameters" button to go to protocol selection. Set the protocol and double-click the icon for the transmission protocol (an envelope). This takes you to the dialog for setting the protocol-specific parameters.

Response to a CPU Stop

Enter the basic parameters in the "Attributes - CP 441" hardware dialog in STEP 7. Open the dialog by double-clicking the CP 441 in the STEP 7 configuration table.

The following table contains a description of the basic parameters.

Table 5- 2 Basic Parameter

Parameter	Description	Value range	Default value
Interrupt Selection	The CP 441 can generate a diagnostics alarm for more serious errors.	<ul style="list-style-type: none"> • Yes • No 	No
Response to a CPU Stop	This parameter influences CP 441 access to local S7 data areas during a CPU stop. The following section contains more detailed information about this.	<ul style="list-style-type: none"> • Continue Work • STOP 	Continue Work

5.1 Parameters for the communications protocols

The "Response to a CPU Stop" parameter is only available for the CP 441-2 (as of 6ES7 441-2AA04-0AE0). It influences CP 441 access to local S7 data areas during a CPU stop when using the **RK512** protocol and the loadable Modbus slave driver as follows:

- The changes only affect remote requests.
- Behavior when using the RK512 protocol:

When a **"SEND"** or **"FETCH"** request is received **remotely** (that is, when attempting to write to or read from local SIMATIC memory areas), the remote requests:

 - Continue to be processed using the communication mechanisms PUT/GET in the case of "Continue Work", also during a CPU stop.
 - Are not passed on to the CPU in the case of "STOP", but rather a RK512 response frame with the error code "0A" is returned to the remote partner that submitted the request.
- Behavior when using the Modbus slave protocol:
 - See Operating Instructions *S7-300/S7-400 Loadable driver for point-to-point CPs: MODBUS protocol, RTU format, S7 is slave*.

Further Information

The basic operation of the parameter assignment interface **CP 441: Configuration Package for Point to Point Communication** is the same and self-explanatory for all communication processors. For this reason, the parameter assignment interface is not described in detail here.

Also, the on-line help provides sufficient support for working with the parameter assignment interface.

5.2 Managing the Parameter Data

Introduction

The CP 441's configuration and parameter assignment data (including the message texts) is stored in the current project (on the hard disk of the programming device/PC).

Data management

When you quit the configuration table by selecting **Station > Save** or **Station > Save As**, the system automatically saves the configuration and parameter assignment data (including the module parameters) to the project/user file you have created.

Loading the Configuration and Parameters

You can now load the configuration and parameters on-line from the programming device onto the CPU (menu item **PLC > Download**). The CPU accepts the parameters immediately after the download.

The module parameters of the CP 441 are transferred to the CP 441 automatically at start-up of the CPU as soon as the CP 441 is accessible via the S7-400 rear panel bus. Default settings apply if parameters are not changed.

Reading Back Parameters

From STEP 7, V5.0 + Service Pack 2 onwards, you can view the parameters of the CP 441 modules online using HW Config. From this view, you cannot change the parameters and they are therefore displayed in gray.

Further Information

In *Configuring Hardware and Communication Connections STEP 7 V5.3*, the manual for STEP 7, you will find detailed descriptions of how to:

- save the configuration and parameters.
- load the configuration and parameters onto the CPU.
- read, modify, copy and print the configuration and the parameters.

Note

STEP 7 (TIA Portal)

Information is available in the STEP 7 (TIA Portal) information system.

5.3 Multiprocessor communication

Maximum number of CPUs

The CP 441 as of 6ES7 441-xAA0y-0AE0 (x = 1, 2 / Y= 4, 5) enables communication with up to 4 CPUs in an automation system.

Prerequisite

STEP 7, Version 4.02 or higher

Note

Please observe the following rules of multiprocessor communication:

- Data can be sent from any CPU.
- In the case of the ASCII driver and the 3964(R) procedure, data can only be received via one CPU, since these protocols do not send any address information with the data.
- In the case of the RK512 computer link, data can be received on 4 CPUs. Addressing takes place with CPU numbers 1 to 4 in the header of the RK512 frame.

The CPU numbers automatically assigned in HW Config (configuration table of STEP 7) are entered by default during connection configuration in the "Connection is selected by means of RK512 CPU no." field of the "Object Properties" dialog (see section ""Properties - PtP Connection" dialog, procedure with RK512 computer link (Page 129)").

5.4 Identification data

Definition

Identification data is stored on a module. This information provides support for:

- Correcting errors in a system
- Checking the system configuration
- Locating hardware changes in a system.

Identification data can be used to identify modules uniquely on the network. As of order number 6ES7 441-xAA05-0AE0, the I&M data I&M 0 and I&M 1 are available on the CP 441.

For writing of I&M 1 data (plant designation (HID) and location ID (LID)) you need at least version V5.5 SP3 when using STEP 7 and at least SP2 Update 3 with HSP0025 (HSP_V11SP2_0025_001_S7400_CP441_2.0) when using STEP 7 V11.

Note

Only I&M0 data are supported in the first delivery stage of the CP 441 (6ES7 441-2AA05-0AE0). This limitation will no longer apply with a future delivery stage (FW version).

Reading the identification data

You can display the I&M data provided by the module with the online function **PLC > Module Information**.

The following subsets are output by the I&M 0 / I&M 1 data in the "**General**" tab:

- I&M 0 data
 - Device name (order number of module)
 - Hardware revision (product version of module)
 - Software revision (firmware version of module)
- I&M 1 data
 - HID (plant designation of the module)
 - LID (location ID of the module)

The following subset is output by the I&M 0 data in the "**Identification**" tab:

- Manufacturer identification (SIEMENS AG)
- Device serial number (serial number of the module)
- Profile ID (F6 00 hex: Internal parameter (generic device, according to PROFIBUS DP))
- Profile-specific type (00 04 hex: Internal parameter (communication module, according to PROFIBUS DP))

5.5 Subsequent Loading of Drivers (Transmission Protocols)

Introduction

To extend the functionality of the CP 441 and adapt it to the communication partner, you can load other transmission protocols on the CP 441-2 (loadable drivers) in addition to the standard protocols in the module firmware (ASCII, 3964(R), RK512, printer).

The loadable drivers are not shipped with the CP 441 or the parameter assignment interface as standard. You have to order them separately (see online Catalog (<http://mall.automation.siemens.com>)).

To find out how to install and assign parameters to a loadable driver and load it onto the CP 441-2, consult the separate documentation for the loadable driver. Only the requirements and the fundamentals are described below.

Requirements

The prerequisites for loading the drivers are:

- STEP 7, as of V5.3
- **CP 441: Configuration Package for Point to Point Communication**, as of V5.1.6
- CP 441-2
- The dongle provided with the driver must be installed on the CP 441-2.

Introduction to the Parameter Assignment Interface

You select the loadable driver for parameter assignment in the **CP 441: Configuration Package for Point to Point Communication** parameter assignment interface.

After you have successfully installed the parameter assignment interface and loadable drivers, you select the driver you want and set the protocol-specific parameters in the same way as you do for the standard protocols. Installation of the Parameter Assignment Interface and Selection of a Transmission Protocol (see section "Connection Configuration (Page 122)").

To find out what is meant by parameter assignment and how to download the drivers to the CP 441, consult the separate documentation for the loadable driver.

Note

The interfaces for the drivers are already integrated in STEP 7 (TIA Portal) as of V11.

Note

Please note the following:

- The loadable driver is stored in the CPU's load memory together with the parameter data and loaded automatically onto the CP 441-2 during the loading operation. You must therefore reserve the requisite memory space in the load memory of the CPU for every interface on which you want to load the driver.
- Loadable drivers are sent only once to the CP 441. The driver download (2 SDBs) is interrupted if you attempt to assign parameters.
- Before you transfer the loadable driver to the CP 441-2, you must increase the value of the parameter for transferring parameters to modules for the relevant CPU. Allow approximately 15 seconds for each loadable driver.
- With the first delivery stage of the CP 441 (6ES7 441-2AA05-0AE0), only the special drivers for Modbus master (RTU), Modbus slave (RTU) and Data Highway (DF1) are supported. This limitation will no longer apply with a future delivery stage (FW version).

5.6 Connection Configuration

Introduction

The CP 441 represents the link between an S7 CPU and a communication partner linked by means of a point-to-point connection. The S7 connections are converted to the address mechanisms of the selected transmission protocol on the CP 441.

When you configure a connection, you specify the route the connection takes from the S7 CPU to the CP 441 via the serial link to the communication partner.

As a result of connection configuration, you obtain the connection ID that you have to specify as the parameter "ID" in your user program when you call a system function block in order to exchange data with the corresponding communication partner.

Simplified Connection Configuration

STEP 7, version 4.0 and later, also allows you to carry out simplified connection configuration. In this case, you do not need to create any PtP subnets or network the interface. To carry out simplified connection configuration, you need to do two things:

1. Enter the connection in the connection table.
2. Set the object properties of the connection.

Complete Connection Configuration

You configure a point-to-point connection between your CP 441 and the communication partner using STEP 7. The connection is configured in five steps:

1. Insert a PtP subnet.
2. Attach the CP 441 to the subnet.
3. Select or insert the connection partner, and attach the partner to the subnet.
4. Enter a connection in the connection table
5. Set the object properties of the connection.

There are differences depending on whether the connection partner is a CP 441 or a CP 340, an S5 CP, a printer or a third-party station or device and on the protocol used for the connection.

Further Information

You will find general information on how to configure connections with STEP 7 in the STEP 7 manual *Configuring Hardware and Communication Connections STEP 7 V5.3*.

In addition, STEP 7's online help system will provide you with assistance in configuring a connection.

5.6.1 Simplified Connection Configuration

Enter a connection in the connection table

Proceed as follows:

1. In SIMATIC Manager, display the "<Offline> (Project)" project window, and double-click the CPU in your SIMATIC 400 station.

Result: The **Connections** object (connection table) appears on the right.

2. Double-click this icon. The "Configuring Connections" dialog appears. Choose **Insert > Connection** to insert your connection in the connection table.

3. In the **New Connection** dialog, select **Unspecified** as the communication partner and enter **S7 PtP Connection** as the connection type. Then click **OK** to exit the dialog.

4. In the **Object Properties** dialog, set the specific properties of the connection:

In the **Object Properties** dialog, change the name of the communication partner from **Unspecified** to an appropriate name (the name is entered automatically in the connection table) and make selections in the **Via PtP CP** and "Interface" list boxes.

No other settings are usually necessary. Read the following sections if you want to define more than one connection per interface (e.g. for multicomputing):

- Chapter ""Properties - PtP Connection" dialog, procedures for the ASCII driver, printer driver and 3964(R) procedure (Page 126)" or
- Chapter ""Properties - PtP Connection" dialog, procedure with RK512 computer link (Page 129)"

5. Click **OK** to return to the "Configuring Connections" dialog.

Result: The "Configuring Connections" dialog displays the connection that you have added and the "Local ID (Hexadecimal)". You have to specify this ID as the parameter "ID" at the system function block in the user program of your CPU.

Note

If your communication partner is a CP 441, please note the following:

Whereas a homogeneous S7 connection ends directly at the two end points (CPUs) of the connection, a point-to-point connection consists of a "partial connection" from the CPU to the CP 441 in one station and a "partial connection" from the CPU to the CP 441 in the partner station. You therefore have to configure a connection on your partner station as well in order to enable a point-to-point connection between the two CPUs, and the local IDs may be different.

5.6.2 Complete Connection Configuration

Introduction

To present the point-to-point connection graphically, proceed as follows:

Select Netpro

1. In SIMATIC Manager, display the "<Offline> (Project)" project window, and double-click the CPU in your SIMATIC 400 station.

Result: The **Connections** object (connection table) appears on the right.

2. Double-click this icon. The "Configuring Connections" dialog appears.

Insert a PtP subnet.

Select **Insert > Network Object** to open a catalog. In the catalog, select **Subnets** and then select **PtP**.

Result: The point-to-point network is displayed.

Select Connection Partner

If your connection partner is another CP 441, the station should already be in the subnet. If your partner is an S5-CP PtP, a printer, a third-party device or an S7-CP PtP, without communication-bus connection (CP 340, CP 341) enter **Other Station** or **SIMATIC S5** as a dummy value. You do so by selecting **Insert > Network Object**. In the open catalog, select **Stations** and then select **Other Station** or **SIMATIC S5**. You then have to identify the station as a PtP station. To do so:

Double-click on the station, select user list and click the **New** button; select PtP station and link the station into the network by selecting the point-to-point network with PtP Network.

Attaching the CP 441 and Connection Partner to the PtP Network

Use the mouse to drag the PtP connection of the CP 441 to the PtP network in order to attach it.

5.6.3 Enter a connection in the connection table

Entering a Connection

1. Select **Insert > Connection** to add a new connection to the connection table of the CPU you selected.
2. In the **New Connection** dialog, select SIMATIC 400 station(2) or **Other Station** or **SIMATIC S5** as communication partner and enter **S7 PTP Connection** as the connection type. Then click **OK** to exit the dialog.
3. In the "Object Properties" dialog, set the specific properties of the connection:
 - "Properties - PtP Connection" dialog, procedures for the ASCII driver, printer driver and 3964(R) procedure (Page 126)
 - "Properties - PtP Connection" dialog, procedure with RK512 computer link (Page 129)
4. Click **OK** to return to the "Configuring Connections" dialog.

Result

The "Configuring Connections" dialog displays the "Local ID (Hexadecimal)" of the connection that you have added. You have to specify this ID as the parameter "ID" at the system function block in the user program of your CPU in the SIMATIC 400 station(1).

Note

If your connection partner is another SIMATIC 400 station with a CP 441, you have to configure a connection on your partner station as well in order to enable a point-to-point connection between the two CPUs, and the local IDs may be different.

Please note that you cannot configure more than 8 connections for each interface of the CP 441.

5.7 Procedure in the "Properties - PtP Connection" dialog

5.7.1 "Properties - PtP Connection" dialog, procedures for the ASCII driver, printer driver and 3964(R) procedure

"Properties - PtP Connection" dialog

In addition to making the entry in the connection table, you also have to set specific properties for each point-to-point connection.

If a point-to-point connection consists of two "partial connections", you have to set the properties - PtP connection for each partial connection.

Below you will find a description of how to open and set the parameters of the "Properties - PtP Connection" dialog for the ASCII driver, the printer driver and the 3964(R) procedure.

Opening the Dialog

The "Properties - PtP Connection" dialog appears automatically when you insert a new connection in the connection table. You can also call this dialog for a connection at a later time:

1. Select the connection from the connection table.
2. Select the menu command **Edit > Properties - PtP Connection**.

Result: The "Properties - PtP Connection" dialog opens.

Settings

You set the properties of a connection in the "Properties - PtP Connection" dialog:

Table 5-3 Settings in the "Properties - PtP Connection" dialog for the ASCII driver, the printer driver and 3964(R) procedure

Parameter	Description
Configured dynamic connection	The check box is grayed and not selected: The connection is set up automatically during startup and is sustained until shutdown.
Active connection setup	The check box is grayed and selected: The connection is always set up by the local station.
Send operating mode messages	The check box is grayed and not selected: Operating status messages cannot be sent.
Local ID	Local ID (hexadecimal) which you have to specify as the parameter "ID" at the system function block in the user program of your CPU. You can change the suggested ID if you have programmed the SFBs with certain IDs.
Communication direction	Specify the direction in which communication is to take place by selecting the appropriate option (see also the sections entitled "One Connection Configured" and "Several Connections Configured")
Interface	Interface The CP 441-2 has two channels (the interfaces IF1 and IF2) via which the point-to-point links can be set up. Select the channel used for the configured connection.
	/Protocol Various protocols can be used to send data via point-to-point links. You specified the protocol when you configured the module.
Connection is selected by means of RK512 CPU no. • RK512 CPU no.	These fields are relevant only to the RK512 computer link. These fields are grayed out.

Note

If your communication partner is a CP 441, you also have to set the PtP connection properties for the partial connection in the partner station.

One connection configured

If you have only configured one connection via an interface, you do not have to specify any settings in the "Properties - PtP Connection" dialog.

Several connections configured

Up to eight connections can go via a single interface. You can send data via all eight connections (active requests: BSEND). You can only receive data (passive requests: BRCV) via only one connection, however, since the ASCII driver and the 3964(R) procedure do not send any address information with the data.

In the "Communication direction" field of the "Properties - PtP Connection" dialog, you have to specify whether you want to send and/or receive data via the selected connection:

1: Local → Partner

For the connections via which you send data. No other settings are necessary.

2: Partner → Local

For the connection via which you receive data. No other settings are necessary.

3: Local ↔ Partner

For the connection via which you send and receive data. No other settings are necessary.

Note

Data can only be received via one connection for each interface. If you have set "2: Partner → Local" or "3: Local ↔ Partner" as the communication direction for a connection via one interface, you can select "1: Local → Partner" as the communication direction.

5.7.2 "Properties - PtP Connection" dialog, procedure with RK512 computer link

"Properties - PtP Connection" dialog

In addition to making the entry in the connection table, you also have to set specific properties for each point-to-point connection.

If a point-to-point connection consists of two "partial connections", you have to set the PtP connection properties for each partial connection.

Below you will find a description of how to open and set the parameters in the "Properties - PtP Connection" dialog for the RK512.

Opening the Dialog

The "Properties - PtP Connection" dialog appears automatically when you insert a new connection in the connection table. You can also call this dialog for a connection at a later time:

1. Select the connection from the connection table.
2. Select the menu command **Edit > Properties - PtP Connection**.

Result: The "Properties - PtP Connection" dialog opens.

Settings

You set the properties of a connection in the "Properties - PtP Connection" dialog:

Table 5- 4 Settings in the "Properties - PtP Connection" dialog for RK512

Parameter	Description
Configured dynamic connection	The check box is grayed and not selected: The connection is set up automatically during startup and is sustained until shutdown.
Active connection setup	The check box is grayed and selected: The connection is always set up by the local station.
Send operating mode messages	The check box is grayed and not selected: Operating status messages cannot be sent.
Local ID	Local ID (hexadecimal) which you have to specify as the parameter "ID" at the system function block in the user program of your CPU. You can change the suggested ID if you have programmed the SFBs with certain IDs.
Communication direction	Specify the direction in which communication is to take place by selecting the appropriate option (see also the sections entitled "One Connection Configured" and "Several Connections Configured")
Interface	Interface The CP 441-2 has two channels (the interfaces IF1 and IF2) via which the point-to-point links can be set up. Select the channel used for the configured connection.
	/Protocol Various protocols can be used to send data via point-to-point links. You specified the protocol when you configured the module.

Parameter	Description
Connection is selected by means of RK512 CPU no.	If you have selected Partner → Local or Local ↔ Partner as the communication direction, enter the CPU number (1 to 4) by means of which your partner can address this connection.
RK512 CPU no.	If you have selected Local → Partner or Local ↔ Partner as the communication direction, enter the CPU number (1 to 4) to which the connection goes.

Note

If your partner is a CP 441, you also have to set the PtP connection properties for the partial connection in the partner station.

One connection configured

If you need only one connection for your interface, you do not need to specify any settings in the "Properties - PtP Connection" dialog.

Several connections configured

In the "Communication direction" field of the "Properties - PtP Connection" dialog, you have to specify whether you want to send (active requests: BSEND, PUT, GET) and/or receive (passive requests: BRCV) telegrams via the selected connection and, for "Partner" and "Local", you have to specify the CPUs via which the connection will be routed. If you want to send and receive telegrams, you must make an entry for both "Partner" and "Local".

1: Local → Partner

For the connections via which you send telegrams (BSEND, PUT, GET).

2: Partner → Local

For the connections via which you receive telegrams (BRCV).

3: Local ↔ Partner

For the connections via which you send and receive telegrams.

Local, connection is selected using RK512 CPU no.

The RK512 protocol allows you to specify a CPU No. in the range 1-4 in the telegram header in order to address up to four 4 CPUs (connections).

When receiving telegrams (BRCV), enter CPU no. 1 to 4 here. The CP 441 compares the CPU number you have set here with the one specified by byte 10 of the header of the receiving RK512 frame. When there is a match, the CP 441 forwards the received data over this connection.

Note

The number of connections per interface via which you can send telegrams is limited to eight. The fact that the CPU numbers in the telegram header are limited to 1 to 4 limits the number of connections via which you can receive telegrams at a single interface to a maximum of four. In the "Local" box, a CPU number that has already been assigned cannot be assigned again for a different connection at the same interface.

If you have set "2: Partner → Local" or "3: Local ↔ Partner" as the communication direction for a connection via one interface, you must enter another CPU no. in the "Local" field for another connection for receiving data or, if you only want to send data, you must select "1: Local → Partner" as the communication direction.

Partner, RK512 CPU no.

When sending telegrams (BSEND, PUT, GET), enter CPU no. 1 to 4 here. The CP 441 compares the CPU number you have set here with the one specified by byte 10 of the header of the sending RK512 frame. This makes it possible via this connection to address one of four different recipients at the partner.

Examples

- **Example 1:**

Task: You want data to be sent (or fetched) by means of RK512 from your S7-400 system. The data is to be stored on the partner's CPU 3 (or fetched by CPU 3).

Parameter assignment: You must specify Local → Partner as the communication direction and enter the CPU number 3 in the "Partner, RK512 CPU No." field.

- **Example 2:**

Task: You want to receive data from the partner by means of RK512, identified by CPU number 2 in the RK512 frame.

Parameter assignment: You must specify Partner → Local as the communication direction and enter the CPU number 2 in the "Local, Connection is selected by means of RK512 CPU no." field.

- **Example 3:**

Task: You want data to be sent from your S7-400 system to the partner (or fetched) by means of RK512. The data is to be stored on the partner's CPU 3 (or fetched by CPU 3). At the same time, you want to use the connection to receive from the partner data identified by the CPU number 2 in the RK512 frame.

Parameter assignment: You must specify Local ↔ Partner as the communication direction and enter the CPU number 3 in the "Partner, RK512 CPU No." field and the CPU number 2 in the "Local, Connection is selected by means of RK512 CPU no." field.

5.8 Firmware Updates

5.8.1 Subsequent Loading of Firmware Updates

Introduction

You can enhance functionality and eliminate errors by downloading firmware updates to system memory of communication processor.

You have the following options to update the firmware:

- Loading firmware in TIA Portal
- Loading firmware in HW Config
- Loading firmware using the parameter assignment interface of the CP 441

Basic Firmware

The CP 441 is shipped with basic firmware preinstalled.

Requirements

The requirements for loading firmware updates are:

- STEP 7 (TIA-Portal), as of V11 or
- STEP 7, as of V4.02 or
- **CP 441: Configuration Package for Point to Point Communication**, as of V5.0.

You must create a valid project under the hardware configuration and upload it to the CPU before you can update the firmware of the communication processor with the parameter assignment interface.

The instructions accompanying the firmware update always detail the destination directories for the files.

The ..\CP441.nnn path always identifies the firmware version.

Loading firmware in STEP 7 V11 (TIA Portal)

Follow the steps below:

1. Open the module in the online and diagnostic view.
2. Select the group "Firmware update" in the "Functions" folder.
3. Click the "Browse" button in the "Firmware update" area to select the path to the firmware update files.
4. Select one of these files. The table lists all modules for which an update is available with the selected firmware file.
5. Optional: Select the "Activate firmware after update" check box to automatically reset the module after loading and to start the new firmware.
6. Click the "Start update" button. If the selected file can be interpreted by the module, it is loaded to the module. If this requires changing the operating mode of the CPU, you are prompted by dialog boxes to do this.

Loading firmware in HW Config

(valid as of order number 6ES7 441-xAA05-0AE0)

Follow the steps below:

1. Switch the CPU to STOP mode.
2. Open **HW Config** and select the required CP 441 module.
3. Select the menu command **PLC > Update Firmware**.

The remaining procedure is described in the online help.

If the update is successful, you receive a confirmation message and the new firmware is activated immediately.

Loading firmware using the parameter assignment interface of the CP 441

You send the firmware update to the CP 441 using the **CP 441: Configuration Package for Point to Point Communication** parameter assignment interface.

Follow the steps below:

1. Switch the CPU to STOP mode.
2. Start the parameter assignment interface:
In SIMATIC Manager: File > Open > Project > Open HW Config > double-click CP 441 > select the "Parameters" button.
3. Select the menu command Options > Firmware Update.

Result:

If a connection can be established to the CP 441, the current module firmware status is displayed.

If there is no firmware loaded on the CP 441, the display shows " - - - ". This can occur, for example, if a firmware update was canceled. The original firmware is deleted prior to the cancellation. You have to upload firmware to the module before it can be restarted.

- Click on the "Find File ..." button to select the firmware to be loaded (*.UPD).

Note:

The basic firmware consists of three files each with a *.UPD extension. Select only the file called HEADER.UPD for the basic firmware.

Result:

The version of the firmware you select is displayed under "Status of selected firmware:".

- Click on the "Load Firmware" button to start uploading to the CP 441. You are prompted for confirmation. The upload procedure is canceled immediately if you click on the "Cancel" button.

Note:

Before the basic firmware is deleted from the module, the CP 441 checks the order number of the firmware to be downloaded in order to ensure that the firmware is approved for the CP 441.

Result:

The new firmware is loaded into the operating system memory of the CP 441. "Done" shows progress in bar-graph form and as a percentage.

LEDs

LEDs during the download of a firmware update:

Table 5- 5 LEDs for firmware update

Status	INTF/ EXTF	FAULT	TXD	RXD	Remark	To correct or avoid errors
Firmware update in progress	on	on	on	on	-	-
Firmware update completed	on	off	off	off	-	-
CP 441 without module firmware	flashes (2 Hz)	on	off	off	Module firmware deleted, firmware update was canceled, firmware update still possible	Reloading the firmware
Hardware fault during firmware update	flashes (2 Hz)	off	flashes (2 Hz)	flashes (2 Hz)	Read/write operation failed	Switch power supply to module off and then on again and reload the firmware. Check whether the module is defective.

5.8.2 Viewing the Firmware Version

Viewing the Hardware and Firmware Version

You can view the current hardware and firmware version of the communication processor in STEP 7 in the "Module Status" dialog. You can open this dialog by:

In SIMATIC Manager: File > Open > Project > HW Config > Station > Open Online > and double-click on communication processor.

Communication via System Function Blocks

Introduction

Communication between the CPU, the CP 441 and a communication partner takes place via the system function blocks of the CPU and the protocols of the CP 441.

Communication between CPU and CP 441

The system function blocks form the software interface between the CPU and the CP 441. They are called from the user program.

Communication between CP 441 and a Communication Partner

The transmission protocol conversion takes place on the CP 441. The protocol is used to adapt the interface of the CP 441 to the interface of the communication partner.

This enables you to link an S7 automation system with any communication partner that can handle the standard protocols ASCII, 3964(R) procedure or RK512 computer link.

6.1 Overview of the System Function Blocks

Introduction

The S7-400 programmable controller provides you with a number of system function blocks which initiate and control communication between the CPU and the CP 441 communication processor in the user program. The system function blocks are stored permanently in the CPU memory.

S7-400 System Function Blocks

The following table shows the system function blocks of the S7-400 programmable controller which you can use for communication between the CPU and the CP 441.

Table 6- 1 System function blocks of the S7-400 programmable controller

SFB	Meaning
BSEND (SFB 12)	The BSEND system function block allows you to send data from an S7 data area to a communication partner with fixed destination.
BRCV (SFB 13)	The BRCV system function block allows you to receive data from a communication partner and transfer it to an S7 data area.
GET (SFB 14)	RK512 only: The GET system function block enables you to fetch data from a communication partner.
PUT (SFB 15)	RK512 only: The PUT system function block enables you to send data to a communication partner with dynamically changeable destination.
PRINT (SFB 16)	The PRINT system function block allows you to output a message text containing up to 4 variables to a printer.
STATUS (SFB 22)	The STATUS system function block allows you to query the device status of a communication partner.

Further Information

For a detailed description of the system function blocks and their parameters, see the reference manual for system function blocks *System Software for S7-300/400, System and Standard Functions*.

Note

STEP 7 V11 (TIA Portal)

The SFBs are called instructions as of STEP 7 V11 (TIA Portal). Information in the instruction for communication between CPU and CP 441 is available in the TIA Portal information system.

6.2 Using the System Function Blocks

Introduction

The following sections describe what you must take into account when supplying parameters for the system function blocks in your own programmable controller (S7-400).

The communication between two CP 441s is described.

For points to note with regard to other communication partners of the CP 441, see the relevant **SIMATIC S5 literature** or **third-party literature**.

Description of the SFB Parameters

The parameters of the SFBs can be subdivided in terms by function into the following five classes (classification):

- Control parameters (for activating communication)
- Addressing parameters (for addressing the remote communication partner)
- Send parameters (which point to the data areas to be sent to the remote partner)
- Receive parameters (which point to the data areas in which the data received from the remote partner is entered)
- Status parameters (for monitoring whether the block has completed a task without errors and for analyzing the errors that occur)

Control Parameters

Data transfer is only activated if the associated control parameters have a defined value when the SFB is called or if the value has changed in a defined way since the last SFB call. We therefore refer to them as level- or edge-triggered control parameters.

Table 6- 2 SFB Control Parameters

Parameter	Meaning	Sender/ Recipient	Function activated at	Description
REQ	Request	Sender of the request	Positive edge (compared to last SFB call). In other words, before you call the SFB with "1", it must have run through once with "0".	Activates data transfer (provided certain conditions are fulfilled)
R	Reset	Sender of the request	Positive edge (compared to last SFB call). In other words, before you call the SFB with "1", it must have run through once with "0".	Activates cancellation of an active data transfer
EN_R	Enabled to receive	Recipient of the request	Level 1	Indicates readiness to receive

Addressing Parameters

Note

The addressing parameters ID and R_ID are only evaluated the first time the block is called (the actual parameters or the predefined values from the instance). The communication relationship (connection) to the remote partner is thus defined at the first call and remains so until the next restart of the CPU.

Table 6- 3 SFB Addressing Parameters

Parameter	Description	Note
ID	At the SFBs you specify as the "ID" the "local ID" (a hexadecimal value between 1000 and 1400) of the connection via which the system function block is to go. In order to do this, you must first have configured the connection using STEP 7. You get the value of the "Local ID" from the "Configuring Connections" dialog in STEP 7.	ID must be specified in the form W#16#wxyz.
R_ID	The meaning of the R_ID parameter is given in the subsequent descriptions of the transmission protocols.	R_ID must be specified in the form W#16#wxyz.

Status Parameters

The status parameters allow you to monitor whether the block has completed its task successfully or is still doing it. They also display errors that occur.

Note

The status parameters are only valid for a single cycle - from the first command following the SFB call to the next SFB call. Consequently, you have to evaluate these parameters after every block cycle.

Table 6- 4 SFB Status Parameters

Parameter	Data type	Sender/ Recipient	Description		
DONE	BOOL	Sender	0:	The request has not yet been started or is still being executed.	
			1:	The request has been completed without error. In other words: <ul style="list-style-type: none"> • With ASCII driver: Request was sent to the communication partner. This does not necessarily mean that the data was received by the communication partner. • With 3964(R) procedure: Request was sent to the communication partner and positive acknowledgement was returned. This does not necessarily mean that the data was forwarded to the partner CPU. • With RK512 computer link: Request was sent to the communication partner, which forwarded it without error to the partner CPU. 	
NDR	BOOL	Receiver	0:	The request has not yet been started or is still running.	
			1:	The request has been completed successfully.	
ERROR STATUS	BOOL WORD	Sender and recipient	Error display:		
			ERROR	STATUS	Meaning
			0	0	Neither a warning nor an error
			0	≠0	Warning. STATUS provides detailed information.
			1	≠0	There is an error. STATUS provides detailed information on the error.
			See section "Diagnostics Messages of the System Function Blocks (Page 190)." You can obtain point-to-point error information that goes beyond this by calling the STATUS system function block (SFB 22) (see section "Diagnostics via the error signaling area SYSTAT (Page 195)").		
Note: The ERROR bit and STATUS remain there only until the next SFB call. To display the STATUS, you should therefore copy it to a free data area.					

Note

The receiving CPU determines data consistency (CPU 412/413: 16 bytes, CPU 414/417: 32 bytes). For further information on data consistency, refer to the reference manual to the system and standard functions. To guarantee further data consistency, please observe the following:

- Sender: Only access the send DB when all data have been completely transferred (DONE = 1).
- Receiver: Only access the receive DB when all data are received (NDR = 1). Then you must inhibit the receive DB (EN_R = 0) until you have processed the data.

Send and Receive Parameters

The SD_i send parameters and the RD_i receive parameters are of the ANY data type, but no bit fields can be used.

See the CP 441 ANY demo project for instructions on how to change the send and receive parameters of the ANY data type at runtime. The demo project is in the "Examples" STEP 7 catalog under CP 441.

If you do not use all the send and receive parameters with an SFB, the first unused parameter must be a NIL pointer, and the used parameters must come one after the other without any gaps.

At the first call, the connection and the maximum amount of data that can be transferred via it per job is fixed. The system creates a communication buffer to ensure data consistency.

At subsequent calls you can send/receive any amount of data as long as it does not exceed that of the first call.

The BSEND and BRCV SFBs represent an exception to this rule. You can transfer up to 64 KB per request using them.

The following applies to the BSEND/BRCV SFBs:

- The number of SD_i and RD_i parameters used at the sending and receiving ends must match.
- The data types of SD_i and RD_i parameters at the sending and receiving ends that belong together must match.
- The amount of data to be sent by means of the SD_i parameter must not be greater than the area made available by the associated RD_i parameter.

If you break these rules, this is indicated to you by means of ERROR = 1 and STATUS = 4.

Examples of Send and Receive Parameters

Access to data blocks, bytes 10-109	P#DB20.DBX10.0 byte 100
Access to memory markers 10-12	P#M10.0 BYTE 3
Access to inputs 20-24	P#E20.0 BYTE 5
Access to outputs 20-24	P#A20.0 BYTE 5
Access to timers 1-5	L#1 TIMER 5
Access to counters 1-10	L#1 COUNTER 10

Jobs which can be processed simultaneously

The number of requests (BSEND and GET) which can be processed simultaneously depends on the data volume transmitted with the individual requests.

The requests are buffered on the CP 441 in data blocks of 450 bytes. Up to 40 data blocks can be buffered per interface.

If no further data blocks can be buffered, the request is terminated with an error (STATUS 02). The message 050FH is entered in the error-signaling area.

Example:

If all requests are 2000 bytes long, for example, 8 requests can be buffered.

Number of transmittable data sets

If an automation system uses more than one CP, the number of data that can be transmitted depends largely on CPU performance. A CPU 416, for example, can handle approximately 80-100 frames of 240 bytes per second.

Table 6- 5 If the communication load is increased please note the following:

Behavior	To correct or avoid errors
Transfer between CP and CPU receives negative acknowledgment (0407 or 0408 in the CP's diagnostic buffer).	<ul style="list-style-type: none"> • Increase the value of the "Cyclic load due to communication" parameter in the CPU screen form and • Call BRCV in the time OB or call BRCV more frequently in the cycle.
Contents of the diagnostic buffer on the CP cannot be read with a programming device.	Increase the value of the "Minimum cycle time" parameter in the CPU screen form "Cycle".
A newly inserted CP is not assigned parameters.	Increase the value of the "Transfer parameters to modules" parameter in the "Startup" CPU screen form.

6.3 Using the System Function Blocks with the 3964(R) Procedure

6.3.1 Applications

Introduction

If you are using the 3964(R) procedure as your transmission procedure, you can transmit data from your S7-400 programmable controller to a communication partner.

Data Transmission to a Communication Partner Using 3964(R)

The figure below illustrates how data is sent to a communication partner.

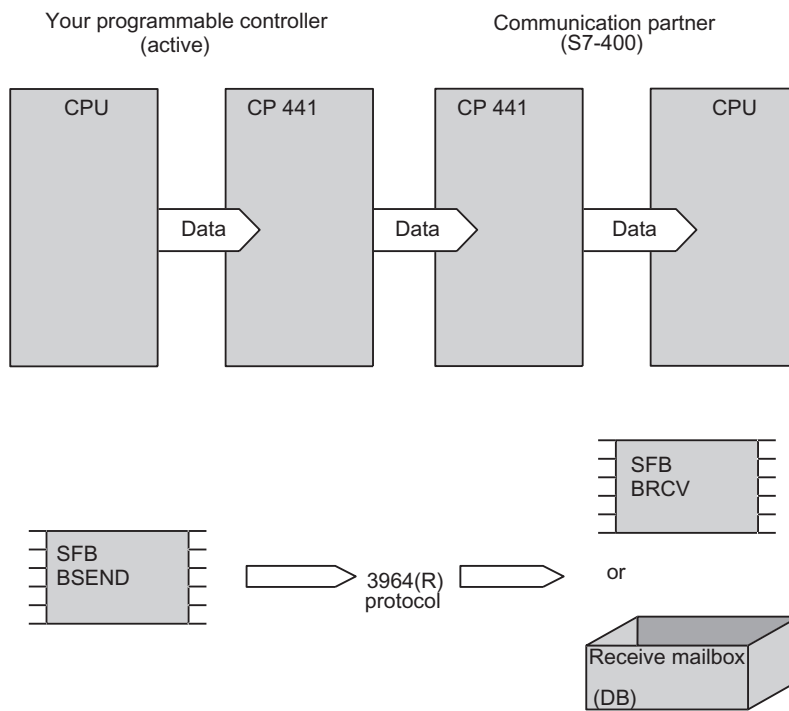

Figure 6-1 Sending Data to a Communication Partner with the 3964(R) Procedure

Data Transmission to the Communication Partner with 3964(R). Options:

To transmit data via the 3964(R) procedure, you have the following options:

- You can send the data with the system function block BSEND and receive the data at the communication partner with the system function block BRCV.

This type of data transmission has the advantage that, using the BRCV, you can interpret the NDR parameter to establish when the complete data was received, and the EN_R parameter to prevent unprocessed data from being overwritten at the receiver.

- You can send the data with the BSEND system function block and use the **CP 441: Configuration Package for Point to Point Communication** parameter assignment interface to define a receive mailbox (DB) on the communication partner for the CP 441; the incoming data are stored in the mailbox on the communication partner's CPU.

If you use this type of data transmission, you do not need to do any programming in the user program of the communication partner. Note, however, that at the receiver you cannot tell when a transmission is taking place. Therefore, the receiving CP 441 cannot prevent unprocessed data from being overwritten at the receiver.

Note

Please note that destination information is not transferred when transmitting data using the 3964(R) protocol. The data can therefore be sent from more than one source (BSENDs), but stored on one destination only per serial interface (BRCV or receive mailbox).

6.3.2 Data Transmission with 3964(R) Using BSEND and BRCV

What To Do

This type of data transmission has the advantage that, using the BRCV, you can interpret the NDR parameter to establish when the complete data was received, and the EN_R parameter to prevent unprocessed data from being overwritten at the receiver.

On Your Programmable Controller

For each communication request you must program a BSEND (SFB12) system function block in the S7 user program of the CPU.

The R_ID parameter takes any value. When programming more than one BSEND you must use different R_IDs.

For the SD_1 parameter (data type ANY), specify which data (source) is to be passed on.

Example: p#DB10.DBX5.0 WORD 1

The length is not evaluated with data type ANY, since the length of the data to be sent is defined in the LEN parameter.

Note that the length of the transmittable data is restricted to 4 KB.

At the CP 441 Communication Partner

In the S7 user program of the CPU you must program the BRCV system function block (SFB 13).

Note

So that no destination information can be transferred to the protocol by this means, the data of all BSENDS with different R_IDs must be received by means of a BRCV. No more than one BRCV system function block can therefore be created for a serial interface. The value "0" must be specified for the R_ID parameter.

For the RD_1 parameter (data type ANY), specify where the data is to be stored (destination). The length defines the maximum length of the block to be received.

Example: p#DB20.DBX10.0 WORD 2048

To prevent unprocessed data from being overwritten, you must call the BRCV with the value 0 at the control input EN_R.

Note that you might have to use the **CP 441: Configuration Package for Point to Point Communication** parameter assignment interface to disable (delete) a receive mailbox on the CP 441, as otherwise the data will be placed in the data block specified in the receive mailbox instead of being forwarded to BRCV.

Example

Table 6- 6 Example of Calling SFB12 (BSEND) using 3964(R)

STL		
L	50	
T	DB60.DBW806	
CALL SFB 12, DB62		Call for SFB 12.
REQ	:=DB60.DBX812.0	Following a rising edge at
R	:=DB60.DBX812.1	the REQ parameter, the data
ID	:=W#16#1000	for a length of 50 bytes
R_ID	:=W#16#5	starting at data byte 5 in
DONE	:=DB60.DBX812.2	DB10 is sent to the
ERROR	:=DB60.DBX812.3	communication partner with
STATUS	:=DB60.DBW802	the BSEND request.
SD_1	:=p#DB10.DBX5.0 WORD 1	
LEN	:=DB60.DBW806	

Table 6- 7 Example of Calling SFB13 (BRCV) using 3964(R)

STL		
SET		
=	DB60.DBX812.4	
CALL SFB 13, DB63		Call for SFB 13.
ID	:=W#16#1001	The data is received with the
R_ID	:=W#16#0	BRCV request and stored in
NDR	:=DB60.DBX812.5	DB20, starting at data byte 10.
ERROR	:=DB60.DBX812.6	The LEN parameter shows the
STATUS	:=DB60.DBW800	length of the received data (50
RD_1	:=p#DB20.DBX10.0 WORD 2048	bytes).
LEN	:=DB60.DBW804	Note that this protocol
		requires 0 as the R_ID of the
		BRCV system function block.

Request Table

The following table lists the data types which can be transmitted.

Table 6-8 Request table for sending data with the 3964(R) using BSEND and BRCV

Source, BSEND from S7	To Destination, Communication Partner	Parameter assignment at SFB BSEND, Parameter SD_1 (source)			Parameter Assignment in BSEND SFB, Parameter LEN (Source)	Parameter Assignment at SFB BRCV, Parameter RD_1 (Destination)		
		S- TYP E	S-DBNO	S-Offset (byte)	Length (max. 4096 byte)	D- TYP E	D-DBNO	D-Offset (byte)
Data block	Data block	DB	1 - *	0 - *	1 - *	DB	1 - *	0 - *
Flag	Data block	MB	irrelevant	0 - *	1 - *	DB	1 - *	0 - *
Inputs	Data block	IB	irrelevant	0 - *	1 - *	DB	1 - *	0 - *
Outputs	Data block	QB	irrelevant	0 - *	1 - *	DB	1 - *	0 - *
Counters	Data block	C	irrelevant	0 - *	1 - *	DB	1 - *	0 - *
Times	Data block	T	irrelevant	0 - *	1 - *	DB	1 - *	0 - *
* This value is dictated by the CPU that you use.								
Abbreviations used in the table: S-TYPE= source type, S-DBNO= source data block number, S-Offset= source start address, length= source length, D-TYPE= destination type, D-DBNO= destination data block number, D-Offset= destination start address								

6.3.3 Data transmission with 3964(R) using BSEND and a receive mailbox

What To Do

This type of data transmission has the advantage that no programming is necessary in the user program of the communication partner.

Note that at the receiver you cannot tell when a transmission is taking place. Therefore, the receiving CP 441 cannot prevent unprocessed data from being overwritten at the receiver. The data is transferred even when the receiving S7 CPU is in STOP mode. The receiving CPU determines data consistency (CPU 412/413: 16 bytes, CPU 414/417: 32 bytes).

Further Information

You will find more information on data consistency in the reference manual on system functions and standard functions *System Software for S7 300/400, System and Standard Functions..*

On Your Programmable Controller

For each communication request you must program a BSEND (SFB12) system function block in the S7 user program of the CPU.

The R_ID parameter takes any value. When programming more than one BSEND you must use different R_IDs.

For the SD_1 parameter (data type ANY), specify which data (source) is to be passed on.

Example: `p#DB10.DBX5.0 WORD 1`

The length is not evaluated with data type ANY, since the length of the data to be sent is defined in the LEN parameter.

At the CP 441 Communication Partner

You must specify a receive mailbox with its data block (DB) on the CP 441 with the aid of the **CP 441: Configuration Package for Point to Point Communication** parameter assignment interface.

In the data block the data arriving via the CP 441 is stored in the CPU. The data block must have been created previously on the CPU. The data block must be 2 bytes longer than the transmittable data, because the receiving CP enters the length of the transmitted data in the first two bytes.

Request Table

The following table lists the data types which can be transmitted.

Table 6- 9 Request Table for Sending Data with 3964(R) Using BSEND and a Receive Mailbox

Source, BSEND from S7	To Destination, Communication Partner	Parameter Assignment in the BSEND SFB, Parameter SD_1 (Source)			Parameter Assignment in the BSEND SFB, Parameter LEN (Source)	Specification of DB in Mailbox
		S-TYPE	S-DBNO	S-Offset (byte)		
					Length max. 4 KB	D-DB
Data block	Data block	DB	1 - *	0 - *	1 - *	1 - *
Flag	Data block	MB	Irrelevant	0 - *	1 - *	1 - *
Inputs	Data block	IB	Irrelevant	0 - *	1 - *	1 - *
Outputs	Data block	QB	Irrelevant	0 - *	1 - *	1 - *
Counters	Data block	C	Irrelevant	0 - *	1 - *	1 - *
Timers	Data block	T	Irrelevant	0 - *	1 - *	1 - *
* This value is dictated by the CPU that you use.						
Abbreviations used in the table: S-TYPE= source type, S-DBNO= source data block number, S-Offset= source start address, length= source length, D-TYPE= destination type, D-DB= destination data block, D-Offset= destination start address						

6.4 Using the system function blocks with the RK512 computer link

Overview

If you are using the RK512 computer link as your transmission method, you can:

- Send data from your S7-400 automation system to a communication partner with a fixed destination (see sections "Send data with a static destination definition with RK512 (Page 151)" to "Sending data with RK512 to the S5 communication partner or third-party device with static destination definition (Page 161)").
- Send data from your S7-400 automation system to a communication partner with a dynamic destination (see section "Sending data with RK512 to a communication partner with dynamic destination definition (Page 167)").
- Fetch data from a communication partner (see section "Fetching data with RK512 from a communication partner (Page 171)").

6.4.1 Send data with a static destination definition with RK512

Transmission sequence

The figure below illustrates how data is sent to a communication partner with static destination definition using RK512.

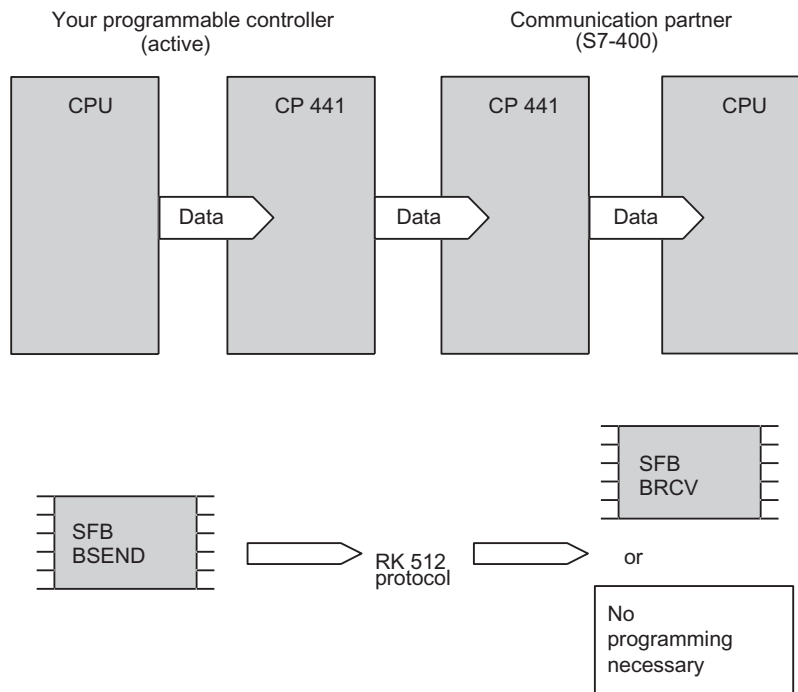

Figure 6-2 Sending data to a communication partner with static destination definition with the RK512 computer link

Note

If you are transmitting data via the RK512 computer link, you must distinguish between sending data to another CP 441 or linking up to an S5 module or third-party device.

Sending an Odd Number of Data

Please note the following when sending an odd number of data:

Note

The RK512 protocol only allows an even number of data to be sent. If you specify an odd number of data, an additional filler byte with a value of "0" is sent at the end.

Data transmission with RK512 to the CP 441 communication partner

If your partner in the link is a CP 441, you have the following options:

- To transmit data, you can program a BSEND at the sender and a BRCV at the receiver, indicated by the data type DX in the RK512 frame header.

This type of data transmission has the advantage that, using the BRCV, you can interpret the NDR parameter to establish when the complete data was received, and the EN_R parameter to prevent unprocessed data from being overwritten at the receiver.

- To transmit data, you can program a BSEND at the sender only, with no programming at the receiver, indicated by the data type DB in the RK512 frame header.

If you use this type of data transmission, you do not need to do any programming in the user program of the communication partner. Note, however, that at the receiver you cannot tell when a transmission is taking place. Therefore, the receiving CP 441 cannot prevent unprocessed data from being overwritten at the receiver.

6.4.2 Sending data with RK512 to the CP 441 communication partner with static destination definition, use of BSEND and BRCV

What To Do

This type of data transmission has the advantage that, using the BRCV, you can interpret the NDR parameter to establish when the complete data was received, and the EN_R parameter to prevent unprocessed data from being overwritten at the receiver.

On Your Programmable Controller

With this programming option, the data source is specified at the sender and the data destination is specified at the receiver.

In the S7 user program of the CPU you must program the BSEND system function block (SFB 12).

For the R_ID parameter you can specify a value from 0 to 255 (decimal). **The value is accepted once during CPU startup and cannot subsequently be changed.** No other values may be specified. The CP 441 transmits the R_ID value 0-255 in the RK512 frame header as DX 0-255 (extended data block) to the CP 441 of the communication partner.

R_ID 0-255 (decimal) → DX 0-255 (decimal)

In the CP 441 of the communication partner, this becomes the R_ID value 0-255 again, with which the corresponding BRCV on the partner CPU can be addressed.

For the SD_1 parameter (data type ANY), specify which data (source) is to be passed on.

Example: p#DB10.DBX5.0 WORD 1

The length is not evaluated with data type ANY, since the length of the data to be sent is defined in the LEN parameter.

Note that the length of the transmittable data is restricted to 4 KB.

Note

If you send data to a CP 441 by means of an S5 CP or a third-party device, in this mode you must specify DX as the destination data block with the corresponding number in the request block (S5 CP). The start address is not evaluated. Interprocessor communication flags are not evaluated either. The connection via which the data is forwarded from the CP 441 to the S7 CPU is selected by means of the CPU number. Up to 4 KB of data can be transferred.

At the CP 441 Communication Partner

The CP 441 of the communication partner recognizes the type of data transmission you have selected using the data type DX in the RK512 frame header. In this case, the specifications in the RK512 frame header are not the destination parameters; they represent the reference to the R_ID of a BRCV (SFB 13) which you must call in the S7 user program of the CPU.

The following applies:

DX 0-255 (decimal) → R_ID=0-255 (decimal)

The actual destination parameters must be specified in the BRCV system function block with the RD_1 parameter (data type ANY). The length defines the maximum length of the block to be received.

Example: p#DB20.DBX10.0 WORD 2048

The IPC flag byte and bit from the RK512 frame header are not interpreted.

To prevent unprocessed data from being overwritten, you must call the BRCV with the value 0 at the control input EN_R.

Example

Table 6- 10 Example of calling SFB12 (BSEND) using RK512:

STL		
L	50	
T	DB60.DBW806	
CALL SFB 12, DB62		Call for SFB 12.
REQ	:=DB60.DBX812.0	Following a rising edge at the REQ parameter, the data for a length of 50 bytes starting at data byte 5 in DB10 is sent to the communication partner with the BSEND request.
R	:=DB60.DBX812.1	
ID	:=W#16#1000	
R_ID	:=W#16#5	
DONE	:=DB60.DBX812.2	
ERROR	:=DB60.DBX812.3	
STATUS	:=DB60.DBW802	
SD_1	:=p#DB10.DBX5.0 WORD 1	
LEN	:=DB60.DBW806	

Table 6- 11 Example of calling SFB13 (BRCV) using RK512:

STL		
SET		
	=	DB60.DBX812.4
CALL SFB 13, DB63		Call for SFB 13.
EN_R		DB60.DBX812.4
ID		:=W#16#1001
R_ID		:=W#16#5
NDR		:=DB60.DBX812.5
ERROR		:=DB60.DBX812.6
STATUS		:=DB60.DBW800
RD_1		:=p#DB20.DBX10.0 WORD 2048
LEN		:=DB60.DBW804

The data is received with the BRCV request and stored in DB20, starting at data byte 10. The LEN parameter shows the length of the received data (50 bytes). Note that the R_ID of the BRCV must be identical to the R_ID of the BSEND.

Request Table

The following table lists the data types which can be transmitted.

Table 6- 12 Request table for sending data with RK512 to the CP 441 communication partner, using BSEND and BRCV

Source, BSEND from S7	To Destination, S7 Communication Partner (BRCV)	Parameter Assignment in the BSEND SFB, Parameter SD_1 (Source)			Parameter Assignment in BSEND SFB, Parameter LEN (Source)	Parameter Assignment in BSEND/BRCV SFB, Parameter R_ID	Parameter Assignment in BRCV SFB, Parameter RD_1 (Destination)		
		S-TYPE	S-DBNO	S-Offset (byte)	Length (max. 4096 byte)	No.	D-TYPE	D-DBNO	D-Offset (byte)
Data block	Data block	DB	1 - *	0 - *	1 - *	0-255	DB	1 - *	0 - *
Flag	Data block	MB	Irrelevant	0 - *	1 - *	0-255	DB	1 - *	0 - *
Inputs	Data block	IB	Irrelevant	0 - *	1 - *	0-255	DB	1 - *	0 - *
Outputs	Data block	QB	Irrelevant	0 - *	1 - *	0-255	DB	1 - *	0 - *
Counter	Data block	Z	Irrelevant	0 - *	1 - *	0-255	DB	1 - *	0 - *
Timers	Data block	T	Irrelevant	0 - *	1 - *	0-255	DB	1 - *	0 - *

* This value is dictated by the CPU that you use.
 Abbreviations: S-TYPE= source type, S-DBNO= source data block number, S-Offset= source start address; D-TYPE= destination type, length= source length, D-DBNO= destination data block number, D-Offset= destination start address

Specifications in the frame header of the RK512 protocol

The following table shows the specifications in the RK512 frame header.

Table 6- 13 Specifications in frame header of RK512 protocol, "Sending data with RK512 to CP 441 communication partner, using BSEND and BRCV"

Source, BSEND from S7	to the destination, S7 Communication Partner (BRCV)	Frame header		
		Bytes 3/4 Command mode*	Bytes 5/6 D-DXNO/D-Offset	Bytes 7/8 Number in
Data block	Data block	OD	DX/DW	Words
Flag	Data block	OD	DX/DW	Bytes
Inputs	Data block	OD	DX/DW	Bytes
Outputs	Data block	OD	DX/DW	Bytes
Counter	Data block	OD	DX/DW	Words
Timers	Data block	OD	DX/DW	Words

* The source information is not transferred to the CP, so the CP always enters the ID for DB (OD) at this point.
 Abbreviations: S-DXNO = extended destination data block number, D-Offset = destination start address,
 DW = Offset in words

6.4.3 Sending data with RK512 to the communication partner CP 441 with static destination definition, using BSEND

What To Do

This type of data transmission has the advantage that no programming is necessary in the user program of the communication partner.

Note that at the receiver you cannot tell when a transmission is taking place. Therefore, the receiving CP 441 cannot prevent unprocessed data from being overwritten at the receiver. Using the "Response to a CPU Stop" parameter, indicate whether data should continue to be transmitted when the S7 CPU is also in STOP mode. The parameter is only available for the CP 441-2 (as of 6ES7 441-2AA04-0AE0).

The receiving CPU determines data consistency (CPU 412/413: 16 bytes, CPU 414/417: 32 bytes).

On Your Programmable Controller

With this type of programming, the source data and the destination data are specified at the sender.

In the S7 user program of the CPU you must program the BSEND system function block (SFB 12).

For the SD_1 parameter (data type ANY), specify which data (source) is to be passed on.

Example: p#DB10.DBX5.0 WORD 1

The length is not evaluated with data type ANY, since the length of the data to be sent is defined in the LEN parameter.

For the destination data area you must specify a data block (DB) between 1 and 255 (decimal). Specify the destination data area of the communication partner in the R_ID parameter. **The value is accepted once during CPU startup and cannot subsequently be changed.** The R_ID parameter (DWORD) is structured as follows:

Byte 1 = ID for data type DB: 1 (hexadecimal)

Byte 2 = Not relevant (any value)

Byte 3 = Offset: 0-255 (decimal, in words)

Byte 4 = DB No.: 1-255 (decimal)

The parameters of the destination data area are transmitted to the communication partner in the RK512 frame header.

Please note that the length of the data that can be transferred is limited to 450 bytes depending on the CPU of the communication partner.

Note also that the parameter limits of the RK512 protocol at the partner only allow you to access data blocks 1 through 255 and to specify a maximum of 255 as the offset.

Note

If you send data to a CP 441 by means of an S5 CP or a third-party device, in this mode you must specify DB as the destination data block with the corresponding number and start address (offset) in the request block. Interprocessor communication flags are not evaluated. The connection via which the data is forwarded from the CP 441 to the S7 CPU is selected by means of the CPU number. The length of the transferable data is 450 bytes.

At the CP 441 Communication Partner

The CP 441 of the communication partner recognizes the type of data transmission you have selected using the data type DB in the RK512 frame header.

No programming is necessary in the S7 user program of the CPU.

Example

Table 6- 14 Example of calling SFB12 (BSEND) using RK512:

STL		
L	B#16#1	Data type DB
T	DB60.DBB820	
L	0	Not relevant
T	DB60.DBB821	
L	20	Starting at data word 20 (offset)
T	DB60.DBB822	
L	71	DB No. 71
T	DB60.DBB823	
CALL SFB 12, DB62		
REQ	:=DB60.DBX812.0	Following a rising edge at the REQ parameter, the data for a length of 50 bytes starting at data byte 5 in DB 10 is sent to the communication partner.
R	:=DB60.DBX812.1	
ID	:=W#16#1000	
R_ID	:=DB60.DBD820	
DONE	:=DB60.DBX812.2	The partner stores the data in DB 71, starting at data word 20. The destination information in the R_ID is accepted once during CPU startup and cannot subsequently be changed.
ERROR	:=DB60.DBX812.3	
STATUS	:=DB60.DBW802	
SD_1	:=p#DB10.DBX5.0 WORD 1	
LEN	:=DB60.DBW806	

Request Table

The following table lists the data types which can be transmitted.

Table 6- 15 Request table for "Sending data with RK512 to the CP 441 communication partner, using BSEND"

Source, BSEND from S7	To Destination, Communication Partner	Parameter Assignment in the BSEND SFB, Parameter SD_1 (Source)			Parameter Assignment in BSEND SFB, Parameter LEN (Source)	Parameter Assignment in the BSEND SFB, Parameter R_ID (Destination)		
		S- TYPE	S-DBNO	S-Offset (byte)		Length max. 450 bytes**	D- TYPE	D-DBNO
Data block	Data block	DB	1 - *	0 - *	1 - *	DB	1-255	0-255
Flag	Data block	MB	Irrelevant	0 - *	1 - *	DB	1-255	0-255
Inputs	Data block	IB	Irrelevant	0 - *	1 - *	DB	1-255	0-255
Outputs	Data block	QB	Irrelevant	0 - *	1 - *	DB	1-255	0-255
Counter	Data block	Z	Irrelevant	0 - *	1 - *	DB	1-255	0-255
Timers	Data block	T	Irrelevant	0 - *	1 - *	DB	1-255	0-255

* This value is dictated by the CPU that you use.

** Depending on the CPU of the communication partner, 450 bytes

Abbreviations: S-TYPE= source type, S-DBNO= source data block number, S-Offset= source start address, length= source length, D-TYPE= destination type, D-DBNO= destination data block number, D-Offset= destination start address

Specifications in the frame header of the RK512 protocol

The following table shows the specifications in the RK512 frame header.

Table 6- 16 Specifications in frame header of RK512 protocol, "Sending data with RK512 to CP 441 communication partner, using BSEND"

Source, BSEND from S7	to the destination, S7 Communication Partner (BRCV)	Frame header		
		Bytes 3/4 Command mode*	Bytes 5/6 D-DBNO/D-Offset	Bytes 7/8 Number in
Data block	Data block	AD	DB/DW	Words
Flag	Data block	AD	DB/DW	Bytes
Inputs	Data block	AD	DB/DW	Bytes
Outputs	Data block	AD	DB/DW	Bytes
Counter	Data block	AD	DB/DW	Words
Timers	Data block	AD	DB/DW	Words

* The source information is not transferred to the CP, so the CP always enters the ID for DB (AD) at this point.

Abbreviations: S-DBNO = destination data block number, D-Offset = destination start address, DW = Offset in words

Further Information

You can find more information on data consistency in the reference manual on system functions and standard functions *System Software for S7 300/400, System and Standard Functions..*

6.4.4 Sending data with RK512 to the S5 communication partner or third-party device with static destination definition

What To Do

If your partner in the link is an S5 CP or a third-party device, proceed as follows:

On Your Programmable Controller

In the S7 user program of the CPU you must program the BSEND system function block (SFB 12).

For the SD_1 parameter (data type ANY), specify which data (source) is to be passed on.

Example: p#DB10.DBX5.0 WORD 1

The length is not evaluated with data type ANY, since the length of the data to be sent is defined in the LEN parameter.

Specify the destination data area of the communication partner in the R_ID parameter. **The value is accepted once during CPU startup and cannot subsequently be changed.** The R_ID parameter (DWORD) is structured as follows:

Byte 1, bit 0,1,2,3	=	ID for data type DX: 0 (hexadecimal) DB: 1 (hexadecimal)
Byte 1, bit 4,5,6,7	=	IPC flag bits 0–7 (hexadecimal); if you are not using an IPC flag, the protocol enters FH in the frame header.
Byte 2	=	Byte for IPC flag 1-233 (decimal), or, if you are not using an IPC flag, 255 (decimal)
Byte 3	=	Offset: 0-255 (decimal, in words)
Byte 4	=	DB No.: 3-255 (decimal)

The parameters of the destination data area are transmitted to the communication partner in the RK512 frame header.

Note that the length of the transmittable data is restricted to 4 KB.

At the S5 Communication Partner or Third-party Device

For the relevant information you should read the notes in the appropriate *S5 manual*, or in the relevant literature if you are using a third-party device.

Example

Table 6- 17 Example of calling SFB12 (BSEND) using RK512:

STL		
L	50	Length = 50 bytes
T	DB60.DBW806	
L	B#16#31	IPC flag bit 3 / data type DB
T	DB60.DBB820	
L	30	Interprocessor communication flag
T	DB60.DBB821	byte 30
L	20	Starting at data word 20 (offset)
T	DB60.DBB822	
L	71	DB No. 71
T	DB60.DBB823	
CALL SFB 12, DB62		
REQ	:=DB60.DBX812.0	Following a rising edge at the REQ
R	:=DB60.DBX812.1	parameter, the data for a length of
ID	:=W#16#1000	50 bytes starting at data byte 5 in
R_ID	:=DB60.DBD820	DB 10 is sent to the communication
DONE	:=DB60.DBX812.2	partner.
ERROR	:=DB60.DBX812.3	The partner stores the data in DB
STATUS	:=DB60.DBW802	71, starting at data word 20.
SD_1	:=p#DB10.DBX5.0 WORD 1	Interprocessor communication flag
LEN	:=DB60.DBW806	byte and IPC bit are also
		transferred. The destination
		information in the R_ID is accepted
		once during CPU startup and cannot
		subsequently be changed.

Request Table

The following table lists the data types which can be transmitted.

Data destination DB:

Table 6- 18 Request table for "Sending data to an S5 communication partner or third-party device with RK512, data destination DB"

Source, BSEND from S7	to the destination, S5 Communication Partner or Third-party Device	Parameter Assignment in the BSEND SFB, Parameter SD_1 (Source)			Assigning parameters to the BSEND SFB, LEN parameter (source)	Parameter Assignment in the BSEND SFB, Parameter R_ID (Destination)		
		S-TYPE	S-DBNO	S- Offset (byte)	Length (max. 4096 byte)	D- TYPE	D-DBNO	D-Offset (words)
Data block	Data block	DB	1 - *	0 - *	1 - *	DB	3-255	0-255
Flag	Data block	MB	Irrelevant	0 - *	1 - *	DB	3-255	0-255
Inputs	Data block	IB	Irrelevant	0 - *	1 - *	DB	3-255	0-255
Outputs	Data block	QB	Irrelevant	0 - *	1 - *	DB	3-255	0-255
Counter	Data block	Z	Irrelevant	0 - *	1 - *	DB	3-255	0-255
Timers	Data block	T	Irrelevant	0 - *	1 - *	DB	3-255	0-255
* This value is dictated by the CPU that you use.								
Abbreviations used in the table: S-TYPE= source type, S-DBNO= source data block number, S-Offset= source start address, length= source length, D-TYPE= destination type, D-DBNO= destination data block number, D-Offset= destination start address								

Specifications in the frame header of the RK512 protocol

The following table shows the specifications in the RK512 frame header.

Data destination DB:

Table 6- 19 Specifications in the frame header of the RK512 protocol, "Sending data to an S5 communication partner or third-party device with RK512, data destination DB"

Source, BSEND from S7	To Destination, S5 Communication Partner or Third-party Device	Frame header		
		Bytes 3/4 Command mode*	Bytes 5/6 D-DBNO/D-Offset	Bytes 7/8 Number in
Data block	Data block	AD	DB/DW	Words
Flag	Data block	AD	DB/DW	Bytes
Inputs	Data block	AD	DB/DW	Bytes
Outputs	Data block	AD	DB/DW	Bytes
Counter	Data block	AD	DB/DW	Words
Timers	Data block	AD	DB/DW	Words
* The source information is not transferred to the CP, so the CP always enters the ID for DB (AD) at this point.				
Abbreviations used in the table: D-DBNO: destination data block number, D-Offset = destination start address, DW = Offset in words				

Request Table

The following table lists the data types which can be transmitted.

Data destination DX:

Table 6- 20 Request table for "Sending data to an S5 communication partner or third-party device with RK512, data destination DB"

Source, BSEND from S7	To Destination, S5 Communication Partner or Third-party Device	Parameter assignment at SFB BSEND, Parameter SD_1 (source)			Parameter Assignment in BSEND SFB, Parameter LEN (Source)	Parameter Assignment at BSEND SFB, Parameter R_ID (Destination)		
		S- TYP E	S-DBNO	S-Offset (byte)	Length (max. 4096 byte)	D- TYP E	D- DBNO	D-Offset (words)
Data block	Extended data block	DB	1 - *	0 - *	1 - *	DX	3-255	0-255
Flag	Extended data block	MB	Irrelevant	0 - *	1 - *	DX	3-255	0-255
Inputs	Extended data block	IB	Irrelevant	0 - *	1 - *	DX	3-255	0-255
Outputs	Extended data block	QB	Irrelevant	0 - *	1 - *	DX	3-255	0-255
Counter	Extended data block	Z	Irrelevant	0 - *	1 - *	DX	3-255	0-255
Timers	Extended data block	T	Irrelevant	0 - *	1 - *	DX	3-255	0-255

* This value is dictated by the CPU that you use.

Abbreviations used in the table: S-TYPE= source type, S-DBNO= source data block number, S-Offset= source start address, length= source length, D-TYPE= destination type, D-DBNO= destination data block number, D-Offset= destination start address

Specifications in the frame header of the RK512 protocol

The following table shows the specifications in the RK512 frame header.

Data destination DX:

Table 6- 21 Specifications in the frame header of the RK512 protocol, "Sending data to an S5 communication partner or third-party device with RK512, data destination DX"

Source, BSEND from S7	To Destination, S5 Communication Partner or Third-party Device	Frame header		
		Bytes 3/4 Command mode*	Bytes 5/6 D-DXNO/D-Offset	Bytes 7/8 Number in
Data block	Extended data block	OD	DX/DW	Words
Flag	Extended data block	OD	DX/DW	Bytes
Inputs	Extended data block	OD	DX/DW	Bytes
Outputs	Extended data block	OD	DX/DW	Bytes
Counter	Extended data block	OD	DX/DW	Words
Timers	Extended data block	OD	DX/DW	Words
* The source information is not transferred to the CP, so the CP always enters the ID for DB (OD) at this point.				
Abbreviations used in the table: S-DXNO = extended destination data block number, D-Offset = destination start address, DW = Offset in words				

6.4.5 Sending data with RK512 to a communication partner with dynamic destination definition

Transmission sequence

The figure below illustrates how data is sent to a communication partner with dynamically modifiable destination definition using RK512.

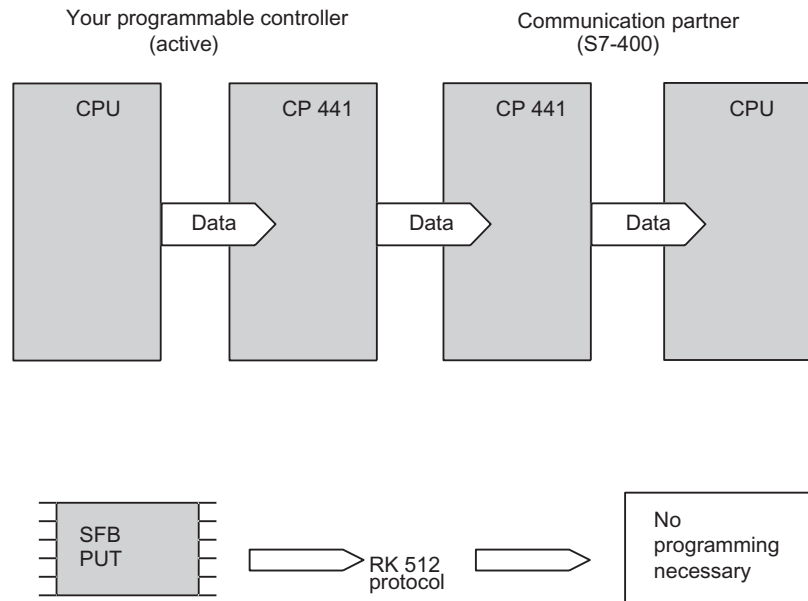

Figure 6-3 Sending data to a communication partner with dynamically modifiable destination definition with the RK512 computer link

Sending data to the communication partner with RK512. What To Do

To send data to a communication partner, proceed as follows:

On Your Programmable Controller

In the S7 user program of the CPU you must program the PUT system function block (SFB 15).

For the SD parameter (ANY data type) you specify the data you want to send to the partner (destination). Only even numbers (a maximum of 450 bytes) can be specified as the offset for the data types DB, C and T. In the case of the data types MB, IB and QB, the maximum offset is 255 bytes.

Example: p#DB10.DBX6.0 WORD 10

For the ADDR parameter (ANY data type) you specify where the data is to be stored on your partner (destination). The length specified must agree with the value specified for the SD parameter. The parameter limits of the RK512 protocol mean that only data blocks 1 to 255 of the partner can be reached. For the transfer of timers and counters, the "CHAR" data type must be specified for the data block in which the timers or numbers are stored.

Example: p#DB10.DBX6.0 CHAR 2

Note that at the receiver you cannot tell when a transmission is taking place. Therefore, the receiving CP 441 cannot prevent unprocessed data from being overwritten at the receiver. Using the "Response to a CPU Stop" parameter, indicate whether data should continue to be transmitted when the S7 CPU is also in STOP mode. The parameter is only available for the CP 441-2 (as of 6ES7 441-2AA04-0AE0). Interprocessor communication flags are not supported when linking with S5 CPs. The sending and receiving CPU determines data consistency (CPU 412/413: 16 bytes, CPU 414/417: 32 bytes). The weaker partner in terms of consistency determines the resulting consistency length for data transfer.

Note

If you send data to a CP 441 by means of an S5 CP or a third-party device, in this mode you must specify DB as the destination data block with the corresponding number and start address (offset) in the request block. Interprocessor communication flags are not evaluated. The connection via which the data is forwarded from the CP 441 to the S7 CPU is selected by means of the CPU number.

At the CP 441 Communication Partner

At the communication partner no programming is necessary in the S7 user program of the CPU.

Example

Table 6- 22 Example for calling SFB 15 (PUT):

STL		
CALL SFB 15, DB52		When this SFB is called, at a positive edge at bit DBX0.0, data is sent to the communication partner, where it is placed in DB30. If several data areas are sent at the same time, additional SD_i and ADDR_i pairs can be assigned parameters.
REQ	:= DB400.DBX0.0	
ID	:=W#16#1000	
DONE	:= DB400.DBX0.4	
ERROR	:= DB400.DBX0.5	
STATUS	:= DB400.DBW12	
ADDR_1	:= P#DB30.DBX 0.0 WORD 10	
ADDR_2		
ADDR_3		
ADDR_4		
SD_1	:= P#DB10.DBX 0.0 WORD 10	
SD_2		
SD_3		
SD_4		

See the CP 441 ANY demo project for instructions on how to change the send and receive parameters of the ANY data type at runtime. The demo project is in the "Examples" STEP 7 catalog under CP 441.

Request Table

The following table lists the data types which can be transmitted.

Table 6- 23 Request table for "Sending data with RK512 to the CP 441 communication partner, using PUT"

Source, PUT from S7	To Destination, Communication Partner	Parameter Assignment in the PUT SFB, Parameter SD_1 (Source)			Parameter Assignment in the PUT SFB, Parameter LEN (Source)	Parameter Assignment in PUT SFB, Parameter ADDR (Destination)		
		S-TYPE	S-DBNO	S Offset (bytes)	Length Max. 450 bytes **	D-TYPE	D-DBNO	D Offset (Words)
Data block	Data block	DB	1 - *	0 - *	1 - *	DB	1-255	0-255
Flag	Data block	MB	Irrelevant	0 - *	1 - *	DB	1-255	0-255
Inputs	Data block	IB	Irrelevant	0 - *	1 - *	DB	1-255	0-255
Outputs	Data block	QB	Irrelevant	0 - *	1 - *	DB	1-255	0-255
Counter	Data block	Z	Irrelevant	0 - *	1 - *	DB	1-255	0-255
Timers	Data block	T	Irrelevant	0 - *	1 - *	DB	1-255	0-255

* This value is dictated by the CPU that you use.
 ** Dependent on the CPU of the communication partner, max. 450 bytes

Abbreviations used in the table: S-TYPE= source type, S-DBNO= source data block number, S-Offset= source start address, D-TYPE= destination type, D-DBNO= destination data block number, D-Offset= destination start address

Specifications in the frame header of the RK512 protocol

The following table shows the specifications in the RK512 frame header.

Table 6- 24 Specifications in frame header of RK512 protocol, "Sending data with RK512 to CP 441 communication partner, using PUT"

Source, PUT from S7	To Destination, S7 Communication Partner (PUT)	Frame header		
		Bytes 3/4 Command mode*	Bytes 5/6 D-DBNO/D-Offset	Bytes 7/8 Number in
Data block	Data block	AD	DB/DW	Words
Flag	Data block	AD	DB/DW	Bytes
Inputs	Data block	AD	DB/DW	Bytes
Outputs	Data block	AD	DB/DW	Bytes
Counter	Data block	AD	DB/DW	Words
Timers	Data block	AD	DB/DW	Words

* The source information is not transferred to the CP, so the CP always enters the ID for DB (AD) at this point.
 Abbreviations: S-DBNO = destination data block number, D-Offset = destination start address, DW = Offset in words

Further Information

You can find more information on data consistency in the reference manual on system functions and standard functions *System Software for S7 300/400, System and Standard Functions..*

See also

Overview of the System Function Blocks (Page 138)

6.4.6 Fetching data with RK512 from a communication partner

Transmission sequence

Fetching data with RK512 from a communication partner:

The figure below illustrates how data are fetched from a communication partner.

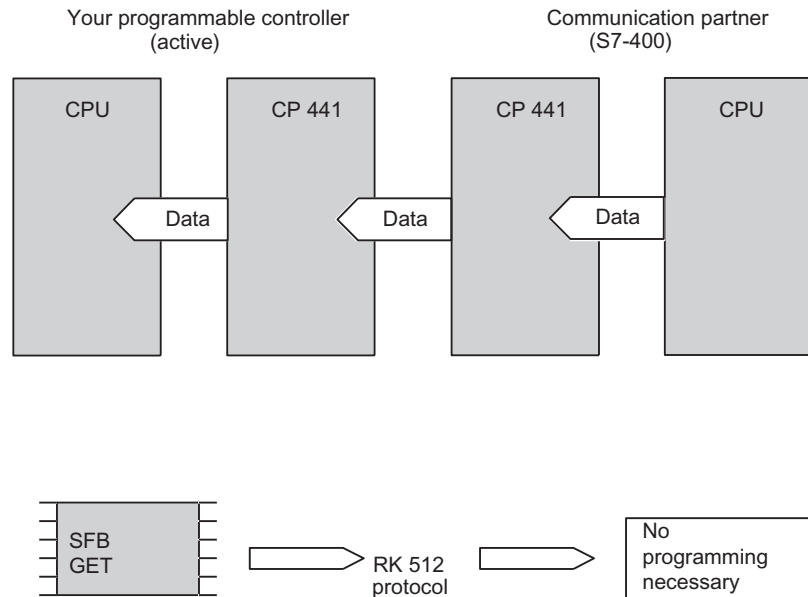

Figure 6-4 Fetching data from a communication partner with the RK512 computer link

Fetching data with RK512 from a communication partner What To Do

To fetch data from a communication partner, proceed as follows:

On Your Programmable Controller

In the S7 user program of the CPU you must program the GET system function block (SFB 14).

For the ADDR parameter (ANY data type) you specify the data you want to fetch from the partner (source). The parameter limits of the RK512 protocol mean that only data blocks 1 to 255 of the partner can be reached. Only even numbers (a maximum of 450 bytes) can be specified as the offset for the data types DB, C and T. In the case of the data types MB, IB and QB, the maximum offset is 255 bytes.

Example: p#DB10.DBX6.0 WORD 10

For the RD parameter (ANY data type) you specify where the data is stored on your module (destination). The length specified must agree with the value specified for the SD parameter. For the transfer of timers and counters, the "CHAR" data type must be specified for the data block in which the timers or numbers are stored.

Example: p#DB10.DBX6.0 CHAR 2

6.4 Using the system function blocks with the RK512 computer link

Please note that the partner cannot recognize when you fetch data. It is therefore not possible to prevent as yet unprocessed data being fetched from the partner. Using the "Response to a CPU Stop" parameter, indicate whether data should continue to be transmitted when the S7 CPU is also in STOP mode. The parameter is only available for the CP 441-2 (as of 6ES7 441-2AA04-0AE0). Interprocessor communication flags are not supported when linking with S5 CPs. The sending and receiving CPU determines data consistency (CPU 412/413: 16 bytes, CPU 414/417: 32 bytes). The weaker partner in terms of consistency determines the resulting consistency length for data transfer.

Further Information

You can find more information on data consistency in the reference manual on system functions and standard functions *System Software for S7 300/400, System and Standard Functions..*

Note

If you fetch data from a CP 441 by means of an S5 CP or a third-party device, you must specify the source data type in the request block (S5 CP). In the case of the source data type DB, you must specify the corresponding number and the start address (offset). Interprocessor communication flags are not evaluated. The connection via which the data is fetched from the S7 CPU is selected by means of the CPU number.

At the CP 441 Communication Partner

At the communication partner no programming is necessary in the S7 user program of the CPU.

Example

Table 6- 25 Example of Calling SFB14 (GET)

STL		
CALL SFB 14, DB14		When this SFB is called at a positive edge at bit DBX10.0, data is fetched from the communication partner. The data source is specified at ADDR_1: DB 10, 10 words starting at byte 6. This data is placed in DB 100, starting at byte 0. The same data length must be specified! If several data areas are fetched at the same time, additional ADDR_i and RD_i pairs can be assigned parameters.
REQ	:= DB10.DBX10.0	
ID	:=W#16#1000	
NDR	:= DB10.DBX10.2	
ERROR	:= DB10.DBX10.3	
STATUS	:= DB10.DBW20	
ADDR_1	:= P#DB10.DBX 6.0 WORD 10	
ADDR_2		
ADDR_3		
ADDR_4		
RD_1	:= P#DB100.DBX 0.0 WORD 10	
RD_2		
RD_3		
RD_4		

Request Table

The following table lists the data types which can be transmitted.

Table 6- 26 Request table "Fetching data with RK512 from a communication partner".

Source, Fetch (GET) from Communication Partner	To Destination, Your S7 PLC	Parameter Assignment in the GET SFB, Parameter ADDR (Source)			Parameter Assignment in the GET SFB, Parameter RD (Destination)			
		S-TYPE	S-DBNO	S-Offset (byte)	Length max. **450 bytes	D-TYPE	D-DBNO	D-Offset (byte)
Data block	Data block	DB	* - 255	0 - 510***	1 - *	DB	1 - *	0 - *
Flag	Data block	MB	Irrelevant	0 - 255*	1 - *	DB	1 - *	0 - *
Inputs	Data block	IB	Irrelevant	0 - 255*	1 - *	DB	1 - *	0 - *
Outputs	Data block	QB	Irrelevant	0 - 255*	1 - *	DB	1 - *	0 - *
Counter	Data block	Z	Irrelevant	0 - 510***	1 - *	DB	1 - *	0 - *
Timers	Data block	T	Irrelevant	0 - 510***	1 - *	DB	1 - *	0 - *
* The maximum value is determined by the partner CPU that you use.								
** Dependent on your CPU and the CPU of the communication partner, max. 450 bytes.								
*** Only even-numbered values are permitted for these data types. The maximum value is determined by the partner CPU.								
Abbreviations used in the table: S-TYPE= source type, S-DBNO= source data block number, S-Offset= source start address, length= source length, D-TYPE= destination type, D-DBNO= destination data block number, D-Offset= destination start address								

Specifications in the frame header of the RK512 protocol

The following table shows the specifications in the RK512 frame header.

Table 6- 27 Specifications in frame header of the RK512 protocol, "Fetching data from the communication partner with RK512"

Source, Fetch (GET) from Communica. Partner	to the destination, your S7 PLC	Frame header		
		Byte 3/4 Command mode	Byte 5/6 S-DBNO/D-Offset	Byte 7/8 Number in
Data block	Data block	ED	DB/DW	Words
Flag	Data block	EM	DB/DW	Bytes
Inputs	Data block	EI	DB/DW	Bytes
Outputs	Data block	EQ	DB/DW	Bytes
Counter	Data block	EC	DB/DW	Words
Timers	Data block	ET	DB/DW	Words

Abbreviations: S-DBNO = Source data block number, S-Offset = source start address, DW = Offset in words

See also

- "Properties - PtP Connection" dialog, procedure with RK512 computer link (Page 129)
- Overview of the System Function Blocks (Page 138)

6.5 Using the System Function Blocks with the ASCII Driver

Introduction

The same functions can be used for data transmission with the ASCII as with the 3964(R) procedure. In other words, the information on the 3964(R) procedure also applies to the ASCII driver.

In addition, when the ASCII driver is used with the RS 232 interface module, you can read and control the RS 232 accompanying signals. The following describes only what you have to do to use these additional functions.

RS232 accompanying signals

Function blocks are available to you for reading and controlling the RS 232 accompanying signals. The table below contains the function blocks of the CP 441 and describes their purpose.

Table 6- 28 Function blocks / functions of the CP 441

FB	Meaning
FB 5 V24_STAT	The V24_STAT function allows you to read the signal states at the RS 232 interface of the CP 441.
FB 6 V24_SET	The V24_SET function allows you to set/reset the outputs at the RS 232 interface of the CP 441.

Scope of Supply and Installation

The function blocks of the CP 441, together with the parameter assignment interface and the programming example, are supplied on CD which comes with this manual.

The function blocks are installed together with the parameter assignment interface. After installation, the function blocks are stored in the following library:

CP441

You open the library in STEP 7 SIMATIC Manager by choosing **File > Open > Library**.

For working with the function blocks, you only need to copy the required function block in your project.

6.5.1 Reading the RS232 accompanying signals

Introduction

The V24_STAT FB reads the RS232 accompanying signals from an interface of the CP 441 and makes them available to the user at the module parameters. The V24_STAT FB is called statically (without conditions) in the cycle or alternatively in a time-controlled program.

The RS232 accompanying signals are updated each time the function is called (cyclic polling). You select the interface by specifying at the V24_STAT FB the "local" ID of one of the connections that uses this interface.

The binary result is not affected.

Block call command

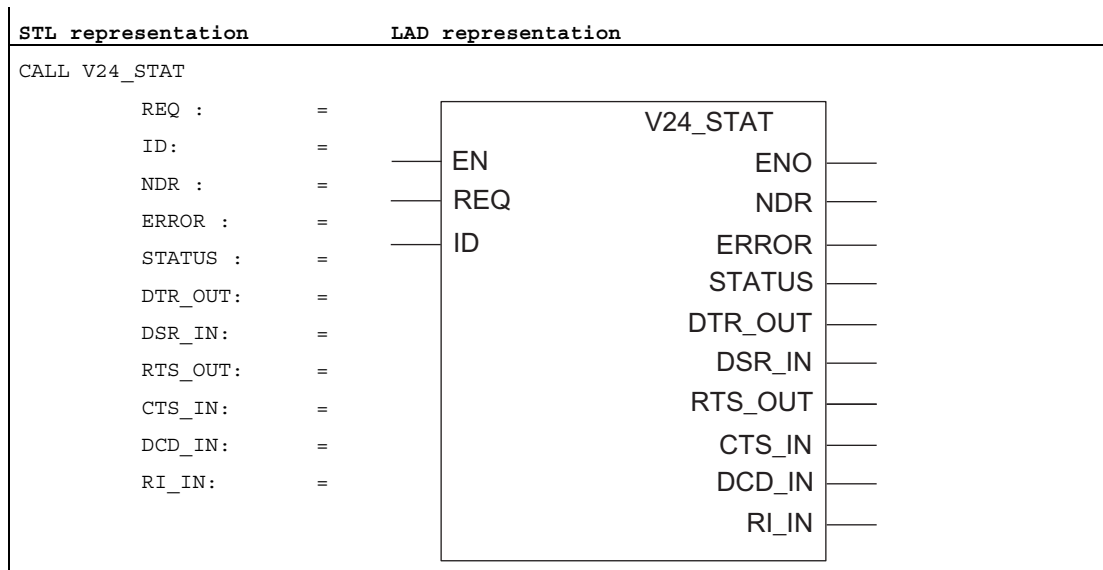

Note

The EN and ENO parameters are only present in the graphical representation (LAD or FBD). To process these parameters, the compiler uses the binary result BR. The binary result is set to signal state "1" if the block was terminated without errors. If there was an error, the binary result is set to "0".

Note

A positive input voltage in the RS232 input signals DSR, CTS, DCD and RI is mapped respectively to the signal state "1" of the FB input signals DSR_IN, CTS_IN, DCD_IN and RI_IN.

FB 5 V24_STAT Parameters

The following table lists the parameters of the 5 V24_STAT FB:

Table 6- 29 FB 5 V24_STAT Parameters

Name	Type	Data type	Description	Permitted values, comment
REQ	VAR_INPUT	BOOL	Activates a transfer at rising edge	-
ID	VAR_INPUT	WORD	Unique communication connection to a communication partner	-
NDR	VAR_OUTPUT	BOOL	Rising edge indicates that new receive data is available to the user program	-
ERROR	VAR_OUTPUT	BOOL	Rising edge indicates error	-
STATUS	VAR_OUTPUT	WORD	Contains detailed error message or warning	-
DTR_OUT	OUTPUT	BOOL	Data terminal ready, CP 441 ready	(CP 441 output)
DSR_IN	OUTPUT	BOOL	Data set ready, Communication partner ready	(CP 441 input)
RTS_OUT	OUTPUT	BOOL	Request to send, CP 441 ready to send ¹	(CP 441 output)
CTS_IN	OUTPUT	BOOL	Clear to send, Communication partner can receive data from the CP 441 (response to RTS = ON of the CP 441)	(CP 441 input)
DCD_IN	OUTPUT	BOOL	Data Carrier detect, receive signal level	(CP 441 input)
RI_IN	OUTPUT	BOOL	Ring Indicator, Indication of incoming call	(CP 441 input)

Example

Table 6- 30 Example of Calling the 5 V24_STAT FB

STL		
CALL FB 5, DB55		
REQ		:= DB30.DBX10.0
ID		:=W#16#1000
NDR		:= DB30.DBX10.1
ERROR		:= DB30.DBX10.2
STATUS		:= DB30.DBW20
DTR_OUT		:= DB30.DBX30.0
DSR_IN		:= DB30.DBX30.1
RTS_OUT		:= DB30.DBX30.2
CTS_IN		:= DB30.DBX30.3
DCD_IN		:= DB30.DBX30.4
RI_IN		:= DB30.DBX30.5

See also

Data Transmission with the ASCII Driver (Page 58)

6.5.2 Controlling the RS232 accompanying signals

Introduction

The user can use the parameter inputs of the V24_SET FB to set or reset the corresponding interface outputs of an interface of the CP 441. The V24_SET FB is called statically (without conditions) in the cycle or alternatively in a time-controlled program.

You select the interface by specifying at the V24_SET FB the "local ID" of one of the connections that uses this interface.

The binary result is not affected.

Block call command

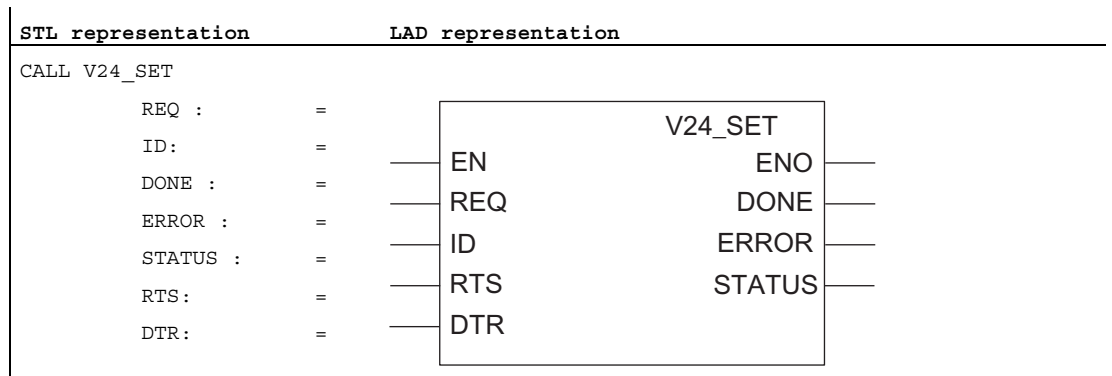

Note

The EN and ENO parameters are only present in the graphical representation (LAD or FBD). To process these parameters, the compiler uses the binary result BR. The binary result is set to signal state "1" if the block was terminated without errors. If there was an error, the binary result is set to "0".

6 V24_SET FB Parameters

The following table lists the parameters of 6 V24_SET FB.

Table 6- 31 6 V24_SET FB Parameters

Name	Type	Data type	Description	Permitted values, comment
REQ	VAR_INPUT	BOOL	Activates a transfer at rising edge	-
ID	VAR_INPUT	WORD	Unique communication connection to a communication partner	-
DONE	VAR_OUTPUT	BOOL	Indicates at a rising edge the error-free completion of a request	-
ERROR	VAR_OUTPUT	BOOL	Rising edge indicates error	-
STATUS	VAR_OUTPUT	WORD	Contains detailed error message or warning	-
RTS	INPUT	BOOL	Request to send, CP 441 ready to send	(Control CP 441 output)
DTR	INPUT	BOOL	Data terminal ready, CP 441 ready	(Control CP 441 output)

Example

Table 6- 32 Example of Calling the 6 V24_SET FB

```

STL
CALL FB 6, DB56
    REQ      := DB40.DBX10.0
    ID       :=W#16#1000
    DONE     := DB40.DBX10.1
    ERROR    := DB40.DBX10.2
    STATUS   := DB40.DBW20
    RTS      := DB40.DBX30.2
    DTR      := DB40.DBX30.0
    
```

See also

Data Transmission with the ASCII Driver (Page 58)

6.6 Using the system function blocks with the printer driver

Introduction

The PRINT system function block (SFB) is available to you for outputting message texts to a printer. PRINT transfers a process message to the CP 441, for example. The CP 441 logs the process message on the connected printer.

Message texts "outputting"

The PRINT SFB transfers a message text with up to four variables to the CP 441. The PRINT SFB is called statically (without conditions) for data transfer cyclically or in a time-controlled program.

The transmission of the message text is initiated by a rising edge at the REQ input. The frame starts with the format string of the message text, This is followed by tags 1 to 4 (SD_1 to SD_4) .

The DONE output shows "request completed without errors". ERROR indicates whether an error has occurred. In STATUS the error number is displayed in the event of an error. If there were no errors, STATUS has the value "0".

What To Do

In the S7 user program of the CPU you must program the PRINT system function block (SFB 16).

You specify as the ID the connection via which PRINT is to be executed (also see Chapter "Connection Configuration (Page 122)").

The PRN_NR parameter (printer number) has no significance for the CP 441, since only one printer can be addressed via a serial interface.

You specify the format string in the FORMAT parameter. Proceed as follows:

1. You must store the format string in a separate data block. If this block does not exist, you must define it.

Make an entry in the declaration field of the DB to output a message text as in the following example:

```
-- Name: Anna  
-- Type: STRING  
-- Start value: 'Content of message text: %N'
```

2. The DB for the format string can only be specified symbolically.

After the DB has been saved, you should therefore set symbolic representation under "View" in the STL compiler and then enter a symbol for the data block in the symbol table under "Options" (e.g. print_db). As the address and data type, you enter in the symbol table the DB in which the format strings are stored.

6.6 Using the system function blocks with the printer driver

- Switch the view of your module in which you call "PRINT" to symbolic representation as well, and enter "print_db".Anna as the FORMAT parameter at the system function block.

Up to four variables can be specified at SD_1 to SD_4 for printer output (the number of the message text to be output is to be specified in the example).

Example

Table 6- 33 Example of Calling the PRINT SFB in a FB

STL		
CALL SFB 16, DB116		PRINT SFB call in an FB
REQ	:=DB60.DBX100.0	
ID	:=W#16#1000	
DONE	:=DB60.DBX100.1	
ERROR	:=DB60.DBX100.2	
STATUS	:=DB60.DBW110	
PRN_NR	:=DB60.DBB120	
FORMAT	:= "print_db".Anna	Byte 200 in DB 60 contains the message text number
SD_1	:=p#DB60.DBX200.0 Byte 1	
SD_2	:=	
SD_3	:=	
SD_4	:=	

Important Notes

Note that the volume of data consisting of format string and variables that can be transferred is limited to 400 bytes.

Note that if changes are made subsequently to the format string, you cannot enter them in the string under "Initial value"; instead, you have to select the data view under "View" and enter the changed format string under "Initial value".

Note that no string can be transferred in the case of the C (character) representation type. Use the S representation type for strings.

Note that you cannot specify the string directly at the SD_i parameter in the case of the S (string) representation type. As in the case of the format string, you have to store the string in a data block and address it symbolically at the SD_i parameter.

6.7 Summary

Overview

The tables below summarize the following information on the protocols:

- The possible communication types
- The system function blocks used
- Whether or not overwrite protection is possible and
- The maximum length of transmittable data.

ASCII Driver and 3964(R)

Table 6- 34 The following applies for the 3964(R) procedure:

Communication type	CP 441 sending data to CP 441 communication partner	
	Programming at Sender and Receiver	Programming at Sender Only
System function block at CP 441	BSEND	BSEND
System function block at CP 441 communication partner	BRCV	none (receive mailbox)
Overwrite protection	Yes	No
Maximum length of transmittable data	4 KB	4 KB, receiving CPU

RK512, Sending data

Table 6- 35 The following applies when sending data via the RK512 computer link:

Communication type	CP 441 sending data to CP 441 communication partner		
	Programming at Sender and Receiver/ (Type DX)	Programming at Sender Only (Type DB)	Programming at Sender Only
System function block at CP 441	BSEND	BSEND	PUT
System function block at CP 441 communication partner	BRCV	none	none
Overwrite protection	Yes	No	No
Maximum length of transmittable data	4 KB	450 bytes*, receiving CPU	450 bytes
Dynamically changeable destination definition	No	No	Yes

* The receiving CP 441 restricts the maximum length of transmittable data. If you use a different communication partner, you can transfer up to 4 kilobytes.

RK512, Fetching data

Table 6- 36 The following applies when fetching data via the RK512 computer link:

Communication type	CP 441 Sending Data to CP 441 Communication Partner
System function block at CP 441	GET
System function block at CP 441 communication partner	none
Overwrite protection	No
Maximum length of transmittable data	450 bytes
Dynamically changeable source definition	Yes

Printer Output

Table 6- 37 The following applies to the output of message texts on a printer:

Communication type	CP 441 Sending Data to the Printer
System function block at CP 441	PRINT
Maximum length of transmittable data (format string and variables)	400 bytes

Start-up Characteristics and Operating Mode Transitions of the CP 441

7

7.1 Startup Characteristics of the CP 441

Start-up behavior

The CP 441 start-up is divided into two phases:

- Initialization (CP 441 in POWER ON mode)
- Parameter assignment

Initialization

As soon as the CP 441 is connected to the power supply, the firmware on the CP 441 is prepared for operation after a hardware test program has been executed.

Parameter Assignment

During parameter assignment, the CP 441 receives the module parameters which have been assigned to the current slot. The CP 441 is now ready for operation.

Note

Please note the following for the start-up behavior of the CP 441:

Note

After power on, the CP 441 requires several seconds for initialization and hardware and memory testing before it is ready for operation. The parameter assignment attempts made by the CPU during this phase are aborted and an error is entered in the diagnostic buffer: "SDB processing error, error class 1", and the SDB is identified, and "Parameter assignment error on module parameter assignment", and the SDB is identified. As soon as the module test has been completed, parameter assignment is performed by the CPU without errors. SFB calls in the user program will result in an error as long as the CP 441 has not been parametered.

7.2 Operating Mode Transitions of the CP 441

Introduction

Once the CP 441 has been started up, all data is exchanged between the CPU and the CP 441 by means of the system function blocks. The operating mode transition behavior of the CP 441 depends on the operating mode of the CPU.

CPU-STOP

Communication direction CPU > CP:

Communication between the CPU and CP 441 still takes place even when the CPU is in STOP mode. When the CPU is in STOP mode, the initiated SFB requests (e.g. BSEND) on the CPU are fully executed and the data is transferred in its entirety to the CP 441 and forwarded to the communication partner.

Communication direction CP > CPU:

The message frames are received in the CP 441. Any attempt to send the data on to the CPU is aborted with an error message

CPU RUN

The CP 441 does not recognize how the CPU switches to RUN mode (cold restart or restart following CPU STOP). The CP 441 behaves identically in both cases.

Cold restart of the CPU

When the CPU is restarted cold, the SFB requests on the CPU are reset, that is all current requests between the CPU and the CP are automatically aborted. The requests on the CP are deleted.

Restart of the CPU

When the CPU is restarted, the SFB requests continue to be processed.

Diagnostics Functions of the CP 441

Introduction

The diagnostics functions of the CP 441 enable you to quickly localize any errors which occur. The following diagnostics options are available:

- Diagnostics via the display elements of the CP 441
- Diagnostics via the STATUS output of the system function blocks
- Diagnostics via the error signaling area SYSTAT
- Diagnostics via the error numbers in the response frame
- Diagnostics via the diagnostic buffer of the CP 441
- Diagnostics interrupt

Display elements (LEDs)

The display elements show the operating mode or possible error states of the CP 441. The display elements give you an initial overview of any internal or external errors as well as interface-specific errors (see section "Diagnostics via the display elements of the CP 441 (Page 189)").

STATUS output of the SFBs

Every system function block has a STATUS output for error diagnostics. Reading the STATUS output of the system function blocks gives you general information on errors which have occurred during communication between the CP 441 and the assigned CPU. You can evaluate the STATUS parameter in the user program (see section "Diagnostics Messages of the System Function Blocks (Page 190)").

Error message area, SYSTAT

The programming of the STATUS system function block in the user program allows you to obtain the status of an interface. By reading SYSTAT you obtain detailed information on errors/events that have occurred during communication between the CP 441, the assigned CPU and the communication partner connected at this interface (see section "Diagnostics via the error signaling area SYSTAT (Page 195)").

Error Numbers in the Response Frame

If you are working with the RK512 computer link and an error occurs at the communication partner in a SEND or GET frame, the communication partner sends a response frame with an error number in the 4th byte (see section "Error Numbers in the Response Message Frame (Page 209)").

Diagnostic Buffer of the CP 441

All the errors/events in the SYSTAT error-signaling area of the CP 441 are also entered in the diagnostic buffer of the CP 441.

In the same way as with the diagnostic buffer of the CPU, you can also use the STEP 7 information functions on the programming device to display the user-relevant information of the CP diagnostic buffer (see section "Diagnostics via the diagnostic buffer of the CP 441 (Page 211)").

Diagnostics interrupt

The CP 441 can trigger a diagnostics interrupt on the CPU assigned to it. CP 441 provides 4 bytes of diagnostics information at the S7-400 rear panel bus. This information is analyzed via the user program (OB 82) or using a programming device to read from the CPU diagnostic buffer.

The CP 441 also writes diagnostic events which have triggered a diagnostics interrupt to its diagnostic buffer .

When a diagnostics interrupt event occurs, the EXTf LED (red) lights up.

See also

Subsequent Loading of Firmware Updates (Page 133)

8.1 Diagnostics via the display elements of the CP 441

Display Functions

The display elements of the CP 441 provide information on the CP 441. The following display functions are distinguished:

- **Special displays**
 - TXDSending active; lights up when the CP is sending user data via the interface.
 - RXDRReceiving active; lights up when the CP is sending user data via the interface.
- **Group error displays**
 - INTF internal error
 - EXTF external error
- **Interface fault LED**
 - FAULT interface error

Error Messages of the Display Elements

The table below describes the error messages of the display elements.

Table 8- 1 Error Messages of the CP 441 Display Elements

Error display	Error Description	To correct or avoid errors
INTF comes on	CP 441 signals internal fault, e.g. hardware fault or software error.	Program the STATUS SFB for detailed information or read the diagnostic buffer of the CP 441.
EXTF comes on	CP 441 signals external fault, e.g. break on the line.	Program the STATUS SFB for detailed information or read the diagnostic buffer of the CP 441.
FAULT off	Interface ready for operation or interface submodule not plugged in.	-
FAULT flashing slowly	Interface initialized and ready for operation but communication via S7-400 backplane bus not possible.	Check configuration and connection configuration for incorrect entries (e.g. slot, ID no., etc.).
FAULT flashing fast	Invalid parameter(s), or wrong or faulty interface submodule inserted (module and interface parameters not compatible).	Check the parameter settings in the CP441:Configuration Package for Point to Point Communication parameter assignment interface and/or the interface submodule.
FAULT lit up	No interface parameters or serious fault in submodule (hardware).	Assign parameters in the CP441:Configuration Package for Point to Point Communication parameter assignment interface or check the interface submodule.

See also

Subsequent Loading of Firmware Updates (Page 133)

8.2 Diagnostics Messages of the System Function Blocks

Status Parameter

Every system function block has a STATUS parameter for error diagnostics. The STATUS message numbers always have the same meaning, irrespective of which system function block is used.

The tables below are copied from the STEP 7 manual and represent only the current status. Refer to the original tables if you discover discrepancies.

Displaying and Evaluating the STATUS Output

You can display and evaluate the STATUS output of the system function blocks using the STEP 7 variable table.

Further Information

For further information on using the variable table, see the STEP 7 manual *Configuring Hardware and Communication Connections with STEP 7 V5.0*.

Messages in the STATUS Output of the SFBs

The tables below list the messages of the STATUS parameter.

Error Information for SFB 12

The table contains all the SFB 12 specific error information that can be output in the ERROR and STATUS parameters.

Table 8-2 Error Information for SFB 12 "BSEND"

ERROR	STATUS (decimal)	Description
0	11	Warning: New request ineffective because previous request not yet completed
1	1	Communication problems, for example: <ul style="list-style-type: none"> • Connection description not loaded (local or remote) • Connection interrupted (e.g. cable, CPU off)
1	2	Negative acknowledgment from partner SFB. The function cannot be executed.
1	3	R_ID is not known on the communication link identified by ID, or receive block not yet called.
1	4	Error in send area pointer SD_1 regarding data length or data type, or the LEN parameter received the value 0 or error in receive area pointer RD_1 of SFB 13 "BRCV"
1	5	The reset request has been completed.
1	6	The status of the partner SFB is DISABLED (value of EN_R is 0)
1	7	Status of partner SFB is not correct (receive block not called since last data transfer).
1	8	Access to remote object in user memory denied.

ERROR	STATUS (decimal)	Description
1	10	Access to local user memory not possible (for example access to deleted DB)
1	12	The SFB call <ul style="list-style-type: none"> specified an instance DB which does not belong to SFB 12 specified a global DB instead of an instance DB did not have an Instance DB (programming device: load a new instance DB)
1	18	R_ID already exists in the link
1	20	Insufficient main memory

Error Information for SFB 13

The table contains all the SFB 13 specific error information that can be output in the ERROR and STATUS parameters.

Table 8- 3 Error Information for SFB 13 "BRCV"

ERROR	STATUS (decimal)	Description
0	11	Warning: New request ineffective because previous request not yet completed
0	17	Warning: block receiving asynchronous data.
1	1	Communication problems, for example: <ul style="list-style-type: none"> Connection description not loaded (local or remote) Connection interrupted (e.g. cable, CPU off)
1	2	The function cannot be executed.
1	4	Error in receive area pointer RD_1 regarding data length or data type (data block sent is longer than receive area).
1	5	Reset request received, incomplete transfer.
1	8	Access to remote object in user memory denied.
1	10	Access to local user memory not possible (for example access to deleted DB)
1	12	The SFB call <ul style="list-style-type: none"> specified an instance DB which does not belong to SFB 13 specified a global DB instead of an instance DB. did not have an Instance DB (programming device: load a new instance DB)
1	18	R_ID already exists in the link
1	20	Insufficient main memory

Error Information for SFB 14

The table contains all the SFB 14 specific error information that can be output in the ERROR and STATUS parameters.

Table 8- 4 Error Information for SFB 14 "GET"

ERROR	STATUS (decimal)	Description
0	11	Warning: New request ineffective because previous request not yet completed
1	1	Communication problems, for example: <ul style="list-style-type: none"> • Connection description not loaded (local or remote) • Connection interrupted (e.g. cable, CPU off)
1	2	Negative acknowledgment from partner device. The function cannot be executed.
1	4	Error in receive area pointers RD_i regarding data length or data type
1	8	Access error at the partner CPU
1	10	Access to local user memory not possible (for example access to deleted DB)
1	12	The SFB call <ul style="list-style-type: none"> • specified an instance DB which does not belong to SFB 14 • specified a global DB instead of an instance DB. • did not have an Instance DB (programming device: load a new instance DB)
1	20	Insufficient main memory

Error Information for SFB 15

The table contains all the SFB 15 specific error information that can be output in the ERROR and STATUS parameters.

Table 8- 5 Error Information for SFB 15 "PUT"

ERROR	STATUS (decimal)	Description
0	11	Warning: New request ineffective because previous request not yet completed
1	1	Communication problems, for example: <ul style="list-style-type: none"> • Connection description not loaded (local or remote) • Connection interrupted (e.g. cable, CPU off)
1	2	Negative acknowledgment from partner device. The function cannot be executed.
1	4	Error in send area pointers SD_i regarding data length or data type
1	8	Access error at the partner CPU
1	10	Access to local user memory not possible (for example access to deleted DB)
1	12	The SFB call <ul style="list-style-type: none"> • specified an instance DB which does not belong to SFB 15 • specified a global DB instead of an instance DB. • did not have an Instance DB (programming device: load a new instance DB)
1	20	Insufficient main memory

Error Information for SFB 16

The table contains all the SFB 16 specific error information that can be output in the ERROR and STATUS parameters.

Table 8- 6 Error Information for SFB 16 "PRINT"

ERROR	STATUS (decimal)	Description
0	11	Warning: New request ineffective because previous request not yet completed
1	1	Communication problems, for example: <ul style="list-style-type: none"> • Connection description not loaded (local or remote) • Connection interrupted (e.g. cable, CPU off)
1	2	Negative acknowledgment from printer. The function cannot be executed.
1	3	PRN_NR is not known on the communication link identified by ID.
1	4	Error in in/put parameter FORMAT or in send area pointers SD_i regarding data length or data type.
1	10	Access to local user memory not possible (for example access to deleted DB)
1	13	Error in the FORMAT in/out parameter
1	20	Insufficient main memory

Error Information for SFB 22

The table contains all the SFB 22 specific error information that can be output in the ERROR and STATUS parameters.

Table 8- 7 Error Information for SFB 22 "STATUS"

ERROR	STATUS (decimal)	Description
0	11	Warning: New request ineffective because previous request not yet completed
1	1	Communication problems, for example: <ul style="list-style-type: none"> • Connection description not loaded (local or remote) • Connection interrupted (e.g. cable, CPU off)
1	2	Negative acknowledgment from partner device. The function cannot be executed.
1	4	Error in PHYS, LOG or LOCAL regarding data length or data type
1	8	Access to remote object denied.
1	10	Access to local user memory not possible (for example access to deleted DB)
1	12	The SFB call <ul style="list-style-type: none"> • specified an instance DB which does not belong to SFB 22 • specified a global DB instead of an instance DB. • did not have an Instance DB (programming device: load a new instance DB)
1	20	Insufficient main memory

8.3 Diagnostics via the error signaling area SYSTAT

The SYSTAT error message area is a data area on the CP 441 by means of which you can query the device status of an interface using the STATUS system function block.

Error-Signaling Area SYSTAT

The error-signaling area SYSTAT is an error area which is available for every interface (ID number). The SYSTAT records all errors/events which can occur during data transmission on an interface.

Note

Because the STATUS request is executed asynchronously to the rest of the requests running at an interface, an SFB with a specific R_ID cannot be assigned to the error messages. This means that although SYSTAT can display which errors have occurred at an interface, it cannot show which SFB call (R_ID number) triggered the error.

Errors/Events

The SYSTAT messages are entered in bytes 2 to 15 of the LOCAL parameter when the STATUS SFB is called. In addition to the error byte (byte 2), the first six errors/events are displayed. Error event 1 is the oldest.

If other error events occur, these cannot be reported until the "old" entries are deleted. The error-signaling area must therefore be deleted in good time. This is done when the STATUS SFB is called.

The errors/events are stored as follows:

- Byte 0 Operating state of CP (02H for RUN, 05H for defective)
- Byte 1 Reserved
- Byte 2 Bit 0 -F Enter error in SYSTAT
Bit 1 -U Error overflow
Bit 2 -B Break
- Byte 3 Reserved
- Byte 4/5 Event 1
- Byte 6/7 Event 2
- Byte 8/9 Event 3
- Byte 10/11 Event 4
- Byte 12/13 Event 5
- Byte 14/15 Event 6

Example

Table 8- 8 Example for calling SFB 22 (STATUS)

STL		
CALL SFB 22,		STATUS SFB call in an FB
DB22		
REQ	:=DB450.DBX0.0	
ID	:=W#16#1000	The errors/events are entered in
NDR	:=DB450.DBX0.4	bytes 20-35 of DB450 following a
ERROR	:=DB450.DBX0.5	rising edge of the REQ parameter.
STATUS	:=DB450.DBW12	SFB22 should not be run unless an
PHYS	:=p#DB450.DBX16.0 Byte 2	error occurs in data transfer. For
LOG	:=p#DB450.DBX18.0 Byte 2	example, the error bit of a BSEND
LOCAL	:=p#DB450.DBX20.0 Byte 16	(ERROR parameter) can be used as the
		request bit for the STATUS (REQ).
		Calling SFB22 automatically clears
		the error-signaling area of SYSTAT.

Numbering Scheme

The numbering scheme for the events in the error-signaling area SYSTAT has the following structure:

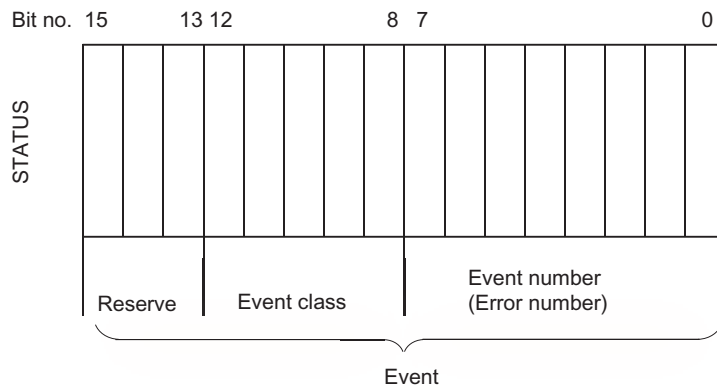

Figure 8-1 Numbering scheme for events in error-signaling area SYSTAT

Event Classes

The table below describes the various event classes and numbers. Event classes and event numbers are listed with hexadecimal notation.

Table 8-9 Event classes and event numbers

Event Class 1 (01H): "Hardware fault on CP"		
Event no.	Event Text	To correct or avoid errors
(01)01H	Fault while testing operating system EPROM of CP	CP defective; replace CP.
(01)02H	RAM test of CP errored	
(01)03H	Request interface of CP defective	
(01)04H	No interface module inserted	Insert suitable interface module for CP.
(01)05H	<ul style="list-style-type: none"> • Parameter memory defective • Interface submodule unplugged after parameter assignment 	Exchange CP or insert suitable interface module for CP.
(01)10H	Fault in CP firmware	Switch module off and on again. If necessary, replace module.

Event Class 2 (02H): "Initialization error"		
Event no.	Event Text	To correct or avoid errors
(02)01H	No parameters Parameter memory empty or has unknown contents	Load interface parameters.
(02)08H	Parameter assignment and interface module incompatible	Check parameters set for interface module.
(02)0FH	Invalid parameter assignment detected at start of parameter communication. Interface could not be parametered.	Correct invalid parameters and restart.

Event Class 3(03H): "Error in parameter assignment of SFB"		
Event no.	Event Text	To correct or avoid errors
(03)01H	Invalid or no source/destination data type Invalid area (start address, length) Invalid or no DB (e.g. DB 0), or Other data type invalid or missing	Check parameters on CPU and CP, and correct if necessary. RK512 only: Partner returns invalid parameters in frame header. Check parameters on CPU and CP; possibly create block. See request tables for valid data types. RK512 only: Partner returns incorrect parameters in frame header.
(03)02H	Area too short	Check parameters on CPU and CP; possibly check block/area. RK512 only: Partner returns incorrect parameters in frame header.
(03)03H	Area cannot be accessed	Check parameters on CPU and CP. Obtain the permissible start addresses and lengths from the request tables. RK512 only: Partner returns incorrect parameters in frame header.

Event Class 4 (04H): "CP detected error in data traffic CP - CPU"		
Event no.	Event Text	To correct or avoid errors
(04)01H	CP cannot accept requests (overload)	In your user program, reduce number of requests called concurrently for CP.
(04)02H	CP cannot process request type	Check if the system function blocks you have called in user program are valid for CP.
(04)03H	Incorrect, unknown or illegal data type	Check program, e.g. for incorrect parameters of SFB.
(04)07H	An error has occurred during data transmission between the CPU and the CP. Data cannot be received because there is no access to the CPU destination frame or the CPU destination frame does not exist or is too short. Writing data to the CPU destination frame or reading data from the CPU source frame during a CPU stop when assigning parameters is not permitted.	Check the destination frame on the CPU. Check the parameter assignment for "Response to a CPU Stop".

Event Class 4 (04H): "CP detected error in data traffic CP - CPU"		
Event no.	Event Text	To correct or avoid errors
(04)08H	<ul style="list-style-type: none"> • Only for 3964R and ASCII drivers • A temporary error has occurred during data transmission between the CPU and the CP (receive). The request is queued for repetition because the CPU is temporarily overloaded or the receive block (BRCV) is requested too infrequently or the receive block has been temporarily blocked. 	<ul style="list-style-type: none"> • Reduce the number of communication requests. Call the receive block more often. Check whether the receive block has been blocked too long.
(04)09H	<ul style="list-style-type: none"> • Only for 3964R and ASCII drivers • An error has occurred during data transmission between the CPU and the CP. Data reception is not possible. After multiple attempts (see (04)07H), the request has canceled after 10 seconds because the receive block (BRCV) could not be called or is blocked. 	<ul style="list-style-type: none"> • Check whether the receive block has been called or has been blocked.
(04)0BH	Error during data transmission between CPU and CP, because <ul style="list-style-type: none"> • no connection has been configured • no receipt possible via configured connection 	<ul style="list-style-type: none"> • Configure the connection in "NetPro" • Enter in "NetPro" under "Object Properties Connection) as communication direction: <ul style="list-style-type: none"> – 2: Partner → local or – 3: Local ↔ partner

Event Class 5 (05H): "Error while processing CPU request"		
Event no.	Event Text	To correct or avoid errors
(05)01H	Current request aborted as a result of CP restart.	No remedy is possible at POWER ON. When changing the parameters of the CP in the programming device, before writing an interface you should ensure there are no more requests running from the CPU.
(05)02H	Request not permitted in this operating mode of CP (e.g. device interface parameters are not set).	Set the parameters for the device interface.
(05)03H	Wrong time, incorrect format	Check the time parameters.
(05)05H	Only for printer drivers: System data block with message texts not available on the CP	Use the parameter assignment software to configure the message text, and then carry out a restart.
(05)06H	Only for printer drivers: Message text not available	Use the parameter assignment software to configure the message texts, and then carry out a restart.

Event Class 5 (05H): "Error while processing CPU request"		
Event no.	Event Text	To correct or avoid errors
(05)07H	Only for printer drivers: Message text too long	Edit the message text to reduce it to a length of less than 150 characters (or no more than 250 characters if it contains variables)
(05)08H	Only for printer drivers: Too many conversion statements	You have configured more conversion statements than variables. The conversion statements without associated variables are ignored.
(05)09H	Only for printer drivers: Too many variables	You have configured more variables than conversion statements. Variables for which there is no conversion statement are not output.
(05)0AH	Only for printer drivers: Unknown conversion statement	Check the conversion statement. Undefined or unsupported conversion statements are replaced in the printout with *****.
(05)0BH	Only for printer drivers: Unknown control statement	Check the control statement. Undefined or incorrect control statements are not executed. The control statement is not output as text either.
(05)0CH	Only for printer drivers: Conversion statement not executable	Check the conversion statement. Conversion statements that cannot be executed are output in the expression in accordance with the defined width and the valid remainder of the conversion statement or the standard representation with * characters.
(05)0DH	Only for printer drivers: Width in conversion statement too small or too great	Correct the specified width of the variable in the conversion statement on the basis of the variable's maximum number of characters in text-based representation types (A, C, D, S, T, Y, Z). Only as many characters as will fit in the specified width appear in the printout; the text is truncated to this width. In all other cases, * characters are output corresponding to the width.
(05)0EH	With ASCII driver only: An error occurred while sending. The defined delimiters did not occur within the maximum allowed length or in the case of automatic appending, the maximum allowed transmission length was exceeded.	Extend the delimiters in the transmission buffer at the desired point or select a shorter frame length for automatic appending.
(05)0FH	Number of requests that can be processed simultaneously too great	Change your STEP 7 program so that fewer requests can run simultaneously.
(05)10H	Area occupied (resource)	Repeat the request.
(05)11H	Length not permissible for this request type	Divide up the data to be transmitted into several requests.
(05)12H	RK512 only: Mismatch between SFB's source and destination parameters.	Obtain the permissible values from the request tables.
(05)13H	Data type error (DB ...): Unknown or impermissible data type (e.g. DE) RK512 only: Mismatch between SFB's source and destination data types.	Obtain the permissible data types and their combinations from the request tables.

Event Class 5 (05H): "Error while processing CPU request"		
Event no.	Event Text	To correct or avoid errors
(05)14H	Specified start addresses too high for desired data type, or start address or DB/DX number too low.	Obtain from the request tables the permissible start addresses and DB/DX numbers that can be specified in the program.
(05)15H	RK512 only: Wrong bit number specified for coordination flag.	Permissible bit numbers: 0 to 7
(05)16H	RK512 only: Specified CPU too high.	Permissible CPU numbers: none, 1, 2, 3 or 4
(05)17H	An error occurred while receiving. The receive frame is longer than 4 KB or is longer than the defined "fixed receive length" or the receive frame does not fit into the destination frame.	Reduce the length of your connection partner's frame or increase the length of your receive DB.
(05)18H	Transmission length at sending too great (>4 KB)	RK512 only: Obtain the permissible lengths from the request tables. Split the request up into several shorter requests.
(05)19H	CP in wrong mode for PLC request	Check if the addressed interface is parametered.
(05)1AH	RK512 only: Error sending a command frame An associated procedure number has just been entered in STATUS.	See the remedy for the previous error number.
(05)1BH	Only for printer drivers: Precision invalid	Correct the specified precision in the conversion statement. The precision is initialized with a dot prefix to identify and limit the width (example: ".2" to output the decimal point and two decimals.) Precision is only relevant to representation types A, D, F and R. It is ignored otherwise.
(05)1CH	Only for printer drivers: Variable invalid (Variable length incorrect/incorrect type)	Correct the specified send variable.

Event Class 6 (06H): "Error processing a partner request" only with RK512		
Event no.	Event Text	To correct or avoid errors
(06)01H	Error in 1st command byte (not 00 or FFH)	Header layout error at partner. Check for malfunction at partner device, possibly by using interface test device switched into the transmission line.
(06)02H	Error in 3rd command byte (not A, 0 or FFH)	Header layout error at partner. Check for malfunction at partner device, possibly by using interface test device switched into the transmission line.
(06)03H	Error in 3rd command byte in the case of continuation frames (command not as for 1st frame)	Header layout error at partner. Check for malfunction at partner device, possibly by using interface test device switched into the transmission line.
(06)04H	Error in 4th command byte (command letter incorrect)	Header layout error at partner or a command combination has been requested that is not permitted at the CP. Check the permissible commands. Check for malfunction at partner device, possibly by using interface test device switched into the transmission line.
(06)05H	Error in 4th command byte in the case of continuation frames (command not as for 1st frame)	Header layout error at partner. Check for malfunction at partner device, possibly by using interface test device switched into the transmission line.
(06)06H	Error in 5th command byte (DB number not permissible)	Obtain from the request tables the permissible DB numbers, start addresses or lengths.
(06)07H	Error in 5th or 6th command byte (start address too high)	Obtain from the request tables the permissible DB numbers, start addresses or lengths.
(06)08H	Error in 7th or 8th command byte (impermissible length)	Obtain from the request tables the permissible DB/DX numbers, start addresses or lengths.
(06)09H	Error in 9th and 10th command byte (coordination flag for this data type impermissible or bit number too high)	Header layout error at partner. Find out from the request tables when a coordination flag is permitted.
(06)0AH	Error in 10th command byte (CPU number not permitted)	Header layout error at partner.
(06)0BH	SEND frame was longer/shorter than expected (more/less data received than announced in frame header).	Correction required at the partner
(06)0CH	GET command frame received with user data	Correction required at the partner
(06)0DH	The CP received a frame during an invalid operating mode. <ul style="list-style-type: none"> • Receive connection between CPU and CP not set up or not yet correctly set up • CP startup is not fully completed. • Parameters for the interface are currently being assigned 	<ul style="list-style-type: none"> • Check whether the addressed connection has been assigned the correct parameters. • This error message can occur only during CP startup. Repeat the request. • This is a temporary error. Repeat the request.

Event Class 6 (06H): "Error processing a partner request" only with RK512		
Event no.	Event Text	To correct or avoid errors
(06)0EH	Synchronous fault of partner <ul style="list-style-type: none"> • New (continuation) command frame received before response frame sent. • 1. 1st command frame expected and continuation frame came. • Continuation command frame expected and 1st frame came 	This error may be reported after your own programming device is restarted in the case of long frames or when the partner is restarted. These cases represent normal system start-up behavior. The error can also occur during operation as a consequence of error statuses only recognized by the partner. Otherwise, you have to assume an error on the part of the partner device. The error may not occur in the case of requests <128 bytes.
(06)0FH	DB locked by coordination function	In local program: After processing of the last transmission data, enable the last receive block with "EN". In partner program: Repeat the request
(06)10H	Message frame received too short (length <4 bytes in the case of continuation or response frames or <10 bytes in the case of command frames)	Check for malfunction at partner device, possibly by using interface test device switched into the transmission line.
(06)11H	Message frame length and length specified in frame header are not the same.	Check for malfunction at partner device, possibly by using interface test device switched into the transmission line.
(06)12H	Error sending the (continuation) response frame. An associated procedure error number has been entered in STATUS immediately beforehand.	See remedy for the error number entered immediately beforehand in STATUS.

Event Class 7 (07H): "Send error"		
Event no.	Event Text	To correct or avoid errors
(07)01H	Sending the first repetition: <ul style="list-style-type: none"> An error was detected during transmission of the frame, or The partner requested a repetition by means of a negative acknowledgment code (NAK). 	A repetition is not an error, however, it can be an indication that there are disturbances on the transmission line or a malfunction of the partner device. If the frame still has not been transmitted after the maximum number of repetitions, an error number describing the first error that occurred is output.
(07)02H	Error during connection setup: <ul style="list-style-type: none"> After STX was sent, NAK or another code (except DLE or STX) was received, or The response came too early, or An initialization conflict occurred 	Check for malfunction at partner device, possibly by using interface test device switched into the transmission line.
(07)03H	Acknowledgment delay time exceeded: After STX was sent, no response came from partner within acknowledgment delay time.	The partner device is too slow or not ready to receive, or there is a break in the transmission line, for example. Check for malfunction at partner device, possibly by using interface test device switched into the transmission line.
(07)04H	Termination by partner: One or more codes were received from the partner during sending	Check whether the partner also indicates an error; possibly it has not received all of the transmitted data (for example, due to an interrupted data link), or because fatal errors are pending, or the behavior of the partner device is faulty. If necessary, use an interface test device switched into the transmission line to check.
(07)05H	Negative acknowledgment during sending	Check whether the partner also indicates an error; possibly it has not received all of the transmitted data (for example, due to an interrupted data link), or because fatal errors are pending, or the behavior of the partner device is faulty. If necessary, use an interface test device switched into the transmission line to check.
(07)06H	Error at end of connection: <ul style="list-style-type: none"> Partner rejected frame at end of connection with NAK or a random string (except for DLE), or Acknowledgment code (DLE) received too early. 	Check whether the partner also indicates an error; possibly it has not received all of the transmitted data (for example, due to an interrupted data link), or because fatal errors are pending, or the behavior of the partner device is faulty. If necessary, use an interface test device switched into the transmission line to check.
(07)07H	Acknowledgment delay time exceeded at end of connection or response monitoring time exceeded after send frame: After connection release with DLE ETX, no response received from partner within acknowledgment delay time.	Partner device too slow or faulty. If necessary, use an interface test device switched into the transmission line to check.
(07)08H	ASCII Driver and printer driver only: The waiting time for XON or CTS = ON has expired	The communication partner has a fault, is too slow or is switched off-line. Check the communication partner or, if necessary, change the parameters.

Event Class 7 (07H): "Send error"		
Event no.	Event Text	To correct or avoid errors
(07)09H	Connection setup not possible. Number of permitted connection attempts exceeded.	Check the interface cable or the transmission parameters.
(07)0AH	The data could not be transmitted. The permitted number of transfer attempts was exceeded.	Check the interface cable or the transmission parameters.

Event Class 8 (08H): "Receive error"		
Event no.	Event Text	To correct or avoid errors
(08)01H	Expecting the first repetition: An error was recognized on receiving a frame and the CP requested repetition from the partner via a negative acknowledgment (NAK).	A repetition is not an error, however, it can be an indication that there are disturbances on the transmission line or a malfunction of the partner device. If the frame still has not been transmitted after the maximum number of repetitions, an error number describing the first error that occurred is output.
(08)02H	Error during connection setup: <ul style="list-style-type: none"> In idle mode, one or more random codes (other than NAK or STX) were received, or after an STX was received, partner sent more codes without waiting for response DLE. After POWER ON of the partner: <ul style="list-style-type: none"> While partner is being activated, CP receives an undefined code. 	Check for malfunction at partner device, possibly by using interface test device switched into the transmission line.
(08)05H	Logical error during receiving: After DLE was received, a further random code (other than DLE or ETX) was received.	Check if partner DLE in frame header and in data string is always in duplicate or the connection is released with DLE ETX. Check for malfunction at partner device, possibly by using interface test device switched into the transmission line.
(08)06H	Character delay time exceeded: <ul style="list-style-type: none"> Two successive characters were not received within character delay time, or 1. 1st character after sending of DLE during connection setup was not received within character delay time. 	Partner device too slow or faulty. Use an interface test device switched into the transmission line to check.
(08)08H	Block check character (BCC) error (only in the case of RK512 with the 3964R procedure and the 3964R procedure) Internally calculated value of BCC does not match BCC received by partner at end of connection.	Check if there is a serious problem with the connection. In this case, error codes of the event class 8/event number 12 sometimes occur. Check for malfunction at partner device, possibly by using interface test device switched into the transmission line.
(08)0AH	There is no free receive buffer available: After receipt of STX, there was no empty receive buffer available to the procedure at connection setup and after an additional waiting time	The function block for receiving must be called more frequently in the user program.

Event Class 8 (08H): "Receive error"		
Event no.	Event Text	To correct or avoid errors
(08)0CH	<p>Transmission error: Transmission error (parity error, stop bit error, overflow error) detected.</p> <p>If faulty character is received in idle mode, the error is reported immediately so that disturbances on the transmission line can be detected early.</p> <p>Only for RK512 and 3964(R): If this occurs during send or receive operation, repetitions are initiated.</p>	<p>Faults on the transmission line cause frame repetitions, thus lowering user data throughput. Danger of an undetected error increases. Change your system setup or the line routing.</p> <p>Check that the settings for data transmission rate, parity and number of stop bits are the same on both devices.</p>
(08)0DH	<p>BREAK The connection line (receive line) to the partner device is interrupted</p>	<p>Set up the connection between the devices or switch the partner device on. In the case of TTY, Check if there is a current loop in the idle state.</p>
(08)12H	<p>With ASCII driver only: More characters were received after the CP had sent XOFF or set CTS to OFF.</p>	<p>Set the parameters for the communications partner again or read data from CP more quickly.</p>
(08)15H	<p>Discrepancy between settings for transfer attempts at CP and communication partner.</p>	<p>Set the same number of transfer attempts at communications partner as at CP. Check for malfunction at partner device, possibly by using interface test device switched into the transmission line.</p>
(08)16H	<ul style="list-style-type: none"> • The length of a received frame was longer than the length agreed upon or • the length of the parametered receive buffer (with CP 441 only) is too short. 	<ul style="list-style-type: none"> • A correction is necessary at the partner or • the length of the receive buffer (with CP 441 only) must be enlarged
(08)18H	<p>With ASCII driver only: DSR = OFF or CTS = OFF</p>	<p>The partner has switched the DSR or CTS signal to "OFF" before or during a transmission.</p> <p>Check the partner's control of the RS232 accompanying signals.</p>

Event Class 9 (09H): "Response frame received from interconnection partner with error or error frame"		
Event no.	Event Text	To correct or avoid errors
(09)02H	<p>RK512 only: Memory access error at partner (no memory)</p> <p>With SIMATIC S5 as partner:</p> <ul style="list-style-type: none"> • Incorrect area at status word, or • Data area does not exist (except DB/DX), or • Data area too short (except DB/DX) 	<p>Check that the partner has the desired data area and that it is big enough, or check the parameters of the called system function block.</p> <p>Check the specified length at the system function block.</p>
(09)03H	<p>RK512 only: DB/DX access error at the partner (DB/DX does not exist or is too short)</p> <p>With SIMATIC S5 as partner:</p> <ul style="list-style-type: none"> • DB/DX does not exist, or • DB/DX too short, or • DB/DX number impermissible <p>Permissible source area for GET request exceeded</p>	<p>Check that the partner has the desired data area and that it is big enough, or check the parameters of the called system function block.</p> <p>Check the specified length at the system function block.</p>
(09)04H	<p>RK512 only: Partner returns "Request type not permitted".</p>	<p>Partner malfunction, because a system command is never issued from the CP 441.</p>
(09)05H	<p>RK512 only: Error at partner or at SIMATIC S5 as partner:</p> <ul style="list-style-type: none"> • Source/destination type not permissible, or • Memory error in partner programmable controller, or • Error notifying CP/CPU at the partner, or • Partner programmable controller is in STOP state 	<p>Check if the partner can transmit the desired data type.</p> <p>Check the structure of the hardware at the partner.</p> <p>Set the partner programmable controller to RUN.</p>
(09)08H	<p>RK512 only: Partner detecting synchronization error:</p> <p>Message frame sequence error.</p>	<p>This error occurs at restart of your own programmable controller or of the partner. This represents normal system start-up behavior. You do not need to correct anything. The error is also conceivable during operation as a consequence of previous errors. Otherwise, you can assume an error on the part of the partner device.</p>
(09)09H	<p>RK512 only: DB/DX disabled at partner by coordination flag</p>	<p>In partner program: After processing of the last transmission data, reset the coordination flag.</p> <p>In own program: Repeat the request.</p>
(09)0AH	<p>RK512 only: Error detected by partner in frame header: 3rd command byte in header is incorrect</p>	<p>Check if the error is the result of disturbances or of a malfunction at the partner. Use an interface test device switched into the transmission line to check.</p>
(09)0BH	<p>RK512 only: Error in frame header: 1. 1st or 4th command byte in header is incorrect</p>	<p>Check if the error is the result of disturbances or of a malfunction at the partner. Use an interface test device switched into the transmission line to check.</p>
(09)0CH	<p>RK512 only: Partner detects incorrect frame length (total length).</p>	<p>Check if the error is the result of disturbances or of a malfunction at the partner. Use an interface test device switched into the transmission line to check.</p>

Event Class 9 (09H): "Response frame received from interconnection partner with error or error frame"		
Event no.	Event Text	To correct or avoid errors
(09)0DH	RK512 only: Partner has not yet restarted.	Restart the partner programmable controller or set the mode selector on the CP or CPU to RUN.
(09)0EH	RK512 only: Unknown error number received in response frame.	Check if the error is the result of disturbances or of a malfunction at the partner. Use an interface test device switched into the transmission line to check.

Event class 10 (0AH): "Errors in response frame of the partner detected by the CP"		
Event no.	Event Text	To correct or avoid errors
(0A)01H	RK512 only: Synchronization error of partner, because: <ul style="list-style-type: none"> • Response frame without request • Response frame received before continuation frame sent • Continuation response frame received after an initial frame was sent • A first response frame was received after a continuation frame was sent 	This error is reported after your own programming device is restarted in the case of long frames or when the partner is restarted. This represents normal system start-up behavior. You do not have to correct anything. The error can also occur during operation as a consequence of error statuses only recognized by the partner. Otherwise, you can assume an error on the part of the partner device. The error may not occur in the case of requests <128 bytes.
(0A)02H	RK512 only: Error in the structure of the received response frame (1st byte not 00 or FF)	Check for malfunction at partner device, possibly by using interface test device switched into the transmission line.
(0A)03H	RK512 only: Received response frame has too many data or not enough data.	Check for malfunction at partner device, possibly by using interface test device switched into the transmission line.
(0A)04H	RK512 only: Response frame for SEND request arrived with data.	Check for malfunction at partner device, possibly by using interface test device switched into the transmission line.
(0A)05H	RK512 only: No response frame from partner within monitoring time.	Is the partner a slow device? This error is also often displayed as a consequence of a previous error. For example, procedure receive errors (event class 8) can be displayed after a GET frame was sent. Reason: As a result of disturbances, the response frame could not be received, and the monitoring time elapsed. This error can also occur if a restart was carried out at the partner before it could respond to the most recently received GET frame.
(0A)06H	RK512 only: Received response frame after GET request has not enough data	Check for malfunction at partner device, possibly by using interface test device switched into the transmission line.

8.4 Error Numbers in the Response Message Frame

Response frame

If you are working with the RK512 computer link and an error occurs at the communication partner in a SEND/PUT or GET frame, the communication partner sends a response frame with an error number in the 4th byte.

Error Numbers in the Response Frame

The table below shows how the error numbers in the response frame (REATEL) are assigned to the event classes/numbers in the STATUS output of the communication partner. The error numbers in the response frame are output as hexadecimal values.

Table 8- 10 Error messages in the response frame with RK512

REATEL	SYSTAT Error Messages
	Event Class/Event Number
0AH Error at the partner or SIMATIC S5 as partner: <ul style="list-style-type: none"> • Source/destination type not permissible, or • Memory error in partner programmable controller, or • Error notifying CP/CPU at the partner, or • Partner programmable controller is in STOP state 	0301H 0303H 0407H 0905H
0CH Memory access error at the partner (no memory) or SIMATIC S5 as partner: <ul style="list-style-type: none"> • Incorrect area at status word, or • Data area does not exist (except DB/DX), or • Data area too short (except DB/DX) 	0301H 0302H 0607H 0609H 060AH 0902H
10H Error in frame header: 1. 1st or 4th command byte in header is incorrect	0601H 0604H 0605H 090BH
12H Partner reports "Illegal request type"	0904H
14H DB/DX access error at the partner (DB/DX does not exist or is too short) or SIMATIC S5 as partner: <ul style="list-style-type: none"> • DB/DX does not exist, or • DB/DX too short, or • DB/DX number impermissible Permissible source area for GET request exceeded	0301H 0302H 0606H 0903H

8.4 Error Numbers in the Response Message Frame

REATEL	SYSTAT Error Messages
	Event Class/Event Number
16H Errors in frame header that are detected by the partner: 3. command byte in the header is wrong	0602H 0603H 090AH
2AH Partner was not yet restarted.	060DH 090DH
32H DB/DX locked at the partner by coordination flag	060FH 0909H

REATEL	SYSTAT Error Messages
	Event Class/Event Number
34H Partner detects incorrect frame length (total length).	0608H 060BH 060CH 0611H 090CH
36H Partner detects synchronous error: Frame sequence error.	060EH 0908H

8.5 Diagnosics via the diagnostic buffer of the CP 441

Diagnostic Buffer of the CP 441

The CP 441 as of 6ES7 441-xAA02-0AE0 (x=1, 2) has its own diagnostic buffer in which all diagnostic events of the CP 441 are entered in the order in which they occurred.

The following are displayed in the diagnostic buffer of the CP 441:

- The operating status of the CP 441
- Hardware/firmware errors on the CP 441
- Initialization and parameter errors
- Errors during execution of a CPU request
- Data transmission errors (send and receive errors)

The diagnostic buffer allows the causes of errors in point-to-point link to be evaluated subsequently in order, for example, to determine the causes of a STOP of the CP 441 or to trace the occurrence of individual diagnostic events.

Note

The diagnostic buffer is a ring buffer for a maximum of 64 diagnostic entries. When the diagnostic buffer is full, the oldest entry is deleted when a new entry is made in it. The most recent entry always comes first. When the POWER OF the CP 441 is switched off, the contents of the diagnostic buffer are lost.

Reading the Diagnostic Buffer at the Programming Device

The contents of the diagnostic buffer of the CP 441 can be read by means of the STEP 7 information functions.

Note

Diagnostic events in the diagnostic buffer of the CP 441 can be read using STEP 7 as of version 4.0.

All the user-relevant information in the CP diagnostic buffer is displayed to you on the "Diagnostic Buffer" in the "Module Information" dialog. You can call the "Module Information" dialog under STEP 7 from SIMATIC Manager.

Prerequisite: In order to obtain the status of the module, there must be an on-line connection from the programming device to the programmable controller (on-line view in the project window).

Proceed as follows:

1. Open the relevant SIMATIC 400 station (by double-clicking it or by choosing the **Edit > Open** menu command).
2. Open the "Hardware" object contained in it (again by double-clicking it or by choosing the **Edit > Open** menu command).

Result: The window containing the configuration table appears.

3. Select the CP 441 in the configuration table.
4. Choose the **PLC > Module Information** menu command.

Result: The "Module Information" dialog appears for the CP 441. The "General" tab is displayed by default the first time you call it.

5. Select the "Diagnostic Buffer" tab.

Result: The "Diagnostic Buffer" tab displays the most recent diagnostic events of the CP 441. Any "result details" on the cause of the problem appears in the lower part of the tab.

The event's numeric code is displayed in the "Event ID" field. The 16#F1C8 leader for interface 1 and the 16#F9C8 leader for interface 2 are non-variables. The rest of the ID code corresponds to event class and event number of the events. By clicking the "Help on Event" button you can display the help text on the event text.

If you click the "Update" button, the current data is read from the CP 441. By clicking the "Help on Event" button you can display a help text on the selected diagnostic event with information on error correction.

See also

Diagnostics via the error signaling area SYSTAT (Page 195)

8.6 Diagnostic interrupt

Introduction

The CP 441 can trigger a diagnostics interrupt on the assigned CPU, thus indicating a malfunction of the CP 441. You can specify during parameter assignment (as of STEP 7 V5.0, SP2) whether the CP 441 is to trigger a diagnostics interrupt or not in the event of serious errors.

"Diagnostic interrupt = NO" is the default.

Diagnostics interrupt

In the event of a fault the CP 441 provides diagnostic information on the S7-400 rear panel bus. In response to a diagnostics interrupt, the CPU reads the system-specific diagnostic data and enters it in its diagnostic buffer. You can read the contents of the diagnostic buffer on the CPU using a programming device.

When a diagnostic interrupt event occurs, the INTF LED (red) lights up. In addition, the OB 82 is called with this diagnostic data as start information.

Organization block OB 82

You have the option of programming error responses in the user program in the OB 82.

If no OB 82 is programmed, the CPU automatically enters STOP mode in the event of a diagnostics interrupt.

Diagnostic Information (as Bit Pattern)

The CP 441 provides 4 bytes of diagnostic information. To display the error that has occurred, these 4 bytes are occupied as follows:

2nd byte:

The 2nd byte of diagnostic data contains the class ID of the CP 441 in bits 0 to 3.

2. byte							
7	6	5	4	3	2	1	0
0	0	0	1	1	1	0	0

8.6 Diagnostic interrupt

1st, 3rd and 4th bytes:

The 1st, 3rd and 4th bytes of the diagnostic data represent the error which has occurred.

Bit 0 in the 1st byte is the group error display (INTF). Bit 0 is always set to "1" if at least one bit from bits 1 to 7 is set to "1", i.e. if at least one error is entered in the diagnostic data.

Event	1. byte								3. byte								4. byte							
	7	6	5	4	3	2	1	0	7	6	5	4	3	2	1	0	7	6	5	4	3	2	1	0
Wire break	0	0	1	0	1	1	0	1	0	0	0	0	0	0	1	0	0	0	0	0	0	0	0	0
Incorrect parameter	1	0	0	0	1	0	1	1	0	0	0	0	0	0	0	0	0	0	0	0	0	0	0	0

Diagnostic Information (Hexadecimal)

The table below shows the 4th byte in diagnostic data of the CP 441 in hexadecimal notation.

Event	1. byte	2. byte	3. byte	4. byte
Wire break	2DH	1CH	02H	00H
Incorrect parameter	8BH	1CH	00H	00H

Diagnostic Information, CP 441 with two Interfaces

DS 1 contains the information as to which interface of your CP 441-2 (6ES7 441-2AA03-0AE0) had an error. You can read DS 1 by calling SFC 59 "RD_REC".

A bit is set in byte 8 for each interface on which an error occurs.

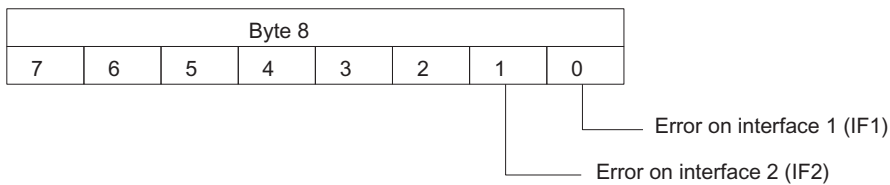

The error is defined in byte 9 for interface 1 or byte 10 for interface 2.

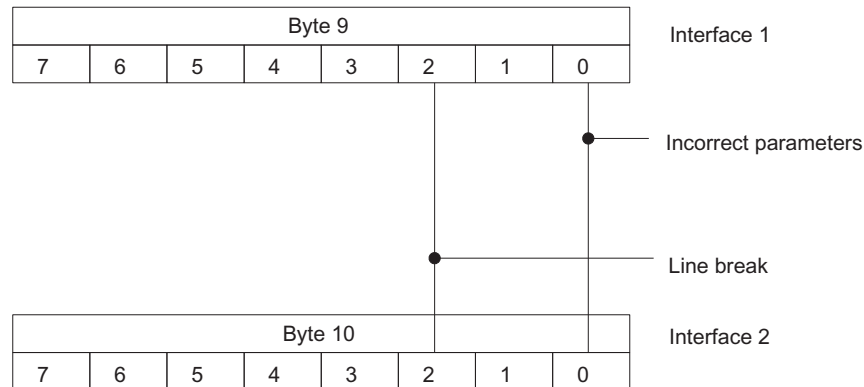

Relationship of the diagnostics interrupt and the CPU operating mode

A diagnostics interrupt is generated via the I/O bus when fault events (rising edge) and back-to-normal events (falling edge) occur.

When the CPU switches from STOP mode to RUN mode, the following happens:

- Events (both fault and back-to-normal) which occurred when the CPU was in STOP mode are not stored,
- Events that are still present when the CPU is back to RUN mode are signaled via the diagnostics interrupt.

Programming Example for System Function Blocks

9.1 General Information

Introduction

The programming example in this chapter describes how to create a project and, by means of a simple data transfer operation, the basic usage of the system function blocks for operating the CP 441 communication processor.

The individual steps described for configuring and programming should make it easier for you to create a project.

Because only the general procedure is presented here and the sequence of the individual steps may vary over the course of time in the individual STEP 7 packages, you should also consult the current documentation for these packages.

At the end of the chapter you will find an example of how to program the output of message texts on a printer.

Objective

The programming example

- aims to show the most important functions,
- is clear and easy to understand,
- can easily be extended for your own purposes.

The example shows how a connection to a communication partner can be configured using the system function blocks BSEND and BRCV (for sending and receiving data respectively).

The CP 441 modules are parameterized by the CPU at CPU start-up.

Prerequisite

The example can be executed with the minimum hardware equipment.

The program example

The examples are on the CD which contains the **CP 441: Configuration Package for Point to Point Communication** parameter assignment interface. They are in compiled form.

These programs are installed together with the parameter assignment interface.

Once installation has completed, the examples are in the STEP 7 "Examples" catalog under CP 441.

Note

STEP 7 (TIA Portal)

Select examples are available for download on the Customer Support pages as of STEP 7 V11 (TIA Portal).

<http://support.automation.siemens.com/WW/view/de/59585200>
(<http://support.automation.siemens.com/WW/view/en/59585200>)

9.2 Device Configuration

Application

To try out the program example, you could use the following devices:

- An S7-400 automation system (mounting rack, power supply, CPU 414 or CPU 417)
- A CP 441
- A programming device (PG)

Data transmission is from interface 1 to interface 2 of the CP 441. If you use a CP 441-1 you can ignore the settings for interface 2; your communication partner receives the data.

Device Configuration

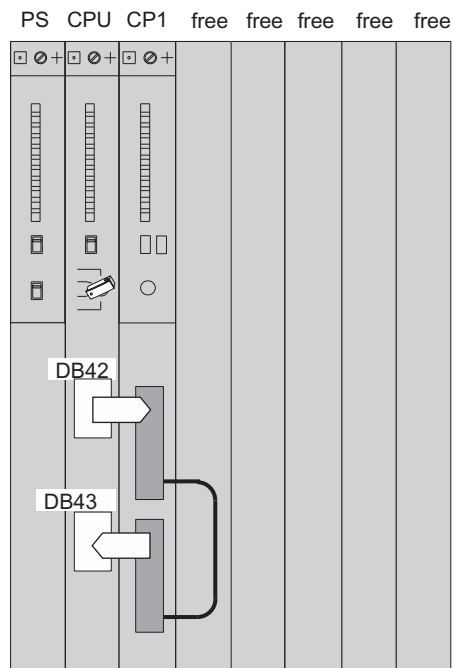

Figure 9-1 Data flow: Device configuration with a CP 441-2

9.3 Configuring the Controller Setup

Configuration

- STEP 7

An S7-400 station is configured using "HW Config" in STEP 7. Place the modules in the configuration table in accordance with your hardware configuration.

In the configuration table you must configure the controller setup as follows:

- Power supply (e. g. PS 10A)

The number of assigned slots depends on the type of power supply.

- CPU

The number of assigned slots depends on the type of CPU.

- CP 441

- STEP 7 (TIA Portal)

An S7-400 station is configured in the device configuration of STEP 7 (TIA Portal). Place the modules in the device view in accordance with your hardware configuration.

The controller design corresponds to that described for STEP 7.

9.4 Parameterizing the CP 441

STEP 7

Once you have arranged the modules in your mounting rack, you can double-click the CP 441 (in the configuration table) to display the "Properties" dialog:

1. Under "Basic Parameters", specify in the "Interface" entry field (1 or 2) the type of the interface module installed here.
2. Choose the "Parameters" button in the "Properties" dialog.

Result: The **CP 441: Configuration Package for Point to Point Communication** parameter assignment interface for assigning CP 441 protocol parameters is opened.

3. Select the desired transmission protocol ("RK512", "3964(R)", "ASCII" or "Printer").

Result: The parameter assignment interface that is available in accordance with the protocol is displayed. The gray buttons allow you to open additional parameter assignment dialogs.

4. Accept the default settings, and return to the configuration table.
5. If necessary, carry out steps 1 to 4 in accordance with your configuration for the second interface of the CP 441.

STEP 7 (TIA Portal)

Once you have selected the modules in the "Hardware catalog" task card and arranged in your module rack, all parameters of the CP 441 are displayed in the "Properties" tab. Configure the CP 441 according to your requirements.

9.5 Configuring the Connection to the Communication Partner

Note

Configuring connection in STEP 7 (TIA Portal)

The procedure for configuring connections in STEP 7 (TIA Portal) is described in detail in the information system of the TIA Portal.

Configuring connection in STEP 7

In STEP 7, you configure a point-to-point connection between your CP 441 and the communication partner using "NETPRO". Proceed as follows:

1. Enter the connection in the connection table.
2. Set the object properties of the connection.

Entering the connection for interface 1 in the connection table

Proceed as follows:

1. Return to the **<Offline> (Project)** project window, and double-click the CPU in the SIMATIC 400 station.

Result:The "Connections" object (connection table) appears on the right.

2. Double-click this icon. The "Configuring Connections" dialog appears. Choose **Insert > Connection** to insert your connection in the connection table.
3. In the **New Connection** dialog, select **Unspecified** as the communication partner and enter **PTP Connection** as the connection type. Then click **OK** to exit the dialog.
4. Set the object properties of the connection:
 - In the "Object Properties" dialog, set the specific properties of the connection for interface 1:
 - In the **Object Properties** dialog, change the name of the communication partner from **Unspecified** to an appropriate name and select the **PTP- CP Rack/Slot** and **IF_1** interface. No other settings are necessary.
5. Click **OK** to return to the **Configure Network** dialog.

Result: The **Configure Network** dialog displays the connection that you have added and the Local ID (Hexadecimal). You have to specify this ID as the parameter **ID** at the BSEND system function block in the user program of your CPU.

Entering the connection for interface 2 in the connection table

Proceed as follows:

1. After returning to the **Configuring Network** dialog, insert the connection in the connection table by choosing **Insert > Connection**.
2. In the **New Connection** dialog, select **Unspecified** as the communication partner and enter **S7 PTP Connection** as the connection type. Then click **OK** to exit the dialog.
3. Set the object properties of the connection:
 - In the **Object Properties** dialog, set the specific properties of the connection for interface 2:
 - In the **Object Properties** dialog, change the name of the communication partner from **Unspecified** to an appropriate name and select the **PTP- CP Rack/Slot** and **IF_2** interface. No other settings are necessary.
4. Click **OK** to return to the **Configure Network** dialog.

Result: The **Configure Network** dialog displays the connection that you have added and the Local ID (Hexadecimal). You have to specify this ID as the parameter **ID** at the **BRCV** system function block in the user program of your CPU.

9.6 Programming an ASCII/3964(R) User Program

Data Transmission with the ASCII-/3964(R) Procedure

If you intend to transfer data using the ASCII/3964(R) protocol (program example CP441 ASCII Send/Recv), you need only make the following changes:

- When parameterizing, you must use the parameter dialogs for the ASCII/3964(R) protocol.
- For data transmission, the block pair **BSEND** and **BRCV** is also used in the user program. Any **R_ID** can be used for **BSEND**, but only **R_ID "0"** can be used for **BRCV**.

9.7 Programming an RK512 user program

9.7.1 Program CP 441 RK512 Send/Recv

General

In OB 1, the blocks FC21 and FC 23 are called cyclically, FC21 for sending data (SFB BSEND) and FC 23 for receiving data (SFB BRCV).

In the example, the system function blocks BSEND and BRCV work with the data blocks DB 12 and DB 13 as instance DBs, and with DB 42 and DB 43 as send and receive DBs respectively.

In the example the system function blocks are parameterized partly via constants and partly via symbolically addressed actual operands.

Connection_ID 1000 (hexadecimal) is entered for the BSEND and the associated STATUS. Connection_ID 1001 (hexadecimal) is entered for the BRCV and the associated STATUS. If you are using a CP 441-1, you must enter connection ID 1000 (hexadecimal) for the BRCV and the associated STATUS. You can then receive data from your communication partner via interface 1.

For the data transmission the block pair BSEND and BRCV are used. The same R_ID is used for both blocks.

The values for R_ID are accepted once during startup and cannot subsequently be changed.

This ensures that the SFBs BSEND and STATUS are run through once at the beginning with REQ = "0" (so the edge rises from "0" to "1" at the REQ input), the REQ parameter in OB 100 is set to "0" once after a complete restart (see Chapter "Diagnostics via the error signaling area SYSTAT (Page 195)").

Description of FC 21 (SEND)

The "Generate edge P_SEND_REQ" program section:

BSEND is run through once at the start with BSEND_REQ = 0. BSEND_REQ is then set to 1. The BSEND request is started when a signal state change from 0 to 1 is detected at the BSEND_REQ control parameter.

When BSEND_DONE = 1 or BSEND_ERROR = 1, BSEND_REQ is reset to "0".

The "BSEND_DONE = 1" program section

If the transfer is successful, BSEND_DONE at the parameter output of the BSEND is set to "1".

To distinguish between consecutive transfers, "BSEND_COUNTER_OK" send counter is included in data word 0 of the source block DB 42.

The "BSEND_ERROR = 1" program section

If BSEND runs through with BSEND_ERROR=1, the BSEND_COUNTER_ERR error counter in data word 2 increments. The BSEND_STATUS is copied, because it will be overwritten with 0 in the next run and could not subsequently be read.

In addition, in the event of an error, the STATUS system function block is activated so that detailed fault messages (LOCAL parameter) can be read.

Description of FC 23 (RECEIVE)

The "Enable Receive Data" program section:

For data to be received, the receive enable (control parameter BRCV_EN_R for the BRCV block) must have the signal "1".

The "BRCV_NDR=1" program section:

When BRCV_NDR is set, new data has been received and the BRCV_COUNTER_OK receive counter increments.

The "BRCV_ERROR = 1" program section:

If the startup is unsuccessful, i.e. if the ERROR bit is set at the parameter output of BRCV, the BRCV_COUNTER_ERR error counter increments. The BSEND_STATUS is copied, because it will be overwritten with 0 in the next run and could not subsequently be read.

In addition, in the event of an error, the STATUS system function block is activated so that detailed fault messages (LOCAL parameter) can be read (see Chapter "Diagnostics via the error signaling area SYSTAT (Page 195)").

All relevant values can be observed for test purposes in the variable table.

Special Features of the CP 441-1:

If you want to receive data from your communication partner, the partner must specify DX 33 (21 hexadecimal) as the destination address. In this way BRCV is referenced with R_ID 21 (hexadecimal) in FC 23.

9.7.2 Blocks Used in the Sample Program

Blocks Used

The table below shows the blocks used for the sample program.

Prerequisite: All symbolic designations have already been declared in the symbol table.

Table 9- 1 Blocks Used in the Sample Program

Block	Symbol	Description
OB 1	CYCLE	Cyclic program processing
OB 100	RESTART	Start-up OB for restart
FC 21	SEND	FC with call and analysis of BSEND SFB
FC 23	RECEIVE	FC with call and analysis of BRCV SFB
DB 12	SEND IDB	Instance DB for BSEND SFB
DB 13	RCV IDB	Instance DB for BRCV SFB
DB 22	STATUS IDB BSEND	Instance DB for STATUS SFB
DB 23	STATUS IDB RECEIVE	Instance DB for STATUS SFB
DB 42	SEND SRC DB	Send data block (source)
DB 43	RCV DST DB	Receive data block (destination)
DB 40	SEND WORK DB	Work DB for BSEND
DB 41	RCV WORK DB	Work DB for BRCV
DB 45	STATUS WORK DB BSEND	Work DB for STATUS
DB 46	STATUS WORK DB BRCV	Work DB for STATUS

See also

Data Transmission with 3964(R) Using BSEND and BRCV (Page 146)

9.8 Programming a Printer User Program

Introduction

The following sections describe an example of how to send data to a printer. The example program indicates the procedure for the editing data and assigning parameters for the PRINT SFB.

Prerequisite

Message texts configured beforehand with the parameter assignment interface **CP 441: Configuration Package for Point to Point Communication** (menu command: **Hardware > Properties of CP 441 > Parameter > Messages**). The messages have been transferred together with the other parameter data on the CP 441.

Message text examples:

- 1:\B%C\B F220340 Share of component no.\B%\B reached\B%10.2Rkg\B
- 2:\B%S\B H244312 Bypass fitting closed
- 3:\B%S\B H620125 Failure of station input hydraulic mechanism
- 4:\B%S\B P215055 Tank gauge pressure %12.4R bar

The result on the printer for message text No. 1, for example, is:

"W F220340 proportion component No. 6 attained 1.45E+02 Kg"

9.8.1 Cyclic Program

General

The organization block OB 1 contains the cyclic program.

In the example the PRINT system function block works with the DB 16 data blocks, and the STATUS system function block works with the DB 22 data block as the instance DB (clipboard).

The same connection ID is to be entered at the appropriate input parameters for the PRINT SFB and the associated STATUS SFB in the program, since the STATUS SFB works on a connection-related basis.

The PRINT request is supplied with data from DB 146, DB 160 and DB 165.

In FB 50, the PRINT SFB and the STATUS SFB are initialized by means of a one-off call with the signal "0" at the REQ input parameter.

Description of the "Printer Output" Program

The print request is sent to the printer when a signal state change from "0" to "1" is detected at the REQ control parameter.

In the event of successful completion of the request, the DONE output parameter is set to the signal "1" at the PRINT SFB. In the event of an error, the ERROR output parameter is set to the signal "1" instead. In the program, the REQ control input is reset to "0" if one of these signals is positive.

In the next cycle, the DONE parameter is set to "0". The REQ input thus becomes "1" and the requested signal state change from "0" to "1" results in data transfer to the printer.

In addition, in the event of an error, the STATUS system function block (SFB 22) is called with DB 22 as the instance DB in order to obtain detailed information on the cause of the error. The ERROR output parameter of the PRINT SFB serves as the trigger for the STATUS SFB.

In the event of a signal state change from "0" to "1", the REQ input of the STATUS SFB is activated. The 16 bytes addressed at the LOCAL parameter receive the current error status of the connection until the next STATUS SFB call.

The status of the memory words or data words is monitored in the variable table. Other test options are available to you if you insert load commands in the program (of any variables) and then monitor them by means of the "Block Status" function in online operation.

You can select other options with the variable table by means of CONTROL VARIABLES.

The ENABLE_JOB_1, ENABLE_JOB_2 and ENABLE_JOB_3 variables offer you a choice of three different jobs.

The first job returns a printout of a message text. The second and third jobs return a simple printout of a single variable or more than one variable, respectively.

9.8.2 Blocks Used in the Sample Program

Blocks Used

The table below shows the blocks used for the sample program.

Prerequisite: All symbolic designations have already been declared in the symbol table.

Table 9- 2 Blocks Used in the Sample Program for Printers

Block	Symbol	Description
OB 1	CYCLE	Cyclic program processing
OB 100	RESTART	Start-up OB for restart
FB 50	PRINT A	"PRINT A"
FB 51	PRINT B	"PRINT B"
FB 52	PRINT C	"PRINT C"
DB 16	PRINT IDB	Instance DB for the PRINT SFB
DB 22	STATUS IDB	Instance DB for STATUS SFB
DB 146	DB_with_Convers_Statem	DB with conversion statement for representation type N
DB 160	Process_Values	DB transfer of process values
DB 165	ME_WA_AL	Message type

9.9 Installation, Error Messages

Installation

The hardware for the example is completely set up and the programming device is connected.

Once the CPU has been reset (operating mode STOP), transfer the example corresponding to your hardware configuration fully into the user memory. Then use the operating mode switch to change from STOP to RUN_P (start-up characteristic CRST).

Malfunction

If an error occurs during start-up, the block calls to be processed cyclically will not be executed and the error LED **INTF** or **EXTF** on the CPU will be set. Detailed information on the cause of the error can be found in the diagnostic buffer.

Technical Specifications

A.1 Technical data of the CP 441 and the interface modules

General technical specifications

In the following table you can find the technical specifications of the CP 441. You can find additional technical specifications of the SIMATIC S7-400 in the *S7-400 Automation System, Module Specifications* reference manual and the *S7-400 Automation System, Installation* installation manual.

Table A- 1 Technical specifications of the CP 441

Technical specifications		
	6ES7 441-xAA04-0AE0	6ES7 441-xAA05-0AE0
Current consumption (rated value)	0.6 A / 5 V	0.3 A / 5 V
Power loss	3.5 W	1.5 W
Degree of protection	IP20	
Dimensions W x H x D	25 x 290 x 210 mm	
Weight	Approx. 0.8 kg	Approx. 0.58 kg
Display elements	LEDs for transmitting (TXD), receiving (RXD) and interface fault (FAULT) Group alarm LEDs for internal fault (INTF) and external fault (EXTF)	
Supplied protocol drivers CP 441-1	<ul style="list-style-type: none"> • ASCII driver • 3964(R) procedure • Printer 	
Supplied protocol drivers CP 441-2	<ul style="list-style-type: none"> • ASCII driver • 3964(R) procedure • RK512 computer link • Printer • Modbus RTU master • Modbus RTU slave 	
Interrupts • Diagnostic Interrupt	Configurable	
Diagnostics • Indicators for internal and external faults	Yes, 2 red LEDs	
Diagnostic information dump	Yes	

A.1 Technical data of the CP 441 and the interface modules

Technical specifications interface module - 6ES7 441-xAA04-0AE0

The following table contains the technical specifications of the plug-in interface modules of the CP 441.

Table A-2 Technical specifications interface module - 6ES7 441-xAA04-0AE0

Technical specifications	RS232	20mA TTY	X27 (RS422/485)
	6ES7 963-1AA00-0AA0	6ES7 963-2AA00-0AA0	6ES7 963-3AA00-0AA0
Current consumption (rated value)	0.1 A at 5 V	0.1 A at 5 V 0.045 A at 24 V	0.25 A at 5 V
Power loss	0.5 W	1.5 W	1.25 W
Degree of protection	IP00	IP00	IP00
Isolation	No	Yes	Yes
Dimensions D x H x W	Approx. 95 x 70 x 20 mm	Approx. 95 x 70 x 20 mm	Approx. 95 x 70 x 20 mm
Weight	80 g	80 g	80 g
Data transmission rate	Max. 115.2 kbps Min. 300 bps	Max. 19.2 kbps Min. 300 bps	Max. 115.2 kbps Min. 300 bps
Cable length	Max. 15 m	Max. 1000 m at 9600 bps	Max. 1200 m at 19200 bps
Front connectors	9-pin sub-d male with screw interlock	9-pin sub-d female with screw interlock	15-pin sub-d female with screw interlock

Technical specifications interface module - 6ES7 441-xAA05-0AE0

The following table contains the technical specifications of the plug-in interface modules of the CP 441.

Table A-3 Technical specifications interface module - 6ES7 441-xAA05-0AE0

Technical specifications	RS232	20mA TTY	X27 (RS422/485)
	6ES7 963-1AA10-0AA0	6ES7 963-2AA10-0AA0	6ES7 963-3AA10-0AA0
Current consumption (rated value)	15 mA at 3.3 V	15 mA at 3.3 V 23 mA at 24 V per current source	41 mA at 3.3 V
Power loss	0.05 W	0.6 W	0.14 W
Degree of protection	IP00	IP00	IP00
Isolation	No	Yes	Yes
Dimensions D x H x W	Approx. 87 x 67 x 19 mm	Approx. 87 x 67 x 19 mm	Approx. 87 x 67 x 19 mm
Weight	80 g	80 g	80 g
Data transmission rate	Max. 115.2 kbps Min. 300 bps	Max. 19.2 kbps Min. 300 bps	Max. 115.2 kbps Min. 300 bps
Cable length	Max. 15 m	Max. 1000 m at 9600 bps	Max. 1200 m at 19200 bps
Front connectors	9-pin sub-d male with screw interlock	9-pin sub-d female with screw interlock	15-pin sub-d female with screw interlock

Cables

B.1 RS232 interface module

Pin assignment

The table below shows the pin assignment for the 9-pin subminiature D male connector in the front panel of the RS232 interface module.

Table B- 1 Pin assignment for the 9-pin subminiature D male connector of the RS232 interface module

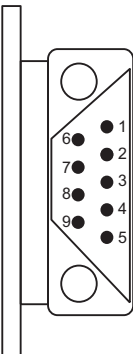
Male Connector on Module*	Pin	Designation	Input/Output	Meaning
	1	DCD Received Detector	Input	Receiver signal level
	2	RXD Received Data	Input	Received data
	3	TXD Transmitted Data	Output	Transmitted data
	4	DTR Data Terminal Ready	Output	Communication terminals ready
	5	GND Ground	-	Signal ground (GND _{int})
	6	DSR Data Set Ready	Input	Ready for operation
	7	RTS Request To Send	Output	Activate transmitter
	8	CTS Clear To Send	Input	Ready for sending
	9	RI Ring Indicator	Input	Receiving call

* View from the front

Cables

If you make your own cables you must remember that unconnected inputs at the communication partner may have to be connected to open-circuit potential.

Please note that you must only use shielded connector casings. A large surface area of both sides of the cable shield must be in contact with the connector casing.

<p>⚠ CAUTION</p> <p>Never connect the cable shield with the GND, as this could destroy the submodules. GND must always be connected on both sides (pin 5), otherwise the submodules could again be destroyed.</p>
--

The following pages contain examples of cables for a point-to-point link between the CP 441 and S7 modules or SIMATIC S5.

RS232 cables (S7 (CP 441) - S7 CP 441/CP 340)

The figure below illustrates the cable for a point-to-point link between a CP 441 and a CP 441/CP 340.

You require the following female connectors for the cables:

- At CP 441 end: 9-pin subminiature D female with screw interlock
- At the communication partner: 9-pin subminiature D female with screw interlock

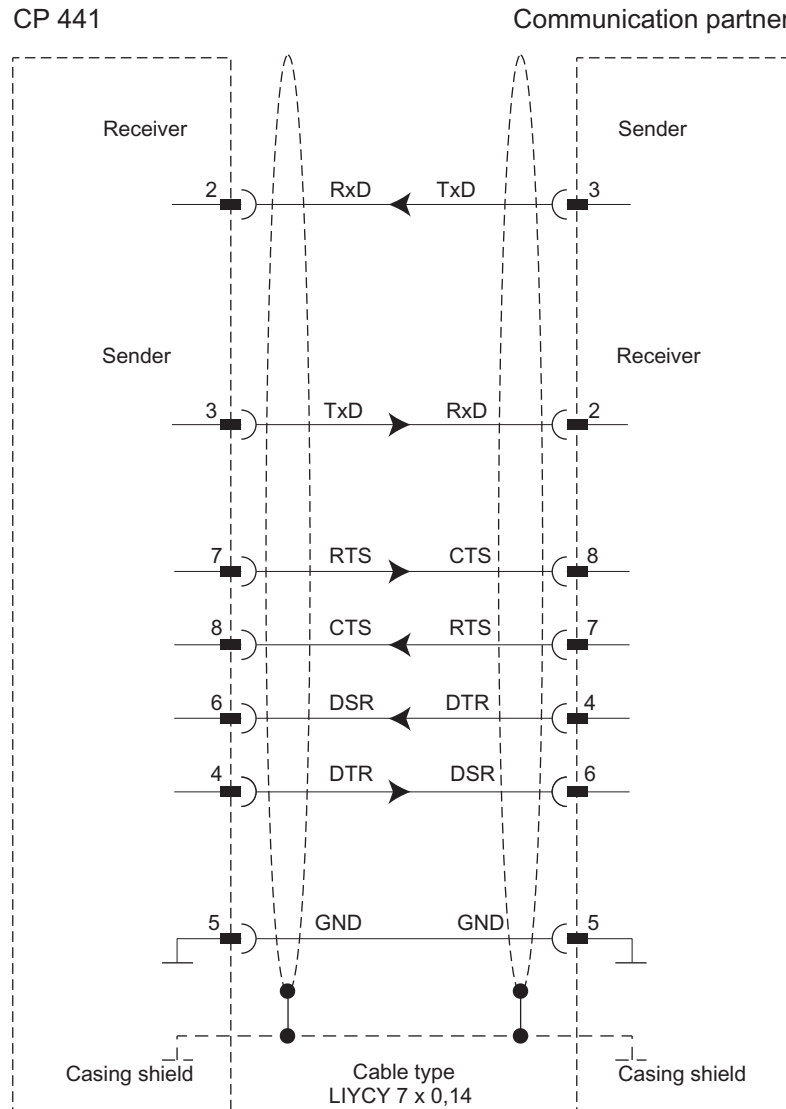

Figure B-1 RS232 cable CP 441 - CP 441/CP 340

The cable is available under the order number (6ES7 902-1...).

RS232 cables (S7 (CP 441) - CP 544, CP 524, CPU 928B, CPU 945, CPU 948)

The figure below illustrates the cable for a point-to-point link between a CP 441 and a CP 544, CP 524, CPU 928B, CPU 945 or CPU 948.

You require the following female/male connectors for the cables:

- At CP 441 end: 9-pin subminiature D female with screw interlock
- At the communication partner: 25-pin subminiature D male with slide latch

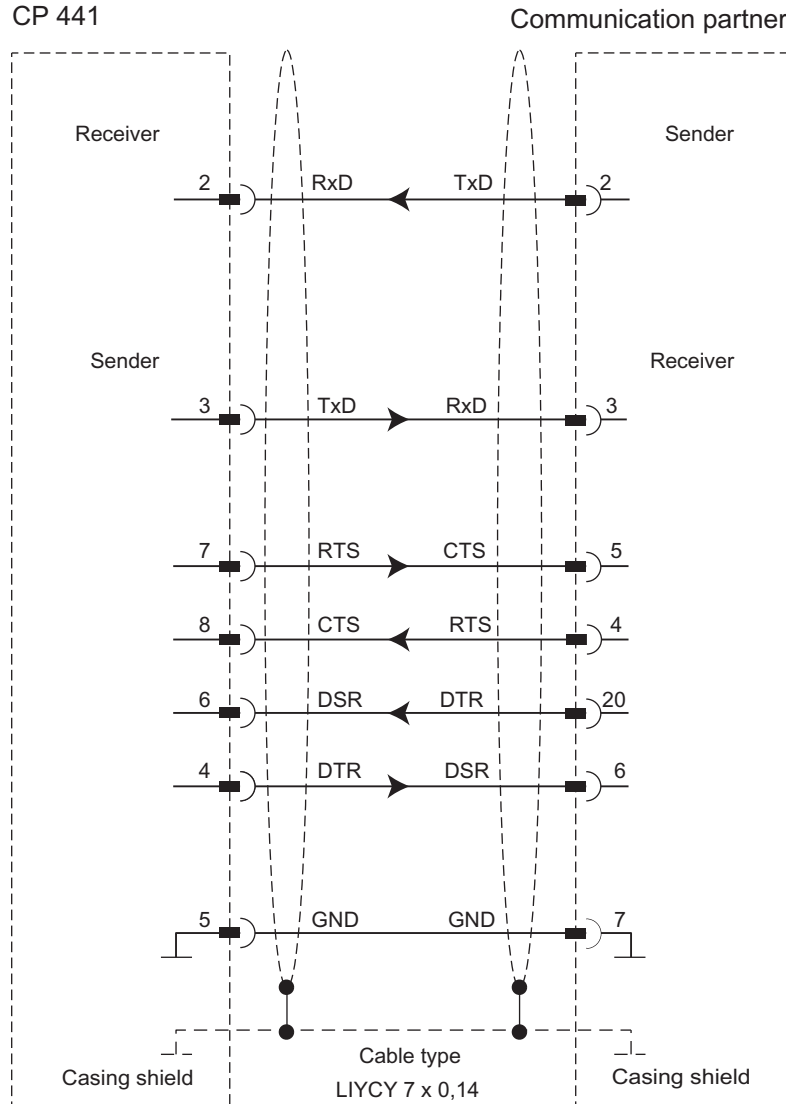

Figure B-2 RS232 cable CP 441 - CP 544, CP 524, CPU 928B, CPU 945, CPU 948

RS232 cables (S7 (CP 441) - CP 521 SI/CP 521 BASIC)

The figure below illustrates the cable for a point-to-point link between a CP 441 and a CP 521 SI/CP 521 BASIC.

You require the following female/male connectors for the cables:

- At CP 441 end: 9-pin subminiature D female with screw interlock
- At the communication partner: 25-pin subminiature D male with screw interlock

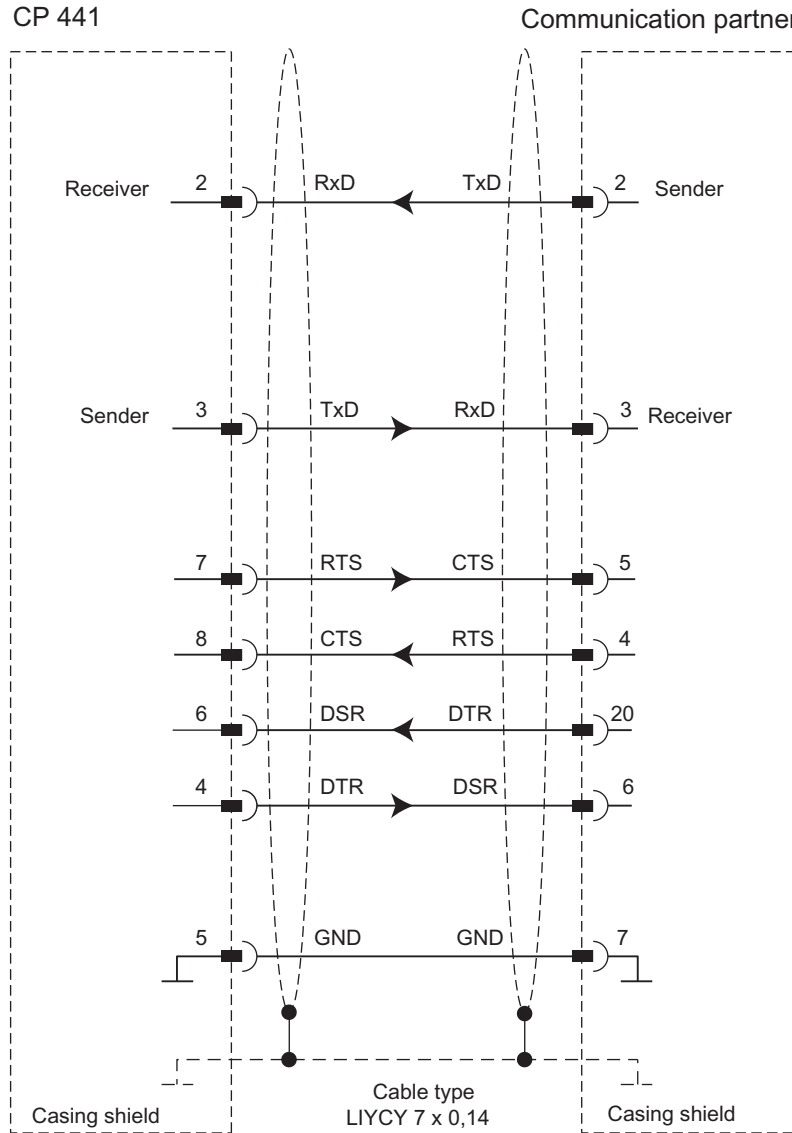

Figure B-3 RS232 cable CP 441 - CP CP 521SI/CP 521BASIC

RS232 cables (S7 (CP 441) - CP 523)

The figure below illustrates the cable for a point-to-point link between a CP 441 and a CP 523.

You require the following female/male connectors for the cables:

- At CP 441 end: 9-pin subminiature D female with screw interlock
- At the communication partner: 25-pin subminiature D male with screw interlock

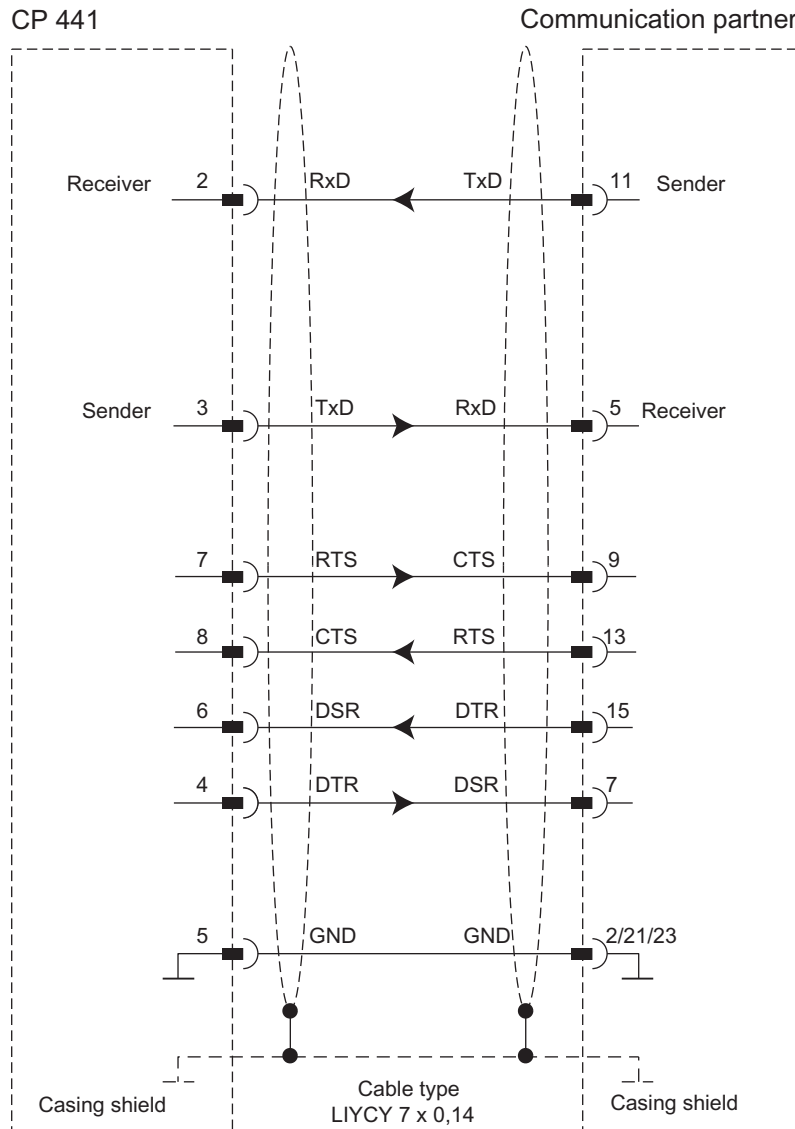

Figure B-4 RS232 cable CP 441 - CP 523

RS232 cable (S7 (CP 441) - IBM-Proprinter (PT 88), DR 230)

The figure below illustrates the cable for a point-to-point link between a CP 441 and an IBM Proprinter with a serial interface (PT 88 or IBM-compatible printer).

You require the following female/male connectors for the cable:

- At CP 441 end: 9-pin subminiature female
- With IBM Proprinter: 25-pin sub-D male connector

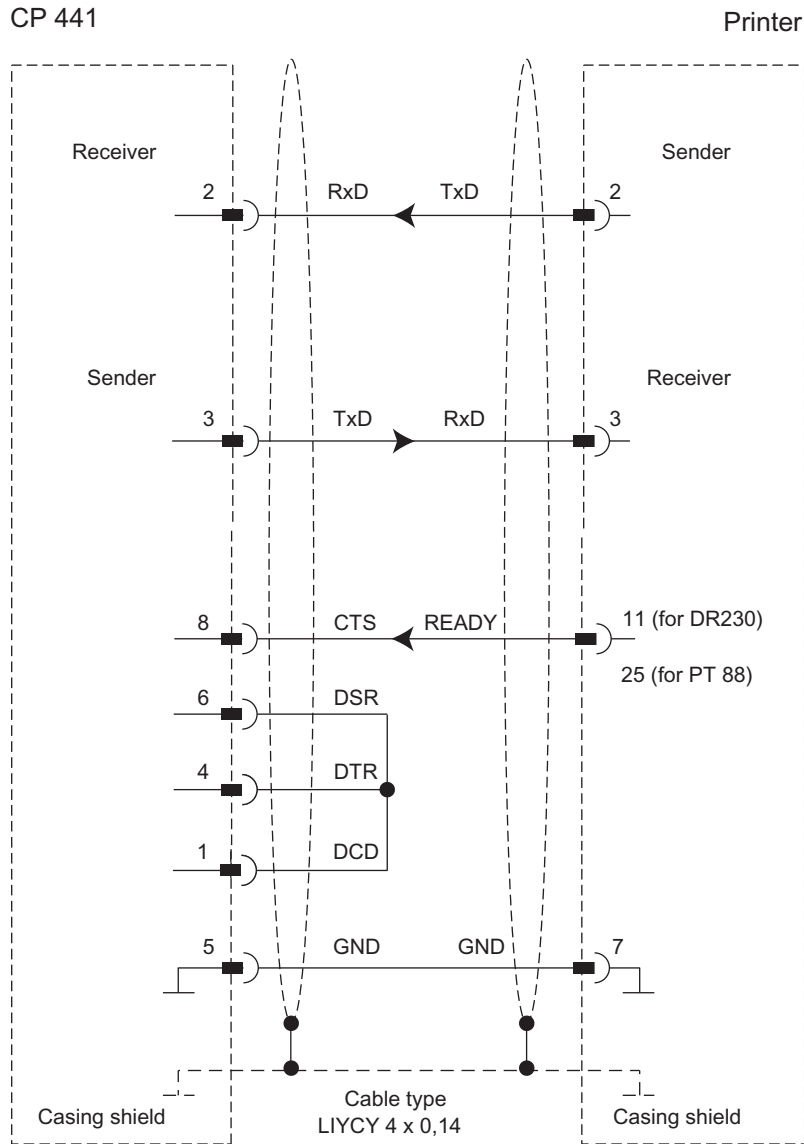

Figure B-5 RS232 cable CP 441 - IBM Proprinter

RS232 cable (S7 (CP 441) - laser printer)

The figure below illustrates the cable for a point-to-point link between a CP 441 and a laser printer with a serial interface (PT 10 or LaserJet Series II).

You require the following female/male connectors for the cable:

- At CP 441 end: 9-pin subminiature female
- With IBM Proprinter: 25-pin sub-D male connector

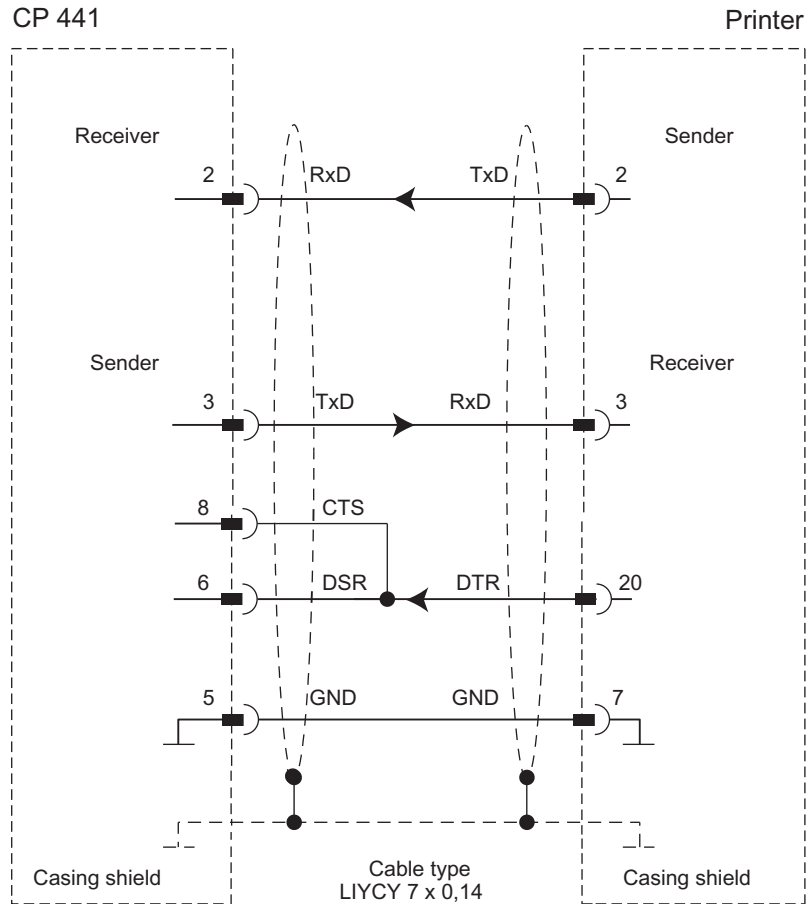

Figure B-6 RS232 cable CP 441 - laser printer

B.2 20mA TTY interface submodule

Pin assignment

The table belows shows the pin assignment for the 9-pin sub D female connector in the front panel of the 20mA TTY interface module.

Table B- 2 Pin assignment for the 9-Pole Sub D female connector on the 20mA TTY interface module

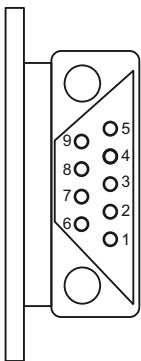
Female Connector on Module*	Pin	Designation	Input/Output	Meaning
	1	TxD -	Output	Transmitted data
	2	20mA -	Input	24 V ground
	3	20mA + (I ₁)	Output	20mA current generator 1
	4	20mA + (I ₂)	Output	20mA current generator 2
	5	RxD +	Input	Received data +
	6	-		
	7	-		
	8	RxD -	Output	Received data -
	9	TxD +	Input	Transmitted data +

* View from the front

Block Diagram

The figure below shows the block diagram for a 20 mA TTY interface IF963-TTY.

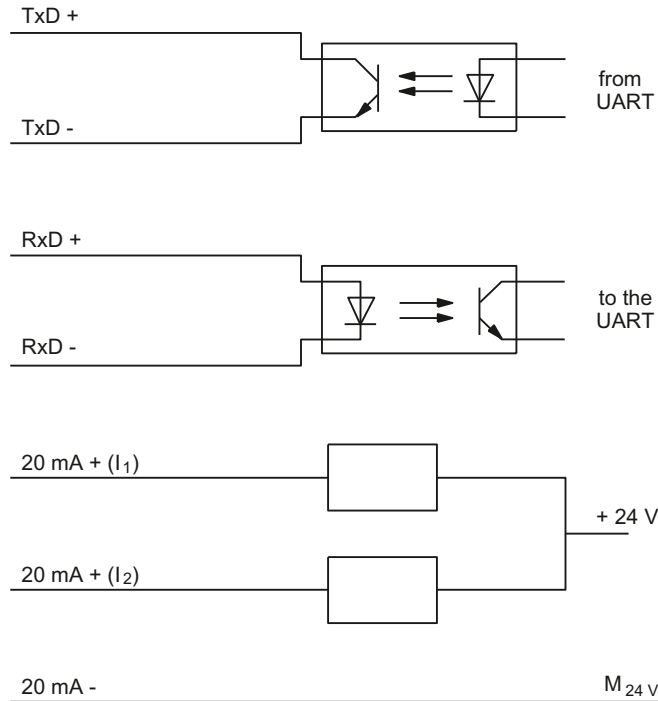

Figure B-7 Block Diagram for the 20mA TTY Interface

Cables

If you make your own cables you must remember that unconnected inputs at the communication partner may have to be connected to open-circuit potential.

Please note that you must only use shielded connector casings. A large surface area of both sides of the cable shield must be in contact with the connector casing.

<p>⚠ CAUTION</p> <p>Never connect the cable shield with the GND, as this could destroy the submodules.</p>

The following pages contain examples of cables for a point-to-point link between the CP 441 and S7 modules or SIMATIC S5.

20 mA-TTY connecting cable (S7 (CP 441) - S7 (CP 441/CP 340))

The figure below illustrates the cable for a point-to-point link between a CP 441 and a CP 441/CP 340.

You require the following male connectors for the cables:

- At CP 441 end: 9-pin sub D male connector with screw-locking
- At the communication partner: 9-pin subminiature D male with screw fixing

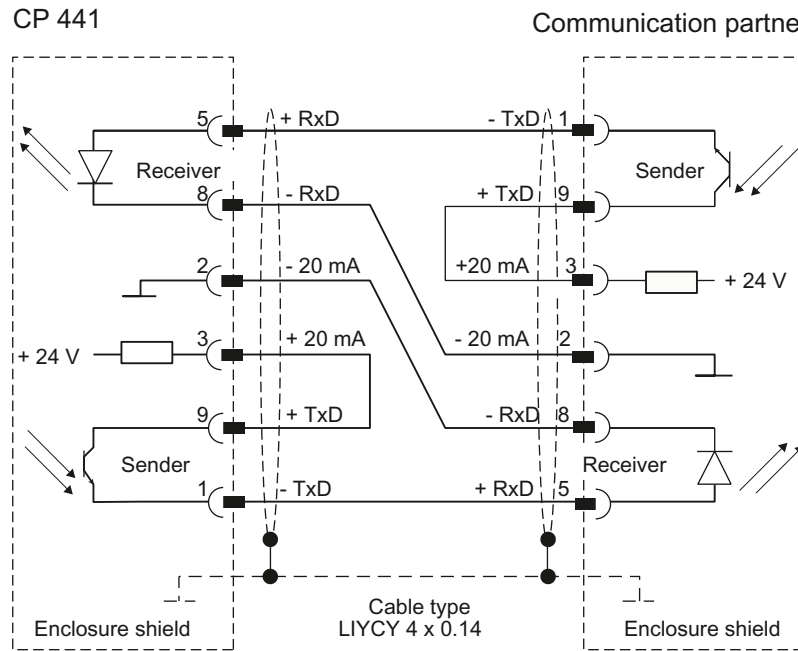

Figure B-8 20mA TTY Connecting Cable CP 441 - CP 441/CP 340

The cable is available under the order number (6ES7 902-2...).

Note

This cable type (LIYCY 4 x 0.14) can be used in the following lengths for the CP 441 as communication partner:

- Max. 1000 m at 9600 bps
- Max. 500 m at 19.2 kbps

20mA-TTY connecting cable (S7 (CP 441) - CP 544, CP 524, CPU 928B, CPU 945, CPU 948)

The figure below illustrates the cable for a point-to-point link between a CP 441 and a CP 544, CP 524, CPU 928B, CPU 945 or CPU 948.

You require the following male connectors for the cables:

- At CP 441 end: 9-pin sub D male connector with screw-locking
- At the communication partner: 25-pin subminiature D male with slide latch

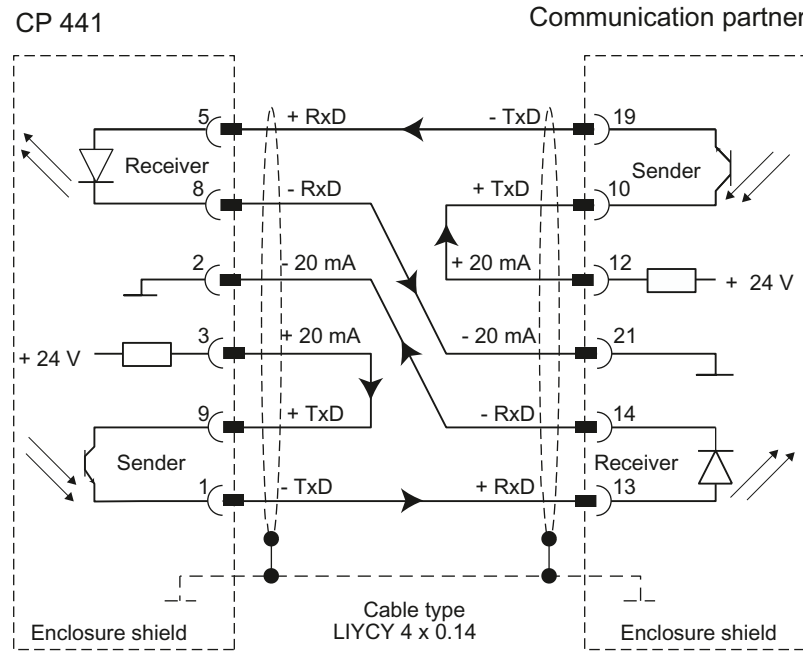

Figure B-9 20mA TTY Connecting Cable CP 441 - CP 544, CP 524, CPU 928B, CPU 945, CPU 948

20mA-TTY connecting cable (S7 (CP 441) - CP 523)

The figure below illustrates the cable for a point-to-point link between a CP 441 and a CP 523.

You require the following male connectors for the cables:

- At CP 441 end: 9-pin sub D male connector with screw-locking
- At the communication partner: 25-pin sub D male with screw fixing

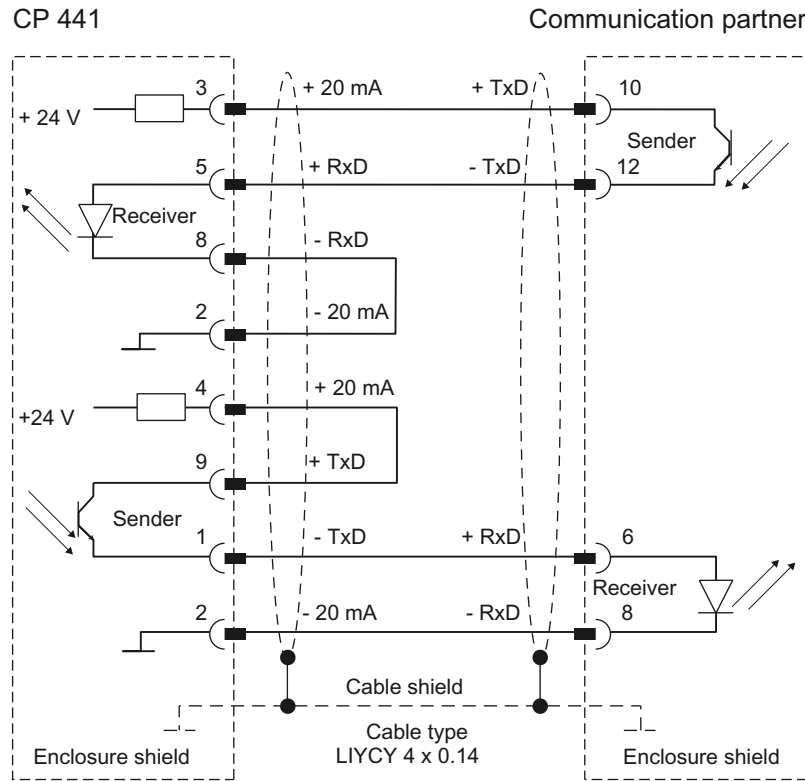

Figure B-10 20-mA-TTY cable CP 441 - CP 523

20mA-TTY connecting cable (S7 (CP 441) - CP 521 SI/CP 521 BASIC/ IBM-compatible printer)

The figure below illustrates the cable for a point-to-point link between a CP 441 and a CP 521 SI/CP 521 BASIC.

You require the following male connectors for the cables:

- At CP 441 end: 9-pin sub D male connector with screw-locking
- At the communication partner: 25-pin subminiature D male with screw interlock

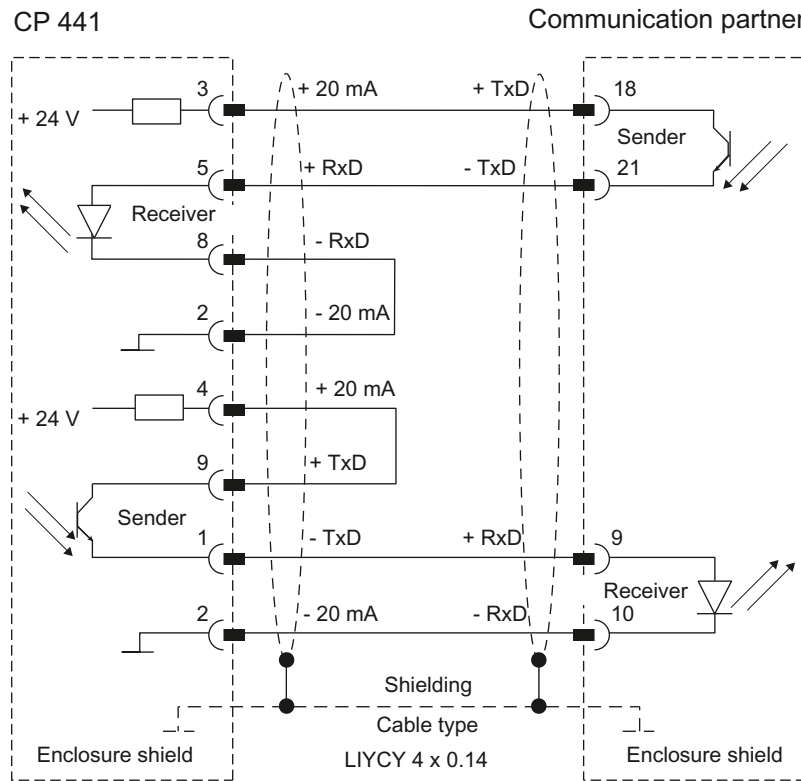

Figure B-11 20-mA-TTY cable CP 441 - CP 521SI/CP 521BASIC

20mA-TTY connecting cable (S7 (CP 441) - CPU 944/AG 95)

The figure below illustrates the cable for a point-to-point link between a CP 441 and a CPU 944/AG 95.

You require the following male connectors for the cables:

- At CP 441 end: 9-pin sub D male connector with screw-locking
- At the communication partner: 15-pin subminiature D male connector with slide latch

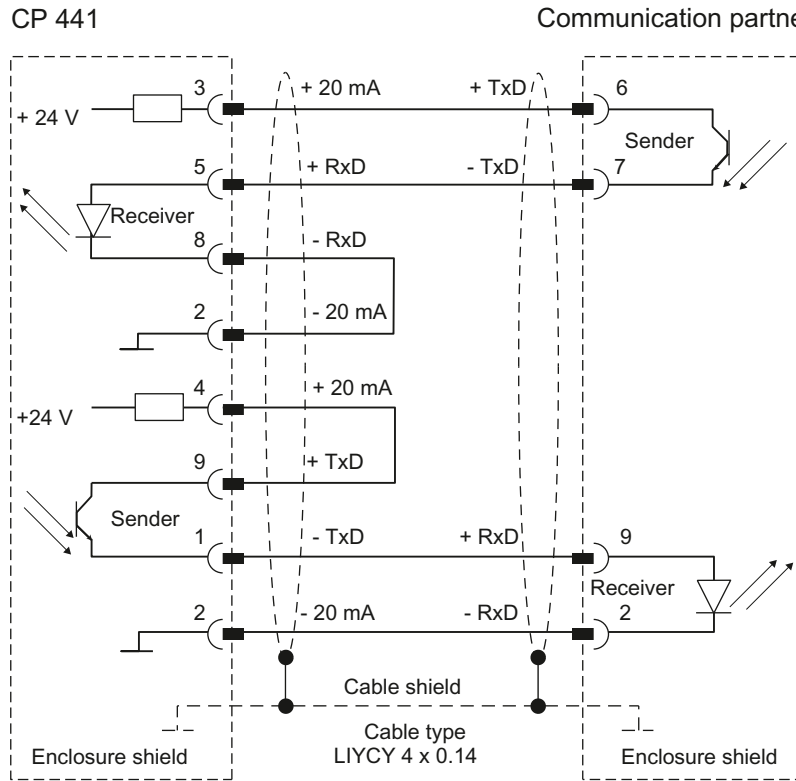

Figure B-12 20mA TTY Connecting Cable CP 441 - CPU 944/AG 95

B.3 X27 (RS422/485) interface module

Pin assignment

The table below shows the pin assignment for the 15-pin subminiature D female connector in the front panel of the X27 interface module.

Table B- 3 Pin assignment for the 15-pin subminiature D female connector of the X27 interface module

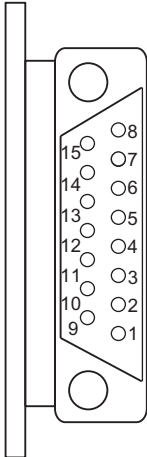
Female Connector on Module*	Pin	Designation	Input/Output	Meaning
	1	-	-	-
	2	T (A)-	Output	Transmitted data (four-wire operation)
	3	-	-	-
	4	R (A)/T (A)-	Input Input/Output	Received data (four-wire operation) Received/transmitted data (two-wire operation)
	5	-	-	-
	6	-	-	-
	7	-	-	-
	8	GND	-	Functional ground (isolated)
	9	T (B)+	Output	Transmitted data (four-wire operation)
	10	-	-	-
	11	R (B)/T (B)+	Input Input/Output	Received data (four-wire operation) Received/transmitted data (two-wire operation)
	12	-	-	-
	13	-	-	-
	14	-	-	-
	15	-	-	-

* View from the front

Cables

If you make your own cables you must remember that unconnected inputs at the communication partner may have to be connected to open-circuit potential.

Please note that you should only use shielded connector casings. A large surface area of both sides of the cable shield must be in contact with the connector casing.

CAUTION

Never connect the cable shield with the GND, as this could destroy the submodules. GND must always be connected on both sides (pin 8), otherwise the submodules could again be destroyed.

The following pages contain examples of cables for a point-to-point link between the CP 441 and S7 modules or SIMATIC S5.

X 27 connecting cables (S7 (CP 441) - CP 441/CP 340)

The figure below illustrates the cable for a point-to-point link between a CP 441 and a CP 441/CP 340 for RS422 operation.

You require the following male connectors for the cables:

- At CP 441 end: 15-pin sub D male connector with screw-locking
- At the communication partner: 15-pin sub D male connector with screw-locking

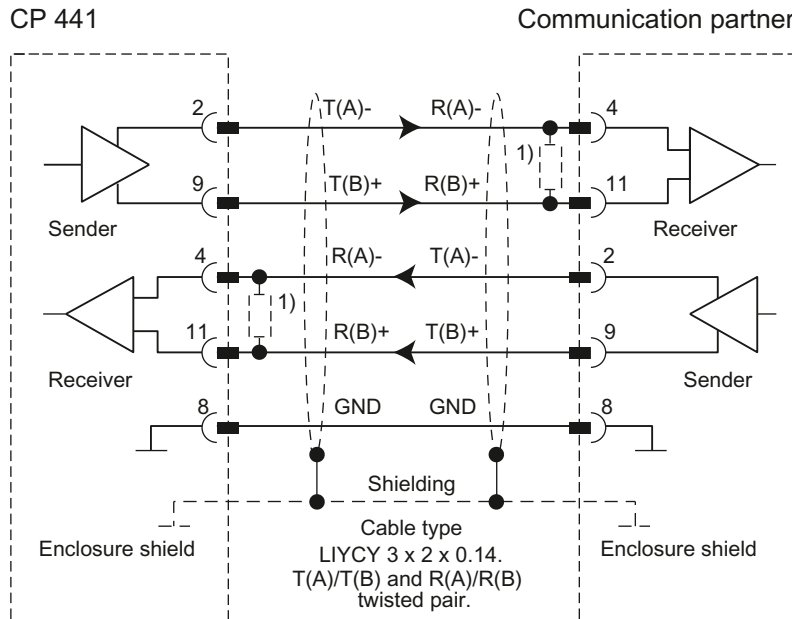

1) To ensure interference-free data exchange with line lengths > 50 m you must solder in a terminating resistance of approx. 330 Ω on the receiver side.

Figure B-13 X27 cable CP 441 - CP 441/CP 340 for RS422 operation (four-wire mode)

The cable is available under the order number (6ES7 902-3...).

Note

This cable type can be used in the following lengths for the CP 441 as communication partner:

- Max. 1200 m at 19 200 bps
- Max. 500 m at 38 400 bps
- Max. 250 m at 76 800 bps
- Max. 200 m at 115 200 bps

X 27 connecting cables (S7 (CP 441) - CP 441/CP 340)

The figure below illustrates the cable for a point-to-point link between a CP 441 and a CP 441/CP 340 for RS485 operation.

You require the following male connectors for the cables:

- At CP 441 end: 15-pin sub D male connector with screw-locking
- At the communication partner: 15-pin sub D male connector with screw-locking

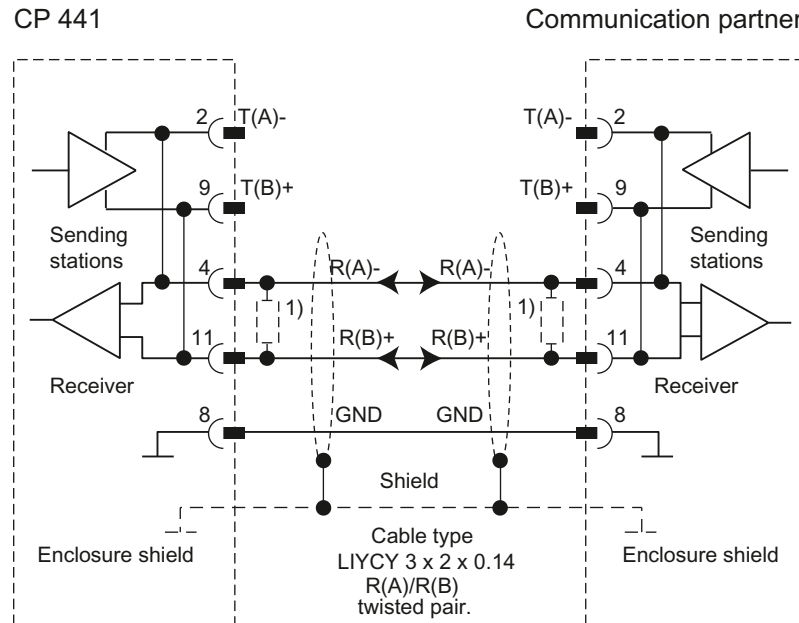

- 1) For cable lengths of more than 50 m you have to solder in a terminating resistor of ca. 330 Ω on the receiving end for trouble-free data traffic.

Figure B-14 X27 cable CP 441 - CP 340/CP 441 for RS485 operation (two-wire mode)

Note

The previous figure shows the wiring if you want to make the connecting cable yourself. In both RS485 mode (two wire) and RS422 mode (four wire), you can also use Siemens cables. The figure below illustrates the internal wiring in the connecting cable.

The jumpers 2-4 and 9-11 are "installed" by parameter assignment of the CP.

Connecting cable X 27 (S7 (CP 441) - CP 544, CP 524, CPU 928B, CPU 945, CPU 948)

The figure below illustrates the cable for a point-to-point link between a CP 441 and a CP 544, CP 524, CPU 928B, CPU 945, CPU 948 for RS422 operation.

You require the following male connectors for the cables:

- At CP 441 end: 15-pin subminiature D male with screw interlock
- At the communication partner: 15-pin subminiature D male connector with slide latch

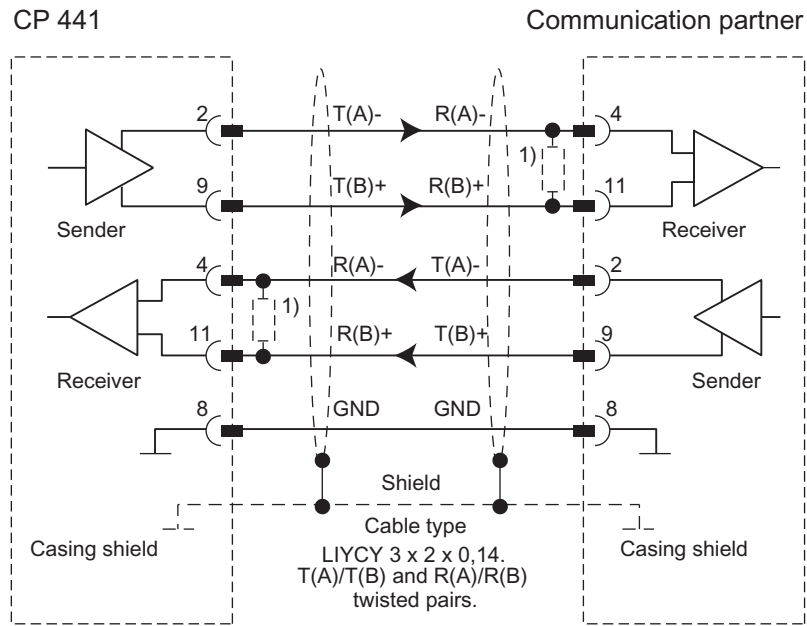

1) In the case of cables longer than 50 m you must solder in a terminating resistor of 330 Ω on the recipient side.

Figure B-15 X27 cable CP 441 - CP 544, CP 524, CPU 928B, CPU 945, CPU 948 for RS422 operation (four-wire mode)

SFB Parameters

Error Messages

Each system function block has a STATUS parameter for error diagnostics. The STATUS message numbers always have the same meaning, irrespective of which system function block is used.

The possible STATUS message numbers are described in section Diagnostics Messages of the System Function Blocks (Page 190).

SFB Parameters

The following tables provides a brief description of the parameters of the system function blocks.

Table C- 1 SFB Parameters

BSEND system function block (SFB 12)			
Parameters	Type	Type	Meaning
REQ	VAR_INPUT	BOOL	Activates a transfer at rising edge
R	VAR_INPUT	BOOL	Activates resetting of BSEND to initial state with rising edge
ID	VAR_INPUT	WORD	Unique communication connection to a communication partner
R_ID	VAR_INPUT	DWORD	Unique block relationship in a communication connection
SD_1	VAR_IN_OUT	ANY	Data to be sent
LEN	VAR_IN_OUT	WORD	Length of data block to be transmitted
DONE	VAR_OUTPUT	BOOL	Signals successful completion of BSEND request with rising edge
ERROR	VAR_OUTPUT	BOOL	Rising edge indicates error
STATUS	VAR_OUTPUT	WORD	Contains detailed error message or warning

BRCV System Function Block (SFB 13)			
Parameter	Type	Type	Meaning
EN_R	VAR_INPUT	BOOL	Rising edge signals that remote communication partner is ready to receive
ID	VAR_INPUT	WORD	Unique communication connection to a communication partner
R_ID	VAR_INPUT	DWORD	Unique block relationship in a communication connection
RD_1	VAR_IN_OUT	ANY	Data to be received
LEN	VAR_IN_OUT	WORD	Length of data block to be transmitted
NDR	VAR_OUTPUT	BOOL	Rising edge indicates that new receive data is available to the user program
ERROR	VAR_OUTPUT	BOOL	Rising edge indicates error
STATUS	VAR_OUTPUT	WORD	Contains detailed error message or warning

GET System Function Block (SFB 14)			
Parameter	Type	Type	Meaning
REQ	VAR_INPUT	BOOL	Activates a transfer at rising edge
ID	VAR_INPUT	WORD	Unique communication connection to a communication partner
ADDR_1 ... ADDR_4	VAR_IN_OUT	ANY	Pointer to the data areas in the partner CPU to be fetched
RD_1 ... RD_4	VAR_IN_OUT	ANY	Pointer to the data areas of the local CPU in which the fetched data is placed.
NDR	VAR_OUTPUT	BOOL	Rising edge indicates that new receive data is available to the user program
ERROR	VAR_OUTPUT	BOOL	Rising edge indicates error
STATUS	VAR_OUTPUT	WORD	Contains detailed error message or warning

PUT System Function Block (SFB 15)			
Parameter	Type	Type	Meaning
REQ	VAR_INPUT	BOOL	Activates a transfer at rising edge
ID	VAR_INPUT	WORD	Unique communication connection to a communication partner
ADDR_1 ... ADDR_4	VAR_IN_OUT	ANY	Pointer to the data areas in the partner CPU into which data will be written.
SD_1 ... SD_4	VAR_IN_OUT	ANY	Pointer to the data areas of the local CPU which contain the data to be sent.
DONE	VAR_OUTPUT	BOOL	Signals successful completion of PUT request with rising edge
ERROR	VAR_OUTPUT	BOOL	Rising edge indicates error
STATUS	VAR_OUTPUT	WORD	Contains detailed error message or warning

PRINT System Function Block (SFB 16)			
Parameter	Type	Type	Meaning
REQ	VAR_INPUT	BOOL	Activates a transfer at rising edge
ID	VAR_INPUT	WORD	Unique communication connection to a communication partner
PRN_NR	VAR_IN_OUT	BYTE	Selects a specific printer when several are connected
FORMAT	VAR_IN_OUT	STRING	Format string for the message text, including the conversion and control statements for variables SD_1 to SD_4
SD_1 ... SD_4	VAR_IN_OUT	ANY	Variables in the message text in order, for example, to display computed values of the user program or dates and times
DONE	VAR_OUTPUT	BOOL	Indicates at a rising edge the error-free completion of the PRINT request
ERROR	VAR_OUTPUT	BOOL	Rising edge indicates error
STATUS	VAR_OUTPUT	WORD	Contains detailed error message or warning

STATUS System Function Block (SFB 22)			
Parameter	Type	Type	Meaning
REQ	VAR_INPUT	BOOL	Activates a transfer at rising edge
ID	VAR_INPUT	WORD	Unique communication connection to a communication partner
PHYS	VAR_IN_OUT	ANY	Logical device status
NDR	VAR_OUTPUT	BOOL	Rising edge indicates that new receive data is available to the user program
ERROR	VAR_OUTPUT	BOOL	Rising edge indicates error
STATUS	VAR_OUTPUT	WORD	Contains detailed error message or warning

Further Information

For detailed information on system function blocks, refer to the *System Software for S7300/400, System and Standard Functions* Reference Manual, or directly to the STEP 7 (TIA Portal) Online Help.

Accessories and Order Numbers

Order Numbers

Table D- 1 The following is an overview of the accessories for the CP 441 (6ES7 441-xAA04-0AE0):

Product	Order Number
CP 441-1	6ES7 441-1AA04-0AE0
CP 441-2	6ES7 441-2AA04-0AE0
Interface module: <ul style="list-style-type: none"> • RS232 module • 20mA TTY module • X27 (RS422/485) module 	<ul style="list-style-type: none"> • 6ES7 963-1AA00-0AA0 • 6ES7 963-2AA00-0AA0 • 6ES7 963-3AA00-0AA0

Table D- 2 The following is an overview of the accessories for the CP 441 (6ES7 441-xAA05-0AE0):

Product	Order Number
CP 441-1	6ES7 441-1AA05-0AE0
CP 441-2	6ES7 441-2AA05-0AE0
Interface module: <ul style="list-style-type: none"> • RS232 module • 20mA TTY module • X27 (RS422/485) module 	<ul style="list-style-type: none"> • 6ES7 963-1AA10-0AA0 • 6ES7 963-2AA10-0AA0 • 6ES7 963-3AA10-0AA0

Table D- 3 The following is an overview of the accessories for the CP 441:

Product	Order Number
Cable (CP 441 - CP 441/CP 340),	
RS232: <ul style="list-style-type: none"> • RS232, 5 m • RS232, 10 m • RS232, 15 m 	<ul style="list-style-type: none"> • 6ES7 902-1AB00-0AA0 • 6ES7 902-1AC00-0AA0 • 6ES7 902-1AD00-0AA0
20mA TTY: <ul style="list-style-type: none"> • 20mA TTY, 5 m • 20mA TTY, 10 m • 20mA TTY, 50 m 	<ul style="list-style-type: none"> • 6ES7 902-2AB00-0AA0 • 6ES7 902-2AC00-0AA0 • 6ES7 902-2AG00-0AA0
X27 (RS422): <ul style="list-style-type: none"> • X27 (RS422), 5 m • X27 (RS422), 10 m • X27 (RS422), 50 m 	<ul style="list-style-type: none"> • 6ES7 902-3AB00-0AA0 • 6ES7 902-3AC00-0AA0 • 6ES7 902-3AG00-0AA0

Literature on SIMATIC S7

Introduction

On the following pages, you will find a comprehensive overview of:

- Manuals that you require for configuring and programming the S7-400,
- Technical overviews which provide you with an overview of the SIMATIC S7 or **STEP 7** and
- Technical overviews with which you can find out about the S7-400.

Manuals for Configuring and Commissioning

An extensive user documentation is available to assist you in configuring and programming the S7-400. You can select and use this documentation as required. The table also provides you with an overview of the documentation to **STEP 7**.

Table E- 1 Manuals for Configuring and Programming the S7-400

Title	Contents
Manual Programming with STEP 7 http://support.automation.siemens.com/W/view/en/18652056	The programming manual offers basic information on the design of the operating system and a user program of an S7 CPU. For novice users of an S7-300/400 it provides an overview of the programming principles on which the design of user programs is based.
Manual Configuring Hardware and Communication Connections with STEP 7 http://support.automation.siemens.com/W/view/en/18652631	The STEP 7 user manual explains the principles for using the STEP 7 automation software and its functions. Novice users of STEP 7 as well as experienced users of STEP 5 are provided with an overview of the configuring, programming and start-up procedures for an S7-300/400. When working with the software, an on-line help assists you if you require detailed information on the software.
Reference Manual System and Standard Functions for S7-300/400 http://support.automation.siemens.com/W/view/en/1214574	The S7 CPU's offer systems and standard functions which are integrated in the operating system. You can use these functions when writing programs in one of the languages, that is STL, LAD and SCL. The manual provides an overview of the functions available with S7 and, for reference purposes, detailed interface descriptions which you require in your user program.

Note

STEP 7 (TIA Portal)

All necessary information is also available in the STEP 7 (TIA Portal) information system.

Glossary

Address

The address indicates the physical storage space and enables direct access to the operand that is stored under this address.

Block

Blocks are parts of the user program that are separated by their function, structure or purpose. STEP 7 has the following blocks:

- Code blocks (FB, FC, OB SFB, SFC)
- Data blocks (DB, SDB) and
- user-defined data types (UDT)

Block call

A block call is the branching of the program processing into the called block.

Block parameter

Block parameters are place holders within multiple use blocks, which are supplied with updated values during the calling up of the corresponding block.

Communication processor

Communication processors are modules for point-to-point connections and bus connections.

Configuring

Configuring refers to the configuration of separate modules of a programmable controller.

Connection configuration

A connection configuration refers to the specification of a connection_ID in the system function block. By means of the connection_ID, the system function blocks can communicate between two communication terminals.

CP 441 programming interface: Configuration Package for Point to Point Communication

Using the **CP 441: Configuration Package for Point to Point Communication** assign parameters to the interface modules of the communication processor and configure the message texts for the printer output.

CPU

Central Processing Unit = Central module of the S7 Programmable Controller with control and computing unit, memory, system program and interfaces to the I/O modules.

Cycle time

The cycle time is the time that the CPU requires to process the user program once.

Cyclic program processing

In cyclic program processing the user program runs in program loop, or cycle, that is constantly repeated.

Data block (DB)

Data blocks are blocks that contain data and parameters with which the user program works. Unlike all other blocks, they do not contain any instructions. There are global data blocks and instance data blocks. The data contained in the data blocks can be accessed absolutely or symbolically. Complex data can be stored in structured form.

Data type

With the help of the data types you can specify how the value of a variable or constant in the user program is to be used. The data types are divided into elementary and structured data types.

Default setting

The default setting is a reasonable basic setting that can be used whenever no other value is specified.

Diagnostic buffer

Each CPU has its own diagnostic buffer, in which detailed information on all the diagnostic events are entered in the sequence in which they occur.

Diagnostic events

Diagnostic events are such as module errors, system errors in the CPU which may be caused by a program error or transitions from one operating mode to another.

Diagnostic functions

The diagnostic functions cover the entire system diagnostics and include the recognition, interpretation and reporting of errors within the Programmable Controller.

Downloading from the programming device

Downloading of load objects (e.g. code blocks) from the programming device into the load memory of the central processing unit (CPU).

Downloading to the programming device

Uploading of load objects (e.g. code blocks) from the load memory of the central processing unit into the programming device.

Function blocks (FBs)

Function blocks are components of the user program and are, according to IEC standard, "blocks with memory". The memory for the function blocks is an allocated data block, the "instance data block". Function blocks can be parametered, i.e. you can use them with and without parameters.

Hardware

Hardware is the entire physical and technical equipment of a programmable controller.

Instance data block

The instance data block is a block allocated to a function block, which contains data for this special function block.

Interface module

Signals are converted physically on the interface module. By selecting different plug-in interface modules, you can adjust the communication processor to suit the properties of the communication partners.

Interrupt

Interrupt is a term that designates the interruption of the processing of a program in the processor of a programmable controller by an external alarm.

Module

Modules are pluggable PCBs for programmable controllers.

Module parameters

Module parameters are values with which the behavior of the module can be set. There are two different types of module parameters: static and dynamic.

Online Help

STEP 7 provides you with the option of having context-dependant help texts displayed on the screen while you are working with the programming software.

Online/Offline

When you are online there is a data connection between the programmable controller and programming device, when you are offline there is no data connection between them.

Operand

An operand is part of a STEP-7 instruction and states with which unit the process should execute something. It can be addressed both absolutely and symbolically.

Operating mode

The SIMATIC S7 programmable controllers have three different operating modes: STOP, START-UP and RUN. The functionality of the CPU is different in the various operating modes.

Operating system of the CPU

The operating system of the CPU organizes all the functions and process of the CPU that are not connected to a special control task.

Parameter assignment

Parameter assignment refers to the setting of a module's behavior.

Parameters

Parameters are values that can be allocated. There are two different types of parameters: block parameters and module parameters.

Point-to-point link

In point-to-point link the communication processor forms the interface between a programmable controller and a communication partner.

Procedure

Procedure refers to the process of a data transmission according to a specific protocol.

Process image

The process image is a special memory area in the programmable controller. At the start of the cyclic program the signal states of the input modules are transmitted to the process image of the inputs. At the end of the cyclic program the process image of the outputs is transmitted as signal state to the output modules.

Programmable controller

A programmable controller is a stored-program control consisting of at least one CPU, various input and output modules, and operating and monitoring devices.

Protocol

All communication partners involved in data transmission must follow fixed rules for handling and implementing the data traffic. Such rules are called protocols.

Rack

The rack is the module rail containing the slots for the modules.

Software

Software refers to the entirety of all programs that are used on a computing system. The operating system and user programs belong to this.

START-UP

The START-UP operating mode forms the transition from STOP mode to RUN mode.

STEP 7

STEP 7 is the programming software of SIMATIC S7.

System blocks

System blocks are different from other block in that they are already integrated into the S7-400 system and are available for already defined system functions. There are system data blocks, system functions and system function blocks.

System function blocks (SFBs)

System functions blocks are blocks without memory that are already integrated into the operating system of the CPU and can be called up by the user whenever necessary.

System functions (SFCs)

System functions are blocks without memory that are already integrated into the operating system of the CPU and can be called up by the user whenever necessary.

TIA Portal

STEP 7 (TIA Portal) is the new engineering software for programming S7 controllers.

STEP 7 (TIA Portal) is based on the new central Totally Integrated Automation Portal (TIA Portal) engineering framework which offers users a consistent, efficient and intuitive solution for all automation tasks.

Tool

A tool is a software utility that can access the functions of the operating system in the programming device or PC.

User program

The user program contains all instructions and declarations for processing the signals used for controlling a system or a process. In SIMATIC S7 the user program is structured and divided into small units, the blocks.

Variable

A variable is an operand (e.g. I 1.0) which can have a symbolic name and therefore also be addressed symbolically.

Working memory

The working memory is a RAM storage unit in the CPU which the processor draws on when running the user program.

Index

3

- 3964(R) procedure, 32
 - Block check character, 34
 - Control characters, 33
 - handling erroneous data, 43
 - initialization conflict, 44
 - Priority, 33
 - Procedure errors, 45
 - Receiving data, 39
 - Sending Data, 35

A

- Acknowledgment delay time (ADT), 76
- ASCII driver, 58
 - Parameter, 80
 - Receive buffer, 67
 - Receiving data, 61
 - RS232 accompanying signals, 68, 72
 - Sending data, 58

B

- Base Connector for S7 Rear Panel Bus, 17
- Block check character, 34
- BUSY Signal, 90

C

- Character delay time, 26
- Character delay time (CDT), 76, 81
- Character frame, 25, 77, 82, 87
- Character set
 - in message texts, 72, 93
- Cold restart of the CPU, 186
- Command frame, 46
- Communication, 139
 - Data Transmission with 3964(R) Using BSEND and a Receive Mailbox, 149
 - data transmission with 3964(R) using BSEND and BRCV, 146
 - Fetching data with RK512 from a communication partner, 171

- Sending data to an S5 communication partner or third-party device with RK512, 161
- Sending data with RK512, use of BSEND and BRCV, 153
- Sending data with RK512, using BSEND, 157
- Connection attempts, 76
- Connection Configuration, 122
 - Simplified, 122
- Continuation frame, 46
- Continuation GET frame, 54
- Continuation SEND frames, 51
- Continuation SEND/PUT frame, 51, 209
- Control and display elements, 16
- Control characters, 33
 - in message texts, 72, 93, 104
- Control statements
 - in message texts, 104
- Conversion statements
 - in message texts, 98
 - Representation types, 99
- CPU RUN, 186
- CPU stop, 115
- CPU-STOP, 186

D

- Data bits, 77, 82, 88
- Data flow control, 83, 90
- Data transmission rate, 77, 82, 87
- Diagnostic messages, 190
- Diagnostics, 187
 - Diagnostic buffer, 195, 211
 - Error Numbers in the Response Frame, 209
 - Error-signaling area SYSTAT, 195
- Diagnostics functions, 187
 - Display elements, 189
 - Messages in the STATUS Output of the SFBs, 190
- Diagnostics interrupt, 213
- Display elements (LED), 16
- Display elements (LEDs), 187

E

- End criterion, 62
- End delimiter, 63
- Expiration of the character delay time, 62
- Fixed frame length, 65

End delimiter, 82
Error message area, SYSTAT, 187

F

Fetching data
 RK512, 52
Firmware updates
 Subsequent downloading, 133
Format string, 94, 97
Frame header
 Format of a RK512 command frame, 47
Full-duplex operation, 24
Function blocks
 Diagnostic messages, 190
Functions
 FC 5 V24_STAT, 177
 FC 6 V24_SET, 180

G

GET frame, 46

H

Half-duplex operation, 24
Handshaking, 90

I

Indicator for end of receive frame, 81
Initial state of receive line, 78, 85, 88
Initialization, 185
initialization conflict, 44
Installation guidelines, 21
Installing the interface modules, 111
Interface
 RS232, 18
 X27 (RS422/485), 20
Interface modules, 14
 20mA TTY, 19
 Applications, 13
Interface submodules
 20 mA TTY, 240
 RS232, 233
 X27 (RS422/485), 247
ISO 7-Layer Reference Model, 28

L

LEDs, 17
Loadable drivers, 120, 133

M

Message frame length when received, 82
Message texts, 72
 Character conversion table, 72
 Control characters, 72
 Control characters table, 72
 Control statements, 104
 Conversion statements for variables, 98
 Format string, 94
 Page layout, 72, 92
 variables, 97
Message texts "outputting",
Mounting the CP 441, 110
Multiprocessor communication, 118

O

Operating mode transitions, 186

P

Page layout
 in message texts, 72, 92
Page number, setting, 101
Parameter assignment, 115, 120
Parameter assignment data
 ASCII driver, 80
 Printer driver, 87
 RK512, 80
Parameter assignment interface, 15
Parity, 77, 83, 88
Printer driver
 BUSY Signal, 90
 Data flow control, 90
 Message Text Output, 72
 Message texts, 72, 97
 Parameter, 87
Priority, 77
Procedure, 27
Programming device (PG), 14
Programming device cable, 14
Protocol, 75
 integrated in module, 12, 25
Protocol parameters, 76, 81
PUT frame, 46

R

- Receive buffer, 67, 78, 84
- Receiving data
 - 3964(R) procedure, 39
 - ASCII driver, 61
- Removing the CP 441, 110
- Removing the interface modules, 111
- Response frame, 46, 48
 - error numbers, 187, 188, 209
 - Structure and contents, 48
- Restart of the CPU, 186
- RK512 computer link, 46
 - Command frame, 46, 47
 - Fetching data, 52
 - Parameter, 80
 - Response frame, 46, 48
 - Sending data, 49
- RS232 accompanying signals, 68
 - Automatic use, 69
 - Controlling, 176, 179
 - Reading, 176

S

- Scope of the manual, 3
- SEND frame, 46
- SEND/PUT frame, 46, 47, 50, 51
- Sending data
 - ASCII driver, 58
 - RK512, 49
- Sending Data
 - 3964(R) procedure, 35
 - ASCII driver, 72
- SFB Parameters, 251
- Slot for Interface Modules, 17
- Slots, 109
- Standard cable, 14
- Start bit, 77, 82, 88
- Start-up behavior, 185
- STATUS output of the SFBs, 187
- Steps, 107
- Stop bits, 77, 83, 88
- System function block
 - 3964(R) procedure, 144
 - for printer driver, 181
- system function blocks
 - 3964(R) procedure, in the case of, 146
- System function blocks, 138
 - Application, 139
 - Parameters, 251
 - with ASCII driver, 175

T

- Transmission attempts, 76
- Transmission integrity, 29
 - for printer driver, 30
 - with 3964R, 30
 - with ASCII driver, 30
 - With RK512, 31

U

- Unidirectional/bidirectional data traffic, 23, 68

