

WINEGARD® TRAV'LER®



SK-73UP MPEG-4 Upgrade Instructions

for TRAV'LER® Shaw Direct Antenna
Model SK-7003

Manuel disponible en français au www.winegard.com/travler-shaw

For Technical Services, email help@winegard.com or call 1-800-788-4417

Product Registration:

Please register your Winegard product by completing the online registration form at <http://www.winegard.com/registration>.



2452441

2452441
Rev1 8-19

Intro

The SK-73UP is compatible with any Shaw Trav'ler manufactured prior to August 23, 2017. However, if you have a Winegard SK-7002 you need to contact Shaw (888-472-2222) to upgrade your LNB to the required triple xKU LNB before completing this upgrade process.

Included Parts

Recommended tools needed:

1/2" Wrench
7/16" Wrench
3/16" Allen wrench
Adjustable wrench
Wire cutter

Included in Hardware Bag:
5/16" Nut driver
4 Modified mounting screws
2 Zip ties



IDU



1. IDU Reset

A) Power on IDU by pressing and holding the Power button for 3 seconds, then press and hold ENTER to enter the user menu.

B) Once "Enter User Menu" appears, press SELECT to move the asterisk to "Yes" and press enter.



C) Press SELECT twice until "Installation" is on the top line with an asterisk and press ENTER.

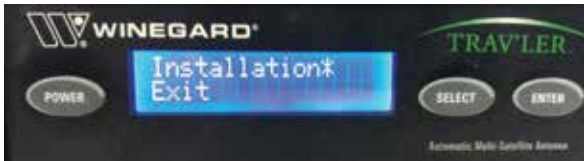

D) You will be prompted to enter the password. Press ENTER four times.



E) Press SELECT once until "Raise Antenna" is on the top line with an asterisk and press ENTER.



F) Press SELECT to move the asterisk to "Yes" and press ENTER.



G) Once the antenna has raised, you will receive a "Raise Antenna - Raised" message. Press ENTER and repeat the "Raise Antenna" process until you receive the "Raise Antenna - Motor Stalled" message.

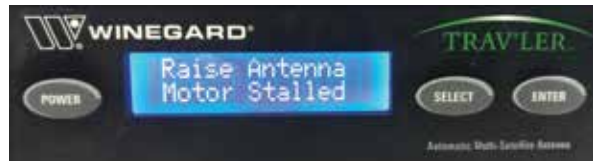

(H) Power off IDU by pressing and holding POWER and SELECT simultaneously. If done correctly you will receive a "Powering Off Thank You" message.



I) Please unplug the 6-wire data cable by pressing down the locking tab and gently pulling the cable out of the "DC OUT/ ANT. COMM.".

Now remove the DC power cord from the "DC IN" terminal.

2. Reflector Removal

Once the IDU has been powered off and the data cable and power cord have been disconnected you will need to get on top of the coach. The tools needed are a 1/2" and 7/16" wrench, 3/16" Allen wrench, adjustable wrench, and the provided 5/16" nut driver.

NOTE: Images shown are for reference only, your unit should be resting on the hardstop – Notice the **"PINCH POINT!"** label.

- A) To remove the reflector you start with removing the 1/2" nuts from the back of the reflector (Figure 1) using a 1/2" wrench. You may also need to use the 3/16" Allen wrench on the front of the reflector to assist you with the removal. Once the two longer screws have been removed you can now remove the wedge shaped clamps.
- B) Proceed to removing the lower 1/2" screws on the reflector bracket. Once removed, you can remove the coax cables with a 7/16" wrench (Figure 2) and the P-Clip (Figure 3) with the provided 5/16" nut driver.



Figure 1



Figure 2



Figure 3

3. Disconnecting Cables

A) Remove the four 5/16" screws from the cable cover, and remove the cable cover (Figure 4).

B) Loosen the exterior nut for the 30' power/control cable (Figure 5).

NOTE: You may need to use the adjustable wrench to loosen the exterior nut.

C) Depending on the tightness of the GPS cable you may need to disconnect the GPS cable as well. To do so you need to gently pull to disconnect the GPS cable and then loosen the exterior GPS nut.

D) Unclip the power coupler from the internal power cable, and unthread and remove the power/control cable retaining nut located inside the turret (Figure 6).

WARNING: Be careful not to lose the retaining nut inside the turret.

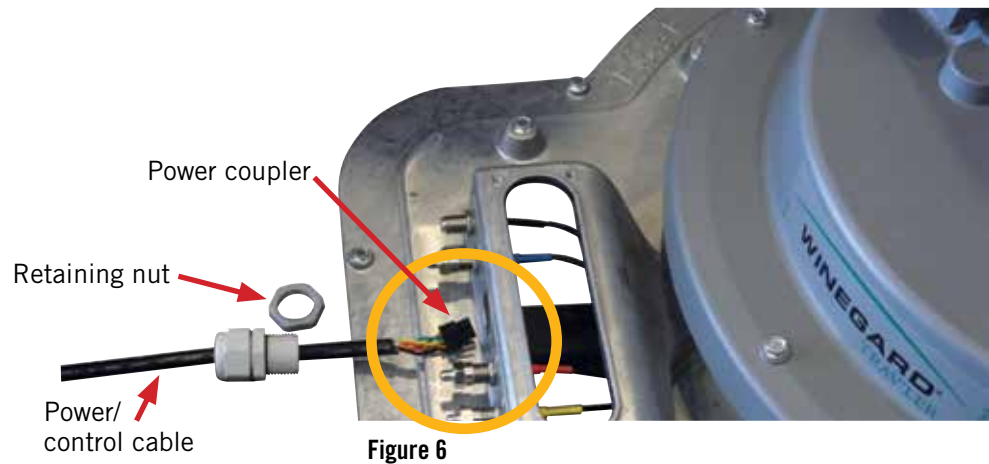
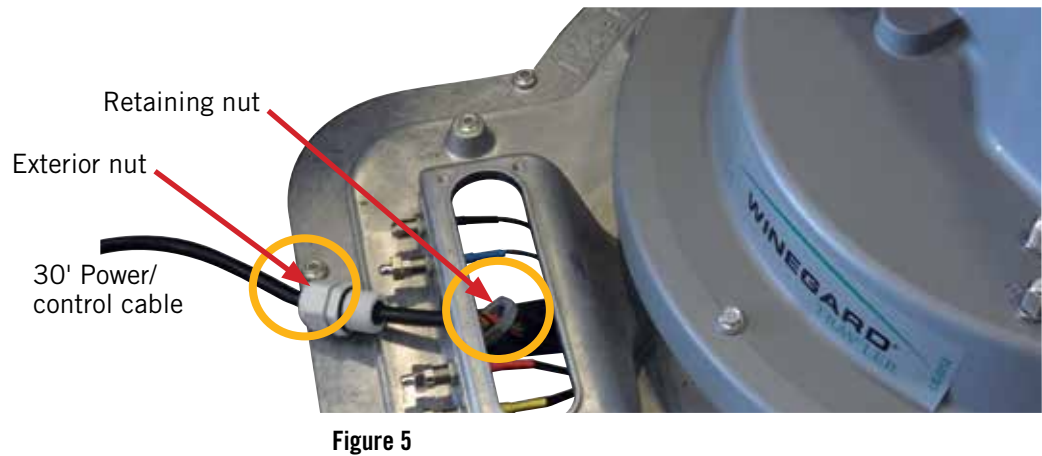
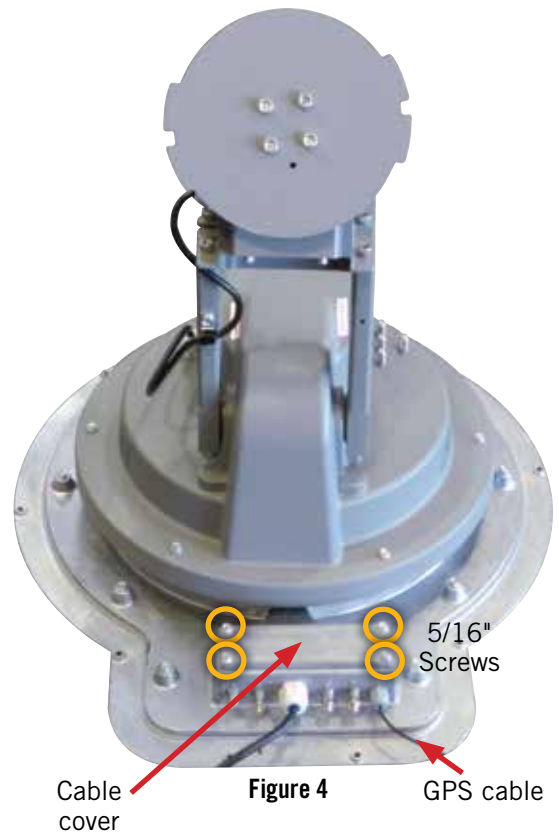

4. Motor Mount Removal

- A) Remove the nine 5/16" screws around the edge of the transition plate (Figure 7). Once removed, flip over the turret top and remove the plastic base seal and gasket, giving you access to the electronics.

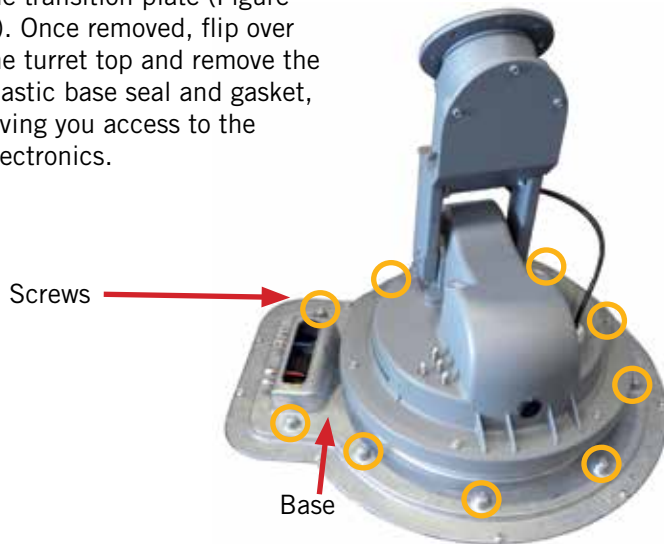
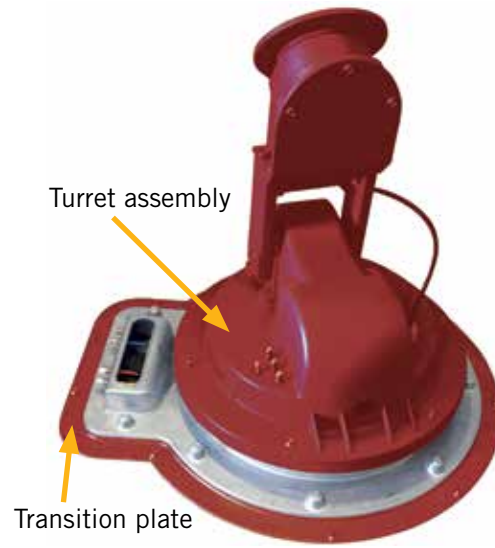

Figure 7

WARNING: DO NOT remove the screws around the edge of the transition plate or the screws on the top side of the turret assembly; these areas are marked in red on the image below.



- B) Remove four 5/16" screws from the ODU with the provided 5/16" nut driver (Figure 8).

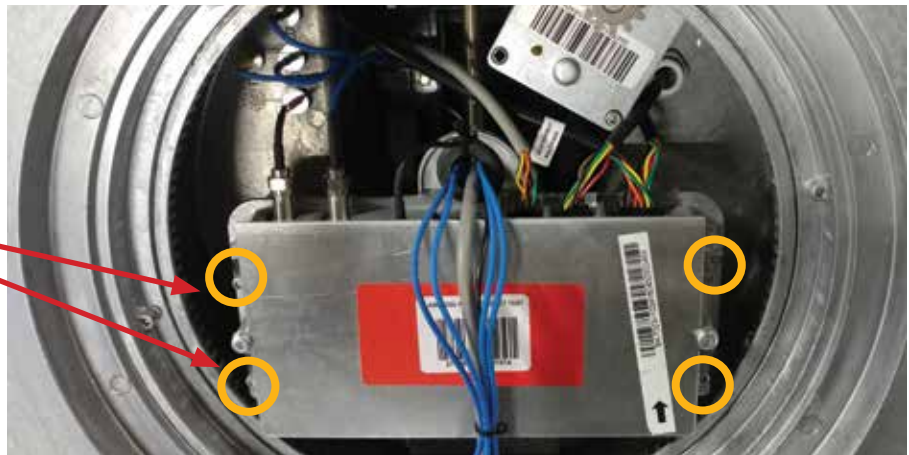

Figure 8

- C) Remove two coax cables with the 7/16" wrench. Gently pull the GPS cable to disconnect from ODU. Once removed, cut the zip tie located on the rubber grommet, then pull the grommet away from the housing.

WARNING: Do NOT cut any cables when cutting zip tie.

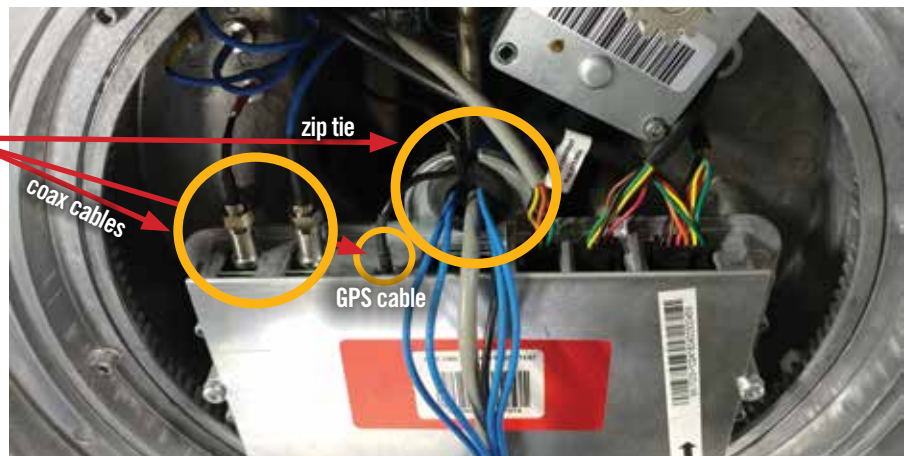

Figure 9

Motor Mount Removal cont.

D) From center of ODU moving right, remove Gray 6-Pin connector (#1), Black 8-Pin connector (#2), and the Black 12-Pin connector (#3) from the ODU. **Be sure to press down on the locking tab to remove connectors.**

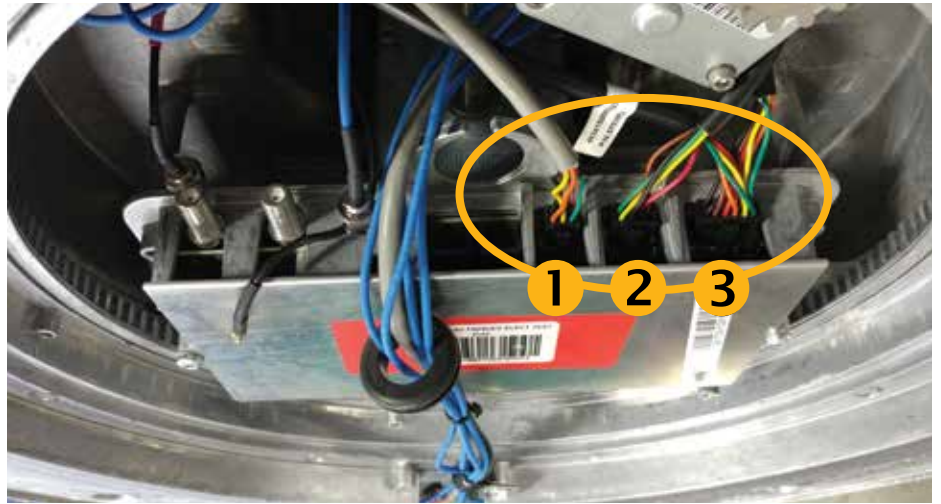

Figure 10

E) Confirm all cables and grommet have been removed from ODU. Once confirmed, remove ODU.



Figure 11

F) The replacement ODU will come with a longer GPS cable.



Figure 12

5. Install New Electronics

- A) Install the new electronics (do not screw down the electronics at this point) and reattach rubber grommet to housing.

Once completed, reinsert the Black 12-Pin connector (#1), Black 8-Pin connector (#2), and Gray 6-Pin connector (#3). Make sure all 3 connectors are fully inserted into the mating connector.

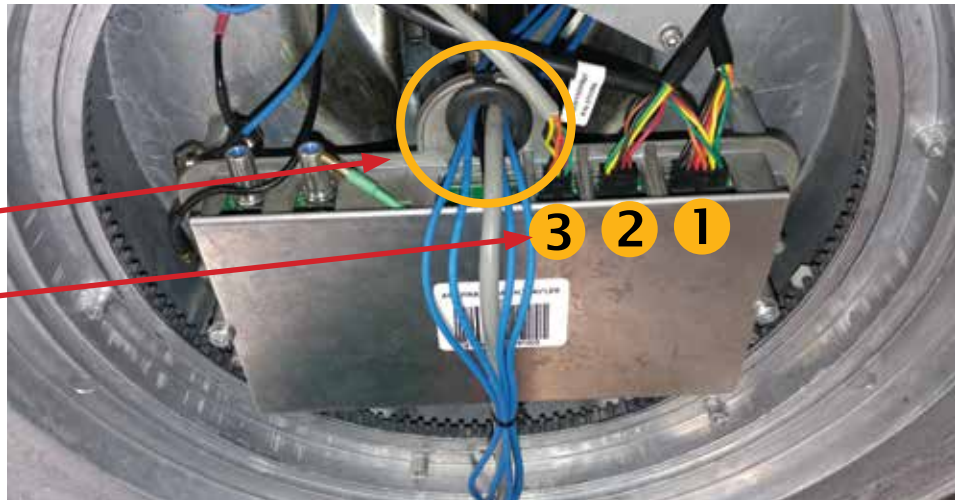

Figure 13

- B) Pull existing GPS cable through the grommet. Reattach two coaxes to ODU (#1 Red Cable on left and #2 Blue cable on right). Finger tighten the coax cables then use a 7/16" wrench to tighten an additional 1/8 turn.

WARNING: Be careful not to overtighten coax.

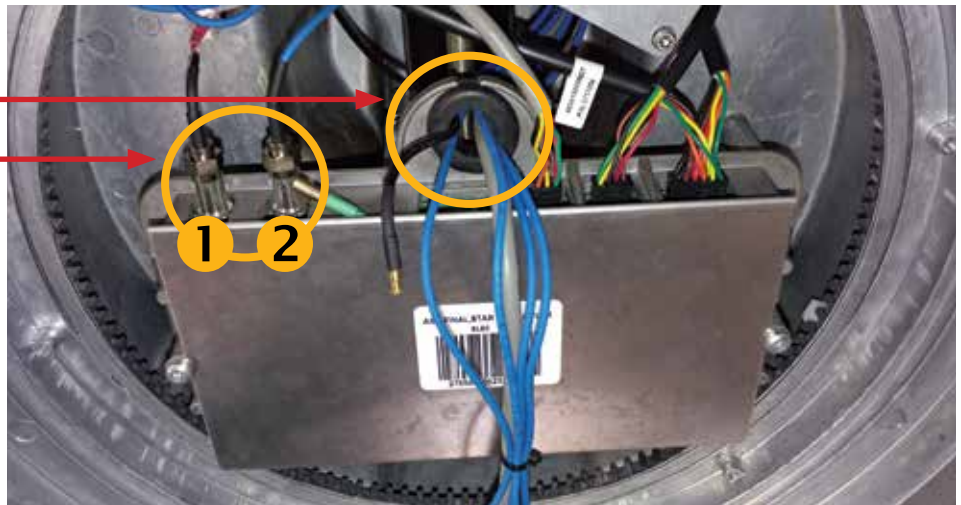

Figure 14

- C) Reconnect GPS cable, secure it to the rubber grommet with a zip tie and cut off the excess zip tie. You can now install the four modified 5/16" screws to the ODU.



Figure 15

Install New Electronics cont.

D) Once complete you need to make sure the base seal and gasket are properly seated on the mounting plate (Figure 16).

E) You can now reinstall the nine 5/16" screws to the transition plate (Figure 17).



Figure 16

Base seal and gasket

6. Reinstall Data Cable

A) Reinstall the data cable, once connected tighten down the retaining nut (Figure 18).

NOTE: Install retaining nut before reconnecting data cable.

B) If you had to remove the GPS cable, feed the GPS cable through the exterior GPS nut and reconnect it. Once connected tighten the exterior GPS nut (Figure 19).

C) Place gasket and cable cover back into position and reinstall the four 5/16" screws (Figure 20).



Figure 17

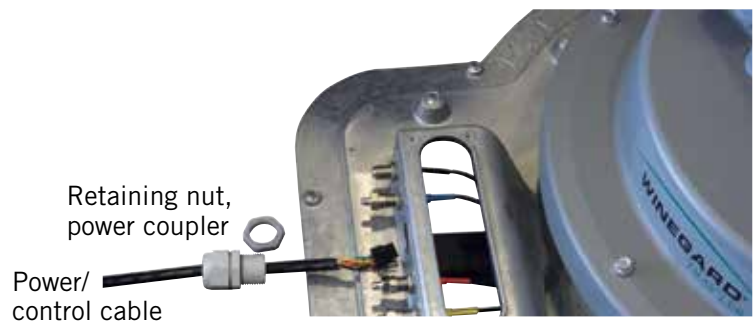

Figure 18

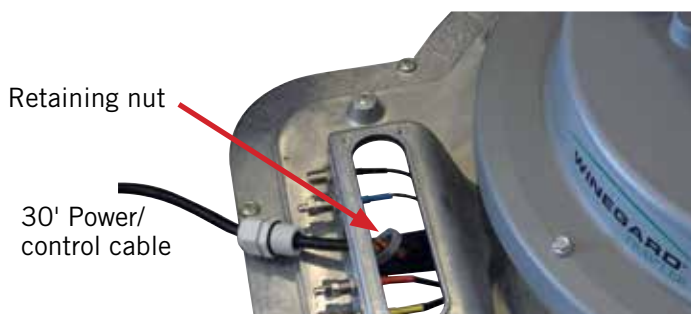

Figure 19

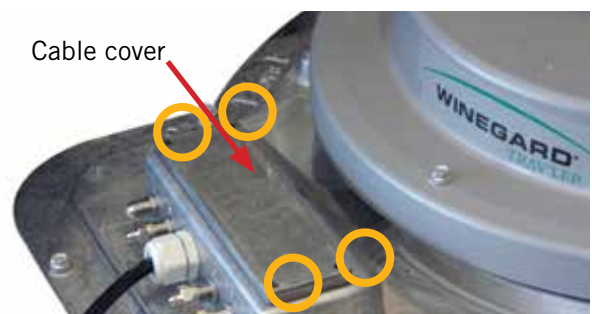
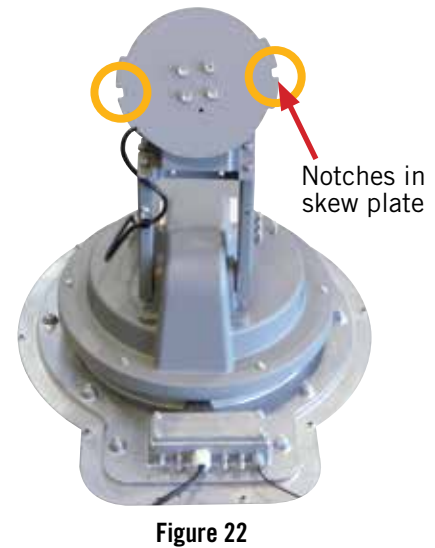
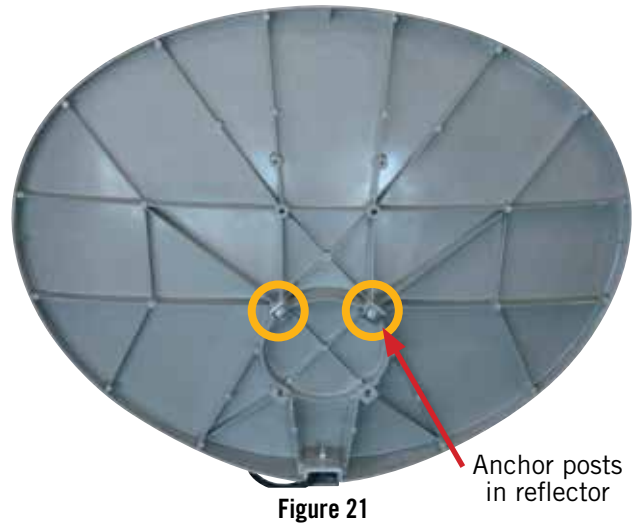

Figure 20

7. Install Reflector, LNBF and Feed Arm

- A) Insert the two longer screws into the top two holes in the front of the reflector.
- B) Slide a wedge-shaped clamp onto each screw sticking out the back of the reflector (Figure 21).
- C) Thread a nut onto each screw; make sure the nut is tight to keep the clamp from falling.
- D) Align the two anchor posts on the back of the reflector with the two notches in the skew plate (Figure 22). Then, set the reflector on the skew plate; the reflector should be positioned with the LNBF arm at the bottom of the plate. Carefully use the clamps on the back of the reflector to hold the reflector in place (Figure 23); make sure that the thicker part of the clamp is to the outside of the reflector.
- E) Once the top screws and clamps are in place, install the lower screws and clamps.
- F) With the bracket mounted securely, connect the four coax cables to the mount (Figure 24).
- G) Locate the cable tie on the coax cables that you just connected to the mount. Place the p-clamp on the cables so that it is just below this cable tie. If the cable tie is missing, install the clamp 14" from the end of the connectors.
- H) Carefully screw this clamp to the front of the lift arm using the provided 5/16" screw (Figure 25).



WARNING: Be careful not to strip out the hole for the 5/16" screw when replacing the clamp holding the coax cables to the arm. Do not use a power tool. Do not overtighten this screw.



8) Replace IDU



A) At this point please go inside the coach and replace the IDU. Make sure the 6-wire data cable and DC power cord are connected before proceeding.

B) Press and hold the “Power” button for two seconds to turn on the IDU. Press the “Power” button again to stow the antenna.

The MPEG-4 Upgrade is now complete.

For additional assistance, email help@winegard.com or call 1-800-788-4417.

WINEGARD COMPANY 90 DAY LIMITED WARRANTY

Winegard Company provides a warranty to the original purchaser of new Winegard Products against proven defects in materials or workmanship for a period of ninety (90) days from date of purchase, subject to the terms herein. If a Product covered under this warranty is determined to be defective within the warranty period, Winegard will, unless otherwise required by applicable law, either repair or exchange the Product at its sole discretion. This Warranty is non-transferable, and does not cover products purchased, services or used outside the United States or Canada. This Warranty does not extend to the elimination of externally generated static.

How to Obtain Warranty Service (Pre-authorization is required)

To obtain warranty service, contact Winegard Company Technical Support via email: help@winegard.com or via phone at 800-788-4417, or visit www.winegard.com. PRE-AUTHORIZATION MUST BE OBTAINED BEFORE SENDING ANY PRODUCT TO WINEGARD. Proof of purchase in the form of a purchase receipt or copy thereof is required to show that a Product is within the warranty period.

Winegard Company will (at its option) repair or replace the defective product at no charge to you. This warranty does not cover any costs incurred in removal or reinstallation of the product. This limited warranty does not apply if the product is damaged, deteriorates, malfunctions or fails from: misuse, improper installation, abuse, neglect, accident, tampering, modification of the product as originally manufactured by Winegard Company, usage not in accordance with product instructions or acts of nature such as damage caused by wind, lightning, ice or corrosive environments such as salt spray and acid rain. This limited Warranty also does not apply if the product becomes unable to perform its' intended function in any way as a result of the television signal provider making any changes in technology or service.

WINEGARD COMPANY WILL NOT ASSUME ANY LIABILITIES FOR ANY OTHER WARRANTIES, EXPRESS OR IMPLIED, MADE BY ANY OTHER PERSON.

ALL OTHER WARRANTIES WHETHER EXPRESS, IMPLIED OR STATUTORY INCLUDING WARRANTIES OF FITNESS FOR A PARTICULAR PURPOSE AND MERCHANTABILITY ARE LIMITED TO THE 90 DAY PERIOD OF THIS WARRANTY.

In states that do not allow limitations on implied warranties, or the exclusion of limitation of incidental or consequential damages, the above limitations or exclusions do not apply.

Some states do not allow limitations on how long an implied warranty lasts, or the exclusion of limitation of incidental or consequential damages, so the above limitations or exclusions may not apply to you.

This warranty gives Customer specific legal rights. Customer may also have other rights which vary from state to state.

Winegard and TRAVLER are registered trademarks of Winegard Company. Shaw Direct is a trademark of Shaw Satellite G.P.

Disclaimer: Although every effort has been made to ensure that the information in this manual is correct and complete, no company shall be held liable for any errors or omissions in this manual.
Information provided in this manual was accurate at time of printing.