

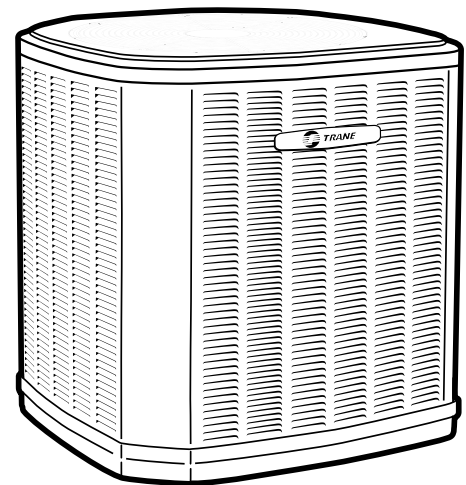

Product Data

Split System Heat Pump

4TWR4018G1000A
4TWR4024G1000A
4TWR4030G1000A
4TWR4036G1000A
4TWR4042G1000A
4TWR4048G1000A
4TWR4060G1000A



Note: "Graphics in this document are for representation only. Actual model may differ in appearance."



Product Specifications

Model No. ^(a)	4TWR4018G1000A	4TWR4024G1000A	4TWR4030G1000A	4TWR4036G1000A
POWER CONNS. — V/PH/HZ ^(b)	208/230/1/60	208/230/1/60	208/230/1/60	208/230/1/60
MIN. BRCH. CIR. AMPACITY	12	14	17	19
BR. CIR. PROT. RTG. — MAX. (AMPS)	20	25	25	30
COMPRESSOR	CLIMATUFF®- SCROLL	CLIMATUFF®- SCROLL	CLIMATUFF®- SCROLL	CLIMATUFF®- SCROLL
RL AMPS — LR AMPS	9 — 56	10.9 — 62.9	12.8 — 67.8	14.7 — 72.2
Outdoor Fan FL AMPS	0.54	0.64	0.71	0.64
Fan HP	1/12	1/8	1/8	1/8
Fan Dia (inches)	23	23	27.5	27.5
Coil	SPINE FIN™	SPINE FIN™	SPINE FIN™	SPINE FIN™
Refrigerant R-410A	5 LBS., 12 OZ	6 LBS., 2 OZ	6 LBS., 13 OZ	6 LBS., 12 OZ
LINE SIZE — IN. O.D. GAS ^(c) ^(d)	3/4	3/4	3/4	3/4
LINE SIZE — IN. O.D. LIQ.	3/8	3/8	3/8	3/8
Charge Spec. Subcooling	10°F	10°F	8°F	10°F
Dimensions H x W X D Crated (IN.)	30.1 x 30 x 26.7	34 x 33 x 30.1	34.4 x 35.1 x 38.7	34.4 x 38.7 x 35.1
Weight — Shipping (lbs.)	161	191	248	248
Weight — Net (lbs.)	141	163	216	216
Optional Accessories:				
Anti-short Cycle Timer	TAYASCT501A	TAYASCT501A	TAYASCT501A	TAYASCT501A
Evaporator Defrost Control	NA	NA	NA	AY28X084
Rubber Isolator Kit	BAYISLT101	BAYISLT101	BAYISLT101	BAYISLT101
Extreme Condition Mount Kit	BAYECMT023	BAYECMT023	BAYECMT004	BAYECMT004
Start Kit	—	—	BAYKSKT263	BAYKSKT263
Crankcase Heater Kit	BAYCCHT302	BAYCCHT302	BAYCCHT302	BAYCCHT302
Seacoast Kit	BAYSEAC001	BAYSEAC001	BAYSEAC001	BAYSEAC001
Low Ambient Kit	BAYLOAM107	BAYLOAM107	BAYLOAM107	BAYLOAM103
Refrigerant Lineset ^(e)	TAYREFLN7*	TAYREFLN7*	TAYREFLN7*	TAYREFLN7*
Sound Enclosure	BAYSDEN003	BAYSDEN003	BAYSDEN003	BAYSDEN003
Service Valve Panel Cover	TAYSVPANL0022AA	TAYSVPANL0032AA	TAYSVPANL0032AA	TAYSVPANL3343AA

^(a) Certified in accordance with the Unitary Air-conditioner equipment certification program which is based on AHRI standard 210/240.

^(b) Calculated in accordance with N.E.C. Only use HACR circuit breakers or fuses.

^(c) Reference the outdoor unit ship-with literature for refrigerant piping length and lift guidelines. Reference the refrigerant piping software pub # 32-3312-xx or refrigerant piping application guide SS-APG006-xx for long line sets or specialty applications (xx denotes latest revision).

^(d) The outdoor condensing units are factory charged with the system charge required for the outdoor condensing unit, ten (10) feet of tested connecting line, and the smallest rated indoor evaporative coil match. Always verify proper system charge via subcooling (TXV/EEV) or superheat (fixed orifice) per the unit nameplate.

^(e) * = 15, 20, 25, 30, 40 and 50 foot lineset available.



Product Specifications

Model No. ^(a)	4TWR4042G1000A	4TWR4048G1000A	4TWR4060G1000A
POWER CONNS. — V/PH/HZ ^(b)	280/230/1/60	280/230/1/60	280/230/1/60
MIN. BRCH. CIR. AMPACITY	25	26	32
BR. CIR. PROT. RTG. — MAX. (AMPS)	40	45	50
COMPRESSOR	CLIMATUFF®- SCROLL	CLIMATUFF®- SCROLL	CLIMATUFF®- SCROLL
RL AMPS — LR AMPS	19.2 — 124	19.6 — 130	24.4 — 144
Outdoor Fan FL AMPS	1.05	1.05	1.05
Fan HP	1/5	1/5	1/5
Fan Dia (inches)	27.5	27.5	27.5
Coil	SPINE FIN™	SPINE FIN™	SPINE FIN™
Refrigerant R-410A	6 LBS., 5 OZ	9 LBS., 0 OZ	10 LBS., 13 OZ
LINE SIZE — IN. O.D. GAS ^(c) ^(d)	7/8	7/8	1 1/8
LINE SIZE — IN. O.D. LIQ.	3/8	3/8	3/8
Charge Spec. Subcooling	10°F	10°F	10°F
Dimensions H x W X D Crated (IN.)	34.4 x 38.7x 35.1	38.4 x 38.7 x 35.1	51 x 38.7 x 35.1
Weight — Shipping (lbs.)	248	256	315
Weight — Net (lbs.)	216	222	278
Optional Accessories:			
Anti-short Cycle Timer	TAYASCT501A	TAYASCT501A	TAYASCT501A
Evaporator Defrost Control	NA	NA	NA
Rubber Isolator Kit	BAYISLT101	BAYISLT101	BAYISLT101
Extreme Condition Mount Kit	BAYECMT004	BAYECMT004	BAYECMT004
Start Kit	BAYKSKT263	BAYKSKT263	BAYKSKT263
Crankcase Heater Kit	BAYCCHT301	BAYCCHT301	BAYCCHT301
Seacoast Kit	BAYSEAC001	BAYSEAC001	BAYSEAC001
Low Ambient Kit	BAYLOAM107	BAYLOAM107	BAYLOAM107
Refrigerant Lineset ^(e)	TAYREFLN3*	TAYREFLN3*	TAYREFLN3*
Sound Enclosure	BAYSDEN004	BAYSDEN004	BAYSDEN004
Service Valve Panel Cover	TAYSVPANL0032AA	TAYSVPANL3343AA	TAYSVPANL0046AA

(a) Certified in accordance with the Unitary Air-conditioner equipment certification program which is based on AHRI standard 210/240.

(b) Calculated in accordance with N.E.C. Only use HACR circuit breakers or fuses.

(c) Reference the outdoor unit ship-with literature for refrigerant piping length and lift guidelines. Reference the refrigerant piping software pub # 32-3312-xx or refrigerant piping application guide SS-APG006-xx for long line sets or specialty applications (xx denotes latest revision).

(d) The outdoor condensing units are factory charged with the system charge required for the outdoor condensing unit, ten (10) feet of tested connecting line, and the smallest rated indoor evaporative coil match. Always verify proper system charge via subcooling (TXV/EEV) or superheat (fixed orifice) per the unit nameplate.

(e) * = 15, 20, 25, 30, 40 and 50 foot lineset available.

Sound Power Level

MODEL	A-Weighted Sound Power Level [dB(A)]	Full Octave Sound Power(dB)							
		63 Hz*	125 Hz	250 Hz	500 Hz	1000 Hz	2000 Hz	4000 Hz	8000 Hz
4TWR4018G1	73	72	66	64	66	71	64	56	47
4TWR4024G1	71	77	72	68	68	69	60	53	47
4TWR4030G1	72	77	72	69	68	65	60	57	52
4TWR4036G1	75	84	75	70	72	67	62	57	50
4TWR4042G1	72	79	70	68	67	64	59	56	51
4TWR4048G1	72	81	73	68	72	67	62	57	51
4TWR4060G1	72	81	72	68	71	68	64	59	54

Note: Rated in accordance with AHRI Standard 270-2008 *For Reference Only



Accessory Description and Usage

Anti-Short Cycle Timer — Solid state timing device that prevents compressor recycling until five (5) minutes have elapsed after satisfying call or power interruptions. Use in area with questionable power delivery, commercial applications, long lineset, etc.

Evaporation Defrost Control — SPST Temperature actuated switch that cycles the condenser off as indoor coil reaches freeze-up conditions. Used for low ambient cooling to 30°F with TXV.

Rubber Isolators — Five (5) large rubber donuts to isolate condensing unit from transmitting energy into mounting frame or pad. Use on any application where sound transmission needs to be minimized.

Hard Start Kit — Start capacitor and relay to assist compressor motor startup. Use in areas with marginal power supply, on long linesets, low ambient conditions, etc.

Extreme Condition Mount Kit — Bracket kits to securely mount condensing unit to a frame or pad without removing any panels. Use in areas with high winds, or on commercial roof tops, etc.

AHRI Standard Capacity Rating Conditions

AHRI Standard 210/240 Rating Conditions

1. Cooling 80°F DB, 67°F WB air entering indoor coil, 95°F DB air entering outdoor coil.
2. High Temperature Heating 47°F DB, 43°F WB air entering outdoor coil, 70°F DB air entering indoor coil.
3. Low Temperature Heating 17°F DB air entering indoor coil.
4. Rated indoor airflow for heating is the same as for cooling.

AHRI Standard 270 Rating Conditions — (Noise rating numbers are determined with the unit in cooling operations.) Standard Noise Rating number is at 95°F outdoor air.

Model Nomenclature

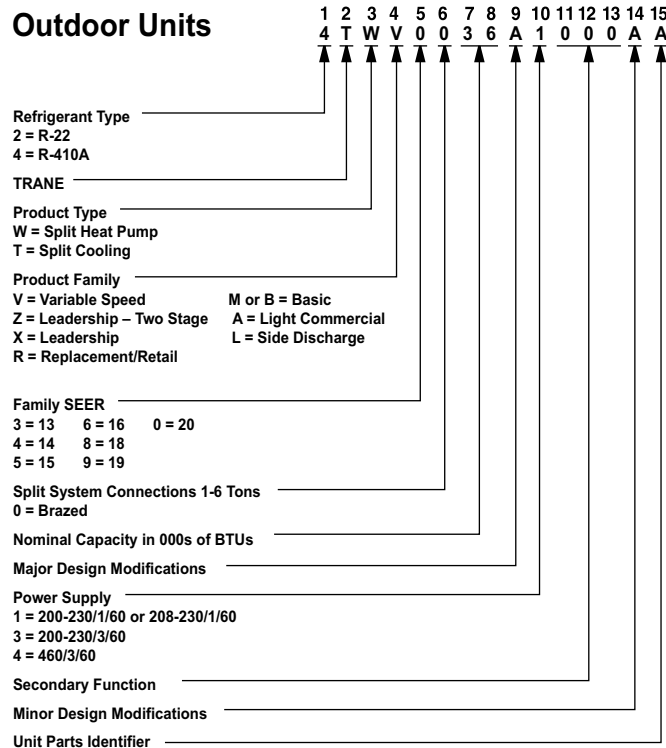

Schematic Diagrams

Figure 1. 1.5, 2.0, 2.5 & 3.5 Ton Models

LEGEND

- ACR A/C RECTIFIER
- CBS COIL BOTTOM SENSOR
- CF FAN CAPACITOR
- CN WIRE CONNECTOR
- CPR COMPRESSOR
- CR RUN CAPACITOR
- CSR STARTING CAPACITOR
- CSR CAPACITOR SWITCHING RELAY
- DFC DEFROST CONTROL
- EEV ELECTRONIC EXP VALVE
- EEVC ELECTRONIC EXP VALVE CONTROL
- F INDOOR FAN RELAY
- HPCO HIGH PRESSURE CUTOFF SWITCH
- IOL INTERNAL OVERLOAD PROTECTOR
- LPFO LOW PRESSURE CUTOFF SWITCH
- MS COMPRESSOR MOTOR CONTACTOR
- ODA OUTDOOR ANTICIPATOR
- OF T OUTDOOR FAN THERMOSTAT
- ODS OUTDOOR TEMPERATURE SENSOR
- ODT OUTDOOR THERMOSTAT
- P-TSD PRESSURE TRANSDUCER
- SC SWITCH OVER VALVE SOLENOID
- SM SYSTEM ON-OFF SWITCH
- TDL DISCHARGE LINE THERMOSTAT
- TDR TIME DELAY RELAY (5 SEC DELAY ON)
- TNS TRANSFORMER
- TEMP SENSOR, TEMPERATURE
- Y2C HIGH CAPACITY CONTROL RELAY

COLOR OF WIRE
BK/BL

COLOR OF MARKER
BK/BL

BK BLACK RD RED OR ORANGE
BL BLUE WH WHITE GR GREEN
BR BROWN YL YELLOW PR PURPLE
PK PINK

POL. PLUG FEMALE HOUSING (MALE TERMINALS)
POL. PLUG MALE HOUSING (FEMALE TERMINALS)
RELAY CONTACT (N.C.)

- THERMISTOR
- TEMP ACTUATED SWITCH
- INTERNAL OVERLOAD PROTECTION
- PRESSURE ACTUATED SWITCH
- RESISTOR OR HEATING ELEMENT
- MOTOR WINDING

FOR CANADIAN INSTALLATIONS
POUR INSTALLATIONS CANADIENNES

CAUTION: NOT SUITABLE FOR USE ON SYSTEMS EXCEEDING 150V-TO-GROUND
ATTENTION: NE CONVIENT PAS AUX INSTALLATIONS DE PLUS DE 150 V A LA TERRE

WARNING

HAZARDOUS VOLTAGE!
DISCONNECT ALL ELECTRICAL POWER INCLUDING REMOTE DISCONNECTS BEFORE SERVICING.
Failure to disconnect power before servicing can cause severe personal injury or death.

CAUTION

USE COPPER CONDUCTORS ONLY!
UNIT TERMINALS ARE NOT DESIGNED TO ACCEPT OTHER TYPES OF CONDUCTORS.
Failure to do so may cause damage to the equipment.

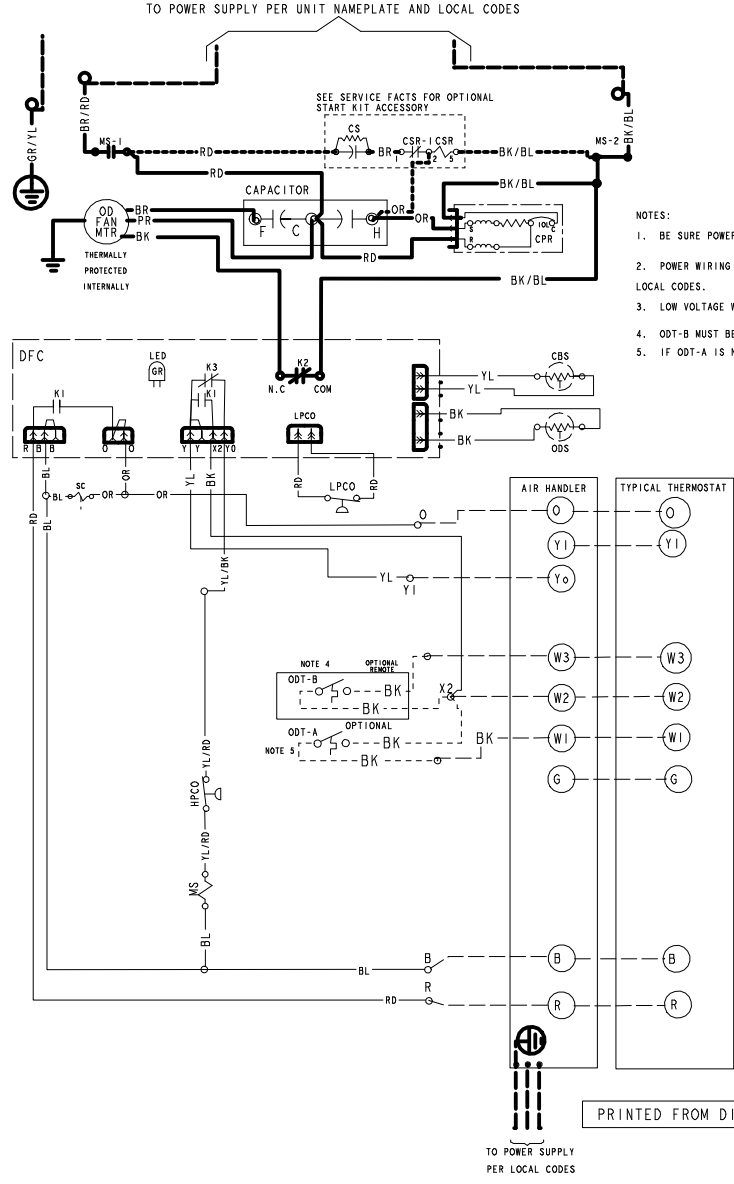

- NOTES:
1. BE SURE POWER SUPPLY AGREES WITH EQUIPMENT NAMEPLATE.
 2. POWER WIRING AND GROUNDING OF EQUIPMENT MUST COMPLY WITH LOCAL CODES.
 3. LOW VOLTAGE WIRING TO BE NO. 18 AWG MINIMUM CONDUCTOR.
 4. ODT-B MUST BE SET LOWER THAN ODT-A
 5. IF ODT-A IS NOT USED, ADD JUMPER BETWEEN W1 AND W2 AT AIR HANDLER

PRINTED FROM DI59478P02 REV A

Figure 2. 1.5, 2.0, 2.5 & 3.5 Ton Models

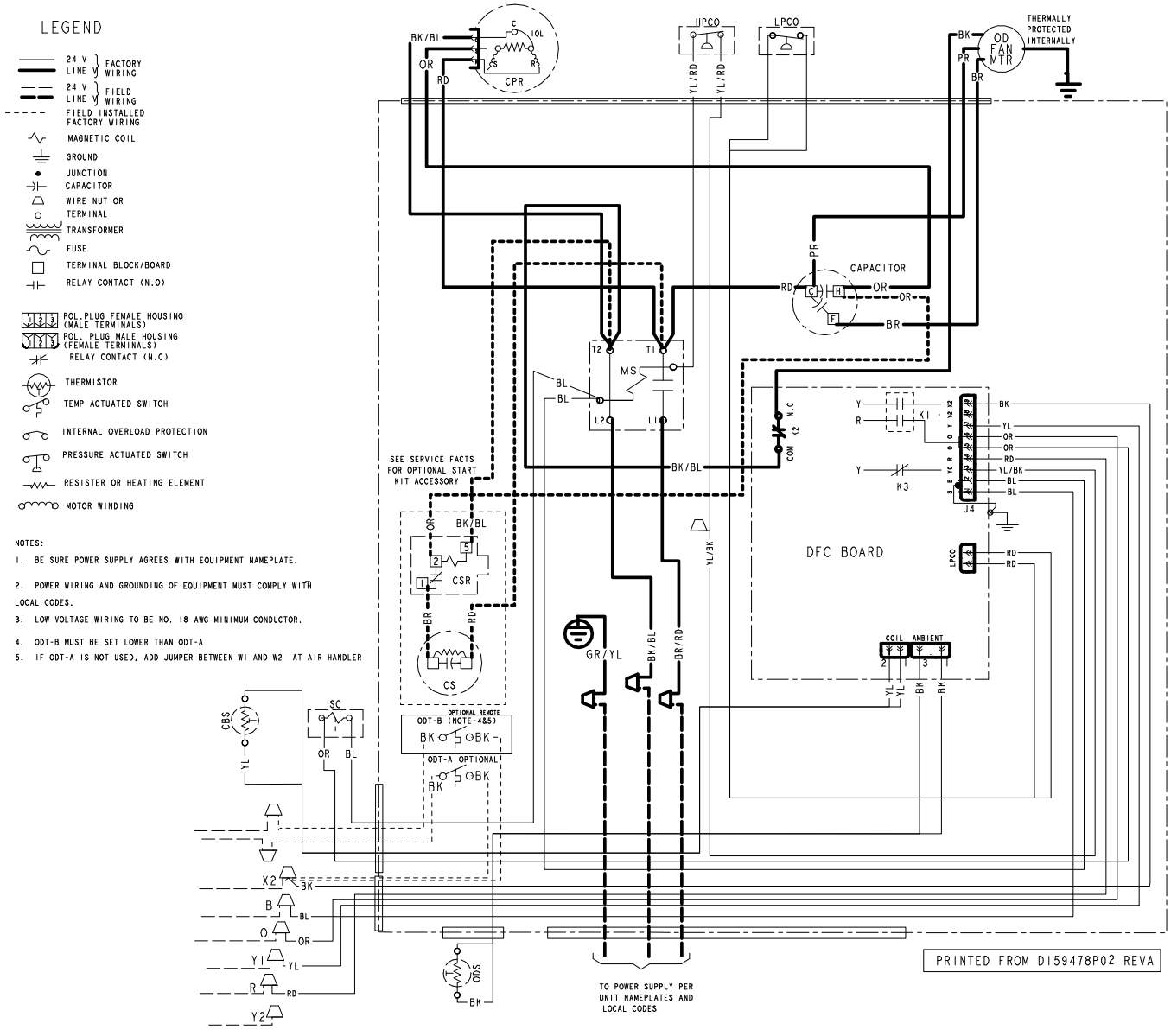

Figure 3. 3.0 Ton

LEGEND

- RELAY CONTACT (N.O)
- RELAY CONTACT (N.C)
- THERMISTOR
- TEMP ACTUATED SWITCH
- INTERNAL OVERLOAD PROTECTION
- PRESSURE ACTUATED SWITCH
- RESISTOR OR HEATING ELEMENT
- MOTOR WINDING
- POL. PLUG FEMALE HOUSING (MALE TERMINALS)
- POL. PLUG MALE HOUSING (FEMALE TERMINALS)
- SINGLE INLINE CONNECTION
- 24 V } FACTORY LINE WIRING
- 24 V } FIELD LINE WIRING
- FIELD INSTALLED FACTORY WIRING
- MAGNETIC COIL
- GROUND
- JUNCTION
- CAPACITOR
- WIRE NUT OR TERMINAL
- TRANSFORMER
- FUSE

WARNING

HAZARDOUS VOLTAGE!
DISCONNECT ALL ELECTRICAL POWER INCLUDING REMOTE DISCONNECTS BEFORE SERVICING.
Failure to disconnect power before servicing can cause severe personal injury or death.

CAUTION

USE COPPER CONDUCTORS ONLY!
UNIT TERMINALS ARE NOT DESIGNED TO ACCEPT OTHER TYPES OF CONDUCTORS.
Failure to do so may cause damage to the equipment.

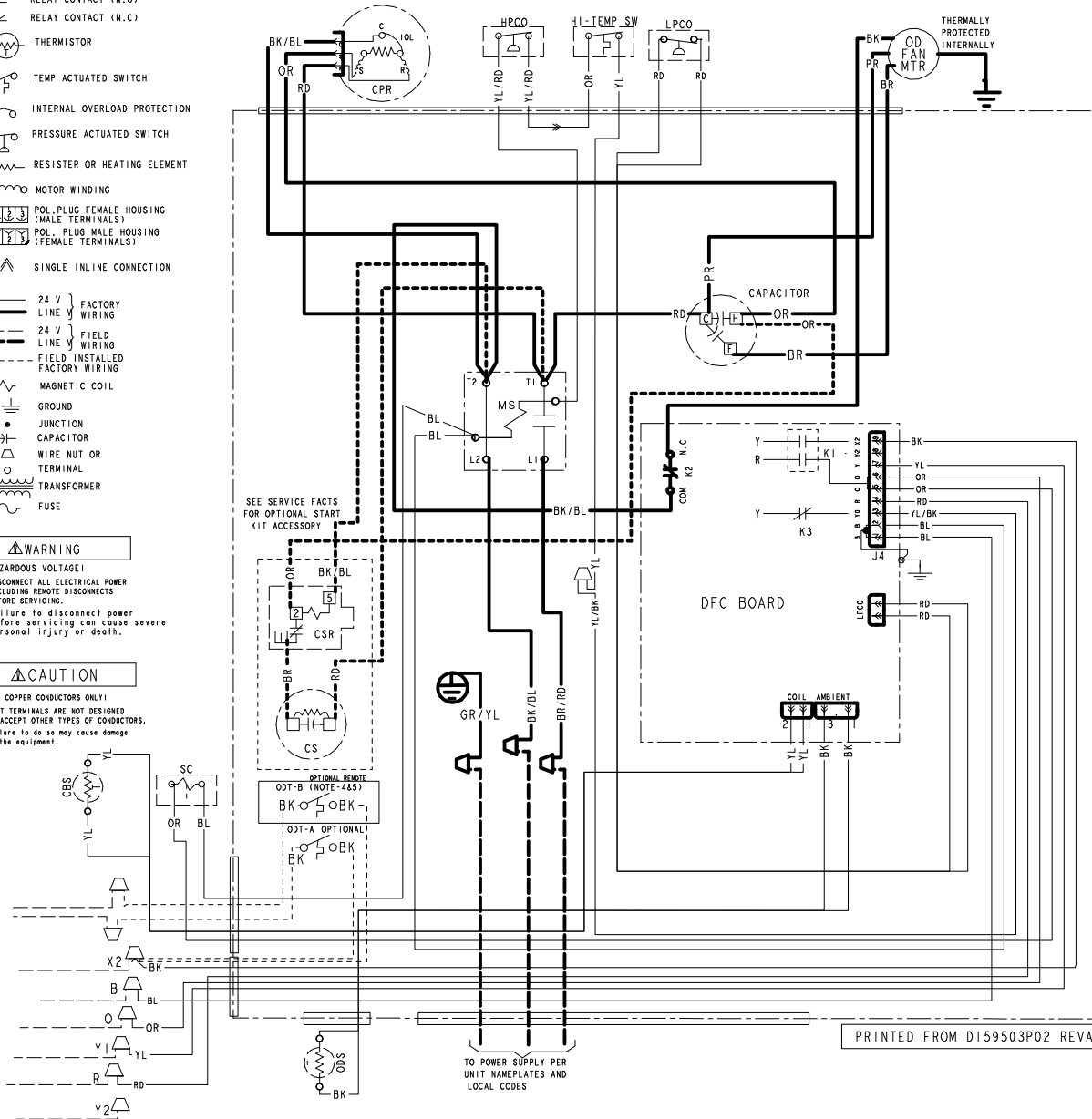

PRINTED FROM D159503P02 REVA

TO POWER SUPPLY PER UNIT NAMEPLATES AND LOCAL CODES

Figure 4. 4 and 5 Ton Models

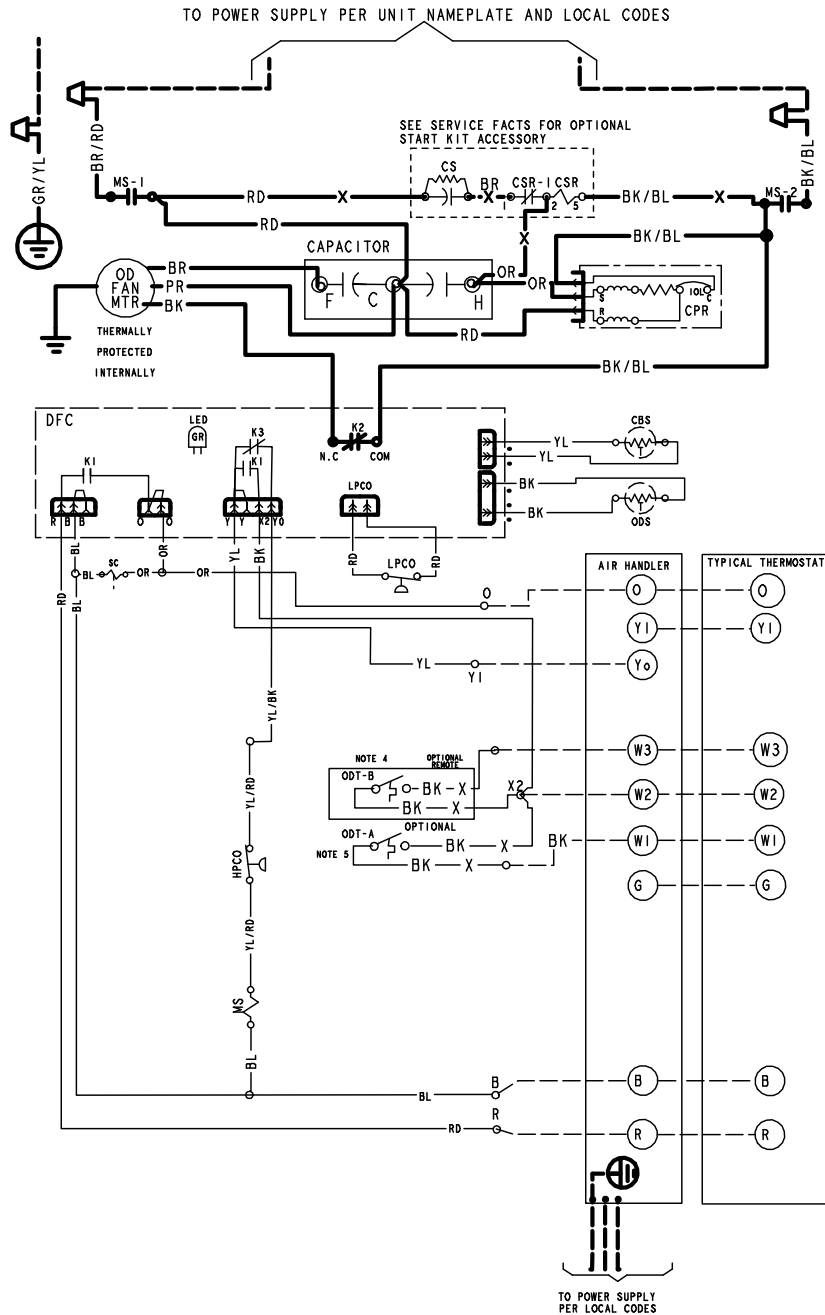

LEGEND

- ACR A/C RECTIFIER
- CBS COIL BOTTOM SENSOR
- CF FAN CAPACITOR
- CN WIRE CONNECTOR
- CPR COMPRESSOR
- CR RUN CAPACITOR
- CS STARTING CAPACITOR
- CSR CAPACITOR SWITCHING RELAY
- DFC DEFROST CONTROL
- EEV ELECTRONIC EXP VALVE
- EEVC ELECTRONIC EXP VALVE CONTROL
- F INDOOR FAN RELAY
- HPCO HIGH PRESSURE CUTOFF SWITCH
- IOL INTERNAL OVERLOAD PROTECTOR
- LPCC LOW PRESSURE CUTOFF SWITCH
- MS COMPRESSOR MOTOR CONTACTOR
- ODA OUTDOOR ANTICIPATOR
- OFT OUTDOOR FAN THERMOSTAT
- ODS OUTDOOR TEMPERATURE SENSOR
- ODT OUTDOOR THERMOSTAT
- P-TRD PRESSURE TRANSDUCER
- SC SWITCH OVER VALVE SOLENOID
- SM SYSTEM ON-OFF SWITCH
- TDL DISCHARGE LINE THERMOSTAT
- TDR TIME DELAY RELAY (5 SEC DELAY ON)
- TNS TRANSFORMER
- TEMP SENSOR, TEMPERATURE
- Y2C HIGH CAPACITY CONTROL RELAY

COLOR OF WIRE
 BK/BL ← COLOR OF MARKER

BK BLACK RD RED OR ORANGE
 BL BLUE WH WHITE GR GREEN
 BR BROWN YL YELLOW PR PURPLE
 PK PINK

WARNING

HAZARDOUS VOLTAGE!
 DISCONNECT ALL ELECTRICAL POWER INCLUDING REMOTE DISCONNECTS BEFORE SERVICING.
 Failure to disconnect power before servicing can cause severe personal injury or death.

CAUTION

USE COPPER CONDUCTORS ONLY!
 UNIT TERMINALS ARE NOT DESIGNED TO ACCEPT OTHER TYPES OF CONDUCTORS.
 Failure to do so may cause damage to the equipment.

FOR CANADIAN INSTALLATIONS
 POUR INSTALLATIONS CANADIENNES

CAUTION: NOT SUITABLE FOR USE ON SYSTEMS EXCEEDING 150V-TO-GROUND
 ATTENTION: NE CONVIENT PAS AUX INSTALLATIONS DE PLUS DE 150 V A LA TERRE

PRINTED FROM D160443P01 REVA

Figure 5. 4 and 5 Ton Models

NOTES:

1. BE SURE POWER SUPPLY AGREES WITH EQUIPMENT NAMEPLATE.
2. POWER WIRING AND GROUNDING OF EQUIPMENT MUST COMPLY WITH LOCAL CODES.
3. LOW VOLTAGE WIRING TO BE NO. 18 AWG MINIMUM CONDUCTOR.
4. ODT-B MUST BE SET LOWER THAN ODT-A
5. IF ODT-A IS NOT USED, ADD JUMPER BETWEEN W1 AND W2 AT AIR HANDLER

LEGEND

	24 V } FACTORY WIRING		RELAY CONTACT (N.O)
	LINE } WIRING		RELAY CONTACT (N.C)
	24 V } FIELD WIRING		THERMISTOR
	LINE } WIRING		TEMP ACTUATED SWITCH
	24 V } FIELD INSTALLED		PRESSURE ACTUATED SWITCH
	LINE } FACTORY WIRING		MOTOR WINDING
	MAGNETIC COIL		PCL PLUG FEMALE HOUSING (MALE TERMINALS)
	GROUND		PCL PLUG MALE HOUSING (FEMALE TERMINALS)
	JUNCTION		SINGLE INLINE CONNECTION
	CAPACITOR		
	WIRE NUT OR CONNECTOR		
	TERMINAL		
	TRANSFORMER		
	FUSE		
	TERMINAL BLOCK/BOARD		

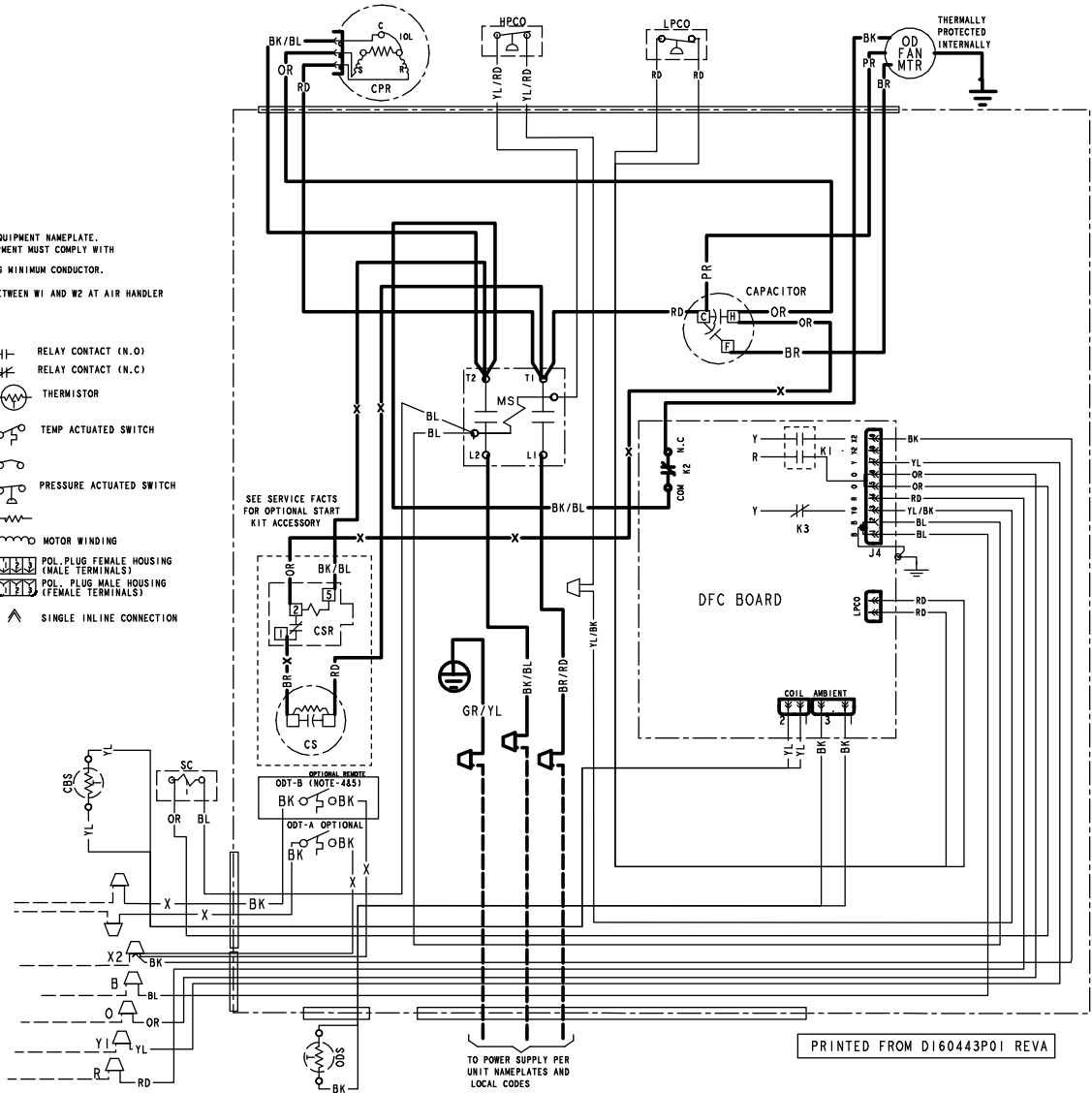

PRINTED FROM D160443P01 REVA



Outline Drawing

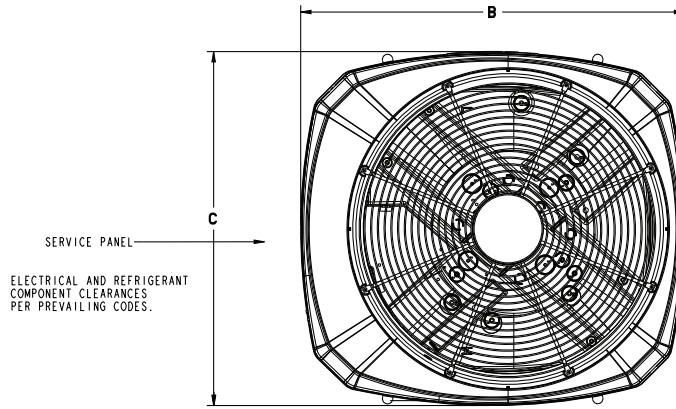

TOP DISCHARGE AREA SHOULD BE UNRESTRICTED FOR AT LEAST 1524 (5 FEET) ABOVE UNIT. UNIT SHOULD BE PLACED SO ROOF RUN-OFF WATER DOES NOT POUR DIRECTLY ON UNIT, AND SHOULD BE AT LEAST 305 (12") FROM WALL AND ALL SURROUNDING SHRUBBERY ON TWO SIDES. OTHER TWO SIDES UNRESTRICTED.

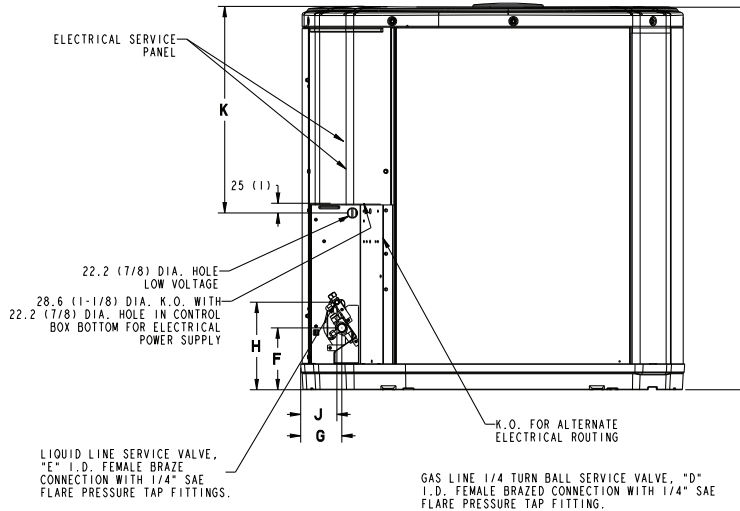

Model	Base	A	B	C	D	E	F	G	H	J	K
4TWR4018G	2	730 (28-3/4)	724 (28-1/2)	651 (25-5/8)	3/4	3/8	127 (5)	57 (2-1/4)	194 (7-5/8)	38 (1-1/2)	457 (18)
4TWR4024G	3	730 (28-3/4)	829 (32-5/8)	756 (29-3/4)	3/4	3/8	127 (5)	76 (3)	197 (7-3/4)	60 (2-3/8)	508 (20)
4TWR4030G	4	741 (29-1/8)	946 (37-1/4)	870 (34-1/4)	3/4	3/8	143 (5-5/8)	83 (3-1/4)	206 (8-1/8)	70 (2-3/4)	508 (20)
4TWR4036G	4	741 (29-1/8)	946 (37-1/4)	870 (34-1/4)	3/4	3/8	156 (6)	98 (3-7/8)	219 (8-5/8)	86 (3-3/8)	508 (20)
4TWR4042G	4	741 (29-1/8)	946 (37-1/4)	870 (34-1/4)	7/8	3/8	143 (5-5/8)	83 (3-1/4)	206 (8-1/8)	70 (2-3/4)	508 (20)
4TWR4048G	4	841 (33-1/8)	946 (37-1/4)	870 (34-1/4)	7/8	3/8	143 (5-5/8)	98 (3-7/8)	219 (8-5/8)	86 (3-3/8)	508 (20)
4TWR4060G	4	1147 (45-1/8)	946 (37-1/4)	870 (34-1/4)	7/8	3/8	152 (6)	98 (3-7/8)	219 (8-5/8)	86 (3-3/8)	813 (32)



Mechanical Specification Options

General

The outdoor condensing units are factory charged with the system charge required for the outdoor condensing unit, ten (10) feet of tested connecting line, and the smallest rated indoor evaporative coil match. This unit is designed to operate at outdoor ambient temperatures as high as 115°F. Cooling capacities are matched with a wide selection of air handlers and furnace coils that are AHRI certified. The unit is certified to UL 1995. Exterior is designed for outdoor application.

Casing

Unit casing is constructed of heavy gauge, galvanized steel and painted with a weather-resistant powder paint finish. The corner panels are prepainted. All panels are subjected to our 1,000 hour salt spray test .

Refrigerant Controls

Refrigeration system controls include condenser fan, compressor contactor and low and high pressure switches. A factory supplied, field installed liquid line drier is standard.

Compressor

The compressor features internal over temperature and pressure protection. Other features include: Centrifugal oil pump and low vibration and noise.

Condenser Coil

The outdoor coil provides low airflow resistance and efficient heat transfer. The coil is protected on all four sides by louvered panels.

Low Ambient Cooling

As manufactured, this system has a cooling capacity to 55°F. The addition of an evaporator defrost control permits operation to 40°F. The addition of an evaporator defrost control with TXV permits low ambient cooling to 30°F.

The addition of the BAYLOAM107A low ambient kit permits ambient cooling to 20°F.

Thermostats—Cooling only and heat/cooling (manual and automatic change over). Sub-base to match thermostat and locking thermostat cover.



Ingersoll Rand (NYSE: IR) advances the quality of life by creating comfortable, sustainable and efficient environments. Our people and our family of brands — including Club Car®, Ingersoll Rand®, Thermo King® and Trane® — work together to enhance the quality and comfort of air in homes and buildings; transport and protect food and perishables; and increase industrial productivity and efficiency. We are a global business committed to a world of sustainable progress and enduring results.



ingersollrand.com



The AHRI Certified mark indicates Ingersoll Rand participation in the AHRI Certification program. For verification of individual certified products, go to www.ahridirectory.org.

Ingersoll Rand has a policy of continuous product and product data improvements and reserves the right to change design and specifications without notice. We are committed to using environmentally conscious print practices.