



## Landscape Drip Application Guide

A Practical Guide for Designing and Installing Drip Irrigation Systems



The Intelligent Use of Water™



## The Efficiency of Drip, Engineered by Rain Bird®

The Rain Bird's low volume irrigation products were coined with the phrase "Xerigation" in the 1990's and include drip irrigation and low volume spray products. The Rain Bird Xerigation system is the most efficient way to water landscapes.

Over the last fifteen years, Rain Bird has been a leader in innovation advances that customers value. Earlier advances included the Xeri-Pop™, the first efficient low volume spray with a spray head that retracts out of sight, the self-cleaning back flush filter that reduces maintenance by automatically flushing out debris, and the PR Series Pressure Regulating Filter that combined the regulator and filter into one component reducing the potential for leaks.

Today, Rain Bird continues the tradition of innovation with the SQ Series Nozzle and the XF Series Dripline featured below. With the broadest product line, Rain Bird's Xerigation systems can be designed to meet any site requirement providing unmatched quality, efficient water use, and ease of installation.

## Featured Rain Bird® Drip Products



### SQ Series Nozzle

For irrigating small areas with dense plantings, the SQ Series Nozzle is the most precise and efficient nozzle available. With built-in pressure compensation and a unique square spraying pattern, the need for overlapping is greatly reduced. This means less overspray, overwatering, and runoff than traditional nozzles. It also means you need less nozzles, dramatically reducing your costs and installation time.



### XF Series Dripline (XFD/XFCV/XFS)

The XF Series Dripline is the most flexible, pressure-compensating inline emitter tubing available. Its unique material offers significantly greater flexibility, allowing tighter turns with fewer elbows for easier installation. The dual-layered tubing (brown over black) provides unmatched resistance to chemicals, UV damage and algae growth.



### Control Zone Kits

Control your zones with preassembled, compact Rain Bird Control Zone Kits. Two components (valve and pressure regulating filter) are combined to create a shorter kit, when compared with the competition. This allows you to fit more control zone kits in a single valve box without cramping the work space inside the box, saving you time and money.

## Benefits of Xerigation®

- ➔ Design flexibility
- ➔ Elimination of overspray and runoff
- ➔ High water efficiency
- ➔ Water is delivered at or near the plant root zone
- ➔ Plants stay healthier and live longer

---

*It is Rain Bird's long-standing*

*commitment to engineering and*

*quality excellence that sets our*

*drip irrigation products apart.*

---

## Demonstrated Water Savings

### Inland Empire Utilities Agency (IEUA) Building - Chino, CA

**Solution:** Rain Bird developed a comprehensible irrigation system for the IEUA site, including Xerigation products.

**Results:** 73% less water used than a comparable facility. First public agency building to achieve a LEED Platinum Rating.



# Table of Contents

## Product Guide

- Anatomy of Xerigation .....2
- Emission Devices .....4
- Control Zone Kits ..... 15

## Application Guide

- Narrow Planting Beds ..... 16
- Parking Lot ..... 26
- Parkways and Walkways ..... 32
- Pots/Baskets/Misc. .... 34
- Slopes ..... 42
- Street Medians ..... 48
- Walls ..... 56
- Golf Courses ..... 58
- Trees ..... 64



Xeri-Bird 8

# Anatomy of Xerigation® / Landscape Drip System Overview

## Broadest Product Line in the Industry

With over 150 products, Rain Bird has the products needed for your application. Systems can be designed to meet any site requirements and offer many exclusive Rain Bird advances including:

- Flexible XF Series dripline with advanced polymers that provide kink- resistance and reduced coil memory for easier installation
- Compact Control Zones with matched pressure regulator and filter to reduce parts, eliminate potential leak problems, and allow for fitting more Control Zones in a valve box
- Precision low volume SQ spray nozzles that offer a square wetting pattern and adjust to either 2.5' or 4' throw distances
- Point-source emitters that provide pressure compensation with a wide selection of flow rates and three inlet options (Barb, 1032 threaded, and 1/2" FPT)
- XFS dripline with Copper Shield Technology™ for use in sub-surface applications under turf or shrub and groundcover areas. The copper chip effectively protects the emitter from root intrusion

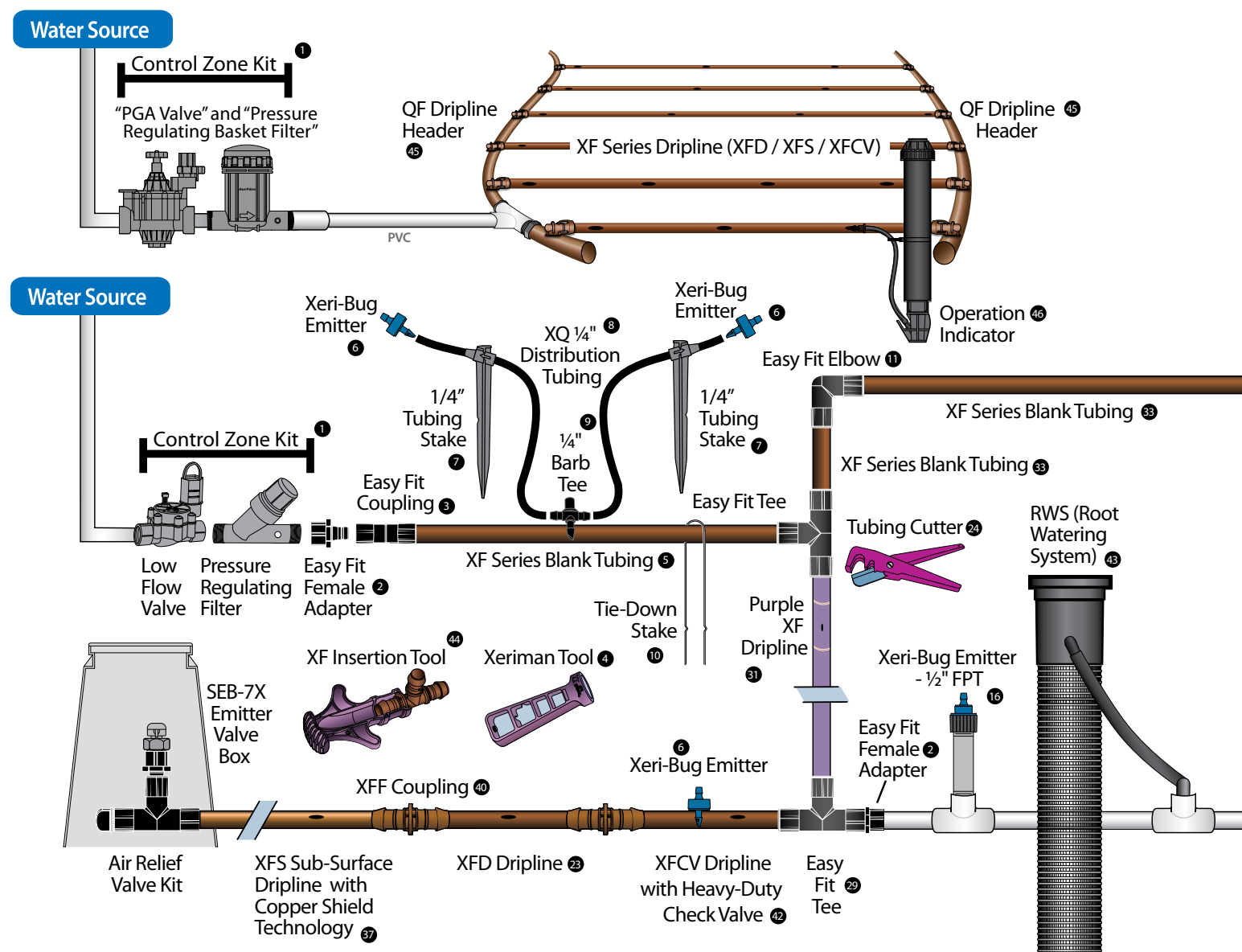



## Targeted Watering with Xerigation® / Landscape Drip

Rain Bird Xerigation/Landscape Drip products are made especially for low-volume irrigation systems. By delivering water at or near the plants' root zones, Rain Bird Xerigation products offer targeted watering with the following advantages:

- Water conservation
- Greater efficiency (target each plant)
- Design flexibility; simple construction and easily expandable
- Healthier plants
- Reduced liability (e.g. no overspray, no runoff)
- Minimization of weed growth
- Cost savings

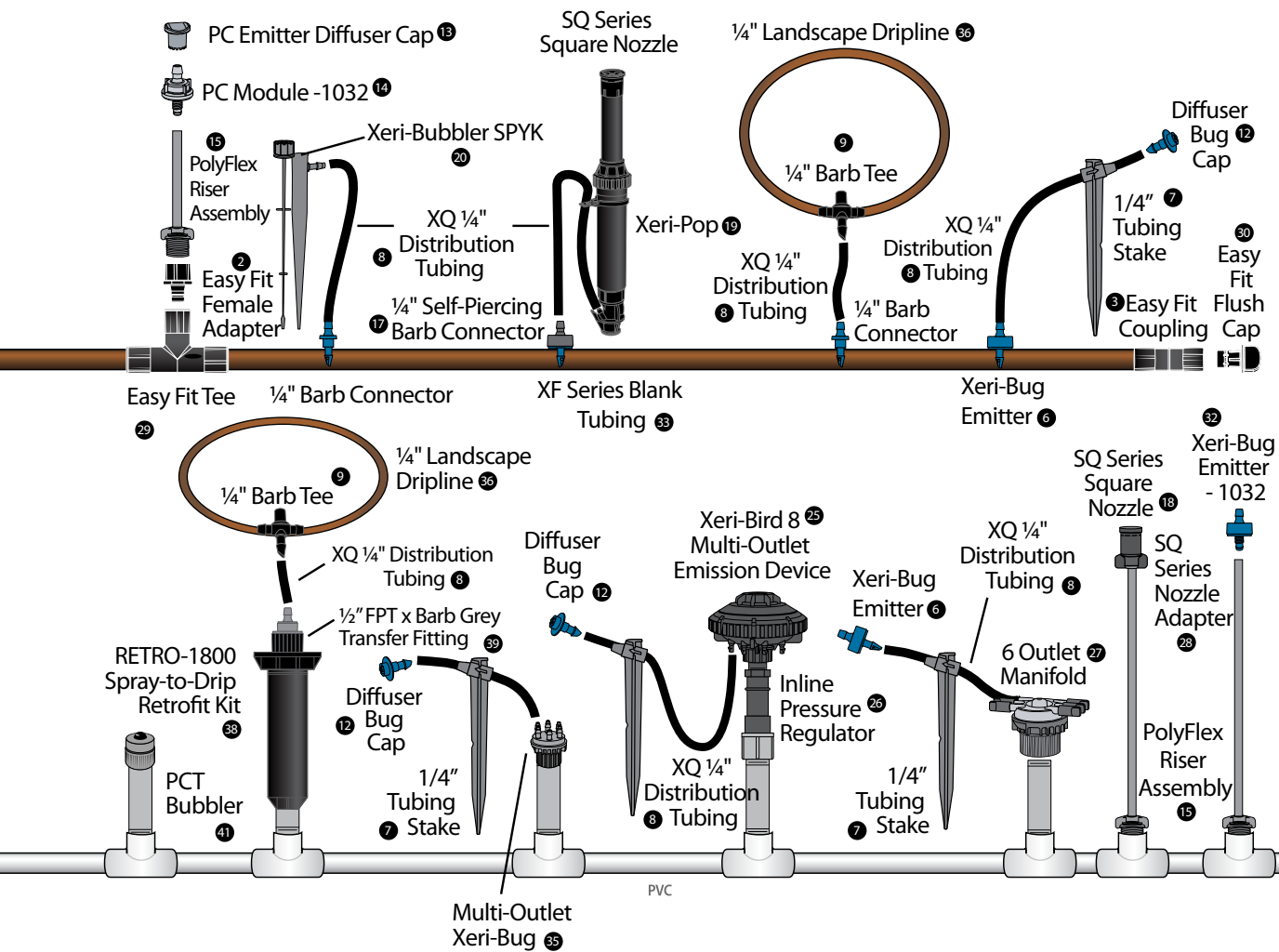

\* NOTE: Not all products listed in the Product Guide section are in the diagram above

# Xeri-Bug™ Emitters

## Barb Inlet x Barb Outlet

Point-source low-flow emitters for watering the root zones of plants, trees, and container plants.



XB-05-PC  
(0.5 GPH)



XB-10-PC  
(1.0 GPH)



XB-20-PC  
(2.0 GPH)



### Installation Option 1

Using a Xeriman Tool, insert an emitter directly into drip tubing or between dripline emitters as needed.

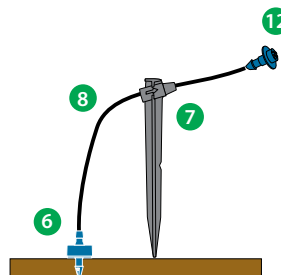

### Installation Option 2

For more precise water placement, use 1/4" distribution tubing, a 1/4" tubing stake, and a bug cap.

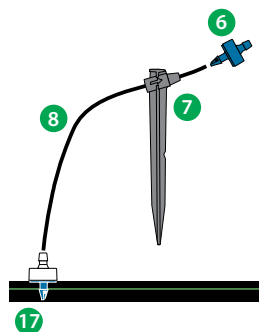

### Installation Option 3

For precise water placement, a barbed connector can be punched into distribution tubing. The emitter is then placed at the end of the 1/4" distribution tubing. NOTE: should the emitter become dislodged, unregulated flow will occur.

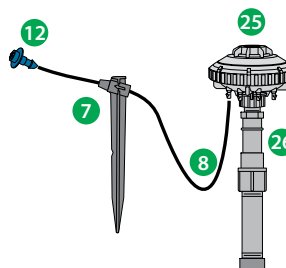

### Installation Option 4

The Xeri-Bird 8 provides a centralized location for up to eight emitters. A mix of Xeri-Bug and/ or PC emitters can be used to provide the flow rates needed for different plant materials. Tentacles of 1/4" distribution tubing, 1/4" tubing stakes, and bug caps allow for precise water placement.

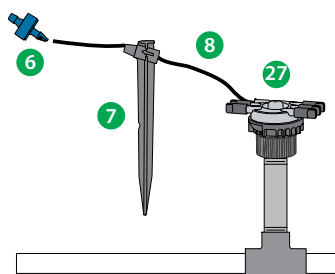

### Installation Option 5

The 6 Outlet Manifold provides a centralized water distribution connection for up to six emission devices. Connect the 1/4" distribution tubing to one of the outlets. Use a 1/4" tubing stake to ensure precise water placement. The emitter is placed on the end of the 1/4" distribution tubing to regulate the water flow. NOTE: should the emitter become dislodged, unregulated flow will occur.

### Drip Tip

When using an emitter at the end of the 1/4" distribution tubing, should the emitter become dislodged (or the 1/4" tubing gets cut) unregulated flow will occur.



## Xeri-Bug™ Emitters

### 10-32 Thread Inlet x Barb Outlet

Point-source low-flow emitters for watering the root zones of plants, trees, and container plants.



XB-05PC-1032  
(0.5 GPH)



XB-10PC-1032  
(1.0 GPH)



XB-20PC-1032  
(2.0 GPH)

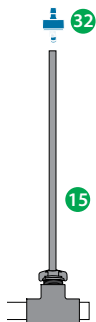

#### Installation Option 1

Use a 10-32 threaded emitter with a PolyFlex Riser for point-source applications in high foot traffic areas. (A pedestrian walking through a flower bed could pull up a staked emitter or otherwise cause misalignment of the ¼" distribution tubing. If they stepped on a PolyFlex Riser, the emitter would stay in place.)

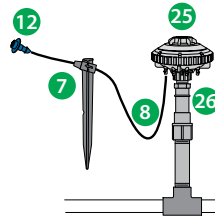

#### Installation Option 2

The Xeri-Bird 8 provides a centralized location for up to eight emitters. A mix of Xeri-Bug and/ or PC emitters can be used to provide the flow rates needed for different plant materials. Tentacles of ¼" distribution tubing, ¼" tubing stakes, and bug caps allow for precise water placement.

## Xeri-Bug™ Emitters

### ½" FPT Inlet x Barb Outlet

Point-source low-flow emitters for watering the root zones of plants, trees, and container plants.



XBT-10  
(1.0 GPH)



XBT-20  
(2.0 GPH)

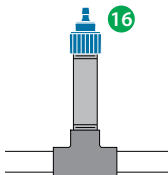

#### Installation Option 1

Use the ½" FPT inlet emitter connected to a PVC schedule 80 riser to regulate flow to plant material.

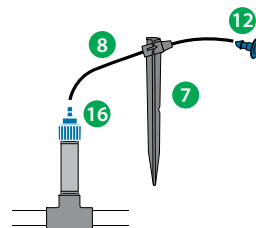

#### Installation Option 2

For more precise water placement, use ¼" distribution tubing, a ¼" tubing stake, and a bug cap.

## Multi-Outlet Xeri-Bug™

### Barb Inlet x Barb Outlet

Six outlet emitter with built-in pressure compensation. Use for watering the root zones of plants, trees, and container plants.



XB-05-6  
(0.5 GPH)



XB-10-6  
(1.0 GPH)



XB-20-6  
(2.0 GPH)

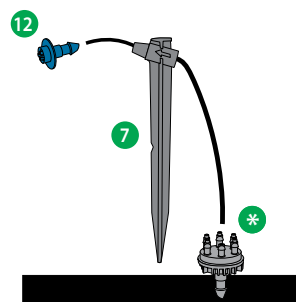

#### Installation Option 1

The Multi-Outlet Xeri-Bug provides centralized water distribution for up to six plants. All six outlets have the same flow rate. Connect the 1/4" distribution tubing to one of the outlets. Use a 1/4" tubing stake to ensure precise water placement. Insert a bug cap at the end of the tubing.

## Multi-Outlet Xeri-Bug™

### 1/2" FPT inlet x Barb Outlet

Six outlet emitter with built-in pressure compensation. Use for watering the root zones of plants, trees, and container plants.



XBT-05-6  
(0.5 GPH)



XBT-10-6  
(1.0 GPH)



XBT-20-6  
(2.0 GPH)

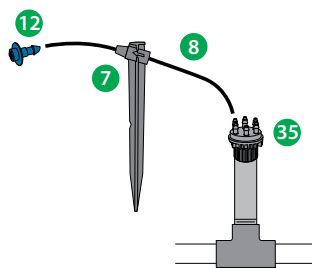

#### Installation Option 1

The Multi-Outlet Xeri-Bug can be mounted on a 1/2" schedule 80 riser to connect to PVC. It provides centralized water distribution for up to six plants. All six outlets have the same flow rate. Connect the 1/4" distribution tubing to one of the outlets. Use a 1/4" tubing stake to ensure precise water placement. Insert a bug cap at the end of the tubing.

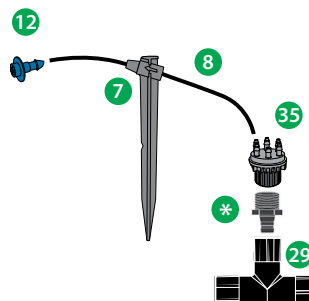

#### Installation Option 2

Using an Easy Fit Tee and Male Adapter, the Multi-Outlet Xeri-Bug can be attached to drip tubing. It provides centralized water distribution for up to six plants. All six outlets have the same flow rate. Connect the 1/4" distribution tubing to one of the outlets. Use a 1/4" tubing stake to ensure precise water placement. Insert a bug cap at the end of the tubing.



## 6 Outlet Manifold – EMT-6XERI

### ½" FPT Inlet

Six outlet manifold without pressure compensation. For use with Xeri-Bug or PC Module emitters, Xeri-Pops, bubblers, and micro-sprays.



EMT-6XERI

#### Installation Option 1

The 6 Outlet Manifold provides a centralized water distribution connection for up to six emission devices. Connect ¼" distribution tubing to one of the outlets. Use a ¼" tubing stake to ensure precise water placement. The emitter is placed on the end of the ¼" distribution tubing to regulate the water flow.

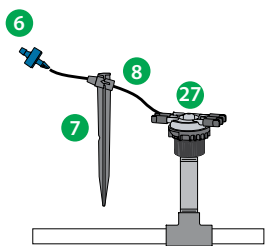

#### Installation Option 2

To incorporate spray heads into your drip system, connect the Xeri-Pop Micro-Spray to a multi-outlet manifold (EMT-6Xeri) via ¼" distribution tubing.

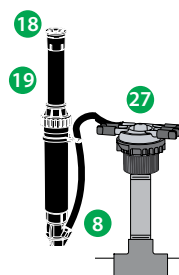

#### Installation Option 3

To incorporate bubblers or micro-sprays into your drip system, connect the needed product to a multi-outlet manifold (EMT-6Xeri) via ¼" distribution tubing.

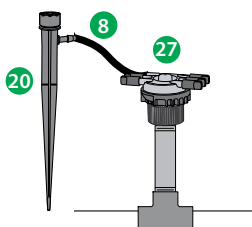

#### Drip Tip

Be conscious of your run times and application rates. Mixing products connected to the EMT-6Xeri can lead to over or under watering.

## Xeri-Bird™ 8 Multi-Outlet Emission Device

### ½" FPT Inlet x Barb Outlet

The most flexible multi-outlet device. Contains eight ports that accept Xeri-Bug emitters or PC Modules for independent flows from 0.5 to 24gph.



XBD-80

#### Installation Option 1

The Xeri-Bird 8 provides a centralized location for up to eight emitters. A mix of Xeri-Bug emitters and/ or PC Modules can be used to provide the flow rates needed for different plant materials. Tentacles of ¼" distribution tubing, ¼" tubing stakes, and bug caps allow for precise water placement.

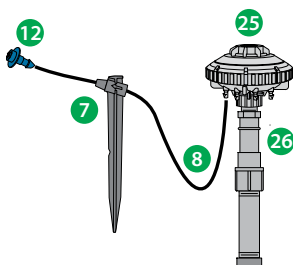

**NOTE:** Always install the emitters with the pointed or threaded end UP.

## Pressure-Compensating Modules

### Barb Inlet x Barb Outlet

Point-source medium-flow modules for watering larger shrubs and trees.



PC-05  
(5 GPH)



PC-07  
(7 GPH)



PC-10  
(10 GPH)



PC-12  
(12 GPH)



PC-18  
(18 GPH)



PC-24  
(24 GPH)

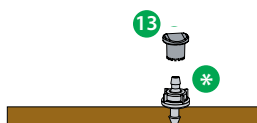

#### Installation Option 1

Using a Xeriman Tool, insert the PC Module directly into drip tubing or between dripline emitters as needed. Use a PC Diffuser Cap to eliminate squirting.

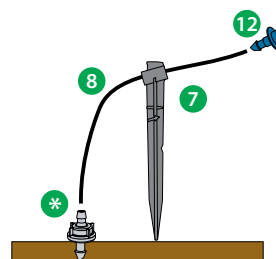

#### Installation Option 2

For more precise water placement, use 1/4" distribution tubing, a 1/4" tubing stake, and a bug cap.

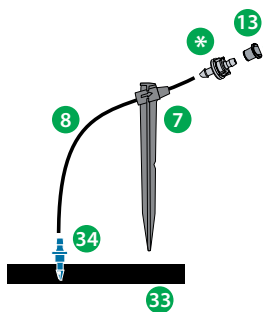

#### Installation Option 3

For precise water placement, a barbed connector can be punched into drip tubing. The PC Module with a PC Diffuser Cap is then placed at the end of the 1/4" distribution tubing. NOTE: should the emitter become dislodged, unregulated flow will occur.

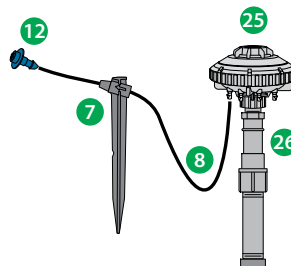

#### Installation Option 4

The Xeri-Bird 8 provides a centralized location for up to eight emitters. A mix of Xeri-Bug emitters and/or PC Modules can be used to provide the flow rates needed for different plant materials. Tentacles of 1/4" distribution tubing, 1/4" tubing stakes, and bug caps allow for precise water placement.

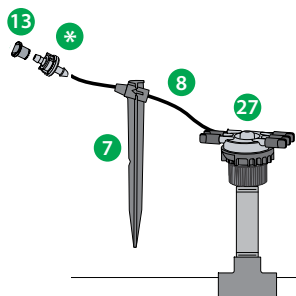

#### Installation Option 5

The 6 Outlet Manifold provides a centralized water distribution connection for up to six emission devices. Connect 1/4" distribution tubing to one of the outlets. Use a 1/4" tubing stake to ensure precise water placement. The PC Module with a PC Diffuser Cap is placed on the end of the 1/4" distribution tubing to regulate the water flow. NOTE: should the emitter become dislodged, unregulated flow will occur.

#### Drip Tip

When using an emitter at the end of the 1/4" distribution tubing, should the emitter become dislodged (or the 1/4" tubing gets cut) unregulated flow will occur.



## Pressure-Compensating Modules

### 10-32 Thread Inlet x Barb Outlet

Point-source medium-flow modules for watering larger shrubs and trees.



PC-05-1032  
(5 GPH)



PC-07-1032  
(7 GPH)



PC-10-1032  
(10 GPH)

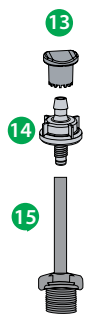

#### Installation Option 1

Use a 10-32 threaded emitter with a PolyFlex Riser for point-source applications in high foot traffic areas. (A pedestrian walking through a flower bed could pull up a staked emitter or otherwise cause misalignment of the 1/4" distribution tubing. If they stepped on a PolyFlex Riser, the emitter would stay in place.)

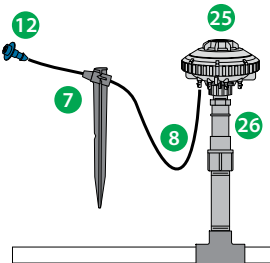

#### Installation Option 2

The Xeri-Bird 8 provides a centralized location for up to eight emitters. A mix of Xeri-Bug emitters and/ or PC Modules can be used to provide the flow rates needed for different plant materials. Tentacles of 1/4" distribution tubing, 1/4" tubing stakes, and bug caps allow for precise water placement.

## PC Diffuser

Use a PC Diffuser cap to eliminate squirting water when using a PC Module staked at the end of a 1/4" distribution tubing or on a PolyFlex Riser.



PC-DIFF-PPL (Purple to designate non-potable water)

#### Installation Option 1

Use a PC Diffuser Cap to eliminate squirting water when using a PC Module staked at the end of 1/4" distribution tubing or on a PolyFlex Riser.

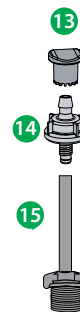

## Pressure Compensating Threaded Bubblers

Rain Bird's new heavy-duty pressure compensating bubblers are designed for a rugged environment. Offered in 5 gph, 7 gph, and 10 gph models, the bubbler style outlet and medium-flow options provide more flexibility for landscape layout. Its heavy-duty design is perfect for commercial applications. The 1/2" FPT threaded inlet makes these devices ideal for installations using a PVC pipe and schedule 80 risers.



PCT-05 PCT-07 PCT-10

#### Installation Option 1

PCT Bubblers can be mounted on a 1/2" schedule 80 riser to connect to PVC

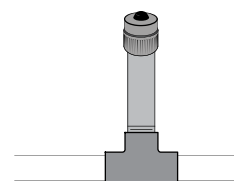

## Diffuser Bug Cap

Prevents bugs and other debris from clogging 1/4" distribution tubing.



DBC-025

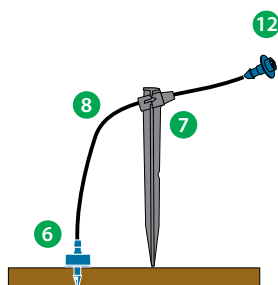

### Installation Option 1

Use a Diffuser Bug Cap at the end of 1/4" distribution tubing to prevent clogging caused by bugs and other debris.

## Xeri-Pop™ Micro-Spray

### 1/2" FPT Inlet x Barb Outlet

Pop-up spray for low-volume irrigation. Ideal for flower beds and vandal-prone areas.



XBT-400X  
(4 inch pop-up)



XBT-600X  
(6 inch pop-up)



XBT-1200X  
(12 inch pop-up)

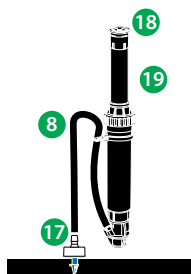

### Installation Option 1

The Xeri-Pop Micro-Spray allows you to incorporate spray heads into your drip system. Connect the Xeri-Pop Micro-Spray to drip tubing via 1/4" distribution tubing and a barb connector.

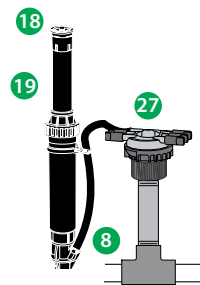

### Installation Option 2

Connect the Xeri-Pop Micro-Spray to a multi-outlet manifold (EMT-6Xeri) via 1/4" distribution tubing.

### Drip Tip

Any SQ nozzle can be swapped out for desired spray pattern. (Xeri-Pop ships with 1/2 pattern nozzle. 1/4 and full pattern nozzles also available)



#### SQ Nozzle Models:

- SQ QTR - Quarter Pattern
- SQ HLF - Half Pattern
- SQ FUL - Full Pattern



# SQ Series Nozzles

The pressure compensated SQ Series is the most precise and efficient, low-volume spray solution for irrigation of small areas. Unique edge-to-edge capability reduces the number of nozzles needed, which decreases cost and dramatically reduces installation time. Each nozzle can easily switch between a 2.5 ft. or 4 ft. throw.



Top View

**Quarter Pattern Nozzle**  
Color: Purple  
Model: SQ QTR



Bottom View

**Half Pattern Nozzle**  
Color: Brown  
Model: SQ HLF



Bottom View

**Full Pattern Nozzle**  
Color: Red  
Model: SQ FUL



Bottom View

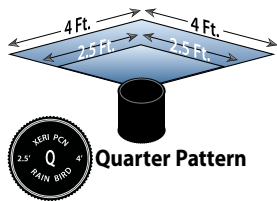

**Quarter Pattern**

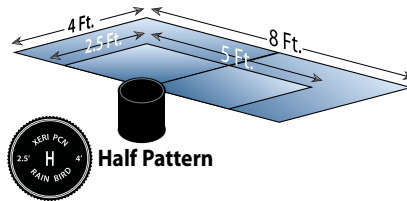

**Half Pattern**

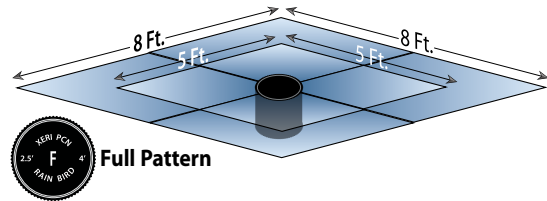

**Full Pattern**

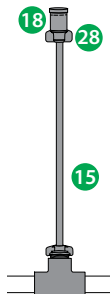

### Installation Option 1

The SQ can be connected to PE or PVC via a PolyFlex Riser via the SQ ADP adapter. The SQ ADP12 is the SQ ADP adapter preassembled to a 12" PolyFlex Riser. The SQ ADP24 is the SQ ADP adapter preassembled to a 24" polyflex riser.

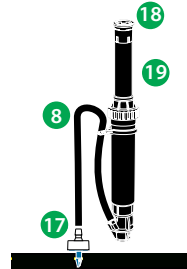

### Installation Option 2

The SQ can be installed on a Xeri-Pop Spray Head. The Xeri-Pop can be connected to PE or PVC. The Xeri-Pop can also be connected to drip or drip line tubing via 1/4" tubing and a barb connector. NOTE: Use one of these configurations in each watering zone to provide a pop-up run indicator for your drip system.



### Installation Option 3

The SQ can be installed on a Rain Bird 1800 Series Spray Head.

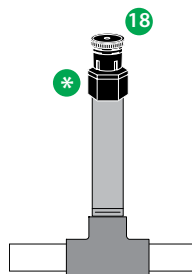

### Installation Option 4

The SQ can be attached to a schedule 80 PVC or PE riser using a PA-8S Plastic Shrub Adapter.

### Drip Tip

With a simple turn of the nozzle to the next preset stop, the SQ Series Nozzle adjusts from a 2.5 foot throw to a 4 foot throw.



## Xeri-Bubblers™

### Spike

Emission device with adjustable flow and radius. Ideal for shrub plantings, trees, containers, and flower beds.



SXB-180-SPYK

SXB-360-SPYK

UXB-360-SPYK

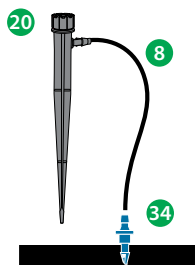

#### Installation Option 1

The Xeri-Bubbler Spike combines a bubbler with a 1/4" tubing stake for precise water placement. Simply connect the Xeri-Bubbler Spike to drip tubing via a barb connector. NOTE: The Xeri-Bubbler Spike comes with its own barb connector.

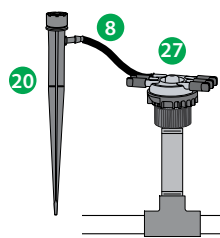

#### Installation Option 2

Connect up to six Xeri-Bubbler Spikes via 1/4" distribution tubing to a multi-outlet manifold (EMT-6Xeri).

## Xeri-Bubblers™

### Barb

Emission device with adjustable flow and radius. Ideal for shrub plantings, trees, containers, and flower beds.



SXB-180-025



SXB-360-025



UXB-360-025

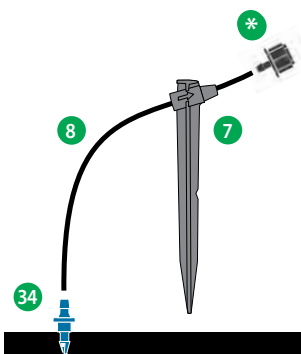

#### Installation Option 1

A barbed connector can be punched into distribution tubing. The Xeri-Bubbler is then placed at the end of the 1/4" distribution tubing. NOTE: should the bubbler become dislodged, unregulated flow will occur.

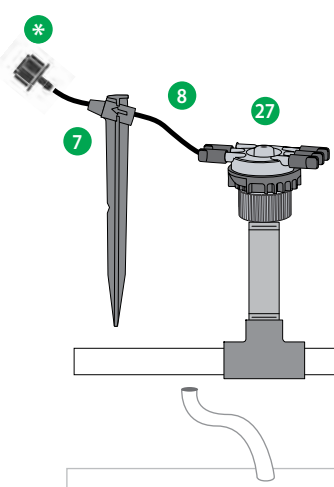

#### Installation Option 2

Connect up to six Xeri-Bubblers via 1/4" distribution tubing to a multi-outlet manifold (EMT-6Xeri). Use a 1/4" tubing stake for precise watering. NOTE: should the bubbler become dislodged, unregulated flow will occur.

Use with 1/2" poly



## Xeri-Bubblers™

### 10-32 Thread

Emission device with adjustable flow and radius. Ideal for shrub plantings, trees, containers, and flower beds.



**SXB-180-1032**  
Half Circle Stream Bubbler



**SXB-360-1032**  
Full Circle Stream Bubbler



**UXB-360-1032**  
Full Circle Umbrella Bubbler

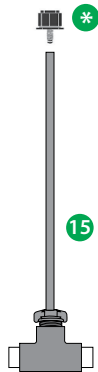

#### Installation Option 1

Use a 10-32 threaded bubbler with a PolyFlex Riser for point-source applications in high foot traffic areas. (A pedestrian walking through a flower bed could pull up a staked bubbler or otherwise cause misalignment of the ¼" distribution tubing. If they stepped on a PolyFlex Riser, the bubbler would stay in place.)

## Xeri-Sprays™ and Misters

### 10-32 Thread

Sprays and misters with adjustable flow and radius. Ideal for ground cover, mass plantings, annual flower beds, and containers.



**XS-090**  
Quarter Circle Spray



**XS-180**  
Half Circle Spray



**XS-360**  
Full Circle Spray



**X-360 ADJMST**  
Full Circle Adjustment Mister

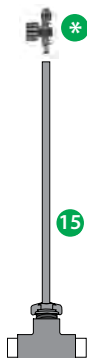

#### Installation Option 1

Use a 10-32 threaded spray or mister with a PolyFlex Riser for point-source applications. Threaded emission devices on PolyFlex Risers are great for high foot traffic areas.

ANATOMY

PRODUCTS

NARROW BEDS

PARKING LOT

PARKWAYS/  
WALKWAYS

POTS/BASKETS

SLOPES

STREET MEDIANS

WALLS

GOLF COURSES

TREES

## Xeri-Spray™ 360° True Spray Spike

True micro-spray with full-circle fan spray pattern. Ideal for ground cover, mass plantings, annual flower beds, and containers.



XS-360TS-SPYK

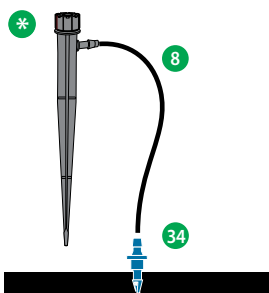

### Installation Option 1

The Xeri-Spray 360° True Spray Spike combines a spray head with a 1/4" tubing stake for precise water placement. Simply connect the Xeri-Spray 360° True Spray Spike to drip tubing via a barb connector. NOTE: The Xeri-Spray 360° True Spray Spike comes with its own barb connector.

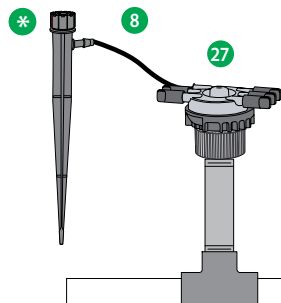

### Installation Option 2

Connect up to six Xeri-Spray 360° True Spray Spikes via 1/4" distribution tubing to a multi-outlet manifold (EMT-6Xeri).

## Xeri-Spray™ 360° True Spray Barb or 10-32 Thread

True micro-spray with full-circle fan spray pattern. Ideal for ground cover, mass plantings, annual flower beds, and containers.



XS-360TS-025



XS-360TS-1032

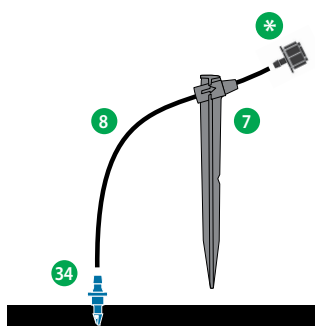

### Installation Option 1

A barbed connector can be punched into drip tubing. The Xeri-Bubbler is then placed at the end of the 1/4" distribution tubing. NOTE: should the bubbler become dislodged, unregulated flow will occur.

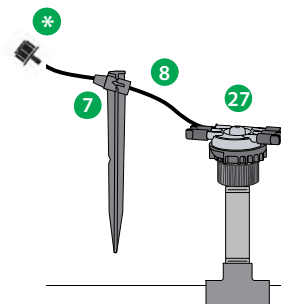

### Installation Option 2

Connect up to six Xeri-Bubblers via 1/4" distribution tubing to a multi-outlet manifold (EMT-6Xeri). Use a 1/4" tubing stake for precise watering. NOTE: should the bubbler become dislodged, unregulated flow will occur.



### Installation Option 3

Use a 10-32 threaded bubbler with a PolyFlex Riser for point-source applications in high foot traffic areas. (A pedestrian walking through a flower bed could pull up a staked bubbler or otherwise cause misalignment of the 1/4" distribution tubing. If they stepped on a PolyFlex Riser, the bubbler would stay in place.)

# Control Zone Kit Selection Guide

Rain Bird Control Zone Kits provide all the components necessary for on/off control, filtration and pressure regulation of a low-volume irrigation zone, making them simpler to order and easier to install.



## Commercial High Flow: 15 - 62 gpm



## Commercial Wide Flow: 0.3 - 20 gpm



## Residential Medium Flow: 3 - 15 gpm



## Residential Low Flow: 0.2 - 10 gpm

## Residential Low Flow: 0.2 - 5 gpm



## Narrow Planting Bed Next To a Structure

### Sparse Applications

#### Solution

*Xeri-Bird 8 & Xeri-Bug Emitters on a PVC Lateral*

#### Advantages

- Up to 60% water savings
- No overspray damage to structures, fences or windows
- Targeted watering reduces weed growth
- Manifold design allows for increase/decrease in future plant water demands



|                   |   |
|-------------------|---|
| <b>XBD-80</b>     | Xeri-Bird 8 Outlet Manifold                                   |
| <b>XB XX*</b>     | Xeri-Bug Pressure Compensating Drip Emitters (0.5 to 2.0 gph) |
| <b>PRS-050-30</b> | In-stem 30 psi Pressure Regulator                             |
| <b>XQ-100</b>     | 1/4" Distribution Tubing                                      |
| <b>TS-025</b>     | 1/4" Tubing Stake   |
| <b>PVC Misc</b>   | PVC Laterals, Fittings, Glue                                  |
| <b>DBC-025</b>    | Diffuser Bug Cap  |
| <b>SEB7X</b>      | Emitter Box (optional)  |

\* Select appropriate emitter flow

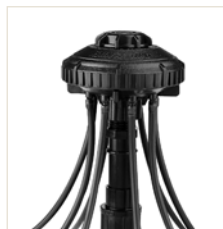

**XBD-80**



**PRS-050-30**



**XB XX**

#### TO DO LIST :

- Trench, cut and glue PVC laterals.
- Connect lines to water source.
- Thread Xeri-Bird 8 Outlet Manifold onto in-stem 30 psi Pressure Regulator, then connect to PVC tee.
- Attach 1/4" distribution tubing to outlets on Xeri-Bird 8 Outlet Manifold.
- Run 1/4" lines to sparse plantings, stake in place with a Diffuser Bug Cap on the end.
- Install the desired Xeri-Bug Emitter inside Xeri-Bird 8 Outlet Manifold.
- Use an SEB7X Emitter Box as added protection for the Xeri-Bird 8. (optional)

#### TIME: (approx.)

1 hr/20'  
1 hr  
5 min/Assembly  
3 min/Xeri-Bird 8  
8 min/Stake  
2 min

#### INSTALLATION AND MAINTENANCE TIPS :

- ◆ Flush the zone after installation and 2-4 times per year.
- ◆ Install XB Emitters in Xeri-Bird 8 Outlet Manifold with self-piercing barb or 1032 thread end up.
- ◆ Adjust watering time as seasons/weather changes.
- ◆ Leave 6" slack in 1/4" tubing in case of unexpected maintenance.





ANATOMY

PRODUCTS

NARROW BEDS

PARKING LOT

PARKWAYS/  
WALKWAYS

POTS/BASKETS

SLOPES

STREET MEDIANS

WALLS

GOLF COURSES

TREES



## Narrow Planting Bed Next To a Structure

### Dense Applications

#### Solution

*XFD Dripline Grid*

#### Advantages

- Up to 60% water savings due to zero wind loss
- No runoff = reduced liability in high traffic areas
- No overspray damage to structures, fences or windows
- XFD Dripline is easy to install, resulting in labor savings



#### Installation

|             |  |
|-------------|--|
| XFD-06-12   | XFD Dripline .6 gph @ 12" Spacing      |
| XCZ-100-PRF | 1" Xeri Control Zone Kit               |
| ARV050      | 1/2" Air Relief Valve                  |
| MDCF Series | Easy Fit Compression Fittings/Adapters |
| <b>OR</b>   |  |
| XFF Series  | XFF Dripline 17mm Insert Fittings      |
| TDS-050     | Tie Down Stake                         |



1/2" AIR RELIEF VALVE KIT



XFF FITTINGS

#### TO DO LIST :

- Assemble Control Zone Kit and connect to water source.
- Cut lengths of XF Dripline to build grid in planting area.
- Connect lengths of XF Dripline to Easy Fit Fittings (or XFF Dripline Fittings) to create grid.  
Add 1/2" Air Relief Valve kit to the zone.
- Connect Easy Fit Adapter to Easy Fit Tee for connection to Control Zone Kit.
- Stake XF Dripline grid in place and flush until clean water flows.
- Install planting material.

#### TIME: (approx.)

- 1hr
- 10min/50'
- 25 min/50'
- 5 min
- 5 min/50'

#### INSTALLATION AND MAINTENANCE TIPS :

- ◆ Flush the zone after installation and 2-4 times per year.
- ◆ Install Air Relief Valve Kit at high point in the system.
- ◆ Leave XFD Dripline coil in the sun while preparing for installation.



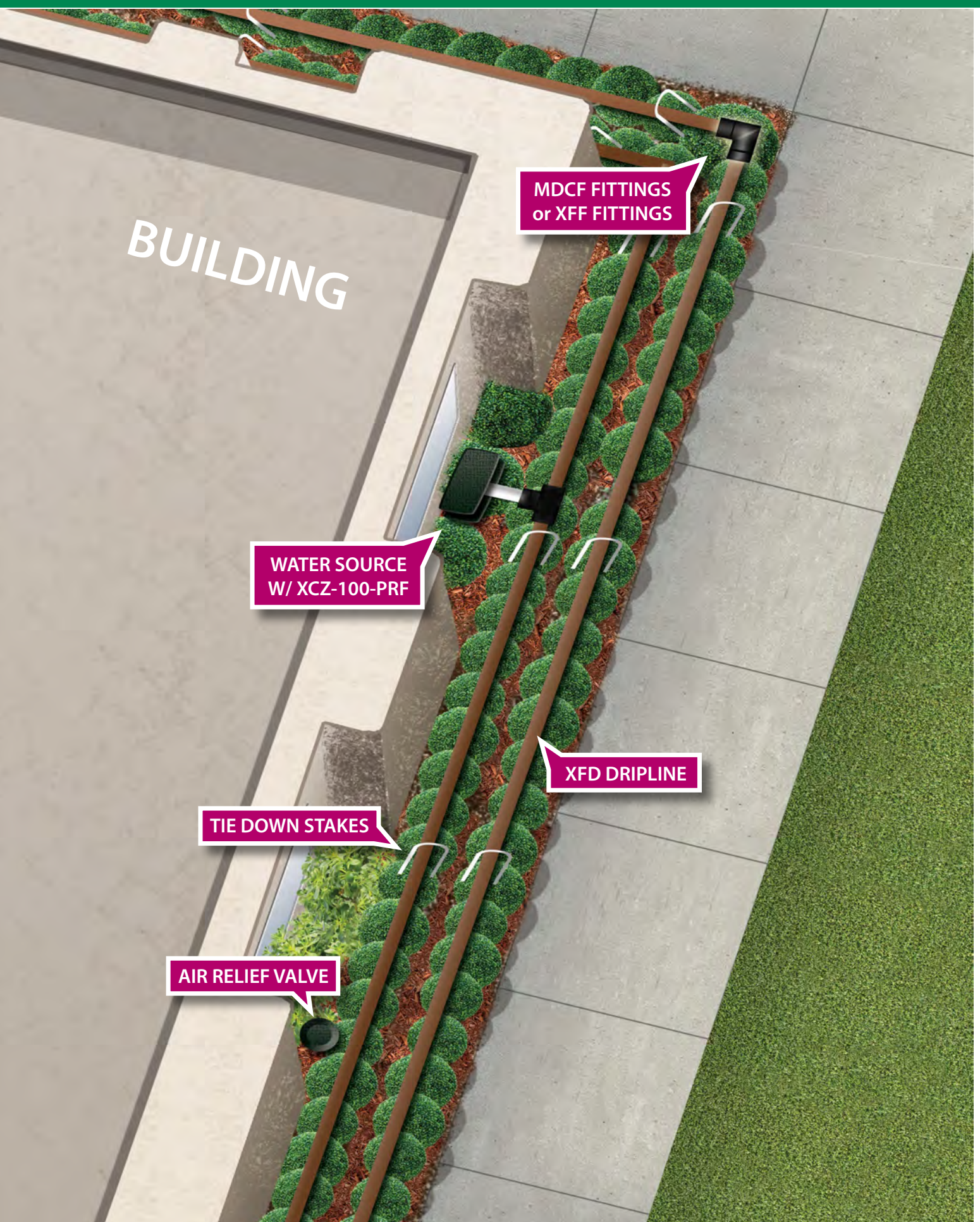

BUILDING

MDCF FITTINGS  
or XFF FITTINGS

WATER SOURCE  
W/ XCZ-100-PRF

XFD DRIPLINE

TIE DOWN STAKES

AIR RELIEF VALVE

ANATOMY

PRODUCTS

NARROW BEDS

PARKING LOT

PARKWAYS/  
WALKWAYS

POTS/BASKETS

SLOPES

STREET MEDIANS

WALLS

GOLF COURSES

TREES



## Narrow Planting Bed Next To a Structure

### Dense Applications

#### Solution

SQ Series Nozzle

#### Advantages

- Precise square wetting pattern – reducing overspray, overwatering, and runoff
- Up to 65% water savings due to efficient control of water placement with pressure compensation
- Adjustable radius or throw in one unit makes design and installation simple
- Highest distribution uniformity in the industry for short radius nozzles



#### Installation

|                       |   |
|-----------------------|---|
| SQ-XXX*               | SQ Series Nozzles   |
| PA-8S<br>OR<br>SQ ADP | Plastic Shrub Adapter for use with Schedule 80 Risers<br>SQ PolyFlex Riser Adapter for use with PFR-FRA PolyFlex Risers |
| PFR-FRA               | 12" PolyFlex Riser with ½" Male Threaded Base Adapter   |
| PVC Misc              | PVC Laterals, Fittings, Glue  |

\* Half, full, or quarter nozzles as needed for planting bed



SQ NOZZLES

#### TO DO LIST :

- Trench, cut and glue PVC laterals.
- Connect lines to water source.
- Thread in Schedule 80 riser, attach PA-8S Adapter and SQ Series Nozzle.  
**OR**
- Thread in PFR-FRA 12" PolyFlex Riser into PVC tee, attach SQ ADP Adapter and SQ Series nozzle.

#### TIME: (approx.)

1 hr / 20'  
1 hr  
5 min / Assembly  
5 min / Assembly

#### INSTALLATION AND MAINTENANCE TIPS :

- ◆ Flush the zone after installation and 2-4 times per year.
- ◆ Adjust watering time as seasons/weather changes.
- ◆ Ensure that all SQ Series Nozzles are adjusted to the appropriate throw distance.

#### Drip Tip

All SQ Series Nozzles in the same zone should be adjusted to either 2.5' or 4' throw. DO NOT mix throw settings in the same zone.



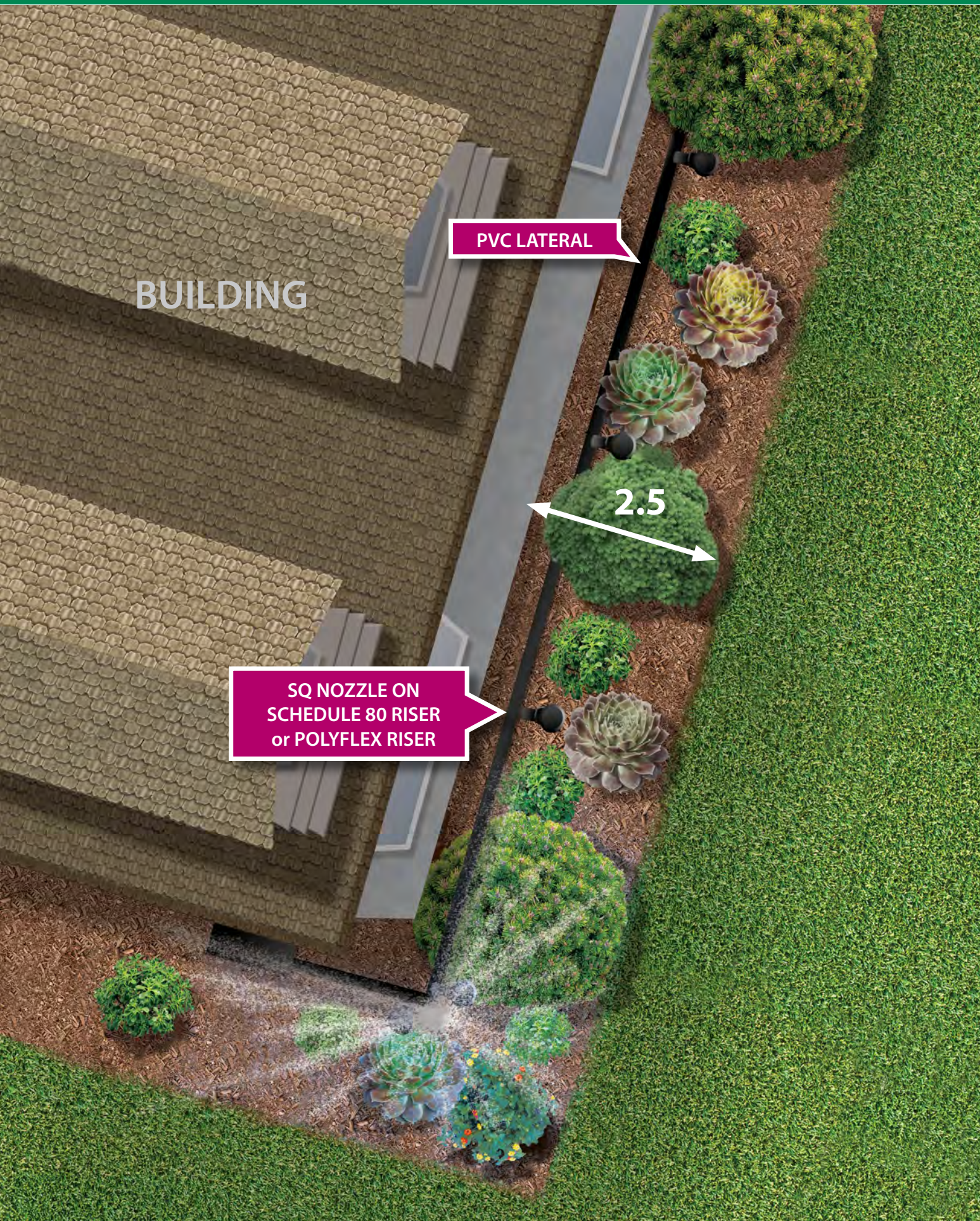

BUILDING

PVC LATERAL

SQ NOZZLE ON  
SCHEDULE 80 RISER  
or POLYFLEX RISER

2.5

ANATOMY

PRODUCTS

NARROW BEDS

PARKING LOT

PARKWAYS/  
WALKWAYS

POTS/BASKETS

SLOPES

STREET MEDIANS

WALLS

GOLF COURSES

TREES



## Narrow Beds

### Raised Beds

#### Solution

XFCV Dripline Grid

#### Advantages

- Up to 60% water savings due to zero wind loss
- Targeted watering helps reduce erosion of wall
- No runoff = reduced liability in high traffic areas
- XFCV Dripline is easy to install, resulting in labor savings



#### Installation

|                                 |   |
|---------------------------------|---|
| XFCV-06-12                      | XFCV Dripline .6 gph @ 12" spacing  |
| MDCF Series<br>OR<br>XFF Series | Easy Fit Compression Fittings/Adapters<br>XFF Dripline 17mm Insert Fittings |
| TDS-050 BEND                    | Tie Down Stake  |



XFF FITTINGS



XFCV Dripline

#### TO DO LIST :

- Assemble Control Zone Kit and connect to water source.
- Cut lengths of XFCV Dripline to build grid in crib wall.
- Connect lengths of XF Series Dripline to Easy Fit Fittings (or XFF Dripline fittings) to create grid. Connect to Control Zone Kit.
- Stake XF Series Dripline grid in place and flush until clean water flows.
- Install planting material.

#### TIME: (approx.)

1 hr  
10 min/50'  
30 min/50'  
5 min/10'

#### INSTALLATION AND MAINTENANCE TIPS :

- ◆ Flush the zone upon installation and 2-4 times per year.
- ◆ Leave XFCV Dripline coil in the sun while preparing for installation.
- ◆ Break up watering cycles to avoid run off or pooling of water in blocks.



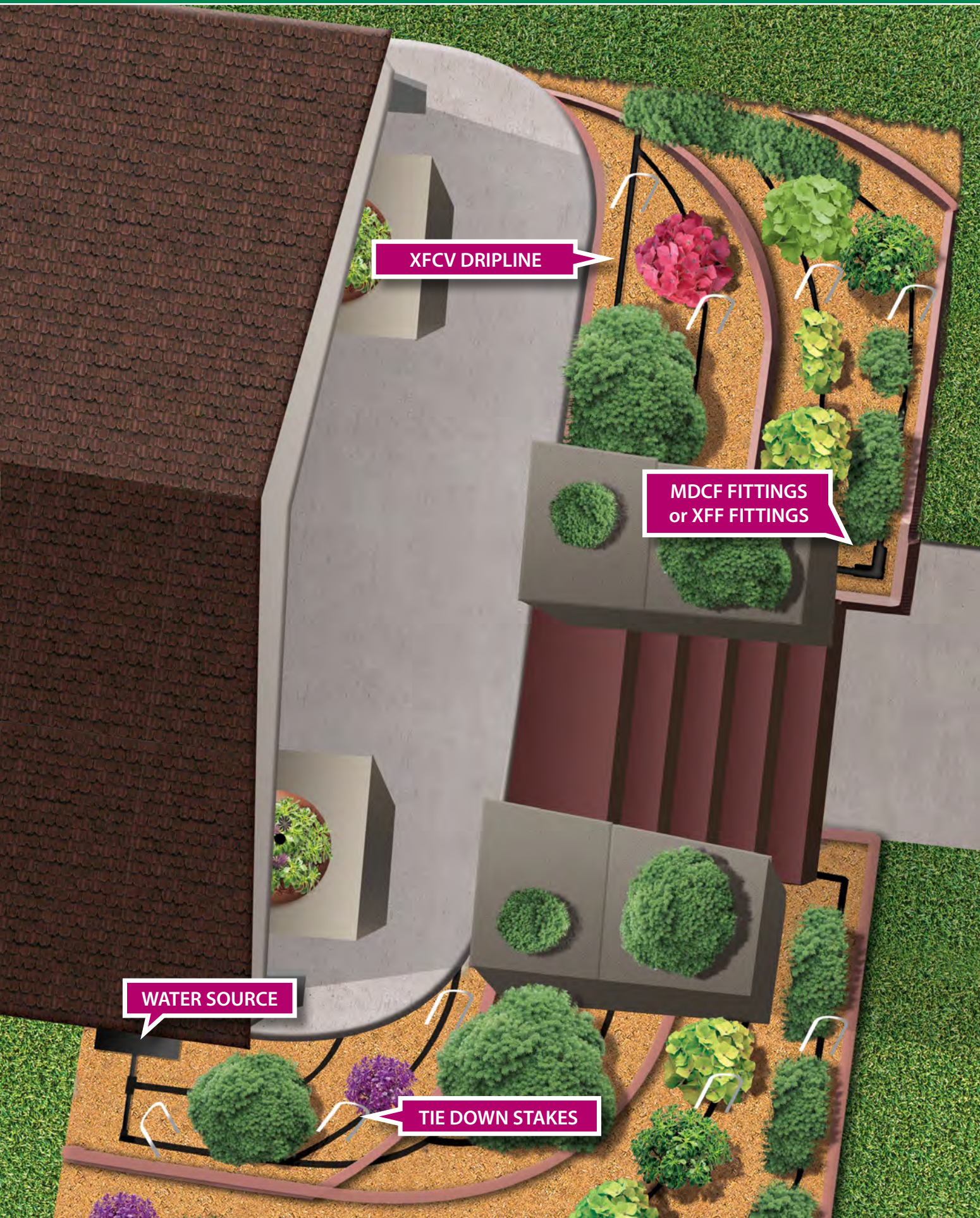

XFCV DRIPLINE

MDCF FITTINGS  
or XFF FITTINGS

WATER SOURCE

TIE DOWN STAKES

|       |              |       |                |        |              |                       |             |             |          |         |
|-------|--------------|-------|----------------|--------|--------------|-----------------------|-------------|-------------|----------|---------|
| TREES | GOLF COURSES | WALLS | STREET MEDIANS | SLOPES | POTS/BASKETS | PARKWAYS/<br>WALKWAYS | PARKING LOT | NARROW BEDS | PRODUCTS | ANATOMY |
|-------|--------------|-------|----------------|--------|--------------|-----------------------|-------------|-------------|----------|---------|



## Narrow Planting Bed Next To a Structure

### Combination Applications

#### Solution

XFD Dripline Grid with Xeri-Bug Emitters

#### Advantages

- Up to 60% water savings due to zero wind loss
- XFD Dripline is easy to install for labor savings
- No overspray damage to structures, fences or windows



#### Installation

|                                 |   |
|---------------------------------|---|
| XFD-06-12                       | XFD Dripline .6 gph @ 12" Spacing   |
| XCZ-075-PRF                     | 3/4" Xeri Control Zone Kit  |
| MDCF Series<br>OR<br>XFF Series | Easy Fit Compression Fittings/Adapters<br>XFF Dripline 17mm Insert Fittings |
| TDS-050 BEND                    | Tie Down Stake  |
| ARV050                          | 1/2" Air Relief Valve   |
| XB XX*                          | Xeri-Bug Pressure Compensating Drip Emitters (0.5 to 2.0 gph)               |
| DT-025                          | 1/4" Distribution Tubing  |
| TS-025                          | 1/4" Tubing Stake   |
| DCB-025                         | Diffuser Bug Cap  |

\* Select appropriate emitter flow rate



XFD

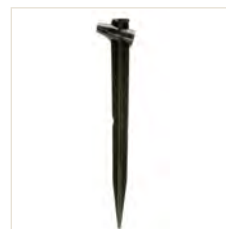

TS-025



XB XX

#### TO DO LIST :

- Assemble Control Zone Kit and connect to water source.
- Cut lengths of XFD Dripline to build grid in planting area.
- Connect lengths of XF Series Dripline to Easy Fit Fittings (or XFF Dripline fittings) to create grid, add Air Relief Valve
- Connect Easy Fit Adapter to Easy Fit Tee for connection to Control Zone Kit.
- Stake XF Series Dripline grid in place.
- Punch self-piercing barb inlet of Xeri-Bug Emitters into XF Series Dripline, connect 1/4" tubing to barb outlet and run 1/4" tubing to larger plant.
- Stake tubing in place and attach Diffuser Bug Cap on the end.
- Flush system until clean water flows.
- Install planting material.

#### TIME: (approx.)

- 1 hr
- 10 min/50'
- 20 min/50'
- 5 min
- 5 min/10'
- 8 min/Emitter
- 3 min/Stake
- 2 min

#### INSTALLATION AND MAINTENANCE TIPS :

- ◆ Supplemental Xeri-Bug Emitters are placed next to larger plants with higher water requirements.
- ◆ Flush the zone upon installation and 2-4 times per year.
- ◆ Install Xeri-Bug Emitters with the Xeriman Tool (XM Tool) for 50% faster installation.
- ◆ Leave XF Series Dripline coil in the sun while preparing for installation.



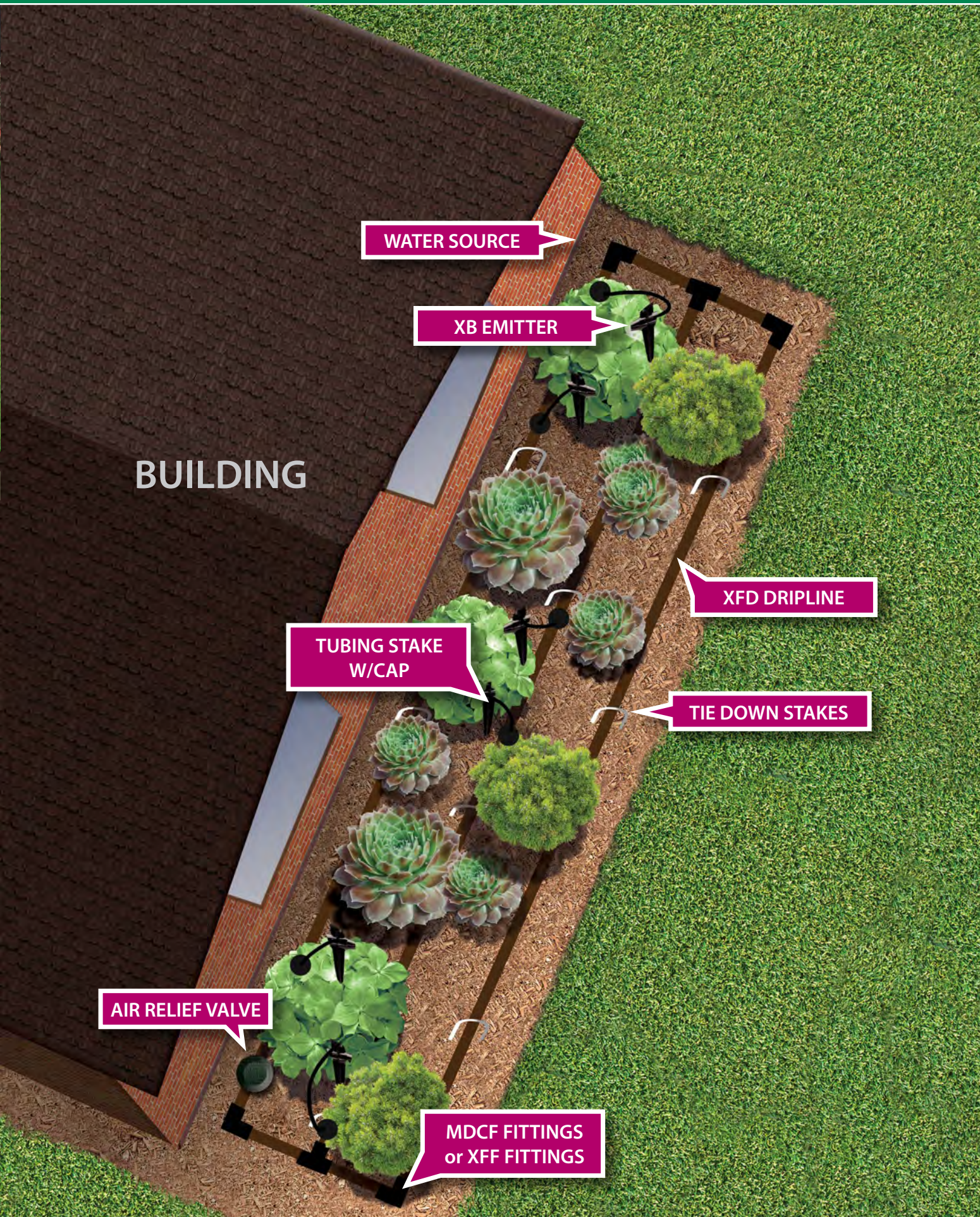

BUILDING

WATER SOURCE

XB EMITTER

XFD DRIPLINE

TUBING STAKE  
W/CAP

TIE DOWN STAKES

AIR RELIEF VALVE

MDCF FITTINGS  
or XFF FITTINGS

ANATOMY

PRODUCTS

NARROW BEDS

PARKING LOT

PARKWAYS/  
WALKWAYS

POTS/BASKETS

SLOPES

STREET MEDIANS

WALLS

GOLF COURSES

TREES



## Narrow Planting Bed/Divider

### Sparse Applications

#### Solution

*PolyFlex Riser/Adapter with Xeri-Bug 10-32 Drip Emitters on a PVC Lateral*

#### Advantages

- Up to 60% water savings
- No overspray damage to vehicles or parking lot
- Targeted watering reduces weed growth
- No runoff = reduced liability in high traffic areas



#### Installation

|              |   |
|--------------|---|
| PFR/FRA      | PolyFlex Riser/Adapter  |
| XB XX* 10-32 | Xeri-Bug Pressure Compensating Drip Emitters (0.5 to 2.0 gph) w/ 10-32 Thread |
| PVC Misc.    | PVC Laterals, Fittings, Glue  |
| XCZ-075-PRF  | 3/4" Xeri Control Zone Kit  |

\* Select appropriate emitter flow rate



XB XX 10-32



PFR-FRA

#### TO DO LIST :

- Trench, cut and glue PVC laterals.
- Assemble Control Zone Kit and position in valve box.
- Connect Control Zone to water source and laterals.
- Thread PolyFlex Riser/Adapter into PVC tees.
- Thread Xeri-Bug Emitter into PolyFlex Riser.
- Flush system until clean water flows.
- Add planting material and mulch.

#### TIME: (approx.)

- 1 hr/20'
- 1 hr
- 1 hr
- 5 min/Tee
- 5 min/PFR
- 2 min

#### INSTALLATION AND MAINTENANCE TIPS :

- ◆ Flush the zone after installation and 2-4 times per year.
- ◆ For larger trees use higher flow PC Modules and Diffuser caps to avoid wash out.
- ◆ Adjust watering time as seasons/weather changes.
- ◆ Cut PolyFlex Risers slightly above grade (before installing the Xeri-Bug Emitters) for an "invisible" installation.
- ◆ The PolyFlex Riser Adapter (FRA) is made of Marlex®, so no Teflon® tape is needed.



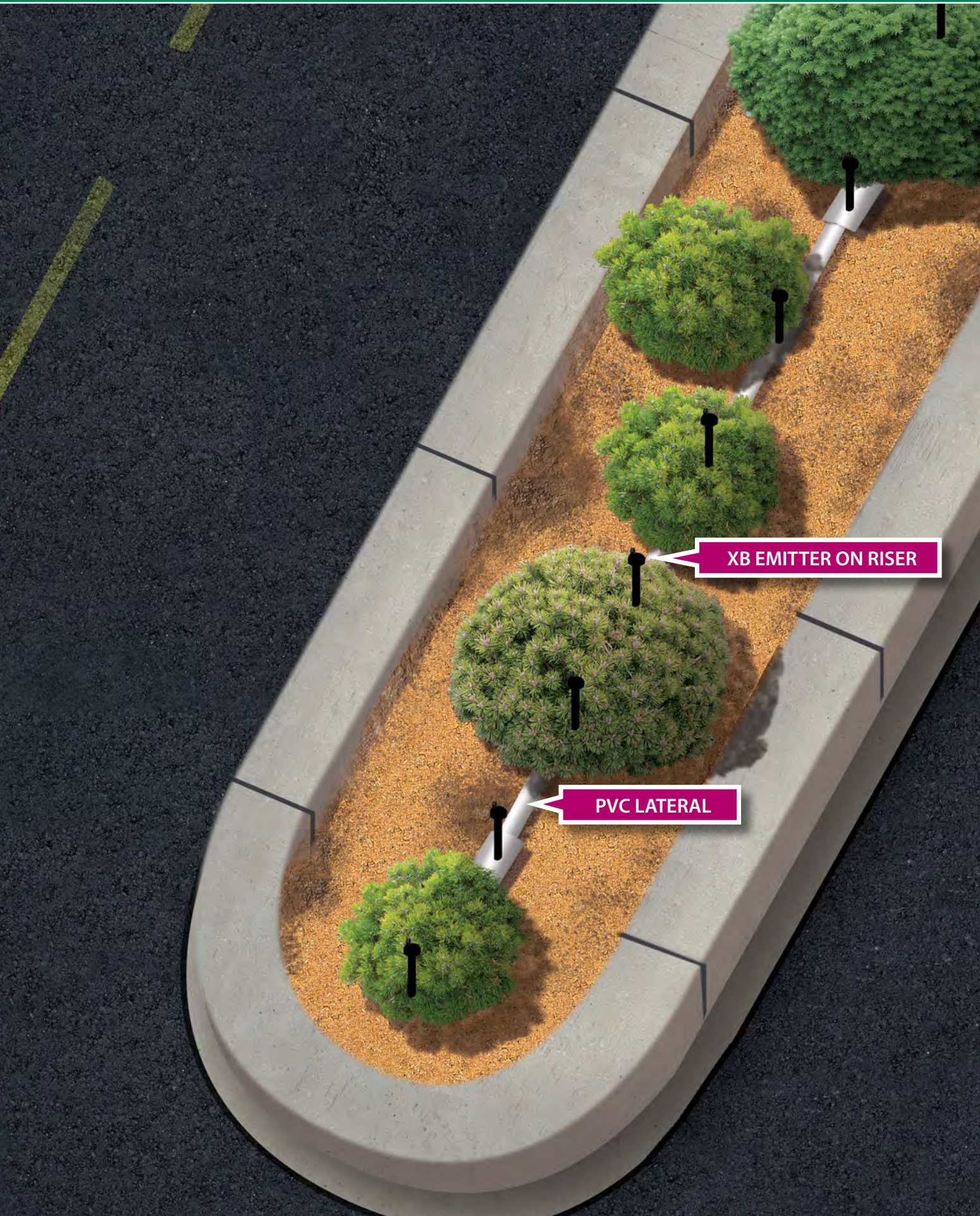

ANATOMY

PRODUCTS

NARROW BEDS

**PARKING LOT**

PARKWAYS/  
WALKWAYS

POTS/BASKETS

SLOPES

STREET MEDIANS

WALLS

GOLF COURSES

TREES



## Narrow Planting Bed/Divider

### Dense & Combination Applications

#### Solution

*XF Series Dripline Grid*

#### Advantages

- Up to 60% water savings due to zero wind loss
- No overspray damage to vehicles
- No runoff = reduced liability in high traffic areas
- XF is easy to install, resulting in labor savings

#### Installation

|                    |  |
|--------------------|--|
| <b>XFD-06-12</b>   | XFD Dripline .6 gph @ 12" Spacing        |
| <b>OR</b>          |  |
| <b>XFS-06-12</b>   | Subsurface Dripline .6 gph @ 12" Spacing |
| <b>XCZ-100-PRF</b> | 1" Control Zone Kit                      |
| <b>ARV-050</b>     | 1/2" Air Relief Valve                    |
| <b>MDCF Series</b> | Easy Fit Compression Fittings/Adapters   |
| <b>OR</b>          |  |
| <b>XFF Series</b>  | XFF Dripline 17mm Insert Fittings        |
| <b>TDS-050</b>     | Tie Down Stake                           |

#### TO DO LIST :

- Assemble Control Zone Kit and connect to water source. (1 hr)
- Connect Easy Fit Adapter to Easy Fit Tee for connection to Control Zone Kit. (5 min)
- Cut lengths of XF Series Dripline to build grid in planting area. (10 min/50')
- Connect lengths of XFD Dripline to Easy Fit (or XFF Insert) Fittings to create grid. Add Air Relief Valve Kit to the zone. (25 min/50')
- Stake XFD Dripline grid in place and flush until clean water flows. (5 min/10')
- Install planting material.

#### INSTALLATION AND MAINTENANCE TIPS :

- ◆ Flush the zone upon installation and 2-4 times per year.
- ◆ Install AR Valve Kit at high point in the system.
- ◆ Leave XF Dripline coil in the sun while preparing for installation.

#### Solution (Combination)

*SQ Series Nozzle on 1800 Spray Heads with Swing Assembly on PVC Lateral*

#### Advantages

- Precise square wetting pattern reduces overspray, overwatering, and runoff = up to 65% water saving
- Adjustable radius in one unit makes design and installation simple
- Highest distribution uniformity in the industry for short radius nozzles

#### Installation

|                 |   |
|-----------------|---|
| <b>SQ-XXX*</b>  | SQ Series Nozzles                                 |
| <b>180X</b>     | 1800 Series Spray Head with Desired Pop-up Height |
| <b>SA-XXX</b>   | SA Series Swing Assembly                          |
| <b>PVC Misc</b> | PVC Laterals, Fittings, Glue                      |

\* Half, full, or quarter nozzles as needed for planting bed

#### TO DO LIST :

- Trench, cut and glue PVC laterals. (1 hr/20')
- Connect lines to water source. (1 hr)
- Thread 1800 Series Spray Head onto swing assembly then thread the swing assembly into the Slip x Slip x Threaded Tee PVC fitting. (5 min/Assembly)
- Cut PVC laterals and glue in Slip x Slip x Threaded Tee assembly. (5 min/Tee)
- Flush system until water flows clear. (As needed)
- Install SQ Series nozzles on 1800 Spray Heads. (2 min/Nozzle)

#### INSTALLATION AND MAINTENANCE TIPS :

- ◆ Flush the zone after installation and 2-4 times per year.
- ◆ Adjust watering time as seasons/weather changes.
- ◆ Ensure that all SQ Series nozzles are adjusted to the appropriate throw distance.



## Solution (Dense)

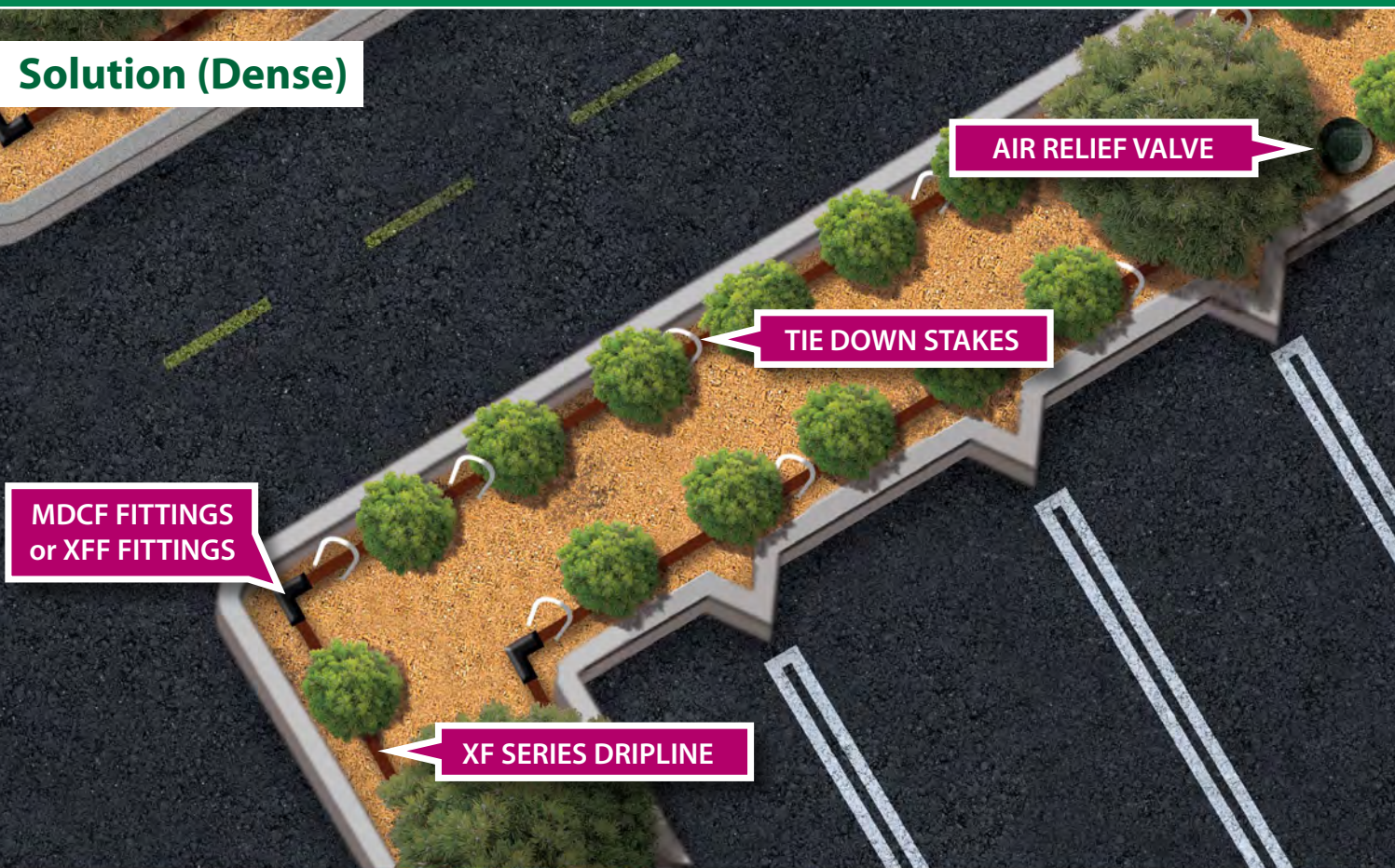

## Solution (Combination)



ANATOMY

PRODUCTS

NARROW BEDS

PARKING LOT

PARKWAYS/  
WALKWAYS

POTS/BASKETS

SLOPES

STREET MEDIANS

WALLS

GOLF COURSES

TREES



## Narrow Planting Bed/Divider Combination Applications

### Solution

*XF Series Dripline Grid with Xeri-Bug Emitters*

### Advantages

- Up to 60% water savings due to zero wind loss
- No over spray damage to vehicles or parking lot
- XF Series Dripline is easy to install for labor savings



### Installation

|             |   |
|-------------|---|
| XFD-06-12   | XF Series Dripline .6 gph @ 12" Spacing                       |
| XCZ-075-PRF | 3/4" Xeri Control Zone Kit                                    |
| ARV050      | 1/2" Air Relief Valve   |
| MDCF Series | Easy Fit Compression Fittings/Adapters                        |
| <b>OR</b>   |   |
| XFF Series  | XFF Dripline 17mm Insert Fittings                             |
| TDS-050     | Tie Down Stake  |
| XB XX*      | Xeri-Bug Pressure Compensating Drip Emitters (0.5 to 2.0 gph) |
| XQ-100      | 1/4" Distribution Tubing                                      |
| TS-025      | 1/4" Tubing Stake   |
| DCB-025     | Diffuser Bug Cap  |

\* Select appropriate emitter flow rate and barbed connection



TS-025



XFD



XB XX



1/2" Air Relief Valve

#### TO DO LIST :

- Assemble Control Zone Kit and connect to water source.
- Connect Easy Fit Adapter to Easy Fit Tee for connection to Control Zone Kit.
- Cut lengths of XF Series Dripline to build grid in planting area.
- Connect lengths of XF Series Dripline to Easy Fit (or XFF Insert) Fittings to create grid. Add 1/2" Air Relief Valve Kit to the zone.
- Stake XF Series Dripline grid in place.
- Punch self-piercing barb inlet of Xeri-Bug Emitters into XF Series Dripline, connect 1/4" tubing to barb outlet and run 1/4" tubing to larger plant.
- Stake 1/4" tubing in place and attach bug cap on the end.
- Flush system until clean water flows.
- Install planting material.

#### TIME: (approx.)

- 1 hr
- 5 min
- 10 min/50'
- 20 min/50'
- 5 min/10'
- 5 min/Emitter
- 5 min/Stake
- 2 min

#### INSTALLATION AND MAINTENANCE TIPS :

- ◆ Supplemental Xeri-Bug Emitters are placed next to larger plants with higher water requirements.
- ◆ Flush the zone upon installation and 2-4 times per year.
- ◆ Install 1/2" Air Relief Valve Kit at high point in the system.
- ◆ Install Xeri-Bug Emitters with the Xeriman Tool (XM Tool) for 50% faster installation.
- ◆ Leave XF Series Dripline coil in the sun while preparing for installation.



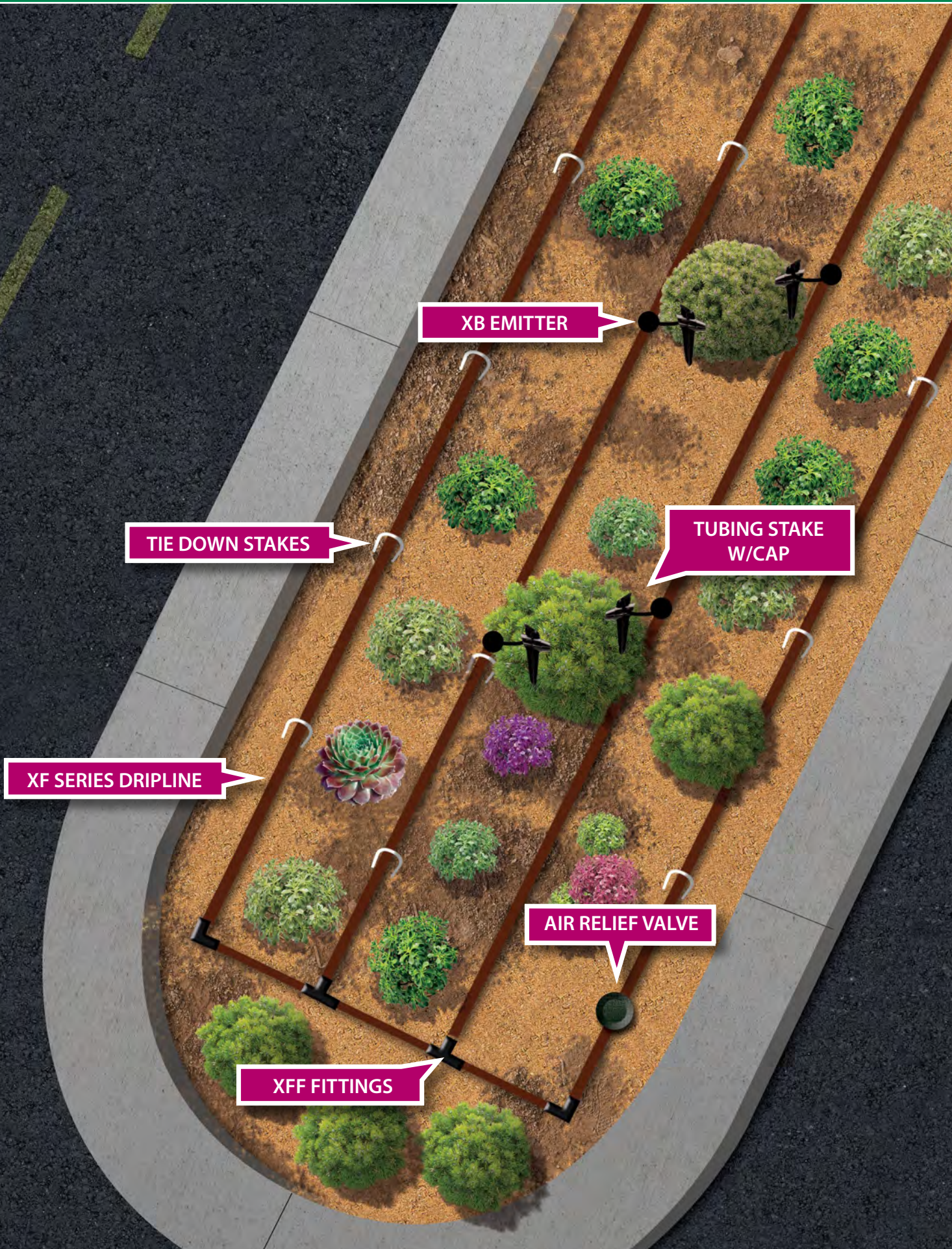

ANATOMY

PRODUCTS

NARROW BEDS

PARKING LOT

PARKWAYS/  
WALKWAYS

POTS/BASKETS

SLOPES

STREET MEDIANS

WALLS

GOLF COURSES

TREES



## Parkway and Walkways

### Dense Applications

#### Solution

*Xeri-Pops & SQ Series Nozzles on a Poly Tubing Lateral*

#### Advantages

- Precise square wetting pattern reduces overspray, overwatering, and runoff
- Up to 65% water savings due to efficient control of water placement with pressure compensation
- Adjustable radius in one unit makes design and installation simple
- Highest distribution uniformity in the industry for short radius nozzles



#### Installation

|                    |                                   |
|--------------------|-----------------------------------|
| <b>XCZ 075-PRF</b> | 3/4" Xeri Control Zone Kit        |
| <b>XP-XX00X</b>    | Desired Xeri-Pop Pop-up Height    |
| <b>SQ-XXX*</b>     | SQ Series Nozzles                 |
| <b>XQ-100</b>      | 1/4" Distribution Tubing          |
| <b>SPB-025</b>     | 1/4" Self Piercing Barb Connector |
| <b>XBS</b>         | Xeri Black Stripe Poly Tubing     |



XP-400X



SQ NOZZLES

\* Half, full, or quarter nozzles as needed for planting bed

#### TO-DO LIST:

- Trench beds (2-6 inches deep), cut and lay out Xeri Black Stripe Poly Tubing.
- Punch 1/4" Self Piercing Barb Connector into Xeri Black Stripe Poly Tubing laterals. Attach 1/4" tubing to outlet barb and run 1/4" tubing to edge of bed.
- Connect 1/4" tubing to inlet barb on Xeri-Pop. Dig small hole (4" wide x pop up depth) for Xeri-Pop.
- Determine desired watering pattern and pick appropriate SQ Series Nozzle.
- Drop Xeri-Pop into hole so the cap is at grade. Fill in dirt around Xeri-Pop so the body is supported in the soil and exit port for nozzle is in the correct position.
- Flush lines until clean water flows and install planting material.

#### TIME: (approx.)

30 min/50'  
10 min/20'  
  
15 min/  
Xeri-Pop  
5 min/Nozzle  
3 min/Nozzle  
  
10 min/  
Xeri-Pop  
2 min

#### INSTALLATION AND MAINTENANCE TIPS :

- ◆ For seasonal replanting, lift Xeri-Pops out of ground and lay aside.
- ◆ Do not disconnect the 1/4" tubing.
- ◆ After replanting, reinstall the Xeri-Pops in the planting area.
- ◆ Operate Xeri-Pops at 40 psi for optimal performance.

#### Drip Tip

With a simple turn of the nozzle to the next preset stop, the SQ Series Nozzle adjusts from a 2.5' throw to a 4' throw. All nozzles in the same zone must be adjusted to the same throw.



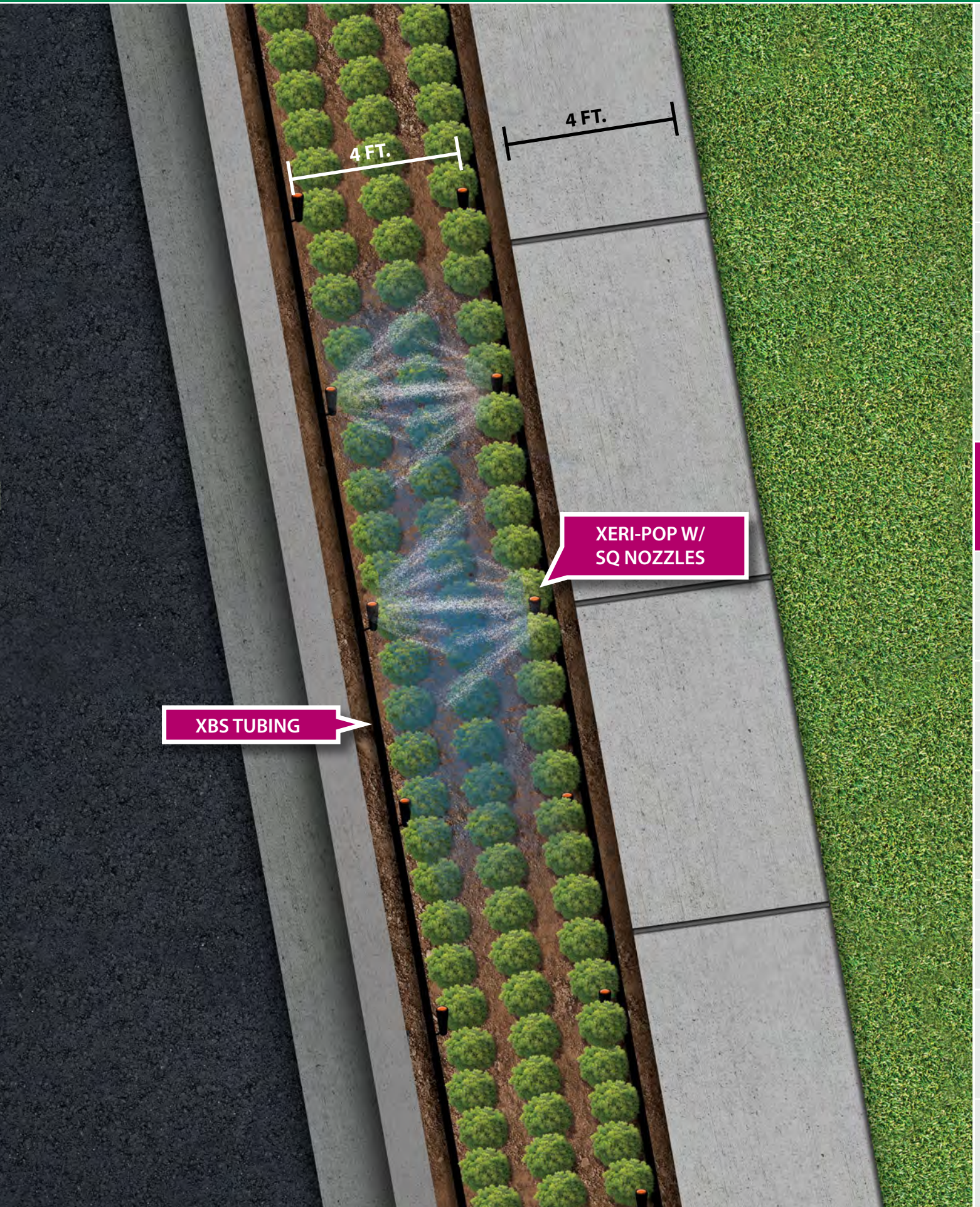

ANATOMY

PRODUCTS

NARROW BEDS

PARKING LOT

PARKWAYS/  
WALKWAYS

POTS/BASKETS

SLOPES

STREET MEDIANS

WALLS

GOLF COURSES

TREES



# Patio Pots on Separate Zone

Page 1 of 3

## Solution

*OPTION A: PVC Tubing with Xeri-Bird 8 & Xeri-Bug Emitters*

*OPTION B: PVC Tubing with 6 Outlet Manifold & 1/4" Landscape Dripline Loop*

## Advantages

- Up to 60% water savings
- Xeri-Bird 8 Manifold with PRS offers pressure regulation, filtration and controlled watering to multiple pots
- Manifold allows for increase/decrease in future plant requirements



## Installation

### Option A

|                  |   |
|------------------|---|
| <b>XBD-80</b>    | Xeri-Bird 8 Outlet Manifold                                   |
| <b>XB XX*</b>    | Xeri-Bug Pressure Compensating Drip Emitters (0.5 to 2.0 gph) |
| <b>PRS-050</b>   | In-stem 30 psi Pressure Regulator                             |
| <b>XQ-100</b>    | 1/4" Distribution Tubing                                      |
| <b>TS-025</b>    | 1/4" Tubing Stake   |
| <b>DCB-025</b>   | Diffuser Bug Cap  |
| <b>PVC Misc.</b> | PVC Laterals, Fittings, Glue                                  |

\* Select appropriate emitter flow rate

#### TO-DO LIST:

- Trench (as needed), cut and glue PVC laterals.
- Connect lines to water source.
- Thread Xeri-Bird 8 Outlet Manifold onto in-stem 30 psi Pressure Regulator and connect to PVC tee.
- Attach 1/4" distribution tubing to outlets on manifold.
- Run 1/4" lines to Pots, stake in place with a bug cap on the end.
- Install the desired Drip Emitter inside manifold.\*

\* Emitter varies by location (0.5 to 2.0 gph)

#### TIME A:

1 hr/20'  
1 hr  
5 min  
2 min/  
XBD-80  
8 min/  
Pot  
2 min

### Option B

|                      |                              |
|----------------------|------------------------------|
| <b>EMT-6XERI</b>     | 6 Outlet Manifold            |
| <b>XQ-100</b>        | 1/4" Distribution Tubing     |
| <b>XBF-3TEE</b>      | 1/4" Barb Tee                |
| <b>LDQ-08-06-100</b> | 1/4" Landscape Dripline      |
| <b>PVC Misc.</b>     | PVC Laterals, Fittings, Glue |

#### TO-DO LIST:

- Trench (as needed), cut and glue PVC laterals.
- Connect lines to water source.
- Thread 6 Outlet Manifold onto riser, then connect to PVC tee.
- Attach 1/4" distribution tubing to outlets on manifold.
- Run 1/4" lines to pots and connect tubing to barb tee. Then run 1/4" Landscape Dripline in a circle inside the pot and connect both ends to the barb tee.

#### TIME B:

1 hr/20'  
1 hr  
2 min/  
EMT-6Xeri  
2 min  
8 min/Pot

### INSTALLATION AND MAINTENANCE TIPS :

- ◆ Flush the zone after installation and 2-4 times per year.
- ◆ Adjust watering time as seasons/weather changes.



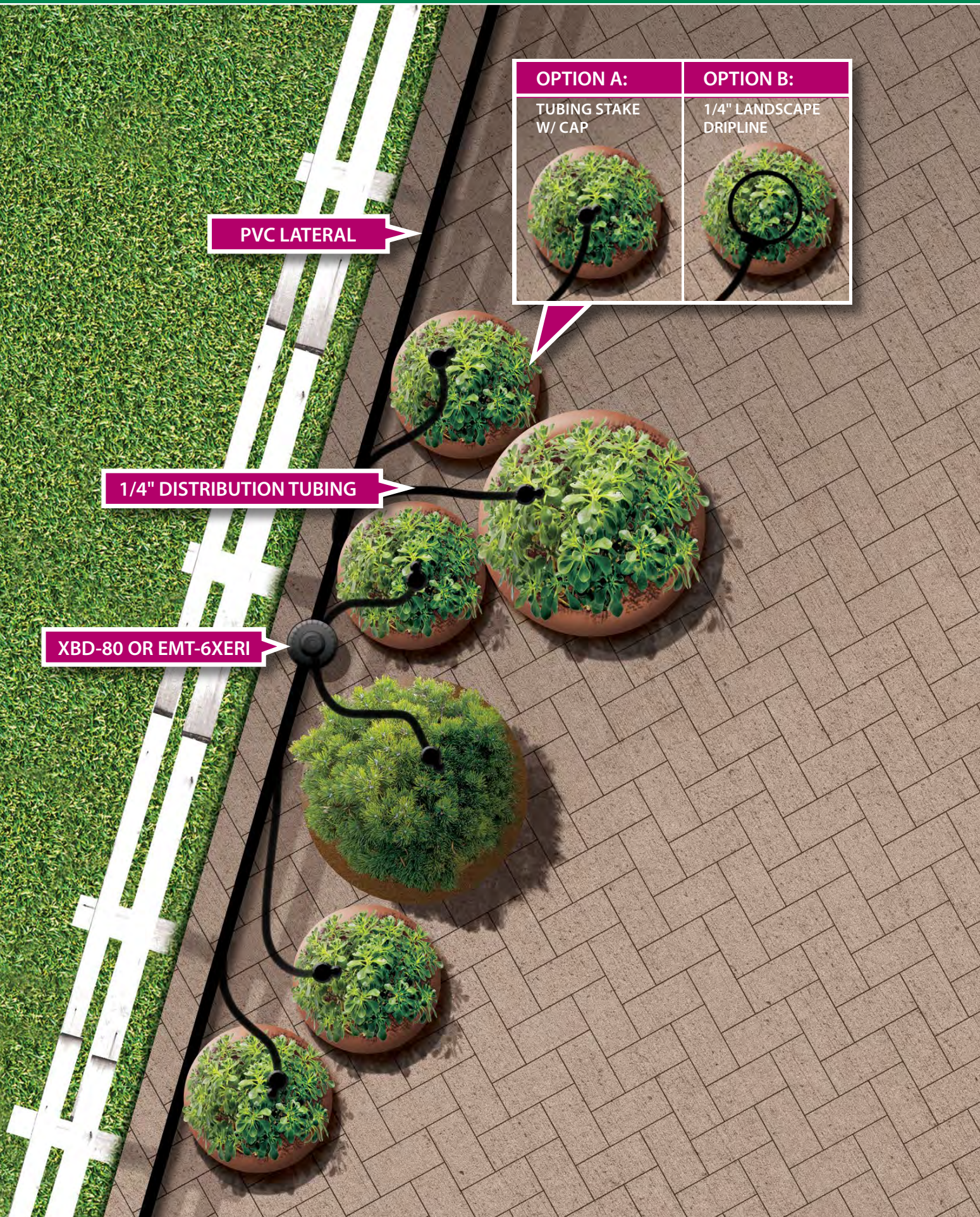

PVC LATERAL

1/4" DISTRIBUTION TUBING

XBD-80 OR EMT-6XERI

| OPTION A:  | OPTION B:   |
|--|---|
| TUBING STAKE W/ CAP  | 1/4" LANDSCAPE DRIPLINE   |
|  |  |

ANATOMY

PRODUCTS

NARROW BEDS

PARKING LOT

PARKWAYS/  
WALKWAYS

POTS/BASKETS

SLOPES

STREET MEDIANS

WALLS

GOLF COURSES

TREES



## Patio Pots on Separate Zone

Page 2 of 3

### Solution

*Poly Tubing Lateral with Multi-Outlet Xeri-Bug*

### Advantages

- Up to 60% water savings
- Poly tubing flexible for odd shaped areas
- Multi-Outlet Xeri-Bug ensures even watering to multiple pots



### Installation

|             |  |
|-------------|--|
| XCZ-075-PRF | 3/4" Xeri Control Zone Kit                                 |
| XB-XX-6*    | Multi-Outlet Xeri-Bug (6 Outlet PC Manifold w/ Barb Inlet) |
| XBS         | Xeri Black Stripe Poly Tubing                              |
| XQ-100      | 1/4" Distribution Tubing                                   |
| TS-025      | 1/4" Tubing Stake  |
| DCB-025     | Diffuser Bug Cap   |

\* Select appropriate emitter flow rate



TS-025



XB-XX-6



XBS

#### TO DO LIST :

- Cut and lay out poly lines.
- Assemble Control Zone Kit and connect to water source and poly lines.
- Punch hole in poly tubing and insert XB-XX-6 manifold.
- Connect 1/4" tubing to XB-XX-6 barb outlets and run tubing to pots.
- Stake in place with a bug cap on the end.

#### TIME: (approx.)

30 min/50'  
1 hr 15 min  
3 min/XB-XX-6  
8 min/Pot  
3 min/Pot

#### INSTALLATION AND MAINTENANCE TIPS :

- ◆ For invisible installation, run 1/4" tubing through the drain hole in the bottom of the pot prior to adding plant material.

#### Drip Tip

Do not run 1/4" tubing more than 5'-8' from the XB emitter device.



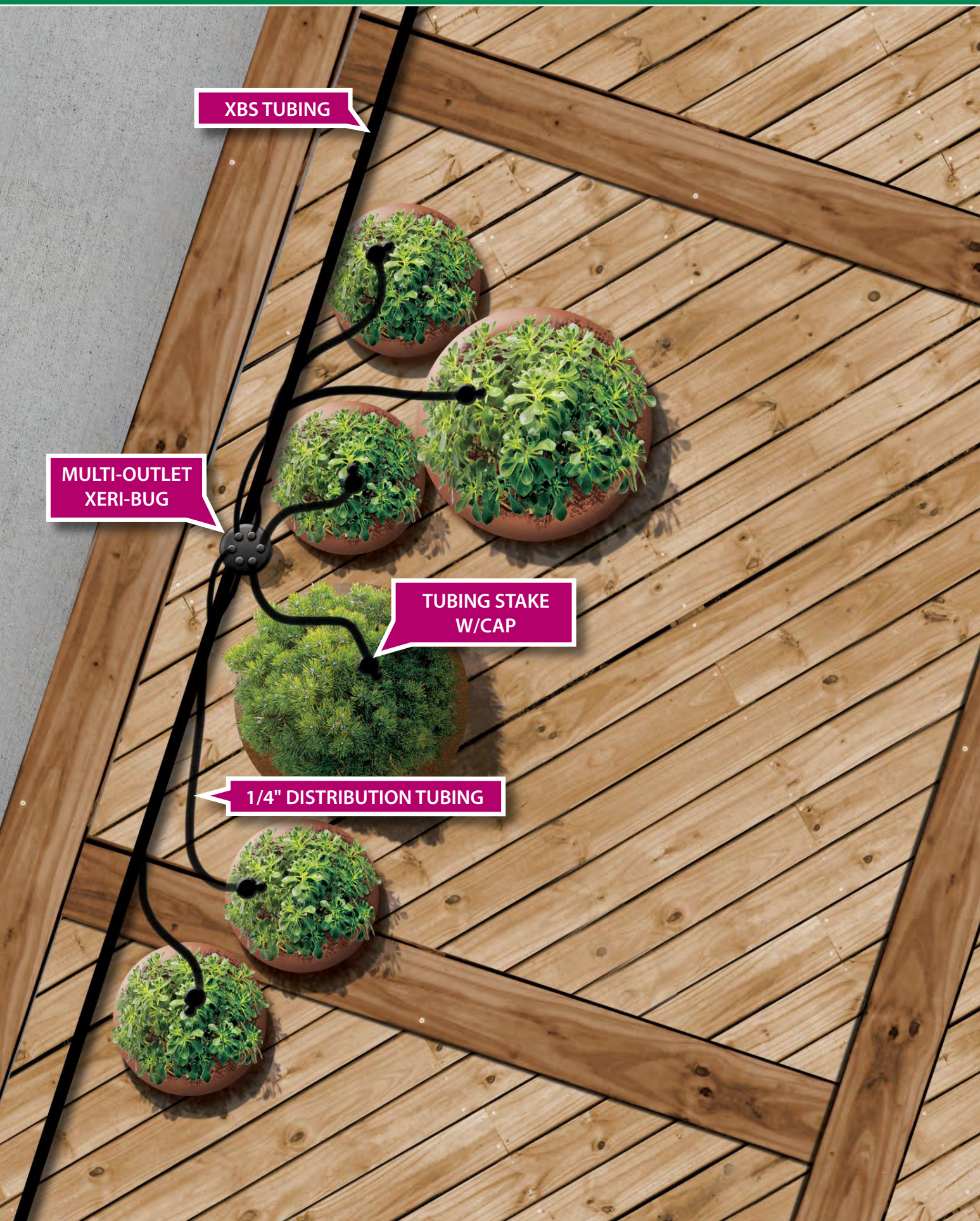

XBS TUBING

MULTI-OUTLET XERI-BUG

TUBING STAKE W/CAP

1/4" DISTRIBUTION TUBING

ANATOMY

PRODUCTS

NARROW BEDS

PARKING LOT

PARKWAYS/  
WALKWAYS

POTS/BASKETS

SLOPES

STREET MEDIANS

WALLS

GOLF COURSES

TREES



# Patio Pots on Separate Zone

Page 3 of 3



## Solution

*OPTION A: Poly Tubing Lateral with Xeri-Bug Barb Emitters*

*OPTION B: Poly Tubing Lateral with 1/4" Landscape Dripline Loop*

## Advantages

- Up to 60% water savings
- Poly tubing flexible for odd shaped areas
- Xeri-Bug Emitters can accommodate the watering needs of a variety of potted plants

## Installation

### Option A

|                    |   |
|--------------------|---|
| <b>XCZ-075-PRF</b> | 3/4" Xeri Control Zone Kit                                    |
| <b>XBS</b>         | Xeri Black Stripe Poly Tubing                                 |
| <b>XQ-100</b>      | 1/4" Distribution Tubing                                      |
| <b>XB XX*</b>      | Xeri-Bug Pressure Compensating Drip Emitters (0.5 to 2.0 gph) |
| <b>TS-025</b>      | 1/4" Tubing Stake   |
| <b>DCB-025</b>     | Diffuser Bug Cap  |

\* Select appropriate emitter flow rate

#### TO-DO LIST:

- |  |                              |
|--|------------------------------|
| <input type="checkbox"/> Cut and lay out poly lines.   | <b>TIME A:</b><br>30 min/50' |
| <input type="checkbox"/> Assemble Control Zone Kit and connect to water source and poly lines.   | 1 hr 15 min                  |
| <input type="checkbox"/> Use Xeri-Bug Emitters' self-piercing barb to connect poly lateral tubing with 1/4" distribution tubes. Run 1/4" distribution tubes to pots. | 8 min/Pot                    |
| <input type="checkbox"/> Connect distribution tubes to Tubing Stake with a bug cap on the end.   | 3 min/Pot                    |

### Option B

|                      |                               |
|----------------------|-------------------------------|
| <b>XCZ-075-PRF</b>   | 3/4" Xeri Control Zone Kit    |
| <b>XBS</b>           | Xeri Black Stripe Poly Tubing |
| <b>XQ-100</b>        | 1/4" Distribution Tubing      |
| <b>XBF1CONN</b>      | 1/4" Barb Connector           |
| <b>XBF 3TEE</b>      | 1/4" Barb Tee                 |
| <b>LDQ-08-06-050</b> | 1/4" Landscape Dripline       |

#### TO-DO LIST:



- |  |                              |
|--|------------------------------|
| <input type="checkbox"/> Cut and lay out poly lines.   | <b>TIME B:</b><br>30 min/50' |
| <input type="checkbox"/> Assemble Control Zone Kit and connect to water source and poly lines.   | 1 hr 15 min                  |
| <input type="checkbox"/> Insert 1/4" barb connector into poly line, connect 1/4" distribution tubing to barb connector, run 1/4" lines to pots and connect tubing to barb tee. Then create loop by running 1/4" Landscape Dripline in a circle inside the pot and connect both ends to the barb tee. | 8 min/Pot                    |

### INSTALLATION AND MAINTENANCE TIPS :

- ◆ Do not run 1/4" tubing more than 5'-8' from the XB emitter device.





| OPTION A:  | OPTION B:   |
|--|---|
| TUBING STAKE W/ CAP  | 1/4" LANDSCAPE DRIPLINE   |
|  |  |

**XBS TUBING**

**1/4" DISTRIBUTION TUBING**

**XB EMITTER or BARB CONNECTOR**

|                       |
|-----------------------|
| ANATOMY               |
| PRODUCTS              |
| NARROW BEDS           |
| PARKING LOT           |
| PARKWAYS/<br>WALKWAYS |
| <b>POTS/BASKETS</b>   |
| SLOPES                |
| STREET MEDIANS        |
| WALLS                 |
| GOLF COURSES          |
| TREES                 |



# Hanging Baskets



## Solution

*OPTION A: Poly Tubing Lateral with Xeri-Bug Emitters*

*OPTION B: Poly Tubing Lateral with 1/4" Landscape Dripline Loop*

## Advantages

- Up to 60% water savings
- Targeted watering in baskets
- Eliminates hand watering
- Connect to irrigation timer for consistent automatic watering

## Installation

### Option A

|                           |   |
|---------------------------|---|
| <b>XCZ-075-PRF</b>        | 3/4" Control Zone with 40 psi Pressure Regulator              |
| <b>XBS</b>                | Xeri Black Stripe Poly Tubing                                 |
| <b>XB XX*</b>             | Xeri-Bug Pressure Compensating Drip Emitters (0.5 to 2.0 gph) |
| <b>XQ-100</b>             | 1/4" Distribution Tubing                                      |
| <b>XM Tool</b>            | XM Installation Tool  |
| <b>Electrical Staples</b> | 1/2" Metal Staples  |
| <b>TS-025</b>             | 1/4" Tubing Stake   |
| <b>DCB-025</b>            | Diffuser Bug Cap  |

\* Select appropriate emitter flow rate and barbed connection

#### TO-DO LIST:

- |  |                        |
|--|------------------------|
| <input type="checkbox"/> Assemble Control Zone Kit at water source and connect poly tube laterals to edge of structure.                    | <b>TIME A:</b><br>1 hr |
| <input type="checkbox"/> Elbow poly lateral in vertical line up structure to eaves Staple poly lateral to structure.                       | 40 min/50'             |
| <input type="checkbox"/> Staple poly lateral along underside of eaves.   | 30 min/50'             |
| <input type="checkbox"/> Use XM Tool to punch Xeri-Bug Emitters into poly lateral above baskets.   | 10 min/<br>Basket      |
| <input type="checkbox"/> Connect short length of 1/4" tubing to Xeri-Bug Emitters and stake in basket. Add bug caps to ends of 1/4" lines. | 8 min/Basket           |

### Option B

|                      |                               |
|----------------------|-------------------------------|
| <b>XCZ-075-PRF</b>   | 3/4" Xeri Control Zone Kit    |
| <b>XBS</b>           | Xeri Black Stripe Poly Tubing |
| <b>XQ-100</b>        | 1/4" Distribution Tubing      |
| <b>XBF1CONN</b>      | 1/4" Barb Connector           |
| <b>XBF 3TEE</b>      | 1/4" Barb Tee                 |
| <b>LDQ-08-06-100</b> | 1/4" Landscape Dripline       |

#### TO-DO LIST:

- |  |                        |
|--|------------------------|
| <input type="checkbox"/> Assemble Control Zone Kit at water source and connect poly tube laterals to edge of structure.  | <b>TIME B:</b><br>1 hr |
| <input type="checkbox"/> Elbow poly lateral in vertical line up structure to eaves. Staple poly lateral to structure.  | 40 min/50'             |
| <input type="checkbox"/> Staple poly lateral along underside of eaves.   | 30 min/50'             |
| <input type="checkbox"/> Use XM Tool to punch 1/4" barb connector into poly lateral above baskets.   | 10 min/<br>Basket      |
| <input type="checkbox"/> Insert 1/4" barb connector into poly line, connect 1/4" distribution tubing to barb connector, run 1/4" lines to baskets and connect tubing to barb tee. Then create loop by running 1/4" Landscape Dripline in a circle inside the basket and connect both ends to the barb tee. | 8 min/Basket           |



#### INSTALLATION AND MAINTENANCE TIPS :

- ◆ Flush the zone after installation and 2-4 times per year.
- ◆ Use XM Tool for faster installation of Xeri-Bug Emitters and 1/4" barb connectors.
- ◆ Break up watering cycles to avoid excess drainage.



# BUILDING

**XBS TUBING  
(INSTALLS UNDER  
ROOF EAVES)**

| <b>OPTION A:</b>  | <b>OPTION B:</b>   |
|---|--|
| <b>TUBING STAKE<br/>W/ CAP</b>  | <b>1/4" LANDSCAPE<br/>DRIPLINE</b>   |
|  |  |

**XB EMITTER or  
BARB CONNECTOR**

ANATOMY

PRODUCTS

NARROW BEDS

PARKING LOT

PARKWAYS/  
WALKWAYS

**POTS/BASKETS**

SLOPES

STREET MEDIANS

WALLS

GOLF COURSES

TREES



## Slopes

### Sparse Applications

#### Solution

*Xeri-Bird 8 & Xeri-Bug Emitters on a PVC Lateral*

#### Advantages

- Up to 65% water savings
- Xeri-Bird 8 manifold with PRS offers pressure regulation, filtration and controlled watering to multiple plants
- Manifold allows for increase/decrease in future plant water demands



#### Installation

|                   |   |
|-------------------|---|
| <b>XBD-80</b>     | Xeri-Bird 8 Outlet Manifold                                   |
| <b>XB XX*</b>     | Xeri-Bug Pressure Compensating Drip Emitters (0.5 to 2.0 gph) |
| <b>PRS-050-30</b> | In-stem 30 psi Pressure Regulator                             |
| <b>XQ-100</b>     | 1/4" Distribution Tubing                                      |
| <b>TS-025</b>     | 1/4" Tubing Stake   |
| <b>DCB-025</b>    | Diffuser Bug Caps   |
| <b>PVC Misc.</b>  | PVC Laterals, Fittings, Glue                                  |
| <b>SEB7X</b>      | Emitter Box (optional)  |

\* Select appropriate emitter flow rate and barbed or threaded connection

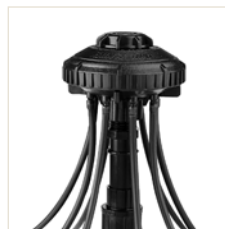

XBD-80



PRS-050-30



XB XX

#### TO DO LIST :

- Trench, cut and glue PVC laterals.
- Connect lines to water source.
- Thread Xeri-Bird 8 Outlet Manifold onto in-stem 30 psi Pressure Regulator, then connect to PVC tee.
- Attach 1/4" distribution tubing to outlets on Xeri-Bird 8 Outlet Manifold.
- Run 1/4" lines to plants, stake in place with a Diffuser Bug Cap on the end.
- Install the desired Xeri-Bug Emitter inside Xeri-Bird 8 Outlet Manifold.
- Use and SEB7X Emitter Box as added protection for the Xeri-Bird 8. (optional)

#### TIME: (approx.)

1 hr/20'  
1 hr  
5 min/Assembly  
  
3 min/XBD-80  
8 min/Stake  
2 min

#### INSTALLATION AND MAINTENANCE TIPS :

- ◆ Flush the zone after installation and 2-4 times per year.
- ◆ Install Xeri-Bug Emitters in Xeri-Bird 8 Outlet Manifold with self-piercing barb or threaded end up.
- ◆ Leave 6" slack in 1/4" tubing next to manifold in case of unexpected maintenance.

#### Drip Tip

Do not run 1/4" tubing more than 5'-8' from the XBD-80.



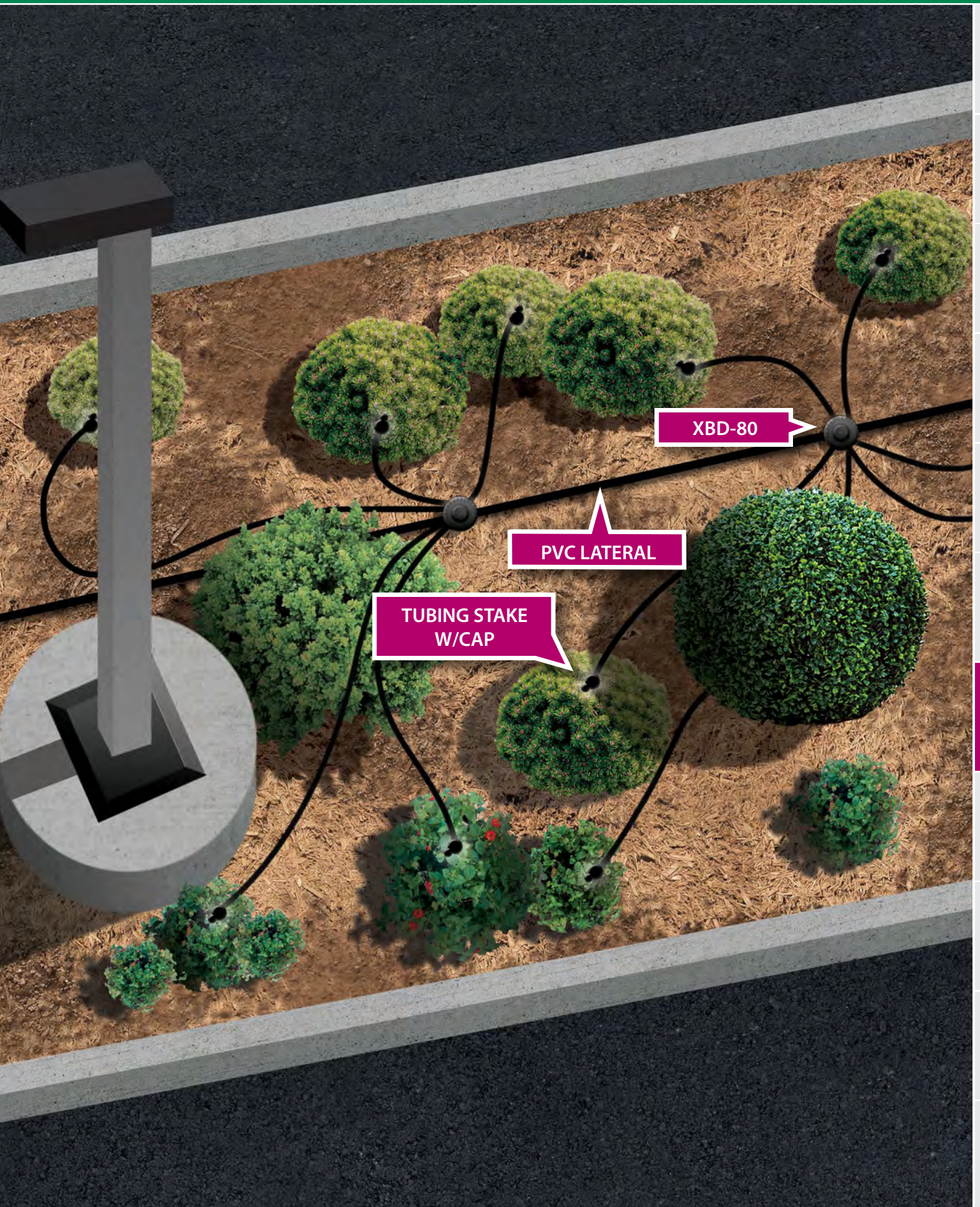

ANATOMY

PRODUCTS

NARROW BEDS

PARKING LOT

PARKWAYS/  
WALKWAYS

POTS/BASKETS

SLOPES

STREET MEDIANS

WALLS

GOLF COURSES

TREES



## Slopes

### Dense or Combination Applications

#### Solution

*XF Series Dripline Grid with Xeri-Bug Emitters*

#### Advantages

- Up to 60% water savings due to zero wind loss
- Low maintenance results in labor savings
- No runoff = reduced liability in high traffic areas
- XF Dripline is easy to install, resulting in labor savings



#### Installation

|  |  |
|--|--|
| <b>XFCV-06-12</b>                        | XFCV Dripline w/Heavy-Duty Check Valve<br>(.6 gph @ 12" Spacing)           |
| <b>XCZ-100-PRF</b>                       | 1" Xeri Control Zone Kit   |
| <b>ARV050</b>                            | ½" Air Relief Valve  |
| <b>MDCF Series<br/>OR<br/>XFF Series</b> | Easy Fit Compression Fittings/Adapters<br>XF Dripline 17mm Insert Fittings |
| <b>XB XX*</b>                            | Xeri-Bug Pressure Compensating<br>Drip Emitters (0.5 to 2.0 gph)           |
| <b>XQ-100</b>                            | 1/4" Distribution Tubing   |
| <b>TS-025</b>                            | 1/4" Tubing Stake  |
| <b>TDS-050</b>                           | Tie Down Stake   |
| <b>XM Tool</b>                           | Xeriman Installation Tool  |
| <b>DCB-025</b>                           | Diffuser Bug Cap   |

\* Select appropriate emitter flow rate



½" Air Relief Valve



XFF FITTINGS

#### TO DO LIST :

- Assemble Control Zone Kit and connect to water source.
- Connect Easy Fit Adapter to Easy Fit Tee for connection to Control Zone Kit.
- Cut lengths of XF Series Dripline to assemble grid in planting area.
- Connect lengths of XF Series Dripline to Easy Fit Fittings (or use XF Dripline fittings) to create grid. Add 1/2" Air Relief Valve Kit to the zone.
- Insert Xeri-Bug Emitters into XF Series Dripline to provide supplemental watering for larger plants.
- Stake XF Series Dripline grid in place and flush until clean water flows.
- Install planting material.

#### TIME: (approx.)

- 1 hr
- 5 min
- 10 min/50'
- 25 min/50'
- 3 min/Emitter
- 5 min/10'

#### INSTALLATION AND MAINTENANCE TIPS :

- ◆ Supplemental Xeri-Bug Emitters are placed next to larger plants with higher water requirements.
- ◆ Flush the zone upon installation and 2-4 times per year.
- ◆ Install 1/2" Air Relief Valve Kit at high point in the system.
- ◆ Leave XF Series Dripline coil in the sun while preparing for installation.
- ◆ Use the Xeriman Tool to install the emitters into XF Series Dripline.



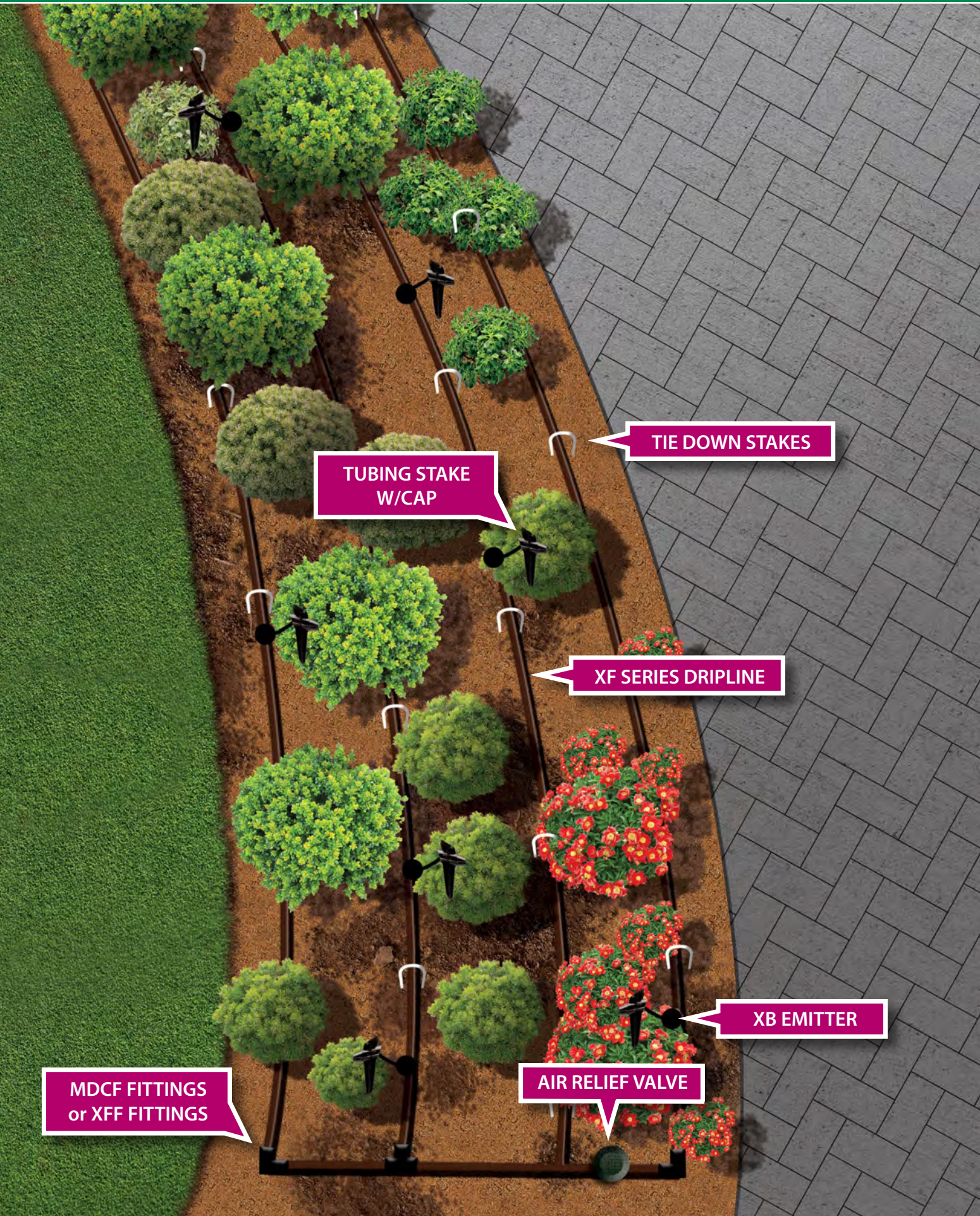

TUBING STAKE  
W/CAP

TIE DOWN STAKES

XF SERIES DRIPLINE

MDCF FITTINGS  
or XFF FITTINGS

AIR RELIEF VALVE

XB EMITTER

|                       |
|-----------------------|
| ANATOMY               |
| PRODUCTS              |
| NARROW BEDS           |
| PARKING LOT           |
| PARKWAYS/<br>WALKWAYS |
| POTS/BASKETS          |
| <b>SLOPES</b>         |
| STREET MEDIANS        |
| WALLS                 |
| GOLF COURSES          |
| TREES                 |



## Slopes

### Combination Applications

#### Solution

XFCV Dripline Grid with Xeri-Bug Emitters

#### Advantages

- Up to 60% water savings due to zero wind loss
- Low maintenance results in labor savings
- XF Dripline is easy to install, resulting in labor savings



#### Installation

|                                 |   |
|---------------------------------|---|
| XFCV-06-12                      | XF Series Dripline .6 gph @ 12" Spacing                                     |
| XCZ-100-PRF                     | 1" Xeri Control Zone Kit  |
| MDCF Series<br>OR<br>XFF Series | Easy Fit Compression Fittings/Adapters<br>XFF Dripline 17mm Insert Fittings |
| XQ-100                          | 1/4" Distribution Tubing  |
| TS-025                          | 1/4" Tubing Stake   |
| TDS-050                         | Tie Down Stake  |
| DCB-025                         | Diffuser Bug Cap  |



XFCV

\* Select appropriate emitter flow rate

#### TO DO LIST :

- Assemble Control Zone Kit and connect to water source.
- Connect Easy Fit adapter to Easy Fit Tee for connection to Control Zone Kit.
- Cut lengths of XF Series Dripline to assemble grid in planting area.
- Use MDCF Fittings (or XFF Dripline fittings) to create grid and stake in place. Insert Xeri-Bug Emitters into XF Series Dripline for supplemental watering.
- Connect 1/4" tubing to Xeri-Bug Emitters, run lines and stake next to larger plants.
- Flush zones until clean water flows.
- Install planting material.

#### TIME: (approx.)

1 hr  
5 min/XCZ  
10 min/50'  
1 hr 30 min  
8 min/Stake  
2 min

#### INSTALLATION AND MAINTENANCE TIPS :

- ◆ Supplemental Xeri-Bug Emitters or Pressure Compensating Modules can be placed next to larger plants with higher water requirements.
- ◆ Flush the zone upon installation and 2-4 times per year.
- ◆ Leave XF Series Dripline coil in the sun while preparing for installation.



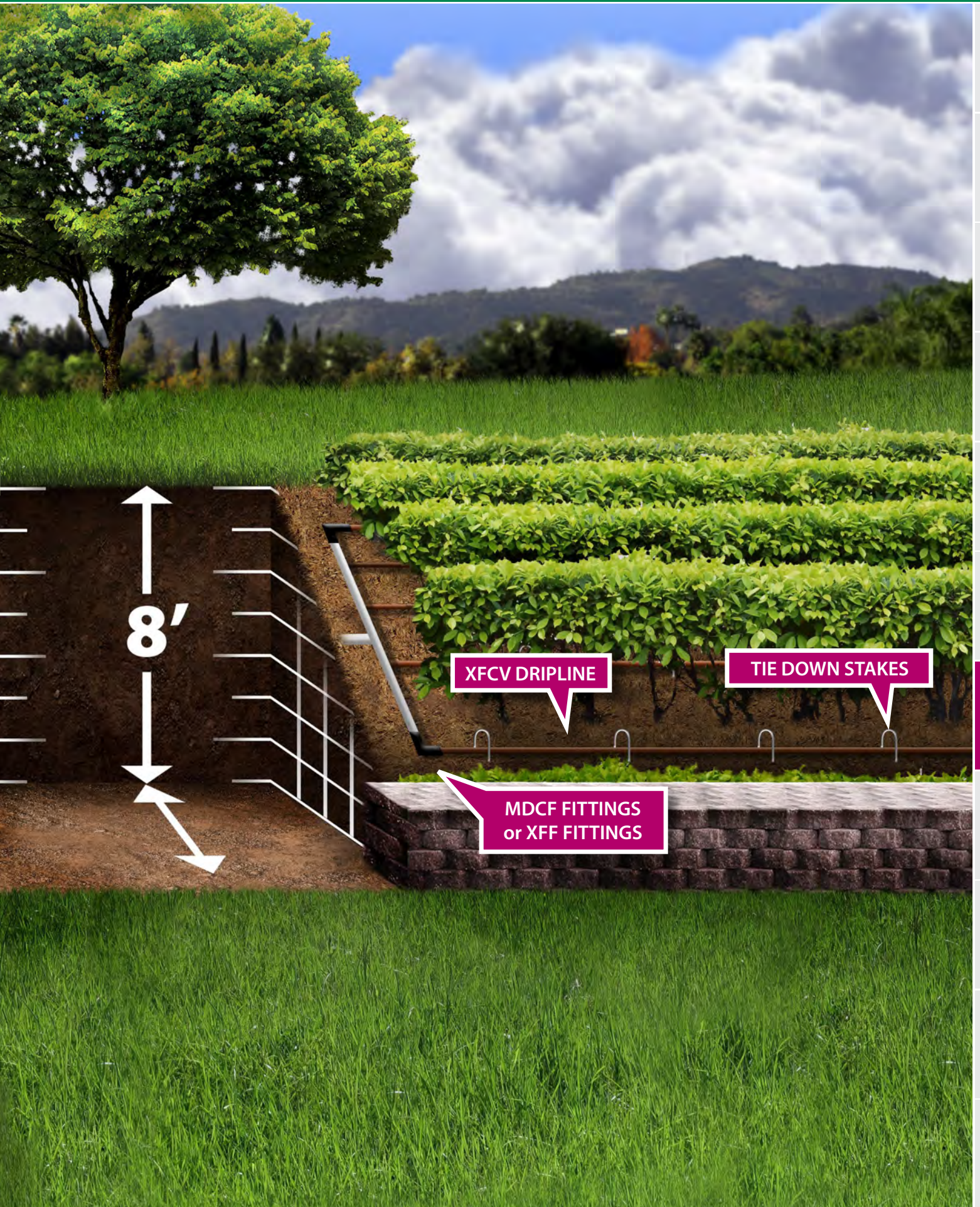

ANATOMY

PRODUCTS

NARROW BEDS

PARKING LOT

PARKWAYS/  
WALKWAYS

POTS/BASKETS

SLOPES

STREET MEDIANS

WALLS

GOLF COURSES

TREES



## Street Medians

### Sparse Applications

#### Solution

*PolyFlex Riser/Adapter & Xeri-Bug Emitters on PVC Lateral*

#### Advantages

- Up to 60% water savings due to zero wind loss
- Targeted watering at plants reduces weed growth
- Pressure Compensating Emitters available from 0.5 to 24 gph for a variety of plant watering needs



#### Installation

|                     |  |
|---------------------|--|
| <b>PFR/FRA</b>      | PolyFlex Riser/Adapter   |
| <b>XB XX* 10-32</b> | Xeri-Bug Pressure Compensating Drip Emitters (0.5 to 2.0 gph) w 10-32 Thread |
| <b>PVC Misc.</b>    | PVC Laterals, Fittings, Glue   |

\* Select appropriate emitter flow rate



PFR/FRA



XB XX 10-32

#### TO DO LIST :

- Trench, cut and glue PVC laterals.
- Assemble Control Zone Kit and connect to water source and laterals.
- Thread PFR/FRA into PVC Tee fitting.
- Thread Xeri-Bug Emitter into PolyFlex Riser.
- Flush system until clean water flows.
- Add planting material and mulch.

#### TIME: (approx.)

- 1 hr
- 1 hr
- 3 min/Tee
- 2 min/PFR
- 2 min

#### INSTALLATION AND MAINTENANCE TIPS :

- ◆ Flush the zone after installation and 2-4 times per year.
- ◆ For larger trees use higher flow Pressure Compensating Modules and Diffuser Caps to avoid wash out.
- ◆ Adjust watering time as seasons/weather changes.
- ◆ Cut PolyFlex Risers slightly above grade (before installing the Xeri-Bug Emitters) for an "invisible" installation.
- ◆ PolyFlex Adapter (FRA) is made of Marlex® so no Teflon® tape is needed.



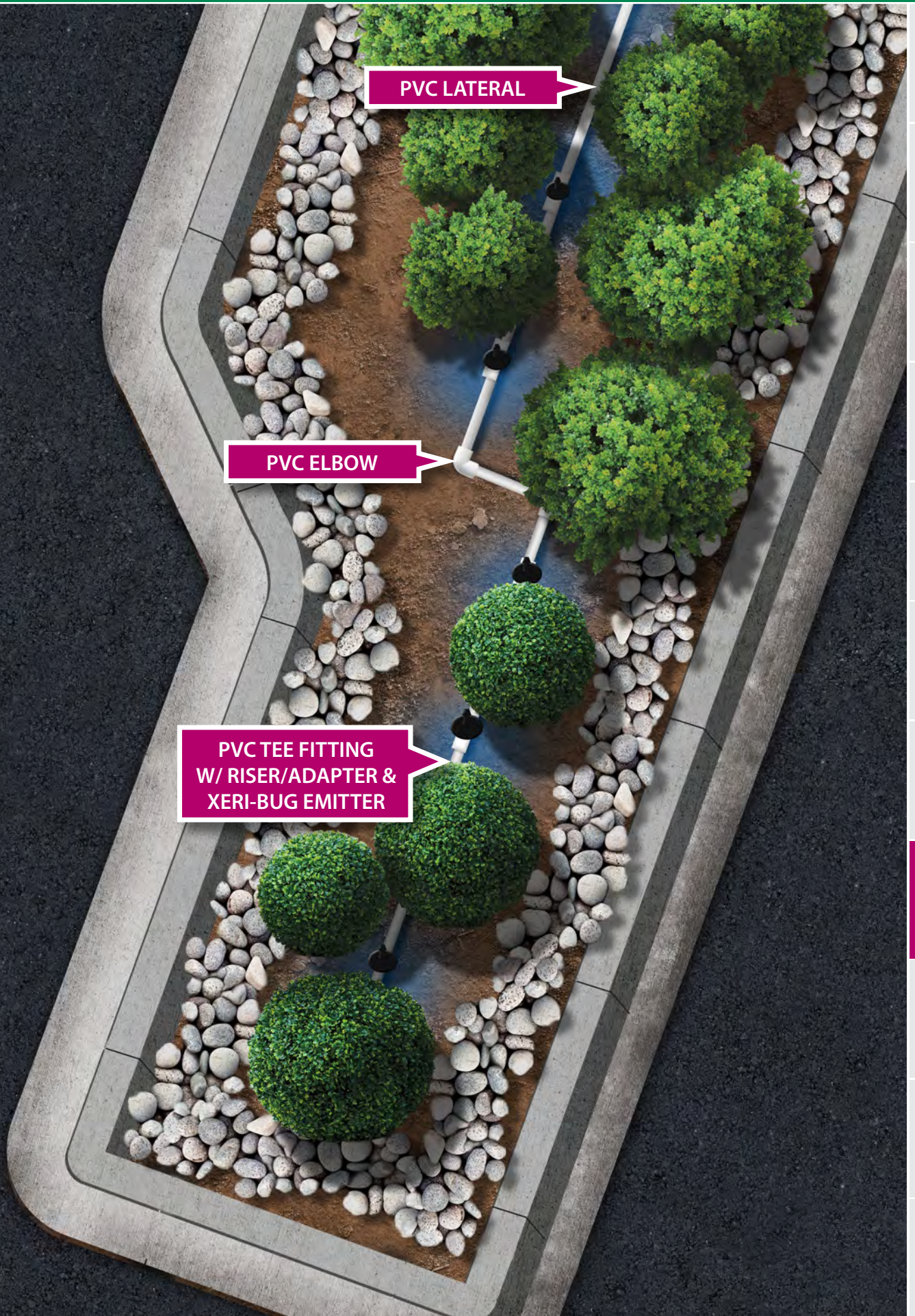

ANATOMY

PRODUCTS

NARROW BEDS

PARKING LOT

PARKWAYS/  
WALKWAYS

POTS/BASKETS

SLOPES

STREET MEDIANS

WALLS

GOLF COURSES

TREES



## Street Medians

### Dense Applications

#### Solution

*XF Series Dripline Grid*

#### Advantages

- Up to 60% water savings due to zero wind loss
- No overspray damage to roadways and vehicles
- No runoff = reduced liability in high traffic areas
- XF Dripline is easy to install, resulting in labor savings

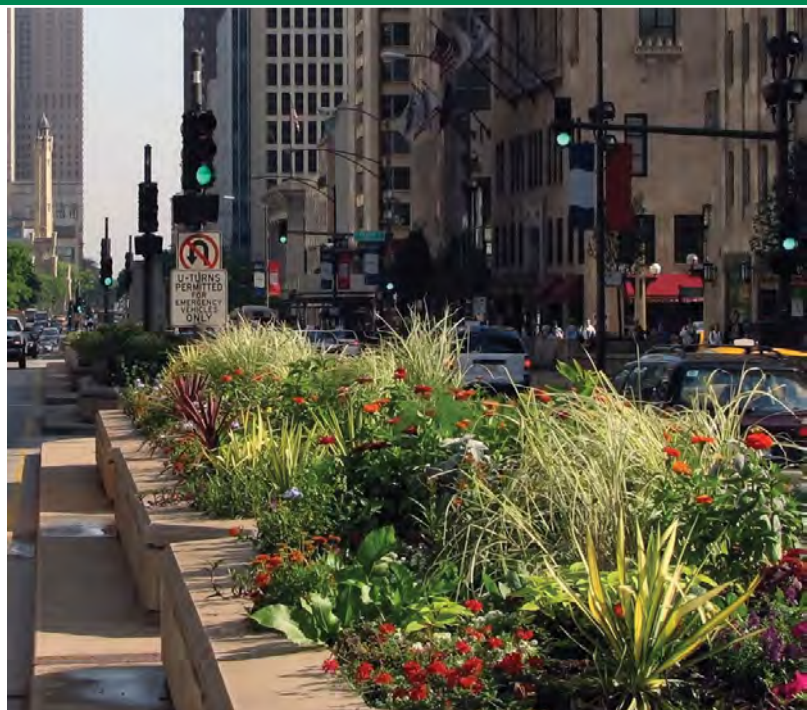

#### Installation

|                                 |   |
|---------------------------------|---|
| XFD-06-12                       | XF Series Dripline .6 gph @ 12" Spacing                                     |
| XCZ-100-PRF                     | 1" Xeri Control Zone Kit  |
| ARV050                          | 1/2" Air Relief Valve Kit   |
| MDCF Series<br>OR<br>XFF Series | Easy Fit Compression Fittings/Adapters<br>XFF Dripline 17mm Insert Fittings |
| TDS-050 BEND                    | Tie Down Stake  |
| PVC Misc.                       | PVC Laterals and Fittings   |
| XP600X                          | Xeri-Pop (optional)   |
| SQ QTR                          | SQ Series Nozzle (optional)   |



XFD



XFF FITTINGS

#### TO DO LIST :

- Assemble Control Zone Kit and connect to water source.
- Cut lengths of XF Series Dripline to build grid in planting area.
- Connect lengths of XF Series Dripline to Easy Fit Fittings (or XF Dripline 17mm fittings) to create grid (add Air Relief Valve Kit to the zone and connect to Control Zone Kit).
- Stake XF Series Dripline grid in place and flush until clean water flows.
- Install planting material.

#### TIME: (approx.)

1 hr  
10 min/50'  
25 min/50'  
5 min/10'

#### INSTALLATION AND MAINTENANCE TIPS :

- ◆ Flush the zone upon installation and 2-4 times per year.
- ◆ Install 1/2" Air Relief Valve Kit at high point in the system.
- ◆ Leave XF Series Dripline coil in the sun while preparing for installation.
- ◆ Use XFS Series Dripline to protect against root intrusion

#### Drip Tip

Add a Xeri-Bubbler Xeri-Pop with an XPCN Series Nozzle to the line nearest Control Zone/Valve box as an indicator for maintenance crews.





MDCF FITTINGS  
or XFF FITTINGS

XF SERIES DRIPLINE

TIE DOWN STAKES

ANATOMY

PRODUCTS

NARROW BEDS

PARKING LOT

PARKWAYS/  
WALKWAYS

POTS/BASKETS

SLOPES

STREET MEDIANS

WALLS

GOLF COURSES

TREES



# Street Medians

## Dense Applications



### Solution

*SQ Series Nozzle on 1800 Spray Heads with Swing Assembly on PVC Lateral*

### Advantages

- Precise square wetting pattern reduces overspray, overwatering, and runoff
- Up to 65% water savings due to efficient control of water placement with pressure compensation
- Adjustable radius in one unit makes design and installation simple
- Highest distribution uniformity in the industry for short radius nozzles

### Installation

|          |   |
|----------|---|
| SQ-XXX*  | SQ Series Nozzles                                 |
| 18XX     | 1800 Series Spray Head with Desired Pop-up Height |
| SA-XXX   | SA Series Swing Assembly                          |
| PVC Misc | PVC Laterals, Fittings, Glue                      |

\* Half, full, or quarter nozzles as needed for planting bed



1806



SQ NOZZLES

#### TO DO LIST :

- Trench, cut, and glue PVC laterals.
- Connect lines to water source.
- Thread 1800 Series Spray Head onto swing assembly then thread the swing assembly into the Slip x Slip x Threaded Tee PVC fitting.
- Cut PVC laterals and glue in Slip x Slip x Threaded Tee assembly.
- Flush system until water flows clear.
- Install SQ Series nozzles on 1800 Spray Heads.

#### TIME: (approx.)

- 1 hr/20'
- 1 hr
- 5 min/Assembly
- 5 min/Tee
- As needed
- 2 min/Nozzle

#### INSTALLATION AND MAINTENANCE TIPS :

- ◆ Flush the zone after installation and 2-4 times per year.
- ◆ Adjust watering time as seasons/weather changes.
- ◆ Ensure that all SQ Series Nozzles are adjusted to the appropriate throw distance.

#### Drip Tip

With a simple turn of the nozzle to the next preset stop, the SQ Series Nozzle adjusts from a 2.5' throw to a 4' throw. All nozzles in the same zone must be adjusted to the same throw.





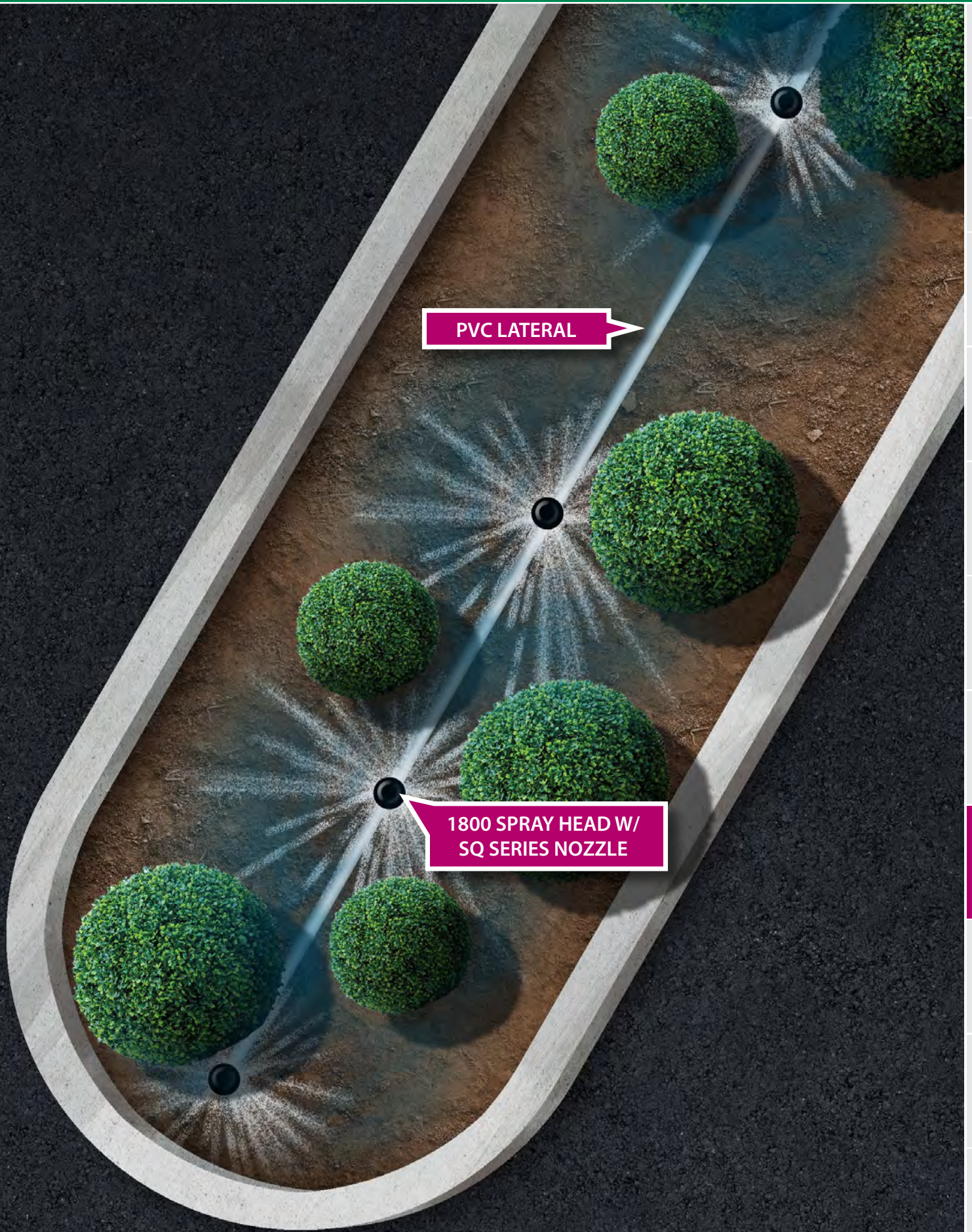

PVC LATERAL

1800 SPRAY HEAD W/  
SQ SERIES NOZZLE

ANATOMY

PRODUCTS

NARROW BEDS

PARKING LOT

PARKWAYS/  
WALKWAYS

POTS/BASKETS

SLOPES

STREET MEDIANS

WALLS

GOLF COURSES

TREES



## Street Medians

### Combination Applications

#### Solution

*XF Series Dripline Grid with Xeri-Bug Emitters*

#### Advantages

- Up to 60% water savings due to zero wind loss
- No overspray damage to roadways and vehicles
- No runoff = reduced liability in high traffic areas
- Low maintenance results in labor savings
- XF Dripline is easy to install, resulting in labor savings



#### Installation

|             |   |
|-------------|---|
| XFD-06-12   | XF Series Dripline .6 gph @ 12" Spacing                       |
| XCZ-100-PRF | 1" Xeri Control Zone Kit                                      |
| ARV050      | 1/2" Air Relief Valve   |
| XFF Series  | XF Dripline 17mm Insert Fittings                              |
| XB XX*      | Xeri-Bug Pressure Compensating Drip Emitters (0.5 to 2.0 gph) |
| XQ-100      | 1/4" Distribution Tubing                                      |
| TS-025      | 1/4" Tubing Stake   |
| TDS-050     | Tie Down Stake  |
| DCB-025     | Diffuser Bug Cap  |

\* Select appropriate emitter flow rate



XFD



XFF FITTINGS

#### TO DO LIST :

- Assemble Control Zone Kit and connect to water source.
- Connect Easy Fit series for connection to Control Zone Kit.
- Cut lengths of XF Series Dripline to assemble grid in planting area.
- Use Easy Fit Compression Fittings (or XFF Dripline fittings) to create XF Series Dripline grid. Add 1/2" Air Relief Valve Kit and stake grid in place. Insert Xeri-Bug Emitters into XF Series Dripline for supplemental watering.
- Connect 1/4" tubing to Xeri-Bug Emitters, run lines and stake next to larger plants.
- Flush zones until clean water flows.
- Install planting material.

#### TIME: (approx.)

1 hr  
5 min  
10 min/50'  
1 hr 30 min  
8 min/Stake  
2 min

#### INSTALLATION AND MAINTENANCE TIPS :

- ◆ Flush the zone upon installation and 2-4 times per year.
- ◆ Install 1/2" Air Relief Valve Kit at high point in the system.
- ◆ Leave XF Series Dripline coil in the sun while preparing for installation.
- ◆ Supplemental Xeri-Bug Emitters or Pressure Compensating Modules are placed next to larger plants with higher water requirements.



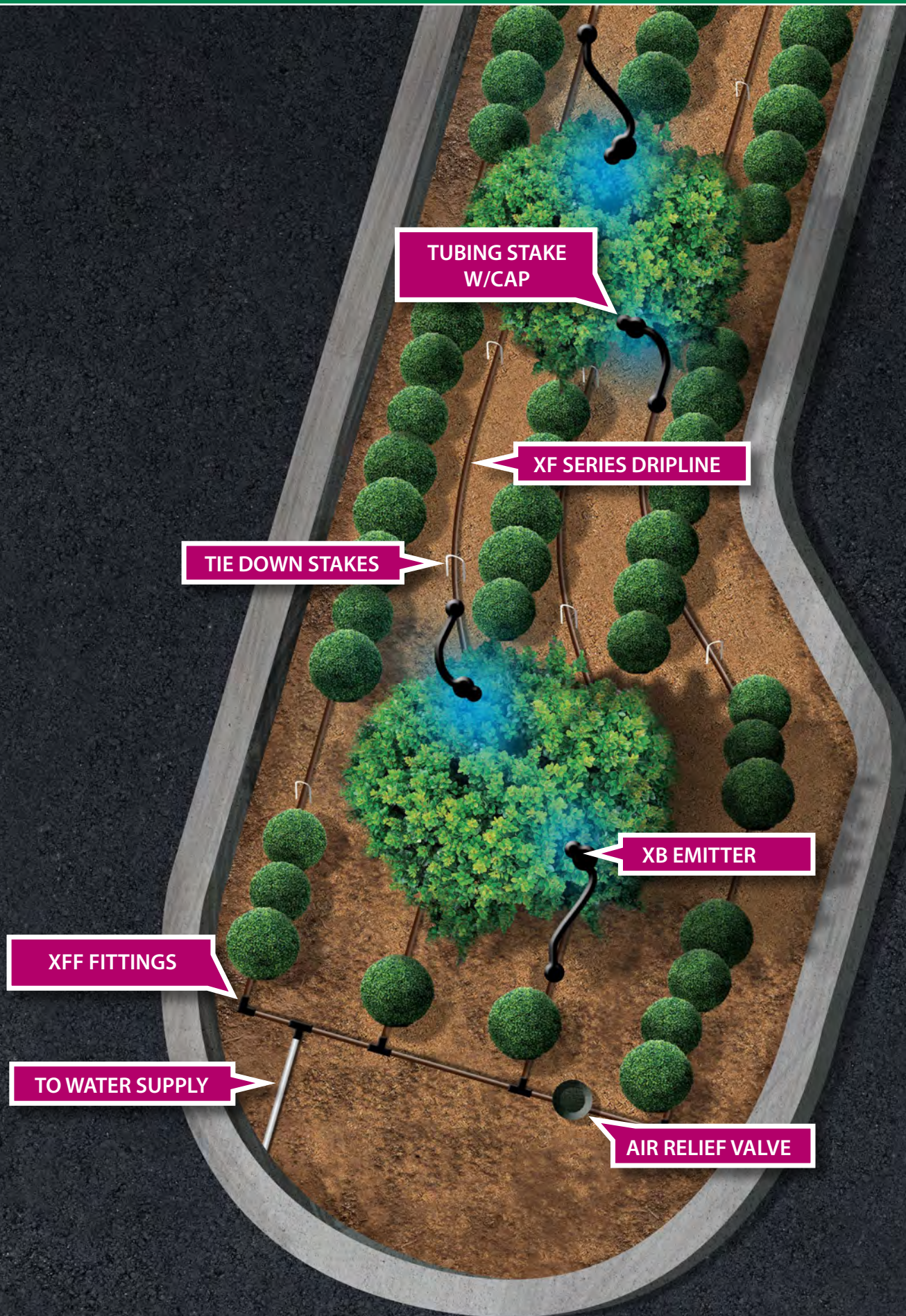

TUBING STAKE W/CAP

XF SERIES DRIPLINE

TIE DOWN STAKES

XB EMITTER

XFF FITTINGS

TO WATER SUPPLY

AIR RELIEF VALVE

ANATOMY

PRODUCTS

NARROW BEDS

PARKING LOT

PARKWAYS/  
WALKWAYS

POTS/BASKETS

SLOPES

STREET MEDIANS

WALLS

GOLF COURSES

TREES



## Walls

### Retaining Walls

#### Solution

*XF Series Dripline*

#### Advantages

- Up to 60% water savings due to zero wind loss
- Targeted watering helps reduce erosion of wall
- No runoff = reduced liability in high traffic areas
- XF Dripline is easy to install, resulting in labor savings



#### Installation

|                                 |   |
|---------------------------------|---|
| XFD-06-12                       | XF Series Dripline .6 gph @ 12" Spacing                                     |
| XCZ-100-PRF                     | 1" Xeri Control Zone Kit  |
| ARV 050                         | 1/2" Air Relief Valve   |
| MDCF Series<br>OR<br>XFF Series | Easy Fit Compression Fittings/Adapters<br>XFF Dripline 17mm Insert Fittings |
| TDS-050 BEND                    | Tie Down Stake  |



XFD



XFF FITTINGS

#### TO DO LIST :

- Assemble Control Zone Kit and connect to water source.
- Cut lengths of XF Series Dripline to lay laterally below retaining wall.
- Connect lengths of XF Series Dripline to Easy Fit Fittings, add 1/2" Air Relief Valve and add Flush Cap to end. Connect to Control Zone Kit.
- Stake XF Series Dripline in place and flush until clean water flows.
- Install planting material.

#### TIME: (approx.)

1 hr  
10 min/50'  
30 min/50'  
5 min/10'

#### INSTALLATION AND MAINTENANCE TIPS :

- ◆ Flush the zone upon installation and 2-4 times per year.
- ◆ Install 1/2" Air Relief Valve Kit at high point in the system.
- ◆ Leave XF Series Dripline coil in the sun while preparing for installation.
- ◆ Break up watering cycles to avoid run off or pooling of water in blocks.
- ◆ Use XFS Series Dripline to protect against root intrusion



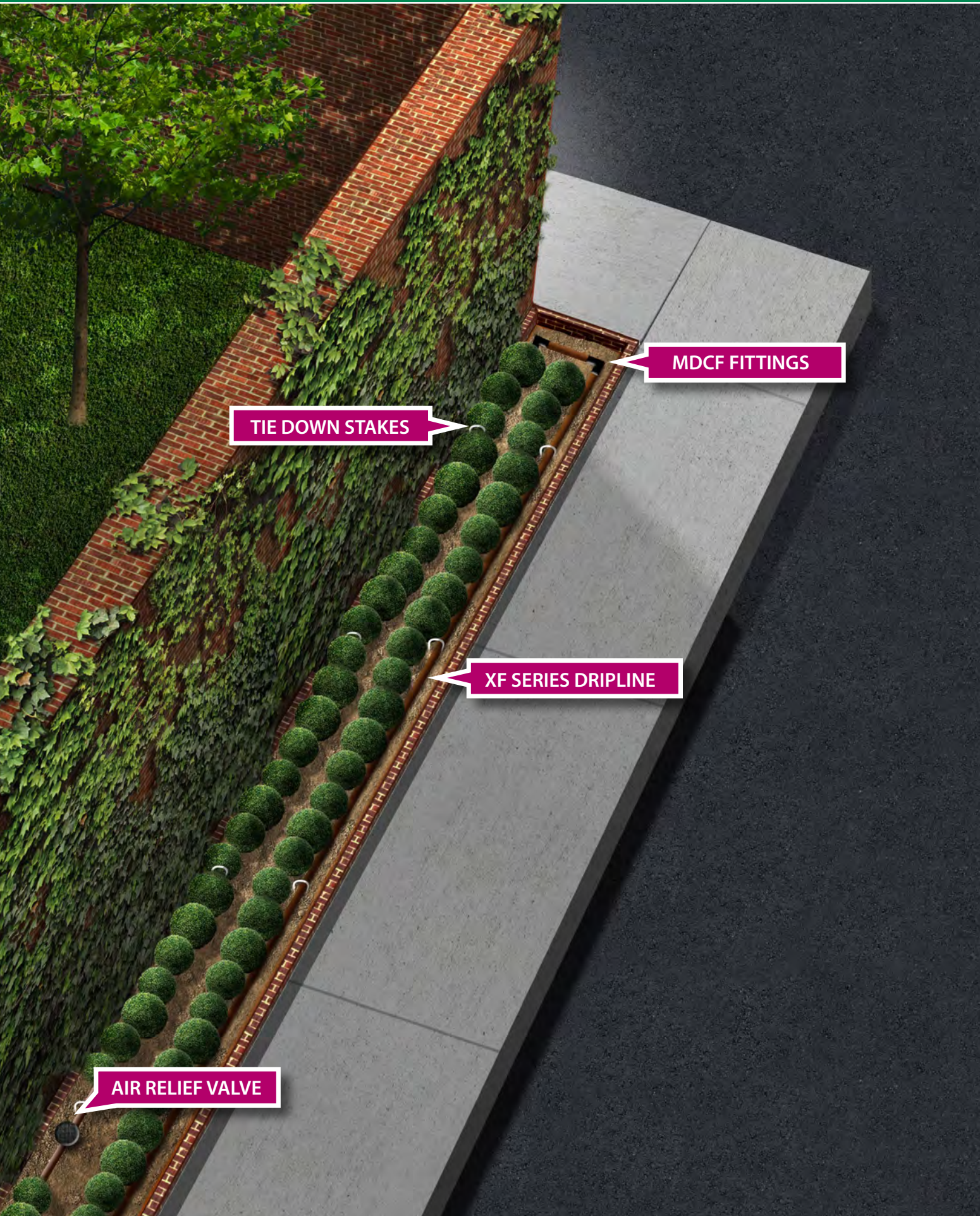

AIR RELIEF VALVE

TIE DOWN STAKES

XF SERIES DRIPLINE

MDCF FITTINGS

|                       |                       |
|-----------------------|-----------------------|
| TREES                 | TREES                 |
| GOLF COURSES          | GOLF COURSES          |
| WALLS                 | WALLS                 |
| STREET MEDIANS        | STREET MEDIANS        |
| SLOPES                | SLOPES                |
| POTS/BASKETS          | POTS/BASKETS          |
| PARKWAYS/<br>WALKWAYS | PARKWAYS/<br>WALKWAYS |
| PARKING LOT           | PARKING LOT           |
| NARROW BEDS           | NARROW BEDS           |
| PRODUCTS              | PRODUCTS              |
| ANATOMY               | ANATOMY               |



## Flower Bed

### Combination Applications

#### Solution

- XF Series Dripline Grid with Xeri-Bug Emitters

#### Advantages

- Up to 60% water savings
- No unsightly run off in high visibility areas
- No damage to walls, entry way or cart paths from overspray
- XF Dripline is easy to install, resulting in labor savings



#### Installation

|             |   |
|-------------|---|
| XFD-06-12   | XF Series Dripline .6 gph @ 12" Spacing                       |
| XCZ-075-PRF | 3/4" Xeri Control Zone Kit                                    |
| MDCF Series | Easy Fit Compression Fittings/Adapters                        |
| <b>OR</b>   |   |
| XFF Series  | XFF Dripline 17mm Insert Fittings                             |
| ARV050      | 1/2" Air Relief Valve   |
| TDS-050-30  | Tie Down Stake  |
| XB XX*      | Xeri-Bug Pressure Compensating Drip Emitters (0.5 to 2.0 gph) |
| XQ-100      | 1/4" Distribution Tubing                                      |
| TS-025      | 1/4" Tubing Stake   |
| DCB-025     | Diffuser Bug Cap  |



XFD



XM TOOL



XB XX

\* Select appropriate emitter flow rate

#### TO DO LIST :

- Assemble Control Zone Kit and connect to water source.
- Cut lengths of XF Series Dripline to build grid in planting area.
- Connect lengths of XF Series Dripline to Easy Fit Fittings to create grid, add 1/2" Air Relief Valve.
- Connect Easy Fit Adapter to Easy Fit Tee for connection to Control Zone Kit.
- Stake XF Series Dripline grid in place.
- Punch self-piercing barb inlet of Xeri-Bug Emitters into XF Series Dripline, connect 1/4" tubing to barb outlet and run 1/4" tubing to larger plant.
- Stake tubing in place and attach Diffuser Bug Cap on the end.
- Flush system until clean water flows.
- Install planting material.

#### TIME: (approx.)

- 1 hr
- 10 min/50'
- 20 min/50'
- 5 min
- 5 min/10'
- 8 min/Emitter
- 3 min/Stake
- 2 min

#### INSTALLATION AND MAINTENANCE TIPS :

- ◆ Supplemental Xeri-Bug Emitters are placed next to larger plants with higher water requirements.
- ◆ Flush the zone upon installation and 2-4 times per year.
- ◆ Install Xeri-Bug Emitters with the Xeriman Tool (XM Tool) for 50% faster installation.
- ◆ Leave XF Series Dripline coil in the sun while preparing for installation.



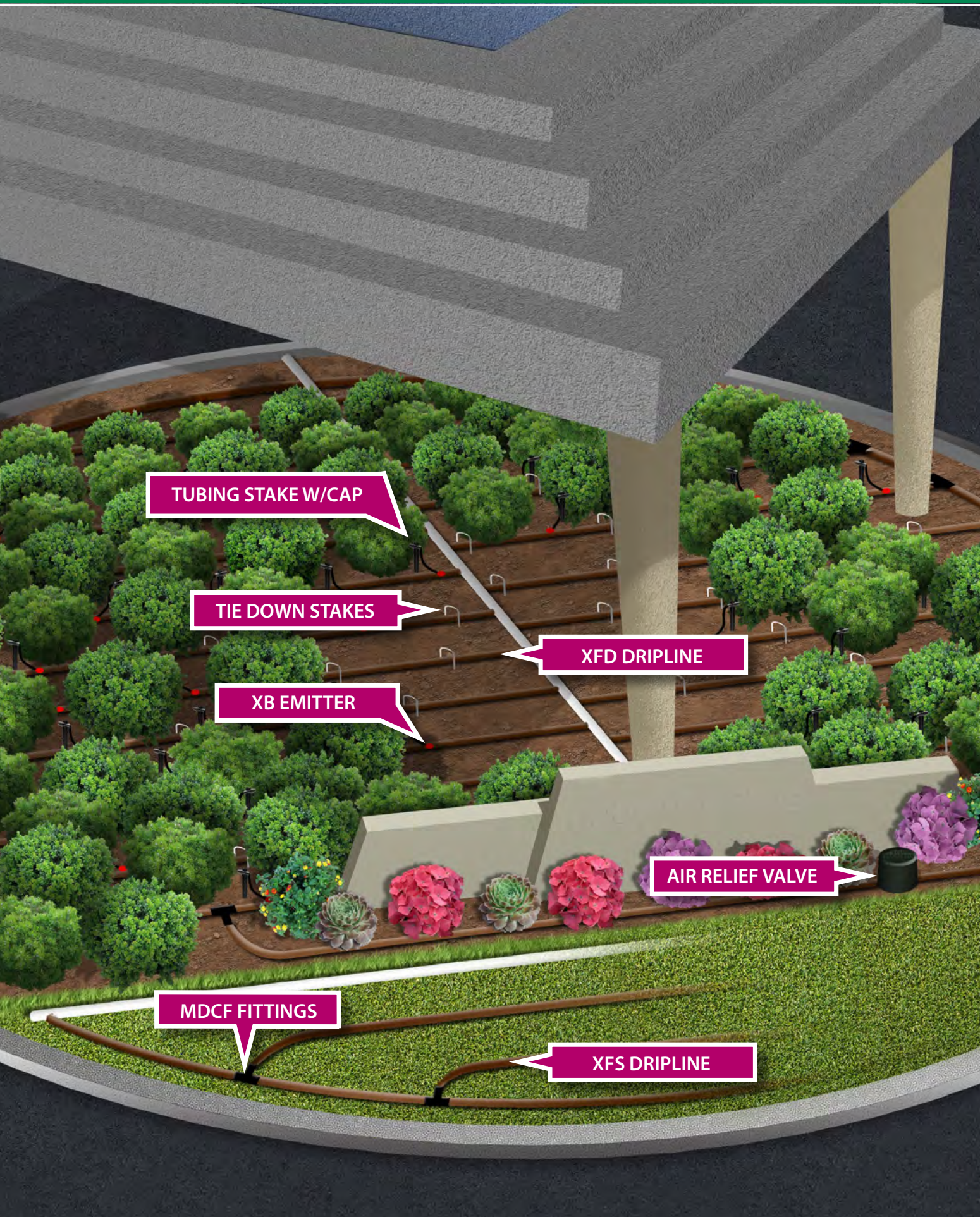

ANATOMY  
PRODUCTS  
NARROW BEDS  
PARKING LOT  
PARKWAYS/  
WALKWAYS  
POTS/BASKETS  
SLOPES  
STREET MEDIANS  
WALLS  
GOLF COURSES  
TREES



## Narrow Planting Bed Next to Clubhouse or Cart Path

### Sparse Application

#### Solution

*Xeri-Bird 8 & Xeri-Bug Emitters on a PVC Lateral*

#### Advantages

- Up to 60% water savings
- Xeri-Bird 8 Manifold with PRS offers pressure regulation, filtration and controlled watering to multiple plants
- Manifold allows for increase/decrease in future plant water demands



#### Installation

|            |   |
|------------|---|
| XBD-80     | Xeri-Bird 8 Outlet Manifold                                   |
| XB XX*     | Xeri-Bug Pressure Compensating Drip Emitters (0.5 to 2.0 gph) |
| PRS-050-30 | In-stem 30 psi Pressure Regulator                             |
| XQ-100     | 1/4" Distribution Tubing                                      |
| TS-025     | 1/4" Tubing Stake   |
| DCB-025    | Diffuser Bug Caps   |
| PVC Misc.  | PVC Laterals, Fittings, Glue                                  |
| SEB7X      | Emitter Box   |

\* Select appropriate emitter flow rate and barbed or threaded connection

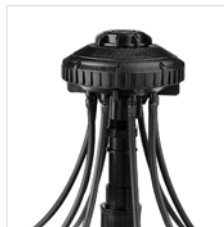

XBD-80



PRS-050-30



XB XX

#### TO DO LIST :

- Trench, cut and glue PVC laterals.
- Connect lines to water source.
- Thread Xeri-Bird 8 Outlet Manifold onto in-stem 30 psi Pressure Regulator, then connect to PVC tee.
- Attach 1/4" distribution tubing to outlets on Xeri-Bird 8 Outlet Manifold.
- Run 1/4" lines to plants, stake in place with a Diffuser Bug Cap on the end.
- Install the desired Xeri-Bug Emitter inside Xeri-Bird 8 Outlet Manifold.
- Use an SEB7X Emitter Box for added protection of the Xeri-Bird 8. (optional)

#### TIME: (approx.)

1 hr/20'  
1 hr  
8 min/Assembly  
  
5 min/XBD-80  
8 min/Stake  
3 min/XBD-80

#### INSTALLATION AND MAINTENANCE TIPS :

- ◆ Flush the zone after installation and 2-4 times per year.
- ◆ Install Xeri-Bug Emitters in Xeri-Bird 8 Outlet Manifold with self-piercing barb end up.
- ◆ Leave 6" slack in 1/4" tubing next to manifold in case of unexpected maintenance.



# BUILDING

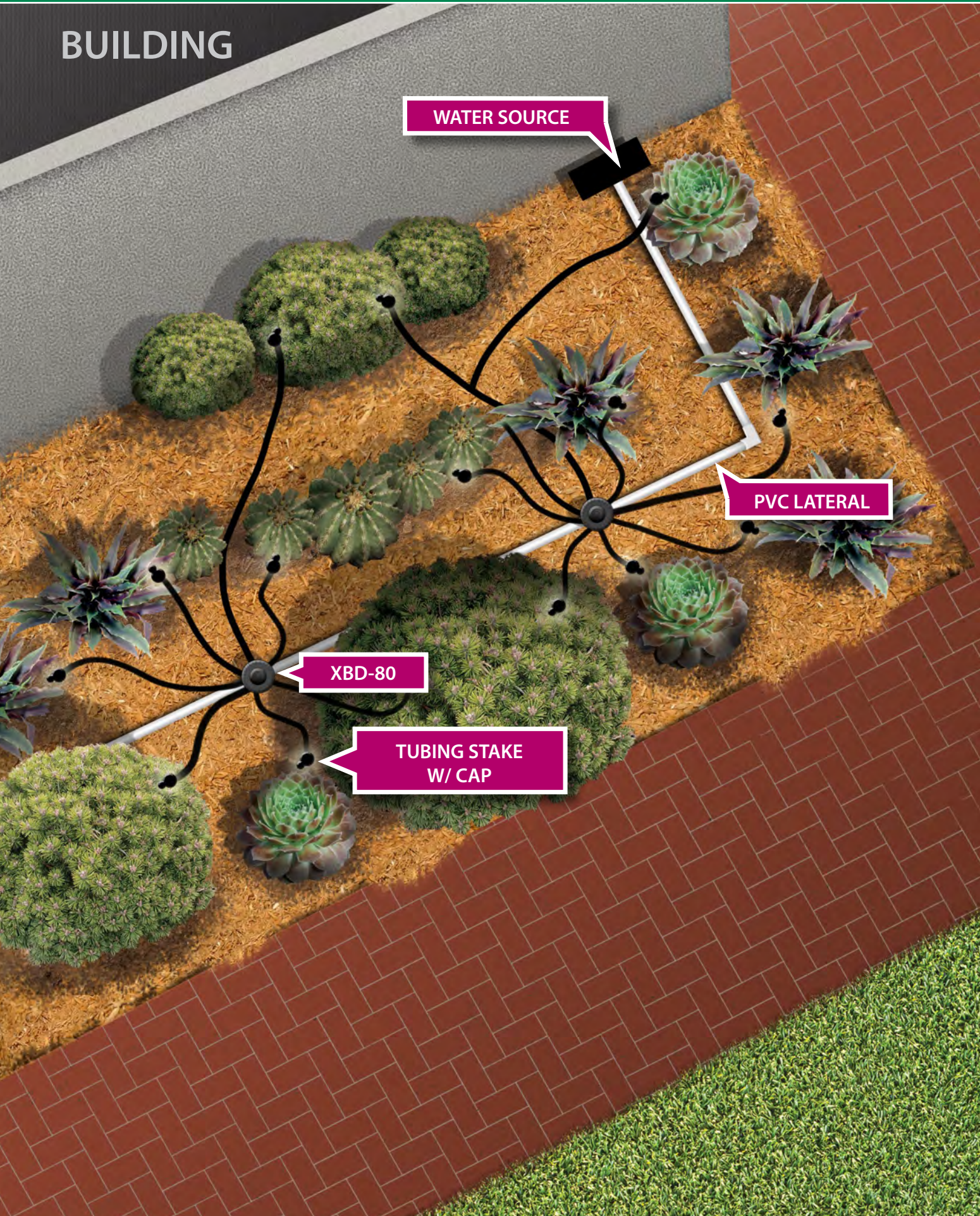

WATER SOURCE

PVC LATERAL

XBD-80

TUBING STAKE  
W/ CAP

|                       |
|-----------------------|
| TREES                 |
| GOLF COURSES          |
| WALLS                 |
| STREET MEDIANS        |
| SLOPES                |
| POTS/BASKETS          |
| PARKWAYS/<br>WALKWAYS |
| PARKING LOT           |
| NARROW BEDS           |
| PRODUCTS              |
| ANATOMY               |



## Landscaped Areas on the Course Adjacent to Tee Box, Fairways or Greens

### Solution

Pressure Compensating Multi-Outlet Xeri-Bug Device on a PVC Lateral

### Advantages

- Up to 60% water savings
- Durable installation in high maintenance areas
- Targeted watering reduces weed growth and extends life of mulch
- Native plant life helps reduce water usage



### Installation

|            |  |
|------------|--|
| XBT-10-6   | 1.0 GPH Multi-Outlet Xeri-Bug Manifold |
| XQ-100     | 1/4" Distribution Tubing               |
| TS-025     | 1/4" Tubing Stake                      |
| 1/2" Riser | Sch-80 Riser 1/2" MPT                  |
| DCB-025    | Diffuser Bug Cap                       |
| PVC Misc.  | PVC Laterals, Fittings, Glue           |
| SEB7X      | Emitter Box (optional)                 |



XBT-10-6



TS-025

#### TO DO LIST :

- Trench, cut and glue PVC laterals.
- Assemble Control Zone Kit and position in valve box.
- Connect Control Zone to water source and laterals.
- Thread 1/2" riser into PVC and thread 1.0 GPH Multi-Outlet Xeri-Bug Manifold onto riser.
- Connect 1/4" lines to manifold outlets and run to sparse plantings.
- Stake in place and add Diffuser Bug Cap to end of lines.
- Flush system until clean water flows.
- Add planting material and mulch.

#### TIME: (approx.)

- 1 hr/20'
- 20 min
- 1 hr
- 5 min/Assembly
- 5 min/Line
- 3 min/Stake
- 2 min

#### INSTALLATION AND MAINTENANCE TIPS :

- ◆ Flush the zone after installation and 2-4 times per year.
- ◆ Do not run 1/4" lines more than 5'-8' from water source for optimal performance.
- ◆ Adjust watering time as seasons/weather changes.

#### Drip Tip

Use an SEB7X Emitter Box for added protection of the XBT-10-6 (optional).



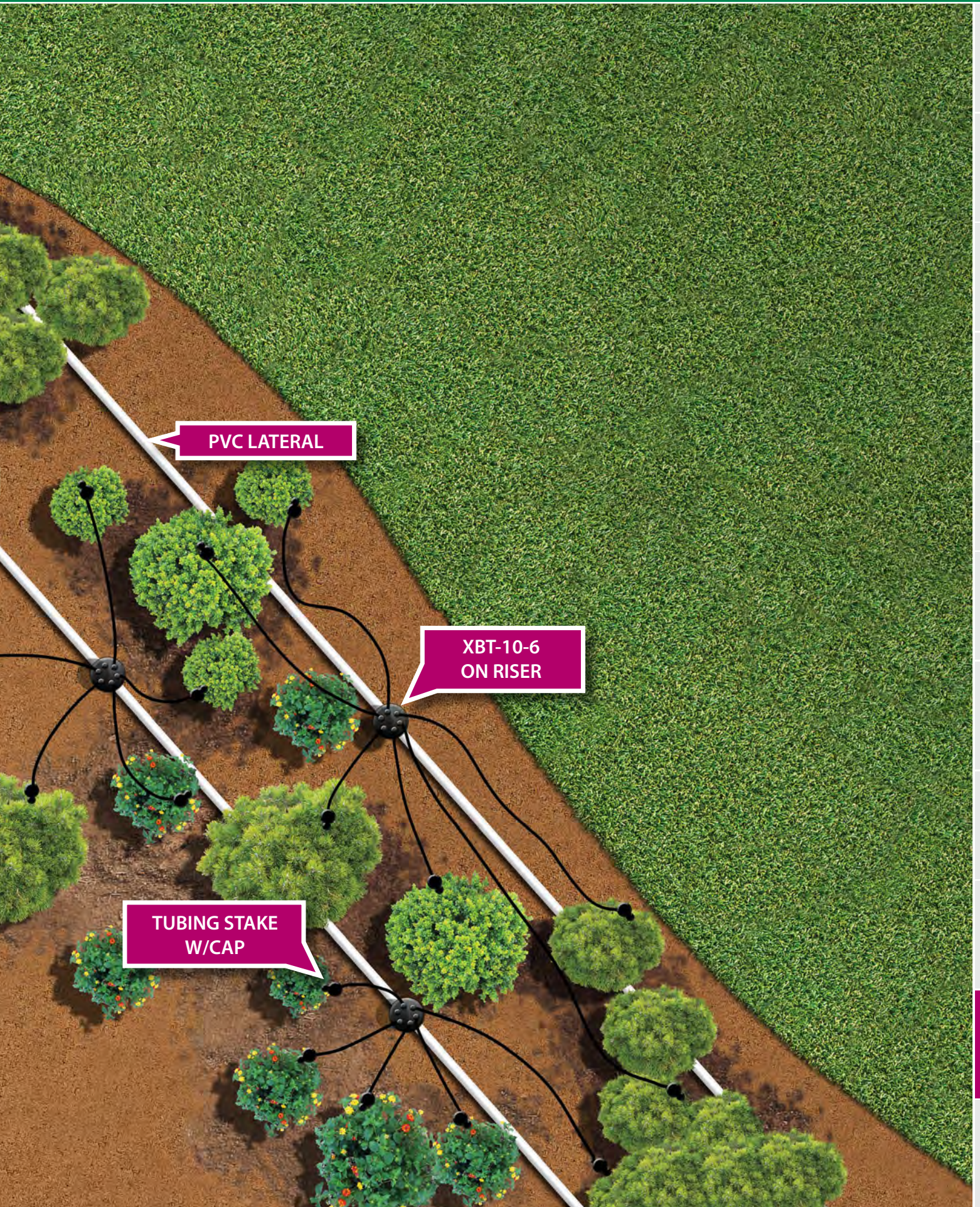

PVC LATERAL

XBT-10-6  
ON RISER

TUBING STAKE  
W/CAP

ANATOMY

PRODUCTS

NARROW BEDS

PARKING LOT

PARKWAYS/  
WALKWAYS

POTS/BASKETS

SLOPES

STREET MEDIANS

WALLS

GOLF COURSES

TREES



## Trees

### Combination Applications

#### Solution

Root Watering Series with XF Series Dripline Blank Tubing

#### Advantages

- Helps prevent damage to hardscapes from tree roots
- Promotes health in trees and shrubs
- Vandal resistant

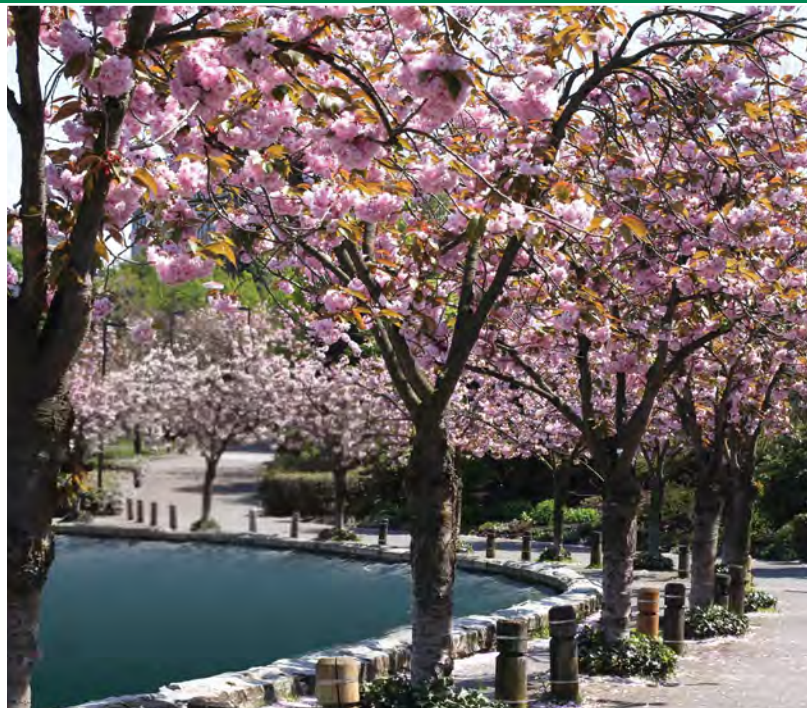

#### Installation

|               |   |
|---------------|---|
| XCZ-100-PRF   | 1" Control Zone Kit   |
| RWS or RWS-M  | RWS Root Watering Series  |
| XFD-XXX       | XF Series Dripline Blank Tubing                                 |
| SPB-025       | 1/4" Self Piercing Barb Connector                               |
| XQ-100        | 1/4" Distribution Tubing  |
| <b>XB XX*</b> | Xeri-Bug Pressure Compensating Drip Emitters (0.5 to 2.0 gph)   |
| <b>OR</b>     |   |
| <b>PC-XX</b>  | Pressure Compensating Module (be sure to use a PC Diffuser Cap) |



XFD



RWS

Add other drip products as needed (optional)

\* Select appropriate emitter flow rate

#### TO DO LIST :

- Assemble Control Zone Kit and connect to water source.
- Connect lengths of XF Blank Tubing and insert two to four 1/4" Self Piercing Barb Connectors for each tree. Attach length of 1/4" distribution tubing to each barb connector.
- Thread the 1/4" distribution tubing through the hole in the side of the RWS Root Watering Series unit, secure the 1/4" distribution tubing in the 1/4" tubing support brackets at the top of the RWS and install the appropriate Xeri-Bug or PC Module with Diffuser Cap emitter at the end of the tubing.
- Install additional drip products as needed for other plant material (optional).
- Flush system until water runs clear.

#### TIME: (approx.)

1 hr  
10 min/50'  
  
10 min/RWS  
  
as needed

#### INSTALLATION AND MAINTENANCE TIPS :

- ◆ Flush the zone after installation and 2-4 times per year.
- ◆ Leave XF Series Dripline Blank Tubing coils in the sun while preparing for installation.
- ◆ Install emitters and 1/4" Self Piercing Barbs with a Xeriman Tool (XM Tool) for 50% faster installation.

#### Drip Tip

Use two RWS for young/newly planted trees.  
Use three to four RWS for older/more mature trees.



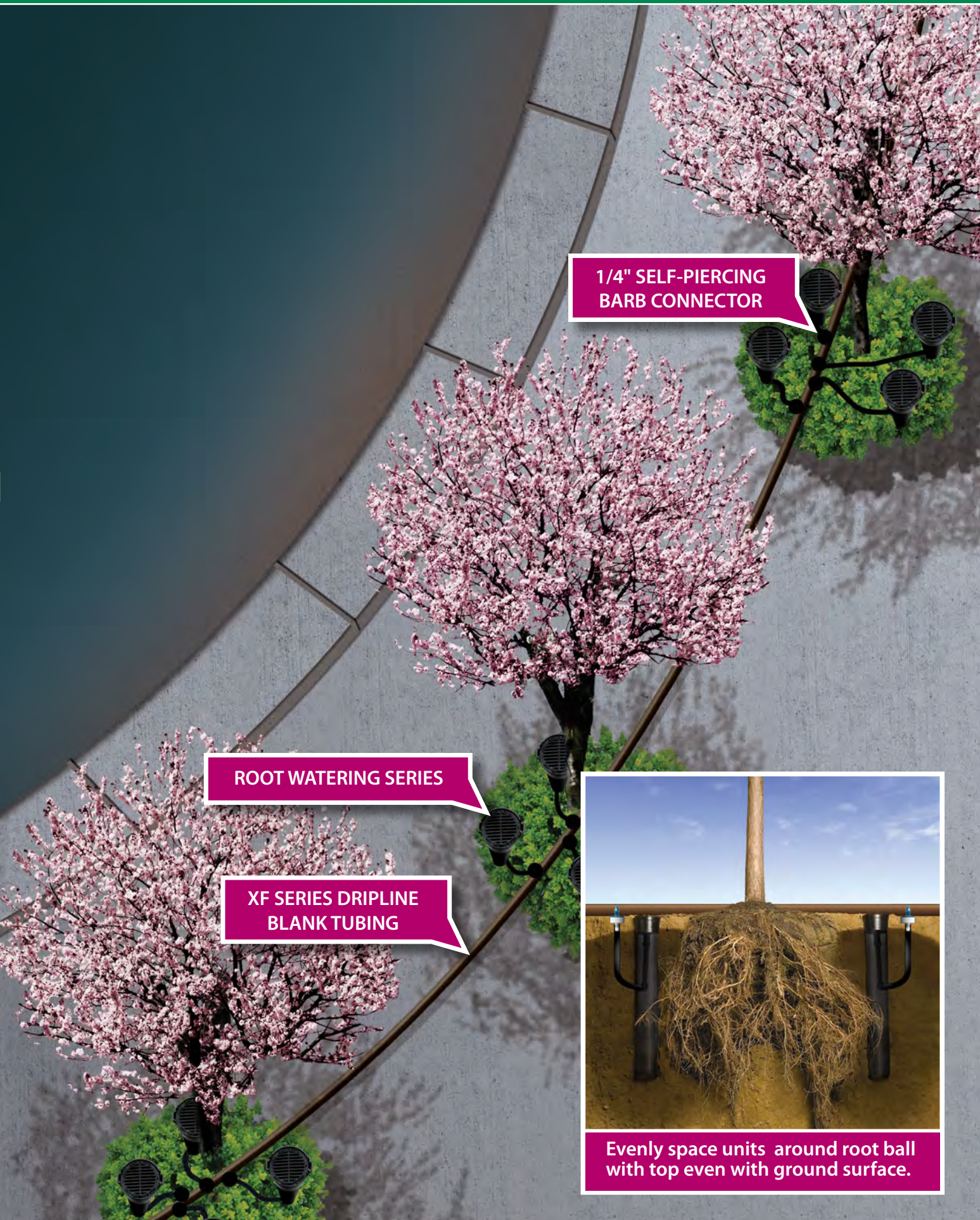

1/4" SELF-PIERCING BARB CONNECTOR

ROOT WATERING SERIES

XF SERIES DRIPLINE BLANK TUBING



Evenly space units around root ball with top even with ground surface.

|                       |
|-----------------------|
| ANATOMY               |
| PRODUCTS              |
| NARROW BEDS           |
| PARKING LOT           |
| PARKWAYS/<br>WALKWAYS |
| POTS/BASKETS          |
| SLOPES                |
| STREET MEDIANS        |
| WALLS                 |
| GOLF COURSES          |
| TREES                 |



## The Intelligent Use of Water.™

LEADERSHIP • EDUCATION • PARTNERSHIPS • PRODUCTS

---

At Rain Bird, we believe it is our responsibility to develop products and technologies that use water efficiently. Our commitment also extends to education, training and services for our industry and our communities.

The need to conserve water has never been greater. We want to do even more, and with your help, we can. Visit [www.rainbird.com](http://www.rainbird.com) for more information about The Intelligent Use of Water.™



**Rain Bird Corporation**  
**Landscape Drip Division**  
970 West Sierra Madre Avenue  
Azusa, CA 91702  
(800) 812-3400  
[www.rainbird.com](http://www.rainbird.com)