

High Performance Vector Control Inverter

FRENIC-VG Series

FRENIC-VG



FUJI INVERTERS

High performance enabled by the comprehensive use of Fuji technology.

Easy maintenance for the end-user.

Maintains safety and protects the environment.

Opens up possibilities for the new generation.

The Dawn of a New Era

The FRENIC-VG is creating a new era via the industry-leading performance.

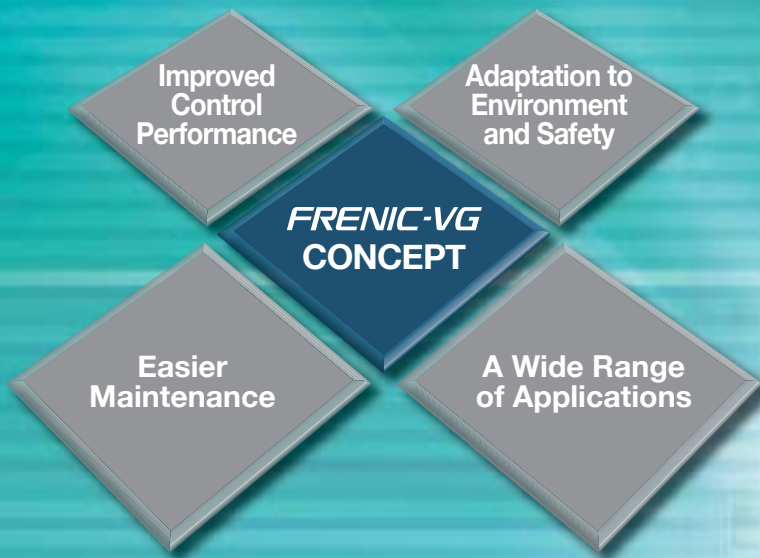

NEW

Capacity expansion realized through adoption of SiC hybrid module for 690V series inverter stack

Unit type



FRENIC-VG

FUJI INVERTERS

High performance enabled by the comprehensive use of Fuji technology.

Easy maintenance for the end-user.

Maintains safety and protects the environment.

Opens up possibilities for the new generation.

With the FRENIC-VG, Fuji has concentrated its technologies to deliver the best-performing inverter on the market. In addition to basic performance, this model features the following dramatic improvements: support for previously difficult applications due to technical and capability limitations, easier, more user-friendly maintenance, and environmental friendliness and safety. Fuji Electric proudly introduces the FRENIC-VG to the world.

Product introduction

Inverter (Unit Type)

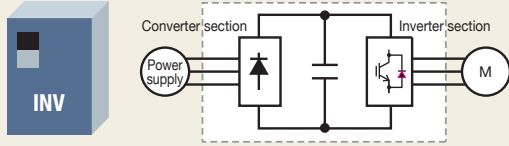

This type consists of the converter and inverter circuits. The inverter can be operated using a commercial power supply.
 * DC power can also be supplied without using the converter circuit.

Structure

- Built-in converter (rectifier)
- Built-in control circuit
- External DC reactor as standard*
- DC input is available.

* Available for 75kW or higher capacity models

Features

Easier arrangement for small-scale system



Inverter (Stack Type)

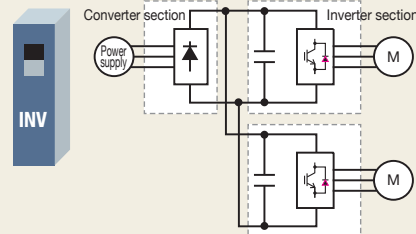

The converter and inverter sections are separately set in this type. The converter (diode stack) or PWM converter is required depending on the intended use. Moreover, a combination of inverters can be used with one converter.

Structure

- The converter (rectifier) is separately set.
- External control circuit
- Built-in DC reactor

Features

- DC supply enables the multi-drive arrangement
- Energy can be shared within DC bus lines.
- Downsized panel
- Large-capacity system is easily built.
- Easier maintenance

Converter

Diode rectifier (Stack Type)
RHD-D series

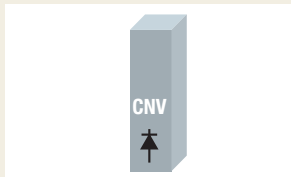

This converter is used where no electric power regeneration is required.

PMW converter (Unit Type)
RHC-C series*

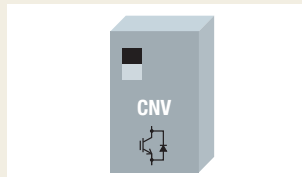

This converter is used where electric power regeneration or harmonic control is required. Peripheral devices are separately required.

* D series and C series differ in form but show identical function and performance. Please use them according to the installation space and purposes.

PMW converter (Stack Type)
RHC-D series*(400V/690V)

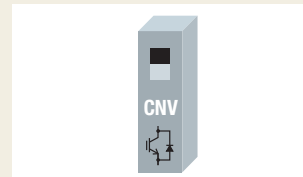

Filter stack (Stack Type)
RHF-D series (400V/690V)

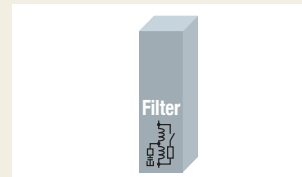

Standard Specifications

Common Specifications

Terminal Functions

Protective Functions

External Dimensions

Names and Functions of Parts

Dedicated Motor Specifications

External Dimensions of Dedicated Motors

Wiring Diagram

Options

Guidelines for Suppressing Harmonics

Comprehensive Line-up

Series lineup (inverters, converters)

- Line-up features unit type and stack type, facilitating easy construction of large-capacity systems.
- The stack type offers support for up to the following capacities through direct parallel connection.
 - Three-phase 400V series: Max. 2400kW (MD spec.), 3000kW (LD spec.)
 - Three-phase 690V series: Max. 1200kW (MD spec.), 1200kW (LD spec.)

Three-phase 200V series

Inverter Products Line-UP Expand capacity range (parallel operation) **Converter** Products Line-UP Expand capacity range (parallel operation)

Type	Series name	Form	Specifications *1 (applicable load)	Nominal applied motor [kW]					
				50	100	500	1000	5000	
Unit	Inverter (FRENIC-VG)	Standard unit	HD (LD)	0.75kW	90kW(110kW)	250kW(300kW) Direct parallel Multiwinding motor	500kW(630kW)		
	PWM Converter (RHC-C)	Standard unit	MD(CT) (LD(VT))	7.5kW(11kW)	90kW(110kW)	250kW(300kW) Isolation-less Isolation	500kW(630kW)		

Three-phase 400V series

Type	Series name	Form	Specifications *1 (applicable load)	Nominal applied motor [kW]				
				50	100	500	1000	5000
Unit	Inverter (FRENIC-VG)	Standard unit	HD (LD)	3.7kW(37kW)		630kW(710kW) Direct parallel Multiwinding motor	1800kW(2000kW)	3700kW(4200kW)
			MD		110kW	450kW Direct parallel Multiwinding motor	1200kW	2600kW
	PWM Converter (RHC-C)	Standard unit	MD(CT) (LD(VT))	7.5kW(11kW)		630kW(710kW) Isolation-less Isolation	1800kW(2000kW)	3700kW(4200kW)
Stack	Inverter (FRENIC-VG)	Standard stack	MD (LD)	30kW(37kW)	315kW(355kW) Direct parallel Multiwinding motor	800kW(1000kW)	1800kW(2000kW)	
		Stack by phase	MD (LD)		630kW (710kW) Direct parallel Multiwinding motor	800kW(1000kW)	2400kW(3000kW)	4800kW(6000kW)
	PWM Converter (RHC-D)	Standard stack	MD (LD)		132kW(160kW) Isolation-less Isolation	315kW(355kW)	800kW(1000kW)	1800kW(2000kW)
		Stack by phase	MD (LD)		630kW (710kW) Isolation-less Isolation	800kW(1000kW)	2400kW(3000kW)	4800kW(6000kW)
	Filter stack (RHF-D)	Standard stack	-		160kW	355kW		
	Diode rectifier (RHD-D)	Standard stack	MD (LD)		200kW (220kW)	315kW(355kW) Parallel connection	1450kW(1640kW)	

Three-phase 690V series

Type	Series name	Form	Specifications *1 (applicable load)	Nominal applied motor [kW]				
				50	100	500	1000	5000
Stack	Inverter (FRENIC-VG)	Standard stack	MD (LD)		90kW (110kW)	450kW(450kW) Direct parallel Multiwinding motor	1200kW(1200kW)	2700kW(2700kW)
			MD (LD)		132kW (160kW)	450kW(450kW) Isolation-less Isolation	1200kW(1200kW)	2700kW(2000kW)
	PWM Converter (RHC-D)	Standard stack	MD (LD)		160kW	450kW		
		Standard stack	MD (LD)		220kW (250kW)	450kW Parallel connection	2000kW	

*1 Refer to "Ratings for intended use" on page 6 for specifications (applicable load).
 * Unit type inverters have built-in brake circuits as standard (160kW or less).
 * Configuration: Standard unit → Can be used with one set. Stack by phase → Categorized by phase, and one inverter set consists of three stacks.
 * Multiple inverters can be connected with a single PWM converter and diode rectifier.
 * Inverters can also be supplied with DC power (with generator, etc.) without the use of a converter circuit.
 * Capacity expansion (parallel operation)
Inverters
 · Direct parallel connection: One single-winding motor is driven by multiple inverters. (Drive is possible with up to three inverters)
 · Multi-winding motor drive: Specialized motor drive system with multiple windings around a single motor. (Drive is possible with up to six inverters)
PWM converters
 · Transformer isolation (parallel system): System used to isolate the receiving power supply system and converter with a transformer. It is necessary to equip each converter input with a transformer. (No. of parallel connection units: max. 6)
 · Transformerless (parallel system): System in which a PWM converter is connected directly to the receiving power supply system. There is no need to isolate with a transformer. (No. of parallel connection units: max. 3)
 * Filter circuits if used with transformerless parallel system (multiple units operating in parallel)
 Standard stack: Use a filter stack. (Filter circuits cannot be configured with peripheral equipment.)
 Stack by phase: Use peripheral equipment.



Improved Control Performance

Realizes the industry-leading control performance

Induction motor

Achieved speed response of 600 Hz

(Tested with a dedicated motor with PG under vector control with speed sensor: about six times greater than our conventional model)

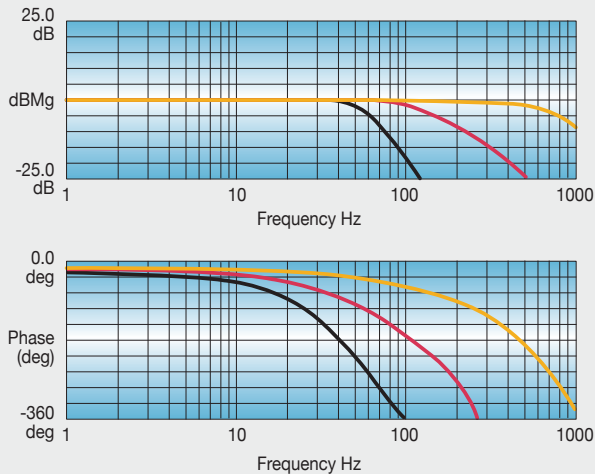

- FRN7.5VG1S-2J(600Hz, -3dB)
- FRN7.5VG7S-2(105Hz, -3dB)
- FRN7.5VG5S-2(54Hz, -3dB)

* With the stack type, "100 Hz" is achieved.

Follow-up characteristics under impact load

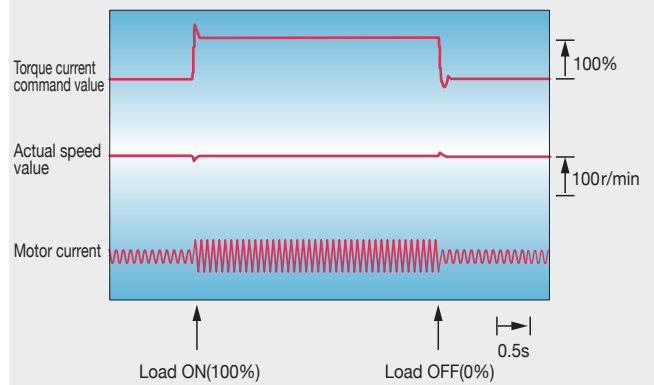

FRN37VG1S-4J, at 500r/min operation

Uneven rotation reduced by one-third

* Compared with our conventional models

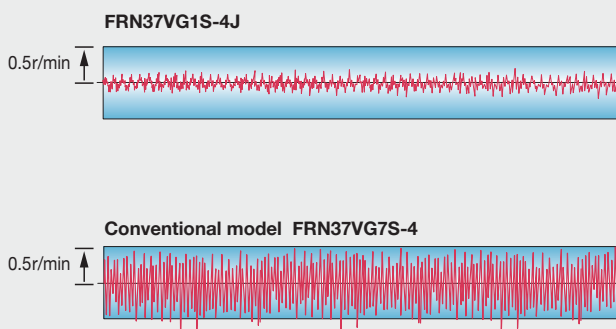

at 30r/min operation

Speed and torque characteristics

Under vector control with sensor

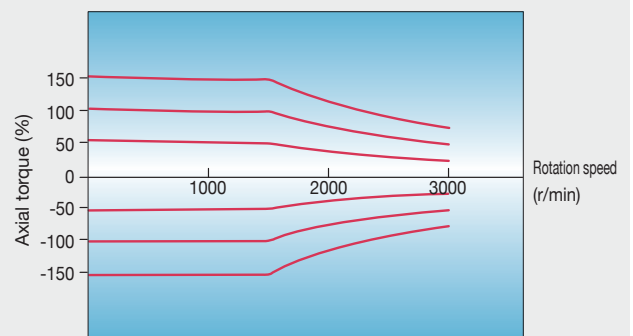

FRN37VG1S-4J

A Wide Range of Applications

Ratings for intended use

The operation mode for the motor is selected according to motor load condition. Motors larger by one or two frames can be driven with medium load (MD) and light load (LD) use.

Specification	Applied load	Feature	Applicable overload rating	Power supply voltage	Applicable motor capacity [kW]	
					Unit Type	Stack Type ²
HD	High Duty Spec	Powerful drive at low noise	Current: 150% 1min/200% 3sec	200V	0.75 to 90	-
				400V	3.7 to 630	-
				690V	-	-
MD	Middle Duty Spec	Can drive motors of frames one size larger ¹	150% 1min	200V	-	-
				400V	110 to 450 *2	30 to 800
				690V	-	90 to 450
LD	Low Duty Spec	Can drive motors of frames one or two sizes larger ¹	Unit type:120% 1min Stack type:110% 1min	200V	37 to 110	-
				400V	37 to 710	37 to 1000
				690V	-	110 to 450

*1 This varies depending on motor specifications and power supply voltage.

*2 Carrier frequency becomes 2kHz.

A standard built-in brake circuit with expanded capacity range

Having a standard built-in brake circuit (with 200V 55kW or less and 400V 160KW or less), is useful when applying the inverter to the vertical transfer machine, which is frequently used under the regenerative load.

* Unit type only

High-speed, high-accuracy position control realized (servo function)

- Built-in position control function as standard with pulse train input (A separate option (OPC-VG1-PG(PR)) is required for pulse train input.)
- High-speed, high-accuracy position control is possible in combination with an E-SX bus and 17-bit high-resolution ABS encoder. (The servo function is supported with a dedicated type.) (Soon to be supported)

Control method

Not only the induction motors but also the synchronous motors can be driven, and for the induction motors, you can select the most suitable control method according to your individual needs.

Target motors	Control method
Induction motor	-Vector control with speed sensor -Speed sensorless vector control -V/f Control
Synchronous motor	- Vector control with speed sensor (including pole position detection)

A wide range of options

- Providing options supporting various interfaces such as high-speed serial communications
- Options can be used by just inserting them into the connectors inside the inverter. Up to four cards can be mounted. (Combination with built-in control option: see page 48)

Category	Name	Type	
Analog card	Synchronized interface	OPC-VG1-SN	
	Analog input/output interface expansion card	OPC-VG1-AIO	
Digital card (for 8-bit bus)	Di interface card	OPC-VG1-DI	
	Dio extension card	OPC-VG1-DIO	
	PG interface card	+5V line driver	OPC-VG1-PG
		Open collector	OPC-VG1-PGo
		ABS encoder with 17-bit high resolution	OPC-VG1-SPGT
	PG card for synchronous motor drive	Line driver	OPC-VG1-PMPG
		Open collector	OPC-VG1-PMPGo
	T-Link communication card	OPC-VG1-TL	
	CC-Link communication card	OPC-VG1-CCL	
	High-speed serial communication card (for UPAC)*1	OPC-VG1-SIU	
Digital card (for 16-bit bus)	SX bus communication card	OPC-VG1-SX	
	E-SX bus communication card	OPC-VG1-ESX	
	User programming card	OPC-VG1-UPAC	
	PROFINET-IRT communication card	OPC-VG1-PNET	
Safety card	Functional safety card	OPC-VG1-SAFE	
Field bus interface card	PROFIBUS-DP communication card	OPC-VG1-PDP	
	DeviceNet communication card	OPC-VG1-DEV	
Control circuit terminal	Terminal block for high-speed communications	OPC-VG1-TBSI	

*1 coming soon



Dedicated design for panel installation (Stack Type)

Panel size reduction realized

The use of a stack type designed specifically for panel installation has resulted in a reduced panel size compared with the conventional design. A 34% reduction in panel width has been achieved over the conventional design (example for crane system).

The dedicated design has also resulted in easier installation of products into the panel and easier replacement.

<Panel configuration example for crane system>

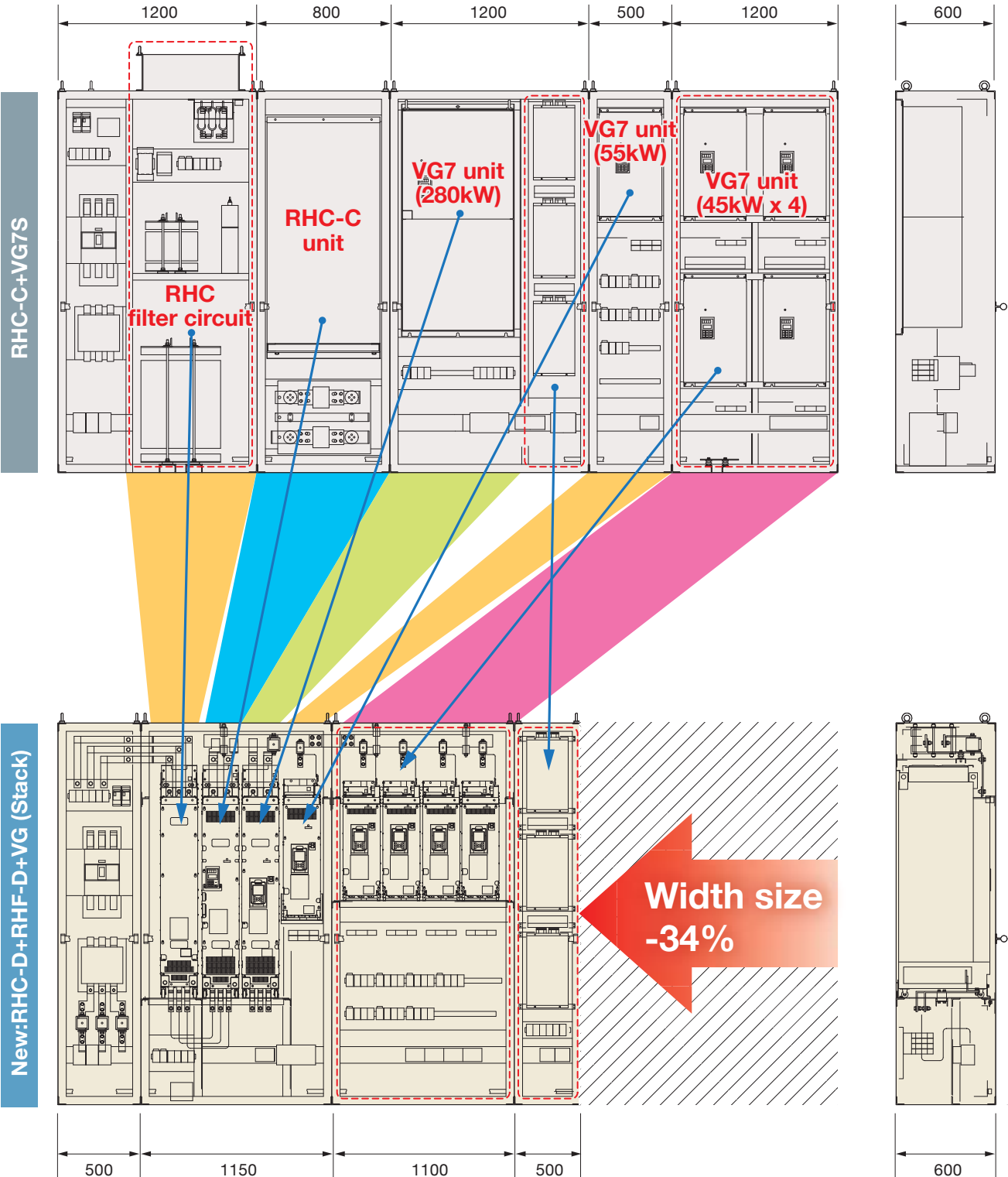

690V Series Inverter Stack Capacity Expansion Through Adoption of SiC Hybrid Module (355 /400/450kW)

Adoption of next-generation device (SiC-SBD)

Fuji handles all processes from new development to production from the device level, and has realized an optimized SiC module design tailored to stacks. This has resulted in a 28% reduction in generated loss, facilitated a reduction in stack size, and allowed capacity to be expanded.

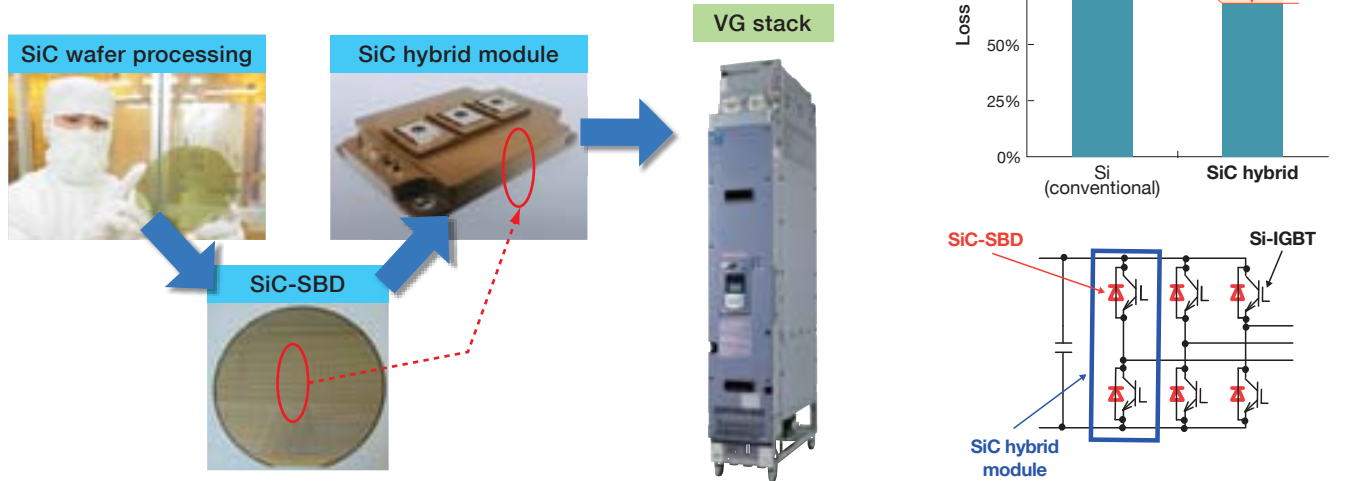

Compact size and capacity expansion through adoption of SiC hybrid module

Through the adoption of an SiC hybrid module, generated loss has been reduced by 28%, and stack single unit capacity has been expanded to 450kW, while ensuring the same dimensions as stacks in the 250 to 315kW capacity range. (Stack width: 226.2 mm)

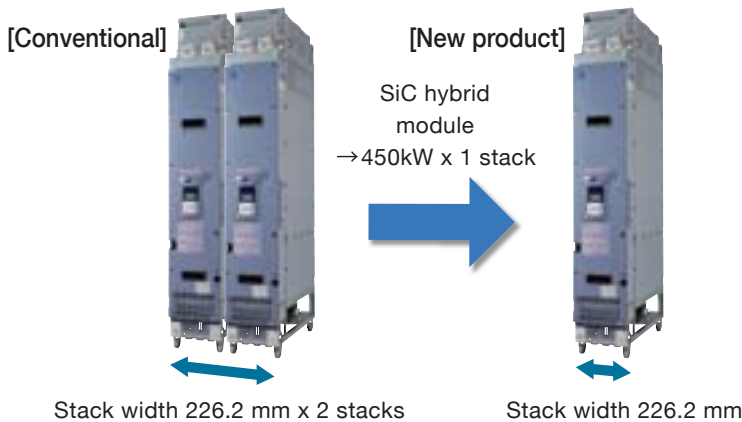

Dimensions and capacity comparison

Single unit capacity	315kW	450kW
Stack width	226.2mm	
Capacity	0.18m ³	

Use of a "single" 450kW system configuration realized with SiC hybrid module application

Also compatible with fan, pump applications

Applicable for even large-scale systems with dedicated fan and pump functions and broad capacity range [Soon to be supported]

- Forced operation (Fire Mode)
The inverter protection function is ignored (retry), allowing operation to be continued. This allows fans and pumps to continue running as much as possible in times of emergency such as when there is a fire.
- Command loss detection function
If analog speed setting signals are interrupted, operation continues at the speed set with a function code.
- Low water quantity stop function
The inverter can be stopped if the pump discharge pressure rises and discharged water quantity drops.
- Broad capacity range
Capacity expansion is easy with parallel operation (direct parallel connection).

Form	Power supply voltage	Unit type: HD spec./Stack type: MD spec.			LD specification		
		Lineup	Capacity expansion *1	No. of parallel units *2	Lineup	Capacity expansion *1	No. of parallel units *2
Unit type	200V series	Up to 90kW	Up to 250kW	3	Up to 110kW	Up to 300kW	3
	400V series	Up to 630kW			Up to 710kW		
Stack type	400V series	Up to 800kW	Up to 2400kW	3	Up to 1000kW	Up to 3000kW	3
	690V series	Up to 450kW			Up to 1200kW		

*1 The capacity expansion value indicates the nominal applied motor capacity.

*2 Capacity expansion applies to the direct parallel connection system. Up to three inverters can be connected in parallel.



Support for ultrahigh-speed E-SX bus

A PLC (MICREX-SX Series: SPH3000MM) and FRENIC-VG can be connected with the ultrahigh-speed communication E-SX bus. With ultrahigh-speed communication, support is possible for even faster, more accurate devices.

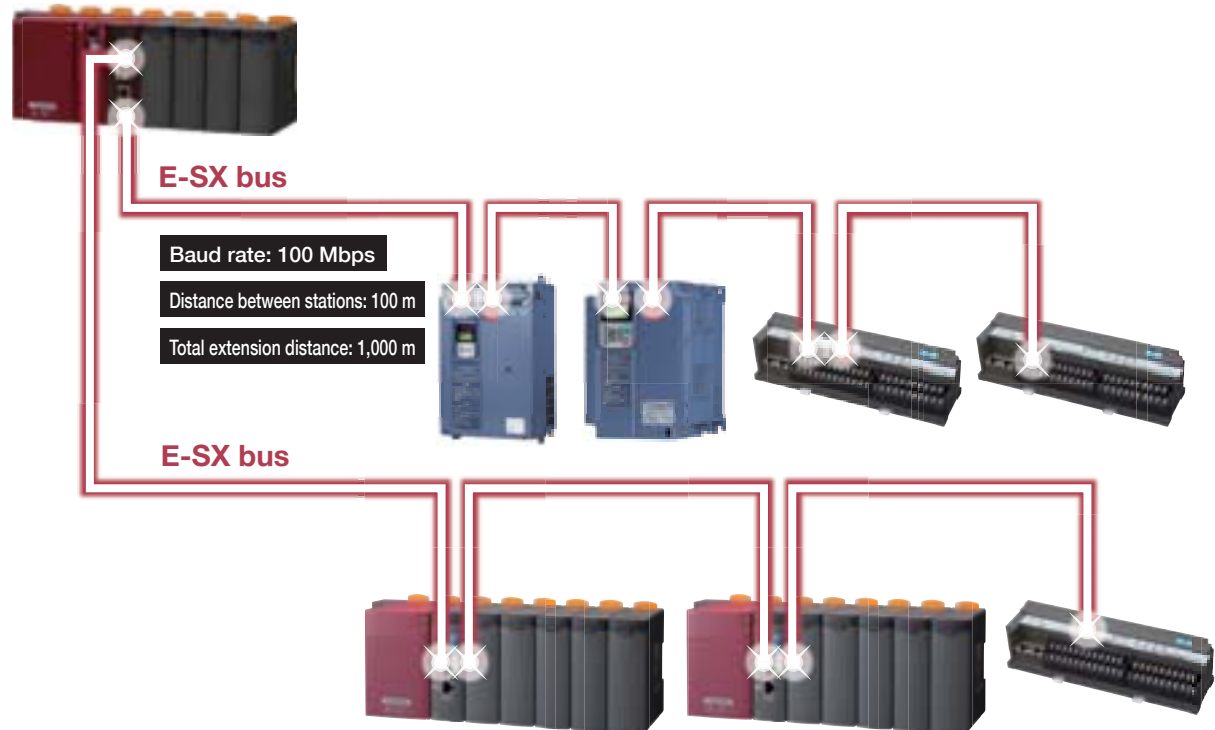

Easier maintenance

Inverter product range and ease of replacement (stack type)

The inverters (stack type) have an arrangement with consideration for the installation of the product into the panel and easier change. The inverters (stack type) (132 to 315 kW) can easily be installed or changed because they have wheels. With the inverters (stack type) (630 to 800 kW), stacks are divided for each output phase (U, V and W), which has realized the lighter weight.

Nominal applied motor capacity [kW] (MD spec)	30 to 110	132 to 450	630 to 800
Type	400V: FRN30SVG1S-4□ to FRN110SVG1S-4□ 690V: FRN90SVG1S-69□ to FRN110SVG1S-69□	400V: FRN132SVG1S-4□ to FRN315SVG1S-4□ 690V: FRN132SVG1S-69□ to FRN450SVG1S-69□	FRN630BVG1S-4□ to FRN800BVG1S-4□
Category	Single unit	Single unit	Stack by phase
Wheels	Not provided	Provided	Provided
Arrangement			
Maintenance	The weight of one stack is reduced (50 kg or less) to give consideration to replacement work.	The models where each stack is heavy have wheels in order to change the stacks easily. A lifter for replacement is available.	Trim weight by dividing the stack into 3 parts by each output phase (U, V and W). In the event of a breakdown, only the target phase needs to be replaced with a new one. The stack to be replaced should be an exclusive part.
Approx. weight [kg]	30 to 45	95 to 135	135×3

Easier Maintenance and Greater Reliability

Upgraded PC loader functions

PC Loader can be used via the USB connector (mini B) provided on the front cover.

- The front cover does not have to be removed.
- No RS-485 converter is needed.
- Commercial cables can be used.

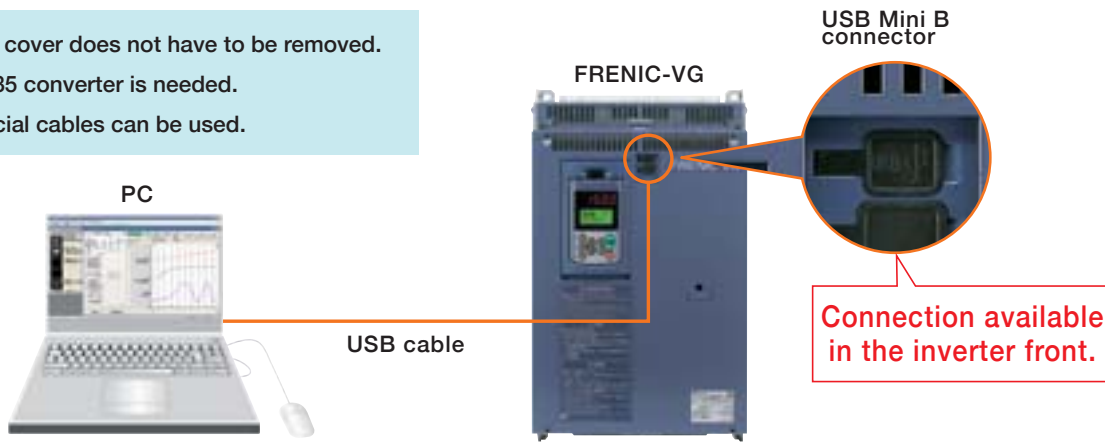

[Fault diagnosis using the trace back function]

Edited on the trace screen on the loader

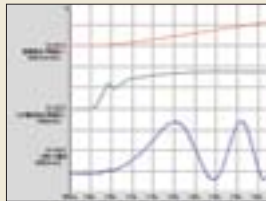

- Internal data, time and date around the fault are recorded. The real-time clock (clock function) is built-in as standard.
- Data are backed up by battery. Trace data can be stored in the memory even while the power is off. *Battery: 30kW or more (built-in as standard), up to 22kW (available as option: OPK-BP)
- Trace waveform can be checked on the PC loader

[Easy edit and detail monitor]

Data editing and detailed data monitor analysis operations are much easier than with a conventional PC loader.

Function code setting

User-defined displays (customized displays), data explanation display for each code.

Trace function

Real-time trace: for long-term monitoring
Historical trace: for detailed data diagnosis for short periods

Trace back: for fault analysis (last three times)

*The paid-for loader software (WPS-VG1-PCL) supports real-time tracing and historical tracing.

*The paid-for loader software (WPS-VG1-STR) is contained in the CD-ROM provided with the product. (Can be downloaded from the Fuji website.)

Multifunctional the Keypad

- Wide 7-segment LED ensures easy view.
- The back-light is incorporated in the LCD panel, which enables the easy inspection in the dark control panel.
- Enhanced copy function
The function codes can be copied to other inverters easily. (Three patterns of function codes can be stored.) Copying data in advance reduces restoration time when problems occur, by replacing the Keypad when changing the inverter.
- Remote control operation is available.
The Keypad can be remotely operated by extending the cable length at the RJ-45 connector.
- JOG (jogging) operation can be executed using the Keypad.
- The HELP key displays operation guidance.
- Supported languages: English, Chinese, Korean (Hangul), Japanese





More reliable functions

Save alarm data

Detailed data are stored for the last four alarms, including:

- Time to sound alarm
- Speed setting value
- Detection speed value
- Torque command value
- Temperature (heat sink, internal temperature)
- Accumulated operation time
- Output current detection value
- Magnetic-flux reference value
- I/O status

OU	Time of occurrence 2011/01/01	m	%
OC	Time of occurrence 2011/01/01	m	%
LU	Time of occurrence 2011/01/02	m	%
OC	Time of occurrence 2011/01/05 12:36:45	m	%
	N* = 1500.0r/m	35°C	190V
	N = 1500.0r/m	256.2A	100%
	f* = 50.0Hz	55°C	200V
	TRQ = 90%	180.0A	100%
	TMP = 45°C	132V	
	Iout = 210.6A		
	Vout = 160V		
	FLX* = 100%		

- The number of alarm data to be stored has been increased from the conventional model.

Thanks to the real-time clock function built-in as standard, the complete data of the latest and last 3 alarm occurrences is stored: time, speed command, torque, current and others. This enables machine units to be checked for abnormalities.

⇒As for previous model, new alarm data overwrite and deleted existing alarm data. This is solved with the new VG model.

Alarm severity selection

Alarm severity (serious and minor) can be selected, eliminating the risk of critical facility stoppage due to a minor fault.

	30-relay output	Y-terminal output	Inverter output	Selection
Motor overload, communications error, DC fan lock, etc.	No output (minor fault) Output	Provided Not provided	Operation continued Shut off	Can be selected for each function.
Blown fuse, excessive current, ground fault, etc.	Output	Not provided	Shut off	Fixed

PG fault diagnosis

- The PG interface circuit incorporated as standard detects disconnection of the power supply line as well as the PG signal line.
- A mode was added that judges if it is a PG fault or a fault on the inverter side. Simulated output mode is provided at the PG pulse output terminal (FA and FB). Operation can be checked by connecting this to the PG input terminal.

Easy change of the cooling fan

Unit Type

The cooling fan can easily be changed without removing the front cover and printed board.



Stack Type

The cooling fan installed at the top can easily be changed without drawing the stacks. However, for the 220kW or above inverter, remove the 2 connection bars from the DC side and change the cooling fan.

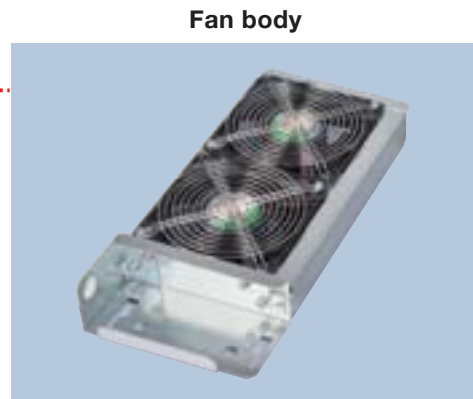

Components with a longer service life

For the various consumable parts inside the inverter, their designed lives have been extended to 10 years. This also extended the equipment maintenance cycles.

Life conditions

Unit type: ambient temperature 40 °C, load factor 100% (HD spec.), 80% (MD spec., LD spec.)
 Stack type: ambient temperature 30 °C, load factor 100% (MD spec.), 80% (LD spec.)

*The planned life is determined by calculation, and is not the guaranteed value.

Life-limited component	Design lifetime*
Cooling fan	10 years
Smoothing capacitor on main circuit	
Electrolytic capacitors on PCB	

Enhanced lifetime alarm

- Lifetime alarms can be checked rapidly on the Keypad and PC loader (optional).
- Facility maintenance can be performed much easier thanks to lifetime alarms.

Items			
Inverter accumulated time (h)	No. of inverter starts (times)	Facility maintenance warning Accumulated time (h) No. of starts (times)	Inverter lifetime alarm information is displayed.

Useful functions for test run and adjustment

- Customization of functions for test run and adjustment (Individual items on the loader can be set to be displayed or not.)
- Simulated fault alarm issued by a special function on the Keypad
- Monitor data hold function
- Simulated operation mode
 Simulated connection allows the inverter to be operated with internal parts in the same way as if they were connected to the motor, without actually being connected.
- The externally input I/O monitor and PG pulse states can be checked on the Keypad.

Easy wiring (removable control terminal block)

- The terminal block can be connected to the inverter after control wiring work is completed. Wiring work is simplified.
- Restoration time for updating equipment, problem occurrence, and inverter replacement has been drastically reduced. Just mount the wired terminal block board to the replaced inverter.

■ Unit Type

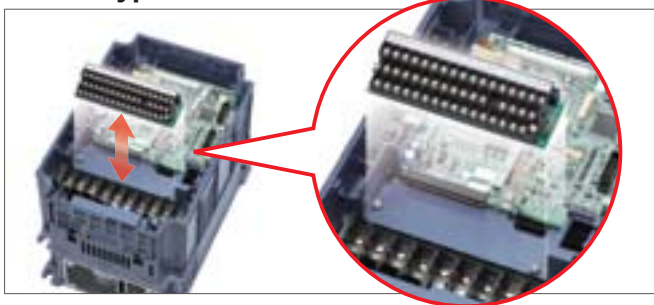

■ Stack Type

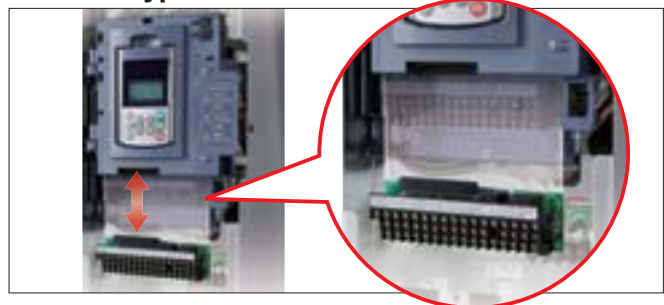



Adaptation to Environment and Safety

Compliance with overseas standards

- Complies with UL and cUL Standards, EC Directives (CE marking), KC certification, and RoHS Directive.
- *The stack type three-phase 690V series does not comply with UL and cUL Standards.
- Directive when the standard model is combined with an option (EMC filter).

EU

US/Canada

Korea

EC Directive (CE marking)

UL Standards/cUL Standards

KC certification
(Stack type: pending certification)

Enhanced environmental resistance

Environmental resistance has been enhanced compared to conventional inverters.

- (1) Environmental resistance of cooling fan has been enhanced.
- (2) Ni and Sn plating are employed on copper bars.

Environmental resistance has been enhanced on the FRENIC-VG compared to conventional models; however, the following environments should be examined based on how the equipment is being used.

- Sulfidizing gas** (present in some activities such as tire manufacturers, paper manufacturers, sewage treatment, and the textile industry)
- Conductive dust and foreign particles** (such as with metal processing, extruding machines, printing machines, and waste treatment)
- Others: under unique environments not included under standard environments**

Contact Fuji before using the product in environments such as those indicated above.

Conforms to safety standards

- The functional safety (FS) function STO that conforms to the FS standard IEC/EN61800-5-2 is incorporated as standard.
- The FS functions STO, SS1, SLS and SBC that conform to FS standard IEC/EN61800-5-2 can be also available by installing the option card OPC-VG1-SAFE. (Available only when controlling the motor using feedback encoder (closed loop).)

Safety function STO: Safe Torque Off

This function shuts off the output of the inverter (motor output torque) immediately.

Safety function SS1: Safe Stop 1

This function decreases the motor speed to shut down the motor output torque (by STO FS function) after the motor reaches the specified speed or after the specified time has elapsed.

Safety function SLS: Safely Limited Speed

This function prevents the motor from rotating over the specified speed.

Safety function SBC: Safe Brake Control

This function outputs a safe signal of the motor brake control.

Conforms to Marine standards

- A Marine standards compatible product lineup has been added as semi-standard products.

These products can be used for shipping equipment. (Certifying body: Classification society DNV GL)

*Three-phase 690V stack type only

A separate EMC filter and Zero phase reactor are required.

Contact Fuji for details.

How to expand the capacity range of the inverters (Stack Type)

Direct parallel connection system and multiwinding motor drive system are provided for driving a large capacity motor.

System		Direct parallel connection system	Multiwinding motor drive system
Features	Drive motor	Single-winding motor	Multiwinding motor (Exclusive use for multiwinding motors)
	Restriction of wiring length	The minimum wiring length (L) varies with the capacity.	There is no particular limit.
	Reduced capacity operation *2	Available	Available (However, the wiring should be switched over.)
Number of inverters to be connected		2 to 3 inverters	2 to 6 inverters
Arrangement diagram		<p>When 2 inverters are connected</p>	<p>When 2 inverters are connected</p>

*1) OPC-VG1-TBSI is separately required.
 *2) Reduced capacity operation. If a stack fails in case of direct parallel connection, the operation continues with lower output power using the stacks that have not failed.

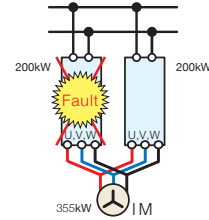

Example) If one inverter fails when 200kW x 2 inverters are driving a 355kW motor, the operation can continue with the 200kW inverter (capacity of one inverter).

(Note) To start the reduced capacity operation, consideration is needed to the switch over operation of PG signals or motor constants and sequence circuit. For details, refer to the operation manual.

Configuration table for direct parallel connection

2 or even 3 inverters of the same capacity can be connected in parallel to increase capacity or facilitate system redundancy. Typical combinations are shown in Table 1, however, other configurations are also possible.

Table 1 Direct parallel combination example (400V series, MD specification)

Connection system	Standard stack				Stack by phase			
	Applicable inverter	Applicable inverter	No. of units	Current [A]	Applicable inverter	Applicable inverter	No. of units	Current [A]
Capacity [kW]	Applicable inverter	Applicable inverter	No. of units	Current [A]	Applicable inverter	Applicable inverter	No. of units	Current [A]
30	FRN30SVG1							
37	FRN37SVG1							
45	FRN45SVG1							
55	FRN55SVG1							
75	FRN75SVG1							
90	FRN90SVG1							
110	FRN110SVG1							
132	FRN132SVG1							
160	FRN160SVG1							
200	FRN200SVG1							
220	FRN220SVG1							
250	FRN250SVG1							
280	FRN280SVG1							
315	FRN315SVG1							
355		FRN200SVG1	2	716				
400		FRN220SVG1	2	789				
500		FRN280SVG1	2	988				
630		FRN220SVG1	3	1183	FRN630BVG1			
710		FRN280SVG1	3	1482	FRN710BVG1			
800		FRN280SVG1	3	1482	FRN800BVG1			
1000					FRN630BVG1	2	2223	
1200					FRN630BVG1	2	2223	
1500					FRN800BVG1	2	2812	
1800					FRN630BVG1	3	3335	
2000					FRN710BVG1	3	3905	
2400					FRN800BVG1	3	4218	

*1) OPC-VG1-TBSI is required for each stack.



How to expand the capacity range of the PWM converters (Stack Type)

A “transformer-less parallel system” and “transformer insulation type parallel system” can be used to expand the total converter capacity.

System	Transformer isolation-less parallel system	Transformer insulation type parallel system
	This system involves connecting converter inputs to the power supply without isolating with a transformer, etc.	This system involves isolating respective converter inputs with a transformer.
Reduced capacity operation	Available	Available
Number of converter to be connected	2 to 3 converters	2 to 6 converters
Arrangement diagram	When 2 converters are connected 	When 2 converters are connected

*2) OPC-VG7-SIR is required for each stack. *3) OPC-VG7-SI is required for each stack.

Transformerless parallel system configuration table

2 or 3 converters of the same capacity can be connected in parallel to increase capacity or facilitate system redundancy. Typical combinations are shown in Table 2, however, other configurations are also possible.

Table 2 Transformerless parallel system combination example (400V series, MD specification)

Connection system	Standard stack			Stack by phase		
	Applicable converter	Applicable converter	No. of units	Applicable converter	Applicable converter	No. of units
Capacity [kW]	Applicable converter	Applicable converter	No. of units	Applicable converter	Applicable converter	No. of units
132	RHC132S-4D					
160	RHC160S-4D					
200	RHC200S-4D					
220	RHC220S-4D					
280	RHC280S-4D					
315	RHC315S-4D					
355		RHC200S-4D	2			
400		RHC200S-4D	2			
500		RHC280S-4D	2			
630		RHC315S-4D	2	RHC630B-4D		
710		RHC280S-4D	3	RHC710B-4D		
800		RHC280S-4D	3	RHC800B-4D		
1000					RHC630B-4D	2
1200					RHC630B-4D	2
1500					RHC800B-4D	2
1800					RHC630B-4D	3
2000					RHC710B-4D	3
2400					RHC800B-4D	3

*2) OPC-VG7-SIR is required for each stack.

System Configuration Overview

■ PWM converter + inverter

Note

- Transformer (multi phase)
- Power Supply
- Single winding motor
- Multi winding motor
- CNV: PWM converter
INV: inverter
- Filter circuit (individual) or filter stack
- Converter unit(RHC-C) or stack(RHC-D)
- Inverter unit or stack
- Optical communication card (option)

No.	System structure	System construction	Filter stack (RHF)(*1)	Filter for RHC-C series (individual type)	Motor capacity (Ex. FRN315SVG1S-4□ parallel use)
1		<p>⊙ Available</p> <p>CNV: 6 pieces/max INV: 6 parallel connection/max</p>	⊙ Available	<p>■ Converter unit (RHC-C) ⊙ Available</p> <p>■ Converter stack (RHC-D) •RHC132S to 315S-4D → X Not Available (*2) •RHC630B to 800B-4D → ⊙ Available</p>	to 1800kW (6 winding motor)
2		<p>X Not available</p> <p>(Use No.3 for direct parallel connection.)</p>	—	—	—
3		<p>⊙ Available</p> <p>CNV: 6 parallel connection/max INV: 3 parallel connection/max</p>	⊙ Available	<p>■ Converter unit (RHC-C) ⊙ Available</p> <p>■ Converter stack (RHC-D) •RHC132S to 315S-4D → X Not Available (*2) •RHC630B to 800B-4D → ⊙ Available</p>	to 800kW (INV: 3 parallel connection)
4		<p>⊙ Available</p> <p>CNV: 6 pieces/max INV: 6 parallel connection/max</p>	⊙ Available	<p>■ Converter unit (RHC-C) ⊙ Available</p> <p>■ Converter stack (RHC-D) •RHC132S to 315S-4D → X Not Available (*2) •RHC630B to 800B-4D → ⊙ Available</p>	to 1800kW (6 winding motor)
5		<p>X Not available</p> <p>(If sharing converter output, use the No.7 connection.)</p>	—	—	—
6		<p>X Not available</p> <p>(If sharing converter output, use the No.8 connection.)</p>	—	—	—
7		<p>⊙ Available</p> <p>CNV: 3 parallel connection/max INV: 6 parallel connection/max</p>	⊙ Available	—	to 1800kW (6 winding motor)
8		<p>⊙ Available</p> <p>CNV: 3 parallel connection/max INV: 3 parallel connection/max</p>	⊙ Available	<p>■ Converter unit (RHC-C) ⊙ Available</p> <p>■ Converter stack (RHC-D) •RHC132S to 315S-4D → X Not Available (*2) •RHC630B to 800B-4D → ⊙ Available</p>	to 800kW (INV: 3 parallel connection)
9		<p>⊙ Available</p> <p>INV: 6 parallel connection/max</p>	⊙ Available	<p>■ Converter unit (RHC-C) ⊙ Available</p> <p>■ Converter stack (RHC-D) •RHC132S to 315S-4D → X Not Available (*2) •RHC630B to 800B-4D → ⊙ Available</p>	to CNV capacity
10		<p>⊙ Available</p> <p>INV: 3 parallel connection/max</p>	⊙ Available	—	to CNV capacity

(*1) The filter stack (RHF-D) is for exclusive use with the PWM converter (RHC-D) stack type. It cannot be used with the PWM converter (RHC-C) unit type.
 (*2) Please note that restrictions apply if using an RHC Series filter (available separately) with the PWM converter (RHC-D) stack type. For details, contact Fuji.
 (Note 1) If using with a direct parallel connection or multi-winding motor drive, ensure that the capacity is the same for all inverters.
 (Note 2) When multiple inverters are powered by a single converter, ensure that the converter capacity ≥ the total inverter capacity.
 (Note 3) When driving a motor with direct parallel connection, a minimum wiring length between the motor and inverter should be maintained.
 (Note 4) The main power supply to all converters should be turned on at the same time.



Diode Rectifier (RHD-D) + inverter

Note

- Transformer (12 phase)
- Power Supply
- Single winding motor
- Multi winding motor
- INV: inverter
- ACR AC reactor
- RFI Diode rectifier
- Inverter unit or stack
- TBSI Optical communication card (option)

No.	System structure	Applicable system Applicable motor capacity (total) (*1)	Remarks
1	RFI:INV= 1:N 	Direct parallel system Multiwinding system Continuous rating (total) MD: to 315kW LD: to 355kW	
2	RFI:INV= 2:2 RFI:INV= 3:3 	Multiwinding system Continuous rating (total) MD: to 945kW LD: to 1065kW	1) If common bus not applied for RFI output (DC output) 2) Not applicable with direct parallel systems
3	RFI:INV= 2:N RFI:INV= 3:N 	Direct parallel system Multiwinding system Continuous rating (total) MD: to 869kW LD: to 979kW	1) A common bus should be applied for RFI output (DC output). 2) Restrictions apply to wiring conditions from TR to INV. 3) Voltage distortion in input voltage (3%, from IEC standards) 4) Wiring restrictions apply from input power supply to DC common bus.
4	RFI:INV= 2:2 	Multiwinding system Continuous rating (total) MD: to 548kW LD: to 617kW	1) If common bus not applied for RFI output (DC output) 2) Not applicable with direct parallel systems 3) Voltage distortion in input voltage (3%, from IEC standards) 4) Use an AC reactor.
5	RFI:INV= 2:N 	Direct parallel system Multiwinding system Continuous rating (total) MD: to 548kW LD: to 617kW	1) Voltage distortion in input voltage (3%, from IEC standards) 2) Use an AC reactor.
6	RFI:INV= 4:N 	Direct parallel system Multiwinding system Continuous rating (total) MD: to 970kW LD: to 1093kW	If using RFI (x4, or 6) structure configuration 1) A common bus should be applied for RFI output (DC output). 2) Restrictions apply to wiring conditions from Transformer to Inverter. 3) Voltage distortion in input voltage (3%, from IEC standards) 4) Use an AC reactor.
7	RFI:INV= 6:N 	Direct parallel system Multiwinding system Continuous rating (total) MD: to 1450kW LD: to 1640kW	If using RFI (x6) structure 1) A common bus should be applied for RFI output (DC output). 2) Restrictions apply to wiring conditions from Transformer to Inverter. 3) Voltage distortion in input voltage (3%, from IEC standards) 4) Use an AC reactor.

(*1) Motor capacity is calculated based on a power supply voltage of 400 V.
 (Note 1) Use inverters of the same capacity for direct parallel systems and multiwinding motor drive systems.
 (Note 2) Turn ON the main power supply for all converters at the same time.

Application Examples

Large crane and overhead crane

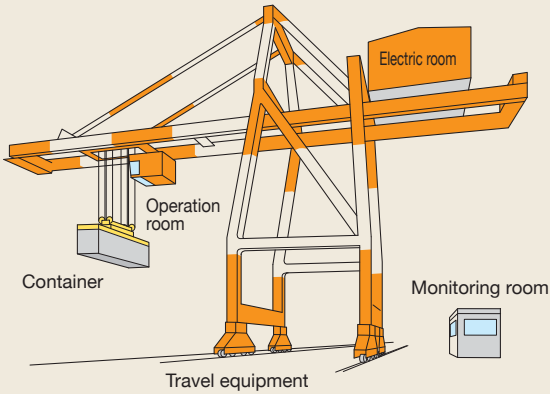

High reliability

VG supports your facility with long life service and high reliability. The trace back function allows easy fault diagnosis.

Bus system support

The bus system is supported to allow centralized control of elevation, traverse, and trolley, as well as centralized monitoring of running conditions.

Application to plants

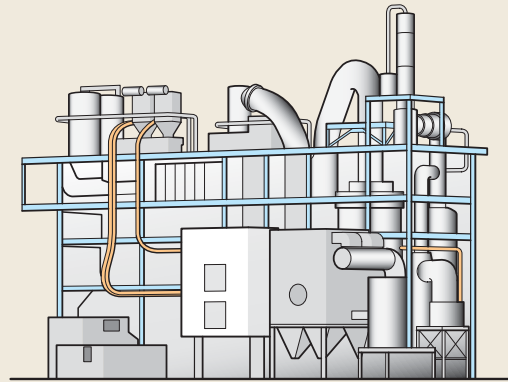

Control with high speed and high accuracy

In addition to high speed and high accuracy, VG contributes to stable facility operation with high reliability and long service life. The trace back function makes diagnosing the cause of problems easy when an abnormality arises.

Bus system support

Centralized control and monitoring are achieved by supporting various fieldbuses.

Servo press: large size for automobiles, small size for machines such as crimping terminal processing machines

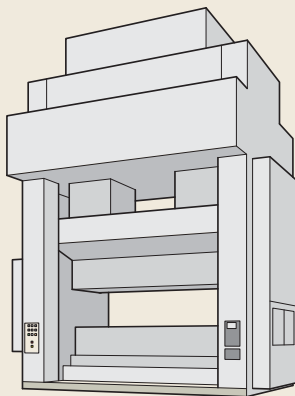

Position control

The press position is controlled based on an instantaneous position command given by the upper order CNC. Control with high responsibility contributes to shortening of the operation cycle.

Precision synchronization control

Large machines are driven with several motors to increase thrust. Precision synchronization control of several inverters and motors using the high-speed bus system can be applied.

Winding equipment (paper and metal)

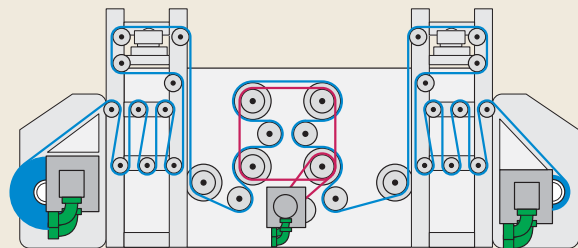

Tension control

Tension-type winding control capability with high accuracy torque control has been improved. Dancer-type winding control capability by the speed control with high speed response has been improved.

System support

The controller that calculates winding diameter achieves constant tension control.



Feeding part of semiconductor manufacturing device, wire saw

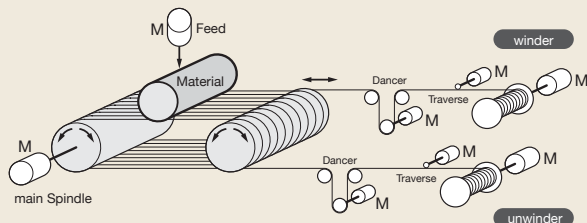

Smooth torque characteristic

The smooth drive characteristic in which torque ripple is suppressed contributes to machining quality.

System support

The system becomes more simple and highly efficient by using same bus system for main axis (spindle) and the other axes (traverse and winding) driven by small capacity servos.

Test equipment for automobiles

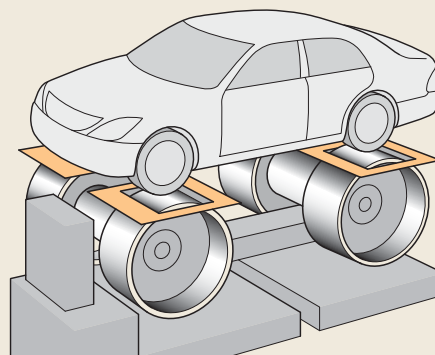

High-speed response control

High-speed rotation and torque control with high response are available for engine and transmission tests.

System support

The system can be supported in cases such as the vehicle body inertia simulation function for a brake test apparatus by combining with the controller.

Shipboard winch

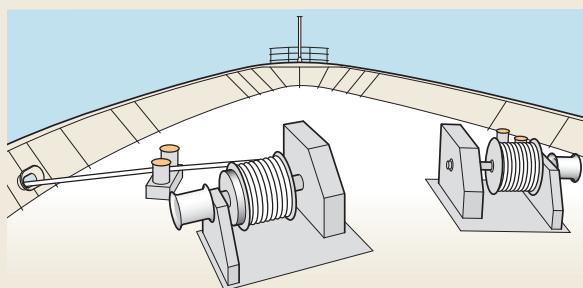

High reliability and tension control

Torque is controlled up to extra low speed using the sensorless feature.

Stable drive is maintained against load variation caused by waves.

Flying shear (Cutting while moving)

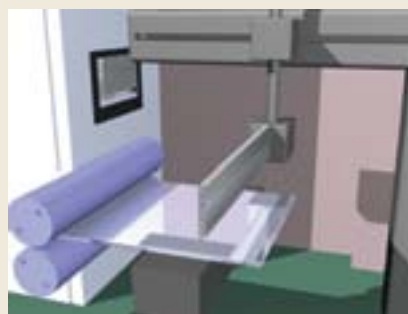

Position control

Position control is performed according to the position command given by the upper order CNC.

The machine cuts the material while moving at the same speed (as the material).

System support

The system is configured by an upper controller that calculates synchronous operation between the material feed axis, cutter feed axis and cut axis.

Model variation (Inverter)

Nominal applied motor (kW)	200V Series		400V Series		
	Unit Type		Unit Type		
	HD (150%, 1 min./200%, 3 sec.)	LD (120%, 1 min.)	HD (150%, 1 min./200%, 3 sec.)	MD (150%, 1 min.)	LD (120%, 1 min.)
Applied load	High Duty Spec	Low Duty Spec	High Duty Spec	Middle Duty Spec	Low Duty Spec
0.75	FRN0.75VG1S-2				
1.5	FRN1.5VG1S-2				
2.2	FRN2.2VG1S-2				
3.7	FRN3.7VG1S-2		FRN3.7VG1S-4		
5.5	FRN5.5VG1S-2		FRN5.5VG1S-4		
7.5	FRN7.5VG1S-2		FRN7.5VG1S-4		
11	FRN11VG1S-2		FRN11VG1S-4		
15	FRN15VG1S-2		FRN15VG1S-4		
18.5	FRN18.5VG1S-2		FRN18.5VG1S-4		
22	FRN22VG1S-2		FRN22VG1S-4		
30	FRN30VG1S-2		FRN30VG1S-4		
37	FRN37VG1S-2	FRN30VG1S-2	FRN37VG1S-4		FRN30VG1S-4
45	FRN45VG1S-2	FRN37VG1S-2	FRN45VG1S-4		FRN37VG1S-4
55	FRN55VG1S-2	FRN45VG1S-2	FRN55VG1S-4		FRN45VG1S-4
75	FRN75VG1S-2	FRN55VG1S-2	FRN75VG1S-4		FRN55VG1S-4
90	FRN90VG1S-2	FRN75VG1S-2	FRN90VG1S-4		FRN75VG1S-4
110		FRN90VG1S-2	FRN110VG1S-4	FRN90VG1S-4	FRN90VG1S-4
132			FRN132VG1S-4	FRN110VG1S-4	FRN110VG1S-4
160			FRN160VG1S-4	FRN132VG1S-4	FRN132VG1S-4
200			FRN200VG1S-4	FRN160VG1S-4	FRN160VG1S-4
220			FRN220VG1S-4	FRN200VG1S-4	FRN200VG1S-4
250				FRN220VG1S-4	
280			FRN280VG1S-4		FRN220VG1S-4
315			FRN315VG1S-4	FRN280VG1S-4	
355			FRN355VG1S-4	FRN315VG1S-4	FRN280VG1S-4
400			FRN400VG1S-4	FRN355VG1S-4	FRN315VG1S-4
450				FRN400VG1S-4	FRN355VG1S-4
500			FRN500VG1S-4		FRN400VG1S-4
630			FRN630VG1S-4		FRN500VG1S-4
710					FRN630VG1S-4
800					
1000					

* With the FRN55VG1S-2J/4J or higher (applicable motor of 75kW or higher), if driving motors of one frame or more from the inverter, the DC reactor provided as standard will differ between the HD, MD, and LD specifications. (Motor capacity becomes 1 frame larger.)

How to read the model number

FRN 30 S VG 1 S - 4 J

Code	Series name
FRN	FRENIC Series
Code	Nominal applied motor capacity
0.75	0.75kW
1.5	1.5kW
2.2	2.2kW
}	}
800	800kW
Code	Form
None	Unit type
S	Standard stack
B	Stack by phase

Code	Destination / Instruction Manual
J	Japanese
E	English
C	Chinese
Code	Input power source
2	Three-phase 200V
4	Three-phase 400V
69	Three-phase 690V
Code	Structure
S	Standard
Code	Developed inverter series
1	1 Series
Code	Application range
VG	High performance vector control

Caution! The product detail described in this document is intended for selecting a model. When using a product, read the Instruction Manual carefully and use the product properly.



Nominal applied motor (kW)	400V Series		690V Series	
	Stack Type		Stack Type	
	MD (150%, 1 min.)	LD (110%, 1 min.)	MD (150%, 1 min.)	LD (110%, 1 min.)
Applied load	Middle Duty Spec	Low Duty Spec	Middle Duty Spec	Low Duty Spec
0.75				
1.5				
2.2				
3.7				
5.5				
7.5				
11				
15				
18.5				
22				
30	FRN30SVG1S-4 □			
37	FRN37SVG1S-4 □	FRN30SVG1S-4 □		
45	FRN45SVG1S-4 □	FRN37SVG1S-4 □		
55	FRN55SVG1S-4 □	FRN45SVG1S-4 □		
75	FRN75SVG1S-4 □	FRN55SVG1S-4 □		
90	FRN90SVG1S-4 □	FRN75SVG1S-4 □	FRN90SVG1S-69 □	
110	FRN110SVG1S-4 □	FRN90SVG1S-4 □	FRN110SVG1S-69 □	FRN90SVG1S-69 □
132	FRN132SVG1S-4 □	FRN110SVG1S-4 □	FRN132SVG1S-69 □	FRN110SVG1S-69 □
160	FRN160SVG1S-4 □	FRN132SVG1S-4 □	FRN160SVG1S-69 □	FRN132SVG1S-69 □
200	FRN200SVG1S-4 □	FRN160SVG1S-4 □	FRN200SVG1S-69 □	FRN160SVG1S-69 □
220	FRN220SVG1S-4 □	FRN200SVG1S-4 □		FRN200SVG1S-69 □
250	FRN250SVG1S-4 □	FRN220SVG1S-4 □	FRN250SVG1S-69 □	
280	FRN280SVG1S-4 □	FRN250SVG1S-4 □	FRN280SVG1S-69 □	FRN250SVG1S-69 □
315	FRN315SVG1S-4 □	FRN280SVG1S-4 □	FRN315SVG1S-69 □	FRN280SVG1S-69 □
355		FRN315SVG1S-4 □	FRN355SVG1S-69 □	FRN315SVG1S-69 □
400			FRN400SVG1S-69 □	FRN355SVG1S-69 □
450			FRN450SVG1S-69 □	FRN400SVG1S-69 □
500				
630	FRN630BVG1S-4 □			
710	FRN710BVG1S-4 □	FRN630BVG1S-4 □		
800	FRN800BVG1S-4 □	FRN710BVG1S-4 □		
1000		FRN800BVG1S-4 □		

Model variation (converter)

Nominal applied motor (kW)	200V Series		400V Series				
	Unit Type (PWM)		Unit Type (PWM)		Stack Type (PWM)	Filter stack	
	HD(CT) (150%, 1 min.)	LD(VT) (120%, 1 min.)	HD(CT) (150%, 1 min.)	LD(VT) (120%, 1 min.)	MD (150%, 1 min.)	LD (110%, 1 min.)	Dedicated RHC-D filter
Applied load	High Duty Spec	Low Duty Spec	High Duty Spec	Low Duty Spec	Middle Duty Spec	Low Duty Spec	-
7.5	RHC7.5-2C		RHC7.5-4C				
11	RHC11-2C	RHC7.5-2C	RHC11-4C	RHC7.5-4C			
15	RHC15-2C	RHC11-2C	RHC15-4C	RHC11-4C			
18.5	RHC18.5-2C	RHC15-2C	RHC18.5-4C	RHC15-4C			
22	RHC22-2C	RHC18.5-2C	RHC22-4C	RHC18.5-4C			
30	RHC30-2C	RHC22-2C	RHC30-4C	RHC22-4C			
37	RHC37-2C	RHC30-2C	RHC37-4C	RHC30-4C			
45	RHC45-2C	RHC37-2C	RHC45-4C	RHC37-4C			
55	RHC55-2C	RHC45-2C	RHC55-4C	RHC45-4C			
75	RHC75-2C	RHC55-2C	RHC75-4C	RHC55-4C			
90	RHC90-2C	RHC75-2C	RHC90-4C	RHC75-4C			
110		RHC90-2C	RHC110-4C	RHC90-4C			
132			RHC132-4C	RHC110-4C	RHC132S-4D□		RHF160S-4D□
160			RHC160-4C	RHC132-4C	RHC160S-4D□	RHC132S-4D□	RHF160S-4D□
200			RHC200-4C	RHC160-4C	RHC200S-4D□	RHC160S-4D□	RHF220S-4D□
220			RHC220-4C	RHC200-4C	RHC220S-4D□	RHC200S-4D□	RHF220S-4D□
250							
280			RHC280-4C	RHC220-4C	RHC280S-4D□		RHF280S-4D□
315			RHC315-4C	RHC280-4C	RHC315S-4D□	RHC280S-4D□	RHF355S-4D□
355			RHC355-4C	RHC315-4C		RHC315S-4D□	RHF355S-4D□
400			RHC400-4C	RHC355-4C			
450							
500			RHC500-4C	RHC400-4C			
630			RHC630-4C		RHC630B-4D□		
710					RHC710B-4D□	RHC630B-4D□	
800					RHC800B-4D□	RHC710B-4D□	
1000						RHC800B-4D□	

Description of converter type

RHC 315 S - 4 D J

Code	Series name
RHC	PMW converter
RHD	Diode rectifier
RHF	Filter stack

Code	Nominal applied motor capacity
132	132kW
?	}
800	800kW

Code	Form
None	Unit type
S	Standard stack
B	Stack by phase

Code	Destination / Instruction Manual
J	Japanese
E	English
C	Chinese

Code	Developed inverter series
C	C Series
D	D Series

Code	Input power source
2	Three-phase 200V
4	Three-phase 400V
69	Three-phase 690V

Caution! The product detail described in this document is intended for selecting a model. When using a product, read the Instruction Manual carefully and use the product properly.



Nominal applied motor (kW)	400V Series		690V Series				
	Diode rectifier		Stack Type (PWM)(Coming soon)		Filter stack (Coming soon)	Diode rectifier	
	MD (150%, 1 min.)	LD (110%, 1 min.)	MD (150%, 1 min.)	LD (110%, 1 min.)	Dedicated RHC-D filter	MD (150%, 1 min.)	LD (110%, 1 min.)
Applied load	Middle Duty Spec	Low Duty Spec	Middle Duty Spec	Low Duty Spec	-	Middle Duty Spec	Low Duty Spec
7.5							
11							
15							
18.5							
22							
30							
37							
45							
55							
75							
90							
110							
132			RHC132S-69D		RHF160S-69D		
160			RHC160S-69D	RHC132S-69D	RHF160S-69D		
200	RHD200S-4D		RHC200S-69D	RHC160S-69D	RHF220S-69D		
220		RHD200S-4D		RHC200S-69D	RHF220S-69D	RHD220S-69D	
250			RHC250S-69D		RHF280S-69D		RHD220S-69D
280			RHC280S-69D	RHC250S-69D	RHF280S-69D		
315	RHD315S-4D		RHC315S-69D	RHC280S-69D	RHF355S-69D		
355		RHD315S-4D	RHC355S-69D	RHC315S-69D	RHF355S-69D		
400			RHC400S-69D	RHC355S-69D	RHF450S-69D		
450			RHC450S-69D	RHC400S-69D	RHF450S-69D	RHD450S-69D	
500							
630							
710							
800							
1000							

Standard specifications

HD specification for heavy overload (Unit Type)

Three-phase 200V series

Type	FRN□VG1S-2□	0.75	1.5	2.2	3.7	5.5	7.5	11	15	18.5	22	30	37	45	55	75	90	
Nominal applied motor [kW]		0.75	1.5	2.2	3.7	5.5	7.5	11	15	18.5	22	30	37	45	55	75	90	
Rated capacity [kVA] (*1)		1.9	3.0	4.1	6.8	10	14	18	24	28	34	45	55	68	81	107	131	
Rated current [A]		5	8	11	18	27	37	49	63	76	90	119	146	180	215	283	346	
Overload current rating		150% of rated current -1min. (*2), 200% -3s(*3)																
Power supply voltage	Main power Phase, Voltage, Frequency	3-phase 200 to 230V, 50Hz/60Hz											3-phase 200 to 220V/50Hz, 200 to 230V/60Hz (*4)					
	Auxiliary control power supply Phase, Voltage, Frequency	Single-phase 200 to 230V, 50Hz/60Hz																
	Auxiliary input for fan power Phase, Voltage, Frequency (*5)	-											Single phase 200 to 220V, 50Hz 200 to 230V/60Hz (*4)					
	Voltage/frequency variation	Voltage: +10 to -15% (Voltage unbalance: 2% or less (*6)), Frequency: +5 to -5%																
Rated current [A]	(with DCR)	3.2	6.1	8.9	15.0	21.1	28.8	42.2	57.6	71.0	84.4	114	138	167	203	282	334	
	(*7) (without DCR)	5.3	9.5	13.2	22.2	31.5	42.7	60.7	80.1	97.0	112	151	185	225	270	-	-	
Required power supply capacity [kVA] (*8)		1.2	2.2	3.1	5.2	7.4	10	15	20	25	30	40	48	58	71	98	116	
Braking method /braking torque		Braking resistor discharge control: 150% braking torque, Separately installed braking resistor (option), Separately installed braking unit (option for FRN75VG1S-2□ or higher)																
Carrier frequency [kHz] (*9)		2 to 15														2 to 10		
Approx.weight [kg]		6.2	6.2	6.2	6.2	6.2	6.2	11	11	11	12	25	32	42	43	62	105	
Enclosure		IP20 closed type UL open type											IP00 open type UL open type (IP20 closed type is available as option)					

Three-phase 400V series

Type	FRN□VG1S-4□	3.7	5.5	7.5	11	15	18.5	22	30	37	45	55	75	90	110	132	160	200	220	280	315	355	400	500	630		
Nominal applied motor [kW]		3.7	5.5	7.5	11	15	18.5	22	30	37	45	55	75	90	110	132	160	200	220	280	315	355	400	500	630		
Rated capacity [kVA] (*1)		6.8	10	14	18	24	29	34	45	57	69	85	114	134	160	192	231	287	316	396	445	495	563	731	891		
Rated current [A]		9.0	13.5	18.5	24.5	32.0	39.0	45.0	60.0	75.0	91.0	112	150	176	210	253	304	377	415	520	585	650	740	960	1170		
Overload current rating		150% of rated current -1min. (*2) 200% -3s. (*3)																									
Power supply voltage	Main power Phase, Voltage, Frequency	3-phase 380 to 480V, 50Hz/60Hz													3-phase 380 to 440V/50Hz, 380 to 480V/60Hz (*4)												
	Auxiliary control power supply Phase, Voltage, Frequency	Single phase 380 to 480V, 50Hz/60Hz																									
	Auxiliary input for fan power Phase, Voltage, Frequency (*5)	-													Single phase 380 to 440V, 50Hz 380 to 480V/60Hz (*4)												
	Voltage/frequency variation	Voltage: +10 to -15% (Voltage unbalance: 2% or less (*6)), Frequency: +5 to -5%																									
Rated current [A]	(with DCR)	7.5	10.6	14.4	21.1	28.8	35.5	42.2	57.0	68.5	83.2	102	138	164	210	238	286	357	390	500	559	628	705	881	1115		
	(*7) (without DCR)	13.0	17.3	23.2	33	43.8	52.3	60.6	77.9	94.3	114	140	-	-	-	-	-	-	-	-	-	-	-	-	-	-	
Required power supply capacity [kVA] (*8)		5.2	7.4	10	15	20	25	30	40	48	58	71	96	114	140	165	199	248	271	347	388	436	489	610	773		
Braking method /braking torque		Braking resistor discharge control: 150% braking torque, Separately installed braking resistor (option), Separately installed braking unit (option for FRN200VG1S-4□ or higher)																									
Carrier frequency [kHz] (*9)		2 to 15													2 to 10										2 to 5		
Approx.weight [kg]		6.2	6.2	6.2	11	11	11	11	25	26	31	33	42	62	64	94	98	129	140	245	245	330	330	555	555		
Enclosure		IP20 closed type UL open type													IP00 open type UL open type (IP20 closed type is available as option)												

Note 1) The specification above are established when the function code F80 = 0 (HD specification) is applied.

Note 2) When using a DC reactor, refer to the following.

- Type FRN □VG1S- □J: 55kW or below: provided as option, 75kW or above: provided as standard.
- Type FRN □VG1S- □E, □C: All capacities are provided as option.

*1) The rated output voltage is 220V for 200V series and 440V for 400V series.

*2) When the inverter output frequency converter value is 10Hz or less, the inverter may trip early due to overload depending on the conditions such as ambient temperature.

*3) When the inverter output frequency converter value is 5Hz or less, the inverter may trip early due to overload depending on the conditions such as ambient temperature.

*4) 200V series: Make an individual order for 220 to 230V/50Hz.

400V series: The inverters with the power supply of 380 to 398V/50Hz and 380 to 430V/60Hz must be switched using a connector inside the inverter.

The output of the inverter with 380V may drop depending on situations. For details, refer to Chapter 10 in the FRENIC-VG User Manual "Unit Type, Function Code Edition" 24A7-□-0019.

*5) The auxiliary power input is used as an AC fan power input when combining the unit such as high power factor PWM converter with power regenerative function.(Generally not used.)

$$*6) \text{ Voltage unbalance [\%]} = \frac{\text{Max. voltage [V]} - \text{Min. voltage [V]}}{\text{Three-phase average voltage [V]}} \times 67$$

Use an AC reactor if the voltage unbalance exceeds 2%.

*7) The value is calculated on assumption that the inverter is connected with a power supply capacity of 500kVA (or 10 times the inverter capacity if the inverter capacity exceeds 50kVA) and %X is 5%.

*8) The values shown apply when a DC reactor is used.

If using a generator for the power source, it may burn out with high-frequency current from the inverter. Use a generator with 3 to 4 times the specified power supply capacity. (When DC reactor not connected: approx. 4 times specified power supply capacity, when DC reactor connected: approx. 3 times specified power supply capacity)

*9) The inverter may automatically reduce carrier frequency in accordance with ambient temperature or output current in order to protect itself.

If the carrier frequency auto reduction selection (H104: digit 100) is cancelled, the unit continuous rated current will drop depending on the carrier frequency setting, and therefore caution is advised.

(For details, refer to Chapter 2 in the FRENIC-VG User Manual "Unit Type, Function Code Edition" 24A7-□-0019.)



MD specification for middle overload (Unit Type)

Three-phase 400V series

Type	FRN□VG1S-4□	90	110	132	160	200	220	280	315	355	400	
Nominal applied motor [kW] (*8)		110	132	160	200	220	250	315	355	400	450	
Rated capacity [kVA] (*1)		160	192	231	287	316	356	445	495	563	640	
Rated current [A]		210	253	304	377	415	468	585	650	740	840	
Overload current rating		150% of rated current -1min. (*2)										
Power supply voltage	Main power Phase, Voltage, Frequency	3-phase 380 to 440V/50Hz, 380 to 480V/60Hz (*3)										
	Auxiliary control power supply Phase, Voltage, Frequency	Single phase 380 to 480V, 50Hz/60Hz										
	Auxiliary input for fan power Phase, Voltage, Frequency (*4)	Single phase 380 to 440V, 50Hz 380 to 480V/60Hz (*3)										
	Voltage/frequency variation	Voltage: +10 to -15% (Voltage unbalance: 2% or less (*5)), Frequency: +5 to -5%										
	Rated current [A] (*6)	(with DCR)	210	238	286	357	390	443	559	628	705	789
		(without DCR)	-									
	Required power supply capacity [kVA] (*7)	140	165	199	248	271	312	388	436	489	547	
Braking method /braking torque		Braking resistor discharge control: 150% braking torque, Separately installed braking resistor (option)					Braking resistor discharge control: 150% braking torque, Separately installed braking resistor (option) Separately installed braking unit (option)					
Carrier frequency [kHz]		2 to 4										
Approx.weight [kg]		62	64	94	98	129	140	245	245	330	330	
Enclosure		IP00 open type UL open type (IP20 closed type is available as option)										

Note 1) The specifications above are established when the function code F80 = 3 (MD specification) is applied.
If using with the MD specification, specify MD specification when placing your order.

With the type FRN□VG1S-□□, a DC reactor with nominal applied motor capacity is provided as standard.

Note 2) When using a DC reactor, refer to the following.

- Type FRN□VG1S-□□: Provided as standard. (Specify MD specification when placing your order.)
- Type FRN□VG1S-□□E, □□C: Option.

*1) When the rated output voltage is 440V

*2) When the converted inverter output frequency is less than 1Hz, the inverter may trip earlier in some ambient temperature conditions if the motor is overloaded

*3) When the power supply is 380 to 398V at 50 Hz or 380 to 430V at 60Hz, a connector inside the inverter must be reconnected accordingly.

The output of the inverter with 380V may drop depending on situations. For details, refer to Chapter 10 in the FRENIC-VG User Manual "Unit Type, Function Code Edition" 24A7-□□-0019.

*4) The auxiliary power input is used as an AC fan power input when combining the unit such as high power factor PWM converter with power regenerative function.(Generally not used.)

$$*5) \text{ Voltage unbalance [\%]} = \frac{\text{Max. voltage [V]} - \text{Min. voltage [V]}}{\text{Three-phase average voltage [V]}} \times 67$$

Use an AC reactor if the voltage unbalance exceeds 2%.

*6) The value is calculated on assumption that the inverter is connected with a power supply capacity of 10 times the inverter capacity and %X is 5%.

*7) The values shown apply when a DC reactor is used.

If using a generator for the power source, it may burn out with high-frequency current from the inverter. Use a generator with 3 to 4 times the specified power supply capacity.
(When DC reactor not connected: approx. 4 times specified power supply capacity, when DC reactor connected: approx. 3 times specified power supply capacity)

*8) Depending on the load condition, motor heating may increase with low carrier frequency, and therefore the MD specification should be specified when ordering the motor.

*9) If running a synchronous motor at low carrier frequency, there is a risk of demagnetization due to permanent magnet overheating as a result of output current harmonics.

The carrier frequency is low (2 to 4kHz), and therefore the motor allowable carrier frequency must always be checked. If unable to use the motor with low carrier frequency (2 to 4kHz), consider the HD specification (H80 = 0).

Standard specifications

LD specifications for light overload (Unit Type)

Three-phase 200V series

Type FRN□VG1S-2□		30	37	45	55	75	90
Nominal applied motor [kW]		37	45	55	75	90	110
Rated capacity [kVA] (*1)		55	68	81	107	131	158
Rated current [A]		146	180	215	283	346	415
Overload current rating		120% of rated current -1min. (*2)					
Power supply voltage	Main power Phase, Voltage, Frequency	3-phase 200 to 220V/50Hz, 200 to 230V/60Hz (*3)					
	Auxiliary control power supply Phase, Voltage, Frequency	Single phase 200 to 230V,50Hz/60Hz					
	Auxiliary input for fan power Phase, Voltage, Frequency (*4)	- Single phase 200 to 220V, 50Hz 200 to 230V, 60Hz (*3)					
	Voltage/frequency variation	Voltage: +10 to -15% (Voltage unbalance: 2% or less (*5)), Frequency: +5 to -5%					
	Rated current [A] (with DCR) (*6)	138	167	203	282	334	410
	Rated current [A] (without DCR)	185	225	270	-	-	-
Required power supply capacity [kVA] (*7)		48	58	71	98	116	143
Braking method /braking torque		Braking resistor discharge control: 110% braking torque, Separately installed braking resistor (option), Separately installed braking unit (option for FRN75VG1S-2□ or higher)					
Carrier frequency [kHz] (*8)		2 to 10				2 to 5	
Approx.weight [kg]		25	32	42	43	62	105
Enclosure		IP00 open type UL open type (IP20 closed type is available as option)					

Three-phase 400V series

Type FRN□VG1S-4□		30	37	45	55	75	90	110	132	160	200	220	280	315	355	400	500	630	
Nominal applied motor [kW]		37	45	55	75	90	110	132	160	200	220	280	355	400	450	500	630	710	
Rated capacity [kVA] (*1)		57	69	85	114	134	160	192	231	287	316	396	495	563	640	731	891	1044	
Rated current [A]		75	91	112	150	176	210	253	304	377	415	520	650	740	840	960	1170	1370	
Overload current rating		120% of rated current -1min. (*2)																	
Power supply voltage	Main power Phase, Voltage, Frequency	3-phase 380 to 480V, 50Hz/60Hz						3-phase 380 to 440V/50Hz, 380 to 480V/60Hz (*3)											
	Auxiliary control power supply Phase, Voltage, Frequency	Single phase 380 to 480V, 50Hz/60Hz																	
	Auxiliary input for fan power Phase, Voltage, Frequency (*4)	-						Single phase 380 to 440V, 50Hz 380 to 480V, 60Hz (*3)											
	Voltage/frequency variation	Voltage: +10 to -15% (Voltage unbalance: 2% or less (*5)), Frequency: +5 to -5%																	
	Rated current [A] (with DCR) (*6)	68.5	83.2	102	138	164	210	238	286	357	390	500	628	705	789	881	1115	1256	
	Rated current [A] (without DCR)	94.3	114	140	-	-	-	-	-	-	-	-	-	-	-	-	-	-	
Required power supply capacity [kVA] (*7)		48	58	71	96	114	140	165	199	248	271	347	436	489	547	611	773	871	
Braking method /braking torque		Braking resistor discharge control: 110% braking torque, Separately installed braking resistor (option), Separately installed braking unit (option for FRN200VG1S-4□ or higher)																	
Carrier frequency [kHz] (*8)		2 to 10						2 to 5											
Approx.weight [kg]		25	26	31	33	42	62	64	94	98	129	140	245	245	330	330	555	555	
Enclosure		IP00 open type UL open type (IP20 closed type is available as option)																	

Note 1) The above specifications are for Function Code F80=1 (LD specification).

If using with an LD specification of 55kW or higher, specify LD specification when placing your order.

With the type FRN□VG1S-□J, a DC reactor with nominal applied motor capacity is provided as standard.

Note 2) When using a DC reactor, refer to the following.

- Type FRN□VG1S-□J: 45kW or below: provided as option, 55kW or above: provided as standard. (Specify LD specification when placing your order.)
- Type FRN□VG1S-□E, □C: All capacities are provided as option.

*1) The rated output voltage is 220V for 200V series and 440V for 400V series.

*2) When the converted inverter output frequency is less than 10Hz, the inverter may trip earlier in some ambient temperature conditions if the motor is overloaded.

*3) 200V series: Make an individual order for 220 to 230V/50Hz.

400V series: The inverters with the power supply of 380 to 398V/50Hz and 380 to 430V/60Hz must be switched using a connector inside the inverter.

The output of the inverter with 380V may drop depending on situations. For details, refer to Chapter 10 in the FRENIC-VG User Manual "Unit Type, Function Code Edition" 24A-□-0019.

*4) The auxiliary power input is used as an AC fan power input when combining the unit such as high power factor PWM converter with power regenerative function.(Generally not used.)

$$*5) \text{ Voltage unbalance [\%]} = \frac{\text{Max. voltage [V]} - \text{Min. voltage [V]}}{\text{Three-phase average voltage [V]}} \times 67$$

Use an AC reactor if the voltage unbalance exceeds 2%.

*6) The value is calculated on assumption that the inverter is connected with a power supply capacity of 500kVA (or 10 times the inverter capacity if the inverter capacity exceeds 50kVA) and %X is 5%.

*7) The values shown apply when a DC reactor is used.

If using a generator for the power source, it may burn out with high-frequency current from the inverter. Use a generator with 3 to 4 times the specified power supply capacity. (When DC reactor not connected: approx. 4 times specified power supply capacity, when DC reactor connected: approx. 3 times specified power supply capacity)

*8) The inverter may automatically reduce carrier frequency in accordance with ambient temperature or output current in order to protect itself.

If the carrier frequency auto reduction selection (H104: digit 100) is cancelled, the unit continuous rated current will drop depending on the carrier frequency setting, and therefore caution is advised.

(For details, refer to Chapter 2 in the FRENIC-VG User Manual "Unit Type, Function Code Edition" 24A7-□-0019.)



MD specifications for middle overload (Stack Type)

Three-phase 400V series

Type	FRN□○VG1S-4□	30S	37S	45S	55S	75S	90S	110S	132S	160S	200S	220S	250S	280S	315S	630B(*5)	710B(*5)	800B(*5)
Nominal applied motor [kW]		30	37	45	55	75	90	110	132	160	200	220	250	280	315	630	710	800
Rated capacity [kVA] (*1)		45	57	69	85	114	134	160	192	231	287	316	356	396	445	891	1044	1127
Rated current [A]		60	75	91	112	150	176	210	253	304	377	415	468	520	585	1170	1370	1480
Overload current rating		150% of rated current -1min. (*2)																
Power supply voltage	Main power	DC input type (Refer to the diode rectifier, PWM converter specifications.)																
	Auxiliary control power supply Phase, Voltage, Frequency	Single phase 380 to 480V, 50/60Hz																
	Auxiliary input for fan power Phase, Voltage, Frequency	No auxiliary input for fan power is needed							Single phase 380 to 440V, 50Hz 380 to 480V, 60Hz (*3)									
	Voltage/frequency variation	Voltage:+10 to -15%, Frequency:+5 to -5%																
Carrier frequency [kHz] (*4)		2																
Approx. weight [kg]		30	30	30	37	37	45	45	95	95	95	125	135	135	135	135x3	135x3	135x3
Enclosure		IP00 open type																

Three-phase 690V series

Type	FRN□SVG1S-69J	90	110	132	160	200	250	280	315	355	400	450
Nominal applied motor [kW] (*6)		90	110	132	160	200	250	280	315	355	400	450
Rated capacity [kVA] (*1)		120	155	167	192	258	317	353	394	436	490	550
Rated current [A]		100	130	140	161	216	265	295	330	365	410	460
Overload current rating		150% of rated current -1min. (*2)										
Power supply voltage	Main power	DC input type (Refer to the diode rectifier, PWM converter specifications.)										
	Auxiliary control power supply Phase, Voltage, Frequency	Single phase 575 to 690V, 50/60Hz										
	Auxiliary input for fan power Phase, Voltage, Frequency	Single phase 660 to 690V, 50/60Hz 575 to 600V, 50/60Hz (*3)										
	Voltage/frequency variation	Voltage:+10 to -15%, Frequency:+5 to -5%										
Carrier frequency [kHz] (*4)		2										
Approx. weight [kg]		45	45	95	95	95	135	135	135	135	135	135
Enclosure		IP00 open type										

Note 1) The specifications above apply when function code F80 = 0, 2, 3 (MD specification). (Default = 0) If F80 = 0, 2, "HD" appears on keypad.

*1) When the rated output voltage is 440 V (400V series) or 690 V (690V series).

*2) When the converted inverter output frequency is less than 1Hz, the inverter may trip earlier in some ambient temperature conditions if the motor is overloaded.

*3) 400V series: When the power supply is 380 to 398 V at 50Hz, or 380 to 430 V at 60Hz, a connector inside the inverter must be reconnected accordingly.

690V series: When the power supply is 575 to 600 V at 50Hz/60Hz, a connector inside the inverter must be reconnected accordingly.

*4) If running a synchronous motor at low carrier frequency, there is a risk of demagnetization due to permanent magnet overheating as a result of output current harmonics.

The carrier frequency is low (2kHz), and therefore the motor allowable carrier frequency must always be checked.

*5) One set of the inverter consists of three stacks.

*6) The nominal applied motor capacity is for a 690 V motor.

For motors of differing voltage specifications and detailed selections, select a capacity that will ensure that the inverter rated current is equal to or greater than the motor rated current.

Standard specifications

LD specifications for light overload (Stack Type)

Three-phase 400V series

Type	FRN□○VG1S-4□	30S	37S	45S	55S	75S	90S	110S	132S	160S	200S	220S	250S	280S	315S	630B(*5)	710B(*5)	800B(*5)
Nominal applied motor [kW]		37	45	55	75	90	110	132	160	200	220	250	280	315	355	710	800	1000
Rated capacity [kVA] (*1)		57	69	85	114	134	160	192	231	287	316	356	396	445	495	1044	1127	1409
Rated current [A]		75	91	112	150	176	210	253	304	377	415	468	520	585	650	1370	1480	1850
Overload current rating		110% of rated current -1min. (*2)																
Power supply voltage	Main power	DC input type (Refer to the diode rectifier, PWM converter specifications.)																
	Auxiliary control power supply Phase, Voltage, Frequency	Single phase 380 to 480V, 50/60Hz																
	Auxiliary input for fan power Phase, Voltage, Frequency	No auxiliary input for fan power is needed							Single phase 380 to 440V, 50Hz 380 to 480V, 60Hz (*3)									
	Voltage/frequency variation	Voltage:+10 to -15%, Frequency:+5 to -5%																
Carrier frequency [kHz] (*4)		2																
Approx. weight [kg]		30	30	30	37	37	45	45	95	95	95	125	135	135	135	135x3	135x3	135x3
Enclosure		IP00 open type																

Three-phase 690V series

Type	FRN□SVG1S-69J	90	110	132	160	200	250	280	315	355	400
Nominal applied motor [kW] (*6)		110	132	160	200	220	280	315	355	400	450
Rated capacity [kVA] (*1)		155	167	192	258	281	353	394	436	490	550
Rated current [A]		130	140	161	216	235	295	330	365	410	460
Overload current rating		110% of rated current -1min. (*2)									
Power supply voltage	Main power	DC input type (Refer to the diode rectifier, PWM converter specifications.)									
	Auxiliary control power supply Phase, Voltage, Frequency	Single phase 575 to 690V, 50/60Hz									
	Auxiliary input for fan power Phase, Voltage, Frequency	Single phase 660 to 690V, 50/60Hz 575 to 600V, 50/60Hz (*3)									
	Voltage/frequency variation	Voltage:+10 to -15%, Frequency:+5 to -5%									
Carrier frequency [kHz] (*4)		2									
Approx. weight [kg]		45	45	95	95	95	135	135	135	135	135
Enclosure		IP00 open type									

Note 1) The above specifications are for Function Code F80=1 (LD specification).

*1) When the rated output voltage is 440V (400V series) or 690V (690V series).

*2) When the converted inverter output frequency is less than 1Hz, the inverter may trip earlier in some ambient temperature conditions if the motor is overloaded.

*3) 400V series: When the power supply is 380 to 398 V at 50Hz, or 380 to 430 V at 60Hz, a connector inside the inverter must be reconnected accordingly.

690V series: When the power supply is 575 to 600 V at 50Hz/60Hz, a connector inside the inverter must be reconnected accordingly.

*4) If running a synchronous motor at low carrier frequency, there is a risk of demagnetization due to permanent magnet overheating as a result of output current harmonics. The carrier frequency is low (2kHz), and therefore the motor allowable carrier frequency must always be checked.

*5) One set of the inverter consists of three stacks.

*6) The nominal applied motor capacity is for a 690 V motor.

For motors of differing voltage specifications and detailed selections, select a capacity that will ensure that the inverter rated current is equal to or greater than the motor rated current.



Common specifications for inverters







Item		Unit Type		Stack Type			
Control	Motor control method	For induction motor		Vector control with speed sensor Speed sensorless vector control V/f control			
		For synchronous motor		Vector control with speed sensor (including magnetic pole position detection)			
		Test mode		Simulated operation mode			
Induction motor control	Vector control with speed sensor	Setting resolution	Speed setting	Analog setting: 0.005% of max. speed Digital setting: 0.005% of max. speed			
			Torque setting Torque current setting	0.01% of rated torque			
		Control accuracy	Speed	Analog setting: $\pm 0.1\%$ of max. speed ($25\pm 10^\circ\text{C}$) Digital setting: $\pm 0.005\%$ of max. speed (-10 to 50°C)	Analog setting: $\pm 0.1\%$ of max. speed ($25\pm 10^\circ\text{C}$) Digital setting: $\pm 0.005\%$ of max. speed (-10 to 40°C)		
			Torque	$\pm 3\%$ of rated torque (with dedicated motor)			
		Control response	Speed	600Hz *1	100Hz		
		Maximum speed		500Hz by inverter output frequency conversion *1 *2		150Hz by inverter output frequency conversion	
		Speed control range		1:1500 When the base speed is 1500 r/min, 1 to 1500 r/min to max. speed (with no. of PG pulses is 1024P/R) 1:6 (constant torque range: constant output range)			
Induction motor control	Speed sensorless vector control	Setting resolution	Speed setting	Analog setting: $\pm 0.005\%$ of max. speed Digital setting: $\pm 0.005\%$ of max. speed			
			Torque setting Torque current setting	0.01% of rated torque			
		Control accuracy	Speed	Analog setting: $\pm 0.1\%$ of max. speed ($25\pm 10^\circ\text{C}$) Digital setting: $\pm 0.1\%$ of max. speed (-10 to 50°C)	Analog setting: $\pm 0.1\%$ of max. speed ($25\pm 10^\circ\text{C}$) Digital setting: $\pm 0.1\%$ of max. speed (-10 to 40°C)		
			Torque	$\pm 5\%$ of rated torque			
		Control response	Speed	40Hz *1	20Hz		
		Maximum speed		500Hz by inverter output frequency conversion *1 *3		150Hz by inverter output frequency conversion	
	Speed control range		1:250 When the base speed is 1500 r/min, 6 to 1500 r/min to max. speed 1:4 (constant torque range: constant output range)				
	V/f control	Setting resolution		Analog setting: 0.005% of max. speed Digital setting: 0.005% of max. speed			
		Output frequency control accuracy		Analog setting: $\pm 0.2\%$ of max. output frequency ($25\pm 10^\circ\text{C}$) Digital setting: $\pm 0.01\%$ of max. output frequency (-10 to 50°C)	Analog setting: $\pm 0.2\%$ of max. output frequency ($25\pm 10^\circ\text{C}$) Digital setting: $\pm 0.01\%$ of max. output frequency (-10 to 40°C)		
		Maximum frequency		500Hz		150Hz	
		Control range		0.2 to 500Hz 1:4 (constant torque range: constant output range)		0.2 to 150Hz 1:4 (constant torque range: constant output range)	
Speed control range		1:250 When the base speed is 1500 r/min, 6 to 1500 r/min to max. speed 1:4 (constant torque range: constant output range)					
Synchronous motor control	Vector control with speed sensor	Setting resolution	Speed setting	Analog setting: 0.005% of max. speed Digital setting: 0.005% of max. speed			
			Torque setting	0.01% of rated torque			
		Control accuracy	Speed	Analog setting: $\pm 0.1\%$ of max. speed ($25\pm 10^\circ\text{C}$) Digital setting: $\pm 0.005\%$ of max. speed (-10 to 50°C)	Analog setting: $\pm 0.1\%$ of max. speed ($25\pm 10^\circ\text{C}$) Digital setting: $\pm 0.005\%$ of max. speed (-10 to 40°C)		
			Torque	$\pm 3\%$ of rated torque (with dedicated motor)			
		Response control	Speed	600Hz *1	100Hz		
Maximum speed		500Hz by inverter output frequency conversion *1		150Hz by inverter output frequency conversion			

*1) Maximum value when the carrier frequency is 10kHz. Depending on conditions such as the carrier frequency setting, etc., this value may not be reached.

*2) Vector control with speed sensor: carrier frequency 5kHz: 400Hz, carrier frequency 2kHz: 150Hz

*3) Sensorless vector control: carrier frequency 5kHz: 250Hz, carrier frequency 2kHz: 120Hz

Common specifications for inverters

Item		Unit Type	Stack Type																							
Synchronous motor control	Vector control with speed sensor	Speed control range	1:1500 (with no. of PG pulses is 1024P/R) When the base speed is 1500 r/min, 1 to 1500 r/min to max. speed																							
Control	Running and operation	KEYPAD operation: CW or CCW operation by  or  key, and  key Digital input signal operation: FWD or REV command, coast-to-stop command, reset input, multistep speed selection command, etc.																								
	Speed setting	KEYPAD operation :  or  key Setting resistor :Potentiometers (variable resistors) (three terminals:1 to 5kΩ) Analog input :0 to ±10V, 4 to 20mA UP/DOWN control :Speed increases when UP signal (DI) is ON, and decreases when DOWN signal (DI) is ON. Multistep speed :Up to 15 different speeds can be selected by combining four external input signals (DI). Digital signal :Can be set by "16-bit parallel signals" available by the option card. Serial link operation :RS-485 (standard). Setting through different communication options is possible. Jogging operation :  or  key, or FWD or REV terminals in jogging mode																								
	Speed detection	Received frequency differs with the speed detector used.																								
		<table border="1"> <thead> <tr> <th colspan="2">PG interface used</th> <th>Speed detector</th> <th>Received frequency</th> </tr> </thead> <tbody> <tr> <td rowspan="3">Induction motor</td> <td>Inverter PG interface</td> <td>Complimentary type PG</td> <td rowspan="2">100kHz/Max</td> </tr> <tr> <td>OPC-VG1-PGo</td> <td>Open collector type PG</td> </tr> <tr> <td>OPC-VG1-PG</td> <td>Line driver type PG</td> <td>500kHz/Max</td> </tr> <tr> <td rowspan="2">Synchronous motor</td> <td>OPC-VG1-PMPG</td> <td>Line driver type PG (with pole position function)</td> <td rowspan="2">100kHz/Max</td> </tr> <tr> <td>OPC-VG1-PMPGo</td> <td>Open collector type PG (with pole position function)</td> </tr> <tr> <td colspan="2">OPC-VG1-SPGT</td> <td>Serial PG (17-bit absolute encoder)</td> <td></td> </tr> </tbody> </table>		PG interface used		Speed detector	Received frequency	Induction motor	Inverter PG interface	Complimentary type PG	100kHz/Max	OPC-VG1-PGo	Open collector type PG	OPC-VG1-PG	Line driver type PG	500kHz/Max	Synchronous motor	OPC-VG1-PMPG	Line driver type PG (with pole position function)	100kHz/Max	OPC-VG1-PMPGo	Open collector type PG (with pole position function)	OPC-VG1-SPGT		Serial PG (17-bit absolute encoder)	
	PG interface used		Speed detector	Received frequency																						
	Induction motor	Inverter PG interface	Complimentary type PG	100kHz/Max																						
		OPC-VG1-PGo	Open collector type PG																							
		OPC-VG1-PG	Line driver type PG	500kHz/Max																						
	Synchronous motor	OPC-VG1-PMPG	Line driver type PG (with pole position function)	100kHz/Max																						
		OPC-VG1-PMPGo	Open collector type PG (with pole position function)																							
	OPC-VG1-SPGT		Serial PG (17-bit absolute encoder)																							
	Speed control	The PI calculation w/ feed forward term is performed. Control parameter switchover: The control parameter can be switched by external signals																								
	Running status signal	Transistor output: Inverter running, Speed equivalence, Speed detection, inverter overload early warning, torque limiting, etc. Analog output: Motor speed, Output voltage, Torque, Load factor, etc.																								
	Acceleration/Deceleration time	0.01 to 3600s (4 independent settings for acceleration and deceleration selectable with external signals) (S-curve acceleration/deceleration in addition to linear acceleration/deceleration)																								
Gain for speed setting	Sets the proportional relationship between analog speed setting and motor speed in the range of 0 to 200%.																									
Jump speed	Jump speed (3 points) and jump width (1 point) can be set.																									
Rotating motor pick up (Flying start)	A rotating motor can be smoothly picked up by the inverter without stopping. (Valid for vector control with speed sensor/sensorless vector control)																									
Auto-restart after momentary power failure	Automatic restart is available without stopping the motor after a momentary power failure.																									
Slip compensation control	Compensates for the decrease of speed due to load and realizes stable operation (by V/f control w/ induction motor).																									
Droop control	The motor speed droops in proportion to output torque (disabled with V/f control).																									
Torque limiting	Limits the torque to predetermined values (selectable from "common to 4 quadrants", "independent driving and braking", etc.) Analog and external signal (2 steps) settings are available.																									
Torque control	Analog setting: 0 to ±10V /0 to ±150% (up to 300% by gain adjustment) Digital setting: A "16-bit parallel signal" setting is available using an optional card.																									
PID control	Analog input by PID control is possible.																									
Cooling fan ON/OFF control	Cooling fan is stopped during motor stoppage and low temperature to elongate the cooling fan life and reduce cooling fan noise.																									
Toggle monitor control	Monitors that the communications between the host device (PLC) and the inverter are working properly.																									
Torque bias	Internal setting (3 steps) and analog setting (hold function) are enabled by combining the fixed values (1 step, polarity switching by motor rotation direction function) and external signal (DI signal).																									



Item		Unit Type	Stack Type	
Control	Motor selection	Motor can be selected from three types by using (F79) or by combining the external signals (DI signals).		
	Temperature detection	NTC thermistor (Fuji Electric product or equivalent item) PTC thermistor (Trip level set by parameter) (for motor overheat protection)		
	PG detection circuit self diagnosis	Self-diagnosis for detection circuit of the pulse encoder input signal (PA, PB)		
	Load adaptive control function	Running efficiency of the unit can be improved by calculating the max. elevation speed achieved by the weight for a vertical transfer unit or other similar units.		
	Multi-winding motor control	Multiple winding motor drive	Option: Use of OPC-VG1-TBSI Maximum number of motor windings: 6 Control specification: Only vector control with a speed sensor is available.	
		Direct parallel connection system *1	Option: Use of OPC-VG1-TBSI Maximum number of parallel modules: 3 Carrier frequency is fixed at 2kHz. Restrictions apply to usage conditions such as the output cable length.	
	UP/DOWN control	Speed setting is possible by combining the UP command, DOWN command, and zero clear command using the external signal (DI signal).		
	Stopping function	3 types of stopping functions: STOP 1, 2 and 3.		
	PG pulse output	Outputs the input pulse such as a motor PG signal by fixed or free frequency dividing. Open collector and complimentary (same voltage as PGP terminal) can be switched by setting the unit internal switch.		
	Observer	Suppresses load disturbances and vibrations.		
	Off-line tuning	Rotary type and non-rotary type are available for tuning the motor constants.		
	On-line tuning	Used for tuning continuously motor constants due to the motor temperature change.		
	Position control	Standard function: position control by servo lock and built-in transmitting circuit. Options: OPC-VG1-PG (PR) : for line driver type pulse command input OPC-VG1-PGo (PR) : for open collector type pulse command input		
Pulse train synchronous operation	Options: OPC-VG1-PG (PR) : for line driver type pulse command input OPC-VG1-PGo (PR) : for open collector type pulse command input			
Display and setting	Keypad	Display	7-segment LED, LCD with backlight	
		Language display	Japanese, English, Chinese, Korean	
		Running/stopping	<ul style="list-style-type: none"> • Detected speed value • Torque reference value • Output voltage • Load shaft speed • Ai adjusted value (I2) • Presence of digital input/output signal • Load factor • Motor accumulated operation time/no. of starts (for each motor), etc. 	<ul style="list-style-type: none"> • Speed reference value • Torque calculation value • DC link circuit voltage • PID reference value • Ai adjusted value (Ai1) • Input power (*) • Output frequency • Power consumption (motor output) • Magnetic-flux reference value • PID feedback value • Ai adjusted value (Ai2) • Motor temperature • Integral power consumption (*) • Torque current reference value • Output current • Magnetic-flux calculation value • PID output value • Optional monitor 1 to 6 • Heat sink temperature • Operation time
		Setting mode	Names and data are displayed.	
		Alarm mode	Displays the following alarm codes; <ul style="list-style-type: none"> <li style="width: 33%;">• dbH (Braking resistor overheat)(*) <li style="width: 33%;">• Er2 (KEYPAD panel communication error) <li style="width: 33%;">• dCF (DC fuse blown) <li style="width: 33%;">• EF (Ground fault) <li style="width: 33%;">• Er1 (Memory error) <li style="width: 33%;">• Er5 (RS-485 error) <li style="width: 33%;">• Er3 (CPU error) <li style="width: 33%;">• Er4 (Network error) <li style="width: 33%;">• Er6 (Operation procedure error) <li style="width: 33%;">• Er7 (Output wiring error) <li style="width: 33%;">• Er8 (A/D converter error) <li style="width: 33%;">• Er9 (Speed disagreement) <li style="width: 33%;">• Lin (Input phase loss)(*) <li style="width: 33%;">• LU (Undervoltage) <li style="width: 33%;">• nrb (NTC thermistor disconnection) <li style="width: 33%;">• OC (Overcurrent) <li style="width: 33%;">• OH1 (Overheating at heat sink) <li style="width: 33%;">• OH2 (External alarm input) <li style="width: 33%;">• OH3 (Inverter internal overheat) <li style="width: 33%;">• OH4 (Motor overheat) <li style="width: 33%;">• OL1 (Motor 1 overload) <li style="width: 33%;">• OL2 (Motor 2 overload) <li style="width: 33%;">• OL3 (Motor 3 overload) <li style="width: 33%;">• OLU (Inverter unit overload) <li style="width: 33%;">• OS (Overspeed) <li style="width: 33%;">• OU (Overvoltage) <li style="width: 33%;">• P9 (PG error) <li style="width: 33%;">• PbF (Charging circuit error) (*) <li style="width: 33%;">• dbA (Braking transistor abnormal) (*) <li style="width: 33%;">• Err (Simulated fault) <li style="width: 33%;">• OPL (Output phase loss detection) <li style="width: 33%;">• dFA (DC fan lock) (*) <li style="width: 33%;">• ErH (Hardware error) <li style="width: 33%;">• EC (Encoder communications error) <li style="width: 33%;">• ErA (UPAC error) *1 <li style="width: 33%;">• Et1 (Encoder error) <li style="width: 33%;">• Erb (Inter-inverter link communication error) <li style="width: 33%;">• ECF (Functional safety circuit error) *1 <li style="width: 33%;">• dO (Excessive position deviation) <li style="width: 33%;">• LOC (Start stall) <li style="width: 33%;">• ArE (E-SX error) <li style="width: 33%;">• ArF (Toggle error) <li style="width: 33%;">• SIF (Functional safety card error) *1 <li style="width: 33%;">• SrF (Functional safety card error) *1 	
		Minor fault	[L-AL] is displayed. Stores and displays the detailed cause that triggers the minor fault.	
		Alarm during running	The latest and last ten pieces of alarm codes and the latest and the last three pieces of alarm detailed data are stored. Stores and displays alarm date and time by the calendar and time display function [accuracy: ±27 sec/month (Ta=25°C)]. Data stored period: 5 years or more (at ambient temperature 25°C) Battery: built-in as standard for 30kW or higher capacity models, available as option for 22kW or lower capacity models. (available as option: OPK-BP)	

*1: Supported when the ROM version is H1/2 0020 or later, and the SER.No. product version is BC or later.
*) The stack type is not supported

Common specifications for inverters

Item		Unit Type	Stack Type
Display and setting	Loader	Historical trace (*1)	Loads sampling data retained in the inverter to display with a graph. Sampling time: 50µs to 1s
		Real-time trace (*1)	Loads data from the inverter on a real-time basis to display with a graph. Sampling time: 1ms to 1s
		Trace back	Loads sampling data retained in the inverter at an alarm to display with a graph. Sampling time: 50µs to 1s (Note that sampling is enabled at 400µs or more except current.) Sampling data are stored into the memory using the battery power. Data stored period: 5 years or more (at ambient temperature 25°C) Battery: built-in as standard for 30kW or higher capacity models, available as option for 22kW or lower capacity models. (available as option: OPK-BP)
		Operation monitor (*1)	I/O monitor, system monitor, alarm history monitor
		Function code setting	Function code setting states can be checked. Also edit, transfer, comparison, initialization are available.
Charge lamp		Lit when the power is being supplied to the inverter body. Lit even with control power.	
Maintenance	Main circuit capacitor life		Auto life judgment function installed
	Common functions		<ul style="list-style-type: none"> Displays and records accumulated time for control PCB capacitor life and cooling fan operation time Displays and records inverter operation time. Displays and records the maximum output current and the maximum internal temperature for the past one hour.
Communications	RS-485		This is a input terminal to connect computers and programmable controllers via RS-485 communications.
	USB		USB connector (Mini B type) for connection with a computer.The following operations are enabled using the inverter support loader: function code edit, transfer verification, and monitoring various states.
Compatibility with earlier models	VG7	Function code data	Set the VG7 function codes to activate each operation of the code (excluding the function codes for the VG7 third motor). Values read from the VG7 can be written to the FRENIC-VG without changing them by using the PC loader (except for some special items).
		Communications	T-Link, SX bus, and CC-Link are fully compatible. The host PLC software can be used without any change (except for some special items).
	Installation adaptor		An adaptor to fit the installation dimensions of earlier models is available as option.
Safety function	Standard function	Stopping function	Safe Torque Off (STO) <ul style="list-style-type: none"> Stops the inverter output transistor by hardware -and therefore stops the output torque of the motor- immediately by turning OFF digital input signals (EN1 terminal or EN2 terminal), which are externally controlled.
Product standard	Conformance to standard(*3)		<ul style="list-style-type: none"> US and Canada Safety Standard UL, cUL (UL508C, C22.2 No.14)(*2) Machinery Directive <ul style="list-style-type: none"> IEC/EN ISO13849-1: PL-d IEC/EN60204-1: stop category 0 IEC/EN61800-5-2: SIL2 IEC/EN62061: SIL2 Low Voltage Directive <ul style="list-style-type: none"> EN61800-5-1: Over voltage category 3 EMC Directive <ul style="list-style-type: none"> IEC/EN 61800-3(Certification being approved), IEC/EN 61326-3-1 (Emission) EMC filter (Option) : <ul style="list-style-type: none"> Unit type (220kW or lower) : Category 2 Unit type (280kW or higher) : Category 3 Stack type : Category 3 (Immunity) 2nd Env.
Installation environment	Usage environment		Indoor use only. Free from corrosive and flammable gases, dusts, and oil mist (pollution degree 2 - IEC60664-1). No direct sunlight.
	Ambient temperature		-10 to +50°C (-10 to +40°C: In case of 22 kW or lower installed side-by-side without clearance) -10 to +40°C
	Ambient humidity		5 to 95% RH (No dew condensation allowed)
	Altitude		3000m or less However, the output may be reduced at the altitude of 1001 to 3000m For use at the altitude of 2001 to 3000m, the insulation class of the control circuit is changed from "Enhanced insulation" to "Basic insulation".
	Vibration		<ul style="list-style-type: none"> 200V 55kW or less, 400V 75kW or less <ul style="list-style-type: none"> 3mm: 2 to 9Hz or less, 9.8m/s²: 9 to 20Hz or less, 2m/s²: 20 to 55Hz or less, 1m/s²: 55 to 200Hz or less 200V 75kW or more, 400V 90kW or more <ul style="list-style-type: none"> 3mm: 2 to 9Hz or less, 2m/s²: 9 to 55Hz or less, 1m/s²: 55 to 200Hz or less
	Storage temperature		-25 to +70°C (-10 to +30°C for long-term storage)
Storage humidity		5 to 95% RH (No dew condensation allowed)	

*1) This function is available by the licensed FRENIC VG Loader (WPS-VG1-PCL).
*2) C22.2 No.14 does not conform to the FRN160, 200, 220, 355, or 400VG1S-4J.
*3) Certification of the stack type three-phase 690V series is currently pending.
*4) The three-phase 690V series does not comply with UL or cUL Standards.



Terminal Functions

Common Specifications

Terminal Functions

Main circuit and analog input terminal

Category	Symbol	Terminal name	Unit Type	Stack Type
Main circuit	L1/R,L2/S,L3/T	Power input	Connects a 3-phase power supply.	Not available in the stack type
	U,V,W	Inverter output	Connects a 3-phase motor.	Connects a 3-phase motor.As for the number of stacks per phase, 1 terminal is allotted per phase (stack).
	P (+),P1	For DC reactor connection	Connects a DC reactor.	The "P1" terminal for connecting a DC reactor is not available with the stack type.
	P (+),N (-)	For BRAKING UNIT connection/For DC bus	Connects a braking resistor via the braking unit. Used for a DC bus connection system.	Used as a DC bus.
	P (+),DB	For EXTERNAL BRAKING RESISTOR connection	Connects an external braking resistor (optional).	The "DB" terminal for connecting an external braking resistor is not available with the stack type.
	⊕ G	Grounding for inverter	Ground terminal for inverter chassis.	
	R0,T0	Auxiliary control power supply	Connects the same AC power supply as that of the main circuit to back up the control circuit power supply.	
	R1,T1	Auxiliary input for fan power	Used as a power input for the AC cooling fan inside the inverter to combine with the high factor PWM converter with power regenerative function (on the models of 200V series 37kW or more, 400V series 75kW or more). Generally this is not necessary as long as the inverter is used individually.	Used as a power input to the AC cooling fan in the inverter. (90kW or higher) Connection is not possible for 75kW or lower.
DCF1 DCF2	DC fuse blow-out detection input	Not available in the unit type	Connects a microswitch to detect blow-out of the DC fuse and corresponds to the "b" contact output. DC24V 12 mA Typ	
Speed setting	13	Potentiometer power supply	Used for power supply for a speed setting POT (variable resistor: 1 to 5kΩ). DC10V 10mA Max	
	12	Voltage input for speed setting	Used for analog reference voltage input. Reversible operation can be selected by ±signals: 0 to +10V DC /0 to max. speed.	
	11	Analog input common	Common terminal to input signals.	
Analog input	Ai1	Analog input 1	The following functions can be selected and set according to the external analog input voltage. 0: Input signal off [OFF] 1: Auxiliary speed setting 1 [AUX-N1] 2: Auxiliary speed setting 2 [AUX-N2] 3: Torque limiter (level 1) [TL-REF1] 4: Torque limiter (level 2) [TL-REF2] 5: Torque bias reference [TB-REF] 6: Torque reference [T-REF] 7: Torque current reference [IT-REF] 8: Creep speed 1 in UP/DOWN setting [CRP-N1] 9: Creep speed 2 in UP/DOWN setting [CRP-N2] 10: Magnetic-flux reference [MF-REF] 11: Detected speed [LINE-N] 12: Motor temperature [M-TMP] 13: Speed override [N-OR] 14: Universal Ai [U-AI] 15: PID feedback value 1 [PID-FB1] 16: PID reference value [PID-REF] 17: PID correction gain [PID-G] 18-24: Custom Ai1 to 7 [C-AI 1 to 7] 25: Speed main setting [N-REFV] 26: Current input speed setting [N-REFC] Ai2 can be switched over between voltage input and current input by an internal switch. However, only a "Speed Setting" is available for the current input.	
	Ai2	Analog input 2		
	M	Analog input common	Common terminal to input signals.	

Digital input terminal

Item	Unit Type	Stack Type
FWD	Forward operation and stop command	[FWD-CM] ON: The motor runs in the forward direction. [FWD-CM] OFF: The motor decelerates and stops.
REV	Reverse operation and stop command	[REV - CM] ON: The motor runs in the reverse direction. [REV - CM] OFF: The motor decelerates and stops.
X1	Digital input 1	0, 1, 2, 3: Multistep speed selection (step 1 to 15) [0: SS1, 1: SS2, 2: SS4, 3: SS8] 4, 5: ASR, ACC/DEC time selection (4 steps) [4: RT1, 5: RT2] 6: Self maintenance selection [HLD] 7: Coast-to-stop command [BX] 8: Alarm reset [RST] 9: Trip command (External fault) [THR] 10: Jogging operation [JOG] 11: Speed setting N2/Speed setting N1 [N2/N1] 12: Motor M2 selection [M-CH2] 13: Motor M3 selection [M-CH3] 14: DC brake command [DCBRK] 15: ACC/DEC cleared to zero command [CLR] 16: Creep speed switching in UP/DOWN setting [CRP-N2/N1] 17: UP command in UP/DOWN setting [UP] 18: DOWN command in UP/DOWN setting [DOWN] 19: Write enable for KYEPAD (data can be changed) [WE-KP] 20: PID control cancel [KP/PID] 21: Inverse mode change over [IVS] 22: Interlock signal for 52-2 [IL] 23: Write enable through link [WE-LK] 24: Operation selection through link [LE] 25: Universal DI [U-DI] 26: Pick up start mode [STM] 27: Synchronization command [SYC] 28: Zero speed locking command [LOCK] 29: Pre-exciting command [EXITE] 30: Speed reference cancel [N-LIM] 31: H41 (torque reference) cancel [H41-CCL] 32: H42 (torque current reference) cancel [H42-CCL] 33: H43 (magnetic-flux reference) cancel [H43-CCL] 34: F40 (Torque control mode 1) cancel [F40-CCL] 35: Torque limit (Selection of level 1 or level 2) [TL2/TL1] 36: Bypass [BPS] 37,38: Torque bias command 1 / 2 [37: TB1, 38: TB2] 39: Droop selection [DROOP] 40: Zero hold [ZH-A1] 41: Ai2 zero hold [ZH-A2] 42: Ai3 zero hold [ZH-A3] 43: Ai4 zero hold [ZH-A4] 44: Ai1 polarity change [REV-A1] 45: Ai2 polarity change [REV-A2] 46: Ai3 polarity change [REV-A3] 47: Ai4 polarity change [REV-A4] 48: PID output inverse changeover [PID-INV] 49: PG alarm cancel [PG-CCL] 50: Undervoltage cancel [LU-CCL] 51: Ai torque bias hold [H-TB] 52: STOP1 (The motor stops with standard deceleration time) [SOPT1] 53: STOP2 (The motor decelerates and stops with deceleration time 4) [STOP2] 54: STOP3 (The motor stops with torque limiter) [STOP3] 55: DIA card enable [DIA] 56: DIB card enable [DIB] 57: Multi-winding motor control cancel [MT-CCL] 58-67: Custom Di 1 to 10 [C-DI 1 to 10] 68: Load adaptive parameter selection [AN-P2/1] 69: PID clear [PID-CCL] 70: PIDFF term effective [PID-FF] 72: Toggle signal 1 [TGL1] 73: Toggle signal 2 [TGL2] 74: Simulated external minor fault [FTB] 75: NTC thermistor alarm cancel [NTC-CCL] 76: Lifetime early warning cancel [LF-CCL] 78: PID Feedback change-over signal [PID-1/2] 79: PID torque bias selection [TB-PID]
X2	Digital input 2	
X3	Digital input 3	
X4	Digital input 4	
X5	Digital input 5	
X6	Digital input 6	
X7	Digital input 7	
X8	Digital input 8	
X9	Digital input 9	

Terminal Functions

Digital input terminal

Item		Unit Type	Stack Type
	PLC	PLC signal power supply	Connects to PLC output signal power supply. It can also be used as a power supply for loads connected to the transistor outputs. +24V (22 to 27) max.100mA
	CM	Digital input common	Common terminal to digital input signals.
Digital input (Safety function)	EN1,EN2	Safety function input terminal	When the circuit is open between EN1-PS or EN2-PS terminals, the switching elements of the inverter main circuit is turned off and the output is shut off.
	PS		

Analog output and transistor output terminal

Item		Unit type	Stack type
Analog output	AO1	Analog output 1	Provides the monitor signal of 0 to ±10V DC for signals from the following: 0: Detected speed (Speedometer, unipolar) [N-FB1+] 1: Detected Speed (Speedometer, bipolar)[F-FB1±] 2: Speed setting 2 (Before acceleration/deceleration calculation) [N-REF2] 3: Speed setting 4 (ASR input) [N-REF4] 4: Detected speed [N-FB2±] 5: Detected line speed [LINE-N±] 6: Torque current reference (Torque ammeter, bipolar) [IT-REF±] 7: Torque current reference (Torque ammeter, unipolar) [IT-REF+] 8: Torque reference (Torque meter, bipolar) [T-REF±] 9: Torque reference (Torque meter, unipolar) [T-REF+] 10: Motor current rms value [V-AC] 11: Motor voltage rms value [V-AC] 12: Input power (motor output) [PWR] 13: DC link circuit voltage [V-DC] 14: +10V output test [P10] 15: -10V output test [N10]30: Universal AO [U-AO] 31-37: Custom AO1 to 7 [C-AO1 to 7] 38: Input power [PWR-IN] 39: Magnetic pole position signal [SMP]40: PID output value [PID-OUT]
	AO2	Analog output 2	
	AO3	Analog output 3	
	M	Analog output common	
Transistor output	Y1	Transistor output 1	Outputs the selected signals from the following items: 0: Inverter running [RUN] 1: Speed existence [N-EX] 2: Speed agreement [N-AG1] 3: Speed equivalence [N-AR] 4, 5, 6: Detected speed 1, 2, 3 [4: N-DT1, 5: N-DT2, 6: N-DT3] 7: Stopping on undervoltage [LUJ] 8: Detected torque polarity (braking/driving) [B/D] 9: Torque limiting [TL] 10, 11: Detected torque [10: T-DT1, 11: T-DT2] 12: KEYPAD operation mode [KP] 13: Inverter stopping [STOP] 14: Operation ready completion [RDY] 15: Magnetic-flux detection signal [MF-DT] 16: Motor M2 selection status [16: SW-M2] 17: Motor M3 selection status [16: SW-M3] 18: Brake release signal [BRK] 19: Alarm indication 1 [AL1] 20: Alarm indication 2 [AL2] 21: Alarm indication 3 [AL4] 22: Alarm indication 4 [AL8] 23: Fan operation signal [FAN] 24: Auto-resetting [TRY] 25: Universal DO [U-DO] 26: Heat sink overheat early warning [INV-OH] 27: Synchronization completion signal [SY-C] 28: Lifetime alarm [LIFE] 29: Under accelerating [U-ACC] 30: Under decelerating [U-DEC] 31: Inverter overload early warning [INV-OL] 32: Motor temperature early warning [M-OH] 33: Motor overload early warning [M-OL] 34: DB overload early warning [DB-OL] 35: Link transmission error [LK-ERR] 36: Load adaptive control under limiting [ANL] 37: Load adaptive control under calculation [ANC] 38: Analog torque bias hold [TBH] 39-48: Custom DO 1 to 10 [C-DO 1 to 10] 50: Z-phase detection signal [Z-RDY] 51: Multiple-winding selected status [MTS] 52: Multiple-winding cancel response [MEC-AB] 53: Master selected status [MSS] 54: Parallel system self station alarm [AL-SF] 55: Communications error stopping [LES] 56: Alarm relay [ALM] 57: Minor fault [L-ALM] 58: Maintenance early warning [MNT] 59: Braking transistor error [DBAL] 60: DC fan lock signal [DCFL] 61: Speed agreement 2 [N-AG2] 62: Speed agreement 3 [N-AG3] 63: Axial fan operation stop signal [MFAN] 66: Droop selection response [DSAB] 67: Torque command/torque current command cancel response [TCL-C] 68: Torque limit mode cancel response [F40-AB] 71: 73 loading command [PRT-73] 72: Y-terminal test output ON [Y-ON] 73: Y-terminal test output OFF[Y-OFF] 75: Clock battery life 80: EN terminal detection circuit error [DECFF] *1 81: EN terminal OFF [ENOFF] *1 82: Safety function running [SF-RUN] *1 84: Performing STO diagnosis [SF-TST] *1
	Y2	Transistor output 2	
	Y3	Transistor output 3	
	Y4	Transistor output 4	
	CMY	Transistor output common	
Relay output	Y5A,Y5C	Relay output	Same functions as for Y1 to Y4 can be selected.
	30A,30B,30C	Alarm relay output(for any fault)	Outputs a potential-free contact signal (1C) when a protective function is activated to stop the inverter. Can select alarm for active or non active conditions.
Communications	DX+,DX-	RS-485 communicationsinput /output	Input/output terminals for RS-485 communications. Can connect up to 31 inverters through a multidrop (daisy chain) connection. Half-duplex method.
	USB port	USB port	Front access, connector type: mini-B, USB 2.0 Full Speed
Speed detection	PA,PB	Pulse generator 2-phase signal input	Terminals for connecting 2-phase signal of pulse generator.
	PGP,PGM	Pulse generator power supply	+15V DC pulse generator power supply (can be switched to +12V).
	FA,FB	Pulse generator output	Outputs pulse encoder signal with a frequency that can be divided by configurable ratio (set by function code). Open collector and complimentary (same voltage as PGP terminal) can be switched.
	CM	Pulse generator output common	Common terminals to FA and FB.
Temperature detection	TH1,THC	NTC Thermistor PTC Thermistor connection	Motor temperature can be detected with the NTC and the PTC thermistors. The motor overheat protective level can be specified by the PTC thermistor function E32.

*1: Supported when the ROM version is H1/2 0020 or later, and the SER.No. product version is BC or later.

*) The stack type is not supported.



Protective Functions

Protective function details

Category	Item	Specifications	Displays	Relevant function codes
Protective Functions	Braking transistor abnormal (*)	Stops the inverter if it detects a braking transistor abnormality. (Unit type: 200 V 55kW or lower, 400 V 160kW or lower) Be sure to shut off the inverter primary power when this alarm is detected.	<i>dbR</i>	H103
	Braking resistor overheating (*)	Estimates the braking resistor temperature and stops the inverter if the allowable value is exceeded. Setting E35 to 37 is required depending on the used resistor.	<i>dbH</i>	E35 to E37
	DC fuse blown	This is displayed if the fuse for the main circuit DC blows because of a short-circuit in the IGBT circuit or other reason. This function is provided to prevent secondary accidents. Since inverter damage may have occurred, contact Fuji immediately. Unit type: Not less than 200V and 75kW, Not less than 400V, 90kW Stack type: Full capacity	<i>dCF</i>	
	Excessive position deviation	Activated if the positional deviation between the command and the detected values exceeds ten times function code o18 "Excessive deviation value" in synchronized operation.	<i>dD</i>	o18
	Encoder communications error	Activated if an encoder communications error is detected when using an ABS encoder of 17-bit high resolution (option card OPC-VG1-SPGT).	<i>EE</i>	
	Safety circuit error *1	Activated when the input for either EN1 or EN2 only turns off (mismatch judged if 50 ms exceeded). Protective function alarms can only be reset by rebooting the power.	<i>EEF</i>	
	Ground fault	Activated by a ground fault in the inverter output circuit. When ground-fault current is large, the overcurrent protective function may be activated. This function is provided to protect the inverter. Connect a separate earth-leakage protective relay or an earth-leakage circuit breaker if it is required to prevent accidents such as injury or fire.	<i>EF</i>	H103
	Memory error	Activated if a fault such as a "write error" occurs in the memory. (The number of times to write into the memory (nonvolatile memory) is limited (100,000 to 1,000,000 times). If data is written frequently and needlessly with the save all function, data changing and saving may be disabled, resulting in a memory error.)	<i>Er1</i>	
	KEYPAD panel communication error	Activated if a communications error is detected between the inverter control circuit and the keypad when the start/stop command from the keypad is valid (function code F02=0). NOTE: A keypad communications error does not display or output an alarm when the inverter is operated by external signal input or the link function. The inverter continues operating.	<i>Er2</i>	F02
	CPU error	Activated if a CPU error occurs.	<i>Er3</i>	
	Network error	Activated if a communication error occurs due to noise, etc. when the inverter is operated through T-Link, SX bus, E-SX bus, CC-Link, field bus, etc.	<i>Er4</i>	o30,o31,H107 E01 to E14 E15 to E28
	RS-485 error	Activated if an RS-485 communications error occurs when function code H32 is set to 0 to 2 during inverter running via RS-485 communications and function code H38 is set between 0.1 and 60.0. This function is activated if the communications circuit is disconnected for longer than the time set in H38.	<i>Er5</i>	H32,H33 H38,H107
	Operation procedure error	This function is activated at the following times: 1) If multiple option cards are installed. 2) If multiple PG options are installed, and two function selection switches are set the same. 3) Activated if H01 auto tuning is started with any of the selected terminals for digital inputs [BX], [STOP1], [STOP2], or [STP3] turned on. 4) Activated if the  key on the keypad is not pressed for 20 seconds or more after selecting H01 auto tuning.	<i>Er6</i>	H01
	Output wiring error	Activated if the wires are not connected in the inverter output circuit during auto tuning.	<i>Er7</i>	H01
	A/D converter error	Activated if an error occurs in the A/D converter circuit.	<i>Er8</i>	
	Speed disagreement	Activated if the difference between the speed reference (speed setting) and the motor speed (detected speed, predicted speed) becomes excessive. The detection level and detection time can be set using function codes.	<i>Er9</i>	E43,E44,E45 H108,H149
	UPAC error *1	Activated when a UPAC option hardware fault occurs, a communication error occurs with the inverter control circuit, or the backup battery is consumed.	<i>ErA</i>	
	Inverter communications error	Activated if a transmission error occurs during communications between inverters using the high-speed serial communications terminal block (option).	<i>ErB</i>	H107
	Simulated fault	A simulated alarm state can be generated by keypad operation or the PC loader.	<i>Err</i>	E01 to E14 H108,H142
	Encoder error	Activated if an encoder error or failure is detected when using an ABS encoder of 17-bit high resolution (option card OPC-VG1-SPGT).	<i>Et1</i>	

*1: Supported when the ROM version is H1/2 0020 or later, and the SER.No. product version is BC or later.

*) The stack type is not supported.

Terminal Functions

Protective Functions

Protective Functions

Protective function details

Category	Item	Specifications	Displays	Relevant function codes
Protective Functions	Input open phase (*)	The inverter is protected against damage due to input open phase. An open phase may not be detected if the connected load is small or a DC reactor is connected.	<i>L in</i>	E45
	Stalled at start	Activated if the torque current reference value is equal or higher than the level set in function code H140, and the detected speed value or estimated speed value is equal or lower than the speed set in function code F37 "stop speed", for the period of time set in function code H141. The detection level and detection time can be set using function codes.	<i>LOC</i>	H108,H140,H141
	Undervoltage	Activated if the DC link circuit voltage decreases to the undervoltage level due to a reduction in the supply voltage. The alarm is not output when the DC link circuit voltage decreases and function code F14 is set to "3 to 5". • Undervoltage detection level: 200V series: 180V DC, 400V series: 360V DC, 690V series: 470V DC	<i>LU</i>	F14
	NTC thermistor disconnection	Activated if the thermistor circuit is disconnected when the use of NTC thermistors for motors M1, 2, 3 is configured with the corresponding function codes P30, A31 and A131. Also activated in extreme low temperatures (approx. -30°C or lower).	<i>nr b</i>	P30,A31,A131 H106
	Overcurrent	Cuts the output if motor current exceeds the inverter overcurrent specified value. This is also activated if the output current to the motor during synchronous motor control exceeds the value set for the overcurrent protection level (P44, A64, A164).	<i>OC</i>	P44,A64,A164
	Overheating of heat sink	Activated if the temperature of the heat sink that cools the rectifier diodes and the IGBTs increases due to cooling fan stoppage.	<i>OH 1</i>	
	External alarm input	The inverter stops when the external alarm signal (THR) becomes active. This alarm is activated via control terminals (assigned to THR) which are connected to alarm terminals of external devices such as a braking unit or a braking resistor (in case these devices trip).	<i>OH 2</i>	E01 to E14 F106
	Inverter internal overheat	Activated if the ambient temperature of the control PC board increases due to poor ventilation of the inverter.	<i>OH 3</i>	
	Motor overheat	Activated if the detected temperature of the built-in NTC thermistor for motor temperature detection exceeds the data of function code E30 "Motor overheat protection."	<i>OH 4</i>	E30,H106
	Motor 1 overload	Activated if the motor 1 current (inverter output current) exceeds the behavior level set by the function code F11.	<i>OL 1</i>	F11,H106
	Motor 2 overload	Activated if the motor 2 current (inverter output current) exceeds the behavior level set by the function code A33.	<i>OL 2</i>	A33,H106
	Motor 3 overload	Activated if the motor 3 current (inverter output current) exceeds the behavior level set by the function code A133.	<i>OL 3</i>	A133,H106
	Inverter overload	Activated if the output current exceeds the overload characteristic of the inverse time characteristic. The inverter is stopped according to the temperatures of the inverter cooling unit and the switching element that is calculated from the output current.	<i>OL U</i>	F80
	Output phase loss detection	Stops the inverter if an open phase is detected in the output wiring during operation.	<i>OPL</i>	H103,P01,A01,A101
	Overspeed	Activated if the motor speed (detected speed value or estimated speed value) exceeds 120% (can be changed by H90) of the setting of function code "maximum speed" (F03, A06, A106).	<i>OS</i>	H90
	Overvoltage	Activated if the DC link circuit voltage exceeds the overvoltage level due to an increase of supply voltage or regenerative braking current from the motor. However, the inverter cannot be protected from excessive voltage (high voltage, for example) supplied by mistake. • Overvoltage detection level 200V series: 405V DC, 400V series: 820V DC, 690V series: 1230V DC	<i>OU</i>	
	PG error	Activated if the PA, PB or power supply circuits of the encoder interface are disconnected. However, a PG error is not activated when sensor-less control or V/f control is selected.	<i>PG</i>	H104
	Charge circuit error (*)	Activated if the bypass circuit of the DC link circuit (magnetic contactor for the charging circuit bypass) is not closed after power is supplied (200V 37kW or more, 400V 75kW or more).	<i>PbF</i>	
	DC fan lock (*)	Activated if the DC fan stops (200V 45kW or more, 400V 75kW or more).	<i>dFA</i>	H108
	Hardware error	Stops the inverter by detecting LSI errors on the PCB.	<i>ErH</i>	
E-SX bus tact out-of-sinc error	Occurs if the E-SX tact cycle and inverter control cycle are out of synch.	<i>RrE</i>	H108	
Toggle error	Occurs if the PLC monitors the 2-bit signal of toggle signal 1 [TGL1] and toggle signal 2 [TGL2], and does not receive the specified change pattern after the time set in H144 elapses.	<i>RrF</i>	H107	
Functional safety card error *1	This is a protective function for the functional safety card. Refer to the functional safety card instruction manual for details. Functional Safety Card Instruction Manual INR-SI47-1541	<i>SrF</i> <i>SrF</i>		

*1: Supported when the ROM version is H1/2 0020 or later, and the SER.No. product version is BC or later.

*) The stack type is not supported.

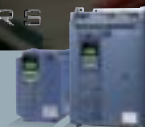

Category	Item	Specifications	Displays	Relevant function codes
Protective Functions	Minor fault (warning)	<p>If an alarm or warning registered as a minor fault occurs, the minor fault indication [L-RL] is displayed on the keypad. For a minor fault, the minor fault output (Y terminal) is output. However, alarm relay output (30ABC) is not output and the inverter continues operating.</p> <p>Items to be set (Can be selected individually):</p> <p>Motor overhear (OH4), motor overload (OL 1-OL3), NTC thermistor disconnection (ncb), external alarm (OH2), RS-485 communications (ERS), option communications error (ER4), inverter link error (RLF), simulated fault (Err), DC fan lock detection (dFR), speed disagreement (ER3), E-SX error (RE), Stalled st Start (LSC), motor overhear early warning, motor overload early warning, battery life, lifetime alarm, fan overheat early warning, overheating at heat sink, inverter overload early warning</p> <p>The cause of each minor fault can be checked on the keypad.</p>	L-RL	H106 to H111
	Surge protection	Protects the inverter from surge voltage coming from the power supply using the surge absorber that is connected to the main circuit power supply terminal (unit type only: L1/R, L2/S, L3/T) and the control power supply terminal (Ro, To) circuit.		
	Main power off detection (*)	Monitors the inverter AC input power to judge if the AC input power (main power) is established or not. If not, whether the inverter is to be operated or not can be selected. (When the power is supplied via a PWM converter or DC bus connection, do not change the setting of function code H76 as no AC input exists.)	---	H76

NOTES:

- All protective functions are reset automatically if the control power voltage decreases to where maintaining the operation of the inverter control circuit is impossible.
- The latest and last ten alarm codes and the latest and the last three alarm detailed data are stored.
- Stoppage due to a protective function can be reset from the RST key of the keypad or turning the circuit between the X terminal (assigned to RST) and the CM OFF and then ON. This action is invalid if the cause of an alarm is not found and resolved. If more than one alarm occurs at the same time, this action cannot be reset before resolving the causes of all alarms (the cause of an alarm that has not been cleared can be checked on the keypad).
- "30A/B/C" do not operate if interrupted by a minor fault.
- Alarm information is not recorded if the main circuit intermediate DC voltage is equal to or less than the undervoltage level.

*) Not available in the stack type

Fuses and microswitches for stack type

Three-phase 400V series

Inverter type	MD specification			LD specification			Microswitches	
	Nominal applied motor capacity [kW]	Fuse type	Q'ty	Nominal applied motor capacity [kW]	Fuse type	Q'ty	Type	Q'ty
FRN30SVG1S-4□	30	170M3394-XA	1	37	170M3394-XA	1	170H3027	1
FRN37SVG1S-4□	37			45				
FRN45SVG1S-4□	45	170M3395-XA	1	55	170M3395-XA	1		
FRN55SVG1S-4□	55			75				
FRN75SVG1S-4□	75	170M3396-XA	1	90	170M3448-XA	1		
FRN90SVG1S-4□	90			110				
FRN110SVG1S-4□	110	170M3448-XA	1	132	170M4445-XA	1		
FRN132SVG1S-4□	132			160				
FRN160SVG1S-4□	160	170M5446-XA	1	200	170M6546-XA	1		
FRN200SVG1S-4□	200			220				
FRN220SVG1S-4□	220	170M6546-XA	1	250	170M6547-XA	1		
FRN250SVG1S-4□	250			280				
FRN280SVG1S-4□	280	170M6548-XA	1	315	170M6500-XA	1		
FRN315SVG1S-4□	315			355				
FRN630BVG1S-4□	630	170M7532	3	710	170M7633	3	170H3027	3
FRN710BVG1S-4□	710			800				
FRN800BVG1S-4□	800	170M7633	3	1000	170M7595	3		

Three-phase 690V series

Inverter type	MD specification			LD specification			Microswitches	
	Nominal applied motor capacity [kW]	Fuse type	Q'ty	Nominal applied motor capacity [kW]	Fuse type	Q'ty	Type	Q'ty
FRN90SVG1S-69□	90	170M3448-XA	2	110	170M3448-XA	2	170H3027	2
FRN110SVG1S-69□	110			132				
FRN132SVG1S-69□	132			160				
FRN160SVG1S-69□	160			200				
FRN200SVG1S-69□	200	170M4445-XA	2	220	170M4445-XA	2		
FRN250SVG1S-69□	250			280				
FRN280SVG1S-69□	280	170M6546-XA	2	315	170M6546-XA	2		
FRN315SVG1S-69□	315			355				
FRN355SVG1S-69□	355	170M6547-XA	2	400	170M6547-XA	2		
FRN400SVG1S-69□	400			450				
FRN450SVG1S-69□	450							

* Fuses and microswitches are manufactured by Cooper Bussmann, but can also be ordered from Fuji.

External Dimensions

External Dimensions (Unit type)

Inverter body

Fig. A

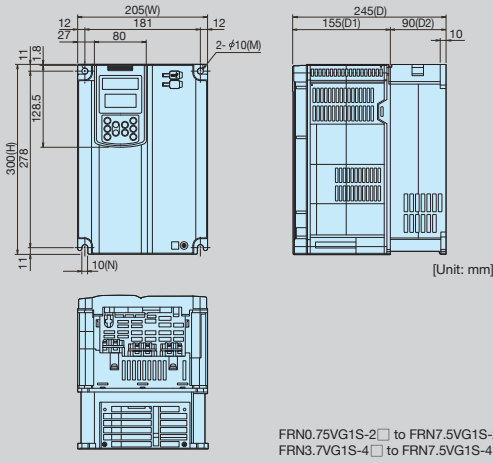

Fig. B

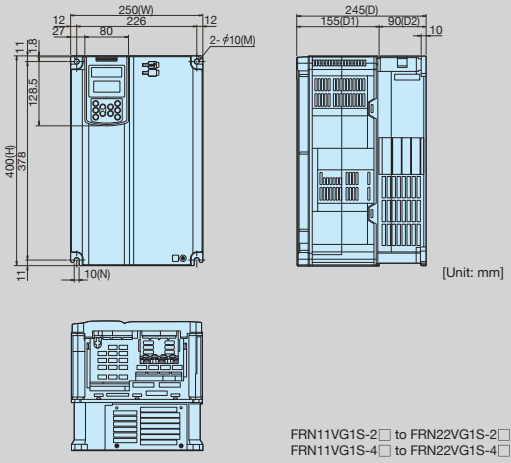

Fig. C

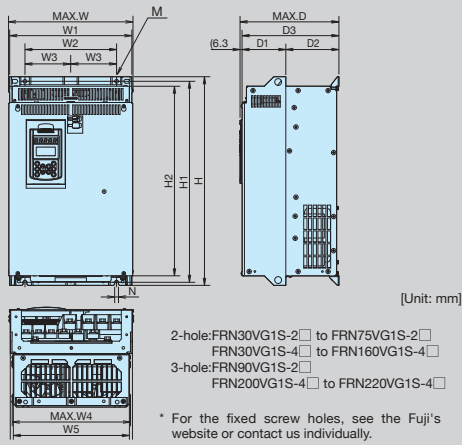
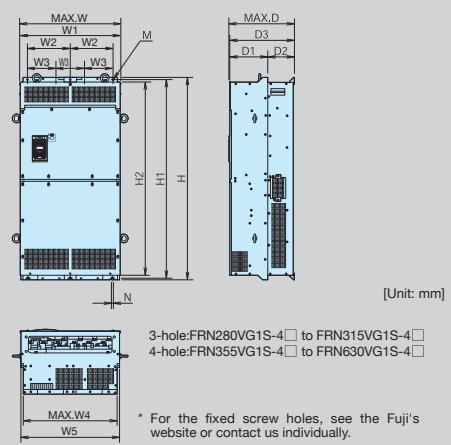
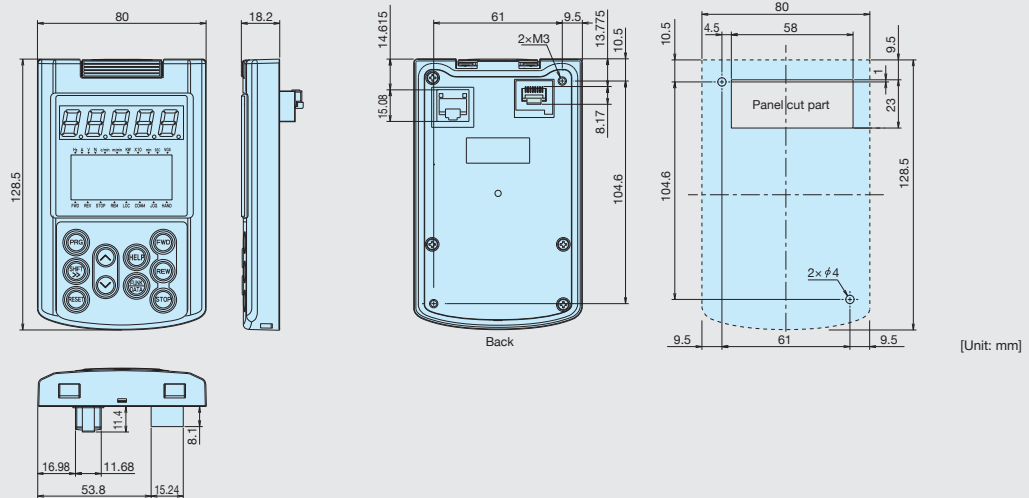

Fig. D



For specific external diagrams, refer to Fuji Electric website. (<http://www.fujielectric.co.jp/products/inverter/download/>)

KEYPAD





[Unit: mm]

Series	Inverter type	Fig	External dimensions														
			W	W1	W2	W3	W4	W5	H	H1	H2	D	D1	D2	D3	M	N
3-phase 200V	FRN0.75VG1S-2□	A	205	-	-	-	-	-	300	-	-	245	155	90	-	2Xφ10	10
	FRN1.5VG1S-2□	A															
	FRN2.2VG1S-2□	A															
	FRN3.7VG1S-2□	A															
	FRN5.5VG1S-2□	A															
	FRN7.5VG1S-2□	A															
	FRN11VG1S-2□	B	250	-	-	-	-	400	-	-	245	155	90	-	2Xφ10	10	
	FRN15VG1S-2□	B															
	FRN18.5VG1S-2□	B															
	FRN22VG1S-2□	B															
	FRN30VG1S-2□	C															
	FRN37VG1S-2□	C															
	FRN45VG1S-2□	C	361.2	355	275	-	345.2	339	740	720	690	276.3	115	155	270	2Xφ15	15
	FRN55VG1S-2□	C															
FRN75VG1S-2□	C																
FRN90VG1S-2□	C																
FRN30VG1S-2□	C																
FRN37VG1S-2□	C																
FRN45VG1S-2□	C	535.8	530	430	290	656.4	650.6	880	850	819.5	366.3	180	180	360	3Xφ15	15	
FRN75VG1S-2□	C																
FRN90VG1S-2□	C																
FRN30VG1S-2□	C																
FRN37VG1S-2□	C																
FRN45VG1S-2□	C																
FRN55VG1S-2□	C	686.4	680	-	-	-	-	-	-	-	-	-	-	-	-	-	
FRN75VG1S-2□	C																
FRN90VG1S-2□	C																
FRN30VG1S-2□	C																
FRN37VG1S-2□	C																
FRN45VG1S-2□	C																
FRN55VG1S-2□	C	326.2	320	240	-	310.2	304	550	530	500	261.3	115	140	255	2Xφ10	10	
FRN75VG1S-2□	C																
FRN90VG1S-2□	C																
FRN30VG1S-2□	C																
FRN37VG1S-2□	C																
FRN45VG1S-2□	C																
FRN55VG1S-2□	C	361.2	355	275	-	345.2	339	615	595	565	276.3	115	155	270	2Xφ15	15	
FRN75VG1S-2□	C																
FRN90VG1S-2□	C																
FRN30VG1S-2□	C																
FRN37VG1S-2□	C																
FRN45VG1S-2□	C																
FRN55VG1S-2□	C	536.4	530	430	290	656.4	650.6	1000	970	939.5	366.3	180	180	360	3Xφ15	15	
FRN75VG1S-2□	C																
FRN90VG1S-2□	C																
FRN30VG1S-2□	C																
FRN37VG1S-2□	C																
FRN45VG1S-2□	C																
FRN55VG1S-2□	C	886.4	880	-	260	859.1	853	1400	1370	1330	446.3	260	440	4Xφ15	15		
FRN75VG1S-2□	D																
FRN90VG1S-2□	D																
FRN30VG1S-2□	D																
FRN37VG1S-2□	D																
FRN45VG1S-2□	D																
FRN55VG1S-2□	D	1006	1000	-	300	972	966	1550	1520	1480	505.9	313.2	186.8	500	4Xφ15	15	
FRN75VG1S-2□	D																
FRN90VG1S-2□	D																
FRN30VG1S-2□	D																
FRN37VG1S-2□	D																
FRN45VG1S-2□	D																

External Dimensions

* Refer to the inverter type descriptions on P20 for details of the content indicated by □.

External Dimensions

External Dimensions (Stack type)

Fig. A

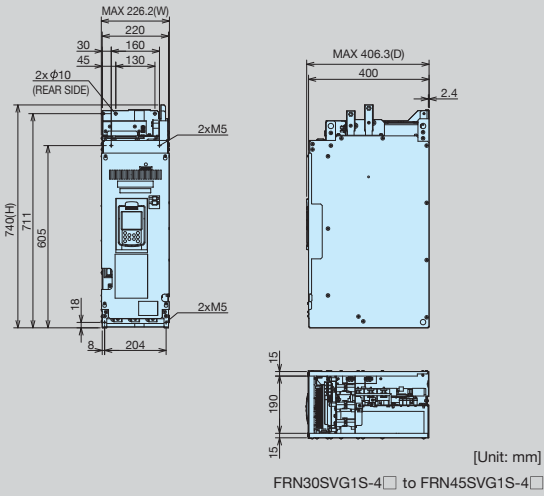

Fig. B

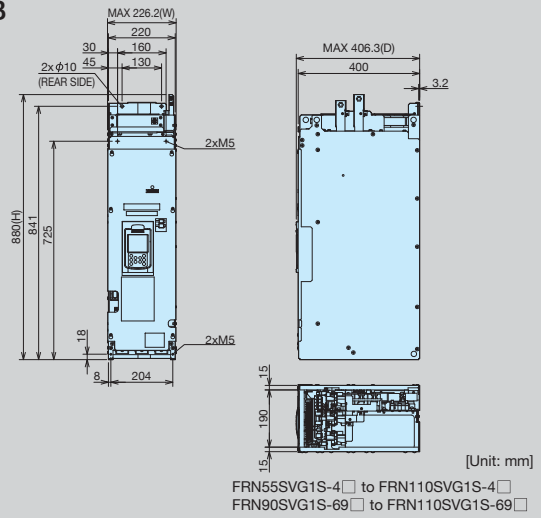

Fig. C

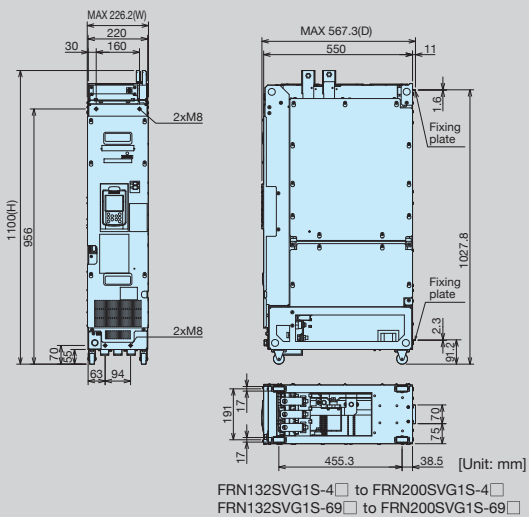

Fig. D

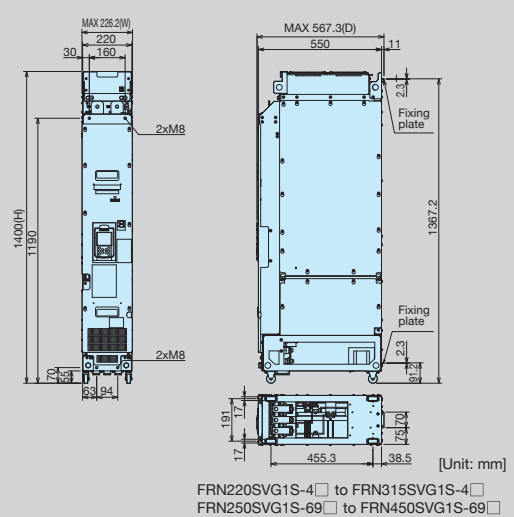
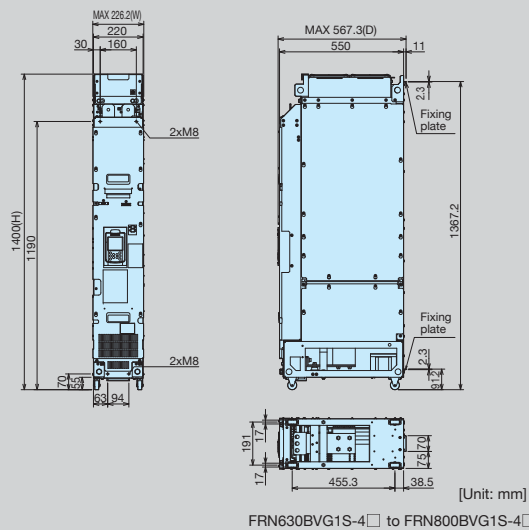
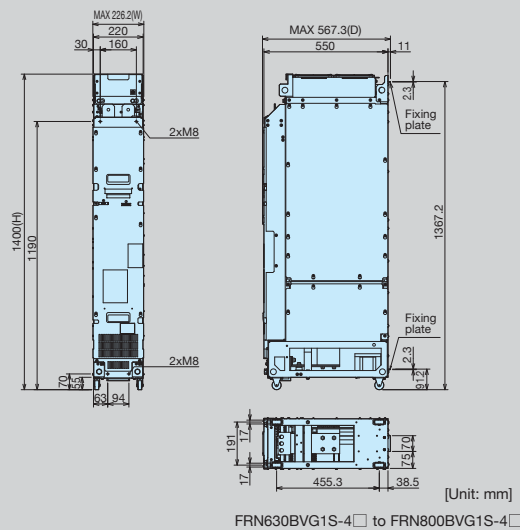

Fig. E

V-phase stack



U-phase, W-phase stack





External Dimensions / Names and Functions of the Keypad

[Unit: mm]

Series	Inverter type	Fig	External dimensions		
			W	H	D
3-phase 400V	FRN30SVG1S-4□	A	226.2	740	406.3
	FRN37SVG1S-4□	A			
	FRN45SVG1S-4□	A			
	FRN55SVG1S-4□	B	226.2	880	406.3
	FRN75SVG1S-4□	B			
	FRN90SVG1S-4□	B			
	FRN110SVG1S-4□	B	226.2	1100	567.3
	FRN132SVG1S-4□	C			
	FRN160SVG1S-4□	C			
	FRN200SVG1S-4□	C	226.2	1400	567.3
	FRN220SVG1S-4□	D			
	FRN250SVG1S-4□	D			
	FRN280SVG1S-4□	D	226.2	1400	567.3
	FRN315SVG1S-4□	D			
	FRN630BVG1S-4□(*1)	E			
FRN710BVG1S-4□(*1)	E	226.2	1400	567.3	
FRN800BVG1S-4□(*1)	E				
3-phase 690V	FRN90SVG1S-69□	B	226.2	880	406.3
	FRN110SVG1S-69□	B			
	FRN132SVG1S-69□	C	226.2	1100	567.3
	FRN160SVG1S-69□	C			
	FRN200SVG1S-69□	C	226.2	1400	567.3
	FRN250SVG1S-69□	D			
	FRN280SVG1S-69□	D			
	FRN315SVG1S-69□	D	226.2	1400	567.3
	FRN355SVG1S-69□	D			
	FRN400SVG1S-69□	D			
FRN450SVG1S-69□	D				

*1) One inverter set consists of three stacks. The keypad comes with the V phase only.
 * Refer to the inverter type descriptions on P20 for details of the content indicated by □.

Names and Functions of the Keypad

Up/Down keys
Operation mode:
 Increases or decreases the speed.
Program mode:
 Changes the function codes and specified data values.

Unit indication
 Displays the units for the information that appears on the LED monitor.

LED monitor
Operation mode:
 Displays the setting frequency, output current, output voltage, motor speed, and line speed.
Trip mode:
 Displays the cause of a trip.

Program key
 Switches the display to the menu screen or the initial screens for operation and alarm modes.

LCD monitor
 Displays different information ranging from operation status to function data.
 A real-time clock is installed as a standard feature. **NEW**
 Operation guidance is scrolled along the bottom.

Shift key (column shift)
 Used to move the cursor horizontally in order to change data, and to jump to other function blocks (when pressed together with the UP/DOWN keys).

Operation key
 Starts motor operation.

Reset key
Program mode:
 Cancels the current input data and changes the screen.
Trip mode:
 Releases a trip.

RUN LED
 Lit during operation by the FWD/REV signal or by operation commands via communications.

Function/Data select key
 Used to switch the displayed value on the LED monitor, input the speed setting and store function code data.

Stop key
 Stops motor operation.

HELP key **NEW**
 Displays guidance screens including the key operation guidance for each LCD monitor display.

External Dimensions
Names and Functions of Parts

Dedicated motor specifications (Induction motor with sensor)

3-phase 200V series standard specifications

Item	Specifications																
	Dedicated motor rated output [kW]																
	0.75	1.5	2.2	3.7	5.5	7.5	11	15	18.5	22	30	37	45	55	75	90	
Applicable motor type (MVK_)	8095A	8097A	8107A	8115A	8133A	8135A	8165A	8167A	8184A	8185A	8187A	8207A	8208A	9224A	9254A	9256A	
Moment of inertia of rotor J [kg·m ²]	0.009	0.009	0.009	0.016	0.030	0.037	0.085	0.11	0.21	0.23	0.34	0.41	0.47	0.53	0.88	1.03	
Rotor GD [kgf·m ²]	0.036	0.036	0.036	0.065	0.12	0.15	0.34	0.47	0.83	0.92	1.34	1.65	1.87	2.12	3.52	4.12	
Base speed/Max. speed [r/min]	1500/3600										1500/3000			1500/2400		1500/2000	
Vibration	V10 or less												V15 or less				
Cooling fan*	Voltage [V], Frequency [Hz]	200 to 210V/50Hz, 200 to 230/60Hz										200V/50Hz, 200, 220V/60Hz					
	Number of phases/poles	Single phase, 4P						3-phase, 4P									
	Input power [W]	40/50						90/120		150/210				80/120		270/390	
	Current [A]	0.29/0.27 to 0.31						0.49/0.44 to 0.48		0.75/0.77 to 0.8				0.76/0.8.0.8		1.9/2.0, 2.0	
Approx. weight [kg]	28	29	32	46	63	73	111	133	190	197	235	280	296	380	510	570	

* Only the MVK8095A (0.75 kW) is a self-cooled type.

3-phase 400V series standard specifications

Item	Specifications																			
	Dedicated motor rated output [kW]																			
	3.7	5.5	7.5	11	15	18.5	22	30	37	45	55	75	90	110	132	160	200	220		
Applicable motor type (MVK_)	8115A	8133A	8135A	8165A	8167A	8184A	8185A	8187A	8207A	8208A	9224A	9254A	9256A	9284A	9286A	528KA	528LA	531FA		
Moment of inertia of rotor J [kg·m ²]	0.016	0.030	0.037	0.085	0.11	0.21	0.23	0.34	0.41	0.47	0.53	0.88	1.03	1.54	1.77	1.72	1.83	2.33		
Rotor GD [kgf·m ²]	0.065	0.12	0.15	0.34	0.47	0.83	0.92	1.34	1.65	1.87	2.12	3.52	4.12	6.16	7.08	6.88	7.32	9.32		
Base speed/Max. speed [r/min]	1500/3600							1500/3000				1500/2400		1500/2000						
Vibration	V10 or less										V15 or less									
Cooling fan	Voltage [V], Frequency [Hz]	200 to 210V/50Hz, 200 to 230V/60Hz					400 to 420V/50Hz, 400 to 440V/60Hz					400V/50Hz, 400, 440V/60Hz								
	Number of phases/poles	Single phase, 4P					3-phase, 4P													
	Input power [W]	40/50			90/120		150/210				80/120		270/390			2200		3700		
	Current [A]	0.29/0.27 to 0.31			0.27/0.24 to 0.25		0.38/0.39 to 0.4				0.39/0.4, 0.4		1.0/1.0, 1.0			4.6/4.3, 4.1		7.8/7.1, 7.6		
Approx. weight [kg]	46	63	73	111	133	190	197	235	280	296	380	510	570	710	760	1270	1310	1630		

3-phase 400V series standard specifications

Item	Specifications					
	Dedicated motor rated output [kW]					
	250	280	300	315	355	400
Applicable motor type (MVK_)	531GA	531HA	535GA	535GA	535HA	535JA
Moment of inertia of rotor J [kg·m ²]	2.52	2.76	5.99	5.99	6.53	7.18
Rotor GD [kgf·m ²]	10.08	11.04	23.96	23.96	26.12	28.72
Base speed/Max. speed [r/min]	1500/2000					
Vibration	V15 or less					
Cooling fan	Voltage [V], Frequency [Hz]	400V/50Hz, 400, 440V/60Hz				
	Number of phases/poles	3-phase, 4P				
	Input power [W]	3700				
	Current [A]	7.8/7.1, 7.6				
Approx. weight [kg]	1685	1745	2230	2230	2310	2420

Common Specifications

Item	Specifications
Insulation class/Number of poles	Class F/4P
Terminal design	Main terminal box (lug type): 3 or 6 main circuit terminals, NTC thermistor terminals = 2 pcs (MVK 8 series), 3 pcs (MVK 9 series, MVK 5 series, 1PC is a spare). Auxiliary terminal box (terminal block): Pulse encoder (P6P, P6M, PA, PB, SS), Cooling fan (FU, FV, FW)
Mounting method	Legs mounted (IMB3) NOTE: Contact FUJI for other methods.
Degree of protection, Cooling method	IP44, Totally enclosed forced-ventilation system with cooling fan motor. A cooling fan blows air over the motor toward the drive-end. * Only the MVK8095A (0.75 kW) is a self-cooled type.
Installation location	Indoor, altitude 1000m or less.
Ambient temperature, humidity	-10 to +40°C, 90%RH or less (no condensation)
Color	Munsell N5
Standard conformity	MVK8 series: JEM1466 or JEC-2137-2000, MVK9 and MVK5 series: JEC-2137-2000
Standard built-in part	Pulse encoder (1024P/R, DC+5V, A, B, Z, U, V, W line driver output), NTC thermistor 1 pc (2 pcs for 110kW or more), cooling fan

Note 1) For motors applicable with 55 kW or more, the torque is accurate to ±5%. If you need more accuracy, contact Fuji.

Note 2) If you need a motor other than the dedicated motor with 4 poles and base speed of 1500 r/min, contact Fuji Electric.

Note 3) An optional holding break (outline drawing 112 or higher) can be manufactured.

Please inquire separately for details on specifications and so on.



External dimensions of dedicated motors (Induction motor with sensor)

MVK

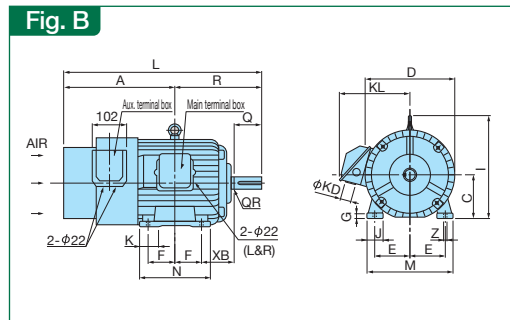
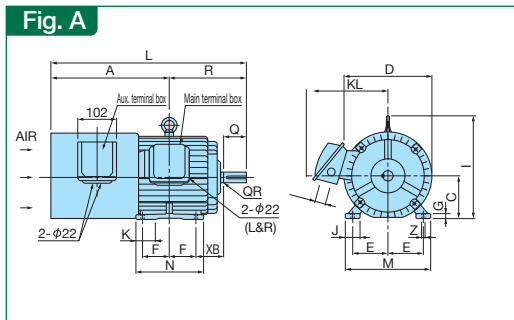

Shaft extension

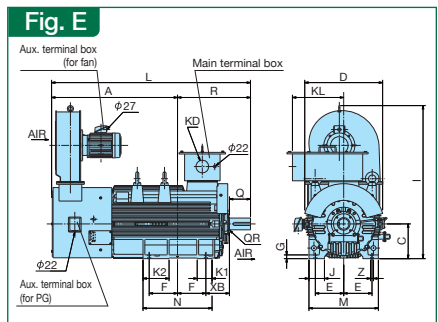
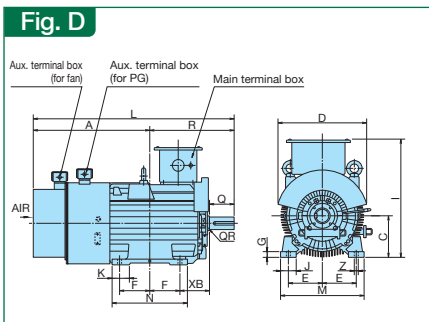
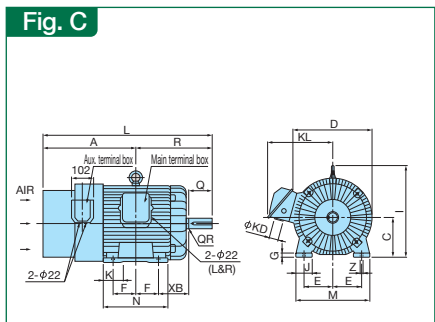
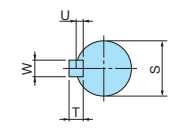

[Unit: mm]

Motor rated output [kW]	Type	Fig	Dimensions																	Shaft extension						Approx. weight [kg]
			A	C	D	E	F	G	I	J	K	K1	K2	KD	KL	L	M	N	R	XB	Z	Q	QR	S	T	
0.75	MVK8095A	A	201.5	90	204	70	62.5	10	195	35.5	35.5	27	189	370	170	150	168.5	56	10	50	0.5	24j6	7	4	8	28
1.5	MVK8097A		277.5																							
2.2	MVK8107A		292	100	80	14	270	40	40	205	499	224	175	200	70	12	80	38k6	46							
3.7	MVK8115A	B	299	112	236	95	70	14	270	40	50	34	223	548	250	180	239	89	80	80	38k6	8	5	10	63	
5.5	MVK8133A		309	132	273	108	89	17	311	45	50	34	223	586	250	212	258	89	80	38k6	73					
7.5	MVK8135A	A	400	160	321	127	105	18	376	50	63	48	272	723	300	250	323	108	14.5	110	1	42k6	8	5	12	111
15	MVK8167A		422																							
18.5	MVK8184A	A	435	180	376	139.5	120.5	20	428	75	75	48	305	786.5	350	292	351.5	121	14.5	110	1.5	48k6	9	5.5	14	190
22	MVK8185A		454																							
30	MVK8187A	C	454	200	411	159	152.5	25	466	80	85	80	364	915.5	390	360	425.5	133	18.5	140	2	60m6	11	7	18	235
37	MVK8207A		723																							
45	MVK8208A	D	693.5	250	545	203	155.5	30	743	100	120	80	106	1157	506	411	463.5	168	24	140	2	75m6	12	7.5	20	280
55	MVK9224A		711.5																							
75	MVK9254A	E	764	280	605	184	209.5	35	798	100	120	102	413	1308	557	468	544	190	24	140	2	85m6	12	7.5	20	710
90	MVK9256A		789.5																							
110	MVK9284A	E	1015.5	315	689	254	254	1425	150	140	240	102	413	1604	560	557	588.5	216	28	170	2	95m6	14	9	22	1230
132	MVK9286A		1111																							
160	MVK528JA	E	1015.5	315	689	254	254	1425	150	140	240	102	413	1604	560	557	588.5	216	28	170	2	95m6	14	9	22	1690
200	MVK528LA		1111																							
220	MVK531FA	E	1015.5	315	689	254	254	1425	150	140	240	102	413	1604	560	557	588.5	216	28	170	2	95m6	14	9	22	1820
250	MVK531GA		1111																							
280	MVK531HA	E	1015.5	315	689	254	254	1425	150	140	240	102	413	1604	560	557	588.5	216	28	170	2	95m6	14	9	22	2310
300	MVK535GA		1111																							
315	MVK535GA	E	1015.5	315	689	254	254	1425	150	140	240	102	413	1604	560	557	588.5	216	28	170	2	95m6	14	9	22	2310
355	MVK535HA		1111																							
400	MVK535JA	E	1111	355	778	305	355	1510	160	180	330	102	413	1956	730	890	845	280	210	100m6	16	10	28	2420	2420	

Note 1) MVK8095A (0.75kW) is a natural cooling type motor (cooling system: IC410). Note 2) MVK8095A (0.75kW) has the cable lead-in hole of φ22 (in 1 place).
 Note 3) MVK9224A (55kW) has an aux. terminal box (for fan) as a supplement for Fig. C.
 Note 4) Allowable tolerance of dimension: Height of rotary shaft C ≤ 250 mm_{0.05}mm, C > 250mm_{0.10}mm

Dedicated Motor Specifications

External Dimensions of Dedicated Motors

Dedicated motor Specifications (Synchronous motor with sensor)

3-phase 200V series standard specification

Item	Specifications												
	Dedicated motor rated output [kW]	5.5	7.5	11	15	18.5	22	30	37	45	55	75	90
Dedicated motor type (GNF_)	2114A	2115A	2117A	2118A	2136A	2137A	2139A	2165A	2167A	2185A	2187A	2207A	
Moment of inertia of rotor [kg·m ²]	0.018	0.021	0.027	0.036	0.065	0.070	0.090	0.153	0.191	0.350	0.467	0.805	
Rotor GD ² [kgf·m ²]	0.072	0.084	0.107	0.143	0.259	0.281	0.360	0.610	0.763	1.401	1.868	3.220	
Base speed/Max. speed [r/min]	1500/2000												
Rated current [A]	20/20	29/29	42/42	57/57	71/70	82/81	113/108	144/144	165/165	200/200	270/270	316/316	
Vibration	V10 or less												
Cooling fan	Voltage [V], frequency [Hz]	200 to 240,50/60						200 to 210/50,200 to 230/60					
	Number of phases/poles	3-phase, 2P						3-phase, 4P					
	Input power [W]	38 to 44/56 to 58				54 to 58/70 to 78				90/120		150/210	
	Current [A]	0.13 to 0.16/0.18 to 0.16				0.18 to 0.18/0.22 to 0.21				0.49/0.44 to 0.48		0.75/0.77 to 0.8	
Approx.weight [kg]	51	55	69	78	100	106	127	170	192	247	325	420	

3-phase 400V series standard specification

Item	Specifications												
	Dedicated motor rated output [kW]	5.5	7.5	11	15	18.5	22	30	37	45	55	75	90
Dedicated motor type (GNF_)	2114A	2115A	2117A	2118A	2136A	2137A	2139A	2165A	2167A	2185A	2187A	2207A	
Moment of inertia of rotor [kg·m ²]	0.018	0.021	0.027	0.036	0.065	0.070	0.090	0.153	0.191	0.350	0.467	0.805	
Rotor GD ² [kgf·m ²]	0.072	0.084	0.107	0.143	0.259	0.281	0.360	0.610	0.763	1.401	1.868	3.220	
Base speed/Max. speed [r/min]	1500/2000												
Rated current [A]	10/10	15/15	21/21	29/29	36/35	41/41	57/54	72/72	83/83	100/100	135/135	158/158	
Vibration	V10 or less												
Cooling fan	Voltage [V], frequency [Hz]	200 to 240,50/60						400 to 420/50,400 to 440/60					
	Number of phases/poles	3-phase, 2P						3-phase, 4P					
	Input power [W]	38 to 44/56 to 58				54 to 58/70 to 78				90/120		150/210	
	Current [A]	0.13 to 0.16/0.18 to 0.16				0.18 to 0.18/0.22 to 0.21				0.27/0.24 to 0.25		0.38/0.39 to 0.4	
Approx.weight [kg]	51	55	69	78	100	106	127	170	192	247	325	420	

3-phase 400V series standard specification

Item	Specifications							
	Dedicated motor rated output [kW]	110	132	160	200	220	250	280
Dedicated motor type (GNF_)	2224B	2226B	2254B	2256B	228FB	228GB	228HB	
Moment of inertia of rotor [kg·m ²]	0.882	0.994	1.96	2.22	2.79	3.12	3.47	
Rotor GD ² [kgf·m ²]	3.53	3.98	7.84	8.88	11.2	12.5	13.9	
Base speed/Max. speed [r/min]	1500/2000							
Rated current [A]	198	232	273	340	390	445	475	
Vibration	V10 or less							
Cooling fan	Voltage [V]	380,400,415/400,415,440,460						
	Number of phases/poles	3-phase, 4P						
	Power frequency	50/60						
	Input power [W]	80/120		270/390				
Current [A]	0.36,0.38,0.41/			0.95,0.95,1/1,1,1,1				
	0.4,0.4,0.4,0.4							
Approx.weight [kg]	520	580	760	810	1000	1050	1100	

Common Specifications

Item	Specifications
Insulation class/Number of poles	Class F/6P
Terminal design	Main terminal box (lug type): 3 or 6 main circuit terminals
	NTC thermistor terminals = 2 pcs(1 pc is a spare), 110kW or more
	Auxiliary terminal box (terminal block): cooling fan (FU, FV, FW) Pulse encoder (connector type), cooling fan (FU, FV, FW)
Rotation direction	CCW direction when viewed from operator
Mounting method	Legs mounted (IMB3) (NOTE): Contact FUJI for other methods.
Overload resistance	150% 1min (*1)
Time rating	S1
Degree of protection, Cooling method	IP44, Totally enclosed forced-ventilation system with cooling fan motor. A cooling fan blows air over the motor toward the drive-end.
Installation location	Indoor, altitude 1000m or less.
Ambient temperature and humidity	-10 to +40°C, 90% RH or less (no condensation)
Noise	5.5kW to 90kW:80 dB(A) or less at 1m,110kW to 300kW:90 dB (A) or less at 1m
Vibration resistance	6.86m/s ² (0.7G)
Painting color	Munsell N1.2
Standard conformity	JEM 1487: 2005
Standard built-in part	Pulse encoder (1024 P/R, DC +5 V, A, B, Z, U, V, W line driver output),
	NTC thermistor 1 pc (2 pcs for 110 kW or more), cooling fan

*1) When using the HD Specification, 150% for 1 min due to motor restriction.

External dimensions of dedicated motors (Synchronous motor with sensor)



GNF2

Shaft extension

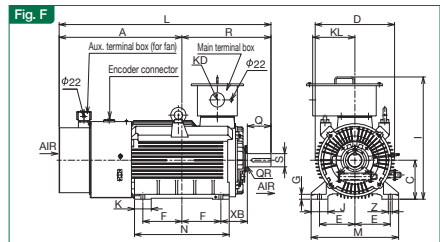
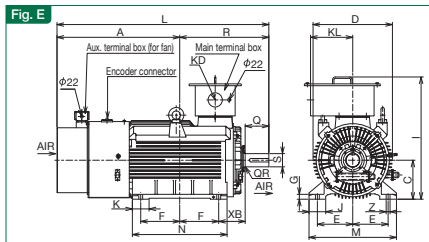
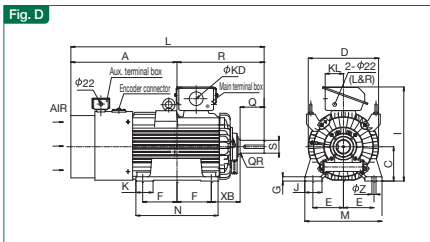
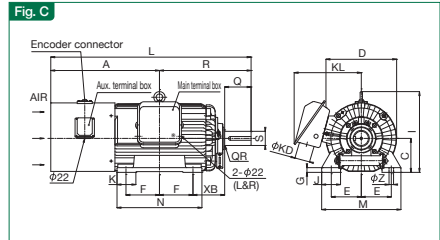
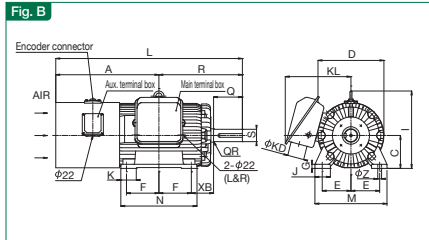
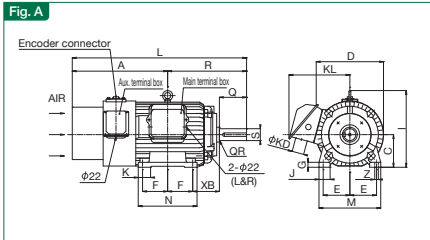
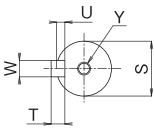

[Unit: mm]

Motor rated output [kW]	Type	Frame no.	Fig	Dimensions														Shaft extension							Approx. weight [kg]			
				A	C	D	E	F	G	I	J	K	KD	KL	L	M	N	R	XB	Z	Q	QR	S	T		U	W	Y
5.5	GNF2114A	112Mh	A	335.5	112	235	95	70	14	270	40	50	34	200	555.5	224	175	220	70	12	80	0.5	38k6	8	5	10	M10x20	51
7.5	GNF2115A			335.5	112	235	95	70	14	270	40	50	34	200	555.5	224	175	220	70	12	80	0.5	38k6	8	5	10	M10x20	55
11	GNF2117A	112Jh	A	380.5	112	235	95	100	18	270	55	50	48	235	698.5	228	238	318	108	14.5	110	1	42k6	8	5	12	M10x20	69
15	GNF2118A			380.5	112	235	95	100	18	270	55	50	48	235	698.5	228	238	318	108	14.5	110	1	42k6	8	5	12	M10x20	78
18.5	GNF2136A	132Lh	A	386	132	272	108	101.5	20	311	45	50	48	247	705.5	250	238	319.5	108	14.5	110	1.5	48k6	9	5.5	14	M10x20	100
22	GNF2137A			386	132	272	108	101.5	20	311	45	50	48	247	705.5	250	238	319.5	108	14.5	110	1.5	48k6	9	5.5	14	M10x20	106
30	GNF2139A	132Hh	A	424.5	132	272	108	140	20	311	45	50	60	247	782.5	250	313	358	108	14.5	110	1.5	55m6	10	6	16	M10x20	127
37	GNF2165A	160Lg	B	470.5	160	319	139.5	127	20	376	75	75	80	320	845.5	350	300	375	108	18.5	140	2	60m6	11	7	18	M12x25	170
45	GNF2167A			470.5	160	319	139.5	127	20	376	75	75	80	320	906.5	350	370	405.5	108	18.5	140	2	60m6	11	7	18	M12x25	192
55	GNF2185A	180Lg	C	510	180	375	159	139.5	25	428	80	85	80	356	910.5	390	330	400.5	121	18.5	140	2	65m6	11	7	18	M12x25	247
75	GNF2187A			510	180	375	159	139.5	25	428	80	85	80	356	910.5	390	330	400.5	121	18.5	140	2	65m6	11	7	18	M12x25	325
90	GNF2207A	200Jg	D	618.5	200	410	178	200	25	549	100	100	80	107	1126.5	450	479	508	168	24	140	2	75m6	12	7.5	20	M12x25	420
110	GNF2224B			711	225	446	203	200	28	628	100	120	80	142	1249	506	526	538	168	24	170	1	85m6	14	9	22	M20x35	520
132	GNF2226B	225Hg	E	761	225	446	203	250	28	628	100	120	80	142	1349	506	626	588	168	24	170	1	85m6	14	9	22	M20x35	580
160	GNF2254B			829	250	508	228.5	280	32	763	100	120	80	203	1469	557	677	640	190	24	170	1	95m6	14	9	25	M20x35	760
200	GNF2256B	250Hg	E	829	250	505	228.5	280	32	763	100	120	80	203	1469	557	677	640	190	24	170	1	95m6	14	9	25	M20x35	810
220	GNF228FB			881	280	570	254	280	35	878	120	120	102	303	1521	628	680	640	190	28	170	1	95m6	14	9	25	M20x35	1000
250	GNF228GB	280Jf	F	881	280	570	254	280	35	878	120	120	102	303	1521	628	680	640	190	28	170	1	95m6	14	9	25	M20x35	1050
280	GNF228HB			881	280	570	254	280	35	878	120	120	102	303	1521	628	680	640	190	28	170	1	95m6	14	9	25	M20x35	1100

Note 1) The models of 110kW or higher are designed to be coupled directly to the load. Contact Fuji in case of coupled to belt.

Note 2) Allowable tolerance of dimension: Height of rotary shaft C ≤ 250mm ····· -0.5 mm, C > 250mm ····· -1.0 mm

● Dedicated inverter connection cables

Cable model	Cable length (L dimension)	Motor side plug type	
		Straight plug	Right angle plug
	5m	CB-VG1-PMPG-05S	CB-VG1-PMPG-05A
	15m	CB-VG1-PMPG-15S	CB-VG1-PMPG-15A
	30m	CB-VG1-PMPG-30S	CB-VG1-PMPG-30A
	50m	CB-VG1-PMPG-50S	CB-VG1-PMPG-50A

● Cable arrangement diagram

<Straight plug>

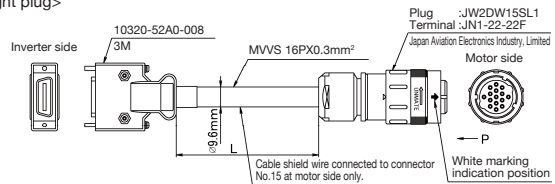

<Right angle plug>

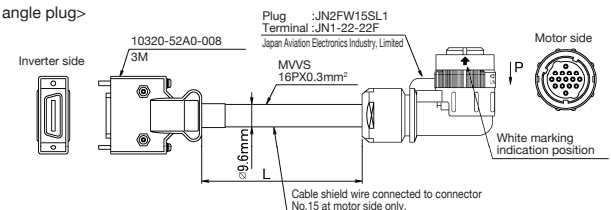

Basic Wiring Diagram (unit type)

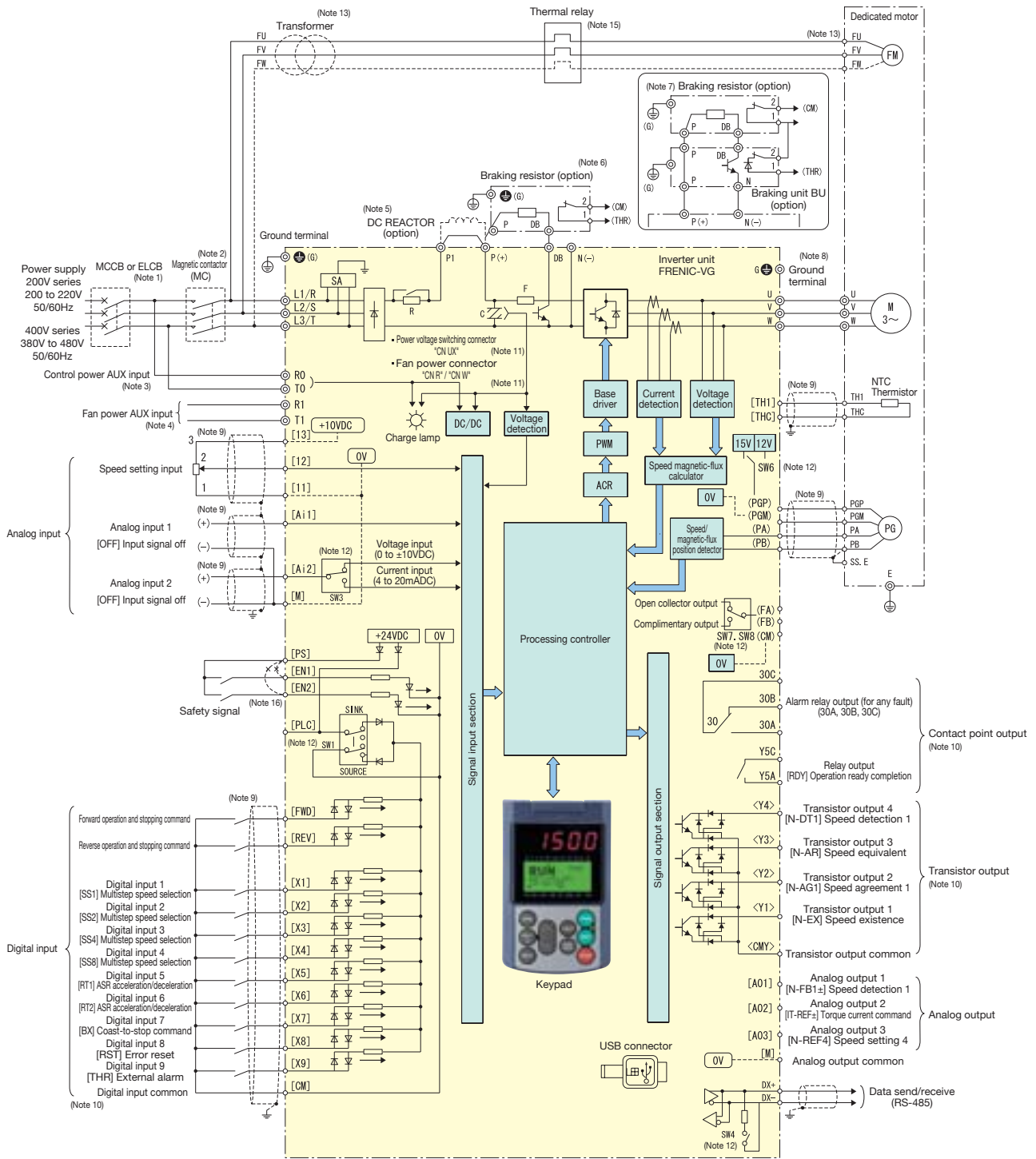

(Note1) Install a recommended molded-case circuit-breaker (MCCB) or an earth-leakage circuit-breaker (ELCB) with an overcurrent protection function in the primary circuit of the inverter to protect the wiring. At this time, ensure that the circuit breaker capacity is equivalent to or lower than the recommended capacity.
 (Note2) Install a magnetic contactor (MC) for each inverter to separate the inverter from the power supply, apart from the MCCB or ELCB, when necessary. Connect a surge absorber in parallel when installing a coil such as the MC or solenoid near the inverter.
 (Note3) Connect this terminal to the power supply to retain relay alarm signal when the protection function is activated, or to keep the Keypad on, even when the inverter main power supply is cut. The inverter can be operated without supplying power to this terminal.
 (Note4) Normally this is not necessary to connect. Used when combining the unit such as high power factor PWM converter with power regenerative function. (RHC series) (200 V series: 37kW or higher, 400V Series: 75kW or higher)
 (Note5) When connecting a DC reactor (DCR option), remove the jumper bar from across the inverter main circuit terminals [P1] and [P(+)]. DC reactor is provided as standard in case of VG1S-□J (Japan) model for 55 kW LD specification and for 75 kW or higher. DC reactor (option) must be used for all capacities under the following conditions: the capacity of the power transformer is 500 kVA or more; or is ten times or more than the inverter rated capacity; or a load with thyristors is connected to the same power supply system.
 (Note6) A braking transistor is built in the inverters with 55kW or less (200V series) and 160kW or less (400V series). It can be directly connected across P(+)-DB.
 (Note7) When connecting a braking resistor to the inverter with a capacity of 75 kW or more (200V series), or 200 kW or more (400V series), be sure to use a braking unit (option). Connect the braking unit (option) across P(+) and N(-). The auxiliary terminals [1] and [2] have polarity. Connect them according to the diagram above.

(Note8) This is a terminal for grounding the motor. To suppress inverter noise, it is recommended to use this terminal for motor grounding.
 (Note9) Use twisted or shielded cables for the control signals. The shield conductor normally should be grounded, however, if noise is significantly induced from external devices, it may be suppressed by connecting it to [OV] ([M], [11], [THC]) or [OV] ([CM], [PGM]). Set apart from the main circuit wiring as far as possible, and avoid installing it in the same conduit. It is recommended to separate the control signals from the main circuit wires more than 10cm. If crossed, arrange the control wires so that they become almost perpendicular to the main circuit wiring.
 (Note10) The functions indicated on terminals [X1] to [X9] (digital inputs), terminals [Y1] to [Y4] (transistor outputs), and terminal [Y5A/C] (contact output) are those assigned from factory default.
 (Note11) This is a switching connector of the main circuit (fan power).
 (Note12) This is a switch on the control PCB.
 (Note13) The motor of 7.5kW or less has a single-phase power supply fan. In that case connect terminals FU and FV. 400 V series motor of 7.5 kW or less has a cooling fan with a supply voltage of 200V / 50 Hz and 200 to 230 V / 60 Hz (single-phase). 400 V series motor with 11 kW or more has a cooling fan with a supply voltage of 400 to 420 V / 50 Hz and 400 to 440 V / 60 Hz (three phase). When the power supply voltage is other than the above, use a transformer to supply the cooling fan.
 (Note14) The [OV] ([M], [11], [THC]) and [OV] ([CM], [PGM]) terminals are insulated on the inverter.
 (Note15) Confirm that the auxiliary contact of thermal relay can trip the line circuit breaker (MCCB) or the electromagnetic contactor (MC).
 (Note16) A short-circuit conductor is connected between the safety function terminals [EN1] [EN2] and [PS] as the factory default. To use this safety function, remove the short-circuit conductor before connection.

Option guides (Example of unit type)

For main power input and inverter output

*1 If not using an R0, T0 terminal, connect a connector at this location.

EMC compliance filter
[EFL-□□□, FS□□, FN□□]

Dedicated filter to comply with the European EMC Directive (Emission). Install the filter while referring to the details in the installation manual.

Power filter for input circuit Technica
[RNF□C□□-□□]

This filter can be used for the same purpose as the EMC compliance filter, but is not an EMC compliance.

*2 If using an R0, T0 terminal, connect a connector at this location.

Filter capacitor for reducing radio noise Technica
[NFM□□M315KPD□]

Used to reduce radio noise. This is effective for the AM radio frequency band.
*Do not use it on the inverter output side.
[Made by Nippon Chemi-con, dealt by Fuji Electric Technica]

Ferrite ring for reducing radio noise
[ACL-40B, ACL-74B, F200160]

Used to reduce radio noise. Suppressive effect to the frequency band is available by approximately 1MHz or more. This is appropriate as a simple measure against noise since it affects broad range in the frequency band.

Power filter for output circuit Technica
[RNF□S□□-□□]

This will become more effective in noise reduction if used together with the power filter for input circuit.

Output circuit filter [OFL-□□□-4A]

Connected to the output of an inverter to:
• Suppress fluctuations of motor terminal voltage.
• Prevent damages to the motor insulation due to surge voltage in 400V series inverter.
*This filter is not limited by carrier frequency. Also, motor can be tuned while this option is installed.

Surge suppression unit
[SSU □□□TA-NS]

Surge voltage is generated if the cable between an inverter and a motor is several ten meters long. This product suppresses the surge voltage, preventing the motor from being damaged.
(Can be used for motors of 75kW or lower)

Surge killer

Absorbs surge voltage coming from L-load of magnetic contactor and solenoid valve to protect electronic devices from malfunctioning.

Surge absorber Technica
(Connect in parallel to the coil that is a generation source of surge.)

[S2-A-O (for magnetic contactor and solenoid valve)]
[S1-B-O (for mini control relay and timer)]

Surge killer for L-load
(Connect to the power circuit that is a generation source of surge.)

[FSL-323 (for 3-phase)]
[FSL-123 (for single-phase)]

* The items indicated with Technica are dealt by Fuji Electric Technica.

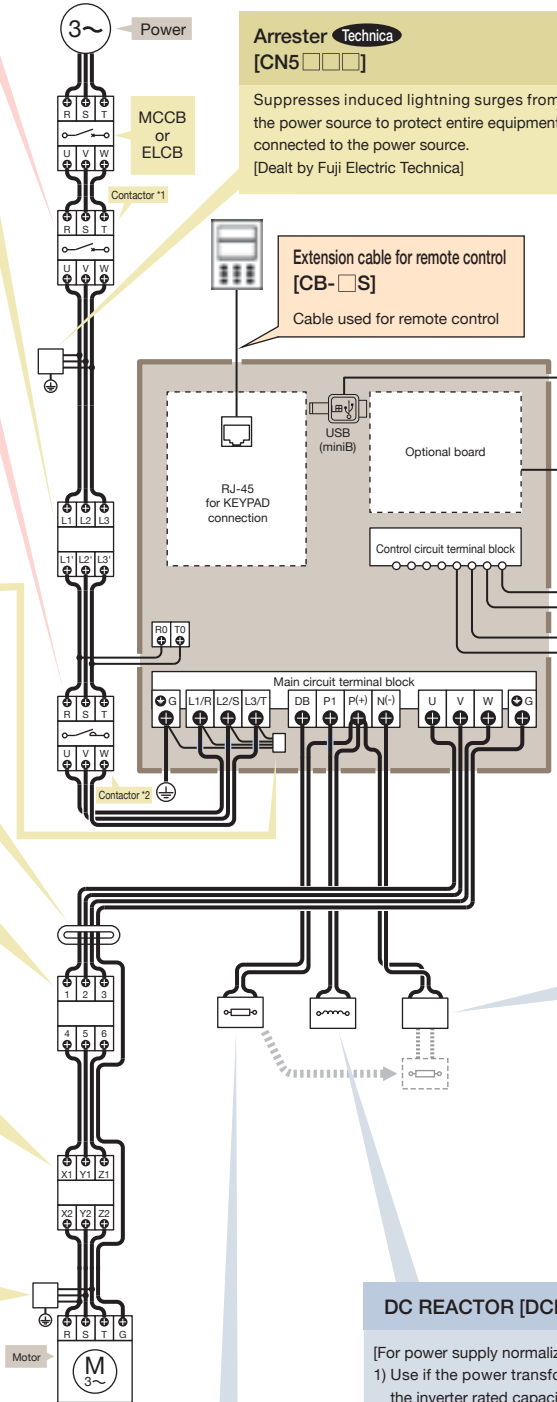

Arrester Technica
[CN5□□□]

Suppresses induced lightning surges from the power source to protect entire equipment connected to the power source.
[Dealt by Fuji Electric Technica]

Extension cable for remote control
[CB-□S]

Cable used for remote control

PC loader for Windows Inverter support software (FRENIC-VG loader)

This software is used to set the function codes of the inverter from a PC, to manage the data. ("WPS-VG1-STR" is available as free download from our website.)



Battery for memory backup, storing trace back memory and calendar function
[OPK-BP]

30kW or more: standard equipment, 22kW: optional

Speed setting potentiometer

Tachometer

Braking unit
[BU□□-□C]

To be used together with a braking resistor to increase the inverter braking performance.

Power regenerative PMW converter, RHC series
[RHC□□-□C]

Used for suppressing power source harmonics of inverters. It is also equipped with a power supply regenerative function to drastically increase braking capability and reduce energy consumption.
* Use in combination with the RHC Series dedicated pressurization reactor, resistor, and capacitor.

DC REACTOR [DCR□-□□□]

[For power supply normalization]

- 1) Use if the power transformer capacity is 500kVA or more and exceeds the inverter rated capacity by 10 times.
- 2) Use if the inverter and a thyristor converter are connected to the same transformer.
*Check if the thyristor converter uses a commutation reactor. If not an AC reactor must be connected to the power supply side.
- 3) Connect to prevent trips when trip occurs due to opening/closing of the phase-advancing capacitor for the power supply lines.
- 4) Use if the voltage unbalance exceeds 2%.

[For improving the input power-factor and reducing harmonics]

- Used to reduce the input harmonic current (correcting power-factor)

* For the drop effect, refer to the guideline appendix.

Braking resistor [DB□□V-□□]

Increases braking capability for highly frequent stopping and large moment of inertia. When used together with a braking unit, connect this to the connection terminal of the braking unit.

Peripheral and structure options

Attachment for external cooling
The attachment to install the heat sink part of the inverter outside the panel. [PBVG7-7.5 (for up to 7.5kW)] [PB-F1-30 (for 11 to 22kW)]



Option guides (Example of stack type)

For main power input and inverter output

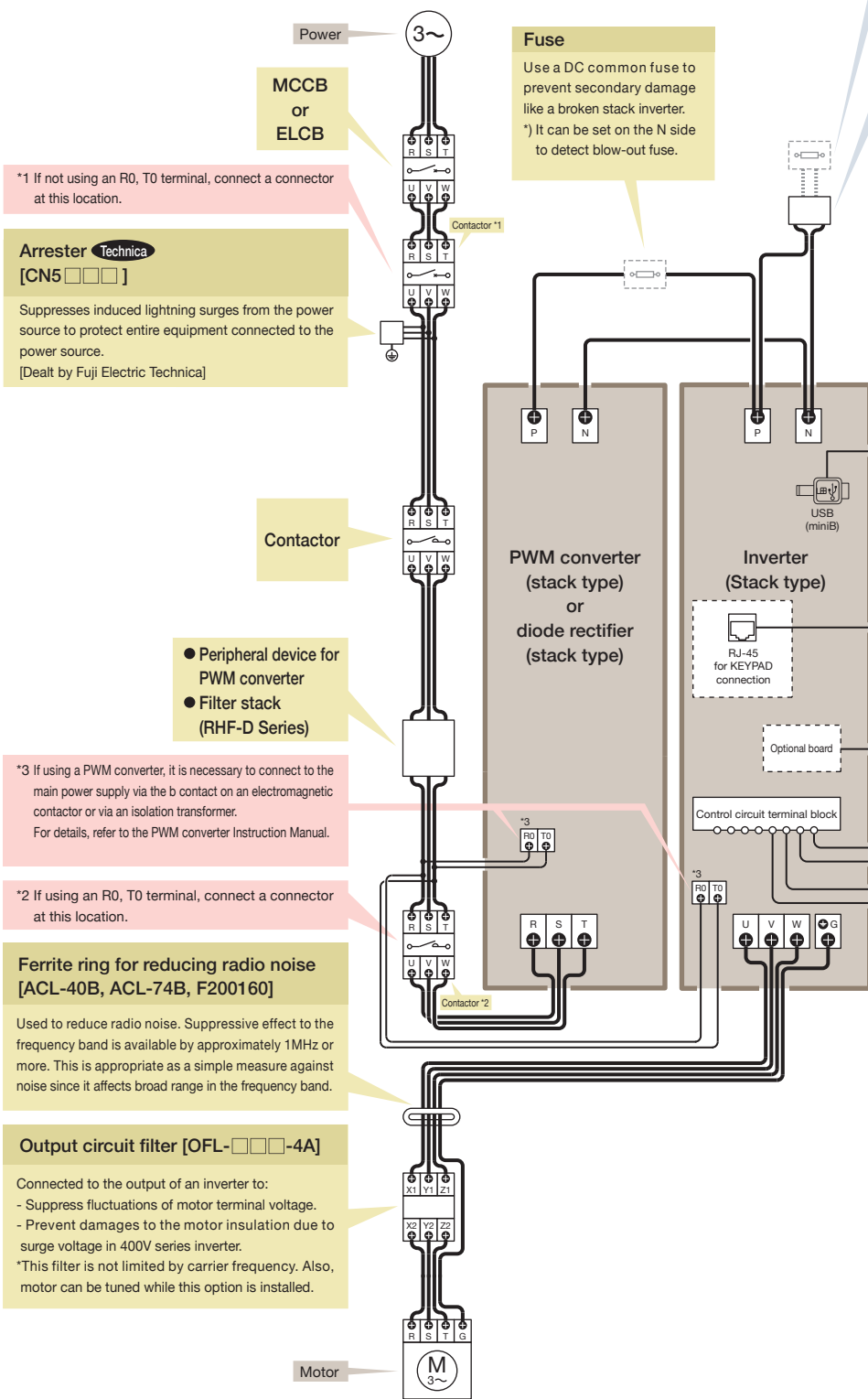

Braking resistor [DB□□V-□□]

Increases braking capability for highly frequent stopping and large moment of inertia. When used together with a braking unit, connect this to the connection terminal of the braking unit.

Braking unit [BU□□-□C]

To be used together with a braking resistor to increase the inverter braking performance.

PC loader for Windows Inverter support software (FRENIC-VG loader)

This software is used to set the function codes of the inverter from a PC, to manage the data. ("WPS-VG1-STR" is available as free download from our website.)



Extension cable for remote control [CB-□S]

Cable used for remote control



Battery for memory backup, storing trace back memory and calendar function [OPK-BP]

Total capacity: Standard equipment

- Speed setting potentiometer
- Tachometer

*1 If not using an R0, T0 terminal, connect a connector at this location.

Arrester Technica [CN5□□□]
Suppresses induced lightning surges from the power source to protect entire equipment connected to the power source.
[Dealt by Fuji Electric Technica]

Fuse
Use a DC common fuse to prevent secondary damage like a broken stack inverter.
*) It can be set on the N side to detect blow-out fuse.

Contactor

- Peripheral device for PWM converter
- Filter stack (RHF-D Series)

*3 If using a PWM converter, it is necessary to connect to the main power supply via the b contact on an electromagnetic contactor or via an isolation transformer.
For details, refer to the PWM converter Instruction Manual.

*2 If using an R0, T0 terminal, connect a connector at this location.

Ferrite ring for reducing radio noise [ACL-40B, ACL-74B, F200160]

Used to reduce radio noise. Suppressive effect to the frequency band is available by approximately 1MHz or more. This is appropriate as a simple measure against noise since it affects broad range in the frequency band.

Output circuit filter [OFL-□□□-4A]

Connected to the output of an inverter to:
- Suppress fluctuations of motor terminal voltage.
- Prevent damages to the motor insulation due to surge voltage in 400V series inverter.
*This filter is not limited by carrier frequency. Also, motor can be tuned while this option is installed.

* The items indicated with Technica are dealt by Fuji Electric Technica.

Optional card

Category	Name	Type	Switch with SW on the Pt board	Specifications	Remarks	
Analog card	Synchronized interface	OPC-VG1-SN		Synchronizing interface circuits for dancer control		
	Aio extension card	OPC-VG1-AIO		Extension card of Ai 2 points + Ao 2 points		
Digital card (8 bit)	Di interface card	OPC-VG1-DI	OPC-VG1-DI (A)	16 bit Di of binary or 4-digit BCD + sign		
			OPC-VG1-DI (B)	For setting the speed, torque and the torque current reference.		
	Dio extension card	OPC-VG1-DIO	OPC-VG1-DIO (A)	Extension of Di (4bits) and Do (8bits) for function selection.		
			OPC-VG1-DIO (B)	Dio option card for direct landing control. Di x 16 bit + Do x10 bit		
	PG interface expansion card	OPC-VG1-PG	OPC-VG1-PG (SD)	+ 5V line driver type, voltage output PGs		
			OPC-VG1-PG (LD)	(A,B and Z-phase signals).		
			OPC-VG1-PG (PR)	Used for detecting motor speed, line speed, position reference and position detection.		
			OPC-VG1-PG (PD)			
			OPC-VG1-PGo	OPC-VG1-PGo (SD)	Open collector type voltage output PGs	
				OPC-VG1-PGo (LD)	(A,B and Z-phase signals).	
	PG card for synchronous motor drive	OPC-VG1-PMPG	OPC-VG1-PGo (PR)	Used for detecting motor speed, line speed, position reference and position detection.		
			OPC-VG1-PGo (PD)			
		OPC-VG1-SPGT		ABS encoder with 17 bit high resolution		
	OPC-VG1-PMPGGo		+5V line driver type	A, B + magnetic pole position (Max. 4bit)		
	OPC-VG1-TL		Open collector type			
	OPC-VG1-CCL		T-Link interface card			
	OPC-VG1-SIU		CC-Link compliant card (Ver2.00)			
	OPC-VG1-SX		High-speed serial connections for UPAC			
	OPC-VG1-ESX		Use for UPAC communication system	coming soon		
	OPC-VG1-PNET		SX bus communication card			
	OPC-VG1-UPAC		E-SX bus communication card			
	OPC-VG1-TBSI		PROFINET-IRT communication card	Compatible only with special inverter type VG1S-□□PN		
	OPC-VG1-DEV		User programming card			
	OPC-VG1-SAFE		PROFIBUS-DP interface card			
	OPC-VG1-TEN		DeviceNet interface card			
	OPC-VG1-DAN		Safety standard compliant card			
	OPC-VG1-POS		Used for multiple-winding motor drive system, reactor connection system			
	WPS-VG1-STR		Inverter support loader	For Windows. (Free version)		
	WPS-VG1-PCL			For Windows. (Paid version)		
	WPS-VG1-TEN		Tension control software	For Windows.		
	WPS-VG1-DAN		Dancer control software	Supplied with inverter support loader (Paid) CD-ROM.		
	WPS-VG1-POS		Position control software			

Cable

Category	Name	Type	Length (m)	Specifications
Cable	Extension cable for remote control	CB-5S	5m	Connection cable between an inverter and the KEYPAD panel
		CB-3S	3m	
		CB-1S	1m	
	Encoder cable for GNF2	Straight plug	CB-VG1-PMPG-05S	5m
			CB-VG1-PMPG-15S	15m
			CB-VG1-PMPG-30S	30m
			CB-VG1-PMPG-50S	50m
		Angle plug	CB-VG1-PMPG-05A	5m
			CB-VG1-PMPG-15A	15m
			CB-VG1-PMPG-30A	30m
			CB-VG1-PMPG-50A	50m
	Dedicated UPAC cable	CB-VG1-UPAC-3S	3m	Connection cable for OPC-VG1-UPAC and computer

Combination with built-in control option

CN	Port	Category	Pattern 1	Pattern 2	Pattern 3
3	A	Digital card (for 8 bit bus),Analog card	1	1	1
2	B	Digital card (for 8 bit bus)	1	0	0
6	C	Field bus interface card	0	0	1
10	D	Digital card (for 16 bit bus)	1	1	0
16	E	Safety card	0	1	1
1	F	Control circuit terminal	1	1	1

- Certain optional communication cards (OPC-VG1-TL and OPC-VG1-CCL, etc.) cannot be installed at the same time. An operation procedure error (Er6) will occur if these cards are installed at the same time.
- The usage of the OPC-VG1-DI, DIO, PG and PGo can be selected by setting the SW on the PCB. 2 cards of each of the types OPC-VG1-DI, DIO, PG and PGo can be installed, but if the SWs for selecting the usage mode are set to the same setting, an operation procedure error (Er6) is indicated.
- If using OPC-VG1-PG for motor speed detection, input from terminals (PA, PB) on the main unit control PCB is disabled.
- The restrictions in the following table apply when installing the OPC-VG1-PG/PGo and OPC-VG1-PMPG/PMPGo.

	VG1-PG/PGo(SD) VG1-PMPG/PMPGo	VG1-PG/PGo(LD)	VG1-PG/PGo(PR)	VG1-PG/PGo(PD)
VG1-PG/PGo(SD) VG1-PMPG/PMPGo	NG			
VG1-PG/PGo(LD)	OK	NG		
VG1-PG/PGo(PR)	OK	NG	NG	
VG1-PG/PGo(PD)	OK	NG	NG	NG

- When you install OPC-VG1-PMPG, you should select terminals according to the control method. The terminals (PA, PB) on the control PC board of the main unit are enabled if vector control for induction motor with speed sensor is selected. The OPC-VG1-PMPG is enabled if vector control for synchronous motor with speed sensor is selected.
- OPC-VG1-SPGT can only be installed in the B port.

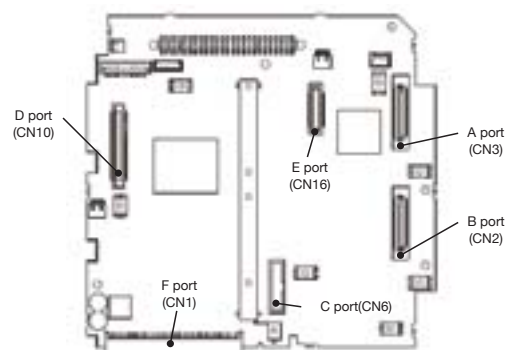



Braking resistor, braking unit (max. 150% torque, 10% ED)

Power supply voltage	Nominal applied motor [kW]	Inverter type Unit type * (HD spec)	Braking unit For unit type		Braking resistor			Continuous braking (150% torque conversion value)			Repetitive braking (100s or less cycle)														
			Type	Q'ty	Type	Ohmic value	Q'ty	Max. braking torque [%]	Braking time [s]	Discharging capability [kW/s]	Duty cycle [%ED]	Average loss [kW]													
3-phase 200V	0.75	FRN0.75VG1S-2□	Built-in unit					150%	10s		10%ED		0.165												
	1.5	FRN1.5VG1S-2□												DB2.2V-21B	30Ω	1	16.5								
	2.2	FRN2.2VG1S-2□												DB3.7V-21B	24Ω	1	27.75								
	3.7	FRN3.7VG1S-2□															41.25								
	5.5	FRN5.5VG1S-2□												DB5.5V-21B	16Ω	1	56.25								
	7.5	FRN7.5VG1S-2□												DB7.5V-21B	12Ω	1	82.5								
	11	FRN11VG1S-2□												DB11V-21B	8Ω	1	112.5								
	15	FRN15VG1S-2□												DB15V-21B	6Ω	1	138.75								
	18.5	FRN18.5VG1S-2□												DB18.5V-21B	4.5Ω	1	165								
	22	FRN22VG1S-2□												DB22V-21B	4Ω	1	225								
	30	FRN30VG1S-2□												DB30V-21B	2.5Ω	1	277.5								
	37	FRN37VG1S-2□												DB37V-21B	2.25Ω	1	337.5								
	45	FRN45VG1S-2□												DB45V-21B	2Ω	1	412.5								
	55	FRN55VG1S-2□												DB55V-21C	1.6Ω	1	562.5								
75	FRN75VG1S-2□	BU55-2C	2	DB75V-21C	2.4Ω/2	1	675	6.75																	
90	FRN90VG1S-2□	BU90-2C	2	DB90V-21C	2Ω/2	1																			
3-phase 400V	3.7	FRN3.7VG1S-4□	Built-in unit					150%	10s		10%ED		0.2775												
	5.5	FRN5.5VG1S-4□												DB3.7V-41B	96Ω	1	27.75								
	7.5	FRN7.5VG1S-4□												DB5.5V-41B	64Ω	1	41.25								
	11	FRN11VG1S-4□												DB7.5V-41B	48Ω	1	56.25								
	15	FRN15VG1S-4□												DB11V-41B	32Ω	1	82.5								
	18.5	FRN18.5VG1S-4□												DB15V-41B	24Ω	1	112.5								
	22	FRN22VG1S-4□												DB18.5V-41B	18Ω	1	138.75								
	30	FRN30VG1S-4□												DB22V-41B	16Ω	1	165								
	37	FRN37VG1S-4□												DB30V-41B	10Ω	1	225								
	45	FRN45VG1S-4□												DB37V-41B	9Ω	1	277.5								
	55	FRN55VG1S-4□												DB45V-41B	8Ω	1	337.5								
	55	FRN55VG1S-4□												DB55V-41C	6.5Ω	1	412.5								
	75	FRN75VG1S-4□												DB75V-41C	4.7Ω	1	562.5								
	90	FRN90VG1S-4□												DB90V-41C	3.9Ω	1	675								
	110	FRN110VG1S-4□												DB110V-41C	3.2Ω	1	825								
	132	FRN132VG1S-4□												DB132V-41C	2.6Ω	1	990								
	160	FRN160VG1S-4□												DB160V-41C	2.2Ω	1	1200								
	200	FRN200VG1S-4□												BU220-4C	2	DB200V-41C	3.5Ω/2	1	1500						
	220	FRN220VG1S-4□														DB220V-41C	3.2Ω/2	1	1650						
	250	-												-	-	-	-	-	-	-	-	-	-	-	-
	280	FRN280VG1S-4□												BU220-4C	2	DB160V-41C	2.2Ω/2	2	2100						
	315	FRN315VG1S-4□														DB160V-41C	2.2Ω/2	2	2363						
355	FRN355VG1S-4□	BU220-4C	3	DB132V-41C	2.6Ω/3	3	2663																		
400	FRN400VG1S-4□			DB132V-41C	2.6Ω/3	3	3000																		
500	FRN500VG1S-4□			DB132V-41C	2.6Ω/4	4	3750																		
630	FRN630VG1S-4□			DB160V-41C	2.2Ω/4	4	4725																		
710	-	-	-	-	-	-	-	-	-	-	-	-	-												
800	-	-	-	-	-	-	-	-	-	-	-	-	-												

* For the unit type (MD / LD) specification and stack type (LD) specification, refer to the User Manual.

(Unit Type, Function Code Edition: 24A7-□-0019, Stack Type Edition: 24A7-□-0018)

(Note 1) The duty cycle [%ED] are calculated as the 150% torque braking used for deceleration as described below.

(Note 2) Two braking resistors are required for each of DB160V-41C, DB200V-41C, or DB220V-41C.

(Note 3) When connecting three braking units or more in parallel, refer to the supplement document of the DB Unit instruction manual (notes in connecting multiple units) INR-HF51614.

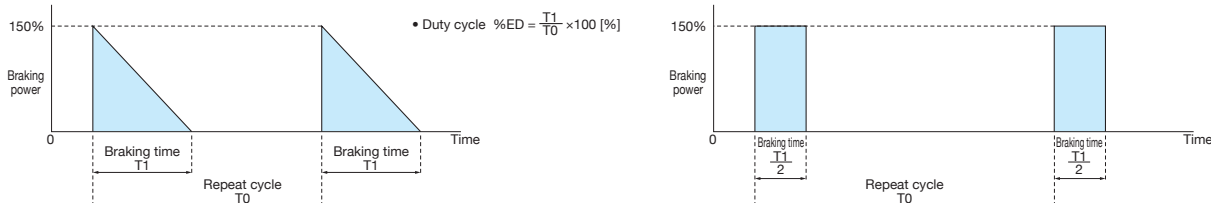

[Selection procedure] All three conditions listed below must be satisfied simultaneously.

- 1 "The maximum braking torque" does not exceed the value shown on the table.
- 2 The energy discharged in the resistor for each braking (the area of the triangle shown in the above figure, area of rectangle in drawing on right) does not exceed "the discharging capability [kW/s]" on the table.
- 3 The average loss (energy discharged in the resistor divided by the braking interval) does not exceed "the average loss [kW]" shown on the table.

Braking resistor (max.150% torque, 10%ED Spec.)

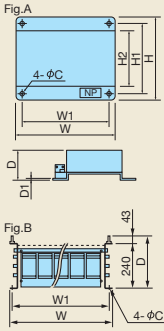
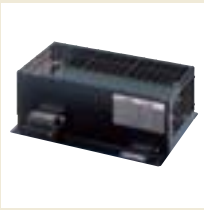

200V Series

Type	Fig	Dimensions [mm]								Approx. weight [kg]
		W	W1	H	H1	H2	D	D1	C	
DB2.2V-21B		330	298	242	210	165	140	1.6	8	4
DB3.7V-21B		400	368	280	248	203	140	1.6	8	5
DB5.5V-21B		400	368	280	248	203	140	1.6	8	5
DB7.5V-21B		400	368	480	448	377	140	1.6	10	6
DB11V-21B		400	368	480	448	377	140	1.6	10	7
DB15V-21B	A	400	368	660	628	557	140	1.6	10	10
DB18.5V-21B		400	368	660	628	557	140	1.6	10	10
DB22V-21B		400	368	660	628	557	240	1.6	10	13
DB30V-21B		400	368	660	628	557	240	1.6	10	18
DB37V-21B		405	368	750	718	647	240	1.6	10	22
DB45V-21B		405	368	750	718	647	340	1.6	10	26
DB55V-21C	B	450	420	440	430	250	283	-	12	35
DB75V-21C		600	570	440	430	250	283	-	12	33
DB90V-21C		700	670	440	430	250	283	-	12	43

400V Series

Type	Fig	Dimensions [mm]								Approx. weight [kg]
		W	W1	H	H1	H2	D	D1	C	
DB3.7V-41B		420	388	280	248	203	140	1.6	8	5
DB5.5V-41B		420	388	480	448	377	140	1.6	10	7
DB7.5V-41B		420	388	480	448	377	140	1.6	10	7
DB11V-41B		420	388	480	448	377	140	1.6	10	8
DB15V-41B	A	420	388	660	628	557	140	1.6	10	11
DB18.5V-41B		420	388	660	628	557	140	1.6	10	11
DB22V-41B		420	388	660	628	557	240	1.6	10	14
DB30V-41B		420	388	660	628	557	240	1.6	10	19
DB37V-41B		425	388	750	718	647	240	1.6	10	21
DB45V-41B		425	388	750	718	647	340	1.6	10	26
DB55V-41C	B	550	520	440	430	250	283	-	12	26
DB75V-41C		550	520	440	430	250	283	-	12	30
DB90V-41C		650	620	440	430	250	283	-	12	41
DB110V-41C		750	720	440	430	250	283	-	12	57
DB132V-41C		750	720	440	430	250	283	-	12	43
DB160V-41C		600	570	440	430	250	283	-	12	37(x2)
DB200V-41C	725	695	440	430	250	283	-	12	50(x2)	
DB220V-41C	725	695	440	430	250	283	-	12	51(x2)	

* For DB160V-41C, DB200V-41C, and DB220V-41C, a pair of resistors of the same type is used.
Be sure to secure the space for installation. A pair of resistors is shipped for the order of one unit.

Braking unit (BU□□-□)

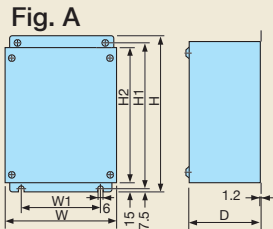

Voltage	Type	Fig	Dimensions [mm]							Approx. weight [kg]
			W	W1	H	H1	H2	D		
3-phase 200V	BU55-2C	A	230	130	240	225	210	160	6	
	BU90-2C	A	250	150	370	355	340		9	
3-phase 400V	BU37-4C	A	150	100	280	265	250	160	4	
	BU55-4C	A	230	130	280	265	250		5.5	
	BU90-4C	A	230	130	280	265	250		5.5	
	BU132-4C	A	250	150	370	355	340		9	
	BU220-4C	A	250	150	450	435	420		13	

Fan unit for braking unit (BU-F)

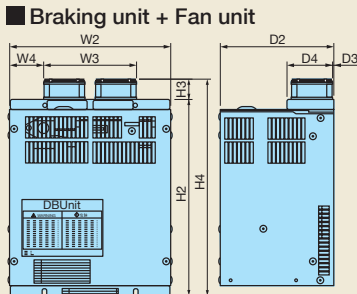

The duty cycle [%ED] of the model with an external braking unit is increased from 10% ED to 30% ED by using this option.

[Fan unit]

Type	Dimensions [mm]			
	W1	H1	D1	ℓ (Fan power supply cable)
BU-F	149	44	76	320

[Braking unit + Fan unit]

Voltage	Type	Dimensions [mm]									
		W2	W3	W4	H2	H3	H4	D2	D3	D4	
3-phase 200V	BU55-2C+BU-F	230	135	47.5	240	30	270	160	1.2	64	
	BU90-2C+BU-F	250		57.5	370		400				
3-phase 400V	BU37-4C+BU-F	150	135	7.5	280	30	310	160	1.2	64	
	BU55-4C+BU-F	230		47.5	280		310				
	BU90-4C+BU-F	230		47.5	280		310				400
	BU132-4C+BU-F	250		57.5	370		400				
BU220-4C+BU-F	250	57.5	450	480							

■ Fan unit

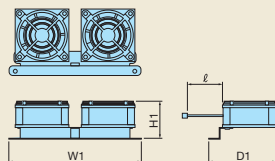



The DC reactor is mainly used for the unit type. With the stack type, the DC reactor is built into the diode converter and is used if necessary.

* For details, refer to the Stack Type User Manual (24A7-□-0018).

DC Reactor (DCR □ - □□□□)

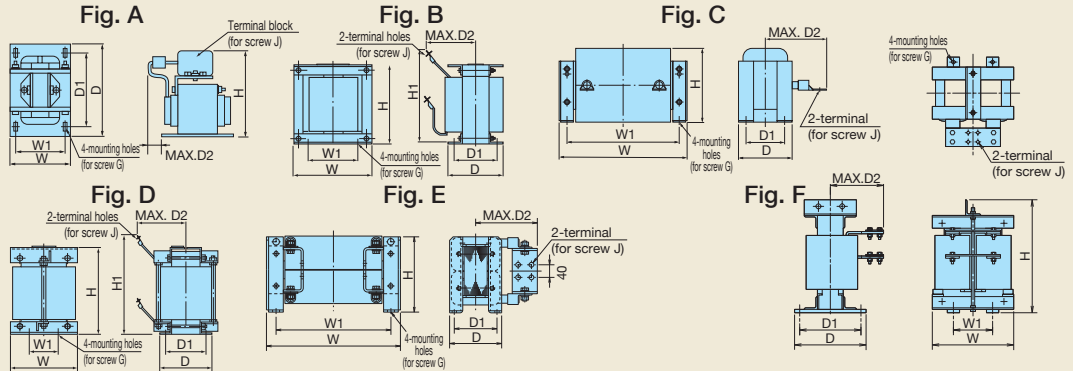

*For models with a standard motor of 75kW or more, it is included as a standard.

Voltage	Nominal applied motor [kW]	Inverter Type			REACTOR Type	Fig	Dimensions [mm]									Approx. weight [kg]
		HD Specification	MD Specification	LD Specification			W	W1	D	D1	D2	G	H	H1	J	
3-phase 200V	0.2				DCR2-0.2	A	66	56	90	72	5	M4(5.2x8)	94	-	M4	0.8
	0.4				DCR2-0.4		66	56	90	72	15	M4(5.2x8)	94	-	M4	1.0
	0.75	FRN0.75VG1S-2□	-	-	DCR2-0.75		66	56	90	72	20	M4(5.2x8)	94	-	M4	1.4
	1.5	FRN1.5VG1S-2□	-	-	DCR2-1.5		66	56	90	72	20	M4(5.2x8)	94	-	M4	1.6
	2.2	FRN2.2VG1S-2□	-	-	DCR2-2.2		86	71	100	80	10	M5(6x9)	110	-	M4	1.8
	3.7	FRN3.7VG1S-2□	-	-	DCR2-3.7		86	71	100	80	20	M5(6x9)	110	-	M4	2.6
	5.5	FRN5.5VG1S-2□	-	-	DCR2-5.5		111	95	100	80	20	M6(7x11)	130	-	M5	3.6
	7.5	FRN7.5VG1S-2□	-	-	DCR2-7.5		111	95	100	80	23	M6(7x11)	130	-	M5	3.8
	11	FRN11VG1S-2□	-	-	DCR2-11		111	95	100	80	24	M6(7x11)	137	-	M6	4.3
	15	FRN15VG1S-2□	-	-	DCR2-15		146	124	120	96	15	M6(7x11)	180	-	M8	5.9
	18.5	FRN18.5VG1S-2□	-	-	DCR2-18.5		146	124	120	96	25	M6(7x11)	180	-	M8	7.4
	22	FRN22VG1S-2□	-	-	DCR2-22A		146	124	120	96	25	M6(7x11)	180	-	M8	7.5
	30	FRN30VG1S-2□	-	-	DCR2-30B		152	90	156	116	115	M6(Φ8)	130	190	M10	12
	37	FRN37VG1S-2□	-	FRN30VG1S-2□	DCR2-37B		171	110	151	110	115	M6(Φ8)	150	200	M10	14
					DCR2-37C		210	185	101	81	125	M6(7x13)	125	-	M10	7.4
	45	FRN45VG1S-2□	-	FRN37VG1S-2□	DCR2-45B		210	110	166	125	120	M6(Φ8)	150	200	M10	16
					DCR2-45C		210	185	106	86	135	M6(7x13)	125	-	M12	8.4
	55	FRN55VG1S-2□	-	FRN45VG1S-2□	DCR2-55B		190	160	131	90	100	M6(Φ8)	210	250	M12	16
				DCR2-55C	255	225	96	76	140	M6(7x13)	145	-	M12	11		
75	FRN75VG1S-2□	-	FRN55VG1S-2□	DCR2-75C	255	225	106	86	145	M6(7x13)	145	-	M12	12		
90	FRN90VG1S-2□	-	FRN75VG1S-2□	DCR2-90C	255	225	116	96	155	M6(7x13)	145	-	M12	14		
110	-	-	FRN90VG1S-2□	DCR2-110C	300	265	116	90	185	M8(10x18)	160	-	M12	17		
3-phase 400V	3.7	FRN3.7VG1S-4□	-	-	DCR4-3.7	A	86	71	100	80	20	M5(6x9)	110	-	M4	2.6
	5.5	FRN5.5VG1S-4□	-	-	DCR4-5.5		86	71	100	80	20	M5(6x9)	110	-	M4	2.6
	7.5	FRN7.5VG1S-4□	-	-	DCR4-7.5		111	95	100	80	24	M6(7x11)	130	-	M5	4.2
	11	FRN11VG1S-4□	-	-	DCR4-11		111	95	100	80	24	M6(7x11)	130	-	M5	4.3
	15	FRN15VG1S-4□	-	-	DCR4-15		146	124	120	96	15	M6(7x11)	168	-	M5	5.9
	18.5	FRN18.5VG1S-4□	-	-	DCR4-18.5		146	124	120	96	25	M6(7x11)	171	-	M6	7.2
	22	FRN22VG1S-4□	-	-	DCR4-22A		146	124	120	96	25	M6(7x11)	171	-	M6	7.2
	30	FRN30VG1S-4□	-	-	DCR4-30B		152	90	157	115	100	M6(Φ8)	130	190	M8	13
	37	FRN37VG1S-4□	-	FRN30VG1S-4□	DCR4-37B		171	110	150	110	100	M6(Φ8)	150	200	M8	15
					DCR4-37C		210	185	101	81	105	M6(7x13)	125	-	M8	7.4
	45	FRN45VG1S-4□	-	FRN37VG1S-4□	DCR4-45B		171	110	165	125	110	M6(Φ8)	150	210	M8	18
					DCR4-45C		210	185	106	86	120	M6(7x13)	125	-	M8	8.4
	55	FRN55VG1S-4□	-	FRN45VG1S-4□	DCR4-55B		171	110	170	130	110	M6(Φ8)	150	210	M8	20
					DCR4-55C		255	225	96	76	120	M6(7x13)	145	-	M10	11
	75	FRN75VG1S-4□	-	FRN55VG1S-4□	DCR4-75C		255	225	106	86	125	M6(7x13)	145	-	M10	13
	90	FRN90VG1S-4□	-	FRN75VG1S-4□	DCR4-90C		255	225	116	96	140	M6(7x13)	145	-	M12	15
	110	FRN110VG1S-4□	FRN90VG1S-4□	FRN90VG1S-4□	DCR4-110C		300	265	116	90	175	M8(10x18)	155	-	M12	19
	132	FRN132VG1S-4□	FRN110VG1S-4□	FRN110VG1S-4□	DCR4-132C		300	265	126	100	180	M8(10x18)	160	-	M12	22
	160	FRN160VG1S-4□	FRN132VG1S-4□	FRN132VG1S-4□	DCR4-160C		350	310	131	103	180	M10(12x22)	190	-	M12	26
	200	FRN200VG1S-4□	FRN160VG1S-4□	FRN160VG1S-4□	DCR4-200C		350	310	141	113	185	M10(12x22)	190	-	M12	30
220	FRN220VG1S-4□	FRN200VG1S-4□	FRN200VG1S-4□	DCR4-220C	350	310	146	118	200	M10(12x22)	190	-	M12	33		
250	-	FRN220VG1S-4□	-	DCR4-250C	350	310	161	133	210	M10(12x22)	190	-	M12	35		
280	FRN280VG1S-4□	-	FRN220VG1S-4□	DCR4-280C	350	310	161	133	210	M10(12x22)	190	-	M16	37		
315	FRN315VG1S-4□	FRN280VG1S-4□	-	DCR4-315C	400	345	146	118	200	M10(12x22)	225	-	M16	40		
355	FRN355VG1S-4□	FRN315VG1S-4□	FRN280VG1S-4□	DCR4-355C	400	345	156	128	200	M10(12x22)	225	-	4xM12	49		
400	FRN400VG1S-4□	FRN355VG1S-4□	FRN315VG1S-4□	DCR4-400C	445	385	145	117	213	M10(12x22)	245	-	4xM12	52		
450	-	FRN400VG1S-4□	-	DCR4-450C	440	385	150	122	215	M10(12x22)	245	-	4xM12	62		
500	FRN500VG1S-4□	-	FRN400VG1S-4□	DCR4-500C	445	390	165	137	220	M10(12x22)	245	-	4xM12	72		
630	FRN630VG1S-4□	-	FRN500VG1S-4□	DCR4-630C	285	145	203	170	195	M12(14x20)	480	-	2xM12	75		
710	-	-	FRN630VG1S-4□	DCR4-710C	340	160	295	255	225	M12(Φ15)	480	-	4xM12	95		

•FRN□VG1S-□J (Japanese)

The DC Reactor (DCR) in thick-frame are provided as standard (supplied adding to the unit).

The DC Reactor (DCR) is provided as standard for FRN55VG1S-2 and FRN55VG1S-4 of the LD specification, but not provided as standard for those units of HD specification.

•FRN□VG1S-□E (English), -□C (Chinese)

The DC reactor (DCR) is optional. (All capacities)

*The DCR2/4-□□B type is also prepared for motors with 75kW or larger, which are applicable as standard. Contact us for ordering product separately.

DC Reactor Type	Remarks
Input power factor of DCR2/4-□□/□□A/□□B: approx. 90 to 95%	The symbol at the end of the type code varies depending on the capacity.
Input power factor of the DCR2/4-□□C: about 86 to 90%	This can be selected with the inverter of 37kW or more.

AC Reactor (ACR □ - □ □ □)

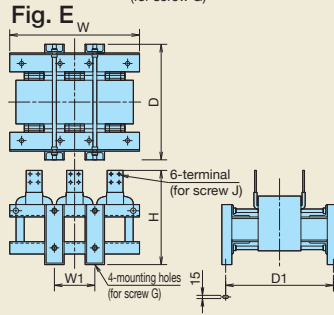
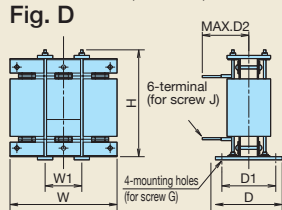
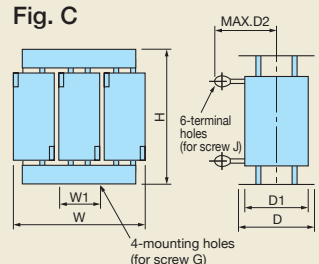
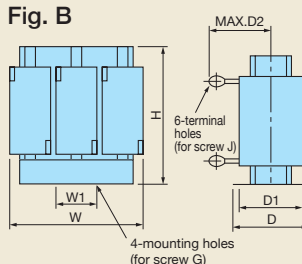
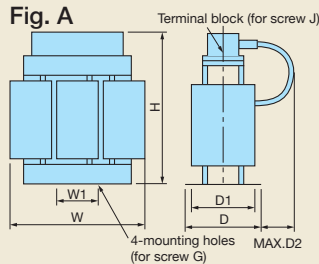
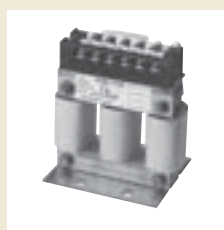

Voltage	Reactor Type	Fig. No.	Dimensions [mm]								Approx. weight [kg]	
			W	W1	D	D1	D2	G	H	J		
3-phase 200V	ACR2-0.75A	A	120	40	100	75	20	M5(6×10)	115	M4	1.9	
	ACR2-1.5A		120	40	100	75	20	M5(6×10)	115	M4	2.0	
	ACR2-2.2A		120	40	100	75	20	M5(6×10)	115	M4	2.0	
	ACR2-3.7A		125	40	100	75	25	M5(6×10)	125	M4	2.4	
	ACR2-5.5A	B	125	40	115	90	25	M5(6×10)	125	M4	3.1	
	ACR2-7.5A		125	40	115	90	106	M5(6×10)	95	M5	3.1	
	ACR2-11A		125	40	125	100	106	M5(6×10)	95	M6	3.7	
	ACR2-15A		180	60	110	85	106	M6(7×11)	115	M6	4.8	
	ACR2-18.5A		180	60	110	85	109	M6(7×11)	115	M6	5.1	
	ACR2-22A		180	60	110	85	109	M6(7×11)	115	M6	5.1	
	ACR2-37	C	190	60	120	90	172	M6(7×11)	190	M8	11	
	ACR2-55		190	60	120	90	200	M6(7×11)	190	M12	13	
	ACR2-75		250	100	120	90	200	M8(9×14)	250	M12	25	
	ACR2-90		285	190	158	120	190	M10(12×20)	210	M12	26	
ACR2-110		280	150	138	110	200	M8(10×20)	270	M12	30		
3-phase 400V	ACR4-3.7A	B	125	40	100	75	106	M5(6×10)	95	M4	2.4	
	ACR4-5.5A		125	40	115	90	106	M5(6×10)	95	M5	3.1	
	ACR4-7.5A		125	40	115	90	106	M5(6×10)	95	M5	3.7	
	ACR4-11A		180	60	110	85	106	M6(7×11)	115	M6	4.3	
	ACR4-15A		180	60	110	85	106	M6(7×11)	137	M6	5.4	
	ACR4-18.5A		180	60	110	85	106	M6(7×11)	137	M6	5.7	
	ACR4-22A	C	180	60	110	85	106	M6(7×11)	137	M6	5.9	
	ACR4-37		190	60	120	90	172	M6(7×11)	190	M8	12	
	ACR4-55		190	60	120	90	200	M6(7×11)	190	M10	14	
	ACR4-75		190	60	126	90	157	M6(7×10)	190	M10	16	
	ACR4-110		250	100	136	105	202	M8(9.5×18)	245	M12	24	
	ACR4-132		250	100	146	115	207	M8(10×16)	250	M12	32	
	ACR4-220	D	320	120	150	110	240	M10(12×20)	300	M12	40	
	ACR4-280		380	130	150	110	260	M10(12×20)	300	M12	52	
	ACR4-355		380	130	150	110	260	M10(12×20)	300	M12	52	
	ACR4-450		460	155	290	230	200	M12(Φ15)	490	4×M12	95	
	ACR4-530		E	480	155	420	370	-	M12(15×25)	380	4×M12	100
	ACR4-630			510	170	420	370	-	M12(15×25)	390	4×M12	110

Note) It is not necessary to use the reactor unless a particularly stable power supply is required, i.e., DC bus connection operation (PN connection operation). Use the DC reactor (DCR) as a measure against harmonics.



Zero-phase reactor for reducing radiated noise (ACL-40B, ACL-74B, F200160)

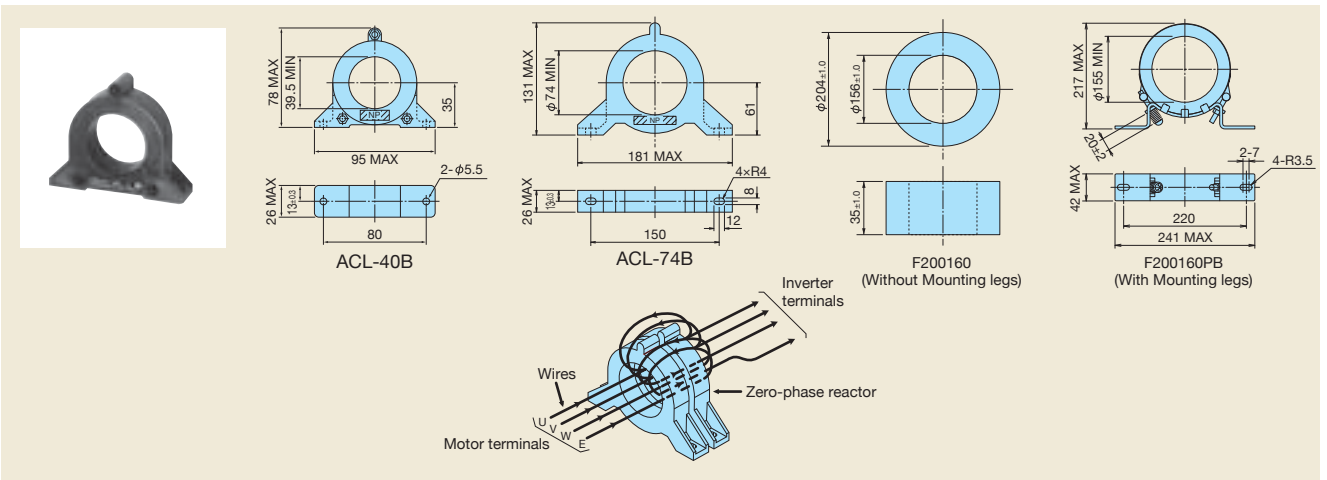

Applied wire size list

Ferrite ring types for reducing radio noise	Q'ty	No. of turns	Recommended wire size [mm ²] Note
ACL-40B	1	4	2.0, 3.5, 5.5
	2	2	8, 14
	4	1	22, 38, 5.5x2, 8x2, 14x2, 22x2
ACL-74B	1	4	8, 14
	2	2	22, 38, 60, 5.5x2, 8x2, 14x2, 22x2
	4	1	100, 150, 200, 250, 38x2, 60x2, 100x2
F200160 F200160PB	1	4	150x2, 200x2, 250x2, 325x2 150x3, 200x3, 250x3, 325x3 250x4, 325x4

NOTE) Use a 600V HIV insulation cable (Allowable temp. 75°C).

Hand Lifter

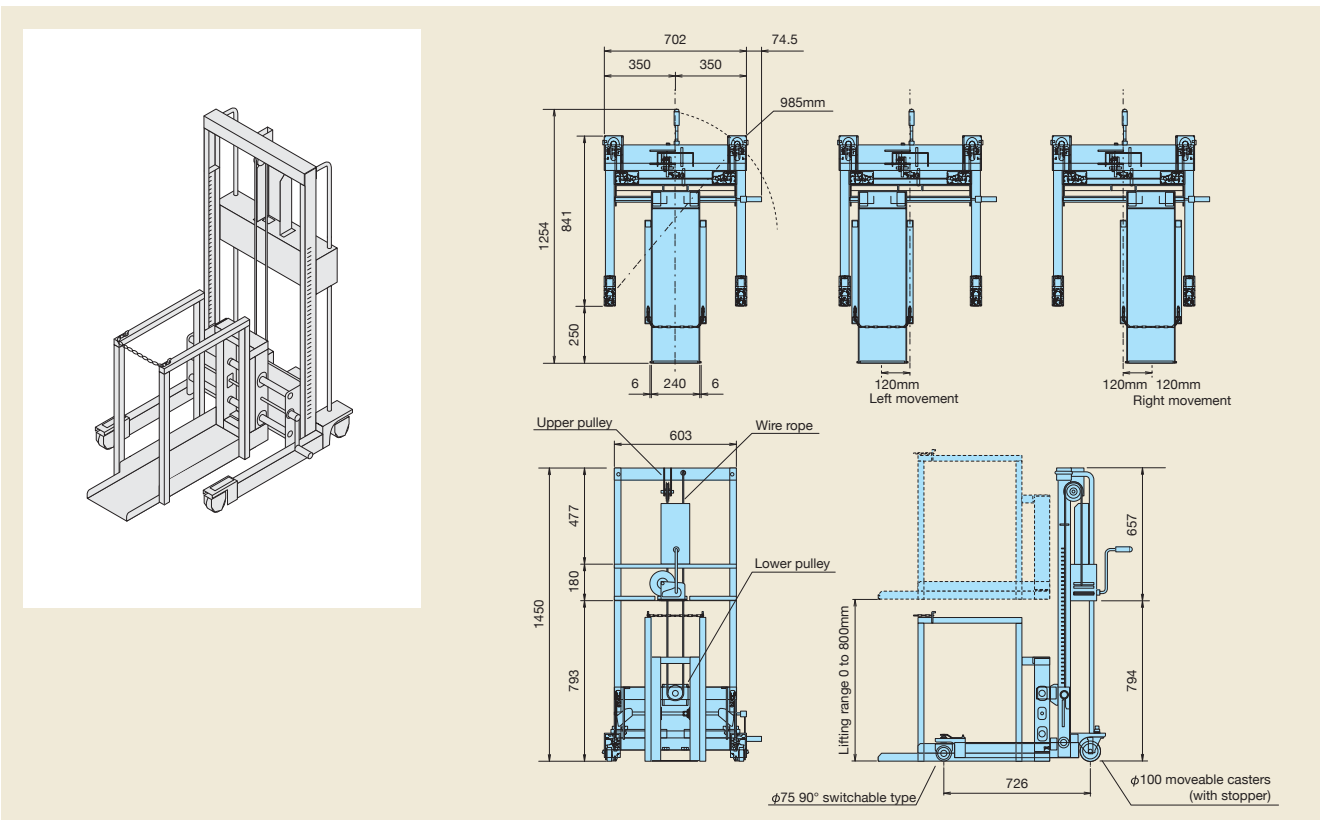

Options

Output circuit filter (OFL- [] [] [] 4A)[400V series]



Filter dimensions (22kW or less)

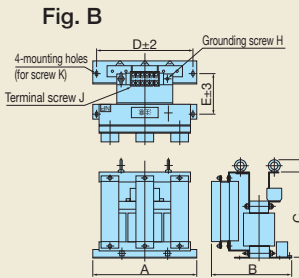
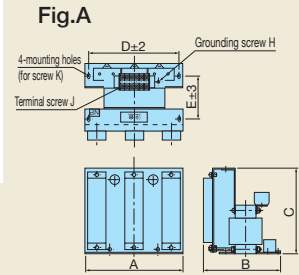

Filter dimensions (30kW or more);reactor

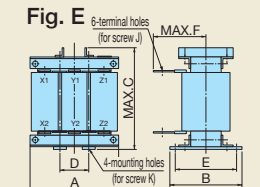
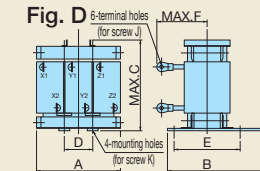
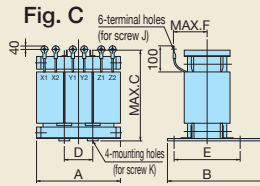

Filter dimensions (30kW or more);resistor/capacitor

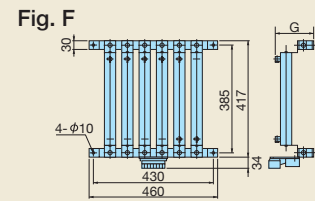

The reactor, capacitor and resistor for filter OFL-30-4A or larger have to be installed separately.
(Those items are not included in the mass indicated in the table below. They are shipped as a set by ordering the filter.)

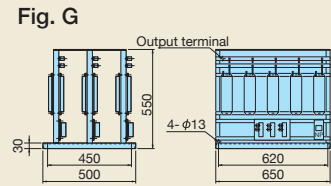

Voltage	Nominal applied motor [kW]	Inverter Type					Filter Type	Fig	Dimensions [mm]							Approx. weight [kg]				
		Unit Type		Stack Type					A	B	C	D	E	F	G		Grounding screw H	Terminal screw J	Mounting screw K	
		HD Specification	MD Specification	LD Specification	MD Specification	LD Specification														
3-phase 400V	3.7	FRN3.7VG1S-4	-	-	-	-	OFL-3.7-4A	A	220	225	220	200	115	-	-	M4	M4	M5	14	
	5.5	FRN5.5VG1S-4	-	-	-	-	OFL-7.5-4A		290	290	230	260	160	-	-	M5	M5	M6	22	
	7.5	FRN7.5VG1S-4	-	-	-	-	-		-	-	-	-	-	-	-	-	-	-	-	-
	11	FRN11VG1S-4	-	-	-	-	-	B	330	275	310	300	145	-	-	M6	M6	M8	35	
	15	FRN15VG1S-4	-	-	-	-	-		330	300	330	300	170	-	-	M6	M6	M8	45	
	18.5	FRN18.5VG1S-4	-	-	-	-	-		-	-	-	-	-	-	-	-	-	-	-	
	22	FRN22VG1S-4	-	-	-	-	-	C/F	210	175	210	70	140	90	160	-	M5	M6	12	
	30	FRN30VG1S-4	-	-	FRN30SVG1S-4	-	-		220	190	220	75	150	95	160	-	M5	M6	15	
	37	FRN37VG1S-4	-	FRN30VG1S-4	FRN37SVG1S-4	FRN30SVG1S-4	FRN30SVG1S-4		OFL-37-4A	220	195	265	70	155	140	160	-	M6	M8	17
	45	FRN45VG1S-4	-	FRN37VG1S-4	FRN45SVG1S-4	FRN37SVG1S-4	FRN37SVG1S-4	OFL-45-4A	260	200	275	85	160	150	160	-	M6	M8	22	
	55	FRN55VG1S-4	-	FRN45VG1S-4	FRN55SVG1S-4	FRN45SVG1S-4	FRN45SVG1S-4	OFL-55-4A	260	210	290	85	170	150	233	-	M8	M10	25	
	75	FRN75VG1S-4	-	FRN55VG1S-4	FRN75SVG1S-4	FRN55SVG1S-4	FRN55SVG1S-4	OFL-75-4A	260	210	290	85	170	155	233	-	M8	M10	28	
	90	FRN90VG1S-4	-	FRN75VG1S-4	FRN90SVG1S-4	FRN75SVG1S-4	FRN75SVG1S-4	OFL-90-4A	300	230	330	100	190	170	233	-	M8	M10	38	
	110	FRN110VG1S-4	FRN90VG1S-4	FRN90VG1S-4	FRN110SVG1S-4	FRN90SVG1S-4	FRN90SVG1S-4	OFL-110-4A	300	240	340	100	200	170	233	-	M10	M10	42	
	132	FRN132VG1S-4	FRN110VG1S-4	FRN110VG1S-4	FRN132SVG1S-4	FRN110SVG1S-4	FRN110SVG1S-4	OFL-132-4A	300	240	340	100	200	180	233	-	M10	M10	48	
	160	FRN160VG1S-4	FRN132VG1S-4	FRN132VG1S-4	FRN160SVG1S-4	FRN132SVG1S-4	FRN132SVG1S-4	OFL-160-4A	320	270	350	105	220	190	333	-	M10	M12	60	
	200	FRN200VG1S-4	FRN160VG1S-4	FRN160VG1S-4	FRN200SVG1S-4	FRN160SVG1S-4	FRN160SVG1S-4	OFL-200-4A	340	300	390	115	250	190	333	-	M10	M12	70	
	220	FRN220VG1S-4	FRN200VG1S-4	FRN200VG1S-4	FRN220SVG1S-4	FRN200SVG1S-4	FRN200SVG1S-4	OFL-220-4A	D/F	350	300	430	115	250	200	333	-	M10	M12	78
	250	-	FRN220VG1S-4	-	FRN250SVG1S-4	FRN220SVG1S-4	FRN220SVG1S-4	OFL-280-4A		440	275	450	150	230	170	-	-	M12	M12	90
	280	FRN280VG1S-4	-	FRN220VG1S-4	FRN280SVG1S-4	FRN250SVG1S-4	FRN250SVG1S-4	-		440	290	480	150	245	175	-	-	M12	M12	100
	315	FRN315VG1S-4	FRN280VG1S-4	-	FRN315SVG1S-4	FRN280SVG1S-4	FRN280SVG1S-4	OFL-315-4A	E/G	440	295	510	150	240	175	-	-	M12	M12	110
	355	FRN355VG1S-4	FRN315VG1S-4	FRN280VG1S-4	-	FRN315SVG1S-4	FRN315SVG1S-4	OFL-355-4A		440	325	470	150	270	195	-	-	M12	M12	125
	400	FRN400VG1S-4	FRN355VG1S-4	FRN315VG1S-4	-	-	-	OFL-400-4A		440	335	500	150	280	210	-	-	M12	M12	145
	450	-	FRN400VG1S-4	FRN355VG1S-4	-	-	-	OFL-450-4A	E/G	480	355	560	150	280	245	-	-	M12	M12	170
	500	FRN500VG1S-4	-	FRN400VG1S-4	-	-	-	OFL-500-4A		-	-	-	-	-	-	-	-	-	-	-
	630	FRN630VG1S-4	-	FRN500VG1S-4	FRN630BVG1S-4	-	-	OFL-630-4A		-	-	-	-	-	-	-	-	-	-	-
	710	-	-	FRN630VG1S-4	FRN710BVG1S-4	FRN630BVG1S-4	FRN630BVG1S-4	-	-	-	-	-	-	-	-	-	-	-	-	-
	800	-	-	-	FRN800BVG1S-4	FRN710BVG1S-4	FRN710BVG1S-4	-	-	-	-	-	-	-	-	-	-	-	-	-
	1000	-	-	-	-	FRN800BVG1S-4	FRN800BVG1S-4	-	-	-	-	-	-	-	-	-	-	-	-	-

* Carrier frequency is not limited with OFL-***-4A.



Power regenerative PWM converter (Unit and Stack Type)

Features

■ Applied Guideline for Suppressing Harmonics

PWM control reduces harmonics current significantly, due to sinusoidal wave at power supply side.

According to "Guideline for Suppressing Harmonics by the Users Who Receive High Voltage or Special High Voltage" issued by the Ministry of Economy, Trade and Industry, the converter factor (Ki) can be set to "0" (meaning harmonics occurrence is 0) when combining with the inverter.

■ Possible to reduce power supply facility capacity

Its power-factor control realizes the same phase current as the power-supply phase-voltage. The equipment, thus, can be operated with the power-factor of almost "1."

This makes it possible to reduce the power transformer capacity and downsize the other devices, compared with those required without the converter.

■ Upgraded braking performance

Regenerated energy occurring at highly frequent accelerating and decelerating operation and elevating machine operation is entirely returned to power supply side. Thus, energy saving during regenerative operation is possible. As the current waveform is sinusoidal during regenerative operation, no troubles are caused to the power supply system.

Rated continuous regeneration	100%
Rated regeneration for 1 min	150% MD (CT) spec. 120% LD (VT) spec. *Stack type: 110%

■ Enhanced maintenance/protective functions

Failure can be easily analyzed with the trace back (option).

- ① The past 10 alarms can be displayed with the keypad LED display. This helps you analyze the alarm causes and take countermeasures.
- ② When momentary power failure occurs, the converter turns off the gates to enable continuous operation after recovery.
- ③ The converter can issue warning signals like overload, heat sink overheating, or the end of service life prior to converter tripping.

■ Enhanced network support

- The converter can be connected to MICREX-SX and CC-Link master devices (using option). The RS-485 interface is provided as standard. (Unit type)



Comparison of input current waveform

<Without PWM converter>

<With PWM converter>

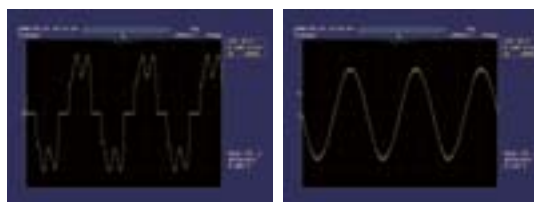

Allowable characteristics of the RHC unit

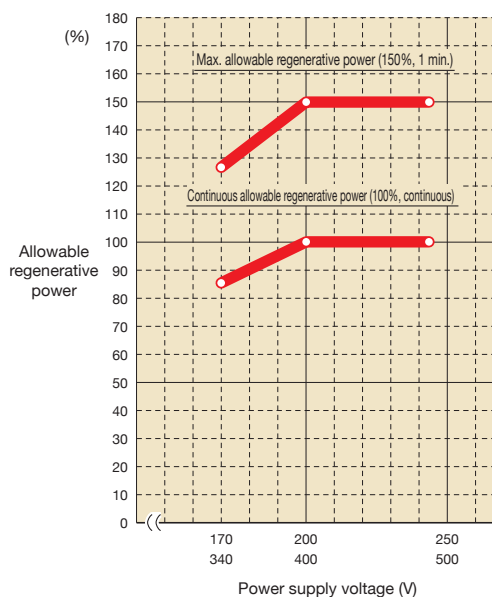

Standard Specifications : MD (CT) specifications of medium overload, light overload LD (VT) specifications (Unit and Stack Type)

Unit type Three-phase 200V series

Item		Standard Specifications										
Type RHC□□□-2C		7.5	11	15	18.5	22	30	37	45	55	75	90
CT Specifications	Applicable inverter capacity [kW]	7.5	11	15	18.5	22	30	37	45	55	75	90
	Continuous capacity [kW]	8.8	13	18	22	26	36	44	53	65	88	103
	Output Overload rating	150% of rated current for 1 min.										
	Output Voltage	DC320 to 355V (Variable with input power supply voltage) (*3)										
	Required power supply capacity [kVA]	9.5	14	19	24	29	38	47	57	70	93	111
Carrier frequency(*5)		Standard 15kHz										Standard 10kHz
VT Specifications	Applicable inverter capacity [kW]	11	15	18.5	22	30	37	45	55	75	90	110
	Continuous capacity [kW]	13	18	22	26	36	44	53	65	88	103	126
	Output Overload rating	120% of rated current for 1 min.										
	Output Voltage	DC320 to 355V (Variable with input power supply voltage) (*3)										
	Required power supply capacity [kVA]	14	19	24	29	38	47	57	70	93	111	136
Carrier frequency(*5)		Standard 10kHz										Standard 6kHz
Power supply voltage	Number of phase/Voltage/Frequency	3-phase, 200 to 220V 50Hz, 220 to 230V 50Hz(*1), 200 to 230V 60Hz										
	Voltage/Frequency variation	Voltage+10 to -15% Frequency ± 5%, Voltage unbalance: 2% or less (*4)										

(*1) 220 to 230V / 50Hz model available on request.

(*2) The tap in the converter must be switched when the power supply voltage is 380 to 398V / 50Hz or 380 to 430V / 60Hz. The capacity must be reduced when the power supply voltage is less than 400V.

(*3) The output voltage is 320 / 640V DC, 343 / 686V DC, 355 / 710V DC when the power supply voltage is 200 / 400V, 220 / 440V and 230 / 460V, respectively.

(*4) Voltage unbalance [%] = (Max. voltage [V] - Min. voltage [V]) / Three-phase average voltage [V] × 67

(*5) The carrier frequency is automatically set to 2.5kHz when OPC-VG7-SIR is installed (transformerless connection).

Unit type Three-phase 400V series

Item		Standard Specifications																						
Type RHC□□□-4C		7.5	11	15	18.5	22	30	37	45	55	75	90	110	132	160	200	220	280	315	355	400	500	630	
CT Specifications	Applicable inverter capacity [kW]	7.5	11	15	18.5	22	30	37	45	55	75	90	110	132	160	200	220	280	315	355	400	500	630	
	Continuous capacity [kW]	8.8	13	18	22	26	36	44	53	65	88	103	126	150	182	227	247	314	353	400	448	560	705	
	Output Overload rating	150% of rated current for 1 min.																						
	Output Voltage	DC640 to 710V (Variable with input power supply voltage) (*3)																						
	Required power supply capacity [kVA]	9.5	14	19	24	29	38	47	57	70	93	111	136	161	196	244	267	341	383	433	488	610	762	
Carrier frequency(*5)		Standard 15kHz											Standard 10kHz						Standard 6kHz					
VT Specifications	Applicable inverter capacity [kW]	11	15	18.5	22	30	37	45	55	75	90	110	132	160	200	220	280	315	355	400	500	-	-	
	Continuous capacity [kW]	13	18	22	26	36	44	53	65	88	103	126	150	182	227	247	314	353	400	448	560	-	-	
	Output Overload rating	120% of rated current for 1 min.																						
	Output Voltage	DC640 to 710V (Variable with input power supply voltage) (*3)																						
	Required power supply capacity [kVA]	14	19	24	29	38	47	57	70	93	111	136	161	196	244	267	341	383	433	488	610	-	-	
Carrier frequency(*5)		Standard 10kHz											Standard 6kHz											
Power supply voltage	Number of phase/Voltage/Frequency	3-phase, 380 to 440V 50Hz, 380 to 460V 60Hz(*2)																						
	Voltage/Frequency variation	Voltage+10 to -10% Frequency ± 5%, Voltage unbalance: 2% or less (*4)																						

(*1) 220 to 230V / 50Hz model available on request.

(*2) The tap in the converter must be switched when the power supply voltage is 380 to 398V / 50Hz or 380 to 430V / 60Hz. The capacity must be reduced when the power supply voltage is less than 400V.

(*3) The output voltage is 320 / 640V DC, 343 / 686V DC, 355 / 710V DC when the power supply voltage is 200 / 400V, 220 / 440V and 230 / 460V, respectively.

(*4) Voltage unbalance [%] = (Max. voltage [V] - Min. voltage [V]) / Three-phase average voltage [V] × 67

(*5) The carrier frequency is automatically set to 2.5kHz when OPC-VG7-SIR is installed (transformerless connection).

Stack type Three-phase 400V series

Item		Standard Specifications								
Type RHC□□□B-4DJ		132S	160S	200S	220S	280S	315S	630B	710B	800B
MD Specifications	Applicable inverter capacity [kW]	132	160	200	220	280	315	630	710	800
	Continuous capacity [kW]	150	182	227	247	314	353	705	795	896
	Output Overload rating	150% of rated current for 1 min.								
	Output Voltage	DC640 to 710V (Variable with input power supply voltage) (*3)								
	Required power supply capacity [kVA]	161	196	244	267	341	383	762	858	967
Carrier frequency(*5)		5kHz								
LD Specifications	Applicable inverter capacity [kW]	160	200	220	-	315	355	710	800	1000
	Continuous capacity [kW]	182	227	247	-	353	400	795	896	1120
	Output Overload rating	110% of rated current for 1 min.								
	Output Voltage	DC640 to 710V (Variable with input power supply voltage) (*3)								
	Required power supply capacity [kVA]	196	244	267	-	383	433	858	967	1210
Carrier frequency(*5)		5kHz								
Power supply voltage	Number of phase/Voltage/Frequency	3-phase, 380 to 440V 50Hz, 380 to 460V 60Hz(*2)								
	Voltage/Frequency variation	Voltage+10 to -10% Frequency ± 5%, Voltage unbalance: 2% or less (*4)								

(*1) A single RHC□□□B-4DJ comprises three stacks.

(*2) The tap in the converter must be switched when the power supply voltage is 380 to 398V / 50Hz or 380 to 430V / 60Hz. The capacity must be reduced when the power supply voltage is less than 400V.

(*3) The output voltage is 640 V DC, 686 V DC, and 710 V DC when the power supply voltage is 400 V, 440 V, and 460 V, respectively.

(*4) Voltage unbalance [%] = (Max. voltage [V] - Min. voltage [V]) / Three-phase average voltage [V] × 67

(*5) The carrier frequency is automatically set to 2.5kHz when OPC-VG7-SIR is installed (transformerless connection).



Standard Specifications : MD (CT) specifications of medium overload, light overload LD (VT) specifications (Unit and Stack Type)

Stack type Three-phase 690V series

Item		Standard Specifications									
Type RHC□○-69D□		132S	160S	200S	250S	280S	315S	355S	400S	450S	
MD Specifications	Applicable inverter capacity [kW]	132	160	200	250	280	315	355	400	450	
	Output	Continuous capacity [kW]	150	182	227	280	314	353	400	448	504
		Overload rating	150% of rated current for 1 min.								
	Voltage	DC895 to 1073V (Variable with input power supply voltage)(*2)									
	Required power supply capacity [kVA]	161	196	244	304	341	383	433	488	549	
Carrier frequency(*4)	5kHz										
LD Specifications	Applicable inverter capacity [kW]	160	200	220	280	315	355	400	450	-	
	Output	Continuous capacity [kW]	182	227	247	314	353	400	448	504	-
		Overload rating	110% of rated current for 1 min.								
	Voltage	DC895 to 1073V (Variable with input power supply voltage)(*2)									
	Required power supply capacity [kVA]	196	245	267	341	383	433	488	549	-	
Carrier frequency(*4)	5kHz										
Power supply voltage	Number of phase/Voltage/Frequency	3-phase, 660 to 690V 50Hz/60Hz, 575 to 600V 50Hz/60Hz(*1)									
	Voltage/Frequency variation	Voltage+15 to -10% Frequency ± 5%, Voltage unbalance: 2% or less(*3)									

(*1)The tap inside the converter must be switched when the power supply voltage is 575 to 600V/50Hz or 575 to 600V/60Hz.

The capacity must be reduced when the power supply voltage is less than 690V.

(*2)The output voltage is 895VDC when the power supply voltage is 575V, and 1073VDC when the power supply voltage is 690V.

(*3)Voltage unbalance [%] = (Max. voltage [V] - Min. voltage [V])/Three-phase average voltage [V] × 67

(*4)The carrier frequency is automatically set to 2.5kHz when OPC-VG7-SIR is installed (transformerless connection).

Common specifications (Unit and Stack Type)

Item	Specifications	
	Unit Type	Stack Type
control	Control method	AVR constant control with ACR minor loop.
	Running and operation	Rectification starts with power ON after connected. Boosting starts with the running signal (RUN-CM short-circuit or running command from communications). Then, preparation for operation is completed.
	Running status signal	Running, driving, regenerating, operation ready, alarm relay output (for any fault), etc.
	MD(CT)/LD(VT) switching	Selecting from MD (CT): Overload rating 150% (1 min.) and LD (VT): Overload rating 120% (1 min.) Selecting from MD (CT): Overload rating 150% (1 min.) and LD (VT): Overload rating 110% (1 min.)
	Carrier frequency	Fixed to high carrier frequency 5kHz (*1)
	Input power factor	Above 0.99 (when 100% loading)
	Input harmonics current	According to the guideline for suppressing harmonics issued by the Ministry of Economy, Trade and Industry, the converter factor (K) can be set to 0.
	Restart mode after momentary power failure	Stops the gates when the voltage level reaches undervoltage level if momentary power failure occurs, and the converter can automatically restart after the power recovers.
Power limit control	Controls the power not to exceed the preset limit value.	
Displays of Keypad	Alarm display (protective functions)	AC fuse blown, AC overvoltage, AC undervoltage, AC overcurrent, AC input current error, Input phase loss, Synchronous power supply frequency error, DC fuse blown, DC overvoltage, DC undervoltage, Charge circuit error, Heat sink overheat, External alarm, Converter overheat, Overload, Memory error, Keypad communication error, CPU error, Network device error, Operation procedure error, A/D converter error, Optical network error, IPM error (*2)
	Alarm history	Records and displays the last 10 alarms. The detailed information of the trip cause for the latest alarm is stored and displayed.
	Monitor	Displays input power, input effective current, input effective voltage, DC intermediate current and power supply frequency.
	Load factor	The load rate can be measured by using the keypad.
	Display language	Text can displayed in 3 languages: Japanese, English and Chinese.
	Charge LED	Lights when the main circuit capacitor is charged. Lights when the main circuit capacitor is charged. Lights even when only input for control power.

(*1) The carrier frequency is automatically set to 2.5kHz when OPC-VG7-SIR is installed (transformerless connection).

(*2) Not available in the stack type

[Terminal Functions] [Communications Specifications], [Function Settings], [Protective Functions], [Structure and environment]

Terminal Functions

Category	Terminal signal	Terminal name	Specifications	
			Unit Type	Stack Type
Main circuit	L1/R, L2/S, L3/T	Main Power input	Connects with a 3-phase power supply via the dedicated reactor.	
	P(+), N(-)	Converter output	Connects with the inverter power supply input terminal P (+), N (-).	
	E(G)	Grounding	Ground terminal for inverter chassis (housing).	
	RO, TO	Auxiliary control power supply input	Connects with the same power circuit as that for the control power backup terminal and the main power circuit.	
Voltage detection	R3, T3	Fan power supply input	-	If using a separate fan power supply, switch the tap inside the converter, and connect the fan power supply to the R3 and T3 terminals.
	R1, S1, T1	Synchronous power supply input for voltage detection	Voltage detection terminals used for the internal converter control. These are connected with the power supply side of the dedicated reactor and filter.	
Input signal	R2, T2	Control monitor input	Terminals that connect with the circuit for detecting disconnection caused by blown AC fuse.	
	RUN	RUN command	The converter starts running when this command is ON between RUN and CM, and stops when OFF.	
	RST	Alarm reset command	In case of alarm stop, eliminate the cause and activate this input by closing the circuit between RST and CM. The protective function is disabled and the alarm state is released.	
	X1	Digital input	0: External fault [THR], 1: Current limit cancel [LMT-CCL], 2: 73 answerback [73ANS], 3: Current limit switching [1-LIM], 4: Optional DI [OPY-DI]	
	CM	Digital input common	Common terminal to digital input signals.	
Output signal	DCF1, DCF2	DC fuse blow-out detection input	-	When a DC fuse is connected to the converter output, a microswitch for detecting blow-out of the DC fuse is connected to this terminal. This terminal corresponds to the "b" contact output. DC 24V 12mA Typ
	PLC	PLC signal power	Connects with the PLC output signal power supply. (Rated voltage: 24V (22 to 27V) DC)	
	30A, 30B, 30C	Alarm relay output (for any fault)	Outputs a signal when a protective function is activated to stop the converter. (Contact at 1C, Circuit between 30A and 30C comes ON when an alarm occurs) (Contact capacity: 250V AC, max 50mA.)	
	Y1, Y2, Y3, Y11 to Y18	General-purpose transistor output	0: Inverter running [RUN] 1: Operation ready output [RDY] 2: Power supply current limiting [IL] 3: Lifetime alarm [LIFE] 4: Cooling fan overload [PRE-OH] 5: Overload alarm [PRE-OL] 6: Driving [DRV] 7: Regenerating [REG] 8: Current limit alarm [CUR] 9: Under restart [U-RES] 10: Power supply frequency synchronizing [SY-HZ] 11: Alarm indication [AL1] 12: Alarm indication 2 [AL2] 13: Alarm indication 4 [AL4] 14: Optional DO [OPT-DO]	
	CME	General-purpose transistor output common	* With OPC-VG7-DIO option, 8-point expanded functions become available (DI function is not available.)	
	Y5A, Y5C	Relay output	0: Input power [PWR] 1: Input current rms [I-AC] 2: Input voltage rms [V-AC] 3: DC link circuit voltage [V-DC] 4: Power supply frequency [FREQ] 5: + 10V output test [P10] - 10V output test [N10]	
	A01, A04, A05	General-purpose analog output	* With OPC-VG7-AIO option, 2-point expanded functions become available (Ai function is not usable.)	
M	Analog output common	Common terminal to analog output signals.		
73A, 73C	Charging circuit relay output	Control output for the input relay of the external charging resistor (73)		

Communication specification

Item	Specifications		
		Unit Type	Stack Type
Communication Specification	General specifications for communication	Enables to show running information and running status, and to monitor the function code (polling), and to control (selecting) RUN, RST, and X1. * No function code can be written.	
	RS-485 (built in as standard)	Communication is possible with the PC or PLC (Fuji standard and RTU protocols are supported).	
	T-Link (option card)	OPC-VG7-TL option allows T-Link communication with the T-Link module in the MICREX-F or MICREX-SX.	
	SX bus (option card)	OPC-VG7-SX option allows connection with MICREX-SX via SX bus.	
	CC-Link (option card)	OPC-VG7-CCL option allows connection with the CC-Link master device.	
Optical communications (optional)	OPC-VG7-SI / OPC-VG7-SIR option allows sharing the load by connecting in parallel 2 or more converters.		

Function Settings

Function code	Name	
	Unit Type	Stack Type
F00	Data protection	
F01	High-frequency filter selection	
F02	Restart mode after momentary power failure (operation selection)	
F03	Current rating switching	
F04	LED monitor (Display selection)	
F05	LCD monitor (Display selection)	
F06	LCD monitor (Language selection)	
F07	LCD monitor (Contrast adjusting)	
F08	Carrier frequency	
E01	X1 function selection	
E02 to 13	Y1, Y2, Y3, Y5, Y11 to 18 function selection	
E14	I/O function normally open/normally closed	
E15	RHC overload early warning level	
E16	Cooling fan ON-OFF control	
E17	Output while limiting the current (hysteresis width)	
E18 to 20	A01, A04, A05 function selection	
E21 to 23	A01, A04, A05 gain setting	
E24 to 26	A01, A04, A05 bias setting	
E27	A01 to 5 filter setting	
S01	Operation method	
S02,03	Power supply current limit (drive/ control)	
H01	Station address	
H02	Communication error processing selection	
H03	Timer operation time	
H04	Baud rate	
H05	Data length selection	
H06	Parity bit selection	
H07	Stop bit selection	
H08	No-response error detection time	
H09	Response interval time	
H10	Protocol selection	
H11	TL transmission format	
H12	Parallel system	
H13	Number of slave stations in parallel system	
H14	Alarm data deletion	
H15,16	Power supply current limit (drive 1/2)	
H17,18	Power supply current limit (control 1/2)	
H19,20	Current limit early warning (level/ timer)	
M09	Power supply frequency	
M10	Input power	
M11	Effective input current	
M12	Effective input voltage	
M13	Run command	
M14	Running status	
M15	Output terminals Y1 to Y18	

Protective Functions

Item	Displays	Protection Specifications		Remarks
		Unit Type	Stack Type	
AC fuse blown	ACF	When the AC fuse is blown (only R and T phases), the converter stops running.		
AC overvoltage	AOV	The converter stops running on detection of AC overvoltage.		
AC undervoltage	ALV	The converter stops running on detection of AC undervoltage.		
AC overcurrent	AOC	The converter stops running if the input current peak value exceeds the overcurrent level.		
AC input current error	ACE	The converter stops running on detection of excessive deviation between AC input and ACR.		
Input phase loss	LPV	The converter stops running if the input phase loss occurs in the power supply.		
Synchronous power supply frequency error	F/E	The power supply frequency is checked after 73 is input. If a frequency error is detected, the converter stops running. Error during converter running (such as momentary power failure) triggers no alarm.		
DC fuse blown	dCF	The converter stops running if the DC fuse is blown (P side).		Above 18.5kW
DC overvoltage	dOV	The converter stops running on detection of DC overvoltage.		200V series: Above 400V ± 3V 400V series: Above 800V ± 5V 690V series: Above 1230V ± 10V
DC undervoltage	dLV	The converter stops running on detection of DC undervoltage.		200V series: Goes off at 185V and restarts at 208V 400V series: Goes off at 371V and restarts at 417V 690V series: Goes off at 470V and restarts at 580V
Charge circuit error	PbF	When the charge circuit error is detected by using the 73 answerback signal configured in the digital input X1, the converter stops running.		Condition: X1 "73 Answerback" is selected.
Cooling fin overheat	OH1	The converter stops running if the cooling fin overheat is detected.		
External alarm	OH2	The converter stops running if an external signal (THR) is input.		Condition: X1 "External alarm" is selected.
Converter internal overheat	OH3	When overheat is detected in the inverter, the converter stops running.		
Converter overload	OLU	When the output current exceeds the overload characteristic of the inverse time characteristic, the converter stops running.		Start point: 105%, 150% 1 minute
Memory error	Er1	When a fault such as "write error" occurs in the memory (checksum values in EEPROM and RAM do not match), the converter stops running.		
Keypad communication error	Er2	Activated if an error is detected during initial communication.		
CPU error	Er3	Activated if an error is detected in the CPU.		
Network device error	Er4	The converter stops running if a fatal error is detected in the master network device (including unconnected power supply).		Applicable to T-Link, SX and CC-Link
Operation procedure error	Er6	When an error is detected in operation procedure, the converter stops running.		
A/D converter error	Er8	When an error is detected in the A/D converter circuit, the converter stops running.		
Optical network error	Erb	The converter stops running if the optical cable is disconnected or a fatal error is detected in an optical device (optional)		
IPM error	IPE	Activated if IPM self-shutoff function is triggered by excessive current or overheat.		Less than 15kW

Structure and environment

Item	Structure, environment and standard		Remarks
	Unit Type	Stack Type	
Structure Specifications	Structure	Installed in the panel and cooled by external device	
	Protective structure	IP00	
	Cooling system	Forced air cooling	
	Installation method	Vertical installation	
	Painting Color	Munsell 5Y3/0.5 half-burnished	
Maintainability	Structure designed for easy parts change		
	* Indoor (location free from corrosive gas, flammable gas, dust and oil mist) (Pollution level 2: IEC 60664-1) * No direct sunlight.		
Environment	Location		
	Ambient temperature	-10 to 50°C	-10 to +40°C
	Humidity	5 to 95% RH Without condensing	
		Less than 3000m	
	Altitude	However, the output may be reduced at the altitude of 1001 to 3000m For use at the altitude of 2001 to 3000m, the insulation class of the control circuit is changed from "Enhanced insulation" to "Basic insulation."	
	Vibration	2 to 9Hz: Amplitude=3mm, 9 to 20Hz: 9.8m / s ² , 20 to 55Hz: 2m / s ² 9 to 55Hz: 2 m / s ² is used if the power is higher than 90kW.)	
	Storage temperature	-20 to 55°C	
Storage humidity	5 to 95%RH		
		Amplitude = 0.3mm, 2 to 9Hz: 1m / s ² :9 to 200Hz ²	
		-25 to 70°C (-10 to +30°C for long-term storage)	



Equipment Configuration List

Unit Type (CT Specifications)

Power Supply Voltage	Nominal applied motor [kW]	PWM converter Type	Charging circuit contactor	Contactor for power source	Charging circuit box (*1)						Boosting reactor		Resistor for filter		Reactor for filter		Capacitor for filter		Filtering circuit contactor			
					Charging resistor		AC Fuse		(Lr)	Q/ty	(Rf)	Q/ty	(Lf)	Q/ty	(Cf)	Q/ty	(6F)	Q/ty				
					(73)	Q/ty	(52)	Q/ty											(CU)	Q/ty	(R0)	Q/ty
3-phase 200V	7.5	RHC7.5-2C	SC-5-1	1		CU7.5-2C	1	(80W 7.5Ω)	(3)	(CR2LS-50/UL)	(2)	LR2-7.5C	1	GRZG80 0.42Ω	3	LFC2-7.5C	1	CF2-7.5C	1			
	11	RHC11-2C	SC-N1	1		CU11-2C	1	(HF5C5504)		(CR2LS-75/UL)	(2)	LR2-15C	1	GRZG150 0.2Ω	3	LFC2-15C	1	CF2-15C	1			
	15	RHC15-2C	SC-N2	1		CU15-2C	1			(CR2LS-100/UL)	(2)											
	18.5	RHC18.5-2C	SC-N3	1		CU18.5-2C	1	(GRZG120 2Ω)	(3)			LR2-22C	1	GRZG200 0.13Ω	3	LFC2-22C	1	CF2-22C	1			
	22	RHC22-2C		1		CU22-2C	1			(CR2L-150/UL)	(2)											
	30	RHC30-2C	SC-N4	1		CU30-2C	1			(CR2L-200/UL)	(2)	LR2-37C	1	GRZG400 0.1Ω	3	LFC2-37C	1	CF2-37C	1			
	37	RHC37-2C	SC-N5	1		CU45-2C	1			(CR2L-260/UL)	(2)											
	45	RHC45-2C	SC-N7	1								LR2-55C	1				LFC2-55C	1	CF2-55C	1		
	55	RHC55-2C	SC-N8	1		CU55-2C	1			(CR2L-400/UL)	(2)											
	75	RHC75-2C	SC-N11	1		CU75-2C	1					LR2-75C	1				LFC2-75C	1	CF2-75C	1		
90	RHC90-2C				CU90-2C	1	(GRZG400 1Ω)	(3)	(A50P600-4)	(2)	LR2-110C	1	GRZG400 0.12Ω [2 parallel]	6	LFC2-110C	1	CF2-110C	1				
3-phase 400V	7.5	RHC7.5-4C	SC-05	1		CU7.5-4C	1	(TK50B 30ΩJ)	(3)	(CR6L-30/UL)	(2)	LR4-7.5C	1	GRZG80 1.74Ω	3	LFC4-7.5C	1	CF4-7.5C	1			
	11	RHC11-4C	SC-4-0	1		CU15-4C	1	(HF5B0416)		(CR6L-50/UL)	(2)	LR4-15C	1	GRZG150 0.79Ω	3	LFC4-15C	1	CF4-15C	1			
	15	RHC15-4C	SC-5-1	1																		
	18.5	RHC18.5-4C	SC-N1	1		CU18.5-4C	1	(80W 7.5ΩJ)	(3)			LR4-22C	1	GRZG200 0.53Ω	3	LFC4-22C	1	CF4-22C	1			
	22	RHC22-4C				CU22-4C	1	(HF5C5504)		(CR6L-75/UL)	(2)											
	30	RHC30-4C	SC-N2	1		CU30-4C	1			(CR6L-100/UL)	(2)	LR4-37C	1	GRZG400 0.38Ω	3	LFC4-37C	1	CF4-37C	1			
	37	RHC37-4C	SC-N2S	1		CU45-4C	1			(CR6L-150/UL)	(2)											
	45	RHC45-4C	SC-N3	1								LR4-55C	1	GRZG400 0.26Ω	3	LFC4-55C	1	CF4-55C	1			
	55	RHC55-4C	SC-N4	1		CU55-4C	1			(CR6L-200/UL)	(2)											
	75	RHC75-4C	SC-N5	1		CU75-4C	1					LR4-75C	1	GRZG400 0.38Ω	3	LFC4-75C	1	CF4-75C	1			
	90	RHC90-4C	SC-N7	1		CU90-4C	1			(CR6L-300/UL)	(2)	LR4-110C	1	GRZG400 0.53Ω [2 parallel]	6	LFC4-110C	1	CF4-110C	1			
	110	RHC110-4C	SC-N8	1		CU110-4C	1	(GRZG120 2Ω)	(3)													
	132	RHC132-4C				CU132-4C	1			(A50P400-4)	(2)	LR4-160C	1	RF4-160C	1	LFC4-160C	1	CF4-160C	1			
	160	RHC160-4C	SC-N11	1		CU160-4C	1			(A50P600-4)	(2)											
	200	RHC200-4C	SC-N12	1		CU200-4C	1	(GRZG400 1Ω)	(3)			LR4-220C	1	RF4-220C	1	LFC4-220C	1	CF4-220C	1			
	220	RHC220-4C				CU220-4C	1			(A70QS800-4)	(2)											
	280	RHC280-4C	SC-N3	1	SC-N14	1			GRZG400 1Ω [2 parallel]	6	A70QS800-4	2	LR4-280C	1	RF4-280C	1	LFC4-280C	1	CF4-280C	1	SC-N4	1
	315	RHC315-4C									A70P1600-4TA	2	LR4-315C	1	RF4-315C	1	LFC4-315C	1	CF4-315C	1		
	355	RHC355-4C											LR4-355C	1	RF4-355C	1	LFC4-355C	1	CF4-355C	1		
	400	RHC400-4C			SC-N16	1							LR4-400C	1	RF4-400C	1	LFC4-400C	1	CF4-400C	1		
500	RHC500-4C			SC-N11	3							LR4-500C	1	RF4-500C	1	LFC4-500C	1	CF4-500C	1(*2)	SC-N4(*3)	1	
630	RHC630-4C			SC-N12	3							LR4-630C	1	RF4-630C	1	LFC4-630C	1	CF4-630C	1(*2)	SC-N7(*3)	1	

(*1) The charging resistor (R0) and AC fuse (F) have been built inside the charging circuit box (CU). When the charging circuit box (CU) is not ordered, the charging resistor (R0) and fuse (F) must be ordered separately.
 (*2) The filter capacitor consists of two capacitors. A pair of capacitors is shipped by ordering "1" pc.
 (*3) If changing the carrier frequency from the factory default value, it is necessary to change the filter circuit contactor (6F). Refer to the PWM converter instruction manual for details.

Stack Type (MD Specifications)

Power Supply Voltage	Nominal applied motor [kW]	PWM converter Type	Charging circuit contactor	Contactor for power source	Charging circuit box (*1)						Boosting reactor		Resistor for filter		Reactor for filter		Capacitor for filter		Filtering circuit contactor			
					Charging resistor		AC Fuse		(Lr)	Q/ty	(Rf)	Q/ty	(Lf)	Q/ty	(Cf)	Q/ty	(6F)	Q/ty				
					(73)	Q/ty	(52)	Q/ty											(CU)	Q/ty	(R0)	Q/ty
3-phase 400V	132	RHC132S-4D□																				
	160	RHC160S-4D□																				
	200	RHC200S-4D□																				
	220	RHC220S-4D□																				
	280	RHC280S-4D□																				
	315	RHC315S-4D□																				
3-phase 690V	630	RHC630B-4D□	SC-N3	1	SC-N12	3			GRZG400 1Ω	6	SA598473	2	LR4-630C	1	RF4-630C	1	LFC4-630C	1	CF4-630C	1(*2)	SC-N7(*3)	1
	710	RHC710B-4D□	SC-N4	1				[2 parallel]			HF5G2655	2	LR4-710C	1	RF4-710C	1	LFC4-710C	1	CF4-710C	1(*2)	SC-N8	1
	800	RHC800B-4D□			SC-N14	3							LR4-800C	1	RF4-800C	1	LFC4-800C	1	CF4-800C	1(*2)		
	132	RHC132S-69D□																				
	160	RHC160S-69D□																				
	200	RHC200S-69D□																				

Use a filter stack (RHF Series).
 * (52) and (Fac) are required separately. For details, refer to the peripheral devices on P70.

Use a filter stack (RHF Series).
 * (52) and (Fac) are required separately. For details, refer to the peripheral devices on P70.

(Note 1) RHC132S-4D□ to RHC315S-4D□: Contact Fuji if using a peripheral device (73, CU, R0, Fac, Lr, Rf, Lf, Cf) other than a filter stack.
 (*1) The charging resistor (R0) and AC fuse (F) have been built inside the charging circuit box (CU). When the charging circuit box (CU) is not ordered, the charging resistor (R0) and fuse (F) must be ordered separately.
 (*2) The filter capacitor consists of two capacitors. A pair of capacitors is shipped by ordering "1" pc.
 (*3) If applying the OPC-VG7-SIR and using with a transformerless parallel system, change (6F) to SC-N8.

Options
PWM converter RHC-C/RHC-D series

Equipment Configuration List

Unit Type (VT Specifications)

Power Supply Voltage	Nominal applied motor [kW]	PWM converter Type	Charging circuit contactor (73)	Q/ty	Contactor for power source (52)	Q/ty	Charging circuit box (*1)					Boosting reactor		Resistor for filter		Reactor for filter		Capacitor for filter		Filtering circuit contactor		
							Charging resistor		AC Fuse			(Lr)	Q/ty	(Rf)	Q/ty	(Lf)	Q/ty	(Cf)	Q/ty	(6F)	Q/ty	
							(CU)	Q/ty	(R0)	Q/ty	(Fac)											Q/ty
3-phase 200V	11	RHC7.5-2C	SC-N1	1			CU7.5-2C	1	(80W 7.5Ω)	(3)	(CR2LS-50/UL)	(2)	LR2-15C	1	GRZG150 0.2Ω	3	LFC2-15C	1	CF2-15C	1		
	15	RHC11-2C	SC-N2	1			CU11-2C	1	(HF5C5504)		(CR2LS-75/UL)	(2)										
	18.5	RHC15-2C	SC-N3	1			CU15-2C	1			(CR2LS-100/UL)	(2)	LR2-22C	1	GRZG200 0.13Ω	3	LFC2-22C	1	CF2-22C	1		
	22	RHC18.5-2C					CU18.5-2C	1	(GRZG120 2Ω)	(3)												
	30	RHC22-2C	SC-N4	1			CU22-2C	1			(CR2L-150/UL)	(2)	LR2-37C	1	GRZG400 0.1Ω	3	LFC2-37C	1	CF2-37C	1		
	37	RHC30-2C	SC-N5	1			CU30-2C	1			(CR2L-200/UL)	(2)										
	45	RHC37-2C	SC-N7	1			CU45-2C	1			(CR2L-260/UL)	(2)	LR2-55C	1			LFC2-55C	1	CF2-55C	1		
	55	RHC45-2C	SC-N8	1																		
	75	RHC55-2C	SC-N11	1			CU55-2C	1			(CR2L-400/UL)	(2)	LR2-75C	1			LFC2-75C	1	CF2-75C	1		
	90	RHC75-2C					CU75-2C	1					LR2-110C	1	GRZG400 0.12Ω [2 parallel]	6	LFC2-110C	1	CF2-110C	1		
	110	RHC90-2C	SC-N12	1			CU90-2C	1	(GRZG400 1Ω)	(3)	(A50P600-4)	(2)										
3-phase 400V	11	RHC7.5-4C	SC-4-0	1			CU7.5-4C	1	(TK50B 30ΩJ)	(3)	(CR6L-30/UL)	(2)	LR4-15C	1	GRZG150 0.79Ω	3	LFC4-15C	1	CF4-15C	1		
	15	RHC11-4C	SC-5-1	1			CU15-4C	1	(HF5B0416)	(2)	(CR6L-50/UL)	(2)										
	18.5	RHC15-4C	SC-N1	1									LR4-22C	1	GRZG200 0.53Ω	3	LFC4-22C	1	CF4-22C	1		
	22	RHC18.5-4C					CU18.5-4C	1	(80W 7.5ΩJ)	(3)												
	30	RHC22-4C	SC-N2	1			CU22-4C	1	(HF5C5504)		(CR6L-75/UL)	(2)	LR4-37C	1	GRZG400 0.38Ω	3	LFC4-37C	1	CF4-37C	1		
	37	RHC30-4C	SC-N2S	1			CU30-4C	1			(CR6L-100/UL)	(2)										
	45	RHC37-4C	SC-N3	1			CU45-4C	1			(CR6L-150/UL)	(2)	LR4-55C	1	GRZG400 0.26Ω	3	LFC4-55C	1	CF4-55C	1		
	55	RHC45-4C	SC-N4	1																		
	75	RHC55-4C	SC-N5	1			CU55-4C	1			(CR6L-200/UL)	(2)	LR4-75C	1	GRZG400 0.38Ω	3	LFC4-75C	1	CF4-75C	1		
	90	RHC75-4C	SC-N7	1			CU75-4C	1					LR4-110C	1	GRZG400 0.53Ω [2 parallel]	6	LFC4-110C	1	CF4-110C	1		
	110	RHC90-4C	SC-N8	1			CU90-4C	1			(CR6L-300/UL)	(2)										
	132	RHC110-4C					CU110-4C	1	(GRZG120 2Ω)	(3)			LR4-160C	1	RF4-160C	1	LFC4-160C	1	CF4-160C	1		
	160	RHC132-4C	SC-N11	1			CU132-4C	1			(A50P400-4)	(2)										
	200	RHC160-4C	SC-N12	1			CU160-4C	1			(A50P600-4)	(2)	LR4-220C	1	RF4-220C	1	LFC4-220C	1	CF4-220C	1		
	220	RHC200-4C					CU200-4C	1	(GRZG400 1Ω)	(3)												
	280	RHC220-4C	SC-N14	1			CU220-4C	1			(A70QS800-4)	(2)	LR4-280C	1	RF4-280C	1	LFC4-280C	1	CF4-280C	1		
	315	RHC280-4C	SC-N3	1	SC-N14	1			GRZG400 1Ω [2 parallel]	6	A70QS800-4	2	LR4-315C	1	RF4-315C	1	LFC4-315C	1	CF4-315C	1	SC-N4	1
	355	RHC315-4C									A70P1600-4TA	2	LR4-355C	1	RF4-355C	1	LFC4-355C	1	CF4-355C	1		
	400	RHC355-4C			SC-N16	1							LR4-400C	1	RF4-400C	1	LFC4-400C	1	CF4-400C	1		
500	RHC400-4C			SC-N11	3							LR4-500C	1	RF4-500C	1	LFC4-500C	1	CF4-500C	1	SC-N4/SF	1	

(*1) The charging resistor (R0) and AC fuse (F) have been built inside the charging circuit box (CU). When the charging circuit box (CU) is not ordered, the charging resistor (R0) and fuse (F) must be ordered separately.
 (*2) The filter capacitor consists of two capacitors. A pair of capacitors is shipped by ordering "1" pc.

Stack Type (LD Specifications)

Power Supply Voltage	Nominal applied motor [kW]	PWM converter Type	Charging circuit contactor (73)	Q/ty	Contactor for power source (52)	Q/ty	Charging circuit box (*1)					Boosting reactor		Resistor for filter		Reactor for filter		Capacitor for filter		Filtering circuit contactor	
							Charging resistor		AC Fuse			(Lr)	Q/ty	(Rf)	Q/ty	(Lf)	Q/ty	(Cf)	Q/ty	(6F)	Q/ty
							(CU)	Q/ty	(R0)	Q/ty	(Fac)										
3-phase 400V	160	RHC132S-4D																			
	200	RHC160S-4D																			
	220	RHC200S-4D																			
	315	RHC280S-4D																			
	355	RHC315S-4D																			
	710	RHC630B-4D	SC-N4	1	SC-N12	3			GRZG400 1Ω [2 parallel]	6	HF5G2655	2	LR4-710C	1	RF4-710C	1	LFC4-710C	1	CF4-710C	1	SC-N8
800	RHC710B-4D			SC-N14	3							LR4-800C	1	RF4-800C	1	LFC4-800C	1	CF4-800C	1		
1000	RHC800B-4D			SC-N16	3							LR4-1000C	1	RF4-1000C	1	LFC4-1000C	1	CF4-1000C	1	SC-N11/SF	1
3-phase 690V	160	RHC132S-69D																			
	200	RHC160S-69D																			
	220	RHC200S-69D																			
	280	RHC250S-69D																			
	315	RHC280S-69D																			
	355	RHC315S-69D																			

Use a filter stack (RHF Series).

* (52) and (Fac) are required separately. For details, refer to the peripheral devices on P70.

Use a filter stack (RHF Series).

* (52) and (Fac) are required separately. For details, refer to the peripheral devices on P70.

(Note 1) RHC132S-4D to RHC315S-4D: Contact Fuji if using a peripheral device (73, CU, R0, Fac, Lr, Rf, Lf, Cf) other than a filter stack.

(*1) The charging resistor (R0) and AC fuse (F) have been built inside the charging circuit box (CU). When the charging circuit box (CU) is not ordered, the charging resistor (R0) and fuse (F) must be ordered separately.

(*2) CF4-630C to CF4-800C comprise two capacitors. When placing your order, two capacitors will be shipped if "1" is specified for the quantity.

CF4-1000C comprises three capacitors. When placing your order, three capacitors will be shipped if "1" is specified for the quantity.

(*3) Contact Fuji.



Basic Wiring Diagram

<Unit Type>
 ■ RHC7.5-2C to RHC90-2C
 ■ RHC7.5-4C to RHC220-4C

*When adapting a charge BOX

Symbol	Part name
Lr	Boosting reactor
Lf	Reactor for filter
Cf	Capacitor for filter
Rf	Resistor for filter
R0	Charging resistor
Fac	AC fuse
73	Electromagnetic contactor for charge circuit

(Note 1) If the main power supply is 400V series, connect a step-down transformer to limit the voltage of the sequence circuit lower than 220V.
 (Note 2) The auxiliary power supply input terminals for the PWM converter (R0, T0) must be connected to the main power supply via the contact "b" of the charging circuit electromagnetic contactor (73 or MC). When applying ungrounded power supply, ground transformer must be set.
 (Note 3) For the capacities FRN37VG1S-2□ and FRN75VG1S-4□ or higher and stack type inverter (all capacity range), connect the inverter fan power auxiliary input terminals (R1, T1) to the main power supply without passing through the contact "b" of 73 or MC.
 (Note 4) Use the sequence that the run command signal is input in the inverter after the PWM converter becomes ready.
 (Note 5) One of terminals (X1 to X9) on the inverter unit must be set to external alarm (THR).
 (Note 6) Be sure to connect the L1/R, L2/S, L3/T, R2, T2, R1, S1, and T1 terminals keeping the phase sequence.

<Unit Type>
 ■ RHC7.5-2C to RHC90-2C
 ■ RHC7.5-4C to RHC220-4C

Symbol	Part name
Lr	Boosting reactor
Lf	Reactor for filter
Cf	Capacitor for filter
Rf	Resistor for filter
R0	Charging resistor
Fac	AC fuse
73	Electromagnetic contactor for charge circuit

(Note 1) If the main power supply is 400V series, connect a step-down transformer to limit the voltage of the sequence circuit lower than 220V.
 (Note 2) The auxiliary power supply input terminals for the PWM converter (R0, T0) must be connected to the main power supply via the contact "b" of the charging circuit electromagnetic contactor (73 or MC). When applying ungrounded power supply, ground transformer must be set.
 (Note 3) For the capacities FRN37VG1S-2□ and FRN75VG1S-4□ or higher and stack type inverter (all capacity range), connect the inverter fan power auxiliary input terminals (R1, T1) to the main power supply without passing through the contact "b" of 73 or MC.
 (Note 4) Use the sequence that the run command signal is input in the inverter after the PWM converter becomes ready.
 (Note 5) One of terminals (X1 to X9) on the inverter unit must be set to external alarm (THR).
 (Note 6) Be sure to connect the L1/R, L2/S, L3/T, R2, T2, R1, S1, and T1 terminals keeping the phase sequence.

<Unit Type>
 ■ RHC280-4C to RHC400-4C

Symbol	Part name
Lr	Boosting reactor
Lf	Reactor for filter
Cf	Capacitor for filter
Rf	Resistor for filter
R0	Charging resistor
Fac	AC fuse
73	Electromagnetic contactor for charge circuit
52	Electromagnetic contactor for power supply
6F	Electromagnetic contactor for filter circuit

(Note 1) Connect a step-down transformer to limit the voltage of the sequence circuit lower than 220V.
 (Note 2) The auxiliary power supply input terminals for the PWM converter (R0, T0) must be connected to the main power supply via the contact "b" of the charging circuit electromagnetic contactor (52). When applying ungrounded power supply, grounded transformer must be set.
 (Note 3) Since the AC fan power supply receives power from R1 and T1 terminals, the power supply must be connected without passing through the contact "b" of 73 or MC.
 (Note 4) Use the sequence that the run command signal is input in the inverter after the PWM converter becomes ready.
 (Note 5) The 52T timer must be set to 1 sec.
 (Note 6) One of terminals (X1 to X9) on the inverter unit must be set to external alarm (THR).
 (Note 7) Be sure to connect the L1/R, L2/S, L3/T, R2, T2, R1, S1, and T1 terminals keeping the phase sequence.

<Unit Type>
 ■ RHC500-4C to RHC630-4C

<Stack Type>
 ■ RHC630S-4D□ to RHC800B-4D□

Symbol	Part name
Lr	Boosting reactor
Lf	Reactor for filter
Cf	Capacitor for filter
Rf	Resistor for filter
R0	Charging resistor
Fac	AC fuse
Fdc	DC fuse
73	Electromagnetic contactor for charge circuit
52	Electromagnetic contactor for power supply
6F	Electromagnetic contactor for filter circuit

(Note 1) Connect a step-down transformer to limit the voltage of the sequence circuit lower than 220V.
 (Note 2) The auxiliary power supply input terminals for the PWM converter (R0, T0) must be connected to the main power supply via the contact "b" of the charging circuit electromagnetic contactor (52). When applying ungrounded power supply, grounded transformer must be set.
 (Note 3) Since the AC fan power supply receives power from R1 and T1 terminals, the power supply must be connected without passing through the contact "b" of 73 or MC.
 (Note 4) Use the sequence that the run command signal is input in the inverter after the PWM converter becomes ready.
 (Note 5) The 52T timer must be set to 1 sec.
 (Note 6) One of terminals (X1 to X9) on the inverter unit must be set to external alarm (THR).
 (Note 7) Be sure to connect the L1/R, L2/S, L3/T, R2, T2, R1, S1, and T1 terminals keeping the phase sequence.
 (Note 8) Not available in the unit type inverter.

Options
PWM converter RHC-C/RHC-D series



External Dimensions

<Boosting reactor>

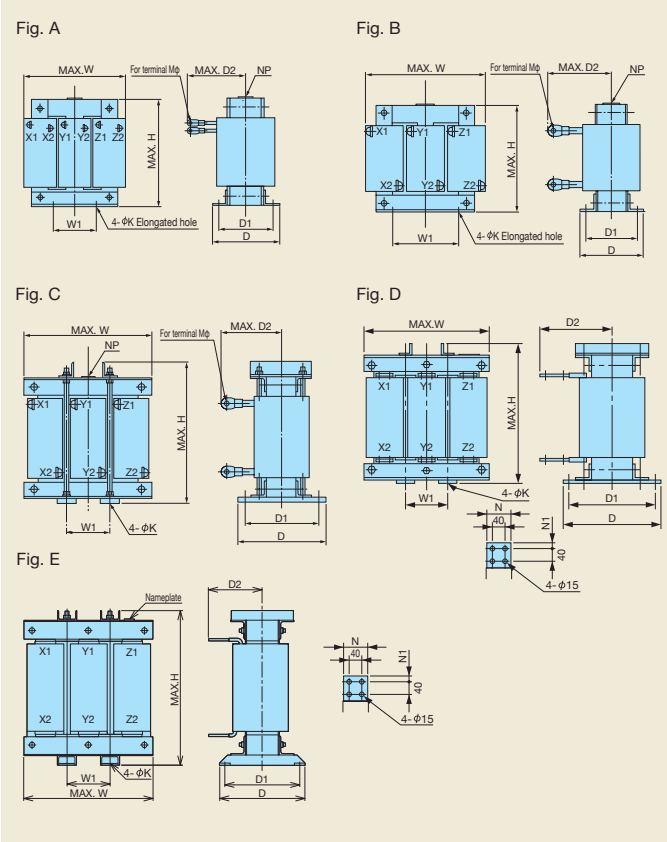

Pressurization reactor Type	Fig	Dimensions [mm]										Approx. weight [kg]	
		W	W1	H	D	D1	D2	K	M	N	N1		
200V series	LR2-7.5C	A	180	75	205	105	85	95	7	M5	-	-	12
	LR2-15C	B	195	75	215	131	110	130	7	M8	-	-	18
	LR2-22C	C	240	80	340	215	180	145	10	M8	-	-	33
	LR2-37C	C	285	95	420	240	205	150	12	M10	-	-	50
	LR2-55C	C	285	95	420	250	215	160	12	M12	-	-	58
	LR2-75C	C	330	110	440	255	220	165	12	M12	-	-	70
LR2-110C	C	345	115	500	280	245	185	12	M12	-	-	100	
400V series	LR4-7.5C	B	180	75	205	105	85	90	7	M4	-	-	12
	LR4-15C	A	195	75	215	131	110	120	7	M5	-	-	18
	LR4-22C	C	240	80	340	215	180	120	10	M6	-	-	33
	LR4-37C	C	285	95	405	240	205	130	12	M8	-	-	50
	LR4-55C	C	285	95	415	250	215	145	12	M10	-	-	58
	LR4-75C	C	330	110	440	255	220	150	12	M10	-	-	70
	LR4-110C	C	345	115	490	280	245	170	12	M12	-	-	100
	LR4-160C	C	380	125	550	300	260	185	15	M12	-	-	140
	LR4-220C	C	450	150	620	330	290	230	15	M12	-	-	200
	LR4-280C	C	480	160	740	330	290	240	15	M16	-	-	250
	LR4-315C	C	480	160	760	340	300	250	15	M16	-	-	270
	LR4-355C	C	480	160	830	355	315	255	15	M16	-	-	310
	LR4-400C	C	480	160	890	380	330	260	19	M16	-	-	340
	LR4-500C	C	525	175	960	410	360	290	19	M16	-	-	420
LR4-630C	D	600	200	640	440	390	285	19	-	75	17.5	450	
LR4-710C	E	645	215	730	440	390	295	19	-	100	30	510	
LR4-800C	E	690	230	850	450	400	290	19	-	100	30	600	
LR4-1000C	E	770	255	940	550	480	340	23	-	100	30	950	

<Filtering reactor>

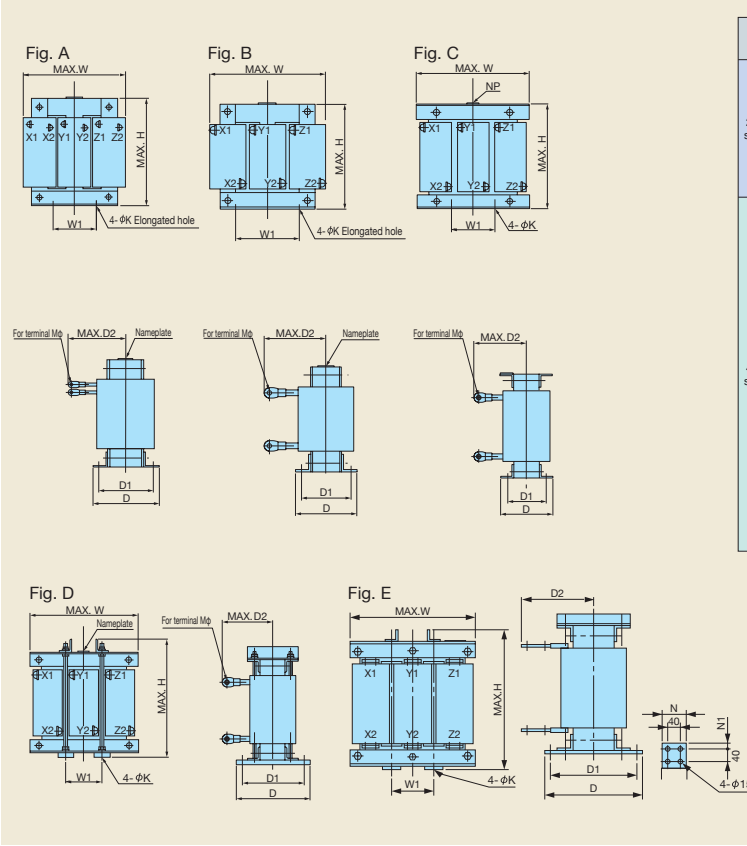

Filtering reactor type	Fig	Dimensions [mm]										Approx. weight [kg]	
		W	W1	H	D	D1	D2	K	M	N	N1		
200V series	LFC2-7.5C	B	125	40	100	85	67	85	6	M5	-	-	2.2
	LFC2-15C	B	125	40	100	93	75	90	6	M8	-	-	2.5
	LFC2-22C	B	125	40	100	93	75	105	6	M8	-	-	3.0
	LFC2-37C	B	150	60	115	103	85	125	6	M10	-	-	5.0
	LFC2-55C	B	175	60	145	110	90	140	6	M12	-	-	8.0
	LFC2-75C	B	195	80	200	120	100	150	7	M12	-	-	13
LFC2-110C	C	255	85	230	118	95	165	7	M12	-	-	20	
400V series	LFC4-7.5C	A	125	40	100	85	67	75	6	M4	-	-	2.2
	LFC4-15C	A	125	40	100	93	75	90	6	M5	-	-	2.5
	LFC4-22C	A	125	40	100	93	75	95	6	M6	-	-	3.0
	LFC4-37C	B	150	60	115	108	90	110	6	M8	-	-	5.0
	LFC4-55C	B	175	60	145	110	90	120	6	M10	-	-	8.0
	LFC4-75C	B	195	80	200	113	93	130	7	M10	-	-	12
	LFC4-110C	C	255	85	220	113	90	145	7	M12	-	-	19
	LFC4-160C	C	255	85	245	137	110	150	10	M12	-	-	22
	LFC4-220C	D	300	100	320	210	180	170	10	M12	-	-	35
	LFC4-280C	D	330	110	320	230	195	195	12	M16	-	-	43
	LFC4-315C	D	315	105	365	230	195	200	12	M16	-	-	48
	LFC4-355C	D	315	105	395	235	200	210	12	M16	-	-	53
	LFC4-400C	D	345	115	420	235	200	235	12	M16	-	-	60
	LFC4-500C	D	345	115	480	240	205	240	12	M16	-	-	72
LFC4-630C	E	435	145	550	295	255	200	15	-	75	17.5	175	
LFC4-710C	E	480	160	570	295	255	215	15	-	100	30	190	
LFC4-800C	E	480	160	600	320	270	220	15	-	100	30	220	
LFC4-1000C	E	480	160	700	320	270	240	15	-	100	30	240	

Options
PWM converter
RHC-C/RHC-D series

External Dimensions

<Filtering capacitor>

Fig. A

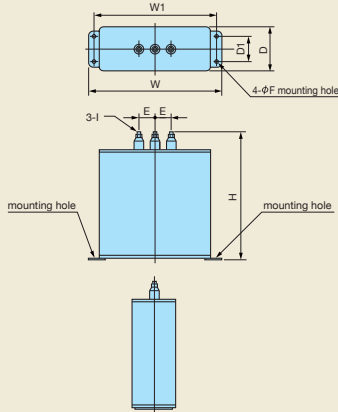
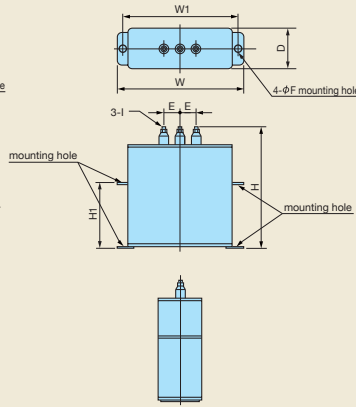

Fig. B



Filtering capacitor type	Fig	Dimensions [mm]									Approx. weight [kg]
		W	W1	H	H1	D	D1	E	F	I	
CF2-7.5C	A	165	150	185	-	70	40	30	7	M5	1.9
CF2-15C	A	205	190	245	-	70	40	30	7	M5	3.5
CF2-22C	A	280	265	215	-	90	55	30	7	M5	5.5
CF2-37C	A	280	265	235	-	90	55	30	7	M5	6.0
CF2-55C	A	280	265	340	-	90	55	80	7	M6	8.5
CF2-75C	A	280	265	235	-	90	55	30	7	M5	6.0
CF2-110C	A	280	265	340	-	90	55	80	7	M8	8.5
CF4-7.5C	A	165	150	135	-	70	40	30	7	M5	1.3
CF4-15C	A	165	150	215	-	70	40	30	7	M5	2.3
CF4-22C	A	205	190	185	-	70	40	30	7	M5	2.5
CF4-37C	A	205	190	205	-	70	40	30	7	M5	2.9
CF4-55C	A	205	190	245	-	70	40	30	7	M5	3.5
CF4-75C	A	205	190	205	-	70	40	30	7	M5	2.9
CF4-110C	A	205	190	245	-	70	40	30	7	M5	3.5
CF4-180C	A	280	265	260	-	90	55	80	7	M6	8.0
CF4-220C	B	435	400	310	125	100	-	80	15 x 20 long hole	M12	13.0
CF4-280C	B	435	400	350	165	100	-	80	15 x 20 long hole	M12	15.0
CF4-315C	B	435	400	460	275	100	-	80	15 x 20 long hole	M12	20.0
CF4-355C	B	435	400	520	335	100	-	80	15 x 20 long hole	M12	23.0
CF4-400C	B	435	400	610	425	100	-	80	15 x 20 long hole	M12	27.0
CF4-500C	B	435	400	310	125	100	-	80	15 x 20 long hole	M12	13.0
CF4-630C	B	435	400	460	275	100	-	80	15 x 20 long hole	M12	20.0
CF4-710C	B	435	400	520	335	100	-	80	15 x 20 long hole	M12	23.0
CF4-800C	B	435	400	610	425	100	-	80	15 x 20 long hole	M12	27.0
CF4-1000C	B	435	400	610	425	100	-	80	15 x 20 long hole	M12	27.0

<Filtering resistor>

Fig. A

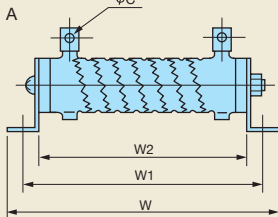

Fig. B

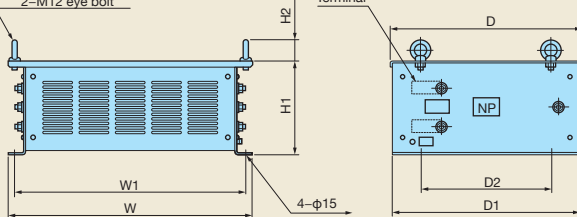
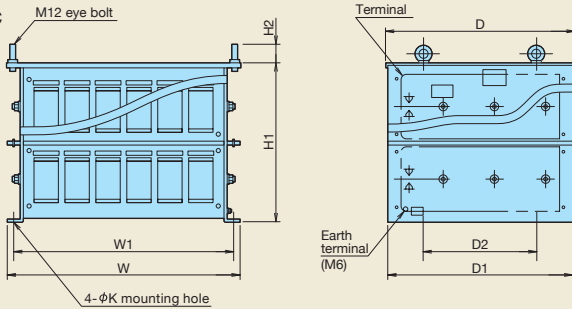
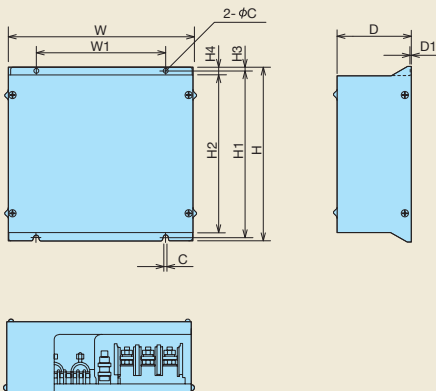

Fig. C



Filtering resistor type	Fig	Dimensions [mm]									Approx. weight [kg]	Q'ty
		W	W1	W2	H1	H2	D	D1	D2	C		
GRZG80 0.42Ω	A	167	148	115	22	32	33	26	6	5.5	0.19	
GRZG150 0.2Ω	A	247	228	195	22	40	33	26	6	8.2	0.3	
GRZG200 0.13Ω	A	306	287	254	22	40	33	26	6	8.2	0.35	
GRZG400 0.1Ω	A	411	385	330	40	46	47	40	9.5	8.2	0.85	
GRZG400 0.12Ω	A	411	385	330	40	46	47	40	9.5	8.2	0.85	
GRZG80 1.74Ω	A	167	148	115	22	32	33	26	6	5.5	0.19	3
GRZG150 0.79Ω	A	247	228	195	22	32	33	26	6	5.5	0.30	3
GRZG200 0.53Ω	A	306	287	254	22	32	33	26	6	5.5	0.35	3
GRZG400 0.38Ω	A	411	385	330	40	46	47	40	9.5	8.2	0.85	3
GRZG400 0.26Ω	A	411	385	330	40	46	47	40	9.5	8.2	0.85	3
GRZG400 0.53Ω	A	411	385	330	40	46	47	40	9.5	8.2	0.85	6
RF4-160C	B	400	370	-	240	55	470	460	320	-	22	1
RF4-220C											25	1
RF4-280C											31	1
RF4-315C											35	1
RF4-355C											38	1
RF4-400C											41	1
RF4-500C											41	1
RF4-630C		655	625	-	440	55	530	520	320	-	70	1
RF4-710C											70	1
RF4-800C											80	1
RF4-1000C	C	755	725	-	440	55	530	520	320	-	-	1

<Charging circuit box>



Charging circuit box type	Dimensions [mm]										Mounting bolt	Approx. weight [kg]
	W	W1	H	H1	H2	H3	H4	D	D1	C		
CU7.5-2C	270	170	300	285	270	7.5	15	100	2.4	6	M5	6
CU11-2C												
CU15-2C												
CU18.5-2C												
CU22-2C												
CU30-2C	300	200	310	295	280	7.5	15	110	2.4	6	M5	7
CU45-2C	330	230	310	295	280	7.5	15	130	2.4	6	M5	8
CU55-2C												
CU75-2C	430	330	560	536	510	12	25	150	3.2	10	M8	17
CU90-2C												20
CU7.5-4C	270	170	300	285	270	7.5	15	100	2.4	6	M5	5.5
CU15-4C												
CU18.5-4C												6
CU22-4C												
CU30-4C	300	200	310	295	280	7.5	15	110	2.4	6	M5	7
CU45-4C												
CU55-4C												
CU75-4C	330	230	310	295	280	7.5	15	130	2.4	6	M5	8
CU90-4C												
CU110-4C												
CU132-4C	430	330	560	536	510	12	25	150	3.2	10	M8	18
CU160-4C												
CU200-4C												
CU220-4C												20



External Dimensions

<Charger resistor>

Fig. A

Fig. B

TK50B 30ΩJ (HF5B0416)

Fig. C

80W 7.5Ω (HF5C5504)

[Unit: mm]

Charger resistor type	Fig	Dimensions [mm]										Approx. weight [kg]
		W	W1	W2	H1	H2	D	D1	D2	C		
GRZG120 2Ω	A	217	198	165	22	32	33	22	6	5.5	250	
GRZG400 1Ω	A	411	385	330	40	39	47	40	9.5	5.5	650	
TK50B 30ΩJ (HF5B0416)	B	-	-	-	-	-	-	-	-	-	150	
80W 7.5Ω (HF5C5504)	C	-	-	-	-	-	-	-	-	-	180	

<Fuse>

Fig. A

Fig. B

Fig. C

Fig. D

[Unit: mm]

Fig. E

[Unit: mm]

Fuse type	Fig	Dimensions [mm]										Approx. weight [kg]
		W	W1	W2	H	D	D1	G	E			
200V series	CR2LS-50/UL	A	56	42	26	18.5	17.5	12	2	6.5x8.5	0.03	
	CR2LS-75/UL											
	CR2LS-100/UL											
	CR2L-150/UL	A	80	58	29.5	30.5	27	20	3	9x11	0.10	
	CR2L-200/UL	A	85	60	30	33.5	30	25	3.2	11x13	0.13	
	CR2L-260/UL											
400V series	CR2L-400/UL	A	95	70	31	42	37	30	4	11x13	0.22	
	A50P600-4	B	113.5	81.75	56.4	-	50.8	38.1	6.4	10.3x18.2	0.60	
	CR6L-30/UL	A	76	62	47	18.5	17.5	12	2	6.5x8.5	42	
	CR6L-50/UL											
	CR6L-75/UL	A	95	70	40	34	30	25	3.2	11x13	150	
	CR6L-100/UL											
	CR6L-150/UL											
	CR6L-200/UL	A	107	82	43	42	37	30	4	11x13	246	
	CR6L-300/UL											
	A50P400-4	B	110	78.6	53.1	-	38.1	25.4	6.4	10.3x18.4	300	
	A50P600-4	B	113.5	81.75	56.4	-	50.8	38.1	6.4	10.3x18.2	600	
	A70QS800-4	B	180.2	129.4	72.2	-	63.5	50.8	9.5	13.5x18.3	1100	
A70P1600-4TA	C	-	-	-	-	-	-	-	-	7400		
A70P2000-4	C	-	-	-	-	-	-	-	-	8000		
HF5G2655	D	-	-	-	-	-	-	-	-	4700		
SA598473	E	-	-	-	-	-	-	-	-	4500		

(Note) *SA598473* is used for the stack type inverter.
For details, refer to the FRENIC-VG User's Manual (Stack Type Edition).

Filter stack : RHF-D series (Stack Type)

- This is a dedicated filter stack for the high power factor PWM converter with power regenerative function (RHC-D Series).
- This device is used in combination with the RHC-D Series, and peripheral devices (filtering circuit, boosting circuit, charging circuit) required by the PWM converter have been combined into a single unit.
- Peripheral device wire reduction and attachment space saving is possible.
- A stack type with same shape as the inverter (stack type) and PWM converter (RHC-D) has been adopted. This has been effective in making panels more compact.



Standard specifications

3-phase 400V series

Type		RHF160S-4D□	RHF220S-4D□	RHF280S-4D□	RHF355S-4D□
Applicable converter type RHC□□□S-4D□	MD application	132 160	200 220	280 -	315 -
	LD application	132 -	160 200	- -	280 315
Rated current [A]		282	384	489	619
Power supply voltage	Main power Phase, Voltage, Frequency	3-Phase 380 to 440V/50Hz, 380 to 460V/60Hz			
	Fan power supply Phase, Voltage, Frequency	400V series	Single-phase 380 to 440V/50Hz, 380 to 460V/60Hz (*1)		
		200V series	Single-phase 200 to 220V/50Hz, 200 to 230V/60Hz (*2)		
Frequency variation		Voltage: +10 to -15%, Frequency: +5 to -5%, Unbalance ratio between voltage phases: within 2% (*3)			
Allowable carrier frequency		2.5kHz or 5kHz			
Approx. weight [kg]		155	195	230	250
Enclosure		IP00 open type			
Noise level		75dB (Condition: A range distance of 1 m) (*4)			

3-phase 690V series

Type		RHF160S-69D□	RHF220S-69D□	RHF280S-69D□	RHF355S-69D□	RHF450S-69D□
Applicable converter type RHC□□□S-69D□	MD application	132 160	200 -	250 280	315 355	400 450
	LD application	132 -	160 200	- 250	280 315	355 400
Rated current [A]		163	223	283	359	455
Power supply voltage	Main power Phase, Voltage, Frequency	3-phase, 660 to 690V 50Hz/60Hz, 575 to 600V 50Hz/60Hz				
	Fan power supply Phase, Voltage, Frequency	690V series	Single-phase 660 to 690V 50Hz/60Hz, 575 to 600V 50Hz/60Hz (*1)			
		200V series	Single-phase 200 to 220V/50Hz, 200 to 230V/60Hz (*2)			
Frequency variation		Voltage: +10 to -15%, Frequency: ±5%, Unbalance ratio between voltage phases: within 2% (*3)				
Allowable carrier frequency		2.5kHz or 5kHz				
Approx. weight [kg]		180	215	230	255	280
Enclosure		IP00 open type				
Noise level		75dB(Condition: A range distance of 1 m) (*4)				

(*1) 400V series: Filter stack internal terminal (U1, U2) switching is required if the power supply is 380 to 398 V, 50Hz or 380 to 430 V, 60Hz.

690V series: Filter stack internal terminal (U1, U2) switching is required if the power supply is 575 to 600 V, 50Hz/60Hz.

(*2) Power can also be supplied from a 200 V power supply. For details, refer to the filter stack (RHF-D) Instruction Manual.

(*3) Interphase unbalance rate (%) = $\frac{\text{Max. voltage [V]} - \text{min. voltage [V]} \times 67}{3\text{-phase average voltage}}$

(*4) This is the noise level at rated operation with a PWM converter and inverter of one-to-one capacity connected to the filter stack.



Terminal Functions

Symbol	Name	Functions	
Main circuit	L1,L2,L3	Main power input	Connects a 3-phase power supply.
	U0,V0,W0	Filter output	Connect to PWM converter power input terminals L1/R, L2/S, and L3/T.
	L4,L5,L6	Charging circuit input	Connects a 3-phase power supply.
	E(G)	Grounding	Ground terminal for filter stack chassis (housing).
	R3,T3	Fan power supply input	To be used as supply input of AC cooling fan inside of filter stack.
	R11,R12 T11,T12	Fan power supply input (at input of 200 V)	Used when 200 VAC is input as the filter stack internal AC cooling fan power supply. When inputting 200 VAC, remove the shorting wires between terminals R11 and R12 and T11 and T12, and connect them to terminals R12 and T12.
	U1,U2	Power supply voltage switching terminal	Change the terminal connection based on the fan power supply input terminal. For details, refer to the filter stack (RHF-D) Instruction Manual.
Input signal	73-1 73-2	Control input of contactor for charging circuit	Input control signal for contactor for charging circuit. <Rated capacity of coil> <400V series> At power on ... 200 V/50 Hz: 120 VA, 220 V/60 Hz: 135 VA At power hold ... 200 V/50 Hz: 12.7 VA, 220 V/60 Hz: 12.4 VA <690V series> At power on ... 200V/50Hz: 120VA, 220V/60Hz: 135VA At power hold ... 200V/50Hz: 12.7V, 220V/60Hz: 12.4VA
	ONA ONB ONC	Operation signal of charging circuit	Auxiliary contact of contactor for charging circuit To be used as signal for operational check of charging circuit. Contact rating: 24 VDC 3 A * Min. working voltage/current: 5 VDC 3 mA
Output signal	1 2	Overheating signal output	Signal is output when internal parts of filter stack are overheated. Contact rating: 24 VDC, 3 mA /max

Wiring Diagram

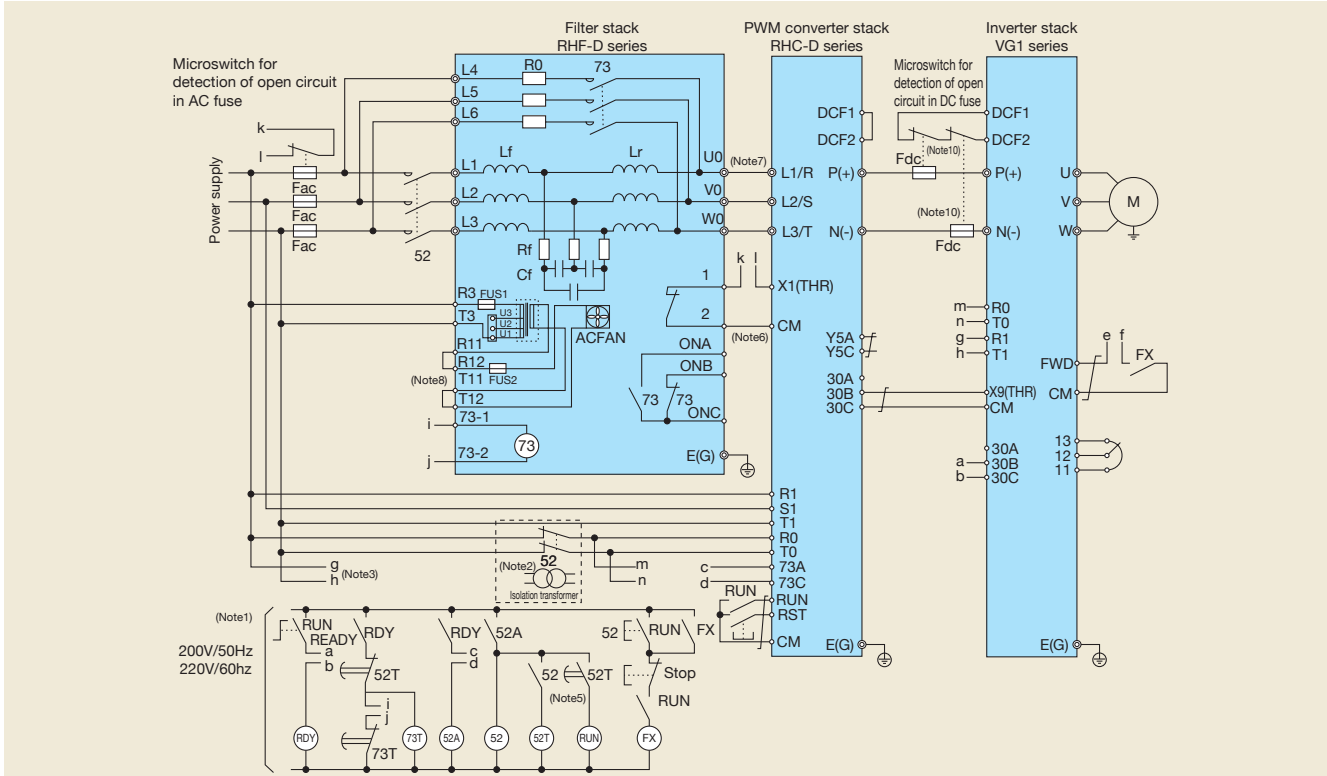

- (Note 1) Connect a step-down transformer, and set the sequence circuit voltage as shown in the basic wiring diagram.
- (Note 2) The auxiliary power supply input terminals (R0, T0) for the PWM converter and inverter must be connected to the main power supply via contact "b" on the charging circuit electromagnetic contactor (52) or via an isolation transformer. When using an ungrounded power supply, it is necessary to install an isolation transformer.
- (Note 3) Since the AC fan power supply receives power from R1 and T1 terminals, the power supply must be connected without passing through the 73 or 52 contact "b".
- (Note 4) Use the sequence in which the run command signal is input to the inverter after the PWM converter is ready.
- (Note 5) The 52T timer must be set to 1 sec.
- (Note 6) Always set the PWM converter digital input terminal (X1) to external alarm (THR), and connect the filter stack overheating signal outputs (1, 2). To ensure input with contact "b", specify the contact "b" input setting for function code E14. Furthermore, connect all microswitches used for detecting AC fuse burnout and overheating signal outputs (1, 2) in series, and then connect them to the digital input terminal (X1).
- (Note 7) Ensure to align the phase sequence when connecting the L1/R, L2/S, L3/T, R2, T2, R1, S1, and T1 terminals.
- (Note 8) When inputting 200 VAC for the fan power supply, remove the shorting wires between terminals R11 and R12 and T11 and T12, and connect them to terminals R12 and T12. These are dedicated terminals for internal fan power supply, and must not be used for other applications.
- (Note 9) The 73T timer must be set to 5 sec.
- (Note 10) If using a separate fan power supply, switch the tap inside the converter, and connect the fan power supply to the R3 and T3 terminals.

Symbol	Part name
Lr	Boosting reactor
Lf	Filtering reactor
Cf	Filtering capacitor
Rf	Filtering resistor
R0	Charger resistor
Fac	AC fuse
Fdc	DC fuse
73	Magnetic contactor for charging circuit
52	Magnetic contactor for power supply

Options
Filter stack RHF-D series

Peripheral Devices

3-phase 400V series

MD application

PWM converter (RHC-D)	Filter stack (RHF-D)	MCCB, ELCB Rated current [A]	Electromagnetic contactor (52)		AC fuse (Fac)		Microswitch	
	Type		Type	Q'ty	Type	Q'ty	Type	Q'ty
RHC132S-4D□	RHF160S-4D□	300	SC-N8	1	170M5446	3	170H3027	3
RHC160S-4D□	RHF160S-4D□	350	SC-N11	1	170M6546	3		
RHC200S-4D□	RHF220S-4D□	500	SC-N12	1	170M6547	3		
RHC220S-4D□	RHF220S-4D□	500	SC-N12	1	170M6547	3		
RHC280S-4D□	RHF280S-4D□	600	SC-N14	1	170M6499	3		
RHC315S-4D□	RHF355S-4D□	700	SC-N14	1	170M6500	3		

LD application

PWM converter (RHC-D)	Filter stack (RHF-D)	MCCB, ELCB Rated current [A]	Electromagnetic contactor (52)		AC fuse (Fac)		Microswitch	
	Type		Type	Q'ty	Type	Q'ty	Type	Q'ty
RHC132S-4D□	RHF160S-4D□	350	SC-N11	1	170M5446	3	170H3027	3
RHC160S-4D□	RHF220S-4D□	500	SC-N12	1	170M6546	3		
RHC200S-4D□	RHF220S-4D□	500	SC-N12	1	170M6547	3		
RHC280S-4D□	RHF355S-4D□	700	SC-N14	1	170M6499	3		
RHC315S-4D□	RHF355S-4D□	800	SC-N14	1	170M6500	3		

* AC fuses and microswitches are manufactured by Cooper Bussmann, but can also be ordered from Fuji.

3-phase 690V series

MD application

PWM converter (RHC-D)	Filter stack (RHF-D)	MCCB, ELCB Rated current [A]	Electromagnetic contactor (52)		AC fuse (Fac)		Microswitch	
	Type		Type	Q'ty	Type	Q'ty	Type	Q'ty
RHC132S-69D□	RHF160S-69D□	175	SC-N6	1	170M5447	3	170H3027	3
RHC160S-69D□	RHF160S-69D□	200	SC-N7	1				
RHC200S-69D□	RHF220S-69D□	250	SC-N8	1	170M5448	3		
RHC250S-69D□	RHF280S-69D□	300	SC-N8	1	170M6548	3		
RHC280S-69D□	RHF280S-69D□	350	SC-N11	1				
RHC315S-69D□	RHF355S-69D□	400	SC-N11	1	170M6500	3		
RHC355S-69D□	RHF355S-69D□	500	SC-N12	1				
RHC400S-69D□	RHF450S-69D□	500	SC-N12	1				
RHC450S-69D□	RHF450S-69D□	600	SC-N14	1				

LD application

PWM converter (RHC-D)	Filter stack (RHF-D)	MCCB, ELCB Rated current [A]	Electromagnetic contactor (52)		AC fuse (Fac)		Microswitch	
	Type		Type	Q'ty	Type	Q'ty	Type	Q'ty
RHC132S-69D□	RHF160S-69D□	200	SC-N7	1	170M5447	3	170H3027	3
RHC160S-69D□	RHF220S-69D□	250	SC-N8	1				
RHC200S-69D□	RHF220S-69D□	300	SC-N8	1	170M5448	3		
RHC250S-69D□	RHF280S-69D□	350	SC-N11	1	170M6548	3		
RHC280S-69D□	RHF355S-69D□	400	SC-N11	1				
RHC315S-69D□	RHF355S-69D□	500	SC-N12	1	170M6500	3		
RHC355S-69D□	RHF450S-69D□	500	SC-N12	1				
RHC400S-69D□	RHF450S-69D□	600	SC-N14	1				

* AC fuses and microswitches are manufactured by Cooper Bussmann, but can also be ordered from Fuji.



Dimensions

Fig. A

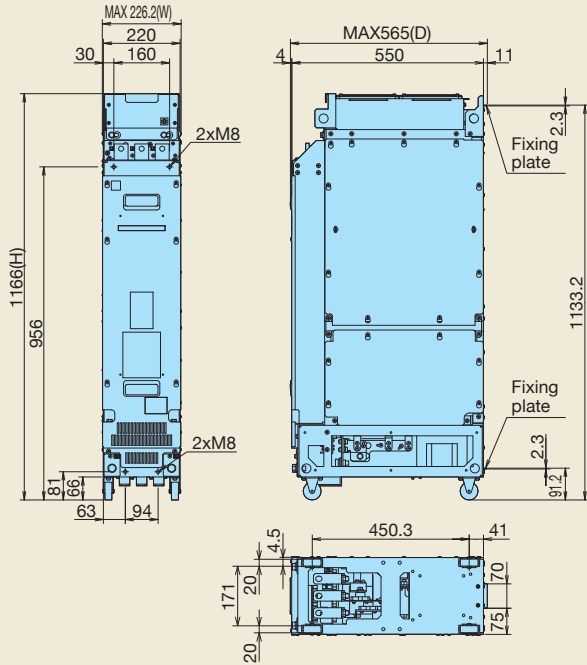

[Unit:mm]

RHF160S-4D □, RHF220S-4D □
RHF160S-69D □

Fig. B

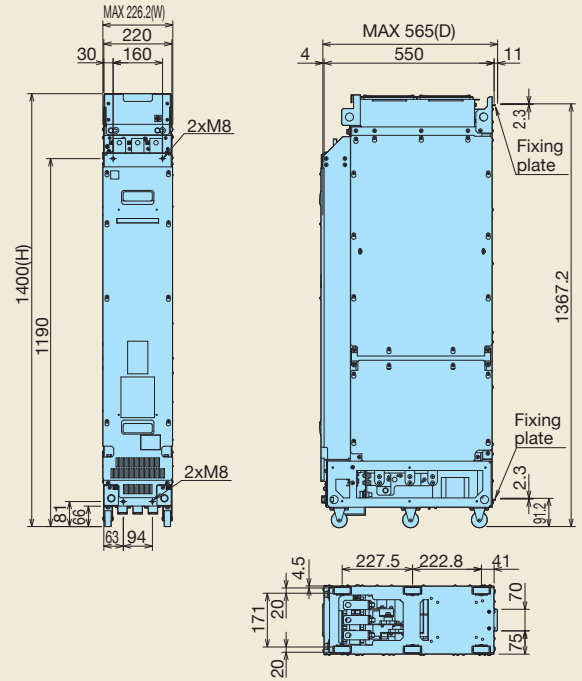

[Unit:mm]

RHF280S-4D □, RHF355S-4D □
RHF220S-69D □, RHF355S-69D □

Fig. C

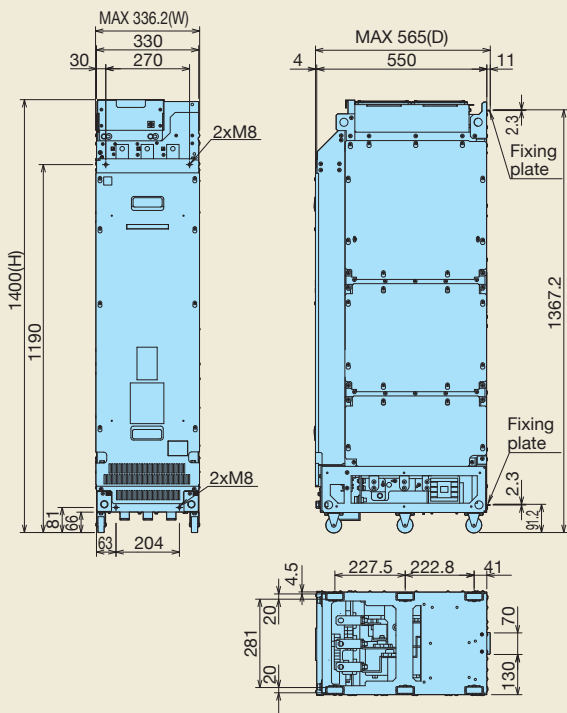

[Unit:mm]

RHF450S-69D □

Series	Filter stack type	Fig	External dimensions [mm]		
			W	H	D
400V Series	RHF160S-4D □	A	226.2	1166	565
	RHF220S-4D □	A	226.2	1400	565
	RHF280S-4D □	B	226.2	1400	565
	RHF355S-4D □	B	226.2	1400	565
690V Series	RHF160S-69D □	A	226.2	1166	565
	RHF220S-69D □	B	226.2	1400	565
	RHF280S-69D □	B	226.2	1400	565
	RHF355S-69D □	B	226.2	1400	565
	RHF450S-69D □	C	336.2	1400	565

Diode rectifier (RHD-D) (Stack Type)

■ Converter type

Diode rectifier converts AC power to DC power, then supplies DC power to inverter.

■ Substantial applicable capacity

A large capacity system may be constructed by connecting converters in parallel.

(3-parallel, 12-pulse rectifying system: using 6 units of diode rectifiers)

•MD specification: 1450kW (400V series), 2000kW (690V series)

•LD specification: 1640kW (400V series)

■ Suppression of harmonic currents *Equipped with DC reactor as standard

This unit is equipped with DC reactor for suppression of the harmonic currents. Further suppression of harmonic currents is made possible by creating a 12-pulse rectifier system in combination with power transformer, when connecting more than one unit in parallel.

■ Control device

A braking unit and braking resistor are available as options (externally attached).

Capacity can be selected based on the amount of regenerative (braking) energy, facilitating a compact system construction.



Standard Specifications: MD Specification for Medium Loads

Three-phase 400V series

Model		RHD200S-4D□	RHD315S-4D□
Output	Continuous rating [kW] (*1)	227	353
	Nominal applied inverter /motor capacity (*1)	200	315
	Overload rating	150% of continuous rating for 1 minute	
	Voltage	DC 513 to 679V (variable with input power supply voltage and load)	
Max. connection capacity [kW] (*1)(*2)		600	945
Min. connection capacity [kW] (*1)		110	180
Required power supply capacity [kVA]		248	388
Input power supply	Main power Phase, Voltage, Frequency	3-phase, 380 to 440V/50Hz, 380 to 480V 60Hz	
	Auxiliary input for fan power	400V series	Single-phase, 380 to 440V/50Hz, 380 to 480V 60Hz (*3)
	Phase, Voltage, Frequency	200V series	Single-phase, 200 to 220V/50Hz, 200 to 230V 60Hz (*4)
	Voltage/frequency variation	Voltage: -15 to +10%, Frequency: +5 to -5%, Voltage unbalance: 2% or less (*5)	
Approximate weight [kg]		125	160
Enclosure		IP00 open type	

Three-phase 690V series

Model		RHD220S-69D□	RHD450S-69D□
Output	Continuous rating [kW] (*1)	252	504
	Nominal applied inverter /motor capacity (*1)	220	450
	Overload rating	150% of continuous rating for 1 minute	
	Voltage	DC 776 to 1091V (variable with input power supply voltage and load)	
Max. connection capacity [kW] (*1)(*2)		660	1350
Min. connection capacity [kW] (*1)		132	250
Required power supply capacity [kVA]		270	549
Input power supply	Main power Phase, Voltage, Frequency	3-phase, 575 to 690V/50Hz, 60Hz	
	Auxiliary input for fan power	690V series	Single-phase, 660 to 690V, 50/60Hz, 575 to 600V, 50/60Hz (*3)
	Phase, Voltage, Frequency	200V series	Single-phase, 200 to 220V/50Hz, 200 to 230V/60Hz (*4)
	Voltage/frequency variation	Voltage: -15 to +10%, Frequency: +5 to -5%, Voltage unbalance: 2% or less (*5)	
Approximate weight [kg]		125	160
Enclosure		IP00 open type	

*1) 400V series: This is the value when the power supply voltage is 400 V. If the power supply voltage is less than 400 V, it is necessary to reduce the capacity. A reduction in capacity is also required if connecting multiple inverters.

690V series: This is the value when the power supply voltage is 690 V. If the power supply voltage is less than 690 V, it is necessary to reduce the capacity. A reduction in capacity is also required if connecting multiple inverters.

*2) This is the total connectable inverter capacity due to initial charging circuit restrictions. However, the capacity that can be run simultaneously is the continuous capacity.

*3) 400V series: Diode rectifier internal terminal (U1, U2) switching is required if the power supply is 380 to 398 V, 50Hz or 380 to 430 V, 60Hz.

690V series: Diode rectifier internal terminal (U1, U2) switching is required if the power supply is 575 to 600 V, 50Hz/60Hz.

*4) Power can also be supplied from a 200 V power supply. For details, refer to the diode rectifier (RHD-D) Instruction Manual.

*5) Interphase unbalance rate (%) = $\frac{\text{max. voltage [V]} - \text{min. voltage [V]}}{3\text{-phase average voltage}} \times 67$



Standard Specifications: LD Specification for Light Loads

Three-phase 400V series

Model		RHD200S-4D□	RHD315S-4D□
Output	Continuous rating [kW] (*1)	247	400
	Nominal applied inverter /motor capacity (*1)	220	355
	Overload rating	110% of continuous rating for 1 minute	
	Voltage	DC 513 to 679V (variable with input power supply voltage and load)	
Max. connection capacity [kW] (*1)(*2)		600	1065
Min. connection capacity [kW] (*1)		110	180
Required power supply capacity [kVA]		271	435
Input power supply	Main power Phase, Voltage, Frequency	3-phase, 380 to 440V/50Hz, 380 to 480V 60Hz	
	Auxiliary input for fan power	400V series	Single-phase, 380 to 440V/50Hz, 380 to 480V 60Hz (*3)
	Phase, Voltage, Frequency	200V series	Single-phase, 200 to 220V/50Hz, 200 to 230V 60Hz (*4)
	Voltage/frequency variation	Voltage: -15 to +10%, Frequency: +5 to -5%, Voltage unbalance: 2% or less (*5)	
Approximate weight [kg]		125	160
Enclosure		IP00 open type	

Three-phase 690V series

Model		RHD220S-69D□	
Output	Continuous rating [kW] (*1)	280	
	Nominal applied inverter /motor capacity (*1)	250	
	Overload rating	110% of continuous rating for 1 minute	
	Voltage	DC 776 to 976V (variable with input power supply voltage and load)	
Max. connection capacity [kW] (*1)(*2)		750	
Min. connection capacity [kW] (*1)		132	
Required power supply capacity [kVA]		308	
Input power supply	Main power Phase, Voltage, Frequency 690V	3-phase, 575 to 690V/50Hz, 60Hz	
	Auxiliary input for fan power	400V series	Single-phase, 660 to 690V, 50/60Hz, 575 to 600V, 50/60Hz (*3)
	Phase, Voltage, Frequency	200V series	Single-phase, 200 to 220V/50Hz, 200 to 230V/60Hz (*4)
	Voltage/frequency variation	Voltage: -15 to +10%, Frequency: +5 to -5%, Voltage unbalance: 2% or less (*5)	
Approximate weight [kg]		125	
Enclosure		IP00 open type	

*1) 400V series: This is the value when the power supply voltage is 400 V. If the power supply voltage is less than 400 V, it is necessary to reduce the capacity. A reduction in capacity is also required if connecting multiple inverters.
690V series: This is the value when the power supply voltage is 690 V. If the power supply voltage is less than 690 V, it is necessary to reduce the capacity. A reduction in capacity is also required if connecting multiple inverters.

*2) This is the total connectable inverter capacity due to initial charging circuit restrictions. However, the capacity that can be run simultaneously is the continuous capacity.

*3) 400V series: Diode rectifier internal terminal (U1, U2) switching is required if the power supply is 380 to 398 V, 50Hz or 380 to 430 V, 60Hz.

690V series: Diode rectifier internal terminal (U1, U2) switching is required if the power supply is 575 to 600 V, 50Hz/60Hz.

*4) Power can also be supplied from a 200 V power supply. For details, refer to the diode rectifier (RHD-D) Instruction Manual.

*5) Interphase unbalance rate (%) = $\frac{\text{max. voltage [V]} - \text{min. voltage [V]}}{3\text{-phase average voltage}} \times 67$

Terminal Functions

Symbol	Name	Functions	
Main circuit	L1/R, L2/S, L3/T	Main supply input	Connect to 3-phase power supply.
	P(+), N(-)	Converter output	Connect to inverter power input terminals P (+) and N (-).
	E(G)	Ground terminal	Ground terminal of diode rectifier chassis (case)
	R1, T1	Fan power supply input	To be used as supply input of AC cooling fan inside of diode rectifier.
	R11, R12 T11, T12	Fan power supply input (at input of 200 V)	Use if inputting 200 VAC for the diode rectifier internal AC cooling fan power supply. When inputting 200 VAC, remove the shorting wires between terminals R11 and R12 and T11 and T12, and connect them to terminals R12 and T12.
	73R 73T	Power supply for charging circuit	Coil supply of charging circuit contactor for charging circuit. Not to be used as power supply for external circuit.
	U1, U2	Power supply voltage switching terminal	Change the terminal connection based on the power supply connected to the fan power supply input terminal. For details, refer to the diode rectifier (RHD-D) Instruction Manual.
Input signal	73-1 73-2	Control input of contactor for charging circuit	Input control signal for charging circuit contactor. Control signal may also be input externally. <ul style="list-style-type: none"> Rated capacity of coil <400V series> At power on ... 200V/50Hz: 390VA, 220V/60Hz: 460VA At power hold ... 200V/50Hz: 28.6VA, 220V/60Hz: 28.8VA <690V series> At power on ... 470V/50Hz: 235VA, 220V/60Hz: 500VA At power hold ... 40.0V/50Hz: 20.0VA, 220V/60Hz: 39.0VA
	73A 73C	Output of control signal for charging circuit	Control signal of charging circuit Can also be used for external sequence circuits. Contact rating : 250 VAC 0.5 A $\cos \phi = 0.3$, 30 VDC 0.5 A
Output signal	ONA ONC	Operation signal of charging circuit	Auxiliary contact of charging circuit contactor. To be used as signal for operational check of charging circuit. Contact rating: 24 VDC 3 A * Min. working voltage/current: 5 VDC 3 mA
	1 2	Overheating signal output	Signal is output when internal parts of diode rectifier are overheated. Contact rating: 24 VDC, 3 mA

(*1) Refer to the basic wiring diagram for the connection method.

Connect contactors after initial charging is complete. Furthermore, do not open contactors while the inverter is running. Failure to observe this may result in damage to the initial charging circuit.

(*2) An output signal timing chart and the intermediate DC voltage (diode rectifier output voltage) during signal output are shown below.

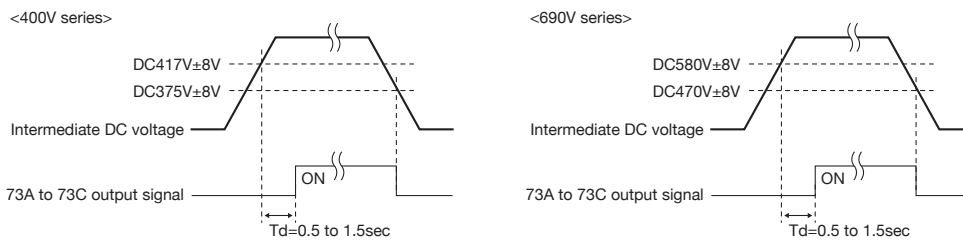



Wiring Diagram

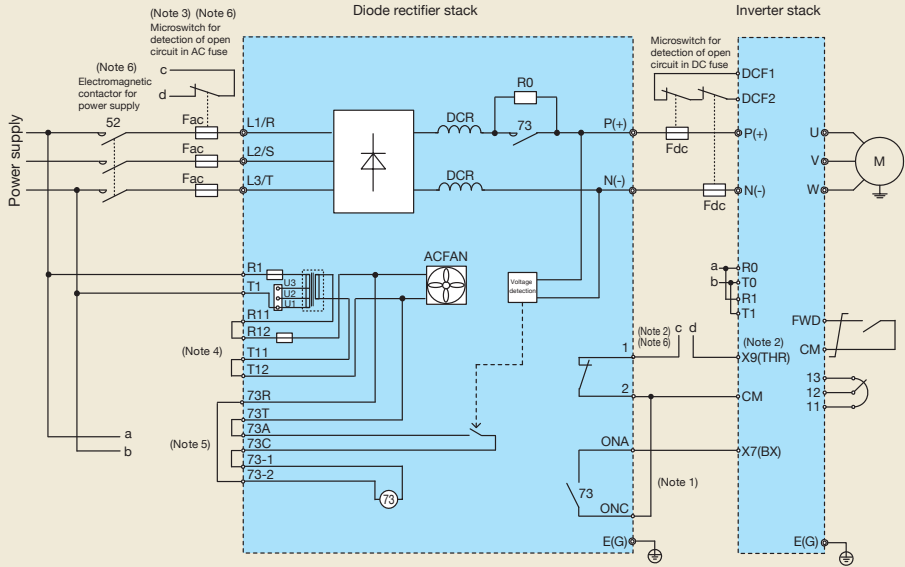

- Note 1) Construct a sequence so that the run command is input to the inverter after the initial charging of the diode rectifier has been completed. Set any of the X1 to X9 inverter terminals to the coast-to-stop command (BX), and set contact "b" input with function code E14 to input with contact "b". With this connection, the motor will coast to a stop if a momentary power failure occurs, and therefore the system should be equipped with an external interlock circuit for applications such as vertical transfer.
- Note 2) Outputs a diode rectifier overheating signal. After setting any of the X1 to X9 inverter terminals to external alarm (THR), it is necessary to connect. Set contact "b" input with function code E14 to input with contact "b".
- Note 3) If using a microswitch to detect AC fuse burnout, set any of the X1 to X9 inverter terminals to external alarm (THR), and then connect all microswitches in series. Set contact "b" input with function code E14 to input with contact "b".
- Note 4) If inputting 200 VAC for the fan power supply, remove the shorting wires between terminals R11 and R12 and T11 and T12, and connect them to terminals R12 and T12.
- Note 5) Control signals for the charging circuit contactor (73) and the drive power supply can be input externally. Wire as shown below. Furthermore, 73A and 73C can also be used for external sequence circuits.
- Note 6) If connecting multiple diode rectifiers, turn on the electromagnetic contactors (52) for the power supply simultaneously. Furthermore, connect alarm relay outputs (1, 2), charging circuit actuating signals (ONA, ONB, ONC), and microswitch outputs for AC fuse burnout detection in series across each stack.
- Note 7) If using the 400V series, connect Fdc (fuse) to the P(+) side. Fdc (fuse) is not required for the N(-) side. If using the 690V series, connect Fdc (fuse) to the P(+) and N(-) sides. (Connect two microswitches in series.)

		Contactor (73) control signals for charging circuit	
		Internal	External
Power supply	Internal	<p><Factory default setting></p>	
	External		

Options

Diode rectifier RHD-D series

Dimensions

Fig. A

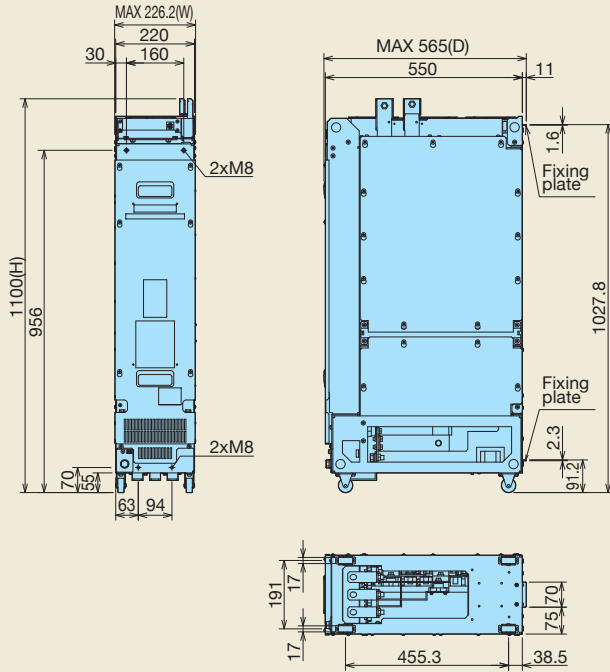
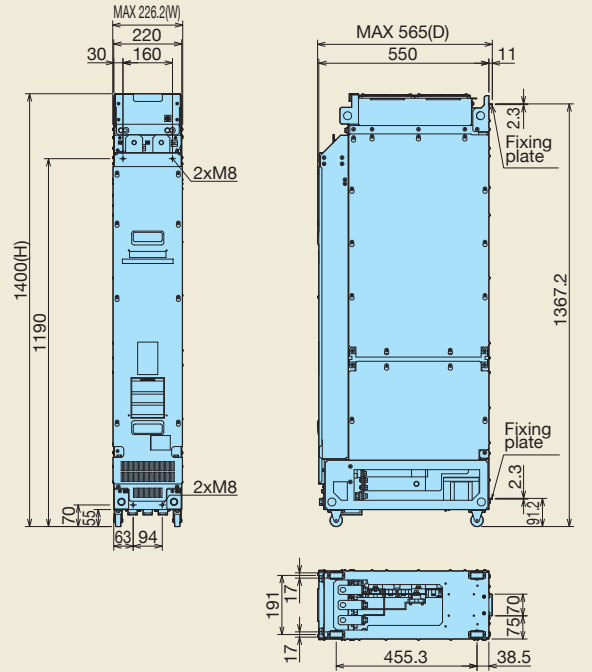

Fig. B



[Unit: mm]

[Unit: mm]

RHD200S-4D □
RHD220S-69D □

RHD315S-4D □
RHD450S-69D □

		[Unit: mm]			
	Diode rectifier type	Fig	W	H	D
400V series	RHD200S-4D □	A	226.2	1100	565
	RHD315S-4D □	B	226.2	1400	565
690V series	RHD220S-69D □	A	226.2	1100	565
	RHD450S-69D □	B	226.2	1400	565

Peripheral Devices

Three-phase 400V series

RHD-D Type	Model	MCCB, ELCB Rated current [A]	Electromagnetic contactor (52)		AC Fuse (Fac)		Microswitch	
			Type	Q'ty	Type	Q'ty	Type	Q'ty
RHD200S-4D □	MD	500	SC-N12	1	170M6547	3	170H3027	3
	LD	500						
RHD315S-4D □	MD	700	SC-N14	1	170M6500	3	170H3027	3
	LD	800						

Three-phase 690V series

RHD-D Type	Model	MCCB, ELCB Rated current [A]	Electromagnetic contactor (52)		AC Fuse (Fac)		Microswitch	
			Type	Q'ty	Type	Q'ty	Type	Q'ty
RHD220S-69D □	MD	300	SC-N11	1	170M6497	3	170H3027	3
	LD	350						
RHD450S-69D □	MD	600	SC-N14	1	170M6501	3	170H3027	3

* AC fuses and microswitches are manufactured by Cooper Bussmann, but can also be ordered from Fuji.



Guideline for Suppressing Harmonics

Application to "Guideline for Suppressing Harmonics by the Users Who Receive High Voltage or Special High Voltage"

These products fall under the scope of the "Guideline for Suppressing Harmonics by Customers Receiving High Voltage or Special High Voltage." When entering into a new contract with an electric power company, or updating your existing contract, you will be requested to submit an accounting statement form by the electric power company.

(1) Scope of regulation

- In principle, the guideline applies to the customers that meet the following two conditions:
 - The customer receives high voltage or special high voltage.
 - The "equivalent capacity" of the converter load exceeds the standard value for the receiving voltage (50kVA at a receiving voltage of 6.6kV).

(2) Regulation method

The level (calculated value) of the harmonic current that flows from the customer's receiving point out to the system is subjected to the regulation. The regulation value is proportional to the contract demand. The regulation values specified in the guideline are shown in Table 1.

Table 1 Upper limits of harmonic outflow current per kW of contract demand [mA/kW]

Receiving voltage	5th	7th	11th	13th	17th	19th	23th	Over 25th
6.6kV	3.5	2.5	1.6	1.3	1.0	0.90	0.76	0.70
22kV	1.8	1.3	0.82	0.69	0.53	0.47	0.39	0.36

1. Calculation of Equivalent Capacity (Pi)

Although the equivalent capacity (Pi) is calculated using the equation of (input rated capacity) x (conversion factor), catalog of conventional inverters do not contain input rated capacities. A description of the input rated capacity is shown below:

(1) "Inverter rated capacity" corresponding to "Pi"

- Calculate the input fundamental current I1 from the kW rating and efficiency of the load motor, as well as the efficiency of the inverter. Then, calculate the input rated capacity as shown below:
 Input rated capacity = $\sqrt{3} \times (\text{power supply voltage}) \times I_1 \times 1.0228/1000[\text{kVA}]$
 Where 1.0228 is the 6-pulse converter's value obtained by (effective current) / (fundamental current).
- When a general-purpose motor or inverter motor is used, the appropriate value shown in Table 2 can be used. Select a value based on the kW rating of the motor used, irrespective of the inverter type.

Table 2 "Input rated capacities" of general-purpose inverters determined by the nominal applied motors

Nominal applied motor [kW]	0.4	0.75	1.5	2.2	3.7	5.5	7.5	11	15	18.5	22	
Pi [kVA]	200V	0.57	0.97	1.95	2.81	4.61	6.77	9.07	13.1	17.6	21.8	25.9
	400V	0.57	0.97	1.95	2.81	4.61	6.77	9.07	13.1	17.6	21.8	25.9
Nominal applied motor [kW]	30	37	45	55	75	90	110	132	160	200	220	
Pi [kVA]	200V	34.7	42.8	52.1	63.7	87.2	104	127				
	400V	34.7	42.8	52.1	63.7	87.2	104	127	153	183	229	252
Nominal applied motor [kW]	250	280	315	355	400	450	500	530	560	630		
Pi [kVA]	200V											
	400V	286	319	359	405	456	512	570	604	638	718	

(2) Values of "Ki (conversion factor)"

- Depending on whether an optional ACR (AC REACTOR) or DCR (DC REACTOR) is used, apply the appropriate conversion factor specified in the appendix to the guideline. The values of the converter factor are shown in Table 3.

Table 3 "Conversion factors Ki" for general-purpose inverters determined by reactors

Circuit category	Circuit Type	Conversion factor Ki	
3	3-phase rectifier (smoothing capacitor)	Without a reactor	K31=3.4
		With a reactor (ACR)	K32=1.8
		With a reactor (DCR)	K33=1.8
		With reactors (ACR and DCR)	K34=1.4
4	Single-phase bridge (capacitor smoothing, voltage doubler rectification system)	Without a reactor	K41=2.3
		With a reactor (ACR)	K42=0.35
	Single-phase bridge (capacitor smoothing, full-wave rectification system)	Without a reactor	K43=2.9
		With a reactor (ACR)	K44=1.3
5	Self-excited three-phase bridge	High-efficiency power supply regeneration When using PWM converter	K5=0

2. Calculation of Harmonic Current

(1) Value of "input fundamental current"

- Apply the appropriate value shown in Table 4 based on the kW rating of the motor, irrespective of the inverter type or whether a reactor is used.
- * If the input voltage is different, calculate the input fundamental current in inverse proportion to the voltage.

Table 4 "Input fundamental currents" of general-purpose inverters determined by the nominal applied motors, 3-phase rectifier (smoothing capacitor)

Nominal applied motor [kW]	0.4	0.75	1.5	2.2	3.7	5.5	7.5	11	15	18.5	22	
Input fundamental current [A]	200V	1.61	2.74	5.50	7.93	13.0	19.1	25.6	36.9	49.8	61.4	73.1
	400V	0.81	1.37	2.75	3.96	6.50	9.55	12.8	18.5	24.9	30.7	36.6
	6.6 kV corrected value [mA]	49	83	167	240	394	579	776	1121	1509	1860	2220
Nominal applied motor [kW]	30	37	45	55	75	90	110	132	160	200	220	
Input fundamental current [A]	200V	98.0	121	147	180	245	293	357				
	400V	49.0	60.4	73.5	89.9	123	147	179	216	258	323	355
	6.6 kV corrected value [mA]	2970	3660	4450	5450	7450	8910	10850	13090	15640	19580	21500
Nominal applied motor [kW]	250	280	315	355	400	450	500	530	560	630		
Input fundamental current [A]	200V											
	400V	403	450	506	571	643	723	804	852	900	1013	
	6.6 kV corrected value [mA]	24400	27300	30700	34600	39000	43800	48700	51600	54500	61400	

(2) Calculation of harmonic current

Table 5 Generated harmonic current [%], 3-phase rectifier (smoothing capacitor)

Degree	5th	7th	11th	13th	17th	19th	23th	25th
Without a reactor	65	41	8.5	7.7	4.3	3.1	2.6	1.8
With a reactor (ACR)	38	14.5	7.4	3.4	3.2	1.9	1.7	1.3
With a reactor (DCR)	30	13	8.4	5.0	4.7	3.2	3.0	2.2
With reactors (ACR and DCR)	28	9.1	7.2	4.1	3.2	2.4	1.6	1.4

- ACR: 3%
- DCR: Accumulated energy equal to 0.08 to 0.15ms (100% load conversion)
- Smoothing capacitor: Accumulated energy equal to 15 to 30ms (100% load conversion)
- Load: 100%

$$\blacksquare \text{ nth harmonic current [A]} = \text{Fundamental current [A]} \times \frac{\text{Generated nth harmonic current [\%]}}{100}$$

Calculate the harmonic current of each order (harmonic number) using the following equation:

(3) Maximum availability factor

- For a load like elevators, which provides intermittent operation, or a load with a over-dimensioned motor rating, reduce the current by multiplying the equation by the "maximum availability factor" of the load.
- The "maximum availability factor of an appliance" means the ratio of the capacity of the harmonic generator in operation at which the availability reaches the maximum, to its total capacity, and the capacity of the generator in operation is an average for 30 minutes.
- In general, the maximum availability factor is calculated according to this definition, but the standard values shown in Table 6 are recommended for inverters for building equipment.

Table 6 Maximum availability factor of inverters, etc. for building equipment (based on equipment type)

Equipment	Inverter capacity category	Single inverter availability factor
Air conditioning system	200kW or less	0.55
	Over 200kW	0.60
Sanitary pump	—	0.30
Elevator	—	0.25
Rising elevator	—	0.65
Falling elevator	—	0.25
Refrigerator, freezer	50kW or less	0.60

[Correction coefficient according to contract demand level]

- Since the total availability factor decreases with increase in the building scale, calculating reduced harmonics with the correction coefficient β defined in Table 7 below is permitted.

Table 7 Correction coefficient according to the building scale

Contract demand [kW]	Correction coefficient β
300	1.00
500	0.90
1000	0.85
2000	0.80

*If the contract demand is between two specified values shown in Table 7, calculate the value by interpolation.

(4) Harmonic order to be calculated

Calculate only the "5th and 7th" harmonic currents

RUN

FUJI INVERTERS





NOTES

When running general-purpose motors

- **Driving a 400V general-purpose motor**
When driving a 400V general-purpose motor with an inverter using extremely long cables, damage to the insulation of the motor may occur. Use an output circuit filter (OFL) if necessary after checking with the motor manufacturer. Fuji's motors do not require the use of output circuit filters because of their reinforced insulation.
- **Torque characteristics and temperature rise**
When the inverter is used to run a general-purpose motor, the temperature of the motor becomes higher than when it is operated using a commercial power supply. In the low-speed range, the cooling effect will be weakened, so decrease the output torque of the motor. If constant torque is required in the low-speed range, use a Fuji inverter motor or a motor equipped with an externally powered ventilating fan.
- **Vibration**
When the motor is mounted to a machine, resonance may be caused by the natural frequencies, including that of the machine. Operation of a 2-pole motor at 60Hz or more may cause abnormal vibration.
* Study use of tier coupling or dampening rubber.
* It is also recommended to use the inverter jump frequencies control to avoid resonance points.
- **Noise**
When an inverter is used with a general-purpose motor, the motor noise level is higher than that with a commercial power supply. To reduce noise, raise carrier frequency of the inverter. High-speed operation at 60Hz or more can also result in more noise.

When running special motors

- **Explosion-proof motors**
When driving an explosion-proof motor with an inverter, use a combination of a motor and an inverter that has been approved in advance.
- **Brake motors**
For motors equipped with parallel-connected brakes, their braking power must be supplied from the primary circuit (commercial power supply). If the brake power is connected to the inverter power output circuit (secondary circuit) by mistake, problems may occur.
Do not use inverters for driving motors equipped with series-connected brakes.
- **Geared motors**
If the power transmission mechanism uses an oil-lubricated gearbox or speed changer/reducer, then continuous motor operation at low speed may cause poor lubrication. Avoid such operation.
- **Single-phase motors**
Single-phase motors are not suitable for inverter-driven variable speed operation. Use three-phase motors.

Environmental conditions

- **Installation location**
Use the inverter in a location with an ambient temperature range of -10 to 50°C.
The inverter and braking resistor surfaces become hot under certain operating conditions. Install the inverter on nonflammable material such as metal.
Ensure that the installation location meets the environmental conditions specified in "Environment" in inverter specifications.

Combination with peripheral devices

- **Installing a molded case circuit breaker (MCCB)**
Install a recommended molded case circuit breaker (MCCB) or an earth leakage circuit breaker (ELCB) in the primary circuit of each inverter to protect the wiring. Ensure that the circuit breaker capacity is equivalent to or lower than the recommended capacity.
- **Installing a magnetic contactor (MC) in the output (secondary) circuit**
If a magnetic contactor (MC) is mounted in the inverter's secondary circuit for switching the motor to commercial power or for any other purpose, ensure that both the inverter and the motor are fully stopped before you turn the MC on or off. Remove the surge killer integrated with the MC.
- **Installing a magnetic contactor (MC) in the input (primary) circuit**
Do not turn the magnetic contactor (MC) in the primary circuit on or off more than once an hour as an inverter fault may result. If frequent starts or stops are required during motor operation, use FWD/REV signals.
- **Protecting the motor**
The electronic thermal facility of the inverter can protect the general-purpose motor. The operation level and the motor type (general-purpose motor, inverter motor) should be set. For high-speed motors or water-cooled motors, set a small value for the thermal time constant to protect the motor.
If you connect the motor thermal relay to the motor with a long cable, a high-frequency current may flow into the wiring stray capacitance. This may cause the relay to trip at a current lower than the set value for the thermal relay. If this happens, lower the carrier frequency or use the output circuit filter (OFL).
- **Discontinuance of power-factor correcting capacitor**
Do not mount power factor correcting capacitors in the inverter (primary) circuit. Use a DC reactor to improve the inverter power factor. Do not use power factor correcting capacitors in the inverter output circuit (secondary). An overcurrent trip will occur, disabling motor operation.
- **Discontinuance of surge killer**
Do not mount surge killers in the inverter output (secondary) circuit.
- **Reducing noise**
Use of a filter and shielded wires are typical measures against noise to ensure that EMC Directives are met.

Measures against surge currents

If an overvoltage trip occurs while the inverter is stopped or operated under a light load, it is assumed that the surge current is generated by open/close of the phase-advancing capacitor in the power system.
We recommend connecting a DC REACTOR to the inverter.

Megger test

When checking the insulation resistance of the inverter, use a 500V megger and follow the instructions contained in the Instruction Manual.

Wiring

- **Wiring distance of control circuit**
When performing remote operation, use twisted shielded wire and limit the distance between the inverter and the control box to 20m.
- **Wiring length between inverter and motor**
If long wiring is used between the inverter and the motor, the inverter will overheat or trip as a result of overcurrent (high-frequency current flowing into the stray capacitance) in the wires connected to the phases. Ensure that the wiring is shorter than 50m. If this length must be exceeded, lower the carrier frequency or mount an output circuit filter (OFL).
When wiring is longer than 50m, and sensorless vector control or vector control with speed sensor is selected, execute off-line tuning.
- **Wiring size**
Select cables with a sufficient capacity by referring to the current value or recommended wire size.
- **Wiring type**
Do not use multicore cables that are normally used for connecting several inverters and motors.
- **Grounding**
Securely ground the inverter using the grounding terminal.

Selecting inverter capacity

- **Driving general-purpose motor**
Select an inverter according to the applicable motor ratings listed in the standard specifications table for the inverter. When high starting torque is required or quick acceleration or deceleration is required, select an inverter with a capacity one size greater than the standard.
- **Driving special motors**
Select an inverter that meets the following condition:
Inverter rated current > Motor rated current.

Transportation and storage

When transporting or storing inverters, follow the procedures and select locations that meet the environmental conditions that agree with the inverter specifications.