



**PLEASE CHECK FOR CHANGE INFORMATION
AT THE REAR OF THIS MANUAL.**

**067-1039-00
PATTERN
GENERATOR**

INSTRUCTION MANUAL

Tektronix, Inc.
P.O. Box 500
Beaverton, Oregon 97077

070-3986-00
Product Group 20

Serial Number _____

First Printing JUL 1982

Copyright © 1981, 1982 Tektronix, Inc. All rights reserved.
Contents of this publication may not be reproduced in
any form without the written permission of Tektronix, Inc.

Products of Tektronix, Inc. and its subsidiaries are
covered by U.S. and foreign patents and/or pending
patents.

TEKTRONIX, TEK, SCOPE-MOBILE, and  are
registered trademarks of Tektronix, Inc. TELEQUIP-
MENT is a registered trademark of Tektronix U.K.
Limited.

Printed in U.S.A. Specification and price change
privileges are reserved.

TABLE OF CONTENTS

LIST OF ILLUSTRATIONS	v
OPERATORS SAFETY SUMMARY	vi

Section 1 GENERAL INFORMATION AND
SPECIFICATIONS

INTRODUCTION	1-1
OVERVIEW	1-2
OPERATORS PART	1-2
SERVICING PART	1-2
STANDARDS	1-3
SPECIFICATION	1-4
ELECTRICAL CHARACTERISTICS	1-4
ENVIRONMENTAL CHARACTERISTICS	1-6
PHYSICAL CHARACTERISTICS	1-7

Section 2 OPERATING INSTRUCTIONS

INTRODUCTION	2-1
ABOUT THE PATTERN GENERATOR	2-1
INSTALLATION	2-1
REPACKAGING	2-2
FUNCTIONS OF THE CONTROLS AND CONNECTORS	2-2
Controls	2-3
Indicators	2-5
Connectors	2-5
OPERATORS CHECKOUT PROCEDURE	2-6
USING THE PATTERN GENERATOR TO CHECK THE 690SR MAINFRAME	2-8

WARNING

THE FOLLOWING SERVICING INSTRUCTIONS ARE FOR USE BY QUALIFIED PERSONNEL ONLY. TO AVOID PERSONAL INJURY, DO NOT PERFORM ANY SERVICING OTHER THAN THAT CONTAINED IN OPERATING INSTRUCTIONS UNLESS YOU ARE QUALIFIED TO DO SO.

SERVICING SAFETY SUMMARY	S-1
Section 3 THEORY OF OPERATION	
HORIZONTAL SYNC GENERATOR (Diagram 1)	3-1
Horizontal Oscillator	3-1
Vertical Line Generator	3-1
Vertical Bar Generator	3-2
Horizontal Interval Timing	3-2
2H (Interlace) Generator	3-3
H Sync Output Buffers	3-4
Power Supplies	3-4
VIDEO LOGIC AND DRIVERS (Diagram 2)	3-5
Power Supplies	3-5
Video Logic	3-5
Video Output Drivers	3-5
HORIZONTAL LINE GENERATOR (Diagram 3)	3-8
Current State Registers and Remainder Up-Counter ..	3-8
Line Spacing Increment and Line Spacing Reset	3-9
Line Spacing Memory	3-10
Scan Line Counter and White Line Generator	3-10
H Bar Generator and Staircase Generator	3-11
Bounce Generator and Program Logic	3-13
VERTICAL SYNC, POWER SUPPLY (Diagram 4)	3-13
Power Supply	3-14
End-of-Field Pulse Generator	3-15
Vertical Blanking Generator	3-15
Composite Sync Driver	3-16
External Video Input	3-17

Section 4 PERFORMANCE CHECK AND ADJUSTMENT

INTRODUCTION	4-1
HISTORY INFORMATION	4-1
RECOMMENDED TEST EQUIPMENT	4-1
PERFORMANCE CHECK	4-3
INCOMING INSPECTION	4-3
PRELIMINARY PREPARATION	4-3
PERFORMANCE CHECK PROCEDURE	4-3
Check White Level	4-3
Check Grey Level	4-4
Check Blanking Level	4-5
Check Blanking Level Shift	4-5
Check Sync Level	4-5
Check Staircase Steps	4-5
Check Horizontal Active Time	4-5
Check Horizontal Blanking Time	4-6
Check Horizontal Sync Width	4-7
Check TTL White Level	4-7
Check TTL Black Level	4-8
Check Interlace	4-9
ADJUSTMENT	4-11
PRELIMINARY PREPARATION	4-12
Adjust Power Supply	4-13
Adjust Horizontal Active Time	4-14
Adjust Internal Horizontal Timing	4-14
Adjust Levels	4-15
Adjust Staircase	4-16
Adjust Crosshatch Width	4-16
Adjust Interlace	4-16

Section 5 MAINTENANCE

PREVENTIVE MAINTENANCE	5-1
Cleaning	5-1
Lubrication	5-1
Adjustment	5-1
TROUBLESHOOTING AIDS	5-2
Theory of Operation	5-2
Diagrams	5-2
Circuit Board Illustrations	5-2
Component and Wiring Color Codes	5-2
Testing Equipment	5-2
TROUBLESHOOTING TECHNIQUES	5-3
Control Settings	5-3
Visual Check	5-3
Static-Sensitive Components	5-4
Test Equipment	5-5
Circuit Isolation	5-5
Voltages and Waveforms	5-6
Component Checking	5-6
Transistors and Integrated Circuits	5-6
Diodes	5-8
Resistors	5-8
Circuit Board Removal	5-8
PARTS ORDERING AND REPLACING	5-9
Ordering	5-9
USING THE REAR INTERFACE CONNECTOR	5-10
Input	5-10
Output	5-10

Section 6 REPLACEABLE ELECTRICAL PARTS

Section 7 DIAGRAMS

CHANGE INFORMATION

LIST OF ILLUSTRATIONS

Fig. 1-1	PATTERN GENERATOR	ix
Fig. 2-1	PATTERN GENERATOR Controls and Connectors	2-4
Fig. 2-2	PATTERN GENERATOR Connections to Display Monitor with Video Decoder Module	2-8
Fig. 3-1	Field Rate Staircase Signal	3-7
Fig. 4-1	Test Equipment Setup for Performance Checks	4-4
Fig. 4-2	Horizontal Active Time (70 us)	4-6
Fig. 4-3	Horizontal Active Times (10 us)	4-6
Fig. 4-4	Horizontal Blanking Time	4-7
Fig. 4-5	Horizontal Sync Width	4-7
Fig. 4-6	TV to TTL Signal Level Adjustment	4-8
Fig. 4-7	Interlace	4-9
Fig. 4-8	Test Equipment Setup for Adjustment Procedure	4-12
Fig. 4-9	+15 V Adjustment Locations on the Vertical Sync Generator Board	4-13
Fig. 4-10	Test points and Adjustments Locations on the Horizontal Sync Generator Board	4-15
Fig. 4-11	Adjustments on the Horizontal Line Generator Board	4-17
Fig. 5-1	Semiconductor Components Basing	5-7

OPERATORS SAFETY SUMMARY

The general safety information in this part of the summary is for both operating and service personnel. Specific warnings and cautions will be found throughout the manual where they apply, but may not appear in this summary.

TERMS

In This Manual

CAUTION statements identify conditions or practices that could result in damage to the equipment or other property.

WARNING statements identify conditions or practices that could result in personal injury or loss of life.

As Marked on Equipment

CAUTION indicates a personal injury hazard not immediately accessible as one reads the marking, or a hazard to property including the equipment itself.

DANGER indicates a personal injury hazard immediately accessible as one reads the marking.

SYMBOLS

In This Manual

This symbol indicates where applicable cautionary or other information is to be found.

As Marked On Equipment

DANGER - High Voltage.

Protective ground (earth) terminal.

ATTENTION - Refer to manual.

Power Source

This product is intended to operate from a power source that will not apply more than 250 volts rms between the supply conductors or between either supply conductor and ground. A protective ground connection by way of the grounding conductor in the power cord is essential for safe operation.

Grounding the Product

This product is grounded through the grounding conductor of the power cord in the mainframe. To avoid electrical shock, plug the mainframe power cord into a properly wired receptacle before connecting to the mainframe input terminals. A protective ground connection by way of the grounding conductor in the mainframe power cord is essential for safe operation.

Danger Arising From Loss of Ground

Upon loss of the protective-ground connection, all accessible conductive parts (including knobs and controls that may appear to be insulating) can render an electric shock.

Use the Proper Fuse

To avoid fire hazard, use only a fuse of the proper type, voltage rating, and current rating as specified in the parts list for your product.

Do Not Operate In Explosive Atmospheres

To avoid explosion, do not operate this product in an atmosphere of explosive gases unless it has been specifically certified for such operation.

Do Not Remove Covers or Panels

To avoid personal injury, do not remove the product covers or panels. Do not operate the product without the covers and panels properly installed.



Fig. 1-1 PATTERN GENERATOR

GENERAL INFORMATION AND SPECIFICATIONS

INTRODUCTION

The 067-1039-00 PATTERN GENERATOR provides a series of video test signals required to calibrate a multi-rate display monitor (such as the 690SR Color Display Mainframe). The 690SR can be used with computer display or television signal sources that use a wide variety of scanning systems. The PATTERN GENERATOR emulates these scan systems and provides a selection of test signals for calibrating the display monitor.

The PATTERN GENERATOR has three front panel controls that allow it to emulate the line and field rates of many scan systems, present or future. The Horizontal Active Time adjustment varies the interval between the horizontal blanking periods (blanking itself is nominally 6.75 us); the Lines per Two Fields is set to the number of scan lines of the chosen standard (an odd number generates 2:1 interlace, an even number is non-interlaced); and the Lines of Vertical Blanking is set to the number of blanked lines in each field. The Frame Period is (6.75 us + Horizontal Active Time) times Lines per Two Fields.

There are 8 pushbutton switches that provide patterns to test the operation of the display monitor. These switches generate the following patterns:

1. Flat Field (White). Tests purity and colorimetry.
2. Flat Field (Grey). Tests low light level calibration.
3. Convergence (Lines/Dots). Tests convergence, geometry, linearity, and video amplifier pulse response.
4. Vertical Bar. Tests the video amplifier for line time distortion and integrity of step response.
5. Horizontal Bar. Tests high voltage supply regulation.
6. Window. Tests crt purity error due to shadow mask heating.
7. Staircase. Tests color balance, nonlinear distortion, and video amp limiting. With an external chrominance signal, tests differential gain and differential phase.

8. Bounce. Tests video clamp response and feedback stability in the beam feedback loop.

OVERVIEW

The Operators part of this manual is intended to help the user obtain maximum performance from the PATTERN GENERATOR. This part covers General Information, Specifications, and Operating Instructions.

The Service Part of this manual covers the Theory of Operation, the Performance Check and Adjustment section, the Maintenance section, and other service information, including the block and schematic diagrams of the PATTERN GENERATOR.

The eight sections of the manual are:

OPERATORS PART

Section 1 - General Information and Specifications; contains the instrument description and a listing of the PATTERN GENERATOR Characteristics and Performance Requirements.

Section 2 - Operating Instructions; introduces the user to the PATTERN GENERATOR/Display Monitor system and demonstrates the functions of the front panel controls.

SERVICING PART

Section 3 - Theory of Operation; describes all major circuits of the PATTERN GENERATOR.

Section 4 - Calibration, Part 1: Performance Check; this subsection is used to verify all of the Performance Requirements in the Specification, and to determine the need for recalibration (adjustment) of the PATTERN GENERATOR.

Section 4 - Performance Check and Adjustment, Part 2: Adjustment Procedure; this subsection is used to return the PATTERN GENERATOR to conformance with the Performance Requirements. The procedure is arranged in functional blocks to facilitate referencing from the Performance Check and the Maintenance Instructions.

General Information - 067-1039-00

Section 5 - Maintenance Instructions; describes routine and corrective maintenance with detailed instructions for replacing assemblies, subassemblies, and individual components.

Section 6 - Replaceable Electrical Parts; provides information necessary to order replaceable parts and assemblies related to the electrical functions of the instrument.

Section 7 - Diagrams; provides functional block diagram and circuit schematics.

Section 8 - Replaceable Mechanical Parts; provides information necessary to order mechanical parts that are being replaced. The list is cross-referenced to replaceable electrical parts where appropriate. The Exploded Diagram shows the assembly sequence and identifies the assemblies. The Accessories page lists the standard and optional accessories. (Not present in the interim manual.)

Changes and Corrections; provides updating information for the manual in the form of inserts. These inserts are incorporated into the manual text and diagrams when the manual is revised.

STANDARDS

The abbreviations and graphic symbols used in the text and diagrams are based on ANSI Y1.1-1972, ANSI Y32.2 1970, and ANSI Y32.14-1973 (American National Standards Institute, 345 East 47 Street, New York, N. Y. 10017)

SPECIFICATION

The following specifications apply to the 067-1039-00 PATTERN GENERATOR. Allow 30 minutes warmup. Items listed in the Performance Requirements column are verified by completing the Performance Check in Section 4 of this manual. Items listed in the Supplemental Information column may not be verified in this manual; they are either explanatory notes or performance characteristics for which no limits are specified.

Table 1-1
ELECTRICAL CHARACTERISTICS

Characteristics	Performance Requirement	Supplemental Information
Video Outputs Impedance		75 ohms with all outputs terminated in 75 ohms
Levels		
White	700 mV +/- 7mV	
Grey	70 mV +/-7 mV	
Blanking	0 V +/- 7 mV	
Blanking Level Shift	Less than 3 mV from 0 to 100 % APL	
Sync	-300 mV +/- 7 mV	
Staircase Steps	87.5 mV +/-2% (8 steps from blanking to white)	[(Peak White)-(Blanking), divided by 8] staircase luminance nonlinear distortion less than 2%
Risetime (Except Staircase)		Less than 2 ns
Falltime (Except Staircase)		Less than 3 ns
Ringing		(8 ns before and after 50% of step) less than 5% peak

Table 1-1 (cont)

Characteristics	Performance Requirement	Supplemental Information
TTL Video Outputs Impedance		Greater than 10,000 ohms.
White Level (into 50 or 75 ohms)	Logic 1 greater than 2.5 V	Maximum output current greater than 50 mA
Black Level (into 50 or 75 ohms)	Logic 0 less than 0.8 V	Output Current = 0
Risetime and Falltime		Less than 7 ns
Bounce Trigger Output Levels		TTL (Logic 1 = Black Video Output)
Rate		Adjustable from 0.2 Hz to 2 Hz
Scan Rate Selection Number of Lines in 2 Fields		21 to 1999 lines
Number of Vertical Blanking Lines		3 to 99 lines (0, 1, and 2 settings result in 3 lines)
Vertical Sync Width		3 lines (fixed)
Horizontal Active Time	10 to 70 us +/- 3% of full scale	
Horizontal Blanking Time	6.75 us +/- 0.2 us	Internally adjustable from 4.5 us to 12 us
Horizontal Sync Width	3 us +/- 0.1 us	Internally adjustable from 2 us to 4.5 us
Front Porch Width Blanking Time	1 us +/- 0.05 us	Internally adjustable from 0.7 us to 1.5 us

Specification - 067-1039-00

Table 1-1 (cont)

Characteristics	Performance Requirement	Supplemental Information
Interlace Accuracy	50 % H period +/-5 % H	
Oscillator Stability		Better than +/-0.005% over 10 minutes
Oscillator Jitter		Less than 20 ns over 500 μ s
Line-to-line Jitter		Less than 5 μ s peak-to-peak
Sync Outputs		
TTL H Sync		TTL levels, logic 1 during sync time
TTL V Sync		
TV Block Sync		-4 V into 75 ohms during H and V sync time; TTL Block Sync equals
		TTL V Sync OR TTL H Sync

Table 1-2
ENVIRONMENTAL CHARACTERISTICS

Characteristic	Description
Temperature Range	
Operating	0 to +50 degrees C
Non-Operating	-55 to +75 degrees C
Humidity	Up to 90% to 95% relative humidity
Altitude Range	
Operating	To 4.5 km (15,000 ft)
Non-Operating	To 15 km (50,000 ft)
Shock and Vibration	30 G (half-sinewave), 0.38 mm (0.015 inches) displacement

Table 1-3
 PHYSICAL CHARACTERISTICS

Characteristic	Description
Front Panel	Lexan Laminated on Aluminum
Dimensions (Maximum)	
Height	12.7 cm (5 in)
Width	13.5 (5.3 in)
Length	29.5 cm (11.6 in)
Weight	
Net	3.44 kg (3 lb 7 oz)
Shipping (Domestic)	2.27 kg (5 lb)
Shipping (Export)	2.27 kg (5 lb)

OPERATING INSTRUCTIONS

INTRODUCTION

This section describes the functions of the PATTERN GENERATOR, the installation procedure, the controls and connectors, and the checkout procedure.

ABOUT THE PATTERN GENERATOR

The 067-1039-00 PATTERN GENERATOR is a two-wide instrument that plugs into a TM 500 mainframe. It provides a series of video test signals required to test a multi-rate display monitor (such as the 690SR Color Display Mainframe). This monitor is suitable for computer displays and broadcast television; with the aid of the PATTERN GENERATOR, it can be calibrated to any scan rate within its operating range.

By setting Horizontal Active Time, Lines per Two Fields, and Lines of Vert Blanking, the PATTERN GENERATOR can emulate the scan system that will be used with display monitor. The monitor can then be calibrated with the pushbutton-selected signals provided by the PATTERN GENERATOR.

INSTALLATION

The PATTERN GENERATOR was inspected both mechanically and electrically before shipment. It should be free of marks or scratches and electrically meet or exceed all specifications. Inspect the instrument for physical damage incurred in transit and check the electrical performance by following the Operators Checkout Procedure in this section. If there is a problem, contact your local Tektronix Field Office or representative.

NOTE

If the PATTERN GENERATOR is used with a NTSC display monitor, the Horizontal Blanking Time should be changed from 6.75 μ sec. to 11.1 μ sec. This is an internal adjustment and should be performed by a qualified technician. Refer to Section 4 for the "Calibrate Internal Horizontal Timing" procedure.

REPACKAGING

Save and re-use the PATTERN GENERATOR shipping container. If the original container is not available or is damaged, repackage the PATTERN GENERATOR as follows:

1. Attach a tag to the PATTERN GENERATOR that shows: name and address of the firm, name of the person responsible for the PATTERN GENERATOR, serial number, and a description of the service required.

2. Obtain a shipping container made of heavy corrugated cardboard or wood. To allow for cushioning, make sure that the inside dimensions are no less than 12 by 12 by 18 inches (300 by 300 by 450 mm). This container should have a carton test strength of no less than 275 pounds (605 kg).

3. To protect the finish of the PATTERN GENERATOR, wrap it in heavy paper or polyethylene. Protect the front panel with urethane foam or strips of cardboard.

4. Cushion the PATTERN GENERATOR by tightly packing urethane foam or dunnage between the PATTERN GENERATOR and the shipping container. Allow at least 3 inches (75 mm) on all sides.

5. Seal the container with shipping tape or an industrial stapler.

If there are any questions, contact the nearest Tektronix Field Office or representative.

FUNCTIONS OF CONTROLS, INDICATORS, AND CONNECTORS

The front panel controls and connectors are shown in Fig. 2-1 and numbered to match the text.

Controls

- ① LINES PER TWO FIELDS -- A four-decade switch that selects the number of video lines in two fields. Its range is 21 through 1999 lines. Odd values provide a 2:1 interlace and even values provide a non-interlaced display.
- ② LINES OF VERT BLANKING -- A two-decade switch that selects the number of video lines of blanking in each field. Its range is 3 through 99 lines. Values less than 3 still provide 3 lines of blanking due to the length of vertical sync (3 lines).
- ③ HORIZONTAL ACTIVE TIME -- A potentiometer that sets the horizontal active time of each video line. Since the blanking interval is set by an internal adjustment, the total horizontal period is the sum of this active time and the preset blanking time of 6.75 usec. (The blanking time should be reset to 11.1 usec. for NTSC display monitors.)
- ④ CONVERGENCE -- A pushbutton switch that selects a convergence pattern (either DOT or LINE pattern depending on the DOT/LINE switch position). This switch cancels either the FLAT FIELD or STAIRCASE/EXT switch when pushed in.
- ⑤ DOT/LINE -- A self-cancelling pushbutton switch that selects either a dot or line convergence pattern when the CONVERGENCE switch is pushed in. Pushbutton switch "in" position is a dot convergence pattern and switch "out" position is a line convergence pattern.
- ⑥ FLAT FIELD -- A pushbutton switch that selects a flat field signal (either white or grey depending on the GREY/WHITE switch position). It cancels either STAIRCASE/EXT or CONVERGENCE switch when pushed in.
- ⑦ GREY/WHITE -- A self-cancelling pushbutton switch that selects either full amplitude (WHITE) or reduced amplitude (GREY) of the convergence or flat field signals. This switch has no effect when the STAIRCASE/EXT switch is pushed in.
- ⑧ STAIRCASE/EXT -- A pushbutton switch that selects either an internal staircase signal or an external video signal, depending on the position of an internal jumper. External video is received via pin 24A on the TM 500 interface. The internal staircase is a full-field, ten-step staircase. All other pushbutton switches have no effect when this switch is pushed in.

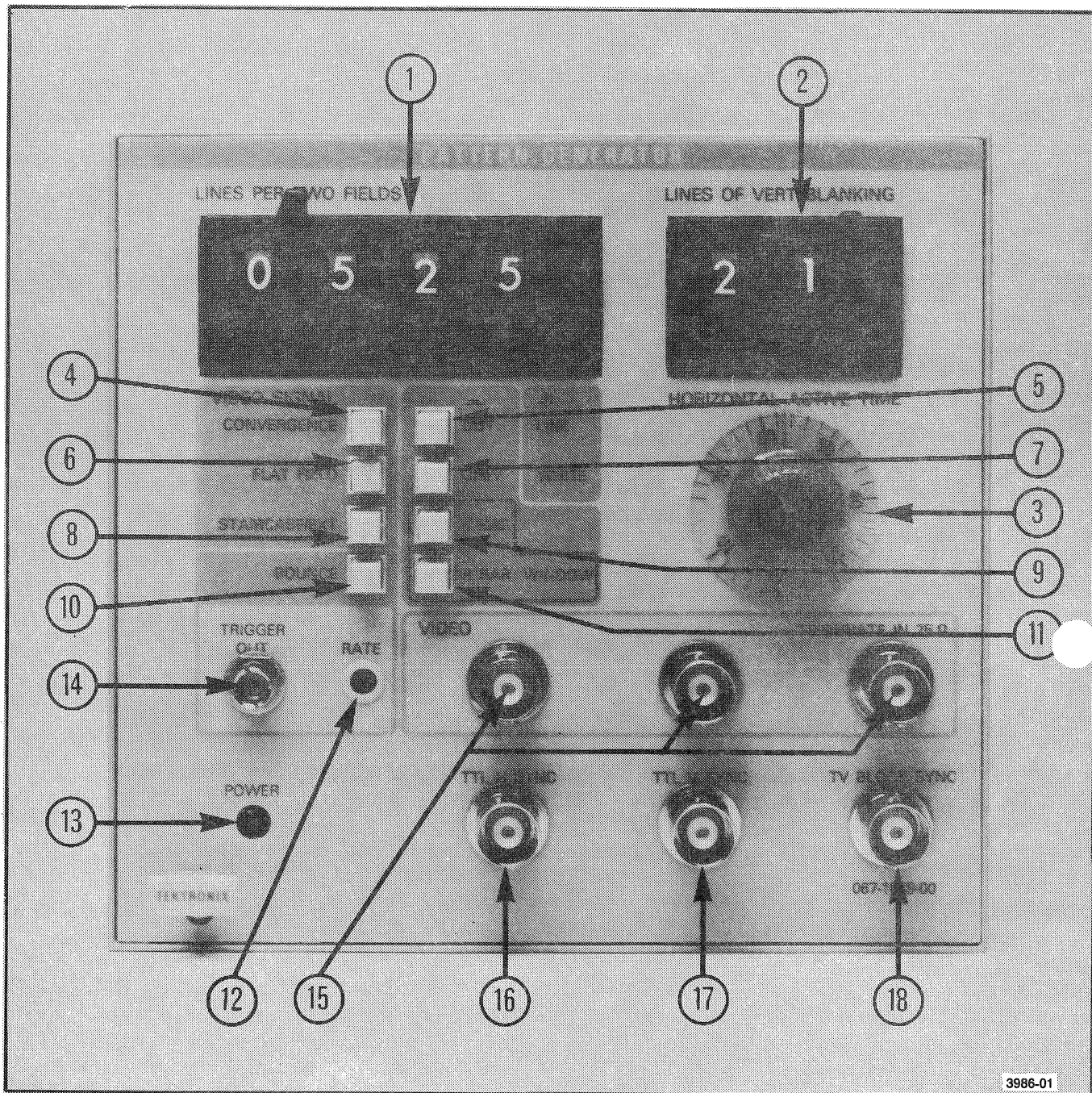

Fig. 2-1 PATTERN GENERATOR Controls and Connectors

- ⑨ V BAR -- A self-cancelling pushbutton switch that inserts a vertical bar into the convergence-pattern signal or adds a vertical bar to a black pattern (CONVERGENCE, FLAT FIELD, and STAIRCASE/EXT switches in the "out" position). When both the V BAR and H BAR switches are depressed at the same time, the resulting signal is a WINDOW signal.
- ⑩ H BAR -- A self-cancelling pushbutton switch that inserts a horizontal bar in the same manner as the V BAR switch.
- ⑪ BOUNCE -- A self-cancelling pushbutton switch that causes the video pattern to be periodically blanked to black with a 50 % squarewave whose period (RATE) is adjustable from 0.2 Hz to 2 Hz. This switch does not affect the video pattern when the STAIRCASE/EXT switch is in the "in" position.
- ⑫ RATE (BOUNCE) -- A front-panel screwdriver adjustment that varies the bounce rate from 0.2 Hz to 2 Hz.

Indicators

- ⑬ POWER -- A red light-emitting diode (LED) that illuminates whenever power is applied to the instrument.

NOTE

The unit receives its power from any TM 500 mainframe.

Connectors

- ⑭ TRIGGER OUT -- A probe tip output connector that provides a TTL signal that is synchronous with the bounce transition. This signal is used to trigger a test oscilloscope so that the clamp response and beam current feedback stability of the 690SR can be easily measured.
- ⑮ VIDEO -- Three bnc output connectors driven at TTL or composite video levels depending on the position of an internal jumper. Each connector is intended to drive a 75 ohm load, and all three connectors are driven by a common driver to eliminate any timing errors. Source-termination resistors provide proper reflection termination when each connector is terminated in 75 ohms. These connectors are provided to drive RGB monitors. Monitors with only one input would use one of the output connectors with the other two output connectors terminated in 75 ohms.

- ①6 TTL H SYNC -- A bnc output connector that provides a horizontal sync-timing signal with TTL levels (logic 1 during horizontal sync time).
- ①7 TTL V SYNC -- A bnc output connector that provides a vertical sync-timing signal with TTL levels (logic 1 during vertical sync time).
- ①8 TV BLOCK SYNC -- A bnc output connector that provides a timing signal with both horizontal and vertical sync timing information at standard video-sync drive levels (-4V p-p into 75 ohms). No serration or equalizer pulses are provided.

OPERATOR'S CHECKOUT PROCEDURE

Prepare the PATTERN GENERATOR/Display Monitor combination as follows:

1. Check that the TM 500 mainframe is OFF. Insert the PATTERN GENERATOR into a TM 500 mainframe. Turn the mainframe ON.
2. If the Display Monitor has a video decoder interface module installed, connect two 75 ohm feedthroughs and one 75 ohm cable to the front panel VIDEO outputs. Connect the cable to the Video In of the monitor. Refer to Fig. 2-2. If necessary, use a 75 ohm terminator at the Video In of the display monitor.
3. If the Display Monitor has a RGB interface module installed, connect three 75 ohm cables between the front panel VIDEO outputs and the three R, G, and B inputs of the display monitor. Terminate these inputs with 75 ohm feedthroughs. Connect V, H, or BLOCK Sync with 75 cable to the Sync input of the display monitor.
4. Set the PATTERN GENERATOR to the scan system used by the Display Monitor. (Refer to the Display Monitor specifications for this information.)
5. Turn on the Display Monitor.
6. Test the operation of the front panel controls. Make sure that the DOT, GREY, V BAR, and H BAR WINDOW pushbuttons are disengaged (in the OUT position).
7. Press CONVERGENCE. The monitor should display a white crosshatch pattern on a black field. There should be 15 vertical lines and 10 horizontal lines.

Operating Instructions - 067-1039-00

8. Press DOTS. The crosshatch should change into a pattern of dots. Disengage DOTS.

9. Press V BAR. A white vertical bar should appear across the crosshatch pattern.

10. Press H BAR WINDOW. A white window should appear in the center of the crosshatch pattern. Disengage V BAR; a white horizontal bar should appear across the crosshatch pattern. Disengage H BAR WINDOW.

11. Press FLAT FIELD. The monitor should display a flat field at white level (700 mV).

12. Press GREY. The monitor should display a grey field (10% or 70 mV). Disengage GREY.

13. Press BOUNCE. The monitor should display an alternating black and white field at a rate controlled by the RATE adjustment. The adjustment covers a range of 0.2 Hz to 2 Hz. Disengage BOUNCE.

14. Press STAIRCASE/EXT. A full-field monochrome staircase should appear on the monitor.

This completes the Operators Checkout Procedure. For further information on calibrating the Display Monitor with these test signals, consult the manual of the Display Monitor.

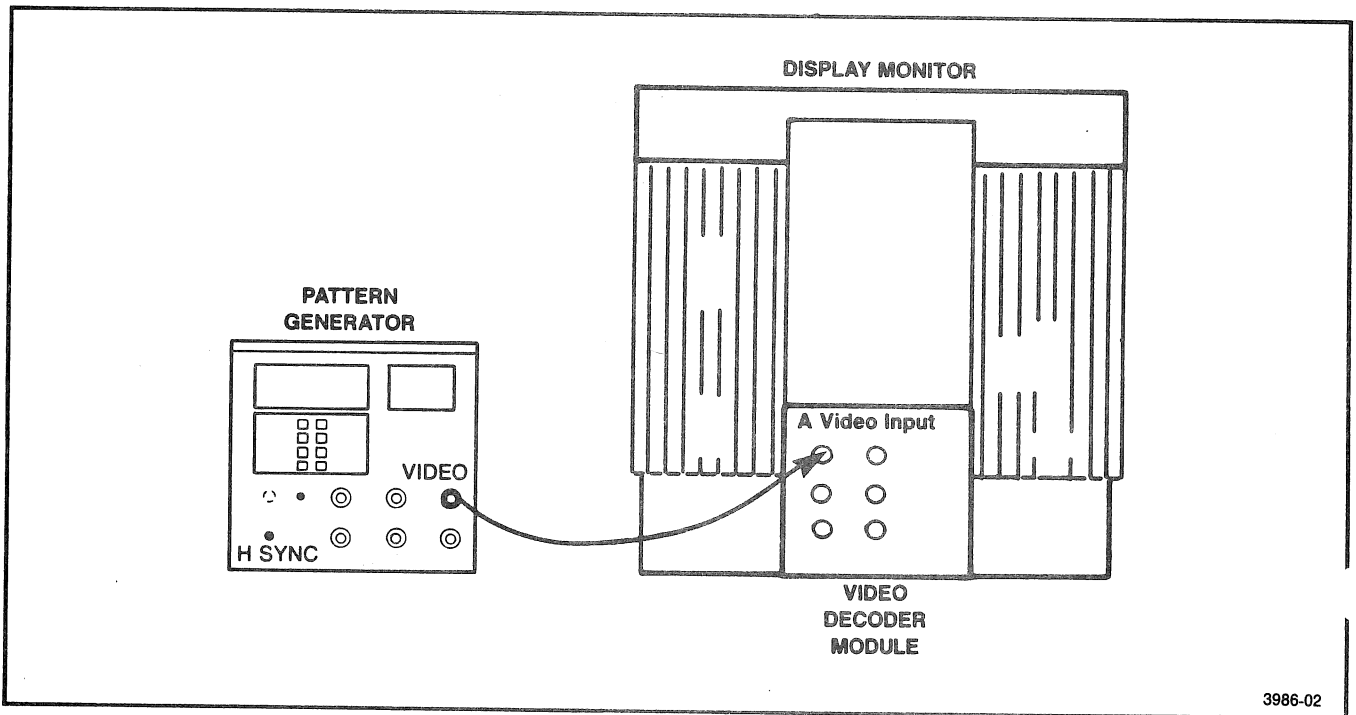

3986-02

Fig. 2-2 PATTERN GENERATOR Connections to Display Monitor with Video Decoder Module

USING THE PATTERN GENERATOR TO CHECK THE 690SR MAINFRAME

The 067-1039-00 PATTERN GENERATOR, when plugged into a TEKTRONIX TM 500 mainframe, provides the necessary video signals to test the 690SR Color Monitor. The crosshatch pattern from the generator is used with the Tektronix Linearity Graticule 067-1034-00 to check the size, centering, and linearity of the monitor's raster. Therefore, it is necessary to set the PATTERN GENERATOR's controls to operate at the desired horizontal and vertical scan rates and to obtain a crosshatch pattern that fills the raster properly.

NOTE

Simply setting the PATTERN GENERATOR controls to provide signals that are equivalent to the user's system may not permit checking the 690SR mainframe performance properly.

The PATTERN GENERATOR front-panel control settings given in the equipment setup illustrations are set to generate a 31.5 kHz scan rate and a 60.6 Hz field rate. The Horizontal Active Time control is set to 25 μ s since 25 μ s active time plus 6.75 μ s horizontal blanking time is equal to 31.75 μ s horizontal period to generate a 31.5 kHz scan rate. (The PATTERN GENERATOR blanking time is factory set at 6.75 μ s to match the 690SR raster blanking time.) The Lines of Vertical Blanking switch is set to obtain approximately 600 μ s vertical blanking time. (The 18 lines chosen times 31.75 μ s is equal to 572 μ s.) The Lines Per Two Fields switch is set to obtain an approximate 60 Hz field rate and at the same time produce full top and bottom crosshatch lines that coincide with the top and bottom edges, respectively, of the raster.

NOTE

If the Lines Per Two Fields switch is set to an odd number; for example, 1039, the display may appear to flicker because the display is interlaced. To obtain a non-interlaced display, set the switch to an even number. When preparing this manual, the Lines Per Two Fields switch was set to 1040.

If the 690SR mainframe is being operated at a horizontal and/or vertical scan rate other than 31.5 kHz and approximately 60 Hz respectively, or if the horizontal blanking time is not 6.75 μ s, then use the following procedure as an aid for setting the PATTERN GENERATOR controls to properly check the 690SR mainframe.

1. Measure the vertical scan period, the horizontal scan period, and horizontal blanking time of the monitor's intended signal source or obtain their specification.
2. Compute the horizontal active time by subtracting the H blanking time from the H scan period. For example:

$$31.75 \mu\text{s} - 6.75 \mu\text{s} = 25 \mu\text{s}.$$

Operating Instructions - 067-1039-00

- a. Set the Horizontal Active Time control on the PATTERN GENERATOR to the computed horizontal active time value.
 - b. If the H blanking time is other than 6.75 μ s and precise linearity adjustment is required, recalibrate the PATTERN GENERATOR's horizontal blanking time. (Refer to step 11 in the Adjustment Procedure of this 690SR manual.) (For quick monitor setups when the linearity requirement is less critical, the horizontal blanking time need not be recalibrated. Instead, use 6.75 μ s during the Performance Check Procedure. Then, readjust the 690SR H Size control, R925, on A8A1 after completing the Performance Check Procedure so the displayed picture from the monitor's intended signal source will be the proper width.)
3. Calculate the number of Lines of Vertical Blanking that the PATTERN GENERATOR should be set to by ignoring the fraction after the decimal point in the number calculated from the following formula.

$$B = \frac{600 \mu\text{s}}{H_p}$$

B = Lines of Vertical Blanking

H_p = Horizontal Scan Period

For example:

$$B = \frac{600 \mu\text{s}}{31.75 \mu\text{s}} = 18.89 \Rightarrow 18$$

Operating Instructions - 067-1039-00

4. Calculate the approximate number of Lines Per Two Fields that the PATTERN GENERATOR should be set to by using the following formula.

$$LA = \frac{2 (Vp)}{Hp}$$

LA = The approximate Lines Per Two Fields setting (truncate this number)

Vp = Vertical Scan Period

Hp = Horizontal Scan Period

For example:

$$LA = \frac{2(16.67 \text{ ms})}{31.75 \mu\text{s}} = 1050.08 \Rightarrow 1050$$

5. Find the exact number of Lines Per Two Fields that the PATTERN GENERATOR should be set to by first setting L in the formula below or equal to LA that was calculated previously. Then, increment L up or down one digit at a time until the calculated value for x becomes a whole number.

$$x = \frac{L - 2B - 24}{20}$$

x = Must be a whole number (i.e., an integer) to obtain a full screen display so that the last horizontal crosshatch line is at the bottom of the raster. The whole number is the number of black horizontal scanning lines between any two white horizontal lines of the displayed crosshatch pattern.

L = Lines Per Two Fields

B = Lines of Vertical Blanking

For example:

$$x = \frac{1040 - 2(18) - 24}{20} = 49 \text{ lines}$$

Hence, L = 1040

WARNING

THE FOLLOWING SERVICING INSTRUCTIONS ARE FOR USE BY QUALIFIED PERSONNEL ONLY. TO AVOID PERSONAL INJURY, DO NOT PERFORM ANY SERVICING OTHER THAN THAT CONTAINED IN OPERATING INSTRUCTIONS UNLESS YOU ARE QUALIFIED TO DO SO. REFER TO OPERATORS SAFETY SUMMARY AND SERVICE SAFETY SUMMARY PRIOR TO PERFORMING ANY SERVICE.

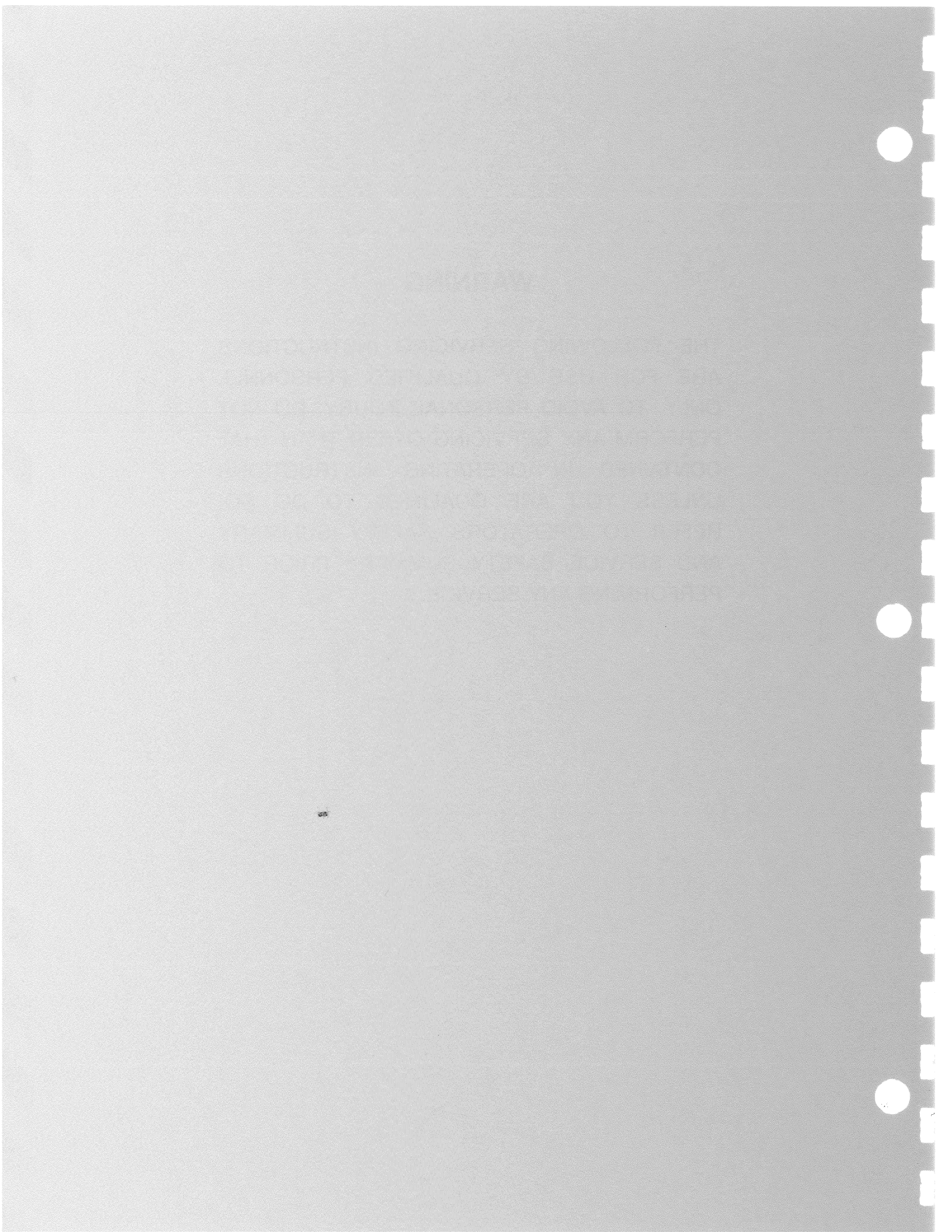

**SERVICING SAFETY SUMMARY
FOR QUALIFIED SERVICE PERSONNEL ONLY**

Refer also to the preceding Operators Safety Summary

Do Not Service Alone

Do not perform internal service or adjustment of this product unless another person capable of rendering first aid and resuscitation is present.

Use Care When Servicing With Power On

Dangerous voltages exist at several points in this product. To avoid personal injury, do not touch the exposed connections and components while power is on.

Disconnect power before removing protective panels, soldering, or replacing components.

Power Source

This product is intended to operate from a power source that does not apply more than 250 volts rms between the supply conductors or between either supply conductor and ground. A protective ground connection by way of the grounding conductor in the power cord is essential for safe operation.

THEORY OF OPERATION

HORIZONTAL SYNC GENERATOR

1

Horizontal Oscillator

The ACTIVE TIME control R682 varies the current out of a current source consisting of Q688, Q685, and the associated circuitry. The current charges holding capacitor C684 to generate a ramp. That ramp is compared to a dc level on pin 2 of U580, a comparator. When the ramp (on pin 1 of U580) crosses that threshold voltage, pin 5 of U580 toggles to a low state and resets the ramp by causing U670A to drive Q680 into saturation and discharging C684.

One-shot multivibrator U575A is triggered at the same time, and generates a pulse at output pin 7 which keeps Q680 "on" for approximately 80 ns. This ensures that C684 is fully discharged before it starts charging up again. The output at pin 6 of U575A drives a binary counter, U564 in the Horizontal Interval Timing circuit block.

Vertical Line Generator

While the ramp signal on C684 is being compared to a dc level at the input of U580, it is also compared to a dc level at pin 2 of U587. The comparison voltage at the input of U587 is slightly less than that at the input of U580.

Since the ramp is positive-going, U587 toggles just before the Horizontal Oscillator resets the ramp, and then remains in that state as long as the amplitude of the ramp signal exceeds the comparison voltage at the input. This results in a pulse at the outputs of U587. The width of this pulse is determined by the amount of time that the amplitude of the ramp signal exceeds the comparison voltage. As the frequency of the Horizontal Oscillator changes and the slope of the ramp changes, the width of the output pulse remains a constant percentage of the horizontal period. As a result, this vertical line pulse appears to have a constant spatial width even as the horizontal scan rate is varied. On the schematic diagram, this pulse is labelled V Line.

The pulse at the output of U587 is used to generate the effective address on the crt of a display monitor from left to right. For example, the vertical bar signal is determined by counting the number

of vertical lines that have occurred since the start of that particular horizontal line.

Vertical Bar Generator

Counter U462 and the logic associated with it constitutes the Vertical Bar Generator. It counts vertical lines and its outputs are combined with an "EXCLUSIVE OR" gate, resulting in a bar signal whose width is approximately six vertical lines. Logic gates U457A, U457B, U556C, and U556D form an "EXCLUSIVE OR" gate.

If this bar signal were displayed on a picture monitor, the crt would display a light bar extending from the top to the bottom and dark at the left and right sides.

Horizontal Interval Timing

The output of the Horizontal Oscillator's one-shot multivibrator U575A is counted by U564, and when the count reaches 14 (pins 11, 12, and 13 all high; pin 14 low), the output of U670B triggers another one-shot multivibrator U575B which controls the horizontal hold-off and blanking times. The output of U575B is clocked by V Line to generate the horizontal blanking time (labeled H Blank at the output of U457D).

The output of U670C (pin 8) forces the Horizontal Oscillator ramp at C684 to be clamped to ground, stopping the Horizontal Oscillator during the horizontal interval hold-off time. Horizontal blanking time is equal to the sum of the horizontal interval hold-off time and the Horizontal oscillator period.

The output of U670C (inverted output of U575B) is fed to a circuit which determines the front porch timing and sync timing. The output of that circuit is horizontal sync. The circuit consists of two cascaded one-shot multivibrators, U552A and U552B together with the associated circuitry. The first multivibrator, U552A, determines the offset of the horizontal sync leading edge from the start of the blanking time which is the front porch time. The second multivibrator, U552B, determines the width of the horizontal sync pulse, and that output pulse (pin 10 of U552B) is fed to the 2H (Interlace) Generator circuit block and to several buffer circuits.

2H (Interlace) Generator

The heart of this circuit is a constant-amplitude ramp generator. It generates a ramp which starts at the end of one horizontal sync pulse, ramps up until the next horizontal sync pulse comes along, resets and starts up again. A comparator is used to compare this ramp with a dc level whose amplitude is automatically adjusted to one half the peak amplitude of the ramp. Each time the ramp amplitude crosses that threshold voltage, the output of the comparator changes states. This results in a square wave output that has a transition halfway between the two horizontal sync pulses. This transition is then used to generate a pulse occurring midway between the two horizontal sync pulses; and the pulse and the horizontal sync pulses are combined with a "NAND" gate to produce a signal having twice the frequency of the horizontal sync signal. This is the 2H signal that is used to generate interlace.

Operational amplifier U420, C420, Q420, and R422 comprise the ramp generator. Operational amplifier U420 is connected as an integrator. A constant dc level applied to R422 supplies a constant current to C420, charging it up until a reset pulse from U328A turns Q420 "on" to discharge C420. The slope of the ramp is determined by the dc level that is applied to R422, and that voltage is determined by sampling the output of the ramp generator. The sampled output of the ramp generator is peak-detected through CR425 and C533, and coupled to the non-inverting input of U530. Capacitor C523 together with U530 form a much slower integrator, essentially making U530 a power source.

A horizontal sync signal from pin 10 of U552B drives one-shot multivibrator U328A. One-shot multivibrator U328A produces horizontal rate pulses with a duration of approximately 0.5 μ s at the output. These pulses are used to momentarily turn "on" Q420 in order to discharge C420. That is, the output of U328A resets the ramp generator.

The inverting input of U530 is connected to a temperature-stabilized power supply. The diode CR525 provides temperature compensation for CR425.

If the peak amplitude of the ramp gets too high at the output of U420, the signal coupled back to pin 3 of U530 gets bigger. That drives the output level at pin 6 higher than it was before. The dc level at pin 6 of U530 is normally negative, and this dc level is made more positive. Consequently, less current flows through R422, resulting in a ramp at the output of U420 that has a lower slope. That is, a lower ramp peak amplitude results. The signal being fed back to pin 3 of U530 will reach a steady state (equilibrium) when the ramp's sampled peak amplitude equals the dc level at pin 2 of U530.

This constant amplitude is independent of how often C420 is discharged.

Comparator U330 compares the ramp at the input with a dc level whose amplitude is equal to one half the peak amplitude of the ramp. Potentiometer R332 (2H Interlace) is used to set the comparison voltage at pin 2 of U330. When the ramp crosses this threshold voltage, the output of U330 changes states resulting in a transition midway between two horizontal sync pulses. This transition is used to trigger one-shot multivibrator U328B. The result at the output of U328B, is a signal with pulses occurring midway between horizontal sync pulses. That is, a pulse occurs once every line in the middle of the horizontal line with a duration of approximately 3 μ s.

The output of U328B and the horizontal sync signal from pin 10 of U552B are combined with a "NAND" gate U234B which acts like an "OR" gate. The output of U234B is the 2H signal, and is routed to the Vertical Sync Generator board.

H Sync Output Buffers

The Horizontal Sync Output Buffers consist of two "NAND" gates connected as inverters. An inverted horizontal sync signal from U552B drives U538A, resulting in a normal polarity signal at the output. This signal is available at the front panel as TTL H SYNC.

Depending on the position of the jumper for J542, U538B may be driven with a normal polarity or inverted horizontal sync signal from U552B. The output (TTL H Sync) is available at pins 26A and 28A at the TM500 interconnect jack.

Power Supplies

Power supply inputs and regulators on the Horizontal Sync Generator board are shown in schematic diagram 2. On schematic diagram 1, VR474 and VR647 are used to derive +5 VC and +5 VD respectively. DC supply +5 VC provides power to U575 and +5 VD provides power to U552.

VIDEO LOGIC AND DRIVERS 2

This schematic diagram consists of Power Supplies, Video Logic, and Video Drivers.

Power Supplies

The Power Supplies provide the following dc voltages: +15 V, +12 V, +11.7 V, +10 V, +5 VA, +5 VB, -10 V, -12 V, and -15 V.

The +15 V and -15 V supplies together with a +8 V supply provided by the TM500 host mainframe are used to derive the rest of the supplies.

The +12 V, +5 VA, +5 VB, and -12 V supplies are obtained through the use of 1% regulators. The rest of the supplies are obtained by placing the appropriate zener diodes across the proper dc busses, with the exception of the +15 V and -15 V.

Video Logic

The Video Logic circuitry combines a number of video signals generated in other parts of the Horizontal Sync Generator board, and other video signals from the Horizontal Line Generator and Vertical Sync Generator boards. These signals consist of the Vertical Bar; Horizontal Blanking; Vertical Blanking; Bounce (alternate "on" and "off" blanking signal); V Line, and signals resulting from the positions of the program switches (front panel controls) such as V Bar Enable (labeled GG), V Line Enable (labeled AA), Horizontal Video (labeled VV); and External Video. These signals are combined with a series of gates resulting in a drive signal at the output of U355C.

A Vertical Sync signal from U238A on the Vertical Sync Generator board is buffered by U495B resulting in TTL V SYNC available at the front panel.

The output of the Video Logic circuit (pin 8 of U355C) drives the Video Output Drivers.

Video Output Drivers

This circuitry consists of a TTL video driver (U495A, Q396, and Q398) and a television video driver.

Theory of Operation - 067-1039-00

The TTL video drives 5 V "ones" and "zeros". It has no sync, just the video with blanking. The TTL video is amplified by a pair of VMOS transistors, Q396 and Q398. These two transistors are connected in parallel in order to produce enough current to drive three 50 ohm loads at the video outputs on the front panel. This circuit is enabled when pins 1 and 2, and pins 3 and 4 of J394 are jumpered; that is, by moving the jumper for J390 to J394. Jumper pins for J390 and J394 are installed side-by-side on the Horizontal Sync Generator board. Either one or the other set of pins is jumpered at any one time, but never both. Therefore, either the TTL video or the television video is available at any one time by placing a jumper on J394 or J390 respectively.

The television video driver consists of one fast and three very fast current sources. The circuit associated with Q188 is the fast white current source; the circuitry associated with R270 (Grey Level adjustment) is the grey current source; the circuitry associated with R178 (Black Level adjustment) is the black current source; and the circuitry associated with R486 (Sync Level adjustment) is the sync current source. The white current source is normally "on" all the time, and sets the output to 700 mV when all three video outputs are terminated in 75 ohms, and the other current sources are normally "off".

The grey current source is turned "on" in order to obtain a grey output level, and most of the current from the white source that would normally go to the output is diverted to the grey current source circuit. That is, the current from the white source now divides between the output load and the grey current source. This is accomplished by turning Q276 "off" which causes Q286 and Q288 to turn "on". Transistor Q276 may be turned "off" by applying ground to the cathode of CR276 (activating the GREY button on the front panel).

The black current source operates in the same manner as the grey current source. It robs additional current from the white current source whenever a black level is desired. During that time, both the grey current source and the black current source circuits are "on". Thus, the sum of the grey current source output and the black current source output is equal to the white current source output. That leaves no current for the output load, and the voltage at the output is zero.

The sync level is accomplished by sinking additional current in the sync current source circuit. Since the white current cannot provide any more current, this current is drawn from the output load, and in this way the output is brought down to -300 mV.

In the case of the staircase signal, the video output is set to a condition that would normally produce a black flat field, essentially sync pulses and no video. However, the staircase circuit on the Horizontal Line Generator is enabled and the resulting signal modulates the current produced by the white current source. The staircase drive signal biases the base of Q188 more negative, causing Q188 to produce additional current. This additional current is sent to the output load instead of being sunk to -12 V in the grey, black, and sync current sources. The staircase drive signal is a result of a digital-to-analog conversion which is proportional to the horizontal line scan number, and as it goes down the field, the current in the white current source undergoes step changes resulting in the staircase signal at the output. See Fig. 3-1.

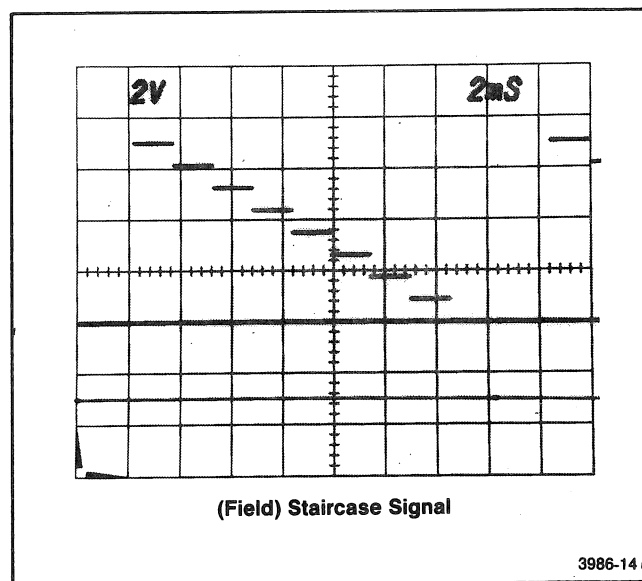

Fig. 3-1 Field Rate Staircase Signal

HORIZONTAL LINE GENERATOR

3

The main input signals are H Sync and V Blank. A horizontal line-generating circuit comprises most of the circuit board. This circuit produces a white line in the raster which will be a horizontal line when displayed. The circuit guarantees that there will be eleven white lines from the top to the bottom of a crosshatch display. Since the Vertical Line Generator on the Horizontal Line Generator board generates fifteen vertical lines, the crosshatch display will be an 11 X 15 pattern. The 11 X 15 pattern is guaranteed regardless of the number of horizontal scan lines the circuit uses. There is circuitry which automatically adjusts the spacing between these white lines to guarantee that there will be fifteen lines that fit the best in that number of scan lines.

The main output from the line generating circuit is H Line. It is available at the output of U665 pin 13. The H Line signal and the H Bar signal (which is a result of that generator as well) are combined with the control panel switch settings to produce three signals namely VV (H Video), AA (V Line Enable, and GG (V Bar Enable). The three signals are routed to the Horizontal Sync Generator board.

Another circuit located on the Horizontal Line Generator board is the Bounce Generator which is a timer whose rate is adjustable from the control panel. Its output acts as an additional blanking signal to the video, and is routed to the Horizontal Sync board where it is combined with vertical and horizontal blanking signals to produce a blanking signal that varies slowly with time.

A third circuit located on this circuit board is the Staircase Generator.

Current State Registers and Remainder Up-Counter

The current state number is CBA where C is U145, B is U265A, and A is U265B. Inputs to the registers are V Blank, H Sync, and All White Lines generated signals.

Register C, a field discriminator, is a divide-by-two T flip-flop [Q output equals zero for Field 0 (1) and one for Field 1 (2)]. Its outputs change states at the end of each vertical blanking period (beginning of pattern). It is clocked by the Q output of register B (U265A).

Register B, clocked vertical blanking, is a J-K flip-flop connected to appear as a D-Type flip-flop. The J-K inputs are V Blanking and inverted V Blanking respectively, and the clock input is

H Sync. The clocked V Blanking signal eliminates the one half line offset which may be present when the number of lines per two fields is odd. This guarantees that the white lines will never start in the middle of a horizontal line. The Q output of U265A is high during clocked V Blanking.

The Q output of register A (U265B) is high after all white lines in one field have been displayed. The J input is driven with an All White Lines pulse that occurs after the last white line in the field, and has a pulse duration of approximately 3 μ s. The negative-going transition of the clock pulse sets the Q output high (one) until a K input pulse comes along and resets the flip-flop. During the time that the Q output is high, the remainder of the scan lines are analyzed.

The Remainder Up-Counter, U255, is enabled after the last white line is generated. It then counts the number of scan lines remaining in the pattern, that is, until V Blanking starts. Each time enough lines have been counted in both fields that would allow the pattern to enlarge, the counter sends out a pulse that may be used to increase the spacing between white lines by one. If the spacing is increased, the remainder counter is cleared and the remainder-counting is resumed.

Line Spacing Increment and Line Spacing Reset (Pattern Too Small and Pattern Too Big)

Logic gates U375A, U375B, U375C, U375D, U575A, and U575B comprise the Line Spacing Increment circuit; and U365A, U365B, U365C, U365D, U355B, U355C, U355D, U275A, and U275B comprise the Line Spacing Reset circuit. Logic gates U375B and U375C form one set-reset flip-flop hereinafter referred to as FF1; and U355B and U355C form another set-reset flip-flop referred to as FF2.

The Line Spacing Increment logic increments the line spacing memory when the pattern is too small. The Remainder Up-Counter (U255) informs the Line Spacing Increment logic with the number of remaining dark lines at the end of the pattern (after the last white line) that it is large enough to increment the Spacing Counter for the pattern field just scanned. (For the 11 white lines, each 10 remaining lines may be distributed into the pattern, one per space between white lines.)

The Line Spacing Memory is incremented only if both pattern fields agree that the pattern is too small. During pattern field zero when the Q output for register C (U145) is zero and the Remainder Counter signals "pattern too small", the decision is remembered by

setting FF1 to 1, but the Remainder Counter is not incremented.

During pattern field 1, when the Remainder Counter signals "pattern too small" and FF1 is set, the Line Spacing Memory is incremented each time the signal is received.

Flip-flop FF1 is reset during vertical blanking at the end of pattern field 1.

The Line Spacing Reset logic clears the Line Spacing Memory when the pattern is too big. The pattern is too big when the start of vertical blanking occurs before the last white line is generated in both fields. This condition occurs when the number of LINES PER TWO FIELDS swith is decreased by more than $[2(\text{Remainder})]$.

Flip-flop FF2 remembers if the pattern in field zero was too big.

If V Blanking starts before the last white line is generated in field 1 and FF2 is set, the Line Spacing Memory is cleared. The correct spacing is then set by the Line Spacing Increment circuit.

Flip-flop FF2 is cleared whenever all white lines have been output ($A = 1$).

Line Spacing Memory

The Line Spacing Memory is an eight-bit binary up-counter consisting of U555 and U545. It contains the number of dark scan lines between white lines. For example, if the memory contains the number 10 and scan line number $(i + 1)$ is a white line, then scan line number $(i + 11)$ is also a white line.

Scan Line Counter and White Line Generator

This circuit consists of an eight-bit binary up-counter (U775 and U565), an eight-bit comparator (U655), a set-reset flip-flop (U675B and U675C, and another eight-bit comparator (White Line Generator U665).

The Scan Line Counter is reset to zero during vertical blanking or after the last white line of the current field has been generated.

When not reset, the Scan Line Counter counts up from zero each horizontal scan line until the counter value equals the Line Spacing Memory. These two values are compared by U655. The output pin 13 of this comparator goes to a high state when the counter equals the Line Spacing Memory and sets the set-reset flip-flop U675B and U675C. The

flip-flop resets the Scan Line Counter to zero, a white line is generated, and the sequence repeats until either the last white line is generated or vertical blanking occurs. Either of these conditions sets the Strobe-NOT pin 11 of U655 to a high state, which forces the output high, holding the set-reset flip-flop set, the Scan Line Counter reset, and disabling the White Line Generator.

The flip-flop is reset one line after vertical blanking ends, that is, at the start of the next pattern field.

The White Line Generator generates a "high" each time the Scan Line Counter is equal to zero during the pattern time (last white line not yet generated and no vertical blanking). The H Sync signal on pin 23 of U665 gates the signal "low" during sync time.

H Bar Generator and Staircase Generator

Integrated circuits U455 and U465C comprise a white line counter. The counter (U455) is enabled during pattern time, and counts the number of white lines generated in the current field. When eleven white lines have been counted, the Max/Min output goes to a high state signaling the end of pattern time. This signal sets register A (U265B) high. The white line counter value is used to generate the H Bar and staircase signals.

The H Bar Generator circuit consists of U465B, D, E, F, U675A, U475A, B, and C. The white line counter value is used to generate a horizontal bar which is centered vertically in the display. There are ten vertical sections between the eleven white lines. The horizontal bar occupies the middle six sections (states 7 through 12). See Table 3-1.

Table 3-1
Counter States

Number of White Lines Counted	Counter Value				\bar{C}	\bar{D}	\bar{A}	\bar{B}	\bar{D}	H Bar
	D	C	B	A	C	D	A	B	D	
0	0	1	0	0	0	0	0	0	0	0
1	0	1	0	1	0	0	0	0	0	0
2	0	1	1	0	0	0	0	0	0	0
3	0	1	1	1	0	0	0	1	1	1
4	1	0	0	0	1	0	0	0	0	1
5	1	0	0	1	1	0	0	0	0	1
6	1	0	1	0	1	0	0	0	0	1
7	1	0	1	1	1	0	0	0	0	1
8	1	1	0	0	0	1	0	0	0	1
9	1	1	0	1	0	0	0	0	0	0
10	1	1	1	0	0	0	0	0	0	0
11	1	1	1	1	0	0	0	0	0	0

$$H \text{ Bar} = \bar{C} D + \bar{A} \bar{B} D + A B \bar{D}$$

The rest of the circuitry in this circuit block comprises the Staircase Generator and a staircase amplifier, U595.

The value of the white line counter is used to generate an eight-level, analog staircase signal. States 6 through 13 of counter U455 enable the inputs to a digital-to-analog converter (D/A) U685 when the STAIRCASE/EXT control is pushed in and the St En (2) signal line is logic high. Binary adder U385 increments the state value so that the input to the D/A varies from 7 through 14 (the D/A input is equal to 15 for all other states).

An inverted staircase signal is present at pin 2 of U685. Note that pin 2 of U685 (Iout-NOT) is equal to zero when the input to the D/A is 15 since the other four input bits are also high. Pin 2 of U685 is at maximum negative amplitude when the input to the D/A is equal to 7. Potentiometer R789 (Staircase Amplitude) is used to adjust this amplitude, which sets the overall staircase amplitude. Pin 2 of U685 equals zero when the STAIRCASE/EXT control is not activated.

Operational amplifier U595 (staircase amplifier) is a non-inverting amplifier. It modulates the white current source (Q188) in the Video Output Drivers circuit on the Horizontal Sync Generator board (diagram 2). The negative-going staircase causes the white

current to further increase, moving the video signal closer to white. If the white current source was not varied during the staircase signal, a black flat field would be displayed because the grey and black current source are "on" while the staircase is being generated.

For signals other than a staircase, U595 sets the white current to a constant value determined by R791 (White Level).

Bounce Generator and Program Logic

The Bounce Generator circuit consists of U552, U435A, and the associated circuitry. The output of U552, a timer, is a square wave signal whose period is determined by R516, the parallel combination of R514 and R518, and C626. This signal is buffered by U435A and is available at the control panel as the BOUNCE TRIGGER. The output of the buffer (U435A) is also routed to the Video Logic circuit on the Horizontal Sync Generator board. BOUNCE RATE control (R514 accessible on the control panel) is used to set the bounce rate.

The Program Logic consists of control panel switches and a series of logic gates. This circuit combines signals and switching logic to produce signals which control the video combination logic on the Horizontal Sync Generator board. Outputs from this circuit are:

VV	H Rate Video (H Line + Flat Field + H Bar)
AA	V Line Enable
GG	V Bar Enable

Note that the WHITE/GREY signal is not combined.

VERTICAL SYNC, POWER SUPPLY



The main input signals to the Vertical Sync Generator board are 2H and Composite Sync. The output signals are block sync, V Blank, and V Sync "NOT". The block sync signal is available at the control panel as TV BLOCK SYNC.

The 2H signal is used to generate the Vertical Sync and Vertical Blank signals. It is counted up by counters and compared to the value of digital switches on the control panel. The digital switches select LINES PER TWO FIELDS or LINES OF VERTICAL BLANKING.

The Composite Sync signal is amplified and routed to the TV BLOCK SYNC connector on the control panel.

Power Supply

The power Supply circuit block provides primary supplies from which the rest of the supply voltages are derived. The primary supplies are +15 V, -15 V, and +8 V.

The +15 V supply is developed by rectifying 25VAC provided by the host mainframe. The divider network composed of R272 and (R275 + R279) is such that the dc level at pin 2 of U375 will be equal to the dc level at pin 3 only when the output voltage at TP170 is +15 V. If the output voltage at TP170 tries to exceed +15 V, the dc level at pin 2 will tend to increase above the reference zener voltage while pin 3 is held to the zener reference, pin 6 of U375 will tend to become less positive, Q283 and the series regulator transistor in the host mainframe will tend to be biased "off", and the output load will be deprived of the excess current demanded by the higher output voltage. The exact opposite is also true. If the output load demands more current (because of variations in the load), the voltage drop across R177 increases and turns Q282 "on" harder. This tends to turn Q283 and the series transistor "off", thereby inhibiting excessive current to the output load. Resistor R177 is the current-sense resistor.

The +15 V supply provides power for the three circuit boards and is used to derive all the positive supplies with the exception of some +5 V supplies which are developed from +8 V through 5 V regulators.

The -15 V supply operates in much the same manner as the +15 V supply. Pin 2 of U478, which is the junction of R370 and R371 (1% resistors), will be at 0 V when the output voltage at TP174 is at -15 V. Note that if pin 6 of U478 tries to become too negative causing the output voltage to exceed -15 V, the dc level at pin 2 becomes negative causing output pin 6 to become more positive and holding the output dc level at -15 V. Resistor R377 is the current-sense resistor. The -15 V supply is used to derive -12 V dc by U189, a -12 V regulator, and is routed to the Horizontal Sync Generator and Horizontal Line Generator boards.

The +8 V supply is provided by the host mainframe and is used to derive +5 V dc.

End-of-Field Pulse Generator

This circuit is made up of five sections with some peripheral circuitry. These five sections are: the LINES PER TWO FIELDS switch, S100A through S100D; an inverting buffer consisting of U445A through U445F, U458A through U458F, and U245D; a digital comparator consisting of U245A, U245B, U450, and U465; a 13-bit counter consisting of U345, U350, U358, and U365; and a set-reset (RS) flip-flop consisting of U250C and U250A.

The 13-bit counter counts 2H pulses. The counter state is then compared with the value of the LINES PER TWO FIELDS switch settings by the digital comparator. When the counter matches the count in the LINES PER TWO FIELDS switch, a reset signal is generated by U250B. Logic gate U250B is driven by the comparator (pin 9 of U465, pin 9 of U450, and pin 6 of U245B). When all three comparator outputs are set high, pin 6 of U250B is set low and resets the RS flip-flop (U250 C and U250A). That indicates the end of the field, and starts the vertical blanking interval counter.

Note the implicit divide-by-two condition achieved. For example, if the LINES PER TWO FIELDS switch number is odd with the switch set for lines per two fields and the input signal being 2H, the count equals the number of 2H pulses reached at the end of one field when the flip-flop is reset. The number of lines from the start of the field to the end of the field will not be a whole number. It will have a half line in it. In this way, interlace is generated.

Vertical Blanking Generator

This circuit is made up of eight sections with some peripheral circuitry. These eight sections are: LINES OF VERT BLANKING switch, S101A and B; a buffer consisting of U430A through U430F, U225D, and U225E; a digital comparator consisting of U438 and U425; an eight-bit counter consisting of U330 and U338 (vertical blanking interval counter); a differentiator consisting of U265A through U265D; a counter enable RS flip-flop consisting of U258C and U258D; and a vertical blanking counter consisting of U238B (a flip-flop) and an RS flip-flop (U325B and U325A); and a vertical sync generator consisting of U225B (a divide-by-six counter) and a flip-flop (U238B).

The 8-bit counter counts 2H pulses during the vertical blanking interval. The counter state is then compared with the value of the LINES OF VERT BLANKING switch settings by the digital comparator. When the counter matches the count in the LINES OF VERT BLANKING switch, a set signal is generated by U325C. Logic gate U325C is driven by the comparator (pin 9 of U425, pin 9 of U438). When the comparator outputs are set high (counter matches the LINES OF VERTICAL

BLANKING switch), pin 8 of U325C is set low and sets the RS flip-flop (U325B and U325A) which clears the 8-bit counter.

Flip-flop U238B and differentiator U265 A through D effectively doubles the number of 2H pulses counted by the counter so that the full number of lines of vertical blanking are counted. This prevents an implicit divide-by-two condition as in the LINES PER TWO FIELDS circuit, since 2H pulses are counted. After the counter is set to zero, it begins counting up again to the value of the LINES OF VERT BLANKING switch.

The V Blanking Reset "NOT" signal is available at pin 3 of U325A and it toggles U238B. The Q "NOT" output of U238B is fed to a differentiator (one-shot circuit) which is composed of four gates (U265A through U265D). The differentiator provides a low short pulse when it receives a low-to-high transition, otherwise its output remains high. The output of this differentiator, pin 8 of U265C, is normally high. It realizes the function (A.A "NOT"). When this circuit is fed a transition which goes from zero to one, it takes a while for that transition to reach pin 10 of U265C. Thus, for the delay time that it takes to get from the input (pins 1 and 2 of U265A) to nearly the output (pin 10 of U265C), the inputs to the NANDS gate U265C look like they are both ones because it has taken a while for the zero to get to pin 10. Therefore, this circuit produces a pulse at the output only on a zero-to-one transition at the output of U238B. This pulse resets the counter enable flip-flop (U258C and U258D) and stops the counter the second time a V Blank reset signal is generated. The first time, the output of U238B went from one to zero and the output of U265C remained high.

Thus, at the beginning of the field, the blanking counter is enabled; flip-flop U238B is cleared; and the Q "NOT" output of U238B is one. Thus, the first time that the 8-bit counter state equals the value of of the LINES OF VERT BLANKING switch, the output of U238B is toggled from a one to zero and does not stop the counter because the one-to-zero transition at the input of the differentiator does not change the output (pin 8 of U265C). However, the 8-bit counter has been reset and it counts up again until U238B clocked again. This time, the output of U238B will be a transition from zero to one and results in a pulse at the output of U265C. This pulse resets RS flip-flop U265C and U265D which disables the 8-bit counter.

Composite Sync Driver

The Composite Sync Driver is an amplifier consisting of Q220, Q317, Q417, and the associated circuitry. The amplifier provides a current drive to the TV BLOCK SYNC output connector on the control panel. It amplifies and shapes composite sync (a combination of

horizontal sync and vertical sync with no serration or equalizing pulses).

The maximum peak-to-peak amplitude of the output signal is determined by the zener diodes at the base of Q417 to approximately 6 V (unterminated). In normal usage, the output is terminated in 75 ohms and the amplitude of the output signal is 4 V peak-to-peak.

External Video Input

The External Video Input circuit consists of a transistor, Q183 with the associated circuitry. The external video signal drives the base of Q183 through the host mainframe edge connector pin 24A. This signal is available at control panel VIDEO output connectors when the STAIRCASE/EXT switch is pushed in and J445 pins are jumpered (J443 pins not jumpered). This external signal switches the video output between black and white during the active (non-blanking) time.

PERFORMANCE CHECK AND ADJUSTMENT

INTRODUCTION

Calibration consists of a Performance Check and an Adjustment Procedure. The Performance Check describes procedures to verify that the instrument is performing properly and meets the specifications listed in Section 1. The Adjustment part provides instructional steps required to recalibrate the instrument circuits. After adjustment, the performance should be checked by the procedure described under the Performance Check part. We recommend only adjusting those circuits that do not meet performance specifications.

The limits, tolerances, and waveform illustrations are aids to calibrate the instrument and are not intended as performance specifications.

HISTORY INFORMATION

The instrument and manual are periodically evaluated and revised. If modifications require changes in the calibration procedure, history applicable to earlier instruments is included as a deviation within a step or as a sub-part to a step.

RECOMMENDED TEST EQUIPMENT

The table below lists the test equipment recommended for the Performance Check and Adjustment Procedure. The characteristics specified are the minimum required for the checks. Equipment that is substituted must meet or exceed these characteristics. See Table 4-1.

Table 4-1
RECOMMENDED TEST EQUIPMENT
- Performance Check -

Equipment	Characteristics	Recommendation and Use
Oscilloscope	Mainframe Bandwidth 200 MHz or more	TEKTRONIX 7104, 7904, 7912, 7834, or 7854
	Plug-in Differential Amplifier Comparator	TEKTRONIX 7A13
	Plug-in Time Base with Delayed Sweep	TEKTRONIX 7B53A, Option 05 or 7B92A, 7B80, 7B85, 7B10
DC Voltmeter	0 to 50 V Range	TEKTRONIX DM 501A, DM 502A DM 502A, or DM 505
TM 500 Power Module	Capable of providing power to the PATTERN GENERATOR	TEKTRONIX TM 503
10X Probe	200 MHz or greater bandpass	TEKTRONIX P6061, P612 P6053B, or P6063B
Feedthrough Terminators	75 ohm (3)	Tektronix Part No. 011-0055-00
	50 ohm (3)	Tektronix Part No. 011-0049-01
Coaxial Cable	75 ohm (1)	Tektronix Part No. 012-0074-00
	50 ohm (1)	Tektronix Part No. 012-0057-01
Plug-In Extender for TM 500 Instruments		Tektronix Part No. 067-0645-01

- Adjustments -

All of the items listed above as well as the following are required for the Adjustment Procedure.

Oscilloscope plug-in	Amplifier with a Bandwidth of 225 MHz or greater.	TEKTRONIX 7A11, 7A16A, 7A19, or 7A24
----------------------	---	--------------------------------------

PERFORMANCE CHECK

INTRODUCTION

The Performance Check is used to confirm the performance of the PATTERN GENERATOR. The following procedures require the use of the test equipment listed in the Equipment Required table. If a specification is not met, turn to the Adjustment Procedure part of this section.

INCOMING INSPECTION

Connect the PATTERN GENERATOR to a display monitor and perform the Operators Checkout Procedure described in Section 2, Operating Instructions. This check is recommended for incoming inspections because it provides a reliable indication that the instrument is performing properly. The Performance Check procedure checks all instrument specifications and requires sophisticated equipment as well as technical expertise to perform.

PRELIMINARY PREPARATION

1. Connect the TTL H SYNC of the PATTERN GENERATOR to the Main Trig In of the oscilloscope timebase using a 50 ohm cable. Connect two 75 ohm feedthrough terminators and a 75 ohm cable to the VIDEO outputs of the PATTERN GENERATOR connect the cable to a 75 ohm feedthrough connected to the + Input of the the 7A13 plug-in. (Refer to Fig. 4-1.)

2. Press the FLAT FIELD button of the PATTERN GENERATOR. Leave the LINES PER TWO FIELDS, LINES OF VERT BLANKING, and HORIZONTAL ACTIVE TIME in the settings used in the Operators Checkout Procedure (these controls may be adjusted to match the standard of the intended picture monitor).

PERFORMANCE CHECK PROCEDURE

1. Check White Level (700 mV +/- 7 mV)

a. Set the 7A13 Volts/Div to 5 mV and Comparison Voltage to +0.700 V. Select Gnd for both (+) and (-) inputs and adjust the Position control to center the trace. Adjust the timebase to display one H line.

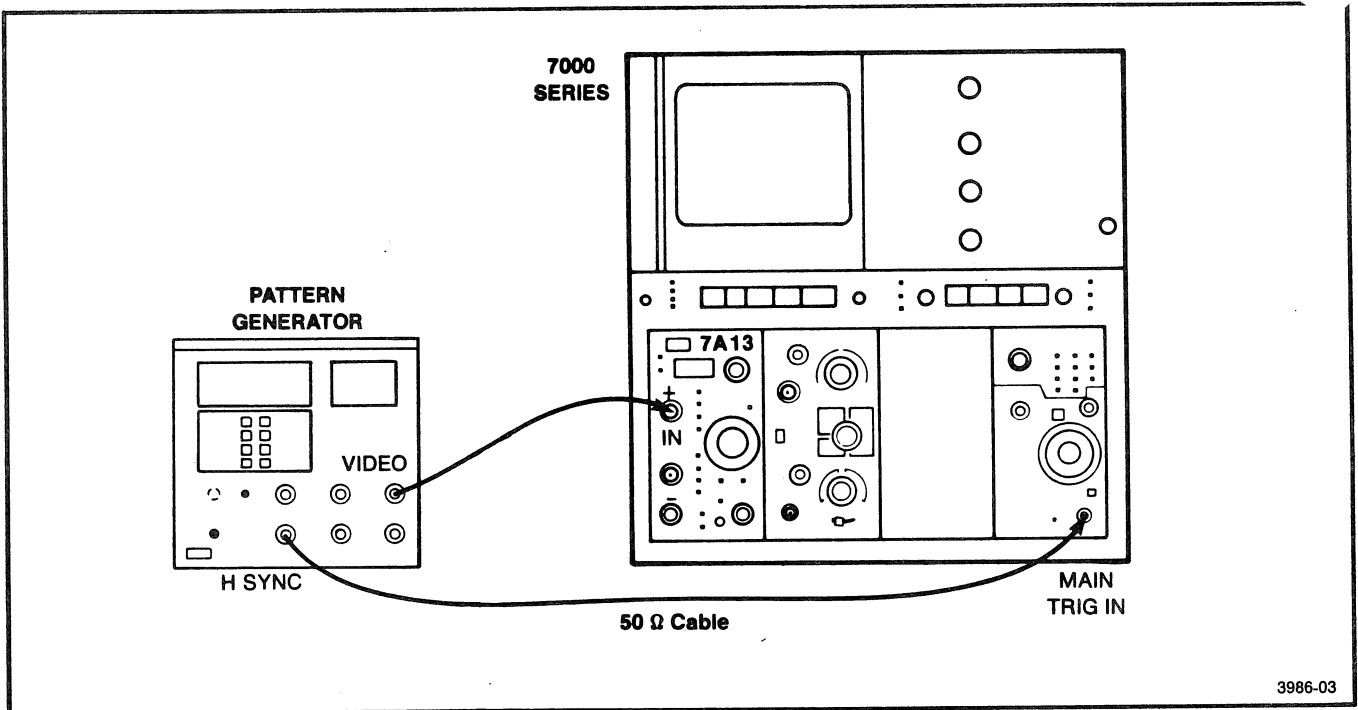

Fig. 4-1 Test Equipment Setup for Performance Checks

b. DC-couple the + input. Set the - input to VC (Voltage Compare). Check that the trace does not shift by more than +/- 7 minor divisions (+/- 7 mV).

2. Check Grey Level
(70 mV +/- 7 mV)

a. Retain the connections used in the previous step. Press the GREY button on the PATTERN GENERATOR.

b. Rotate the 7A13 Comparison Voltage to + 0.070 V.

c. Check that the trace is no further than +/- 7 minor divisions from the center (+/- 7 mV).

3. Check Blanking Level
(0 V +/- 7 mV)

a. Press Gnd on the - input of the 7A13. The trace should be within +/- 7 minor divisions of the center (+/- 7 mV).

4. Check Blanking Level Shift
(<3 mV from 0 to 100 APL)

a. Set HORIZONTAL ACTIVE TIME on the PATTERN GENERATOR to 70 μ sec. Disengage the GREY/WHITE button, leaving it out (WHITE). Push the BOUNCE button.

b. Check that the back porch (on the right side of the sync pulse) does not shift more than 3 minor divisions (+/- 3 mV) with the bouncing APL.

c. Disengage BOUNCE on PATTERN GENERATOR.

5. Check Sync Level
(-300 mV +/- 7 mV)

a. Set Comparison Voltage on 7A13 to - 0.300 V. Press VC (Voltage Compare) on the - input.

b. Check that sync tip level is within +/- 7 minor divisions (7 mV) of center screen.

6. Check Staircase Steps
(87.5 mV +/- 2%)

a. Press STAIRCASE/EXT on the PATTERN GENERATOR.

b. Set Comparison Voltage on the 7A13 to + 0.700 V.

c. Check that the top trace is within +/- 14 minor divisions of center (+/- 14 mV).

7. Check Horizontal Active Time
(10 to 70 μ sec. +/- 3% of Full Scale)

a. Press FLAT FIELD on the PATTERN GENERATOR; confirm that HORIZONTAL ACTIVE TIME is set precisely to 70 μ sec.

b. Set the oscilloscope timebase to 10 $\mu\text{sec}/\text{div}$. Set the 7A13 Volts/Div to 0.2 V, the - input to Gnd.

c. Measuring from the 50% point of the active line, check that the white pulse is 7 major divisions (70 μsec .) wide, ± 1 minor division (2 μsec .) Refer to Fig. 4-2.

d. Set the PATTERN GENERATOR HORIZONTAL ACTIVE TIME to 10 μsec .

e. Reset the oscilloscope timebase to 2 $\mu\text{sec}/\text{div}$. Measuring from the bottom of the active line, check that the white pulse is 5 major divisions (10 μsec .) across with a tolerance of ± 1 major division ($\pm 2 \mu\text{sec}$.) Refer to Fig. 4-3.

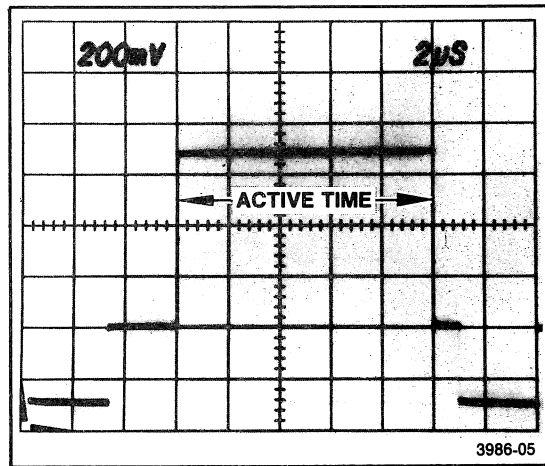
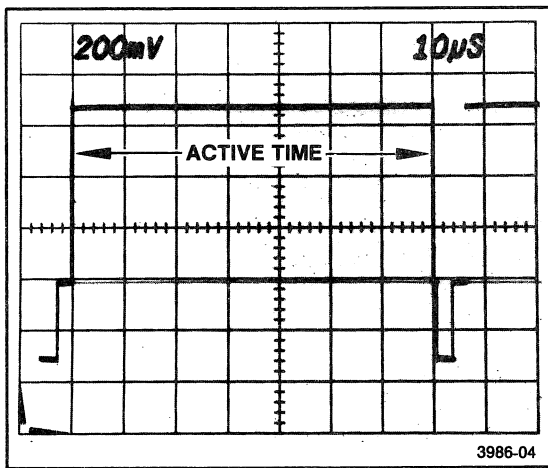

Fig. 4-2 Horizontal Active Time (70 μs)

Fig. 4-3 Horizontal Active Time (10 μs)

8. Check Horizontal Blanking Time (6.75 μsec . \pm 0.2 μsec .)

a. Set the timebase to display 1 $\mu\text{sec}/\text{div}$. Activate the delayed timebase and adjust the delay time multiplier to produce a display similar to Fig. 4-4.

b. The 50% point of the rise- and fall-time of the upper trace should be 6.75 μsec , with a tolerance of 1 minor division. If the PATTERN GENERATOR is set up for a NTSC display monitor, the horizontal blanking time should be 11.1 μsec .

9. Check Horizontal Sync Width
(3 μ sec. \pm 0.1 μ sec.)

a. Set the timebase to display 500 nsec/div. Activate the delay timebase and adjust the delay time multiplier to produce a display similar to Fig. 4-5.

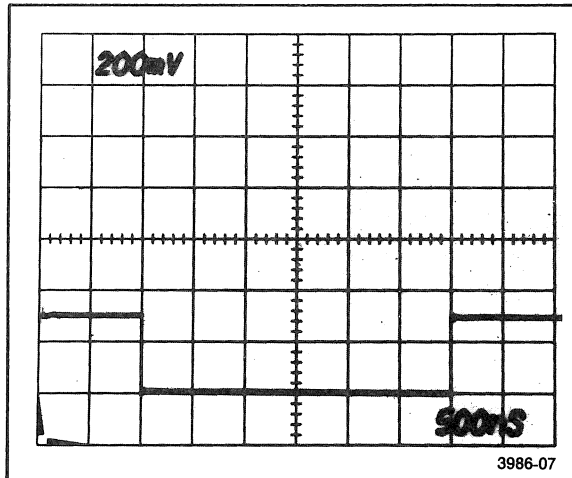
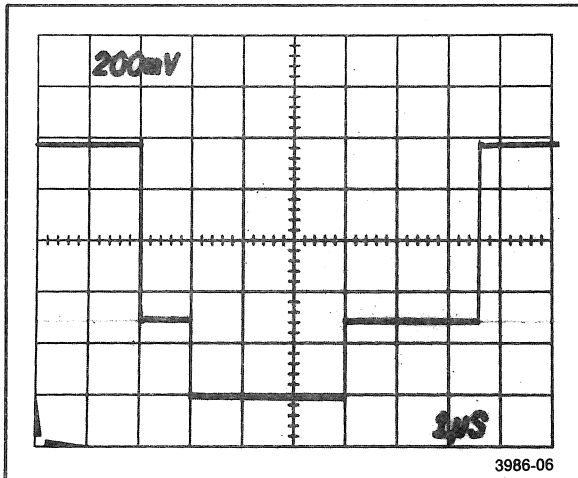

Fig. 4-4 Horizontal Blanking Time

Fig. 4-5 Horizontal Sync Width

b. The 50% point of the rise- and fall-time of the lower trace should be 6 divisions wide. The tolerance is \pm 1 minor division.

10. Check TTL White Level
(Logic 1 greater than 2.5 V)

a. Disconnect the cables from the PATTERN GENERATOR and turn off the power to the TM 500 mainframe. Remove the PATTERN GENERATOR from the mainframe, remove the cover from the left side, and change the jumper near the front of the instrument from TV to TTL (from J390 to J394). Refer to Fig. 4-6. Replace the left-side cover and replace the PATTERN GENERATOR in the TM 500 mainframe. Restore power.

b. Change the two terminators on the VIDEO output to 50 ohm feedthroughs. Change the cable to the 7A13 to a 50 ohm cable and change the feedthrough on the 7A13 to a 50 ohm type. Reconnect the TTL H SYNC output to the Main Trig In of the oscilloscope time base.

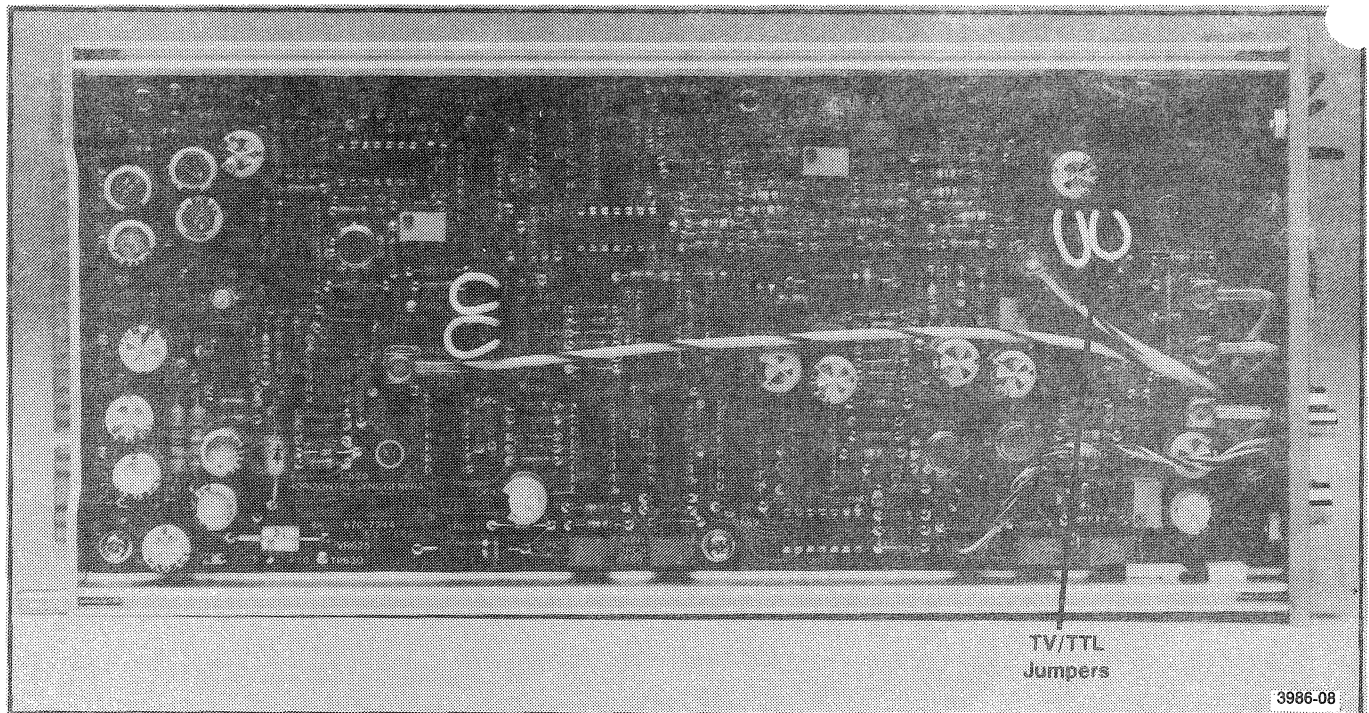

Fig. 4-6 TV to TTL Signal Level Selection

c. Set the oscilloscope Volts/Div to 1V, the - input to Gnd, and adjust the timebase to display one H line.

d. Check that the white level is greater than 2.5 V.

11. Check TTL Black Level
(Logic 0 less than 0.8 V)

a. Check that the black level is less than 0.8 V.

b. Disconnect the cables from PATTERN GENERATOR and turn off the power to the TM 500 mainframe. Remove the PATTERN GENERATOR from the mainframe, remove the cover from the left side, and change the jumper near the front of the instrument from TTL to TV (from J394 to J390). Change the three 50 ohm feedthroughs to 75 ohm feedthroughs; change the 50 ohm cable back to 75 ohm cable.

12. Check Interlace
(50% H Period +/- 5%)

a. Connect the plug-in extender between the rear connector of the PATTERN GENERATOR and the TM 500 mainframe socket. Replace the cable going to the + input of 7A13 with a 10X probe; connect the 10X probe to test point TP132 on the left side of the PATTERN GENERATOR. (TP132 is towards the rear of the Horizontal Sync Board; refer to Fig. 4-6.) Reconnect the cable from TTL H SYNC to the Main Trig Input of the oscilloscope time base.

b. Set the HORIZONTAL ACTIVE TIME control on the PATTERN GENERATOR to 10 μ sec.

c. Set the 7A13 Volts/Div to 1V. Set the time base to 1 μ sec. and adjust the Variable Sweep control so that the first and third positive-going edges of the waveform are ten divisions apart at the 2.4 V point (refer to Fig. 4-7).

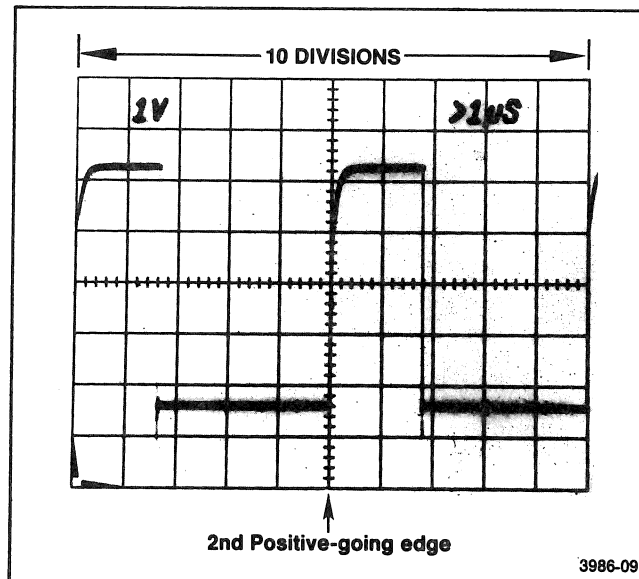

Fig. 4-7 Interlace

d. The second positive-going edge should be within +/- half a major division of the center graticule (+/- 5%).

e. Set the HORIZONTAL ACTIVE TIME to 70 μ sec.

f. Setting the time base to 5 μ sec., repeat steps "c" and "d".

Performance Check Procedure - 067-1039-00

g. Turn off the TM 500 mainframe, disconnect the plug-in extender and scope probe, and replace the cover for the left side of the PATTERN GENERATOR. Replace the PATTERN GENERATOR in the TM 500 mainframe.

This concludes the Performance Check part of the Calibration Procedure. If any specifications are not met, refer to the Adjustment Procedure that follows.

ADJUSTMENT

If the PATTERN GENERATOR is out of tolerance for a particular specification, determine the cause, repair if necessary, then use the appropriate adjustment procedure to return the instrument to specification. After any adjustment, repeat the Performance Check to verify operation.

Allow the instrument to warm up for at least 30 minutes in ambient air of +20 degrees C to +30 degrees C before performing an adjustment.

Adjustment steps that interact are noted, and reference is made within the procedure to the affected circuit or steps.

CAUTION

STATIC DISCHARGE CAN DAMAGE MANY SEMICONDUCTOR COMPONENTS USED IN THIS INSTRUMENT.

Many semiconductors, especially MOS types, can be damaged by static discharge. Damage may not be catastrophic and therefore not immediately apparent. It usually appears as a 'weakening' of the semiconductor characteristics. Devices that are particularly susceptible are: MOS, CMOS, JFETS, and high impedance operational amplifiers. Damage can be significantly reduced by observing the following precautions.

1. Handle static-sensitive components or circuit assemblies on a static-free surface. Work station areas should contain a static-free bench cover or work plane such as conductive polyethylene sheeting and a grounding wrist strap. The work plane should be connected to earth ground.
2. All test equipment, accessories, and soldering tools should be connected to earth ground.
3. Minimize handling by keeping the components in their original containers until ready for use. Minimize the removal and installation of semiconductors from their circuit boards.
4. Hold the IC devices by their body rather than the terminals.
5. Use containers made of conductive material or filled with conductive material for storage and transportation. Avoid using ordinary plastic containers. Any static sensitive part or assembly that is returned to Tektronix, Inc., should be packaged in its original container or one with anti-static packaging material.

PRELIMINARY PREPARATION

To prepare the PATTERN GENERATOR for adjustment, perform the following:

1. Disconnect all cables and turn off power to the TM 500 mainframe.
2. Remove the PATTERN GENERATOR from the mainframe and remove the left and right side panels.
3. Connect the plug-in extender cable between the mainframe socket and the PATTERN GENERATOR card edge.
4. Connect two 75 ohm feedthroughs and a 75 ohm cable to the VIDEO outputs. Connect the cable to a 75 ohm feedthrough connected to the oscilloscope amplifier plug-in. The plug-in response should equal or exceed 225 MHz.
5. Connect the TTL H SYNC output to the Main Trig In of the oscilloscope using a 50 ohm cable. Refer to Fig. 4-8. Press the FLAT FIELD button on the PATTERN GENERATOR.

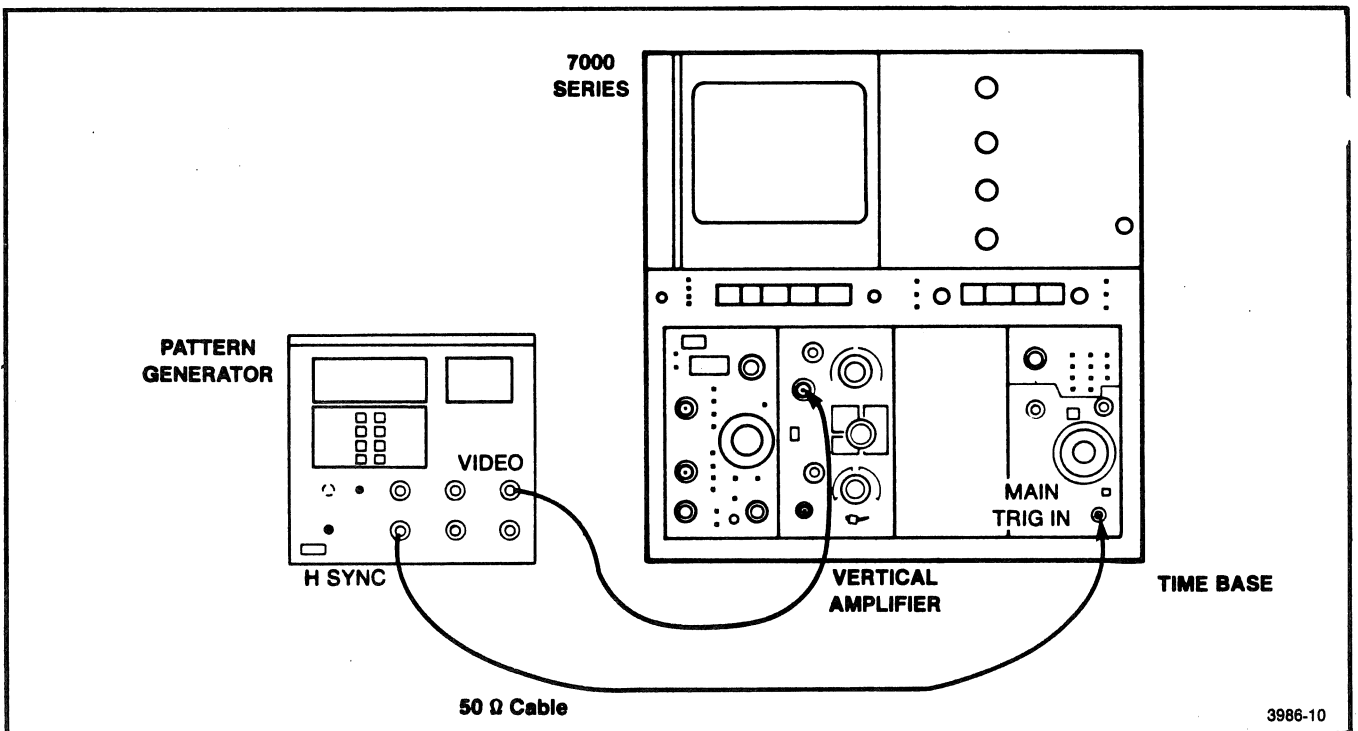

Fig. 4-8 Test Equipment Setup for Adjustment Procedure

6. Turn on the TM 500 mainframe and allow a 30-minute warmup.

ADJUSTMENT PROCEDURE

1. Adjust Power Supply

- a. Connect a 1X probe to the digital voltmeter. Clip the probe to TP174 on the Vertical Sync Generator board on the right side of the instrument (see Fig. 4-9).
- b. Adjust R275 to obtain a meter reading of +15 V +/- 0.01 V.
- c. Disconnect probe from TP174.

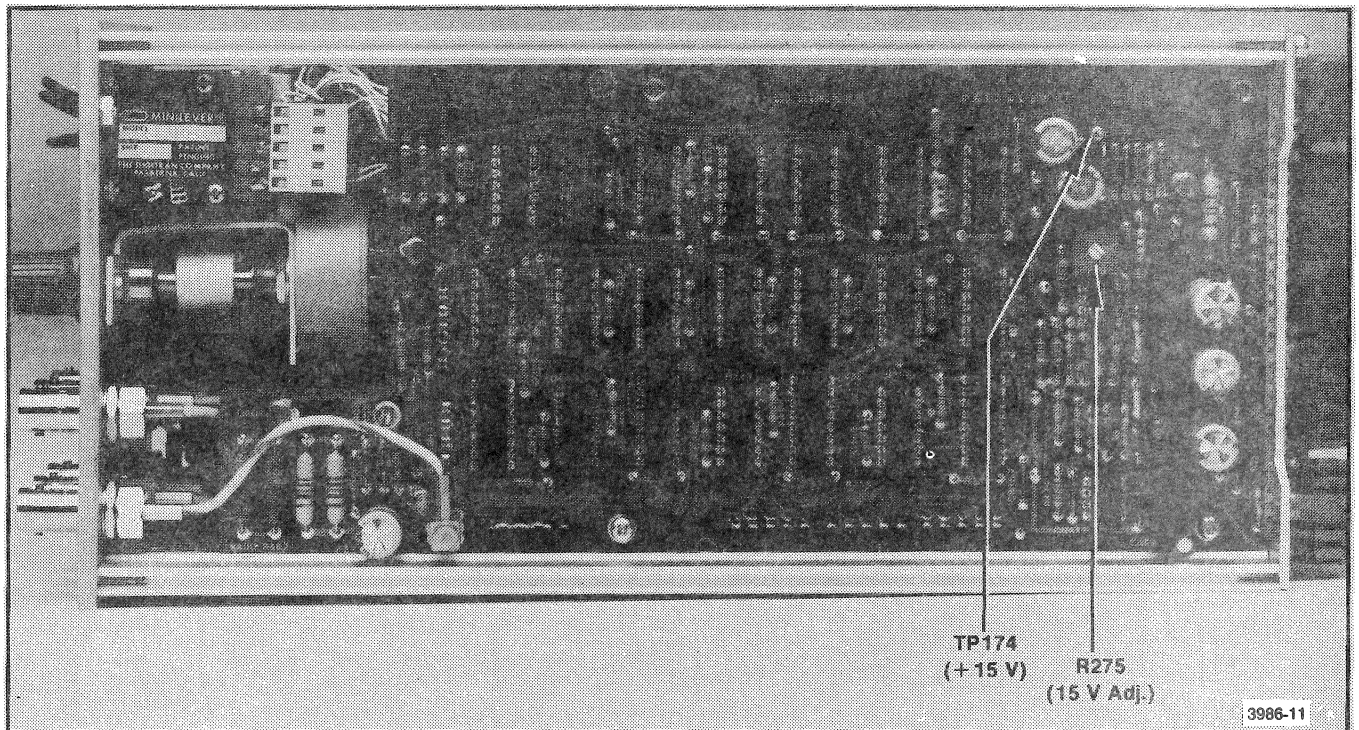

Fig. 4-9 Adjustment Locations on the Vertical Sync Generator Board

NOTE

All adjustments and test points are located on the Horizontal Sync Generator Board A1 unless specifically noted.

2. Adjust Horizontal Active Time

a. Place the PATTERN GENERATOR left-side up, revealing the Horizontal Sync Generator board.

b. Set the jumper at location J394 to TTL (refer to Fig. 4-10 for this and the following steps). This produces a TTL level video output at the VIDEO output bnc connectors.

c. Set the front panel HORIZONTAL ACTIVE TIME to 20 μ sec. Adjust R688 (AT/H) to produce a trace with a Horizontal Active Time (high level) of 20 μ sec.

d. Set the HORIZONTAL ACTIVE TIME to 70 μ sec. Adjust R692 (AT/L) to produce a trace with a Horizontal Active Time (high level) of 70 μ sec.

e. Repeat steps "c" and "d" to correct the effects of interaction.

3. Adjust Internal Horizontal Timing

a. Set the jumper to TV at location J390 (refer to Fig. 4-10 for this and the following steps). This produces a composite video level output at the VIDEO bnc connectors. Set the oscilloscope input to ac coupled.

b. Adjust R659 (Front Porch) for Front Porch width of 1 μ sec.

c. Adjust R656 (Sync) for a Horizontal Sync width of 3 μ sec.

d. Adjust R475 (H Blanking) for a Horizontal Blanking Width of 6.75 μ sec. If the PATTERN GENERATOR is to be used with a NTSC display monitor, adjust the Horizontal Blanking Width for 11.1 μ sec.

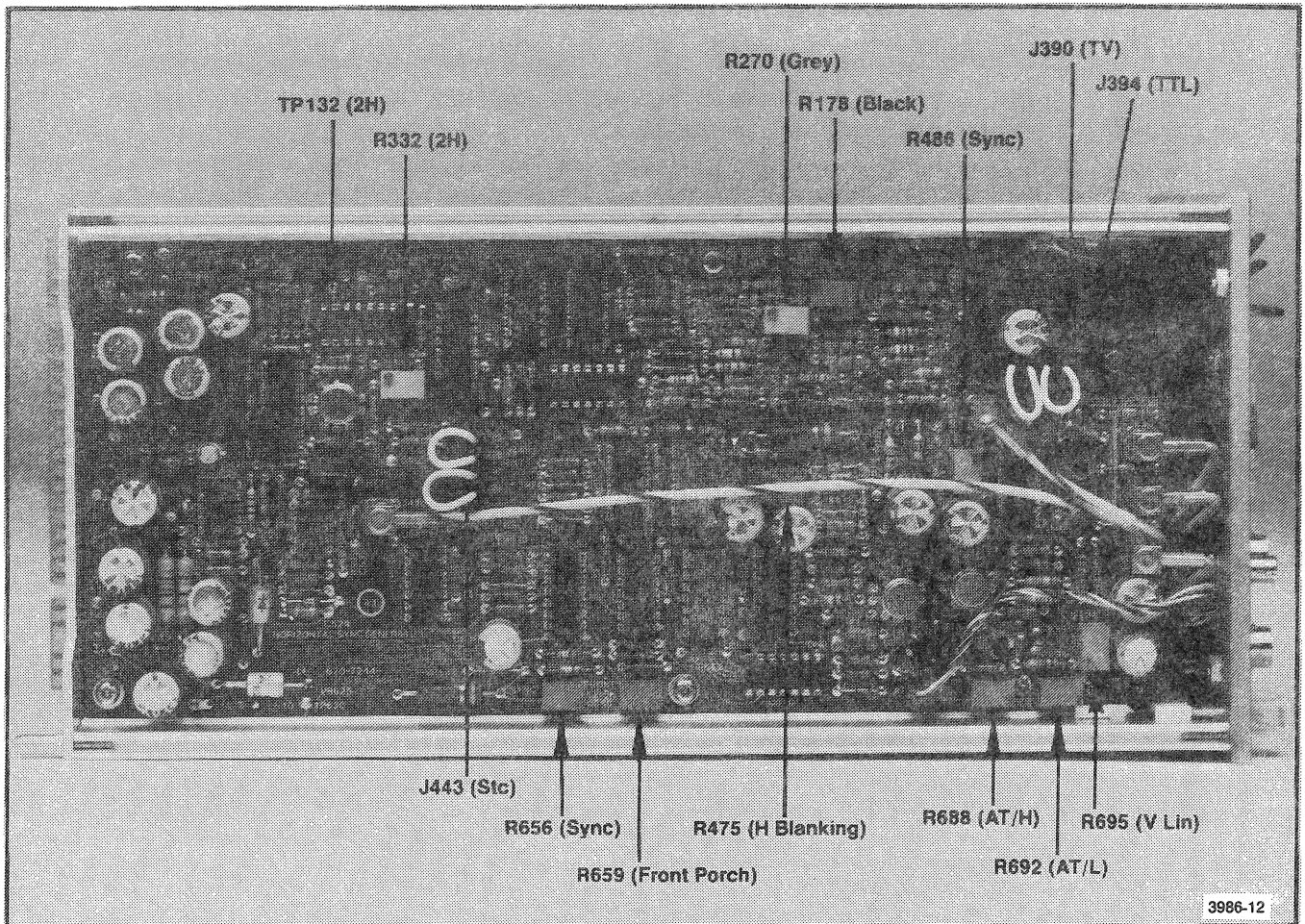

Fig. 4-10 Test Points and Adjustment Locations on the Horizontal Sync Generator Board

4. Adjust Levels

- a. Change oscilloscope input to dc coupling.
- b. Adjust R791 (Wht) on the Horizontal Line Generator board A2 so the White Level is +700 mV. Refer to Fig. 4-11.
- c. Press the GREY/WHITE button on the front panel. This produces a grey level flat field.
- d. Adjust R270 (Grey) so the Grey Level is +70 mV. Refer to Fig. 4-10.

e. Adjust R178 (Black) so the Blanking Level is 0 V.

f. Adjust R486 (Sync) so the Sync Level is -300 mV.

g. Disengage the GREY/WHITE button on the front panel. This produces a white level flat field. Repeat steps "b" through "e" to remove the effects of control interaction.

5. Adjust Staircase

a. Set Stc/Ext jumper to J443 (Stc). Press the STAIRCASE/EXT button on the front panel.

b. Set top step of staircase to 700 mV by adjusting R789 on the rear of the Horizontal Line Generator Board A2. Refer to Fig. 4-11.

6. Adjust Crosshatch Width

a. Press the CONVERGENCE button the front panel; confirm that the GREY/WHITE button is out. Set the HORIZONTAL ACTIVE TIME control to 70 μ sec. Adjust the oscilloscope to view a single vertical convergence pulse.

b. Adjust R695 (V Lin) for a half-amplitude line width of 87.5 nsec +/- 5 nsec. Refer to Fig. 4-10 for control location.

7. Adjust Interlace

a. Connect a probe to the oscilloscope input; clip the probe to test point TP132 on the Horizontal Sync Generator board (refer to Fig. 4-10).

b. Adjust R332 (2H) so the positive-going edge of the 2H pulse is centered between the positive-going edges of the H rate pulses.

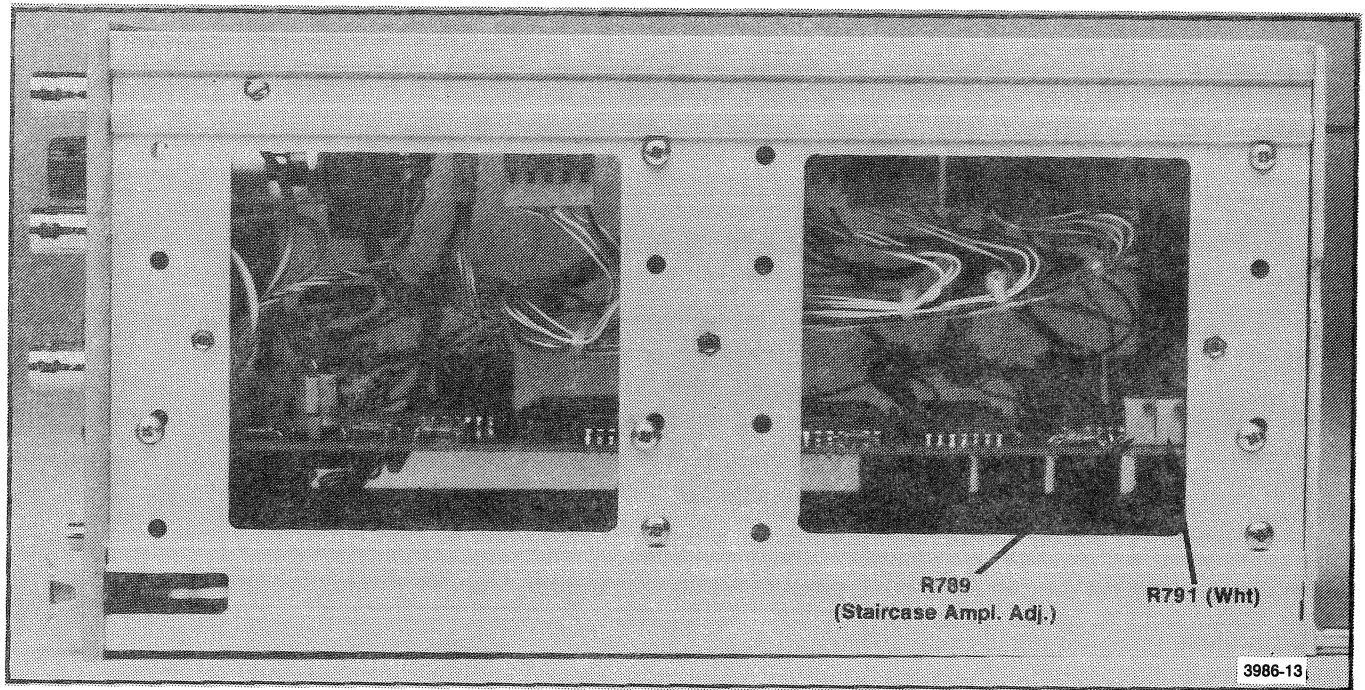

Fig. 4-11 Adjustment Locations on the Horizontal Line Generator Board

This concludes the Adjustment Procedure. Refer to the appropriate Performance Check to verify the specifications.

MAINTENANCE

PREVENTIVE MAINTENANCE

Preventive maintenance steps performed on a regular basis will improve the reliability of the PATTERN GENERATOR. However, checks of the semiconductors in the absence of a malfunction are not recommended as a maintenance measures. The recommended time for performing preventative maintenance is just before instrument adjustment.

Cleaning

CAUTION

Do not use acetone, MEK, MIBK, Benzene, toluene, carbon tetrachloride, trichloroethylene, methyl alcohol, methylene chloride, sulphuric acid, or Freon compounds for cleaning the PATTERN GENERATOR. Use only clean water and mild detergent.

Exterior - Loose dust may be removed with a soft cloth or dry brush. Water and a mild detergent may be used; however, abrasive cleaners should never be used.

Interior - Cleaning the interior of the unit should precede adjustment since the cleaning process could alter the settings of calibration adjustments. Use low-velocity compressed air to blow off accumulated dust. Hardened dirt can be removed with a soft dry brush, cotton-tipped swab, or a cloth dampened in a solution of water and mild detergent.

Lubrication

Push button switches and decade switches should receive occasional spray applications of "No Noise" lubricant and cleaner to the gold areas of the switch and circuit board.

Adjustment

After cleaning or repairs, do the performance check as described

in Section 4 of this manual. If all functions are within specification, no adjustment is needed. If one or more of the specifications are not met, calibrate the instrument as directed in Section 4.

TROUBLESHOOTING AIDS

Theory of Operation

Section 3 of this manual explains circuit operation in detail. The section is a troubleshooting aid when used in conjunction with the circuit diagrams.

Diagrams

A block diagram and detailed circuit diagrams are located on foldout pages in the Diagram section. The circuit diagrams show the component values and assigned circuit reference numbers of each component. The first page of the Diagram section defines the circuit symbols and reference designators used in the manual. Important waveforms and voltages are shown within the diagrams.

Circuit Board Illustrations

To identify electrical components when troubleshooting, turn to the Parts Location Grid that is located on the back of a foldout page at the left of the related circuit diagrams. Component values, descriptions, and ordering data are given in the Replaceable Electrical Parts list.

Component and Wiring Color Codes

Colored strips or dots on electrical components signify electrical values, tolerances, etc., according to EIA standards. Components not color coded usually have information printed on the body. Some wiring coding follow the same EIA standards.

Testing Equipment

A wideband oscilloscope (200 MHz or more) with the specified plug-ins and a DVM are required perform waveform and voltage checks for diagnostic purposes. The same equipment is used to perform the Performance Check Procedure and Adjustment Procedure.

TROUBLESHOOTING TECHNIQUES

This troubleshooting procedure is arranged in an order that checks the simple trouble possibilities before proceeding to extensive troubleshooting.

Control Settings

Incorrect control settings can appear to be an equipment problem. If there is any question about the correct function or operation of any control, see the operation instructions in Section 2.

Check for proper interconnections between the TM 500 mainframe and the plug-in module. Check that the signal is properly connected and that the interconnecting cables and signal source are not defective. Check the power source.

If the TM 500 mainframe is suspected, move the PATTERN GENERATOR to the other compartments to determine if the trouble is confined to one compartment or is common to all of them. If the trouble persists, try substituting another PATTERN GENERATOR known to be good into the power module.

Visual Check

Remove the covers from the PATTERN GENERATOR and look for broken wires, loose or unsoldered connections, or damage to the circuit board. If components damaged from overheating are found, determine the cause of overheating before replacing the component; otherwise, the new component may also be damaged.

Static-Sensitive Components



Static discharge can damage any semiconductor component in this instrument.

This instrument contains electrical components that are susceptible to damage from static discharge. See Table 5-1 for relative susceptibility of various classes of semiconductors. Static voltages of 1 kV to 30 kV are common in unprotected environments.

Observe the following precautions to avoid damage:

1. Minimize handling of static-sensitive components.
2. Transport and store static-sensitive components or assemblies in their original containers, on a metal rail, or on conductive foam. Label any package that contains static-sensitive assemblies or components.
3. Discharge the static voltage from your body by wearing a grounded wrist strap while handling these components. Servicing static-sensitive assemblies or components should be performed only at a static-free workstation by qualified service personnel.
4. Nothing capable of generating or holding a static charge should be allowed on the work station surface.
5. Keep the component leads shorted together whenever possible.
6. Pick up components by the body, never by the leads.
7. Do not slide the components over any surface.
8. Avoid handling components in areas that have a floor or work surface covering capable of generating a static charge.
9. Use a soldering iron that is connected to earth ground.
10. Use only special antistatic suction type or wick type desoldering tools.

Table 5-1

RELATIVE SUSCEPTIBILITY TO
STATIC DISCHARGE DAMAGE

Semiconductor Classes	Relative Susceptibility Levels'
Microcircuits with MOS inputs (most sensitive)	1
Schottky TTL	2
High-frequency bipolar transistors	3
Linear microcircuits	4
Low-power Schottky TTL	5
TTL (least sensitive)	6

1 = 100 to 500 V 4 = 400 to 1000 V (est.)
 2 = 500 V 5 = 900 V
 3 = 400 to 500 V 6 = 1200 V

(Voltage discharged from a 100 pF capacitor through a resistance of 100 ohms.)

Test Equipment

Before using any test equipment to make measurements on static-sensitive components or assemblies, be certain that any voltage or current supplied by the test equipment does not exceed the limits of the component to be tested.

Circuit Isolation

Note the symptom. It often identifies the circuit in which the trouble is located. When trouble symptoms appear in more than one circuit, check the affected circuits by making waveform and voltage measurements.

Incorrect operating of all circuits often means trouble in power supplies. Using a multimeter, check first for correct voltages of the individual regulated supplies according to the circuit diagrams and adjustment procedures. Then check the unregulated supplies of the power modules. Defective components elsewhere in the instruments can appear as power supply problems. In these instances, suspected circuits should be disconnected from apparently bad power supplies one at a time to narrow the search.

Voltages and Waveforms

Often defective components can be located by using waveform and voltage indications when they appear on the circuit diagram and in the theory of operation sections. Such waveforms and voltage labels are typical indications and will vary between instruments.

Component Checking

If a component cannot be disconnected from its circuit, the effects of the associated circuitry must be considered when evaluating the measurement. Except for soldered-in transistors and integrated circuits, most components can be unsoldered and lifted at one end from the circuit board.

Transistors and Integrated Circuits (IC)

Turn the power switch off before removing or replacing any semiconductor. See Fig. 5-1 for semiconductor basing.

A good check of transistor operation is actual performance under operating conditions. A transistor can most effectively be checked by substituting a new component for it (or one which has been checked previously). However, be sure that circuit conditions are not such that a replacement transistor might also be damaged. If substitute transistors are not available, use a dynamic tester. Static-type testers are not recommended since they do not check operation under simulated operating conditions. An antistatic suction-type desoldering tool can be used to remove soldered-in transistors; see component replacement procedure for details.

Integrated circuits can be checked with a voltmeter, test oscilloscope, or by direct substitution. A good understanding of the circuit description is essential to troubleshooting circuits containing integrated circuits. Operating waveforms, logic levels, and other operating information for the integrated circuits are given in the circuit description information. Use care when checking

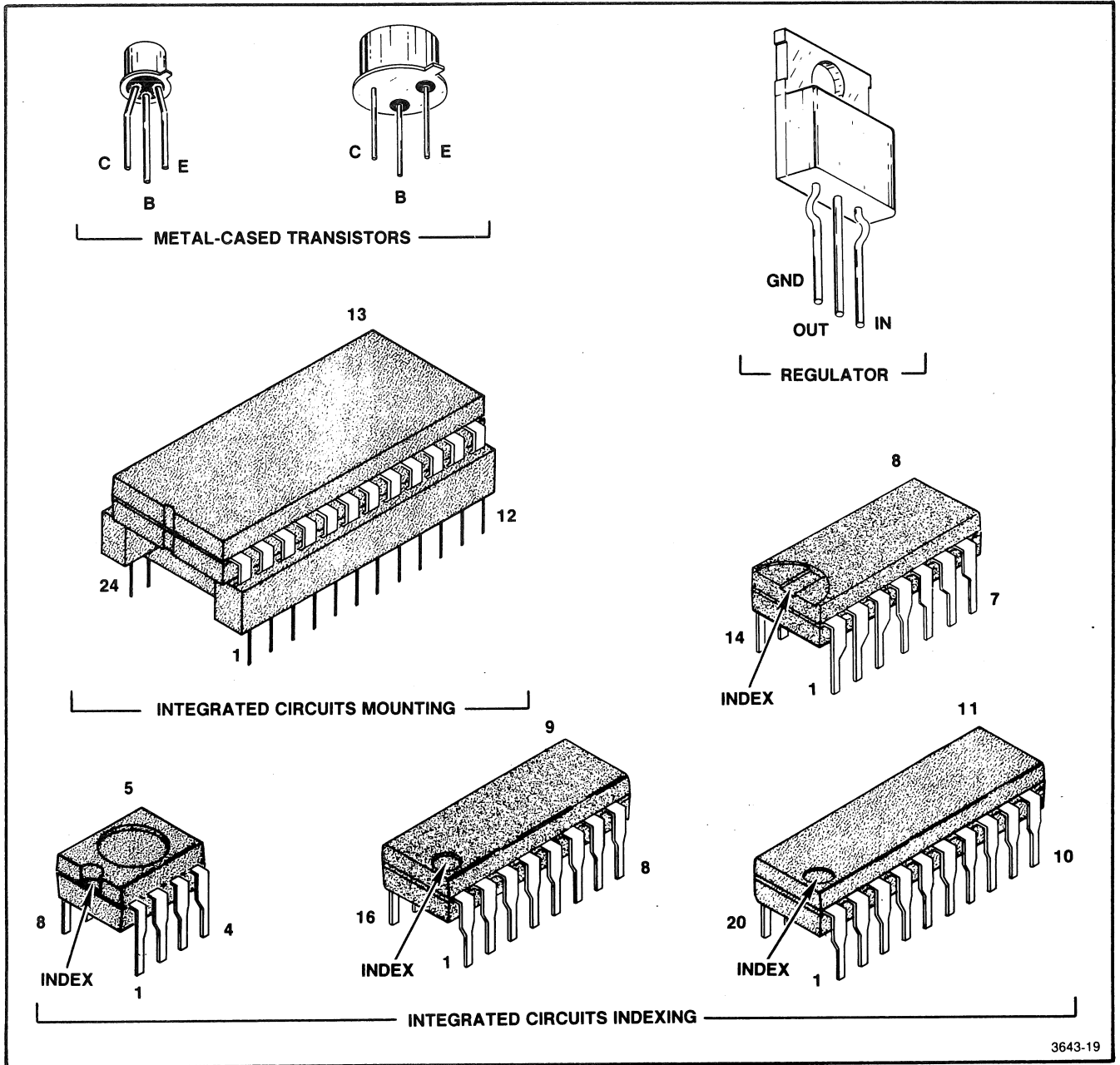

3643-19

Fig. 5-1 Semiconductor Components Basing

voltages and waveforms around the integrated circuits so that adjacent leads are not shorted together. A convenient means of clipping a test probe to the 14- and 16-pin in-line integrated circuits is with an integrated circuit test clip.

Replacement semiconductors should be of the original type or a direct replacement. Figure 5-1 shows the lead configuration of the semiconductors used in this instrument system.

Diodes

Ordinary signal diodes may be checked for an open or shorted condition by measuring the resistance between the terminals. With the ohmmeter set to the R x 1000 scale, the resistance should be very high in one direction and very low when the leads are reversed.

Resistors

Check resistors with an ohm-meter. Resistor tolerances are given in the Replaceable Electrical Parts list. Replace if value falls outside of marked tolerance.

Circuit Board Removal

NOTE

Tag or note the locations of all leads and plugs for reassembly reference.

To remove the Horizontal Sync Generator board (A1), the Horizontal Line Generator board (A2), or the Vertical Sync Generator board (A3) from the PATTERN GENERATOR follow these steps.

1. Remove the two side covers; grasp the cover at the rear of the PATTERN GENERATOR and pull away from the chassis.
2. Remove the top and bottom covers; there are screws holding each of the covers.
3. Remove the back panel; four screws and two locating posts hold the back panel.

4. Remove the nut block screws; at the top and bottom of the PATTERN GENERATOR chassis. Leave the nut blocks themselves on the boards. The Horizontal Sync Generator (A1) and the Vertical Sync Generator boards have four nut blocks each; the Horizontal Line Generator board has five nut blocks.
5. Remove the interconnect cables; both coaxial and ribbon wire.
6. Slide the boards out the back using the guide rails.

PARTS ORDERING AND REPLACING

Ordering

Standard Parts - All electrical and mechanical replacement parts can be obtained through the local Tektronix Field Office or representative. However, many of the standard electronic components can be obtained locally. Before purchasing or ordering replacement parts, check the Replaceable Parts lists for value, tolerance, rating, and description. When selecting replacement parts, it is important to remember that the physical size and shape of the component may affect its performance in an instrument. All replacement parts should be direct replacements unless it is known that a different component will not adversely affect the instrument performance.

Special Parts - Some parts are manufactured or selected by Tektronix, Inc., to satisfy particular requirements, or are manufactured for Tektronix Inc., to our specifications. Most of the mechanical parts used in this system have been manufactured by Tektronix Inc. Order all special parts directly from the local Tektronix Field Office or representative.

Ordering Procedure - When ordering replacement parts from Tektronix, Inc., please include the following minimum information:

1. Instrument type (067-1039-00 PATTERN GENERATOR).
2. Instrument serial number (for example, B010165).
3. A description of the part (if electrical, include the circuit number).
4. Tektronix part number.

A listing of Tektronix Field Offices, Service Centers, and Representatives can be found in the Tektronix Product Catalog and Supplements.

USING THE REAR INTERFACE CONNECTOR (See Table 5-2)

Input

The STAIRCASE/EXT switch provides either an internally generated monochrome staircase or an external signal. Jumper J445 on the Horizontal Sync Generator board (A1) selects the TTL external signal, which is applied to Pin 24A on the edge connector. The ground for this signal is Pin 23A.

One 25 volt ac supply is connected to Pins 1A and 1B. This is fused with a 2 amp fast-blow fuse.

A second 25 volt ac supply is connected to Pins 13A and 13B. This is fused with a 2 amp fast-blow fuse.

A +11.5 volt unregulated dc supply is connected to Pins 2A and 2B and fused with a 5 amp medium-blow fuse.

The power supply grounds are connected to Pins 3A, 3B, 4A, 4B, 25A, and 27A.

Output

The H Sync TTL output is applied to Pins 26A and 28A. The Staircase Analog output (0.7 v p-p high impedance) is applied to Pin 28B.

Table 5-2

REAR INTERFACE CONNECTOR ASSIGNMENTS

VERTICAL SYNC GENERATOR BOARD A3
B PIN# A

25 Vac Fuse-protected	01	25 Vac Fuse protected #1
+11.5 Vdc Fuse-protected	02	+11.5 Vdc Fuse-protected #2
Power Supply Ground	03	Power Supply Ground
Power Supply Ground	04	Power Supply Ground
	NC 05	NC
	NC 06	NC
	NC 07	NC
	NC 08	NC
	NC 09	NC
	NC 10	NC
	NC 11	NC
	NC 12	NC
25 Vac Fuse-protected	13	25 Vac Fuse-protected #1
	NC 14	NC
	NC 15	NC
	NC 16	NC
	NC 17	NC
	NC 18	NC
	NC 19	NC
	NC 20	NC
	NC 21	NC
	NC 22	NC
	NC 23	External TTL Video In Ground
	NC 24	External TTL Video In Signal
	NC 25	Ground
	NC 26	H Sync TTL Output
	NC 27	Ground
Staircase Analog Output	28	H Sync TTL Output

*1 Uses 2A Fast-blow

*2 Uses 5A Medium-blow

Table 5-3

MAINTENANCE AIDS

(Items required for some maintenance procedures in this instrument)

Description	Specifications	Use
1. Soldering Iron	15 Watt	General soldering and unsoldering
2. Screwdrivers	Phillips #1 tip Phillips #2 tip	Assembly and disassembly
3. Nutdrivers	3/16", 3/8"	General
4. Open End Wrench	3/16", 1/4", 7/16"	General
5. Solder Wick		Unsoldering
6. Spray Cleaner	No Noise	All push button switches
7. Vacuum Desoldering Tool	Antistatic	General

REPLACEABLE ELECTRICAL PARTS

PARTS ORDERING INFORMATION

Replacement parts are available from or through your local Tektronix, Inc. Field Office or representative.

Changes to Tektronix instruments are sometimes made to accommodate improved components as they become available, and to give you the benefit of the latest circuit improvements developed in our engineering department. It is therefore important, when ordering parts, to include the following information in your order: Part number, instrument type or number, serial number, and modification number if applicable.

If a part you have ordered has been replaced with a new or improved part, your local Tektronix, Inc. Field Office or representative will contact you concerning any change in part number.

Change information, if any, is located at the rear of this manual.

LIST OF ASSEMBLIES

A list of assemblies can be found at the beginning of the Electrical Parts List. The assemblies are listed in numerical order. When the complete component number of a part is known, this list will identify the assembly in which the part is located.

CROSS INDEX-MFR. CODE NUMBER TO MANUFACTURER

The Mfr. Code Number to Manufacturer index for the Electrical Parts List is located immediately after this page. The Cross Index provides codes, names and addresses of manufacturers of components listed in the Electrical Parts List.

ABBREVIATIONS

Abbreviations conform to American National Standard Y1.1.

COMPONENT NUMBER (column one of the Electrical Parts List)

A numbering method has been used to identify assemblies, subassemblies and parts. Examples of this numbering method and typical expansions are illustrated by the following:

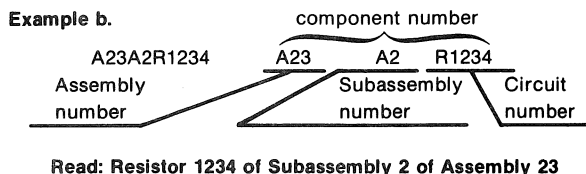
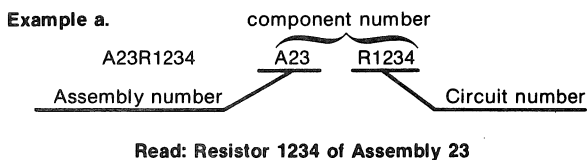

Only the circuit number will appear on the diagrams and circuit board illustrations. Each diagram and circuit board illustration is clearly marked with the assembly number. Assembly numbers are also marked on the mechanical exploded views located in the Mechanical Parts List. The component number is obtained by adding the assembly number prefix to the circuit number.

The Electrical Parts List is divided and arranged by assemblies in numerical sequence (e.g., assembly A1 with its subassemblies and parts, precedes assembly A2 with its subassemblies and parts).

Chassis-mounted parts have no assembly number prefix and are located at the end of the Electrical Parts List.

TEKTRONIX PART NO. (column two of the Electrical Parts List)

Indicates part number to be used when ordering replacement part from Tektronix.

SERIAL/MODEL NO. (columns three and four of the Electrical Parts List)

Column three (3) indicates the serial number at which the part was first used. Column four (4) indicates the serial number at which the part was removed. No serial number entered indicates part is good for all serial numbers.

NAME & DESCRIPTION (column five of the Electrical Parts List)

In the Parts List, an Item Name is separated from the description by a colon (:). Because of space limitations, an Item Name may sometimes appear as incomplete. For further Item Name identification, the U.S. Federal Cataloging Handbook H6-1 can be utilized where possible.

MFR. CODE (column six of the Electrical Parts List)

Indicates the code number of the actual manufacturer of the part. (Code to name and address cross reference can be found immediately after this page.)

MFR. PART NUMBER (column seven of the Electrical Parts List)

Indicates actual manufacturers part number.

CROSS INDEX—MFR. CODE NUMBER TO MANUFACTURER

Mfr. Code	Manufacturer	Address	City, State, Zip
00853	SANGAMO ELECTRIC CO., S. CAROLINA DIV.	P O BOX 128	PICKENS, SC 29671
01121	ALLEN-BRADLEY COMPANY	1201 2ND STREET SOUTH	MILWAUKEE, WI 53204
01295	TEXAS INSTRUMENTS, INC., SEMICONDUCTOR GROUP	P O BOX 5012, 13500 N CENTRAL EXPRESSWAY	DALLAS, TX 75222
02111	SPECTROL ELECTRONICS CORPORATION	17070 EAST GALE AVENUE	CITY OF INDUSTRY, CA 91745
04222	AVX CERAMICS, DIVISION OF AVX CORP.	P O BOX 867, 19TH AVE. SOUTH	MYRTLE BEACH, SC 29577
04713	MOTOROLA, INC., SEMICONDUCTOR PROD. DIV.	5005 E MCDOWELL RD, PO BOX 20923	PHOENIX, AZ 85036
05397	UNION CARBIDE CORPORATION, MATERIALS SYSTEMS DIVISION	11901 MADISON AVENUE	CLEVELAND, OH 44101
07126	DIGITRAN CO.	855 SOUTH ARROYO PARKWAY	PASADENA, CA 91105
07263	FAIRCHILD SEMICONDUCTOR, A DIV. OF FAIRCHILD CAMERA AND INSTRUMENT CORP.	464 ELLIS STREET	MOUNTAIN VIEW, CA 94042
14433	ITT SEMICONDUCTORS	3301 ELECTRONICS WAY P O BOX 3049	WEST PALM BEACH, FL 33402
16546	GLOBE UNION INC. USCC/CENTRALAB ELECTRONICS DIV.	4561 COLORADO	LOS ANGELES, CA 90039
24546	CORNING GLASS WORKS, ELECTRONIC COMPONENTS DIVISION	550 HIGH STREET	BRADFORD, PA 16701
27014	NATIONAL SEMICONDUCTOR CORP.	2900 SEMICONDUCTOR DR.	SANTA CLARA, CA 95051
32997	BOURNS, INC., TRIMPOT PRODUCTS DIV.	1200 COLUMBIA AVE.	RIVERSIDE, CA 92507
50434	HEWLETT-PACKARD COMPANY	640 PAGE MILL ROAD	PALO ALTO, CA 94304
54473	MATSUSHITA ELECTRIC, CORP. OF AMERICA	1 PANASONIC WAY	SECAUCUS, NJ 07094
55680	NICHICON/AMERICA/CORP.	6435 N PROESEL AVENUE	CHICAGO, IL 60645
56289	SPRAGUE ELECTRIC CO.	87 MARSHALL ST.	NORTH ADAMS, MA 01247
72982	ERIE TECHNOLOGICAL PRODUCTS, INC.	644 W. 12TH ST.	ERIE, PA 16512
73138	BECKMAN INSTRUMENTS, INC., HELIPOT DIV.	2500 HARBOR BLVD.	FULLERTON, CA 92634
75042	TRW ELECTRONIC COMPONENTS, IRC FIXED RESISTORS, PHILADELPHIA DIVISION	401 N. BROAD ST.	PHILADELPHIA, PA 19108
75915	LITTELFUSE, INC.	800 E. NORTHWEST HWY	DES PLAINES, IL 60016
80009	TEKTRONIX, INC.	P O BOX 500	BEAVERTON, OR 97077
91637	DALE ELECTRONICS, INC.	P. O. BOX 609	COLUMBUS, NE 68601
95275	VITRAMON, INC.	P O BOX 544	BRIDGEPORT, CT 06601

Replaceable Electrical Parts—067-1039-00

Component No.	Tektronix Part No.	Serial/Model No. Eff Dscont	Name & Description	Mfr Code	Mfr Part Number
A1	670-7244-00		CKT BOARD ASSY:HORIZONTAL SYNC GENERATOR	80009	670-7244-00
A2	670-7243-00		CKT BOARD ASSY:HORIZONTAL LINE GENERATOR	80009	670-7243-00
A3	670-7242-00		CKT BOARD ASSY:VERTICAL SYNC GENERATOR	80009	670-7242-00
A1	-----		CKT BOARD ASSY:HORIZONTAL SYNC GENERATOR		
A1C110	290-0778-00		CAP., FXD, ELCTLT: 1UF, +50-10%, 50V	54473	ECE-A50N1
A1C167	281-0775-00		CAP., FXD, CER DI: 0.1UF, 20%, 50V	72982	8005D9AABZ5U104M
A1C176	283-0615-00		CAP., FXD, MICA D: 33PF, 5%, 500V	00853	D155E330J0
A1C213	290-0950-00		CAP., FXD, ELCTLT: 100UF, +50-10%, 50V	55680	50ULB100VA-T
A1C215	290-0950-00		CAP., FXD, ELCTLT: 100UF, +50-10%, 50V	55680	50ULB100VA-T
A1C222	290-0846-00		CAP., FXD, ELCTLT: 47UF, -10+75%, 35 WVDC	54473	ECE-A35V47LU
A1C225	281-0775-00		CAP., FXD, CER DI: 0.1UF, 20%, 50V	72982	8005D9AABZ5U104M
A1C228	281-0775-00		CAP., FXD, CER DI: 0.1UF, 20%, 50V	72982	8005D9AABZ5U104M
A1C238	281-0775-00		CAP., FXD, CER DI: 0.1UF, 20%, 50V	72982	8005D9AABZ5U104M
A1C256	281-0775-00		CAP., FXD, CER DI: 0.1UF, 20%, 50V	72982	8005D9AABZ5U104M
A1C270	281-0775-00		CAP., FXD, CER DI: 0.1UF, 20%, 50V	72982	8005D9AABZ5U104M
A1C314	290-0950-00		CAP., FXD, ELCTLT: 100UF, +50-10%, 50V	55680	50ULB100VA-T
A1C315	290-0778-00		CAP., FXD, ELCTLT: 1UF, +50-10%, 50V	54473	ECE-A50N1
A1C319	290-0950-00		CAP., FXD, ELCTLT: 100UF, +50-10%, 50V	55680	50ULB100VA-T
A1C320	283-0616-00		CAP., FXD, MICA D: 75PF, 5%, 500V	00853	D155E750J0
A1C324	283-0594-00		CAP., FXD, MICA D: 0.001UF, 1%, 100V	00853	D151F102F0
A1C332	281-0775-00		CAP., FXD, CER DI: 0.1UF, 20%, 50V	72982	8005D9AABZ5U104M
A1C356	281-0775-00		CAP., FXD, CER DI: 0.1UF, 20%, 50V	72982	8005D9AABZ5U104M
A1C364	281-0775-00		CAP., FXD, CER DI: 0.1UF, 20%, 50V	72982	8005D9AABZ5U104M
A1C366	281-0775-00		CAP., FXD, CER DI: 0.1UF, 20%, 50V	72982	8005D9AABZ5U104M
A1C382	281-0775-00		CAP., FXD, CER DI: 0.1UF, 20%, 50V	72982	8005D9AABZ5U104M
A1C416	290-0770-00		CAP., FXD, ELCTLT: 100UF, +50-10%, 25V	56289	502D230
A1C420	283-0689-00		CAP., FXD, MICA D: 550PF, 0.5%, 300V	00853	D153F551E0
A1C432	283-0660-00		CAP., FXD, MICA D: 510PF, 2%, 500V	00853	D155F511G0
A1C436	281-0775-00		CAP., FXD, CER DI: 0.1UF, 20%, 50V	72982	8005D9AABZ5U104M
A1C438	281-0775-00		CAP., FXD, CER DI: 0.1UF, 20%, 50V	72982	8005D9AABZ5U104M
A1C462	283-0353-00		CAP., FXD, CER DI: 0.1UF, 10%, 50V	95275	VJ1210Y104K-H
A1C475	281-0775-00		CAP., FXD, CER DI: 0.1UF, 20%, 50V	72982	8005D9AABZ5U104M
A1C482	290-0770-00		CAP., FXD, ELCTLT: 100UF, +50-10%, 25V	56289	502D230
A1C485	281-0775-00		CAP., FXD, CER DI: 0.1UF, 20%, 50V	72982	8005D9AABZ5U104M
A1C497	290-0771-00		CAP., FXD, ELCTLT: 220UF, +50-10%, 10VDC	54473	ECE-A10V220L
A1C498	281-0775-00		CAP., FXD, CER DI: 0.1UF, 20%, 50V	72982	8005D9AABZ5U104M
A1C512	290-0770-00		CAP., FXD, ELCTLT: 100UF, +50-10%, 25V	56289	502D230
A1C522	281-0775-00		CAP., FXD, CER DI: 0.1UF, 20%, 50V	72982	8005D9AABZ5U104M
A1C523	290-0778-00		CAP., FXD, ELCTLT: 1UF, +50-10%, 50V	54473	ECE-A50N1
A1C524	281-0775-00		CAP., FXD, CER DI: 0.1UF, 20%, 50V	72982	8005D9AABZ5U104M
A1C525	281-0775-00		CAP., FXD, CER DI: 0.1UF, 20%, 50V	72982	8005D9AABZ5U104M
A1C526	290-0950-00		CAP., FXD, ELCTLT: 100UF, +50-10%, 50V	55680	50ULB100VA-T
A1C529	281-0775-00		CAP., FXD, CER DI: 0.1UF, 20%, 50V	72982	8005D9AABZ5U104M
A1C533	283-0203-00		CAP., FXD, CER DI: 0.47UF, 20%, 50V	72982	8131N075E474M
A1C542	281-0775-00		CAP., FXD, CER DI: 0.1UF, 20%, 50V	72982	8005D9AABZ5U104M
A1C552	283-0353-00		CAP., FXD, CER DI: 0.1UF, 10%, 50V	95275	VJ1210Y104K-H
A1C565	290-0846-00		CAP., FXD, ELCTLT: 47UF, -10+75%, 35 WVDC	54473	ECE-A35V47LU
A1C570	290-0770-00		CAP., FXD, ELCTLT: 100UF, +50-10%, 25V	56289	502D230
A1C580	283-0353-00		CAP., FXD, CER DI: 0.1UF, 10%, 50V	95275	VJ1210Y104K-H
A1C584	283-0649-00		CAP., FXD, MICA D: 105PF, 1%, 300V	00853	D153F1050F0
A1C586	290-0770-00		CAP., FXD, ELCTLT: 100UF, +50-10%, 25V	56289	502D230
A1C587	283-0353-00		CAP., FXD, CER DI: 0.1UF, 10%, 50V	95275	VJ1210Y104K-H
A1C590	281-0775-00		CAP., FXD, CER DI: 0.1UF, 20%, 50V	72982	8005D9AABZ5U104M
A1C597	290-0770-00		CAP., FXD, ELCTLT: 100UF, +50-10%, 25V	56289	502D230
A1C612	290-0770-00		CAP., FXD, ELCTLT: 100UF, +50-10%, 25V	56289	502D230

Replaceable Electrical Parts—067-1039-00

Component No.	Tektronix Part No.	Serial/Model No. Eff Dscont	Name & Description	Mfr Code	Mfr Part Number
A1C614	290-0770-00		CAP., FXD, ELCTLT: 100UF, +50-10%, 25V	56289	502D230
A1C620	290-0950-00		CAP., FXD, ELCTLT: 100UF, +50-10%, 50V	55680	50ULB100VA-T
A1C626	281-0775-00		CAP., FXD, CER DI: 0.1UF, 20%, 50V	72982	8005D9AABZ5U104M
A1C646	290-0846-00		CAP., FXD, ELCTLT: 47UF, -10+75%, 35 WVDC	54473	ECE-A35V47LU
A1C648	283-0353-00		CAP., FXD, CER DI: 0.1UF, 10%, 50V	95275	VJ1210Y104K-H
A1C650	283-0252-00		CAP., FXD, CER DI: 1000PF, 10%, 50V	04222	ULA105C102K2T60
A1C652	283-0338-00		CAP., FXD, CER DI: 330PF, 10%, 100V	16546	N100CJ331K
A1C654	283-0353-00		CAP., FXD, CER DI: 0.1UF, 10%, 50V	95275	VJ1210Y104K-H
A1C662	283-0353-00		CAP., FXD, CER DI: 0.1UF, 10%, 50V	95275	VJ1210Y104K-H
A1C666	283-0397-00		CAP., FXD, CER DI: 1160PF, 2%, 100V	04222	3430100A1160PFG
A1C667	283-0353-00		CAP., FXD, CER DI: 0.1UF, 10%, 50V	95275	VJ1210Y104K-H
A1C672	283-0416-00		CAP., FXD, CER DI: 47PF, 5%, 100V	05397	C1005C470J1GAH
A1C673	281-0775-00		CAP., FXD, CER DI: 0.1UF, 20%, 50V	72982	8005D9AABZ5U104M
A1C684	283-0597-00		CAP., FXD, MICA D: 470PF, 10%, 300V	00853	D153E471K0
A1C688	283-0177-00		CAP., FXD, CER DI: 1UF, +80-20%, 25V	56289	273C5
A1C692	283-0353-00		CAP., FXD, CER DI: 0.1UF, 10%, 50V	95275	VJ1210Y104K-H
A1C694	283-0353-00		CAP., FXD, CER DI: 0.1UF, 10%, 50V	95275	VJ1210Y104K-H
A1C698	290-0846-00		CAP., FXD, ELCTLT: 47UF, -10+75%, 35 WVDC	54473	ECE-A35V47LU
A1CR164	152-0141-02		SEMICON D DEVICE: SILICON, 30V, 150MA	01295	1N4152R
A1CR175	152-0141-02		SEMICON D DEVICE: SILICON, 30V, 150MA	01295	1N4152R
A1CR188	152-0141-02		SEMICON D DEVICE: SILICON, 30V, 150MA	01295	1N4152R
A1CR244	152-0141-02		SEMICON D DEVICE: SILICON, 30V, 150MA	01295	1N4152R
A1CR256	152-0141-02		SEMICON D DEVICE: SILICON, 30V, 150MA	01295	1N4152R
A1CR262	152-0141-02		SEMICON D DEVICE: SILICON, 30V, 150MA	01295	1N4152R
A1CR264	152-0322-00		SEMICON D DEVICE: SILICON, 15V, HOT CARRIER	50434	5082-2672
A1CR267	152-0322-00		SEMICON D DEVICE: SILICON, 15V, HOT CARRIER	50434	5082-2672
A1CR268	152-0322-00		SEMICON D DEVICE: SILICON, 15V, HOT CARRIER	50434	5082-2672
A1CR280	152-0322-00		SEMICON D DEVICE: SILICON, 15V, HOT CARRIER	50434	5082-2672
A1CR347	152-0141-02		SEMICON D DEVICE: SILICON, 30V, 150MA	01295	1N4152R
A1CR360	152-0141-02		SEMICON D DEVICE: SILICON, 30V, 150MA	01295	1N4152R
A1CR362	152-0141-02		SEMICON D DEVICE: SILICON, 30V, 150MA	01295	1N4152R
A1CR374	152-0322-00		SEMICON D DEVICE: SILICON, 15V, HOT CARRIER	50434	5082-2672
A1CR377	152-0141-02		SEMICON D DEVICE: SILICON, 30V, 150MA	01295	1N4152R
A1CR382	152-0141-02		SEMICON D DEVICE: SILICON, 30V, 150MA	01295	1N4152R
A1CR424	152-0141-02		SEMICON D DEVICE: SILICON, 30V, 150MA	01295	1N4152R
A1CR425	152-0246-01		SEMICON D DEVICE: SILICON, SW, 40V, 200MA, TEST	80009	152-0246-01
A1CR453	152-0141-02		SEMICON D DEVICE: SILICON, 30V, 150MA	01295	1N4152R
A1CR454	152-0141-02		SEMICON D DEVICE: SILICON, 30V, 150MA	01295	1N4152R
A1CR466	152-0141-02		SEMICON D DEVICE: SILICON, 30V, 150MA	01295	1N4152R
A1CR479	152-0141-02		SEMICON D DEVICE: SILICON, 30V, 150MA	01295	1N4152R
A1CR525	152-0246-01		SEMICON D DEVICE: SILICON, SW, 40V, 200MA, TEST	80009	152-0246-01
A1CR547	152-0141-02		SEMICON D DEVICE: SILICON, 30V, 150MA	01295	1N4152R
A1CR550	152-0141-02		SEMICON D DEVICE: SILICON, 30V, 150MA	01295	1N4152R
A1CR554	152-0141-02		SEMICON D DEVICE: SILICON, 30V, 150MA	01295	1N4152R
A1CR560	152-0141-02		SEMICON D DEVICE: SILICON, 30V, 150MA	01295	1N4152R
A1CR658	152-0141-02		SEMICON D DEVICE: SILICON, 30V, 150MA	01295	1N4152R
A1CR677	152-0141-02		SEMICON D DEVICE: SILICON, 30V, 150MA	01295	1N4152R
A1Q178	151-0712-00		TRANSISTOR: SILICON, NPN	04713	SPS8223
A1Q188	151-0220-00		TRANSISTOR: SILICON, PNP	07263	S036228
A1Q276	151-0712-00		TRANSISTOR: SILICON, NPN	04713	SPS8223
A1Q282	151-0367-01		TRANSISTOR: SILICON, NPN, SEL	01295	SKC0536
A1Q286	151-0367-01		TRANSISTOR: SILICON, NPN, SEL	01295	SKC0536
A1Q288	151-0367-01		TRANSISTOR: SILICON, NPN, SEL	01295	SKC0536
A1Q290	151-0367-01		TRANSISTOR: SILICON, NPN, SEL	01295	SKC0536
A1Q372	151-0712-00		TRANSISTOR: SILICON, NPN	04713	SPS8223
A1Q396	151-1120-00		TRANSISTOR: FE, P CHANNEL, SI, VP-3, TO-92	80009	151-1120-00
A1Q398	151-1120-00		TRANSISTOR: FE, P CHANNEL, SI, VP-3, TO-92	80009	151-1120-00

Replaceable Electrical Parts—067-1039-00

Component No.	Tektronix Part No.	Serial/Model No. Eff Dscnt	Name & Description	Mfr Code	Mfr Part Number
A1Q420	151-0302-01		TRANSISTOR:SILICON,NPN,SEL	80009	151-0302-01
A1Q680	151-0424-03		TRANSISTOR:2N5769,SCREENED	80009	151-0424-03
A1Q685	151-0216-02		TRANSISTOR:PNP,SI PRESTRESSED & TESTED	80009	151-0216-02
A1Q688	151-0216-02		TRANSISTOR:PNP,SI PRESTRESSED & TESTED	80009	151-0216-02
A1R115	307-0093-00		RES.,FXD,CMPSN:1.2 OHM,5%,0.50W	01121	EB12G5
A1R119	307-0093-00		RES.,FXD,CMPSN:1.2 OHM,5%,0.50W	01121	EB12G5
A1R136	315-0101-00		RES.,FXD,CMPSN:100 OHM,5%,0.25W	01121	CB1015
A1R154	321-0184-00		RES.,FXD,FILM:806 OHM,1%,0.125W	91637	MFF1816G806ROF
A1R155	315-0102-00		RES.,FXD,CMPSN:1K OHM,5%,0.25W	01121	CB1025
A1R156	315-0102-00		RES.,FXD,CMPSN:1K OHM,5%,0.25W	01121	CB1025
A1R158	315-0102-00		RES.,FXD,CMPSN:1K OHM,5%,0.25W	01121	CB1025
A1R175	315-0752-00		RES.,FXD,CMPSN:7.5K OHM,5%,0.25W	01121	CB7525
A1R176	315-0470-00		RES.,FXD,CMPSN:47 OHM,5%,0.25W	01121	CB4705
A1R177	321-0232-00		RES.,FXD,FILM:2.55K OHM,1%,0.125W	91637	MFF1816G25500F
A1R178	311-1943-00		RES.,VAR,NONWIR:10K OHM,10%,0.50W	73138	68-10-0
A1R184	315-0470-00		RES.,FXD,CMPSN:47 OHM,5%,0.25W	01121	CB1025
A1R186	315-0223-00		RES.,FXD,CMPSN:22K OHM,5%,0.25W	01121	CB2235
A1R188	321-0193-00		RES.,FXD,FILM:1K OHM,1%,0.125W	91637	MFF1816G10000F
A1R192	321-0110-00		RES.,FXD,FILM:137 OHM,1%,0.125W	91637	MFF1816G137ROF
A1R212	307-0093-00		RES.,FXD,CMPSN:1.2 OHM,5%,0.50W	01121	EB12G5
A1R217	307-0093-00		RES.,FXD,CMPSN:1.2 OHM,5%,0.50W	01121	EB12G5
A1R225	315-0102-00		RES.,FXD,CMPSN:1K OHM,5%,0.25W	01121	CB1025
A1R226	315-0102-00		RES.,FXD,CMPSN:1K OHM,5%,0.25W	01121	CB1025
A1R227	315-0112-00		RES.,FXD,CMPSN:1.1K OHM,5%,0.25W	01121	CB1125
A1R228	315-0472-00		RES.,FXD,CMPSN:4.7K OHM,5%,0.25W	01121	CB4725
A1R233	315-0112-00		RES.,FXD,CMPSN:1.1K OHM,5%,0.25W	01121	CB1125
A1R235	315-0104-00		RES.,FXD,CMPSN:100K OHM,5%,0.25W	01121	CB1045
A1R238	315-0112-00		RES.,FXD,CMPSN:1.1K OHM,5%,0.25W	01121	CB1125
A1R255	315-0102-00		RES.,FXD,CMPSN:1K OHM,5%,0.25W	01121	CB1025
A1R256	315-0102-00		RES.,FXD,CMPSN:1K OHM,5%,0.25W	01121	CB1025
A1R260	321-0253-00		RES.,FXD,FILM:4.22K OHM,1%,0.125W	91637	MFF1816G42200F
A1R266	315-0470-00		RES.,FXD,CMPSN:47 OHM,5%,0.25W	01121	CB4705
A1R268	321-0135-00		RES.,FXD,FILM:249 OHM,1%,0.125W	91637	MFF1816G249ROF
A1R269	321-0184-00		RES.,FXD,FILM:806 OHM,1%,0.125W	91637	MFF1816G806ROF
A1R270	311-1175-00		RES.,VAR,NONWIR:100 OHM,10%,0.50W	73138	68WR100
A1R272	321-0227-00		RES.,FXD,FILM:2.26K OHM,1%,0.125W	91637	MFF1816G22600F
A1R274	315-0470-00		RES.,FXD,CMPSN:47 OHM,5%,0.25W	01121	CB4705
A1R276	315-0470-00		RES.,FXD,CMPSN:47 OHM,5%,0.25W	01121	CB4705
A1R278	315-0470-00		RES.,FXD,CMPSN:47 OHM,5%,0.25W	01121	CB4705
A1R282	315-0101-00		RES.,FXD,CMPSN:100 OHM,5%,0.25W	01121	CB1015
A1R284	321-0154-00		RES.,FXD,FILM:392 OHM,1%,0.125W	91637	MFF1816G392ROF
A1R286	321-0154-00		RES.,FXD,FILM:392 OHM,1%,0.125W	91637	MFF1816G392ROF
A1R287	315-0131-00		RES.,FXD,CMPSN:130 OHM,5%,0.25W	01121	CB1315
A1R289	315-0101-00		RES.,FXD,CMPSN:100 OHM,5%,0.25W	01121	CB1015
A1R298	315-0101-00		RES.,FXD,CMPSN:100 OHM,5%,0.25W	01121	CB1015
A1R320	315-0682-00		RES.,FXD,CMPSN:6.8K OHM,5%,0.25W	01121	CB6825
A1R325	321-0289-00		RES.,FXD,FILM:10K OHM,1%,0.125W	91637	MFF1816G10001F
A1R330	315-0472-00		RES.,FXD,CMPSN:4.7K OHM,5%,0.25W	01121	CB4725
A1R332	311-1944-00		RES.,VAR,NONWIR:1K OHM,10%,0.50W	32997	3299W-R27-102
A1R339	321-0256-00		RES.,FXD,FILM:4.53K OHM,1%,0.125W	91637	MFF1816G45300F
A1R345	315-0102-00		RES.,FXD,CMPSN:1K OHM,5%,0.25W	01121	CB1025
A1R346	315-0472-00		RES.,FXD,CMPSN:4.7K OHM,5%,0.25W	01121	CB4725
A1R348	315-0102-00		RES.,FXD,CMPSN:1K OHM,5%,0.25W	01121	CB1025
A1R362	321-0184-00		RES.,FXD,FILM:806 OHM,1%,0.125W	91637	MFF1816G806ROF
A1R364	321-0253-00		RES.,FXD,FILM:4.22K OHM,1%,0.125W	91637	MFF1816G42200F
A1R366	321-0253-00		RES.,FXD,FILM:4.22K OHM,1%,0.125W	91637	MFF1816G42200F
A1R369	315-0112-00		RES.,FXD,CMPSN:1.1K OHM,5%,0.25W	01121	CB1125

Replaceable Electrical Parts—067-1039-00

Component No.	Tektronix Part No.	Serial/Model No. Eff Dscont	Name & Description	Mfr Code	Mfr Part Number
A1R372	321-0165-00		RES., FXD, FILM: 511 OHM, 1%, 0.125W	91637	MFF1816G511ROF
A1R379	303-0151-00		RES., FXD, CMPSN: 150 OHM, 5%, 1W	01121	GB1515
A1R380	321-0160-00		RES., FXD, FILM: 453 OHM, 1%, 0.125W	91637	MFF1816G453ROF
A1R385	315-0101-00		RES., FXD, CMPSN: 100 OHM, 5%, 0.25W	01121	CB1015
A1R399	321-0039-00		RES., FXD, FILM: 24.9 OHM, 1%, 0.125W	91637	MFF1816G24R90F
A1R412	315-0472-00		RES., FXD, CMPSN: 4.7K OHM, 5%, 0.25W	01121	CB4725
A1R414	315-0104-00		RES., FXD, CMPSN: 100K OHM, 5%, 0.25W	01121	CB1045
A1R422	321-0338-00		RES., FXD, FILM: 32.4K OHM, 1%, 0.125W	91637	MFF1816G32401F
A1R424	315-0105-00		RES., FXD, CMPSN: 1M OHM, 5%, 0.25W	01121	CB1055
A1R430	321-0256-00		RES., FXD, FILM: 4.53K OHM, 1%, 0.125W	91637	MFF1816G45300F
A1R432	315-0472-00		RES., FXD, CMPSN: 4.7K OHM, 5%, 0.25W	01121	CB4725
A1R434	321-0228-00		RES., FXD, FILM: 2.32K OHM, 1%, 0.125W	91637	MFF1816G23200F
A1R452	315-0112-00		RES., FXD, CMPSN: 1.1K OHM, 5%, 0.25W	01121	CB1125
A1R453	315-0102-00		RES., FXD, CMPSN: 1K OHM, 5%, 0.25W	01121	CB1025
A1R456	315-0112-00		RES., FXD, CMPSN: 1.1K OHM, 5%, 0.25W	01121	CB1125
A1R458	315-0472-00		RES., FXD, CMPSN: 4.7K OHM, 5%, 0.25W	01121	CB4725
A1R459	315-0472-00		RES., FXD, CMPSN: 4.7K OHM, 5%, 0.25W	01121	CB4725
A1R465	315-0112-00		RES., FXD, CMPSN: 1.1K OHM, 5%, 0.25W	01121	CB1125
A1R468	315-0472-00		RES., FXD, CMPSN: 4.7K OHM, 5%, 0.25W	01121	CB4725
A1R475	311-1897-00		RES., VAR, NONWIR: 25K OHM, 10%, 0.50W	32997	3299W-1-253
A1R480	321-0192-00		RES., FXD, FILM: 976 OHM, 1%, 0.125W	91637	MFF1816G976ROF
A1R484	321-0227-00		RES., FXD, FILM: 2.26K OHM, 1%, 0.125W	91637	MFF1816G22600F
A1R486	311-1175-00		RES., VAR, NONWIR: 100 OHM, 10%, 0.50W	73138	68WR100
A1R488	315-0472-00		RES., FXD, CMPSN: 4.7K OHM, 5%, 0.25W	01121	CB4725
A1R490	315-0181-00		RES., FXD, CMPSN: 180 OHM, 5%, 0.25W	01121	CB1815
A1R491	308-0710-00		RES., FXD, WW: 0.27 OHM, 10%, 1W	75042	BW20-R2700J
A1R492	315-0181-00		RES., FXD, CMPSN: 180 OHM, 5%, 0.25W	01121	CB1815
A1R494	321-0039-00		RES., FXD, FILM: 24.9 OHM, 1%, 0.125W	91637	MFF1816G24R90F
A1R514	307-0093-00		RES., FXD, CMPSN: 1.2 OHM, 5%, 0.50W	01121	EB12G5
A1R515	323-0112-00		RES., FXD, FILM: 143 OHM, 1%, 0.50W	75042	CECT0-1430F
A1R516	323-0119-00		RES., FXD, FILM: 169 OHM, 1%, 0.50W	75042	CECT0-1690F
A1R523	315-0472-00		RES., FXD, CMPSN: 4.7K OHM, 5%, 0.25W	01121	CB4725
A1R524	315-0224-00		RES., FXD, CMPSN: 220K OHM, 5%, 0.25W	01121	CB2245
A1R532	321-0418-00		RES., FXD, FILM: 221K OHM, 1%, 0.125W	91637	MFF1816G22102F
A1R542	315-0472-00		RES., FXD, CMPSN: 4.7K OHM, 5%, 0.25W	01121	CB4725
A1R543	315-0112-00		RES., FXD, CMPSN: 1.1K OHM, 5%, 0.25W	01121	CB1125
A1R545	315-0112-00		RES., FXD, CMPSN: 1.1K OHM, 5%, 0.25W	01121	CB1125
A1R548	315-0112-00		RES., FXD, CMPSN: 1.1K OHM, 5%, 0.25W	01121	CB1125
A1R549	315-0472-00		RES., FXD, CMPSN: 4.7K OHM, 5%, 0.25W	01121	CB4725
A1R562	315-0112-00		RES., FXD, CMPSN: 1.1K OHM, 5%, 0.25W	01121	CB1125
A1R568	321-0296-00		RES., FXD, FILM: 11.8K OHM, 1%, 0.125W	91637	MFF1816G11801F
A1R572	315-0472-00		RES., FXD, CMPSN: 4.7K OHM, 5%, 0.25W	01121	CB4725
A1R574	315-0821-00		RES., FXD, CMPSN: 820 OHM, 5%, 0.25W	01121	CB8215
A1R575	321-0385-00		RES., FXD, FILM: 100K OHM, 1%, 0.125W	91637	MFF1816G10002F
A1R576	315-0821-00		RES., FXD, CMPSN: 820 OHM, 5%, 0.25W	01121	CB8215
A1R577	315-0472-00		RES., FXD, CMPSN: 4.7K OHM, 5%, 0.25W	01121	CB4725
A1R578	321-0231-00		RES., FXD, FILM: 2.49K OHM, 1%, 0.125W	91637	MFF1816G24900F
A1R592	321-0039-00		RES., FXD, FILM: 24.9 OHM, 1%, 0.125W	91637	MFF1816G24R90F
A1R593	315-0472-00		RES., FXD, CMPSN: 4.7K OHM, 5%, 0.25W	01121	CB4725
A1R594	315-0104-00		RES., FXD, CMPSN: 100K OHM, 5%, 0.25W	01121	CB1045
A1R596	321-0303-00		RES., FXD, FILM: 14K OHM, 1%, 0.125W	91637	MFF1816G14001F
A1R597	321-0289-00		RES., FXD, FILM: 10K OHM, 1%, 0.125W	91637	MFF1816G10001F
A1R598	321-0249-00		RES., FXD, FILM: 3.83K OHM, 1%, 0.125W	91637	MFF1816G38300F
A1R599	321-0261-00		RES., FXD, FILM: 5.11K OHM, 1%, 0.125W	91637	MFF1816G51100F
A1R612	307-0093-00		RES., FXD, CMPSN: 1.2 OHM, 5%, 0.50W	01121	EB12G5
A1R622	315-0202-00		RES., FXD, CMPSN: 2K OHM, 5%, 0.25W	01121	CB2025
A1R645	303-0151-00		RES., FXD, CMPSN: 150 OHM, 5%, 1W	01121	GB1515

Component No.	Tektronix Part No.	Serial/Model No. Eff Dscont	Name & Description	Mfr Code	Mfr Part Number
AlR652	321-0260-00		RES., FXD, FILM: 4.99K OHM, 1%, 0.125W	91637	MFF1816G49900F
AlR654	321-0260-00		RES., FXD, FILM: 4.99K OHM, 1%, 0.125W	91637	MFF1816G49900F
AlR656	311-1897-00		RES., VAR, NONWIR: 25K OHM, 10%, 0.50W	32997	3299W-1-253
AlR657	315-0821-00		RES., FXD, CMPSN: 820 OHM, 5%, 0.25W	01121	CB8215
AlR658	315-0821-00		RES., FXD, CMPSN: 820 OHM, 5%, 0.25W	01121	CB8215
AlR659	311-1943-00		RES., VAR, NONWIR: 10K OHM, 10%, 0.50W	73138	68-10-0
AlR662	315-0112-00		RES., FXD, CMPSN: 1.1K OHM, 5%, 0.25W	01121	CB1125
AlR670	315-0112-00		RES., FXD, CMPSN: 1.1K OHM, 5%, 0.25W	01121	CB1125
AlR674	315-0271-00		RES., FXD, CMPSN: 270 OHM, 5%, 0.25W	01121	CB2715
AlR676	315-0821-00		RES., FXD, CMPSN: 820 OHM, 5%, 0.25W	01121	CB8215
AlR682	321-0385-00		RES., FXD, FILM: 100K OHM, 1%, 0.125W	91637	MFF1816G10002F
AlR688	311-1895-00		RES., VAR, NONWIR: 2K OHM, 10%, 0.50W	32997	3299W-R27-202
AlR690	315-0202-00		RES., FXD, CMPSN: 2K OHM, 5%, 0.25W	01121	CB2025
AlR692	311-1895-00		RES., VAR, NONWIR: 2K OHM, 10%, 0.50W	32997	3299W-R27-202
AlR694	321-0179-00		RES., FXD, FILM: 715 OHM, 1%, 0.125W	91637	MFF1816G715R0F
AlR695	311-1944-00		RES., VAR, NONWIR: 1K OHM, 10%, 0.50W	32997	3299W-R27-102
AlR697	315-0101-00		RES., FXD, CMPSN: 100 OHM, 5%, 0.25W	01121	CB1015
AlTP116	214-0579-00		TERM, TEST POINT: BRS CD PL	80009	214-0579-00
AlTP127	214-0579-00		TERM, TEST POINT: BRS CD PL	80009	214-0579-00
AlTP132	214-0579-00		TERM, TEST POINT: BRS CD PL	80009	214-0579-00
AlTP133	214-0579-00		TERM, TEST POINT: BRS CD PL	80009	214-0579-00
AlTP134	214-0579-00		TERM, TEST POINT: BRS CD PL	80009	214-0579-00
AlTP136	214-0579-00		TERM, TEST POINT: BRS CD PL	80009	214-0579-00
AlTP142	214-0579-00		TERM, TEST POINT: BRS CD PL	80009	214-0579-00
AlTP158	214-0579-00		TERM, TEST POINT: BRS CD PL	80009	214-0579-00
AlTP174	214-0579-00		TERM, TEST POINT: BRS CD PL	80009	214-0579-00
AlTP313	214-0579-00		TERM, TEST POINT: BRS CD PL	80009	214-0579-00
AlTP358	214-0579-00		TERM, TEST POINT: BRS CD PL	80009	214-0579-00
AlTP416	214-0579-00		TERM, TEST POINT: BRS CD PL	80009	214-0579-00
AlTP418	214-0579-00		TERM, TEST POINT: BRS CD PL	80009	214-0579-00
AlTP432	214-0579-00		TERM, TEST POINT: BRS CD PL	80009	214-0579-00
AlTP510	214-0579-00		TERM, TEST POINT: BRS CD PL	80009	214-0579-00
AlTP536	214-0579-00		TERM, TEST POINT: BRS CD PL	80009	214-0579-00
AlTP572	214-0579-00		TERM, TEST POINT: BRS CD PL	80009	214-0579-00
AlTP620	214-0579-00		TERM, TEST POINT: BRS CD PL	80009	214-0579-00
AlTP630	214-0579-00		TERM, TEST POINT: BRS CD PL	80009	214-0579-00
AlTP673	214-0579-00		TERM, TEST POINT: BRS CD PL	80009	214-0579-00
AlTP687	214-0579-00		TERM, TEST POINT: BRS CD PL	80009	214-0579-00
AlTP691	214-0579-00		TERM, TEST POINT: BRS CD PL	80009	214-0579-00
AlU234	156-0180-04		MICROCIRCUIT, DI: QUAD 2 INP NAND GATE	01295	SN74S00NP3
AlU242	156-0180-04		MICROCIRCUIT, DI: OPNL 2 INP NAND GATE	01295	SN74S00NP3
AlU248	156-0413-02		MICROCIRCUIT, DI: QUAD 2 INP SCMIT TRIGGER	01295	SN74S132
AlU252	156-0690-03		MICROCIRCUIT, DI: QUAD 2 INP NOR GATE, BURN IN	01295	SN74S02
AlU328	156-1195-01		MICROCIRCUIT, DI: DUAL RETRIG/RESET	80009	156-1195-01
AlU330	156-0251-01		MICROCIRCUIT, LI: HIGH SPEED COMPTR, BURN-IN	27014	LM361H/A+
AlU355	156-0321-02		MICROCIRCUIT, DI: TRIPLE 3 INP NAND GATE	01295	SN74S10
AlU420	156-0742-02		MICROCIRCUIT, LI: OPERATIONAL AMPLIFIER, SEL	01295	LM318P3
AlU457	156-0180-04		MICROCIRCUIT, DI: QUAD 2 INP NAND GATE	01295	SN74S00NP3
AlU462	156-1198-01		MICROCIRCUIT, DI: SYNCHRONOUS 4BIT CNTR	01295	SN74S163J4
AlU495	156-0419-02		MICROCIRCUIT, DI: DUAL 4 INP NAND LINE DRVR	07263	74S140
AlU530	156-0067-13		MICROCIRCUIT, LI: OPNL AMPL, SELECTED	04713	MC1741CUDS
AlU538	156-0419-02		MICROCIRCUIT, DI: DUAL 4 INP NAND LINE DRVR	07263	74S140
AlU552	156-1195-01		MICROCIRCUIT, DI: DUAL RETRIG/RESET	80009	156-1195-01
AlU556	156-0690-03		MICROCIRCUIT, DI: QUAD 2 INP NOR GATE, BURN IN	01295	SN74S02
AlU564	156-1198-01		MICROCIRCUIT, DI: SYNCHRONOUS 4BIT CNTR	01295	SN74S163J4
AlU575	156-1195-01		MICROCIRCUIT, DI: DUAL RETRIG/RESET	80009	156-1195-01
AlU580	156-0251-01		MICROCIRCUIT, LI: HIGH SPEED COMPTR, BURN-IN	27014	LM361H/A+

Replaceable Electrical Parts—067-1039-00

Component No.	Tektronix Part No.	Serial/Model No. Eff Dscont	Name & Description	Mfr Code	Mfr Part Number
A1U587	156-0251-01		MICROCIRCUIT,LI:HIGH SPEED COMPTR,BURN-IN	27014	LM361H/A+
A1U670	156-0047-02		MICROCIRCUIT,DI:TP1 3 INP,NAND GATE	27014	DM7410NA+ OR JA+
A1VR263	152-0461-00		SEMICONV DEVICE:ZENER,0.4W,6.2V,5%	04713	1N821
A1VR376	152-0461-00		SEMICONV DEVICE:ZENER,0.4W,6.2V,5%	04713	1N821
A1VR474	152-0662-00		SEMICONV DEVICE:ZENER,0.4W,5V,1%	04713	SZG195
A1VR482	152-0461-00		SEMICONV DEVICE:ZENER,0.4W,6.2V,5%	04713	1N821
A1VR527	152-0120-00		SEMICONV DEVICE:ZENER,1W,10V,5%	80009	152-0120-00
A1VR528	152-0647-00		SEMICONV DEVICE:ZENER,0.4W,6.8V,5%	80009	152-0647-00
A1VR625	152-0120-00		SEMICONV DEVICE:ZENER,1W,10V,5%	80009	152-0120-00
A1VR647	152-0662-00		SEMICONV DEVICE:ZENER,0.4W,5V,1%	04713	SZG195
A1VR697	152-0589-00		SEMICONV DEVICE:ZENER,0.4W,11.7V,5%	80009	152-0589-00

Component No.	Tektronix Part No.	Serial/Model No. Eff Dscont	Name & Description	Mfr Code	Mfr Part Number
A2	-----		CKT BOARD ASSY:HORIZONTAL LINE GENERATOR		
A2C149	281-0775-00		CAP.,FXD,CER DI:0.1UF,20%,50V	72982	8005D9AABZ5U104M
A2C152	283-0772-00		CAP.,FXD,MICA D:497PF,1%,500V	00853	D15-5F4970F0
A2C237	281-0775-00		CAP.,FXD,CER DI:0.1UF,20%,50V	72982	8005D9AABZ5U104M
A2C240	281-0775-00		CAP.,FXD,CER DI:0.1UF,20%,50V	72982	8005D9AABZ5U104M
A2C258	281-0775-00		CAP.,FXD,CER DI:0.1UF,20%,50V	72982	8005D9AABZ5U104M
A2C268	281-0775-00		CAP.,FXD,CER DI:0.1UF,20%,50V	72982	8005D9AABZ5U104M
A2C278	281-0775-00		CAP.,FXD,CER DI:0.1UF,20%,50V	72982	8005D9AABZ5U104M
A2C284	281-0775-00		CAP.,FXD,CER DI:0.1UF,20%,50V	72982	8005D9AABZ5U104M
A2C292	281-0504-00		CAP.,FXD,CER DI:10PF,+/-1PF,500V	72982	301-055C0G0100F
A2C296	290-0846-00		CAP.,FXD,ELCLTLT:47UF,-10+75%,35 WVDC	54473	ECE-A35V47LU
A2C297	281-0504-00		CAP.,FXD,CER DI:10PF,+/-1PF,500V	72982	301-055C0G0100F
A2C336	281-0775-00		CAP.,FXD,CER DI:0.1UF,20%,50V	72982	8005D9AABZ5U104M
A2C348	281-0775-00		CAP.,FXD,CER DI:0.1UF,20%,50V	72982	8005D9AABZ5U104M
A2C358	281-0775-00		CAP.,FXD,CER DI:0.1UF,20%,50V	72982	8005D9AABZ5U104M
A2C368	281-0775-00		CAP.,FXD,CER DI:0.1UF,20%,50V	72982	8005D9AABZ5U104M
A2C374	281-0775-00		CAP.,FXD,CER DI:0.1UF,20%,50V	72982	8005D9AABZ5U104M
A2C388	281-0775-00		CAP.,FXD,CER DI:0.1UF,20%,50V	72982	8005D9AABZ5U104M
A2C436	281-0775-00		CAP.,FXD,CER DI:0.1UF,20%,50V	72982	8005D9AABZ5U104M
A2C439	281-0775-00		CAP.,FXD,CER DI:0.1UF,20%,50V	72982	8005D9AABZ5U104M
A2C458	281-0775-00		CAP.,FXD,CER DI:0.1UF,20%,50V	72982	8005D9AABZ5U104M
A2C462	281-0775-00		CAP.,FXD,CER DI:0.1UF,20%,50V	72982	8005D9AABZ5U104M
A2C477	281-0775-00		CAP.,FXD,CER DI:0.1UF,20%,50V	72982	8005D9AABZ5U104M
A2C488	281-0775-00		CAP.,FXD,CER DI:0.1UF,20%,50V	72982	8005D9AABZ5U104M
A2C496	283-0648-00		CAP.,FXD,MICA D:10PF,5%,100V	00853	D151C100D0
A2C546	281-0775-00		CAP.,FXD,CER DI:0.1UF,20%,50V	72982	8005D9AABZ5U104M
A2C556	281-0775-00		CAP.,FXD,CER DI:0.1UF,20%,50V	72982	8005D9AABZ5U104M
A2C566	281-0775-00		CAP.,FXD,CER DI:0.1UF,20%,50V	72982	8005D9AABZ5U104M
A2C572	281-0775-00		CAP.,FXD,CER DI:0.1UF,20%,50V	72982	8005D9AABZ5U104M
A2C588	281-0775-00		CAP.,FXD,CER DI:0.1UF,20%,50V	72982	8005D9AABZ5U104M
A2C596	281-0775-00		CAP.,FXD,CER DI:0.1UF,20%,50V	72982	8005D9AABZ5U104M
A2C597	281-0775-00		CAP.,FXD,CER DI:0.1UF,20%,50V	72982	8005D9AABZ5U104M
A2C598	281-0775-00		CAP.,FXD,CER DI:0.1UF,20%,50V	72982	8005D9AABZ5U104M
A2C616	281-0775-00		CAP.,FXD,CER DI:0.1UF,20%,50V	72982	8005D9AABZ5U104M
A2C620	281-0773-00		CAP.,FXD,CER DI:0.01UF,10%,100V	04222	GC70-1C103K
A2C626	290-0846-00		CAP.,FXD,ELCLTLT:47UF,-10+75%,35 WVDC	54473	ECE-A35V47LU
A2C645	281-0775-00		CAP.,FXD,CER DI:0.1UF,20%,50V	72982	8005D9AABZ5U104M
A2C677	281-0775-00		CAP.,FXD,CER DI:0.1UF,20%,50V	72982	8005D9AABZ5U104M
A2C684	281-0773-00		CAP.,FXD,CER DI:0.01UF,10%,100V	04222	GC70-1C103K
A2C686	281-0775-00		CAP.,FXD,CER DI:0.1UF,20%,50V	72982	8005D9AABZ5U104M
A2C695	281-0775-00		CAP.,FXD,CER DI:0.1UF,20%,50V	72982	8005D9AABZ5U104M
A2C765	281-0775-00		CAP.,FXD,CER DI:0.1UF,20%,50V	72982	8005D9AABZ5U104M
A2C777	281-0775-00		CAP.,FXD,CER DI:0.1UF,20%,50V	72982	8005D9AABZ5U104M
A2C780	281-0775-00		CAP.,FXD,CER DI:0.1UF,20%,50V	72982	8005D9AABZ5U104M
A2C785	281-0775-00		CAP.,FXD,CER DI:0.1UF,20%,50V	72982	8005D9AABZ5U104M
A2R150	315-0472-00		RES.,FXD,CMPSN:4.7K OHM,5%,0.25W	01121	CB4725
A2R152	321-0294-00		RES.,FXD,FILM:11.3K OHM,1%,0.125W	91637	MFF1816G11301F
A2R198	315-0100-00		RES.,FXD,CMPSN:10 OHM,5%,0.25W	01121	CB1005
A2R252	315-0472-00		RES.,FXD,CMPSN:4.7K OHM,5%,0.25W	01121	CB4725
A2R272	315-0472-00		RES.,FXD,CMPSN:4.7K OHM,5%,0.25W	01121	CB4725
A2R295	315-0100-00		RES.,FXD,CMPSN:10 OHM,5%,0.25W	01121	CB1005
A2R299	315-0103-00		RES.,FXD,CMPSN:10K OHM,5%,0.25W	01121	CB1035
A2R322	315-0472-00		RES.,FXD,CMPSN:4.7K OHM,5%,0.25W	01121	CB4725
A2R324	315-0472-00		RES.,FXD,CMPSN:4.7K OHM,5%,0.25W	01121	CB4725
A2R328	315-0472-00		RES.,FXD,CMPSN:4.7K OHM,5%,0.25W	01121	CB4725
A2R392	315-0472-00		RES.,FXD,CMPSN:4.7K OHM,5%,0.25W	01121	CB4725
A2R393	321-0666-00		RES.,FXD,FILM:3.04K OHM,0.5%,0.125W	91637	MFF1816D30400D

Replaceable Electrical Parts—067-1039-00

Component No.	Tektronix Part No.	Serial/Model No. Eff Dscont	Name & Description	Mfr Code	Mfr Part Number
A2R396	321-0242-00		RES.,FXD,FILM:3.24K OHM,1%,0.125W	91637	MFF1816G32400F
A2R422	315-0472-00		RES.,FXD,CMPSN:4.7K OHM,5%,0.25W	01121	CB4725
A2R424	315-0472-00		RES.,FXD,CMPSN:4.7K OHM,5%,0.25W	01121	CB4725
A2R452	315-0472-00		RES.,FXD,CMPSN:4.7K OHM,5%,0.25W	01121	CB4725
A2R493	315-0101-00		RES.,FXD,CMPSN:100 OHM,5%,0.25W	01121	CB1015
A2R514	311-1336-00		RES.,VAR,NONWIR:100K OHM,0.50W	02111	43P104T672
A2R515	321-0193-00		RES.,FXD,FILM:1K OHM,1%,0.125W	91637	MFF1816G10000F
A2R516	321-0289-00		RES.,FXD,FILM:10K OHM,1%,0.125W	91637	MFF1816G10001F
A2R518	321-0481-00		RES.,FXD,FILM:1M OHM,1%,0.125W	24546	NA4D1004F
A2R532	315-0472-00		RES.,FXD,CMPSN:4.7K OHM,5%,0.25W	01121	CB4725
A2R534	315-0472-00		RES.,FXD,CMPSN:4.7K OHM,5%,0.25W	01121	CB4725
A2R536	315-0472-00		RES.,FXD,CMPSN:4.7K OHM,5%,0.25W	01121	CB4725
A2R538	315-0472-00		RES.,FXD,CMPSN:4.7K OHM,5%,0.25W	01121	CB4725
A2R552	315-0472-00		RES.,FXD,CMPSN:4.7K OHM,5%,0.25W	01121	CB4725
A2R557	315-0472-00		RES.,FXD,CMPSN:4.7K OHM,5%,0.25W	01121	CB4725
A2R562	315-0472-00		RES.,FXD,CMPSN:4.7K OHM,5%,0.25W	01121	CB4725
A2R624	315-0472-00		RES.,FXD,CMPSN:4.7K OHM,5%,0.25W	01121	CB4725
A2R630	315-0472-00		RES.,FXD,CMPSN:4.7K OHM,5%,0.25W	01121	CB4725
A2R632	315-0472-00		RES.,FXD,CMPSN:4.7K OHM,5%,0.25W	01121	CB4725
A2R636	315-0472-00		RES.,FXD,CMPSN:4.7K OHM,5%,0.25W	01121	CB4725
A2R638	315-0103-00		RES.,FXD,CMPSN:10K OHM,5%,0.25W	01121	CB1035
A2R656	315-0222-00		RES.,FXD,CMPSN:2.2K OHM,5%,0.25W	01121	CB2225
A2R668	315-0222-00		RES.,FXD,CMPSN:2.2K OHM,5%,0.25W	01121	CB2225
A2R692	321-0216-00		RES.,FXD,FILM:1.74K OHM,1%,0.125W	91637	MFF1816G17400F
A2R700	315-0221-00		RES.,FXD,CMPSN:220 OHM,5%,0.25W	01121	CB2215
A2R780	321-0251-00		RES.,FXD,FILM:4.02K OHM,1%,0.125W	91637	MFF1816G40200F
A2R781	321-0178-00		RES.,FXD,FILM:698 OHM,1%,0.125W	91637	MFF1816G698ROF
A2R782	321-0268-00		RES.,FXD,FILM:6.04K OHM,1%,0.125W	91637	MFF1816G60400F
A2R783	321-0242-00		RES.,FXD,FILM:3.24K OHM,1%,0.125W	91637	MFF1816G32400F
A2R787	315-0472-00		RES.,FXD,CMPSN:4.7K OHM,5%,0.25W	01121	CB4725
A2R789	311-1860-00		RES.,VAR,NONWIR:TRMR,10K OHM,0.50W	32997	3299X-R27-103
A2R791	311-1860-00		RES.,VAR,NONWIR:TRMR,10K OHM,0.50W	32997	3299X-R27-103
A2R793	321-0261-00		RES.,FXD,FILM:5.11K OHM,1%,0.125W	91637	MFF1816G51100F
A2S315	263-0010-00		SWITCH PB ASSY:1 PUSH,7.5MM,W/2 CONTACTS	80009	263-0010-00
A2S317	263-0093-00		SW PB ASSY:3 LATCH,1 PUSH-PUSH,7.5MM,8 CONT	80009	263-0093-00
A2S318	263-0010-00		SWITCH PB ASSY:1 PUSH,7.5MM,W/2 CONTACTS	80009	263-0010-00
A2S415	263-0010-00		SWITCH PB ASSY:1 PUSH,7.5MM,W/2 CONTACTS	80009	263-0010-00
A2S418	263-0010-00		SWITCH PB ASSY:1 PUSH,7.5MM,W/2 CONTACTS	80009	263-0010-00
A2TP132	214-0579-00		TERM,TEST POINT:BRS CD PL	80009	214-0579-00
A2TP134	214-0579-00		TERM,TEST POINT:BRS CD PL	80009	214-0579-00
A2TP135	214-0579-00		TERM,TEST POINT:BRS CD PL	80009	214-0579-00
A2TP137	214-0579-00		TERM,TEST POINT:BRS CD PL	80009	214-0579-00
A2TP139	214-0579-00		TERM,TEST POINT:BRS CD PL	80009	214-0579-00
A2TP152	214-0579-00		TERM,TEST POINT:BRS CD PL	80009	214-0579-00
A2TP164	214-0579-00		TERM,TEST POINT:BRS CD PL	80009	214-0579-00
A2TP248	214-0579-00		TERM,TEST POINT:BRS CD PL	80009	214-0579-00
A2TP448	214-0579-00		TERM,TEST POINT:BRS CD PL	80009	214-0579-00
A2TP567	214-0579-00		TERM,TEST POINT:BRS CD PL	80009	214-0579-00
A2U145	156-0387-02		MICROCIRCUIT,DI:DUAL J-K FF,BURN IN	80009	156-0387-02
A2U235	156-0464-02		MICROCIRCUIT,DI:DUAL 4 INP NAND GATE	80009	156-0464-02
A2U245	156-0479-02		MICROCIRCUIT,DI:QUAD 2-INP ORGATE	01295	SN74LS32NP3
A2U255	156-0422-02		MICROCIRCUIT,DI:UP/DOWN SYN BINARY CNTR	01295	SN74LS191
A2U265	156-0387-02		MICROCIRCUIT,DI:DUAL J-K FF,BURN IN	80009	156-0387-02
A2U275	156-0480-02		MICROCIRCUIT,DI:QUAD 2 INP & GATE	01295	SN74LS08NP3
A2U285	156-0721-02		MICROCIRCUIT,DI:QUAD 2-IN NAND SCHMITT TRI	04713	SN74LS132NDS
A2U335	156-0382-02		MICROCIRCUIT,DI:QUAD 2-INP NAND GATE	01295	SN74LS00
A2U345	156-0480-02		MICROCIRCUIT,DI:QUAD 2 INP & GATE	01295	SN74LS08NP3

Component No.	Tektronix Part No.	Serial/Model No. Eff Dscont	Name & Description	Mfr Code	Mfr Part Number
A2U355	156-0382-02		MICROCIRCUIT,DI:QUAD 2-INP NAND GATE	01295	SN74LS00
A2U365	156-0480-02		MICROCIRCUIT,DI:QUAD 2 INP & GATE	01295	SN74LS08NP3
A2U375	156-0382-02		MICROCIRCUIT,DI:QUAD 2-INP NAND GATE	01295	SN74LS00
A2U385	156-0679-01		MICROCIRCUIT,DI:4 BIT BINARY ADDER,BURN-IN	04713	SN74LS283NDS
A2U435	156-0480-02		MICROCIRCUIT,DI:QUAD 2 INP & GATE	01295	SN74LS08NP3
A2U445	156-0480-02		MICROCIRCUIT,DI:QUAD 2 INP & GATE	01295	SN74LS08NP3
A2U455	156-0422-02		MICROCIRCUIT,DI:UP/DOWN SYN BINARY CNTR	01295	SN74LS191
A2U465	156-0385-02		MICROCIRCUIT,DI:HEX INVERTER	01295	SN74LS04
A2U475	156-0386-02		MICROCIRCUIT,DI:TRIPLE 3 INP NAND GATE	01295	SN74LS10NP3
A2U485	156-0386-02		MICROCIRCUIT,DI:TRIPLE 3 INP NAND GATE	01295	SN74LS10NP3
A2U525	156-0402-02		MICROCIRCUIT,LI:TIMER,CHK	27014	SL34829/A+
A2U545	156-0646-02		MICROCIRCUIT,DI:4 BIT BINARY COUNTER	01295	SN74LS93
A2U555	156-0646-02		MICROCIRCUIT,DI:4 BIT BINARY COUNTER	01295	SN74LS93
A2U565	156-0646-02		MICROCIRCUIT,DI:4 BIT BINARY COUNTER	01295	SN74LS93
A2U575	156-0480-02		MICROCIRCUIT,DI:QUAD 2 INP & GATE	01295	SN74LS08NP3
A2U585	156-0479-02		MICROCIRCUIT,DI:QUAD 2-INP ORGATE	01295	SN74LS32NP3
A2U595	156-0742-02		MICROCIRCUIT,LI:OPERATIONAL AMPLIFIER,SEL	01295	LM318P3
A2U655	156-0537-01		MICROCIRCUIT,DI:10 BIT COMPARATOR,SCREENED	80009	156-0537-01
A2U665	156-0537-01		MICROCIRCUIT,DI:10 BIT COMPARATOR,SCREENED	80009	156-0637-01
A2U675	156-0382-02		MICROCIRCUIT,DI:QUAD 2-INP NAND GATE	01295	SN74LS00
A2U685	156-1255-01		MICROCIRCUIT,LI:DA CONVERTER,BURN-IN	80009	156-1255-01
A2U775	156-0646-02		MICROCIRCUIT,DI:4 BIT BINARY COUNTER	01295	SN74LS93

Replaceable Electrical Parts—067-1039-00

Component No.	Tektronix Part No.	Serial/Model No. Eff Dscont	Name & Description	Mfr Code	Mfr Part Number
A3	-----		CKT BOARD ASSY:VERTICAL SYNC GENERATOR		
A3C122	281-0775-00		CAP., FXD, CER DI: 0.1UF, 20%, 50V	72982	8005D9AABZ5U104M
A3C170	290-0950-00		CAP., FXD, ELCTLT: 100UF, +50-10%, 50V	55680	50ULB100VA-T
A3C173	290-0950-00		CAP., FXD, ELCTLT: 100UF, +50-10%, 50V	55680	50ULB100VA-T
A3C177	290-0816-00		CAP., FXD, ELCTLT: 400UF, +75-10%, 50V	56289	39D985
A3C184	290-0778-00		CAP., FXD, ELCTLT: 1UF, +50-10%, 50V	54473	ECE-A50N1
A3C186	290-0920-00		CAP., FXD, ELCTLT: 33PF+50 10%, 35V	55680	35ULB33V-T
A3C235	281-0775-00		CAP., FXD, CER DI: 0.1UF, 20%, 50V	72982	8005D9AABZ5U104M
A3C240	281-0775-00		CAP., FXD, CER DI: 0.1UF, 20%, 50V	72982	8005D9AABZ5U104M
A3C242	281-0775-00		CAP., FXD, CER DI: 0.1UF, 20%, 50V	72982	8005D9AABZ5U104M
A3C250	281-0775-00		CAP., FXD, CER DI: 0.1UF, 20%, 50V	72982	8005D9AABZ5U104M
A3C255	281-0775-00		CAP., FXD, CER DI: 0.1UF, 20%, 50V	72982	8005D9AABZ5U104M
A3C262	281-0523-00		CAP., FXD, CER DI: 100PF, +/-20PF, 500V	72982	301-000U2M0101M
A3C265	281-0775-00		CAP., FXD, CER DI: 0.1UF, 20%, 50V	72982	8005D9AABZ5U104M
A3C277	290-0816-00		CAP., FXD, ELCTLT: 400UF, +75-10%, 50V	56289	39D985
A3C334	281-0775-00		CAP., FXD, CER DI: 0.1UF, 20%, 50V	72982	8005D9AABZ5U104M
A3C340	281-0775-00		CAP., FXD, CER DI: 0.1UF, 20%, 50V	72982	8005D9AABZ5U104M
A3C347	281-0775-00		CAP., FXD, CER DI: 0.1UF, 20%, 50V	72982	8005D9AABZ5U104M
A3C353	281-0775-00		CAP., FXD, CER DI: 0.1UF, 20%, 50V	72982	8005D9AABZ5U104M
A3C362	281-0775-00		CAP., FXD, CER DI: 0.1UF, 20%, 50V	72982	8005D9AABZ5U104M
A3C368	281-0775-00		CAP., FXD, CER DI: 0.1UF, 20%, 50V	72982	8005D9AABZ5U104M
A3C377	290-0816-00		CAP., FXD, ELCTLT: 400UF, +75-10%, 50V	56289	39D985
A3C383	290-0770-00		CAP., FXD, ELCTLT: 100UF, +50-10%, 25V	56289	502D230
A3C384	290-0770-00		CAP., FXD, ELCTLT: 100UF, +50-10%, 25V	56289	502D230
A3C389	290-0778-00		CAP., FXD, ELCTLT: 1UF, +50-10%, 50V	54473	ECE-A50N1
A3C408	290-0920-00		CAP., FXD, ELCTLT: 33UF, +50-10%, 35V	55680	55ULB33V-T
A3C411	290-0770-00		CAP., FXD, ELCTLT: 100UF, +50-10%, 25V	56289	502D230
A3C425	281-0775-00		CAP., FXD, CER DI: 0.1UF, 20%, 50V	72982	8005D9AABZ5U104M
A3C428	281-0775-00		CAP., FXD, CER DI: 0.1UF, 20%, 50V	72982	8005D9AABZ5U104M
A3C429	281-0775-00		CAP., FXD, CER DI: 0.1UF, 20%, 50V	72982	8005D9AABZ5U104M
A3C438	281-0775-00		CAP., FXD, CER DI: 0.1UF, 20%, 50V	72982	8005D9AABZ5U104M
A3C442	281-0775-00		CAP., FXD, CER DI: 0.1UF, 20%, 50V	72982	8005D9AABZ5U104M
A3C450	281-0775-00		CAP., FXD, CER DI: 0.1UF, 20%, 50V	72982	8005D9AABZ5U104M
A3C455	281-0775-00		CAP., FXD, CER DI: 0.1UF, 20%, 50V	72982	8005D9AABZ5U104M
A3C465	281-0775-00		CAP., FXD, CER DI: 0.1UF, 20%, 50V	72982	8005D9AABZ5U104M
A3C477	290-0816-00		CAP., FXD, ELCTLT: 400UF, +75-10%, 50V	56289	39D985
A3C481	290-0778-00		CAP., FXD, ELCTLT: 1UF, +50-10%, 50V	54473	ECE-A50N1
A3C484	290-0770-00		CAP., FXD, ELCTLT: 100UF, +50-10%, 25V	56289	502D230
A3CR120	152-0141-02		SEMICONV DEVICE: SILICON, 30V, 150MA	01295	1N4152R
A3CR168	152-0066-00		SEMICONV DEVICE: SILICON, 400V, 750MA	14433	LG4016
A3CR175	152-0066-00		SEMICONV DEVICE: SILICON, 400V, 750MA	14433	LG4016
A3CR177	152-0141-02		SEMICONV DEVICE: SILICON, 30V, 150MA	01295	1N4152R
A3CR180	152-0141-02		SEMICONV DEVICE: SILICON, 30V, 150MA	01295	1N4152R
A3CR380	152-0488-01		SEMICONV DEVICE: SILICON, 200V, 0.5A; SEL	80009	152-0488-01
A3CR408	152-0141-02		SEMICONV DEVICE: SILICON, 30V, 150MA	01295	1N4152R
A3CR409	152-0141-02		SEMICONV DEVICE: SILICON, 30V, 150MA	01295	1N4152R
A3CR469	152-0141-02		SEMICONV DEVICE: SILICON, 30V, 150MA	01295	1N4152R
A3CR471	152-0141-02		SEMICONV DEVICE: SILICON, 30V, 150MA	01295	1N4152R
A3CR480	152-0488-01		SEMICONV DEVICE: SILICON, 200V, 0.5A; SEL	80009	152-0488-01
A3F378	159-0208-00		FUSE WIRE LEAD: 2A, 125V, 5 SEC	80009	159-0208-00
A3F478	159-0208-00		FUSE WIRE LEAD: 2A, 125V, 5 SEC	80009	159-0208-00
A3F489	159-0152-00		FUSE, WIRE LEAD: 5A, 125V, FAST BLOW	75915	275-005
A3Q183	151-0127-00		TRANSISTOR: SILICON, NPN	07263	S006075
A3Q220	151-0127-00		TRANSISTOR: SILICON, NPN	07263	S006075
A3Q282	151-0190-05		TRANSISTOR: SILICON, NPN	80009	151-0190-05
A3Q283	151-0190-05		TRANSISTOR: SILICON, NPN	80009	151-0190-05
A3Q317	151-0221-00		TRANSISTOR: SILICON, PNP	04713	SPS246

Component No.	Tektronix Part No.	Serial/Model No. Eff Dscont	Name & Description	Mfr Code	Mfr Part Number
A3Q381	151-0188-03		TRANSISTOR:SILICON,PNP,SEL	80009	151-0188-03
A3Q407	151-0127-00		TRANSISTOR:SILICON,NPN	07263	S006075
A3Q417	151-0127-00		TRANSISTOR:SILICON,NPN	07263	S006075
A3Q480	151-0188-03		TRANSISTOR:SILICON,PNP,SEL	80009	151-0188-03
A3R115	315-0511-00		RES.,FXD,CMPSN:510 OHM,5%,0.25W	01121	CB5115
A3R117	315-0511-00		RES.,FXD,CMPSN:510 OHM,5%,0.25W	01121	CB5115
A3R162	315-0100-00		RES.,FXD,CMPSN:10 OHM,5%,0.25W	01121	CB1005
A3R176	315-0102-00		RES.,FXD,CMPSN:1K OHM,5%,0.25W	01121	CB1025
A3R177	308-0755-00		RES.,FXD,WW:0.75 OHM,5%,2W	75042	BWH-R7500J
A3R178	315-0102-00		RES.,FXD,CMPSN:1K OHM,5%,0.25W	01121	CB1025
A3R179	315-0203-00		RES.,FXD,CMPSN:20K OHM,5%,0.25W	01121	CB2035
A3R218	315-0271-00		RES.,FXD,CMPSN:270 OHM,5%,0.25W	01121	CB2715
A3R238	315-0472-00		RES.,FXD,CMPSN:4.7K OHM,5%,0.25W	01121	CB4725
A3R245	315-0472-00		RES.,FXD,CMPSN:4.7K OHM,5%,0.25W	01121	CB4725
A3R272	321-0261-00		RES.,FXD,FILM:5.11K OHM,1%,0.125W	91637	MFF1816G51100F
A3R275	311-1417-00		RES.,VAR,NONWIR:2.5K OHM,10%,0.25W	73138	72-58-0
A3R277	315-0202-00		RES.,FXD,CMPSN:2K OHM,5%,0.25W	01121	CB2025
A3R279	321-0269-00		RES.,FXD,FILM:6.19K OHM,1%,0.125W	91637	MFF1816G61900F
A3R280	308-0710-00		RES.,FXD,WW:0.27 OHM,10%,1W	75042	BW20-R2700J
A3R315	321-0222-00		RES.,FXD,FILM:2K OHM,1%,0.125W	91637	MFF1816G20000F
A3R317	315-0221-00		RES.,FXD,CMPSN:220 OHM,5%,0.25W	01121	CB2215
A3R370	321-0289-00		RES.,FXD,FILM:10K OHM,1%,0.125W	91637	MFF1816G10001F
A3R371	321-0289-00		RES.,FXD,FILM:10K OHM,1%,0.125W	91637	MFF1816G10001F
A3R373	315-0432-00		RES.,FXD,CMPSN:4.3K OHM,5%,0.25W	01121	CB4325
A3R374	315-0100-00		RES.,FXD,CMPSN:10 OHM,5%,0.25W	01121	CB1005
A3R376	315-0470-00		RES.,FXD,CMPSN:47 OHM,5%,0.25W	01121	CB4705
A3R377	308-0755-00		RES.,FXD,WW:0.75 OHM,5%,2W	75042	BWH-R7500J
A3R386	307-0093-00		RES.,FXD,CMPSN:1.2 OHM,5%,0.50W	01121	EB12G5
A3R400	323-0085-00		RES.,FXD,FILM:75 OHM,1%,0.50W	91637	MFF1226G75R00F
A3R402	323-0085-00		RES.,FXD,FILM:75 OHM,1%,0.50W	91637	MFF1226G75R00F
A3R405	323-0106-00		RES.,FXD,FILM:124 OHM,1%,0.50W	91637	MFF1226G124R0F
A3R407	323-0106-00		RES.,FXD,FILM:124 OHM,1%,0.50W	91637	MFF1226G124R0F
A3R416	315-0330-00		RES.,FXD,CMPSN:33 OHM,5%,0.25W	01121	CB3305
A3R417	323-0085-00		RES.,FXD,FILM:75 OHM,1%,0.50W	91637	MFF1226G75R00F
A3R430	307-0650-01		RES.,NTWK,FXD,FI:9,2.7K OHM,5%,0.15W CHK	80009	307-0650-01
A3R431	315-0103-00		RES.,FXD,CMPSN:10K OHM,5%,0.25W	01121	CB1035
A3R438	307-0650-01		RES.,NTWK,FXD,FI:9,2.7K OHM,5%,0.15W CHK	80009	307-0650-01
A3R447	315-0103-00		RES.,FXD,CMPSN:10K OHM,5%,0.25W	01121	CB1035
A3R455	307-0650-01		RES.,NTWK,FXD,FI:9,2.7K OHM,5%,0.15W CHK	80009	307-0650-01
A3R462	315-0103-00		RES.,FXD,CMPSN:10K OHM,5%,0.25W	01121	CB1035
A3R470	315-0332-00		RES.,FXD,CMPSN:3.3K OHM,5%,0.25W	01121	CB3325
A3R471	315-0152-00		RES.,FXD,CMPSN:1.5K OHM,5%,0.25W	01121	CB1525
A3R472	315-0102-00		RES.,FXD,CMPSN:1K OHM,5%,0.25W	01121	CB1025
A3R474	315-0100-00		RES.,FXD,CMPSN:10 OHM,5%,0.25W	01121	CB1005
A3R476	315-0202-00		RES.,FXD,CMPSN:2K OHM,5%,0.25W	01121	CB2025
A3R477	315-0470-00		RES.,FXD,CMPSN:47 OHM,5%,0.25W	01121	CB4705
A3R479	308-0710-00		RES.,FXD,WW:0.27 OHM,10%,1W	75042	BW20-R2700J
A3R486	307-0093-00		RES.,FXD,CMPSN:1.2 OHM,5%,0.50W	01121	EB12G5
A3TP170	214-0579-00		TERM,TEST POINT:BRS CD PL	80009	214-0579-00
A3TP174	214-0579-00		TERM,TEST POINT:BRS CD PL	80009	214-0579-00
A3U225	156-0385-02		MICROCIRCUIT,DI:HEX INVERTER	01295	SN74LS04
A3U230	156-1108-02		MICROCIRCUIT,DI:DIVIDE BY 12 COUNTER,SCRN	80009	156-1108-02
A3U238	156-0387-02		MICROCIRCUIT,DI:DUAL J-K FF,BURN IN	80009	156-0387-02
A3U245	156-0381-02		MICROCIRCUIT,DI:QUAD 2-INP EXCL OR GATE	01295	SN74LS86
A3U250	156-0386-02		MICROCIRCUIT,DI:TRIPLE 3 INP NAND GATE	01295	SN74LS10NP3
A3U258	156-0382-02		MICROCIRCUIT,DI:QUAD 2-INP NAND GATE	01295	SN74LS00
A3U265	156-0382-02		MICROCIRCUIT,DI:QUAD 2-INP NAND GATE	01295	SN74LS00

Replaceable Electrical Parts—067-1039-00

Component No.	Tektronix Part No.	Serial/Model No. Eff Dscont	Name & Description	Mfr Code	Mfr Part Number
A3U325	156-0382-02		MICROCIRCUIT,DI:QUAD 2-INP NAND GATE	01295	SN74LS00
A3U330	156-0656-02		MICROCIRCUIT,DI:DECADE COUNTER,BURN-IN	80009	156-0656-02
A3U338	156-0656-02		MICROCIRCUIT,DI:DECADE COUNTER,BURN-IN	80009	156-0656-02
A3U345	156-0656-02		MICROCIRCUIT,DI:DECADE COUNTER,BURN-IN	80009	156-0656-02
A3U350	156-0656-02		MICROCIRCUIT,DI:DECADE COUNTER,BURN-IN	80009	156-0656-02
A3U358	156-0656-02		MICROCIRCUIT,DI:DECADE COUNTER,BURN-IN	80009	156-0656-02
A3U365	156-0656-02		MICROCIRCUIT,DI:DECADE COUNTER,BURN-IN	80009	156-0656-02
A3U375	156-0067-13		MICROCIRCUIT,LI:OPNL AMPL,SELECTED	04713	MC1741CUDS
A3U425	156-0845-02		MICROCIRCUIT,DI:6 BIT COMPARATOR,BURN-IN	80009	156-0845-02
A3U430	156-0385-02		MICROCIRCUIT,DI:HEX INVERTER	01295	SN74LS04
A3U438	156-0845-02		MICROCIRCUIT,DI:6 BIT COMPARATOR,BURN-IN	80009	156-0845-02
A3U445	156-0385-02		MICROCIRCUIT,DI:HEX INVERTER	01295	SN74LS04
A3U450	156-0845-02		MICROCIRCUIT,DI:6 BIT COMPARATOR,BURN-IN	80009	156-0845-02
A3U458	156-0385-02		MICROCIRCUIT,DI:HEX INVERTER	01295	SN74LS04
A3U465	156-0845-02		MICROCIRCUIT,DI:6 BIT COMPARATOR,BURN-IN	80009	156-0845-02
A3U478	156-0067-13		MICROCIRCUIT,LI:OPNL AMPL,SELECTED	04713	MC1741CUDS
A3VR372	152-0166-00		SEMICOND DEVICE:ZENER,0.4W,6.2V,5%	04713	SZ11738
A3VR407	152-0647-00		SEMICOND DEVICE:ZENER,0.4W,6.8V,5%	80009	152-0647-00

Component No.	Tektronix Part No.	Serial/Model No. Eff Dscont	Name & Description	Mfr Code	Mfr Part Number
CHASSIS PARTS					
DS724	150-1001-02		LT EMITTING DIO:RED,660NM,50MA MAX	80009	150-1001-02
R682	311-0536-01		RES.,VAR,WW:PNL,10K OHM,2.7W	02111	132-103
S100	260-2002-01		SWITCH,LEVER:4 SECT,10 POSN,BCD CODING	07126	28501-4
S101	260-1351-00		SWITCH,LEVER:2 SECT,10 POSN,BCD OUT	07126	28501-2
U189	156-0872-02		MICROCIRCUIT,LI:VOLTAGE REGULATOR,SCRN	80009	156-0872-02
U210	156-0872-02		MICROCIRCUIT,LI:VOLTAGE REGULATOR,SCRN	80009	156-0872-02
U389	156-0277-01		MICROCIRCUIT,LI:POSITIVE VOLTAGE REG	80009	156-0277-01
U410	156-0285-02		MICROCIRCUIT,LI:VOLTAGE REGULATOR	27014	LM340T-12
U489	156-0277-01		MICROCIRCUIT,LI:POSITIVE VOLTAGE REG	80009	156-0277-01
U510	156-0277-01		MICROCIRCUIT,LI:POSITIVE VOLTAGE REG	80009	156-0277-01
U610	156-0277-01		MICROCIRCUIT,LI:POSITIVE VOLTAGE REG	80009	156-0277-01

DIAGRAMS AND CIRCUIT BOARD ILLUSTRATIONS

Symbols

Graphic symbols and class designation letters are based on ANSI Standard Y32.2-1975.

Logic symbology is based on ANSI Y32.14-1973 in terms of positive logic. Logic symbols depict the logic function performed and may differ from the manufacturer's data.

The overline on a signal name indicates that the signal performs its intended function when it is in the low state.

Abbreviations are based on ANSI Y1.1-1972.

Other ANSI standards that are used in the preparation of diagrams by Tektronix, Inc. are:

- Y14.15, 1966 Drafting Practices.
- Y14.2, 1973 Line Conventions and Lettering.
- Y10.5, 1968 Letter Symbols for Quantities Used in Electrical Science and Electrical Engineering.

American National Standard Institute
1430 Broadway
New York, New York 10018

Component Values

Electrical components shown on the diagrams are in the following units unless noted otherwise:

- Capacitors = Values one or greater are in picofarads (pF).
Values less than one are in microfarads (μ F).
- Resistors = Ohms (Ω).

———— The information and special symbols below may appear in this manual. ————

Assembly Numbers and Grid Coordinates

Each assembly in the instrument is assigned an assembly number (e.g., A20). The assembly number appears on the circuit board outline on the diagram, in the title for the circuit board component location illustration, and in the lookup table for the schematic diagram and corresponding component locator illustration. The Replaceable Electrical Parts list is arranged by assemblies in numerical sequence; the components are listed by component number *(see following illustration for constructing a component number).

The schematic diagram and circuit board component location illustration have grids. A lookup table with the grid coordinates is provided for ease of locating the component. Only the components illustrated on the facing diagram are listed in the lookup table. When more than one schematic diagram is used to illustrate the circuitry on a circuit board, the circuit board illustration may only appear opposite the first diagram on which it was illustrated; the lookup table will list the diagram number of other diagrams that the circuitry of the circuit board appears on.

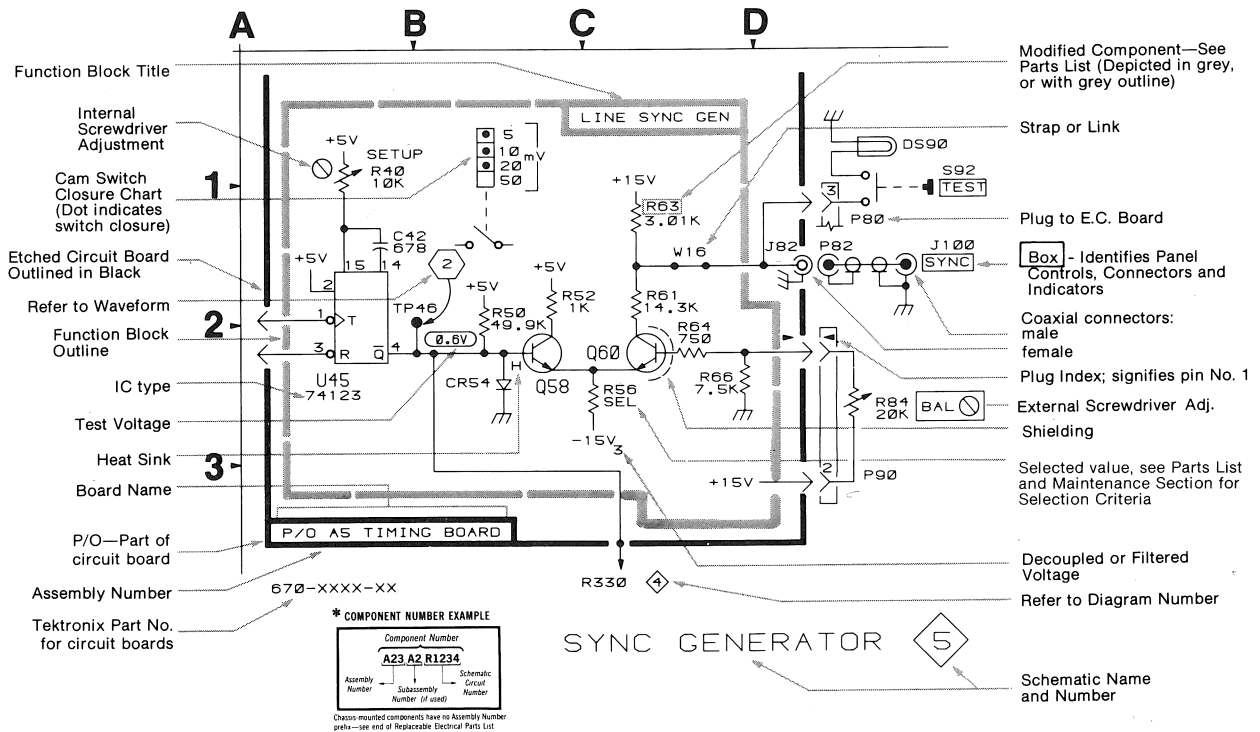

WAVEFORM CONDITIONS

LINES PER TWO FIELDS	1024
LINES OF VERTICAL BLANKING	18
HORIZONTAL ACTIVE TIME	24.75 us (Frequency Counter Reads 31.5 us)
Selected Output Signal	VERT BAR

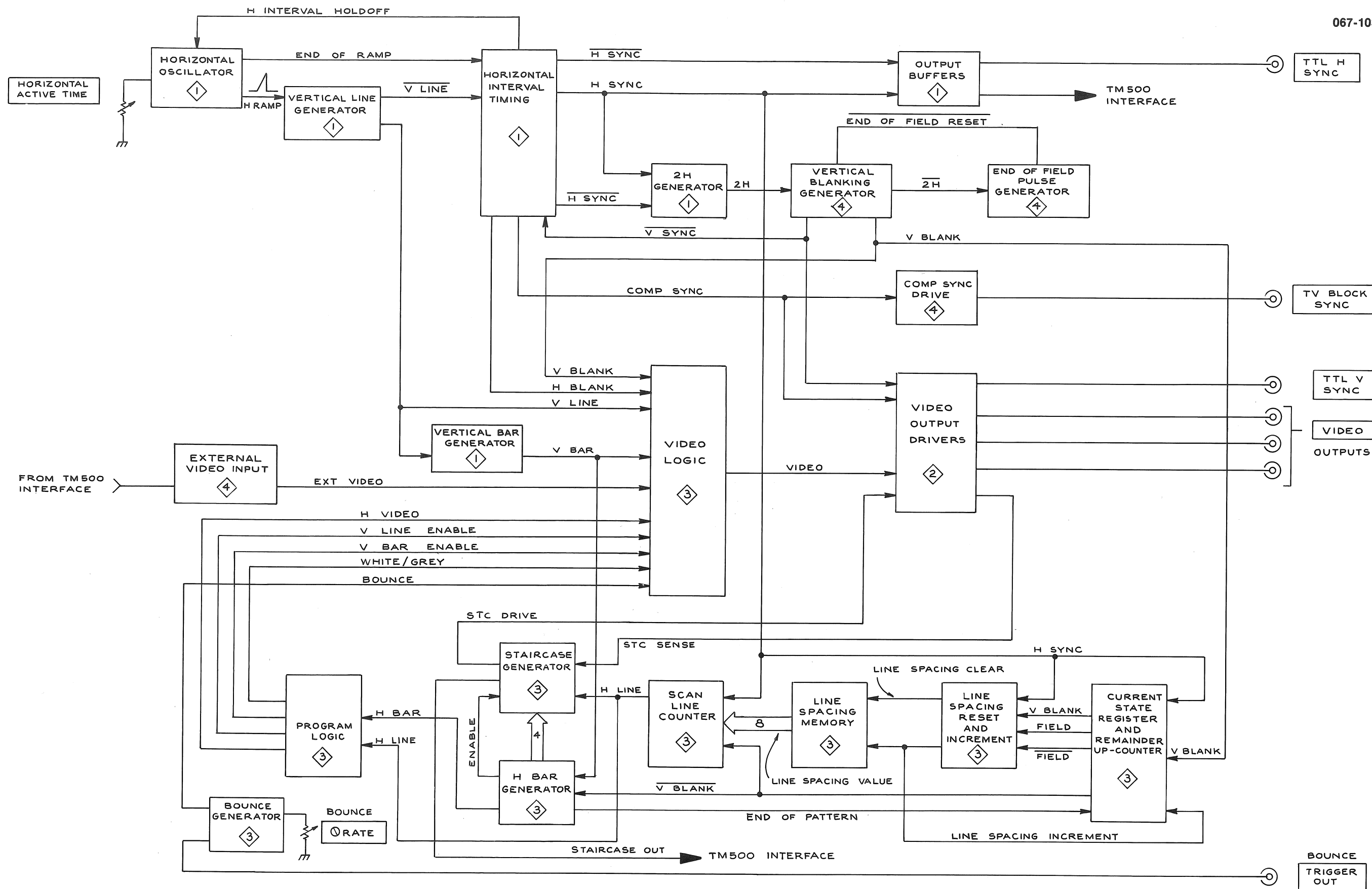

BLOCK DIAGRAM

1
 HORIZONTAL SYNC GENERATOR-A1
 PARTS LOCATION TABLE

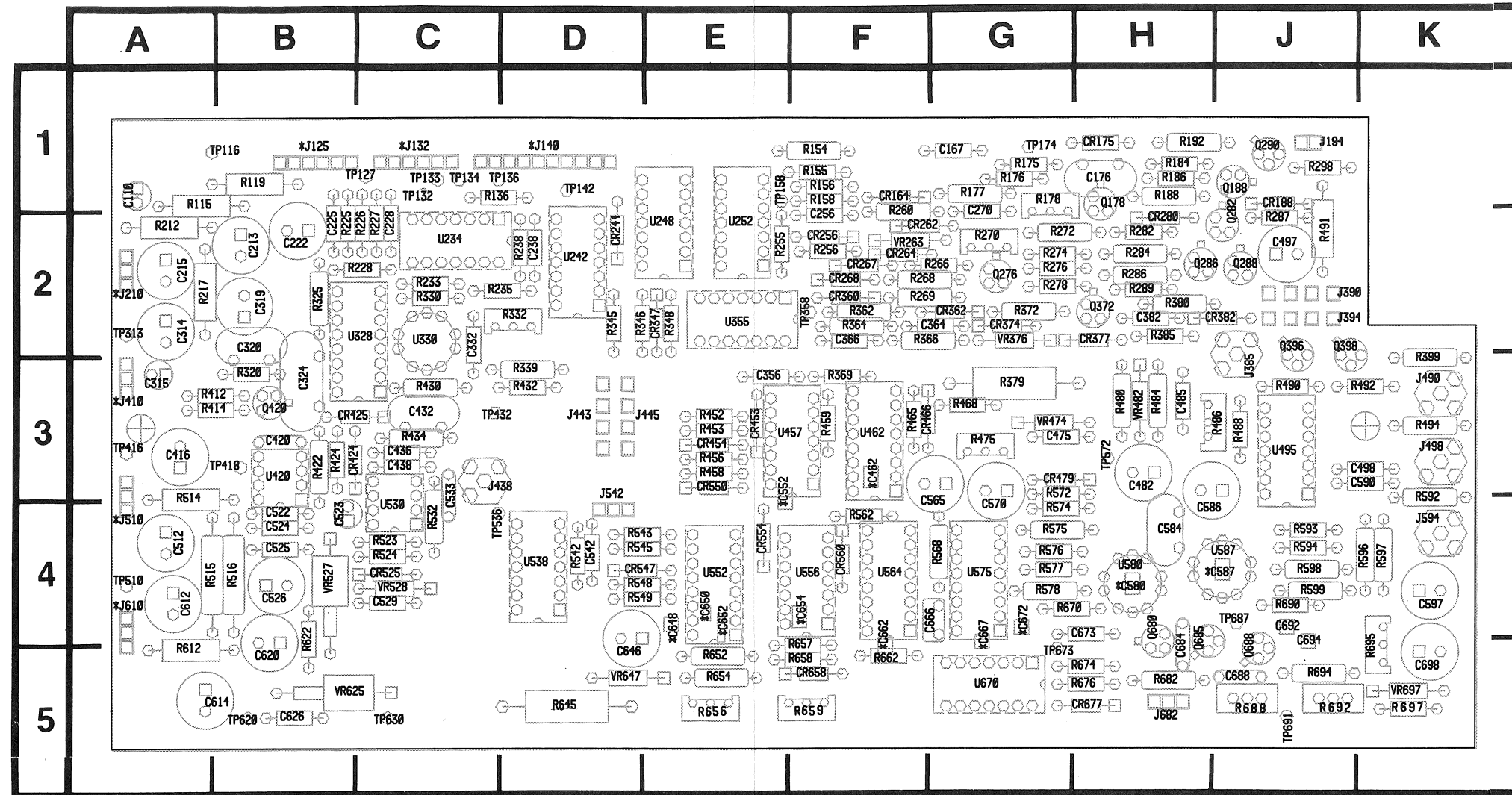
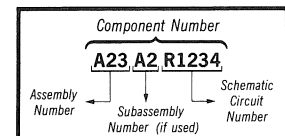

Figure 7-1. A1-Horizontal Sync Generator board.

COMPONENT NUMBER EXAMPLE



Chassis-mounted components have no Assembly Number prefix—see end of Replaceable Electrical Parts List.

Static Sensitive Devices
 See Maintenance Section

HORIZONTAL SYNC GENERATOR DIAGRAM



ASSEMBLY A1 *Partial A1 also shown on diagram 2.*

CIRCUIT NUMBER	SCHEM LOCATION	BOARD LOCATION	CIRCUIT NUMBER	SCHEM LOCATION	BOARD LOCATION	CIRCUIT NUMBER	SCHEM LOCATION	BOARD LOCATION
C222	D3	B2	J542	G2	D4	R657	E2	F5
C225	F5	B2	J682	C1	H5	R658	E2	F5
C228	G4	C2				R659	F1	F5
C238	G4	D2	Q420	C4	B3	R662	D1	F5
C256	E3	F2	Q680	B3	H4	R670	F1	G4
C320	D4	B2	Q685	B1	H5	R674	C3	H5
C324	E4	B3	Q688	B1	J5	R676	C2	H5
C332	D4	C2				R682	B1	H5
C420	C4	B3	R225	G4	B2	R682	C1	H5
C432	E4	C3	R226	D4	B2	R688	B1	J5
C436	C4	C3	R227	H4	C2	R690	B3	J4
C438	B5	C3	R228	E4	B2	R692	B1	J5
C462	F5	F3	R233	H3	C2	R694	B1	J5
C475	A1	G3	R235	D5	C2	R695	A3	K5
C482	D2	H3	R238	G4	D2			
C522	C4	B4	R320	D4	B3	TP132	H4	C1
C523	B4	B4	R325	F3	B2	TP133	H1	C1
C524	D5	B4	R330	E4	D3	TP134	H3	C1
C529	A4	C4	R332	A5	D2	TP142	H3	D1
C533	B5	C3	R339	A5	D3	TP358	G3	F2
C542	H1	D4	R345	H3	D2	TP418	D4	B3
C552	F5	E3	R369	F2	F3	TP536	H2	C4
C565	A1	G4	R379	A1	G3	TP572	C3	H3
C570	D2	G4	R412	C4	A3	TP687	B2	J4
C580	B2	H4	R414	C4	A3	TP691	B1	J5
C584	C2	H4	R422	C4	B3			
C586	B3	H4	R424	C4	B3	U234A	H3	C2
C587	B3	J4	R430	A5	C3	U234B	H4	C2
C590	B3	K3	R434	E3	C3	U234D	G3	C2
C597	F5	K4	R456	F3	E3	U248B	H3	E2
C646	A2	D5	R458	G1	E3	U328A	D4	B2
C648	A2	E4	R459	E1	F3	U328B	F4	B2
C650	G1	E4	R465	D1	F3	U330	D5	C2
C652	F1	E4	R468	D2	G3	U420	C5	B3
C654	F5	F4	R475	E1	G3	U457A	E3	E3
C662	F5	F4	R523	B4	C4	U457B	E3	E3
C666	E1	F4	R524	B4	C4	U457C	F3	E3
C667	A1	G4	R532	B5	C4	U457D	F2	E3
C672	C1	G4	R542	H1	D4	U462	D2	F3
C673	C1	H4	R543	H1	D4	U530	B5	C4
C684	B3	H5	R545	G1	D4	U538A	H2	D4
C688	B1	J5	R548	G1	D4	U538B	H1	D4
C692	B1	J4	R549	F2	D4	U552A	F1	E4
			R562	F2	F4	U552B	G1	E4
CR424	C4	B3	R568	E1	G4	U556A	E2	F4
CR425	B5	B3	R572	B3	G3	U556B	E2	F4
CR453	F3	E3	R574	D1	G4	U556C	E3	F4
CR466	C2	F3	R575	C2	G4	U556D	E3	F4
CR479	D2	G3	R576	C2	G4	U564	D2	F4
CR525	A4	C4	R577	C1	G4	U575A	C2	G4
CR547	G1	D4	R578	C1	G4	U575B	E1	G4
CR550	F3	E3	R593	D3	J4	U580	B2	H4
CR554	F2	E4	R594	B4	J4	U587	B3	J4
CR560	E2	F4	R596	B2	K4	U587	B3	J4
CR658	F2	F5	R597	B2	K4	U670A	C3	G5
CR677	C3	H5	R598	A3	J4	U670B	E1	G5
			R599	A3	J4	U670C	F2	G5
J132	H1	C1	R622	A4	B4			
J132	H3	C1	R645	A1	D5	VR474	A1	G3
J140	G3	D1	R652	F1	E5	VR528	A4	C4
J140	H3	D1	R654	G1	E5	VR647	A2	D5
J438	H2	C3	R656	G1	E5			

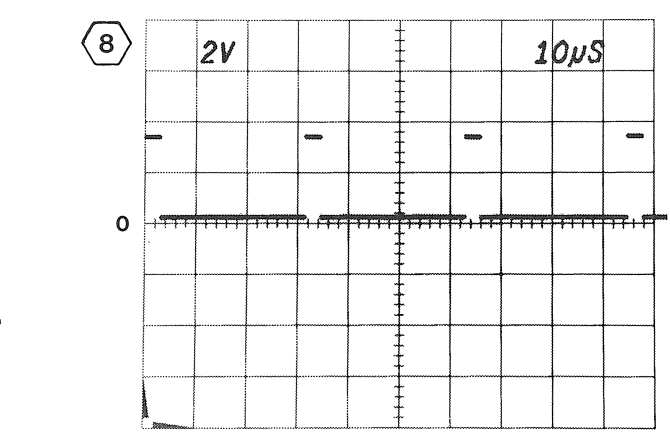
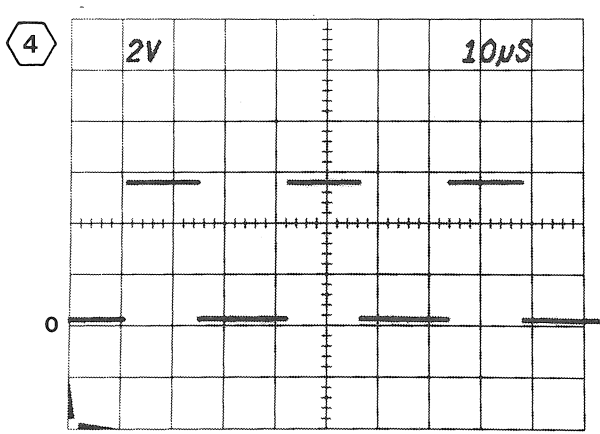
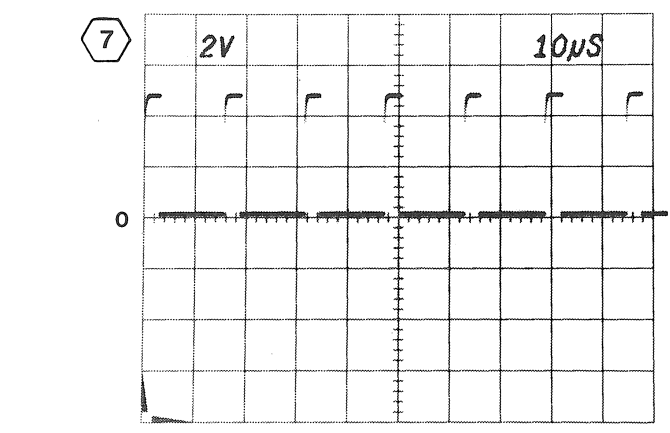
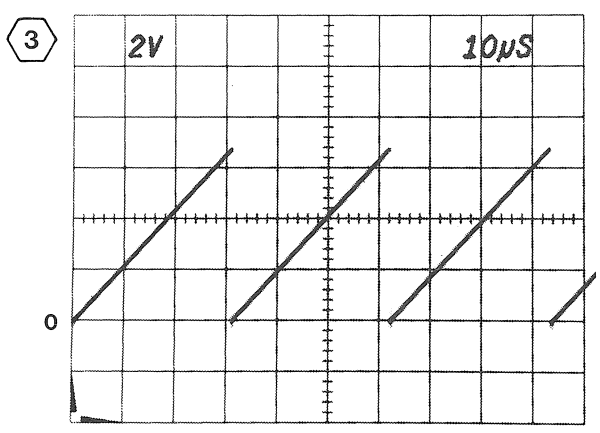
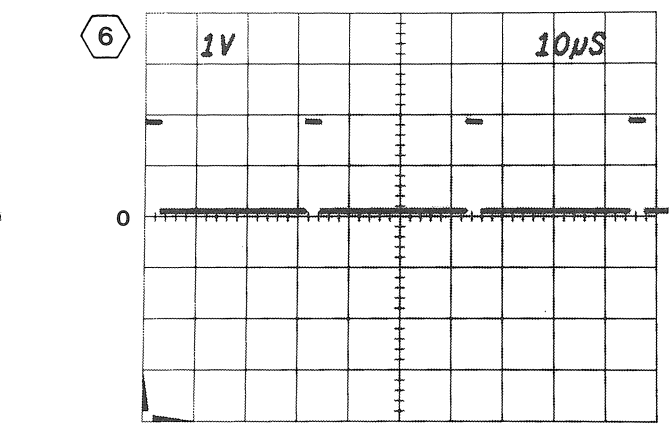
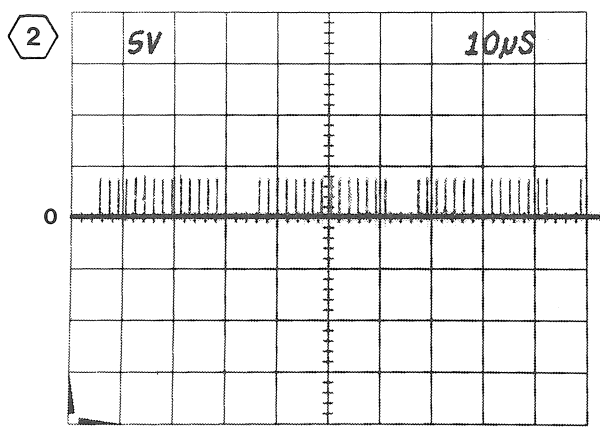
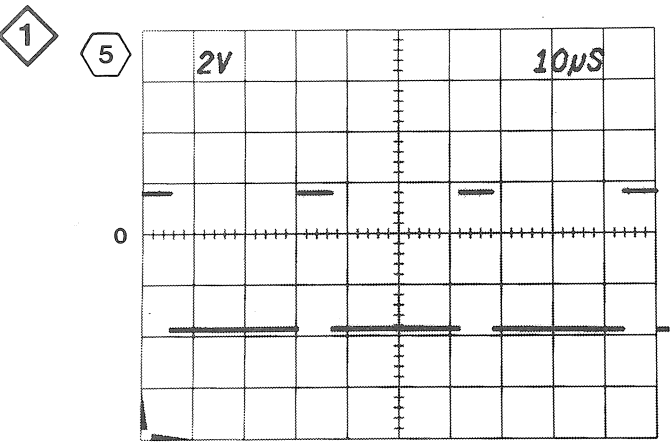
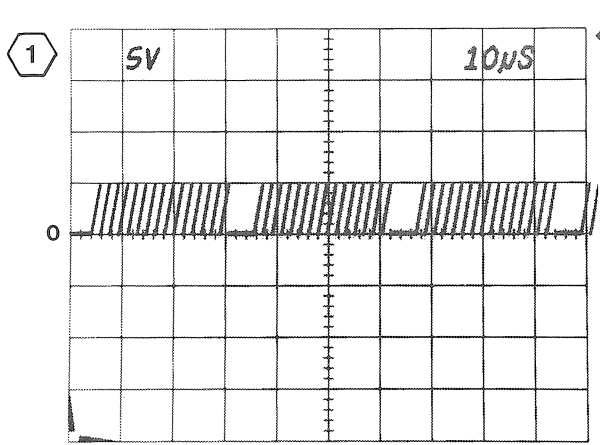

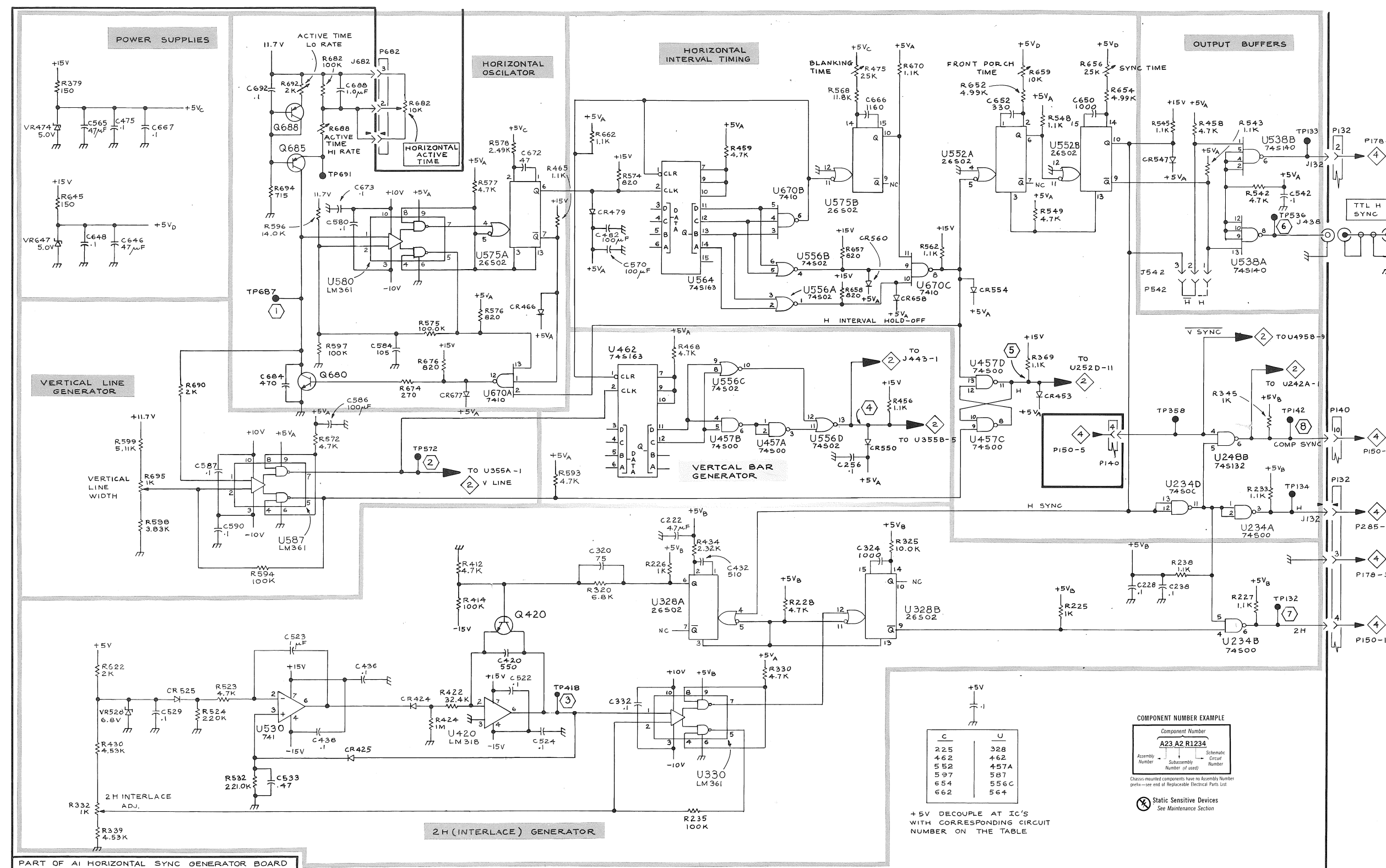

067-1039-00

3986-26

HORIZONTAL SYNC GENERATOR

HORIZONTAL SYNC GENERATOR

1

VIDEO LOGIC AND DRIVERS DIAGRAM



ASSEMBLY A1 *Partial A1 also shown on diagram 1.*

CIRCUIT NUMBER	SCHEM LOCATION	BOARD LOCATION	CIRCUIT NUMBER	SCHEM LOCATION	BOARD LOCATION	CIRCUIT NUMBER	SCHEM LOCATION	BOARD LOCATION
C110	A5	A1	J443	C2	D3	R364	D4	F2
C167	E5	G1	J445	E2	D3	R366	F4	F2
C176	G3	H1	J490	H2	K3	R372	G4	G2
C213	A5	B2	J498	H2	K3	R380	G5	H2
C215	C5	A2	J510	B4	A4	R385	E4	H2
C270	F5	G2	J510	C4	A4	R399	H2	K3
C314	C3	A2	J594	H3	K4	R432	C2	D3
C315	B3	A3	J610	B3	A4	R452	E1	E3
C319	A2	B2	J610	C4	A4	R453	E1	E3
C356	E1	E3				R480	E4	H3
C364	F5	G2	Q178	E5	H1	R484	G4	H3
C366	D5	F2	Q188	G3	J1	R486	G5	J3
C382	E5	H2	Q276	D4	G2	R488	G1	J3
C416	C4	A3	Q282	F5	J2	R490	F1	J3
C485	G5	H3	Q286	D4	H2	R491	G1	J2
C497	G1	J2	Q288	E4	J2	R492	F1	K3
C498	G1	K3	Q290	G5	J1	R494	H2	K3
C512	B4	A4	Q372	G4	H2	R514	B4	A3
C525	A3	B4	Q396	F1	J3	R515	A5	A4
C526	B3	B4	Q398	G1	J3	R516	A3	B4
C612	C4	A4				R592	H3	K4
C614	B4	A5	R115	A5	A1	R612	B4	A5
C620	B5	B5	R119	A5	B1	R697	A2	K5
C626	B5	B5	R136	B2	C1			
C694	B2	J5	R154	E5	F1	TP116	C4	B1
C698	A3	K5	R155	G4	F1	TP127	B2	C1
			R156	B1	F1	TP136	B1	D1
CR164	E5	F1	R158	C1	F1	TP158	B1	E1
CR175	F3	H1	R175	F3	G1	TP174	A4	G1
CR188	G3	J1	R176	E5	G1	TP313	C3	A2
CR244	B2	D2	R177	E4	G1	TP416	C4	A3
CR256	D1	F2	R178	F5	G1	TP432	A4	C3
CR262	F5	F2	R184	G3	H1	TP510	C3	A4
CR264	E3	F2	R186	F3	H1	TP620	B5	B5
CR267	D3	F2	R188	F5	H1	TP630	B3	C5
CR268	E3	F2	R192	G3	H1	TP673	A4	G5
CR280	F5	H2	R212	A2	A2			
CR347	B2	E2	R217	B3	A2	U242A	F4	D2
CR360	D4	F2	R255	D1	E2	U242B	E2	D2
CR362	F4	G2	R256	D1	F2	U242 D	D2	D2
CR374	G4	G2	R260	E4	F2	U248A	E1	E2
CR377	E4	H2	R266	D4	G2	U248C	D2	E2
CR382	G5	J2	R268	D4	F2	U248D	D2	E2
CR454	F1	E3	R269	F5	F2	U252A	C1	E2
			R270	D5	G2	U252B	B1	E2
J125	A3	B1	R272	F5	G2	U252D	D1	E2
J132	A2	C1	R274	D4	G2	U355A	C1	E2
J132	H5	C1	R276	D5	G2	U355B	E1	E2
J140	A1	D1	R278	F5	G2	U355C	E1	E2
J140	B3	D1	R282	F5	H2	U495A	F1	J3
J140	C3	D1	R284	D5	H2	U495B	G1	J3
J194	H3	J1	R286	E5	H2			
J210	B4	A2	R287	E4	J2	VR263	F5	F2
J210	C5	A2	R289	D4	H2	VR376	E4	G2
J385	H1	J3	R298	G4	J1	VR482	G5	H3
J390	H2	J2	R346	D2	D2	VR527	A3	B4
J394	H1	J2	R348	E2	E2	VR625	A5	B5
J410	B3	A3	R362	D5	F2	VR697	A3	K5
J410	C3	A3						
CHASSIS MOUNTED PARTS								
CIRCUIT NUMBER	SCHEM LOCATION	BOARD LOCATION	CIRCUIT NUMBER	SCHEM LOCATION	BOARD LOCATION	CIRCUIT NUMBER	SCHEM LOCATION	BOARD LOCATION
U210	C4	CHASSIS	U510	C4	CHASSIS			
U410	C3	CHASSIS	U610	C3	CHASSIS			



PARTS LOCATION TABLE

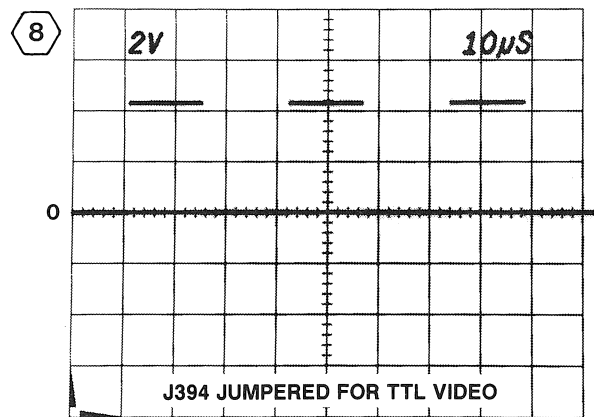
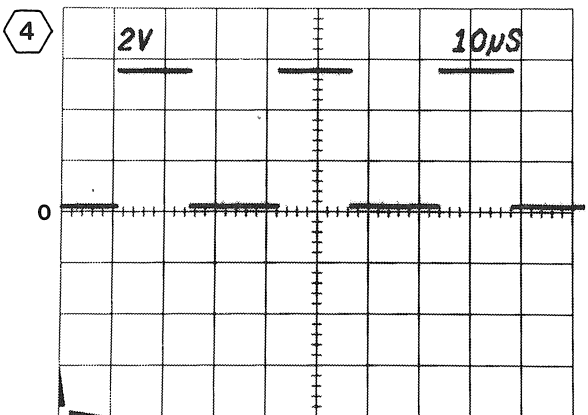
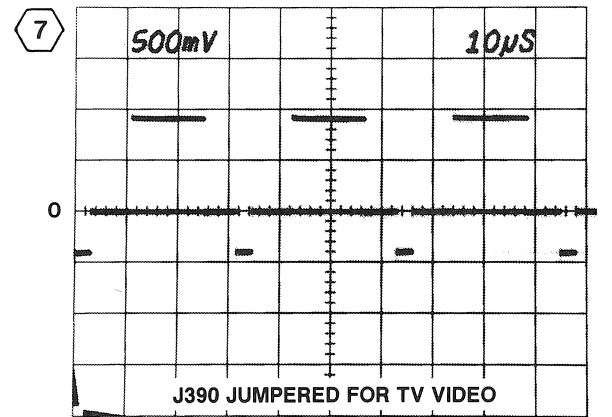
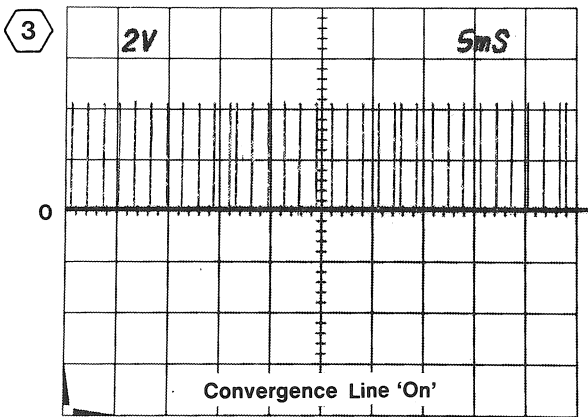
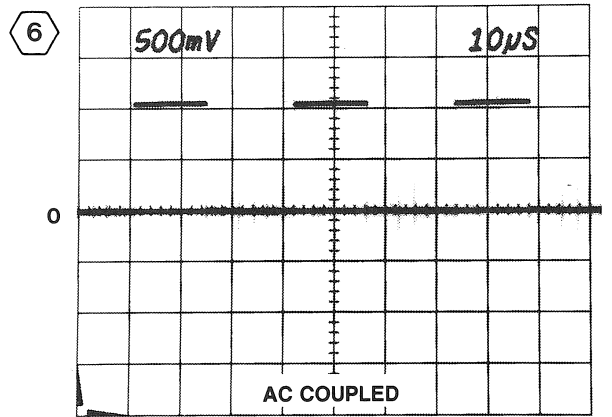
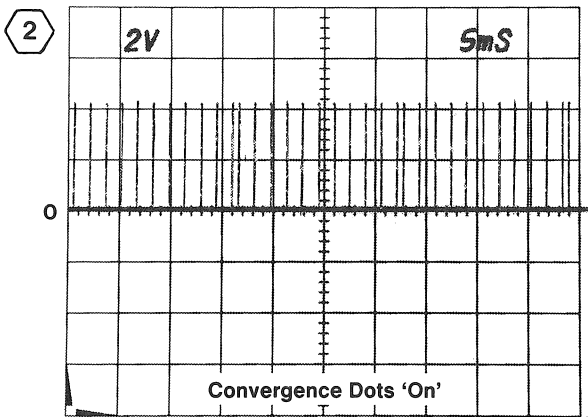
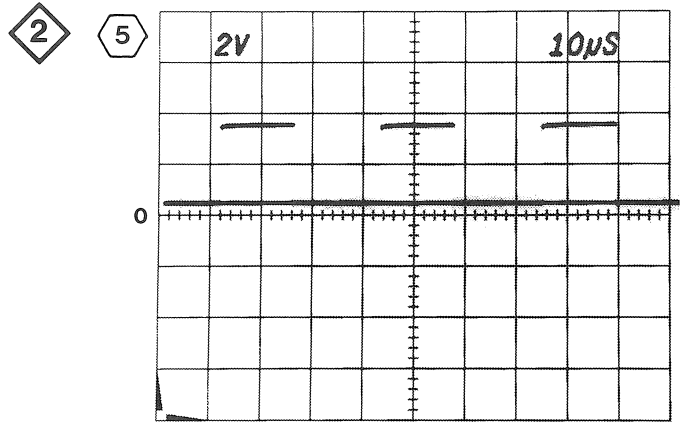
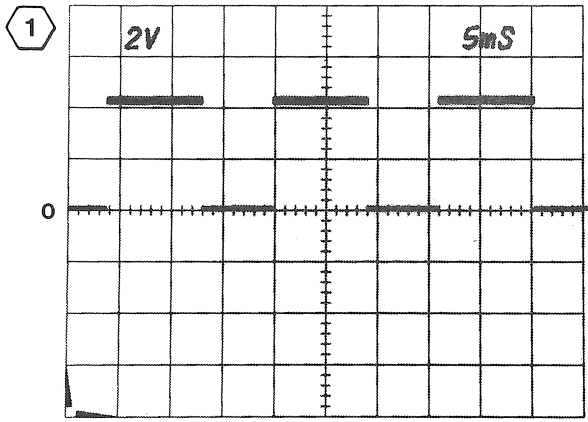

A B C D E F G H

1
2
3
4
5

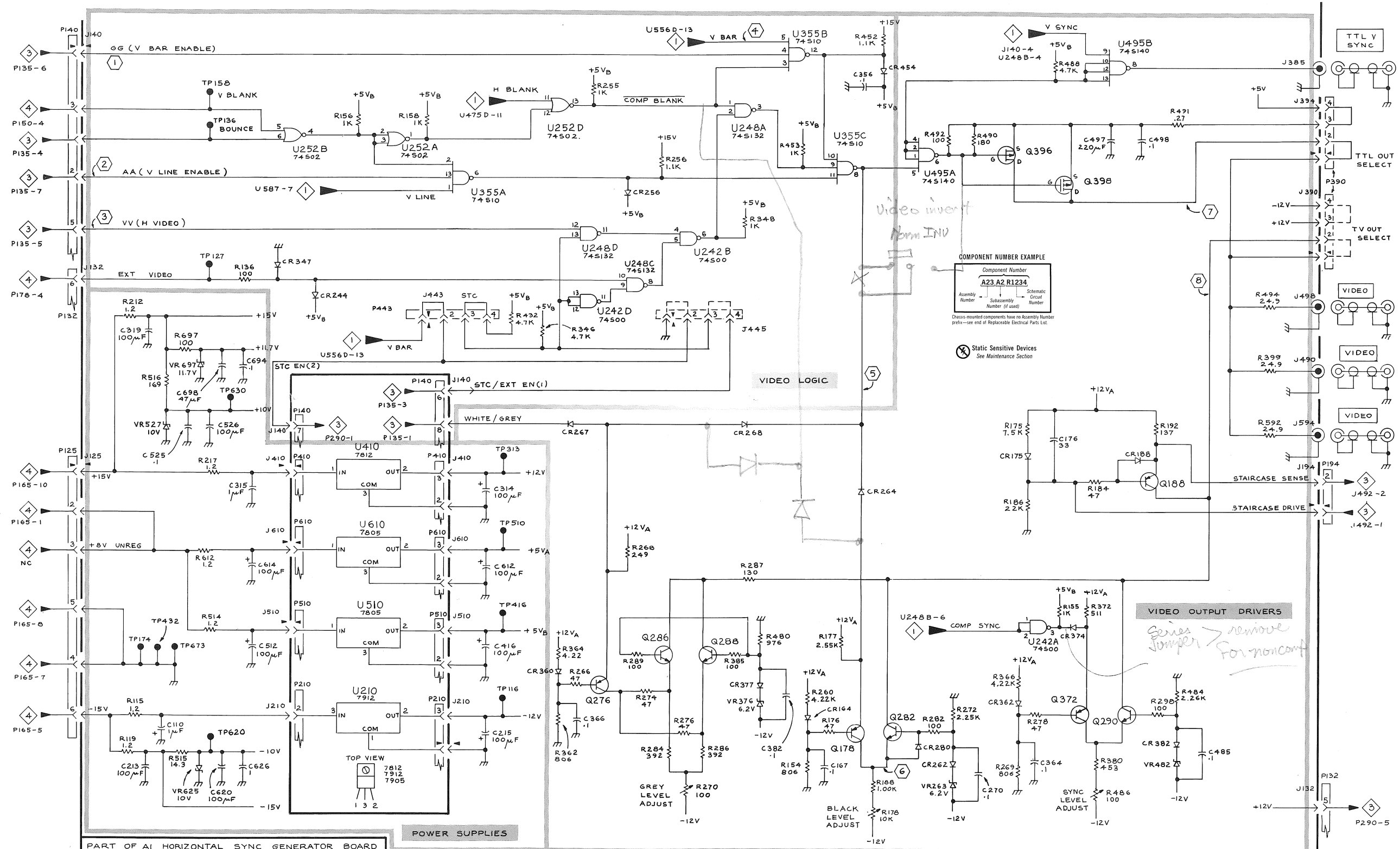

DRIVERS

2

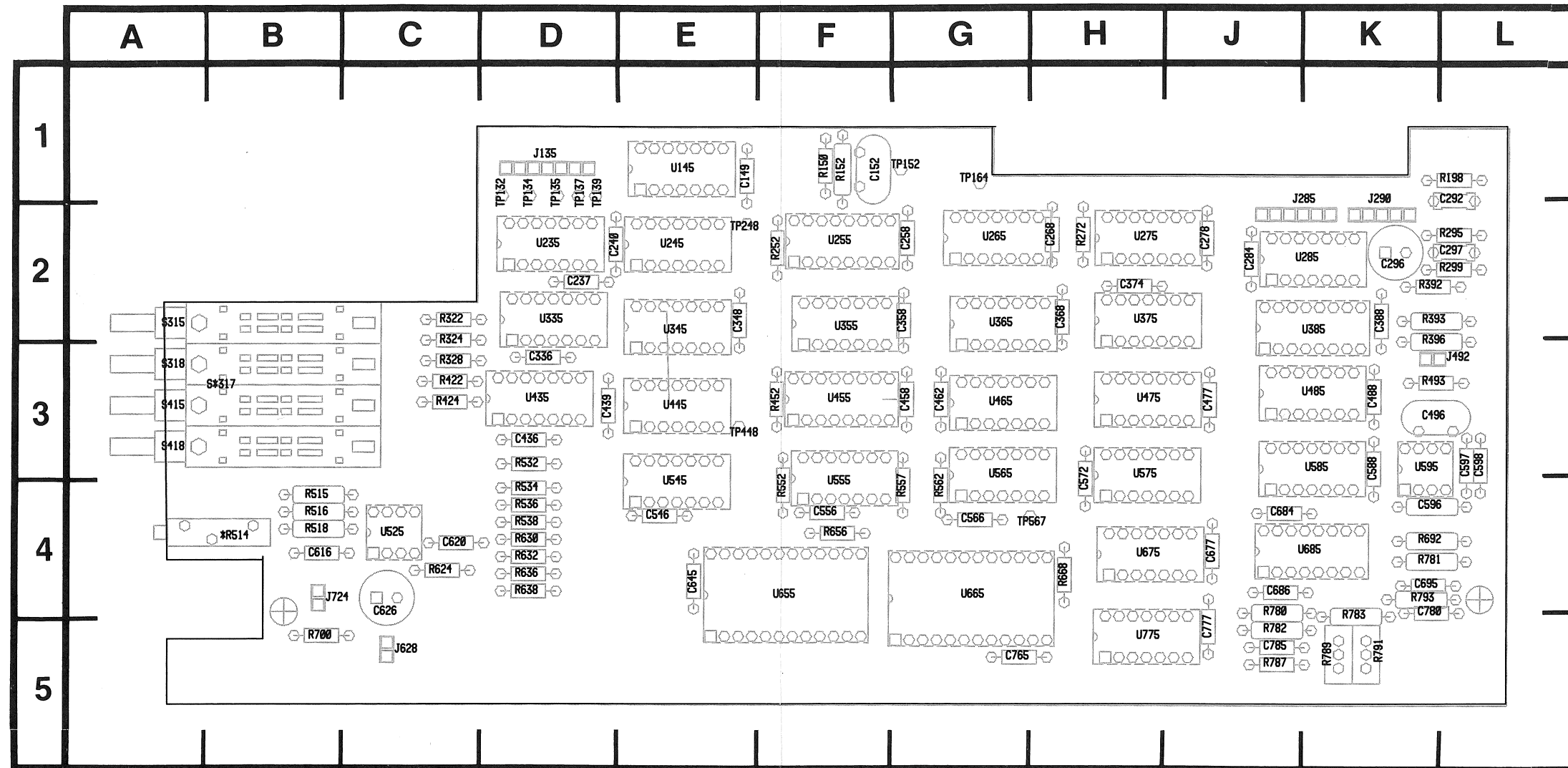
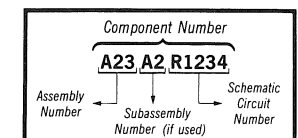

Figure 7-2. A2-Horizontal Line Generator board.

COMPONENT NUMBER EXAMPLE



Chassis-mounted components have no Assembly Number prefix—see end of Replaceable Electrical Parts List.

Static Sensitive Devices
See Maintenance Section

HORIZONTAL LINE GENERATOR DIAGRAM

3

ASSEMBLY A2

CIRCUIT NUMBER	SCHEM LOCATION	BOARD LOCATION	CIRCUIT NUMBER	SCHEM LOCATION	BOARD LOCATION	CIRCUIT NUMBER	SCHEM LOCATION	BOARD LOCATION
C149	A2	E1	R396	E5	L2	U275D	C1	H2
C152	F5	F1	R422	H2	C3	U285A	C4	K2
C237	A2	D2	R424	G4	C3	U285B	D5	K2
C240	A2	D2	R452	A4	F3	U285C	A1	K2
C258	A2	G2	R493	F5	L3	U285D	E4	K2
C268	A2	H2	R514	G1	B4	U335B	H4	D2
C278	A2	J2	R515	G1	B4	U335C	H5	D2
C284	A2	J2	R516	G1	B4	U335D	H3	D2
C292	A1	L1	R518	G1	B4	U345A	G3	E2
C296	A2	K2	R532	G3	D3	U345C	H4	E2
C297	A1	L2	R534	G4	D4	U345D	H4	E2
C336	A2	D3	R536	H5	D4	U355A	C2	F2
C348	A2	E2	R538	G4	D4	U355B	D1	F2
C358	A2	G2	R552	E1	F4	U355C	D1	F2
C368	A2	H2	R557	E2	G4	U355D	D1	F2
C374	A2	H2	R562	E3	G4	U365A	C1	G2
C388	C3	K2	R624	G1	C4	U365B	C1	G2
C436	A2	D3	R630	H5	D4	U365C	D1	G2
C439	A2	D3	R632	G4	D4	U365D	C1	G2
C458	A2	G3	R636	F5	D4	U375A	D1	H2
C462	A2	G3	R638	H1	D4	U375B	D1	H2
C477	A2	J3	R656	F1	F4	U375C	D2	H2
C488	A2	K3	R668	F3	H4	U375D	D2	H2
C496	F5	L3	R692	E3	K4	U385	C3	K2
C546	A2	E4	R700	H1	B5	U435A	H1	D3
C556	A2	F4	R780	D3	J4	U435B	G5	D3
C566	A2	G4	R781	E3	K4	U435C	H4	D3
C572	A2	H3	R782	E3	J5	U445A	G4	E3
C588	A2	K3	R783	D3	K4	U445B	H4	E3
C596	F4	K4	R787	E4	J5	U445C	H3	E3
C597	F5	L3	R789	D3	K5	U445D	H2	E3
C598	F5	L3	R791	E5	K5	U455	B4	F3
C616	A2	B4	R793	E5	K4	U465A	F2	G3
C620	H1	C4				U465B	C4	G3
C626	G1	C4	S315	G3	A2	U465C	A4	G3
C645	A2	E4	S317A	G2	B3	U465D	C4	G3
C677	A2	J4	S317B	G4	B3	U465E	B4	G3
C684	D4	J4	S317C	G5	B3	U465F	B4	G3
C686	D4	J4	S317D	G1	B3	U475A	C4	H3
C695	F4	K4	S318	G2	A3	U475B	D4	H3
C765	A2	G5	S415	G4	A3	U475C	D4	H3
C777	A2	J5	S418	G5	A3	U485A	C5	K3
C780	D3	K4				U485B	D5	K3
C785	D3	J5	TP132	H2	D1	U485C	C5	K3
			TP134	H5	D1	U525	H1	C4
J135	H1	D1	TP135	H3	D1	U545	E1	E4
J285	A1	K2	TP137	H4	D1	U555	E2	F4
J290	A4	K2	TP139	H3	D1	U565	E3	G3
J492	A5	L3	TP152	F5	G1	U575A	D2	H3
J628	H1	C5	TP164	B1	G1	U575C	C2	H3
J724	H1	B4	TP248	D5	E2	U575D	C2	H3
			TP448	F5	E3	U585A	D3	K3
R150	B2	F1	TP567	G3	G4	U585C	D4	K3
R152	F5	F1				U585D	D3	K3
R198	A1	L1	U145	B3	E1	U595	F4	K3
R252	C2	F2	U235	H3	D2	U655	F1	F4
R272	B1	H2	U245A	H3	E2	U665	F4	G4
R295	A1	L2	U245C	H5	E2	U675A	D4	H4
R299	D4	L2	U255	C1	F2	U675B	F1	H4
R322	G5	C2	U265A	B1	G2	U675C	F1	H4
R324	G2	C2	U265B	B2	G2	U675D	G1	H4
R328	H3	C3	U275A	D1	H2	U685	D3	K4
R392	D4	K2	U275B	E2	H2	U775	E4	H5
R393	C5	L2	U275C	B2	H2			

CHASSIS MOUNTED PARTS

CIRCUIT NUMBER	SCHEM LOCATION	BOARD LOCATION	CIRCUIT NUMBER	SCHEM LOCATION	BOARD LOCATION	CIRCUIT NUMBER	SCHEM LOCATION	BOARD LOCATION
DS724	H1	CHASSIS						

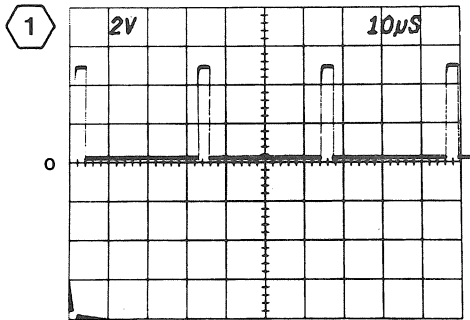

3

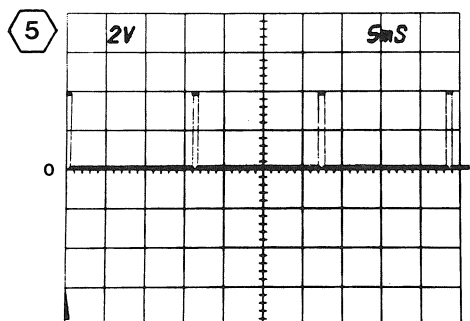
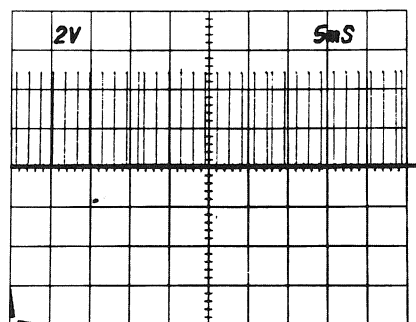
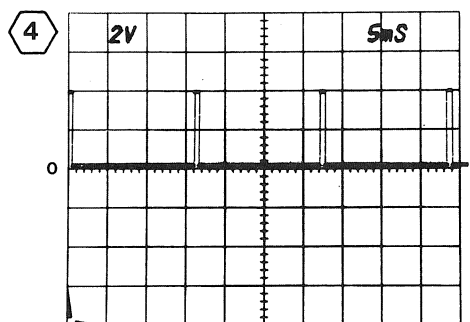
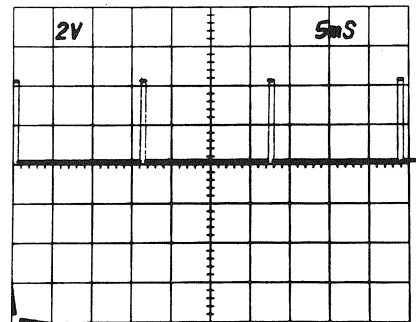
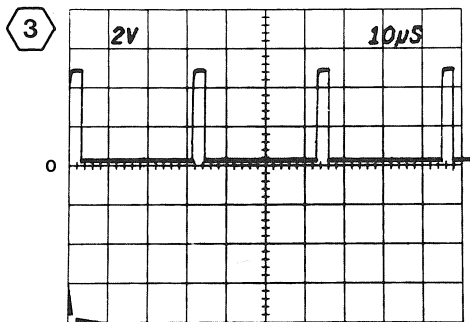
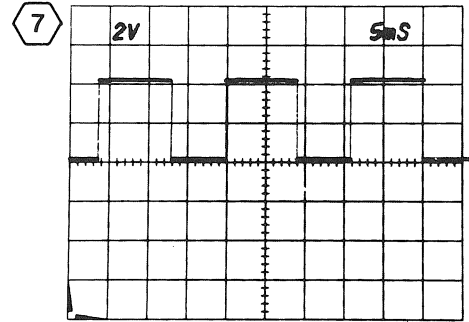
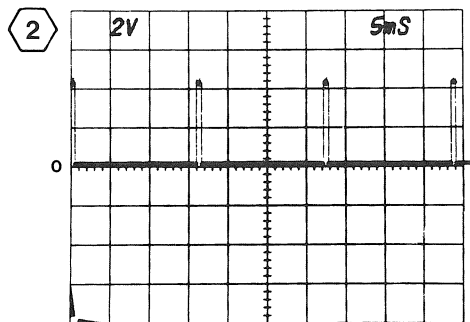
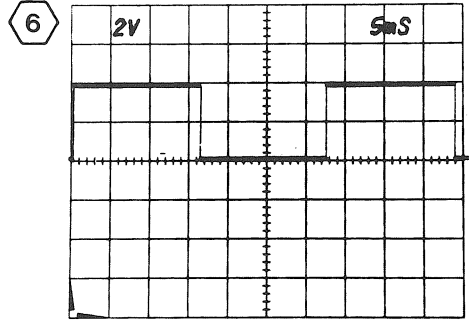

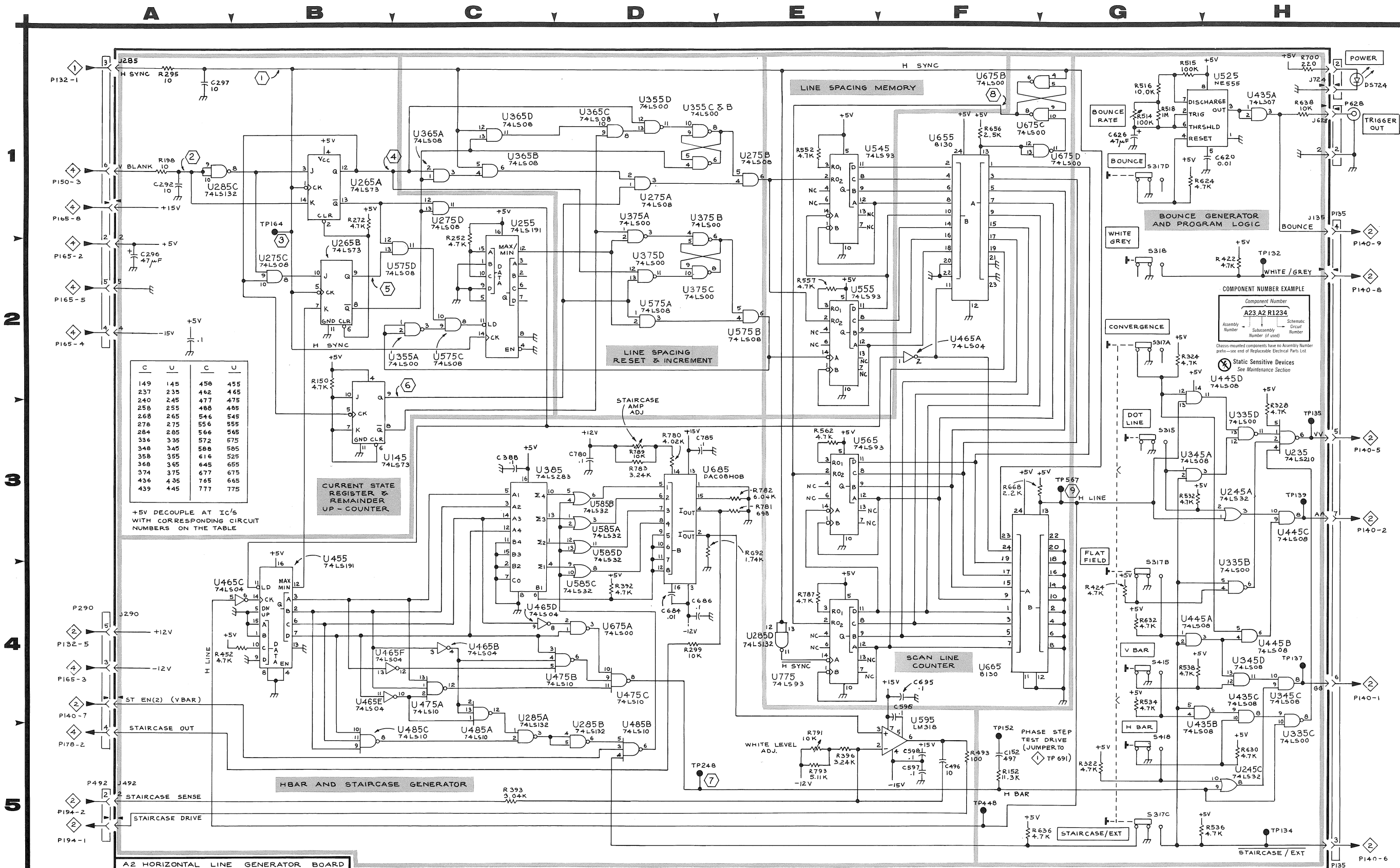

C	U	C	U
149	145	458	455
237	235	462	465
240	245	477	475
258	255	488	485
268	265	546	545
278	275	556	555
284	285	566	565
336	335	572	575
348	345	588	585
358	355	616	625
368	365	645	655
374	375	677	675
436	435	765	765
439	445	777	775

+5V DECOUPLE AT IC'S WITH CORRESPONDING CIRCUIT NUMBERS ON THE TABLE

067-1039-00

3986-28

HORIZONTAL LINE GENERATOR

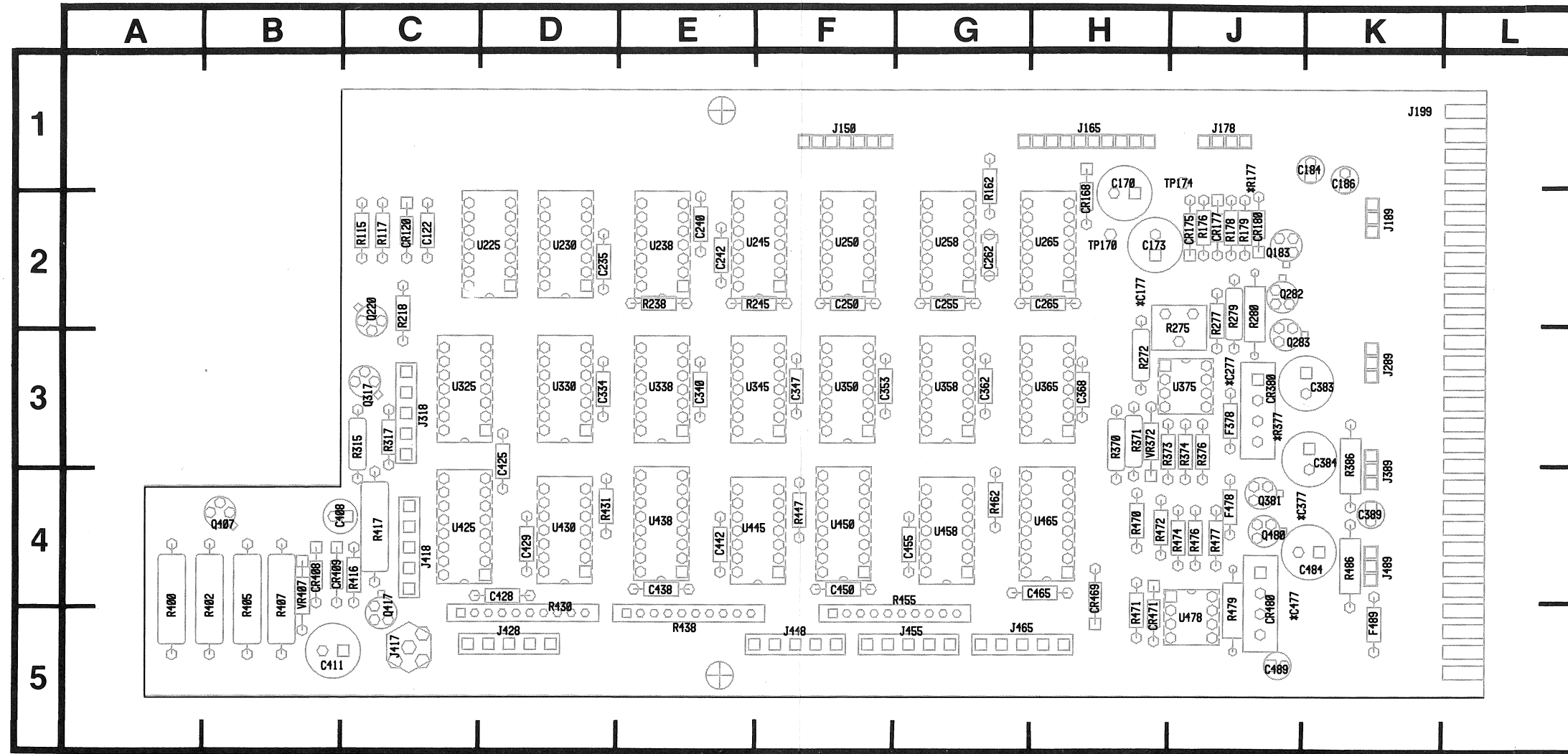
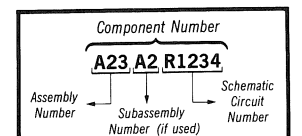

Figure 7-3. A3-Vertical Sync Generator board.

COMPONENT NUMBER EXAMPLE



Chassis-mounted components have no Assembly Number prefix—see end of Replaceable Electrical Parts List.

Static Sensitive Devices
See Maintenance Section

VERTICAL SYNC , POWER SUPPLY DIAGRAM



ASSEMBLY A3

CIRCUIT NUMBER	SCHEM LOCATION	BOARD LOCATION	CIRCUIT NUMBER	SCHEM LOCATION	BOARD LOCATION	CIRCUIT NUMBER	SCHEM LOCATION	BOARD LOCATION	CIRCUIT NUMBER	SCHEM LOCATION	BOARD LOCATION
C122	D2	C2	CR480	A2	J5	R275	B1	J2	U250A	D3	F2
C170	B2	H1				R277	B1	J2	U250B	D3	F2
C173	B1	H2	F378	A1	J3	R279	B1	J2	U250C	D3	F2
C177	B1	H2	F478	A2	J4	R280	B1	J2	U258A	A5	G2
C184	A3	K1	F489	A4	K5	R315	D1	C3	U258B	C4	G2
C186	B3	K1				R317	D1	C3	U258C	D5	G2
C235	D2	D2	J150	A5	F1	R370	A1	H3	U258C	D5	G2
C240	D2	E2	J150	C2	F1	R371	B2	H3	U258D	D5	G2
C242	D2	E2	J150	C4	F1	R373	B1	J3	U265A	D5	H2
C250	D2	F2	J165	C1	H1	R374	B1	J3	U265B	D5	H2
C255	D2	G2	J165	C2	H1	R376	B1	J3	U265C	D5	H2
C262	A5	G2	J178	B4	J1	R377	B2	J3	U265D	D5	H2
C265	D2	H2	J189	B3	K2	R386	A3	K3	U325A	D4	C3
C277	B1	J3	J199	A1	K1	R400	D1	A5	U325B	D4	C3
C334	D2	D3	J199	A2	K1	R402	D1	B5	U325C	D4	C3
C340	D2	E3	J199	C1	K1	R405	D1	B5	U325D	D5	C3
C347	D2	F3	J199	C2	K1	R407	D1	B5	U330	E4	D3
C353	D2	F3	J289	B4	K3	R416	D1	C4	U338	E5	E3
C362	D2	G3	J318	G4	C3	R417	D1	C4	U345	E1	F3
C368	D2	H3	J389	B3	K3	R430	F4	D5	U350	E2	F3
C377	B2	K4	J417	G1	C5	R431	F4	D4	U358	E2	G3
C383	A4	K3	J418	G5	C4	R438	G1	E4	U365	E3	H3
C384	B4	K3	J428	G1	D5	R447	F1	F4	U375	B1	J3
C389	B4	K4	J448	G1	F5	R455	F2	G4	U425	E4	C4
C408	D1	B4	J455	G2	G5	R462	F2	G4	U430A	F5	D4
C408	D1	B4	J465	G3	G5	R470	A1	H4	U430B	F5	D4
C411	D1	B5	J489	B3	K4	R471	B1	H5	U430C	F5	D4
C425	D2	D3				R472	B2	H4	U430D	F5	D4
C428	D2	D4	Q183	A4	J2	R474	B2	J4	U430E	F5	D4
C429	D2	D4	Q220	C1	C2	R476	B2	J4	U430F	F5	D4
C438	D2	E4	Q282	B1	J2	R477	B2	J4	U438	F5	E4
C442	D2	E4	Q283	B1	J3	R479	A2	J5	U445A	F2	E4
C450	D2	F4	Q317	D1	C3	R486	A3	K4	U445B	F2	E4
C455	D2	G4	Q381	B2	J4				U445C	F1	E4
C465	D2	H4	Q407	D1	B4	TP170	B1	H2	U445D	F1	E4
C477	B2	J5	Q417	D1	C5	TP174	B2	J1	U445E	F1	E4
C484	A3	K4	Q480	B2	J4				U445F	F1	E4
C489	B3	J5				U225A	E5	D2	U450	F2	F4
			R115	D2	C2	U225B	C5	D2	U458A	F3	G4
CR120	D2	C2	R117	C2	C2	U225C	D5	D2	U458B	F3	G4
CR168	B1	H2	R162	A5	G1	U225D	F4	D2	U458C	F3	G4
CR175	B2	J2	R176	A4	J2	U225E	F4	D2	U458D	F3	G4
CR177	B4	J2	R177	B1	J1	U230	B5	D2	U458E	F3	G4
CR180	A4	J2	R178	A4	J2	U238A	C5	E2	U458F	F3	G4
CR380	A1	J3	R179	A4	J2	U238B	C5	E2	U465	F3	H4
CR408	D1	B4	R218	C1	C2	U245A	F1	F2	U478	B2	J5
CR409	D1	B4	R238	C5	E2	U245B	E1	F2			
CR469	B2	H4	R245	F1	E2	U245C	D3	F2	VR372	A1	H3
CR471	B2	H5	R272	B1	H3	U245D	F1	F2	VR407	D1	B4

CHASSIS MOUNTED PARTS

CIRCUIT NUMBER	SCHEM LOCATION	BOARD LOCATION	CIRCUIT NUMBER	SCHEM LOCATION	BOARD LOCATION	CIRCUIT NUMBER	SCHEM LOCATION	BOARD LOCATION
U189	B3	CHASSIS	U389	B3	CHASSIS	U489	B3	CHASSIS

Pattern Gen addition in BOS

Ckt To Blank a field in 2 or 4 or 8 and leave V sync high during that time

74LS74 156-0388-00
74LS32 156-0479-02

11-22-82
AMB

From U250A-12

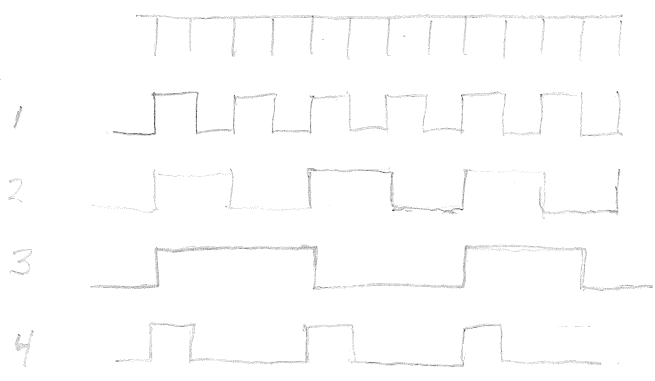
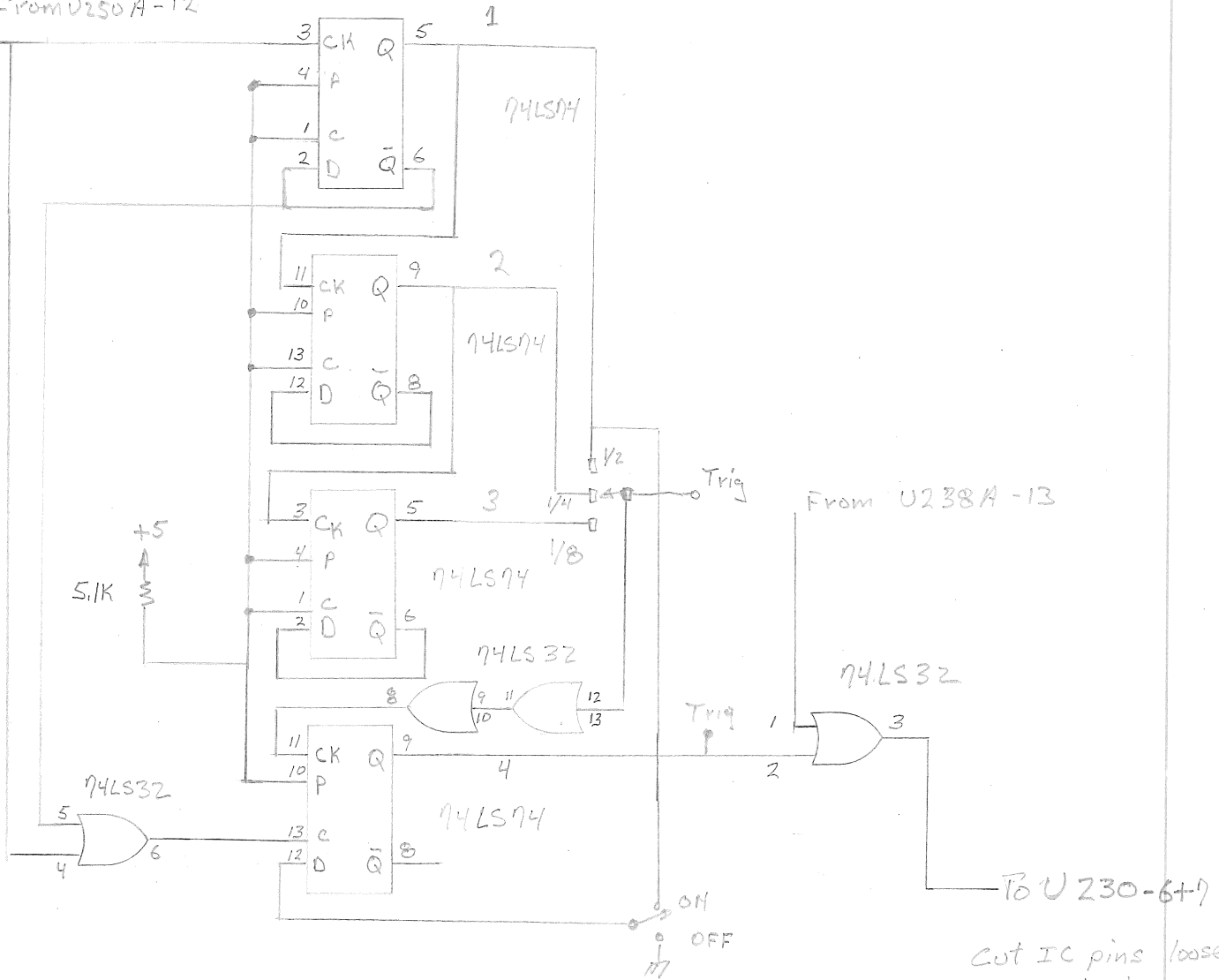

when sw on and jumper in 1/4 Blanking

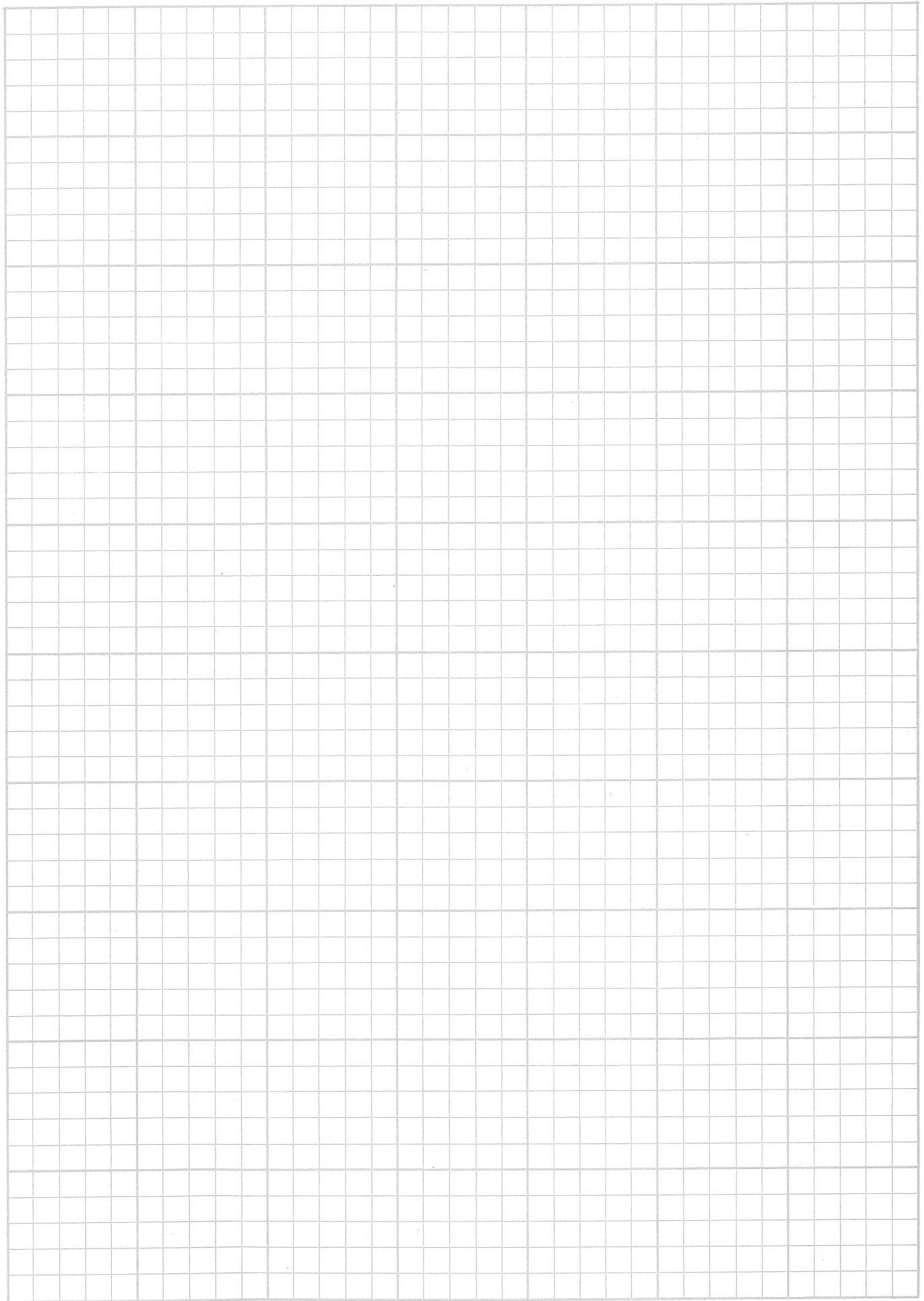

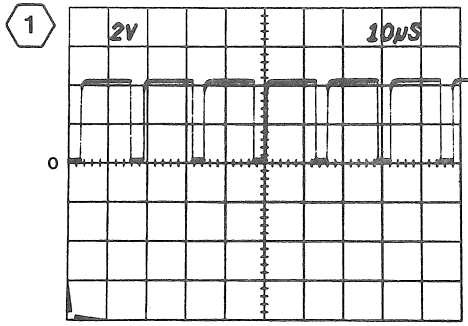

4

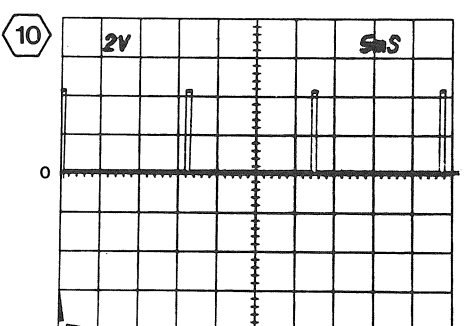
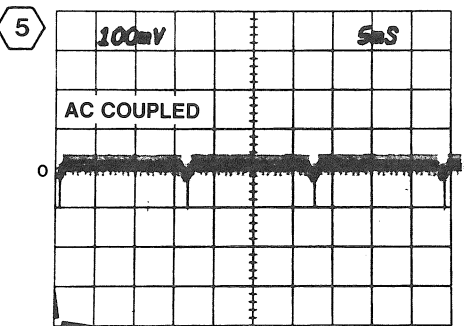
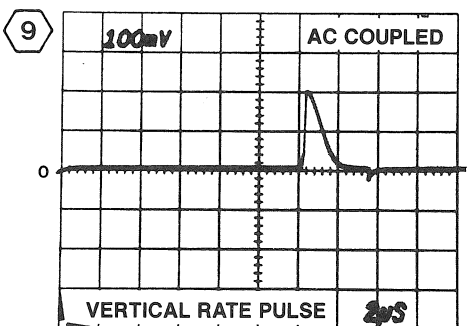
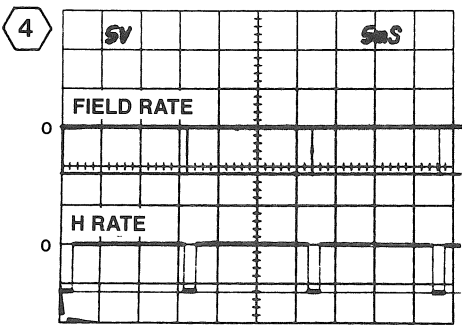
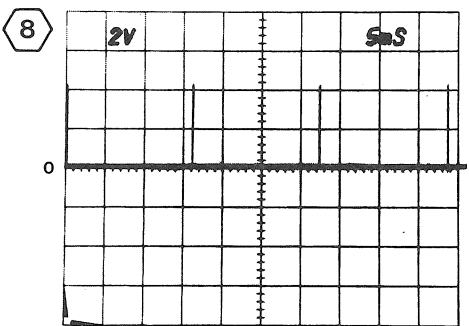
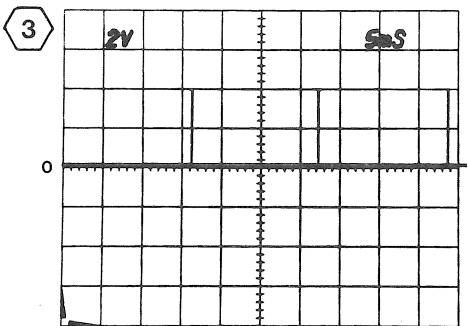
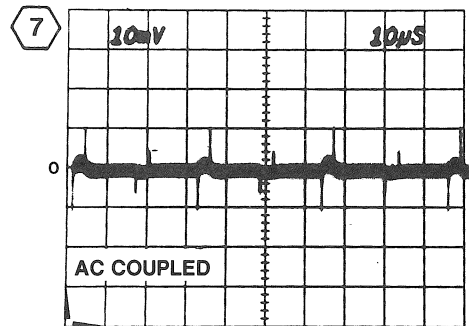
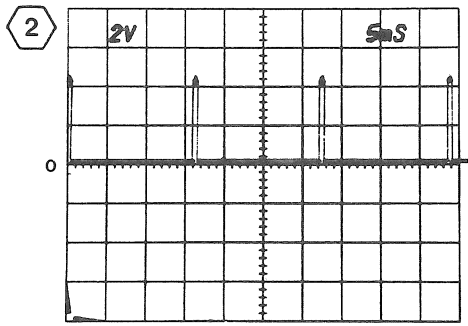
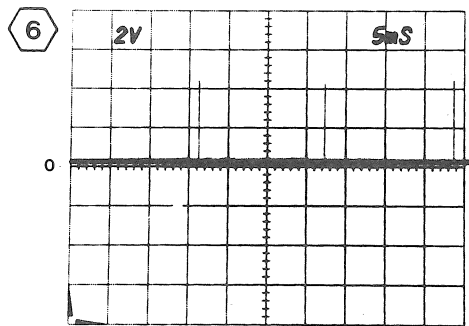

A B C D E F G H

1
2
3
4
5

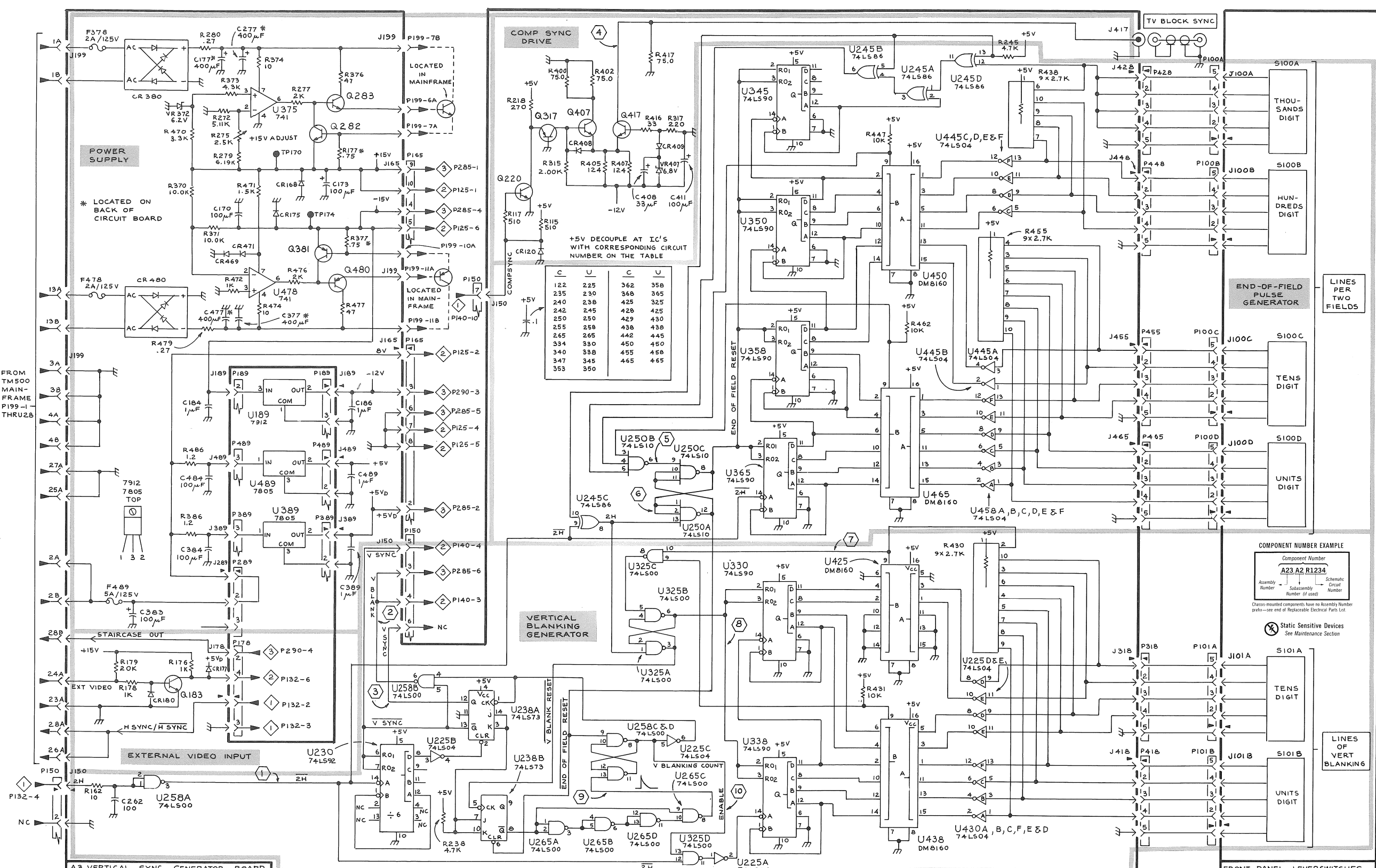

C	U	C	U
122	225	362	358
235	230	368	365
240	238	425	325
242	245	428	425
250	250	429	430
255	258	438	438
265	265	442	445
334	330	450	450
340	338	455	458
347	345	465	465
353	350		

COMPONENT NUMBER EXAMPLE

Component Number
A23 A2 R1234

Assembly Number Subassembly Number (if used) Schematic Circuit Number

Chassis-mounted components have no Assembly Number prefix—see end of Replaceable Electrical Parts List

ⓧ Static Sensitive Devices
 See Maintenance Section

VERTICAL SYNC POWER SUPPLY 4

REPLACEABLE MECHANICAL PARTS

PARTS ORDERING INFORMATION

Replacement parts are available from or through your local Tektronix, Inc. Field Office or representative.

Changes to Tektronix instruments are sometimes made to accommodate improved components as they become available, and to give you the benefit of the latest circuit improvements developed in our engineering department. It is therefore important, when ordering parts, to include the following information in your order: Part number, instrument type or number, serial number, and modification number if applicable.

If a part you have ordered has been replaced with a new or improved part, your local Tektronix, Inc. Field Office or representative will contact you concerning any change in part number.

Change information, if any, is located at the rear of this manual.

SPECIAL NOTES AND SYMBOLS

X000 Part first added at this serial number
00X Part removed after this serial number

FIGURE AND INDEX NUMBERS

Items in this section are referenced by figure and index numbers to the illustrations.

INDENTATION SYSTEM

This mechanical parts list is indented to indicate item relationships. Following is an example of the indentation system used in the description column.

1 2 3 4 5 *Name & Description*

Assembly and/or Component

Attaching parts for Assembly and/or Component

---*---

Detail Part of Assembly and/or Component

Attaching parts for Detail Part

---*---

Parts of Detail Part

Attaching parts for Parts of Detail Part

---*---

Attaching Parts always appear in the same indentation as the item it mounts, while the detail parts are indented to the right. Indented items are part of, and included with, the next higher indentation. The separation symbol ---*--- indicates the end of attaching parts.

Attaching parts must be purchased separately, unless otherwise specified.

ITEM NAME

In the Parts List, an Item Name is separated from the description by a colon (:). Because of space limitations, an Item Name may sometimes appear as incomplete. For further Item Name identification, the U.S. Federal Cataloging Handbook H6-1 can be utilized where possible.

ABBREVIATIONS

"	INCH	ELCTRN	ELECTRON	IN	INCH	SE	SINGLE END
#	NUMBER SIZE	ELEC	ELECTRICAL	INCAND	INCANDESCENT	SECT	SECTION
ACTR	ACTUATOR	ELCTLT	ELECTROLYTIC	INSUL	INSULATOR	SEMICON	SEMICONDUCTOR
ADPTR	ADAPTER	ELEM	ELEMENT	INTL	INTERNAL	SHLD	SHIELD
ALIGN	ALIGNMENT	EPL	ELECTRICAL PARTS LIST	LPHLDR	LAMPHOLDER	SHLDR	SHOULDERED
AL	ALUMINUM	EQPT	EQUIPMENT	MACH	MACHINE	SKT	SOCKET
ASSEM	ASSEMBLED	EXT	EXTERNAL	MECH	MECHANICAL	SL	SLIDE
ASSY	ASSEMBLY	FIL	FILLISTER HEAD	MTG	MOUNTING	SLFLKG	SELF-LOCKING
ATTEN	ATTENUATOR	FLEX	FLEXIBLE	NIP	NIPPLE	SLVG	SLEEVING
AWG	AMERICAN WIRE GAGE	FLH	FLAT HEAD	NON WIRE	NOT WIRE WOUND	SPR	SPRING
BD	BOARD	FLTR	FILTER	OB	ORDER BY DESCRIPTION	SQ	SQUARE
BRKT	BRACKET	FR	FRAME or FRONT	OD	OUTSIDE DIAMETER	SST	STAINLESS STEEL
BRS	BRASS	FSTNR	FASTENER	OVH	OVAL HEAD	STL	STEEL
BRZ	BRONZE	FT	FOOT	PH BRZ	PHOSPHOR BRONZE	SW	SWITCH
BSHG	BUSHING	FXD	FIXED	PL	PLAIN or PLATE	T	TUBE
CAB	CABINET	GSKT	GASKET	PLSTC	PLASTIC	TERM	TERMINAL
CAP	CAPACITOR	HDL	HANDLE	PN	PART NUMBER	THD	THREAD
CER	CERAMIC	HEX	HEXAGON	PNH	PAN HEAD	THK	THICK
CHAS	CHASSIS	HEX HD	HEXAGONAL HEAD	PWR	POWER	TNSN	TENSION
CKT	CIRCUIT	HEX SOC	HEXAGONAL SOCKET	RCPT	RECEPTACLE	TPG	TAPPING
COMP	COMPOSITION	HLCPS	HELICAL COMPRESSION	RES	RESISTOR	TRH	TRUSS HEAD
CONN	CONNECTOR	HLEXT	HELICAL EXTENSION	RGD	RIGID	V	VOLTAGE
COV	COVER	HV	HIGH VOLTAGE	RLF	RELIEF	VAR	VARIABLE
CPLG	COUPLING	IC	INTEGRATED CIRCUIT	RTNR	RETAINER	W/	WITH
CRT	CATHODE RAY TUBE	ID	INSIDE DIAMETER	SCH	SOCKET HEAD	WSHR	WASHER
DEG	DEGREE	IDNT	IDENTIFICATION	SCOPE	OSCILLOSCOPE	XFMR	TRANSFORMER
DWR	DRAWER	IMPLR	IMPELLER	SCR	SCREW	XSTR	TRANSISTOR

CROSS INDEX—MFR. CODE NUMBER TO MANUFACTURER

Mfr. Code	Manufacturer	Address	City, State, Zip
K0099	JACKSON BROS (LONDON) LTD.	258 BROADWAY	NEW YORK, NEW YORK 10007
000CY	NORTHWEST FASTENER SALES, INC.	7923 SW CIRRUS DRIVE	BEAVERTON, OR 97005
00779	AMP, INC.	P O BOX 3608	HARRISBURG, PA 17105
07707	USM CORP. USM FASTENER DIV.	510 RIVER RD.	SHELTON, CT 06484
11897	PLASTIGLIDE MFG. CORPORATION	P O BOX 867, 1757 STANFORD ST.	SANTA MONICA, CA 90406
18565	CHOMERICS INC.	77 DRAGON COURT	WOBURN, MA 01801
22526	BERG ELECTRONICS, INC.	YOUK EXPRESSWAY	NEW CUMBERLAND, PA 17070
49671	RCA CORPORATION	30 ROCKEFELLER PLAZA	NEW YORK, NY 10020
73743	FISCHER SPECIAL MFG. CO.	446 MORGAN ST.	CINCINNATI, OH 45206
78189	ILLINOIS TOOL WORKS, INC. SHAKEPROOF DIVISION	ST. CHARLES ROAD	ELGIN, IL 60120
79807	WROUGHT WASHER MFG. CO.	2100 S. O BAY ST.	MILWAUKEE, WI 53207
80009	TEKTRONIX, INC.	P O BOX 500	BEAVERTON, OR 97077
83385	CENTRAL SCREW CO.	2530 CRESCENT DR.	BROADVIEW, IL 60153
86445	PENN FIBRE AND SPECIALTY CO., INC.	2032 E. WESTMORELAND ST.	PHILADELPHIA, PA 19134
86928	SEASTROM MFG. COMPANY, INC.	701 SONORA AVENUE	GLENDALE, CA 91201
87308	N L. INDUSTRIES, INC., SOUTHERN SCREW DIV.	P. O. BOX 1360	STATESVILLE, NC 28677
91836	KINGS ELECTRONICS CO., INC.	40 MARBLEDALE ROAD	TUCKAHOE, NY 10707
93907	TEXTRON INC. CAMCAR DIV	600 18TH AVE	ROCKFORD, IL 61101
98291	SEAELECTRO CORP.	225 HOYT	MAMARONECK, NY 10544

Replaceable Mechanical Parts—067-1039-00

Fig. & Index No.	Tektronix Part No.	Serial/Model No. Eff Dscont	Qty	1	2	3	4	5	Name & Description	Mfr Code	Mfr Part Number
1-	067-1039-00		1						FIXTURE,CAL:PATTERN GENERATOR	80009	067-1039-00
-1	337-1399-04		2						. SHIELD,ELEC:SIDE	80009	337-1399-04
-2	200-2696-00		2						. COVER,PLUG-IN:ALUMINUM (ATTACHING PARTS)	80009	200-2696-00
-3	211-0207-00		6						. SCR,ASSEM WSHR:4-40 X 0.312 DOUBLE SEMS - - - * - - -	83385	OBD
-4	131-0258-01		1						. CONN,RCPT,ELEC:PROBE TIP (J628) (ATTACHING PARTS)		
-5	210-0223-00		1						. TERMINAL,LUG:0.25 INCH DIA,SE	86928	A313-136
-6	210-0940-00		1						. WASHER,FLAT:0.25 ID X 0.375 INCH OD,STL - - - * - - -	79807	OBD
-7	366-1690-00		1						. KNOB:SIL GY,0.53 X0.23 X 1.059	80009	366-1690-00
-8	366-1559-00		8						. PUSH BUTTON:SIL GY,0.18 SQ X 0.43	80009	366-1559-00
-9	426-1072-00		8						. FRAME,PUSH BTN:PLASTIC	80009	426-1072-00
-10	358-0301-02		1						. BUSHING,SLEEVE:GRAY PLASTIC	80009	358-0301-02
-11	366-1024-02		1						. KNOB:GY,0.252 ID X0.706 OD X 0.6H (ATTACHING PARTS)	80009	366-1024-02
	213-0153-00		1						. . SETSCREW:5-40 X 0.125,STL BK OXD,HEX SKT - - - * - - -	000CY	OBD
-12	354-0630-01		1						. RING,KNOB SKIRT:CLEAR PLASTIC,W/BUSHING	80009	354-0630-01
-13	175-4003-00		1						. CABLE ASSY,RF:75 OHM COAX,9.0 L,9-4 (J594)	80009	175-4003-00
-14	131-0818-00		1						. . CONNECTOR,RCPT,:BNC,FEMALE (J594)	91836	KC19-153BNC
-15	175-4285-00		1						. CABLE ASSY,RF:75 OHM COAX,4.0 L,9-3 (J417)	80009	175-4285-00
	131-0818-00		1						. . CONNECTOR,RCPT,:BNC,FEMALE (J417)	91836	KC19-153BNC
-16	175-4000-00		1						. CABLE ASSY,RF:75 OHM COAX,8.0 L,9-1 (J385)	80009	175-4000-00
	131-0818-00		1						. . CONNECTOR,RCPT,:BNC,FEMALE	91836	KC19-153BNC
-17	175-4001-00		2						. CABLE ASSY,RF:75 OHM COAX,7.0 L,9-2 (J490,J498)	80009	175-4001-00
	131-0818-00		2						. . CONNECTOR,RCPT,:BNC,FEMALE (J490,J498)	91836	KC19-153BNC
-18	175-4002-00		1						. CABLE ASSY,RF:75 OHM COAX,11.0 L,9-3 (J438)	80009	175-4002-00
	131-0818-00		1						. . CONNECTOR,RCPT,:BNC,FEMALE (J438)	91836	KC19-153BNC
-19	175-4004-00		1						. CABLE ASSY,RF:50 OHM COAX,5.0 L,9-4 (J628)	80009	175-4004-00
-20	333-2848-00		1						. PANEL,FRONT: (ATTACHING PARTS)	80009	333-2848-00
-21	210-0586-00		3						. NUT,PL,ASSEM WA:4-40 X 0.25,STL CD PL - - - * - - -	83385	OBD
-22	-----		1						. LT EMITTING DIO:(SEE DS724 REPL)		
-23	105-0718-01		1						. BAR,LATCH RLSE:	80009	105-0718-01
-24	105-0719-00		1						. LATCH,RETAINING:PLUG-IN (ATTACHING PARTS)	80009	105-0719-00
-25	213-0113-00		1						. SCR,TPG,THD FOR:2-32 X 0.312 INCH,PNH STL - - - * - - -	93907	OBD
-26	-----		1						. SWITCH:(SEE S100 REPL) (ATTACHING PARTS)		
-27	211-0030-00		4						. SCREW,MACHINE:2-56 X 0.25"82 DEG,FLH STL	83385	OBD
-28	210-1307-00		4						. WASHER,LOCK:0.115 ID,SPLIT,0.025 THK	86928	A384-25N
-29	210-0405-00		4						. NUT,PLAIN,HEX.:2-56 X 0.188 INCH,BRS - - - * - - -	73743	2X12157-402
-30	131-1807-00		1						. CONTACT ASSY,EL:31,0.025 SQ,0.15 CTR,0.54L	22526	65603-131
-31	-----		1						. SWITCH:(SEE S101 REPL) (ATTACHING PARTS)		
-32	211-0030-00		4						. SCREW,MACHINE:2-56 X 0.25"82 DEG,FLH STL	83385	OBD
-33	210-1307-00		4						. WASHER,LOCK:0.115 ID,SPLIT,0.025 THK	86928	A384-25N
-34	210-0405-00		4						. NUT,PLAIN,HEX.:2-56 X 0.188 INCH,BRS - - - * - - -	73743	2X12157-402

Replaceable Mechanical Parts—067-1039-00

Fig. & Index No.	Tektronix Part No.	Serial/Model No. Eff Dscont	Qty	1	2	3	4	5	Name & Description	Mfr Code	Mfr Part Number
1-35	131-1807-00		1						. CONTACT ASSY,EL:31,0.025 SQ,0.15 CTR,0.54L	22526	65603-131
-36	407-2823-00		1						. BRACKET,CMPNT:VAR RESISTOR,AL (ATTACHING PARTS)	80009	407-2823-00
-37	211-0503-00		2						. SCREW,MACHINE:6-32 X 0.188 INCH,PNH STL - - - * - - -	83385	OBD
-38	-----		1						. RES.,VAR,WW:(SEE R682 REPL) (ATTACHING PARTS)		
-39	210-0413-00		1						. NUT,PLAIN,HEX.:0.375-32 X 0.50 INCH,STL	73743	3145-402
-40	210-0012-00		1						. WASHER,LOCK:INTL,0.375 ID X 0.50" OD STL - - - * - - -	78189	1220-02-00-0541C
-41	376-0032-00		1						. CPLG,SHAFT,RIGI:0.252 & 0.268ID,AL	80009	376-0032-00
-42	401-0270-00		1						. GR ASSY,SP RDCN:5 TO 1	K0099	4112
-43	386-3385-09		1						. SUBPANEL,FRONT: (ATTACHING PARTS)	80009	386-3385-09
-44	213-0227-00		4						. SCR,TPG,THD FOR:6-32 X 0.50 DEG,FLH ST - - - * - - -	83385	OBD
-45	333-2842-00		1						. PANEL,REAR: (ATTACHING PARTS)	80009	333-2842-00
-46	213-0192-00		2						. SCR,TPG,THD FOR:6-32 X 0.50 INCH,PNH STL	87308	OBD
-47	386-3657-01		2						. SUPPORT,PLUG IN: - - - * - - -	93907	OBD
-48	255-0334-00		1						. PLASTIC CHANNEL:12.75 X 0.175X 0.155,NYL	11897	122-37-2500
-49	-----		2						. MICROCIRCUIT:(SEE U189,U210 REPL) (ATTACHING PARTS)		
-50	211-0207-00		2						. SCR,ASSEM WSHR:4-40 X 0.312 DOUBLE SEMS	83385	OBD
-51	210-1178-00		2						. WSHR,SHOULDERED:FOR MTG TO-220 TRANSISTOR	49671	DF 137A
-52	342-0563-00		2						. INSULATOR,PLATE:TRANSISTOR,FIBERGLAS	18565	OBD
-53	175-3034-00		2						. CA ASSY,SP,ELEC:3,26 AWG,3.0 L - - - * - - -	80009	175-3034-00
-54	-----		4						. MICROCIRCUIT:(SEE U389,U489,U510,U610 REPL) (ATTACHING PARTS)		
-55	211-0207-00		4						. SCR,ASSEM WSHR:4-40 X 0.312 DOUBLE SEMS	83385	OBD
-56	210-1178-00		4						. WSHR,SHOULDERED:FOR MTG TO-220 TRANSISTOR	49671	DF 137A
	175-3034-00		4						. CA ASSY,SP,ELEC:3,26 AWG,3.0 L - - - * - - -	80009	175-3034-00
-57	-----		1						. MICROCIRCUIT:(SEE U410 REPL) (ATTACHING PARTS)		
-58	211-0207-00		1						. SCR,ASSEM WSHR:4-40 X 0.312 DOUBLE SEMS	83385	OBD
-59	210-1178-00		1						. WSHR,SHOULDERED:FOR MTG TO-220 TRANSISTOR	49671	DF 137A
	175-3034-00		1						. CA ASSY,SP,ELEC:3,26 AWG,3.0 L - - - * - - -	80009	175-3034-00
-60	-----		1						. CKT BOARD ASSY:(SEE A1 REPL) (ATTACHING PARTS)		
-61	211-0207-00		4						. SCR,ASSEM WSHR:4-40 X 0.312 DOUBLE SEMS - - - * - - -	83385	OBD
-62	220-0455-00		4						. NUT,BLOCK:0.281"SQ,THREE 4-40 THRU THDS (ATTACHING PARTS)	80009	220-0455-00
-63	211-0207-00		4						. SCR,ASSEM WSHR:4-40 X 0.312 DOUBLE SEMS - - - * - - -	83385	OBD
-64	214-0579-00		-						. CKT BOARD ASSY INCLUDES:		
-65	131-0993-00		22						. . TERM,TEST POINT:BRS CD PL	80009	214-0579-00
-66	131-0589-00		1						. BUS,CONDUCTOR:2 WIRE BLACK	00779	530153-2
-67	198-4346-00		16						. . TERM,PIN:0.46 L X 0.025 SQ.PH BRZ GL	22526	47350
-68	131-0391-00		2						. . WIRE SET,ELEC:	80009	198-4346-00
	-----		5						. . CONNECTOR,RCPT,:50 OHM,COAX,SNAP-ON MALE - . . (J385,J438,J490,J498,J594)	98291	51-051-0049
-69	210-1160-00		5						. . WASHER,NONMETAL:0.109 ID X 0.25 INCH OD	86445	OBD
-70	131-0608-00		42						. . TERMINAL,PIN:0.365 L X 0.025 PH BRZ GOLD	22526	47357
-71	-----		1						. CKT BOARD ASSY:(SEE A2 REPL) (ATTACHING PARTS)		
-72	211-0207-00		5						. SCR,ASSEM WSHR:4-40 X 0.312 DOUBLE SEMS - - - * - - -	83385	OBD

Replaceable Mechanical Parts—067-1039-00

Fig. & Index No.	Tektronix Part No.	Serial/Model No. Eff Dscont	Qty	1 2 3 4 5	Name & Description	Mfr Code	Mfr Part Number
1-73	220-0455-00		5	.	NUT,BLOCK:0.281"SQ,THREE 4-40 THRU THDS (ATTACHING PARTS)	80009	220-0455-00
-74	211-0207-00		5	.	SCR,ASSEM WSHR:4-40 X 0.312 DOUBLE SEMS - - - * - - -	83385	OBD
-75	214-0579-00		-	.	CKT BOARD ASSY INCLUDES:		
-76	131-0608-00		10	.	TERM,TEST POINT:BRS CD PL	80009	214-0579-00
-77	131-0608-00		24	.	TERMINAL,PIN:0.365 L X 0.025 PH BRZ GOLD	22526	47357
-78	343-0495-04		1	.	SWITCH PB ASSY:(SEE A2S317 REPL)		
-79	210-3050-00		1	.	CLIP,SWITCH:FRONT,7.5 MM,4 UNIT (ATTACHING PARTS)	80009	343-0495-04
-80	210-3050-00		2	.	EYELET,METALLIC:0.218 L X 0.059 OD,BRS - - - * - - -	07707	SE-27
-81	343-0499-04		1	.	CLIP,SWITCH:REAR,7.5MM X 4 UNIT (ATTACHING PARTS)	80009	343-0499-04
-82	210-3050-00		2	.	EYELET,METALLIC:0.218 L X 0.059 OD,BRS - - - * - - -	07707	SE-27
-83	343-0495-04		4	.	SWITCH PB ASSY:(SEE A2S315,A2S318,A2S415, A2S418 REPL)		
-84	210-3050-00		1	.	CLIP,SWITCH:FRONT,7.5 MM,4 UNIT (ATTACHING PARTS)	80009	343-0495-04
-85	210-3050-00		2	.	EYELET,METALLIC:0.218 L X 0.059 OD,BRS - - - * - - -	07707	SE-27
-86	343-0499-04		1	.	CLIP,SWITCH:REAR,7.5MM X 4 UNIT (ATTACHING PARTS)	80009	343-0499-04
-87	210-3050-00		2	.	EYELET,METALLIC:0.218 L X 0.059 OD,BRS - - - * - - -	07707	SE-27
-88	211-0207-00		1	.	CKT BOARD ASSY:(SEE A3 REPL)		
-89	211-0207-00		4	.	SCR,ASSEM WSHR:4-40 X 0.312 DOUBLE SEMS - - - * - - -	83385	OBD
-90	220-0455-00		4	.	NUT,BLOCK:0.281"SQ,THREE 4-40 THRU THDS (ATTACHING PARTS)	80009	220-0455-00
-91	211-0207-00		4	.	SCR,ASSEM WSHR:4-40 X 0.312 DOUBLE SEMS - - - * - - -	83385	OBD
-92	342-0596-00		-	.	CKT BOARD ASSY INCLUDES:		
-93	131-0608-00		1	.	INSULATOR PLATE:CAPACITOR,FISH PAPER	80009	342-0596-00
-94	131-0589-00		33	.	TERMINAL,PIN:0.365 L X 0.025 PH BRZ GOLD	22526	47357
-95	131-0993-00		30	.	TERM,PIN:0.46 L X 0.025 SQ.PH BRZ GL	22526	47350
-96	131-0391-00		1	.	BUS,CONDUCTOR:2 WIRE BLACK	00779	530153-2
-97	210-1160-00		1	.	CONNECTOR,RCPT,:50 OHM,COAX,SNAP-ON MALE (J417)	98291	51-051-0049
-98	214-0579-00		1	.	WASHER,NONMETAL:0.109 ID X 0.25 INCH OD	86445	OBD
-99	426-1871-00		2	.	TERM,TEST POINT:BRS CD PL	80009	214-0579-00
-100	214-1061-00		2	.	FR SECT,PLUG-IN:	80009	426-1871-00
-101	198-4458-00		1	.	SPRING,GROUND:FLAT	80009	214-1061-00
-102	175-4557-00		1	.	WIRE SET,ELEC:	80009	198-4458-00
-103	198-4521-00		1	.	CA ASSY,SP,ELEC:2,26 AWG,12.0L,RIBBON	80009	175-4557-00
-104	179-2854-00		1	.	WIRE SET,ELEC:	80009	198-4521-00
-105	179-2855-00		1	.	WIRING HARNESS:SWITCH	80009	179-2854-00
-106	179-2855-00		1	.	WIRING HARNESS:MAIN	80009	179-2855-00

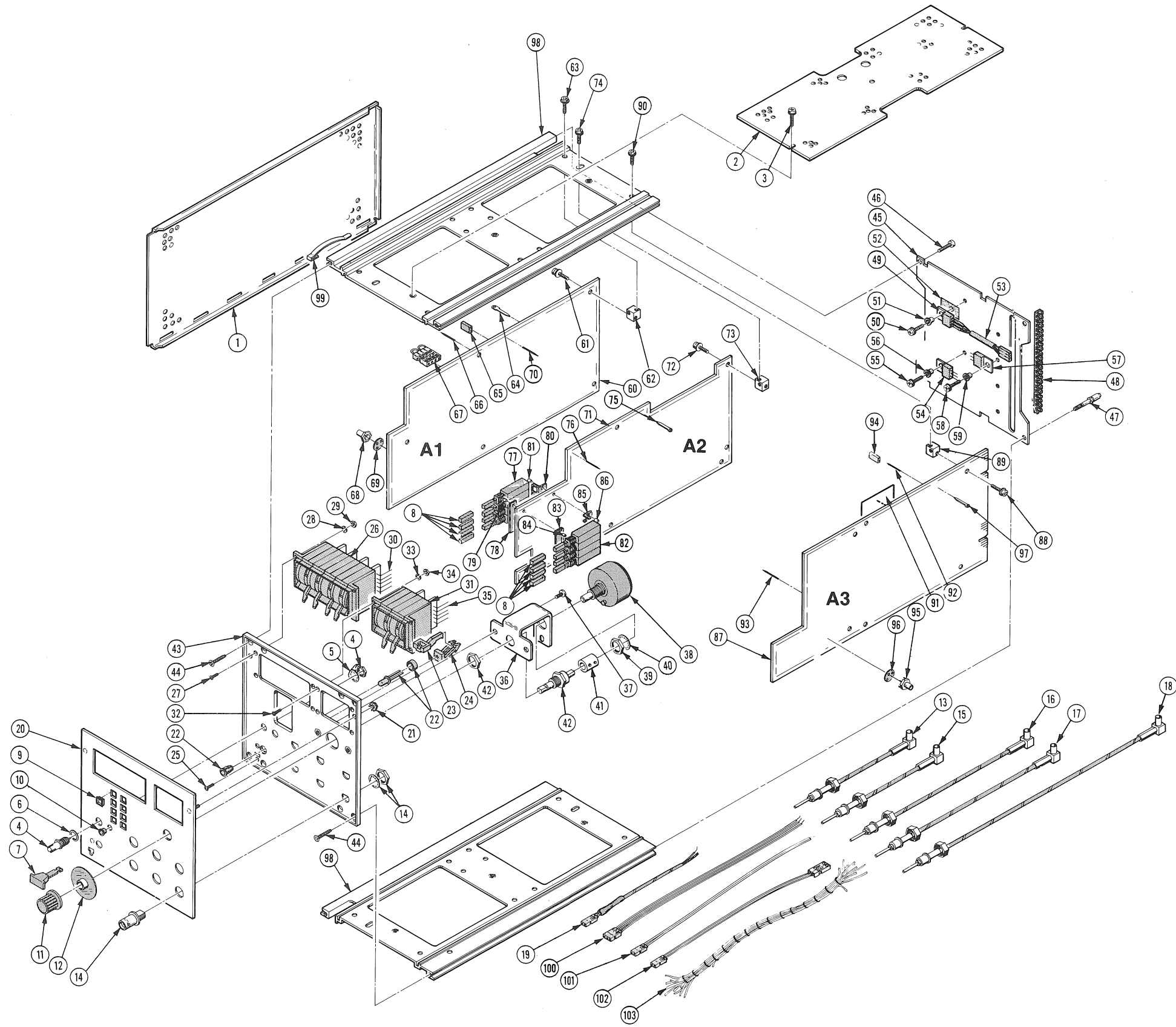

067-1039-00 PATTERN GENERATOR

Fig. & Index No.	Tektronix Part No.	Serial/Model No. Eff	Dscont	Qty	1	2	3	4	5	Name & Description	Mfr Code	Mfr Part Number
------------------	--------------------	----------------------	--------	-----	---	---	---	---	---	--------------------	----------	-----------------

STANDARD ACCESSORIES

070-3986-00				1						MANUAL, TECH: INTERIM, INSTR	80009	070-3986-00
-------------	--	--	--	---	--	--	--	--	--	------------------------------	-------	-------------

ACCESSORIES

MANUAL CHANGE INFORMATION

At Tektronix, we continually strive to keep up with latest electronic developments by adding circuit and component improvements to our instruments as soon as they are developed and tested.

Sometimes, due to printing and shipping requirements, we can't get these changes immediately into printed manuals. Hence, your manual may contain new change information on following pages.

A single change may affect several sections. Since the change information sheets are carried in the manual until all changes are permanently entered, some duplication may occur. If no such change pages appear following this page, your manual is correct as printed.

