



Operation Manual

Series PID00A-40X

Design >10



Electronics for Closed Loop Control

**Parker Hannifin
Manufacturing Germany GmbH & Co. KG**
Hydraulic Controls Division Europe
Gutenbergstr. 38
41564 Kaarst, Germany
Tel.: (+49) 181 99 44 43 0
E-mail: infohcd@parker.com
Copyright © 2013, Parker Hannifin Corp.

Note

This document and other information from Parker-Hannifin Corporation, its subsidiaries and authorized distributors provide product or system options for further investigation by users having technical expertise.

The user, through its own analysis and testing, is solely responsible for making the final selection of the system and components and assuring that all performance, endurance, maintenance, safety and warning requirements of the application are met. The user must analyze all aspects of the application, follow applicable industry standards, and follow the information concerning the product in the current product catalog and in any other materials provided from Parker or its subsidiaries or authorized distributors.

To the extent that Parker or its subsidiaries or authorized distributors provide component or system options based upon data or specifications provided by the user, the user is responsible for determining that such data and specifications are suitable and sufficient for all applications and reasonably foreseeable uses of the components or systems.

Operation Manual**Series PID00A-40X**

Content	Page
1. Introduction	4
1.1. Front view / dimensions	4
1.2. Ordering code	4
1.3. Name plate	4
1.4. Block diagram	5
1.5. Characteristics	5
1.6. Technical data	6
1.7. Signal flow diagram	7
2. Safety instructions	8
2.1. Symbols	8
2.2. Marking, name plates	8
2.3. Work at the electronics	8
3. Important details	8
3.1. Intended usage	8
3.2. Common instructions	8
3.3. Liability	8
3.4. Storage	8
4. Mounting / Installation	9
4.1. Scope of supply	9
4.2. Mounting	9
4.3. Operational limits	9
4.4. Electrical connection	9
4.5. Electrical interfacing	10
5. Operating instructions	20
5.1. Operating software program	20
5.2. Program installation	21
5.3. Software operating	22
5.4. Adjustment parameters	23
5.5. Guideline for closed loop applications	28
5.5.1. Application: Closed loop systems for position	28
5.5.2. Application: Closed loop systems for pressure	32
5.5.3. Application: Closed loop systems for velocity	36
5.6. Fade out function	40
5.7. Error messages	41
6. Maintenance	42
7. Trouble-shooting	42
8. Repair / Service	43

Operation Manual

1. Introduction

1.1. Front view / dimensions

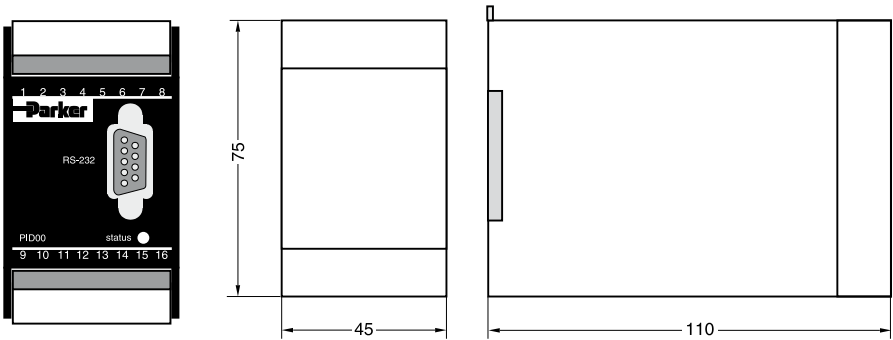

1.2. Ordering code

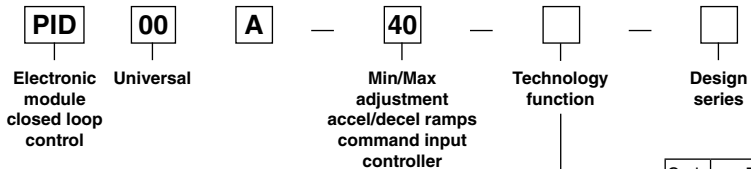

Code	Function
0	Standard
1	Linearization

1.3. Name plate

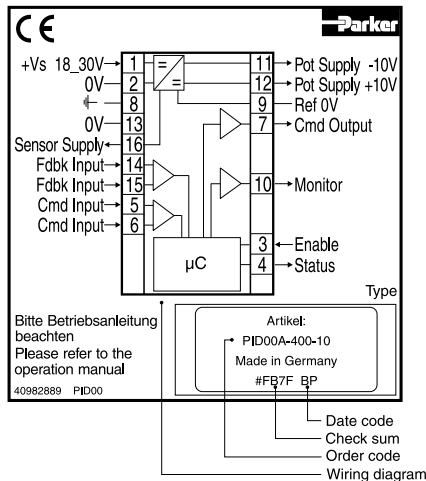

Operation Manual

Series PID00A-40X

1.4. Block diagram

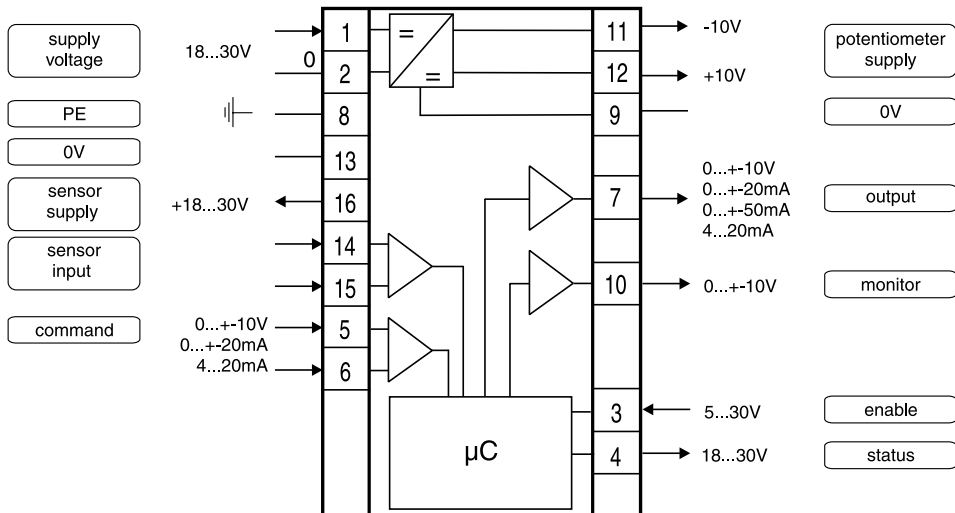

Parker electronic modules PID00A-40* for rail mounting are compact, easy to install and provide time-saving wiring by disconnectable terminals. The digital design of the circuit results in good accuracy and optimal adaption for closed loop controls by a comfortable interface program. The described electronic unit combines all necessary functions for the optimal operation of closed loop controls. The most important features are:

- Compatible to the relevant European EMC standards
- Optional technology function "linearization"
- Comfortable interface program. Download free of charge www.parker.com/euro_hcd → **Services** → **downloads**

1.5. Characteristics

- Extended PID controls
- Velocity control with position feedback
- Differential input stage with different signal options
- Output stage with different output options
- Four-quadrant ramp function
- Status indicator
- Digital circuit design
- Parametering by serial interface RS-232C
- Connection by disconnectable terminals



Operation Manual

1.6. Technical data

General		
Model		Module package for snap-on mounting on EN 50022 rail
Package material		Polycarbonate
Inflammability class		V2..V0 acc. UL 94
Installation position		Any
Ambient temperature range	[°C]	-20...+60
Protection class		IP 20 acc. to EN 60529
Weight	[g]	160
Electrical		
Duty ratio	[%]	100
Supply voltage	[VDC]	18...30, ripple < 5% eff., surge free
Current consumption max.	[mA]	100
Pre-fusing	[mA]	500
Command signal options	[V] [mA] [mA]	+10...0...-10, ripple <0.01 % eff., surge free, Ri = 100 kOhm +20...0...-20, ripple <0.01 % eff., surge free, Ri = 200 Ohm 4...12...20, ripple <0.01 % eff., surge free, Ri = 200 Ohm <3.6 mA = solenoid output 0V/0 mA/12 mA acc. output option >3.8 mA = solenoid output on (acc. NAMUR NE43)
Input signal resolution	[%]	0.025
Differential input voltage max.	[V]	30 for terminals 5 and 6 against PE (terminal 8)
Status signal	[V]	0...0.5: Off / Us: On / rated max. 15 mA
Enable signal	[V]	0...1: Off / 5...30: On / Ri = 100 kOhm
Monitor signal	[V]	+10...0...-10, rated max. 5 mA, signal resolution 0.4 %
Output signal options	[V] [mA] [mA] [mA]	+10...0...-10, rated max. 15 mA +20...0...-20, Ro < 500 Ohm +50...0...-50, Ro < 200 Ohm 4...12...20, Ro < 500 Ohm
Output signal resolution	[%]	0.025
Potentiometer supply	[V]	+10...0...-10 2%, rated max. 15 mA
Sensor supply	[V]	18...30 (Us), rated max. 100 mA
Adjustment ranges	Min [%] Max [%] Ramp [s] Zero offset [%]	0...50 50...100 0...32.5 +100...-100
Interface		RS 232C, DSub 9p. male for null modem cable
EMC		EN 50081-2, EN 50082-2
Connection		Screw terminals 0.2...2.5 mm ² , disconnectable
Cable specification	[AWG]	20 overall braid shield
Cable length	[m]	50
Options		
Technology function	Code1	Software adjustable transfer function with 10 compensation points for linearization of valve behaviour.

Operation Manual

1.7. Signal flow diagram

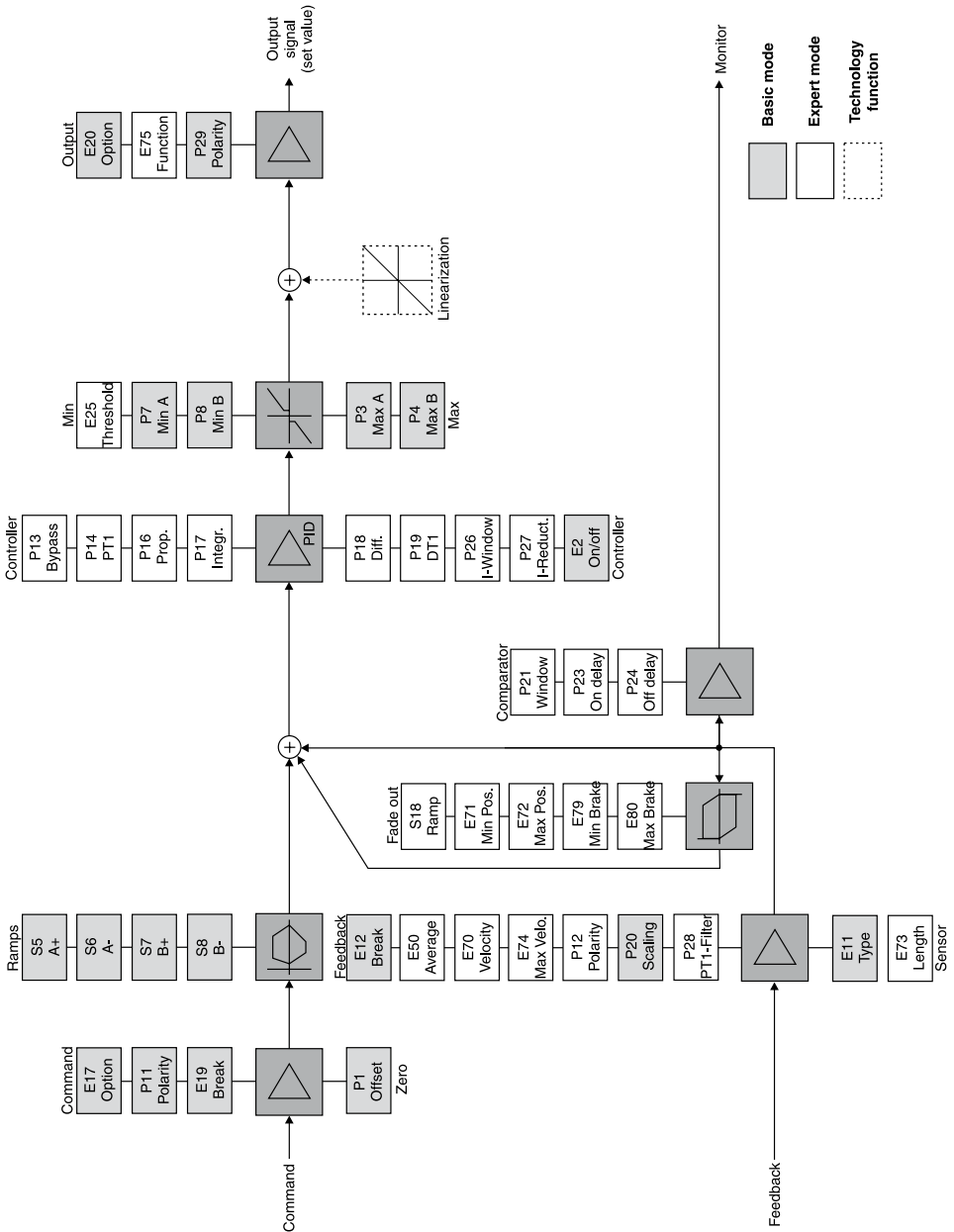

Operation Manual

2. Safety instructions

Please read the operation manual before installation, startup, service, repair or stocking! Paying no attention may result in damaging the electronics or incorporated system parts.

2.1. Symbols

This manual uses symbols which have to be followed accordingly:



Instructions with regard to the warranty



Instructions with regard to possible damaging of the electronics or linked system components



Helpful additional instructions

2.2. Marking, name plates

Instructions applied on the electronics, i.e. wiring diagrams and name plates, must be observed and maintained legibly.

2.3. Work at the electronics

Working in the area of installation and commissioning of the electronics may only be allowed by qualified personnel. This means persons who due to education, experience and instruction, have sufficient knowledge of relevant directives and approved technical rules.

3. Important details

3.1. Intended usage

This operation manual is valid for module electronics PID00A-40X series. Any use diverging or going beyond is deemed to be as not intended. The manufacturer is not liable for warranty claims resulting from this.

3.2. Common instructions

We reserve the right of technical modifications of the described product. Illustrations and drawings within this manual are simplified representations. Due to further development, improvement and modification of the product, the illustrations might not match precisely with the described device. The technical specifications and dimensions are not binding. No claim may result from it. Copyrights reserved.

3.3. Liability

The manufacturer does not assume liability for damage due to the following failures:

- incorrect mounting / installation
- improper handling
- lack of maintenance
- operation outside the specifications



Do not disassemble the electronics! In case of suspicion for a defect please return the unit to the factory.

3.4. Storage

In case of temporary storage the electronics must be protected against contamination, atmospheric exposure and mechanical damages.

Operation Manual

4. Mounting / Installation

4.1. Scope of supply

Please check immediately after receiving the electronics, if the content is matching with the specified scope of supply. The delivery includes:

- module electronics
- operation manual

☞ Please check the delivery immediately after receiving the shipment for apparent damages due to shipping. Report shipment losses at once to the carrier, the insurance company and the supplier!

4.2. 4.2. Mounting

- Compare electronics type (located on the name plate) with part list resp. circuit diagram.
- The module may be mounted in any direction.
- The module has to be mounted within a shielded environment (i.e. control cabinet).
- For mounting an assembly rail acc. EN 50022 is required.

Dimensions assembly rail

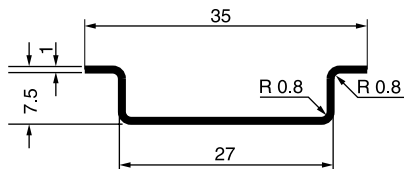

Work flow for module installation

Mounting:

5. Apply the module with the assembly rail guide at the lower edge of the rail.
6. Engage the module upward.

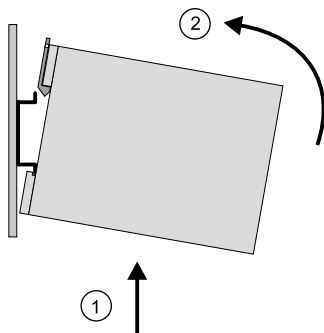

Removing:

5. Lift the metal socket lock with a suitable screwdriver (approx. 4x1 mm blade) against the spring force.
6. Demount the module at the top edge of the assembly rail.

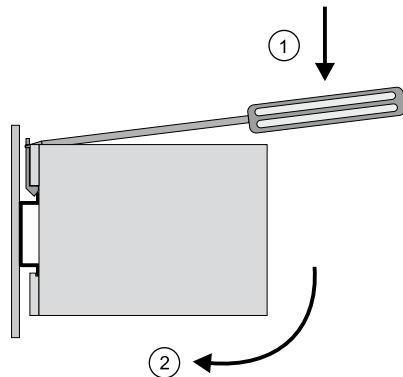

4.3. Operational limits

The electronics may be operated within the determined limits only. Please refer to the "technical data" section.



Follow the environmental conditions! Unallowable temperatures, shock load, moisture exposure, radiation exposure, illegal electromagnetic emissions may result in system malfunction and may lead to failure! Follow the operating limits listed in the "specifications" table!

4.4. Electrical connection

The electrical connection of the module electronics is via the front accessible screw terminal blocks.



This easy-to-install connection allows fast module replacement and a visible separation of the electrical connection. An additional folding "unlocking lever" allows simple removing of the terminal blocks and serves at once as shock hazard protection and marking strip.

Operation Manual

The connecting wires have to comply to the following specification:

Wire type: hookup cable, stranded
Cross sections: min. AWG 20/0.5mm²
Wire length: max. 50m

☞ For wire lengths > 50 m consult factory.

Stripping length for the connection wires



The screw terminals are designed to allow termination of all kinds of copper wires without the need for preparation. Copper wire end sleeves may be used as conductor stripping protection for the stranded wires.

⚠ Soldering of the connection wires is not permitted.

To ensure EMC-compatibility the wiring of the module has partly to be undertaken by shielded cables. Detailed information relating to this subject are available in the chapter entitled "Electrical Interfacing".

⚠ The installation should only be undertaken by qualified personnel! A short between individual conductors, loose wires or improper shielded connections may result in malfunction and breakdown of the electronics resp. the connected valve!

⚠ The mounting surface of the valve must be grounded to the machine frame. Both end of the interconnecting cable shield must be grounded and tied to terminal 8. It is necessary to use a low ohmic potential connection between control unit and machine frame to prevent earth loops (cross section min. AWG 6 / 10mm²).

4.5. Electrical interfacing

Supply Voltage:

The supply voltage for the electronics is connected via terminals 1 and 2 of the module electronics, the range of which is 18...30V, residual ripple may not exceed 5% eff.

⚠ The applied power supply must comply to the relevant regulations (DIN EN 61558) and must carry a CE-mark. The operating voltage for the electronics must be free of inductive surges. Do not exceed the max. value of 30V! Non-observance of this rule may result in permanent damaging of the electronics resp. the connected valve!

⚠ The increased inrush current of the valve should be considered when selecting the power supply. A stabilized power supply with "over current" limiting feature should not be used. Due to the inrush current of the electronics the current limit circuit may respond prematurely and create problems during energizing of the supply voltage.

Wiring diagram of supply voltage

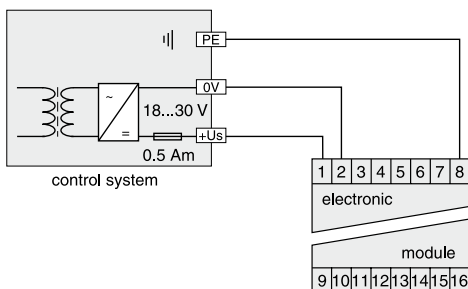

⚠ The operation of the electronics is blocked if the supply voltage polarity is inverted.

⚠ Each electronics module requires a separate pre-fuse of 0.5 Amp time lag. Non-observance of this instruction may create irreparable damage of electronics resp. incorporated system parts.

Operation Manual

Enable input

A signal voltage applied to the terminals 3 and 13 enables the solenoid output of the electronics. Continuous operation of the electronics requires a permanent voltage 5...30V (i.e. the supply voltage). In case of disabling the signal the output of the electronics will be switched off in no time independently from the command signal value. At the same time the controller output will be clamped. In case of re-starting the enable signal, the output signal waveform defaults to the zero position of the controller.

Preferably the enable signal should be switched on together with the hydraulic pressure supply to avoid unwanted reaction of the down streamed system.



The enable function should not be considered to be a safety arrangement in isolation but should form a part of an overall safety systems strategy.

Wiring diagram of enable input

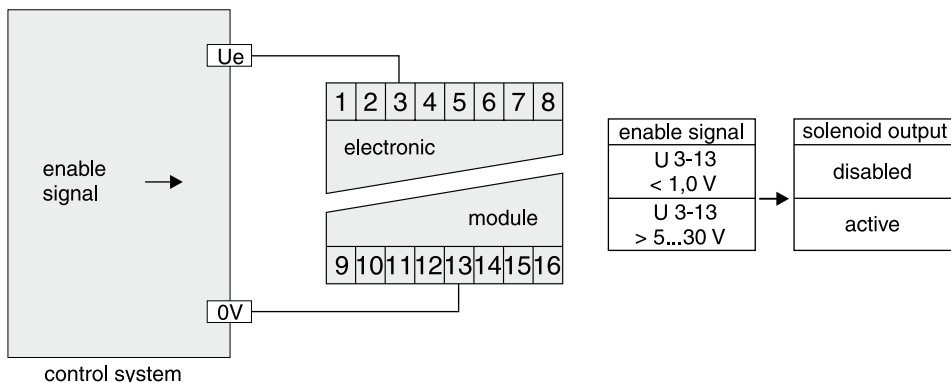

Command signal input

The command signal will be connected to the terminals 5 and 6 of the difference signal input of the electronics. All inter connecting signal cables should be shielded and appropriately grounded. By means of reviewing and subsequent selection of the programmable parameters different command signal can be utilized as described below. For the function description terminal 6 is assumed as signal reference (0V).



Details are available in the technical specifications. The parameter options for the command signal input are described in the chapter "Operating Instructions".



The command input signal should be filtered and free of inductive surges/modulations there by providing a high quality in signal averting drive malfunctions.



Incorrect signal amplitude levels may disturb functionality and may damage the module!

Operation Manual

Wiring diagram of voltage command input +10...0...-10V

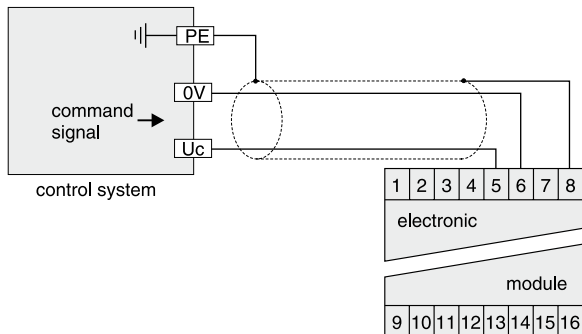

Wiring diagram of voltage command input +20...0...-20mA

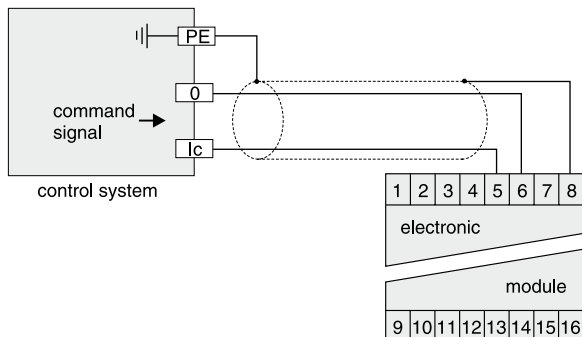

Wiring diagram of current input 4...12...20mA

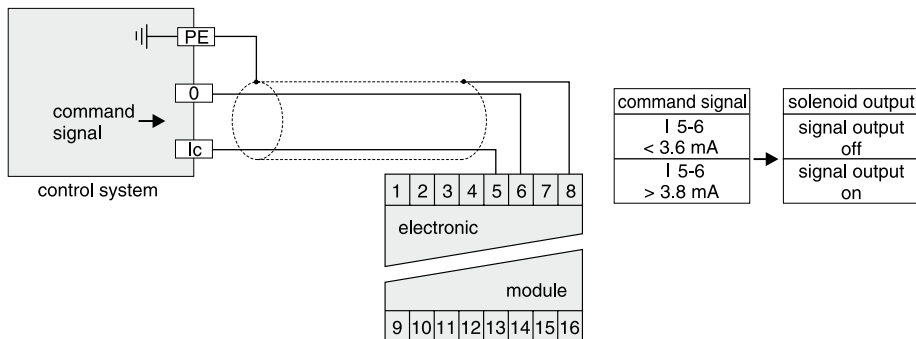

☞ The 4...20mA option uses the “0mA” condition as breakdown-information. This means the presence of an evaluable failure information if the input signal line is interrupted. In this case the solenoid output will be switched off. The output will switched on when the input signal reaches a value of 3.8mA, it switches

off when the command falls below 3.6mA. This is in line with the NAMUR-specification NE43. If necessary, the command signal cable break detection can be disabled by selecting the parameter E19.

NAMUR is an association of users of process control technology.

Operation Manual

Monitor output (optional comparator output)

A reference voltage representing the feedback signal is available from terminals 7 and 13. The voltage span of +10V...0...-10V equates to +100...0...-100% feedback signal range. The signal resolution of this output averages 8 bit = 0,4%. In case of a breakdown within the sensor cable the monitor output will be switched off, provided that the feedback signal cable break detection is in use (parameter E12). If a comparator window for the feedback signal

monitoring is defined via parameter P21, the output generates a voltage signal of 0V if the upper or lower threshold is detected. Within the window the output value is typ. 10V.

☞ The monitor output is not calibrated and is a simple trend indicator.

⚠ The output may drive a load of max. 5mA. Exceeding this limit leads to malfunction.

Wiring diagram of monitor output

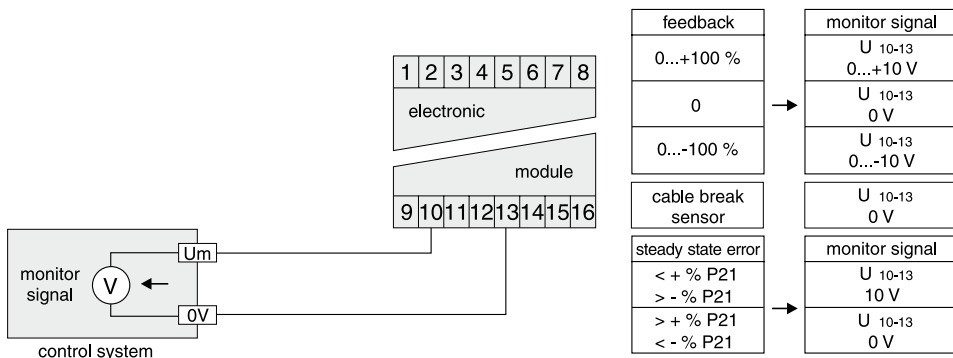

Status output

Connections to 4 and 13 provides status information related to the electronics. The following information is available:

- feedback signal cable break (not for voltage options / ±20mA)
- command signal cable break (only for option 4...20mA)

- internal processor fault
- enable off

⚠ The output may drive a load of max. 15mA. Exceeding this limit leads to malfunction.

Wiring diagram of status output

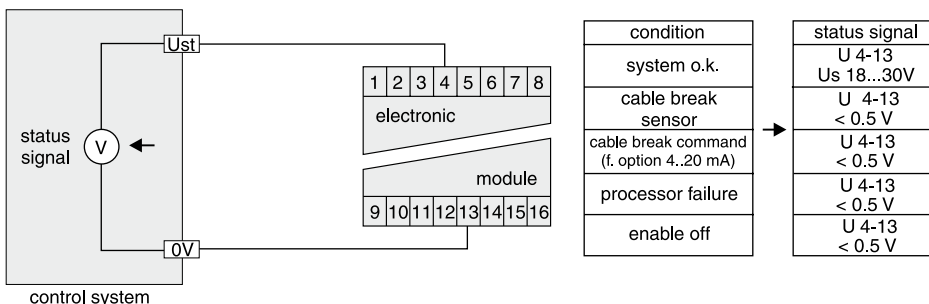

Operation Manual

Signal output:

The terminals 7 and 9 provides the output signal (set value), which may be used to control external amplifier modules, integrated valve amplifiers as well as servo valves. Different versions of out-

put signal processing are available, which are described below.



The output signal option has to be selected according to the requirements of the downstream electronic (parameter E20).

Wiring diagram of voltage output +10...0...-10V

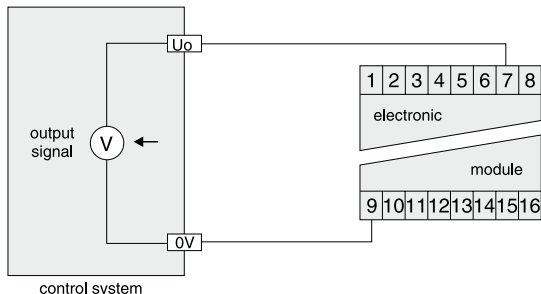

Wiring diagram of current output +20...0...-20mA

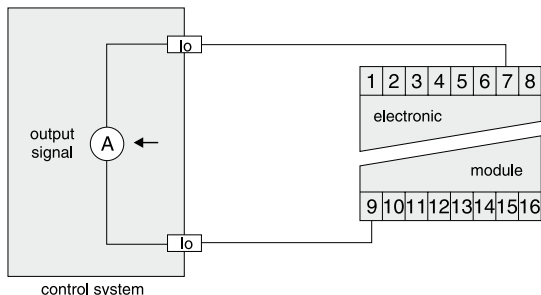

Wiring diagram of current output +4...12...20mA

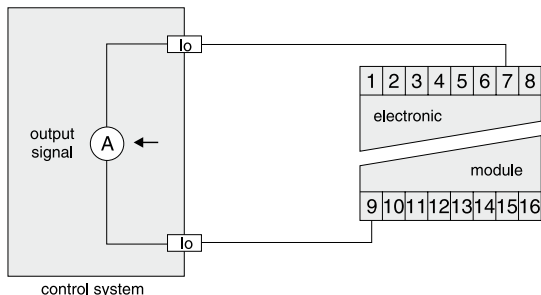

Sensor input

The sensor has to be wired to the terminals 13 and 16, the earth ground connection will be made via terminal 8. The connection has to be shielded. The sensor type is selectable via software parameter E11.



Connection of an inappropriate sensor may lead to permanent damage to the electronics module.

Wiring diagram of sensor input 0...±10V

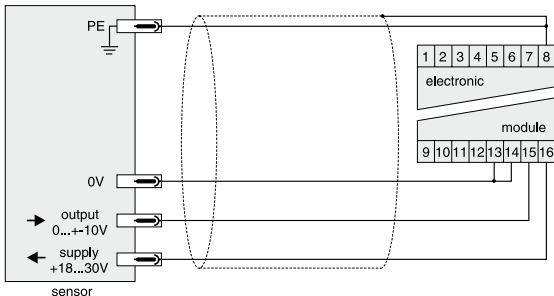

Wiring diagram of sensor input 0...+20mA / 4...12...20mA, 3-wire

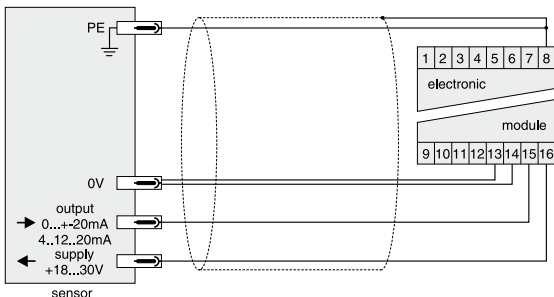

Wiring diagram of sensor input 0...+20mA / 4...12...20mA, 2-wire

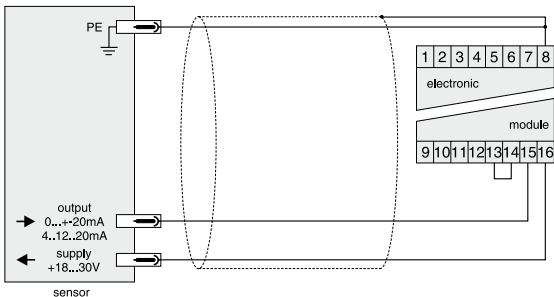

Operation Manual

Wiring Examples:

△ Partially the wiring requires a shielded performance. for the sake of clarify the appropriate illustration is omitted.

Example 1:

Closed loop position control of a hydraulic cylinder, utilizing a proportional directional control valve with integrated electronics (D*FP). Command signal preset using a potentiometer.

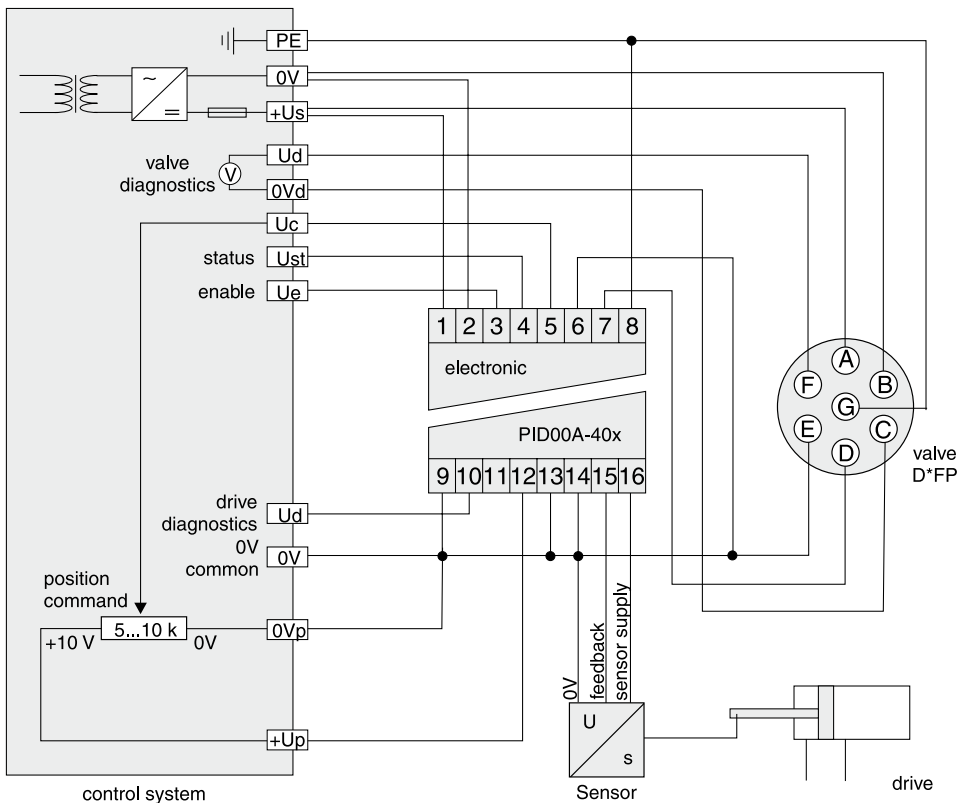

Operation Manual

Example 2:

Closed loop position control of a hydraulic cylinder, performed via proportional directional control valve with external electronic (D*FC, D*FS). Command preset via external control signal.

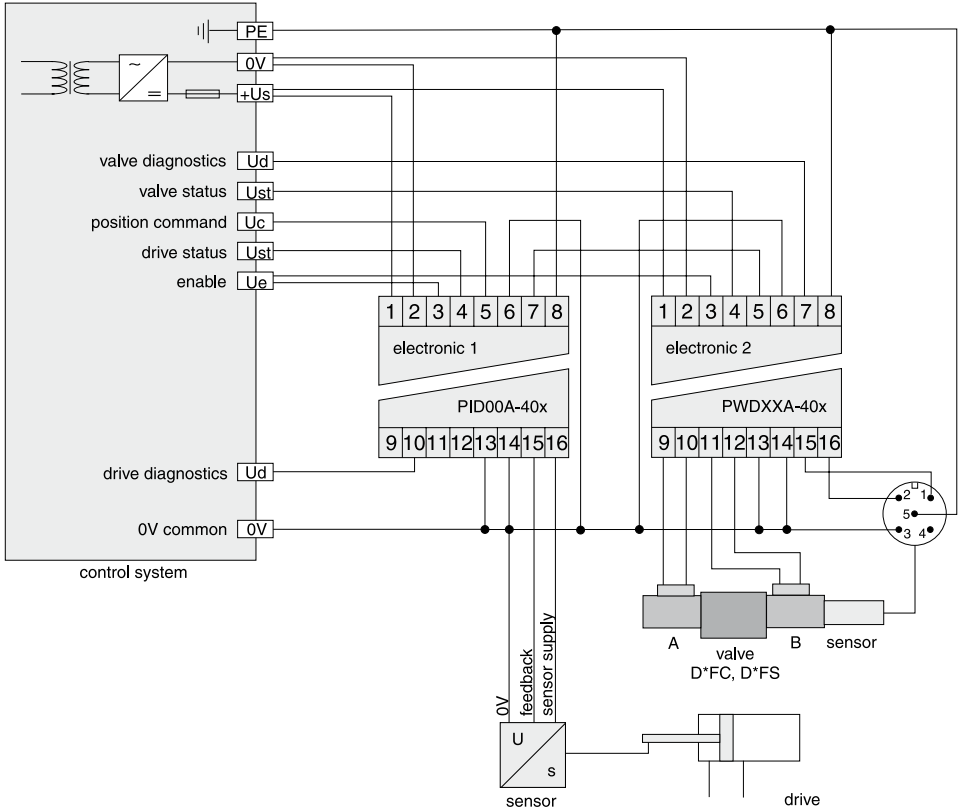

Operation Manual

Example 3:

Closed loop pressure control within a hydraulic cylinder, performed utilizing a proportional pressure control valve with external electronic (RE*W, VMY). Command preset via external control signal.

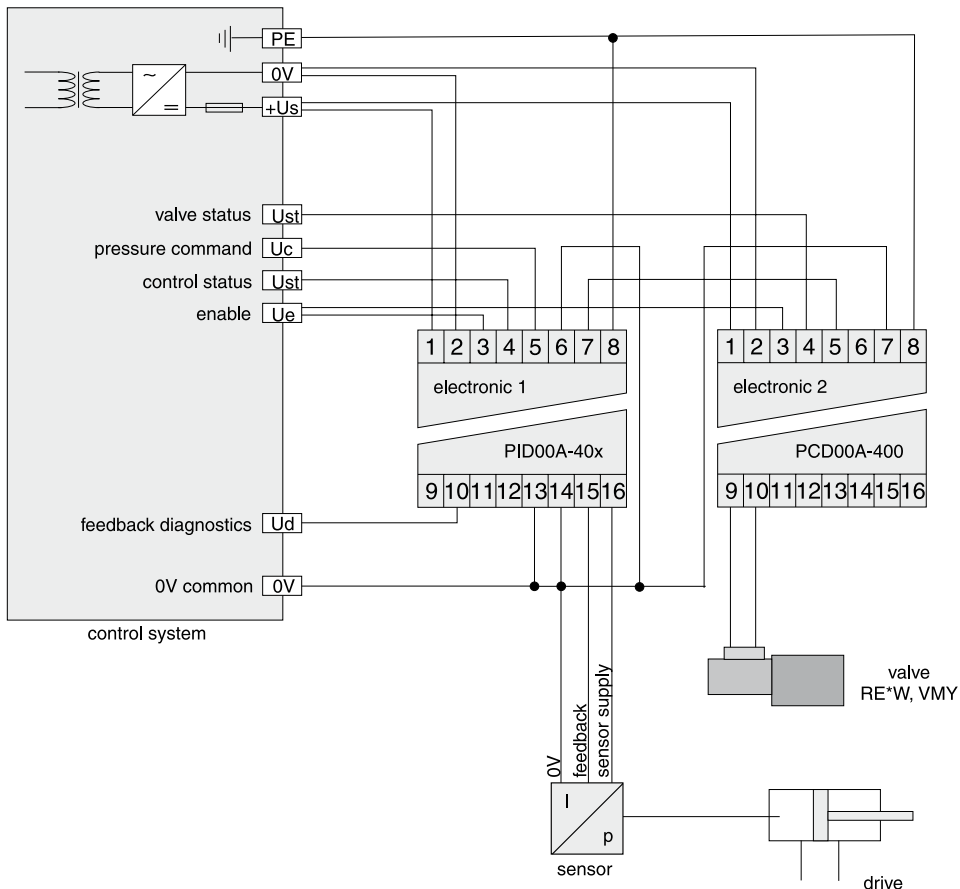

Operation Manual

Example 4:

Closed loop position control of a hydraulic cylinder, utilizing a proportional directional control valve (D*FB) with external drive electronics PWD00. Command preset via external control signal.

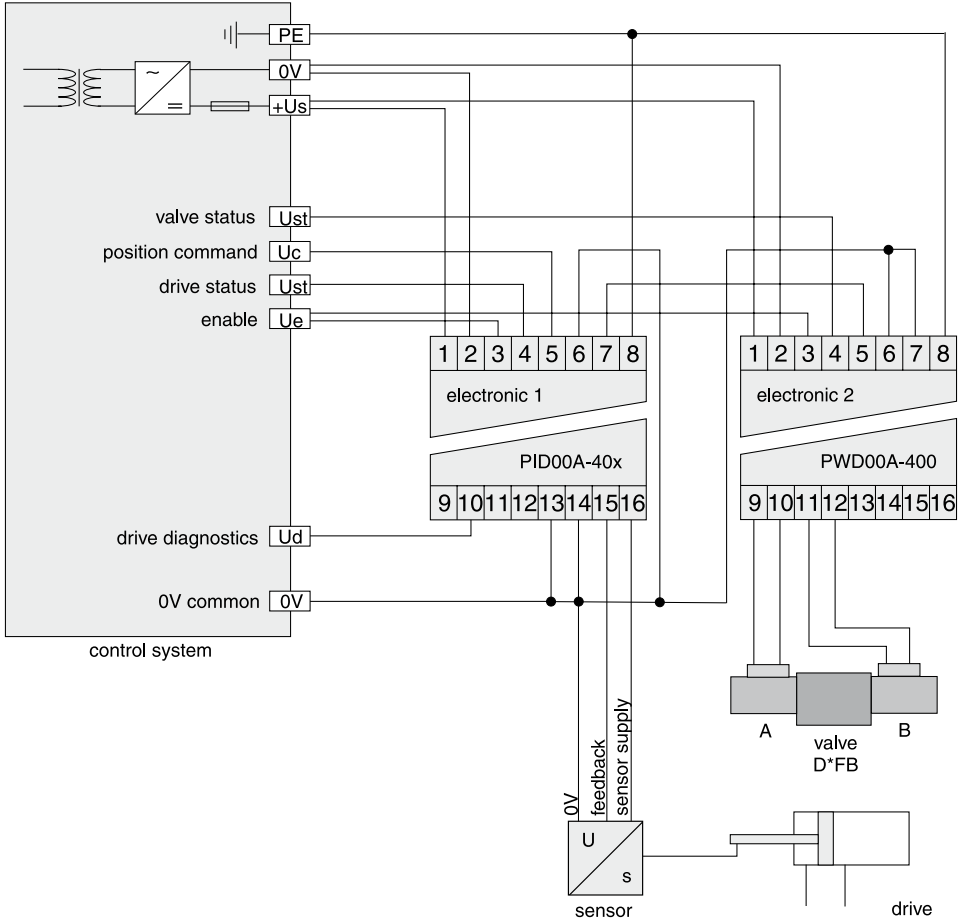

Operation Manual

5. Operating instructions

The electronics module performs the task of comparing the command input signal value with the feedback signal value (eg. cylinder position). The difference is then feed to a closed loop controller, that in turn provides an output to a power amplifier stage which sets the value for the valve drive amplifier.



The connected drive may not operated before loading the appropriate parameter set from the PC into the module electronics!

Features

- Easy to use editing of all parameters
- Display and documentable parameter settings
- Loading and storage of optimized parameter settings
- Compatible with all Windows® operating systems from Windows® XP upwards
- Plain communication between PC and electronics module via the RS-232C serial interface and nullmodem cable

5.1. Operating software program

ProPxD parameterizing software:

The ProPxD software provides a simple and easy to use interface for parameter selection within the module. The menu and drop down tables facilitate an easy selection of parameter values. Once the parameters have been selected they may be stored for future use (Floppy disc or Hard drive), outputted as a text file for documentation purposes or down loaded to the none volatile module memory. Stored parameter sets may be loaded anytime and transmitted to the module electronics in the same manner as the basic parameters which are available. Inside the electronics a nonvolatile memory stores the data with the option for recalling or modification.

The ProPxD operating software may be ordered under code 5715543. Alternatively, the program is available as a download from the Parker internet homepage address:

http://www.parker.com/euro_hcd

ProPxD screenshot

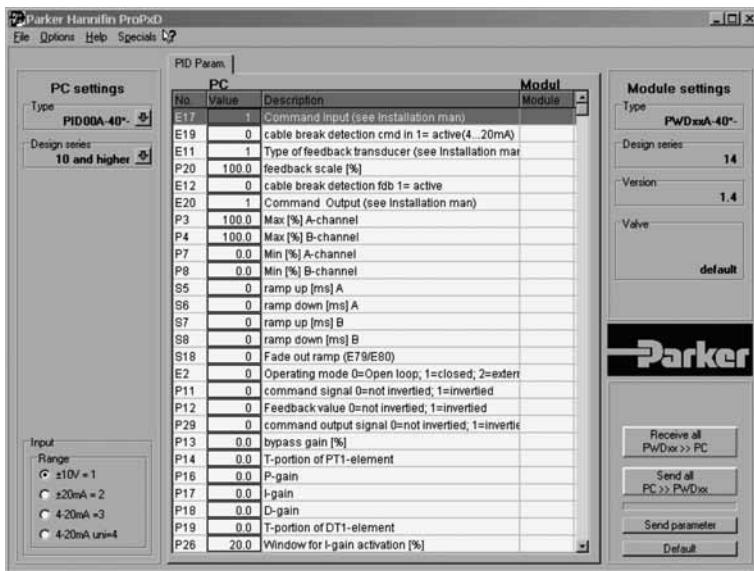

Operation Manual

Hardware requirements

- PC with a minimum operating system of Windows® XP upwards
- RS-232C interface
- display resolution min. 800 x 600
- nullmodem connection cable between PC and electronics module
- storage requirement approx. 4 MB

 It is recommended to select “small fonts” at the display setting, otherwise distortion of the display may occur.

Null modem cable

The connection of the module electronics to a PC requires a so-called “null modem cable”. Cables can normally be obtained from computer shops or distributors for electronic components. Interconnection is via an unused serial port COM1 or COM2 of the PC and the 9 pin D type connector located on the front face of the module.

Connection diagram of the null modem cable

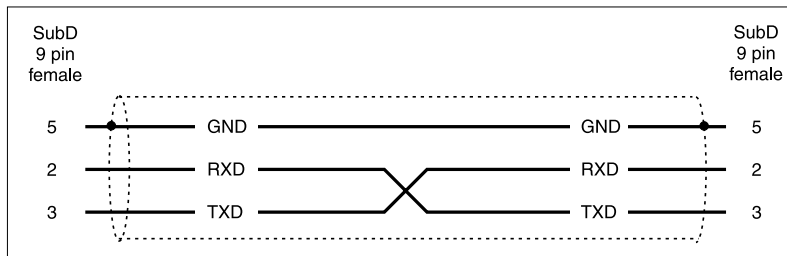

Buying sources for the null modem cable

Supplier	Order-nr.
Viking	G2E-71B10
Farnell	976880
DisData	672786
Staples	IM1511680
Newark	83F7101
DigiKey	AE1033-ND
CompUSA	50023590

5.2. Program installation

Please check before the installation of the above hardware that the system requirements are met. In addition to which, if your PC has already stored an older version of the “ProPxD” program, it should be deleted by using the Windows® - system control feature.

Program installation sequence

- Terminate the execution of other programs.
- Insert ProPxD-software CD.
- Execute the file “setup.exe”.
- Follow the instructions on the screen.

Answer the question, if an older version should be overwritten, with “**ok**”. During the installation you may change destination drive resp. installation path, if needed (i.e. if the storage space on drive “c” is not sufficient).

Please answer also “**ok**” if at the end of the installation the program reports any system information. After successful installation the desktop display shows the ProPxD icon for starting the program. According to the operating system the installation of some drivers (DLLs) may be disabled. Failure messages relating to this may be ignored. Prior to the updating of older versions these has to be deinstalled via the Windows® Control Panel.

Operation Manual

5.3. Software operating



Incorrect settings may lead to malfunction! In case of parameter changes shut the drive down!

Brief instruction for first startup

- Connect the module electronics to the supply voltage.
- Connect the module to a PC via null modem cable.
- Click on the ProPxD icon to start the operating program.
- After displaying the program resp. data base version a program window opens and the connected electronics will be automatically identified (possibly a manual identification via the button "**Receive all**" is necessary).
- Select the desired version via the menu "**Options**" with the menu item "**Language**".
- Select the engaged valve from the provided type table via the menu "**Options**" and the item "**Valve type**".
- Subsequently the program inserts the default parameters into the parameter table.
- Individual parameters may be selected via mouse or the arrow buttons at the center of the program screen.
- Parameter changes are possible via mouse or the arrow buttons on the bottom left within the program screen, also the parameter values may be edited via the keyboard.
- Modified parameters will be stored via the "**Enter**" key or via the button "**Update list**".
- After completing of all modifications, the entire parameter set may be transmitted to the electronics via the button "**send all**", also the parameters will be nonvolatile stored.
- The chosen parameters may be optionally stored on the PC via the "**File**" menu with the menu item "**Save as**", data retrieving is always possible via the function "**Load out of database**".

Extended functions

The user software is shared into 2 parameter ranges:

- basic mode
- expert mode

For normal startup the basic mode is sufficient. It permits the setting of all **application** specific parameters to match the valve function with the task setting, the default parameters will be selected from the valve library. In case of special applications the parameters may be adapted via the expert mode.

The operating mode may be selected from the "**Options**" menu and remains after termination and restart of the program.



Changing of expert parameters is only permitted by qualified personnel.

To prevent an unauthorized access for the expert mode, a password is required. The name is "**park-er**" and cannot be changed. Thus additionally to the button "**Default**" for loading of the default parameters, the button "**Send parameter**" appears in the "**Expert**"-operating mode. This button transmits only the setting of one single parameter to the connected module electronics. Thus a quick tuning of single parameters is permitted during the setup.

Operation Manual

 A horizontal bar graph readout between the communication buttons shows the data transfer state.

 Information on the technology functions is provided within the help function of the operating software.

Additional to the device parameters, the electronics stores also the device types, selected from the valve library. Via the button “**receive all**” the valve parameters will be read out of the electronics and stored including the valve type. If expert parameters will be modified and transferred, the valve information memory inside the electronics will be erased and the word “**customized**” is shown within the valve display area. Via an arrow button located beside the view boxes of “**Type**”, “**Design series**” and “**Valve**”, the corresponding selection table may be accessed.

5.4. Adjustment parameters

The available parameters may be divided into multiple groups and are characterized by different letters:

S-parameters	internal commands and ramps
P-parameters	operating parameters
E-parameters	extended parameters

 Because the ProPxD program has also offline (i.e. without connection to the electronics) functionality, a manual pre-selection of the parameters is possible. After selection of the electronics type via the menu “**Options**” the parameters may be set and stored for later transmission. Note the design series while selection of the electronics!

The “**File**” menu provides the functions “**Printer setup**”, “**Print preview**” and “**Print**”. The print preview includes the option for parameter set storage as text file (format **.txt**) prior to further processing. The “**Options**” menu provides also the selection of the RS-232 interface port via the menu item “**Port**”. Via the menu item “**Load out of database**” previously stored parameter sets may be loaded.

Operation Manual

Series PID00A-40X

Parameter overview for basic mode

Parameter	Description	Unit	Parameter range		Default setting
			from	up to	
S5	ramp accel. A	ms	0	32500	0
S6	ramp decel. A	ms	0	32500	0
S7	ramp accel. B	ms	0	32500	0
S8	ramp decel. B	ms	0	32500	0
S18	fade out ramp	ms	0	32500	0
P3	MAX A	%	50.0	100.0	100.0
P4	MAX B	%	50.0	100.0	100.0
P7	MIN A	%	0.0	50.0	0.0
P8	MIN B	%	0.0	50.0	0.0
P11	polarity command	–	0	1	0
P12	polarity feedback	–	0	1	0
P20	feedback scale	%	0	200.0	100.0
P29	polarity set value	–	0	1	0
E2	closed loop control	–	0 = inactive (open loop) 2 = active (closed loop)		0 = inactive
E11	sensor type feedback	–	1 = $\pm 10V$ 2 = $\pm 20mA$ 3 = 4-20mA bipolar 12 = 4-20mA unipolar 15 = 0-10V unipolar		1 = $\pm 10V$
E12	cable break detection feedback	–	0 (inactive)	voltage: 0 (inactive) current $\pm 20mA$: 0 (inactive) current 4-20mA: 1 (active)	0 = (inactive)
E17	option command input	–	1 = $\pm 10V$ 2 = $\pm 20mA$ 3 = 4-20mA		1 = $\pm 10V$
E19	cable break detection command	–	0 (inactive)	$\pm 10V$: 0 (inactive) $\pm 20mA$: 0 (inactive) 4-20mA: 1 (active)	0 = inactive
E20	option command output	–	1 = $\pm 10V$ 2 = $\pm 20mA$ 3 = 4-20mA bipolar 12 = 4-20mA unipolar 15 = 0-10V unipolar 16 = $\pm 50mA$		1 = $\pm 10V$

Individual description of basic parameters

S5 ramp accel. A	Adjustment of ramp rate for increasing of positive polarity signal. To avoid switching noise.
S6 ramp decel. A	Adjustment of ramp rate for decreasing of positive polarity signal. To avoid switching noise.
S7 ramp accel. B	Adjustment of ramp rate for increasing of negative polarity signal. To avoid switching noise.
S8 ramp decel. B	Adjustment of ramp rate for decreasing of negative polarity signal. To avoid switching noise.
S18 fade out ramp	Adjustment of ramp rate for position dependent decreasing of signal. To automate motion sequences.
P3 MAX A	Adjustment of maximum signal span for positive polarity output signal. To match the command signal span to the drive operating range.
P4 MAX B	Adjustment of maximum signal span for negative polarity output signal. To match the command signal span to the drive operating range.
P7 MIN A	Adjustment of positive polarity signal step. To compensate for the overlap of the valve spool.
P8 MIN B	Adjustment of negative polarity signal step. To compensate for the overlap of the valve spool.
P11 command signal polarity	Adjustment of the command signal polarity. To match the command signal polarity to the control path.
P12 feedback signal polarity	Adjustment of the feedback signal polarity. To match the sensor signal polarity to the control path.
P20 feedback scale	Adjustment of the feedback scaling. To match the drive operating range to the feedback input signal span.
P29 polarity set value	Adjustment of the set value signal polarity. To match the set value signal polarity to the control path.
E2 closed loop control	Adjustment of the operating mode for the controller. To select the control function.
E11 type of feedback device	Adjustment of the feedback device type. To match the feedback input to the signal device features.
E12 cable break detection feedback	Adjustment of the operating mode for the feedback cable break detection. To turn on resp. off of the cable break detection for the feedback signal.
E17 type of command signal device	Adjustment of the command signal option. To match the command signal input to the input signal mode.
E19 cable break detection command	Adjustment of the operating mode for the command cable break detection. To turn on resp. off of the cable break detection for the command signal at a selected command signal option of 4...20mA..

Operation Manual

Series PID00A-40X

Parameter overview for expert mode

Parameter	Description	Unit	Parameter range		Default setting
			from	up to	
P1	zero	%	-100.0	+100.0	0.0
P13	bypass gain	%	0	100.0	0
P14	T-portion PT1-element	–	0	100.0	0
P16	P-portion	–	0	100.0	0
P17	I-portion	–	0	100.0	0
P18	D-portion	–	-100.0	+100.0	0
P19	T-portion DT1-element	–	0	100.0	0
P21	comparator function window	%	0	200.0	0
P23	comparator rise delay time	ms	0	10000	0
P24	comparator turn-off delay time	ms	0	10000	0
P26	window I-portion	%	0	20	20
P27	reduct. window I-portion	–	0	100.0	100.0
P28	T-portion PT1-filter	–	0	100.0	0
E25	MIN operating threshold	–	0 = 1% 1 = 0.01%		0 = 1%
E50	average quantity	–	1	10	1
E70	velocity feedback	–	0 = inactive 1 = active		0 = inactive
E71	MIN position	%	-120.0	+120.0	-120.0
E72	MAX position	%	-120.0	+120.0	+120.0
E73	sensor length	mm	1	10000	10000
E74	MAX velocity	mm/s	1	10000	10000
E75	set value output function	–	0 = y=X (synchronous) 1 = y=1-x (reversal)		0 = y=x
E79	MIN fadeout position	%	-120.0	+120.0	-120.0
E80	MAX fadeout position	%	-120.0	+120.0	+120.0

Individual description of expert parameters

P1 offset	Adjustment of zero position shifting (offset). To compensate for unbalances.
P13 bypass gain	Adjustment of the bypass gain for the controller. To improve the control dynamic via feed forward factor.
P14 T-portion of PT1	Adjustment of the integral action time for the PT1-portion of the controller. To attenuate for the P-portion.
P16 P-portion	Adjustment of the P-portion for the controller. For the basic tuning of the controller.
P17 I-portion	Adjustment of the I-portion (integration time) for the controller. To reduce the control failure.
P18 D-portion	Adjustment of the D-portion for the controller. To improve the control dynamic.
P19 T-portion of DT1	Adjustment of the pre-hold time for the DT1-portion of the controller. To attenuate for the D-portion.
P21 window for comparator function	Adjustment of the comparator window for the feedback monitoring. To adjust the feedback monitoring range.
P23 comparator rise delay time	Adjustment of the comparator rise delay time. To delay the rise threshold for the comparator function.
P24 comparator turn-off delay time	Adjustment of the comparator turn-off delay time. To delay the turn-off threshold for the comparator function.
P26 window for I-gain activation	Adjustment of the I-portion active range in terms of the control difference. To limit the I-portion on a certain range.
P27 I-gain window reduction	Adjustment of the I-portion outside the window in terms of the control difference. To match the response behavior of the I-portion.
P28 T-portion of PT1-filter	Adjustment of the damping for the PT1-portion of the sensor. To smooth the differentiated velocity feedback signal.
E25 MIN operating threshold	Adjustment of the MIN operating threshold. To match the response sensitivity for the stroke step.
E50 average quantity	Adjustment of the number of samples for average calculating. To smooth the velocity feedback signal.
E70 velocity feedback	Adjustment of the velocity control mode. To select the control function.
E71 MIN position	Adjustment of the MIN switching point for the immediate set value re- duction to zero. To automate motion sequences.
E72 MAX position	Adjustment of the MAX switching point for the immediate set value reduction to zero. To automate motion sequences.
E73 sensor length	Adjustment of the sensor length. To calculate the feedback signal for velocity control.
E74 MAX velocity	Adjustment of the MAX velocity. To match the command signal span to the velocity range.
E75 set value output function	Adjustment of the set value signal waveform. To match the set value developing to the control path characteristic.
E79 MIN fadeout position	Adjustment of the MIN switching point for the ramped set value reduction to zero. To automate motion sequences.
E80 MAX fadeout position	Adjustment of the MAX switching point for the ramped set value re- duction to zero. To automate motion sequences.

Operation Manual

5.5. Guideline for closed loop applications

Practical guidelines for the adjustment of the control parameters are summarized below. They are divided into different application categories and include common rules of thumb.

 The commissioning of a closed loop systems requires detailed knowledge of process control technology. Therefore on-site works support is recommended.

 An incorrect wiring resp. parameter setting may lead to malfunction and permanent damaging of electronics and drive system!

5.5.1. Application: Closed loop systems for position

Introduction

The electronics uses a feedback control loop which automatically adjusts the electrical input to the valve amplifier to move the drive to a commanded position. At the heart of this feedback loop is a digital controller which computes and updates the signal output (set value output) every one millisecond. The controller has adjustable coefficients, which must be set by the user for the particular application.

The controller provides a standard PID control capability plus extra features you can use to improve the performance beyond the limits of PID.

Basic information for the control algorithm

Why tuning?

The controller can be used with valves that vary greatly in flow capacity, frequency response, saturation and deadband, with different kinds of load, and with cylinders of any area and stroke. The user must adjust the control coefficients for the specific system. There are no fixed sets of values for the controller coefficients that will handle every situation well.

The electronics utilizes a "PID" controller for its basic control action. The name PID comes from the fact that the controller output is the sum of three terms, called proportional (P), integral (I) and derivative (D), each with a user adjustable coefficient. The user software provides therefore the parameters P16 (P), P17 (I) and P18 (D).

P - P16

This term provides an immediate output signal, proportional to the error between commanded and measured position. If this parameter is set too high, sustained oscillations may occur. If it is set too low, accuracy and speed of response may be poor.

I - P17

This term causes the output to change at a rate proportional to the error in measured position over time (integration time), in a direction to drive the steady state error to zero. P17 is active within a window, which might be adjustable by parameter P26. P26 shall be adjusted in the way that the window lies near the final position or in the stationary range of the drive. A too higher value of P17 causes oscillations, in addition to which the selection of a too lower value may result in a slow action.

D - P18

The D-term provides an output proportional to the rate of change of the measured drive position. Depending on the polarity of the parameter prefix, this term causes damping or acceleration. For hydraulic drives this term should be set to a low value.

Parameter ranges

The controller provides two parameter ranges of **BASIC** and **EXPERT**. The **BASIC** mode serves for adjustment of the fundamental function parameters, while the application specific setting of the control coefficients may be made via the **EXPERT** mode. The operating mode is selected via the menu **OPTIONS**.

Simple tuning of a position control loop

Before trying anything complicated, you should adjust the proportional gain, accessible by P16. In many cases this coefficient will be all you need, and you will not have to bother with any of the other control features. If you do need the other features, you cannot adjust them properly without first adjusting the P-gain. Adjusting the P-gain is done by setting all the other control coefficients P13 – 19 as well as P26 – 28 to zero and increasing P16 to the highest value that does not result in sustained oscillations of the drive position.

Operation Manual

Guarantee of control functionality

Before the tuning of the control loop may be commenced, the functionality of the control circuit must be ensured. As previously mentioned, the controller compares command and feedback signal and adjusts the electrical input to the valve amplifier to move the drive to the commanded position. To ensure this functionality, the polarities of command and feedback signal must be equal.

How can the functionality of the control loop be achieved?

At first you should set off the control loop (set parameter E2 to value 0 = open loop and transmit to the electronic) and cause the drive via manual control to the middle of the cylinder stroke. Afterwards adjust at first the control coefficients as described in chapter "Simple tuning of a position control loop" (P16 at 10%) as well as the parameter E2 at 2 = external closed loop and transmit to the electronic. If this results in a rapid movement of the drive to an end position, the polarities are incorrect. Access now the parameter P12 = feedback signal polarity, change the value and transmit the data. The drive should be adjustable and remain in its position when you switch on the closed loop control via parameter E2. Now you should preset position commands and supervise the drive movement. If the drive even though is running in closed loop mode, but the direction of the movement is not as required, you have to change the polarities of both command and feedback signal via the parameters P11 and P12. After that the drive is running as desired, you can continue with tuning of the loop.

Tuning of the closed loop control

1. Create a suitable tuning test profile – otherwise it may be difficult for you to tell how good the system response is (the test profile may also be generated by an upstreamed electronic module PZD00A-400). The test profile should so programmed to causing the drive to move from the start position with the desired maximum acceleration and velocity to the required final position. In the final position the drive should be commanded to dwell, that will give you enough time to watch the load position to see if it oscillates or remains stationary. This should be followed by returning of the drive to the start position, where the dwell in position may also be evaluated.

2. Check once more to be sure that P17 and P18 are set to zero.
3. Adjust P16 to a low value, i.e. 10%, and try the system on the test profile.

Observe the result of the test. There are three possible outcomes:

- The drive oscillates continuously
Stop the system quickly. Reduce the P16-value to $\frac{1}{2}$ of the initial guess, and try again.
 - The drive overshoots, but stops after one or two oscillations
Reduce the P16-value to $\frac{3}{4}$ of the initial guess, and try again.
 - The drive reaches the commanded position with no overshoot
The system is usable with the estimated value of P-gain. You should experiment with stepwise increasing of the P16-value to see how high a value the system will tolerate. Accuracy and response are improved by high values, but do not allow permanent oscillation!
4. You have now completed the basic tuning for your control loop. The next step is to test the performance of the system to see if it meets your requirements. If not, the electronic has additional control features you can use to improve performance, as explained below.

 **The parameters P28, E50, E73, E74 will be needed only for closed loop velocity control systems and should therefore not be changed.**

Operation Manual

The table below gives information, which approaches may be embarked if typical problems with position control loops appear.

Problem	Solution
Position error too large, when drive is stationary	Use parameter P17 = I-gain (only active if P26 > 0)
Repeatable position error by using a valve with overlap/hysteresis	Use dead band compensation feature P7 = MIN channel A resp. P8 = MIN channel B
Position error too large when following constant velocity position command	Use parameter P13 = bypass gain
Slow, small amplitude, position oscillation	Use integrator window P26 = window I-gain
Disappointingly low P-gain	Check the frequency response of the valve and position transducer, or possibly the drive resonant frequency (s. items below)
Response too slow	Be sure P16 = p-gain is adjusted high enough (s. also previous items)
Unexplainable problems	Check the setting of all parameters

Improving system performance**Using the parameter P17 = I-gain**

The integrator gain (abbreviated I) can be adjusted to reduce or eliminate the error between the commanded position and the position measured by the feedback transducer, subject to the command remaining constant. Higher values of I-gain will cause the response to be slower and more prone to oscillation with the combined effect of a reduced stationary error. Lower values will require an extended time to reach zero steady state error. This parameter is only active if a window (> 0) is defined via P26.

Elimination of slow, small amplitude oscillation in position

Because of friction and other imperfections, use of the I-gain sometimes causes a slow, small amplitude oscillation in load position. This is an entirely different problem from the vigorous oscillations that occur when the P-gain is set too high. The electronic provides a "Window" feature (sometimes called "in-position-window") to solve this problem. Select the parameter P26. Stepwise increasing of the window size to a large enough value will stop the slow oscillations.

Operation Manual

Repeatable position error too large because of valve dead band or hysteresis

Utilization of the integrated dead band compensation coefficient enables this effect to be reduced or eliminated. There are separate adjustable parameters P7 and P8 for both valve sides. This feature generates constant correction signals which will be active for the dedicated valve site if a signal occurs on the command signal input. As a result this will cause the valve to "Jump" through the overlap region of the spool.

Increasing load stiffness

"Load stiffness" is the term given to the resistance of the servo loop to deflection of the drive by external forces. Adjusting P16 to the highest practical value is important.

Disappointing control loop function

The higher the value of P-gain that can be used, the better is the static and dynamic performance of the system. You may not have any direct need for fast response, but may still need a high value of P to reduce static error, reduce following error or increase actuator stiffness. High values of P cause faster system response, whether you need it or not. As the system frequency response gets too close to the frequency response of one of your components, the system response becomes oscillatory.

- **Valve**

The frequency response of the valve can be obtained from the datasheets. As a first guess, it needs to be at least twice the system frequency response.

- **Position transducer**

Some analog output transducers will present problems because of filtering intended to smooth the output. To ensure the best system dynamic, sensors with integrated D/A-converter should operate with a high sampling rate. Magnetostrictive transducers with digital output often have a low sampling rate, because an interaction with the achievable resolution. Please obtain detailed information from the transducer supplier.

- **Drive**

There is a mode of mechanical vibration created by the mass of the load and the compressibility of the hydraulic fluid in the whole system. This frequency is often surprisingly low when using long stroke cylinders.

Update rate of the controller

The controller updates the electrical output to the valve at 1000Hz. This rate is fast enough to have negligible effect in almost all hydraulic applications, but it does set an absolute limit on the response of the system.

Position transducer accuracy and resolution

A control system is no better than its transducer. Here are points to watch for:

- **Absolute accuracy**

The controller positions the load as closely as possible to the position measured by the feedback transducer. The absolute accuracy of the measured position is determined by the transducer.

- **Resolution**

The electronics cannot position the load more accurately than the resolution of the transducer. Be sure the resolution of your sensor is adequate. When using a true analog transducer (analog measurement principle and analog output), the resolution is limited by the utilized A/D-converter, which is 12 bit ($1/4096 = 0.025\%$).

- **Installation**

The installation of the position transducer plays a most important role for the proper functionality of the closed loop control. By all means it has to be secured, that the mounting of transducer and actuating device provides absolute freedom from vibration and clearance effects. This is most important even for the commonly expected velocities and accelerations. Also, the transducer has to be laid out for the dynamic requirements.

Operation Manual

5.5.2. Application: Closed loop systems for pressure (via pressure control valves)

Introduction

The electronics uses a feedback control loop which automatically adjusts the electrical input to the valve amplifier that the commanded pressure appears. At the heart of this feedback loop is a digital controller which computes and updates the signal output (set value output) with a one millisecond update time. The controller has adjustable coefficients, which must be set by the user for the particular application.

The controller provides a standard PID control capability plus extra features which may be utilized to improve the performance beyond the limits of PID.

Basic information for the control algorithm

Why tuning?

The controller can be used with valves that vary greatly in flow capacity, frequency response, saturation, dead band, load, and cylinders with a variety of area and stroke. The user must adjust the control coefficients for their specific system. There are no fixed sets of values for the controller coefficients that will handle every situation.

The electronics uses a "PID" controller for its basic control action. The name PID comes from the fact that the controller output is the sum of three terms, called proportional (P), integral (I) and derivative (D), each with a user adjustable coefficient. The user software provides therefore the parameters P16 (P), P17 (I) and P18 (D).

P - P16

This term provides an immediate output signal, proportional to the error between commanded and measured pressure. If this parameter is set too high, sustained oscillations may occur. If it is set too low, accuracy and speed of response may be poor.

I - P17

This term causes the output to change at a rate proportional to the error in measured pressure, in a direction to drive the steady state error to zero. P17 is active when a window will be leaving, which might be adjustable by parameter P26. P26 shall be adjusted in the way that the window lies near the final pressure. A too low a value of P17 causes low frequency oscillations, with a too higher value the required pressure may be reached too slowly.

D - P18

The D-term provides an output proportional to the rate of change of the measured pressure. Depending on the polarity of the parameter prefix, this term causes damping or accelerating. For hydraulic drives this term should be set to a very low value.

Parameter ranges

The controller provides two parameter ranges, of course the operating modes **BASIC** and **EXPERT**. Herewith the **BASIC** mode serves for adjustment of the fundamental function parameters, while the application specific setting of the control coefficients may be done via the **EXPERT** mode. The operating mode may be selected via the menu **OPTIONS**.

Simple tuning of a pressure control loop

Before trying anything complicated, you should adjust the bypass gain, accessible by P13. Herewith a "feedforward" of the output will be achieved, the PID-control loop will be "bypassed". For this adjustment all other control parameters P14 –19 as well as P26 – 28 has to be set to zero. Then P13 will be increased accordingly, until the feedback signal appears 10...20% below the command signal. Mostly a setup value of 40...50% is practicable. Following is the adjusting of the proportional gain, accessible by P16.

Adjusting the P-gain is done by increasing P16 to the highest value that does not result in sustained oscillations of the pressure. In many cases this two coefficients will be all you need, and you will not have to bother with any of the other control features. If you do need the other features, you cannot adjust them properly without first adjusting the P-gain.

Guarantee of control functionality

Before the tuning of the control loop may be started, the functionality of the control circuit must be ensured. As previously mentioned, the controller compares command and feedback signal and adjusts the electrical input to the valve amplifier to achieve the commanded pressure. To ensure this functionality, the polarities of command and feedback signal must be equal.

Operation Manual

How can the functionality of the control loop be achieved?

At first you should set off the control loop (set parameter E2 to value 0 = open loop and transmit to the electronic) and cause the pressure via manual control to the middle of the system pressure. Next adjust the control coefficients as described in chapter "Simple tuning of a pressure control loop" (P16 at 10%) as well as the parameter E2 at 2 = external closed loop and transmit to the electronic. If this results in a jump of the pressure into its minimum or maximum final value, the polarities are incorrect. Access the parameter P12 = feedback signal polarity, change the value and transmit the data. By now the pressure should be adjustable and must remain on its value when you switch on the closed loop control via parameter E2. The next task will be to preset the pressure command and monitor the pressure behavior. If the pressure even though is running in closed loop mode, the behavior of the pressure rise and fall is not as required, it is necessary to change the polarities of both command and feedback signal via the parameters P11 and P12. The control loop should now be running as desired, you can continue with tuning of the loop.

Tuning of the closed loop control

1. Create a suitable tuning test profile – otherwise it may be difficult for you to tell how good the system response is (the test profile may also be generated by an up-stream electronic module PZD00A-400). The test profile should start causing the system from the circulation pressure with the desired maximum acceleration and velocity to the required final pressure. At the final pressure the system should remain for a while, that will give you enough time to watch the pressure value to see if it oscillates or remains stationary. This should be followed by returning of the pressure to the start value, where the stationary value may also be evaluated.

2. Check once more to be sure that P17 and P18 are set to zero.
3. Adjust P16 to a low value, i.e. 10%, and run the system using the test profile.

Observe the result of the test. There are three possible outcomes:

- The pressure oscillates continuously
Stop the system quickly. Reduce the P16-value to $\frac{1}{2}$ of the initial guess, and try again.
- The pressure overshoots, but stops after one or two oscillations
Reduce the P16-value to $\frac{3}{4}$ of the initial guess, and try again.
- The pressure reaches the commanded value with no overshoot
The system is usable with the estimated value of P-gain. You should experiment with stepwise increasing of the P16-value to see how high a value the system will tolerate. Accuracy and response are improved by high values, but do not allow permanent oscillation!

4. You have now completed the basic tuning for your control loop. The next step is to test the performance of the system to see if it meets your requirements. If not, the electronics has additional control features that may be used to improve performance, as explained below.



The parameters P28, E50, E73, E74 will be needed only for closed loop velocity control systems and should therefore not be changed.

Operation Manual

The table below gives information, which approaches may be embarked if typical problems with pressure control loops appear.

Problem	Solution
Variation error too large, when pressure command remains constant	Use parameter P17 = I-gain (only effective for P26 >0)
Repeatable deviation by using a valve with overlap/hysteresis	Use deadband compensation feature P7 = MIN channel A
Sequence error too large when following pressure command profile	Use parameter P13 = bypass gain
Disappointingly low P-gain	Check the frequency response of valve and pressure transducer, and the system resonant frequency (s. items below)
Response too slow	Be sure P16 = p-gain is adjusted high enough (s. also previous items) and check the flow capacity of the valve
In explainable problems	Check the setting of all parameters

Improving system performance**Using the parameter P17 = I-gain**

The integrator gain (abbreviated I) can be adjusted to reduce or eliminate the error between the commanded pressure and the feedback pressure measured by the transducer, when the command is constant. Higher values of I-gain will cause a better error reduction while the response will be longer. This parameter is only effective if a window (>0) is defined via P26.

Eliminating a slow, small amplitude oscillation in stationary condition

Due to the possible effects of friction and or other application variables, use of the I-gain sometimes causes a slow, small amplitude oscillation in the stationary condition. This is a different problem from the vigorous oscillations that occur when the P-gain is set too high. The electronics provide a "Window" feature (sometimes called "in-position-window") to solve this problem. In this case the integrator operates only within this window. Select this option via parameter P26. Step increases of the window size will eliminate the oscillation.

Increasing load stiffness

"Load stiffness" is the term for the resistance of the servo loop characteristics to deflection by external forces. Adjusting P16 to the highest practical value is important.

Disappointing control loop function

The higher the value of P-gain that can be used, the better is the static and dynamic performance of the system. You may not have any direct need for fast response, but may still need a high value of P to reduce static error, reduce following error or increase load stiffness. High values of P cause faster system response, whether you need it or not. As the system frequency response gets too close to the frequency response of one of your components, the system response becomes oscillatory.

Operation Manual

- **Valve**

The frequency response of the valve can be obtained from the datasheets. As a first guess, it needs to be at least twice the system frequency response.

- **Pressure transducer**

Some analog output transducers will present problems due to the use of filters intended to smooth the output. To ensure best system dynamics, sensors with integrated D/A-converter should operate with a high sampling rate. Magnetostrictive transducers with digital output often have a low sampling rate, causing an interaction with the achievable resolution. Please obtain detailed information from the transducer supplier.

- **System**

The cutoff frequency will be determined by mass and compressibility of the hydraulic media in the entire system (cylinder, piping, valves). Mostly the value is quite low, particularly for the usage of large system volumes.

Pay attention for pressure peaks!

High pressure peaks may occur particularly at closed loop pressure controls systems. Therefore the dynamic pressure behavior should be investigated after the controller tuning utilizing a data acquisition device such as a storage oscilloscope. If the measured pressure peaks exceed the system design hardware specification, reductions may be achieved by adjustment of the control parameters.

Update rate of the controller

The controller updates the electrical output to the valve at 1000Hz. This rate is fast enough to have negligible effect in almost all hydraulic applications, but it does set an absolute limit on the response of the system.

Pressure transducer accuracy and resolution

A control system is no better than its transducer. Here are points to watch for:

- **Absolute accuracy**

The controller adjusts the system as closely as possible to the pressure measured by the feedback device. The absolute accuracy of the measured pressure is also determined by the transducer. On the other hand, the signal span of the transducer should be oversized to achieve a safe operation even if pressure peaks appeared. For example a system pressure of 300bar requires a sensor with 400bar nominal pressure. This results in a value of 75% for the feedback scaling P20 (300bar means 75% of 400bar).

- **Resolution**

The electronics is unable to set a pressure more accurately than the resolution of the transducer. Be sure the resolution of your sensor is adequate. When using a true analog transducer (analog measurement principle and analog output), the resolution is limited by the utilized A/D-converter, which is 12 bit ($1/4096 = 0.025\%$).

- **Installation**

The installation of a pressure transducer plays an important role in the proper functionality of a closed loop pressure control system. The pressure transducer should be located as close to the point of control as is practical.

Example: A closed loop pressure control is required for a given hydraulic cylinder. In this case the pressure control valve and transducer should be mounted close together, otherwise poor closed loop control will result.

Operation Manual

5.5.3. Application: Closed loop systems for velocity (via proportional directional control valves)

Introduction

The electronics in a feedback control loop automatically adjusts the electrical input to the valve amplifier to move the drive with the desired commanded velocity. At the heart of this feedback loop is a digital controller which computes and updates the signal output (set value output) every one millisecond. The controller has adjustable coefficients, which must be set by the user for the particular application.

The controller provides a standard PID control capability plus extra features you can use to improve the performance beyond the limits of PID.

Basic information for the control algorithm

Why tuning?

The controller can be used with valves that vary greatly in flow capacity, frequency response, saturation, dead band, loads, and cylinders with differing areas and stroke. The user must adjust the control coefficients for their specific system. There is no fixed set of values for the controller coefficients that will handle every situation.

The electronics uses a "PID" controller for its basic control action. The name PID comes from the fact that the controller output is the sum of three terms, called proportional (P), integral (I) and derivative (D), each with a user adjustable coefficient. The user software provides therefore the parameters P16 (P), P17 (I) and P18 (D).

P - P16

This term provides an immediate output signal, proportional to the error between commanded and measured velocity. If this parameter is set too high, sustained oscillations may occur. If it is set too low, accuracy and speed of response may be poor.

I - P17

This term causes the output to change at a rate proportional to the error in measured pressure, in a direction to drive the steady state error to zero.

P17 is active when a window will be leaving, which might be adjustable by parameter P26. P26 shall be adjusted in the way that the window lies near the commanded velocity. Too low a value of P17 causes low frequency oscillations, with too high a value the required pressure may be reached too slowly.

D - P18

The D-term provides an output proportional to the rate of change of the measured drive velocity. Depending on the polarity of the parameter prefix, this term causes damping or accelerating. For hydraulic drives this term should be set to a very low value.

Parameter ranges

The controller provides two parameter ranges, of course the operating modes **BASIC** and **EXPERT**. Herewith the **BASIC** mode serves for adjustment of the fundamental function parameters, while the application specific setting of the control coefficients may be done via the **EXPERT** mode. The operating mode may be selected via the menu **OPTIONS**.

Simple tuning of a velocity control loop

Before trying anything complicated, you should adjust the bypass gain, accessible by P13. Herewith a "feedforward" of the output will be achieved, the PID-control loop will be "bypassed". For this adjustment all other control parameters P14 –19 as well as P26 – 28 should be set to zero. Then P13 will be increased accordingly, until the feedback signal appears 10...20% below the command signal. In most cases a setup value of 40...50% is practicable. The next action is to adjust the proportional gain, accessible by P16.

Adjusting the P-gain is achieved by increasing P16 to the highest value that does not result in sustained oscillations of the drive. In many cases the adjustment of two coefficients will be sufficient, and it will not be necessary to utilize any of the other control features. If you do need the other features, you cannot adjust them properly without first adjusting the P-gain.

Operation Manual

Guarantee of control functionality

Before the tuning of the control loop can commence, the functionality of the control circuit must be ensured. As previously mentioned, the controller compares command and feedback signal and adjusts the electrical input to the valve amplifier to ensure the required velocity. To ensure this functionality, the polarities of command and feedback signal must be equal.

How can the functionality of the control loop be achieved?

Firstly you should set off the control loop (set parameter E2 to value 0 = open loop and transmit to the electronic) and cause the drive via manual control to a medium velocity. Subsequently adjust the first control coefficients as described in chapter "Simple tuning of a velocity control loop" (P16 at 10%) as well as the parameter E2 at 2 = external closed loop and transmit to the electronic. If this results in a jump of the drive into its minimum or maximum velocity, the polarities are incorrect. Access now the parameter P12 = feedback signal polarity, change the value and transmit the data. By now the drive should be adjustable and must remain on its actual value when you switch on the closed loop control via parameter E2. Now you should preset velocity commands and supervise the drive movement. If the drive even though is running in closed loop mode, but the direction of the rise and fall of velocity is not as required, you have to change the polarities of both command and feedback signal via the parameters P11 and P12. After that the closed loop control is running as desired, you can continue with tuning of the loop.

Tuning of the closed loop control

1. Create a suitable tuning test profile – this will enable you to evaluate your system response (A test profile may be generated by an up-streamed electronic module PZD00A-400). The test profile should cause the drive to move from the start position with the required maximum acceleration to the required velocity. At the commanded velocity the drive should dwell at that rate, this will give you the opportunity to observe the load velocity for oscillation. This should be followed by returning of the drive with a different velocity to evaluate also the opposite drive direction.

2. Check once more to be sure that P17 and P18 are set to zero.
3. Adjust P16 to a low value, i.e. 10%, and try the system on the test profile.

Observe the result of the test. There are three possible outcomes:

- The drive oscillates continuously
Stop the system quickly. Reduce the P16-value to $\frac{1}{2}$ of the initial guess, and try again.
 - The Velocity overshoots the commanded value, but stops after one or two oscillations
Reduce the P16-value to $\frac{3}{4}$ of the initial guess, and try again.
 - The drive reaches the commanded position with no overshoot
The system is usable with the estimated value of P-gain. You should experiment with stepwise increasing of the P16-value to see how high a value the system will tolerate. Accuracy and response are improved by high values, but do not allow permanent oscillation!
4. You have now completed the basic tuning for your control loop. The next step is to test the performance of the system to see if it meets your requirements. If not, the electronic has additional control features you can use to improve performance, as explained below.



The parameters P28, E50, E70, E73, E74 will be needed for closed loop velocity control systems and should therefore be adjusted accordingly (s. section "Generating feedback signals").

Operation Manual

The table below gives information, which approaches may be embarked if typical problems with velocity control loops appear.

Problem	Solution
Variation error too large, when velocity command remains constant	Use parameter P17 = I-gain (only effective for P26 >0)
Repeatable deviation by using a valve with overlap/hysteresis	Use dead band compensation feature P7 = MIN channel A resp. P8 = MIN channel B
Following error too large during velocity profile execution	Use parameter P13 = bypass gain
Slow, small amplitude oscillation during constant velocity	Use integrator window P26 = window I-gain
Disappointingly low P-gain	Check the frequency response of valve and position transducer, the drive resonant frequency and the feedback value processing (s. items below)
Response too slow	Be sure P16 = p-gain is adjusted high enough (s. also previous items)
In explainable problems	Check the setting of all parameters

Improving system performance**Using the parameter P17 = I-gain**

The integrator gain (abbreviated I) can be adjusted to reduce or eliminate the error between the commanded and the measured velocity, when the command remains constant. Higher values of I-gain will cause a better error reduction while the response will be slower. This parameter is only effective if a window (>0) is defined via P

Elimination of a slow oscillation with small amplitude in position

Due to friction and other application/system characteristics, use of the I-gain sometimes causes a slow, small amplitude during constant velocity. This is a different problem from the vigorous oscillations that occur when the P-gain is set too high. The electronic provides a "Window" feature (sometimes called "in-position-window") to solve this problem. Select the parameter P26. Small step adjustments increasing the window size, sufficient to stop the slow oscillations.

Repeatable velocity errors due to valve dead band or hysteresis

You can use the integrated dead band compensation coefficient to compensate for this. There are separate adjustable parameters P7 and P8 for both valve sides. This feature generates constant correction signals which will be active for the dedicated valve site if a signal occurs on the command signal input. As a result this will cause the valve to "Jump through" the overlap region of the spool.

Increasing load stiffness

"Load stiffness" is the term for the resistance of the servo loop to drive deflection by external forces. Adjusting P16 to the highest practical value is important.

Disappointing control loop function

The higher the value of the P-gain that can be used, will result in better static and dynamic performance of the system. You may not have any direct need for fast response, but may still need a high value of P

Operation Manual

to reduce static error, reduce following error or increase actuator stiffness. High values of P cause faster system response, whether you need it or not. As the system frequency response gets too close to the frequency response of one of your components, the system response becomes oscillatory.

- **Valve**

The frequency response of the valve can be obtained from the datasheets. As a first guess, it needs to be at least twice the system frequency response.

- **Position transducer**

Some analog output transducers will present problems because of filtering intended to smooth the output. This is most important for this application, because in this case the actual velocity feedback signal will be calculated from the position transducer signal. To ensure best system dynamic, sensors with integrated D/A-converter should operate with a most high sampling rate. Magnetostrictive transducers with digital output often have a low sampling rate, because an interaction with the achievable resolution. Please obtain detailed information from the transducer supplier.

- **Drive**

There is a mode of instability caused by a combination of the mass of the load and the compressibility of the hydraulic fluid in the system. This frequency is often surprisingly low when using long stroke cylinders.

Update rate of the controller

The controller updates the electrical output to the valve at 1000Hz. This rate is fast enough to have negligible effect in almost all hydraulic applications, but it does set an absolute limit on the response of the system.

Generating feedback signals

The electronics derives the feedback signal for the velocity control from the differentiation of the position transducer output signal. The disadvantage of such a circuit is the creation of noise in the feedback signal. Thus different filter algorithms are implemented. To match the functionality of a certain feedback generator to the utilized position transducer, the parameters below have to be adjusted:

T-portion of PT1-filter – P28

This parameter is usable for the adjustment of the low pass filter damping of the differentiated feedback signal. The higher this parameter value is, the better is the smoothing of the feedback signal within the controller, but all the damping of the filter. Thus the level of the parameter has negative influences to the dynamic of the control.

Average quantity – E50

To smooth the differentiated feedback signal several values will be sampled resulting in an average value. The bigger the number of values will be selected, the better is the quality of the feedback signal. This function is dedicated for the noise suppression and has virtually a filter function. Yet the average quantity creates negative effects for the dynamic of the feedback signal.

Feedback velocity – E70

This parameter enables the generation of the velocity-feedback signal from a position transducer signal.

Sensor length – E73

The specification of the sensor length is required for calculating the velocity.

MAX velocity – E74

Required to match the maximum velocity with 100% command signal span. Example: That results for a command signal span of 0...10V a velocity which is adjusted by this parameter.



The performance of the velocity signal may be examined via the diagnostic function of the operating software. For this purpose begin with starting of the ProPXD-Software.

- Type the key combination “CTR + S + E”
- The service window will be opened, type the password “service”
- Select test point “MP5”
- Close the service window
- Release the diagnostic screen via the menu “service” below “monitor”
- Tick the “monitor output signal” box
- The button “start” activates the display of the feedback signal

Operation Manual

Position transducer accuracy and resolution

A control system is no better than its transducer.

Here are points to watch for:

- Absolute accuracy

The controller accelerates the drive with the highest possible accuracy to a velocity, which has been measured by the position transducer and converted to the feedback signal via the above described calculation. The absolute accuracy of the measured position is determined by the transducer.

- Resolution

The electronic cannot position the load more accurately than the resolution of the transducer. Be sure the resolution of your sensor is adequate. When using a true analog transducer (analog measurement principle and analog output), the resolution is limited by the utilized A/D-converter, which is 12 bit ($1/4096 = 0.025\%$).

- Installation

The installation of the position transducer plays a most important rule for the proper functionality of the closed loop control. By all means it has to be secured, that the mounting of transducer and actuating device provides absolute freedom from vibration and clearance effects. This is most important even for the commonly expected velocities and accelerations. Also, the transducer has to be laid out for the dynamic requirements.

5.6. Fade out function

This function allows for a controlled fade out of the output signal, independently from the command signal processing. This might be useful as simple

“semi automatic” while operating a cylinder approach, or as adjustable system limit.

The diagram below explains the mode of operation.

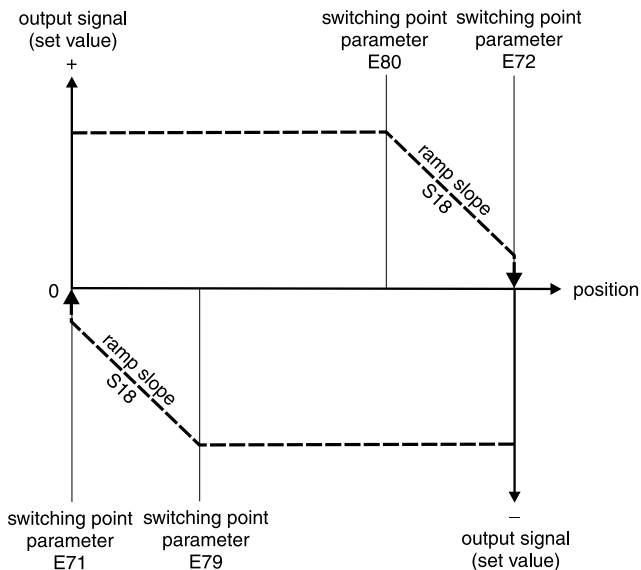

The ranges may be used independently from each other. One range is inactive, if it contains the default values given from the operating software.

Operation Manual**Series PID00A-40X****5.7. Error messages**

Malfunctions when using the ProPxD software program will be indicated via appropriate failure messages.

Failure messages and corrective actions

Failure message	Description/corrective action
The Com Port is not available!	Terminate the other program, or quit the message and select another RS-232 port via the menu " Options > Port ". Afterwards reconnect the null modem cable.
Unable to open COM port	Com port is not available. Quit the message and select another RS-232 port via the menu " Options > Port ". Afterwards reconnect the null modem cable.
There is no module connected or the communication is disturbed!	No data exchange possible. Either the electronics has been removed, the port is mismatched, or the connection will be disturbed by strong electrical fields. Check if the Com port is set for " 9600, 8, 1, none, none " via the menu " Options > Port ".
Wrong password!	Retype the password, notice the exact spelling (case sensitivity).
Wrong input!	An invalid character or a value outside the permitted range has been used at parameter entry.
Keep the entered parameters?	During parameter loading from the electronics module memory the preset parameters from the left hand screen display may be rejected or maintained.
The chosen module isn't the same as the connected hardware!	In principle, parameters dedicated to a type which deviates from the connected electronics module may be edited. However, for data transmitting the correct module has to be connected. If parameters will be loaded from a module which deviates from the selected one, the parameters from the left hand side screen display of the program will be overwritten.
File name.pxd already exists. Do you want to replace the file?	The file name already exists within the indicated directory. Select another name, another directory or overwrite the existing file with " OK ".

Operation Manual

6. Maintenance

Periodical maintenance is essential for the longevity of the unit and guarantees reliability and availability.

The following properties of the electronics have to be checked in continuous short time intervals:

- tight fit on the mounting rail
- tight fit of the disconnectable terminals
- tight fit of the terminal screws
- environmental temperature level
- supply voltage level
- cleanliness of the ambience

 Service work may only be carried out by qualified personnel. Detailed knowledge of the machine functions concerning switching on and off as well as of the required safety relevant technical tasks is necessary!

7. Trouble-shooting

Basis of trouble-shooting is always a systematic approach. At first the following questions have to be checked:

- Are there practical experiences with similar failures?
- Have system adjustments been changed?

 In either case the available diagnostic options should be used. The electronics permits a diagnostic of the valve function via the monitor output. The status output monitors the working condition of the electronics, an additional visual status results from an LED indicator.

Location of status indicator

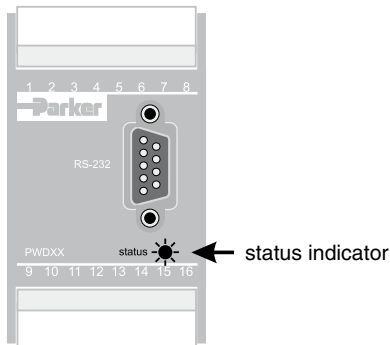

Function assignment

Operating condition	LED-display
no failure	green
no supply voltage	off
no enable signal	yellow
cable break feedback sensor (not for options voltage/±20 mA)	red
cable break command signal (only for option 4...20 mA)	red
internal processor fault	red

Afterwards starting of trouble-shooting by means of a priority list of the **most likely** reasons.

 Trouble-shooting in a hydraulic system requires in either case a systematic approach. The work may exclusively be performed by qualified personnel, as it requires detailed knowledge of the function and construction of the system. Reversals or disassembly may not be taken imprudently! Prior to the works it has to be clarified, if the system has been operated properly until the failure occurred.

8. Repair / Service

When you buy a Parker component, full technical support from Parker After Sales Service.

Our highly qualified team will be glad to assist you in all industrial and mobile applications.

- We offer full service:
- general support for starting up Parker hydraulic controls
- maintenance of Parker controls
- repair of all Parker related hydraulic and electrical devices
- assistance in the supply of spare parts worldwide
- direct service for mobile applications at our Service Center in Kaarst, Germany
- direct replacement for parts subject to wear at our Service Center in Kaarst, Germany
- technical training in theory and practice

For further questions please contact us:

Parker Hannifin GmbH

Hydraulic Controls Division

After Sales Service

Gutenbergstr. 38

D-41564 Kaarst

Phone: (+49)181-9944-430

