

SIEMENS

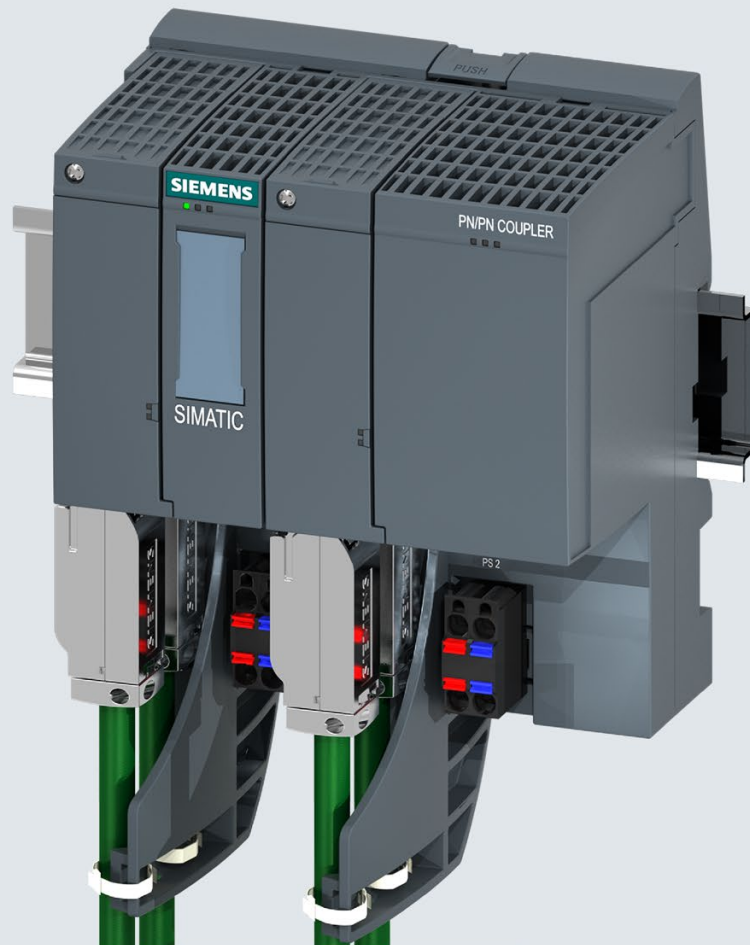

Installation and operating manual

SIMATIC

Bus links

PN/PN Coupler

Edition

09/2019

support.industry.siemens.com

SIEMENS

SIMATIC

Bus links PN/PN coupler

Hardware Installation and Operating Manual

Preface

Documentation guide

1

Product overview

2

Assembling

3

Connecting

4

Configuring, parameter
assignment and
commissioning

5

Functions

6

Interrupts, error messages
and diagnostics and system
alarms

7

Operation and maintenance

8

Technical specifications

9

Dimension drawing

A

Article numbers and
accessories

B

Response times

C



Compatibility

D

Legal information

Warning notice system

This manual contains notices you have to observe in order to ensure your personal safety, as well as to prevent damage to property. The notices referring to your personal safety are highlighted in the manual by a safety alert symbol, notices referring only to property damage have no safety alert symbol. These notices shown below are graded according to the degree of danger.

 DANGER
indicates that death or severe personal injury will result if proper precautions are not taken.
 WARNING
indicates that death or severe personal injury may result if proper precautions are not taken.
 CAUTION
indicates that minor personal injury can result if proper precautions are not taken.
NOTICE
indicates that property damage can result if proper precautions are not taken.

If more than one degree of danger is present, the warning notice representing the highest degree of danger will be used. A notice warning of injury to persons with a safety alert symbol may also include a warning relating to property damage.

Qualified Personnel

The product/system described in this documentation may be operated only by **personnel qualified** for the specific task in accordance with the relevant documentation, in particular its warning notices and safety instructions. Qualified personnel are those who, based on their training and experience, are capable of identifying risks and avoiding potential hazards when working with these products/systems.

Proper use of Siemens products

Note the following:

 WARNING
Siemens products may only be used for the applications described in the catalog and in the relevant technical documentation. If products and components from other manufacturers are used, these must be recommended or approved by Siemens. Proper transport, storage, installation, assembly, commissioning, operation and maintenance are required to ensure that the products operate safely and without any problems. The permissible ambient conditions must be complied with. The information in the relevant documentation must be observed.

Trademarks

All names identified by ® are registered trademarks of Siemens AG. The remaining trademarks in this publication may be trademarks whose use by third parties for their own purposes could violate the rights of the owner.

Disclaimer of Liability

We have reviewed the contents of this publication to ensure consistency with the hardware and software described. Since variance cannot be precluded entirely, we cannot guarantee full consistency. However, the information in this publication is reviewed regularly and any necessary corrections are included in subsequent editions.

Preface

Purpose of this manual

This manual provides all the necessary information for configuring, installing, connecting and commissioning the PN/PN Coupler.

Required basic knowledge

The following knowledge is required in order to understand the manual:

- General knowledge of automation technology
- Knowledge of the use of computers or PC -like tools (e.g. programming devices) under the Windows operating system.
- Knowledge of working with STEP 7 You can find information on this topic in the STEP 7 online help.

Scope of the manual

This manual is valid for PN/PN Coupler V4.2 with article number 6ES7158-3AD10-0XA0.

This manual contains a description of the components that were valid at the time the manual was published. We reserve the right to include up-to-date Product Information with new components and new versions of components.

Recycling and disposal

The PN/PN Coupler is low in contaminants and can therefore be recycled. For environmentally friendly recycling and disposal of your old equipment, contact a certified electronic waste disposal company and dispose of the equipment according to the applicable regulations in your country.

Security information

Siemens provides products and solutions with industrial security functions that support the secure operation of plants, systems, machines and networks.

In order to protect plants, systems, machines and networks against cyber threats, it is necessary to implement – and continuously maintain – a holistic, state-of-the-art industrial security concept. Siemens' products and solutions constitute one element of such a concept.

Customers are responsible for preventing unauthorized access to their plants, systems, machines and networks. Such systems, machines and components should only be connected to an enterprise network or the internet if and to the extent such a connection is necessary and only when appropriate security measures (e.g. firewalls and/or network segmentation) are in place.

For additional information on industrial security measures that may be implemented, please visit (<https://www.siemens.com/industrialsecurity>).

Siemens' products and solutions undergo continuous development to make them more secure. Siemens strongly recommends that product updates are applied as soon as they are available and that the latest product versions are used. Use of product versions that are no longer supported, and failure to apply the latest updates may increase customers' exposure to cyber threats.

To stay informed about product updates, subscribe to the Siemens Industrial Security RSS Feed under (<https://www.siemens.com/industrialsecurity>).

Siemens Industry Online Support

You can find current information on the following topics quickly and easily here:

- **Product support**

All the information and extensive know-how on your product, technical specifications, FAQs, certificates, downloads, and manuals.

- **Application examples**

Tools and examples to solve your automation tasks – as well as function blocks, performance information and videos.

- **Services**

Information about Industry Services, Field Services, Technical Support, spare parts and training offers.

- **Forums**

For answers and solutions concerning automation technology.

- **mySupport**

Your personal working area in Industry Online Support for messages, support queries, and configurable documents.

This information is provided by the Siemens Industry Online Support in the Internet (<https://support.industry.siemens.com/cs>).

Industry Mall

The Industry Mall is the catalog and order system of Siemens AG for automation and drive solutions on the basis of Totally Integrated Automation (TIA) and Totally Integrated Power (TIP).

You can find catalogs for all automation and drive products on the Internet (<https://mall.industry.siemens.com>).

Table of contents

	Preface	3
1	Documentation guide	9
2	Product overview	12
2.1	New functions compared to PN/PN Coupler up to V4.0	12
2.2	Area of application and function	13
2.3	Properties	18
2.4	Operator controls and display elements	21
3	Assembling	23
3.1	Assembly rules	23
3.2	Assembling the PN/PN coupler	24
3.3	Disassembling the PN/PN coupler	24
3.4	Applying labeling strips	25
3.5	Applying reference identification labels	25
3.6	Strain relief	26
4	Connecting	28
4.1	Electrical isolation and grounding	28
4.1.1	Introduction	28
4.1.2	General operating rules and regulations	29
4.2	Connections	31
4.3	Connecting the power supply	32
4.4	Connecting the SIMATIC BusAdapter	34
4.5	Block diagram	35

5	Configuring, parameter assignment and commissioning.....	36
5.1	Configuring and commissioning of the PN/PN coupler (overview).....	36
5.2	Requirements.....	37
5.3	Assignment of the modules	38
5.4	Configuring the PN/PN Coupler with STEP 7 TIA Portal.....	40
5.4.1	Configuring the PN/PN Coupler with STEP 7 TIA Portal.....	40
5.4.2	Example: Configuring with STEP 7 TIA Portal	41
5.4.3	Generating a GSD file with STEP 7 TIA Portal.....	43
5.5	Configuring the PN/PN Coupler with a different configuration tool.....	45
5.6	Parameters	47
5.7	Commissioning the PN/PN coupler	49
5.8	Identification data.....	49
6	Functions.....	52
6.1	Data record transfer from one IO controller to another IO controller.....	52
6.1.1	How cross-network data record transfer works	52
6.1.2	How local data record transfer works	56
6.1.3	Structure and meaning of status information for the data record transfer	60
6.1.4	Local data record transfer as an example	62
6.2	PROFINET IO functions	64
6.2.1	Device replacement.....	64
6.2.2	Isochronous real-time communication	65
6.2.3	Prioritized startup.....	66
6.2.4	Media redundancy (MRP).....	67
6.2.5	Shared Device	68
6.2.6	Media Redundancy with Planned Duplication (MRPD)	71
6.2.7	Docking station	71
6.3	Shared Input/Shared Output as communication functions	73
6.3.1	Interface local distribution of IO data	73
6.3.2	Coupling across the network and interface local distribution of IO data.....	75
6.3.3	Coupling across the network and distribution and interface local distribution of IO data	77
6.4	System redundancy S2.....	79
6.4.1	Field of application.....	79
6.4.2	Media and system redundancy S2	84
6.4.3	System redundancy S2 on one and both sides	86
6.4.4	Configuration.....	88

7	Interrupts, error messages and diagnostics and system alarms	89
7.1	Diagnostics via LED displays.....	89
7.2	Diagnostics by user program	93
7.2.1	Extended channel diagnostics	93
7.2.2	Interrupts	94
7.2.3	Diagnostics readout	96
7.2.4	Data validity display	97
7.2.5	Diagnosis in Shared Device.....	97
7.2.6	STOP of the IO controller and recovery of the IO device	98
7.3	Reading service data	98
8	Operation and maintenance.....	99
8.1	Updating firmware via PROFINET IO	99
8.2	Replacing defective PN/PN coupler.....	100
8.3	Reset to factory settings	101
9	Technical specifications	103
9.1	General technical specifications	103
9.1.1	Introduction	103
9.1.2	Standards and approvals	103
9.1.3	Electromagnetic compatibility	109
9.1.4	Transport and storage conditions	111
9.1.5	Mechanical and climatic ambient conditions for operation	112
9.1.6	Specifications for insulation tests, safety class and degree of protection	115
9.1.7	Rated voltage	115
9.2	Technical specifications of PN/PN Coupler (6ES7158-3AD10-0XA0).....	116
A	Dimension drawing	120
B	Article numbers and accessories	121
C	Response times	123
D	Compatibility	124
	Glossary	125
	Index.....	133

Documentation guide

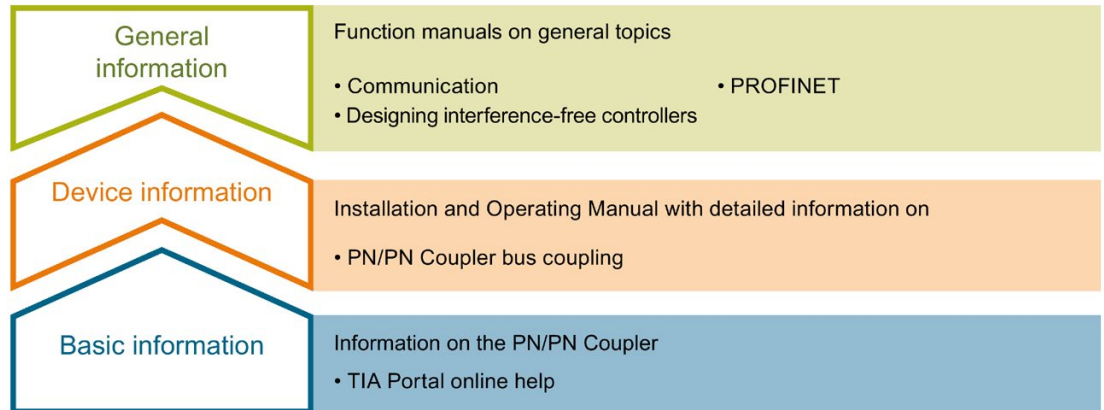

Device information

The PN/PN Coupler Installation and Operating Manual contains information, for example, on properties, assembling, connecting, configuring and parameter assignment, alarms and diagnostics and technical specifications of the PN/PN Coupler.

General information

The function manuals contain detailed descriptions on general topics such as PROFINET and communication.

You can download the documentation free of charge from the Internet (<https://support.industry.siemens.com/cs/ww/en/view/109742709>).

"mySupport"

With "mySupport", your personal work area, you make the most of your Industry Online Support.

In "mySupport" you can store filters, favorites and tags, request CAx data and compile your own personal library in the Documentation area. Furthermore, your data is automatically filled in for support requests and you can get a quick overview of your current requests.

You need to register once to use the full functionality of "mySupport".

You can find "mySupport" on the Internet (<https://support.industry.siemens.com/My/ww/en>).

"mySupport" - Documentation

In the Documentation area of "mySupport", you have the possibility to combine complete manuals or parts of them to make your own manual.

You can export the manual in PDF format or in an editable format.

You can find "mySupport" - Documentation on the Internet (<https://support.industry.siemens.com/My/ww/en/documentation>).

"mySupport" - CAx Data

In the CAx Data area of "mySupport", you can access the latest product data for your CAx or CAe system.

You configure your own download package with a few clicks.

In doing so you can select:

- Product images, 2D dimension drawings, 3D models, internal circuit diagrams, EPLAN macro files
- Manuals, characteristics, operating instructions, certificates
- Product master data

You can find "mySupport" - CAx Data on the Internet (<https://support.industry.siemens.com/my/ww/en/CAxOnline>).

Application examples

The application examples support you with various tools and examples for solving your automation tasks. Here, solutions involving the interaction of multiple components in the system are shown, thus departing from the focus on individual products.

You can find the application examples on the Internet (<https://support.industry.siemens.com/sc/ww/en/sc/2054>).

SIMATIC Automation Tool

You can use the SIMATIC Automation Tool to perform commissioning and maintenance activities simultaneously on various SIMATIC S7 stations as a bulk operation independent of the TIA Portal.

The SIMATIC Automation Tool provides a multitude of functions:

- Scanning of a PROFINET/Ethernet system network and identification of all connected CPUs
- Address assignment (IP, subnet, gateway) and station name (PROFINET device) to a CPU
- Transfer of the date and the programming device/PC time converted to UTC time to the module
- Program download to CPU
- RUN/STOP mode switchover
- CPU localization by means of LED flashing
- Reading out of CPU error information
- Reading of the CPU diagnostic buffer
- Reset to factory settings
- Firmware update of the CPU and connected modules

You can find the SIMATIC Automation Tool on the Internet (<https://support.industry.siemens.com/cs/ww/en/view/98161300>).

PRONETA

With SIEMENS PRONETA (PROFINET network analysis), you analyze the plant network during commissioning. PRONETA features two core functions:

- The topology overview independently scans PROFINET and all connected components.
- PRONETA also scans: configuration of the station name, IP subnet mask and identification and maintenance data (I&M1..3)

You can find SIEMENS PRONETA on the Internet

(<https://support.industry.siemens.com/cs/ww/en/view/67460624>).

Product overview

2.1 New functions compared to PN/PN Coupler up to V4.0

New functions of PN/PN Coupler in firmware version V4.2

The following table lists the new functions of the PN/PN Coupler.

Table 2- 1 New functions of the PN/PN Coupler with FW version 4.2 compared with firmware version \leq V4.0

New functions	Applications	Customer benefits	Where can I find the information?
System redundancy S2	<p>The S7-1500R/H or S7-400H redundant system offers a high degree of reliability and system availability. A redundant configuration of the most important automation components reduces the probability of production downtimes and the consequences of component errors.</p> <p>The higher the risks and costs of a production downtime, the more worthwhile the use of a redundant system. You can compensate for the generally higher investment costs by avoiding production downtimes.</p>	<p>In redundantly operated systems, failure or malfunction of individual automation components must not impede the operation of the plant. Redundant systems are used in the following areas, for example:</p> <ul style="list-style-type: none"> • Power plants • Steel mills • Wastewater treatment plants • Shipbuilding • Tunnel • Subways • Baggage handling systems • Highbay storage • Airports 	Section System redundancy S2 (Page 79)
PN/PN Coupler as docking station	The PN/PN Coupler as a docking station can operate several docking units. These are operated as "Tool Changers" on the PN/PN Coupler.	<p>You can use the PROFINET "Tool Changer" functionality, for example, for tool changing in robots. Typical tools include:</p> <ul style="list-style-type: none"> • Welding guns • Positioning tools for manufacturing parts 	Section Docking station (Page 71)
Local data record transfer	With local record transfer, you provide a copy of your data records to up to 3 CPUs at the same time.	You distribute data from one CPU on a network side to several CPUs on their own side at one time.	Section Data record transfer from one IO controller to another IO controller (Page 52)

2.2 Area of application and function

Area of application and customer benefits

You use the PN/PN Coupler in order to:

- Interconnect two PROFINET subnets with system redundancy S2
- Interconnect two Ethernet subnets
- Exchange data
- Share or couple data with up to 4 IO controllers

To do this, use:

- User data via input or output address ranges which can be separated or coupled
- Shared input/shared output or local shared output
- Data records or local data records

The maximum size of the transferable input and output data is:

- 1440 bytes of input data and 1440 bytes of output data
- 1000 bytes of inputs and 1000 bytes of outputs with system redundancy S2
- 1440 bytes of input data and 1440 bytes of output data with system redundancy S2 and Shared Device. Each number is the total for all IO controllers involved. For system redundancy S2 the input/output length is counted twice (see also System redundancy S2 (Page 79)).

The input and output data can be divided as desired. For example, you configure 1200 bytes of input data and 1340 bytes of output data.

The PN/PN Coupler is a device with two PROFINET interfaces that are each connected to a subnet.

The two subnets are electrically isolated.

During configuring, STEP 7 creates two IO devices with their subnets from a PN/PN Coupler. The other part of the PN/PN Coupler in each case is known as the coupling partner.

2.2 Area of application and function

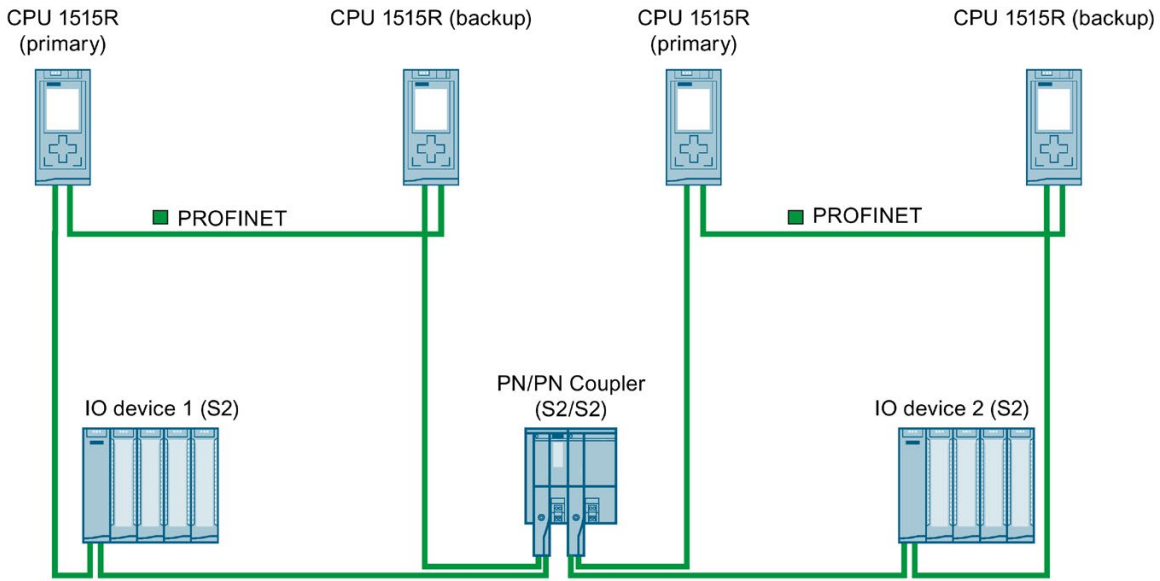

Figure 2-1 Configuration with PN/PN Coupler with system redundancy S2-S2 on both sides

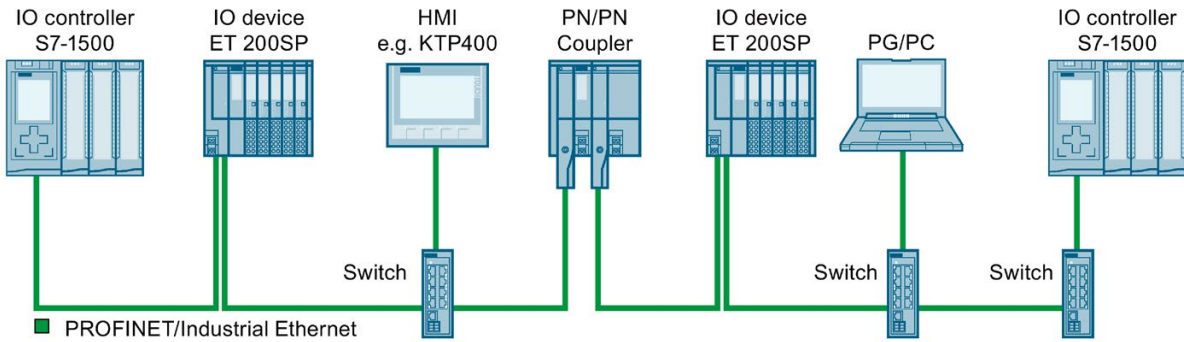

Figure 2-2 Coupling of two PROFINET IO subnets with one PN/PN Coupler

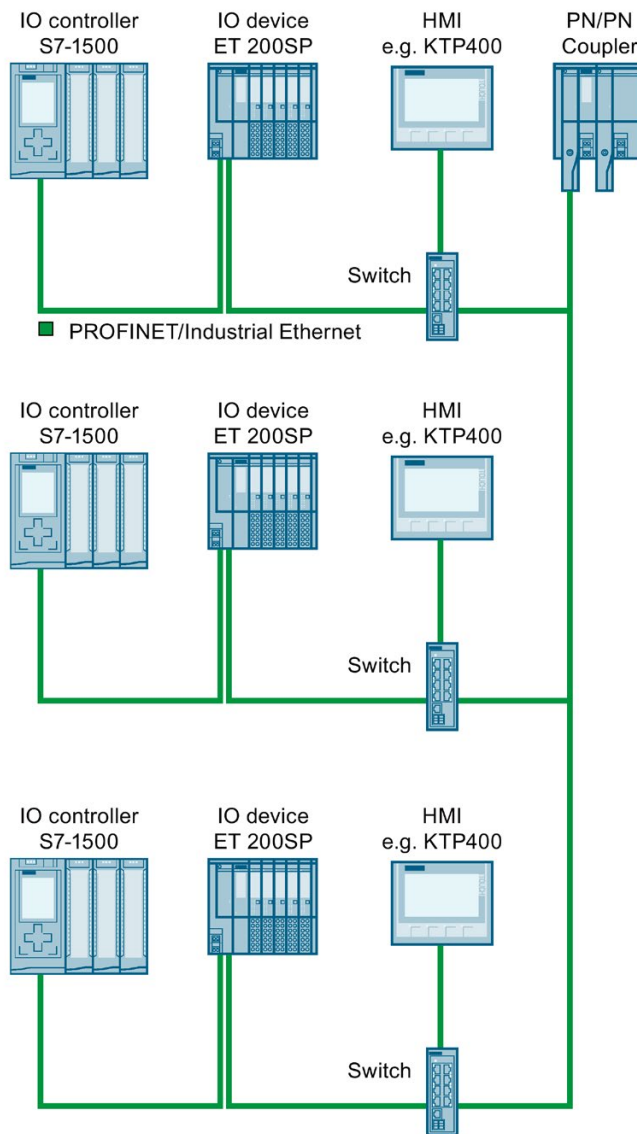

Figure 2-3 Communication between IO controllers on the same network side

2.2 Area of application and function

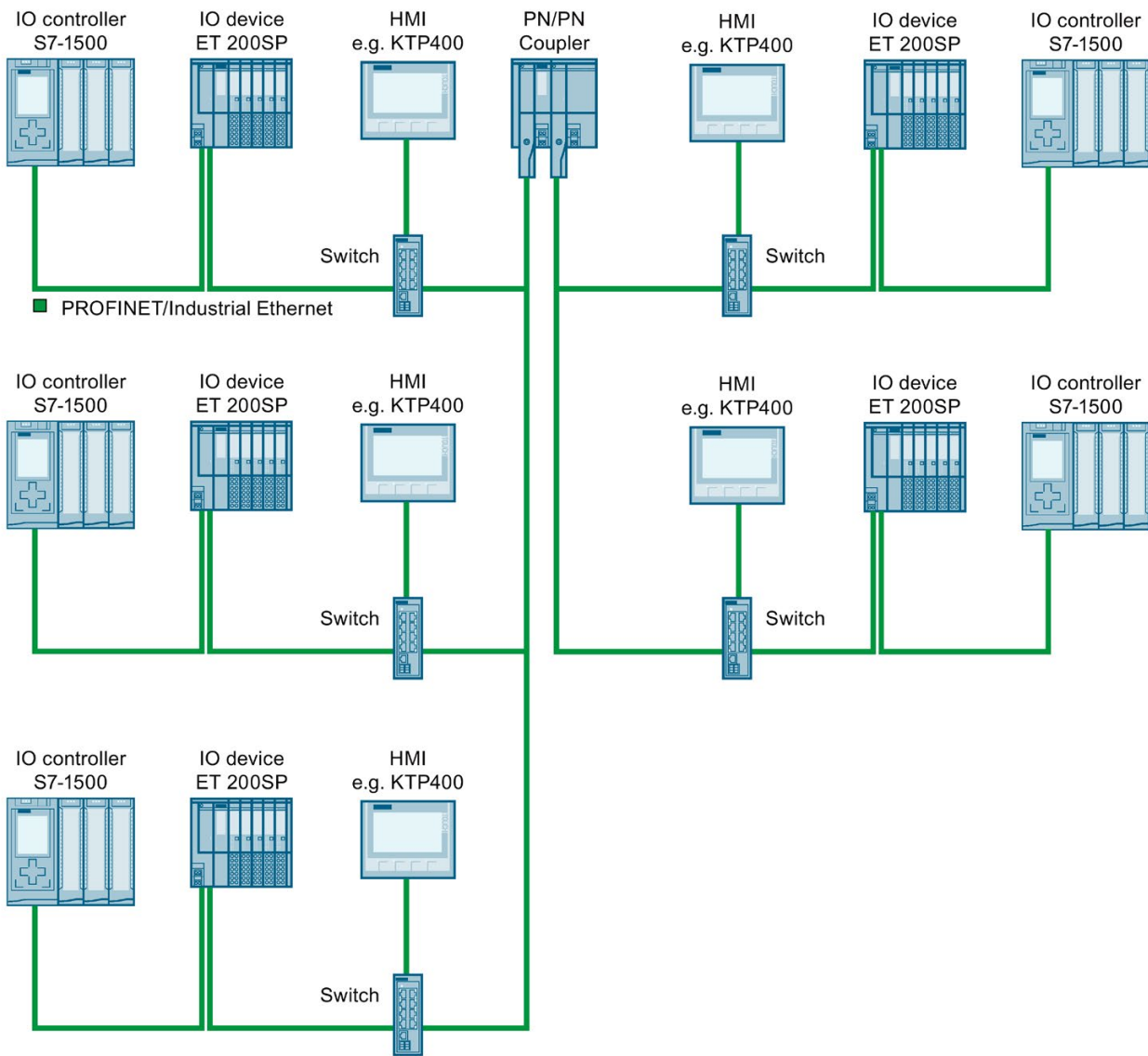

Figure 2-4 Communication between IO controllers on different network sides

Principle of operation

- Data exchange with I/O modules:

Through the configured inputs of a slot, the local CPU reads the values that the CPU of the other subnet writes over the configured outputs of the coupling partner.

Through the configured outputs of a slot, the local CPU writes values that the CPU of the other subnet receives over the configured inputs of the coupling partner.

- Data record transfer:

The module types Publisher and Storage are available. Each type consists of Read and Write modules (see Assignment of the modules (Page 38)). These modules receive address areas which have to be specified for the data record job (see How cross-network data record transfer works (Page 52)).

- System redundancy S2

You can connect redundantly-configured subnets to each other via a PN/PN Coupler. A system-redundant and a non-system-redundant subnet can also be connected (see System redundancy S2 (Page 79)).

Using a redundancy system with S7-1500R/H or S7-400H is required for the implementation of system-redundant subnets. The redundant system consists of two high-availability controllers (lead and redundant CPU). The IO devices used in the subnet connected with system redundancy must also support system redundancy.

2.3 Properties

Article number

6ES7158-3AD10-0XA0

View

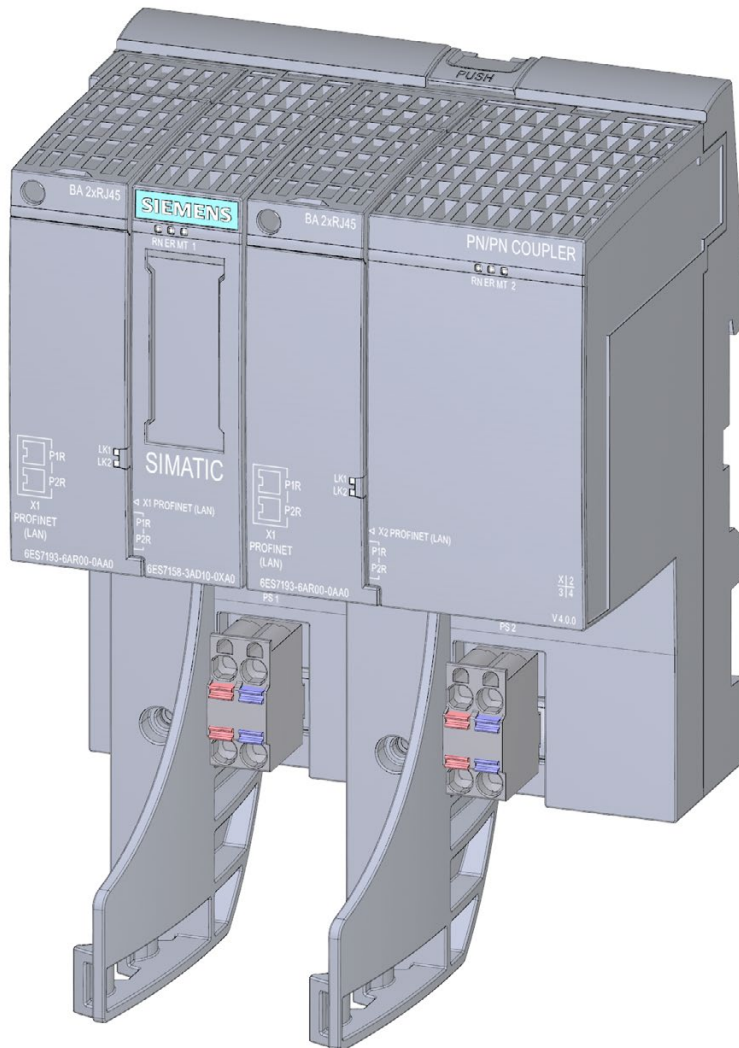

Figure 2-5 View of the PN/PN Coupler with mounted strain relief (accessory)

Properties

The PN/PN Coupler has the following properties:

- Fast and deterministic data exchange between up to 4 PN IO controllers per network side over virtual IO modules or data record communication
- Data exchange between PN IO controllers across network boundaries while maintaining network separation, which means no support of routing functions.
- Local data exchange between up to 4 PN IO controllers on one network side
- Exchange of fail-safe data between 2 SIMATIC F controllers
- One-sided and two-sided system redundancy
- Data exchange in total of up to
 - 1440 bytes of input data and 1440 bytes of output data
 - 1000 bytes of input data and 1000 bytes of output data with system redundancy S2
 - 1440 bytes of input data and 1440 bytes of output data with system redundancy S2 with Shared Devicewith any allocation on up to 4 IO controllers (see also section Field of application (Page 79)).
- When using system redundancy S2, one redundancy system consisting of two IO controllers in system redundancy S2 as well as two additional IO controllers for operation as Shared Device are supported per interface.
- Maximum of 16 input areas/output areas for exchange of data with the following virtual modules:
 - IN
 - OUT
 - IN/OUT
 - RD WRITE STO
 - RD READ STO
 - RD LOCAL STO
 - RD WRITE PUB
 - RD READ PUB
 - RD LOCAL PUB
 - MSI
 - MSO
 - MSI/MSO
 - MSO LOCAL
- Electrical isolation between the two PROFINET IO subnets
- Redundant power supply
- Supply voltage 1L+ 24 V DC (SELV/PELV)

- SIMATIC BusAdapter
- Diagnostics interrupts
- Extended channel diagnostics
- Status information of the input user data when using the "IO Modules" module operating mode
- Update interrupts
- Reset to factory settings via RESET button
- Docking station
- Errors on one network side do not have an effect on the opposite network side but can be diagnosed.

Properties via PROFINET IO

- Integrated switch on both sides with 2 ports
- Supported Ethernet services: ping, arp, SNMP, LLDP
- Port diagnostics
- Port disabling
- Device replacement without removable medium/programming device
- Isochronous real-time communication
- Firmware update via PROFINET IO
- Prioritized startup
- Media redundancy MRP or MRPD
- Shared Device with 4 IO controllers, on both sides in each case
- Module-internal Shared Input/Shared Output (MSI/MSO)
- System redundancy S2

Accessories

You order the following accessories separately:

- SIMATIC BusAdapter
- Strain relief
- Labeling strips
- Reference identification label

You can find a detailed list of available accessories in the appendix Article numbers and accessories (Page 121).

2.4 Operator controls and display elements

Display elements and interfaces

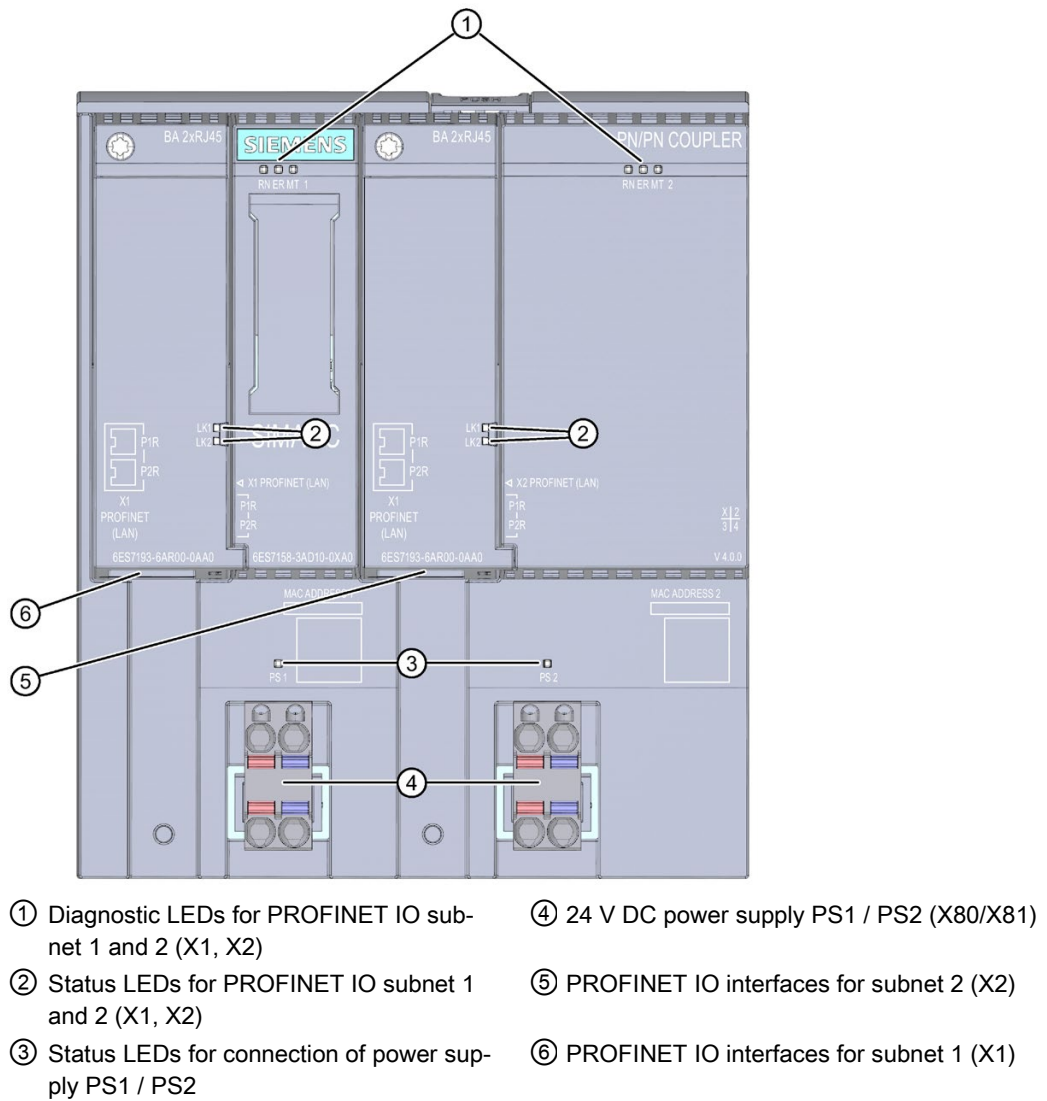

Figure 2-6 Display elements and interfaces of the PN/PN Coupler

X1 PROFINET and X2 PROFINET

For easier assignment of the BusAdapters, they are separated by left and right:

left BusAdapter	right BusAdapter
To the right of it: X300 BA slot	To the right of it: X301 BA slot
For the bus connections: P1R P2R	For the bus connections: P1R P2R

Assembling

3.1 Assembly rules

Mounting position

You can install the PN/PN Coupler under the following conditions:

- for horizontal mounting $T_{max} = 60\text{ °C}$
- for vertical mounting $T_{max} = 50\text{ °C}$

You can find more information on the operating conditions in section General technical specifications (Page 103).

Open equipment

The PN/PN Coupler is open equipment (IP 20). This means that you may only install the PN/PN Coupler in enclosures, cabinets or electrical operating areas. The housings, cabinets and electrical operating rooms must guarantee protection against electric shock and spread of fire. The requirements regarding mechanical strength must also be observed. The housings, cabinets, and electrical operating rooms must not be accessible without a key or tool. Access may only be possible for instructed or authorized personnel.

Mounting technology

You install the PN/PN Coupler on a standard mounting rail (7.5 mm and 15 mm). For non-obstructed mounting, provide a clearance of 10 mm to the left of the module and 20 mm above the module.

3.2 Assembling the PN/PN coupler

Necessary components

- PN/PN Coupler
- SIMATIC BusAdapter
- Strain relief for mechanical load of the PROFINET connections
- Mounting rail:
 - Standard mounting rail (7.5 mm), or
 - Standard mounting rail (15 mm)

You can find the article numbers for the components in the appendix Article numbers and accessories (Page 121).

Installing the PN/PN Coupler on the standard mounting rail

1. Mount the standard mounting rail in such a way that sufficient space remains for installation of and heat dissipation of the module (at least 10 mm on the left and 20 mm above the module).
2. Hook the PN/PN Coupler into the standard mounting rail and swing it downward until you can hear it latch into place on the standard mounting rail.
3. Plug the BusAdapter onto the PN/PN Coupler and screw it on.
4. Connect the PN/PN Coupler as described in section Connecting (Page 28).

Note

Low resistance connection

If the standard mounting rail is mounted on a grounded metal plate or a grounded device support plate, you must ensure a low-resistance connection between the standard mounting rail and base. For example, on painted or anodized metals, use suitable contacting agent or contact washers.

3.3 Disassembling the PN/PN coupler

Uninstalling the PN/PN Coupler

1. Switch off the power supply of the PN/PN Coupler. Disconnect the two 24 V DC connectors PS1 and PS2 from the PN/PN Coupler.
2. Remove the SIMATIC BusAdapter.
3. Press the mounting rail release above the PN/PN Coupler.
4. While pressing the mounting rail release, swing the PN/PN Coupler off of the mounting rail.

3.4 Applying labeling strips

Procedure

Proceed as follows to apply a labeling strip:

1. Label the strip.
2. Insert the labeling strip into the PN/PN Coupler.

3.5 Applying reference identification labels

Procedure

Proceed as follows to apply a reference identification label:

1. Break off the reference identification labels from the sheet.
2. Insert the reference identification labels into the opening on the PN/PN Coupler. The insertion opening is located on the top in each case.

Note

Reference identification label

The printable side of the reference identification label must face forward.

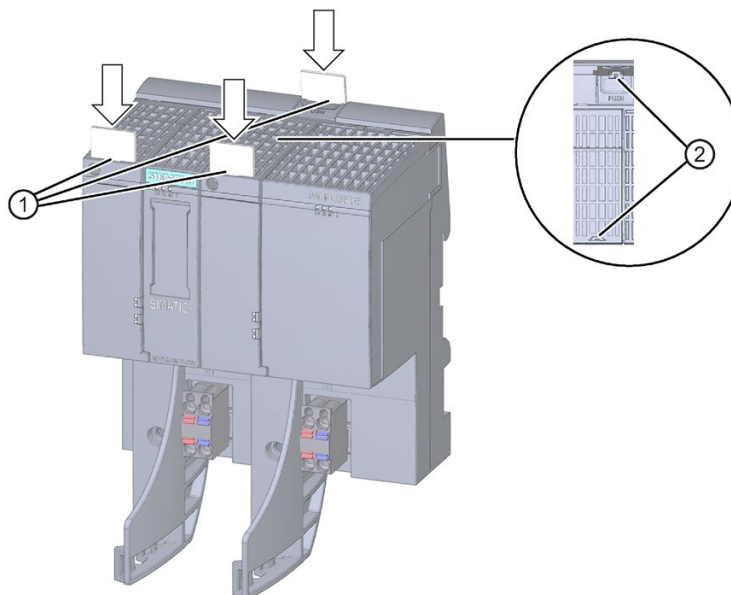

- ① Reference identification labels
- ② Insertion openings

Figure 3-1 Applying reference identification labels

3.6 Strain relief

Article number

6ES7193-6RA00-1AN0 (5 strain relief units incl. screws)

View

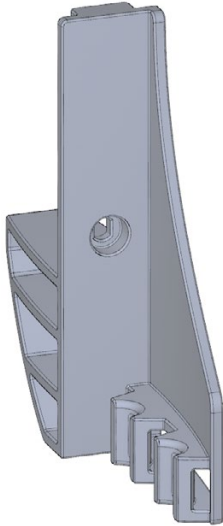

Figure 3-2 Strain relief

Properties

- The strain relief is a mechanical protective device for the electrical PROFINET cables on the BusAdapter.
- The strain relief is suitable for all optical and electrical PROFINET cables of the BusAdapter.
- The strain relief is an optional accessories.
- The cable ties are not included in the delivery. We recommend cable ties with a width of 4.8 mm. The maximum width is 7.0 mm. The length of the cable tie is min. 60 mm.
- The PROFINET cables are not inserted on the BusAdapter. The inserted PROFINET cables hamper the mounting of the strain relief.
- BusAdapter and strain relief can be mounted separately.

Required tools

Screwdriver TX10 (torx).

Procedure

To install the strain relief, follow these steps:

1. Press the strain relief below the BusAdapter seat of the PROFINET device.
2. Fasten the strain relief (1 screw with 0.7 to 0.8 Nm tightening torque).
3. Plug the BusAdapter into the PROFINET device.
4. Screw the BusAdapter to the PROFINET device (1 screw with 0.2 Nm tightening torque).
5. Fasten each PROFINET cable individually to the strain relief with the cable ties.

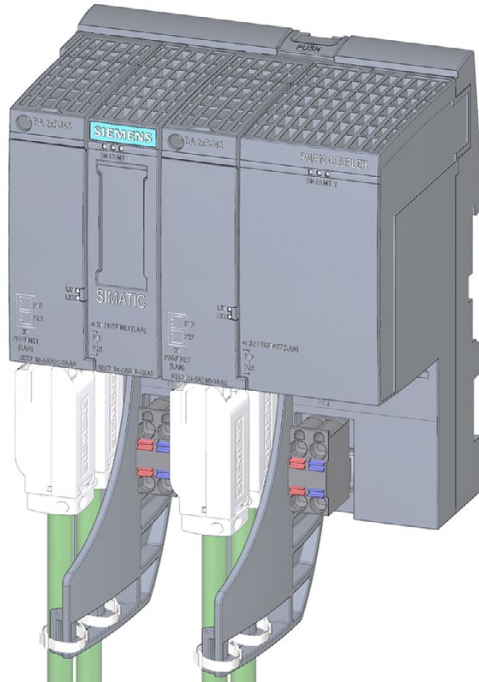

Figure 3-3 Strain relief installed

Connecting

4.1 Electrical isolation and grounding

4.1.1 Introduction

Redundant 24 V DC power supply

You can connect the PN/PN Coupler to two independent 24 V DC power supplies (SELV/PELV). Only one 24 V DC power supply is active at a time. If one power supply fails, the other becomes active automatically. You identify which power supplies (PS1, PS2 or both) are connected and will be diagnosed in the parameter assignment. The connection of one 24 V DC power supply is generally sufficient for operation of the PN/PN Coupler.

Properties of the PN/PN Coupler

- The two PROFINET IO subnets are galvanically isolated from each other.
- The two PROFINET IO subnets are galvanically isolated from the 24 V DC power supply.
- The two 24 V DC power supplies are galvanically isolated from each other.

Ungrounded infeed

It is always possible to configure an ungrounded setup of the PN/PN Coupler as the PN/PN Coupler has no fixed ground connection. The power pack/power supply module for 24 V DC must also be ungrounded and electrically isolated.

4.1.2 General operating rules and regulations

Introduction

For the PN/PN Coupler as a component of a system, special rules and regulations must be adhered to depending on the area of application.

The most important rules, which you must observe for safe integration into a plant or system, are listed below.

Specific application

Observe the safety and accident prevention regulations that are applicable to specific applications (e.g. machine protection guidelines).

EMERGENCY STOP equipment

EMERGENCY STOP devices according to IEC 60204 (corresponds to DIN VDE 113) must remain in effect in all operating modes of the plant or system.

System startup after certain events

The table below identifies situations you must pay attention to when the system starts up after the occurrence of certain events.

For
<ul style="list-style-type: none"> • startup after a voltage dip or power failure • startup after bus communication has been interrupted 	no dangerous operating states may occur. If necessary, "EMERGENCY STOP" must be forced!
<ul style="list-style-type: none"> • startup after unlocking the emergency stop device • startup without the IO controller activating the IO devices 	an uncontrolled or undefined startup must not occur

24 V DC power supply

The table below identifies what you must pay attention to for the 24 V supply.

For ...	you must ensure ...	
Buildings	External lightning protection	Provide lightning protection measures (e.g. Blitzductors)
24 V DC supply cables, signal cables	Internal lightning protection	
24 V supply	Safety extra-low voltage (SELV/PELV) with safe electrical isolation.	

Note

You can find additional information on lightning protection in function manual Installing S7-1500, ET 200MP, ET 200SP, ET 200AL controllers in an interference-proof manner (<https://support.industry.siemens.com/cs/ww/en/view/59193566>).

Protection from external electrical effects

The table below identifies what you must pay attention to for protection from electrical effects or faults.

For ...	you must ensure that ...
all systems in which the modules are integrated	... the system is connected to the protective conductor or the functional earth to discharge electromagnetic interference.
Connection, signal and bus cables	... the cable routing and installation are correct.

4.2 Connections

PN/PN Coupler I/Os

The following figure shows all the connections that you establish to and from the PN/PN Coupler (in the figure, with BA 2×RJ45 BusAdapters):

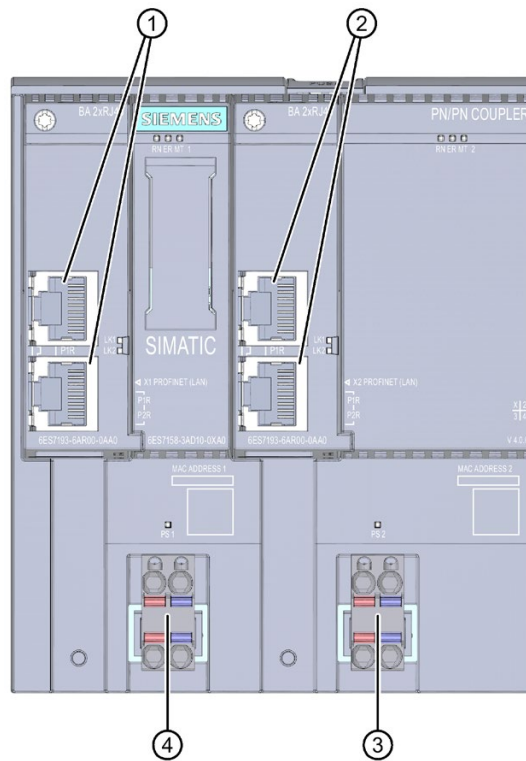

- ① PROFINET IO subnet 1 (X1 PROFINET)
- ② PROFINET IO subnet 2 (X2 PROFINET)
- ③ Power supply 2 (24 V DC)
- ④ Power supply 1 (24 V DC)

Figure 4-1 PN/PN Coupler I/Os

4.3 Connecting the power supply

Required tools

You need a screwdriver with a maximum blade width of 3.5 mm to connect the power supply.

Power supply unit

Only SELV/PELV power supplies with safe, electrically isolated, safety extra-low voltage ($\leq 60V$ DC) may be used.

Redundant power supply

You can supply the PN/PN Coupler from two voltage sources (redundant power supply):

- If one voltage source fails, the PN/PN Coupler automatically switches over to the other voltage source.
- If voltage is applied to both connections (PS1 / PS2), the PN/PN Coupler automatically uses the voltage source of PS1.
- If you only connect the PN/PN Coupler to one power supply, it is preferable to connect it to PS1.

Note

You can evaluate the diagnostics to determine whether the PN/PN Coupler is connected to both 24 V DC power supplies.

24 V DC supply voltage (X80/X81)

Table 4- 1 Terminal assignment 24 V DC supply voltage

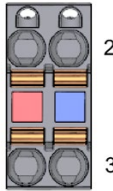
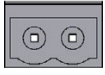
View		Signal name ¹⁾		Description
Connector (PS1/PS2)	Connection (X80/X81)			
		1	1L+	+ 24 V DC of the supply voltage
		2	1M	Ground of the supply voltage
		3	2M	Ground of the supply voltage for loop-through ²⁾
		4	2L+	+ 24 V DC of the supply voltage for loop-through ²⁾

1) 1L+ and 2L+ as well as 1M and 2M are bridged internally.

2) Maximum 10 A permitted

The maximum cross-section of the connection is 2.5 mm². A strain relief is not present. The connection plugs offer you the option of looping the power supply uninterrupted, even in unplugged state.

Procedure

To connect the power supply, follow these steps:

1. Strip 10 mm of insulation from the wires.
2. Press the spring release and insert the cable into the round opening of the connection plug as far as it will go. (The connection plugs are plugged into the power supply connection in the delivery state.)

If you have a redundant power supply of the PN/PN Coupler, connect the second power supply to the second connection plug.

If you are using only one voltage source, it is preferable to connect it to PS1.

Wiring rules for PN/PN Coupler

Wiring rules for ...		PN/PN Coupler (supply voltage)
Permitted cable cross-sections of solid cables (Cu)		0.2 to 2.5 mm ² AWG*: 24 to 13
Permitted cable cross-sections of flexible cables (Cu)	Without wire-end ferrule	0.2 to 2.5 mm ² AWG*: 24 to 13
	With wire-end ferrule (with plastic sleeve)***	0.25 mm to 1.5 mm ² ** AWG*: 24 to 16
	With TWIN wire-end ferrule***	0.5 mm to 1 mm ² AWG*: 20 to 17
Stripped length of the wires		8 to 10 mm
Wire-end ferrules in accordance with DIN 46228 with plastic sleeve***		8 and 10 mm long

* AWG: American Wire Gauge

** Wire-end ferrules without plastic sleeve: 0.25 to 2.5 mm²/AWG: 24 to 13

*** See note on wire-end ferrules

Note

Wire-end ferrules

Optimum results with respect to a high-quality and permanent electrical connection with maximum conductor pull forces at the same time can be achieved by using crimping dies, preferably with smooth surfaces, which are provided, for example, with rectangular and trapezoidal crimp cross-sections.

Due to the large number of crimping dies used in the industry, we can recommend others on request. Crimping dies with a pronounced wave profile are unsuitable.

Permissible cable temperature

Note

Permissible cable temperatures

At the maximum ambient temperature of the PN/PN Coupler, you must select sufficiently large wire cross-sections so that the permissible cable temperatures are not exceeded.

Examples:

- At an ambient temperature of 60° C, a current of, for example, 4 A per wire and a cross-section of 1.5 mm² Cu, a connecting conductor must be rated for a temperature range of at least 90° C.
 - At an ambient temperature of 60° C, a current of, for example, 2 A per wire and a cross-section of 1.5 mm² Cu, a connecting conductor must be rated for a temperature range of at least 80° C.
-

4.4 Connecting the SIMATIC BusAdapter

SIMATIC BusAdapter

The SIMATIC BusAdapters connect PROFINET IO to the PN/PN Coupler. You select the required connection technology and connection method for your process from the different versions of the SIMATIC BusAdapter.

You can find the SIMATIC BusAdapters that are available and how they are connected in the ET 200SP BusAdapter (<https://support.industry.siemens.com/cs/ww/en/view/109751716>) device manual.

4.5 Block diagram

Block diagram

The following figure shows the block diagram of the PN/PN Coupler.

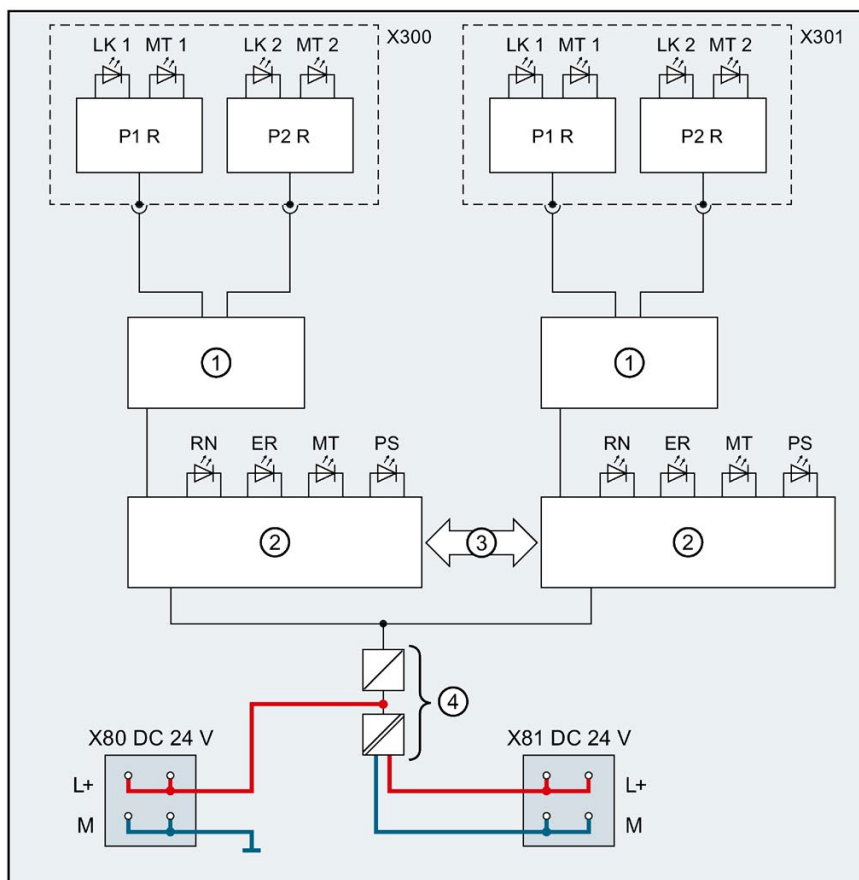

- | | | | |
|---------|--------------------------------------|---------|----------------------------|
| ① | Switch (component of the controller) | L+ | 24 V DC supply voltage |
| ② | Controller, right and left | M | Ground |
| ③ | Coupling | LK 1, 2 | Link LED |
| ④ | Internal power supply | MT 1, 2 | FiberOptic LED (SCRJ port) |
| 24 V DC | Supply voltage infeed | RN | RUN LED (green) |
| X300 | BusAdapter PROFINET interface X1 | ER | ERROR LED (red) |
| X301 | BusAdapter PROFINET interface X2 | MT | MAINT LED (yellow) |
| P1 R | PROFINET interface X1, X2 Port 1 | PS | POWER LED (green) |
| P2 R | PROFINET interface X1, X2 Port 2 | | |

Figure 4-2 PN/PN Coupler block diagram

Configuring, parameter assignment and commissioning

5

5.1 Configuring and commissioning of the PN/PN coupler (overview)

Overview

The following table shows the steps you must perform up to and including commissioning.

Table 5- 1 Procedure for configuring and commissioning the PN/PN Coupler

Step	Action	Content	Additional information in section
1	Mounting	Mount the PN/PN Coupler on the mounting rail.	Assembling (Page 23)
2	Connecting	Connect the PN/PN Coupler to the power supply and PROFINET IO.	Connecting (Page 28)
3	Configuring the PN/PN Coupler	Configure the PN/PN Coupler with the STEP 7 TIA Portal	Configuring the PN/PN Coupler with STEP 7 TIA Portal (Page 40)
		Configuring with a different configuration tool	Configuring the PN/PN Coupler with a different configuration tool (Page 45)
4	Parameter assignment	Assign the PN/PN Coupler parameters with a different configuration tool.	Parameters (Page 47) and STEP 7 online help
5	Commissioning the PN/PN Coupler	Switch on the PN/PN Coupler and download the configuration.	Commissioning the PN/PN coupler (Page 49)

5.2 Requirements

To configure the PN/PN Coupler, you need one of the following components:

- STEP 7 TIA Portal V15 or higher
- GSD file of the PN/PN Coupler The GSD files can be downloaded on the Internet (<https://support.industry.siemens.com/cs/ww/en/view/23742537>).

5.3 Assignment of the modules

Introduction

You configure the PN/PN Coupler by configuring both sides separately.

The assignment of the modules is only shown from network side 1 to network side 2. It is also possible to swap the network sides.

Table 5- 2 Assignment of the modules in the "IO Modules" module operating mode

Modules network side 1	Assigned IO modules network side 2
Output module (OUT)	Input module (IN)
Output module (OUT)	MSI coupling module (MSI)
Input module (IN)	Output module (OUT)
Input module (IN)	MSO coupling module (MSO)
PROFIsafe IN/OUT ¹	PROFIsafe IN/OUT ¹
MSI/MSO ²	MSI/MSO ²
MSO coupling module (MSO)	Input module (IN)
MSO coupling module (MSO)	MSI coupling module (MSI)
MSI coupling module (MSI)	Output module (OUT)
MSI coupling module (MSI)	MSO coupling module (MSO)
Local MSO module (MSO Local)	---
Local MSO module (MSO Local)	Local MSO module (MSO Local)
Local MSO module (MSO Local)	RD LOCAL PUB
Local MSO module (MSO Local)	RD LOCAL STO
RD WRITE STO	RD READ STO
RD READ STO	RD WRITE STO
RD WRITE PUB	RD READ PUB
RD READ PUB	RD WRITE PUB
RD LOCAL PUB	---
RD LOCAL PUB	Local MSO module (MSO Local)
RD LOCAL PUB	RD LOCAL PUB
RD LOCAL PUB	RD LOCAL STO
RD LOCAL STO	---
RD LOCAL STO	Local MSO module (MSO Local)
RD LOCAL STO	RD LOCAL PUB
RD LOCAL STO	RD LOCAL STO

¹ Only for PROFIsafe communication

² Can also be used as IN/OUT module if only one subslot is configured

PROFIsafe module

You have to observe the following for PROFIsafe IN/OUT:

- Only the PROFIsafe IN/OUT must be used for failsafe communication in module operating mode "IO Modules".
- The data status byte is not available, because the validity of the coupled user data is guaranteed by the mechanisms of the failsafe communication.

We recommend that you do not use the respective modules for other applications due to the missing data status byte (DS).

Note

Safety-related communication

For safety-related communication between F-CPU S7-1500/1200 and a configured PN/PN Coupler from the integrated hardware catalog, the fail-safe instructions "SENDDP/RCVDP" support "IO Modules" as well as "IO Modules (ext. V3.x comp.)".

For safety-related communication with F-CPU S7-300/400, use the fail-safe instructions "SENDDP/RCVDP" and the "IO Modules (ext. V3.x comp.)".

You will find details in the table below:

Table 5- 3 You use the following module operating modes of the PN/PN Coupler from the hardware catalog (not GSD configured):

X1/X2	F-CPU S7-300	F-CPU S7-400	F-CPU S7-1200	F-CPU S7-1500
F-CPU S7-300	"IO Modules (ext. V3.x comp)"	"IO Modules (ext. V3.x comp)"	"IO Modules (ext. V3.x comp)"	"IO Modules (ext. V3.x comp)"
F-CPU S7-400	"IO Modules (ext. V3.x comp)"	"IO Modules (ext. V3.x comp)"	"IO Modules (ext. V3.x comp)"	"IO Modules (ext. V3.x comp)"
F-CPU S7-1200	"IO Modules (ext. V3.x comp)"	"IO Modules (ext. V3.x comp)"	"IO Modules" or "IO Modules (ext. V3.x comp)"	"IO Modules" or "IO Modules (ext. V3.x comp)"
F-CPU S7-1500	"IO Modules (ext. V3.x comp)"	"IO Modules (ext. V3.x comp)"	"IO Modules" or "IO Modules (ext. V3.x comp)"	"IO Modules" or "IO Modules (ext. V3.x comp)"

GSD

Alternatively, you can use a PN/PN Coupler configured with GSD in both module operating modes "IO Modules" as well as "IO Modules (ext. V3.x comp.)".

5.4 Configuring the PN/PN Coupler with STEP 7 TIA Portal

5.4.1 Configuring the PN/PN Coupler with STEP 7 TIA Portal

Configuration of the PN/PN Couplers

1. Start STEP 7 TIA Portal with your project and open the hardware configuration.
2. Drag PN/PN Coupler 6ES7158-3AD10-0XA0 from the Network components/Gateways directory of the hardware catalog to the PROFINET network.
3. Double-click the symbol of the PN/PN Coupler.
4. Assign a device name for the PN/PN Coupler and confirm with OK.

The device name must be unique on the Ethernet subnet. The device name must comply with the DNS conventions. You can find more information about assigning the device name in the STEP 7 online help.

5. For configuring the left side of the bus (X1), click the symbol of the PN/PN Coupler.
6. Open the "Module parameters/Transfer mapping" table in PNP Coupler.x1. Create up to 16 slots of the PN/PN Coupler in the table. Note the permitted assignment of modules (see Assignment of the modules (Page 38)).

Note

Assigning the device name

Assign the device name to the PN/PN Coupler online.

Result

Configuring is complete for both sides of the PN/PN Coupler.

Coupling both subnets

The two sides are constantly kept consistent in the TIA Portal. Changes to side X1 lead automatically to the adaptation of side X2, and vice versa. This requires that the two bus sides X1 and X2 are in the same project or in a multi-project.

Recommended procedure when you make changes on the couple partner:

1. Perform the changes (e.g. add I/O modules).
2. Execute the "Save and compile" function for both bus sides.

Result: The configuration is consistent.

5.4.2 Example: Configuring with STEP 7 TIA Portal

Task

You want to transfer I/O data and data records to or from the IO controller:

Bus side X1	Bus side X2
2 bytes inputs (IN 2 bytes)	2 bytes outputs (OUT 2 bytes)
8 bytes outputs (OUT 8 bytes)	8 bytes inputs (IN 8 bytes)
8 bytes inputs (IN 8 bytes)	8 bytes outputs (OUT 8 bytes)
2 bytes outputs (OUT 2 bytes)	2 bytes inputs (IN 2 bytes)
6 byte inputs / 12 byte outputs (IN/OUT 6 bytes / 12 bytes)	12 bytes inputs / 6 bytes outputs (IN/OUT 12 bytes / 6 bytes)
RD READ STO	RD WRITE STO
RD WRITE STO	RD READ STO

Configuring the PN/PN Coupler in subnet 1 in STEP 7 TIA Portal

The configuration of the PN/PN Coupler in subnet 1 (bus side X1) looks like the following:

Transfer area	Virtual slot	Type	I-length		Q-length		I-address	Q-address
Transfer area_1	1	IN	2	Byte(s)			10...11	
Transfer area_2	2	OUT			8	Byte(s)		8...15
Transfer area_3	3	IN	8	Byte(s)			12...19	
Transfer area_4	4	OUT			8	Byte(s)		16...23
Transfer area_5	5	IN/OUT	6	Byte(s)	12	Byte(s)	20...25	24...35
Transfer area_6	6	RECORD_READ_STO	5	Byte(s)	1	Byte(s)	26...30	36
Transfer area_7	7	RECORD_WRITE_STO	2	Byte(s)			31...32	

Configuring the PN/PN Coupler in subnet 2 in STEP 7 TIA Portal

The configuration of the PN/PN Coupler is made exactly opposite the configuration in subnet 1. This configuration takes place at the same time in the "Mapping of IO data from PROFINET interface X1 to X2". The configuration of the PN/PN Coupler in subnet 2 (bus side X2) looks like the following:

Transfer area	Virtual slot	Type	I-length		Q-length		I-address	Q-address
Transfer area_1	1	OUT			2	Byte(s)		10...11
Transfer area_2	2	IN	8	Byte(s)			8...15	
Transfer area_3	3	OUT			8	Byte(s)		12...19
Transfer area_4	4	IN	8	Byte(s)			16...23	
Transfer area_5	5	IN/OUT	12	Byte(s)	6	Byte(s)	24...35	20...25
Transfer area_6	6	RECORD_WRITE_STO	2	Byte(s)			36...37	
Transfer area_7	7	RECORD_READ_STO	5	Byte(s)	1	Byte(s)	38...42	26

Result

You have configured your I/O data and data records in the PN/PN Coupler.

5.4.3 Generating a GSD file with STEP 7 TIA Portal

Generating a GSD file for only one side

You have finished configuring your PN/PN Coupler and want to generate a GSD file for side X1 or X2.

1. Click the "Export" button in the "Export generic station description file (GSD)" field in the transfer mapping.
2. The "Export generic station description (GSD)" for X1 or X2 is offered. Enter the path and the file name.
3. Select "Export".

Result: The GSD file has been created for one PROFINET side.

Example: GSD file for X2

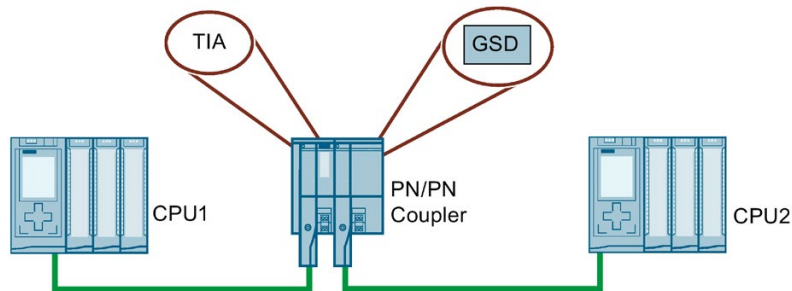

Figure 5-1 PN/PN Coupler and GSD file

Configuration

You have configured both CPU with inputs and outputs. This is how it looks in the "Module parameters/transfer mapping" table:

Table 5-4 Configuration in subnet 1 (bus side X1)

	Transfer area	Virtual slot	Type	I-length		Q-length		I-address	Q-address	Access
1	Transfer_area_1	1	IN	2	Byte(s)			13..14		CPU1
2	Transfer_area_2	2	OUT			8	Byte(s)		20...27	CPU1
3	Transfer_area_3	3	IN	8	Byte(s)			15...23		CPU1
4	Transfer_area_4	4	OUT			8	Byte(s)		28...35	CPU1

Table 5- 5 Configuration in subnet 2 (bus side X2)

Transfer area	Virtual slot	Type	I-length		Q-length		I-address	Q-address	Access
Transfer_area_1	1	OUT			2	Byte(s)		10...11	CPU2
Transfer_area_2	2	IN	8	Byte(s)			8...15		CPU2
Transfer_area_3	3	OUT			8	Byte(s)		12...19	CPU2
Transfer_area_4	4	IN	8	Byte(s)			16...23		CPU2

GSD from bus side X2

Click the "Export" button in the "Export generic station description file (GSD)" field in the transfer mapping. The "Export device description (GSD)" function is offered for X2. Enter the path and the file name. Then select "Export".

The GSD file is created for the PROFINET page X2. And you can use them, for example, for other machine manufacturers.

5.5 Configuring the PN/PN Coupler with a different configuration tool

Introduction

You configure the PN/PN Coupler using a GSD file. You integrate the PN/PN Coupler as an IO device in your configuration tool using this file. The GSD files can be downloaded on the Internet (<https://support.automation.siemens.com/WW/view/en/23742537>).

GSD file

The following GSD file is available for the PN/PN Coupler:

GSDML-V2.34-Siemens-PNPNIOC-"Date in format yyyyymmdd".xml

You can find more information on the procedure with GSD files in the STEP 7 online help.

Configuring the PN/PN Coupler

You configure the PN/PN Coupler with your configuration tool like any other IO device on PROFINET IO.

Download the complete GSD file for the PN/PN Coupler to your configuration tool. You configure the PN/PN Coupler separately in each of the two subnets. Select the IO device labeled with X1 or X2 in each case.

Note the following when assigning the device name for the PN/PN Coupler: The device name must be unique on the Ethernet subnet. The device name must comply with the DNS conventions.

When configuring using a GSD file, various modules are available for the data record transfer, each of which has a fixed length. Support for configuring the coupling of the two subnets (as is available in STEP 7) is not possible when configuring using a GSD file. Note the permitted assignment of modules (see Assignment of the modules (Page 38)).

IO modules in two versions

The GSD offers IO modules in two versions:

- IO Modules (recommended)

The validity of the coupled user data is displayed in the input data due to the included data status byte (DS).

- IO Modules (ext. comp. V3.x)

In this operating mode, monitoring of the user data validity is ensured by the PROFINET system by transfer and coupling of the user data flags IOxS. To do so, the information for evaluation of user data validity is provided by the organization blocks (error OB 85 or 122) in the SIMATIC CPU. You check the availability of the submodules first after the device has returned in OB86. For submodules that do not become available until after the device has returned (e.g. by including a submodule in the same slot on the other bus side), the PN/PN Coupler sends a ReturnOfSubmodule alarm to the controller that results in a OB83 call within a SIMATIC CPU. In operating mode IO Modules (ext. comp. V3.x), the PN/PN Coupler is compatible with the PN/PN Coupler V3.0.

In operating mode IO Modules (ext. comp. V3.x), the PN/PN Coupler is compatible with the PN/PN Coupler V3.x.

Note

IO Modules are not compatible with IO Modules (ext. comp. V3.x)

It is not permitted to mix operating modes on the local or the partner interface.

This must also be ensured when using the PN/PN Coupler as PROFINET shared device with multiple controllers.

5.6 Parameters

Table 5- 6 Parameters for the PN/PN Coupler

Parameter	Range of values	Default setting
Voltage check PS1	deactivated/activated	deactivated
Voltage check PS2	deactivated/activated	deactivated
Diagnostics Undervoltage	deactivated/activated	deactivated
Data validity display DIA	deactivated/activated	deactivated
Diagnostics for data validity	deactivated/activated	activated
Diagnostics for error in other network	deactivated/activated	activated
Diagnostics for difference in network configuration	deactivated/activated	activated

You can assign the parameters separately for the two sides of the PN/PN Coupler.

STEP 7 generates interrupts (e.g. when monitoring a power supply) separately for each side.

Voltage check PS1 / PS2

If you have enabled the voltage check PS1 / PS2, the PN/PN Coupler diagnoses the failure of the power supply on the two bus sides independent of one another. Only activate the voltage check if the corresponding power supply is actually connected.

Diagnostics Undervoltage

An undervoltage diagnostics is triggered when the supply voltage drops below 19.2 V.

Once the supply voltage exceeds 20.4 V again, an undervoltage diagnostics is no longer shown.

If the voltage falls below the lower voltage limit at only one of the two feeds, the diagnostics is not yet triggered, because measurements are taken at the common internal voltage supply (see Block diagram (Page 35)).

The undervoltage diagnostics is supported from hardware function status FS04 according to the above description and is displayed as a maintenance interrupt after being enabled via the module parameters (Interrupts (Page 94)).

Data validity display DIA

You use the data validity display DIA to determine whether or not the IO controller connected via the PN/PN Coupler still supplies valid data from the "other" subnet.

Only activate the data validity display DIA if you have configured inputs on the relevant side of the PN/PN Coupler. Modules for the data record transfer are not taken into consideration for this.

The validity of the data is always displayed in bit 0 of the least significant input byte of the PN/PN Coupler: The least significant input byte is the lowest slot number of the first input module.

5.6 Parameters

Bit 0 = 1: received data are valid.
Bit 0 = 0: received data are invalid.
Possible causes:

- An interface of the PN/PN Coupler is faulty
- The PN/PN Coupler in the other subnet has failed
- The PN/PN Coupler in the other subnet is in STOP state.



CAUTION

Incorrect program interpretation

If you have activated the "Data validity display DIA", you must not use the first bit of the first configured input byte for input data or the associated first bit of the first configured output byte in the other subnet for output data!

Diagnostics for data validity

You use the diagnostics for data validity to determine if the IO controller of the other subnet is in STOP state. The online diagnostics indicates "Data invalid" for the respective slot.

This diagnostic message is selected by default and can be disabled for each interface separately.

Diagnostics for error in other network

You use the diagnostics for error in other network to determine that the other bus side has no configuration data.

This diagnostic message is selected by default and can be disabled for each interface separately.

Diagnostics for difference in network configuration

With the diagnostics for difference in network configuration, the PN/PN Coupler outputs a diagnostics interrupt indicating an invalid mapping for the two bus sites.

This diagnostic message is selected by default and can be disabled for each interface separately.

Reference

You can find additional information in section "Diagnostics for Shared Device".

5.7 Commissioning the PN/PN coupler

Requirements

The following requirements must be met before commissioning the PN/PN Coupler:

- You have completely configured and connected the PN/PN Coupler as described in sections Assembling (Page 23) and Connecting (Page 28).
- You have completely set up both PROFINET IO subnets. PROFINET IO is ready for operation.
- You have configured the PN/PN Coupler.
- You have assigned the PN/PN Coupler parameters.

Commissioning the PN/PN Coupler

1. Switch on the power supply for the PN/PN Coupler.
2. Assign a device name to the PN/PN Coupler for each subnet.
3. Download the configuration to the target system.

5.8 Identification data

Definition

Identification data is data that is stored in a module that supports you in:

- Checking the system configuration
- Locating hardware changes in a system
- Troubleshooting in a system

You can unambiguously identify and localize modules online with the identification data.

In STEP 7 TIA Portal, the identification data is displayed on the "Module status - PN/PN Coupler" and "Properties - PN/PN Coupler" tabs (see STEP 7 online help).

Reading the identification data

Each of the two bus sides of the PN/PN Coupler has its own memory area for identification data. You can enter and read out the identification data separately for each of the two bus sides (except I&M0).

You selectively access certain identification data using **Read data record**. Under the associated data record index you obtain the corresponding part of the identification data.

5.8 Identification data

The data records are structured according to the following principle:

Table 5- 7 Basic structure of data records with identification data

Content	Length (bytes)	Coding (hex)
Header information		
BlockType	2	I&M0: 0020 I&M1: 0021 I&M2: 0022 I&M3: 0023
BlockLength	2	I&M0: 0038 I&M1: 0038 I&M2: 0012 I&M3: 0038
BlockVersionHigh	1	01
BlockVersionLow	1	00
Identification data		
Identification data (see table below)	I&M0: 54 I&M1: 54 I&M2: 16 I&M3: 54	

The data structures in the data records correspond to the specifications of PROFINET IO.

Table 5- 8 Identification data

Identification data	Access	Default setting	Explanation
Identification data 0: (data record index AFF0 hex)			
VendorIDHigh	Read (1 byte)	00 hex	Name of the manufacturer: 42 dec = SIEMENS AG
VendorIDLow	Read (1 byte)	2A hex	
Order_ID	Read (20 bytes)	6ES7158-3AD10-0XA0	Article number of the module
IM_SERIAL_NUMBER	Read (16 bytes)		Serial number (device-specific)
IM_HARDWARE_REVISION	Read (2 bytes)	1	Corresponding Hardware version
IM_SOFTWARE_REVISION	Read	Firmware version	Firmware version of the module
• SWRevisionPrefix	(1 byte)	V, R, P, U, T	
• IM_SWRevision_Functional_Enhancement	(1 byte)	01 - FF hex	
• IM_SWRevision_Bug_Fix	(1 byte)	00 - FF hex	
• IM_SWRevision_Internal_Change	(1 byte)	00 - FF hex	
IM_REVISION_COUNTER	Read (2 bytes)	-	Configured changes on the module
IM_PROFILE_ID	Read (2 bytes)	0000	Generic Device
IM_PROFILE_SPECIFIC_TYPE	Read (2 bytes)	0005 hex	On interface modules
IM_VERSION	Read	0101 hex	Version of the identification data (0101 hex = Version 1.1)
• IM_Version_Major	(1 byte)		
• IM_Version_Minor	(1 byte)		
IM_SUPPORTED	Read (2 bytes)	000E hex	Available identification data (I&M1 to I&M3)
Maintenance data 1: (data record index AFF1 hex)			
IM_TAG_FUNCTION	Read/write (32 bytes)	-	Enter an identifier for the module here, that is unique system-wide.
IM_TAG_LOCATION	Read/write (22 bytes)	-	Enter the installation location of the module here.
Maintenance data 2: (data record index AFF2 hex)			
IM_DATE	Read/write (16 bytes)	YYYY-MM-DD HH:MM	Enter the installation date of the module here.
Maintenance data 3: (data record index AFF3 hex)			
IM_DESCRIPTOR	Read/write (54 bytes)	-	Enter a comment about the module here.

Functions

6.1 Data record transfer from one IO controller to another IO controller

Introduction

The following section describe data record transfer:

- How cross-network data record transfer works
- How local data record transfer works
- The form and significance of status information for cross-network and local data record transmission

6.1.1 How cross-network data record transfer works

Introduction

The data record transfer via the PN/PN Coupler starting from article number 6ES7158-3AD10-0XA0 enables you to transfer up to 4096 bytes of data per slot acyclically from one IO controller (sender) to another IO controller (receiver).

This acyclic data record transfer enables you to exceed the cyclic I/O data transfer of 1440 bytes of inputs and 1440 bytes of outputs (in total).

The PN/PN Coupler can buffer a maximum of 8 data records per slot with the Storage module type, i.e. provide for reading.

The buffer memory operates according to the first in, first out (FIFO) principle. The module type Publisher does not buffer data records, which means the data record transferred last is overwritten.

Principle of operation

The **Storage** and **Publisher** module types are available for transferring data records. The following figure shows the sequence of the transfer of a data record from one IO controller to another:

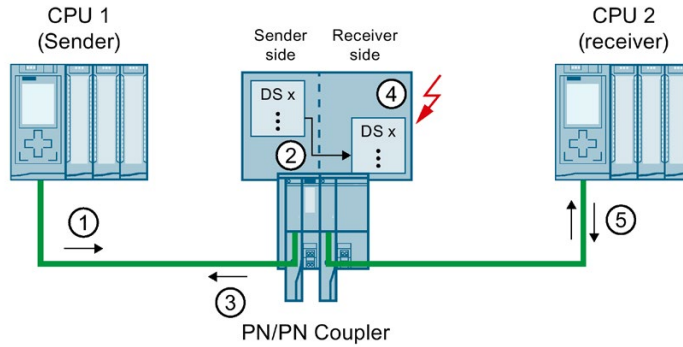

- ① IO controller 1 (sender) issues a write request to the PN/PN Coupler and transfers the data record to the PN/PN Coupler.
- ② The PN/PN Coupler transfers the data record from its sender side to its receiver side.
- ③ The PN/PN Coupler sends an acknowledgment to IO controller 1 that the data record was received.
- ④ The PN/PN Coupler indicates on its receiver side that a data record is available for reading (via status information of the PN/PN Coupler and optionally via an update interrupt in IO controller 2 (receiver)).
- ⑤ Only module type Storage: IO controller 2 (receiver) reads the status information and the data record and acknowledges the receipt.

Figure 6-1 Sequence of the data record transfer

6.1 Data record transfer from one IO controller to another IO controller

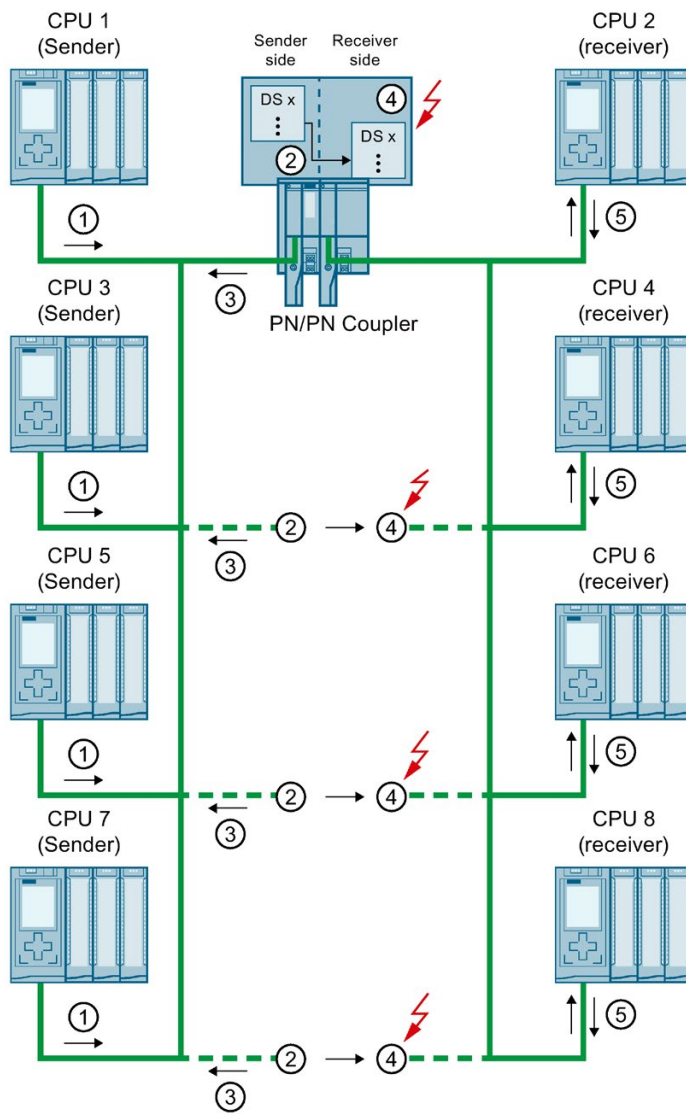

- ① IO controller (sender) issues a write request to the PN/PN Coupler and transfers the data record to the PN/PN Coupler.
- ② The PN/PN Coupler transfers the data record from its sender side to its receiver side.
- ③ The PN/PN Coupler sends an acknowledgment to IO controller (sender) that the data record was received.
- ④ The PN/PN Coupler indicates on its receiver side that a data record is available for reading (via status information of the PN/PN Coupler and optionally via an update alarm in the IO controller (receiver)).
- ⑤ Only module type Storage: IO controller (receiver) reads the status information and the data record and acknowledges the receipt.

Figure 6-2 Data transfer from IO controller to IO controller

Boundary conditions for data record transfer

- Data record transfer does not correspond to data record routing.
- The I/O data (status information) are not coupled as a mirror image.
- The data records are transferred in one direction, from the sender to the receiver.
- Both sides of the PN/PN Coupler must be exchanging data with the connected IO controllers. If one side is not exchanging data and data for reading has already been provided, this data is deleted when the side starts exchanging data. Data record transfer begins from a defined state when both sides are exchanging data with the IO controllers.

Note**Redundancy S2**

With redundancy S2, the data record transfer may have to be repeated. Not all operations for data record transfer may have been executed during switchover from the primary CPU to the backup CPU.

Data record transfer with the Storage module type

- The Storage module type can buffer a maximum of 8 data records per slot, i.e. provide for reading. The buffer memory operates according to the first in, first out (FIFO) principle.
- If the receiver has successfully read a data record, it must explicitly acknowledge this so that this data record is deleted from the buffer memory of the PN/PN Coupler, thereby allowing the next data record to be read.
- If a sender attempts to write a data record to the PN/PN Coupler even though its buffer memory is full, the data record will be rejected by the PN/PN Coupler.

Data record transfer with the Publisher module type

- The Publisher module type does not buffer data records.
- The sender writes only data records with the same "record_index". This "record_index" is set as a parameter of the module on the sender side.
- If the sender delivers the next data record, the previous data record is overwritten.
- The PN/PN Coupler indicates the existence of a new data record using a circulating counter on the receiver side.
- The receiver can read a data record as often as desired.
- If the receiver does not know the length of the data record, you must request the maximum possible length of 4096 bytes in the read request to ensure that the entire data record is read.

6.1 Data record transfer from one IO controller to another IO controller

Configuring for the data record transfer

For the data record transfer, you configure a virtual module on both sides of the PN/PN Coupler (X1 and X2).

- Module type **Storage**: "RD WRITE STO" on the sender side and "RD READ STO" on the receiver side.
- Module type **Publisher**: "RD WRITE PUB" on the sender side and "RD READ PUB" on the receiver side.

Maximum number of sender and receiver modules

You can configure a maximum of 16 "RD WRITE STO", "RD READ STO", "RD WRITE PUB" and "RD READ PUB" modules for each interface of the PN/PN Coupler (max. data record length of 4096 bytes per module).

6.1.2 How local data record transfer works

Introduction

The local data set transmission via the PN/PN Coupler with article number 6ES7158-3AD10-0XA0 is possible as of firmware version V4.2.

Local data set transfer via the PN/PN Coupler allows you to send up to 4096 bytes of data per slot acyclically from one IO controller (sender) to up to 3 IO controllers (receiver) on the same side.

This acyclic data record transfer enables you to exceed the cyclic I/O data transfer of 1440 bytes of inputs and 1440 bytes of outputs (in total).

The PN/PN Coupler can buffer a maximum of 8 data records per slot with the Storage module type, i.e. provide for reading.

The buffer memory operates according to the FIFO (first in - first out) principle. The Publisher module type does not buffer data records. A data record in the PN/PN Coupler is always updated. This means that the last data record transferred is updated when it is written again.

Principle of operation

The module types **Storage** (RD LOCAL STO) and **Publisher** (RD LOCAL PUB) are available for this transfer.

The following figure shows the transfer of a data record from one IO controller to the 3 other IO controllers.

6.1 Data record transfer from one IO controller to another IO controller

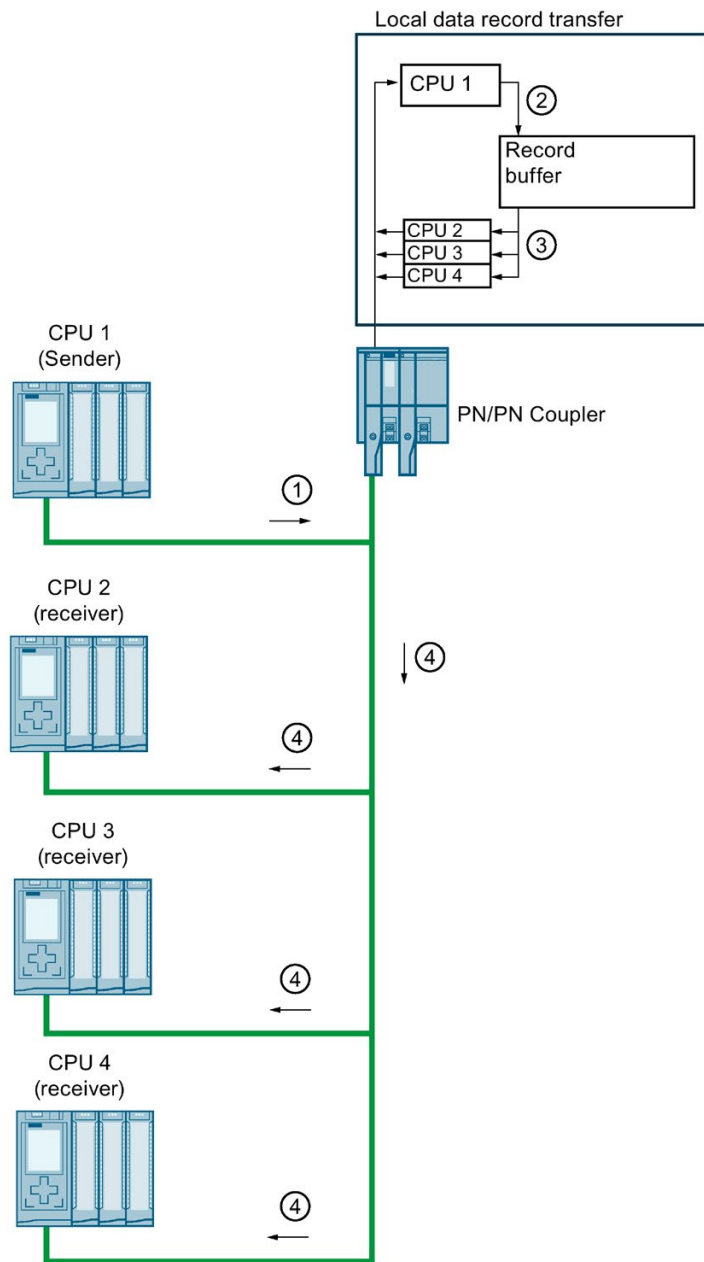

- ① CPU 1 (sender) submits a send request to the PN/PN Coupler and transfers the local data record to the PN/PN Coupler.
- ② The PN/PN Coupler saves the local data record in the record buffer.
- ③ RD LOCAL STO or RD LOCAL PUB can be used to read from the record buffer in the subslots of CPUs 2 to 4.
- ④ The local data record is read.

Figure 6-3 How local data record transfer works

6.1 Data record transfer from one IO controller to another IO controller

Constraints on local data record transmission

- Data record transfer does not correspond to data record routing.
- The I/O data (status information) are not coupled as a mirror image.
- The data records are transferred in one direction, from the sender to the receiver.
- One side of the PN/PN Coupler must be exchanging data with the connected IO controllers. If one side is not exchanging data and data for reading has already been provided, this data is deleted when the side starts exchanging data. Data record transfer begins from a defined state when both sides are exchanging data with the IO controllers.

Data record transfer with the Local Storage module type

- The Local Storage module type can buffer a maximum of 8 data records, i.e. provide for reading. The buffer memory operates according to the first in, first out (FIFO) principle.
- If all receivers have successfully read a data record, they must explicitly acknowledge this so that this data record is deleted from the buffer memory of the PN/PN Coupler, thereby allowing the next data record to be read.
- If a sender attempts to write a data record to the PN/PN Coupler even though its buffer memory is full, the data record will be rejected by the PN/PN Coupler.

Data record transfer with the Local Publisher module type

- The Local Publisher module type does not buffer data records.
- The sender writes only data records with the same "record_index". This "record_index" is set as a parameter of the module on the sender side for all receivers.
- If the sender delivers the next data record, the previous data record is overwritten.
- The PN/PN Coupler indicates the existence of a new data record using a circulating counter ("cycle_counter") on the receiver side.
- The receiver can read a data record as often as desired.
- If the receiver does not know the length of the data record, you must request the maximum possible length of 4096 bytes in the read request to ensure that the entire data record is read.

Configuration for local data record transfer

For the data record transfer, you configure a virtual module on one side of the PN/PN Coupler (X1 or X2).

- Sender: **Storage** module type: "RD LOCAL STO"
- Receiver: **Publisher** module type: "RD LOCAL PUB"

Maximum number of sender and receiver modules

- You can configure a maximum of 16 "RD LOCAL STO" and "RD LOCAL PUB" modules for each interface of the PN/PN Coupler (max. data record length of 4096 bytes per module).
- For each "RD LOCAL STO" module, you can
 - for the sender: Configure 1 submodule LOCAL RD WRITE STO and
 - as receiver: Configure up to 3 LOCAL RD READ STO submodules.
- For each "RD LOCAL PUB" module, you can
 - for the sender: Configure 1 submodule LOCAL RD WRITE PUB and
 - as receiver: Configure up to 3 LOCAL RD READ PUB submodules.

6.1.3 Structure and meaning of status information for the data record transfer

Structure and meaning of status information for the data record transfer in the PN/PN Coupler

The form and meaning of the status information for data record transfer in the PN/PN Coupler are identical for

- cross-network data record transfer and
- local data record transfer.

Table 6- 1 Status information for the data record transfer - Storage module type

Assigned I/O areas	Description	Function
Sender module RD WRITE STO and LOCAL RD WRITE STO		
IB x	provider_status	Bit 0 = 1 Communication with the other bus side is established and module "RD READSTO" has been configured on the other bus side.
	fifo_not_full	Bit 1 = 1 Query the "level_counter": Maximum value of 8 data records was not reached.
	-	Bit 2..6 = 0 reserved
	write_accept	Bit 7 = 1 Enable of the data record transfer in the PN/PN Coupler (= group enable; combines information from bit 0 and bit 1).
IB x+1	level_counter	per module: Indicates the fill level of the buffer (maximum of 8 data records)
Receiver module RD READ STO and LOCAL RD READ STO		
IW x	record_index	Display of the data record number of the data record that can be read on the receiver side.
IW x+2	record_length	Length of the data record that can be read on the receiver side.
IB x+4	cycle_counter	Each change in the value (incremental) means that a new data record can be read on the receiver side.
QB x	ack_counter	An acknowledgment for the reading of the data record by the receiver is made by writing the ack_counter output with the value of the cycle_counter input. The data record is then deleted from the buffer.

Note

Writing data records with RD WRITE STO and LOCAL RD WRITE STO

You can write data records with a data record number in the value range from 2 to 0x7FFF.

Structure and meaning of status information for the data record transfer in the PN/PN Coupler

Table 6- 2 Status information for the data record transfer - Publisher module type

Assigned I/O areas	Description	Function
Sender module RD WRITE PUB and LOCAL RD WRITE PUB		
IB x	provider_status	Bit 0 = 1 Communication with the other bus side is established and the "RD READ PUB" and "LOCAL RD READ PUB" modules have been configured on the other bus side.
Receiver module RD READ PUB and LOCAL RD READ PUB		
IW x	record_index	Display of the data record number of the data record that can be read on the receiver side.
EB x+2	cycle_counter	Each change in the value (incremental) means that a new data record can be read on the receiver side.

Note

Writing data records with RD WRITE PUB and LOCAL RD WRITE PUB

You can only write data records with the data record number specified as a parameter in advance in the hardware configuration. Setting range: 2 (default setting) to 0x7FFF.

Update interrupt (OB 56)

You can optionally enable an update interrupt in the configuration of the "RD READ STO"/"LOCAL RD READ STO" or "RD READ PUB"/"LOCAL RD READ PUB" module, that signals the receiver that a new data record is ready for reading in the buffer of the PN/PN Coupler. The update interrupt is disabled by default. A new update interrupt can only be issued when the preceding interrupt has been acknowledged in the user program.

Note

For the Publisher module type, the sender can overwrite the previous data record as often as desired. As a result, it is not guaranteed that the receiver receives an update interrupt for each new data record.

The update interrupt has interrupt type 6. The update interrupt uses the optional structure element AlarmItem, which consists of:

Data	Storage module type	Publisher module type
Unsigned16	UserStructurIdentifier 0x0050	
Unsigned16	RecordIndex	
Unsigned32	RecordDataLength	0x00000000 (Reserved)

6.1.4 Local data record transfer as an example

Interface local data record transfer

In this example, the data is transferred from one controller to 3 other controllers via the PROFINET interface X1 with local data record transfer.

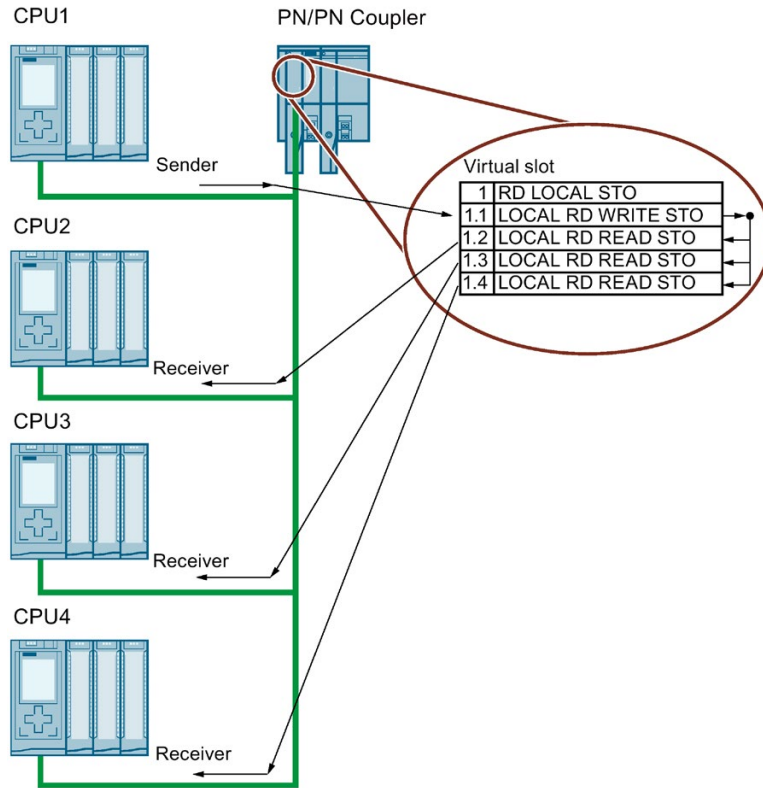

Figure 6-4 Local data record transfer as an example

Configuration

Table 6- 3 Configuration for the PROFINET interface X1

PROFINET interface (X1)						
Virtual slot	Type	I-length		Q-length		Access
1	RD LOCAL STO		-		-	-
1.1	LOCAL RD WRITE STO	2	Byte		-	CPU 1
1.2	LOCAL RD READ STO	5	Byte	1	Byte	CPU 2
1.3	LOCAL RD READ STO	5	Byte	1	Byte	CPU 3
1.4	LOCAL RD READ STO	5	Byte	1	Byte	CPU 4

Editing in the user program

CPU 1 writes data records to the LOCAL RD WRITE STO submodule in the virtual slot 1.1. These data are available to the controllers CPU 2 to CPU 4 with the submodules LOCAL RD READ STO.

You can also use local data record transfer:

- With fewer controllers
- When configuring additional modules in other slots

When the RD LOCAL STO module is used, data records are cached in the buffer and all CPUs read by LOCAL RD READ STO must acknowledge a data record by writing the "ack_counter". Only then is the next data record available for reading.

You can also implement this example with RD LOCAL PUB. In this case, individual non-reading CPUs from LOCAL RD READ PUB do not block the data record transfer to other LOCAL RD READ PUB of the same module.

6.2 PROFINET IO functions

6.2.1 Device replacement

Device replacement without topology configuration

The device name is also automatically permanently stored on the SIMATIC BusAdapter in addition to the PN/PN Coupler. A device name stored in the BusAdapter is required for device replacement without topology configuration.

Storing the name on the BusAdapter and the PN/PN Coupler produces a range of scenarios for using the device name when the PN/PN Coupler is replaced.

Table 6- 4 Scenarios for using the device name

	PN/PN Coupler without a device name	PN/PN Coupler with a device name
BusAdapter without a device name	No device name available	The device name from the PN/PN Coupler is used and copied to the BusAdapter.
BusAdapter with device name	The device name from the BusAdapter is used and copied to the PN/PN Coupler.	The device name from the BusAdapter is used and copied to the PN/PN Coupler if the device names are different

Note the following constraints:

- Resetting to factory settings deletes the device name in both the PN/PN Coupler and the BusAdapter. To prevent the device name from being deleted in the BusAdapter, you can remove the BusAdapter from the PN/PN Coupler before resetting to factory settings.
- When a BusAdapter is replaced, a device name stored in the BusAdapter is applied in the PN/PN Coupler after a POWER ON.
- Removal/insertion of the BusAdapter under voltage is not permitted. If you nevertheless remove or insert the BusAdapter under voltage, the PN/PN Coupler restarts.

Device replacement with topology configuration

IO devices with this function can be replaced in a simple manner. The device name does not have to be assigned with the PG/PC.

The replacement IO device is assigned the device name by the IO controller and not by the PG/PC. The IO controller uses the configured topology and the neighborhood relationships determined by the IO devices for this purpose. All involved devices must support the LLDP protocol (Link Layer Discovery Protocol). The configured topology must match the actual topology.

IO devices that were already used in another configuration must be reset to factory settings before being reused.

You can find more information:

- In the STEP 7 online help
- as of STEP 7 V14, in the SIMATIC PROFINET Function Manual (<https://support.industry.siemens.com/cs/ww/en/view/49948856>).

6.2.2 Isochronous real-time communication

Isochronous real-time communication

Synchronized transmission method for the cyclic exchange of IRT data between PROFINET devices. A reserved bandwidth within the send clock is available for IRT data. The reserved bandwidth ensures that the IRT data can be transmitted in time-synchronized intervals, unaffected by other high network loading (e.g. TCP/IP communication or additional real time communication).

A topology configuration is required for IRT.

Note

IO controller as sync master with IRT communication

Operation of the IO controller as a sync master is recommended when configuring the IRT communication.

Otherwise, IO devices with IRT and RT configuration could fail as a result of sync master failure.

You can find more information on configuring synchronized PROFINET devices in sync domains:

- In the STEP 7 online help
- as of STEP 7 V14, in the SIMATIC PROFINET Function Manual (<https://support.industry.siemens.com/cs/ww/en/view/49948856>).

6.2.3 Prioritized startup

Prioritized startup

Prioritized startup is the PROFINET IO functionality for accelerating the startup of IO devices in a PROFINET IO system with IRT and RT communication.

The function reduces the time needed for correspondingly configured IO devices to return to cyclic user data exchange in the following cases:

- After recovery of supply voltage
- After station recovery
- After activation of IO devices

Note

Dependency of the startup time

The PN/PN Coupler enables startup times starting from 750 ms.

You can find more information:

- in the online help for STEP 7 and
- as of STEP 7 V14, in the SIMATIC PROFINET Function Manual (<https://support.industry.siemens.com/cs/ww/en/view/49948856>).

Note

Prioritized startup and media redundancy

It is not possible to include an IO device with prioritized startup in a ring topology with media redundancy.

6.2.4 Media redundancy (MRP)

Media redundancy (MRP)

Function for safeguarding communication and system availability. A ring topology ensures that an alternative communication path is made available if a transmission route fails.

You can find more information:

- In the STEP 7 online help
- as of STEP 7 V14, in the SIMATIC PROFINET Function Manual (<https://support.industry.siemens.com/cs/ww/en/view/49948856>).

Note

Prioritized startup and media redundancy

It is not possible to include an IO device with prioritized startup in a ring topology with media redundancy.

6.2.5 Shared Device

Shared Device

IO device that makes its data available to up to four IO controllers.

The PN/PN Coupler supports Shared Device at submodule level.

If the **engineering system does not perform a plausibility check of shared device projects**, note the following:

- Ensure the consistency of the configurations. In particular, each module or submodule may only be assigned to one IO controller. Multiple assignment will result in an error. The module or submodule will only be available in the first IO controller.
- If you reconfigure Shared Device configurations without the validity check mentioned above, you must commission the PN/PN Coupler again. This means you must download the projects of all involved IO controllers to the respective CPU again after reconfiguration and, if necessary, perform a POWER OFF/POWER ON of the PN/PN Coupler.

You can find more information:

- In the STEP 7 online help
- as of STEP 7 V14, in the SIMATIC PROFINET Function Manual (<https://support.industry.siemens.com/cs/ww/en/view/49948856>).

Note

For a Shared Device application, ensure that all IO controllers work with the same send clock. If IO controllers do not have the same send clock, the different send clock can result in communication relationships not being set up.

If you set up all IO controllers in one project, the same send clock is ensured. Set the same send clock when engineering in separate projects.

Module-internal Shared Input/Shared Output (MSI/MSO)

The module-internal Shared Input function enables an input module to make its input data available to up to four IO controllers. Each IO controller has read access to the same channels.

The module-internal Shared Output function enables an output module to be operated by up to four IO controllers. One IO controller has write access. Up to three additional IO controllers can have read access to the same channels.

You can find more information:

- In the STEP 7 online help
- as of STEP 7 V14, in the SIMATIC PROFINET Function Manual (<https://support.industry.siemens.com/cs/ww/en/view/49948856>).

PN/PN Coupler as a shared device

When configuring the PN/PN Coupler as a Shared Device, the following conditions apply:

- You can assign a slot to only one IO controller (no Shared Input).
- Slots of one IO device must be assigned one-to-one to the other IO device (couple partner) (e.g. slot 3 on left bus side = slot 3 on right bus side).
- The slots of an IO device can be assigned to an IO controller as desired. An associated slot area is not required.
- You can configure up to four IO controllers on both bus sides.

Example of communication relationship for a shared device

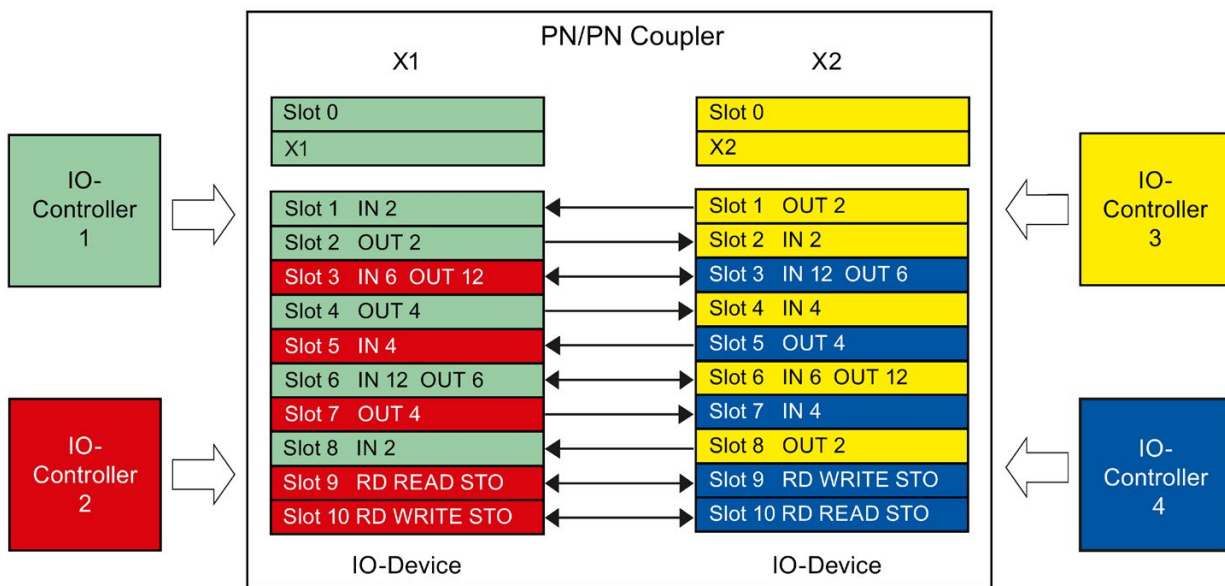

Figure 6-5 Example of communication relationship for a shared device

Example of asymmetric communication relationship for a shared device

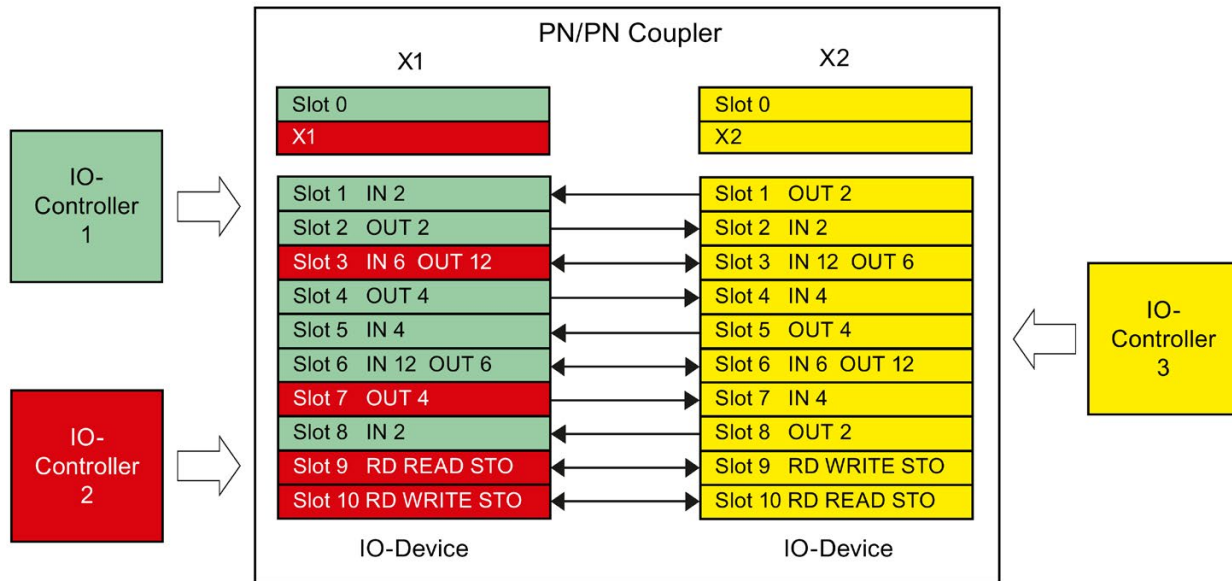

Figure 6-6 Example of asymmetric communication relationship for a shared device

Further information

You can find more information on this topic in the STEP 7 online help.

You can find additional examples in the section Shared input/shared output as communication functions (Page 73).

6.2.6 Media Redundancy with Planned Duplication (MRPD)

Media Redundancy with Planned Duplication (MRPD)

If your goal is to have media redundancy and short update times (together with IRT), use "Media Redundancy with Planned Duplication (MRPD)".

You can find more information

- In the STEP 7 online help
- as of STEP 7 V14, in the SIMATIC PROFINET Function Manual (<https://support.industry.siemens.com/cs/ww/en/view/49948856>).

6.2.7 Docking station

PN/PN Coupler as docking station and docking unit

The PN/PN Coupler is available as a docking station and also as a docking unit.

The following figure shows an automation cell with a PN/PN Coupler as a docking station and several docking units.

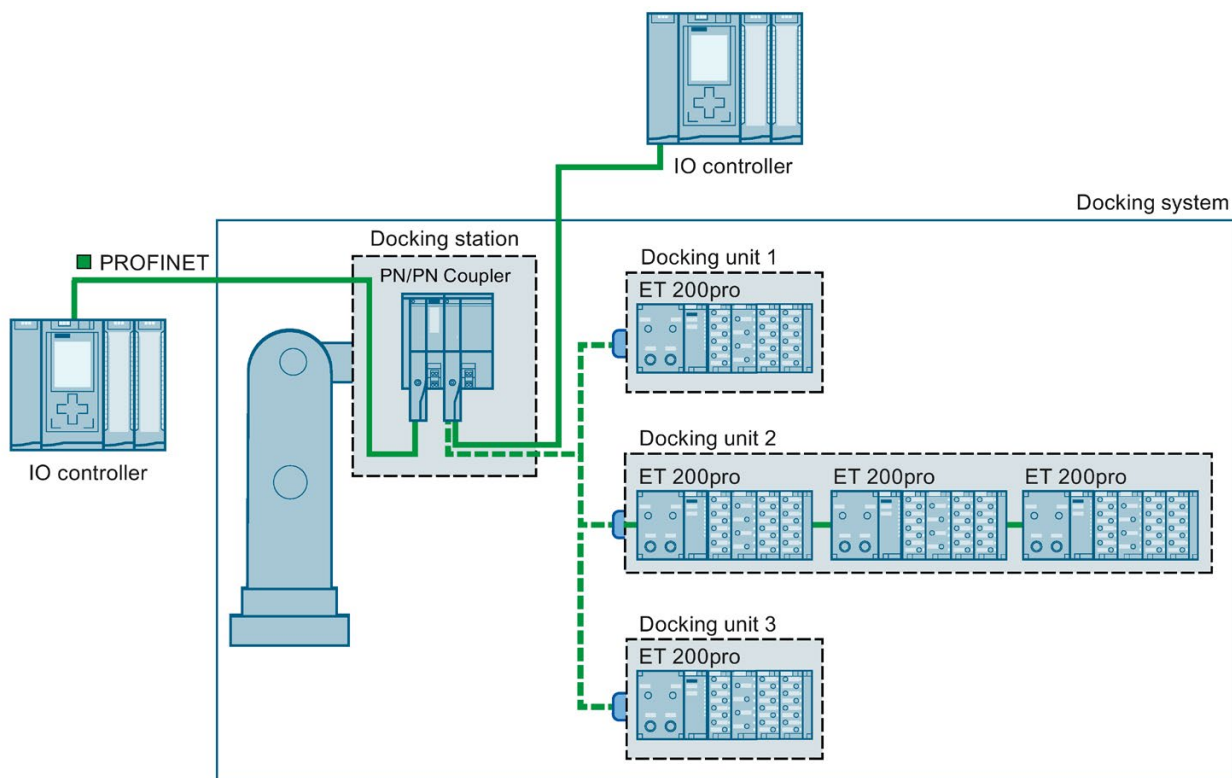

Figure 6-7 PN/PN Coupler as docking station

The following figure shows an automation cell with an PN/PN Coupler as a docking unit.

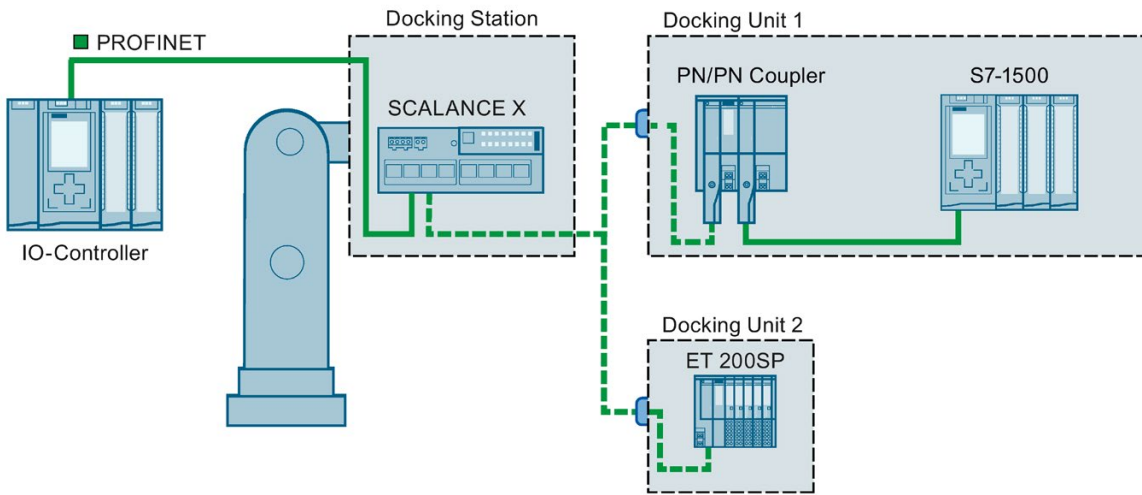

Figure 6-8 PN/PN Coupler as docking unit

Requirements

You need to be aware of the following points:

- The IO devices of all docking units must be deactivated as default in the configuration.
- Only one docking unit can be active at any one time.

Reaction time with PROFINET IO

You use the PN/PN Coupler as a docking unit. In this function you must note the different startup times of the respective interfaces of the PN/PN Coupler:

Startup times of up to

- Side X1: 650 ms
- Side X2: 750 ms can be reached.

Area of application

You can use the PROFINET "Tool Changer" functionality, for example, for tool changing in robots. Typical tools include:

- Welding guns
- Positioning tools for manufacturing parts

See also

See also in STEP 7 online help.

6.3 Shared Input/Shared Output as communication functions

6.3.1 Interface local distribution of IO data

Module-internal Shared Output is transferred to other controllers

In this example, the output data of one controller are transferred to the inputs of other controllers of the same PROFINET interface X1 over MSO Local.

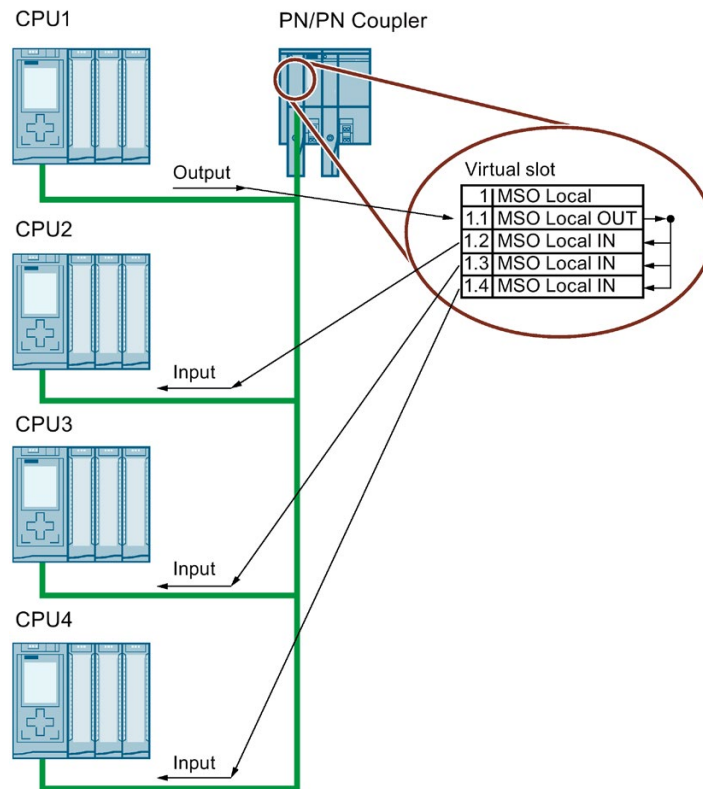

Figure 6-9 IO data are transferred to other controllers on bus side X1

Configuration

Table 6- 5 Configuration for the PROFINET interface X1

PROFINET interface (X1)				
Virtual slot	Type	I-length	Q-length	Access
1	MSO Local	-	-	-
1.1	MSO Local OUT	-	4 bytes	CPU 1
1.2	MSO Local IN	5 bytes incl. 1 byte DS	-	CPU 2
1.3	MSO Local IN	5 bytes incl. 1 byte DS	-	CPU 3
1.4	MSO Local IN	5 bytes incl. 1 byte DS	-	CPU 4

No configuration is required for network side 2.

Editing in the user program

CPU 1 writes IO data to the MSO Local OUT submodule with the virtual slot 1.1 of the PN/PN Coupler. The data is available to CPUs 2 to 4 for reading with the remaining MSO Local IN submodules. The PN/PN Coupler operates CPUs 1 to 4 only over one network side. The validity of the provided user data is displayed by the data status byte (DS) of the MSO Local IN submodules.

Side X2 of the PN/PN Coupler is not used in this specific example.

MSO Local modules:

- can be used with fewer controllers
- configured with other virtual submodules
- combined with other local modules on the partner side

6.3.2 Coupling across the network and interface local distribution of IO data

Module-internal Shared Output is sent and transferred

In this example, the output data of one controller at the PROFINET interface X1 are sent via MSO module

- to a controller at the PROFINET interface X2 and
- other controllers of the same PROFINET interface can receive these output data via inputs by means of the MSO IN submodules if a coupling relationship has been established over the virtual slot with subslot 1 to the partner interface.

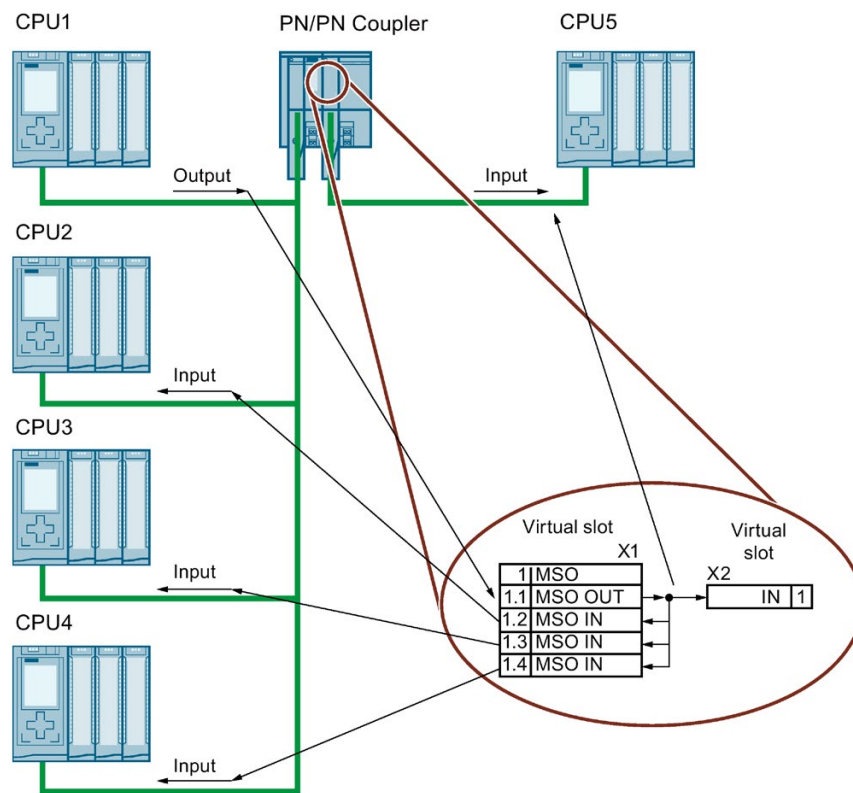

Figure 6-10 IO data are sent to the X2 side and transferred to the X1 side.

Configuration

Table 6- 6 Configuration for the PROFINET interface X1

PROFINET interface (X1)				
Virtual slot	Type	I-length	Q-length	Access
1	MSO	-	-	-
1.1	MSO OUT	-	4 bytes	CPU 1
1.2	MSO IN	5 bytes incl. 1 byte DS	-	CPU 2
1.3	MSO IN	5 bytes incl. 1 byte DS	-	CPU 3
1.4	MSO IN	5 bytes incl. 1 byte DS	-	CPU 4

Table 6- 7 Configuration for the PROFINET interface X2

PROFINET interface (X2)				
Virtual slot	Type	I-length	Q-length	Access
1	IN	5 bytes incl. 1 byte DS	-	CPU 5
2	-	-	-	-
3	-	-	-	-
4	-	-	-	-

Editing in the user program

CPU 1 writes IO data to the MSO OUT module with the virtual slot 1.1 of the PN/PN Coupler. The data is available to CPUs 2 to 4 for reading with the remaining MSO IN modules.

The PN/PN Coupler also makes the written IO data of the MSO OUT module of network side X1 available to the network side X2 by means of an IN module of the PLC 5. The validity of the provided user data on the network sides is displayed by the data status byte (DS) of the MSO Local IN and IN modules.

You can also use this example:

- with fewer controllers and
- configure it with other virtual modules.

6.3.3 Coupling across the network and distribution and interface local distribution of IO data

Module-internal Shared Output is sent and transferred to multiple controllers

In this example, the output data of one controller at the PROFINET interface X1 are transferred via MSO module

- to other controllers at the PROFINET interface X1 and
- to a controller at the PROFINET interface X2 and
- are made available to other controllers of the same PROFINET interface over the MSI IN submodules as input data if a coupling relationship has been established over the virtual slot with subplot 1 to the partner interface.

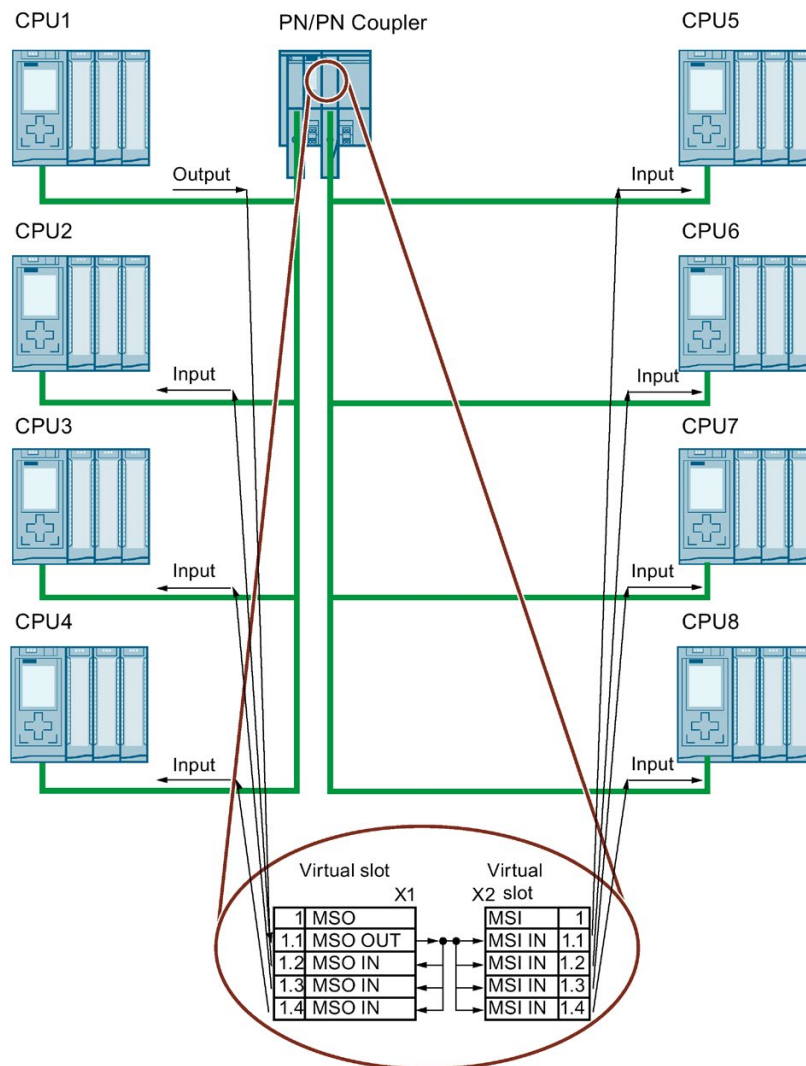

Figure 6-11 IO data are transferred to the X1 side and sent to the X2 side and transferred there

Configuration

Table 6- 8 Configuration for the PROFINET interface X1

PROFINET interface (X1)				
Virtual slot	Type	I-length	Q-length	Access
1	MSO	-	-	-
1.1	MSO OUT	-	4 bytes	CPU 1
1.2	MSO IN	5 bytes incl. 1 byte DS	-	CPU 2
1.3	MSO IN	5 bytes incl. 1 byte DS	-	CPU 3
1.4	MSO IN	5 bytes incl. 1 byte DS	-	CPU 4

Table 6- 9 Configuration for the PROFINET interface X2

PROFINET interface (X2)				
Virtual slot	Type	I-length	Q-length	Access
1	MSI	-	-	-
1.1	MSI IN	5 bytes incl. 1 byte DS	-	CPU 5
1.2	MSI IN	5 bytes incl. 1 byte DS	-	CPU 6
1.3	MSI IN	5 bytes incl. 1 byte DS	-	CPU 7
1.4	MSI IN	5 bytes incl. 1 byte DS	-	CPU 8

Editing in the user program

CPU 1 writes IO data to the MSO OUT submodule with the virtual slot 1.1 of the PN/PN Coupler. The data is available to CPUs 2 to 4 for reading with the remaining MSO IN submodules.

The PN/PN Coupler also makes the written output data available on the network side X2 to CPUs 5 to 8 through multiple MSI IN submodules. The validity of the transferred user data on the network sides is displayed by the data status byte (DS) of the MSO OUT and MSI IN submodules.

You can also use this example:

- with fewer controllers and
- configure it with other virtual modules.

Note

Data status byte (DS)

In operating mode "IO Modules (ext. comp. V3.x)" the data status byte (DS) is not available. The data validity of the transferred user data is then signaled by the user data flags coupled between the two networks sides of the PROFINET system.

6.4 System redundancy S2

6.4.1 Field of application

Requirements

- PN/PN Coupler firmware version V4.2 or higher
- Using a high availability system with, for example, S7-1500H controllers is required for the implementation of system-redundant subnets. The system consists of two high-availability controllers (lead and redundant CPU). The IO devices used in the subnet connected with system redundancy must also support system redundancy.

Note

Compatibility

The compatibility with older firmware versions is not guaranteed.

Advantages of high-availability automation systems

- Optimization of failure, functional and operational safety
- Avoidance of expensive downtime and restart time
- Increased productivity

Field of application

You can connect redundantly-configured subnets to each other via PN/PN Coupler. You can also connect a subnet with system redundancy and a subnet without system redundancy.

The maximum size of the transferable input and output data in system-redundant mode is

- 1000 bytes of inputs and 1000 bytes of outputs with system redundancy S2 (2 AR with primary CPU and backup CPU)

The following examples illustrate how you can configure close to the maximum amount of input and output data:

- CPU 1 with system redundancy S2: 1000 inputs and 1000 outputs
- CPU 2 with system redundancy S2: 1000 inputs and 1000 outputs
- CPU 3 with system redundancy S2: 1000 inputs and 1000 outputs
- CPU 4 with system redundancy S2: 1000 inputs and 1000 outputs

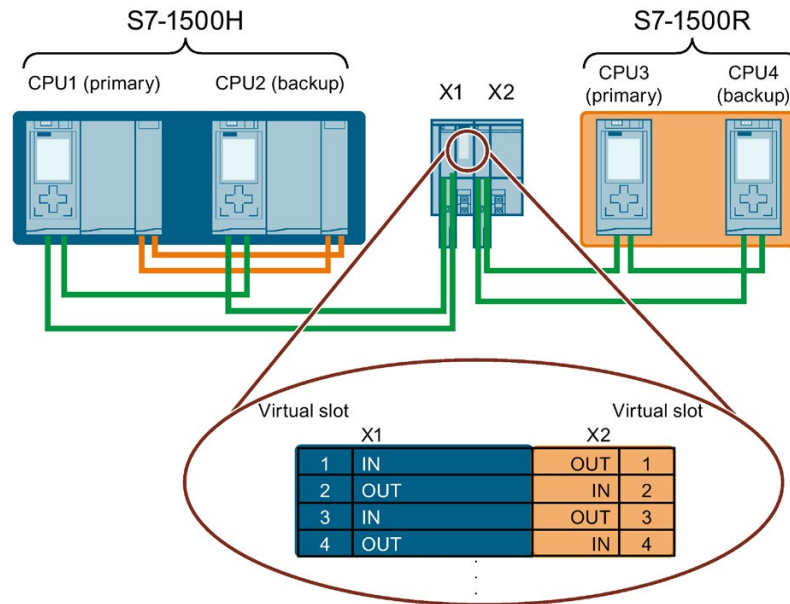

Figure 6-12 Two-sided system redundancy with S7-1500H and S7-1500R

PROFINET interface (X1)				
Virtual slot	Type	I-length ¹	Q-length	Access ²
1	IN	244 bytes	-	Primary CPU 1
2	OUT	-	244 bytes	Primary CPU 1
3	IN	244 bytes	-	Primary CPU 1
4	OUT	-	244 bytes	Primary CPU 1
5	IN	250 bytes	-	Primary CPU 1
6	OUT	-	250 bytes	Primary CPU 1
7	IN	250 bytes	-	Primary CPU 1
8	OUT	-	250 bytes	Primary CPU 1

¹ Length of the user data including data status and without user data qualifier

² As with the configuration, only the primary CPU is shown but the backup CPU is working with the same values in the background

PROFINET interface (X2)				
Virtual slot	Type	I-length ¹	Q-length	Access ²
1	OUT	-	244 bytes	Primary CPU 3
2	IN	244 bytes	-	Primary CPU 3
3	OUT	-	244 bytes	Primary CPU 3
4	IN	244 bytes	-	Primary CPU 3
5	OUT	-	250 bytes	Primary CPU 3
6	IN	250 bytes	-	Primary CPU 3
7	OUT	-	250 bytes	Primary CPU 3
8	IN	250 bytes	-	Primary CPU 3

¹ Length of the user data including data status and without user data qualifier

² As with the configuration, only the primary CPU is shown but the backup CPU is working with the same values in the background

- 1440 bytes of input data and 1440 bytes of output data with system redundancy S2 and Shared Device (only for S7-400H)

6.4 System redundancy S2

The following examples illustrate how you can configure close to the maximum amount of input and output data with a shared device:

- CPU 1 with system redundancy S2: 500 inputs and 500 outputs
- CPU 2 with system redundancy S2: 500 inputs and 500 outputs
- CPU 3: 300 inputs and 300 outputs
- CPU 4: 140 inputs and 140 outputs
- CPU 5 with system redundancy S2: 500 inputs and 500 outputs
- CPU 6 with system redundancy S2: 500 inputs and 500 outputs

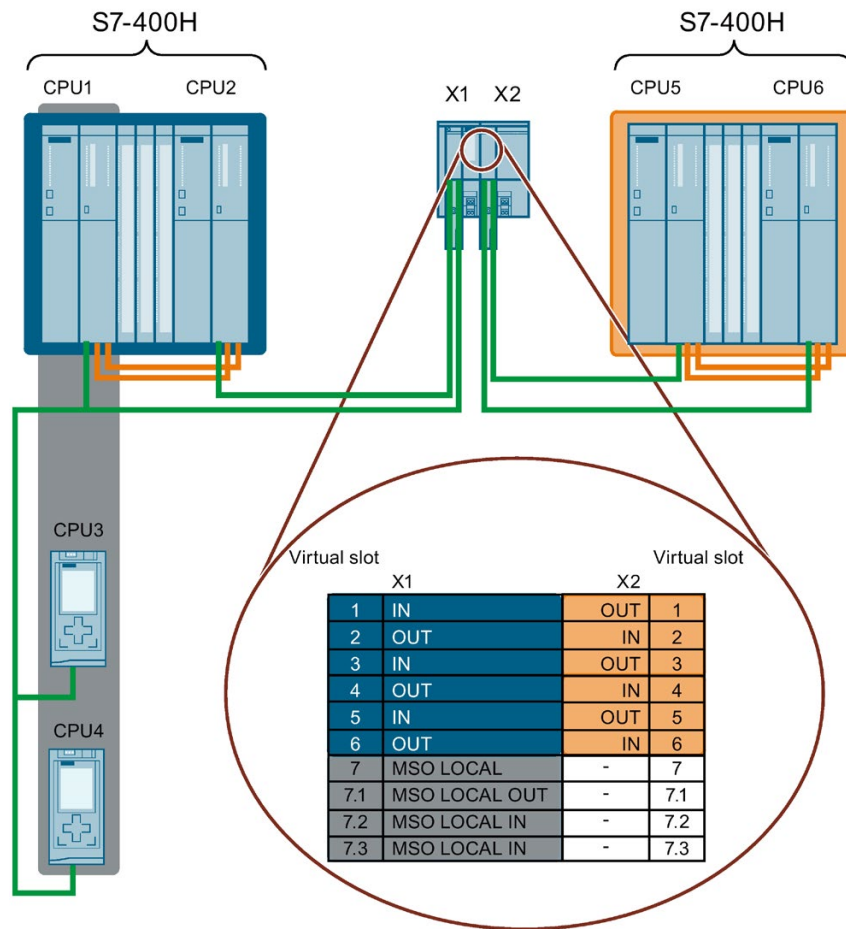

Figure 6-13 System redundancy with S7-400H and MSI/MSO

PROFINET interface (X1)				
Virtual slot	Type	I-length ¹	Q-length	Access ²
1	IN	215 bytes	-	CPU 1
2	OUT	-	215 bytes	CPU 1
3	IN	250 bytes	-	CPU 1
4	OUT	-	250 bytes	CPU 1
5	IN	210 bytes	-	CPU 4
6	OUT	-	210 bytes	CPU 4
7	MSO Local	-	-	-
7.1	MSO Local OUT	-	139 bytes	CPU 1
7.2	MSO Local IN	139 bytes	-	CPU 3
7.3	MSO Local IN	139 bytes	-	CPU 4

¹ Length of the user data including data status and without user data qualifier

² As with the configuration, only one CPU of the redundant system S7-400H is shown, but the other CPU is working with the same values in the background.

PROFINET interface (X2)				
Virtual slot	Type	I-length ¹	Q-length	Access ²
1	OUT	-	215 bytes	CPU 5
2	IN	215 bytes	-	CPU 5
3	OUT	-	250 bytes	CPU 5
4	IN	250 bytes	-	CPU 5
5	OUT	-	210 bytes	CPU 5
6	IN	210 bytes	-	CPU 5

¹ Length of the user data including data status and without user data qualifier

² As with the configuration, only one CPU of the redundant system S7-400H is shown, but the other CPU is working with the same values in the background.

Supported functions for system redundancy

The PN/PN Coupler as of V4.2 only supports the functions listed below:

- One-sided and two-sided system redundancy
- Maximum connection of one redundant system each (S7-1500R/H) per subnet of the PN/PN Coupler
- Maximum connection of 50 PN/PN Coupler to one redundant system (S7-1500R/H)
- Maximum data volume in system-redundant mode is 1000 bytes of inputs and 1000 bytes of outputs per PN/PN Coupler

Note

IO Modules operating mode (GSD)

For S7-1500R/H redundant systems use I/O modules of the "IO Modules" operating mode for the system-redundant S2 mode.

The operating mode "IO Modules (ext. comp. V3.x)" operating mode is not supported in combination with S2 redundancy in a S7-1500R/H redundant system.

6.4.2 Media and system redundancy S2

Media redundancy on the redundant S7 1500R/H system

In the redundant S7 1500R/H system, both CPUs are in a ring topology with MRP (media redundancy method) (PROFINET ring). All PROFINET devices in the PROFINET ring are connected to the S7 1500R/H media redundant. If the PROFINET ring is interrupted, reconfiguration may occur. After a short reconfiguration time, the PROFINET devices can be accessed again via an alternative path.

In redundant mode, the redundant S7 1500H system uses two redundancy connections via optical fibers to synchronize the two CPUs. The primary CPU and the backup CPU continuously send H Sync frames via the H-Sync interfaces X3 and X4 of the CPUs.

In redundant mode, the redundant S7 1500R system uses the PROFINET ring to synchronize the two CPUs. The primary CPU and the backup CPU continuously send H Sync frames via the two ports of the PROFINET interface X1 via the PROFINET ring. All PROFINET devices in the PROFINET ring of the S7 1500R must support H Sync Forwarding.

System redundancy S2

In S2 operating mode, an IO device establishes one system redundancy AR each to both IO controllers of the redundant system.

Response in redundant mode:

- The primary CPU is always the active IO controller. The active PROFINET communication runs on the system redundancy AR between the IO device and the primary CPU (primary AR).
- The backup CPU also maintains PROFINET communication with the IO device but it is marked as invalid (backup). The I/O data of the system redundancy AR between the IO device and the backup CPU are not used (backup AR).

If the primary CPU fails, the previous backup CPU takes over the PROFINET communication with the IO device. To do this, the CPU uses the previous backup AR.

Note**Reconfiguration time**

Media redundancy and system redundancy generally do not influence each other. However, if the reconfiguration time of the media redundancy is too long, the redundant system assumes there is an interruption in the PROFINET connection and switches from the lead CPU to the redundant CPU. The reconfiguration time must be sufficiently short (≤ 224 ms) to prevent this switchover of the system redundancy. The reconfiguration time in a ring with up to 50 stations is 224 ms in the worst case scenario.

Configuring the watchdog time of the PN/PN Coupler in subnet 1 in STEP 7 TIA Portal

Note**Watchdog time**

If the media redundancy reconfiguration time is greater than the selected watchdog time of the PN/PN Coupler, the communication path is interrupted. This means the configured watchdog time must be ≥ 224 ms.

Follow these steps to configure the watchdog time:

1. Drag the PN/PN Coupler as of V4.2 from the hardware catalog to the PROFINET network.
2. Left-click the symbol of the PN/PN Coupler to select it.
3. Right-click to select slot X1 in the station window.
4. Go to the "Real time settings" menu command and select the "IO cycle" tab.
5. Configure the watchdog time in the "Number of accepted update cycles with missing IO data" field.

You can find additional information on configuring the watchdog time in the STEP 7 online help.

Active redundancy

Active redundancy means that all redundant resources are constantly in operation and are simultaneously involved in the execution of the control task. Active redundancy compensates for the failure of a CPU, an IO device or the interruption of the ring without the loss of information. The user program is completely identical in both CPUs for the S7-1500H. Both CPUs process the user program asynchronously. The system synchronizes the data between the CPUs event-controlled and thus ensures fast and bumpless switchover.

6.4.3 System redundancy S2 on one and both sides

You can configure the following examples for one-sided and two-sided system redundancy either on the X1 or X2 side of the PN/PN Coupler.

Note

Topology

The topology of the plant alone does not indicate if an IO device is connected with one-sided, two-sided system redundancy or no system redundancy at all. You specify the design in your configuration.

One-sided system redundancy S2

The redundant S7-1500R/H system cyclically exchanges IO data with another PROFINET IO system via a PN/PN-Coupler.

In the following figure, the PN/PN-Coupler connects a redundant S7-1517H system to another PROFINET IO system. The left-hand side of the PN/PN-Coupler is assigned to the S7-1517H redundant system. This means this side of the PN/PN-Coupler is operated with system redundancy and media redundancy. The right side of the PN/PN-Coupler is assigned to the CPU 1516 (IO controller). The PROFINET IO system of CPU 1516 has no redundancy in this example.

The subnet in the right half is neither system-redundant nor media-redundant. This means failures are not compensated. The purpose of this subnet is, for example, to transmit production data from the field level to the production management level.

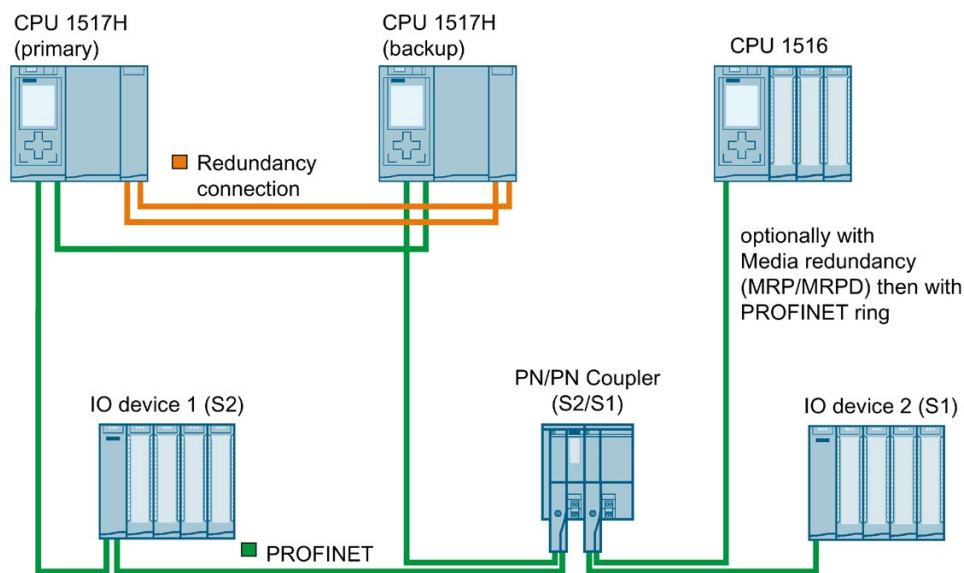

Figure 6-14 Configuration with the PN/PN Coupler with one-sided system redundancy (S2/S1)

Two-sided system redundancy S2

Two redundant S7-1500R/H systems cyclically exchange IO data via the PN/PN-Coupler.

In the following figure, the PN/PN-Coupler connects two redundant S7-1515R systems to each other. Each of the two PN/PN-Coupler sides are assigned to a redundant S7-1515R system. Each of the two sides of the PN/PN-Coupler are connected to the respective redundant S7-1515R system in a system-redundant and media-redundant manner.

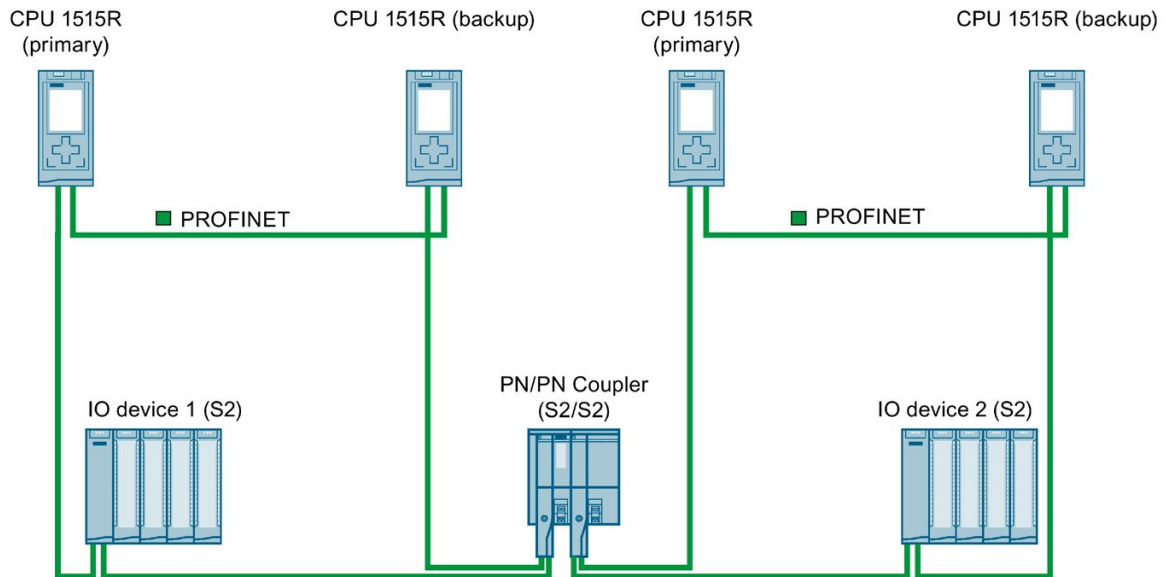

Figure 6-15 Configuration with the PN/PN Coupler with two-way system redundancy (S2/S2)

6.4.4 Configuration

STEP 7 TIA Portal

In STEP 7 TIA Portal as of V15.1, you can find PN/PN Coupler as of V4.2 in the hardware catalog.

Configuring in STEP 7

You can find information on configuring redundant systems in the system manual for Redundant System S7-1500R/H.

You can find information on configuring the PN/PN Coupler in the section Configuring, parameter assignment and commissioning (Page 36).

See also

PROFINET with STEP 7 V15
(<https://support.industry.siemens.com/cs/ww/en/view/49948856>)

Interrupts, error messages and diagnostics and system alarms

7

7.1 Diagnostics via LED displays

LEDs on the PN/PN Coupler

The LEDs on the PN/PN Coupler and their function are described below.

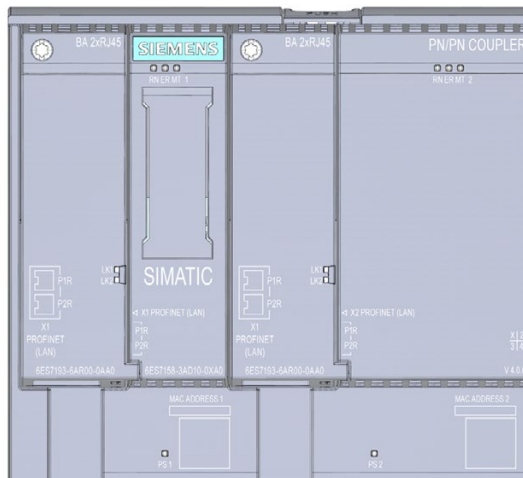

- RN 1 RUN LED PROFINET IO network side 1 (green)
- RN 2 RUN LED PROFINET IO network side 2 (green)
- ER 1 ERROR LED PROFINET IO network side 1 (red)
- ER 2 ERROR LED PROFINET IO network side 2 (red)
- MT 1 Maintenance indicator PROFINET IO network side 1 (yellow)
- MT 2 Maintenance indicator PROFINET IO network side 2 (yellow)
- LK 1 Connection to a switch or IO controller (green) at Port1
- LK 2 Connection to a switch or IO controller (green) at Port2
- PS 1 Power supply PROFINET IO network side 1 (green)
- PS 2 Power supply PROFINET IO network side 2 (green)

Figure 7-1 LEDs on the PN/PN Coupler





Meaning of the LED displays

The following tables contain the meanings of the status and error displays.

RN/ER/MT LEDs on the PN/PN Coupler

Table 7- 1 Status and error displays of RN/ER/MT LEDs

LEDs			Meaning	Remedy
RN 1/2 (RUN)	ER 1/2 (ERROR)	MT 1/2(M AINT)		
□ off	□ off	□ off	Missing or insufficient supply voltage on the PN/PN Coupler.	Check the supply voltage.
■ on	■ on	■ on	Test of LEDs during startup: The three LEDs light up simultaneously for approximately 0.25 s.	---
			RN/ER/MT LEDs are continuously On and RN/ER/MT LEDs of the other interface are Off or flashing: Hardware or firmware defective. Error information will be determined and stored retentively on the Flash memory.	Do not disconnect the PN/PN Coupler from the supply voltage as long as X1 LEDs are continuously lit (this process may take a few minutes).
			RN/ER/MT LEDs are continuously On and RN/ER LEDs of the other interface are flashing: Startup was stopped because a BusAdapter that is defective or not supported was detected on the other interface.	Replace the BusAdapter of the other interface.
☀ Flashes	Not relevant	Not relevant	PN/PN Coupler is deactivated.	Activate the PN/PN Coupler with the configuration software or the user program.
			PN/PN Coupler is not configured.	Configure the PN/PN Coupler with the configuration software.
			PN/PN Coupler is starting up.	---
			PN/PN Coupler is being assigned parameters.	---
■ on	Not relevant	Not relevant	PN/PN Coupler is currently exchanging data with the IO controller.	---
Not relevant	☀ Flashes	Not relevant	Group errors and group channel faults.	Evaluate the diagnostics and eliminate the error.
			The preset configuration does not match the actual configuration of the PN/PN Coupler .	Check the configuration of the PN/PN Coupler: <ul style="list-style-type: none"> • Whether a module is missing or defective • Whether an unconfigured module is inserted
			Parameter assignment error	Evaluate the display of the module status in STEP 7. Eliminate the error in the corresponding I/O module.
Not relevant	Not relevant	■ on	Maintenance demanded	See section Interrupts (Page 94)

LEDs			Meaning	Remedy
RN 1/2 (RUN)	ER 1/2 (ERROR)	MT 1/2(M AINT)		
 Flashes	 Flashes	 Flashes	The "Node flash test" is running (the LK1 and LK2 LEDs of the PROFINET interface also flash).	---
			Hardware or firmware defective (The LK1 and LK2 LEDs of the PROFINET interface do not flash).	Restart the device by disconnecting and reconnecting the supply voltage. Run a firmware update. If the error persists, contact Siemens Industry Online Support (see also Reading service data (Page 98)). Replace the PN/PN Coupler.
 Flashes	 Flashes	Not relevant	Startup was stopped because a BusAdapter that is defective or not supported was detected.	Replace the BusAdapter of this interface.

PS LEDs on the PN/PN Coupler

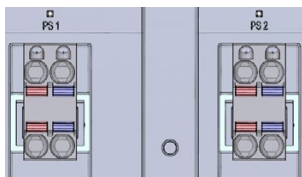









Figure 7-2 PS LEDs on the PN/PN Coupler

Table 7-2 Status display of the PS LED

PS 1/2 LED	Meaning	Remedy
 off	Missing or insufficient supply voltage	Check the supply voltage.
 on	Supply voltage present	---

LK1/LK2 and MT1/MT2 LEDs on the BusAdapter

Table 7- 3 Status and error displays of LK1/LK2 and MT1/MT2 LEDs

LED		Meaning	Remedy
LK1/LK2	MT1/MT2*		
 off	Not relevant	There is no Ethernet connection between the PROFINET IO interface of your PROFINET device and a communication partner (e.g. IO controller).	Check whether the bus cable to the switch/IO controller is interrupted.
 on	Not relevant	There is an Ethernet connection between the PROFINET IO interface of your PROFINET device and a communication partner (e.g. IO controller).	---
 Flashes	Not relevant	The "Node flash test" is running. (The RN/ER/MT LEDs are also flashing.)	---
Not relevant	 off	No error	---
Not relevant	 on	<ul style="list-style-type: none"> Fiber-optic error Maintenance demanded: attenuation through the fiber-optic cable is already so high that operation will soon no longer be possible. 	Causes and measures for the transmission route: <ul style="list-style-type: none"> Replacement of fiber-optic cable if damaged or aged Correct installation of the PROFINET connector/PROFINET connections Adherence to maximum length of 50 m for POF cable or 100 m for PCF cable Secure fit of the FOC connector.

* Present only on BA 2xSCRJ,BA SCRJ/RJ45 andBA SCRJ/FC BusAdapters

7.2 Diagnostics by user program

7.2.1 Extended channel diagnostics

Function

The channel diagnostics provides information about channel faults of the PN/PN Coupler.

Channel faults are mapped as channel diagnostics in IO diagnostic data records.

You read the data record with the "RDREC" instruction.

Structure of the diagnostic data records

The data records supported by the PN/PN Coupler are based on the PROFINET IO standard - Application Layer Service Definition V2.3.

If necessary, you can purchase the standard from the PROFIBUS Nutzerorganisation (PROFIBUS user organization (<https://www.profibus.com>)).

Codes of the extended channel diagnostics

The following extended channel diagnostics are signaled for the PN/PN Coupler:

Slot number	ChannelError-Type (CET)	ExtendedChannelError-Type (ECET)	Associated value AddValue	Diagnostics
0	0x0601	0x0681	0x00	Transmitted IO data invalid (partially bad-flagged)
0	0x0602	0x069C	0x00	Invalid BusAdapter on the PN/PN Coupler
0	0x0603	0x06A0	0x00	Error on other network
0	0x0603	0x06A1	Slot	Differences between the two networks at slot n
0	0x0603	0x06A2	0x00	No input data configured for the activated data validity display
0	0x0603	0x06A5	Slot	Shared Device conflict, invalid submodule assignment at slot n
0	0x0610	0x06B3	Number	Power supply fault (power supply number n)
0	0x0610	0x06B4	0x00	Diagnostics Undervoltage

See also

Block diagram (Page 35)

Parameters (Page 47)

7.2.2 Interrupts

The IO device initiates interrupts following certain errors. The evaluation of the interrupt is dependent on the IO controller used.

The PN/PN Coupler supports the following interrupts:

- Diagnostics interrupts

If the communication relation exists between the IO controller and the **PN/PN Coupler**, manufacturer-specific diagnostics of the PN/PN Coupler also become active as interrupts. The interrupts trigger the call of an OB 82 in a SIMATIC CPU.

Note

Start information of the OB

Diagnostics on the PN/PN Coupler can already be pending, which will not be reported by a diagnostics interrupt. You must then explicitly read the diagnostic information with a diagnostic data record in the user program.

Use the start information of OB 86, for example, and the list of the diagnostics and configuration data records

(<https://support.industry.siemens.com/cs/ww/en/view/19289930>) for PROFINET IO for this purpose.

- Update interrupt (OB 56) for modules "RD READ STO" and "RD READ PUB":

You can optionally enable an update interrupt when configuring the "RD READ STO" and "RD READ PUB" modules: This indicates to the receiver that a new data record is available for reading in the buffer of the PN/PN Coupler.

The update interrupt is disabled by default. A new update interrupt can only be issued when the preceding interrupt has been acknowledged in the user program.

Note

Module "RD READ PUB"

When new data records are received in quick succession, it is not ensured that a separate update interrupt will be issued for each received data record.

- Maintenance alarms

The PN/PN Coupler supports diagnostics and the maintenance concept in PROFINET according to IEC 61158-6-10. The goal is to detect and remove potential problems as early as possible.

For the PN/PN Coupler, maintenance alarms signal to the user when a network component must be checked or replaced.

Maintenance alarms

The PN/PN Coupler signals a maintenance alarm to the higher-level diagnostics system when the following events occur:

Maintenance alarms	Event	Message/Meaning
Maintenance demanded <i>(maintenance demanded)</i> MT LED is lit	Loss of synchronization	<ul style="list-style-type: none"> No synchronization message frame received After parameterization or during operation, the sync master did not receive a synchronization message frame within the timeout period. <ul style="list-style-type: none"> Successive synchronization message frames are outside the permissible limits (jitter).
	Critical FOC attenuation	The received light intensity at the FOC port is critical. The FOC should be replaced.
	Diagnostics Undervoltage	Undervoltage diagnostics applies when the power supply supplies a value from ≤ 19.2 V to ≥ 20.4 V.

System alarms in STEP 7

The maintenance information is generated in STEP 7 with the following system alarm:

- Maintenance demanded, identified by a yellow wrench icon at the relevant port.

7.2.3 Diagnostics readout

Options for reading out the diagnostic data

You can evaluate vendor-specific diagnostics using the corresponding data records (e.g. 0x800B) or using diagnostics interrupts.

Table 7- 4 Reading out the diagnostic data with STEP 7.

Automation system with IO controller	Application	See ...
SIMATIC S7	Diagnostics as plain text in STEP 7 in online and diagnostics view	Online help for STEP 7 and as of STEP 7 V 14 SIMATIC PROFINET Function Manual (https://support.industry.siemens.com/cs/ww/en/view/49948856)
	Instruction "RDREC" (SFB 52)	
	Reading data records from the IO device	
	Instruction "RALRM" (SFB 54)	
	Receiving alarms from the IO device	

Data status byte

Based on the data status byte (DS) value in the last byte, the user can recognize the following scenarios. Below you can find a description of the structure of the DS byte:

- 0x40: There is no valid coupling partner of the module input data in the other subnet.
- 0x60: The IO controller in the other subnet is in STOP state.
- 0x80 Valid user data received from coupling partner

Structure of the diagnostic data records

You can find the structure of the diagnostic data records and programming examples in the Programming Manual (<https://support.industry.siemens.com/cs/ww/en/view/19289930>) in sections Structure of the diagnostic data records and Examples for the diagnostic data records.

The data records supported by the PN/PN Coupler are based on the PROFINET IO standard - Application Layer Service Definition V2.0.

You can download the standard from the Internet free of charge (PROFIBUS (<https://www.profibus.com/>)).

7.2.4 Data validity display

Using the DIA parameter (data validity display), you query information about the validity of the input data supplied from the other bus side of the PN/PN Coupler directly in the user program.

See also

Parameters (Page 47)

7.2.5 Diagnosis in Shared Device

Particularities for diagnostics and data validity:

The following conditions apply to diagnostics and data validity for the PN/PN Coupler as a Shared Device .

- Diagnostics are signaled only to an IO controller that has slot 0 with subslot 1 or an interface.
- The configuration-related diagnostics involve all slots:
 - The diagnosis "Other network side is not configured or has failed" is generated if a partner slot is not available for any individual configured slot.
 - The diagnosis "Different configuration of subnets X1 and X2" is generated if there is a difference in the module ID of the partner slot for at least one slot.
- The diagnosis "Data validity DIA is set, but no input data is configured" covers only the slots that belong to the IO controller that has slot 0.
- Shared Device conflict: invalid submodule assignment at slot n
 - For MSI and MSO modules, submodules of the same length of output and input data must be used.
 - For local MSO modules, the output submodule and at least 1 input submodule must be controlled by the IO controller assigned in each case.

7.2.6 STOP of the IO controller and recovery of the IO device

STOP of IO controller

The PN/PN Coupler indicates the STOP state of the IO controller of the other bus side using the optional "Data validity" diagnostics.

Diagnostics after STOP of the IO controller

If diagnostics are received from the IO device while the IO controller is in STOP state, the corresponding organization blocks are not initiated after startup of the IO controller. You must get an idea of the state of the IO device in OB 100. Evaluate the data status byte (DS) of the input modules in your user program.

Diagnostics after recovery of the IO device

Following recovery of an IO device, you must read data record E00CH with the "RDREC" instruction. This contains all the diagnostics data for the slots assigned to an IO controller in an IO device.

7.3 Reading service data

Service data

Service data for the PN/PN Coupler include:

- Fatal error information
- Device trace for X1 and X2 interface
- Device memory statistics

These are all cases where you can call Siemens Industry Online Support for help. Only Siemens Industry Online Support can evaluate this binary file.

STEP 7 V5.6 or higher

You can load the service data in STEP 7 as of V5.6 HF3. The service data is only available via the "Accessible devices".

See also

See the online help for STEP 7.

Operation and maintenance

You update the firmware of the PN/PN Coupler via PROFINET IO: In SIMATIC Manager using **PLC > Show accessible devices**

To update the firmware, you will need files (*.UPD) containing the current firmware.

You can find the latest firmware on the Internet
(<https://support.industry.siemens.com/cs/de/de/ps/6ES7-3AD10-0XA0/dl>).

8.1 Updating firmware via PROFINET IO

Updating firmware via PROFINET IO

You update the firmware using one of the two PROFINET IO interfaces.

Requirements:

- The PN/PN Coupler must be accessible online for the firmware update.
- The files with the current firmware version must be available in the file system of your programming device or PC.

Note

Firmware activated after download

If you have selected the "Activate firmware after download" option for the firmware update via PROFINET IO, both sides of the coupler will interrupt the data transfer temporarily when the firmware is activated.

Further information

The STEP 7 online help system provides information on how to proceed.

8.2 Replacing defective PN/PN coupler

Introduction

For a new PN/PN Coupler, the R/W objects (I&M, SNMP and parameter assignment data) in the PN/PN Coupler are set to factory settings.

Replacement part case

You must bring a previously used PN/PN Coupler to the "Reset to factory settings" state before using it as a replacement part.

Procedure

To replace a defective PN/PN Coupler, follow these steps:

1. De-energize the PN/PN Coupler.
2. Unscrew the BusAdapter.
3. Remove the BusAdapter from the PROFINET IO interfaces of the defective PN/PN Coupler.
4. Remove the power supply of the defective PN/PN Coupler.
5. Replace the defective PN/PN Coupler.
6. Plug the BusAdapters onto the PROFINET IO interfaces of the new PN/PN Coupler and screw them in place.
7. Connect the power supply connection to the new PN/PN Coupler.
8. Switch on the voltage again.

8.3 Reset to factory settings

Requirement

The supply voltage on the PN/PN Coupler is switched on.

Required tools

3 to 3.5 mm screwdriver (for resetting with a RESET button)

Procedure using the RESET button

To reset the PN/PN Coupler to factory settings using the RESET button, follow these steps:

1. Remove the PN/PN Coupler from the mounting rail, see *Disassembling the PN/PN coupler* (Page 24), and swing it downwards.

Note**Power supply must be supplied with voltage**

Both power supply connections must be supplied with voltage.

2. The RESET button is located on the back of the PN/PN Coupler behind a small opening: Press a screwdriver into the small opening for at least 3 seconds to activate the RESET button.

Note**One RESET button but two power supplies**

When the RESET button is pressed, the power supply must be supplied on this side of the PN/PN Coupler.

This means that if the left side of the PN/PN Coupler is to be reset, only the left power supply must be supplied with power and vice versa.

3. Mount the PN/PN Coupler again on the mounting rail, see *Assembling the PN/PN coupler* (Page 24).
4. Reassign the PN/PN Coupler parameters.

For additional information on retentively stored data, refer to the PROFINET Function Manual (<https://support.industry.siemens.com/cs/ww/en/view/49948856>).

Procedure using STEP 7 TIA Portal

To restore the factory settings for the PN/PN Coupler using the STEP 7 TIA Portal, follow these steps:

Ensure there is an online connection to the PN/PN Coupler.

1. Open the list of accessible devices of your PG/PC interface.
2. In the "Functions" folder of any network side of the PN/PN Coupler, select "Reset to factory settings".
3. If you want to keep the I&M data, select the "Retain I&M data" option button. If you want to delete the I&M data, select the "Delete I&M data" option button.
4. Click the "Reset" button.
5. Click "Yes" in response to the confirmation prompt for the process.

Result: The PN/PN Coupler then performs a "Reset to factory settings" for both network sides. All data of the PN/PN Coupler are reset to factory settings. Firmware updates are retained. The included data of the BusAdapters are also deleted.

Technical specifications

9.1 General technical specifications

9.1.1 Introduction

Scope of general technical specifications

The general technical specifications include:

- The standards and test values that are complied with and met by the described components.
- The test criteria based on which the described components were tested.

9.1.2 Standards and approvals

Currently valid markings and approvals

Note**Information on the housing of the PN/PN Coupler**

The currently valid markings and approvals are printed on the housing of the PN/PN Coupler.

5 safety rules for working in and on electrical installations

A set of rules, which are summarized in DIN VDE 0105 as the "five safety rules", are defined for work in or on electrical installations as a preventative measure against electrical accidents:

1. De-energize
2. Secure to prevent reconnection
3. Verify safe isolation from the supply
4. Connect to ground and short-circuit
5. Cover or provide barriers from adjacent live parts

These five safety rules must be applied in the above-indicated order before starting work on electrical equipment. After completing the work, proceed in the reverse order.

It is assumed that every electrician is familiar with these rules.

CE approval



The PN/PN Coupler meets the requirements and protection targets of the following EC guidelines and complies with the harmonized European standards (EN) for programmable logic controllers published in the official gazettes of the European Community:

- 2014/30/EU "Electromagnetic Compatibility" (EMC Directive)
- 2014/34/EU "Equipment and protective systems intended for use in potentially explosive atmospheres" (Explosion Protection Directive)
- 2011/65/EU "Restriction of the use of certain hazardous substances in electrical and electronic devices" (RoHS Directives).

The EU conformity declaration certificates are available for the responsible authorities and are kept at the following address:

Siemens AG
Digital Factory

Factory Automation
DF FA AS SYS
P.O. Box 1963
D-92209 Amberg, Germany

They are also available for download on the Siemens Industry Online Support website, under the keyword "Declaration of Conformity".

cULus approval



Underwriters Laboratories Inc. according to

- UL 508 (Industrial Control Equipment)
- CSA C22.2 No. 142 (Process Control Equipment)

OR

cULus HAZ. LOC. approval



Underwriters Laboratories Inc. according to

- UL 508 (Industrial Control Equipment)
- CSA C22.2 No. 142 (Process Control Equipment)
- ANSI/ISA 12.12.01
- CSA C22.2 No. 213 (Hazardous Location)

APPROVED for use in
Class I, Division 2, Group A, B, C, D Tx;
Class I, Zone 2, Group IIC Tx

Installation Instructions for cULus haz.loc.

- WARNING - Explosion Hazard - Do not disconnect while circuit is live unless area is known to be non-hazardous.
- WARNING - Explosion Hazard - Substitution of components may impair suitability for Class I, Division 2 or Zone 2.
- This equipment is suitable for use in Class I, Division 2, Groups A, B, C, D; Class I, Zone 2, Group IIC; or non-hazardous locations.

WARNING: EXPOSURE TO SOME CHEMICALS MAY DEGRADE THE SEALING PROPERTIES OF MATERIALS USED IN THE RELAYS.

OR

FM approval



Factory Mutual Research (FM) according to

- Approval Standard Class Number 3611, 3600, 3810
- ANSI/ISA 82.02.01 (IEC 61010-1)
- CSA C22.2 No. 213
- CSA 22.2 No. 1010.1

APPROVED for use in Class I, Division 2, Group A, B, C, D Tx;
Class I, Zone 2, Group IIC Tx

Installation Instructions for FM

- WARNING - Explosion Hazard - Do not disconnect while circuit is live unless area is known to be non-hazardous.
- WARNING - Explosion Hazard - Substitution of components may impair suitability for Class I, Division 2 or Zone 2.
- This equipment is suitable for use in Class I, Division 2, Groups A, B, C, D; Class I, Zone 2, Group IIC; or non-hazardous locations.

WARNING: EXPOSURE TO SOME CHEMICALS MAY DEGRADE THE SEALING PROPERTIES OF MATERIALS USED IN THE RELAYS.

OR

9.1 General technical specifications

ATEX approval



In accordance with EN 60079-15 (Electrical apparatus for potentially explosive atmospheres; Type of protection "n") and EN 60079-0 (Electrical apparatus for potentially explosive gas atmospheres - Part 0: General Requirements)



II 3 G Ex nA IIC Tx Gc
DEKRA 12ATEX0038X

OR

IECEX approval



According to IEC 60079-15 (Explosive atmospheres - Part 15: Equipment protection by type of protection "n") and IEC 60079-0 (Explosive atmospheres - Part 0: Equipment - General requirements)



Ex nA IIC Tx Gc
IECEX DEK 13.0010X

RCM (C-Tick) Declaration of conformity for Australia/New Zealand



The ET 200SP distributed I/O system fulfills the requirements of the standards

- EN 61000-6-4.

Korea Certification



KC registration number: KCC-REM-S49-DPPA

Please note that this device corresponds to limit value class A in terms of the emission of radio frequency interference. This device can be used in all areas, except residential areas.

이 기기는 업무용(A급) 전자파 적합기기로서 판매자 또는 사용자는 이 점을 주의하시기 바라며 가정 외의 지역에서 사용하는 것을 목적으로 합니다.

Marking for the Eurasian Customs Union



EAC (Eurasian Conformity)

Customs Union of Russia, Belarus and Kazakhstan

Declaration of conformity with the technical requirements of the Customs Union (TR CU).

IEC 61131

The described components meet the requirements and criteria of IEC 61131-2 standard (Programmable logic controls, part 2: Equipment requirements and tests).

Marine approval

The following marine approvals are planned for the PN/PN Coupler:

Classification organizations:

- ABS (American Bureau of Shipping)
- BV (Bureau Veritas)
- DNV-GL (Det Norske Veritas-Germanischer Lloyd)
- KR (Korean Register of Shipping) and CCS (China Classification Society)
- LRS (Lloyds Register of Shipping)
- Class NK (Nippon Kaiji Kyokai)

WEEE mark (European Union)



Disposal information, observe the local regulations.

PROFINET standard

The described components are based on the IEC 61158-6-10 standard.

Use in industrial environments

The PN/PN Coupler is designed for use in industrial environments. It meets the following standards for this type of use:

- Requirements on interference emission EN 61000-6-4: 2011
- Requirements on immunity EN 61000-6-2: 2005

Use in mixed areas

Under specific prerequisites you can use the PN/PN Coupler in a mixed area. A mixed area is used for residential purposes and for commercial operations that do not significantly impact the residential purpose.

If you want to use the PN/PN Coupler in residential areas, you must ensure that its radio frequency interference emission complies with limit class B in accordance with EN 61000-6-3. Suitable measures for observing these limits for use in a mixed area are, for example:

- Installation of the PN/PN Coupler in grounded control cabinets
- Use of filters in supply lines

An additional individual acceptance test is also required.

Use in residential areas

Note

PN/PN Coupler not intended for use in residential areas

The PN/PN Coupler is not intended for use in residential areas. If you are using the PN/PN Coupler in residential areas, radio and TV reception may be affected.

Reference

The certificates for the markings and approvals can be found on the Internet under Service&Support (<https://support.industry.siemens.com/>).

9.1.3 Electromagnetic compatibility

Definition

Electromagnetic compatibility (EMC) is the ability of an electrical installation to function satisfactorily in its electromagnetic environment without interfering with that environment.

Among other things, the PN/PN Coupler also meets the requirements of the EMC legislation for the European single market. The prerequisite for this is that the PN/PN Coupler complies with the requirements and guidelines relating to electrical configuration.

Pulse-shaped interference

The table below shows the electromagnetic compatibility of the described components with regard to pulse-shaped interference. This requires that the system comply with the requirements and guidelines for electrical assembly.

Table 9- 1 Pulse-shaped interference

Pulse-shaped interference	Tested with	Corresponds with degree of severity
Electrostatic discharge in accordance with IEC 61000-4-2	Air discharge: ± 8 kV	3
	Contact discharge: ± 6 kV	3
Burst pulses (fast transient interference) in accordance with IEC 61000-4-4	± 2 kV (power supply cable)	3
	± 2 kV (signal cable >30 m)	3
	± 1 kV (signal cable <30 m)	
High-energy single pulse (surge) in accordance with IEC 61000-4-5		2
• Symmetric coupling	± 0.5 kV (power supply cable)	
• Asymmetric coupling	± 1 kV (power supply cable to functional earth FE) ± 1 kV (signal cable/data cable to functional earth FE)	

Sinusoidal interference

The following table shows the electromagnetic compatibility of the PN/PN Coupler with regard to sinusoidal interference (HF radiation).

Sinusoidal interference	Test values
HF radiation (electromagnetic fields) according to IEC 61000-4-3	80% amplitude modulation at 1 kHz <ul style="list-style-type: none"> to 10 V/m from 80 MHz to 1 GHz to 10 V/m from 1.4 GHz to 2 GHz to 1 V/m from 2 GHz to 6 GHz
HF current feed on cables and cable shields according to IEC 61000-4-6	Test voltage 10 V at 80 % amplitude modulation of 1 kHz in the range from 10 kHz to 80 MHz

9.1 General technical specifications

The following table shows the electromagnetic compatibility of the PN/PN Coupler with respect to sinusoidal interference (RF radiation).

Table 9- 2 Sinusoidal interference – RF radiation

RF radiation in accordance with IEC 61000-4-3/NAMUR 21 Electromagnetic RF field, amplitude-modulated		Corresponds with degree of severity
80 to 1000 MHz; 1.4 to 2 GHz	2.0 GHz to 6 GHz	3
10 V/m	3 V/m	
80% AM (1 kHz)		

The following table shows the electromagnetic compatibility of the PN/PN Coupler with respect to sinusoidal interference (RF coupling).

Table 9- 3 Sinusoidal disturbance variables – RF coupling

RF coupling in accordance with IEC 61000-4-6	Corresponds with degree of severity
from 10 kHz	3
10 V _{rms}	
80% AM (1 kHz)	
150 Ω source impedance	

Emission of radio interferences

Emission of interference from electromagnetic fields in accordance with EN 55011: limit class A, group 1.

Table 9- 4 Interference emission of electromagnetic fields

Frequency	Interference emission
from 30 to 230 MHz	<40 dB (μV/m) Q
from 230 to 1000 MHz	<47 dB (μV/m) Q
from 1 to 3 GHz	<66 dB (μV/m) P
from 3 to 6 GHz	<70 dB (μV/m) P

Emission of interference via AC supply voltage in accordance with EN 55011: limit class A, group 1.

from 0.15 to 0.5 MHz	< 79 dB (μV)Q < 66 dB (μV)M
from 0.5 to 30 MHz	< 73 dB (μV)Q < 60 dB (μV)M

9.1.4 Transport and storage conditions

Introduction

The described components meet the requirements regarding transport and storage conditions according to IEC 61131-2. The following information applies to modules that are transported and stored in their original packaging.

Transport and storage of modules

Table 9- 5 Transport and storage conditions

Type of condition	Permitted range
Free fall (in shipping package)	≤ 1 m
Temperature	-40 °C to +70 °C
Barometric pressure	1140 hPa to 660 hPa (corresponds to an elevation of -1000 m to 3500 m)
Relative humidity	5% to 95%, without condensation
Sinusoidal vibrations according to IEC 60068-2-6	5 - 8.4 Hz: 3.5 mm 8.4 - 500 Hz: 9.8 m/s ²
Shock according to IEC 60068-2-27	250 m/s ² , 6 ms, 1000 shocks

9.1.5 Mechanical and climatic ambient conditions for operation

Operating conditions

The described components are intended for weather-proof, stationary use.

The device was tested with the following extensions and restrictions in accordance with IEC 60721-3-3 Class 3K3:

Type of condition	Mounting position	Permitted range
Temperature	Horizontal	-30 ... 60 °C (without condensation or ice)
Temperature	Vertical	-30 ... 50 °C (without condensation or ice)
Barometric pressure ¹ , altitude	1140 ... 795 hPa, corresponds with an altitude of -1000 to 2000 m	
Relative humidity	From 10% to 90%, no condensation	
Pollutant concentration	SO ₂ : < 0.5 ppm; relative humidity < 60%, no condensation H ₂ S: < 0.1 ppm; relative humidity < 60%, no condensation	

¹ No pressure differential permitted inside and outside of housing/control cabinet

Use with additional measures

Without additional measures the described components must **not** be used in the following locations:

- Locations with a high amount of ionizing radiation
- Locations with difficult operating conditions; e.g. caused by
 - Dust formation
 - Corrosive vapors or gases
 - Strong electrical or magnetic fields
- Equipment that requires special monitoring, e.g.
 - Elevators
 - Electrical equipment in especially hazardous areas

Mechanical environmental conditions

The following table specifies the mechanical environmental conditions for the described components for sinusoidal vibrations.

Table 9- 6 Mechanical environmental conditions

Frequency range	PN/PN Coupler for operation with a BusAdapter without an RJ45 socket	PN/PN Coupler for operation with a BusAdapter with an RJ45 socket
$5 \leq f \leq 8.4$ Hz	3.5 mm amplitude	
$8.4 \leq f \leq 150$ Hz	1 g constant acceleration	
$10 \leq f \leq 60$ Hz	0.35 mm amplitude	---
$60 \leq f \leq 1000$ Hz	5 g constant acceleration	

Reduction of vibrations

If the described components are exposed to stronger shocks or vibrations, take appropriate measures to reduce the acceleration or the amplitude.

We recommend mounting the described components on damping materials (for example, rubber-metal vibration dampers).

Tests for mechanical environmental conditions

The following table provides information about the type and scope of the tests for environmental mechanical conditions.

Table 9- 7 Tests for mechanical environmental conditions

Test for ...	Test standard	Comment
Vibrations	Vibration test according to IEC 60068-2-6 (sinusoidal)	Type of vibration: Frequency sweeps with a rate of change of 1 octave/minute. BusAdapter with an RJ45 socket <ul style="list-style-type: none"> • 5 Hz ≤ f ≤ 8.4 Hz, 3.5 mm constant amplitude • 8.4 Hz ≤ f ≤ 150 Hz, 1 g constant acceleration BusAdapter without an RJ45 socket <ul style="list-style-type: none"> • 10 Hz ≤ f ≤ 60 Hz, 0.35 mm constant amplitude • 60 Hz ≤ f ≤ 1000 Hz, 5 g constant acceleration Duration of vibration: 10 frequency sweeps per axis in each of three perpendicular axes
Shock	Shock, tested according to IEC 60068-2-27	Type of shock: Half-sine Shock intensity: 150 m/s ² peak value, 11 ms duration Direction of shock: 3 shocks in +/- direction in each of three perpendicular axes
Continuous shock	Shock, tested according to IEC 60068-2-27	Type of shock: Half-sine Shock intensity: 25 g peak value, 6 ms duration Direction of shock: 1000 shocks in +/- direction in each of three perpendicular axes

Climatic environmental conditions

The described components may be used in the following climatic ambient conditions:

Table 9- 8 Climatic environmental conditions

Environmental conditions	Permitted range
Temperature: horizontal installation vertical installation	from -30 to 60 °C (without condensation or ice) from -30 to 50 °C (without condensation or ice)
Relative humidity	from 10% to 90%,
Barometric pressure	1140 to 795 hPa
Pollutant concentration	ISA-71.04 severity level G1; G2; G3

9.1.6 Specifications for insulation tests, safety class and degree of protection

Isolation

The isolation is designed in accordance with the requirements of EN 61131-2: 2007.

Note

Galvanic isolation with 707 V DC (Type Test) is tested for modules with 24 V DC supply voltage (SELV/PELV).

Pollution degree/overvoltage category according to IEC 61131

- Pollution degree 2
- Overvoltage category: II

Protection class according to IEC 61131-2: 2007

The entire system meets protection class I and includes parts of protection classes II and III. The PN/PN Coupler contains electric circuits of protection class III.

The grounding of the mounting rail must meet the requirements for a functional earth FE.

Recommendation: For an interference-proof setup, the ground conductor should have a cross-section $> 6 \text{ mm}^2$.

To meet the requirements of protection class I, the installation location (e.g. enclosure, control cabinet) must have a protective conductor connection conforming to standards.

Degree of protection IP20

Degree of protection IP20 in accordance with IEC 60529 for the PN/PN Coupler, i.e.:

- Protection against contact with standard test finger
- Protection against foreign objects with diameters greater than 12.5 mm
- No protection against water

9.1.7 Rated voltage

Rated voltage for operation

The components described operate with a nominal voltage of 24 V DC (SELV/PELV). The tolerance range is from 19.2 to 28.8 V DC.

9.2 Technical specifications of PN/PN Coupler (6ES7158-3AD10-0XA0)

Technical specifications of the PN/PN Coupler

Article number	6ES7158-3AD10-0XA0
General information	
Product type designation	PN/PN coupler
Firmware version	
<ul style="list-style-type: none"> FW update possible 	Yes
Product function	
<ul style="list-style-type: none"> I&M data 	Yes; I&M0 to I&M3
<ul style="list-style-type: none"> Tool changer 	Yes; Docking station and docking unit
<ul style="list-style-type: none"> Local coupling, IO data 	Yes
<ul style="list-style-type: none"> <ul style="list-style-type: none"> Number of coupling modules 	16
<ul style="list-style-type: none"> <ul style="list-style-type: none"> Number of coupling submodules per module 	4; 1x write, 3x read
<ul style="list-style-type: none"> Local coupling, data records 	Yes
<ul style="list-style-type: none"> <ul style="list-style-type: none"> Number of coupling modules 	16
<ul style="list-style-type: none"> <ul style="list-style-type: none"> Number of coupling submodules per module 	4; 1x write, 3x read
<ul style="list-style-type: none"> <ul style="list-style-type: none"> Record length, max. 	4 096 byte
<ul style="list-style-type: none"> <ul style="list-style-type: none"> FIFO depth in storage mode 	8
Engineering with	
<ul style="list-style-type: none"> STEP 7 TIA Portal configurable/integrated as of version 	STEP 7 V15.1 or higher
<ul style="list-style-type: none"> PROFINET as of GSD version/GSD revision 	V2.3
Installation type/mounting	
Mounting	Mounting rail 7.5 mm and 15 mm
Supply voltage	
Rated value (DC)	24 V
permissible range, lower limit (DC)	19.2 V
permissible range, upper limit (DC)	28.8 V
Reverse polarity protection	Yes
Mains buffering	
<ul style="list-style-type: none"> Mains/voltage failure stored energy time 	10 ms
Input current	
Current consumption, max.	360 mA; For 19.2 V input voltage at the right-hand supply terminal, including 2 plugged BA 2x LC
Inrush current, max.	1.6 A

9.2 Technical specifications of PN/PN Coupler (6ES7158-3AD10-0XA0)

Article number	6ES7158-3AD10-0XA0
I ² t from supply voltage 1L+, max.	0.031 A ² ·s 320 mA; For 19.2 V input voltage at the left-hand supply terminal, including 2 plugged BA 2x LC
Power loss	
Power loss, typ.	4 W; For 24 V input voltage and 2 plugged BA 2x RJ45 If BusAdapters with an optical interface are plugged, there is an additional 750 mW per optical interface (3 W with 2 plugged BA 2x LC)
Address area	
Address space per module	
<ul style="list-style-type: none"> Address space per module, max. 	254 byte; max. 254 bytes of input data and 253 bytes of output data
Address space per station	
<ul style="list-style-type: none"> Address space per station, max. 	1 440 byte; per input / output
Hardware configuration	
Submodules	
<ul style="list-style-type: none"> Number of submodules per station, max. 	116
Interfaces	
Number of PROFINET interfaces	2; One PROFINET interface per line side
With optical interface	Yes; Via SIMATIC BusAdapter
Supports protocol for PROFINET IO	
<ul style="list-style-type: none"> automatic detection of transmission rate Transmission rate, max. 	Yes 100 Mbit/s
1. Interface	
Interface types	
<ul style="list-style-type: none"> Number of ports integrated switch BusAdapter (PROFINET) 	2; via BusAdapter Yes Yes; Compatible BusAdapter: BA 2x RJ45, BA 2x FC, BA 2x SCRJ, BA SCRJ / RJ45, BA SCRJ / FC, BA 2x LC, BA LC / RJ45, BA LC / FC
Protocols	
<ul style="list-style-type: none"> PROFINET IO Device Open IE communication Media redundancy 	Yes Yes Yes; As MRP or MRPD client; max. 50 or 30 devices in the ring
2. Interface	
Interface types	
<ul style="list-style-type: none"> Number of ports integrated switch 	2; via BusAdapter Yes
Protocols	
<ul style="list-style-type: none"> PROFINET IO Device Open IE communication 	Yes Yes

Article number	6ES7158-3AD10-0XA0
Interface types	
RJ 45 (Ethernet)	
<ul style="list-style-type: none"> • Transmission procedure • 10 Mbps • Autonegotiation • Autocrossing 	<p>PROFINET with 100 Mbit/s full duplex (100BASE-TX)</p> <p>No</p> <p>Yes</p> <p>Yes</p>
Protocols	
Supports protocol for PROFINET IO	Yes
Protocols (Ethernet)	
<ul style="list-style-type: none"> • TCP/IP • SNMP • LLDP • ping • ARP 	<p>Yes</p> <p>Yes</p> <p>Yes</p> <p>Yes</p> <p>Yes</p>
PROFINET IO Device	
Services	
<ul style="list-style-type: none"> – Isochronous mode – Open IE communication – IRT – PROFINergy – Prioritized startup – Shared device – Number of IO Controllers with shared device, max. 	<p>No</p> <p>Yes</p> <p>Yes</p> <p>No</p> <p>Yes</p> <p>Yes</p> <p>4; per line side</p>
Redundancy mode	
<ul style="list-style-type: none"> • MRP • MRPD • PROFINET system redundancy (S2) • H-Sync forwarding 	<p>Yes</p> <p>Yes</p> <p>Yes; NAP S2 acc. to IEC</p> <p>Yes</p>
Open IE communication	
<ul style="list-style-type: none"> • TCP/IP • SNMP • LLDP 	<p>Yes</p> <p>Yes</p> <p>Yes</p>
Isochronous mode	
<p>Isochronous operation (application synchronized up to terminal)</p>	No; For operation on isochronous bus

9.2 Technical specifications of PN/PN Coupler (6ES7158-3AD10-0XA0)

Article number	6ES7158-3AD10-0XA0
Interrupts/diagnostics/status information	
Diagnostics indication LED	
<ul style="list-style-type: none"> • RUN LED 	Yes; Green LED
<ul style="list-style-type: none"> • ERROR LED 	Yes; Red LED
<ul style="list-style-type: none"> • MAINT LED 	Yes; Yellow LED
<ul style="list-style-type: none"> • Monitoring of the supply voltage (PWR-LED) 	Yes; Green PWR LED
<ul style="list-style-type: none"> • Connection to network LINK (green) 	Yes; 2x green link LEDs on BusAdapter
Potential separation	
between supply voltage and electronics	Yes; to power input 2
between Ethernet and electronics	Yes
Isolation	
Isolation tested with	707 V DC (type test)
Ambient conditions	
Ambient temperature during operation	
<ul style="list-style-type: none"> • min. 	-30 °C; From FS05
<ul style="list-style-type: none"> • max. 	60 °C; = Tmax for horizontal installation; for vertical installation Tmax = 50 °C
Altitude during operation relating to sea level	
<ul style="list-style-type: none"> • Installation altitude above sea level, max. 	2 000 m; On request: Installation altitudes greater than 2 000 m
Mechanics/material	
Strain relief	Yes; Optional, for RJ45 and FC BusAdapter only
Dimensions	
Width	100 mm; Minimized with good handling
Height	117 mm
Depth	74 mm; with mounting rail
Weights	
Weight, approx.	200 g; without BusAdapter

Dimension drawing

Dimension drawing

Dimension drawing for PN/PN Coupler (dimensions in mm)

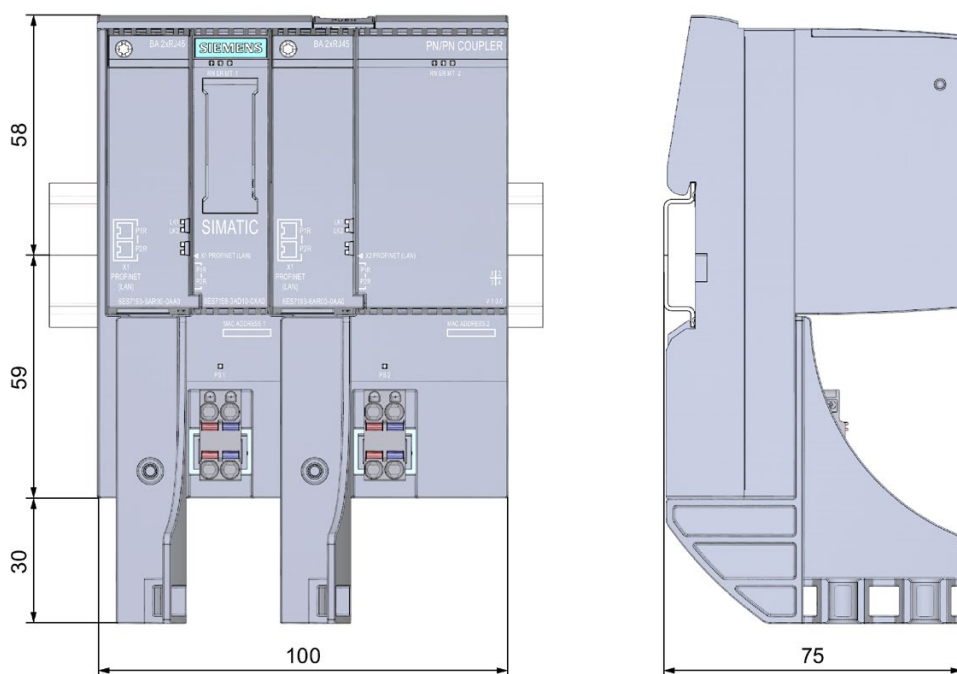

The mounting rail is 7.5 mm deep in the dimension drawing. You can also use a mounting rail with 15 mm.

Article numbers and accessories

Overview

Table B- 1 Article numbers for the PN/PN Coupler

Component	Number in pack	Article number
PN/PN Coupler	1 unit	6ES7158-3AD10-0XA0
BusAdapter		
<ul style="list-style-type: none"> BA 2×RJ45 (PROFINET BusAdapter with standard Ethernet socket) 	1 unit	6ES7193-6AR00-0AA0
<ul style="list-style-type: none"> BA 2×FC (PROFINET BusAdapter with FastConnect Ethernet connection) 	1 unit	6ES7193-6AF00-0AA0
<ul style="list-style-type: none"> BA 2×SCRJ (PROFINET BusAdapter with POF/PCF fiber-optic cable connection) 	1 unit	6ES7193-6AP00-0AA0
<ul style="list-style-type: none"> BA SCRJ/RJ45 (media converter, PROFINET BusAdapter with POF/PCF fiber-optic cable ⇔ standard RJ45 connector) 	1 unit	6ES7193-6AP20-0AA0
<ul style="list-style-type: none"> BA SCRJ/FC (media converter, PROFINET BusAdapter with POF/PCF fiber-optic cable ⇔ direct connection of bus cable) 	1 unit	6ES7193-6AP40-0AA0
<ul style="list-style-type: none"> BA 2xLC (PROFINET BusAdapter with glass fiber-optic cable connection) 	1 unit	6ES7193-6AG00-0AA0
<ul style="list-style-type: none"> BA LC/RJ45 (media converter, PROFINET BusAdapter with glass fiber-optic cable ⇔ standard RJ45 connector) 	1 unit	6ES7193-6AG20-0AA0
<ul style="list-style-type: none"> BA LC/FC (media converter, PROFINET BusAdapter with glass fiber-optic cable ⇔ direct connection of bus cable) 	1 unit	6ES7193-6AG40-0AA0
Cover for the BusAdapter interface	5 units	6ES7591-3AA00-0AA0
24 V DC connector	10 units	6ES7193-4JB00-0AA0
Reference identification label, sheet with 16 labels	10 units	6ES7193-6LF30-0AW0
Labeling strips (for labeling the I/O modules)		

Component	Number in pack	Article number
<ul style="list-style-type: none"> Roll, light gray labeling strips (with a total of 500 strips), film, for labeling with thermal transfer roll printer 	1 unit	6ES7193-6LR10-0AA0
<ul style="list-style-type: none"> Roll, yellow labeling strips (with a total of 500 strips), film, for labeling with thermal transfer roll printer 	1 unit	6ES7193-6LR10-0AG0
<ul style="list-style-type: none"> DIN A4 sheets, light gray labeling strips (with a total of 1000 labels), paper, perforated, for labeling with laser printer 	10 units	6ES7193-6LA10-0AA0
<ul style="list-style-type: none"> DIN A4 sheets, yellow labeling strips (with a total of 1000 labels), paper, perforated, for labeling with laser printer 	10 units	6ES7193-6LA10-0AG0
Mounting rails, tin-plated steel strip		
<ul style="list-style-type: none"> Length: 483 mm 	1 unit	6ES5710-8MA11
<ul style="list-style-type: none"> Length: 530 mm 	1 unit	6ES5710-8MA21
<ul style="list-style-type: none"> Length: 830 mm 	1 unit	6ES5710-8MA31
<ul style="list-style-type: none"> Length: 2000 mm 	1 unit	6ES5710-8MA41
Strain relief	5 units	6ES7193-6RA00-1AN0

Response times

Response times

The time that elapses between an IO controller writing to the process image outputs and when this data can be read in the process image of the second IO controller depends on the following:

- CPU cycle time of the two IO controllers
- Bus cycle time of the associated IO controller
- Duration for copying within the PN/PN Coupler (T_{COPY})
- Total data length in bytes (input/output)

The copying duration of the PN/PN Coupler depends on the data transmission rate used. It consists of the copy routine for the inputs and for the outputs. The following maximum values apply:

$$T_{COPY} = 25 \mu\text{s} + n_{IN} \times 0.06 \mu\text{s} + n_{OUT} \times 0.03 \mu\text{s} + (n_{SUB}-1) \times 3.5 \mu\text{s}$$

- n_{IN} : Number of bytes of inputs
- n_{OUT} : Number of bytes of outputs
- n_{SUB} : Number of submodules used

Influencing factors for the response times

The following applies to time-critical applications:

- Divide the data among as few modules and submodules as possible.
- Do not use data record modules.
- Exchange as little data as possible via the PN/PN Coupler.
- Do not request diagnostic data from the IO controller.
- Do not activate the data validity display DIA.
- Do not activate the data validity diagnostics.

Compatibility

Replacing PN/PN Coupler ≤ V3.0 with PN/PN Coupler ≥ V4.0

If you replace PN/PN Coupler ≤ V3.0 with PN/PN Coupler ≥ V4.0, no reconfiguring or rewiring is necessary, except in the following cases:

- You used a SIMATIC memory card in the project. Because PN/PN Coupler V4.0 and higher no longer has a SIMATIC memory card, the BusAdapter acts as a memory card. In this case, you must provide the PN/PN Coupler with the device name, e.g. with STEP 7 TIA Portal or with PRONETA.
- You have used an angled 90° PROFINET connector and you want to use the following BusAdapters:
 - BusAdapter with RJ45 socket: Replace the angled PROFINET connector with the BusAdapter 2×RJ45 socket (for example with SIMATIC NET IE FC RJ45 Plug 180).
 - BusAdapter with FC connection: Connect the PROFINET cable directly.

Note

New assembly

You do not have to remove the PROFINET cables again for a new assembly.

- The transmission rate of 10 Mbps for Ethernet services is not supported.
- You have configured the IRT operating mode with "Flexibility". You now need to re-configure the PN/PN Coupler with the "IRT" operating mode for STEP 7 TIA Portal.
- Vendor-specific diagnostics: the User Structure Identifier (USI) is reduced from 4 bytes to 3 bytes.

PN/PN Coupler ≥ V4.0 with configuration for firmware version ≤ V3.0

If you are using a PN/PN-Coupler as of article number 6ES7 158-3AD10-0XA0 and firmware version V4.0 under configuration of a PN/PN Coupler with FW version ≤ V3.0 (compatibility mode), the PN/PN Coupler works in the module operating mode "IO Modules".

The data validity of the coupled user data in this module operating mode is ensured by the provided user data flags of the PROFINET system.

Note

Module operating mode for PN/PN Coupler with firmware version ≤ 3.0"

The module operating mode "IO Modules" for the firmware version ≤ V3.0 uses the concept of closer data coupling. This means no additional data status byte (DS) is used for the input modules.

Glossary

Autonegotiation

Configuration protocol in Fast Ethernet. Before the actual data transfer, the devices on the network agree on a transfer mode that each participating device can work with (100 Mbps or 10 Mbps, full-duplex or half-duplex).

Bus

A common transfer route connecting all nodes and having two defined ends.

BusAdapter

Enables free selection of the connection technology and layout for the PROFINET fieldbus.

Cross-over cable

A cross-over cable is a four-wire or eight-wire twisted pair cable in which specific cable wires are swapped in one of the two RJ45 connectors. You can use a cross-over cable to connect two controllers directly with each other.

Data record routing

Forwarding of data records beyond subnet boundaries from a sender to receivers via a router.

Data status byte (for inputs only)

Users need the data status byte (DS) to check the validity of the coupled user data. An additional byte is added to all input modules; it can be evaluated in the user program.

Device name

Before an IO Device can be addressed by an IO Controller, it must have a device name. This procedure was selected for PROFINET because names are easier to handle than complex IP addresses.

Assignment of a device name for a specific IO Device can be compared with the setting of the PROFIBUS address for a DP slave.

An IO Device does not have a device name upon delivery. Only once a device name has been assigned using the PG/PC, can an IO Device be addressed by an IO Controller, e.g. for the transmission of configuring data (including the IP address) during start-up or for the exchange of useful data in cyclic mode.

Device replacement without removable medium/programming device

IO Devices having this function can be replaced simply:

- A removable medium (such as Micro Memory Card) with the stored device name is not required.
- The device name does not have to be assigned using the programming device.

The replaced IO Device receives the device name from the IO Controller, not from the removable medium or from the programming device. For this purpose, the IO Controller uses the configured topology and the neighborhood relationships determined by the IO Devices. The configured setpoint topology must agree with the actual topology.

Diagnostics

Diagnostics is the detection, localization, classification, display and further evaluation of errors, faults, and messages.

Diagnostics provides monitoring functions that run automatically while the system is in operation. This increases the availability of systems by reducing setup times and downtimes.

Earth

The conductive earth whose electric potential can be set to zero at any point.

Electromagnetic compatibility (EMC)

Electromagnetic compatibility is understood as the ability of a piece of electrical equipment to function perfectly in a specified environment without impacting on its surroundings in an impermissible way.

Equipment, electrical

All components, power circuits or parts of power circuits that are normally to be found in one single enclosure.

Equipotential bonding

Electrical connection (equipotential bonding conductor) that brings the conductive parts of electrical equipment and other conductive parts to the same or approximately the same potential in order to prevent troublesome or dangerous voltages arising between these parts.

External lightning protection

External lightning protection is part of the lightning protection system and comprises an interception device, an arrester and a grounding system. In the event of a lightning strike, the external lightning protection serves to divert the lightning current safely to the ground.

Corresponds with lightning protection zone 0_A and 0_B.

Fast Ethernet

Fast Ethernet describes the standard for transmitting data at 100 Mbps. This transfer technology uses the 100 Base-T standard for this.

Firmware update

Updating of firmware of interface module

After (compatible) function extensions or after improvements to performance, the interface module can be updated to the latest firmware version.

Ground

The ground refers to all the interconnected inactive parts of a piece of equipment that, even in the event of a fault, cannot pick up voltage that is dangerous to touch.

Grounding

Grounding means connecting an electrically conductive part to a grounding system by means of the ground electrode.

GSD file

The properties of a PROFINET device are described in a GSD file (General Station Descriptor), which contains all the information required for configuration.

As with PROFIBUS, you can link a PROFINET device in STEP 7 by means of a GSD file.

In PROFINET IO, the GSD file is always in XML format. The structure of the GSD file corresponds to ISO 15734, the worldwide standard for device descriptions.

HW Config

Part of STEP 7 for configuring hardware.

Isochronous real-time communication

Synchronized transmission method for the cyclic exchange of IRT data between PROFINET devices.

A reserved bandwidth is available within the send cycle for IRT IO data. The reserved bandwidth guarantees that IRT data can also be transferred at reserved, synchronized intervals while other, higher network loads are active (for example, TCP/IP communication, or additional real-time communication).

LAN

Local Area Network; interconnects multiple computers within a company. The geographical topology of a LAN is limited to the local premises and is only available to the operating company or institution.

LLDP

LLDP (Link Layer Discovery Protocol) is a protocol that is used to detect the closest neighbors. It enables a device to send information about itself and to save information received from neighboring devices in the LLDP MIB. This information can be looked up via the SNMP. This information allows a network management system to determine the network topology.

MAC address

Each PROFINET device is assigned a worldwide unique device identifier in the factory. This 6-byte long device identifier is the MAC address.

The MAC address consists of:

- 3-byte manufacturer ID and
- 3-byte device ID (sequential number).

The MAC address is placed legibly on the front of the device
e.g.: 08-00-06-6B-80-C0

MDI

In network connections it is normal for each device to be equipped with separate cable wires for transmitting and receiving. The network sockets (MDI) must be coupled in such a way that the transmit wire of one device lines up with the receive wire of the other device. If you use a cross-over cable, the wires are thereby interchanged (crossed) and communication is possible without additional devices.

MDI-X

The MDI-X connection type refers to a socket that is already internally crossed in the device. It is common in distribution devices, such as switches.

Parameter assignment

The term parameterization denotes the transfer of parameters from the IO Controller to the IO Device.

PELV

Protective Extra Low Voltage = extra low voltage with safe isolation that is grounded.

Power supply unit

A power supply unit supplies power to the field devices and the distributed process I/Os connected to them.

Prioritized startup

Prioritized startup denotes PROFINET functionality for accelerating the startup of IO Devices in a PROFINET IO system with RT and IRT communication. The function reduces the time that the correspondingly configured IO Devices require in order to return to the cyclic user data exchange in the following cases:

- After the supply voltage has returned
- After station recovery
- After IO Devices have been activated

Process image

The process image is part of the IO Controller's system memory. The signal states of the input modules are transferred to the process-image inputs at the beginning of the cyclic program. At the end of the cyclic program, the process image of the outputs is transferred to the IO Controller as signal status.

PROFIBUS International

Technical committee dedicated to the definition and development of the PROFIBUS and PROFINET standard.

PROFINET

Within the context of Totally Integrated Automation (TIA), PROFINET is the systematic continuation of the following systems:

- PROFIBUS DP, the established fieldbus
- Industrial Ethernet, the communication bus for the cell level

Experiences from both systems have been and are being integrated in PROFINET.

PROFINET is an Ethernet-based automation standard of PROFIBUS International (previously PROFIBUS User Organization e.V.), and defines a multi-vendor communication, automation, and engineering model. PROFINET has been part of IEC 61158 since 2003.

See PROFIBUS International

PROFINET components

A PROFINET component includes all data of the hardware configuration, the parameters of the modules, and the associated user program. The PROFINET component comprises the following elements:

- Technological function
The (optional) technological (software) function includes the interface to other PROFINET components as interconnectable inputs and outputs.
- Device
The device represents the physical automation device or field device, including the IO, sensors and actuators, mechanical system, and device firmware.

PROFINET device

A PROFINET device always has at least one Industrial Ethernet port. Additionally, a PROFINET device can have a PROFIBUS connection: as master with proxy functions. In exceptions, a PROFINET device can also have a several PROFIBUS connections (for example CP 5614).

PROFINET IO Controller

Device by means of which connected IO Devices are addressed. In other words: The IO Controller exchanges input and output signals with the assigned field devices. The IO Controller is often the controller in which the automation program is executed.

PROFINET IO

Within the context of PROFINET, PROFINET IO is a communication concept for implementing modular, distributed applications.

PROFINET IO allows you to create automation solutions familiar from PROFIBUS.

Implementation of PROFINET IO is carried out on the one hand via the PROFINET standard for automation devices and on the other by using the engineering tool STEP 7.

This means that you have the same application layer in STEP 7 – regardless of whether you configure PROFINET devices or PROFIBUS devices. The programming of your user program is identical for PROFINET IO and PROFIBUS DP when you use the blocks and system status lists expanded for PROFINET IO.

PROFINET IO Device

Distributed field device which is assigned to one of the IO Controllers (e.g. remote IO, valve terminals, frequency converter, switches).

Reference potential

Potential that is used to view and/or measure voltages for each circuit involved.

SELV

Safety extra low voltage (SELV) is voltage ≤ 30 V AC/60 V DC that is generated via a safety transformer or accumulator.

SNMP

SNMP (Simple Network Management Protocol) is the standardized protocol, for diagnosing and also configuring the Ethernet network infrastructure.

In the office setting and in automation engineering, devices from many different manufacturers support SNMP on the Ethernet.

SNMP-based applications can be operated on the same network in parallel to applications with PROFINET.

The scope of the supported functions differs depending on the device type. For example, a switch has more functions than a CP 1616.

Switch

PROFIBUS is a linear network. The communication nodes are connected with one another by means of a passive line - the bus.

By contrast, the Industrial Ethernet consists of point-to-point connections: each communication node is directly connected to exactly one communication node.

If a communication node is connected with several communication nodes, this communication node is connected to the port of an active network component - the switch. Additional communication nodes (including switches) can now be connected to the other ports of the switch. The connection between a communication node and the switch remains a point-to-point connection.

A switch also has the task of regenerating and distributing received signals. The switch "learns" the Ethernet address(es) of a connected PROFINET device or other switches and only forwards signals, which are destined for the connected PROFINET device or the connected switch.

A switch has a specific number of ports. You connect at most one PROFINET device or additional switch to each port.

TN-S system

In a TN-S system, the neutral conductor (N) and protective conductor (PE) are wire with separate insulation. The neutral conductor is connected to the grounded protective conductor at a central point, and only there. The protective conductor can be grounded any number of times.

Transmission rate

The transmission rate specifies the number of bits transmitted per second.

ungrounded

Having no conductive connection to earth

User data flag

Each IO module is assigned a value in the input or output data message; this value provides a statement on the quality of this user datum. For example, outputs of a specific module can be switched off by means of this without affecting other modules.

Index

2

- 24 V DC connector, 121
- 24 V DC power supply, 30

A

- Accessories, 20, 121
- Approval
 - ATEX, 106
 - CE, 104
 - cULus, 104
 - cULus HAZ. LOC., 105
 - IECEX, 106
- Approvals, 103
 - FM, 105
- Area of application, 13
- Article number, 18, 121
- Assignment of the modules, 38
- ATEX approval, 106

B

- Basic knowledge, 3
- Boundary conditions
 - cross-network data record transfer, 55
 - Local data record transfer, 58
- BusAdapter, 121

C

- CE approval, 104
- Climatic environmental conditions, 114
- Commissioning, 49
- Compatibility limitations, 124
- Components for mounting, 24
- Configuration
 - Overview, 36
- Configuring, 56
 - cross-network data record transfer, 56
 - Local data record transfer, 58
 - RD LOCAL PUB, 56, 58
 - RD LOCAL STO, 56, 58
 - with a different configuration tool, 45

- with GSD file, 45
 - with STEP 7 TIA Portal, 40
- Configuring with STEP 7 TIA Portal
 - Example, 41
- Connections, 31
- cULus approval, 104
- cULus HAZ. LOC approval, 105
- Customer benefits, 13

D

- Data record transfer, (Storage module type)
 - cross-network, 52
 - Local, 56
 - Publisher module type, 61
- Data status byte, 96
- Data validity display, 97
- Degree of protection, 115
- Delivery state, 101
- Device name
 - Deleting, 101
- Device replacement, 64
- Diagnostic data records
 - Structure, 96
- Diagnostics
 - after IO controller STOP, 98
 - after recovery of the IO device, 98
 - Extended channel diagnostics, 93
 - Options for reading out, 96
 - Shared Device, 97
- Diagnostics interrupt, 94
- Dimension drawing, 120
- Display elements, 21, 89
- Disposal, 3

E

- Electrical isolation, 28
- Electromagnetic compatibility (EMC), 109
- EMC (Electromagnetic compatibility), 109
- EMERGENCY STOP equipment, 29
- Environmental conditions
 - Climatic, 114
 - Mechanical, 113, 114
 - Operation, 112
 - Transport and storage, 111

Equipment
 Open, 23
ER (LED), 89
Error displays, 89
Extended channel diagnostics, 93

F

Factory settings
 Delivery state, 101
 Resetting to, 101
FM approval, 105
Functions
 New, 12

G

Galvanic properties, 28
Grounding, 28
GSD file, 45
 of STEP 7 TIA Portal, 43

I

Identification data, 49
IEC 61131, 106
IECEX approval, 106
Installation
 Ungrounded, 28
Installation rules
 Mounting position, 23
Interfaces, 21
Interference
 Pulse-shaped, 109
 sinusoidal, 109
Interrupt
 Diagnostics interrupt, 94
 Update interrupt, 94
IO controller STOP
 Subsequent diagnostics, 98
Isochronous real-time communication, 65
Isolation, 115

K

Korea Certification, 106

L

Labeling strips, 121

LEDs, 89
Lightning protection
 24 V DC power supply, 30
LK (LED), 89

M

Maintenance alarm, 94
Marine approval, 107
Marking for the Eurasian Customs Union, 106
Mechanical environmental conditions, 114
Media redundancy, 67, 84
Media Redundancy with Planned Duplication (MRPD), 71
Module
 PROFIsafe, 39
Module replacement, 100
Module type
 Publisher, 56
 Storage, 56
Module-internal Shared Input/Shared Output, 68
Modules
 Assignment, 38
Mounting, 24
Mounting position, 23
Mounting rail, 121
Mounting technology, 23
MT (LED), 89

O

OB 56, 61
One-sided system redundancy S2, 86
Operating conditions, 112

P

Parameters, 47
PN/PN Coupler
 as docking station, 71
 as docking unit, 71
 Mounting, 24
 Parameter assignment, 47
 Replacing, 100
 Uninstalling, 24
Power supply
 Connecting, 32
 on both sides, 32
Principle of operation, 17
Prior knowledge, 3
Prioritized startup, 66

PROFINET IO
Standard, 107
PROFIsafe module, 39
Properties, 19, 28
 via PROFINET IO, 20
Protection class, 115, 115
PS (LED), 89
Purpose of this manual, 3

R

Radio interference, 108
Radio interferences
 Emission of, 110
Rated voltage, 115
RCM Declaration of conformity for Australia/New Zealand, 106
Reading out service data, 98
Recovery of the IO device
 Subsequent diagnostics, 98
Recycling, 3
Redundancy
 active, 85
Reference identification label, 121
Replacement
 Defective PN/PN Coupler, 100
Response times, 123
 Influencing factors, 123
RN (LED), 89

S

Safety rules, 103
Scope, 3
Shared Device, 68
 Diagnostics, 97
Standard mounting rail, 24
Standards, 103, 104
Status and error displays
 LEDs, 89
Status displays, 89
Strain relief, 26, 121
System redundancy, 83
System redundancy S2, 84
 One-sided, 86
 Two-sided, 87

T

Technical specifications
 Electromagnetic compatibility (EMC), 109

PN/PN Coupler, 116
Standards and approvals, 103
Test voltage, 115
Two-sided power supply, 32
Two-sided system redundancy S2, 87

U

Ungrounded installation, 28
Uninstalling, 24
Update interrupt, 61, 94
Updating firmware, 99
Use
 in industrial environments, 107
 in mixed areas, 107
 in residential areas, 108

V

Vibrations, 113
View, 18

W

WEEE mark (European Union), 107