

DIGITAL GRAND PIANO

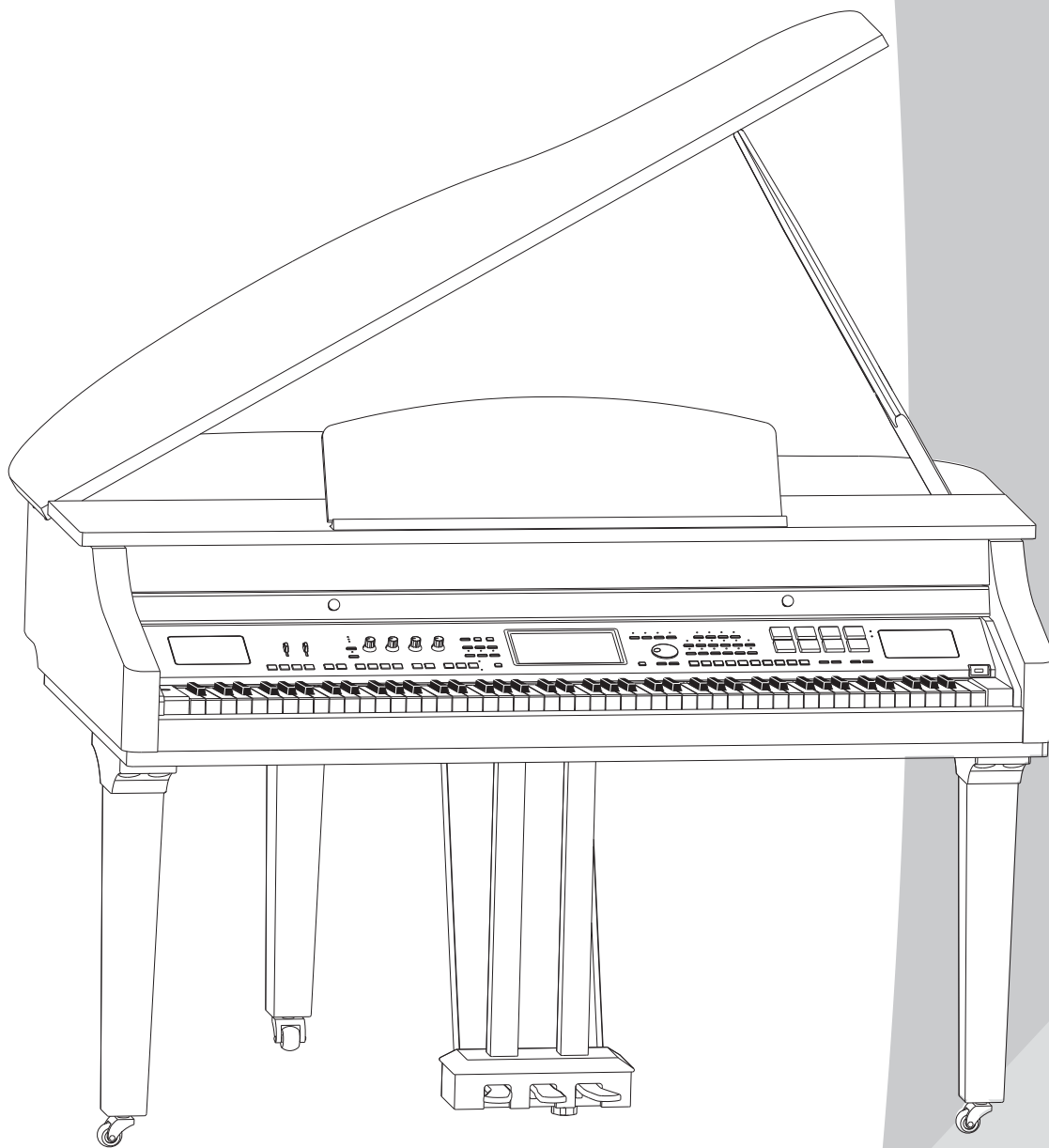

Quick Start Guide

INFORMATION FOR YOUR SAFETY!

THE FCC REGULATION WARNING (for USA)

This equipment has been tested and found to comply with the limits for a Class B digital device, pursuant to Part 15 of the FCC Rules.

These limits are designed to provide reasonable protection against harmful interference in a residential installation. This equipment generates, uses, and can radiate radio frequency energy and, if not installed and used in accordance with the instructions, may cause harmful interference to radio communications. However, there is no guarantee that interference will not occur in a particular installation. If this equipment does cause harmful interference to radio or television reception, which can be determined by turning the equipment off and on, the user is encouraged to try to correct the interference by one or more of the following measures:

- Reorient or relocate the receiving antenna.
- Increase the separation between the equipment and receiver.
- Connect the equipment into an outlet on a circuit different from that to which the receiver is connected.
- Consult the dealer or an experienced radio/TV technician for help.

Unauthorized changes or modification to this system can void the user's authority to operate this equipment.

CAUTION

The normal function of the product may be disturbed by Strong Electro Magnetic Interference. If so, simply reset the product to resume normal operation by following the owner's manual. In case the function could not resume, please use the product in other location.

Regarding the display

This instrument display is a precision device created using extremely high technology, and careful attention has been paid to its product quality. Although you may notice some of the issues listed below, please be aware that these are due to the characteristics of LCD displays, and are not malfunctions.

- There may be pixels in the display that are always dark (unlit) or always bright (lit).
- Depending on the displayed content, the brightness of the display may appear uneven.
- Depending on the displayed content, horizontal stripes of shading may be visible.
- Depending on the displayed content, flickering or moire patterns may be visible.

PRECAUTIONS

PLEASE READ CAREFULLY BEFORE PROCEEDING

Please keep this manual in a safe place for future reference.

Power Supply

Please connect the designated Power Cord to an AC outlet of the correct voltage.

Do not connect it to an AC outlet of voltage other than that for which your instrument is intended.

Unplug the Power Cord when not using the instrument, or during electrical storms.

Connections

Before connecting the instrument to other devices, turn off the power to all units. This will help prevent malfunction and / or damage to other devices.

Location

Do not expose the instrument to the following conditions to avoid deformation, discoloration, or more serious damage:

- Direct sunlight
- Extreme temperature or humidity
- Excessive dusty or dirty location
- Strong vibrations or shocks
- Close to magnetic fields

Interference with other electrical devices

Radios and televisions placed nearby may experience reception interference. Operate this unit at a suitable distance from radios and televisions.

Cleaning

Clean only with a soft, dry cloth.

Do not use paint thinners, solvents, cleaning fluids, or chemical-impregnated wiping cloths.

Handling

Do not apply excessive force to the switches or controls.

Do not let paper, metallic, or other objects into the instrument. If this happens, unplug the Power Cord from the wall outlet. Then have the instrument inspected by qualified service personnel.

Disconnect all cables before moving the instrument.

Introduction

Panel & Display Description	
Front Panel.....	4
Rear Panel.....	5
Main Display.....	6
Setup	
Part List.....	7
Setup Guide.....	8
Connections	
Power Supply.....	12
Connecting a pair of Headphones.....	12
Connecting an Audio Equipment.....	12
Connecting an MP3/CD Player.....	13
Connecting a Microphone.....	13
Connecting a Computer.....	13
Connecting External MIDI Devices.....	13

Quick Start

Basic Operations	
Selection Operation.....	14
Soft Keyboard Operation.....	14
Setting Operation.....	15
Playing the Demos	16
Playing Voices	17
Playing with a Style	18
Playing Songs	19
Recording Your Performance to MIDI	20
Recording Your Performance as Audio	21
Using a USB Storage Device	22

Appendices

Troubleshooting	23
Specification	24
Appendices	
Voice List.....	25
Style List.....	31
Song List.....	32
Demo List.....	32
Chord List.....	33
MIDI Implementation List.....	34

Panel & Display Description

Front Panel

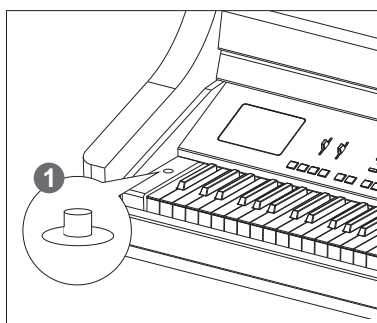
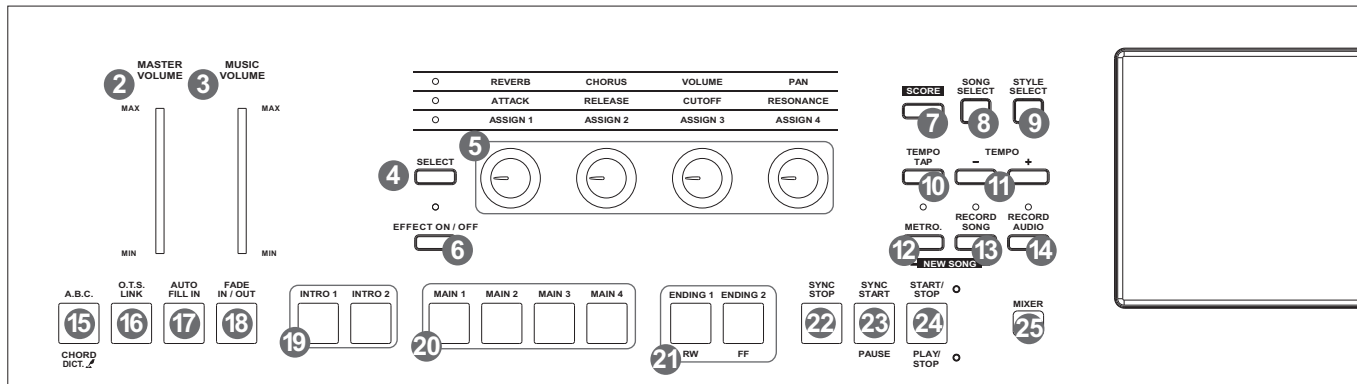

1. POWER ON/OFF BUTTON

Turn the power on or off.

2. MASTER VOLUME SLIDER

Adjust the master volume.

3. MUSIC VOLUME SLIDER

Adjust the volume of the playing style or the playing song.

4. SELECT BUTTON

Select the three effect combinations of GROUP KNOBS sequentially.

5. GROUP KNOBS

Effect1: Adjust reverb level, chorus level, volume, pan of the RIGHT 1 voice.

Effect2: Adjust attack time, release time, the filter cut off frequency, the amount of resonance applied at the filter cutoff frequency of the RIGHT 1 voice.

Effect3: The knob effect can be assigned separately. See “Controller”.

6. EFFECT ON/OFF BUTTON

Turns the keyboard effect (arpeggio, harmony, chopper) on or off.

7. SCORE BUTTON

Show the staff of the current song (SMF).

8. SONG SELECT BUTTON

Enter the SONG SELECT interface.

9. STYLE SELECT BUTTON

Enter the STYLE SELECT interface.

10. TEMPO TAP BUTTON

Change the tempo by “tapping” out the tempo with this button.

11. TEMPO+, TEMPO- BUTTONS

Adjust the current tempo.

12. METRO. BUTTON

Turn the Metronome on or off.

13. RECORD SONG BUTTON

Enter the RECORD SONG interface. You’ll record your performance in SMF format.

14. RECORD AUDIO BUTTON

Enter the audio recording is in ready state. You’ll record your performance in WAV format.

15. A.B.C. BUTTON

Turn the A.B.C. MODE on or off.

16. O.T.S. LINK BUTTON

Turn the O.T.S. LINK on or off. If it is turned on, the One Touch Settings can be changed when you select different style.

17. AUTO FILL IN BUTTON

Turn the AUTO FILL IN on or off.

18. FADE IN/OUT BUTTON

Turn the FADE IN or OUT on or off.

19. INTRO 1, 2 BUTTONS

Play the intro.

20. MAIN 1, 2, 3, 4 BUTTONS

Play the main part.

STYLE CONTROL

21. ENDING 1, 2 BUTTONS

Play the ending.

22. SYNC. STOP BUTTON

Turn the SYNC. STOP on or off.

23. SYNC. START BUTTON

Turn the SYNC. START on or off.

24. START/STOP BUTTON

Start or stop playing the style.

SONG

21. RW, FF BUTTONS

Rewind and fast forward the song.

23. PAUSE BUTTON

Pause the song playback.

24. PLAY/STOP BUTTON

Start playing the song or stop the song playback.

25. MIXER BUTTON

Enter the MIXER interface.

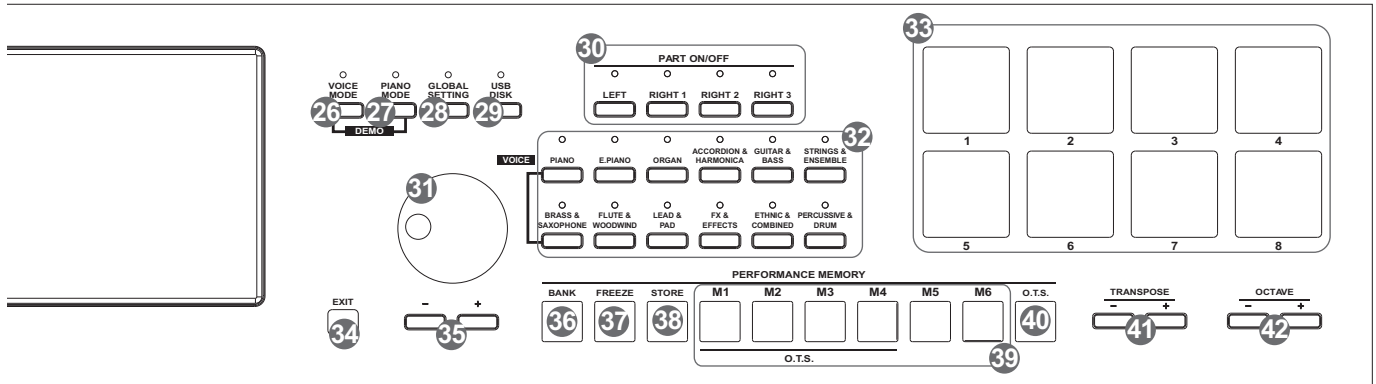

26. VOICE MODE BUTTON
Enter the VOICE mode.

27. PIANO MODE BUTTON
Enter the PIANO mode.

28. GLOBAL SETTING BUTTON
Enter the GLOBAL SETTING interface.

29. USB DISK BUTTON
Enter the USB DISK interface.

30. PART ON/OFF BUTTONS
Turn LEFT, RIGHT1, RIGHT2, RIGHT3 on and off individually.

31. DATA DIAL
Increase and decrease the value.

32. VOICE BUTTONS
Enter the VOICE SELECT interface. You'll select a voice category.

33. MULTI PADS
Add spice to your performance with special dynamic phrases by pressing them.

34. EXIT BUTTON
Exit the current interface and return to the previous display.

35. +, - BUTTONS
Increase and decrease the value by 1.

36. BANK BUTTON
Enter the PERFORMANCE SELECT interface.

37. FREEZE BUTTON
Turn the FREEZE function on or off.

38. STORE BUTTON
Save the panel setups to one of the performance memories.

39. M1-M6 BUTTONS
PERFORMANCE MEMROY:
Recall the panel setups from one of the performance memories.
O.T.S (M1-M4):
Call up all the settings (voice, effect, etc) that match the current style.

40. O.T.S. BUTTON
Switch to the O.T.S. function.

41. TRANSPOSE+, TRANSPOSE-BUTTONS
Adjust the TRANSPOSE value.

42. OCTAVE+, OCTAVE-BUTTONS
Adjust the OCTAVE value.

43. USB PORT
Connect the USB storage device.

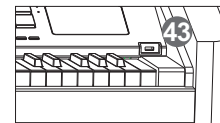

Rear Panel

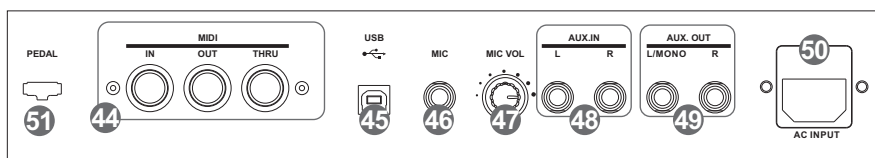

44. MIDI IN/OUT/THRU JACKS
Connect other products equipped with a MIDI interface.

45. USB JACK
Connect to a computer.

46. MIC JACK
Connect a microphone.

47. MIC VOL KNOB
Adjust the input volume of the microphone.

48. AUX IN JACKS
Connect any external audio source, such as an MP3 or CD player.

49. AUX OUT JACKS
Connect to your amp/audion system. For monaural output, use the L/MONO jack.

50. AC POWER INLET
Connect the AC power cable to this inlet.

51. PEDAL JACK
Connect pedals.

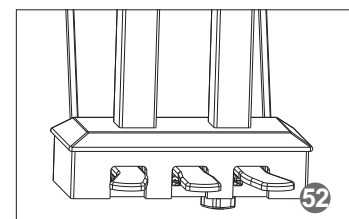

52. PEDALS
The function of pedal can be set. The default settings are soft, sostenuto, sustain from left to right.

Panel & Display Description

Main Display



1. Voice

Display voice name and octave data of each part.
(Right1, Right2, Right3, Left)

How to select the voice for each part?

For example:

1. Pressing anywhere in the R1 display area makes the R1 part selected.
2. Pressing again will call up the Voice Selection display.
Now, you can select the voice for R1.

2. Style&Song

Display the currently selected style name, for example "8Beat Ballad". Pressing this name will call up the Style Selection.

Pressing song tab will display the currently selected song name, for example "Brahms Waltz". Pressing this name will call up the Song Selection display.

3. Performance

Display the currently selected performance name.
Pressing this name will call up the Performance Selection display.

4. Chord

Display the chord name and related information.

- A. Chord Name
- B. Chord Mode
- C. Split

5. Shortcut to setup pages

- Pressing "Split Point" will call up the Split Setting quickly.
- Pressing "Effect" will call up the Effect Setting quickly.
- Pressing "Controllers" will call up the Controllers display quickly.

6. Others

- The amount of transposition in semitone units.
- Current tempo.
- Current playback position.
- Current time signature.

This section contains information about setting up your instrument and preparing to play. Please go through this section carefully before turning the power on.

Part List

Before you proceeding to assemble the stand, get a Philip's screwdriver (not supplied). Make sure you have the following parts, which are supplied into package.

A	Pedal component
B	Right leg component
C	Left leg component
D	Rear leg component
E	Piano body
F	Slice
G	M12X45mm hexagonal bolt
H	3x15mm screw
I	Copper pole
J	Wrench

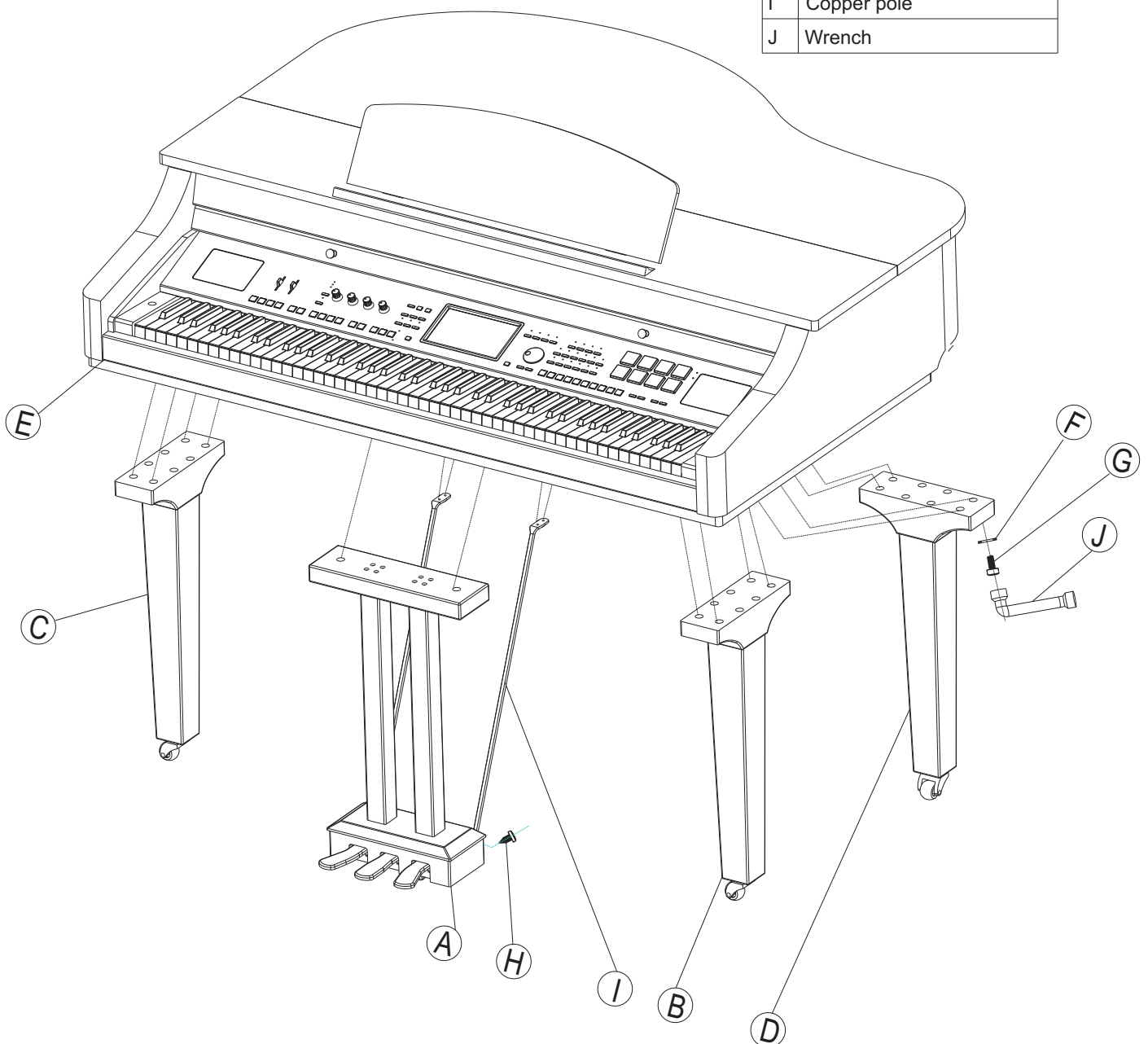

Setup Guide

- A. Please reverse the carton to upside down and place it in the horizontal before you initial assembly the piano. Make sure the bottom surface of carton is up. Then open the box, take off the foams which used for protected piano body.

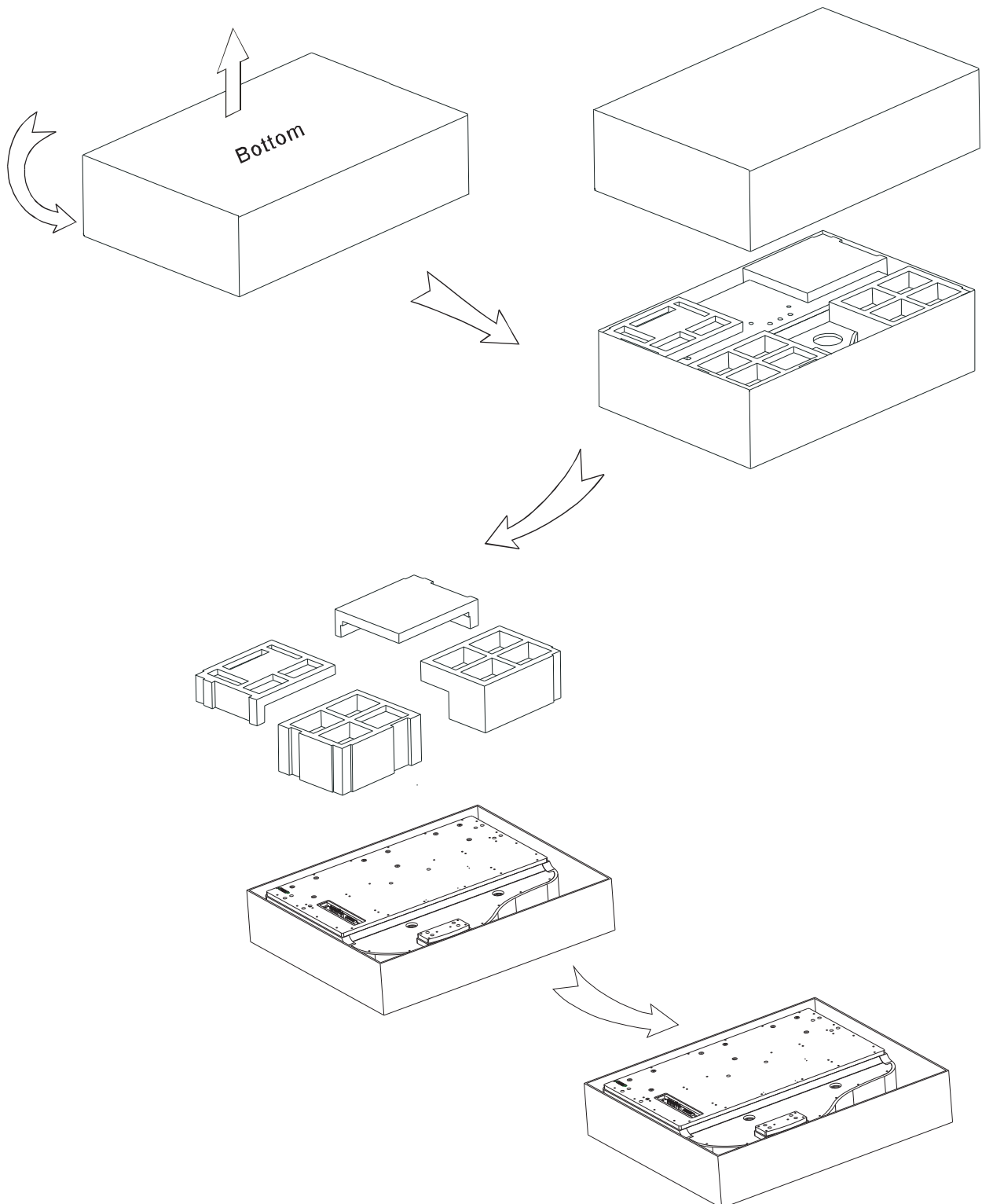

B. Put the left leg component(C) on the left of piano body. Find the sunken hole on the leg component and correspond the hole on the piano body. Then place a washer into this sunken hole, Use Wrench (J) to tighten 4 pieces of hexagonal bolt (2 on each side) by clockwise turn.

Please see below illustrator for you detail reference.

(Make sure the direction of the placement is correct before screwing)

Fix the Right leg component(B) and Rear leg component(D) to Piano body (E) with Hexagonal bolt(G) according finished assembly in left leg component.

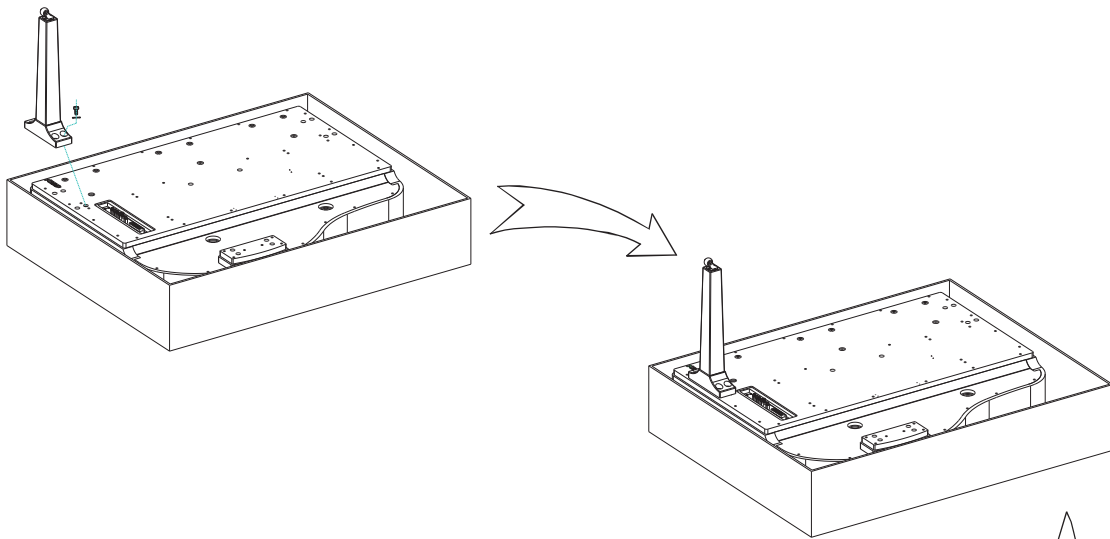

How to screwing the hexagonal bolt?

Put a Washer into the sunken hole on the leg component.

* Put the hexagonal bolt into the sunken hole, then screwing it

* Use the Wrench snapped the cap of Hexagonal bolt, put together the leg component and the piano body by clockwise turn the wrench.

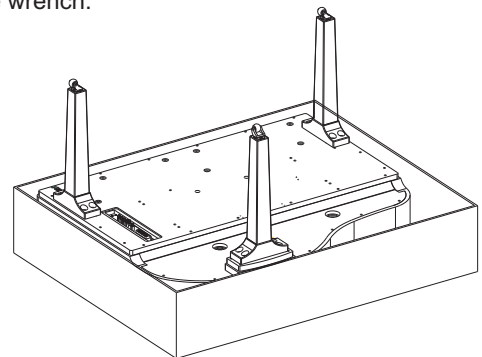
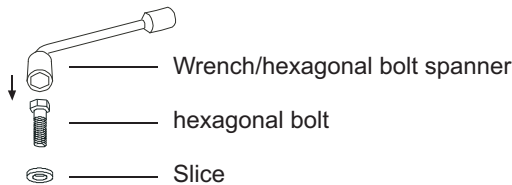
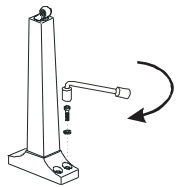

Setup

- C. Use screws(H) to tighten the two copper poles (I) onto the back of Pedal component(A). Make sure the direction of the placement is correct before screwing.

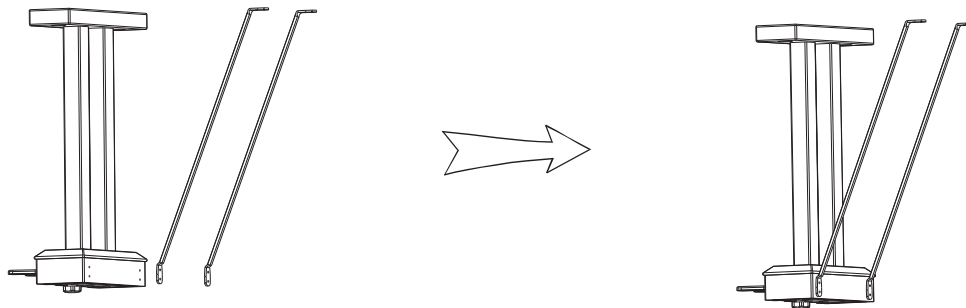

- D. Then reserved the Pedal component with two copper poles(I), and use the hexagonal bolt(G) to tightly settled it with the piano body according finished assembly in left leg component, fix the other side of copper Pole onto the piano body (E). The assembly are finished.

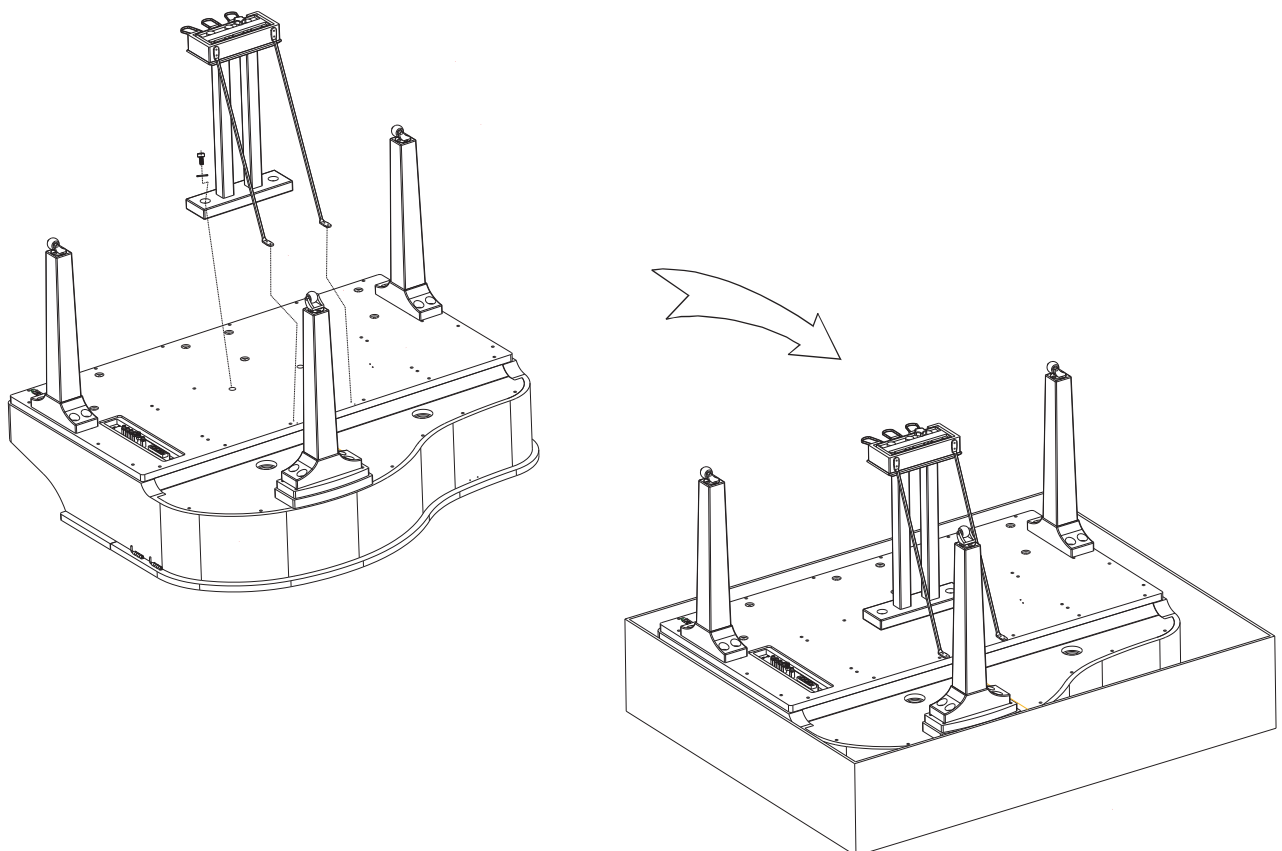

E. Reverse the piano after finished assembly.
Please carefully reverse the piano avoid touched floor cause
damaged or broke any leg components or pedal component. Then
moved the carton box and all package goods.
You can enjoy play the piano now.

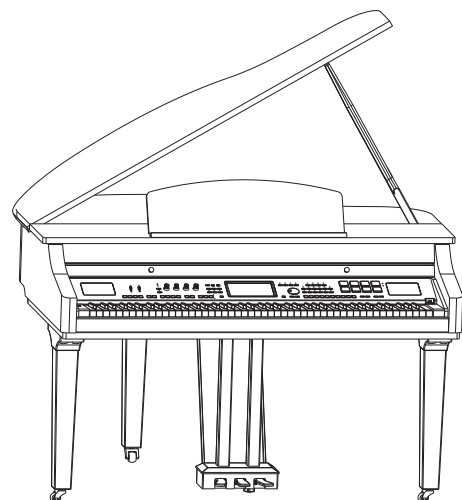
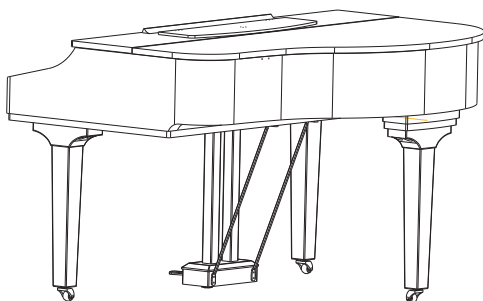
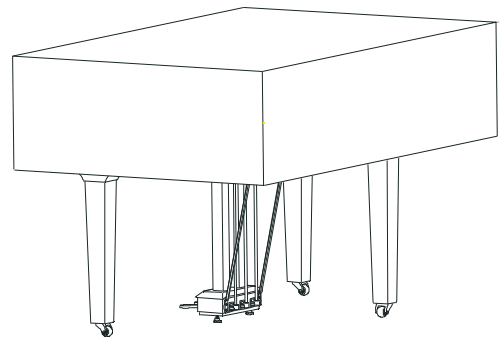
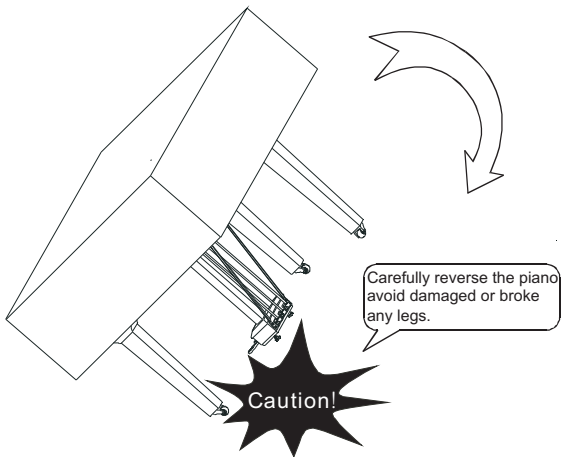
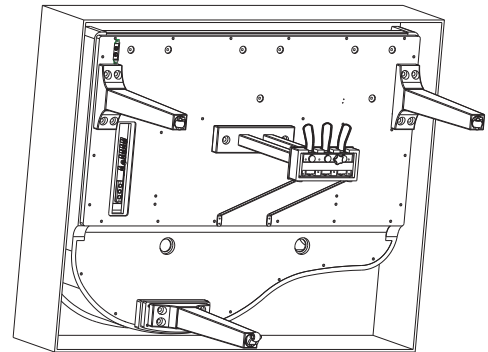
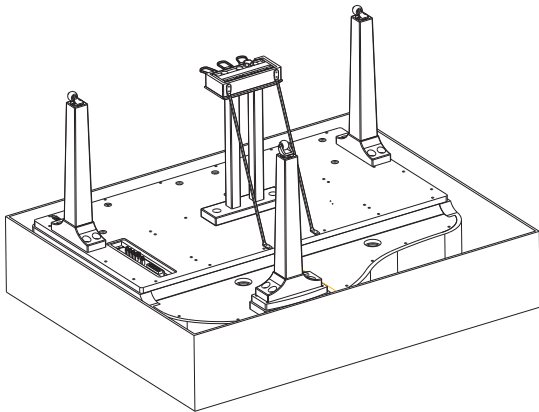

Connections

Power Supply

1. Move the MASTER and MUSIC VOLUME sliders downward to set the minimum volume level.
2. Connect the AC power cable to AC power inlet on the underside of the piano body.
3. Plug the AC power cable into an AC outlet.
4. Turn the power ON. The LCD on the panel will light up.

Note:

1. In order to save energy, we have designed the Auto Power Off function to this instrument. With this function, the instrument will be automatically powered off in 30 minutes if you do not take any action on the instrument. For more details, please refer to **Global Setting chapter**.
2. When the piano is not in use or in the time of thunderstorm, please disconnect the power for safety purpose.
3. To prevent malfunction and / or damage, always use the panel power button to power off the piano. Never unplug the power adapter before the piano is powered off, doing so may cause damage to your product.

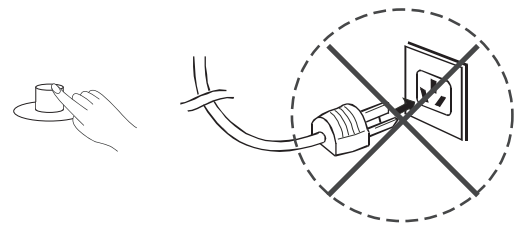
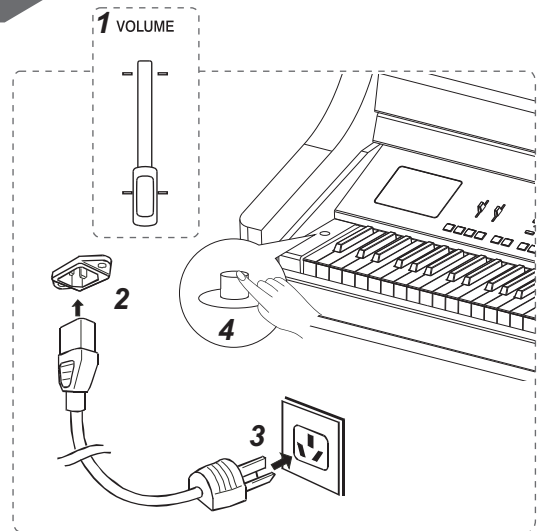

Connecting a pair of Headphones

There are two headphones jacks on the left underneath the piano body.

1. When an optional pair of stereo headphones is connected with the headphones jack 2, the sound from speakers will switch off automatically resulting in only the sound from headphone to be heard.
2. When jack 1 is connected with the stereo headphones, the sound can be heard from both headphones and speakers of the piano.
3. Connect two pairs of headphones to jack1 and jack 2, it helps the user play with the teacher or friend in a quiet surrounding.

Note:

Do not listen with the headphones at high volume for long periods of time. Doing so may cause hearing loss.

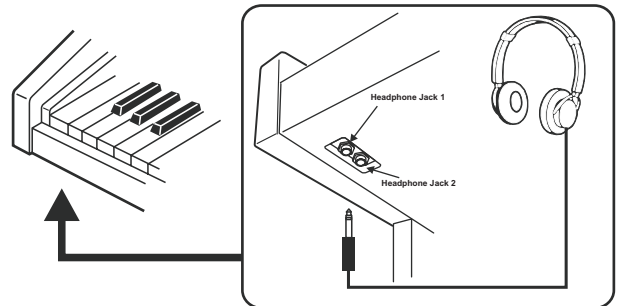

Connecting an Audio Equipment

Connect the rear-panel AUX.OUT jack to amplified speakers, amplifiers or domestic hi-fi units for external amplification. For monaural output, use the L/MONO jack.

Note:

To avoid damaging the speakers, please ensure that the volume has been set to the minimum level before connecting the power and other devices.

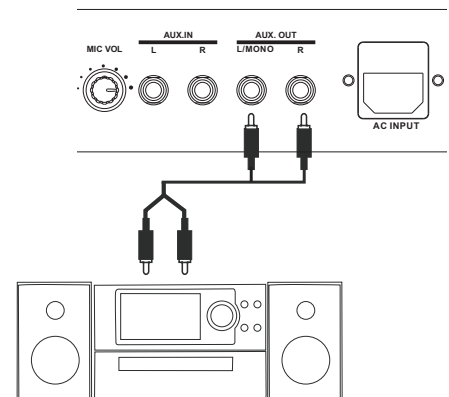

Connecting an MP3/CD Player

Connect the audio output of an MP3/CD player or other audio source to the stereo AUX IN jacks on the rear panel.

The input signal is mixed with the instrument signal, allowing you to play along.

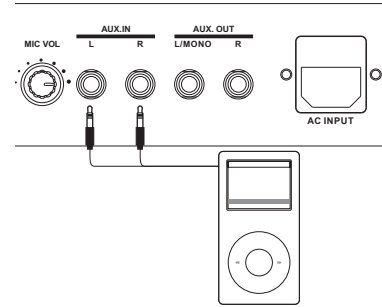

Connecting a Microphone

You can connect an external microphone to MIC IN jack. Adjust the input volume of the microphone by using MIC VOLUME knob.

Note:

Turn the volume switch counter-clockwise to reach the minimum volume level when connecting or disconnecting a microphone.

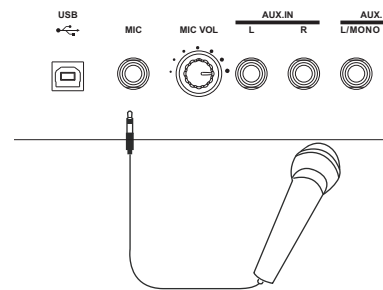

Connecting a Computer

You can simply connect the computer with USB cable via the USB connector.

You can use a commercially available MIDI interface to connect the piano to the computer via the MIDI connectors.

After the driver is installed and initialization is finished, you can choose USB Audio Device in the device menu of the software to transfer midi data.

Note:

Do not select USB audio device in both of input and output setting together, otherwise the sound overlaps.

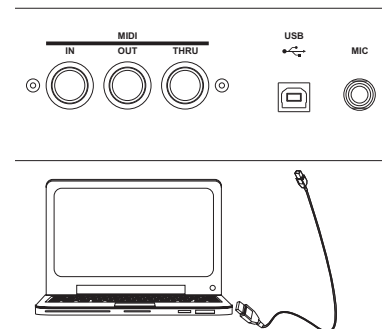

Connecting External MIDI Devices

You can use standard MIDI cables to connect external MIDI devices.

MIDI IN: Receive MIDI message from an external MIDI device.
 MIDI OUT: Transmits MIDI message generated by the instrument.
 MIDI THRU: Simply relays the MIDI message received at MIDI IN.

Note:

To avoid damages, please be sure to turn off the power switches before you disconnect the related devices from the piano.

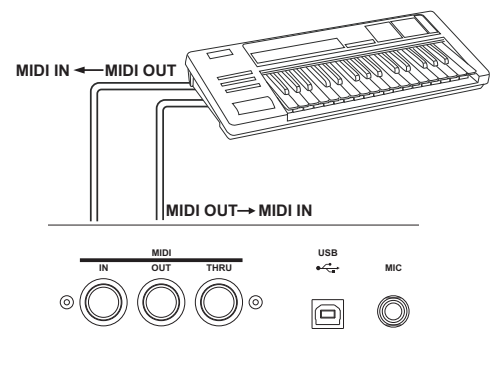

Basic Operations

Selection Operation

There are some selection interfaces: voice selection, style selection, song selection, performance selection, etc.
How to select the file in these selection interfaces?

For example:

1. Location of data

- Preset:** Location where pre-programmed (preset) data is stored.
- User:** Location where recorded or edited data is saved.
- USB:** Location where data on USB storage device is saved.

2. Category of data

The files are divided into categories according to their types. The categorization will be selected by pressing this categorization name on LCD. For example: The voice file (Grand Piano) is in the Piano categorization. Pressing "Piano" will select the Piano categorization.

3. Flip and File Browsing

10 files can be listed in one page, use screen page up or page down button to browsing files by pages.

4. File Selecting

Select the desired file by pressing the file name on the current page.

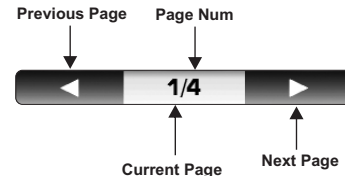

Using the Soft Keyboard

When you name or rename a file or a folder, you should call up soft keyboard display.

1. Deleting characters:

Press the delete button.

2. Moving the cursor:

Press the right or left cursor button.

3. Entering capital characters:

Press the CAPS button, the capital characters will be displayed.

4. Entering space:

Press the space button.

5. Entering numbers or marks:

Press the numbers button, the numbers and marks will be displayed.

Enter the number or mark by pressing its button.

6. Confirming OK or Cancel:

After you have finished name editing, press the OK button to actually enter the new name and return to the previous display. Or you can press the CANCEL button to cancel operations and return to the previous display.



Setting Operation

In order to have a quick reference for basic parameter settings, please remember these panel button operations during all edit procedure.

Select a voice, a style or a song

Use the DATA DIAL or [+] / [-] button to select a desired item. Quickly press [+] / [-] button for once to increase/decrease value gradually. Press and hold for a while to have a quickly change in value.

EXIT button

This is a very useful button. Sometimes, you may “lost” in a selection/setting interface, and you want back to the main display, don’t worry and just press [EXIT] button times until you get the goal display.

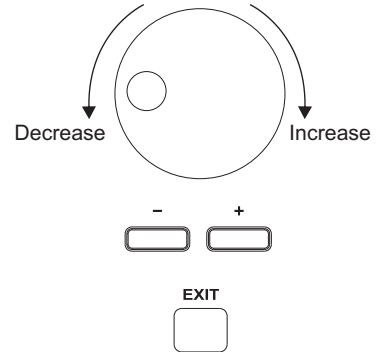

There are three types on parameter setting.

1. ON/OFF (as in the picture: ON OFF)

Press this “ON” button to switch the keyboard touch response ON or OFF.

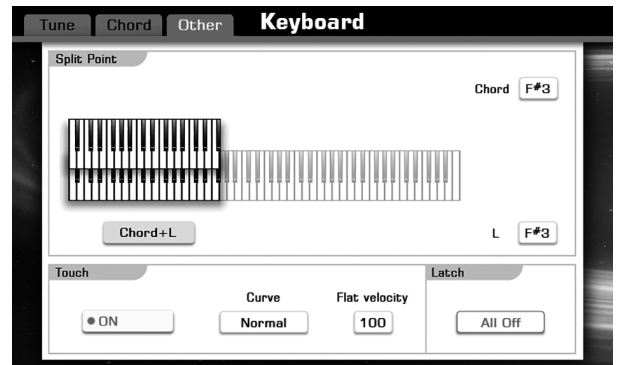

2. LIST (as in the picture: Curve

Press this “Normal” button, all available parameters would be listed.

Directly press a desired parameter on the display, or you can also use DATA DIAL or [+] / [-] button.

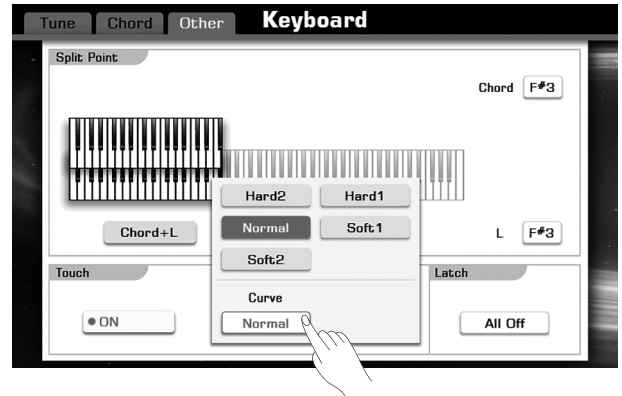

Note:

The selected parameter will be highlighted.

3. DATA (as in the picture: Flat velocity

Press this “100” button to call up a pop-up box.

Press the screen button “▲” or “▼” to adjust the data. Or you can also use DATA DIAL or [+] / [-] button.

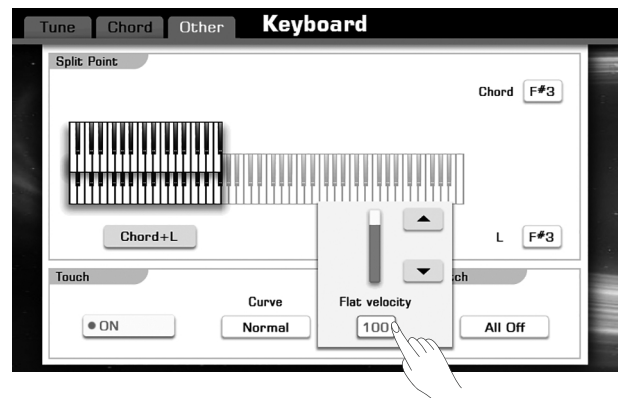

Playing the Demos

The instrument features 9 wonderful demos. Please refer to **DEMO LIST**.

Press the [VOICE MODE] and [PIANO MODE] buttons simultaneously to start playing the demo.

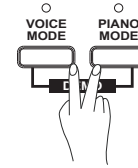

Select your desired demo

Press the Demo name on LCD or use the DATA DIAL, the [+] or the [-] button to select your desired demo.

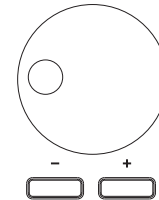

Pause the demo

Press the [PAUSE] button to pause the demo playing or continue playing the demo.



Stop the demo

Press the [PLAY/STOP] button to stop the demo playback.

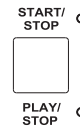

Adjust the tempo of the demo playback

Press the [TEMPO+] or [TEMPO-] button to adjust the tempo of the playback demo.



Exit the demo

Press the [EXIT] button to stop the demo playback and return to the main display.



Playing Voices

The piano has 672 remarkably realistic built-in voices, including Piano, Woodwind, Saxophone, Drum Kits and many more. Please refer to **Voice List**.

Turn the R1 PART on

Normally, the default setting is R1, or you can press PART ON/OFF [RIGHT 1] to turn the right 1 part on.

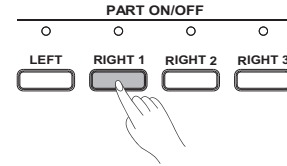

Note:

You can also turn most 4 parts on at the same time (L, R1, R2, and R3), refer to **Playing Different Voices with the Left and Right Hands** chapter for details.

Select a Voice for R1 PART

1. Select a voice category, call up voice selection display.

There are 2 methods to select a voice category:

- Panel button: press one of the panel voice category buttons located on the right-top of instrument. For example "PIANO", as the picture shown.
- Screen button: in main display, tap the R1 part.

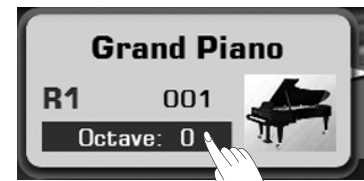
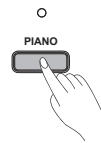

2. Select an exactly voice.

Use DATA DIAL or [+] / [-] button move cursor position step by step. The last voice you have selected will be saved as your new choice. See **Basic Operations** page description. Also can use screen page up or page down button to browsing files by pages.



Play the Voice Demo

Press the "Voice Demo" on the Voice Selection display to start the demo for the selected voice. Press the "Voice Demo" again to stop it.

Note:

If there isn't voice demo for the selected voice, "Voice Demo" will not be displayed.



Play the keyboard and listen to the selected voice.

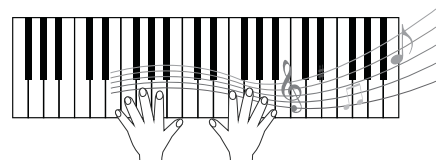

Playing with a Style

The instrument features 240 styles in a variety of different musical genres. Try selecting some of the different styles (Refer to **Style List**) and play with the auto accompaniment.

Select a style

1. Select a style category, call up style selection display.
There are 2 methods to select a style category:
 - Panel button: press the panel [STYLE SELECT] button.
 - Screen button: in main display, tap the style tab area.
2. Select an exactly style.
Use DATA DIAL or [+] / [-] button move cursor position step by step. The last style you have selected will be saved as your new choice. See **Basic Operations** page description. Also can use screen page up or page down button to browsing files by pages.



Start a style

1. Press the [A.B.C.] button.
When the [A.B.C.] is switched on, the chords you played in the specified Chord section of the keyboard will be automatically detected and will be used to control the playback of the selected style.
2. Press the [SYNC START] button.
Set Auto Accompaniment to standby—letting you simultaneously start the accompaniment as soon as you start playing in Chord section.
3. Playing the keyboard as your performance should be.
4. Press the [START/STOP] button to stop the accompaniment.

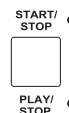
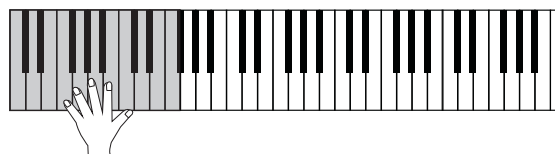
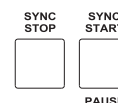

Playing Songs

The instrument features 10 piano songs. You can playback and enjoy these classical piano songs, or you can learn how to play them from the score display.

Select a Song

1. Call up the song selection display.
There are 2 methods:
 - Panel button: press the panel [SONG SELECT] button.
 - Screen button: in main display, tap the song tab area.

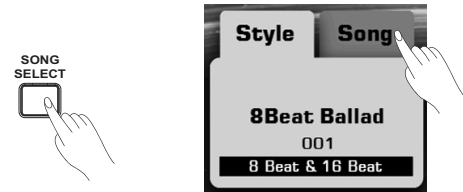

Note:

Normally, the main display shows style area as default setting, you may firstly tap the song tab in need.

2. Select an exactly song.
Use DATA DIAL or [+] / [-] button move cursor position step by step. The last song you have selected will be saved as your new choice. See **Basic Operations** page description.



Playback a Song

The instrument automatically switches to song control mode, corresponding indicator lights up.

1. Press the [PLAY/STOP] button to start playing a selected song.
There is a pre-count, about a measure length, at the beginning of one song. [PLAY/STOP] button flashes in red and blue, and the red light represents the first stressed beat.
2. If you want to pause playing.
Press [PAUSE] button to pausing a song playing, press [PAUSE] again to continue playing back.
3. Press the [PLAY/STOP] button to stop playing song.

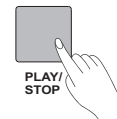
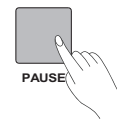
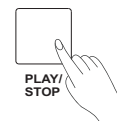

Recording Your Performance to MIDI

It is convenient to record your performance, play back your performance, and share your performance.

1. Press the [METRO.] and [RECORD SONG] panel buttons simultaneously to call up the Recording Display. A blank song ("New Song") is called up and the system is in recording standby mode. The screen displays "Waiting to Record...", at the mean time, the [RECORD SONG] starts flashing.

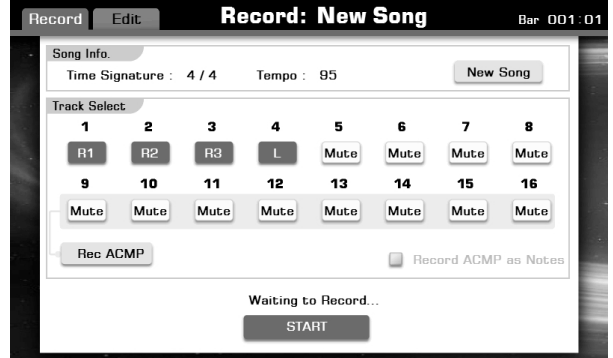
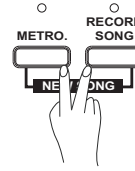

2. Play notes on the keyboard or press the [PLAY/ STOP] button to start recording. The [RECORD SONG] button will stop flashing and keep lighting.

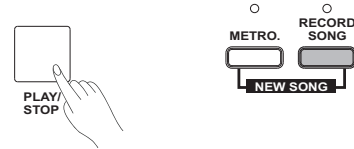

3. Press the [RECORD SONG] button or tap the "STOP" button to stop recording. There will pop-up a soft keyboard to remind you to rename the new recording or not.

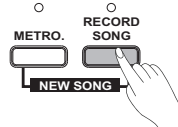

4. Enter a new name and press "OK" button to save this new recording into user location.

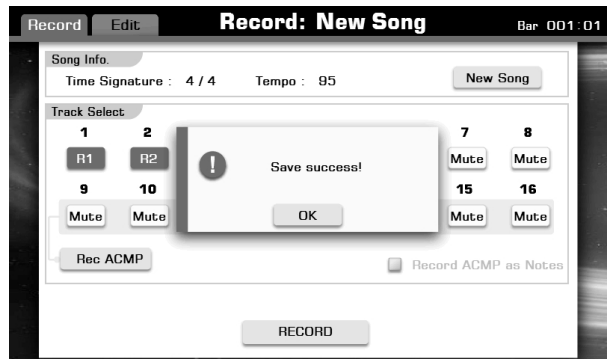

5. Press the [PLAY/ STOP] button to playback the recorded user song.

If you want to record R1, R2, R3, L or record melody and accompaniment simultaneously, you may refer to **MIDI RECORDING** for details.



Recording Your Performance as Audio

You can also record your own performance as CD quality audio file. The procedure is very simple.

1. Insert your USB disk to the USB slot.
2. Press the [RECORD AUDIO] button to start recording. The [RECORD AUDIO] lights up.
3. Play your performance immediately on the keyboard.
4. Press the [RECORD AUDIO] button again to stop recording. The soft keyboard will pop up and the [RECORD AUDIO] stops lighting.

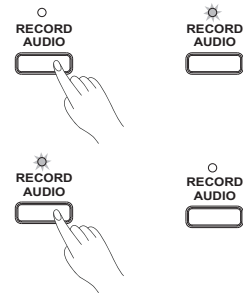

5. In soft keyboard display, enter the name and press “OK” button to confirm save operation.



6. Press the [PLAY/STOP] button to play back the recorded audio song.

For more details, please refer to **Audio Recording** chapter.



Using a USB Storage Device

By connecting a USB storage device to your instrument, you can save data you've created to the connected device, as well as read data from the connected device.

Note

Compatible USB device

Recommended Brand: KINGSTON, SANDISK, SONY, LEXAR, TRANSCEND

Format: FAT 16/32

Capacity: 1G,2G,4G,8G,16G,32G

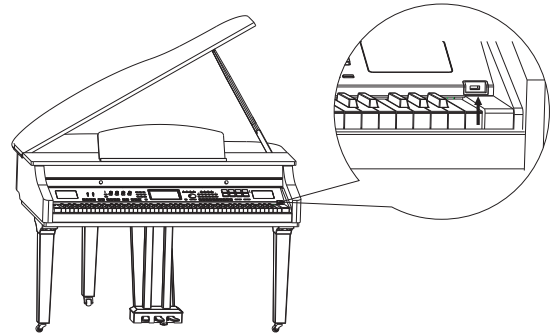

Using the USB device

1. Connect the USB storage device to the USB port.



2. Press the [USB DISK] button to display the folders and files under the root directory of USB device.

3. Press the USB tab on each selection display (such as voice, style, song, performance), enter the relevant folder directly, and save, rename or delete the user files from USB device.



Note

If you save your files to your USB storage device in file selection displays (like VOICE Selection or Song Selection), the files would be saved into folder "PianoUser" in the root directory of your USB storage device.



Problem	Possible Cause and Solution
The speakers produce a “pop” sound whenever the power is turned ON or OFF.	This is normal and is no cause for alarm.
No sound when the keyboard is played.	The R1/R2/R3/L voice volume (Mixer) settings could be set to low. Make sure the voice volumes are set at appropriate levels.
When using a mobile phone, noise is produced.	Using a mobile phone in close proximity to the instrument may produce interference. To prevent this, turn off the mobile phone or use it further away from the instrument.
The auto accompaniment does not play back even Sync is in standby condition and a key is pressed.	You may be trying to start accompaniment by playing a key in the right-hand range of the keyboard. To start the accompaniment with Sync Start, make sure to play a key in the left-hand range of the keyboard.
Certain notes sound at wrong pitch.	Make sure that the Master Tune is set to “440.1hz” and turn off the Scale Tune.
The Harmony function does not operate.	Harmony cannot be turned on when the Full Keyboard fingering mode is selected. And Harmony cannot be turned on when a drum kit is selected for the voice R1.

Specifications

Keyboard

88 keys

Display

7" TFT , 800 x 480 color touch screen

Polyphony

128

Voice

672 (including 256 GM2 instrument voices and 17 drum kits)

Effect

Reverb, Chorus, Master EQ, Arpeggio, Harmony, Chopper

Style

240

Style Control

STYLE SELECT, START/STOP, SYNC STOP, SYNC START, INTRO 1, INTRO 2, MAIN A, MAIN B, MAIN C, MAIN D, ENDING 1, ENDING 2, A.B.C., AUTO FILL IN, O.T.S. LINK, FADE IN/OUT

Song

10 Preset Songs

Song Control

SONG SELECT, PLAY/STOP, PAUSE, RW, FF

SCORE

Display the Music Notation

Record

MIDI Recorder and USB Audio Recorder

Demo

9

Tempo

30-280, Tap Tempo

Performance Memory

10(BANK)*6(M1-M6), FREEZE, STORE

Multi Pad

8

Other Control

MASTER VOLUME SLIDER, SELECT, 4 KNOBS, EFFECT ON/OFF, GLOBAL SETTING, MIXER, VOICE DIRECT BUTTONS, DATA DIAL, +, -, PART ON/OFF BUTTONS, EXIT, SUSTAIN, TRANSPOSE+, TRANSPOSE-, OCTAVE+, OCTAVE-, O.T.S., MODULATION, PITCH BEND

USB Device

Save the user data (Ex: User voices, User Song, User Memory, etc.)

Play the User Song (Format: SMF/WAV/MP3/WMA)

Connectors

MIC IN, AC IN, Headphones, AUX. IN, AUX. OUT, Soft Pedal, Sustain Pedal, Sostenuto Pedal, USB, MIDI IN, MIDI OUT, MIDI THRU, USB PORT.

Speaker

40W+40W, 70W+70W, 15W+15W

Dimensions

1476mm(W) x 1200mm(D) x 937.5mm(H)

Weight

141Kg

* All specifications and appearances are subject to change without notice.

Voice List

No.	Name	LCD Name
PIANO		
1	Acoustic Grand Piano	Grand Piano
2	Acoustic Grand Piano (wide)	Grand Piano/Wide
3	Acoustic Grand Piano (dark)	Grand Piano/Dark
4	Bright Acoustic Piano	Bright Piano
5	Bright Acoustic Piano (wide)	Bright Piano/Wide
6	Electric Grand Piano	Electric Grand
7	Electric Grand Piano (wide)	Elec.Grand/Wide
8	Honky Tonk Piano	Honky Tonk
9	Honky Tonk Piano (wide)	Honky Tonk/Wide
10	Harpsichord	Harpsichord
11	Harpsichord (octave mix)	Harpsichord/Octave
12	Harpsichord (wide)	Harpsichord/Wide
13	Acoustic Grand Piano (stereo)	Stereo Grand Piano
14	Octave Grand Piano 1	Octave Piano 1
15	Octave Grand Piano 2	Octave Piano 2
16	Piano & Strings 1	Piano&Strings 1
17	Piano & Pad 1	Piano&Pad 1
18	Piano & Choir 1	Piano&Choir 1
19	Piano & EP 1	Piano&EP 1
20	Piano & Vibraphone 1	Piano&Vibra 1
21	Jazz Piano	Jazz Piano 1
22	Pop Piano	Pop Piano
23	Rock Piano	Rock Piano
24	Club Piano	Club Piano 1
25	Piano & Strings 2	Piano&Strings 2
26	Piano & Pad 2	Piano&Pad 2
27	Piano & Choir 2	Piano&Choir 2
28	Piano & EP 2	Piano&EP 2
29	Piano & Vibraphone 2	Piano&Vibra 2
30	Electric Grand Piano (dark)	Elec.Grand/Dark
31	Fusion Electric Grand Piano	Fusion Piano
32	Club Electric Grand Piano	Club Piano 2
33	Wah Electric Grand Piano	Wah Piano
34	Honky Tonk Piano (dark)	Honky Tonk/Dark
35	Honky Tonk Piano (stereo)	Honky Tonk/Stereo
36	Harpsichord (with key off)	Harpsichord/KeyOff
37	Harpsichord 2	Harpsichord 2
E.PIANO		
38	Electric Piano 1	E.Piano 1
39	Electric Piano 2	E.Piano 2
40	Detuned Electric Piano 1	Detuned EP 1
41	Electric Piano 1 (velocity mix)	Velocity EP 1
42	60's Electric Piano	60's EP
43	Detuned Electric Piano 2	Detuned EP 2
44	Electric Piano 2 (velocity mix)	Velocity EP 2
45	EP Legend	EP Legend
46	Phase EP 1	Phase EP 1
47	Clavi	Clavi
48	Pulse Clavi	Pulse Clavi
49	Fusion Electric Piano	Fusion EP
50	Club Electric Piano	Club EP
51	Jazz Electric Piano	Jazz EP
52	Phase EP 2	Phase EP 2
53	Tremolo EP 1	Tremolo EP 1
54	Funk EP 1	Funk EP 1
55	Modern EP 1	Modern EP 1

56	Warm EP 1	Warm EP 1
57	Choir EP 1	Choir EP 1
58	Wah EP 1	Wah EP 1
59	EP & Strings 1	EP&Strings 1
60	Tremolo EP 2	Tremolo EP 2
61	Funk EP 2	Funk EP 2
62	Modern EP 2	Modern EP 2
63	Warm EP 2	Warm EP 2
64	Choir EP 2	Choir EP 2
65	Wah EP 2	Wah EP 2
66	EP & Strings 2	EP&Strings 2
67	Clavi 2	Clavi 2
68	Phase Clavi	Phase Clavi
69	Wah Clavi	Wah Clavi
70	E.Clavi	E.Clavi
Organ		
71	Drawbar Organ	Drawbar Organ
72	Detuned Drawbar Organ	Detuned DrawOrg
73	Italian 60's Organ	60's Organ
74	Drawbar Organ 2	Drawbar Organ 2
75	Percussive Organ	Percussive Organ
76	Detuned Percussive Organ	Detuned PercOrgan
77	Percussive Organ 2	Percussive Organ 2
78	Rock Organ	Rock Organ
79	Church Organ	Church Organ
80	Church Organ (octave mix)	ChurchOrg/Octave
81	Detuned Church Organ	Detune ChurchOrg
82	Reed Organ	Reed Organ
83	Soft Stereo Drawbar Organ	Soft St DrawOrg
84	Mellow Drawbar Organ	Mellow DrawOrg
85	Detuned Drawbar Organ 2	Detuned DrawOrg 2
86	Bright Drawbar Organ 1	Bright DrawOrg 1
87	Bright Drawbar Organ 2	Bright DrawOrg 2
88	70's Percussive Organ	70's PercOrgan
89	Light Click Organ 1	Light Click Org 1
90	Light Click Organ 2	Light Click Org 2
91	Detuned Percussive Organ 2	Detuned PercOrg 2
92	Stereo Rotary Organ	Stereo RotaryOrg
93	Rock Organ 2	Rock Organ 2
94	Rotary Organ 1	Rotary Organ 1
95	Rotary Organ 2	Rotary Organ 2
96	Slow Rotary Organ	Slow Rotary Organ
97	Church Organ 2	Church Organ 2
98	Detuned Church Organ 2	Detune ChurchOrg 2
99	Church Organ 3	Church Organ 3
100	Puff Organ	Puff Organ
Accordion & Harmonica		
101	Accordion	Accordion
102	Accordion 2	Accordion 2
103	Harmonica	Harmonica
104	Tango Accordion	Tango Accordion
105	Accordion 3	Accordion 3
106	Chorus Accordion	Chorus Accordion
107	Musette	Musette
108	Accord It Solo	Accord It Solo
109	Sweet Harmonica	Sweet Harmonica
110	Harmonica 2	Harmonica 2
111	Wah Harmonica	Wah Harmonica

Voice List

112	Tango Accordion 2	Tango Accordion 2
Guitar & Bass		
113	Acoustic Guitar (nylon)	Nylon Guitar
114	Ukulele	Ukulele
115	Acoustic Guitar (nylon + key off)	NylonGtr/KeyOff
116	Acoustic Guitar (nylon 2)	Nylon Guitar 2
117	Acoustic Guitar (steel)	Steel Guitar
118	12-Strings Guitar	12Strings Guitar
119	Mandolin	Mandolin
120	Steel Guitar with Body Sound	SteelGtr/BodySd
121	Electric Guitar (jazz)	Jazz Guitar
122	Electric Guitar (pedal steel)	Pedal Guitar
123	Electric Guitar (clean)	Clean Guitar
124	Electric Guitar (detuned clean)	Detuned CleanGtr
125	Mid Tone Guitar	Mid Tone Guitar
126	Electric Guitar (muted)	Muted Guitar
127	Electric Guitar (funky cutting)	Funk Guitar
128	Electric Guitar (muted velo-sw)	Velocity MutedGtr
129	Jazz Man	Jazz Man
130	Overdriven Guitar	OverdrivenGtr
131	Guitar Pinch	Guitar Pinch
132	Distortion Guitar	DistortionGtr 1
133	Distortion Guitar (with feedback)	Feedback Guitar
134	Distorted Rhythm Guitar	Rhythm DistGtr
135	Guitar Harmonics	Guitar Harmonics
136	Guitar Feedback	Feedback Guitar 3
137	Velocity Nylon Guitar	Velocity NylonGtr
138	Chorus Nylon Guitar	Chorus NylonGtr
139	Bright Nylon Guitar	Bright NylonGtr
140	Steel Guitar 2	Steel Guitar 2
141	Tremolo Steel Guitar 1	Tremolo SteelGtr 1
142	Tremolo Steel Guitar 2	Tremolo SteelGtr 2
143	Velocity Steel Guitar	Velocity SteelGtr
144	Mandolin 2	Mandolin 2
145	12-Strings Guitar 2	12Strings Guitar 2
146	Chorus Steel Guitar	Chorus SteelGtr
147	Nylon & Steel Guitar	Nylon&SteelGtr
148	Pedal Steel Guitar	Pedal Steel Guitar
149	Electric Guitar (jazz) 2	Jazz Guitar 2
150	Mellow Guitar	Mellow Guitar
151	Velocity Jazz Guitar	Velocity JazzGtr
152	Detuned Jazz Guitar	Detuned JazzGtr
153	Stereo Clean Guitar	Stereo CleanGtr
154	Velocity Clean Guitar	Velocity CleanGtr
155	Stereo Muted Guitar	Stereo MutedGtr.
156	Overdriven Guitar 2	OverdrivenGtr 2
157	Distortion Guitar 2	DistortionGtr 2
158	Distortion Guitar (with feedback) 2	Feedback Guitar 2
159	5th Distortion	5th Distortion
160	Distortion Guitar Octave	Octave DistGtr
161	Stereo Distorted Guitar	Stereo DistGtr
162	Guitar Harmonics 2	Guitar Harmonics 2
163	Acoustic Bass	Acoustic Bass
164	Electric Bass (finger)	Finger Bass
165	Finger Slap Bass	Finger Slap Bass
166	Electric Bass (pick)	Pick Bass
167	Fretless Bass	Fretless Bass
168	Slap Bass 1	Slap Bass 1

169	Slap Bass 2	Slap Bass 2
170	Synth Bass 1	Synth Bass 1
171	Synth Bass 2	Synth Bass 2
172	Acoustic Bass 2	Acoustic Bass 2
173	Acoustic Bass 3	Acoustic Bass 3
174	Acoustic Bass Detuned	Detuned AcousBass
175	Acoustic Bass Filter	Filter AcousBass
176	Jazz Style	Jazz Style
177	Acoustic Bass & Mute Guitar	AcoBass&MuteGtr
178	Electric Bass (finger) 2	Finger Bass 2
179	Detuned Finger Bass	Detuned FngrBass
180	Dark Finger Bass	Dark Finger Bass
181	Finger Slap Bass 2	Finger Slap Bass 2
182	Resonant Finger Bass	Resonant FngrBass
183	Wah Finger Bass	Wah Finger Bass
184	Bass & Distorted Electric Guitar	Bass&DistortedGtr
185	Electric Bass (pick) 2	Pick Bass 2
186	Mute Pick Bass	Mute Pick Bass
187	Detuned Pick Bass	Detuned Pick Bass
188	Fretless Bass 2	Fretless Bass 2
189	90's Bass	90's Bass
190	Fretless Bass & Sine	Fretless&Sine
191	Fretless Bass Detuned 1	Detuned Fretless 1
192	Fretless Bass Detuned 2	Detuned Fretless 2
193	Fretless Bass Detuned 3	Detuned Fretless 3
194	Slap Bass 3	Slap Bass 3
195	Slap Bass 4	Slap Bass 4
196	Power Slap Bass	Power Slap Bass
197	Lash Thumb Bass	Lash Thumb Bass
198	Resonant Slap Bass	Resonant SlapBass
199	Wah Slap Bass 1	Wah Slap Bass 1
200	Velocity Switch Slap Bass	Velocity SlapBass
201	Wah Slap Bass 2	Wah Slap Bass 2
202	Synth Bass (warm)	Warm Synth Bass
203	Synth Bass 3 (resonance)	Resonance SynBass
204	Clavi Bass	Clavi Bass
205	Hammer	Hammer
206	Synth Bass 4 (attack)	Attack Bass
207	Synth Bass (rubber)	Rubber Bass
208	Attack Pulse	Attack Pulse
Strings & Ensemble		
209	Violin	Violin
210	Violin (slow attack)	Slow Violin
211	Viola	Viola
212	Cello	Cello
213	Contrabass	Contrabass
214	Tremolo Strings	Tremolo Strings
215	Pizzicato Strings	PizzicatoStr
216	Orchestral Harp	Orchestral Harp
217	Yang Chin	Yang Chin
218	Timpani 1	Timpani 1
219	String Ensembles 1	String Ensembles 1
220	String Ensembles 2	String Ensembles 2
221	Strings & Brass	Strings&Brass
222	60's Strings	60's Strings
223	Synth Strings 1	Synth Strings 1
224	Synth Strings 2	Synth Strings 2
225	Synth Strings 3	Synth Strings 3

Voice List

226	Choir Aahs	Choir Aahs
227	Choir Aahs 2	Choir Aahs 2
228	Voice Oohs	Voice Oohs
229	Humming	Humming
230	Anlong Voice	Anlong Voice
231	Synth Voice	Synth Voice
232	Orchestra Hit	Orchestra Hit
233	The Violin	The Violin
234	Violin 2	Violin 2
235	Mono Violin	Mono Violin
236	Octave Violin	Octave Violin
237	Electric Violin	Electric Violin
238	Violin & Viola	Violin&Viola
239	Two Violin	Two Violin
240	Soft Violin	Soft Violin
241	Velocity Violin	Velocity Violin
242	Viola 2	Viola 2
243	Viola 3	Viola 3
244	Dark Viola	Dark Viola
245	Cello 2	Cello 2
246	Cello 3	Cello 3
247	Cello 4	Cello 4
248	Celloen 16'	Celloen 16'
249	Chamber Music	Chamber Music
250	Contrabass 2	Contrabass 2
251	Tremolo Strings 2	Tremolo Strings 2
252	Slow Tremolo Strings 1	Slow TremoloStr 1
253	Slow Tremolo Strings 2	Slow TremoloStr 2
254	Pizzicato Strings 2	PizzicatoStr 2
255	Octave Pizzicato	Octave Pizzicato
256	Orchestral Harp 2	Orchestral Harp 2
257	Yang Chin 2	Yang Chin 2
258	Africa 1	Africa 1
259	Africa 2	Africa 2
260	Timpani 2	Timpani 2
261	Stereo Slow Strings	Stereo SlowStr
262	Slow Strings	Slow Strings
263	Legato Strings	Legato Strings
264	Orchestra 1	Orchestra 1
265	Arco Strings	Arco Strings
266	Resonant Strings	Resonant Strings
267	The Strings	The Strings
268	70's Strings	70's Strings
269	Solo Strings	Solo Strings
270	Synth Strings 4	Synth Strings 4
271	Synth Strings 5	Synth Strings 5
272	Choir Aahs 3	Choir Aahs 3
273	Choir Aahs 4	Choir Aahs 4
274	Mellow Choir	Mellow Choir
275	Stereo Choir Aahs	Stereo Choir Aahs
276	Strings & Choir 1	Strings&Choir 1
277	Strings & Choir 2	Strings&Choir 2
278	Strings & Voice 1	Strings&Voice 1
279	Strings & Voice 2	Strings&Voice 2
280	Analog Voice	Analog Voice
281	Bass Hit Plus	Bass Hit Plus
282	6th Hit	6th Hit
283	Euro Hit	Euro Hit

284	Octave Orchestra Hit	Octave OrchHit
Brass & Saxophone		
285	Trumpet	Trumpet
286	Dark Trumpet Soft	DarkTrump Soft
287	Trombone	Trombone
288	Trombone 2	Trombone 2
289	Bright Trombone	Bright Trombone
290	Tuba	Tuba
291	Muted Trumpet	Muted Trumpet
292	Muted Trumpet 2	Muted Trumpet 2
293	French Horn	French Horn
294	French Horn 2 (warm)	French Horn 2
295	Brass Section	Brass Section
296	Brass Section 2 (octave mix)	Brass Section 2
297	Synth Brass 1	Synth Brass 1
298	Synth Brass 2	Synth Brass 2
299	Synth Brass 3	Synth Brass 3
300	Synth Brass 4	Synth Brass 4
301	Trumpet 2	Trumpet 2
302	Dark Trumpet Soft 2	DarkTrump Soft 2
303	Resonant Trumpet	Resonant Trumpet
304	Sweet Trumpet	Sweet Trumpet
305	Wah Trumpet	Wah Trumpet
306	Dark Trombone	Dark Trombone
307	Dark Trombone 2	Dark Trombone 2
308	Strings & Trombone	Strings&Tromb
309	Tuba 2	Tuba 2
310	Tuba 3	Tuba 3
311	Tuba Solo	Tuba Solo
312	Soft Tuba	Soft Tuba
313	Muted Trumpet 3	Muted Trumpet 3
314	French Horn 3	French Horn 3
315	French Horn 4	French Horn 4
316	Stereo French Horn	Stereo FrHorn
317	Fifth Horn Orchestra	Fifth HornOrch
318	Brass Section 3	Brass Section 3
319	Brass Section 4	Brass Section 4
320	Dark Brass 1	Dark Brass 1
321	Brassband	Brassband
322	Bright Brass Section	Bright Brass
323	Dark Brass 2	Dark Brass 2
324	Mute Brass Ensemble	Mute BrassEns
325	Sforzato Brass	Sforzato Brass
326	Brass & Strings	Brass&Strings 1
327	Analog Synth Brass 1	Analog SynBrass 1
328	Analog Synth Brass 2	Analog SynBrass 2
329	Jump Brass	Jump Brass
330	Octave Synth Brass	Octave SynBrass
331	Synth Brass & Strings 1	Brass&Strings 2
332	Synth Brass & Strings 2	Brass&Strings 3
333	Echo Brass	Echo Brass
334	Soprano Sax	Soprano Sax
335	Alto Sax	Alto Sax
336	Tenor Sax	Tenor Sax
337	Baritone Sax	Baritone Sax
338	Soprano Sax 2	Soprano Sax 2
339	Soprano Sax Soft	Soprano Sax Soft
340	Slow Soprano Sax	Slow Soprano Sax

Voice List

341	Sweet Soprano Sax	Sweet Soprano Sax
342	Alto Sax 2	Alto Sax 2
343	Soft Alto Sax	Soft Alto Sax
344	Super Alto Sax	Super Alto Sax
345	Sax Band	Sax Band
346	Tenor Sax 2	Tenor Sax 2
347	Baritone Sax 2	Baritone Sax 2
348	Soft Baritone Sax	Soft Baritone Sax
Flute & Woodwind		
349	Oboe	Oboe
350	English Horn	English Horn
351	Bassoon	Bassoon
352	Clarinet	Clarinet
353	Piccolo	Piccolo
354	Flute	Flute
355	Recorder	Recorder
356	Pan Flute	Pan Flute
357	Blown Bottle	Blown Bottle
358	Shakuhachi	Shakuhachi
359	Whistle	Whistle
360	Ocarina	Ocarina
361	Oboe 2	Oboe 2
362	Sweet Oboe	Sweet Oboe
363	English Horn 2	English Horn 2
364	Analog Horns	Analog Horns
365	Woodwinds	Woodwinds
366	Bassoon 2	Bassoon 2
367	Clarinet 2	Clarinet 2
368	Piccolo 2	Piccolo 2
369	Flute 2	Flute 2
370	Sweet Flute	Sweet Flute
371	Recorder 2	Recorder 2
372	Sweet Pan Flute	Sweet Pan Flute
373	Pan Flute 2	Pan Flute 2
374	Dark Pan Flute	Dark Pan Flute
375	Blown Bottle 2	Blown Bottle 2
376	Shakuhachi 2	Shakuhachi 2
377	Whistle 2	Whistle 2
378	Ocarina 2	Ocarina 2
Lead & Pad		
379	Lead 1 (square)	Square Lead
380	Lead 1a (square 2)	Square Lead 2
381	Lead 1b (sine)	Sine Lead
382	Lead 2 (sawtooth)	Sawtooth
383	Lead 2a (sawtooth 2)	Sawtooth 2
384	Lead 2b (saw + pulse)	Sawtooth&Pulse
385	Lead 2c (double sawtooth)	Double Sawtooth
386	Lead 2d (sequenced analog)	Sequenced analog
387	Lead 3 (calliope)	Calliope
388	Lead 4 (chiff)	Chiffer Lead
389	Lead 5 (charang)	Charang Lead
390	Lead 5a (wire lead)	Wire Lead
391	Lead 6 (voice)	Voice Lead
392	Lead 7 (fifths)	Fifths Lead
393	Lead 8 (bass + lead)	Bass&Lead
394	Lead 8a (soft wrl)	Soft wrl
395	Pad 1 (new age)	New age Pad
396	Pad 2 (warm)	Warm Pad

397	Pad 2a (sine pad)	Sine pad
398	Pad 3 (polysynth)	Poly Synth
399	Pad 4 (choir)	Choir Pad
400	Pad 4a (itopia)	Itopia Pad
401	Pad 5 (bowed)	Bowed Pad
402	Pad 6 (metallic)	Metallic Pad
403	Pad 7 (halo)	Halo Pad
404	Pad 8 (sweep)	Sweep Pad
405	Square	Square
406	Slow Square Lead	Slow Square Lead
407	Sine Solo	Sine Solo
408	Square Lead	Square Lead 3
409	Thick Square	Thick Square
410	Corrie	Corrie
411	Quint	Quint
412	2Oscillators Lead	2Oscillators Lead
413	Wavy Sawtooth	Wavy Sawtooth
414	Super Analog	Super Analog
415	Big Lead	Big Lead
416	Bauble Lead	Bauble Lead
417	PWM 4th	PWM 4th
418	PWM 4th Soft	PWM 4th Soft
419	Synth Calliope Soft	SynCalliope Soft
420	Chiffer Lead 2	Chiffer Lead 2
421	Chiffer Lead 3	Chiffer Lead 3
422	Charang 2	Charang 2
423	Wire Lead 2	Wire Lead 2
424	Charang 3	Charang 3
425	Soft Vox	Soft Vox
426	5th SawWave 2	5th SawWave
427	Fifth Lead Soft	Fifth Lead Soft
428	Fifth Lead	Fifth Lead 2
429	Massiness	Massiness
430	Delayed Lead 2	Delayed Lead 2
431	Delayed Lead 3	Delayed Lead 3
432	New Age Pad 2	New Age Pad 2
433	New Age Pad 3	New Age Pad 3
434	Slow Square	Slow Square
435	New Year Pad	New Year Pad
436	Warm Pad 2	Warm Pad 2
437	PWM Pad	PWM Pad
438	Warmly Pad	Warmly Pad
439	Horn Pad	Horn Pad
440	Poly Synth 2	Poly Synth 2
441	Click Pad	Click Pad
442	Analog Pad	Analog Pad
443	Poly Pad	Poly Pad
444	Poly Synth 3	Poly Synth 3
445	Space Voice	Space Voice
446	Bowed Pad 2	Bowed Pad 2
447	Bowed Pad 3	Bowed Pad 3
448	Metallic Pad 2	Metallic Pad 2
449	Pan Pad 1	Pan Pad 1
450	Pan Pad 2	Pan Pad 2
451	Halo Pad 2	Halo Pad 2
452	Halo Pad 3	Halo Pad 3
453	Sweep Pad 2	Sweep Pad 2
454	Dipolar Pad	Dipolar Pad

Voice List

455	Rising	Rising
456	Congregate	Congregate
FX & Effects		
457	FX 1 (rain)	FX 1 Rain
458	FX 2 (soundtrack)	FX 2 SoundTrack
459	Prelude	Prelude
460	FX 3 (crystal)	FX 3 Crystal
461	FX 3a (synth mallet)	Synth Mallet
462	Crystal 2	Crystal 2
463	FX 4 (atmosphere)	FX 4 Atmosphere
464	Warm Air	Warm Air
465	FX 5 (brightness)	FX 5 Brightness
466	Smog	Smog
467	FX 6 (goblins)	FX 6 Goblins
468	Goblin 2	Goblin 2
469	Choir Bell 1	Choir Bell 1
470	Choir Bell 2	Choir Bell 2
471	FX 7 (echoes)	FX 7 Echoes
472	FX 7a (echo bell)	Echo bell
473	FX 7b (echo pan)	Echo pan
474	Echo Drops 2	Echo Drops 2
475	Echo Bell 2	Echo Bell 2
476	FX 8 (sci-fi)	FX 8 Sci-Fi
477	Sci-Fi 2	Sci-Fi 2
478	Guitar Fret Noise	Guitar Fret Noise
479	Guitar Cutting Noise	Gtr Cutting Noise
480	Acoustic Bass String Slap	AcBass String Slap
481	Guitar Fret Noise 2	Gtr Fret Noise 2
482	Guitar Cutting Noise 2	Cutting Noise 2
483	Acoustic Bass String Slap 2	Bass String Slap 2
484	Breath Noise	Breath Noise
485	Flute Key Click	Flute Key Click
486	Breath Noise 2	Breath Noise 2
487	Flute Key Click 2	Flute Key Click 2
488	Seashore	Seashore
489	Rain	Rain
490	Thunder	Thunder
491	Wind	Wind
492	Stream	Stream
493	Bubble	Bubble
494	Seashore 2	Seashore 2
495	Bird Tweet	Bird Tweet
496	Dog	Dog
497	Horse Gallop	Horse Gallop
498	Bird Tweet 2	Bird Tweet 2
499	Sheep	Sheep
500	Telephone Ring	Telephone Ring
501	Telephone Ring 2	Telephone Ring 2
502	Door Creaking	Door Creaking
503	Door	Door
504	Scratch	Scratch
505	Wind Chime	Wind Chime
506	Helicopter	Helicopter
507	Car Engine	Car Engine
508	Car Stop	Car Stop
509	Car Pass	Car Pass
510	Car Crash	Car Crash
511	Siren	Siren

512	Train	Train
513	Jetplane	Jetplane
514	Starship	Starship
515	Burst Noise	Burst Noise
516	Applause	Applause
517	Laughing	Laughing
518	Screaming	Screaming
519	Punch	Punch
520	Heart Beat	Heart Beat
521	Footsteps	Footsteps
522	Gunshot	Gunshot
523	Machine Gun	Machine Gun
524	Lasergun	Lasergun
525	Explosion	Explosion
Ethnic & Combined		
526	Sitar	Sitar
527	Sitar 2 (bend)	Sitar 2/Bend
528	Sitar & Strings 1	Sitar&Strings 1
529	Sitar & Strings 2	Sitar&Strings 2
530	Banjo	Banjo
531	Banjo 2	Banjo 2
532	Shamisen	Shamisen
533	Shamisen 2	Shamisen 2
534	Koto	Koto
535	Taisho Koto	Taisho Koto
536	Koto 2	Koto 2
537	Taisho Koto 2	Taisho Koto 2
538	Kalimba	Kalimba
539	Kalimba 2	Kalimba 2
540	Bag Pipe	Bag Pipe
541	Bag pipe 2	Bag pipe 2
542	Fiddle	Fiddle
543	Fiddle 2	Fiddle 2
544	Shanai	Shanai
545	Shanai 2	Shanai 2
546	Stereo Piano & Glockenspiel	Piano&Glocken
547	Stereo Piano & Calliope	Piano&Callio
548	Stereo Piano & Sweep	Piano&Sweep
549	Honky Tonk Piano & Fifths	Honk&Fifths
550	Honky Tonk Piano & Sweep	Honk&Sweep
551	FM Electric Piano	FM E.Piano
552	Digital Piano	Digital Piano
553	E.Piano & Pad	E.Piano&Pad
554	E.Piano & Sweep	E.Piano&Sweep
555	E.Piano 2 & Pad	E.Piano 2&Pad
556	E.Piano 2 & Sweep	E.Piano 2&Sweep
557	E.Piano 2 & Warm	E.Piano 2&Warm
558	Harpsichord & Stereo Strings	Harpsichord&StStr
559	Music Box & Stereo Strings	MusicBox&StStr
560	Vibraphone & Stereo Strings	Vibra&StStr
561	Vibraphone Octave	Vibraphone Octave
562	Vibraphone & Marimba & Kalimba	Vibra&Mar&Kal
563	Marimba & Kalimba	Marimba&Kalimba
564	Marimba Delay	Marimba Delay
565	Xylophone Octave	Xylophone Octave
566	Organ & Stereo Strings	Organ&StStrings
567	Stereo Organ & Piano	StereoOrg&Piano
568	Rock Organ & Strings	RockOrg&Strings

Voice List

569	Church Organ & Choir	ChurchOrg&Choir
570	Church Organ & Strings	ChurchOrg&Str
571	Harmonica & Acoustic Guitar	Harmonica&AcGtr
572	Harmonica & Strings	Harmonica&Str
573	Acoustic Guitar & Flute	AcGtr&Flute
574	Acoustic Guitar & Clavi	AcGtr&Clavi
575	24-Strings Guitar	24-Strings Guitar
576	24-Strings Guitar & Strings	24-StrGtr&Str
577	Steel Guitar & Warm Pad	SteelGtr&WarmPd
578	Stereo Strings & Horn	Strings&Horn
579	Orchestra 2	Orchestra 2
580	Full Strings 1	Full Strings 1
581	Full Strings 2	Full Strings 2
582	Symphonic	Symphonic
583	Stereo Choir & Strings	Choir&Str
584	Stereo Choir & Steel Guitar	Choir&SteelGtr
585	3Trumpets Loose	3Trumpets Loose
586	Trombone & Stereo Strings	Trombone&Str
587	3Trombones Loose	3Trombones Loose
588	3Muted Trumpets Loose	3MuteTrump Loose
589	Club Brass	Club Brass
590	Brass & Woodwinds	Brass&Wood
591	Woodwinds & Strings	Wood&Strings
592	Section Woods Small	Woods Small
593	Pan Flute & Strings Pad	PanFlute&StrPad
594	Koto & Shamisen	Koto&Shamisen
595	Koto & Shamisen & Strings	Koto&Sham&Str
Percussive & Drum		
596	Celesta	Celesta
597	Celesta 2	Celesta 2
598	Birght Celesta	Birght Celesta
599	Celesta & Sine	Celesta&Sine
600	Reecho Bell	Reecho Bell
601	Celesta & Music Box	Celes&MusicBox
602	Glockenspiel I	Glockenspiel I
603	Glockenspiel 2	Glockenspiel 2
604	Glockenspiel & Sine	Glockenspiel&Sine
605	Glockenspiel & Celesta	Glocken&Celes
606	Music Box	Music Box
607	Music Box 2	Music Box 2
608	Music Box 3	Music Box 3
609	Toy Box	Toy Box
610	Music Box & Harp	Music Box&Harp
611	Vibraphone	Vibraphone
612	Vibraphone (wide)	Vibraphone/Wide
613	Stereo Vibraphone	Stereo Vibraphone
614	Rigid Vibraphone	Rigid Vibraphone
615	Vibraphone 2	Vibraphone 2
616	Vibraphone 2 (wide)	Vibraphone/Wide 2
617	Vibraphone & Bell	Vibraphone&Bell
618	Vibraphone & Harpsichord	Vibra&Harpsic
619	Vibraphone & Strings 1	Vibra&Strings 1
620	Vibraphone & Strings 2	Vibra&Strings 2
621	Marimba	Marimba
622	Marimba (wide)	Marimba/Wide
623	Marimba 2	Marimba 2
624	SinMarimba	SinMarimba
625	Stereo Marimba	Stereo Marimba

626	Marimba & Vibraphone	Marimba&Vibra
627	Wood Drum	Wood Drum
628	Xylophone	Xylophone
629	Xylophone 2	Xylophone 2
630	Tubular Bells	Tubular Bells
631	Church Bell	Church Bell
632	Carillon	Carillon
633	Dulcimer	Dulcimer
634	Santur	Santur
635	Shorty	Shorty
636	Tinkle Bell	Tinkle Bell
637	Tinkle Bell 2	Tinkle Bell 2
638	Agogo	Agogo
639	Agogo 2	Agogo 2
640	Steel Drums	Steel Drums
641	Steel Drums 2	Steel Drums 2
642	Woodblock	Woodblock
643	Castanets	Castanets
644	Woodblock 2	Woodblock 2
645	Castanets 2	Castanets 2
646	Taiko Drum	Taiko Drum
647	Taiko Drum 2	Taiko Drum 2
648	ConcertBass Drum	ConBass Drum
649	ConcertBass Drum 2	ConBass Drum 2
650	Melodic Tom	Melodic Tom
651	Melodic Tom 2 (power)	Power Melodic Tom
652	Synth Drum	Synth Drum
653	Rhythm Box Tom	Rhythm Box Tom
654	Electric Drum	Electric Drum
655	Electric Drum 2	Electric Drum 2
656	Reverse Cymbal	Reverse Cymbal
657	Reverse Cymbal 2	Reverse Cymbal 2
658	Standard Set	Standard Set
659	Room Set	Room Set
660	Power Set	Power Set
661	Electronic Set	Electronic Set
662	Analog Set	Analog Set
663	Jazz Set	Jazz Set
664	Brush Set	Brush Set
665	Orchestra Set	Orchestra Set
666	SFX Set	SFX Set
667	Dance Set	Dance Set
668	Funk Set	Funk Set
669	Rock Set	Rock Set
670	Latin Set	Latin Set
671	Pop Set	Pop Set
672	Punk Set	Punk Set

Style List

No.	Name	LCD Name
8BEAT & 16BEAT		
1	8Beat Ballad	8BtBld
2	8Beat Piano	8BtPiano
3	8Beat 1	8Beat1
4	Guitar Pop 1	GtPop1
5	8Beat Hip Hop	8BtHiHop
6	8Beat R&B	8BeatR&B
7	8Beat Pop	8BtPop
8	Pop Funk 1	PopFunk1
9	Rhythm&Beat 1	Rhy&Bt1
10	8Beat Disco 1	8BtDisc1
11	8Beat Rock	8BtRock
12	Guitar Pop 2	GtPop2
13	8Beat 2	8Beat2
14	Sweet Beat	SweetBt
15	8Beat Dance	8BtDance
16	8Beat Disco 2	8BtDisc2
17	Pop Funk 2	PopFunk2
18	8Beat 3	8Beat3
19	60's 8Beat	60's8Bt
20	Rhythm&Beat 2	Rhy&Bt2
21	16Beat 1	16Beat1
22	16Beat Funk 1	16BtFuk1
23	16Beat Ballad 1	16BtBld1
24	16Beat R&B	16BtR&B
25	Pop 16Beat 1	Pop16Bt1
26	16Beat Funk 2	16BtFuk2
27	16Beat Dance	16BtDanc
28	Pop 16Beat 2	Pop16Bt2
29	16Beat 2	16Beat2
30	Pop 16Beat 3	Pop16Bt3
31	Pop 16Beat 4	Pop16Bt4
32	Modern 16Beat	Modrn16B
33	16Beat Hot	16BtHot
34	16Beat Modern	16BtModr
35	16Beat Funk 3	16BtFuk3
36	16Beat 3	16Beat3
37	Cool Beat	CoolBeat
38	16Beat Ballad 2	16BtBld2
39	16Beat 4	16Beat4
40	Pop Shffle	PopShfl
Pop & Ballad		
41	Pop Rock 1	PopRock1
42	Pop Dance 1	PopDanc1
43	Pop Fusion	PopFusn
44	Analog Night 1	AnalgNt1
45	6/8 Pop	6/8Pop
46	Brit. Pop 1	BritPop1
47	Brit. Pop 2	BritPop2
48	Pop Hit	PopHit
49	Fusion Shuffle	FusShufl
50	Analog Night 2	AnalgNt2
51	Guitar Pop 3	GtPop3
52	Pop Beat	PopBeat
53	Soft Beat	SoftBeat
54	60's Pop	60'sPop
55	Sting Latin	StigLatn

56	R&B Ballad 1	R&BBld1
57	Guitar Ballad	GtBallad
58	Ballad Rock	BalladRk
59	Piano Pop 1	PianoPop
60	Soft Ballad	SoftBald
61	Natural Ballad	NatuBld
62	Love Ballad	LoveBld
63	Easy Ballad	EasyBld
64	Miami Ballad	MiamiBld
65	Slow Ballad	SlowBald
66	Folk Ballad	FolkBld
67	Pop Ballad 1	PopBld1
68	Pop Ballad 2	PopBld2
69	EP Ballad	EPBallad
70	New R&B Ballad	NewRBBld
Rock		
71	Rock	Rock
72	New Wave	NewWave
73	Ska	Ska
74	Pop Rock 2	PopRock2
75	Slow Rock	SlowRock
76	70's Rock&Roll	70'sRock
77	Folk Rock	FolkRock
78	Soft Rock	SoftRock
79	Old Rock	OldRock
80	Easy Rock	EasyRock
81	New Shuffle	NewShufl
82	Rock Hip Hop	RkHipHop
83	Rock&Roll 1	R'N'R1
84	Rock Shuffle	RockShfl
85	Rock&Roll 2	R'N'R2
Ballroom		
86	Tango 1	Tango1
87	Spain Matador	Matador
88	Twist 1	Twist1
89	Twist 2	Twist2
90	Big Band Fox	BandFox
91	Tango 2	Tango2
92	Slow Fox	SlowFox
93	Slow Waltz 1	SlowWlz1
94	Swing Fox	SwingFox
95	Salsa 1	Salsa1
96	Cha Cha 1	ChaCha1
97	Cha Cha 2	ChaCha2
98	Beguine 1	Beguine1
99	Beguine 2	Beguine2
100	Rumba 1	Rumba1
101	Samba 1	Samba1
102	Samba 2	Samba2
103	Jive	Jive
104	Fox Trot	FoxTrot
Dance		
105	Techno 1	Techno1
106	Hip Hop 1	HipHop1
107	Dream Dance	DrnDance
108	House	House
109	Pop Dance 2	PopDanc2
110	Down Beat	DownBeat

111	Techno 2	Techno2
112	Progressive	Progress
113	Rap 1	Rap1
114	Rap 2	Rap2
115	Disco	Disco
116	Soft Disco	SoftDisc
117	Disco Party	DscParty
118	70's Disco	70'sDisc
119	70's Disco Funk	70'sFunk
120	Club Dance	ClubDanc
121	Euro Dance	EuroDanc
122	Hip Hop 2	HipHop2
123	Garage	Garage
Soul & Funk		
124	Funk 1	Funk1
125	Classic Funk	ClasFunk
126	Jay R&B	JayR&B
127	Gospel Swing	GopSwing
128	Gospel	Gospel
129	Funk 2	Funk2
130	Electric Funk	ElecFunk
131	Groove Funk	GrooveFk
132	Rubber Funk	RubberFk
133	Cool Funky	ColFunky
134	Jazz Funk	JazzFunk
135	Groove	Groove
136	Soul	Soul
137	Hip Hop Soul	HipHopSl
138	Hip Hop Beat	HipHopBt
139	R&B	R&B
140	Soul Beat	SoulBeat
141	R&B Ballad 2	R&BBld2
142	British Soul Pop	BritSoul
Swing & Jazz		
143	Latin Jazz 1	LatinJz1
144	Big Band	BigBand
145	Dixieland 1	Dixland1
146	Guitar Swing 1	GtSwing1
147	Broadway Big Band	BwayBand
148	Swing	Swing
149	Latin Jazz 2	LatinJz2
150	Fusion	Fusion
151	Acid Jazz	AcidJazz
152	Cool Jazz Ballad	CoolJzBd
153	Swing Shuffle	SwingSfl
154	Big Band Medium	BandMid
155	Dixieland 2	Dixland2
156	Acoustic Jazz	AcoustJz
157	Guitar Swing 2	GtSwing2
158	Ragtime	Ragtime
159	Modern Jazz Ballad	MdJzBald
160	Swing Ballad	SwingBal
161	Orchestra Swing	OrhSwing
Country		
162	Country Pop 1	CntyPop1
163	Bluegrass 1	Bluegrs1
164	Country 8Beat	Ct8Beat
165	Modern Country	ModernCt

Style List

166	Country Pop 2	CntyPop2
167	Bluegrass 2	Bluegrs2
168	2/4 Country	2/4Cntry
169	Country Quick Steps	QuickStp
170	Country Folk	CntyFolk
171	Country Shuffle	CnyShuffl
Latin & Latin Dance		
172	Samba 3	Samba3
173	Bossa Nova	BosaNov
174	Latin	Latin
175	New Reggae	NewRegga
176	Dance Reggae	DanRegga
177	Pasodoble	Pasodobl
178	Lite Bossa	LteBossa
179	Latin Rock	LatinRck
180	Beguine 3	Beguine3
181	Slow Bolero	SIBolero
182	Disco Samba	DscSamba
183	Mambo	Mambo
184	Meneito	Meneito
185	Rumba 2	Rumba2
186	Rumba 3	Rumba3
187	Tikitikita	Tikitkta
188	Lambada	Lambada
189	Pop Cha Cha 1	PChaCha1
190	Pop Cha Cha 2	PChaCha2
191	Salsa 2	Salsa2

Waltz & Traditional		
192	Waltz	Waltz
193	Old Waltz	OldWaltz
194	English Waltz	EngWaltz
195	German Waltz	GemWaltz
196	Italian Mazurka	ItaMazuk
197	Mexico Waltz	MexWaltz
198	Vienna Waltz	VinaWtz
199	Slow Waltz 2	SlwWltz2
200	Jazz Waltz	JzWaltz
201	Polka	Polka
202	6/8 March	6/8March
203	German Polka	GerPolka
204	Party Polka	PtyPolka
205	Army March	ArmMarch
206	March	March
207	US March	USMarch
208	Musette	Musette
209	French Musette	FMusette
210	Mazurke	Mazurke
World		
211	Enka Ballad	EnkaBald
212	Laendler	Laendler
213	Hawaiian	Hawaiian
214	Sirtake	Sirtake
215	Dangdut	Dangdut
216	6/8 Flipper	6/8Flipp

217	New Age	NewAge
218	Tarantella	Tarantel
219	Scottish	Scottish
220	Norteno	Norteno
Pianist		
221	Pianist 1	Pianist1
222	Pianist 2	Pianist2
223	Pianist 3	Pianist3
224	Jazz 1	Jazz1
225	Jazz 2	Jazz2
226	Jazz Pub	JazzPub
227	Piano Rock	PianoRk
228	Pop Bossa	PopBossa
229	March 1	March1
230	March 2	March2
231	Piano Beat	PianoBt
232	Piano Bar	PianoBar
233	Blues	Blues
234	Pop Waltz	PopWaltz
235	Slow Waltz	SlwWltz
236	Ballad 1	Ballad1
237	Ballad 2	Ballad2
238	6/8 Ballad	6/8Ballad
239	Pop 1	Pop1
240	Pop 2	Pop2

Song List

NO.	Song Name
1	Mazurka
2	Tchaikovsky Waltz
3	Salut d' Amour
4	French Suites
5	Neapolitan Song
6	Minuet
7	Prelude
8	Barcarole
9	Sonata K.331
10	Brahms Waltz

Demo List

NO.	Demo Name	Short Name
1	Ballad	Ballad
2	Funk	Funk
3	Modern R&B	ModernR&B
4	Pop	Pop
5	Bossa Nova	BosaNov
6	Electric	Electric
7	Fusion	Fusion
8	Piano	Piano
9	Jazz	Jazz

Chord List

Chord Name	Abbreviation	Normal Voicing	Display for Root "C"
Major	M	1+3+5	C
Sixth	6	1+(3)+5+6	C6
Major seventh	M7	1+3+(5)+7	Cm7
Major seventh add sharp eleventh	M7(#11)	1+(2)+3+#4+5+7	CM7(#11)
Add ninth	(9)	1+2+3+5	C(9)
Major seventh ninth	M7(9)	1+2+3+(5)+7	CM7(9)
Sixth ninth	6(9)	1+2+3+(5)+6	C6(9)
Augmented	aug	1+3+#5	Caug
Seventh augmented	7aug	1+3+#5+b7	C7aug
Major seventh augmented	M7aug	1+(3)+#5+7	CM7aug
Minor	m	1+b3+5	Cm
Minor sixth	m6	1+b3+5+6	Cm6
Minor seventh	m7	1+b3+(5)+b7	Cm7
Minor seventh flatted fifth	m7b5	1+b3+b5+b7	Cm7b5
Minor add ninth	m(9)	1+2+b3+5	Cm(9)
Minor seventh ninth	m7(9)	1+2+b3+(5)+b7	Cm7(9)
Minor seventh eleventh	m7(11)	1+(2)+b3+4+5+(b7)	Cm7(11)
Minor major seventh	mM7	1+b3+(5)+7	CmM7
Minor major seventh ninth	mM7(9)	1+2+b3+(5)+7	CmM7(9)
Diminished	dim	1+b3+b5	Cdim
Diminished seventh	dim7	1+b3+b5+6	Cdim7
Seventh	7	1+3+(5)+b7	C7
Seventh suspended fourth	7sus4	1+4+5+b7	C7sus4
Seventh ninth	7(9)	1+2+3+(5)+b7	C7(9)
Seventh add sharp eleventh	7(#11)	1+(2)+3+#4+5+b7	C7(#11)
Seventh add thirteenth	7(13)	1+ 3+(5)+6+b7	C7(13)
Seventh flatted fifth	7b5	1+3+b5+b7	C7b5
Seventh flatted ninth	7(b9)	1+b2+3+(5)+b7	C7(b9)
Seventh add flatted thirteenth	7(b13)	1+3+5+b6+b7	C7(b13)
Seventh sharp ninth	7(#9)	1+#2+3+(5)+b7	C7(#9)
Suspended fourth	sus4	1+4+5	Csus4
One plus two plus five	sus2	1+2+5	C/Csus2

MIDI Implementation List

Function		Transmitted	Recognized	Remarks
Basic Channel	Default	1ch	ALL	
	Changed	1ch	1-16ch	
Mode	Default	x	3	
	Messages	x	3	
	Altered	*****	x	
Note Number	Note	21—108	0—127	
	:True voice	*****	0—127	
Velocity	Note on	o 9nH,V=1-127	o 9nH,V=1-127	
	Note off	x (9nH,V=0)	o(9nH,V=0; 8nH,V=0-127)	
After Touch	key's	x	x	
	Ch's	x	x	
Pitch Bend		x	o	
Control Change	0	o	o	Bank Select
	1	o	o	Modulation
	5	o	o	Portamento Time
	6	o	o	Data Entry
	7	o	o	Volume
	10	o	o	Pan
	11	o	o	Expression
	64	o	o	Sustain Pedal
	65	o	o	Portamento ON/OFF
	66	o	o	Sostenuto Pedal
	67	o	o	Soft Pedal
	80	o	o	Reverb Program
	81	o	o	Chorus Program
	91	o	o	Reverb Level
	93	o	o	Chorus Level
	120	x	o	All Sound Off
	121	x	o	Reset All Controllers
	123	o	o	All Notes Off
	Program Change	:true	*****	0—127
System Exclusive		o	o	
System Common	:SongPosition	x	x	
	:Song Select	x	x	
	:Tune	x	x	
System Real Time	:Clock	x	x	
	:Commands	x	x	
Aux Messages	:LOCAL ON/OFF	x	x	
	:All Notes Off	o	o	
	:Active sense	o	o	
	:Reset	x	o	
Notes:				

• Mode 1: OMNI ON, POLY

• Mode 2: OMNI ON, MONO o: YES

• Mode 3: OMNI OFF, POLY

• Mode 4: OMNI OFF, MONO x: NO

