



PowerFlex 755/755T Integrated Safety Functions Option Module

Catalog Number 20-750-S4



Allen-Bradley

by ROCKWELL AUTOMATION

User Manual

Original Instructions

Important User Information

Read this document and the documents listed in the additional resources section about installation, configuration, and operation of this equipment before you install, configure, operate, or maintain this product. Users are required to familiarize themselves with installation and wiring instructions in addition to requirements of all applicable codes, laws, and standards.

Activities including installation, adjustments, putting into service, use, assembly, disassembly, and maintenance are required to be carried out by suitably trained personnel in accordance with applicable code of practice.

If this equipment is used in a manner not specified by the manufacturer, the protection provided by the equipment may be impaired.

In no event will Rockwell Automation, Inc. be responsible or liable for indirect or consequential damages resulting from the use or application of this equipment.

The examples and diagrams in this manual are included solely for illustrative purposes. Because of the many variables and requirements associated with any particular installation, Rockwell Automation, Inc. cannot assume responsibility or liability for actual use based on the examples and diagrams.

No patent liability is assumed by Rockwell Automation, Inc. with respect to use of information, circuits, equipment, or software described in this manual.

Reproduction of the contents of this manual, in whole or in part, without written permission of Rockwell Automation, Inc., is prohibited.

Throughout this manual, when necessary, we use notes to make you aware of safety considerations.



WARNING: Identifies information about practices or circumstances that can cause an explosion in a hazardous environment, which may lead to personal injury or death, property damage, or economic loss.



ATTENTION: Identifies information about practices or circumstances that can lead to personal injury or death, property damage, or economic loss. Attentions help you identify a hazard, avoid a hazard, and recognize the consequence.

IMPORTANT Identifies information that is critical for successful application and understanding of the product.

Labels may also be on or inside the equipment to provide specific precautions.



SHOCK HAZARD: Labels may be on or inside the equipment, for example, a drive or motor, to alert people that dangerous voltage may be present.



BURN HAZARD: Labels may be on or inside the equipment, for example, a drive or motor, to alert people that surfaces may reach dangerous temperatures.



ARC FLASH HAZARD: Labels may be on or inside the equipment, for example, a motor control center, to alert people to potential Arc Flash. Arc Flash will cause severe injury or death. Wear proper Personal Protective Equipment (PPE). Follow ALL Regulatory requirements for safe work practices and for Personal Protective Equipment (PPE).

Preface

Summary of Changes 9
 Conventions..... 9
 Terminology..... 10
 Product Firmware and Release Notes 12
 Additional Resources 13

About Safe Stop and Safe Monitor Functions

Chapter 1

What Is the Integrated Safety Functions Option Module? 15
 Compatible Drives 17
 Compatible Safety Controllers 17
 Safety Application Requirements 18
 Safety Certification..... 18
 Important Safety Considerations 18
 Stop Category Definitions 19
 Performance Level and Safety Integrity Level (SIL) CL3 19
 Proof Tests 20
 PFD and PFH Definitions 20
 PFD and PFH Data 21
 Safety Data for Safe Torque Off 21
 Safety Data for Safe Feedback..... 21
 Safety Data for Safety I/O..... 22
 Spurious Trip Rate 23
 Safety Reaction Time..... 23
 Considerations for Safety Ratings..... 24
 Encoder Considerations 24
 Supported Encoders 24
 Encoder Diagnostics 24
 General Encoder Diagnostics 25
 Digital AqB Diagnostics 27
 Sine/Cosine and Hiperface Diagnostics 27
 Contact Information If Safety Option Failure Occurs 28

Installation

Chapter 2

Remove Power to the System..... 30
 Access the Control Pod..... 30
 Set the SAFETY and Hardware ENABLE Jumpers 31
 Install the Safety Option Module..... 32
 Feedback Installation Guidelines..... 33
 I/O Wiring..... 34
 Cabling 34
 Power Supply Requirements 35

Safety I/O

Chapter 3

Safety Inputs..... 37

- Safety Input Operation 37
- Latch Input Error Operation in Single Channel Mode..... 39
- Single Channel Safety Input Status Data 40
- Dual-channel Safety Input Operation 41
- Equivalent Dual-channel Input Operation..... 42
- Complementary Dual-channel Input Operation 43
- Standard Input Operation..... 44
- Safety Input Safety Data 44
- Safety Input Alarms 47
- Determining Safety Input Alarm Type 48
- Safety Input Alarm Recovery 49
- Input Delays 49
- Use With PowerFlex 750-Series ATEX Option Module 50

Safety Outputs..... 50

- Safety Output with Test Pulse..... 50
- Single-channel Mode 51
- Latch Output Error Operation in Single Channel Mode..... 52
- Dual-channel Mode 53
- Latch Output Error Operation in Dual Channel Mode..... 53
- Safety Output Safety Data..... 55
- Commanding Safety and Test Outputs..... 57
- Safety Output Alarms..... 58
- Determining Safety Output Alarm Type 59
- Safety Output Alarm Recovery 60

Test Output 60

- Standard Output Mode..... 61
- Test Output Mode 61
- Power Supply Output..... 61

Test Output Data 61

- Test Output Status 62
- Test Output Ready 63

Chapter 4

Drive-based Safe Stop Functions

Safety Output Assembly Safe Stop Function Tags..... 65

Safety Input Assembly Safe Stop Function Tags..... 66

Safety Function in Response to Connection Event..... 68

- Connection Loss Action 68
- Connection Idle Action..... 69

Safe Torque Off Function 69

- Safe Torque Off Activation 70
- Safe Torque Off Reset 70
- Safe Torque Off Delay 71
- Safe Torque Off Operation..... 72
- Safe Torque Off Stopping Action and Source..... 74

	STO Safety Fault	75
	Safe Stop 1 Function	76
	Safe Stop 1 Activation	76
	Safe Stop 1 Reset	77
	Safe Stop 1 Stopping Action and Source	78
	Timed Safe Stop 1	78
	Monitored Safe Stop 1	79
	SS1 Safety Fault	82
	Safe Brake Control Function	83
	Safe Brake Control Activation	83
	Safe Brake Control Reset	84
	Safe Brake Control Modes	85
	Safe Brake Control Operation	86
	SBC Safety Fault	91
	Connecting a Safety Brake	91
	Chapter 5	
Controller-based Safety Functions	Drive Safety Instructions	93
	Before Adding the Safety Instructions	95
	Drive Safety Instruction Example	95
	Pass-through Data Using Standard I/O Mode	96
	Pass-through Data Using Integrated Motion	98
	SFX Instruction	99
	SFX Instruction Example	100
	Chapter 6	
Standard I/O Mode – Configuration, Programming, and Operation	Safety Assembly Tags	103
	Configure Safety in the Logix Designer Application	104
	Add a PowerFlex 755 Drive/755T Drive Product to the Safety Controller Project	104
	Add an Option Module to a PowerFlex 755 Drive	106
	Using a 20-750-ENETR Dual-port EtherNet/IP Option Module with a 20-750-S4 Option Module	124
	Safety Configuration Signature and Ownership	126
	Reset Ownership	126
	Programming	126
	Safety Tags in Standard Routines	126
	Standard Tags in Safety Routines (tag mapping)	126
	Standard and Safety Tasks	127
	Safety Function Operation	128
	Pass-through Data	129
	Falling Edge Reset	130
	Understand Integrated Safety Drive Replacement	130
	Replace an Integrated Safety Drive in a GuardLogix System ..	130
	PowerFlex 755 IO Mode Using SFX, SS1, and SLS Instructions ..	133
Studio 5000 Logix Designer Application Configuration	133	

Programming Example..... 136

**Integrated Motion –
Configuration, Programming,
and Operation**

Chapter 7

Safety Assembly Tags..... 143

Configure the Integrated Safety Function Option Module in
the Logix Designer Application..... 144

 Add a PowerFlex 755 Drive to the Controller Project..... 144

Understand Module Properties Categories 145

 Module Properties>General Category..... 146

 Module Properties>Connection and Safety Categories 149

 Motion Safety>Actions Category..... 152

 Motion Safety>Primary Feedback Category 153

 Motion Safety>Secondary Feedback Category 155

 Motion Safety>Scaling Category..... 156

 Motion Safety>Discrepancy Checking Category 157

 Motion Safety>STO Category..... 158

 Motion Safety>SS1 Category..... 159

 Motion Safety>SBC Category..... 160

 Motion Safety>Input Configuration Category..... 161

 Motion Safety>Test Output Category 162

 Motion Safety>Output Configuration Category 163

 Axis Properties > Actions > Safety Actions 164

 Module Properties > Associated Axes Motor and Load
 Feedback Device..... 165

 Generate the Safety Network Number (SNN) 166

 Safety Configuration Signature and Ownership 167

 Reset Ownership 168

 Replace an Integrated Safety Drive in a GuardLogix System .. 168

 Motion Direct Commands in Motion Control Systems..... 169

Programming 176

 Motion and Safety Tasks..... 176

 Motion Safety Instances..... 176

 Safety Function Operation 176

 Safe Monitor Network Communication..... 179

 Explicit Messages 183

Application Example - Using SFX, SS1, and SLS Instructions
with Integrated Motion..... 184

 Studio 5000 Logix Designer Application Configuration 185

 Programming Example..... 187

Chapter 8

**Monitoring and
Troubleshooting**

Monitor Status Using Status Indicators 195

 Module Status Indicator (DS1)..... 196

 Network Status Indicator (DS2)..... 196

 Motion Output Status Indicator (DS3) 197

 Safety Fault Indicator (DS4)..... 197

	Safety Fault Names	197
	Understand Safety Faults	199
	Safety Supervisor State	199
	Safety Core Fault	199
	Safe Torque Off Fault	200
	Safe Stop 1 Fault	201
	Safe Brake Control Fault	202
	SS2, SOS, SLS, SLP, and SDI Faults	202
	Safety Feedback Faults	203
	Safety Fault Reset	204
	Monitor Status with a HIM or Software	205
	Fault Messages on HIM, Drive Module, and Connected Components Workbench Software	205
	Monitor Status Using Integrated Motion	210
	Out-of-Box State	214
	Recognize Out-of-Box State	214
	Restore the Drive to Out-of-Box State	214
	Appendix A	
Safety Function Validation Checklist	Safe Stop 1 (SS1)	218
	Safe Stop 2 (SS2)	220
	Safe Operating Speed (SOS)	223
	Safely-limited Speed (SLS)	225
	Safely-limited Position (SLP)	226
	Safe Direction (SDI)	228
	Safe Feedback Interface (SFX)	229
	Safe Brake Control (SBC)	231
	Appendix B	
Specifications, Certifications, and CE Conformity	Integrated Safety Functions Option Module Specifications	233
	Electrical Requirements	234
	Environmental Specifications	235
	Certifications	236
	CE Conformity	236
	Machinery Directive (2006/42/EC)	236
	EMC Directive (2014/30/EU)	237
	Waste Electrical and Electronic Equipment (WEEE)	237
	Appendix C	
Safety I/O Assemblies and Safety Attributes	Safety Assembly Tags	240
	Safety Feedback Attributes	245
	Safe Stop Function Attributes	247
	Explicit Messages	251
	Example: Read SS1 Fault Type	251

Parameter Data	Appendix D
	Parameters and Settings in a Linear List 253
	Device Parameters 253
	Host Config Parameters 259
	Index 263

This user manual explains how to use PowerFlex® 755 drives and PowerFlex 755T drive products in safety applications up to safety integrity level 3 (SIL 3), performance level e (PLe), category 4.

This user manual is intended for people that design, install, configure, or troubleshoot safety applications that use the Integrated Safety Functions option module (catalog number 20-750-S4).

This user manual covers using network safety with drives in Standard I/O mode and Integrated Motion mode. All chapters apply to both modes with the following exceptions:

- [Chapter 6](#) is specific to Standard I/O mode and can be skipped if you are using Integrated Motion mode.
- [Chapter 7](#) is specific to Integrated Motion mode and can be skipped if you are using Standard I/O mode.

IMPORTANT You must have a basic understanding of electrical circuitry and familiarity with PowerFlex 755 drives and PowerFlex 755T drive products. You must also be trained and experienced in the creation, operation, and maintenance of safety systems.

This user manual describes the safety requirements, including probability of dangerous failure on demand (PFD) and average frequency of a dangerous failure (PFH) per hour values and application verification information (see [PFD and PFH Data on page 21](#)).

Summary of Changes

This publication contains new and updated information as indicated in the following table.

Topic	Page
Added attention statement regarding ambient temperature to Environmental Specifications in Appendix B.	235

Conventions

This manual identifies parameter names by listing the parameter number first, followed by the name in brackets. For example, P7 [STO Fault Type].

Both the Host Config and Device Config parameters exist for this option module and the parameter numbers overlap. For example, there is a P3 [Device Config Identity State] and a P3 [Host Config Safety State]. Host Config parameters reside on the Host (that is, the drive) side of the option module and are specific to supporting the option module. Device Config parameters reside on the option module itself.

Throughout this manual, the PowerFlex 755/755T Integrated Safety Functions option module is also referred to as the Integrated Safety Functions option module.

Throughout this manual, the PowerFlex 755TL low harmonic drives, PowerFlex 755TR regenerative drives, PowerFlex 755TM drive systems are also referred to as PowerFlex 755T drive products.

The PowerFlex 755 drive is used for the examples in this manual.

Terminology

[Table 1](#) defines the abbreviations that are used in this manual.

Table 1 - Abbreviations and Definitions

Abbreviation	Full Term	Definition
Timed SS1	Timed Safe Stop 1	Timed SS1 and Safe Stop 1 time-controlled (SS1-t) are synonymous. Both mean a safe stop where the motor speed is decelerated to zero and once the maximum stop-time elapses, torque is removed from the motor. <ul style="list-style-type: none"> Safe Stop 1 time-controlled (SS1-t) is according to EN/IEC 61800-5-2.
SS1-t	Safe Stop 1 time-controlled	
Monitored SS1	Monitored Safe Stop 1	Monitored SS1 and Safe Stop 1 ramp-monitored (SS1-r) are synonymous. Both mean a safe stop where the motor speed is reduced to standstill within deceleration limits and once standstill speed is reached or the maximum stop-time elapses, torque is removed from the motor. <ul style="list-style-type: none"> Safe Stop 1 ramp-monitored (SS1-r) is according to EN/IEC 61800-5-2.
SS1-r	Safe Stop 1 ramp-monitored	
1oo2	One out of Two	Refers to the behavioral design of a dual-channel safety system.
CAT	Category	Classification of the safety-related parts of a control system in respect of their resistance to faults and their subsequent behavior in the fault condition, and which is achieved by the structural arrangement of the parts, fault detection, and/or by their reliability (source ISO 13849-1).
CL	Claim Limit	The maximum SIL rating that can be claimed for a safety-related electrical control system subsystem in relation to architectural constraints and systematic safety integrity (source IEC 62061).
CIP™	Common Industrial Protocol	Protocol for industrial automation applications and trademarked by ODVA, Inc.
EN	European Norm	The official European Standard.
ESD	Emergency Shutdown Systems	A system, usually independent of the main control system, which is designed to shut down an operating system safely.
ESPE	Electro-sensitive Protective Equipment	An assembly of devices and/or components working together for protective tripping or presence-sensing purposes and includes as a minimum: <ul style="list-style-type: none"> A sensing device. Controlling/monitoring devices. Output signal-switching devices (OSSD).
HFT	Hardware Fault Tolerance	The HFT equals n , where $n+1$ faults could cause the loss of the safety function. An HFT of one means that two faults are required before safety is lost.
HIM	Human Interface Module	A module that is used to configure a device.
IEC	International Electrotechnical Commission	The International Electrotechnical Commission (IEC) is the organization that prepares and publishes international standards for all electrical, electronic, and related technologies.
IGBT	Insulated Gate Bi-polar Transistors	Typical power switch that is used to control main current.
ISO	International Organization for Standardization	The International Organization for Standardization is an international standard-setting body that is composed of representatives from various national standards organizations.
NC	Normally Closed	A set of contacts on a relay or switch that are closed when the relay is de-energized or the switch is de-activated.
NO	Normally Open	A set of contacts on a relay or switch that are open when the relay is de-energized or the switch is de-activated.
OSSD	Output Signal Switching Device	The component of the electro-sensitive protective equipment (ESPE) connected to the control system of a machine. When the sensing device is actuated during normal operation, the device responds by going to the OFF-state.

Table 1 - Abbreviations and Definitions (Continued)

Abbreviation	Full Term	Definition
PELV	Protective Extra Low Voltage	An electrical system where the voltage cannot exceed ELV under normal conditions, and under single-fault conditions, except earth faults in other circuits.
PES	Programmable Electronic Systems	System for control, protection, or monitoring based on one or more programmable electronic devices, including all elements of the system such as power supplies, sensors and other input devices, data highways and other communication paths, and actuators and other output devices.
PF	Probability of Dangerous Failure on Demand	The average probability of a system to fail to perform its design function on demand.
PFH	Average Frequency of a Dangerous Failure per hour	The average frequency of a system to have a dangerous failure occur per hour.
PL	Performance Level	EN ISO 13849-1 safety rating
PM	Permanent Magnet	In permanent magnet (PM) motors, magnets mounted on or embedded in the rotor, couple with the current-induced internal magnetic fields of the motor generated by electrical input to the stator.
SBC	Safe Brake Control	Controls safety discrete outputs that actuate a brake. Sets timing between brake and Safe Torque Off.
SDI	Safe Direction	Monitors position of a motor to detect movement of more than a defined amount in the unintended direction.
SELV	Safety Extra Low Voltage Circuit	A secondary circuit that is designed and protected so that, under normal and single fault conditions, its voltages do not exceed a safe value.
SFX	Safety Feedback Interface	A GuardLogix® Drive Safety interface that scales feedback position into position units and feedback velocity into position units per time unit. Feedback Position and Velocity are read from a Safety Input assembly to an integrated Safe Speed drive.
SIL	Safety Integrity Level	A measure of a products ability to lower the risk that a dangerous failure could occur.
SLP	Safely-Limited Position	Prevents the motor shaft from exceeding one or more specified position limits.
SLS	Safely-Limited Speed	Monitors the speed of a motor and sets the SLS Limit output if the speed exceeds the Active Limit input value.
SNN	Safety Network Number	Uniquely identifies a network across all networks in the safety system. You are responsible for assigning a unique number for each safety network or safety subnet within a system.
SOS	Safe Operating Stop	Prevents the motor from deviating more than a defined amount from the stopped position. The drive provides energy to the motor to enable it to resist external forces.
SS1-r	Safe Stop 1 Ramp Monitored	Safe stop where the motor speed is decelerated to zero and once the maximum stop-time elapses, torque is removed from the motor. Safe Stop 1 ramp-monitored (SS1-r) is according to EN/IEC 61800-5-2 and is Stop Category 1, as defined in IEC 60204
SS1-t	Safe Stop 1 Time Controlled	Safe stop where the motor speed is reduced to standstill within deceleration limits and once standstill speed is reached or the maximum stop-time elapses, torque is removed from the motor. Safe Stop 1 time-controlled (SS1-t) is according to EN/IEC 61800-5-2 and is Stop Category 1, as defined in IEC 60204
STO	Safe Torque Off	The Safe Torque Off (STO) function is used to help prevent unexpected motor rotation during an emergency while the drive remains connected to the power supply. When STO is activated, the torque power cannot reach the drive, which stops and prevents any motor shaft rotation. Safe Torque Off (STO) is according to EN/IEC 61800-5-2 and is Stop Category 0 as defined in IEC 60204.

Product Firmware and Release Notes

Product firmware and release notes are available online within the Product Compatibility and Download Center.

1. From the Search bar on <http://www.ab.com>, choose Compatibility and Downloads.

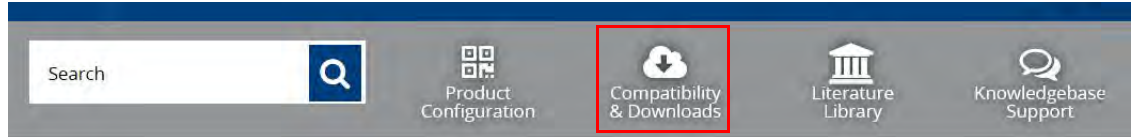

2. Search for your product.

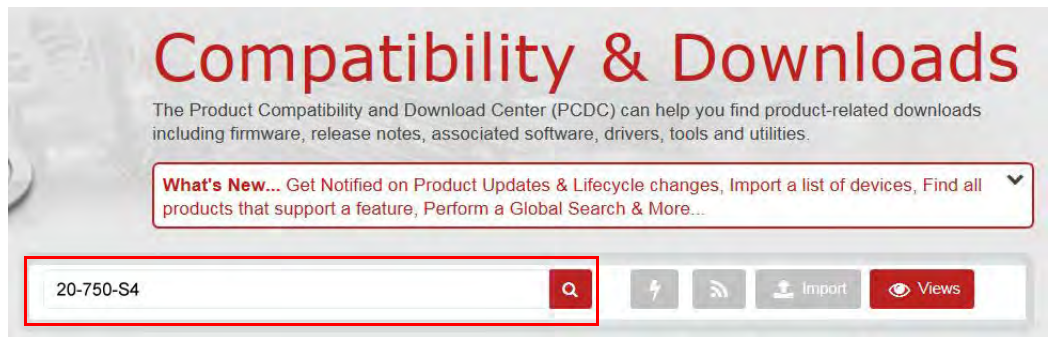

3. On the search results page, find the firmware and release notes for your product. If no firmware/release notes are available, the module is still shipping with its original firmware release.

IMPORTANT Both standard connections to the drive and safety connections to the card must be closed to update the Integrated Safety Functions Module.

See the Product Compatibility and Download Center Quick Start Guide, publication [PCDC-QS001](#), for instructions on how to find and download firmware and release notes.

Additional Resources

These documents contain additional information concerning related Rockwell Automation products.

Resource	Description
PowerFlex 750-Series Products with TotalFORCE® Control Installation Instructions, publication 750-IN100	Provides the basic steps to install PowerFlex 755TL low harmonic drives, PowerFlex 755TR regenerative drives, and PowerFlex 755TM drive systems.
PowerFlex 755TM IP00 Open Type Kits Installation Instructions, publication 750-IN101	Provides instructions to install IP00 Open Type kits in user-supplied enclosures.
PowerFlex Drives with TotalFORCE Control Programming Manual, publication 750-PM100	Provides detailed information on: <ul style="list-style-type: none"> • I/O, control, and feedback options • Parameters and programming • Faults, alarms, and troubleshooting
PowerFlex 750-Series AC Drive Installation Instructions, publication 750-IN001	Provides information on how to install the Safe Torque Off option module in PowerFlex 750-Series drive.
PowerFlex 750-Series AC Drives Programming Manual, publication 750-PM001	Provides information on how to mount, install, and configure PowerFlex 750-Series drives.
Enhanced PowerFlex 7-Class Human Interface Module (HIM) User Manual, publication 20HIM-UM001	Provides information for using the 20-HIM-A6 HIM module to configure PowerFlex 750-Series drives and the Safe Torque Off option module.
GuardLogix Safety Application Instruction Set Reference Manual, publication 1756-RM095	Provides information that describes the GuardLogix Safety Application Instruction set.
EtherNet/IP Network Devices User Manual, publication ENET-UM006	Describes how to configure and use EtherNet/IP devices to communicate on the EtherNet/IP network.
EtherNet/IP Device Level Ring Application Technique, publication ENET-AT007	Describes Device Level Ring (DLR) topologies, configuration considerations, and diagnostic methods.
System Design for Control of Electrical Noise Reference Manual, publication GMC-RM001	Information, examples, and techniques that are designed to minimize system failures caused by electrical noise.
Safety Guidelines for the Application, Installation, and Maintenance of Solid-State Control, publication SGI-1.1	Describes important differences between solid-state control and hardwired electromechanical devices.
GuardLogix 5580 and Compact GuardLogix 5380 Controller Systems Safety Reference, publication 1756-RM012	Provides information on safety application requirements for GuardLogix 5580 and Compact GuardLogix 5380 controllers in Studio 5000 Logix Designer® applications.
ControlLogix® 5580 Controllers User Manual, publication 1756-UM543	Provides information on how to use standard ControlLogix 5580 controllers.
CompactLogix™ 5380 Controllers User Manual, publication 5069-UM001	Provides information on how to use standard CompactLogix 5380 controllers.
Product Certification s website, rok.auto/certifications	Provides declarations of conformity, certificates, and other certification details.

You can view or download publications at rok.auto/literature.

Notes:

About Safe Stop and Safe Monitor Functions

This chapter provides information on safety considerations for the Integrated Safety Functions option module.

Topic	Page
What Is the Integrated Safety Functions Option Module?	15
Compatible Drives	17
Compatible Safety Controllers	17
Safety Application Requirements	18
Safety Certification	18
Proof Tests	20
PFD and PFH Definitions	20
PFD and PFH Data	21
Safety Reaction Time	23
Contact Information If Safety Option Failure Occurs	28

What Is the Integrated Safety Functions Option Module?

The Integrated Safety Functions option module provides a networked STO (Safe Torque Off) function via an EtherNet/IP® network. It is also equipped for Integrated (drive-based) Timed SS1, Monitored SS1, and Safe Brake Control, which operate in the drive and are activated through the network safety connection.

The Integrated Safety Functions option module also supports select controller-based EN/IEC 61800-5-2 safety functions operating in GuardLogix® 5580 or Compact GuardLogix 5380 controllers that use the EtherNet/IP network to communicate with the safety I/O. This support includes the new safety function instructions that are provided on the Drive Safety tab in the Logix Designer application.

The Integrated Safety Functions option module includes these features:

- Is designed to remove power from the gate firing circuits of the drive output power devices (IGBTs). With the power removed, the drive output power devices cannot turn on to generate AC power to the motor.
- Can be used in combination with other safety devices to satisfy the requirements of IEC 61508, EN/IEC 61800-5-2 SIL 3, ISO 13849-1 PL_e, and Category 4 for Safe Torque Off (STO).

When used for safe speed monitoring, the drive can be configured for single- or dual-feedback to achieve the following safety ratings:

- Single-feedback configurations using safety encoders provide up to SIL 2 PLd capability.
- Dual-feedback configurations provide up to SIL 3 PLe capability when discrepancy testing (either velocity, position, or both) is enabled. Safety functions that use position check have up to SIL 2 PLd capability. In this configuration, at least one encoder (the primary encoder) has to comply with SIL 2, PL d. The second encoder can be a standard encoder.

IMPORTANT The Integrated Safety Functions option module is suitable for performing mechanical work on the drive train or affected area of a machine only. It does not provide electrical safety.



ATTENTION: The Integrated Safety Functions option module does not remove dangerous voltages at the drive output. Before performing any electrical work on the drive or motor, turn off the input power to the drive, and follow all safety procedures. See [Remove Power to the System on page 30](#) for more information.

IMPORTANT Multiple safety option modules in a single drive are not allowed. Only one of these safety option modules can be installed in the drive:

- PowerFlex® 750-Series Safe Torque Off option module (catalog number 20-750-S)
 - PowerFlex 750-Series Safe Speed Monitor option module (catalog number 20-750-S1)
 - PowerFlex 755/755T Integrated Safety - Safe Torque Off option module (catalog number 20-750-S3)
 - PowerFlex 755/755T Integrated Safety Functions option module (catalog number 20-750-S4)
-



ATTENTION: If two output IGBTs fail in the drive, when the Integrated Safety Functions option module has controlled the drive outputs to the Off state, the drive can provide stored energy for up to 180° of rotation in a 2-pole motor before torque production in the motor stops.



ATTENTION: The STO function only disables motor torque. A mechanical force on the motor shaft such as suspended loads, back pressure in a pump or fan, can cause motor rotation.

IMPORTANT Do not use this option module as a control for starting or stopping the drive.

Compatible Drives

The Integrated Safety Functions option module is compatible with these PowerFlex 755 drives and PowerFlex 755T drive products:

- PowerFlex 755 drives (v14.xxx or later)
- PowerFlex 755TL low harmonic drives (v4.xxx or later)
- PowerFlex 755TR regenerative drives (v4.xxx or later)
- PowerFlex 755TM common bus inverters (v4.xxx or later)

IMPORTANT The Integrated Safety Functions option module is not compatible with PowerFlex 753 drives.

Integrated safety functions are controlled via the embedded Ethernet port on the drive only. The 20-750-ENETR can still be used, but only in conjunction with the embedded Ethernet port by being in Tap mode (safety messages must go through the embedded Ethernet port on drive).

The following Add-on Profiles (AOPs) are needed depending on the drive and type of control used:

Product	Standard Control	Integrated Motion
755	v5.03 (or later)	v19.00.00 (or later)
755T	v5.04 (or later)	Future

Compatible Safety Controllers

A GuardLogix safety controller is required for use of the Integrated Safety Functions option module that is used in Network mode control ('Safety', 'Standard and Safety', or 'Motion and Safety' used for Connection type). The following GuardLogix controllers can be used:

Controller	Studio 5000 Logix Designer® Application Version / Controller Firmware
GuardLogix 5580 safety controller	v31 (or later)
Compact GuardLogix 5380 safety controller	v31 (or later)

IMPORTANT The Integrated Safety Functions option module is not supported by GuardLogix 5570 and GuardLogix 5370 (or earlier) safety controllers.

Safety Application Requirements

Create, record, and verify the safety signature as part of the required safety application development process. The safety controller creates the safety signature, which consists of an identification number, date, and time that uniquely identifies the safety portion of a project. This signature covers all safety logic, data, and safety I/O configuration.

If the Drive Safety Function Instructions are used in the safety application, special consideration must be taken to verify the application. See [Appendix A](#) for guidance on verifying the drive safety function instructions.

For safety system requirements, including information on the safety network number (SNN), verifying the safety signature, and functional verification tests, see the GuardLogix Controller Systems Safety Reference Manuals that are listed in the [Additional Resources on page 13](#).

Safety Certification

The TÜV Rheinland group has approved the PowerFlex 755 Integrated Safety Functions option module (catalog number 20-750-S4) as suitable for use in integrated safety applications:

- Up to and including SIL 3 according to IEC 61508
- Up to and including SIL CL3 according to IEC 62061
- Up to and including PLe (Category 4) according to ISO 13849-1.

In these applications, the removal of motion-producing power is considered to be the safe state. All components in the system must be chosen and applied correctly to achieve the desired level of operator safeguarding.

Important Safety Considerations

You are responsible for these system safety considerations:

- Set-up, safety rating, and validation of any sensors or actuators connected to the system.
- Complete a system-level risk assessment, and reassess the system anytime a change is made.
- Certification of the system to the desired safety Performance Level/ Safety Integrity Level.
- Project management and proof testing.
- Programming the application software and the safety option module configurations in accordance with the information in this manual.
- Access control to the system.
- Analyze all configuration settings and choose the proper setting to achieve the required safety rating.
- Validation and documentation of all safety functions used.

IMPORTANT Only qualified, authorized personnel that are trained and experienced in functional safety can plan, implement, and apply functional safety systems.



ATTENTION: When designing your system, consider how various personnel can interact with the machine. Additional safeguard devices can be required for your specific application.



ATTENTION: In circumstances where external influences (for example, suspended loads that can fall) are present, additional measures (for example, mechanical brakes) can be necessary to help prevent any hazard.

Stop Category Definitions

There are three stop categories:

- Stop Category 0 is achieved with immediate removal of power to the machine actuators, which results in an uncontrolled coast-to-stop. An STO accomplishes a Stop Category 0 stop.
- Stop Category 1 is achieved with a Ramp to Stop followed with immediate removal of power to the machine actuators. This can be achieved using SS1 with STO.
- Stop Category 2 is a controlled stop with power left available to the machine actuators. This can be achieved using controller-based SS2 / SOS with the PowerFlex 755T drive products.

IMPORTANT When designing the machine application, consider timing and distance for a coast-to-stop (Stop Category 0 or Safe Torque Off). For more information on stop categories and Safe Torque Off, see EN 60204-1 and EN/IEC 61800-5-2.

Performance Level and Safety Integrity Level (SIL) CL3

For safety-related control systems, Performance Level (PL), according to ISO 13849-1, and SIL levels, according to IEC 61508 and EN 62061, include a rating of the ability of the system to perform its safety functions. All safety-related components of the control system must be included in both a risk assessment and the determination of the achieved levels.

See the ISO 13849-1, IEC 61508, and EN 62061 standards for complete information on requirements for PL and SIL determination.

Proof Tests

IEC 61508 requires you to perform various proof tests of the equipment that is used in the system. Proof tests are performed at user-defined times. For example, proof tests can be once a year, once every 15 years, or whatever time frame is appropriate.

The Integrated Safety Functions option module has a useful life of 20 years, no proof test required. Other components of the system, such as safety I/O devices, sensors, and actuators can have different useful life times.

IMPORTANT The time frame for the proof test interval depends on the specific application.

PFD and PFH Definitions

Safety-related systems can be classified as operating in either a Low Demand mode, or in a High Demand/Continuous mode.

- Low Demand mode: where the frequency of demands for operation, made on a safety-related system, is no greater than one per year, or no greater than twice the proof-test frequency.
- High Demand/Continuous mode: where the frequency of demands for operation, made on a safety-related system, is greater than once per year, or greater than twice the proof test interval.

The SIL value for a low-demand safety-related system is directly related to order-of-magnitude ranges of its average probability of failure to perform its safety function on demand or, simply, average probability of dangerous failure on demand (PFD_{avg}).

The SIL value for a High Demand/Continuous mode safety-related system is directly related to the average frequency of a dangerous failure (PFH) per hour.

PFD and PFH Data

These PFD_{avg} and PFH calculations are based on the equations from Part 6 of EN 61508 and show worst-case values.

Safety Data for Safe Torque Off

[Table 2](#), and [Table 3](#) provide PFD_{avg} and PFH values for the Safe Torque Off (STO) or Timed Safe Stop 1 functions. These values apply when Safety Instance is set to ‘Safe Stop Only – No Feedback’.

Table 2 - PFD and PFH for PowerFlex 755 Drives STO and Timed SS1

Attribute	Frames 1...7	Frame 8	Frame 9	Frame 10
$PFD_{(average)}$	4.08E-5	1.81E-4	2.73E-4	3.64E-4
PFH (1/hour)	4.77E-10	2.09E-9	3.14E-9	4.19E-9
SIL	3	3	3	3
PL	e	e	e	e
Category	4	4	4	4
MTTF _D years	204.1 (high)	93.3 (high)	69.1 (high)	55.1 (high)
DC _{avg} %	97.5% (medium)	97.4% (high)	97.5% (high)	97.5% (high)
HFT	1 (1oo2)	1 (1oo2)	1 (1oo2)	1 (1oo2)
Mission time	20 years	20 years	20 years	20 years

Table 3 - PFD and PFH for PowerFlex 755T Drive Products STO and Timed SS1

Attribute	Frames 5 and 6	Frames 7 and 8	Frame 9	Frame 10	Frame 11	Frame 12	Frame 13	Frame 14	Frame 15
$PFD_{(average)}$	4.49E-5	2.56E-4	2.82E-4	3.08E-4	3.34E-4	3.60E-4	3.86E-4	4.38E-4	4.90E-4
PFH (1/hour)	5.24E-10	2.96E-9	3.25E-9	3.55E-9	3.85E-9	4.15E-9	4.45E-9	5.05E-9	5.65E-9
SIL	3	3	3	3	3	3	3	3	3
PL	e	e	e	e	e	e	e	e	e
Category	4	4	4	4	4	4	4	4	4
MTTF _D years	187.5 (high)	102.6 (high)	87.8 (high)	76.7 (high)	68.1 (high)	61.2 (high)	55.6 (high)	47 (high)	40.7 (high)
DC _{avg} %	97.4% (high)	97.0% (high)	97.0% (high)	97.0% (high)	97.0% (high)	96.9% (high)	96.9% (high)	96.9% (high)	96.9% (high)
HFT	1 (1oo2)	1 (1oo2)	1 (1oo2)	1 (1oo2)	1 (1oo2)	1 (1oo2)	1 (1oo2)	1 (1oo2)	1 (1oo2)
Mission time	20 years	20 years	20 years	20 years	20 years	20 years	20 years	20 years	20 years

Safety Data for Safe Feedback

[Table 4](#) provides PFD_{avg} and PFH values to add to the PFD_{avg} and PFH values from [Table 2](#) or [Table 3](#) for safety functions that require safe encoder feedback. Safety functions using safe encoder feedback include drive based Monitored Safe Stop 1 and controller-based safety functions SS1, SS2, SOS, SLS, SLP, and SDI.

In general, the PFD_{avg} and PFH values from [Table 4](#) should be added to [Table 2](#) and [Table 3](#) when Safety Instance is set to ‘Single Feedback Monitoring’ or ‘Dual Feedback Monitoring’.

When using Dual Feedback Monitoring, enable Discrepancy Testing.

Table 4 - PFD or PFH to Add When Safety Functions Use Safety Feedback

Attribute	Single Encoder Feedback	Dual Encoder Feedback ⁽¹⁾
PFD (average)	6.75E-4	4.32E-5
PFH (1/hour)	7.70E-9	4.93E-10
SIL	2	3
PL	d	e
Category	3	4
MTTFD years	1446.7 (high)	1427.7 (high)
DCavg%	90.0% (medium)	99.0% (high)
HFT	1 (1002)	1 (1002)
Mission time	20 years	20 years

(1) Dual channel values apply with discrepancy checking configured.

The safe motion-monitoring option can be configured for single feedback or dual feedback to achieve the following safety rating:

- Single feedback configurations provide up to SIL 2 PLd capability.
- Dual-feedback configurations provide up to SIL 3 PLe capability when discrepancy testing (either velocity, position, or both) is enabled.

IMPORTANT Achievable safety rating depends on each system component. For Safe Feedback, the safety rating of the selected encoders may limit the safety rating of the system.

Safety Data for Safety I/O

The Integrated Safety Functions option module provides four safety inputs and two safety outputs. [Table 5](#) provides PFD_{avg} and PFH values to add for safety functions that use this Safety I/O.

Table 5 - PFD or PFH to Add When Safety Functions Use Safety I/O

Attribute	Single Channel Safety I/O	Dual Channel Safety I/O
PFD (average)	3.35E-4	2.49E-4
PFH (1/hour)	3.83E-9	2.84E-9
SIL	2	3
PL	d	e
Category	2	4
MTTFD years	1064.9 (high)	1998.0 (high)

Table 5 - PFD or PFH to Add When Safety Functions Use Safety I/O

Attribute	Single Channel Safety I/O	Dual Channel Safety I/O
DCavg%	96.4% (high)	94.2% (high)
HFT	0 (1oo1)	1 (1oo2)
Mission time	20 years	20 years

IMPORTANT Single channel safety I/O is only certified for use in functional safety applications with process safety times greater than or equal to 300 ms; or applications with demand rates less than or equal to 1 demand per 30 seconds.

IMPORTANT If single channel safety I/O is used, pulse testing (external pulse testing for safety inputs, pulse testing for safety outputs) **MUST** be enabled on the single channel I/O points.

Spurious Trip Rate

[Table 6](#) shows the Spurious Trip Rate (STR) and Mean Time to Failure Spurious ($MTTF_{\text{Spurious}}$) values for the Integrated Safety Functions option module, calculated according to the ISA TR-84 method.

Table 6 - STR and MTTF Spurious Values

Attribute	Value
Spurious Trip Rate	3.00E-6
MTTF _{Spurious} (years)	37.0

Safety Reaction Time

The safety reaction time is the length of time from a safety-related event as input to the system until the system is in the safe state. [Table 7](#) shows the safety reaction time from an input signal condition that triggers a safe stop, to the initiation of the configured Stop Type. For details on how to calculate system reaction times with GuardLogix controllers, see the GuardLogix Controller Systems Safety Reference Manuals listed in the [Additional Resources on page 13](#).

Table 7 - Safety Reaction Time

Drive Family	Network STO Reaction Time, Max
PowerFlex 755 drives (firmware revision 13 or later), Frames 1...10 PowerFlex 755TL low harmonic drives, Frames 7...15 PowerFlex 755TR regenerative drives, Frames 7...15 PowerFlex 755TM, Frames 8...15	15 ms
PowerFlex 755TL low harmonic drives, Frames 5 and 6	26 ms

IMPORTANT An input signal condition that is present for less than the reaction time may not result in the safety function being performed. Repeated requests of the safety function for less than the reaction time can result in a spurious detection of a fault.

IMPORTANT In network STO Mode, the safety reaction time in [Table 7](#) does not include the connection reaction time limit. See the GuardLogix Controller Systems Safety Reference Manuals, listed in the [Additional Resources on page 13](#), for details.

Considerations for Safety Ratings

The achievable safety rating of an application that uses the Integrated Safety Functions option module that is installed in PowerFlex 755/755T drive products is dependent upon many factors, drive options, and the type of motor.

A safety rating up to and including SIL 3, PLe, and Category 4 can be achieved.

Encoder Considerations

This section describes factors to consider when using an encoder with the Integrated Safety Functions option module.

Supported Encoders

[Table 8](#) describes the supported encoder types based on the feedback card that is used and the physical terminal it is connected to. You must determine the safety capability of a system based on the supported encoder types and the encoder diagnostics that are described in this chapter.

Table 8 - Supported Feedback Cards and Encoder Types

Feedback Option	Primary Channel		Secondary Channel		Achievable System Safety Rating
	Encoder Type	Encoder Motion Axis	Encoder Type	Encoder Motion Axis	
20-750-UFB-1	Sine/Cosine	Motor Feedback	Not Used	Not Used	SIL 2/PL d with safety rated encoder
			Digital AqB	Load Feedback	SIL 3/PL e
20-750-DENC-1	Digital AqB		Not Used	Not Used	SIL 2/PL d with safety rated encoder
			Digital AqB	Load Feedback	SIL 3/PL e

Encoder Diagnostics

Depending on the encoder type, the module performs several diagnostic tests on encoder signals to detect faults in the encoder. You must determine if the combination of the selected encoder device type and the diagnostics that are described in this chapter will satisfy the required safety function rating. The use of non-safety, standard encoders may require further analysis and assessment activities.

General Encoder Diagnostics

The following encoder diagnostics are available for all supported encoder types:

- Encoder Voltage Monitoring (Configurable)
- Maximum Speed Limit (Configurable)
- Maximum Acceleration (Configurable)
- Maximum Encoder Input Frequency
- Dual Encoder Velocity and/or Position Discrepancy (Configurable)

IMPORTANT These diagnostics are based on the capability of the chosen encoder and its rated limits. They do not provide a safety-rated safety function.

Encoder Voltage Monitoring

The voltage monitoring diagnostic samples the voltage being supplied to the encoder to confirm that its level is within its configured range. If the voltage monitoring diagnostic detects a voltage that is out of the configured range, the safety feedback instance reports a voltage monitoring fault and causes the module to enter the safe state.

The following voltage monitoring ranges are supported:

- 4.75...5.25V (Recommended setting when using 20-750-DENC-1 card with the 12V Jumper in the 'Storage' position)
- 11.4...12.6V (Recommended setting when using 20-750-DENC-1 card with the 12V Jumper in the 'Enabled' position)
- 7...12V (Recommended setting when using 20-750-UFB-1)

If a voltage range is not specified, then the voltage monitoring diagnostic is not performed.

Maximum Speed Limit

The maximum speed limit diagnostic detects when encoder speed is above a configured limit. If the speed of the encoder is greater than the configured max speed limit, an exceeded max speed fault is reported by the safety feedback instance. This causes the module to enter the safe state.

If the encoder being used specifies a maximum speed, set the maximum speed limit configuration value to this value or lower. If the limit is configured as 0, this diagnostic is not performed.

Maximum Acceleration

The maximum acceleration diagnostic detects when encoder acceleration is above a configured limit. If the module detects that the acceleration of the

encoder has exceeded the configured limit, a max acceleration fault is reported by the safety feedback instance. This causes the module to enter the safe state.

If the encoder being used specifies a maximum acceleration, set the maximum acceleration configuration value to this value or lower. If the maximum acceleration is configured as 0, this diagnostic is not performed.

Maximum Encoder Input Frequency

The maximum encoder input frequency diagnostic confirms that the safety feedback signals do not exceed the maximum frequency (encoder counts per second) supported by the module. This value is not configurable and has fixed values based on the encoder type. [Table 9](#) shows the maximum frequency based on encoder type.

Table 9 - Maximum Frequency of Encoder Types

Encoder Type	Max Frequency
Digital AqB	250 kHz
Sine/Cosine and Hiperface	163.8 kHz

If the module detects an encoder input frequency above the limit, a max frequency fault is reported in the safety feedback instance and the module enters the safe state.

Dual Encoder Velocity and/or Position Discrepancy

The dual encoder velocity and position discrepancy diagnostic confirms that the position and/or velocity of the two encoders match within a configurable tolerance. The position and velocity discrepancy limits are individually configurable; setting the limit to a value of 0 disables the diagnostic check. If the module detects that the difference between the position and/or velocity of both encoders is outside the configured limit, a discrepancy error is reported in both safety feedback instances and the module enters the safe state. This diagnostic is only available when the module is configured in a dual feedback configuration.

Digital AqB Diagnostics

The following diagnostic functions are implemented in the module to perform diagnostics for digital AqB encoders:

- Inverse Signal Monitoring
- Quadrature Error Detection

Inverse Signal Monitoring

The inverse signal monitoring diagnostic confirms that the inverted and non-inverted signals are always at opposite signal levels. If the module detects a non-inverted signal, a feedback signal lost fault is reported in the safety feedback instance and the module enters the safe state. This diagnostic is meant to detect encoder wiring errors, such as open, short, or short to power.

Quadrature Error Detection

The quadrature error detection confirms that the A and B signals from the digital AqB encoder do not change simultaneously. This diagnostic is also referred to as an exclusive bit check. If the module detects a quadrature error, the safety feedback instance reports a quadrature error fault and enters the safe state. A simultaneous change indicates an error with the encoder wiring or an issue with the encoder itself.

Sine/Cosine and Hiperface Diagnostics

The following diagnostic functions are implemented in the module to perform diagnostics on Hiperface and or Sine/Cosine type encoders:

- $\text{Sin}^2 + \text{Cos}^2$ Vector Length Monitoring
- Zero-crossing Detection
- Signal Offset (Sine/Cosine Encoder Type Only)

$\text{Sin}^2 + \text{Cos}^2$ Vector Length Monitoring

The $\text{Sin}^2 + \text{Cos}^2$ vector length monitoring diagnostic confirms that the sine and cosine signals are sinusoidal and 90° apart. This diagnostic is meant to detect errors in the wiring of the encoder and problems within the encoder itself. [Table 10](#) describes the tolerance of encoder output signal amplitudes for this diagnostic. [Table 11](#) describes the phase tolerance of the diagnostic. If the module detects that the amplitude and or phase of the signals is out of range, the safety feedback instance reports a $\text{Sin}^2 + \text{Cos}^2$ fault and the module is placed in the safe state.

Table 10 - $\text{Sin}^2 + \text{Cos}^2$ Vector Length Monitoring Amplitude Range

Max	Min
1.3 Vpp	0.7 Vpp

Table 11 - $\text{Sin}^2 + \text{Cos}^2$ Vector Length Monitoring Phase Tolerance

Tolerance
$90^\circ \pm 20^\circ$

Zero-crossing Detection

The zero-crossing detection diagnostic confirms that the sine and cosine signals have a similar offset to ground. The offset tripping point is ± 50 mV. If the offset of the sine and cosine signals is greater than the tripping point, the zero-crossing detection diagnostic will fail, a signal lost fault is reported in the safety feedback instance, and the module is placed in the safe state.

Signal Offset

The signal offset diagnostic confirms that a Sine/Cosine type encoder is producing the proper offset on the Sine and Cosine signals. This diagnostic is not performed when the feedback device type is configured as Hiperface.

[Table 12](#) describes the offset tolerance of the diagnostic. If the offset of the Sine and or Cosine signals are outside the tolerance range, the safety feedback instance reports a signal offset fault and the module is placed in the safe state.

Table 12 - Signal Offset Tolerance

Max	Min
3.0V	2.0V

Contact Information If Safety Option Failure Occurs

If you experience a failure with any safety-certified device, contact your local Allen-Bradley distributor to request any of these actions:

- Return the device to Rockwell Automation so the failure is appropriately logged for the catalog number that is affected and a record is made of the failure.
- Request a failure analysis (if necessary) to determine the probable cause of the failure.

In case of malfunction or damage, no attempts at repair should be made. The option module should be returned to the manufacturer for repair. Do not dismantle the option module.

For more information about replacing drives, see [Replace an Integrated Safety Drive in a GuardLogix System on page 130](#) and [Replace an Integrated Safety Drive in a GuardLogix System on page 168](#).

Installation

This chapter provides installation, jumper settings, and wiring for the Integrated Safety Functions option module.

Topic	Page
Remove Power to the System	30
Access the Control Pod	30
Set the SAFETY and Hardware ENABLE Jumpers	31
Install the Safety Option Module	32
I/O Wiring	34
Cabling	34



ATTENTION: The following information is a guide for proper installation. Rockwell Automation does not assume responsibility for the compliance or the noncompliance to any code, national, local, or otherwise for the proper installation of this equipment. A hazard of personal injury and/or equipment damage exists if codes are ignored during installation.

IMPORTANT Installation must be in accordance with the instructions in this user manual and the installation instructions for your drive.

Only qualified, authorized personnel that are trained and experienced in functional safety can plan, implement, and apply functional safety systems.

IMPORTANT During installation and maintenance, check your drive firmware release notes for known anomalies and verify that there are not safety-related anomalies.

The Integrated Safety Functions option module is intended to be part of the safety-related control system. Before installation, perform a risk assessment that compares the Integrated Safety Functions option module specifications and all foreseeable operational and environmental characteristics of the control system.

A safety analysis is required to determine how often to test the safety function for proper operation during the life of the machine.

Remove Power to the System

Before performing any work on the drive, remove all power to the system.



ATTENTION:

- Electrical Shock Hazard. Verify that all sources of AC and DC power are de-energized and locked out or tagged out in accordance with the requirements of ANSI/NFPA 70E, Part II.
- To avoid an electric shock hazard, verify that the voltage on the bus capacitors has discharged before performing any work on the drive. Measure the DC bus voltage at the +DC and -DC terminals or test points. The voltage must be zero. For the location of the terminal block and test point sockets, see the manual for your drive:
 - PowerFlex® 750-Series AC Drive Installation Instructions, publication [750-IN001](#)
 - PowerFlex 750-Series Products with TotalFORCE® Control Installation Instructions, publication [750-IN100](#)
 - PowerFlex 755TM IP00 Open Type Kits Installation Instructions, publication [750-IN101](#)
- In Safe Torque Off mode, hazardous voltages may still be present at the motor. To avoid an electric shock hazard, disconnect power to the motor and verify that the voltage is zero before performing any work on the motor.

Access the Control Pod

The option module is installed in the drive control pod. Different drives have different ways to access the control pod. To access the control pod, follow these steps.

1. Remove the door or cover.
2. Loosen the retention screw on the HIM cradle.
3. Lift the cradle until the latch engages.

See the installation instructions for your drive for more information.

Figure 1 - Access the Control Pod.

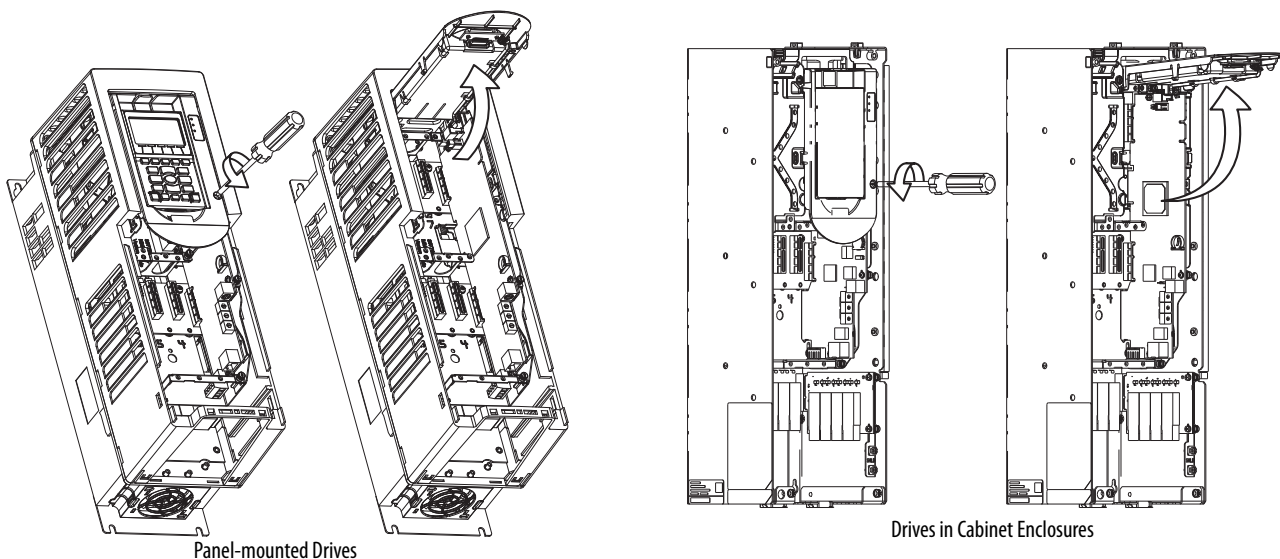

Set the SAFETY and Hardware ENABLE Jumpers

The PowerFlex 755/755T drive products ship with the safety jumper (SAFETY) installed.

If the Integrated Safety Functions option module is installed, the control board SAFETY jumper must be removed. If the SAFETY jumper is not removed, a 'Safety Jumper In' fault occurs.

IMPORTANT PowerFlex 755 drives (frames 8...10) control boards do not have a SAFETY jumper.

If the Integrated Safety Functions option module is installed, the control board hardware ENABLE jumper must be installed. If the hardware ENABLE jumper is not installed, a 'HW Enbl Jmpr Out' fault occurs (only frames 1...7 of PowerFlex 755 drives and all frame sizes of PowerFlex 755T drive products).

Figure 2 - PowerFlex 755 Drives Jumper Locations, Frames 1...7

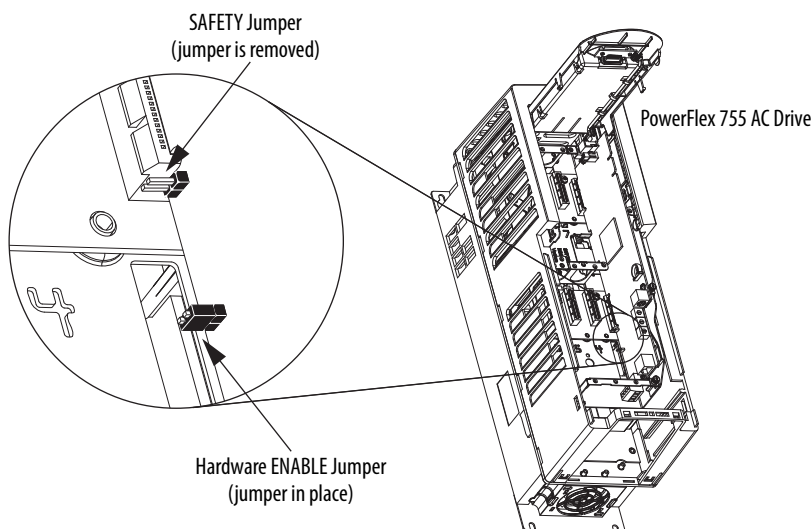
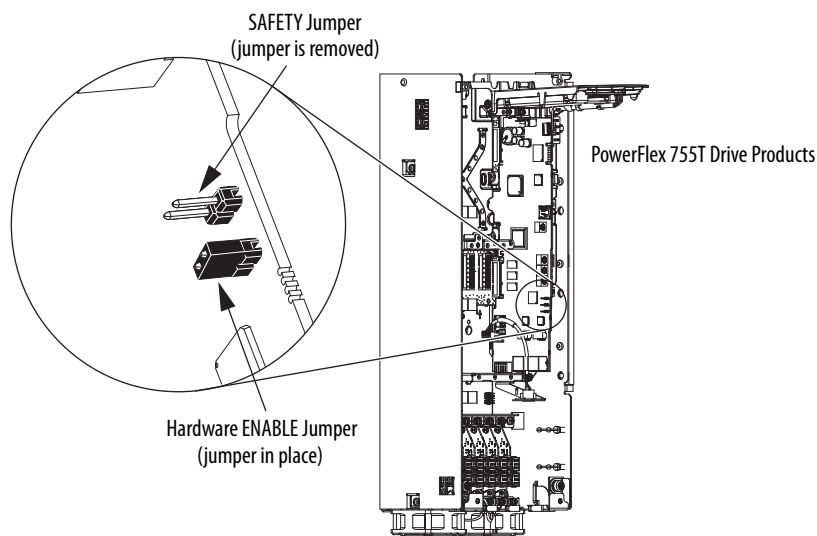

Figure 3 - PowerFlex 755T Drive Products Jumper Locations (all frame sizes)



Install the Safety Option Module

To install the Integrated Safety Functions option module in a drive port, follow these steps:

1. Firmly press the module edge connector into the desired port.

IMPORTANT The Integrated Safety Functions option module can be installed in ports 4, 5, or 6 when used in Standard I/O mode. When used in an Integrated Motion application, the Integrated Safety Functions option module must be installed in Port 6.

2. Tighten the top and bottom retaining screws.
 - Recommended torque = 0.45 N•m (4.0 lb•in)
 - Recommended screwdriver = T15 Hexalobular

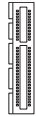

6 5 4

IMPORTANT Do not overtighten the retaining screws.

IMPORTANT Only one safety option module can be installed in a drive. Multiple safety option modules or duplicate safety option module installations are not supported.

Figure 4 - PowerFlex 755 Drives, Frames 1...7

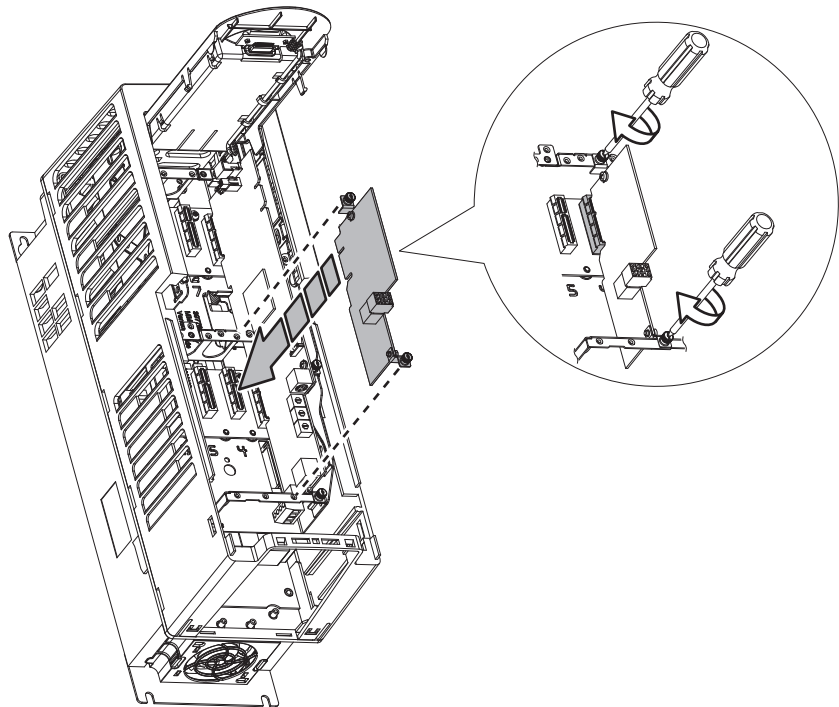

Feedback Installation Guidelines

Follow these guidelines for the Integrated Safety Functions option module.

Feedback Devices

The Integrated Safety Functions option module can be used with one of the following feedback devices when safe feedback monitoring is used:

- Dual-incremental Encoder module, catalog number 20-750-DENC-1
- Universal Feedback module catalog number 20-750-UFB-1

Only one feedback card can be used in conjunction with the Integrated Safety Functions module. For information on the supported encoder types for a given feedback device, see [Encoder Considerations](#) in [Chapter 1](#).

Port Assignment

Follow these guidelines for port assignment:

- The Integrated Safety Functions option module and the feedback device must be installed on the same backplane using ports 4, 5, or 6.
- When used in an Integrated Motion application, the Integrated Safety Functions option module must be installed in port 6.
- Only one safety option module can be installed in a drive. Multiple safety options or duplicate safety option installations are not supported.

Jumper Settings

Follow these guidelines for jumper settings:

- Verify the hardware enable jumper (ENABLE) on the main control board is installed. See [Figure 2](#) or [Figure 3](#) for location. If not installed, the drive will fault when powered up.
- Verify the safety enable jumper (SAFETY) on the main control board is removed (Frames 1...7 only). See [Figure 2](#) or [Figure 3](#) for location.

I/O Wiring

This section describes the onboard safety I/O and wiring considerations. A power supply must be connected between the SP and SC terminals in order for the safety I/O to be used. See [Power Supply Requirements](#) on page 35 for information on selecting a power supply.

IMPORTANT External 24V power is only required to the module when hardwired safety is used. It is NOT required when the module is used for networked safety operation.

Table 13 - Terminal Designation

	Terminal	Name	Description
To1	To1	Test Output 1	Test 24V DC output 1
Si2	Si2	Safety Input 2	Safety 24V DC input 2
SC	SC	Safety Common	Safety power common
Si3	Si3	Safety Input 3	Safety 24V DC input 3
To0	To0	Test Output 0	Test 24V DC output 0
NC	NC	No Connection	
So0	So0	Safety Output 0	Safety 24V DC output 0
SC	SC	Safety Common	Safety power common
So1	So1	Safety Output 1	Safety 24V DC output 1
Si0	Si0	Safety Input 0	Safety 24V DC input 0
SC	SC	Safety Common	Safety power common
Si1	Si1	Safety Input 1	Safety 24V DC input 1
SC	SC	Safety Common	Safety power common (required if safety I/O used)
SP	SP	Safety Power	Safety 24V DC power (required if safety I/O used)

For examples of wiring devices to the safety I/O, see the Guard I/O™ EtherNet/IP Safety Modules User Manual, publication [1791ES-UM001](#).

For technical specifications of the safety I/O, see [Integrated Safety Functions Option Module Specifications](#) in [Appendix B](#).

Cabling

Follow these guidelines for cabling:

- Safety wiring must be protected against external damage by cable ducts, conduit, armored cable, or other means.
- Shielded cable is required.
- When installed in a PowerFlex 755 Frame 8 or larger drive, an EMC Core Kit, catalog number 20-750-EMCSSM1-F8, is required.

Power Supply Requirements

IMPORTANT The external power supply must conform to the Directive 2006/95/EC Low Voltage by applying the requirements of EN61131-2 Programmable Controllers, Part 2 - Equipment Requirements and Tests, and one of the following:

- EN60950 - SELV (Safety Extra Low Voltage)
 - EN60204 - PELV (Protective Extra Low Voltage)
 - IEC 60536 Safety Class III (SELV or PELV)
 - UL 508 Limited Voltage Circuit
 - 24V DC $\pm 10\%$ must be supplied by a power supply that complies with IEC 60204 and IEC 61558-1.
-

For more information, see the guidelines in Industrial Automation Wiring and Grounding Guidelines, publication [1770-4.1](#).

Notes:

Safety I/O

This chapter provides information that is related to the embedded safety inputs and outputs on the Integrated Safety Functions option module.

Topic	Page
Safety Inputs	37
Safety Outputs	50

Safety Inputs

Read this section for information about safety inputs and their operation modes. The safety inputs can be used in a single or dual-channel configuration for monitoring a safety input device. A safety input can also be configured for external pulse testing with an associated test output.

Safety Input Operation

The Integrated Safety Functions option module provides two modes of operation for its safety inputs: Safety Input with External Pulse Tests and Standard Input.

The safety inputs also support configuring a sample delay time. You can configure both on→off and off→on sample delay times for each input point. You can also configure a latch error time, which specifies the minimum amount of time that a safety input alarm is reported.

Safety Input with External Pulse Tests Operation

A test output can be used in combination with a safety input for short-circuit detection. Configure the test output as a pulse test source and configure the safety input as 'Used with Test Output'. Test Output 0 is associated with safety inputs 0 and 2. Test Output 1 is associated with safety inputs 1 and 3.

When the external input contact is closed, a test pulse is output from the test output terminal to diagnose the field wiring and input circuitry. By using this function, short circuits between input signal lines and the power supply (positive side), and short circuits between redundant input signal lines of one external device can be detected. Safe wiring by customer action is required.

Table 14 - Typical External Pulse Width and Period

Pulse Width	Period
500 μ s	300 ms

Figure 5 - Test Pulse in a Cycle

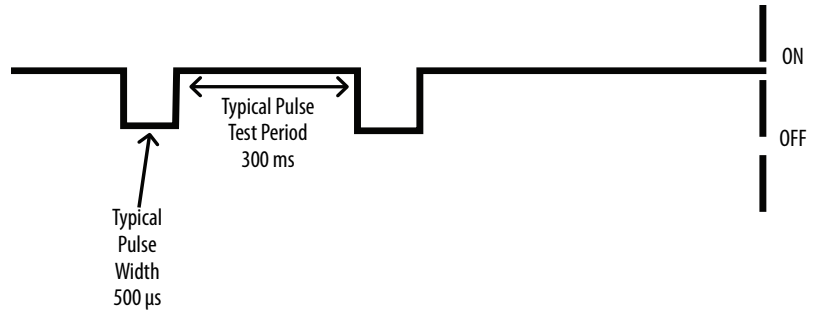

IMPORTANT When using external pulse testing in single-channel mode, the demand rate of the input must be greater than 30 seconds.

Figure 6 - Short-circuit Between Input Signal Lines

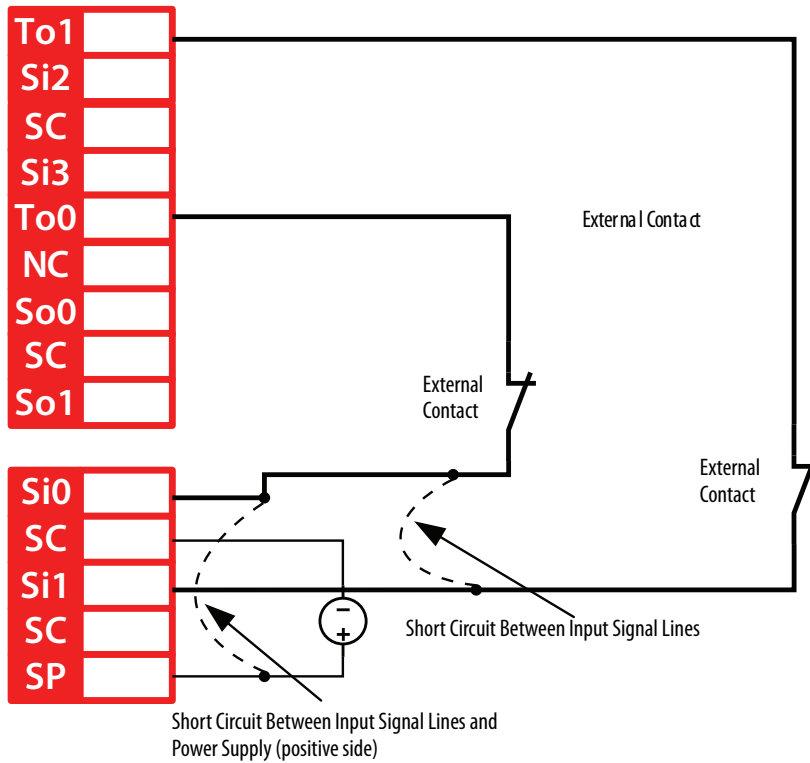

Latch Input Error Operation in Single Channel Mode

The safety input subsystem allows for a configurable time for which an alarm state is held. This is referred to as Input Latch Error Time. In single channel mode, the input latch error time describes the period between when the alarm condition is removed and when the safety input stops reporting the alarm. [Figure 7](#) shows the operation of input latch error time in single channel mode. See [Safety Input Alarm Recovery on page 49](#) for information on removing an alarm.

Figure 7 - Single Channel Input Latch Error Behavior (not to scale)

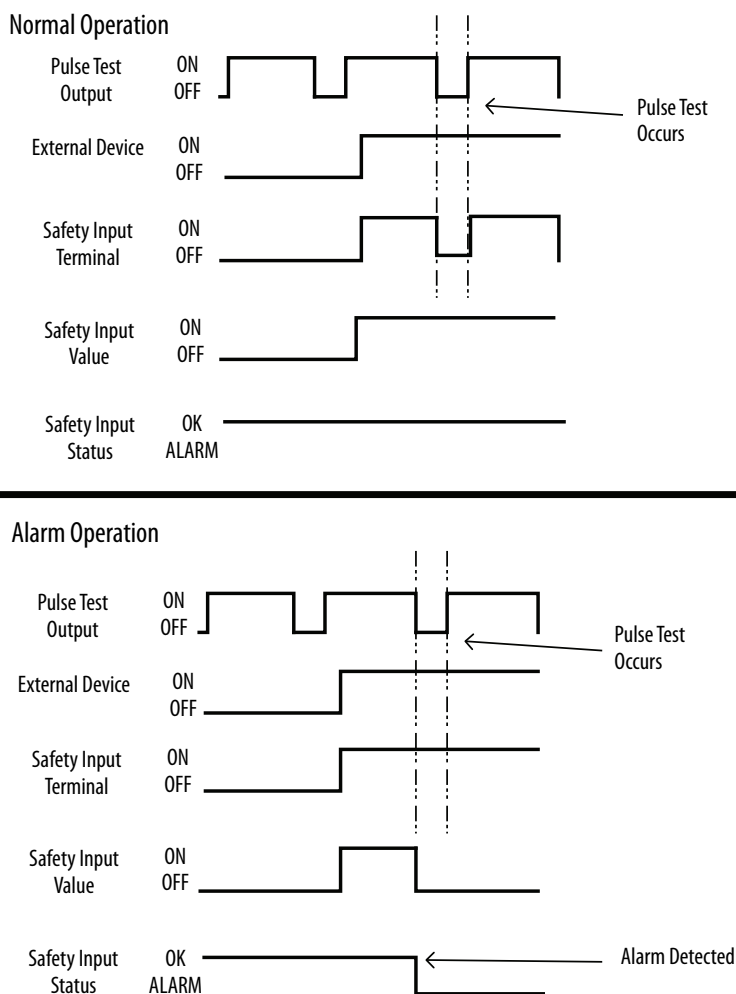

Single Channel Safety Input Status Data

Figure 8 describes the status and value that is reported by the Safety IO subsystem for normal and alarm states. In normal operation, the Safety Input value reported is the value being read on the input terminal. The Safety Input status is on. When a fault is detected, the Safety Input value and status are forced off.

Figure 8 - Single Channel Normal Operation and Alarm Detection (not to scale)

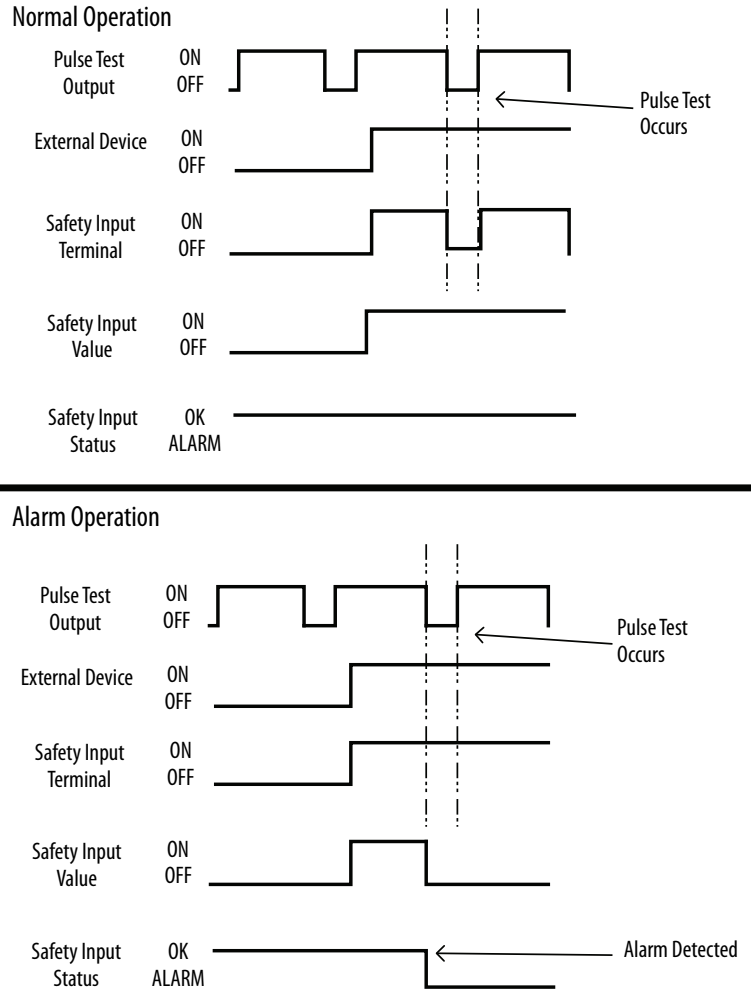

Dual-channel Safety Input Operation

To support redundant safety devices, the consistency between signals on two input points can be evaluated. This is referred to as Dual-channel operation. Two modes are available when using dual-channel inputs: equivalent and complementary.

When using either dual-channel input mode, the time from when a discrepancy is created and when the discrepancy is reported can be configured. This is referred to as Discrepancy Time. The configured discrepancy time is 0 (deactivated)...65,530 ms in increments of 1 ms.

IMPORTANT The dual-channel function is used with two consecutive inputs that are paired together, this process starts at an even input number, such as inputs 0 and 1; 2 and 3; and so on.

IMPORTANT Do not set the discrepancy time longer than necessary. The purpose of the discrepancy time is to allow for normal differences between contact switching when demands are placed on safety inputs. For discrepancy checking to operate correctly, only one demand on the safety input is expected during the discrepancy time. If the discrepancy time is set too high, and multiple demands occur during this time, then both safety input channels will alarm.

[Table 15](#) shows the relation between physical input terminal states and the data and status reported by the Safety Input subsystem.

Table 15 - Terminal Input Status and Controller I/O Data

Dual-channel Mode	Input Terminal		Controller Input Data and Status				Dual-channel Resultant Data	Dual-channel Input Status
	Si0	Si1	Safety Input 0 Data	Safety Input 1 Data	Safety Input 0 Status	Safety Input 1 Status		
Dual-channels, Equivalent	OFF	OFF	OFF	OFF	OK	ON	OFF	OK
	OFF	ON	OFF	OFF	ALARM	OFF	OFF	Alarm
	ON	OFF	OFF	OFF	ALARM	OFF	OFF	Alarm
	ON	ON	ON	ON	OK	ON	ON	OK
Dual-channels, Complementary	OFF	OFF	OFF	ON	ALARM	OFF	OFF	Alarm
	OFF	ON	OFF	ON	OK	ON	OFF	OK
	ON	OFF	ON	OFF	OK	ON	ON	OK
	ON	ON	OFF	ON	ALARM	OFF	OFF	Alarm

Equivalent Dual-channel Input Operation

In Equivalent mode, both inputs of a pair must typically be in the same (equivalent) state. When a transition occurs in one channel of the pair, before the transition of the second channel of the pair, a discrepancy occurs. If the second channel transitions to the appropriate state before the discrepancy time elapses, the inputs are considered equivalent.

If the second transition does not occur before the discrepancy time elapses, the channels transition to the alarm state. In the alarm state, the input and status for both channels are set low (off). When configured as an equivalent dual pair, the data bits for both channels are sent to the controller as equivalent, both high or both low.

Figure 9 shows the operation of dual channel equivalent inputs under normal and alarm conditions.

Figure 9 - Equivalent, Normal Operation, and Alarm Detection (not to scale)



Complementary Dual-channel Input Operation

In Complementary mode, the inputs of a pair are typically in the opposite (complementary) state. When a transition occurs in one channel of the pair before the transition of the second channel of the pair, a discrepancy occurs. If the second channel transitions to the appropriate state before the discrepancy time elapses, the inputs are considered complementary.

If the second transition does not occur before the discrepancy time elapses, the channels transition to the alarm state. The alarm state of complementary inputs is the even-numbered input turned off and the odd-numbered input turned on. If in the alarm state, both channel status bits are set low. When configured as a complementary dual-channel pair, the data bits for both channels are sent to the controller in complementary, or opposite states.

[Figure 10](#) shows the operation of dual-channel complementary inputs under normal and alarm conditions.

Figure 10 - Complementary, Normal Operation and Alarm Detection (not to scale)

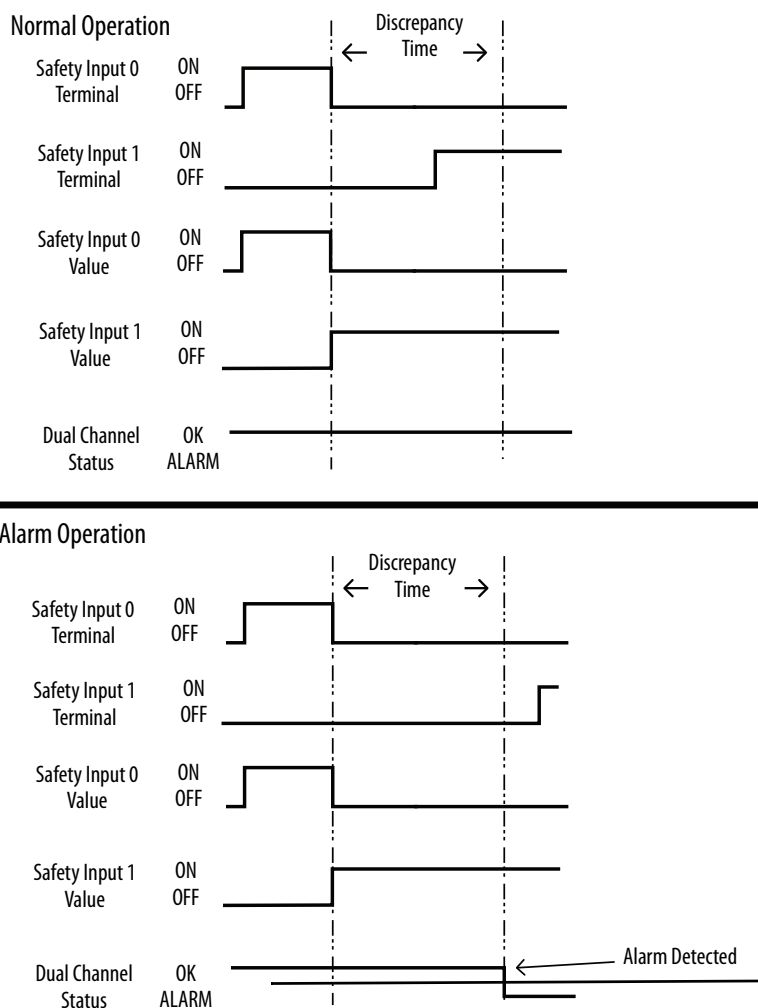

Standard Input Operation

When a safety input is configured for standard input operation, no diagnostics are performed on the input. Unlike safety inputs, a standard input cannot be used with pulse testing and can only be used in single channel mode. A standard input can still be configured to have an on→off and off→on filter time.

IMPORTANT Do not use standard inputs for safety purposes.

Table 16 - Standard Input Value Attribute

Parameter	Value	Description
Service Code	0x0E	Get Attribute Single
Class	0x3D	Safety Discrete Input Point Object
Instance	$i + 1$	Safety Input Instance (where i is the number of the safety input being used as a standard input)
Data Type	BYTE	8 Bits
Attribute	0xA	Filtered Input Value 0 = Input OFF 1 = Input ON

Safety Input Safety Data

The Safety Input data of the Integrated Safety Functions module can be monitored through:

- Safety Input Assembly
- DPI™ Parameters
- CIP™ Messaging

IMPORTANT Only the Safety Input Value and Status in the Safety Input Assembly can be considered safety data. Input values read through DPI parameters or CIP messages are not safety data. Do not use standard inputs for safety purposes.

The following Safety Input data is available in the Integrated Safety Functions Module:

- Safety Input Status
- Safety Input Value
- Safety Input Valid

Each safety input point reports its own status, value, and valid attributes.

IMPORTANT If a safety input is configured for standard input mode, its associated safety data is forced in the safe state.

Safety Input Status

The safety input status indicates whether an alarm is present in the safety input point. The safety input status is provided in the safety input assembly, as shown in [Table 17](#). [Table 18](#) describes the attributes for reading the safety status via CIP messaging.

The safety input status is also provided in the first four bits of device parameter P13 [Safety IO Status].

Table 17 - Safety Input Assembly Tags for Safety Input Status

Safety Input Assembly Tag Name (safety controller to S4 option)	Type/[bit]	Description
<i>module:SI.InputStatus</i>	SINT	A collection of safety input values and status for each safety input
<i>module:SI.In01Status</i>	[4]	Status of Safety Input 0 0 = Alarm 1 = OK
<i>module:SI.In01Status</i>	[5]	Status of Safety Input 1 0 = Alarm 1 = OK
<i>module:SI.In02Status</i>	[6]	Status of Safety Input 2 0 = Alarm 1 = OK
<i>module:SI.In03Status</i>	[7]	Status of Safety Input 3 0 = Alarm 1 = OK

Table 18 - MSG Configuration for Safety Input Status

Parameter	Value	Description
Service Code	0x0E	Get attribute single
Class	0x3D	Safety Discrete Input Point Object
Instance	i + 1	Where i is the number of the safety input
Data Type	USINT	Unsigned integer value
Attribute	0x4 4	Safety Status 0 = Alarm 1 = OK

Safety Input Value

The safety input value is the value of the input after safety and on/off delay evaluations when the safety input is not in the alarm state. If the safety input is in the alarm state, this value will always be 0.

The safety input value is provided in the safety input assembly, as shown in [Table 19](#). [Table 20](#) describes the attributes for reading the safety value via CIP messaging. The safety input value is also provided in the first four bits of device parameter P12 [Safety IO Values].

Table 19 - Safety Input Assembly Tags for Safety Input Values

Safety Input Assembly Tag Name (safety controller to S4 option)	Type/[bit]	Description
<i>module:SI.InputStatus</i>	SINT	A collection of safety input values and status for each safety input
<i>module:SI.In00Data</i>	[0]	Value of Safety Input 0 0 = OFF 1 = ON
<i>module:SI.In01Data</i>	[1]	Value of Safety Input 1 0 = OFF 1 = ON
<i>module:SI.In02Data</i>	[2]	Value of Safety Input 2 0 = OFF 1 = ON
<i>module:SI.In03Data</i>	[3]	Value of Safety Input 3 0 = OFF 1 = ON

Table 20 - MSG Configuration for Safety Input Value

Parameter	Value	Description
Service Code	0x0E	Get attribute single
Class	0x3D	Safety Discrete Input Point Object
Instance	i + 1	Where i is the number of the safety input
Data Type	USINT	Unsigned integer value
Attribute	0x7 7	Safety Input Logical Value 0 = OFF 1 = ON

Safety Input Valid

When set, the safety input valid attribute indicates that the safety input is configured for safety use and producing valid data. If this value is not set, the data that is associated with the safety input is no longer valid safety data.

IMPORTANT The Safety Input Valid attribute should be checked before using safety input data in a safety application.

The safety input valid attribute is provided in the safety input assembly, as shown in [Table 21](#). [Table 22](#) describes the attributes for reading the safety value via CIP messaging.

Table 21 - Safety Input Assembly Tags for Safety Input Valid

Safety Input Assembly Tag Name (safety controller to S4 option)	Type/[bit]	Description
<i>module:SI.IOSupport</i>	SINT	A collection of bits describing safety IO functionality
<i>module:SI.In0Valid</i>	[0]	Safety Input 0 Valid 0 = Data invalid 1 = Data valid
<i>module:SI.In01 Valid</i>	[1]	Safety Input 1 Valid 0 = Data invalid 1 = Data valid
<i>module:SI.In02 Valid</i>	[2]	Safety Input 2 Valid 0 = Data invalid 1 = Data valid
<i>module:SI.In03 Valid</i>	[3]	Safety Input 3 Valid 0 = Data invalid 1 = Data valid

Table 22 - MSG Configuration for Safety Input Valid

Configuration Item	Value	Description
Service Code	0x0E	Get attribute single
Class	0x3D	Safety Discrete Input Point Object
Instance	$i + 1$	Where i is the number of the safety input
Data Type	USINT	Unsigned integer value
Attribute	0x64 100	Safety Input Valid 0 = Data invalid 1 = Data Valid

Safety Input Alarms

The safety input logic can detect configuration, circuit, and discrepancy errors for each safety input. When an error is detected, the associated safety input data is put into the safe state, and the alarm type attribute is set.

Configuration Error

A configuration error occurs when a safety input's configuration data is invalid. If this error occurs, check to make sure that the configuration attributes for the safety input are valid. A configuration error can also occur if the safety input is selected for external pulse testing and the associated test output's configuration is not valid for this mode.

Circuit Error

A circuit error occurs in a safety input when a pulse test fails. There are two types of circuit errors that can be reported:

- Internal Circuit Error
- External Circuit Error

An internal circuit error occurs when an internal pulse test fails. This means that circuitry inside the module has failed. An internal circuit error may not be recoverable; replacing the module may be required.

An external circuit error occurs when pulse testing by the safety input's associated test output fails. This error indicates the input circuitry external to the card has failed.

Discrepancy and Dual Channel Errors

The discrepancy and dual channel errors are related, as a discrepancy can only occur when the safety input is in dual channel mode. A discrepancy error occurs when one of the dual channel safety inputs is not reporting the expected safety input value. The safety input with the unexpected value reports the discrepancy error. The other associated safety input will also be put in the safe state and report a dual channel error alarm.

Determining Safety Input Alarm Type

To determine if a safety input is reporting an alarm, examine the safety input's input status attribute (see [Safety Input Status on page 45](#) for information on accessing this attribute). If the input is reporting an alarm, the alarm type can be accessed through DPI parameters or CIP messaging.

Determine Safety Input Alarm Type with DPI Parameters

To read an alarm type of safety input with DPI parameters, follow these steps:

1. Set device parameter P14 [Input Alarm Indx] to the integer value $i + 1$, where i is the number of the safety input.
2. Read device parameter P15 [Input Alarm].

Determine Safety Input Alarm Type with CIP Messaging

The safety input alarm type can also be read via CIP messaging. See [Table 21](#) for the attributes that are required to read the alarm type.

Table 23 - MSG Configuration for Safety Input Alarm Type

Parameter	Value	Description
Service Code	0x0E	Get attribute single
Class	0x3D	Safety Discrete Input Point Object
Instance	i + 1	Where i is the number of the safety input
Data Type	USINT	Unsigned integer value
Attribute	0x6E 110	Safety Input Alarm Type 0 = No Alarm 1 = Configuration Error 2 = External Circuit Error 3 = Internal Circuit Error 4 = Discrepancy Error 5 = Dual Channel error

Safety Input Alarm Recovery

If an error is detected, the safety input data remains in the off state. Follow this procedure to activate the safety input data.

1. Remove the cause of the error.
2. Place the safety input (or safety inputs if in dual channel mode) into the safe state.

The safety input status turns on (alarm cleared) after the input-error latch time has elapsed.

TIP If the latch error time has expired, but the safety input is not yet in the safe state, the alarm will not be cleared. Once the safety input is in the safe state, the alarm will clear immediately.

Input Delays

Each safety input has a configurable filter time for sampling the input. Both the on→off and off→on filter values can be configured. Unlike other configuration values, these values can be configured in standard input mode

Off-on Delay

An input signal is treated as logic 0 during the on-delay time (0...126 ms, in increments of 1 ms) after the rising edge of the input contact. The input only turns on if the input contact remains on after the on-delay time has elapsed. This delay helps prevent rapid changes of the input data due to contact bounce.

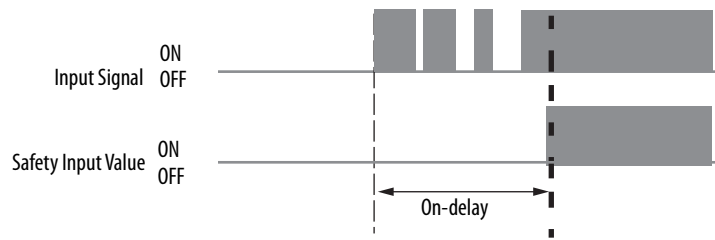
Figure 11 - Off-on Delay

On-off Delay

An input signal is treated as logic 1 during the off-delay time (0...126 ms, in increments of 1 ms) after the falling edge of the input contact. The input only turns off if the input contact remains off after the off delay time has elapsed. This delay helps prevent rapid changes of the input data due to contact bounce.

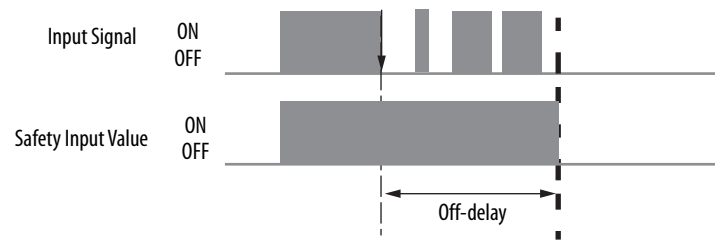
Figure 12 - On-off Delay

Use With PowerFlex 750-Series ATEX Option Module

The 20-750-ATEX option can be wired to an S4 safety input. This is a general-purpose safety input, so the user is responsible for the GuardLogix programming logic to tie the input to the SO.STOOutput tag. See the PowerFlex 750-Series ATEX Option Module User Manual, publication [750-UM003](#), for more information.

Safety Outputs

Read this section for information about safety outputs. The safety outputs can operate in single channel mode or dual channel mode. In either mode, the safety output can also be configured to run pulse test diagnostics.

Safety Output with Test Pulse

When the safety output is on, the safety output can be configured to pulse test the safety output channel. By using this function, you can continuously test the ability of the safety output to remove power from the output terminals of the module. If an error is detected, the safety output data and individual safety output status turn to the safe state.

Figure 13 - Test Pulse in a Cycle

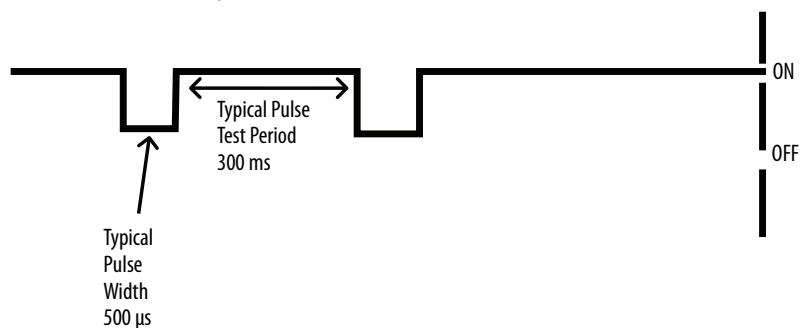

Table 24 - Typical External Pulse Width and Period

Pulse Width	Period
500 μs	300 ms

IMPORTANT To help prevent the test pulse from causing the connected device to malfunction, pay careful attention to the input response time of the device that is connected to the output.

Single-channel Mode

IMPORTANT When using pulse testing in single channel mode, the demand rate of the output must be greater than 30 seconds.

In single-channel mode, when the safety output is requested to the on state, the output will turn on if there is no alarm. If an alarm is detected on the channel, the safety output data and safety output status turn off, and commanding the output will have no effect.

Figure 14 - Single-channel Setting (not to scale)

Normal Operation

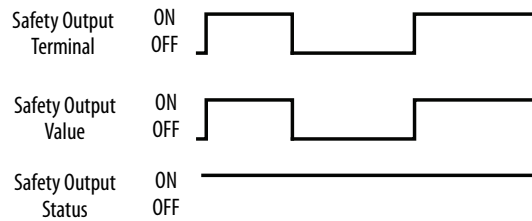

Alarm Operation

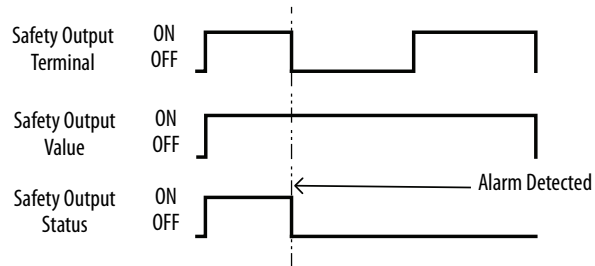

Latch Output Error Operation in Single Channel Mode

The safety output subsystem allows for a latch error time to be configured. The latch error time is the minimum time an output alarm will be held before the alarm can be cleared. This latch error time is used by all safety outputs. [Figure 15](#) shows the behavior of the safety output latch time in single channel mode. See [Safety Output Alarm Recovery on page 60](#) for information on clearing alarms.

Figure 15 - Single Channel Output Latch Error Behavior

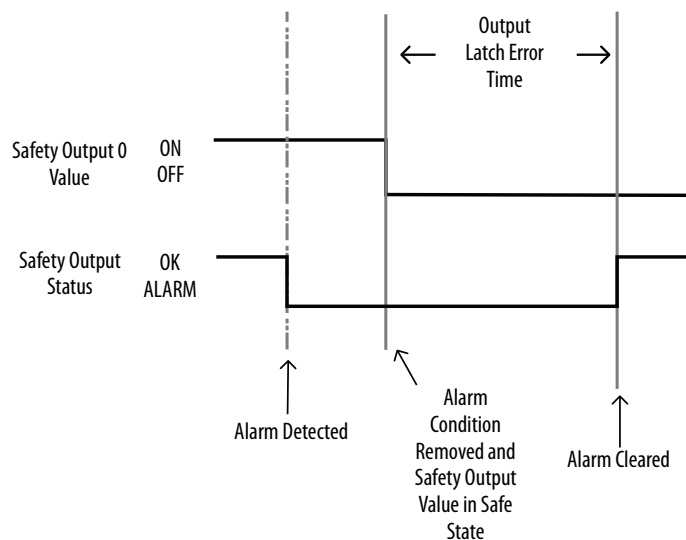

Dual-channel Mode

When the data of both channels is in the on state, and neither channel has an alarm, the outputs are turned on. The status is normal. If an alarm is detected on one channel, the safety output data and individual safety output status turn off for both channels.

[Figure 16](#) shows the operation of dual channel outputs under normal and alarm conditions.

Figure 16 - Dual-channel Setting (Not to Scale)

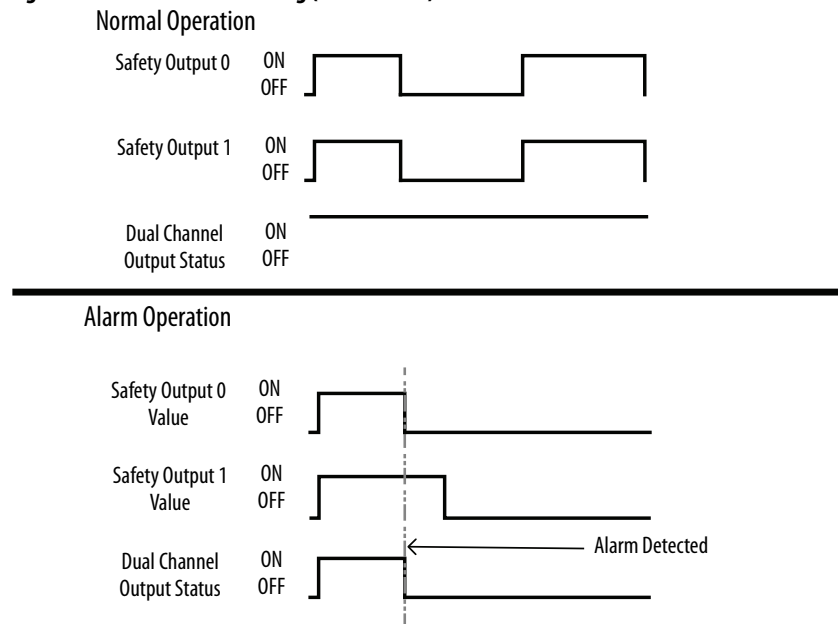

Latch Output Error Operation in Dual Channel Mode

In dual channel mode, the output latch error time describes the period between when the alarm condition is removed and when the dual channel safety output stops reporting the alarm. [Figure 17](#) shows the normal operation of output latch error time in dual channel mode. When one or both of the associated output points has an alarm (such as a Pulse Test Failure), and there is a discrepancy between the two channels, the alarm and discrepancy must be cleared before the latch error timer begins counting. [Figure 18](#) shows this special case operation. See [Safety Output Alarm Recovery on page 60](#) for information on removing an alarm.

Figure 17 - Dual Channel Output Latch Error Behavior

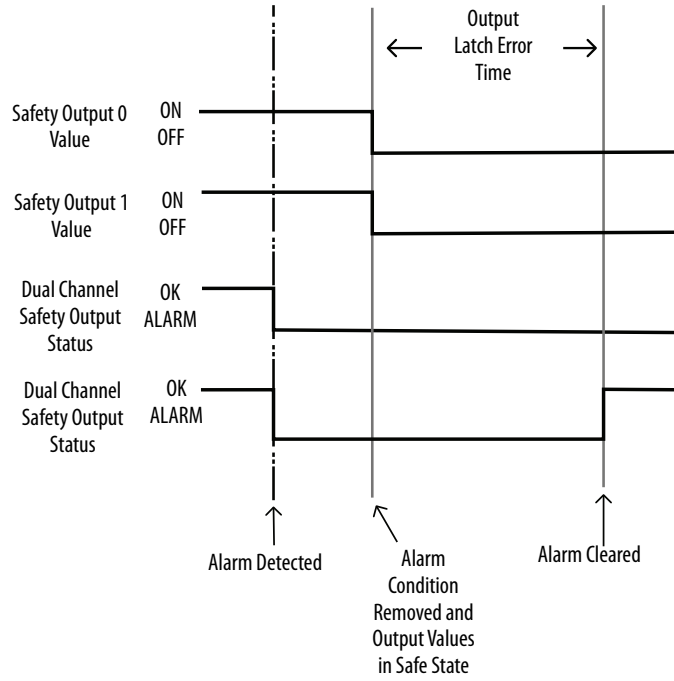
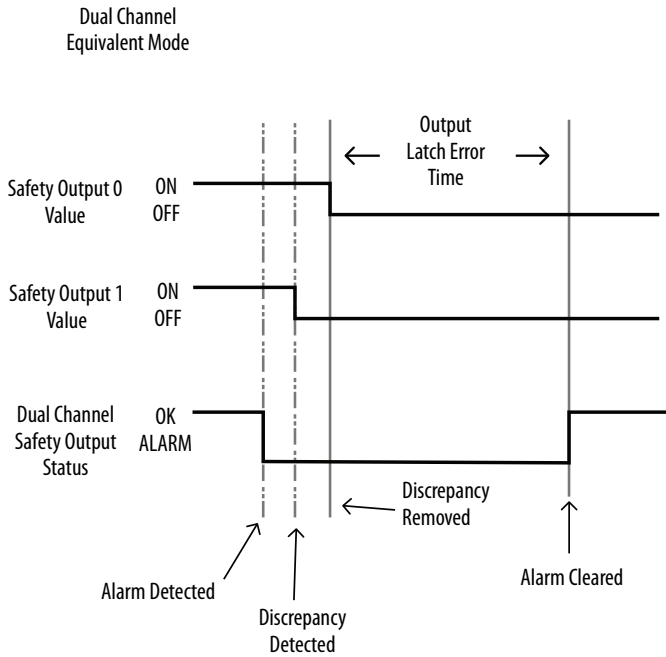

Figure 18 - Dual Channel Output Latch Error Behavior With Alarm and Discrepancy (not to scale)



Safety Output Safety Data

The Safety Output data of the Integrated Safety Functions module can be monitored through:

- Safety Input Assembly
- DPI Parameters
- CIP Messaging

The following Safety Output data is available in the Integrated Safety Functions Module:

- Safety Output Status
- Safety Output Ready
- Output Monitor Value

Each safety output point reports its own status, monitor value, and ready attributes.

Safety Output Status

The safety output status indicates whether an alarm is present in the safety output point. The safety output status is provided in the safety input assembly, as shown in [Table 25](#). [Table 26](#) describes the attributes for reading the safety status via CIP messaging. The safety output status is also provided in bits 6 and 7 of device parameter P13 [Safety IO Status].

Table 25 - Safety Input Assembly Tags for Safety Output Status

Safety Input Assembly Tag Name (safety controller to S4 option)	Type / [bit]	Description
<i>module:SI.OutputStatus</i>	SINT	A collection of safety output status, safety output monitor values, and test output status
<i>module:SI.Out00Status</i>	[4]	Status of Safety Output 0 0 = Alarm 1 = OK
<i>module:SI.Out01Status</i>	[5]	Status of Safety Output 1 0 = Alarm 1 = OK

Table 26 - MSG Configuration for Safety Output Status

Parameter	Value	Description
Service Code	0x0E	Get attribute single
Class	0x3B	Safety Discrete Output Point Object
Instance	$i + 1$	Where i is the number of the safety output
Data Type	USINT	Unsigned integer value
Attribute	0x5 5	Safety Status 0 = Alarm 1 = OK

Safety Output Ready

When set, the safety output ready attribute indicates that the safety output is configured for safety use and ready to be commanded.

IMPORTANT Check the Safety Output Ready attribute before commanding the safety output.

The safety output ready attribute is provided in the safety input assembly, as shown in [Table 27](#). [Table 28](#) describes the attributes for the Safety Output Ready attribute via CIP messaging.

Table 27 - Safety Input Assembly Tags for Safety Output Ready

Safety Input Assembly Tag Name (safety controller to S4 option)	Type/[bit]	Description
<i>module:SI.IOSupport</i>	SINT	A collection of bits describing safety IO functionality
<i>module:SI.Out00Ready</i>	[4]	Safety Output 0 Ready 0 = Not Ready 1 = Ready
<i>module:SI.Out01Ready</i>	[5]	Safety Output 1 Ready 0 = Not Ready 1 = Ready

Table 28 - MSG Configuration for Safety Output Ready

Parameter	Value	Description
Service Code	0x0E	Get attribute single
Class	0x3B	Safety Discrete Output Point Object
Instance	$i + 1$	Where i is the number of the safety output
Data Type	USINT	Unsigned integer value
Attribute	0x64 100	Safety Status 0 = Not Ready 1 = Ready

Output Monitor Value

IMPORTANT Safety Output Monitor Value is not safety data and has no defined safe state. Use Output Monitor Value for diagnostic purposes only.

The output monitor value of a safety output is the value of the output that is read by module. It is expected that the output monitor value is the same as the commanded safety output value in normal operation. The output monitor value can be used to diagnose output alarms.

The output monitor value is provided in the safety input assembly, as shown in [Table 29](#). [Table 30](#) describes the attributes for reading the output monitor

value via CIP messaging. The output monitor value is also provided in bits 6 and 7 of DPI device parameter P12 [Safety IO Values].

Table 29 - Safety Input Assembly Tags for Safety Output Monitor Value

Safety Input Assembly Tag Name (safety controller to S4 option)	Type/[bit]	Description
module:SI.OutputStatus	SINT	A collection of safety output status, safety output monitor values, and test output status
<i>module:SI.Out00Monitor</i>	[0]	Output Monitor Value of Safety Output 0 0 = OFF 1 = ON
<i>module:SI.Out01Monitor</i>	[1]	Output Monitor Value of Safety Output 1 0 = Not Ready 1 = Ready

Table 30 - MSG Configuration for Safety Output Monitor Value

Parameter	Value	Description
Service Code	0x0E	Get attribute single
Class	0x3B	Safety Discrete Output Point Object
Instance	$i + 1$	Where i is the number of the safety output
Data Type	USINT	Unsigned integer value
Attribute	0x4 4	Output Monitor Value 0 = OFF 1 = ON

Commanding Safety and Test Outputs

The value of a safety and test outputs can be commanded by setting tags in the safety output assembly. [Table 31](#) shows the output command tags of the module.

Table 31 - Safety Input Assembly Tags for Safety Output Ready

Safety Input Assembly Tag Name (safety controller to S4 option)	Type/[bit]	Description
module:SO.SafetyIOCommands	SINT	A collection of safety status bits for commanding IO values
<i>module:SO.Out00Output</i>	[0]	Commanded Safety Output 0 Value 0 = OFF 1 = ON
<i>module:SO.Out01Output</i>	[1]	Commanded Safety Output 1 Value 0 = OFF 1 = ON

Safety Output Alarms

The Safety Output logic can detect the following errors:

- Configuration
- Circuit
- Dual Channel Discrepancy (Dual Channel Configuration Only)
- Partner Channel (Dual Channel Configuration Only)

When an error is detected, the associated safety output data is put into the safe state and the Alarm Type attribute is set.

Configuration Error

A configuration error occurs when a safety output's configuration data is invalid. If this error occurs, verify that the configuration attributes for the safety outputs are valid.

Circuit Error

When a safety output is configured for use with test pulses, a circuit error occurs when a pulse test fails. There are three types of circuit errors that can be reported:

- Stuck Low
- Stuck High
- Cross Connection

A stuck low error occurs when the output is expected to be in the on state, but the feedback indicates the output is in the off state.

A stuck high error occurs when a pulse test expects the output to be in the off state but the output does not transition to the off state during the pulse test interval.

A cross connection error occurs when a pulse test of one safety output causes another safety output to change value. This usually indicates that two outputs are shorted together.

If a circuit error occurs in a safety output, check the wiring of the safety outputs for errors.

Dual Channel Discrepancy Error

When the safety outputs are configured for dual channel mode, a dual channel discrepancy error occurs when there is a mismatch in the commanded output values of the dual channel outputs. Both outputs will report a Dual Channel Discrepancy error.

Partner Channel Error

When the safety outputs are configured for dual channel mode, and one of the safety outputs experiences a circuit or configuration error, the other safety output will report a Partner Channel error.

TIP The safety output data will still be placed in the safe state when a Partner Channel error occurs.

Determining Safety Output Alarm Type

To determine if a safety output is reporting an alarm, examine the safety output's output status attribute. See [Safety Output Safety Data on page 55](#) for information on safety output status. If the output is reporting an alarm, the alarm type can be accessed through DPI parameters or CIP messaging.

Determine Safety Input Alarm Type with DPI Parameters

To read an alarm type of safety output with DPI parameters, follow these steps.

1. Set device parameter P16 [Output Alarm Indx] to the integer value $i + 1$, where i is the number of the safety output
2. Read device parameter P17 [Output Alarm].

Determine Safety Output Alarm Type with CIP Messaging

The safety input alarm type can also be read via CIP messaging. See [Table 32](#) for the attributes that are required to read the alarm type.

Table 32 - MSG Configuration for Safety Output Alarm Type

Parameter	Value	Description
Service Code	0x0E	Get attribute single
Class	0x3B	Safety Discrete Output Point Object
Instance	$i + 1$	Where i is the number of the safety output
Data Type	USINT	Unsigned integer value
Attribute	0x6E 110	Safety Output Alarm Type 0 = No Alarm 1 = Configuration 3 = Stuck Low 4 = Stuck High 5 = Partner Channel 8 = Dual Channel 9 = Cross Connection

Safety Output Alarm Recovery

If an alarm is detected, the safety outputs are switched to the safe state and remain in the safe state. Follow this procedure to activate the safety output data again.

1. Remove the cause of the alarm.
2. Command the safety output (or safety outputs in dual channel mode) into the safe state.
3. Allow the output-error latch time to elapse and monitor the output ready attribute and the output status attribute to determine when the output can be commanded again.

TIP If the latch error time has expired, but the safety output is not yet commanded to the safe state, the alarm will not be cleared. Once the safety output is commanded to the safe state, the alarm will clear immediately.

Test Output

The test outputs of the Integrated Safety Function module can be configured in the following modes:

- Standard Output
- Test Output
- Power Supply Output



ATTENTION: Test Output points that are configured as Pulse Test or Power Supply become active whenever you apply input power to the module. These configured functions are independent of the I/O connections to the module.



ATTENTION: If a module with Test Outputs configured as Pulse Test or Power Supply is incorrectly installed in an application where actuators are connected to these Test Output points, the actuators are activated when input power is applied.

To prevent this possibility, follow these procedures.

- When installing or replacing a module, be sure that the module is correctly configured for the application or in the out-of-box condition before applying input power.
 - Reset modules to their out-of-box condition when removing them from an application.
 - Be sure that all modules in replacement stock are in their out-of-box condition.
-



ATTENTION: Do not use test outputs as safety outputs. Test outputs do not function as safety outputs.

Standard Output Mode

When a test output is configured for standard output mode, the test output point operates as a general purpose output. The output can be commanded through the safety output assembly. [Table 33](#) shows the tags in the safety output assembly to command test outputs when in standard output mode.

Table 33 - Safety Output Assembly Tags for Test Output Commands

Safety Input Assembly Tag Name	Type / [bit]	Description
<i>module:SO.SafetyIOCommands</i>	SINT	A collection of safety status bits for commanding IO values
<i>module:SO.Test00Output</i>	[2]	Test Output 0 Value 0 = OFF 1 = ON
<i>module:SO.Test01Output</i>	[3]	Test Output 1 Value 0 = OFF 1 = ON

Test Output Mode

When in test output mode, the test output point operates in conjunction with a safety input to perform pulse testing on the external safety input circuitry. Please see the Safety Input with External Pulse Tests Operation section for information on this mode. Commanding the output point via the safety output assembly will have no effect in this mode.

Power Supply Output

In power supply output mode, the output point is forced on, and will only shut off in the case of a critical fault. Commanding the output point via the safety output assembly will have no effect in this mode.

Test Output Data

The Test Output data of the Integrated Safety Functions module can be monitored through:

- Safety Input Assembly
- DPI Parameters
- CIP Messaging

The following Test Output data is available in the Integrated Safety Functions module:

- Test Output Status
- Test Output Ready

Each test output point reports its own status and ready attributes.

IMPORTANT Test Output data is not safety data and cannot be used for safety applications.

Test Output Status

The test output status indicates whether an alarm is present in the test output point. When in standard output mode, the status will always be OK, unless there is a critical fault, in that case, the status is forced to Alarm. In all other modes test output status is set to Alarm.

The test output status is provided in the safety input assembly, as shown in [Table 34](#). [Table 35](#) describes the attributes for reading the test output status via CIP messaging. The test output status is also provided in bits 4 and 5 of device parameter P13 [Safety IO Status].

Table 34 - Safety Input Assembly Tags for Test Output Status

Safety Input Assembly Tag Name (safety controller to S4 option)	Type/[bit]	Description
<i>module:SI.OutputStatus</i>	SINT	A collection of safety output and test output data
<i>module:SI.Test00Status</i>	[4]	Status of Test Output 0 0 = Alarm 1 = OK
<i>module:SI.Test01Status</i>	[5]	Status of Test Output 1 0 = Alarm 1 = OK

Table 35 - MSG Configuration for Test Output Alarm Type

Parameter	Value	Description
Service Code	0x0E	Get attribute single
Class	0x9	Discrete Output Point Object
Instance	$i + 1$	Where i is the number of the test output
Data Type	USINT	Unsigned integer value
Attribute	0x4 4	Output Status 0 = Alarm 1 = OK

Test Output Ready

When set, the test output ready attribute indicates that the test output is configured for standard output mode, and is ready to be commanded. In other modes, the test output ready attribute is forced to the safe (alarm) state.

IMPORTANT The Test Output Ready attribute should be checked before commanding the test output.

The test output ready attribute is provided in the safety input assembly, as shown in [Table 36](#). [Table 37](#) describes the attributes for ready the test output ready attribute via CIP messaging.

Table 36 - Safety Input Assembly Tags for Test Output Ready

Safety Input Assembly TagName (safety controller to S4 option)	Type/ [bit]	Description
<i>module:SI.IOSupport</i>	SINT	A collection of bits describing safety IO functionality
<i>module:SI.Test00Ready</i>	[6]	Test Output 0 Ready 0 = Not Ready 1 = Ready
<i>module:SI.Test01Ready</i>	[7]	Test Output 1 Ready 0 = Not Ready 1 = Ready

Table 37 - MSG Configuration for Test Output Ready

Parameter	Value	Description
Service Code	0x0E	Get attribute single
Class	0x9	Discrete Output Point Object
Instance	$i + 1$	Where i is the number of the test output
Data Type	USINT	Unsigned integer value
Attribute	0x82 130	Output Ready 0 = Not Ready 1 = Ready

Notes:

Drive-based Safe Stop Functions

Use this chapter to learn more about the Safe Torque Off, Timed Safe Stop 1, Monitored Safe Stop 1, and Safe Brake Control stopping functions that are built into the Integrated Safety Functions option module.

IMPORTANT The information in this section describes Safety Stop Functions operating in the drive. For information on using the Drive Safety instructions operating in the GLX controller, see [Chapter 5](#).

Topic	Page
Safety Output Assembly Safe Stop Function Tags	65
Safety Input Assembly Safe Stop Function Tags	66
Connection Action	68
Safe Torque Function	69
Safe Stop 1 Function	76
Connecting a Safety Brake	91

Safety Output Assembly Safe Stop Function Tags

The safety output assembly for Integrated Safe Speed consists of 48 Logix tags:

- 35 tags for pass thru status and faults
- 8 tags for safety stop function commands
- 5 tags for safety I/O commands

Table 38 - Safety Output Assembly Tags for Safety Stop Functions

Safety Output Assembly Tag Name (safety controller to S4 option)	Type/[bit]	Description
<i>module:SO.SafetyStopFunctions</i>	SINT	A collection of bits used to activate (request) safety functions as described in this table.
<i>module:SO.STOOutput</i>	[0]	Control Safe Torque Off (STO): 0 = Disable Torque 1 = Enable Torque
<i>module:SO.SBCOutput</i>	[1]	If Safe Brake Control (SBC) is configured: 0 = Engage Brake (So0 and So1 OFF) 1 = Release Brake (So0 and So1 ON) If Safe Brake Control is not configured, this tag must be set to 0. If set to 1, will cause SBC fault.

Table 38 - Safety Output Assembly Tags for Safety Stop Functions (Continued)

Safety Output Assembly Tag Name (safety controller to S4 option)	Type/[bit]	Description
<i>module:SO.SS1Request</i>	[2]	If Safe Stop 1 (SS1) is configured: 0 = No Request 1 = Request Safe Stop 1 If Safe Stop 1 is not configured, this tag must be set to 0. If set to 1, will cause SS1 fault.
<i>module:SO.SS2Request</i>	[3]	Reserved for future use. This tag must be set to 0; will cause SS2 fault if set to 1.
<i>module:SO.SOSRequest</i>	[4]	Reserved for future use. This tag must be set to 0; will cause SOS fault if set to 1.
<i>module:SO.SMTRequest</i>	[5]	Reserved for future use. This tag must be set to 0; will cause SMT fault if set to 1.
<i>module:SO.ResetRequest</i>	[7]	A 0→1 transition is required to reset Safety Faults. If Restart Type is 'Manual', a 0 →1 transition is required to restart a Safety Stop Functions.

Safety Input Assembly Safe Stop Function Tags

The safety input assembly for Integrated Safe Speed consists of 56 Logix tags:

- 3 tags for connection status
- 28 tags for safety feedback and stop function status
- 25 tags for safety I/O status

Table 39 - Safety Input Assembly Tags for Safety Stop Functions

Safety Input Assembly Tag Name (S4 option to safety controller)	Type/[bit]	Description
<i>module:SI.ConnectionStatus</i>	SINT	A collection of the following bits.
<i>module:SI.RunMode</i>	[0]	Safety Connection 0= Idle 1 = Run
<i>module:SI.ConnectionFaulted</i>	[1]	Safety Connection 0=Normal 1= Faulted
<i>module:SI.FeedbackPosition</i>	DINT	Primary Feedback Position from drive-module safety instance. Value is in encoder counts.
<i>module:SI.FeedbackVelocity</i>	REAL	Primary Feedback Velocity from drive-module safety instance. Value is in Rev/s or Meter/s.
<i>module:SI.SecondaryFeedbackPosition</i>	DINT	Secondary Feedback Position from drive-module safety instance. Value is in encoder counts. Secondary channel may only be used for discrepancy comparison with primary channel.
<i>module:SI.SecondaryFeedbackVelocity</i>	REAL	Secondary Feedback Velocity from drive-module safety instance. Value is in Rev/s or Meter/s. Secondary channel may only be used for discrepancy comparison with primary channel.
<i>module:SI.StopStatus</i>	SINT	A collection of the following bits.
<i>module:SI.STOActive</i>	[0]	Safe Torque Off (STO) function status 0 = Permit Torque 1 = Disable Torque

Table 39 - Safety Input Assembly Tags for Safety Stop Functions

Safety Input Assembly Tag Name (S4 option to safety controller)	Type/[bit]	Description
<i>module:SI.SBCActive</i>	[1]	Safe Brake Control (SBC) function status: 0 = Release Brake (So0 and So1 ON) 1 = Engage Brake (So0 and So1 OFF)
<i>module:SI.SS1Active</i>	[2]	Safe Stop 1 (SS1) function status: 0 = SS1 not Active 1 = SS1 Active
<i>module:SI.SS2Active</i>	[3]	Reserved for future use; always 0.
<i>module:SI.SOSStandstill</i>	[4]	Reserved for future use; always 0.
<i>module:SI.SMTOvertemp</i>	[4]	Reserved for future use; always 0.
<i>module:SI.SafetyFault</i>	[6]	1 = Safe Stop Fault present
<i>module:SI.RestartRequired</i>	[7]	1 = Fault Reset or Stop Restart is required
<i>module:SI.SafeStatus</i>	SINT	A collection of the following bits.
<i>module:SI.TorqueDisabled</i>	[0]	0 = Torque Permitted 1 = Torque Disabled
<i>module:SI.BrakeEngaged</i>	[1]	0 = Brake Released (So0 and So1 ON) 1 = Brake Engaged (So0 and So1 OFF)
<i>module:SI.MotionStatus</i>	SINT	A collection of the following bits.
<i>module:SI.MotionPositive</i>	[0]	1 = Feedback Velocity > Primary Feedback Standstill Speed
<i>module:SI.MotionNegative</i>	[1]	1 = Feedback Velocity < Primary Feedback Standstill Speed
<i>module:SI.FunctionSupport</i>	SINT	A collection of the following bits.
<i>module:SI.PrimaryFeedbackValid</i>	[0]	0 = Secondary Feedback not configured or Faulted 1 = Secondary Feedback Value is valid
<i>module:SI.SecondaryFeedbackValid</i>	[1]	0 = Secondary Feedback not configured or Faulted 1 = Secondary Feedback Value is valid
<i>module:SI.DiscrepancyCheckingActive</i>	[2]	1 = Feedback Velocity Discrepancy checking is active not faulted
<i>module:SI.SBCReady</i>	[3]	0 = Drive-based SBC function is not configured or faulted 1 = Drive-based SBC function is configured and ready for operation
<i>module:SI.SS1Ready</i>	[4]	0 = Drive-based SS1 function is not configured or faulted 1 = Drive-based SS1 function is configured and ready for operation
<i>module:SI.SS2Ready</i>	[5]	Reserved for future use; always 0.
<i>module:SI.SOSReady</i>	[6]	Reserved for future use; always 0.
<i>module:SI.SMTReady</i>	[7]	Reserved for future use; always 0.

IMPORTANT Review the CONNECTION_STATUS Data section of the GuardLogix 5580 and Compact GuardLogix 5380 Controller Systems Safety Reference Manual, publication [1756-RM012](#), for information on how to use the connection status tags.



ATTENTION: Safety I/O connections and produced/consumed connections cannot be automatically configured to fault the controller if a connection is lost and the system transitions to the safe state. If you must detect a device fault so that the system maintains the required SIL level, you must monitor the Safety I/O CONNECTION_STATUS bits and initiate the fault via program logic.

Safety Function in Response to Connection Event

The module allows for a safety function to be executed when the safety connection to the module is lost or the connection enters the idle state. This operation is referred to as the connection action. There are two configurable connection actions that are defined as follows:

- Connection Loss Action - The safety function to be executed if the network connection from the module to the safety controller is lost or closed.
- Connection Idle Action - The safety function to be executed if the safety controller connected to the module enters program mode.

In both of these cases, the safety function must be executed by the drive/module. Therefore, only the drive-based safety functions may be used in these cases.

Connection Loss Action

When the connection loss event is detected, the following attributes will be set:

- In Standard Control Mode
 - Host: P3 [Safety State] = Idle
 - Host: P4 [Safety Status] Conn Closed = 1
- In Motion Control Mode
 - axis.AxisSafetyState = 2
 - axis.SafetyOutputConnectionClosedStatus = 1

The following drive-based safety functions are supported as a connection loss action:

- STO
- SS1

A safety function will operate as configured when activated by a connection loss and the Connection Loss bit will be set in its activation attribute. See the following sections for information on the safety function operation.

In standard control mode, change the Comm Flt Action parameter of the EtherNet/IP® module in the drive from its default value of 'Fault' to another applicable setting in order for the drive to initiate the stopping action. In the

PowerFlex 755 drive, this is done using parameter 54. In the PowerFlex 755T drive, this done using port 0 parameter 360. If this parameter is not changed, the safety function that is triggered by the connection loss may fault.

Connection Idle Action

When the connection idle event is detected, the following attributes will be set:

- In Standard Control Mode
 - Host: P4 [Safety Status] Conn Idle = 1
- In Motion Control Mode
 - axis.SafetyOutputConnectionIdleStatus = 1

The following drive-based safety functions are supported as a connection idle action:

- STO
- SS1

A safety function will operate as configured when activated by a connection idle and the Connection Idle bit will be set in its activation attribute. See the following sections for information on Safety Function operation.

In standard control mode, change P55 [Idle Flt Action] of the EtherNet/IP port in the drive from its default value of 'Fault' to another applicable setting in order for the drive to initiate the stopping action. If this parameter is not changed, the safety function that is triggered by the connection loss may fault.

Safe Torque Off Function

The Safe Torque Off (STO) function provides a method, with sufficiently low probability of failure, to force the power-transistor control signals to a disabled state. When the command to execute the STO function is received from the GuardLogix controller, all drive output-power transistors are released from the ON-state. This results in a condition where the drive is coasting.

Safe Torque Off (STO) will prevent the motor from applying torque to a system but in some systems torque is also applied to the mechanical system by a suspended load, unbalanced load, back pressure, and so on. In such a system, application of a mechanical brake is required to hold the load while motor torque is disabled by STO. See [Safe Brake Control Function](#) beginning on page [83](#) for information on using a mechanical brake with the Integrated Safety Functions Module.

Safe Torque Off Activation

Safe Torque Off can be initiated by one or more sources:

- STO Output – Setting the Safety Output Assembly Tag (*module:SO.STOOutput = 1*)
- SS1 Complete – Completion of a Safe Stop 1
- Stop Fault – Any Safety Fault
- Limit Fault – Reserved for future use
- Limit Active – Reserved for future use
- Connection Loss – Loss of connection to the safety controller
- Connection Idle – Safety controller in program mode

When STO is activated, all sources of activation are stored in an attribute as a bit mask. The attribute can then be read to determine the causes of a STO activation. [Figure 19](#) shows the operation of the STO activation attribute. The STO Activation attribute can be read with explicit messaging (see attribute 265 in [Table 18 on page 247](#)).

Figure 19 - Safe Torque Off Activation

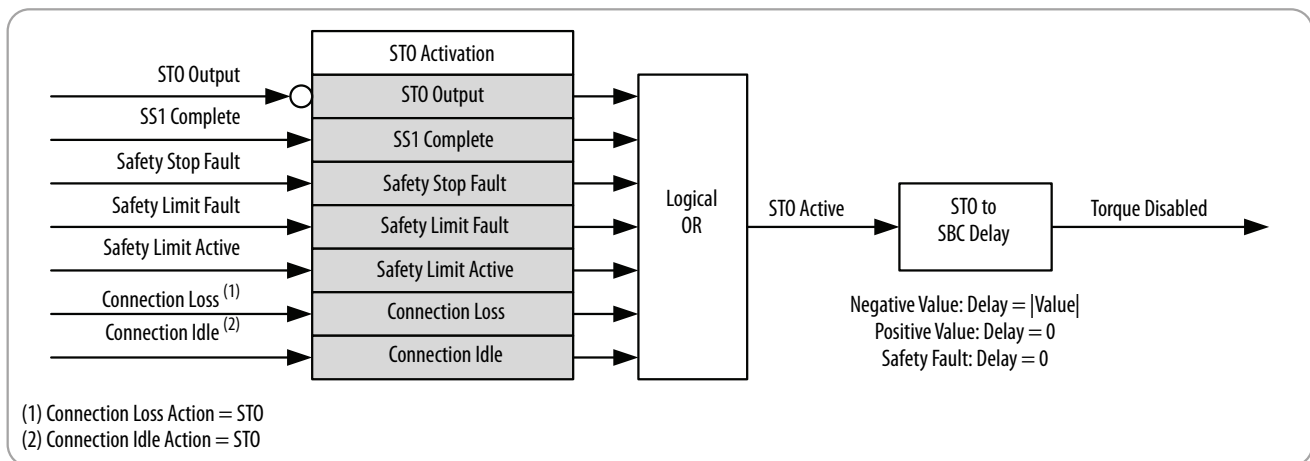

Safe Torque Off Reset

After torque is disabled due to a STO activation, the STO function must be reset in order to enable torque. When the STO function must be reset, the following attribute values are set:

- *module:SI.STOActive = 1*
- *module:SI.RestartRequired = 1*
- In Standard Control Mode
 - Host: P4 [Safety Status] STO Active = 1
 - Host: P4 [Safety Status] Restart Req = 1

- In Motion Control Mode
 - *axis.SafeTorqueOffActiveStatus* = 1
 - *axis.SafetyResetRequiredStatus* = 1

The steps to reset the STO function depend on the cause of STO activation and the Restart/Cold Start Type configured in the module.

Safety Fault STO Activation Reset

IMPORTANT When the STO function is activated by a Safety Fault, the cause of the safety fault must be removed before STO can be reset, regardless of the configured restart type.

Once the cause of the fault is removed, a 0→1 transition on the *module:SO.ResetRequest* tag will reset the STO function to the Torque Enabled state.

Connection Loss/Idle STO Activation Reset

If the STO function is activated by a connection loss/idle event, the connection must be reestablished and running before the STO function can be reset. The function must be reset based on the configured Cold Start type.

STO Automatic Cold Start/Restart Type Operation

If there are no Safety Faults and no safety demands, the STO function can be reset.

STO Manual Cold Start/Restart Type Operation

If there are no Safety Faults and no safety demands present in the module, the STO function can be reset by a 1→0 transition on the *module:SO.STOOutput* tag then a 0→1 transition on *module:SO.ResetRequest* tag.

TIP Setting *module:SO.STOOutput* = 1 and *module:SO.RequestReset* = 1 in the same program scan will enable torque.

Safe Torque Off Delay

A delay to provide time for the drive to stop the load in response to STO Active can be programmed. This delay time is referred to as STO Delay. If no delay is desired, set the STO Delay to 0. The STO Delay must be a positive integer value.

If Safe Brake Control is being used, the STO delay must be 0. If an STO delay is desired with the use of the Safe Brake Control function, see [Safe Brake Control Function](#) beginning on page [83](#) for information on configuring STO

to SBC delay. In the case of STO activation by a safety fault, any configured delay is ignored, and torque is disabled instantly.

Safe Torque Off Operation

The operation of the STO function and its attributes is dependent on the configuration of the STO function and the activation reason. For all STO activations besides safety fault, the operation of STO is dependent on STO Delay. For STO activations caused by a safety fault, the operation ignores STO Delay. See the following sections for more information.

Figure 20 - STO Without Delay

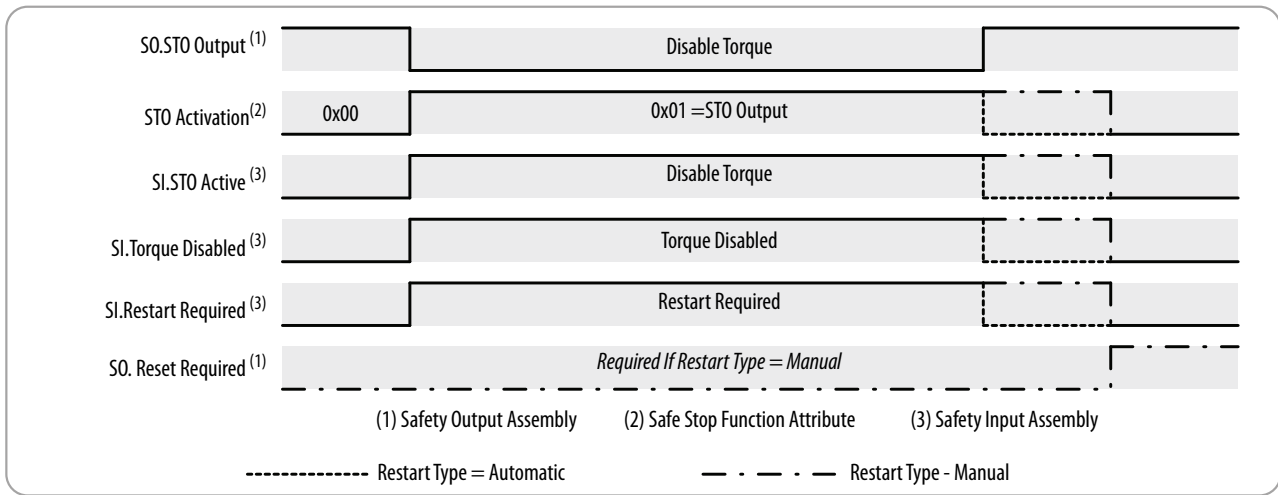

Safe Torque Off With Delay Operation

When the STO Delay is configured for a positive non-zero value, the delay is inserted between STO Active and Torque Disabled. The STO Delay is meant to serve as a delay between the configured STO drive stopping action and when torque is disabled. The delay allows the drive to complete the stop before torque is disabled. This is effectively a Timed Safe Stop 1 function. See [Safe Torque Off Stopping Action and Source](#) on page 74 for information on configuring a drive stop type in response to a STO activation.

[Figure 21](#) shows the timing of STO status and torque attributes in response to a STO activation, along with the restart type behavior, when STO Delay is configured.

Figure 21 - STO with Delay

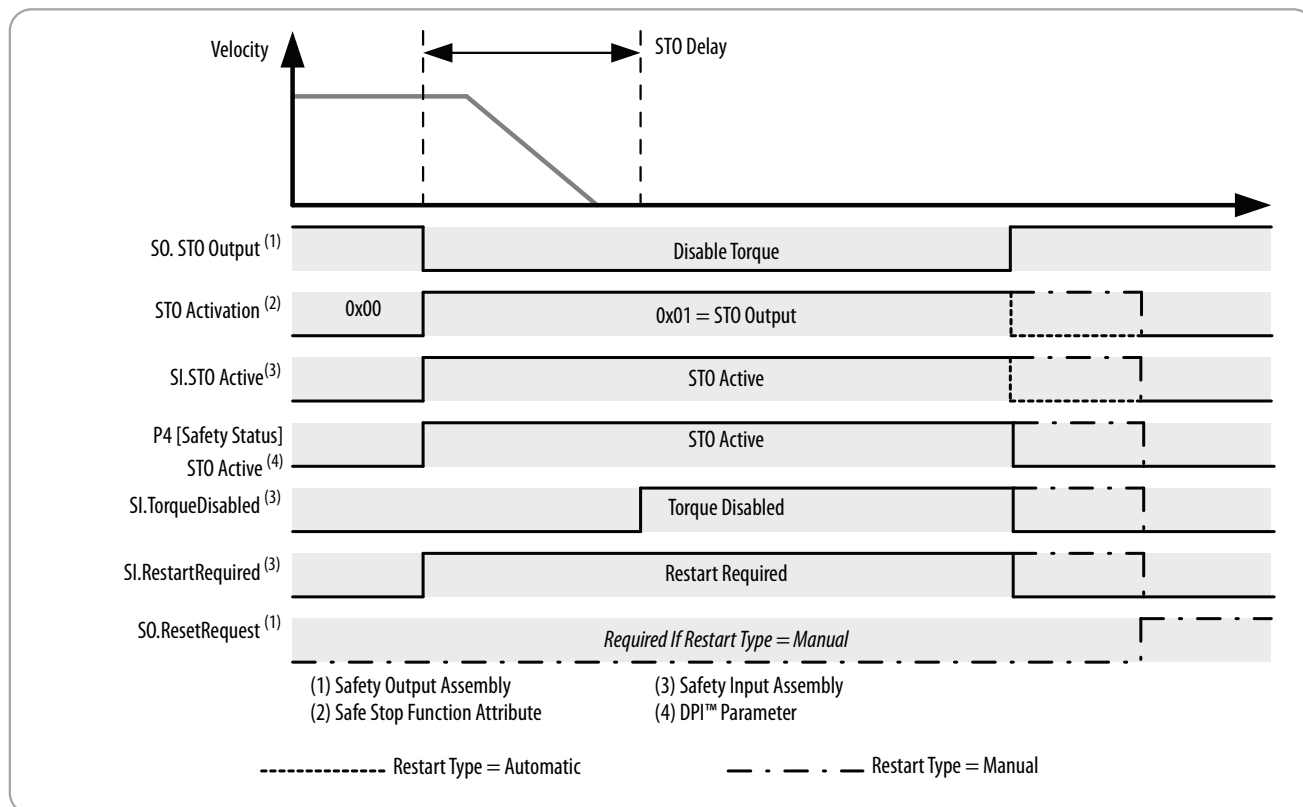

IMPORTANT The Safe Brake Control (SBC) Mode must be set to 'Not Used' to permit STO Delay. If Mode is not set to 'Not Used', Delay is set to zero.

Safe Torque Off Safety Fault Operation

When a safety fault occurs in the module, the STO function is forced to the Safe State, which is the Torque Disabled state. In this case, the configured STO Delay value is bypassed and torque is immediately disabled. [Figure 22](#) shows the timing of STO and torque attributes in response to STO activation by a Safety Fault.

Clearing a Safety Fault requires correcting the fault condition, then a 0→1 transition on Request Reset.

Figure 22 - STO with Safety Fault

SI.Safety Fault ⁽¹⁾	Safety Fault	
STO Activation ⁽²⁾	0x04 = Safety Stop Fault	
SI.STO Active ⁽³⁾	Disable Torque	
SI.Torque Disabled ⁽³⁾	Torque Disabled	
SI.Restart Required ⁽³⁾	Restart Required	
SO.Reset Request ⁽¹⁾	<i>Always Required to Reset a Fault</i>	Fault Cleared

(1) Safety Output Assembly

(2) Safe Stop Function Attribute

(3) Safety Input Assembly



ATTENTION: In the case of STO activation by a safety fault, the configured STO Delay time is ignored, and torque is immediately disabled.

Safe Torque Off Stopping Action and Source

In response to an STO activation, the type of stop and the source responsible for controlling the stop are configurable. These configuration attributes are defined as:

- STO Stopping Action – Configures what stopping action to perform in response to a STO activation.
- STO Stopping Action Source – Configures where the stopping action is performed (drive-based or controller-based).

When STO is activated, the drive control will initiate the selected stop type if:

- The STO Action Source is configured as Drive or
- There is currently not a Standard I/O connection through the Embedded EtherNet/IP port to the drive control or
- There is currently a Standard I/O connection through the Embedded EtherNet/IP port to the drive control but it is in Idle mode (the controller is in program mode)

Otherwise, the controller that owns the Standard I/O connection is expected to respond when STO is activated. In this case, the configured STO Stopping Action is ignored, and the stopping logic must be programmed in the controller that owns the Standard I/O connection.

If the STO Stopping Action Source is Controller, or the STO Stopping Action is configured for a non-default value, a STO Delay may need to be specified in order for the Stopping Action to be completed before torque is disabled.

See the drive's reference manual for information on its supported stop modes.

IMPORTANT You are responsible for providing logic in the controller standard task to implement a stop action when the STO Action Source is configured as Controller.

IMPORTANT If STO Delay is zero, there is no time for the drive to complete a stop before torque is disabled. In that case, the stop action is effectively 'Coast' (default).

STO Safety Fault

When the module experiences a STO Fault, the module is placed in the safe state and the cause of the fault is recorded. If the STO function detects a fault, it will set the following attributes:

- *module*:SI.SafetyFault = 1
- *module*:SI.RestartRequired = 1
- STO Fault Type
 - In Standard Control Mode
 - Device: P7 [STO Fault Type] = varies depending on the cause of the fault. See description of STO Fault Type in [Table 105](#) on page [254](#).
 - Host: P4 [Safety Status] Safety Fault = 1
 - Host: P4 [Safety Status] Restart Req = 1
 - Host: P5 [Safety Faults] STO Fault = 1
 - 755 Port 0: P933 [Start Inhibits], bit 7 = 'Safety'
 - 755T Port 0: P351 [M Start Inhibits], bit 8 = 'Safety'
 - 755 Port 0: P951 [Last Fault Code] = 'Safety Brd Flt'
 - 755T Port 0: P610 [Last Fault Code] = 'Safety Brd Flt'
 - In Motion Control Mode
 - *Axis*.SafetyFault = 1
 - *axis*.SafeTorqueOffActiveInhibit = 1
 - *axis*.SafetyFaultStatus = 1
 - *axis*.SafetyResetRequiredStatus = 1
 - *axis*.STOFault = 1

For more information on STO Fault Types and troubleshooting methods, see [Understand Safety Faults on page 199](#).

Safe Stop 1 Function

The Safe Stop 1 (SS1) function signals the configured SS1 Stop Action Source to initiate a stopping action, then the safety module monitors the stop. When the Safe Stop 1 is complete, STO is activated and torque is disabled. If the drive does not complete the stop within the limits that are configured in the Safe Stop 1 function, an SS1 Fault is annunciated.

Safe Stop 1 Activation

Safe Stop 1 can be initiated by one or more sources:

- SS1 Request – Setting the Safety Output Assembly Tag (*module:SO.SS1Request = 1*)
- Limit Active – Reserved for future use
- Connection Loss – Loss of connection to the safety controller
- Connection Idle – Safety controller in program mode

When SS1 is activated, all sources of activation are stored in an attribute as a bit mask and the attribute can then be read to determine the causes of an SS1 activation. [Figure 23](#) shows the operation of the SS1 activation attribute. The SS1 Activation attribute can be read with explicit messaging (see attribute 289 in [Table 18 on page 247](#)).

Unlike the STO function, SS1 does not get activated by a safety fault.

Figure 23 - Safe Stop 1 Activation

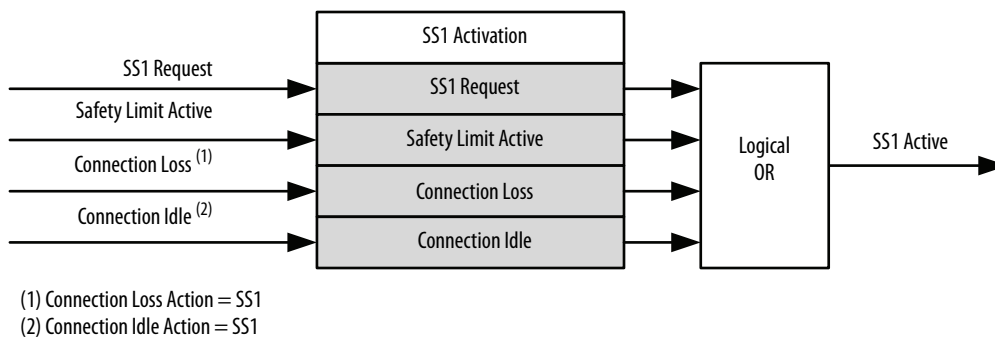

Safe Stop 1 Reset

After an SS1 action is complete, the SS1 function must be reset in order to enable torque. When the STO Function needs to be reset, the following attribute values are set:

- *module*:SI.SS1Active = 1
- *module*:SI.RestartRequired = 1
- In Standard Control Mode:
 - Host: P4 [Safety Status] SS1 Active = 1
 - Host: P4 [Safety Status] Restart Required = 1
- In Motion Control Mode:
 - *axis*:SS1ActiveStatus = 1
 - *axis*.SafetyResetRequiredStatus = 1

The steps to reset the SS1 function depend on the cause of SS1 activation and the Restart/Cold Start Type configured in the module.

Connection Loss/Idle SS1 Activation Reset

If the SS1 function is activated by a connection loss/idle event, the connection must be reestablished and running before the SS1 function can be reset. The function must be reset based on the configured Cold Start type.

SS1 Automatic Cold Start/Restart Type Operation

If there are no Safety Faults present in the module, the SS1 function can be reset by a 1→0 transition on the *module*:SO.SS1Request tag.

SS1 Manual Cold Start/Restart Type Operation

If there are no Safety Faults in the module, the SS1 function can be reset by a 1→0 transition on the *module*:SO.SS1Request tag then a 0→1 transition on *module*:SO.ResetRequest tag.

Safe Stop 1 Stopping Action and Source

In response to an SS1 activation, the type of stop and the source responsible for controlling the stop is configurable. These configuration attributes are defined as:

- SS1 Stopping Action – Configures what stopping action to perform in response to an SS1 Activation.
- SS1 Stopping Action Source – Configures where the stopping action is performed (drive-based or controller-based).

When SS1 is activated the drive control will initiate the selected stop type if:

- The SS1 Action Source is configured as Drive
- There is currently not a Standard I/O connection through the Embedded EtherNet/IP port to the drive control
- There is currently a Standard I/O connection through the Embedded EtherNet/IP port to the drive control but it is in Idle mode (the controller is in program mode)

Otherwise, the controller that owns the Standard I/O connection is expected to respond when SS1 is activated. In this case, the configured SS1 Stopping Action is ignored, and the stopping logic must be programmed in the controller that owns the Standard I/O connection.

See the drive's reference manual for information on its supported stop modes.

IMPORTANT You are responsible for providing logic in the controller standard task to implement a stop action when the SS1 action source is Controller.

Timed Safe Stop 1

A Timed Safe Stop 1 involves initiating motor deceleration and initiating the STO function after the configured time delay.

Timed Safe Stop 1 Operation

When the module is configured for Timed Safe Stop 1 Mode, the Safe Stop 1 function is initiated by setting the *module:SO.SS1Request* safety output tag. This sets the 'SS1 Request' bit in the SS1 Activation attribute and sets the *module:SI.SS1Active* safety input tag. When the SS1 Active bit is set, the SS1 Stop Action will be executed by the source indicated by the SS1 Stop Action Source. See [Safe Stop 1 Stopping Action and Source](#) for more information.

The SS1 function waits for the configured SS1 Max Stop Time, then sets the SS1 Complete flag in the STO Activation attribute, which sets STO Active to Disable Torque. In Timed Safe Stop 1 mode, speed and deceleration are not monitored so this mode does not require Safety Feedback. [Figure 24](#) shows the

After the SS1 Active bit is set, the configured SS1 Decel Monitor Delay timer begins. After the configured Decel Monitor Delay expires, an internal speed ramp value is computed every time that the encoder is sampled. If the magnitude of *module:SI.FeedbackVelocity* exceeds the sum of the internal ramp plus Decel Speed Tolerance, the SS1 Fault Type attribute is set to 'Deceleration Rate' and the SS1 Fault attribute is set to Faulted.

[Figure 25](#) describes the equations that are used for computing the deceleration reference rate and tolerance.

Figure 25 - SS1 Deceleration Reference Rate and Tolerance Calculation

$$\text{Decel Reference Rate} = \frac{\text{Decel Reference Speed}}{1000 \times \text{Stop Delay}}$$

If Time Units = Seconds,

$$\text{SS1 Decel Ref Rate} = \frac{\text{Decel Reference Rate} \times \text{Position Scaling}}{\text{Feedback Resolution}}$$

$$\text{SS1 Decel Tolerance} = \frac{\text{Decel Reference Tolerance} \times \text{Position Scaling}}{\text{Feedback Resolution}}$$

If Time Units = Minutes,

$$\text{SS1 Decel Ref Rate} = \frac{\text{Decel Reference Rate} \times \text{Position Scaling}}{\text{Feedback Resolution} \times 60}$$

TIP A Configured Decel Reference Rate of 0 disables the ramp check. SS1 will fault if the drive does not slow to less than the Standstill Speed.

If the magnitude of *module:SI.FeedbackVelocity* is not less than the configured Standstill Speed before Max Stop Time expires, the SS1 Fault Type is set to 'Maximum Time' and the SS1 Fault attribute is set to 'Faulted'. [Figure 26](#) describes the equations that are used for computing the standstill speed.

Figure 26 - SS1 Standstill Speed Calculation

If Time Units = Seconds,

$$\text{SS1 Standstill Speed} = \frac{\text{Standstill Speed} \times \text{Position Scaling}}{\text{Feedback Resolution}}$$

If Time Units = Minutes,

$$\text{SS1 Standstill Speed} = \frac{\text{Standstill Speed} \times \text{Position Scaling}}{\text{Feedback Resolution} \times 60}$$

Where *Standstill Speed*, *Position Scaling*, and *Feedback Resolution* are user-configured values.

When the magnitude of *module:SI.FeedbackVelocity* is less than the Standstill Speed, the SS1 Complete flag in the STO Activation attribute is set, and STO Active is set. If STO Delay is positive (and SBC Mode = Not Used) or if STO

to SBC Delay is negative (and STO Activates SBC = Linked), then the Torque Disabled attribute is set after the configured time delay. Otherwise, the Torque Disabled attribute is set immediately.

Figure 27 shows the timing of the Monitored SS1 operation, along with the restart type behavior.

Figure 27 - Monitored Safe Stop 1

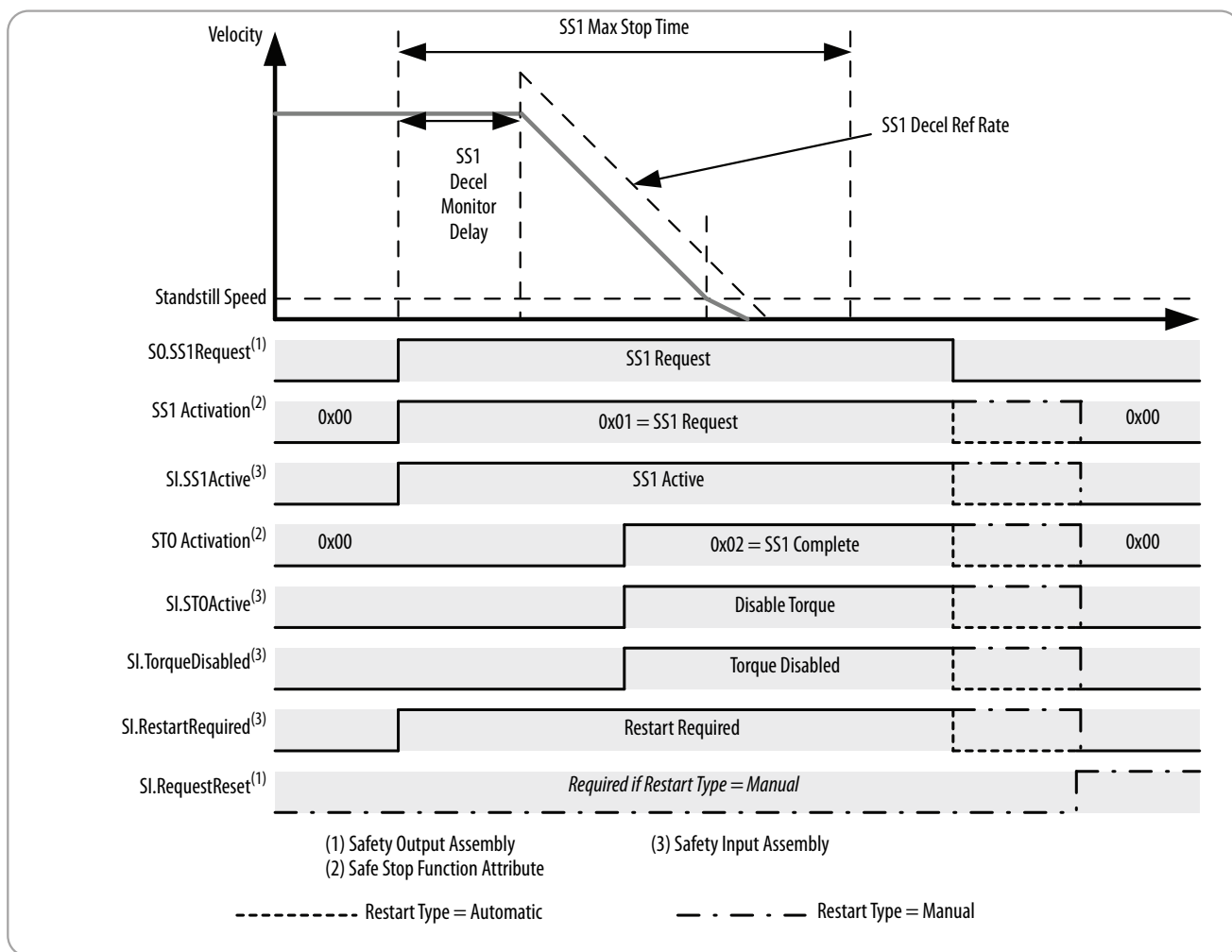

TIP Speed units are configured by the 'Position Units' and 'Time Units' AOP Controls on the Scaling page.

TIP A Configured Decel Reference Rate of 0 disables the ramp check. SS1 will fault if the drive does not slow to less than the Standstill Speed within Max Stop Time.

SS1 Safety Fault

When an SS1 Safety Fault occurs, the STO function is activated immediately and torque is disabled. [Figure 27](#) describes the timing of attributes when an SS1 fault occurs during SS1 execution. [Figure 28](#) describes the operation of SS1 when an SS1 fault is detected.

The 'Safe State' of the SS1 function is the Torque Disabled state. If the SS1 function detects a fault, it will set:

- *module*:SI.SafetyFault = 1
- *module*:SI.RestartRequired = 1
- SS1 Fault Type
- In Standard Control Mode
 - Device: P10 [SS1 Fault Type] = varies depending on the cause of the fault. See descriptions of faults in [Table 105](#) on page [255](#).
 - Host: P4 [Safety Status] Safety Fault = 1
 - Host: P4 [Safety Status] Restart Req = 1
 - Host: P5 [Safety Faults] SS1 Fault = 1
 - 755 Port 0: P933 [Start Inhibits], bit 7 = 'Safety'
 - 755T Port 0: P351 [M Start Inhibits], bit 8 = 'Safety'
 - 755 Port 0: P951 [Last Fault Code] = 'Safety Brd Flt'
 - 755T Port 0: P610 [Last Fault Code] = 'Safety Brd Flt'
- In Motion Control Mode
 - *axis*.SafetyFault = 1
 - *axis*.SafeTorqueOffActiveInhibit = 1
 - *axis*.SafetyFaultStatus = 1
 - *axis*.SafetyResetRequiredStatus = 1
 - *axis*.SS1Fault = 1

Clearing a Safety Fault requires correcting the fault condition and a 0→1 transition on Request Reset. For more information on SS1 Safety Faults, see [Understand Safety Faults on page 199](#).

Figure 28 - Safe Stop 1 Fault Operation

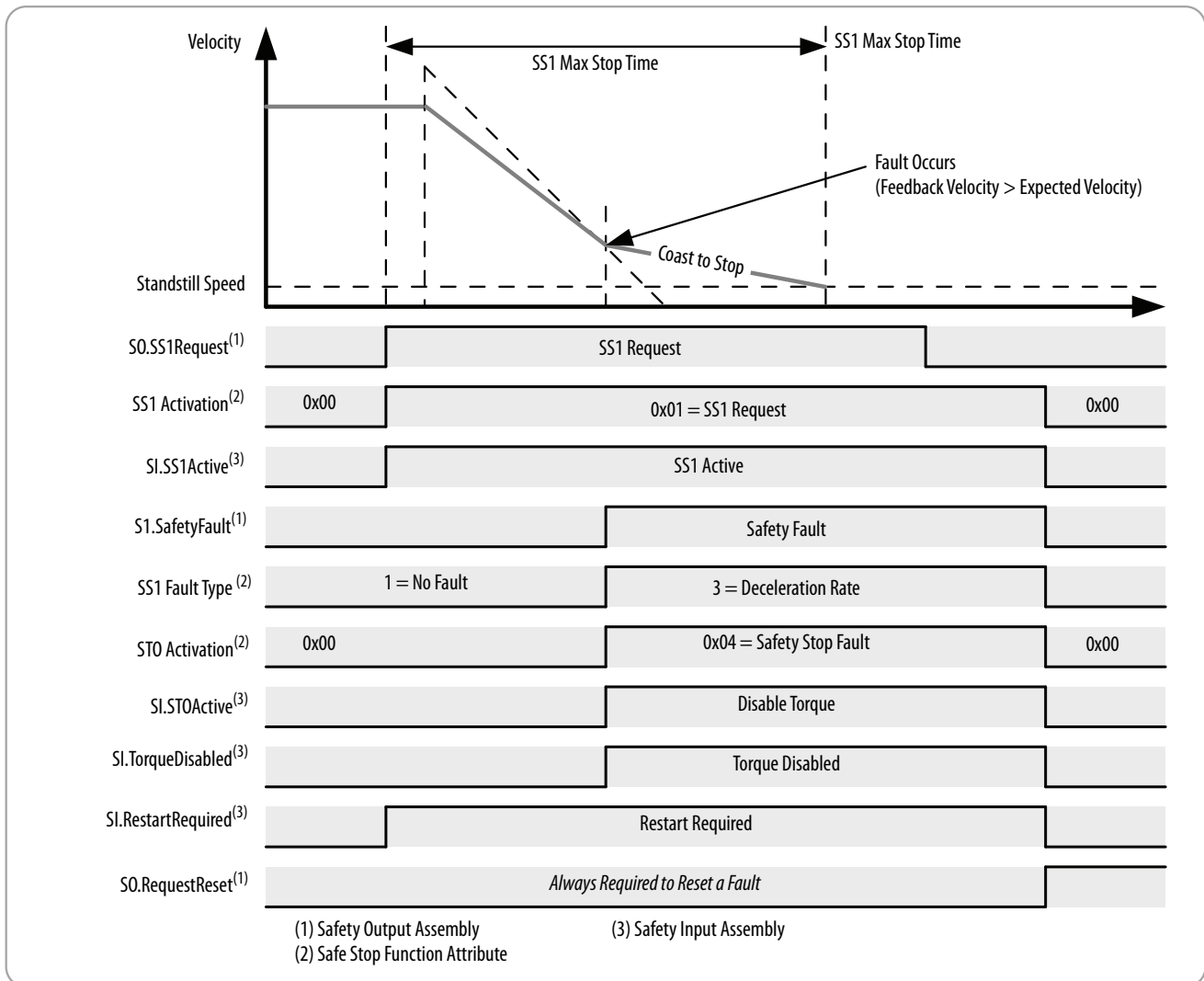

Safe Brake Control Function

The Safe Brake Control function (SBC) function utilizes the module's safety outputs to control an electromechanical brake that is attached to the motor. The SBC function releases the brake to allow motion or engages the brake to prevent motion.

Safe Brake Control Activation

Safe Brake Control can be initiated by one or more sources:

- SBC Output – Clearing the Safety Output Assembly Tag (*module:SO.SBCOutput* = 0)
- STO Active – If STO Activates, SBC is configured as 'Linked'
- Safe Stop Fault – Any Safety Fault
- Safe Limit Fault – Reserved for future use

When SBC is activated, all sources of activation are stored in an attribute as a bit mask, and the attribute can then be read to determine the causes of an SBC activation. [Figure 29](#) shows the operation of the SBC activation attribute. The SBC Activation attribute can be read with explicit messaging (see attribute 365 in [Table 18 on page 247](#)).

Figure 29 - Safe Brake Control Activation

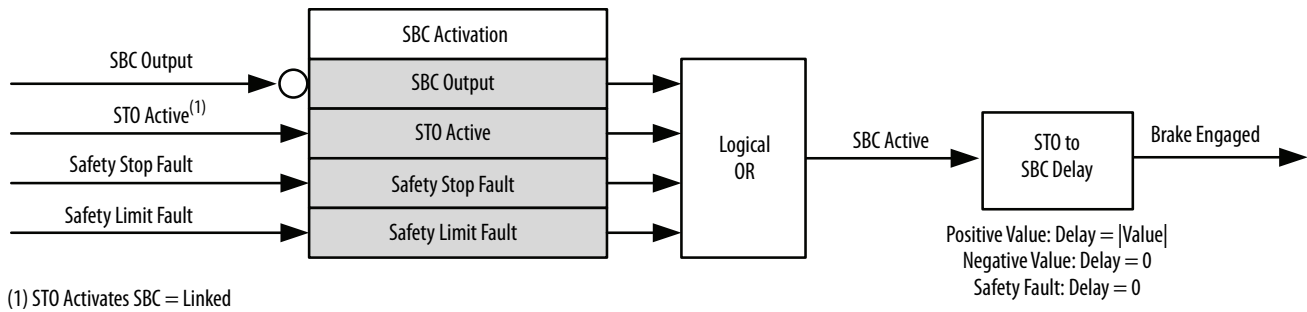

If the SBC Activation bit mask indicates that only STO Active is the source of activation, then the STO to SBC Delay is executed. If the activation is not by STO Active, or other activation bits are also set, the STO to SBC Delay is not executed and the brake is immediately engaged.

Safe Brake Control Reset

After the brake is engaged due to an SBC activation, the SBC function must be reset in order to release the brake. When the SBC function must be reset, the following attribute values are set:

- *module*:SI.SBCActive = 1
- *module*:SI.RestartRequired = 1
- In Standard Control Mode
 - Host: P4 [Safety Status] SBCActive = 1
 - Host: P4 [Safety Status] Restart Req = 1
- In Motion Control Mode
 - *axis*.SBCActiveStatus = 1
 - *axis*.SafetyResetRequiredStatus = 1

The steps to reset the SBC function depend on the cause of SBC activation and the Restart/Cold Start Type configured in the module.

Safety Fault SBC Activation Reset

IMPORTANT When the SBC function is activated by a Safety Fault, the cause of the safety fault must be removed before the SBC function can be reset, regardless of the configured restart type.

Once the fault is removed, a 0→1 transition on *module:SO.ResetRequest* tag will reset the SBC function to the Brake Released state.

SBC Automatic Cold Start/Restart Type Operation

If there are no Safety Faults in the module, the STO function can be reset by a 0→1 transition on the *module:SO.SBCOutput* tag.

SBC Manual Cold Start/Restart Type Operation

If Restart Type is set to 'Manual' and there are no Safety Faults in the module, the SBC function can be reset by a 0→1 transition on the *module:SO.SBCOutput* tag, then a 0→1 transition on *module:SO.ResetRequest* tag.

TIP Setting *module:SO.SBCOutput* = 1 and *module:SO.RequestReset* = 1 in the same scan will enable torque.

Safe Brake Control Modes

SBC Mode specifies if the SBC functionality is used and how the safety outputs controlling the brake operate. The mode also changes the instances of the CIP objects controlling the safety outputs. The following modes are supported by the module.

Not Used

In 'Not Used' mode, the SBC function will not be used by the application. The associated safety outputs are not under SBC control, and can be configured independently. The safety outputs are mapped to the following CIP objects:

- So0: Safety Discrete Output Point Object Instance 1
- So1: Safety Discrete Output Point Object Instance 2
- Safety Dual Channel Output Object Instance 1

Used, No Test Pulses

In 'Used, No Test Pulses' mode, the associated safety outputs are not pulse tested. The associated safety outputs are under SBC control and cannot be configured independently. The safety outputs are mapped to the following CIP objects:

- So0: Safety Discrete Output Point Object Instance 3

- So1: Safety Discrete Output Point Object Instance 4
- Safety Dual Channel Output Object Instance 2

Used, Test Pulses

In 'Used, Test Pulses' mode, the associated safety outputs are tested with a 500 μ s pulse every 300 ms when the brake is in the released state (outputs energized). Pulse tests of So0 and So1 outputs are shifted in time, allowing So0 to So1 shorts to be detected. There is no difference in implementation of Safety Outputs pulse testing in SBC control versus direct control.

In the 'Used, Test Pluses' mode, the safety outputs are under SBC control and cannot be configured independently. The safety outputs are mapped to the same CIP objects as the 'Used, No Test Pulses' mode.

For more information on the pulse testing that is performed by the SBC function, see [Latch Output Error Operation in Single Channel Mode on page 52](#).

IMPORTANT If the Safe Brake Mode is set to 'Not Used', then setting the Safety Output tag *module:SO.SBCOutput = 1* sets the SBC Fault and sets the SBC Fault Type to 'Config'.

IMPORTANT If the Safe Brake Mode is set to 'Not Used', then the state of the two safety outputs So0 and So1 are controlled by Safety Output Assembly tags; otherwise, the two Safety Outputs are controlled by the Safe Brake Function.

IMPORTANT If the Safe Brake Mode is set to 'Used', then the Safety Input Assembly tags associated with safety outputs will be forced to:

module:SI.Out00Monitor = 0

module:SI.Out01Monitor = 0

module:SI.Out00Status = 0

module:SI.Out01Status = 0

module:SI.Out00Ready = 0

module:SI.Out01Ready = 0

Safe Brake Control Operation

Safe Brake Control (SBC) operation can be activated by the safety output assembly or by STO.

SBC Operation when Activated by Safety Output Assembly

When the SBC function is activated by clearing the *module:SO.SBCOutput* tag, the associated safety outputs are deenergized, forcing the brake to engage, and torque is still enabled. [Figure 30](#) shows the timing of SBC attributes when the SBC function is executed independently.

Figure 30 - SBC Operation by Safety Output Assembly

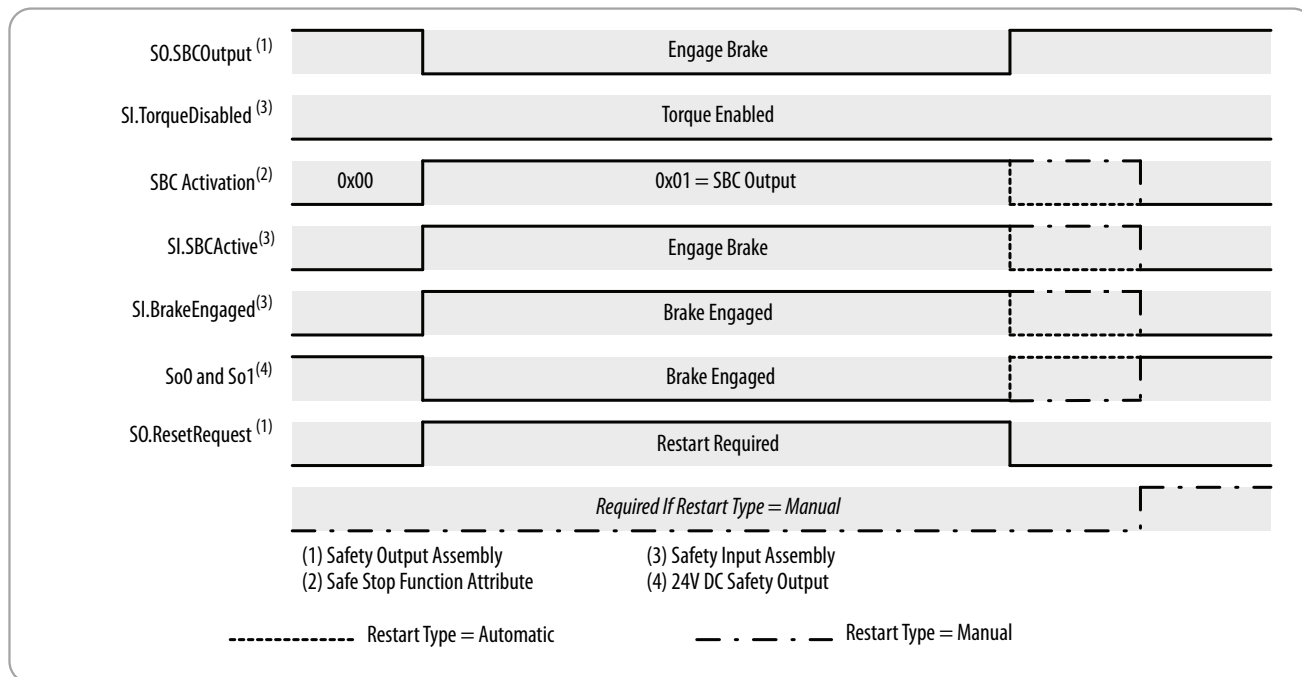

STO Activates SBC Operation

If the SBC function is configured to link STO and SBC activation, any STO activation will cause the SBC function to be activated as well. The brake is engaged (deenergized) by the SBC function when torque is disabled by the STO function.

If the SBC function is configured to link STO activation to SBC activation, you can configure an STO to SBC Delay time where:

- STO to SBC Delay > 0 configures a delay between when STO is activated and the brake is released. [Figure 31](#) describes this operation.
- STO to SBC Delay < 0 configures the brake to engage when STO is activated and delays disabling torque. [Figure 32](#) describes this operation.

Figure 31 - SBC Linked to STO with Positive Delay

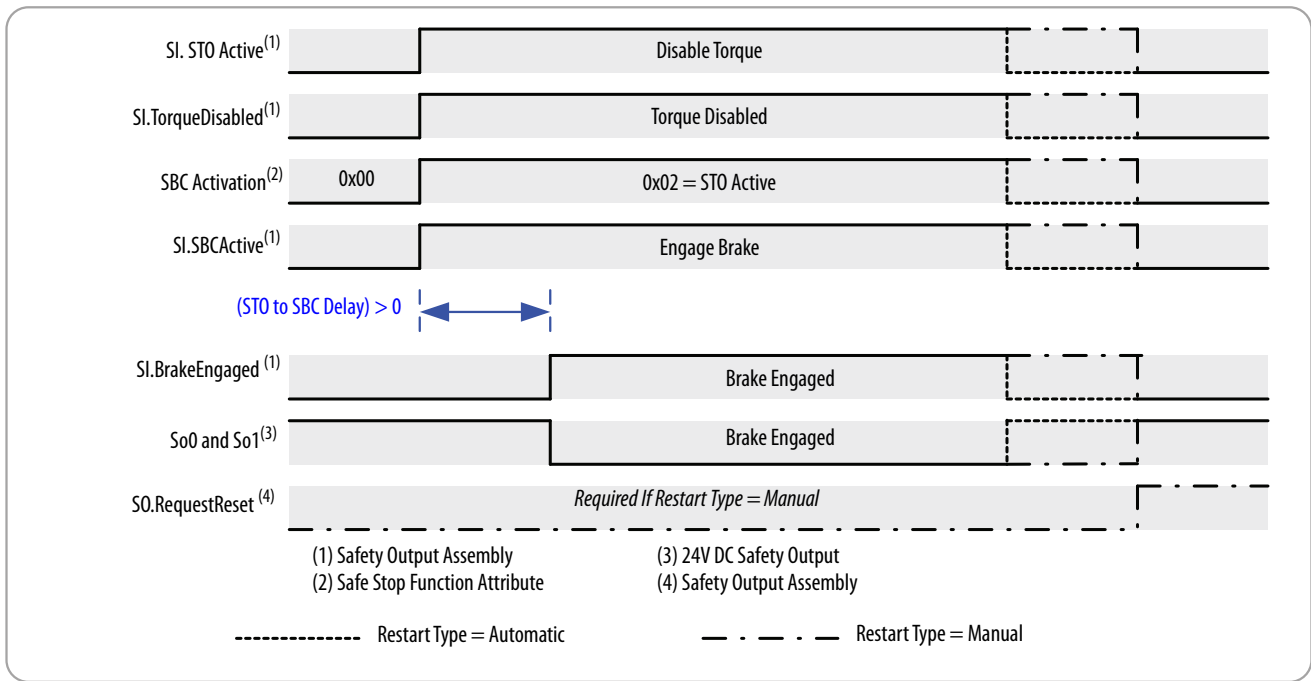
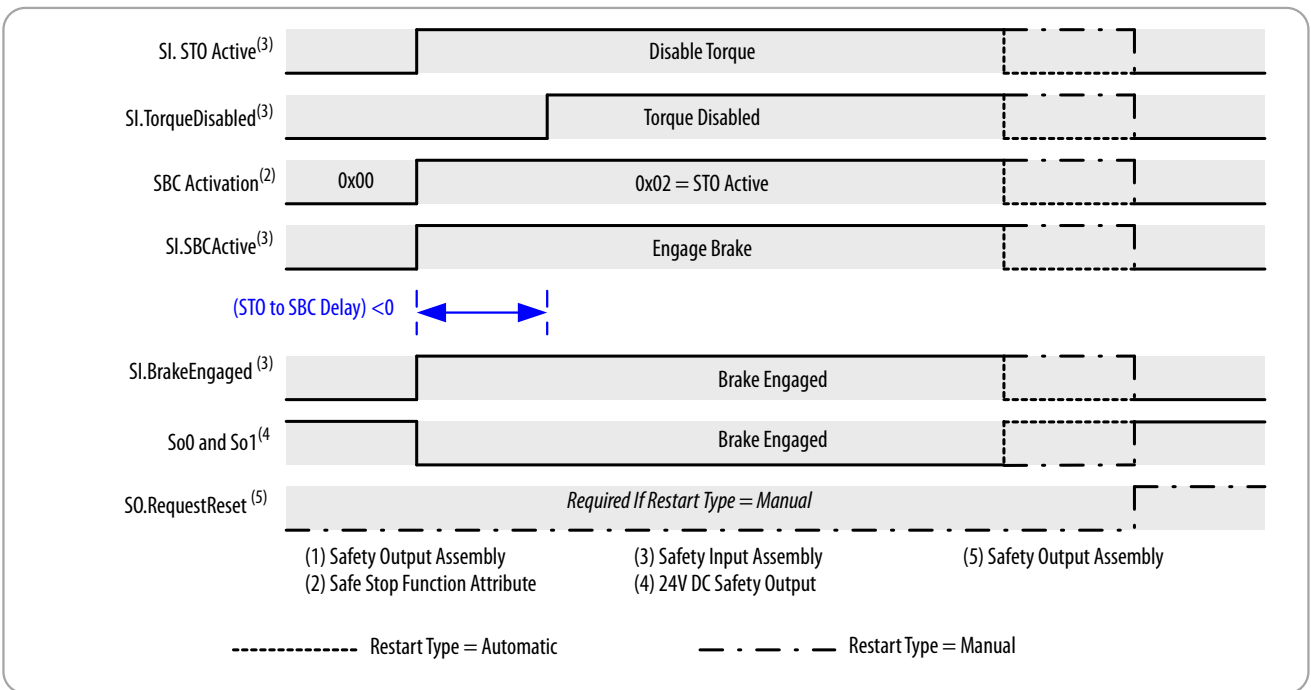

Figure 32 - SBC Linked to STO with Negative Delay



SBC Safety Fault Operation

The operation of SBC under a safety fault condition is dependent on its configuration. If the SBC function is not configured for use, the SBC function is not activated when a safety fault occurs. If configured for use, a safety fault will force the SBC function to the safe state, but the sequence of events leading

to the safe state changes. The 'Safe State' of the SBC function is the 'Brake Engaged' state.

SBC not Linked to STO Safety Fault Operation

When a safety fault is detected in the module (and the SBC function is configured to not be linked to STO activation), the SBC function will be activated with the SBC activation reason being 'Safety Stop Fault'. The SBC function can be reset once the safety fault is cleared. [Figure 33](#) shows the timing of SBC and torque attributes in response to a safety fault in this scenario.

Figure 33 - SBC Operation Under Safety Fault Condition (not linked to STO)

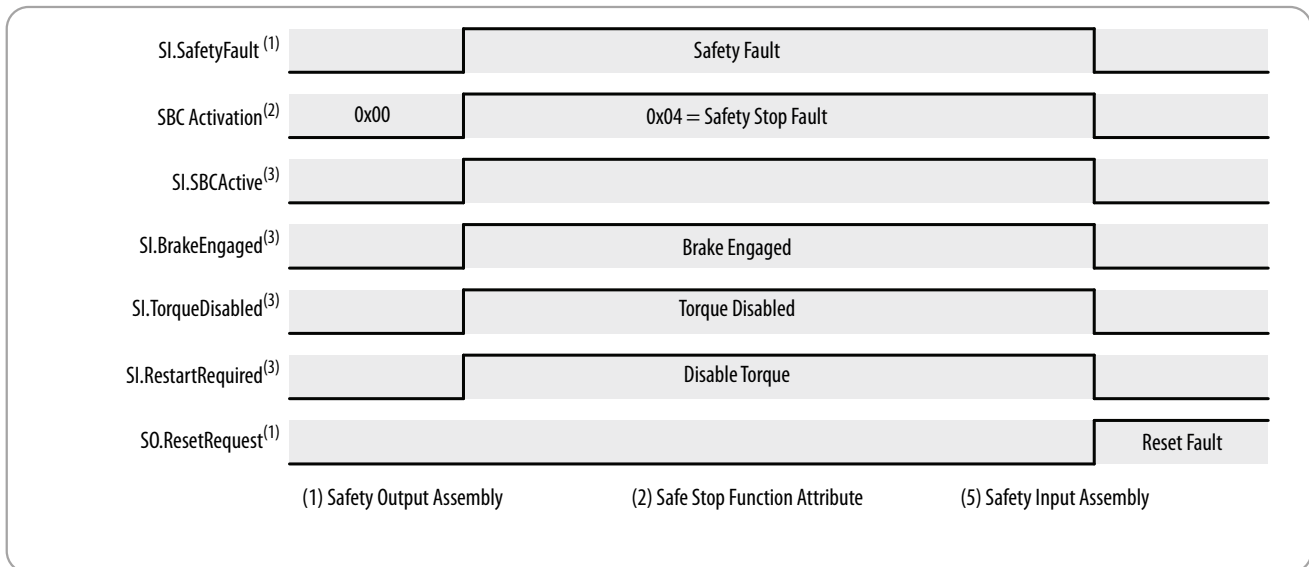

STO Linked to SBC Safety Fault Operation

When a safety fault is detected in the module and the SBC function is configured to link STO and SBC activation, the SBC function will be activated with the SBC activation reason being 'STO Active' and 'Safety Stop Fault'. The SBC and STO function can be reset once the safety fault is cleared.

[Figure 34](#) and [Figure 35](#) show the operation of the SBC function under a safety fault condition when linked to STO.

Figure 34 - SBC Operation under Safety Fault Condition (linked to STO with positive delay)

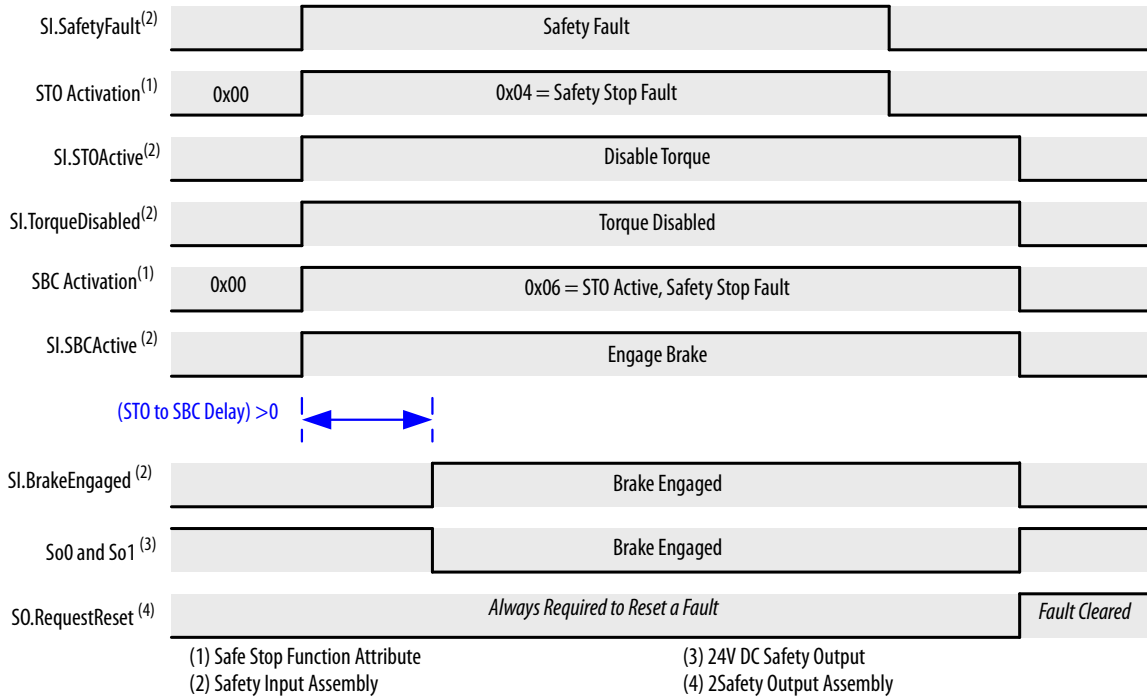
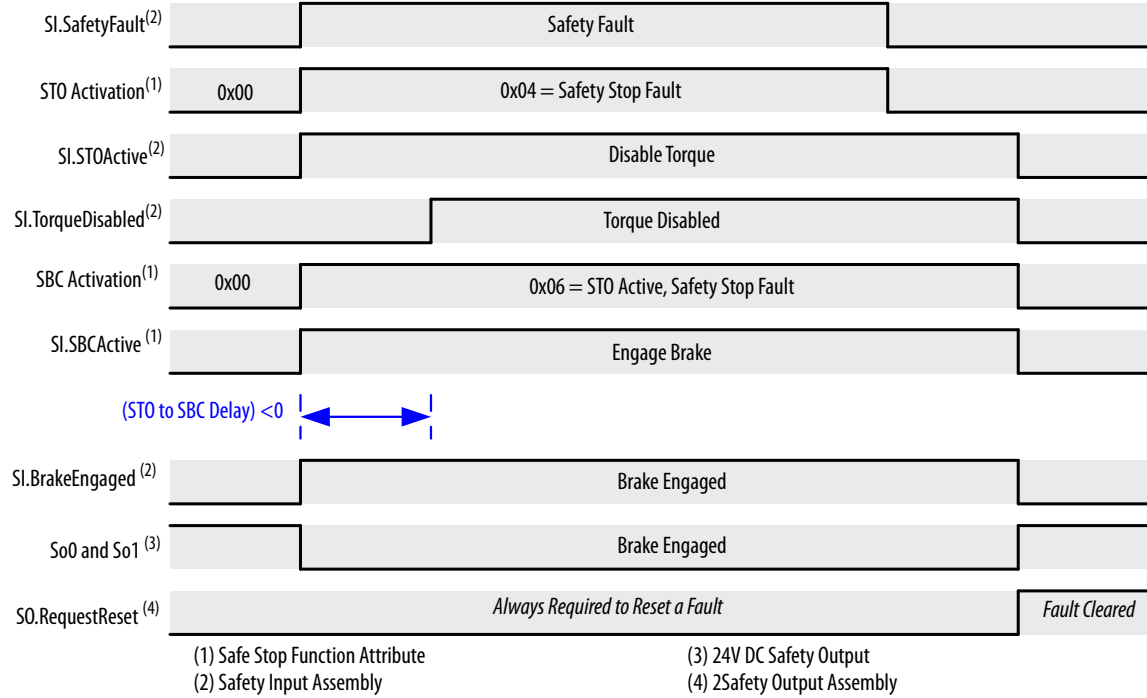

Figure 35 - SBC Operation under Safety Fault Condition (linked to STO with negative delay)



SBC Safety Fault

When the module experiences an SBC Fault, the module is placed in the safe state and the cause of the fault is recorded.

If SBC function detects a fault, it will set:

- *module*:SI.SafetyFault = 1
- *module*:SI.RestartRequired = 1
- *module*:SI.SBCReady = 0

- In Standard Control Mode
 - Host P4 [Safety Status] Safety Fault = 1
 - Host P4 [Safety Status] Restart Req = 1
 - Host P5 [Safety Faults] SBC Fault = 1

- In Motion Control Mode
 - *axis*.SafetyFaultStatus = 1
 - *axis*.SafetyResetRequiredStatus = 1
 - *axis*.SBCFault = 1

For more information on SBC fault types and troubleshooting methods, see the [Understand Safety Faults](#) chapter beginning on page [199](#).

Connecting a Safety Brake

The safety brake control function uses the safety outputs So0 and So1 to control a safety brake.

The design of a safety brake circuit is application-dependent and is based on the following factors:

- Choice of safety brake for the application
- If the brake provides feedback in the application
- If the application uses single or dual channel

The safety brake function interfaces to the safety brake through the two safety outputs So0 and So1. So0 and So1 are 24V DC, 1 A sourcing outputs. [Figure 36](#) shows a wiring example for connecting a brake to the module.

Usually the voltage and current rating of the safety brake is much higher than the 24V DC and 1 A that the safety outputs can directly control. To support brakes with that require higher voltage and higher current, an interposing safety relay such as the 700S-CF Safety Control Relay is required.

Safety brakes typically require a voltage suppression device. Most safety brakes provide a suppression device as an option or they specify a diode or MOV to use. Use the recommended suppression devices.

The drive-based SBC function does not implement checking of brake feedback; however, the available safety inputs can be used to send the status of brake feedback to the safety controller that is programmed with a diagnostic check.

TIP The controller-based SBC instruction does perform a diagnostic check of brake feedback while drive-based SBC does not. However, drive-based SBC can be configured to complete a Safe Stop 1 before engaging the brake in reaction to a Comm Loss or a Comm Idle.

Figure 36 - Safety Brake Wiring

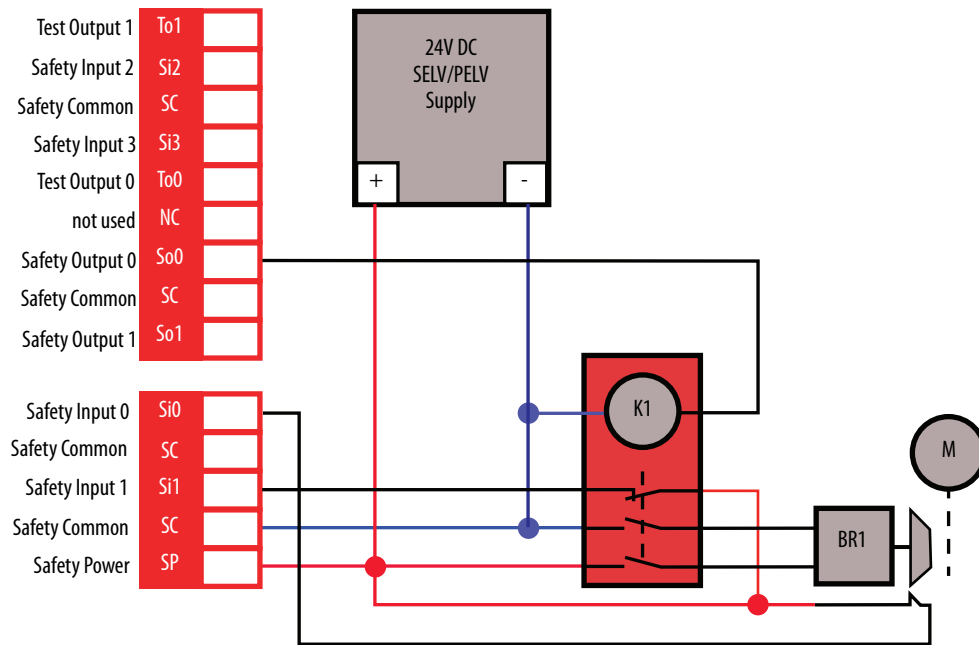

Controller-based Safety Functions

Use this chapter to become familiar with the GuardLogix® controller-based Drive Safety instructions and how they interact with PowerFlex® 755/755T drive products with a 20-750-S4 Integrated Safety Functions option module.

Topic	Page
Drive Safety Instructions	93
Pass-through Data Using Standard I/O Mode	96
Pass-through Data Using Integrated Motion	98
SFX Instruction	99

See the GuardLogix Safety Application Instruction Set Reference Manual, publication [1756-RM095](#), for more information on the Drive Safety instructions and TÜV Rheinland certification.

Drive Safety Instructions

The Drive Safety instructions (see [Table 40 on page 94](#)) are designed to work with the 20-750-S4 option module. They are available in the Studio 5000 Logix Designer® application, version 31.00 or later, in the Drive Safety instruction element group that is enabled when the Safety Program - MainRoutine is open (see [Figure 37 on page 94](#)).

Controller-based safety functions operate in GuardLogix 5580 or Compact GuardLogix 5380 controllers and use the EtherNet/IP™ network to communicate with the safety I/O. Drive Safety instructions use safety feedback, provided by PowerFlex 755/755T drive products to the Safety Task of the controller, to perform safe monitoring functions.

Table 40 - Drive Safety Instructions

Safety Instruction		Description
Safety Feedback Interface	SFX	The SFX function scales feedback position into position units and feedback velocity into position units per time unit. SFX is used with other Drive Safety instructions.SFX also provides unwind for rotary applications and position homing.
Safe Stop 1	SS1	The SS1 function monitors the motor deceleration rate within set limits during motor stopping and provides an indication to initiate Safe Torque Off (STO) function when the motor speed is below the specified limit.
Safe Stop 2	SS2	The SS2 function monitors the motor deceleration rate within set limits during motor stopping and initiates the Safe Operating Stop (SOS) function when the motor speed is below the specified limit.
Safe Operational Stop	SOS	The SOS function prevents the motor from deviating more than a defined amount from the stopped position.
Safely-limited Speed	SLS	The SLS function prevents the motor from exceeding the specified speed limit.
Safely-limited Position	SLP	The SLP function prevents the motor shaft from exceeding the specified position limits.
Safe Direction	SDI	The SDI function prevents the motor shaft from moving in the unintended direction.
Safe Brake Control	SBC	The SBC function provides safe output signals to control an external brake.

Figure 37 - Drive Safety Tab and Instructions

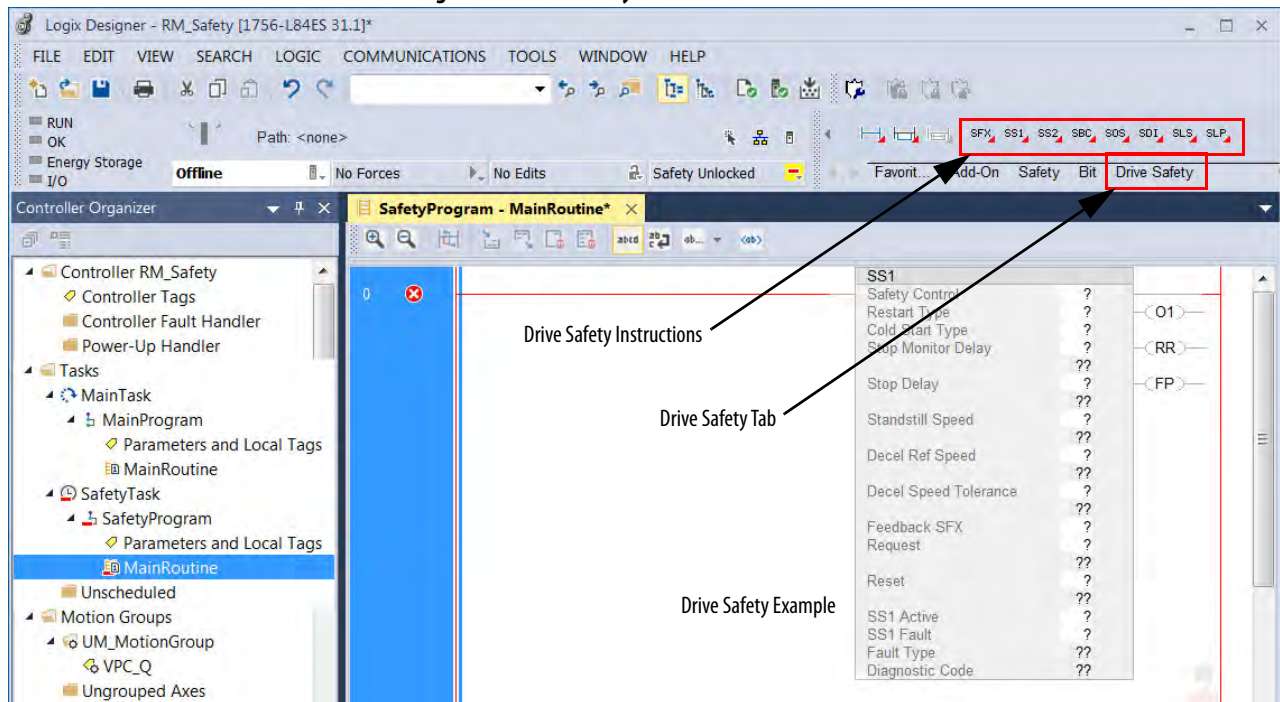

Before Adding the Safety Instructions

Before adding drive safety instructions to your Logix Designer application, you must have PowerFlex 755/755T drive products with 20-750-S4 options installed in your project.

Drive Safety Instruction Example

Drive Safety instructions provide the following information. In this example, the Safely-limited Speed (SLS) instruction is shown.

Figure 38 - SLS Drive Safety Instruction

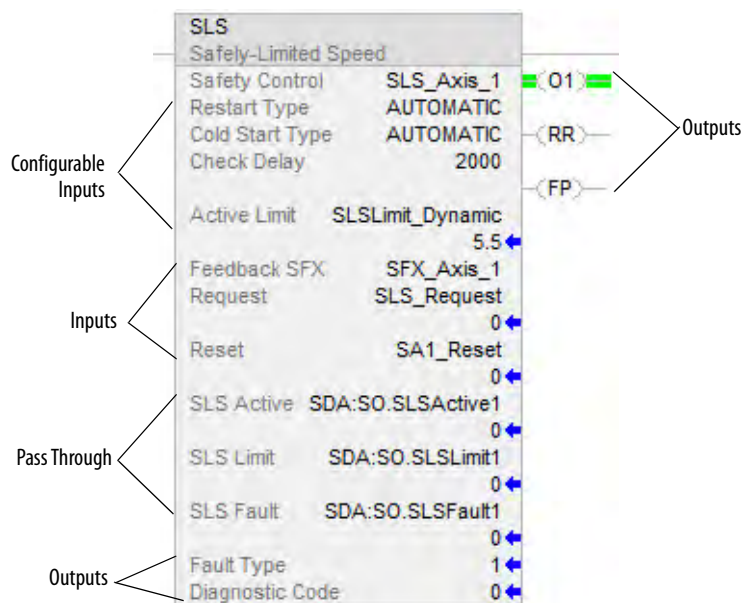

Table 41 - Drive Safety Instruction Definitions

Instruction Information	Description
Configurable Inputs	Safety function parameters that are used to define how the safety function operates.
Inputs	<ul style="list-style-type: none"> Feedback SFX is the link to the SFX instruction for an axis. Request initiates the safe monitoring function. Reset initiates a safety instruction reset.
Pass Through	Safety Output Assembly Object tags pass safety function status information from the Safety Task of the safety controller to the safety instance of the drive module. The status is made available to the motion controller. In standard I/O mode, datalinks must also be configured to provide status information to the standard controller.
Outputs	<ul style="list-style-type: none"> Fault Type is the instruction fault code that indicates the type of fault that occurred. Diagnostic Code provides additional details on the fault. O1 - Output 1 indicates the status of the instruction. When ON (1), it indicates that the input conditions are satisfied. RR - Reset Required indicates when a reset is needed to restart the instruction or to clear faults. FP - Fault Present indicates whether a fault is present in the instruction.

Pass-through Data Using Standard I/O Mode

The Drive Safety instructions provide safety function monitoring in the safety task of a controller. Control of the drive is done in the main program within the standard (main) task of a controller. For the main program to receive safety status information from the Drive Safety instruction, tag data in the safety output assembly for the drive module (safety task) is passed to the drive and then data linked to tags in the main task.

This is especially useful when the user's program is in a separate controller from the safety program that is in a safety controller. [Figure 39](#) shows how this works for the SLS instruction.

IMPORTANT Pass-through data is for status information only and does not impact configured safety functions.

Figure 39 - Pass-through Data Path (Standard I/O Mode)

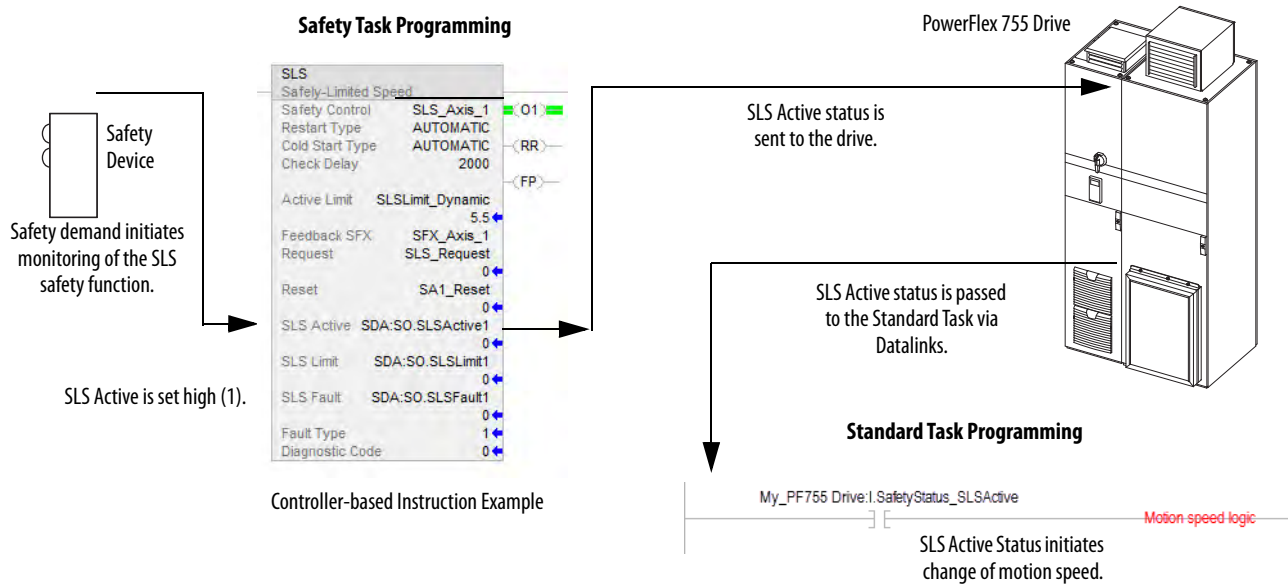

SLS Active status and safety faults are passed to the standard task via user-configured datalinks (inputs) to the following host config parameters in the Integrated Safety Functions option module:

- P4 [Safety Status]
- P5 [Safety Faults]

TIP Other safety parameters may also need to be data linked depending on your application.

Table 42 - SLS Tag Information

Safety Output Assembly Tag	Axis Tag
<i>module:SO.SLSActive</i>	<i>Drive:1.SafetyStatus SLSActive</i>
<i>module:SO.SLSLimit</i>	<i>Drive:1.SafetyStatus SLSLimit</i>
<i>module:SO.SLSFault</i>	<i>Drive:1.SafetyStatus SLSFault</i>

TIP The words *module* and *drive* (italic) in these tag names represent the module and drive name that is assigned in the Logix Designer application.

The following steps correspond to the activity in [Figure 39](#).

1. Safety device reports a request to the safety zone. Initiates monitoring by the SLS instruction (Safety Task).
2. SLS Active status is passed to the Standard program (Safety Task to Standard Task via the drive).
3. The Standard program adjusts the speed of the drive to below the SLS Active Limit during the Check Delay (Standard Task).
4. If the drive speed exceeds the SLS Active Limit (Safety Task) during SLS monitoring, the SLS Limit output is set.
 - Optionally, a stopping safety function can be initiated within the safety program.

Pass-through Data Using Integrated Motion

The Drive Safety instructions provide safety function monitoring in the safety task of the controller. Control of the drive is done in the motion programming within the standard task of the controller. For the main program to receive status information from the Drive Safety instruction, tag data in the output assembly for the drive module (safety task) are passed to the drive and then to the corresponding tag in the axis structure (standard task).

This is especially useful when the motion program is in a separate controller from the safety program that is in a safety controller. [Figure 40](#) shows how this works for the SLS instruction.

IMPORTANT Pass-through data is for status information only and does not impact configured safety functions.

Figure 40 - Pass-through Data Path

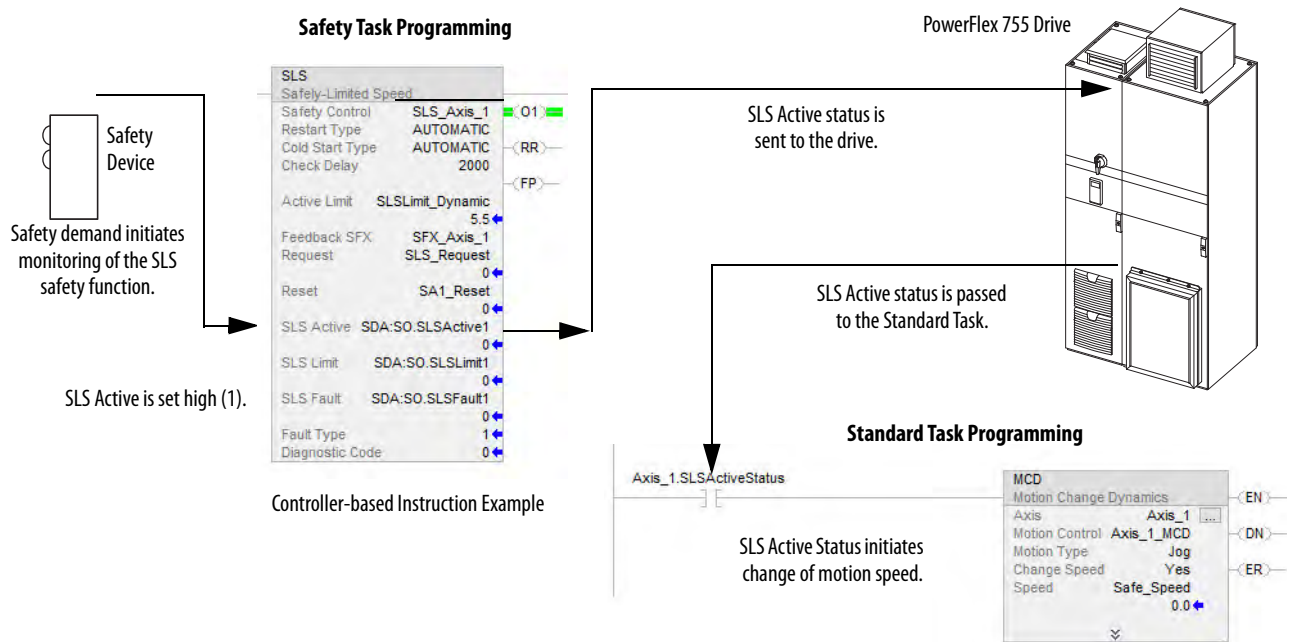

Table 43 - SLS Tag Information

Safety Output Assembly Tag	Axis Tag
<i>module</i> :SO.SLSActive	<i>Axis</i> .SLSActiveStatus
<i>module</i> :SO.SLSLimit	<i>Axis</i> .SLSLimitStatus
<i>module</i> :SO.SLSFault	<i>Axis</i> .SLSFault

TIP The words *module* and *axis* (italic) in these tag names represent the module and axis name that is assigned in the Logix Designer application.

The following steps correspond to the activity in [Figure 40](#).

1. Safety device reports a request to the safety zone.
Initiates monitoring by the SLS instruction (Safety Task).
2. SLS Active status is passed to the motion program (Safety Task to Standard Task via the drive).
3. The motion program adjusts the speed of the drive to below the SLS Active Limit during the Check Delay (Standard Task).
4. If the drive speed exceeds the SLS Active Limit (Safety Task) during SLS monitoring, the SLS Limit output is set.
 - Optionally, a stopping safety function can be initiated within the safety program.

SFX Instruction

The Safety Feedback Interface (SFX) instruction scales feedback position into position units and feedback velocity into speed units per unit of time. Feedback position and velocity are read from the safety input assembly and become inputs to the instruction. The SFX instruction also sets a reference position from a home input and performs position unwind in rotary applications. Typically, one SFX instruction is used per safety drive. This instruction provides the position and velocity feedback that is used by other safety instructions, also used by the same safety drive.

The PowerFlex 755/755T drive provides safe position and velocity feedback. Up to SIL 3 PLe safety rating can be achieved by using dual feedback with velocity and/or position discrepancy checking.

The outputs of the SFX instruction are used as inputs to other Drive safety instructions. For any drive with an Integrated Safety Functions option module to execute a controller-based safety function, an SFX instruction is required. Although the SFX instruction is a safety instruction, it alone does not perform a safety function.

In [Figure 41](#), the SS1 instruction uses the Actual Speed output from the SFX instruction during execution of the SS1 safety function.

Figure 41 - SFX Instruction Feeds Data to SS1 Instruction

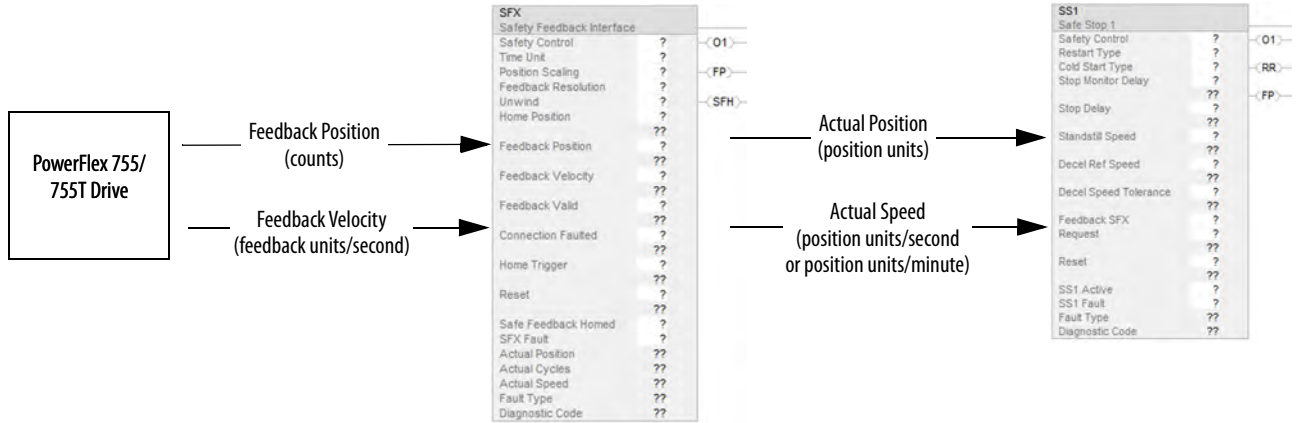

SFX Instruction Example

In this SFX example, an encoder has 512 feedback counts per motor revolution and is scaled for position to have 512 counts per motor revolution.

The SFX instruction scales the applicable safety instructions with feedback position units from the safety encoder/motor, into position feedback units used in applicable safety instructions. It also scales feedback velocity units from the safety encoder/motor into position feedback units per time unit.

Scaling Setup

When configuring the SFX instruction, calculate the value for 'Position Scaling' so that the 'Actual Position' and 'Actual Speed' output from the instruction matches the 'Actual Position' and 'Actual Velocity' in the motion controller.

Values from 'Axis Properties>Scaling and Motion Safety>Primary Feedback' are required to calculate the instruction input.

The Feedback Resolution is determined based on the feedback device and the Effective Resolution of the feedback. This information is configured on the 'Module Properties>Motion Safety>Primary Feedback' category.

Figure 42 - Effective Resolution Parameter

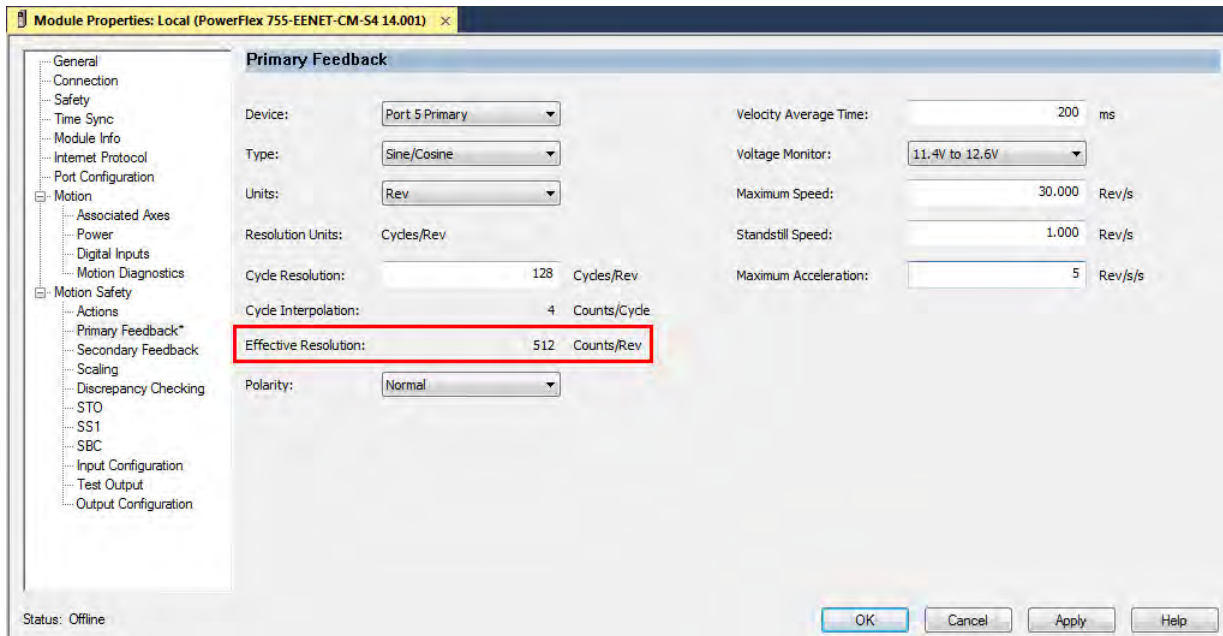

In this example, the motor is used in a rotary application where the unwind is set to roll over each motor revolution. Therefore, the unwind of '512 Counts/Rev' was added in the SFX instruction appropriately.

Figure 43 - Scaling

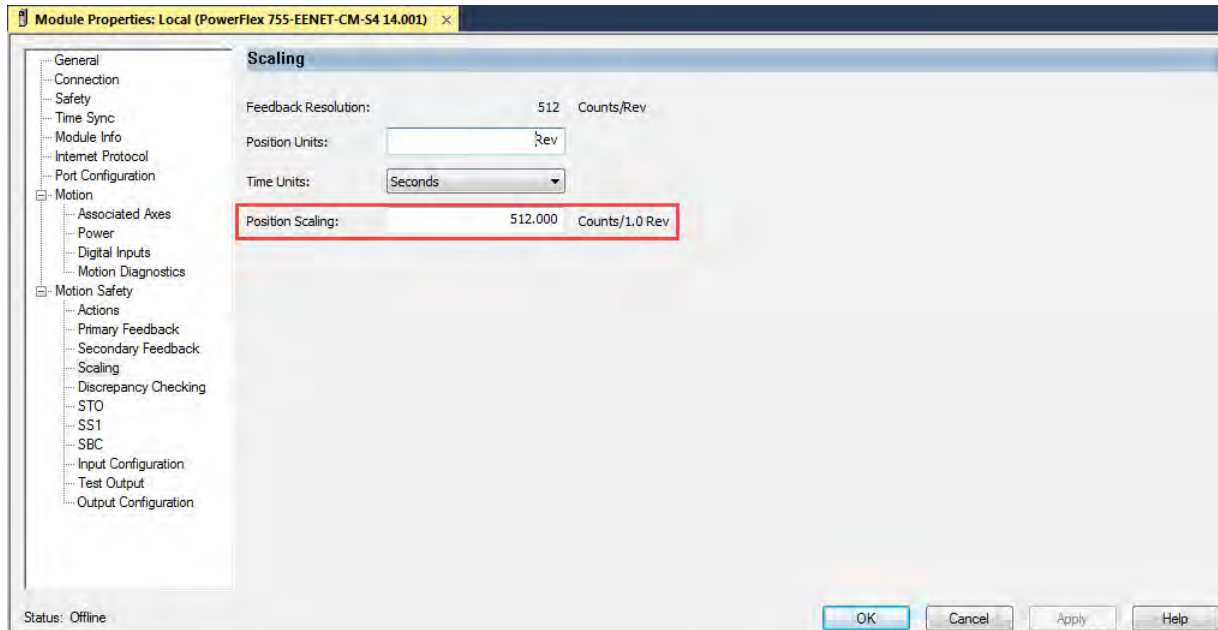

Homing

Setting the 'Actual Position' output to the 'Home Position input' (homing) of the instruction is required if using a position-based drive safety instruction like

Safely-limited Position (SLP). If a position-based drive safety instruction is not being used on an axis, homing the SFX instruction is not required.

The data in the Primary Feedback category, Scaling category, and motor unwind value is used to populate the SFX instruction.

Figure 44 - SFX Instruction Example

The screenshot shows the SFX instruction configuration window. A red box highlights the 'Position Scaling', 'Feedback Resolution', 'Unwind', and 'Home Position' fields. Arrows point from text annotations to these fields:

- Position Scaling value from Figure 43.** (points to 512.0)
- Feedback Resolution value from Figure 42.** (points to 512)
- Unwind value as specified for the motor used in this example.** (points to 512)
- Used only with position-based drive safety instructions** (points to the Unwind field)
- See the GuardLogix Safety Application Instruction Set Reference Manual, publication 1756-RM095** (points to the Home Position field)

Parameter	Value	Unit / Comment
SFX		
Safety Feedback Interface		
Safety Control	SFX_Axis_1	O1
Time Unit	Seconds	
Position Scaling	512.0	(FP)
Feedback Resolution	512	(SFH)
Unwind	512	
Home Position	0.0	
Feedback Position	SDA:SI.FeedbackPosition1	621748
Feedback Velocity	SDA:SI.FeedbackVelocity1	29.997238
Feedback Valid	SDA:SI.PrimaryFeedbackValid1	1
Connection Faulted	SDA:SI.ConnectionFaulted	0
Home Trigger	SA1_HomeTrigger	0
Reset	SA1_Reset	0
Safe Feedback Homed	SDA:SO.SFHomed1	
SFX Fault	SDA:SO.SFXFault1	
Actual Position		0.3515625
Actual Cycles		1214
Actual Speed		29.997238
Fault Type		1
Diagnostic Code		0

See the GuardLogix Safety Application Instruction Set Reference Manual, publication [1756-RM095](#), for more information on the drive safety instructions.

Standard I/O Mode – Configuration, Programming, and Operation

This chapter provides information for network installation and operation of the Integrated Safety Functions option module in Standard I/O mode. If using Integrated Motion mode, see [Chapter 7](#).

Topic	Page
Safety Assembly Tags	103
Configure Safety in the Logix Designer Application	104
Programming	126
Safety Function Operation	128
Pass-through Data	129

Safety Assembly Tags

Using network safety, a GuardLogix® 5580 or Compact GuardLogix 5380 safety controller controls the PowerFlex® 755/755T Safe Torque Off function through the SO.SafeTorqueOff tag in the safety output assembly.

The SO.SafetyStopFunctions tags are sent from the GuardLogix safety output assembly to the PowerFlex 755 safety output assembly to control the safety functions.

The SO.Output00Output, SO.Output01Output, SO.Test00Output, and SO.Test01Output tags are sent from the GuardLogix safety output assembly to the PowerFlex 755 safety output assembly to control the safety and test outputs on the Integrated Safety Functions option module.

The SI.StopStatus tags are sent from the PowerFlex 755 to the GuardLogix safety input assembly and indicate the PowerFlex 755 safety control status.

The SI.OutputStatus, SI.InputStatus, and SI.IOSupport tags are sent from the PowerFlex 755/755T drive product to the GuardLogix safety input assembly and indicate the status of the safety inputs, safety outputs, and test outputs.

The SI.ConnectionStatus tags indicate the safety input connection status.

See [Appendix C](#) for more information about assembly tags.

Configure Safety in the Logix Designer Application

This section provides instructions for how to add and configure an Integrated Safety Functions option module in a PowerFlex 755/ 755T drive product to an existing project in the Logix Designer application. This chapter is specific to safety and does not cover all aspects of drive configuration. The PowerFlex 755 drive is used for the examples in this chapter.

Before you can configure your option module in the Logix Designer application:

- You must have a safety controller project with an EtherNet/IP® network connection configured. See the documentation for your controller, drive, and Ethernet adapter for information on configuring those products (see [Additional Resources on page 13](#)).
- You must add a PowerFlex 755/755T drive product and 20-750-S4 option module to your project.
- If using speed monitoring functions, install a 20-750-DENC-1 or 20-750-UFB-1 option module in port 4, 5, or 6.

Add a PowerFlex 755 Drive/755T Drive Product to the Safety Controller Project

1. Select the Ethernet network in the I/O Configuration folder and select **New Module**.

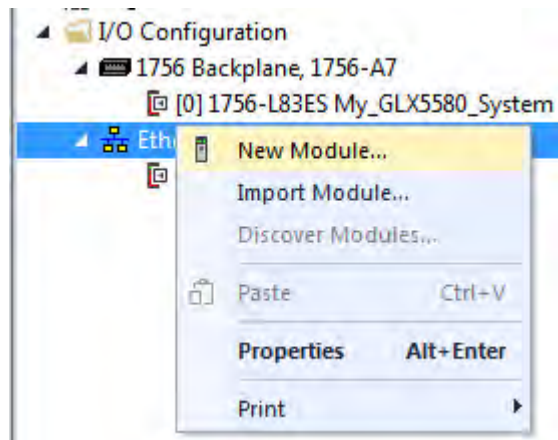

2. Select from the following drive products and click **Create**.
 - PowerFlex 755 HiPwr-EENET
 - PowerFlex 755-EENET
 - PowerFlex 755T

TIP If you want to use a 20-750-ENETR Dual-port EtherNet/IP option module with the PowerFlex 755/755T Integrated Safety Functions option module, you must select PowerFlex 755-EENET or PowerFlex 755 HiPwr-EENET from this list. Later in this procedure, you will use the Synchronize command so that the module reflects an ENETR module and will work with the PowerFlex 755/755T Integrated Safety Functions option module.

This example uses the PowerFlex 755-EENET.

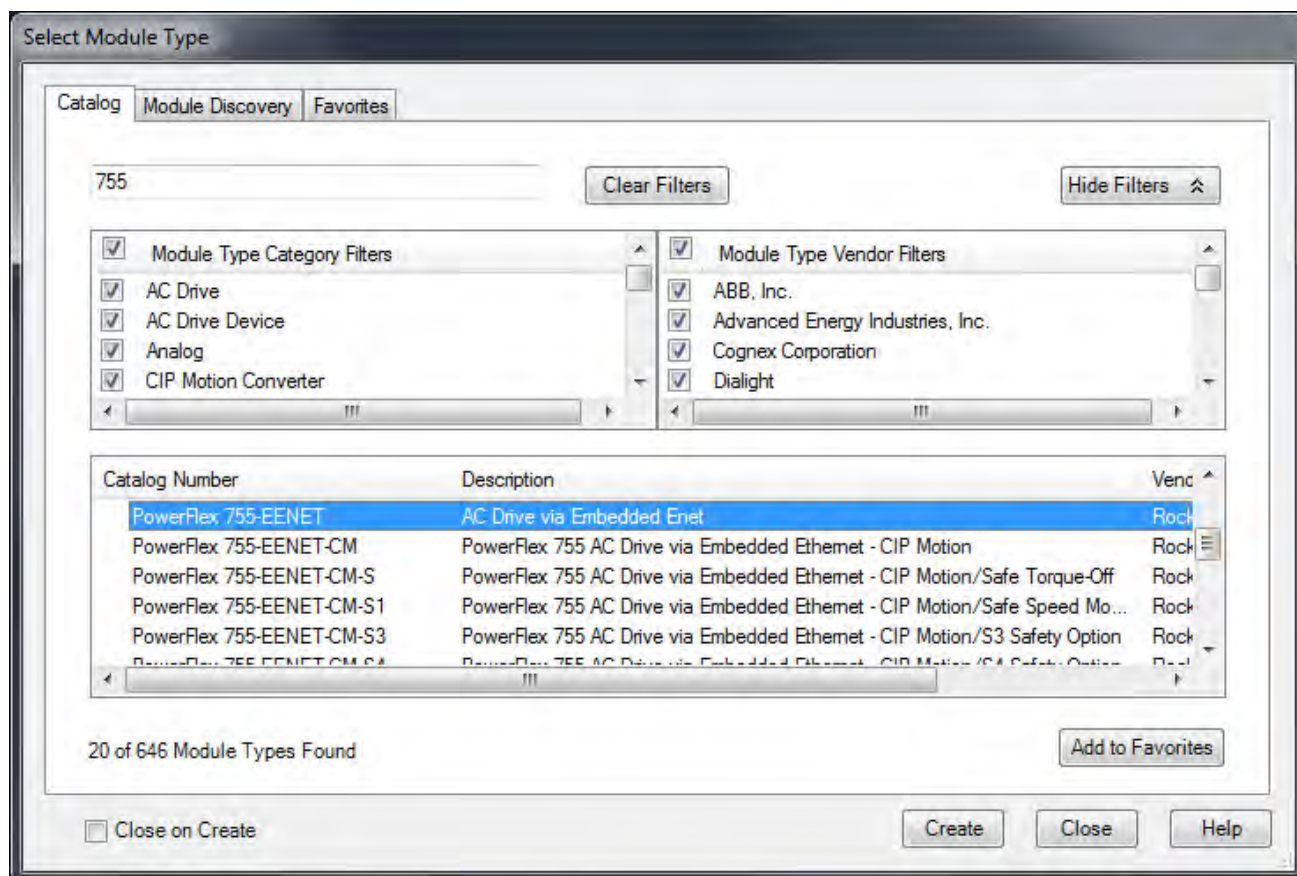

Add an Option Module to a PowerFlex 755 Drive

1. In the Device Definition dialog box, enter the connection type that you want to use. Select from one of the following types. The ‘Standard and Safety’ connection is used in this example.

Connection Type	Description	Requires Controller Firmware Revision
Standard	Control is managed by this controller. Safety is managed by another controller.	V31 or later
Standard and Safety	Both control and network safety connections are managed by this controller. A Standard and Safety connection can only be made from a GuardLogix 5580 or Compact GuardLogix 5380 controller.	V31.012 or later
Safety Only	Network safety connection is managed by this controller. Control is managed by another controller. A Safety connection can only be made from a GuardLogix 5580 or Compact GuardLogix 5380 controller.	V31 or later

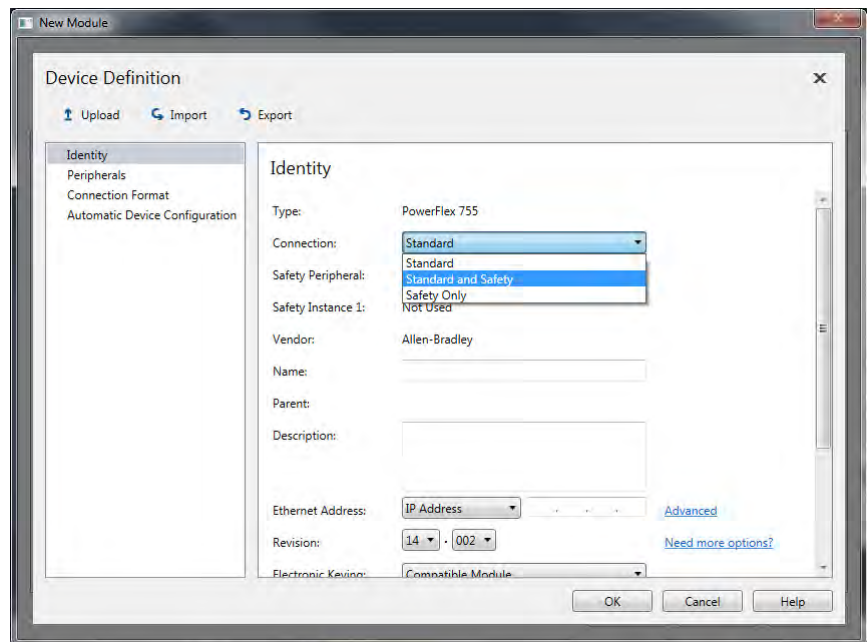

- When a network safety connection is selected, the 20-750-S3 Network STO option is selected by default. Click the **Safety Peripheral** pull-down menu and select **20-750-S4**.

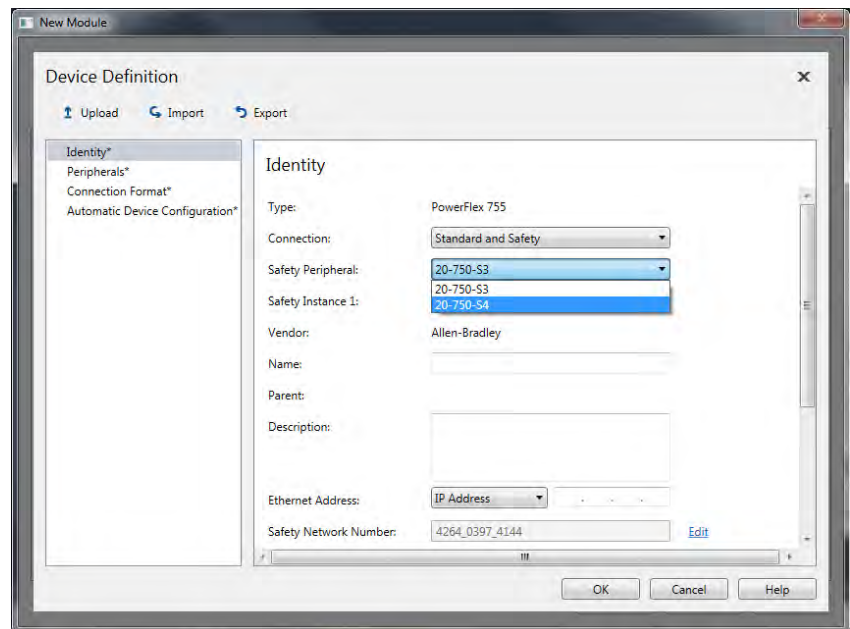

- If feedback is being used (indicated by the selection in Safety Instance 1), enter a feedback device for the **Safety Feedback Module**.

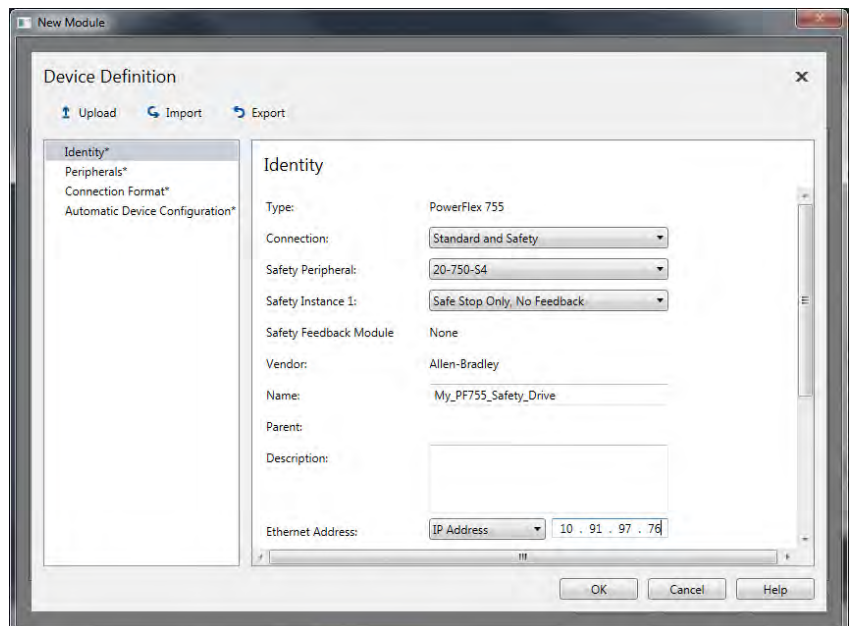

4. Scroll down and enter additional Device Definition data for the drive product being used.

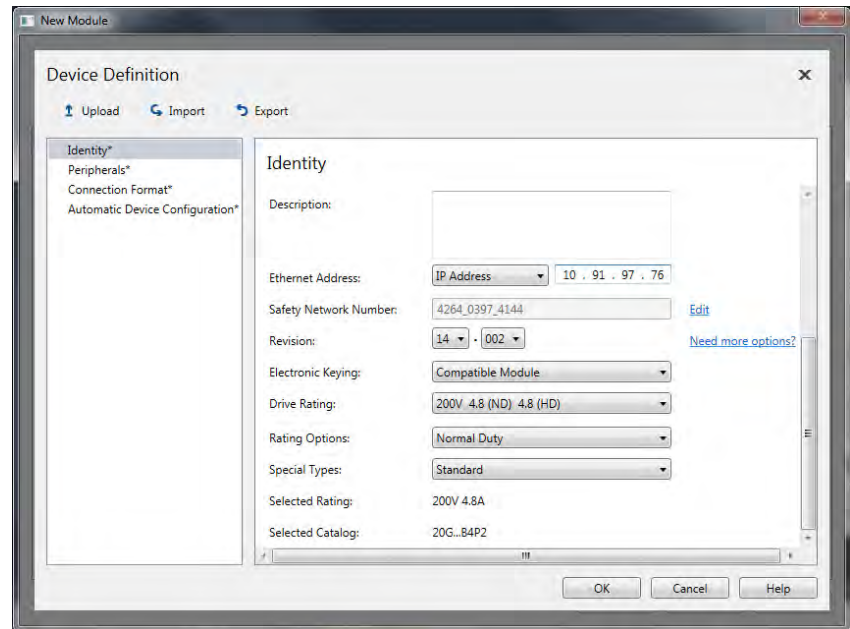

Generate the Safety Network Number (SNN)

The assignment of a time-based SNN is automatic when you create a GuardLogix safety controller project and add new Safety I/O devices.

Manual manipulation of an SNN is required in the following situations:

- If safety consumed tags are used
- If the project consumes safety input data from a device whose configuration is owned by some other device
- If a safety project is copied to another hardware installation within the same routable Safety system

If an SNN is assigned manually, the SNN has to be unique.

IMPORTANT If you assign an SNN manually, make sure that the system expansion does not result in duplication of SNN and node address combinations. A warning appears if your project contains duplicate SNN and node address combinations. You can still verify the project, but Rockwell Automation recommends that you resolve the duplicate combinations.

To edit the SNN, follow these steps.

- a. In the Device Definition dialog box, click **Edit** to the right of the Safety Network Number.
- b. Select either **Time-based** or **Manual**.
If you select **Manual**, enter a value from 1...9999 decimal.
- c. Click **Generate**.
- d. Click **OK**.

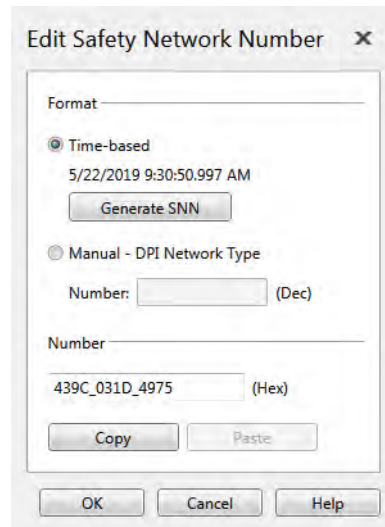

Electronic Keying

The electronic keying options are for the standard connection to the drive.

Electronic Keying	
Exact Match	Indicates that all keying attributes must match to establish communication. If any attribute does not match precisely, communication with the device does not occur.
Compatible Module	<p>Lets the installed device accept the key of the device that is defined in the project when the installed device can emulate the defined device. With Compatible Module, you can typically replace a device with another device that has the following characteristics:</p> <ul style="list-style-type: none"> • Same catalog number • Same or higher Major Revision • Minor Revision as follows: <ul style="list-style-type: none"> – If the Major Revision is the same, the Minor Revision must be the same or higher. – If the Major Revision is higher, the Minor Revision can be any number.
Disable Keying	<p>Indicates that the keying attributes are not considered when attempting to communicate with a device. With Disable Keying, communication can occur with a device other than the type specified in the project.</p> <hr/> <div style="display: flex; align-items: center;">  <div> <p>ATTENTION: Be extremely cautious when using Disable Keying; if used incorrectly, this option can lead to personal injury or death, property damage, or economic loss.</p> <p>We strongly recommend that you do not use Disable Keying. If you use Disable Keying, you must take full responsibility for understanding whether the device being used can fulfill the functional requirements of the application.</p> <p>ATTENTION: Disable Keying is not permitted for safety devices.</p> </div> </div> <hr/>

5. Click **Peripherals** in the navigation tree and click the arrow in the top left corner to expand the **Network SSM *S4** section. The port location can be changed if needed (uses ports 4, 5 or 6). The electronic keying options that are specified here are for the safety connection with the safety controller. 'Exact Match' or 'Compatible Module' must be used.

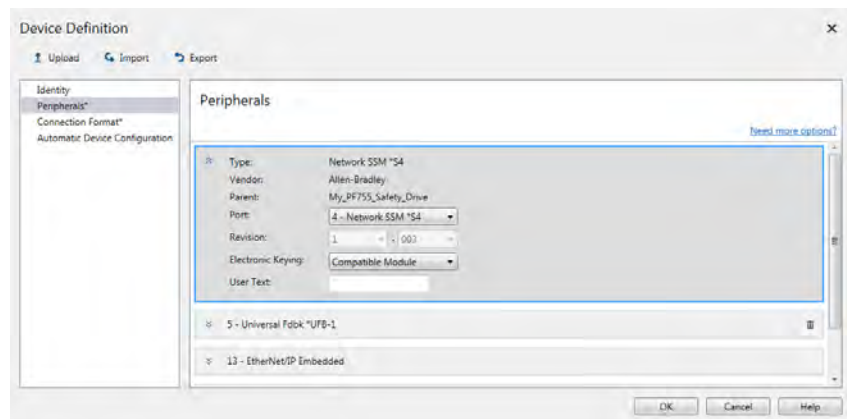

- Click the **Add new peripheral** pull-down menu to add any additional peripherals, such as feedback devices to use with the safety option module.

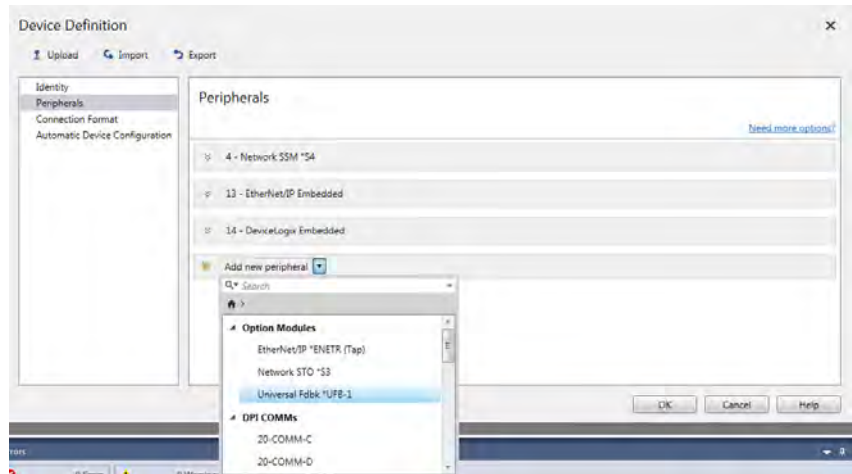

In this example, a '20-750-UFB-1 Universal Feedback' option module has been added.

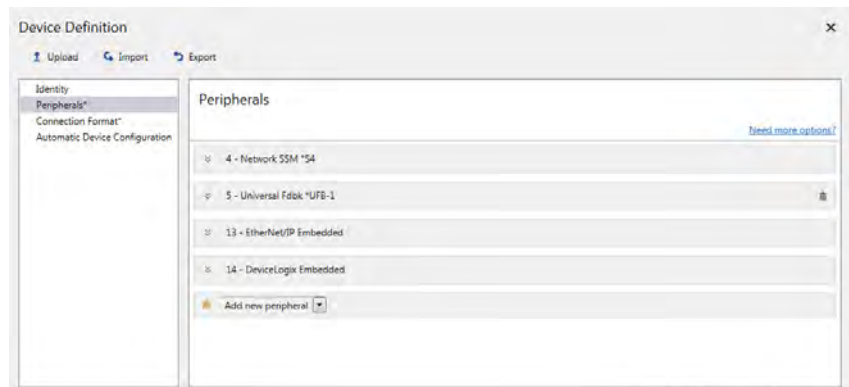

- Click **Connection Format** in the navigation tree to open the Connection Format page.

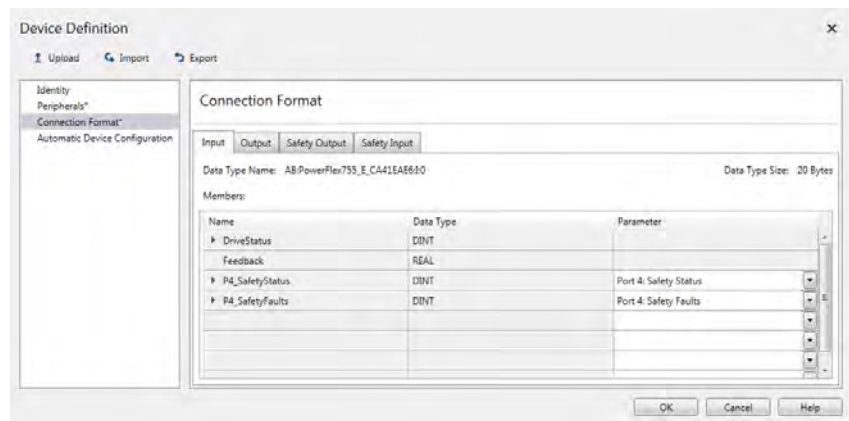

The Input and Output tabs are for setting the datalinks between the drive and the controller that is performing control. Add P4 [Safety Status] and P5 [Safety Faults] to provide pass-thru data from the safety task/safety controller to the main task/standard controller. Enter additional datalinks as desired for your application.

The Safety Output and Safety Input tabs show the fixed safety data between the drive and safety controller.

8. If Automatic Device Configuration (ADC) will be used, click **Automatic Device Configuration** in the navigation tree to open the Automatic Device Configuration page. The 20-750-S4 option module has Host configuration parameters that can be set using the ADC process.

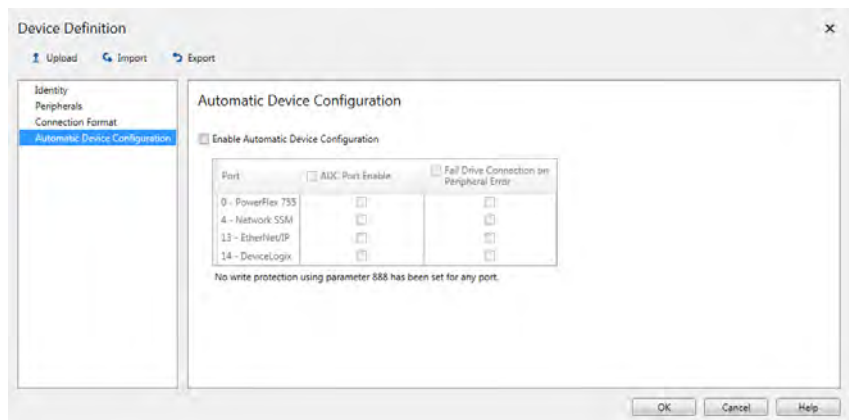

9. Click **OK** to use the Automatic Device Configuration settings.

TIP You can click the Device Definition button from the Overview page to reopen the Device Definition dialog box and make edits to the previous steps.

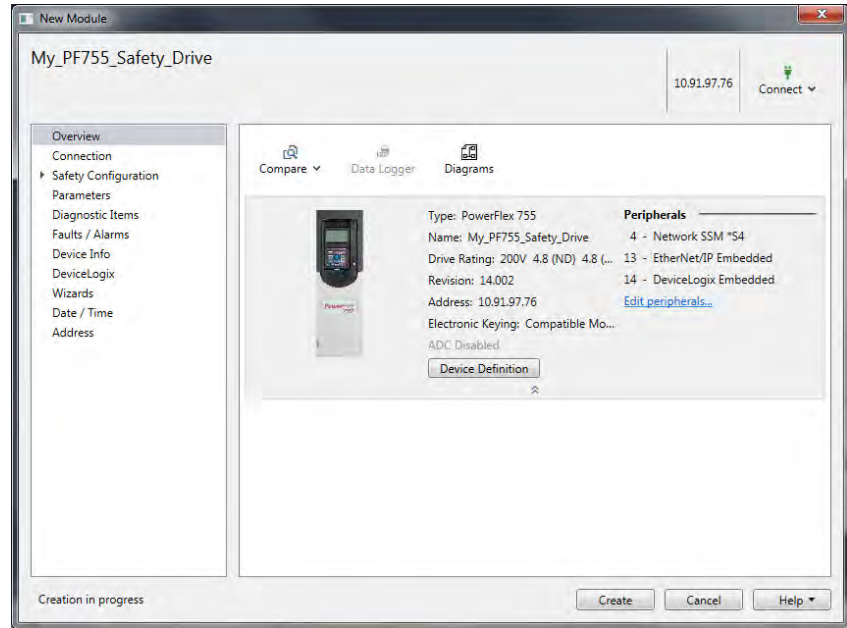

10. Click **Create** to create the drive and have it added to the I/O Configuration folder. Save the project to save any edits and double-click the drive in the I/O Configuration folder to reopen the drive properties window.
11. Click **Connection** in the navigation tree to open the Connection page. The safety output connection, safety input connection, and standard connection configuration information is shown on this page. The **Requested Packet Interval (RPI)** and **Connection Reaction Time Limit** can be set according to the application.

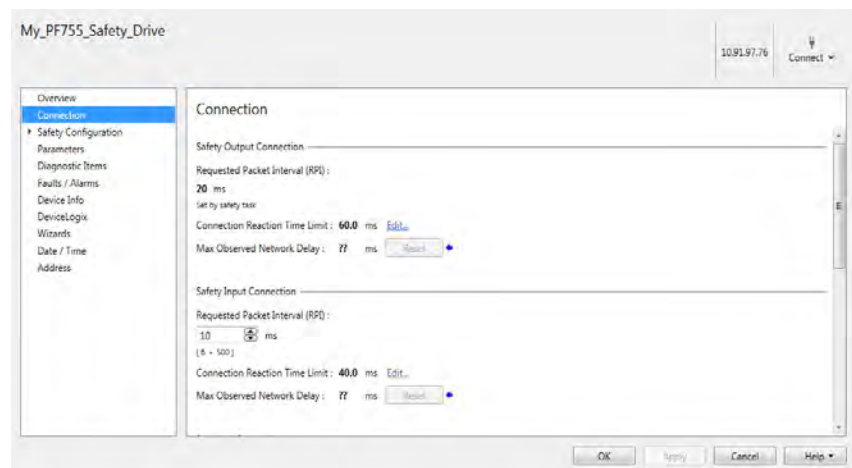

The **RPI** for the Safety Output connection is fixed based on the period of the safety task in the controller.

The **Connection Reaction Time Limit** sets the maximum age of safety packets on the associated connection. If the age of the data that is used

by the consuming device exceeds the connection reaction time limit, a connection fault occurs.

For safety output connections, the **Max Observed Network Delay** displays the value that is generated by the output module. For safety input connections, it displays the value that is generated by the controller. The **Max Observed Network Delay** value is updated automatically at a rate similar to the rate used by the **Max Scan Time**. The **Max Observed Network Delay** displays '??' when the status is Faulted or Connecting.

12. Click **Safety Configuration** in the navigation tree to open the Safety Configuration pages.

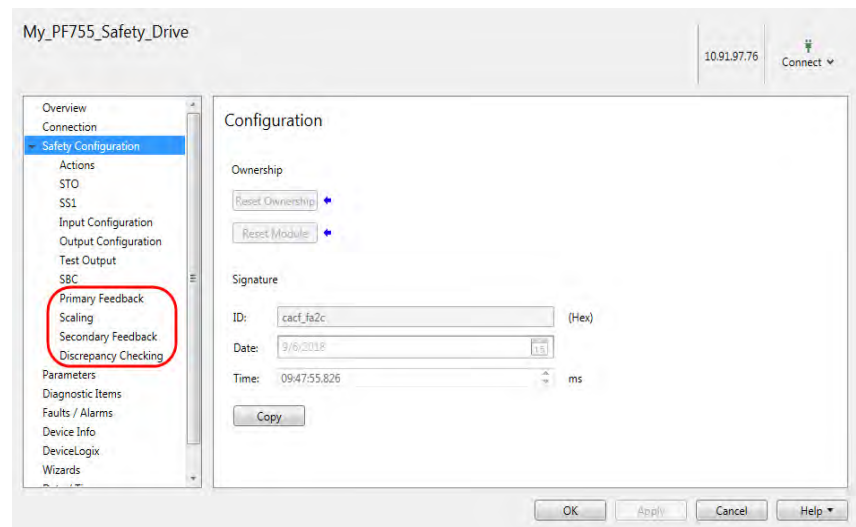

Primary Feedback, Scaling, Secondary Feedback, and Discrepancy Checking will only be displayed if a feedback device is selected for the Safety Feedback Module on the Device Definition Identity page (shown on [page 107](#)).

Ownership indicates whether the current controller owns the configuration of the safety module. The value is read directly from the module and is available only online. When working offline, the label is unavailable and a value does not appear. The value is updated when you open the page and when you change to or from Run mode.

- **Local** is displayed when the current controller owns the module configuration.
- **Remote (SNN: nnnn_nnnn_nnnn, Address: mm)** is displayed when another device owns the module configuration. SNN: nnnn_nnnn_nnnn is the owning device. Address: mm is the node or slot number.
- **read fails,??** is typically displayed when the module status is faulted or connecting.

Reset Ownership resets the ownership of the safety module. If the reset ownership is confirmed, the module enters its out-of-box state

(configuration). The module is not owned. It becomes owned by the first originator that successfully configures the module.

13. Click **Actions** under **Safety Configuration** in the navigation tree to open the Actions page.

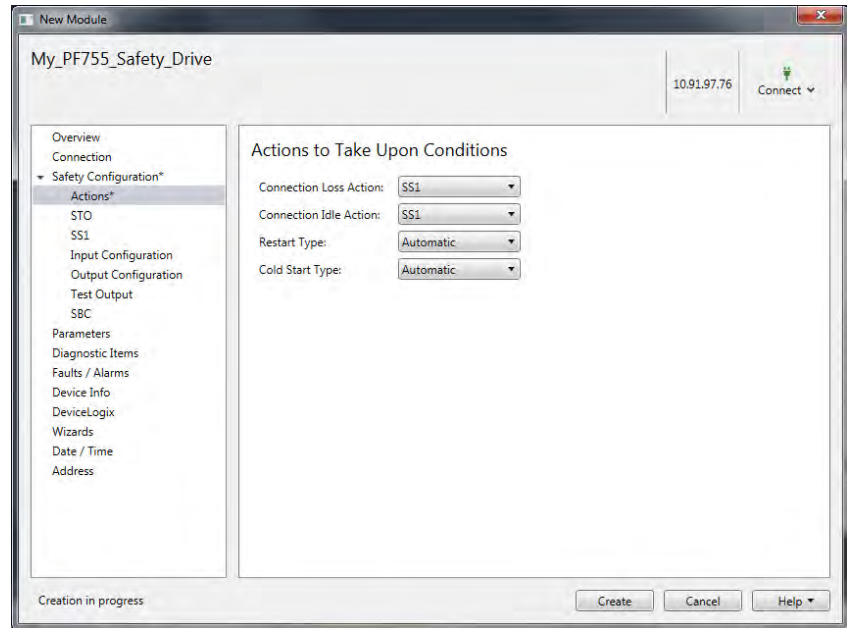

Use the settings on the Actions page to:

- Define the action to take when the safety connection is lost.
- Define the action to take when the safety connection goes idle.
- Define the restart and cold start behavior.

Restart is the restart behavior while operating. A cold start is the restart behavior when applying controller power or controller mode changes to 'Run'.

- Click **STO** under Safety Configuration in the navigation tree to open the STO page. The **Delay** value is the time delay between the STO Active condition and Safe Torque Disabled. This allows the drive to bring the motor to a controlled stop before disabling torque.

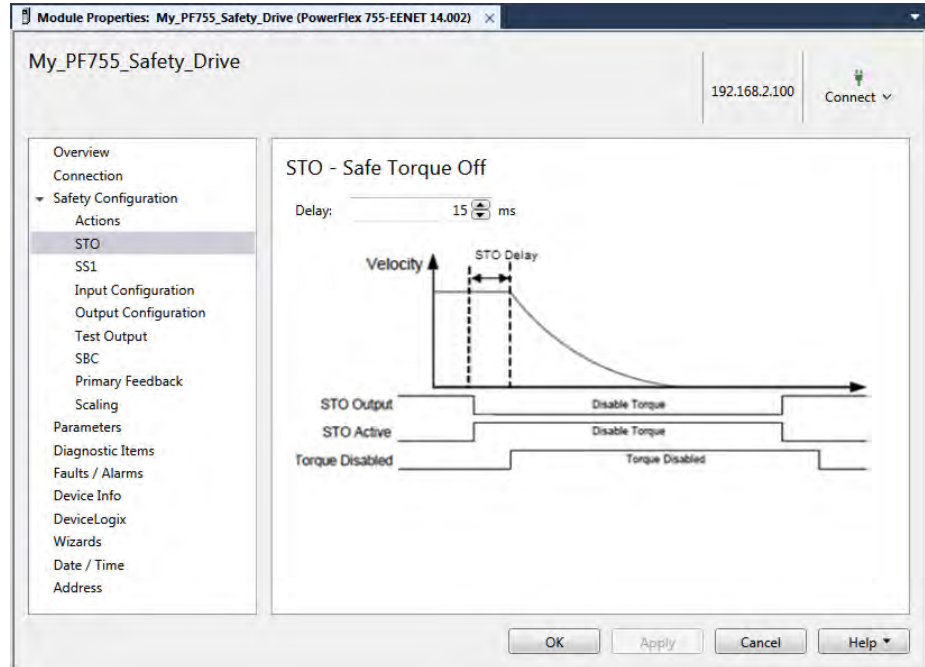

- Click **SS1** under **Safety Configuration** in the navigation tree to open the SS1 page. Use the settings to configure the drive-based Safe Stop 1 (SS1) function, which decelerates the motor and then initiates a Safe Torque Off (STO) in the drive.

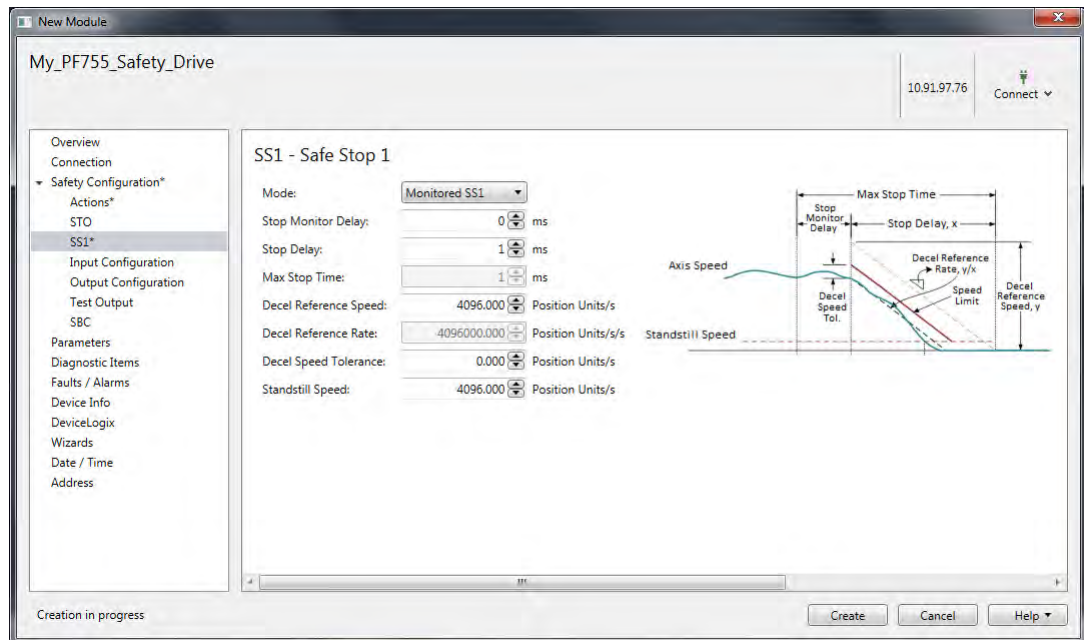

Property	Description
Mode	Specifies the mode of the SS1 function. The Mode selection determines which parameters on the tab are available to configure. The available options are: <ul style="list-style-type: none"> Not Used Timed SS1 Monitored SS1 <p>TIP Monitored SS1 is unavailable when Safety Instance 1 on the Identity page is set to 'Safe Stop, No Feedback'.</p>
Stop Monitor Delay	The delay time before deceleration is monitored. Valid values are 0...65535. This option is not available when 'Mode' is 'Timed SS1'.
Stop Delay	The stop delay time used when the SS1 function is initiated by a stop type condition.
Max Stop Time	Displays the SS1 maximum stop time. This value is the sum of 'Stop Delay' and 'Stop Monitor Delay'.
Decel Reference Speed	Specifies the deceleration speed to monitor for SS1. This parameter is unavailable when 'Mode' is 'Timed SS1'.
Decel Reference Rate	The minimum rate of deceleration while stopping. <p>TIP Changing the Stop Delay value recalculates the Decel Reference Rate.</p> This parameter is unavailable when 'Mode' is 'Timed SS1'.
Decel Speed Tolerance	The speed tolerance that is applied to the deceleration ramp check.
Standstill Speed	The speed limit that is used to declare motion as stopped.

16. Click **Input Configuration** under **Safety Configuration** in the navigation tree to open the Input Configuration page. If the general-purpose safety inputs on the 20-750-S4 option module will be used, configure the input points to match the application.

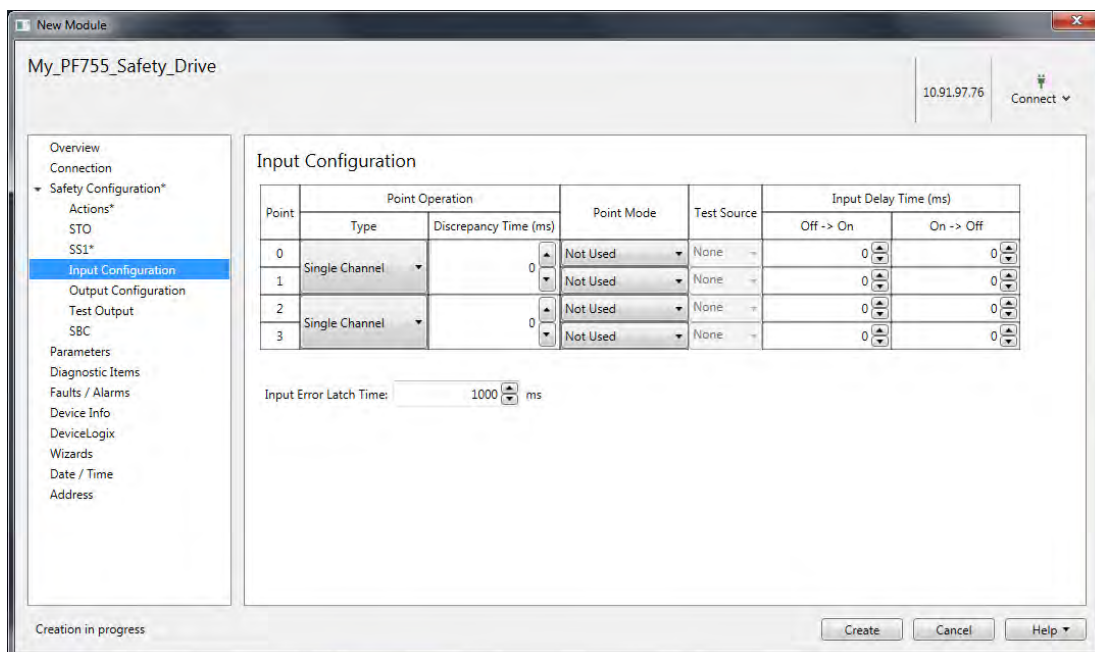

Property	Description
Point	The physical input points available for configuration (terminals Si0, Si1, Si2, and Si3).
Point Operation - Type	Specifies the type of operation for the input. Available options are: <ul style="list-style-type: none"> • Single Channel • Dual Channel Equivalent • Dual Channel Complementary
Point Operation - Discrepancy Time	The time in milliseconds that a discrepancy must exist before a discrepancy alarm is raised. Valid values are 0...65535. This property is unavailable when 'Point Operation - Type' is set to 'Single Channel'.
Point Mode	Specifies the mode of the input. Available options are: <ul style="list-style-type: none"> • Not Used • Safety Pulse Test- The associated test output point shown in the 'Test Source' field will be used to pulse test the external wiring of the safety input. • Safety Semiconductor Input - The time in milliseconds that a discrepancy must exist between two corresponding safety inputs before an alarm is generated. • Safety Standard Input - The safety input will be treated as a standard input. No diagnostics are run. When using a safety input as a standard input, the 'Point Operation Type' must be set to 'Single Channel'.
Test Source	Specifies the Test Output associated with the input. This property is only available when 'Point Mode' is set to 'Used with Test Output'.
Input Delay Time (ms) Off → On	Specifies the filter time in milliseconds for off to on transition of the input. Valid values are 0...65535.
Input Delay Time (ms) On → Off	Specifies the filter time in milliseconds for on to off transition of the input. Valid values are 0...65535.
Input Error Latch Time	Specifies the amount of time in milliseconds an Input error will be latched. If the error is no longer present after this time, the error condition can be reset.

- Click **Output Configuration** under **Safety Configuration** in the navigation tree to open the Actions page. If the safety outputs on the 20-750-S4 option module will be used, configure the output points to match the application. Safety outputs cannot be used if Safe Brake control is enabled.

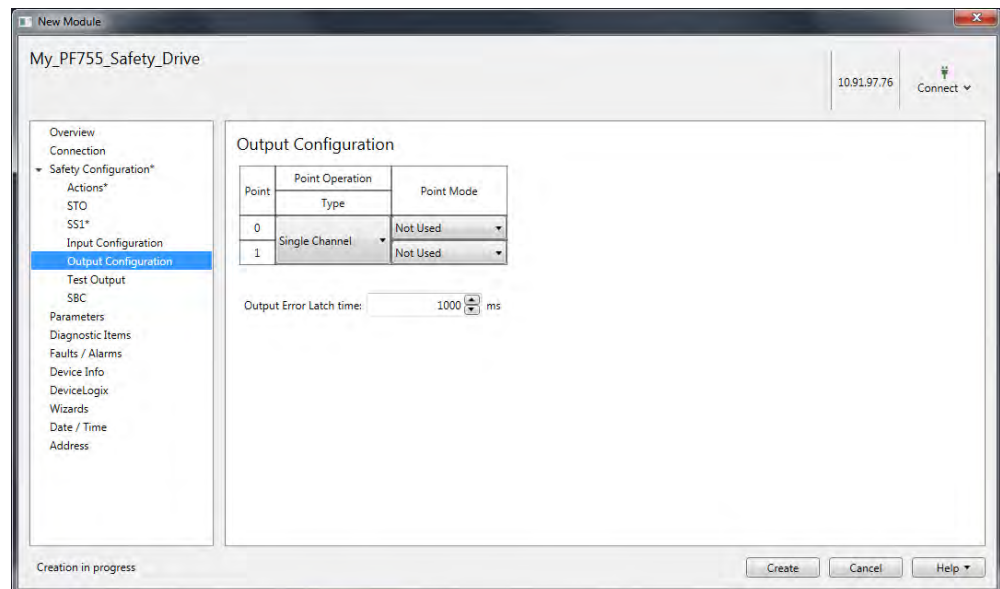

Property	Description
Point	The physical output points available for configuration (terminals So0 and So1).
Point Operation - Type	Specifies the type of operation for the output. Available options are: <ul style="list-style-type: none"> • Single Channel • Dual Channel
Point Mode	Specifies the mode of the output. Available options are: <ul style="list-style-type: none"> • Not Used • Safety • Safety Pulse Test
Output Error Latch Time	Specifies the amount of time in milliseconds an Output error will be latched. If the error is no longer present after this time, the error condition can be reset.

18. Click **Test Output** under **Safety Configuration** in the navigation tree to open the Actions page. If the test outputs on the 20-750-S4 option module will be used, configure the test output points to match the application.

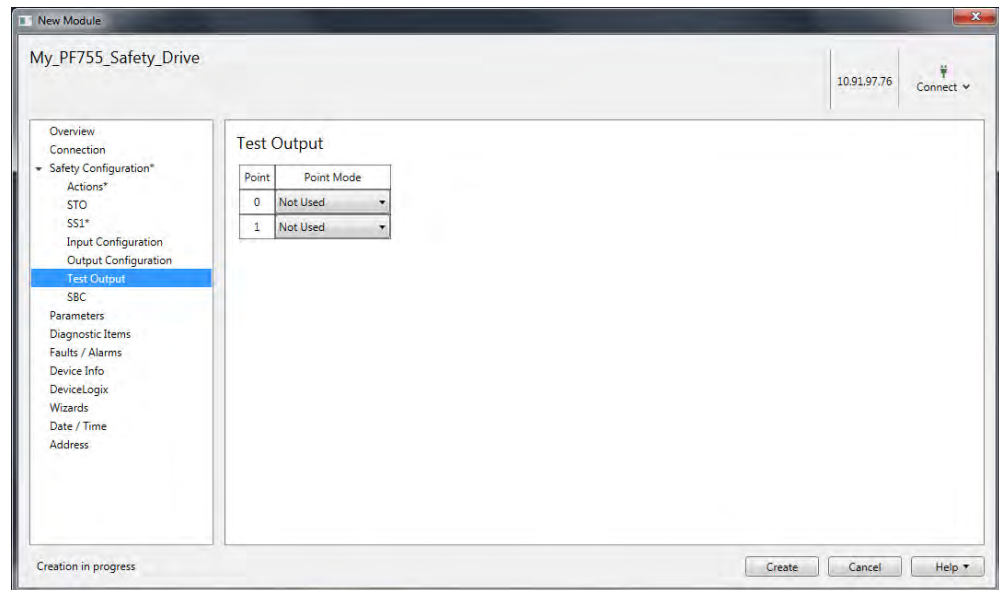

Property	Description
Point	The physical test output point being configured (Terminals To1 and To0).
Point Mode	Specifies the mode of the test output. Available options are: <ul style="list-style-type: none"> • Not Used - test point is not used • Standard Output - used as a standard safety output • Pulse Test Output - used to test a safety input for short circuit detection • Power Supply Output - used as a 24V DC power supply for an external input circuit

19. Click **SBC** under **Safety Configuration** in the navigation tree to open the Actions page. If the drive-based Safe Brake Control on the 20-750-S4 option module will be used, configure SBC to match the application.

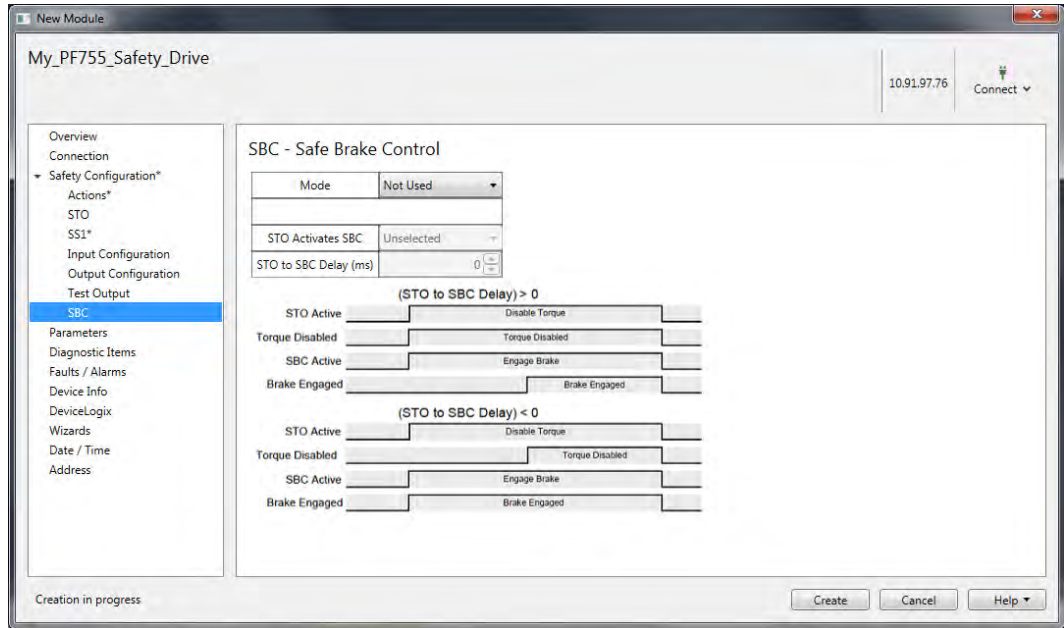

Property	Description
Mode	Specifies the mode of the SBC function. Available options are: <ul style="list-style-type: none"> • Not Used • Safety • Safety Pulse Test
STO Activates SBC	Identifies if Safe Torque Off (STO) activation triggers the SBC function. Available options are: <ul style="list-style-type: none"> • Unselected • Selected - the brake is engaged during an STO event, based on the 'STO to SBC Delay' attribute. Only valid when 'Mode' is set to 'Safety' or 'Safety Pulse Test'.
STO to SBC Delay (ms)	Specifies the time in milliseconds from when the Safe Torque Off function is active to when the brake is engaged. For positive values, the brake will engage after the delay has expired. For negative values, the brake will engage immediately and torque will be disabled after the delay has expired.

TIP Primary Feedback, Scaling, Secondary Feedback, and Discrepancy Checking will only be displayed if a feedback device is selected for the Safety Feedback Module on the Device Definition Identity page (shown on [page 107](#)). Skip to if these are not used.

20. Enter the information for the device that is being used for the primary feedback. Red boxes indicate items that need to be updated if the feature is used in your application. The properties available on this page are determined by the safety feedback device selected when the drive module was created.

The Maximum Speed and Maximum Acceleration diagnostics are based on the capability of the chosen encoder and its rated limits. They do not provide a safety-rated safety function.

My_PF755_Safety_Drive

10.91.97.76 Connect

Overview
Connection
Safety Configuration
 Actions
 STO
 SS1
 Input Configuration
 Output Configuration
 Test Output
 SBC
 Primary Feedback
 Scaling
 Secondary Feedback
 Discrepancy Checking
Parameters
Diagnostic Items
Faults / Alarms
Device Info
DeviceLogix
Wizards

Primary Feedback

Device: 20-750-UF8-1 Velocity Average Time: 0 ms

Type: Not Specified Voltage Monitor: Not Monitored

Units: Rev Maximum Speed: 0.000 Rev/s

Resolution Units: Cycles/Unit Standstill Speed: 1.000 Rev/s

Cycle Resolution: 1024 Cycles/Rev Maximum Acceleration: 0.000 Rev/s/s

Cycle Interpolation: 4 Counts/Cycle

Effective Resolution: 4096 Counts/Rev

Polarity: Normal

OK Apply Cancel Help

21. Enter scaling information to configure the feedback position and time in terms of counts per position unit in the safe monitoring functions.

My_PF755_Safety_Drive

10.91.97.76 Connect

Overview
Connection
Safety Configuration
 Actions
 STO
 SS1
 Input Configuration
 Output Configuration
 Test Output
 SBC
 Primary Feedback
 Scaling
 Secondary Feedback
 Discrepancy Checking
Parameters
Diagnostic Items
Faults / Alarms
Device Info
DeviceLogix
Wizards

Scaling

Feedback Resolution: 4096 Counts/Rev

Position Units: Position Units

Time Units: Seconds

Position Scaling: 1.000 Counts/1.0 Position Units

OK Apply Cancel Help

22. Enter the information for the device being used for the secondary feedback. Red boxes indicate items that need to be updated if the feature is used in your application. The properties available on this page are determined by the safety feedback device selected when the drive module was created.

The Maximum Speed and Maximum Acceleration diagnostics are based on the capability of the chosen encoder and its rated limits. They do not provide a safety-rated safety function.

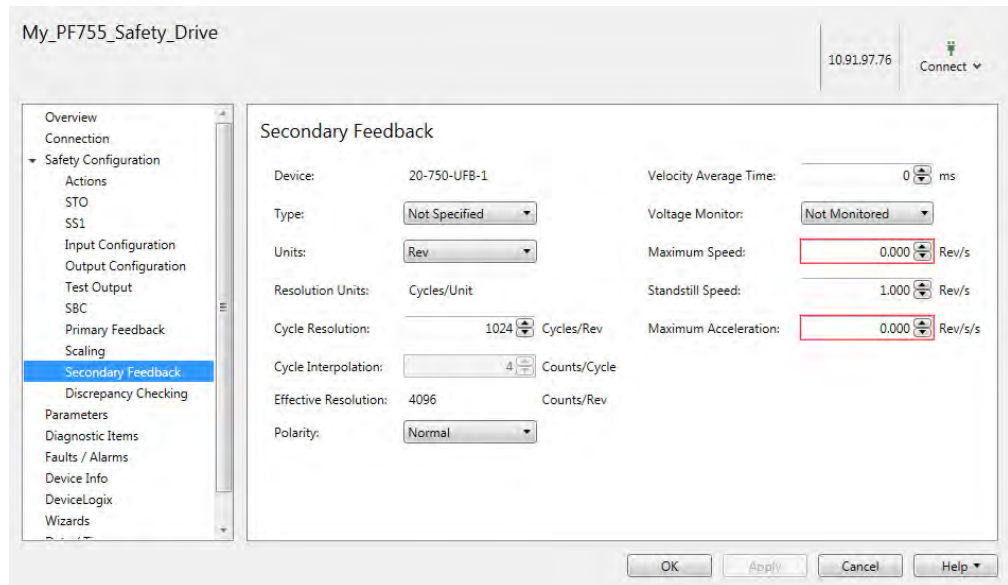

23. Enter discrepancy checking information to determine the checking mode and the allowed discrepancy between feedback channels. Discrepancy checking is only used with dual-feedback monitoring and is required for SIL 3 PL e.

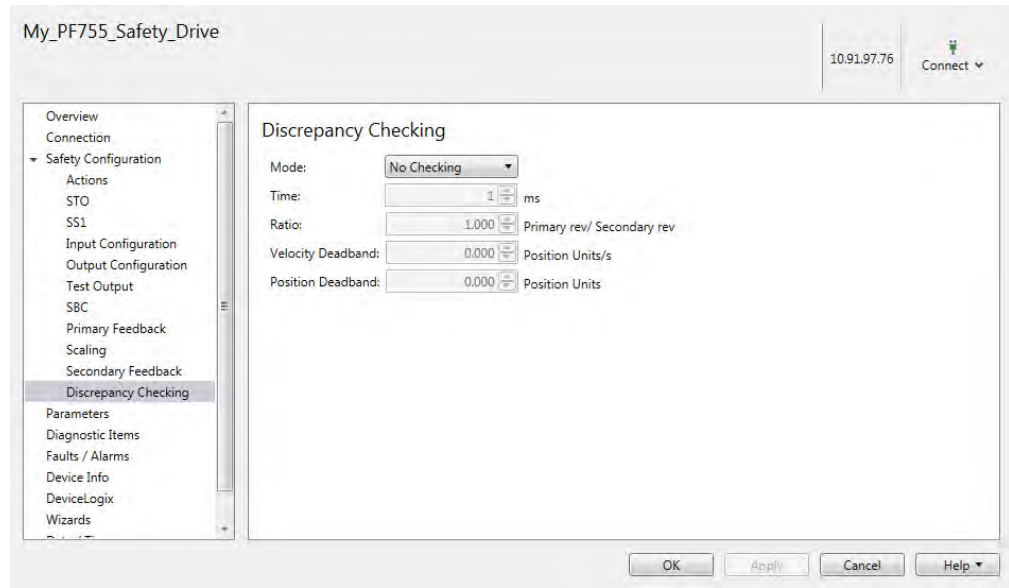

24. Configure the rest of the drive as needed for the application:

- Parameters – Parameters for all ports in the drive.
- DeviceLogix™ – DeviceLogix program editor.
- Wizards – Simplified startup and application configuration.

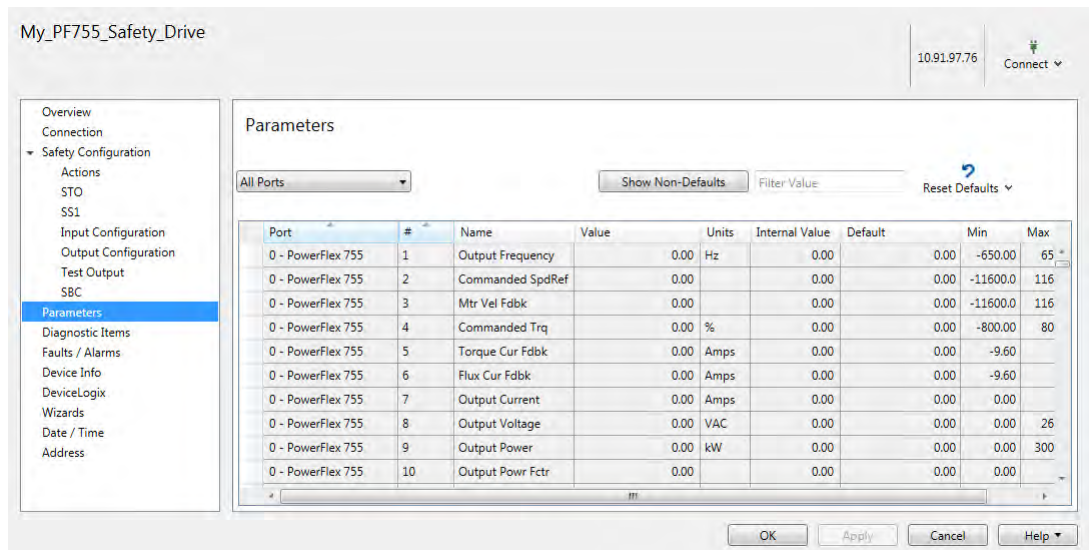

25. Click **OK**. The drive will be displayed in the 'I/O Configuration' folder in the Logix Designer application.

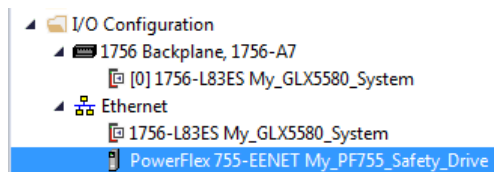

Using a 20-750-ENETR Dual-port EtherNet/IP Option Module with a 20-750-S4 Option Module

When using a PowerFlex 755 drive with 20-750-ENETR and 20-750-S4 option modules, the drive must be added to the Controller Organizer as a PowerFlex 755-EENET module instead of a PowerFlex 755-ENETR module. (See page 105 for more information.)

1. Make sure that the jumper on the 20-750-ENETR option module is in the Tap position.
2. Select **Synchronize** from the **Connect** menu. (The Connection to the PowerFlex 755/755T drive product must be 'Standard' or 'Standard and Safety' in order for Synchronize option to be selectable.)

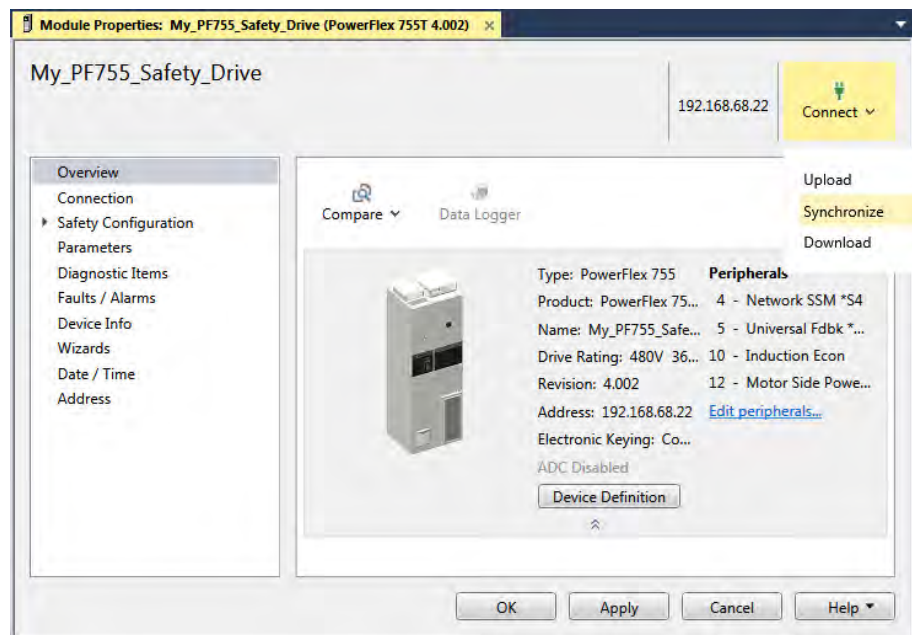

3. If necessary, select your drive in the Synchronize - Identifying Device dialog box, and then click Continue.

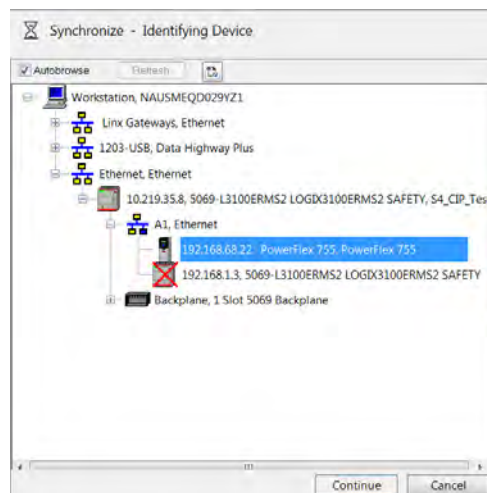

- After selecting **Synchronize**, select the check box for **Use Physical**. This will match the project's configuration to the physical configuration of the drive.

TIP If you have already configured parameters offline, you can select the Use Project check box associated with the Parameters Category so that your parameters will not be overwritten during the synchronization. Selecting Use Project sets the parameters in the drive to match the parameter configuration of the offline project.

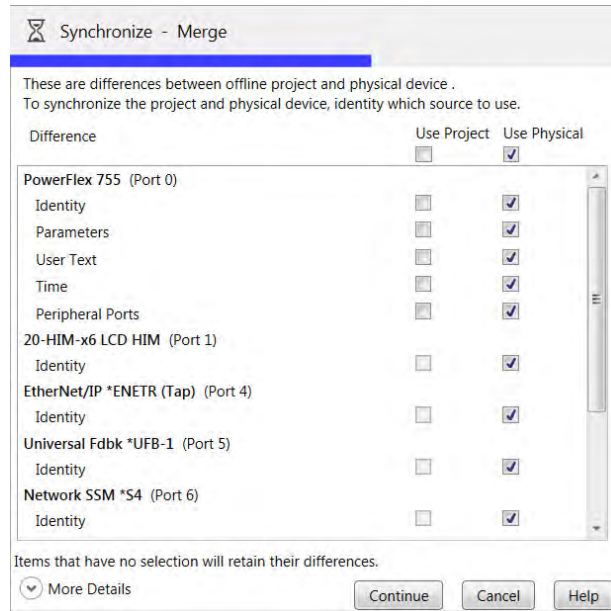

- Select **Continue**.
- After the synchronization is completed, verify that the 20-750-ENETR option module appears as EtherNet/IP *ENETR (TAP), indicating that the option module is in tap mode.

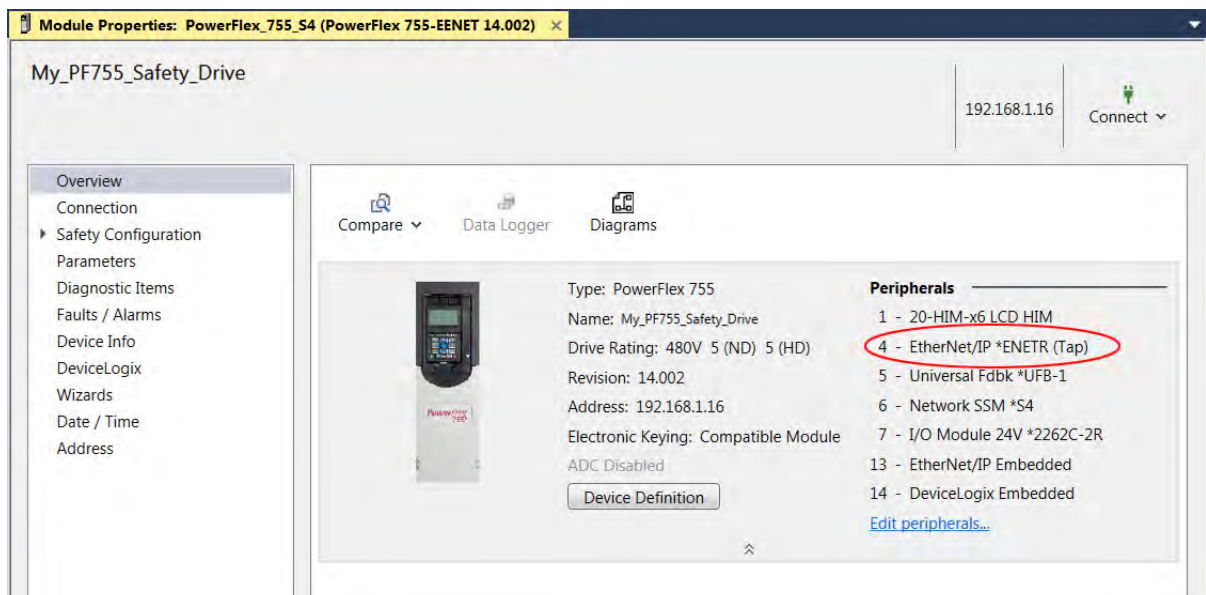

Safety Configuration Signature and Ownership

The connection between the controller and the drive is based on the following criteria:

- Drive catalog number must be for PowerFlex 755 drives
- Drive Safety Network Number (SNN) (displayed in drive module General tab)
- GuardLogix slot number
- GuardLogix safety network number
- Path from the GuardLogix 5580 safety controller or Compact GuardLogix 5380 safety controller to the PowerFlex 755 drive
- Configuration signature (displayed on the Safety tab of the drive Module Properties dialog box)

If any differences are detected, the safety connection between the safety controller and the drive is not established (for a new drive/system) or lost (for an existing drive/system). A yellow icon appears next to the drive in the controller project tree to indicate a lost or unestablished connection. Configuration Ownership has to be reset to establish a new connection or to reestablish an existing connection.

Reset Ownership

To reset ownership, see [Restore the Drive to Out-of-Box State on page 214](#).

Programming

Safety Tags in Standard Routines

Tags that are classified as safety tags are either controller-scoped or program-scoped.

- Controller-scoped safety tags are read by either standard or safety logic or other communication devices.
- Controller-scoped safety tags are written only by safety logic or another GuardLogix safety controller.

Program-scoped safety tags are accessible only by local safety routines. These routines reside within the safety program.

Standard Tags in Safety Routines (tag mapping)

Controller-scoped standard tags can be mapped into safety tags, providing a mechanism to synchronize standard and safety actions. In the Logix Designer application, click **Logic > Map Safety Tags...** to open the Safety Tag Mapping window.

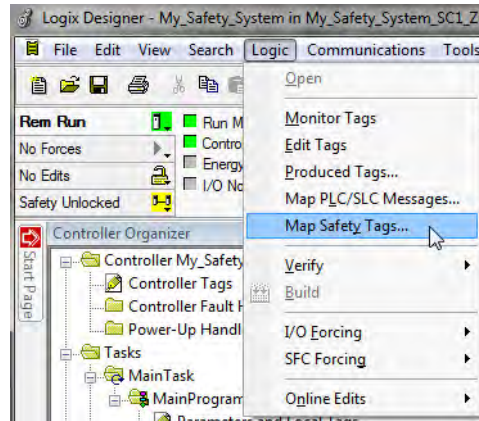

ATTENTION: When using standard data in a safety routine, you are responsible to verify that the data is used in an appropriate manner. The use of standard data in a safety tag does not make it safety data.
Do not directly control a safety output with standard tag data.

Standard and Safety Tasks

Control systems built using Rockwell Automation® Integrated Architecture® components have separate control and safety functions. In a typical control application with standard and safety connections, control and safety tasks run in the following Logix 5000™ controllers:

- Control functions operate in the main task / main program of a standard ControlLogix® controller.
- The safety task, operating in a GuardLogix controller, communicates with the drive module with a safety connection over the EtherNet/IP network.
- The main task, operating in either of these controllers, communicates with the drive with a standard connection over the EtherNet/IP network.
- The standard and safety controllers communicate safety-related information via pass-through data (datalinked parameters) in the Integrated Safety Function option module.

The PowerFlex 755/755T drive products, with the Integrated Safety Function option module, provides integrated safety functions. Safety functionality operates independently of the inverters and feedback that is used for motion. The Integrated Safety Function option module receives encoder safety feedback from the feedback option module for use with the integrated safety functions. The safety feedback is supplied to the controller safety task over the safety connection for use with controller-based safety functions that may operate in the controller.

A standard (control) and safety system can be configured so that a safety function operates in the controller. This type of configuration is referred to as a

‘controller-based’ safety function. The system can also be configured so that some safety functions operate in the drive module with the initiation and monitoring of the function in the safety task. This type of safety function is referred to as ‘drive-based’ safety. A control system can have both controller-based and drive-based safety functions.

Safety Function Operation

The following example describes how a standard and safety control system operates and how main and safety tasks are coordinated. In typical standard and safety system applications, an E-stop switch is used to stop the system. In the example, the switch is used to initiate the process that brings the drive to a controlled stop before removing power. This type of stop is called Stop Category 1.

The main task and drive inverter are responsible for bringing the motor to a Category 1 stop. At the same time, to make sure that the Stop Category 1 is correctly executed by the control system, the safety task initiates a Monitored SS1 safety function. The SS1 safety function can be configured to use the drive-based SS1 function or it can be configured to use the controller-based SS1 function.

This sequence of events represents the steps required for a Monitored SS1 drive-based safety function.

1. The safety task reads the E-stop input and detects the switch actuation.
2. The safety task communicates an SS1 request by setting the bit: module:SO.SS1Request tag of the drive. This bit is also present in P4 [Safety Status], which is data linked with the standard controller via the standard connection.
3. The request is available to the standard controller main task via the module:IP4_SafetyStatus_SS1Active tag.

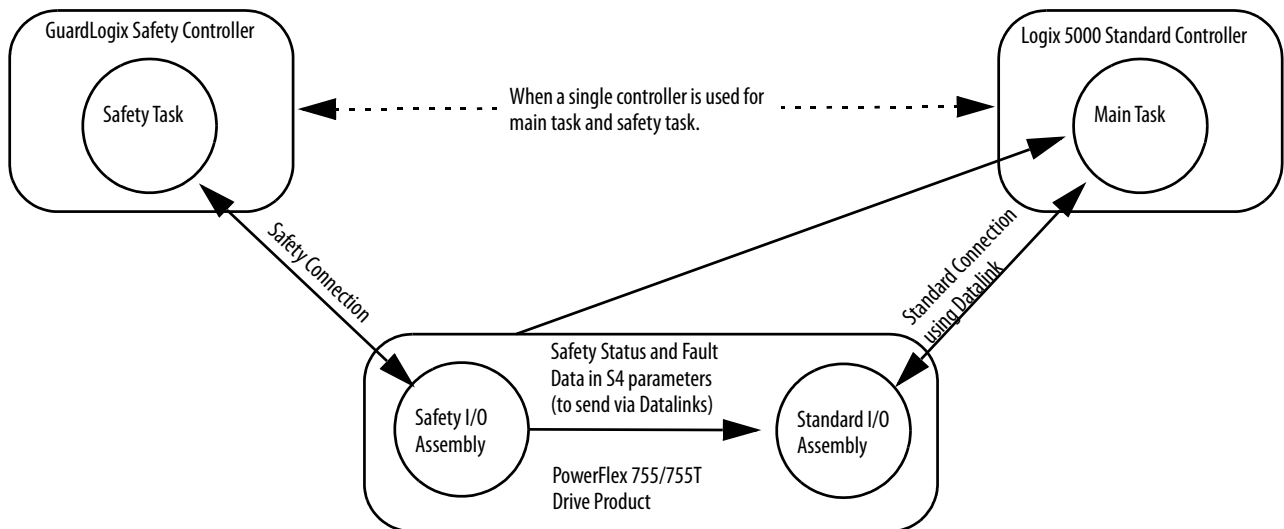

4. The main task controls the drive to bring the motor to a stop within the Monitored SS1 limits for speed and time.
5. While the drive is stopping, the SS1 function (in the motion-safety instance) monitors the motor speed to make sure it remains below the speed limit and maximum stopping time.
6. When the drive reaches standstill speed, the 20-750-S4 activates the Safe Torque Off function.

This sequence of events represents the steps that are required for a Monitored SS1 controller-based safety function.

1. The safety task reads the E-stop input and detects the switch actuation.
2. The safety task activates the SS1 safety instruction running in the safety task.
3. The SS1 instruction communicates an SS1 active by setting the bit: module:SO.SS1Active tag of the drive (inverter) motion-safety instance.
4. The motion-safety instance in the drive communicates to the drive motion core of the Axis Safety Status.
5. The motion core communicates with the motion controller running the motion task by updating the motion axis tag axis.SS1ActiveStatus.
6. The motion task controls the axis to bring the motor to a stop within the Monitored SS1 limits for speed and time.
7. While all events are occurring, the motion-safety instance updates the Feedback Velocity tag, module:S1.FeedbackVelocity, in the safety controller. The SS1 function running in the safety task receives the speed scaled by the SFX safety instruction and makes sure that the axis remains below the speed limit and maximum stopping time.
8. When the axis reaches standstill speed the SS1 safety instruction outputs SS1 complete.

The safety task communicates to the drive motion safety instance to activate STO by clearing the bit: module:SO.STOOutput tag of the drive.

Pass-through Data

Some of the safety data (parameters) in the 20-750-S4 module must be communicated with the standard controller. The safety controller only requests safety functions and monitors. If, for example, a controller-based safety function is to be performed (such as SLS), this request and the status / fault data that is associated with it must be passed on to the standard controller. This data comes from 20-750-S4 parameters that are data linked to the standard controller where the associated tags are used by the main program. This data is referred to as pass-through data.

Understand Integrated Safety Drive Replacement

Falling Edge Reset

ISO 13849-1 stipulates that instruction reset functions must occur on falling edge signals. To comply with this requirement, a One Shot Falling (OSF) instruction is used on the reset rung. Then, the OSF instruction Output Bit tag is used as the reset bit for the STO output or enable rungs.

GuardLogix controllers retain I/O device configuration onboard and are able to download the configuration to the replacement device.

IMPORTANT If the replacement card/module was used before, clear the existing configuration before installing the card/module on a safety network by resetting the card/module to the out-of-box state. See [Out-of-Box State on page 214](#) for more information.

Replacing an entire PowerFlex 755 drive or PowerFlex 755T drive product on an integrated safety network is more involved than replacing standard devices because of the safety network number (SNN). The device number and SNN is the safety Device ID of the device. Safety devices require this complex identifier to make sure that duplicate device numbers do not compromise communication between the safety devices. The SNN is also used to provide integrity on the initial download to the PowerFlex 755 drive or PowerFlex 755T drive product.

When the Logix Designer application is online, the Safety tab of the Module Properties dialog box displays the current configuration ownership. When the opened project owns the configuration, Local is displayed.

Configuration Ownership: Local

A communication error is displayed if the module read fails. See [Replace an Integrated Safety Drive in a GuardLogix System on page 130](#) for integrated safety drive replacement examples.

Replace an Integrated Safety Drive in a GuardLogix System

When you replace an integrated safety drive, the replacement device must be configured properly and the replacement drives operation be user-verified.



ATTENTION: During drive replacement or functional test, the safety of the system must not rely on any portion of the affected drive.

Two options for safety drive replacement are available on the Safety tab of the Controller Properties dialog box in the Logix Designer application:

- Configure Only When No Safety Signature Exists
- Configure Always

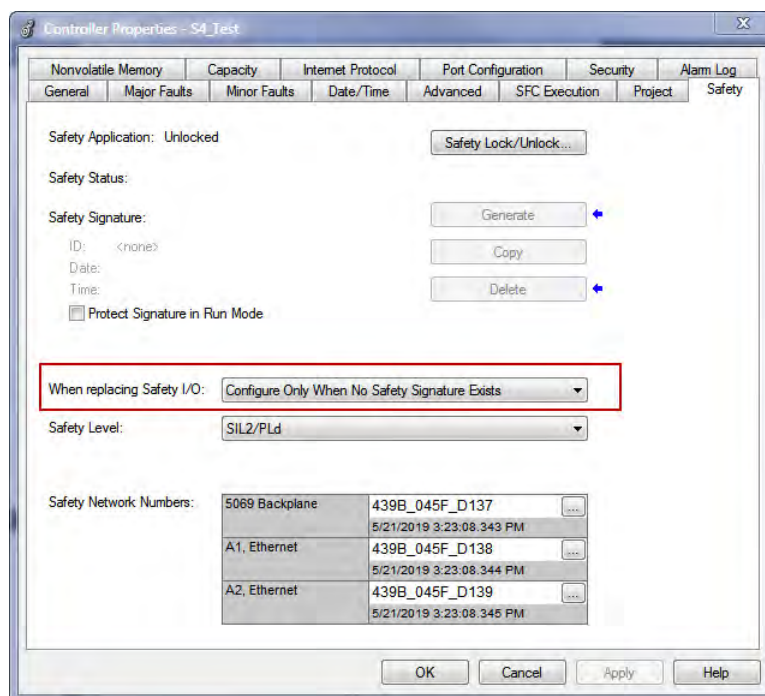
Figure 45 - Safety Drive Replacement Options

Configure Only When No Safety Signature Exists

This setting instructs the GuardLogix controller to automatically configure a safety drive only when the safety task does not have a safety task signature, and the replacement drive is in an out-of-box condition, meaning that a safety network number does not exist in the safety drive.

If the safety task has a safety task signature, the GuardLogix controller automatically configures the replacement CIP Safety I/O device only if the following is true:

- The device already has the correct safety network number.
- The device electronic keying is correct.
- The node or IP address is correct.

For detailed information, see the GuardLogix 5580 Controllers User Manual, publication [1756-UM543](#) or Compact GuardLogix 5380 Controllers User Manual, publication [5069-UM001](#).

Configure Always

When the Configure Always feature is enabled, the controller automatically checks for and connects to a replacement drive that meets all of the following requirements:

- The controller has configuration data for a compatible drive at that network address
- The drive has an SNN that matches the configuration



ATTENTION: Enable the Configure Always feature only if the entire integrated safety control system is not being relied on to maintain SIL 3 behavior during the replacement and functional testing of a PowerFlex 755/755T drive product.

If other parts of the integrated safety control system are being relied upon to maintain SIL 3, make sure that the controller's Configure Always feature is disabled.

It is your responsibility to implement a process to make sure proper safety functionality is maintained during device replacement.



ATTENTION: Do not place any devices in the out-of-box condition on any integrated safety network when the Configure Always feature is enabled, except while following the device replacement procedure in the GuardLogix user manual appropriate for your Logix 5000 controller:

- GuardLogix 5580 Controllers User Manual, publication [1756-UM543](#)
 - Compact GuardLogix 5580 Controllers User Manual, publication [5069-UM001](#).
-

PowerFlex 755 IO Mode Using SFX, SS1, and SLS Instructions

In this example, a PowerFlex 755 drive (equipped with embedded Ethernet) controls an induction motor with a 1024 PPR incremental encoder. A Dual Incremental Encoder option module (catalog number 20-750-DENC-1) and an Integrated Safety Function option module (catalog number 20-750-S4) are used to interface to a GuardLogix 5580 safety controller (catalog number 1756-L84ES).

This example shows the programming and configuration required for three of the most common safe monitoring functions:

- Safe Feedback (SFX safety instruction)
- Safe Stop 1 (SS1 safety instruction)
- Safe Limited Speed (SLS safety instruction)

An 800FP push button is configured as an emergency stop. It is monitored using a DCS ESTOP Instruction and is wired to one dual-channel S4 Safety Input. This input can generate Safe Stop 1 at any time during operation of the drive.

A Guard Locking Switch (catalog number TLS-Z GD2) is mapped to one of the S4 Safety Outputs. This switch can be opened when the Safe Stop 1 is complete and when the Safe Limited Speed is below the required speed for an operator to access the machine function.

The Safety Reset and Home Request functions are programmed with the other two S4 Safety inputs. These do not need to be safety-rated devices. For the purpose of this example, other inputs and outputs are toggled for simplicity. At any time, you can implement additional safety or IO devices as required based on the machine risk assessment.

Both the standard programming and safety programming must be completed for a successful implementation.

Studio 5000 Logix Designer Application Configuration

Figure 46 - Studio 5000® Logix Designer Application Configuration Example

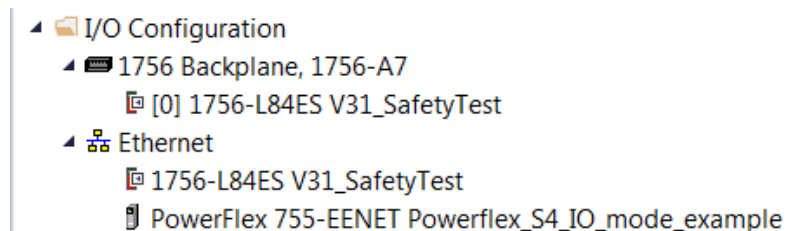
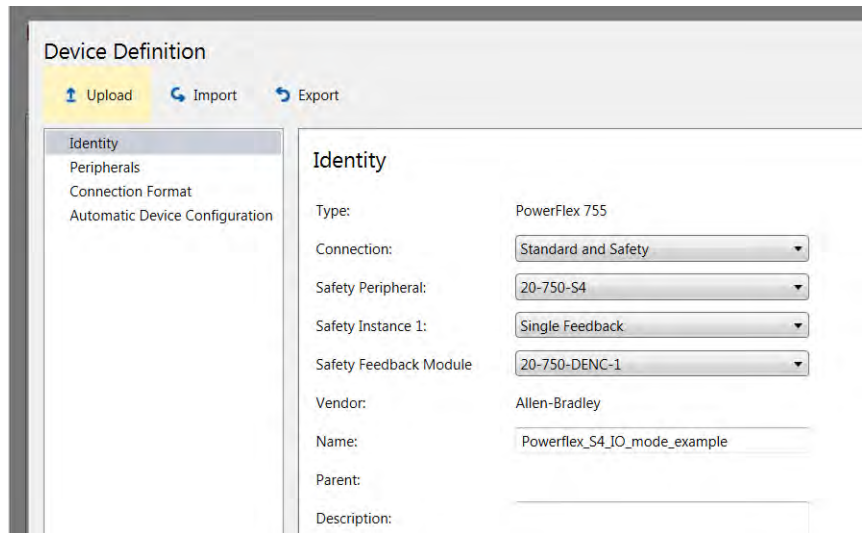

Figure 47 - Studio 5000 Connection Set to Standard and Safety



Studio 5000 Connection is set to 'Standard and Safety' since the GuardLogix controller will provide both in this example.

Figure 48 - Studio 5000 Powerflex 755 EENET Configuration

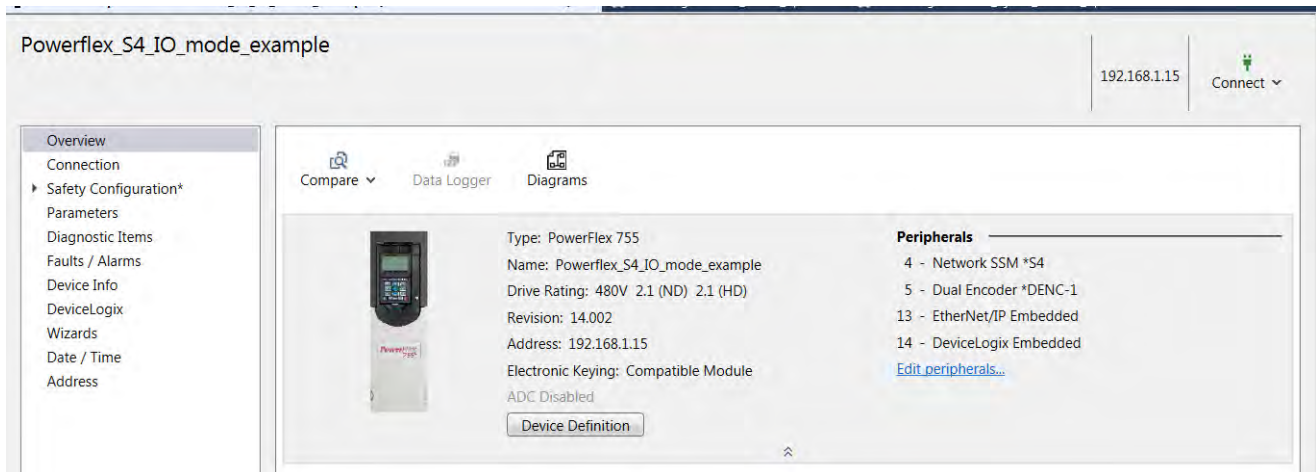

Figure 49 - Studio 5000 Safety Primary Feedback Configuration

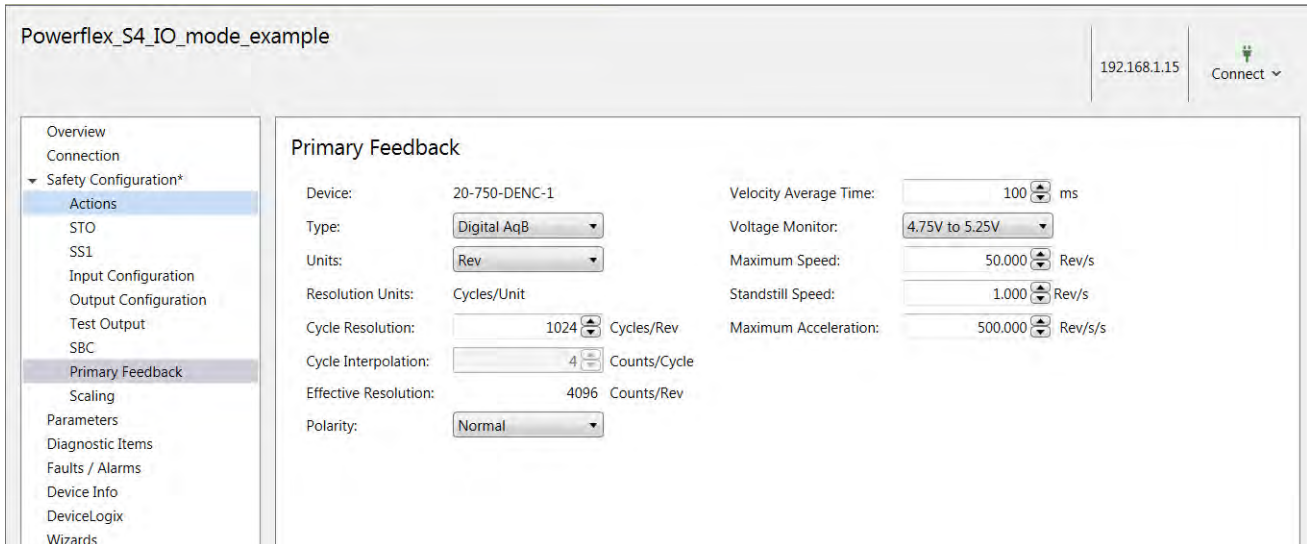

Figure 50 - Studio 5000 Safety Scaling Configuration

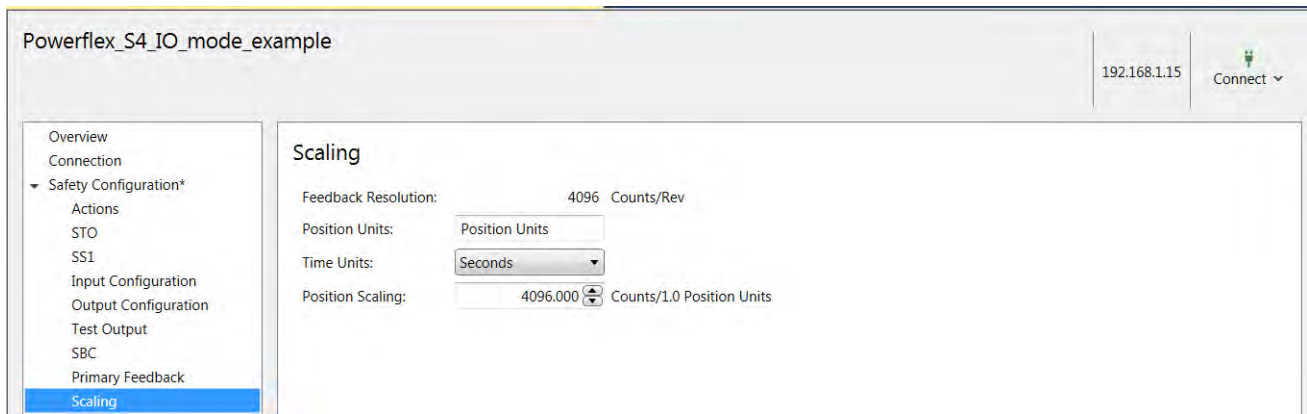
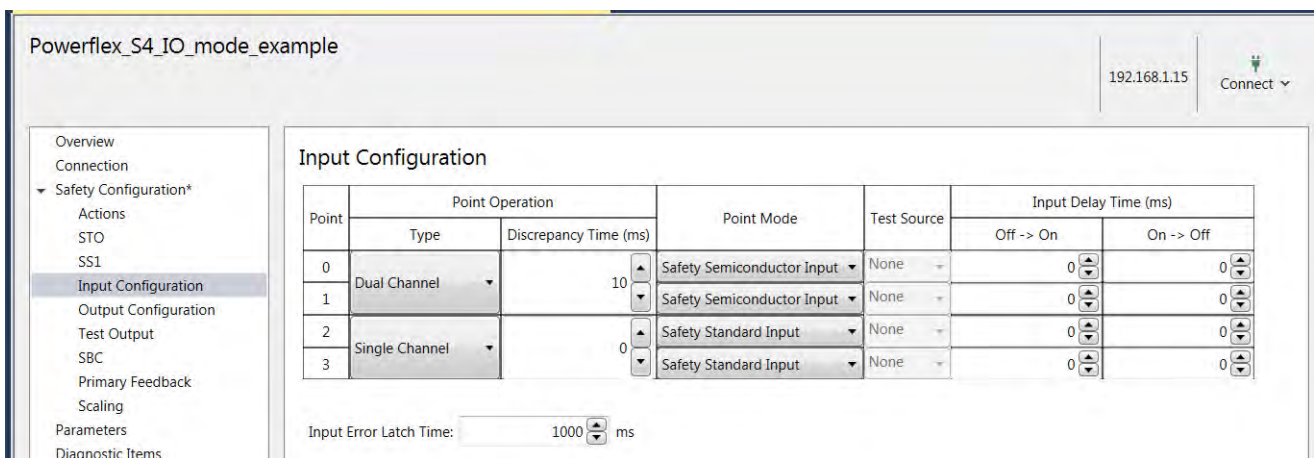

Figure 51 - Studio 5000 Input Configuration



- Inputs 0 and 1 are used with an OSSD Estop input from the 800FP.

- Input 2 is a standard digital input from a push button to safety reset the S4 module.
- Input 3 is a standard digital input from a push button to set the SFX home.

Figure 52 - Studio 5000 Output Configuration

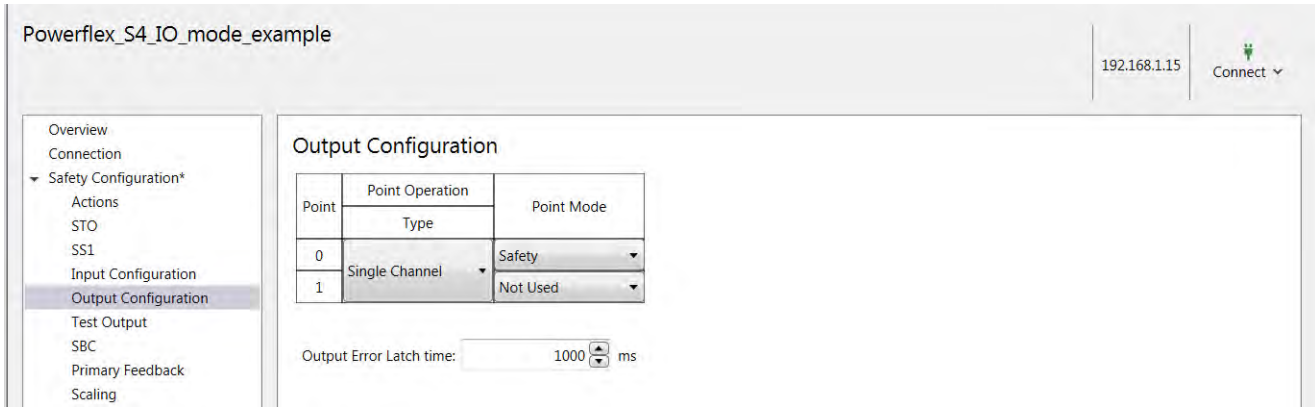

- Output 1 is used with the guard locking switch TLS-Z GD2 to open the gate door.

Programming Example

This example illustrates configuration of the safety input, logic, and output routines.

TIP Configure your system based on the required safety level devices and ratings.

Safety Input

The DCS Instruction is responsible for evaluating the dual-input validity into the GuardLogix safety controller.

Figure 53 - DCS Instruction with the S4 is Mapped to the 800FP

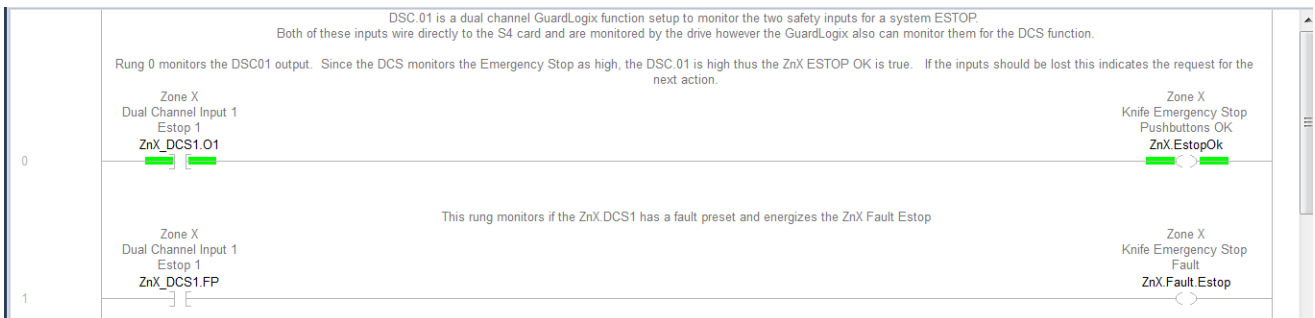



Safety Logic

The Safety Logic is used to configure when a safety reset occurs, the home trigger, and the execution of the SFX instruction (which must have primary feedback valid for it to execute properly).

Both the Safe Stop 1 and Safe Limited Speed use the SFX instruction for correct monitoring of feedbacks. The Safe Stop 1 requests when the 800FP inputs are removed. The Safe Limited Speed requests, in this example, with the toggling of the Examine On tag.

Figure 54 - Safety Logic Example

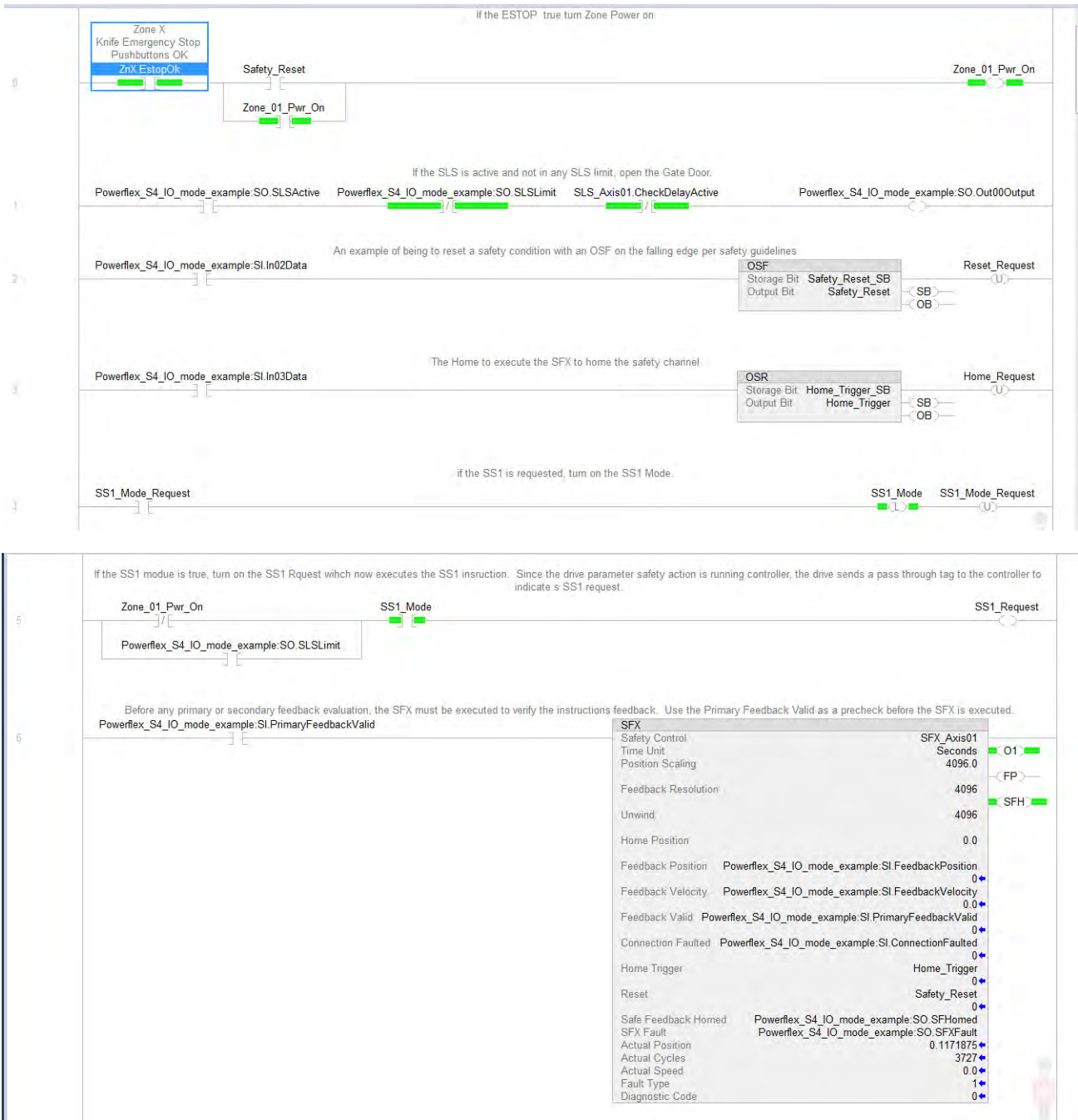

7

The SS1.01 is active once the SFX has been verified. However the SS1 mode only executes when the SS1_Request is given in the program.

SFX_Axis01.O1

SS1	
Safety Control	SS1_Axis01
Restart Type	AUTOMATIC
Cold Start Type	AUTOMATIC
Stop Monitor Delay	500
Stop Delay	5000
Standstill Speed	0.1
Decel Ref Speed	6.0
Decel Speed Tolerance	1.0
Feedback SFX	SFX_Axis01
Request	SS1_Request
Reset	Safety_Reset
SS1 Active	Powerflex_S4_IO_mode_example:SO.SS1Active
SS1 Fault	Powerflex_S4_IO_mode_example:SO.SS1Fault
Fault Type	1
Diagnostic Code	0

8

The Request for the SLS function verifies the SLS command is valid then gives the SLS Request.

Request_for_SLS SLS_Axis01.O1 SLS_Request

Even though the SFX function is true and the SLS function is monitoring, the SLS Request generates the request for the SLS Active. There is a 7 second difference waiting for the drive to put the motor to the SLS monitoring speed or SLS active limit of 5 rev/sec.

9

SFX_Axis01.O1

SLS	
Safety Control	SLS_Axis01
Restart Type	AUTOMATIC
Cold Start Type	AUTOMATIC
Check Delay	7000
Active Limit	SLS_Active_Limit
Feedback SFX	SFX_Axis01
Request	SLS_Request
Reset	Safety_Reset
SLS Active	Powerflex_S4_IO_mode_example:SO.SLSActive
SLS Limit	Powerflex_S4_IO_mode_example:SO.SLSLimit
SLS Fault	Powerflex_S4_IO_mode_example:SO.SLSFault
Fault Type	1
Diagnostic Code	0

(End)

Safety Output

The Safe Torque Off output must be true in order for any of the preceding safe monitoring functions (namely SFX, SS1, and SLS) to function.

Figure 55 - Safety Output Example

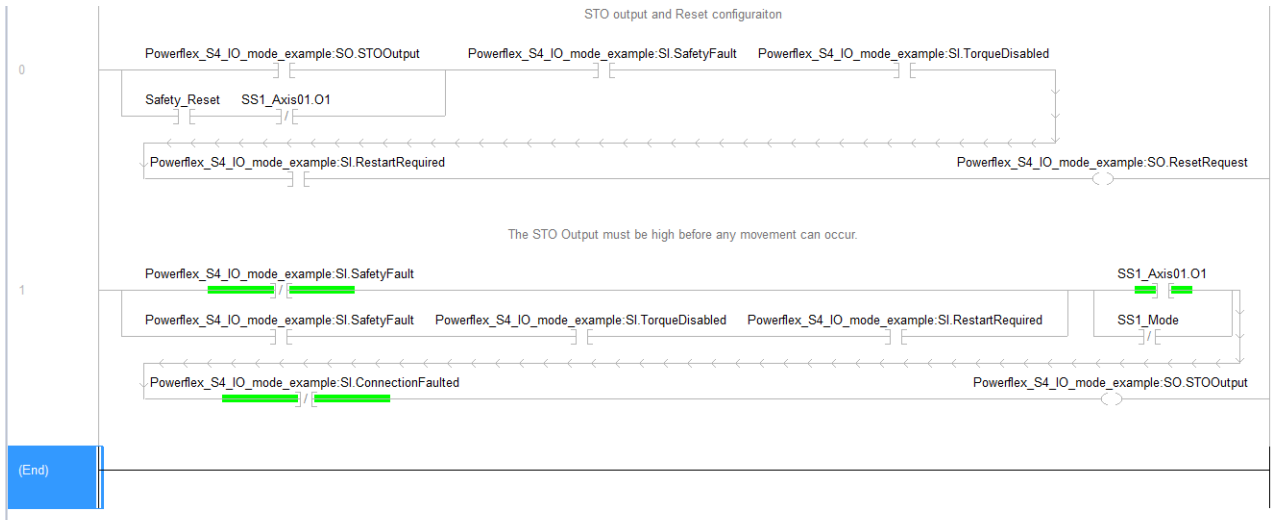

The PowerFlex 755 S4 safety actions can be configured based on the required reaction to various machine requirements. In this instance, the STO request is executed by the PowerFlex 755 in causing a disable and coast reaction. However, the request to the SS1 (requested by the GuardLogix Safety Task) is executed by the GuardLogix Standard Task with the use of pass-through tags. In this case, the Stop command is used to control stop the motor, as shown by the programming example.

Figure 56 - Safety Output Programming Example

Powerflex_S4_IO_mode_example 192.168.1.15 Connect

Overview
 Connection
 Safety Configuration*
 Parameters
 Diagnostic Items
 Faults / Alarms
 Device Info
 DeviceLogix
 Wizards
 Date / Time
 Address

Parameters

4 - Network SSM All Parameters Show Non-Defaults Filter Value Reset Defaults

Port	#	Name	Value	Units	Internal Value	Default	Min	Max
4	33	Enc2 Fault Type	No Fault		1	No Fault	1	101
4	34	Enc2 Unit	Revolution		0	Revolution	0	1
4	3	Safety State	Testing		1	Testing	1	52
4	4	Safety Status	00000000 000000...		0	00000000 000000...		
4	5	Safety Faults	00000000 000000...		0	00000000 000000...		
4	6	Safe Status Mfg	00000000 000000...		0	00000000 000000...		
4	7	Safe Faults Mfg	00000000 000000...		0	00000000 000000...		
4	8	Safety Data A	0		0	0	-21474...	214748...
4	9	Safety Data B	0		0	0	-21474...	214748...
4	11	STO Actn Src	Drive		0	Drive	0	1
4	12	STO Stp Actn	Coast		0	Coast	0	6
4	13	SS1/SS2 Actn Src	Controller		1	Drive	0	1
4	14	SS1 Stp Actn	Ramp		1	Ramp	0	6

The Safe Limited Speed (and any other safe monitoring instruction requests besides STO, SS1, and SS2) are handled with the use of pass-through tags in the GuardLogix Standard Task. The GuardLogix Safety Task uses pass-

through tags to the Standard I/O Routine to change the speed reference for the SLS request, as shown in the programming example.

Figure 57 - The Use of Datalink is Required to Pass Data from the S4 Safety Function to the Standard I/O Routine

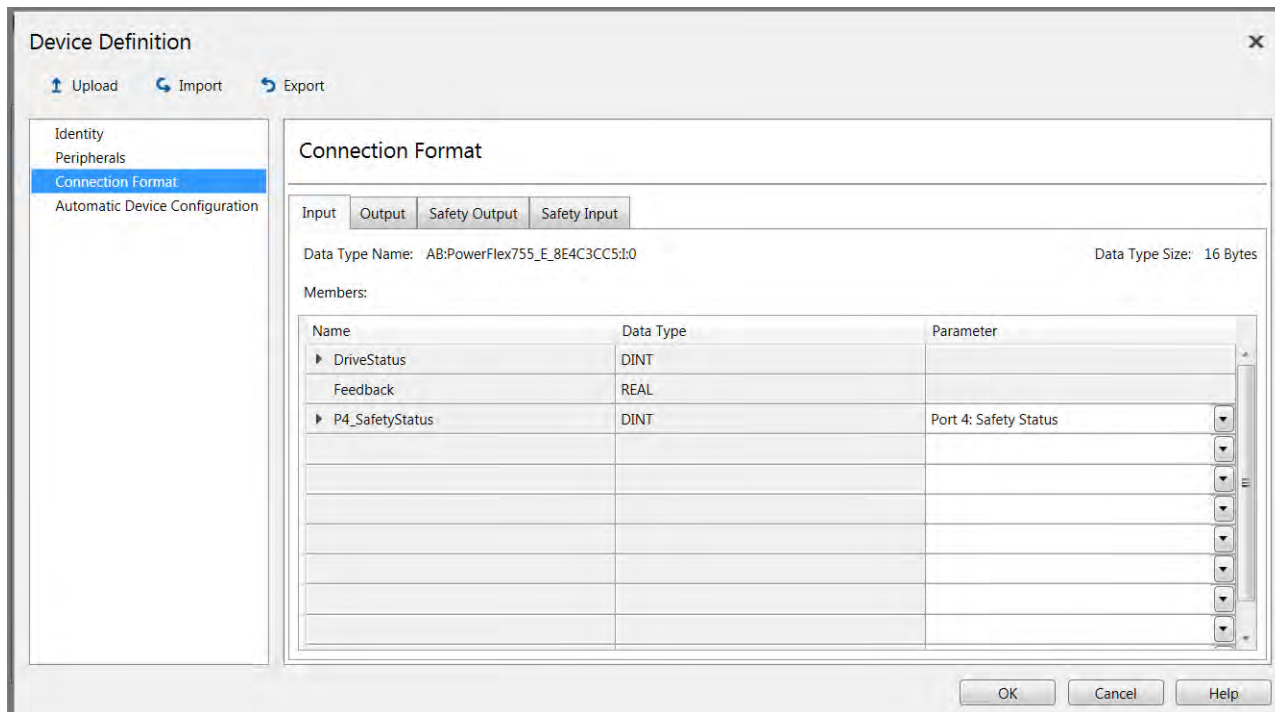

Figure 58 - Standard I/O Routine That Starts and Stops the PowerFlex 755



Figure 59 - Standard I/O Routine That Runs the Drive at Velocity and Changes to Safe Limited Speed Velocity When Requested by the Safety Task



Figure 60 - Standard I/O Routine That Commands the Drive to Zero Velocity Once the SS1 Request is Made by the Safety Task

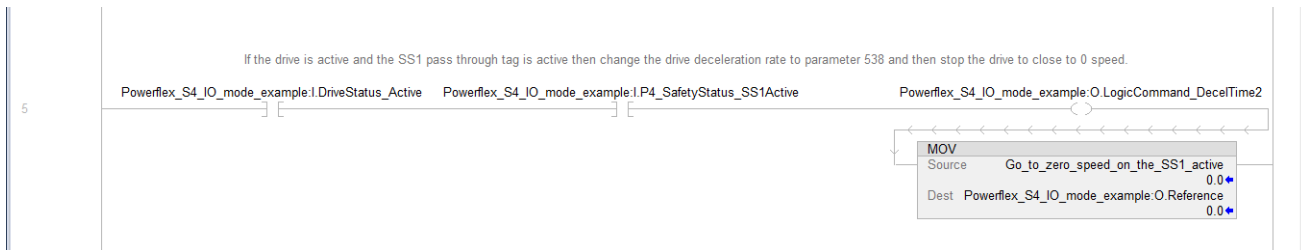
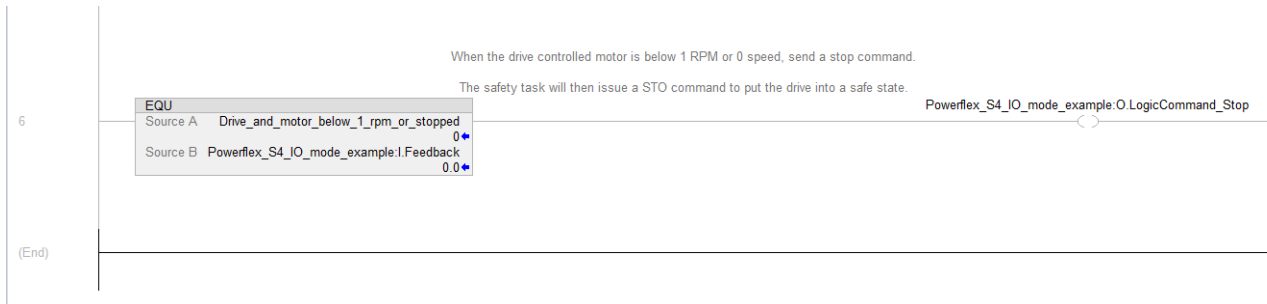

Figure 61 - Standard I/O Routine That Monitors When at Zero Speed and Stops the Drive



Integrated Motion – Configuration, Programming, and Operation

This chapter provides information for network installation and operation of the Integrated Safety Functions option module when used in Integrated Motion mode. If using Standard I/O mode, see [Chapter 6](#).

Topic	Page
Safety Assembly Tags	143
Configure the Integrated Safety Function Option Module in the Logix Designer Application	144
Understand Module Properties Categories	145
Programming	176

Safety Assembly Tags

Using network safety, a GuardLogix® 5580 or Compact GuardLogix 5380 safety controller controls the PowerFlex® 755 Safe Torque Off function through the SO.SafeTorqueOff tag in the safety output assembly.

The SO.SafetyStopFunctions tags are sent from the GuardLogix safety output assembly to the PowerFlex 755 safety output assembly to control the safety functions.

The SO.Output00Output, SO.Output01Output, SO.Test00Output, and SO.Test01Output tags are sent from the GuardLogix safety output assembly to the PowerFlex 755 safety output assembly to control the safety and test outputs on the Integrated Safety Functions option module.

The SI.StopStatus tags are sent from the PowerFlex 755 to the GuardLogix safety input assembly and indicate the PowerFlex 755 safety control status.

The SI.OutputStatus, SI.InputStatus, and SI.IOSupport tags are sent from the PowerFlex 755/755T drive product to the GuardLogix safety input assembly and indicate the status of the safety inputs, safety outputs, and test outputs.

The SI.ConnectionStatus tags indicate the safety input connection status.

See [Appendix C](#) for more information about assembly tags.

Configure the Integrated Safety Function Option Module in the Logix Designer Application

This section provides instructions for how to add and configure an Integrated Safety Functions option module in a PowerFlex 755 drive to an existing project in the Logix Designer application. This chapter is specific to safety and does not cover all aspects of drive configuration.

Before you can configure your option module in the Logix Designer application:

- You must have a safety controller project with an EtherNet/IP network connection configured and Time Sync enabled. See the documentation for your controller, drive, and Ethernet adapter for information on configuring those products in [Additional Resources](#) on page 13.
- When using a PowerFlex 755 drive in Integrated Motion Mode, the Integrated Safety Functions option module must be installed in port 6.
- If using speed monitoring functions, install a 20-750-DENC-1 or 20-750-UFB-1 card in port 4 or port 5.

Add a PowerFlex 755 Drive to the Controller Project

1. Right-click **Ethernet** network and choose **New Module**.

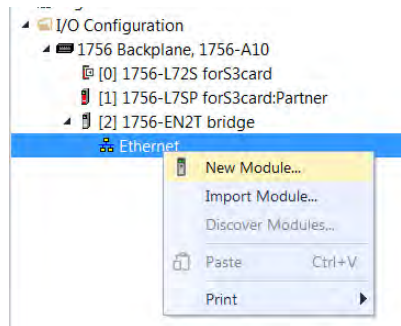

2. Select a PowerFlex 755 drive for Integrated Motion on EtherNet/IP® networks (catalog number ends in -CM-S4 for drives with the Integrated Safety Functions option).

Catalog Number	Description	Vendor	Category
PowerFlex 755 HiPwr PMM-EENET	High Power AC Drive, Permanent Magnet Motor, Deep Well	Rockwell Aut...	Drive
PowerFlex 755 HiPwr-EENET	AC Drive	Rockwell Aut...	Drive
PowerFlex 755 HiPwr-ENETR	AC Drive	Rockwell Aut...	Drive
PowerFlex 755 HiPwr-NET-E	AC Drive via 20-COMM-E	Rockwell Aut...	Drive
PowerFlex 755 PMM-EENET	AC Drive, Permanent Magnet Motor, Deep Well	Rockwell Aut...	Drive
PowerFlex 755-EENET	AC Drive	Rockwell Aut...	Drive
PowerFlex 755-EENET-CM	PowerFlex 755 AC Drive via Embedded Ethernet - CIP Motion	Rockwell Aut...	Drive,Motion
PowerFlex 755-EENET-CM-S	PowerFlex 755 AC Drive via Embedded Ethernet - CIP Motion/Safe Torque-Off	Rockwell Aut...	Drive,Motion
PowerFlex 755-EENET-CM-S1	PowerFlex 755 AC Drive via Embedded Ethernet - CIP Motion/Safe Speed Monitor	Rockwell Aut...	Safety,Drive,Motion
PowerFlex 755-EENET-CM-S3	PowerFlex 755 AC Drive via Embedded Ethernet - CIP Motion/S3 Safety Option	Rockwell Aut...	Safety,Drive,Motion
PowerFlex 755-EENET-CM-S4	PowerFlex 755 AC Drive via Embedded Ethernet - CIP Motion/S4 Safety Option	Rockwell Aut...	Safety,Drive,Motion
PowerFlex 755-ENETR	AC Drive	Rockwell Aut...	Drive
PowerFlex 755-HiPwr-EENET-CM	PowerFlex 755 High Power AC Drive via Embedded Ethernet - CIP Motion	Rockwell Aut...	Drive,Motion
PowerFlex 755-HiPwr-EENET-CM-S	PowerFlex 755 High Power AC Drive via Embedded Ethernet - CIP Motion/Safe Torque-Off	Rockwell Aut...	Drive,Motion
PowerFlex 755-HiPwr-EENET-CM-S1	PowerFlex 755 High Power AC Drive via Embedded Ethernet - CIP Motion/Safe Speed Monitor	Rockwell Aut...	Safety,Drive,Motion
PowerFlex 755-HiPwr-EENET-CM-S3	PowerFlex 755 High Power AC Drive via Embedded Ethernet - CIP Motion/S3 Safety Option	Rockwell Aut...	Safety,Drive,Motion
PowerFlex 755-HiPwr-EENET-CM-S4	PowerFlex 755 High Power AC Drive via Embedded Ethernet - CIP Motion/S4 Safety Option	Rockwell Aut...	Safety,Drive,Motion
PowerFlex 755-NET-E	AC Drive via 20-COMM-E	Rockwell Aut...	Drive
PowerFlex 755T	PowerFlex 755TM Common Bus Inverter via Embedded Ethernet	Rockwell Aut...	Drive
PowerFlex 755TM-Bus Supply	PowerFlex 755TM Regenerative Bus Supply via Embedded Ethernet	Rockwell Aut...	Drive

Understand Module Properties Categories

The Integrated Safety Function module and its safe speed monitor functions are configured in the Studio 5000 Logix Designer® application. Follow these guidelines when configuring your safety application.

IMPORTANT For access to Motion Safety module properties, the Connection pull-down menu in the Module Definition dialog box must be configured for Motion and Safety or Safety Only.

Right-click your safety drive module and choose **Properties**. The Module Properties dialog box appears.

Figure 62 - Module Properties

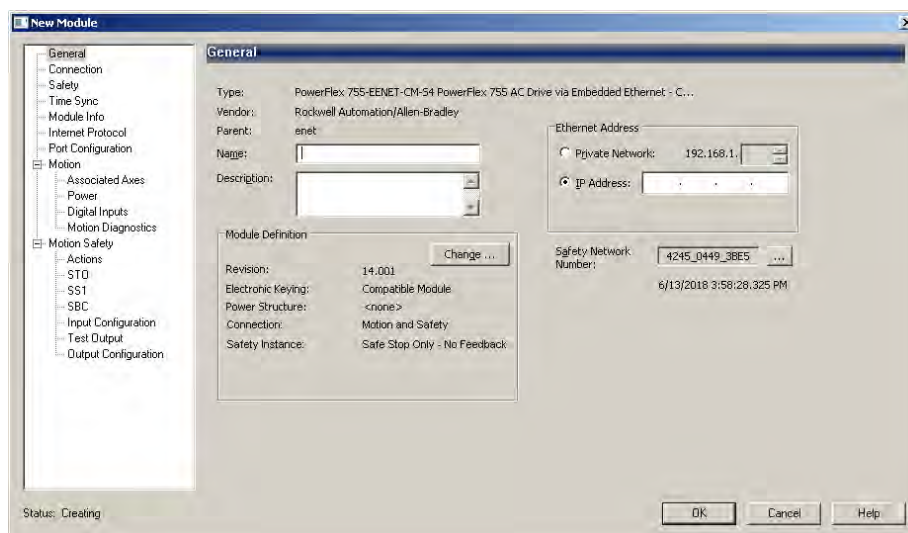

Module Properties Category	Page
General	page 146
Connection and Safety	page 149
Motion Safety	
Actions	page 152
Primary Feedback	page 153
Secondary Feedback	page 155
Scaling	page 156
Discrepancy Checking	page 157
STO	page 158
SS1	page 159
SBC	page 160
Input Configuration	page 161
Test Output	page 162
Output Configuration	page 163
Associated Axes Motor and Load Feedback Device	page 165

Module Properties > General Category

Follow these steps to configure the Module Definition dialog box properties.

1. Select the **General** category and click **Change** to open the Module Definition dialog box.

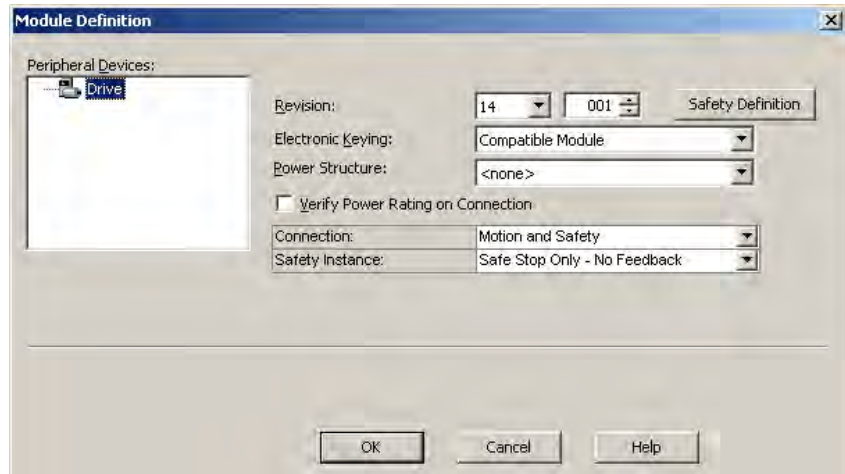

2. From the **Revision** pull-down menu, choose the drive firmware revision.
3. From the **Electronic Keying** pull-down menu, choose the type of electronic keying. See [Table 44](#) for more details.

Table 44 - Electronic Keying Methods

Electronic Keying	
Exact Match	Indicates that all keying attributes must match to establish communication. If any attribute does not match precisely, communication with the device does not occur.
Compatible Module	<p>Lets the installed device accept the key of the device that is defined in the project when the installed device can emulate the defined device. With Compatible Module, you can typically replace a device with another device that has the following characteristics:</p> <ul style="list-style-type: none"> • Same catalog number • Same or higher Major Revision • Minor Revision as follows: <ul style="list-style-type: none"> – If the Major Revision is the same, the Minor Revision must be the same or higher. – If the Major Revision is higher, the Minor Revision can be any number.
Disable Keying	<p>Indicates that the keying attributes are not considered when attempting to communicate with a device. With Disable Keying, communication can occur with a device other than the type specified in the project.</p> <hr/> <div style="display: flex; align-items: center;">  <p>ATTENTION: Be extremely cautious when using Disable Keying; if used incorrectly, this option can lead to personal injury or death, property damage, or economic loss.</p> <p>We strongly recommend that you do not use Disable Keying. If you use Disable Keying, you must take full responsibility for understanding whether the device being used can fulfill the functional requirements of the application.</p> <p>ATTENTION: Disable Keying is not permitted for safety devices.</p> </div> <hr/>

4. From the **Connection** pull-down menu, choose the Connection mode for your motion application. See [Table 45](#) for definitions.



TIP When 'Safety' appears in the Connection mode, integrated safety is implied.

Table 45 - Module Connection Definitions

Connection Mode	Safety Options	Description
Motion and Safety	Integrated mode	Motion connections and integrated safety functions are managed by this controller.
Motion Only	Integrated mode	<ul style="list-style-type: none"> • Motion connections are managed by this controller. • Integrated safety functions are managed by another controller that has a Safety-only connection to the drive.
Safety Only ⁽¹⁾	Integrated mode	<ul style="list-style-type: none"> • Integrated safety functions are managed by this controller. • Motion connections are managed by another controller that has a Motion-only connection to the drive.

(1) When the Connection mode is Safety Only, you do not need to configure a motion axis.

5. From the **Safety Instance** pull-down menu, choose the integrated safety type. See [Table 46](#) on [page 149](#) for definitions. If 'Safe Stop Only mode' is selected, skip to [step 7](#).

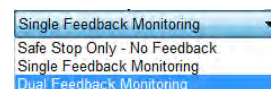

6. When using 'Single' or 'Dual Feedback Monitoring' mode, use these steps to add a safety feedback device.
 - a. Right-click the drive under **Peripheral Devices**, and then click **New Peripheral Device...** to bring up the Peripheral Device Definition dialog box.

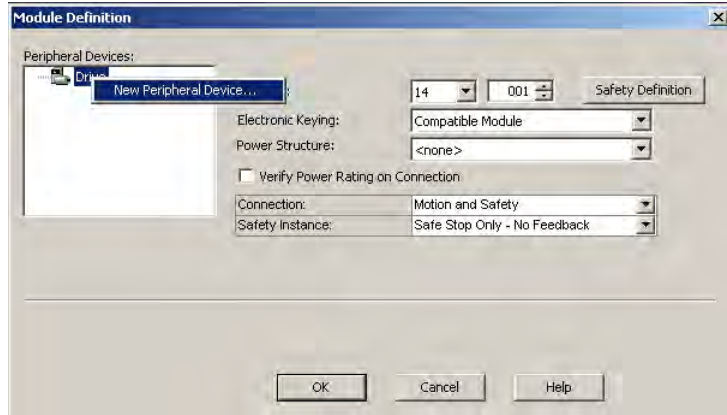

- b. Select the **Port**.
- c. Select the catalog number of the feedback option module installed in the **Peripheral Device** pull-down menu.
- d. Check **Safe Feedback** and click **OK** to close the Peripheral Device Definition dialog box.

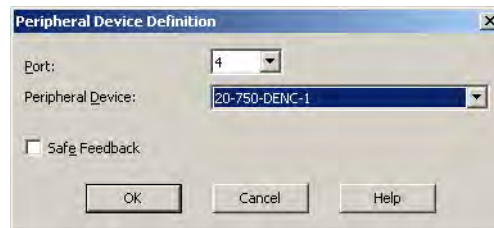

7. Click **Safety Definition** to configure the Integrated Safety Functions module's revision and electronic keying settings. See [Table 44 on page 147](#) for information on electronic keying.

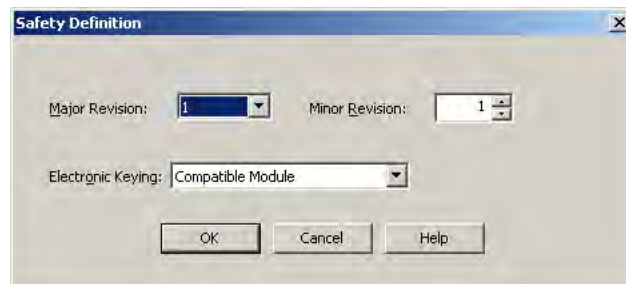

8. Click **OK** to close the Safety Definition dialog box.
9. Click **OK** to close the Module Definition dialog box.

Table 46 - Motion Safety Instance Definitions

Motion Safety Instance Mode	Module Connection Options	Description
Safe Stop Only - No Feedback	<ul style="list-style-type: none"> Motion and Safety Safety only 	STO function and Timed SS1 Safe Stop functions are available.
Single Feedback Monitoring		Primary feedback is used in the safety object for safe monitoring.
Dual Feedback Monitoring		In addition to primary feedback, an external feedback device is used to provide error checking of the primary feedback device. A secondary encoder is considered part of the encoder diagnostics and the data it produces is not rated safety data.

Module Properties > Connection and Safety Categories

Follow these steps to configure the Safety Output and Safety Input requested packet interval (RPI) values.

1. Click **Connection**.

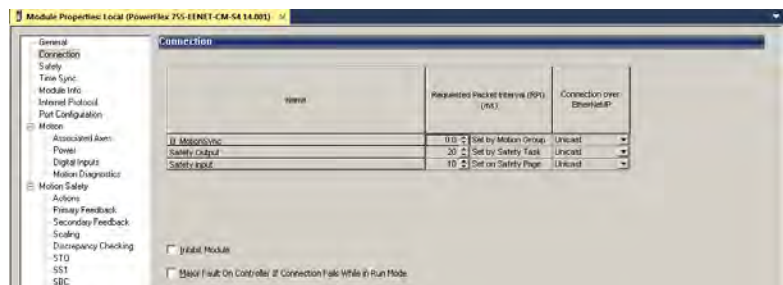

From the Connection category you can observe the status of the Safety Output and Safety Input RPI values. The default values are shown.

IMPORTANT The Safety Output and Safety Input values, when viewed from the Connection category, is for status only. To set the Safety Output and Safety Input values, continue with [step 2](#) through [step 6](#).

2. To set the Safety Output value, right-click **Safety Task** in the Controller Organizer and click **Properties**.

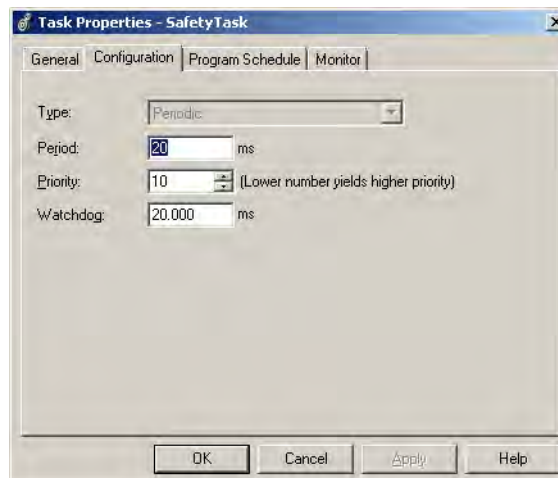

- Click the Configuration tab.

The default safety task Period value (and output RPI) is 20 ms.

IMPORTANT The 'Period' is the interval at which the safety task executes. The 'Watchdog' must be less than the period.

For more safety task information, see the GuardLogix 5580 and Compact GuardLogix 5380 Controller Systems Safety Reference Manual, publication [1756-RM012](#).

- Click **OK**.
- To set the Safety Input RPI and other safety connection attributes, select the **Safety** category on the module properties page and click **Advanced....** See [Table 47 on page 151](#) for information on other safety connection attributes.

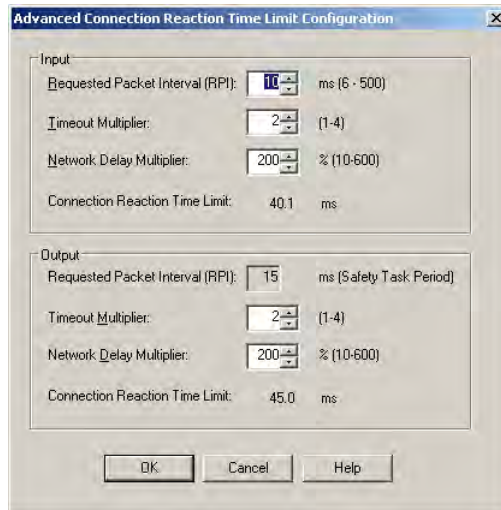
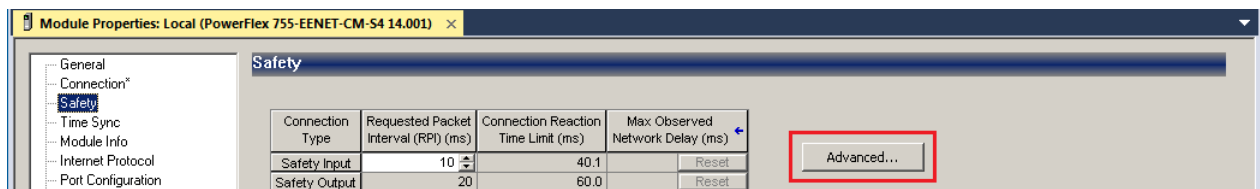

The default Safety Input RPI value is 10 ms. Edit as appropriate for your application.

Table 47 - Advanced Reaction Connection Time Limit Configuration Settings

Advanced Reaction Connection Time Limit Configuration Settings	Description
Requested Packet Interval (RPI)	<p>The RPI specifies the period that data updates over a connection. For example, an input module produces data at the RPI that you assign. For safety input connections, you can set the RPI on the Safety tab of the Module Properties dialog box. The RPI is entered in 1 ms increments, with a range of 6 . . . 500 ms. The default is 10 ms.</p> <p>The Connection Reaction Time Limit is adjusted immediately when the RPI is changed via the Logix Designer application.</p> <p>For safety output connections, the RPI is fixed at the safety task period. If the corresponding Connection Time Reaction Limit is not satisfactory, you can adjust the safety task period via the Safety Task Properties dialog box of the safety controller. See the user manual for the controller.</p> <p>For typical applications, the default RPI is sufficient.</p>
Timeout Multiplier	<p>The Timeout Multiplier determines the number of RPIs to wait for a packet before declaring a connection timeout. This value translates into the number of messages that can be lost before a connection error is declared. For example, a Timeout Multiplier of 1 indicates that messages must be received during each RPI interval. A Timeout Multiplier of 2 indicates that one message can be lost as long as at least one message is received in two times the RPI (2 x RPI).</p>
Network Delay Multiplier	<p>The Network Delay Multiplier defines the message transport time that the safety protocol enforces. The Network Delay Multiplier specifies the round-trip delay from the producer to the consumer and the acknowledge back to the producer. You can use the Network Delay Multiplier to reduce or increase the Connection Reaction Time Limit in cases where the enforced message transport time is significantly less or more than the RPI. For example, to adjust the Network Delay Multiplier is helpful when the RPI of an output connection is the same as a lengthy safety task period.</p>
Connection Reaction Time Limit	<p>The Connection Reaction Time Limit is the maximum age of safety packets on the associated connection. If the age of the data that is used by the consuming device exceeds the Connection Reaction Time Limit, a connection fault occurs. The following equations determine the Connection Reaction Time Limit:</p> <p>Input Connection Reaction Time Limit = Input RPI x [Timeout Multiplier + Network Delay Multiplier]</p> <p>Output Connection Reaction Time Limit = Safety Task Period x [Timeout Multiplier + Network Delay Multiplier - 1]</p>

IMPORTANT If the drive is used with an induction motor, there is a general rule of no repeated (three or more) start/stops with less than 10 seconds between them (assumes the highest RPI of 500 ms is used). Otherwise a safety connection loss can occur. If less than 10 seconds is needed, a lower RPI can be used per the following formula:

$$\text{RPI (ms)} * 19 = \text{Min. Repeated Start/Stop time (seconds)}$$

For example, a 50 ms RPI equates to a minimum of 0.95 seconds required between repeated start/stops.

6. Click **Apply**.

Motion Safety > Actions Category

The Actions category provides fault behavior options. Determine the preferred machine function when a connection loss or connection idle condition occurs. Safe Torque-off (STO) means that the drive immediately disables the motor power outputs causing a coast condition for the motor and load. Safe Stop 1 (SS1) means that the drive decelerates the load to zero speed before removing the motor power outputs causing a controlled stop for the motor and load. [Table 48](#) describes the attributes and the values available on the Actions page.

Follow these steps to configure the Actions to Take Upon Conditions dialog box. For more information on connection action operation, please see [Safety Function in Response to Connection Event](#) on page 68.

1. Select the **Motion Safety > Actions** category.

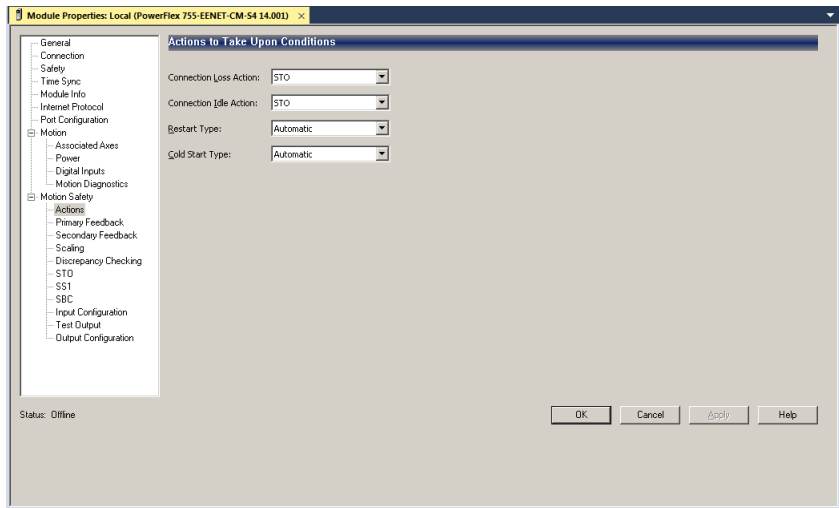
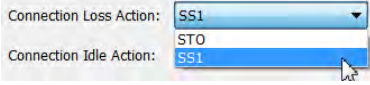

Table 48 - Motion Safety Actions

Attribute	Description	Values	Description
Connection Loss Action	<ul style="list-style-type: none"> • Connection loss is caused by removal of the Ethernet cable from the drive. • The loss could also be an indication of excessive traffic, causing the drive to lose synchronization to the grandmaster clock/motion controller. 	SS1	Drive-based Safe Stop 1 function is initiated and operates according to the SS1 configuration.
		STO	Torque is removed according to the STO configuration.
Connection Idle Action	Connection idle is caused by the safety output task becoming disabled because the controller is in Remote Program mode.	SS1	Drive-based Safe Stop 1 function is initiated and operates according to the SS1 configuration.
		STO	Torque is removed according to the STO configuration.
Restart Type	Restart type means that the safety function resets and will be ready for subsequent operation when the reset conditions are met. See specific function for more detail.	Automatic	Restart allowed after safety function completes and function request is removed. If restart is required due to a fault, the fault condition must also be removed.
		Manual	Restart is allowed after a 0→1 transition of SO.ResetRequest bit.
Cold Start Type	Cold start type means that the configured safety function is ready for operation immediately after the controller enters run mode.	Automatic	Restart allowed after safety function completes and function request is removed. If restart is required due to a fault, the fault condition must also be removed.
		Manual	Restart is allowed after a 0→1 transition of SO.ResetRequest bit.

- From the **Connection Loss Action** and **Connection Idle Action** pull-down menus, choose **SS1** or **STO** as required for your application.
 
- From the **Restart Type** and **Cold Start Type** pull-down menus, choose **Automatic** or **Manual** as required for your application.
- Click **Apply**.

Motion Safety > Primary Feedback Category

Configure primary feedback if you intend to use any drive-based or controller-based safety function that monitors motion. There are many different combinations of feedback for motion control and safety that can be configured.

Follow these steps to configure the Primary Feedback.

- Select the **Motion Safety > Primary Feedback** category.

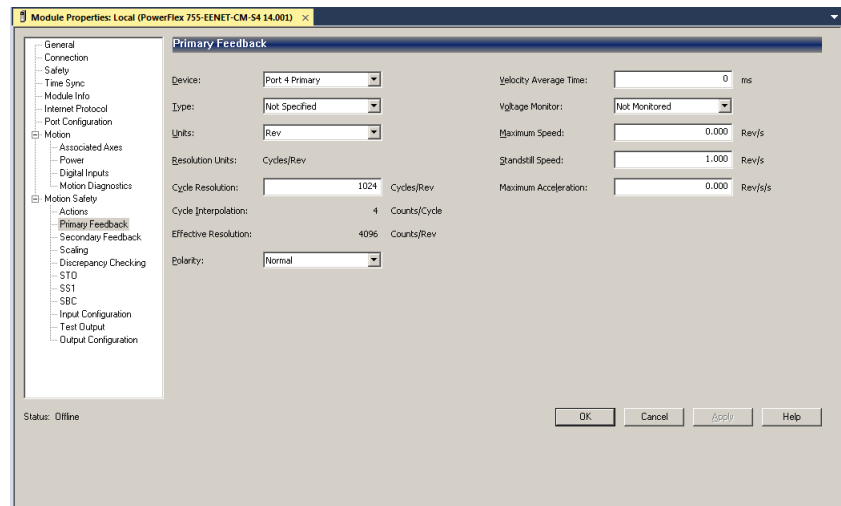

- From the **Device** pull-down menu, choose the feedback device that was defined as the Safety Feedback device during module configuration.
- From the **Type** pull-down menu, choose the feedback type.

[Table 49](#) shows the valid feedback types based on the module configuration.
- Set the remaining Primary Feedback attributes. See [Table 50](#) for the descriptions of these attributes.
- Click **Apply**.

Table 49 - Feedback Options

Feedback Option			
		20-750-UFB-1	20-750-DENC-1
Feedback Instance	Primary	Sine/Cosine Hiperface	Digital AqB
	Secondary	Digital AqB	Digital AqB

Table 50 - Safety Feedback Configuration Attributes

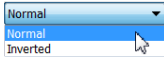
Attribute	Description
Units	Specify the units of the encoder. Default value is revolutions (Rev) that supports rotary motors. When using a linear encoder, select Meter.
Resolution Units	Cycles per Encoder Unit. Default value is Cycles/Revolution (Rev).
Cycle Resolution	Used in the Effective Resolution calculation. The actual motor encoder cycle resolution. This is the raw encoder cycle resolution of the motor or encoder device type.
Cycle Interpolation	Used in the Effective Resolution calculation. The safety primary-feedback interpolated counts as oppose to the motion axis-feedback interpolated counts. For the Integrated Safety Functions module, this value is 4 and cannot be changed.
Effective Resolution	The product of cycle resolution and cycle interpolation for the primary safety function evaluation.
Polarity	Based on encoder rotation and evaluation requirements. Choose  between Normal (default) or Inverted as appropriate for your application.
Velocity Average Time	The velocity average time attribute is a moving-average window of time for which the velocity samples are averaged. A small value results in more deviation in the velocity evaluation. A large value results in less deviation in the velocity evaluation, but also adds more delay to the resulting evaluation. Consider this delay with system requirements for over-speed response.
Voltage Monitor	The voltage monitor attribute indicates the valid range of the feedback's power supply. If a voltage outside of the range is detected, a Safety Feedback Fault will occur. See Table 50 to find the correct voltage monitoring range based on feedback device.
Maximum Speed ⁽¹⁾	This value sets the maximum speed of the encoder. If a speed above the limit is detected, a Safety Feedback fault will occur. If set to 0.0, the speed check is disabled.
Standstill Speed	Used in the safe-monitoring process to indicate to the safety controller that the motor has stopped rotating. The system is at standstill when the speed detected is less than or equal to the configured Standstill Speed. The Standstill Speed parameter defines the speed limit before the drive determines standstill has been reached.
Maximum Acceleration ⁽¹⁾	This value sets the maximum acceleration of the encoder. If an acceleration above the limit is detected, a Safety Feedback fault will occur. If set to 0.0, the acceleration check is disabled.

(1) These diagnostics are based on the capability of the chosen encoder and its rated limits. They do not provide a safety-rated safety function.

Table 51 - Voltage Monitoring Values for Feedback Device

Feedback Devices			
		20-750-UFB	20-750-DENC
Feedback Instance	Primary	Not monitored 7...12V 4.75V...5.25V	Not monitored 4.75...5.25V 7...12V 11.4...12.6V
	Secondary	Not monitored 7...12V 4.75...5.25V	Not monitored 4.75...5.25V 7...12V 11.4...12.6V

Motion Safety > Secondary Feedback Category

If the Safety Instance is configured for Dual Feedback monitoring, the Secondary Feedback must be configured. The attributes for the Secondary Feedback configuration are the same as the Primary Feedback. See the [Motion Safety > Primary Feedback Category](#) section for information on the attributes that can be configured for the Secondary Feedback Instance.

IMPORTANT The secondary feedback is intended to provide diagnostic coverage of the primary encoder. The data produced by the secondary feedback device is not safety data.

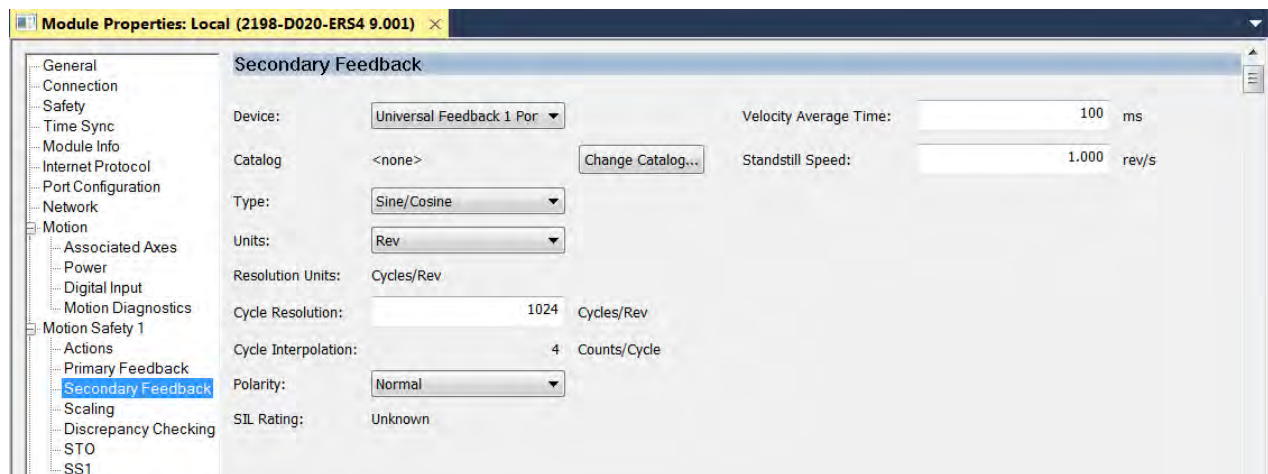

Motion Safety > Scaling Category

The Primary Feedback category set safety resolution in terms of counts per encoder unit. The Scaling category configures the position and time to be used in terms of counts per position unit in the safe monitoring functions.

Figure 63 - Scaling Category (default settings)

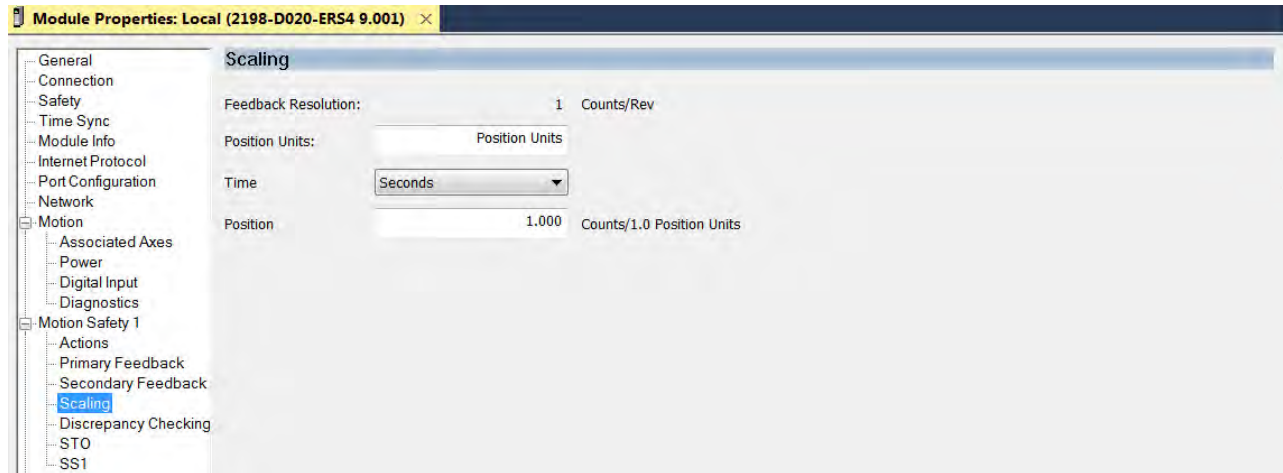



Table 52 - Scaling Category Attributes

Attribute	Description
Feedback Resolution	The number of counts per motor revolution, which is determined by the Primary Feedback category.
Position Units	The position units for this safety application. Enter text for the name of your units.
Time	The evaluation of position per unit of time for a velocity evaluation. Choose between Seconds (default) and Minutes as appropriate for your application. 
Position	The conversion constant showing the counts per position units. This is the number of counts for one of your position units.

Motion Safety > Discrepancy Checking Category

Discrepancy checking is only used in applications where the 'Module Definition>Safety Instance' is configured for 'Dual Feedback Monitoring'. Its purpose is to perform an evaluation of the speed and position discrepancy between primary and secondary feedback. A ratio can also be configured that describes the expected gear ratio of primary to secondary feedback.

If primary feedback and secondary feedback differ in position or velocity for the configured time period, a discrepancy fault occurs.

Figure 64 - Discrepancy Checking Dialog Box (default attributes)

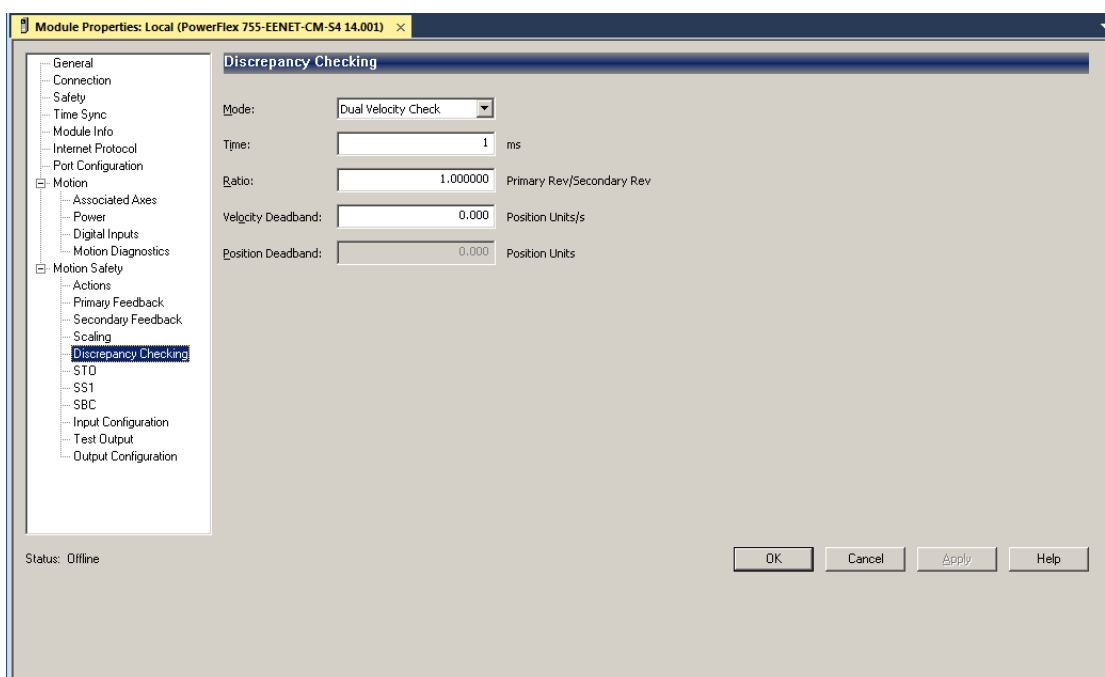

IMPORTANT When setting discrepancy tolerances in terms of the velocity deadband attribute, consider that configuring a high gear-ratio between primary feedback and secondary feedback can lead to unexpected dual-feedback position faults. This is because a very large primary feedback movement translates into very small secondary feedback increments.

When 'Module Definition>Safety Instance' is configured for Single Feedback Monitoring, the discrepancy checking mode is set to the default value of 'Not Used', and cannot be changed. When configured for Dual Feedback Monitoring, the discrepancy checking mode is set to 'Dual Velocity Check'. In the Dual Feedback Monitoring configuration, the 'Dual Position' and 'Velocity/Position Check' modes are also available.

Use the 'Dual Velocity Check' mode to measure the difference between primary feedback speed and secondary feedback speed. Use 'Dual Position Check' mode to measure the difference between primary feedback position

and secondary feedback position. Use the 'Velocity/Position Check' mode if position and velocity checking are needed.

Follow these steps to configure the Discrepancy Checking attribute.

1. From the **Mode** pull-down menu, choose the appropriate discrepancy checking mode for your application.
2. Set the remaining Discrepancy Checking attributes.

Attribute	Description
Time	The amount of time (ms) specified for velocity deadband to be evaluated and trigger a safety fault condition.
Ratio	The gear ratio of one primary feedback revolution to one secondary feedback revolution.
Velocity Deadband	The velocity units of the difference between primary and secondary feedback speed for the velocity discrepancy check.
Position Deadband	The position units of the difference between primary and secondary feedback position for the position discrepancy check.

3. Click **Apply**.

Motion Safety > STO Category

The STO category provides a disable and coast fault action. However, if a torque disable delay is needed following a STO Active command, you can enter a value in the Delay field (see [Safe Torque Off With Delay Operation on page 72](#) for more information.)

Figure 65 - Motion Safety STO

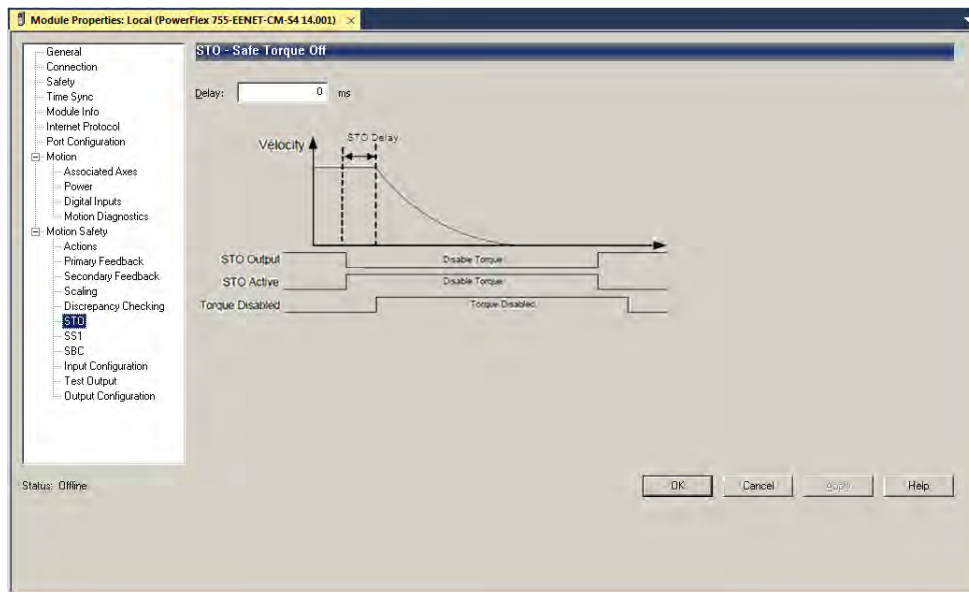

STO becomes active if any of the following inputs to STO are asserted:

- STO Output = 0
- Safety Connection Loss and Connection Loss Action = STO
- Safety Connection is Idle and Connection Idle Action = STO
- Drive-based SS1 Function is Complete (= 1)
- Safety Stop Fault = 1
- Critical Safety fault occurs

STO Output is a tag in the safety output assembly used to activate the STO function and is written by the GuardLogix controller. When any source for STO is asserted, STO Active becomes high to indicate that the STO function is operating.

STO Delay follows this sequence of events.

1. STO becomes active and the STO delay timer begins.
2. The STO delay timer expires.

Torque producing power is removed from the inverter output.

- If STO is activated by a Safety Stop fault or Critical Safety fault, torque is removed immediately without the STO delay.
- If STO is reset by removing all inputs, torque is immediately permitted without delay.

Motion Safety > SS1 Category

The 'Motion Safety > SS1' category is configured when a Timed or Monitored Safe Stop 1 condition is desired.

'Timed SS1' mode is available when the module is configured with or without safety feedback monitoring. The 'Monitored SS1' mode is only available when the module is configured for feedback monitoring (for more information on the drive-based Safe Stop 1 function, see [Safe Stop 1 Function on page 76](#).)

Timed SS1 is a fixed time for the motor to stop before removing torque. Motor feedback is not monitored. 'Stop Delay' is the only parameter used for 'Timed SS1' and determines the 'Max Stop Time'.

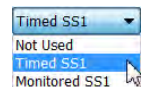
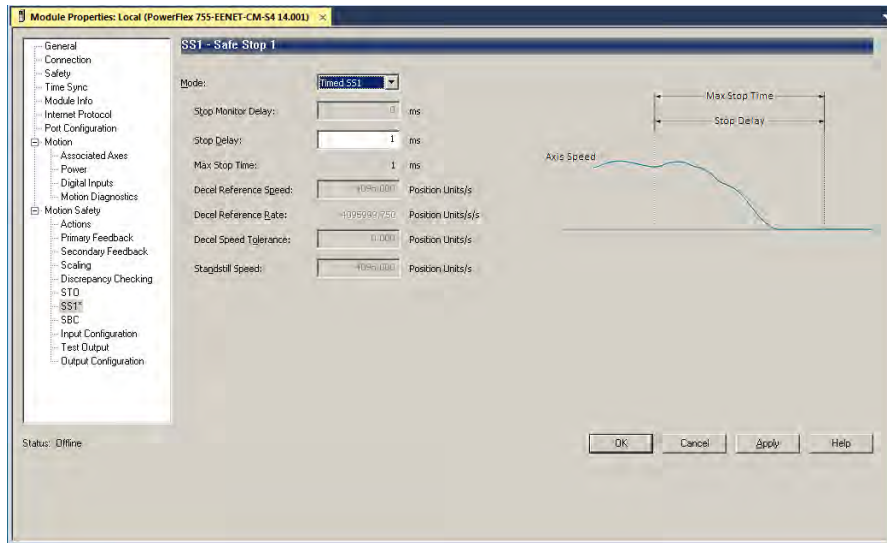
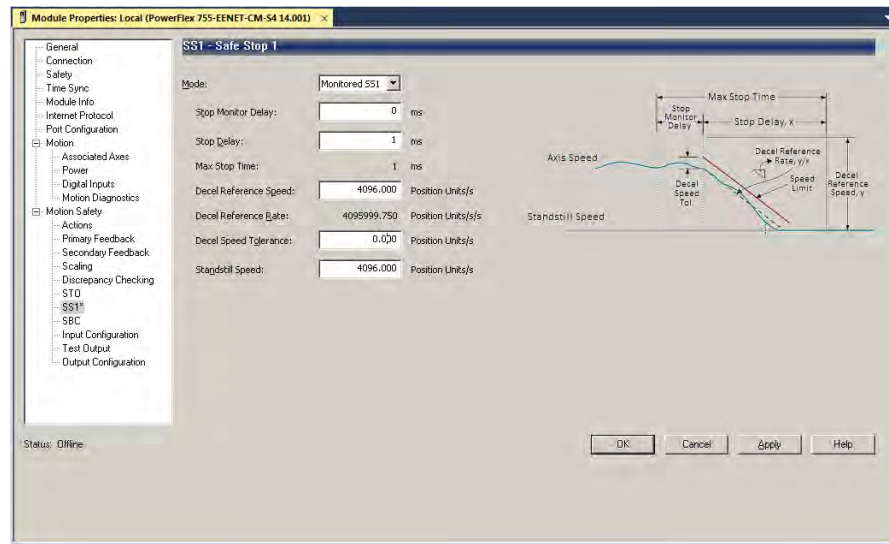

Figure 66 - SS1 Dialog Box (Timed SS1, default)



Monitored SS1 is a ramped safe-stop where the motion safety instance monitors the speed ramp to standstill speed, while either the motion task or the drive controls the deceleration to standstill speed. When standstill is reached, the motion safety instance removes torque from the motor.

Figure 67 - SS1 Dialog Box (Monitored SS1)



Motion Safety > SBC Category

The 'Motion Safety > SBC Category' is configured when Safe Brake Control functionality is desired in an application.

The default mode for SBC is 'Not Used'. If the SBC functionality is desired, setting the mode to 'Used', 'Test Pulses', or 'Used, No Test Pulses', will enable the SBC function. When configured for 'Used, Test Pulses mode', pulse testing

of the physical brake outputs are performed. For more information on the drive-based SBC function, see [Safe Brake Control Function on page 83](#).

See [Table 53](#) for descriptions of the SBC attributes.

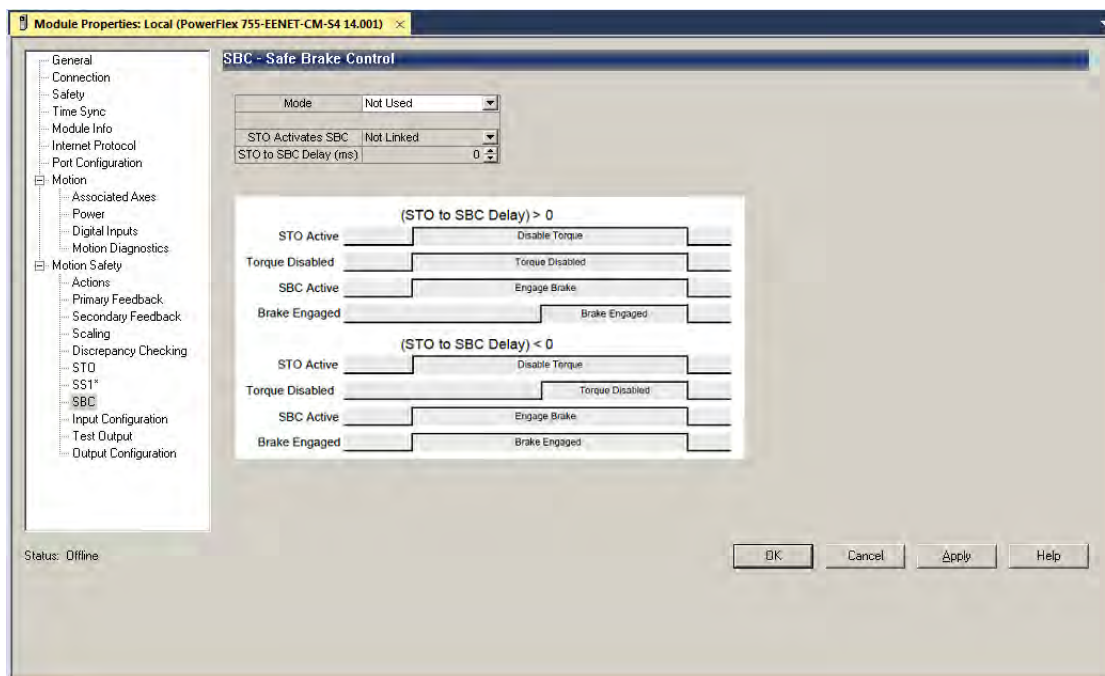

Table 53 - SBC Attributes

Attribute	Description
STO Activates SBC	Determines if an STO event engages the brake. If set to 'Not Linked', an STO event does not engage the brake. If set to 'Linked', the brake is engaged during an STO event based on the 'STO to SBC Delay' attribute. This attribute is only valid when the 'Mode' is set to 'Used'.
STO to SBC Delay	The delay of brake engagement in milliseconds. If the value is a positive number, the delay specifies the time between when STO is activated and the brake is engaged. If the value is a negative number, the brake is engaged immediately after STO is activated, and the delay specifies the time between STO activation and when torque is actually disabled. This attribute is only valid when 'STO Activates SBC' is set to 'Linked'.

Motion Safety > Input Configuration Category

The Input Configuration category allows configuration of the safety input instances of the device.

The Point Operation of a safety input configures the type of input operation and its discrepancy time. See [Table 54](#) for descriptions of these attributes.

The Point Mode configures the mode of the safety input. [Table 55](#) describes the valid values of this attribute.

The Input Delay Time configures the delay in sample time after a state change of the input. See [Input Delays on page 49](#) for more information. The Input

Error Latch Time attribute configures the time that a discrepancy must exist before a Safety Input alarm is generated. See [Latch Input Error Operation in Single Channel Mode on page 39](#) for more information.

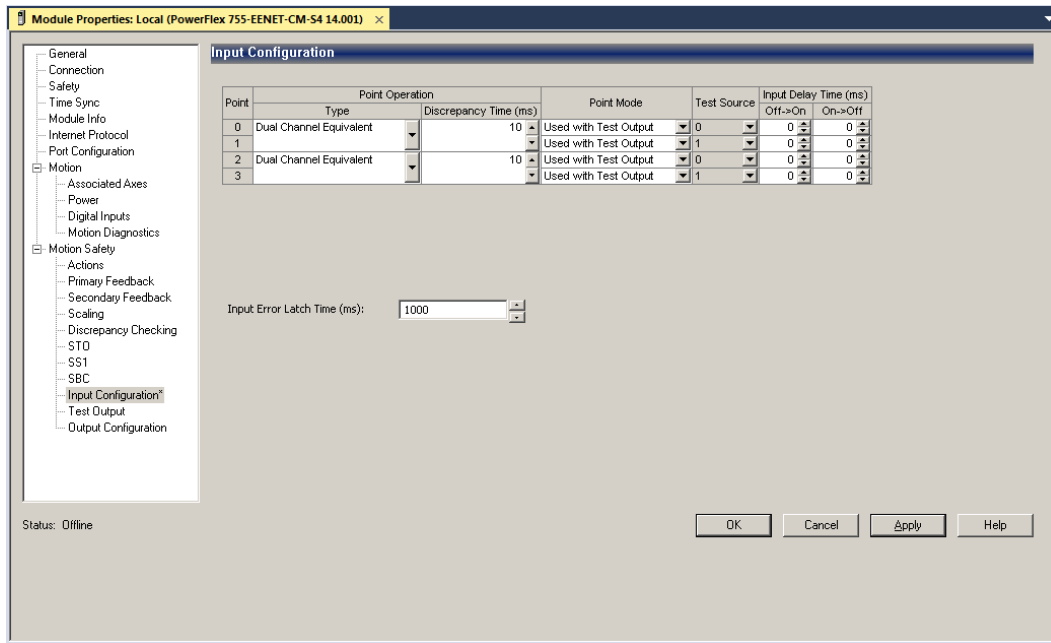

Table 54 - Safety Input Point Operation Attributes

Attribute	Description
Type	Determines the operation mode of the Safety Input. See Safety Inputs beginning on page 37 for more information on the types of safety input operation.
Discrepancy Time	The time in milliseconds that a discrepancy must exist between two corresponding safety inputs before an alarm is generated. See Dual-channel Safety Input Operation on page 41 for more information on discrepancy time.

Table 55 - Safety Input Point Mode Values

Value	Description
Not Used	The safety input will not be used.
Used with Test Output	The associated test output point shown in the 'Test Source' field will be used to pulse test the external wiring of the safety input. See Standard Input Operation on page 44 for more information.
Used without Test Output	The time in milliseconds that a discrepancy must exist between two corresponding safety inputs before an alarm is generated. See Dual-channel Safety Input Operation on page 41 for more information on discrepancy time.
Used as Standard Input	The safety input will be treated as a standard input. No diagnostics are run. When using a safety input as a standard input, the 'Point Operation Type' must be set to 'Single Channel'.

Motion Safety > Test Output Category

The Test Output category allows for configuration of the Test Outputs of the device. See [Table 56](#) for descriptions of the attributes. For more information on test output operation, see [Test Output on page 60](#).

TIP If a safety input's Point Mode is configured for 'Used with Test Output', the Test Output indicated by the 'Test Source' field must have its 'Point Mode' configured as 'Pulse Test Output'.

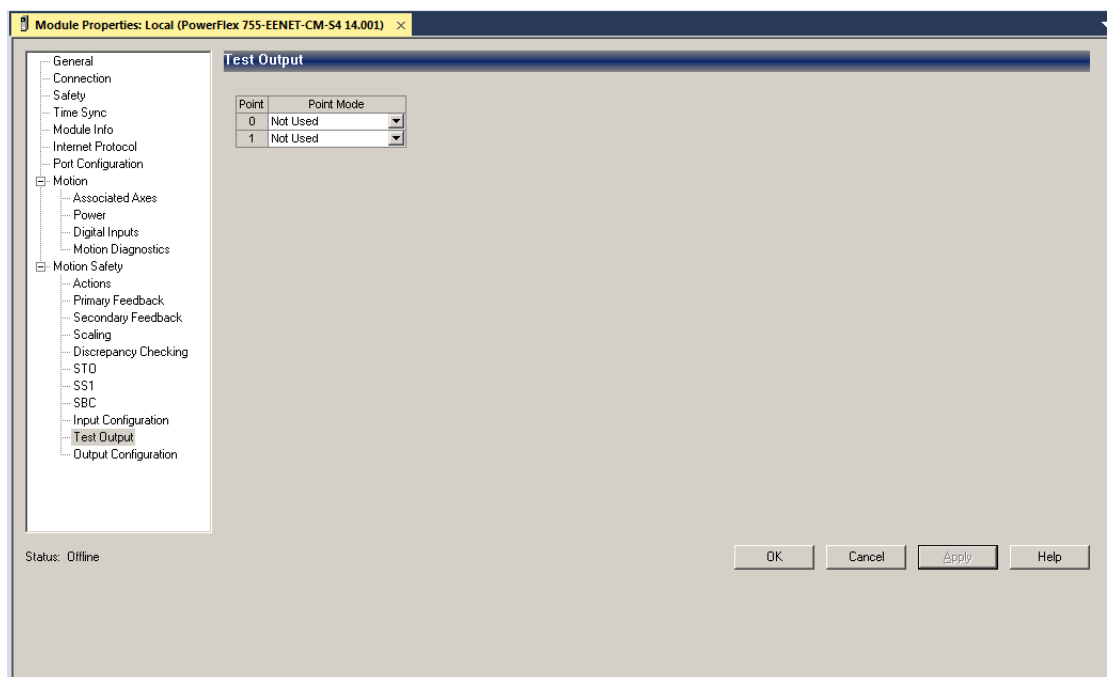

Table 56 - Test Output Point Mode Values

Value	Description
Not Used	The safety input will not be used.
Standard Output	The test output will be treated as a standard output No diagnostics are run.
Pulse Test Output	The test output is used as a pulse test output for the associated safety input.
Power Supply Output	The test output is used as a power supply output.

Motion Safety > Output Configuration Category

The Output Configuration category allows the safety outputs of the device to be configured. The **Point Operation Type** of the safety output configures the type of safety output according to [Table 57](#).

The **Point Mode** of the safety output configures the mode of the safety output according to [Table 58](#).

The **Output Error Latch Time** attribute configures the time that a discrepancy must exist before a Safety Output alarm is generated (see [Safety Outputs on page 50](#) for more information).

TIP If SBC mode is set to used, the safety outputs are under control of the SBC function, and cannot be separately configured.

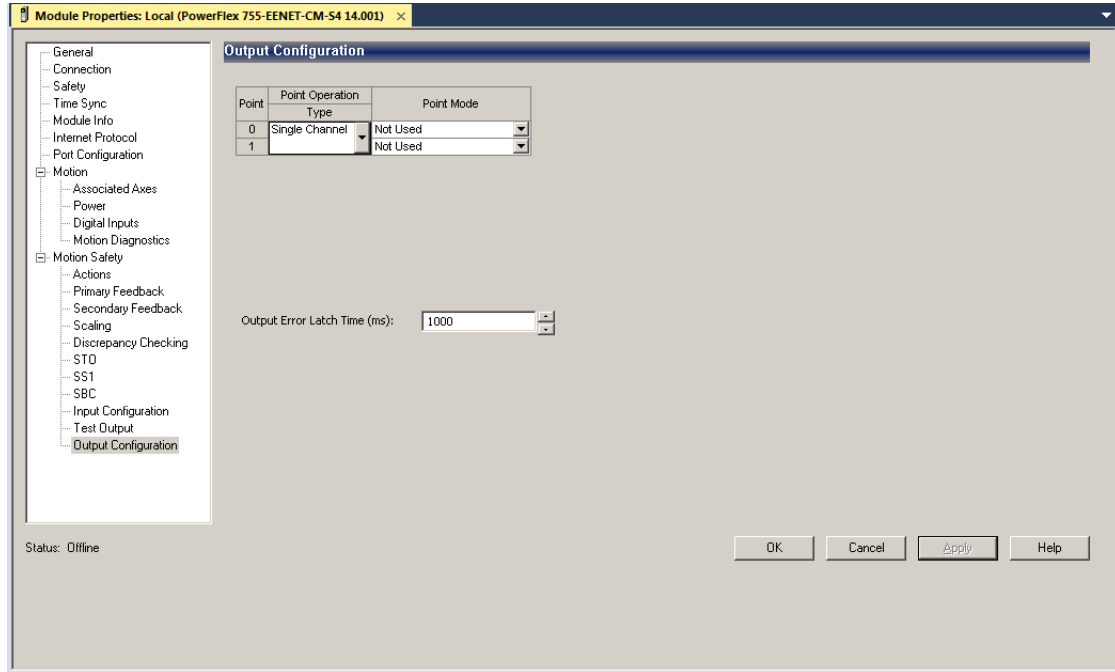

Table 57 - Point Operation Type Values

Value	Description
Single Channel	The safety output operates in single channel mode. See Single-channel Mode on page 51 for more information.
Dual Channel	The safety output operates in dual channel mode with its partner safety output. See Dual-channel Mode on page 53 for more information.

Table 58 - Point Mode Values

Value	Description
Not Used	The safety output is not used. The 'Point Operation Type' must be set to 'Single Channel' if the Point Mode is set to 'Not Used'.
Used without Test Pulses	The safety output is used. No pulse test diagnostics are performed.
Used with Test Pulses	The safety output is used. Pulse testing of the safety output is performed periodically.

Axis Properties > Actions > Safety Actions

To set the stop action taken in response to a safety function activation, open the **Axis Properties** and select the **Actions** page. The Safety Actions section of this page is used to select Safe Torque Off and Safe Stopping actions and sources.

Make sure that these settings will allow the drive to complete a stop without causing a safety function fault during normal operation. See the Stopping Action section for the specific safety function in [Chapter 4](#) for more information.

Figure 68 on page 165 shows the Actions page. Table 59 on page 165 describes the Safety Action attributes.

Figure 68 - Axis Properties > Actions Page

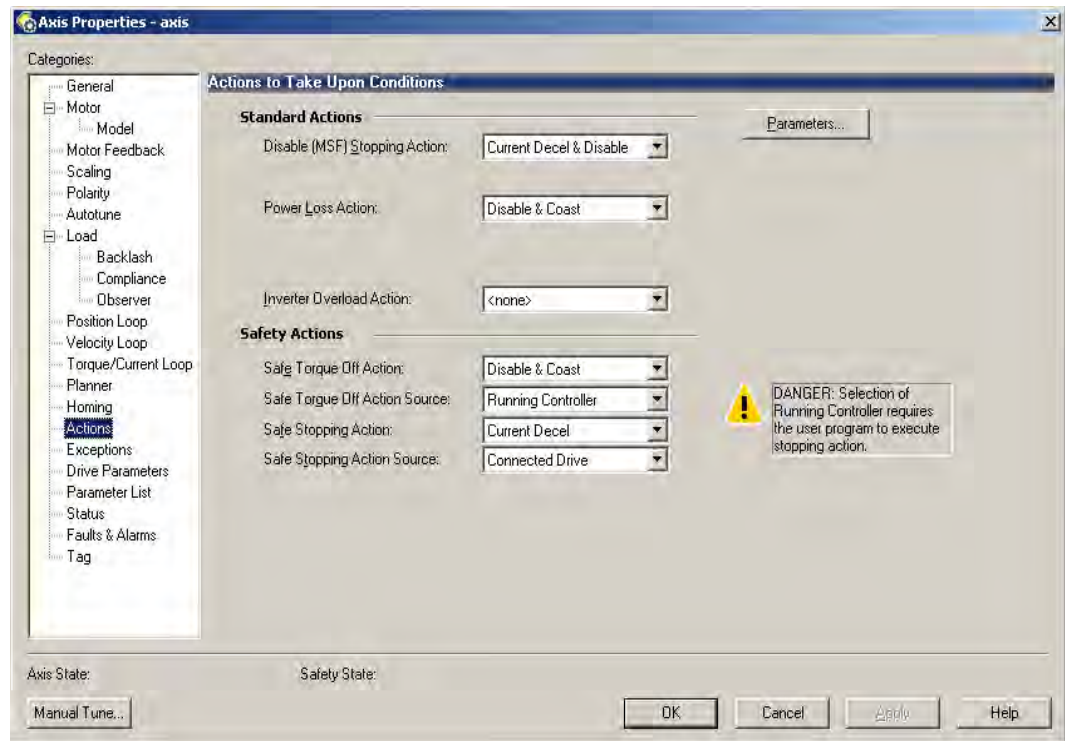

Table 59 - Safety Actions Attributes Descriptions

Attribute	Description
Safe Torque Off Action	Specifies the stopping action that will be executed in response to a STO Activation. This selection is only valid when 'Safe Torque Off Action Source' is set to 'Connected Drive'.
Safe Torque Off Action Source	Specifies which controller or drive product is responsible for initiating and performing the stop action specified in the 'Safe Torque Off Action' attribute.
Safe Stopping Action	Specifies the stopping action that will be executed in response to a Safe Stop Activation. This selection is only valid when 'Safe Stopping Action Source' is set to 'Connected Drive'.
Safe Stopping Action Source	Specifies which controller or drive product is responsible for initiating and performing the stop action specified in the 'Safe Stopping Action' attribute.

Module Properties > Associated Axes Motor and Load Feedback Device

Special consideration must be taken when setting Motor and Load feedback devices on the Associated Axes page. Table 60 on page 166 shows the correct Motor/Load feedback device selection based on the physical terminal the encoder is connected to per the supported feedback card.

Table 60 - Motor/Load Feedback Device Selection

	Terminal	Safety Feedback Device Selection	Motor/Load Feedback Device Selection
20-750-UFB-1	- SN	<i>Port X Primary</i>	<i>Port X Channel B</i>
	+ SN		
	- CS		
	+ SN		
	- A	<i>Port X Secondary</i>	<i>Port X Channel A</i>
	A		
	- B		
	B		
- Z			
Z			
20-750-DENC-1	0A	<i>Port X Primary</i>	<i>Port X Channel A</i>
	0A-		
	0B		
	0B-		
	0Z		
	0Z-		
	1A	<i>Port X Secondary</i>	<i>Port X Channel B</i>
	1A-		
	1B		
	1B-		
	1Z		
	1Z-		

Port X indicates the DPI™ port where the encoder card is installed.

Generate the Safety Network Number (SNN)

The assignment of a time-based SNN is automatic when you create a GuardLogix safety controller project and add new Safety I/O devices.

Manual manipulation of an SNN is required in the following situations:

- If safety consumed tags are used
- If the project consumes safety input data from a device whose configuration is owned by some other device
- If a safety project is copied to another hardware installation within the same routable Safety system

If an SNN is assigned manually, the SNN has to be unique.

IMPORTANT If you assign an SNN manually, make sure that the system expansion does not result in duplication of SNN and node address combinations.

A warning appears if your project contains duplicate SNN and node address combinations. You can still verify the project, but Rockwell Automation recommends that you resolve the duplicate combinations.

To edit the SNN, follow these steps.

1. To open the Safety Network Number dialog box, click  to the right of the Safety Network Number.
2. Select either **Time-based** or **Manual**.
If you select **Manual**, enter a value from 1...9999 decimal.
3. Click **Generate**.
4. Click **OK**.

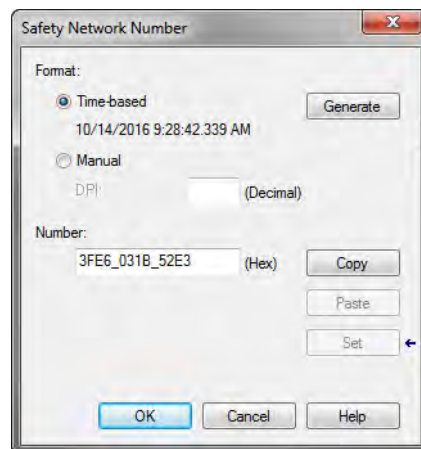

Safety Configuration Signature and Ownership

The connection between the controller and the drive is based on the following criteria:

- Drive catalog number must be for PowerFlex 755 drives
- Drive Safety Network Number (SNN) (displayed in drive module General tab)
- GuardLogix slot number
- GuardLogix safety network number
- Path from the GuardLogix 5580 safety controller or Compact GuardLogix 5380 safety controller to the PowerFlex 755 drive
- Configuration signature (displayed on the Safety tab of the drive Module Properties dialog box)

If any differences are detected, the safety connection between the safety controller and the drive is not established (for a new drive/system) or lost (for an existing drive/system). A yellow icon appears next to the drive in the controller project tree to indicate a lost or unestablished connection. Configuration Ownership has to be reset to establish a new connection or to reestablish an existing connection.

Reset Ownership

To reset ownership, see [Restore the Drive to Out-of-Box State on page 214](#).

Replace an Integrated Safety Drive in a GuardLogix System

When you replace an integrated safety drive, the replacement device must be configured properly and the replacement drives operation be user-verified.



ATTENTION: During drive replacement or functional test, the safety of the system must not rely on any portion of the affected drive.

Two options for safety drive replacement are available on the Safety tab of the Controller Properties dialog box in the Logix Designer application:

- Configure Only When No Safety Signature Exists
- Configure Always

Figure 69 - Safety Drive Replacement Options

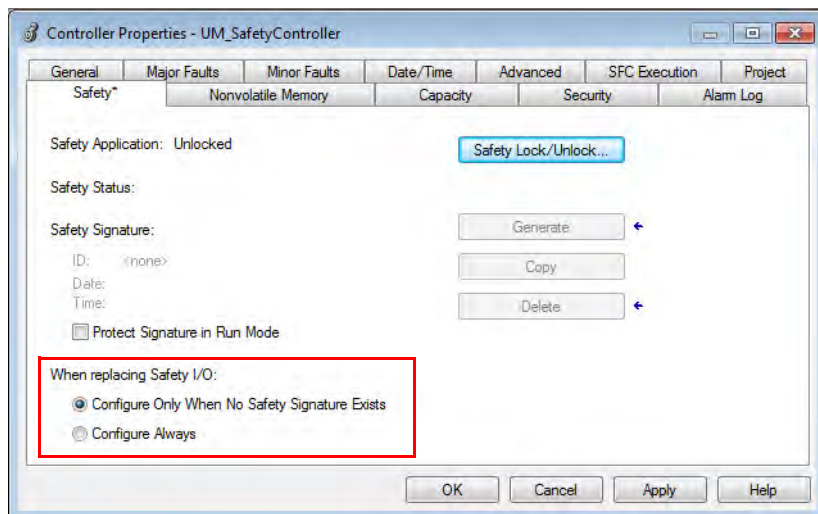

Configure Only When No Safety Signature Exists

This setting instructs the GuardLogix controller to automatically configure a safety drive only when the safety task does not have a safety task signature, and

the replacement drive is in an out-of-box condition, meaning that a safety network number does not exist in the safety drive.

If the safety task has a safety task signature, the GuardLogix controller automatically configures the replacement CIP Safety I/O device only if the following is true:

- The device already has the correct safety network number.
- The device electronic keying is correct.
- The node or IP address is correct.

For detailed information, see the GuardLogix 5580 Controllers User Manual, publication [1756-UM543](#) or Compact GuardLogix 5380 Controllers User Manual, publication [5069-UM001](#).

Configure Always

When the Configure Always feature is enabled, the controller automatically checks for and connects to a replacement drive that meets all of the following requirements:

- The controller has configuration data for a compatible drive at that network address.
- The drive has an SNN that matches the configuration.



ATTENTION: Enable the 'Configure Always' feature only if the entire integrated safety control system is not being relied on to maintain SIL 3 behavior during the replacement and functional testing of a PowerFlex 755/755T drive product.

If other parts of the integrated safety control system are being relied upon to maintain SIL 3, make sure that the controller's 'Configure Always' feature is disabled.

It is your responsibility to implement a process to make sure proper safety functionality is maintained during device replacement.



ATTENTION: Do not place any devices in the out-of-box condition on any integrated safety network when the 'Configure Always' feature is enabled, except while following the device replacement procedure in the GuardLogix user manual appropriate for your Logix 5000™ controller:

- GuardLogix 5580 Controllers User Manual, publication [1756-UM543](#).
 - Compact GuardLogix 5580 Controllers User Manual, publication [5069-UM001](#).
-

Motion Direct Commands in Motion Control Systems

You can use the Motion Direct Command (MDC) feature to initiate motion while the controller is in Program mode, independent of application code that

is executed in Run mode. These commands let you perform a variety of functions, for example, move an axis, jog an axis, or home an axis.

A typical use might involve a machine integrator testing different parts of the motion system while the machine is being commissioned or a maintenance engineer, under certain restricted scenarios in accordance with safe machine operating procedures, wanting to move an axis (like a conveyor) to clear a jam before resuming normal operation.



ATTENTION: To avoid personal injury or damage to equipment, follow these rules regarding Run mode and Program mode.

- Allow only authorized, trained personnel with knowledge of safe machine operation to use Motion Direct Commands.
 - Use additional supervisory methods, like removing the controller key switch, to maintain the safety integrity of the system after returning the safety controller to Run mode.
-

Understand STO Bypass When Using Motion Direct Commands

If a Safety-only connection between the GuardLogix safety controller and the PowerFlex 755/755T drive product was established at least once after it was received from the factory, then it does not allow motion while the safety controller is in Program mode by default.

This is because the safety task is not executed while the GuardLogix safety controller is in Program mode. This applies to applications running in a single-safety controller (with Motion and Safety connections). When an integrated safety drive has a Motion connection to a standard controller and a separate Safety connection to a dual-safety controller, the standard controller can transition to Program mode while the safety controller stays in Run mode and continues to execute the safety task.

However, PowerFlex 755/755T drive systems are designed with a bypass feature for the STO function in single-safety controller configurations. You can use the MDC feature to allow motion while following all necessary and prescribed steps per your machine's safety operating procedures.



ATTENTION: Consider the consequences of allowing motion through the use of MDC when the controller is in Program mode. You must acknowledge warning messages in the Logix Designer application that warn of the drive bypassing the STO function and unintended motion can occur. The integrated safety drive does not respond to requests of the STO function if MDC mode is entered.

It is your responsibility to maintain machine safety integrity while executing motion direct commands. One alternative is to provide ladder logic for Machine Maintenance mode that leaves the controller in Run mode with safety functions executing.

Logix Designer Application Warning Messages

When the controller is in Run mode, executing safety functions, the PowerFlex 755 drive follows the commands that it receives from the safety controller. The controller reports 'Safety State = Running' and 'Axis State = Stopped/Running', as shown in [Figure 70](#).

Figure 70 - Safety State Indications When Controller is in Run Mode (safety task executing)

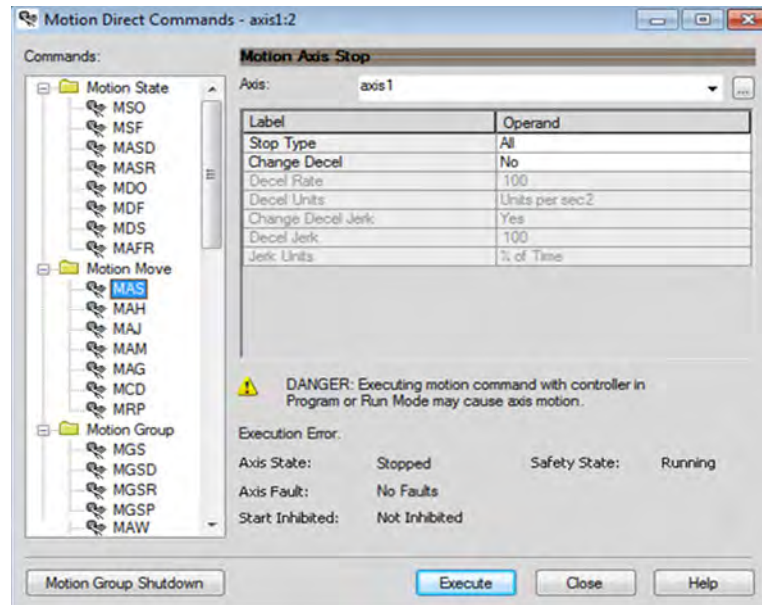

When the controller transitions to Program mode, the integrated safety drive is in the safe state (torque is not permitted). The controller reports 'Safety State = Not Running' and 'Axis State = Start Inhibited', as shown in [Figure 71](#).

Figure 71 - Safety State Indications After Controller Transitions to Program Mode

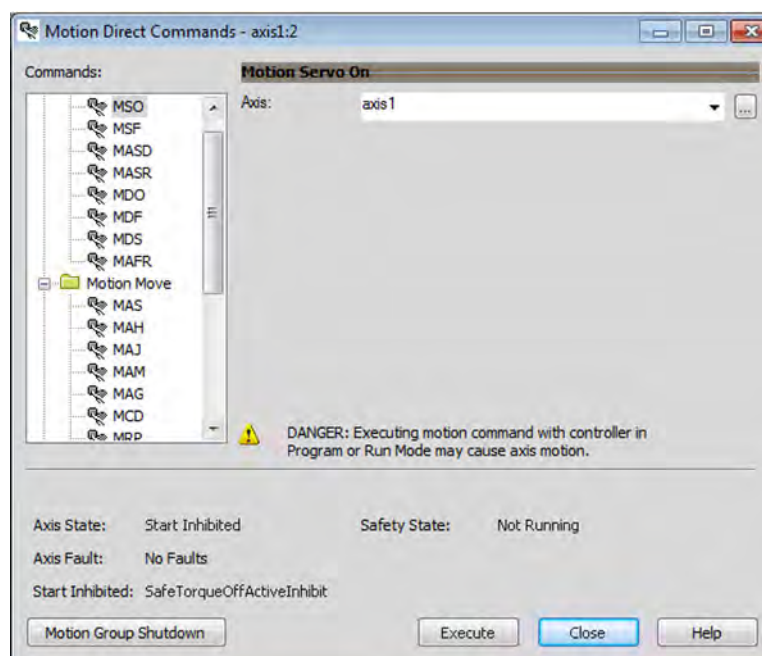

When you issue a motion direct command to an axis to produce torque in Program mode, for example MSO or MDS, with the safety connection present to the drive, a warning message is presented before the motion direct command is executed, as shown in [Figure 72](#).

Figure 72 - STO Bypass Prompt When the Safety Controller is in Program Mode

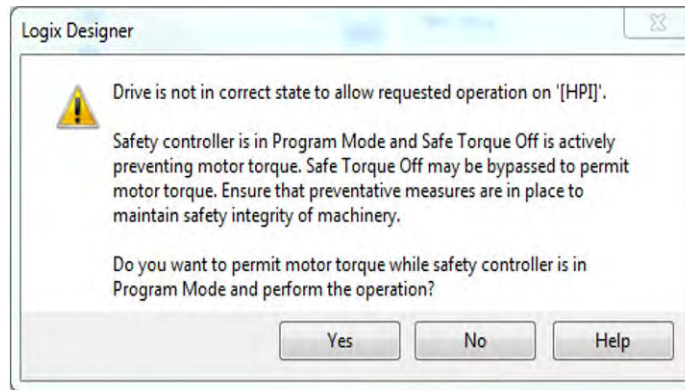

IMPORTANT The warning in [Figure 72](#) is displayed only the first time a motion direct command is issued.

After you acknowledge the warning message by clicking **Yes**, torque is permitted by the drive and a warning message is indicated in the software as shown in [Figure 73](#). The controller reports 'Safety State = Not Running (Torque Permitted)', 'Axis State = Stopped/Running' and 'Persistent Warning = Safe Torque Off bypassed'.

IMPORTANT Switch the controller to Run mode to exit Motion Direct Command mode and end the STO function bypass.

Figure 73 - Safety State Indications After Controller Transitions to Program Mode (MDC executing)

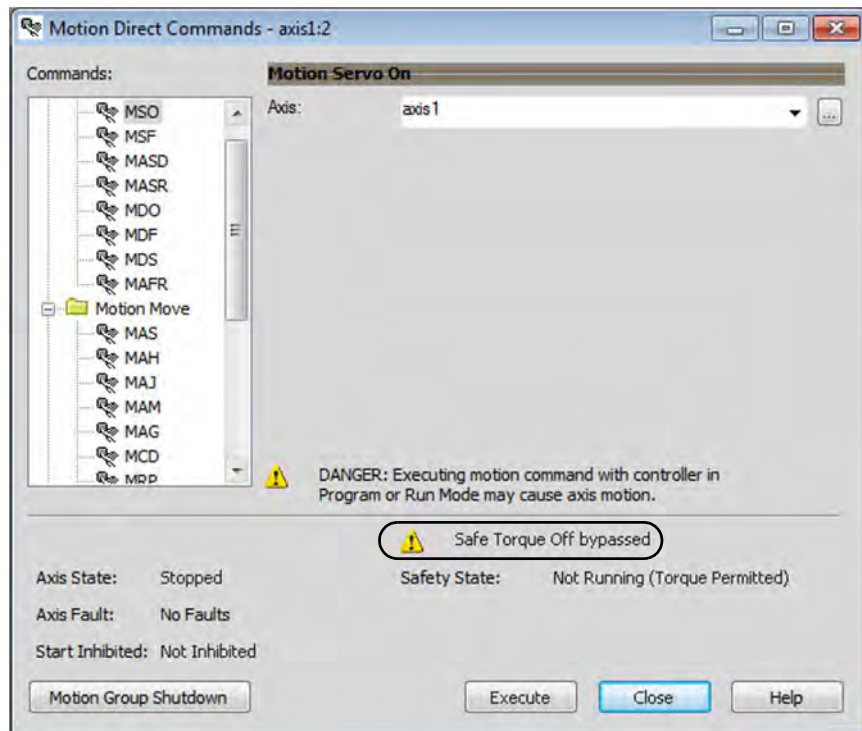

IMPORTANT The persistent warning message text 'Safe Torque Off bypassed' appears when a motion direct command is executed. The warning message persists even after the dialog is closed and reopened as long as the integrated safety drive is in STO Bypass mode. The persistent warning message is removed only after the integrated safety drive's Safety State is restored to the Running state.

Torque Permitted in a Multi-workstation Environment

The warning in [Figure 74](#) is displayed to notify a second user working in a multi-workstation environment that the first user has placed the integrated safety drive in the STO state and that the current action is about to bypass the STO state and permit torque.

Figure 74 - STO Bypass Prompt When MDC is Issued in Multi-workstation Environment

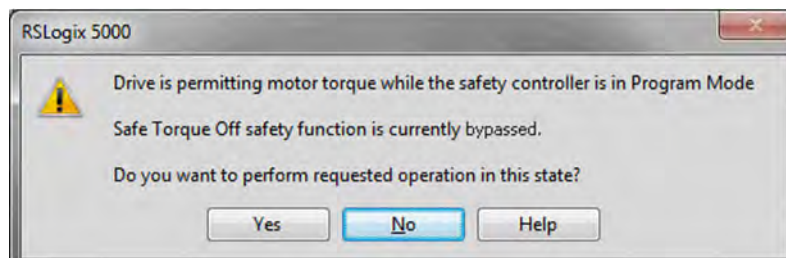

Warning Icon and Text in Axis Properties

In addition to the other warnings that require your acknowledgement, the Logix Designer application also provides warning icons and persistent warning messages in other Axis Properties dialog boxes when the integrated safety drive is in STO Bypass mode.

Figure 75 - Axis and Safe State Indications on the Hookup Services Dialog Box

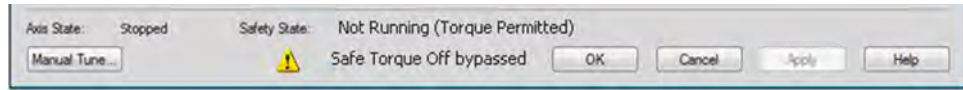

Figure 76 - Axis and Safe State Indications on Motion Direct Commands Dialog Box

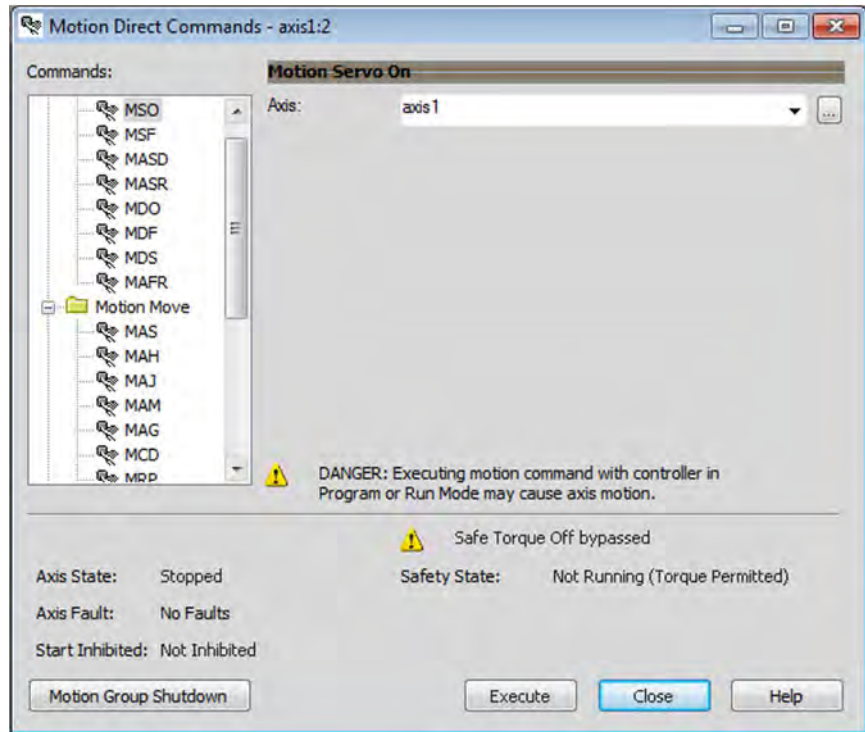
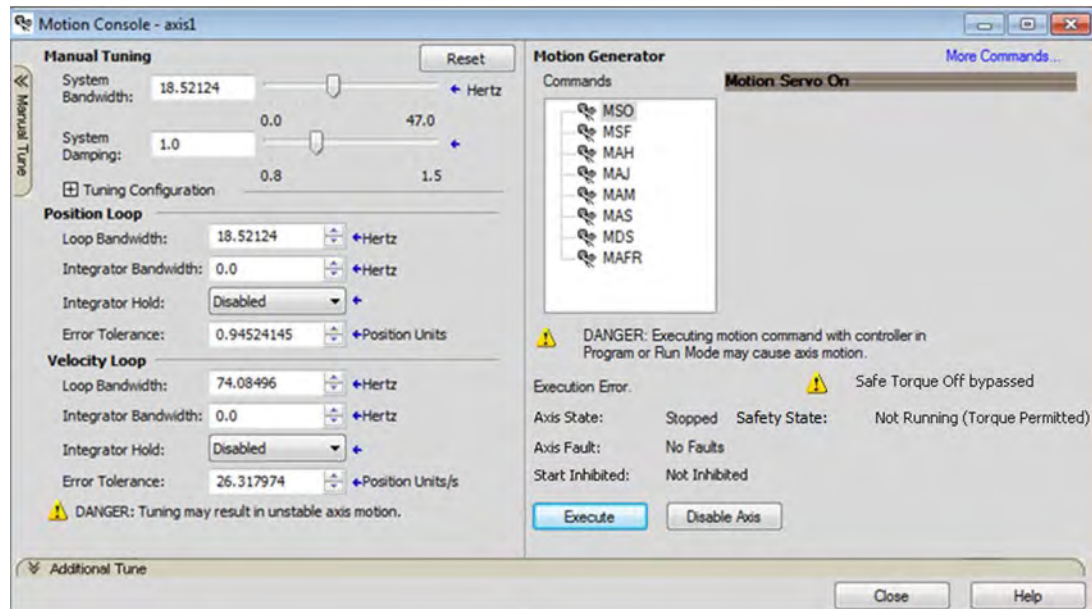

Figure 77 - Axis and Safe State Indications on the Motion Console Dialog Box



Functional Safety Considerations



ATTENTION: Before maintenance work can be performed in Program mode, the developer of the application must consider the implications of allowing motion through motion direct commands. Consider developing logic for runtime maintenance operations to meet the requirements of machine safety operating procedures.



ATTENTION: Motion is allowed and the STO function is not available when motion direct commands are used in Program mode. Motion direct commands issued when the controller is in Program mode cause the drive to bypass the STO Active condition. It is your responsibility to implement additional preventive measures to maintain safety integrity of the machinery during execution of motion direct commands in Program mode.



ATTENTION: To avoid personal injury and damage to equipment in the event of unauthorized access or unexpected motion during authorized access, return the controller to Run mode and remove the key before leaving the machine unattended.

Programming

Motion and Safety Tasks

Motion systems built using Rockwell Automation® Integrated Architecture™ components have separate motion and safety functions. In a typical control application with motion and safety connections, motion and safety tasks run in the following Logix 5000 controllers:

- Motion functions operate in a motion task of any ControlLogix® or CompactLogix™ (Logix 5000) controller
- Safety functions operate in a safety task of only GuardLogix 5580 or Compact GuardLogix 5380 controllers
- Motion tasks and safety tasks can operate in the same GuardLogix controller or in separate controllers
- The safety task, operating in a GuardLogix controller, communicates with the drive module with a safety connection over the EtherNet/IP® network. See Safety Task in [Figure 79](#) on [page 179](#).
- The motion task, operating in any of these controllers, communicates with the drive module Associated Axes with a motion connection over the EtherNet/IP network. See Motion Task in [Figure 79](#) on [page 179](#).
- The PowerFlex 755 and PowerFlex 755T drives and drive products contain one inverter for control of one motor and one motion axis.
- Feedback from position encoders, supplied to the motion tasks, is also associated with the axis.

Motion Safety Instances

The PowerFlex 755/755T drive products, with the Integrated Safety Function option module, contain one Motion Safety instance to provide integrated safety functions. The safety instance operates independently of the inverters and feedback used for motion. The drive module safety instance receives encoder safety feedback for use with the integrated safety functions. The safety feedback is also supplied to the controller safety task over the safety connection for use with controller-based safety functions that may operate in the controller.

A motion and safety system can be configured so that a safety function operates in the controller. This type of configuration is referred to as a controller-based safety function. The system can also be configured so that the safety function operates in the drive module with the initiation and monitoring of the function in the safety task. This type of safety function is referred to as drive-based safety. A motion system can have both controller-based and drive-based safety functions.

Safety Function Operation

In this example we describe how a motion and safety control system operates and how motion and safety tasks are coordinated. In typical motion and safety

system applications, an E-stop switch is used to stop the system. In the following example, the switch is used to initiate the process that brings the axis to a controlled stop before removing power. This type of stop is called Stop Category 1. The motion task and drive inverter are responsible for bringing the axis to a Category 1 stop. At the same time, to make sure that the Stop Category 1 is correctly executed by the motion system, the safety task initiates a Monitored SS1 safety function. The SS1 safety function can be configured to use the drive-based SS1 function or it can be configured to use the controller-based SS1 function.

This sequence of events represents the steps required for a Monitored SS1 drive-based safety function.

1. The safety task reads the E-stop input and detects the switch actuation.
2. The safety task communicates an SS1 request by setting the bit: `module:SO.SS1Request` tag of the drive (inverter) motion-safety instance.
3. The motion-safety instance in the drive communicates to the drive motion core of the Axis Safety Status.
4. The motion core communicates with the motion controller running the motion task by updating the motion axis tag `axis.SS1ActiveStatus`.
5. The motion task controls the axis to bring the motor to a stop within the Monitored SS1 limits for speed and time.
6. While the axis is stopping, the SS1 function (in the motion-safety instance) monitors the axis speed to make sure it remains below the speed limit and maximum stopping time.
7. When the axis reaches standstill speed, the motion-safety core activates the Safe Torque Off function.

This sequence of events represents the steps required for a Monitored SS1 controller-based safety function.

1. The safety task reads the E-stop input and detects the switch actuation.
2. The safety task activates the SS1 safety instruction running in the safety task.
3. The SS1 instruction communicates an SS1 active by setting the bit: `module:SO.SS1Active` tag of the drive (inverter) motion-safety instance.
4. The motion-safety instance in the drive communicates to the drive motion core of the Axis Safety Status.
5. The motion core communicates with the motion controller running the motion task by updating the motion axis tag `axis.SS1ActiveStatus`.
6. The motion task controls the axis to bring the motor to a stop within the Monitored SS1 limits for speed and time.

7. While all events are occurring, the motion-safety instance updates the Feedback Velocity tag, module:S1.FeedbackVelocity, in the safety controller. The SS1 function running in the safety task receives the speed scaled by the SFX safety instruction and makes sure the axis remains below the speed limit and maximum stopping time.
8. When the axis reaches standstill speed the SS1 safety instruction outputs SS1 complete.

The safety task communicates to the drive motion safety instance to activate STO by clearing the bit: module:SO.STOOutput tag of the drive motion-safety instance.

This figure shows how the safety task and motion tasks communicate with the drive.

Figure 78 - Safe Monitor System Communication

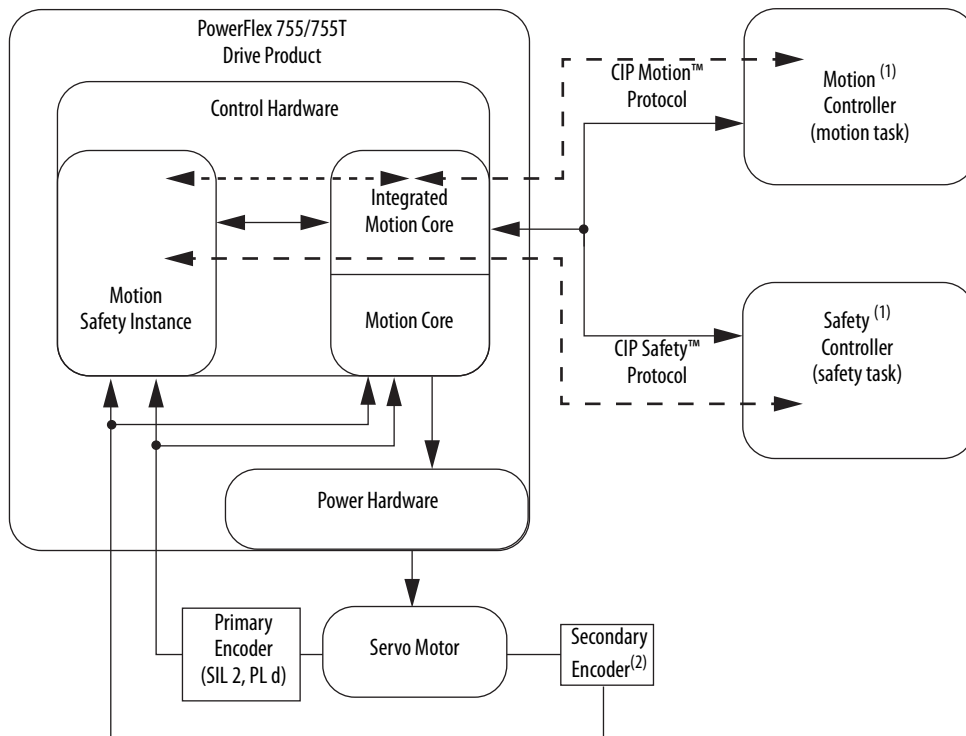

(1) Motion and Safety connections can be made from a single Safety controller or two separate Motion and Safety controllers.
 (2) The secondary encoder is required to meet a SIL 3 system rating.

Safe Monitor Network Communication

The safe monitor network executes motion and safety tasks by using CIP protocol.

Figure 79 - Motion and Safety Connections

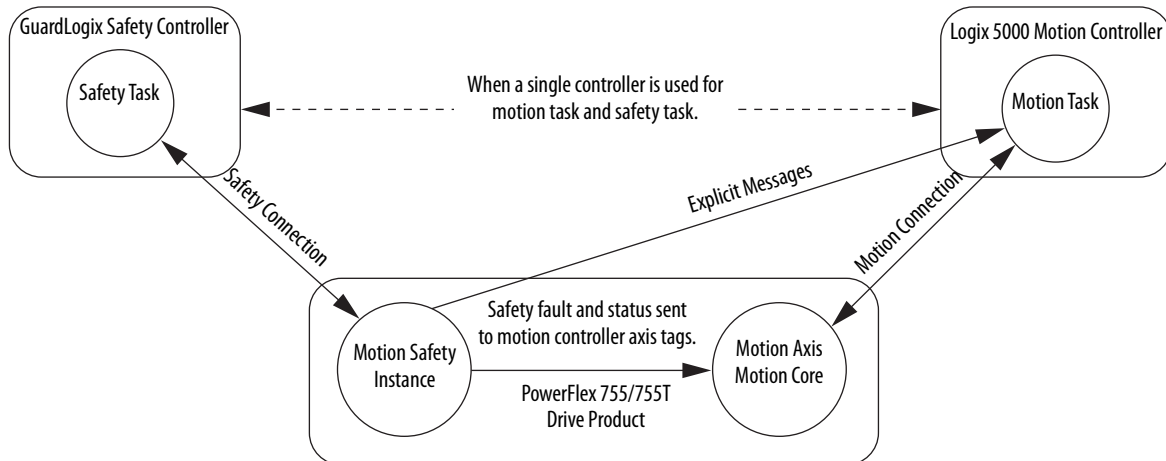

Motion Connection

The motion connection communicates drive motion and safety status to the motion task. The motion connection also receives motion commands from the motion task in the motion controller. Data is exchanged at a periodic rate over the connection. To configure the drive-module motion connection Axis Properties in the Logix Designer application, see the PowerFlex 750-Series AC Drives Programming Manual, publication [750-PM001-EN-P](#) or the PowerFlex Drives with TotalFORCE® Control Programming Manual, publication [750-PM100-EN-P](#).

Some of the axis tags are updated from fault and safety status provided by the safety instance in the drive module. The safety instance sends this status to the motion core and then on to the motion controller. Axis tags show the updated status. See [Figure 79](#) for an illustration on how status is sent to the motion controller.

IMPORTANT Axis tags are for status only and are not used by the safety function.

Table 61 - Motion Connection Axis Tags

Axis Tag Name (motion controller)	Motion Connection Attribute #	Data Type	Description	Safety Output Assembly Tag Name (safety controller)
Axis.AxisSafetyState	760	DINT	Drive module Safety Supervisor state. See the Safety Supervisor State on page 184 for more details.	None
Axis.AxisSafetyDataA	986	DINT	32-bit data container holding general-purpose safety data passed from the safety controller.	module:SO.SafetyDataA[instance]
Axis.AxisSafetyDataB	987	DINT	32-bit data container holding general-purpose safety data passed from the safety controller.	module:SO.SafetyDataA[instance]
Axis.AxisSafetyStatus	761	DINT	Collection of bits indicating the status of the standard safety functions for the axis as reported by Drive Safety Instance.	See individual bits below.
Axis.SafetyFaultStatus	[0]	BOOL	Any Safe Stop Fault occurring in the Safety Instance. 0 = Not Faulted 1 = Safety Fault	none
Axis.SafetyResetRequestStatus	[1]	BOOL	Indicates that the state of the reset request output from the safety controller (in the safety output assembly) connected with the drive safety instance. This is the reset input to the safety instance in the drive module. 0 = Reset Request OFF 1 = Reset Request ON	module:SO.ResetRequest[inst]
Axis.SafetyResetRequiredStatus	[2]	BOOL	Indicates that the drive-module safety instance associated with this Axis requires a reset of the safety function. 0 = Normal 1 = Reset Required	none
Axis.SafeTorqueOffActiveStatus	[3]	BOOL	Indicates that the state of the STO output from the safety controller, which is the STO input to the drive-module safety instance associated with this axis. 0 = STO Output Is active 1 = STO is not active, STO is not requested	module:SO.STO0up[inst]
Axis.SafeTorqueDisabledStatus	[4]	BOOL	Indicates that the drive-module safety instance Torque Disabled Status. 0 = Axis power structure is not inhibited by the safety instance 1 = Axis power structure is inhibited	none
Axis.SBCActiveStatus	[5]	BOOL	Indicates that the SBC function is active and the sequence to set the Safety Brake has started. This function is only available as a controller-based function. 0 = SBC Function is not Active 1 = SBC Function is Active	module:SO.SBCActive
Axis.SBCEngagedStatus	[6]	BOOL	Indicates that the External Safety Brake is engaged by the controller-based SBC function. 0 = Brake is Engaged 1 = Brake is Released	module:SO.SBCBrakeEngaged
Axis.SS1ActiveStatus	[7]	BOOL	Indicates that the controller-based or the drive-based SS1 function is active. 0 = SS1 Function is not Active 1 = SS1 Function is Active	module:SO.SSActive[inst]
Axis.SS2ActiveStatus	[8]	BOOL	Indicated that the controller-based SS2 function is active. 0 = SS2 Function is not Active 1 = SS2 Function is Active	module:SO.SSActive [inst]
Axis.SOSActiveStatus	[9]	BOOL	Indicates that the controller-based SOS function is active. 0 = SOS Function is not Active 1 = SOS Function is Active	module:SO.SOSActive[inst]
Axis.SOSSStandstillStatus	[10]	BOOL	Indicates that the controller-based SOS function has detected standstill according to the function configuration. 0 = monitored axis is not at Standstill 1 = monitored axis is at standstill	module:SO.SOSLimit[inst]
Axis.SMTActiveStatus	[11]	BOOL	Always 0. This function is not available	none
Axis.SMTOvertemperatureStatus	[12]	BOOL	Always 0. This function is not available.	none
Axis.SSMAActiveStatus	[16]	BOOL	For use with a controller-based SSM function.	module:SO.SSMAActive[inst]
Axis.SSMStatus	[17]	BOOL	For use with a controller-based SSM function.	module:SO.SSMStatus[inst]

Table 61 - Motion Connection Axis Tags (Continued)

Axis Tag Name (motion controller)	Motion Connection Attribute #	Data Type	Description	Safety Output Assembly Tag Name (safety controller)
<i>Axis.SLSActiveStatus</i>	[18]	BOOL	Indicates that the controller-based SLS function is active. 0 = SLS Function is not Active 1 = SLS Function is Active	<i>module:SO.SLSActive[inst]</i>
<i>Axis.SLSLimitStatus</i>	[19]	BOOL	Indicates that the controller-based SLS function has detected the monitored axis speed above the limit setpoint. 0 = axis is below setpoint speed 1 = axis is greater than or equal to the setpoint speed	<i>module:SO.SLSLimit[inst]</i>
<i>Axis.SLAAActiveStatus</i>	[20]	BOOL	Always 0. This function is not available.	none
<i>Axis.SLALimitStatus</i>	[21]	BOOL	Always 0. This function is not available.	none
<i>Axis.SDIActiveStatus</i>	[22]	BOOL	Indicates that the controller-based SDI function is active. 0 = SDI Function is not Active 1 = SDI Function is Active	<i>module:SO.SDIActive[inst]</i>
<i>Axis.SDILimitStatus</i>	[23]	BOOL	Indicates that the controller-based SDI function detected motion greater than the limit in the unintended direction. 0 = Limit not reached 1 = Unintended motion	<i>module:SO.SDILimit[inst]</i>
<i>Axis.SafePositiveMotionStatus</i>	[24]	BOOL	Always 0. This function is not available.	none
<i>Axis.SafeNegativeMotionStatus</i>	[25]	BOOL	Always 0. This function is not available.	none
<i>Axis.SCAActiveStatus</i>	[26]	BOOL	For use with a controller-based SCA function.	<i>module:SO.SCAActive[inst]</i>
<i>Axis.SCAStatus</i>	[27]	BOOL	For use with a controller-based SCA function.	<i>module:SO.SCAStatus[inst]</i>
<i>Axis.SLPActiveStatus</i>	[28]	BOOL	Indicates that the controller-based SLP function is active. 0 = SLP Function is not Active 1 = SLP Function is Active	<i>module:SO.SLPActive[inst]</i>
<i>Axis.SLPLimitStatus</i>	[29]	BOOL	Indicates that the controller-based SLP function has detected the monitored axis position outside of the setpoint limits. 0 = axis position is within the limits 1 = axis position is outside of the limits	<i>module:SO.SLPLimit[inst]</i>
<i>Axis.SafetyOutputConnectionClosedStatus</i>	[30]	BOOL	Indicates the safety connection status from the controller to the drive module. 0 = connection open 1 = connection closed	none
<i>Axis.SafetyOutputConnectionIdleStatus</i>	[31]	BOOL	Indicates the safety connection status from the controller to the drive module. 0 = connection active 1 = connection idle	none
<i>Axis.AxisSafetyStatusRA</i>	762	DINT	Collection of bits indicating the status of Rockwell Automation specific safety functions for the axis as reported by Drive Safety Instance.	See individual bits below.
<i>Axis.SafeBrakeIntegrityStatus</i>	[0]	BOOL	Status of an external safety brake controlled by SBC instruction. The brake status, released or engaged, is undetermined. 0 = SBC fault 1 = No faults detected	<i>module:SO.SBCIntegrity[inst]</i>
<i>Axis.SafeFeedbackHomedStatus</i>	[1]	BOOL	Status of the controller-based SFX position homing function.	<i>module:SO.SFHome[inst]</i>
<i>Axis.AxisSafetyFaults</i>	763	DINT	Collection of bits indicating the Safety Fault status of the drive-module safety instances and integrated safety functions.	See individual bits below.
<i>Axis.SafetyCoreFault</i>	[0]	BOOL	Indicates an internal fault occurred within the drive-module safety instance. In the case of dual-axis inverters, both safety instances fault. 0 = Normal Operation 1 = Fault	None (use explicit message)
<i>Axis.SafetyFeedbackFault</i>	[2]	BOOL	Indicates a fault occurred with the safety feedback or with the safety dual-channel feedback. 0 = Normal Operation 1 = Fault	None (use explicit message)

Table 61 - Motion Connection Axis Tags (Continued)

Axis Tag Name (motion controller)	Motion Connection Attribute #	Data Type	Description	Safety Output Assembly Tag Name (safety controller)
<i>Axis.SafeTorqueOffFault</i>	[3]	BOOL	Indicates a fault occurred within the STO function of the drive-module safety instance. 0 = Normal Operation 1 = Fault	None (use explicit message)
<i>Axis.SS1Fault</i>	[4]	BOOL	Indicates that a fault occurred with the drive-based or a controller-based SS1 function. 0 = Normal Operation 1 = Fault	<i>module:SO.SS1Fault[inst]</i>
<i>Axis.SS2Fault</i>	[5]	BOOL	Indicates that a fault occurred with the drive-based SS2 function. 0 = Normal Operation 1 = Fault	<i>module:SO.SS2Fault[inst]</i>
<i>Axis.SOSFault</i>	[6]	BOOL	Indicates that a fault occurred with the drive-based SOS function. 0 = Normal Operation 1 = Fault	<i>module:SO.SOSFault[inst]</i>
<i>Axis.SBCFault</i>	[7]	BOOL	Indicates that a fault occurred with the controller-based SS2 function. 0 = Normal Operation 1 = Fault	<i>module:SO.SBCFault[inst]</i>
<i>Axis.SMTFault</i>	[8]	BOOL	Always 0. This function is not available.	–
<i>Axis.SSMFault</i>	[16]	BOOL	Controller-based SSM fault. 0 = Normal Operation 1 = Fault	<i>module:SO.SSMFault[inst]</i>
<i>Axis.SLSFault</i>	[17]	BOOL	Controller-based SLS fault. 0 = Normal Operation 1 = Fault	<i>module:SO.SLSFault[inst]</i>
<i>Axis.SLAFault</i>	[18]	BOOL	Always 0. This function is not available.	–
<i>Axis.SDIFault</i>	[19]	BOOL	Controller-based SDI fault. 0 = Normal Operation 1 = Fault	<i>module:SO.SDIFault[inst]</i>
<i>Axis.SCAFault</i>	[20]	BOOL	Controller-based SCA fault. 0 = Normal Operation 1 = Fault	<i>module:SO.SCAFault[inst]</i>
<i>Axis.SLPFault</i>	[21]	BOOL	Controller-based SLP fault. 0 = Normal Operation 1 = Fault	<i>module:SO.SLPFault[inst]</i>
<i>Axis.SafetyValidatorFault</i>	[30]	BOOL	Always 0. This function is not available.	–
<i>Axis.SafetyUNIDFault</i>	[31]	BOOL	Always 0. This function is not available.	–
<i>Axis.AxisSafetyFaultsRA</i>	764	DINT	Collection of bits indicating the safety fault status of Rockwell Automation safety functions.	See individual bits below.
<i>Axis.SFXFault</i>	[1]	BOOL	Controller-based SFX fault. 0 = Normal Operation 1 = Fault	<i>module:SO.SFXFault[inst]</i>
<i>Axis.AxisSafetyAlarms</i>	753	DINT	Reserved for future use.	–

Pass-through Data

Some of the Motion Connection axis tags are updated from information that is received from the Safety Connection. This data originates in the safety controller as Safety Output assembly tags and are passed through the drive and on to the motion controller where the corresponding axis tag is updated. These data are called pass-through data.

The pass-through data includes items such as status and faults for controller-based safety functions. Two general-purpose 32-bit words are provided in the output assembly from the safety controller and appear as AxisSafetyDataA and Axis SafetyDataB in the motion controller associated axis.

Safety Data A and B are provided for the safety and motion application for additional safety program status. A typical use of Safety Data A and Safety Data B can be to indicate the value of a safety limit that is currently in effect for the motion application to control the motion accordingly.

IMPORTANT Axis tags are for status only and are not used by the safety function.

Safety Connection

The safety controller communicates with the safety instance in the drive module over the safety connection. Cyclic data are passed in each direction over the safety connection that appears in Safety Controller tag structures called input and output assembly. The safety connection cyclic rate is configured in the Logix Designer application.

The Safety Input Assembly tag structure is data from the drive module safety instance to the safety controller. The Safety Output Assembly tag structure is data from the safety controller to the drive module safety instance.

Explicit Messages

Use explicit messages to communicate with a drive and obtain additional fault, status, or configuration information that is not available in the Safety I/O Tag structure. Attribute data is useful for additional diagnostic information. An explicit message can be sent by any controller on the network and used to read any drive module attribute. See [Motion Connection](#) on [page 179](#) for the drive-module safety attribute names and numbers that can be used by an MSG instruction. See [Figure 79](#) on [page 179](#) to see how explicit messages are part of motion and safety communication.

When an explicit message is used, a class ID must be specified. The class ID identifies the safety object type in the drive module that is accessed.

Table 62 - Object Classes Available in Motion Safety Instances

Object Class	Motion Safety Instances
Safety Supervisor	1
Safe Stop Functions	1
Safety Feedback	2
Dual-channel Safety Feedback	1

IMPORTANT Explicit messages must not be used for any safety-related function.

Safety Supervisor State

In the drive module, the connection to the safety instance or instances is controlled by a safety supervisor. The supervisor status can be read by the motion controller through the motion connection and the safety controller through the Safety Input Assembly or by an explicit message.

The safety supervisor state provides information on the state of the integrated safety connection and the mode of operation. There is only one safety supervisor object per drive module.

Table 63 - Safety Supervisor State: MSG

Parameter	Value	Description
Service Code	0x0E	Get attribute single
Class	0x39	Safety supervisor
Instance	1	Drive-module safety instance associated with an axis
Attribute	0x0B	Device status
Data Type	SINT	Short integer

Table 64 - Safety Supervisor States

Value	Safety Supervisor State	Definition	Safety Mode
2	Configured (no safety connection)	No active connections	Integrated
4	Running	Normal running state	Integrated
7	Configuring	Transition state	Integrated
8	Not Configured	Hard-wired STO mode with torque disabled	Hard-wired (out of the box)
51	Not Configured (torque permitted)	Hard-wired STO mode with torque permitted	Hard-wired (out of the box)
52	Running (torque permitted)	STO bypass state	Integrated

Application Example - Using SFX, SS1, and SLS Instructions with Integrated Motion

In this example, a PowerFlex 755 drive (equipped with embedded Ethernet) controls a servo motor (catalog number MPL-B430P-M). A Universal Feedback option module (catalog number 20-750-UFB-1) and an Integrated Safety Function option module (catalog number 20-750-S4) are used to interface to a GuardLogix 5580 safety controller (catalog number 1756-L84ES).

This example shows the programming and configuration required for three of the most common safe monitoring functions:

- Safe Feedback
- Safe Stop 1
- Safe Limited Speed

An 800FP push button is configured as an emergency stop. It is monitored using a DCS ESTOP Instruction and is wired to one dual-channel S4 Safety Input. This input can generate Safe Stop 1 at any time during operation of the drive.

Figure 82 - Peripheral Device Definition

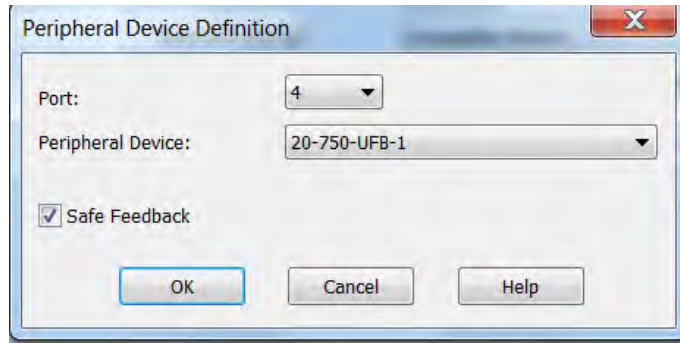

This PowerFlex 755 drive is configured with the 20-750-UFB-1 in port 4. The Safe Feedback checkbox must be checked for proper configuration and agreement with the safety switches on the Universal Feedback option module.

IMPORTANT The 20-750-S4 and 20-750-UFB-1 must reside in the same backplane board.

Figure 83 - Primary Feedback Configuration

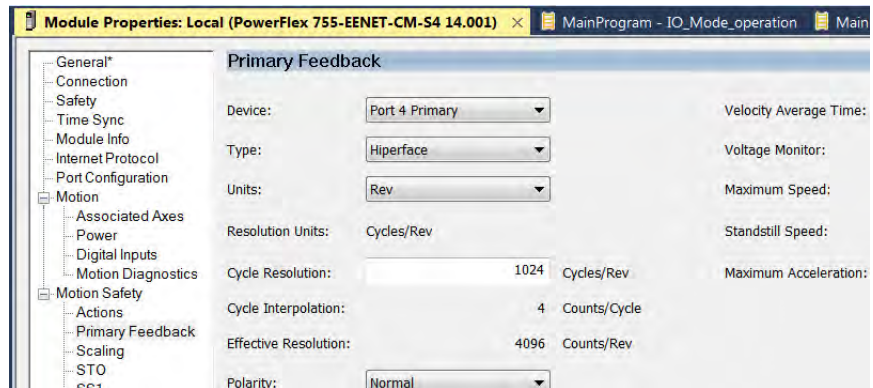

Since the MPL-B430P-M device is used for the primary safety channel, the normal cycles per revolution are 1024 and must be configured in the Primary Feedback tab.

Figure 84 - Studio 5000 Safety Scaling Configuration Example

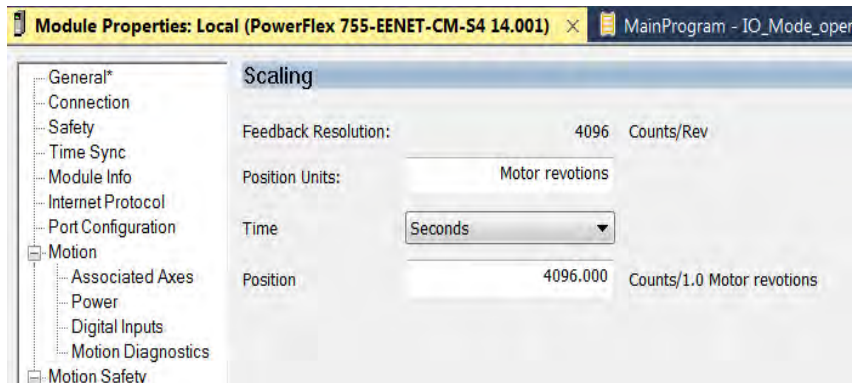
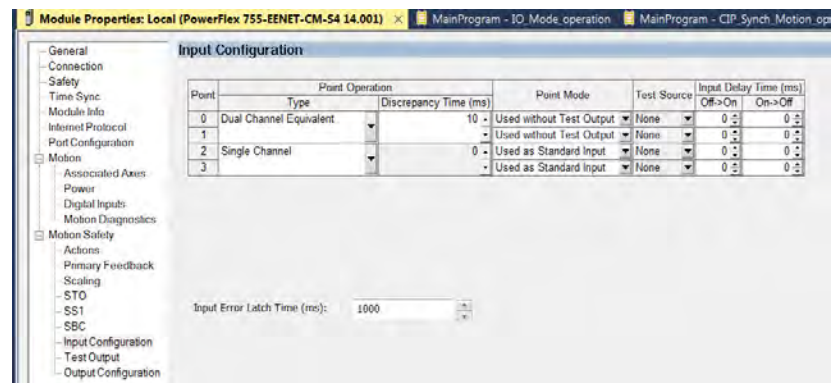
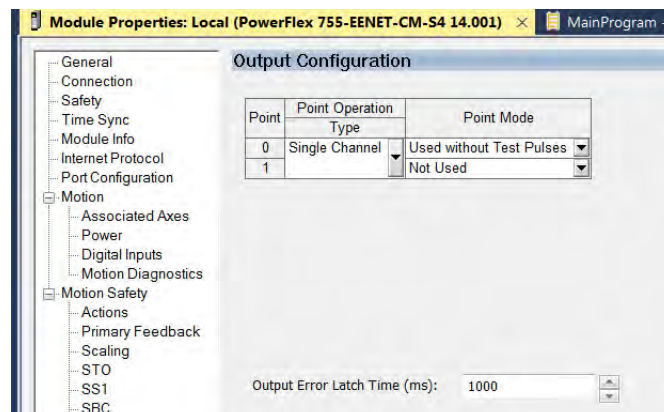

Figure 85 - Studio 5000 Safety Input Configuration Example



- Inputs 0 and 1 are used with an OSSD Estop input from the 800FP.
- Input 2 is a standard digital input from a push button to safety reset the S4 module.
- Input 3 is a standard digital input from a push button to set the SFX home.

Figure 86 - Studio 5000 Output Configuration Example



Programming Example

This example illustrates configuration of the safety input, logic, and output routines.

TIP Configure your system based on the required safety level devices and ratings.

Safety Input

The DCS Instruction is responsible for evaluating the dual-input validity into the GuardLogix safety controller.

Figure 87 - DCS Instruction with the S4 is Mapped to the 800FP

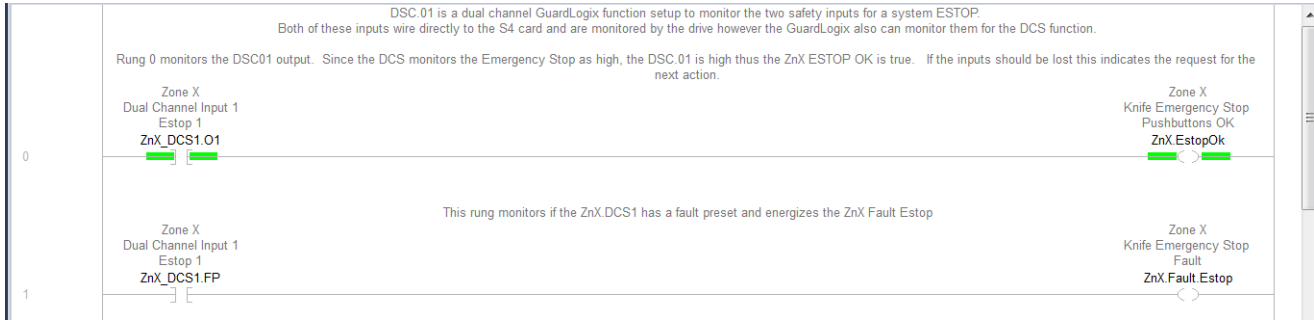
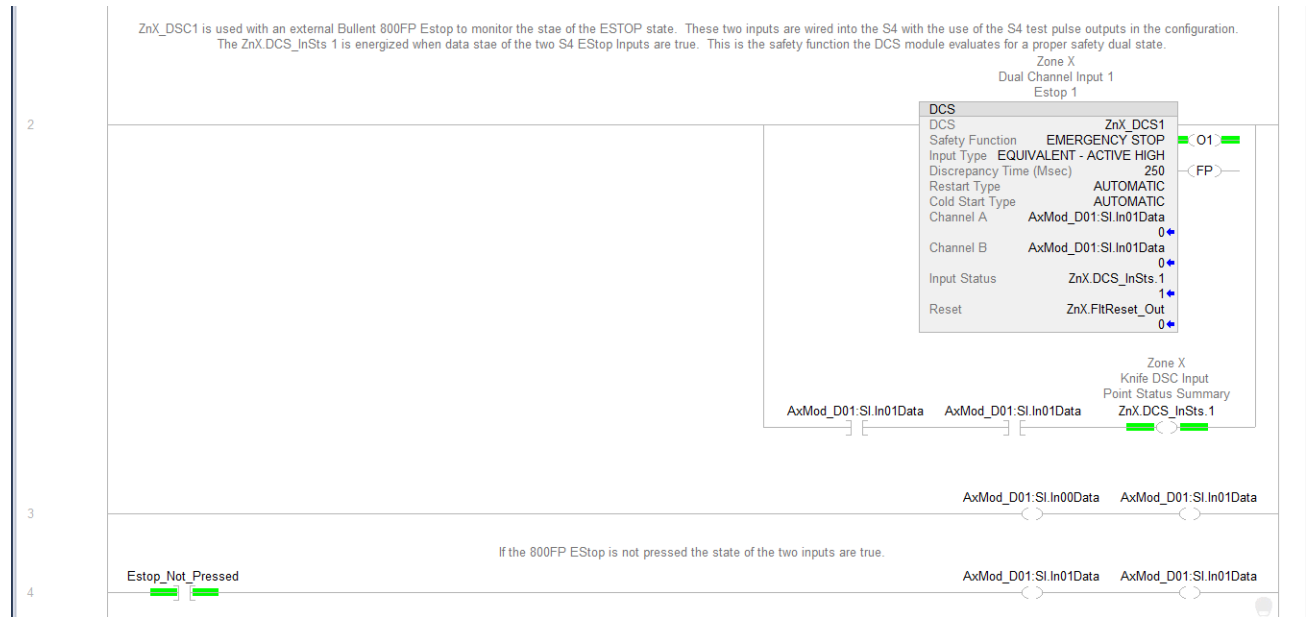

Figure 88 - DCS Instruction Evaluates Dual-input Validity



Safety Logic

The Safety Logic is used to configure when a safety reset occurs, the home trigger, and the execution of the SFX instruction (which must have primary feedback valid for it to execute properly).

Both the Safe Stop 1 and Safe Limited Speed use the SFX instruction for correct monitoring of feedbacks. The Safe Stop 1 requests when the 800FP inputs are removed. The Safe Limited Speed requests, in this example, with the toggling of the Examine On tag.

Figure 89 - Safety Logic Example

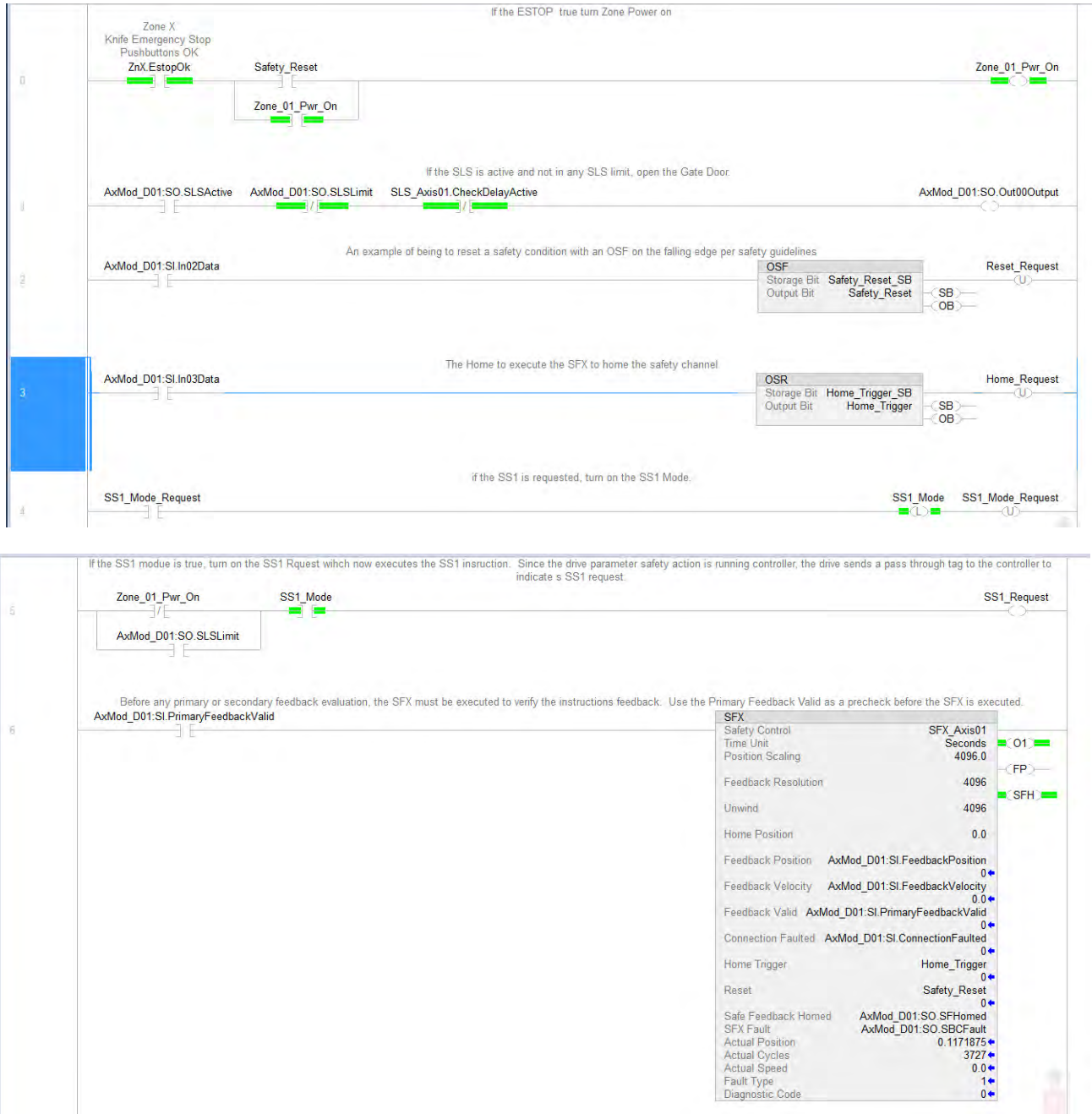

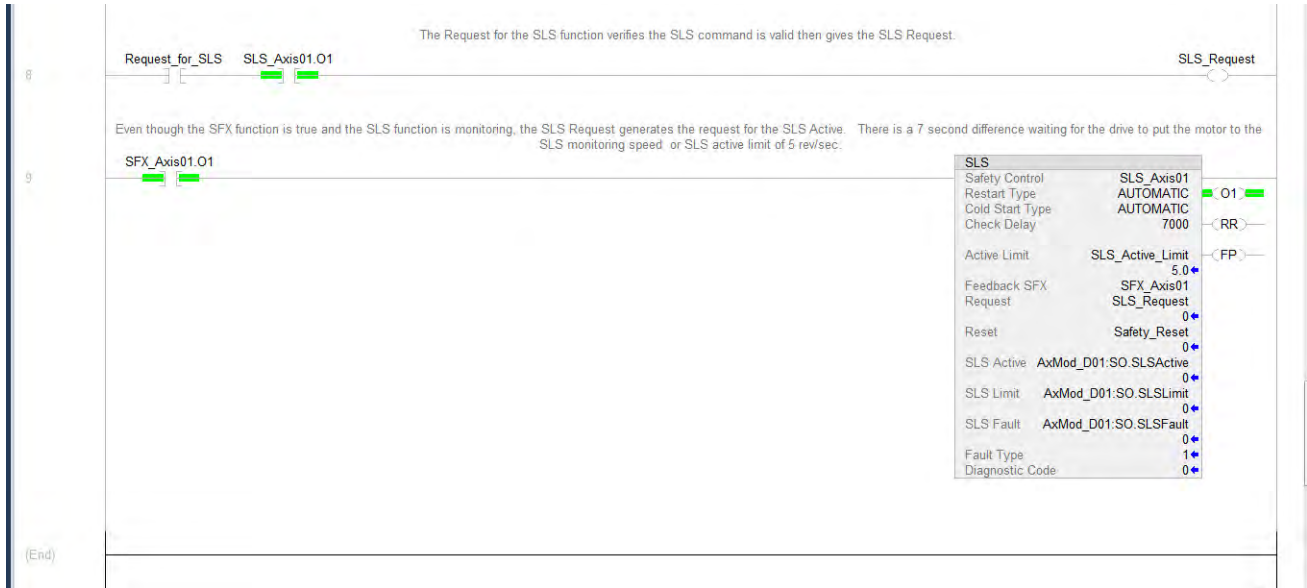

Safety Output

The Safe Torque Off output must be true in order for any of the preceding safe monitoring functions (namely SFX, SS1, and SLS) to function.

Figure 90 - Safety Output Example

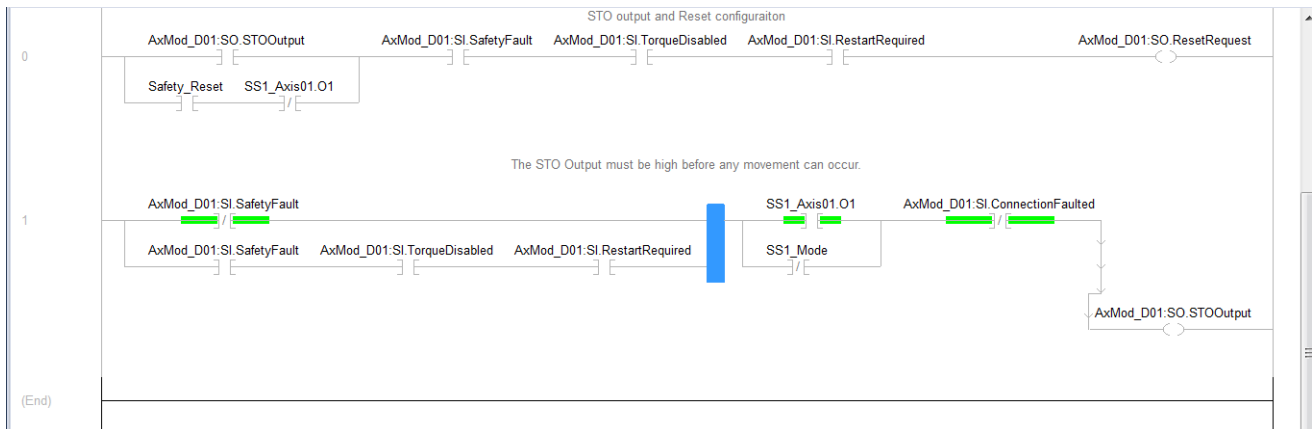

The PowerFlex 755 S4 safety actions can be configured based on the required reaction to various machine requirements. In this instance, the STO request is executed by the PowerFlex 755 in causing a disable and coast reaction. However, the request to the SS1 (requested by the GuardLogix Safety Task) is executed by the GuardLogix Motion Controller (not the Safety Controller) with the use of pass-through tags. In this case, the Motion Axis Stop is used to control stop the motor, as shown by the programming example.

Figure 91 - Safety Output Programming Example

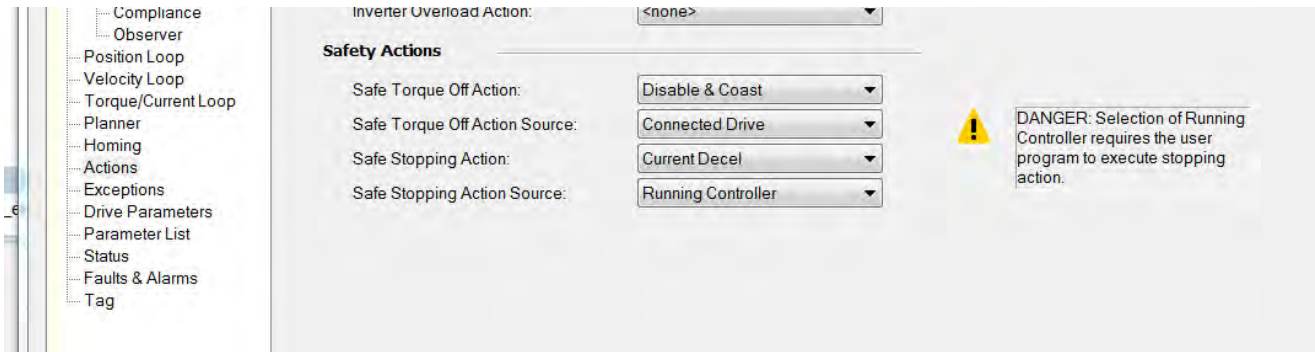

The Safe Limited Speed (and any other safe monitoring instruction requests besides STO, SS1, and SS2) are handled with the use of pass-through tags in the GuardLogix Motion Controller. The GuardLogix Safety Controller uses pass-through tags to the Motion Controller to use the Motion Change Dynamics instruction for the SLS request, as shown in the programming example.

Figure 92 - Motion Instructions Used to Motion Servo On and Motion Servo Off

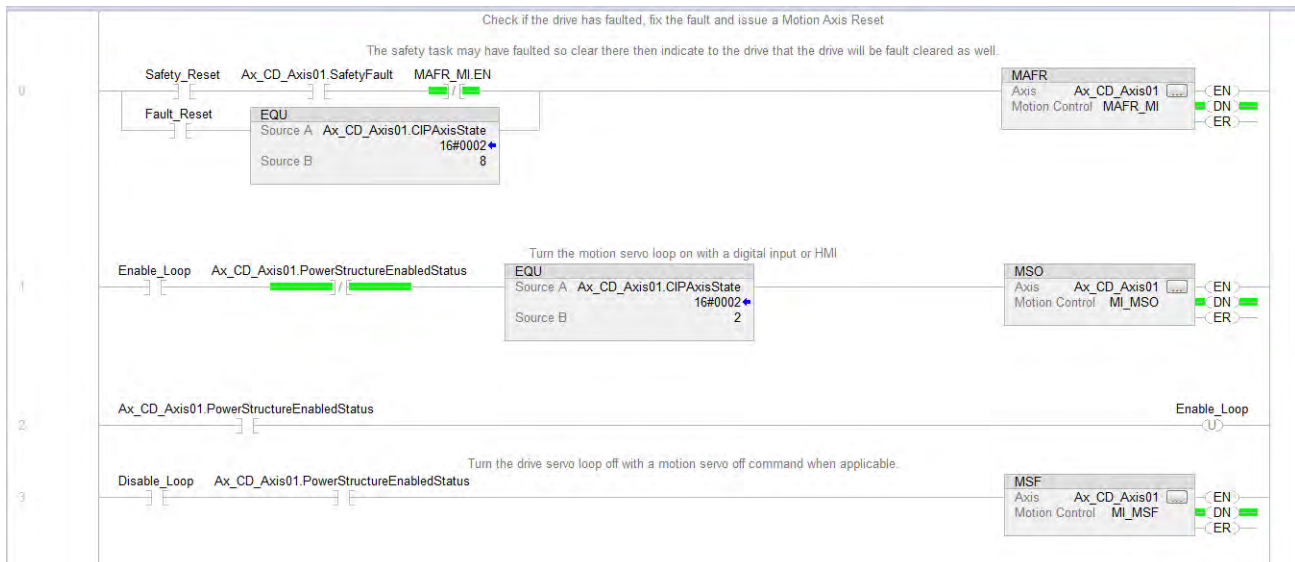

Figure 93 - Motion Instructions to Run the Motor at a Specific Velocity



Figure 94 - Use of the Motion Change Dynamics Instruction to Change from Normal Operating Speed to Safe Limited Speed and Back based on the Safety Task Request

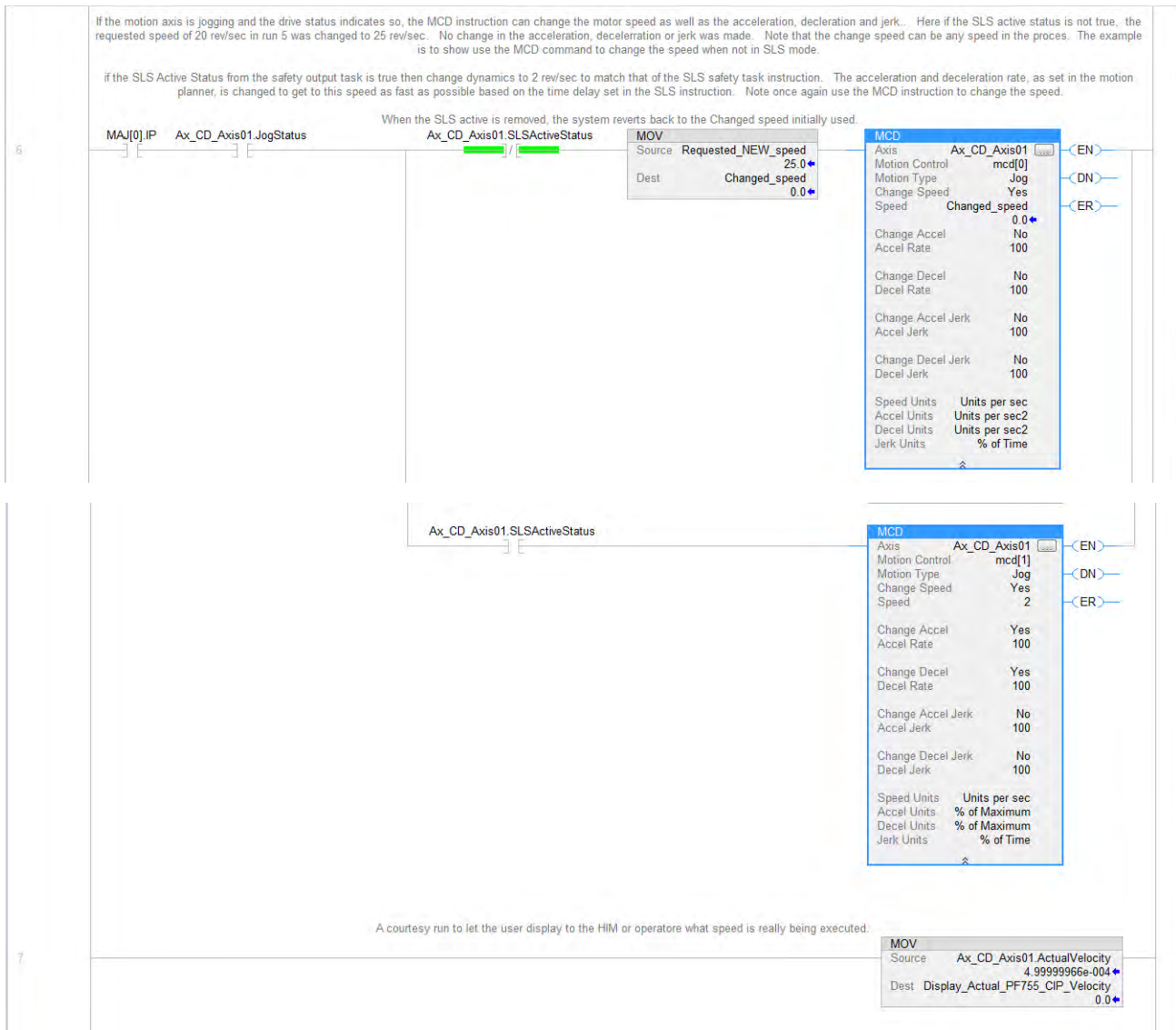
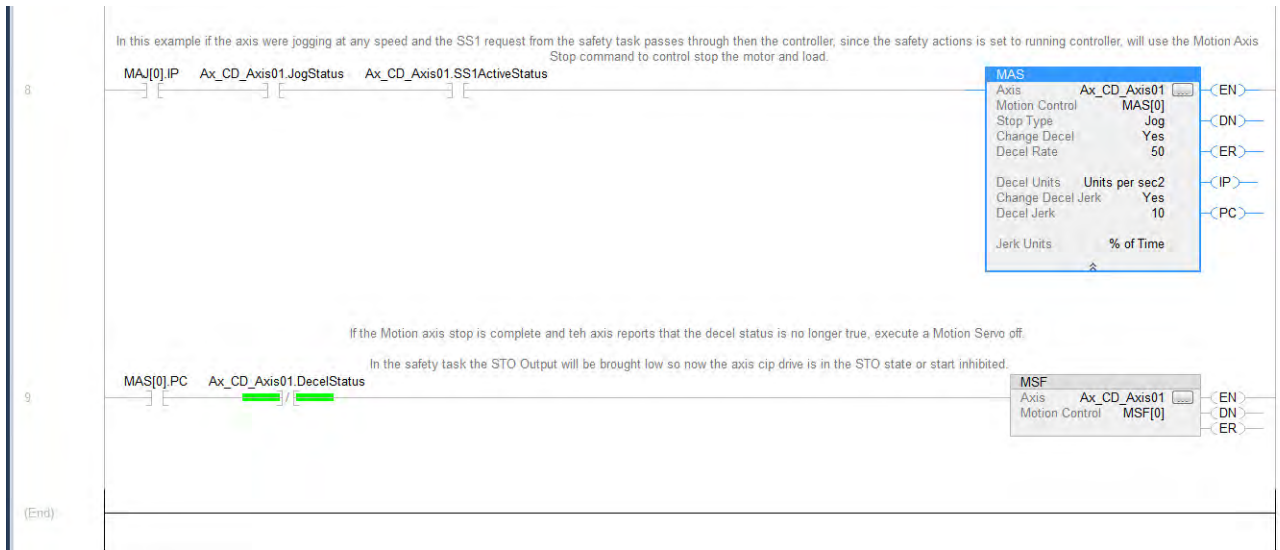

Figure 95 - Use of the Motion Axis Stop Instruction to Bring the Motor to 0 Speed Once the SS1 Request is Made From the Safety Task



When the stop is complete and 0 speed, the Motion Servo Off is given to open the position loop and stop modulating the drive. The Safety Task then uses the STO Output off to put the drive and motor into a Safe Torque Off state.

Monitoring and Troubleshooting

This chapter provides information for monitoring and troubleshooting the Integrated Safety Functions option module.

Topic	Page
Monitor Status Using Status Indicators	195
Monitor Status with a HIM or Software	205

Monitor Status Using Status Indicators

The option module has four status indicators to provide status of the module, safety network, and motion output of the drive:

- Module status (DS1)
- Network status (DS2)
- Motion output status (DS3)
- Safety fault (DS4)

IMPORTANT Status indicators are not reliable for safety functions. Use status indicators only for general diagnostics during commissioning or troubleshooting. Do not attempt to use status indicators to determine operational status.

Module Status Indicator (DS1)

[Table 65](#) provides information for the module status indicator.

Table 65 - Module Status LED (DS1)

For Safety Supervisor State ⁽¹⁾	Status Indicator	Description or Problem
No power	Off	No power is applied to drive
Device self-test (1)	Flashing red/green	Device is performing its power-on self-test
Waiting for TUNID (8) Configuring (7)	Flashing red/green	Module is not configured
Executing (5)	Green	Module is not configured
Idle state (2)	Flashing green	Standby (drive is not configured)
Abort (5)	Flashing red	Recoverable fault detected by drive
Firmware update in progress	Flashing red	Firmware update in progress (if DS2 is also flashing red)
Critical fault (6)	Red	Non-recoverable fault detected by drive

(1) The numbers in parentheses are the values in the Host Config P3 [Safety State] parameter.

Network Status Indicator (DS2)

[Table 66](#) provides information for the network status indicator.

Table 66 - Network Status LED (DS2)

State	Status Indicator	Description or Problem
Not powered/not online	Off	Device is not online or device is not powered – check Module Status LED
Self-test	Flashing red/green	Device is performing its power-on test
Setting safety network number	Fast flashing red/green	Replace device
No connection	Flashing green	Device is online but has no connections in the established state
Connected	Green	Device is online and has connections in the established state
Connection timeout	Flashing red	One or more I/O connections are in the timed-out state
Firmware update is in progress	Flashing red	Firmware update in progress (If DS1 is also flashing red)
Critical link failure	Red	Failed communications device – device has detected an error and it is not able to communicate on the network

Motion Output Status Indicator (DS3)

[Table 67](#) provides information for the motion output status indicator.

Table 67 - Motion Output Status LED (DS3)

State	Status Indicator	Problem
Torque disabled	Off	Torque is disabled
Torque permitted	Solid green	STO circuit is permitting torque
Circuit fault	Flashing red	STO circuit is faulted

Safety Fault Indicator (DS4)

[Table 68](#) provides information for the safety fault status indicator.

Table 68 - Safety Fault LED (DS4)

State	Status Indicator	Problem
No fault	Solid green	Safety functions and safety I/O are operational
Safety functions fault	Flashing red	There is a safety function fault and or safety I/O alarm
Critical Fault	Solid red	The module has experienced a serious critical fault

Safety Fault Names

The Motion Safety instance in the Integrated Safety Functions option module reports faults to the drive through the AxisSafetyFaults and AxisSafetyFaultsRA tags. Each bit in these tags indicates a specific fault. This information is used by the drive to log and display faults.

The Logix Designer application displays axis faults and status. When an axis is selected in the Controller Organizer, axis faults and status are displayed in the QuickView® software window.

Figure 96 - Axis Faults and Status

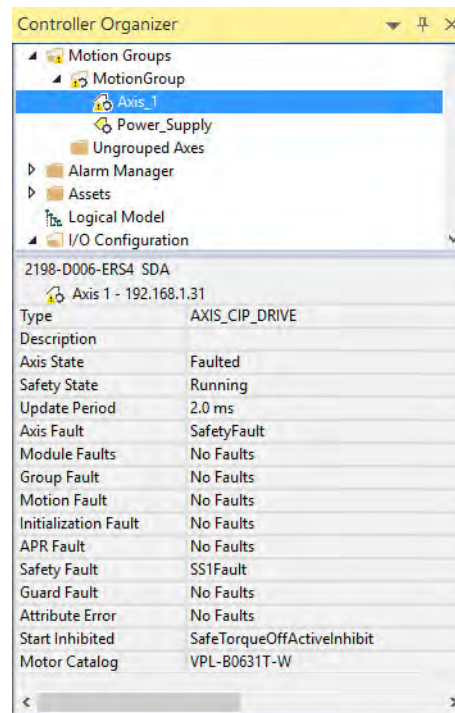

The safety faults named in [Table 69](#) appear as Safety Faults when they occur. In addition, if any of these faults are present, a safety fault appears under the axis fault. Corresponding axis tags are set with any of the faults.

Table 69 - Safety Fault Names

Fault Name	Description
SafetyCoreFault	Internal fault in the drive's safety processor
STOFault	A fault was detected by the Safe Torque Off function
SS1Fault ⁽¹⁾	A fault was detected by the Safe Stop 1 function
SS2Fault	A fault was detected by the Safe Stop 2 function
SOSFault	A fault was detected by the Safe Operating Stop function
SBCFault ⁽¹⁾	A fault was detected by the Safe Brake Control function
SSM Fault	A fault was detected by the Safe Speed Monitor function
SLSFault	A fault was detected by the Safely-limited Speed function
SDIFault	A fault was detected by the Safe Direction function
SCA Fault	A fault was detected by the Safe Cam function
SLPFault	A fault was detected by the Safe Limited Position function
SafetyFeedbackFault	The Safety processor has detected a problem with one or more of the safety feedback devices associated with the axis.

(1) A safety function fault bit can be set because the fault was detected by the internal drive safety function (if it is configured), or by the connected safety controller. Read the safety function's fault attribute from the drive to determine if the fault was generated by the drive or received from the safety controller.

Understand Safety Faults

To obtain more detailed information about any faults that are detected in the drive, most faults have a corresponding fault-type attribute. These attributes are read by using an MSG instruction in the ladder program to read the specific attribute information, or by reading the corresponding DPI™ parameter. Details of the various fault-type attributes are described in the following sections.

See [Explicit Messages on page 251](#) on for an example of using the MSG instruction to read status.

Safety Supervisor State

The Safety Supervisor State provides information on the state of the safety connection and the mode of operation. It can be read in the user's Logix program using explicit messaging via the MSG instruction.

Table 70 - Safety Supervisor State: MSG

Parameter	Value	Description
Service Code	0x0E	Get Attribute Single
Class	0x39	Safety Supervisor
Instance	1	–
Attribute	0x0B	Device Status
Data Type	SINT	Unsigned Short Integer

For P3 [Safety State] information, see [Table 78 on page 207](#).

Safety Core Fault

The Motion Safety instance has detected a non-recoverable fault or internal error. When this happens, the Motion Safety instance reboots itself and attempts to re-establish normal operation.

If this fault persists through power cycles, return the drive and safety module for repair. In case of malfunction or damage, no attempts at repair should be made. Do not dismantle the option module.

Safe Torque Off Fault

The Safe Torque Off (STO) function detected a fault. The safe stop function records the specific fault type in the STO Fault Type attribute. The STO Fault Type attribute is also recorded in P7 [STO Fault Type]. [Table 71](#) describes the parameters for an MSG instruction. [Table 72](#) describes the fault types.

Table 71 - Safe Torque Off Fault Type: MSG

Parameter	Value	Description
Service Code	0x0E	Get attribute single
Class	0x5A	Safety stop functions
Instance	1	Drive-module safety instance
Attribute	0x108	STO fault type
Data Type	SINT	Short integer

Table 72 - STO Fault Types

STO Fault Type Value	STO Fault Type Name	Description
3	Circuit Err	Internal STO diagnostics has found an issue with STO circuitry.
4	Stuck Low	Internal STO health and/or power input stuck low.
5	Stuck High	Internal STO health and/or power input stuck high.

Safe Stop 1 Fault

The Safe Stop 1 (SS1) function detected a fault. The safe stop function records the specific fault type in the Safe Stop Fault attribute. The SS1 Fault Type is also recorded in P10 [SS1 Fault Type]. [Table 74](#) describes the parameters for an MSG instruction. The drive immediately disables torque, ignoring STO delay, if an SS1 fault is detected. If the SS1 Fault Type is reported as 1 (no fault), the SS1 fault was generated by the connected safety controller and reported to the drive over the safety connection.

Table 73 - Safe Stop 1 Fault Type: MSG

Parameter	Value	Description
Service Code	0x0E	Get attribute single
Class	0x5A	Safety stop functions
Instance	1	Drive-module safety instance
Attribute	0x11c	SS1 fault type
Data Type	SINT	Short integer

Table 74 - SS1 Fault Types

SS1 Fault Type Value	SS1 Fault Type Name	Description
1	No Fault	No Fault is present
2	Config	The drive-based SS1 function has been requested when it has been configured as 'not used'.
3	Decel Rate	Applies only when SS1 is configured for Monitored SS1 mode. The SS1 function has detected that the feedback speed is not decelerating as fast as expected.
4	Maximum Time	Applies only when SS1 is configured for Monitored SS1 mode. The SS1 function has detected that the device has not reached standstill speed within the maximum stopping time.
101	Feedback Invalid	The Monitored SS1 function was requested when the associated safety feedback is not valid.

Safe Brake Control Fault

The Safe Brake Control (SBC) function detected a fault. The safe stop function records the specific fault type in the SBC Fault Type attribute. The SBC fault type is also recorded in P11 [SBC Fault Type]. [Table 75](#) describes the parameters for an MSG instruction. [Table 76](#) describes the fault types.

Table 75 - SBC Fault Type: MSG

Parameter	Value	Description
Service Code	0x0E	Get attribute single
Class	0x5A	Safety stop functions
Instance	1	Drive-module safety instance
Attribute	0x16C	SBC fault type
Data Type	SINT	Short integer

Table 76 - SBC Fault Types

STO Fault Type Value	STO Fault Type Name	Description
1	No Fault	No Fault is present.
2	Config	The drive-based SBC function has been requested when it has been configured as 'not used'.
3	Over Current	The current on an output controlling the safety brake has exceeded the maximum.
4	Stuck Low	An output controlling the safety brake is stuck low.
5	Stuck High	An output controlling the safety brake is stuck high.
6	Cross Conn	The outputs controlling the safety brake are cross connected.
7	Relay Fail	A relay of the outputs controlling the safety brake has failed.

SS2, SOS, SLS, SLP, and SDI Faults

The Integrated Safety Functions option module does not support drive-based SS2, SOS, SLS, SLP, and SDI safe stop/safety limit functions. If the drive reports one of these faults, then the fault was detected by the safety controller and reported to the drive over the safety output connection, or the request tag was set through the safety output assembly. Additional information for these faults must be obtained from the safety controller that is associated with the drive. In addition, the safety controller is responsible for issuing a torque disable request.

Safety Feedback Faults

When configured for safety feedback, the device performs periodic diagnostics to make sure that the feedback device is operating correctly. Explicit messaging can be used to read the fault type information from the drive. For example, if an error is detected, the Safe Feedback object (class code 0x58) updates the Safe Feedback Fault Type attribute (attribute ID 0x09) with the reason for the fault.

Table 77 - Safety Feedback Faults

Safe Feedback Fault Type Value	Safe Feedback Fault Type Name	Description
1	No Fault	No Fault is present.
2	Config	The encoder's configuration is invalid.
3	Max Speed	The encoder speed has exceeded the configured maximum speed.
4	Max Accel	The encoder acceleration has exceeded the configured maximum acceleration.
5	Sin ² +Cos ²	The encoder has failed the vector length or aspect ratio checks.
6	Quadrature	The encoder has exceeded the maximum number of quadrature signal errors.
7	Discrepancy	The associated dual channel feedback instance has reported a discrepancy.
8	Partner	The associated dual channel feedback instance has detected a fault in the other encoder.
9	Voltage	The associated dual channel feedback instance has detected a fault in the other encoder.
10	SignalNoise	The encoder signals have noise that is preventing operation.
11	Signal Lost	The encoder signals are not present.
12	Data Lost	Stopped receiving data from a Digital Encoder.
13	Device Fail	The encoder device has failed.
107	Max Freq	The frequency of the encoder has exceeded the maximum level for this product.
108	SinCosOffset	The offset of the Sine/Cosine signal from ground is outside the required level.
109	Pos Rollover	The encoder position count has exceeded the maximum value that can be represented in this product.

Safety Fault Reset

If the drive motion safety instance detects a fault, the input assembly tag *module:SI.SafetyFault* is set to 1. The associated *axis.SafetyFault* tag is also set to 1.

A Safety Fault can result from the SS1 stopping function, STO function, safety feedback, SBC function, or other safety diagnostics.

To clear (reset) the Safety Fault, the fault conditions must be removed first and then a transition from logic 0 to 1 of the *module:SO.ResetRequest* tag is required. It is only the 0 to 1 transition that clears the fault.

To clear an axis fault that is associated with a Safety Fault, first clear the Safety Fault from the safety task of your application, then clear the axis fault using the MAFR command from the motion application. If the drive is not in integrated motion, then first clear the safety fault in the safety task and then clear the drive fault by writing to the *O.LogicCommand_ClearFaults* bit.

See [Figure 97](#) on [page 205](#) for more information about the Integrated Safety Functions option module state restart functionality.

Figure 97 - Reset Safe Stop Fault Diagram

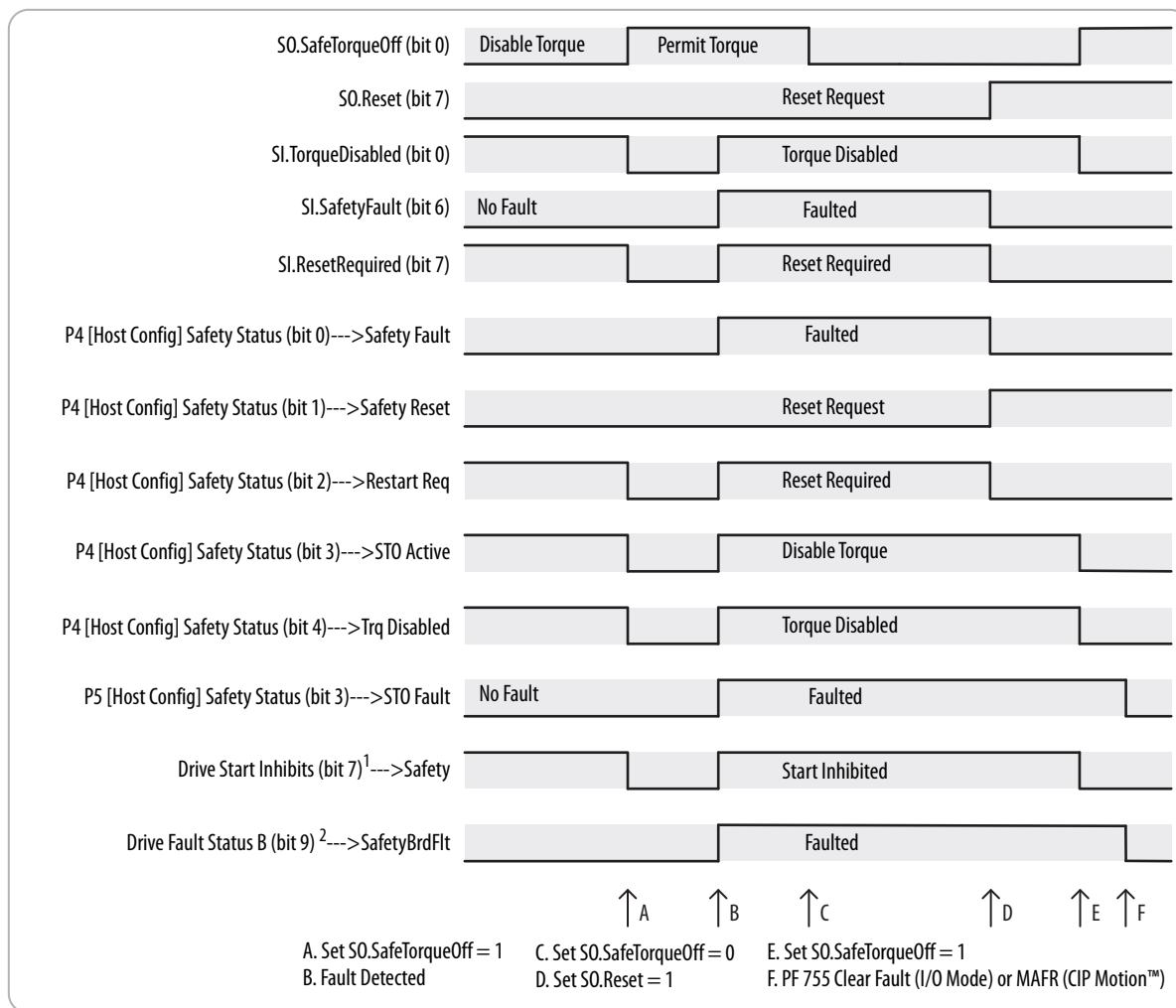

Monitor Status with a HIM or Software

This section describes safety-related status information available for viewing with a HIM, Drive Module Properties in the Logix Designer application, or Connected Components Workbench™ software.

Fault Messages on HIM, Drive Module, and Connected Components Workbench Software

The only message that is displayed for any fault originating from the module is 'SAFETY BRD FAULT' with a fault code of F211 for PowerFlex 755 drives and a code of F87 for PowerFlex 755T drives. This fault is displayed by the HIM, drive module, and Connected Components Workbench software. To determine the cause of the fault, examine the bits set in P4 [Safety Status] in Connected Components Workbench, or by examining the SO.PassThruStopFaults and SO.PassThruLimitFaults in the Logix Designer

application. After determining the fault type, see the [Understand Safety Faults](#) section for more information on the fault.

Safety board faults are also stored in the drive fault queue:

Figure 98 - Drive Fault Queue

#	Code	Description	Time Stamp
1	211	Safety Brd Fault	1970-10-12 02:32:16.849
2	51	Cr Fault Queue	1970-10-12 02:30:51.128

Further information on the cause of the fault is also recorded in the Integrated Safety Functions module events queue:

Figure 99 - Mobile Events Queue

#	Code	Description	Elapsed Time
1	36	SSI Fault	00:00:41.5500000
2	25	Trq Disabled	00:00:41.5490000
3	24	STO Active	00:00:41.5490000
4	20	Sfty JO Flur	00:00:38.1580000
5	26	Trq Enabled	00:00:38.1580000
6	18	Sfty JO Open	00:00:38.0570000
7	25	Trq Disabled	00:00:07.0710000
8	24	STO Active	00:00:07.0710000
9	21	Safety Reset	00:00:07.0710000
10	27	INCLIP Host Sync	00:00:07.0300000
11	6	DPE Baud 500kpps	00:00:06.4200000
12	13	SI Online	00:00:06.4080000
13	2	Device Power Up	00:00:00



ATTENTION: The status data that are described in this section is STANDARD data (not SAFETY data) and cannot be used as part of a safety function.

For diagnostic purposes, you can also view status attributes by accessing the following Host Config parameters. These parameters are different than the 'Device Config' parameters from a HIM, Connected Components Workbench software, or the Logix Designer application:

- P3 [Safety State]
- P4 [Safety Status]
- P5 [Safety Faults]
- P6 [Safe Status Mfg]
- P7 [Safe Faults Mfg]

See [Table 78](#) through [Table 84](#) for a description of these parameters.

Table 78 - P3 [Safety State]

Value	Display Text	Description
1	Testing	Device is performing test diagnostics
2	Idle	No active connections
3	Test Flt	A fault has occurred while executing test diagnostics
4	Executing	Normal running state
5	Abort	A major recoverable fault has occurred
6	Critical Flt	A critical fault has occurred
7	Configuring	Transition state
8	Waiting	Out-of-box state
51	Wait w Trq	Out-of-box state
52	Exec w Trq	STO bypass state

Table 79 - P4 [Safety Status]

Bit	Display Text	Description
0	Safety Fault	Indicates the existence of a safety fault. 0 = no fault 1 = faulted
1	Safety Reset	A transition from 0 to 1 resets the safety function.
2	Restart Req	Indicates whether a manual restart is required following a stop function. 0 = restart not required 1 = restart required
3	STO Active	Indicates whether STO control is active. 0 = Not Active (Permit Torque) 1 = Active (Disable Torque)
4	Trq Disable	Displays the status of STO control. 0 = Torque Permitted 1 = Torque Disabled
5	SBC Active	Indicates whether the Safe Brake Control function is active. 0 = Not Active 1 = Active
6	Brak Engage	Indicates whether the Safe Brake Control function has engaged the brake. 0 = Brake Released 1 = Brake Engaged
7	SS1 Active	Indicates whether the Safe Stop 1 function is active. 0 = Not Active 1 = Active
8	SS2 Active	Indicates whether the Safe Stop 2 function is active. 0 = Not Active 1 = Active
9	SOS Active	Indicates whether the Safe Operating Stop function is active. 0 = Not Active 1 = Active
10	SOS StndStll	Indicates whether the Safe Operating Stop function is comparing the actual feedback value to the set point. 0 = Not comparing 1 = Comparing
11	SMT Active	Indicates whether the Safe Motor Temperature function is active. Reserved for future use. Always 0.
12	SMT OvrTemp	Indicates whether the Safe Motor Temperature function has detected a temperature above the limit. Reserved for future use. Always 0.

Table 79 - P4 [Safety Status] (Continued)

Bit	Display Text	Description
16	SSM Active	Indicates if the Safe Speed Monitoring function is active. 0 = Not Active 1 = Active
17	SSM Limit	Indicates the status of the Safe Speed Monitoring function. 0 = Speed is below limit 1 = Speed is above limit
18	SLS Active	Indicates if the Safely Limited Speed function is active. 0 = Not Active 1 = Active
19	SLS Limit	Indicates if the speed exceeds the SLS limit. 0 = Speed within limit 1 = Speed exceeds limit
20	SLA Active	Indicates if the Safely Limited Acceleration function is active. Reserved for future use. Always 0.
21	SLA Limit	Indicates if the acceleration exceeds the SLA limit. Reserved for future use. Always 0.
22	SDI Active	Indicates if the Safe Direction function is active. 0 = Not Active 1 = Active
23	SDI Limit	Indicates if the Safe Direction function has detected movement in the prohibited direction. 0 = Direction OK 1 = Prohibited Direction
24	Pos Motion	The feedback device indicates a positive position value.
25	Neg Motion	The feedback device indicates a negative position value.
26	SCA Active	Same as event description.
27	SCA Status	Same as event description.
28	SLP Active	Same as event description.
29	SLP Status	Same as event description.
30	Conn Closed	No active connection of an output assembly from the safety controller exists.
31	Conn Idle	An active output assembly connection exists but the safety controller is in Program mode.

Table 80 - P5 [Safety Faults]

Bit	Display Text	Description
1	Core Fault	The module has detected an unrecoverable fault.
2	Fdbk Fault	A fault is present in a safety feedback device.
3	STO Fault	This bit indicates the fault status of the STO function. 0 = no fault 1 = faulted The cause of the fault is recorded in device P7 [STO Fault Type].
4	SS1 Fault	This bit indicates the fault status of the SS1 function. 0 = No fault 1 = Faulted The cause of the fault is recorded in device P1 [SS1 Fault Type].
5	SS2 Fault	This bit indicates the fault status of the SS2 function. 0 = No fault 1 = Faulted
6	SOS Fault	This bit indicates the fault status of the SOS function. 0 = No fault 1 = Faulted
7	SBC Fault	This bit indicates the fault status of the SBC function. 0 = No fault 1 = Faulted
8	SMT Fault	This bit indicates the fault status of the SMT function. Reserved for future use. Always 0.
16	SSM Fault	This bit indicates the fault status of the SSM function. 0 = No fault 1 = Faulted
17	SLS Fault	This bit indicates the fault status of the SLS function. 0 = No fault 1 = Faulted
18	SLA Fault	This bit indicates the fault status of the SLA function. Reserved for future use. Always 0.
19	SDI Fault	This bit indicates the fault status of the SDI function. 0 = No fault 1 = Faulted
20	SCA Fault	This bit indicates the fault status of the SCA function. 0 = No fault 1 = Faulted
21	SLP Fault	This bit indicates the fault status of the SLP function. 0 = No fault 1 = Faulted
30	VAL Fault	The Safety Validator Object has detected a fault.
31	UNID Fault	The Safety Validator Object has detected a fault relating to the Unique Identifier number.

Table 81 - P6 [Safe Status MFG]

Bit	Display Text	Description
0	Brak Intgrty	Indicates the brake controlled by the Safe Brake Control function has integrity.
1	Fdbk Homed	Indicates the Safety Feedback homing has been completed and the Safety Feedback position is tracking from a known reference position.

Table 82 - P7 [Safe Faults Mfg]

Bit	Display Text	Description
1	SFX Fault	The Safety Feedback Interface Add On Instruction has experienced a fault.

Table 83 - P8 [Safety Data A]

Data Type	Display Text	Description
DWORD	Safety Data A	User-defined data sent from Safety Controller.

Table 84 - P9 [Safety Data B]

Data Type	Display Text	Description
DWORD	Safety Data B	User-defined data sent from Safety Controller.

Monitor Status Using Integrated Motion

This section describes safety-related status information available in the Integrated Motion Axis tags in the motion controller. These tags can be monitored by user programs in the motion controller and they can be examined when the Logix Designer application is online with the motion controller.

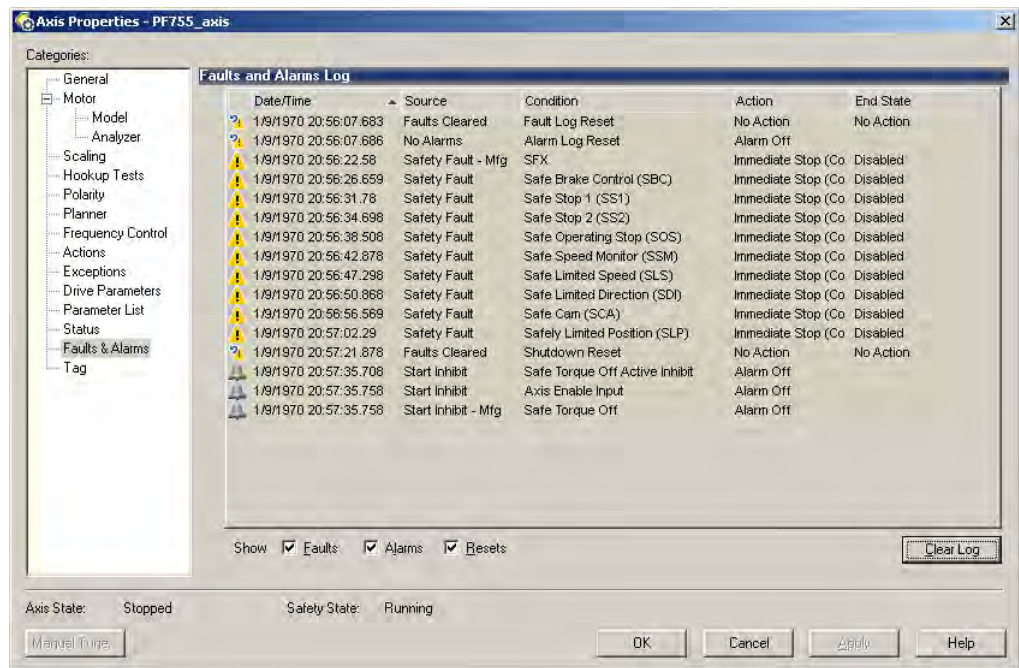

Table 85 - Motion Connection Axis Tags

Axis Tag Name (motion controller)	MDAO Attribute or [bit]	Data Type	Description
Axis.CIPStartInhibits	676	DINT	A bit map that specifies the current state of all standard conditions that inhibits starting of the axis.
Axis.SafeTorqueOffActiveInhibit	[5]	BOOL	Indicates if the Safe Torque Off function is inhibiting the axis from starting. 0 = STO is not inhibiting axis 1 = STO is inhibiting axis
Axis.AxisSafetyState	760	DINT	Drive module Safety Supervisor state. See Safety Supervisor State on page 199 for more details.
Axis.AxisSafetyStatus	761	DINT	Collection of bits indicating the status of the standard safety functions for the axis as reported by Drive Safety Instance.

Table 85 - Motion Connection Axis Tags (Continued)

Axis Tag Name (motion controller)	MDAO Attribute or [bit]	Data Type	Description
Axis.SafetyFaultStatus	[0]	BOOL	Indicates that a fault was detected by a drive-based safety function. 0 = No Fault 1 = Faulted
Axis.SafetyResetRequestStatus	[1]	BOOL	Indicates the state of the module:SO.ResetRequest controller output tag. A transition from 0 to 1 resets drive-based safety functions.
Axis.SafetyResetRequiredStatus	[2]	BOOL	Indicates that the drive-module safety instance that is associated with this Axis requires a reset of the safety function. 0 = Normal 1 = Reset Required
Axis.SafeTorqueOffActiveStatus	[3]	BOOL	Set if the drive-based STO function is active (to disable torque).
Axis.SafeTorqueDisabledStatus	[4]	BOOL	Set if the drive-based STO function has disabled torque.
Axis.SBCActiveStatus	[5]	BOOL	Set if the drive-based SBC instruction is active (to engage brake) or if the controller-output tag module:SO.SBCBrakeEngaged is set.
Axis.SBCEngagedStatus	[6]	BOOL	Set if the drive-based SBC instruction has engaged the brake OR if the controller-output tag module:SO.SBCBrakeEngaged is set.
Axis.SS1ActiveStatus	[7]	BOOL	Set if the drive-based SS1 instruction is active OR if the module:SO.SS1Active controller tag is set.
Axis.SS2ActiveStatus	[8]	BOOL	Indicates the status of the module:SO.SS2Status controller output tag. See the controller-based SS2 instruction.
Axis.SOSActiveStatus	[9]	BOOL	Indicates the status of the module:SO.SS2Status controller output tag. See the controller-based SS2 instruction.
Axis.SOSStandstillStatus	[10]	BOOL	Indicates the status of the module:SO.SOSStandstill controller output tag. See the controller-based SOS instruction.
Axis.SMTActiveStatus	[11]	BOOL	Reserved for future use. Always 0.
Axis.SMTOvertemperatureStatus	[12]	BOOL	Reserved for future use. Always 0.
Axis.SSMActiveStatus	[16]	BOOL	Indicates the state of the module:SO.SSMActive controller output tag.
Axis.SSMStatus	[17]	BOOL	Indicates the state of the module:SO.SSMStatus controller output tag.
Axis.SLSActiveStatus	[18]	BOOL	Indicates the state of the module:SO.SLSActive controller output tag.
Axis.SLSLimitStatus	[19]	BOOL	Indicates the state of the module:SO.SLSLimit controller output tag.
Axis.SLAAActiveStatus	[20]	BOOL	Indicates the state of the module:SO.SLAAActive controller output tag. Reserved for future use. Always 0.
Axis.SLALimitStatus	[21]	BOOL	Indicates the state of the module:SO.SLALimit controller output tag. Reserved for future use. Always 0.
Axis.SDIActiveStatus	[22]	BOOL	Indicates the state of the module:SO.SDIActive controller output tag. See the controller-based SDI instruction.
Axis.SDILimitStatus	[23]	BOOL	Indicates the state of the module:SO.SDILimit controller output tag. See the controller-based SDI instruction.
Axis.SafePositiveMotionStatus	[24]	BOOL	Set if the primary feedback velocity is greater than Standstill Speed.
Axis.SafeNegativeMotionStatus	[25]	BOOL	Set if the primary feedback velocity is less than Standstill Speed.
Axis.SCAActiveStatus	[26]	BOOL	Indicates the state of the module:SO.SCAActive controller output tag.
Axis.SCAStatus	[27]	BOOL	Indicates the state of the module:SO.SCAStatus controller output tag.
Axis.SLPActiveStatus	[28]	BOOL	Indicates the state of the module:SO.SLPActive controller output tag. See the controller-based SLP instruction.
Axis.SLPLimitStatus	[29]	BOOL	Indicates the state of the module:SO.SLPStatus controller output tag. See the controller-based SLP instruction.
Axis.SafetyOutputConnectionClosedStatus	[30]	BOOL	No active connection of an output assembly from the safety controller exists.

Table 85 - Motion Connection Axis Tags (Continued)

Axis Tag Name (motion controller)	MDAO Attribute or [bit]	Data Type	Description
Axis.SafetyOutputConnectionIdleStatus	[31]	BOOL	An active output assembly connection exists but the safety controller is in Program mode.
Axis.AxisSafetyStatusRA	762	DINT	Collection of bits indicating the status of Rockwell Automation specific safety functions for the axis as reported by Drive Safety Instance.
Axis.SafeBrakeIntegrityStatus	[0]	BOOL	Indicates the state of the module:SO.SBCIntegrity controller output tag. See the controller-based SBC instruction description.
Axis.SafeFeedbackHomedStatus	[1]	BOOL	Indicates the state of the module:SO.SFHomed controller output tag. See the controller-based SFX instruction description.
Axis.AxisSafetyFaults	763	BOOL	Collection of bits indicating the Safety Fault status of the drive-module safety instances and integrated safety functions.
Axis.SafetyCoreFault	[0]	BOOL	Internal SSM fault. Cycle drive power to reset. If the fault reoccurs, replace the option module.
Axis.SafetyFeedbackFault	[2]	BOOL	A feedback fault was detected.
Axis.SafeTorqueOffFault	[3]	BOOL	This bit indicates the fault status of the STO function (0 = no fault, 1 = faulted). The cause of the fault is recorded in P7 [Device Config STO Fault Type].
Axis.SS1Fault	[4]	BOOL	The drive-based SS1 function has detected a fault OR the controller-output tag module:SO.SS1Fault is set. Enters 'Safe Stop 1 (SS1)' in the Axis Properties Faults and Alarms Log. Cleared by a Motion Axis Fault Reset (MAFR). For Drive-based SS1 Fault, see P10 [SS1 Fault Type] for more information. For controller-based SS1, see the SS1 instruction description.
Axis.SS2Fault	[5]	BOOL	Set if the module:SO.SS2Fault controller output tag is set. Enters 'Safe Stop 2 (SS2)' in the Axis Properties Faults and Alarm Log. Cleared by a Motion Axis Fault Reset (MAFR). See the controller-based SS1 instruction description.
Axis.SOSFault	[6]	BOOL	Set if the module:SO.SOSFault controller output tag is set. Enters 'Safe Operating Stop (SOS)' in the Axis Properties Faults and Alarms Log. Cleared by a Motion Axis Fault Reset (MAFR). See the controller-based SOS instruction description.
Axis.SBCFault	[7]	BOOL	Set when the drive-based SBC function has detected a fault or the controller-output tag module:SO.SBCFault is set. Enters 'Safe Brake Control (SBC)' in the Axis Properties Faults and Alarms Log. Cleared by a Motion Axis Fault Reset (MAFR). For a drive-based SBC Fault, see P11 [SBC Fault Type] for more information. For a controller-based SBC Fault, see the SBC instruction description.
Axis.SMTFault	[8]	BOOL	Reserved for future use. Always 0.
Axis.SSMFault	[16]	BOOL	Set if the module:SO.SSMFault controller output tag is set. Enters 'Safe Speed Monitor (SSM)' in the Axis Properties Faults and Alarms Log. Cleared by a Motion Axis Fault Reset (MAFR).
Axis.SLSFault	[17]	BOOL	Set if the module:SO.SLSFault controller output tag is set. Enters 'Safe Limited Speed (SLS)' in the Axis Properties Faults and Alarms Log. Cleared by a Motion Axis Fault Reset (MAFR). See the controller-based SLS instruction description.
Axis.SLAFault	[18]	BOOL	Reserved for future use. Always 0.
Axis.SDIFault	[19]	BOOL	Set if the module:SO.SDIFault controller output tag is set. Enters 'Safely Limited Direction (SDI)' in the Axis Properties Faults and Alarms Log. Cleared by a Motion Axis Fault Reset (MAFR). See the controller-based SDI instruction description.
Axis.SCAFault	[20]	BOOL	Set if the module:SO.SCAFault controller output tag is set. Enters 'Safe Cam (SCA)' in P45 [SDI Fault] in the Axis Properties Faults and Alarms Log. Cleared by a Motion Axis Fault Reset (MAFR).
Axis.SLPFault	[21]	BOOL	Set if the module:SO.SLPFault controller output tag is set. Enters 'Safely Limited Position (SLP)' in P46 [SLP Fault] in the Axis Properties Faults and Alarms Log. Cleared by a Motion Axis Fault Reset (MAFR). See the controller-based SLP instruction description.

Table 85 - Motion Connection Axis Tags (Continued)

Axis Tag Name (motion controller)	MDAO Attribute or [bit]	Data Type	Description
Axis.SafetyValidatorFault	[30]	BOOL	The Safety Validator Object has detected a fault.
Axis.SafetyUNIDFault	[31]	BOOL	The Safety Validator Object has detected a fault relating to the Unique Identifier number.
Axis.AxisSafetyFaultsRA	764	DINT	Collection of bits indicating the safety fault status of Rockwell Automation safety functions.
Axis.SFXFault	[1]	BOOL	Set if the module:SO.SFXFault controller output tag is set. Enters 'SFX' in the Axis Properties Faults and Alarms Log. Cleared by a Motion Axis Fault Reset (MAFR). See the controller-based SFX instruction description.
Axis.AxisSafetyAlarms	753	DINT	Reserved for future use.

Out-of-Box State

This section describes the out-of-box state.

Recognize Out-of-Box State

You can determine if the drive is in the out-of-box state by using a diagnostic parameter or by using the Logix Designer application.

IMPORTANT Only authorized personnel can reset ownership. The safety connection must be inhibited before the reset. If any active connection is detected, the safety reset is rejected.

The safety control state can be read from P3 [Host Config Safety State] via the HIM or Connected Components Workbench software. You can also use an MSG command in Logix Designer application to read the Safety Supervisor Status.

If the state is 'Waiting' (8), then the safety control is in the out-of-box state.

Restore the Drive to Out-of-Box State

Use the Safety Reset [#14] Diagnostic Item (only online)

Before you can reset the drive to out-of-box state, the value of the Safety Reset [#14] diagnostic item must be 'Ready' (1) or the reset is not allowed. Set the Safety Reset [#14] diagnostic item to 'Reset' (2) by using a HIM or Connected Components Workbench software.

Reset the Drive by Using the Logix Designer Application

After the integrated safety connection configuration is applied to the PowerFlex® 755 drive at least once, you can follow these steps to restore your PowerFlex 755 drive to the out-of-box state while online.

1. Right-click the PowerFlex 755 drive you created, and choose **Properties**.

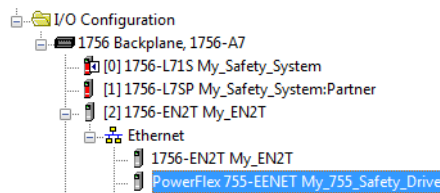

- Click the Connection tab.

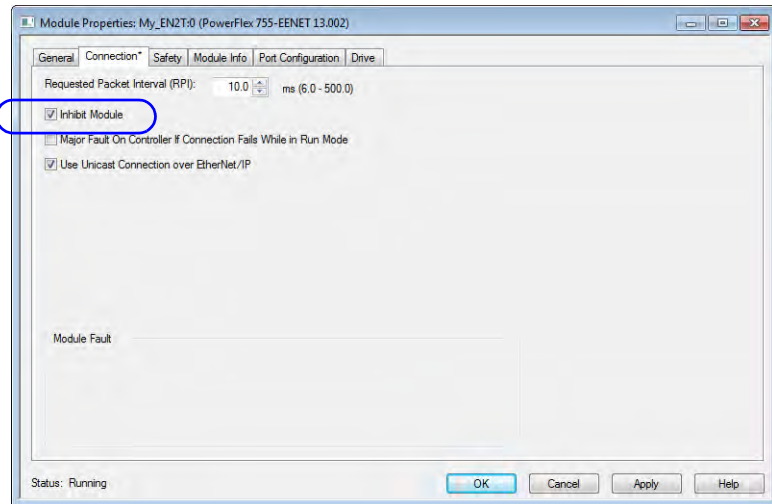

- Check **Inhibit Module**.
- Click **Apply**.
- Click the Safety Tab.

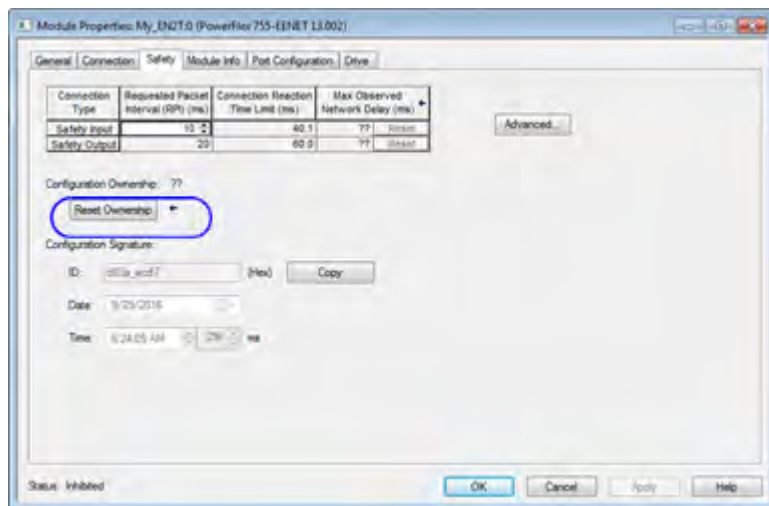

- Click **Reset Ownership**.
- Click the Connection tab.
- Clear the **Inhibit Module** checkbox.
- Click **Apply**.
- Click **OK**.

Notes:

Safety Function Validation Checklist

Use this appendix to validate your drive safety instructions. Each instruction has a checklist with test commands and results to verify for normal operation and abnormal operation scenarios.

Topic	Page
Safe Stop 1 (SS1)	218
Safe Stop 2 (SS2)	220
Safe Operating Speed (SOS)	223
Safely-limited Speed (SLS)	225
Safely-limited Position (SLP)	226
Safe Direction (SDI)	228
Safe Feedback Interface (SFX)	229
Safe Brake Control (SBC)	231

Safe Stop 1 (SS1)

Use this SS1 instruction checklist to verify normal operation and the abnormal operation scenarios.

IMPORTANT Perform I/O verification and validation before validating your safety ladder program. SFX instruction must be verified within your application.

When possible, use immediate operands for instructions to reduce the possibility of systematic errors in your ladder program.

Instruction operands must be verified for your safety ladder program.

Table 86 - SS1 Instruction Checklist

Test Type	Test Description	Test Status
Normal Operation	Initiate a Start command. <ul style="list-style-type: none"> Verify that the machine is in a normal machine run condition Verify proper machine status and safety application program status 	
	Operate the machine at the desired operating system speed.	
	Set up a trend with expected time scale and the following tags to graphically capture this information: <ul style="list-style-type: none"> SFX_Name.ActualSpeed SS1_Name.SpeedLimit SS1_Name.DecelerationRamp SS1_Name.01 	
	Initiate SS1 demand.	
	Make sure that the instruction output SS1_Name.01 turns off without generating a fault and that the drive initiates an STO instruction. <ul style="list-style-type: none"> Verify that the STO instruction de-energizes the motor for a normal safe condition. 	
	While the system is stopped with the sensor subsystems in a safe state, initiate a Start command. <ul style="list-style-type: none"> Verify that the STO instruction remains de-energized for a normal safe condition Verify proper machine status and safety application program status 	
	While the system is stopped with the SS1 demand removed, initiate a Reset command of the STO and SS1 instructions. <ul style="list-style-type: none"> Verify that the STO instruction remains de-energized Verify proper machine status and safety application program status 	
Abnormal Operation 1	Change the actual motion deceleration rate within the motion task that is associated with this SS1 function so that it is slower than the calculated speed limit used by the SS1 instruction.	
	Initiate a Start command. <ul style="list-style-type: none"> Verify that the machine is in a normal machine run condition Verify proper machine status and safety application program status 	
	Operate machine at the desired operating system speed.	
	Set up a trend with expected time scale and the following tags to graphically capture this information: <ul style="list-style-type: none"> SFX_Name.ActualSpeed SS1_Name.SpeedLimit SS1_Name.DecelerationRamp SS1_Name.01 	
	Initiate SS1 demand.	
	Make sure that the instruction generates a deceleration fault and that the drive initiates an STO instruction. <ul style="list-style-type: none"> Verify that the STO instruction de-energizes the motor for a normal safe condition 	
	While the system is stopped with the sensor subsystems in a safe state, initiate a Start command. <ul style="list-style-type: none"> Verify that the STO instruction remains de-energized for a normal safe condition Verify proper machine status and safety application program status 	
While the system is stopped with the SS1 demand removed, initiate a Reset command of the STO and SS1 instructions. <ul style="list-style-type: none"> Verify that the STO instruction remains de-energized Verify proper machine status and safety application program status 		

Table 86 - SS1 Instruction Checklist (Continued)

Test Type	Test Description	Test Status
Abnormal Operation 2	Change the motion deceleration rate within the motion task that is associated with this SS1 function so that the stop delay time is exceeded without triggering a deceleration fault.	
	Initiate a Start command. <ul style="list-style-type: none"> • Verify that the machine is in a normal machine run condition • Verify proper machine status and safety application program status 	
	Operate machine at desired operating system speed.	
	Set up a trend with expected time scale and the following tags to graphically capture this information: <ul style="list-style-type: none"> • <i>SFX_Name</i>.ActualSpeed • <i>SS1_Name</i>.SpeedLimit • <i>SS1_Name</i>.DecelerationRamp • <i>SS1_Name</i>.01 	
	Initiate SS1 demand.	
	Make sure that the instruction generates a maximum time fault and that the drive initiates an STO instruction. <ul style="list-style-type: none"> • Verify that the STO instruction de-energizes the motor for a normal safe condition 	
	While the system is stopped with the sensor subsystems in a safe state, initiate a Start command. <ul style="list-style-type: none"> • Verify that the STO instruction remains de-energized for a normal safe condition • Verify proper machine status and safety application program status 	
	While the system is stopped with the SS1 demand removed, initiate a Reset command of the STO and SS1 instructions. <ul style="list-style-type: none"> • Verify that the STO instruction remains de-energized • Verify proper machine status and safety application program status 	

Safe Stop 2 (SS2)

Use this SS2 instruction checklist to verify normal operation and the abnormal operation scenarios.

IMPORTANT Perform I/O verification and validation before validating your safety ladder program. SFX instruction must be verified within your application.

When possible, use immediate operands for instructions to reduce the possibility of systematic errors in your ladder program.

Instruction operands must be verified for your safety ladder program.

Table 87 - SS2 Instruction Checklist

Test Type	Test Description	Test Status
Normal Operation	Initiate a Start command. <ul style="list-style-type: none"> Verify that the machine is in a normal machine run condition Verify proper machine status and safety application program status 	
	Operate machine at the desired operating system speed.	
	Set up a trend with expected time scale and the following tags to graphically capture this information: <ul style="list-style-type: none"> SFX_Name.ActualSpeed SS2_Name.SpeedLimit SS2_Name.DecelerationRamp SS2_Name.ActualPosition SS2_Name.StandstillSetPoint SS2_Name.Output 1 	
	Initiate SS2 demand.	
	Make sure that while the SS2 instruction is monitoring that the motor decelerates below the SS2_Name.SS2StandstillSpeed setting and then maintains a speed below the SS2_Name.SOSStandstillSpeed (or for position mode, maintains the SS2_Name.StandstillSetpoint without exceeding the SS2_Name.StandstillDeadband setting).	
	While the system is in standstill state and with the sensor subsystems in a safe state, remove the SS2 demand. <ul style="list-style-type: none"> Verify proper machine status and safety application program status. 	
	Resume normal machine operation. <ul style="list-style-type: none"> Verify proper machine status and safety application program status. 	
	Change the actual motion deceleration rate within the motion task that is associated with this SS2 function so that it is slower than the calculated speed limit used by the SS2 instruction.	
Abnormal Operation 1	Initiate a Start command. <ul style="list-style-type: none"> Verify that the machine is in a normal machine run condition Verify proper machine status and safety application program status 	
	Operate machine at the desired operating system speed.	
	Set up a trend with expected time scale and the following tags to graphically capture this information: <ul style="list-style-type: none"> SFX_Name.ActualSpeed SS2_Name.SpeedLimit SS2_Name.DecelerationRamp SS2_Name.ActualPosition SS2_Name.StandstillSetPoint SS2_Name.Output 1 	
	Initiate SS2 demand.	
	Make sure that the instruction generates a deceleration fault and that the drive initiates an STO instruction. <ul style="list-style-type: none"> Verify that the STO instruction de-energizes the motor for a normal safe condition 	
	While the system is stopped with the sensor subsystems in a safe state, initiate a Start command. <ul style="list-style-type: none"> Verify that the STO instruction remains de-energized for a normal safe condition Verify proper machine status and safety application program status 	
	While the system is stopped with the SS1 demand removed, initiate a Reset command of the STO and SS2 instructions. <ul style="list-style-type: none"> Verify that the STO instruction remains de-energized Verify proper machine status and safety application program status 	

Table 87 - SS2 Instruction Checklist (Continued)

Test Type	Test Description	Test Status
Abnormal Operation 2	Change the motion deceleration rate within the motion task that is associated with this SS2 function so that the stop delay time is exceeded without triggering a deceleration fault.	
	Initiate a Start command. <ul style="list-style-type: none"> Verify that the machine is in a normal machine run condition Verify proper machine status and safety application program status 	
	Operate machine at desired operating system speed.	
	Set up a trend with expected time scale and the following tags to graphically capture this information: <ul style="list-style-type: none"> SFX_Name.ActualSpeed SS2_Name.SpeedLimit SS2_Name.DecelerationRamp SS2_Name.ActualPosition SS2_Name.StandstillSetPoint SS2_Name.Output 1 	
	Initiate SS2 demand.	
	Make sure that the instruction generates a maximum time fault and that the drive initiates an STO instruction. <ul style="list-style-type: none"> Verify that the STO instruction de-energizes for a normal safe condition 	
	While the system is stopped with the sensor subsystems in a safe state, initiate a Start command. <ul style="list-style-type: none"> Verify that the STO instruction remains de-energized for a normal safe condition Verify proper machine status and safety application program status 	
	While the system is stopped with the SS2 demand removed, initiate a Reset command of the STO and SS2 instructions. <ul style="list-style-type: none"> Verify that the STO instruction remains de-energized Verify proper machine status and safety application program status 	
Abnormal Operation 3 (Speed mode)	Initiate a Start command. <ul style="list-style-type: none"> Verify that the machine is in a normal machine run condition Verify proper machine status and safety application program status 	
	Operate the machine at maximum (normal) operating system speed.	
	Set up a trend with expected time scale and the following tags to graphically capture this information: <ul style="list-style-type: none"> SFX_Name.ActualSpeed SS2_Name.SpeedLimit SS2_Name.DecelerationRamp SS2_Name.ActualPosition SS2_Name.StandstillSetPoint SS2_Name.Output 1 	
	Initiate SS2 demand.	
	Make sure that while the SS2 instruction is monitoring, the motor decelerates below the SS2_Name.SS2StandstillSpeed setting and then maintains a speed below the SS2_Name.SOSStandstillSpeed.	
	While the system is in the standstill state, initiate a motion command that violates the standstill speed. <ul style="list-style-type: none"> Verify that standstill speed fault is generated and STO is initiated Verify that the STO instruction de-energizes for a normal safe condition 	
	While the system is stopped with the sensor subsystems in a safe state, initiate a Start command. <ul style="list-style-type: none"> Verify that the STO instruction remains de-energized for a normal safe condition Verify proper machine status and safety application program status 	
	While the system is stopped with the SS2 demand removed, initiate a Reset command of the STO and SS2 instructions. <ul style="list-style-type: none"> Verify that the STO instruction remains de-energized Verify proper machine status and safety application program status 	

Table 87 - SS2 Instruction Checklist (Continued)

Test Type	Test Description	Test Status
Abnormal Operation 4 (Position mode)	Initiate a Start command. <ul style="list-style-type: none"> • Verify that the machine is in a normal machine run condition • Verify proper machine status and safety application program status 	
	Operate the machine at maximum (normal) operating system speed.	
	Set up a trend with expected time scale and the following tags to graphically capture this information: <ul style="list-style-type: none"> • <i>SFX_Name</i>.ActualSpeed • <i>SS2_Name</i>.SpeedLimit • <i>SS2_Name</i>.DecelerationRamp • <i>SS2_Name</i>.ActualPosition • <i>SS2_Name</i>.StandstillSetPoint • <i>SS2_Name</i>.Output 1 	
	Initiate SS2 demand.	
	Make sure that while SS2 instruction is monitoring, the motor maintains the <i>SS2_Name</i> .StandstillSetPoint without exceeding the <i>SS2_Name</i> .StandstillDeadband setting).	
	While the system is in the standstill state, initiate a motion command that violates the standstill deadband. <ul style="list-style-type: none"> • Verify that standstill position fault is generated and STO is initiated • Verify that the STO instruction de-energizes for a normal safe condition 	
	While the system is stopped with the sensor subsystems in a safe state, initiate a Start command. <ul style="list-style-type: none"> • Verify that the STO instruction remains de-energized for a normal safe condition • Verify proper machine status and safety application program status 	
While the system is stopped with the SS2 demand removed, initiate a Reset command of the STO and SS2 instructions. <ul style="list-style-type: none"> • Verify that the STO instruction remains de-energized • Verify proper machine status and safety application program status 		

Safe Operating Speed (SOS)

Use this SOS instruction checklist to verify normal operation and the abnormal operation scenarios.

IMPORTANT Perform I/O verification and validation before validating your safety ladder program. SFX instruction must be verified within your application.

When possible, use immediate operands for instructions to reduce the possibility of systematic errors in your ladder program.

Instruction operands must be verified for your safety ladder program.

Table 88 - SOS Instruction Checklist

Test Type	Test Description	Test Status
Normal Operation	Initiate a Start command. <ul style="list-style-type: none"> Verify that the machine is in a normal machine run condition Verify proper machine status and safety application program status 	
	Operate machine at the desired operating system speed.	
	Set up a trend with expected time scale and the following tags to graphically capture this information: <ul style="list-style-type: none"> SFX_Name.ActualSpeed SFX_Name.ActualPosition SOS_Name.StandstillSpeed SOS_Name.StandstillDeadband SOS_Name.Output 1 	
	Initiate SOS demand.	
	Make sure that while the SOS instruction maintains a speed below the SOS_Name.StandstillSpeed (or for position mode, maintains position within the SOS_Name.StandstillDeadband setting).	
	While the system is in standstill state and with the sensor subsystems in a safe state, remove the SOS demand. <ul style="list-style-type: none"> Verify proper machine status and safety application program status 	
	Resume normal machine operation. <ul style="list-style-type: none"> Verify proper machine status and safety application program status 	
Abnormal Operation 1 (Speed mode)	Initiate a Start command. <ul style="list-style-type: none"> Verify that the machine is in a normal machine run condition Verify proper machine status and safety application program status 	
	Operate machine at the desired operating system speed.	
	Set up a trend with expected time scale and the following tags to graphically capture this information: <ul style="list-style-type: none"> SFX_Name.ActualSpeed SFX_Name.ActualPosition SOS_Name.StandstillSpeed SOS_Name.StandstillDeadband SOS_Name.Output 1 	
	Initiate SOS demand.	
	Make sure that the SOS instruction maintains a speed below the SOS_Name.StandstillSpeed.	
	While the system is in the standstill state, initiate a motion command that violates the SOS_Name.StandstillSpeed. <ul style="list-style-type: none"> Verify that the standstill speed fault is generated and that the STO is initiated Verify that the STO instruction de-energizes for a normal safe condition 	
	While the system is stopped with the sensor subsystems in a safe state, initiate a Start command. <ul style="list-style-type: none"> Verify that the STO instruction remains de-energized for a normal safe condition Verify proper machine status and safety application program status 	
While the system is stopped with the SOS demand removed, initiate a Reset command of the STO and SOS instructions. <ul style="list-style-type: none"> Verify that the STO instruction remains de-energized Verify proper machine status and safety application program status 		

Table 88 - SOS Instruction Checklist (Continued)

Test Type	Test Description	Test Status
Abnormal Operation 2 (Position mode)	Initiate a Start command. <ul style="list-style-type: none"> • Verify that the machine is in a normal machine run condition • Verify proper machine status and safety application program status 	
	Operate the machine at maximum (normal) operating system speed.	
	Set up a trend with expected time scale and the following tags to graphically capture this information: <ul style="list-style-type: none"> • <i>SFX_Name</i>.ActualSpeed • <i>SFX_Name</i>.ActualPosition • <i>SOS_Name</i>.StandstillSpeed • <i>SOS_Name</i>.StandstillDeadband • <i>SOS_Name</i>.Output 1 	
	Initiate SOS demand.	
	Make sure that the SOS instruction maintains position within the <i>SOS_Name</i> .StandstillDeadband setting.	
	While the system is in the standstill state, initiate a motion command that violates the <i>SOS_Name</i> .StandstillDeadband. <ul style="list-style-type: none"> • Verify that standstill position fault is generated and STO is initiated • Verify that the STO instruction de-energizes for a normal safe condition 	
	While the system is stopped with the sensor subsystems in a safe state, initiate a Start command. <ul style="list-style-type: none"> • Verify that the STO instruction remains de-energized for a normal safe condition • Verify proper machine status and safety application program status 	
	While the system is stopped with the SOS demand removed, initiate a Reset command of the STO and SOS instructions. <ul style="list-style-type: none"> • Verify that the STO instruction remains de-energized • Verify proper machine status and safety application program status 	

Safely-limited Speed (SLS)

Use this SLS instruction checklist to verify normal operation and the abnormal operation scenarios.

IMPORTANT Perform I/O verification and validation before validating your safety ladder program. SFX instruction must be verified within your application.

When possible, use immediate operands for instructions to reduce the possibility of systematic errors in your ladder program.

Instruction operands must be verified for your safety ladder program.

Table 89 - SLS Instruction Checklist

Test Type	Test Description	Test Status
Normal Operation	Initiate a Start command. <ul style="list-style-type: none"> Verify that the machine is in a normal machine run condition Verify proper machine status and safety application program status 	
	Operate the machine within the desired speed range.	
	Set up a trend with expected time scale and the following tags to graphically capture this information: <i>SFX_Name.ActualSpeed</i> <i>SLS_Name.SLSLimit</i> <i>SLS_Name.ActiveLimit</i> <i>SLS_Name.Output 1</i>	
	Initiate SLS demand.	
	Verify that the drive achieves the speed below the <i>SLS_Name.ActiveLimit</i> without asserting the <i>SLS_Name.SLSLimit</i> output.	
	While the system is in SLS monitoring state and with the sensor subsystems in a safe state, remove the SLS demand. <ul style="list-style-type: none"> Verify proper machine status and safety application program status 	
	Resume normal machine operation. <ul style="list-style-type: none"> Verify proper machine status and safety application program status 	
Abnormal Operation 1	Initiate a Start command. <ul style="list-style-type: none"> Verify that the machine is in a normal machine run condition Verify proper machine status and safety application program status 	
	Operate the machine within the normal speed range.	
	Set up a trend with expected time scale and the following tags to graphically capture this information: <i>SFX_Name.ActualSpeed</i> <i>SLS_Name.SLSLimit</i> <i>SLS_Name.ActiveLimit</i> <i>SLS_Name.Output 1</i>	
	Initiate SLS demand.	
	Verify that the drive achieves the speed below the <i>SLS_Name.ActiveLimit</i> without asserting the <i>SLS_Name.SLSLimit</i> output.	
	While the system is in the SLS monitoring state, initiate a motion command that violates the <i>SLS_Name.ActiveLimit</i> . <ul style="list-style-type: none"> Verify that the <i>SLS_Name.SLSLimit</i> output is asserted and the programmed stop action is initiated 	
	While the system is stopped with the sensor subsystems in a safe state, initiate a Start command. <ul style="list-style-type: none"> Verify proper machine status and safety application program status 	
	While the system is stopped, initiate a Reset command. <ul style="list-style-type: none"> Verify proper machine status and safety application program status 	

Safely-limited Position (SLP)

Use this SLP instruction checklist to verify normal operation and the abnormal operation scenarios.

IMPORTANT Perform I/O verification and validation before validating your safety ladder program. SFX instruction must be verified within your application.

When possible, use immediate operands for instructions to reduce the possibility of systematic errors in your ladder program.

Instruction operands must be verified for your safety ladder program.

Table 90 - SLP Instruction Checklist

Test Type	Test Description	Test Status
Normal Operation	Initiate a Start command. <ul style="list-style-type: none"> Verify that the machine is in a normal machine run condition Verify proper machine status and safety application program status 	
	Operate the machine within the desired position range.	
	Set up a trend with expected time scale and the following tags to graphically capture this information: <ul style="list-style-type: none"> SFX_Name.ActualPosition SLP_Name.SLPLimit SLP_Name.PositiveTravelLimit SLP_Name.NegativeTravelLimit SLP_Name.Output 1 	
	Initiate SLP demand.	
	Verify that the drive achieves and maintains a position between the SLP_Name.PositiveTravelLimit and the SLP_Name.NegativeTravelLimit without asserting the SLP_Name.SLPLimit output.	
	While the system is in SLP monitoring state and with the sensor subsystems in a safe state, remove the SLP demand. <ul style="list-style-type: none"> Verify proper machine status and safety application program status 	
	Resume normal machine operation. <ul style="list-style-type: none"> Verify proper machine status and safety application program status 	
Abnormal Operation 1	Initiate a Start command. <ul style="list-style-type: none"> Verify that the machine is in a normal machine run condition Verify proper machine status and safety application program status 	
	Operate the machine within the desired position range.	
	Set up a trend with expected time scale and the following tags to graphically capture this information: <ul style="list-style-type: none"> SFX_Name.ActualPosition SLP_Name.SLPLimit SLP_Name.PositiveTravelLimit SLP_Name.NegativeTravelLimit SLP_Name.Output 1 	
	Initiate SLP demand.	
	Verify that the drive achieves and maintains a position between the SLP_Name.PositiveTravelLimit and the SLP_Name.NegativeTravelLimit without asserting the SLP_Name.SLPLimit output.	
	While the system is in the SLP monitoring state, initiate a motion command that violates the SLP_Name.PositiveTravelLimit. <ul style="list-style-type: none"> Verify that SLP_Name.SLPLimit output is asserted and the programmed stop action is initiated 	
	While the system is stopped with the sensor subsystems in a safe state, initiate a Start command. <ul style="list-style-type: none"> Verify proper machine status and safety application program status 	
	While the system is stopped, initiate a Reset command. <ul style="list-style-type: none"> Verify proper machine status and safety application program status 	

Table 90 - SLP Instruction Checklist (Continued)

Test Type	Test Description	Test Status
Abnormal Operation 2	Initiate a Start command. <ul style="list-style-type: none"> Verify that the machine is in a normal machine run condition Verify proper machine status and safety application program status 	
	Operate the machine within the desired position range.	
	Set up a trend with expected time scale and the following tags to graphically capture this information: <ul style="list-style-type: none"> <i>SFX_Name.ActualPosition</i> <i>SLP_Name.SLPLimit</i> <i>SLP_Name.PositiveTravelLimit</i> <i>SLP_Name.NegativeTravelLimit</i> <i>SLP_Name.Output 1</i> 	
	Initiate SLP demand.	
	Verify that the drive achieves and maintains a position between the <i>SLP_Name.PositiveTravelLimit</i> and the <i>SLP_Name.NegativeTravelLimit</i> without asserting the <i>SLP_Name.SLPLimit</i> output.	
	While the system is in the SLP monitoring state, initiate a motion command that violates the <i>SLP_Name.NegativeTravelLimit</i> . <ul style="list-style-type: none"> Verify that <i>SLP_Name.SLPLimit</i> output is asserted and the programmed stop action is initiated 	
	While the system is stopped with the sensor subsystems in a safe state, initiate a Start command. <ul style="list-style-type: none"> Verify proper machine status and safety application program status 	
	While the system is stopped, initiate a Reset command. <ul style="list-style-type: none"> Verify proper machine status and safety application program status 	

Safe Direction (SDI)

Use this SDI instruction checklist to verify normal operation and the abnormal operation scenarios.

IMPORTANT Perform I/O verification and validation before validating your safety ladder program. SFX instruction must be verified within your application.

When possible, use immediate operands for instructions to reduce the possibility of systematic errors in your ladder program.

Instruction operands must be verified for your safety ladder program.

Table 91 - SDI Instruction Checklist

Test Type	Test Description	Test Status
Normal Operation	Initiate a Start command. <ul style="list-style-type: none"> Verify that the machine is in a normal machine run condition Verify proper machine status and safety application program status 	
	Operate the machine within the desired operating range.	
	Set up a trend with expected time scale and the following tags to graphically capture this information: <ul style="list-style-type: none"> SFX_Name.ActualPosition SDI_Name.SDILimit SDI_Name.PositionWindow SDI_Name.Output 1 	
	Initiate SDI demand.	
	Verify that motion is in the intended direction and the SDI_Name.SDILimit output is not asserted.	
	While the system is in SDI monitoring state and with the sensor subsystems in a safe state, remove the SDI demand. <ul style="list-style-type: none"> Verify proper machine status and safety application program status 	
	Resume normal machine operation. <ul style="list-style-type: none"> Verify proper machine status and safety application program status 	
Abnormal Operation 1	Initiate a Start command. <ul style="list-style-type: none"> Verify that the machine is in a normal machine run condition Verify proper machine status and safety application program status 	
	Operate the machine within the desired operating range.	
	Set up a trend with expected time scale and the following tags to graphically capture this information: <ul style="list-style-type: none"> SFX_Name.ActualPosition SDI_Name.SDILimit SDI_Name.PositionWindow SDI_Name.Output 1 	
	Initiate SDI demand.	
	Verify that motion is in the intended direction and the SDI_Name.SDILimit output is not asserted.	
	While the system is in the SDI monitoring state, initiate a motion command that violates the SDI_Name.PositionWindow in the unintended direction. <ul style="list-style-type: none"> Verify that SDI_Name.SDILimit output is asserted and the programmed stop action is initiated 	
	While the system is stopped with the sensor subsystems in a safe state, initiate a Start command. <ul style="list-style-type: none"> Verify proper machine status and safety application program status 	
While the system is stopped, initiate a Reset command. <ul style="list-style-type: none"> Verify proper machine status and safety application program status 		

Safe Feedback Interface (SFX)

Use this SFX instruction checklist to verify normal operation and the abnormal operation scenarios.

IMPORTANT Perform I/O verification and validation before validating your safety ladder program. SFX instruction must be verified within your application.

When possible, use immediate operands for instructions to reduce the possibility of systematic errors in your ladder program.

Instruction operands must be verified for your safety ladder program.

Table 92 - SFX Instruction Checklist

Test Type	Test Description	Test Status
Normal Scaling Operation	Initiate a Start command. <ul style="list-style-type: none"> Verify that the machine is in a normal machine run condition Verify proper machine status and safety application program status 	
	Operate the machine within the normal operating range.	
	Set up a trend with the expected time scale and the following tags to graphically compare the motion position and speed from the Main task to the scaled position and speed in the Safety task. <ul style="list-style-type: none"> <i>Axis_Name</i>.ActualPosition <i>Axis_Name</i>.ActualSpeed <i>SFX_Name</i>.ActualPosition <i>SFX_Name</i>.ActualSpeed 	
	Verify that the standard and safety position and speed are correlated as expected.	
Normal Homing Operation	Initiate a Start command.	
	Initiate a Homing procedure. <ul style="list-style-type: none"> Verify that the Home Position in the SFX instruction is set 	
	Set up a trend with the expected time scale and the following tags to graphically compare the motion position and speed from the Main task to the scaled position and speed in the Safety task. <ul style="list-style-type: none"> <i>Axis_Name</i>.ActualPosition <i>SFX_Name</i>.ActualPosition 	
	Verify that the standard and safety position are correlated as expected.	
Abnormal Operation 1	Initiate a Start command. <ul style="list-style-type: none"> Verify that the machine is in a normal machine run condition Verify proper machine status and safety application program status 	
	Operate the machine within the normal operating range.	
	Set up a trend with the expected time scale and the following tags to graphically compare the motion position and speed from the Main task to the scaled position and speed in the Safety task. <ul style="list-style-type: none"> <i>Axis_Name</i>.ActualPosition <i>Axis_Name</i>.ActualSpeed <i>SFX_Name</i>.ActualPosition <i>SFX_Name</i>.ActualSpeed 	
	Verify that the standard and safety position and speed are correlated as expected.	
	Disconnect the feedback between the motor/encoder and drive.	
	Verify the generation of a Fault Type: 100 Feedback Invalid by checking <i>Device_Name</i> .SI.PrimaryFeedbackValid tag.	
	Verify that the system fault action takes place as configured.	
	While the system is stopped with the sensor subsystems in a safe state, initiate a Start command. <ul style="list-style-type: none"> Verify proper machine status and safety application program status 	
While the system is stopped, initiate a Reset command. <ul style="list-style-type: none"> Verify proper machine status and safety application program status 		

Table 92 - SFX Instruction Checklist (Continued)

Test Type	Test Description	Test Status
Abnormal Operation 2	Initiate a Start command. <ul style="list-style-type: none"> • Verify that the machine is in a normal machine run condition • Verify proper machine status and safety application program status 	
	Operate the machine within the normal operating range.	
	Set up a trend with the expected time scale and the following tags to graphically compare the motion position and speed from the Main task to the scaled position and speed in the Safety task. <ul style="list-style-type: none"> • <i>Axis_Name</i>.ActualPosition • <i>Axis_Name</i>.ActualSpeed • <i>SFX_Name</i>.ActualPosition • <i>SFX_Name</i>.ActualSpeed 	
	Verify that the standard and safety position and speed are correlated as expected.	
	Disconnect the Ethernet cable between the controller and the drive.	
	Verify the generation of a Fault Type: 101 Connection Fault by checking the <i>Device_Name</i> .SI.ConnectionFaulted tag.	
	Verify that the system fault action takes place as configured	
	While the system is stopped with the sensor subsystems in a safe state, initiate a Start command. <ul style="list-style-type: none"> • Verify proper machine status and safety application program status 	
	While the system is stopped, initiate a Reset command. <ul style="list-style-type: none"> • Verify proper machine status and safety application program status 	

Safe Brake Control (SBC)

Use this SBC instruction checklist to verify normal operation and the abnormal operation scenarios.

IMPORTANT Perform I/O verification and validation before validating your safety ladder program.

When possible, use immediate operands for instructions to reduce the possibility of systematic errors in your ladder program.

Instruction operands must be verified for your safety ladder program.

Table 93 - SBC Instruction Checklist

Test Type	Test Description	Test Status
Normal Operation	Verify that the brake feedback is properly wired to the input module as documented.	
	Initiate a Start command. <ul style="list-style-type: none"> Verify that the machine is in a normal machine run condition Verify proper machine status and safety application program status 	
	Set up a trend with expected time scale and the following tags to graphically capture this information: <ul style="list-style-type: none"> <i>SBC_Name</i>.B01 <i>SBC_Name</i>.B02 <i>SBC_Name</i>.TOR <i>Device_Name</i>.STOOutput 	
	Initiate an SBC request and initiate the STO event. <ul style="list-style-type: none"> Verify expected coordination of the STO output initiation and the <i>SBC_Name</i>.B01 and <i>SBC_Name</i>.B02 outputs Verify proper machine status and safety application program status 	
	While the system is stopped, initiate a Start command. <ul style="list-style-type: none"> Verify that the system remains de-energized for a normal safe condition Verify proper machine status and safety application program status 	
	While the system is stopped, initiate a Reset command. <ul style="list-style-type: none"> Verify that the system remains de-energized for a normal safe condition Verify proper machine status and safety application program status 	
Abnormal Operation	Verify that brake feedback is properly wired to the input module as documented.	
	Initiate a Start command. <ul style="list-style-type: none"> Verify that the machine is in a normal machine run condition Verify proper machine status and safety application program status 	
	Initiate machine function to make sure that the brake is released.	
	Set up a trend with expected time scale and the following tags to graphically capture this information: <ul style="list-style-type: none"> <i>SBC_Name</i>.B01 <i>SBC_Name</i>.B02 <i>SBC_Name</i>.TOR <i>Device_Name</i>:STOOutput 	
	Remove brake feedback wires from the input module.	
	<ul style="list-style-type: none"> Verify that the appropriate diagnostic code is generated Verify that the brake output <i>SBC_Name</i>.B01 and <i>SBC_Name</i>.B02 bits clear Verify the external brake engagement 	
	While the system is stopped with the sensor subsystems in a safe state, initiate a Start command. <ul style="list-style-type: none"> Verify proper machine status and safety application program status 	
	While the system is stopped, initiate a Reset command. <ul style="list-style-type: none"> Verify proper machine status and safety application program status 	

Notes:

Specifications, Certifications, and CE Conformity

This appendix provides general specifications for the Integrated Safety Functions option module.

Topic	Page
Integrated Safety Functions Option Module Specifications	233
Environmental Specifications	235
Certifications	236

Integrated Safety Functions Option Module Specifications

These specifications apply to the Integrated Safety Functions option module. For additional specifications, see these publications:

- PowerFlex® 755 AC Drives Technical Data, publication [750-TD001](#)
- PowerFlex 750-Series Products with TotalFORCE® Control Technical Data, publication [750-TD100](#)

Table 94 - General Specifications

Attribute	Value
Standards (when used with PowerFlex 755 drives)	IEC 61800-5-2, EN 61800-5-1, EN 61800-3, EN ISO 13849-1, EN 62061, EN 60204-1, IEC 61508
Safety ratings (when used with PowerFlex 755 drives)	SIL 3 according to EN 62061 / IEC 61508 SIL CL 3 according to IEC 61800-5-2 / EN 62061 / IEC 61508 Cat. 4 and PL e according to EN ISO 13849-1
Standards (when used with PowerFlex 755T drive products)	EN 61800-5-2, EN 61800-5-1, EN 61800-3, EN ISO 13849-1, EN 62061, EN 60204-1, IEC 61508
Safety ratings (when used with PowerFlex 755T drive products)	SIL 3 according to EN 62061 / IEC 61508 SIL CL 3 according to EN 61800-5-2 / EN 62061 / IEC 61508 Cat. 4 and PL e according to EN ISO 13849-1
Power supply (user I/O)	24V DC ±10%, 0.8 . . . 1.1 x rated voltage ⁽²⁾ PELV or SELV
Conductor type	Multi-conductor shielded cable
Conductor size ⁽¹⁾	0.3 . . . 0.8 mm ² (28 . . . 18 AWG)
Strip length	10 mm (0.39 in.)
Recovery time (approximate time before drive can start after the torque enable request is made)	Network STO mode: 100 ms

(1) See the Industrial Automation Wiring and Grounding Guidelines, publication [1770-4.1](#).

(2) Safety outputs need additional fuse for reverse voltage protection of the control circuit. Install a 6 A slow-blow or 10 A fast-acting fuse.

Electrical Requirements

Table 95 - Safety Input Specifications

Attribute	Value
Input type	Current sinking
IEC 61131-2 (input type)	Type 3
Voltage, on-state	11...30V DC
Voltage, off-state	-3...5V DC
Current, on-state, minimum	2 mA
Current, off-state, maximum	1.5 mA
Input reaction time, maximum	<10 ms + set values of ON/OFF delays

Table 96 - Safety Output Specifications

Attribute	Value
Output type	Current sourcing
Output current	1 A
Test pulse width	500 μ s
Test pulse period	300 ms
Maximum field capacitance	950 nF
Residual voltage, maximum	0.3V
Leakage current, maximum	0.1 mA
Output reaction time, maximum	<10 ms + set values of ON/OFF delays
Short circuit protection	Yes

Table 97 - Test Output Specifications

Attribute	Value
Output type	Current sourcing
Output current	0.5 A
Test pulse width	500 μ s
Test pulse period	300 ms
Maximum field capacitance	100 nF
Residual voltage, maximum	0.3V
Leakage current, maximum	0.1 mA
Short circuit protection	Yes

Environmental Specifications The installation must comply with all environmental, pollution degree, and drive enclosure rating specifications required for the operating environment.

Category	Specification
Ambient temperature	For detailed information on environmental, pollution degree, and drive enclosure rating specifications, see the technical data publication for your drive. <ul style="list-style-type: none"> • PowerFlex 750-Series AC Drives Technical Data, publication 750-TD001 • PowerFlex 750-Series Products with TotalFORCE Control Technical Data, publication 750-TD100 • PowerFlex 755TM IP00 Open Type Kits Technical Data, publication 750-TD101
Storage temperature	
Shock	
Operating	
Packaged for shipment	
Vibration	
Operating	
Packaged for shipment	
Sinusoidal loose load	
Random secured	
Surrounding environment	



ATTENTION: Failure to maintain the specified ambient temperature can result in a failure of the safety function.

IMPORTANT Products with a safety function installed must be protected against conductive contamination by one of the following methods:

- Select a product with an enclosure type of at least IP54, NEMA/UL Type 12
- Provide an environmentally controlled location for the product that does not contain conductive contamination

Table 98 - Environmental Pollution Degree Description (EN 61800-5-1)

Surrounding Environment Pollution Degree	Conductive Contamination Allowed by Pollution Degree	Acceptable Enclosures
Pollution degree 1 and 2	No possibility of conductive dust.	All enclosures are acceptable.
Pollution degree 3 and 4	The possibility of conductive dust is allowed.	Enclosure that meets or exceeds IP54, NEMA/UL Type 12 is required.

Certifications

Certification ⁽¹⁾	Value
c-UL-us ⁽²⁾	UL Listed, certified for US and Canada
CE	European Union and 2014/30/EU EMC Directive, compliant with: EN 61800-3; PowerFlex 750-Series AC Drive, Emissions, and Immunity European Union 2006/42/EC Machinery Directive: EN ISO 13849-1; Safety Function EN ISO 13849-2; Safety Function EN 60204-1; Safety Function EN 62061; Safety Function EN 61800-5-2; Safety Function
C-Tick	Australian Radiocommunications Act, compliant with: EN 61800-3; categories C2 and C3
TÜV	Certified by TÜV Rheinland for Functional Safety: Up to SIL 3, according to EN 61800-5-2 and IEC 61508, and SIL CL3 according to EN IEC 62061; Up to Performance Level PL e and Category 4, according to EN ISO 13849-1; When used as described in this PowerFlex 755 Integrated Safety Functions User Manual, publication 750-UM004 .

(1) See the Product Certification link at rok.auto/certifications for Declarations of Conformity, Certificates, and other certifications details.

(2) Underwriters Laboratories Inc. has not evaluated the Integrated Safety Functions, or Safe Speed Monitor option modules for functional safety.

CE Conformity

CE Declarations of Conformity are available online at: rok.auto/certifications.

The PowerFlex 755/755T Integrated Safety Functions Option Module (catalog number 20-750-S4), when installed and maintained in accordance with the instructions in this document, is in conformity with the essential requirements of these directives:

- 2006/42/EC Machinery Directive
- 2014/30/EU EMC Directive

The following standards have been applied to demonstrate conformity.

Machinery Directive (2006/42/EC)

- EN ISO 13849-1 Safety of machinery - Safety related parts of control systems - Part 1: General principles for design
- EN 60204-1 Safety of machinery - Electrical equipment of machines - Part 1: General requirements
- EN 62061 Safety of machinery - Functional safety of safety-related electrical, electronic and programmable electronic control systems
- EN 61800-5-2 Adjustable speed electrical power drive systems - Part 5-2: Safety requirement - Functional
- IEC 61508 Part 1...7 Functional safety of electrical/electronic/programmable electronic safety-related systems

EMC Directive (2014/30/EU)

- EN 61800-3 - Adjustable speed electric power drive systems - Part 3: EMC requirements and specific test methods

Waste Electrical and Electronic Equipment (WEEE)



At the end of its life, this equipment should be collected separately from any unsorted municipal waste.

Notes:

Safety I/O Assemblies and Safety Attributes

Controller axis tags are used by the motion controller motion task to read the status of safety functions and coordinator motion. This appendix lists the motion controller tags that are associated with the safety instances and with safety functions operating in the safety task of the controller.

Topic	Page
Safety Assembly Tags	240
Safety Feedback Attributes	245
Safe Stop Function Attributes	247

Safety attributes provide additional information not available through the tag structure. Attributes are read using explicit messages.

IMPORTANT The controller axis tags and the safety attributes read by using explicit messages must not be used in the operation of a safety function.

Safety Assembly Tags

Safety assembly tags are associated with a safety connection from a safety controller to a drive module. The data in these tags are communicated at the configured connection rate.

Safety Input Assembly tags contain the data that is transferred from the drive to the GuardLogix® using CIP Safety™ protocol over EtherNet/IP®. This is the network safety status data. Safety Output Assembly tags contain the data that is transferred from the GuardLogix controller to the drive option module using CIP Safety protocol over EtherNet/IP. This is the network safety control data.

CIP Safety protocol over EtherNet/IP transfers data with integrity up to SIL 3 and PL e.

TIP The Output and Input designations are relative to the GuardLogix controller.

Table 99 - Safety Input Assembly Tags

Safety Input Assembly Tag Name (input to safety controller)	Type/[bit]	Description
<i>module:SI.ConnectionStatus</i>	SINT	See the following descriptions of individual bits.
<i>module:SI.RunMode</i>	[0]	Safety Connection 0= idle 1 = Run
<i>module:SI.ConnectionFaulted</i>	[1]	Safety Connection 0=normal 1= Faulted
<i>module:SI.FeedbackPosition</i>	DINT	Primary Feedback Position from drive-module safety instance. Value is in feedback counts.
<i>module:SI.FeedbackVelocity</i>	REAL	Primary Feedback Velocity from drive-module safety instance. Value is in revolutions/second.
<i>module:SI.SecondaryFeedbackPosition</i>	DINT	Secondary Feedback Position from drive-module safety instance. Value is in position counts.
<i>module:SI.SecondaryFeedbackVelocity</i>	REAL	Secondary Feedback Velocity from drive-module safety instance. Value is in revolutions/second.
<i>module:SI.StopStatus</i>	SINT	See the following descriptions of individual bits.
<i>module:SI.STOActive</i>	[0]	Indicates STO function status. 0 = STO function not active (permit torque) 1 = STO function active (disable torque)
<i>module:SI.SBCActive</i>	[1]	Safe Brake Control (SBC) function status 0 = Release Brake (So0 and So1 ON) 1 = Engage Brake (So0 and So1 OFF)
<i>module:SI.SS1Active</i>	[2]	Indicates drive-based SS1 active status. 0 = SS1 function not active 1 = SS1 function active
<i>module:SI.SS2Active</i>	[3]	Always 0
<i>module:SI.SOSSStandstill</i>	[4]	Always 0
<i>module:SI.SMTOvertemp</i>	[5]	Always 0
<i>module:SI.SafetyFault</i>	[6]	1 = Safe Stop Fault present
<i>module:SI.RestartRequired</i>	[7]	1 = Reset is required
<i>module:SI.SafeStatus</i>	SINT	See the following descriptions of individual bits.
<i>module:SI.TorqueDisabled</i>	[0]	0 = Torque Permitted 1 = Torque Disabled
<i>module:SI.BrakeEngaged</i>	[1]	0 = Brake Released (So0 and So1 ON) 1 = Brake Engaged (So0 and So1 OFF)
<i>module:SI.MotionStatus</i>	SINT	A collection of the following bits.

Table 99 - Safety Input Assembly Tags (Continued)

Safety Input Assembly Tag Name (input to safety controller)	Type/[bit]	Description
<i>module:SI.MotionPositive</i>	[3]	1 = Feedback Velocity > Primary Feedback Standstill Speed
<i>module:SI.MotionNegative</i>	[4]	1 = Feedback Velocity < Primary Feedback Standstill Speed
<i>module:SI.FunctionSupport</i>	SINT	See the following descriptions of individual bits.
<i>module:SI.PrimaryFeedbackValid</i>	[0]	0 = Primary Feedback not configured or Faulted 1 = Primary Feedback Value is valid
<i>module:SI.SecondaryFeedbackValid</i>	[1]	See the following descriptions of individual bits.
<i>module:SI.DiscrepancyCheckingActive</i>	[2]	1 = Feedback Velocity Discrepancy checking is active
<i>module:SI.SBCReady</i>	[3]	0 = Drive-based SBC function is not configured or faulted 1 = Drive-based SBC function is configured and ready for operation
<i>module:SI.SS1Ready</i>	[4]	0 = Drive-based SS1 function is not configured or faulted 1 = Drive-based SS1 function is configured and ready for operation
<i>module:SI.SS2Ready</i>	[5]	Always 0
<i>module:SI.SOSReady</i>	[6]	Always 0
<i>module:SI.SMTRReady</i>	[7]	Always 0
Module:SI.OutputStatus	SINT	See the following descriptions of individual bits.
Module:SI.Out00Monitor	[0]	The readback value of Safety Output 0
Module:SI.Out01Monitor	[1]	The readback value of Safety Output 0
Module:SI.Out00Status	[3]	The status of Safety Output 1
Module:SI.Out01Status	[4]	The status of Test output 0
Module:SI.Test00Status	[5]	The status of Test output 1
Module:SI.InputStatus	SINT	See the following descriptions of individual bits.
Module:SI.In00Data	[0]	The value read from Safety Input 0
Module:SI.In01Data	[1]	The value read from Safety Input 1
Module:SI.In02Data	[2]	The value read from Safety Input 2
Module:SI.In03Data	[3]	The value read from Safety Input 3
Module:SI.In00Status	[4]	The status of safety input 0
Module:SI.In01Status	[5]	The status of safety input 1
Module:SI.In02Status	[6]	The status of safety input 2
Module:SI.In03Status	[7]	The status of safety input 3
Module:SI.IOSupport	SINT	See the following descriptions of individual bits.
Module:SI.In00Valid	[0]	Safety Input 0 producing valid data
Module:SI.In01Valid	[1]	Safety Input 1 producing valid data
Module:SI.In02Valid	[2]	Safety Input 2 producing valid data
Module:SI.In03Valid	[3]	Safety Input 3 producing valid data
Module:SI.Out00Ready	[4]	Safety Output 0 Ready
Module:SI.Test01Ready	[5]	Safety Output 1 Ready
Module:SI.Test00Ready	[6]	Test Output 0 Ready
Module:SI.Test01Ready	[7]	Test Output 1 Ready

Table 100 - Safety Output Assembly Tags

Safety Output Assembly Tag Name (output to safety controller)	Type/[bit]	Description
<i>module:SO.PassThruDataA[instance]</i>	DINT	32-bit data container holding general-purpose safety data passed from the safety controller.
<i>module:SO.PassThruDataB[instance]</i>	DINT	32-bit data container holding general-purpose safety data passed from the safety controller.
<i>module:SO.PassThruStopStatus[instance]</i>	SINT	See the following descriptions of Safe Stop Function Status bits.
<i>module:SO.SBCIntegrity[instance]</i>	[0]	Status of an external Safety Brake controlled by SBC function. 0 = SBC fault. The brake status, released or engaged, is undetermined. 1 = No faults detected.
<i>module:SO.SBCActive[instance]</i>	[1]	Indicates that the SBC function is active and the sequence to set the Safety Brake has started. This function is only available as a controller-based function. 0 = SBC Function is not Active 1 = SBC Function is Active
<i>module:SO.SBCBrakeEngaged[instance]</i>	[2]	Indicates that the External Safety Brake is engaged by the controller-based SBC function. 0 = Brake is Engaged 1 = Brake is Released
<i>module:SO.SS1Active[instance]</i>	[3]	Indicates that the controller-based SS1 function is active. 0 = SS1 Function is not Active 1 = SS1 Function is Active
<i>module:SO.SS2Active[instance]</i>	[4]	Indicated that the controller-based SS2 function is active. 0 = SS2 Function is not Active 1 = SS2 Function is Active
<i>module:SO.SOSActive[instance]</i>	[5]	Indicates that the controller-based SOS function is active. 0 = SOS Function is not Active 1 = SOS Function is Active
<i>module:SO.SOSStandstill[instance]</i>	[6]	Indicates that the controller-based SOS function has detected Standstill according to the function configuration. 0 = Monitored axis is not at Standstill 1 = Monitored axis is at Standstill
<i>module:SO.PassThruSpeedLimitStatus[instance]</i>	SINT	See the following descriptions of Limit Function Status bits.
<i>module:SO.SSMActive[inst]</i>	[0]	For use with a controller-based SSM function.
<i>module:SO.SSMStatus[inst]</i>	[1]	For use with a controller-based SSM function.
<i>module:SO.SLSActive[instance]</i>	[2]	Indicates that the controller-based SLS function is active. 0 = SLS Function is not active 1 = SLS Function is active
<i>module:SO.SLSLimit[instance]</i>	[3]	Indicates that the controller-based SLS function has detected the monitored axis speed above the limit setpoint. 0 = axis is below setpoint speed 1 = axis is greater than or equal to the setpoint speed
<i>module:SO.SDIActive[instance]</i>	[6]	Indicates that the controller-based SDI function is active. 0 = SDI Function is not active 1 = SDI Function is active
<i>module:SO.SDILimit[instance]</i>	[7]	Indicates that the controller-based SDI function detected motion greater than the limit in the unintended direction. 0 = Limit not reached 1 = Unintended motion
<i>module:SO.PassThruPositionLimitStatus[instance]</i>	SINT	See the following descriptions of individual bits, indicating the Monitoring Function Limit status of controller-based functions.
<i>module:SO.SCAAActive[inst]</i>	[0]	For use with a controller-based SCA function.
<i>module:SO.SSMStatus[inst]</i>	[1]	For use with a controller-based SSM function.

Table 100 - Safety Output Assembly Tags (Continued)

Safety Output Assembly Tag Name (output to safety controller)	Type/[bit]	Description
<i>module:SO.SLSActive[instance]</i>	[2]	Indicates that the controller-based SLS function is active. 0 = SLS Function is not active 1 = SLS Function is active
<i>module:SO.SLSLimit[instance]</i>	[3]	Indicates that the controller-based SLS function has detected the monitored axis speed above the limit setpoint. 0 = axis is below setpoint speed 1 = axis is greater than or equal to the setpoint speed
<i>module:SO.SDIActive[instance]</i>	[6]	Indicates that the controller-based SDI function is active. 0 = SDI Function is not active 1 = SDI Function is active
<i>module:SO.SDILimit[instance]</i>	[7]	Indicates that the controller-based SDI function detected motion greater than the limit in the unintended direction. 0 = Limit not reached 1 = Unintended motion
<i>module:SO.PassThruPositionLimitStatus[instance]</i>	SINT	See the following descriptions of individual bits, indicating the Monitoring Function Limit status of controller-based functions.
<i>module:SO.SCAActive[inst]</i>	[0]	For use with a controller-based SCA function.
<i>module:SO.SCAStatus[inst]</i>	[1]	For use with a controller-based SCA function.
<i>module:SO.SLPActive[instance]</i>	[2]	Indicates that the controller-based SLP function is active. 0 = SLP Function is not active 1 = SLP Function is active
<i>module:SO.SLPLimit[instance]</i>	[3]	Indicates that the controller-based SLP function has detected the monitored axis position outside of the setpoint limits. 0 = axis position is within the limits 1 = axis position is outside of the limits
<i>module:SO.SFHomed[instance]</i>	[7]	Status of the controller-based SFX position homing function. 1 = SFX Homed
<i>module:SO.PassThruStopFaults[instance]</i>	SINT	See the following descriptions of individual bits, indicating the Safety Fault status of controller-based safety functions.
<i>module:SO.SFXFault[instance]</i>	[0]	Indicates that a fault occurred with the controller-based SFX function. 0 = Normal Operation 1 = Fault
<i>module:SO.SBCFault[instance]</i>	[1]	Indicates that a fault occurred with the controller-based SBC function. 0 = Normal Operation 1 = Fault
<i>module:SO.SS1Fault[instance]</i>	[2]	Indicates that a fault occurred with the controller-based SS1 function. 0 = Normal Operation 1 = Fault
<i>module:SO.SS2Fault[instance]</i>	[3]	Indicates that a fault occurred with the controller-based SS2 function. 0 = Normal Operation 1 = Fault
<i>module:SO.SOSFault[instance]</i>	[4]	Not available, always 0.
<i>module:SO.PassThruLimitFaults[instance]</i>	SINT	See the following descriptions of individual bits, indicating the Safety Fault status of controller-based safety functions.
<i>module:SO.SSMFault[inst]</i>	[0]	Controller-based SSM fault. 0 = Normal Operation 1 = Fault

Table 100 - Safety Output Assembly Tags (Continued)

Safety Output Assembly Tag Name (output to safety controller)	Type/[bit]	Description
<i>module:SO.SLSFault[instance]</i>	[1]	Controller-based SLS fault. 0 = Normal Operation 1 = Fault
<i>module:SO.SDIFault[instance]</i>	[2]	Controller-based SDI fault. 0 = Normal Operation 1 = Fault
<i>module:SO.SCAFault[inst]</i>	[3]	Controller-based SCA fault. 0 = Normal Operation 1 = Fault
<i>module:SO.SLPFault[instance]</i>	[4]	Controller-based SLP fault. 0 = Normal Operation 1 = Fault
<i>module:SO.SafetyStopFunctions[instance]</i>	SINT	See the following descriptions of individual bits used to activate (request) safety functions.
<i>module:SO.STOOutput[instance]</i>	[0]	0 = Activate STO Function 1 = Permit Torque
<i>module:SO.SBCOutput[instance]</i>	[1]	Drive-based function not available.
<i>module:SO.SS1Request[instance]</i>	[2]	0 = Remove SS1 Request 1 = Activate Drive-based SS1 Function
<i>module:SO.SS2Request[instance]</i>	[3]	Drive-based function not available.
<i>module:SO.SOSRequest[instance]</i>	[4]	Drive-based function not available.
<i>module:SO.SMTRequest[inst]</i>	[5]	Drive-based function not available.
<i>module:SO.ResetRequest[instance]</i>	[7]	0 → 1 transition resets drive-based Safe Stop function.
Module:SO.SafetyIOCommands	SINT	See the following descriptions of individual bits.
Module:SO.Out000Output	[0]	Command Safety Output 0
Module:SO.Out010Output	[1]	Command Safety Output 1
Module:SO.Test000Output	[2]	Command Test Output 0
Module:SO.Test010Output	[3]	Command Test Output 1

Safety Feedback Attributes

Safety feedback attributes provide configuration and status information for safety feedback. The module has two safety feedback instances. The safety feedback instances contain safety feedback attributes and safety feedback configuration data. The following attributes can be read.

Table 101 - Safety Feedback Instance Numbers

Safety Feedback Instance Number	Safety Feedback Device
1	Primary Feedback
2	Secondary Feedback

Table 102 - Safety Feedback Attributes (Class 0x58)

Attribute ID Decimal (Hex)	Attribute Name	Attribute Description	Values
1 (0x1)	Velocity Data Type	Determines the data type of feedback velocity and feedback acceleration and all related attributes.	1 = REAL (hard-coded)
2 (0x2)	Feedback Position	Actual position of the feedback device.	Feedback Counts Safety data with a safe value defined by Position Safe State Behavior
3 (0x3)	Feedback Velocity	Actual velocity of the feedback device.	Feedback Units/s Safety data with a safe value defined by Velocity Safe State Behavior
4 (0x4)	Feedback Acceleration	Actual acceleration of the feedback device.	Feedback Units/s ² Safety data with a safety state of 0.
5 (0x5)	Feedback Mode	Motion Feedback mode.	0 = Not Used (default) 1 = Used
8 (0x8)	Feedback Fault	Status of this motion feedback channel.	0 = No Fault 1 = Faulted
9 (0x9)	Feedback Fault Reason	Determines cause of the fault detected.	1 = No Fault 2 = Config 3 = Max Speed 4 = Max Accel 5 = Sin ² +Cos ² 6 = Quadrature 7 = Discrepancy 8 = Partner 9 = Voltage 10 = SignalNoise 11 = Signal Lost 12 = Data Lost 13 = Device Fail 107 = Max Freq 108 = SinCosOffset 109 = Pos Rollover
10 (0xA)	Reset Feedback Fault	Resets a motion feedback fault (read/write access).	0 to 1 transition will reset a safety feedback fault once the fault condition is removed
11 (0xB)	Position Safe State Behavior	Defines behavior for value reporting when faulted.	2 = Hold Last Value
13 (0xD)	Velocity Safe State Behavior	Defines behavior for value reporting when faulted.	0 = Use Velocity Safe State Value (default)
14 (0xE)	Velocity Safe State Value	Safe Velocity Feedback and Acceleration Feedback value.	Default = 0
16 (0x10)	Feedback Unit	Unit of measure for the feedback device.	0 = Revolution (default) 1 = Meter

Table 102 - Safety Feedback Attributes (Class 0x58) (Continued)

Attribute ID Decimal (Hex)	Attribute Name	Attribute Description	Values
17 (0x11)	Feedback Type	Identifies the type of feedback device.	0 = Not Specified (default) 1 = Digital Aqb 2 = Sine/Cosine 3 = Hiperface
18 (0x12)	Feedback Polarity	Feedback polarity of Normal provides increasing position values when the feedback device is moved in position according to the encoder manufacture specifications. For feedback devices internal to Allen-Bradley® motors, the Normal direction is clockwise rotation of the shaft when facing the end of the motor shaft.	0 = Normal (default) 1 = Inverted
19 (0x13)	Feedback Cycle Resolution	This is the number of feedback cycles per revolution of the encoder. For a Sin/Cos encoder, this is the number of sinusoidal cycles per revolution.	0 = Default
20 (0x14)	Feedback Cycle interpolation	This value is the number of feedback counts per feedback cycle. This value is always 4 for sin/cos or incremental encoders.	Counts/Cycle Default = 0 4 for Feedback Type=1/2/3
22 (0x16)	Velocity Average Time	A moving average filter is applied to velocity that is provided by the Motion Safety instance of the drive. This parameter specifies the window of time where the average is taken. Feedback velocity is provided as a REAL data type.	0 = Disable Averaging (default) 1...65565 ms
23 (0x17)	Acceleration Average Time	A moving average filter is applied to acceleration that is provided by the safety feedback instance of the drive. This parameter specifies the window of time where the average is taken.	0 = Disable Averaging (default) 1...65565 ms
24 (0x18)	Feedback Voltage Monitor	Defines the expected range of encoder voltage supply.	0 = Voltage Monitoring Not Performed 1 = 4.75 V...5.15 V 2 = 7 V...12 V 3 = 11.4 V...12.6 V
26 (0x1A)	Feedback Maximum Speed	Absolute maximum speed for this feedback device. Exceeding this speed is a fault.	Feedback Units/s 0 = Disable Max Speed Check (Default)
27 (0x1B)	Feedback Maximum Acceleration	Absolute maximum acceleration for this feedback device. Exceeding this acceleration is a fault.	Feedback Units/s ² 0 = Disable Max Speed Check (Default)
31 (0x1F)	Motion Positive	Indicates positive motion.	0 = No Positive Motion 1 = Positive Motion
32 (0x20)	Motion Negative	Indicates negative motion.	0 = No Negative Motion 1 = Negative Motion
33 (0x21)	Standstill Speed	Defines what maximum magnitude of Feedback Velocity is considered standstill. Feedback Velocity above standstill will set either Motion Negative or Motion Positive to 1.	Feedback Units/s (Default of 0)

Safe Stop Function Attributes

Safe-stop function attributes provide configuration and status information for safety feedback.

The module has one safe stop function instance. Safe-stop function attributes provide status and configuration data. All attributes can be read using explicit messages. Attributes that can be written are indicated in the table.

Configuration attributes can be read but cannot be written using an explicit message.

Table 103 - Safe Stop Function Attributes (Class 0x5A)

Attribute ID Decimal (Hex)	Attribute Name	Attribute Description	Values
10 (0xA)	Safety Reset	Reset all safety functions.	0 to 1 transition required to reset
11 (0xB)	Restart Type	Selects safety function restart behavior while operating.	0 = Manual 1 = Automatic
12 (0xC)	Cold Start Type	Selects safety function restart behavior when applying controller power or mode change to Run.	0 = Manual 1 = Automatic
20 (0x14)	Safety Feedback Instance	Instance ID of a Safety Feedback instance to provide position, velocity, and acceleration data used by safe stop functions.	0 = No feedback (default)
21 (0x15)	Safety Feedback Fault	Copy of feedback status from the Safety Feedback instance.	0 = No Fault 1 = Faulted
30 (0x1E)	Safety Function Fault	Logical OR of all Fault attributes that reference this instance.	0 = No Fault 1 = Faulted
31 (0x1F)	Safety Stop Fault	Logical OR of all Stop Fault attributes in this instance.	0 = No Fault 1 = Faulted
32 (0x20)	Safety Limit Fault	Logical OR of all Limit Fault attributes that reference this instance.	0 = No Fault No Limit Functions Supported
33 (0x21)	Safety Limit Active	Logical OR of all Limit Active attributes that reference this instance.	0 = No Limit No Limit Functions Supported
34 (0x22)	Restart Required	A stop function has been activated and Restart Type is Manual.	0 = Restart Not Required 1 = Restart Required
40 (0x28)	Safety Stop Status	Collection of Safety Stop Status bits:	Bit: 0 = Safety Function Fault 1 = Safety Reset Request 2 = Restart Required 3 = STO Active 4 = Torque Disabled 5 = SBC Active 6 = Brake Engaged 7 = SS1 Active 8 = SS2 Active 9 = SOS Active 10 = SOS Standstill 11 = SMT Active 12 = SMT OVertemp
41 (0x29)	Safety Stop Faults	Collection of Safety Stop Fault bits:	Bit: 2 = Feedback Fault 3 = STO Fault 4 = SS1 Fault 5 = SS2 Fault 6 = SOS Fault 7 = SBC Fault 8 = SMT Fault

Table 103 - Safe Stop Function Attributes (Class 0x5A) (Continued)

Attribute ID Decimal (Hex)	Attribute Name	Attribute Description	Values
50 (0x32)	Connection Loss Action	Safety Output Connection is lost (or closed) and optional Connection Loss Action is Set to STO (default).	0 = STO (default) 1 = SS1
51 (0x33)	Connection Idle Action	Safety Output Connection's Run/Idle bit transitions from Run to Idle and Optional Connection Idle Action is Set to STO (default).	0 = STO (default) 1 = SS1
101 (0x65)	STO Delay	Specify delay time from STO Active to Torque Disabled. This delay allows the time for an external brake to engage before torque disabled.	Delay in milliseconds Default = 0
110 (0x6E)	SBC Ready	Safe Break Control safety function is supported, configured, and ready for operation.	0 = Not Ready SBC Function Not Supported
111 (0x6F)	SS1 Ready	Safe Stop 1 safety function is supported, configured, and ready for operation.	0 = Not Ready 1 = Ready
112 (0x70)	SS2 Ready	Safe Stop 2 safety function is configured and ready for activation.	0 = Not Ready SS2 Function Not Supported
113 (0x71)	SOS Ready	Safe Operating Stop safety function is configured and ready for activation.	0 = Not Ready SOS Function Not Supported
114 (0x72)	SMT Ready	Safe Motor Temperature safety function is configured and ready for activation.	0 = Not Ready SMT Function Not Supported
260 (0x104)	STO Mode	Safe Torque Off mode.	1 = Used 2 = Permit Torque
261 (0x105)	STO Output	Enables or disables energy to the motor that can generate torque (or force if linear motor).	0 = Disable Torque 1 = Permit Torque Safety data with a safety state of 0.
262 (0x106)	STO Active	Output of STO Activation block.	0 = Permit Torque 1 = Disable Torque
263 (0x107)	STO Fault	Safe Torque Off fault.	0 = No Fault 1 = Faulted
264 (0x108)	STO Fault Type	Detailed information about a fault.	1 = No Fault 2 = Invalid Configuration 3 = Circuit Error 4 = Stuck At Low 5 = Stuck At High 6 = Cross Connection 102 = Hard-wired STO Input Discrepancy 104 = Hard-wired STO Input Active in Network Safety
265 (0x109)	STO Activation	Bit string showing status of all inputs to the STO Activation block.	Bit: 0 = STO Output Active 1 = SS1 Complete 2 = Safety Stop Fault 3 = Safety Limit Fault 4 = Safety Limit Action 5 = Connection Loss 6 = Connection Idle
266 (0x10A)	Torque Disabled	Status of Safe Torque Off.	0 = Torque Permitted 1 = Torque Disabled
280 (0x118)	SS1 Mode	Safe Stop 1 mode.	0 = Not Used 1 = Timed SS1 (default) 2 = Monitored SS1
281 (0x119)	SS1 Request	Select Safe Stop 1 request.	0 = No Request 1 = Request

Table 103 - Safe Stop Function Attributes (Class 0x5A) (Continued)

Attribute ID Decimal (Hex)	Attribute Name	Attribute Description	Values
282 (0x11A)	SS1 Active	Safe Stop 1 function active.	0 = Not Active 1 = Active
283 (0x11B)	SS1 Fault	Safe Stop 1 fault.	0 = No Fault 1 = Faulted
284 (0x11C)	SS1 Fault Type	Describes detailed information about the Fault.	1 = No Fault 2 = Invalid Configuration 3 = Deceleration Rate 4 = Maximum Time 100 = STO Request during SS1 101 = SS1 Request while Feedback not valid
285 (0x11D)	SS1 Max Stop Time	Allowed time to stop.	0...65535 milliseconds Default = 0
286 (0x11E)	SS1 Standstill Speed	Defines the speed below which motion is considered stopped.	Feedback Units / s Default = 0
287 (0x11F)	SS1 Stop Monitor Delay	Delay before deceleration is monitored.	0...65535 milliseconds Default = 0
288 (0x120)	SS1 Decel Ref Rate	Minimum rate of deceleration while stopping.	Feedback Units / s ² 0 = No Decel Check (default)
289 (0x121)	SS1 Activation	The source of the SS1 activation.	Bit: 0 = SS1 Request 1 = Safe Limit Active 2 = Connection Loss 3 = Connection Idle
290 (0x122)	SS1 Decel Rev Tolerance	Defines the speed tolerance that is applied to the deceleration ramp check. This attribute is optional in the implementation.	Feedback Units/s ² Default = 0
291 (0x123)	SS1 Ext Max Stop Time	Allowed time to stop with extended range to support possibility of long stop times. This attribute is optional in the implementation.	0...4294967296 ms Default = 0
292 (0x124)	SS1 Max Stop Time Source	Selects which Max Stop Time attribute determines the allowed time to stop. Must be supported if optional SS1 Ext Max Stop Time is supported.	0 = Max Stop Time 1 = Ext Max Stop Time
303 (0x12F)	SS2 Fault	Safe Stop 2 fault.	0 = No Fault 1 = Faulted
304 (0x130)	SS2 Fault Type	Detailed information about a fault.	1 = No Fault 2 = Invalid Configuration SS2 Function Not Supported
323 (0x143)	SOS Fault	Safe Operating Stop fault.	0 = No Fault 1 = Faulted
324 (0x144)	SOS Fault Type	Detailed information about a fault.	1 = No Fault 2 = Invalid Configuration SOS Function Not Supported
341 (0x155)	SMT Fault	Safe Motor Temperature fault.	0 = No Fault 1 = Faulted
342 (0x156)	SMT Fault Type	Detailed information about a fault.	1 = No Fault 2 = Invalid Configuration SMT Function Not Supported
360 (0x168)	SBC Mode	Safe Brake Control Mode.	0 = Not Used (default) 1 = Used, No Test Pulses 2 = Used, with Test Pulses

Table 103 - Safe Stop Function Attributes (Class 0x5A) (Continued)

Attribute ID Decimal (Hex)	Attribute Name	Attribute Description	Values
361 (0x169)	SBC Output	Commanded state of the SBC Outputs.	0 = Engage Brake (default) 1 = Release Brake Permit
362 (0x16A)	SBC Active	Indicates that the brake is currently engaged, and can be released.	0 = SBC Not Active 1 = SBC Active
363 (0x16B)	SBC Fault	Safe Brake Control fault.	0 = No Fault 1 = Faulted
364 (0x16C)	SBC Fault Type	Detailed information about a fault.	1 = No Fault 2 = Invalid Configuration SBC Function Not Supported
365 (0x16D)	SBC Activation	Indicates the sources of SBC activation.	0 = SBC Output Active 1 = STO Active 2 = Safety Stop Fault 3 = Safety Limit Fault
366 (0x16E)	SBC Brake Engaged	Indicates the state of the signals controlling the SBC Output.	0 = Brake Released 1 = Brake Engaged
367 (0x16F)	SBC Output Monitor Value	Read back value of the safety outputs.	0 = Brake De-energized 1 = Brake Energized
368 (0x170)	STO Activates SBC	Configures Safe Brake Control to engage a mechanical brake when Safe Torque Off disables torque.	0 = Not Linked (default) 1 = STO Engages a mechanical
369 (0x171)	STO to SBC Delay	When STO Activates SBC is set, this attribute configures a time delay between torque disabled and brake engaged.	0 = No Delay (default)

Explicit Messages

Use explicit messages to communicate with a drive and obtain additional fault, status, or configuration information that is not available in the Safety I/O Tag structure. Attribute data is useful for additional diagnostic information.

IMPORTANT Explicit messages must not be used for any safety related function.

Example: Read SS1 Fault Type

In the drive module, the connection to the safety instance or instances is controlled by a safety supervisor. The supervisor status can be read by the motion controller through the motion connection and the safety controller through the Safety Input Assembly or by an explicit message.

Table 104 - Safe Stop 1 Fault Type: MSG

Parameter	Value	Description
Service Code	0x0E	Get attribute single
Class	0x5A	Safety Stop Functions Object
Instance	1	
Attribute	0x11C	SS1 Fault Type
Data Type	USINT	Unsigned short integer

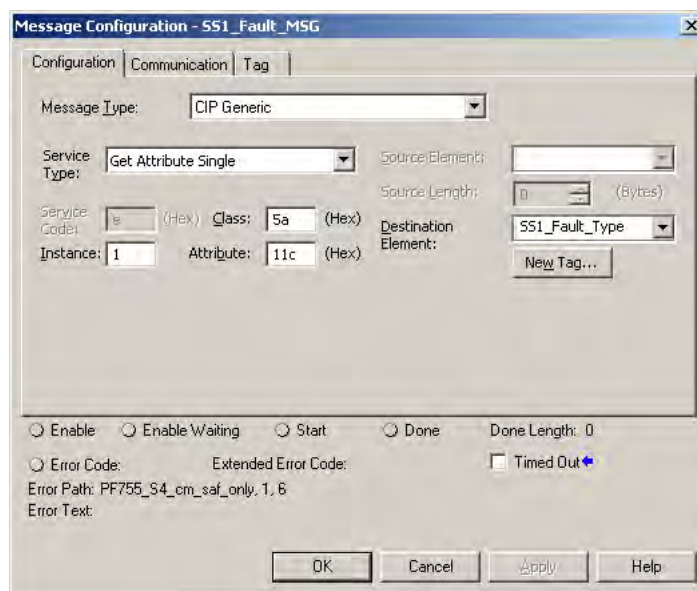

The 20-750-S4 option is accessed by a MSG command using CIP 'Bridging and Routing'. To access the S4, the routing information has to be manually appended to the Path in the MSG configuration. This means appending '*1, <port>*' where '1' indicates that the message is routed across the PF755

backplane and <port> is the number of the backplane port where the 20-750-S4 option is installed. This can be port 4, 5, or 6. In CIP Motion applications the 20-750-S4 must be installed in port 6.

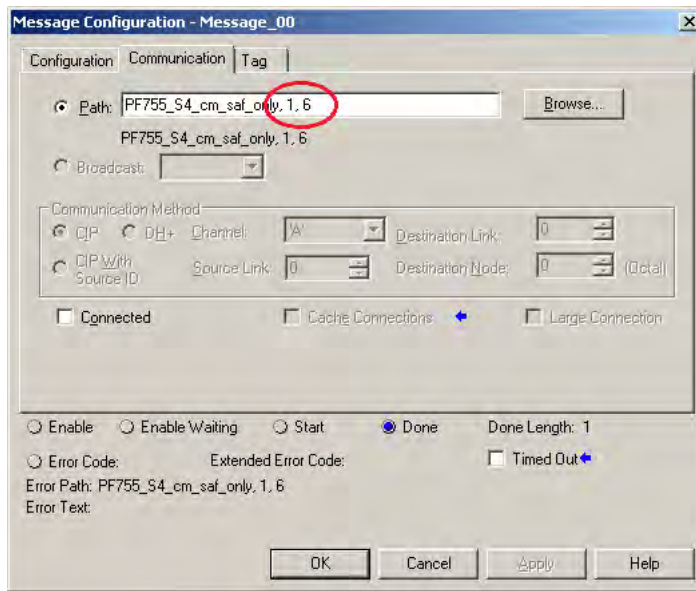

Parameter Data

This appendix provides a description of the device parameters and host config parameters.

Parameters and Settings in a Linear List

This section describes the status parameters and their values in numerical order.

Device Parameters

You are not able to create datalinks to these Device parameters. If you need to read them, you could use a message instruction.

Table 105 - Device Config Parameters

No.	Display Name Full Name Description	Values	Description	Data Type
1	Identity Status Describes the status of the module.	"Owned" (0)	Indicates whether the safety option module has an owner. 1 = owned 0 = not owned	DWORD
		"Configured" (1)	Indicated whether the safety option module has a configuration other than out-of-box. 1 = configured 0 = out of box configuration	
		"Min Rec Flt" (8)	If set (1), the safety option module has detected a minor recoverable fault. The device does not enter a faulted state.	
		"Min Unr Flt" (9)	If set (1), the safety option module has detected a minor unrecoverable fault. The device does not enter a faulted state.	
		"Maj Rec Flt" (10)	If set (1), the safety option module has detected a major recoverable fault and is in the major recoverable fault state.	
		"Maj Unr Flt" (11)	If set (1), the safety option module has detected a major unrecoverable fault is in the major unrecoverable fault state.	

Table 105 - Device Config Parameters (Continued)

No.	Display Name Full Name Description	Values	Description	Data Type
2	Extended Status Detailed description of the module status based on Identity State.	"Self Test" (0)	A self test is in progress.	USINT
		"FW Update" (1)	A firmware update is in progress.	
		"IO Faulted" (2)	At least one I/O connection is faulted.	
		"No IO Connect" (3)	No I/O connections are established.	
		"Config Err" (4)	Non-volatile configuration is bad.	
		"Major Flt" (5)	A major fault has occurred.	
		"IO In Run" (6)	At least one I/O connection is in Run mode.	
	"IO In Idle" (7)	At least one I/O connection is in Idle mode.		
3	Identity State State of the module.	"Invalid" (0)	The device is without power.	USINT
		"Self Test" (1)	The device is executing self tests.	
		"Standby" (2)	The device has incorrect or incomplete configuration.	
		"Operational" (3)	The device is currently operating in normal fashion.	
		"Maj Rec Flt" (4)	The device has experienced a fault that is recoverable.	
		"Maj Unr Flt" (5)	Device has encountered a fault that is unrecoverable.	
4	Max Data Age Maximum data age	–	Holds the largest data age detected in 128 μ s increments.	UINT
5	Cons Flt Count Consumer connection fault count	–	The number of faults detected in this hour from the consumer connection.	UINT
6	Prod Flt Count Producer connection fault count	–	The number of faults detected in this hour from the producer connection.	UINT
7	STO Fault Type Indicates the current STO fault type of the module.	"No Fault" (1)	STO functions are not faulted.	USINT
		"Circuit Err" (3)	Internal STO circuitry error.	
		"Stuck Low" (4)	Internal STO Health and/or Power input stuck low.	
		"Stuck High" (5)	Internal STO Health and/or Power input stuck high.	
		"Discrepancy" (102)	Hardwired input discrepancy.	
	"Mode Conflict" (104)	Hardwired input is detected in Network mode.		

Table 105 - Device Config Parameters (Continued)

No.	Display Name Full Name Description	Values	Description	Data Type
10	SS1 Fault Type The fault reported by the Safe Stop 1 function.	"No Fault" (1)	No fault being reported by the Safe Stop 1 function.	BYTE
		"Config" (2)	Invalid configuration of Safe Stop 1 function.	
		"Decel Rate" (3)	Acceleration less than Decel Reference Rate (Monitored SS1).	
		"Maximum Time" (4)	Above Standstill Speed at Max Stop Time (Monitored SS1).	
		"Fdbk Invalid" (101)	A fault is present in the encoder.	
11	SBC Fault Type The fault reported by the Safe Brake Control function.	"No Fault" (1)	No fault is reported by the Safe Brake Control function.	BYTE
		"Config" (2)	Invalid configuration of the Safe Brake Control.	
		"OverCurrent" (3)	Current exceeded maximum on an output controlling the Safety Brake.	
		"Stuck Low" (4)	An output controlling the Safety Brake is stuck low.	
		"Stuck High" (5)	An output controlling the Safety Brake is stuck high.	
		"Cross Conn" (6)	The outputs controlling the Safety Brake are cross-connected.	
		"Relay Fail" (7)	A relay of the outputs controlling the Safety Brake has failed.	
12	Safety IO Values The values being read from input and output points.	"In0 Value" (0)	The value read from Input 0.	BYTE
		"In1 Value" (1)	The value read from Input 1.	
		"In2 Value" (2)	The value read from Input 2.	
		"In3 Value" (3)	The value read from Input 3.	
		"Tst0 Value" (4)	The value of test output 0.	
		"Tst1 Value" (5)	The value of test output 1.	
		"Out0 Value" (6)	The value of output 0.	
		"Out1 Value" (7)	The value of output 1.	
13	Safety IO Status The status of the input and output points.	"In0 Status" (0)	The status of input 0.	BYTE
		"In1 Status" (1)	The status of input 1.	
		"In2 Status" (2)	The status of input 2.	
		"In3 Status" (3)	The status of input 3.	
		"Tst0 Status" (4)	The status of test output 0.	
		"Tst1 Status" (5)	The status of test output 1.	
		"Out0 Status" (6)	The status of output 0.	
		"Out1 Status" (7)	The status of output 1.	
14	Input Alarm Index The number of the input instance whose alarm type will be displayed in parameter 15 - (Input Alarm).			BYTE

Table 105 - Device Config Parameters (Continued)

No.	Display Name Full Name Description	Values	Description	Data Type
15	Input Alarm The alarm being reported by the input instance specified in parameter 14 - (Input Alarm Indx).	"No Alarm" (0)	No alarm reported by the input instance.	BYTE
		"Config" (1)	The input instance's configuration is invalid.	
		"Ext Circuit" (2)	External Pulse Test has failed.	
		"Int Circuit" (3)	Internal Pulse Test has failed.	
		"Discrepancy" (4)	The Dual Channel function controlling this instance is reporting an alarm.	
		"Dual Ch" (5)	The Dual Channel function controlling this instance has detected a fault in the other channel.	
16	Output Alarm Index The number of the output instance whose alarm type will be displayed in parameter 17 - (Output Alarm).			BYTE
17	Output Alarm The alarm being reported by the output instance specified in parameter 16 - (Output Alarm Indx).	"No Alarm" (0)	No alarm reported by the output instance.	BYTE
		"Config" (1)	The output instance's configuration is invalid.	
		"OverCurrent" (2)	Current exceeded maximum on the output.	
		"ShortCircuit" (3)	The output is stuck low.	
		"Stuck High" (4)	The output is stuck high.	
		"Partner Err" (5)	The Dual Channel function controlling this instance has detected a fault in the associated output instance.	
		"Relay Err" (6)	Read back signal error during an expected high state.	
		"Relay Fail" (7)	The output relay has failed.	
		"Dual Ch" (8)	The output values of the associated dual channel instance are not the same.	
		"Cross Conn" (9)	The outputs of the associated dual channel instance are cross-connected.	
20	Enc1 Position The position count being reported by the primary encoder.			DWORD
21	Enc1 Velocity Primary encoder velocity in units/s. The units of this value are of the type reported by parameter 24 - (En1 Unit).			REAL

Table 105 - Device Config Parameters (Continued)

No.	Display Name Full Name Description	Values	Description	Data Type
22	Enc1 Accel Primary encoder acceleration in units/ s^2 . The units of this value are of the type reported by parameter 24 - (En1 Unit).			REAL
23	Enc1 Fault Type The fault type being reported by the primary encoder.	"No Fault" (1)	No fault reported by the primary encoder.	BYTE
		"Config" (2)	The encoder's configuration is invalid.	
		"Max Speed" (3)	The encoder speed has exceeded the configured maximum speed.	
		"Max Accel" (4)	The encoder acceleration has exceeded the configured maximum acceleration.	
		"Sin ² +Cos ² " (5)	The encoder has failed the vector length or aspect ratio checks.	
		"Quadrature" (6)	The encoder has exceeded the maximum number of quadrature signal errors.	
		"Discrepancy" (7)	The associated dual channel feedback instance has reported a discrepancy.	
		"Partner" (8)	The associated dual channel feedback instance has detected a fault in the other encoder.	
		"Voltage" (9)	The encoder voltage supply has gone out of the configured range.	
		"SignalNoise" (10)	The encoder signals have noise that is preventing operation.	
		"Signal Lost" (11)	The encoder signals are not present.	
		"Data Lost" (12)	Stopped receiving data from a Digital Encoder.	
		"Device Fail" (13)	The encoder device has failed.	
		"Max Freq" (107)	The frequency of the encoder has exceeded the maximum level for this product.	
"SinCosOffset" (108)	The offset of the Sine/Cosine signal from ground is outside the required level.			
"Pos Rollover" (109)	The encoder position count has exceeded the maximum value that can be represented in this product.			
24	Enc1 Unit Primary encoder feedback units (set by safety configuration).	"Revolution" (0)	Encoder units are represented in terms of revolutions.	BYTE
		"Meter" (1)	Encoder units are represented in terms of meters.	
30	Enc2 Position The position count being reported by the secondary encoder.			DWORD

Table 105 - Device Config Parameters (Continued)

No.	Display Name Full Name Description	Values	Description	Data Type
31	Enc2 Velocity Secondary encoder velocity in Units/s. The units of this value are of the type reported by P34 [Enc2 Unit].			REAL
32	Enc2 Accel Secondary encoder acceleration in units/s ² . The units of this value are of the type reported by P34 [Enc2 Unit].			REAL
33	Enc2 Fault Type The fault type being reported by the secondary encoder.	"No Fault" (1)	No fault reported by the secondary encoder.	BYTE
		"Config" (2)	The encoder's configuration is invalid.	
		"Max Speed" (3)	The encoder speed has exceeded the configured maximum speed.	
		"Max Accel" (4)	The encoder acceleration has exceeded the configured maximum acceleration.	
		"Sin ² +Cos ² " (5)	The encoder has failed the vector length or aspect ratio checks.	
		"Quadrature" (6)	The encoder has exceeded the maximum number of quadrature signal errors.	
		"Discrepancy" (7)	The associated dual channel feedback instance has reported a discrepancy.	
		"Partner" (8)	The associated dual channel feedback instance has detected a fault in the other encoder.	
		"Voltage" (9)	The encoder voltage supply has gone out of the configured range.	
		"SignalNoise" (10)	The encoder signals have noise that is preventing operation.	
		"Signal Lost" (11)	The encoder signals are not present.	
		"Data Lost" (12)	Stopped receiving data from a Digital Encoder.	
		"Device Fail" (13)	The encoder device has failed.	
34	Enc2 Unit Secondary encoder feedback units (set by safety configuration).	"Revolution" (0)	Encoder units are represented in terms of revolutions.	BYTE
		"Meter" (1)	Encoder units are represented in terms of meters.	
		"Max Freq" (107)	The frequency of the encoder has exceeded the maximum level for this product.	
		"SinCosOffset" (108)	The offset of the Sine/Cosine signal from ground is outside the required level.	
		"Pos Rollover" (109)	The encoder position count has exceeded the maximum value that can be represented in this product.	

Host Config Parameters

These parameters are part of the host configuration parameters. Host Parameters 3...9 provide status of the safety functions. These parameters can be data linked to the controller input assembly to provide the fastest possible update of safety status to the controller. In Integrated Motion operation, these parameters are sent to the motion controller as part of the Motion Connection Axis Tags.

Host Parameters 11...14 configure how the PowerFlex® 755 drive reacts to a change in the status of the safety functions. These configuration parameters are **not** part of the 'Safety' configuration, they **are** part of the PowerFlex 755 drive configuration.

Table 106 - Host Config Parameters

No.	Display Name Full Name Description	Values	Read-Write	Data Type
1	Reserved			
2	Reserved			
3	Safety State Provides information on the state of the safety connection and the mode of operation. "Testing" (1) – The safety option module is in self-test "Idle" (2) – No active connections (networked) "Test Flt" (3) - Indicates a fault has occurred during testing of the safety module "Executing" (4) – Normal running state (networked) "Abort" (5) - Safety module is in a recoverable fault state "Critical Flt" (6) - A critical fault has occurred "Configuring" (7) – Transition state (networked) "Waiting" (8) – Out-of-Box state (hardwired) "Wait w Trq" (51) – Out-of-Box state (hardwired) "Exec w Trq" (52) – STO Bypass state (networked)		RO	DWORD

Table 106 - Host Config Parameters (Continued)

No.	Display Name Full Name Description	Values	Read-Write	Data Type																																																																																																		
4	<p>Safety Status Indicates status of the safety functions.</p> <table border="1" data-bbox="207 409 1328 588"> <thead> <tr> <th data-bbox="207 409 284 514">Options</th> <th data-bbox="284 409 316 514">Conn Idle</th> <th data-bbox="316 409 349 514">Conn Closed</th> <th data-bbox="349 409 381 514">SLP Status</th> <th data-bbox="381 409 414 514">SLP Active</th> <th data-bbox="414 409 446 514">SCA Status</th> <th data-bbox="446 409 479 514">SCA Active</th> <th data-bbox="479 409 511 514">Neg Motion</th> <th data-bbox="511 409 544 514">Pos Motion</th> <th data-bbox="544 409 576 514">SDI Limit</th> <th data-bbox="576 409 609 514">SDI Active</th> <th data-bbox="609 409 641 514">SLA Limit</th> <th data-bbox="641 409 673 514">SLA Active</th> <th data-bbox="673 409 706 514">SLS Limit</th> <th data-bbox="706 409 738 514">SLS Active</th> <th data-bbox="738 409 771 514">SSM Limit</th> <th data-bbox="771 409 803 514">SSM Active</th> <th data-bbox="803 409 836 514">Reserved</th> <th data-bbox="836 409 868 514">Reserved</th> <th data-bbox="868 409 901 514">Reserved</th> <th data-bbox="901 409 933 514">SMT Ovr Temp</th> <th data-bbox="933 409 966 514">SMT Active</th> <th data-bbox="966 409 998 514">SOS StndStil</th> <th data-bbox="998 409 1031 514">SOS Active</th> <th data-bbox="1031 409 1063 514">SS2 Active</th> <th data-bbox="1063 409 1096 514">SS1 Active</th> <th data-bbox="1096 409 1128 514">Brak Engage</th> <th data-bbox="1128 409 1161 514">SBS Active</th> <th data-bbox="1161 409 1193 514">Trq Disabled</th> <th data-bbox="1193 409 1226 514">STO Active</th> <th data-bbox="1226 409 1258 514">Restart Req</th> <th data-bbox="1258 409 1291 514">Safety Reset</th> <th data-bbox="1291 409 1323 514">Safety Fault</th> </tr> </thead> <tbody> <tr> <td data-bbox="207 514 284 556">Default</td> <td data-bbox="284 514 316 556">0</td> <td data-bbox="316 514 349 556">0</td> <td data-bbox="349 514 381 556">0</td> <td data-bbox="381 514 414 556">0</td> <td data-bbox="414 514 446 556">0</td> <td data-bbox="446 514 479 556">0</td> <td data-bbox="479 514 511 556">0</td> <td data-bbox="511 514 544 556">0</td> <td data-bbox="544 514 576 556">0</td> <td data-bbox="576 514 609 556">0</td> <td data-bbox="609 514 641 556">0</td> <td data-bbox="641 514 673 556">0</td> <td data-bbox="673 514 706 556">0</td> <td data-bbox="706 514 738 556">0</td> <td data-bbox="738 514 771 556">0</td> <td data-bbox="771 514 803 556">0</td> <td data-bbox="803 514 836 556">0</td> <td data-bbox="836 514 868 556">0</td> <td data-bbox="868 514 901 556">0</td> <td data-bbox="901 514 933 556">0</td> <td data-bbox="933 514 966 556">0</td> <td data-bbox="966 514 998 556">0</td> <td data-bbox="998 514 1031 556">0</td> <td data-bbox="1031 514 1063 556">0</td> <td data-bbox="1063 514 1096 556">0</td> <td data-bbox="1096 514 1128 556">0</td> <td data-bbox="1128 514 1161 556">0</td> <td data-bbox="1161 514 1193 556">0</td> <td data-bbox="1193 514 1226 556">0</td> <td data-bbox="1226 514 1258 556">0</td> <td data-bbox="1258 514 1291 556">0</td> <td data-bbox="1291 514 1323 556">0</td> </tr> <tr> <td data-bbox="207 556 284 588">Bit</td> <td data-bbox="284 556 316 588">31</td> <td data-bbox="316 556 349 588">30</td> <td data-bbox="349 556 381 588">29</td> <td data-bbox="381 556 414 588">28</td> <td data-bbox="414 556 446 588">27</td> <td data-bbox="446 556 479 588">26</td> <td data-bbox="479 556 511 588">25</td> <td data-bbox="511 556 544 588">24</td> <td data-bbox="544 556 576 588">23</td> <td data-bbox="576 556 609 588">22</td> <td data-bbox="609 556 641 588">21</td> <td data-bbox="641 556 673 588">20</td> <td data-bbox="673 556 706 588">19</td> <td data-bbox="706 556 738 588">18</td> <td data-bbox="738 556 771 588">17</td> <td data-bbox="771 556 803 588">16</td> <td data-bbox="803 556 836 588">15</td> <td data-bbox="836 556 868 588">14</td> <td data-bbox="868 556 901 588">13</td> <td data-bbox="901 556 933 588">12</td> <td data-bbox="933 556 966 588">11</td> <td data-bbox="966 556 998 588">10</td> <td data-bbox="998 556 1031 588">9</td> <td data-bbox="1031 556 1063 588">8</td> <td data-bbox="1063 556 1096 588">7</td> <td data-bbox="1096 556 1128 588">6</td> <td data-bbox="1128 556 1161 588">5</td> <td data-bbox="1161 556 1193 588">4</td> <td data-bbox="1193 556 1226 588">3</td> <td data-bbox="1226 556 1258 588">2</td> <td data-bbox="1258 556 1291 588">1</td> <td data-bbox="1291 556 1323 588">0</td> </tr> </tbody> </table> <p>Bit 0 "Safety Fault" – Indicates the existence of a safety fault, where 0 = no fault and 1 = faulted. Bit 1 "Safety Reset" – A transition from 0 to 1 resets the safety function. Bit 2 "Restart Req" – Indicates whether a manual restart is required following a stop function, where 0 = restart not required and 1 = restart required. Bit 3 "STO Active" – Indicates whether STO control is active, where 0 = Not Active (Permit Torque) and 1 = Active (Disable Torque). Bit 4 "Trq Disabled" – Displays the status of STO control, where 0 = Torque Permitted and 1 = Torque Disabled. Bit 5 "SBC Active" – Indicates whether the Safe Brake Control function is active, where 0 = Not Active and 1 = Active. Bit 6 "Brak Engage" – Indicates whether the Safe Brake Control function has engaged the brake, where 0 = Brake Released and 1 = Brake Engaged. Bit 7 "SS1 Active" – Indicates whether the Safe Stop 1 function is active, where 0 = Not Active and 1 = Active. Bit 8 "SS2 Active" – Indicates whether the Safe Stop 2 function is active, where 0 = Not Active and 1 = Active. Bit 9 "SOS Active" – Indicates whether the Safe Operating Stop function is active, where 0 = Not Active and 1 = Active. Bit 10 "SOS StndStil" – Indicates whether the Safe Operating Stop function is comparing the actual feedback value to the set point, where 0 = Not comparing and 1 = Comparing. Bit 11 "SMT Active" – Reserved for future use. Always 0. Bit 12 "SMT Ovr Temp" – Reserved for future use. Always 0. Bit 16 "SSM Active" – Indicates if the Safe Speed Monitoring function is active, where 0 = Not Active and 1 = Active. Bit 17 "SSM Limit" – Indicates the status of the Safe Speed Monitoring function, where 0 = Speed is below limit and 1 = Speed is above limit. Bit 18 "SLS Active" – Indicates if the Safely Limited Speed function is active, where 0 = Not Active and 1 = Active. Bit 19 "SLS Limit" – Indicates if the speed exceeds the SLS limit, where 0 = Speed within limit and 1 = Speed exceeds limit. Bit 20 "SLA Active" – Reserved for future use. Always 0. Bit 21 "SLA Limit" – Reserved for future use. Always 0. Bit 22 "SDI Active" – Indicates if the Safe Direction function is active, where 0 = Not Active and 1 = Active. Bit 23 "SDI Limit" – Indicates if the Safe Direction function has detected movement in the prohibited direction, where 0 = Direction OK and 1 = Prohibited Direction. Bit 24 "Pos Motion" – The feedback device indicates a positive position value. Bit 25 "Neg Motion" – The feedback device indicates a negative position value. Bit 26 "SCA Active" – The Safe Cam function is active. Bit 27 "SCA Status" – The Safe Cam function has detected a motor shaft position outside the specified range. Bit 28 "SLP Active" – The Safety Limited Position function is active. Bit 29 "SLP Status" – The Safety Limited Position function has detected a position outside the specified range. Bit 30 "Conn Closed" – No active connection of an output assembly from the safety controller exists. Bit 31 "Conn Idle" – An active output assembly connection exists but the safety controller is in Program mode.</p>	Options	Conn Idle	Conn Closed	SLP Status	SLP Active	SCA Status	SCA Active	Neg Motion	Pos Motion	SDI Limit	SDI Active	SLA Limit	SLA Active	SLS Limit	SLS Active	SSM Limit	SSM Active	Reserved	Reserved	Reserved	SMT Ovr Temp	SMT Active	SOS StndStil	SOS Active	SS2 Active	SS1 Active	Brak Engage	SBS Active	Trq Disabled	STO Active	Restart Req	Safety Reset	Safety Fault	Default	0	0	0	0	0	0	0	0	0	0	0	0	0	0	0	0	0	0	0	0	0	0	0	0	0	0	0	0	0	0	0	0	Bit	31	30	29	28	27	26	25	24	23	22	21	20	19	18	17	16	15	14	13	12	11	10	9	8	7	6	5	4	3	2	1	0	RO	BOOL[32]
Options	Conn Idle	Conn Closed	SLP Status	SLP Active	SCA Status	SCA Active	Neg Motion	Pos Motion	SDI Limit	SDI Active	SLA Limit	SLA Active	SLS Limit	SLS Active	SSM Limit	SSM Active	Reserved	Reserved	Reserved	SMT Ovr Temp	SMT Active	SOS StndStil	SOS Active	SS2 Active	SS1 Active	Brak Engage	SBS Active	Trq Disabled	STO Active	Restart Req	Safety Reset	Safety Fault																																																																						
Default	0	0	0	0	0	0	0	0	0	0	0	0	0	0	0	0	0	0	0	0	0	0	0	0	0	0	0	0	0	0	0	0																																																																						
Bit	31	30	29	28	27	26	25	24	23	22	21	20	19	18	17	16	15	14	13	12	11	10	9	8	7	6	5	4	3	2	1	0																																																																						

Table 106 - Host Config Parameters (Continued)

No.	Display Name Full Name Description	Values	Read-Write	Data Type																																																																																																			
5	<p>Safety Faults Indicates what type of safety fault has occurred.</p> <table border="1" data-bbox="203 409 1331 567"> <thead> <tr> <th>Options</th> <th>UNID Fault</th> <th>VAL Fault</th> <th>Reserved</th> <th>Reserved</th> <th>Reserved</th> <th>Reserved</th> <th>Reserved</th> <th>Reserved</th> <th>Reserved</th> <th>Reserved</th> <th>Reserved</th> <th>SLP Fault</th> <th>SCA Fault</th> <th>SDI Fault</th> <th>SLA Fault</th> <th>SLS Fault</th> <th>SSM Fault</th> <th>Reserved</th> <th>Reserved</th> <th>Reserved</th> <th>Reserved</th> <th>Reserved</th> <th>Reserved</th> <th>SBC Fault</th> <th>SMT Fault</th> <th>SOS Fault</th> <th>SS2 Fault</th> <th>SS1 Fault</th> <th>STO Fault</th> <th>Fdbk Fault</th> <th>Core Fault</th> <th>Reserved</th> </tr> </thead> <tbody> <tr> <td>Default</td> <td>0</td> <td>0</td> <td>0</td> <td>0</td> <td>0</td> <td>0</td> <td>0</td> <td>0</td> <td>0</td> <td>0</td> <td>0</td> <td>0</td> <td>0</td> <td>0</td> <td>0</td> <td>0</td> <td>0</td> <td>0</td> <td>0</td> <td>0</td> <td>0</td> <td>0</td> <td>0</td> <td>0</td> <td>0</td> <td>0</td> <td>0</td> <td>0</td> <td>0</td> <td>0</td> <td>0</td> <td>0</td> </tr> <tr> <td>Bit</td> <td>31</td> <td>30</td> <td>29</td> <td>28</td> <td>27</td> <td>26</td> <td>25</td> <td>24</td> <td>23</td> <td>22</td> <td>21</td> <td>20</td> <td>19</td> <td>18</td> <td>17</td> <td>16</td> <td>15</td> <td>14</td> <td>13</td> <td>12</td> <td>11</td> <td>10</td> <td>9</td> <td>8</td> <td>7</td> <td>6</td> <td>5</td> <td>4</td> <td>3</td> <td>2</td> <td>1</td> <td>0</td> </tr> </tbody> </table> <p>Bit 1 “Core Fault” – The module has detected an unrecoverable fault. Bit 2 “Fdbk Fault” – A fault is present in a safety feedback device. Bit 3 “STO Fault” – Indicates the fault status of the STO function, where 0 = No Fault and 1 = Faulted. The cause of the fault is recorded in device P7 [STO Fault Type]. Bit 4 “SS1 Fault” – Indicates the fault status of the SS1 function, where 0 = No Fault and 1 = Faulted. The cause of the fault is recorded in device P1 [SS1 Fault Type]. Bit 5 “SS2 Fault” – Indicates the fault status of the SS2 function, where 0 = No Fault and 1 = Faulted. Bit 6 “SOS Fault” – Indicates the fault status of the SOS function, where 0 = No Fault and 1 = Faulted. Bit 7 “SMT Fault” – Indicates the fault status of the SBC function, where 0 = No Fault and 1 = Faulted. Reserved for future use. Bit 8 “SBC Fault” – Indicates the fault status of the SMT function, where 0 = No Fault and 1 = Faulted. Bit 16 “SSM Fault” – Reserved for future use. Always 0. Bit 17 “SLS Fault” – Indicates the fault status of the SLS function, where 0 = No Fault and 1 = Faulted. Bit 18 “SLA Fault” – Reserved for future use. Always 0. Bit 19 “SDI Fault” – Indicates the fault status of the SDI function, where 0 = No Fault and 1 = Faulted. Bit 20 “SCA Fault” – Indicates the fault status of the SCA function, where 0 = No Fault and 1 = Faulted. Bit 21 “SLP Fault” – Indicates the fault status of the SLP function, where 0 = No fault 1 = Faulted. Bit 30 “VAL Fault” – The Safety Validator Object has detected a fault. Bit 31 “UNID Fault” – The Safety Validator Object has detected a fault relating to the Unique Identifier number.</p>	Options	UNID Fault	VAL Fault	Reserved	Reserved	Reserved	Reserved	Reserved	Reserved	Reserved	Reserved	Reserved	SLP Fault	SCA Fault	SDI Fault	SLA Fault	SLS Fault	SSM Fault	Reserved	Reserved	Reserved	Reserved	Reserved	Reserved	SBC Fault	SMT Fault	SOS Fault	SS2 Fault	SS1 Fault	STO Fault	Fdbk Fault	Core Fault	Reserved	Default	0	0	0	0	0	0	0	0	0	0	0	0	0	0	0	0	0	0	0	0	0	0	0	0	0	0	0	0	0	0	0	0	Bit	31	30	29	28	27	26	25	24	23	22	21	20	19	18	17	16	15	14	13	12	11	10	9	8	7	6	5	4	3	2	1	0		RO	BOOL[32]
Options	UNID Fault	VAL Fault	Reserved	Reserved	Reserved	Reserved	Reserved	Reserved	Reserved	Reserved	Reserved	SLP Fault	SCA Fault	SDI Fault	SLA Fault	SLS Fault	SSM Fault	Reserved	Reserved	Reserved	Reserved	Reserved	Reserved	SBC Fault	SMT Fault	SOS Fault	SS2 Fault	SS1 Fault	STO Fault	Fdbk Fault	Core Fault	Reserved																																																																							
Default	0	0	0	0	0	0	0	0	0	0	0	0	0	0	0	0	0	0	0	0	0	0	0	0	0	0	0	0	0	0	0	0																																																																							
Bit	31	30	29	28	27	26	25	24	23	22	21	20	19	18	17	16	15	14	13	12	11	10	9	8	7	6	5	4	3	2	1	0																																																																							
6	<p>Safe Status Mfg Indicates status of the manufacturer specific safety functions. “Brak Intgrty” (0) – Indicates that the brake controlled by the Safe Brake Control function has integrity. “Fdbk Homed” (1) – Indicates the that Safety Feedback homing has been completed and the Safety Feedback position is tracking from a known reference position.</p>		RO	BOOL[32]																																																																																																			
7	<p>Safe Faults Mfg Indicates status of the safety functions.</p> <table border="1" data-bbox="203 1417 1331 1554"> <thead> <tr> <th>Options</th> <th>Reserved</th> <th>Reserved</th> <th>Reserved</th> <th>Reserved</th> <th>Reserved</th> <th>Reserved</th> <th>Reserved</th> <th>Reserved</th> <th>Reserved</th> <th>Reserved</th> <th>Reserved</th> <th>Reserved</th> <th>Reserved</th> <th>Reserved</th> <th>Reserved</th> <th>Reserved</th> <th>Reserved</th> <th>Reserved</th> <th>Reserved</th> <th>Reserved</th> <th>Reserved</th> <th>Reserved</th> <th>Reserved</th> <th>Reserved</th> <th>Reserved</th> <th>Reserved</th> <th>Reserved</th> <th>Reserved</th> <th>Reserved</th> <th>Reserved</th> <th>SFX Fault</th> <th>Reserved</th> </tr> </thead> <tbody> <tr> <td>Default</td> <td>0</td> <td>0</td> <td>0</td> <td>0</td> <td>0</td> <td>0</td> <td>0</td> <td>0</td> <td>0</td> <td>0</td> <td>0</td> <td>0</td> <td>0</td> <td>0</td> <td>0</td> <td>0</td> <td>0</td> <td>0</td> <td>0</td> <td>0</td> <td>0</td> <td>0</td> <td>0</td> <td>0</td> <td>0</td> <td>0</td> <td>0</td> <td>0</td> <td>0</td> <td>0</td> <td>0</td> <td>0</td> </tr> <tr> <td>Bit</td> <td>31</td> <td>30</td> <td>29</td> <td>28</td> <td>27</td> <td>26</td> <td>25</td> <td>24</td> <td>23</td> <td>22</td> <td>21</td> <td>20</td> <td>19</td> <td>18</td> <td>17</td> <td>16</td> <td>15</td> <td>14</td> <td>13</td> <td>12</td> <td>11</td> <td>10</td> <td>9</td> <td>8</td> <td>7</td> <td>6</td> <td>5</td> <td>4</td> <td>3</td> <td>2</td> <td>1</td> <td>0</td> </tr> </tbody> </table> <p>Bit 1 “SFX Fault” – The Safety Feedback Interface Add On Instruction has experienced a fault.</p>	Options	Reserved	Reserved	Reserved	Reserved	Reserved	Reserved	Reserved	Reserved	Reserved	Reserved	Reserved	Reserved	Reserved	Reserved	Reserved	Reserved	Reserved	Reserved	Reserved	Reserved	Reserved	Reserved	Reserved	Reserved	Reserved	Reserved	Reserved	Reserved	Reserved	Reserved	SFX Fault	Reserved	Default	0	0	0	0	0	0	0	0	0	0	0	0	0	0	0	0	0	0	0	0	0	0	0	0	0	0	0	0	0	0	0	0	Bit	31	30	29	28	27	26	25	24	23	22	21	20	19	18	17	16	15	14	13	12	11	10	9	8	7	6	5	4	3	2	1	0		RO	BOOL[32]
Options	Reserved	Reserved	Reserved	Reserved	Reserved	Reserved	Reserved	Reserved	Reserved	Reserved	Reserved	Reserved	Reserved	Reserved	Reserved	Reserved	Reserved	Reserved	Reserved	Reserved	Reserved	Reserved	Reserved	Reserved	Reserved	Reserved	Reserved	Reserved	Reserved	Reserved	SFX Fault	Reserved																																																																							
Default	0	0	0	0	0	0	0	0	0	0	0	0	0	0	0	0	0	0	0	0	0	0	0	0	0	0	0	0	0	0	0	0																																																																							
Bit	31	30	29	28	27	26	25	24	23	22	21	20	19	18	17	16	15	14	13	12	11	10	9	8	7	6	5	4	3	2	1	0																																																																							
8	<p>Safety Data A A 32-bit data container holding general purpose safety-data passed from the safety controller.</p>	Default: 0 Min/Max: -2147483648 / 2147483647	RO	DWORD																																																																																																			
9	<p>Safety Data B A 32-bit data container holding general purpose safety-data passed from the safety controller.</p>	Default: 0 Min/Max: -2147483648 / 2147483647	RO	DWORD																																																																																																			
10	<p>Reserved</p>		RO	USINT																																																																																																			

Table 106 - Host Config Parameters (Continued)

No.	Display Name Full Name Description	Values		Read-Write	Data Type
11	STO Actn Src Determines whether the drive or the controller initiates a stop when the Safety Status STO Active bit is set. This does not apply when an SS1 or SS2 action initiates the STO function.	Default: Options:	0 - Drive 0 - Drive 1 - Controller	RW	DWORD
12	STO Stp Actn Selects a stop mode to initiate when the Safety Status STO Active bit is set.	Default: Options:	0 - Coast 0 - Coast 1 - Ramp 2 - Ramp to hold 3 - DC Brake 4 - DCBrkAutoOff 5 - Current Lmt 6 - Fast Brake	RW	DWORD
13	SS1/SS2 Actn Src Determines whether the drive or the controller initiates a stop when the Safety Status SS1 Active bit or the Safety Status SS2 Active bit is set.	Default: Options:	0 - Drive 0 - Drive 1 - Controller	RW	DWORD
14	SS1 Stp Actn Selects a stop mode to initiate when the Safety Status SS1 Active bit is set.	Default: Options:	0 - Coast 0 - Coast 1 - Ramp To Hold 2 - Ramp 3 - DC Brake 4 - DCBrkAutoOff 5 - Current Lmt 6 - Fast Brake	RW	DWORD

Numerics

20-750-S 16
20-750-S1 16
20-750-S3 16

A

actions category 152
ADC 112
additional resources 13
assembly tag
 input 240
 output 242
attribute
 feedback 245
automatic device configuration. *See* **ADC**
axis tag 180

C

certification
 TÜV Rheinland 93
checklist. *See* **validation checklist**
CIP messaging 48, 59
circuit error 47, 58
cold start type 152
Compact GuardLogix 5380 controller 17, 93,
 143, 150, 167, 176
compatible drive 17
complementary mode 43
configuration
 error 47, 58
 ownership 126, 130, 168
configure
 action 152
 discrepancy checking 157
 general 145
 module
 definition 146
 motion safety instance 149
 primary feedback 153
 safety connection 147
 safety input 149
 safety output 149
 scaling 156
 secondary feedback 155
 STO 158
configure always feature 169
connection
 idle 69
 idle action 68, 152
 loss 68
 loss action 68, 152
 reaction time limit 151
continuous mode 20
controller-based
 instruction 93
cosine diagnostic 27

cycle

interpolation 154
 resolution 154

D

diagnostic 206
 cosine 27
 encoder 25
 hiperface 27
digital AqB encoder 27
discrepancy 162
 checking 157
 error 48
 testing 22
 time 162
documentation
 additional resources 13
DPI parameter 48, 59
drive replacement 130
 integrated safety 130
drive safety instruction 93
drive safety instructions
 adding instruction 95
 example 95
 homing 101
 pass-through data 98
 SFX instruction 99
 tab 94
DS1 195, 196
DS2 195, 196
DS3 195, 197
DS4 195, 197
dual channel
 discrepancy error 58
 error 48
 mode 51, 53, 164
dual feedback 22
 configuration 16
 monitoring 22, 148, 155, 157
dual velocity check 157
duplicate device number 130

E

effective resolution 154
electronic keying 110, 146
encoder diagnostic 25
encoder input frequency diagnostic 26
environmental pollution degree 235
equivalent mode 42
explicit message 183
external pulse test 37
external pulse tests 37

F

failure analysis 28

falling edge

- reset 130
- signal 130

fault 203

- actions 152
- code 211 205
- message 205
- name 198
- recovery 49, 60
- safety core 199
- SS1 201
- SS2, SOS, SBC, SLS, SLP, SDI 202
- STO 200

feedback

- attribute 245
- resolution 156

firmware revision 12**G****gate firing circuit** 15**general** 145

GuardLogix 5580 controller 17, 93, 103, 143, 150, 167, 176

H**hardware enable jumper** 33**hazard prevention** 19**high demand mode** 20**hiperface diagnostic** 27**homing** 101**I****IGBT** 15

- failure 16

input

- assembly tag 45, 46, 47, 55, 56, 57, 62, 63, 240

- latch error time 39

input valid (safety) 46**integrated**

- STO bypass 170
- STO mode
 - drive replacement 130
 - STO state reset 204

ISA TR-84 23**J****jumper location**

- Powerflex 755 drive 31
- PowerFlex 755T drive product 31

jumper setting 29**K****kit catalog number**

- dual incremental encoder module (20-750-DENC-1) 33
- EMC Core (20-750-EMCSSM1-F8) 34
- universal feedback module (20-750-UFB-1) 33

L**latch error time** 52, 53**LED**

- module status 196
- motion output status 197
- network status 196

Logix Designer application 104, 145, 170, 174, 197

Logix 5000 127

low demand mode 20

M**mapping**

- safety tag 126

maximum

- acceleration 154
 - diagnostic 25
- encoder input frequency diagnostic 26
- speed 154
 - speed limit diagnostic 25

mean time to failure spurious 23

mechanical

- brake 19
 - force
 - back pressure 16
 - suspended load 16

mission time 21

module

- definition 146
- status 195

monitored SS1 79, 159, 160

- definition 10

motion

- and safety connection 179
- connection 179
 - connection axis tag 180
 - output status 195
 - safety instance 149, 176, 178
 - task 176, 178

motion direct command

- STO bypass 170
- warning message 171

MSG command 214

N

network delay multiplier 151

network status 195

no test pulse mode 85

not used 85, 162, 163, 164

O

off state 16
off-delay function 50
on-delay function 49
one shot falling instruction. See OSF instruction
OSF instruction 130
out-of-box state
 restore 214
 verify 214
output
 assembly tag 61, 65, 70, 76, 83, 86
output assembly tag 242
output monitor value 56

P

diagnostic parameter
 safety state 207
 safety status 207
 safety fault 209
parameter
 host 259
partner channel error 59
pass-through data 98, 129, 182, 183
 and integrated motion 98
 in standard I/O mode 96
PFD 20, 21, 22
 PowerFlex 755 drive 21
 PowerFlex 755T drive product 21
PFH 20, 21, 22
 definition 11
 PowerFlex 755 drive 21
 PowerFlex 755T drive product 21
polarity 154
pollution degree 235
port 148
position 156
 deadband 158
 unit 156
power supply output 163
 mode 61
primary
 encoder 178
 feedback 153, 156
probability of dangerous failure per hour. See PFH
probability of failure on demand. See PFD
product compatibility and download center
 12
proof
 test interval 20
 testing 18
pulse test output 163

R

ratio 158
redundant channel safety device 41

release note 12
replace 168
 PowerFlex 755 drive
 on an integrated safety network 130
requested packet interval. See RPI
reset ownership 126
resolution unit 154
response time 51
restart type 152
risk assessment 18, 19, 29
RPI 113, 149, 150, 151

S

Safe Break Control. See SBC
safe direction instruction. See SDI
safe operating speed. See SOS
safe stop function
See also SS1, SS2
safe stopping action source 165
safe torque off. See STO
safeguarding devices 19
safely-limited position instruction. See SLP
safely-limited speed. See SLS
safety
 analysis 29
 brake 91
 category 233
 connection 147, 183
 control state 214
 core fault 199
 DeviceID 130
 digital output 50, 60
 enable jumper 33
 fault 195
 feedback 203
 feedback fault 203
 function 177, 178
 safety input 37
 function operation 128
 function testing 29
 input 37, 149
 input alarm 47
 input alarm recovery 49
 input assembly tag 66
 input status 45
 input valid 46
 input value 45
 jumper 31
 network number

- edit 167
 - output 149
 - output alarm 58
 - output assembly tag 65
 - output data 55
 - output ready 56
 - output status 55
 - output with test pulse 50
 - performance level 18
 - rating 18, 24
 - reset 214
 - routine 126
 - signature 18
 - supervisor
 - state 184, 199
 - status 214
 - supervisor state 199
 - system requirement 18
 - tag 126
 - tag mapping 126
 - tags 126
 - task 176, 178
- SAFETY BRD FAULT** 205
- safety feedback interface instruction. See SFX**
- safety network number. See SNN**
- SBC** 83, 119, 202, 231
 - activated by STO 87
 - activation 83
 - control mode 85
 - fault 91, 202
 - operation 86
 - reset 84
 - validation checklist 231
- scaling** 156
 - SFX 100
- SDI** 228
 - fault 202
 - validation checklist 228
- secondary**
 - encoder 178
 - feedback 155
- SFX** 99, 178, 229
 - instruction 99
 - scaling 100
 - validation checklist 229
- short circuit** 37
- signal offset diagnostic** 28
- sine diagnostic** 27
- single channel mode** 51, 164
- single feedback** 22
 - configurations 16
 - monitoring 22, 148, 157
- SLP** 226
 - fault 202
 - validation checklist 226
- SLS** 225
 - example 95
 - fault 202
 - validation checklist 225
- SNN** 18, 108, 130, 166, 167, 169
- SOS** 223
 - fault 202
 - validation checklist 223
- spurious trip rate** 23
- SS1** 76, 128, 129, 159, 177, 201, 218
 - activation 76
 - fault 201
 - reset 77
 - safety fault 82
 - stopping action and source 78
 - validation checklist 218
- SS1-r**
 - definition 10
- SS1-t**
 - definition 10
- SS2** 220
 - fault 202
 - validation checklist 220
- standard data**
 - in a safety routine 127
 - in a safety tag 127
- standard input** 162
 - operation 44
- standard output** 163
 - mode 61
- standard tag** 126
- standstill speed** 154, 160
- status**
 - attributes 206
 - indicators 195
 - LED
 - module status (DS1) 196
 - motion output status (DS3) 197
 - network status (DS2) 196
- STO** 69, 70, 116, 158
 - action 165
 - action source 165
 - activates SBC 87, 161
 - delay 71, 72
 - fault 75, 200
 - operation 72
 - reset 70
 - state reset 204
 - stopping action 74
 - source 74
 - to SBC Delay 161
- STO fault message** 206
 - Circuit Err(3) 200
 - Stuck High(5) 200
 - Stuck Low(4) 200
- stop**
 - category 19
 - 0 19
 - 1 19
 - category 1 177
 - category 2 19
- stored energy** 16
- suspended load** 19
- synchronize action** 126
- system**
 - safety considerations 18

T

tap mode 17
test output 162
 mode 61
 ready 63
 status 62
test pulse 50, 51
test pulses 164
test pulses mode 86
time 156, 158
timed
 SS1 78, 159
 SS1 definition 10
timeout multiplier 151
TÜV Rheinland 18
type 162

U

units 154
used
 as standard input 162
 no test pulse mode 85
 test pulses mode 86
 with test output 162
 with test pulses 164
 without pulse test 164
 without test output 162

V

validation checklist 218, 220, 223, 225, 226,
 228, 229, 231
velocity average time 154
velocity deadband 158
voltage monitor 154

W

Wait w Trq 214
waiting 214
warning icon 174
wiring 29
with test output 162
without test output 162
without test pulse 164

Z

zero crossing detection diagnostic 28

Notes:

Rockwell Automation Support

Use these resources to access support information.

Technical Support Center	Find help with how-to videos, FAQs, chat, user forums, and product notification updates.	rok.auto/support
Knowledgebase	Access Knowledgebase articles.	rok.auto/knowledgebase
Local Technical Support Phone Numbers	Locate the telephone number for your country.	rok.auto/phonesupport
Literature Library	Find installation instructions, manuals, brochures, and technical data publications.	rok.auto/literature
Product Compatibility and Download Center (PCDC)	Download firmware, associated files (such as AOP, EDS, and DTM), and access product release notes.	rok.auto/pcdc

Documentation Feedback

Your comments help us serve your documentation needs better. If you have any suggestions on how to improve our content, complete the form at rok.auto/docfeedback.

Waste Electrical and Electronic Equipment (WEEE)



At the end of life, this equipment should be collected separately from any unsorted municipal waste.





Rockwell Automation maintains current product environmental compliance information on its website at rok.auto/pec.

Allen-Bradley, Connected Components Workbench, CompactLogix, ControlLogix, DeviceLogix, DPI, Expanding Human Possibilities, Integrated Architecture, Guard I/O, GuardLogix, Logix 5000, PowerFlex, QuickView, Rockwell Automation, Rockwell Software, Studio 5000, Studio 5000 Logix Designer, and TotalFORCE are trademarks of Rockwell Automation, Inc.

EtherNet/IP is a trademark of ODVA, Inc.

Trademarks not belonging to Rockwell Automation are property of their respective companies.

Rockwell Otomasyon Ticaret A.Ş. Kar Plaza İş Merkezi E Blok Kat:6 34752, İçerenköy, İstanbul, Tel: +90 (216) 5698400 EEE Yönetmeliğine Uygundur

Connect with us.    

rockwellautomation.com ————— **expanding human possibility™**

AMERICAS: Rockwell Automation, 1201 South Second Street, Milwaukee, WI 53204-2496 USA, Tel: (1) 414.382.2000, Fax: (1) 414.382.4444

EUROPE/MIDDLE EAST/AFRICA: Rockwell Automation NV, Pegasus Park, De Kleetlaan 12a, 1831 Diegem, Belgium, Tel: (32) 2 663 0600, Fax: (32) 2 663 0640

ASIA PACIFIC: Rockwell Automation, Level 14, Core F, Cyberport 3, 100 Cyberport Road, Hong Kong, Tel: (852) 2887 4788, Fax: (852) 2508 1846

Publication 750-UM005C-EN-P - February 2021

Supersedes Publication 750-UM005B-EN-P - September 2019

Copyright © 2021 Rockwell Automation, Inc. All rights reserved. Printed in the U.S.A.