



TECHNICAL MANUAL



Technical Manual



This equipment complies
with the EMC Directive
2004/108/EC and
LVD 2006/95/EC

This product is approved to
safety standards:

IEC 60065: 2001
EN60065:2002
UL6500 7th Edition: 2003
CAN/CSA-E60065-03

And EMC standards
EN55103-1: 1996 (E2)
EN55103-2: 1996 (E2)

For further details contact:

Harman International Industries Ltd.
Cranborne House, Cranborne Road
Potters Bar, Hertfordshire, EN6 3JN, UK

Tel: +44 (0) 1707 665000
Fax: +44 (0) 1707 660742
e-mail: info@soundcraft.com

© Harman International Industries Ltd. 2007

All rights reserved

Parts of the design of this product may be protected by worldwide patents.

Part No. ZM0365-01

Soundcraft is a trading division of Harman International Industries Ltd. Information in this manual is subject to change without notice and does not represent a commitment on the part of the vendor. Soundcraft shall not be liable for any loss or damage whatsoever arising from the use of information or any error contained in this manual.

No part of this manual may be reproduced, stored in a retrieval system, or transmitted, in any form or by any means, electronic, electrical, mechanical, optical, chemical, including photocopying and recording, for any purpose without the express written permission of Soundcraft.



Harman International Industries Limited
Cranborne House
Cranborne Road
POTTERS BAR
Hertfordshire
EN6 3JN
UK

Tel: +44 (0)1707 665000
Fax: +44 (0)1707 660742
<http://www.soundcraft.com>

E & OE.

CONTENTS

Safety Notices	Section 1
Block Diagram	Section 2
Specifications	Section 3
Schematic Diagrams	Section 4
Parts List	Section 5

SAFETY NOTICES

For your own safety and to avoid invalidation of the warranty please read this section carefully.

IMPORTANT SAFETY INSTRUCTIONS

Read these instructions.

Keep these instructions.

Heed all warnings.

Follow all instructions.

Do not use this apparatus near water.

Clean only with a dry cloth.

Do not block any ventilation openings. Install in accordance with the manufacturer's instructions.

Do not install near any heat sources such as radiators, heat registers, stoves, or other apparatus (including amplifiers) that produce heat.

Do not defeat the safety purpose of a polarised or grounding type plug. A polarised plug has two blades with one wider than the other. A grounding type plug has two blades and a third grounding prong. The wide blade or the third prong are provided for your safety. If the provided plug does not fit into your outlet, consult an electrician for replacement of the obsolete outlet

Protect the power cord from being walked on or pinched particularly at plugs, convenience receptacles and the point where they exit from the apparatus.

Only use attachments/accessories specified by the manufacturer.



Use only with the cart, stand, tripod, bracket or table specified by the manufacturer, or sold with the apparatus. When a cart is used, use caution when moving the cart/apparatus combination to avoid injury from tip-over.

Unplug this apparatus during lightning storms or when unused for long periods of time.

Refer all servicing to qualified service personnel. Servicing is required when the apparatus has been damaged in any way, such as power-supply cord or plug is damaged, liquid has been spilled or objects fallen into the apparatus, the apparatus has been exposed to rain or moisture, does not operate normally, or has been dropped.

Note: It is recommended that all maintenance and service on the product should be carried out by Soundcraft or its authorised agents. Soundcraft cannot accept any liability whatsoever for any loss or damage caused by service, maintenance or repair by unauthorised personnel.

WARNING: To reduce the risk of fire or electric shock, do not expose this apparatus to rain or moisture.

Do not expose the apparatus to dripping or splashing and do not place objects filled with liquids, such as vases, on the apparatus.

No naked flame sources, such as lighted candles, should be placed on the apparatus. Ventilation should not be impeded by covering the ventilation openings with items such as newspapers, table cloths, curtains etc.

THIS APPARATUS MUST BE EARTHED. Under no circumstances should the safety earth be disconnected from the mains lead.

The mains supply disconnect device is the mains plug. It must remain accessible so as to be readily operable when the apparatus is in use.

If any part of the mains cord set is damaged, the complete cord set should be replaced. The following information is for reference only.

The wires in the mains lead are coloured in accordance with the following code:

Earth (Ground):	Green and Yellow (US - Green/Yellow)
Neutral:	Blue (US - White)
Live (Hot):	Brown (US - Black)

As the colours of the wires in the mains lead may not correspond with the coloured markings identifying the terminals in your plug, proceed as follows:

The wire which is coloured Green and Yellow must be connected to the terminal in the plug which is marked with the letter E or by the earth symbol. 

The wire which is coloured Blue must be connected to the terminal in the plug which is marked with the letter N

The wire which is coloured Brown must be connected to the terminal in the plug which is marked with the letter L

Ensure that these colour codes are followed carefully in the event of the plug being changed

This unit is capable of operating over a range of mains voltages as marked on the rear panel.

NOTE: This equipment has been tested and found to comply with the limits for a Class A digital device, pursuant to Part 15 of the FCC Rules. These limits are designed to provide reasonable protection against harmful interference when the equipment is operated in a commercial environment. This equipment generates, uses and can radiate radio frequency energy and, if not installed and used in accordance with the instruction manual, may cause harmful interference to radio communications. Operation of this equipment in a residential area is likely to cause harmful interference in which case the user will be required to correct the interference at his own expense.

This Class A digital apparatus meets the requirements of the Canadian Interference-Causing Equipment Regulations.

Cet appareil numérique de la Classe A respecte toutes les exigences du Règlement sur le matériel brouilleur du Canada.

SAFETY SYMBOL GUIDE

For your own safety and to avoid invalidation of the warranty all text (in product documentation supplied with the product and/or supplied separately, and/or on the product itself) marked with these symbols should be read carefully.



WARNINGS

The lightning flash with arrowhead symbol, is intended to alert the user to the presence of un-insulated “dangerous voltage” within the product’s enclosure that may be of sufficient magnitude to constitute a risk of electric shock to persons.



CAUTIONS

The exclamation point within an equilateral triangle is intended to alert the user to the presence of important operating and maintenance (servicing) instructions in the literature accompanying the appliance.



NOTES

Contain important information and useful tips on the operation of your equipment.



HEADPHONES SAFETY WARNING

Contain important information and useful tips on headphone outputs and monitoring levels.

Recommended Headphone Impedance ≥ 150 Ohms.

BLOCK DIAGRAM

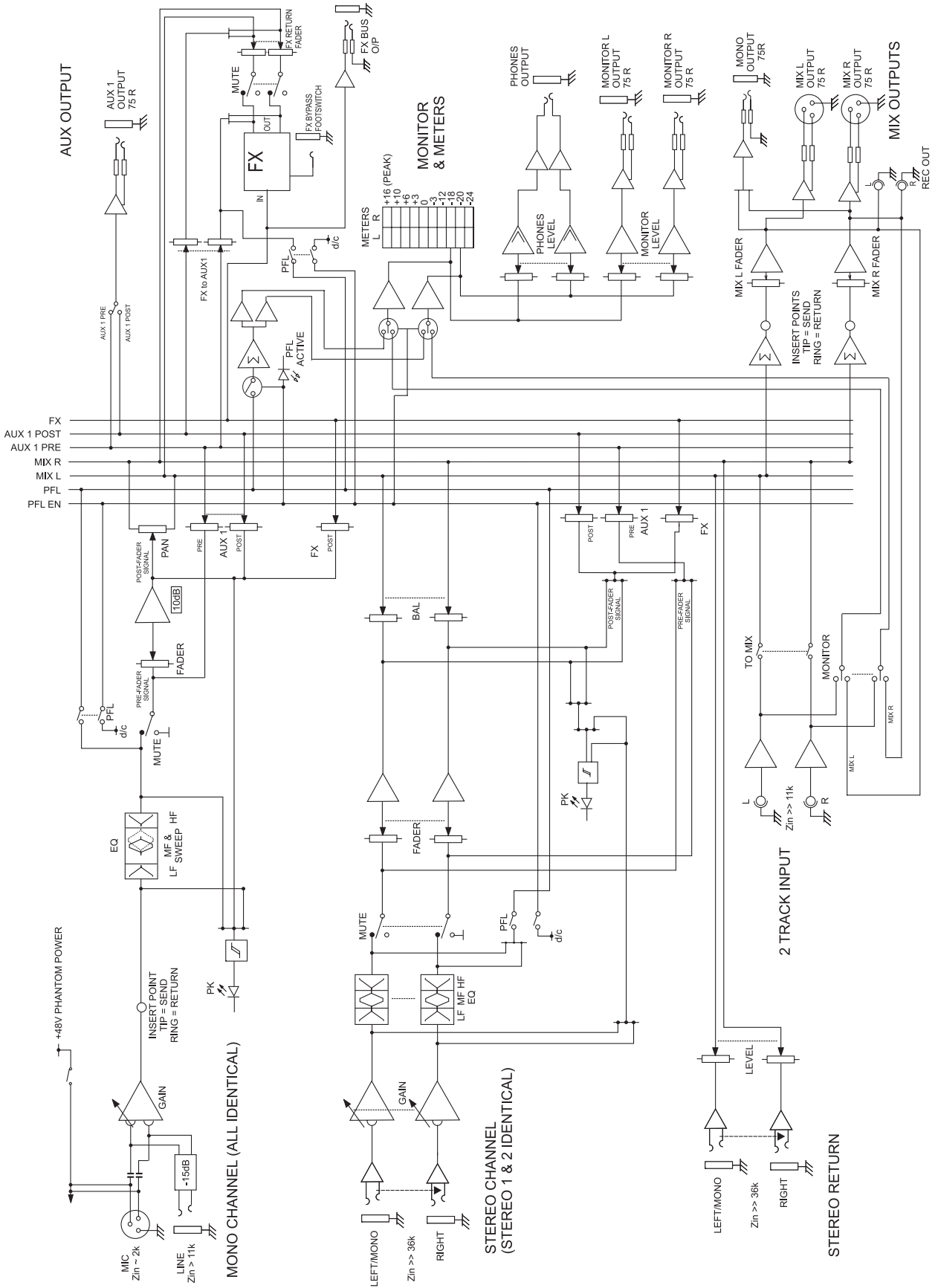

EFX TYPICAL SPECIFICATIONS

Frequency Response

Mic / Line Input to any Output +/-1.5dB, 20Hz – 20kHz

T.H.D.

Mic Sensitivity -30dBu, +14dBu @ Mix output < 0.02% @ 1kHz

Noise

Mic Input E.I.N. (maximum gain) -127dBu (150Ω source)

Aux, Mix and Masters (@ 0dB, faders down)..... < -85dBu

Crosstalk (@ 1kHz)

Channel Mute..... > 96dB

Fader Cut-off (rel +10 mark)..... > 96dB

Aux Send Pots Offness..... > 86dB

EQ (Mono inputs)

HF 12kHz, +/-15dB

MF (swept)..... 150Hz – 3.5kHz, +/-15dB

LF..... 80Hz, +/-15dB

Q..... 1.5

EQ (Stereo inputs)

HF 12kHz, +/-15dB

MF..... 720Hz, +/-15dB

LF 80Hz, +/-15dB

Power Consumption..... Less than 35W

Operating Conditions

Temperature Range..... 5°C to 40°C

Input & Output Levels

Mic Input +15dBu max

Line Input..... +30dBu max

Stereo Input +30dBu max

Mix Output +20dBu max

Headphones (@150Ω) 300mW

Input & Output Impedances

Mic Input 2kΩ

Line Input 10kΩ

Stereo Input 65kΩ (stereo), 35kΩ (mono)

Outputs 150Ω (balanced), 75Ω (unbalanced)

E & OE.

Soundcraft reserves the right to change specifications without notice.

SCHEMATIC DIAGRAMS

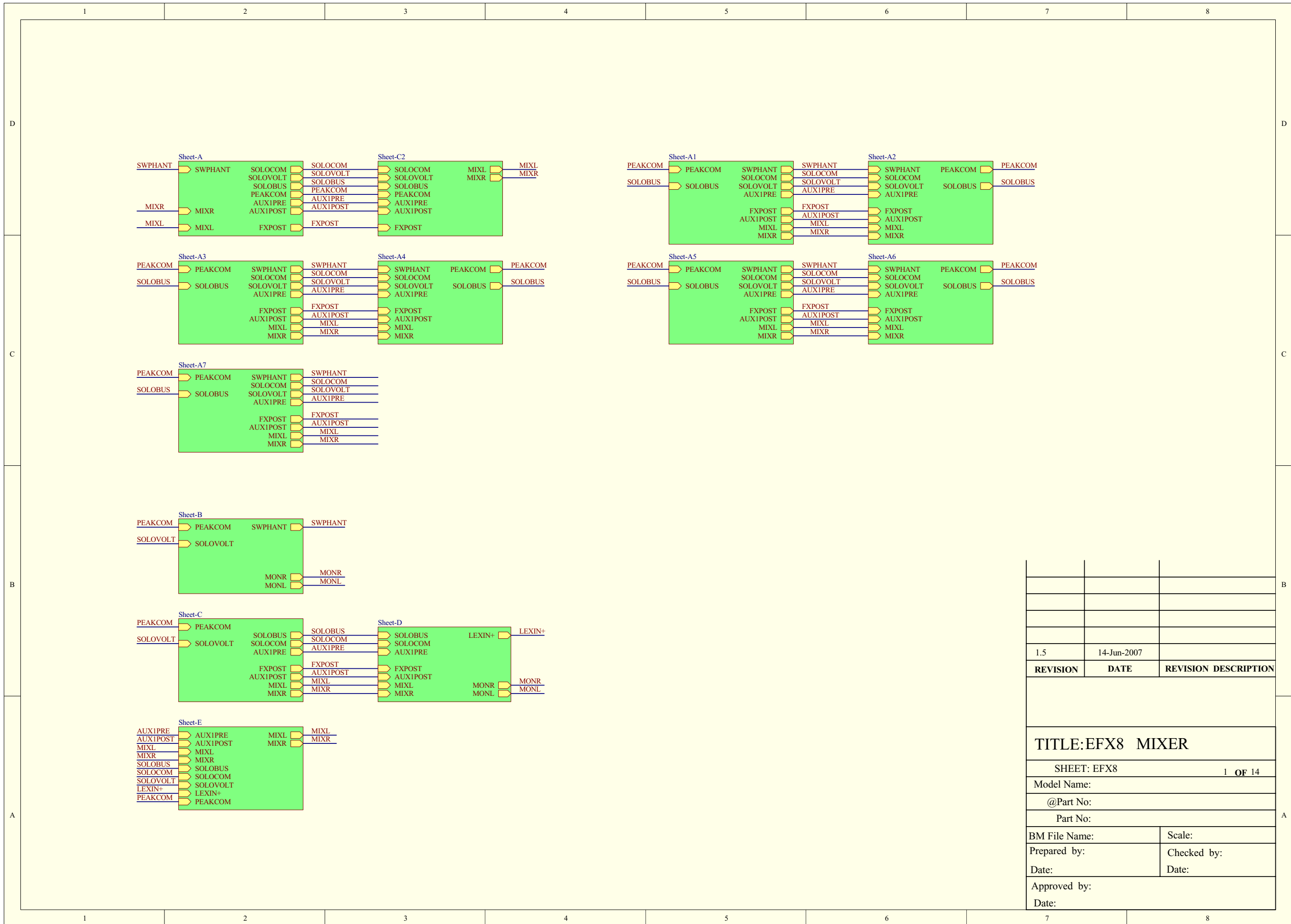

REVISION	DATE	REVISION DESCRIPTION
1.5	14-Jun-2007	
<p>TITLE: EFX8 MIXER</p> <p>SHEET: EFX8 1 OF 14</p> <p>Model Name:</p> <p>@Part No:</p> <p>Part No:</p> <p>BM File Name: Scale:</p> <p>Prepared by: Checked by:</p> <p>Date: Date:</p> <p>Approved by:</p> <p>Date:</p>		

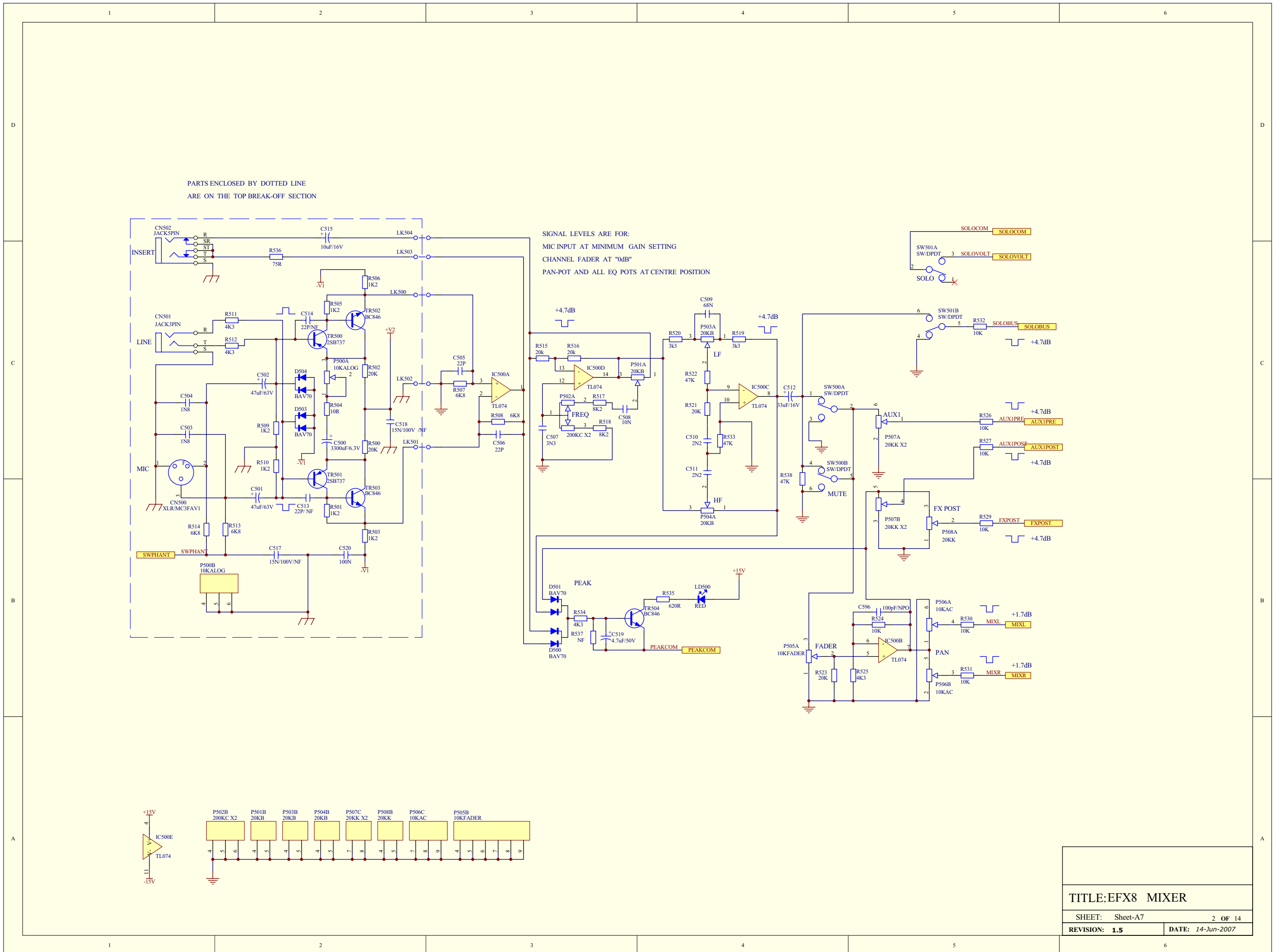

TITLE: EFX8 MIXER
 SHEET: Sheet-A7 2 OF 14
 REVISION: 1.5 DATE: 14-Jun-2007

PARTS ENCLOSED BY DOTTED LINE
ARE ON THE TOP BREAK-OFF SECTION

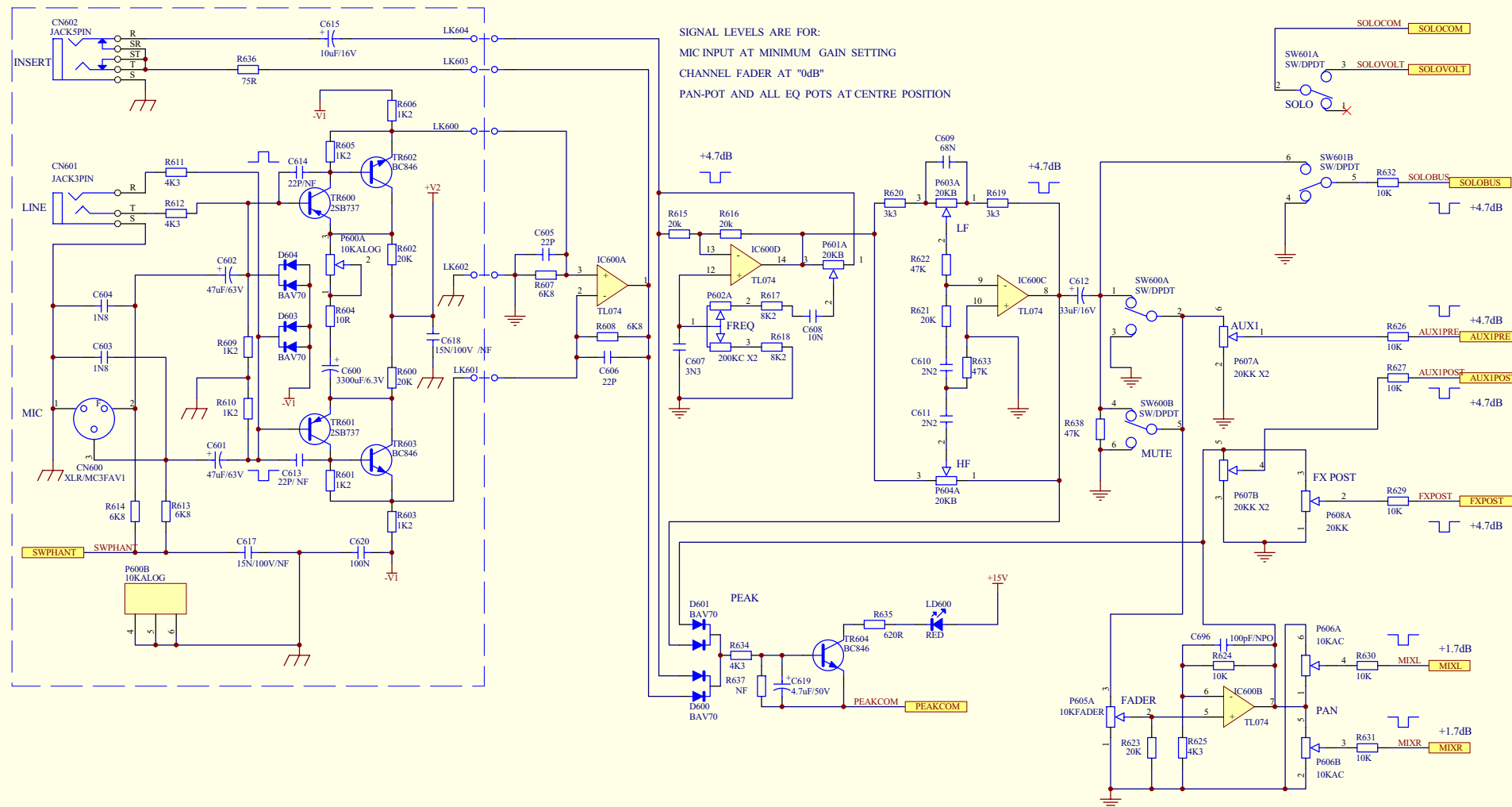

SIGNAL LEVELS ARE FOR:
MIC INPUT AT MINIMUM GAIN SETTING
CHANNEL FADER AT "0dB"
PAN-POT AND ALL EQ POTS AT CENTRE POSITION

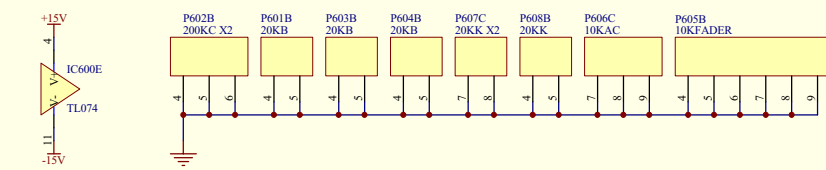

TITLE: EFX8 MIXER	
SHEET: Sheet-A6	3 OF 14
REVISION: 1.5	DATE: 14-Jun-2007

PARTS ENCLOSED BY DOTTED LINE
ARE ON THE TOP BREAK-OFF SECTION

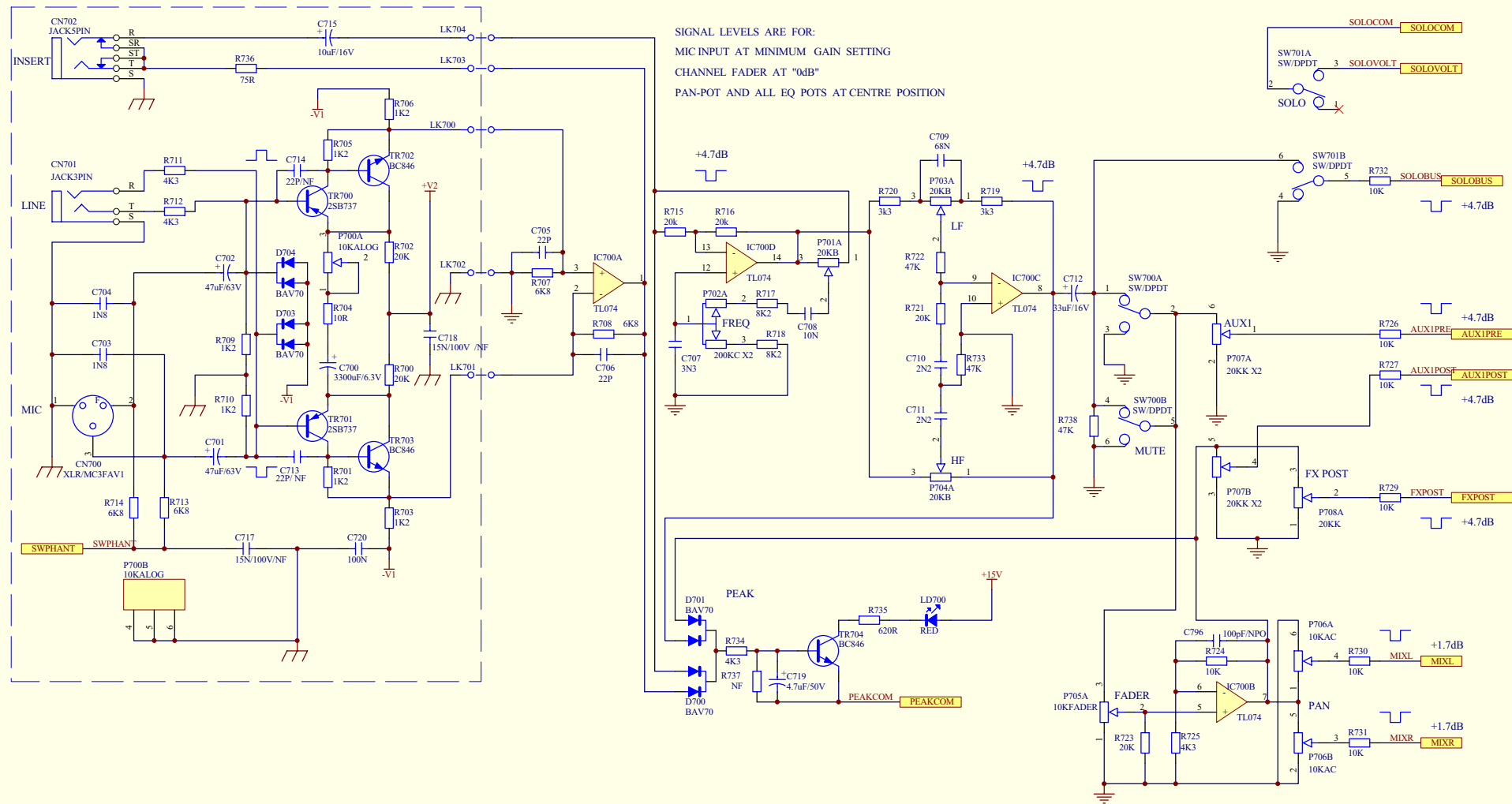

SIGNAL LEVELS ARE FOR:
MIC INPUT AT MINIMUM GAIN SETTING
CHANNEL FADER AT "0dB"
PAN-POT AND ALL EQ POT AT CENTRE POSITION

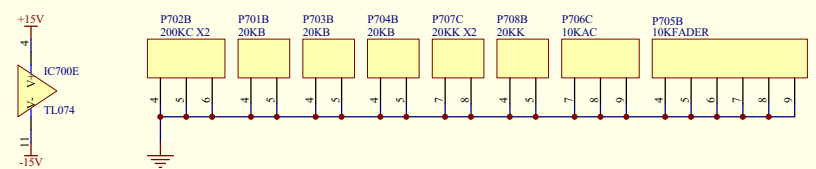

TITLE: EFX8 MIXER
SHEET: Sheet-A5 4 OF 14
REVISION: 1.5 DATE: 14-Jun-2007

PARTS ENCLOSED BY DOTTED LINE
ARE ON THE TOP BREAK-OFF SECTION

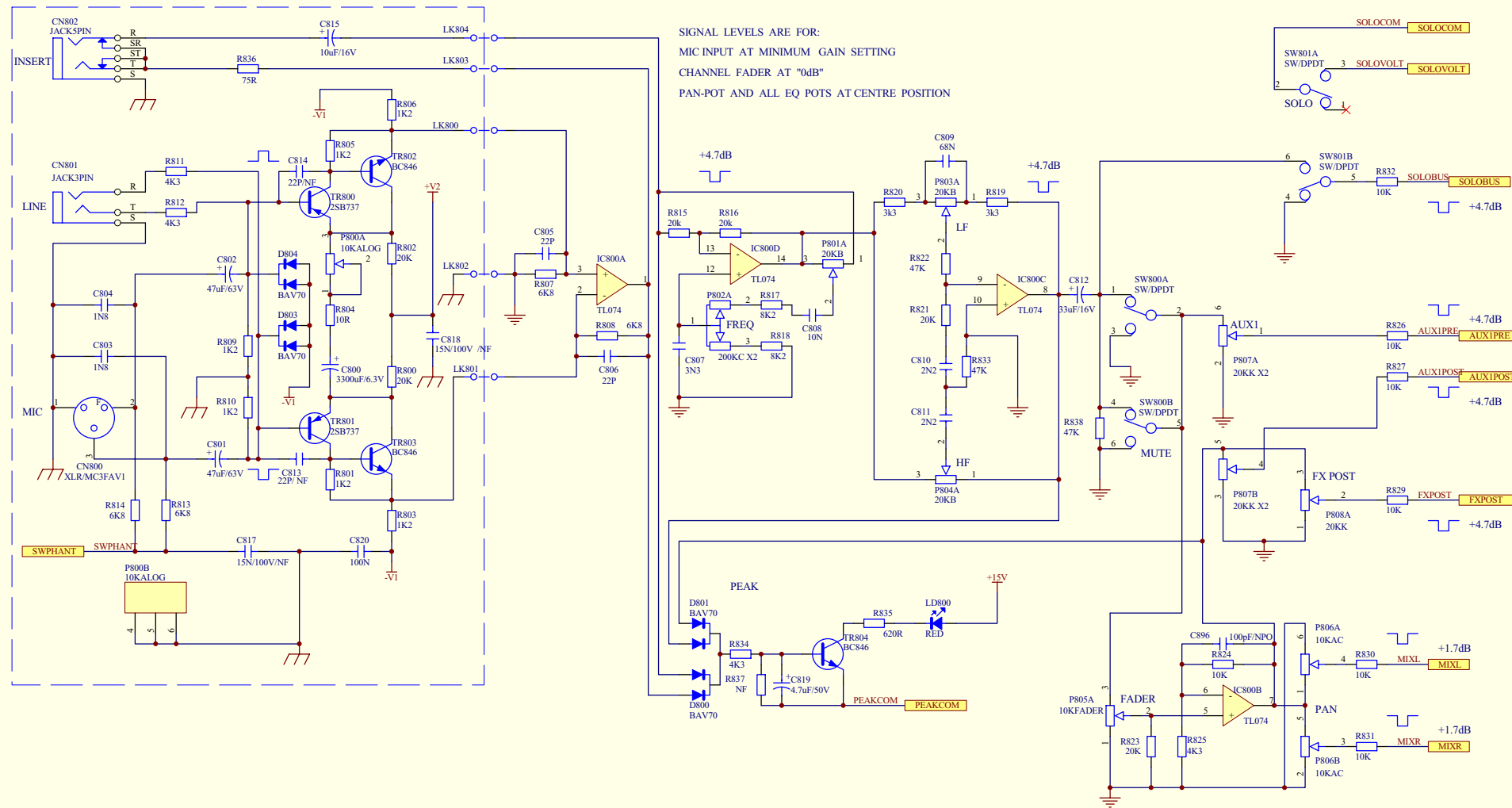

SIGNAL LEVELS ARE FOR:
MIC INPUT AT MINIMUM GAIN SETTING
CHANNEL FADER AT "0dB"
PAN-POT AND ALL EQ POTS AT CENTRE POSITION

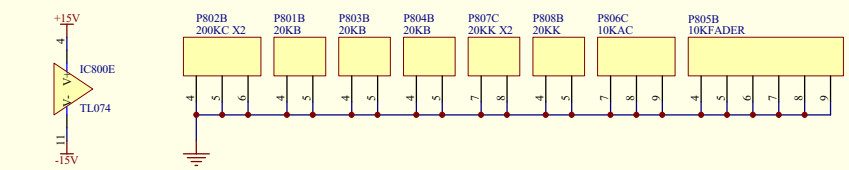

TITLE: EFX8 MIXER	
SHEET: Sheet-A4	5 OF 14
REVISION: 1.5	DATE: 14-Jun-2007

PARTS ENCLOSED BY DOTTED LINE
ARE ON THE TOP BREAK-OFF SECTION

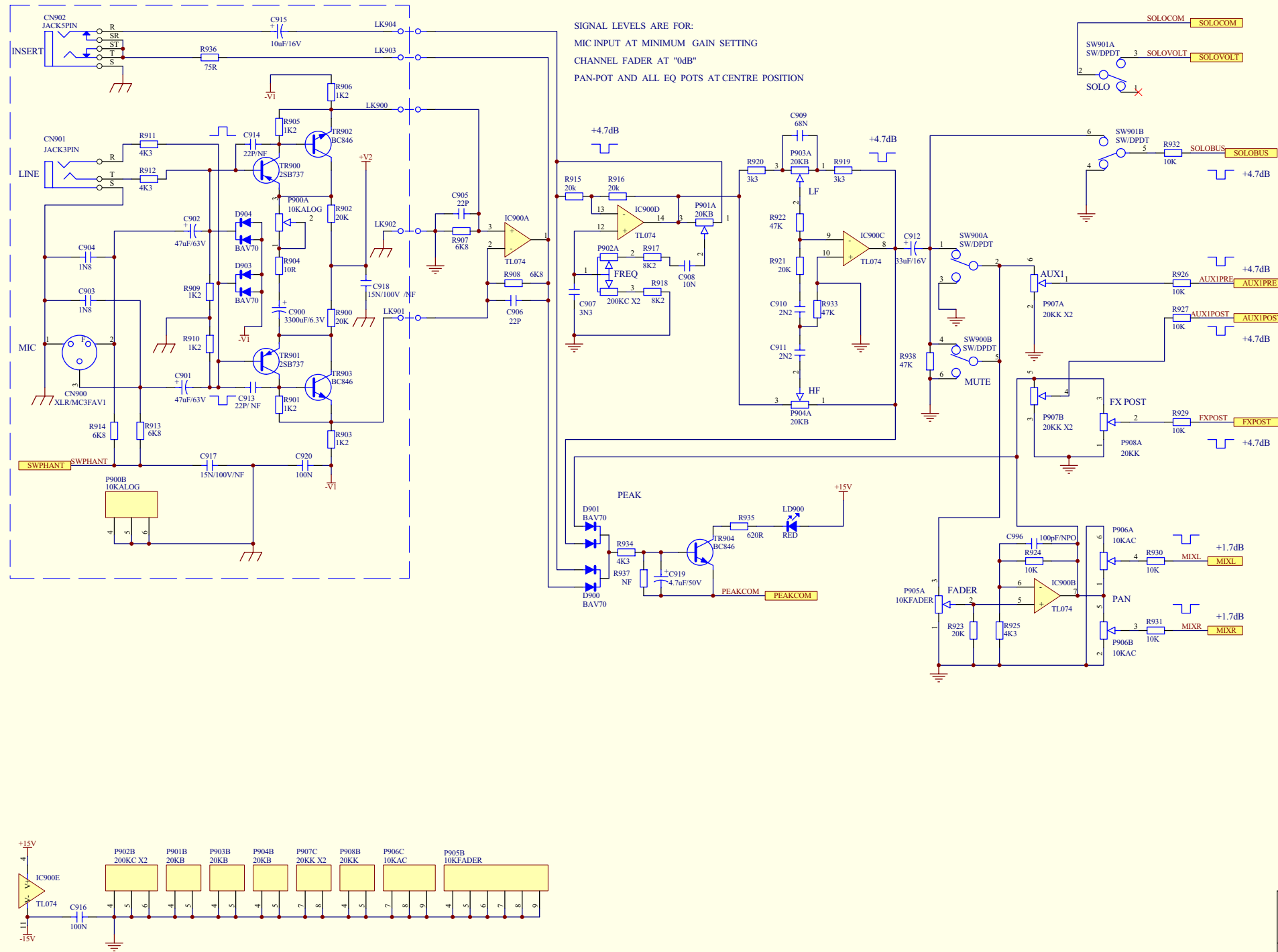

SIGNAL LEVELS ARE FOR:
MIC INPUT AT MINIMUM GAIN SETTING
CHANNEL FADER AT "0dB"
PAN-POT AND ALL EQ POTS AT CENTRE POSITION

TITLE: EFX8 MIXER	
SHEET: Sheet-A3	6 OF 14
REVISION: 1.5	DATE: 14-Jun-2007

PARTS ENCLOSED BY DOTTED LINE
ARE ON THE TOP BREAK-OFF SECTION

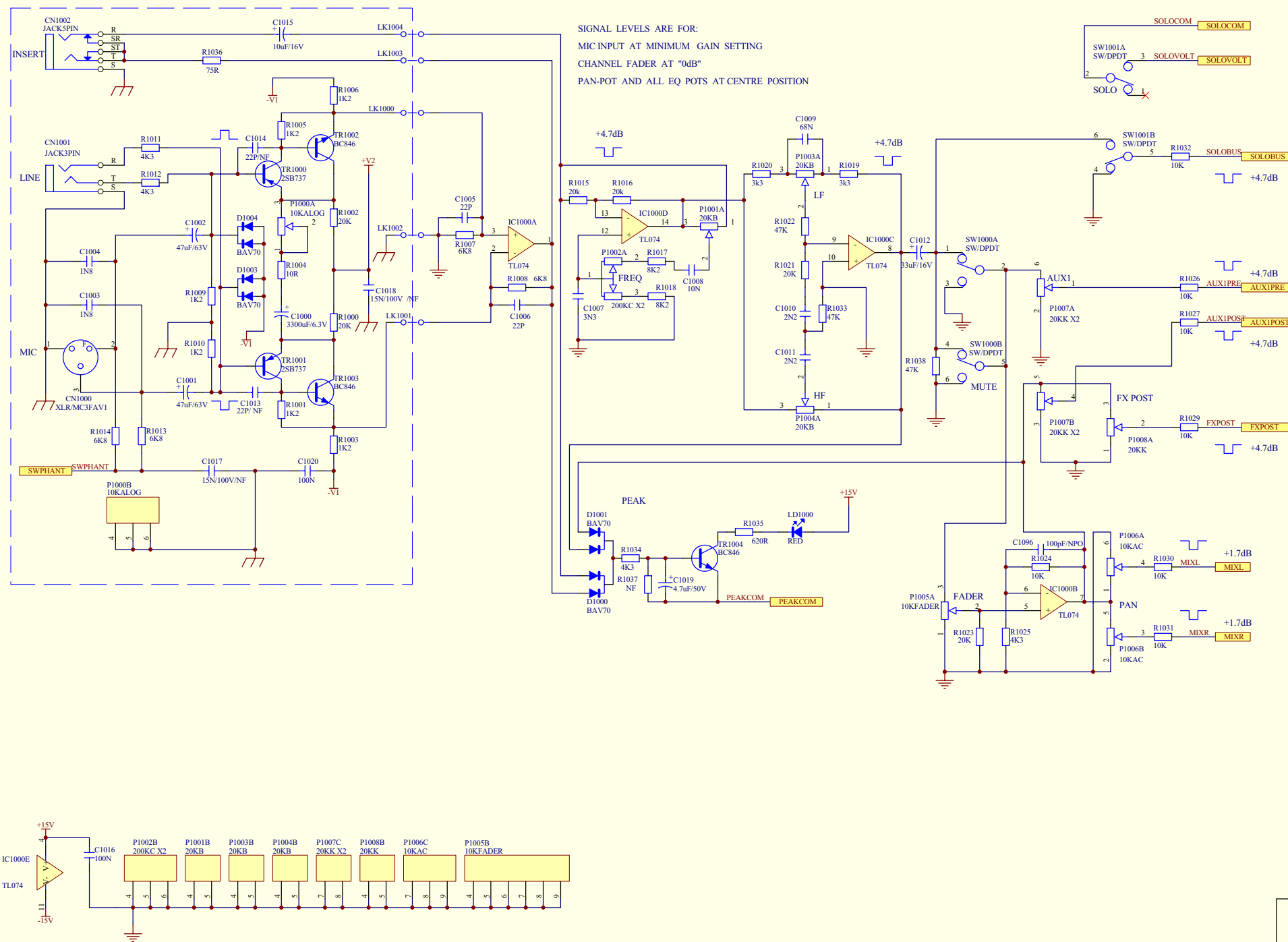

TITLE: EFX8 MIXER

SHEET: Sheet-A2 7 OF 14
REVISION: 1.5 DATE: 14-Jun-2007

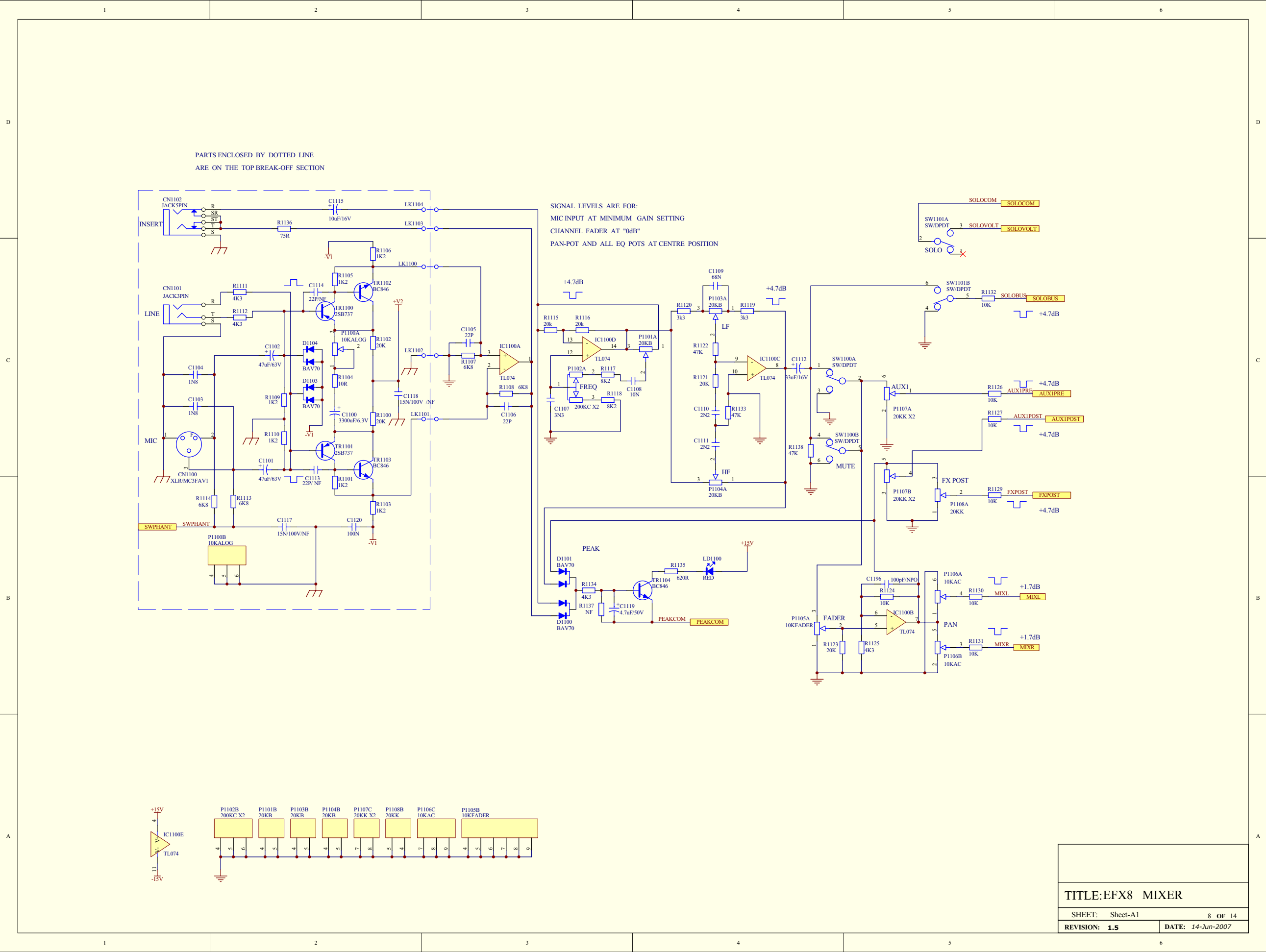

PARTS ENCLOSED BY DOTTED LINE
ARE ON THE TOP BREAK-OFF SECTION

SIGNAL LEVELS ARE FOR:
MIC INPUT AT MINIMUM GAIN SETTING
CHANNEL FADER AT "0dB"
PAN-POT AND ALL EQ POTS AT CENTRE POSITION

TITLE: EFX8 MIXER	
SHEET: Sheet-A1	8 OF 14
REVISION: 1.5	DATE: 14-Jun-2007

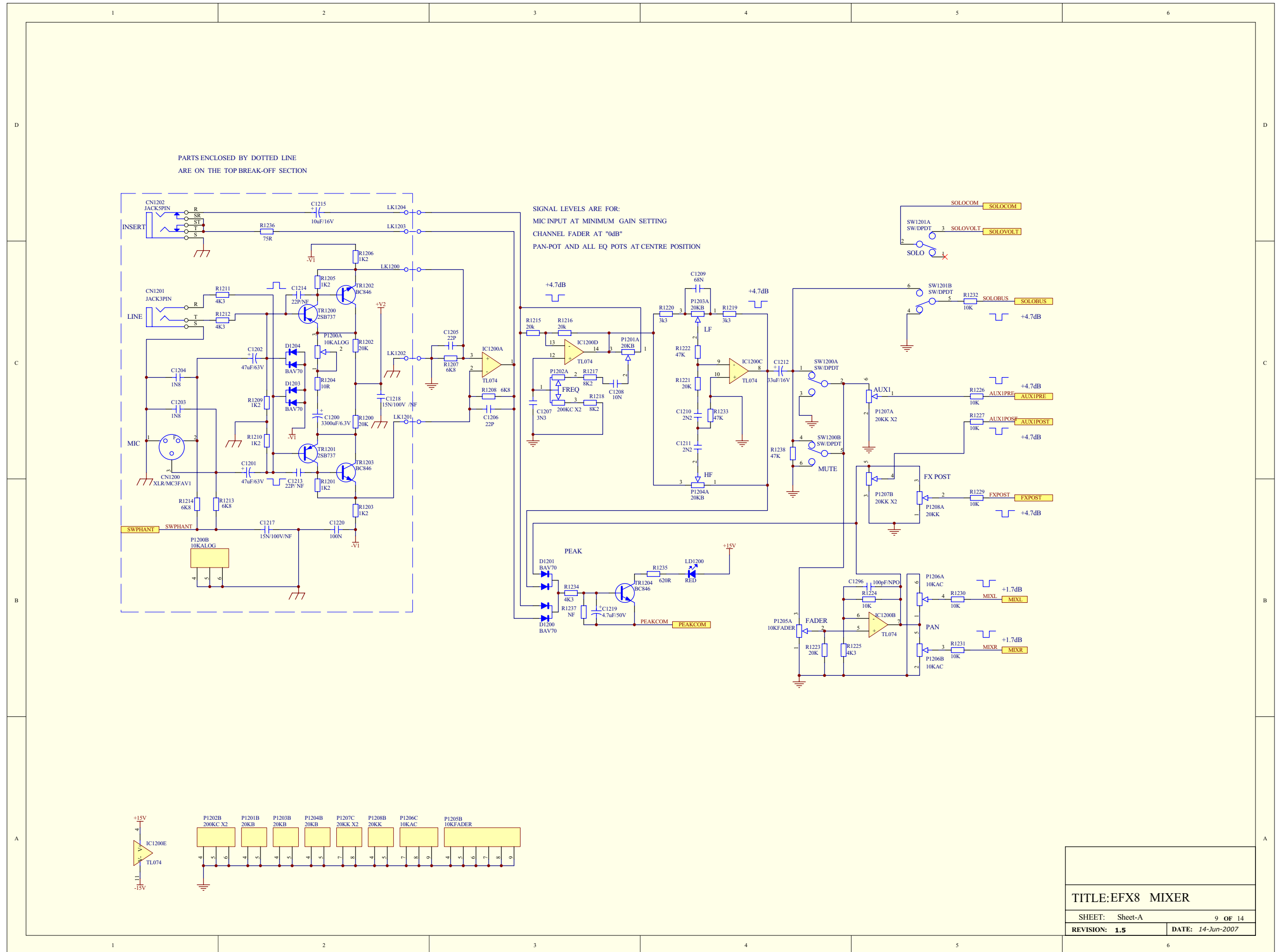

PARTS ENCLOSED BY DOTTED LINE
ARE ON THE TOP BREAK-OFF SECTION

SIGNAL LEVELS ARE FOR:
MIC INPUT AT MINIMUM GAIN SETTING
CHANNEL FADER AT "0dB"
PAN-POT AND ALL EQ POTS AT CENTRE POSITION

TITLE: EFX8 MIXER	
SHEET: Sheet-A	9 OF 14
REVISION: 1.5	DATE: 14-Jun-2007

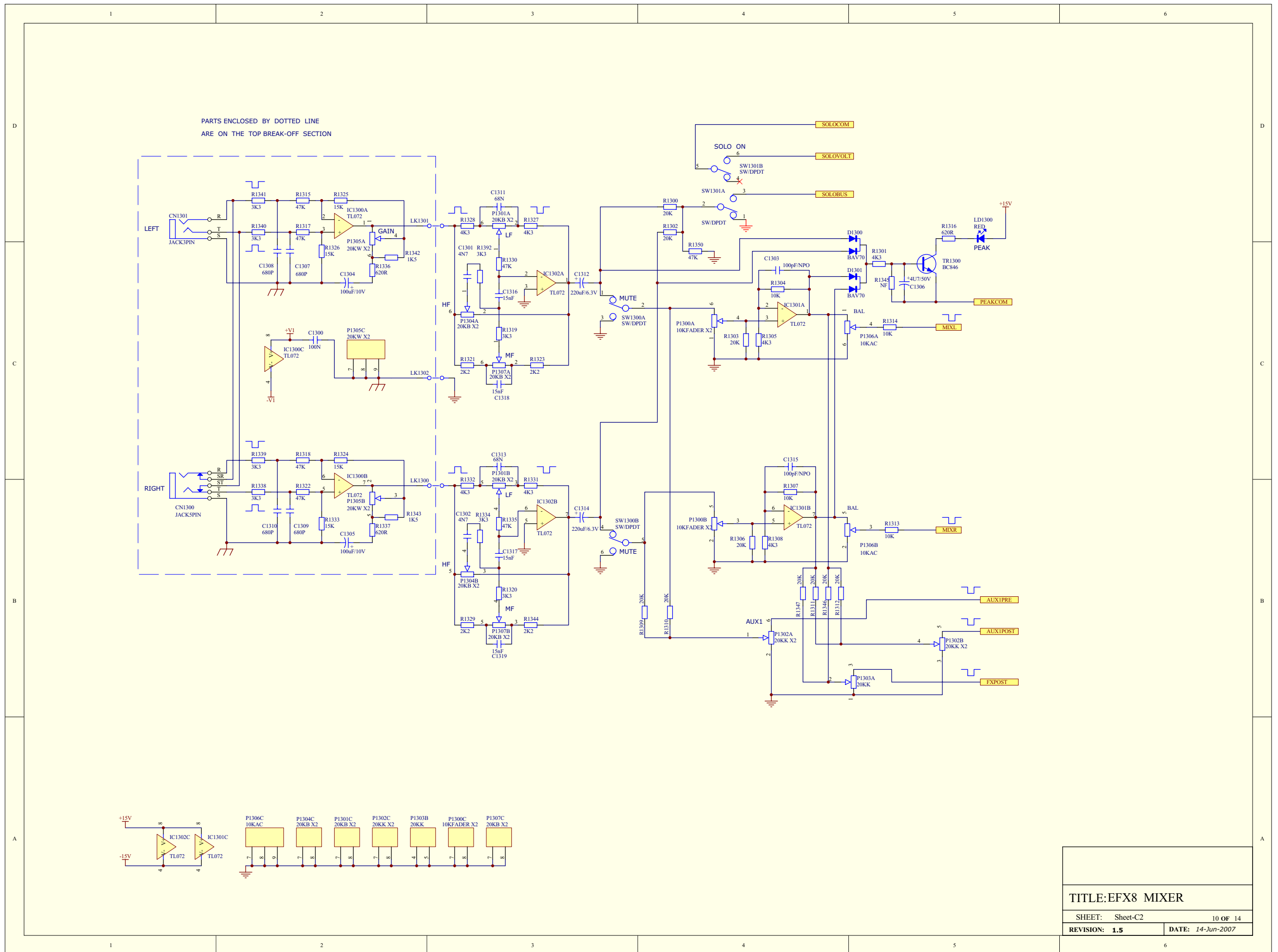

TITLE: EFX8 MIXER	
SHEET: Sheet-C2	10 OF 14
REVISION: 1.5	DATE: 14-Jun-2007

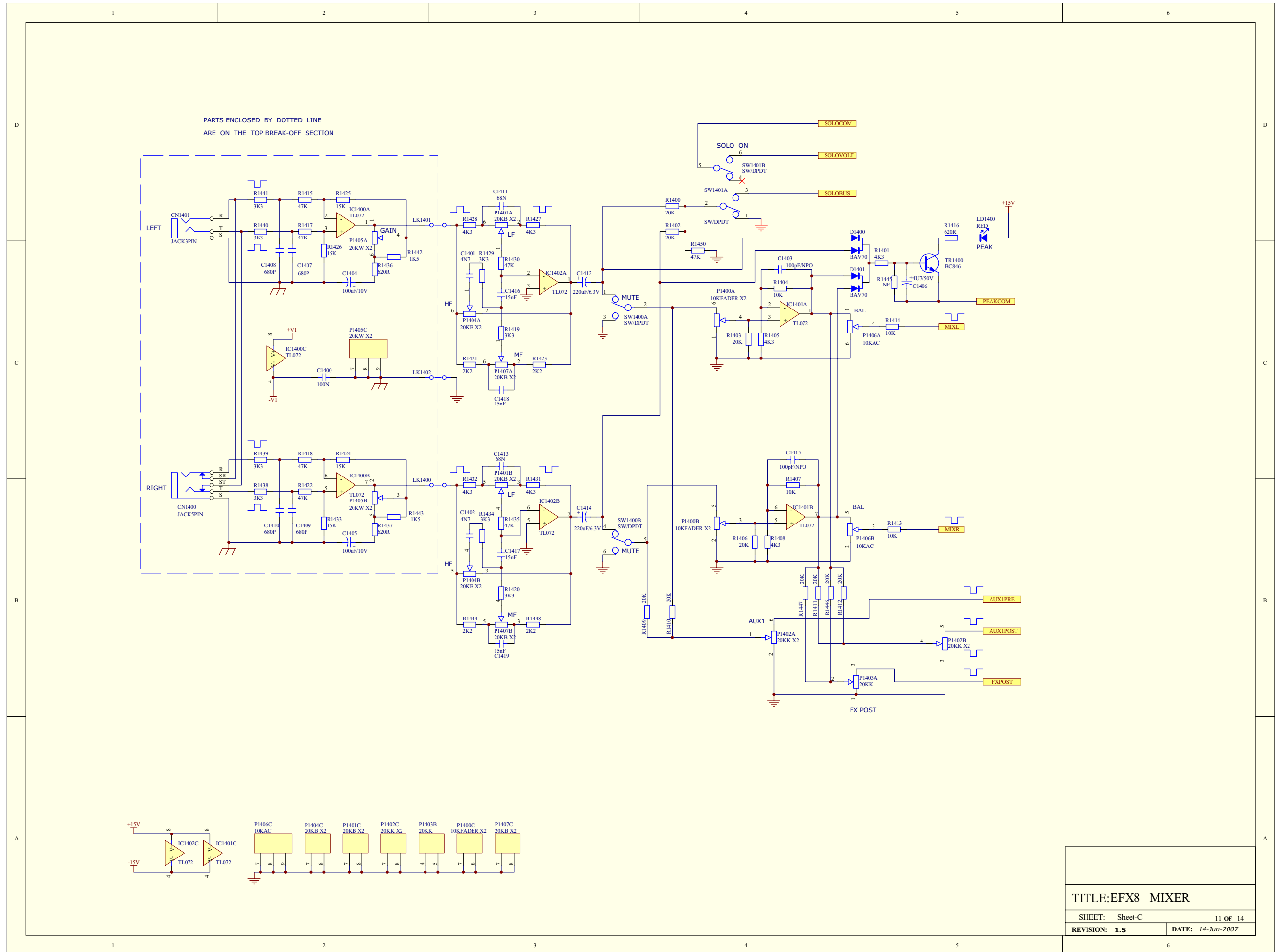

TITLE: EFX8 MIXER	
SHEET: Sheet-C	11 OF 14
REVISION: 1.5	DATE: 14-Jun-2007

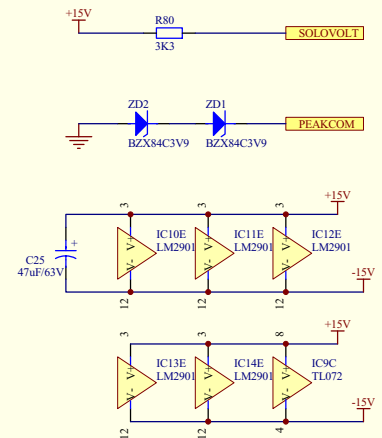
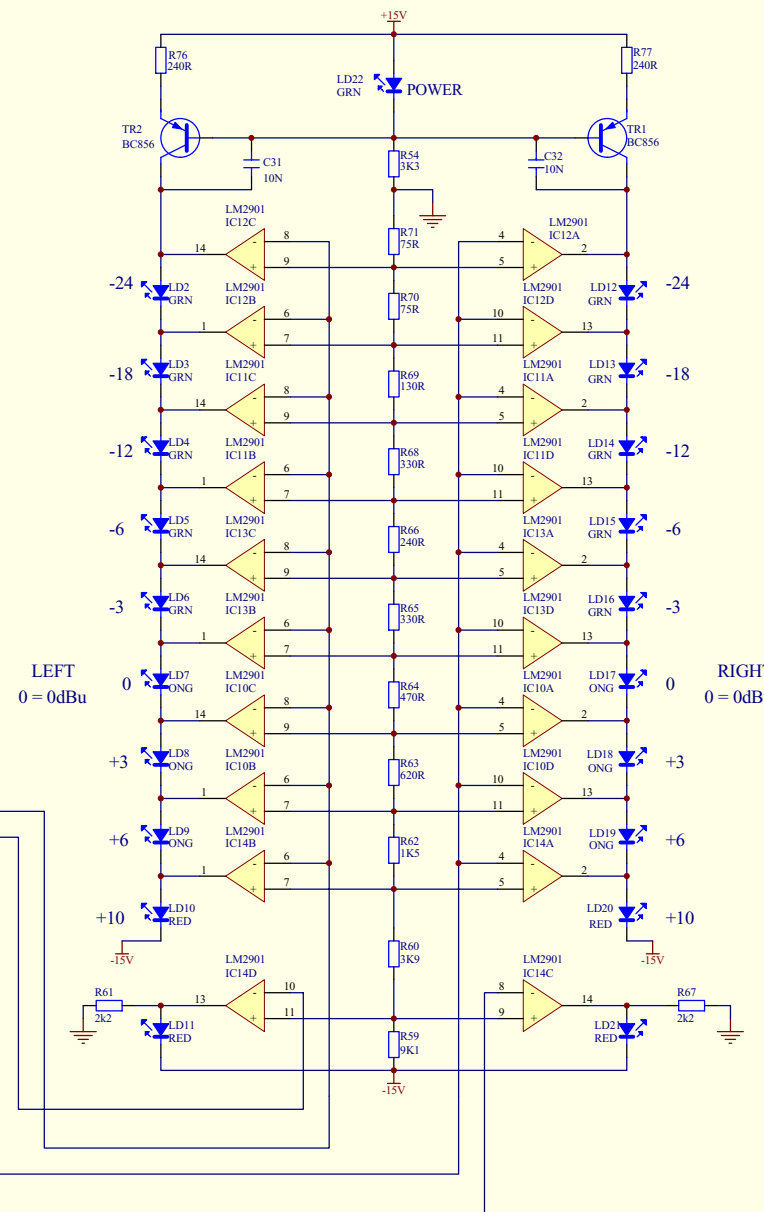
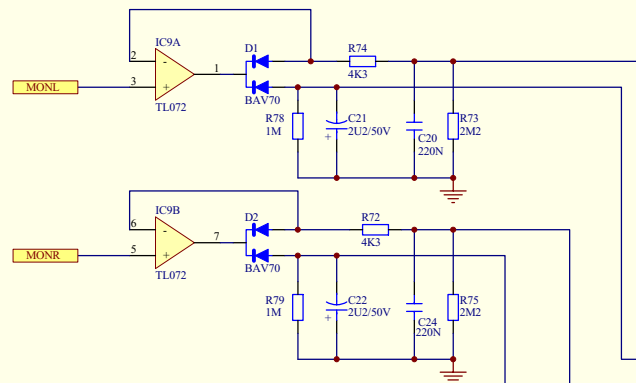
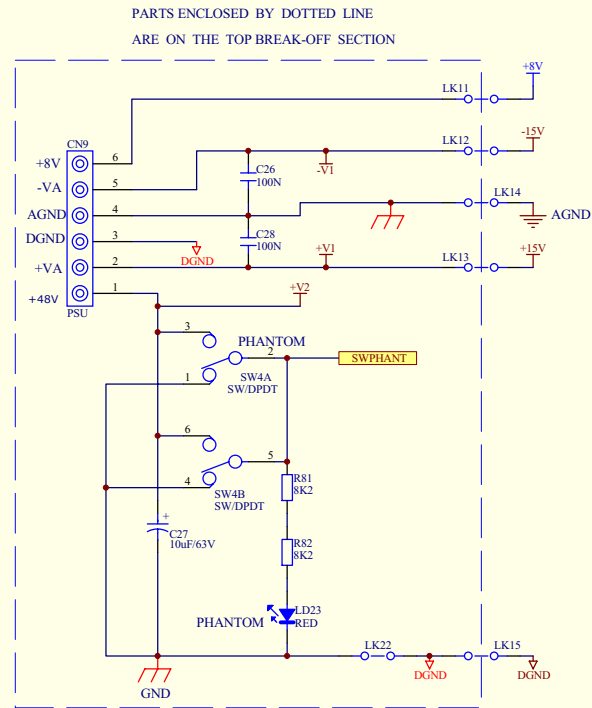

TITLE: EFX8 MIXER	
SHEET: Sheet-B	12 OF 14
REVISION: 1.5	DATE: 14-Jun-2007

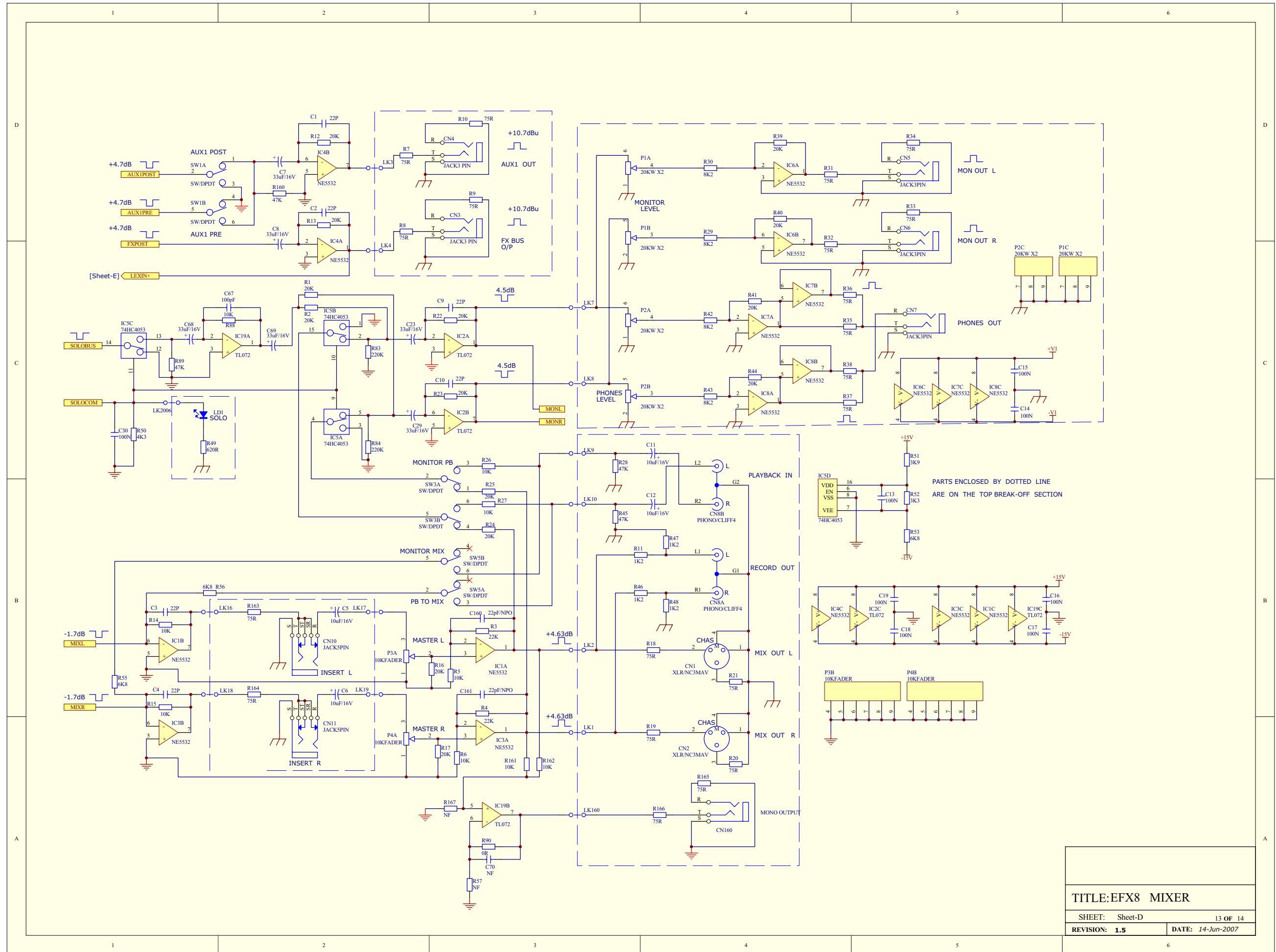

TITLE: EFX8 MIXER
 SHEET: Sheet-D 13 OF 14
 REVISION: 1.5 DATE: 14-Jun-2007

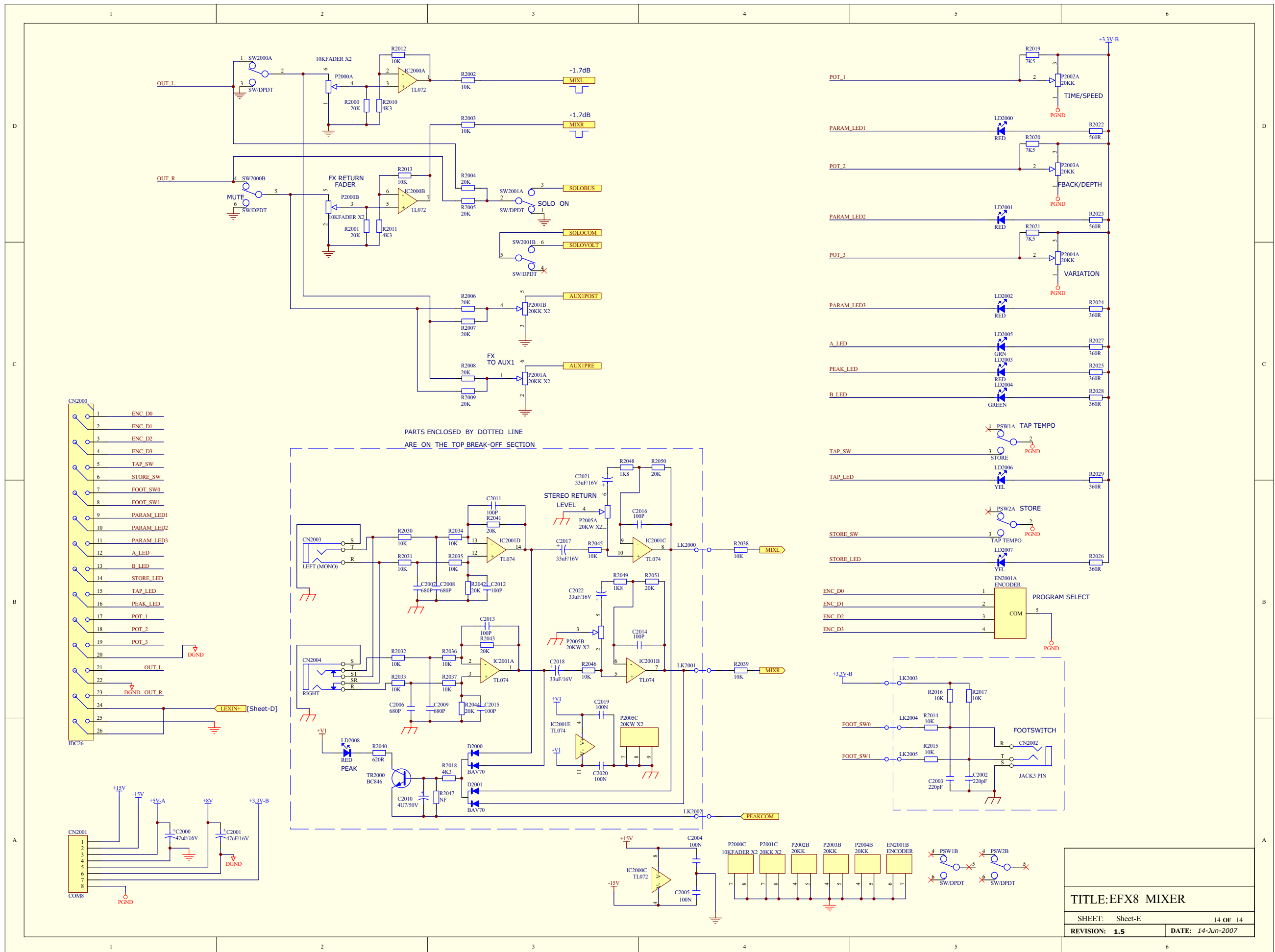

TITLE: EFX8 MIXER
 SHEET: Sheet-E 14 OF 14
 REVISION: 1.5 DATE: 14-Jun-2007

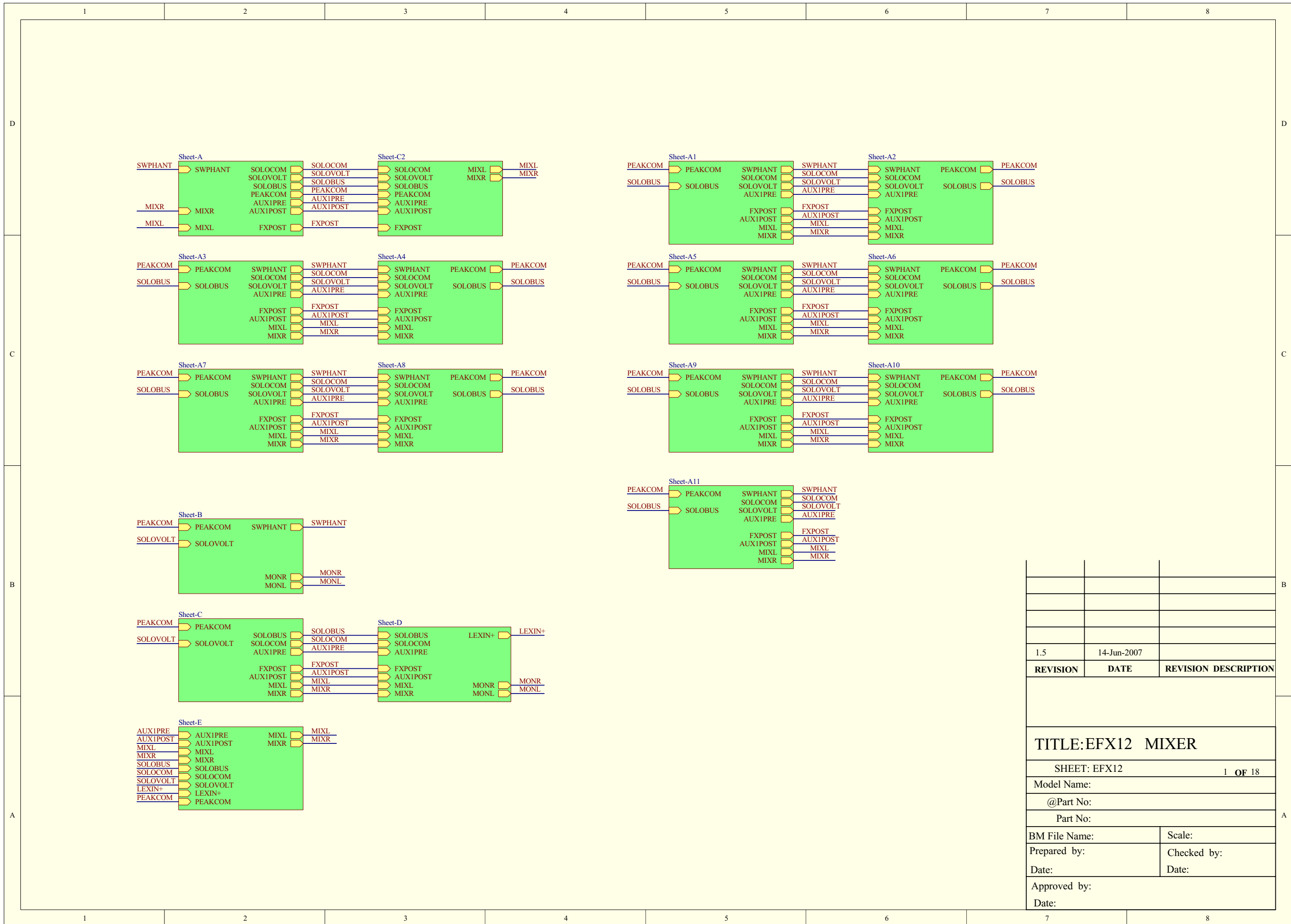

1.5	14-Jun-2007	
REVISION	DATE	REVISION DESCRIPTION
TITLE: EFX12 MIXER		
SHEET: EFX12		1 OF 18
Model Name:		
@Part No:		
Part No:		
BM File Name:	Scale:	
Prepared by:	Checked by:	
Date:	Date:	
Approved by:		
Date:		

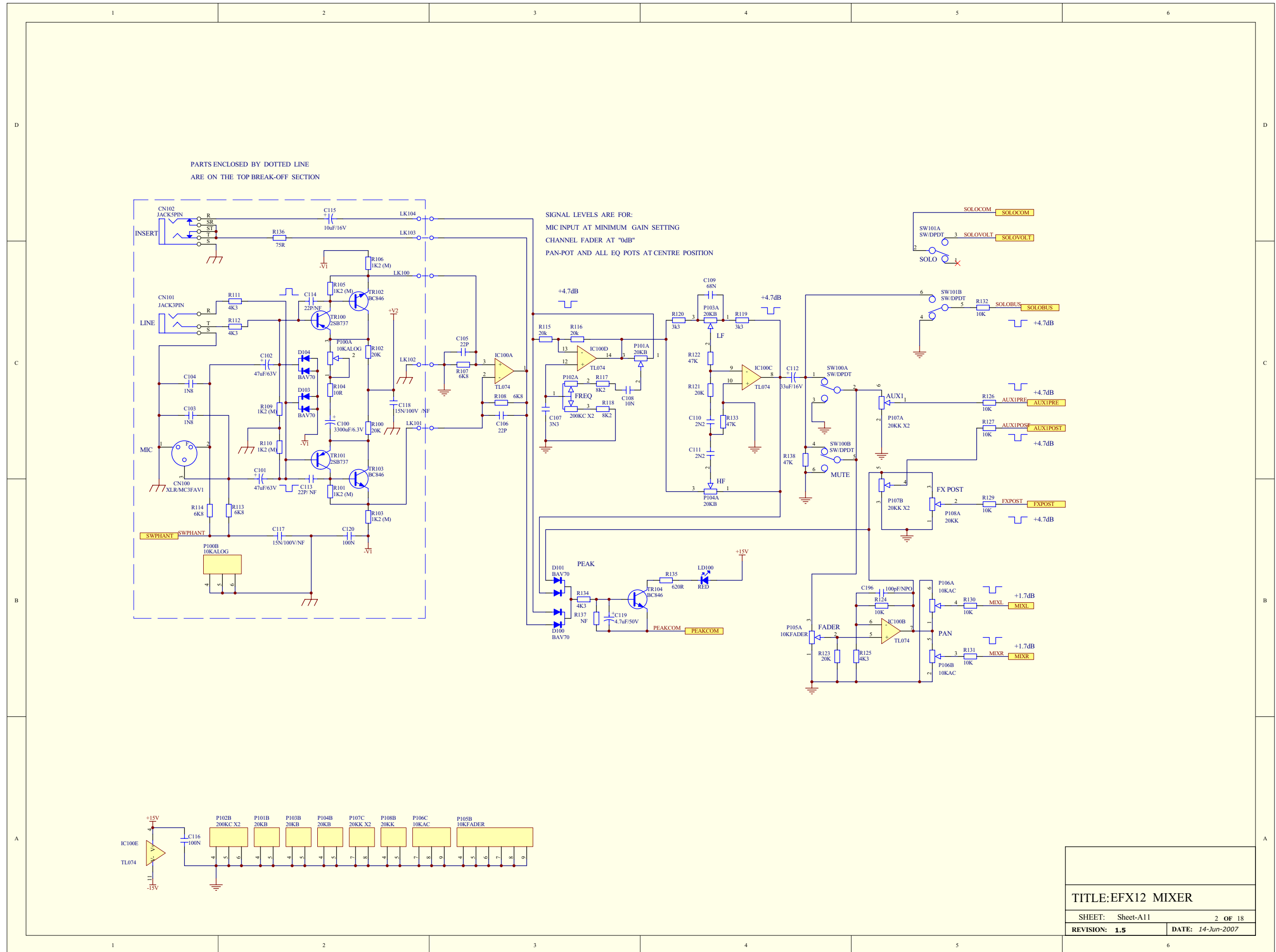

SIGNAL LEVELS ARE FOR:
 MIC INPUT AT MINIMUM GAIN SETTING
 CHANNEL FADER AT "0dB"
 PAN-POT AND ALL EQ POTS AT CENTRE POSITION

PARTS ENCLOSED BY DOTTED LINE
 ARE ON THE TOP BREAK-OFF SECTION

TITLE: EFX12 MIXER	
SHEET: Sheet-A11	2 OF 18
REVISION: 1.5	DATE: 14-Jun-2007

PARTS ENCLOSED BY DOTTED LINE
ARE ON THE TOP BREAK-OFF SECTION

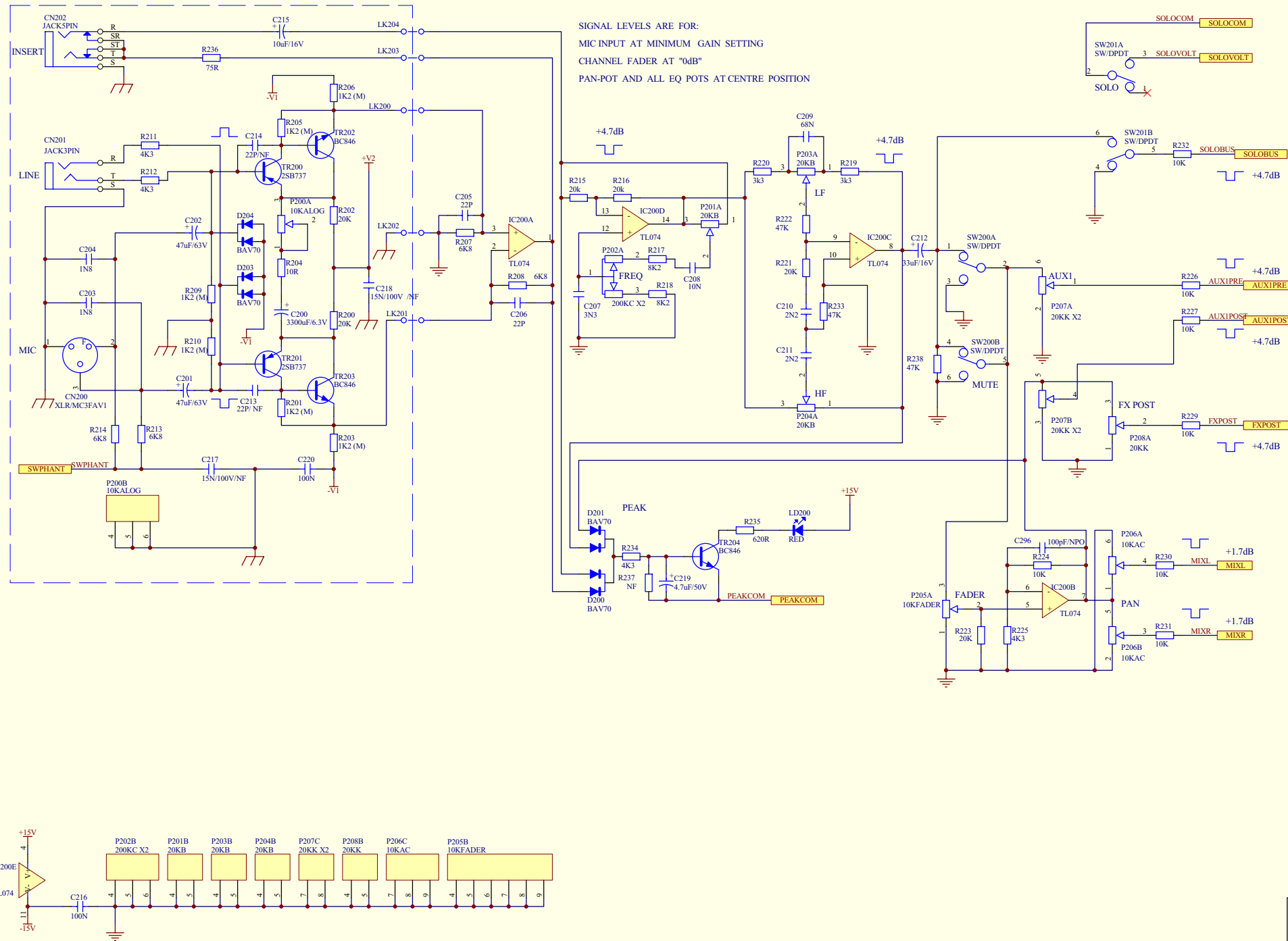

TITLE: EFX12 MIXER	
SHEET: Sheet-A10	3 OF 18
REVISION: 1.5	DATE: 14-Jun-2007

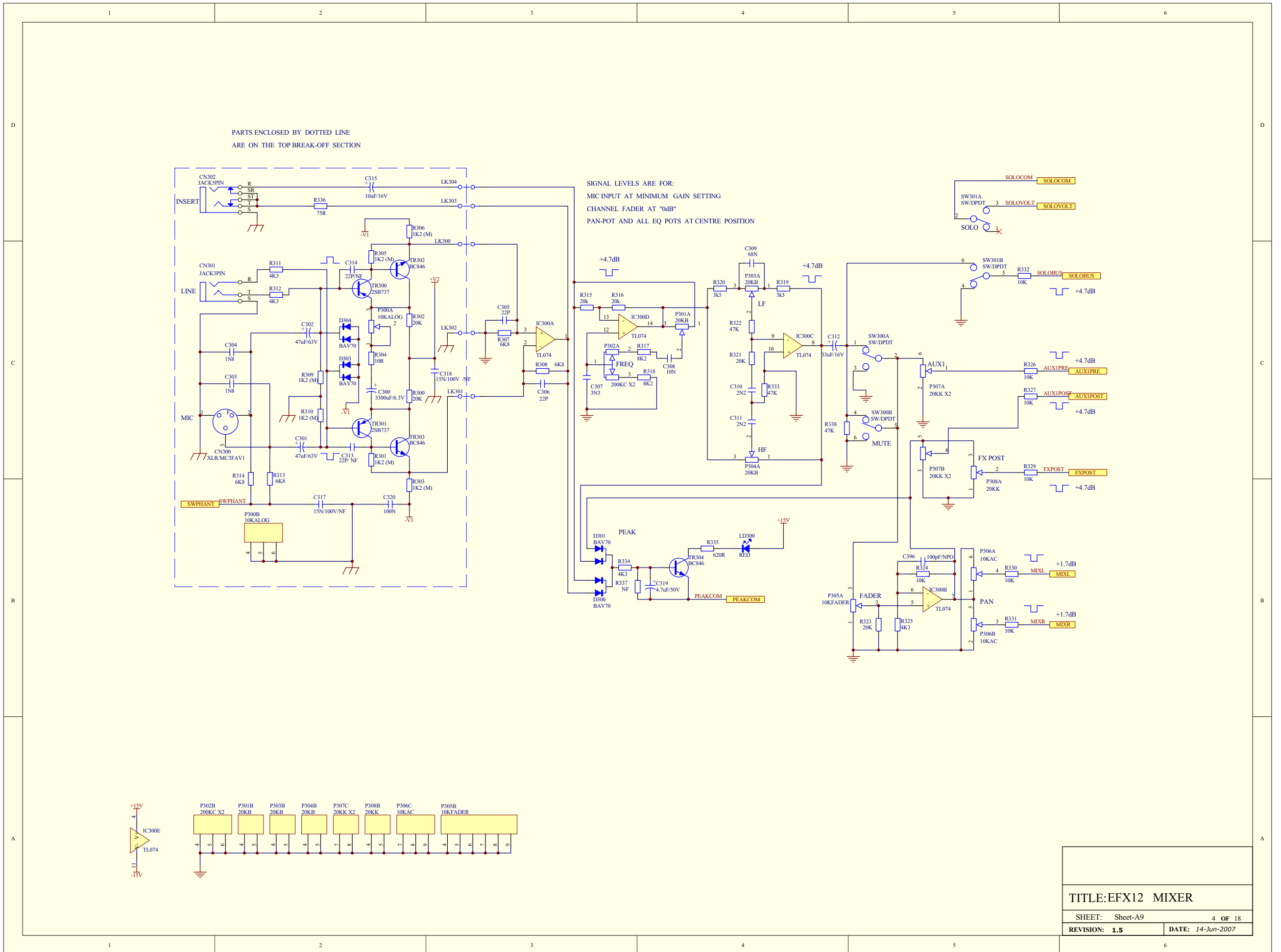

TITLE: EFX12 MIXER
 SHEET: Sheet-A9 4 OF 18
 REVISION: 1.5 DATE: 14-Jun-2007

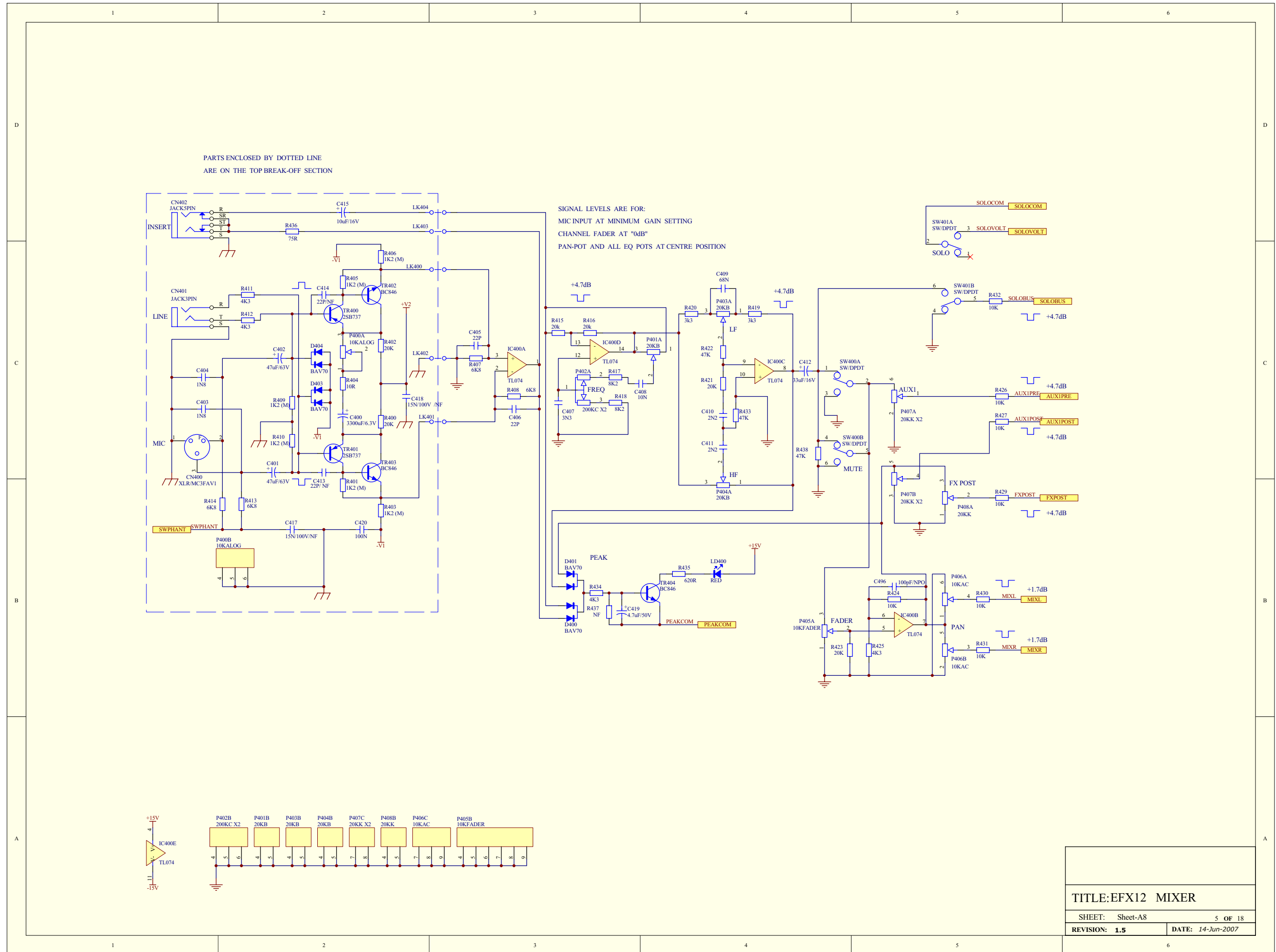

TITLE: EFX12 MIXER
 SHEET: Sheet-A8 5 OF 18
 REVISION: 1.5 DATE: 14-Jun-2007

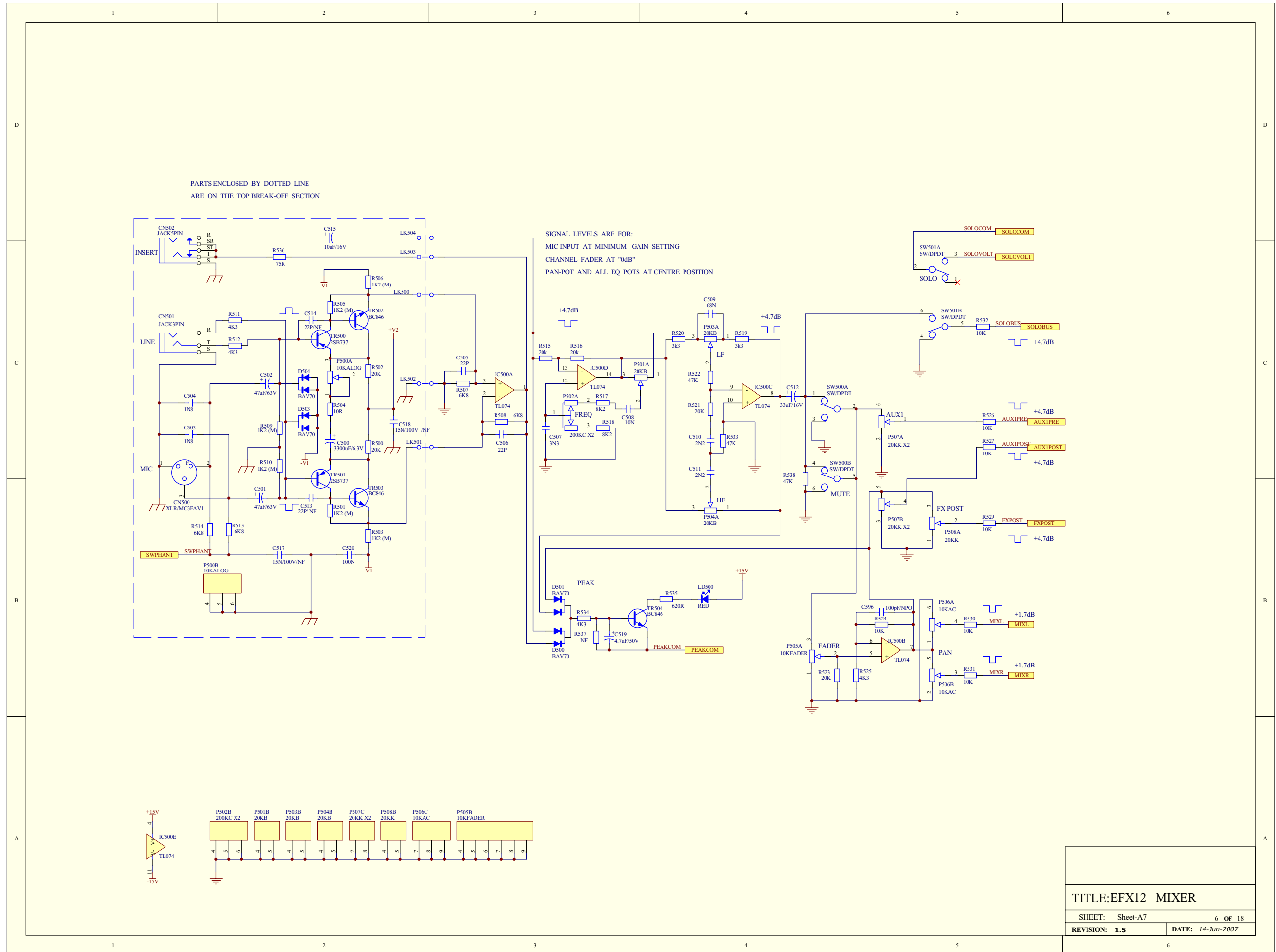

TITLE: EFX12 MIXER
 SHEET: Sheet-A7 6 OF 18
 REVISION: 1.5 DATE: 14-Jun-2007

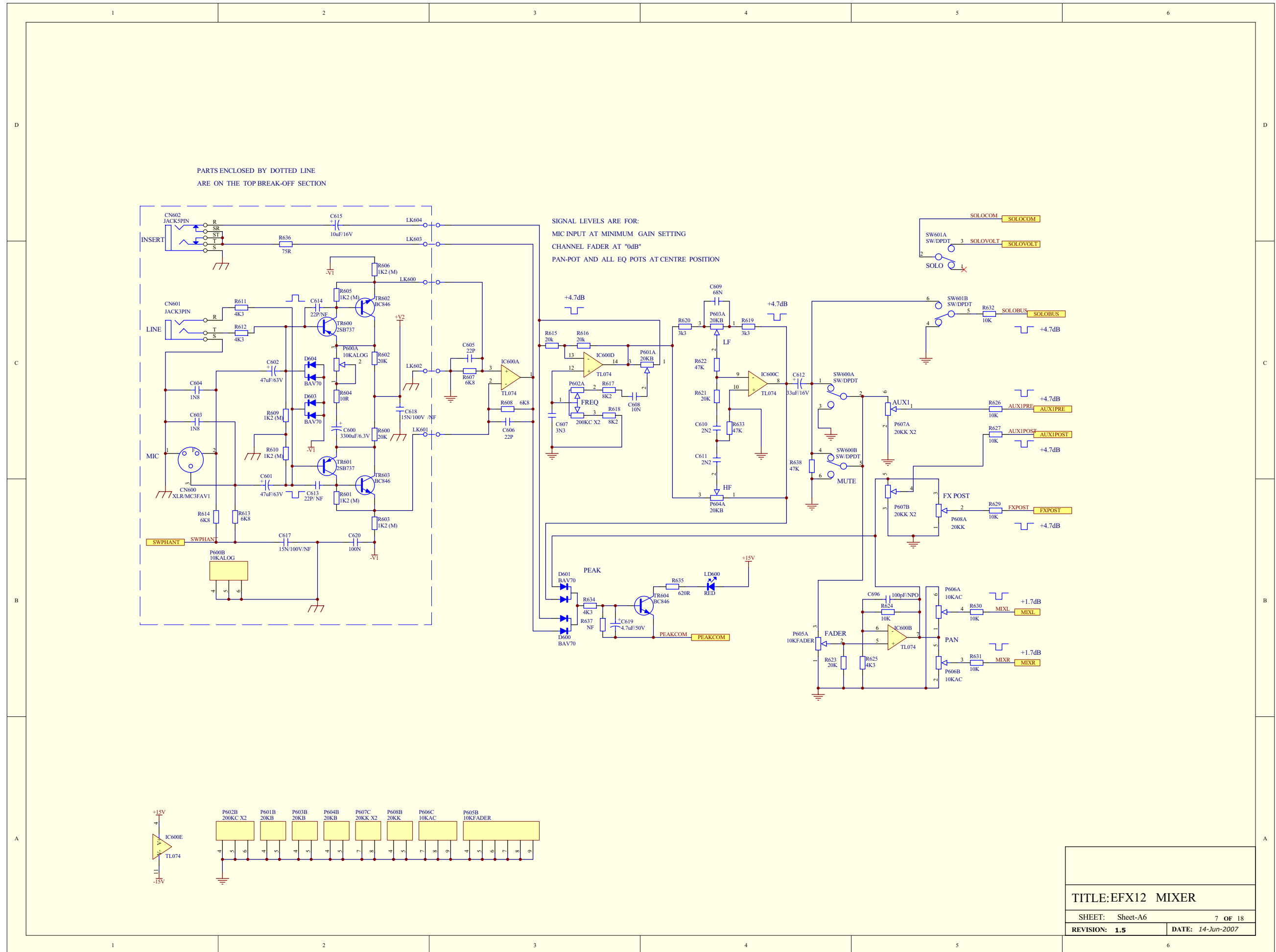

TITLE: EFX12 MIXER
 SHEET: Sheet-A6 7 OF 18
 REVISION: 1.5 DATE: 14-Jun-2007

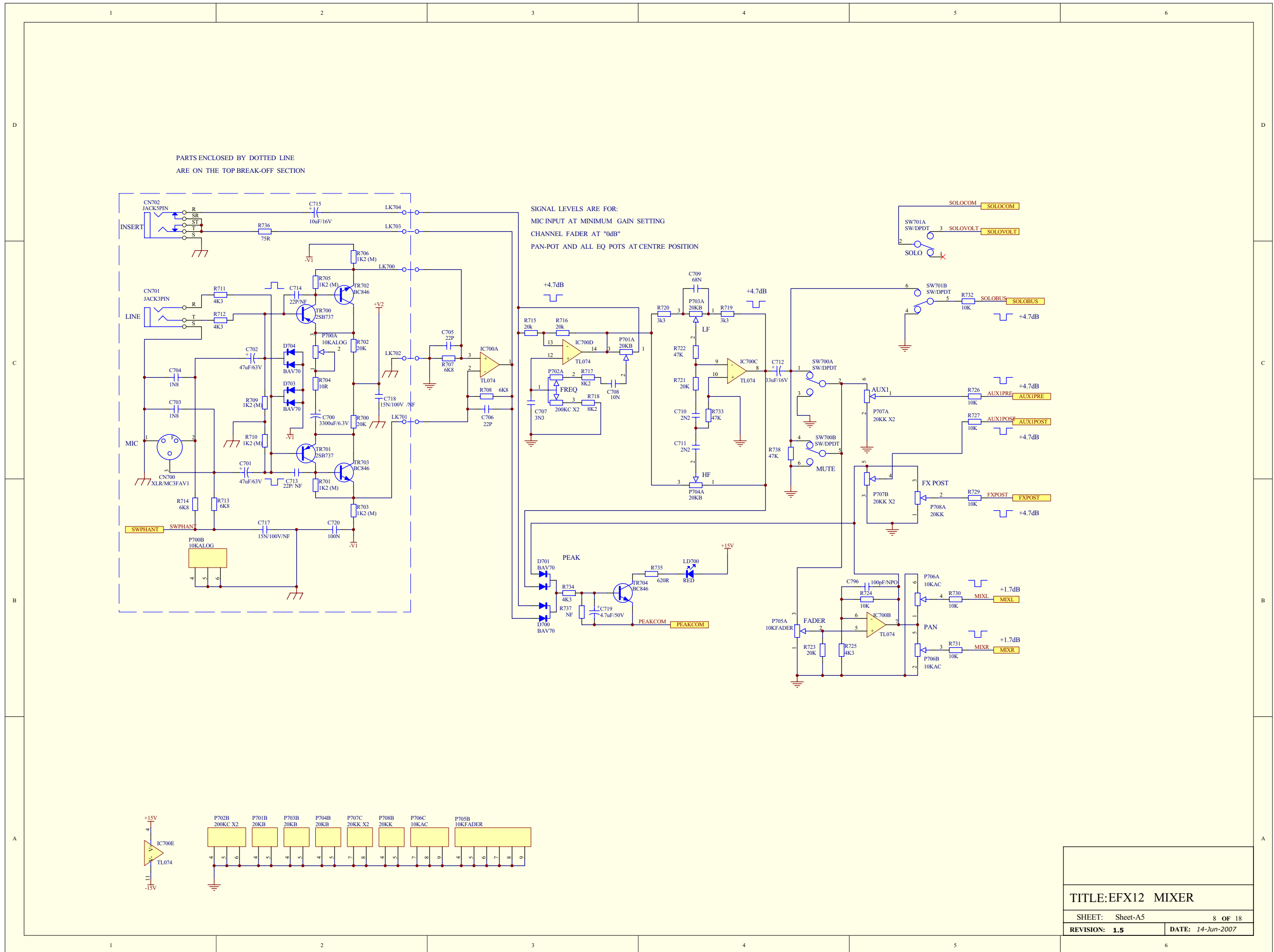

TITLE: EFX12 MIXER
 SHEET: Sheet-A5 8 OF 18
 REVISION: 1.5 DATE: 14-Jun-2007

PARTS ENCLOSED BY DOTTED LINE
ARE ON THE TOP BREAK-OFF SECTION

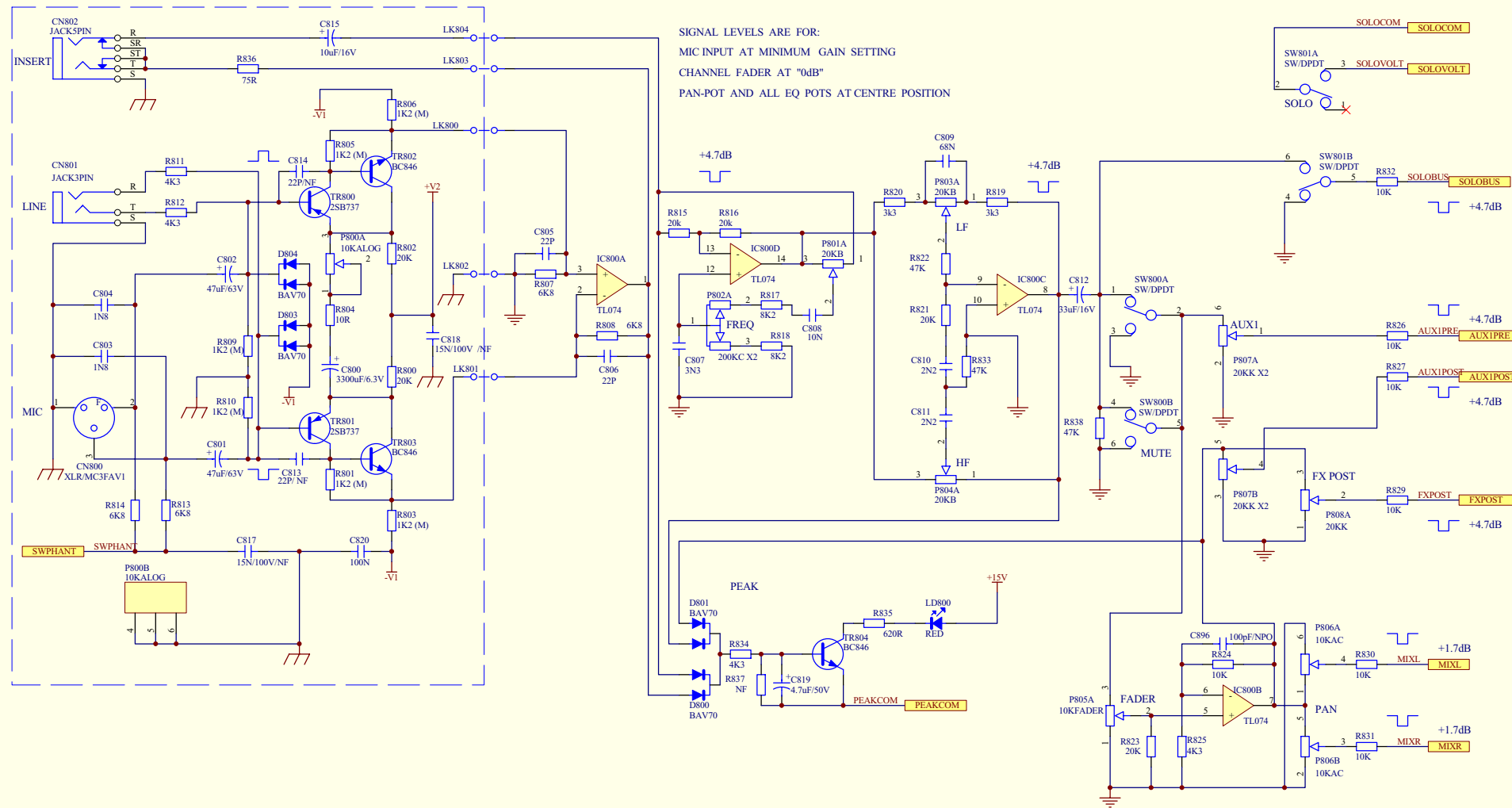

SIGNAL LEVELS ARE FOR:
MIC INPUT AT MINIMUM GAIN SETTING
CHANNEL FADER AT "0dB"
PAN-POT AND ALL EQ POTS AT CENTRE POSITION

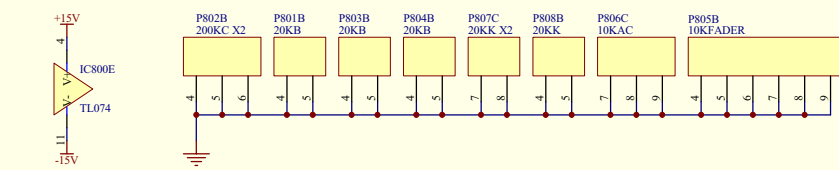

TITLE: EFX12 MIXER	
SHEET: Sheet-A4	9 OF 18
REVISION: 1.5	DATE: 14-Jun-2007

PARTS ENCLOSED BY DOTTED LINE
ARE ON THE TOP BREAK-OFF SECTION

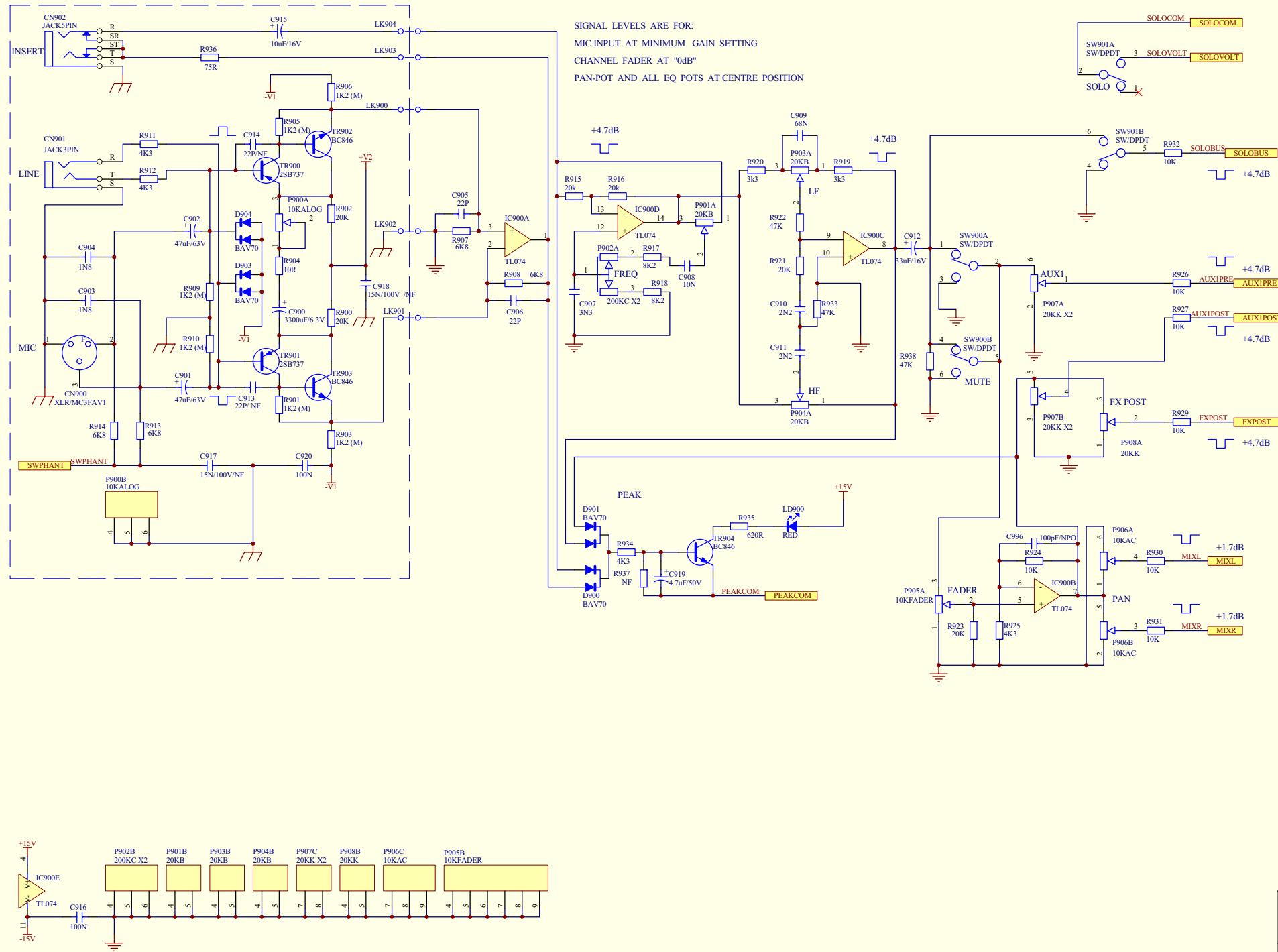

SIGNAL LEVELS ARE FOR:
MIC INPUT AT MINIMUM GAIN SETTING
CHANNEL FADER AT "0dB"
PAN-POT AND ALL EQ POTS AT CENTRE POSITION

TITLE: EFX12 MIXER	
SHEET: Sheet-A3	10 OF 10
REVISION: 1.5	DATE: 14-Jun-2007

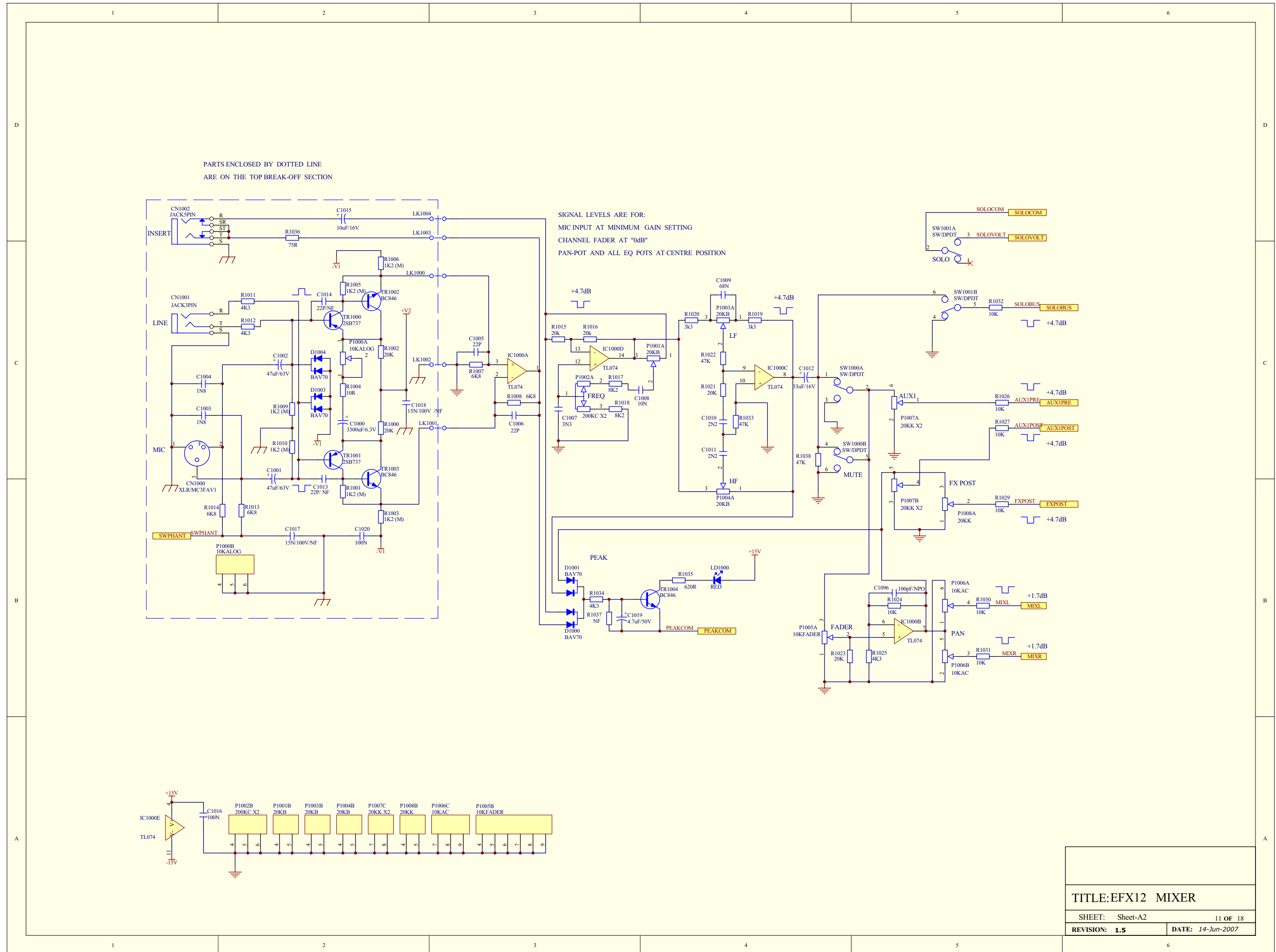

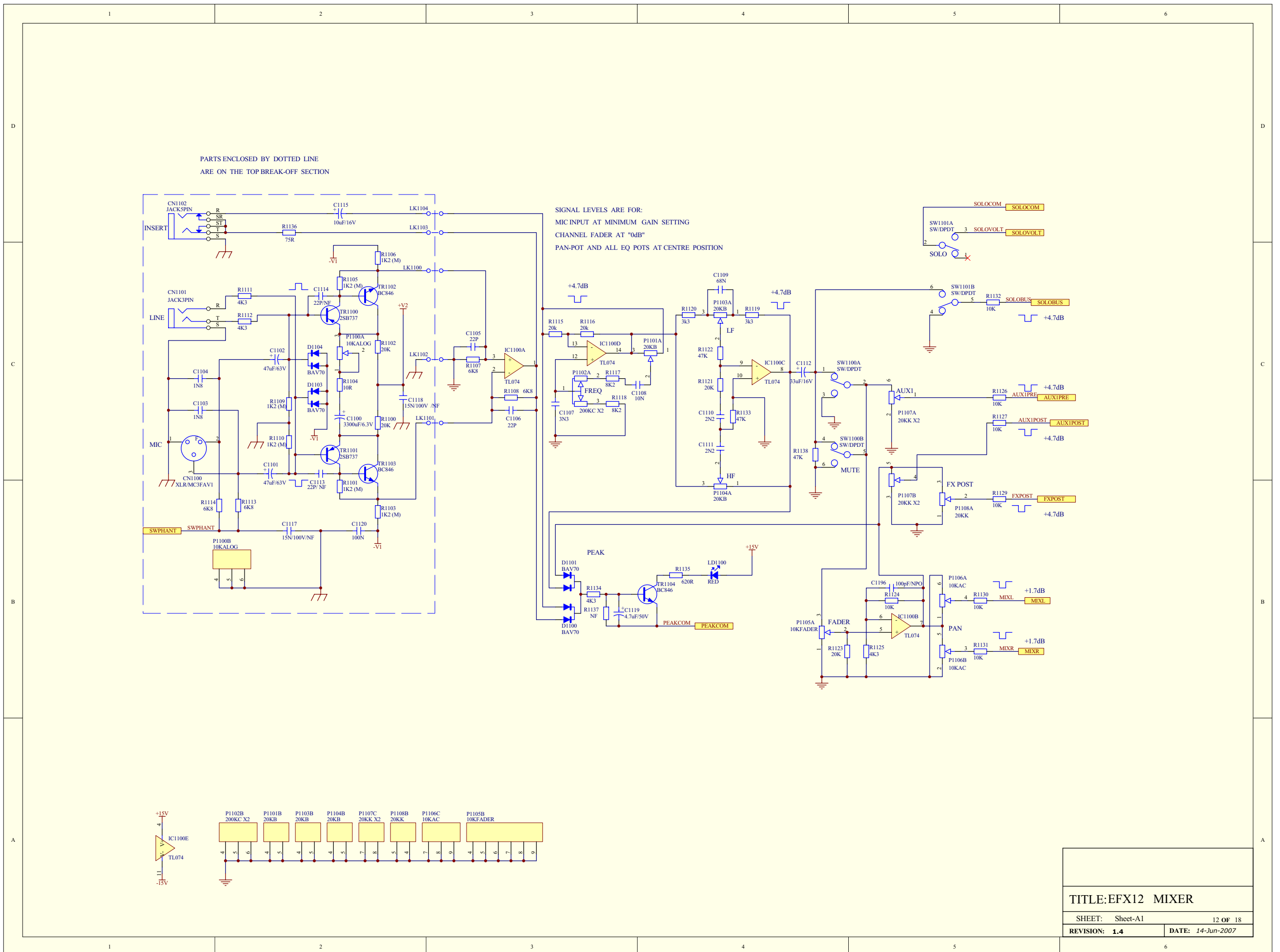

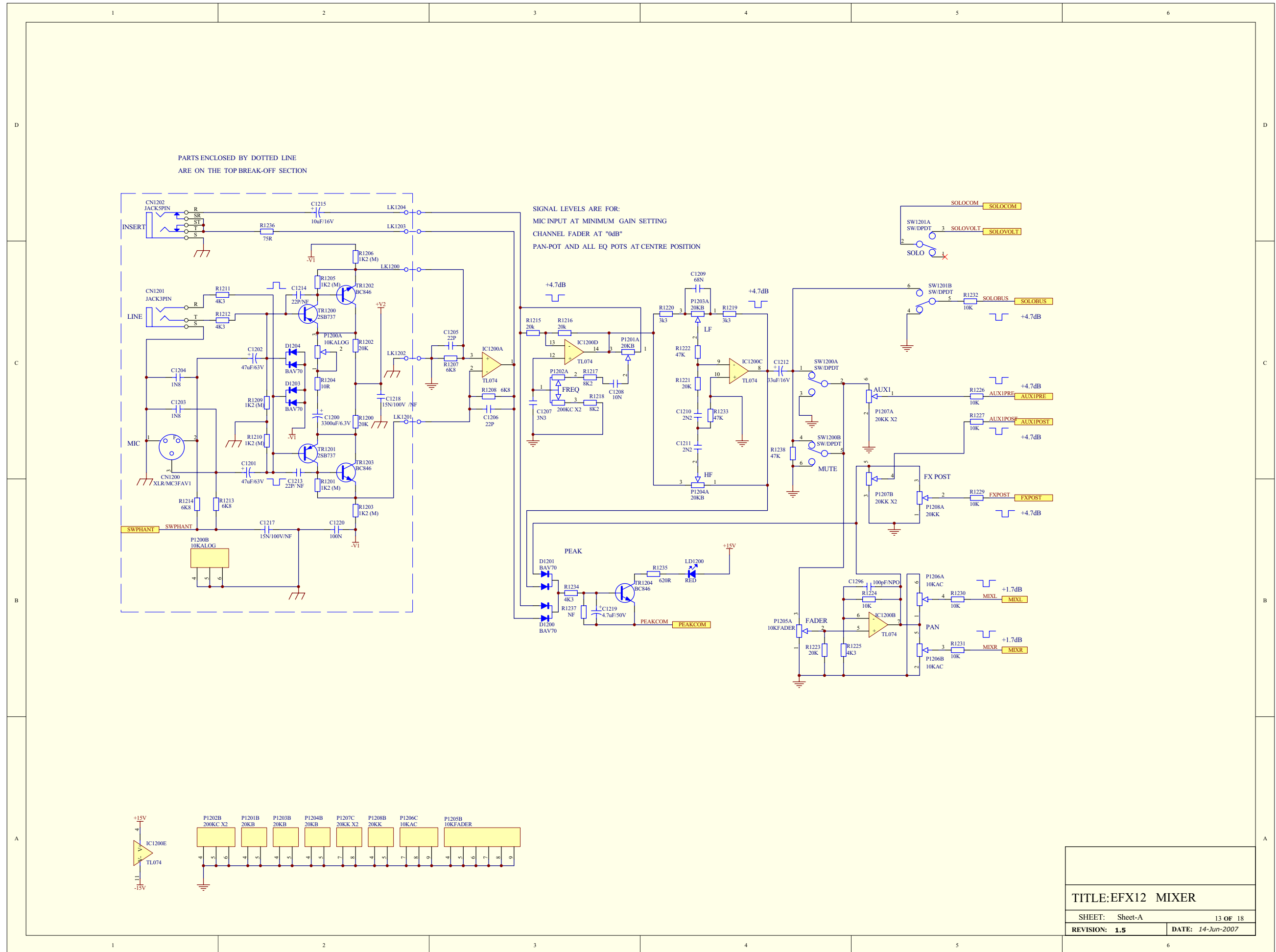

TITLE: EFX12 MIXER
 SHEET: Sheet-A 13 OF 18
 REVISION: 1.5 DATE: 14-Jun-2007

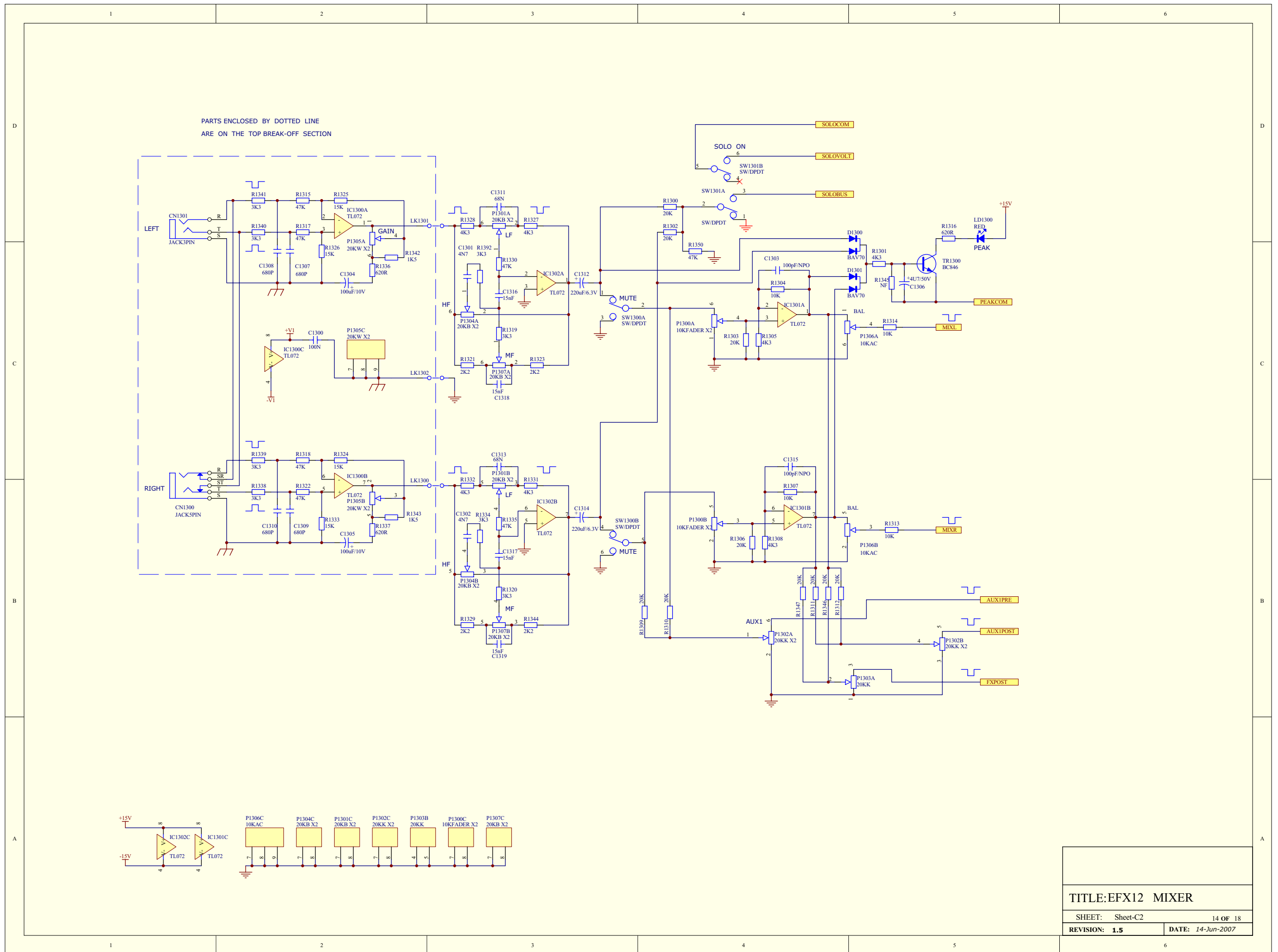

TITLE: EFX12 MIXER
 SHEET: Sheet-C2 14 OF 18
 REVISION: 1.5 DATE: 14-Jun-2007

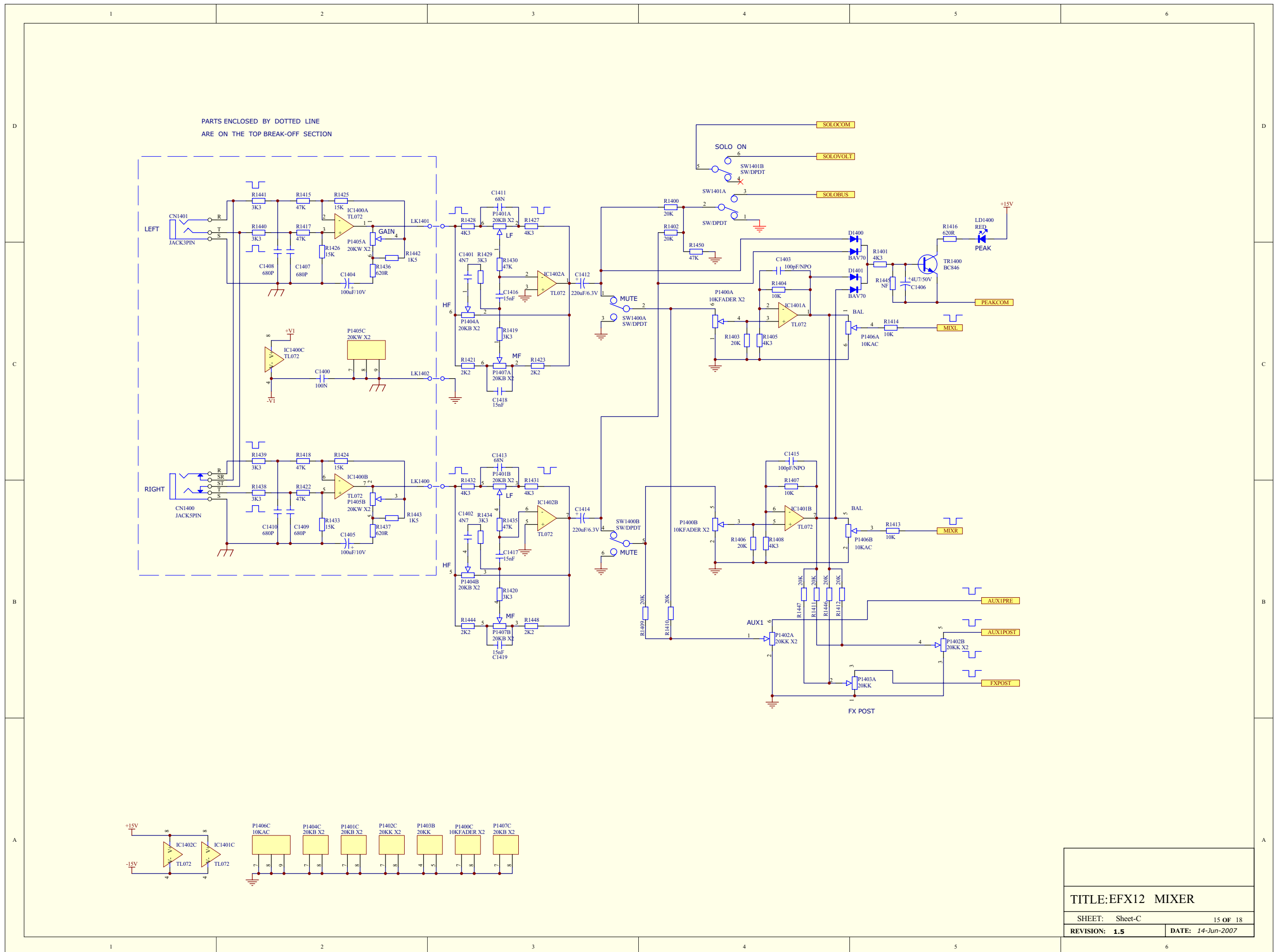

TITLE: EFX12 MIXER	
SHEET: Sheet-C	15 OF 18
REVISION: 1.5	DATE: 14-Jun-2007

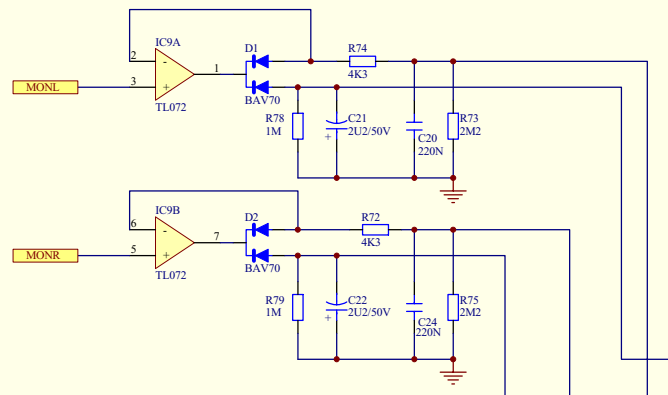
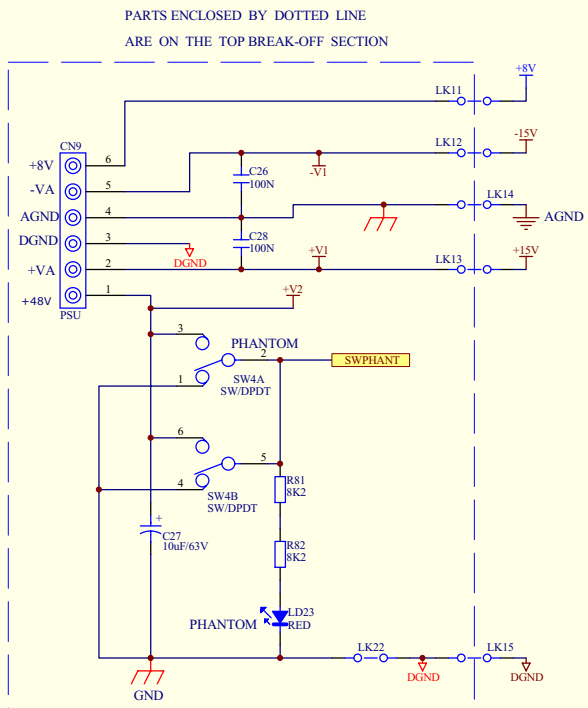
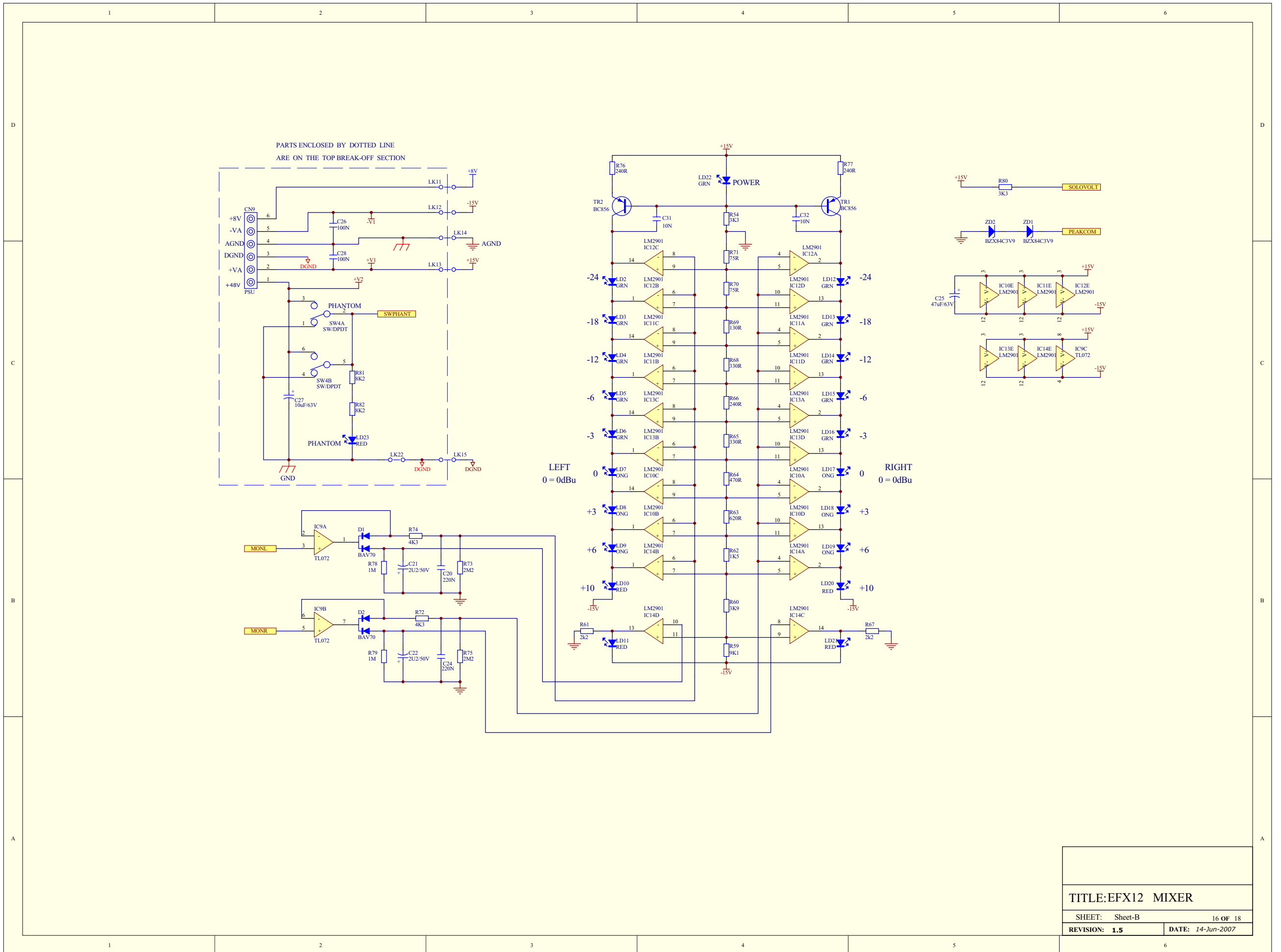

LEFT
0 = 0dBu

RIGHT
0 = 0dBu

TITLE: EFX12 MIXER	
SHEET: Sheet-B	16 OF 18
REVISION: 1.5	DATE: 14-Jun-2007

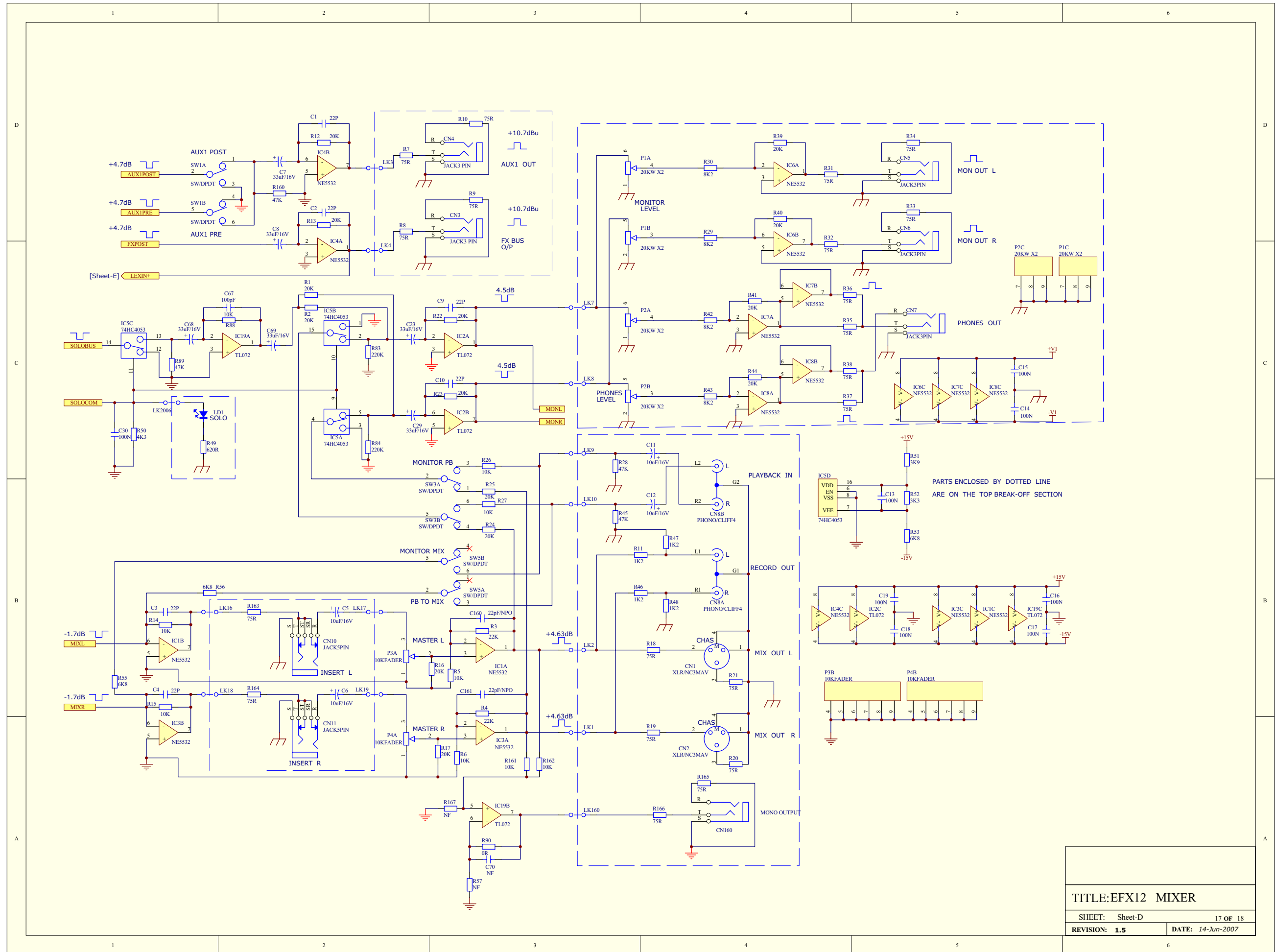

TITLE: EFX12 MIXER
 SHEET: Sheet-D 17 OF 18
 REVISION: 1.5 DATE: 14-Jun-2007

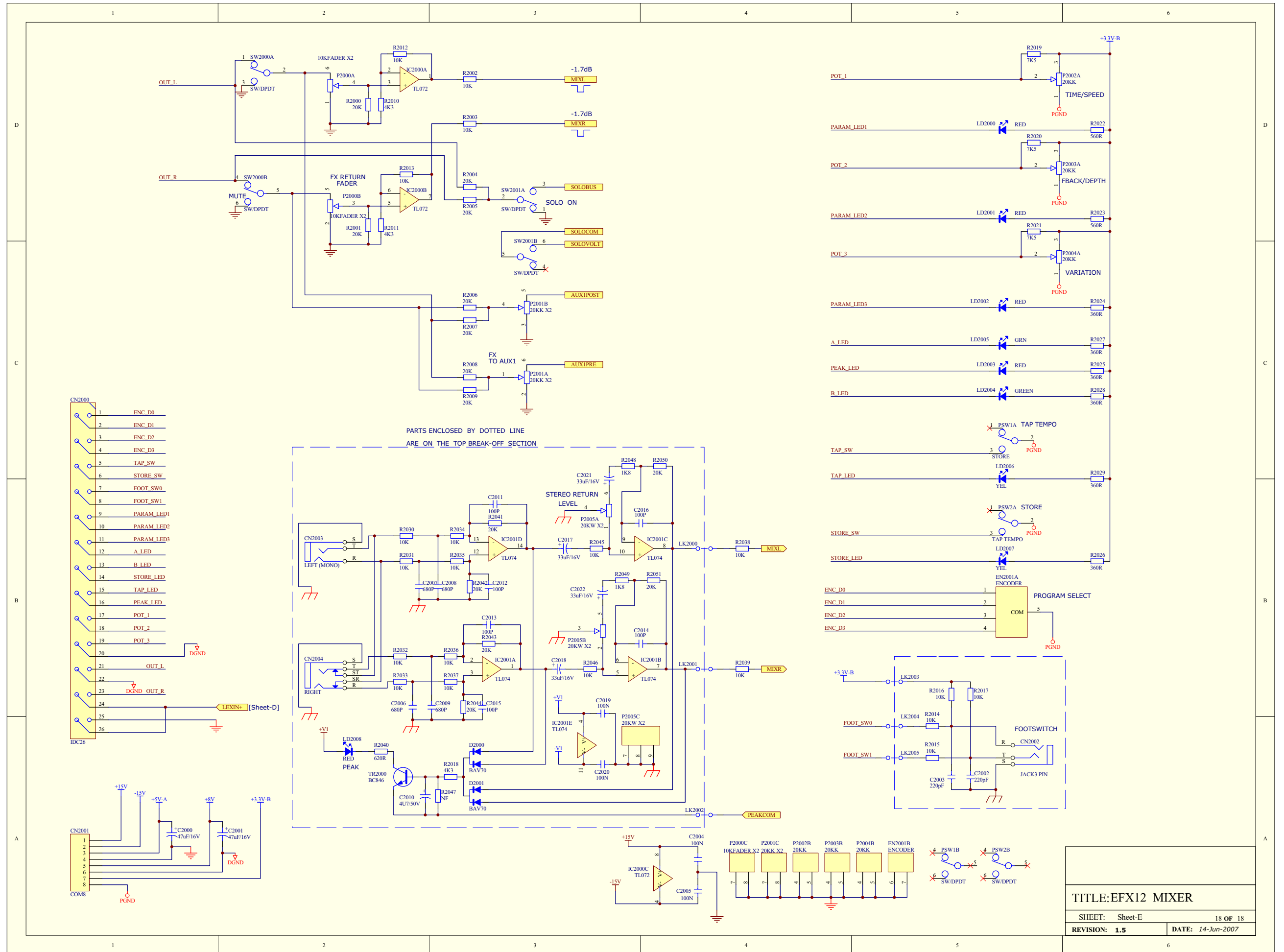

- CN2000
- 1 ENC_D0
 - 2 ENC_D1
 - 3 ENC_D2
 - 4 ENC_D3
 - 5 TAP_SW
 - 6 STORE_SW
 - 7 FOOT_SW0
 - 8 FOOT_SW1
 - 9 PARAM_LED1
 - 10 PARAM_LED2
 - 11 PARAM_LED3
 - 12 A_LED
 - 13 B_LED
 - 14 STORE_LED
 - 15 TAP_LED
 - 16 PEAK_LED
 - 17 POT_1
 - 18 POT_2
 - 19 POT_3
 - 20
 - 21 OUT_L
 - 22 DGND OUT_R
 - 23
 - 24
 - 25
 - 26
- IDC26

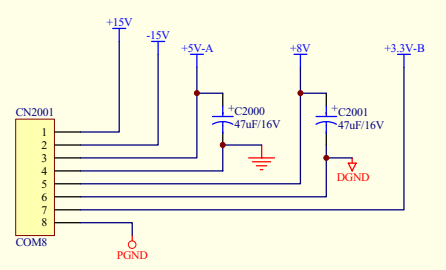

TITLE: EFX12 MIXER	
SHEET: Sheet-E	18 OF 18
REVISION: 1.5	DATE: 14-Jun-2007

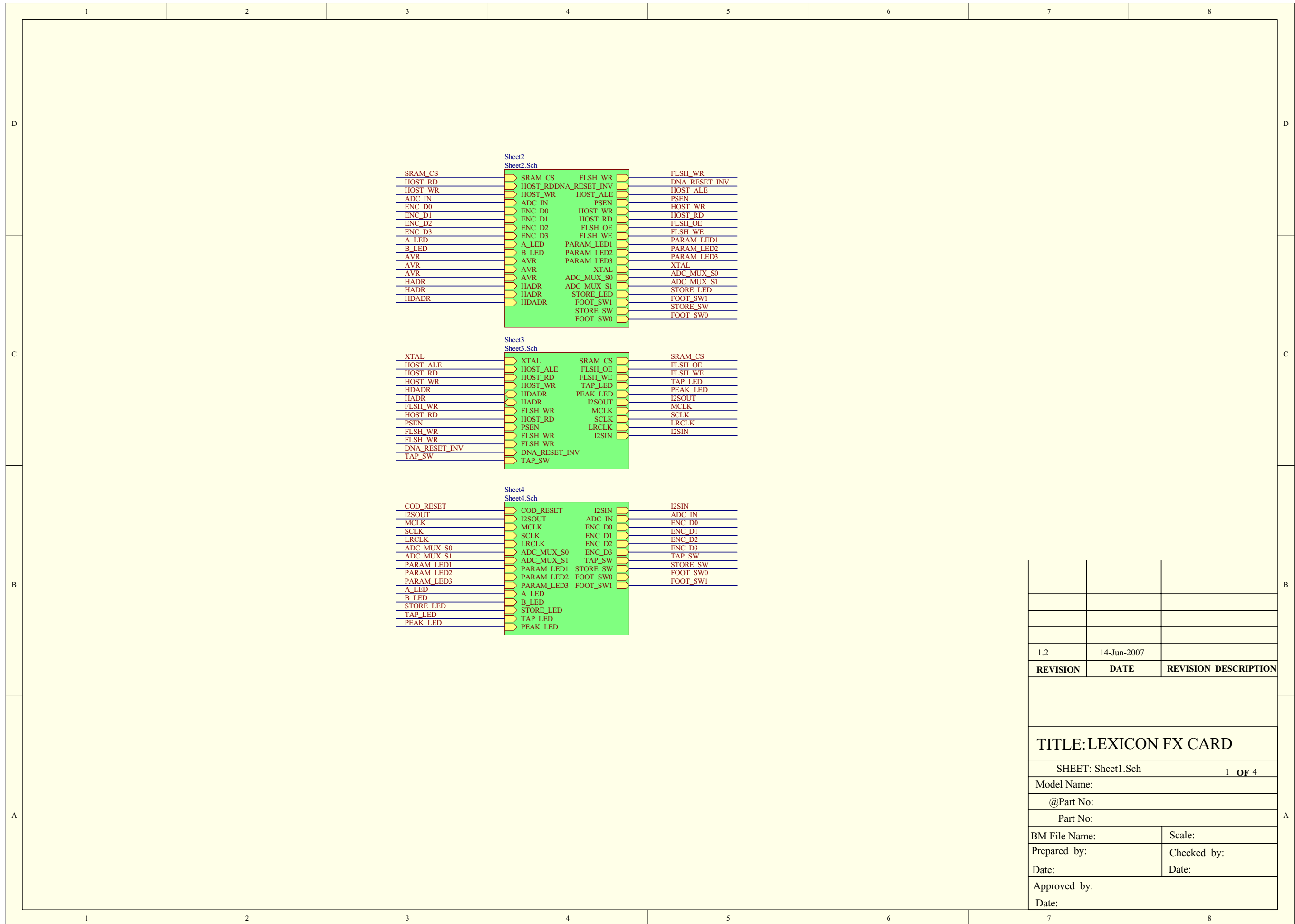

1.2	14-Jun-2007	
REVISION	DATE	REVISION DESCRIPTION
TITLE: LEXICON FX CARD		
SHEET: Sheet1.Sch		1 OF 4
Model Name:		
@Part No:		
Part No:		
BM File Name:	Scale:	
Prepared by:	Checked by:	
Date:	Date:	
Approved by:		
Date:		

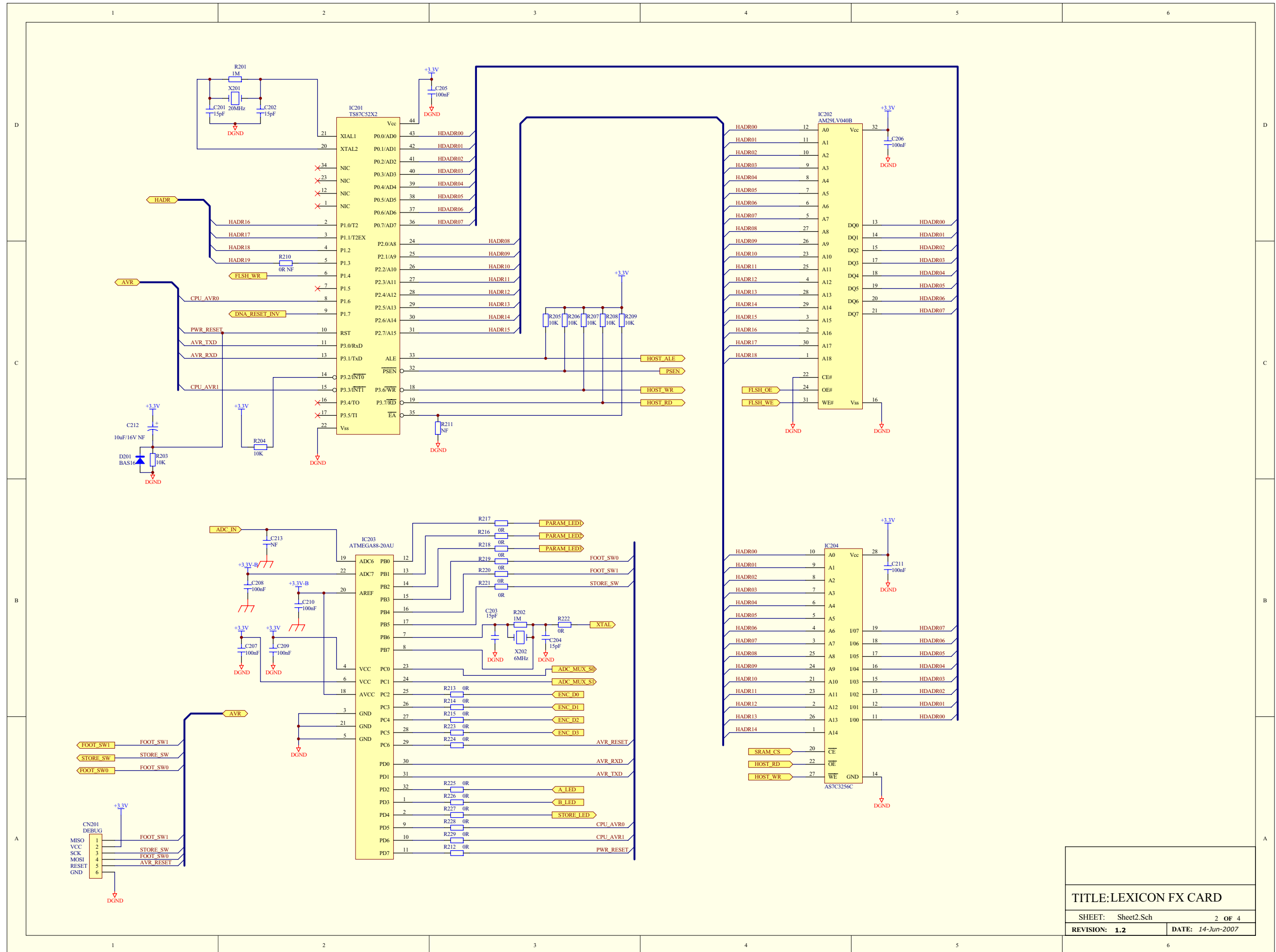

TITLE: LEXICON FX CARD
 SHEET: Sheet2.Sch 2 OF 4
 REVISION: 1.2 DATE: 14-Jun-2007

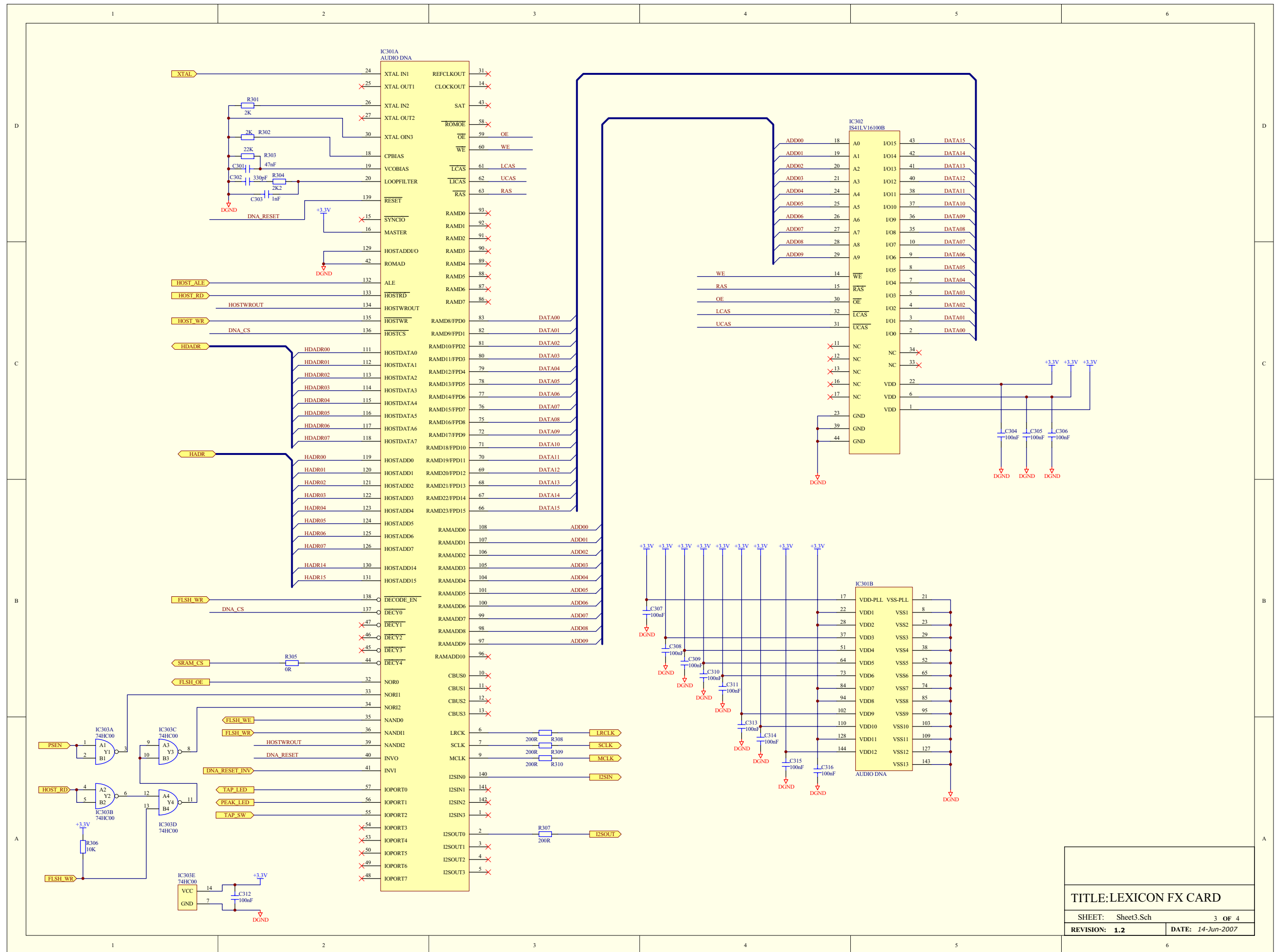

TITLE: LEXICON FX CARD
 SHEET: Sheet3.Sch 3 OF 4
 REVISION: 1.2 DATE: 14-Jun-2007

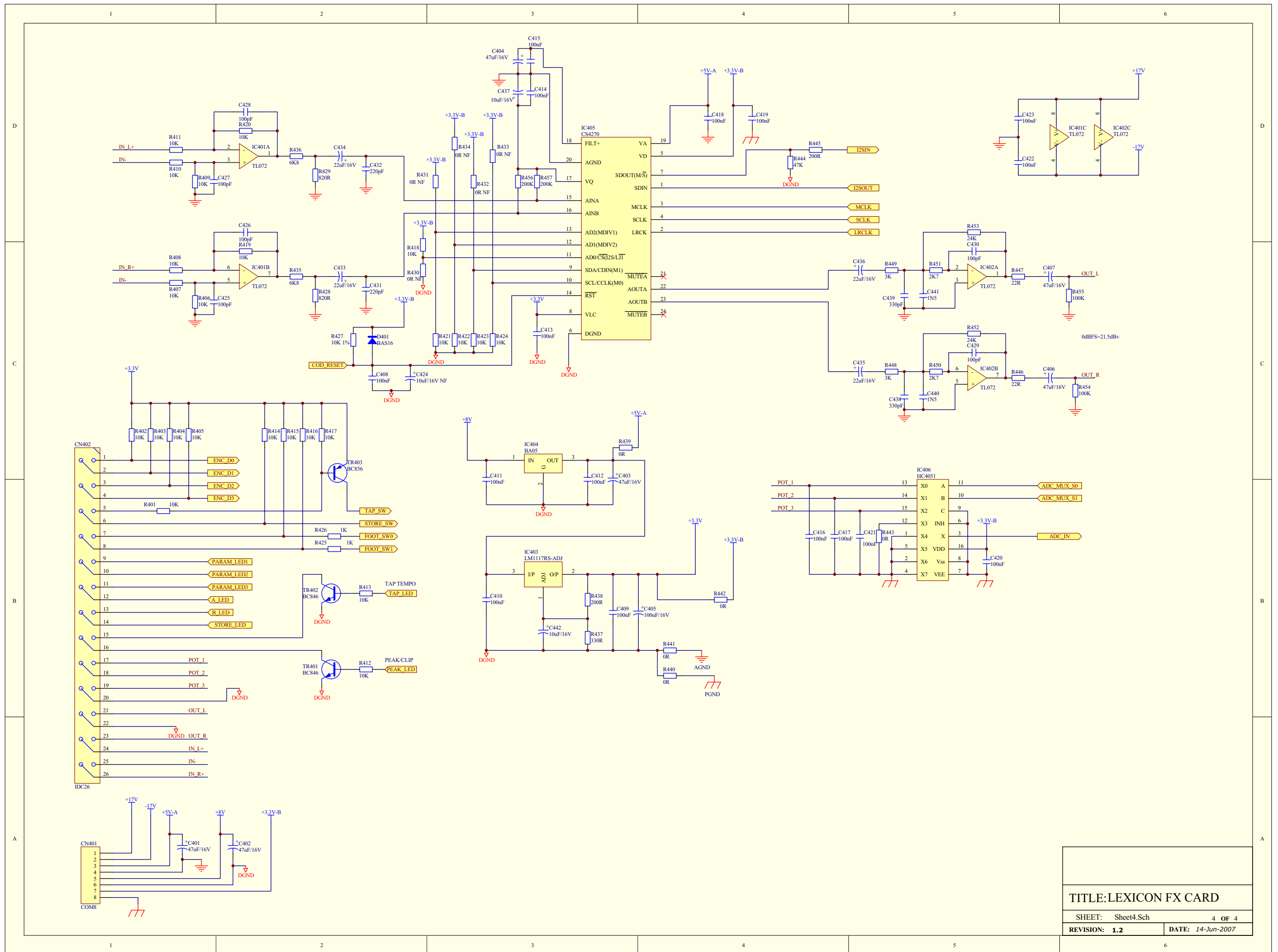

TITLE: LEXICON FX CARD
 SHEET: Sheet4.Sch 4 OF 4
 REVISION: 1.2 DATE: 14-Jun-2007

DRAWING NUMBER ISSUE
E0307B-05A

HARMAN INTERNATIONAL INDUSTRIES LIMITED
CRANBORNE HOUSE
CRANBORNE ROAD
POTTERS BAR
HERTS
EN6 3JN
Tel 01707 660667
Fax 01707 660755

TITLE: MFX8/EFX8/EFX12 PSU
SHEET 1 OF 1 CIRCUIT DIAGRAM

FILENAME: E0307B-05A.SCH

DRAWN: PST/AP

DATE: 09/09/05

CHECKED:

MATERIAL:

FINISH:

ISSUE COMMENTS:

5. FIRST RELEASE 08/08/07

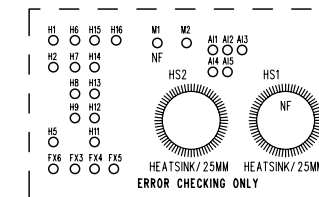
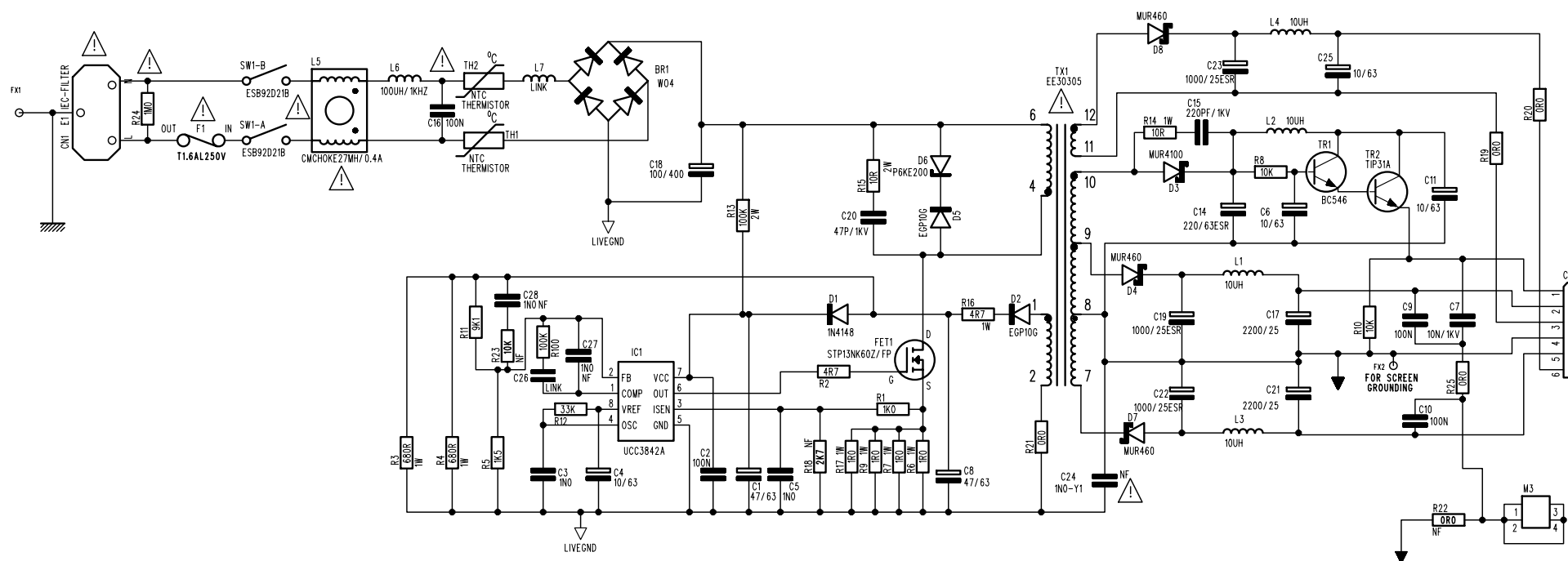

THIS DRAWING IS THE COPYRIGHT OF HARMAN INTERNATIONAL INDUSTRIES Ltd.
ALL REPRODUCTION AND COPYING THAN THAT FOR LICENCED MANUFACTURES
OWN INTERNAL USE, OR DISCLOSURE OF PART OR WHOLE TO A THIRD PARTY
WITHOUT PRIOR WRITTEN AUTHORISATION IS IN VIOLATION OF THE COPYRIGHT.

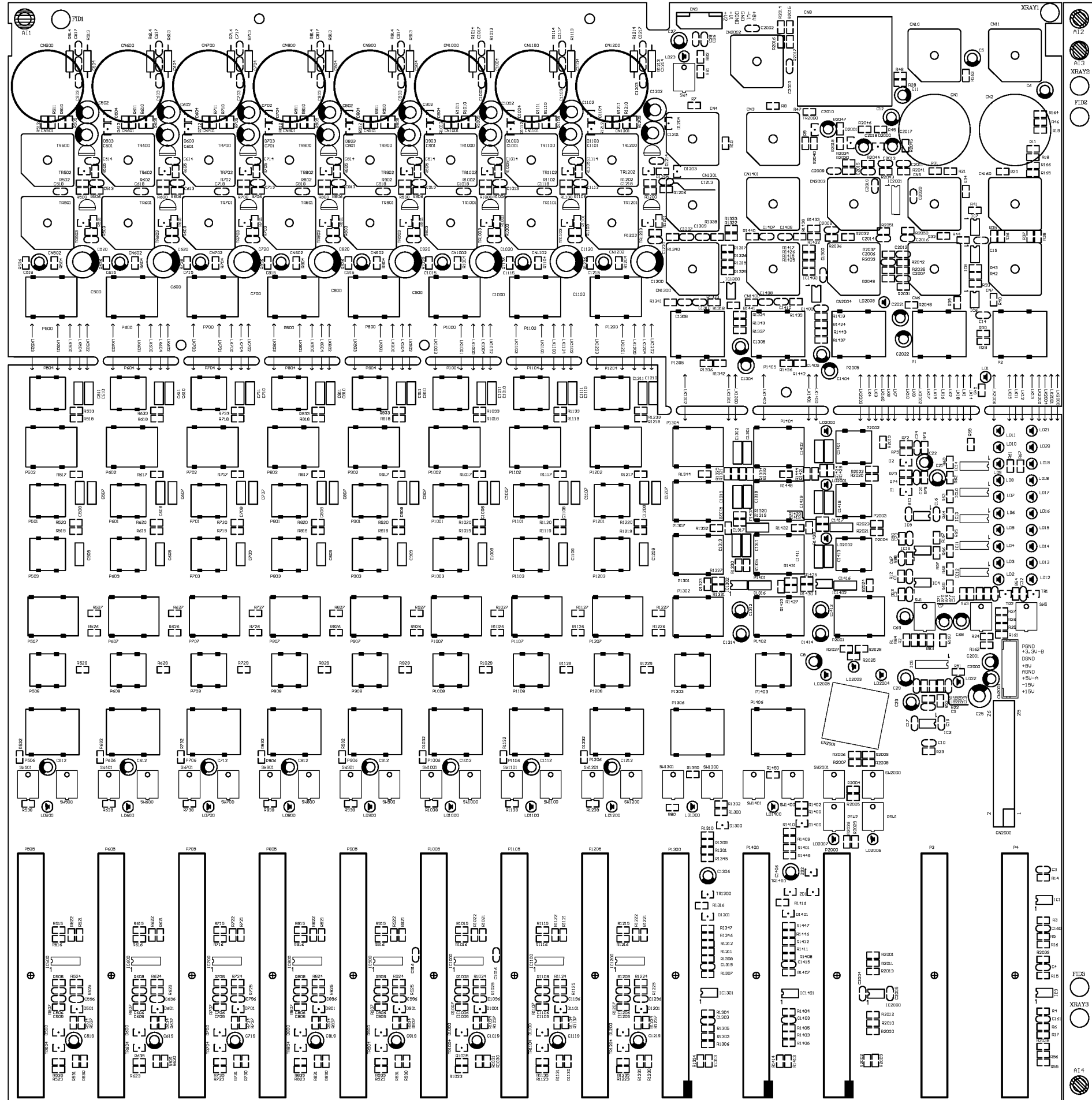

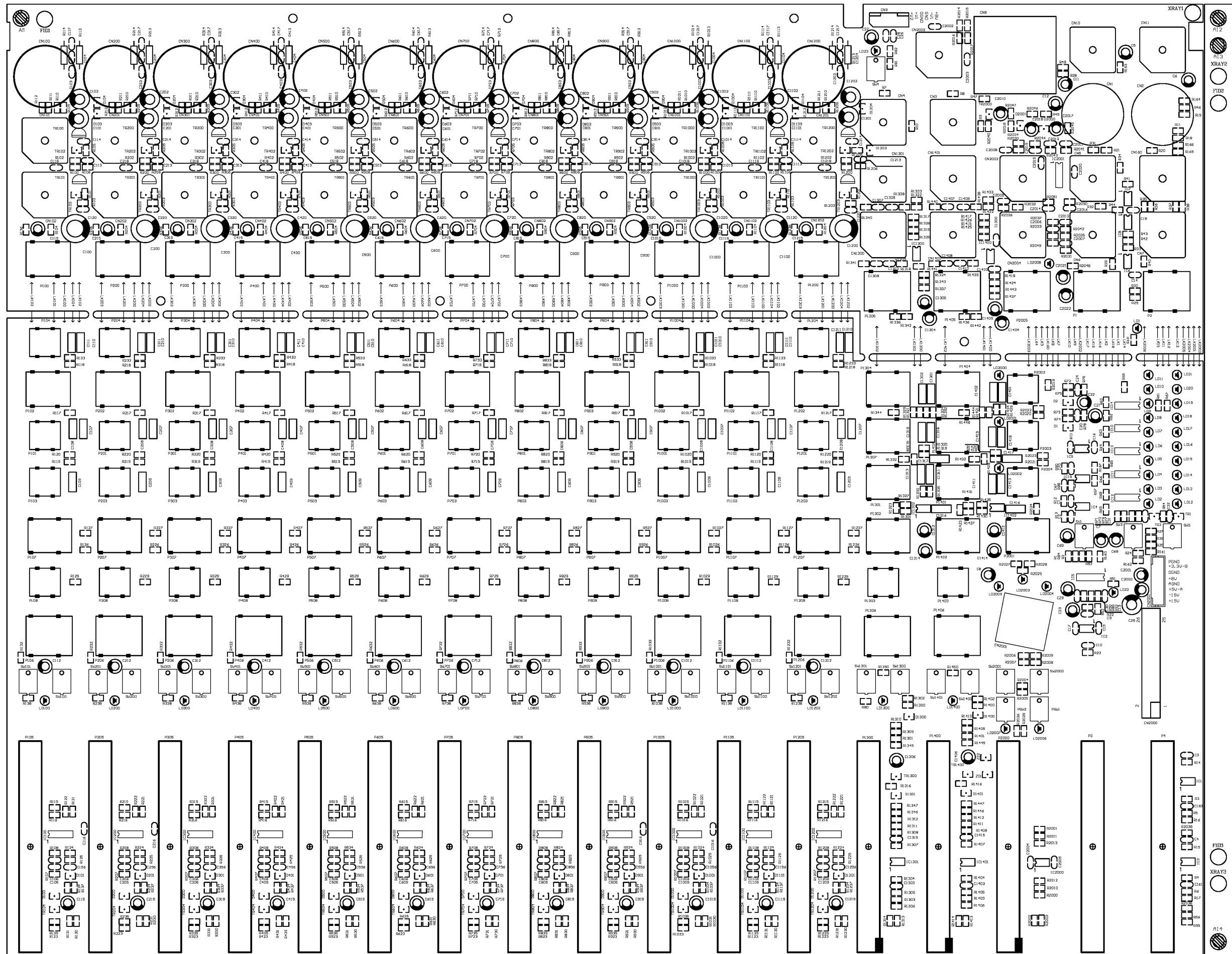

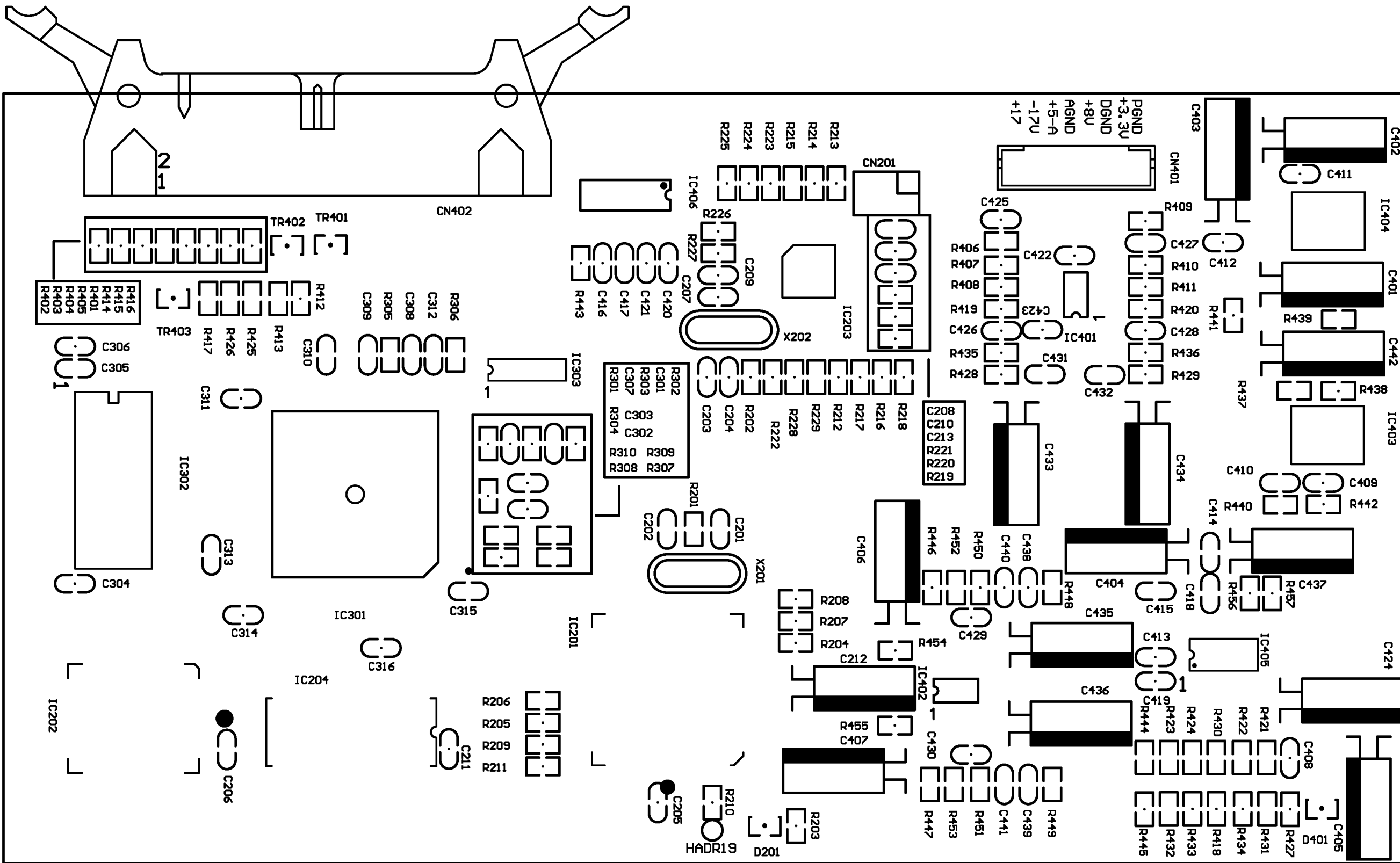

EFX Spare Parts

CONTENTS

CONSOLES	3
EFX8 CONSOLE	RW5758..... 3
EFX12 CONSOLE	RW5759..... 4
MAIN ASSEMBLIES	5
EFX8 FRONT PANEL	P0946-01..... 5
EFX8 BASE PANEL	P0947-01..... 5
EFX8 SHIELD BOX	P0948-01..... 5
EFX8 GOSS SHIELD PLATE	P0949-01..... 5
EFX12 FRONT PANEL	P0950-01..... 5
EFX12 BASE PANEL	P0951-01..... 5
EFX12 SHIELD BOX	P0952-01..... 5
EFX12 GOSS SHIELD PLATE	P0953-01..... 5
MFx8/EFX8/EFX12 PSU ASSEMBLY	R0307B-05-AF 5
EFX8 MAIN BOARD ASSY	R0527A-01-AF 6
EFX12 MAIN BOARD ASSY	R0528A-01-AF 24
EFX/MFX LEXICON FX BOARD (Safety Critical Part)!	R0529A-01-AF 47
FUSE T1.6A 250V 5X20MM	ZD80016 50
EFX USER GUIDE	ZM0356-01 50
WIREFORMS USED IN THE FRAMES 50
SWITCH TOPS, FADER TOPS AND KNOBS	51
FADERS	52
MODULES	53
FX16II ANALOG FX HOST	RX3062..... 53
FX16II ANALOG FX FLASH	RX3063..... 53
MISCELLANEOUS HARDWARE	54

CONSOLES

EFX8 CONSOLE

RW5758

Description	Part Number
11MM FDR KNOB DK BL W/WHT LINE	KA0406
11MM FDR KNOB YL W/BLK LINE	KA0407
11MM FDR KNOB WHT W/BLK LINE	KA0408
KNOB 10MM DK\GRY BODY RED TOP	KA0451
KNOB 10MM LT\GRY BODY BLK TOP	KA0452
KNOB 10MM DK\GRY BODY WHT TOP	KA0453
KNOB 10MM DK\GRY BODY GRN TOP	KA0454
KNOB 10MM DK\GRY BODY PUR TOP	KA0456
KNOB 10MM DK\GRY BODY YEL TOP	KA0457
KNOB 11MM FDR PURPLE W\BLK LIN	KA0458
SERIES TWO SWITCH CAP GREY	KB2260
PSU SWITCH CAP 7.5DIA BLACK	KB2262
LX7II SWITCH CAP RED	KB2379
SWITCH CAP 6X6MM LONG RED FITS	KB2385
SCRW M3X6MM P/POZI S/COLOUR DI	NA0155
SCRW NO4X3/8" P/POZI S/TAP BLK	NA0249
SCRW M3X6MM P/POZI TAP/T ZP DI	NA0437
SCRW M3X8MM P/POZI BLK ISO7045	NA0452
SCRW M3X10MM HEX/HD SKT S/LOCK	NA0478
SCRW M4X6MM P/POZI BLK	NA10045
SCRW M3X8MM NYLON	NA10117
NUT M3 NYLOC ZP	NB0113
NUT M4 NYLOC ZP	NB0160
NUT M9 POT ROUNDED CORNERS	NB0169
WSHR FIBRE 5.54MMX3.05MMX0.8MM	NC0301
WSHR M3 EXT S/PROOF ST/STL DIN	NC10031
WSHR PVC 13MMODX9.5MMID	NC10040
SPCR M3X30MM HEX BRASS NP	ND0464
EFX8 FRONT PANEL	P0946-01
EFX8 BASE PANEL	P0947-01
EFX8 SHIELD BOX	P0948-01
EFX8 GOSS SHIELD PLATE	P0949-01
2MM 6WY CRIMP/CRIMP WFM-210MM	RV4353-210
2MM 8WY CRIMP/CRIMP WFM-100MM	RV4354-100
MFx8/EFx8/EFx12 PSU ASSEMBLY	R0307B-05-AF
EFX8 MAIN BOARD ASSY	R0527A-01-AF
EFX/MFX LEXICON FX BOARD	R0529A-01-AF
PLASTIC BAG 1U 18 X 24IN XT01-	TZ10000
SILICA GELL PACK 60 GRAM	TZ10022
POLYBAG 6.5"X 11" W/H P/WARNIN	TZ10023
POLYBAG 10"X 15" W/H P/WARNING	TZ10024
EARTH LABEL SELF-ADH 12.5X12.5	ZA0793
LABEL WHITE 44X8MM	ZA0816
LABEL 8MM DIA -GREEN RECYCLE	ZA10089
LABEL ROHS COMPLIANT 30X45MM	ZA10093
LABEL ROHS COMPLIANT 15X22.5MM	ZA10094
EFX8 SERIAL NO LABEL-UNIT	ZA10126
EFX8 SERIAL NO LABEL-INNER	ZA10127
EFX8 SERIAL NO LABEL-OUTER	ZA10128
!EFX PSU INSULATING SHT	ZC8000
!EFX8 PSU INSULATING SHT FR700	ZC8001
!EFX8 PSU INSULATING SHT FR700	ZC8002
!FUSE T1.6A 250V 5X20MM	ZD80016
EFX USER GUIDE	ZM0356-01

EFX12 CONSOLE**RW5759**

Description	Part Number
11MM FDR KNOB DK BL W/WHT LINE	KA0406
11MM FDR KNOB YL W/BLK LINE	KA0407
11MM FDR KNOB WHT W/BLK LINE	KA0408
KNOB 10MM DK\GRY BODY RED TOP	KA0451
KNOB 10MM LT\GRY BODY BLK TOP	KA0452
KNOB 10MM DK\GRY BODY WHT TOP	KA0453
KNOB 10MM DK\GRY BODY GRN TOP	KA0454
KNOB 10MM DK\GRY BODY PUR TOP	KA0456
KNOB 10MM DK\GRY BODY YEL TOP	KA0457
KNOB 11MM FDR PURPLE W\BLK LIN	KA0458
SERIES TWO SWITCH CAP GREY	KB2260
PSU SWITCH CAP 7.5DIA BLACK	KB2262
LX7II SWITCH CAP RED	KB2379
SWITCH CAP 6X6MM LONG RED FITS	KB2385
SCRW M3X6MM P/POZI S/COLOUR DI	NA0155
SCRW NO4X3/8" P/POZI S/TAP BLK	NA0249
SCRW M3X6MM P/POZI TAP/T ZP DI	NA0437
SCRW M3X8MM P/POZI BLK ISO7045	NA0452
SCRW M3X10MM HEX/HD SKT S/LOCK	NA0478
SCRW M4X6MM P/POZI BLK	NA10045
SCRW M3X8MM NYLON	NA10117
NUT M3 NYLOC ZP	NB0113
NUT M4 NYLOC ZP	NB0160
NUT M9 POT ROUNDED CORNERS	NB0169
WSHR FIBRE 5.54MMX3.05MMX0.8MM	NC0301
WSHR M3 EXT S/PROOF ST/STL DIN	NC10031
WSHR PVC 13MMODX9.5MMID	NC10040
SPCR M3X30MM HEX BRASS NP	ND0464
EFX12 FRONT PANEL	P0950-01
EFX12 BASE PANEL	P0951-01
EFX12 SHIELD BOX	P0952-01
EFX12 GOSS SHIELD PLATE	P0953-01
2MM 6WY CRIMP/CRIMP WFM-210MM	RV4353-210
2MM 8WY CRIMP/CRIMP WFM-100MM	RV4354-100
MFx8/EFx8/EFx12 PSU ASSEMBLY	R0307B-05-AF
EFX12 MAIN BOARD ASSY	R0528A-01-AF
EFX/MFX LEXICON FX BOARD	R0529A-01-AF
SILICA GELL PACK 60 GRAM	TZ10022
POLYBAG 6.5"X 11" W/H P/WARNIN	TZ10023
POLYBAG 10"X 15" W/H P/WARNING	TZ10024
POLY BAG 200G - 24X30	TZ2440
EARTH LABEL SELF-ADH 12.5X12.5	ZA0793
LABEL WHITE 44X8MM	ZA0816
LABEL 8MM DIA -GREEN RECYCLE	ZA10089
LABEL ROHS COMPLIANT 30X45MM	ZA10093
LABEL ROHS COMPLIANT 15X22.5MM	ZA10094
EFX12 SERIAL NO LABEL-UNIT	ZA10129
EFX12 SERIAL NO LABEL-INNER	ZA10130
EFX12 SERIAL NO LABEL-OUTER	ZA10131
!EFX PSU INSULATING SHT	ZC8000
!EFX12 PSU INSULATING SHT FR70	ZC8003
!EFX12 PSU INSULATING SHT FR70	ZC8004
!FUSE T1.6A 250V 5X20MM	ZD80016
EFX USER GUIDE	ZM0356-01

MAIN ASSEMBLIES

EFX8 FRONT PANEL	P0946-01
EFX8 BASE PANEL	P0947-01
EFX8 SHIELD BOX	P0948-01
EFX8 GOSS SHIELD PLATE	P0949-01
EFX12 FRONT PANEL	P0950-01
EFX12 BASE PANEL	P0951-01
EFX12 SHIELD BOX	P0952-01
EFX12 GOSS SHIELD PLATE	P0953-01
MFX8/EFX8/EFX12 PSU ASSEMBLY	R0307B-05-AF

Ident	Description	Part Number
---	HEATSINK 7121D 25MM TO220 MPM	PN1289
---	PCB MPM PSU BOARD	S0307-05
BR1	BDG RECT W04G 1.5A 400V	BC0217
C1	CAP ELC RD 47UF 63V 0.2"	CE0402
C2	CAP CER 0.1µF 50V 5MM	CA0026
C3	CAP CER 1000PF 100V 5%	CA0015
C4	CAP ELEC VERT 10UF 63V SKP 5X1	CE0462
C5	CAP CER 1000PF 100V 5%	CA0015
C6	CAP ELEC VERT 10UF 63V SKP 5X1	CE0462
C7	CAP CER 10NF 1KV 5MM	CA0054
C8	CAP ELC RD 47UF 63V 0.2"	CE0402
C9	CAP CER 0.1µF 50V 5MM	CA0026
C10	CAP CER 0.1µF 50V 5MM	CA0026
C11	CAP ELEC VERT 10UF 63V SKP 5X1	CE0462
C14	CAP ELEC 220UF 63V 105C XC06-	CE10033
C15	CAP CER 220PF 1KV DISC CA-CP	CA10018
C16	(Safety Critical Part)!	
	CAP MPF 0.1UF 275V 20% CLASS	CC0323
C17	CAP ELEC VERT 2200UF 25V SKR 2	CE0460
C18	CAP ELEC VERT 100UF 400V 10MM	CE0488
C19	CAP ELC RD 1000UF 25V ESR12.5X	CE0512
C20	CAP CER 220PF 1KV DISC CA-CP	CA10018
C21	CAP ELEC VERT 2200UF 25V SKR 2	CE0460
C22	CAP ELC RD 1000UF 25V ESR12.5X	CE0512
C23	CAP ELC RD 1000UF 25V ESR12.5X	CE0512
C25	CAP ELEC VERT 10UF 63V SKP 5X1	CE0462
CN1	(Safety Critical Part)!	
	IEC INLET FILTERED 10A R/A PC	FJ10005
CN3	6WY 2MM L/PRF VERT LCKG ML HDR	FF1019
D1	DSL 1N4148TR DO-35	BA0001
D2	DIODE FAST TYPE EGP10G 400V 1A	BA10014
D3	DRC AX MUR4100E 4A 1KV	BA10015
D4	DFR MUR460 4A 600V AX	BA0038
D5	DIODE FAST TYPE EGP10G 400V 1A	BA10014
D6	DVS P6KE200A	BB0141
D7	DFR MUR460 4A 600V AX	BA0038
D8	DFR MUR460 4A 600V AX	BA0038

F1	(Safety Critical Part)!	
	FUSE HOLDER 6.3A PCB MTG	ZD8023
FET1	TRS MOSFET PWR 600V 13A N-CH	BD10051
IC1	IC PWR SUPPLY 30V 1A DIP8	BE0525
L1	INDCT 10æH TOKO A823LY-100K	HC0028
L2	INDCT 10æH TOKO A823LY-100K	HC0028
L3	INDCT 10æH TOKO A823LY-100K	HC0028
L4	INDCT 10æH TOKO A823LY-100K	HC0028
L5	(Safety Critical Part)!	
	CHOKE COMMON MODE 27æH 0.5A	HC0068
L6	INDCT 100æH 2A 20%	HC0069
R1	RES MF 1K0 1% 0.25W	AP1349
R2	RES MF 4R7 1% 0.25W	AP1293
R3	RES MF 680R 5% 1W PRO1	AE10033
R4	RES MF 680R 5% 1W PRO1	AE10033
R5	RES MF 1K5 1% 0.25W	AP1353
R6	RES MF 1R0 5% 1W PRO1	AE0010
R7	RES MF 1R0 5% 1W PRO1	AE0010
R8	RES MF 10K 1% 0.25W	AP1373
R9	RES MF 1R0 5% 1W PRO1	AE0010
R10	RES MF 10K 1% 0.25W	AP1373
R11	RES MF 9K1 1% 0.25W	AP1372
R12	RES MF 33K 1% 0.25W	AP1385
R13	RES MF 100K 5% 2W PRO2	AE10037
R14	RES MF 10R 5% 1W PRO1	AE0100
R15	RES MF 10R 5% 2W PRO2	AE10015
R16	RES MF 4R7 5% 1W PRO1	AE0047
R17	RES MF 1R0 5% 1W PRO1	AE0010
R19	RES 0R0 METAL SLUG	AZ2222
R20	RES 0R0 METAL SLUG	AZ2222
R21	RES 0R0 METAL SLUG	AZ2222
R24	(Safety Critical Part)!	
	RES MF 1M 5% 0.5W VR37	AD8106
R25	RES 0R0 METAL SLUG	AZ2222
R100	RES MF 100K 1% 0.25W	AP1397
SW1	(Safety Critical Part)!	
	PANASONIC DPST HOR MAINS SWT	DJ8002
TX1	TRANSFORMER MPM UNIT	P0454-02
TH1,TH2	(Safety Critical Part)!	
	THERMISTER 3A INRUSH LIMITER	AZ2279
TR1	TRS BC546BT NPN TPD	BD0394R
TR2	TIP31A TRANS NPN T0220	BD0372
pcb ass	(Safety Critical Part)!	
	W/FORM M4 EARTH	RL8010-130

EFX8 MAIN BOARD ASSY

R0527A-01-AF

Ident	Description	Part Number
---	EFX8 MAIN BOARD	S0527-01
C1	CAP SM CER 22PF 5% 50V NPO 080	CS1220R-0805J
C2	CAP SM CER 22PF 5% 50V NPO 080	CS1220R-0805J
C3	CAP SM CER 22PF 5% 50V NPO 080	CS1220R-0805J
C4	CAP SM CER 22PF 5% 50V NPO 080	CS1220R-0805J
C5	CAP ELC RD 10UF 100V 6.3X11MM	CE0463
C6	CAP ELC RD 10UF 100V 6.3X11MM	CE0463
C7	CAP ELC RD 33UF 16V	CE0457
C8	CAP ELC RD 33UF 16V	CE0457
C9	CAP SM CER 22PF 5% 50V NPO 080	CS1220R-0805J
C10	CAP SM CER 22PF 5% 50V NPO 080	CS1220R-0805J
C11	CAP ELC RD 10UF 100V 6.3X11MM	CE0463
C12	CAP ELC RD 10UF 100V 6.3X11MM	CE0463
C13	CAP SM CER 100NF 10% 50V X5R 0	CS7104R-0805K

C14	CAP SM CER 100NF 10% 50V X5R 0	CS7104R-0805K
C15	CAP SM CER 100NF 10% 50V X5R 0	CS7104R-0805K
C16	CAP SM CER 100NF 10% 50V X5R 0	CS7104R-0805K
C17	CAP SM CER 100NF 10% 50V X5R 0	CS7104R-0805K
C18	CAP SM CER 100NF 10% 50V X5R 0	CS7104R-0805K
C19	CAP SM CER 100NF 10% 50V X5R 0	CS7104R-0805K
C20	CAP SM CER 220NF 10% 25V X7R 0	CS7224R-0805K
C21	CAP ELC RD 2.2UF 50V TPD 0.2"	CE0416
C22	CAP ELC RD 2.2UF 50V TPD 0.2"	CE0416
C23	CAP ELC RD 33UF 16V	CE0457
C24	CAP SM CER 220NF 10% 25V X7R 0	CS7224R-0805K
C25	CAP ELC RD 47UF 63V 0.2"	CE0402
C26	CAP SM CER 100NF 10% 50V X5R 0	CS7104R-0805K
C27	CAP ELEC VERT 10UF 63V SKP 5X1	CE0462
C28	CAP SM CER 100NF 10% 50V X5R 0	CS7104R-0805K
C29	CAP ELC RD 33UF 16V	CE0457
C30	CAP SM CER 100NF 10% 50V X5R 0	CS7104R-0805K
C31	CAP SM CER 10NF 10% 50V X7R 08	CS7103R-0805K
C32	CAP SM CER 10NF 10% 50V X7R 08	CS7103R-0805K
C67	CAP SM CER 100PF 5% 50V NPO 08	CS1101R-0805J
C68	CAP ELC RD 33UF 16V	CE0457
C69	CAP ELC RD 33UF 16V	CE0457
C160	CAP SM CER 22PF 5% 50V NPO 080	CS1220R-0805J
C161	CAP SM CER 22PF 5% 50V NPO 080	CS1220R-0805J
C500	CAP ELC RD 3300UF 6.3V	CE0549
C501	CAP ELC RD 47UF 63V 0.2"	CE0402
C502	CAP ELC RD 47UF 63V 0.2"	CE0402
C503	CAP SM CER 1.8NF 10% 100V X7R	CS7182R-0805K
C504	CAP SM CER 1.8NF 10% 100V X7R	CS7182R-0805K
C505	CAP SM CER 22PF 5% 50V NPO 080	CS1220R-0805J
C506	CAP SM CER 22PF 5% 50V NPO 080	CS1220R-0805J
C507	CAP MICRO-BOX 3.3NF 63V 5% 5MM	CC0241
C508	CAP MICRO-BOX 10NF 63V 5% 5MM	CC0244
C509	CAP MICRO-BOX 68NF 63V 5% 5MM	CC0249
C510	CAP MICRO-BOX 2.2NF 63V 5%	CC0240
C511	CAP MICRO-BOX 2.2NF 63V 5%	CC0240
C512	CAP ELC RD 33UF 16V	CE0457
C515	CAP ELC RD 10UF 100V 6.3X11MM	CE0463
C519	CAP ELC RD 4.7UF 50V	CE0440
C520	CAP SM CER 100NF 10% 50V X5R 0	CS7104R-0805K
C596	CAP SM CER 100PF 5% 50V NPO 08	CS1101R-0805J
C600	CAP ELC RD 3300UF 6.3V	CE0549
C601	CAP ELC RD 47UF 63V 0.2"	CE0402
C602	CAP ELC RD 47UF 63V 0.2"	CE0402
C603	CAP SM CER 1.8NF 10% 100V X7R	CS7182R-0805K
C604	CAP SM CER 1.8NF 10% 100V X7R	CS7182R-0805K
C605	CAP SM CER 22PF 5% 50V NPO 080	CS1220R-0805J
C606	CAP SM CER 22PF 5% 50V NPO 080	CS1220R-0805J
C607	CAP MICRO-BOX 3.3NF 63V 5% 5MM	CC0241
C608	CAP MICRO-BOX 10NF 63V 5% 5MM	CC0244
C609	CAP MICRO-BOX 68NF 63V 5% 5MM	CC0249
C610	CAP MICRO-BOX 2.2NF 63V 5%	CC0240
C611	CAP MICRO-BOX 2.2NF 63V 5%	CC0240
C612	CAP ELC RD 33UF 16V	CE0457
C615	CAP ELC RD 10UF 100V 6.3X11MM	CE0463
C619	CAP ELC RD 4.7UF 50V	CE0440
C620	CAP SM CER 100NF 10% 50V X5R 0	CS7104R-0805K
C696	CAP SM CER 100PF 5% 50V NPO 08	CS1101R-0805J
C700	CAP ELC RD 3300UF 6.3V	CE0549
C701	CAP ELC RD 47UF 63V 0.2"	CE0402
C702	CAP ELC RD 47UF 63V 0.2"	CE0402

C703	CAP SM CER 1.8NF 10% 100V X7R	CS7182R-0805K
C704	CAP SM CER 1.8NF 10% 100V X7R	CS7182R-0805K
C705	CAP SM CER 22PF 5% 50V NPO 080	CS1220R-0805J
C706	CAP SM CER 22PF 5% 50V NPO 080	CS1220R-0805J
C707	CAP MICRO-BOX 3.3NF 63V 5% 5MM	CC0241
C708	CAP MICRO-BOX 10NF 63V 5% 5MM	CC0244
C709	CAP MICRO-BOX 68NF 63V 5% 5MM	CC0249
C710	CAP MICRO-BOX 2.2NF 63V 5%	CC0240
C711	CAP MICRO-BOX 2.2NF 63V 5%	CC0240
C712	CAP ELC RD 33UF 16V	CE0457
C715	CAP ELC RD 10UF 100V 6.3X11MM	CE0463
C719	CAP ELC RD 4.7UF 50V	CE0440
C720	CAP SM CER 100NF 10% 50V X5R 0	CS7104R-0805K
C796	CAP SM CER 100PF 5% 50V NPO 08	CS1101R-0805J
C800	CAP ELC RD 3300UF 6.3V	CE0549
C801	CAP ELC RD 47UF 63V 0.2"	CE0402
C802	CAP ELC RD 47UF 63V 0.2"	CE0402
C803	CAP SM CER 1.8NF 10% 100V X7R	CS7182R-0805K
C804	CAP SM CER 1.8NF 10% 100V X7R	CS7182R-0805K
C805	CAP SM CER 22PF 5% 50V NPO 080	CS1220R-0805J
C806	CAP SM CER 22PF 5% 50V NPO 080	CS1220R-0805J
C807	CAP MICRO-BOX 3.3NF 63V 5% 5MM	CC0241
C808	CAP MICRO-BOX 10NF 63V 5% 5MM	CC0244
C809	CAP MICRO-BOX 68NF 63V 5% 5MM	CC0249
C810	CAP MICRO-BOX 2.2NF 63V 5%	CC0240
C811	CAP MICRO-BOX 2.2NF 63V 5%	CC0240
C812	CAP ELC RD 33UF 16V	CE0457
C815	CAP ELC RD 10UF 100V 6.3X11MM	CE0463
C819	CAP ELC RD 4.7UF 50V	CE0440
C820	CAP SM CER 100NF 10% 50V X5R 0	CS7104R-0805K
C896	CAP SM CER 100PF 5% 50V NPO 08	CS1101R-0805J
C900	CAP ELC RD 3300UF 6.3V	CE0549
C901	CAP ELC RD 47UF 63V 0.2"	CE0402
C902	CAP ELC RD 47UF 63V 0.2"	CE0402
C903	CAP SM CER 1.8NF 10% 100V X7R	CS7182R-0805K
C904	CAP SM CER 1.8NF 10% 100V X7R	CS7182R-0805K
C905	CAP SM CER 22PF 5% 50V NPO 080	CS1220R-0805J
C906	CAP SM CER 22PF 5% 50V NPO 080	CS1220R-0805J
C907	CAP MICRO-BOX 3.3NF 63V 5% 5MM	CC0241
C908	CAP MICRO-BOX 10NF 63V 5% 5MM	CC0244
C909	CAP MICRO-BOX 68NF 63V 5% 5MM	CC0249
C910	CAP MICRO-BOX 2.2NF 63V 5%	CC0240
C911	CAP MICRO-BOX 2.2NF 63V 5%	CC0240
C912	CAP ELC RD 33UF 16V	CE0457
C915	CAP ELC RD 10UF 100V 6.3X11MM	CE0463
C916	CAP SM CER 100NF 10% 50V X5R 0	CS7104R-0805K
C919	CAP ELC RD 4.7UF 50V	CE0440
C920	CAP SM CER 100NF 10% 50V X5R 0	CS7104R-0805K
C996	CAP SM CER 100PF 5% 50V NPO 08	CS1101R-0805J
C1000	CAP ELC RD 3300UF 6.3V	CE0549
C1001	CAP ELC RD 47UF 63V 0.2"	CE0402
C1002	CAP ELC RD 47UF 63V 0.2"	CE0402
C1003	CAP SM CER 1.8NF 10% 100V X7R	CS7182R-0805K
C1004	CAP SM CER 1.8NF 10% 100V X7R	CS7182R-0805K
C1005	CAP SM CER 22PF 5% 50V NPO 080	CS1220R-0805J
C1006	CAP SM CER 22PF 5% 50V NPO 080	CS1220R-0805J
C1007	CAP MICRO-BOX 3.3NF 63V 5% 5MM	CC0241
C1008	CAP MICRO-BOX 10NF 63V 5% 5MM	CC0244
C1009	CAP MICRO-BOX 68NF 63V 5% 5MM	CC0249
C1010	CAP MICRO-BOX 2.2NF 63V 5%	CC0240
C1011	CAP MICRO-BOX 2.2NF 63V 5%	CC0240

C1012	CAP ELC RD 33UF 16V	CE0457
C1015	CAP ELC RD 10UF 100V 6.3X11MM	CE0463
C1016	CAP SM CER 100NF 10% 50V X5R 0	CS7104R-0805K
C1019	CAP ELC RD 4.7UF 50V	CE0440
C1020	CAP SM CER 100NF 10% 50V X5R 0	CS7104R-0805K
C1096	CAP SM CER 100PF 5% 50V NPO 08	CS1101R-0805J
C1100	CAP ELC RD 3300UF 6.3V	CE0549
C1101	CAP ELC RD 47UF 63V 0.2"	CE0402
C1102	CAP ELC RD 47UF 63V 0.2"	CE0402
C1103	CAP SM CER 1.8NF 10% 100V X7R	CS7182R-0805K
C1104	CAP SM CER 1.8NF 10% 100V X7R	CS7182R-0805K
C1105	CAP SM CER 22PF 5% 50V NPO 080	CS1220R-0805J
C1106	CAP SM CER 22PF 5% 50V NPO 080	CS1220R-0805J
C1107	CAP MICRO-BOX 3.3NF 63V 5% 5MM	CC0241
C1108	CAP MICRO-BOX 10NF 63V 5% 5MM	CC0244
C1109	CAP MICRO-BOX 68NF 63V 5% 5MM	CC0249
C1110	CAP MICRO-BOX 2.2NF 63V 5%	CC0240
C1111	CAP MICRO-BOX 2.2NF 63V 5%	CC0240
C1112	CAP ELC RD 33UF 16V	CE0457
C1115	CAP ELC RD 10UF 100V 6.3X11MM	CE0463
C1119	CAP ELC RD 4.7UF 50V	CE0440
C1120	CAP SM CER 100NF 10% 50V X5R 0	CS7104R-0805K
C1196	CAP SM CER 100PF 5% 50V NPO 08	CS1101R-0805J
C1200	CAP ELC RD 3300UF 6.3V	CE0549
C1201	CAP ELC RD 47UF 63V 0.2"	CE0402
C1202	CAP ELC RD 47UF 63V 0.2"	CE0402
C1203	CAP SM CER 1.8NF 10% 100V X7R	CS7182R-0805K
C1204	CAP SM CER 1.8NF 10% 100V X7R	CS7182R-0805K
C1205	CAP SM CER 22PF 5% 50V NPO 080	CS1220R-0805J
C1206	CAP SM CER 22PF 5% 50V NPO 080	CS1220R-0805J
C1207	CAP MICRO-BOX 3.3NF 63V 5% 5MM	CC0241
C1208	CAP MICRO-BOX 10NF 63V 5% 5MM	CC0244
C1209	CAP MICRO-BOX 68NF 63V 5% 5MM	CC0249
C1210	CAP MICRO-BOX 2.2NF 63V 5%	CC0240
C1211	CAP MICRO-BOX 2.2NF 63V 5%	CC0240
C1212	CAP ELC RD 33UF 16V	CE0457
C1215	CAP ELC RD 10UF 100V 6.3X11MM	CE0463
C1219	CAP ELC RD 4.7UF 50V	CE0440
C1220	CAP SM CER 100NF 10% 50V X5R 0	CS7104R-0805K
C1296	CAP SM CER 100PF 5% 50V NPO 08	CS1101R-0805J
C1300	CAP SM CER 100NF 10% 50V X5R 0	CS7104R-0805K
C1301	CAP MICRO-BOX 4.7NF 63V 5% 5MM	CC0242
C1302	CAP MICRO-BOX 4.7NF 63V 5% 5MM	CC0242
C1303	CAP SM CER 100PF 5% 50V NPO 08	CS1101R-0805J
C1304	CAP ELC RD 100UF 10V TPD 0.2"	CE0403
C1305	CAP ELC RD 100UF 10V TPD 0.2"	CE0403
C1306	CAP ELC RD 4.7UF 50V	CE0440
C1311	CAP MICRO-BOX 68NF 63V 5% 5MM	CC0249
C1312	CAP ELC RD 220UF 10V	CE0454
C1313	CAP MICRO-BOX 68NF 63V 5% 5MM	CC0249
C1314	CAP ELC RD 220UF 10V	CE0454
C1315	CAP SM CER 100PF 5% 50V NPO 08	CS1101R-0805J
C1316	CAP MICRO-BOX 15NF 63V 5% 5MM	CC0245
C1317	CAP MICRO-BOX 15NF 63V 5% 5MM	CC0245
C1318	CAP MICRO-BOX 15NF 63V 5% 5MM	CC0245
C1319	CAP MICRO-BOX 15NF 63V 5% 5MM	CC0245
C1400	CAP SM CER 100NF 10% 50V X5R 0	CS7104R-0805K
C1401	CAP MICRO-BOX 4.7NF 63V 5% 5MM	CC0242
C1402	CAP MICRO-BOX 4.7NF 63V 5% 5MM	CC0242
C1403	CAP SM CER 100PF 5% 50V NPO 08	CS1101R-0805J
C1404	CAP ELC RD 100UF 10V TPD 0.2"	CE0403

C1405	CAP ELC RD 100UF 10V TPD 0.2"	CE0403
C1406	CAP ELC RD 4.7UF 50V	CE0440
C1411	CAP MICRO-BOX 68NF 63V 5% 5MM	CC0249
C1412	CAP ELC RD 220UF 10V	CE0454
C1413	CAP MICRO-BOX 68NF 63V 5% 5MM	CC0249
C1414	CAP ELC RD 220UF 10V	CE0454
C1415	CAP SM CER 100PF 5% 50V NPO 08	CS1101R-0805J
C1416	CAP MICRO-BOX 15NF 63V 5% 5MM	CC0245
C1417	CAP MICRO-BOX 15NF 63V 5% 5MM	CC0245
C1418	CAP MICRO-BOX 15NF 63V 5% 5MM	CC0245
C1419	CAP MICRO-BOX 15NF 63V 5% 5MM	CC0245
C2000	CAP ELC RD 47UF 25V TPD 0.2"	CE0401
C2001	CAP ELC RD 47UF 25V TPD 0.2"	CE0401
C2002	CAP SM CER 220PF 5% 100V NPO 0	CS1221R-0805J
C2003	CAP SM CER 220PF 5% 100V NPO 0	CS1221R-0805J
C2004	CAP SM CER 100NF 10% 50V X5R 0	CS7104R-0805K
C2005	CAP SM CER 100NF 10% 50V X5R 0	CS7104R-0805K
C2010	CAP ELC RD 4.7UF 50V	CE0440
C2011	CAP SM CER 100PF 5% 50V NPO 08	CS1101R-0805J
C2012	CAP SM CER 100PF 5% 50V NPO 08	CS1101R-0805J
C2013	CAP SM CER 100PF 5% 50V NPO 08	CS1101R-0805J
C2014	CAP SM CER 100PF 5% 50V NPO 08	CS1101R-0805J
C2015	CAP SM CER 100PF 5% 50V NPO 08	CS1101R-0805J
C2016	CAP SM CER 100PF 5% 50V NPO 08	CS1101R-0805J
C2017	CAP ELC RD 33UF 16V	CE0457
C2018	CAP ELC RD 33UF 16V	CE0457
C2019	CAP SM CER 100NF 10% 50V X5R 0	CS7104R-0805K
C2020	CAP SM CER 100NF 10% 50V X5R 0	CS7104R-0805K
C2021	CAP ELC RD 33UF 16V	CE0457
C2022	CAP ELC RD 33UF 16V	CE0457
CN1	XLR A-SRS PLASTIC ML PIN1 GND	FK0970
CN2	XLR A-SRS PLASTIC ML PIN1 GND	FK0970
CN3	JACK SKT STEREO VERT 3PINMAT N	FH0807
CN4	JACK SKT STEREO VERT 3PINMAT N	FH0807
CN5	JACK SKT STEREO VERT 3PINMAT N	FH0807
CN6	JACK SKT STEREO VERT 3PINMAT N	FH0807
CN7	JACK SKT STEREO VERT 3PINMAT N	FH0807
CN8	CON QUAD PC PHONO SKT.GOLD PLT	FH0804
CN9	6WY 2MM L/PRF VERT LCKG ML HDR	FF1019
CN10	JACK SKT STEREO VERT 5PIN MATT	FH0808
CN11	JACK SKT STEREO VERT 5PIN MATT	FH0808
CN160	JACK SKT STEREO VERT 3PINMAT N	FH0807
CN500	XLR CON FML VERT	FK0967-01
CN501	JACK SKT STEREO VERT 3PINMAT N	FH0807
CN502	JACK SKT STEREO VERT 5PIN MATT	FH0808
CN600	XLR CON FML VERT	FK0967-01
CN601	JACK SKT STEREO VERT 3PINMAT N	FH0807
CN602	JACK SKT STEREO VERT 5PIN MATT	FH0808
CN700	XLR CON FML VERT	FK0967-01
CN701	JACK SKT STEREO VERT 3PINMAT N	FH0807
CN702	JACK SKT STEREO VERT 5PIN MATT	FH0808
CN800	XLR CON FML VERT	FK0967-01
CN801	JACK SKT STEREO VERT 3PINMAT N	FH0807
CN802	JACK SKT STEREO VERT 5PIN MATT	FH0808
CN900	XLR CON FML VERT	FK0967-01
CN901	JACK SKT STEREO VERT 3PINMAT N	FH0807
CN902	JACK SKT STEREO VERT 5PIN MATT	FH0808
CN1001	JACK SKT STEREO VERT 3PINMAT N	FH0807
CN1002	JACK SKT STEREO VERT 5PIN MATT	FH0808
CN1100	XLR CON FML VERT	FK0967-01
CN1101	JACK SKT STEREO VERT 3PINMAT N	FH0807

CN1102	JACK SKT STEREO VERT 5PIN MATT	FH0808
CN1200	XLR CON FML VERT	FK0967-01
CN1201	JACK SKT STEREO VERT 3PINMAT N	FH0807
CN1202	JACK SKT STEREO VERT 5PIN MATT	FH0808
CN1300	JACK SKT STEREO VERT 5PIN MATT	FH0808
CN1301	JACK SKT STEREO VERT 3PINMAT N	FH0807
CN1400	JACK SKT STEREO VERT 5PIN MATT	FH0808
CN1401	JACK SKT STEREO VERT 3PINMAT N	FH0807
CN1000	XLR CON FML VERT	FK0967-01
CN2001	8WY 2MM L/PRF VERT LCKG ML HDR	FF1020
CN2002	JACK SKT STEREO VERT 3PINMAT N	FH0807
CN2003	JACK SKT STEREO VERT 3PINMAT N	FH0807
CN2004	JACK SKT STEREO VERT 5PIN MATT	FH0808
D1	DHS BAV70 C/CTHD	BS0013R-SOT23
D2	DHS BAV70 C/CTHD	BS0013R-SOT23
D1000	DHS BAV70 C/CTHD	BS0013R-SOT23
D1001	DHS BAV70 C/CTHD	BS0013R-SOT23
D1003	DHS BAV70 C/CTHD	BS0013R-SOT23
D1004	DHS BAV70 C/CTHD	BS0013R-SOT23
D1100	DHS BAV70 C/CTHD	BS0013R-SOT23
D1101	DHS BAV70 C/CTHD	BS0013R-SOT23
D1103	DHS BAV70 C/CTHD	BS0013R-SOT23
D1104	DHS BAV70 C/CTHD	BS0013R-SOT23
D1200	DHS BAV70 C/CTHD	BS0013R-SOT23
D1201	DHS BAV70 C/CTHD	BS0013R-SOT23
D1203	DHS BAV70 C/CTHD	BS0013R-SOT23
D1204	DHS BAV70 C/CTHD	BS0013R-SOT23
D1300	DHS BAV70 C/CTHD	BS0013R-SOT23
D1301	DHS BAV70 C/CTHD	BS0013R-SOT23
D1400	DHS BAV70 C/CTHD	BS0013R-SOT23
D1401	DHS BAV70 C/CTHD	BS0013R-SOT23
D2000	DHS BAV70 C/CTHD	BS0013R-SOT23
D2001	DHS BAV70 C/CTHD	BS0013R-SOT23
D500	DHS BAV70 C/CTHD	BS0013R-SOT23
D501	DHS BAV70 C/CTHD	BS0013R-SOT23
D503	DHS BAV70 C/CTHD	BS0013R-SOT23
D504	DHS BAV70 C/CTHD	BS0013R-SOT23
D600	DHS BAV70 C/CTHD	BS0013R-SOT23
D601	DHS BAV70 C/CTHD	BS0013R-SOT23
D603	DHS BAV70 C/CTHD	BS0013R-SOT23
D604	DHS BAV70 C/CTHD	BS0013R-SOT23
D700	DHS BAV70 C/CTHD	BS0013R-SOT23
D701	DHS BAV70 C/CTHD	BS0013R-SOT23
D703	DHS BAV70 C/CTHD	BS0013R-SOT23
D704	DHS BAV70 C/CTHD	BS0013R-SOT23
D800	DHS BAV70 C/CTHD	BS0013R-SOT23
D801	DHS BAV70 C/CTHD	BS0013R-SOT23
D803	DHS BAV70 C/CTHD	BS0013R-SOT23
D804	DHS BAV70 C/CTHD	BS0013R-SOT23
D900	DHS BAV70 C/CTHD	BS0013R-SOT23
D901	DHS BAV70 C/CTHD	BS0013R-SOT23
D903	DHS BAV70 C/CTHD	BS0013R-SOT23
D904	DHS BAV70 C/CTHD	BS0013R-SOT23
EN2001	SWT RTRY ENCDR BIN 16P 16POS 3	DH10012
IC1	DUAL OP-AMP	BS7009R-SO8
IC3	DUAL OP-AMP	BS7009R-SO8
IC4	DUAL OP-AMP	BS7009R-SO8
IC5	IC 74HC4053 3X2CH DMPLX/MPLX A	BS10035
IC6	DUAL OP-AMP	BS7009R-SO8
IC7	DUAL OP-AMP	BS7009R-SO8
IC8	DUAL OP-AMP	BS7009R-SO8

IC10	IC QUAD COMPARATOR LM2901MX	BS7007R-SO14
IC11	IC QUAD COMPARATOR LM2901MX	BS7007R-SO14
IC12	IC QUAD COMPARATOR LM2901MX	BS7007R-SO14
IC13	IC QUAD COMPARATOR LM2901MX	BS7007R-SO14
IC14	IC QUAD COMPARATOR LM2901MX	BS7007R-SO14
IC1000	QUAD OP-AMP	BS7002
IC1100	QUAD OP-AMP	BS7002
IC1200	QUAD OP-AMP	BS7002
IC2001	QUAD OP-AMP	BS7002
IC500	QUAD OP-AMP	BS7002
IC600	QUAD OP-AMP	BS7002
IC700	QUAD OP-AMP	BS7002
IC800	QUAD OP-AMP	BS7002
IC900	QUAD OP-AMP	BS7002
LD1	LED RED 3MM S/B"17.5"-MD6748	JA0109
LD2	LED GREEN 3MM S/B"17.5"-MD6748	JA0110
LD3	LED GREEN 3MM S/B"17.5"-MD6748	JA0110
LD4	LED GREEN 3MM S/B"17.5"-MD6748	JA0110
LD5	LED GREEN 3MM S/B"17.5"-MD6748	JA0110
LD6	LED GREEN 3MM S/B"17.5"-MD6748	JA0110
LD7	LED AMBER 3MM S/B 17.5 MD6748	JA0129
LD8	LED AMBER 3MM S/B 17.5 MD6748	JA0129
LD9	LED AMBER 3MM S/B 17.5 MD6748	JA0129
LD10	LED RED 3MM S/B"17.5"-MD6748	JA0109
LD11	LED RED 3MM S/B"17.5"-MD6748	JA0109
LD12	LED GREEN 3MM S/B"17.5"-MD6748	JA0110
LD13	LED GREEN 3MM S/B"17.5"-MD6748	JA0110
LD14	LED GREEN 3MM S/B"17.5"-MD6748	JA0110
LD15	LED GREEN 3MM S/B"17.5"-MD6748	JA0110
LD16	LED GREEN 3MM S/B"17.5"-MD6748	JA0110
LD17	LED AMBER 3MM S/B 17.5 MD6748	JA0129
LD18	LED AMBER 3MM S/B 17.5 MD6748	JA0129
LD19	LED AMBER 3MM S/B 17.5 MD6748	JA0129
LD20	LED RED 3MM S/B"17.5"-MD6748	JA0109
LD21	LED RED 3MM S/B"17.5"-MD6748	JA0109
LD22	LED GREEN 3MM S/B"17.5"-MD6748	JA0110
LD23	LED RED 3MM S/B"17.5"-MD6748	JA0109
LD1000	LED RED 3MM S/B"17.5"-MD6748	JA0109
LD1100	LED RED 3MM S/B"17.5"-MD6748	JA0109
LD1200	LED RED 3MM S/B"17.5"-MD6748	JA0109
LD1300	LED RED 3MM S/B"17.5"-MD6748	JA0109
LD1400	LED RED 3MM S/B"17.5"-MD6748	JA0109
LD2000	LED RED 3MM S/B"17.5"-MD6748	JA0109
LD2001	LED RED 3MM S/B"17.5"-MD6748	JA0109
LD2002	LED RED 3MM S/B"17.5"-MD6748	JA0109
LD2003	LED RED 3MM S/B"17.5"-MD6748	JA0109
LD2004	LED GREEN 3MM S/B"17.5"-MD6748	JA0110
LD2005	LED GREEN 3MM S/B"17.5"-MD6748	JA0110
LD2006	LED AMBER 3MM S/B 17.5 MD6748	JA0129
LD2007	LED AMBER 3MM S/B 17.5 MD6748	JA0129
LD2008	LED RED 3MM S/B"17.5"-MD6748	JA0109
LD500	LED RED 3MM S/B"17.5"-MD6748	JA0109
LD600	LED RED 3MM S/B"17.5"-MD6748	JA0109
LD700	LED RED 3MM S/B"17.5"-MD6748	JA0109
LD800	LED RED 3MM S/B"17.5"-MD6748	JA0109
LD900	LED RED 3MM S/B"17.5"-MD6748	JA0109
LK22	RES SM 0R0 1% 0.1W 0805	AS0000R-0805F
P1	ALPS 14MM VERT 20KWX2 37.5MM	DM1381
P2	ALPS 14MM VERT 20KWX2 37.5MM	DM1381
P3	FDR PAN 75MM 10KA MONO	DD0408
P4	FDR PAN 75MM 10KA MONO	DD0408

P1000	ALPS 11MM 10K MIC LAW 37.5MM	DM1398
P1001	POT 20K 9MM V/MNT C/D TA	DM10029
P1002	ALPS 11MM VERT 200KCX2 HIGH/D	DM1323
P1003	POT 20K 9MM V/MNT C/D TA	DM10029
P1004	POT 20K 9MM V/MNT C/D TA	DM10029
P1005	FDR PAN 75MM 10KA MONO	DD0408
P1006	POT 10KAC C/D 14MM V/MNT TA	DM10034
P1007	POT 20KK DUAL 12MM TA	DM10035
P1008	POT 20KK 9MM V/MNT TA	DM10030
P1100	ALPS 11MM 10K MIC LAW 37.5MM	DM1398
P1101	POT 20K 9MM V/MNT C/D TA	DM10029
P1102	ALPS 11MM VERT 200KCX2 HIGH/D	DM1323
P1103	POT 20K 9MM V/MNT C/D TA	DM10029
P1104	POT 20K 9MM V/MNT C/D TA	DM10029
P1105	FDR PAN 75MM 10KA MONO	DD0408
P1106	POT 10KAC C/D 14MM V/MNT TA	DM10034
P1107	POT 20KK DUAL 12MM TA	DM10035
P1108	POT 20KK 9MM V/MNT TA	DM10030
P1200	ALPS 11MM 10K MIC LAW 37.5MM	DM1398
P1201	POT 20K 9MM V/MNT C/D TA	DM10029
P1202	ALPS 11MM VERT 200KCX2 HIGH/D	DM1323
P1203	POT 20K 9MM V/MNT C/D TA	DM10029
P1204	POT 20K 9MM V/MNT C/D TA	DM10029
P1205	FDR PAN 75MM 10KA MONO	DD0408
P1206	POT 10KAC C/D 14MM V/MNT TA	DM10034
P1207	POT 20KK DUAL 12MM TA	DM10035
P1208	POT 20KK 9MM V/MNT TA	DM10030
P1300	FDR PAN 75MM 10KX2 STER A	DD0409
P1301	POT 20KBX2 12MM V/MNT TA	DM10036
P1302	POT 20KK DUAL 12MM TA	DM10035
P1303	POT 20KK 9MM V/MNT TA	DM10030
P1304	POT 20KBX2 12MM V/MNT TA	DM10036
P1305	ALPS 14MM VERT 20KWX2 37.5MM	DM1381
P1306	POT 10KAC C/D 14MM V/MNT TA	DM10034
P1307	POT 20KBX2 12MM V/MNT TA	DM10036
P1400	FDR PAN 75MM 10KX2 STER A	DD0409
P1401	POT 20KBX2 12MM V/MNT TA	DM10036
P1402	POT 20KK DUAL 12MM TA	DM10035
P1403	POT 20KK 9MM V/MNT TA	DM10030
P1404	POT 20KBX2 12MM V/MNT TA	DM10036
P1405	ALPS 14MM VERT 20KWX2 37.5MM	DM1381
P1406	POT 10KAC C/D 14MM V/MNT TA	DM10034
P1407	POT 20KBX2 12MM V/MNT TA	DM10036
P2000	FDR PAN 75MM 10KX2 STER A	DD0409
P2001	POT 20KK DUAL 12MM TA	DM10035
P2002	POT 20KK 9MM V/MNT TA	DM10030
P2003	POT 20KK 9MM V/MNT TA	DM10030
P2004	POT 20KK 9MM V/MNT TA	DM10030
P2005	ALPS 14MM VERT 20KWX2 37.5MM	DM1381
P500	ALPS 11MM 10K MIC LAW 37.5MM	DM1398
P501	POT 20K 9MM V/MNT C/D TA	DM10029
P502	ALPS 11MM VERT 200KCX2 HIGH/D	DM1323
P503	POT 20K 9MM V/MNT C/D TA	DM10029
P504	POT 20K 9MM V/MNT C/D TA	DM10029
P505	FDR PAN 75MM 10KA MONO	DD0408
P506	POT 10KAC C/D 14MM V/MNT TA	DM10034
P507	POT 20KK DUAL 12MM TA	DM10035
P508	POT 20KK 9MM V/MNT TA	DM10030
P600	ALPS 11MM 10K MIC LAW 37.5MM	DM1398
P601	POT 20K 9MM V/MNT C/D TA	DM10029
P602	ALPS 11MM VERT 200KCX2 HIGH/D	DM1323

P603	POT 20K 9MM V/MNT C/D TA	DM10029
P604	POT 20K 9MM V/MNT C/D TA	DM10029
P605	FDR PAN 75MM 10KA MONO	DD0408
P606	POT 10KAC C/D 14MM V/MNT TA	DM10034
P607	POT 20KK DUAL 12MM TA	DM10035
P608	POT 20KK 9MM V/MNT TA	DM10030
P700	ALPS 11MM 10K MIC LAW 37.5MM	DM1398
P701	POT 20K 9MM V/MNT C/D TA	DM10029
P702	ALPS 11MM VERT 200KCX2 HIGH/D	DM1323
P703	POT 20K 9MM V/MNT C/D TA	DM10029
P704	POT 20K 9MM V/MNT C/D TA	DM10029
P705	FDR PAN 75MM 10KA MONO	DD0408
P706	POT 10KAC C/D 14MM V/MNT TA	DM10034
P707	POT 20KK DUAL 12MM TA	DM10035
P708	POT 20KK 9MM V/MNT TA	DM10030
P800	ALPS 11MM 10K MIC LAW 37.5MM	DM1398
P801	POT 20K 9MM V/MNT C/D TA	DM10029
P802	ALPS 11MM VERT 200KCX2 HIGH/D	DM1323
P803	POT 20K 9MM V/MNT C/D TA	DM10029
P804	POT 20K 9MM V/MNT C/D TA	DM10029
P805	FDR PAN 75MM 10KA MONO	DD0408
P806	POT 10KAC C/D 14MM V/MNT TA	DM10034
P807	POT 20KK DUAL 12MM TA	DM10035
P808	POT 20KK 9MM V/MNT TA	DM10030
P900	ALPS 11MM 10K MIC LAW 37.5MM	DM1398
P901	POT 20K 9MM V/MNT C/D TA	DM10029
P902	ALPS 11MM VERT 200KCX2 HIGH/D	DM1323
P903	POT 20K 9MM V/MNT C/D TA	DM10029
P904	POT 20K 9MM V/MNT C/D TA	DM10029
P905	FDR PAN 75MM 10KA MONO	DD0408
P906	POT 10KAC C/D 14MM V/MNT TA	DM10034
P907	POT 20KK DUAL 12MM TA	DM10035
P908	POT 20KK 9MM V/MNT TA	DM10030
PSW1	ALPS SWT L/TRAVEL VERT MOM	DF0662
PSW2	ALPS SWT L/TRAVEL VERT MOM	DF0662
R1	RES SM 20K 1% 0.1W 0805	AS0203R-0805F
R2	RES SM 20K 1% 0.1W 0805	AS0203R-0805F
R3	RES SM 22K 1% 0.1W 0805	AS0223R-0805F
R4	RES SM 22K 1% 0.1W 0805	AS0223R-0805F
R5	RES SM 10K 1% 0.1W 0805	AS0103R-0805F
R6	RES SM 10K 1% 0.1W 0805	AS0103R-0805F
R7	RES SM 75R 1% 0.1W 0805	AS0750R-0805F
R8	RES SM 75R 1% 0.1W 0805	AS0750R-0805F
R9	RES SM 75R 1% 0.1W 0805	AS0750R-0805F
R10	RES SM 75R 1% 0.1W 0805	AS0750R-0805F
R11	RES SM 1K2 1% 0.1W 0805	AS0122R-0805F
R12	RES SM 20K 1% 0.1W 0805	AS0203R-0805F
R13	RES SM 20K 1% 0.1W 0805	AS0203R-0805F
R14	RES SM 10K 1% 0.1W 0805	AS0103R-0805F
R15	RES SM 10K 1% 0.1W 0805	AS0103R-0805F
R16	RES SM 20K 1% 0.1W 0805	AS0203R-0805F
R17	RES SM 20K 1% 0.1W 0805	AS0203R-0805F
R18	RES SM 75R 1% 0.1W 0805	AS0750R-0805F
R19	RES SM 75R 1% 0.1W 0805	AS0750R-0805F
R20	RES SM 75R 1% 0.1W 0805	AS0750R-0805F
R21	RES SM 75R 1% 0.1W 0805	AS0750R-0805F
R22	RES SM 20K 1% 0.1W 0805	AS0203R-0805F
R23	RES SM 20K 1% 0.1W 0805	AS0203R-0805F
R24	RES SM 20K 1% 0.1W 0805	AS0203R-0805F
R25	RES SM 20K 1% 0.1W 0805	AS0203R-0805F
R26	RES SM 10K 1% 0.1W 0805	AS0103R-0805F

R27	RES SM 10K 1% 0.1W 0805	AS0103R-0805F
R28	RES SM 47K 1% 0.1W 0805	AS0473R-0805F
R29	RES SM 8K2 1% 0.1W 0805	AS0822R-0805F
R30	RES SM 8K2 1% 0.1W 0805	AS0822R-0805F
R31	RES SM 75R 1% 0.1W 0805	AS0750R-0805F
R32	RES SM 75R 1% 0.1W 0805	AS0750R-0805F
R33	RES SM 75R 1% 0.1W 0805	AS0750R-0805F
R34	RES SM 75R 1% 0.1W 0805	AS0750R-0805F
R35	RES SM 75R 1% 0.1W 0805	AS0750R-0805F
R36	RES SM 75R 1% 0.1W 0805	AS0750R-0805F
R37	RES SM 75R 1% 0.1W 0805	AS0750R-0805F
R38	RES SM 75R 1% 0.1W 0805	AS0750R-0805F
R39	RES SM 20K 1% 0.1W 0805	AS0203R-0805F
R40	RES SM 20K 1% 0.1W 0805	AS0203R-0805F
R41	RES SM 20K 1% 0.1W 0805	AS0203R-0805F
R42	RES SM 8K2 1% 0.1W 0805	AS0822R-0805F
R43	RES SM 8K2 1% 0.1W 0805	AS0822R-0805F
R44	RES SM 20K 1% 0.1W 0805	AS0203R-0805F
R45	RES SM 47K 1% 0.1W 0805	AS0473R-0805F
R46	RES SM 1K2 1% 0.1W 0805	AS0122R-0805F
R47	RES SM 1K2 1% 0.1W 0805	AS0122R-0805F
R48	RES SM 1K2 1% 0.1W 0805	AS0122R-0805F
R49	RES SM 620R 1% 0.1W 0805	AS0621R-0805F
R50	RES SM 4K3 1% 0.1W 0805	AS0432R-0805F
R51	RES SM 3K9 1% 0.1W 0805	AS0392R-0805F
R52	RES SM 3K3 1% 0.1W 0805	AS0332R-0805F
R53	RES SM 6K8 1% 0.1W 0805	AS0682R-0805F
R54	RES SM 3K3 1% 0.1W 0805	AS0332R-0805F
R55	RES SM 6K8 1% 0.1W 0805	AS0682R-0805F
R56	RES SM 6K8 1% 0.1W 0805	AS0682R-0805F
R59	RES SM 9K1 1% 0.1W 0805	AS0912R-0805F
R60	RES SM 3K9 1% 0.1W 0805	AS0392R-0805F
R61	RES SM 2K2 1% 0.1W 0805	AS0222R-0805F
R62	RES SM 1K5 1% 0.1W 0805	AS0152R-0805F
R63	RES SM 620R 1% 0.1W 0805	AS0621R-0805F
R64	RES SM 470R 1% 0.1W 0805	AS0471R-0805F
R65	RES SM 330R 1% 0.1W 0805	AS0331R-0805F
R66	RES SM 240R 1% 0.1W 0805	AS0241R-0805F
R67	RES SM 2K2 1% 0.1W 0805	AS0222R-0805F
R68	RES SM 330R 1% 0.1W 0805	AS0331R-0805F
R69	RES SM 130R 1% 0.1W T200	AS0131R-0805F
R70	RES SM 75R 1% 0.1W 0805	AS0750R-0805F
R71	RES SM 75R 1% 0.1W 0805	AS0750R-0805F
R72	RES SM 4K3 1% 0.1W 0805	AS0432R-0805F
R73	RES SM 2M2 1% 0.1W 0805	AS0225R-0805F
R74	RES SM 4K3 1% 0.1W 0805	AS0432R-0805F
R75	RES SM 2M2 1% 0.1W 0805	AS0225R-0805F
R76	RES SM 240R 1% 0.1W 0805	AS0241R-0805F
R77	RES SM 240R 1% 0.1W 0805	AS0241R-0805F
R78	RES SM 1M0 1% 0.1W 0805	AS0105R-0805F
R79	RES SM 1M0 1% 0.1W 0805	AS0105R-0805F
R80	RES SM 3K3 1% 0.1W 0805	AS0332R-0805F
R81	RES SM 8K2 1% 0.1W 0805	AS0822R-0805F
R82	RES SM 8K2 1% 0.1W 0805	AS0822R-0805F
R83	RES SM 220K 1% 0.1W 0805	AS0224R-0805F
R84	RES SM 220K 1% 0.1W 0805	AS0224R-0805F
R88	RES SM 10K 1% 0.1W 0805	AS0103R-0805F
R89	RES SM 47K 1% 0.1W 0805	AS0473R-0805F
R90	RES SM 0R0 1% 0.1W 0805	AS0000R-0805F
R160	RES SM 47K 1% 0.1W 0805	AS0473R-0805F
R161	RES SM 10K 1% 0.1W 0805	AS0103R-0805F

R162	RES SM 10K 1% 0.1W 0805	AS0103R-0805F
R163	RES SM 75R 1% 0.1W 0805	AS0750R-0805F
R164	RES SM 75R 1% 0.1W 0805	AS0750R-0805F
R165	RES SM 75R 1% 0.1W 0805	AS0750R-0805F
R166	RES SM 75R 1% 0.1W 0805	AS0750R-0805F
R500	RES SM 20K 1% 0.2W MICROMELF	AS2203R-0102F
R501	RES SM 1K2 1% 0.2W MICROMELF	AS2122R-0102F
R502	RES SM 20K 1% 0.2W MICROMELF	AS2203R-0102F
R503	RES SM 1K2 1% 0.2W MICROMELF	AS2122R-0102F
R504	RES SM 10R 1% 0.1W 0805	AS0100R-0805F
R505	RES SM 1K2 1% 0.2W MICROMELF	AS2122R-0102F
R506	RES SM 1K2 1% 0.2W MICROMELF	AS2122R-0102F
R507	RES SM 6K8 1% 0.1W 0805	AS0682R-0805F
R508	RES SM 6K8 1% 0.1W 0805	AS0682R-0805F
R509	RES SM 1K2 1% 0.2W MICROMELF	AS2122R-0102F
R510	RES SM 1K2 1% 0.2W MICROMELF	AS2122R-0102F
R511	RES SM 4K3 1% 0.1W 0805	AS0432R-0805F
R512	RES SM 4K3 1% 0.1W 0805	AS0432R-0805F
R513	RES MF 6K8 1% 0.25W	AP1369
R514	RES MF 6K8 1% 0.25W	AP1369
R515	RES SM 20K 1% 0.1W 0805	AS0203R-0805F
R516	RES SM 20K 1% 0.1W 0805	AS0203R-0805F
R517	RES SM 8K2 1% 0.1W 0805	AS0822R-0805F
R518	RES SM 8K2 1% 0.1W 0805	AS0822R-0805F
R519	RES SM 3K3 1% 0.1W 0805	AS0332R-0805F
R520	RES SM 3K3 1% 0.1W 0805	AS0332R-0805F
R521	RES SM 20K 1% 0.1W 0805	AS0203R-0805F
R522	RES SM 47K 1% 0.1W 0805	AS0473R-0805F
R523	RES SM 20K 1% 0.1W 0805	AS0203R-0805F
R524	RES SM 10K 1% 0.1W 0805	AS0103R-0805F
R525	RES SM 4K3 1% 0.1W 0805	AS0432R-0805F
R526	RES SM 10K 1% 0.1W 0805	AS0103R-0805F
R527	RES SM 10K 1% 0.1W 0805	AS0103R-0805F
R529	RES SM 10K 1% 0.1W 0805	AS0103R-0805F
R530	RES SM 10K 1% 0.1W 0805	AS0103R-0805F
R531	RES SM 10K 1% 0.1W 0805	AS0103R-0805F
R532	RES SM 10K 1% 0.1W 0805	AS0103R-0805F
R533	RES SM 47K 1% 0.1W 0805	AS0473R-0805F
R534	RES SM 4K3 1% 0.1W 0805	AS0432R-0805F
R535	RES SM 620R 1% 0.1W 0805	AS0621R-0805F
R536	RES SM 75R 1% 0.1W 0805	AS0750R-0805F
R538	RES SM 47K 1% 0.1W 0805	AS0473R-0805F
R600	RES SM 20K 1% 0.2W MICROMELF	AS2203R-0102F
R601	RES SM 1K2 1% 0.2W MICROMELF	AS2122R-0102F
R602	RES SM 20K 1% 0.2W MICROMELF	AS2203R-0102F
R603	RES SM 1K2 1% 0.2W MICROMELF	AS2122R-0102F
R604	RES SM 10R 1% 0.1W 0805	AS0100R-0805F
R605	RES SM 1K2 1% 0.2W MICROMELF	AS2122R-0102F
R606	RES SM 1K2 1% 0.2W MICROMELF	AS2122R-0102F
R607	RES SM 6K8 1% 0.1W 0805	AS0682R-0805F
R608	RES SM 6K8 1% 0.1W 0805	AS0682R-0805F
R609	RES SM 1K2 1% 0.2W MICROMELF	AS2122R-0102F
R610	RES SM 1K2 1% 0.2W MICROMELF	AS2122R-0102F
R611	RES SM 4K3 1% 0.1W 0805	AS0432R-0805F
R612	RES SM 4K3 1% 0.1W 0805	AS0432R-0805F
R613	RES MF 6K8 1% 0.25W	AP1369
R614	RES MF 6K8 1% 0.25W	AP1369
R615	RES SM 20K 1% 0.1W 0805	AS0203R-0805F
R616	RES SM 20K 1% 0.1W 0805	AS0203R-0805F
R617	RES SM 8K2 1% 0.1W 0805	AS0822R-0805F
R618	RES SM 8K2 1% 0.1W 0805	AS0822R-0805F

R619	RES SM 3K3 1% 0.1W 0805	AS0332R-0805F
R620	RES SM 3K3 1% 0.1W 0805	AS0332R-0805F
R621	RES SM 20K 1% 0.1W 0805	AS0203R-0805F
R622	RES SM 47K 1% 0.1W 0805	AS0473R-0805F
R623	RES SM 20K 1% 0.1W 0805	AS0203R-0805F
R624	RES SM 10K 1% 0.1W 0805	AS0103R-0805F
R625	RES SM 4K3 1% 0.1W 0805	AS0432R-0805F
R626	RES SM 10K 1% 0.1W 0805	AS0103R-0805F
R627	RES SM 10K 1% 0.1W 0805	AS0103R-0805F
R629	RES SM 10K 1% 0.1W 0805	AS0103R-0805F
R630	RES SM 10K 1% 0.1W 0805	AS0103R-0805F
R631	RES SM 10K 1% 0.1W 0805	AS0103R-0805F
R632	RES SM 10K 1% 0.1W 0805	AS0103R-0805F
R633	RES SM 47K 1% 0.1W 0805	AS0473R-0805F
R634	RES SM 4K3 1% 0.1W 0805	AS0432R-0805F
R635	RES SM 620R 1% 0.1W 0805	AS0621R-0805F
R636	RES SM 75R 1% 0.1W 0805	AS0750R-0805F
R638	RES SM 47K 1% 0.1W 0805	AS0473R-0805F
R700	RES SM 20K 1% 0.2W MICROMELF	AS2203R-0102F
R701	RES SM 1K2 1% 0.2W MICROMELF	AS2122R-0102F
R702	RES SM 20K 1% 0.2W MICROMELF	AS2203R-0102F
R703	RES SM 1K2 1% 0.2W MICROMELF	AS2122R-0102F
R704	RES SM 10R 1% 0.1W 0805	AS0100R-0805F
R705	RES SM 1K2 1% 0.2W MICROMELF	AS2122R-0102F
R706	RES SM 1K2 1% 0.2W MICROMELF	AS2122R-0102F
R707	RES SM 6K8 1% 0.1W 0805	AS0682R-0805F
R708	RES SM 6K8 1% 0.1W 0805	AS0682R-0805F
R709	RES SM 1K2 1% 0.2W MICROMELF	AS2122R-0102F
R710	RES SM 1K2 1% 0.2W MICROMELF	AS2122R-0102F
R711	RES SM 4K3 1% 0.1W 0805	AS0432R-0805F
R712	RES SM 4K3 1% 0.1W 0805	AS0432R-0805F
R713	RES MF 6K8 1% 0.25W	AP1369
R714	RES MF 6K8 1% 0.25W	AP1369
R715	RES SM 20K 1% 0.1W 0805	AS0203R-0805F
R716	RES SM 20K 1% 0.1W 0805	AS0203R-0805F
R717	RES SM 8K2 1% 0.1W 0805	AS0822R-0805F
R718	RES SM 8K2 1% 0.1W 0805	AS0822R-0805F
R719	RES SM 3K3 1% 0.1W 0805	AS0332R-0805F
R720	RES SM 3K3 1% 0.1W 0805	AS0332R-0805F
R721	RES SM 20K 1% 0.1W 0805	AS0203R-0805F
R722	RES SM 47K 1% 0.1W 0805	AS0473R-0805F
R723	RES SM 20K 1% 0.1W 0805	AS0203R-0805F
R724	RES SM 10K 1% 0.1W 0805	AS0103R-0805F
R725	RES SM 4K3 1% 0.1W 0805	AS0432R-0805F
R726	RES SM 10K 1% 0.1W 0805	AS0103R-0805F
R727	RES SM 10K 1% 0.1W 0805	AS0103R-0805F
R729	RES SM 10K 1% 0.1W 0805	AS0103R-0805F
R730	RES SM 10K 1% 0.1W 0805	AS0103R-0805F
R731	RES SM 10K 1% 0.1W 0805	AS0103R-0805F
R732	RES SM 10K 1% 0.1W 0805	AS0103R-0805F
R733	RES SM 47K 1% 0.1W 0805	AS0473R-0805F
R734	RES SM 4K3 1% 0.1W 0805	AS0432R-0805F
R735	RES SM 620R 1% 0.1W 0805	AS0621R-0805F
R736	RES SM 75R 1% 0.1W 0805	AS0750R-0805F
R738	RES SM 47K 1% 0.1W 0805	AS0473R-0805F
R800	RES SM 20K 1% 0.2W MICROMELF	AS2203R-0102F
R801	RES SM 1K2 1% 0.2W MICROMELF	AS2122R-0102F
R802	RES SM 20K 1% 0.2W MICROMELF	AS2203R-0102F
R803	RES SM 1K2 1% 0.2W MICROMELF	AS2122R-0102F
R804	RES SM 10R 1% 0.1W 0805	AS0100R-0805F
R805	RES SM 1K2 1% 0.2W MICROMELF	AS2122R-0102F

R806	RES SM 1K2 1% 0.2W MICROMELF	AS2122R-0102F
R807	RES SM 6K8 1% 0.1W 0805	AS0682R-0805F
R808	RES SM 6K8 1% 0.1W 0805	AS0682R-0805F
R809	RES SM 1K2 1% 0.2W MICROMELF	AS2122R-0102F
R810	RES SM 1K2 1% 0.2W MICROMELF	AS2122R-0102F
R811	RES SM 4K3 1% 0.1W 0805	AS0432R-0805F
R812	RES SM 4K3 1% 0.1W 0805	AS0432R-0805F
R813	RES MF 6K8 1% 0.25W	AP1369
R814	RES MF 6K8 1% 0.25W	AP1369
R815	RES SM 20K 1% 0.1W 0805	AS0203R-0805F
R816	RES SM 20K 1% 0.1W 0805	AS0203R-0805F
R817	RES SM 8K2 1% 0.1W 0805	AS0822R-0805F
R818	RES SM 8K2 1% 0.1W 0805	AS0822R-0805F
R819	RES SM 3K3 1% 0.1W 0805	AS0332R-0805F
R820	RES SM 3K3 1% 0.1W 0805	AS0332R-0805F
R821	RES SM 20K 1% 0.1W 0805	AS0203R-0805F
R822	RES SM 47K 1% 0.1W 0805	AS0473R-0805F
R823	RES SM 20K 1% 0.1W 0805	AS0203R-0805F
R824	RES SM 10K 1% 0.1W 0805	AS0103R-0805F
R825	RES SM 4K3 1% 0.1W 0805	AS0432R-0805F
R826	RES SM 10K 1% 0.1W 0805	AS0103R-0805F
R827	RES SM 10K 1% 0.1W 0805	AS0103R-0805F
R829	RES SM 10K 1% 0.1W 0805	AS0103R-0805F
R830	RES SM 10K 1% 0.1W 0805	AS0103R-0805F
R831	RES SM 10K 1% 0.1W 0805	AS0103R-0805F
R832	RES SM 10K 1% 0.1W 0805	AS0103R-0805F
R833	RES SM 47K 1% 0.1W 0805	AS0473R-0805F
R834	RES SM 4K3 1% 0.1W 0805	AS0432R-0805F
R835	RES SM 620R 1% 0.1W 0805	AS0621R-0805F
R836	RES SM 75R 1% 0.1W 0805	AS0750R-0805F
R838	RES SM 47K 1% 0.1W 0805	AS0473R-0805F
R900	RES SM 20K 1% 0.2W MICROMELF	AS2203R-0102F
R901	RES SM 1K2 1% 0.2W MICROMELF	AS2122R-0102F
R902	RES SM 20K 1% 0.2W MICROMELF	AS2203R-0102F
R903	RES SM 1K2 1% 0.2W MICROMELF	AS2122R-0102F
R904	RES SM 10R 1% 0.1W 0805	AS0100R-0805F
R905	RES SM 1K2 1% 0.2W MICROMELF	AS2122R-0102F
R906	RES SM 1K2 1% 0.2W MICROMELF	AS2122R-0102F
R907	RES SM 6K8 1% 0.1W 0805	AS0682R-0805F
R908	RES SM 6K8 1% 0.1W 0805	AS0682R-0805F
R909	RES SM 1K2 1% 0.2W MICROMELF	AS2122R-0102F
R910	RES SM 1K2 1% 0.2W MICROMELF	AS2122R-0102F
R911	RES SM 4K3 1% 0.1W 0805	AS0432R-0805F
R912	RES SM 4K3 1% 0.1W 0805	AS0432R-0805F
R913	RES MF 6K8 1% 0.25W	AP1369
R914	RES MF 6K8 1% 0.25W	AP1369
R915	RES SM 20K 1% 0.1W 0805	AS0203R-0805F
R916	RES SM 20K 1% 0.1W 0805	AS0203R-0805F
R917	RES SM 8K2 1% 0.1W 0805	AS0822R-0805F
R918	RES SM 8K2 1% 0.1W 0805	AS0822R-0805F
R919	RES SM 3K3 1% 0.1W 0805	AS0332R-0805F
R920	RES SM 3K3 1% 0.1W 0805	AS0332R-0805F
R921	RES SM 20K 1% 0.1W 0805	AS0203R-0805F
R922	RES SM 47K 1% 0.1W 0805	AS0473R-0805F
R923	RES SM 20K 1% 0.1W 0805	AS0203R-0805F
R924	RES SM 10K 1% 0.1W 0805	AS0103R-0805F
R925	RES SM 4K3 1% 0.1W 0805	AS0432R-0805F
R926	RES SM 10K 1% 0.1W 0805	AS0103R-0805F
R927	RES SM 10K 1% 0.1W 0805	AS0103R-0805F
R929	RES SM 10K 1% 0.1W 0805	AS0103R-0805F
R930	RES SM 10K 1% 0.1W 0805	AS0103R-0805F

R931	RES SM 10K 1% 0.1W 0805	AS0103R-0805F
R932	RES SM 10K 1% 0.1W 0805	AS0103R-0805F
R933	RES SM 47K 1% 0.1W 0805	AS0473R-0805F
R934	RES SM 4K3 1% 0.1W 0805	AS0432R-0805F
R935	RES SM 620R 1% 0.1W 0805	AS0621R-0805F
R936	RES SM 75R 1% 0.1W 0805	AS0750R-0805F
R938	RES SM 47K 1% 0.1W 0805	AS0473R-0805F
R1000	RES SM 20K 1% 0.2W MICROMELF	AS2203R-0102F
R1001	RES SM 1K2 1% 0.2W MICROMELF	AS2122R-0102F
R1002	RES SM 20K 1% 0.2W MICROMELF	AS2203R-0102F
R1003	RES SM 1K2 1% 0.2W MICROMELF	AS2122R-0102F
R1004	RES SM 10R 1% 0.1W 0805	AS0100R-0805F
R1005	RES SM 1K2 1% 0.2W MICROMELF	AS2122R-0102F
R1006	RES SM 1K2 1% 0.2W MICROMELF	AS2122R-0102F
R1007	RES SM 6K8 1% 0.1W 0805	AS0682R-0805F
R1008	RES SM 6K8 1% 0.1W 0805	AS0682R-0805F
R1009	RES SM 1K2 1% 0.2W MICROMELF	AS2122R-0102F
R1010	RES SM 1K2 1% 0.2W MICROMELF	AS2122R-0102F
R1011	RES SM 4K3 1% 0.1W 0805	AS0432R-0805F
R1012	RES SM 4K3 1% 0.1W 0805	AS0432R-0805F
R1013	RES MF 6K8 1% 0.25W	AP1369
R1014	RES MF 6K8 1% 0.25W	AP1369
R1015	RES SM 20K 1% 0.1W 0805	AS0203R-0805F
R1016	RES SM 20K 1% 0.1W 0805	AS0203R-0805F
R1017	RES SM 8K2 1% 0.1W 0805	AS0822R-0805F
R1018	RES SM 8K2 1% 0.1W 0805	AS0822R-0805F
R1019	RES SM 3K3 1% 0.1W 0805	AS0332R-0805F
R1020	RES SM 3K3 1% 0.1W 0805	AS0332R-0805F
R1021	RES SM 20K 1% 0.1W 0805	AS0203R-0805F
R1022	RES SM 47K 1% 0.1W 0805	AS0473R-0805F
R1023	RES SM 20K 1% 0.1W 0805	AS0203R-0805F
R1024	RES SM 10K 1% 0.1W 0805	AS0103R-0805F
R1025	RES SM 4K3 1% 0.1W 0805	AS0432R-0805F
R1026	RES SM 10K 1% 0.1W 0805	AS0103R-0805F
R1027	RES SM 10K 1% 0.1W 0805	AS0103R-0805F
R1029	RES SM 10K 1% 0.1W 0805	AS0103R-0805F
R1030	RES SM 10K 1% 0.1W 0805	AS0103R-0805F
R1031	RES SM 10K 1% 0.1W 0805	AS0103R-0805F
R1032	RES SM 10K 1% 0.1W 0805	AS0103R-0805F
R1033	RES SM 47K 1% 0.1W 0805	AS0473R-0805F
R1034	RES SM 4K3 1% 0.1W 0805	AS0432R-0805F
R1035	RES SM 620R 1% 0.1W 0805	AS0621R-0805F
R1036	RES SM 75R 1% 0.1W 0805	AS0750R-0805F
R1038	RES SM 47K 1% 0.1W 0805	AS0473R-0805F
R1100	RES SM 20K 1% 0.2W MICROMELF	AS2203R-0102F
R1101	RES SM 1K2 1% 0.2W MICROMELF	AS2122R-0102F
R1102	RES SM 20K 1% 0.2W MICROMELF	AS2203R-0102F
R1103	RES SM 1K2 1% 0.2W MICROMELF	AS2122R-0102F
R1104	RES SM 10R 1% 0.1W 0805	AS0100R-0805F
R1105	RES SM 1K2 1% 0.2W MICROMELF	AS2122R-0102F
R1106	RES SM 1K2 1% 0.2W MICROMELF	AS2122R-0102F
R1107	RES SM 6K8 1% 0.1W 0805	AS0682R-0805F
R1108	RES SM 6K8 1% 0.1W 0805	AS0682R-0805F
R1109	RES SM 1K2 1% 0.2W MICROMELF	AS2122R-0102F
R1110	RES SM 1K2 1% 0.2W MICROMELF	AS2122R-0102F
R1111	RES SM 4K3 1% 0.1W 0805	AS0432R-0805F
R1112	RES SM 4K3 1% 0.1W 0805	AS0432R-0805F
R1113	RES MF 6K8 1% 0.25W	AP1369
R1114	RES MF 6K8 1% 0.25W	AP1369
R1115	RES SM 20K 1% 0.1W 0805	AS0203R-0805F
R1116	RES SM 20K 1% 0.1W 0805	AS0203R-0805F

R1117	RES SM 8K2 1% 0.1W 0805	AS0822R-0805F
R1118	RES SM 8K2 1% 0.1W 0805	AS0822R-0805F
R1119	RES SM 3K3 1% 0.1W 0805	AS0332R-0805F
R1120	RES SM 3K3 1% 0.1W 0805	AS0332R-0805F
R1121	RES SM 20K 1% 0.1W 0805	AS0203R-0805F
R1122	RES SM 47K 1% 0.1W 0805	AS0473R-0805F
R1123	RES SM 20K 1% 0.1W 0805	AS0203R-0805F
R1124	RES SM 10K 1% 0.1W 0805	AS0103R-0805F
R1125	RES SM 4K3 1% 0.1W 0805	AS0432R-0805F
R1126	RES SM 10K 1% 0.1W 0805	AS0103R-0805F
R1127	RES SM 10K 1% 0.1W 0805	AS0103R-0805F
R1129	RES SM 10K 1% 0.1W 0805	AS0103R-0805F
R1130	RES SM 10K 1% 0.1W 0805	AS0103R-0805F
R1131	RES SM 10K 1% 0.1W 0805	AS0103R-0805F
R1132	RES SM 10K 1% 0.1W 0805	AS0103R-0805F
R1133	RES SM 47K 1% 0.1W 0805	AS0473R-0805F
R1134	RES SM 4K3 1% 0.1W 0805	AS0432R-0805F
R1135	RES SM 620R 1% 0.1W 0805	AS0621R-0805F
R1136	RES SM 75R 1% 0.1W 0805	AS0750R-0805F
R1138	RES SM 47K 1% 0.1W 0805	AS0473R-0805F
R1200	RES SM 20K 1% 0.2W MICROMELF	AS2203R-0102F
R1201	RES SM 1K2 1% 0.2W MICROMELF	AS2122R-0102F
R1202	RES SM 20K 1% 0.2W MICROMELF	AS2203R-0102F
R1203	RES SM 1K2 1% 0.2W MICROMELF	AS2122R-0102F
R1204	RES SM 10R 1% 0.1W 0805	AS0100R-0805F
R1205	RES SM 1K2 1% 0.2W MICROMELF	AS2122R-0102F
R1206	RES SM 1K2 1% 0.2W MICROMELF	AS2122R-0102F
R1207	RES SM 6K8 1% 0.1W 0805	AS0682R-0805F
R1208	RES SM 6K8 1% 0.1W 0805	AS0682R-0805F
R1209	RES SM 1K2 1% 0.2W MICROMELF	AS2122R-0102F
R1210	RES SM 1K2 1% 0.2W MICROMELF	AS2122R-0102F
R1211	RES SM 4K3 1% 0.1W 0805	AS0432R-0805F
R1212	RES SM 4K3 1% 0.1W 0805	AS0432R-0805F
R1213	RES MF 6K8 1% 0.25W	AP1369
R1214	RES MF 6K8 1% 0.25W	AP1369
R1215	RES SM 20K 1% 0.1W 0805	AS0203R-0805F
R1216	RES SM 20K 1% 0.1W 0805	AS0203R-0805F
R1217	RES SM 8K2 1% 0.1W 0805	AS0822R-0805F
R1218	RES SM 8K2 1% 0.1W 0805	AS0822R-0805F
R1219	RES SM 3K3 1% 0.1W 0805	AS0332R-0805F
R1220	RES SM 3K3 1% 0.1W 0805	AS0332R-0805F
R1221	RES SM 20K 1% 0.1W 0805	AS0203R-0805F
R1222	RES SM 47K 1% 0.1W 0805	AS0473R-0805F
R1223	RES SM 20K 1% 0.1W 0805	AS0203R-0805F
R1224	RES SM 10K 1% 0.1W 0805	AS0103R-0805F
R1225	RES SM 4K3 1% 0.1W 0805	AS0432R-0805F
R1226	RES SM 10K 1% 0.1W 0805	AS0103R-0805F
R1227	RES SM 10K 1% 0.1W 0805	AS0103R-0805F
R1229	RES SM 10K 1% 0.1W 0805	AS0103R-0805F
R1230	RES SM 10K 1% 0.1W 0805	AS0103R-0805F
R1231	RES SM 10K 1% 0.1W 0805	AS0103R-0805F
R1232	RES SM 10K 1% 0.1W 0805	AS0103R-0805F
R1233	RES SM 47K 1% 0.1W 0805	AS0473R-0805F
R1234	RES SM 4K3 1% 0.1W 0805	AS0432R-0805F
R1235	RES SM 620R 1% 0.1W 0805	AS0621R-0805F
R1236	RES SM 75R 1% 0.1W 0805	AS0750R-0805F
R1238	RES SM 47K 1% 0.1W 0805	AS0473R-0805F
R1300	RES SM 20K 1% 0.1W 0805	AS0203R-0805F
R1301	RES SM 4K3 1% 0.1W 0805	AS0432R-0805F
R1302	RES SM 20K 1% 0.1W 0805	AS0203R-0805F
R1303	RES SM 20K 1% 0.1W 0805	AS0203R-0805F

R1304	RES SM 10K 1% 0.1W 0805	AS0103R-0805F
R1305	RES SM 4K3 1% 0.1W 0805	AS0432R-0805F
R1306	RES SM 20K 1% 0.1W 0805	AS0203R-0805F
R1307	RES SM 10K 1% 0.1W 0805	AS0103R-0805F
R1308	RES SM 4K3 1% 0.1W 0805	AS0432R-0805F
R1309	RES SM 20K 1% 0.1W 0805	AS0203R-0805F
R1310	RES SM 20K 1% 0.1W 0805	AS0203R-0805F
R1311	RES SM 20K 1% 0.1W 0805	AS0203R-0805F
R1312	RES SM 20K 1% 0.1W 0805	AS0203R-0805F
R1313	RES SM 10K 1% 0.1W 0805	AS0103R-0805F
R1314	RES SM 10K 1% 0.1W 0805	AS0103R-0805F
R1315	RES SM 47K 1% 0.1W 0805	AS0473R-0805F
R1316	RES SM 620R 1% 0.1W 0805	AS0621R-0805F
R1317	RES SM 47K 1% 0.1W 0805	AS0473R-0805F
R1318	RES SM 47K 1% 0.1W 0805	AS0473R-0805F
R1319	RES SM 3K3 1% 0.1W 0805	AS0332R-0805F
R1320	RES SM 3K3 1% 0.1W 0805	AS0332R-0805F
R1321	RES SM 2K2 1% 0.1W 0805	AS0222R-0805F
R1322	RES SM 47K 1% 0.1W 0805	AS0473R-0805F
R1323	RES SM 2K2 1% 0.1W 0805	AS0222R-0805F
R1324	RES SM 15K 1% 0.1W 0805	AS0153R-0805F
R1325	RES SM 15K 1% 0.1W 0805	AS0153R-0805F
R1326	RES SM 15K 1% 0.1W 0805	AS0153R-0805F
R1327	RES SM 4K3 1% 0.1W 0805	AS0432R-0805F
R1328	RES SM 4K3 1% 0.1W 0805	AS0432R-0805F
R1329	RES SM 2K2 1% 0.1W 0805	AS0222R-0805F
R1330	RES SM 47K 1% 0.1W 0805	AS0473R-0805F
R1331	RES SM 4K3 1% 0.1W 0805	AS0432R-0805F
R1332	RES SM 4K3 1% 0.1W 0805	AS0432R-0805F
R1333	RES SM 15K 1% 0.1W 0805	AS0153R-0805F
R1334	RES SM 3K3 1% 0.1W 0805	AS0332R-0805F
R1335	RES SM 47K 1% 0.1W 0805	AS0473R-0805F
R1336	RES SM 620R 1% 0.1W 0805	AS0621R-0805F
R1337	RES SM 620R 1% 0.1W 0805	AS0621R-0805F
R1338	RES SM 3K3 1% 0.1W 0805	AS0332R-0805F
R1339	RES SM 3K3 1% 0.1W 0805	AS0332R-0805F
R1340	RES SM 3K3 1% 0.1W 0805	AS0332R-0805F
R1341	RES SM 3K3 1% 0.1W 0805	AS0332R-0805F
R1342	RES SM 1K5 1% 0.1W 0805	AS0152R-0805F
R1343	RES SM 1K5 1% 0.1W 0805	AS0152R-0805F
R1344	RES SM 2K2 1% 0.1W 0805	AS0222R-0805F
R1346	RES SM 20K 1% 0.1W 0805	AS0203R-0805F
R1347	RES SM 20K 1% 0.1W 0805	AS0203R-0805F
R1350	RES SM 47K 1% 0.1W 0805	AS0473R-0805F
R1392	RES SM 3K3 1% 0.1W 0805	AS0332R-0805F
R1400	RES SM 20K 1% 0.1W 0805	AS0203R-0805F
R1401	RES SM 4K3 1% 0.1W 0805	AS0432R-0805F
R1402	RES SM 20K 1% 0.1W 0805	AS0203R-0805F
R1403	RES SM 20K 1% 0.1W 0805	AS0203R-0805F
R1404	RES SM 10K 1% 0.1W 0805	AS0103R-0805F
R1405	RES SM 4K3 1% 0.1W 0805	AS0432R-0805F
R1406	RES SM 20K 1% 0.1W 0805	AS0203R-0805F
R1407	RES SM 10K 1% 0.1W 0805	AS0103R-0805F
R1408	RES SM 4K3 1% 0.1W 0805	AS0432R-0805F
R1409	RES SM 20K 1% 0.1W 0805	AS0203R-0805F
R1410	RES SM 20K 1% 0.1W 0805	AS0203R-0805F
R1411	RES SM 20K 1% 0.1W 0805	AS0203R-0805F
R1412	RES SM 20K 1% 0.1W 0805	AS0203R-0805F
R1413	RES SM 10K 1% 0.1W 0805	AS0103R-0805F
R1414	RES SM 10K 1% 0.1W 0805	AS0103R-0805F
R1415	RES SM 47K 1% 0.1W 0805	AS0473R-0805F

R1416	RES SM 620R 1% 0.1W 0805	AS0621R-0805F
R1417	RES SM 47K 1% 0.1W 0805	AS0473R-0805F
R1418	RES SM 47K 1% 0.1W 0805	AS0473R-0805F
R1419	RES SM 3K3 1% 0.1W 0805	AS0332R-0805F
R1420	RES SM 3K3 1% 0.1W 0805	AS0332R-0805F
R1421	RES SM 2K2 1% 0.1W 0805	AS0222R-0805F
R1422	RES SM 47K 1% 0.1W 0805	AS0473R-0805F
R1423	RES SM 2K2 1% 0.1W 0805	AS0222R-0805F
R1424	RES SM 15K 1% 0.1W 0805	AS0153R-0805F
R1425	RES SM 15K 1% 0.1W 0805	AS0153R-0805F
R1426	RES SM 15K 1% 0.1W 0805	AS0153R-0805F
R1427	RES SM 4K3 1% 0.1W 0805	AS0432R-0805F
R1428	RES SM 4K3 1% 0.1W 0805	AS0432R-0805F
R1429	RES SM 3K3 1% 0.1W 0805	AS0332R-0805F
R1430	RES SM 47K 1% 0.1W 0805	AS0473R-0805F
R1431	RES SM 4K3 1% 0.1W 0805	AS0432R-0805F
R1432	RES SM 4K3 1% 0.1W 0805	AS0432R-0805F
R1433	RES SM 15K 1% 0.1W 0805	AS0153R-0805F
R1434	RES SM 3K3 1% 0.1W 0805	AS0332R-0805F
R1435	RES SM 47K 1% 0.1W 0805	AS0473R-0805F
R1436	RES SM 620R 1% 0.1W 0805	AS0621R-0805F
R1437	RES SM 620R 1% 0.1W 0805	AS0621R-0805F
R1438	RES SM 3K3 1% 0.1W 0805	AS0332R-0805F
R1439	RES SM 3K3 1% 0.1W 0805	AS0332R-0805F
R1440	RES SM 3K3 1% 0.1W 0805	AS0332R-0805F
R1441	RES SM 3K3 1% 0.1W 0805	AS0332R-0805F
R1442	RES SM 1K5 1% 0.1W 0805	AS0152R-0805F
R1443	RES SM 1K5 1% 0.1W 0805	AS0152R-0805F
R1444	RES SM 2K2 1% 0.1W 0805	AS0222R-0805F
R1446	RES SM 20K 1% 0.1W 0805	AS0203R-0805F
R1447	RES SM 20K 1% 0.1W 0805	AS0203R-0805F
R1448	RES SM 2K2 1% 0.1W 0805	AS0222R-0805F
R1450	RES SM 47K 1% 0.1W 0805	AS0473R-0805F
R2000	RES SM 20K 1% 0.1W 0805	AS0203R-0805F
R2001	RES SM 20K 1% 0.1W 0805	AS0203R-0805F
R2002	RES SM 10K 1% 0.1W 0805	AS0103R-0805F
R2003	RES SM 10K 1% 0.1W 0805	AS0103R-0805F
R2004	RES SM 20K 1% 0.1W 0805	AS0203R-0805F
R2005	RES SM 20K 1% 0.1W 0805	AS0203R-0805F
R2006	RES SM 20K 1% 0.1W 0805	AS0203R-0805F
R2007	RES SM 20K 1% 0.1W 0805	AS0203R-0805F
R2008	RES SM 20K 1% 0.1W 0805	AS0203R-0805F
R2009	RES SM 20K 1% 0.1W 0805	AS0203R-0805F
R2010	RES SM 4K3 1% 0.1W 0805	AS0432R-0805F
R2011	RES SM 4K3 1% 0.1W 0805	AS0432R-0805F
R2012	RES SM 10K 1% 0.1W 0805	AS0103R-0805F
R2013	RES SM 10K 1% 0.1W 0805	AS0103R-0805F
R2014	RES SM 2K2 1% 0.1W 0805	AS0222R-0805F
R2015	RES SM 2K2 1% 0.1W 0805	AS0222R-0805F
R2016	RES SM 10K 1% 0.1W 0805	AS0103R-0805F
R2017	RES SM 10K 1% 0.1W 0805	AS0103R-0805F
R2018	RES SM 4K3 1% 0.1W 0805	AS0432R-0805F
R2019	RES SM 7K5 1% 0.1W 0805	AS0752R-0805F
R2020	RES SM 7K5 1% 0.1W 0805	AS0752R-0805F
R2021	RES SM 7K5 1% 0.1W 0805	AS0752R-0805F
R2022	RES SM 560R 1% 0.1W 0805	AS0561R-0805F
R2023	RES SM 560R 1% 0.1W 0805	AS0561R-0805F
R2024	RES SM 360R 1% 0.1W 0805	AS0361R-0805F
R2025	RES SM 360R 1% 0.1W 0805	AS0361R-0805F
R2026	RES SM 360R 1% 0.1W 0805	AS0361R-0805F
R2027	RES SM 360R 1% 0.1W 0805	AS0361R-0805F

R2028	RES SM 360R 1% 0.1W 0805	AS0361R-0805F
R2029	RES SM 360R 1% 0.1W 0805	AS0361R-0805F
R2030	RES SM 10K 1% 0.1W 0805	AS0103R-0805F
R2031	RES SM 10K 1% 0.1W 0805	AS0103R-0805F
R2032	RES SM 10K 1% 0.1W 0805	AS0103R-0805F
R2033	RES SM 10K 1% 0.1W 0805	AS0103R-0805F
R2034	RES SM 10K 1% 0.1W 0805	AS0103R-0805F
R2035	RES SM 10K 1% 0.1W 0805	AS0103R-0805F
R2036	RES SM 10K 1% 0.1W 0805	AS0103R-0805F
R2037	RES SM 10K 1% 0.1W 0805	AS0103R-0805F
R2038	RES SM 10K 1% 0.1W 0805	AS0103R-0805F
R2039	RES SM 10K 1% 0.1W 0805	AS0103R-0805F
R2040	RES SM 620R 1% 0.1W 0805	AS0621R-0805F
R2041	RES SM 20K 1% 0.1W 0805	AS0203R-0805F
R2042	RES SM 20K 1% 0.1W 0805	AS0203R-0805F
R2043	RES SM 20K 1% 0.1W 0805	AS0203R-0805F
R2044	RES SM 20K 1% 0.1W 0805	AS0203R-0805F
R2045	RES SM 10K 1% 0.1W 0805	AS0103R-0805F
R2046	RES SM 10K 1% 0.1W 0805	AS0103R-0805F
R2048	RES SM 1K8 1% 0.1W 0805	AS0182R-0805F
R2049	RES SM 1K8 1% 0.1W 0805	AS0182R-0805F
R2050	RES SM 20K 1% 0.1W 0805	AS0203R-0805F
R2051	RES SM 20K 1% 0.1W 0805	AS0203R-0805F
SW1	SWT LONG TRAVEL V/MNT ALPS	DF0660
SW3	SWT LONG TRAVEL V/MNT ALPS	DF0660
SW4	SWT LONG TRAVEL V/MNT ALPS	DF0660
SW5	SWT LONG TRAVEL V/MNT ALPS	DF0660
SW1000	SWT LONG TRAVEL V/MNT ALPS	DF0660
SW1001	SWT LONG TRAVEL V/MNT ALPS	DF0660
SW1100	SWT LONG TRAVEL V/MNT ALPS	DF0660
SW1101	SWT LONG TRAVEL V/MNT ALPS	DF0660
SW1200	SWT LONG TRAVEL V/MNT ALPS	DF0660
SW1201	SWT LONG TRAVEL V/MNT ALPS	DF0660
SW1300	SWT LONG TRAVEL V/MNT ALPS	DF0660
SW1301	SWT LONG TRAVEL V/MNT ALPS	DF0660
SW1400	SWT LONG TRAVEL V/MNT ALPS	DF0660
SW1401	SWT LONG TRAVEL V/MNT ALPS	DF0660
SW2000	SWT LONG TRAVEL V/MNT ALPS	DF0660
SW2001	SWT LONG TRAVEL V/MNT ALPS	DF0660
SW500	SWT LONG TRAVEL V/MNT ALPS	DF0660
SW501	SWT LONG TRAVEL V/MNT ALPS	DF0660
SW600	SWT LONG TRAVEL V/MNT ALPS	DF0660
SW601	SWT LONG TRAVEL V/MNT ALPS	DF0660
SW700	SWT LONG TRAVEL V/MNT ALPS	DF0660
SW701	SWT LONG TRAVEL V/MNT ALPS	DF0660
SW800	SWT LONG TRAVEL V/MNT ALPS	DF0660
SW801	SWT LONG TRAVEL V/MNT ALPS	DF0660
SW900	SWT LONG TRAVEL V/MNT ALPS	DF0660
SW901	SWT LONG TRAVEL V/MNT ALPS	DF0660
TR1000	TRS PNP 2SB737 LOW RBB	BD0346
TR1001	TRS PNP 2SB737 LOW RBB	BD0346
TR1002	TRS BC846A NPN	BS0513R-SOT23
TR1003	TRS BC846A NPN	BS0513R-SOT23
TR1004	TRS BC846A NPN	BS0513R-SOT23
TR1100	TRS PNP 2SB737 LOW RBB	BD0346
TR1101	TRS PNP 2SB737 LOW RBB	BD0346
TR1102	TRS BC846A NPN	BS0513R-SOT23
TR1103	TRS BC846A NPN	BS0513R-SOT23
TR1104	TRS BC846A NPN	BS0513R-SOT23
TR1200	TRS PNP 2SB737 LOW RBB	BD0346
TR1201	TRS PNP 2SB737 LOW RBB	BD0346

TR1202	TRS BC846A NPN	BS0513R-SOT23
TR1203	TRS BC846A NPN	BS0513R-SOT23
TR1204	TRS BC846A NPN	BS0513R-SOT23
TR1300	TRS BC846A NPN	BS0513R-SOT23
TR1400	TRS BC846A NPN	BS0513R-SOT23
TR2000	TRS BC846A NPN	BS0513R-SOT23
TR500	TRS PNP 2SB737 LOW RBB	BD0346
TR501	TRS PNP 2SB737 LOW RBB	BD0346
TR502	TRS BC846A NPN	BS0513R-SOT23
TR503	TRS BC846A NPN	BS0513R-SOT23
TR504	TRS BC846A NPN	BS0513R-SOT23
TR600	TRS PNP 2SB737 LOW RBB	BD0346
TR601	TRS PNP 2SB737 LOW RBB	BD0346
TR602	TRS BC846A NPN	BS0513R-SOT23
TR603	TRS BC846A NPN	BS0513R-SOT23
TR604	TRS BC846A NPN	BS0513R-SOT23
TR700	TRS PNP 2SB737 LOW RBB	BD0346
TR701	TRS PNP 2SB737 LOW RBB	BD0346
TR702	TRS BC846A NPN	BS0513R-SOT23
TR703	TRS BC846A NPN	BS0513R-SOT23
TR704	TRS BC846A NPN	BS0513R-SOT23
TR800	TRS PNP 2SB737 LOW RBB	BD0346
TR801	TRS PNP 2SB737 LOW RBB	BD0346
TR802	TRS BC846A NPN	BS0513R-SOT23
TR803	TRS BC846A NPN	BS0513R-SOT23
TR804	TRS BC846A NPN	BS0513R-SOT23
TR900	TRS PNP 2SB737 LOW RBB	BD0346
TR901	TRS PNP 2SB737 LOW RBB	BD0346
TR902	TRS BC846A NPN	BS0513R-SOT23
TR903	TRS BC846A NPN	BS0513R-SOT23
TR904	TRS BC846A NPN	BS0513R-SOT23
ZD1,ZD2	ZENER DIODE 300MW 3V9 BZX84C	BS0011R-SOT23

EFX12 MAIN BOARD ASSY

R0528A-01-AF

Ident	Description	Part Number
---	CAP CER 100NF 100V TPD ML	CA0058
---	LED SPACER 0.1"PITCH 12MM	JZ2230
---	LED SPACER 4MM PITCH 22MM	JZ2249
---	EFX12 MAIN BOARD	S0528-01
C1	CAP SM CER 22PF 5% 50V NPO 080	CS1220R-0805J
C2	CAP SM CER 22PF 5% 50V NPO 080	CS1220R-0805J
C3	CAP SM CER 22PF 5% 50V NPO 080	CS1220R-0805J
C4	CAP SM CER 22PF 5% 50V NPO 080	CS1220R-0805J
C5	CAP ELC RD 10UF 16V	CE0448
C6	CAP ELC RD 10UF 16V	CE0448
C7	CAP ELC RD 33UF 16V	CE0457
C8	CAP ELC RD 33UF 16V	CE0457
C9	CAP SM CER 22PF 5% 50V NPO 080	CS1220R-0805J
C10	CAP SM CER 22PF 5% 50V NPO 080	CS1220R-0805J
C11	CAP ELC RD 10UF 16V	CE0448
C12	CAP ELC RD 10UF 16V	CE0448
C13	CAP SM CER 100NF 10% 50V X5R 0	CS7104R-0805K
C14	CAP SM CER 100NF 10% 50V X5R 0	CS7104R-0805K
C15	CAP SM CER 100NF 10% 50V X5R 0	CS7104R-0805K
C16	CAP SM CER 100NF 10% 50V X5R 0	CS7104R-0805K
C17	CAP SM CER 100NF 10% 50V X5R 0	CS7104R-0805K
C18	CAP SM CER 100NF 10% 50V X5R 0	CS7104R-0805K
C19	CAP SM CER 100NF 10% 50V X5R 0	CS7104R-0805K
C20	CAP SM CER 220NF 10% 25V X7R 0	CS7224R-0805K
C21	CAP ELC RD 2.2UF 50V TPD 0.2"	CE0416
C22	CAP ELC RD 2.2UF 50V TPD 0.2"	CE0416

C23	CAP ELC RD 33UF 16V	CE0457
C24	CAP SM CER 220NF 10% 25V X7R 0	CS7224R-0805K
C25	CAP ELC RD 47UF 63V 0.2"	CE0402
C26	CAP SM CER 100NF 10% 50V X5R 0	CS7104R-0805K
C27	CAP ELEC VERT 10UF 63V SKP 5X1	CE0462
C28	CAP SM CER 100NF 10% 50V X5R 0	CS7104R-0805K
C29	CAP ELC RD 33UF 16V	CE0457
C30	CAP SM CER 100NF 10% 50V X5R 0	CS7104R-0805K
C31	CAP SM CER 10NF 10% 50V X7R 08	CS7103R-0805K
C32	CAP SM CER 10NF 10% 50V X7R 08	CS7103R-0805K
C67	CAP SM CER 100PF 5% 50V NPO 08	CS1101R-0805J
C68	CAP ELC RD 33UF 16V	CE0457
C69	CAP ELC RD 33UF 16V	CE0457
C100	CAP ELC RD 3300UF 6.3V	CE0549
C101	CAP ELC RD 47UF 63V 0.2"	CE0402
C102	CAP ELC RD 47UF 63V 0.2"	CE0402
C103	CAP SM CER 1.8NF 10% 100V X7R	CS7182R-0805K
C104	CAP SM CER 1.8NF 10% 100V X7R	CS7182R-0805K
C105	CAP SM CER 22PF 5% 50V NPO 080	CS1220R-0805J
C106	CAP SM CER 22PF 5% 50V NPO 080	CS1220R-0805J
C107	CAP MICRO-BOX 3.3NF 63V 5% 5MM	CC0241
C108	CAP MICRO-BOX 10NF 63V 5% 5MM	CC0244
C109	CAP MICRO-BOX 68NF 63V 5% 5MM	CC0249
C110	CAP MICRO-BOX 2.2NF 63V 5%	CC0240
C111	CAP MICRO-BOX 2.2NF 63V 5%	CC0240
C112	CAP ELC RD 33UF 16V	CE0457
C115	CAP ELC RD 10UF 16V	CE0448
C116	CAP SM CER 100NF 10% 50V X5R 0	CS7104R-0805K
C119	CAP ELC RD 4.7UF 50V	CE0440
C120	CAP SM CER 100NF 10% 50V X5R 0	CS7104R-0805K
C160	CAP SM CER 22PF 5% 50V NPO 080	CS1220R-0805J
C161	CAP SM CER 22PF 5% 50V NPO 080	CS1220R-0805J
C196	CAP SM CER 100PF 5% 50V NPO 08	CS1101R-0805J
C200	CAP ELC RD 3300UF 6.3V	CE0549
C201	CAP ELC RD 47UF 63V 0.2"	CE0402
C202	CAP ELC RD 47UF 63V 0.2"	CE0402
C203	CAP SM CER 1.8NF 10% 100V X7R	CS7182R-0805K
C204	CAP SM CER 1.8NF 10% 100V X7R	CS7182R-0805K
C205	CAP SM CER 22PF 5% 50V NPO 080	CS1220R-0805J
C206	CAP SM CER 22PF 5% 50V NPO 080	CS1220R-0805J
C207	CAP MICRO-BOX 3.3NF 63V 5% 5MM	CC0241
C208	CAP MICRO-BOX 10NF 63V 5% 5MM	CC0244
C209	CAP MICRO-BOX 68NF 63V 5% 5MM	CC0249
C210	CAP MICRO-BOX 2.2NF 63V 5%	CC0240
C211	CAP MICRO-BOX 2.2NF 63V 5%	CC0240
C212	CAP ELC RD 33UF 16V	CE0457
C215	CAP ELC RD 10UF 16V	CE0448
C216	CAP SM CER 100NF 10% 50V X5R 0	CS7104R-0805K
C219	CAP ELC RD 4.7UF 50V	CE0440
C220	CAP SM CER 100NF 10% 50V X5R 0	CS7104R-0805K
C296	CAP SM CER 100PF 5% 50V NPO 08	CS1101R-0805J
C300	CAP ELC RD 3300UF 6.3V	CE0549
C301	CAP ELC RD 47UF 63V 0.2"	CE0402
C302	CAP ELC RD 47UF 63V 0.2"	CE0402
C303	CAP SM CER 1.8NF 10% 100V X7R	CS7182R-0805K
C304	CAP SM CER 1.8NF 10% 100V X7R	CS7182R-0805K
C305	CAP SM CER 22PF 5% 50V NPO 080	CS1220R-0805J
C306	CAP SM CER 22PF 5% 50V NPO 080	CS1220R-0805J
C307	CAP MICRO-BOX 3.3NF 63V 5% 5MM	CC0241
C308	CAP MICRO-BOX 10NF 63V 5% 5MM	CC0244
C309	CAP MICRO-BOX 68NF 63V 5% 5MM	CC0249

C310	CAP MICRO-BOX 2.2NF 63V 5%	CC0240
C311	CAP MICRO-BOX 2.2NF 63V 5%	CC0240
C312	CAP ELC RD 33UF 16V	CE0457
C315	CAP ELC RD 10UF 16V	CE0448
C319	CAP ELC RD 4.7UF 50V	CE0440
C320	CAP SM CER 100NF 10% 50V X5R 0	CS7104R-0805K
C396	CAP SM CER 100PF 5% 50V NPO 08	CS1101R-0805J
C400	CAP ELC RD 3300UF 6.3V	CE0549
C401	CAP ELC RD 47UF 63V 0.2"	CE0402
C402	CAP ELC RD 47UF 63V 0.2"	CE0402
C403	CAP SM CER 1.8NF 10% 100V X7R	CS7182R-0805K
C404	CAP SM CER 1.8NF 10% 100V X7R	CS7182R-0805K
C405	CAP SM CER 22PF 5% 50V NPO 080	CS1220R-0805J
C406	CAP SM CER 22PF 5% 50V NPO 080	CS1220R-0805J
C407	CAP MICRO-BOX 3.3NF 63V 5% 5MM	CC0241
C408	CAP MICRO-BOX 10NF 63V 5% 5MM	CC0244
C409	CAP MICRO-BOX 68NF 63V 5% 5MM	CC0249
C410	CAP MICRO-BOX 2.2NF 63V 5%	CC0240
C411	CAP MICRO-BOX 2.2NF 63V 5%	CC0240
C412	CAP ELC RD 33UF 16V	CE0457
C415	CAP ELC RD 10UF 16V	CE0448
C419	CAP ELC RD 4.7UF 50V	CE0440
C420	CAP SM CER 100NF 10% 50V X5R 0	CS7104R-0805K
C496	CAP SM CER 100PF 5% 50V NPO 08	CS1101R-0805J
C500	CAP ELC RD 3300UF 6.3V	CE0549
C501	CAP ELC RD 47UF 63V 0.2"	CE0402
C502	CAP ELC RD 47UF 63V 0.2"	CE0402
C503	CAP SM CER 1.8NF 10% 100V X7R	CS7182R-0805K
C504	CAP SM CER 1.8NF 10% 100V X7R	CS7182R-0805K
C505	CAP SM CER 22PF 5% 50V NPO 080	CS1220R-0805J
C506	CAP SM CER 22PF 5% 50V NPO 080	CS1220R-0805J
C507	CAP MICRO-BOX 3.3NF 63V 5% 5MM	CC0241
C508	CAP MICRO-BOX 10NF 63V 5% 5MM	CC0244
C509	CAP MICRO-BOX 68NF 63V 5% 5MM	CC0249
C510	CAP MICRO-BOX 2.2NF 63V 5%	CC0240
C511	CAP MICRO-BOX 2.2NF 63V 5%	CC0240
C512	CAP ELC RD 33UF 16V	CE0457
C515	CAP ELC RD 10UF 16V	CE0448
C519	CAP ELC RD 4.7UF 50V	CE0440
C520	CAP SM CER 100NF 10% 50V X5R 0	CS7104R-0805K
C596	CAP SM CER 100PF 5% 50V NPO 08	CS1101R-0805J
C600	CAP ELC RD 3300UF 6.3V	CE0549
C601	CAP ELC RD 47UF 63V 0.2"	CE0402
C602	CAP ELC RD 47UF 63V 0.2"	CE0402
C603	CAP SM CER 1.8NF 10% 100V X7R	CS7182R-0805K
C604	CAP SM CER 1.8NF 10% 100V X7R	CS7182R-0805K
C605	CAP SM CER 22PF 5% 50V NPO 080	CS1220R-0805J
C606	CAP SM CER 22PF 5% 50V NPO 080	CS1220R-0805J
C607	CAP MICRO-BOX 3.3NF 63V 5% 5MM	CC0241
C608	CAP MICRO-BOX 10NF 63V 5% 5MM	CC0244
C609	CAP MICRO-BOX 68NF 63V 5% 5MM	CC0249
C610	CAP MICRO-BOX 2.2NF 63V 5%	CC0240
C611	CAP MICRO-BOX 2.2NF 63V 5%	CC0240
C612	CAP ELC RD 33UF 16V	CE0457
C615	CAP ELC RD 10UF 16V	CE0448
C619	CAP ELC RD 4.7UF 50V	CE0440
C620	CAP SM CER 100NF 10% 50V X5R 0	CS7104R-0805K
C696	CAP SM CER 100PF 5% 50V NPO 08	CS1101R-0805J
C700	CAP ELC RD 3300UF 6.3V	CE0549
C701	CAP ELC RD 47UF 63V 0.2"	CE0402
C702	CAP ELC RD 47UF 63V 0.2"	CE0402

C703	CAP SM CER 1.8NF 10% 100V X7R	CS7182R-0805K
C704	CAP SM CER 1.8NF 10% 100V X7R	CS7182R-0805K
C705	CAP SM CER 22PF 5% 50V NPO 080	CS1220R-0805J
C706	CAP SM CER 22PF 5% 50V NPO 080	CS1220R-0805J
C707	CAP MICRO-BOX 3.3NF 63V 5% 5MM	CC0241
C708	CAP MICRO-BOX 10NF 63V 5% 5MM	CC0244
C709	CAP MICRO-BOX 68NF 63V 5% 5MM	CC0249
C710	CAP MICRO-BOX 2.2NF 63V 5%	CC0240
C711	CAP MICRO-BOX 2.2NF 63V 5%	CC0240
C712	CAP ELC RD 33UF 16V	CE0457
C715	CAP ELC RD 10UF 16V	CE0448
C719	CAP ELC RD 4.7UF 50V	CE0440
C720	CAP SM CER 100NF 10% 50V X5R 0	CS7104R-0805K
C796	CAP SM CER 100PF 5% 50V NPO 08	CS1101R-0805J
C800	CAP ELC RD 3300UF 6.3V	CE0549
C801	CAP ELC RD 47UF 63V 0.2"	CE0402
C802	CAP ELC RD 47UF 63V 0.2"	CE0402
C803	CAP SM CER 1.8NF 10% 100V X7R	CS7182R-0805K
C804	CAP SM CER 1.8NF 10% 100V X7R	CS7182R-0805K
C805	CAP SM CER 22PF 5% 50V NPO 080	CS1220R-0805J
C806	CAP SM CER 22PF 5% 50V NPO 080	CS1220R-0805J
C807	CAP MICRO-BOX 3.3NF 63V 5% 5MM	CC0241
C808	CAP MICRO-BOX 10NF 63V 5% 5MM	CC0244
C809	CAP MICRO-BOX 68NF 63V 5% 5MM	CC0249
C810	CAP MICRO-BOX 2.2NF 63V 5%	CC0240
C811	CAP MICRO-BOX 2.2NF 63V 5%	CC0240
C812	CAP ELC RD 33UF 16V	CE0457
C815	CAP ELC RD 10UF 16V	CE0448
C819	CAP ELC RD 4.7UF 50V	CE0440
C820	CAP SM CER 100NF 10% 50V X5R 0	CS7104R-0805K
C896	CAP SM CER 100PF 5% 50V NPO 08	CS1101R-0805J
C900	CAP ELC RD 3300UF 6.3V	CE0549
C901	CAP ELC RD 47UF 63V 0.2"	CE0402
C902	CAP ELC RD 47UF 63V 0.2"	CE0402
C903	CAP SM CER 1.8NF 10% 100V X7R	CS7182R-0805K
C904	CAP SM CER 1.8NF 10% 100V X7R	CS7182R-0805K
C905	CAP SM CER 22PF 5% 50V NPO 080	CS1220R-0805J
C906	CAP SM CER 22PF 5% 50V NPO 080	CS1220R-0805J
C907	CAP MICRO-BOX 3.3NF 63V 5% 5MM	CC0241
C908	CAP MICRO-BOX 10NF 63V 5% 5MM	CC0244
C909	CAP MICRO-BOX 68NF 63V 5% 5MM	CC0249
C910	CAP MICRO-BOX 2.2NF 63V 5%	CC0240
C911	CAP MICRO-BOX 2.2NF 63V 5%	CC0240
C912	CAP ELC RD 33UF 16V	CE0457
C915	CAP ELC RD 10UF 16V	CE0448
C916	CAP SM CER 100NF 10% 50V X5R 0	CS7104R-0805K
C919	CAP ELC RD 4.7UF 50V	CE0440
C920	CAP SM CER 100NF 10% 50V X5R 0	CS7104R-0805K
C996	CAP SM CER 100PF 5% 50V NPO 08	CS1101R-0805J
C1000	CAP ELC RD 3300UF 6.3V	CE0549
C1001	CAP ELC RD 47UF 63V 0.2"	CE0402
C1002	CAP ELC RD 47UF 63V 0.2"	CE0402
C1003	CAP SM CER 1.8NF 10% 100V X7R	CS7182R-0805K
C1004	CAP SM CER 1.8NF 10% 100V X7R	CS7182R-0805K
C1005	CAP SM CER 22PF 5% 50V NPO 080	CS1220R-0805J
C1006	CAP SM CER 22PF 5% 50V NPO 080	CS1220R-0805J
C1007	CAP MICRO-BOX 3.3NF 63V 5% 5MM	CC0241
C1008	CAP MICRO-BOX 10NF 63V 5% 5MM	CC0244
C1009	CAP MICRO-BOX 68NF 63V 5% 5MM	CC0249
C1010	CAP MICRO-BOX 2.2NF 63V 5%	CC0240
C1011	CAP MICRO-BOX 2.2NF 63V 5%	CC0240

C1012	CAP ELC RD 33UF 16V	CE0457
C1015	CAP ELC RD 10UF 16V	CE0448
C1016	CAP SM CER 100NF 10% 50V X5R 0	CS7104R-0805K
C1019	CAP ELC RD 4.7UF 50V	CE0440
C1020	CAP SM CER 100NF 10% 50V X5R 0	CS7104R-0805K
C1096	CAP SM CER 100PF 5% 50V NPO 08	CS1101R-0805J
C1100	CAP ELC RD 3300UF 6.3V	CE0549
C1101	CAP ELC RD 47UF 63V 0.2"	CE0402
C1102	CAP ELC RD 47UF 63V 0.2"	CE0402
C1103	CAP SM CER 1.8NF 10% 100V X7R	CS7182R-0805K
C1104	CAP SM CER 1.8NF 10% 100V X7R	CS7182R-0805K
C1105	CAP SM CER 22PF 5% 50V NPO 080	CS1220R-0805J
C1106	CAP SM CER 22PF 5% 50V NPO 080	CS1220R-0805J
C1107	CAP MICRO-BOX 3.3NF 63V 5% 5MM	CC0241
C1108	CAP MICRO-BOX 10NF 63V 5% 5MM	CC0244
C1109	CAP MICRO-BOX 68NF 63V 5% 5MM	CC0249
C1110	CAP MICRO-BOX 2.2NF 63V 5%	CC0240
C1111	CAP MICRO-BOX 2.2NF 63V 5%	CC0240
C1112	CAP ELC RD 33UF 16V	CE0457
C1115	CAP ELC RD 10UF 16V	CE0448
C1119	CAP ELC RD 4.7UF 50V	CE0440
C1120	CAP SM CER 100NF 10% 50V X5R 0	CS7104R-0805K
C1196	CAP SM CER 100PF 5% 50V NPO 08	CS1101R-0805J
C1200	CAP ELC RD 3300UF 6.3V	CE0549
C1201	CAP ELC RD 47UF 63V 0.2"	CE0402
C1202	CAP ELC RD 47UF 63V 0.2"	CE0402
C1203	CAP SM CER 1.8NF 10% 100V X7R	CS7182R-0805K
C1204	CAP SM CER 1.8NF 10% 100V X7R	CS7182R-0805K
C1205	CAP SM CER 22PF 5% 50V NPO 080	CS1220R-0805J
C1206	CAP SM CER 22PF 5% 50V NPO 080	CS1220R-0805J
C1207	CAP MICRO-BOX 3.3NF 63V 5% 5MM	CC0241
C1208	CAP MICRO-BOX 10NF 63V 5% 5MM	CC0244
C1209	CAP MICRO-BOX 68NF 63V 5% 5MM	CC0249
C1210	CAP MICRO-BOX 2.2NF 63V 5%	CC0240
C1211	CAP MICRO-BOX 2.2NF 63V 5%	CC0240
C1212	CAP ELC RD 33UF 16V	CE0457
C1215	CAP ELC RD 10UF 16V	CE0448
C1219	CAP ELC RD 4.7UF 50V	CE0440
C1220	CAP SM CER 100NF 10% 50V X5R 0	CS7104R-0805K
C1296	CAP SM CER 100PF 5% 50V NPO 08	CS1101R-0805J
C1300	CAP SM CER 100NF 10% 50V X5R 0	CS7104R-0805K
C1301	CAP MICRO-BOX 4.7NF 63V 5% 5MM	CC0242
C1302	CAP MICRO-BOX 4.7NF 63V 5% 5MM	CC0242
C1303	CAP SM CER 100PF 5% 50V NPO 08	CS1101R-0805J
C1304	CAP ELC RD 100UF 10V TPD 0.2"	CE0403
C1305	CAP ELC RD 100UF 10V TPD 0.2"	CE0403
C1306	CAP ELC RD 4.7UF 50V	CE0440
C1311	CAP MICRO-BOX 68NF 63V 5% 5MM	CC0249
C1312	CAP ELC RD 220UF 10V	CE0454
C1313	CAP MICRO-BOX 68NF 63V 5% 5MM	CC0249
C1314	CAP ELC RD 220UF 10V	CE0454
C1315	CAP SM CER 100PF 5% 50V NPO 08	CS1101R-0805J
C1316	CAP MICRO-BOX 15NF 63V 5% 5MM	CC0245
C1317	CAP MICRO-BOX 15NF 63V 5% 5MM	CC0245
C1318	CAP MICRO-BOX 15NF 63V 5% 5MM	CC0245
C1319	CAP MICRO-BOX 15NF 63V 5% 5MM	CC0245
C1400	CAP SM CER 100NF 10% 50V X5R 0	CS7104R-0805K
C1401	CAP MICRO-BOX 4.7NF 63V 5% 5MM	CC0242
C1402	CAP MICRO-BOX 4.7NF 63V 5% 5MM	CC0242
C1403	CAP SM CER 100PF 5% 50V NPO 08	CS1101R-0805J
C1404	CAP ELC RD 100UF 10V TPD 0.2"	CE0403

C1405	CAP ELC RD 100UF 10V TPD 0.2"	CE0403
C1406	CAP ELC RD 4.7UF 50V	CE0440
C1411	CAP MICRO-BOX 68NF 63V 5% 5MM	CC0249
C1412	CAP ELC RD 220UF 10V	CE0454
C1413	CAP MICRO-BOX 68NF 63V 5% 5MM	CC0249
C1414	CAP ELC RD 220UF 10V	CE0454
C1415	CAP SM CER 100PF 5% 50V NPO 08	CS1101R-0805J
C1416	CAP MICRO-BOX 15NF 63V 5% 5MM	CC0245
C1417	CAP MICRO-BOX 15NF 63V 5% 5MM	CC0245
C1418	CAP MICRO-BOX 15NF 63V 5% 5MM	CC0245
C1419	CAP MICRO-BOX 15NF 63V 5% 5MM	CC0245
C2000	CAP ELC RD 47UF 25V TPD 0.2"	CE0401
C2001	CAP ELC RD 47UF 25V TPD 0.2"	CE0401
C2002	CAP SM CER 220PF 5% 100V NPO 0	CS1221R-0805J
C2003	CAP SM CER 220PF 5% 100V NPO 0	CS1221R-0805J
C2004	CAP SM CER 100NF 10% 50V X5R 0	CS7104R-0805K
C2005	CAP SM CER 100NF 10% 50V X5R 0	CS7104R-0805K
C2010	CAP ELC RD 4.7UF 50V	CE0440
C2011	CAP SM CER 100PF 5% 50V NPO 08	CS1101R-0805J
C2012	CAP SM CER 100PF 5% 50V NPO 08	CS1101R-0805J
C2013	CAP SM CER 100PF 5% 50V NPO 08	CS1101R-0805J
C2014	CAP SM CER 100PF 5% 50V NPO 08	CS1101R-0805J
C2015	CAP SM CER 100PF 5% 50V NPO 08	CS1101R-0805J
C2016	CAP SM CER 100PF 5% 50V NPO 08	CS1101R-0805J
C2017	CAP ELC RD 33UF 16V	CE0457
C2018	CAP ELC RD 33UF 16V	CE0457
C2019	CAP SM CER 100NF 10% 50V X5R 0	CS7104R-0805K
C2020	CAP SM CER 100NF 10% 50V X5R 0	CS7104R-0805K
C2021	CAP ELC RD 33UF 16V	CE0457
C2022	CAP ELC RD 33UF 16V	CE0457
CN1	XLR A-SRS PLASTIC ML PIN1 GND	FK0970
CN2	XLR A-SRS PLASTIC ML PIN1 GND	FK0970
CN3	JACK SKT STEREO VERT 3PINMAT N	FH0807
CN4	JACK SKT STEREO VERT 3PINMAT N	FH0807
CN5	JACK SKT STEREO VERT 3PINMAT N	FH0807
CN6	JACK SKT STEREO VERT 3PINMAT N	FH0807
CN7	JACK SKT STEREO VERT 3PINMAT N	FH0807
CN8	CON QUAD PC PHONO SKT.GOLD PLT	FH0804
CN9	6WY 2MM L/PRF VERT LCKG ML HDR	FF1019
CN10	JACK SKT STEREO VERT 5PIN MATT	FH0808
CN11	JACK SKT STEREO VERT 5PIN MATT	FH0808
CN100	XLR CON FML VERT	FK0967-01
CN101	JACK SKT STEREO VERT 3PINMAT N	FH0807
CN102	JACK SKT STEREO VERT 5PIN MATT	FH0808
CN160	JACK SKT STEREO VERT 3PINMAT N	FH0807
CN200	XLR CON FML VERT	FK0967-01
CN201	JACK SKT STEREO VERT 3PINMAT N	FH0807
CN202	JACK SKT STEREO VERT 5PIN MATT	FH0808
CN300	XLR CON FML VERT	FK0967-01
CN301	JACK SKT STEREO VERT 3PINMAT N	FH0807
CN302	JACK SKT STEREO VERT 5PIN MATT	FH0808
CN400	XLR CON FML VERT	FK0967-01
CN401	JACK SKT STEREO VERT 3PINMAT N	FH0807
CN402	JACK SKT STEREO VERT 5PIN MATT	FH0808
CN500	XLR CON FML VERT	FK0967-01
CN501	JACK SKT STEREO VERT 3PINMAT N	FH0807
CN502	JACK SKT STEREO VERT 5PIN MATT	FH0808
CN600	XLR CON FML VERT	FK0967-01
CN601	JACK SKT STEREO VERT 3PINMAT N	FH0807
CN602	JACK SKT STEREO VERT 5PIN MATT	FH0808
CN700	XLR CON FML VERT	FK0967-01

CN701	JACK SKT STEREO VERT 3PINMAT N	FH0807
CN702	JACK SKT STEREO VERT 5PIN MATT	FH0808
CN800	XLR CON FML VERT	FK0967-01
CN801	JACK SKT STEREO VERT 3PINMAT N	FH0807
CN802	JACK SKT STEREO VERT 5PIN MATT	FH0808
CN900	XLR CON FML VERT	FK0967-01
CN901	JACK SKT STEREO VERT 3PINMAT N	FH0807
CN902	JACK SKT STEREO VERT 5PIN MATT	FH0808
CN1001	JACK SKT STEREO VERT 3PINMAT N	FH0807
CN1002	JACK SKT STEREO VERT 5PIN MATT	FH0808
CN1100	XLR CON FML VERT	FK0967-01
CN1101	JACK SKT STEREO VERT 3PINMAT N	FH0807
CN1102	JACK SKT STEREO VERT 5PIN MATT	FH0808
CN1200	XLR CON FML VERT	FK0967-01
CN1201	JACK SKT STEREO VERT 3PINMAT N	FH0807
CN1202	JACK SKT STEREO VERT 5PIN MATT	FH0808
CN1300	JACK SKT STEREO VERT 5PIN MATT	FH0808
CN1301	JACK SKT STEREO VERT 3PINMAT N	FH0807
CN1400	JACK SKT STEREO VERT 5PIN MATT	FH0808
CN1401	JACK SKT STEREO VERT 3PINMAT N	FH0807
CN1000	XLR CON FML VERT	FK0967-01
CN2001	8WY 2MM L/PRF VERT LCKG ML HDR	FF1020
CN2002	JACK SKT STEREO VERT 3PINMAT N	FH0807
CN2003	JACK SKT STEREO VERT 3PINMAT N	FH0807
CN2004	JACK SKT STEREO VERT 5PIN MATT	FH0808
D1	DHS BAV70 C/CTHD	BS0013R-SOT23
D2	DHS BAV70 C/CTHD	BS0013R-SOT23
D100	DHS BAV70 C/CTHD	BS0013R-SOT23
D1000	DHS BAV70 C/CTHD	BS0013R-SOT23
D1001	DHS BAV70 C/CTHD	BS0013R-SOT23
D1003	DHS BAV70 C/CTHD	BS0013R-SOT23
D1004	DHS BAV70 C/CTHD	BS0013R-SOT23
D101	DHS BAV70 C/CTHD	BS0013R-SOT23
D103	DHS BAV70 C/CTHD	BS0013R-SOT23
D104	DHS BAV70 C/CTHD	BS0013R-SOT23
D1100	DHS BAV70 C/CTHD	BS0013R-SOT23
D1101	DHS BAV70 C/CTHD	BS0013R-SOT23
D1103	DHS BAV70 C/CTHD	BS0013R-SOT23
D1104	DHS BAV70 C/CTHD	BS0013R-SOT23
D1200	DHS BAV70 C/CTHD	BS0013R-SOT23
D1201	DHS BAV70 C/CTHD	BS0013R-SOT23
D1203	DHS BAV70 C/CTHD	BS0013R-SOT23
D1204	DHS BAV70 C/CTHD	BS0013R-SOT23
D1300	DHS BAV70 C/CTHD	BS0013R-SOT23
D1301	DHS BAV70 C/CTHD	BS0013R-SOT23
D1400	DHS BAV70 C/CTHD	BS0013R-SOT23
D1401	DHS BAV70 C/CTHD	BS0013R-SOT23
D200	DHS BAV70 C/CTHD	BS0013R-SOT23
D2000	DHS BAV70 C/CTHD	BS0013R-SOT23
D2001	DHS BAV70 C/CTHD	BS0013R-SOT23
D201	DHS BAV70 C/CTHD	BS0013R-SOT23
D203	DHS BAV70 C/CTHD	BS0013R-SOT23
D204	DHS BAV70 C/CTHD	BS0013R-SOT23
D300	DHS BAV70 C/CTHD	BS0013R-SOT23
D301	DHS BAV70 C/CTHD	BS0013R-SOT23
D303	DHS BAV70 C/CTHD	BS0013R-SOT23
D304	DHS BAV70 C/CTHD	BS0013R-SOT23
D400	DHS BAV70 C/CTHD	BS0013R-SOT23
D401	DHS BAV70 C/CTHD	BS0013R-SOT23
D403	DHS BAV70 C/CTHD	BS0013R-SOT23
D404	DHS BAV70 C/CTHD	BS0013R-SOT23

D500	DHS BAV70 C/CTHD	BS0013R-SOT23
D501	DHS BAV70 C/CTHD	BS0013R-SOT23
D503	DHS BAV70 C/CTHD	BS0013R-SOT23
D504	DHS BAV70 C/CTHD	BS0013R-SOT23
D600	DHS BAV70 C/CTHD	BS0013R-SOT23
D601	DHS BAV70 C/CTHD	BS0013R-SOT23
D603	DHS BAV70 C/CTHD	BS0013R-SOT23
D604	DHS BAV70 C/CTHD	BS0013R-SOT23
D700	DHS BAV70 C/CTHD	BS0013R-SOT23
D701	DHS BAV70 C/CTHD	BS0013R-SOT23
D703	DHS BAV70 C/CTHD	BS0013R-SOT23
D704	DHS BAV70 C/CTHD	BS0013R-SOT23
D800	DHS BAV70 C/CTHD	BS0013R-SOT23
D801	DHS BAV70 C/CTHD	BS0013R-SOT23
D803	DHS BAV70 C/CTHD	BS0013R-SOT23
D804	DHS BAV70 C/CTHD	BS0013R-SOT23
D900	DHS BAV70 C/CTHD	BS0013R-SOT23
D901	DHS BAV70 C/CTHD	BS0013R-SOT23
D903	DHS BAV70 C/CTHD	BS0013R-SOT23
D904	DHS BAV70 C/CTHD	BS0013R-SOT23
EN2001,	SWT RTRY ENCDR BIN 16P 16POS 3	DH10012
IC1	DUAL OP-AMP	BS7009R-SO8
IC3	DUAL OP-AMP	BS7009R-SO8
IC4	DUAL OP-AMP	BS7009R-SO8
IC5	IC 74HC4053 3X2CH DMPLX/MPLX A	BS10035
IC6	DUAL OP-AMP	BS7009R-SO8
IC7	DUAL OP-AMP	BS7009R-SO8
IC8	DUAL OP-AMP	BS7009R-SO8
IC10	IC QUAD COMPARATOR LM2901MX	BS7007R-SO14
IC11	IC QUAD COMPARATOR LM2901MX	BS7007R-SO14
IC12	IC QUAD COMPARATOR LM2901MX	BS7007R-SO14
IC13	IC QUAD COMPARATOR LM2901MX	BS7007R-SO14
IC14	IC QUAD COMPARATOR LM2901MX	BS7007R-SO14
IC100	QUAD OP-AMP	BS7002
IC1000	QUAD OP-AMP	BS7002
IC1100	QUAD OP-AMP	BS7002
IC1200	QUAD OP-AMP	BS7002
IC200	QUAD OP-AMP	BS7002
IC2001	QUAD OP-AMP	BS7002
IC300	QUAD OP-AMP	BS7002
IC400	QUAD OP-AMP	BS7002
IC500	QUAD OP-AMP	BS7002
IC600	QUAD OP-AMP	BS7002
IC700	QUAD OP-AMP	BS7002
IC800	QUAD OP-AMP	BS7002
IC900	QUAD OP-AMP	BS7002
LD1	LED RED 3MM S/B"17.5"-MD6748	JA0109
LD2	LED GREEN 3MM S/B"17.5"-MD6748	JA0110
LD3	LED GREEN 3MM S/B"17.5"-MD6748	JA0110
LD4	LED GREEN 3MM S/B"17.5"-MD6748	JA0110
LD5	LED GREEN 3MM S/B"17.5"-MD6748	JA0110
LD6	LED GREEN 3MM S/B"17.5"-MD6748	JA0110
LD7	LED AMBER 3MM S/B 17.5 MD6748	JA0129
LD8	LED AMBER 3MM S/B 17.5 MD6748	JA0129
LD9	LED AMBER 3MM S/B 17.5 MD6748	JA0129
LD10	LED RED 3MM S/B"17.5"-MD6748	JA0109
LD11	LED RED 3MM S/B"17.5"-MD6748	JA0109
LD12	LED GREEN 3MM S/B"17.5"-MD6748	JA0110
LD13	LED GREEN 3MM S/B"17.5"-MD6748	JA0110
LD14	LED GREEN 3MM S/B"17.5"-MD6748	JA0110
LD15	LED GREEN 3MM S/B"17.5"-MD6748	JA0110

LD16	LED GREEN 3MM S/B"17.5"-MD6748	JA0110
LD17	LED AMBER 3MM S/B 17.5 MD6748	JA0129
LD18	LED AMBER 3MM S/B 17.5 MD6748	JA0129
LD19	LED AMBER 3MM S/B 17.5 MD6748	JA0129
LD20	LED RED 3MM S/B"17.5"-MD6748	JA0109
LD21	LED RED 3MM S/B"17.5"-MD6748	JA0109
LD22	LED GREEN 3MM S/B"17.5"-MD6748	JA0110
LD23	LED RED 3MM S/B"17.5"-MD6748	JA0109
LD100	LED RED 3MM S/B"17.5"-MD6748	JA0109
LD1000	LED RED 3MM S/B"17.5"-MD6748	JA0109
LD1100	LED RED 3MM S/B"17.5"-MD6748	JA0109
LD1200	LED RED 3MM S/B"17.5"-MD6748	JA0109
LD1300	LED RED 3MM S/B"17.5"-MD6748	JA0109
LD1400	LED RED 3MM S/B"17.5"-MD6748	JA0109
LD200	LED RED 3MM S/B"17.5"-MD6748	JA0109
LD2000	LED RED 3MM S/B"17.5"-MD6748	JA0109
LD2001	LED RED 3MM S/B"17.5"-MD6748	JA0109
LD2002	LED RED 3MM S/B"17.5"-MD6748	JA0109
LD2003	LED RED 3MM S/B"17.5"-MD6748	JA0109
LD2004	LED GREEN 3MM S/B"17.5"-MD6748	JA0110
LD2005	LED GREEN 3MM S/B"17.5"-MD6748	JA0110
LD2006	LED AMBER 3MM S/B 17.5 MD6748	JA0129
LD2007	LED AMBER 3MM S/B 17.5 MD6748	JA0129
LD2008	LED RED 3MM S/B"17.5"-MD6748	JA0109
LD300	LED RED 3MM S/B"17.5"-MD6748	JA0109
LD400	LED RED 3MM S/B"17.5"-MD6748	JA0109
LD500	LED RED 3MM S/B"17.5"-MD6748	JA0109
LD600	LED RED 3MM S/B"17.5"-MD6748	JA0109
LD700	LED RED 3MM S/B"17.5"-MD6748	JA0109
LD800	LED RED 3MM S/B"17.5"-MD6748	JA0109
LD900	LED RED 3MM S/B"17.5"-MD6748	JA0109
LK22	RES SM 0R0 1% 0.1W 0805	AS0000R-0805F
P1	ALPS 14MM VERT 20KWX2 37.5MM	DM1381
P2	ALPS 14MM VERT 20KWX2 37.5MM	DM1381
P3	FDR PAN 75MM 10KA MONO	DD0408
P4	FDR PAN 75MM 10KA MONO	DD0408
P100	ALPS 11MM 10K MIC LAW 37.5MM	DM1398
P1000	ALPS 11MM 10K MIC LAW 37.5MM	DM1398
P1001	POT 20K 9MM V/MNT C/D TA	DM10029
P1002	ALPS 11MM VERT 200KCX2 HIGH/D	DM1323
P1003	POT 20K 9MM V/MNT C/D TA	DM10029
P1004	POT 20K 9MM V/MNT C/D TA	DM10029
P1005	FDR PAN 75MM 10KA MONO	DD0408
P1006	POT 10KAC C/D 14MM V/MNT TA	DM10034
P1007	POT 20KK DUAL 12MM TA	DM10035
P1008	POT 20KK 9MM V/MNT TA	DM10030
P101	POT 20K 9MM V/MNT C/D TA	DM10029
P102	ALPS 11MM VERT 200KCX2 HIGH/D	DM1323
P103	POT 20K 9MM V/MNT C/D TA	DM10029
P104	POT 20K 9MM V/MNT C/D TA	DM10029
P105	FDR PAN 75MM 10KA MONO	DD0408
P106	POT 10KAC C/D 14MM V/MNT TA	DM10034
P107	POT 20KK DUAL 12MM TA	DM10035
P108	POT 20KK 9MM V/MNT TA	DM10030
P1100	ALPS 11MM 10K MIC LAW 37.5MM	DM1398
P1101	POT 20K 9MM V/MNT C/D TA	DM10029
P1102	ALPS 11MM VERT 200KCX2 HIGH/D	DM1323
P1103	POT 20K 9MM V/MNT C/D TA	DM10029
P1104	POT 20K 9MM V/MNT C/D TA	DM10029
P1105	FDR PAN 75MM 10KA MONO	DD0408
P1106	POT 10KAC C/D 14MM V/MNT TA	DM10034

P1107	POT 20KK DUAL 12MM TA	DM10035
P1108	POT 20KK 9MM V/MNT TA	DM10030
P1200	ALPS 11MM 10K MIC LAW 37.5MM	DM1398
P1201	POT 20K 9MM V/MNT C/D TA	DM10029
P1202	ALPS 11MM VERT 200KCX2 HIGH/D	DM1323
P1203	POT 20K 9MM V/MNT C/D TA	DM10029
P1204	POT 20K 9MM V/MNT C/D TA	DM10029
P1205	FDR PAN 75MM 10KA MONO	DD0408
P1206	POT 10KAC C/D 14MM V/MNT TA	DM10034
P1207	POT 20KK DUAL 12MM TA	DM10035
P1208	POT 20KK 9MM V/MNT TA	DM10030
P1300	FDR PAN 75MM 10KX2 STER A	DD0409
P1301	POT 20KBX2 12MM V/MNT TA	DM10036
P1302	POT 20KK DUAL 12MM TA	DM10035
P1303	POT 20KK 9MM V/MNT TA	DM10030
P1304	POT 20KBX2 12MM V/MNT TA	DM10036
P1305	ALPS 14MM VERT 20KWX2 37.5MM	DM1381
P1306	POT 10KAC C/D 14MM V/MNT TA	DM10034
P1307	POT 20KBX2 12MM V/MNT TA	DM10036
P1400	FDR PAN 75MM 10KX2 STER A	DD0409
P1401	POT 20KBX2 12MM V/MNT TA	DM10036
P1402	POT 20KK DUAL 12MM TA	DM10035
P1403	POT 20KK 9MM V/MNT TA	DM10030
P1404	POT 20KBX2 12MM V/MNT TA	DM10036
P1405	ALPS 14MM VERT 20KWX2 37.5MM	DM1381
P1406	POT 10KAC C/D 14MM V/MNT TA	DM10034
P1407	POT 20KBX2 12MM V/MNT TA	DM10036
P200	ALPS 11MM 10K MIC LAW 37.5MM	DM1398
P2000	FDR PAN 75MM 10KX2 STER A	DD0409
P2001	POT 20KK DUAL 12MM TA	DM10035
P2002	POT 20KK 9MM V/MNT TA	DM10030
P2003	POT 20KK 9MM V/MNT TA	DM10030
P2004	POT 20KK 9MM V/MNT TA	DM10030
P2005	ALPS 14MM VERT 20KWX2 37.5MM	DM1381
P201	POT 20K 9MM V/MNT C/D TA	DM10029
P202	ALPS 11MM VERT 200KCX2 HIGH/D	DM1323
P203	POT 20K 9MM V/MNT C/D TA	DM10029
P204	POT 20K 9MM V/MNT C/D TA	DM10029
P205	FDR PAN 75MM 10KA MONO	DD0408
P206	POT 10KAC C/D 14MM V/MNT TA	DM10034
P207	POT 20KK DUAL 12MM TA	DM10035
P208	POT 20KK 9MM V/MNT TA	DM10030
P300	ALPS 11MM 10K MIC LAW 37.5MM	DM1398
P301	POT 20K 9MM V/MNT C/D TA	DM10029
P302	ALPS 11MM VERT 200KCX2 HIGH/D	DM1323
P303	POT 20K 9MM V/MNT C/D TA	DM10029
P304	POT 20K 9MM V/MNT C/D TA	DM10029
P305	FDR PAN 75MM 10KA MONO	DD0408
P306	POT 10KAC C/D 14MM V/MNT TA	DM10034
P307	POT 20KK DUAL 12MM TA	DM10035
P308	POT 20KK 9MM V/MNT TA	DM10030
P400	ALPS 11MM 10K MIC LAW 37.5MM	DM1398
P401	POT 20K 9MM V/MNT C/D TA	DM10029
P402	ALPS 11MM VERT 200KCX2 HIGH/D	DM1323
P403	POT 20K 9MM V/MNT C/D TA	DM10029
P404	POT 20K 9MM V/MNT C/D TA	DM10029
P405	FDR PAN 75MM 10KA MONO	DD0408
P406	POT 10KAC C/D 14MM V/MNT TA	DM10034
P407	POT 20KK DUAL 12MM TA	DM10035
P408	POT 20KK 9MM V/MNT TA	DM10030
P500	ALPS 11MM 10K MIC LAW 37.5MM	DM1398

P501	POT 20K 9MM V/MNT C/D TA	DM10029
P502	ALPS 11MM VERT 200KCX2 HIGH/D	DM1323
P503	POT 20K 9MM V/MNT C/D TA	DM10029
P504	POT 20K 9MM V/MNT C/D TA	DM10029
P505	FDR PAN 75MM 10KA MONO	DD0408
P506	POT 10KAC C/D 14MM V/MNT TA	DM10034
P507	POT 20KK DUAL 12MM TA	DM10035
P508	POT 20KK 9MM V/MNT TA	DM10030
P600	ALPS 11MM 10K MIC LAW 37.5MM	DM1398
P601	POT 20K 9MM V/MNT C/D TA	DM10029
P602	ALPS 11MM VERT 200KCX2 HIGH/D	DM1323
P603	POT 20K 9MM V/MNT C/D TA	DM10029
P604	POT 20K 9MM V/MNT C/D TA	DM10029
P605	FDR PAN 75MM 10KA MONO	DD0408
P606	POT 10KAC C/D 14MM V/MNT TA	DM10034
P607	POT 20KK DUAL 12MM TA	DM10035
P608	POT 20KK 9MM V/MNT TA	DM10030
P700	ALPS 11MM 10K MIC LAW 37.5MM	DM1398
P701	POT 20K 9MM V/MNT C/D TA	DM10029
P702	ALPS 11MM VERT 200KCX2 HIGH/D	DM1323
P703	POT 20K 9MM V/MNT C/D TA	DM10029
P704	POT 20K 9MM V/MNT C/D TA	DM10029
P705	FDR PAN 75MM 10KA MONO	DD0408
P706	POT 10KAC C/D 14MM V/MNT TA	DM10034
P707	POT 20KK DUAL 12MM TA	DM10035
P708	POT 20KK 9MM V/MNT TA	DM10030
P800	ALPS 11MM 10K MIC LAW 37.5MM	DM1398
P801	POT 20K 9MM V/MNT C/D TA	DM10029
P802	ALPS 11MM VERT 200KCX2 HIGH/D	DM1323
P803	POT 20K 9MM V/MNT C/D TA	DM10029
P804	POT 20K 9MM V/MNT C/D TA	DM10029
P805	FDR PAN 75MM 10KA MONO	DD0408
P806	POT 10KAC C/D 14MM V/MNT TA	DM10034
P807	POT 20KK DUAL 12MM TA	DM10035
P808	POT 20KK 9MM V/MNT TA	DM10030
P900	ALPS 11MM 10K MIC LAW 37.5MM	DM1398
P901	POT 20K 9MM V/MNT C/D TA	DM10029
P902	ALPS 11MM VERT 200KCX2 HIGH/D	DM1323
P903	POT 20K 9MM V/MNT C/D TA	DM10029
P904	POT 20K 9MM V/MNT C/D TA	DM10029
P905	FDR PAN 75MM 10KA MONO	DD0408
P906	POT 10KAC C/D 14MM V/MNT TA	DM10034
P907	POT 20KK DUAL 12MM TA	DM10035
P908	POT 20KK 9MM V/MNT TA	DM10030
PSW1	ALPS SWT L/TRAVEL VERT MOM	DF0662
PSW2	ALPS SWT L/TRAVEL VERT MOM	DF0662
R1	RES SM 20K 1% 0.1W 0805	AS0203R-0805F
R2	RES SM 20K 1% 0.1W 0805	AS0203R-0805F
R3	RES SM 22K 1% 0.1W 0805	AS0223R-0805F
R4	RES SM 22K 1% 0.1W 0805	AS0223R-0805F
R5	RES SM 10K 1% 0.1W 0805	AS0103R-0805F
R6	RES SM 10K 1% 0.1W 0805	AS0103R-0805F
R7	RES SM 75R 1% 0.1W 0805	AS0750R-0805F
R8	RES SM 75R 1% 0.1W 0805	AS0750R-0805F
R9	RES SM 75R 1% 0.1W 0805	AS0750R-0805F
R10	RES SM 75R 1% 0.1W 0805	AS0750R-0805F
R11	RES SM 1K2 1% 0.1W 0805	AS0122R-0805F
R12	RES SM 20K 1% 0.1W 0805	AS0203R-0805F
R13	RES SM 20K 1% 0.1W 0805	AS0203R-0805F
R14	RES SM 10K 1% 0.1W 0805	AS0103R-0805F
R15	RES SM 10K 1% 0.1W 0805	AS0103R-0805F

R16	RES SM 20K 1%	0.1W 0805	AS0203R-0805F
R17	RES SM 20K 1%	0.1W 0805	AS0203R-0805F
R18	RES SM 75R 1%	0.1W 0805	AS0750R-0805F
R19	RES SM 75R 1%	0.1W 0805	AS0750R-0805F
R20	RES SM 75R 1%	0.1W 0805	AS0750R-0805F
R21	RES SM 75R 1%	0.1W 0805	AS0750R-0805F
R22	RES SM 20K 1%	0.1W 0805	AS0203R-0805F
R23	RES SM 20K 1%	0.1W 0805	AS0203R-0805F
R24	RES SM 20K 1%	0.1W 0805	AS0203R-0805F
R25	RES SM 20K 1%	0.1W 0805	AS0203R-0805F
R26	RES SM 10K 1%	0.1W 0805	AS0103R-0805F
R27	RES SM 10K 1%	0.1W 0805	AS0103R-0805F
R28	RES SM 47K 1%	0.1W 0805	AS0473R-0805F
R29	RES SM 8K2 1%	0.1W 0805	AS0822R-0805F
R30	RES SM 8K2 1%	0.1W 0805	AS0822R-0805F
R31	RES SM 75R 1%	0.1W 0805	AS0750R-0805F
R32	RES SM 75R 1%	0.1W 0805	AS0750R-0805F
R33	RES SM 75R 1%	0.1W 0805	AS0750R-0805F
R34	RES SM 75R 1%	0.1W 0805	AS0750R-0805F
R35	RES SM 75R 1%	0.1W 0805	AS0750R-0805F
R36	RES SM 75R 1%	0.1W 0805	AS0750R-0805F
R37	RES SM 75R 1%	0.1W 0805	AS0750R-0805F
R38	RES SM 75R 1%	0.1W 0805	AS0750R-0805F
R39	RES SM 20K 1%	0.1W 0805	AS0203R-0805F
R40	RES SM 20K 1%	0.1W 0805	AS0203R-0805F
R41	RES SM 20K 1%	0.1W 0805	AS0203R-0805F
R42	RES SM 8K2 1%	0.1W 0805	AS0822R-0805F
R43	RES SM 8K2 1%	0.1W 0805	AS0822R-0805F
R44	RES SM 20K 1%	0.1W 0805	AS0203R-0805F
R45	RES SM 47K 1%	0.1W 0805	AS0473R-0805F
R46	RES SM 1K2 1%	0.1W 0805	AS0122R-0805F
R47	RES SM 1K2 1%	0.1W 0805	AS0122R-0805F
R48	RES SM 1K2 1%	0.1W 0805	AS0122R-0805F
R49	RES SM 620R 1%	0.1W 0805	AS0621R-0805F
R50	RES SM 4K3 1%	0.1W 0805	AS0432R-0805F
R51	RES SM 3K9 1%	0.1W 0805	AS0392R-0805F
R52	RES SM 3K3 1%	0.1W 0805	AS0332R-0805F
R53	RES SM 6K8 1%	0.1W 0805	AS0682R-0805F
R54	RES SM 3K3 1%	0.1W 0805	AS0332R-0805F
R55	RES SM 6K8 1%	0.1W 0805	AS0682R-0805F
R56	RES SM 6K8 1%	0.1W 0805	AS0682R-0805F
R59	RES SM 9K1 1%	0.1W 0805	AS0912R-0805F
R60	RES SM 3K9 1%	0.1W 0805	AS0392R-0805F
R61	RES SM 2K2 1%	0.1W 0805	AS0222R-0805F
R62	RES SM 1K5 1%	0.1W 0805	AS0152R-0805F
R63	RES SM 620R 1%	0.1W 0805	AS0621R-0805F
R64	RES SM 470R 1%	0.1W 0805	AS0471R-0805F
R65	RES SM 330R 1%	0.1W 0805	AS0331R-0805F
R66	RES SM 240R 1%	0.1W 0805	AS0241R-0805F
R67	RES SM 2K2 1%	0.1W 0805	AS0222R-0805F
R68	RES SM 330R 1%	0.1W 0805	AS0331R-0805F
R69	RES SM 130R 1%	0.1W T200	AS0131R-0805F
R70	RES SM 75R 1%	0.1W 0805	AS0750R-0805F
R71	RES SM 75R 1%	0.1W 0805	AS0750R-0805F
R72	RES SM 4K3 1%	0.1W 0805	AS0432R-0805F
R73	RES SM 2M2 1%	0.1W 0805	AS0225R-0805F
R74	RES SM 4K3 1%	0.1W 0805	AS0432R-0805F
R75	RES SM 2M2 1%	0.1W 0805	AS0225R-0805F
R76	RES SM 240R 1%	0.1W 0805	AS0241R-0805F
R77	RES SM 240R 1%	0.1W 0805	AS0241R-0805F
R78	RES SM 1M0 1%	0.1W 0805	AS0105R-0805F

R79	RES SM 1M0 1% 0.1W 0805	AS0105R-0805F
R80	RES SM 3K3 1% 0.1W 0805	AS0332R-0805F
R81	RES SM 8K2 1% 0.1W 0805	AS0822R-0805F
R82	RES SM 8K2 1% 0.1W 0805	AS0822R-0805F
R83	RES SM 220K 1% 0.1W 0805	AS0224R-0805F
R84	RES SM 220K 1% 0.1W 0805	AS0224R-0805F
R88	RES SM 10K 1% 0.1W 0805	AS0103R-0805F
R89	RES SM 47K 1% 0.1W 0805	AS0473R-0805F
R90	RES SM 0R0 1% 0.1W 0805	AS0000R-0805F
R100	RES SM 20K 1% 0.2W MICROMELF	AS2203R-0102F
R101	RES SM 1K2 1% 0.2W MICROMELF	AS2122R-0102F
R102	RES SM 20K 1% 0.2W MICROMELF	AS2203R-0102F
R103	RES SM 1K2 1% 0.2W MICROMELF	AS2122R-0102F
R104	RES SM 10R 1% 0.1W 0805	AS0100R-0805F
R105	RES SM 1K2 1% 0.2W MICROMELF	AS2122R-0102F
R106	RES SM 1K2 1% 0.2W MICROMELF	AS2122R-0102F
R107	RES SM 6K8 1% 0.1W 0805	AS0682R-0805F
R108	RES SM 6K8 1% 0.1W 0805	AS0682R-0805F
R109	RES SM 1K2 1% 0.2W MICROMELF	AS2122R-0102F
R110	RES SM 1K2 1% 0.2W MICROMELF	AS2122R-0102F
R111	RES SM 4K3 1% 0.1W 0805	AS0432R-0805F
R112	RES SM 4K3 1% 0.1W 0805	AS0432R-0805F
R113	RES MF 6K8 1% 0.25W	AP1369
R114	RES MF 6K8 1% 0.25W	AP1369
R115	RES SM 20K 1% 0.1W 0805	AS0203R-0805F
R116	RES SM 20K 1% 0.1W 0805	AS0203R-0805F
R117	RES SM 8K2 1% 0.1W 0805	AS0822R-0805F
R118	RES SM 8K2 1% 0.1W 0805	AS0822R-0805F
R119	RES SM 3K3 1% 0.1W 0805	AS0332R-0805F
R120	RES SM 3K3 1% 0.1W 0805	AS0332R-0805F
R121	RES SM 20K 1% 0.1W 0805	AS0203R-0805F
R122	RES SM 47K 1% 0.1W 0805	AS0473R-0805F
R123	RES SM 20K 1% 0.1W 0805	AS0203R-0805F
R124	RES SM 10K 1% 0.1W 0805	AS0103R-0805F
R125	RES SM 4K3 1% 0.1W 0805	AS0432R-0805F
R126	RES SM 10K 1% 0.1W 0805	AS0103R-0805F
R127	RES SM 10K 1% 0.1W 0805	AS0103R-0805F
R129	RES SM 10K 1% 0.1W 0805	AS0103R-0805F
R130	RES SM 10K 1% 0.1W 0805	AS0103R-0805F
R131	RES SM 10K 1% 0.1W 0805	AS0103R-0805F
R132	RES SM 10K 1% 0.1W 0805	AS0103R-0805F
R133	RES SM 47K 1% 0.1W 0805	AS0473R-0805F
R134	RES SM 4K3 1% 0.1W 0805	AS0432R-0805F
R135	RES SM 620R 1% 0.1W 0805	AS0621R-0805F
R136	RES SM 75R 1% 0.1W 0805	AS0750R-0805F
R138	RES SM 47K 1% 0.1W 0805	AS0473R-0805F
R160	RES SM 47K 1% 0.1W 0805	AS0473R-0805F
R161	RES SM 10K 1% 0.1W 0805	AS0103R-0805F
R162	RES SM 10K 1% 0.1W 0805	AS0103R-0805F
R163	RES SM 75R 1% 0.1W 0805	AS0750R-0805F
R164	RES SM 75R 1% 0.1W 0805	AS0750R-0805F
R165	RES SM 75R 1% 0.1W 0805	AS0750R-0805F
R166	RES SM 75R 1% 0.1W 0805	AS0750R-0805F
R200	RES SM 20K 1% 0.2W MICROMELF	AS2203R-0102F
R201	RES SM 1K2 1% 0.2W MICROMELF	AS2122R-0102F
R202	RES SM 20K 1% 0.2W MICROMELF	AS2203R-0102F
R203	RES SM 1K2 1% 0.2W MICROMELF	AS2122R-0102F
R204	RES SM 10R 1% 0.1W 0805	AS0100R-0805F
R205	RES SM 1K2 1% 0.2W MICROMELF	AS2122R-0102F
R206	RES SM 1K2 1% 0.2W MICROMELF	AS2122R-0102F
R207	RES SM 6K8 1% 0.1W 0805	AS0682R-0805F

R208	RES SM 6K8 1% 0.1W 0805	AS0682R-0805F
R209	RES SM 1K2 1% 0.2W MICROMELF	AS2122R-0102F
R210	RES SM 1K2 1% 0.2W MICROMELF	AS2122R-0102F
R211	RES SM 4K3 1% 0.1W 0805	AS0432R-0805F
R212	RES SM 4K3 1% 0.1W 0805	AS0432R-0805F
R213	RES MF 6K8 1% 0.25W	AP1369
R214	RES MF 6K8 1% 0.25W	AP1369
R215	RES SM 20K 1% 0.1W 0805	AS0203R-0805F
R216	RES SM 20K 1% 0.1W 0805	AS0203R-0805F
R217	RES SM 8K2 1% 0.1W 0805	AS0822R-0805F
R218	RES SM 8K2 1% 0.1W 0805	AS0822R-0805F
R219	RES SM 3K3 1% 0.1W 0805	AS0332R-0805F
R220	RES SM 3K3 1% 0.1W 0805	AS0332R-0805F
R221	RES SM 20K 1% 0.1W 0805	AS0203R-0805F
R222	RES SM 47K 1% 0.1W 0805	AS0473R-0805F
R223	RES SM 20K 1% 0.1W 0805	AS0203R-0805F
R224	RES SM 10K 1% 0.1W 0805	AS0103R-0805F
R225	RES SM 4K3 1% 0.1W 0805	AS0432R-0805F
R226	RES SM 10K 1% 0.1W 0805	AS0103R-0805F
R227	RES SM 10K 1% 0.1W 0805	AS0103R-0805F
R229	RES SM 10K 1% 0.1W 0805	AS0103R-0805F
R230	RES SM 10K 1% 0.1W 0805	AS0103R-0805F
R231	RES SM 10K 1% 0.1W 0805	AS0103R-0805F
R232	RES SM 10K 1% 0.1W 0805	AS0103R-0805F
R233	RES SM 47K 1% 0.1W 0805	AS0473R-0805F
R234	RES SM 4K3 1% 0.1W 0805	AS0432R-0805F
R235	RES SM 620R 1% 0.1W 0805	AS0621R-0805F
R236	RES SM 75R 1% 0.1W 0805	AS0750R-0805F
R238	RES SM 47K 1% 0.1W 0805	AS0473R-0805F
R300	RES SM 20K 1% 0.2W MICROMELF	AS2203R-0102F
R301	RES SM 1K2 1% 0.2W MICROMELF	AS2122R-0102F
R302	RES SM 20K 1% 0.2W MICROMELF	AS2203R-0102F
R303	RES SM 1K2 1% 0.2W MICROMELF	AS2122R-0102F
R304	RES SM 10R 1% 0.1W 0805	AS0100R-0805F
R305	RES SM 1K2 1% 0.2W MICROMELF	AS2122R-0102F
R306	RES SM 1K2 1% 0.2W MICROMELF	AS2122R-0102F
R307	RES SM 6K8 1% 0.1W 0805	AS0682R-0805F
R308	RES SM 6K8 1% 0.1W 0805	AS0682R-0805F
R309	RES SM 1K2 1% 0.2W MICROMELF	AS2122R-0102F
R310	RES SM 1K2 1% 0.2W MICROMELF	AS2122R-0102F
R311	RES SM 4K3 1% 0.1W 0805	AS0432R-0805F
R312	RES SM 4K3 1% 0.1W 0805	AS0432R-0805F
R313	RES MF 6K8 1% 0.25W	AP1369
R314	RES MF 6K8 1% 0.25W	AP1369
R315	RES SM 20K 1% 0.1W 0805	AS0203R-0805F
R316	RES SM 20K 1% 0.1W 0805	AS0203R-0805F
R317	RES SM 8K2 1% 0.1W 0805	AS0822R-0805F
R318	RES SM 8K2 1% 0.1W 0805	AS0822R-0805F
R319	RES SM 3K3 1% 0.1W 0805	AS0332R-0805F
R320	RES SM 3K3 1% 0.1W 0805	AS0332R-0805F
R321	RES SM 20K 1% 0.1W 0805	AS0203R-0805F
R322	RES SM 47K 1% 0.1W 0805	AS0473R-0805F
R323	RES SM 20K 1% 0.1W 0805	AS0203R-0805F
R324	RES SM 10K 1% 0.1W 0805	AS0103R-0805F
R325	RES SM 4K3 1% 0.1W 0805	AS0432R-0805F
R326	RES SM 10K 1% 0.1W 0805	AS0103R-0805F
R327	RES SM 10K 1% 0.1W 0805	AS0103R-0805F
R329	RES SM 10K 1% 0.1W 0805	AS0103R-0805F
R330	RES SM 10K 1% 0.1W 0805	AS0103R-0805F
R331	RES SM 10K 1% 0.1W 0805	AS0103R-0805F
R332	RES SM 10K 1% 0.1W 0805	AS0103R-0805F

R333	RES SM 47K 1% 0.1W 0805	AS0473R-0805F
R334	RES SM 4K3 1% 0.1W 0805	AS0432R-0805F
R335	RES SM 620R 1% 0.1W 0805	AS0621R-0805F
R336	RES SM 75R 1% 0.1W 0805	AS0750R-0805F
R338	RES SM 47K 1% 0.1W 0805	AS0473R-0805F
R400	RES SM 20K 1% 0.2W MICROMELF	AS2203R-0102F
R401	RES SM 1K2 1% 0.2W MICROMELF	AS2122R-0102F
R402	RES SM 20K 1% 0.2W MICROMELF	AS2203R-0102F
R403	RES SM 1K2 1% 0.2W MICROMELF	AS2122R-0102F
R404	RES SM 10R 1% 0.1W 0805	AS0100R-0805F
R405	RES SM 1K2 1% 0.2W MICROMELF	AS2122R-0102F
R406	RES SM 1K2 1% 0.2W MICROMELF	AS2122R-0102F
R407	RES SM 6K8 1% 0.1W 0805	AS0682R-0805F
R408	RES SM 6K8 1% 0.1W 0805	AS0682R-0805F
R409	RES SM 1K2 1% 0.2W MICROMELF	AS2122R-0102F
R410	RES SM 1K2 1% 0.2W MICROMELF	AS2122R-0102F
R411	RES SM 4K3 1% 0.1W 0805	AS0432R-0805F
R412	RES SM 4K3 1% 0.1W 0805	AS0432R-0805F
R413	RES MF 6K8 1% 0.25W	AP1369
R414	RES MF 6K8 1% 0.25W	AP1369
R415	RES SM 20K 1% 0.1W 0805	AS0203R-0805F
R416	RES SM 20K 1% 0.1W 0805	AS0203R-0805F
R417	RES SM 8K2 1% 0.1W 0805	AS0822R-0805F
R418	RES SM 8K2 1% 0.1W 0805	AS0822R-0805F
R419	RES SM 3K3 1% 0.1W 0805	AS0332R-0805F
R420	RES SM 3K3 1% 0.1W 0805	AS0332R-0805F
R421	RES SM 20K 1% 0.1W 0805	AS0203R-0805F
R422	RES SM 47K 1% 0.1W 0805	AS0473R-0805F
R423	RES SM 20K 1% 0.1W 0805	AS0203R-0805F
R424	RES SM 10K 1% 0.1W 0805	AS0103R-0805F
R425	RES SM 4K3 1% 0.1W 0805	AS0432R-0805F
R426	RES SM 10K 1% 0.1W 0805	AS0103R-0805F
R427	RES SM 10K 1% 0.1W 0805	AS0103R-0805F
R429	RES SM 10K 1% 0.1W 0805	AS0103R-0805F
R430	RES SM 10K 1% 0.1W 0805	AS0103R-0805F
R431	RES SM 10K 1% 0.1W 0805	AS0103R-0805F
R432	RES SM 10K 1% 0.1W 0805	AS0103R-0805F
R433	RES SM 47K 1% 0.1W 0805	AS0473R-0805F
R434	RES SM 4K3 1% 0.1W 0805	AS0432R-0805F
R435	RES SM 620R 1% 0.1W 0805	AS0621R-0805F
R436	RES SM 75R 1% 0.1W 0805	AS0750R-0805F
R438	RES SM 47K 1% 0.1W 0805	AS0473R-0805F
R500	RES SM 20K 1% 0.2W MICROMELF	AS2203R-0102F
R501	RES SM 1K2 1% 0.2W MICROMELF	AS2122R-0102F
R502	RES SM 20K 1% 0.2W MICROMELF	AS2203R-0102F
R503	RES SM 1K2 1% 0.2W MICROMELF	AS2122R-0102F
R504	RES SM 10R 1% 0.1W 0805	AS0100R-0805F
R505	RES SM 1K2 1% 0.2W MICROMELF	AS2122R-0102F
R506	RES SM 1K2 1% 0.2W MICROMELF	AS2122R-0102F
R507	RES SM 6K8 1% 0.1W 0805	AS0682R-0805F
R508	RES SM 6K8 1% 0.1W 0805	AS0682R-0805F
R509	RES SM 1K2 1% 0.2W MICROMELF	AS2122R-0102F
R510	RES SM 1K2 1% 0.2W MICROMELF	AS2122R-0102F
R511	RES SM 4K3 1% 0.1W 0805	AS0432R-0805F
R512	RES SM 4K3 1% 0.1W 0805	AS0432R-0805F
R513	RES MF 6K8 1% 0.25W	AP1369
R514	RES MF 6K8 1% 0.25W	AP1369
R515	RES SM 20K 1% 0.1W 0805	AS0203R-0805F
R516	RES SM 20K 1% 0.1W 0805	AS0203R-0805F
R517	RES SM 8K2 1% 0.1W 0805	AS0822R-0805F
R518	RES SM 8K2 1% 0.1W 0805	AS0822R-0805F

R519	RES SM 3K3 1% 0.1W 0805	AS0332R-0805F
R520	RES SM 3K3 1% 0.1W 0805	AS0332R-0805F
R521	RES SM 20K 1% 0.1W 0805	AS0203R-0805F
R522	RES SM 47K 1% 0.1W 0805	AS0473R-0805F
R523	RES SM 20K 1% 0.1W 0805	AS0203R-0805F
R524	RES SM 10K 1% 0.1W 0805	AS0103R-0805F
R525	RES SM 4K3 1% 0.1W 0805	AS0432R-0805F
R526	RES SM 10K 1% 0.1W 0805	AS0103R-0805F
R527	RES SM 10K 1% 0.1W 0805	AS0103R-0805F
R529	RES SM 10K 1% 0.1W 0805	AS0103R-0805F
R530	RES SM 10K 1% 0.1W 0805	AS0103R-0805F
R531	RES SM 10K 1% 0.1W 0805	AS0103R-0805F
R532	RES SM 10K 1% 0.1W 0805	AS0103R-0805F
R533	RES SM 47K 1% 0.1W 0805	AS0473R-0805F
R534	RES SM 4K3 1% 0.1W 0805	AS0432R-0805F
R535	RES SM 620R 1% 0.1W 0805	AS0621R-0805F
R536	RES SM 75R 1% 0.1W 0805	AS0750R-0805F
R538	RES SM 47K 1% 0.1W 0805	AS0473R-0805F
R600	RES SM 20K 1% 0.2W MICROMELF	AS2203R-0102F
R601	RES SM 1K2 1% 0.2W MICROMELF	AS2122R-0102F
R602	RES SM 20K 1% 0.2W MICROMELF	AS2203R-0102F
R603	RES SM 1K2 1% 0.2W MICROMELF	AS2122R-0102F
R604	RES SM 10R 1% 0.1W 0805	AS0100R-0805F
R605	RES SM 1K2 1% 0.2W MICROMELF	AS2122R-0102F
R606	RES SM 1K2 1% 0.2W MICROMELF	AS2122R-0102F
R607	RES SM 6K8 1% 0.1W 0805	AS0682R-0805F
R608	RES SM 6K8 1% 0.1W 0805	AS0682R-0805F
R609	RES SM 1K2 1% 0.2W MICROMELF	AS2122R-0102F
R610	RES SM 1K2 1% 0.2W MICROMELF	AS2122R-0102F
R611	RES SM 4K3 1% 0.1W 0805	AS0432R-0805F
R612	RES SM 4K3 1% 0.1W 0805	AS0432R-0805F
R613	RES MF 6K8 1% 0.25W	AP1369
R614	RES MF 6K8 1% 0.25W	AP1369
R615	RES SM 20K 1% 0.1W 0805	AS0203R-0805F
R616	RES SM 20K 1% 0.1W 0805	AS0203R-0805F
R617	RES SM 8K2 1% 0.1W 0805	AS0822R-0805F
R618	RES SM 8K2 1% 0.1W 0805	AS0822R-0805F
R619	RES SM 3K3 1% 0.1W 0805	AS0332R-0805F
R620	RES SM 3K3 1% 0.1W 0805	AS0332R-0805F
R621	RES SM 20K 1% 0.1W 0805	AS0203R-0805F
R622	RES SM 47K 1% 0.1W 0805	AS0473R-0805F
R623	RES SM 20K 1% 0.1W 0805	AS0203R-0805F
R624	RES SM 10K 1% 0.1W 0805	AS0103R-0805F
R625	RES SM 4K3 1% 0.1W 0805	AS0432R-0805F
R626	RES SM 10K 1% 0.1W 0805	AS0103R-0805F
R627	RES SM 10K 1% 0.1W 0805	AS0103R-0805F
R629	RES SM 10K 1% 0.1W 0805	AS0103R-0805F
R630	RES SM 10K 1% 0.1W 0805	AS0103R-0805F
R631	RES SM 10K 1% 0.1W 0805	AS0103R-0805F
R632	RES SM 10K 1% 0.1W 0805	AS0103R-0805F
R633	RES SM 47K 1% 0.1W 0805	AS0473R-0805F
R634	RES SM 4K3 1% 0.1W 0805	AS0432R-0805F
R635	RES SM 620R 1% 0.1W 0805	AS0621R-0805F
R636	RES SM 75R 1% 0.1W 0805	AS0750R-0805F
R638	RES SM 47K 1% 0.1W 0805	AS0473R-0805F
R700	RES SM 20K 1% 0.2W MICROMELF	AS2203R-0102F
R701	RES SM 1K2 1% 0.2W MICROMELF	AS2122R-0102F
R702	RES SM 20K 1% 0.2W MICROMELF	AS2203R-0102F
R703	RES SM 1K2 1% 0.2W MICROMELF	AS2122R-0102F
R704	RES SM 10R 1% 0.1W 0805	AS0100R-0805F
R705	RES SM 1K2 1% 0.2W MICROMELF	AS2122R-0102F

R706	RES SM 1K2 1% 0.2W MICROMELF	AS2122R-0102F
R707	RES SM 6K8 1% 0.1W 0805	AS0682R-0805F
R708	RES SM 6K8 1% 0.1W 0805	AS0682R-0805F
R709	RES SM 1K2 1% 0.2W MICROMELF	AS2122R-0102F
R710	RES SM 1K2 1% 0.2W MICROMELF	AS2122R-0102F
R711	RES SM 4K3 1% 0.1W 0805	AS0432R-0805F
R712	RES SM 4K3 1% 0.1W 0805	AS0432R-0805F
R713	RES MF 6K8 1% 0.25W	AP1369
R714	RES MF 6K8 1% 0.25W	AP1369
R715	RES SM 20K 1% 0.1W 0805	AS0203R-0805F
R716	RES SM 20K 1% 0.1W 0805	AS0203R-0805F
R717	RES SM 8K2 1% 0.1W 0805	AS0822R-0805F
R718	RES SM 8K2 1% 0.1W 0805	AS0822R-0805F
R719	RES SM 3K3 1% 0.1W 0805	AS0332R-0805F
R720	RES SM 3K3 1% 0.1W 0805	AS0332R-0805F
R721	RES SM 20K 1% 0.1W 0805	AS0203R-0805F
R722	RES SM 47K 1% 0.1W 0805	AS0473R-0805F
R723	RES SM 20K 1% 0.1W 0805	AS0203R-0805F
R724	RES SM 10K 1% 0.1W 0805	AS0103R-0805F
R725	RES SM 4K3 1% 0.1W 0805	AS0432R-0805F
R726	RES SM 10K 1% 0.1W 0805	AS0103R-0805F
R727	RES SM 10K 1% 0.1W 0805	AS0103R-0805F
R729	RES SM 10K 1% 0.1W 0805	AS0103R-0805F
R730	RES SM 10K 1% 0.1W 0805	AS0103R-0805F
R731	RES SM 10K 1% 0.1W 0805	AS0103R-0805F
R732	RES SM 10K 1% 0.1W 0805	AS0103R-0805F
R733	RES SM 47K 1% 0.1W 0805	AS0473R-0805F
R734	RES SM 4K3 1% 0.1W 0805	AS0432R-0805F
R735	RES SM 620R 1% 0.1W 0805	AS0621R-0805F
R736	RES SM 75R 1% 0.1W 0805	AS0750R-0805F
R738	RES SM 47K 1% 0.1W 0805	AS0473R-0805F
R800	RES SM 20K 1% 0.2W MICROMELF	AS2203R-0102F
R801	RES SM 1K2 1% 0.2W MICROMELF	AS2122R-0102F
R802	RES SM 20K 1% 0.2W MICROMELF	AS2203R-0102F
R803	RES SM 1K2 1% 0.2W MICROMELF	AS2122R-0102F
R804	RES SM 10R 1% 0.1W 0805	AS0100R-0805F
R805	RES SM 1K2 1% 0.2W MICROMELF	AS2122R-0102F
R806	RES SM 1K2 1% 0.2W MICROMELF	AS2122R-0102F
R807	RES SM 6K8 1% 0.1W 0805	AS0682R-0805F
R808	RES SM 6K8 1% 0.1W 0805	AS0682R-0805F
R809	RES SM 1K2 1% 0.2W MICROMELF	AS2122R-0102F
R810	RES SM 1K2 1% 0.2W MICROMELF	AS2122R-0102F
R811	RES SM 4K3 1% 0.1W 0805	AS0432R-0805F
R812	RES SM 4K3 1% 0.1W 0805	AS0432R-0805F
R813	RES MF 6K8 1% 0.25W	AP1369
R814	RES MF 6K8 1% 0.25W	AP1369
R815	RES SM 20K 1% 0.1W 0805	AS0203R-0805F
R816	RES SM 20K 1% 0.1W 0805	AS0203R-0805F
R817	RES SM 8K2 1% 0.1W 0805	AS0822R-0805F
R818	RES SM 8K2 1% 0.1W 0805	AS0822R-0805F
R819	RES SM 3K3 1% 0.1W 0805	AS0332R-0805F
R820	RES SM 3K3 1% 0.1W 0805	AS0332R-0805F
R821	RES SM 20K 1% 0.1W 0805	AS0203R-0805F
R822	RES SM 47K 1% 0.1W 0805	AS0473R-0805F
R823	RES SM 20K 1% 0.1W 0805	AS0203R-0805F
R824	RES SM 10K 1% 0.1W 0805	AS0103R-0805F
R825	RES SM 4K3 1% 0.1W 0805	AS0432R-0805F
R826	RES SM 10K 1% 0.1W 0805	AS0103R-0805F
R827	RES SM 10K 1% 0.1W 0805	AS0103R-0805F
R829	RES SM 10K 1% 0.1W 0805	AS0103R-0805F
R830	RES SM 10K 1% 0.1W 0805	AS0103R-0805F

R831	RES SM 10K 1% 0.1W 0805	AS0103R-0805F
R832	RES SM 10K 1% 0.1W 0805	AS0103R-0805F
R833	RES SM 47K 1% 0.1W 0805	AS0473R-0805F
R834	RES SM 4K3 1% 0.1W 0805	AS0432R-0805F
R835	RES SM 620R 1% 0.1W 0805	AS0621R-0805F
R836	RES SM 75R 1% 0.1W 0805	AS0750R-0805F
R838	RES SM 47K 1% 0.1W 0805	AS0473R-0805F
R900	RES SM 20K 1% 0.2W MICROMELF	AS2203R-0102F
R901	RES SM 1K2 1% 0.2W MICROMELF	AS2122R-0102F
R902	RES SM 20K 1% 0.2W MICROMELF	AS2203R-0102F
R903	RES SM 1K2 1% 0.2W MICROMELF	AS2122R-0102F
R904	RES SM 10R 1% 0.1W 0805	AS0100R-0805F
R905	RES SM 1K2 1% 0.2W MICROMELF	AS2122R-0102F
R906	RES SM 1K2 1% 0.2W MICROMELF	AS2122R-0102F
R907	RES SM 6K8 1% 0.1W 0805	AS0682R-0805F
R908	RES SM 6K8 1% 0.1W 0805	AS0682R-0805F
R909	RES SM 1K2 1% 0.2W MICROMELF	AS2122R-0102F
R910	RES SM 1K2 1% 0.2W MICROMELF	AS2122R-0102F
R911	RES SM 4K3 1% 0.1W 0805	AS0432R-0805F
R912	RES SM 4K3 1% 0.1W 0805	AS0432R-0805F
R913	RES MF 6K8 1% 0.25W	AP1369
R914	RES MF 6K8 1% 0.25W	AP1369
R915	RES SM 20K 1% 0.1W 0805	AS0203R-0805F
R916	RES SM 20K 1% 0.1W 0805	AS0203R-0805F
R917	RES SM 8K2 1% 0.1W 0805	AS0822R-0805F
R918	RES SM 8K2 1% 0.1W 0805	AS0822R-0805F
R919	RES SM 3K3 1% 0.1W 0805	AS0332R-0805F
R920	RES SM 3K3 1% 0.1W 0805	AS0332R-0805F
R921	RES SM 20K 1% 0.1W 0805	AS0203R-0805F
R922	RES SM 47K 1% 0.1W 0805	AS0473R-0805F
R923	RES SM 20K 1% 0.1W 0805	AS0203R-0805F
R924	RES SM 10K 1% 0.1W 0805	AS0103R-0805F
R925	RES SM 4K3 1% 0.1W 0805	AS0432R-0805F
R926	RES SM 10K 1% 0.1W 0805	AS0103R-0805F
R927	RES SM 10K 1% 0.1W 0805	AS0103R-0805F
R929	RES SM 10K 1% 0.1W 0805	AS0103R-0805F
R930	RES SM 10K 1% 0.1W 0805	AS0103R-0805F
R931	RES SM 10K 1% 0.1W 0805	AS0103R-0805F
R932	RES SM 10K 1% 0.1W 0805	AS0103R-0805F
R933	RES SM 47K 1% 0.1W 0805	AS0473R-0805F
R934	RES SM 4K3 1% 0.1W 0805	AS0432R-0805F
R935	RES SM 620R 1% 0.1W 0805	AS0621R-0805F
R936	RES SM 75R 1% 0.1W 0805	AS0750R-0805F
R938	RES SM 47K 1% 0.1W 0805	AS0473R-0805F
R1000	RES SM 20K 1% 0.2W MICROMELF	AS2203R-0102F
R1001	RES SM 1K2 1% 0.2W MICROMELF	AS2122R-0102F
R1002	RES SM 20K 1% 0.2W MICROMELF	AS2203R-0102F
R1003	RES SM 1K2 1% 0.2W MICROMELF	AS2122R-0102F
R1004	RES SM 10R 1% 0.1W 0805	AS0100R-0805F
R1005	RES SM 1K2 1% 0.2W MICROMELF	AS2122R-0102F
R1006	RES SM 1K2 1% 0.2W MICROMELF	AS2122R-0102F
R1007	RES SM 6K8 1% 0.1W 0805	AS0682R-0805F
R1008	RES SM 6K8 1% 0.1W 0805	AS0682R-0805F
R1009	RES SM 1K2 1% 0.2W MICROMELF	AS2122R-0102F
R1010	RES SM 1K2 1% 0.2W MICROMELF	AS2122R-0102F
R1011	RES SM 4K3 1% 0.1W 0805	AS0432R-0805F
R1012	RES SM 4K3 1% 0.1W 0805	AS0432R-0805F
R1013	RES MF 6K8 1% 0.25W	AP1369
R1014	RES MF 6K8 1% 0.25W	AP1369
R1015	RES SM 20K 1% 0.1W 0805	AS0203R-0805F
R1016	RES SM 20K 1% 0.1W 0805	AS0203R-0805F

R1017	RES	SM	8K2	1%	0.1W	0805	AS0822R-0805F
R1018	RES	SM	8K2	1%	0.1W	0805	AS0822R-0805F
R1019	RES	SM	3K3	1%	0.1W	0805	AS0332R-0805F
R1020	RES	SM	3K3	1%	0.1W	0805	AS0332R-0805F
R1021	RES	SM	20K	1%	0.1W	0805	AS0203R-0805F
R1022	RES	SM	47K	1%	0.1W	0805	AS0473R-0805F
R1023	RES	SM	20K	1%	0.1W	0805	AS0203R-0805F
R1024	RES	SM	10K	1%	0.1W	0805	AS0103R-0805F
R1025	RES	SM	4K3	1%	0.1W	0805	AS0432R-0805F
R1026	RES	SM	10K	1%	0.1W	0805	AS0103R-0805F
R1027	RES	SM	10K	1%	0.1W	0805	AS0103R-0805F
R1029	RES	SM	10K	1%	0.1W	0805	AS0103R-0805F
R1030	RES	SM	10K	1%	0.1W	0805	AS0103R-0805F
R1031	RES	SM	10K	1%	0.1W	0805	AS0103R-0805F
R1032	RES	SM	10K	1%	0.1W	0805	AS0103R-0805F
R1033	RES	SM	47K	1%	0.1W	0805	AS0473R-0805F
R1034	RES	SM	4K3	1%	0.1W	0805	AS0432R-0805F
R1035	RES	SM	620R	1%	0.1W	0805	AS0621R-0805F
R1036	RES	SM	75R	1%	0.1W	0805	AS0750R-0805F
R1038	RES	SM	47K	1%	0.1W	0805	AS0473R-0805F
R1100	RES	SM	20K	1%	0.2W	MICROMELF	AS2203R-0102F
R1101	RES	SM	1K2	1%	0.2W	MICROMELF	AS2122R-0102F
R1102	RES	SM	20K	1%	0.2W	MICROMELF	AS2203R-0102F
R1103	RES	SM	1K2	1%	0.2W	MICROMELF	AS2122R-0102F
R1104	RES	SM	10R	1%	0.1W	0805	AS0100R-0805F
R1105	RES	SM	1K2	1%	0.2W	MICROMELF	AS2122R-0102F
R1106	RES	SM	1K2	1%	0.2W	MICROMELF	AS2122R-0102F
R1107	RES	SM	6K8	1%	0.1W	0805	AS0682R-0805F
R1108	RES	SM	6K8	1%	0.1W	0805	AS0682R-0805F
R1109	RES	SM	1K2	1%	0.2W	MICROMELF	AS2122R-0102F
R1110	RES	SM	1K2	1%	0.2W	MICROMELF	AS2122R-0102F
R1111	RES	SM	4K3	1%	0.1W	0805	AS0432R-0805F
R1112	RES	SM	4K3	1%	0.1W	0805	AS0432R-0805F
R1113	RES	MF	6K8	1%	0.25W		AP1369
R1114	RES	MF	6K8	1%	0.25W		AP1369
R1115	RES	SM	20K	1%	0.1W	0805	AS0203R-0805F
R1116	RES	SM	20K	1%	0.1W	0805	AS0203R-0805F
R1117	RES	SM	8K2	1%	0.1W	0805	AS0822R-0805F
R1118	RES	SM	8K2	1%	0.1W	0805	AS0822R-0805F
R1119	RES	SM	3K3	1%	0.1W	0805	AS0332R-0805F
R1120	RES	SM	3K3	1%	0.1W	0805	AS0332R-0805F
R1121	RES	SM	20K	1%	0.1W	0805	AS0203R-0805F
R1122	RES	SM	47K	1%	0.1W	0805	AS0473R-0805F
R1123	RES	SM	20K	1%	0.1W	0805	AS0203R-0805F
R1124	RES	SM	10K	1%	0.1W	0805	AS0103R-0805F
R1125	RES	SM	4K3	1%	0.1W	0805	AS0432R-0805F
R1126	RES	SM	10K	1%	0.1W	0805	AS0103R-0805F
R1127	RES	SM	10K	1%	0.1W	0805	AS0103R-0805F
R1129	RES	SM	10K	1%	0.1W	0805	AS0103R-0805F
R1130	RES	SM	10K	1%	0.1W	0805	AS0103R-0805F
R1131	RES	SM	10K	1%	0.1W	0805	AS0103R-0805F
R1132	RES	SM	10K	1%	0.1W	0805	AS0103R-0805F
R1133	RES	SM	47K	1%	0.1W	0805	AS0473R-0805F
R1134	RES	SM	4K3	1%	0.1W	0805	AS0432R-0805F
R1135	RES	SM	620R	1%	0.1W	0805	AS0621R-0805F
R1136	RES	SM	75R	1%	0.1W	0805	AS0750R-0805F
R1138	RES	SM	47K	1%	0.1W	0805	AS0473R-0805F
R1200	RES	SM	20K	1%	0.2W	MICROMELF	AS2203R-0102F
R1201	RES	SM	1K2	1%	0.2W	MICROMELF	AS2122R-0102F
R1202	RES	SM	20K	1%	0.2W	MICROMELF	AS2203R-0102F
R1203	RES	SM	1K2	1%	0.2W	MICROMELF	AS2122R-0102F

R1204	RES SM 10R 1% 0.1W 0805	AS0100R-0805F
R1205	RES SM 1K2 1% 0.2W MICROMELF	AS2122R-0102F
R1206	RES SM 1K2 1% 0.2W MICROMELF	AS2122R-0102F
R1207	RES SM 6K8 1% 0.1W 0805	AS0682R-0805F
R1208	RES SM 6K8 1% 0.1W 0805	AS0682R-0805F
R1209	RES SM 1K2 1% 0.2W MICROMELF	AS2122R-0102F
R1210	RES SM 1K2 1% 0.2W MICROMELF	AS2122R-0102F
R1211	RES SM 4K3 1% 0.1W 0805	AS0432R-0805F
R1212	RES SM 4K3 1% 0.1W 0805	AS0432R-0805F
R1213	RES MF 6K8 1% 0.25W	AP1369
R1214	RES MF 6K8 1% 0.25W	AP1369
R1215	RES SM 20K 1% 0.1W 0805	AS0203R-0805F
R1216	RES SM 20K 1% 0.1W 0805	AS0203R-0805F
R1217	RES SM 8K2 1% 0.1W 0805	AS0822R-0805F
R1218	RES SM 8K2 1% 0.1W 0805	AS0822R-0805F
R1219	RES SM 3K3 1% 0.1W 0805	AS0332R-0805F
R1220	RES SM 3K3 1% 0.1W 0805	AS0332R-0805F
R1221	RES SM 20K 1% 0.1W 0805	AS0203R-0805F
R1222	RES SM 47K 1% 0.1W 0805	AS0473R-0805F
R1223	RES SM 20K 1% 0.1W 0805	AS0203R-0805F
R1224	RES SM 10K 1% 0.1W 0805	AS0103R-0805F
R1225	RES SM 4K3 1% 0.1W 0805	AS0432R-0805F
R1226	RES SM 10K 1% 0.1W 0805	AS0103R-0805F
R1227	RES SM 10K 1% 0.1W 0805	AS0103R-0805F
R1229	RES SM 10K 1% 0.1W 0805	AS0103R-0805F
R1230	RES SM 10K 1% 0.1W 0805	AS0103R-0805F
R1231	RES SM 10K 1% 0.1W 0805	AS0103R-0805F
R1232	RES SM 10K 1% 0.1W 0805	AS0103R-0805F
R1233	RES SM 47K 1% 0.1W 0805	AS0473R-0805F
R1234	RES SM 4K3 1% 0.1W 0805	AS0432R-0805F
R1235	RES SM 620R 1% 0.1W 0805	AS0621R-0805F
R1236	RES SM 75R 1% 0.1W 0805	AS0750R-0805F
R1238	RES SM 47K 1% 0.1W 0805	AS0473R-0805F
R1300	RES SM 20K 1% 0.1W 0805	AS0203R-0805F
R1301	RES SM 4K3 1% 0.1W 0805	AS0432R-0805F
R1302	RES SM 20K 1% 0.1W 0805	AS0203R-0805F
R1303	RES SM 20K 1% 0.1W 0805	AS0203R-0805F
R1304	RES SM 10K 1% 0.1W 0805	AS0103R-0805F
R1305	RES SM 4K3 1% 0.1W 0805	AS0432R-0805F
R1306	RES SM 20K 1% 0.1W 0805	AS0203R-0805F
R1307	RES SM 10K 1% 0.1W 0805	AS0103R-0805F
R1308	RES SM 4K3 1% 0.1W 0805	AS0432R-0805F
R1309	RES SM 20K 1% 0.1W 0805	AS0203R-0805F
R1310	RES SM 20K 1% 0.1W 0805	AS0203R-0805F
R1311	RES SM 20K 1% 0.1W 0805	AS0203R-0805F
R1312	RES SM 20K 1% 0.1W 0805	AS0203R-0805F
R1313	RES SM 10K 1% 0.1W 0805	AS0103R-0805F
R1314	RES SM 10K 1% 0.1W 0805	AS0103R-0805F
R1315	RES SM 47K 1% 0.1W 0805	AS0473R-0805F
R1316	RES SM 620R 1% 0.1W 0805	AS0621R-0805F
R1317	RES SM 47K 1% 0.1W 0805	AS0473R-0805F
R1318	RES SM 47K 1% 0.1W 0805	AS0473R-0805F
R1319	RES SM 3K3 1% 0.1W 0805	AS0332R-0805F
R1320	RES SM 3K3 1% 0.1W 0805	AS0332R-0805F
R1321	RES SM 2K2 1% 0.1W 0805	AS0222R-0805F
R1322	RES SM 47K 1% 0.1W 0805	AS0473R-0805F
R1323	RES SM 2K2 1% 0.1W 0805	AS0222R-0805F
R1324	RES SM 15K 1% 0.1W 0805	AS0153R-0805F
R1325	RES SM 15K 1% 0.1W 0805	AS0153R-0805F
R1326	RES SM 15K 1% 0.1W 0805	AS0153R-0805F
R1327	RES SM 4K3 1% 0.1W 0805	AS0432R-0805F

R1328	RES	SM	4K3	1%	0.1W	0805	AS0432R-0805F
R1329	RES	SM	2K2	1%	0.1W	0805	AS0222R-0805F
R1330	RES	SM	47K	1%	0.1W	0805	AS0473R-0805F
R1331	RES	SM	4K3	1%	0.1W	0805	AS0432R-0805F
R1332	RES	SM	4K3	1%	0.1W	0805	AS0432R-0805F
R1333	RES	SM	15K	1%	0.1W	0805	AS0153R-0805F
R1334	RES	SM	3K3	1%	0.1W	0805	AS0332R-0805F
R1335	RES	SM	47K	1%	0.1W	0805	AS0473R-0805F
R1336	RES	SM	620R	1%	0.1W	0805	AS0621R-0805F
R1337	RES	SM	620R	1%	0.1W	0805	AS0621R-0805F
R1338	RES	SM	3K3	1%	0.1W	0805	AS0332R-0805F
R1339	RES	SM	3K3	1%	0.1W	0805	AS0332R-0805F
R1340	RES	SM	3K3	1%	0.1W	0805	AS0332R-0805F
R1341	RES	SM	3K3	1%	0.1W	0805	AS0332R-0805F
R1342	RES	SM	1K5	1%	0.1W	0805	AS0152R-0805F
R1343	RES	SM	1K5	1%	0.1W	0805	AS0152R-0805F
R1344	RES	SM	2K2	1%	0.1W	0805	AS0222R-0805F
R1346	RES	SM	20K	1%	0.1W	0805	AS0203R-0805F
R1347	RES	SM	20K	1%	0.1W	0805	AS0203R-0805F
R1350	RES	SM	47K	1%	0.1W	0805	AS0473R-0805F
R1392	RES	SM	3K3	1%	0.1W	0805	AS0332R-0805F
R1400	RES	SM	20K	1%	0.1W	0805	AS0203R-0805F
R1401	RES	SM	4K3	1%	0.1W	0805	AS0432R-0805F
R1402	RES	SM	20K	1%	0.1W	0805	AS0203R-0805F
R1403	RES	SM	20K	1%	0.1W	0805	AS0203R-0805F
R1404	RES	SM	10K	1%	0.1W	0805	AS0103R-0805F
R1405	RES	SM	4K3	1%	0.1W	0805	AS0432R-0805F
R1406	RES	SM	20K	1%	0.1W	0805	AS0203R-0805F
R1407	RES	SM	10K	1%	0.1W	0805	AS0103R-0805F
R1408	RES	SM	4K3	1%	0.1W	0805	AS0432R-0805F
R1409	RES	SM	20K	1%	0.1W	0805	AS0203R-0805F
R1410	RES	SM	20K	1%	0.1W	0805	AS0203R-0805F
R1411	RES	SM	20K	1%	0.1W	0805	AS0203R-0805F
R1412	RES	SM	20K	1%	0.1W	0805	AS0203R-0805F
R1413	RES	SM	10K	1%	0.1W	0805	AS0103R-0805F
R1414	RES	SM	10K	1%	0.1W	0805	AS0103R-0805F
R1415	RES	SM	47K	1%	0.1W	0805	AS0473R-0805F
R1416	RES	SM	620R	1%	0.1W	0805	AS0621R-0805F
R1417	RES	SM	47K	1%	0.1W	0805	AS0473R-0805F
R1418	RES	SM	47K	1%	0.1W	0805	AS0473R-0805F
R1419	RES	SM	3K3	1%	0.1W	0805	AS0332R-0805F
R1420	RES	SM	3K3	1%	0.1W	0805	AS0332R-0805F
R1421	RES	SM	2K2	1%	0.1W	0805	AS0222R-0805F
R1422	RES	SM	47K	1%	0.1W	0805	AS0473R-0805F
R1423	RES	SM	2K2	1%	0.1W	0805	AS0222R-0805F
R1424	RES	SM	15K	1%	0.1W	0805	AS0153R-0805F
R1425	RES	SM	15K	1%	0.1W	0805	AS0153R-0805F
R1426	RES	SM	15K	1%	0.1W	0805	AS0153R-0805F
R1427	RES	SM	4K3	1%	0.1W	0805	AS0432R-0805F
R1428	RES	SM	4K3	1%	0.1W	0805	AS0432R-0805F
R1429	RES	SM	3K3	1%	0.1W	0805	AS0332R-0805F
R1430	RES	SM	47K	1%	0.1W	0805	AS0473R-0805F
R1431	RES	SM	4K3	1%	0.1W	0805	AS0432R-0805F
R1432	RES	SM	4K3	1%	0.1W	0805	AS0432R-0805F
R1433	RES	SM	15K	1%	0.1W	0805	AS0153R-0805F
R1434	RES	SM	3K3	1%	0.1W	0805	AS0332R-0805F
R1435	RES	SM	47K	1%	0.1W	0805	AS0473R-0805F
R1436	RES	SM	620R	1%	0.1W	0805	AS0621R-0805F
R1437	RES	SM	620R	1%	0.1W	0805	AS0621R-0805F
R1438	RES	SM	3K3	1%	0.1W	0805	AS0332R-0805F
R1439	RES	SM	3K3	1%	0.1W	0805	AS0332R-0805F

R1440	RES SM 3K3 1% 0.1W 0805	AS0332R-0805F
R1441	RES SM 3K3 1% 0.1W 0805	AS0332R-0805F
R1442	RES SM 1K5 1% 0.1W 0805	AS0152R-0805F
R1443	RES SM 1K5 1% 0.1W 0805	AS0152R-0805F
R1444	RES SM 2K2 1% 0.1W 0805	AS0222R-0805F
R1446	RES SM 20K 1% 0.1W 0805	AS0203R-0805F
R1447	RES SM 20K 1% 0.1W 0805	AS0203R-0805F
R1448	RES SM 2K2 1% 0.1W 0805	AS0222R-0805F
R1450	RES SM 47K 1% 0.1W 0805	AS0473R-0805F
R2000	RES SM 20K 1% 0.1W 0805	AS0203R-0805F
R2001	RES SM 20K 1% 0.1W 0805	AS0203R-0805F
R2002	RES SM 10K 1% 0.1W 0805	AS0103R-0805F
R2003	RES SM 10K 1% 0.1W 0805	AS0103R-0805F
R2004	RES SM 20K 1% 0.1W 0805	AS0203R-0805F
R2005	RES SM 20K 1% 0.1W 0805	AS0203R-0805F
R2006	RES SM 20K 1% 0.1W 0805	AS0203R-0805F
R2007	RES SM 20K 1% 0.1W 0805	AS0203R-0805F
R2008	RES SM 20K 1% 0.1W 0805	AS0203R-0805F
R2009	RES SM 20K 1% 0.1W 0805	AS0203R-0805F
R2010	RES SM 4K3 1% 0.1W 0805	AS0432R-0805F
R2011	RES SM 4K3 1% 0.1W 0805	AS0432R-0805F
R2012	RES SM 10K 1% 0.1W 0805	AS0103R-0805F
R2013	RES SM 10K 1% 0.1W 0805	AS0103R-0805F
R2014	RES SM 2K2 1% 0.1W 0805	AS0222R-0805F
R2015	RES SM 2K2 1% 0.1W 0805	AS0222R-0805F
R2016	RES SM 10K 1% 0.1W 0805	AS0103R-0805F
R2017	RES SM 10K 1% 0.1W 0805	AS0103R-0805F
R2018	RES SM 4K3 1% 0.1W 0805	AS0432R-0805F
R2019	RES SM 7K5 1% 0.1W 0805	AS0752R-0805F
R2020	RES SM 7K5 1% 0.1W 0805	AS0752R-0805F
R2021	RES SM 7K5 1% 0.1W 0805	AS0752R-0805F
R2022	RES SM 560R 1% 0.1W 0805	AS0561R-0805F
R2023	RES SM 560R 1% 0.1W 0805	AS0561R-0805F
R2024	RES SM 360R 1% 0.1W 0805	AS0361R-0805F
R2025	RES SM 360R 1% 0.1W 0805	AS0361R-0805F
R2026	RES SM 360R 1% 0.1W 0805	AS0361R-0805F
R2027	RES SM 360R 1% 0.1W 0805	AS0361R-0805F
R2028	RES SM 360R 1% 0.1W 0805	AS0361R-0805F
R2029	RES SM 360R 1% 0.1W 0805	AS0361R-0805F
R2030	RES SM 10K 1% 0.1W 0805	AS0103R-0805F
R2031	RES SM 10K 1% 0.1W 0805	AS0103R-0805F
R2032	RES SM 10K 1% 0.1W 0805	AS0103R-0805F
R2033	RES SM 10K 1% 0.1W 0805	AS0103R-0805F
R2034	RES SM 10K 1% 0.1W 0805	AS0103R-0805F
R2035	RES SM 10K 1% 0.1W 0805	AS0103R-0805F
R2036	RES SM 10K 1% 0.1W 0805	AS0103R-0805F
R2037	RES SM 10K 1% 0.1W 0805	AS0103R-0805F
R2038	RES SM 10K 1% 0.1W 0805	AS0103R-0805F
R2039	RES SM 10K 1% 0.1W 0805	AS0103R-0805F
R2040	RES SM 620R 1% 0.1W 0805	AS0621R-0805F
R2041	RES SM 20K 1% 0.1W 0805	AS0203R-0805F
R2042	RES SM 20K 1% 0.1W 0805	AS0203R-0805F
R2043	RES SM 20K 1% 0.1W 0805	AS0203R-0805F
R2044	RES SM 20K 1% 0.1W 0805	AS0203R-0805F
R2045	RES SM 10K 1% 0.1W 0805	AS0103R-0805F
R2046	RES SM 10K 1% 0.1W 0805	AS0103R-0805F
R2048	RES SM 1K8 1% 0.1W 0805	AS0182R-0805F
R2049	RES SM 1K8 1% 0.1W 0805	AS0182R-0805F
R2050	RES SM 20K 1% 0.1W 0805	AS0203R-0805F
R2051	RES SM 20K 1% 0.1W 0805	AS0203R-0805F
SW1	SWT LONG TRAVEL V/MNT ALPS	DF0660

SW3	SWT	LONG	TRAVEL	V/MNT	ALPS	DF0660
SW4	SWT	LONG	TRAVEL	V/MNT	ALPS	DF0660
SW5	SWT	LONG	TRAVEL	V/MNT	ALPS	DF0660
SW100	SWT	LONG	TRAVEL	V/MNT	ALPS	DF0660
SW1000	SWT	LONG	TRAVEL	V/MNT	ALPS	DF0660
SW1001	SWT	LONG	TRAVEL	V/MNT	ALPS	DF0660
SW101	SWT	LONG	TRAVEL	V/MNT	ALPS	DF0660
SW1100	SWT	LONG	TRAVEL	V/MNT	ALPS	DF0660
SW1101	SWT	LONG	TRAVEL	V/MNT	ALPS	DF0660
SW1200	SWT	LONG	TRAVEL	V/MNT	ALPS	DF0660
SW1201	SWT	LONG	TRAVEL	V/MNT	ALPS	DF0660
SW1300	SWT	LONG	TRAVEL	V/MNT	ALPS	DF0660
SW1301	SWT	LONG	TRAVEL	V/MNT	ALPS	DF0660
SW1400	SWT	LONG	TRAVEL	V/MNT	ALPS	DF0660
SW1401	SWT	LONG	TRAVEL	V/MNT	ALPS	DF0660
SW200	SWT	LONG	TRAVEL	V/MNT	ALPS	DF0660
SW2000	SWT	LONG	TRAVEL	V/MNT	ALPS	DF0660
SW2001	SWT	LONG	TRAVEL	V/MNT	ALPS	DF0660
SW201	SWT	LONG	TRAVEL	V/MNT	ALPS	DF0660
SW300	SWT	LONG	TRAVEL	V/MNT	ALPS	DF0660
SW301	SWT	LONG	TRAVEL	V/MNT	ALPS	DF0660
SW400	SWT	LONG	TRAVEL	V/MNT	ALPS	DF0660
SW401	SWT	LONG	TRAVEL	V/MNT	ALPS	DF0660
SW500	SWT	LONG	TRAVEL	V/MNT	ALPS	DF0660
SW501	SWT	LONG	TRAVEL	V/MNT	ALPS	DF0660
SW600	SWT	LONG	TRAVEL	V/MNT	ALPS	DF0660
SW601	SWT	LONG	TRAVEL	V/MNT	ALPS	DF0660
SW700	SWT	LONG	TRAVEL	V/MNT	ALPS	DF0660
SW701	SWT	LONG	TRAVEL	V/MNT	ALPS	DF0660
SW800	SWT	LONG	TRAVEL	V/MNT	ALPS	DF0660
SW801	SWT	LONG	TRAVEL	V/MNT	ALPS	DF0660
SW900	SWT	LONG	TRAVEL	V/MNT	ALPS	DF0660
SW901	SWT	LONG	TRAVEL	V/MNT	ALPS	DF0660
TR100	TRS	PNP	2SB737	LOW	RBB	BD0346
TR1000	TRS	PNP	2SB737	LOW	RBB	BD0346
TR1001	TRS	PNP	2SB737	LOW	RBB	BD0346
TR1002	TRS	BC846A	NPN			BS0513R-SOT23
TR1003	TRS	BC846A	NPN			BS0513R-SOT23
TR1004	TRS	BC846A	NPN			BS0513R-SOT23
TR101	TRS	PNP	2SB737	LOW	RBB	BD0346
TR102	TRS	BC846A	NPN			BS0513R-SOT23
TR103	TRS	BC846A	NPN			BS0513R-SOT23
TR104	TRS	BC846A	NPN			BS0513R-SOT23
TR1100	TRS	PNP	2SB737	LOW	RBB	BD0346
TR1101	TRS	PNP	2SB737	LOW	RBB	BD0346
TR1102	TRS	BC846A	NPN			BS0513R-SOT23
TR1103	TRS	BC846A	NPN			BS0513R-SOT23
TR1104	TRS	BC846A	NPN			BS0513R-SOT23
TR1200	TRS	PNP	2SB737	LOW	RBB	BD0346
TR1201	TRS	PNP	2SB737	LOW	RBB	BD0346
TR1202	TRS	BC846A	NPN			BS0513R-SOT23
TR1203	TRS	BC846A	NPN			BS0513R-SOT23
TR1204	TRS	BC846A	NPN			BS0513R-SOT23
TR1300	TRS	BC846A	NPN			BS0513R-SOT23
TR1400	TRS	BC846A	NPN			BS0513R-SOT23
TR200	TRS	PNP	2SB737	LOW	RBB	BD0346
TR2000	TRS	BC846A	NPN			BS0513R-SOT23
TR201	TRS	PNP	2SB737	LOW	RBB	BD0346
TR202	TRS	BC846A	NPN			BS0513R-SOT23
TR203	TRS	BC846A	NPN			BS0513R-SOT23
TR204	TRS	BC846A	NPN			BS0513R-SOT23

TR300	TRS PNP 2SB737 LOW RBB	BD0346
TR301	TRS PNP 2SB737 LOW RBB	BD0346
TR302	TRS BC846A NPN	BS0513R-SOT23
TR303	TRS BC846A NPN	BS0513R-SOT23
TR304	TRS BC846A NPN	BS0513R-SOT23
TR400	TRS PNP 2SB737 LOW RBB	BD0346
TR401	TRS PNP 2SB737 LOW RBB	BD0346
TR402	TRS BC846A NPN	BS0513R-SOT23
TR403	TRS BC846A NPN	BS0513R-SOT23
TR404	TRS BC846A NPN	BS0513R-SOT23
TR500	TRS PNP 2SB737 LOW RBB	BD0346
TR501	TRS PNP 2SB737 LOW RBB	BD0346
TR502	TRS BC846A NPN	BS0513R-SOT23
TR503	TRS BC846A NPN	BS0513R-SOT23
TR504	TRS BC846A NPN	BS0513R-SOT23
TR600	TRS PNP 2SB737 LOW RBB	BD0346
TR601	TRS PNP 2SB737 LOW RBB	BD0346
TR602	TRS BC846A NPN	BS0513R-SOT23
TR603	TRS BC846A NPN	BS0513R-SOT23
TR604	TRS BC846A NPN	BS0513R-SOT23
TR700	TRS PNP 2SB737 LOW RBB	BD0346
TR701	TRS PNP 2SB737 LOW RBB	BD0346
TR702	TRS BC846A NPN	BS0513R-SOT23
TR703	TRS BC846A NPN	BS0513R-SOT23
TR704	TRS BC846A NPN	BS0513R-SOT23
TR800	TRS PNP 2SB737 LOW RBB	BD0346
TR801	TRS PNP 2SB737 LOW RBB	BD0346
TR802	TRS BC846A NPN	BS0513R-SOT23
TR803	TRS BC846A NPN	BS0513R-SOT23
TR804	TRS BC846A NPN	BS0513R-SOT23
TR900	TRS PNP 2SB737 LOW RBB	BD0346
TR901	TRS PNP 2SB737 LOW RBB	BD0346
TR902	TRS BC846A NPN	BS0513R-SOT23
TR903	TRS BC846A NPN	BS0513R-SOT23
TR904	TRS BC846A NPN	BS0513R-SOT23
ZD1,ZD2	ZENER DIODE 300MW 3V9 BZX84C	BS0011R-SOT23

EFX/MFX LEXICON FX BOARD

R0529A-01-AF

Ident	Description	Part Number
---	EFX/MFX LEXICON FX BOARD	S0529-01
C201	CAP SM CER 15PF 5% 50V NPO 080	CS1150R-0805J
C202	CAP SM CER 15PF 5% 50V NPO 080	CS1150R-0805J
C203	CAP SM CER 15PF 5% 50V NPO 080	CS1150R-0805J
C204	CAP SM CER 15PF 5% 50V NPO 080	CS1150R-0805J
C205	CAP SM CER 100NF 10% 50V X5R 0	CS7104R-0805K
C206	CAP SM CER 100NF 10% 50V X5R 0	CS7104R-0805K
C207	CAP SM CER 100NF 10% 50V X5R 0	CS7104R-0805K
C208	CAP SM CER 100NF 10% 50V X5R 0	CS7104R-0805K
C209	CAP SM CER 100NF 10% 50V X5R 0	CS7104R-0805K
C210	CAP SM CER 100NF 10% 50V X5R 0	CS7104R-0805K
C211	CAP SM CER 100NF 10% 50V X5R 0	CS7104R-0805K
C301	CAP SM CER 1NF 10% 50V X7R 080	CS7102R-0805K
C302	CAP SM CER 220PF 5% 100V NPO 0	CS1221R-0805J
C303	CAP SM CER 1NF 10% 50V X7R 080	CS7102R-0805K
C304	CAP SM CER 100NF 10% 50V X5R 0	CS7104R-0805K
C305	CAP SM CER 100NF 10% 50V X5R 0	CS7104R-0805K
C306	CAP SM CER 100NF 10% 50V X5R 0	CS7104R-0805K
C307	CAP SM CER 100NF 10% 50V X5R 0	CS7104R-0805K
C308	CAP SM CER 100NF 10% 50V X5R 0	CS7104R-0805K
C309	CAP SM CER 100NF 10% 50V X5R 0	CS7104R-0805K
C310	CAP SM CER 100NF 10% 50V X5R 0	CS7104R-0805K

C311	CAP SM CER 100NF 10% 50V X5R 0	CS7104R-0805K
C312	CAP SM CER 100NF 10% 50V X5R 0	CS7104R-0805K
C313	CAP SM CER 100NF 10% 50V X5R 0	CS7104R-0805K
C314	CAP SM CER 100NF 10% 50V X5R 0	CS7104R-0805K
C315	CAP SM CER 100NF 10% 50V X5R 0	CS7104R-0805K
C316	CAP SM CER 100NF 10% 50V X5R 0	CS7104R-0805K
C401	CAP ELC RD 47UF 25V	CE0438
C402	CAP ELC RD 47UF 25V	CE0438
C403	CAP ELC RD 47UF 25V	CE0438
C404	CAP ELC RD 47UF 25V	CE0438
C405	CAP ELC RD 100UF 16V	CE0532
C406	CAP ELC RD 47UF 25V	CE0438
C407	CAP ELC RD 47UF 25V	CE0438
C408	CAP SM CER 100NF 10% 50V X5R 0	CS7104R-0805K
C409	CAP SM CER 100NF 10% 50V X5R 0	CS7104R-0805K
C410	CAP SM CER 100NF 10% 50V X5R 0	CS7104R-0805K
C411	CAP SM CER 100NF 10% 50V X5R 0	CS7104R-0805K
C412	CAP SM CER 100NF 10% 50V X5R 0	CS7104R-0805K
C413	CAP SM CER 100NF 10% 50V X5R 0	CS7104R-0805K
C414	CAP SM CER 100NF 10% 50V X5R 0	CS7104R-0805K
C415	CAP SM CER 100NF 10% 50V X5R 0	CS7104R-0805K
C416	CAP SM CER 100NF 10% 50V X5R 0	CS7104R-0805K
C417	CAP SM CER 100NF 10% 50V X5R 0	CS7104R-0805K
C418	CAP SM CER 100NF 10% 50V X5R 0	CS7104R-0805K
C419	CAP SM CER 100NF 10% 50V X5R 0	CS7104R-0805K
C420	CAP SM CER 100NF 10% 50V X5R 0	CS7104R-0805K
C421	CAP SM CER 100NF 10% 50V X5R 0	CS7104R-0805K
C422	CAP SM CER 100NF 10% 50V X5R 0	CS7104R-0805K
C423	CAP SM CER 100NF 10% 50V X5R 0	CS7104R-0805K
C424	CAP ELC RD 10UF 16V	CE0448
C425	CAP SM CER 100PF 5% 50V NPO 08	CS1101R-0805J
C426	CAP SM CER 100PF 5% 50V NPO 08	CS1101R-0805J
C427	CAP SM CER 100PF 5% 50V NPO 08	CS1101R-0805J
C428	CAP SM CER 100PF 5% 50V NPO 08	CS1101R-0805J
C429	CAP SM CER 100PF 5% 50V NPO 08	CS1101R-0805J
C430	CAP SM CER 100PF 5% 50V NPO 08	CS1101R-0805J
C431	CAP SM CER 220PF 5% 100V NPO 0	CS1221R-0805J
C432	CAP SM CER 220PF 5% 100V NPO 0	CS1221R-0805J
C433	CAP ELEC RD 22UF 25V 5X11MM	CE0425
C434	CAP ELEC RD 22UF 25V 5X11MM	CE0425
C435	CAP ELEC RD 22UF 25V 5X11MM	CE0425
C436	CAP ELEC RD 22UF 25V 5X11MM	CE0425
C437	CAP ELC RD 470UF 6.3V 8X12MM	CE0449
C438	CAP SM CER 220PF 5% 100V NPO 0	CS1221R-0805J
C439	CAP SM CER 220PF 5% 100V NPO 0	CS1221R-0805J
C440	CAP SM CER 1NF 10% 50V X7R 080	CS7102R-0805K
C441	CAP SM CER 1NF 10% 50V X7R 080	CS7102R-0805K
C442	CAP ELC RD 4700UF 50V 22MM DIA	CE0450
CN201	6WY HEADER DIL 0.1-2 ROWS OF 3	FF10074
CN401	8WY 2MM L/PRF VERT LCKG ML HDR	FF1020
CN402	CON 26WY ML IDC R/A LATCH HDR	FA0063
D201	DHS BAS16	BS0001R-SOT23
D401	DHS BAS16	BS0001R-SOT23
IC201	FX16II ANALOG FX HOST	RX3062
IC202	FX16II ANALOG FX FLASH	RX3063
IC203	8 BIT RISC MICRO AVR48 8K	BS9114R-TQFP32
IC204	SRAM CMOS 32KX8 15NS 3.3V	BS9446R-SQJ28
IC301	AUDIO DNA ATMEL QFT-144	BS9106R-QFP144
IC302	DRAM 1M X 16 (16-MBIT)	BS9447R-TSOP44
IC303	IC 74HC00D 4X2I/P NAND CMOS	BS2001R
IC403	VOLT REG 1.25V/13.8V 0.8A	BS7036R-TO252

IC404	VREG BA05FP 5V TO252	BS0559R-TO252
IC405	24BIT 192KHZ STEREO CODEC	BS9241R-TSSOP24
IC406	IC 74HC405D 8:1 ANLOG MPLX	BS2511R-SO16
R201	RES SM 1M0 1% 0.1W 0805	AS0105R-0805F
R202	RES SM 1M0 1% 0.1W 0805	AS0105R-0805F
R203	RES SM 10K 1% 0.1W 0805	AS0103R-0805F
R204	RES SM 10K 1% 0.1W 0805	AS0103R-0805F
R205	RES SM 10K 1% 0.1W 0805	AS0103R-0805F
R206	RES SM 10K 1% 0.1W 0805	AS0103R-0805F
R207	RES SM 10K 1% 0.1W 0805	AS0103R-0805F
R208	RES SM 10K 1% 0.1W 0805	AS0103R-0805F
R209	RES SM 10K 1% 0.1W 0805	AS0103R-0805F
R212	RES SM 0R0 1% 0.1W 0805	AS0000R-0805F
R213	RES SM 0R0 1% 0.1W 0805	AS0000R-0805F
R214	RES SM 0R0 1% 0.1W 0805	AS0000R-0805F
R215	RES SM 0R0 1% 0.1W 0805	AS0000R-0805F
R216	RES SM 0R0 1% 0.1W 0805	AS0000R-0805F
R217	RES SM 0R0 1% 0.1W 0805	AS0000R-0805F
R218	RES SM 0R0 1% 0.1W 0805	AS0000R-0805F
R219	RES SM 0R0 1% 0.1W 0805	AS0000R-0805F
R220	RES SM 0R0 1% 0.1W 0805	AS0000R-0805F
R221	RES SM 0R0 1% 0.1W 0805	AS0000R-0805F
R222	RES SM 0R0 1% 0.1W 0805	AS0000R-0805F
R223	RES SM 0R0 1% 0.1W 0805	AS0000R-0805F
R224	RES SM 0R0 1% 0.1W 0805	AS0000R-0805F
R225	RES SM 0R0 1% 0.1W 0805	AS0000R-0805F
R226	RES SM 0R0 1% 0.1W 0805	AS0000R-0805F
R227	RES SM 0R0 1% 0.1W 0805	AS0000R-0805F
R228	RES SM 0R0 1% 0.1W 0805	AS0000R-0805F
R229	RES SM 0R0 1% 0.1W 0805	AS0000R-0805F
R301	RES SM 2K0 1% 0.1W 0805	AS0202R-0805F
R302	RES SM 2K0 1% 0.1W 0805	AS0202R-0805F
R303	RES SM 22K 1% 0.1W 0805	AS0223R-0805F
R304	RES SM 2K2 1% 0.1W 0805	AS0222R-0805F
R305	RES SM 0R0 1% 0.1W 0805	AS0000R-0805F
R306	RES SM 10K 1% 0.1W 0805	AS0103R-0805F
R307	RES SM 200R 1% 0.1W 0805	AS0201R-0805F
R308	RES SM 200R 1% 0.1W 0805	AS0201R-0805F
R309	RES SM 200R 1% 0.1W 0805	AS0201R-0805F
R310	RES SM 200R 1% 0.1W 0805	AS0201R-0805F
R401	RES SM 10K 1% 0.1W 0805	AS0103R-0805F
R402	RES SM 10K 1% 0.1W 0805	AS0103R-0805F
R403	RES SM 10K 1% 0.1W 0805	AS0103R-0805F
R404	RES SM 10K 1% 0.1W 0805	AS0103R-0805F
R405	RES SM 10K 1% 0.1W 0805	AS0103R-0805F
R406	RES SM 10K 1% 0.1W 0805	AS0103R-0805F
R407	RES SM 10K 1% 0.1W 0805	AS0103R-0805F
R408	RES SM 10K 1% 0.1W 0805	AS0103R-0805F
R409	RES SM 10K 1% 0.1W 0805	AS0103R-0805F
R410	RES SM 10K 1% 0.1W 0805	AS0103R-0805F
R411	RES SM 10K 1% 0.1W 0805	AS0103R-0805F
R412	RES SM 10K 1% 0.1W 0805	AS0103R-0805F
R413	RES SM 10K 1% 0.1W 0805	AS0103R-0805F
R414	RES SM 10K 1% 0.1W 0805	AS0103R-0805F
R415	RES SM 1M0 1% 0.1W 0805	AS0105R-0805F
R416	RES SM 1M0 1% 0.1W 0805	AS0105R-0805F
R417	RES SM 10K 1% 0.1W 0805	AS0103R-0805F
R418	RES SM 10K 1% 0.1W 0805	AS0103R-0805F
R419	RES SM 10K 1% 0.1W 0805	AS0103R-0805F
R420	RES SM 10K 1% 0.1W 0805	AS0103R-0805F
R421	RES SM 10K 1% 0.1W 0805	AS0103R-0805F

R422	RES SM 10K 1% 0.1W 0805	AS0103R-0805F
R423	RES SM 10K 1% 0.1W 0805	AS0103R-0805F
R424	RES SM 10K 1% 0.1W 0805	AS0103R-0805F
R425	RES SM 1K0 1% 0.1W 0805	AS0102R-0805F
R426	RES SM 1K0 1% 0.1W 0805	AS0102R-0805F
R427	RES SM 10K 1% 0.1W 0805	AS0103R-0805F
R428	RES SM 820R 1% 0.1W 0805	AS0821R-0805F
R429	RES SM 820R 1% 0.1W 0805	AS0821R-0805F
R435	RES SM 6K8 1% 0.1W 0805	AS0682R-0805F
R436	RES SM 6K8 1% 0.1W 0805	AS0682R-0805F
R437	RES SM 330R 1% 0.1W 0805	AS0331R-0805F
R438	RES SM 200R 1% 0.1W 0805	AS0201R-0805F
R439	RES SM 0R0 1% 0.1W 0805	AS0000R-0805F
R440	RES SM 0R0 1% 0.1W 0805	AS0000R-0805F
R442	RES SM 0R0 1% 0.1W 0805	AS0000R-0805F
R443	RES SM 0R0 1% 0.1W 0805	AS0000R-0805F
R444	RES SM 10K 1% 0.1W 0805	AS0103R-0805F
R445	RES SM 200R 1% 0.1W 0805	AS0201R-0805F
R446	RES SM 22R 1% 0.1W 0805	AS0220R-0805F
R447	RES SM 22R 1% 0.1W 0805	AS0220R-0805F
R448	RES SM 3K0 1% 0.1W 0805	AS0302R-0805F
R449	RES SM 3K0 1% 0.1W 0805	AS0302R-0805F
R450	RES SM 2K7 1% 0.1W 0805	AS0272R-0805F
R451	RES SM 2K7 1% 0.1W 0805	AS0272R-0805F
R452	RES SM 24K 1% 0.1W 0805	AS0243R-0805F
R453	RES SM 24K 1% 0.1W 0805	AS0243R-0805F
R454	RES SM 100K 1% 0.1W 0805	AS0104R-0805F
R455	RES SM 100K 1% 0.1W 0805	AS0104R-0805F
R456	RES SM 200K 1% 0.1W 0805	AS0204R-0805F
R457	RES SM 200K 1% 0.1W 0805	AS0204R-0805F
TR401	TRS BC846A NPN	BS0513R-SOT23
TR402	TRS BC846A NPN	BS0513R-SOT23
X201	XTAL 20MHZ HC49V/4H	ZE0415
X202	XTAL 6MHZ HC49	ZE0419

(Safety Critical Part)!

FUSE T1.6A 250V 5X20MM	ZD80016
-------------------------------	----------------

EFX USER GUIDE	ZM0356-01
-----------------------	------------------

WIREFORMS USED IN THE FRAMES

Description	Part Number	Used in: (part number)
IDC TO SOLDER TRANS TYPE "A"	RV3604-26-200	R0527A-01-AF, R0528A-01-AF

SWITCH TOPS, FADER TOPS AND KNOBS

Description	Part Number	Used in (part number)
11MM FDR KNOB DK BL W/WHT LINE	KA0406	RW5758
11MM FDR KNOB WHT W/BLK LINE	KA0408	RW5758
11MM FDR KNOB YL W/BLK LINE	KA0407	RW5758
KNOB 10MM DK\GRY BODY GRN TOP	KA0454	RW5758
KNOB 10MM DK\GRY BODY PUR TOP	KA0456	RW5758
KNOB 10MM DK\GRY BODY RED TOP	KA0451	RW5758
KNOB 10MM DK\GRY BODY WHT TOP	KA0453	RW5758
KNOB 10MM DK\GRY BODY YEL TOP	KA0457	RW5758
KNOB 10MM LT\GRY BODY BLK TOP	KA0452	RW5758
KNOB 11MM FDR PURPLE W\BLK LIN	KA0458	RW5758
LX7II SWITCH CAP RED	KB2379	RW5758
PSU SWITCH CAP 7.5DIA BLACK	KB2262	RW5758
SERIES TWO SWITCH CAP GREY	KB2260	RW5758
SWITCH CAP 6X6MM LONG RED FITS	KB2385	RW5758

FADERS

Description	Part Number	Used in: (part number)
FDR PAN 75MM 10KA MONO	DD0408	R0527A-01-AF, R0528A-01-AF
FDR PAN 75MM 10KX2 STER A	DD0409	R0527A-01-AF, R0528A-01-AF

MODULES

FX16II ANALOG FX HOST

Ident	Description
---	8BIT MCU 30MHZ PLCC-44
---	35MM SLIDE LABEL 46X11.1 ZA022

RX3062

Part Number
BS9109R-PLCC44
ZA10074

FX16II ANALOG FX FLASH

Ident	Description
---	FLASH 512KX8 70NS 3V PLCC32
---	35MM SLIDE LABEL 46X11.1 ZA022

RX3063

Part Number
BS9432R-PLCC32
ZA10074

MISCELLANEOUS HARDWARE

Description	Part Number	Used in: (part number)
NUT M3 NYLOC ZP	NB0113	R0307B-05-AF, RW5758
NUT M4 NYLOC ZP	NB0160	RW5758
NUT M9 POT ROUNDED CORNERS	NB0169	RW5758
SCRW M3X10MM HEX/HD SKT S/LOCK	NA0478	RW5758
SCRW M3X6MM P/POZI S/COLOUR DI	NA0155	RW5758
SCRW M3X6MM P/POZI TAP/T ZP DI	NA0437	RW5758
SCRW M3X8MM NYLON	NA10117	RW5758
SCRW M3X8MM P/POZI BLK ISO7045	NA0452	RW5758
SCRW M3X8MM P/POZI SZP DIN7985	NA0116	R0307B-05-AF
SCRW M4X6MM P/POZI BLK	NA10045	RW5758
SCRW NO4X1/4" P/POZI ST/STL DI	NA0475	R0307B-05-AF
SCRW NO4X3/8" P/POZI S/TAP BLK	NA0249	RW5758
SPCR M3X30MM HEX BRASS NP	ND0464	RW5758
WSHR FIBRE 5.54MMX3.05MMX0.8MM	NC0301	RW5758
WSHR M3 EXT S/PROOF ST/STL DIN	NC10031	RW5758
WSHR PVC 13MMODX9.5MMID	NC10040	RW5758



SOUNDCRAFT
Harman International Industries Ltd.,
Cranborne House, Cranborne Road,
Potters Bar, Herts., EN6 3JN U.K.
Tel: +44 (0) 1707 665000
Fax: +44 (0) 1707 660742
EMAIL: info@soundcraft.com

SOUNDCRAFT USA,
8500 Balboa Blvd
Northridge
CA 91329
Tel: +1-818- 920-3212
Fax: 1-818- 920-3208
Toll Free: 888 251 8352
EMAIL: soundcraft-usa@harman.com



This equipment complies
with the EMC directive
89/336/EEC
Modified by
92/31/EEC
93/68/EEC
91/263/EEC
and LVD 73/23/EEC
modified by 93/68/EEC

This product is approved to
safety standards:

IEC 60065: 2001
EN60065:2002
UL6500 7th Edition: 2003
CAN/CSA-E60065-03

And EMC standards
EN55103-1: 1996 (E2)
EN55103-2: 1996 (E2)

For further details contact:

Harman International Industries Ltd.
Cranborne House, Cranborne Road
Potters Bar, Hertfordshire, EN6 3JN, UK

Tel:+44 (0) 1707 665000
Fax:+44 (0) 1707 660742
e-mail:info@soundcraft.com

H A Harman International Company

www.soundcraft.com