

# THE GENERREX\* EXCITATION SYSTEM: DESCRIPTION AND PERFORMANCE

## PART I

### DESCRIPTION AND TESTS OF THE GENERREX EXCITATION SYSTEM FOR LARGE STEAM TURBINE-GENERATORS

**G. M. Cotzas and K. F. Drexler**  
*General Electric Company  
Schenectady, New York*

**J. J. Dvorscak, and R. K. Gerlitz**  
*General Electric Company  
Waynesboro, Virginia*

## PART II

### GENERATOR AND POWER SYSTEM PERFORMANCE WITH THE GENERREX EXCITATION SYSTEM

**P. H. Beagles**  
*The Montana Power Company  
Butte, Montana*

**K. Carlsen, M. L. Crenshaw, and M. Temoshok**  
*General Electric Company  
Schenectady, New York*

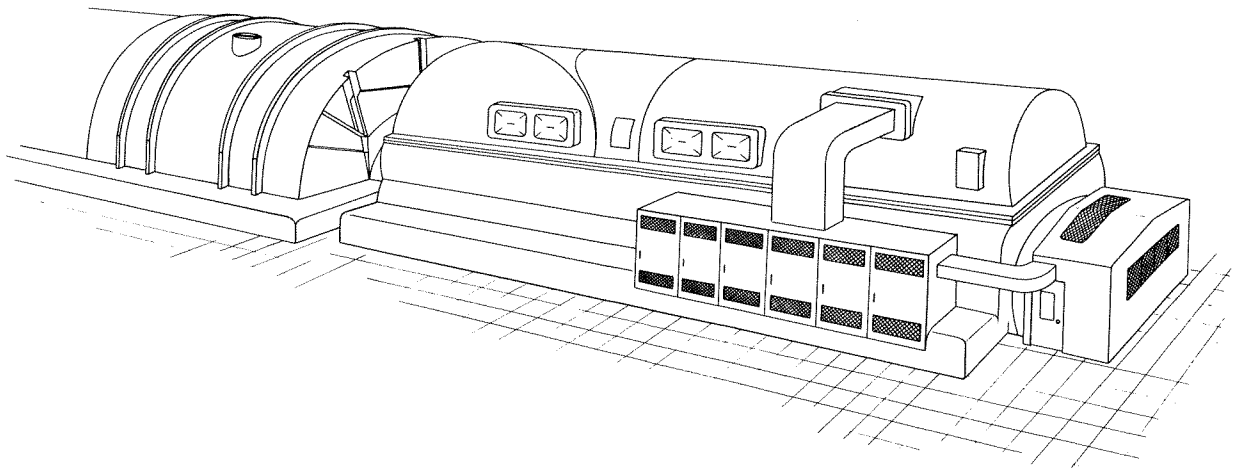

Presented at the

**JOINT POWER GENERATION TECHNICAL CONFERENCE  
INSTITUTE OF ELECTRICAL AND ELECTRONICS ENGINEERS  
AMERICAN SOCIETY OF MECHANICAL ENGINEERS  
AMERICAN SOCIETY OF CIVIL ENGINEERS**

Portland, Oregon

September 28 – October 1, 1975



# PART I

## DESCRIPTION AND TESTS OF THE GENERREX\* EXCITATION SYSTEM FOR LARGE STEAM TURBINE-GENERATORS

G. M. Cotzas, K. F. Drexler, J. J. Dvorscak, and R. K. Gerlitz

### ABSTRACT

A new excitation system has been developed employing a power source which is an integral part of the generator. Excitation power originates from the generator air-gap flux and from the generator stator winding currents. The physical arrangement of the excitation power source components provides compactness to this self-excited, essentially self-regulated and high initial response system. It facilitates generator maintenance, by eliminating rotating parts from the collector end of the turbine-generator shaft, and simplifies the station layout. The ac excitation power is rectified by means of a full-wave bridge with silicon diodes and shunt silicon-controlled rectifiers (thyristors). Extensive use of static components is made in the generator voltage control system coupled with redundant features which permit maintenance during operation.

This new excitation system aims for a high degree of reliability and sustained generator availability, while enhancing generator and system performance by contributing to dynamic and transient system stability.

A description of this GENERREX\* excitation system is given, with emphasis on the excitation power components. Development programs leading to the prototype equipment are described. Tests of the prototype excitation system with the generator are identified and results of selected tests are presented.

### INTRODUCTION

The principle and operation of a new excitation system, called the GENERREX\* excitation system, have been previously described.<sup>1</sup> It is a high initial response system, with its power source an integral part of the generator. The first commercial application of this new system, with a 3.5 response ratio, is on a 377-MVA, two-pole generator, for The Montana Power Company, as the first unit of its Colstrip Station. The generator and the excitation system were tested in the factory of the authors' company, in April 1974, following a comprehensive program of careful component development.

\*Trademark of The General Electric Company

A three-phase diagram of the prototype excitation system and the generator is given in Figure 1, indicating the manner in which the various components are electrically connected. The generator stator winding is depicted with heavy lines.

In this system, the outputs of a potential (voltage) source and of a current source are combined in three excitation transformers to provide an ac output responsive to generator load, voltage, current, and power factor. The core of one transformer only is shown in Figure 1. The potential source consists of a three-phase, water-cooled winding, which is connected to the potential input or "P" windings of the three single-phase excitation transformers and to three linear reactors. The potential source winding is located in the top of the generator stator winding slot wedges; it is called the generator excitation potential winding. The voltage produced in the excitation potential winding is responsive to the generator air-gap flux and provides all of the generator field excitation under no-load conditions. The current source consists of the three neutral leads of the generator stator winding as they pass through the windows of the excitation transformers. This will be referred to as the current, or "C" winding; it is a second transformer input winding and provides the additional field excitation needed under load conditions. The "C" winding also provides the excitation power during system faults when the system voltage — and hence the machine air-gap flux — are at depressed levels.

The ac output from the excitation transformer windings, or "F" windings, supplies the generator field winding through power rectifiers which consist of silicon diodes and shunt thyristors with necessary firing and control circuits. The available voltage output is designed to be somewhat greater than that required by the generator field, and excitation to the generator field is closely regulated by the voltage regulator through control of the firing circuits to the shunt thyristors in the rectifier bridges.

The exciter power source inherently tracks the excitation voltage required by the generator field winding as the generator load changes. This self-regulating effect of the excitation source is called "compounding".

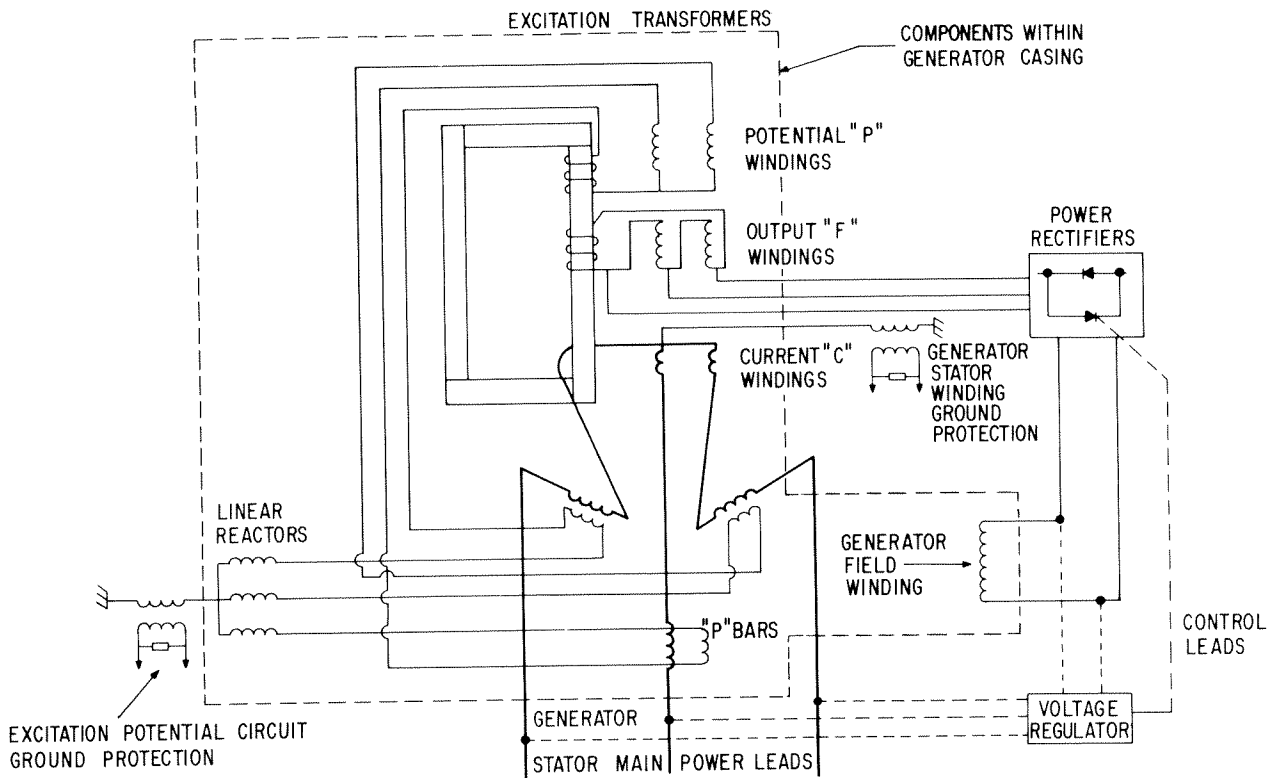

Figure 1. Three-phase schematic diagram of the generator and excitation system

The compounding effect is illustrated in Figure 2 for the steady-state performance of the prototype excitation system generator. The available voltage in p.u. of the excitation power source and the required excitation voltage by the generator field winding are plotted versus various power factors corresponding to points on the generator capability curve. The generator field winding voltage at rated load is taken as the base value.

## DESCRIPTION OF COMPONENTS

The components of the exciter power source are located within the generator casing. The excitation transformers, the linear reactors, and the generator neutrals are located on top of the generator. They are enclosed in a dome, and use the hydrogen ventilation circuit of the generator. The generator excitation potential winding, located on top of the generator stator winding slot wedges, uses the cooling water system of the generator stator winding. The exciter cubicle is arranged alongside the generator and set into the generator appearance lagging, providing a close-coupled arrangement. The heat generated in the diodes and shunt thyristors is removed by water-cooled heat sinks, supplied, also, from the generator stator winding cooling water

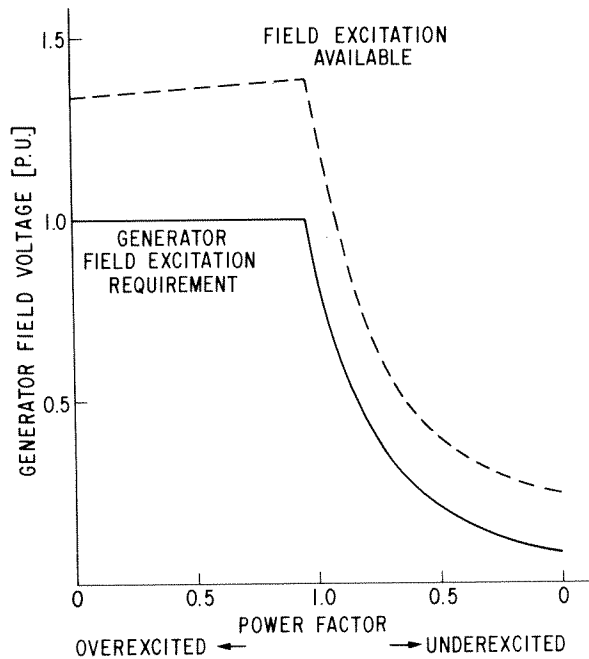

Figure 2. Compounding curve for the prototype excitation system

pumping unit. An alternating-current busway provides the connection from the three excitation power source output bushings on the side of the dome, to the exciter cubicle, and from there a dc busway provides the connection to the collectors for the generator field winding.

The generator regulator cubicle is located in a clean air-conditioned atmosphere, such as the power station relay room. Only low voltage control leads connect the exciter cubicle with the regulator cubicle.

## Excitation Transformer

The excitation system includes three single-phase three-winding transformers. A conservative approach has been taken in the design of the excitation power source components since they constitute an integral part of the generator and function in a hydrogen atmosphere. The components are built with materials and manufacturing processes used in the main generator, and with which many years of experience have been accumulated. Temperature limits and insulation practices conform to generator design practice. The size of the excitation transformer core is designed to accommodate the excitation system ceiling voltage, which is obtained when the core of the excitation transformer saturates.

A schematic representation of the transformer is illustrated in Figure 3. The winding connected to the potential power source, and the output winding, consist of stranded and transposed coils. The strand insulation is similar to that used for the generator stator winding. A spacing separates adjacent turns to provide dielectric clearance and a passage for the cooling hydrogen. The core is laminated and cooled with hydrogen. Core materials and insulation are the same

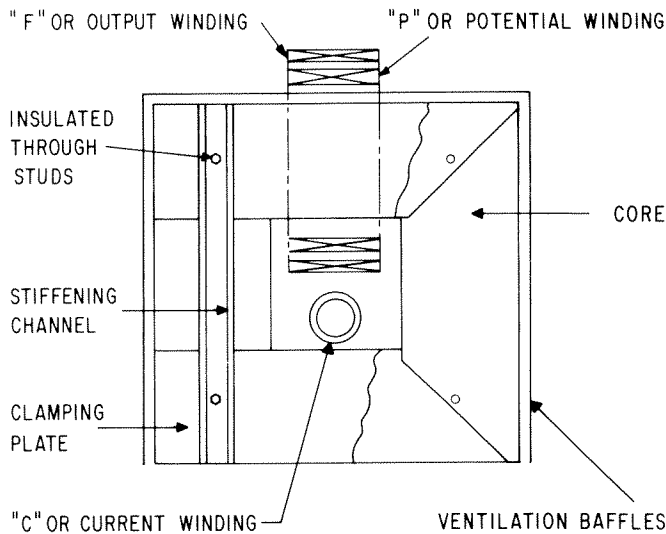

Figure 3. Sketch of excitation transformer

as in the generator. The lamination enamel insulation is overcoated with an epoxy cement and the laminations are bonded together in an oven bake.

The core is clamped together by means of insulated through-studs and a nonmagnetic steel frame. The core is cooled with hydrogen gas which is guided and contained by a system of nonmetallic baffles. The winding connected to the potential source and the output winding are built in a subassembly which is flooded with epoxy resin as a final treatment prior to assembly in the core.

One of the prototype excitation transformers is illustrated in Figure 4. Not shown are the ventilation baffles that cover the core sides, and the corresponding generator neutral lead which constitutes the third winding of the transformer by passing through the transformer window.

## Linear Reactor

A schematic of the linear reactor is given in Figure 5. The reactors are of the shell-type construction with two separate cores. Each core is laminated and bonded as in the transformer. The laminations have a trapezoidal shape and the reactor air-gaps are located in the diagonals of each core (a total of eight reactor air-gaps in the two cores). This arrangement yields low electromagnetic forces.

For mechanical strength the core is divided in packets which are separated by "E"-shaped plates that span both cores as shown in Figure 5. This mechanical design leaves the core air-gaps free for hydrogen to circulate and cool the reactor core. The end pressure plates are designed to permit adjustment of the air-gaps in order to obtain a predetermined reactance. All frame plate material is non-magnetic stainless steel.

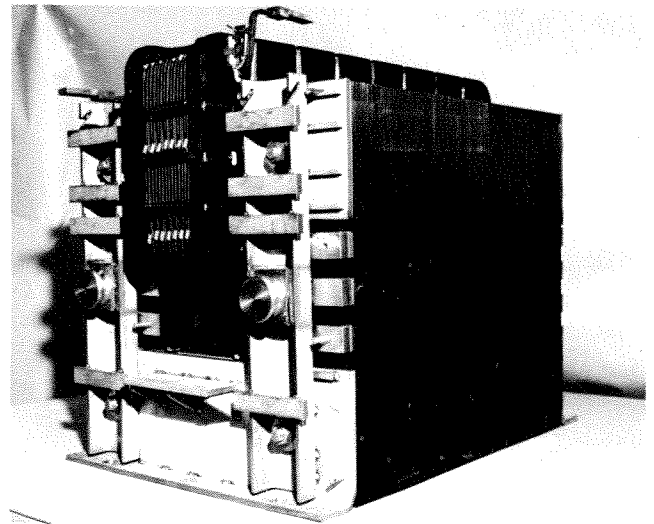

Figure 4. Single-phase transformer of prototype excitation system

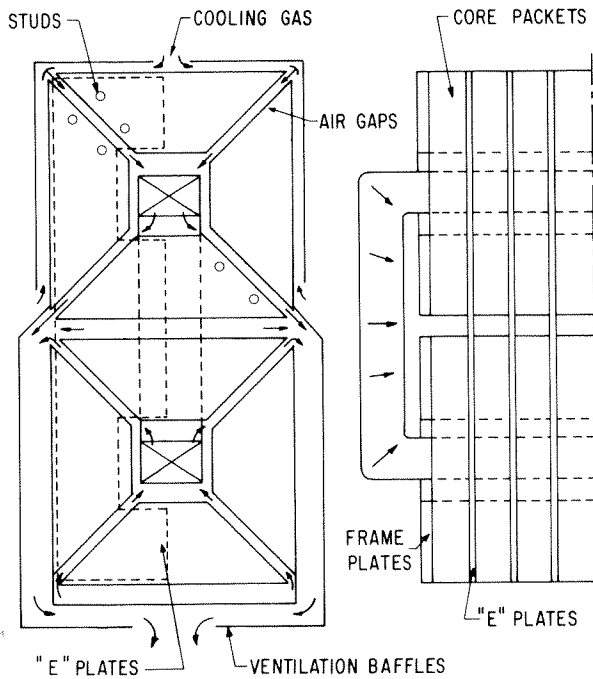

Figure 5. Sketch of linear reactor

The reactor winding and core are of the same structural design as that of the transformer and are cooled by hydrogen flowing through the air-gaps, the winding turns, and along the sides of the core. The gas is contained and guided by nonmetallic baffles.

The design of the reactor core and gaps restricts the reactor to operate linearly and to not saturate within the operating range of the exciter.

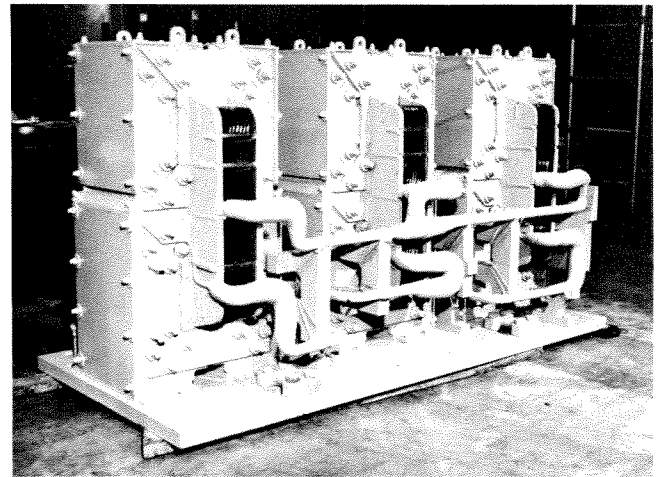

Figure 6. Linear reactor base plate assembly

Three reactors are supplied, one for each phase. The assembly of the three prototype reactors on a common base is shown in Figure 6. The maximum steady-state duty on the reactor occurs during generator operation at no-load when the excitation power is supplied by the potential source only.

### Generator Excitation Potential Winding or "P" Bars

The potential source is a three-phase winding. There is one conductor bar per phase placed on top of the wedges in selected stator winding slots in the generator core. Figure 7

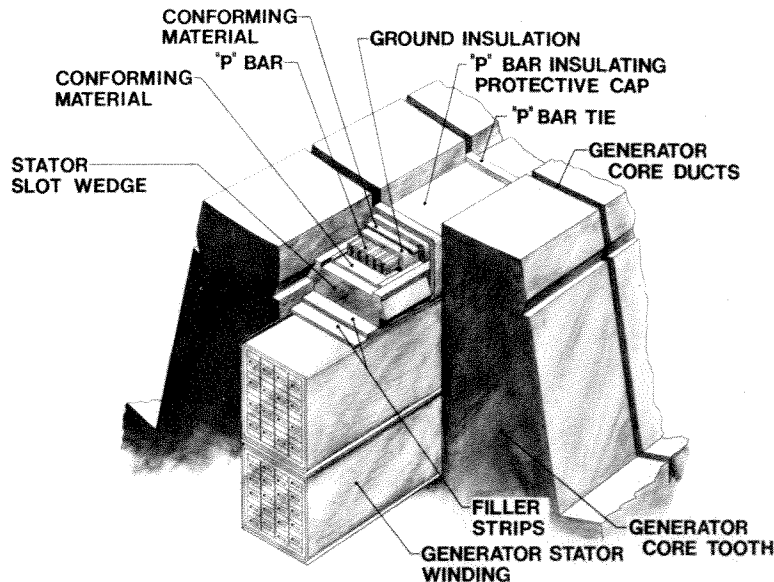

Figure 7. Location of the generator excitation potential winding – "P" bar

shows a slot cross-section containing such a "P" bar. The "P" bar is water-cooled by the high purity water system used for the generator stator winding. Water flows through high resistivity alloy hollow strands. There is also a large number of small, solid copper strands — thus making it a "mixed-strand" bar. The "P" bar is designed to minimize and withstand the effects of stray losses resulting from the generator cross-slot flux and the generator air-gap flux.

The "P" bar is insulated with the insulation system used for the generator stator winding. Layers of insulating conforming material are placed between the "P" bar and the generator slot wedge as well as between the top of the bar and a protective insulating cap as shown in Figure 7. The cap and "P" bar are held in place by means of thermosetting resin impregnated glass roving tied around the cap, through the generator core ventilation ducts, and around the slot wedges. There is a tie in every generator core ventilation duct, or about every three to four inches. This supporting arrangement yields a firm and compact "P" bar assembly.

The "P" bars constitute a low-voltage, low-current winding. Characteristically, for the generator with the prototype excitation system, at rated generator load condition, the effective value of the fundamental-frequency component of voltage will be in the order of 630 V, and that of current in the order of 200 A. The three "P" bars are placed 120 mechanical degrees apart in the generator circumference. The stator slot is designed so that the "P" bar may protrude slightly above the top of the slot. Such a placement exposes the "P" bar to much lower radial flux densities than exist in the air-gap, hence resulting in low losses. To prevent damaging the "P" bar during rotor

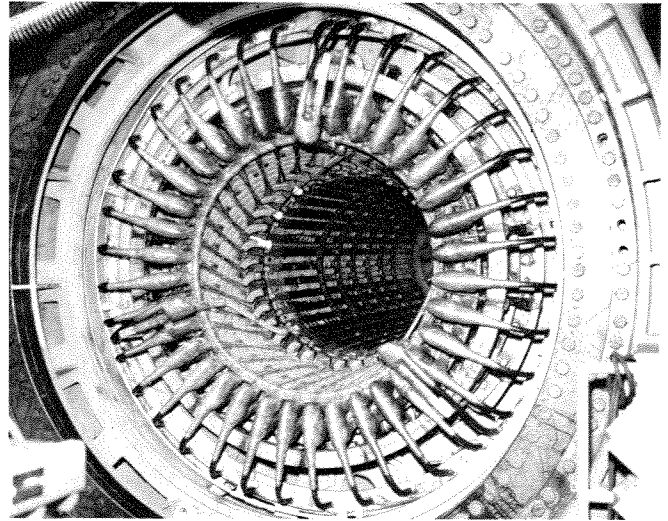

Figure 8. End winding view of the generator with the prototype excitation system showing the "P" bars

assembly, the "P" bars are not placed in the lower 60 degrees of the generator core.

Figure 8 is a photograph of the end winding of the generator with the prototype excitation system, where the "P" bar end arms and related water hoses can be seen.

### Assembly of the Prototype Excitation System on the Generator

Figure 9 is a top view of The Montana Power generator, photographed from a factory crane, prior to the assembly

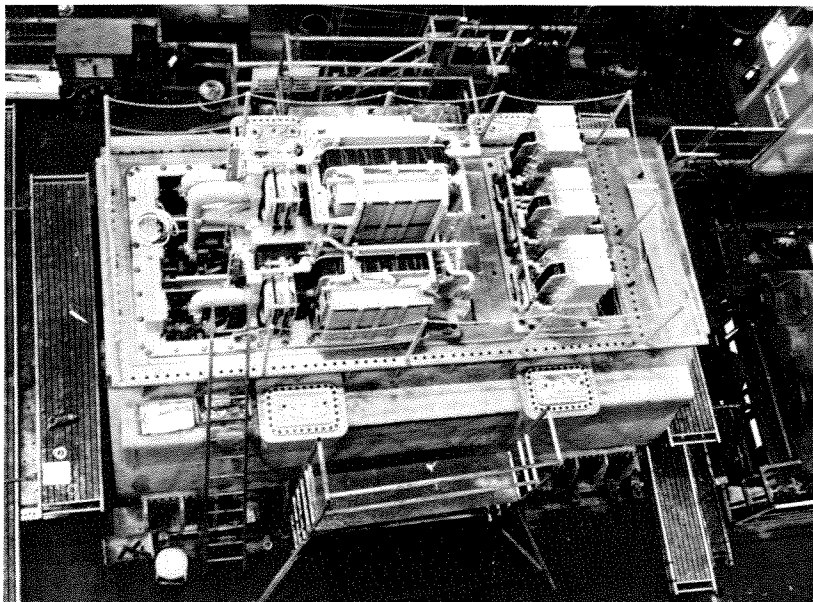

Figure 9. Top view of the generator for The Montana Power Company, Colstrip 1, with the prototype excitation power source assembled

of the dome. The generator frame is of the vertical-cooler-type design. In the left of the picture, the generator stator winding neutral leads emerge from the generator proper and pass through the current transformers and the excitation transformers. The stator winding neutral connection is formed in back of the transformers and a neutral lead is brought out to an external grounding transformer<sup>2</sup>. In the right of the picture the bank of the three linear reactors can be seen.

## Rectifier Bridge and Exciter Cubicle

A schematic diagram of the rectifier bridge is shown in Figure 10. It basically represents a three-phase full-wave rectifier bridge, with silicon diodes. To regulate the generator field voltage, shunt thyristors, or silicon-controlled rectifiers, are arranged across the diodes which are connected to the negative terminal of the field winding. This type of rectifier bridge is called a shunt thyristor bridge. Each electrical leg has two semiconductors in series to prevent loss of generator field excitation (should one short out) and to provide adequate voltage-withstand capability during system disturbances.

Depending on the rating of the generator, several such bridges are contained in the exciter rectifier cubicle and connected in parallel. Each bridge is provided with a five-pole disconnect switch which permits electrical isolation for maintenance under load. The system is designed so that with one rectifier bridge removed from service, full generator steady-state and transient current requirements can be accommodated.

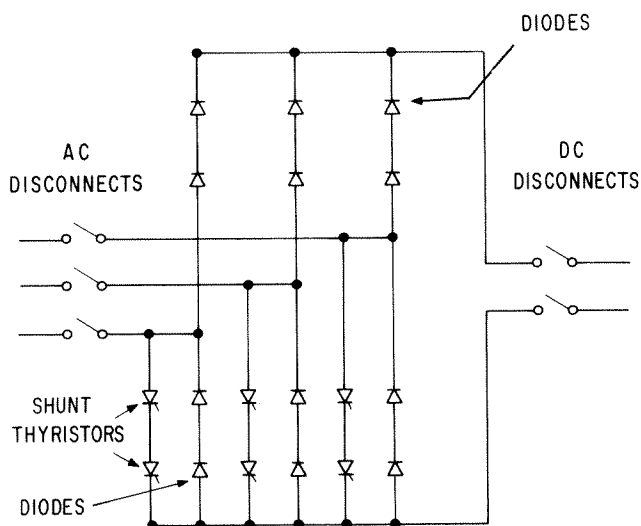

Figure 10. Schematic diagram of the rectifier bridge

The diodes and the thyristors are of the unit-cell type — that is, they are clamped between heat sinks which are water-cooled from the same water system used for the generator stator winding. The materials used in the hydraulic circuit are similar to those used in the generator hydraulic circuit. Mounted on the door of each rectifier section are 18 light-emitting diodes which monitor semiconductor conditions. In addition to the rectifier sections, the exciter cubicle contains a field breaker section with the field breaker and discharge resistor, a field voltage despiking circuit, and a shaft voltage suppressor circuit. It also includes a control section containing the thyristor firing circuit, synchronizing and pulse generating boards along with associated power supplies. This section also contains the generator field flashing circuit and the ground detecting relays for the field and for the excitation potential circuit.

## Excitation Control System — Voltage Regulator

The excitation control system is designed to provide automatic regulation, and to incorporate protective relaying and protective circuits. The regulator is of modular construction using printed-circuit-boards. It features integrated-circuit operational amplifiers, static switching with static regulator transfer, a miniaturized operator control panel (mounted in the power station control room) with remote indication of status (mimic bus), coordinated volts/hertz regulator, hard limits to prevent overshooting, light-emitting diodes indicating the condition of the printed-circuit-boards, on-line metering, circuit test capability, redundant power sources, board pins and sensing circuits. Among the control, protective, and limit circuits are power system stabilizer, underexcited ampere limit, maximum excitation limit, de-excitation and generator field over-current control. The protective circuits comprise generator field ground, generator volts/hertz overexcitation protection, excitation potential circuit ground and exciter output unbalanced voltage.

The design, arrangement and features of the excitation power source, rectifiers and voltage regulator aim to provide improvements in reliability and operation in comparison with older excitation systems.<sup>3,4,5</sup>

## Collector

The generator field collector and the brushholder rigging assembly are located in a walk-in housing. Collector-ring ventilation is provided through fans and filters, and removable-type brush magazines allow easy maintenance. For 3600-RPM units a steady bearing is provided within the housing, at the end of the turbine-generator shaft.



## OVER-ALL DEVELOPMENT PROGRAM

Development work on the GENERREX\* system was started during the latter part of the 1960's.<sup>6,7,8</sup>

The shunt thyristor bridge has been used with ship service generators on U.S. navy vessels for more than a decade. Several hundreds have been installed with generator ratings up to 3000 kilowatts.

In addition a prototype shunt thyristor bridge<sup>9</sup> has been in successful operation since 1968 with a 19.5-MVA steam turbine-generator unit equipped with a static excitation system.

### Preprototype Test and Component Endurance Test

Excitation transformers, linear reactors, and "P" bar assemblies were built in advance of the design and construction of the prototype excitation system, and subsequently tested in conjunction with factory running tests on a 405-MVA two-pole generator, in March of 1972. This test was aimed for, and confirmation was obtained of, soundness of the mechanical, electrical and thermal design of the components involved, as well as proof of the adequacy of the applied manufacturing processes. The "P" bars were assembled in the generator for the test and removed before the machine was shipped. During the test

they were loaded electrically by the reactors through the transformers, while the generator stator winding was connected open-circuit. The transformers and reactors were located on a special base, external to the generator, and were air-cooled. Cooling air flow was provided by a motor-driven blower so as to simulate flows and velocities with hydrogen cooling within the generator. Leads were run from the generator stator winding neutral terminals and formed the "C" windings of the transformers so that, with the generator connected short-circuit, the "C" windings would excite the transformers which were loaded with the reactors.

Following the preprototype test, a mechanical and insulation endurance test was performed with a laboratory generator stator winding slot model.<sup>10</sup> Current from the slot model was used to excite one of the transformers through its "C" winding. The output winding of the transformer was loaded with one of the reactors in series with a "P" bar which was located in one of the slots of the model, as indicated in Figure 11. During this endurance test the "C" winding current was 1.81 times and the magnetic force on the "P" bar was 9.3 times the corresponding rated load design values for the prototype unit, providing accelerated loading. The test was run for six months. Electrical, magnetic, thermal and mechanical vibratory performances were observed throughout the test. After the test, all components were disassembled and thoroughly inspected for any evidence of distress or wear. The results obtained were very successful in all respects.

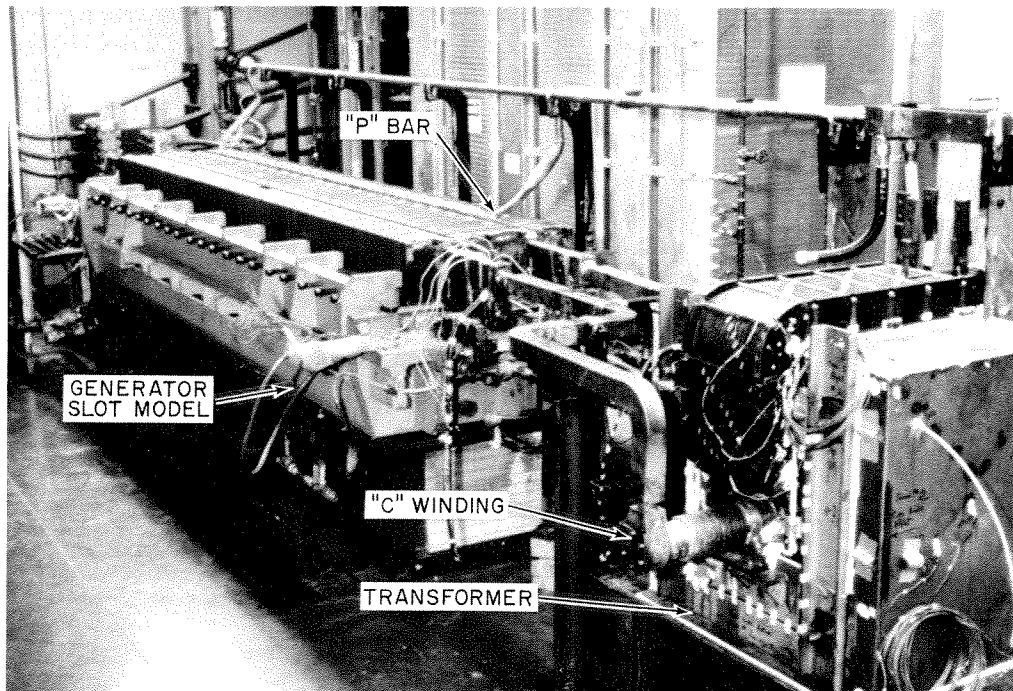

Figure 11. Exciter components assembled for endurance tests with generator slot model

## Excitation System Model Performance Tests

In June 1972, excitation system model tests were begun with a diesel-driven 200-KW generator model with "P" bars, model excitation power source, shunt thyristor bridge, and the advance design excitation control system which included ac and dc regulator, volts/hertz regulator, field current regulator, maximum excitation limit, under-excited reactive ampere limit, etc. Steady-state, time and frequency response tests were conducted while the model generator stator winding was connected open-circuited or loaded into the local utility system. These tests provided the necessary support to the analysis of the performance of the excitation control system and the shunt thyristor bridge, including stability characteristics. The excitation model controls are shown in Figure 12.

The generator and complete prototype excitation system were tested in the factory in April 1974. The test program and selected results are presented in the next section.

Following the factory prototype tests, one transformer and one reactor of the prototype excitation system were extensively tested in the laboratory. The objective of this test was to conduct more detailed ventilation studies and evaluations of thermal performance of both components. In addition, the transformer saturation curve, reactor saturation curve, and transformer reactance tests were obtained.

In the middle and latter part of 1975, startup and load tests were made for The Montana Power generator and the prototype excitation system in the power station. The tests included steady-state and transient performance of the excitation system power source components and of the voltage regulator, as well as evaluation of the component performance characteristics at various generator load points.

## PROTOTYPE EXCITATION SYSTEM AND GENERATOR FACTORY TESTS

The fully assembled machine with excitation dome in place, as tested in the factory, is shown in Figure 13. For convenience, the five-section exciter cubicle and the two-section regulator cubicle were located at the floor level as shown. In the picture the generator stator winding cooling water pumping unit and the area where most of the test read-out instruments were installed are also visible.

Tests were performed with the following generator stator winding connections:

1. Generator stator winding connected open-circuit, with excitation supplied by the prototype excitation system.

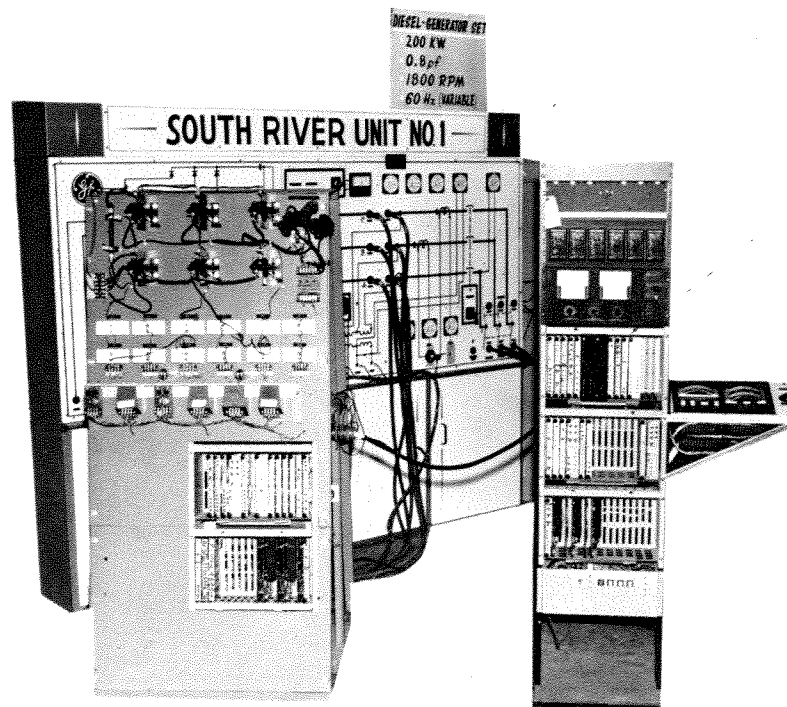

Figure 12. Controls of the excitation system model

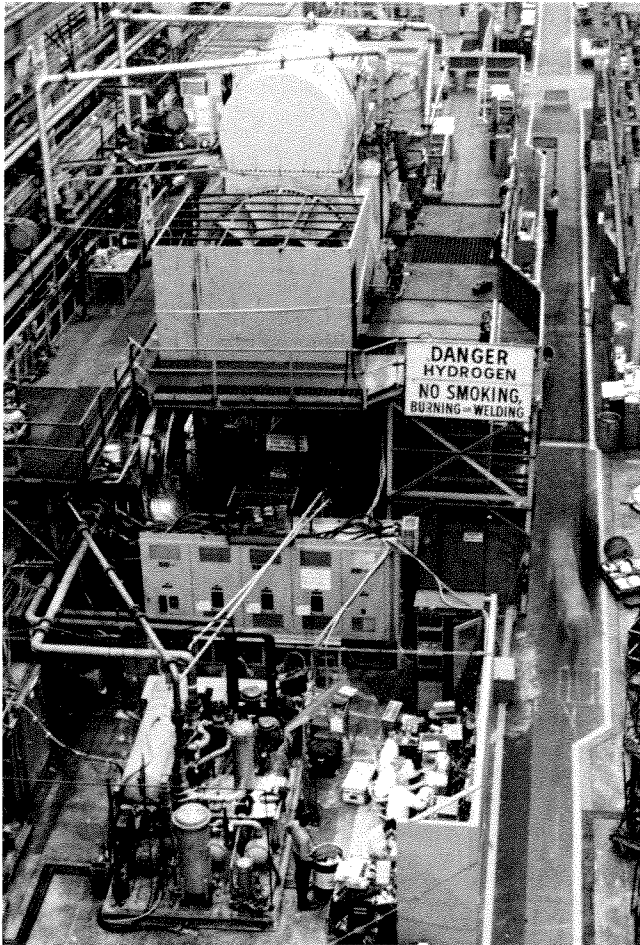

Figure 13. Generator with prototype excitation system assembled for factory test

2. Generator stator winding connected short-circuit, with excitation supplied by the excitation system.
3. Generator stator winding connected short-circuit with the generator field excited from an external source. The excitation power source was not supplying any load, with the power rectifier disconnected from it.

The tests consisted of heat runs to evaluate the electrical and thermal performance of the exciter power source components, generator and control system performance tests, de-excitation tests, generator saturation and synchronous impedance curves, generator losses, over-all machine ventilation surveys, and generator acceleration and deceleration runs to measure mechanical performance. Output from over 400 sensors in the generator and exciter internal power source components was recorded, including resistance-temperature-detectors, thermocouples, voltage and current measuring devices, flux search coils, accelerometers and pressure taps. A brief summary of the information sought, the description of the tests on the excitation system, and some selected results follow.

## Thermal and Mechanical Performance

The generator tested is rated at 45 psig hydrogen pressure, and heat runs were carried out at 45, 30 and 5 psig hydrogen pressure, for various steps of generator open-circuit voltage, and short-circuit current. Thermocouples sensed the temperatures of the cores, windings, and warm gas outlets of the excitation transformers and linear reactors, of "P" bar water outlets as well as the generator core teeth adjacent to the "P" bar slots, of instrument current transformers, of generator neutral leads and of generator dome walls and transformer base plates.

The "P" bar water outlet temperature was sensed by a thermocouple inside a well in the water hose fitting, the same practice used in the generator stator winding cooling system. The transformer and reactor winding temperatures were sensed by thermocouples placed on the strand insulation. The excitation transformer and linear reactor core thermocouples were imbedded, to measure internal temperature.

Figure 14 presents the linear reactor and excitation transformer maximum temperature rise as a function of generator stator current for the case of generator short-circuit test, and as a function of generator terminal voltage for the case of open-circuit operation. For the short-circuit

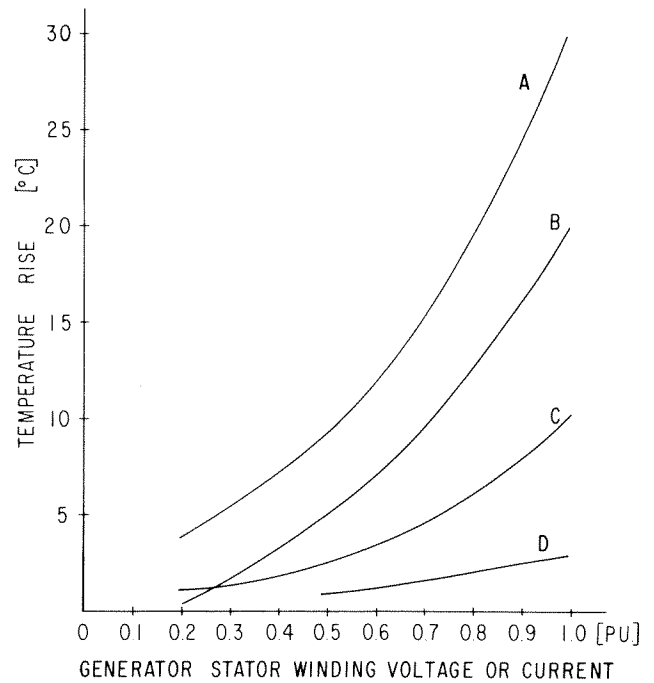

- A – Reactor – generator stator winding connected open-circuit
- B – Reactor – generator stator winding connected short-circuit
- C – Transformer – generator stator winding connected short-circuit
- D – Transformer – generator stator winding connected open-circuit

Figure 14. Prototype excitation system magnetic component temperature rise. Hottest core and frame thermocouple – 45 psig H<sub>2</sub>

test at 1.0 p.u. stator current, the outermost coils of the reactor and the transformer output windings read a temperature rise of less than  $4.0^{\circ}\text{C}$ ; the "P" bar water outlet temperature rise was about  $7.0^{\circ}\text{C}$ . At 1.0 p.u. voltage, open-circuit, the "P" bar temperature rise was about  $3.2^{\circ}\text{C}$ . When the generator operates at rated load, the "P" bar temperature rise is expected to approximately equal the sum of the above two rises ( $10.2^{\circ}\text{C}$ ), the transformer and the reactor core maximum temperature rise is expected to be less than  $35^{\circ}\text{C}$ , and the transformer and reactor windings temperature rise is expected to be less than  $8^{\circ}\text{C}$  at the locations indicated previously.

Accelerometers were mounted on the excitation transformer base plate, on the connections from one of the "P" bars to the corresponding transformer, on the linear reactor base plate between reactors, on a "C" winding where it passes through the current transformers, on a "P" bar connection ring, on the end winding section of a "P" bar, and on the dome outer surface. Accelerometers were also mounted on generator parts to measure vibration displacements in various directions. Accelerometer measurements were made for rated generator current on short-circuit, rated generator voltage on open-circuit at rated speed as well as for short-circuit and open-circuit deceleration tests. Deceleration tests consisted in letting the generator rotor slow down starting from 3600 RPM. The results fully satisfied all vibration limits and criteria.

## System Performance

Time response and frequency response tests were performed on the excitation system to verify the performance of the combined generator and regulator system. Performance variables were recorded on Brush recorders and light-beam oscillographs.

With the generator stator winding connected open-circuit, the time response tests consisted of introducing a disturbance signal into the regulator, calling for a step change in the generator terminal voltage of 5 percent or 10 percent. As a result of this step input, the regulator would cease firing the shunt thyristors and the bridge would operate as a diode bridge until the desired generator terminal voltage level was obtained. When the thyristors are thus turned off, an excitation output voltage jump occurs within milliseconds, applied across the generator field. Figure 15 presents the variation in time of the average field voltage and the generator terminal voltage for a 10 percent step change in the regulator, starting from 1.0 p.u. voltage at open-circuit. The time response tests indicated that the new excitation system was stable during such severe step changes, and ascertained that the excitation system has high initial response, as defined by IEEE.<sup>11</sup>

The purpose of the frequency-response tests was to confirm an analytical model of the generator-exciter system

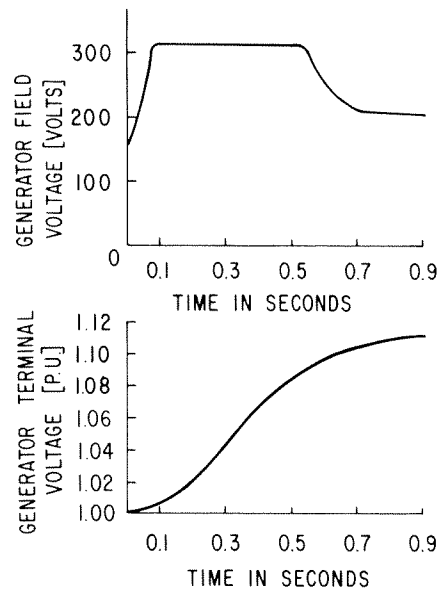

Figure 15. Transient performance of generator and prototype excitation system with the generator stator winding connected open-circuit

and more accurately determine the gains and time constants that should be used in the various transfer functions in the block diagram representation of the excitation system.<sup>2</sup> The frequency-response tests were run with the generator open-circuited and short-circuited. With each connection the tests were run with various regulator gain settings.

## De-excitation Test

The prototype excitation system for Colstrip 1 is provided with a generator field circuit breaker. At the time the field breaker is signaled to interrupt exciter current, a command is given to fire the shunt thyristors in all three phases of the rectifier bridge. The simultaneous firing of the thyristors has the effect of short-circuiting the generator field terminals, and is a means of providing redundant de-excitation to the discharge resistance inserted by the field circuit breaker.

These tests were conducted under two generator conditions, rated current at short-circuit and rated voltage at open-circuit. De-excitation was effected first by means of the field breaker, and discharge resistor, then by the thyristors, and then by both breaker and thyristors. Figure 16 gives the generator open-circuit de-excitation curves with generator terminal voltage plotted versus time. Similar curves of generator stator current for the case of generator short-circuit are also shown. Curves for de-excitation with both the field breaker and the shunt thyristors are not shown, but they are close to those obtained with breaker de-excitation.

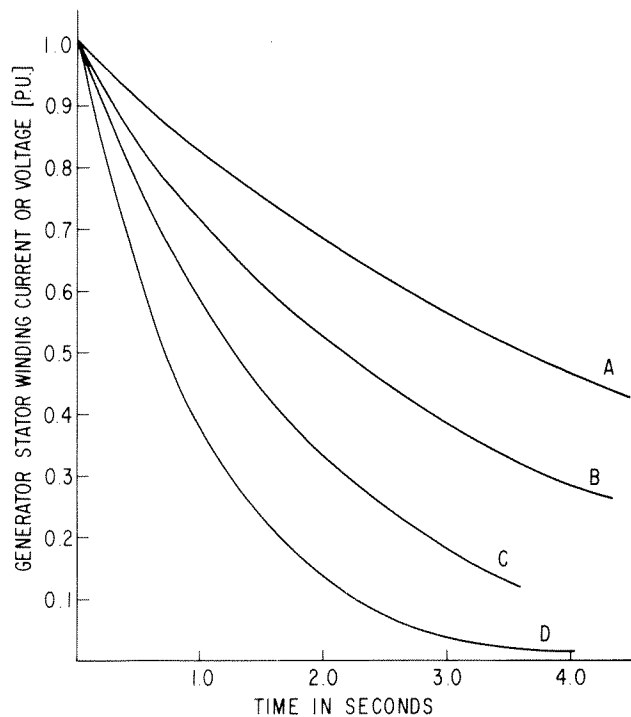

- A – Generator stator winding connected open-circuit. De-excitation with the bridge thyristors.
- B – Generator stator winding connected open-circuit. De-excitation with the field circuit breaker and discharge resistor.
- C – Generator stator winding connected short-circuit. De-excitation with the bridge thyristors.
- D – Generator stator winding connected short-circuit. De-excitation with the field circuit breaker and discharge resistor.

Figure 16. De-excitation tests on prototype excitation system and generator

## Ceiling Voltage Test

For this test the generator stator winding was connected short-circuit, the rectifier bridge disconnected and the generator field was excited by an external dc source. In terms of 60 Hz power, only two windings in each excitation transformer were involved – namely, the “C” winding, which is the generator neutral, and the winding connected to the “P” bars and linear reactors. The output or “F” windings were open-circuited, and being delta-connected, only triplen harmonics could flow.

A number of heat runs were conducted at 45 psig hydrogen pressure with these connections, and temperatures, currents and voltages across the components were recorded. Since the harmonics that are normally introduced by the thyristors in the rectifier bridge were not present, a 60 Hz reactor saturation curve and losses were obtained.

In the ceiling voltage test the generator stator current was driven to 1.86 p.u. for a few seconds forcing the

excitation transformers to saturate and hence yield the Thevenin voltage<sup>2</sup> which will be available whenever the generator excitation goes to ceiling, as a result of balanced ac short-circuit currents; hence this test was termed ceiling test. Due to the short duration of the test, magnetic tapes as well as Brush recorders were used for acquiring data.

That the transformers saturated is clear in Figure 17 where the transformer output (“F”) winding voltage flattens out as the generator stator winding current increases. In that graph 1.0 p.u.  $V_F$  corresponds to the transformer voltage, behind the transformer leakage reactance that produces generator field voltage at rated-load operation conditions. The transformer output winding voltage reached the level of 2.06 p.u. which is about seven percent more than what is needed to supply ceiling voltage to the generator field for this 3.5 response ratio system.

If the excitation system were supplying the generator field while the stator winding was connected short-circuit, it would have taken more than 3.0 p.u. generator stator winding current to saturate the transformers. This high value of stator winding current was the reason for the selection of the type of connections for conducting the ceiling test.

This test also demonstrated the range in which the reactors would remain linear. They remained linear up to a stator current value of about 1.2 p.u. amperes, after which a slight curvature of the reactor rms voltage curve, as a function of its current, occurred as indicated in Figure 18. In this figure the voltage base was taken equal to the base of the transformer “F” winding, defined above, multiplied by the transformer ratio, between “P” and “F” windings. The reactor current base is equal to the generator stator winding current base divided by the turns ratio of “P” to “C” winding. The reactance unbalance among the three reactors was very small.

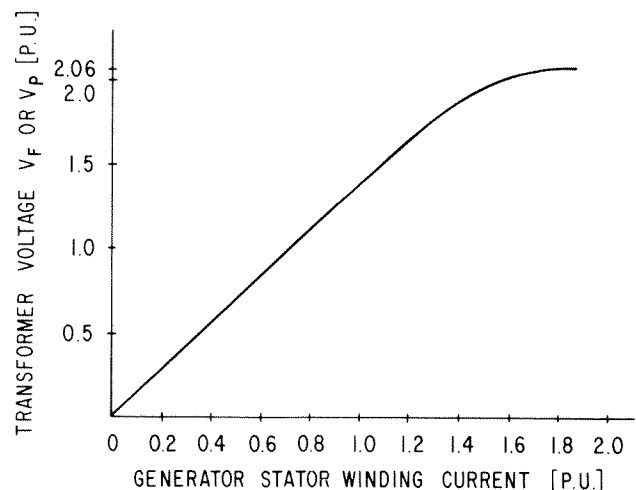

Figure 17. Prototype excitation system ceiling test. Saturation characteristic of transformer #1

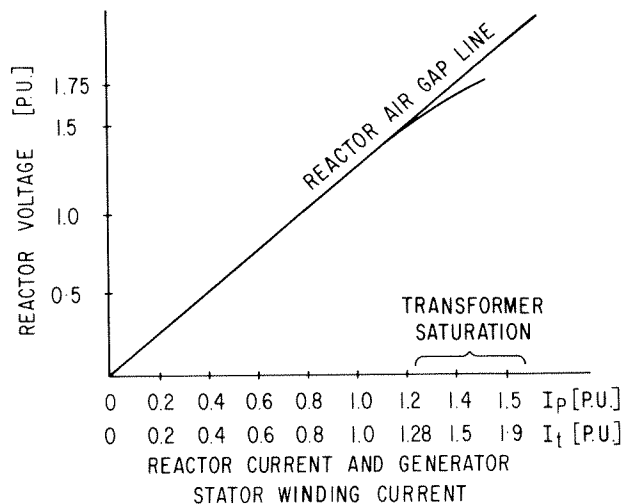

Figure 18. Prototype excitation system ceiling test. Saturation characteristic of reactor #1

## CONCLUSION

A new concept in excitation has been developed for large steam turbine-generators. Performance features of the new system include thyristor response and a compounded power source, with the ability to provide field forcing during periods of depressed generator voltage conditions. The new excitation system has a static power source, unit-cell rectifiers, and an advanced solid-state modular control system. It provides for a compact station arrangement, shorter over-all unit length, easier access to the main generator for maintenance and rotor removal, and includes the function of the generator neutral enclosure.

These features have been verified by design, manufacture, and factory test of a prototype unit. Detailed appraisal of the results indicates excellent performance of the generator and the new excitation system. Measured quantities agree very well with expected values. These results have stimulated and further encouraged work towards extending the design to future applications.

## REFERENCES

(1) R. K. Gerlitz, R. E. Gorman, and M. Temoshok, "The GENERREX\* Excitation System for Large Steam Turbine-Generators," presented at the Pacific Coast Electric Association Engineering and Operation Conference, Culver City, California, March 20-21, 1975.

- (2) M. L. Crenshaw, K. Carlsen, M. Temoshok and P. H. Beagles, "Generator and Power System Performance with the GENERREX\* Excitation System," *IEEE Transactions Power Apparatus and Systems*, Vol. PAS-95, pp. 489-493, March/April 1976, disc. Vol. PAS-96, pp. 1062-1063, July/August 1976.
- (3) L. J. Lane, J. E. Mendel, D. N. Ewart, M. L. Crenshaw, and J. M. Todd, "A Static Excitation System for Steam Turbine-Generators," *IEEE CP 65-208*, presented at the 1965 Winter Power Meeting, New York.
- (4) L. J. Lane, D. F. Rodgers, and P. A. Vance, "Design and Tests of a Static Excitation System for Industrial and Utility Steam Turbine-Generators," *AIEE Transactions Power Apparatus and Systems*, Vol. 80, Part III, pp. 1077-1085, 1961.
- (5) L. M. Domeratzky, A. S. Rubenstein, and M. Temoshok, "A Static Excitation System for Industrial and Steam Turbine-Generators," *AIEE Transactions*, Vol. 80, Part III, pp. 1066-1072.
- (6) K. F. Drexler, "Compound Excitation System," Patent No. 3,479,543, issued November 18, 1969.
- (7) H. W. Kudlacik and D. M. Willyoung, "Internal Static Excitation System for a Dynamoelectric Machine," Patent No. 3,702,964, issued November 14, 1972.
- (8) K. F. Drexler and H. W. Kudlacik, "Internal Static Excitation System for a Dynamoelectric Machine," Patent No. 3,702,965, issued November 14, 1972.
- (9) L. J. Lane, "Control Circuits," Patent No. 3,369,171, issued February 13, 1968.
- (10) C. A. Bucci, A. D. Coggeshall, K. F. Drexler, and E. E. Gibbs, "Control of Electromagnetic Forces on Stator Windings of Large Turbine-Generators," *IEEE Transactions on Power Apparatus and Systems*, pp. 2548-2554, November-December, 1971.
- (11) IEEE Standard Criteria and Definitions for Excitation Systems for Synchronous Machines, IEEE Std. 421-1972.

## DISCUSSION

D. I. Gorden  
Westinghouse Electric Corporation  
East Pittsburgh, Pennsylvania

The authors are to be complimented on their explicit account of factory testing of the GENERREX\* excitation system as a high response system. In my discussion I wish to address myself to this aspect of the paper, comment on and ask questions about the procedures used, and raise other points of interest to the user.

1. What is the approximate KVA parts ratio to exciter KW rating (including "P" Windings, Linear Reactors and current transformers)?
2. Assuming that the linear reactors function to convert the potential derived component of excitation into a current which is then vectorially combined with the component of excitation derived from the current transformer, i.e., the linear reactors effectively convert the potential source into a current source. It would seem that switching shunt control against such a current source might produce substantial transient spikes. Would the authors comment on the nature of any transients due to the switching action which they

have observed? Are there any special protective devices or special control means required?

3. With the complex system of GENERREX\* what use of "Failure Mode and Effects Analysis Techniques" were used in the design developments? For example, what provision is made for the event that the shunt thyristors would remain on the "ON" or "OFF" stage under incorrect conditions such as failure in the firing circuits? Were failures simulated during the testing to verify the assumptions made during design?
4. Figure 2 needs clarification. If 1.0 PU generator field voltage is required, it implies a reduction in generator MVA load with P.F. (in the over-excited region). How would the compounding effect look for constant generator MVA as the P.F. varies?
5. Since this type excitation cannot be tested in regard to speed of response or time to 95 percent difference between rated load field voltage and ceiling voltage, unless the unit experiences a severe fault it seems that one would have to rely on a calculation method to determine the high initial response capability. What method is used in determining capability?

## AUTHORS' CLOSURE

The authors would like to thank Mr. D. I. Gorden, for through his comments they realize the opportunity to expand further on various points of interest concerning the GENERREX\* excitation system. The answers that follow are numbered so that they correspond to Mr. Gorden's questions.

1. At rated generator load conditions the ratio of the excitation power supply fundamental frequency KVA to the exciter KW rating is about 1.50; this number includes the excitation transformers, the "P" bars and the linear reactors.
2. The linear reactors do convert the potential source into a current source. However, the numerical values of the components used yield a Thevenin equivalent circuit in which the internal impedance is relatively high and in which the Thevenin voltage is about two times the normal output voltage of the equivalent circuit. Therefore, in practice, the resulting maximum voltage is limited to 800 volts rms for a 500-volt field. The resulting transient voltage is very similar to any other type of rectifier switching transient and can be analyzed and calculated using the same methods with equally accurate results. A simple RC filter is used

across the rectifier output to damp this transient and, in conjunction with inherent circuit damping, is very effective as shown on the oscilloscope photo (Figure A) taken at the field site of the first GENERREX\* excitation system.

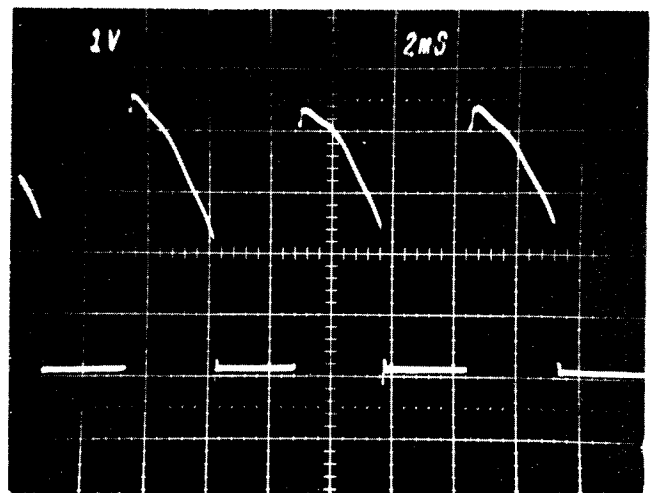

Figure A. Prototype GENERREX\* excitation system generator field voltage

3. A major objective in the design of the GENERREX\* excitation system was to provide a new high performance excitation system, of a complete static nature, which would provide the performance parameters required by utilities, while maintaining or improving the very high reliability and availability records of the ALTERREX and ALTHYREX excitation systems. The GENERREX\* excitation system as designed and developed has accomplished these objectives in a system incorporating proven features and providing major simplification and compaction of the arrangement of equipment in the power plant.

In order to assure high availability, the use of Failure Mode and Effects Analysis Techniques is a necessity. The particular item questioned is a good example of the application, in concept and in hardware, of these techniques. Firing circuits can be defined to consist of trigger circuits plus gate drivers. It is not feasible to produce failures in all trigger circuits and gate drivers at one time so that all the thyristors are turned fully on or fully off. However, there are contingencies such as a failure of a single thyristor either fully on or fully off which could be caused by a failure of the thyristor or a gate driver. A failure of a single thyristor, either fully on or off, would have no effect on the system operation because of the redundancy in the rectifier cubicle design — i.e., two cells in series per leg and one fully redundant bridge. All misoperations are indicated by LED's.

Failure Mode and Effects Analysis was also used in the design of the voltage regulator system as well as in the design and location of the various components of the excitation power source components such as the linear reactors, the excitation transformers, the generator excitation potential winding ("P" bars), etc.

4. Figure 2 of the paper compares the required generator field voltage with the available exciter voltage if steady-state diode operation were established. From the standpoint of the generator operation, as is well known, in the overexcited region the KVA capability is less than rated because of rotor winding thermal considerations. In the underexcited region, stator and end-iron thermal considerations become limiting. The "rated" MVA is applicable only in the area between rated PF overexcited (0.95 for this design) and 0.95 PF underexcited. Transient operation beyond these limits is, of course, permissible for limited times. With this understanding, Figure B illustrates the compounding for the assumption of rated voltage, rated MVA from 0.0 PF overexcited to 0.0 PF underexcited. The curves in Figure 2 of the paper and Figure B of the discussion were plotted by using the same methods and for the same generator field temperature. The accuracy of our calculation

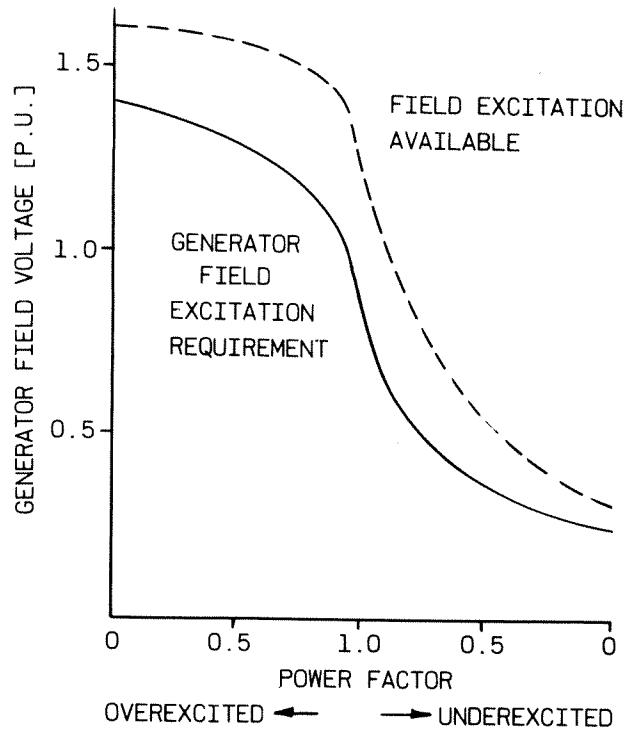

Figure B. Prototype GENERREX\* excitation system compounding curves for constant generator KVA

methods has been proven to be excellent through the generator factory tests, and load tests at the field.

5. The speed of response and response ratio of the GENERREX\* excitation system are dependent upon two factors: a) changing of the firing control of the shunt thyristors in the power rectifier bridge, and b) the bridge supply voltage level. The time response of the AC voltage regulator in changing the thyristor firing control to achieve maximum output can be determined by injecting an artificial error signal into the reference circuit; this action is demonstrated by the transient test shown in Figure 15 of the paper. The bridge supply voltage, developed through transformer action, has virtually no time delay associated with it; it may be calculated for generator loading conditions which are impractical to test either in the factory or in the field. Tests on the individual power supply components will verify their design as illustrated by Figures 17 and 18 of the paper. Thus the ability of the system to deliver the expected speed of response and voltage response ratio may be verified by test. Since the maximum excitation system performance is desired for power system conditions which cause terminal voltage reductions of 20 percent or greater, the increased stator currents must be accounted for and, in general, analytical techniques such as described in reference (2) are utilized.



# PART II

## GENERATOR AND POWER SYSTEM PERFORMANCE WITH THE GENERREX\* EXCITATION SYSTEM

P. H. Beagles, K. Carlsen, M. L. Crenshaw, and M. Temoshok

### ABSTRACT

Increasing pressures to limit transmission facilities while increasing the utilization of remote coal reserves and generating station sites are providing a challenge to the Nation's utilities. Delays in obtaining construction permits, intervener actions, and difficulties in obtaining the required capital for financing have added to the challenge.

The generator excitation controls can play an important role in achieving the goal of high service reliability under conditions which tend to reduce stability margins. High initial response excitation systems with high ceiling voltage capabilities can produce significant performance improvements, particularly in conjunction with power system stabilizer controls.

A new concept featuring a high initial response excitation system has been developed which combines the excitation system power supply as an integral part of the generator design, utilizing common parts and cooling systems. Analytical prediction of the on-line performance of this new excitation concept is a vital requirement for both detailed design of the equipment and confirmation of power system design. Correlation of analytical results with factory test data on the prototype unit, The Montana Power Company Colstrip 1, establishes a measure of confidence in the ability to predict performance of this new equipment.

### INTRODUCTION

The concept of the GENERREX\* system retains desirable features of the ALTHYREX\* system<sup>1,2</sup> and adds features produced by recent developments. The new system incorporates a static power supply, a shunt thyristor bridge for rectification, with advanced design of unit cell diodes and thyristors, an improved water cooling system for the rectifier cells, and an advanced solid-state, modular construction control system.

The concept of the GENERREX\* excitation system aims to accomplish several key objectives: improved reliability with a static system, retention of the performance of a thyristor system, and incorporation of a compounded power source which provides excitation forcing during depressed generator voltage conditions.

The GENERREX\* excitation system is applicable over the full range of generator ratings suitable for electric utility application, including the largest now foreseen for the future. Voltage response ratios up to and including 3.5 per unit can be furnished. The majority of the GENERREX\* excitation systems manufactured or scheduled to be manufactured will be furnished with a response ratio of 2.0 to 3.5 per unit.

The need for additional resources to carry area load growth led The Montana Power Company together with the Puget Sound Power and Light Company to build a mine-mouth generating plant in coal fields at Colstrip, Montana. This phase of development comprises two 350-MW tandem, single reheat units connected to the 230-kV transmission network overlaying lower voltage systems and extending over 450 line miles to the western intertie point at Hot Springs, Montana (see Figure 1).

Stability studies indicated relatively little stability margin and demonstrated the need for high performance excitation systems together with power system stabilizers to provide positive damping to the turbine-generators following a system disturbance. The GENERREX\* excitation system provides a number of benefits:

1. A 3.5 voltage response ratio could be furnished with a high initial response characteristic.
2. The turbine-generator over-all length is reduced since a shaft-driven exciter is not required, with savings in foundation costs.

---

\*Trademark of The General Electric Company

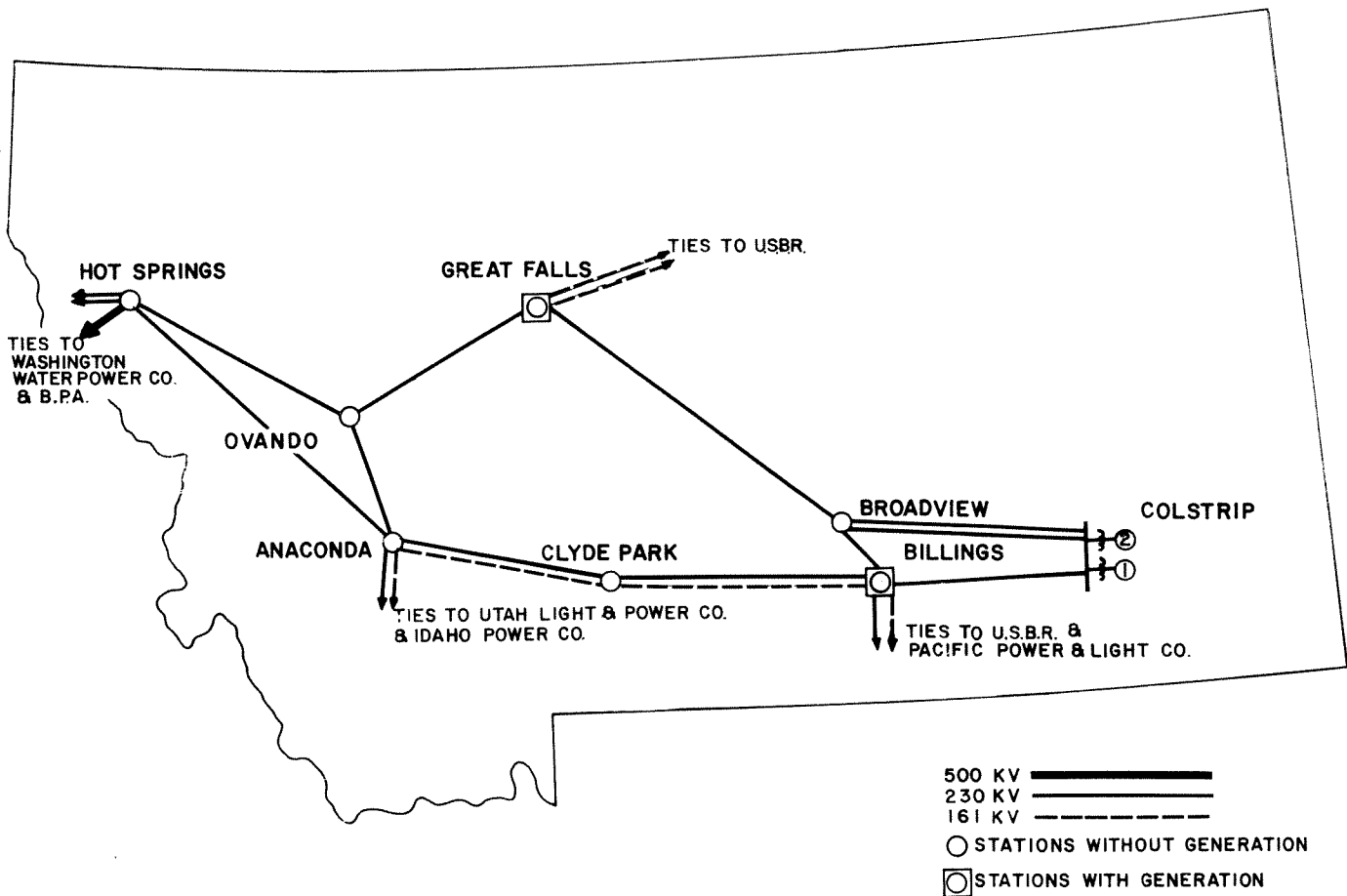

Figure 1. Montana Power Transmission and Power Station one-line diagram

3. A reduction in the number of masses comprising the turbine-generator unit reduces the potential for sub-synchronous, shaft torsional resonance problems which can be encountered when series compensation is used in the transmission system.

## EXCITATION SYSTEM DESCRIPTION

The basic concept of the GENERREX\* excitation system is illustrated in the one-line diagram of Figure 2.<sup>3,4</sup> Field excitation power is derived from the generator internal fluxes and currents. Ac voltage from this source is phase controlled by thyristors (silicon-controlled rectifiers) to furnish dc voltage for the generator field. Thus, all components of this excitation system are stationary.

The *excitation potential winding* consisting of three single, transposed strand bars, called "P" bars, is a

three-phase winding mounted in three of the generator slots. This winding develops a voltage proportional to the generator flux. It provides all of the excitation power during no-load operation of the generator.

The *excitation transformers* are single-phase units having three windings, labeled "C", "P", and "F". One input winding, "C", carries the generator stator current. The other input winding, "P", is connected to a "P" bar with a *linear reactor* in series. The output windings, "F", of the three transformers provide a voltage source which is converted to dc for the field of the generator.

The *shunt controlled bridge* is a unique combination of diodes and thyristors. A normal complement of diodes forms a full-wave, three-phase bridge and performs the duty of rectification of the ac to dc. The thyristors provide control action through periodic short-circuiting of the ac power source. The excitation system output is the net effect of the thyristor control signal and the variable power source voltage from the excitation transformers.



As the terminal conditions of the generator change, the value of the bridge supply voltage varies over a wide range. This accentuates the nonlinear effect of the shunt thyristor bridge control action. A field voltage regulator provides a closed loop regulating function to minimize these effects. This feedback action is analogous to that used to linearize the control valve characteristics in modern turbine governor controls.<sup>5</sup> This regulator also serves in the alternate dc field voltage regulating mode. When the ac regulator is removed from service, an adjustable dc reference voltage is substituted, as shown in Figure 3.

The ac voltage regulator and stabilization circuit provide the normal mode of generator control. The ranges of adjusting within this regulator allow a wide degree of operating flexibility. The stabilization circuit is analogous to the exciter voltage rate-feedback employed in virtually all previous voltage regulating equipments.<sup>6</sup> An adjustment to provide high gain over a wide bandwidth with minimal stabilization will generally result in dependence upon the power system stabilizer, and the generator under only voltage control could be unstable at full output load levels. More conservative adjustments of the series stabilization (transient gain reduction) will reduce this need for external stabilizing signals with minimal performance reduction.<sup>7</sup>

## GENERREX\* SYSTEM FACTORY TEST

Since The Montana Power Company Colstrip 1 unit is equipped with the prototype GENERREX\* excitation system, an extensive factory test program was carried out to ascertain and document the performance under various operating modes. The system was tested with the generator stator winding connected either open-circuit or short-circuit. The regulator was thoroughly tested both in ac regulator control mode and dc regulator control mode. The factory test included electrical, mechanical, and thermal measurements of the various excitation components.<sup>4</sup> The subject paper will report only on the portion of the tests which are related to the dynamic performance of the system and which provided confirmation of the computer simulation procedure.

Dynamic performance tests on the GENERREX\* excitation system served two main objectives. The first was to demonstrate that the control components and circuits would perform as predicted. The second was to obtain test data which could be used to validate the dynamic simulation model. The responses of the excitation system and the open-circuited generator to step changes in the reference voltage were obtained. The magnitude of the step change was varied to observe the effect of nonlinearities in the system. Large step changes were applied to observe the effects of the various system limits and nonlinearities. This testing procedure was executed with the excitation system in both ac and dc control modes. Changes were made in

system control parameters, gains and time constants, to observe the sensitivity of the system performance to these changes and also to aid in the dynamic model verification process.

In addition to the transient response tests, the relative magnitude and phase shift between various points in the system were obtained over a wide range of frequencies. Both closed and open loop frequency response data were obtained for the over-all voltage regulation loop. This frequency response data served as a valuable complement to the time response data in validation of the computer model.

A number of test runs were conducted to obtain correlation between the tested performance and simulated performance of the GENERREX\* system. Examples are illustrated in Figures 4 and 5. These figures illustrate key excitation test results — a change in exciter output voltage which is applied to the generator field, and the change in generator terminal voltage, with the generator under no load conditions. Figure 4 illustrates the case for a signal applied at the voltage regulator input, calling for a 5% increase in generator terminal voltage. The change in the voltage applied to the generator field illustrates the fast performance of a shunt thyristor bridge system. Correlation between tested and simulated performance is illustrated for generator field voltage, field current, and terminal voltage.

Figure 5 is similar to Figure 4 except for a signal calling for a 10 percent decrease in generator terminal voltage. With the fairly large signal to decrease voltage, advanced, full-on firing of the thyristors drives the exciter output to zero voltage in milliseconds time.

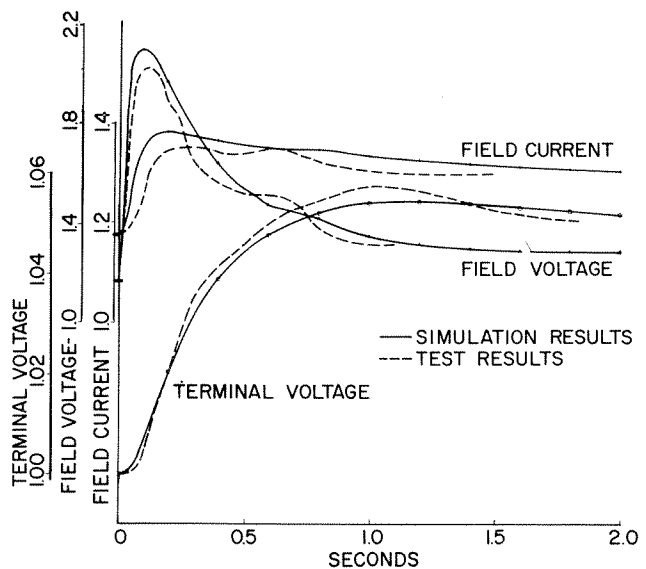

Figure 4. Factory test and simulated results for a five percent positive step-change in terminal voltage reference

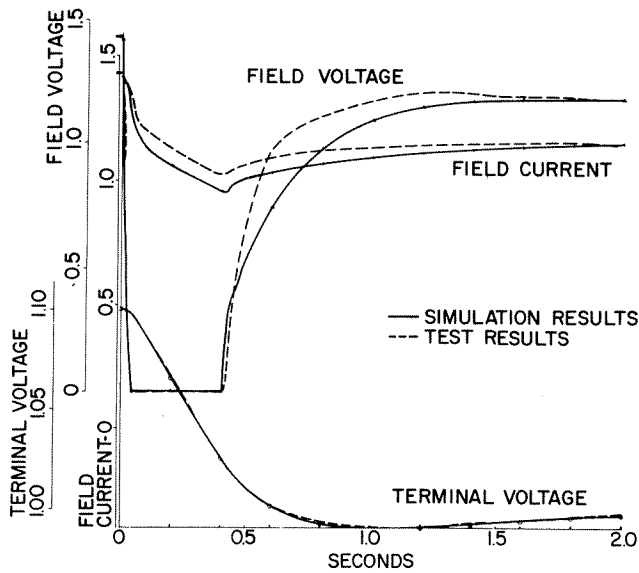

Figure 5. Factory test and simulated results for a 10 percent negative step-change in terminal voltage reference

Figure 6 illustrates a fast change in exciter output voltage to a ceiling value during actual factory test conditions with the generator under no-load conditions. A signal was applied at the voltage regulator input calling for an increase of 10 percent in generator terminal voltage. The exciter ceiling voltage applied to the generator field was achieved well within 0.100 seconds (six cycles) which is required by the definition of a "high initial response"

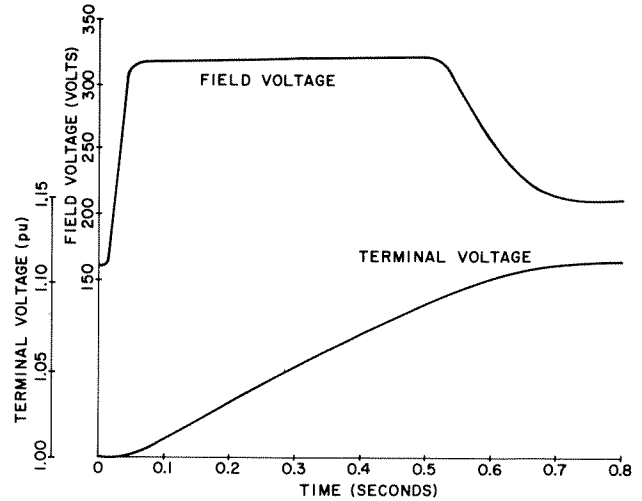

Figure 6. Transient test performance of generator with excitation system

excitation system by official IEEE definitions.<sup>6</sup> The 10 percent generator voltage change was accomplished in less than one second. This illustrates the results of the action of a fast, aggressive excitation system.

It should be noted that the value of ceiling voltage measured during the test with no-load conditions is less than would be obtained during a power system disturbance with the generator under load. The high generator stator current during the fault and recovery periods would force the excitation system to a higher ceiling value. This ceiling value can be observed in Figure 7.

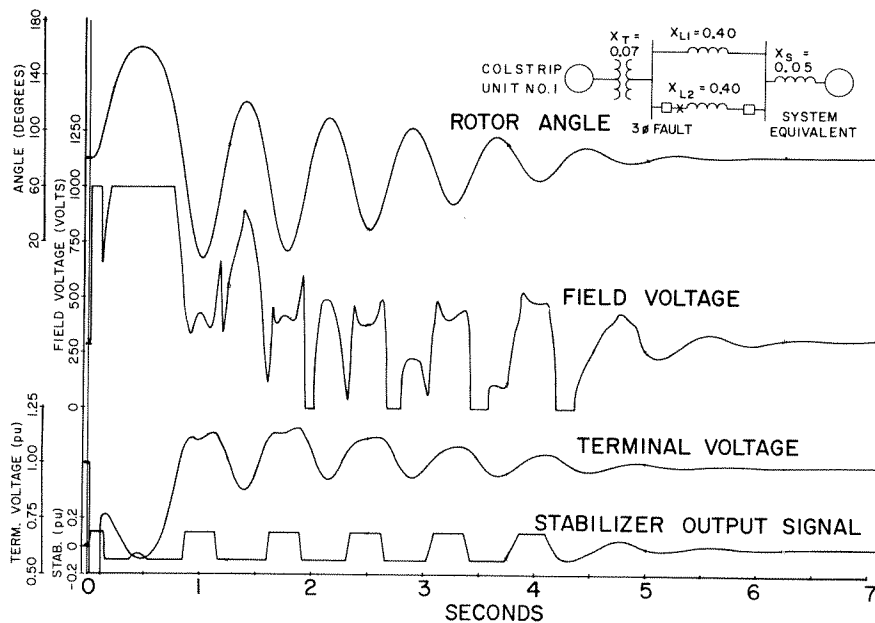

Figure 7. Simulated responses of generator and excitation system to a severe system fault

Although a fast change in exciter output voltage is important, it should be accomplished in a stable manner without undesirable oscillations. The changes both in exciter output voltage, and the generator terminal voltage, as illustrated in Figures 4, 5, and 6, indicate a very stable performance of the excitation system, and generator.

In summary, excellent correlation is obtained between tested and simulated performances of the GENERREX\* system and generator for both small and large signal changes and for signals calling for an increase as well as a decrease in generator terminal voltage. The disturbances imposed upon the system were of sufficient magnitude to test the modeling of the system nonlinearities and some of the system limits.

## POWER SYSTEM PERFORMANCE

The performance features of the GENERREX\* excitation system which will be of significance for the Colstrip Plant operation are the high excitation system response ratio, the fast initial voltage response, the short excitation system time delays, the ceiling voltage under severe conditions, and the expected performance with power system stabilizers to provide generator and system damping. These features provide benefits to both transient stability first swing reduction and to damping of subsequent swings. The degree of these benefits may be appraised in Figure 7 from the computer-simulated performance of the Colstrip 1 unit for a three-phase fault close to the station, which was cleared in six cycles. The system impedance as viewed from the generator terminals changed from 0.32 per unit to 0.52 per unit (on the unit MVA base), representing the opening of the faulted line section. A series of computer runs was made leading to the case illustrated. The transient stability limit is approached, as evidenced by a rotor angle excursion to  $160^\circ$ . The excitation system is contributing to a maximum degree, as evidenced by ceiling output operation for a period of 3/4 second. The effectiveness of the power

system stabilizer combined with the low time constant, thyristor action is demonstrated by the well-damped performance following this severe disturbance. The terminal voltage recovery in five seconds is further evidence of the over-all well-damped performance.

A unique feature of the GENERREX\* system is the utilization of both the generator voltage and current for the bridge supply voltage. For a fault in the power system, the bridge supply voltage increases as soon as the generator current increases. This increases the field voltage, even before the control action can adjust the thyristor firing. The field voltage is forced to ceiling almost instantly for severe faults and the exceptionally high initial response of the excitation system is enhanced. If the rectifiers were fed only from the generator or power plant auxiliary bus voltage, the excitation system ceiling voltage would be a function only of the ac input voltage available which may be severely depressed during the fault and recovery periods.

## POWER SYSTEM STUDY COMPUTER MODEL

For large-scale power system studies, a less rigorous computer model than described in the previous section of this paper is definitely advantageous. Figure 8 illustrates a simplified model embodying the essential elements necessary to predict performance extending to frequencies of 3 Hz. The major elements include:

1. The voltage regulator dc gain and stabilization or "transient gain reduction".
2. The excitation power source, combining voltage and current sources, and the saturation level of the excitation transformers.
3. The regulation effect due to the flow of field current.

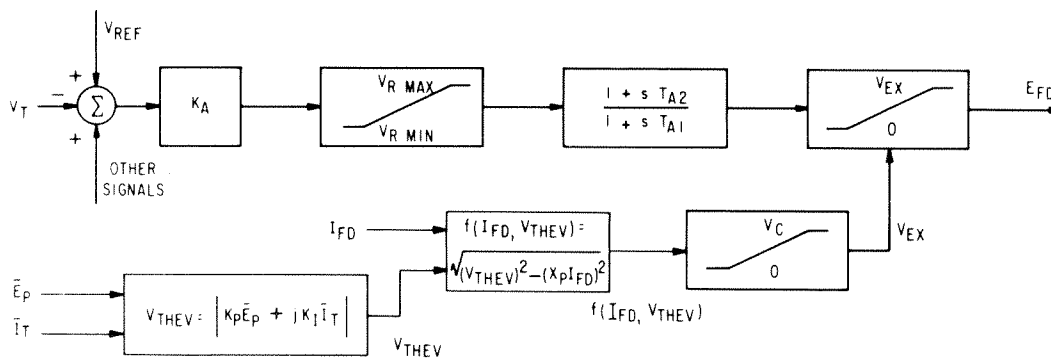

Figure 8. Large system study computer model

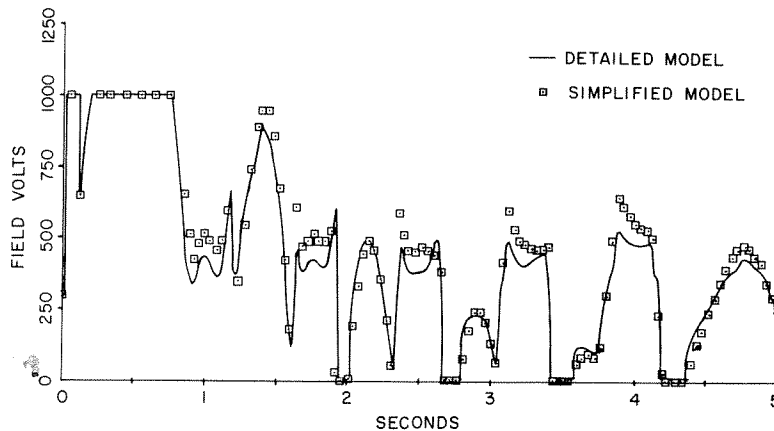

Figure 9. Comparison of detailed vs. simple computer model simulations

The effectiveness of the field voltage regulator eliminates the need for detailed modeling of this control loop and the nonlinear shunt-controlled bridge characteristic. In order to verify the accuracy of the simplified model, a comparison between the outputs of the detailed and simplified excitation system models with identical inputs is shown in Figure 9. The case studied is that illustrated in Figure 7. This comparison indicates good agreement and for power system design studies the simplified model is justified.

The Appendix provides specific data applicable to the prototype Colstrip Unit 1.

## SUMMARY

This paper has discussed the design, performance, factory tests and modeling of a new excitation system concept. Computer simulations have been developed to predict the over-all performance of this new equipment under a variety of power system disturbances. The following conclusions can be made:

1. The GENERREX\* system is a high initial response excitation system, which can be supplied with high values of voltage response ratios.
2. Computer analysis indicates that the GENERREX\* system can improve transient stability and provide fast damping of subsequent rotor swings.
3. Computer simulations of the excitation system and generator have demonstrated excellent correlation with factory tests.
4. A simplified analytical model of the GENERREX\* system has been developed for power system design studies and has demonstrated close correlation with the detailed design model.

## REFERENCES

- (1) M. L. Crenshaw, W. J. Miller, R. P. Schulz, and M. Temoshok, "ALTHYREX Excitation System with Power System Stabilizer," IEEE Paper 70 CP 563-PWR, July 1970.
- (2) M. L. Crenshaw, R. G. Farmer, R. P. Schulz, and M. Temoshok, "System Design Considerations and Operating Experience with High Performance Thyristor Excitation Systems," American Power Conference, April 22, 1971.
- (3) R. E. Gorman, R. K. Gerlitz, and M. Temoshok, "The GENERREX\* Excitation System for Large Steam Turbine-Generators," presented at the Pacific Coast Electric Association Engineering & Operation Conference, Culver City, California, March 20-21, 1975.
- (4) G. M. Cotzas, K. F. Drexler, J. J. Dvorscak, and R. K. Gerlitz, "Description and Tests of the GENERREX\* Excitation System for Large Steam Turbine-Generators," IEEE Transactions, Volume PAS-95 #3, May-June, 1976, pp. 803-810.
- (5) M. A. Eggenberger, "An Electrohydraulic Control System for Reheat Turbines," Proc. American Power Conference, Vol. 27, 1965, pp. 351-361.
- (6) IEEE Standard 421-1972 "IEEE Standard Criteria and Definitions for Excitation Systems for Synchronous Machines."
- (7) W. Watson, G. Manchur, "Experience with Supplementary Damping Signals for Generator Static Excitation Systems," IEEE Trans., Vol. PAS-92, No. 1, Jan./Feb. 1973, pp. 199-201, discussion pp. 201-203.

## APPENDIX

The Montana Power Company Colstrip 1 generator has the following design parameters:

$X_d$	= 1.72	$T'_{do}$	= 5.5 sec.
$X_q$	= 1.71	$T'_{qo}$	= 1.8 sec.
$X_{\ell}$	= 0.175	$T''_{do}$	= 0.03 sec.
$X'_d$	= 0.277	$T''_{qo}$	= 0.07 sec.
$X'_q$	= 0.373	$S_E$ (1.0 V.)	= 0.184
$X''_d$	= 0.253	$S_E$ (1.2 V.)	= 0.454
$X''_q$	= 0.253		

The 3.5 response ratio GENERREX\* excitation system for this unit has the following design parameters:

$K_A$	= 200	$K_P$	= 2.96
$V_{R\ MAX}$	= 50	$K_I$	= 4.18
$V_{R\ MIN}$	= -50	$X_P$	= 1.30
$T_{A1}$	= 10 sec.	$V_C$	= 6.00
$T_{A2}$	= 1 sec.		

The base for this data is 377 MVA, 22 kV.

## DISCUSSION

**D. I. Gorden**  
Westinghouse Electric Corporation  
East Pittsburgh, Pennsylvania

**Glenn R. Meloy**  
Corps of Engineers  
Portland, Oregon

The authors are to be complimented on their explicit account of the generator and power system performance with the GENERREX\* excitation system as a high response system. In my discussion I wish to address myself to this aspect of the paper, comment on and ask questions about the procedures used.

1. On page 1 of the paper, in the second paragraph of the ABSTRACT, the authors refer to stability margins. What was the stability margin and how much was it improved?
2. The number two benefit listed for GENERREX\* is savings in foundation costs. Considering the necessary foundation required for the generator shaft removal, it is a question as to the real net savings in foundation costs.
3. Which IEEE EXCITATION SYSTEM MODEL can be used to simulate GENERREX\*?
4. There is no question that GENERREX\* gives a fast change in the exciter output. On page 3, in the paragraph explaining Figure 6, the third sentence states that "high initial response" is achieved well within 0.10 seconds. Since a "HIGH INITIAL RESPONSE" excitation system is one which achieves 95% of the difference between ceiling voltage and rated load field voltage in 0.10 second or less, how does Figure 6 support compliance with the high initial response definition?
5. What were the load and power factor conditions preceding the disturbance shown in Figure 7?

The excitation system described combines many of the plus features which have evolved through many years of experience. The static components, coupled with the autonomy of a power source integral with the generator, build in a high probability of reliability. The basic simplicity of the concept is also noteworthy with the exception of complication required for the current forcing concept. It would appear that the current forcing provision has the effect of maintaining available ceiling voltage during fault conditions. Have the authors made any studies to determine generator voltage fluctuations during fault conditions and the need to leave the generator connected to the system? It would appear that the generator should be separated from the system for "close-in" faults and that for the more distant faults the generator voltage would remain closer to rated. This should mitigate the need for current forcing. Providing ceiling capability at reduced terminal voltage (or higher ceiling at rated terminal voltage) should provide the needed performance for those faults where it is desirable to leave the generator connected to the power system. Would the authors discuss the merits and tradeoffs of the additional complication of the current forcing provision versus providing sufficient ceiling voltage at reduced terminal voltage. The latter approach would provide additional excitation capability at normal generator voltage which could be utilized to advantage for system disturbance which did not result in a severely depressed generator terminal voltage.



## AUTHORS' CLOSURE

We appreciate the interest shown by the discussors and welcome the opportunity to provide further clarification. We would like to first address the specific questions raised by Mr. Gorden, in order:

1. Stability margins can be expressed in a number of ways. For severe transients, perhaps the simplest is to determine the maximum period of time a fault can persist and just maintain stability — the critical clearing time. Generalized studies<sup>1</sup> have shown that for  $3\phi$  faults close to remotely located generating units which are equipped with a 0.5 response ratio excitation system having an appreciable time constant, critical clearing time will be in the neighborhood of four cycles. A High Initial Response, 3.5 Response Ratio excitation system will increase the critical clearing time by about 20 percent. For dynamic stability problems, the limit of power flow over a transmission circuit is often used as a criterion. If the unit under consideration is remote, the influence of a High Initial Response excitation system and Power System Stabilizer control will be significant and stability will be maintained with rotor angles in excess of 90 degrees. The relative influence of a single unit equipped with a High Initial Response excitation system and Power System Stabilizer cannot be readily assessed. Generalized studies<sup>2</sup> with all units in the power system so equipped have indicated improvements of 20 percent in the interchange capability are possible.
2. Benefits in power station design due to the reduced over-all turbine-generator unit length may be evaluated in many different ways. The turbine-generator unit foundation pedestal may be shorter when a shaft-driven exciter is not furnished and support is not required. The area allocated for rotor removal need not be suitable for weight bearing since generator rotor removal is almost always accomplished with a crane. In the Colstrip Plant, the units are placed end-to-end and, in addition to the shorter foundation length, the space between units for generator rotor pull is shared between the units and with the turbine deck access opening.
3. The general purpose IEEE Type 1 model<sup>3</sup> with appropriate constants will give reasonably good results for stability studies. A working group of the Excitation Systems Subcommittee is presently engaged in updating and expanding this earlier work to cover newer excitation systems. It is expected that the more complete model shown in Figure 8 of the paper will be adopted.
4. The speed of response and response ratio of the GENERREX\* excitation system is dependent upon

two factors: a) the firing of the shunt thyristors in the power rectifier bridge and b) the bridge supply voltage level. The time response of AC voltage regulator in changing the thyristor firing control to achieve maximum output can be determined by injecting an artificial error signal into the reference circuit. The factory test condition, illustrated by Figure 6 of the paper, demonstrates the time response of the voltage regulator control of the thyristor firing signals. Since the disturbance was generated artificially by a step change in the voltage regulator reference, the bridge supply voltage did not change from the open circuit — no load condition. The bridge supply voltage, developed through transformer action, is readily calculated for particular generator load conditions. The increased currents drawn from the generator by the power system, which indeed cause the terminal voltage change, will act through transformer action to change the bridge voltage without time delay. This bridge voltage may be calculated for loading conditions which may be impractical to test either in the factory or in the field. Thus, transient testing of regulator control along with verification of the bridge supply ceiling voltage capability is sufficient to confirm the response characteristics.

5. The initial conditions for the computer run of Figure 7 of the paper were rated voltage, 0.95 per unit kilowatts, and 0.15 per unit kilovars underexcited. These were selected to represent an initial condition with a large initial rotor angle and marginal stability.

We will now address the questions raised by Mr. Meloy:

Generator voltage fluctuations during the fault and the swings immediately following the fault clearing can be quite severe if the limit of stability is approached. For the case illustrated by Figure 7 of the paper, terminal voltage during the crucial first 1/2 second period of time averages only about 0.6 per unit. Thus an excitation system relying only on this voltage source would require power components which could provide ceiling voltages (with rated input) of almost twice the design level required by the compound-source system described in this paper to approach equivalent performance. Such an excitation system, capable of producing four times the full load field voltage, would require large component designs as well as challenge the design and protection of the generator field winding itself. Our studies indicate the bus fed thyristor excitation systems with the level of ceiling voltages which have been furnished in the U.S. and Canada (roughly twice rated output with rated input voltage) have transient stability

performance equivalent only to a 0.5 response ratio for severe faults close to the generator high voltage bus.

The current forcing provision requires the addition of the "C" windings and the linear reactors. Static Excitation System equipments furnished by the authors' company utilizing this same concept of compounding have performed outstandingly, establishing a very high reliability record. It is expected that the new GENERREX\* excitation system performance will produce an equally impressive record.

Power system design criteria and operating practices will greatly affect the evaluation of excitation system performance benefits. A high performance excitation system provides an attractive alternative to other methods of achieving improved stability margins such as additional transmission lines or increased amounts of series capacitors.

## REFERENCES

1. "Effects of Trends in Large Steam Turbine-Driven Generator Parameters on Power System Stability", by C. Concordia, P. G. Brown, IEEE Trans. Vol. PAS-90, No. 5, September/October 1971, pp. 2211-2218.
2. "System Design Considerations and Operating Experience with High Performance Thyristor Excitation Systems", by M. L. Crenshaw, R. G. Farmer, R. P. Schulz, M. Temoshok, American Power Conference, April 22, 1971.
3. "Computer Representation of Excitation Systems", IEEE Committee Report, IEEE Trans. Vol. PAS-87, No. 6, June 1968, pp. 1460-1464.



LARGE STEAM TURBINE-GENERATOR OPERATIONS  
SCHENECTADY, NEW YORK 12345

**GENERAL**  **ELECTRIC**