



Phoenix Series Water Heaters

Installation

Start-Up

Maintenance

Parts

Warranty

PH100 / PH130
PH160 / PH199 Models*

* "LP" Denotes Propane Gas Operation
"S" Denotes Solar Models
"SA" Denotes Sanitizer Booster Models
"M" Denotes Multi Fit Models

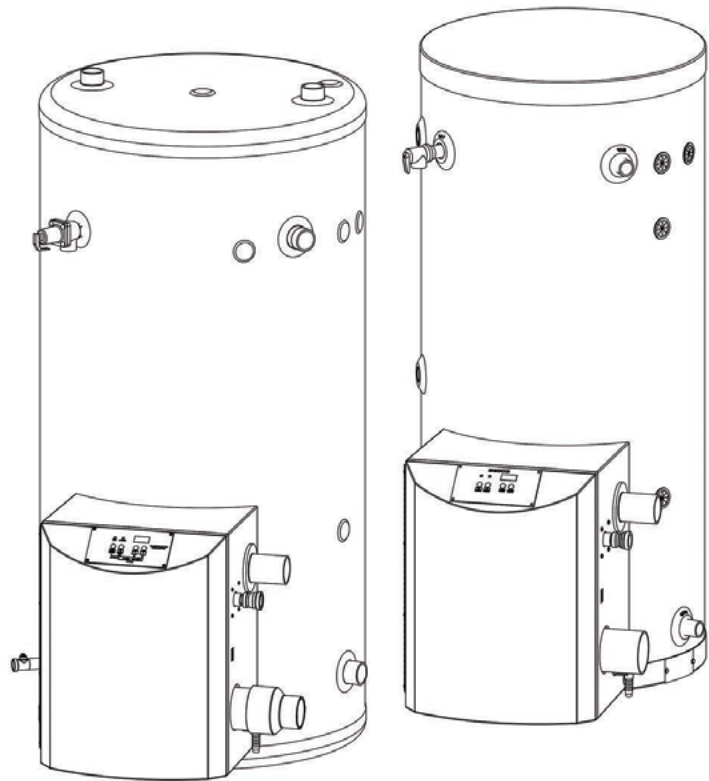

This Manual For Use With Water Heaters Manufactured After
May 1, 2015



⚠ DANGER

This manual must only be used by a qualified installer / service technician. Read all instructions in this manual before installing. Perform steps in the given order. Failure to do so could result in substantial property damage, severe personal injury, or death.

⚠ WARNING

Improper installation, adjustment, alteration, service, or maintenance could void product warranty and cause property damage, severe personal injury, or death.

California Proposition 65 Warning: This product contains chemicals known to the State of California to cause cancer, birth defects, or other reproductive harm.

NOTICE

HTP reserves the right to make product changes or updates without notice and will not be held liable for typographical errors in literature.

The surfaces of these products contacted by potable (consumable) water contain less than 0.25% lead by weight as required by the Safe Drinking Water Act, Section 1417.

NOTE TO CONSUMER: PLEASE KEEP ALL INSTRUCTIONS FOR FUTURE REFERENCE.

▲ WARNING

IF THE INFORMATION IN THIS MANUAL IS NOT FOLLOWED EXACTLY, A FIRE OR EXPLOSION MAY RESULT, CAUSING PROPERTY DAMAGE, PERSONAL INJURY, OR LOSS OF LIFE. DO NOT STORE GASOLINE OR OTHER FLAMMABLE VAPORS AND LIQUIDS IN THE VICINITY OF THIS OR ANY OTHER APPLIANCE.

WHAT TO DO IF YOU SMELL GAS

- Do not try to light any appliance.
- Do not touch any electrical switch.
- Do not use any phone in your building.
- Immediately call your gas supplier from a neighbor's phone. Follow the gas supplier's instructions.
- If you cannot reach your gas supplier, call the fire department. Installation and service must be provided by a qualified installer, service agency, or the gas supplier.

FOR YOUR SAFETY READ BEFORE OPERATING

WARNING: If you do not follow these instructions exactly, a fire or explosion may result, causing property damage, personal injury or loss of life.

- | | |
|--|--|
| <p>A. This appliance does not have a pilot. It is equipped with an ignition device which automatically lights the burner. Do <u>not</u> try to light the burner by hand.</p> <p>B. BEFORE OPERATING smell all around the appliance area for gas. Be sure to smell next to the floor because some gas is heavier than air and will settle on the floor.</p> | <ul style="list-style-type: none"> • If you cannot reach your gas supplier, call the fire department. <p>C. Use only your hand to turn the gas control knob. Never use tools. If the handle will not turn by hand, don't try to repair it, call a qualified service technician. Force or attempted repair may result in a fire or explosion.</p> |
|--|--|

WHAT TO DO IF YOU SMELL GAS

- | | |
|---|---|
| <ul style="list-style-type: none"> • Do not try to light any appliance • Do not touch any electric switch; do not use any phone in your building • Immediately call your gas supplier from a neighbor's phone. Follow the gas suppliers' instructions. | <p>D. Do not use this appliance if any part has been under water. Immediately call a qualified service technician to inspect the appliance and to replace any part of the control system and any gas control which has been under water.</p> |
|---|---|

OPERATING INSTRUCTIONS

- | | |
|---|---|
| <ol style="list-style-type: none"> 1. STOP! Read the safety information above. 2. Set the thermostat to lowest setting. 3. Turn off all electric power to the appliance. 4. This appliance is equipped with an ignition device which automatically lights the burner. Do not try to light the burner by hand. | <ol style="list-style-type: none"> 5. Remove front cover. 6. Turn gas shutoff valve to "off". Handle will be across the piping, do not force. 7. Wait five (5) minutes to clear out any gas. If you then smell gas, STOP! Follow "B" in the safety information above on this label. If you don't smell gas, go to next step. |
|---|---|

GAS VALVE
ON

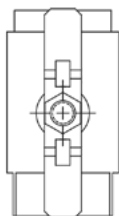

GAS VALVE
OFF

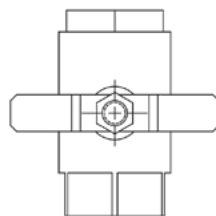



8. Turn gas shutoff valve to "on". Handle will be in line with piping.
9. Install Front Cover.
10. Turn on all electric power to appliance.
11. Set thermostat to desired setting.
12. If the appliance will not operate, follow the instructions "To Turn Off Gas To Appliance" and call your service technician or gas supplier.

TO TURN OFF GAS TO APPLIANCE

- | | |
|--|--|
| <ol style="list-style-type: none"> 1. Set the thermostat to lowest setting. 2. Turn off all electric power to the appliance if service is to be performed. 3. Remove Front Cover. | <ol style="list-style-type: none"> 4. Turn gas shutoff valve to "off". Handle will be across the piping. Do not force. 5. Install Front Cover. |
|--|--|

LP-175 Rev. 4 3-11-08

SPECIAL ATTENTION BOXES	
The following defined terms are used throughout this manual to bring attention to the presence of hazards of various risk levels or to important product information.	
	DANGER
DANGER indicates an imminently hazardous situation which, if not avoided, will result in serious personal injury or death.	
	WARNING
WARNING indicates a potentially hazardous situation which, if not avoided, could result in personal injury or death.	
	CAUTION
CAUTION indicates a potentially hazardous situation which, if not avoided, may result in moderate or minor personal injury.	
CAUTION	
CAUTION used without the safety alert symbol indicates a potentially hazardous situation which, if not avoided, may result in property damage.	
NOTICE	
NOTICE is used to address practices not related to personal injury.	

Foreword

This manual is intended to be used in conjunction with other literature provided with the water heater. This includes all related control information. It is important that this manual, all other documents included in this system, and additional publications including the *Code for the Installation of Heat Producing Appliances* and *National Fuel Gas Code - ANSI Z223.1* (latest versions), be reviewed in their entirety before beginning any work.

Installation should be made in accordance with the regulations of the Authority Having Jurisdiction, local code authorities, and utility companies which pertain to this type of water heating equipment.

Authority Having Jurisdiction (AHJ) – The AHJ may be a federal, state, local government, or individual such as a fire chief, fire marshal, chief of a fire prevention bureau, labor department or health department, building official or

electrical inspector, or others having statutory authority. In some circumstances, the property owner or his/her agent assumes the role, and at government installations, the commanding officer or departmental official may be the AHJ.

NOTE: HTP, Inc. reserves the right to modify product technical specifications and components without prior notice.

For the Installer

This water heater must be installed by qualified and licensed personnel. The installer should be guided by the instructions furnished with the water heater, and by local codes and utility company requirements. In the absence of local codes, preference should be given to the *National Fuel Gas Code - ANSI Z223.1*, latest version.

Installations Must Comply With:

Local, state, provincial, and national codes, laws, regulations, and ordinances.

The latest version of the *National Fuel Gas Code, ANSI Z223.1*, from American Gas Association Laboratories, 8501 East Pleasant Valley Road, Cleveland, OH 44131.

In Canada - *CGA No. B149* (latest version), from Canadian Gas Association Laboratories, 55 Scarsdale Road, Don Mills, Ontario, Canada M3B 2R3. Also, *Canadian Electrical Code, C 22.1*, from Canadian Standards Association, 5060 Spectrum Way, Suite 100, Mississauga, Ontario, Canada L4W 5N6.

Code for the Installation of Heat Producing Appliances (latest version) from American Insurance Association, 85 John Street, New York, NY 11038.

The latest version of the *National Electrical Code, NFPA No. 70*.

NOTE: The gas manifold and controls met safe lighting and other performance criteria when undergoing tests specified in *ANSI Z21.10.3* - latest edition.

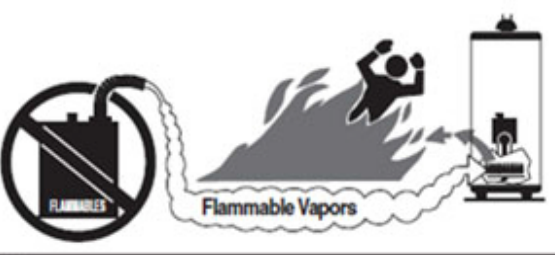
⚠ DANGER	
	
<p>⚠ Vapors from flammable liquids will explode and catch fire causing death or severe burns. Do not use or store flammable products such as gasoline, solvents or adhesives in the same room or area near the water heater. Keep flammable products: 1. far away from heater, 2. in approved containers, 3. tightly closed and 4. out of children's reach.</p>	<p>Water heater has a main burner and pilot flame. The pilot flame: 1. which can come on at any time and 2. will ignite flammable vapors. Vapors: 1. cannot be seen, 2. are heavier than air, 3. go a long way on the floor and 4. can be carried from other rooms to the pilot flame by air currents.</p>
<p>Installation: Do not install water heater where flammable products will be stored or used unless the main burner and pilot flames</p>	<p>are at least 18" above the floor. This will reduce, but not eliminate, the risk of vapors being ignited by the main burner or pilot flame.</p>
<p>Read and follow water heater warnings and instructions. If owners manual is missing, contact the retailer or manufacturer.</p>	

⚠ DANGER	
	
<p>Water temperature over 125°F can cause severe burns instantly or death from scalds. Children, disabled and elderly are at highest risk of being scalded. See instruction manual before setting temperature at water heater. Feel water before bathing or showering. Temperature limiting valves are available, see manual.</p>	

Table of Contents

Part 1 - General Safety Information		
A. Improper Combustion		
B. Gas		
C. When Servicing the Water Heating System		
D. Heater Water		
E. Freeze Protection		
F. High Elevation Installations		
G. Water Temperature Adjustment		
Part 2 - Before You Start		
A. What's in the Box		
B. How the Heater Operates		
C. Optional Equipment		
Part 3 - Prepare the Water Heater		
A. Locating the Water Heater		
B. Leveling		
C. Clearances for Service Access		
D. Residential Garage and Closet Installations		
E. Exhaust Vent and Intake Pipe		
1. Direct Vent of Exhaust and Intake		
2. Power Venting, Indoor Combustion Air in Confined or Unconfined Space		
F. Carbon Monoxide Detectors		
G. Prevent Combustion Air Contamination		
H. Removing a Heater from a Common Vent System		
I. Water Chemistry Requirements		
Part 4 - Piping		
A. Heater Plumbing		
B. Auxiliary Connections		
C. Backflow Preventer		
D. Potable Expansion Tank		
E. Temperature and Pressure Relief Valve		
F. Scalding		
G. Filling the Heater		
H. Applications		
Part 5 - Venting and Condensate Removal		
A. General		
B. Approved Materials for Exhaust Vent and Intake Pipe		
C. Additional Requirements for Installation in Canada		
D. Exhaust Vent and Intake Pipe Location		
E. Exhaust Vent and Intake Pipe Sizing		
F. Longer Vent Runs		
G. Exhaust Vent and Intake Pipe Installation		
H. Applications		
1. Direct Vent Installation of Exhaust and Intake		
2. Venting Through an Existing System		
3. Power Venting, Indoor Combustion Air in Confined or Unconfined Space		
I. Condensate Removal System		
Part 6 - Wiring		
A. Line Voltage Input		
B. Line Voltage Condensate Output		
C. Low Voltage Outdoor Sensor Input		
D. Alarm Connections		
E. Optional 0-10 Volt Building Control Signal		
F. Internal Wiring Diagram		
Part 7 - Gas Connections		
A. Gas Piping		
B. Gas Table		
Part 8 - Start-Up Procedure		
A. Operating Instructions		
B. Overall Water Heater and Control Operation		
C. Status Menu		
D. Outdoor Reset		
E. Test Mode		
F. Maintenance		36
Part 9 - Shutdown		37
A. Shutdown Procedure		37
B. Vacation Procedure		37
C. Failure to Operate		37
D. Important Notice		37
Part 10 - Troubleshooting		37
A. Error Code		37
B. Heater Error		38
C. Lockout		38
Part 11 - Installation Checklist		42
Part 12 - Maintenance		43
Limited Warranty		45
Massachusetts Supplemental Commercial Use Warranty		
For Multiple Water Heater Installations		47
Maintenance Notes		49
Customer Installation Record Form		50
Part 1 - General Safety Information		
This water heater is approved for indoor installations only and is not intended for use as a pool heater. Clearance to combustible materials: 0" top, bottom, sides, and back. Heater must have room for service: 24" front and 12" sides are minimum recommended service clearances. (A combustible door or removable panel is acceptable front clearance.) This water heater has been approved for closet installation and installation on combustible flooring. Do not install directly on carpeting. Install the water heater in a location where temperature and pressure relief valve discharge or a leak will not result in damage to the surrounding area. If such a location is not available, install an auxiliary catch pan. Use only Category IV vent systems.		
WARNING		
Installer - Read all instructions in this manual before installing. Perform steps in the given order.		
User - This manual is for use only by a qualified heating installer / service technician. Have this water heater serviced / inspected annually by a qualified service technician.		
FAILURE TO ADHERE TO THE GUIDELINES ON THIS PAGE CAN RESULT IN SUBSTANTIAL PROPERTY DAMAGE, SEVERE PERSONAL INJURY, OR DEATH.		
Altering any HTP, Inc. water heater with parts not manufactured by HTP, Inc. WILL INSTANTLY VOID the water heater warranty and could result in property damage, personal injury, or death.		
NOTE: If the water heater is exposed to the following, do not operate. Immediately call a qualified service technician.		
1. Fire		
2. Damage		
3. Water		
Failure to follow this information could result in property damage, severe personal injury, or death.		
NOTE: Obey all local codes. Obtain all applicable permits before installing the water heater.		
NOTE: Install all system components and piping in such a manner that does not reduce the performance of any fire rated assembly.		

⚠ WARNING

DO NOT USE THIS WATER HEATER IF ANY PART HAS BEEN SUBMERGED IN WATER. Immediately call a qualified service technician. The water heater **MUST BE** replaced if it has been submerged. Attempting to operate a water heater that has been submerged could create numerous harmful conditions, such as a potential gas leakage causing a fire and/or explosion, or the release of mold, bacteria, or other harmful particulates into the air. Operating a previously submerged water heater could result in property damage, severe personal injury, or death.

NOTE: Water heater damage due to flood or submersion is considered an Act of God, and **IS NOT** covered under product warranty.

This water heater has been designed to heat potable water **ONLY**. Using this water heater to heat non-potable fluid **WILL VOID** product warranty, and could result in property damage, personal injury, or death.

CAUTION

Do not use this water heater for anything other than its intended purpose (as described in this manual). Doing so could result in property damage and **WILL VOID** product warranty.

High heat sources (sources generating heat 100°F / 37°C or greater, such as stove pipes, space heaters, etc.) may damage plastic components of the water heater as well as plastic vent pipe materials. Such damages **ARE NOT** covered by warranty. It is recommended to keep a minimum clearance of 8" from high heat sources. Observe heat source manufacturer instructions, as well as local, state, provincial, and national codes, laws, regulations and ordinances when installing this water heater and related components near high heat sources.

A. Improper Combustion

⚠ WARNING

Do not obstruct the flow of combustion and ventilating air. Adequate air is necessary for safe operation. Failure to keep the exhaust vent and combustion air intake clear of ice, snow, or other debris could result in property damage, serious personal injury, or death.

B. Gas

Should overheating or gas supply fail to shut off, turn off the manual gas control valve to the water heater.

C. When Servicing the Water Heating System

⚠ WARNING

Be sure to disconnect electrical power before performing service. Failure to do so could result in electrical shock, property damage, serious personal injury, or death.

To avoid electric shock, disconnect electrical supply before performing maintenance.

NOTE: When inquiring about service or troubleshooting, reference the model and serial numbers from the water heater rating label.

To avoid severe burns, allow water heater and associated equipment to cool before servicing.

D. Heater Water

Do not use petroleum-based cleaning or sealing compounds in a water heating system. Gaskets and seals in the system may be damaged. This can result in substantial property damage.

Do not use "homemade cures" or "patent medicines". Damage to the water heater, substantial property damage, and/or serious personal injury may result.

E. Freeze Protection

NOTE: Consider piping and installation when determining heater location.

CAUTION

Failure of the water heater due to freeze related damage **IS NOT** covered by product warranty.

⚠ WARNING

NEVER use any toxic chemical, including automotive, standard glycol antifreeze, or ethylene glycol made for hydronic (non-potable) systems. These chemicals can attack gaskets and seals in water systems, are poisonous if consumed, and can cause personal injury or death.

NOTICE

UNCRATING THE WATER HEATER - Any claims for damage or shortage in shipment must be filed immediately against the transportation company by the consignee.

F. High Elevation Installations

⚠ WARNING

Natural gas at high elevation might contain less heating value than typical 1,000 BTU/cu ft and therefore can cause improper air / gas mix leading to improper combustion. For natural gas installations above 3,000 ft, call your gas provider to determine the heating value of the supplied natural gas.

G. Water Temperature Adjustment

If the water heater is going to have a set temperature above 120°F, you must use an ASSE 1017 rated mixing valve to avoid severe burns or death from scalding temperatures.

⚠ WARNING

Households with small children, disabled, or elderly persons may require a 120°F or lower temperature setting to prevent severe personal injury or death due to scalding.

Approximate Time / Temperature Relationships in Scalds	
120°F	More than 5 minutes
125°F	1 1/2 to 2 minutes
130°F	About 30 seconds
135°F	About 10 seconds
140°F	Less than 5 seconds
145°F	Less than 3 seconds
150°F	About 1 1/2 seconds
155°F	About 1 second

Table 1 - Approximate Time / Temperature Relationships in Scalds

Part 2 - Before You Start

Remove all sides of the shipping crate of the water heater.

A. What's in the Box

Components included with the water heater:

- Intake PVC Tee with Screens
- Exhaust PVC Coupling with Screens
- Temperature and Pressure Relief Valve
- Two Threaded Brass Caps (PHM Models Only)
- Solar Addendum (S Models Only)
- LP Conversion Kit (NG Models Only)
- Installation Manual and Warranty
- User's Information Manual

B. How the Heater Operates

Modulating Condensing Technology is an intelligent system that delivers highly efficient water heating, maximizing efficiency by measuring the data parameters of your water heating system. Some of its features are:

Stainless Steel Water Storage Tank

The stainless steel water storage tank has a combustion chamber submerged into the tank water. When the water heater is fired, combustion gases heat the combustion chamber walls, transferring heat directly into the surrounding water. These hot gases are blown into secondary heat exchanger coils, where more heat from these gases is transferred into the water.

Modulating Combustion System

The control monitors the water heating system and temperatures, regulating burner output during operation to match system demand. This increase in efficiency allows for substantial fuel savings.

Gas Valve

The gas valve senses suction from the blower, allowing gas to flow only if the gas valve is energized and combustion air is flowing.

Upper Outlet Tank Sensor

This sensor monitors the upper portion water temperature (outlet) of the water heater. The control module adjusts burner firing rate so the outlet water temperature meets the set point.

Lower Inlet Tank Sensor

This sensor monitors the lower portion water temperature (inlet) of the water heater. The control module reduces or increases input, depending on how close the inlet water temperature is to the outlet water temperature set point.

Control

The integrated control system monitors upper and lower water temperature and adjusts fan speed to regulate the heater's energy output. This allows the unit to deliver the required amount of heated energy and nothing more.

Burner

Constructed of high grade stainless steel, the burner uses pre-mixed air and gas and provides a wide range of firing rates.

Condensate Drain System

This is a condensing high efficiency water heater with a condensate removal system. Condensate is nothing more than water vapor derived from combustion products, similar to that of an automobile when it is initially started. It is very important that the condensate line slopes away from the water heater and down to a suitable inside drain.

If the condensate outlet on the heater is lower than the drain, us

a condensate removal pump (Part # 554200, available from HTP). In addition, local authorities may require an additional condensate neutralizer to neutralize the condensate. Condensate neutralizers are made up of lime crystals, marble, or phosphate chips. Neutralizers can be installed in the field by the installer and purchased from HTP (p/n 7450P-212).

It is also very important not to expose the condensate line to freezing temperatures or any type of blockage. Plastic tubing must be the only material used for the condensate line. Steel, brass, copper, or other materials will be subject to corrosion or deterioration. A second vent may be necessary to prevent condensate line vacuum lock on a long horizontal run. Also, an increase in pipe size may be necessary to allow condensate to drain properly. Support of the condensate line may be necessary to avoid blockage of the condensate flow.

Spark Ignition

The burner flame is ignited by applying high voltage to the system spark electrode. This causes a spark from electrode to ground.

Outdoor Sensor

Monitors outdoor temperature and adjusts set point to provide greater efficiency.

C. Optional Equipment

Optional equipment available from HTP (and Part #):

- 3" Stainless Steel Vent Termination Kit (V1000)
- 4" Stainless Steel Vent Termination Kit (V2000)
- 2" PVC Concentric Vent Kit (KGAVT0501CVT)
- 3" PVC Concentric Vent Kit (KGAVT0601CVT)
- 3" Polypro Vent Kit (8400P-001)
- 3" Polypro Pipe
(33' length # 8400P-002, 49.5' length # 8400P-003)
- Outdoor Sensor (7250P-319)
- PC Connection Kit (7250P-320)
- Condensate Neutralizer (7450P-212)
- Sanitizer Booster Kit (VSBK-1200)

Part 3 - Prepare the Water Heater

Remove all sides of the shipping crate to allow the heater to be moved into its installation location.

CAUTION

COLD WEATHER HANDLING - If the water heater has been stored in a very cold location (BELOW 0°F) before installation, handle with care until the components come to room temperature. Failure to do so could result in damage to the water heater.

CAUTION

Carefully consider installation when determining heater location. Please read the entire manual before attempting installation. Failure to properly take factors such as heater venting, piping, condensate removal, and wiring into account before installation could result in wasted time, money, and possible property damage and personal injury.

A. Locating the Water Heater

WARNING

This water heater is certified for indoor use only. DO NOT INSTALL OUTDOORS. Outdoor installations ARE NOT covered by warranty. Failure to install the water heater indoors could result in property damage, severe personal injury, or death.

Incorrect ambient conditions can lead to damage to the heating system and put safe operation at risk. Ensure that the installation location adheres to the information included in this manual. Failure to do so could result in property damage, serious personal injury, or death. Failure of heater or components due to incorrect operating conditions IS NOT covered by product warranty.

This water heater must be installed upright in the vertical position as described in this manual. DO NOT attempt to install this water heater in any other orientation. Doing so will result in improper water heater operation and property damage, and could result in serious personal injury or death.

1. Installation Area (Mechanical Room) Operating Conditions

- Ensure ambient temperatures are higher than 32°F / 0°C and lower than 104°F / 40°C
- Prevent the air from becoming contaminated by the products, places, and conditions listed in this manual
- Avoid continuously high levels of humidity
- Never close existing ventilation openings
- Ensure a minimum 1" clearance around hot water and exhaust vent pipes
- NOTE: To prevent condensing in the fan, it is recommended to avoid prolonged exposure to temperatures below 45°F

WARNING

This water heater has a condensate disposal system that may freeze if exposed to sustained temperatures below 32°F. Precautions should be taken to protect the condensate trap and drain lines from sustained freezing conditions. Failure to take precautions could result in property damage, severe personal injury, or death.

2. Check for nearby connections to:

- System water piping
- Venting connections
- Gas supply piping
- Electrical power
- Condensate drain

3. Check area around heater. Remove any combustible materials, gasoline, and other flammable liquids.

WARNING

Failure to keep the water heater area clear and free of combustible materials, liquids, and vapors can result in substantial property damage, severe personal injury, or death.

CAUTION

The service life of the water heater's exposed metallic surfaces, such as the casing, as well as internal surfaces, such as the heat exchanger, are directly influenced by proximity to damp and salty marine environments. In such areas higher concentration levels of chlorides from sea spray coupled with relative humidity can lead to degradation of water heater components. In these environments, heaters must not be installed using direct vent systems which draw outdoor air for combustion. Such heaters must be installed using room air for combustion. Indoor air will have a much lower relative humidity, and hence potential corrosion will be minimized.

High heat sources (generating heat 100°F / 37°C or greater, such as boiler flue pipes, space heaters, etc.) may damage plastic components of the water heater as well as plastic vent pipe materials. Such damages ARE NOT covered by warranty. It is recommended to keep a minimum clearance of 8" from high heat sources. Observe heat source manufacturer instructions, as well as local, state, provincial, and national codes, laws, regulations, and ordinances when installing this water heater and related components near high heat sources.

Locate the water heater where any leakage from the relief valve, related piping, tank, or connections will not result in damage to surrounding areas or lower floors of the building. The water heater should be located near a floor drain or installed in a drain pan. Leakage damages ARE NOT covered by warranty.

Failure of the water heater or components due to incorrect operating conditions IS NOT covered by product warranty.

4. Gas control system components must be protected from dripping water during operation and service.

5. If the heater is to replace an existing heater, check for and correct any existing system problems, such as:

- System leaks
- Location that could cause the system and heater to freeze and leak
- Incorrectly sized expansion tank

6. Clean and flush system when reinstalling a heater.

NOTE: When installing in a zero clearance location, it may not be possible to read or view some product labeling. It is recommended to make note of the heater model and serial number.

NOTE: A combustible door or removable panel is acceptable front clearance.

B. Leveling

CAUTION

In order for the condensate to properly flow out of the collection system, the area where you locate the heater must be level. Location must also fully support the weight of the filled water heater.

C. Clearances for Service Access

CAUTION

All water heaters eventually leak. It is recommended to install a catch pan beneath the water heater. This catch pan should be sized with a maximum depth of 2", and a minimum diameter 2" greater than the diameter of the water heater. The catch pan should empty into an open drain line. This drain line should be 3/4" ID minimum, piped to an open drain. Failure to follow these instructions could result in property damage. Such damages ARE NOT covered by product warranty.

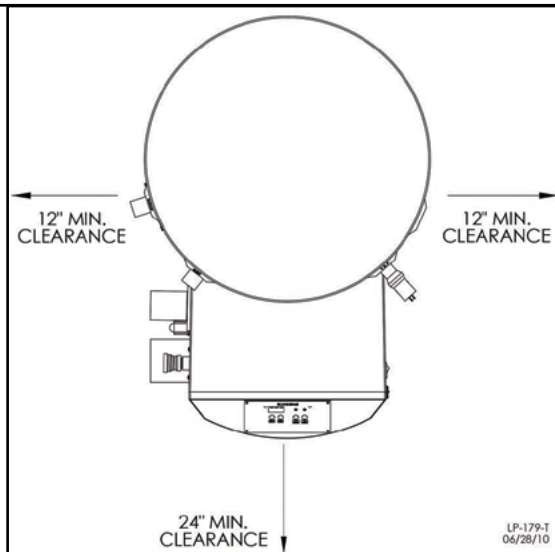
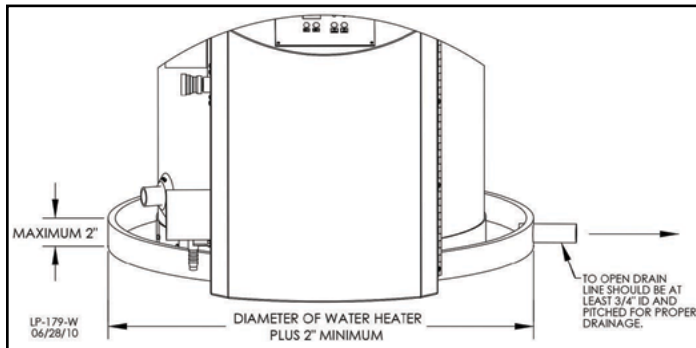

Figure 1 - Catch Pan Dimensions and Recommended Service Clearances

NOTE: In addition, on PHM models, it is recommended to provide a minimum service clearance of 6" from the top of the water heater to allow for piping of the top ports. Depending on the installation, this clearance may need to be substantially greater than 6".

NOTE: If you do not provide the minimum clearances shown in Figure 1 it might not be possible to service the heater without removing it from the space.

WARNING

The space must be provided with combustion / ventilation air openings correctly sized for all other appliances located in the same space as the heater. The heater cover must be securely fastened to prevent the heater from drawing air from the heater room. This is particularly important if the heater is in a room with other appliances. Failure to comply with the above warnings could result in substantial property damage, severe personal injury, or death.

D. Residential Garage and Closet Installations

CAUTION

Check with your local Authority Having Jurisdiction for requirements when installing the water heater in a garage or closet. Please read the entire manual before attempting installation. Failure to properly take factors such as venting, piping, condensate removal, and wiring into account before installation could result in wasted time, money, and possible property damage and personal injury.

Precautions

If the heater is located in a residential garage, per ANSI Z223.1:

- Install the water heater burner and ignition devices a minimum of 18" above the floor of the garage. This will ensure the burner and ignition devices are well off the floor.
- When raising the water heater ensure the entire bottom and fully filled weight of the water heater are fully supported.
- Locate or protect the water heater so it cannot be damaged by a moving vehicle.

WARNING

The space must be provided with correctly sized combustion/ventilation air openings for all other appliances located in the space with the water heater. For power venting installations using room air for combustion, refer to the venting section, this manual, for descriptions of confined and unconfined spaces. Do not install the water heater in an attic. Failure to comply with these warnings could result in substantial property damage, severe personal injury, or death.

E. Exhaust Vent and Intake Pipe

The heater is rated ANSI Z21.10.3 Category IV (pressurized vent, likely to form condensate in the vent) and requires a special vent system designed for pressurized venting.

NOTE: The venting options described here (and further detailed in the Venting section, this manual) are the lone venting options approved for this water heater. Failure to vent the water heater in accordance with the provided venting instructions will void the warranty.

DANGER

Failure to vent the water heater properly will result in serious personal injury or death.

WARNING

Do not attempt to vent this water heater by any means other than those described in this manual. Doing so will void the warranty and may result in severe personal injury or death.

Vents must be properly supported. Heater exhaust and intake connections are not designed to carry heavy weight. Vent support brackets must be within 1' of the heater and the balance at 4' intervals. Heater must be readily accessible for visual inspection for first 3' from the water heater. Failure to properly support vents could result in property damage, severe personal injury, or death.

The exhaust discharged by this water heater may be very hot. Avoid touching or other direct contact with the exhaust gases of the vent termination assembly. Doing so could result in severe personal injury or death.

1. Direct Vent of Exhaust and Intake

If installing a direct vent option, combustion air must be drawn from the outdoors directly into the water heater intake and exhaust must terminate outdoors. There are three basic direct vent options detailed in this manual: 1. Side Wall Venting, 2. Roof Venting, and 3. Unbalanced Venting.

Be sure to locate the heater such that the exhaust vent and intake piping can be routed through the building and properly terminated. Different vent terminals can be used to simplify and eliminate multiple penetrations in the building structure (see Optional Equipment in Venting Section). The exhaust vent and intake piping lengths, routing, and termination methods must all comply with the methods and limits given in the Venting Section, this manual.

When installing a combustion air intake from outdoors, care must be taken to utilize uncontaminated combustion air. **To prevent combustion air contamination, see Table 2.**

2. Power Venting, Indoor Combustion Air in Confined or Unconfined Space

This heater requires fresh, uncontaminated air for safe operation and must be installed in a mechanical room where there is adequate combustion and ventilating air. **NOTE: To prevent combustion air contamination, see Table 2.**

Combustion air from the indoor space can be used if the space has adequate area or when air is provided through a duct or louver to supply sufficient combustion air based on the water heater input. Never obstruct the supply of combustion air to the water heater. If the water heater is installed in areas where indoor air is contaminated (see Table 2) it is imperative that the water heater be installed as direct vent so that all combustion air is taken directly from the outdoors into the water heater intake connection.

Unconfined space is space with volume greater than 50 cubic feet per 1,000 BTU/hr (4.8 cubic meters per kW) of the total input rating of all fuel-burning appliances installed in that space. Rooms connected directly to this space through openings not furnished with doors are considered part of the space. See Venting Section for details.

Confined space is space with volume less than 50 cubic feet per 1,000 BTU/hr (4.8 cubic meters per kW) of the total input rating of all fuel-burning appliances installed in that space. Rooms connected directly to this space through openings not furnished with doors are considered part of the space.

When drawing combustion air from inside a conventionally constructed building to a confined space, such space should be provided with two permanent openings: one located 6" (15 cm) below the space ceiling, the other 6" (15cm) above the space floor. Each opening should have a free area of one square inch per 1,000 BTU/hr (22cm²/kW) of the total input of all appliances in the space, but not less than 100 square inches (645cm²).

If the confined space is within a building of tight construction, air for combustion must be obtained from the outdoors as outlined in the Venting section of this manual.

CAUTION
When drawing combustion air from the outside into the mechanical room, care must be taken to provide adequate freeze protection.

WARNING
Failure to provide an adequate supply of fresh combustion air can cause poisonous flue gases to enter the living space, resulting in severe personal injury or death. To prevent combustion air contamination, see Table 2.

**F. Carbon Monoxide Detectors
In the Commonwealth of Massachusetts and As Required by State and Local Codes:**

Installation of Carbon Monoxide Detectors: At the time of installation or replacement of the vented gas fueled appliance, the installing plumber or gas fitter shall observe that a hard wired carbon monoxide detector with an alarm and battery back-up is installed on the floor level where the gas appliance is installed, unless the appliance is located in a detached, uninhabitable structure separate from the dwelling, building, or structure used in whole or in part for residential purposes.

In addition, the installing plumber or gas fitter shall observe that a hard wired carbon monoxide detector with an alarm and battery back-up is installed on each additional level of the dwelling, building, or structure served by the vented gas appliance. It shall be the responsibility of the property owner to secure the service of qualified licensed professionals for the installation of hard wired carbon monoxide detectors.

- a. In the event that the vented gas fueled appliance is installed in a crawl space or attic, the hard wired carbon monoxide detector with alarm and battery back-up shall be installed on the next adjacent floor level.
- b. In the event that these requirements cannot be met at the time of completion of installation, the owner shall have a period of thirty (30) days to comply with the above requirements; provided, however, that during said thirty (30) day period, a battery operated carbon monoxide detector with an alarm shall be installed.

WARNING
Do not attempt to vent this water heater by any means other than those described in this manual. Doing so will void the warranty and may result in severe personal injury or death.

Approved Carbon Monoxide Detectors: Each carbon monoxide detector as required in accordance with the above provisions shall comply with NFPA 70 and be ANSI/UL 2034 listed and IAS certified.

G. Prevent Combustion Air Contamination

Install intake air piping for the heater as described in the Venting Section, this manual. Do not terminate exhaust in locations that can allow contamination of intake air.

WARNING
Ensure that the intake air will not contain any of the contaminants in Table 2. Contaminated air will damage the heater, resulting in possible substantial property damage, severe personal injury, or death. For example, do not pipe intake air near a swimming pool or laundry facilities. These areas always contain contaminants.

Products to Avoid	Areas Likely to Have Contaminants
Spray cans containing fluorocarbons	Dry cleaning / laundry areas and establishments
Permanent wave solutions	Swimming pools
Chlorinated waxes / cleaners	Metal fabrication plants
Chlorine-based swimming pool chemicals	Beauty shops
Calcium chloride used for thawing	Refrigeration repair shops
Sodium chloride used for water softening	Photo processing plants
Refrigerant leaks	Auto body shops
Paint or varnish removers	Plastic manufacturing plants
Hydrochloric or Muriatic acid	Furniture refinishing areas and establishments
Cements and glues	New building construction
Antistatic fabric softeners used in clothes dryers	Remodeling areas
Chlorine-type bleaches, laundry detergents, and cleaning solvents	Garages and workshops
Adhesives used to fasten building products	

Table 2 - Products and Areas Likely to Have Contaminants

NOTE: DAMAGE TO THE HEATER CAUSED BY EXPOSURE TO CORROSIVE VAPORS IS NOT COVERED BY WARRANTY. (Refer to the limited warranty for complete terms and conditions.)

H. Removing a Heater from a Common Vent System

! DANGER

Do not install the heater into a common vent with any other appliance. This will cause flue gas spillage or appliance malfunction, resulting in possible substantial property damage, severe personal injury, or death.

! WARNING

Failure to follow all instructions can result in flue gas spillage and carbon monoxide emissions, causing severe personal injury or death.

When removing an existing heater, follow the steps below.

1. Seal any unused openings in the common venting system.
2. Visually inspect the venting system for proper size and horizontal pitch to determine if there is blockage, leakage, corrosion, or other deficiencies that could cause an unsafe condition.
3. If practical, close all building doors, windows, and doors between the space in which the water heater remains connected to the common venting system and other spaces in the building. Turn on clothes dryers and any appliances not connected to the common venting system. Turn on any exhaust fans, such as range hoods and bathroom exhausts, at maximum speed. Do not operate a summer exhaust fan. Close all fireplace dampers.
4. Place in operation the appliance being inspected. Follow the lighting instructions. Adjust the thermostat so the appliance will operate continuously.
5. Test for spillage at the draft hood relief opening after 5 minutes of main burner operation. Use the flame of a match or candle or smoke from a cigarette.

6. After it has been determined that each appliance remaining connected to the common venting system properly vents when tested as outlined, return doors, windows, exhaust fans, fireplace dampers, and any other gas burning appliances to their previous condition of use.

7. Any improper operation of the common venting system should be corrected to conform to the National Fuel Gas Code, ANSI Z223.1. When resizing any portion of the common venting system, the system should approach the minimum size as determined using the appropriate tables in Appendix G of ANSI Z223.1.

! WARNING

Breathing Hazard - Carbon Monoxide Gas



- Do not operate heater if flood damaged.
- Install vent system in accordance with local codes and manufacturers installation instructions.
- Do not obstruct heater air intake or exhaust. Support all vent piping per manufacturers installation instructions.
- Do not place chemical vapor emitting products near unit.
- According to NFPA 720, carbon monoxide detectors should be installed outside each sleeping area.
- Never operate the heater unless it is vented to the outdoors.
- Analyze the entire vent system to make sure that condensate will not become trapped in a section of vent pipe and therefore reduce the open cross sectional area of the vent.

LP-304-FR

Breathing carbon monoxide can cause brain damage or death. Always read and understand instruction manual.

Figure 2 - CO Warning Label

I. Water Chemistry Requirements

CAUTION

Chemical imbalance of the water supply may affect efficiency and cause severe damage to the appliance and associated equipment. Water quality must be professionally analyzed to determine whether it is necessary to treat the water. Various solutions are available to adjust water quality. Adverse water quality will affect the reliability of the system. In addition, operating temperatures above 135°F will accelerate the build-up of lime scale and possibly shorten appliance service life. Failure of an appliance due to lime scale build-up, low pH, or other chemical imbalance IS NOT covered by the warranty.

The water must be potable, free of corrosive chemicals, sand, dirt, and other contaminants. It is up to the installer to ensure the water does not contain corrosive chemicals or elements that can damage the heat exchanger. Potable water is defined as drinkable water supplied from utility or well water in compliance with EPA secondary maximum contaminant levels (40 CFR Part 143.3). If the water contains contaminants higher than outlined by the EPA, water treatment is recommended and additional, more frequent maintenance may be required.

If you suspect that your water is contaminated in any way, discontinue use of the appliance and contact an authorized technician or licensed professional.

- **Water pH between 6.5 and 8.5**
 - pH levels below 6.5 can cause an increase in the rate of corrosion. pH of 8.5 or higher can potentially cause lime scale build-up
 - Maintain water pH between 6.5 and 8.5. Check with litmus paper or have it chemically analyzed by a local water treatment company.
 - If the pH is not between 6.5 and 8.5, consult a local water treatment company for solutions.
- **Hardness less than 12 grains (200 mg/L) (Residential Use - water temperatures below 140°F)**
- **Hardness less than 7 grains (120 mg/L) (Commercial Use - water temperatures of 140°F and greater)**
 - Hardness levels above the required amounts can lead to lime scale build-up throughout the system. Water below 5 grains/gallon (85 mg/L) may be over softened.
 - Consult local water treatment companies for unusually hard water areas (above the required amounts) or for other treatment solutions if water is being over softened (below 5 grains/gallon [85 mg/L]).
- **Chloride concentration less than 100 ppm (mg/L)**
 - Do not fill appliance or operate with water containing chlorides in excess of 100 ppm (mg/L).
 - Using chlorinated fresh water should be acceptable as levels are typically less than 5 ppm (mg/L).
 - Do not connect the appliance to directly heat swimming pool or spa water.
- **Total Dissolved Solids (TDS) less than 500 ppm (mg/L)**
 - Total dissolved solids are minerals, salts, metals, and charged particles that are dissolved in water.
 - The greater the amounts of TDS present, the higher the corrosion potential due to increased conductivity in the water.
 - If using softened water to fill the appliance, it is still possible to have high TDS. This water can be corrosive. Consult local water treatment companies for other treatment solutions to reduce this effect.

***NOTE:** To promote appliance service life, it is strongly recommended to follow the maintenance procedures in this manual.

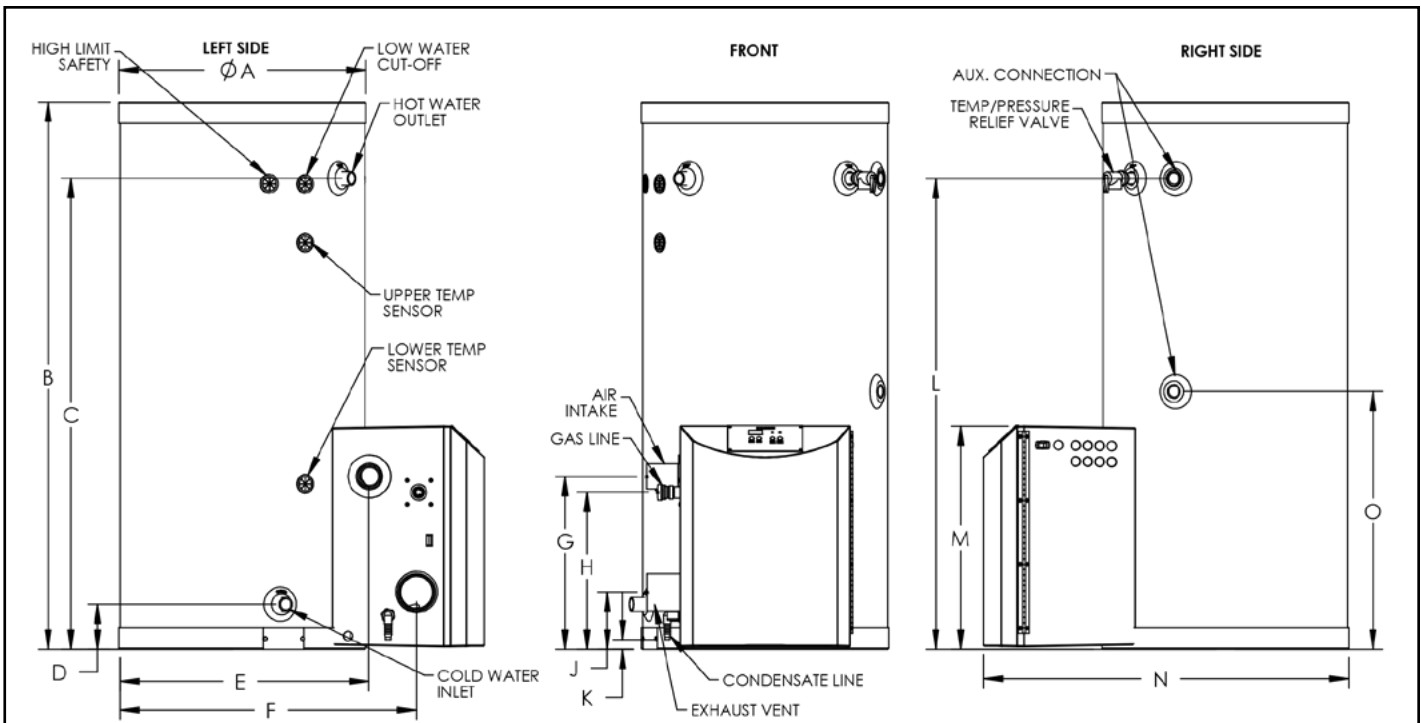

WATER HEATER AND SANITIZER BOOSTER DIMENSIONS

MODEL*	GAL.	A	B	C	D	E	F	G	H	J	K	L	M	N	O
100-55/130-55/160-55/199-55	55	23"	52"	45"	5"	23-1/4"	27-3/4"	16-1/4"	14-3/4"	5-1/4"	1"	45"	21"	34-1/4"	27-1/2"
100-80/130-80/160-80/199-80	80	23"	72"	64"	5-3/4"	27-1/2"	32"	18-1/2"	17"	7-3/4"	3-1/4"	64"	24-3/4"	34-1/4"	29-3/4"
100-119/130-119/160-119/199-119	119	27"	74"	66-1/4"	7-1/2"	27-1/2"	32"	21-1/2"	18-3/4"	10-1/2"	5"	66-1/2"	24-3/4"	38-1/2"	31"
199-55SA	55	23"	52"	45"	5"	23-1/4"	27-3/4"	16-1/4"	14-3/4"	5-1/4"	1"	45"	21"	34-1/4"	27-1/2"

WATER HEATER SPECIFICATIONS

MODEL*	INPUT MODULATION	AIR INTAKE/ EXHAUST VENT SIZE	INLET/ OUTLET SIZE	AUXILIARY CONN.	GAS LINE CONN.	SYSTEM RELIEF PIPE SIZE	SHIPPING WEIGHT	MAX. TEMPERATURE LIMIT
100-55	30,000 - 100,000	2"	1" NPT	1" FNPT	3/4"	3/4"	175 LBS.	160°
130-55	30,000 - 130,000	2"	1" NPT	1" FNPT	3/4"	3/4"	175 LBS.	160°
160-55	40,000 - 160,000	3"	1" NPT	1" FNPT	3/4"	3/4"	175 LBS.	160°
199-55	40,000 - 199,000	3"	1" NPT	1" FNPT	3/4"	3/4"	175 LBS.	160°
100-80	30,000 - 100,000	2"	1-1/2" NPT	1" FNPT	3/4"	3/4"	235 LBS.	160°
130-80	30,000 - 130,000	2"	1-1/2" NPT	1" FNPT	3/4"	3/4"	235 LBS.	160°
160-80	40,000 - 160,000	3"	1-1/2" NPT	1" FNPT	3/4"	3/4"	235 LBS.	160°
199-80	40,000 - 199,000	3"	1-1/2" NPT	1" FNPT	3/4"	3/4"	235 LBS.	160°
100-119	30000 - 100,000	2"	1-1/2" NPT	1" FNPT	3/4"	3/4"	405 LBS.	160°
130-119	30,000 - 130,000	2"	1-1/2" NPT	1" FNPT	3/4"	3/4"	405 LBS.	160°
160-119	40,000 - 160,000	3"	1-1/2" NPT	1" FNPT	3/4"	3/4"	405 LBS.	160°
199-119	40,000 - 199,000	3"	1-1/2" NPT	1" FNPT	3/4"	3/4"	405 LBS.	160°

SANITIZER BOOSTER SPECIFICATIONS

199-55SA	40,000 - 199,000	3"	1"	1" FNPT	3/4"	3/4"	175 LBS.	184°
----------	------------------	----	----	---------	------	------	----------	------

*ALL DIMENSIONS ARE APPROXIMATE, A SUFFIX OF "LP" DENOTES PROPANE GAS

LP-179-B
12/14/16

Figure 3 - Water Heater Dimensions - NOTE: All Dimensions Are Approximate

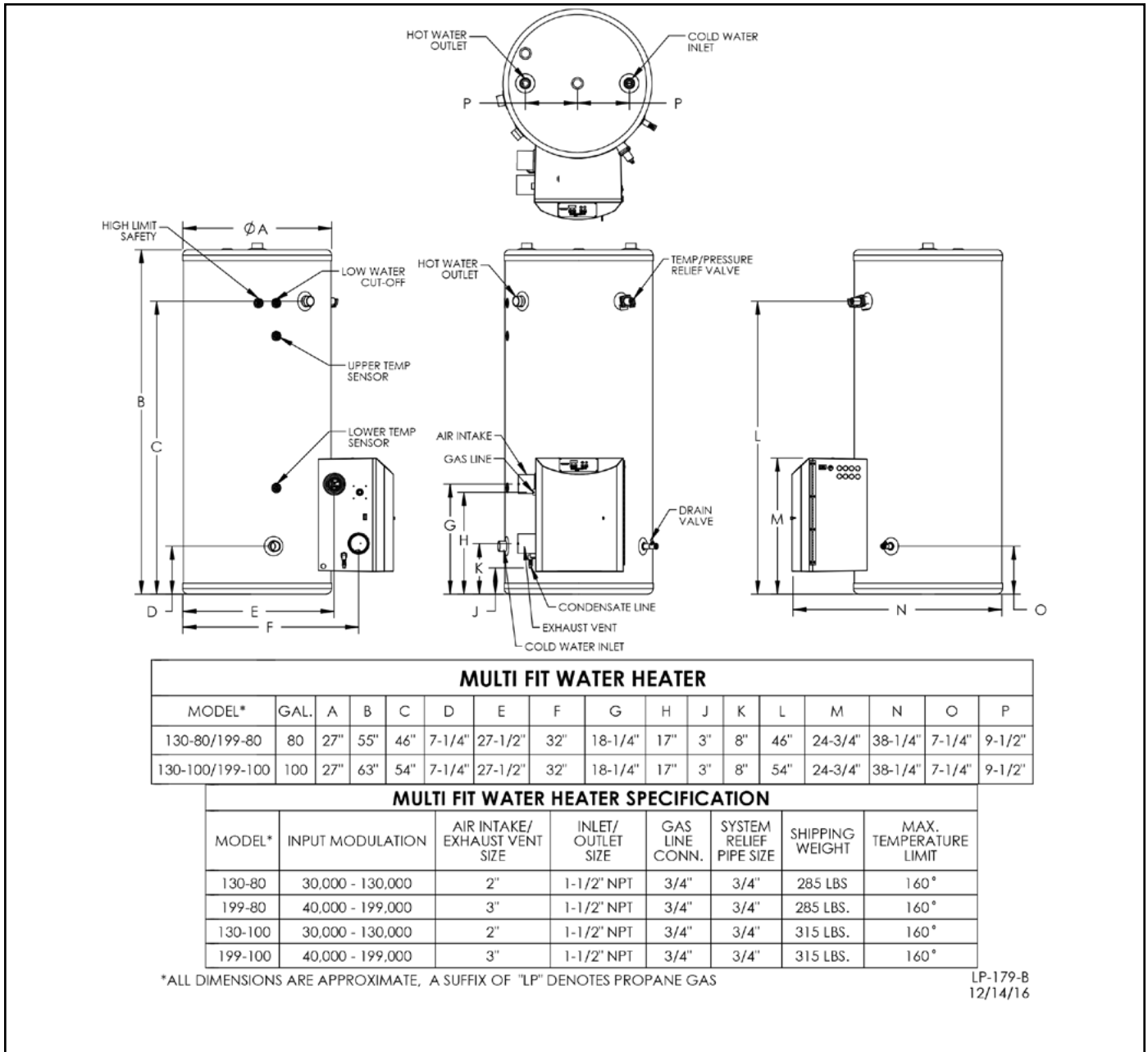

Figure 4 - Water Heater Dimensions - NOTE: All Dimensions Are Approximate

Performance Specifications for Phoenix Models

BTU/Hr	Efficiency	Temperature Rise in Degrees Fahrenheit (F) and Celsius (C)											
		(°F)	40	50	60	70	80	90	100	110	120	130	140
		(°C)	22	28	33	39	44	50	56	61	67	72	78
100,000	96%	GPH	298	240	202	173	152	136	123	110	101	94	88
		LPH	1128	908	765	655	575	515	466	416	382	356	333
130,000		GPH	384	309	260	222	195	175	158	141	130	120	112
		LPH	1454	1170	984	840	738	662	598	534	492	454	424
160,000		GPH	470	378	317	271	238	213	192	173	159	147	137
		LPH	1779	1431	1200	1026	901	806	727	655	602	556	519
199,000		GPH	582	468	392	335	294	263	237	213	196	181	169
		LPH	2203	1772	1484	1268	1113	996	897	806	742	685	640

Table 3 - Recovery on Rating Plate is based at 94% Thermal Efficiency at 70° Fahrenheit rise, as required by ANSI

Performance Equations

$$\text{GPM} = \frac{\text{Rated Input} \times .9}{\text{Temp Rise } (^\circ\text{F}) \times 500} \qquad \text{GPH} = \text{GPM} \times 60$$

Part 4 - Piping

WARNING

Failure to follow the instructions in this section WILL VOID the warranty and may result in property damage, severe personal injury, or death.

CAUTION

Dielectric unions or galvanized steel fittings must not be used in a system with this water heater. Doing so WILL VOID the warranty. Use only copper, brass, or stainless steel fittings. Teflon thread sealant must be used on all connections.

DO NOT pipe this water heater with black iron, galvanized steel, steel, or lead pipe. Doing so will result in premature product failure and property damage, and WILL VOID the warranty.

A. Heater Plumbing

CAUTION

Use two wrenches when tightening water piping at heater. Use one wrench to prevent the heater return or supply line from turning. Failure to prevent piping connections from turning could cause damage to heater components.

The heater control module uses temperature sensors to provide both high limit protection and modulating temperature control. The control module also provides low water protection by sensing the water level in the tank. Some codes / jurisdictions may require additional external controls.

The domestic water connections must be installed in accordance to all local and national plumbing codes, or any applicable standard which prevails. The inlet (cold) and outlet (hot) ports are 1" on 55 gallon models, and 1 1/2" on 80 and 119 gallon models.

On the cold inlet, install a 1" brass tee on 55 gallon models, or a 1 1/2" tee on 80 and 119 gallon models. On the run of the 1" brass tee, install a 1" brass drain cock or equivalent with pipe sealant compound. In the branch of the 1" or 1 1/2" brass tee, install a copper male adapter to match your copper plumbing system. For convenience, it is recommended to install a sweat shut-off valve and a union in the cold inlet piping and hot outlet to ease future servicing. If there is a backflow preventer or any type of a no return valve in the system, install an additional tee here, suitable for a potable hot water expansion tank.

In the hot outlet, install a suitable adapter to match the copper tubing of the plumbing system. A thermal trap or heat trap loop may be installed here to provide additional energy savings and prevent the thermal siphoning of domestic hot water.

B. Auxiliary Connections

The auxiliary connections are additional connections for a recirculation connection, air handlers, plate exchangers, or other devices that supply hot water. These connections must be installed in accordance with all local and national codes or any applicable standard that prevails. Auxiliary connections are 1" on all models. Never use dielectric unions or galvanized steel fittings. Use only copper or brass fittings. Sealant must be used on all connections. The top port is the outlet and the bottom port is the inlet.

WARNING

Never connect auxiliary connections to any system that uses glycol or other solutions formulated for hydronic systems. These auxiliary connections are to be used only in a potable water system. Failure to follow this warning could result in serious injury or death.

C. Backflow Preventer

Use a backflow preventer specifically designed for water heater installations. This valve should be installed on the cold water fill supply line per local codes.

D. Potable Expansion Tank

A potable hot water expansion tank is required to offset heated water expansion. In most city plumbing systems, the water meter has a no return or back flow device built into the system to prevent back flowing of water into city mains. Some local codes require back flow preventers on all incoming water supplies. The hot water expansion tank must be listed for potable water use. The expansion tank should be located on the cold inlet piping close to the water heater.

Expansion Tank and Make-Up Water

1. Ensure that the expansion tank is sized to correctly handle heater and system water volume and temperature.

CAUTION

Undersized expansion tanks cause system water to be lost from the relief valve, causing make-up water to be added. Eventual heater failure can result due to excessive make-up water addition. **SUCH FAILURE IS NOT COVERED BY WARRANTY.**

The expansion tank must be suitable for hot potable water systems.

2. The expansion tank must be located as shown in Applications, this manual, or following recognized design methods. See expansion tank manufacturer's instructions for details.

E. Temperature and Pressure Relief Valve

WARNING

Overheated water and high pressures can cause water tank explosion. A properly sized temperature and pressure relief valve must be installed in the opening provided on the water heater. Failure to install a properly sized temperature and pressure relief valve could result in explosion and property damage, serious injury, or death.

To avoid water damage or scalding due to relief valve operation:

- Discharge line must be connected to relief valve outlet and run to a safe place of disposal. Terminate the discharge line in a manner that will prevent possibility of severe burns or property damage should the relief valve discharge.
- Discharge line must be as short as possible and the same size as the valve discharge connection throughout its entire length.
- Discharge line must pitch downward from the valve and terminate at least 6" above the floor drain, making discharge clearly visible.
- The discharge line shall terminate plain, not threaded, with a material serviceable for temperatures of 375°F or greater.
- Do not pipe discharge to any location where freezing

- could occur.
- No valve may be installed between the relief valve and heater or in the discharge line. Do not plug or place any obstruction in the discharge line.
 - Test the operation of the relief valve after filling and pressurizing the system by lifting the lever. Make sure the valve discharges freely. If the valve fails to operate correctly, immediately replace with a new properly rated relief valve.
 - Test T&P valve at least once annually to ensure the waterway is clear. If valve does not operate, turn the heater "off" and call a plumber immediately.
 - Take care whenever operating relief valve to avoid scalding injury or property damage.
- FAILURE TO COMPLY WITH THE ABOVE GUIDELINES COULD RESULT IN FAILURE OF RELIEF VALVE OPERATION, RESULTING IN POSSIBILITY OF SUBSTANTIAL PROPERTY DAMAGE, SEVERE PERSONAL INJURY, OR DEATH.

WARNING

Do not thread a cap or plug into the relief valve or relief valve line under any circumstances! Explosion and property damage, serious injury, or death may result.

RE-INSPECTION OF T&P RELIEF VALVES: T&P valves should be inspected AT LEAST ONCE EVERY THREE YEARS, and replaced if necessary, by a licensed plumbing contractor or qualified service technician to ensure that the product has not been affected by corrosive water conditions and to ensure that the valve and discharge line have not been altered or tampered with illegally. Certain naturally occurring conditions may corrode the valve and its components over time, rendering the valve inoperative. Such conditions can only be detected if the valve and its components are physically removed and inspected. **Do not attempt to conduct an inspection on your own.** Contact your plumbing contractor for a re-inspection to assure continued safety.

FAILURE TO RE-INSPECT THE T&P VALVE AS DIRECTED COULD RESULT IN UNSAFE TEMPERATURE AND/OR PRESSURE BUILD-UP WHICH CAN RESULT IN PROPERTY DAMAGE, SERIOUS PERSONAL INJURY, OR DEATH.

F. Scalding

This water heater can deliver scalding water. Be careful whenever using hot water to avoid scalding injury. Certain appliances such as dishwashers and automatic clothes washers may require increased water temperatures. By setting the thermostat on this heater to obtain the increased water temperature required by these appliances you may create the potential for scald injury.

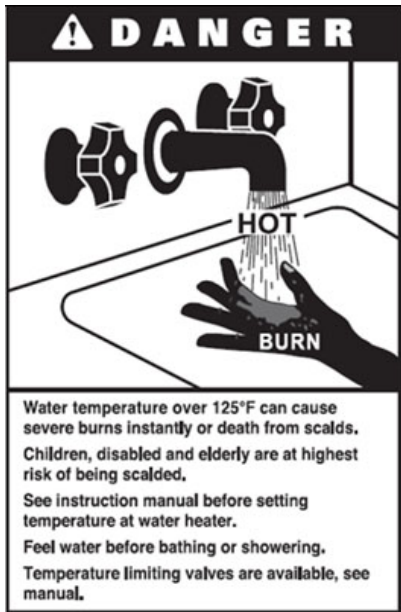

To protect against injury, install a mixing valve in the water system. This valve will reduce point of use discharge temperatures by mixing cold and hot water in branch supply lines. Such valves are available from your local plumbing supplier.

Table 4 details the relationship of water temperature and time with regard to scald injury and may be used as a guide in determining the safest water temperature for your applications.

WARNING

An ASSE 1017 or ASSE 1070 temperature limiting or mixing valve is recommended in installations servicing disabled or elderly persons, or children. Mixing valves do not eliminate the risk of scalding.

To avoid scalding:

- Set the water heater set point temperature as low as possible.
- Feel water before bathing or showering.
- If thermostatic valves are required, use devices specifically designed for such purpose. Install these devices in accordance with instructions provided by the manufacturer.

Failure to install a temperature limiting or mixing valve and follow these instructions could result in property damage, severe personal injury, or death due to scalds.

Approximate Time / Temperature Relationships in Scalds	
120°F	More than 5 minutes
125°F	1 1/2 to 2 minutes
130°F	About 30 seconds
135°F	About 10 seconds
140°F	Less than 5 seconds
145°F	Less than 3 seconds
150°F	About 1 1/2 seconds
155°F	About 1 second

Table 4 - Approximate Time / Temperature Relationships in Scalds

G. Filling the Heater

WARNING

The water heater must be full of water and the system fully purged BEFORE powering the water heater. When filling the water heater, open a hot water tap to release air in the tank and piping. All air has been purged from the system when water runs freely from the faucets.

Applying power to the water heater when it is not full of water will damage the heat exchanger, and could result in property damage, serious personal injury, or death. Such damages ARE NOT covered by water heater warranty.

- Make certain the drain valve is completely closed.
- Open the shut-off valve in the cold water supply line.
- Open the hot water faucets to allow air to vent from the heater and piping.
- Allow sufficient time for the heater to completely fill with water.

H. Applications

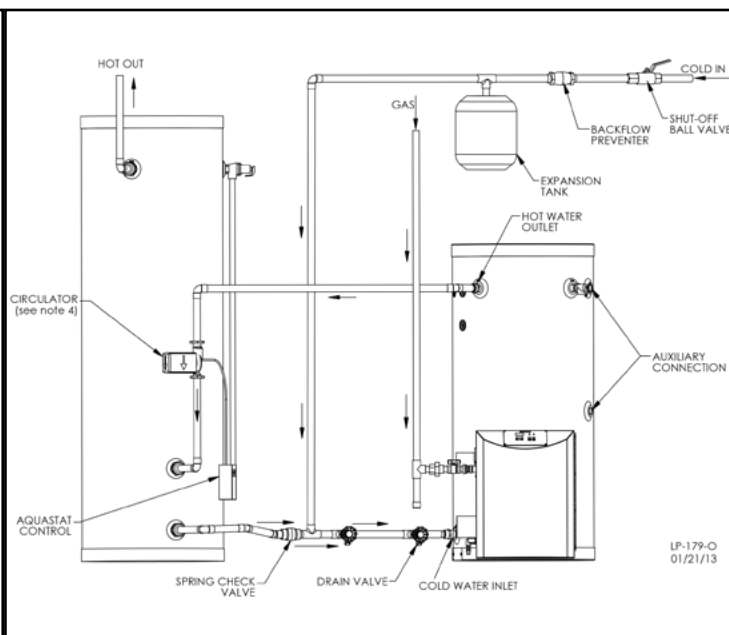
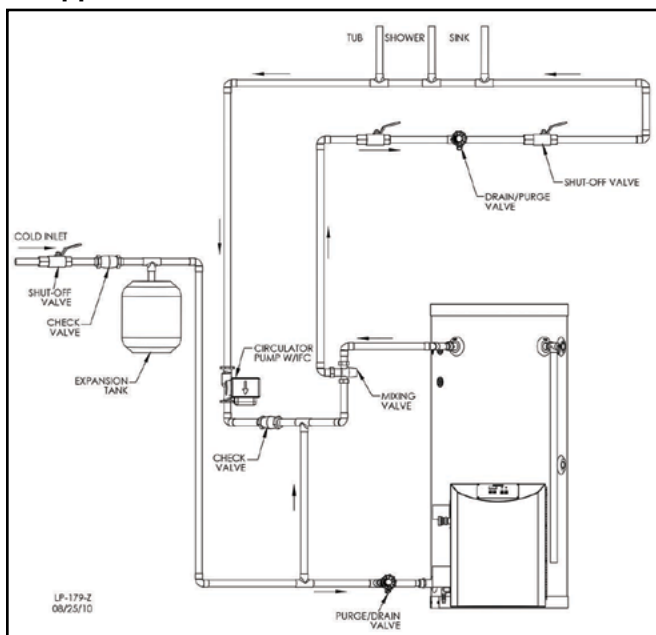

Figure 5 - Piping with Recirculation Line and Thermostatic Mixing Valve

Figure 6 - Piping with Storage Tank

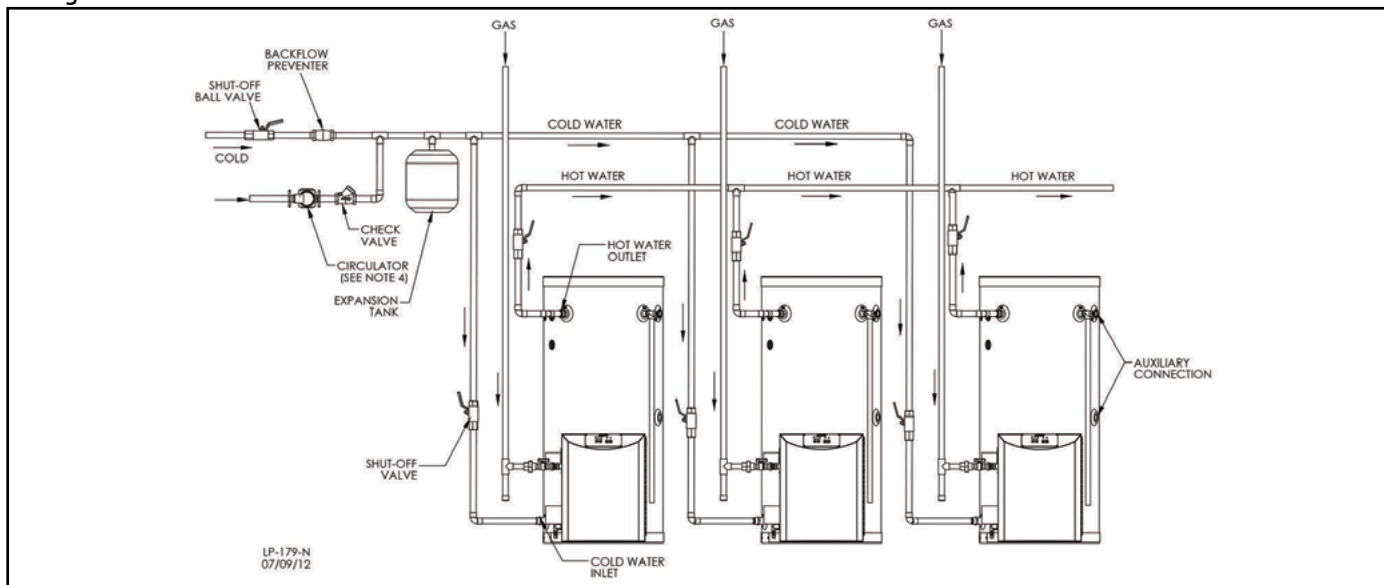

Figure 7 - Reverse Manifold Piping Diagram for Multiple Water Heaters

NOTES:

1. Minimum pipe size should match connection size. Upsize pipe accordingly if greater flow is required.
2. A thermal expansion tank suitable for potable water must be sized and installed within this piping system between the backflow preventer and the cold water inlet.
3. All circulators should have an integral flow check.
4. Drains and check valve between unit and storage tank will assist in purging air from system.
5. These drawings are meant to demonstrate system piping only. The installer is responsible for all equipment and detailing required by local codes. In Massachusetts, you must install a vacuum relief valve per 248 CMR.
6. Mixing valve application is optional, but recommended to help prevent scalding.
7. Always shut off power to the water heater or isolate the heater from the system if ANY plumbing work is to be done. Running the water heater without water will result in dry-firing.

WARNING

An ASSE 1017 thermostatic mixing valve **MUST** be installed when using outdoor reset. Failure to do so could result in substantial property damage, serious injury, or death.

The piping will not support the weight of the water heater circulator pump. Refer to the pump manufacturer's installation instructions to properly support the circulator pump. Failure to comply with these instructions could result in substantial property damage, severe personal injury, or death.

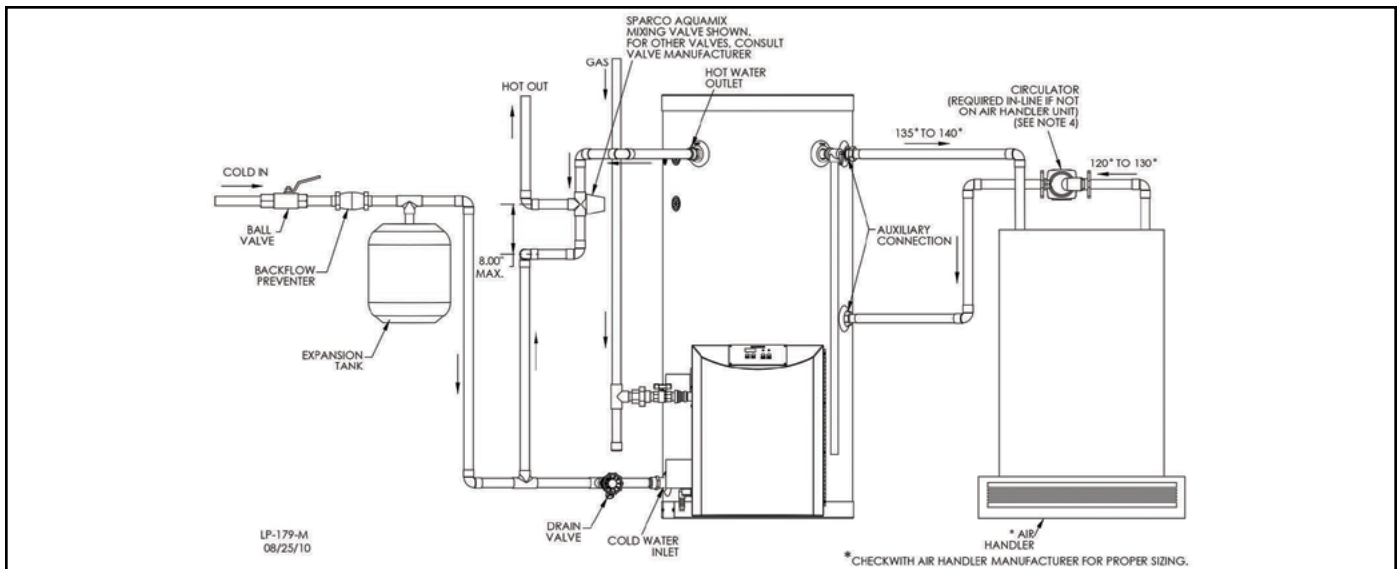

Figure 8 - Piping with Air Handler on Side

NOTES:

1. Minimum pipe size should match connection size. Upsize pipe accordingly if greater flow is required.
2. A thermal expansion tank suitable for potable water must be sized and installed within this piping system between the backflow preventer and the cold water inlet.
3. All circulators should have an integral flow check.
4. Drains and check valve between unit and storage tank will assist in purging air from system.
5. These drawings are meant to demonstrate system piping only. The installer is responsible for all equipment and detailing required by local codes. In Massachusetts, you must install a vacuum relief valve per 248 CMR.
6. Mixing valve application is optional, but recommended to help prevent scalding.
7. Always shut off power to the water heater or isolate the heater from the system if ANY plumbing work is to be done. Running the water heater without water will result in dry-firing.

NOTES FOR AIR HANDLER APPLICATION:

1. MASSACHUSETTS STATE PLUMBING CODE REQUIRES A DISTANCE NO GREATER THAN 50 FEET FROM THE WATER HEATER TO THE FAN COIL IN THE AIR HANDLER.
2. MASSACHUSETTS STATE PLUMBING CODE REQUIRES AN ELECTRONICALLY TIMED CIRCULATOR PUMP TO ACTIVATE EVERY SIX HOURS FOR 60 SECONDS. THIS CIRCULATOR IS REQUIRED TO BE BRONZE OR STAINLESS.
3. ALL WATER PIPING MUST BE INSULATED.
4. YOU MUST INSTALL A VACUUM RELIEF VALVE PER 248 CMR.

NOTE: THIS DRAWING IS MEANT TO DEMONSTRATE SYSTEM PIPING ONLY. THE INSTALLER IS RESPONSIBLE FOR ALL EQUIPMENT AND DETAILING REQUIRED BY LOCAL CODES.

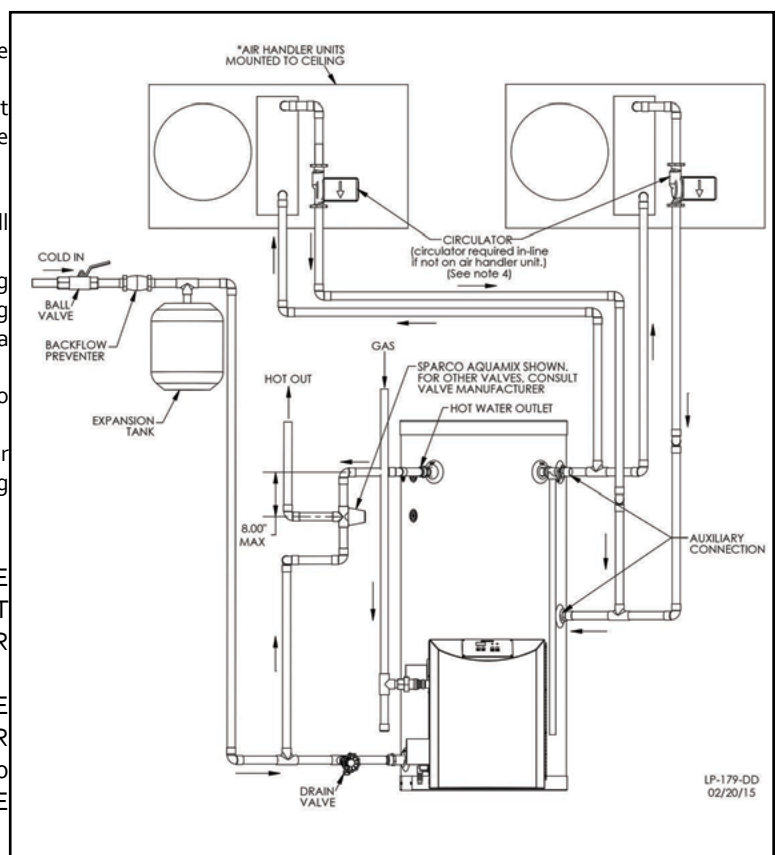

Figure 9 - Piping with Air Handlers

WARNING

An ASSE 1017 thermostatic mixing valve **MUST** be installed when using outdoor reset. Failure to do so could result in substantial property damage, serious injury, or death.

The piping will not support the weight of the water heater circulator pump. Refer to the pump manufacturer's installation instructions to properly support the circulator pump. Failure to comply with these instructions could result in substantial property damage, severe personal injury, or death.

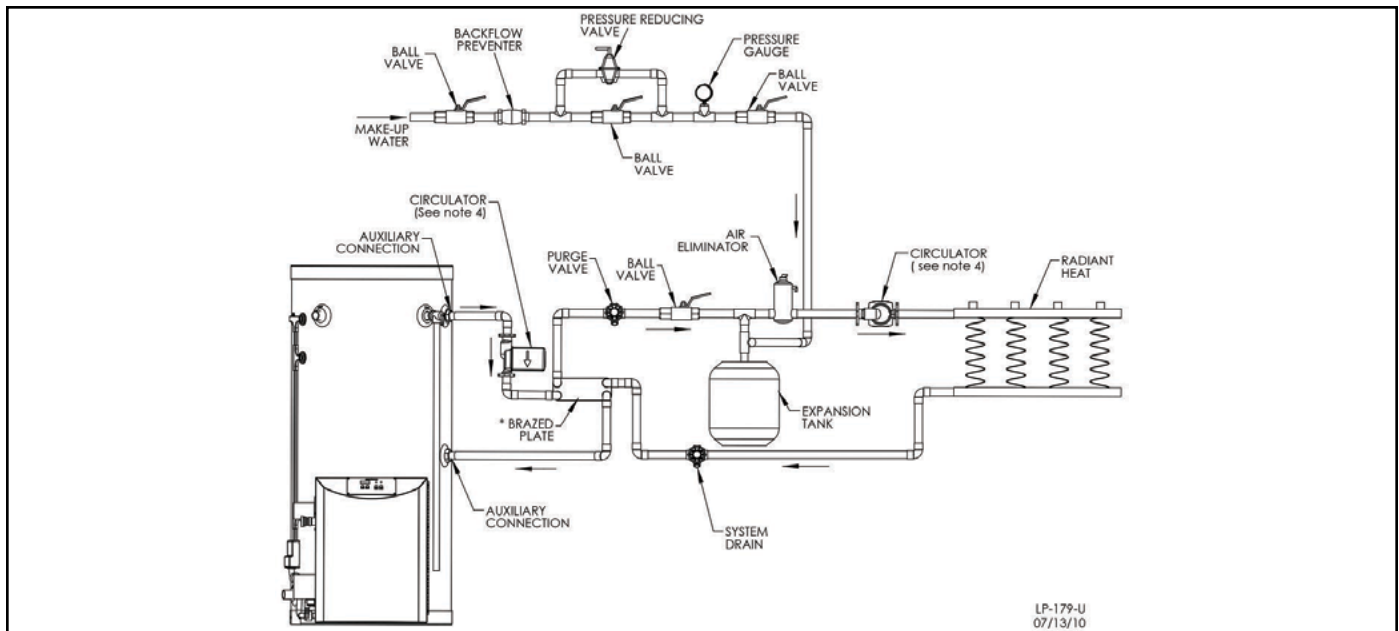

Figure 10 - Piping with Closed Loop for Radiant Heating

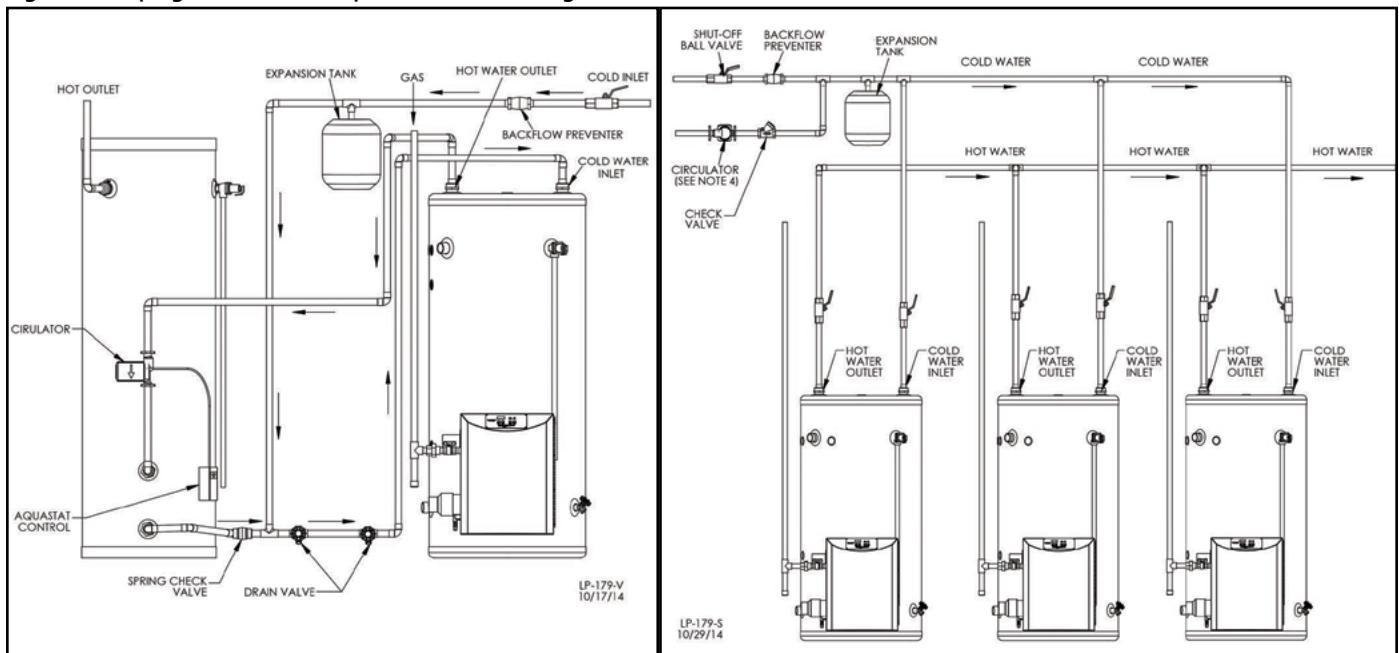

Figure 11 - PHM Model Piping with Storage Tank and Thermostatic Mixing Valve

Figure 12 - Reverse Manifold Piping Diagram for Multiple PHM Models

NOTES:

1. Minimum pipe size should match connection size. Upsize pipe accordingly if greater flow is required.
2. A thermal expansion tank suitable for potable water must be sized and installed within this piping system between the backflow preventer and the cold water inlet.
3. All circulators should have an integral flow check.
4. Drains and check valve between unit and storage tank will assist in purging air from system.
5. These drawings are meant to demonstrate system piping only. The installer is responsible for all equipment and detailing required by local codes. In Massachusetts, you must install a vacuum relief valve per 248 CMR.
6. Mixing valve application is optional, but recommended to help prevent scalding.
7. Always shut off power to the water heater or isolate the heater from the system if ANY plumbing work is to be done. Running the water heater without water will result in dry-firing.

WARNING
An ASSE 1017 thermostatic mixing valve MUST be installed when using outdoor reset. Failure to do so could result in substantial property damage, serious injury, or death.
The piping will not support the weight of the water heater circulator pump. Refer to the pump manufacturer's installation instructions to properly support the circulator pump. Failure to comply with these instructions could result in substantial property damage, severe personal injury, or death.

NOTICE

The standard unit does not meet the required temperature settings for sanitizer booster applications. Use only the Sanitizer Booster that delivers temperatures of 184°F. Inlet water to the booster must be supplied at 140°F.

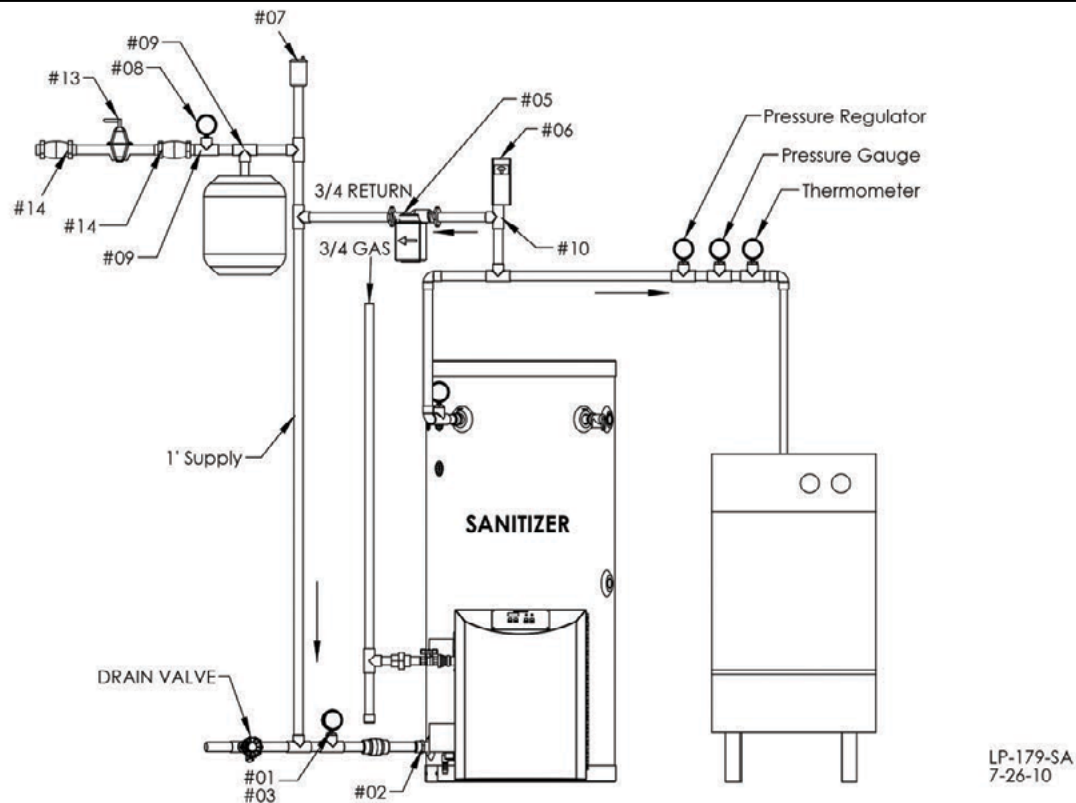

WARNING; INCOMING SUPPLY MUST BE NO FURTHER THAN 5' FROM THE SANITIZER
VERY IMPORTANT: INSULATE ALL PIPES ON RECIRCULATION LINE TO AND FROM SANITIZER
 THE ITEMS LISTED BELOW ARE THE ITEMS AND PART NUMBERS IN THE VSBK-1200 SANITIZER BOOSTER KIT

ITEM	PART	DESCRIPTION	PART NUMBER	ITEM	PART	DESCRIPTION	PART NUMBER
#01	NIBCO TEE	1"X1"X 1/2"	7000-708	#08	PRESSURE GAUGE		7000-716
#02	FEMALE ADAPTER	1"	7000-709	#09	NIBCO TEE	1" X 1" X 3/4" 712R	7000-728
#03	DIAL THERMOMETER		7000-710	#10	NIBCO TEE	1" X 1/2" X 1" COPPER	7000-739
#04	EXPANSION TANK 4.5 GAL		7000-711	#11	NIBCO TEE	1" X 1/2" X 1" R	7000-730
#05	GRUNDFOS 3 SPEED PUMP	W/ CHECK VALVE	7000-712	#12	REDUCING COUPLING		7000-732
#06	NIBCO TEE	1/2" X 1/2" FITTING AIR CHAMBER	7000-737	#13	PRESSURE REDUCING VALVE		7000-733
#07	VACUUM RELIEF VALVE		7000-714	#14	NIBCO MALE ADAPTERS		7000-736

Figure 13 - SA Model Installation

NOTES:

1. Minimum pipe size should match connection size. Upsize pipe accordingly if greater flow is required.
2. A thermal expansion tank suitable for potable water must be sized and installed within this piping system between the backflow preventer and the cold water inlet.
3. All circulators should have an integral flow check.
4. Drains and check valve between unit and storage tank will assist in purging air from system.
5. This drawing is meant to demonstrate system piping only. The installer is responsible for all equipment and detailing required by local codes. In Massachusetts, you must install a vacuum relief valve per 248 CMR.
6. Always shut off power to the water heater or isolate the heater from the system if ANY plumbing work is to be done. Running the water heater without water will result in dry-firing.
7. For further energy savings, install the SA Model on the same electrical circuit as the dishwasher.

WARNING

The piping will not support the weight of the water heater circulator pump. Refer to the pump manufacturer's installation instructions to properly support the circulator pump. Failure to comply with these instructions could result in substantial property damage, severe personal injury, or death.

Part 5 - Venting and Condensate Removal

DANGER

The heater must be vented as detailed in this section. Ensure exhaust vent and intake piping complies with these instructions regarding vent system. Inspect finished exhaust vent and intake piping thoroughly to ensure all joints are well secured, airtight, and comply with all applicable code requirements, as well as the instructions provided in this manual. Failure to properly install the vent system will result in severe personal injury or death.

A. General

DANGER

This heater is certified as a "Category IV" appliance and requires a special venting system. The vent system will operate with a positive pressure in the pipe. Exhaust gases must be piped directly outdoors using the vent materials and rules outlined in these instructions. Do not connect vent connectors serving appliances vented by natural draft into any portion of mechanical draft systems operating under positive pressure. Follow the venting instructions carefully. Failure to do so will result in substantial property damage, severe personal injury, or death.

1. Installation should be made in accordance with the regulations of the Authority Having Jurisdiction, local code authorities, and utility companies which pertain to this type of water heating equipment.
2. Install the venting system in accordance with these instructions and with the National Fuel Gas Code, ANSI Z223.1/ NFPA 54, CAN/CGA B149, and / or applicable provisions of local building codes.
3. This water heater must be vented with materials, components, and systems listed and approved for Category IV appliances.

DANGER

Exhaust and intake are to be piped separately. This heater cannot share a common exhaust or intake with multiple appliances. Failure to follow these instructions will result in substantial property damage, severe personal injury, or death.

NOTE: To avoid contamination often contained in indoor air, it is best to pipe all intake combustion air directly to the outdoors.

NOTE: If exhaust vent pipe system passes through an unheated space such as an alcove or attic, the space must be heated.

WARNING

Improper seating of vent pipe gaskets can cause eventual gasket failure and exhaust gas leakage. Ensure the exhaust vent pipe is properly beveled and seated before insertion into the flue adapter. Failure to do so could result in property damage, severe personal injury, or death.

WARNING

Breathing Hazard - Carbon Monoxide Gas



- Do not operate heater if flood damaged.
- Install vent system in accordance with local codes and manufacturers installation instructions.
- Do not obstruct heater air intake or exhaust. Support all vent piping per manufacturers installation instructions.
- Do not place chemical vapor emitting products near unit.
- According to NFPA 720, carbon monoxide detectors should be installed outside each sleeping area.
- Never operate the heater unless it is vented to the outdoors.
- Analyze the entire vent system to make sure that condensate will not become trapped in a section of vent pipe and therefore reduce the open cross sectional area of the vent.

LP-304-FR

Breathing carbon monoxide can cause brain damage or death. Always read and understand instruction manual.

DANGER

Due to the extreme flammability of most glues, cements, solvents, and primers used to join plastic exhaust vent and intake pipes, explosive solvent vapors must be cleared from all vent piping before start-up. Avoid using excess cement or primer, as this may pool in the vent pipes. Vent assemblies should be allowed to cure for a period of at least 8 hours before powering a connected appliance. Failure to follow these instructions will result in substantial property damage, severe personal injury, or death. It is the installers' responsibility to understand the hazards associated with explosive solvents and take the necessary precautions to avoid these risks.

WARNING

CPVC, Polypropylene, or Stainless Steel pipe material **MUST** be used for the first 3 feet of the vent run if the exhaust vent passes through an enclosed space greater than 6", such as a wall. The balance of the vent run can be installed with standard Schedule 40 PVC pipe. Failure to comply with this warning could result in property damage, severe personal injury, or death.

Exhaust vent adaptors are not designed as load-bearing devices, and must not be used to support exhaust vent piping. All vent pipes must be properly connected, supported, and the exhaust vent must be pitched a minimum of 1/4" per foot back to the heater to allow drainage of condensate. Failure to properly support vent piping and follow the information in this statement could result in product damage, severe personal injury, or death.

B. Approved Materials for Exhaust Vent and Intake Pipe

Item	Material	Standards for Installation In:	
		United States	Canada
Exhaust Vent or Intake Pipe and Fittings	PVC Schedule 40/80	ANSI / ASTM D1785	PVC, CPVC, and PP Venting Must be ULC-S636 Certified. IPEX is an approved manufacturer in Canada.
	PVC-DWV*	ANSI / ASTM D2665	
	CPVC Schedule 40/80	ANSI / ASTM F441	
	Polypropylene	UL-1738 or ULC-S636	
	Stainless Steel AL29-4C	Certified for Category IV and Direct Vent Appliance Venting	
Pipe Cement	PVC	ANSI / ASTM D2564	IPEX System 636 Cements and Primers
	CPVC	ANSI / ASTM F493	
Pipe Primer	PVC / CPVC	ASTM F656	

⚠ DANGER

- The exhaust and intake components installed with this heater must be used for near heater piping BEFORE transitioning to the approved materials listed above. DO NOT REMOVE these installed components. Doing so WILL VOID heater warranty.
- PVC / CPVC pipe and fittings of the same diameter are considered interchangeable.
- Use of cellular core pipe PVC (ASTM F891), cellular core CPVC, or Radel® (polyphenylsulfone) in nonmetallic venting systems is prohibited.
- DO NOT connect PVC/CPVC to Polypropylene without an approved vent connector.
- Any transition to Polypropylene MUST be done in the vertical within five (5) feet of the appliance.
- When installing AL29-4C vent piping, install a PVC-to-stainless adapter at the heater vent connection, and at the termination when using a PVC termination kit. DO NOT mix AL29-4C piping from different manufacturers unless using adapters specifically designed for the purpose by the manufacturer.
- Covering non-metallic vent pipe and fittings with thermal insulation is prohibited.
- A double wall vent may be used when using stainless steel vent material in a freezing climate.
- *PVC-DWV may be used for air intake applications ONLY.
- Contact the venting material manufacturer if there is any question about the applicability of the proposed venting material.

Failure to follow these directions will result in substantial property damage, severe personal injury, or death.

Table 5 - Approved Materials for Exhaust Vent and Intake Pipe

⚠ WARNING

DO NOT mix components from different venting systems. The vent system could fail, causing leakage of flue products into the living space. Use only the approved pipe and fitting materials, and primer and cement specifically designed for the material used, as listed in the above table. Failure to do so could result in property damage, serious injury, or death.

CAUTION

High heat sources (generating heat 100°F / 37°C or greater, such as boiler flue pipes, space heaters, etc.) may damage plastic components of the water heater as well as plastic vent pipe materials. Such damages ARE NOT covered by warranty. It is recommended to keep a minimum clearance of 8" from high heat sources. Observe heat source manufacturer instructions, as well as local, state, provincial, and national codes, laws, regulations, and ordinances when installing this water heater and related components near high heat sources.

NOTE: The use of double-wall vent or insulated material for the combustion air intake pipe is recommended in cold climates to prevent the condensation of airborne moisture in the incoming combustion air.

⚠ DANGER

You must not use "B" vent in an exhaust application. "B" vent is for intake applications ONLY. Using "B" vent in an exhaust application will result in serious injury or death.

C. Additional Requirements for Installation in Canada

1. Installations must be made with a vent pipe system certified to ULC-S636. IPEX is an approved vent manufacturer in Canada supplying vent material listed to ULC-S636. Additionally, you may use AL29-4C stainless steel venting to comply with Canadian requirements.
2. The first three (3) feet of vent pipe from the water heater flue outlet must be readily accessible for visual inspection.
3. The components of the certified vent system must not be interchanged with other vent systems or unlisted pipe / fittings.

D. Exhaust Vent and Intake Pipe Location

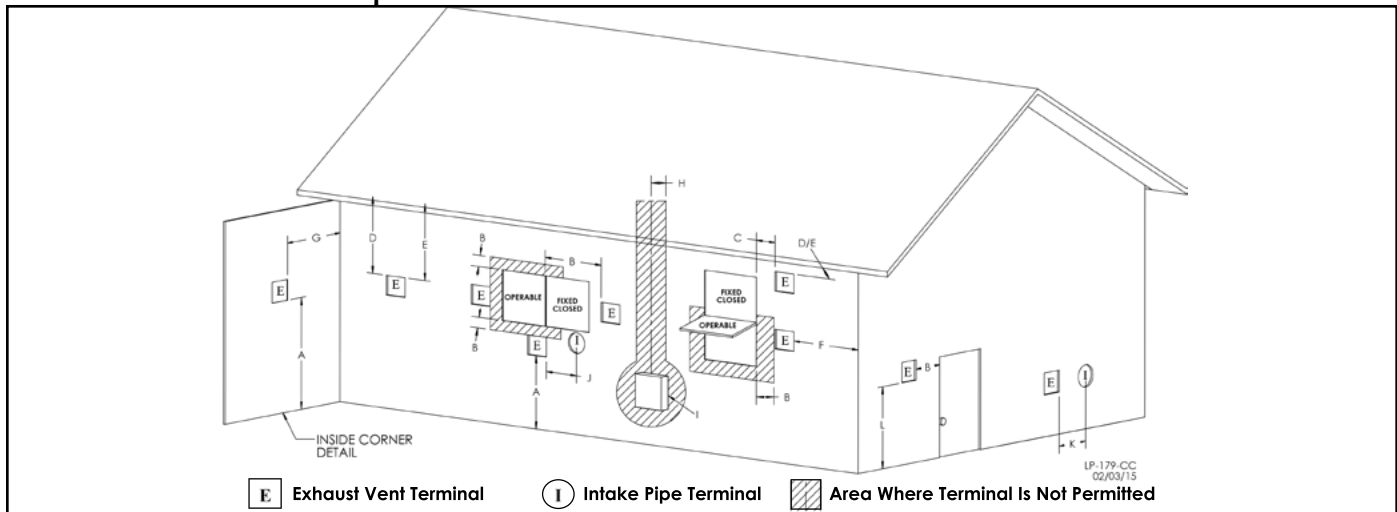

Figure 14 - Exit Terminals for Direct Vent Systems - ANSI Z223.1 / NFPA 54 for US and CAN/CSA B149.1 for Canada

DETERMINE EXHAUST VENT AND INTAKE PIPE LOCATION – NOTES:

INSTALLATIONS IN THE UNITED STATES

A. Provide a minimum of 1 foot clearance from the bottom of the exhaust vent and intake pipe above the expected snow accumulation level. Snow removal may be necessary to maintain clearance.

B. Provide a minimum of 1 foot distance from exhaust vent termination to any door, operable window, or gravity intake into any building.

C. Provide a minimum of 1 foot distance from exhaust vent termination to any permanently closed door or window.

D. Provide a minimum of 4 feet vertical clearance from the exhaust vent to all roof overhangs.

E. Locating exhaust vent termination near roof overhangs will result in the formation of icicles in freezing weather, and could result in blockage of the exhaust vent. To prevent icicles from forming, maintain 4 feet vertical clearance from the exhaust vent to all roof overhangs.

F. Provide 4 feet clearance from the outside corner of vertical walls, chimneys, etc., as well as horizontal corners created by roof overhangs.

G. Provide 6 feet clearance from the inside corner of vertical walls, chimneys, etc., as well as horizontal corners created by roof overhangs.

H. Provide 4 feet clearance from center line within a height of 15 feet above electrical meters, gas meters, gas regulators, relief equipment, exhaust fans and inlets.

I. Provide 4 feet horizontal clearance from electrical meters, gas meters, gas regulators, relief equipment, exhaust fans and inlets. In no case shall the exit terminal be above or below the aforementioned equipment unless the 4 foot horizontal distance is maintained.

J. This water heater vent system shall terminate at least 3 feet (0.9 m) above any forced air intake located within 10 ft (3 m).

NOTE: This does not apply to the combustion air intake of a direct-vent appliance.

K. When venting with a two pipe system, maximum distance between exhaust vent and intake pipe is 6 feet (1.8 m). Minimum distance between exhaust vent and intake pipe on single direct vented appliance is 10" (0.255 m) center-to-center. Minimum distance between exhaust vents and intake pipes on multiple water heaters is 10" (0.255 m) center-to-center.

L. When adjacent to a public walkway, locate exit terminal at least 7 feet above grade.

In addition:

- Total length of vent piping shall not exceed the limits specified in this manual.

- The vent piping for this direct vented appliance is approved for zero clearance to combustible construction.
- The flue products coming from the exhaust vent will create a large plume when the heater is in operation. Avoid venting in areas that will affect neighboring buildings or be considered objectionable.
- DO NOT locate exhaust vent or intake pipe in a parking area where machinery may damage the pipe.
- DO NOT locate the exhaust vent or intake pipe terminals under a porch, balcony, or veranda.
- Avoid terminating exhaust vents near shrubs, air conditioners, or other objects that will obstruct the exhaust stream.
- DO NOT vent over a public walkway. Condensate could drip or freeze and create a nuisance or hazard.
- DO NOT vent near soffit vents, crawl space vents, or other areas where condensate or vapor could create a nuisance or hazard or cause property damage.
- DO NOT vent where condensate vapor could cause damage or could be detrimental to the operation of regulators, relief valve, or other equipment.
- DO NOT vent the water heater in a chimney flue serving a separate appliance designed to burn solid fuel. The water heater may only be vented in vacant chimneys.
- NOTE:** Due to potential moisture build-up, sidewall venting may not be the preferred venting option. Carefully consider venting installation and location to save time and cost.

INSTALLATIONS IN CANADA

NOTE: Canadian installation must comply with the CAN/CSA B149.1 code and applicable local codes and supersede the restrictions for the United States outlined in this section.

 WARNING
The building owner is responsible for keeping the exhaust and intake terminations free of snow, ice, or other potential blockages, as well as scheduling routing maintenance. Failure to keep the vent piping terminations clear and properly maintain the heater could result in property damage, severe personal injury, or death.
For each floor containing bedroom(s), a carbon monoxide detector and alarm shall be placed in the living area outside the bedrooms, as well as in the room that houses the heater. Detectors and alarms shall comply with NFPA 720 (latest edition). Failure to comply with these requirements could result in product damage, severe personal injury, or death.

E. Exhaust Vent and Intake Pipe Sizing

1. The exhaust vent and intake pipe size is 2" for 100 and 130kBTU models and 3" for 160 and 199kBTU models.
2. The maximum total equivalent length of 2" exhaust vent and intake pipe **should not exceed 85 feet**. The maximum total equivalent length of 3" exhaust vent and intake pipe **should not exceed 200 feet**.

a. The equivalent length of elbows, tees, and other fittings are listed in the Friction Loss Table.

Friction Loss Equivalent in Piping and Fittings			
Fittings or Piping	Equivalent Feet		
	2"	3"	4"
90 Degree Elbow*	5'	5'	3'
45 Degree Elbow	3'	3'	1'
Coupling	0'	0'	0'
Air Inlet Tee	0'	0'	0'
Straight Pipe	1'	1'	1'
Concentric Kit	3'	3'	N/A
V500 2" Kit	1'	N/A	N/A
V1000 3" Kit	N/A	1'	1'
V2000 4" Kit	N/A	1'	1'

Table 6 - *Friction loss for long radius elbow is 1 foot less. NOTE: Consult Polypropylene venting instructions for friction loss and pressure drop equivalents.

b. For example: If the exhaust vent has two 90° elbows and 10 feet of PVC pipe we will calculate:

Exhaust Vent Equivalent Length = (2x5) + 10 = 20 feet.

Further, if the intake pipe has two 90° elbows, one 45° elbow, and 10 feet of PVC pipe, the following calculation applies:

Intake Pipe Equivalent Length = (2x5) + 3 + 10 = 23 feet.

Finally, if a concentric kit is used we find:

Total Equivalent Length = 20 + 23 + 3 = 46 feet.

The total equivalent length is 46 feet, well below the maximum of 85 feet for 2" pipe.

c. Effort should be made to keep a minimum difference in equivalent length between the exhaust vent and intake pipe.

3. The minimum total equivalent length is 16 feet.

CAUTION
Do not exceed the maximum lengths for vent pipes. Excessive length could result in heater shutdown and property damage.
Failure to provide a minimum total vent length of 16 equivalent feet could result in property damage and improper product operation.

F. Longer Vent Runs

The maximum total equivalent length can be extended by increasing the diameter of both the exhaust vent and intake pipes equally. However, the transitions should begin a minimum of 15 equivalent feet from the water heater.

a. The maximum total equivalent length for increased diameter vent pipes is 125 feet for 2" transitioning to 3" pipe (this length includes the minimum 15 total equivalent feet necessary for transition).

NOTE: 3" vent pipe can be increased in diameter, but total equivalent length cannot be increased beyond 200 feet.

b. Transitions should always be made in vertical sections of

pipe to prevent the condensate from pooling in the vent pipe.

Standard Vent Connection and Maximum Total Equivalent Length	Reducing Coupling	Increased Vent Size and Maximum Total Equivalent Length
2" (85')	3" x 2"	3" (125')

Table 7 - Vent Run Transition

c. If transition occurs at a distance greater than 15 equivalent feet from the water heater, the maximum equivalent length will be reduced.

 DANGER
Total maximum equivalent length of increased diameter exhaust vent and intake pipe must not exceed the lengths defined in this manual. 125 maximum total equivalent feet for 2" increased to 3" vent pipe; 200 maximum total equivalent feet for any increase to 3" vent pipe diameter. Failure to keep the total equivalent length below the maximum lengths determined in this manual will result in faulty water heater operation, substantial property damage, serious personal injury, or death.

Transition Point (Ft. from Heater)	TEL of Oversized Vent Pipe (Ft.)*	Maximum TEL of all Vent Pipe (Ft.)
15	95	125
20	77 1/2	117 1/2
25	60 1/2	110 1/2
30	43	103
35	26	96
40	8 1/2	88 1/2
NONE	0	85

Table 8 - TEL = Total Equivalent Length *Oversized vent pipe diameter is 1" or greater than factory supplied connection.

G. Exhaust Vent and Intake Pipe Installation

 WARNING
All joints of positive pressure vent systems must be sealed completely to prevent leakage of flue products into the living space. Failure to do so could result in property damage, serious injury, or death.

1. Use only solid PVC, CPVC, or stainless steel pipe or a Polypropylene vent system approved for use with Category IV appliances.

FOAM CORE PIPING IS NOT APPROVED FOR EXHAUST VENT APPLICATIONS. Foam core piping may be used on air inlet piping **only**.

2. Remove all burrs and debris from joints and fittings.

3. When using PVC or CPVC pipe, all joints must be properly cleaned, primed, and cemented. Use only cement and primer approved for use with the pipe material. Cement must conform to ASTM D2564 for PVC and ASTM F493 for CPVC pipe. **NOTE: DO NOT CEMENT POLYPROPYLENE PIPE.**

4. Ensure the vent is located where it will not be exposed to prevailing winds.

5. In all roof venting applications, exhaust discharge must point away from the pitch of the roof.

6. If the exhaust vent is to be terminated in a walled off area

(such as a roof with a parapet wall), ensure the exhaust vent terminates a minimum of 10' from nearest wall and extends level with or above the top of the wall. This will ensure flue gas does not get trapped and possibly recirculated into the intake air pipe, which could contaminate the combustion air.

7. To prevent water leakage, install adequate roof flashing where the pipe enters the roof.

8. Do not locate vent over public walkways, driveways, or parking lots. Condensate could drip and freeze, resulting in a slip hazard or damage to vehicles and machinery.

9. Due to potential moisture build-up, sidewall venting may not be the preferred venting option. To save time and cost, carefully consider venting installation and location.

10. Horizontal lengths of exhaust vent must slope back towards the water heater not less than ¼" per foot to allow condensate to drain from the vent pipe.

11. The exhaust vent must terminate where vapors cannot make accidental contact with people or pets, or damage shrubs or plants.

12. In vacant chimney applications, install and seal a rain cap over existing chimney openings.

13. All piping must be fully supported. Use pipe hangers at a minimum of 4 foot intervals to prevent sagging of the pipe where condensate may form.

14. Do not use the heater to support any piping.

15. A screened straight coupling is provided with the heater for use as an outside exhaust termination.

16. A screened inlet air tee is provided with the heater to be used as an outside intake termination.

17. Maximum Snow Level Determination: These installation instructions reference snow levels in establishing a minimum height for the installation of exhaust vent or air intake terminations. Snow levels shall be determined as follows:

- The installation location may, by ordinance, designate how snow levels are calculated in that location; or
- In the absence of specific ordinances, snow levels shall be calculated from the average monthly maximum depth of snow accumulation as indicated by the National Weather Service's 10 year statistics for the installation location/geographical area.

In the Commonwealth of Massachusetts and as Required by State and Local Codes:

- The vented gas fueled appliance shall not be installed so its combustion, ventilation, or dilution air is obtained from a bedroom or bathroom.
- Signage: Whenever any through-the-wall (horizontal or sidewall) vent is installed less than seven feet above the finished grade, a metal or plastic identification plate shall be permanently mounted to the exterior of the building at a minimum height of eight feet above grade directly in line with the exhaust vent terminal. The sign shall read, in print no less than 0.5 inches in size, "GAS VENT DIRECTLY BELOW. KEEP CLEAR OF ALL OBSTRUCTIONS".
- Marking of Exhaust Vent and Intake Pipe: Piping used for ventilation, make-up, or combustion air intake shall be labeled as follows:
 - Throughout the entire developed length:
 - Labels must be placed every ten feet for exposed/visible piping; or

- Labels must be placed every three feet for concealed piping.

- At all changes of direction;

- On each side of a penetration through a partition, wall or ceiling; and

- The labels shall be black lettering that:

- Indicates that the piping is used for ventilation, make-up, or combustion air intake, and

- The letters shall be sized equal to a minimum of the pipe diameter. However, for piping with a diameter exceeding two inches, said lettering does not need to be larger than two inches.

The following table lists optional exhaust/intake terminations available from HTP:

Description	Stock Code
2" PVC Concentric Termination Kit	KGAVT0501CVT
3" PVC Concentric Termination Kit	KGAVT0601CVT
2" Stainless Steel Termination Kit	V500
3" Stainless Steel Termination Kit	V1000
4" Stainless Steel Termination Kit	V2000
3" Polypro Vent Kit	8400P-001

Table 9 - Optional Vent Kits

H. Applications

1. Direct Vent Installation of Exhaust and Intake

If installing a direct vent option, combustion air must be drawn from the outdoors directly into the water heater intake, and exhaust must terminate outside. There are three basic direct vent options detailed in this manual: 1. Side Wall Venting, 2. Roof Venting, and 3. Unbalanced Venting.

Be sure to locate the heater such that the exhaust vent and intake pipe can be routed through the building and properly terminated. Different vent terminals can be used to simplify and eliminate multiple penetrations in the building structure (see Optional Equipment in Venting Section). The exhaust vent and intake pipe lengths, routing and termination methods must all comply with the methods and limits given in the Venting section of this manual.

When installing a combustion air intake from outdoors, care must be taken to utilize uncontaminated combustion air. **NOTE:** To prevent combustion air contamination, see Table 2.

 WARNING
<p>Take extra precaution to adequately support the weight of vent pipes terminating through the roof. Failure to properly support roof terminated piping could result in property damage, serious injury, or death.</p>

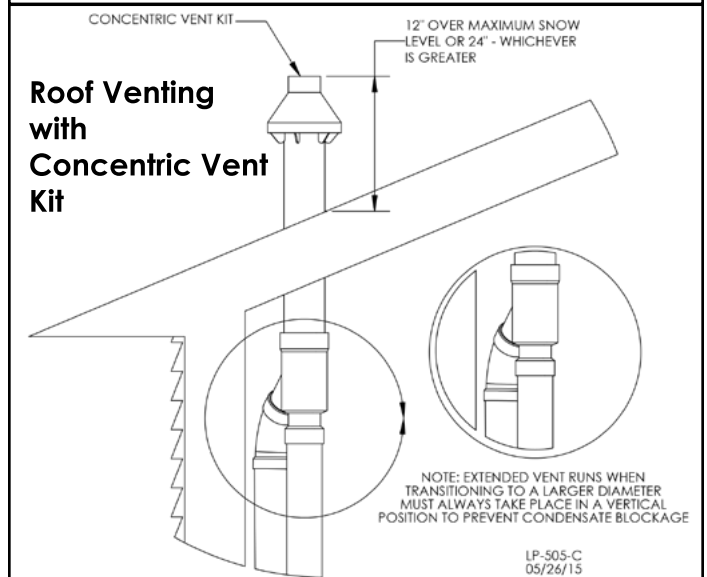
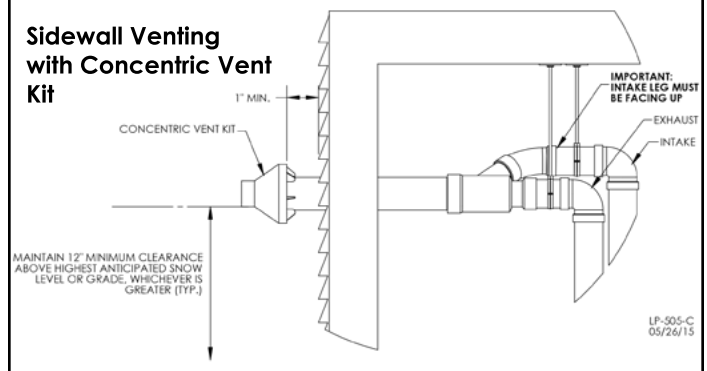
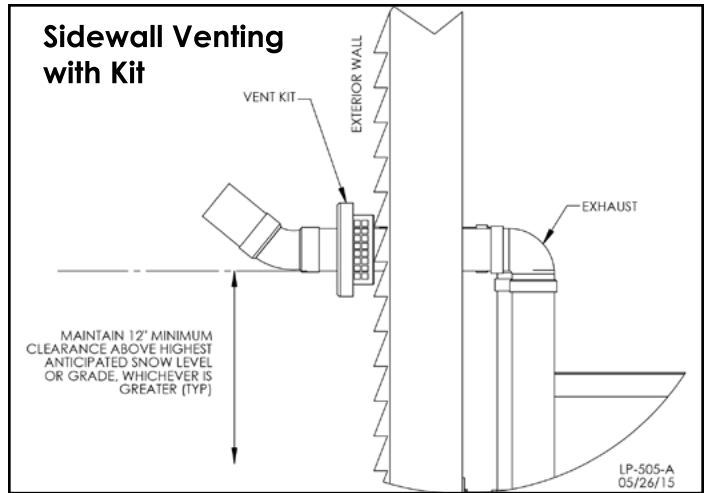
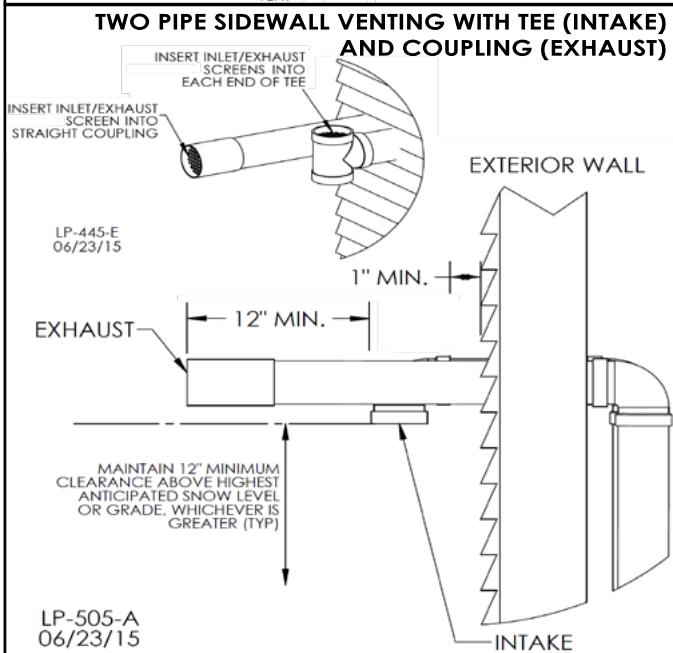
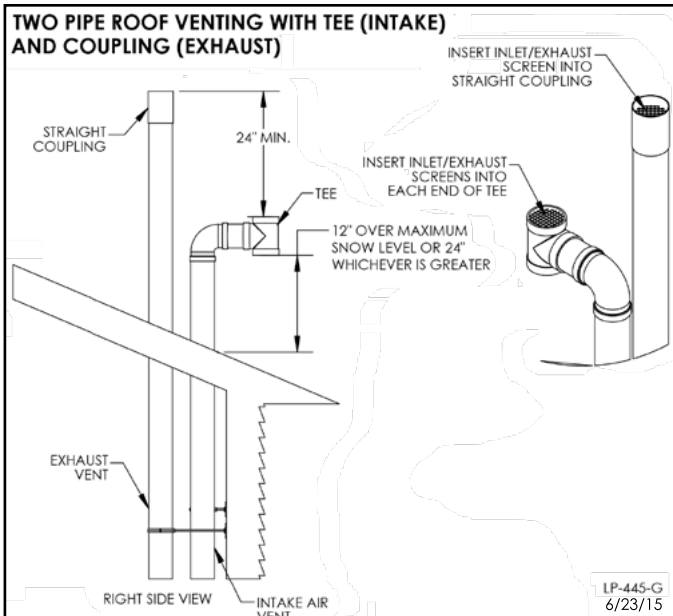

Figure 15 - Two Pipe Roof and Sidewall Venting with Included Equipment (Tee and Coupling)

NOTE: These drawings are meant to demonstrate system venting only. The installer is responsible for all equipment and detailing required by local codes.

WARNING

All vent pipes must be glued, properly supported, and the exhaust pitched a minimum of 1/4" per foot back to the heater to allow drainage of condensate. When placing support brackets on vent piping, the first bracket must be within 1 foot of the water heater and the balance of 4 foot intervals on the vent pipe. Venting must be readily accessible for visual inspection from the first three feet from the heater.

Figure 16 - Venting with Optional Kits (NOT INCLUDED WITH THE WATER HEATER)

NOTE: These drawings are meant to demonstrate system venting only. The installer is responsible for all equipment and detailing required by local codes.

WARNING

All vent pipes must be glued, properly supported, and the exhaust pitched a minimum of 1/4" per foot back to the heater to allow drainage of condensate. When placing support brackets on vent piping, the first bracket must be within 1 foot of the water heater and the balance of 4 foot intervals on the vent pipe. Venting must be readily accessible for visual inspection from the first three feet from the heater.

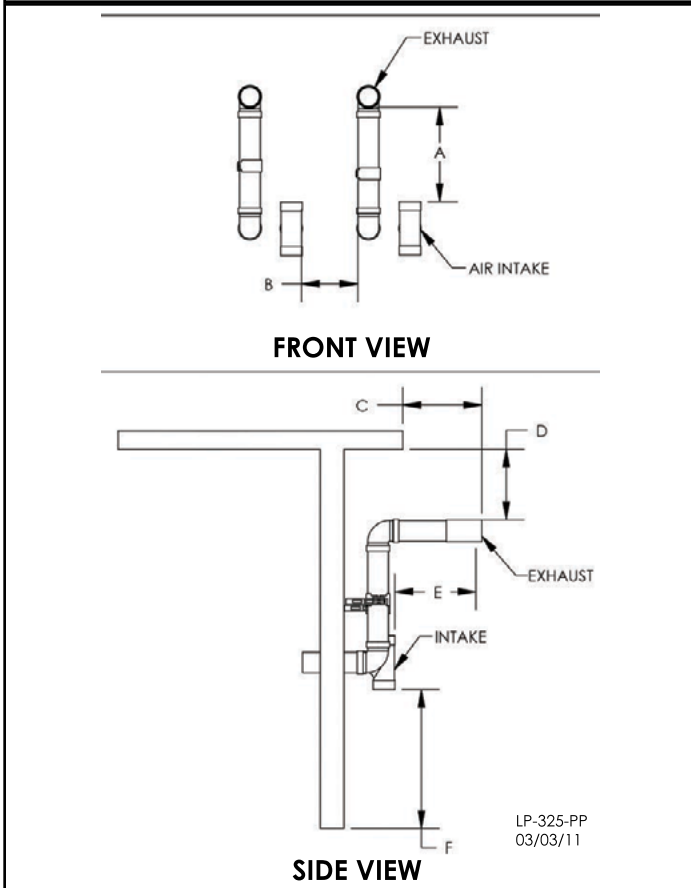
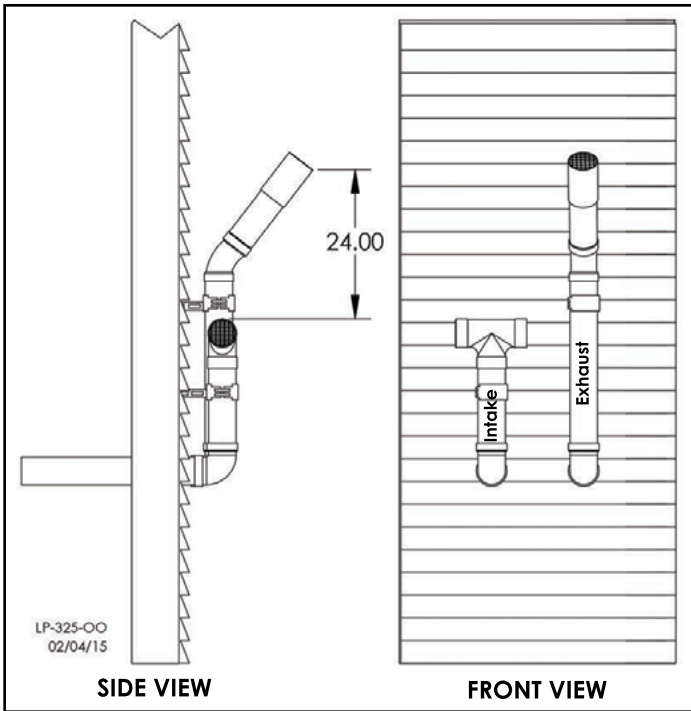

Figure 17 - Horizontal (Snorkel) Venting

NOTES:

- A. For every 1" of overhang, the exhaust vent must be located 1" vertical below overhang (overhang means top of building structure and not two adjacent walls [corner of building]).
- B. Typical installations require 12" minimum separation between bottom of exhaust outlet and top of air intake.
- C. Maintain 12" minimum clearance above highest anticipated snow level or grade (whichever is greater).
- D. Minimum 12" between vents when installing multiple vents.
- E. 12" minimum beyond air intake.

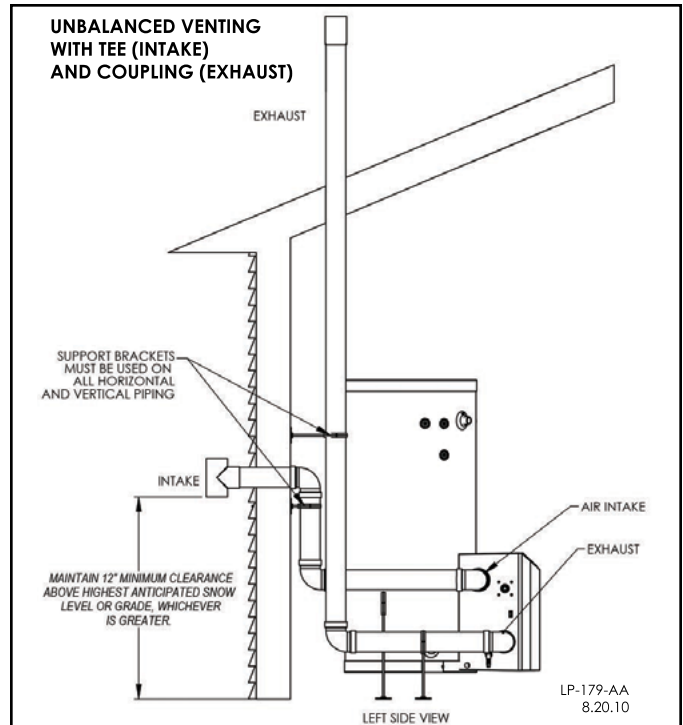

Figure 18 - Unbalanced Venting - Roof Exhaust and Sidewall Intake

NOTE: These drawings are meant to demonstrate system venting only. The installer is responsible for all equipment and detailing required by local codes.

WARNING

All vent pipes must be glued, properly supported, and the exhaust pitched a minimum of 1/4" per foot back to the heater to allow drainage of condensate. When placing support brackets on vent piping, the first bracket must be within 1 foot of the water heater and the balance of 4 foot intervals on the vent pipe. Venting must be readily accessible for visual inspection from the first three feet from the heater.

2. Venting Through an Existing System

This heater may be vented through an existing unused vent system. The inner diameter of the existing vent system is utilized for the combustion air source. Two methods have been approved for such venting: Concentric Venting Through an Existing System and Venting as a Chase.

Vent / Air Inlet Size	Minimum Existing Vent / Chase Size
2"	4"
3"	5"
4"	7"

Table 10 - Minimum Existing Vent / Chase Sizing

DANGER

Do not install the heater into a common existing vent with any other appliance. This will cause flue gas spillage or heater malfunction, resulting in substantial property damage, serious personal injury, or death.

CAUTION

Contractors must check state and local codes before installing through an existing vent opening. State and local codes always take precedence over manufacturer's instructions. Failure to check state and local codes before installing through an existing opening could result in property damage and add significantly to installation costs.

If an existing venting system is converted for use with this heater, the installer must ensure that the existing venting system is clean and free from particulate contamination that could damage the heater. Failure to do so could result in property damage and heater failure. Such failure IS NOT covered under warranty.

**DANGER**

The upper and lower vent terminations as well as all joints in the venting system must be properly sealed to ensure that all combustion air is drawn properly and exhaust does not leak from the system. Failure to properly seal the venting system will result in property damage, serious personal injury, or death.

Chase Venting Through an Existing System

When venting as a chase, follow all instructions included in this Venting section, including those in the previous Concentric Venting Through an Existing System section. See Figure 19-3 for chase venting demonstration.

Concentric Venting Through an Existing System

NOTE: The following instructions refer only to venting through an existing vent system, and not to venting with HTP's optional concentric vent kits. Refer to Concentric Vent Kit installation manual (LP-166) for further information on venting with the optional concentric vent kits.

Concentric venting through an existing system must run vertically through the roof. See Table 9 for proper minimum vent sizing. Use only the approved venting materials specified in Table 5 for piping the system. All instructions listed in this Venting section apply. See Figures 19-1 and 19-2 for venting demonstrations.

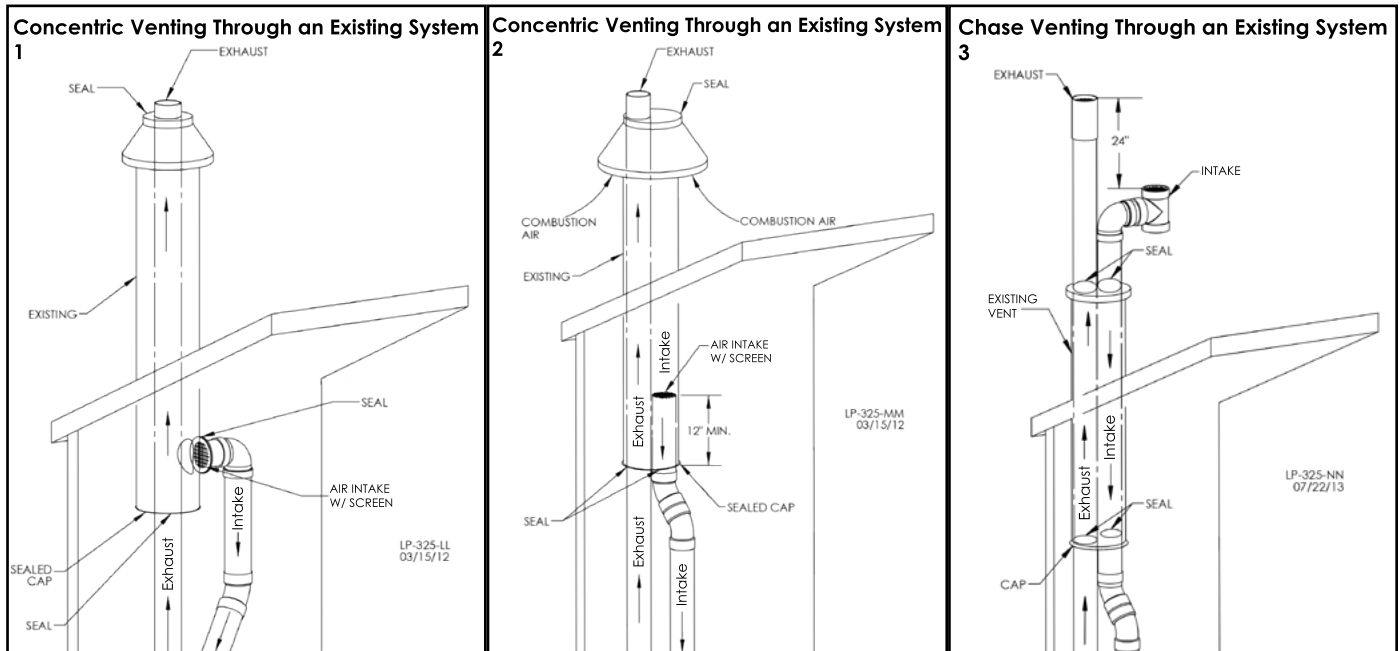

Figure 19 - 1, 2 - Concentric Venting Through an Existing System, 3, Chase Venting Through an Existing System

NOTE: These drawings are meant to demonstrate system venting only. The installer is responsible for all equipment and detailing required by local codes.

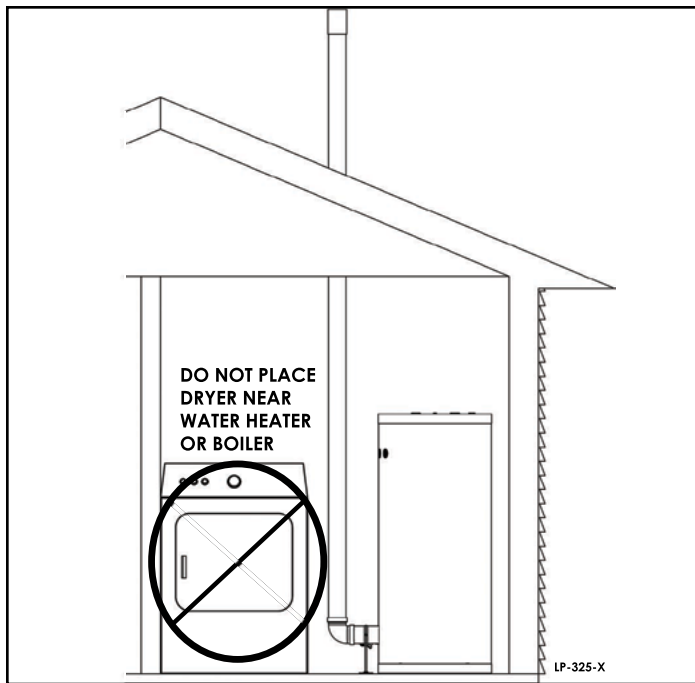

Figure 20 - Do Not Place Appliance Near Dryer

3. Power Venting, Indoor Combustion Air in Confined or Unconfined Space

This heater requires fresh, uncontaminated air for safe operation and must be installed in a mechanical room where there is adequate combustion and ventilating air. **NOTE: To prevent combustion air contamination, see Table 2.**

Combustion air from the indoor space can be used if the space has adequate area or when air is provided through a duct or louver to supply sufficient combustion air based on the water heater input. **Never obstruct the supply of combustion air to the water heater.** If the water heater is installed in areas where indoor air is contaminated (see Figure 20) it is imperative that the water heater be installed as direct vent so that all combustion air is taken directly from the outdoors into the water heater intake connection.

Unconfined space is space with volume greater than 50 cubic feet per 1,000 Btu/hour (4.8 cubic meters per kW) of the total input rating of all fuel-burning appliances installed in that space. Rooms connected directly to this space, through openings not furnished with doors, are considered part of the space.

Confined space is space with volume less than 50 cubic feet per 1,000 Btu/hour (4.8 cubic meters per kW) of the total input rating of all fuel-burning appliances installed in that space. Rooms connected directly to this space, through openings not furnished with doors, are considered part of the space.

When drawing combustion air from inside a conventionally constructed building to a confined space, such space should be provided with two permanent openings: one located 6" (15 cm) below the space ceiling, the other 6" (15cm) above the space floor. Each opening should have a free area of one square inch per 1,000 Btu/hr (22cm²/kW) of the total input of all appliances in the space, but not less than 100 square inches (645cm²).

If the confined space is within a building of tight construction, air for combustion must be obtained from the outdoors as outlined in the Venting section of this manual. See Figure 21.

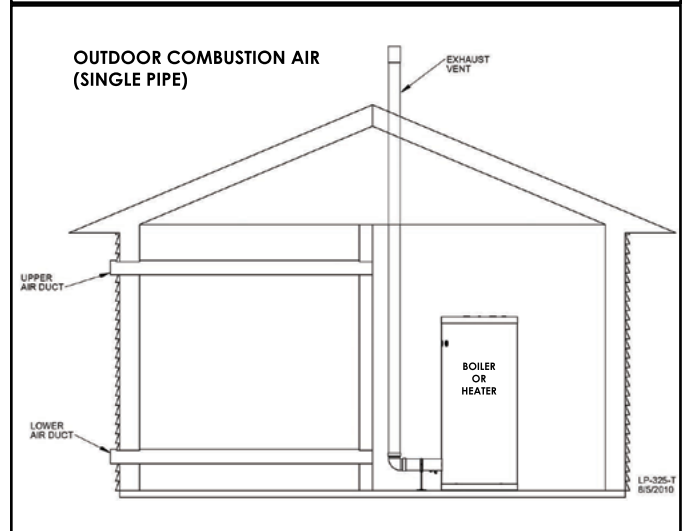
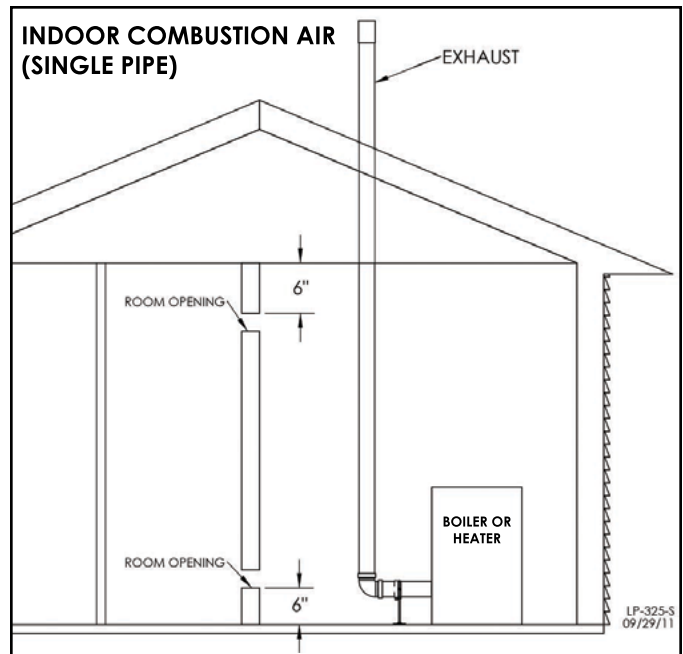

Figure 21 - Indoor and Outdoor Combustion Air - Single Pipe

⚠ WARNING	
Breathing Hazard - Carbon Monoxide Gas	
	<ul style="list-style-type: none"> • Do not operate heater if flood damaged. • Install vent system in accordance with local codes and manufacturers installation instructions. • Do not obstruct heater air intake or exhaust. Support all vent piping per manufacturers installation instructions. • Do not place chemical vapor emitting products near unit. • According to NFPA 720, carbon monoxide detectors should be installed outside each sleeping area. • Never operate the heater unless it is vented to the outdoors. • Analyze the entire vent system to make sure that condensate will not become trapped in a section of vent pipe and therefore reduce the open cross sectional area of the vent.
LP-304.FR	
Breathing carbon monoxide can cause brain damage or death. Always read and understand instruction manual.	

I. Condensate Removal System

NOTE: Check with your local gas company to determine if combustion condensate disposal is permitted in your area. In the state of Massachusetts, condensate must be neutralized before entering a drain.

This condensing high efficiency water heater has a condensate removal system. Condensate is water vapor derived from combustion products, similar to that produced by an automobile when it is initially started. It is very important that the condensate line is sloped down away from the heater and to a suitable drain.

If the heater condensate outlet is lower than the drain, you must use a condensate removal pump (kit p/n 554200 available from HTP). If required by local authorities, a condensate filter of lime crystals, marble, or phosphate chips will neutralize slightly acidic condensate. This can be installed in the field and purchased from HTP (p/n 7450P-212).

subject to corrosion or deterioration.

3. A frozen condensate line could result in a blocked vent condition. It is very important to protect the condensate line from freezing temperatures or any type of blockage. In installations that may encounter sustained freezing conditions, the use of heat tape is recommended to avoid freezing of the condensate line. It is also recommended to bush up the condensate line size to 1" and terminate condensate discharge as close to the unit as possible. Longer condensate runs are more prone to freezing. Damages due to frozen or blocked condensate lines ARE NOT covered by warranty.

4. Support of the condensate line may be necessary to avoid blockage of the condensate flow.

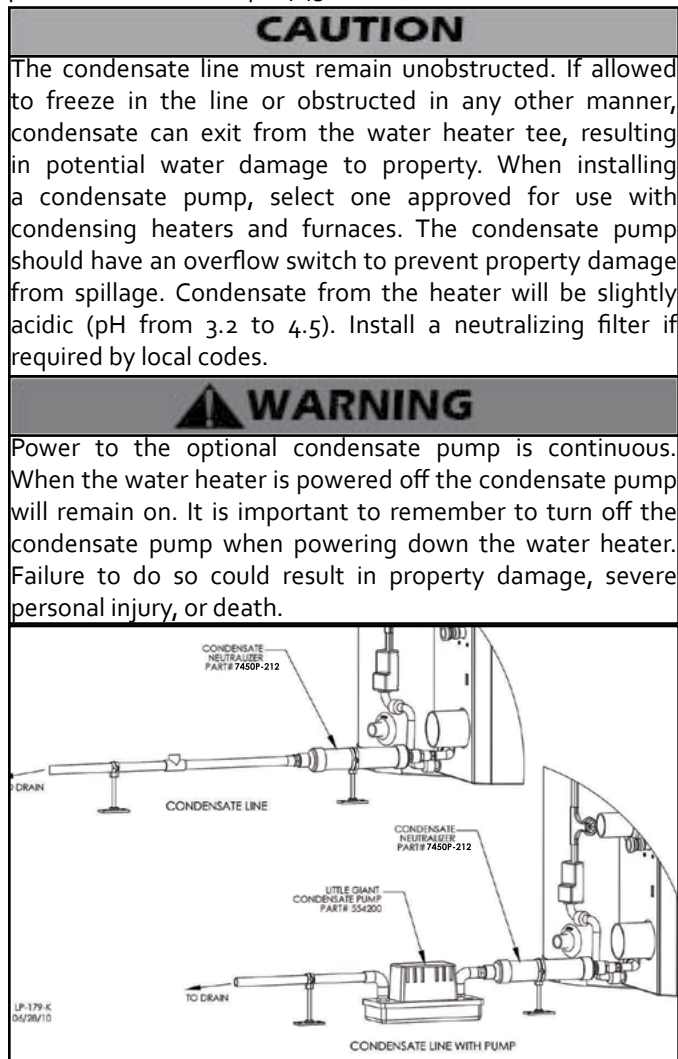

Figure 22 - Condensate Piping

NOTES:

1. Condensate line must be pitched at least $\frac{1}{4}$ " per foot to properly drain. If this cannot be done, or a very long length of condensate hose is used, increase the condensate line to a minimum of 1" ID and place a tee in the line after the condensate neutralizer to properly reduce vacuum lock in the drain line.
2. PVC or CPVC pipe should be the only material used for condensate line. Steel, brass, copper, and other metals will be

Part 6 - Wiring

WARNING

To avoid electrical shock, turn off all power to the heater prior to opening an electrical box within the unit. Ensure the power remains off while any wiring connections are being made. Failure to follow these instructions could result in component or product failure, serious injury, or death. Such product failure IS NOT covered by warranty.

Jumping out control circuits or components WILL VOID product warranty and can result in property damage, personal injury, or death.

A. Line Voltage Input

The heater must be wired to a 120 volt circuit by a qualified electrician. It is recommended that the heater be wired on its own circuit to minimize the possibility of circuit failure due to outside causes. The heater requires a maximum of 8 amps at 120 volts in use.

B. Line Voltage Condensate Output

The heater has the capability of supplying power to a condensate pump. The connection is 120 VAC +/- 10% at a max of 2 amps. Power is supplied to the pump only when the heater is connected to power, and the power switch is in the on position.

C. Low Voltage Outdoor Sensor Input

The heater has the capability of an outdoor reset. Connecting an outdoor sensor allows the heater to operate at optimum efficiency. HTP offers an outdoor sensor, p/n 7250P-319.

The outdoor sensor must be a 12K NTC sensor. Use a minimum 22 AWG wire for runs of 100 feet or less and minimum 18 AWG wire for runs up to 150 feet. Instructions are included with the outdoor sensor to correctly mount the sensor on the exterior surface of the building. It is preferable to mount the sensor on the north side in an area that will not be affected by direct sunlight but will be exposed to varying weather conditions. Connect the outdoor sensor to terminals marked "Outdoor".

WARNING

It is of extreme importance that this unit be properly grounded. It is very important that the building system ground is inspected by a qualified electrician prior to making this connection. Electrical power must only be turned on when the heater is completely filled with cold water. Failure to follow these instructions could result in component or product failure, serious injury, or death.

An ASSE 1017 thermostatic mixing valve MUST be installed when using 0-10V or outdoor reset. Failure to do so could result in substantial property damage, serious injury, or death.

CAUTION

Label all wires prior to disconnecting them when servicing the heater. Wiring errors can cause improper and dangerous operation. Failure to follow these instructions may result in property damage or personal injury.

D. Alarm Connections

The control includes an alarm output. This circuit is rated at 3 amps at 120 volts. This contact can be used to activate an alarm light or bell or notify a building management system if the water heater goes into a lockout condition.

E. Optional 0-10 Volt Building Control Signal

A signal from a building management system may be connected to the water heater to enable remote control. This signal should be a 0-10 volt positive-going DC signal. When this input is enabled using the installer menu, a building control system can be used to control the set point temperature of the water heater. The control interprets the 0-10 volt signal as follows; when the signal is between 0 and 1.5 volts, the water heater will be in stand-by mode, not firing. When the signal rises above 1.5 volts, the water heater will ignite. As the signal continues to rise towards its maximum of 10 volts, the water heater will increase in set point temperature. See Part 10 for details on the setting of function 16.

NOTE: During 0-10V operation, the minimum tank temperature set point (default 95°F) will be at the activation input of 1.5 volts. The maximum temperature set point value will be at the input voltage of 10 volts. The maximum temperature set point can be changed by increasing or decreasing the **DU** setting (Range: 77°F – 160°F / Default 119°F). Once programmed, the 0-10V feature will change the set point temperature automatically.

1. Connect a building management system or other auxiliary control signal to the terminals marked 0-10 VOLT + and 0-10 VOLT – in the electronics assembly (shown in Figure 25). Caution should be used to ensure that the 0-10 VOLT + connection does not become connected to ground.
2. Configuring the appliance for 0-10 volt operation (change only the functions in the descriptions below):
 - a. Press and hold **S3** and **S4** together for 5 seconds
 - b. Use **S1** and **S2** to adjust flashing **ooo** to code **975**. Press **S3** until you enter the menu.
 - c. Use **S3** to scroll to Function 16 to enable/disable 0-10 volt operation. Use **S1** and **S2** to adjust display to desired setting (Range: 0 = Off, 2 = On / Default Off).
 - d. Press and hold **S4** to exit the menu.

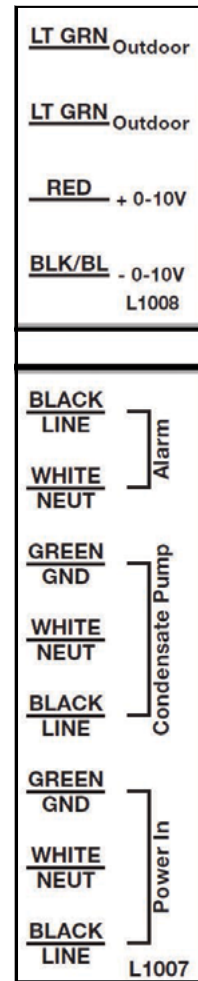

Figure 23 - Field Wiring

F. Internal Wiring Diagram

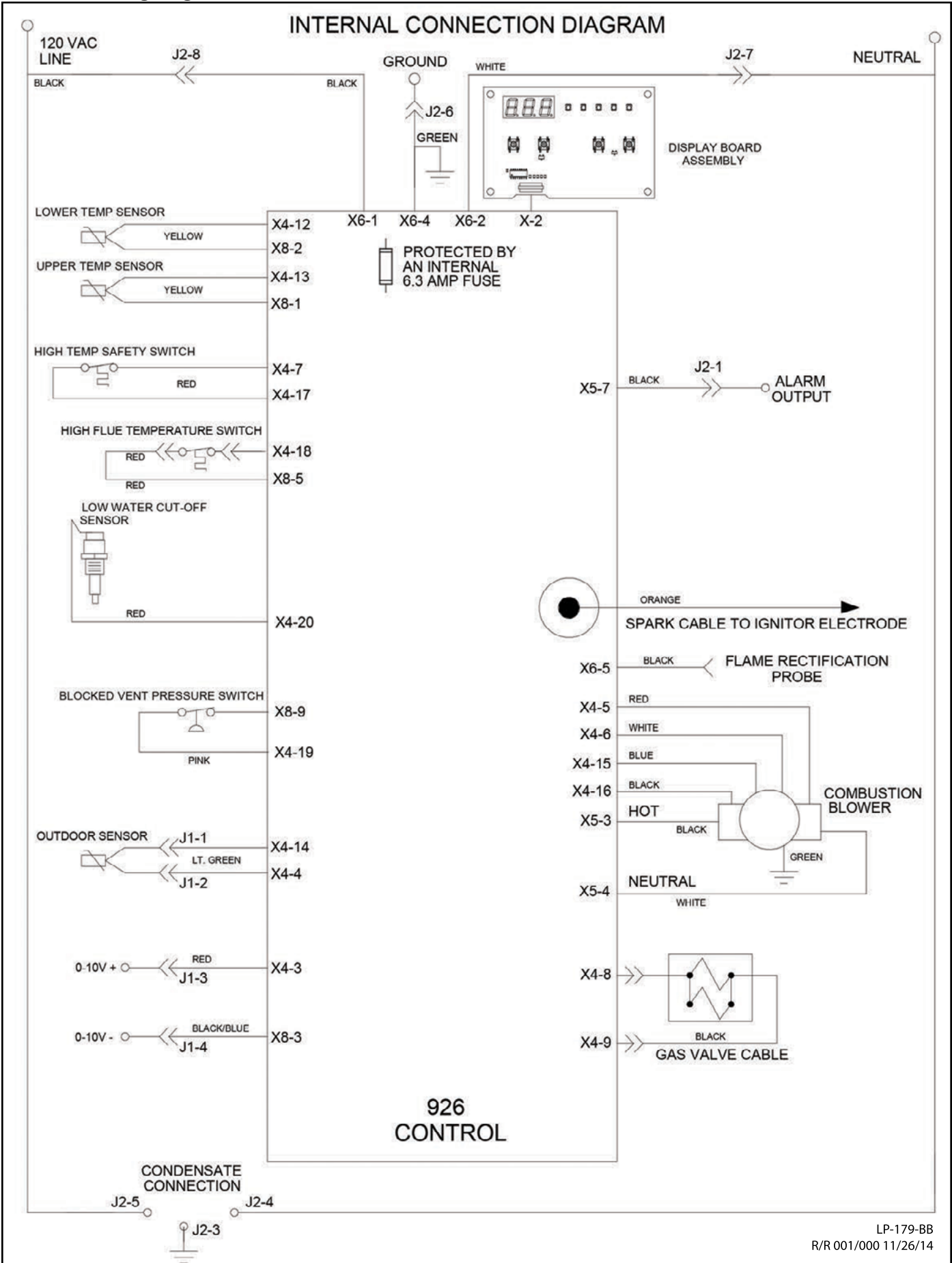

Figure 24 - Internal Wiring Diagram

LP-179-BB
R/R 001/000 11/26/14

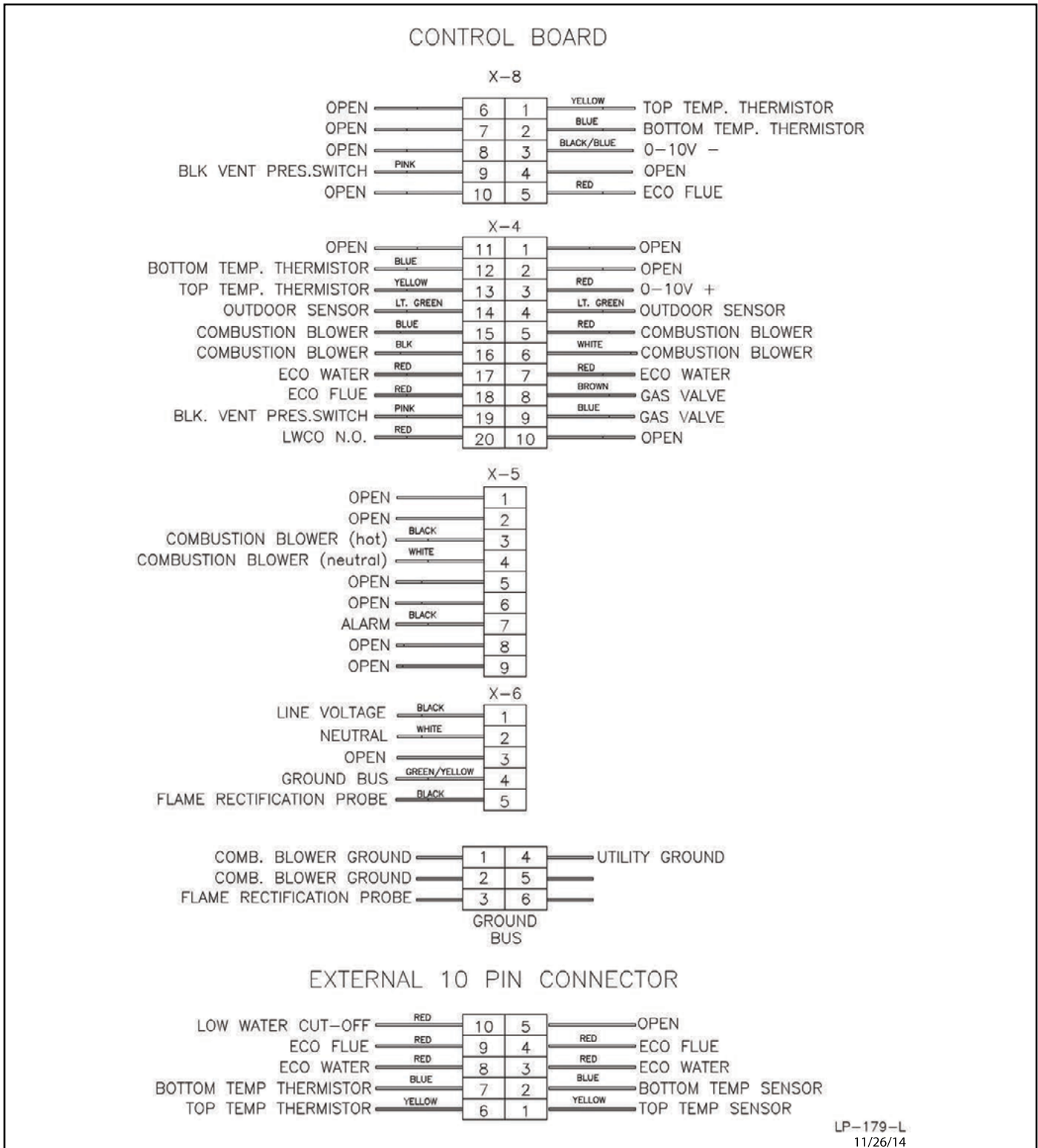

Figure 25 - Control Board Wiring

Part 7 - Gas Connections

WARNING

Failure to follow all precautions could result in fire, explosion, severe injury, or death.

Ensure the gas on which the water heater will operate is the same type specified on the rating plate. Failure to do so could result in water heater malfunction, property damage, personal injury, or death.

The gas supply shall have a maximum inlet pressure of less than 14" water column (350 mm), ½ pound pressure (3.5 kPa), and a minimum of 3.5" water column. The entire piping system, gas meter and regulator must be sized properly to prevent pressure drop greater than 0.5" WC as stated in the National Fuel Gas Code. This information is listed on the rating plate.

It is very important that you are connected to the type of gas as noted on the rating plate: "LP" for liquefied petroleum, propane gas, or "Nat" for natural or city gas. All gas

connections must be approved by the local gas supplier or utility, in addition to the governing authority, prior to turning the gas supply on.

Do not remove the adaptor in Figure 26! It is mandatory that this fitting is used for connection to a field fabricated drip leg per the National Fuel Gas Code. You must ensure that the entire gas line to the connection at the water heater is no smaller than 3/4".

Once all inspections have been performed, the piping must be leak tested. If the leak test requirement is a higher test pressure than the maximum gas inlet pressure, you must isolate the heater from the gas line to continue leak testing. To do this, you must turn off the factory and field-installed gas cocks. This will minimize the possibility of damaging the gas valve. Failure to do so may damage the gas valve. In the event the gas valve is exposed to a pressure greater than 1/2 PSI, 14" water column, the gas valve must be replaced. Never use an open flame (match, lighter, etc.) to check gas connections.

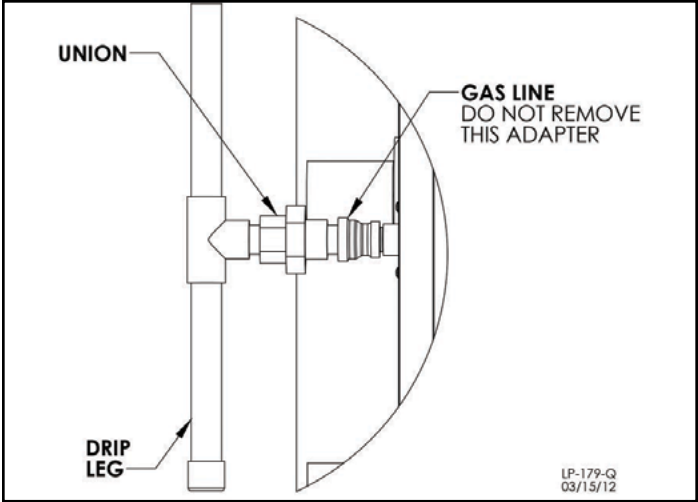

Figure 26 - Gas Connection

WARNING

UL recognized fuel gas detectors are recommended in all enclosed propane and natural gas applications where there is a potential for an explosive mixture of fuel gas to accumulate. The installation of these detectors should be made in accordance with the detector manufacturer's recommendations, and/or local laws. Failure to install fuel gas detectors in these applications could result in fire, explosion, property damage, severe personal injury, or death.

A. Gas Piping

Run the gas supply line in accordance with all applicable codes. Locate and install manual shutoff valves in accordance with local and state requirements.

WARNING

Support gas supply piping with hangers, not by the heater or its accessories. The heater gas valve and blower will not support the weight of the piping. Make sure the gas piping is protected from physical damage and freezing, where required. Failure to follow these instructions could result in gas leakage, and result in fire, explosion, property damage, severe personal injury, or death.

Do not use Teflon tape on gas line pipe thread. Use a pipe compound rated for use with natural and propane gases. Apply sparingly on male pipe ends, leaving the two end threads bare. Failure to follow these instructions could result in gas leakage, and result in fire, explosion, property damage, severe personal injury, or death.

B. Gas Table

Refer to the table below to size the supply piping to minimize pressure drop between meter or regulator and unit.

Maximum capacity of pipe in cubic feet of gas per hour for gas pressures of .5 psi or less and a pressure drop of .3 inch water column.

It is recommended that a soapy solution be used to detect leaks. Bubbles will appear on the pipe to indicate a leak is present. The gas piping must be sized for proper flow and length of pipe to avoid excessive pressure drop. Both the gas meter and the gas regulator must be properly sized for the total gas load. If you experience a pressure drop greater than 1" WC, the meter, regulator or gas line is undersized or in need of service. You can attach a manometer to the incoming gas drip leg by removing the cap. The gas pressure must remain between 3.5" WC and 14" WC during stand-by (static) mode and while in operating (dynamic) mode at full output.

If an in-line regulator is used, it must be a minimum of 10 feet from the heater. It is very important that the gas line is properly purged by the gas supplier or utility. Failure to properly purge the lines or improper line sizing will result in ignition failure. This problem is especially noticeable in NEW LP installations and also in empty tank situations. This can also occur when a utility company shuts off service to an area to provide maintenance to their lines. The gas valve must not be replaced with a conventional gas valve under any circumstances. As an additional safety feature, the gas valve in this water heater has a flanged connection to the swirl plate and blower.

Nominal Iron Pipe Size (in.)	Internal Dia. (in.)	Length of Pipe (Feet)														BTU's Per Hour x 1,000
		10	20	30	40	50	60	70	80	90	100	125	150	175	200	
3/4	.824	278	190	152	130	115	105	96	90	84	79	72	64	59	55	
1	1.049	520	650	285	245	215	195	180	170	160	150	130	120	110	100	
1 1/4	1.38	1050	730	590	500	440	400	370	350	320	305	275	250	225	210	
1 1/2	1.61	1600	1100	890	760	670	610	560	530	490	460	410	380	350	320	

Table 11 - Source - ANSI Z223.1

⚠ DANGER

Do not do a gas conversion on this water heater without an officially approved conversion kit and instructions supplied by HTP. Failure to use a conversion kit when converting the heater to fire on Natural or Propane gas will result in extremely dangerous burner operation, leading to fire, explosion, severe personal injury, or death.

⚠ WARNING

Strain on the gas valve and fittings may result in vibration, premature component failure and gas leakage, and result in fire, explosion, property damage, severe personal injury, or death.

Adjustments to the throttle screw or offset may only be made by a qualified gas technician using a calibrated combustion analyzer capable of measuring CO₂ and CO. Failure to follow this instruction could result in fire, explosion, property damage, severe personal injury, or death.

⚠ WARNING

Breathing Hazard - Carbon Monoxide Gas



- Do not operate heater if flood damaged.
- Install vent system in accordance with local codes and manufacturers installation instructions.
- Do not obstruct heater air intake or exhaust. Support all vent piping per manufacturers installation instructions.
- Do not place chemical vapor emitting products near unit.
- According to NFPA 720, carbon monoxide detectors should be installed outside each sleeping area.
- Never operate the heater unless it is vented to the outdoors.
- Analyze the entire vent system to make sure that condensate will not become trapped in a section of vent pipe and therefore reduce the open cross sectional area of the vent.

LP-304-FR

Breathing carbon monoxide can cause brain damage or death. Always read and understand instruction manual.

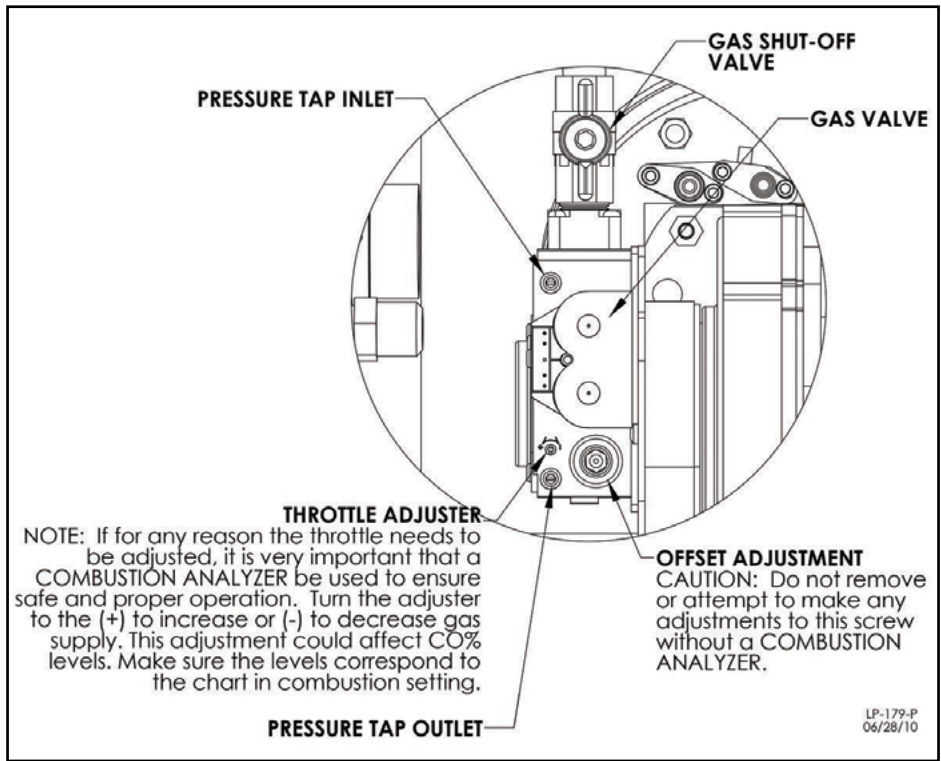

Figure 27 - Gas Valve

Part 8 - Start-Up Procedure

⚠ WARNING

FOR YOUR OWN SAFETY READ BEFORE OPERATING

- This water heater does not have a pilot. It is equipped with an ignition device which automatically lights the burner. Do not try to light the burner by hand.
- BEFORE OPERATING:** Smell all around the water heater area for gas. Be sure to smell next to the floor because some gas is heavier than air and will settle on the floor.

WHAT TO DO IF YOU SMELL GAS

 - Do not try to light any water heater.
 - Do not touch any electric switch, do not use any phone in your building.
 - Immediately call your gas supplier from a neighbor's phone. Follow the gas suppliers' instructions.
 - If you cannot reach your gas supplier, call the fire department.
 - Turn off the gas shutoff valve (located outside the water heater) so that the handle is crosswise to the gas pipe. If the handle will not turn by hand, don't try to force or repair it, call a qualified service technician. Force or attempted repair may result in a fire or explosion.
- Do not use this water heater if any part has been under water. Immediately call a qualified service technician to inspect the water heater and to replace any part of the control system and any gas control that has been damaged.
- The water heater shall be installed so the gas ignition system components are protected from water (dripping, spraying, rain, etc.) during water heater operation and service (circulator replacement, condensate trap, control replacement, etc.)
Failure to follow these instructions could result in property damage, serious personal injury, or death.

A. Operating Instructions

If you smell gas, STOP. Follow listed safety instructions above. If you do not smell gas, follow the next steps.

1. Make sure tank is full with cold water and purge all piping. To assure adequate purging, open all hot water faucets.

⚠ WARNING

Ensure the water heater is full of water before firing the burner. Failure to do so will damage the heater. Such damage IS NOT covered by warranty, and could result in property damage, serious personal injury, or death.

2. Turn on all electric power to water heater.
3. Adjust the temperature set point of the heater to the desired level. The factory default setting is 119°F. If changes are necessary, follow "Overall Water Heater and Control Operation" in this section.
4. If the water heater fails to start, refer to the Troubleshooting section in the back of this manual.

B. Overall Water Heater and Control Operation

To adjust the temperature of stored water, press and hold **S3** for 2 seconds. The first item is **du**: Water Temperature Set Point - factory set at 119°F. Adjust down by pressing **S1** to a temperature as low as 95°F. Adjust up as high as 160°F by pressing **S2**. Press **S3** again to display **dh**: Differential, which is

factory set at 7°F and adjustable down to 1°F by pressing **S1** and up to 18°F by pressing **S2**. NOTE: Due to the highly advanced control on this water heater, which compensates for varying inlet water temperature, the actual differential temperature may vary slightly from the setting. Press **S3** again to display the factory default temperature measurement in Fahrenheit. Change the default to Celsius by pressing **S1**. When finished, press **S3** one final time to place unit back in operation. The control automatically restarts if no key is pressed for 2 minutes. **NOTE:** If Outdoor Reset is used, Function 9 must match the **du** setting. Failure to match Function 9 and the **du** setting will result in improper water heater operation.

C. Status Menu

Installers are also able to check the current status of the heater parameters by pressing **S4** for 3 seconds. Once activated, the display will show **d1** alternating with the actual upper supply tank temperature. Actual values are displayed for each function. To view the next value, simply press **S4** to go to the next displayed value. Listed below are the values which can be displayed. These values cannot be changed. To exit this menu, press **S3** to resume normal operation.

Function	Value
d1	Actual temperature from upper tank sensor
d2	Actual temperature from lower tank sensor
d3	0 - Not Used
d4	308 - Not Used
d5	Outdoor Sensor
d6	Actual Fan Speed divided by 10 (Example: If fan speed displayed is 410 x 10 = 4100 RPM actual fan speed)
d7	Actual Ionization Current read from flame rectification probe
d8	0 - Not Used
d9	1 - Not Used
d10	Actual status of bus communication - co = connected, nc = not connected
d11	32 - Not Used
d12	Power on hours in thousands (display will not read until 100 hours)
d13	Total water heating hours in thousands (display will not read until 100 hours)
d14	0 - Not Used
d15	Passed ignition attempts in thousands

Table 12 - Status Menu Functions and Values

D. Outdoor Reset

NOTE: The outdoor reset function cannot be used if the 0-10 volt function is enabled.

This unit is supplied with outdoor reset wire connection terminals. **When an outdoor sensor (p/n 7250P-319) is connected, operation of the unit immediately changes.** Refer to the following steps to properly set up the unit with an outdoor sensor.

⚠ WARNING

An ASSE 1017 thermostatic mixing valve **MUST** be installed when using outdoor reset. Failure to do so could result in substantial property damage, severe personal injury, or death.

1. Connect the outdoor sensor to the terminals marked "outdoor".
2. Press and hold **S3**. An alternating **du** and temperature value will appear on the display. Set **du** to the maximum desired tank temperature (default 119°F). After setting the temperature, press **S3** to exit the menu.
3. Setting the outdoor reset curve (change only the functions listed in the descriptions below):
 - a. Press and hold **S3** and **S4** together for 5 seconds.
 - b. Use **S1** and **S2** to adjust the flashing **ooo** to code **975**. Press **S3** until you enter the menu.
 - c. Use **S3** to scroll to Function 8 to adjust minimum outdoor temperature. Use **S1** and **S2** to adjust temperature to desired setting (Range: -49°F - 32°F / Default 5°F).
 - d. Use **S3** to scroll to Function 9 to adjust maximum water heater storage temperature. Use **S1** and **S2** to adjust temperature to desired setting (Range: 77°F - 160°F / Default 119°F). **NOTE:** Function 9 must match the **du** setting.
 - e. Use **S3** to scroll to Function 10 to adjust maximum outdoor temperature (warm weather shutdown temperature). Use **S1** and **S2** to adjust temperature to desired setting (Range: 32°F - 95°F / Default 68°F).
 - f. Use **S3** to scroll to Function 11 to adjust minimum water heater storage temperature. Use **S1** and **S2** to adjust temperature to desired setting. This temperature must be set to the maximum desired DHW temperature (Range: 32°F - 160°F / Default 159°F).
 - g. Use **S3** to scroll to Function 12 to adjust desired DHW temperature (minimum tank temperature). Use **S1** and **S2** to adjust temperature to desired setting (Range: 32°F - 160°F / Default 95°F).
 - h. Press and hold **S4** to exit the menu.

if temperature limit is exceeded. It is recommended to draw water out of the tank to lower temperature so tests can be performed. After 10 minutes, Test Mode stops automatically. To exit Test Mode, press **S1** and **S2** simultaneously for 1 second.

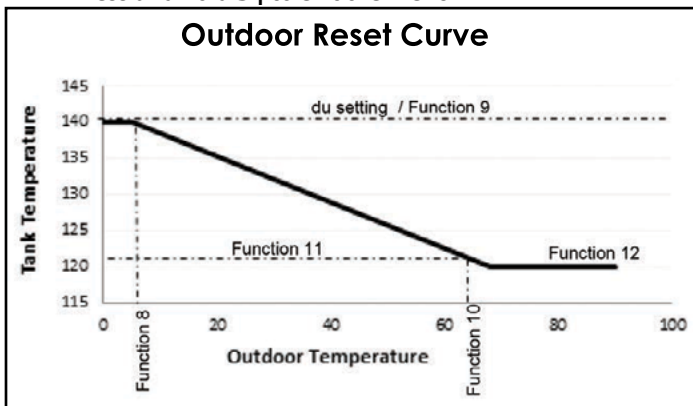
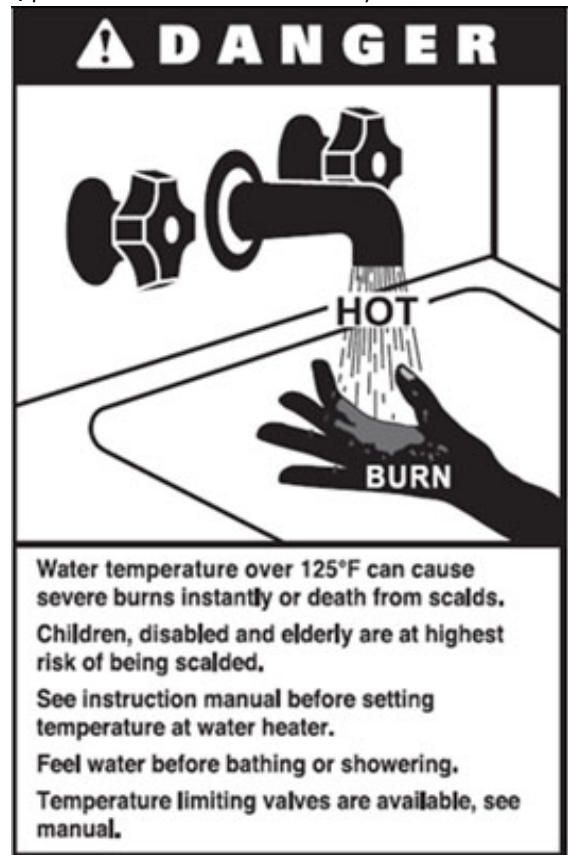

Figure 28 - NOTE: The maximum tank temperature is 160°F, independent of all settings described above.

E. Test Mode

This function is intended to simplify gas valve adjustment if necessary. Listed on the following page are recommended limits on each heater and the combustion settings. Automatic modulation does not take place when the controller is in Test Mode, only temperature limitation based on the heater set point. Fan speed can be increased or decreased by pressing either **S1** or **S2**.

To activate Test Mode, press **S2** and **S3** simultaneously for 1 second. Once activated, **Ser** will display and alternate with the actual fan speed. The measurement of the combustion levels should always be taken at the highest and lowest fan speed. When in Test Mode, the heater's limit will shut down the burner

Combustion Settings on All Models						
Fan Speed	Natural Gas (NG)			Propane (LP)		
	Low	Ignition	High	Low	Ignition	High
Carbon Monoxide (CO) PPM	1-10	2-15	2-20	1-10	2-15	2-20
Carbon Dioxide (CO ₂) %	8-10			8 1/2 - 10 1/2		9-11

Table 13 - Combustion Settings - All Models

Fan Speeds			
BTU	Ignition	Min	Max
100,000	3000	2000	5700
130,000			7300
160,000			7450
199,000			9100

Table 14 - Fan Speeds

F. Maintenance

The control system requires no periodic maintenance under normal conditions. However, in unusually dirty or dusty conditions, periodic vacuuming of the cover to maintain visibility of the display and indicators is recommended. In dirty environments, such as construction sites, care must be taken to keep the water heater burner cover in place and drywall or saw dust away from water heater.

CAUTION

In unusually dirty or dusty conditions care must be taken to keep water heater burner door in place. Failure to do so VOIDS warranty.

WARNING

Allowing the heater to operate with a dirty combustion chamber will hurt operation. Failure to clean the heat exchanger as needed by the installation location could result in heater failure, property damage, personal injury, or death. Such product failures ARE NOT covered under warranty.

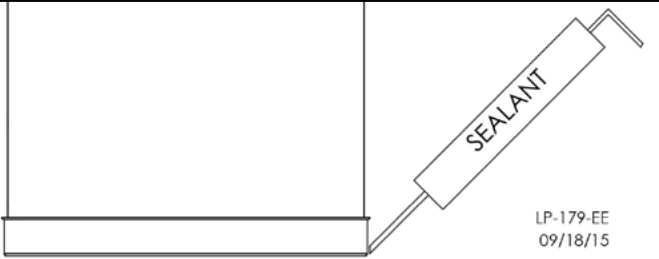

Sealing Per NSF Standard 5 - For Sanitary Applications
Apply a 3/8" bead of RTV Silicone completely around the tank to seal the base to the floor and prevent seepage underneath.

Figure 29 - Sealing the Water Heater for Sanitary Applications

Part 9 - Shutdown

A. Shutdown Procedure

If the burner is not operating, disconnect the electrical supply. If the burner is operating, lower the set point value to 70°F and wait for the burner to shut off. Continue to wait for the combustion blower to stop, so all latent combustion gases are purged from the system. This should take a maximum of 40 to 90 seconds. After combustion gases are purged turn off electrical power to the water heater.

B. Vacation Procedure

If there is danger of freezing, change the set point to 70°F. DO NOT turn off electrical power. If there is no danger of freezing, follow "Shutdown Procedure".

C. Failure to Operate

Should the burner fail to light, the control will perform two more ignition trials prior to entering a lockout state. Note that each subsequent ignition trial will not occur immediately. After a failed ignition trial, the blower must run for approximately 10 seconds to purge the system. Therefore, a time period of approximately 40 to 90 seconds will expire between each ignition trial.

If the burner lights during any one of these three ignition trials, normal operation will resume. If the burner lights, but goes off in about 4 seconds, check the polarity of the wiring. See electrical connection section of this manual.

If the burner does not light after the third ignition trial, the control will enter a lockout state. This lockout state indicates that a problem exists with the water heater, the controls, or the gas supply. Under such circumstances, a qualified service technician should be contacted immediately to properly service the water heater and correct the problem.

If a technician is not available, pressing the **S4** button will remove the lockout state so additional trials for ignition can be performed. The unit will try to relight once every 6 minutes.

D. Important Notice

NOTICE

It is extremely important that whenever work is performed on the plumbing system that either:

- The water heater is powered off, or,
- The water heater is valved off and isolated from the plumbing system.

Failure to take these measures could result in a dry-firing condition.

Resistance Table for Supply Temperature Sensor	
High / Low Temp Sensor Temp. (°F)	Resistance (Ohms)
32	32550
41	25340
50	19870
59	15700
68	12490
77	10000
86	8059
95	6535
104	5330
113	4372
122	3605
131	2989
140	2490
149	2084
158	1753
167	1481
176	1256
185	1070
194	915
202	786
212	667

Table 15 - Supply Temperature Resistance Sensor

WARNING

The water heater must be full of water and the system fully purged BEFORE powering the water heater. Performing any work in the plumbing system without either powering off the water heater or isolating the water heater through the use of shut-off valves could result in a condition referred to as "dry-firing". Dry-firing the water heater will damage the heat exchanger, and could result in property damage, serious personal injury, or death. Such damages ARE NOT covered by water heater warranty.

Part 10 - Troubleshooting

A. Error Code

An error code may occur during installation of the heater. This condition may lead to a lock out condition of the controller, which will need to be manually reset by pressing **S4**. The following information will help the installer correct the problem before going into a lockout condition, which will require a manual reset.

B. Heater Error

1. When an error condition occurs the controller will display an error code on the display module.
2. These error codes and several suggested corrective actions are included in Table 16.
3. In the case of E00, E13, and E14 error codes, if uncorrected, the water heater will go into a fault condition as described in section C. Lockout.

C. Lockout

1. When an fault condition occurs, the controller will illuminate the red fault indication light and display a fault code (example: Foo).
2. Note the fault code and refer to Table 17 for an explanation of the fault code along with several suggestions for corrective actions.
3. Press **S4** to clear the fault and resume operation. Be sure to observe the operation of the unit to prevent a recurrence of the fault.

 CAUTION
The water heater has wire function labels on all internal wiring. Observe the position of each wire before removing it. Wiring errors may cause improper and dangerous operation. Verify proper operation after servicing.

 WARNING
DO NOT USE THIS APPLIANCE IF ANY PART HAS BEEN SUBMERGED IN WATER. Immediately call a qualified service technician. The appliance MUST BE replaced if it has been submerged. Attempting to operate an appliance that has been submerged could create numerous harmful conditions, such as a potential gas leakage causing a fire and/or explosion, or the release of mold, bacteria, or other harmful particulates into the air. Operating a previously submerged appliance could result in property damage, severe personal injury, or death.
NOTE: Appliance damage due to flood or submersion is considered an Act of God, and IS NOT covered under product warranty.
When servicing or replacing any components of this water heater be certain that: <ul style="list-style-type: none"> • The gas is off. • All electrical power is disconnected. In addition, when servicing or replacing components of this water heater in direct contact with heater water: <ul style="list-style-type: none"> • There is no pressure in the heater. Pull the release on the relief valve to relieve pressure in the heater. • Heater water is not hot. Failure to follow these precautions could result in property damage, serious personal injury, or death. Such damages ARE NOT covered by water heater warranty.

g26 Control Board Error Codes			
Code	Description	Duration	Corrective Action
E13	Combustion blower speed is less than 70% of expected	60 seconds	1. Check blower wiring. Ensure all wires are plugged in and undamaged. 2. Replace the blower. 3. Replace the control board.
E14	Combustion blower speed is greater than 130% of expected		1. Check blower wiring. Ensure all wires are plugged in and undamaged. 2. Replace the blower. 3. Replace the control board.
LEO	Water level in tank is low	Until corrected	1. Ensure all air is bled from system. 2. Inspect low level switch and wiring for damage and repair if necessary.
FLU	Blocked Vent, Pressure Switch open, Condensate Cup full, Condensate Cup not present		1. Check the flue vent to be sure it is not blocked or damaged. 2. Check blocked vent pressure switch operation by applying a jumper. If the switch is not functioning properly, replace it.
LOU	24 Volt low		1. Check line voltage. Must be between 100 - 128 volts. 2. If available, connect a PC and, using HTP service software, check the 24V supply display in the lower left corner of the screen. The number displayed must be greater than 128 and should be greater than 250. Use this as a troubleshooting guide as you follow the steps below. 3. Remove 10 pin Molex connector from customer connection board. If the LOU code clears, the problem is with external sensor wiring. Examine external sensor wiring for shorts to ground, repairing as necessary. If LOU code is still present and the heater is so equipped, disconnect high gas pressure switch, then low gas pressure switch, then UL 353 low water cutoff in this order, one at a time, to see if LOU code clears. Replace faulty part. Check low voltage wire harness in heater for shorts to ground. 4. If LOU only occurs when burner tries to light, check gas valve for excessive current draw. 5. If LOU is present with the low voltage harness disconnected from the g26 control board, replace the g26 control board.

Table 16 - Error Codes

g26 Control Board Fault Codes		
Code	Description	Corrective Action
F00	High temperature switch limit exceeded 194°F	<ol style="list-style-type: none"> 1. Try to reset the water heater. If F00 repeats, create a demand for hot water. (WARNING: Use caution to prevent burn injury.) If water is above 194°F, test upper and lower temperature sensors with an ohmmeter. (Refer to resistance chart, this section.) Replace bad sensor. If water is below 194°F, test high temperature switch and wiring with ohmmeter. Switch should be closed at this point. If not, replace switch. 2. If heater did reset successfully, let the heater run and go into the status menu to check the upper and lower temperature sensors. If either reading displayed does not make sense, check appropriate sensor with ohmmeter. (Refer to resistance chart, Table 15.) Replace bad sensor. Do an OHMs reading on both sensors to check continuity.
F01	Vent temperature limit exceeded	<ol style="list-style-type: none"> 1. Inspect all flue piping. If the flue is damaged or shows signs of overheating, repair or replace the flue parts as necessary before proceeding. 2. If the flue piping is intact, undamaged, and there is no sign of the flue overheating (such as discoloration or melting of the flue pipe), push the red reset button on the flue switch. 3. Be sure the heater is connected to a water supply and is full of water. 4. Push the RESET button on the heater control panel. The water heater should light. If the water heater lights, proceed to step 5. If the water heater does not light and the display again begins to flash F01, inspect the wiring to the flue switch, repairing or replacing as necessary. If the wiring is intact, replace the flue switch, using care to mount the new flue switch in the same position and mounting holes as the old one. If the display flashes a code other than F01, follow the troubleshooting guide for the code. 5. Observe operation for 5 minutes. Place the probe of an exhaust analyzer into the flue system within 6 feet of the heater. The exhaust temperature should not rise above 190°F after several minutes of operation. 6. If the flue temperature is below 190°F and the heater again goes into lockout displaying F01, replace the flue switch, using care to mount the new flue switch in the same position and mounting holes as the old one. If the display flashes a code other than F01, follow the troubleshooting guide for that code. 7. If the flue temperature increases to over 190°F, consult HTP for further assistance.
F02	Interrupted or shorted upper temperature sensor	<ol style="list-style-type: none"> 1. Check the electrical connection to the appropriate temperature sensor. 2. If connection is intact, replace the sensor.
F03	Interrupted or shorted lower temperature sensor	
F05	Upper temp. sensor exceeds 194°F	<ol style="list-style-type: none"> 1. If water in tank is less than 194°F, check wiring. Repair if damaged.
F06	Lower temp. sensor exceeds 194°F	<ol style="list-style-type: none"> 2. If wiring is intact, check appropriate sensor with ohmmeter and compare to reading in Table 15. If reading does not agree with water temperature, replace the sensor.
F09	No flame detected - Heater will make three attempts at ignition before the control goes into this lockout condition. Will reset in 1 hour.	<ol style="list-style-type: none"> 1. Watch the igniter through the observation window provided. 2. If there is no spark, check the spark electrode for the proper 1/4" gap. 3. Remove any corrosion from the spark electrode and flame rectifier probe. 4. If there is a spark but no flame, check the gas supply to the heater. 5. If there is a flame, check the flame sensor. 6. Check for any flue or condensate blockages.
F10	Loss of flame signal - The heater will attempt to relight four times before the control goes into this condition. Will reset in 1 hour.	<ol style="list-style-type: none"> 1. Monitor the gas pressure to the unit while in operation. 2. Assure that the flame is stable when lit. 3. Check to see if the green light on the display module is out while the heater is running. 4. If the green light doesn't come on or goes off during operation check the flame signal on the status menu. 5. If the signal reads less than 1 microampere, clean the flame rectifier probe. 6. If the flame rectifier probe continues to read low, replace it.
F11	False flame signal - Occurs if heater senses a flame signal when there should be none present.	<ol style="list-style-type: none"> 1. Turn the gas off to the unit as the service valve. 2. If the flame signal is still present replace the igniter. 3. If the flame signal is not present after turning off the gas supply, check the gas valve electrical connection. 4. If there is no power to the gas valve, remove the valve and check for obstruction in the valve seat or replace the gas valve. 5. Turn the gas on at the service valve after corrective action is taken.
F13	Blower speed incorrect - Occurs if blower speed is less than 70% expected for more than 60 seconds.	<ol style="list-style-type: none"> 1. Check blower wiring. 2. Replace the blower. 3. Replace the control board.

Table 17 - Fault Codes - NOTE: If you replace a part to remedy a fault, it is recommended that you cycle the water heater at least three or four times to assure the fault has been resolved.

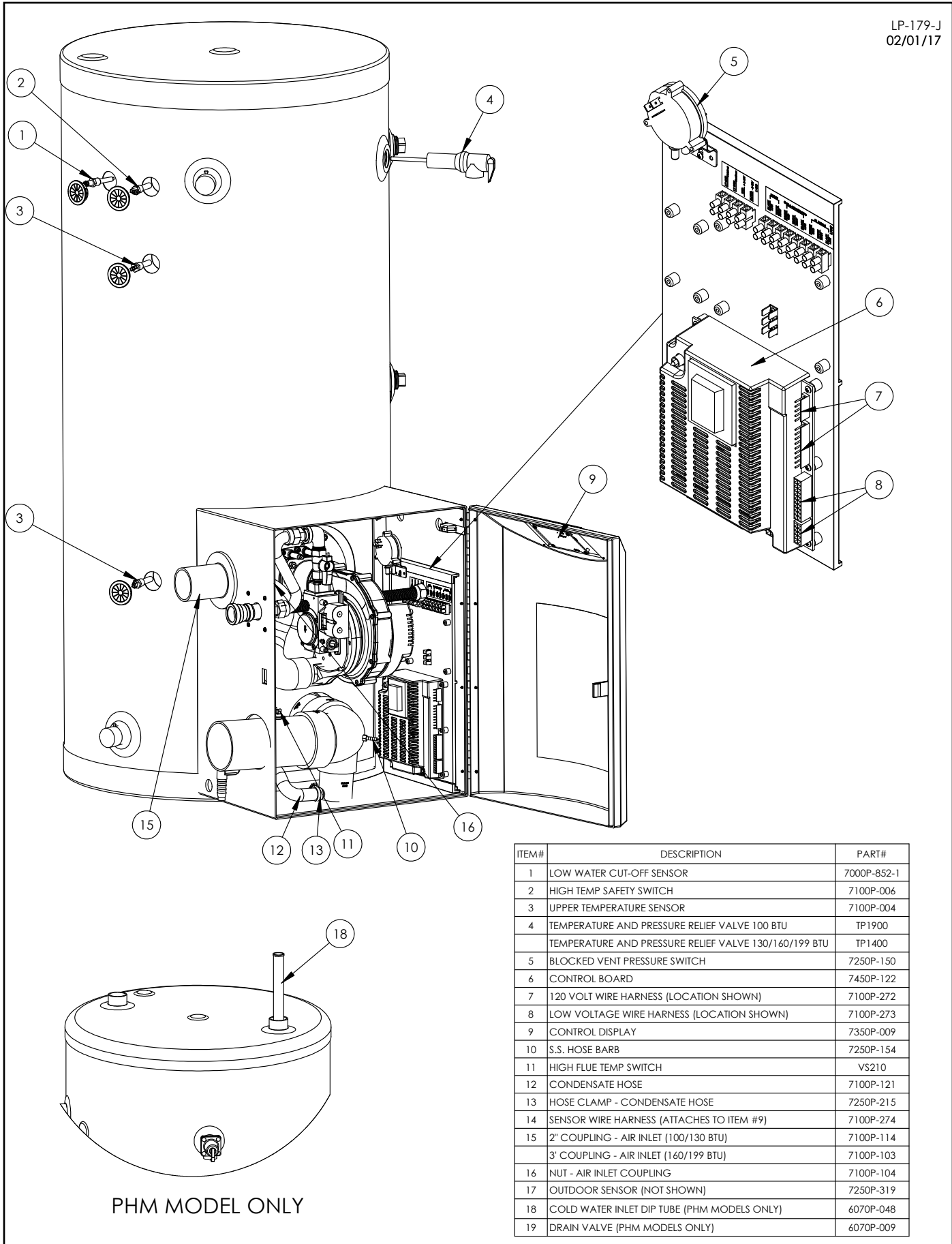

ITEM#	DESCRIPTION	PART#
1	LOW WATER CUT-OFF SENSOR	7000P-852-1
2	HIGH TEMP SAFETY SWITCH	7100P-006
3	UPPER TEMPERATURE SENSOR	7100P-004
4	TEMPERATURE AND PRESSURE RELIEF VALVE 100 BTU	TP1900
	TEMPERATURE AND PRESSURE RELIEF VALVE 130/160/199 BTU	TP1400
5	BLOCKED VENT PRESSURE SWITCH	7250P-150
6	CONTROL BOARD	7450P-122
7	120 VOLT WIRE HARNESS (LOCATION SHOWN)	7100P-272
8	LOW VOLTAGE WIRE HARNESS (LOCATION SHOWN)	7100P-273
9	CONTROL DISPLAY	7350P-009
10	S.S. HOSE BARB	7250P-154
11	HIGH FLUE TEMP SWITCH	VS210
12	CONDENSATE HOSE	7100P-121
13	HOSE CLAMP - CONDENSATE HOSE	7250P-215
14	SENSOR WIRE HARNESS (ATTACHES TO ITEM #9)	7100P-274
15	2" COUPLING - AIR INLET (100/130 BTU)	7100P-114
	3" COUPLING - AIR INLET (160/199 BTU)	7100P-103
16	NUT - AIR INLET COUPLING	7100P-104
17	OUTDOOR SENSOR (NOT SHOWN)	7250P-319
18	COLD WATER INLET DIP TUBE (PHM MODELS ONLY)	6070P-048
19	DRAIN VALVE (PHM MODELS ONLY)	6070P-009

Figure 30 - Replacement Parts

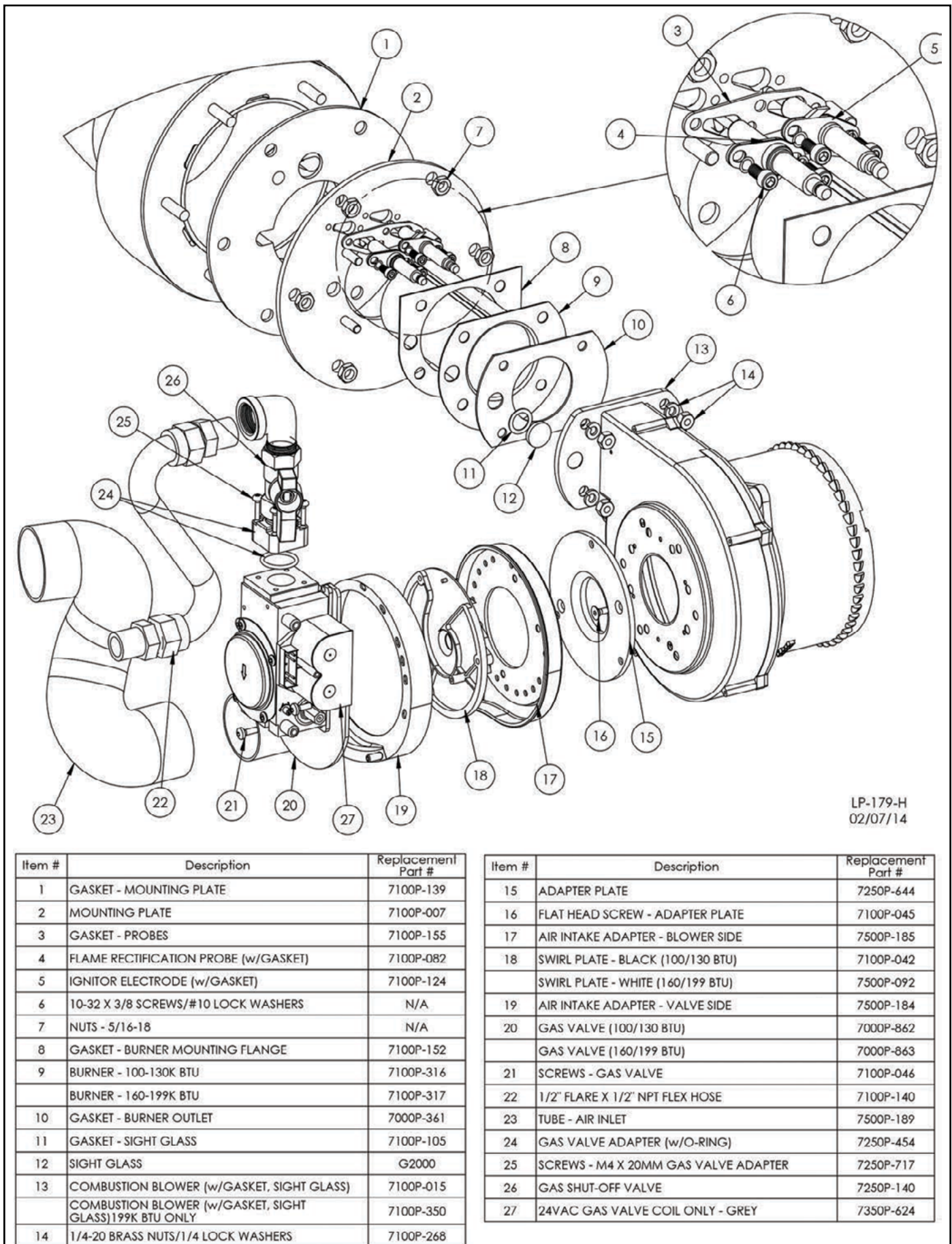

Figure 31 - Replacement Parts - Combustion System

Part 11 - Installation Checklist

Before Installing	Yes	No
Is there enough space to ensure proper installation?		
Does installation location allow for proper service clearances?		
Are water and gas lines properly sized and set at proper pressures for the installation?		
Is water heater location as near the exhaust vent / intake pipe terminations as possible?		
Have combustibile materials been cleared from the installation location?		
Is there a drain close to the water heater?		
Water Piping	Yes	No
Does water heater loop piping meet the minimum sizing requirements listed? NOTE: Smaller piping will cause performance problems.		
Has water chemistry been checked?		
Does water chemistry meet requirements?		
If water chemistry does not meet requirements, have treatment measures been put in place?		
Has the system been cleaned and flushed?		
Install Exhaust Vent and Intake Piping	Yes	No
Has the water heater been vented with the approved materials listed in this manual or to meet local codes?		
Is air supply sufficient for proper water heater operation?		
Is total vent piping length within the maximum vent length restriction listed in this manual?		
Have venting lengths been minimized?		
Are terminations properly spaced from windows, doors, and other intake vents?		
Have all vent terminations been installed at least one foot above exterior grade and one foot above normal snow accumulation level?		
Is vent piping properly supported?		
Has vent piping been checked for leaks?		
Has the exhaust vent line been pitched back to the water heater at a rate of 1/4" per foot?		
Have the exhaust vent and intake pipes been properly installed to the water heater?		
Install Condensate Piping / Tubing and Components	Yes	No
Have all condensate components included with the water heater been installed?		
Is the condensate line piped with approved materials listed in this manual?		
Has the condensate line been routed to a laundry tub or other drain?		
Install Gas Piping	Yes	No
Is the gas supply line a minimum of 3/4" in diameter?		
Is the gas supply line length and diameter adequate to deliver the required BTUs?		
Has gas supply line pressure been measured?		
Does the gas type match the type indicated on the water heater rating plate?		
Has a union and shut-off valve been installed?		
Relief Valve	Yes	No
Is the Temperature and Pressure Relief Valve properly installed and discharge line run to open drain?		
Is the discharge line protected from freezing?		
Wiring	Yes	No
Has the power and control been wired per water heater wiring diagram, this manual?		
Is the electrical connection polarity within water heater requirements?		
Does the power supply voltage agree with the water heater rating plate?		
Is the branch circuit wire and fusing or circuit breaker of proper size?		
Are electrical connections tight and properly grounded?		

Start-Up, Adjust, and Test	Yes	No
Has the water heater been started?		
If necessary, has the water heater gas valve been adjusted?		
Has the installation been customized per installation location requirements?		
Have all customized system parameters been tested?		
Has proper water heater operation been confirmed?		
Final Installation Approvals		
Signed by Technician	Date	

Table 18 - Installation Checklist

Part 12 - Maintenance

CAUTION
In unusually dirty or dusty conditions, care must be taken to keep water heater cabinet door in place at all times. Failure to do so VOIDS the warranty.
 WARNING
Allowing the water heater to operate with a dirty combustion chamber will hurt operation. Failure to clean the heat exchanger as needed by the installation location could result in water heater failure, property damage, personal injury, or death. Such product failures ARE NOT covered under warranty.
Hydrogen gas can build up in a hot water system served by this water heater that has not been used for a long period of time (generally two weeks or more). When opening a hot water faucet in a system that has been out of use for a time, keep all ignition sources (electrical appliances, open flame, etc.) away from the faucet. If hydrogen is present, there will be a sound of air escaping as water begins to flow. Allow the water to run for a few minutes to dissipate built up hydrogen from the system. Failure to follow these instructions can result in property damage, personal injury, or death.

The water heater requires minimal periodic maintenance under normal conditions. However, in unusually dirty or dusty conditions, periodic vacuuming of the cover to maintain visibility of the display and indicators is recommended.

Periodic maintenance should be performed once a year by a qualified service technician to assure that all the equipment is operating safely and efficiently. The owner should make necessary arrangements with a qualified heating contractor for periodic maintenance of the heater. Installer must also inform the owner that the lack of proper care and maintenance of the heater may result in a hazardous condition.

NOTICE
It is extremely important that whenever work is performed on the plumbing system that either: <ul style="list-style-type: none"> • The water heater is powered off, or, • The water heater is valved off and isolated from the plumbing system. Failure to take these measures could result in a dry-firing condition.

 WARNING
The water heater must be full of water and the system fully purged BEFORE powering the water heater. Performing any work in the plumbing system without either powering off the water heater or isolating the water heater through the use of shut-off valves could result in a condition referred to as "dry-firing". Dry-firing the water heater will damage the heat exchanger, and could result in property damage, serious personal injury, or death. Such damages ARE NOT covered by water heater warranty.

Inspection Activities		Date Last Completed			
Piping		1st Year	2nd Year	3rd Year	4th Year*
Near heater piping	Check heater and system piping for any sign of leakage; make sure pipes are properly supported.				
Vent	Check condition of all vent pipes and joints. Ensure the vent piping terminations are free of obstructions and blockages.				
Gas	Check gas piping. Test for leaks and signs of aging. Make sure all pipes are properly supported.				
System		1st Year	2nd Year	3rd Year	4th Year*
Visual	Do a full visual inspection of all system components.				
Functional	Test all functions of the system (Heat, Safeties).				
Temperatures	Verify safe settings on heater or anti-scald valve.				
	Verify programmed temperature settings.				
Electrical					
Connections	Check wire connections. Make sure connections are tight.				
Smoke and CO Detector	Verify devices are installed and working properly. Change batteries if necessary.				
Circuit Breakers	Check to see that the circuit breaker is clearly labeled. Exercise circuit breaker.				
Chamber / Burner		1st Year	2nd Year	3rd Year	4th Year*
Combustion Chamber	Check burner tube and combustion chamber coils. Clean according to maintenance section of manual. Vacuum combustion chamber. Replace any gaskets that show signs of damage.				
Spark Electrode	Clean. Set gap at 1/4" Clean probe with plumbers cloth to remove oxides.				
Combination Ignitor and Flame Probe	Check ionization in uA (d7 in Status Menu in Start-Up Procedures). Record high fire and low fire. Clean probe with plumbers cloth to remove oxides.				
Condensate		1st Year	2nd Year	3rd Year	4th Year*
Neutralizer	Check condensate neutralizer. Replace if necessary.				
Condensate Pipe	Disconnect condensate pipe. Clean out dirt. Fill with water to level of outlet and reinstall. (NOTE: Verify the flow of condensate, making sure that the hose is properly connected during final inspection.)				
Gas		1st Year	2nd Year	3rd Year	4th Year*
Pressure	Measure incoming gas pressure (3.5" to 10" WC for Natural Gas, 8" to 14" WC for Propane).				
Pressure Drop	Measure drop in pressure on light off (no more than 1" WC).				
Check Gas Pipe for Leaks	Check piping for leaks. Verify that all are properly supported.				
Combustion		1st Year	2nd Year	3rd Year	4th Year*
CO / CO ₂ Levels	Check CO and CO ₂ levels in exhaust. See Start-Up Procedures for ranges. Record at high and low fire.				
Safeties		1st Year	2nd Year	3rd Year	4th Year*
ECO (Energy Cut Out)	Check continuity on flue and water ECO. Replace if corroded.				
Sensors	Check wiring. Verify through ohms reading.				
Final Inspection		1st Year	2nd Year	3rd Year	4th Year*
Check List	Verify that you have completed entire check list. WARNING: FAILURE TO DO SO COULD RESULT IN SERIOUS INJURY OR DEATH.				
Homeowner	Review what you have done with the homeowner.				

Table 19 - *Continue annual maintenance beyond the 4th year as required.

**Phoenix® Gas Water Heater and Solar Gas Water Heater
Limited Warranty
For Residential and Commercial Use**

HTP warrants each Phoenix® water heater and its parts to be free from defects in materials and workmanship according to the following terms, conditions, and time periods. UNLESS OTHERWISE NOTED THESE WARRANTIES COMMENCE ON THE DATE OF INSTALLATION. This limited warranty is only available to the original owner of this water heater, and is non-transferable.

Residential Use Warranty

(Seven (7) years – Tank, One (1) year – Parts)

“Residential” setting shall mean water heater usage in a single family dwelling, or usage in a multiple family dwelling, provided that the water heater services only one (1) dwelling **in which the original consumer purchaser resides on a permanent basis and operating temperatures do not exceed 140°F.**

Commercial Use Warranty

(Three (3) years – Tank, One (1) year – Parts)

Water heaters used in a commercial setting shall mean any usage not falling within the definition of a “residential” setting.

COVERAGE

- A. During the first year after the original date of installation in the dwelling, HTP warrants that it will repair or replace, at its option, any defective or malfunctioning component of the water heater with a component of equivalent size and current model. Replacement components will be warranted for ninety (90) days.
- B. Should a defect or malfunction result in a leakage of water within the above-stated warranty periods due to defective material or workmanship, malfunction, or failure to comply with the above warranty, HTP will replace the defective or malfunctioning water heater with a replacement of the nearest comparable model available at the time of replacement. The replacement water heater will be warranted for the unexpired portion of the applicable warranty period of the original water heater.
- C. In the event of a leakage of water of a replacement water heater due to defective material or workmanship, malfunction, or failure to comply with the above warranty, HTP reserves the right to refund to the original purchaser the published wholesale price available at the date of manufacture of the original water heater.
- D. If government regulations, industry certification, or similar standards require the replacement water heater or part(s) to have features not found in the defective water heater or part(s), you will be charged the difference in price represented by those required features. If you pay the price difference for those required features and/or to upgrade the size and/or other features available on a new replacement water heater or part(s), you will also receive a complete new limited warranty for that replacement water heater or part(s).
- E. If at the time of a request for service the purchaser cannot provide a copy of the original sales receipt or the warranty card registration, the warranty period for the water heater shall then be deemed to have commenced thirty (30) days after the date of manufacture of the water heater and NOT the date of installation of the water heater.
- F. This warranty extends only to Phoenix® Gas Water Heaters or Solar Gas Water Heaters utilized in heating applications that have been properly installed by qualified professionals based upon the manufacturer’s installation instructions.
- G. It is expressly agreed between HTP and the original consumer purchaser that repair, replacement, or refund are the exclusive remedies of the original consumer purchaser.

OWNER RESPONSIBILITIES

To avoid the exclusion list in this warranty, the owner or installer must:

1. Maintain the water heater in accordance with the maintenance procedure listed in the manufacturer’s provided instructions. Preventive maintenance can help avoid any unnecessary breakdown of your water heater and keep it running at optimum efficiency.
2. Maintain all related heating components in good operating condition.
3. Check all condensate lines to confirm that all condensate drains properly from the water heater.
4. Use the water heater in an open system, or in a closed system with a properly sized and installed thermal expansion tank.
5. Use the water heater at water pressures not exceeding the working pressure shown on the rating plate.

WARRANTY EXCLUSIONS

This limited warranty will not cover:

1. Any water heater purchased from an unauthorized dealer.
2. Any water heater not installed by a qualified heating installer/service technician.
3. Service trips to teach you how to install, use, maintain, or to bring the water heater installation into compliance with local building codes and regulations.
4. Failure to locate the water heater in an area where leakage of the tank or water line connections and the combination temperature and relief valve will not result in damage to the area adjacent to the water heater or lower floors of the structure.
5. Any failed components of the heat system not manufactured by HTP as part of the water heater.
6. Water heaters repaired or altered without the prior written approval of HTP.
7. Damages, malfunctions, or failures resulting from failure to install the water heater in accordance with applicable building codes/ordinances or good plumbing and electrical trade practices.
8. Damages, malfunctions, or failures resulting from improper installation, failure to operate the water heater at pressures not exceeding the working pressure shown on the rating plate, or failure to operate and maintain the water heater in accordance with the manufacturer’s provided instructions.
9. Failure to operate the water heater in an open system, or in a closed system with a properly sized and installed thermal expansion tank.
10. Failure or performance problems caused by improper sizing of the water heater, expansion device, piping, or the gas supply line, the venting connection, combustion air openings, electric service voltage, wiring or fusing.
11. Damages, malfunctions, or failures caused by improper conversion from natural gas to LP gas or LP gas to natural gas.
12. Damages, malfunctions, or failures caused by operating the water heater with modified, altered, or unapproved parts.
13. Damages, malfunctions, or failures caused by abuse, accident, fire, flood, freeze, lightning, acts of God and the like.
14. Tank failures (leaks) caused by operating the water heater in a corrosive or contaminated atmosphere.
15. Damages, malfunctions, or failures caused by operating the water heater with an empty or partially empty tank (“dry firing”), or failures caused by operating the water heater when it is not supplied with potable water, free to circulate at all times.
16. Failure of the heater due to the accumulation of solid materials and lime deposits.
17. Any damage or failure resulting from improper water chemistry. WATER CHEMISTRY REQUIREMENTS (RESIDENTIAL USE) – Water pH between 6.5 and 8.5. Operating temperatures

not exceeding 140°F. Hardness less than 12 grains (200 mg/L). Chloride concentration less than 100 ppm (mg/L). TDS less than 500 ppm (mg/L). (COMMERCIAL USE) - Water pH between 6.5 and 8.5. Hardness less than 7 grains (120 mg/L). Chloride concentration less than 100 ppm (mg/L). TDS less than 500 ppm (mg/L).

18. Any damages, malfunctions, or failures resulting from the use of dielectric unions.

19. Components of the water heater that are not defective, but must be replaced during the warranty period as a result of reasonable wear and tear.

20. Damages, malfunctions, or failures caused by subjecting the tank to pressures or firing rates greater than those shown on the rating label.

21. Damages, malfunctions, or failures resulting from the use of any attachment(s) not supplied by HTP.

22. Water heaters installed outside the fifty states (and the District of Columbia) of the United States of America and Canada.

23. Water heaters moved from the original installation location.

24. Water heaters that have had their rating labels removed.

PROCEDURES FOR WARRANTY SERVICE REQUESTS

Any claim for warranty assistance must be made promptly. Determine if the water heater is "in-warranty" (that is, within the applicable warranty period) by reviewing a copy of the original sales receipt. You must present a copy of the original sales receipt for a warranty service request.

If your water heater is "in-warranty", contact the retailer from whom the water heater was purchased (or the installer) for assistance. Be prepared to provide the retailer or installer with a copy of your original receipt, complete model and serial numbers, and the date of installation of your water heater, in addition to explanation of your water heater problem.

Warranty coverage is subject to validation of "in-warranty" coverage by HTP claims department personnel. All alleged defective or malfunctioning parts must be returned to HTP via the local distribution channels where original purchase was made.

NOTE: Any parts or heaters returned to HTP for warranty analysis will become the property of HTP and will not be returned, even if credit is denied. If all warranty conditions are satisfied, HTP will provide replacement parts to the retailer.

If you have questions about the coverage of this warranty, please contact HTP at the address or phone number stated below:

HTP
272 Duchaine Road
New Bedford, MA
02745
Attention: Warranty Service Department
1(800) 323-9651

SERVICE, LABOR AND SHIPPING COSTS

This limited warranty does not extend to any shipping charges, delivery expenses, or administrative fees incurred by the purchaser in repairing or replacing the water heater or part(s). This warranty does not extend to labor costs beyond the coverage specified in this warranty document. All such expenses are your responsibility.

LIMITATIONS OF YOUR HTP WARRANTY AND REMEDIES
THE FOREGOING WARRANTIES ARE EXCLUSIVE AND ARE GIVEN AND ACCEPTED IN LIEU OF ANY AND ALL OTHER WARRANTIES, EXPRESS OR IMPLIED, INCLUDING WITHOUT LIMITATION THE IMPLIED WARRANTIES OF MERCHANTABILITY AND FITNESS FOR A PARTICULAR PURPOSE AND ANY OBLIGATION, LIABILITY, RIGHT, CLAIM OR REMEDY IN CONTRACT OR TORT, WHETHER OR NOT ARISING FROM HTP'S NEGLIGENCE, ACTUAL OR IMPUTED.

THE REMEDIES OF THE PURCHASER SHALL BE LIMITED TO THOSE PROVIDED HEREIN TO THE EXCLUSION OF ANY OTHER REMEDIES INCLUDING WITHOUT LIMITATION, INCIDENTAL OR CONSEQUENTIAL DAMAGES, SAID INCIDENTAL AND CONSEQUENTIAL DAMAGES INCLUDING, BUT NOT LIMITED TO, PROPERTY DAMAGE, LOST PROFIT OR DAMAGES ALLEGED TO HAVE BEEN CAUSED BY ANY FAILURE OF HTP TO MEET ANY OBLIGATION UNDER THIS AGREEMENT INCLUDING THE OBLIGATION TO REPAIR AND REPLACE SET FORTH ABOVE. NO AGREEMENT VARYING OR EXTENDING THE FOREGOING WARRANTIES, REMEDIES OR THIS LIMITATION WILL BE BINDING UPON HTP. UNLESS IN WRITING AND SIGNED BY A DULY AUTHORIZED OFFICER OF HTP. THE WARRANTIES STATED HEREIN ARE NOT TRANSFERABLE AND SHALL BE FOR THE BENEFIT OF THE ORIGINAL PURCHASER ONLY.

NO OTHER WARRANTIES

Your HTP Warranty gives you specific legal rights, and you may also have other rights that vary from state to state. Some states do not allow the exclusion or limitation of incidental or consequential damages so this limitation or exclusion may not apply to you.

These are the only written warranties applicable to the Phoenix® Gas Water Heater and Solar Gas Water Heater manufactured and sold by HTP. HTP neither assumes nor authorizes anyone to assume for it any other obligation or liability in connection with said Phoenix® Gas Water Heater and Solar Gas Water Heaters. HTP reserves the right to change specifications or discontinue models without notice.

**Phoenix® and Phoenix® Multi-Fit Gas Water Heater
Massachusetts Supplemental Commercial Use Warranty
For Multiple Water Heater Installations**

When properly registered by an HTP, Inc. sales representative, HTP will warrant a minimum of two (2) to a maximum of four (4) Phoenix® or Phoenix® Multi-Fit units installed in a Reverse Manifold Piping Installation in the State of Massachusetts to be free from defects in materials and workmanship according to the following terms, conditions, and stated time periods. UNLESS OTHERWISE NOTED THESE WARRANTIES COMMENCE ON THE DATE OF INSTALLATION. This limited warranty is only available to the original owner of the water heater, and is non-transferable.

**Massachusetts Supplemental Commercial Use Warranty
For Multiple Water Heater Installations
(Ten [10] years – Tank, One [1] year – Parts)**

COVERAGE

- A. This warranty extends only to installations of a minimum of two (2) to a maximum of four (4) Phoenix® and Phoenix® Multi-Fit Gas Water Heaters utilized in reverse manifold piping commercial applications in the State of Massachusetts that have been properly installed by qualified professionals based upon the manufacturer's installation instructions.
- B. During the first year after the original date of installation in the building, HTP warrants that it will repair or replace, at its option, any defective or malfunctioning component of the water heater with a component of equivalent size and current model. Replacement components will be warranted for ninety (90) days.
- C. Should a defect or malfunction result in a leakage of water within the above-stated warranty periods due to defective material or workmanship, malfunction, or failure to comply with the above warranty, HTP will replace the defective or malfunctioning water heater with a replacement of the nearest comparable model available at the time of replacement. The replacement water heater will be warranted for the unexpired portion of the applicable warranty period of the original water heater.
- D. In the event of a leakage of water of a replacement water heater due to defective material or workmanship, malfunction, or failure to comply with the above warranty, HTP reserves the right to refund to the original purchaser the published wholesale price available at the date of manufacture of the original water heater.
- E. If government regulations, industry certification, or similar standards require the replacement water heater or part(s) to have features not found in the defective water heater or part(s), you will be charged the difference in price represented by those required features. If you pay the price difference for those required features and/or to upgrade the size and/or other features available on a new replacement water heater or part(s), you will also receive a complete new limited warranty for that replacement water heater or part(s).
- F. If at the time of a request for service the purchaser cannot provide a copy of the original sales receipt or the warranty card registration, the warranty period for the water heater shall then be deemed to have commenced thirty (30) days after the date of manufacture of the water heater and NOT the date of installation of the water heater.
- G. It is expressly agreed between HTP and the original consumer purchaser that repair, replacement, or refund are the exclusive remedies of the original consumer purchaser.

OWNER RESPONSIBILITIES

To avoid the exclusion list in this warranty, the owner or installer must:

1. Maintain the water heater in accordance with the maintenance procedure listed in the manufacturer's provided instructions. Preventive maintenance can help avoid any unnecessary breakdown of your water heater and keep it running at optimum efficiency.
2. Maintain all related heating components in good operating condition.
3. Check all condensate lines to confirm that all condensate drains properly from the water heater.
4. Use the water heater in an open system, or in a closed system with a properly sized and installed thermal expansion tank.
5. Use the water heater at water pressures not exceeding the working pressure shown on the rating plate.

WARRANTY EXCLUSIONS

This limited warranty will not cover:

1. Any water heater purchased from an unauthorized dealer.
2. Any water heater not installed by a licensed plumber.
3. Service trips to teach you how to install, use, maintain, or to bring the water heater installation into compliance with local building codes and regulations.
4. Failure to locate the water heater in an area where leakage of the tank or water line connections and the combination temperature and relief valve will not result in damage to the area adjacent to the water heater or lower floors of the structure.
5. Any failed components of the heat system not manufactured by HTP as part of the water heater.
6. Water heaters repaired or altered without the prior written approval of HTP.
7. Damages, malfunctions, or failures resulting from failure to install the water heater in accordance with applicable building codes/ordinances or good plumbing and electrical trade practices.
8. Damages, malfunctions, or failures resulting from improper installation, failure to operate the water heater at pressures not exceeding the working pressure shown on the rating plate, or failure to operate and maintain the water heater in accordance with the manufacturer's provided instructions.
9. Failure to operate the water heater in an open system, or in a closed system with a properly sized and installed thermal expansion tank.
10. Failure or performance problems caused by improper sizing of the water heater, expansion device, piping, or the gas supply line, the venting connection, combustion air openings, electric service voltage, wiring or fusing.
11. Damages, malfunctions, or failures caused by improper conversion from natural gas to LP gas or LP gas to natural gas.
12. Damages, malfunctions, or failures caused by operating the water heater with modified, altered, or unapproved parts.
13. Damages, malfunctions, or failures caused by abuse, accident, fire, flood, freeze, lightning, acts of God and the like.
14. Tank failures (leaks) caused by operating the water heater in a corrosive or contaminated atmosphere.
15. Damages, malfunctions, or failures caused by operating the water heater with an empty or partially empty tank ("dry firing"), or failures caused by operating the water heater when it is not supplied with potable water, free to circulate at all times.
16. Failure of the heater due to the accumulation of solid materials and lime deposits.
17. Any damage or failure resulting from improper water chemistry. WATER CHEMISTRY REQUIREMENTS (COMMERCIAL USE) - Water pH between 6.5 and 8.5. Hardness less than 7 grains (120 mg/L). Chloride concentration less than 100 ppm (mg/L). TDS less than 500 ppm (mg/L).

18. Any damages, malfunctions, or failures resulting from the use of dielectric unions.

19. Components of the water heater that are not defective, but must be replaced during the warranty period as a result of reasonable wear and tear.

20. Damages, malfunctions, or failures caused by subjecting the tank to pressures or firing rates greater than those shown on the rating label.

21. Damages, malfunctions, or failures resulting from the use of any attachment(s) not supplied by HTP.

22. Water heaters installed outside Massachusetts.

23. Water heaters moved from the original installation location.

24. Water heaters that have had their rating labels removed.

25. Installations of less than two (2) or more than four (4) water heaters.

26. Water heaters utilized in any installation other than parallel-piped commercial applications.

PROCEDURES FOR WARRANTY SERVICE REQUESTS

Any claim for warranty assistance must be made promptly. Determine if the water heater is "in-warranty" (that is, within the applicable warranty period) by reviewing a copy of the original sales receipt. You must present a copy of the original sales receipt for a warranty service request.

If your water heater is "in-warranty", contact the retailer from whom the water heater was purchased (or the installer) for assistance. Be prepared to provide the retailer or installer with a copy of your original receipt, complete model and serial numbers, and the date of installation of your water heater, in addition to explanation of your water heater problem.

Warranty coverage is subject to validation of "in-warranty" coverage by HTP claims department personnel. All alleged defective or malfunctioning parts must be returned to HTP via the local distribution channels where original purchase was made. NOTE: Any parts or heaters returned to HTP for warranty analysis will become the property of HTP and will not be returned, even if credit is denied. If all warranty conditions are satisfied, HTP will provide replacement parts to the retailer.

If you have questions about the coverage of this warranty, please contact HTP at the following address or phone number: HTP, 272 Duchaine Road., New Bedford, MA, 02745, Attention: Warranty Service Department, 1(800) 323-9651.

SERVICE, LABOR AND SHIPPING COSTS

This limited warranty does not extend to any shipping charges, delivery expenses, or administrative fees incurred by the purchaser in repairing or replacing the water heater or part(s). This warranty does not extend to labor costs beyond the coverage specified in this warranty document. All such expenses are your responsibility.

LIMITATIONS OF YOUR HTP WARRANTY AND REMEDIES
THE FOREGOING WARRANTIES ARE EXCLUSIVE AND ARE GIVEN AND ACCEPTED IN LIEU OF ANY AND ALL OTHER WARRANTIES, EXPRESS OR IMPLIED, INCLUDING WITHOUT LIMITATION THE IMPLIED WARRANTIES OF MERCHANTABILITY AND FITNESS FOR A PARTICULAR PURPOSE AND ANY OBLIGATION, LIABILITY, RIGHT, CLAIM OR REMEDY IN CONTRACT OR TORT, WHETHER OR NOT ARISING FROM HTP'S NEGLIGENCE, ACTUAL OR IMPUTED. THE REMEDIES OF THE PURCHASER SHALL BE LIMITED TO THOSE PROVIDED HEREIN TO THE EXCLUSION OF ANY OTHER REMEDIES INCLUDING WITHOUT LIMITATION, INCIDENTAL OR CONSEQUENTIAL DAMAGES, SAID INCIDENTAL AND CONSEQUENTIAL DAMAGES INCLUDING, BUT NOT LIMITED TO, PROPERTY DAMAGE, LOST PROFIT OR DAMAGES ALLEGED TO HAVE BEEN CAUSED BY ANY FAILURE OF HTP TO MEET ANY OBLIGATION UNDER THIS

AGREEMENT INCLUDING THE OBLIGATION TO REPAIR AND REPLACE SET FORTH ABOVE. NO AGREEMENT VARYING OR EXTENDING THE FOREGOING WARRANTIES, REMEDIES OR THIS LIMITATION WILL BE BINDING UPON HTP. UNLESS IN WRITING AND SIGNED BY A DULY AUTHORIZED OFFICER OF HTP. THE WARRANTIES STATED HEREIN ARE NOT TRANSFERABLE AND SHALL BE FOR THE BENEFIT OF THE ORIGINAL PURCHASER ONLY.

NO OTHER WARRANTIES

Your HTP Warranty gives you specific legal rights, and you may also have other rights that vary from state to state. Some states do not allow the exclusion or limitation of incidental or consequential damages so this limitation or exclusion may not apply to you.

These are the only written warranties applicable to the Phoenix® and Phoenix® Multi-Fit Gas Water Heater manufactured and sold by HTP. HTP neither assumes nor authorizes anyone to assume for it any other obligation or liability in connection with said Phoenix® and Phoenix® Multi-Fit Gas Water Heater.

HTP reserves the right to change specifications or discontinue models without notice.

Customer Installation Record Form	
The following form should be completed by the installer for you to keep as a record of the installation in case of a warranty claim. After reading the important notes at the bottom of the page, please also sign this document.	
Customer's Name	
Date of Installation	
Installation Address	
Product Name / Serial Number(s)	
Comments	
Installer's Code / Name	
Installers Phone Number	
Signed by Installer	
Signed by Customer	
Installation Notes	

IMPORTANT

Customer: Please only sign after the installer has fully reviewed the installation, safety, proper operation, and maintenance of the system. If the system has any problems please call the installer. If you are unable to make contact, please call your sales representative.
 Distributor / Dealer: Please insert contact details.