

INTEGRITY TREADMILL

(INTSC, INTSX, INTDX, INTDSE, INTDST, INTSSE, INTST, INTOTF, PF-INT-TRD, Club Series +)

Assembly Instructions



User and Service Documents Link

Operation Manuals and other Product Information available at
<https://www.lftechsupport.com/web/document-library/documents>

أدلة التشغيل ومعلومات أخرى عن الجهاز متاحة على الموقع <https://www.lftechsupport.com/web/document-library/documents>

操作マニュアルおよびその他の製品情報については、<https://www.lftechsupport.com/web/document-library/documents> をご覧ください。

如需操作手册和其他产品信息，请登录：<https://www.lftechsupport.com/web/document-library/documents>

操作手册和其他产品资讯请见 <https://www.lftechsupport.com/web/document-library/documents>

작동 설명서 및 기타 제품 정보는 <https://www.lftechsupport.com/web/document-library/documents> 에서 찾을 수 있습니다.

Trobareu el manual de funcionament i altra informació de producte a
<https://www.lftechsupport.com/web/document-library/documents>

Mae Llawlyfrau Gweithredu a Gwybodaeth Arall am Beiriannau ar gael yn
<https://www.lftechsupport.com/web/document-library/documents>

Die Betriebsanleitung und andere Produktinformationen erhalten Sie unter
<https://www.lftechsupport.com/web/document-library/documents>

Encontrará el manual de funcionamiento y otra información de producto en
<https://www.lftechsupport.com/web/document-library/documents>

Erabiltzailearen Eskuliburua eta Beste Produktuei buruzko Informazioa eskuratu
<https://www.lftechsupport.com/web/document-library/documents> gunean

Käyttöoppaat ja muut tuotetiedot ovat saatavana osoitteessa
<https://www.lftechsupport.com/web/document-library/documents>

Les manuels d'utilisation, ainsi que d'autres informations sur les Produits, sont disponibles sur
<https://www.lftechsupport.com/web/document-library/documents>

Felhasználói kézikönyvek és más termékinformációk: <https://www.lftechsupport.com/web/document-library/documents>

Manuali di funzionamento e altre informazioni sui prodotti disponibili su
<https://www.lftechsupport.com/web/document-library/documents>

Instrukcje obsługi i inne informacje o produktach dostępne na stronie
<https://www.lftechsupport.com/web/document-library/documents>

Manuais de Operação e Informações sobre outros produtos disponíveis em
<https://www.lftechsupport.com/web/document-library/documents>

Руководства по эксплуатации и другую касающуюся нашей продукции информацию можно найти, перейдя по ссылке
<https://www.lftechsupport.com/web/document-library/documents>

Kullanım Kılavuzları ve Diğer Ürün Bilgileri <https://www.lftechsupport.com/web/document-library/documents>'da bulunmaktadır

Corporate Headquarters

Columbia Centre III, 9525 West Bryn Mawr Avenue, Rosemont, Illinois 60018 • U.S.A.
847.288.3300 • FAX: 847.288.3703
Service phone number: 800.351.3737 (toll-free within U.S.A., Canada)
Global Website: www.lifefitness.com

International Offices

AMERICAS North America Life Fitness, Inc.

Columbia Centre III
9525 West Bryn Mawr Avenue
Rosemont, IL 60018 U.S.A.
Telephone: (847) 288 3300
Service Email: customersupport@lifefitness.com
Sales/Marketing Email:
commercialsales@lifefitness.com

United Kingdom Life Fitness UK LTD

Queen Adelaide
Ely, Cambs, CB7 4UB
Telephone: General Office (+44) 1353.666017
Customer Support (+44) 1353.665507
Service Email: uk.support@lifefitness.com
Sales/Marketing Email: life@lifefitness.com

All Other EMEA Countries and Distributor Business EMEA*

Bijdorpplein 25-31
2992 LB Barendrecht
THE NETHERLANDS
Telephone: (+31) 180 646 644
Service Email:
EMEAServiceSupport@lifefitness.com

Brazil Life Fitness Brasil

Av. Rebouças, 2315
Pinheiros
São Paulo, SP 05401-300
BRAZIL
SAC: 0800 773 8282 option 2
Telephone: +55 (11) 3095 5200 option 2
Service Email: suportebr@lifefitness.com
Sales/Marketing Email: vendasbr@lifefitness.com

Germany, Austria, and Switzerland Life Fitness Europe GMBH

Neuhofweg 9
85716 Unterschleißheim
GERMANY
Telephone:
+49 (0) 89 / 31775166 Germany
+43 (0) 1 / 6157198 Austria
+41 (0) 848 / 000901 Switzerland
Service Email: kundendienst@lifefitness.com
Sales/Marketing Email: vertrieb@lifefitness.com

ASIA PACIFIC (AP) Japan

Life Fitness Japan, Ltd

4-17-33 Minami Aoyama 1F/B1F
Minato-ku - Tokyo 107-0062
Japan
Telephone: (+81) 0120.114.482
Fax: (+81) 03-5770-5059
Service Email: service.lfj@lifefitness.com
Sales/Marketing Email:
sales@lifefitnessjapan.com

Latin America and Caribbean* Life Fitness, Inc.

Columbia Centre III
9525 West Bryn Mawr Avenue
Rosemont, IL 60018 U.S.A.
Telephone: (847) 288 3300
Service Email: customersupport@lifefitness.com
Sales/Marketing Email:
commercialsales@lifefitness.com

Spain Life Fitness IBERIA

C/Frederic Mompou 5,1*1ª
08960 Sant Just Desvern Barcelona
SPAIN
Telephone: (+34) 93.672.4660
Service Email: servicio.tecnico@lifefitness.com
Sales/Marketing Email:
info.iberia@lifefitness.com

Hong Kong Life Fitness Asia Pacific LTD

32/F, Global Trade Square
21 Wong Chuk Hang Road
Hong Kong
Telephone: (+852) 2575.6262
Service Email: Service.HK@lifefitness.com
Sales/Marketing Email:
hongkong.sales@lifefitness.com

EUROPE, MIDDLE EAST, and AFRICA (EMEA) Netherlands and Luxemburg

Life Fitness Atlantic BV

Bijdorpplein 25-31
2992 LB Barendrecht
THE NETHERLANDS
Telephone: (+31) 180 646 666
Service Email: service.benelux@lifefitness.com
Sales/Marketing Email:
marketing.benelux@lifefitness.com

Belgium Life Fitness Benelux NV

Parc Industriel de Petit-Rechain
4800 Verviers
BELGIUM
Telephone: (+32) 87 300 942
Service Email: service.benelux@lifefitness.com
Sales/Marketing Email:
marketing.benelux@lifefitness.com

All Other Asia Pacific countries and distributor business Asia Pacific*

32/F, Global Trade Square
21 Wong Chuk Hang Road
Hong Kong
Telephone: (+852) 2575.6262
Fax: (+852) 2575.6894
Service Email: Service.AP@lifefitness.com
Sales/Marketing Email:
Marketing.HK.Asia@lifefitness.com

*Also check www.lifefitness.com for local representation or distributor/dealer

Table of Contents

Getting Started

Safety Instructions.....	6
Consignes de Sécurité.....	8
Set-Up.....	10
Electrical Power Requirements.....	10
Grounding Instructions.....	10
How to Position and Stabilize the Treadmill.....	11
Safety Clearances.....	11
Power Switch.....	11
Turning the Unit On.....	12
Stride Sensor Auto-Shutoff System.....	12
Immobilization Method - Basic Console.....	12
Immobilization Method - Featured Console.....	13

Product Overview

INTDX, INTDSE, INTDST, PF-INT-TRD, & Club Series +.....	14
INTSX & INTSC.....	15
INTOTF.....	16
Mounting and Dismounting the Treadmill.....	16
User Position.....	16
Using and Testing the Emergency Stop System.....	17

Service and Technical Data

Preventive Maintenance Tips.....	18
Approved and Compatible Cleaners.....	18
Preventive Maintenance Schedule.....	19
Troubleshooting the Treadmill.....	19
Troubleshooting the Polar® Heart Rate Chest Strap.....	21
How to Adjust and Tension the Striding Belt.....	22
Belt Tensioning Bolts.....	22
Tracking (Centering) A Striding Belt.....	22
Tensioning an Existing Striding Belt.....	23
Service Wheel (optional).....	23
How to Obtain Product Service.....	24

Assembly: INTSC, INTSX, INTDX, INTDSE, INTDST, INTSSE, INTST, INTOTF, Club Series +

Hardware and Required Tools.....	25
Attach Uprights.....	25
Secure Grounding Braid Cable to Base Frame.....	26
Attach Bridge Weldment to Uprights.....	26

Secure Grounding Braid Cable to Uprights.....	27
Connect Cables.....	27
Connect Base Cables.....	28
Attach Upper Plastics to Bridge.....	29
Base to Console Cable Connections - Integrity X / Integrity C.....	29
Base to Console Cable Connections - Discover SE3 / SE3 HD.....	29
Attach Integrity X / Integrity C Console.....	30
Attach Discover Console.....	30
Secure Ferrite to Console to Base Power Cable.....	30
Route E-Stop Cable.....	31
Attach Lower Plastics to Bridge.....	31
Attach Rear Cover.....	32
Attach End Caps.....	32
Attach Side Shrouds.....	33
Attach Motor Side Shrouds.....	34
Attach Anti-Slip Rails.....	34
Attach Front Shroud.....	35
Attach Motor Cover.....	35
Install the Power Cord.....	36

Assembly: PF-INT-TRD

Hardware and Required Tools.....	37
Attach Integrity X / Integrity C Console.....	37
Attach Rear Cover.....	38
Lifting The Uprights.....	38
Attach Uprights to Base.....	39
Secure Grounding Braid Cable to Base Frame.....	39
Attach Motor Side Shrouds.....	40
Attach Anti-Slip Rails.....	40
Attach Front Shroud.....	41
Attach Motor Cover.....	41
Install the Power Cord.....	42

Specifications

Specifications.....	43
---------------------	----

Life Fitness® is a registered trademark of Brunswick Corporation.

Gym Wipes® is a registered trademark of the 2XL Corporation. PureGreen 24 is a trademark of Pure Green.

© Copyright 2018, Life Fitness, a division of Brunswick Corporation. All Rights Reserved.











Columbia Center III - 9525 West Bryn Mawr Ave., Rosemont, IL 60018 • 847-288-3300

www.lifefitness.com • 1006193-0001 AF • 2018

1. Getting Started

Safety Instructions

Read all instructions before use.

-  **CAUTION:** Any changes or modifications to this equipment could void the product warranty.
 -  **CAUTION:** Risk of injury to persons - to avoid injury, use extreme caution when stepping onto or off of a moving belt. Read assembly instruction manual before using.
 -  **WARNING:** Health-related injuries may result from incorrect or excessive use of exercise equipment. Life Fitness STRONGLY recommends seeing a physician for a complete medical exam before undertaking an exercise program, particularly if the user has a family history of high blood pressure or heart disease, is over the age of 45, smokes, has high cholesterol, is obese, or has not exercised regularly in the past year. If, at any time while exercising, the user experiences faintness, dizziness, pain, or shortness of breath, he or she must stop immediately.
 -  **WARNING:** To reduce the risk of burns, fire, electric shock, or injury, it is imperative to connect each product to a properly grounded electrical outlet.
 -  **WARNING:** Heart rate monitoring systems may be inaccurate. Over exercising may result in serious injury or death. If you feel faint, stop exercising immediately.
 -  **WARNING:** Keep the area 6.5 ft. (2 m) by 3 ft. (0.9 m) behind the treadmill clear of any obstructions, including walls, furniture, and other equipment. Contact Customer Support Services for an optional longer power cord if necessary.
 -  **WARNING:** Be sure the emergency stop lanyard is clipped to the user and in proper position on the treadmill before beginning any workout.
 -  **WARNING:** The belt centering adjustment must be performed if the belt is not between the marks indicating the maximum allowed lateral positions. Refer to Treadmill Assembly Instructions.
 -  **WARNING:** This product can expose you to chemicals including Acrylonitrile, which is known to the State of California to cause cancer and birth defects or other reproductive harm. For more information go to <http://www.P65Warnings.ca.gov>
 -  **DANGER:** To reduce the risk of electrical shock or injury from moving parts, always unplug product before cleaning or attempting any maintenance activity.
- Never operate the product if it has a damaged power cord or electrical plug, or if it has been dropped, damaged, or even partially immersed in water. Contact Customer Support Services.
 - Position the product so that the power cord plug to the wall is accessible to the user. Make sure that the power cord is not knotted or twisted and that it is not trapped under any equipment or other objects.
 - If the electrical supply cord is damaged, it must be replaced by the manufacturer, an authorized service agent, or a similarly qualified person to avoid a hazard.
 - Always follow the console instructions for proper operation.
 - This appliance is not intended for use by persons (including children) with reduced physical, sensory, or mental capabilities, or lack of experience or knowledge unless they have supervision or been given instruction concerning the use of the appliance by a person responsible for their safety.
 - Do not use this product outdoors, near swimming pools or in areas of high humidity.
 - Never operate the product with the air openings blocked. Keep air openings free of lint, hair, or any other obstructing material.
 - Never insert objects into any opening in these products. If an object should drop inside, turn off the power, unplug the power cord from the outlet, and carefully retrieve it. If the item cannot be reached, contact Customer Support Services.
 - Never place liquids of any type directly on the unit, except in an accessory tray or holder. Containers with lids are recommended.
 - Do not use these products in bare feet. Always wear shoes. Wear shoes with rubber or high-traction soles. Do not use shoes with heels, leather soles, cleats or spikes. Make sure no stones are embedded in the soles.
 - Keep all loose clothing, shoelaces, and towels away from moving parts.
 - Do not reach into, or underneath, the unit or tip it on its side during operation.
 - This equipment is not intended for use by children. Keep children under the age of 14 away from the machine.

- Do not allow other people to interfere in any way with the user or equipment during a workout.
- Allow LCD consoles to “normalize” with respect to temperature for one hour before plugging the unit in and using.
- The product should never be left unattended when plugged in. Disconnect from the electrical outlet when not in use, and before putting on or taking off parts. To disconnect, turn power OFF at the ON/OFF switch, then remove plug from electrical outlet.
- Keep the power cord away from heated surfaces. Do not pull the equipment by the power cord or use the cord as a handle. Do not run the power cord on the floor under or along the side of the treadmill.
- Handrails may be held to enhance stability as needed, but are not for continuous use.
- Never mount or dismount the treadmill while the running belt is moving. Use the handrails whenever additional stability is required. In case of an emergency, such as tripping, grasp the handrails, and place the feet on the side platforms.
- Never walk or jog backwards on the treadmill.
- Do not use this product in areas where aerosol spray products are being used or where oxygen is being administered. Such substances create the danger of combustion and explosion.
- Use these products for their intended use as described in this manual. Do not use attachments that have not been recommended by the manufacturer.
- In conformity with the European Union Machinery Directive 2006/42/EC, this equipment unloaded runs at sound pressure levels below 70 dB (A) at the average operating speed of 12 km/hr (commercial units) and 8 km/hr (home units). Noise emission under load is higher than without load.
- Free standing equipment shall be installed on a stable and leveled surface.
- Read all warnings on each product prior to starting a workout.
- If warnings are missing or damaged, please contact Customer Support Services immediately for replacement warning labels. Warning labels are shipped with every product and should be installed before product is used. Life Fitness is not responsible for missing or damaged warning labels.

Consignes de Sécurité

Lire toutes les instructions avant usage.

 **Avertissement :** Une utilisation incorrecte ou excessive de l'appareil peut entraîner des blessures. Life Fitness Recommande VIVEMENT aux utilisateurs de passer un examen médical complet avant d'entamer un programme d'entraînement, et tout particulièrement dans les cas suivants : antécédents familiaux d'hypertension (pression sanguine trop élevée) ou de pathologies cardiaques, utilisateurs de 45 ans ou plus, tabagisme, hypercholestérolémie (taux de cholestérol sanguin trop élevé), obésité, absence d'exercice physique depuis un an ou plus. Si, pendant l'usage de l'appareil, l'utilisateur éprouve un malaise, des vertiges, des douleurs ou des difficultés à respirer, il doit s'arrêter immédiatement.

 **Mise En Garde :** Toute modification apportée à cet équipement pourrait en annuler la garantie.

 **Danger :** Pour réduire les risques de chocs électriques ou de blessures en raison des pièces mobiles, débranchez toujours les produits avant de les nettoyer ou de procéder aux tâches d'entretien.

 **Avertissement :** Pour réduire les risques de brûlures, d'incendies, de chocs électriques ou de blessures, il est essentiel de brancher chaque appareil sur une prise électrique correctement mise à la terre.

 **Avertissement :** Les systèmes de surveillance de la fréquence cardiaque peuvent être inexacts. Un exercice trop intensif peut entraîner des blessures graves, voire mortelles. Si vous ressentez une sensation de malaise, arrêtez immédiatement l'exercice.

 **Avertissement :** Laissez un espace de 2 m sur 0,9 m (6,5 pi. sur 3 pi.) autour de la machine. Ne placez pas cette dernière près de murs, meubles ou autres équipements qui pourraient en obstruer l'accès. Contactez le service à la clientèle pour obtenir un cordon plus long au besoin.

 **Avertissement :** Avant de commencer tout exercice, il convient de s'assurer que le cordon de sécurité est bien fixé à l'utilisateur et correctement placé sur le tapis de course.

 **Avertissement :** La surface de course doit être recentrée si elle ne se situe pas entre les marques indiquant les positions latérales maximales autorisées. Consultez les instructions d'assemblage du tapis de course.

 **Mise En Garde :** Risque de blessures - pour éviter toute blessure, faire preuve d'extrême prudence pour monter sur un tapis en mouvement, ou pour en descendre. Lisez les instructions d'assemblage avant toute utilisation.

- Ne faites jamais fonctionner le produit dont la fiche ou le cordon d'alimentation sont altérés, ni aucun appareil qui serait tombé, aurait été endommagé ou même partiellement plongé dans l'eau. Contactez le Service clients.
- Placez l'appareil de façon à ce que l'utilisateur ait accès à la fiche du cordon d'alimentation. Assurez-vous que le cordon d'alimentation n'est pas noué ou tordu et qu'il n'est pas coincé sous un autre appareil ou sous tout autre objet.
- Si le cordon d'alimentation électrique est endommagé, il doit être remplacé par le fabricant, par un réparateur agréé ou par une personne qualifiée afin d'éviter tout danger.
- Pour un fonctionnement correct, suivez toujours les instructions de la console.
- Cet appareil n'est pas destiné à être utilisé par des personnes ou des enfants présentant des capacités physiques, sensorielles ou mentales réduites, ou un manque d'expérience et de connaissances, sauf en cas de supervision ou d'instructions relatives à son utilisation par une personne responsable de leur sécurité.
- N'utilisez pas ce produit à l'extérieur, près d'une piscine ou dans des endroits très humides.
- Ne jamais utiliser le produit en ayant les ouvertures d'air bloquées. Maintenez les bouches d'aération exemptes de peluches, de cheveux ou de toute autre obstruction.
- N'insérez jamais d'objet dans les ouvertures de cet appareil. Si un objet tombe dans l'appareil, mettez ce dernier hors tension, débranchez le cordon d'alimentation et récupérez l'objet avec précaution. Si vous ne pouvez pas l'atteindre, contactez le Service clients.
- Ne placez jamais de liquides d'aucune sorte directement sur l'appareil, sauf si vous disposez d'un support ou d'un plateau pour accessoires. Nous vous recommandons de n'utiliser que des récipients pourvus d'un bouchon.
- N'utilisez pas l'appareil pieds nus. Portez toujours des chaussures. Portez des chaussures avec semelles en caoutchouc ou antidérapantes. N'utilisez pas de chaussures à talon, à semelle en cuir, à crampons ou à pointes. S'assurer qu'aucun caillou ne s'est incrusté dans les semelles.
- Éloignez les vêtements amples, les lacets de chaussure et les serviettes des parties mobiles de l'appareil.
- Ne placez pas les mains à l'intérieur ou sous l'appareil ou ne le faites pas basculer sur le côté durant son fonctionnement.
- Cet équipement n'est pas destiné à être utilisé par les enfants. Tenez les enfants âgés de moins de 14 ans à l'écart de la machine.

- Ne laissez aucune personne gêner l'utilisateur ou le fonctionnement de l'appareil pendant l'exercice.
- Laissez les consoles LCD s'adapter à la température ambiante pendant une heure avant de brancher l'appareil et de l'utiliser.
- Ne laissez jamais l'appareil sans surveillance lorsqu'il est branché. Débranchez-le systématiquement après son utilisation, et avant l'ajout et le retrait de pièces. Pour débrancher l'appareil, placez l'interrupteur sur ARRÊT et ôtez la prise électrique du mur.
- Maintenez le cordon d'alimentation à l'écart des surfaces chaudes. Ne tirez pas l'appareil par son cordon et n'utilisez pas celui-ci comme une poignée. Ne faites pas passer le cordon sur le sol, sous le tapis de course, ni le long de l'appareil.
- Les barres d'appui latérales peuvent servir à améliorer la stabilité, le cas échéant, mais elles ne sont pas conçues pour être utilisées de façon continue.
- Ne montez et ne descendez jamais du tapis de course lorsqu'il est en marche. Le cas échéant, utilisez les barres latérales pour renforcer votre stabilité. En cas d'urgence, si vous trébuchez par exemple, saisissez les barres latérales et placez les pieds sur les plates-formes latérales.
- Ne reculez jamais sur le tapis, que ce soit en marchant ou en courant.
- N'utilisez pas l'appareil en présence d'aérosols ou en cas d'administration d'oxygène. Ces substances pourraient entraîner des risques d'incendie et d'explosion.
- Utilisez cet équipement uniquement aux fins auxquelles il est destiné et de la manière décrite dans le présent manuel. N'utilisez pas d'accessoires non recommandés par le fabricant.
- Conformément à la directive Machines 2006/42/EC de l'Union européenne, à vide, cet équipement fonctionne à des niveaux de pression acoustique inférieurs à 70 dB(A) à une vitesse de fonctionnement moyenne de 12 km/h (gamme commerciale) et 8 km/h (gamme domestique). Les émissions sonores sont plus élevées si l'appareil est sous tension qu'à l'état hors tension.
- L'appareil utilisé de manière autonome doit être installé sur une surface stable et plane.
- Lisez les avertissements avant de commencer à vous entraîner.
- Si certaines étiquettes d'avertissement sont manquantes ou endommagées, contactez immédiatement le Service à la clientèle. Nous vous en fournirons de nouvelles. Les étiquettes d'avertissement sont expédiées avec les appareils et doivent être installées avant utilisation de ces derniers. Life Fitness n'est pas responsable des étiquettes manquantes ou endommagées.

Set-Up

Read the entire manual before setting up the treadmill. Place the treadmill where it will be used before beginning the setup procedure.

Electrical Power Requirements

The treadmill requires a dedicated* line with isolated neutral according to the electrical configurations listed in the chart below.







Supply Voltage	Frequency (Hz)	Commercial Units Outlet & Breaker (Amps)	Consumer / Home Units Outlet & Breaker (Amps)
100 / 120	50 / 60	20	15
200 / 220 / 230 / 240	50 / 60	10	10

* **Commercial Units Only:** One individual branch circuit for each treadmill per NEC article 210-21 (b) (1) and 210-22 (or other appropriate, country specific electrical compliance guidelines). The hot and neutral wires must each be routed independently (not looped or tied to other circuits).

 **NOTE:** Do not modify the plug provided with this product. If the plug does not fit into an available electrical outlet, have a proper outlet installed by a qualified electrician.

Grounding Instructions

This product must be properly grounded. If the unit malfunctions or breaks down, proper grounding provides a path of least resistance for the electric current, which reduces the risk of shock to anyone touching or using the equipment. Each unit is equipped with an electrical cord, which includes an equipment grounding conductor and a grounding plug. The plug must be inserted into an outlet that has been properly installed and grounded in accordance with all local codes and ordinances.

-  **WARNING:** A temporary adapter MUST NOT BE USED to connect this plug to a two-pole receptacle in North America. If a properly grounded, 20-amp outlet is not available, one must be installed by a qualified electrician. Models drawing 16 amps or more must be installed on a dedicated line. (Commercial Units Only).
-  **Avertissement :** Si vous êtes aux États-Unis, n'utilisez PAS d'adaptateur temporaire pour raccorder la fiche à un adaptateur bipolaire. Si aucune prise de 20 A correctement mise à la terre n'est disponible, il convient d'en faire installer une par un électricien qualifié. Les modèles utilisant 16 A ou plus doivent être installés sur des lignes qui leur sont réservées. (Gamme commerciale uniquement).
-  **WARNING:** A temporary adapter MUST NOT BE USED to connect this plug to a two-pole receptacle in North America. If a properly grounded, 15-amp outlet is not available, one must be installed by a qualified electrician. (Consumer Units Only).
-  **Avertissement :** Si vous êtes aux États-Unis, n'utilisez PAS d'adaptateur temporaire pour raccorder la fiche à un adaptateur bipolaire. Si aucune prise de 15 A correctement mise à la terre n'est disponible, il convient d'en faire installer une par un électricien qualifié. (Gamme grand public uniquement).
-  **DANGER:** A risk of electrical shock may result from improper connection of the equipment-grounding conductor. Check with a qualified electrician if in doubt as to proper grounding technique. DO NOT modify the plug provided with the product. If it will not fit an electrical outlet, have a proper outlet installed by a qualified electrician. Any modification to the electrical plug will result in a voided warranty.
-  **Danger :** Un branchement incorrect du fil de terre peut entraîner des risques de choc électrique. Consultez un électricien si des doutes subsistent quant à la technique de mise à la terre. NE MODIFIEZ PAS la fiche fournie avec l'appareil. Si cette dernière n'entre pas dans la prise, faites effectuer l'installation par un technicien qualifié. Toute modification de la fiche entraînerait une annulation de la garantie.

How to Position and Stabilize the Treadmill

Follow all safety instructions. Move the treadmill to the location in which it will be used.

 **NOTE:** See *How to Adjust and Tension the Striding Belt* to center the striding belt.

Safety Clearances

The following information is supplied as regional reference data regarding safety clearances around the exterior of the treadmill.

- **EU:** The European EN ISO 20957 Safety Standard requires a 6.5 ft. (2 m) minimum from the rear of the treadmill to any object or surface and at least as wide as the treadmill.
- **U.S. and other regions:** The ASTM International (ASTM) F2115 - 12 Standard recommends the minimum dimensions to be 1.64 ft. (0.5 m) on each side of the treadmill and 6.5 ft. (2 m) behind the rearward most portion of the usable moving surface or 6.5 ft. (2 m) behind the furthest rearward obstruction to emergency egress from the treadmill.

Free area

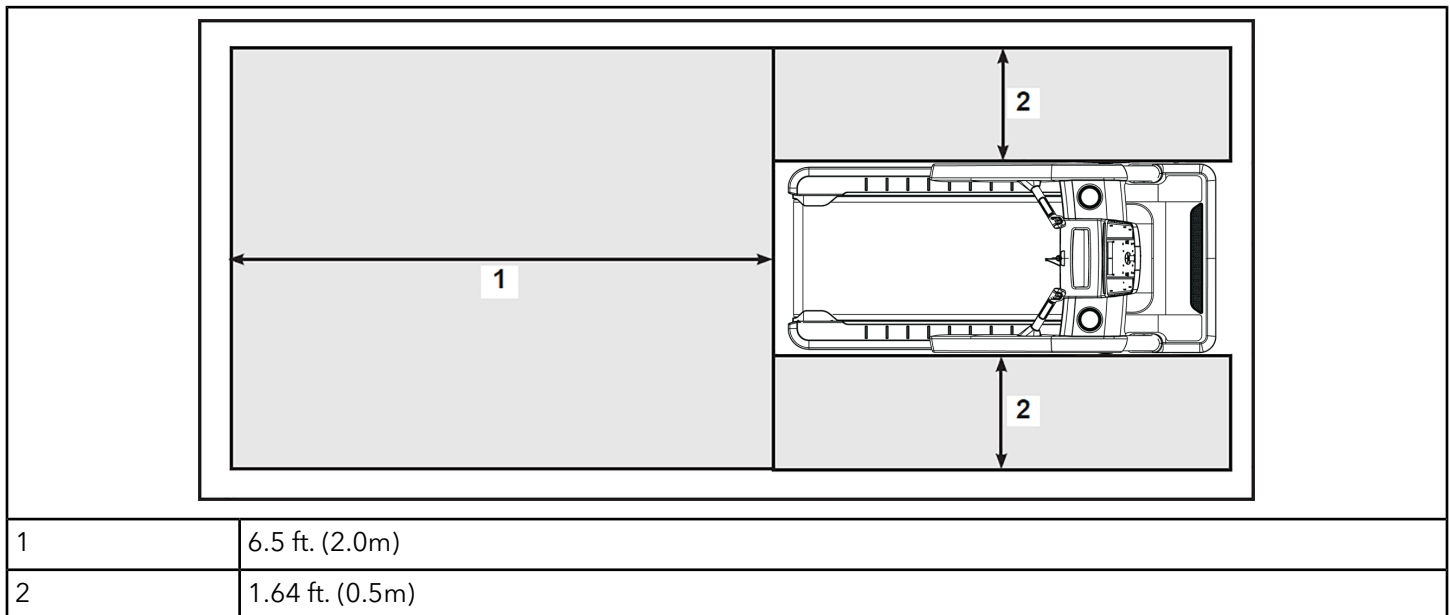

After placing the unit where it will be used, check its stability. If there is even a slight rocking motion or the unit is not stable, determine which stabilizing leg is not resting on the floor. To adjust, loosen the Jam Nut, and turn the Stabilizing Leg until the rocking motion ceases, and both stabilizing legs rest firmly on the floor. Retighten the Jam Nut.

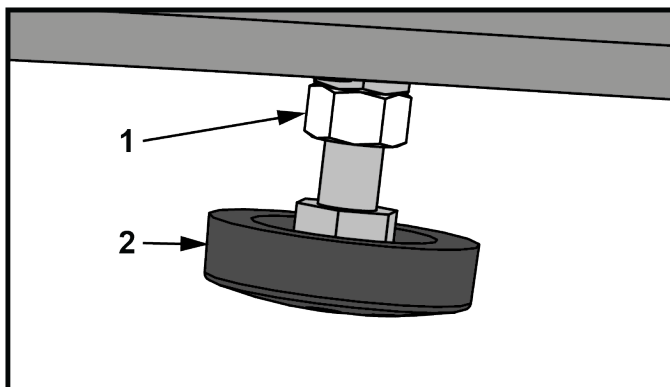

	Description
1	Jam Nut
2	Stabilizing Leg

 **NOTE:** It is extremely important that the stabilizing leg be correctly adjusted for proper operation. An unbalanced unit may cause striding belt misalignment. A bubble level is recommended to ensure proper leveling.

Power Switch

Located on the front panel at the base of the treadmill, the ON/OFF switch has two positions: "I" (one) for ON and "0" (zero) for OFF.

Turning the Unit On

To turn the treadmill on, locate the ON/OFF power switch at the front of the treadmill and turn it ON.

Stride Sensor Auto-Shutoff System

The Stride Sensor auto-shutoff system detects whether a user is on the belt/deck. If the user leaves the belt/deck during a workout, the system is triggered and the following message is displayed, **User not detected on belt - press "OK" to continue workout**. If the user presses **OK** during this message the workout will continue without interruption. If the user does not press **OK** another message will be displayed, **User not detected on belt; RESUME WORKOUT / EXIT WORKOUT**. At this point power to the belt will shut off as the treadmill enters Pause mode. If the user presses **RESUME WORKOUT** during the second message the workout will be resumed. If the user does not press **RESUME WORKOUT**, the treadmill will continue in Pause mode and eventually end the workout. This feature can be disabled in the Manager's Configuration.

Immobilization Method - Basic Console

The purpose of immobilizing the treadmill is to prevent unauthorized use. The system causes immobilization of the treadmill when a pre-defined hard key sequence has been activated.

To prevent false toggling of the Immobilized feature, this sequence must be done in a 5-10 second period.

1. Press the **STOP** key 3 times.
2. Press the **SPEED DOWN** arrow key 3 times.

Immobilization Method - Featured Console

The purpose of immobilizing the treadmill is to prevent unauthorized use. The system causes immobilization of the treadmill when activated.

1. Go to the Workouts Selection Screen.
2. The touch sequence is **UPPER-LEFT, UPPER-RIGHT, UPPER-LEFT**, and **UPPER-RIGHT**.

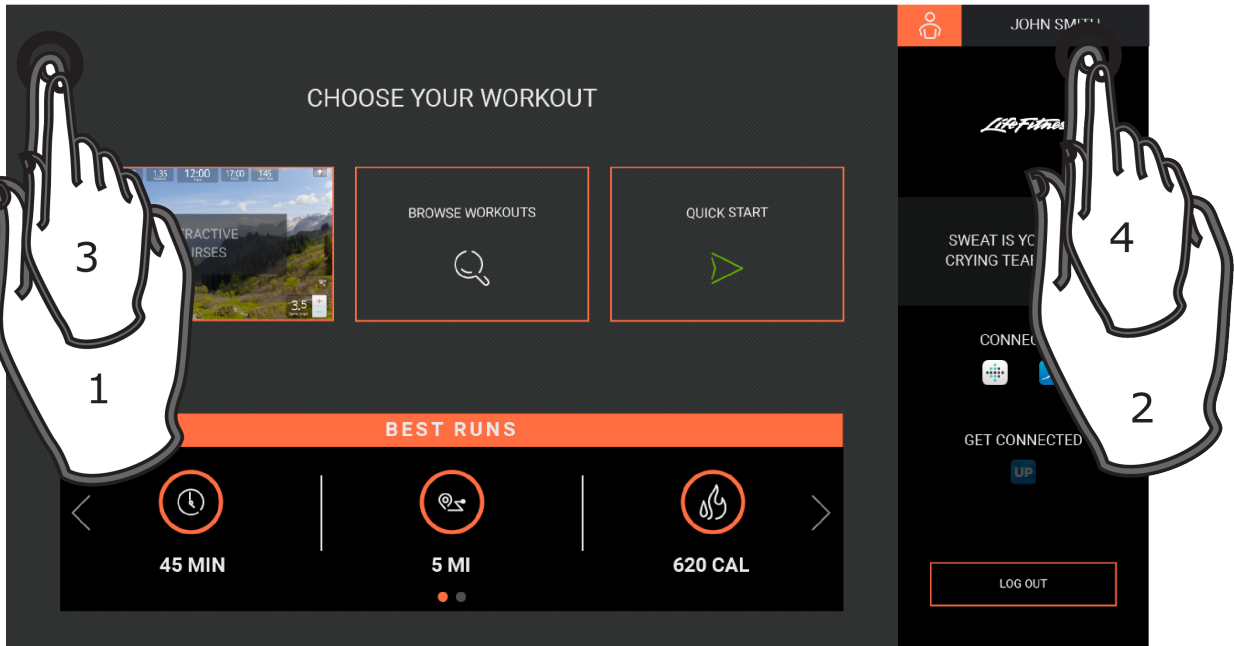

3. Tap the **Immobilize Unit** icon. **Enabled** will be displayed.

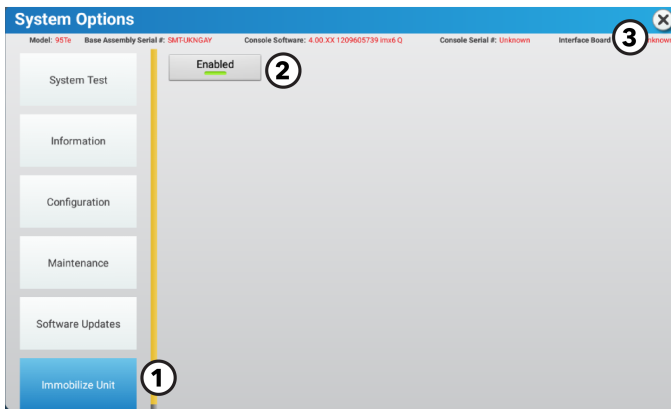

Item	Description	Qty.
1	Immobilize Unit icon	1
2	Enabled icon	1
3	Exit icon	1

4. Tap the exit icon **X** to exit **System Options**.

To turn immobilization off, enter **System Options** and tap the **Immobilize Unit** icon to disable.

2. Product Overview

INTDX, INTDSE, INTDST, PF-INT-TRD, & Club Series +

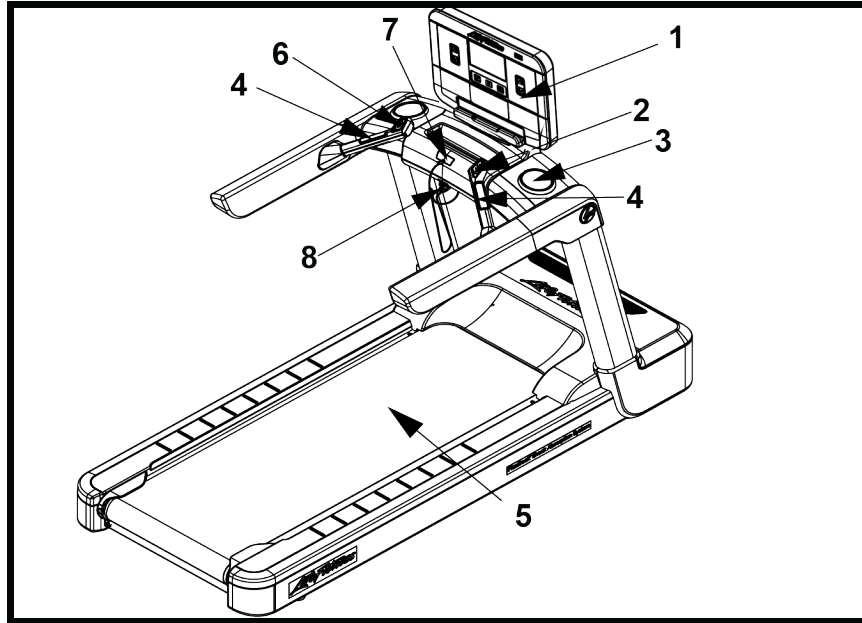

Item	Description
1	Console
2	Speed Up/Down Arrows
3	Cup Holder
4	Contact Heart Rate Sensors
5	Walking Belt
6	Incline Up/Down Arrows
7	Emergency Stop Magnet
8	Emergency Stop Lanyard

INTSX & INTSC

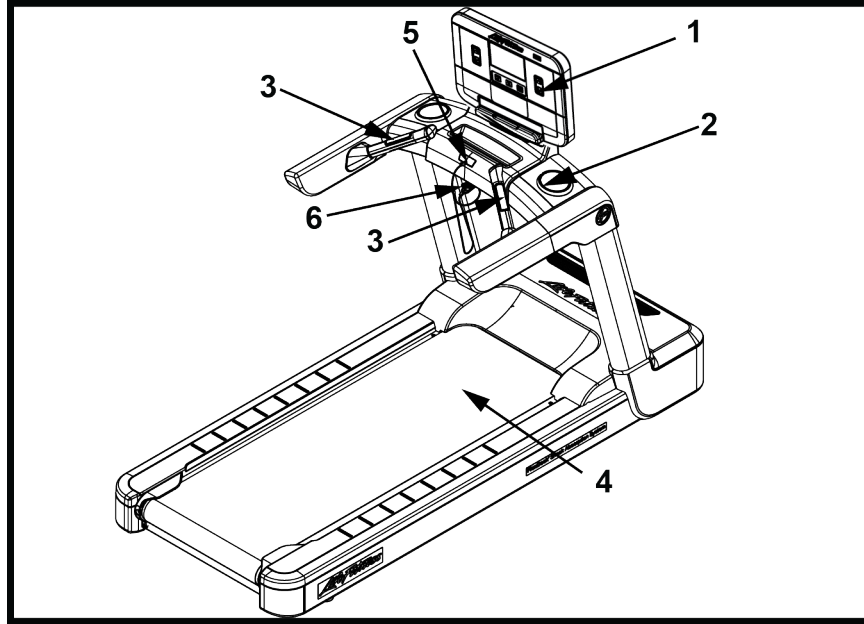

Item	Description
1	Console
2	Cup Holder
3	Contact Heart Rate Sensors
4	Walking Belt
5	Emergency Stop Magnet
6	Emergency Stop Lanyard

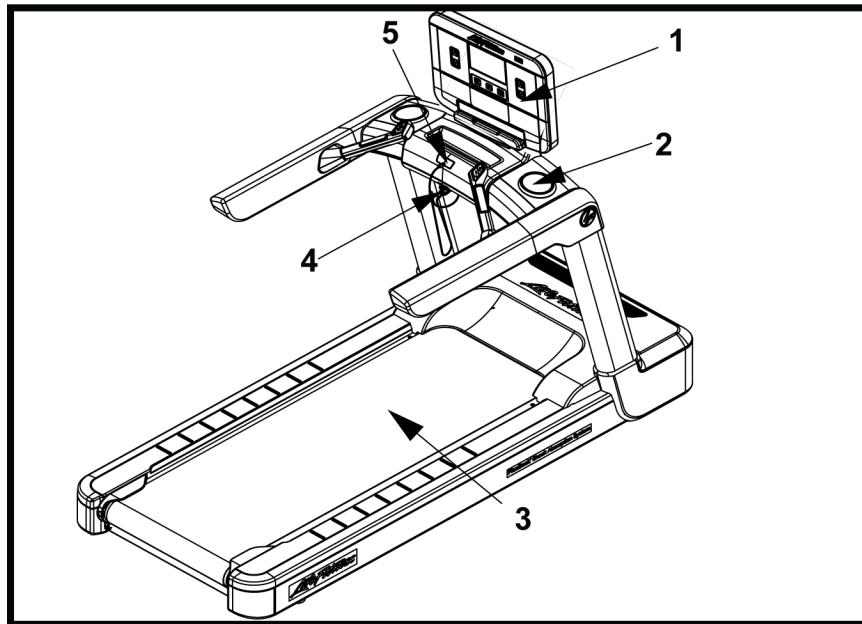

Item	Description
1	Console
2	Cup Holder
3	Walking Belt
4	Emergency Stop Lanyard
5	Emergency Stop Magnet

Mounting and Dismounting the Treadmill

Use the handrails to enhance stability when mounting or dismounting a treadmill. Never mount or dismount the treadmill while the running belt is moving. Use the STOP button on the console to end a workout and stop the running belt. Use the Emergency Stop System to stop the belt immediately.

User Position

The width of the moving walking/running surface is 22 in. (55 cm). Users must keep their feet within this width while in motion. If standing on the stationary side rails, a user should ensure that his/her feet are completely on the non-moving portion. Never step partially on the moving surface and partially on the non-moving surface simultaneously.

- Users can adjust their fore-aft position on the moving belt as desired for reach to the console and handles, clearance for arm swing and attachment of the safety stop pull cord. Do not step on the rear roller.
- It is recommended that the user run within the length of the side handrails to allow usage of the side arms to dismount the belt if needed.

Using and Testing the Emergency Stop System



The treadmill is equipped with an Emergency Stop System. The system consists of a rectangular stop magnet (located on the upper bridge plastic) attached to a safety stop pull cord.

Before starting a workout, attach the lanyard on the safety stop pull cord to an item of the user's clothing. During a workout, pull the cord to remove the magnet from the bridge. This will immediately stop the treadmill belt.

 **NOTE:** Test the safety stop pull cord by attaching the lanyard to a user's item of clothing during operation of the treadmill. While the treadmill is on and the console display is active, remove the safety stop pull cord / magnet from the bridge. A message will be displayed on the console similar to "Replace the emergency stop switch". With the safety stop pull cord removed no keys shall function on the treadmill. Place the safety stop pull cord back in place. The treadmill will reset and will be ready for operation.

3. Service and Technical Data

Preventive Maintenance Tips

-  **NOTE:** Safety of the equipment can be maintained only if the equipment is examined regularly for damage or wear. Keep the equipment out of use until defective parts are repaired or replaced. Pay special attention to parts that are subject to wear, as outlined below.
-  **Remarque :** Pour assurer la sécurité du matériel, il convient de l'inspecter régulièrement afin de déceler tout signe d'usure ou d'endommagement. N'utilisez pas l'appareil avant d'avoir réparé ou remplacé les pièces défectueuses. Prêtez une attention particulière aux pièces sujettes à usure, tel que décrit ci-dessous.

The following preventive maintenance tips will keep the product operating at peak performance:

- Locate the product in a cool, dry place.
 - Clean the display console and all exterior surfaces with an approved or compatible cleaner (see Approved and Compatible Cleaners) and a microfiber cloth.
 - Long fingernails may damage or scratch the surface of the console; use the pad of the finger to press the selection buttons on the console.
 - Check operation of the emergency stop system once a week.
 - Inspect and vacuum the area directly surrounding and under the unit regularly.
 - Vacuum around the striding belt regularly to keep debris from accumulating.
 - Inspect exterior parts regularly for wear, particularly the striding belt, deck and line cord.
 - Check to make sure the unit is properly leveled.
 - Check the position (centering) of the striding belt.
-  **NOTE:** Normal belt operating position is for the belt to be located within the belt travel indicators on the rear roller guards. Refer to *Tracking (Centering) A Striding Belt* or contact Customer Support Services for proper alignment instructions.

Approved and Compatible Cleaners

Two preferred cleaners have been approved by reliability experts: PureGreen 24 and Gym Wipes. Both cleaners will safely and effectively remove dirt, grime and sweat from equipment. PureGreen 24 and the Antibacterial Force formula of Gym Wipes are both disinfectants that are effective against MRSA and H1N1.

PureGreen 24 is available in a spray which is convenient for gym staff to use. Apply the spray to a microfiber cloth and wipe down the equipment. Use PureGreen 24 on the equipment for at least 2 minutes for general disinfection purposes and at least 10 minutes for fungus and viral control.

Gym Wipes are large, durable pre-moistened wipes to use on the equipment before and after workouts. Use Gym Wipes on the equipment for at least 2 minutes for general disinfection purposes.

Contact Customer Support Services to order these cleaners (1-800-351-3737 or email: customersupport@lifefitness.com).

Mild soap and water or a mild non-abrasive household cleaner can also be used to clean the display and all exterior surfaces. Use a soft microfiber cloth only. Apply the cleaner to the microfiber cloth before cleaning. DO NOT use ammonia or acid based cleaners. DO NOT use abrasive cleaners. DO NOT use paper towels. DO NOT apply cleaners directly to the equipment surfaces.

Preventive Maintenance Schedule

Item	Weekly	Monthly	Biannually
Console Overlays	Clean		Inspect
Bottle Holders / Accessory Trays	Clean	Inspect	
Console Mounting Bolts			Inspect
Hardware			Inspect
Frame	Clean		Inspect
Plastic Covers	Clean	Inspect	
Lifepulse Sensors	Clean / Inspect		
Striding Belt Centered	Inspect		
Emergency Stop Magnet	Clean / Inspect		
Motor Cover	Clean	Vacuum / Clean	
Motor Electronic Compartment			Inspect
Drive Belt			Inspect
Leg Levelers		Inspect / Adjust	
Front and Rear Rollers			Inspect
Side Step Area	Clean	Inspect	
Side Hand Rails	Clean		Inspect
Ergo™ Front Handlebar	Clean		Inspect

Troubleshooting the Treadmill

No power

Probable Cause	Corrective Action
ON / OFF switch is not in proper position.	Turn the switch to the ON position.
Power source is insufficient.	<p>Plug treadmill into an appropriate circuit. Refer to Grounding Instructions.</p> <p>NOTE: In North America use a dedicated 20 amp circuit for Commercial Units or a 15 amp circuit for Consumer Units.</p> <p> Using a voltmeter, verify power at outlet. If no power exists, reset circuit breaker at panel.</p>
Line cord is damaged.	Replace line cord. Contact Life Fitness Customer Support.
Line cord is improperly seated in socket.	Inspect power connections at wall outlet and at machine for proper contact.

Striding belt slips off- center.

Probable Cause	Corrective Action
Floor surface is uneven.	Check levelers and level treadmill. Check striding belt & re-tension as necessary. Refer to <i>How to Adjust and Tension the Striding Belt</i> .

Maximum speed is reduced.

Probable Cause	Corrective Action
User is pushing striding belt. This occurs when the runner is running faster than the striding belt will travel, with the result of the striding belt being pushed with the runner's feet.	Instruct users not to push striding belt in either direction.
User is stalling striding belt. This occurs with heavier users at lower striding belt speeds. The striding belt will "stall" if the user is traveling slower than the striding belt.	
Striding belt/deck malfunctions. The deck laminate is worn through or the underside of striding belt is glazed over (hard, glossy).	Replace belt and deck.
Power source is insufficient.	Plug treadmill into an appropriate circuit. Refer to Grounding Instructions.  NOTE: In North America use a dedicated 20 amp circuit for Commercial Units or a 15 amp circuit for Consumer Units.

Rubbing sound comes from underneath machine.

Probable Cause	Corrective Action
Foreign objects may be stuck underneath the machine.	Power down the unit and disconnect AC power. Inspect underneath striding belt and machine. Remove any debris or objects that may cause interference with the treadmill.

Display does not illuminate when machine is powered on.

Probable Cause	Corrective Action
<ul style="list-style-type: none"> No power. Loose connection(s). Incorrect console or power supply. 	Check all electrical connections for proper attachment. <ul style="list-style-type: none"> AC outlet and line cord Line cord at treadmill Power switch All console connections All lower electronics connections Contact Life Fitness Customer Support.

Unit resets randomly or pauses.

Probable Cause	Corrective Action
Power source is insufficient.	Plug treadmill into an appropriate circuit. Refer to Grounding Instructions.  NOTE: In North America use a dedicated 20 amp circuit for Commercial Units or a 15 amp circuit for Consumer Units.
Damaged ground prong is on line cord.	Replace line cord.
Line cord improperly seated in electrical outlet.	Inspect power connection at electrical outlet and at machine for proper contact.
Emergency stop magnet is not engaged.	Re-engage the emergency stop magnet.

Probable Cause	Corrective Action
Towel or other item may be making contact with stop switch while user is running.	Move all possible obstructions off display console and handlebar. Contact Life Fitness Customer Support.
Stop switch is activated with very light pressure or returns slowly after being pressed.	
Stop switch cable is not making proper contact.	
Main wire harness is pinched.	
Ground path is open.	

Troubleshooting the Polar® Heart Rate Chest Strap

Heart rate reading is erratic or absent entirely

Probable Cause	Corrective Action
Belt transmitter electrodes are not wet enough to pick up accurate heart rate readings.	Wet the belt transmitter electrodes.
Belt transmitter electrodes are not laying flat against the skin.	Ensure the belt transmitter electrodes are laying flat against the skin.
Belt transmitter needs cleaning.	Wash the belt transmitter with mild soap and water.
Belt transmitter not properly set up.	Setup of the belt transmitter is accomplished by initially bringing it within 1 foot of the receiver. The receiver is in the console. After the heart rate is displayed on the console the range is extended to 3 feet.
Chest strap battery is depleted.	Contact Customer Support Services for instructions on how to have the chest strap replaced.

Abnormally elevated heart rate readings

Probable Cause	Corrective Action
Electromagnetic interference from television sets and/or antennas.	Move the exercise equipment a few inches away from the probable cause, or move the probable cause a few inches away from the exercise equipment, until the heart rate readings are accurate.
Electromagnetic interference from cell phones.	
Electromagnetic interference from computers.	
Electromagnetic interference from cars.	
Electromagnetic interference from high voltage power lines.	
Electromagnetic interference from motor driven exercise equipment.	

How to Adjust and Tension the Striding Belt

Do not move the treadmill or place hands under the treadmill while it is plugged into an electrical outlet!

Belt Tensioning Bolts

An 8mm hex key wrench is required for this task. The treadmill has access holes in the rear roller guards which allow access to the tensioning bolts. These tensioning bolts make it possible to adjust the tracking and centering of the striding belt without removing the guards.

NOTE: It is extremely important that the treadmill be correctly leveled prior to any tracking adjustments. An unstable unit may cause striding belt misalignment. See *How To Stabilize the Treadmill* prior to attempting any rear roller adjustments.

Before proceeding, it is helpful to visualize the pivot point of the rear roller. Each adjustment made to one side of the roller must be met with an equal and opposite adjustment to the other side of the roller to maintain an ideal belt tension at the pivot point.

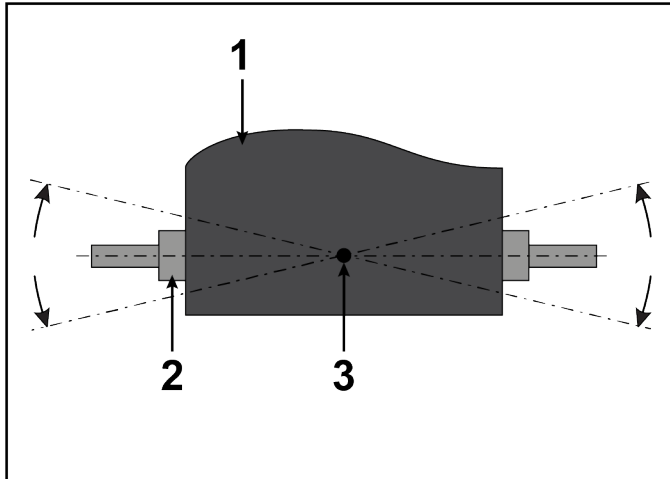

Item	Description	Qty.
1	Belt	1
2	Rear Roller	1
3	Pivot Point of Rear Roller	1

Tracking (Centering) A Striding Belt

Two people are needed to perform this procedure.

1. Locate the two access holes to the belt tensioning bolts on each of the rear roller guards.
2. One person stands on the side rails of the treadmill and straddles the belt. This person presses GO and sets the belt speed to 2.5 MPH (4.0 KPH).
3. If the striding belt has moved to the right, the second person turns the right tension bolt a quarter-turn clockwise and then turns the left tension bolt a quarter-turn counter-clockwise to make the striding belt track back to the center of the roller. If the striding belt has moved to the left, turn the left tension bolt a quarter-turn clockwise and then turn the right tension bolt a quarter-turn counter-clockwise to make the striding belt track back to the center of the roller.

NOTE: If the striding belt has moved as far as to the edge of the roller (either right or left side), it must be re-centered per the above procedure.

4. Repeat the adjustments until the striding belt appears centered. Allow the machine to continue running for several minutes at 4.0 MPH. (6.4 KPH) to observe if tracking remains stabilized.

NOTE: Do not exceed one full turn of the adjusting screws in either direction. If after one full turn the belt does not track properly, contact Life Fitness Customer Support. Do not overtighten the tensioning bolts while making belt adjustments. Overtightening of bolts may over stretch and damage the striding belt or roller.

Tensioning an Existing Striding Belt

1. Press GO and operate the treadmill for five minutes at 5.0 MPH (8.0 KPH).
 **NOTE:** Do not run or walk on belt!
2. Reduce the speed to 2.0 MPH (3.2 KPH). Walk on the treadmill. Tightly grip the handrails and apply force with feet on the striding belt near the motor cover against the moving belt direction. If the belt slips, continue to Step 3. If it does not slip, the tension is correct.
3. Using the STOP key, stop the treadmill. Turn the belt tensioning bolts a quarter-turn clockwise for each side.
4. Repeat STEPS 2 and 3 until the belt no longer slips. Do not exceed one full turn (four quarter turns) per side when adjusting the belt tensioning bolts.
5. Press GO, operate the treadmill at 2.0 MPH (3.2 KPH) and check to insure proper tracking (see *Tracking (Centering) A Striding Belt*). If the striding belt drifts to the left or right see *Centering an Existing or New Striding Belt*. Do not overtighten the tensioning bolts while making belt adjustments. Overtightening of bolts may over stretch and damage the striding belt or roller bearings. Do not exceed one full turn of either bolt in either direction.

Service Wheel (optional)

A service wheel lever is located at the rear end of the unit. This lever will engage a wheel and elevate the rear end of the unit. The treadmill can then be easily moved for cleaning or servicing.

-  **WARNING:** Shock and electrocution hazard.
- Unplug unit and let sit 10 minutes before cleaning or performing maintenance.
 - Electrical charge can remain in unit after unplugging.
 - Keep water and liquids away from electrical parts.

Engage service wheel

1. Unplug power cord from power outlet.
2. Grasp the service wheel lever and slide to the right and down to lock in place.

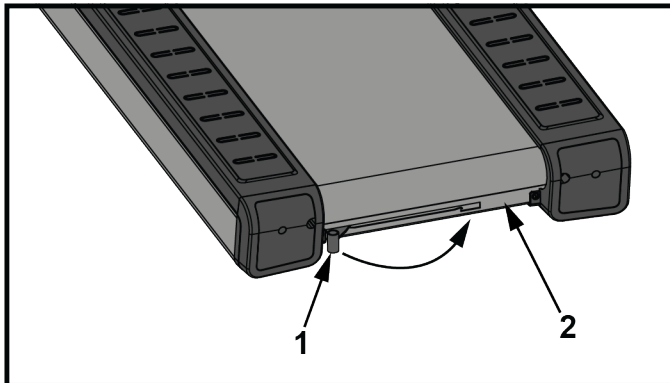

	Description	Qty.
1	Service wheel lever	1
2	Frame	1

The service wheel will lower and raise the rear feet off the floor.

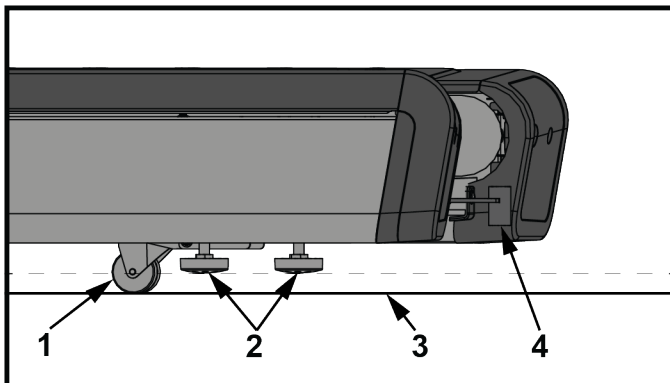

	Description	Qty.
1	Service wheel	1
2	Rear feet	2
3	Floor	1
4	Service wheel lever	1

3. Move treadmill as needed.

Disengage service wheel

⚠ WARNING: Trip and fall hazard. To avoid injury, make sure service wheel lever is not engaged prior to use.

1. Grasp the service wheel lever and slide to the right, lift up, and slide to the left.

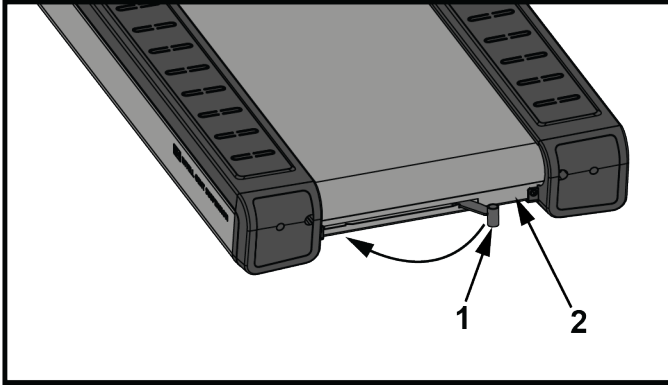

	Description	Qty.
1	Service wheel lever	1
2	Frame	1

2. Plug the power cord into the power outlet.

How to Obtain Product Service

1. Verify the symptom and review the operating instructions. The problem may be unfamiliarity with the product and its features and workouts.
2. Locate and write down the serial number of the unit which is located on the back of the unit near the toe guard.
3. Contact Customer Support at <http://www.lifefitness.com>.

4. Assembly: INTSC, INTSX, INTDX, INTDSE, INTDST, INTSSE, INTST, INTOTF, Club Series +

Hardware and Required Tools

Hardware

1	M8 X 20 FLANGE HEX HEAD CAP SCREW
2	M4.2 X 19 PHILLIPS PAN HEAD SCREW
3	M6 X 16 PHILLIPS PAN HEAD SCREW
4	GROMMET
5	M5 X 14 PHILLIPS PAN HEAD SCREW
6	M5 X 16 PHILLIPS PAN HEAD SCREW

Required Tools:

- 13mm Socket
- Phillips Screw Driver

Attach Uprights

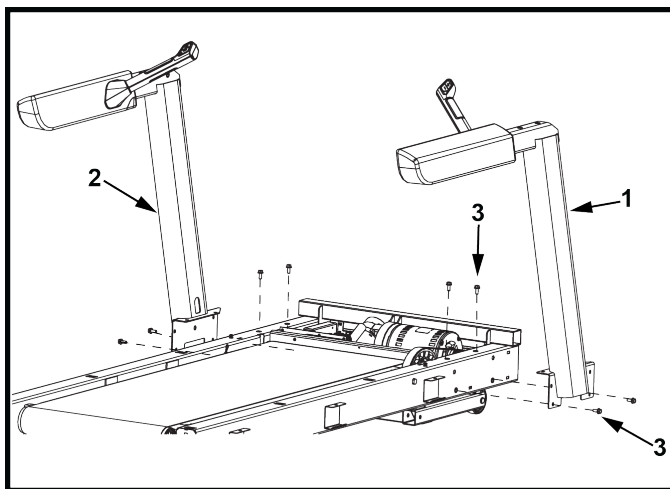

	Description	Qty.
1	Right Upright Assembly	1
2	Left Upright Assembly	1
3	M8 X 20 Flange Hex Head Cap Screw	8
	17.5 Nm (12.9 ft. lbs.)	

Secure Grounding Braid Cable to Base Frame

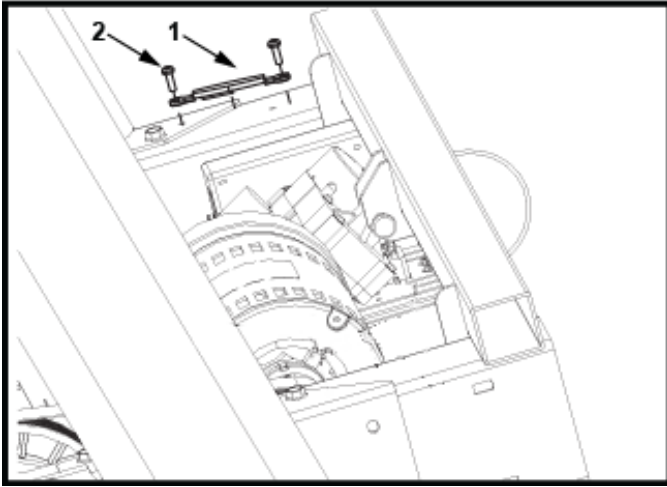

	Description	Qty.
1	Grounding Braid Cable	1
2	M5 X 16 Phillips Pan Head Screw	2
	2.8 Nm (2.0 ft. lbs.)	

Attach Bridge Weldment to Uprights

1. Attach bridge weldment to uprights.

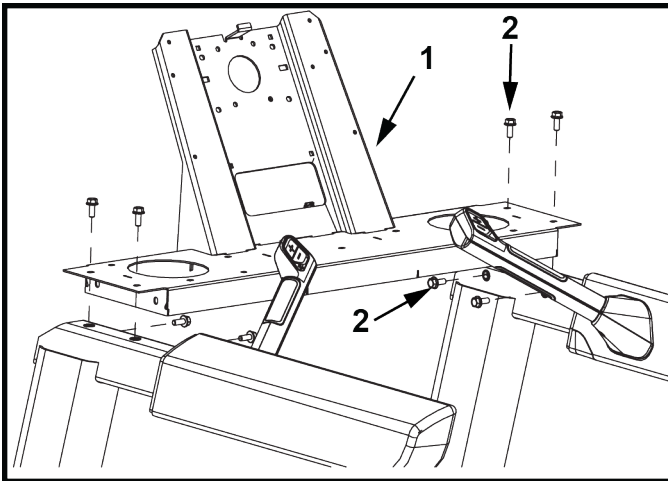

	Description	Qty
1	Bridge Weldment	1
2	M8 X 20 Flange Hex Head Cap Screw	8

2. Torque SIDE screws to 17.5 Nm (12.9 ft. lbs.)
3. Torque TOP screws to 17.5 Nm (12.9 ft. lbs.)

Secure Grounding Braid Cable to Uprights

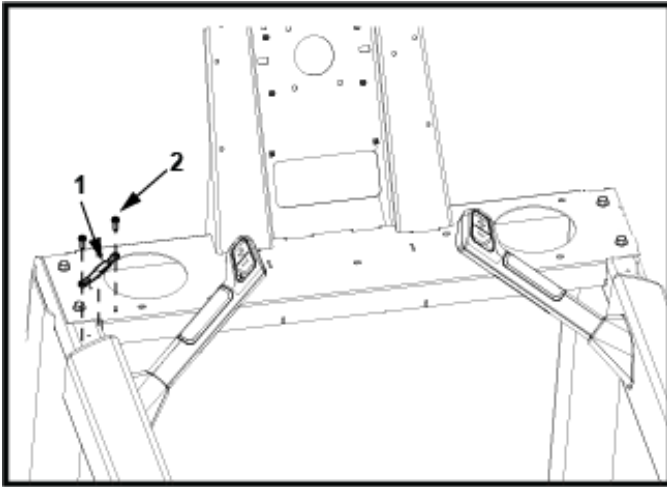

	Description	Qty.
1	Grounding Braid Cable	1
2	M5 X 16 Phillips Pan Head Screw	2
	2.8 Nm (2.0 ft. lbs.)	

Connect Cables

INTDX & Club Series + Bases: Connect Heart Rate Cables and Keypad Cables.

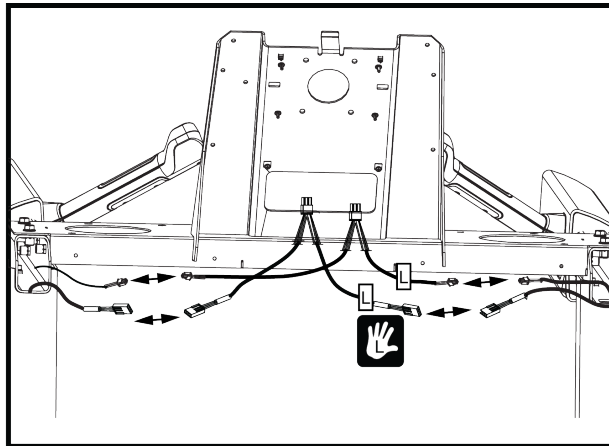

INTSX & INTSC Bases: Connect Heart Rate Cables.

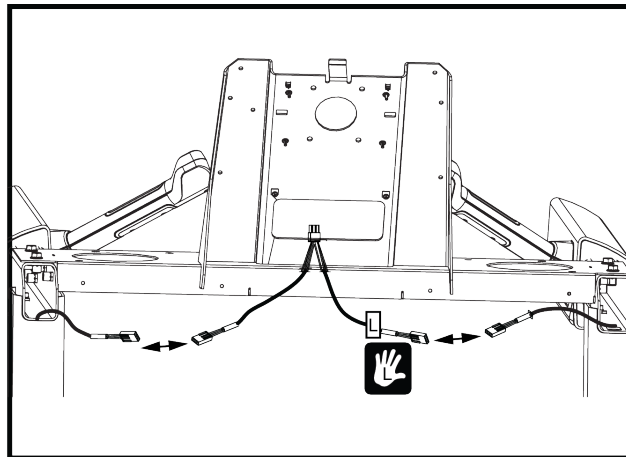

Connect Base Cables

1. Connect cables from left upright to the SIB.

 **NOTE:** Prior to handling electronics or cables, the installer should touch the metal frame of the unit to discharge static build up. This reduces the risk of damaging control electronics due to electrostatic discharge.

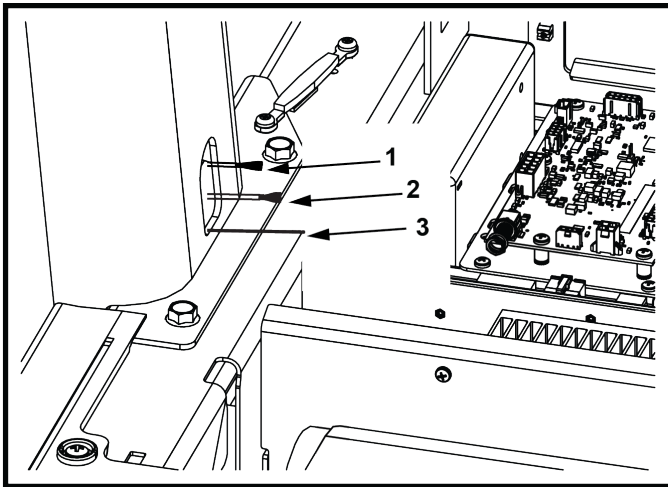

	Description
1	Cable, Console Power
2	Cable, Console to Base Signal
3	Cable, Ground

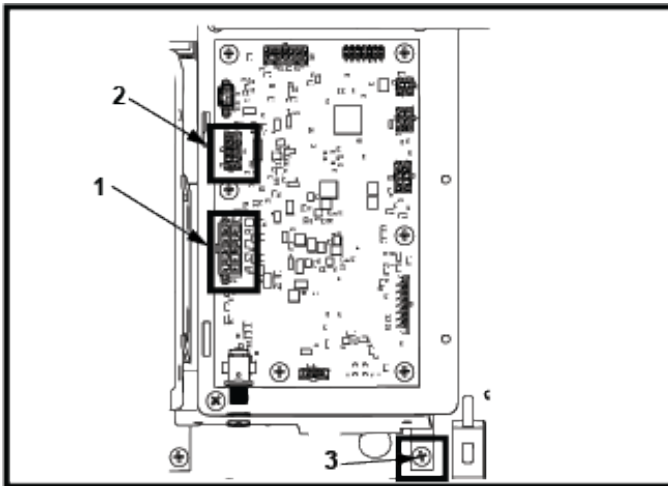

2. Run coax cable (for attachable tv) up the left upright. Tie to other cables.

Attach Upper Plastics to Bridge

 **NOTE:** Align the bridge plastic to the foam arms before securing the bridge plastic to the bridge! Make sure there is a consistent gap across the two sides of the machine.

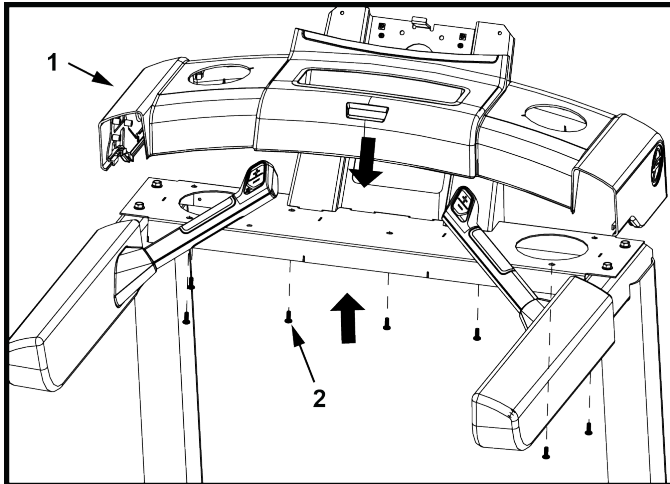

	Description	Qty.
1	Bridge Plastic, Upper	1
2	M6 X 16 Phillips Pan Head Screw	7
	4 Nm (3 ft. lbs.)	

Base to Console Cable Connections - Integrity X / Integrity C

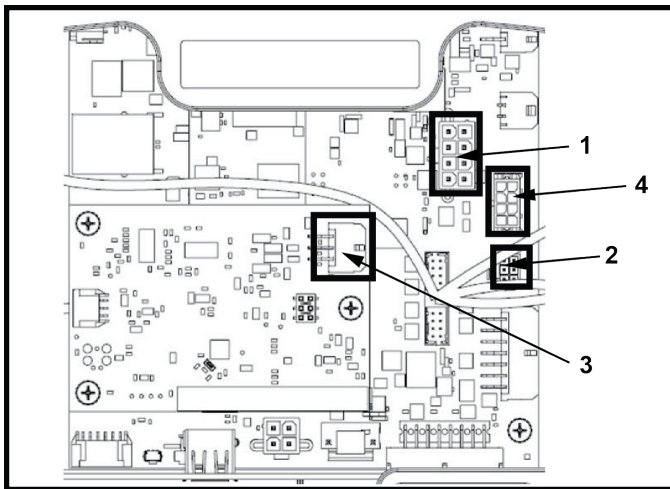

	Description
1	Console to Base Power  NOTE: Initial console production units have a right-angle connector.
2	Bullhorn (Speed / Incline) Keypad Switches
3	Lifepulse
4	Base Signal

Base to Console Cable Connections - Discover SE3 / SE3 HD

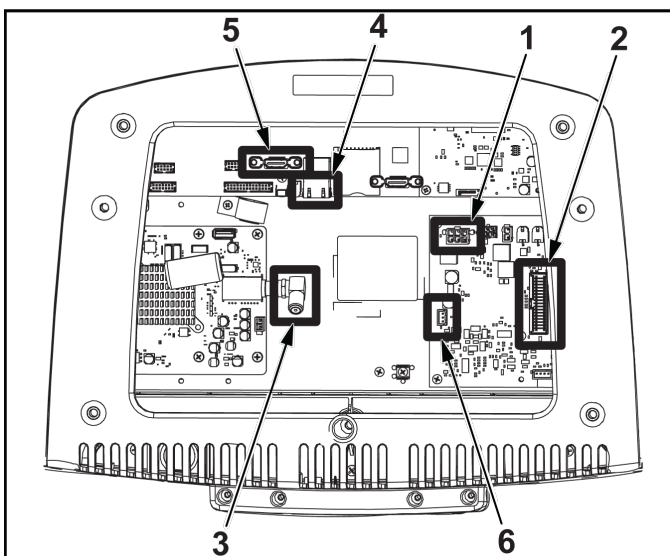

	Description
1	External Power Cable
2	PCB to Console Cable
3	Coaxial Cable
4	CAT5e
5	HDMI
6	IR

Attach Integrity X / Integrity C Console

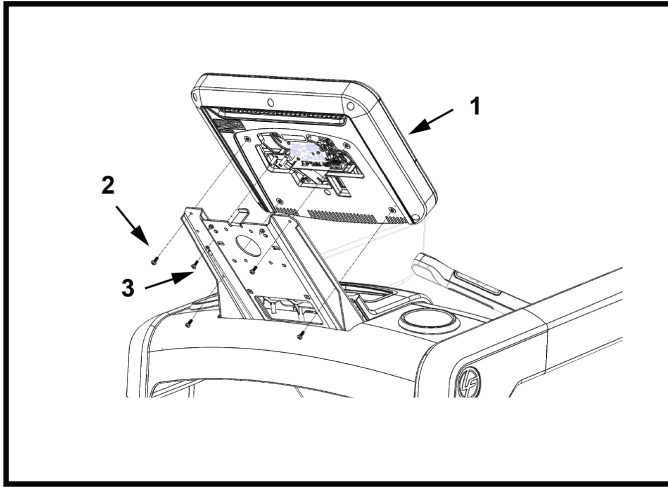

	Description	Qty.
1	Console	1
2	M5 X 14 Phillips Pan Head Screw	5
3	Ground Screw	(see Note)
	1.9 Nm (1.4 ft. lbs.)	

 **NOTE:** The Ground Screw is one of the M5 X 14 Phillips Pan Head Screws accounted for in the row above.

Attach Discover Console

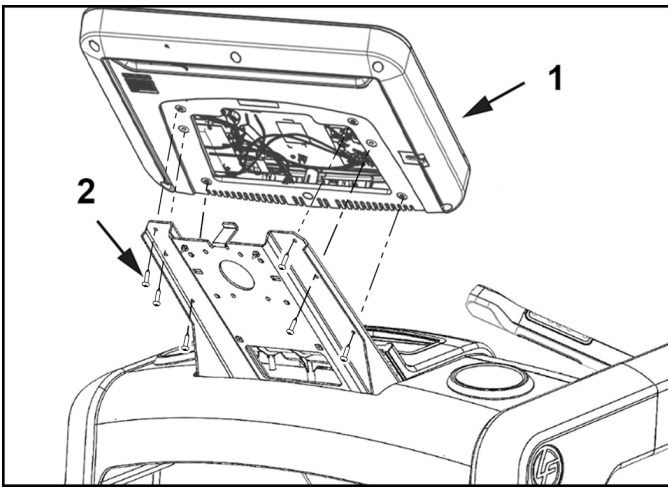

	Description	Qty.
1	Console	1
2	M5 X 14 Phillips Pan Head Screw	6
	1.9 Nm (1.4 ft. lbs.)	

Secure Ferrite to Console to Base Power Cable

Clamp the ferrite to the console to base power cable.

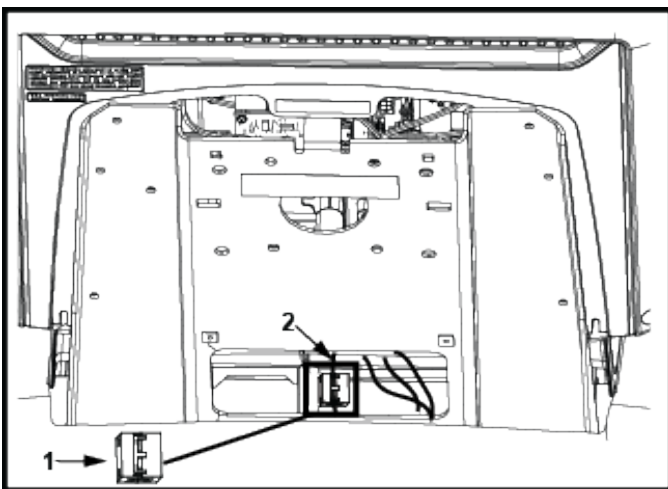

	Description	Qty.
1	Ferrite	1
2	Console to Base Power Cable	1

Route E-Stop Cable

Route the E-stop cable through the lower bridge plastic, and attach the E-Stop cable to the upper bridge plastic.

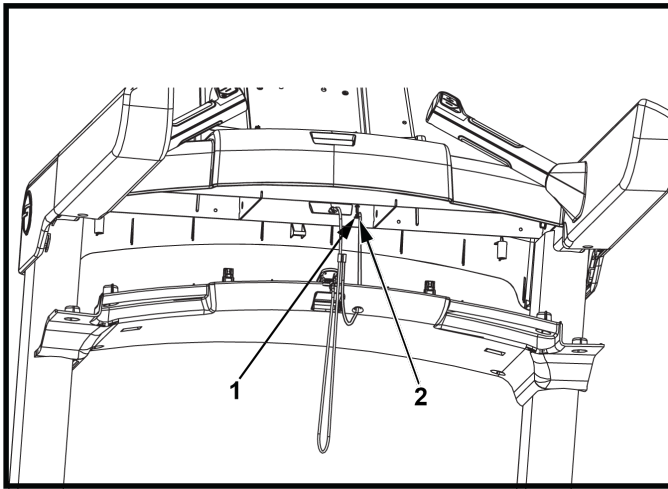

	Description	Qty.
1	E-Stop Cable	1
2	Screw	1

Attach Lower Plastics to Bridge

1. Attach lower bridge plastics to upper bridge plastics.

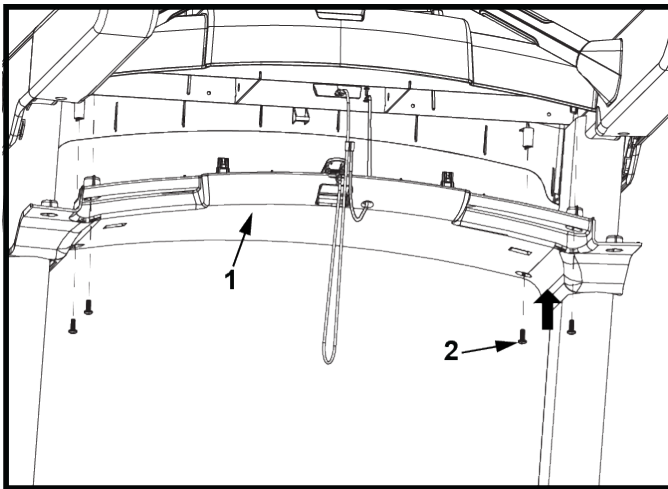

	Description	Qty
1	Bridge Plastics, Lower	1
2	M6 X 16 Phillips Pan Head Screw	4
	4 Nm (3 ft. lbs.)	

2. Secure lower bridge plastics to user arms. Attach emergency stop magnet.

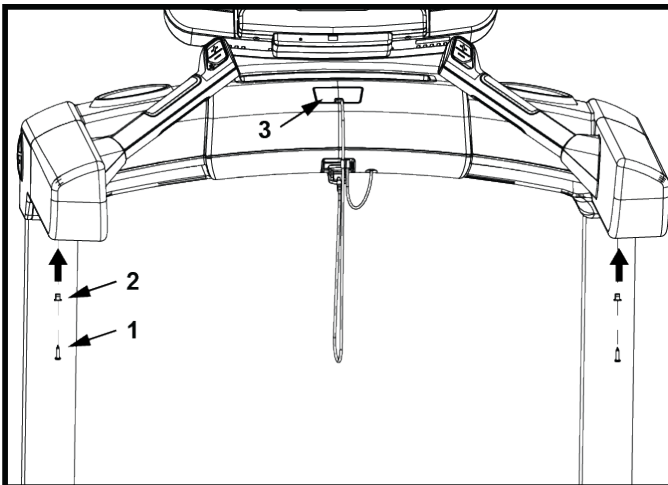

	Description	Qty
1	M4.2 X 19 Phillips Pan Head Screw	2
2	Grommet	2
3	Emergency Stop Switch Magnet	1
	1.5 Nm (1.1 ft. lbs.)	

3. Insert cup holders. Press downward on the cup holders until the cup holders lock into position.

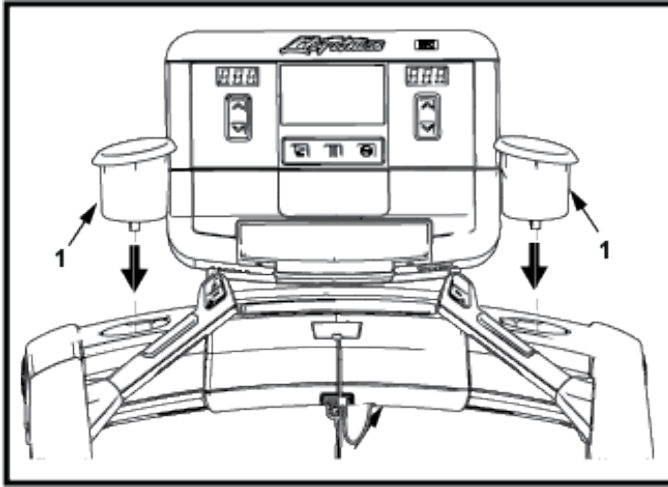

	Description	Qty
1	Cup Holder	2

Attach Rear Cover

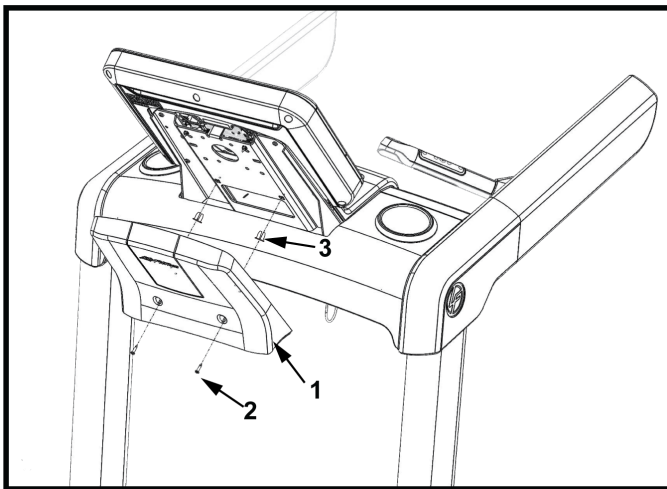

	Description	Qty.
1	Rear Cover	1
2	M4.2 X 19 Phillips Pan Head Screw	2
3	Grommet	2
	1.5 Nm (1.1 ft. lbs.)	

Attach End Caps

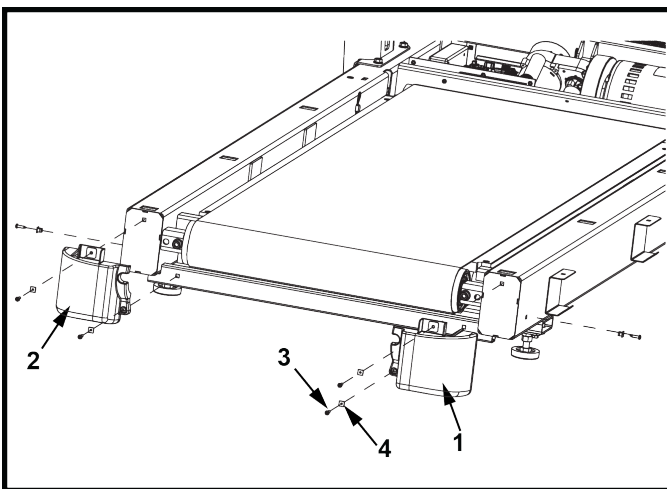

	Description	Qty.
1	End Cap, Right	1
2	End Cap, Left	1
3	M4.2 X 19 Phillips Pan Head Screw	6
4	Grommet	6
	1.5 Nm (1.1 ft. lbs.)	

Attach Side Shrouds

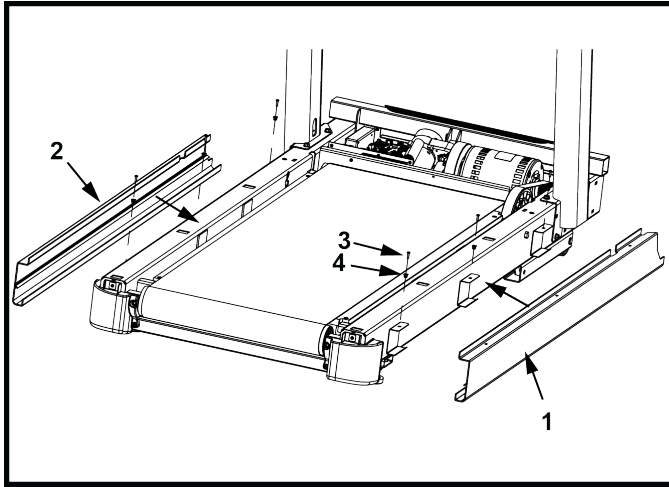

	Description	Qty.
1	Side Shroud, Right	1
2	Side Shroud, Left	1
3	M4.2 X 19 Phillips Pan Head Screw	6
4	Grommet	6
	1.5 Nm (1.1 ft.lbs.)	

Attach Motor Side Shrouds

Snap the motor side shrouds to the base frame.

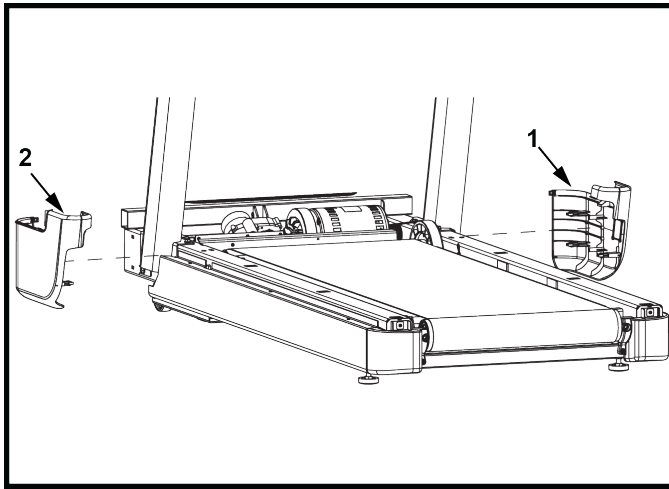

Item	Description	Qty.
1	Motor Side Shroud, Right	1
2	Motor Side Shroud, Left	2

Insert and tighten the screws into the motor side shrouds.

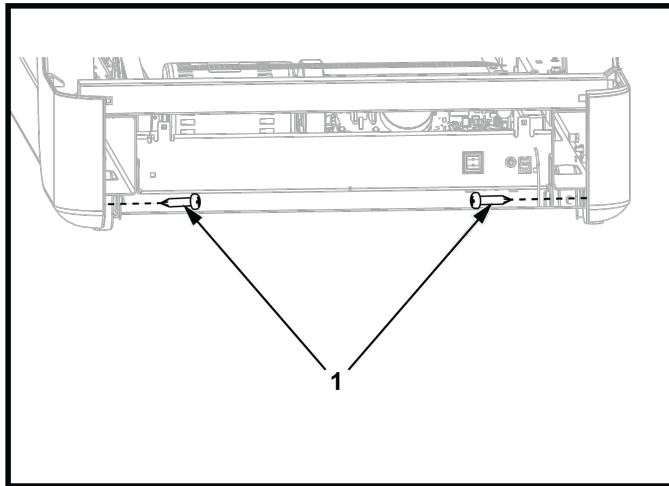

Item	Description	Qty.
1	M6x1.0x16 Screw	2
	4 Nm (3 ft. lbs.)	

Attach Anti-Slip Rails

 **NOTE:** Push the anti-slip rail forward to lock into place. Secure with the screw.

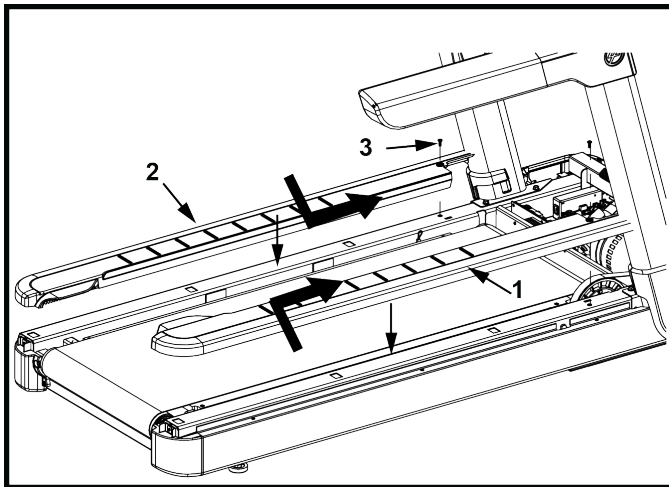

	Description	Qty.
1	Anti-Slip Rail, Right	1
2	Anti-Slip Rail, Left	1
3	M6 X 1.0 X 16 Phillips Pan Head Screw	2
	4 Nm (3 ft. lbs.)	

Attach Front Shroud

1. Insert the grommets into the base frame.

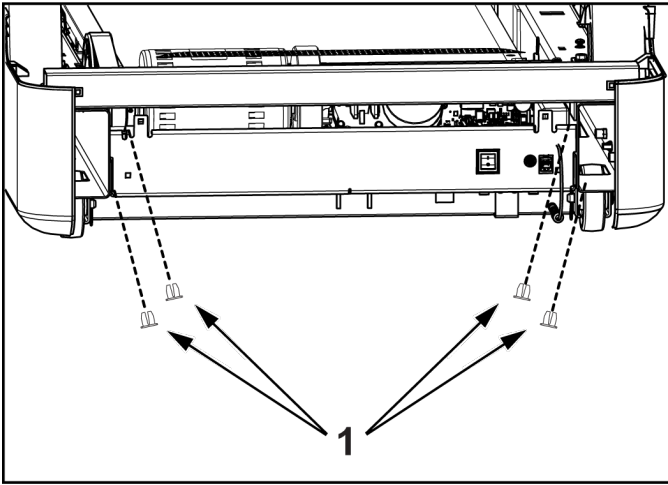

	Description	Qty
1	Grommet	4

2. Tightly secure the four screws to the base frame.

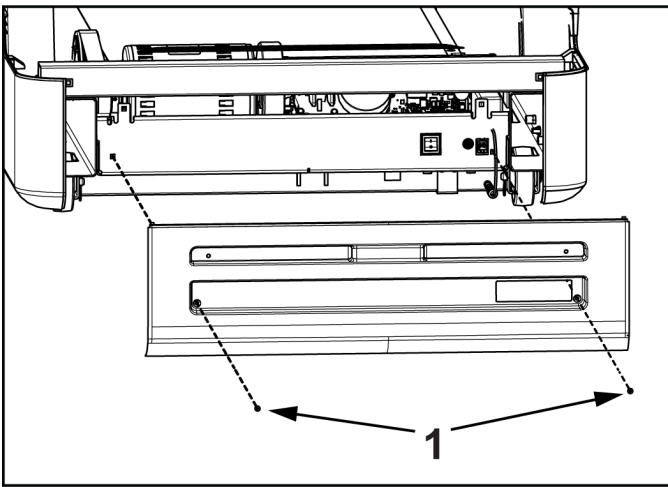

	Description	Qty
1	M4.2 X 19 Phillips Pan Head Screw	4
	1.5 Nm (1.1 ft. lbs.)	

Attach Motor Cover

1. Snap the Tinnerman clips on the motor cover into place.

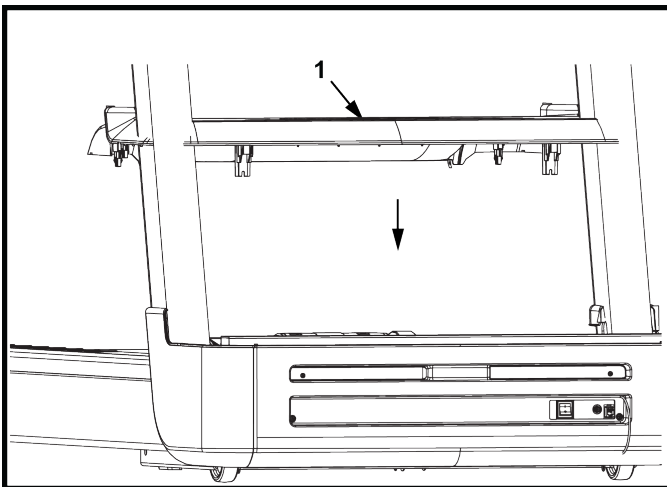

	Description	Qty
1	Motor Cover	1

- Securely tighten the two top screws of the front shroud.

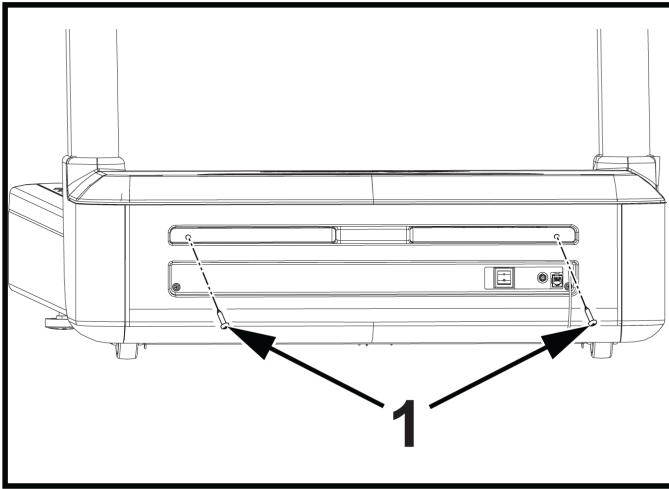

Item	Description	Qty
1	Screw	2
	1.5 Nm (1.1 ft. lbs.)	

Install the Power Cord

- Insert the power cord into the receptacle.

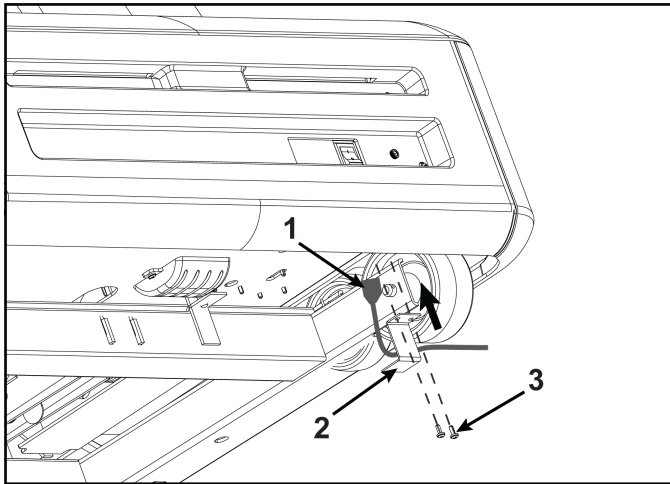

Item	Description	Qty
1	Power cord	1
2	Cable support bracket	1
3	Screws	2

- Attach the cable support bracket to the console using the two screws.

5. Assembly: PF-INT-TRD

Hardware and Required Tools

Hardware

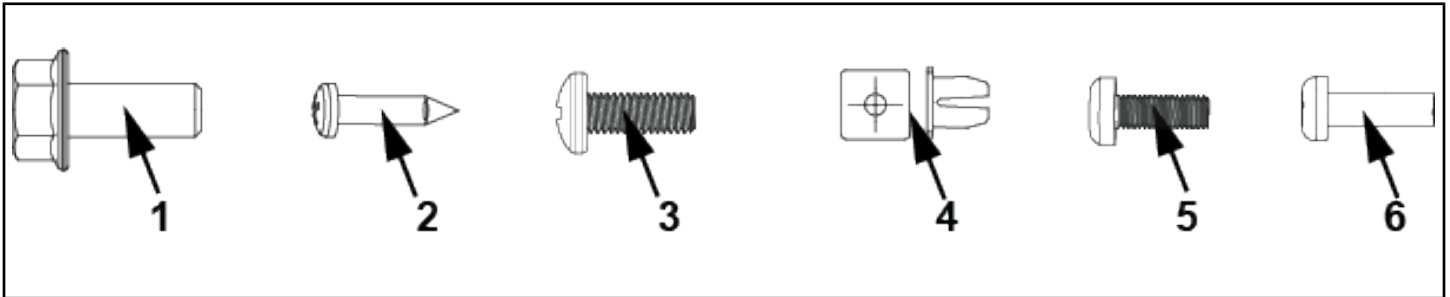



Item	Description	Qty
1	M8 X 1.25 SCREW	6
2	M4.2 X 19 PHILLIPS SCREW	6
3	M6 X 1.0 X 16 PHILLIPS SCREW	4
4	GROMMET	10
5	M5 X 14 PHILLIPS SCREW	5
6	M5 X 16 PHILLIPS SCREW	1

Required Tools:

- 13mm Socket
- 13mm box wrench
- Phillips Screw Driver

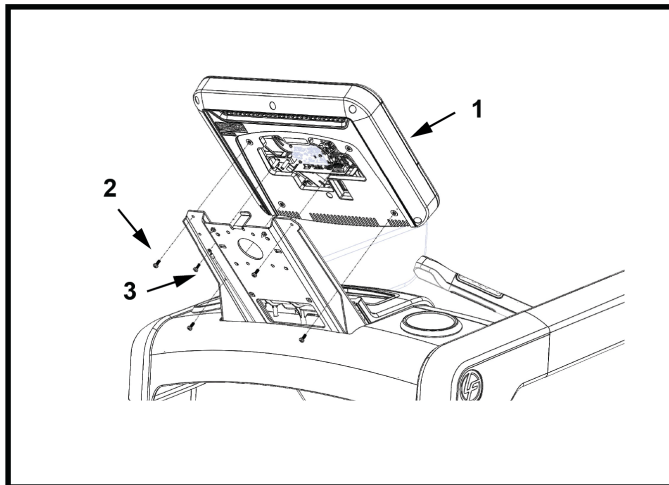
Attach Integrity X / Integrity C Console



	Description	Qty.
1	Console	1
2	M5 X 14 Phillips Pan Head Screw	5
3	Ground Screw	(see Note)
	1.9 Nm (1.4 ft. lbs.)	

NOTE: The Ground Screw is one of the M5 X 14 Phillips Pan Head Screws accounted for in the row above.

Attach Rear Cover

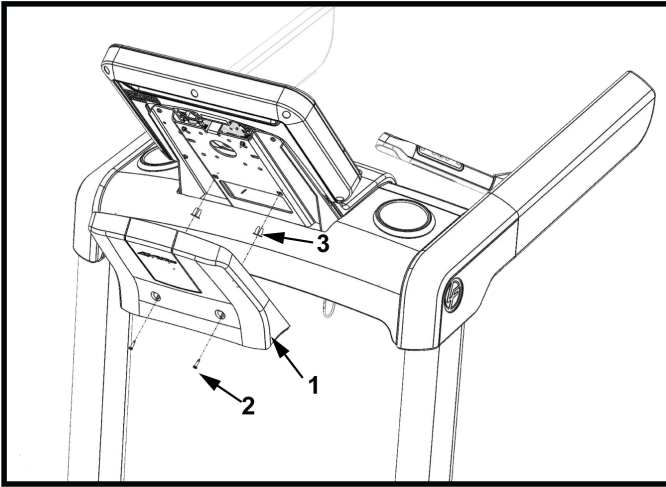

	Description	Qty.
1	Rear Cover	1
2	M4.2 X 19 Phillips Pan Head Screw	2
3	Grommet	2
	1.5 Nm (1.1 ft. lbs.)	

Lifting The Uprights

1.  **NOTE:** Do not remove the pivot screws.

Loosen the pivot screws on the left side and right side of the upright.

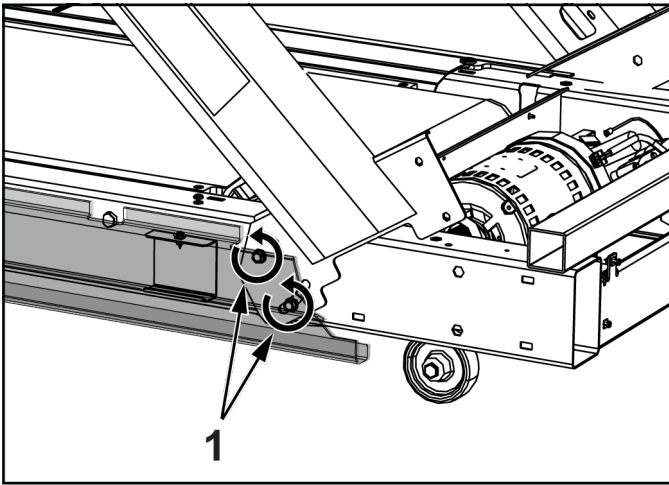

Item	Description	Qty
1	Screw	4

2.  **NOTE:** Two people are required to lift the upright into position.

Lift the upright into position.

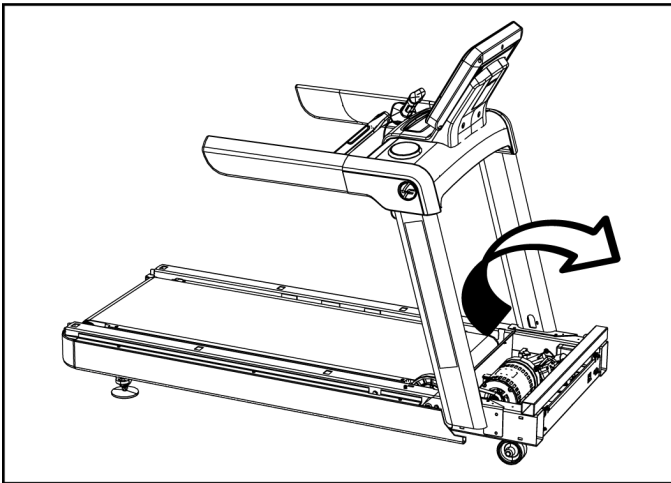

Attach Uprights to Base

Install the screws.

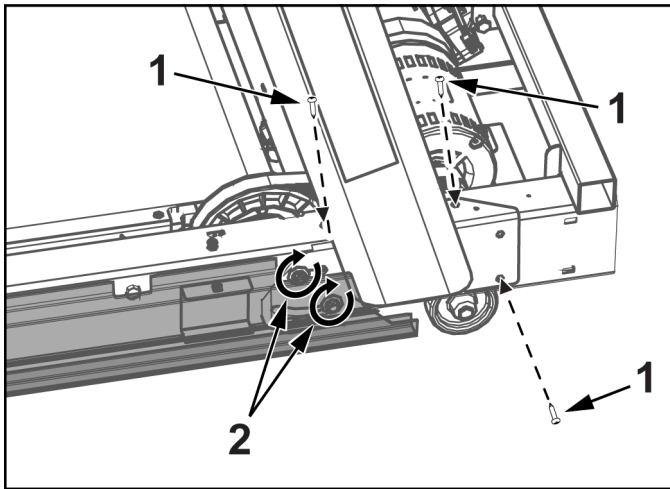

Item	Description	Qty
1	M8 x 1.25 Screw	6
2	Pivot Screw	4
	17.5 Nm (12.9 ft. lbs.)	

Secure Grounding Braid Cable to Base Frame

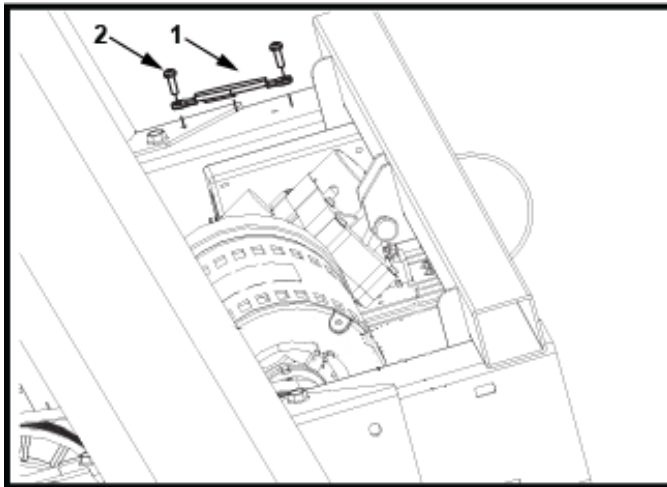

	Description	Qty.
1	Grounding Braid Cable	1
2	M5 X 16 Phillips Pan Head Screw	2
	2.8 Nm (2.0 ft. lbs.)	

Attach Motor Side Shrouds

Snap the motor side shrouds to the base frame.

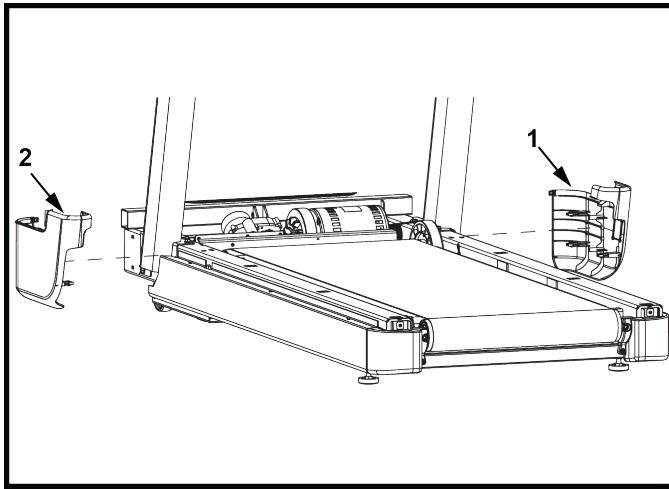

Item	Description	Qty.
1	Motor Side Shroud, Right	1
2	Motor Side Shroud, Left	2

Insert and tighten the screws into the motor side shrouds.

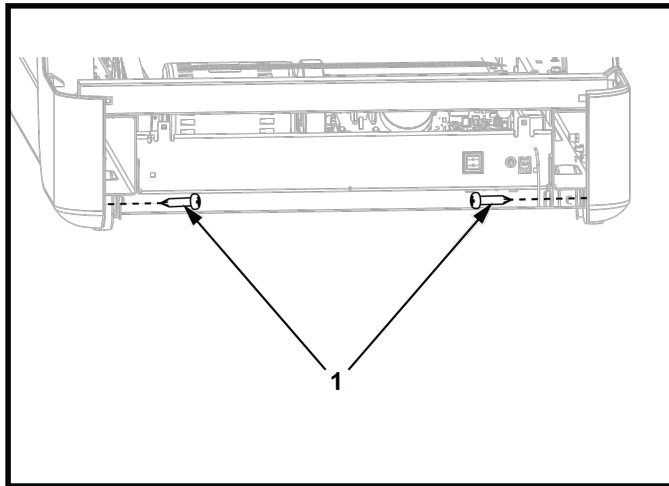

Item	Description	Qty.
1	M6x1.0x16 Screw	2
	4 Nm (3 ft. lbs.)	

Attach Anti-Slip Rails

 **NOTE:** Push the anti-slip rail forward to lock into place. Secure with the screw.

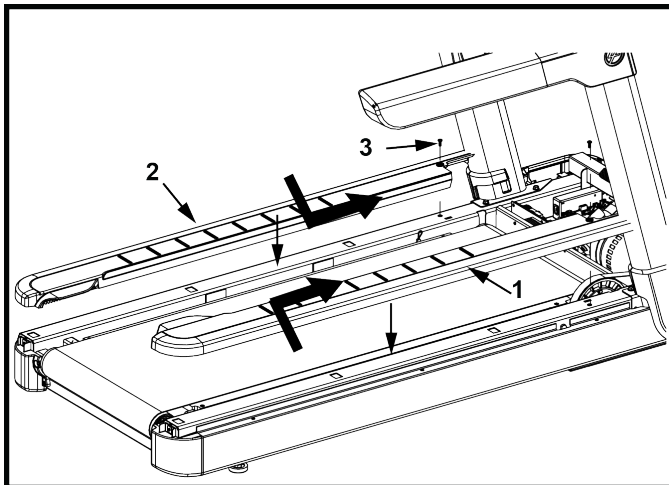

	Description	Qty.
1	Anti-Slip Rail, Right	1
2	Anti-Slip Rail, Left	1
3	M6 X 1.0 X 16 Phillips Pan Head Screw	2
	4 Nm (3 ft. lbs.)	

Attach Front Shroud

1. Insert the grommets into the base frame.

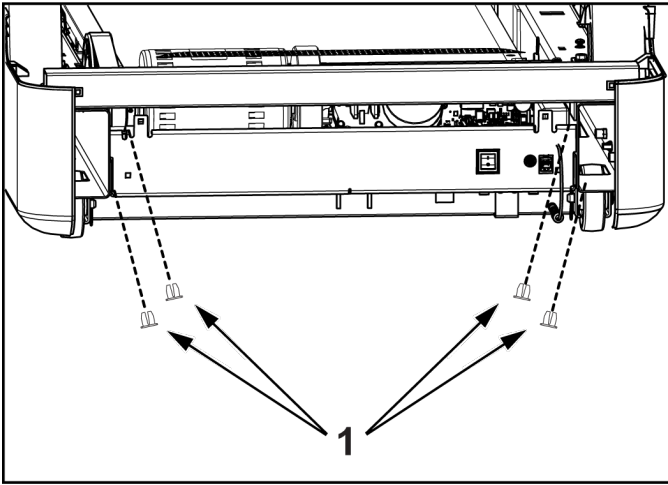

	Description	Qty
1	Grommet	4

2. Tightly secure the four screws to the base frame.

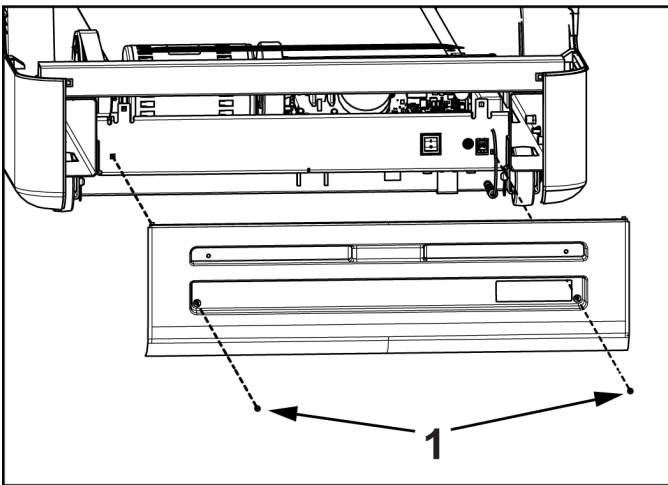

	Description	Qty
1	M4.2 X 19 Phillips Pan Head Screw	4
	1.5 Nm (1.1 ft. lbs.)	

Attach Motor Cover

1. Snap the Tinnerman clips on the motor cover into place.

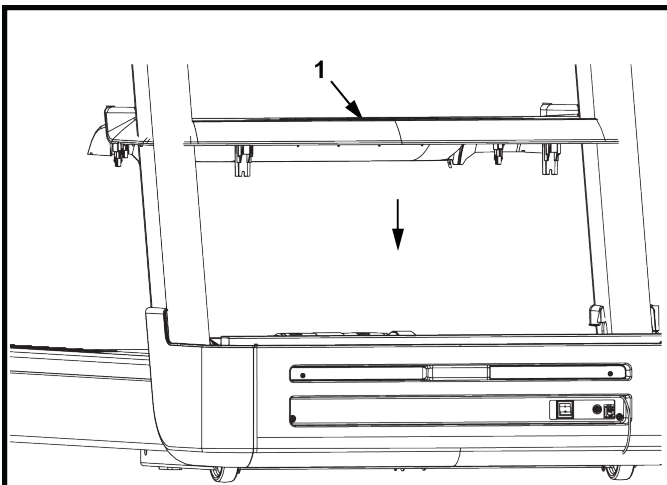

	Description	Qty
1	Motor Cover	1

- Securely tighten the two top screws of the front shroud.

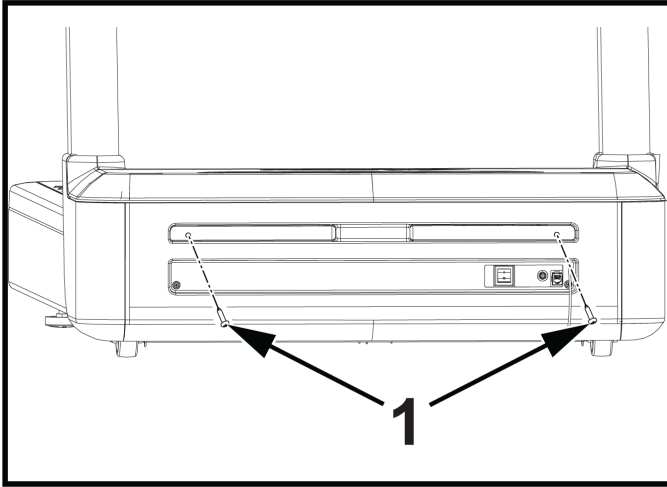

Item	Description	Qty
1	Screw	2
	1.5 Nm (1.1 ft. lbs.)	

Install the Power Cord

- Insert the power cord into the receptacle.

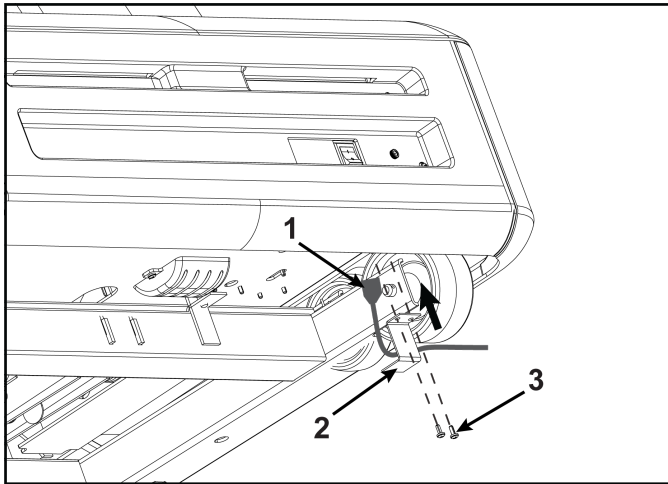

Item	Description	Qty
1	Power cord	1
2	Cable support bracket	1
3	Screws	2

- Attach the cable support bracket to the console using the two screws.

6. Specifications

Specifications

Designed Use	Heavy / Commercial (INTSX, INTDX, INTSC, INTSSE, INTST, INTDSE, INTDST, PF-INT-TRD) EN ISO 20957 Class S
	Home (Club Series +) EN ISO 20957 Class H
Maximum User Weight	400 lbs. / 181 kg
Speed Range	0.5 - 14.0 MPH (0.8 - 23 KPH) in 0.1 increments (INTDX, INTSX, INTSC, INTSSE, INTST, INTDSE, INTDST, PF-INT-TRD)
	0.5 - 12.0 MPH (0.8 - 19 KPH) in 0.1 increments (Club Series +)
Elevation Range	0% - 15%
Drive Train	AC motor with variable speed controller
Motor Type	AC Induction
Motor Size	4-HP AC Continuous Duty (8-HP Peak Duty) Motor. Motor efficiency rated IE2 at 2-HP.
Power Requirements	See <i>Electrical Requirements</i> for requirements outside the U.S.
	Dedicated 120 volt, 20 amp (U.S.) (INTDX, INTSX, INTSC, INTSSE, INTST, INTDSE, INTDST, PF-INT-TRD)
	120 volt, 15 amp (U.S.) (Club Series +)
Rollers	3.5" (9 cm) diameter, precision-crowned, front and back
Striding Belt	60" Length x 22" Width (152 cm Length x 55 cm Width)
Waxing System	Lubricant -infused Striding Belt
Deck Type	3/4" medium density reversible fiberboard
Shock Absorption System	Patented FlexDeck® Shock Absorption System with Lifesprings™
Side Handrail	16" (41 cm) flared
Stop Systems	<ul style="list-style-type: none"> • Red magnetic lanyard emergency stop system • Stride Sensor (INTDX only)
Heart Rate Monitoring Systems	Patented Lifepulse™ digital contact heart rate and Polar® telemetry compatible heart rate monitoring system
CATV (1)	F-type connector

	Physical Dimensions	Shipped Dimensions Box 1	Shipped Dimensions Box 2	Shipped Dimensions S/N PHT
Length	82.25 in. / 2090 mm	87 in. / 2209.8 mm	44 in. / 1116.6 mm	88 in. / 2235.2 mm
Width	36.25 in. / 921 mm	43 in. / 1092.2 mm	68 in. / 1727.2 mm	41 in. / 1041.4 mm
Height	56 in. / 1420 mm	17 in. / 431.8 mm	14 in. / 355.6 mm	53 in. / 1346.2 mm
Step-Up Height	8 in. / 203 mm	N/A	N/A	N/A
Weight	434 lbs. / 197 kg (<i>with console</i>)	354 lbs. / 160.5 kg	140 lbs. / 63.5 kg	572 lbs. / 259.4 kg