

POWERHOUSE[®]

PH3300i Digital Inverter Generator

Owner's Manual



PLEASE READ THIS MANUAL CAREFULLY BEFORE OPERATING THE GENERATOR

Table of Contents

PREFACE	3
QUICK START	4
1. SAFETY INSTRUCTIONS	5
2. COMPONENT IDENTIFICATION	6
2.1. PH3300i Generator	6
2.2. PH3300i Control Panel.....	7
2.3. Generator Identification Numbers	8
3. SETUP & PRE-OPERATION CHECKS	9
3.1. Connecting the 12V Starting Battery.....	9
3.2. Charging the 12V Starting Battery.....	10
3.3. Checking and Adding Engine Oil.....	11
3.4. Checking and Adding Fuel	13
4. STARTUP & OPERATION	14
4.1. Batteries Used During Startup.....	14
4.2. Understanding the Manual Choke.....	14
4.2.1. Basic Choke Settings for Startup and Operation.....	14
4.2.2. Choke Positions: Adjusting for Environmental and Engine Temperatures.....	15
4.3. Electric Start	16
4.4. Recoil Pull Start.....	17
4.5. Environmental Impacts on Generator Performance.....	18
4.5.1. High Altitudes	18
4.5.2. Extreme Temperatures	19
5. USING THE GENERATOR	20
5.1. Run & Overload Lights	21
5.2. Low Oil Alarm System	22
5.3. Stopping the Generator	22
5.4. AC Application	23
5.5. DC Application	24
5.5.1. Powering a DC Device	24
5.5.2. Smart USB Ports	24
5.5.3. Charging an External 12V Battery.....	25
5.6. Powering an Air Conditioner (13,500 BTU).....	26
5.6.1. Using a Start Capacitor When Powering an Air Conditioner	26
6. MAINTENANCE	27
6.1. Maintenance Schedule.....	27
6.2. Changing the Engine Oil	28
6.3. Cleaning the Air Filter Element.....	30
6.4. Cleaning the Spark Plug.....	31
6.5. Cleaning the Spark Arrestor	33
6.6. Replacing the 12V Starting Battery	34
6.7. Replacing the Lithium Ion Batteries.....	35
6.7.1. Checking the Lithium Ion Batteries.....	37
7. TRANSPORTING AND STORING THE GENERATOR	38
7.1. Transporting	38
7.2. Short-Term Storage	38
7.3. Long-Term Storage.....	39
7.4. Exercising the Generator.....	40
8. TROUBLESHOOTING	41
8.1. Engine Will Not Start	41
8.2. Engine Will Not Crank With the Key.....	42
8.3. Appliance Does Not Operate.....	42
8.4. No Output at the DC Receptacle.....	42
9. SPECIFICATIONS	43
10. WARRANTY AND CONSUMER INFORMATION	44
10.1. POWERHOUSE® GENERATOR WARRANTY.....	44
10.2. CALIFORNIA EMISSION CONTROL WARRANTY STATEMENT	45
10.3. EMISSION CONTROL SYSTEM WARRANTY	46
11. APPENDIX A - EMISSION CONTROL SYSTEM	47
12. APPENDIX B - VEHICLE BATTERY CHARGING AND SAFETY INSTRUCTIONS	49

Preface

Thank you for purchasing a POWERHOUSE® generator.

This manual covers the operation and maintenance of the POWERHOUSE® inverter generator model PH3300i.

This manual should be considered a permanent part of the generator and should remain with it if it is resold.

- All information in this publication is based on the latest product information available at the time of printing.
- We reserve the right to make changes at any time without notice and without incurring any obligation.
- No part of this publication may be reproduced without written permission.

If you have a problem with this generator, do not return it to the store where you purchased it.



For warranty support:

Call 1-877-544-4449 from 8am to 6pm ET

Email us at warranty@powerhouse-products.com

Send a fax to 1-855-242-8922

Pay special attention to statements preceded by the following icons:

- | | |
|--|---|
|  WARNING | ▲ Indicates a strong possibility of severe personal injury or death if instructions are not followed. |
|  CAUTION | ▲ Indicates a possibility of personal injury or equipment damage if instructions are not followed. |
| NOTE | Gives helpful information. |

Quick Start

Before starting the generator, read and comply with all safety warnings and cautions in **Section 1: Safety**.

NOTES

- If you are using the generator at high altitude or in extreme temperatures, see **Environmental Impacts on Generator Performance**.
- If you are using the generator to power an air conditioner, see **Powering an Air Conditioner (13,500 BTU)**.
- For details on connecting appliances and operation, see **Using the Generator**.

- 1. CONNECT 12V STARTING BATTERY:** Remove the maintenance door and connect the quick connect cable to the battery wiring harness. Replace the maintenance door.
- 2. CHARGE THE 12V STARTING BATTERY:** Connect an external 12V (max 5A) battery charger to the DC receptacle on the control panel. For details, see **Charging the 12V Starting Battery**.
- 3. ADD OIL:** Remove the engine oil access door. Check the oil level on the dipstick. Fill the oil reservoir with 33.8 fl oz (1.0 L) of a high-detergent, premium quality, 4-stroke engine oil (synthetic or conventional). Ensure the oil level is at the top mark on the dipstick. Replace the engine oil access door. For oil cautions, see **Checking and Adding Engine Oil**.
 - For environmental temperatures above 32°F (0°C), use SAE 10W-30 viscosity oil.
 - For environmental temperatures below 32°F (0°C), use SAE 0W-30 or 0W-40 viscosity oil, preferably synthetic.
- 4. ADD FUEL:** On the top of the generator, remove the fuel cap and carefully add 4.3 gal (16.3 L) regular unleaded automotive gasoline over the fuel strainer. Do not overfill. Replace fuel cap. For fuel cautions and details, see **Checking and Adding Fuel**.
- 5. TURN FUEL VALVE TO ON.** You may need to wait a minute to allow fuel to flow to the carburetor if fuel was added for the first time or after refueling an empty tank.
- 6. SET THE CHOKE TO START.**
- 7. START THE GENERATOR.** For details, see **Startup & Operation**.
 - **Electric Start:** Insert the ignition key. Turn and hold the ignition key in the START position for 15 seconds or until the engine starts. If the engine does not start, stop turning the key for 5 seconds before trying it again.
 - **Recoil Pull Start:** Insert the ignition key. Turn the key to the ON position. On the right side of the generator, grasp the starter grip and pull back lightly until resistance is felt, then pull briskly out. Repeat until the engine starts. Faster pulls generate more spark and enable successful startup.
- 8. MOVE THE CHOKE AFTER ENGINE STARTUP:**
 - **In cold environments**, move the choke slowly toward to the 1/2 position. Allow the engine to warm up, then move the choke slowly toward the RUN (open) position.

NOTES

- In freezing temperatures, allow the generator to warm up for 3 to 5 minutes before connecting heavy loads.
- If the engine falters while moving the choke to the RUN position, move the choke back to the 1/2 or START position. Allow the engine to warm up a little longer, then move the choke to the RUN position again.
- For details, see **Adjusting the Choke for Environmental and Engine Temperatures**.
- **In warm environments**, move the choke slowly to the RUN (open) position.

The green “RUN” light illuminates when the generator is ready for use.

NOTE

If the green RUN light does not illuminate, this is an indication that the inverter self-protection mode has been triggered. You must shut down and restart the generator.

9. BEFORE CONNECTING ANY LOADS:

CAUTION

- ▲ Ground the generator with a length of heavy cable by connecting the generator’s grounding terminal to an external ground source.
- ▲ Make sure that appliances are switched off, in good working condition, and that the combined electrical rating of all connected appliances does not exceed that of the generator (3300W max).

NOTE

For shutdown, see **Stopping the Generator**.

1. Safety Instructions

This generator is designed to give safe and dependable service if operated according to instructions.

Read and understand this Owner's Manual and all labels before operating the generator. Failure to follow instructions could result in personal injury or equipment damage.

WARNING

- ▲ **FAILURE TO FOLLOW SAFETY WARNINGS CAN RESULT IN PROPERTY DAMAGE, SERIOUS INJURY, OR DEATH!**
- ▲ **Generators produce carbon monoxide from exhaust gas. Carbon monoxide is a poisonous, colorless, odorless gas. When inhaled, carbon monoxide can build up to dangerous levels in the bloodstream and cause unconsciousness, leading to serious injury or death within minutes.**
- ▲ Never run the generator in an enclosed or partly enclosed area. Be sure to provide adequate ventilation.
- ▲ Indoor use of a generator can kill quickly. Generators should be used outdoors only, away from garages and open windows, but protected from rain and snow.
- ▲ Do not install this generator inside a compartment which can lead to overheating, fire, or carbon monoxide (CO) poisoning that can cause death by asphyxiation.
- ▲ Gasoline is extremely flammable and explosive under certain conditions. High temperatures inside could cause residual fuel to vaporize resulting in possible explosion.

To ensure safe operation:

WARNING

- ▲ Check for spilled fuel or leaks. Clean and/or repair before use.
- ▲ Keep cigarettes, sparks, and any source of ignition away from generator and the fuel tank at all times.
- ▲ Always stop engine before refueling. Wait 5 minutes before restarting.
- ▲ When refueling, if you accidentally spill gasoline into the engine compartment, allow all fuel to evaporate before starting the engine.
- ▲ Wipe up spilled gasoline at once.
- ▲ The muffler becomes very hot during operation and remains hot for several minutes after stopping the engine. Be careful not to touch the muffler while it is hot.
- ▲ This portable generator is not intended, nor designed, for use as a standby power supply, or to be connected to a manual or automatic transfer switch (ATS); it should never be used as such. Severe damage to the inverter module, property damage, and/or severe personal injury or death may result. Such back feed may electrocute utility company workers or others who contact the lines during a power outage. When utility power is restored the generator may explode, burn, or cause fires in the building's electrical system.

CAUTION

- ▲ To avoid accidents or equipment damage, always perform a pre-operation inspection before you start the engine.
- ▲ This portable generator is not meant to be used as a permanent back-up power system for the home. A permanently installed stationary generator is designed to be safely used for this specific purpose.
- ▲ Let the engine cool before storing the generator indoors.
- ▲ Place the generator at least 3ft. (1m) away from buildings or other equipment during operation.
- ▲ Operate the generator on a level surface. If the generator is tilted, fuel spillage may result.
- ▲ Know how to stop the generator quickly and understand operation of all controls. Never permit anyone to operate the generator without proper instructions.
- ▲ Keep children and pets away from the generator when it is in operation.
- ▲ Keep away from moving parts while the generator is running.
- ▲ Generators are a potential source of electrical shocks when misused; do not operate with wet hands.
- ▲ Do not operate the generator in rain or snow and do not let it get wet.
- ▲ Do not modify the enclosure of this generator.

2. Component Identification

2.1. PH3300i GENERATOR

FRONT OF GENERATOR, RIGHT SIDE

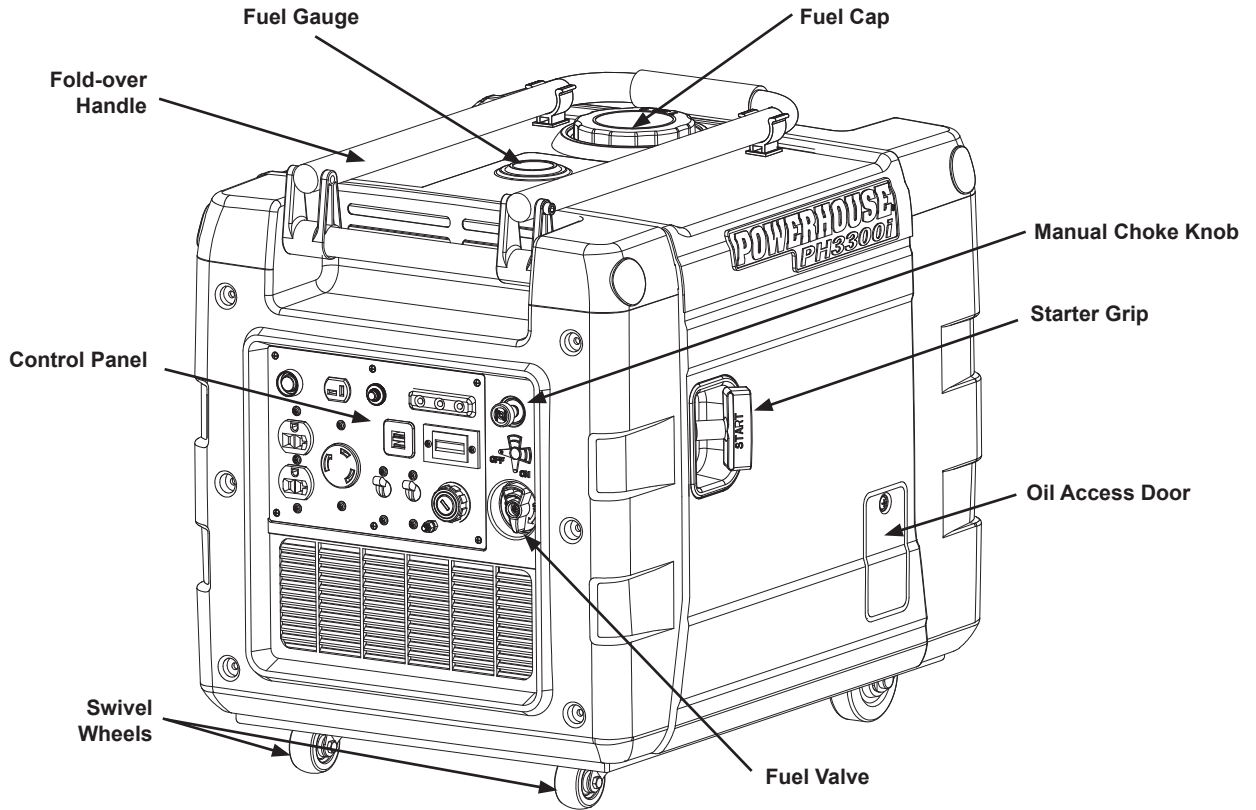

BACK OF GENERATOR, LEFT SIDE

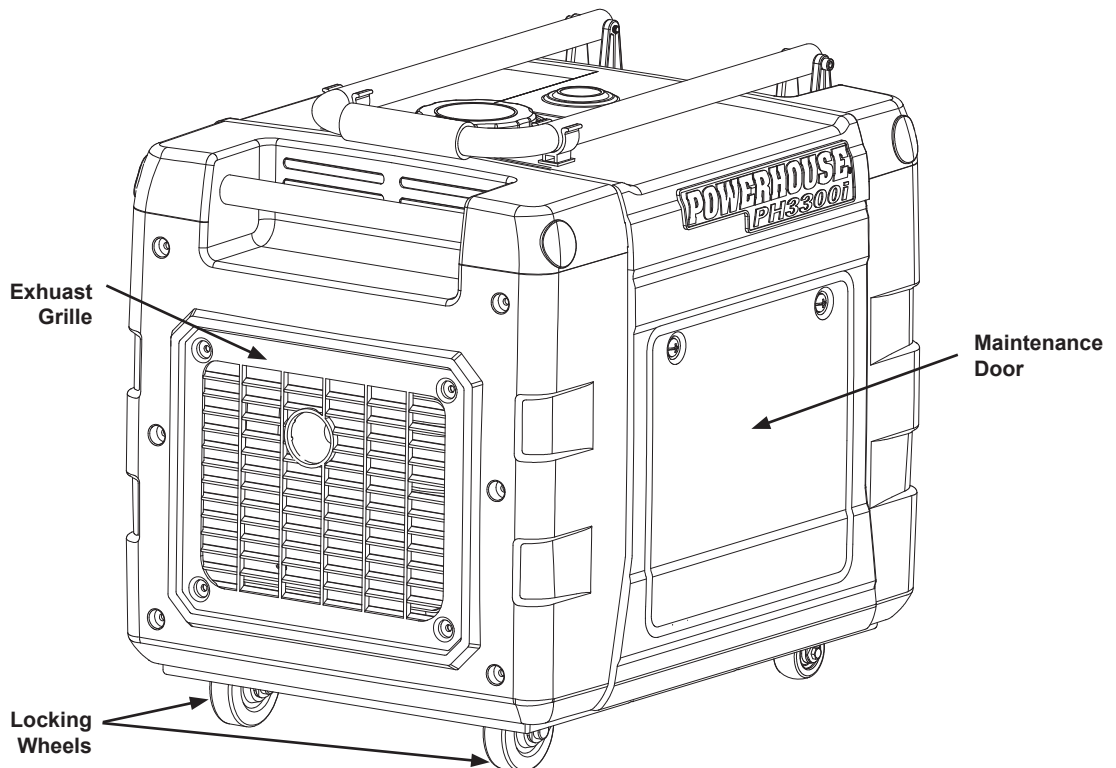

2.2. PH3300i CONTROL PANEL

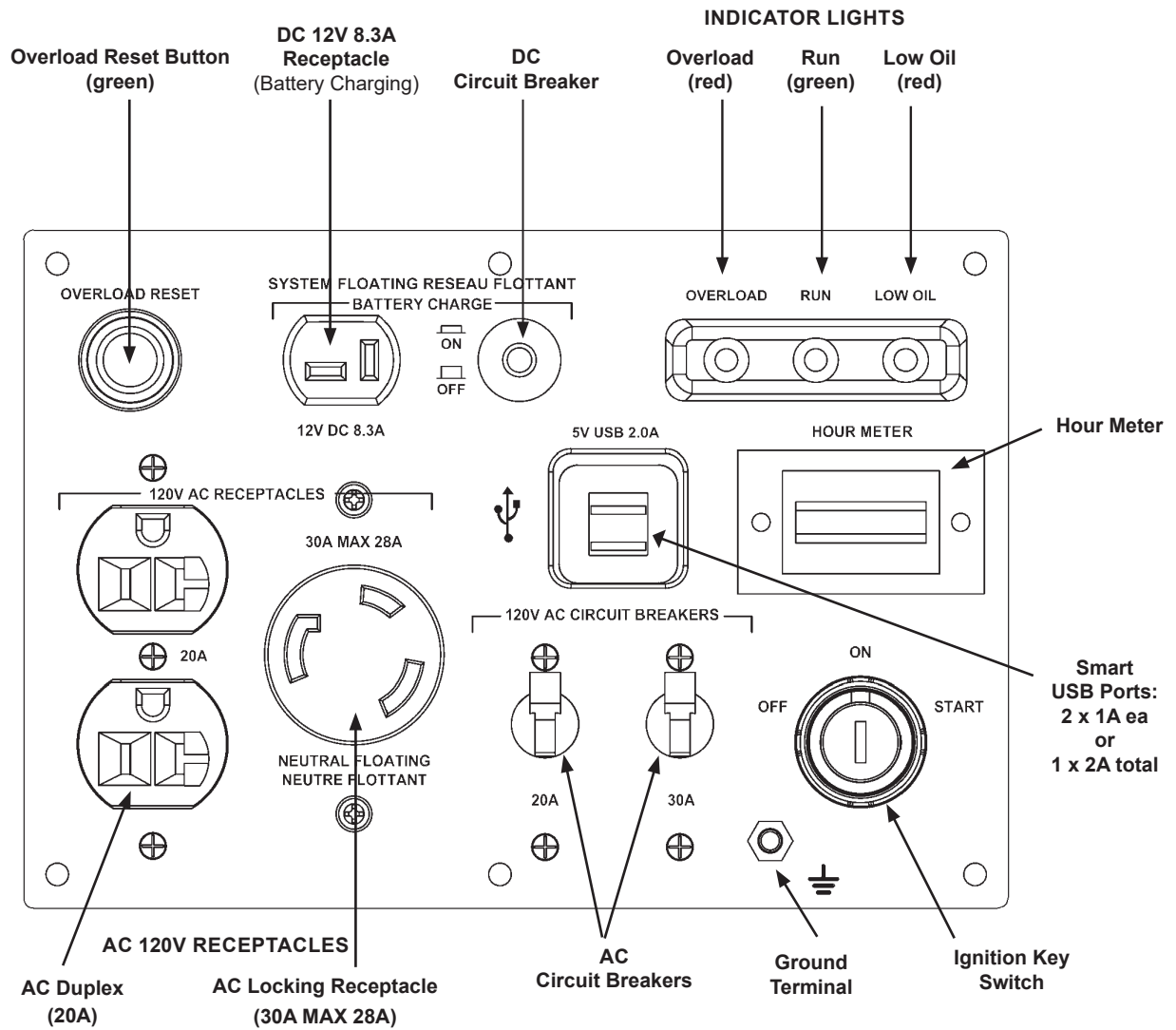

2.3. GENERATOR IDENTIFICATION NUMBERS

The engine serial number (ESN) and the generator barcode number (BCN) identify your particular unit and are necessary when ordering parts and accessories. These two numbers are used by your dealer and DTS Manufacturing for warranty administration and must be supplied before any work can be done.

Engine Serial Number (ESN)

The ESN is stamped on the engine block above the oil dipstick. It is visible when the oil access door is removed.

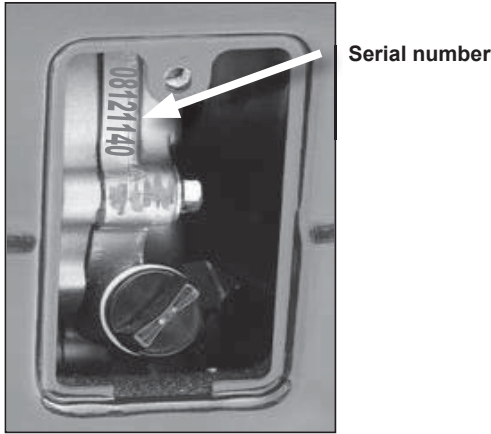

Barcode Number (BCN)

The BCN is found in two locations:

1. On the right side of the generator next to the oil access door.
2. On the back page of this Owner's Manual.

If you have the shipping carton for your generator, the BCN is also on the foil label on the carton.

BCN # 100122377055322

Sample BCN

Please record your generator identification numbers below and keep this manual in a safe place along with the bill of sale.

Engine Serial Number (ESN)	
Barcode Number (BCN)	
Date of Purchase	
Name of Selling Dealership	

Warranty Registration

Please go to www.powerhouse-products.com/register and register your unit today. Online registration will be accepted as proof of purchase. Online registration will make sure you are protected in the event you have lost your receipt, and will significantly speed up the process in the event warranty service is necessary.

For warranty assistance:

Phone: 1-877-544-4449

Fax: 1-855-242-8922

E-mail: warranty@powerhouse-products.com

3. Setup & Pre-Operation Checks

CAUTION Ensure that the generator is OFF and on a level surface for all setup and pre-operation checks.

3.1. CONNECTING THE 12V STARTING BATTERY

The generator ships from the factory with the internal 12V starting battery disconnected. You need to connect the 12V starting battery to enable the generator to start.

NOTE For maintenance details, see *Replacing the 12V Starting Battery*.

To connect the 12V starting battery:

1. On the left side of the generator, remove the two screws and the maintenance door.

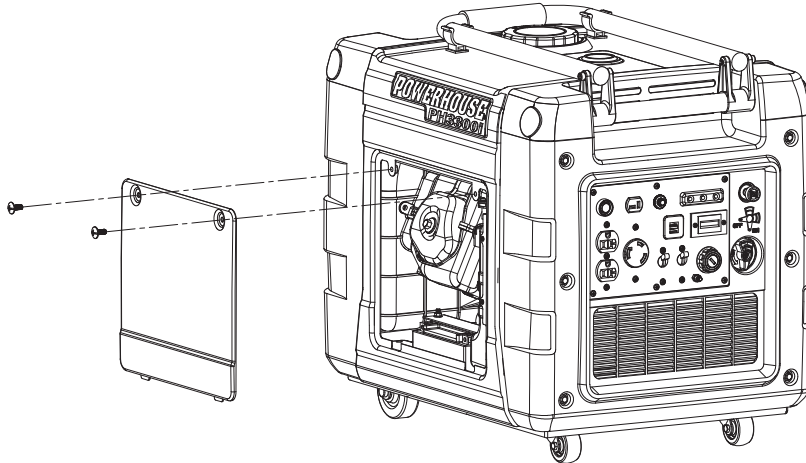

2. Plug the quick connect cable into the wiring harness.

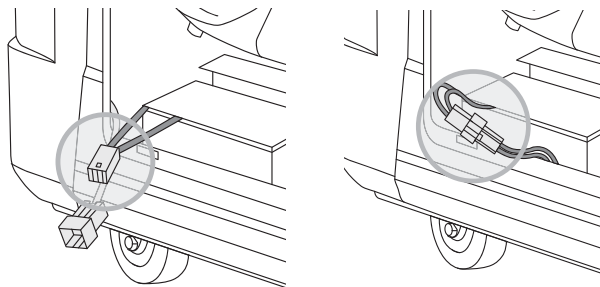

3. Reinstall the maintenance door and two screws back onto the generator.

3.2. CHARGING THE 12V STARTING BATTERY

Before you can start the generator, the 12V starting battery needs to be fully charged. You can charge the generator's 12V starting battery by connecting an external battery charger to the DC receptacle on the control panel. The generator does not have to be running to back-charge the starting battery, and there are no special control panel settings to enable the battery to charge.

CAUTION

- ▲ Use a 12V external battery charger with a maximum of 5A output.

NOTES

- For maintenance details, see **Replacing the 12V Starting Battery**.
- The DC receptacle is designed for charging the 12V battery, but you can also remove the battery access door and charge the 12V battery directly.

To charge the 12V starting battery:

1. Choose an option to connect battery charging cables:

- To connect an external 12V (max 5A) battery charger to the DC receptacle, use the battery charging cable supplied with your generator:
 - Connect the positive and negative alligator clips to the corresponding wires on the 12V charger.
 - Plug the T-style end of the charging cable into the DC receptacle.

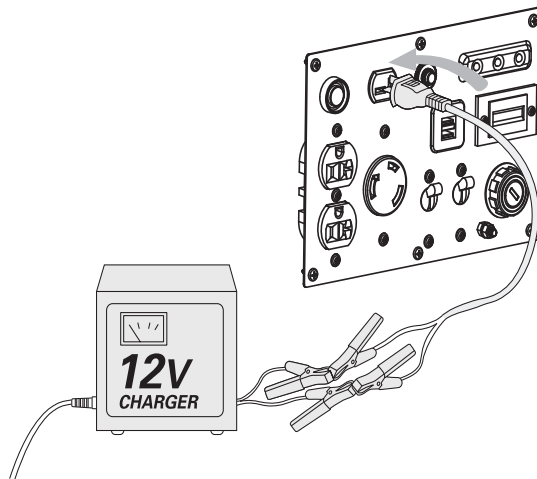

- To connect directly to the battery:
 - Remove the maintenance door and screw.
 - Unplug the quick connect cable from the wiring harness.
 - Remove the two nuts and the battery hold down bracket, and then remove the battery.
 - Connect the positive and negative alligator clips of your charging cables to the corresponding battery terminals.

2. Charge the battery for 3 hours or until fully charged.

3. After the battery is fully charged:

- After back-charging, disconnect the battery charger from the DC receptacle.
- After charging the battery directly, reinstall the 12V battery and the maintenance door and screw.

NOTE

Remember to recharge the 12V starting battery after long-term storage because a lead acid battery may become depleted when it's not in use.

3.3. CHECKING AND ADDING ENGINE OIL

The generator ships from the factory without engine oil, so you must add oil before starting the generator for the first time. Use a high-detergent, premium quality, 4-stroke engine oil, certified to meet or exceed U.S. automobile manufacturer's requirements for API Service Classification SG/SF.

Engine oil capacity: 33.8 fl oz (1.0 L)

- For environmental temperatures above 32°F (0°C), use SAE 10W-30 viscosity oil.
- For environmental temperatures below 32°F (0°C), use SAE 0W-30 or 0W-40 viscosity oil, preferably synthetic.

NOTES

- For information about selecting engine oil for very cold climates, see **Extreme Temperatures**.
- For maintenance details, see **Changing the Engine Oil**.

CAUTION

- ▲ Do not use non-detergent oil or 2-stroke engine oil which void the warranty and shorten the engine's service life.
- ▲ Change the oil in a new engine within the first 4 to 6 hours of operation to clean out manufacturing debris and contamination during the break-in period.

To check and add oil:

1. On the right side of the generator, remove the screw and the oil access door.

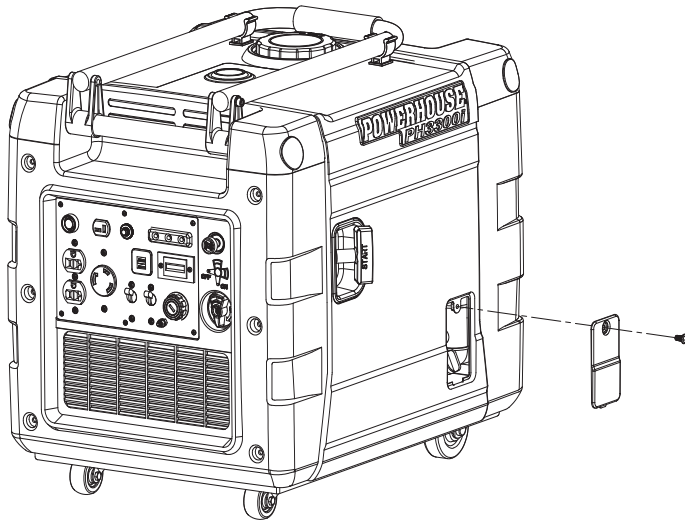

2. Remove the dipstick from the oil reservoir, then wipe it with a clean rag.

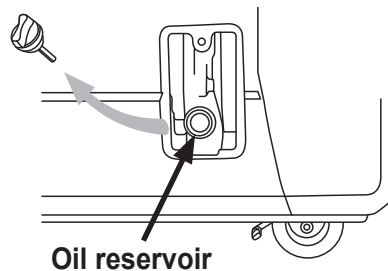

3. Check the oil level and add oil if necessary.
 - a. Insert the dipstick back into the oil reservoir. (To ensure an accurate reading, do not tighten or screw the dipstick into the reservoir.) Remove it, and check the oil level.

b. If the oil level is at the bottom mark on the dipstick, refill with recommended oil. Do not overfill.

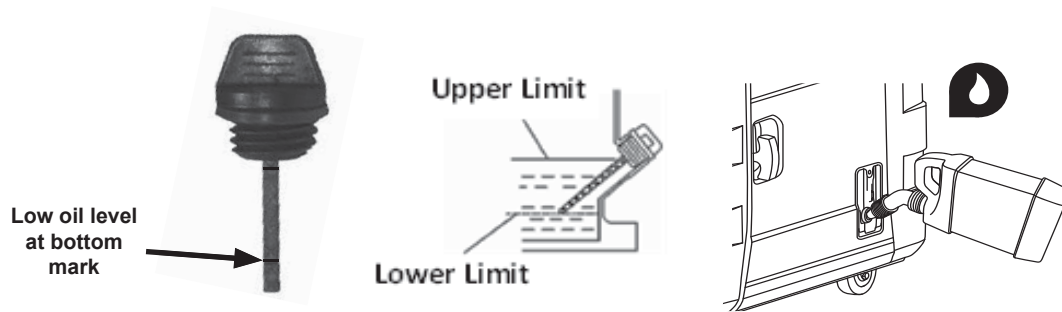

c. After refilling, check the oil level again, and ensure that the oil level is at the top mark on the dipstick.



4. Reinsert and tighten the dipstick in the oil reservoir.

5. Reinstall the oil access door and screw back onto the generator.

WARNING

- ▲ Running the engine with insufficient oil can cause serious engine damage.
- ▲ The low oil alarm system will automatically stop the engine before the oil level falls below a safe limit. However, to avoid the inconvenience of an unexpected shutdown, it is still advisable to visually inspect the oil level regularly.

3.4. CHECKING AND ADDING FUEL

The generator ships from the factory without fuel, so you must supply add fuel before starting the generator for the first time. Use only automotive unleaded gasoline in the generator, preferably with an octane rating of 87 or higher.

Fuel tank capacity: 4.3 gal (16.3 L)

⚠ WARNING

- ▲ Gasoline is extremely flammable and is explosive under certain conditions.
- ▲ Refuel in a well-ventilated area with the engine stopped. Keep cigarettes, sparks, and any source of ignition away from generator and the fuel tank at all times.
- ▲ Do not overfill the fuel tank past the upper fuel limit. After refueling, make sure the fuel cap is closed properly and securely.
- ▲ Be careful not to spill fuel when refueling. Spilled fuel or fuel vapor may ignite. If any fuel is spilled, make sure the area is dry before starting the engine.
- ▲ When refueling, if you accidentally spill gasoline into the engine compartment, allow all fuel to evaporate before starting the engine.
- ▲ Avoid repeated or prolonged contact of fuel with skin or breathing of fuel vapor. KEEP OUT OF REACH OF CHILDREN.

NOTES

- It is recommended that you use a fuel stabilizer, such as STA-BIL[®], to help prevent fuel oxidation (breakdown) and the formation of gum and varnish, and to inhibit corrosion in the fuel system and carburetor.
- Never use an oil/gasoline mixture or dirty gasoline.

To check and add fuel:

1. Ensure that the generator is OFF.
2. On the top of the generator, check the fuel gauge. You can also remove the fuel cap and the fuel strainer to visually inspect the fuel level inside the tank. Replace the fuel strainer when done.

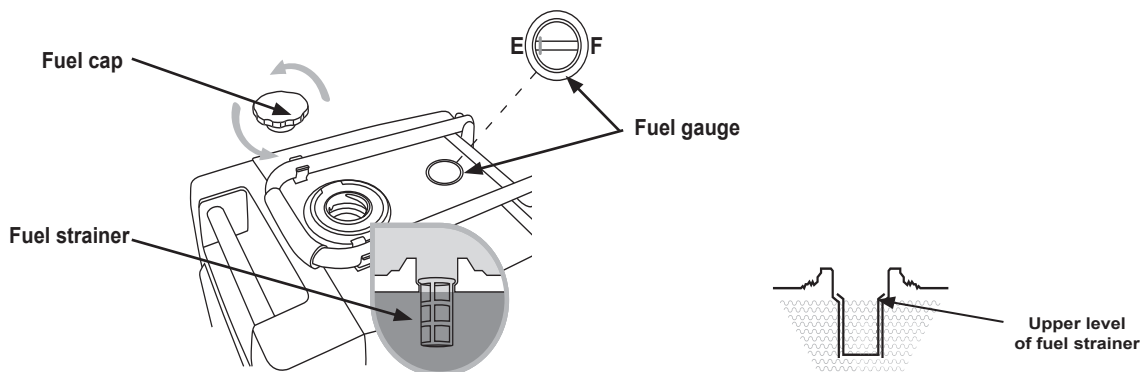

3. If fuel is low, with the fuel cap off, pour fuel slowly over the fuel strainer. Do not fill past the upper level of the fuel strainer. Avoid getting dirt, dust or water in the fuel tank.

NOTE

Temperature changes affect the volume of gasoline. Make sure that you leave extra room at the top of the tank when you fill it, to allow for fuel expansion on warm days.

4. Replace and tighten the fuel cap securely.

Cautions on Gasoline Blends

⚠ CAUTION

- ▲ Do not use gasoline containing methanol.
- ▲ Do not use a gasoline blend that contains more than 10% ethanol.
- ▲ Before buying gasoline from an unfamiliar station, determine if it contains ethanol. Make sure you do not use a blend with more than 10% ethanol. If you notice any undesirable operating symptoms while using a gasoline that contains ethanol, or one that you think contains ethanol, replace it with a gasoline that you know has the proper blend.
- ▲ Fuel system damage or engine performance problems resulting from the use of gasoline that contains an improper alcohol blend, or from adding oil to the fuel, are not covered under warranty.

4. Startup & Operation

Before starting the generator, read and comply with all safety warnings and cautions in Section 1: Safety.

NOTES

- If you are using the generator at high altitude or in extreme temperatures, see ***Environmental Impacts on Generator Performance***.
- If you are using the generator to power an air conditioner, see ***Powering an Air Conditioner (13,500 BTU)***.
- For details on connecting appliances and operation, see ***Using the Generator***.

4.1. BATTERIES USED DURING STARTUP

During startup, the generator uses a 12V starting battery and two 3.6V lithium ion (Li-ion) batteries for powering the ignition system. Before starting the generator, make sure the 12V starting battery is fully charged. The ignition (Li-ion) batteries are charged while the generator is running.

NOTES

- The generator may be difficult to start if both the starting (12V) battery and the ignition (Li-ion) batteries are depleted. If both types of batteries are depleted, do one of the following:
 - Charge the starting (12V) battery to enable an electric key start of the generator.
 - Use fast, strong pulls to enable a recoil pull start of the generator.
- For maintenance details, see ***Replacing the 12V Starting Battery*** and ***Replacing the Lithium Ion Batteries***.

4.2. UNDERSTANDING THE MANUAL CHOKE

This generator has a manual choke. The choke opens or closes (chokes) airflow to the carburetor, which affects the air-fuel ratio supplied to the engine. Use the choke to provide a better starting blend of fuel when the engine is cold.

- A closed choke (in the START position) enables a cold engine to start easier.
- A half-closed choke (in the 1/2 position) enables a warm engine to start easier.
- An open choke (in the RUN position) enables a hot engine to start easier.

4.2.1. Basic Choke Settings for Startup and Operation

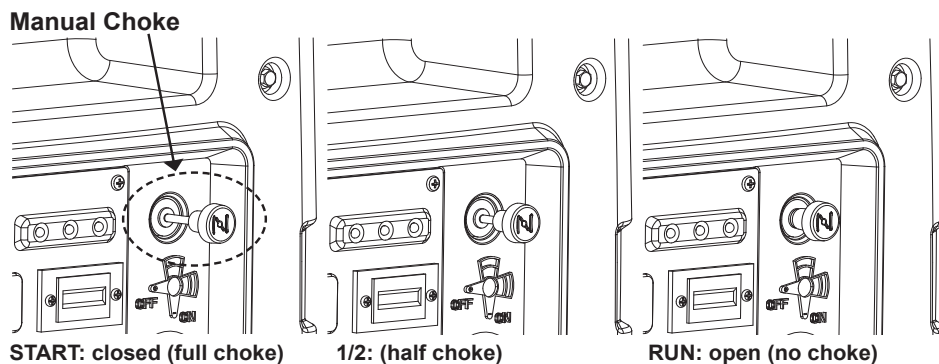





4.2.2. Choke Positions: Adjusting for Environmental and Engine Temperatures

Environmental and engine temperatures affect the choke setting you use during startup.

When the engine or environmental temperatures are cold, fuel condenses and doesn't vaporize easily, so the engine needs more choke (richer fuel) to overcome the inadequate combustion. When the engine or environmental temperatures are hot, fuel vaporizes easily, so the engine needs less choke (leaner fuel) to assist with startup.

Use the following table to find the best choke position for varying startup conditions.

TEMPERATURE	STARTUP CONDITIONS	CHOKE POSITION DURING STARTUP	MOVING THE CHOKE AFTER STARTUP
0° to 30°F (-18° to -1°C) 	Cold day, Cold engine start	START (full choke)	<p>In cold environments, move the choke slowly toward to the 1/2 position.</p> <ul style="list-style-type: none"> In freezing temperatures, allow the generator to warm up for 3 to 5 minutes before connecting heavy loads. Allow the engine to warm up, then move the choke slowly toward the RUN (open) position. If the engine falters while moving the choke to the RUN position, move the choke back to the 1/2 or START position. Allow the engine to warm up a little longer, then move the choke to the RUN position again. <p>In warm environments, move the choke slowly to the RUN (open) position.</p> <p>Once the generator is started and running well, the choke should always be in the RUN position during operation.</p>
	Cold day, Warm engine restart	1/2 (half choke) Allow engine to warm up at 1/2 choke for 45-60 seconds.	
30° to 50°F (-1° to 10°C) 	Cold day, Cold engine start	START (full choke)	
	Cold day, Warm engine restart	1/2 (half choke) Allow engine to warm up at 1/2 choke for 30-45 seconds.	
50° to 80°F (10° to 27°C) 	Warm day, Cold engine start	1/2 (half choke)	
	Warm day, Warm engine restart*	RUN (no choke)*	
80° to 113°F (27° to 45°C) 	Hot day, Cold engine start	1/2 (half choke)	
	Hot day, Warm engine restart*	RUN (no choke)*	

*In most circumstances, no choke is needed for a warm or hot engine. Start and run the generator with the choke in the RUN position. If the engine does not start, move the choke to the 1/2 or START position and try again.

4.3. ELECTRIC START

1. On the right side of the control panel, turn the fuel valve to the ON position.

NOTE

You may need to wait a minute to allow fuel to flow to the carburetor if fuel was added for the first time or after refueling an empty tank.

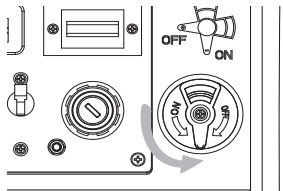

2. Set the choke for startup:

- To start a cold engine, set the choke to the START (closed) position.
- To restart a warm engine, set the choke to the 1/2 or RUN (open) position.

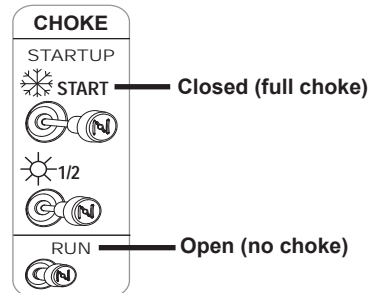

3. On the control panel, insert the ignition key. Turn and hold the ignition key in the START position.

NOTE

If the engine does not start within 15 seconds, stop turning the key for 5 seconds before trying it again.

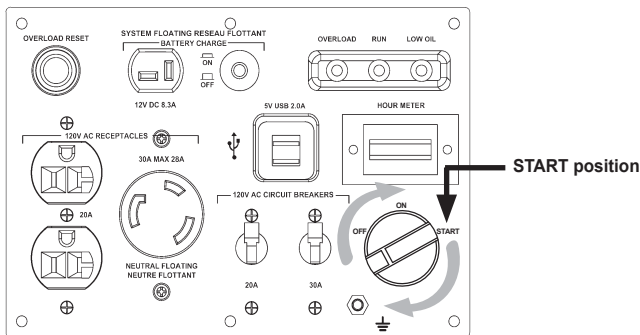

4. Move the choke after engine startup:

- **In cold environments**, move the choke slowly toward to the 1/2 position. Allow the engine to warm up, then move the choke slowly toward the RUN (open) position.

NOTES

- In freezing temperatures, allow the generator to warm up for 3 to 5 minutes before connecting heavy loads.
- If the engine falters while moving the choke to the RUN position, move the choke back to the 1/2 or START position. Allow the engine to warm up a little longer, then move the choke to the RUN position again.
- For details, see **Adjusting the Choke for Environmental and Engine Temperatures**.

- **In warm environments**, move the choke slowly to the RUN (open) position.

The green “RUN” light illuminates when the generator is ready for use.

NOTE

If the green RUN light does not illuminate, this is an indication that the inverter self-protection mode has been triggered. You must shut down and restart the generator.

5. Before connecting any loads:

CAUTION

- ▲ Ground the generator with a length of heavy cable by connecting the generator’s grounding terminal to an external ground source.
- ▲ Make sure that appliances are switched off, in good working condition, and that the combined electrical rating of all connected appliances does not exceed that of the generator (3300W max).

NOTE

For the shutdown sequence, see **Stopping the Generator**.

4.4. RECOIL PULL START

1. On the right side of the control panel, turn the fuel valve to the ON position.

NOTE

You may need to wait a minute to allow fuel to flow to the carburetor if fuel was added for the first time or after refueling an empty tank.

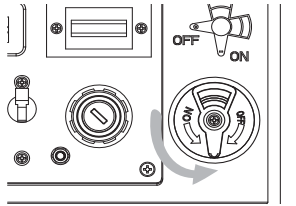

2. Set the choke for startup:
 - To start a cold engine, set the choke to the START (closed) position.
 - To restart a warm engine, set the choke to the 1/2 or RUN (open) position.

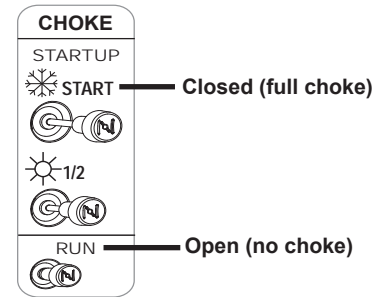

3. On the control panel, insert the ignition key and turn to the ON position.

4. On the right side of the generator, grasp the starter grip and pull back lightly until resistance is felt, then pull briskly out. Repeat until the engine starts. Faster pulls generate more spark and enable successful startup.

CAUTION

- ▲ Do not allow the starter grip to snap back. Return it slowly by hand.
- ▲ Do not let the starter rope rub against the generator body or the rope will wear out prematurely.
- ▲ Do not pull the starter rope while the generator is running.

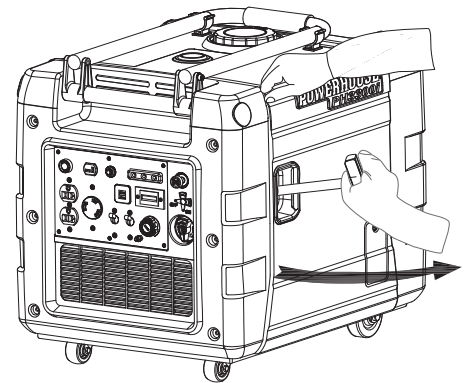

5. Move the choke after engine startup:
 - In cold environments, move the choke slowly toward to the 1/2 position. Allow the engine to warm up, then move the choke slowly toward the RUN (open) position.

NOTES

- In freezing temperatures, allow the generator to warm up for 3 to 5 minutes before connecting heavy loads.
- If the engine falters while moving the choke to the RUN position, move the choke back to the 1/2 or START position. Allow the engine to warm up a little longer, then move the choke to the RUN position again.
- For details, see *Adjusting the Choke for Environmental and Engine Temperatures*.
- In warm environments, move the choke slowly to the RUN (open) position.

The green "RUN" light illuminates when the generator is ready for use.

NOTE

If the green RUN light does not illuminate, this is an indication that the inverter self-protection mode has been triggered. You must shut down and restart the generator.

6. Before connecting any loads:

CAUTION

- ▲ Ground the generator with a length of heavy cable by connecting the generator's grounding terminal to an external ground source.
- ▲ Make sure that appliances are switched off, in good working condition, and that the combined electrical rating of all connected appliances does not exceed that of the generator (3300W max).

NOTE

For the shutdown sequence, see *Stopping the Generator*.

4.5. ENVIRONMENTAL IMPACTS ON GENERATOR PERFORMANCE

Environmental conditions, such as high altitude and extreme temperatures, adversely impact the generator's performance. When environmental conditions are combined in any way, performance issues are compounded.

In other words, running the generator in an extreme temperature comes with its own considerations, but if you are also at a high altitude any performance issues are multiplied and increasingly difficult to overcome.

Environment	Rate of increase of environmental condition	Decrease in generator performance
High Altitude	Every 1000 ft. (305m) increase in altitude	3.5% decrease in engine horsepower
High Temperature	Every 10°F (5.5°C) increase in temperature above 85°F (29°C)	1% decrease in engine horsepower

4.5.1. High Altitudes

At high altitude, the standard carburetor air-fuel mixture will be excessively rich, performance will decrease, and fuel consumption will increase.

High altitude performance can be improved by installing a smaller diameter main fuel jet in the carburetor. If you always operate the generator at altitudes higher than 6000 feet (1800 meters) above sea level, have your authorized dealer install a high altitude main jet.

Even with suitable carburetor jetting, engine horsepower will decrease approximately 3.5% for each 1000 ft. (305m) increase in altitude. The effect of altitude on the horsepower will be greater than this if no carburetor modification is made.



- ▲ Be sure to have any carburetor modification reversed before operating at lower altitudes. Operation of the generator at an altitude lower than the carburetor is jetted for may result in reduced performance, overheating, and serious engine damage caused by an excessively lean air/fuel mixture.

4.5.2. Extreme Temperatures

The normal operating range of this generator is 0° to 113°F (-18° to 45°C). Outside of this range, extreme temperatures adversely affect generator startup and operation.

CAUTION

- ▲ Do not operate the generator when the ambient temperature is below 0°F (-18°C).
- ▲ Do not operate the generator when the ambient temperature is above 113°F (45° C).

High Temperatures

In extremely high temperatures, the performance of the generator decreases 1% for each 10°F (5.5°C) increase in temperature above 85°F (29°C).

Cold Temperatures

In extremely cold temperatures, the engine will be more difficult to start. To operate the generator in very cold climates, it is important to:

- Have a fully charged battery.
- Use a lower viscosity engine oil.
- Leave the choke closed or partially closed longer.

Oil Viscosity for Cold Climates

Synthetic SAE 0W-30 or 0W-40 oil is recommended for temperatures below 32° F. Refer to the chart below for oil viscosity recommendations.

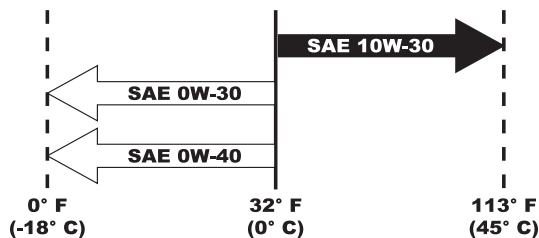

NOTE

Because you need to use a thin low viscosity oil in extremely cold climates, the engine will actually take longer than normal to warm up due to reduced internal friction. But once the engine reaches operating temperature a 0W-40 oil is no thinner than a straight 40W.

Manual Choke for Cold Climates

In very cold climates, you may need to keep the manual choke closed or partially closed longer to help the engine warm up before you open the choke. The length of time you keep the choke closed or partially closed depends on how cold the air is and how long it's been since the generator was last running.

NOTES

- In freezing temperatures, allow the generator to warm up for 3 to 5 minutes before connecting heavy loads.
- For details, see *Adjusting the Choke for Environmental and Engine Temperatures*.

5. Using the Generator

This generator is intended as a portable power source for appliances requiring less than 3300W maximum output.

You can connect appliances or devices to all receptacles on the control panel simultaneously as long as 1) the power load is not exceeded on each receptacle, and 2) the combined power load of all appliances does not exceed the generator's total power output. Keep in mind that most appliance motors will require more than their rated wattage for startup.

Before using the generator, read Section 1: Safety.

WARNING

- ▲ **Generators produce carbon monoxide from exhaust gas. Carbon monoxide is a poisonous, colorless, odorless gas. When inhaled, carbon monoxide can build up to dangerous levels in the bloodstream and cause unconsciousness, leading to serious injury or death within minutes.**
- ▲ **Indoor use of a generator can kill quickly. Generators should be used outdoors only. Never run the generator in an enclosed or partly enclosed area.**
- ▲ This portable generator is not intended or designed for use as a standby power supply, or to be connected to a manual or automatic transfer switch (ATS); it should never be used as such. Severe damage to the inverter module, property damage, and/or severe personal injury or death may result from misuse of the generator. Such back feed may electrocute utility company workers or others who contact the lines during a power outage. When utility power is restored the generator may explode, burn, or cause fires in the building's electrical system.
- ▲ Keep the generator away from other electric cables or wires such as commercial power supply lines.
- ▲ To prevent electrical shock from faulty appliances, the generator should be grounded. Connect a length of heavy cable between the generator's grounding terminal and an external ground source.

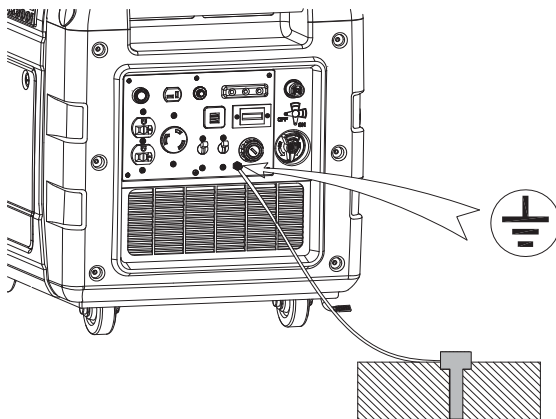

CAUTION

- ▲ To avoid a potential shock, make sure that all appliances are in good working order before connecting them to the generator. If an appliance begins to operate abnormally, becomes sluggish, or stops suddenly, turn off the generator immediately. Disconnect the appliance and examine it for signs of malfunction.
- ▲ Do not exceed the current limit specified for any one receptacle.
- ▲ Do not connect the generator to a household circuit. This could cause damage to the generator or to electrical appliances in the house.
- ▲ Do not modify or use the generator for purposes other than its intended use.
- ▲ Do not connect an extension to the exhaust pipe.
- ▲ When an extension cord is required, be sure to use an insulated flexible cord. Also be sure to use the proper size and length cord.
 - 16 Gauge Cords - a 16 gauge cord between 0 and 100 feet long will safely handle tool and appliance loads up to 10 amps.
 - 14 Gauge Cords - a 14 gauge cord between 0 and 50 feet long will safely handle tool and appliance loads between 10 and 15 amps.
 - 12 Gauge Cords - a 12 gauge cord between 50 and 100 feet will safely handle tool and appliance loads between 10 and 15 amps.

5.1. RUN & OVERLOAD LIGHTS

On the control panel, you can monitor the generator's operating status by observing the Run and Overload lights.

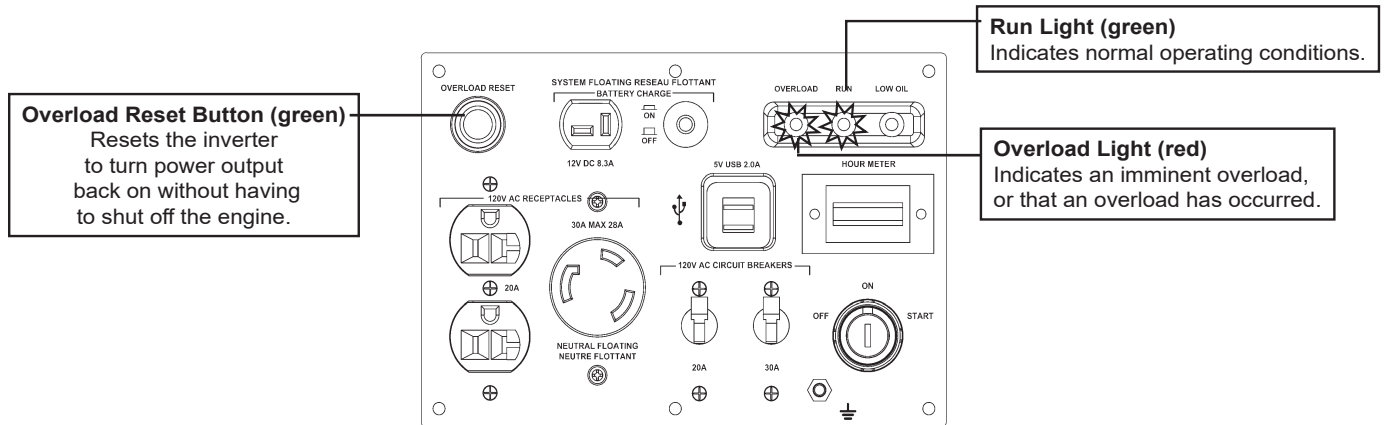

Run Light

The run light (green) indicates normal operating conditions.

NOTE

If the green RUN light does not illuminate, this is an indication that the inverter self-protection mode has been triggered. You must shut down and restart the generator.

Overload Light

The overload light (red) indicates that the generator experienced a power load in excess of its maximum power output rating (3300W).

- As an overload point is being reached, the green run light goes off and the red overload light begins to flicker.
- If the overload is imminent, the red light illuminates steadily for two seconds.
- When the overload occurs, the red overload light stays on and power to all receptacles is turned off.

NOTE

When the generator is started, the overload indicator light (red) may go on momentarily while the output indicator light (green) remains on. This is not a problem as long as the overload light only flickers on briefly.

Overload Resets

All POWERHOUSE® generators come with InverterProtec™ technology. When an overload occurs, power to the inverter is turned off but the engine can continue to run to enable quicker overload resets.

1. Turn off and disconnect all appliances (all electrical loads) from the generator, then investigate and resolve the cause of the overload. An overload can be caused by an electrical short in the connected appliance.
2. Reset the overload condition in one of two ways:
 - Press the green overload reset button.
 - Turn off and restart the generator.

NOTE

After resetting from an overload, if the overload indicator light stays on and there is no power at the receptacle, turn off the generator and restart it.

3. Before reconnecting appliances to the generator, check for the following conditions:
 - The green RUN light on the control panel is illuminated.
 - Appliances are turned off and in good working condition without faulty performance or electrical shorts.
 - The combined electrical rating of all appliances does not exceed the maximum power output rating (3300W) for the generator.

5.2. LOW OIL ALARM SYSTEM

The low oil alarm system is designed to prevent engine damage caused by an insufficient amount of oil in the crankcase. Before the oil level in the crankcase falls below a safe limit, the low oil alarm system will automatically shut down the engine.

If the low oil sensor shuts down the engine, the low oil light (red) will come on when you operate the starter, and the engine will not run. If this occurs, add enough of the recommended engine oil to raise the level to the top mark on the dipstick.

NOTE

For details on adding oil, see **Checking and Adding Engine Oil**.

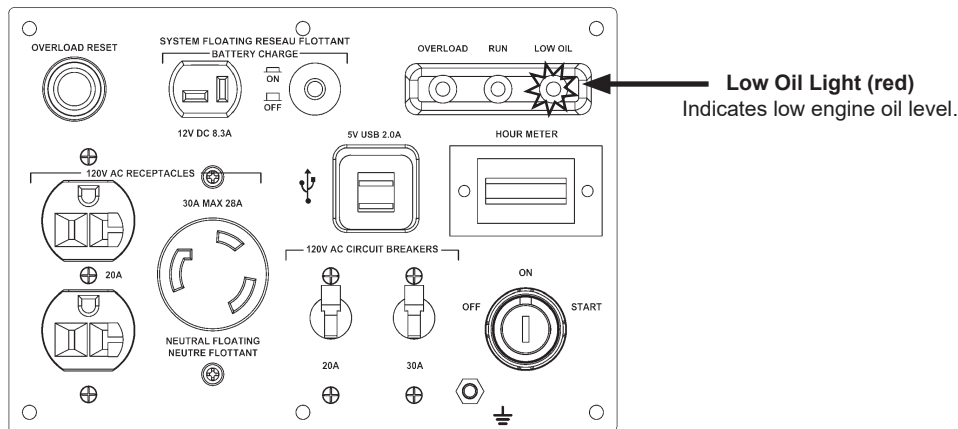

5.3. STOPPING THE GENERATOR

1. Turn off any appliances connected to the generator.
2. On the control panel, turn the ignition key to the OFF position.

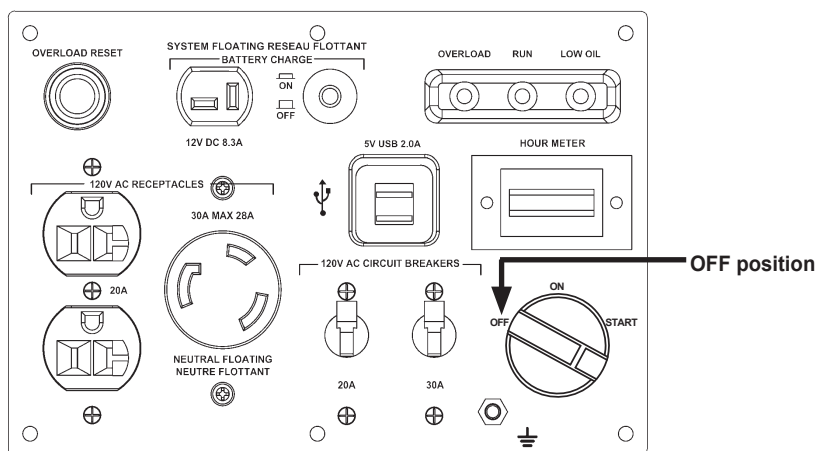

3. Turn the fuel valve to the OFF position.

5.4. AC APPLICATION

The generator provides two AC receptacles on the control panel:

- 120V, 20A supply through a 5-20R duplex receptacle
- 120V, 30A supply through an L5-30R receptacle

NOTES

- The AC receptacles may be used while the DC power is in use.
- In the event of an overloaded AC circuit, reset the AC circuit breaker to resume operation.

Before connecting to the generator:

CAUTION

- ▲ To avoid a potential shock, make sure that all appliances are in good working order before connecting them to the generator. If an appliance begins to operate abnormally, becomes sluggish, or stops suddenly, turn off the generator immediately. Disconnect the appliance and examine it for signs of malfunction.
- ▲ Make sure that the combined electrical rating of all connected appliances does not exceed the maximum power output (3300W) of the generator.

To connect to the AC receptacle:

1. Make sure that the appliance is OFF before plugging it into the AC receptacle
2. Start the engine and make sure only the green RUN light comes on.

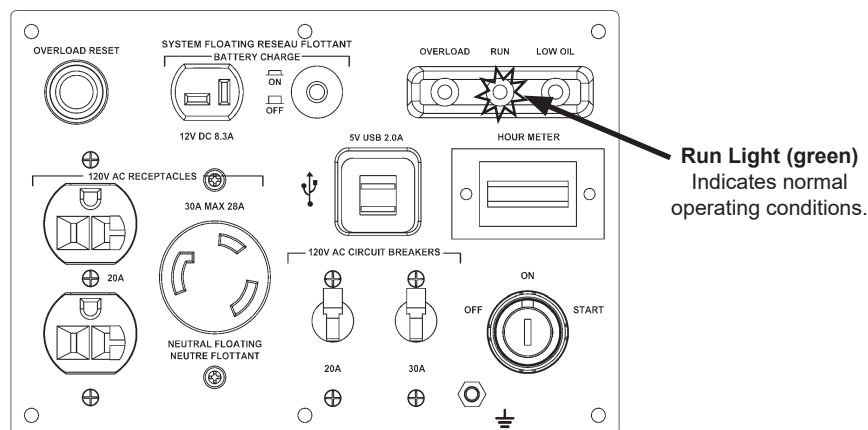

NOTES

- When the generator is started, the overload indicator light (red) may go on momentarily while the output indicator light (green) remains on. This is not a problem as long as the overload light only flickers on briefly.
- If the green RUN light does not illuminate, this is an indication that the inverter self-protection mode has been triggered. You must shut down and restart the generator.

3. Plug in, and then turn on the appliance.

NOTE

This generator uses a system ground which connects the ground terminals in the AC receptacles on the control panel to the unit frame. The AC neutral wire is not connected to the system ground. If you check the receptacles on this generator with a receptacle tester, the ground circuit condition will appear different than it would for a receptacle in your home.



5.5. DC APPLICATION

This generator provides a polarized, system floating 12V, 8.3A supply through the DC receptacle on the control panel. The DC receptacle is designed for charging a 12V battery, but it can also be used to power a maximum 7A DC device.

NOTES

- The DC receptacle may be used while generator is running.
- You can use DC power while AC power is in use.
- The DC output comes directly from the battery, so powering a DC device places a load on the battery. If the generator is not running when you power a DC device, the 12V starting battery will become depleted. Once the 12V starting battery is depleted you need to fully recharge it in order to restart the generator.
- In the event of an overloaded DC circuit, reset the DC circuit breaker to resume operation.

Before connecting to the generator:

CAUTION

- ▲ To avoid a potential shock, make sure that all appliances are in good working order before connecting them to the generator. If an appliance begins to operate abnormally, becomes sluggish, or stops suddenly, turn off the generator immediately. Disconnect the appliance and examine it for signs of malfunction.

5.5.1. Powering a DC Device

When the generator is running, the DC receptacle can be used to charge a DC device.

To power a DC device:

1. Start the generator and let it run for a few minutes to reach its normal operating temperature.
2. On the control panel, plug the T-style end of the device cable into the DC receptacle.

5.5.2. Smart USB Ports

This generator has two Smart USB ports which monitor the charge of the device you plug in. Smart USB ports trim back the power as the device reaches a full charge, which prevents over-charging of the device.

When the generator is running, you can use the Smart USB ports for powering small electronic devices. Both ports can be used at the same time to draw 1.0A each, or you can use only one port to draw a maximum of 2.0A.

5.5.3. Charging an External 12V Battery

While the generator is running, the DC receptacle can be used to charge an external 12V lead acid battery.

⚠ WARNING

- ▲ Do not charge any other type of external battery except a 12V lead acid battery. Other types of batteries may burst causing personal injury or damage.
- ▲ Batteries give off explosive gases; keep sparks, flames and cigarettes away. Provide adequate ventilation when charging.
- ▲ Batteries contain sulfuric acid (electrolyte). Contact with skin or eyes may cause severe burns. Wear protective clothing and a face shield.
 - If electrolyte gets on your skin, flush with water.
 - If electrolyte gets in your eyes, flush with water for at least 15 minutes and call a physician immediately.
- ▲ Electrolyte is poisonous.
 - If swallowed, drink large quantities of water or milk and follow with milk of magnesia or vegetable oil and call a physician immediately.
- ▲ KEEP OUT OF REACH OF CHILDREN.

Charging a Vehicle Battery

⚠ WARNING

- ▲ Before connecting charging cables to a battery that is installed in a vehicle, disconnect the vehicle's ground battery cable. Reconnect the vehicle's ground battery cable after the charging cables are removed. This procedure will prevent the possibility of a short circuit and sparks if you make accidental contact between a battery terminal and the vehicle's frame or body.
- ▲ Do not attempt to start an automobile engine with the generator still connected to the battery. The generator may be damaged.

To charge an external 12V battery:

1. Start the generator and let it run for a few minutes to reach its normal operating temperature.
2. Connect the two charging cables to the corresponding positive and negative battery terminals.

⚠ CAUTION

- ▲ Make sure you match the positive charging cable to the positive battery terminal. Do not reverse the charging cables or serious damage to the generator, the 12V starting battery, or personal injury may occur.
- ▲ To prevent the possibility of creating a spark near the battery, always connect to the battery terminals first, and then connect to the generator.

3. On the control panel, connect the T-style end of the charging cable to the DC receptacle.

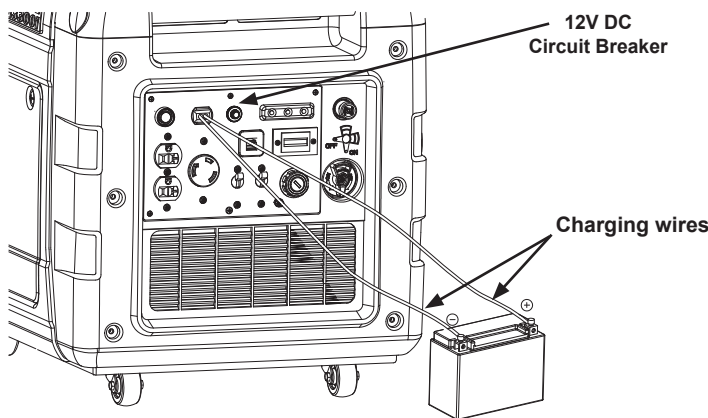

4. When charging is complete, disconnect the charging cable from the generator, then disconnect from the battery.

5.6. POWERING AN AIR CONDITIONER (13,500 BTU)

You can power a single 13.5K air conditioner, however it is important to follow these steps and use a start capacitor.

1. Bring the generator up to normal operating temperatures before applying the air conditioning load.
2. Always allow a 2 minute wait period when manually cycling an air conditioner off and on. A longer wait period may be required under unusually hot weather conditions.
3. Additionally, all other loads should be turned off until the air conditioner has started and is performing normally. It is also important to follow the air conditioner manufacturer's instructions for starting and restarting for proper operation.

5.6.1. Using a Start Capacitor When Powering an Air Conditioner

It is recommended that you use an air conditioner that has a built-in start capacitor. A start capacitor in an air conditioner helps provide immediate starting power so that the air condition doesn't pull too much current during startup. If there is no start capacitor, the air conditioner can overload the generator by pulling too much starting current.

NOTES

- Not all air conditioners have a start capacitor, and some air conditioner manufacturers may offer a start capacitor as an extra cost option.
- If you are having problems starting your air conditioner, check to see if it has a start capacitor installed. If it doesn't, we recommend contacting your air conditioner dealer to buy and install one.

6. Maintenance

Use the Maintenance Schedule to keep your generator in the best operating condition. Maintenance includes checking the condition of a part used in the generator, as well as cleaning, adjusting, or replacing a part. The oil should be changed after the first 4 to 6 hours of operation to remove any manufacturing debris or contamination.

⚠ WARNING

- ▲ Shut off the engine before performing any maintenance. If the engine must be on, make sure the area is well ventilated. The exhaust contains poisonous carbon monoxide gas which is a colorless, odorless gas. When inhaled, carbon monoxide can build up to dangerous levels in the bloodstream and cause unconsciousness, leading to serious injury or death within minutes.

⚠ CAUTION

- ▲ Use genuine POWERHOUSE® parts or the equivalent. The use of replacement parts which are not of equivalent quality may damage the generator or void the warranty.
- ▲ When repairing or replacing the components of the emission control system, make sure to use OEM EPA-compliant components.

6.1. MAINTENANCE SCHEDULE

Item	Maintenance Procedure	Regular Service period (1). Perform at every indicated month or operating hour interval, whichever occurs first.				
		Each Use	1st Month or 4 to 6 Hours	Every 3 Months or 50 Hours	Every 6 Months or 100 Hours	1x per Year or 300 Hours
Engine Oil	Check	O				
	Change		O		O	
Air cleaner	Check	O				
	Clean			O (2)		
Spark Plug	Clean / Adjust				O	
Spark Arrestor	Clean				O	
Fuel Filter	Check	O				
	Replace					O (2)
Valve clearance	Check / Adjust					O (3)
Fuel tank & strainer	Clean					O (2)
Fuel line	Check	Every 2-years (Replace as necessary) (3)				
12V Starting Battery	Clean / Charge	Charge monthly during long term storage. Check terminals for corrosion monthly, clean as needed. Expected battery life is 2 years, but can be affected by operating environment.				
Lithium Ion Ignition Batteries	Check	Expected battery life is 2 years, but can be affected by operating environment. The Li-ion batteries are charged while the generator is running. (replace as necessary)				

NOTES

- (1) Log hours of operation to determine proper maintenance.
- (2) Service more frequently when used in dusty areas.
- (3) These items should be serviced by an authorized dealer unless the owner has the proper tools and is mechanically proficient. See the Service Manual.

Service Period for Oil Changes	Normal Operating Temperature
Normal –100 hr	77°F (25°C)
95 hr	86°F (30°C)
85 hr	95°F (35°C)
70 hr	104°F (40°C)

6.2. CHANGING THE ENGINE OIL

The oil should be changed after the first 4 to 6 hours of operation to remove any manufacturing debris or contamination.

Use a high-detergent, premium quality, 4-stroke engine oil, certified to meet or exceed U.S. automobile manufacturer's requirements for API Service Classification SG/SF.

Engine oil capacity: 33.8 fl oz (1.0 L)

- For environmental temperatures above 32°F (0°C), use SAE 10W-30 viscosity oil.
- For environmental temperatures below 32°F (0°C), use SAE 0W-30 or 0W-40 viscosity oil, preferably synthetic.

NOTE

For information about selecting engine oil for very cold climates, see **Extreme Temperatures**.

To change the engine oil:

NOTE

Change the oil while the generator is OFF and the engine is still warm to assure rapid and complete draining.

1. On the right side of the generator, remove the screw and the oil access door.

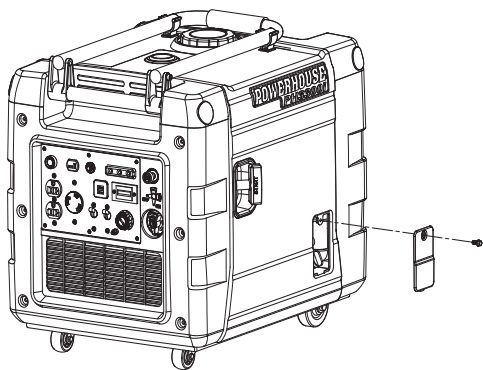

2. Remove the dipstick from the oil reservoir.

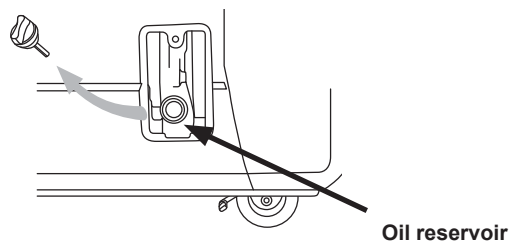

3. Insert the oil drain pipe (included with the generator) into the oil reservoir.
4. Tilt the generator to drain the dirty oil into a container. Be sure to allow time for the oil to drain completely.

CAUTION

▲ Use caution when draining hot oil from an engine which can cause severe burns.

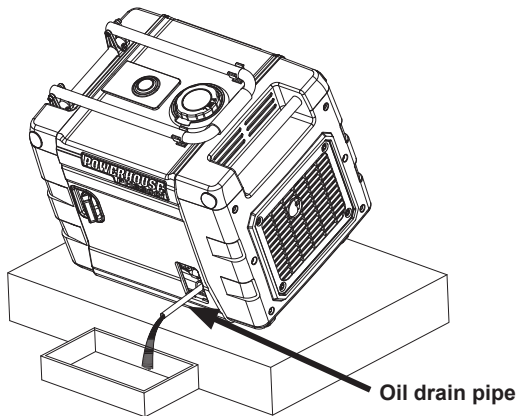

5. Place a funnel into the oil reservoir, and then refill with the recommended oil. Do not overfill.

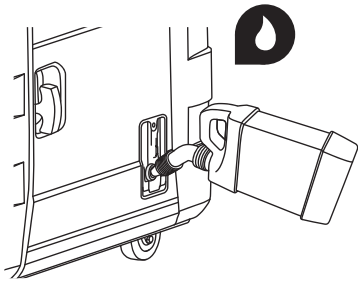

6. After refilling, insert the dipstick back into the oil reservoir. (To ensure an accurate reading, do not tighten or screw the dipstick into the reservoir.) Remove it, and ensure that the oil level is at the top full mark on the dipstick.

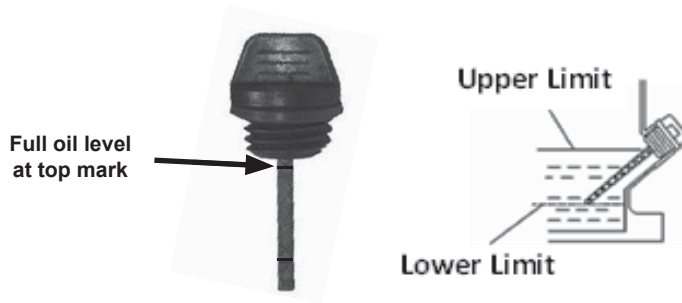

7. Reinsert and tighten the dipstick in the oil reservoir.

8. Reinstall the oil access door and screw back onto the generator.

WARNING

- ▲ Running the engine with insufficient oil can cause serious engine damage.
- ▲ The low oil alarm system will automatically stop the engine before the oil level falls below a safe limit. However, to avoid the inconvenience of an unexpected shutdown, it is still advisable to visually inspect the oil level regularly.

NOTE

Please dispose of used motor oil in a manner that is compatible with the environment and local disposal regulations. Do not throw it in the trash or pour it on the ground.

6.3. CLEANING THE AIR FILTER ELEMENT

A dirty air filter will restrict airflow to the carburetor. To prevent carburetor malfunction, clean the air filter element regularly. Clean more frequently when operating the generator in extremely dirty areas with high dust or sand. Use a soapy solution or non-flammable solvent to clean the air filter element.

⚠ WARNING

▲ Do not use gasoline or low flash point solvents for cleaning because they are flammable and explosive under certain conditions.

⚠ CAUTION

▲ Never run the generator without the air filter element; rapid engine wear may result.

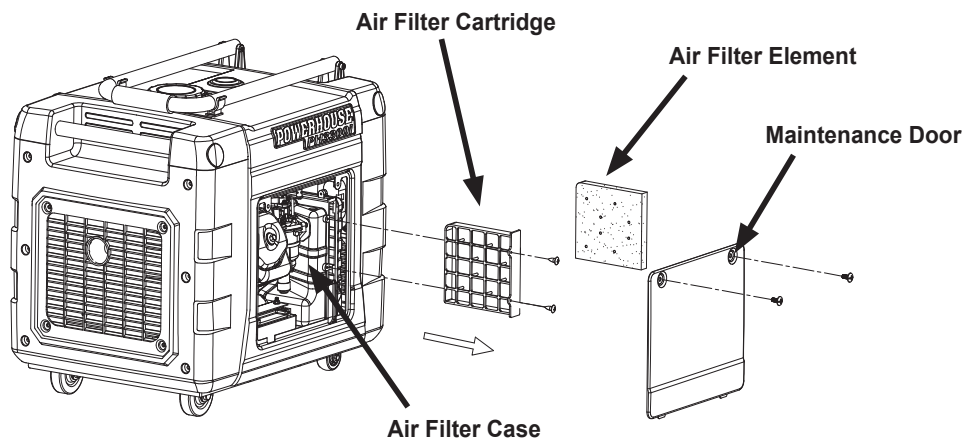

To clean the air filter element:

1. On the left side of the generator, remove the two screws and the maintenance door.
2. On the air filter case, remove the screws and the air filter cartridge.
3. Remove the air filter element from the cartridge.
4. Inspect the air filter element. If the element is dirty, wash it in a soapy solution and let it dry thoroughly.
5. Place the air filter element back into the air filter cartridge.
6. Reinstall the air filter cartridge and screws.
7. Reinstall the maintenance door and two screws back onto the generator.

6.4. CLEANING THE SPARK PLUG

Recommended spark plug: F7RTC

To ensure proper engine operation, the spark plug must be properly cleaned, gapped, and free of deposits.

CAUTION

- ▲ Always use an F7RTC resistor-type spark plug. Using a non-resistor spark plug will interfere with AC output and the electronics and may prevent the engine from starting.
- ▲ When replacing a spark plug, always purchase an exact equivalent to the spark plug recommended in this manual. Using a spark plug with a different number designation could result in overheating and damage the generator.

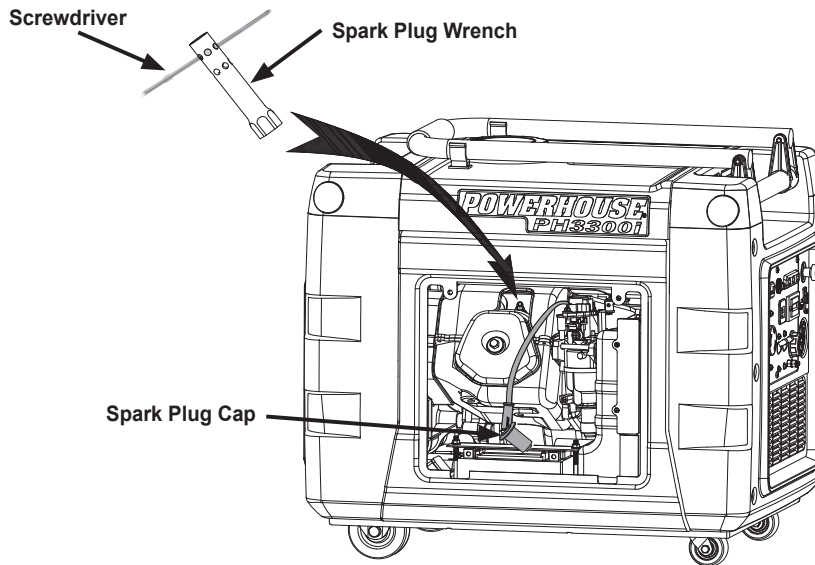

To clean the spark plug:

NOTE

A screwdriver and a spark plug wrench are provided with the generator. Use the screwdriver as a handle when inserted through a side hole on the spark plug wrench.

1. On the left side of the generator, remove the two screws and the maintenance door.
2. Remove the spark plug cap.
3. Clean any dirt from around the spark plug base.
4. Use the screwdriver with the spark plug wrench to loosen and remove the spark plug.
5. Visually inspect and clean the spark plug.

NOTE

If the insulator is cracked or chipped, or if the electrode has excessive wear, discard and replace the spark plug.

6. Clean the spark plug with a wire brush.
7. Measure the plug gap with a feeler gauge. The gap should be 0.024-0.028 in. (0.6-0.7mm). Adjust the gap as needed by carefully bending the side electrode.

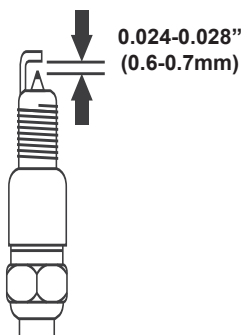

8. Reinstall the spark plug carefully.

- a. To avoid cross-threading, start threading by hand.
- b. After seating the spark plug by hand, use the spark plug wrench with the screwdriver to tighten the spark plug by 1/8 to 1/4 turn.

 CAUTION

▲ The spark plug must be correctly and securely seated to avoid loss of spark or damage to the generator.

NOTE

For a new spark plug, tighten by a 1/2 turn in order to adequately compress the gasket.

9. Put the spark plug cap back on the spark plug securely.

10. Reinstall the maintenance door and two screws back onto the generator.

6.5. CLEANING THE SPARK ARRESTOR

To ensure optimal engine performance, clean the spark arrestor every 100 hours to remove any carbon buildup.

CAUTION ▲ Failure to remove carbon buildup on the spark arrestor can cause a decrease in horsepower.

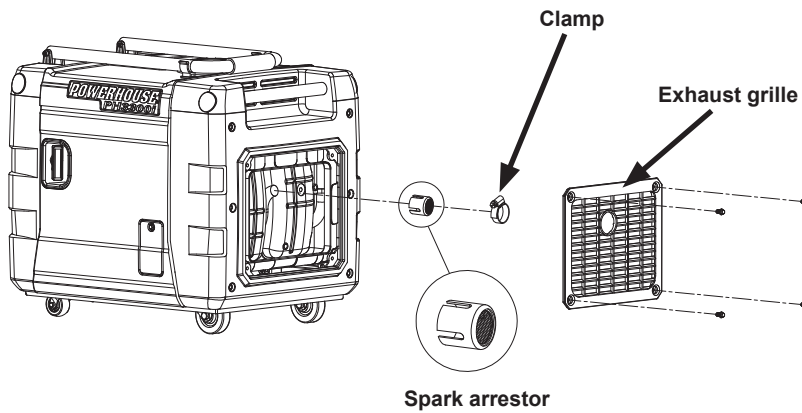

To clean the spark arrestor:

CAUTION ▲ Make sure the generator is OFF. If the generator has been running, the muffler will be very hot. Allow it to cool before proceeding.

1. On the back of the generator, remove the four screws and the exhaust grille.
2. Loosen the clamp and remove the spark arrestor from the muffler.
3. Inspect the spark arrestor for any tears or holes, and replace if necessary.
4. Use a wire brush to remove any carbon deposits from the spark arrestor.
5. Reinstall the spark arrestor and tighten the clamp.
6. Reinstall the exhaust grille and the four screws back onto the generator.

6.6. REPLACING THE 12V STARTING BATTERY

To remove the battery for maintenance or replacement:

1. On the left side of the generator, remove the two screws and the maintenance door.

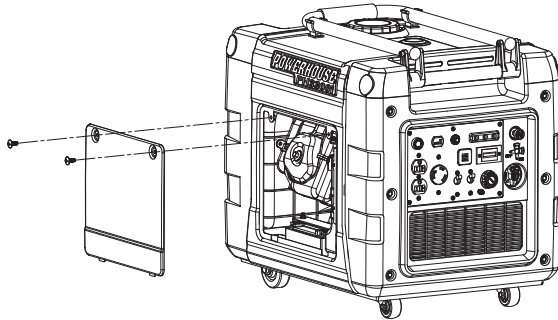

2. Unplug the quick connect cable from the wiring harness.

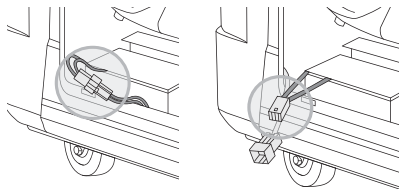

3. On the top of the battery, remove the two nuts and the battery hold down bracket.

CAUTION

- ▲ Ensure that you don't accidentally short the battery by dropping tools across the battery leads.

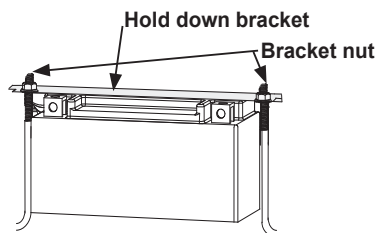

4. Tilt and lift the battery out of the compartment.

CAUTION

- ▲ Ensure that you don't accidentally short the battery when removing it by touching the positive terminal to the chassis.

5. Unscrew the positive and negative battery wires from the battery terminals.

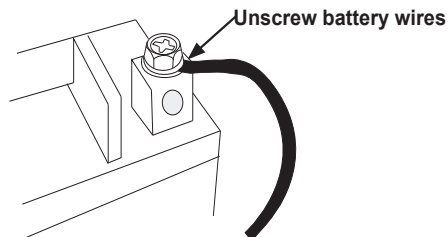

6. To replace the battery:

- a. Reattach the positive and negative battery wires onto the corresponding battery terminals.
- b. Tilt and place the new battery into the compartment. Ensure the battery is seated flat.
- c. Reinstall the two nuts and the battery hold down bracket.
- d. Plug the quick connect cable back into the wiring harness.

7. Reinstall the maintenance door and two screws back onto the generator.

6.7. REPLACING THE LITHIUM ION BATTERIES

The generator draws power from the lithium ion (Li-ion) batteries during startup. The Li-ion batteries are located inside the generator behind the control panel.

You may need to periodically replace the two Li-ion batteries when:

- The charge is depleted from long-term inactivity, such as the generator is stored for a long period of time.
- The normal life expectancy is exceeded (appx. 2 years).
- The Li-ion batteries are defective.

Li-ion Battery Specifications

Li-ion battery type	Panasonic NCR18650B A 3000 milliampere hours battery with the "protected circuit" feature.
Dimensions	18mm diameter x 65mm length
Voltage	3.6V

CAUTION

- ▲ Using the wrong battery type or installing the batteries incorrectly could result in damage to the generator which is not covered by warranty.

To replace the Li-ion batteries:

1. On the front end of the generator, remove the six screws and the control panel.

NOTE

The cables going from the generator to the control panel will remain connected during this process. You do not need to disconnect any cables.

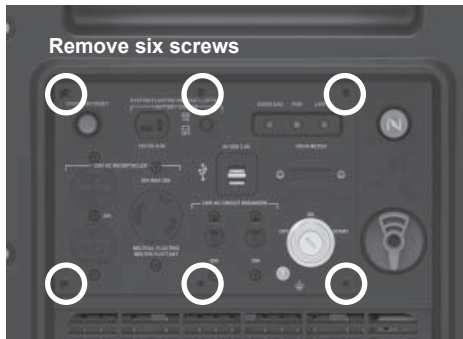

2. Locate and remove the two Li-ion batteries.

NOTE

As you look inside the generator, the two Li-ion batteries are located on the left side. They are seated vertically inside the battery tray.

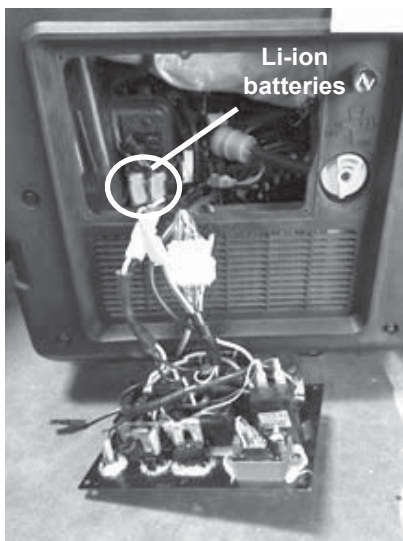

3. Remove the two Li-ion batteries.

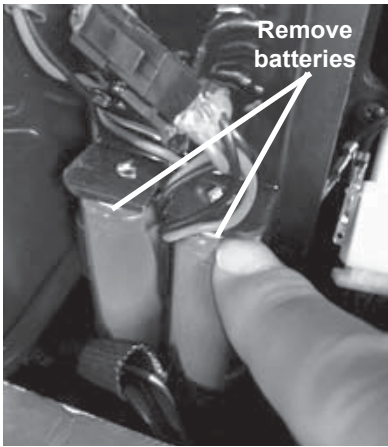

4. Insert two new Li-ion batteries.

NOTES

- Make sure the new Li-ion batteries are the same type and voltage specified in this manual.
- Identify and match the positive and negative ends of the batteries to the corresponding markings inside the Li-ion battery tray.



5. Reinstall the control panel and six screws back onto the generator.

NOTE

Ensure that all wires are tucked behind the control panel.

6. Reinstall the control panel and six screws back onto the generator.

6.7.1. Checking the Lithium Ion Batteries

To ensure optimal startup performance, check the state of the two lithium ion (Li-ion) batteries every two years.

To check the Li-ion batteries:

1. Remove the Li-ion batteries. See ***Replacing the Lithium Ion Batteries***.
2. Check the voltage of each battery with a voltmeter.

NOTES

- The nominal voltage is 3.6V, however a healthy battery will range from 3.2-4.0V depending on the outside temperature.
- If the voltage is $\leq 2.7V$, replace both batteries.

3. Inspect the batteries for any signs of damage, swelling, cracking, or corrosion. If defects are detected, replace and reinstall with new batteries.
4. Reinstall the Li-ion batteries.

NOTES

- Make sure the new Li-ion batteries are the same type and voltage specified in this Owner's Manual.
- Identify and match the positive and negative ends of the batteries to the corresponding markings inside the Li-ion battery tray.



7. Transporting and Storing the Generator

7.1. TRANSPORTING

To prevent fuel spillage when transporting, the generator should be secured upright in its normal operating position with the fuel valve and ignition switch in the OFF position.

When transporting the generator:



- ▲ Do not operate the generator while it is on or in a vehicle.
- ▲ If you must transport the generator in an enclosed vehicle, drain all fuel from the generator.

7.2. SHORT-TERM STORAGE

During short term storage, the generator should be secured upright in its normal operating position with the fuel valve and ignition switch in the OFF position.



- ▲ Avoid placing the generator in direct sunlight when storing.
- ▲ Avoid storing the generator in an enclosed area or vehicle. Gasoline is extremely flammable and explosive under certain conditions. High temperatures inside could cause residual fuel to vaporize resulting in possible explosion.

7.3. LONG-TERM STORAGE

During long term storage, the generator should be secured upright in its normal operating position with the fuel valve and ignition switch in the OFF position.

⚠ WARNING ▲ Avoid storing the generator in an enclosed area or vehicle. Gasoline is extremely flammable and explosive under certain conditions. High temperatures inside could cause residual fuel to vaporize resulting in possible explosion.

▲ Keep cigarettes, sparks, and any source of ignition away from generator and the fuel tank at all times.

⚠ CAUTION ▲ Unused fuel stored too long in the engine can cause clogging of the fuel system and carbon canister resulting in fuel varnishing which is not covered by warranty. When the generator is used infrequently, it is important to add a fuel stabilizer, such as STA-BIL® Fuel Stabilizer, to help prevent fuel oxidation (breakdown) and the formation of gum and varnish, and to inhibit corrosion in the fuel system and carburetor.

1. Be sure the storage area is free of excessive humidity and dust, and out of direct sunlight.
2. Depending on long how you are storing the generator, decide if you want to keep fuel in the engine.
 - **When storing up to one year:** Keep gasoline in the tank and add a gasoline fuel treatment (such as STA-BIL®) to prevent contamination of your fuel supply.

NOTE

It is best to keep the tank at least 95% full, as condensation will be less likely to occur in the fuel tank during storage if the tank is full. Do not overfill the tank, as the fuel will need room to expand on hot days. Add an appropriate amount of fuel stabilizer (per the instructions on the bottle) and run the generator for 5 minutes to ensure that any fuel trapped in the system has the stabilizer in it. You may also opt to add the fuel stabilizer and run the unit until it is out of fuel.

- **When storing for more than one year:** Drain fuel completely until no fuel remains in the fuel tank or fuel system.

3. **If you opt to drain the fuel, do the following, then continue on with the instructions below.**
 - a. To drain the gasoline from the fuel tank, ensure that the ignition key is in the OFF position.
 - b. Attach a hose to the drain fitting on the carburetor and place the other end of the hose into an approved gasoline container.
 - c. Turn the fuel valve to the ON position, and loosen the carburetor drain screw and drain the gasoline into the approved gasoline container.
 - d. After the fuel tank has been drained, with the drain screw loosened, disconnect the spark plug wire and pull the starter grip 3 to 4 times to drain the gasoline from the fuel pump.
 - e. Turn the fuel valve to the OFF position, and tighten the drain screw securely.
4. Change the engine oil.
5. Remove the spark plug and pour about a tablespoon of clean engine oil into the cylinder.
6. Crank the engine several revolutions to distribute the oil and then reinstall the spark plug.
7. Slowly pull the starter grip until resistance is felt. At this point, the piston is coming up on its compression stroke and both the intake and exhaust valves are closed. Storing the engine in this position will help to protect it from internal corrosion.
8. Once a month, use a trickle charger to recharge the 12V starting battery.

7.4. EXERCISING THE GENERATOR

It is essential that you exercise the generator on a regular basis, which helps to:

- Prevent accumulation of varnish or sludge in the fuel system.
- Keep the battery properly charged by removing moisture from the generator windings.
- Keep the engine seals and moving components lubricated.
- Maintain the charge for the 12V starting battery and the two lithium ion batteries.

Exercise the generator by running it with at least a 1/2 load (1600W) for 15 minutes per month.

CAUTION

- ▲ Unused fuel stored too long in the engine can cause clogging of the fuel system and carbon canister resulting in fuel varnishing which is not covered by warranty. When the generator is used infrequently, it is important to add a fuel stabilizer, such as STA-BIL® Fuel Stabilizer, to help prevent fuel oxidation (breakdown) and the formation of gum and varnish, and to inhibit corrosion in the fuel system and carburetor.

8. Troubleshooting

8.1. ENGINE WILL NOT START

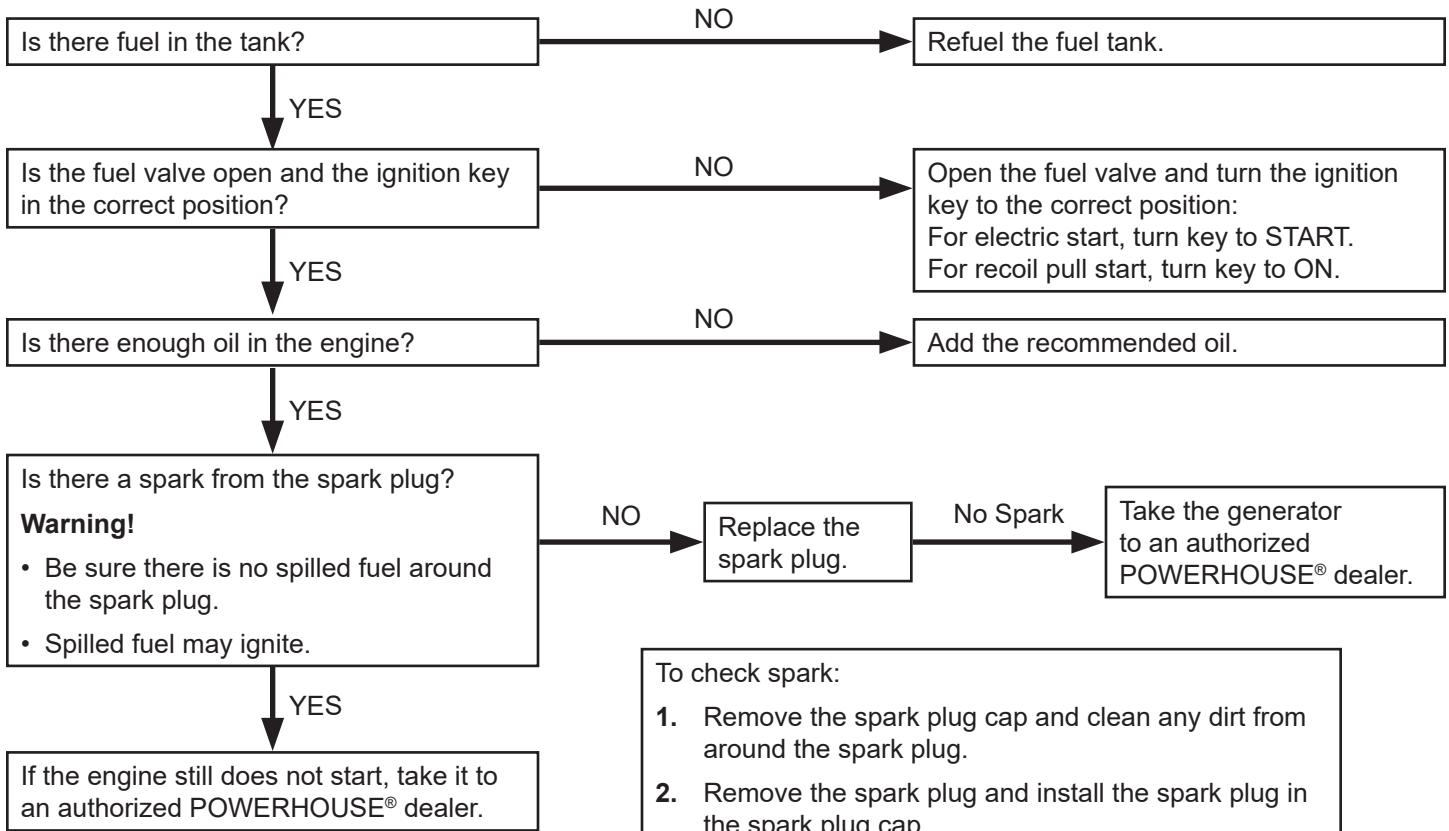

To check spark:

1. Remove the spark plug cap and clean any dirt from around the spark plug.
2. Remove the spark plug and install the spark plug in the spark plug cap.
3. Attach the plug side electrode to your ground wire.
4. Quickly turn the ignition key in the START position for a few cycles -- sparks should jump across the spark plug gap.

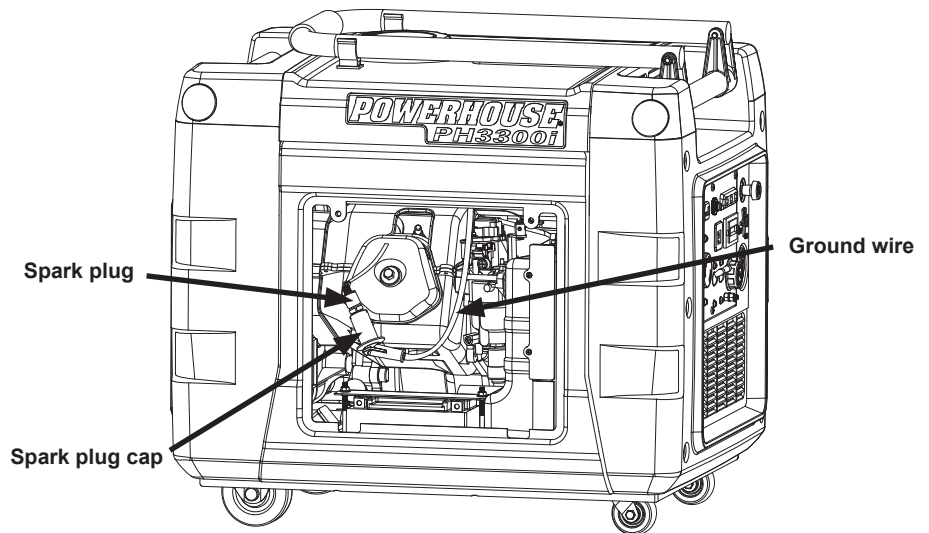

8.2. ENGINE WILL NOT CRANK WITH THE KEY

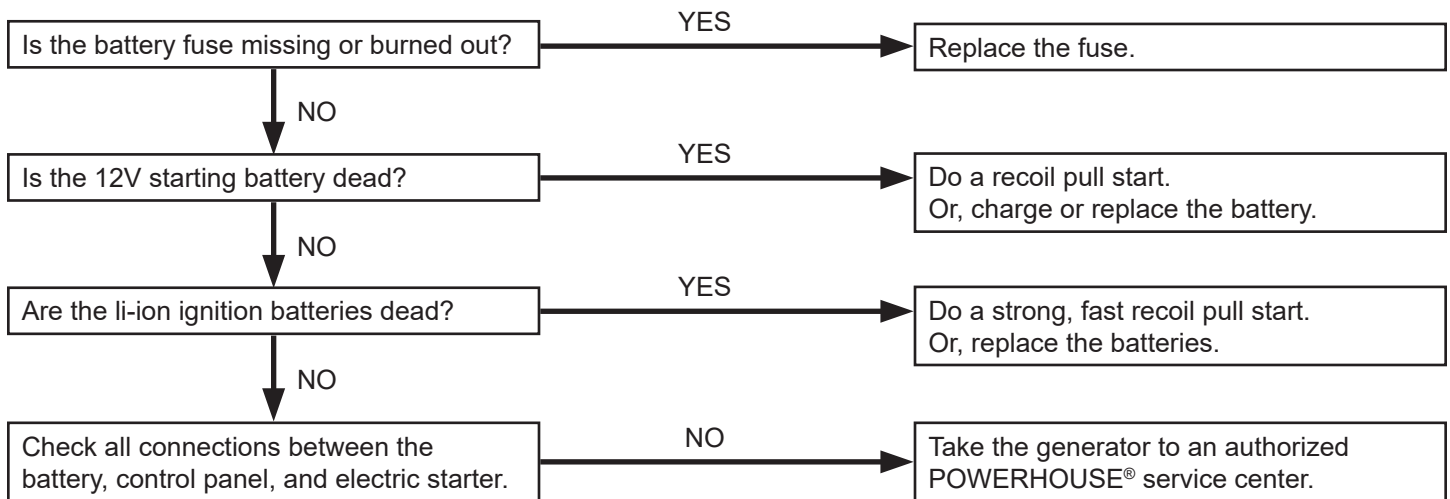

8.3. APPLIANCE DOES NOT OPERATE

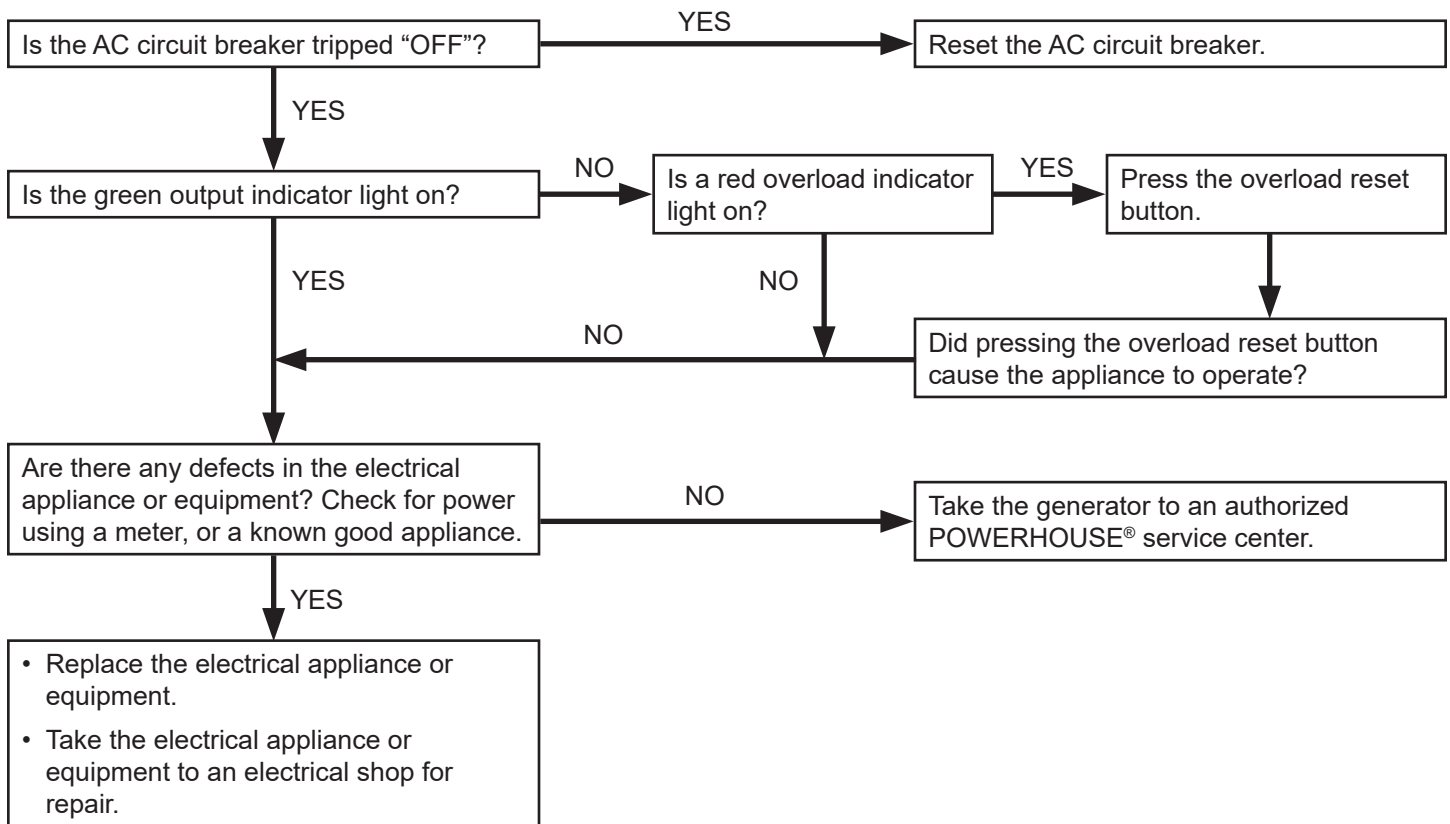

8.4. NO OUTPUT AT THE DC RECEPTACLE

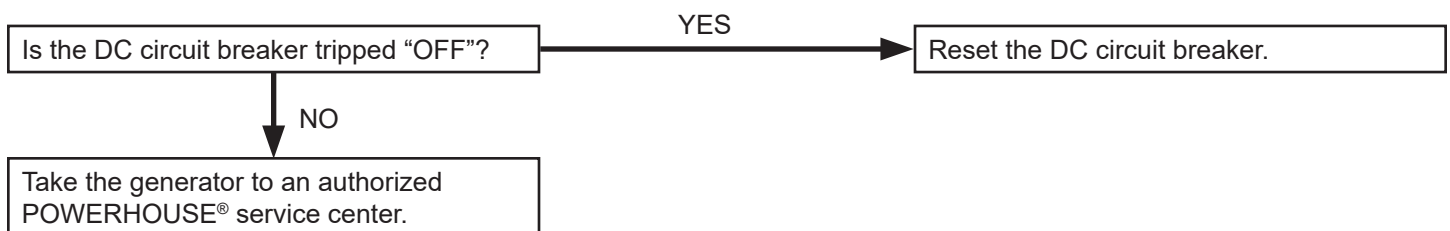

9. Specifications

Generator

Model	PH3300i
Part number	67226
Rated frequency	60Hz
Rated voltage	120V
Rated current	26.7A
Max current	27.5A
Rated output	3200W
Max output	3300W
DC output	12V, 8.3A
Phase	Single
Starting Battery (1)	12V Lead Acid Battery
Ignition Batteries (2)	3.6V Lithium Ion Batteries (Panasonic NCR18650B)
Battery fuse	20 Amp, ATC style

Engine

Model	XG-177F
Type	4 stroke, 1-cylinder, air-cooled, OHV, gasoline engine
Horsepower / Displacement	6.4hp / 270cc
Compression ratio	9.2:1
Engine speed (max)	3600 RPM
Ignition system	Capacitor Discharge (CDI)
Spark plug	F7RTC
Starting system	Electric & Recoil
Fuel	Automotive Unleaded Gasoline
Lube oil (synthetic or conventional)	Above 32°F: SAE 10W-30 Below 32°F: 0W-30 / 0W-40
Oil Capacity	33.8 fl oz (1.0L)
Fuel tank capacity	4.3 gal. (16.3L)
Continuous running time at (rated output)	7.3 hours
Continuous running time at (½ load)	10.9 hours
Continuous running time at (¼ load)	16.6 hours
Noise level (no load - full load) dB@ 23' (7m)	63 – 73 dB

Tune Up Specifications

Spark Plug Gap	0.024–0.028 in. (0.6–0.7 mm)
Spark plug	F7RTC
Valve Clearance (Intake)	0.003±0.004 in (0.08±0.10 mm)
Valve Clearance (Exhaust)	0.004±0.006 in (0.10±0.15 mm)

Dimensions

Overall dimensions - H×W×D in. (mm)	21.25" x 18.75" x 23.75" (546 x 476 x 603 mm)
Dry weight, with battery	134 lbs. (61kg)

10. Warranty and Consumer Information

10.1. POWERHOUSE® GENERATOR WARRANTY

Generators are covered by this warranty from the date of original retail purchase for a period of 1 year or 500 hours (whichever expires first) for residential use and 6 months or 250 hours (whichever expires first) for commercial applications. Units used in rental fleets, reconditioned or as demonstration models will be considered commercial usage. Starting batteries that are supplied with applicable products as standard, original equipment will be covered for a period of 6 months. The warranty coverage is continual from the original date of purchase, and does not restart upon the replacement of any part or complete unit. Individual parts replaced at any point during the warranty period are only eligible for warranty coverage for the balance of the original warranty period.

Eligibility

To be eligible for warranty replacement, the product must be purchased in the United States or Canada from an authorized POWERHOUSE® dealer. This warranty applies to the original retail purchaser only, and is not transferable. Proof of purchase and the serial number are required.

Coverage

Pre-approved parts and labor costs will be covered by POWERHOUSE® for any failure that is proven to be a failure in material or workmanship under normal use during the applicable warranty time period. This coverage is limited to parts, labor and ground shipping of repair parts. It is the responsibility of the end user to return the product to the nearest authorized repair center as directed by the warranty administration center. If in the event that the generator is deemed to be not repairable or the necessary repair would be economically unfeasible, the warranty department will authorize its prepaid return to the nearest location and Keystone Automotive Operations, Inc. will prepay the returned shipping to the dealer, repair center or consumer. Keystone Automotive Operations, Inc. reserves the right to repair or replace any part or unit at its option. Keystone Automotive Operations, Inc. may request defective parts to be returned. Anything replaced under warranty becomes the property of Keystone Automotive Operations, Inc..

To Obtain Warranty Service

Do not return this generator to the store where you purchased it. Contact any authorized dealer or contact our national customer service center at:

Phone: 1-877-544-4449 (8am to 6pm ET)
Fax: 1-855-242-8922
E-mail: www.powerhouse-products.com

If contacting us by fax or e-mail, be sure to include a description of the problem as well as all return contact info such as address, phone number, fax number, e-mail, etc. Engine serial number and proof of purchase is required.

Exclusions

THIS WARRANTY DOES NOT EXTEND TO PARTS AFFECTED OR DAMAGED BY ACCIDENT AND/OR COLLISION, NORMAL WEAR, FUEL CONTAMINATION OR DEGRADATION, USE IN AN APPLICATION FOR WHICH THE PRODUCT WAS NOT DESIGNED OR ANY OTHER MISUSE, NEGLIGENCE, INCORPORATION OR USE OF UNSUITABLE ATTACHMENTS OR PARTS, UNAUTHORIZED ALTERATION, OR ANY CAUSES OTHER THAN DEFECTS IN MATERIAL OR WORKMANSHIP OF THE PRODUCT. THIS WARRANTY DOES NOT EXTEND TO NORMAL MAINTENANCE ITEMS SUCH AS BELTS, HOSES, SPARK PLUGS, BATTERIES, WHEELS AND FILTERS PAST THE FIRST SCHEDULED REPLACEMENT OR SERVICE INTERVAL FOR THESE ITEMS WHICHEVER COMES FIRST.

Disclaimer of consequential Damage and Limitation of Implied Warranties

KEYSTONE AUTOMOTIVE OPERATIONS, INC. DENIES ANY RESPONSIBILITY FOR LOSS OF TIME OR USE OF THE PRODUCT, TRANSPORTATION, COMMERCIAL LOSS, OR ANY OTHER INCIDENTAL OR CONSEQUENTIAL DAMAGE. ANY IMPLIED WARRANTIES ARE LIMITED TO THE DURATION OF THIS WRITTEN LIMITED WARRANTY.

Some states do not allow limitations on how long an implied warranty lasts and/or do not allow the exclusion or limitation of incidental or consequential damages. Therefore, the above exclusions and limitations may not apply to you. This warranty gives you specific legal rights, and you may also have other rights, which vary from state to state.

Replacement Parts Availability

To purchase replacement parts please refer to the www.powerhouse-products.com website.



10.2. CALIFORNIA EMISSION CONTROL WARRANTY STATEMENT

Your Warranty Rights and Obligations

The California Air Resources Board and Keystone Automotive Operations, Inc. (POWERHOUSE®) are pleased to explain the emissions control system warranty on your 2008 and later small off-road engine (SORE). In California, new SOREs must be designed, built and equipped to meet the State's stringent anti-smog standards. Keystone Automotive Operations, Inc. (POWERHOUSE®) must warrant the emissions control system on your SOREs for the periods of time listed below provided there has been no abuse, neglect or improper maintenance of your SOREs.

Your emission control system may include parts such as the carburetor, fuel tanks, fuel caps, fuel lines, the ignition system, and catalytic converter. Also included may be hoses, belts, clamps, connectors and other emission-related assemblies.

Where a warrantable condition exists, Keystone Automotive Operations, Inc. (POWERHOUSE®) will repair your small off-road engine at no cost to you including diagnosis, parts and labor.

Manufacturer's Warranty Coverage

The emissions control system is warranted for two years. If any emissions-related part on your engine is defective, the part will be repaired or replaced by Keystone Automotive Operations, Inc. (POWERHOUSE®).

Owner's Warranty Responsibilities

- As the SORE owner, you are responsible for the performance of the required maintenance listed in your owner's manual. Keystone Automotive Operations, Inc. (POWERHOUSE®) recommends that you retain all receipts covering maintenance on your SORE, but Keystone Automotive Operations, Inc. (POWERHOUSE®) can not deny warranty solely for the lack of receipts or for your failure to ensure the performance of all scheduled maintenance.
- As the SORE owner, you should however be aware that Keystone Automotive Operations, Inc. (POWERHOUSE®) may deny your warranty coverage if your SORE or a part has failed due to abuse, neglect, improper maintenance or unapproved modifications.
- You are responsible for presenting your SORE to a distribution center or service center authorized by Keystone Automotive Operations, Inc. (POWERHOUSE®) as soon as the problem exists. The warranty repairs should be completed in a reasonable amount of time, not to exceed 30 days.

If you have any questions regarding your warranty coverage, you should contact the North America service center for POWERHOUSE® products:

Phone: 1-877-544-4449

Fax: 1-855-242-8922

Email: www.powerhouse-products.com



10.3. EMISSION CONTROL SYSTEM WARRANTY

Your POWERHOUSE® generator engine complies with U.S. Environmental Protection Agency, Environment of Canada, and the state of California (if the model is certified by CARB). The following systems and/or parts are covered by this warranty. Failures or improper operation of the following systems and components will be diagnosed and repaired with no charge for labor or parts.

Fuel System

- Carburetor including the choke system and replaceable high altitude jets
- Engine speed control system (Economy Throttle)
- Intake manifold
- Engine control module

Evaporative Control System

- Fuel tank
- Fuel cap
- Fuel strainer
- Fuel valve
- Fuel pump
- Fuel lines
- Carbon canister (including brackets and connectors)

Air Induction System

- Air filter element*
- Air filter housing

Ignition system

- Ignition module
- Ignition coil
- Ignition winding
- Spark plug*
- Spark plug cap and wire

Exhaust system

- Catalytic converter
- Exhaust manifold
- Secondary air injection assembly

Miscellaneous

Pipes, tubes, hoses and clamps, o-rings, seals, and gaskets associated with the above systems.

* Covered up to the first scheduled replacement only. See the Maintenance Schedule.

11. APPENDIX A - Emission Control System

Your generator has an engine that has been approved by the California Air Resources Board. Other than the tune up procedures specified in the **Maintenance Schedule** of this Owner's Manual, no additional maintenance is required.

The emission control system has the following components:

1. **Fuel System:** The fuel tank, cap, indicator and hoses are specially designed and constructed to not allow fuel vapors to permeate and be released to the atmosphere.
2. A carbon activated canister collects gasoline vapors from the fuel tank and returns them to the combustion chamber for burning.
3. A catalytic converter is built into the muffler to further treat the engine exhaust.
4. A secondary air injection valve adds fresh air to ignite unburned fuel in the exhaust.
5. Contact your authorized POWERHOUSE® service center to obtain the correct replacement parts and service on this system.

Emission source

Exhaust gas contains carbon monoxide, nitrogen oxides (NOX), and hydrocarbons. It is very important to control the emissions of NOX and hydrocarbons as they are a major contributor to air pollution. Carbon monoxide is a poisonous gas. The emission of fuel vapors is a source of pollution as well. The POWERHOUSE® generator engine utilizes a precise air-fuel ratio and emission control system to reduce the emissions of carbon monoxide, NOX, hydrocarbons, and evaporative fuel emissions.

Regulation

Your engine has been designed to meet current Environmental Protection Agency (EPA) and the California Air Resources Board (CARB) clean air standards. The regulations dictate that the manufacturer provides operation and maintenance standards regarding the emission control system. Tune up specifications are provided in the Specifications section and a description of the emission control system may be found in the appendix to this manual. Adherence to the following instructions will ensure your engine meets the emission control standards.

Modification

Modification of the emission control system may lead to increased emissions. Modification is defined as the following:

- Disassembling or modifying the function or parts of the intake, fuel or exhaust system.
- Modifying or destroying the speed governing function of the generator.

Engine Faults That May Affect Emission

Any of the following faults must be repaired immediately. Consult with your authorized POWERHOUSE® service center for diagnosis and repair:

- Hard starting or shut down after starting
- Unstable idle speed
- Shut down or backfire after applying an electrical load
- Backfire or after fire
- Black smoke and/or excessive fuel consumption

Replacement Parts and Accessories

The parts making up the emission control system applied to POWERHOUSE® engine have been specifically approved and certified by the regulatory agencies. You can trust that the replacement parts supplied by POWERHOUSE® have been manufactured to the same production standard as the original parts. The use of replacement parts or accessories which are not designed by POWERHOUSE® may affect the engine emission performance. The manufacturers of replacement parts and accessories have the responsibility to guarantee that their replacement products will not adversely affect emission performance.

Maintenance

Maintain the generator according to the **Maintenance Schedule** in this section. Service items more frequently when used in dusty areas, or under conditions of high load, temperature, and humidity.

Air Quality Index (only for California certified models)

CARB requires that an air quality index label be attached to every certified engine showing the engine emission information for the emission duration period. The label is provided for the user to compare the emission performance of different engines. The lower the air index, the better the engine emission performance. The description of durability is helpful for the user to learn the engine emission duration period and the service life of emission control system. Refer to the Warranty section of this owner’s manual for more information.

The air quality index label is designed to be permanently affixed to the generator and removal should not be attempted.



(Example Label)

12. APPENDIX B - Vehicle Battery Charging and Safety Instructions

- (a) SAVE THESE INSTRUCTIONS. THIS MANUAL CONTAINS IMPORTANT SAFETY AND OPERATING INSTRUCTIONS.
- (b) WORKING IN THE VICINITY OF A LEAD-ACID BATTERY IS DANGEROUS. BATTERIES GENERATE EXPLOSIVE GASES DURING NORMAL BATTERY OPERATION. FOR THIS REASON IT IS OF THE UTMOST IMPORTANCE THAT EACH TIME BEFORE USING YOUR CHARGER, YOU READ AND FOLLOW THE INSTRUCTIONS PROVIDED EXACTLY.
- (c) TO REDUCE RISK OF BATTERY EXPLOSION, FOLLOW THESE INSTRUCTIONS AND THOSE MARKED ON THE BATTERY.
- (d) NEVER SMOKE OR ALLOW AN OPEN SPARK OR FLAME IN THE VICINITY OF THE BATTERY OR ENGINE.
- (e) USE CHARGER FOR CHARGING A LEAD-ACID BATTERY ONLY. IT IS NOT INTENDED TO SUPPLY POWER TO AN EXTRA-LOW-VOLTAGE ELECTRICAL SYSTEM OR TO CHARGE DRY-CELL BATTERIES. CHARGING DRY-CELL BATTERIES MAY CAUSE THEM TO BURST AND CAUSE INJURY TO PERSONS AND DAMAGE TO PROPERTY.
- (f) NEVER CHARGE A FROZEN BATTERY.
- (g) IF IT IS NECESSARY TO REMOVE BATTERY FROM VEHICLE TO CHARGE IT, ALWAYS REMOVE GROUNDED TERMINAL FROM BATTERY FIRST. MAKE SURE ALL ACCESSORIES IN THE VEHICLE ARE OFF IN ORDER TO PREVENT AN ARC.
- (h) STUDY ALL BATTERY MANUFACTURER'S SPECIFIC PRECAUTIONS SUCH AS REMOVING OR NOT REMOVING CELL CAPS WHILE CHARGING AND RECOMMENDED RATES OF CHARGE.
- (i) FOR A CHARGER HAVING AN OUTPUT VOLTAGE SELECTOR SWITCH, REFER TO THE CAR OWNER'S MANUAL IN ORDER TO DETERMINE THE VOLTAGE OF THE BATTERY AND TO MAKE SURE THE OUTPUT VOLTAGE IS SET AT THE CORRECT VOLTAGE. IF AN OUTPUT VOLTAGE SELECTOR SWITCH IS NOT PROVIDED, DO NOT USE THE BATTERY CHARGER UNLESS THE BATTERY VOLTAGE MATCHES THE OUTPUT VOLTAGE RATING OF THE CHARGER.
- (j) NEVER PLACE THE CHARGER DIRECTLY ABOVE OR BELOW THE BATTERY BEING CHARGED; GASES OR FLUIDS FROM THE BATTERY WILL CORRODE AND DAMAGE THE CHARGER. LOCATE THE CHARGER AS FAR AWAY FROM THE BATTERY AS DC CABLES PERMIT.
- (k) DO NOT OPERATE CHARGER IN A CLOSED-IN AREA OR RESTRICT VENTILATION IN ANY WAY.
- (l) CONNECT AND DISCONNECT DC OUTPUT CLIPS ONLY AFTER SETTING ANY CHARGER SWITCHES TO THE OFF POSITION AND REMOVING AC CORD FROM THE ELECTRIC OUTLET. NEVER ALLOW CLIPS TO TOUCH EACH OTHER.
- (m) FOLLOW THESE STEPS WHEN BATTERY IS INSTALLED IN VEHICLE. A SPARK NEAR BATTERY MAY CAUSE A BATTERY EXPLOSION. TO REDUCE RISK OF A SPARK NEAR BATTERY:
 - i. POSITION AC AND DC CORDS TO REDUCE RISK OF DAMAGE BY HOOD, DOOR, OR MOVING ENGINE PARTS;
 - ii. STAY CLEAR OF FAN BLADES, BELTS, PULLEYS, AND OTHER PARTS THAT CAN CAUSE INJURY TO PERSONS;
 - iii. CHECK POLARITY OF BATTERY POSTS. A POSITIVE (POS, P, +) BATTERY POST USUALLY HAS A LARGER DIAMETER THAN A NEGATIVE (NEG, N, -) POST;
 - iv. DETERMINE WHICH POST OF BATTERY IS GROUNDED (CONNECTED) TO THE CHASSIS. IF NEGATIVE POST IS GROUNDED TO CHASSIS (AS IN MOST VEHICLES), SEE ITEM (v). IF POSITIVE POST IS GROUNDED TO THE CHASSIS, SEE ITEM (vi);
 - v. FOR A NEGATIVE-GROUNDED VEHICLE, CONNECT THE POSITIVE (RED) CLIP FROM BATTERY CHARGER TO POSITIVE (POS, P, +) UNGROUNDED POST OF BATTERY. CONNECT THE NEGATIVE (BLACK) CLIP TO VEHICLE CHASSIS OR ENGINE BLOCK AWAY FROM BATTERY. DO NOT CONNECT CLIP TO CARBURETOR, FUEL LINES, OR SHEET-METAL BODY PARTS. CONNECT TO A HEAVY GAUGE METAL PART OF THE FRAME OR ENGINE BLOCK;
 - vi. FOR A POSITIVE-GROUNDED VEHICLE, CONNECT THE NEGATIVE (BLACK) CLIP FROM BATTERY CHARGER TO NEGATIVE (NEG, N, -) UNGROUNDED POST OF BATTERY. CONNECT THE POSITIVE (RED) CLIP TO VEHICLE CHASSIS OR ENGINE BLOCK AWAY FROM BATTERY. DO NOT CONNECT CLIP TO CARBURETOR, FUEL LINES, OR SHEET-METAL BODY PARTS. CONNECT TO A HEAVY GAUGE METAL PART OF THE FRAME OR ENGINE BLOCK;
 - vii. CONNECT CHARGER AC SUPPLY CORD TO ELECTRIC OUTLET; AND
 - viii. WHEN DISCONNECTING CHARGER, TURN SWITCHES TO OFF, DISCONNECT AC CORD, REMOVE CLIP FROM VEHICLE CHASSIS, AND THEN REMOVE CLIP FROM BATTERY TERMINAL.
- (n) FOLLOW THESE STEPS WHEN BATTERY IS OUTSIDE VEHICLE. A SPARK NEAR THE BATTERY MAY CAUSE A BATTERY EXPLOSION. TO REDUCE RISK OF A SPARK NEAR BATTERY:
 - i. CHECK POLARITY OF BATTERY POSTS. A POSITIVE (POS, P, +) BATTERY POST USUALLY HAS A LARGER DIAMETER THAN A NEGATIVE (NEG, N, -) POST;
 - ii. ATTACH AT LEAST A 60 CM 6-GAUGE (AWG) INSULATED BATTERY CABLE TO A NEGATIVE (NEG, N, -) BATTERY POST;
 - iii. CONNECT THE POSITIVE (RED) CHARGER CLIP TO THE POSITIVE (POS, P, +) POST OF BATTERY;
 - iv. POSITION YOURSELF AND THE FREE END OF CABLE AS FAR AWAY FROM BATTERY AS POSSIBLE, THEN CONNECT THE NEGATIVE (BLACK) CHARGER CLIP TO FREE END OF THE INSULATED BATTERY CABLE;
 - v. DO NOT FACE BATTERY WHEN MAKING FINAL CONNECTION;
 - vi. CONNECT CHARGER AC SUPPLY CORD TO ELECTRICAL OUTLET; AND
 - vii. WHEN DISCONNECTING CHARGER, ALWAYS DO SO IN REVERSE SEQUENCE OF CONNECTING PROCEDURE AND BREAK FIRST CONNECTION WHILE STANDING AS FAR AWAY FROM BATTERY AS PRACTICAL.
- (o) USE OF AN ADAPTER IS NOT ALLOWED IN CANADA. IF A GROUNDING TYPE RECEPTACLE IS NOT AVAILABLE, DO NOT USE THIS APPLIANCE UNTIL THE PROPER OUTLET IS INSTALLED BY A QUALIFIED ELECTRICIAN.
- (p) THE GENERATOR (STATOR WINDING) IS ISOLATED FROM THE FRAME AND FROM THE AC RECEPTACLE GROUND PIN.
- (q) ELECTRICAL DEVICES THAT REQUIRE A GROUNDED RECEPTACLE PIN CONNECTION WILL NOT FUNCTION IF THE RECEPTACLE GROUND PIN IS NOT FUNCTIONAL.



POWERHOUSE[®]

POWERHOUSE Products

DTS Manufacturing

7930 S.W. Burns Way, Unit C

Wilsonville, OR 97070

www.powerhouse-products.com

BCN # Label For This Unit

This manual version applies to BCNs equal to or greater than:

161110436722001

PH3300i Owner's Manual
(Revision 2016-10-24)

© DTS Manufacturing, 2016.
All rights reserved.