

MODEL RANGE

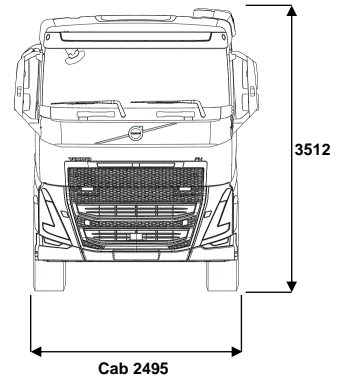

Volvo Trucks. Driving Progress

NEW FH 13 6x2 Pusher Tractor - Standard or Lite - Rear Air Suspension FH 62T P3A

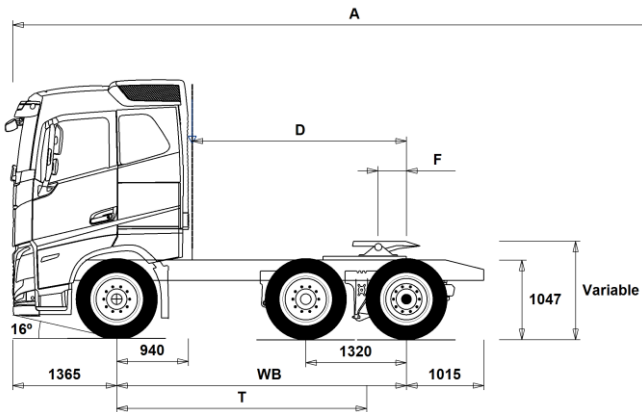

Chassis Dimensions [mm]

WB Wheelbase	3800	3900	4000	4100
A Overall Chassis Length	8945	8945	8945	8945
D Center of rear axle to back of cab	2810	2910	3010	3110
F Fifth Wheel Position (EC Directive 96/53)	675	675	675	675
T Theoretical Wheelbase	3279	3379	3479	3579

Chassis Weights [kg]

Front Axle	4690	4695	4695	4695
Rear Bogie	3005	3010	3015	3025
Kerb Weight	7695	7705	7710	7720

Turning Diameter [mm]

Turning Circle Diameter Kerb to Kerb	12100	12400	12700	13000
Turning Circle Diameter Wall to Wall	13400	13700	14000	14300

Plated Weights [kg]

	Plated	Design
Gross Vehicle Weight	22800	26500
Gross Combination Weight	44000	44000
Front Axle	7500	7500
Rear Bogie	19000	19000

Important Notes

Chassis Dimensions

Cab Height: +305 mm for CAB-HSLP, -285 mm for CAB-LSLP, +450 mm for CAB-XHSL.

Front Axle to Back of Cab: +141 mm for CAB-LSLP.

D-measure includes a front clearance of 50 mm and for rigid trucks also a subframe of 100 mm.

Height can vary ± 20 mm for leaf and ± 10 mm for air suspension.

All dimensions are for unladen chassis and any tag axles down. Chassis height used: CHH-HIGH.

Height change when chassis height CHH-MED,FRAME266: 0 mm.

Weight and dimensions are based upon the following tyres:

Front Axle Tyres:	315/80R22.5
Drive Axle Tyres:	315/80R22.5
Trailing/Tractor Axle Tyres:	315/80R22.5

Chassis weight includes oil, water, AdBlue, 0 litres fuel and without driver. Kerb weight can vary $\pm 3\%$.

Turning diameters are theoretically calculated. Tag axle used: PA-FIXED.

Legal weights can differ from country to country.

For more detailed weight information, including optional equipment weights, ask your Volvo sales contact to enter your specification into the Volvo Weight Information system (WIS).

Do NOT use this drawing for bodybuilding. Refer to Volvo Bodybuilder Instructions and chassis assembly drawing FH62TP3A.

MODEL RANGE

NEW FH 13 6x2 Pusher Tractor - Standard or Lite - Rear Air Suspension FH 62T P3A

CORE COMPONENTS

- CHH-HIGH** Chassis Height - High - for loading heights check the unique BEP chassis drawing
- CHH-LOW** Chassis Height - Low - for loading heights check the unique BEP chassis drawing
- CHH-MED** Chassis Height - Medium - for loading heights check the unique BEP chassis drawing
- CHH-XLOW** Chassis Height - Extra-low - for loading heights check the unique BEP chassis drawing
- PU-EHYS** Pusher axle - Electro-hydraulically steered
- PU-FIXS** Pusher axle - Fixed
- RAPD-G4** Rear air suspension, 2 axles - 1 lite pusher / 1 driven
- RAPD-GR** Rear air suspension, 2 axles - 1 pusher/1 driven
- FH-HSLP5** Globetrotter cab - all steel safety cage design with roof mounted emergency escape hatch. Designed and built to Swedish impact and ECE R29 regulations
- FH-LSLP5** Cab - Low Sleeper - all-steel safety cage design. Built to Swedish impact and ECE R29 regulations
- FH-SLP5** Cab - Sleeper - all-steel safety cage design with roof-mounted emergency escape hatch. Designed and built to Swedish impact and ECE R29 regulations
- FH-XHSL5** Globetrotter XL cab - all steel safety cage design with roof mounted emergency escape hatch. Designed and built to Swedish impact and ECE R29 regulations
- EU6HT** Emission level - Euro VI step E
- EU6SCR** Emission level - Euro VI step E
- D13 420S** Engine - D13K420 12.8 litre developing 420hp at 14-1800rpm. Peak torque 2100Nm at 860 -1400rpm.
- D13 460S** Engine - D13K460 12.8 litre developing 460hp at 14-1800rpm. Peak torque 2300Nm at 900-1400rpm.
- D13 460T** Engine - D13K460TC 12.8 litre Turbo-compound diesel developing 460hp at 14-1800rpm. Peak torque 2600Nm at 900-1250rpm.
- D13 500S** Engine - D13K500 12.8 litre developing 500hp at 14-1800rpm. Peak torque 2500Nm at 1000-1400rpm.
- D13 500T** Engine - D13K500TC 12.8 litre Turbo-compound diesel developing 500hp at 14-1800rpm. Peak torque 2800Nm at 900-1250rpm.
- D13 540S** Engine - D13K540 12.8 litre developing 540hp at 14-1800rpm. Peak torque 2600Nm at 1000-1450rpm.
- D13K420** D13K420 - 420hp engine
- D13K460** D13K460 - 460hp engine
- D13K500** D13K500 - 500hp engine
- D13K540** D13K540 - 540hp engine
- EBR-EPG** Engine Brake Type - Exhaust brake controlled by steering column switch
- EBR-EPGC** Engine Brake Type - Exhaust pressure governor for I shift gearbox
- EBR-VEB+** Engine Brake Type - Volvo engine brake + and exhaust pressure governor, enhanced performance from additional exhaust rocker control. Retardation 375kW
- AT2612F** Gearbox - AT2612F 12-speed "I-shift" automated mechanical suitable for gross train weights up to 60tonne only. Refer to sales engineering when used in conjunction with a PTO
- AT2812F** Gearbox - AT2812E 12-speed "I-shift" automated mechanical suitable for gross train weights up to 60 tonne. Refer to sales engineering when used in conjunction with a PTO
- ATO2612F** Gearbox - ATO2612F 12-speed "I-shift" overdrive automated mechanical, suitable for gross train weights up to 60tonne. Refer to sales engineering when used in conjunction with a PTO
- ATO3112F** Gearbox - ATO3112F 12-speed "I-shift" overdrive automated mechanical, suitable for gross train weights up to 60tonne. Refer to sales engineering when used in conjunction with a PTO

- SPO2812** Gearbox - SPO2812 - 12-speed I-shift Dual Clutch automated mechanical GCW 60tonne
- ASO-C** Crawler gear - Ratio direct top gearbox 19:1 Ratio Overdrive gearbox 17:1
- ASO-ULC** Ultra low crawler and crawler gear - Ratios direct top gearbox 32:1 and 19:1 Ratios Overdrive box 32:1 and 17:1
- RSH1370F** Drive Axle - RSH1370F 13-tonne hub reduction with differential lock - design GCW 70 tonne
- RSS1344E** Drive Axle - RSS1344E single reduction with differential lock - design GCW 44 tonne
- RSS1352A** Drive Axle - RSS1352A single reduction 13 tonne with differential lock - design GCW 52 tonne
- RSS1370A** Drive Axle - RSS1370A single reduction 13 tonne with differential lock - design GCW 70 tonne
- RSS1370B** Drive Axle - RSS1370B single reduction 13 tonne with differential lock - design GCW 70 tonne

PACKAGES

- FUELECO+** Fuel Package - Eco+ with improved economy mode for Volvo FH with I-Save
- FUELPACK** Long Haul Fuel Economy driving package
- DRIVE5** Drive Package
- DRIVE5+** Drive+ Package
- DRIVE5++** Drive++ Package
- 1LIVIN++** Sleep & Resting Package - Living one-bed ++
- 1LIVING** Sleep & Resting Package - Living one-bed
- 1LIVING+** Sleep & Resting Package - Living one-bed +
- 2LIVIN++** Sleep & Resting Package - Living two-bed ++
- 2LIVING** Sleep & Resting Package - Living two-bed
- 2LIVING+** Sleep & Resting Package - Living two-bed +
- INFOBAS** Basic media package without secondary display
- INFODF** Media Information Platform with Dynafleet Support
- INFOMED** Media Information Platform - Medium level
- INFONAV** Media Information Platform with Navigation
- INFONDF** Media Information Platform with Navigation & Dynafleet Support
- VISI5** Visibility Package
- VISI5+** Visibility+ Package
- VISI5++** Visibility++ Package
- VISIC5** Visibility Package
- VISIC5+** Visibility+ Package
- SAFE-VE** Active Safety Package
- SAFE-VE+** Active Safety+ Package

CHASSIS

- FST-AIR** Front suspension type - Air
- FST-PAR** Front suspension type - 2 leaf parabolic springs
- FSLs-BAS** Front suspension levelling - basic stroke
- FSLs-HI** Front suspension levelling - high stroke for demount operations - check with bodybuilder
- FAL7.5** Front axle design capacity - 7.5 tonne
- FAL8.0** Front axle design capacity - 8.0 tonne - check tyre capacity
- FAL8.5** Front axle design capacity - 8.5 tonnes
- FAL9.0** Front axle design capacity - 9.0 tonne - check tyre capacity
- FSTAB** Front anti-roll bar - Normal stiffness
- FSTAB2** Front anti-roll bar - Medium stiffness
- FSTAB3** Front anti-roll bar - High stiffness
- RAL16** Rear bogie design capacity - 16 tonne
- RAL19** Rear bogie design capacity - 19 tonne
- RSTAB1** Rear anti-roll bar - Normal stiffness
- RSTAB3** Rear anti-roll bar - Stiff
- RALIM115** Rear-axle load limiter -11.5 tonne - speed controlled
- ASF-DL1** Air suspension with 1 driving level
- ASF-DL3** Air suspension with 3 driving levels

Standard Equipment

Optional Equipment

For more detailed information about cab and powertrain equipment, please refer to separate specification sheets.

For all possible options and combinations of options please consult your Volvo sales contact who can create a specification to match your requirements using the Volvo Sales Support system (VSS).

The factory reserves the right to modify design and change equipment without previous notification. The specification can vary from country to country.

MODEL RANGE

NEW FH 13 6x2 Pusher Tractor - Standard or Lite - Rear Air Suspension FH 62T P3A

- ACTST-TO** Active Steering- Volvo Dynamic Steering - VDS - with extra electronic pump and torque overlay
- ASFE-BAS** Active steering feature - Basic - Volvo Dynamic Steering - VDS - only
- ASFE-OG** Active steering feature - Volvo Dynamic Steering - VDS - with stability assist - oversteer
- ASFE-PO** Active steering feature - Volvo Dynamic Steering - VDS - with personal settings and stability assist
- ASFE-PS** Active steering feature - Volvo Dynamic Steering - VDS - with personal settings
- PSP-FIX** Power steering pump - Fixed displacement
- PSP-VAR** Power steering pump - Variable displacement
- EBS-MED** Brake package - EBS medium including "hill" hold function
- FRAME266** Chassis frame section external height - 266 mm
- FRAME300** Chassis frame section external height - 300 mm
- FST6565** Chassis frame thickness - 6.5 mm web and flange
- FST7070** Chassis frame thickness - 7 mm web and flange
- FST8080** Chassis frame thickness - 8 mm web and flange
- FIL-EEEB** Chassis frame inner liner - From the end of the engine to the end of the bogie
- FIL-TXEB** Chassis frame inner liner - From gearbox member to the end of the bogie
- BBOX-EF** Battery box position - End of the frame in rear overhang
- BBOX-L** Battery box position - Left hand side
- BATS-D** Dual energy battery system - 2 living batteries and 2 starter batteries.
- BATS-S** Single energy battery system (2 batteries)
- 2BAT210B** Battery Capacity - 2 x 210 Ah - Gel type
- 2BAT210C** Battery Capacity - 2 x 210 Ah - AGM Absorbent Glass-fibre Material type
- BATTAMP** Battery management - Voltage and current gauge
- BATTIND** Battery management - Charge indicator
- ADR2** ADR Adaptation - For transportation of dangerous goods on the road - Note does NOT include safe loading pass package if required this is quoted separately
- MSWI-A** Battery master switch - ADR switch circuit shut down
- MSWI-C** Battery master switch - Chassis mounted toggle by the battery box
- MSWI-R** Battery master switch - Key fob operated remote controlled
- UR-FUEL** Without right-hand fuel tank
Min volume 150l
Max volume 365l
- L480A71S** Left fuel tank - 480litre aluminium diameter 710mm with catwalk & steps
Min volume 160l
Max volume 680l
- ADTP-BC** AdBlue tank position - Behind and under the cab on the right-hand side
- ADTP-R** AdBlue tank position - Chassis mounted on the right-hand side
- ADB048** Plastic AdBlue tank - 48 litre
- ADB064** Plastic AdBlue tank - 64 litre
- ADB065** Plastic AdBlue tank - 65 litre under/behind the cab
- ADB068** Plastic AdBlue tank - 68 litre
- ADB090** Plastic AdBlue tank - 90 litre
- ADB100** Plastic AdBlue tank - 100 litre
- ADTC-BF** AdBlue tank cover with satin alloy look decorative cover
- FCAP-L** Diesel and AdBlue filler cap - Locking
- FUFF-AS** Fuel filler - Anti-spill device
- FUFF-ATS** Fuel filler - Anti-spill & anti-syphon device
- ESH-REAR** Exhaust - Horizontal silencer - rear outlet
- ESH-RIGH** Exhaust - Horizontal silencer - right outlet
- ESH-VERT** Exhaust - Horizontal silencer - vertical outlet
- EXST-SSP** Stainless steel exhaust stack - NOT polished
- EXST-ST** Steel exhaust stack
- WHC-FOL2** Two foldable wheel chocks
- WHCP-F** Wheel chock carrier position - In the front part of the vehicle
- WHCP-T** Wheel chock carrier position - Outer luggage locker
- SUP-BAS** EC approved chassis side guards
- CHAIN-S** Snow chains
- HOOK-SC** Snow chain hooks
- TOWF-NO1** Front towing device - One detachable - stored in cab
- TOWF-NO2** Front towing device - Two detachable - stored in cab
- TOWR-ONE** Towing hitch attached to rear crossmember
- TREL15** Trailer electrical connection - Single 15 pin - ADR certified
- TREL7** 7 pole - 24N trailer electrical suzie
- TREL7-7** Trailer electrical connection - 2 x 7 pin - 24N and 24S
- TBC-DUO** Duomatic type air line connectors
- TBC-EC** Trailer brakes with EC palm coupling connectors
- TBC-GBR** 'C' and 'CA' type air line connectors
- TRBR-HCF** Full pressure hand controlled trailer brake
- TRBR-STA** Stationary trailer brake control
- TRB-STRE** Stretch Brake - Automatic low speed trailer brake activation to avoid jack-knifing and improve steerability
- RFEND-B** Three piece EC approved rear mud wings and spray flaps
- RFH-BAS** Basic rear wing height
- RFH-HIG** High rear wing height - higher wing tops
- RFH-LOW** Lower rear wing height - shallower wing tops
- ATANK-AL** Air tanks - Aluminium
- ATANK-ST** Air tanks - Steel
- TL-LED** Rear lights - LED
- BLIGHT-E** Emergency brake light

WHEELS & TYRES

- RT-AL** Wheels - Alcoa brushed aluminium rims - standard holes for long stud fixing
- RT-ALDP** Wheels - Alcoa Dura-Bright aluminium rims - standard holes for long stud fixing
- RT-ALDPD** Wheels - Alcoa Dura-Bright EVO aluminium rims - countersunk holes for short stud fixing
- RT-ALDU** Wheels - Alcoa brushed aluminium rims - countersunk holes for short stud fixing
- RT-STEEL** Wheels - Steel rims
- WCAP** Aerodynamic hub caps
- JACK-12T** 12 tonne bottle jack
- JACK-15T** 15 tonne bottle jack
- JACK-20T** 20 tonne bottle jack
- TOOL-BAS** Basic Toolkit
- TOOLKIT** Complete tool kit
- INFLAHOS** Tyre inflation hose
- GAUGE-TP** Tyre pressure gauge

DRIVELINE EQUIPMENT

- TRAP-HD** Reinforced gearbox application
- DRM-BE** Balanced & Economy Drive Mode
- DRM-E** Economy Drive Mode
- PVT-MAP** I-See Predictive Cruise Control - using map based topography information
- CRUIS-E** Eco cruise control (with eco-roll and I-cruise, controls in steering wheel)
- CRUIS-E4** Eco fleet software - with cruise speed 85, I-See and push button I-shift.
- CRUIS-E5**
- CRUISEC** Cruise control, standard

Standard Equipment Optional Equipment

For more detailed information about cab and powertrain equipment, please refer to separate specification sheets.

For all possible options and combinations of options please consult your Volvo sales contact who can create a specification to match your requirements using the Volvo Sales Support system (VSS).

The factory reserves the right to modify design and change equipment without previous notification. The specification can vary from country to country.

MODEL RANGE

NEW FH 13 6x2 Pusher Tractor - Standard or Lite - Rear Air Suspension FH 62T P3A

- AMSO-AUT** Enhanced I-shift software with manual shift available in auto mode and kickdown facility on accelerator pedal
- AVO-ENH** I-Shift application software - for construction and off road applications
- APF-ENH** I-shift enhanced PTO functions
- RET-TH** Gearbox mounted retarder
- TC-MAOH2** Extra high performance transmission oil cooler - air to oil with front mounted radiator
- TC-MWO** Basic transmission oil cooler - water to oil
- 2COM1100** Air compressor - Two-cylinder 1100 litres per minute
- 2COMP900** Air compressor - Two-cylinder 900 litres per minute
- CLU-AIRC** Clutchable air compressor
- AIRIN-FR** Front air intake fitted to the underside of cab engine tunnel
- AIRIN-HI** Air intake - Roof-mounted behind cab on the left-hand side
- AIRIN-LO** Low level air intake behind cab on left hand side
- ACL1ST-S** Air filter - two-stage element
- 24AL110B** Alternator capacity - 110 amp
- 24AL120B** Alternator capacity - 120 amp alternator
- 24AL150B** Alternator capacity - 150 amp
- CCV-C** Closed crankcase engine ventilation
- CCV-OX** Closed crankcase ventilation for cold markets
- PRIM-EL** Electrical priming pump
- PRIM-MAN** Manual priming pump
- AF-R** Hot fuel recirculation heated fuel filter
- FUEFE2LW** Large engine mounted dual fuel filter with water separator
- EST-AID** Engine starting aid -Preheating element in the air inlet manifold
- 220EBH15** 220V/1.5Kw electric engine block heater
- PTER-100** Engine power-take-off - Rear-mounted with DIN100/ISO7646 flange
- PTER-DIN** Engine power-take-off - Rear-mounted with DIN5462 (female) splined shaft for a close-coupled pump
Models with 3 steering axles will use this to drive the steering pump (AUXPSP)
- PTER1400** Engine power-take-off - Rear-mounted with SAE 1410 flange
- HPE-F101** Parker F1-101, engine mounted, fixed displacement, single flow, engine mounted hydraulic pump
- HPE-F41** Parker F1-41, engine mounted, fixed displacement, single flow, engine mounted hydraulic pump
- HPE-F51** Parker F1-51, engine mounted, fixed displacement, single flow, engine mounted hydraulic pump
- HPE-F61** Parker F1-61, engine mounted, fixed displacement, single flow, engine mounted hydraulic pump
- HPE-F81** Parker F1-81, engine mounted, fixed displacement, single flow, engine mounted hydraulic pump
- HPE-T53** Parker F2-53/53, engine mounted, Fixed displacement, Twin flow engine mounted hydraulic pump
- HPE-T70** Parker F2-70/35, engine mounted, Fixed displacement, Twin flow engine mounted hydraulic pump
- HPE-V45** Parker VP1-45, variable displacement, single flow, engine mounted hydraulic pump
- HPE-V75** Parker VP1-75, variable displacement, single flow, engine mounted hydraulic pump
- PTR-D** Gearbox PTO for plug-in pump, 0.71xeng speed
- PTR-DH** Gearbox driven high speed PTO for one plug-in hydraulic pump
- PTR-DM** Gearbox driven medium speed PTO for one plug-in hydraulic pump
- PTR-F** Gearbox driven PTO with rear flange connection
- PTR-FH** Gearbox driven high speed PTO with SAE drive flange
- PTR-FL** Gearbox driven low speed PTO with SAE drive flange
- PTRD-D** Gearbox driven HIGH SPEED PTO for two plug-in hydraulic pumps
- PTRD-D1** PTRD-D1 Gearbox driven HIGH SPEED PTO (1 SAE flange & 1 plug-in hydraulic pump)
- PTRD-D2** Gearbox driven HIGH SPEED PTO (2 SAE flanges & 1 plug-in hyd pump)
- PTRD-F** PTO with 1 DIN + 1 flange connection rear, manual gearbox
- HPG-F101** Parker F1-101 gearbox mounted, fixed displacement, single flow, hydraulic pump
- HPG-F41** Parker F1-41 gearbox mounted, fixed displacement, single flow, hydraulic pump
- HPG-F51** Parker F1-51 gearbox mounted, fixed displacement, single flow, hydraulic pump
- HPG-F61** Parker F1-61 gearbox mounted, fixed displacement, single flow, hydraulic pump
- HPG-F81** Parker F1-81 gearbox mounted, fixed displacement, single flow, hydraulic pump
- STWPOS-R** Steering wheel position - RIGHT-HAND DRIVE
- STWM-LE** Leather steering wheel
- STGW-AD2** Adjustable steering wheel with neck tilt
- STGW-ADJ** Adjustable steering wheel
- AIRBAG** SRS Driver's air bag
- INST-BAS** Basic level instruments
- DRC-AMII** DPF Regeneration control switch - for manual and switching off regeneration
- 1DAYDIG2** Tachograph - Continental VDO 4.0
- ARSL** Additional road speed limit - switch in dashboard
- ESP-BAS1** Electronic Stability Control
- ESPC-RO** ESP (Electronic Stability Program) functionality control - Reduced / Off
- HWSS-ACB** Adaptive cruise control ACC with forward collision warning and AEBS advanced emergency brake system
- HWSS-FCB** Forward collision warning with AEBS advanced emergency brake system
- LSS-DW** Lane departure-warning system
- LCS** Lane change support
- DAS-W** Driver Alert Support system
- RSENS-W** Rain sensing windscreen wipers
- CU-ECC** Cab Climate Unit - Electrically controlled air conditioning with sun sensor
- CU-ECC2** Cab Climate Unit - Electrically controlled air conditioning with a carbon filter, sun, mist, and air quality sensor
- CU-MCC** Cab Climate Unit - Manual air conditioning
- IMMOBIL** Thatcham H2 approved immobiliser
- ALARM-E** Enhanced vehicle alarm - Thatcham H1 approved - Cab plus external sensor for body/trailer
- ALCOLOCK** Alcolock
- AMPL400** Radio amplifier, 8 channel, 400 W with subwoofer
Located in right hand external storage box
- BUPMON** Back up monitor - Digital reverse camera, parameter & lead supplied loose in cab.
- PHONE-PK** Telephone preparation kit (antenna, antenna attachm. cable incl.)
- ISUNS-BS** Side sun visor - Driver & passenger side
- ISUNS-DS** Side sun visor - Driver-side
- ISUNF-RE** Electrically operated textile interior sun blind
- ISUNF-RM** Manually operated textile interior sun blind
- CSPL-BX** Lower center dash open storage box
- CSPL-BXD** Lower centre dash drawer
- CSPU-SDR** One open storage and one drawer - behind push open lid - in upper part of the centre dash panel
- CSPU-SS** Two open storages - behind push open lid in upper part of the centre dash panel

■ Standard Equipment

Optional Equipment

For more detailed information about cab and powertrain equipment, please refer to separate specification sheets.

For all possible options and combinations of options please consult your Volvo sales contact who can create a specification to match your requirements using the Volvo Sales Support system (VSS).

The factory reserves the right to modify design and change equipment without previous notification. The specification can vary from country to country.

MODEL RANGE

NEW FH 13 6x2 Pusher Tractor - Standard or Lite - Rear Air Suspension FH 62T P3A

- | | |
|--|--|
| <ul style="list-style-type: none"> <input type="checkbox"/> ADFS Two extra DIN slots in front shelf - can be fitted with card or drawer available as an accessory ■ BUPALARM Reverse alarm <input type="checkbox"/> RTOLL-PK Road toll PREPARATION kit for trucks operating with "Toll Collect" in Germany <input type="checkbox"/> LOADIND Load indicator with central dashboard display <input type="checkbox"/> REMC-MF Multi-functio wireless remote control <input type="checkbox"/> FIREXT3S Fire extinguisher - 3kg mounted on the seat base <input type="checkbox"/> WARNVEST High visibility warning vest - no sleeves <input type="checkbox"/> AIDKIT First aid kit - Legal demand for EU markets including delivery to EU bodybuilder <input type="checkbox"/> AIDKIT1B First aid kit - Legal demand for trucks transiting Germany <input type="checkbox"/> WARNLAMP Portable warning lamp <input type="checkbox"/> LAMP-IN Inspection lamp <input type="checkbox"/> BULBKIT Bulb and fuse kit ■ WRITEPAD Writing pad ■ DST-CF4 Driver seat - Suspended, adjustable shock absorber, travel, backrest & lumbar controls - seatbelt mounted to the seat <input type="checkbox"/> DST-CF5 Driver seat - Suspended with adjustable shock absorber, travel, backrest, lumbar & heat controls - seatbelt mounted to the seat <input type="checkbox"/> DST-CF6 Driver seat - Suspended with adjustable shock absorber, travel, backrest, lumbar, heat and ventilation controls - seatbelt mounted to the seat <input type="checkbox"/> DST-LUX1 Driver seat - Deluxe 1: electrical adjustment with memory function, lumbar support, heating & ventilation - seatbelt mounted to the seat <input type="checkbox"/> DST-LUX2 Driver seat - Deluxe 2: electrical adjustment with memory function, lumbar support & heating - seatbelt mounted to the seat <input type="checkbox"/> SBD-RED Seat belt colour - Red <input type="checkbox"/> SBPRE-DS Driver seat belt pretensioner <input type="checkbox"/> PST-BAS1 Passenger seat - Fixed non suspended fold up with seatbelt mounted in cab <input type="checkbox"/> PST-CF4 Passenger seat - Suspended, adjustable shock absorber, travel, backrest & lumbar controls - seatbelt mounted to the seat <input type="checkbox"/> PST-CF5 Passenger seat - Suspended with adjustable shock absorber, travel, backrest, lumbar & heat controls - seatbelt mounted to the seat <input type="checkbox"/> PST-RX1 Passenger seat - Fixed non suspended, features: 90-degree rotation and tilt function with seatbelt mounted in cab <input type="checkbox"/> PST-STD2 Passenger seat - Fixed with backrest adjustment, non suspended with seatbelt mounted in cab ■ PST-STD4 Passenger seat - Standard suspended with seatbelt mounted in cab <input type="checkbox"/> SBPRE-PS Passenger seat belt pretensioner <input type="checkbox"/> ARMRE-BB Armrests - Two on both driver & passenger seats <input type="checkbox"/> ARMRE-DB Armrests - Two on the driver seat <input type="checkbox"/> ARMRE-PB Armrests - Two on the passenger seat <input type="checkbox"/> ARU-BAS Armrest upholstery - Vinyl <input type="checkbox"/> ARU-LEA Armrest upholstery - Leather ■ GRABHI-B Steel instep cab grab handle <input type="checkbox"/> GRABHI-L Leather covered instep cab grab handle ■ FMAT-RUB Footwell floor mats - Rubber <input type="checkbox"/> FMAT-TX2 Footwell floor mats - Two sets, Rubber and textile with an embossed pile supplied in the cab ■ LBK80F Lower fixed bunk with wide middle section 815 in the centre x 2000 mm <input type="checkbox"/> LBK80FRE Lower electrically operated recline bunk with wide middle section 815 in the centre x 2000 mm <input type="checkbox"/> LBK80FRM Lower manually operated recline bunk with wide middle section 815 in the centre x 2000 mm | <ul style="list-style-type: none"> <input type="checkbox"/> MATL-FI Firm lower bunk pocket sprung mattress <input type="checkbox"/> MATL-FI4 Lower mattress - firm, memory foam, 2000x700x130 mm ■ MATL-SF Lower flexizone mattress - semi-firm, pocket springs up to 100kg - 16 stone <input type="checkbox"/> OLMAT-BA 35mm mattress overlay protector <input type="checkbox"/> OLMAT-PR 50mm premium mattress overlay protector <input type="checkbox"/> TBK60AD Height adjustable foldable top bunk 600 x 1900mm <input type="checkbox"/> TBK60F Fixed foldable top bunk 600 x 1900mm <input type="checkbox"/> TBK70AD Height adjustable foldable top bunk 700 x 1900mm <input type="checkbox"/> TBK70F Fixed foldable top bunk 700 x 1900mm <input type="checkbox"/> PH-CAB2 1.8kW Air to air night heater <input type="checkbox"/> PH-ENGCA Engine and cab night heater <input type="checkbox"/> CPC-ADV I-ParkCool - Advanced cab parking cooler with 120V DC electrical compressor ■ SLCP-BAS Sleeper control panel - Basic with switches for interior light, night heater, roof hatch and door lock <input type="checkbox"/> SLCP-LUX Sleeper control panel - Luxury with switches for interior light, night heater, roof hatch, door lock, alarm clock, window and radio <input type="checkbox"/> SAFE Safe box for driver's personal items <input type="checkbox"/> RUS-BAS Rear cab upper storage - 300 mm high <input type="checkbox"/> RUS-HIG Rear cab upper storage - 440 mm high - volume 245 litres <input type="checkbox"/> TABLE Folding and height adjustable table - on lower bunk <input type="checkbox"/> REFR-RUS Fridge - 28 litre rear upper wall mounted with dividers <input type="checkbox"/> REFRIG Fridge - 33 litre under-bunk mounted with freezer dividers <input type="checkbox"/> MICRO-PK Wiring preparation kit for microwave oven <input type="checkbox"/> BOTH-D One bottle holder under dashboard centre section <input type="checkbox"/> BOTH-DL Two bottle holders, one under dashboard centre section and one mounted to the under bunk drawer <input type="checkbox"/> BOTH-L One bottle holder mounted to the under bunk drawer <input type="checkbox"/> COFMA-PK Coffee maker, preparation kit. ■ INLI-BAS Interior white LED lights - basic <input type="checkbox"/> INLI-NL Interior white and red night LED light with no dimmer <input type="checkbox"/> INLI-NLD Interior white and red night LED light with dimmer <input type="checkbox"/> ARL-FLEX Two flexible reading lamps (snake lamps) ■ RH-EE Fixed tinted glass sky window with emergency exit <input type="checkbox"/> RH-ER Steel roof hatch - Electrically operated, rear opening with emergency exit <input type="checkbox"/> RH-ETR Tinted glass roof hatch - Electrically operated, rear opening with emergency exit <input type="checkbox"/> RH-MTR Tinted glass roof hatch - Manually operated, rear opening with emergency exit ■ GLAS-TIN Tinted windows. <input type="checkbox"/> SWIND-BS Extra side window on both sides behind "B" pillar ■ VANMIR Vanity mirror in front shelf <input type="checkbox"/> AS-FUS Extra shelf in front upper storage compartments <input type="checkbox"/> INFOT-PK Preparation kit for the mounting of a flat screen TV in cab above the driver's door, includes bracket, electrical and speaker connections |
|--|--|

CAB EXTERIOR

- **EXTL-BAS** Basic exterior finish - Satin Volvo badges, grey grille, instep, bumper, bumper spoiler, grille, door handles mirror housing and sunvisor if specified.
- EXTL-EN2** Enhanced complete painted finish - Satin Volvo badges. Main grille, instep, door handles, mirror housing, and bumper in cab colour. Aluminium step inserts. Sunvisor and bumper spoiler in cab colour if specified.
- EXTL-ENH** Enhanced exterior finish - Painted grille in cab colour with grey instep, bumper, bumper spoiler, grille, door handles mirror housing and sunvisor if specified, and aluminium step inserts
- **DGLAS-H** Tempered door glass
- DGLAS-L** Laminated door glass

■ Standard Equipment

Optional Equipment

For more detailed information about cab and powertrain equipment, please refer to separate specification sheets.

For all possible options and combinations of options please consult your Volvo sales contact who can create a specification to match your requirements using the Volvo Sales Support system (VSS).

The factory reserves the right to modify design and change equipment without previous notification. The specification can vary from country to country.

MODEL RANGE

NEW FH 13 6x2 Pusher Tractor - Standard or Lite - Rear Air Suspension FH 62T P3A

- **LOCK-REM** Door locks - Remote central locking
 - **BUMP-B** Plastic front bumper
 - **BUMP-B2** Steel front bumper
 - **BUMP-HD** Heavy duty front bumper
 - **BUMP-SP** Front bumper spoiler
 - **GUARD-EH** Engine guard to protect sump and engine hoses
 - **BUGNET** Insect screen in front of radiator
 - **CTILT-P-E** Electrically operated hydraulic cab tilt
 - **CTILT-P-M** Manually operated hydraulic cab tilt
 - **FCABS-A** Front cab suspension - Air
 - **FCABS-M** Front cab suspension - Mechanical spring
 - **RCABS-A** Rear cab suspension - Air
 - **RCABS-M** Rear cab suspension - Mechanical spring
 - **HCC-INEX** Exterior and interior hood catch control
 - **MIRFCFPCS** Mirrors - Electrically heated and operated main and wide-angle with manually adjusted kerb view mirror on the passenger side and position camera in nearside mirror arm.
 - **MIRCOMF** Electrically heated and operated main and wide angle mirrors and manually adjusted kerb view mirror on passenger side
 - **MIRSTD** Electrically heated main and wide angle mirrors and manually adjusted kerb view mirror on passenger side
 - **AMIR-F20** Auxiliary front view mirror with a 200mm radius
 - **SUNV-H** External smoke grey sunvisor
 - **AD-ROOF** Roof air deflector
 - **AD-SIDEL** Side air deflector extension panels
 - **AD-CHASX** Chassis side skirts
 - **ADCF-F** Additional black edging on chassis side skirt
 - **HL-BASIC** Halogen H7 head lamps
 - **HL-CLEAN** Head lamp cleaner - washer jets
 - **HLP-ST** Headlamp protection
 - **HL-ADJ** Headlight adjustment - Switch in cab
 - **DRIVL2** Two spot lamps
 - **UDRIVL** Without auxiliary driving lights
 - **FOGL-WC** Front fog lights
 - **CL-STAT** Static corner lights
 - **ASL-RF2** Two Hella H11 70W spotlamps in sign box - only available with the basic headlight and no lower driving lights.
 - **BEACOA2F** Roof beacons - Two front roof mounted amber LED
 - **BEACOA2R** Roof beacons - Two rear roof mounted amber LED
 - **BEACON-P** Roof beacons - wiring preparation only
 - **BEACONA4** Roof beacons - Four amber LED - two front/ two rear
 - **CABPT-R1** Single outlet for roof mounted accessories
 - **CABPT-R2** Twin outlets for roof mounted accessories.
 - **SPOTP-F** Spotlamp preparation in front, max 280W
 - **SPOTP-R** Spotlamp preparation on roof, max 280W
 - **SPOTP-RF** Spotlamp preparation on cab roof and in cab front, max 2x280W
 - **ROS-IL2** Preparation kit for illuminated roof sign with switch loose in cab, fit after registration
 - **CSGN-GTR** "Globetrotter" headboard logo
 - **HORN-F1S** Horn - Air single tone - chassis mounted
 - **HORN-R2S** Horn - Air - Two roof-mounted
 - **ANT-CBR** Roof mounted antenna for CB radio, single aerial
 - **ACCB-R-AP** Front, middle & rear roof mounted accessory brackets
 - **ACCB-R-F** Front roof mounted accessory bracket
 - **ACCB-R-FM** Front & middle roof mounted accessory brackets
 - **ACCB-R-FR** Front & rear roof mounted accessory brackets
 - **ACCB-R-M** Middle roof mounted accessory bracket
 - **ACCB-R-R** Rear roof mounted accessory bracket
 - **ACCB-R-RM** Rear & middle roof mounted accessory brackets
 - **STUC-B** Left and right storage compartments under cab
 - **STUC-L** Left storage compartment under cab
 - **STUC-R** Right storage compartment under cab
 - **RFCAR-BC** Rear mudwing carrier, back of cab
 - **LADDER** Ladder back of cab
 - **REFS-TW** White cab conspicuity markings by packed in cab
 - **REFS-TY** Yellow cab conspicuity markings by packed in cab
- ### SUPERSTRUCTURE PREPARATIONS
- **5WM-ASL** Mount - Air operated slider with 4mm L profiles
 - **5WM-ASM** Mount - Air operated slider with 50mm L profiles
 - **5WM-ISOL** Mount - Flush L profiles with 12mm ISO plate - 16mm high above chassis frame
 - **5WM-ISOM** Mount - 50mm L profiles with 10mm ISO plate - 60mm high above chassis frame
 - **5WM-LPRO** Mount - Direct to frame with inverted 'L'-profiles
 - **5WM-MASM** Mount - Manual slider with 50mm L profiles
 - **5WH150** Leg-height - 150 mm
 - **5WH160** Leg-height - 160 mm
 - **5WH175** Leg-height - 175mm
 - **5WH185** Leg-height - 185 mm
 - **5WH195** Leg-height - 195mm
 - **5WH200** Leg-height - 200 mm
 - **5WH205** Leg-height - 205 mm
 - **5WH210** Leg-height - 210 mm
 - **5WH220** Leg-height - 220mm
 - **5WH230** Leg-height - 230 mm
 - **5WT-FO14** Fifth wheel - Fontaine 150SP2 pressed steel
 - **5WT-FO15** Fifth wheel - Fontaine 3000 lightweight cast air operated slider - for moderate duty off-road.
 - **5WT-JO10** Fifth wheel - Jost JSK 36 pressed
 - **5WT-JO8** Fifth wheel - Jost JSK 37 cast
 - **5WT-JO9** Fifth wheel - Jost JSK 42 cast
 - **5WT-SH** Fifth wheel - SAF-Holland/+GF+ SK-S 36.20 cast
 - **5WLM-B** Maintenance - Basic fifth wheel - standard top plate
 - **5WLM-L** Maintenance - Low maintenance with nylon top plate
 - **5WL-S1** Fifthwheel lubrication - locking mechanism and top plate
 - **5WL-S2** Fifthwheel lubrication - locking mechanism
 - **TCIND** Trailer connection indicator - Sensors for height, kingpin and coupling lock
 - **RDECK** Catwalk - Single plate and step
 - **RDECK-M** Catwalk - Extended with two plates and step
 - **SRWL-PK** Chassis-mounted working lamps - Side work and reverse lamp preparation and 3 position switch - Max load 280W
 - **SWL-2RW** Chassis-mounted working lamps - Two white rear-mounted LED lamps
 - **SWL-PK** Chassis-mounted working lamps - Side work lamp preparation and 2 position switch - Max load 280W
 - **WL-TA1W** Coupling light - White
 - **WLC-H2W** Two H3/70W white working lamps high mounted on the back of cab
 - **WLC-PKH** Preparation kit, cables and switch for high mounted working lamps back of cab
 - **WLC-PKL** Preparation kit, cables and switch for low mounted working lamps back of cab
 - **WLC-PKLH** Preparation kit - cables and switch for low and high mounted working lamps back of cab.
 - **ECBB-HIG** Body builder electrical centre with body builder module
 - **BBCHAS1** One 7-pole connector for Body builder interface
 - **BBCHAS3** Three 7-pole connectors for Body builder interface
 - **BEPR-T2** Body builder electrical software preparation for tipper with remote control

■ Standard Equipment

□ Optional Equipment

For more detailed information about cab and powertrain equipment, please refer to separate specification sheets.

For all possible options and combinations of options please consult your Volvo sales contact who can create a specification to match your requirements using the Volvo Sales Support system (VSS).

The factory reserves the right to modify design and change equipment without previous notification. The specification can vary from country to country.

MODEL RANGE

NEW FH 13 6x2 Pusher Tractor - Standard or Lite - Rear Air Suspension FH 62T P3A

- EXSTER** External steering control - Volvo dynamic steering and bodybuilder module prepared for external control system, installed and computer by bodybuilder
- TD-LED** Trailer detection with LED sensing
- AUXL-SPK** Electrical preparation kit - wiring and switch for snow plough lights
- TAILPRE2** Tail lift preparation kit, wireless remote operation
- TAILPREP** Taillift preparation kit - cab switch and warning in driver display
- AESW2** Two Body builder bistable electrical switches (marked AUX1 / AUX2)
- AESW2PK** 2 Body builder bistable el.switches (marked AUX1/AUX2) and prep. for 4 more switches
- AUXSW-4** Wiring for 4 extra switches (from Body builder electrical centre to switch positions)

DELIVERY SERVICES

- TGW-4GWL** Telematics gateway - GSM/GPRS/4G modem, LTE & WLAN
- FMS-PK** Fleet Management System gateway
- DRUT2** Driver utility app - "My Truck" - two-year subscription
For mobile phone, tablet, with android and IOS systems.
Only available with Volvo Connect subscription



Volvo Truck Corporation
volvotrucks.com