

Maintenance Manual

Series MG3702XA RF/Microwave Signal Generators

**Fast Switching Microwave Signal Generator
100 μ sec Switching Speed
10 MHz to 20 GHz**

The Anritsu logo is located in the bottom right corner of the page. It consists of the word "Anritsu" in a bold, sans-serif font. The letter "A" is stylized with a diagonal slash through it. The logo is rendered in a dark blue color.

WARRANTY

The Anritsu product(s) listed on the title page is (are) warranted against defects in materials and workmanship for three year from the date of shipment.

Anritsu's obligation covers repairing or replacing products which prove to be defective during the warranty period. Buyers shall prepay transportation charges for equipment returned to Anritsu for warranty repairs. Obligation is limited to the original purchaser. Anritsu is not liable for consequential damages. Accessories included with this product are not included in the standard warranty.

LIMITATION OF WARRANTY

The foregoing warranty does not apply to Anritsu connectors that have failed due to normal wear. Also, the warranty does not apply to defects resulting from improper or inadequate maintenance, unauthorized modification or misuse, or operation outside of the environmental specifications of the product. No other warranty is expressed or implied, and the remedies provided herein are the Buyer's sole and exclusive remedies.

DISCLAIMER OF WARRANTY

DISCLAIMER OF WARRANTIES. TO THE MAXIMUM EXTENT PERMITTED BY APPLICABLE LAW, ANRITSU COMPANY AND ITS SUPPLIERS DISCLAIM ALL WARRANTIES, EITHER EXPRESSED OR IMPLIED, INCLUDING, BUT NOT LIMITED TO, IMPLIED WARRANTIES OF MERCHANTABILITY AND FITNESS FOR A PARTICULAR PURPOSE, WITH REGARD TO THE PRODUCT. THE USER ASSUMES THE ENTIRE RISK OF USING THE PRODUCT. ANY LIABILITY OF PROVIDER OR MANUFACTURER WILL BE LIMITED EXCLUSIVELY TO PRODUCT REPLACEMENT.

NO LIABILITY FOR CONSEQUENTIAL DAMAGES. TO THE MAXIMUM EXTENT PERMITTED BY APPLICABLE LAW, IN NO EVENT SHALL ANRITSU COMPANY OR ITS SUPPLIERS BE LIABLE FOR ANY SPECIAL, INCIDENTAL, INDIRECT, OR CONSEQUENTIAL DAMAGES WHATSOEVER (INCLUDING, WITHOUT LIMITATION, DAMAGES FOR LOSS OF BUSINESS PROFITS, BUSINESS INTERRUPTION, LOSS OF BUSINESS INFORMATION, OR ANY OTHER PECUNIARY LOSS) ARISING OUT OF THE USE OF OR INABILITY TO USE THE PRODUCT, EVEN IF ANRITSU COMPANY HAS BEEN ADVISED OF THE POSSIBILITY OF SUCH DAMAGES. BECAUSE SOME STATES AND JURISDICTIONS DO NOT ALLOW THE EXCLUSION OR LIMITATION OF LIABILITY FOR CONSEQUENTIAL OR INCIDENTAL DAMAGES, THE ABOVE LIMITATION MAY NOT APPLY TO YOU.

TRADEMARK ACKNOWLEDGMENTS

Windows, Windows XP, Microsoft Paint, Microsoft Word, Microsoft Access, Microsoft Excel, Microsoft PowerPoint, and Visual Studio are all registered trademarks of Microsoft Corporation.

Acrobat Reader is a registered trademark of Adobe Corporation.

MATLAB is a registered trademark of The MathWorks Corporation.

NI is a trademark of the National Instruments Corporation.

NOTICE

Anritsu Company has prepared this manual for use by Anritsu Company personnel and customers as a guide for the proper installation, operation and maintenance of Anritsu Company equipment and computer programs. The drawings, specifications, and information contained herein are the property of Anritsu Company, and any unauthorized use or disclosure of these drawings, specifications, and information is prohibited; they shall not be reproduced, copied, or used in whole or in part as the basis for manufacture or sale of the equipment or software programs without the prior written consent of Anritsu Company.

UPDATES

Updates, if any, can be downloaded from the Documents area of the Anritsu Website at:

<http://www.anritsu.com>

For the latest service and sales contact information in your area, please visit:

<http://www.anritsu.com/contact.asp>

END-USER LICENSE AGREEMENT FOR ANRITSU SOFTWARE

IMPORTANT-READ CAREFULLY: This End-User License Agreement ("EULA") is a legal agreement between you (either an individual or a single entity) and Anritsu for the Anritsu software product identified above, which includes computer software and associated media and printed materials, and may include "online" or electronic documentation ("SOFTWARE PRODUCT" or "SOFTWARE"). By receiving or otherwise using the SOFTWARE PRODUCT, you agree to be bound by the terms of this EULA.

SOFTWARE PRODUCT LICENSE

The SOFTWARE PRODUCT is protected by copyright laws and international copyright treaties, as well as other intellectual property laws and treaties. The SOFTWARE PRODUCT is licensed, not sold.

1. **GRANT OF LICENSE.** This EULA grants you the following rights:

a. You may use ONE copy of the Software Product identified above only on the hardware product (Anritsu instrument and its internal computer) which it was originally installed. The SOFTWARE is in "use" on a computer when it is loaded into temporary memory (for example, RAM) or installed into permanent memory (for example, hard disk, CD-ROM, or other storage device) of that computer. However, installation on a network server for the sole purpose of internal distribution to one or more other computer(s) shall not constitute "use."

b. Solely with respect to electronic documents included with the SOFTWARE, you may make an unlimited number of copies (either in hardcopy or electronic form), provided that such copies shall be used only for internal purposes and are not republished or distributed to any third party.

2. **OWNERSHIP.** Except as expressly licensed to you in this Agreement, Anritsu retains all right, title, and interest in and to the SOFTWARE PRODUCT; provided, however, that, subject to the license grant in Section 1.a and Anritsu's ownership of the underlying SOFTWARE PRODUCT, you shall own all right, title and interest in and to any Derivative Technology of the Product created by or for you.

3. **COPYRIGHT.** All title and copyrights in and to the SOFTWARE PRODUCT (including but not limited to any images, photographs, animations, video, audio, music, text, and "applets" incorporated into the SOFTWARE PRODUCT), the accompanying printed materials, and any copies of the SOFTWARE PRODUCT are owned by Anritsu or its suppliers. The SOFTWARE PRODUCT is protected by copyright laws and international treaty provisions. Therefore, you must treat the SOFTWARE PRODUCT like any other copyrighted material except that you may make one copy of the SOFTWARE PRODUCT solely for backup or archival purposes. You may not copy any printed materials accompanying the SOFTWARE PRODUCT.

4. **DESCRIPTION OF OTHER RIGHTS AND LIMITATIONS.**

a. **Limitations on Reverse Engineering, Decompilation, and Disassembly.** You may not reverse engineer, decompile, or disassemble the SOFTWARE, except and only to the extent that such activity is expressly permitted by applicable law notwithstanding this limitation.

b. **Rental.** You may not rent or lease the SOFTWARE PRODUCT.

c. **Software Transfer.** You may permanently transfer all of your rights under this EULA, provided that you retain no copies, you transfer all of the SOFTWARE PRODUCT (including the Anritsu instrument, all component parts, the media and printed materials, any upgrades, this EULA, and, if applicable, the Certificate of Authenticity), and the recipient agrees to the terms of this EULA.

d. **Termination.** Without prejudice to any other rights, Anritsu may terminate this EULA if you fail to comply with the terms and conditions of this EULA. In such event, you must destroy all copies of the SOFTWARE PRODUCT.

5. **U.S. GOVERNMENT RESTRICTED RIGHTS. THE SOFTWARE PRODUCT AND DOCUMENTATION ARE PROVIDED WITH RESTRICTED RIGHTS. USE, DUPLICATION, OR DISCLOSURE BY THE GOVERNMENT IS SUBJECT TO RESTRICTIONS AS SET FORTH IN SUBPARAGRAPH (C)(1)(II) OF THE RIGHTS IN TECHNICAL DATA AND COMPUTER SOFTWARE CLAUSE AT DFARS 252.227-7013 OR SUBPARAGRAPHS (C)(1) AND (2) OF THE COMMERCIAL COMPUTER SOFTWARE-RESTRICTED RIGHTS AT 48 CFR 52.227-19, AS APPLICABLE. MANUFACTURER IS ANRITSU COMPANY, 490 JARVIS DRIVE, MORGAN HILL, CALIFORNIA 95037-2809.**

The Anritsu software is copyright © 2015, Anritsu Company. All rights are reserved by all parties.

DECLARATION OF CONFORMITY

Manufacturer's Name: ANRITSU COMPANY

Manufacturer's Address: Microwave Measurements Division
490 Jarvis Drive
Morgan Hill, CA 95037-2809
USA

declares that the product specified below:

Product Name: Fast Switching Microwave Signal Generator

Model Number: MG3702XA

conforms to the requirement of:

EMC Directive: 2004/108/EC
Low Voltage Directive: 2006/95/EC

Electromagnetic Compatibility: EN61326:2006

Emissions: EN55011: 2007 Group 1 Class A

Immunity:	EN 61000-4-2:1995 +A1:1998 +A2:2001	4kV CD, 8kV AD
	EN 61000-4-3:2002 +A1:2006	3V/m
	EN 61000-4-4:2004	0.5kV SL, 1kV PL
	EN 61000-4-5:2006	0.5kV L-L, 1kV L-E
	EN 61000-4-6: 2007	3V
	EN 61000-4-11: 2004	100% @ 20msec

Electrical Safety Requirement:

Product Safety: EN 61010-1:2001

Morgan Hill, CA

Eric McLean, Corporate Quality Director

31 Jan 2008
Date

European Contact: For Anritsu product EMC & LVD information, contact Anritsu LTD, Rutherford Close, Stevenage Herts, SG1 2EF UK, (FAX 44-1438-740202)

Notes On Export Management

This product and its manuals may require an Export License or approval by the government of the product country of origin for re-export from your country.

Before you export this product or any of its manuals, please contact Anritsu Company to confirm whether or not these items are export-controlled.

When disposing of export-controlled items, the products and manuals need to be broken or shredded to such a degree that they cannot be unlawfully used for military purposes.

CE Conformity Marking

Anritsu affixes the CE Conformity marking onto its conforming products in accordance with Council Directives of The Council Of The European Communities in order to indicate that these products conform to the EMC and LVD directive of the European Union (EU).



C-tick Conformity Marking

Anritsu affixes the C-tick marking onto its conforming products in accordance with the electromagnetic compliance regulations of Australia and New Zealand in order to indicate that these products conform to the EMC regulations of Australia and New Zealand.



Mercury Notification

This product uses an LCD backlight lamp that may contain mercury. Disposal may be regulated due to environmental considerations. Please contact your local authorities for disposal or recycling information.

Perchlorate Material – Special Handling May Apply

Notification for California customers: this product uses a small Lithium battery installed internally on the circuit board that may contain perchlorate. Disposal may be regulated due to environmental considerations. Please contact your local authorities for disposal or recycling information. For information, see: <http://www.dtsc.ca.gov/hazardouswaste/perchlorate/>

European Parliament and Council Directive 2002/96/EC

Equipment Marked with the crossed-out Wheellie Bin symbol complies with the European Parliament and Council Directive 2002/96/EC (the "WEEE Directive") in the European Union.



For Products placed on the EU market after August 13, 2005, please contact your local Anritsu representative at the end of the product's useful life to arrange disposal in accordance with your initial contract and the local law.

Chinese RoHS Compliance Statement

产品中有毒有害物质或元素的名称及含量

For Chinese Customers Only YLNB

部件名称	有毒有害物质或元素					
	铅 (Pb)	汞 (Hg)	镉 (Cd)	六价铬 [Cr (VI)]	多溴联苯 (PBB)	多溴二苯醚 (PBDE)
印刷线路板 (PCA)	×	○	×	×	○	○
机壳、支架 (Chassis)	×	○	×	×	○	○
LCD	×	×	×	×	○	○
其他 (电缆、风扇、连接器等) (Appended goods)	×	○	×	×	○	○

○：表示该有毒有害物质在该部件所有均质材料中的含量均在 SJ/T11363-2006 标准规定的限量要求以下。
 ×：表示该有毒有害物质至少在该部件的某一均质材料中的含量超出 SJ/T11363-2006 标准规定的限量要求。

环保使用期限



这个标记是根据 2006/2/28 公布的「电子信息产品污染控制管理办法」以及 SJ/T 11364-2006 「电子信息产品污染控制标识要求」的规定，适用于在中国销售的电子信息产品的环保使用期限。仅限于在遵守该产品的安全规范及使用注意事项的基础上，从生产日起算的该年限内，不会因产品所含有害物质的泄漏或突发性变异，而对环境污染，人身及财产产生深刻地影响。

注) 生产日期标于产品序号的前四码 (如 S/N 0728XXXX 为 07 年 28 周生产)。

Safety Symbols

To prevent the risk of personal injury or loss related to equipment malfunction, Anritsu Company uses the following symbols to indicate safety-related information. For your own safety, please read the information carefully *before* operating the equipment.

Symbols Used in Manuals

Danger



This indicates a very dangerous procedure that could result in serious injury or death, and possible loss related to equipment malfunction, if not performed properly.

Warning



This indicates a hazardous procedure that could result in light-to-severe injury or loss related to equipment malfunction, if proper precautions are not taken.

Caution



This indicates a hazardous procedure that could result in loss related to equipment malfunction if proper precautions are not taken.

Safety Symbols Used on Equipment and in Manuals

The following safety symbols are used inside or on the equipment near operation locations to provide information about safety items and operation precautions. Ensure that you clearly understand the meanings of the symbols and take the necessary precautions *before* operating the equipment. Some or all of the following five symbols may or may not be used on all Anritsu equipment. In addition, there may be other labels attached to products that are not shown in the diagrams in this manual.



This indicates a prohibited operation. The prohibited operation is indicated symbolically in or near the barred circle.



This indicates a compulsory safety precaution. The required operation is indicated symbolically in or near the circle.



This indicates a warning or caution. The contents are indicated symbolically in or near the triangle.



This indicates a note. The contents are described in the box.



These indicate that the marked part should be recycled.

For Safety

Warning



Always refer to the operation manual when working near locations at which the alert mark, shown on the left, is attached. If the operation, etc., is performed without heeding the advice in the operation manual, there is a risk of personal injury. In addition, the equipment performance may be reduced.

Moreover, this alert mark is sometimes used with other marks and descriptions indicating other dangers.

Warning



or



When supplying power to this equipment, connect the accessory 3-pin power cord to a 3-pin grounded power outlet. If a grounded 3-pin outlet is not available, use a conversion adapter and ground the green wire, or connect the frame ground on the rear panel of the equipment to ground. If power is supplied without grounding the equipment, there is a risk of receiving a severe or fatal electric shock.

Warning



This equipment can not be repaired by the operator. Do not attempt to remove the equipment covers or to disassemble internal components. Only qualified service technicians with a knowledge of electrical fire and shock hazards should service this equipment. There are high-voltage parts in this equipment presenting a risk of severe injury or fatal electric shock to untrained personnel. In addition, there is a risk of damage to precision components.

Warning



Use two or more people to lift and move this equipment, or use an equipment cart. There is a risk of back injury if this equipment is lifted by one person.

Caution



Electrostatic Discharge (ESD) can damage the highly sensitive circuits in the instrument. ESD is most likely to occur as test devices are being connected to, or disconnected from, the instrument's front and rear panel ports and connectors. You can protect the instrument and test devices by wearing a static-discharge wristband. Alternatively, you can ground yourself to discharge any static charge by touching the outer chassis of the grounded instrument before touching the instrument's front and rear panel ports and connectors. Avoid touching the test port center conductors unless you are properly grounded and have eliminated the possibility of static discharge.

Repair of damage that is found to be caused by electrostatic discharge is not covered under warranty.

Table of Contents

Chapter 1—General Information

1-1	Introduction	1-1
1-2	Description	1-1
1-3	Identification Number	1-1
1-4	Document Typographic Conventions	1-1
1-5	Online Manual	1-2
1-6	Related Manuals	1-2
	Operation Manual	1-2
	Programming Manual	1-2
1-7	Options	1-2
	Determining Existing Options on Your Signal Generator	1-3
1-8	Level of Maintenance	1-3
	Preventive Maintenance	1-3
	Performance Verification	1-3
	Adjustment	1-3
	Troubleshooting	1-4
	Repair	1-4
1-9	ESD Requirements	1-4
1-10	Preventive Maintenance	1-4
	Cleaning LCD Display Touch Screen	1-4
	Maintain Operating System Integrity	1-4
	Antivirus Protection	1-4
	Windows Updates	1-4
	Hard Disk Drive Data Backup	1-5
	Air flow	1-5
	Microprocessor Battery	1-5
	Updating Instrument Operating Software	1-5
1-11	Communicating with Anritsu Customer Service	1-6
1-12	Test Equipment List	1-6

Chapter 2—Functional Description

2-1	Introduction	2-1
2-2	Major Subsystems	2-1
	Microprocessor and Digital Section	2-1
	Front Panel Assembly	2-4
	Frequency Synthesis	2-4
	ALC/Pulse Modulator	2-4
	RF Deck	2-5
	AC Power and DC Voltage Regulation	2-5
	Instrument Inputs/Outputs	2-7
	Motherboard/Interconnections	2-7

Table of Contents (Continued)

2-3	Frequency Synthesis	2-7
	A7 PCB	2-7
	A9 PCB	2-8
2-4	ALC/Pulse Modulation	2-9
	ALC Loop Operation	2-9
	Pulse Generator Operation	2-10
2-5	RF Deck Assemblies	2-10
	RF Deck Configurations	2-10
	RF Signal Flow	2-11
	0.01 to 2.2 GHz Digital Down Converter (Option 004)	2-11
	Step Attenuator	2-11

Chapter 3—Performance Verification

3-1	Introduction	3-1
3-2	Test Records	3-1
3-3	Connector and Key Notation	3-1
3-4	Test Equipment List	3-2
3-5	Measurement Uncertainty	3-4
3-6	Internal Time Base Aging Rate Test (Optional)	3-5
	Test Setup	3-5
	Procedure	3-5
3-7	Spurious Signals Tests	3-6
	Harmonics and Harmonically Related Signals Test	3-7
	Non-Harmonic Signals Test	3-8
3-8	SSB Phase Noise Test	3-11
	Procedure Using Agilent Equipment	3-11
	Procedure Using AeroFlex Equipment	3-16
3-9	Power Level Accuracy and Flatness Tests	3-21
	Test Setup	3-21
	Power Level Log Conformity	3-22
	Power Level Accuracy (Models without Option 002)	3-24
	Power Level Accuracy (Models with Option 002)	3-25
	Power Level Flatness	3-29
	Maximum Levelled Power	3-31
3-10	Pulse Modulation Tests	3-34
	Test Setup	3-34
	Pulse Rise Time, Fall Time and Overshoot	3-35
	Pulse Power Accuracy	3-37
	External Pulse Power Accuracy	3-38
	Pulse On/Off Ratio	3-41

Chapter 4—Adjustment

4-1	Introduction	4-1
4-2	Test Equipment List	4-1
4-3	Test Records	4-1

Table of Contents (Continued)

4-4	Adjustments after Subassembly Replacement	4-2
4-5	Calibration File Updates	4-4
4-6	Utility DVM Adjustment	4-5
4-7	Frequency Reference Adjustment	4-6
4-8	Level Detector Tables and Level Flatness Adjustment	4-7
4-9	Level SWF Band Adjustment	4-8
4-10	Level ALC Adjustment	4-9
4-11	Touch Screen Accuracy Adjustment	4-10

Chapter 5—Troubleshooting

5-1	Introduction	5-1
5-2	Test Equipment List	5-2
5-3	Error Messages	5-2
	System Self-Test	5-2
	Normal Operation Error and Warning/Status Messages	5-4
	Error Log	5-4
5-4	No Error Message	5-5
5-5	Troubleshooting Tables	5-5
	Checking DC Voltages	5-16

Chapter 6—Removal and Replacement Procedures

6-1	Introduction	6-1
6-2	Replaceable Parts	6-2
6-3	Calibration and Verification after Subassembly Replacement	6-3
6-4	Removing the Instrument Covers	6-6
	Tool Required	6-6
	Preliminary	6-6
	Procedure	6-6
6-5	Front Panel and RF Output Connector	6-8
	Preliminary	6-8
	Procedure	6-8
6-6	A2 CPU Assembly and Hard Drive	6-10
	Preliminary	6-10
	A2 and Hard Drive Replacement Procedure	6-10
	Battery Replacement Procedure	6-12
6-7	A7 or A9 PCB	6-13
	Preliminary	6-13
	Procedure	6-13
6-8	A4, A6, A8 PCBs	6-14
	Preliminary	6-14
	Procedure	6-14

Table of Contents (Continued)

6-9	Main Power Supply, Auxiliary Power Supply or Regulator PCB	6-15
	Preliminary	6-15
	Main Power Supply	6-15
	Auxiliary Power Supply	6-15
	A3 Regulator PCB	6-15
6-10	Rear Panel BNC Interface PCB	6-17
	Preliminary	6-17
	Procedure	6-17
6-11	Rear Panel Digital Interface PCB	6-18
	Preliminary	6-18
	Procedure	6-18
6-12	Cooling Fans	6-19
	Main System Fan	6-19
	Power Supply Fan	6-20
	A2 CPU Cooling Fan	6-21
6-13	RF Components	6-23

Appendix A—Test Records

A-1	Introduction	A-1
A-2	Uncertainty Specifications	A-1
A-3	Test Records	A-1
	Section 3-6 Internal Time Base Aging Rate Test (Optional)	A-1
	Section 3-7 Harmonics and Harmonically Related Signals Test (without Option 15)	A-2
	Section 3-7 Harmonics and Harmonically Related Signals Test (with Option 15)	A-3
	Section 3-7 Non-Harmonic Signals Test (Part 1)	A-4
	Section 3-7 Non-Harmonic Signals Test (Part 2)	A-7
	Section 3-8 SSB Phase Noise Test: Agilent Test Equipment	A-8
	Section 3-8 SSB Phase Noise Test: Agilent Test Equipment	A-10
	Section 3-8 SSB Phase Noise Test: AeroFlex Test Equipment	A-13
	Section 3-8 SSB Phase Noise Test: AeroFlex Test Equipment	A-16
	Section 3-9 Power Level Accuracy and Flatness Tests	A-18
	Section 3-9 Power Level Accuracy and Flatness Tests	A-20
	Section 3-9 Power Level Accuracy and Flatness Tests	A-22
	Section 3-9 Power Level Flatness	A-28
	Section 3-9 Power Level Flatness	A-28
	Section 3-9 Maximum Leveled Power	A-29
	Section 3-9 Maximum Leveled Power	A-29
	Section 3-9 Maximum Leveled Power	A-29
	Section 3-10 Pulse Modulation Tests	A-30
	Section 4-4 Adjustments after Subassembly Replacement	A-31

Appendix B—Performance Specifications

B-1	MG3702xA Technical Data Sheet	B-1
-----	---	-----

Index

Chapter 1 — General Information

This manual provides service information for the Series MG3702xA Fast Switching Microwave Signal Generator. The service information includes a replaceable parts list, troubleshooting, verification and adjustment procedures, functional circuit descriptions, block diagrams and subassembly replacement procedures. Throughout this manual, the terms *MG3702xA*, *synthesizer*, or *DUT (device under test)* are used to refer to the instrument. Manual organization is shown in the table of contents.

1-1 Introduction

This chapter provides a general description of the MG3702xA, identification numbers, related manuals and options. This chapter also includes information about the level of maintenance needed, ESD requirements, preventative maintenance procedures and a test equipment list needed to support the MG3702xA.

1-2 Description

The MG3702xA fast switching microwave signal generator is a microprocessor-based, synthesized signal source with high resolution phase-lock capability. It generates both discrete CW frequencies and broad (full range) or narrow band step sweeps across the frequency range of 2 GHz to 20 GHz. Options are available to extend the low end of the frequency range to 10 MHz. All signal generator functions are fully controllable either locally from the front panel or remotely (except for power on/standby) via the IEEE-488 General Purpose Interface Bus (GPIB), Ethernet, or USB network ports. A complete instrument description with performance specifications can be found in the MG3702xA technical data sheet, Anritsu part number: 11410-00429, which is also available online. Updated versions of this manual and the technical data sheet may be downloaded from the Anritsu Internet site at: <http://www.anritsu.com>.

1-3 Identification Number

Anritsu synthesizers are assigned a unique six-digit or seven-digit ID number, such as “090101.” The Model number, ID number and all options installed are imprinted on a decal that is affixed to the rear panel of the instrument. Special-order instrument configurations also have an additional special number tag attached to the rear panel of the instrument, such as SM1234.

When ordering parts or corresponding with Anritsu customer service, please use the correct serial number with reference to the specific instrument’s model number (i.e., model MG37022A Signal Generator, Serial No. 090101, options and the special’s number, if appropriate).

1-4 Document Typographic Conventions

The typographic conventions used throughout this manual are as follows:

The front panel function keys are identified by using bold sans serif text. For example: **Frequency**.

Menus and Menu buttons found in the graphical user interface are identified by using sans serif text. For example: Edit F1.

Instrument status and warning messages are shown as they appear on the display, for example: CW Ramp.

Menu selection sequences are presented as a string of actions separated with a vertical pipe. For example:

Press **System** | Maint | **12345** | **Enter** | Calibration | Frequency.

This string means you would: press the **System** hard key | press the Maint soft key | press the numeric hard keys **12345** | Press the **Enter** hard key | Press Calibration soft key | press the Frequency soft key.

1-5 Online Manual

This manual is available on CD ROM as an Adobe Acrobat Portable Document Format (*.pdf) file. The file can be viewed using Acrobat Reader, a free program that is also included on the CD ROM. The file is “linked” such that the viewer can choose a topic to view from the displayed “bookmark” list and “jump” to the manual page on which the topic resides. The text can also be searched.

1-6 Related Manuals

This is one of a three manual set that consists of an operation manual, a GPIB and SCPI programming manual, and this maintenance manual.

Operation Manual

The Anritsu part number for the model MG3702xA Operation Manual is 10370-10370.

The operation manual provides instructions for operating the MG3702xA using the front panel controls. It also includes general information, performance specifications, installation instructions, and operation verification procedures.

Programming Manual

The Anritsu part number for the model MG3702xA Programming Manual is 10370-10371.

The programming manual provides information for remote operation of the Series MG3702xA Synthesized High Performance Signal Generator using commands sent from an external controller via the IEEE-488 General Purpose Interface Bus (GPIB), USB, and Ethernet. It includes the following:

- A general description of the GPIB and the bus data transfer and control functions
- A listing of the IEEE-488 Interface Function Messages recognized by the signal generator with a description of its response
- A complete listing and description of all the Standard Commands for Programmable Instruments (SCPI) commands that can be used to control signal generator operation with examples of command usage
- A table of supported MG3702xA commands and their SCPI equivalent

This manual is intended to be used in conjunction with the Series MG3702xA Operation Manual, P/N: 10370-10370. Refer to that manual for general information about the MG3702xA, including equipment set up and front panel (manual mode) operating instructions.

1-7 Options

The options available for the Anritsu MG3702xA series signal generators are described in the technical data sheet (PN: 11410-00429) which is located in Appendix B of the print manual and online at the Anritsu web site (<http://www.anritsu.com>). For convenience, below is the options list as of July 2011:

Table 1-1. Anritsu MG3702xA Options (1 of 2)

Option	Description
MG37022A-001	Rack Mount with Slides — Kit contains a set of track slides, mounting ears and front panel handles for a standard 19 inch equipment rack.
MG37022A-002	Mechanical Step Attenuator — Adds a 110 dB range, 10 dB/step attenuator. RF output power is reduced.
MG37022A-004	10 MHz to 2.2 GHz RF Coverage — Uses a digital down converter to significantly reduce SSB phase noise
MG37022A-009	Rear Panel Output — Moves the RF output connector to the rear panel.

Table 1-1. Anritsu MG3702xA Options (2 of 2)

Option	Description
MG37022A-011	Rack Mount without Slides — Kit contains mounting ears and front panel handles for a standard 19 inch equipment rack.
MG37022A-015	High Power — Adds high-power RF components to the instrument to increase the output power level.
MG37022A-017	Delete Front Panel — Deletes the front panel for use in remote controlled applications. (Only available with Option 1)
MG37022A-026	Pulse Modulation — Includes internal waveform generator and external input via a rear panel BNC connector.
MG37022A-035	Removable Hard Drive — Provides the capability to remove the internal hard drive, and includes one replacement hard drive with instrument software.
MG37022A-036	Ultra Stable Phase Track — Provides the capability for ultra-stable phase tracking between instruments using the internal 100 MHz reference.
MG37022A-037	Performance Suite — For ease of ordering and package pricing, this option bundles Options 2, 4, 15 and 26.
MG37022A-088	250 μsec Switching Speed Limit — Limits the frequency switching speed to 250 μ sec to comply with United States Export Control regulations

Determining Existing Options on Your Signal Generator

You can determine what options are installed by viewing the serial number and options label on the rear of the unit.

Options may be retrofitted to instruments (typically) at any time. Contact Anritsu Customer Service (1-800-anritsu) for information on option retrofitting.

1-8 Level of Maintenance

Maintenance of the MG3702xA consists of:

- Preventive maintenance
- Performance Verification
- Calibration
- Troubleshooting the instrument to a replaceable subassembly or RF component
- Repair by replacing the failed subassembly or RF component

Preventive Maintenance

Preventive maintenance on the MG3702xA consists of a few procedures detailed in section [Section 1-10](#).

Performance Verification

Refer to [Chapter 3, “Performance Verification”](#) for a detailed description of the MG37022A verification procedures.

Adjustment

The MG3702xA may require adjustment after repair or when verification procedures fail. Refer to [Chapter 4, “Adjustment”](#) for a listing of requirements and procedures.

Troubleshooting

The MG3702xA firmware includes internal diagnostics that self-test most of the internal assemblies. When the MG3702xA fails self-test, one or more error messages appear on screen to aid in isolating the failure to a replaceable subassembly or RF component. [Chapter 5, “Troubleshooting”](#) lists and describes the self-test error messages and provides procedures for isolating MG3702xA failures to a replaceable subassembly or RF component.

Repair

Most instrument failures are field repairable by replacing the failed subassembly or RF component. Detailed instructions for removing and replacing failed subassemblies and components are provided in [Chapter 6, “Removal and Replacement Procedures”](#).

1-9 ESD Requirements

All electronic devices, components, and instruments can be damaged by electrostatic discharge. It is important to take preventive measures to protect the instrument and its internal subassemblies from electrostatic discharge.

An ESD safe work area and proper ESD handling procedures that conform to ANSI/ESD S20.20-1999 or ANSI/ESD S20.20-2007 is mandatory to avoid ESD damage when handling subassemblies or components found in the MG3702xA instrument.

1-10 Preventive Maintenance

Cleaning LCD Display Touch Screen

The touch screen is protected by a plastic display filter. To clean the display filter, dampen a soft cloth with a mild soap and water solution. Do not use abrasive cleaners, tissues, or paper towels that can scratch the plastic surface. Gently wipe the display filter to clean.

Maintain Operating System Integrity

The Microsoft Windows XP operation system on the MG3702xA is configured for optimum performance when the instrument leaves the factory. To maintain the system's operating integrity, follow proper Windows shutdown procedure and DO NOT modify the operating system configuration, the firewall settings, the system registry, the hard disk drive partitions, or the Anritsu user accounts.

Antivirus Protection

The MG3702xA is tested with Trend Micro antivirus software, but stability is not guaranteed with all antivirus software. Anritsu recommends connecting the instrument only to a secure network. The user assumes the responsibility to provide virus protection because this is not supplied with the instrument. Contact your network administrator for information about your network security and antivirus protection policies.

Windows Updates

Not all Microsoft updates are compatible with the MG3702xA and, if installed, may affect the performance of the instrument.

Hard Disk Drive Data Backup

Anritsu recommends that you make a backup copy of your critical data stored on the MG3702xA's hard disk drive as often as possible.

Note

Anritsu reserves the right to reformat or replace the MG3702xA hard disk drive as part of the repair. In such incidence, all user data on the hard disk drive will be erased.

Air flow

The MG3702xA must always receive adequate ventilation. Depending on environmental conditions, the external fan filters may need to be cleaned. A clogged fan filter will result in heat buildup and degraded instrument operation. Check and clean the rear panel fan honeycomb filters periodically, especially in dusty environments. Clean the filter as follows.

1. Turn off the synthesizer and disconnect the power cord from the instrument.
2. Use a #3 screwdriver to remove the four screws that fasten the filter guard to the rear panel (see [Figure 1-1](#)). Retain the screws for reassembly.
3. Vacuum the honeycomb filter to clean it.
4. Reinstall the filter and guard.

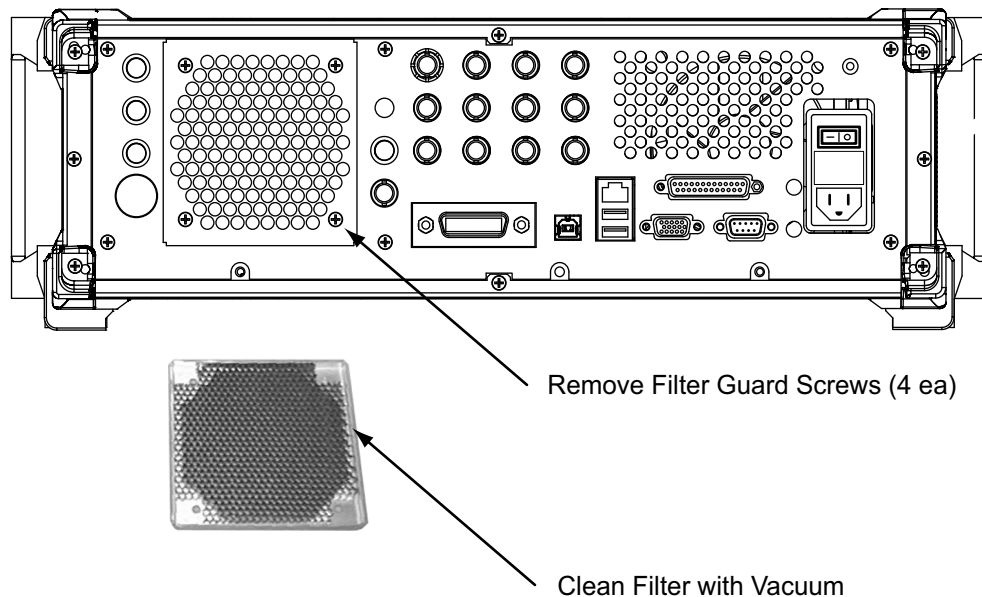

Figure 1-1. Removal/Replacement of the Fan Filter Guard

Microprocessor Battery

The processor (RTC) battery on the CPU assembly has a finite lifespan and may need replacement (refer to [Chapter 6](#)).

Updating Instrument Operating Software

Installing new versions of operating software in modern electronic equipment is often accomplished by simply downloading new software from the company internet website. This is not feasible for the MG3702xA for the following reasons:

It is expected that changes in hardware will occur over time. New options, increasing memory capacity, increasing digital communication speed, and occasional parts obsolescence issues are common reasons for hardware changes. It often becomes necessary to cease offering software upgrades when earlier hardware is present in the instrument.

The firmware is under export control.

As a precaution, new versions of operating software may be installed only after a compatibility and export control check by an Anritsu Service Engineer. Contact your Anritsu Sales Engineer or Service Center for information on installing software upgrades.

1-11 Communicating with Anritsu Customer Service

The current locations of Anritsu Service Centers (world-wide) are posted on the USA website <http://www.anritsu.com>. To find the location listing, on the home page, click on **Service**. Locations and phone numbers of USA Service Centers appear. Additionally, a pull-down list of world-wide service centers appears.

USA customers may also call 1-800-anritsu and select **Service** from the menu. To provide the service, we may require details of your instrument as described below.

All Anritsu instruments are assigned a six or seven digit serial number which appears on the rear panel and is also found in one or more software menus. Specially modified instruments for specific customer requirements are often created and are identified with an “SM” number printed on a label on the rear panel.

When ordering parts or corresponding with Anritsu Customer Service, the instrument model, serial number, options and SMxxxx number, if present, will usually be required. In rare instances, the operating software version will be requested, and may be found within software menus.

1-12 Test Equipment List

Table 1-2 provides a list of recommended test equipment needed for the performance verification, calibration, and troubleshooting procedures presented in this manual. The test equipment setup is critical to making accurate measurements. In some cases, you may substitute test equipment having the same critical specifications as the test equipment indicated in the test equipment list (refer to “[Measurement Uncertainty](#)” on page 3-4).

Table 1-2. Test Equipment List (1 of 4)

Instrument	Critical Specification	Manufacturer/Model	Usage ^(a)
Computer running Windows XP	The following configuration must be dedicated during calibration and verification activities: Pentium 4 2.8 GHz 1 GB RAM 2 Serial ports CDROM Mouse Keyboard Monitor Network	Dell or other common source	C, P
National Instrument PCI GPIB card	PCI GPIB card for computer	National Instrument	C, P
Anritsu RF verification and calibration software	Requires the Mixer box and BNC low pass filters listed below.	Anritsu 2300-497	C, P
Spectrum Analyzer	Frequency: 100 kHz to 50 GHz Resolution bandwidth: 10 Hz	Agilent 8565EC	C, P

Table 1-2. Test Equipment List (2 of 4)

Instrument	Critical Specification	Manufacturer/Model	Usage ^(a)
Phase noise measurement system	Frequency range: 5 MHz to 26.5 GHz	Aeroflex/Comstron PN9000 with: PN9060-00 Status Module PN9470-00 Noise Output Module PN9450-00 Lock Control Module PN9342-00 Phase Detector Module PN9530-00 Crystal Oscillator Module Agilent Phase Noise Station: Anritsu K222B Insertable F-F Anritsu 34NKF50 N Male to K Female Adapter Anritsu K241C Power Splitter Anritsu SC3855 3670K50-2 KM-KM flex cable Agilent E5052B Signal Source Analyzer Agilent E5053A Down Converter Two Anritsu K120MM-20CM Semi ridged cables Two Anritsu K120MM0-20CM Semi ridged cables (will need to be bent on site to fit) Optical Mouse, PS2/USB for E5052B USB Keyboard for E5052B	P
Frequency counter	Frequency range: 0.01 GHz to 20 GHz Input impedance: 50 Ω Resolution: 1 Hz Other: External time base input	Anritsu model MF2412B	C
Power meter	Frequency: 100 kHz to 20 GHz Power range: -70 to +20 dBm	Anritsu model ML2437A/38A	C, P
Power sensor for power meter	Frequency: 0.01 to 40 GHz (K) Power range: -70 to +20 dBm	Anritsu model MA2474D	C, P
Power sensor for power meter	Frequency: 100 kHz to 18 GHz (N) Power range: -70 to +20 dBm	Anritsu model SC7400	C, P
Adapter for power sensor SC7400	N female to K adapter	Anritsu model 34NFK50	C, P
Adapter for power sensor calibration	N(m) to K(f)	Anritsu 34NKF50	C, P
Special AUX I/O cable assembly	Provides interface between the MG3702xA and the power meter	Anritsu PN: 806-97	P
Digital multimeter	Minimum 1% RMS ACV accuracy at 100 kHz	Agilent 34401A	P
Function generator	Frequency: 0.1 Hz to 15 MHz	Agilent 33120A	C, P
Digital sampling oscilloscope	Frequency: 50 GHz	Agilent 86100A with 83484A 50 GHz module	P

Table 1-2. Test Equipment List (3 of 4)

Instrument	Critical Specification	Manufacturer/Model	Usage ^(a)
Frequency reference	Frequency: 10 MHz Accuracy: 5×10^{-12} parts/day	Absolute Time Corp., model 300 or Symmetricom (Datum) model 9390-9600	P
Measuring receiver ^(b)	Noise floor: < -140 dBm @ 500 MHz	Anritsu model ML2530A	C, P
Local oscillator ^(b)	Frequency: 0.01 GHz to 20 GHz Power: >+13 dBm 10 MHz to 20 GHz	Anritsu Model MG3692C with: Options 3, 4, 16, and SM6191 (unit must not have options 15x, 22 or 2B)	C, P
One of the following ^(b) : Mixer Box (for low level calibration) ^(b) and Low Pass Filter (2 each) ^(b) or Mixer ^(b) and M to M Adapter ^(b)	Frequency Range: 0.01 GHz to 40 GHz 1.9 GHz LPF or Frequency Range: 500 MHz to 40 GHz Conversion loss: 10dBm (typical) K(m) to K(m)	Anritsu PN: T2579 and Anritsu PN: 1030-104 or Anritsu PN: 60-114 and Anritsu PN: K220B	C, P
Attenuator	Frequency range: DC to 40 GHz Attenuation: 3, 6, 10, and 20 dB (sizes and counts are determined depending on options and maximum output power of instrument)	Anritsu part number SC7879 K set of attenuators (41KC-3, 41KC-6, 41KC-10, 41KC-20) calibrated from 100 K to 40 GHz	C, P
BNC 50Ω terminator		Any common source	C, P
BNC Tee connectors		Any common source	C, P
Generic 50Ω BNC RF cables and connectors		Any common source	C, P
Generic GPIB cables		Any common source	C, P
BNC to SMA adapter		Any common source	P
K(m) to K(m) flex cables or semi-rigid cables	K(m) to K(m) flex cables or Semi-rigid cables	Anritsu SC3855 3670K50-2 K(m) to K(m) flex cable or Anritsu K120mm-60CM custom semi-rigid cable	C, P
If the unit does not have a front panel, the following items are required: Monitor USB Keyboard USB Mouse	PC compatible	Any common source	C, P

Table 1-2. Test Equipment List (4 of 4)

Instrument	Critical Specification	Manufacturer/Model	Usage^(a)
USB memory stick with 1 GB of available space (Used to save calibration data).	<1 GB available space	Any common source	C, P
BNC to Banana Adapter for DMM		Any common source	P
Inline BNC 6 dB attenuator		Any common source	P

a. P = Performance Verification Tests, C = Calibration, T = Troubleshooting

b. Only needed if option 2X is installed.

Chapter 2 — Functional Description

2-1 Introduction

This chapter provides brief functional descriptions of the major subsystems that are contained in each model of the MG3702xA. In addition, the operation of the frequency synthesis, automatic level control (ALC), and RF deck subsystems is described so that the instrument operator may better understand the overall operation of the MG3702xA. Block diagrams are included to supplement the written descriptions.

2-2 Major Subsystems

The MG3702xA circuitry consists of various distinct subsystems that are contained on one or more printed circuit board (PCB) assemblies or in microwave components located on the RF deck. The following paragraphs identify the subsystems that make up the instrument and provide a brief description of each. [Figure 2-1 on page 2-2](#) shows a two page functional block diagram of a typical MG3702xA synthesizer with applicable options.

Microprocessor and Digital Section

CPU Module (A2 PCB)

The MG3702xA Processor Board (A2 assembly) shown in [Figure 2-2 on page 2-12](#) is the CPU and communications hub of the synthesizer. It contains an Intel Celeron™ processor PCB utilizing the Windows XP™ operating system supporting a touch screen display, instrument keypad, several standard communication ports and a hard disk drive.

The hard disk drive holds the Windows™ operating software, the instrument operating software, and the factory calibration files. The hard drive has the same functional capabilities as a standard hard drive on a Windows-based PC.

The A2 PCB provides other functionality including processing temperature, voltage and current monitoring, transient protection, processor (RTC) battery, power monitoring, debugging ports, address and data buffering, JTAG and other programmable logic control.

The A2 PCB utilizes a PCI-type interface (IEEE1386 PMC) for communication among three on-board modules: DSP controller, GPIB and USB controllers.

The DSP controller interfaces to the system modules using the PMC interface standard. There are 4M x 32 bits of SDRAM available for DSP memory. Also available is a flash memory device with 512 KB of main memory and 32 KB of secondary memory. The flash is provided for non-volatile storage requirements and the SDRAM is used for all other DSP memory requirements, including DSP firmware which is downloaded via the PCI bus at power on.

The PMC-GPIB section allows the instrument to interface to an external computer via GPIB. This section interfaces to the system via the PCI bus using the PMC interface standard. This module is not capable of being a GPIB controller.

The PMC-USB section allows the instrument to appear as a USB device to an external computer, allowing the synthesizer to be controlled in that manner.

FPGA / Synthesizer Digital Control Module (A8 PCB)

The FPGA (Field Programmable Gate Array) / Synthesizer Digital Control PCB (also in [Figure 2-2](#)) provides interface between the CPU and the RF synthesis hardware (A7 and A9 PCBs). The FPGA programs the synthesis hardware for desired frequency output.

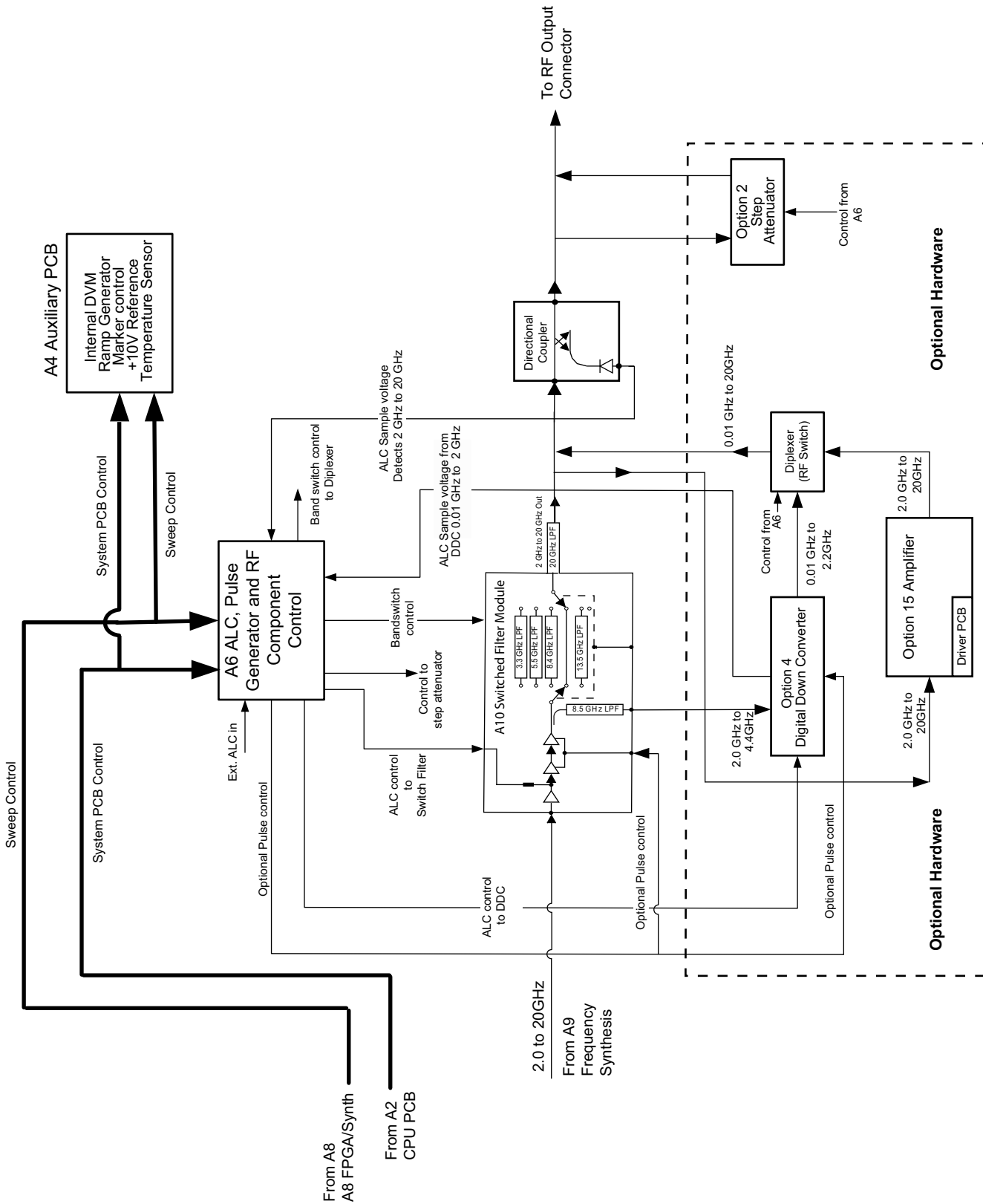

Figure 2-1. Block Diagram of MG3702xA System (1 of 2)

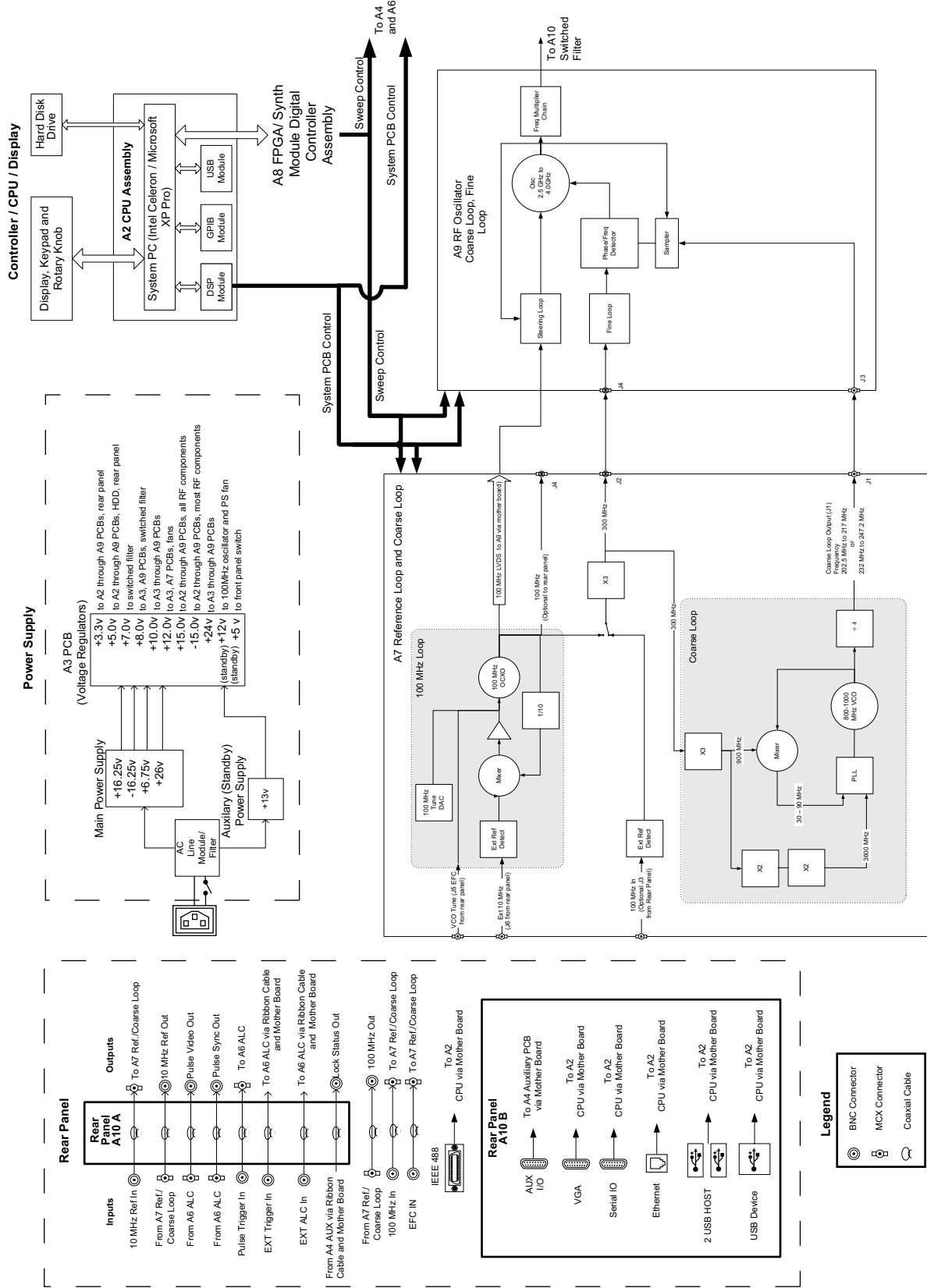

Figure 2-1. Block Diagram of MG3702xA System (2 of 2)

Front Panel Assembly

This circuit subsystem shown in [Figure 2-2 on page 2-12](#) consists of the front panel, the front panel rotary data knob, the front panel control PCB, and the liquid crystal display (LCD). The subsystem interfaces the front panel LCD, light emitting diodes (LEDs), and keys to the CPU via the dedicated data and address bus. The front panel rotary data knob is also linked to the CPU via the data and address bus.

The front panel PCB contains the keyboard matrix conductive rubber switches. It has circuits to control the LCD, turn the front panel LEDs on and off, and convert keyboard switch matrix signals to parallel key code. It also contains the standby/operate line switch and the optical encoder for the rotary data knob.

Frequency Synthesis

The frequency synthesis subsystem shown in [Figure 2-3 on page 2-13](#) consists of the A7 Reference/Coarse Loop and A9 Oscillator PCB's. The RF Output of the MG3702xA synthesizer originates from a 2.5 GHz to 4 GHz voltage controlled oscillator (VCO) within the A9 PCB. By multiplying and dividing this signal, any frequency between 2 GHz and 20 GHz is obtained. The VCO located on the A9 PCB is controlled directly and indirectly by 4 phase-locked loops:

- 100 MHz Reference Loop
- Steering Loop
- Coarse Loop
- Fine Loop

The A9 PCB also houses the steering loop, the fine loop, and the frequency multiplication section.

The A7 PCB contains:

- 100MHz oscillator
- Coarse loop
- 100MHz reference loop
- 10 MHz reference

Refer to [Section 2-3](#) for a functional overview of the frequency synthesis subsystem.

ALC/Pulse Modulator

This ALC circuit subsystem shown in [Figure 2-4 on page 2-14](#) consists of the A6 ALC PCB and the A4 Auxiliary Control PCB. It provides the following:

- Level control of the RF output power.
- Current drive signals to the PIN switches located in the switched filter assembly (SWF).
- Drive signals for the step attenuator (Option 2).
- Pulse modulation control (option 26)

Refer to [Section 2-4](#) for a functional overview of the ALC subsystem.

RF Level Control Assembly (A6 ALC PCB)

This assembly controls the automatic level control (ALC) for the MG3702xA Synthesizer. The A6 selects appropriate frequency paths via PIN diode based switches and is the control block in the feedback loop that provides the user with desired output power levels. It contains the internal and external pulse modulation control (Option 26) and PIN switch drivers for the switched filter. The drivers for the optional step attenuator and diplexer are also included.

Other components providing level controls within the ALC loop are the switched filter, the optional digital down converter, and the leveling coupler.

The A6 ALC PCB connects to the CPU module via the 32-bit data bus. The A6 on-board FPGA provides all programmed control signals and sends status information back to the CPU module.

The external ALC circuits have provisions for leveling with either an external crystal detector or power meter. The output polarity of the detector or power meter may either be positive or negative.

Auxiliary Control (A4 PCB)

Precision +10 and –10 volt references are created for the DVM, Ramp Generator, and Horizontal Output circuits, all of which are generated by this PCB. The DVM circuit is used to monitor most systems in the synthesizer.

Marker, sequential sync, retrace and band switch blanking signals are also created by the A4 and sent to the rear panel Aux I/O connector.

RF Deck

The RF Deck subsystem shown in [Figure 2-4 on page 2-14](#) contains those elements related to the generation, modulation, and control of the sweep and CW-frequency RF signals. These elements include the:

- A9 RF oscillator/coarse loop/fine loop PCB
- Switched filter assembly
- Down converter assembly (option 004)
- Directional coupler/level detector
- Optional step attenuator (option 002)

Refer to [Section 2-5](#) for a functional overview of the RF deck subsystem.

AC Power and DC Voltage Regulation

AC power for the synthesizer passes through a rear panel on/off switch and a line filter module before arriving at the power supplies. See the block diagram in [Figure 2-2 on page 2-12](#). A main power supply and a separate standby power supply provide several DC voltages to the A3 voltage regulation PCB.

The rear panel on/off switch provides complete disconnection from the AC power and should not be used for normal power on/off purposes.

Note

Use of the rear panel switch instead of the front panel switch prevents important instrument functions from being performed and can lead to Microsoft Windows XP operation errors.

When the rear panel switch is set to the ON position, the standby power supply is always on regardless of the state of the instrument. The standby supply provides constant power to the internal 100MHz oscillator, power supply fan and the front panel switch, in addition to a control signal for the main power supply.

When the instrument is turned on using the front panel switch or at initial power on, the main power supply is activated and produces outputs of +16.25V, -16.25V, +6.75V and +26V which is routed to the voltage regulator board via a cable.

Voltage Regulation (A3 PCB)

The purpose of this PCB is to convert and regulate the coarse switching main and standby power supply output voltages to the many precise voltages required by the various assemblies in the synthesizer.

[Table 2-1](#) shows the applications for the various output voltages. The regulation removes the power supply ripple due to switching transients. The A3 PCB also converts the standby power supply voltage (+13V) to +12V and +5V.

In addition to buffering the +16.25V, -16.25V, +6.75V, +13V and +26 volts from the main power supply, there are 2 signals that are routed into and out of the A3 PCB:

- PWRFAIL is the status line from the main power supply which provides a TTL “High” signal when the AC input voltage is within the acceptable range.
- PSINHIBIT is the control signal from the instrument front panel “ON/OFF” switch which is fed to the main power supply to activate the power supply.

Table 2-1. A3 PCB Outputs

Output	Application
+15VA/-15VA	A7 and A9 PCBs and optional step attenuator
+15VB/-15VB	RF components and A6 PCB
+15V_MMW/-15V_MMW	Optional external frequency multiplication modules
+15VC for	RF components
+5VA	All +5V power
+24V_TUNE	Not currently used
+24VB	General-purpose high voltage use
+3.3VA	All +3.3V power
+12VF	Rear panel fan
+12VPSF	Power supply fan, from standby power supply
+12VS	Oscillator heaters, power-up circuitry, from standby power supply
+5V_SB	Front panel switch, from standby power supply
+10VB	A9 PCB
+8VA	Not currently used
+8VB	A7 PCB and switched filter
+7VA	Switched filter

Instrument Inputs/Outputs

The A10 rear panel PCBs and the A2 microprocessor PCB contain the interface circuits for the majority of the rear panel input and output connectors as shown in [Table 2-2](#) and in [Figure 2-2 on page 2-12](#).

Table 2-2. Instrument Input/Output Interfaces

Input/Output Connectors	Interface
10 MHz REF OUT and 10 MHz REF IN	Routed through the A10 rear panel PCBs and coupled to the A7 Reference/Course Loop PCB via coaxial cables.
PULSE TRIG IN, PULSE SYNC OUT and PULSE VIDEO OUT	Routed through the A10 rear panel PCBs, and then to the A6 ALC PCB via coaxial cables.
EXT ALC IN,	Routed through the A10 rear panel PCBs, and then to the A6 ALC PCB via a cable and the mother board.
EXT TRIG and LOCK STATUS OUT	Routed through the A10 rear panel PCBs, and then to the A4 AUX PCB via a cable and the mother board.
VGA, ETHERNET, USB HOST, USB AND SERIAL	Routed through the A10 rear panel PCBs and then through the motherboard to the A2 microprocessor PCB.
AUXI/O	Routed through the A10 rear panel PCBs and then through the motherboard to the various PCB.
IEEE-488 GPIB	Routed through the rear panel to the motherboard and then to the A2 microprocessor PCB.
100 MHz IN and 100 MHz REF OUT	Routed through from the rear panel to the A7 Reference/Course Loop PCB via coaxial cables
EFC IN	Routed to the A7 Reference/Course Loop PCB via coaxial cable.

Motherboard/Interconnections

The motherboard PCB and associated cables provide the interconnections for the flow of data, signals, and DC voltages between all internal components and assemblies throughout the MG3702xA.

2-3 Frequency Synthesis

The frequency synthesis subsystem provides phase-lock control of the MG3702xA output frequency. It consists of three phase-lock loops: the 100MHz loop, the coarse loop and the fine loop. Operating together, the three phase-lock loops produce an accurately synthesized, low-noise RF output signal. The circuitry is contained within two PCBs: the A7 Reference Loop and Coarse loop, and the A9 RF Oscillator, Coarse Loop and Fine Loop). These boards work together to generate an output of 2 to 20 GHz. The following paragraphs describe phase-lock loops and the overall operation of the frequency synthesis subsystem. See [Figure 2-3 on page 2-13](#).

A7 PCB

The A7 Reference/Coarse Loop module generates the reference frequencies used within the MG3702xA. It combines the fixed references (10 MHz, 100 MHz and 300 MHz) with a fast switching coarse loop. The coarse loop section provides coarse frequency steps on the output of the fast switching frequency synthesizer. The two main parts are the 100 MHz Reference Loop and the Coarse Loop.

100 MHz Reference Loop

The 100 MHz Reference Loop has 3 methods for controlling the 100 MHz heater stabilized crystal oscillator:

1. With no external reference attached, the oscillator frequency is set by the Reference Tuning DAC, the value of which is determined by a calibration procedure and stored in the onboard flash memory.
2. If an external 10 MHz is detected, the loop will attempt to lock to this signal.
3. A voltage applied to the external VCO Tune line (EFC J5) will directly bias the VCO. Note that if an external reference is also attached, the loop will work against the VCO Tune line, and the only effect this line will have is to send the loop out of lock.

The output of the 100 MHz reference is directed to the 100 MHz Reference Select module, which has the ability to automatically connect to an external 100 MHz source. If option 036 (100 MHz External Reference Loop) is installed, a 100 MHz output is provided on J4. If a 100 MHz signal is detected on J3, the module will automatically use this signal as the reference to the coarse loop and fine loop multiplier chains.

Coarse Loop

The coarse loop section provides coarse frequency steps on the output of the fast switching frequency synthesizer.

The first part of the coarse loop (which is not actually a phase-locked loop) takes the 100MHz from the reference section and generates 900MHz from it. This is accomplished by frequency tripling two times. Each tripler is followed by a narrowband bandpass filter which removes the second, fourth, and other unwanted harmonics but allows the desired third harmonic to pass. This 900MHz output from the A-loop must be as spurious-free and as noise-free as possible because it can degrade the performance of the coarse loop module.

The 100 MHz output is multiplied by a factor of 3 to create the 300MHz used by the A9 board. The 300 MHz is again multiplied by a factor of 3 to create the 900MHz used by the coarse loop and is routed to two paths:

- **Path 1:** Part of the 900 MHz (not actually a phase-locked loop) is multiplied by a factor of 2 to create the 1800 MHz and then multiplied by a factor of 2 to create the 3600 MHz which is routed to the PLL.
- **Path 2:** Part of the 900 MHz is sent to the mixer. The result from the mixer and the 800 to 1000 MHz VCO output is fed back to the PLL.

The signals from these two paths lock the PLL and 800 to 1000 MHz VCO to the programmed coarse frequency. The goal is to provide a very fast switching loop. A PLL IC is part of this loop which locks the 800 to 1000 MHz VCO from 820 to 870 MHz and 930 to 980 MHz. The coarse output is then divided by 4 and sent to the A9 PCB via J1 connector at a frequency range of 202.5 to 217.5 or 232 to 247.2 MHz.

A9 PCB

The A9 VCO Output / Fine loop module provides phase and frequency locking to the VCO from 2.5 to 4 GHz and then multiplies and divides this signal to synthesize any frequency from 2 to 20 GHz. This module also holds the Fine loop for fine frequency control.

The A9 VCO Output / Fine loop module contains all the necessary circuitry to lock the 2.5 to 4 GHz VCO to a comb-line of the coarse loop. This is accomplished by the following steps:

1. Frequency Acquisition: before handing over control, the VCO is steered to the closest 10 MHz by the Steering loop. Once this has happened, the main loop is closed, allowing the down-sampled VCO frequency to be phase locked to the Fine Loop. As a result, the steering loop will now be unlocked.
2. The Fine Loop is a Direct Digital Synthesizer used to generate frequencies between 30 and 40 MHz. This is fed into the PFD (Phase Frequency Detector).
3. The output of the VCO is sent to the sampler which combines it to the coarse loop and feeds it into the PFD which locks the frequency.

The output of the VCO is then routed to the Multiplier Chain which multiplies the frequency to 2 to 20 GHz.

RF Outputs 10 MHz to 20 GHz

Refer to the block diagrams shown in [Figure 2-3 on page 2-13](#) and [Figure 2-4 on page 2-14](#) for the following descriptions. The MG3702xA uses VCOs and multipliers capable of generating RF signals in the frequency range of 2.0 GHz to 20 GHz. All other frequencies output by the instrument are derived from the fundamental frequencies generated by the VCO and multipliers.

0.01 to 2.2 GHz (Option 004)

RF output frequencies of 0.01 to 2.2 GHz are developed by down converting the fundamental frequencies of 2 GHz to 4.4 GHz. This is achieved by using a series of dividers and 16 bandpass filters. Precise control of the 0.01GHz to 2.2 GHz frequencies to 0.01 Hz resolution is achieved through phase-lock control of the fundamental frequencies prior to division.

Step and List Sweep Mode

Step (digital) frequency sweeps of the VCO oscillator and multiplier RF output consist of a series of discrete, synthesized steps between a start and stop frequency. Each frequency step is made by changing the fine and coarse loops, then phase-locking the RF output. Every frequency step in the sweep range is phase-locked.

2-4 ALC/Pulse Modulation

The MG3702xA ALC and pulse modulation subsystems provide automatic level control (ALC) and pulse modulation of the RF output signal. The ALC loop consists of circuits located on the A6 ALC PCB. These circuits interface with the A10 switched filter assembly, the digital down converter assembly and the directional coupler/level detector (all located on the RF deck). Pulse modulation of the RF output signal is provided by circuits on the A6 ALC PCB. These circuits interface directly with the switched filter assembly located on the RF deck via coaxial cables. (In instruments with Option 4, these circuits interface directly with the digital down converter and are looped through the digital down converter to the switched filter assembly.)

The ALC subsystem is shown in [Figure 2-4](#). The following paragraphs describe the operation of the subsystem components.

ALC Loop Operation

In the MG3702xA, a portion of the RF output is detected and coupled out of the directional coupler/level detector as the feedback input to the ALC loop. The feedback signal from the detector is routed to the A6 ALC PCB where it is compared with a reference voltage that represents the desired RF power output level. If the two voltages do not match, an error correction signal is fed to the modulator shaper amplifier circuits located on the A6 PCB. The resulting ALC control voltage output causes the level control circuits, located on the A10 switched filter assembly, to adjust the RF output level. Thus, the feedback signal voltage from the level detector will be set equal to the reference voltage.

Note

The instrument uses two internal level detection circuits. For frequencies < 2 GHz, the level detector is part of the digital down converter. The signal from this detector is routed to the A6 ALC PCB as the Detector 0 input. For frequencies ≥ 2 GHz, the level detector is part of the main directional coupler. The signal from this detector is routed to the A6 ALC PCB as the Detector 1 input.

The level reference DAC, under the control of the CPU, provides the RF level reference voltage. By setting the output of this DAC to the appropriate voltage, the CPU adjusts the RF output power to the level selected by the user.

External Leveling

In the external leveling mode, an external detector or power meter monitors the RF output level of the MG3702xA instead of the internal level detector. The signal from the external detector goes to the A6 ALC PCB assembly from the rear panel input. The ALC controls the RF power output level as previously described.

Power Sweep

In this mode, the CPU has the ALC step the RF output through a range of levels specified by the user. This feature can be used in conjunction with the sweep mode to produce a set of identical frequency sweeps, each with a different RF power output level.

Pulse Modulation Operation

During pulse modulation, the ALC level amplifier (A6 ALC PCB) is operated as a sample/hold amplifier. The level amplifier is synchronized with the modulating pulses from the A8 Function Generator or A13 Pulse Generator PCB so that the ALC loop effectively operates only during the ON portion of the pulsed modulated RF output.

Pulse Generator Operation

The A6 built in Function Generator provides the internal pulse generating function for the MG3702xA. It also interfaces external pulse inputs from the rear panel connector to the pulse modulator driver in the external mode.

The A6 internal pulse generator produces a pulse modulation waveform consisting of single, doublet, triplet, or quadruplet pulse trains at variable pulse rates, widths, and delays. In addition, the A6 internal pulse generator produces a sync pulse and video pulse output that goes to the rear panel. The sync pulse output is for synchronizing auxiliary instruments to the internally generated pulse; the video pulse is a TTL level copy of the RF output pulse; and the sample/hold signal synchronizes the ALC loop to the ON portion of the pulse modulating waveform.

2-5 RF Deck Assemblies

The primary purpose of the RF deck assembly is to generate CW RF signals and route these signals to the front panel RF OUTPUT connector. It is capable of generating RF signals in the frequency range of 10 MHz to 20 GHz.

The series MG3702xA use a VCO and Multiplexer. All other frequencies are derived from the fundamental frequencies generated by this oscillator, as follows:

- RF output frequencies of 0.01GHz to 2 GHz are developed by digital down converting the fundamental frequencies of 2.0 to 4.4 GHz.
- RF output frequencies of 2 to 20 GHz are produced directly from the VCO and Multipliers.

RF Deck Configurations

All MG3702xA RF deck assemblies contain a VCO oscillator and multiplier, a switched filter assembly, and a directional coupler. Beyond that, the configuration of the RF deck assembly varies according to the particular options installed.

Refer to the block diagrams in [Figure 2-4](#), and [Figure 2-5](#) through [Figure 2-7](#), which show the various RF deck configurations and include all of the common RF components found in the series MG3702xA RF deck assemblies. Refer to these block diagrams while reading the following paragraphs.

RF Signal Flow

The RF signal from the VCO oscillator and Multiplier is routed to the level control circuits located on the switched filter assembly and then, via PIN switches, to switched low-pass filters. The PIN switch drive current signals are generated on the A6 ALC PCB and routed to the switch control input on the switched filter assembly.

The switched low-pass filters provide rejection of the harmonics that are generated by the VCO oscillator and multiplier. In MG3702xA, the 2 to 20 GHz RF signal from the level control circuits has four filtering paths and a through path. The four filtering paths are 3.3 GHz, 5.5 GHz, 8.4 GHz, and 13.5 GHz. Signals above 13.5 GHz are routed via the through path.

To generate RF signals from 0.01GHz to 2 GHz, the MG3702xA couples the RF signal to the digital down converter. A coupler in the switched filter path provides this RF signal, which is routed through a 8.5 GHz low-pass filter to connector J3, and then to the digital down converter. The 0.01 to 2 GHz RF signal output from the down converter is routed to a diplexer which is connected to the output of the switched filter.

After going through the appropriate path, the RF signal is multiplexed by the PIN switches and routed through a 20 GHz low-pass filter to the switched filter assembly output connector J2. From J2, the RF signal goes to the input of the directional coupler or to an amplifier if the instrument is fitted with Option 015.

Instruments fitted with option 015 all use a fixed gain amplifier before the directional coupler as shown in [Figure 2-6](#).

0.01 to 2.2 GHz Digital Down Converter (Option 004)

The 0.01GHz to 2.2 GHz digital down converter assembly maintains the same basic functionality and control as the 0.01GHz to 2 GHz down converter. During CW or step frequency operations in the 0.01 to 2.2 GHz frequency range, a 2 to 4.4 GHz RF signal output from J3 of the switched filter assembly goes to the input connector J1 of the down converter. This signal is then down converted through a series of dividers resulting in a 0.01 to 2.2 GHz RF signal output.

The resultant RF signal is fed through a series of band-pass filters, then detected, amplified, and coupled out for use in internal leveling before being routed to the output connector J3. The detected RF sample is routed to the A6 ALC PCB.

Step Attenuator

The optional step attenuator (option 002) used in the MG3702xA is a 110 dB Mechanical Step Attenuator.

It provides attenuation of the RF output in 10 dB steps. Maximum rated RF output power is reduced. The step attenuator drive current for Option 002 is supplied by the A6 PCB.

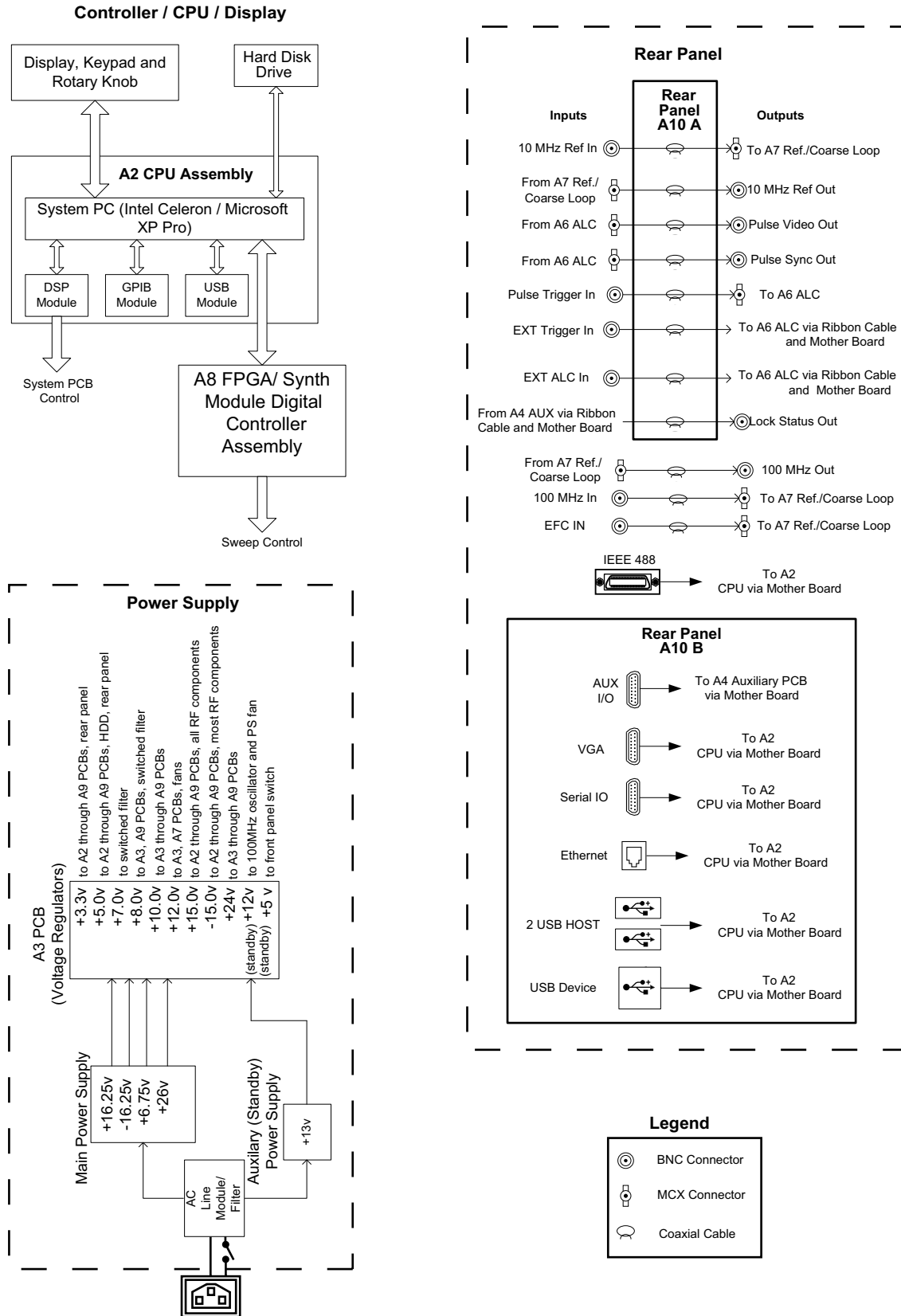

Figure 2-2. Block Diagram of A2 CPU, A8 Controller, Power Supply, A10 Rear Panel for MG3702xA

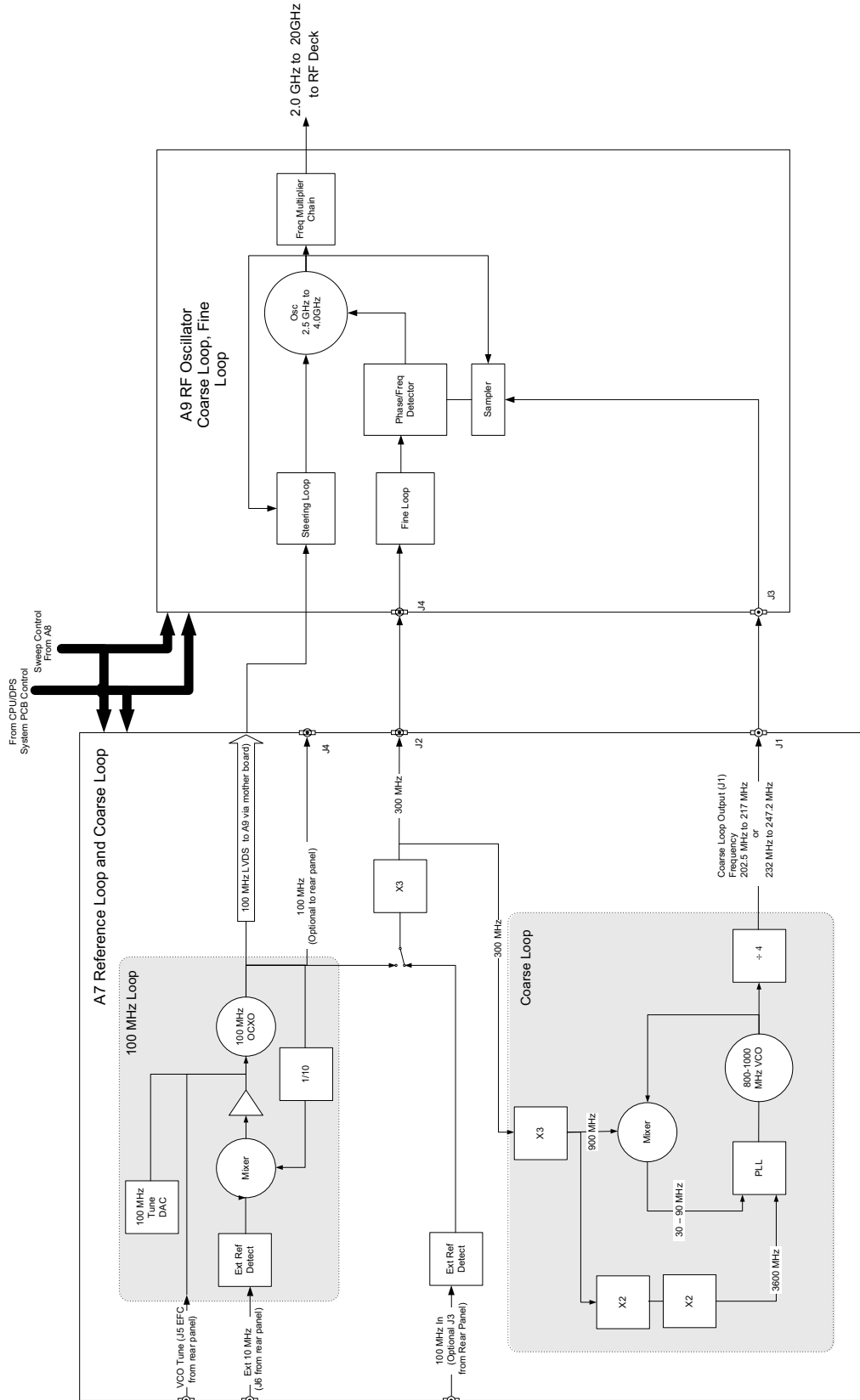

Figure 2-3. Block Diagram of Frequency Synthesis Section for MG3702xA

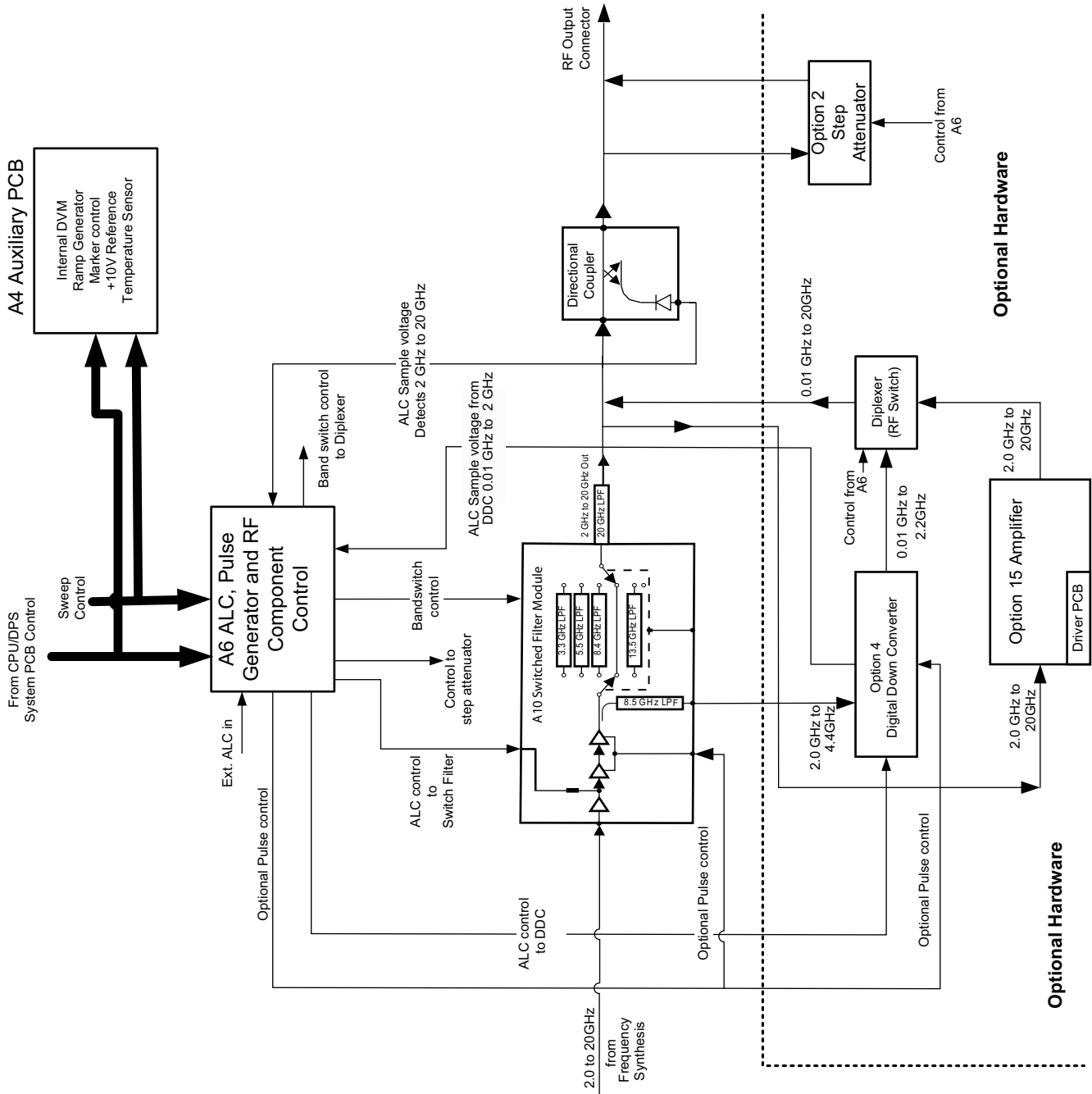

Figure 2-4. Block Diagram of A4, A6, and RF Deck Assembly for MG3702xA

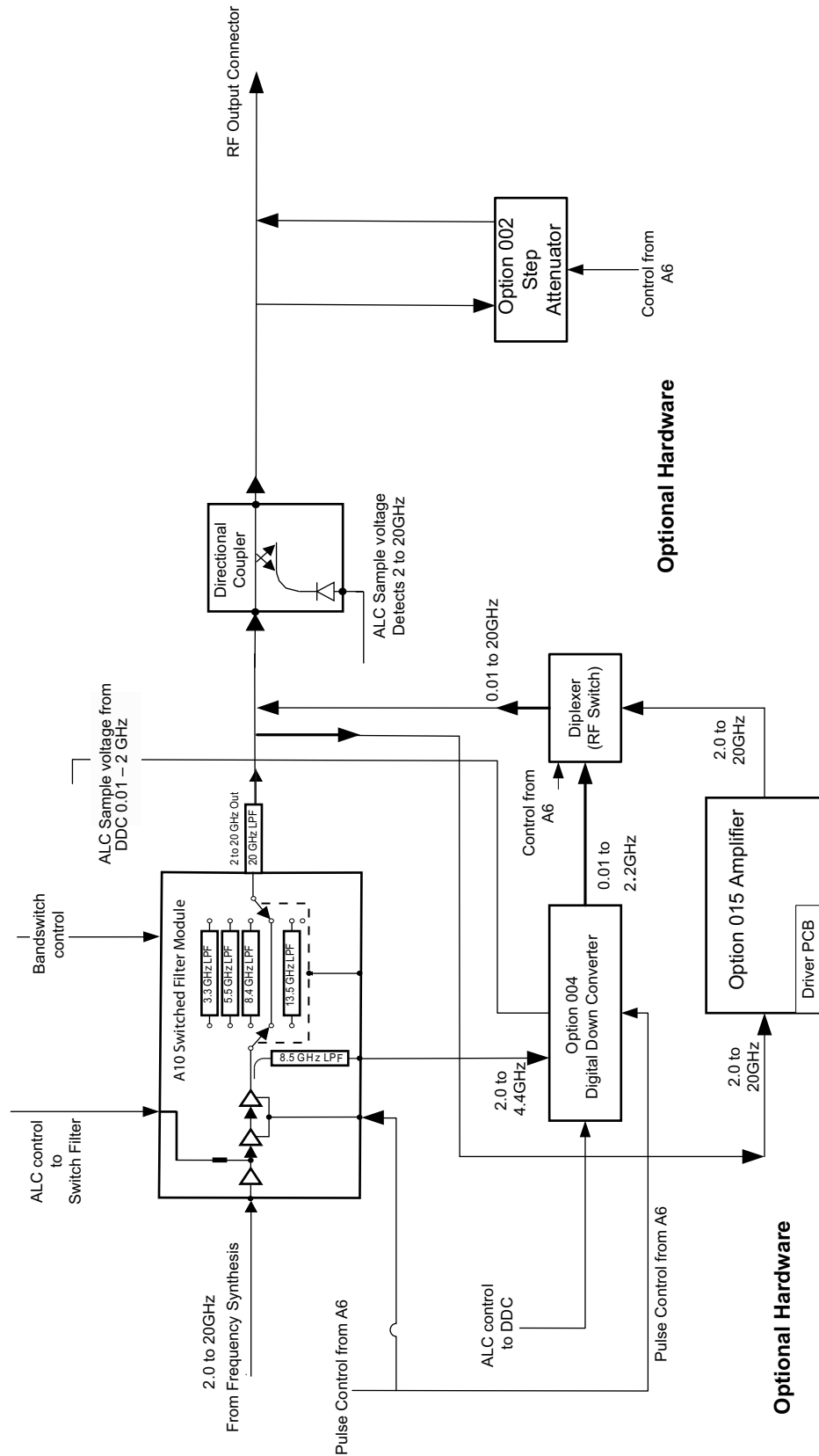

Figure 2-5. Block Diagram of RF deck with Options 002, 004 and 015 for MG3702xA

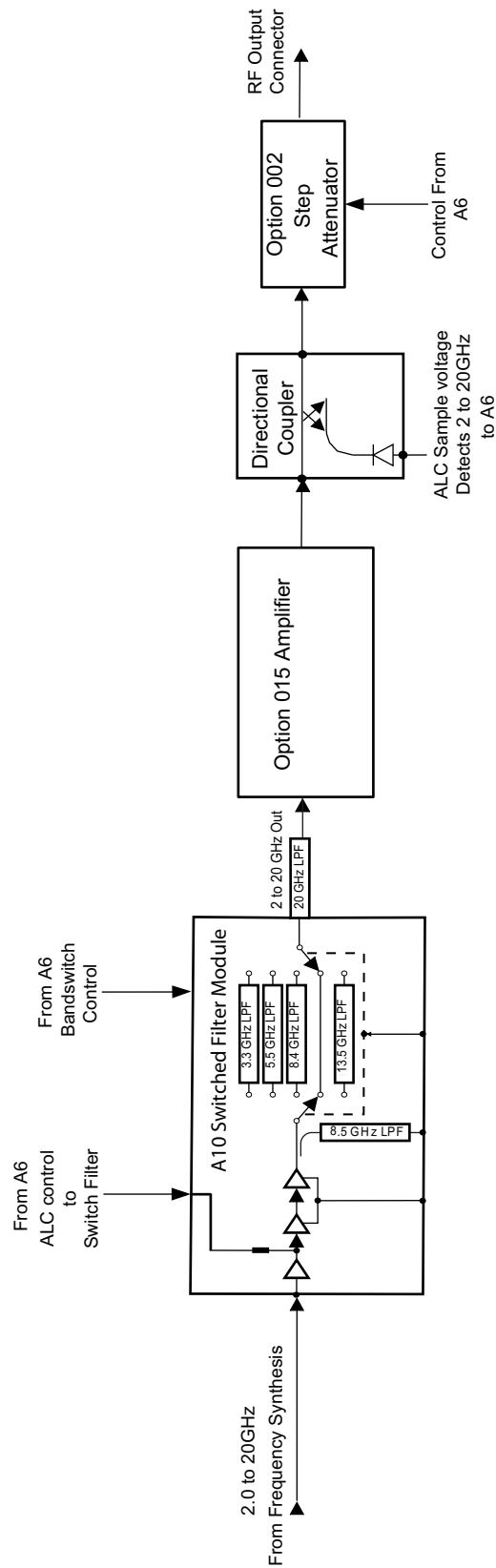

Figure 2-6. Block Diagram of RF deck with Options 002 and 015 for MG3702xA

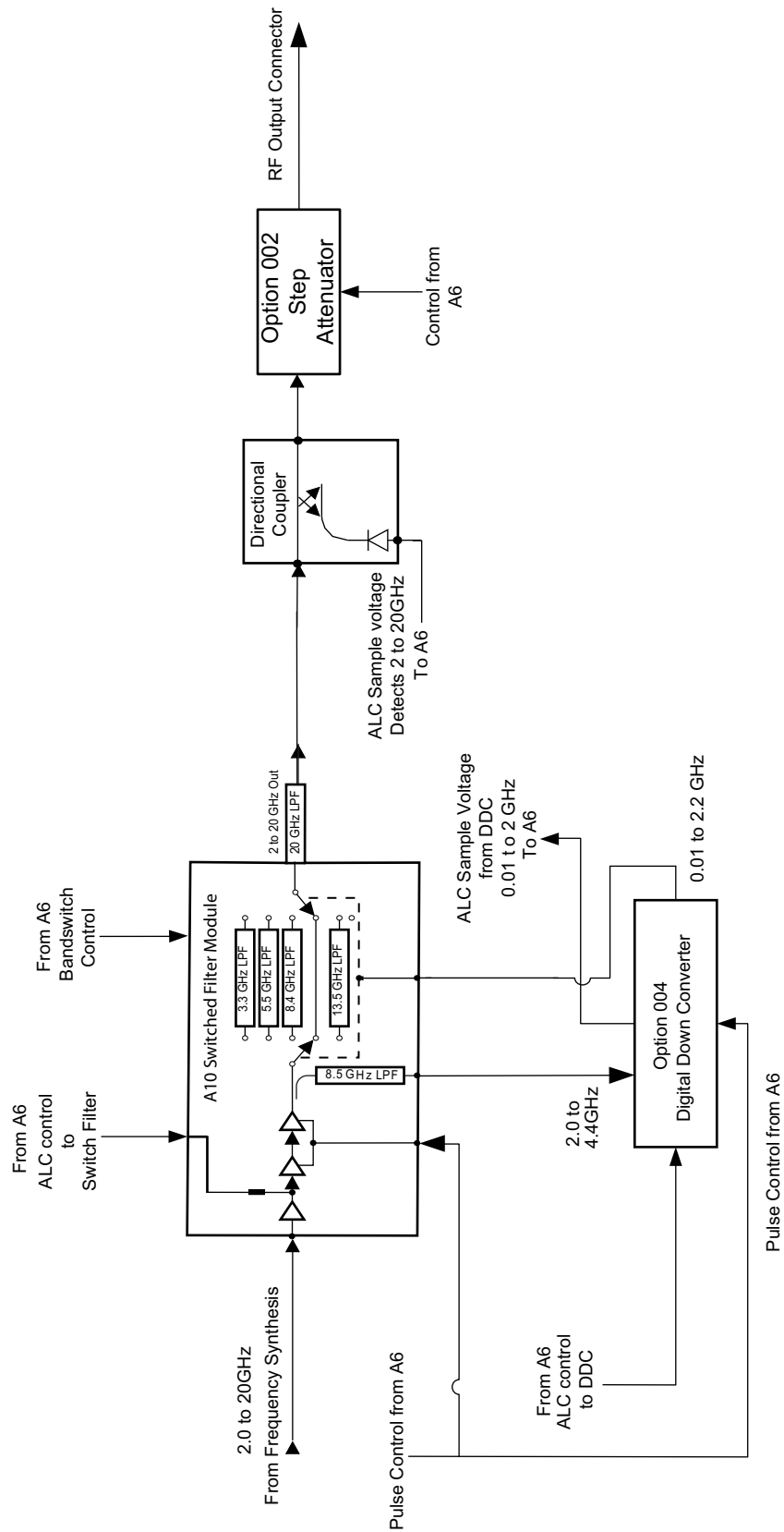

Figure 2-7. Block Diagram of RF deck with Options 002 and 004 for MG3702xA

Chapter 3 — Performance Verification

3-1 Introduction

This chapter contains tests that can be used to verify the performance of the series MG3702xA Synthesized Signal Generators to specifications. These tests support all instrument models having any version of firmware and instrument models with the following options:

- Option 001 (rack mount with slides)
- Option 002 (mechanical step attenuator)
- Option 004 (digital down converter)
- Option 009 (rear panel RF output which moves the RF output to the rear of unit)
- Option 011 (rack Mount without slides)
- Option 015 (high power output)
- Option 017 (deletes the front panel)
- Option 026 (pulse modulation)
- Option 035 (removable hard drive)
- Option 036 (ultra stable phase track)
- Option 037 (performance suite) see options 002, 004, 015 and 026
- Option 088 (250 μ sec Switching speed limit for export control)

3-2 Test Records

A blank copy of a sample performance verification test record for the MG3702xA models is provided in Appendix A. Each test record contains the model-specific variables called for by the test procedures. It also provides a means for maintaining an accurate and complete record of instrument performance. We recommend that you copy these pages and use them to record the results of your initial testing of the instrument. These initial test results can later be used as benchmark values for future tests of the same instrument.

3-3 Connector and Key Notation

The test procedures include many references to equipment interconnections and control settings. For all MG3702xA references, specific labels are used to denote the appropriate menu key, data entry key, data entry control, or connector (such as RF Output). Most references to supporting test equipment use general labels for commonly used controls and connections (such as Span or RF Input). In some cases, a specific label is used that is a particular feature of the test equipment listed in [Table 3-1 on page 3-2](#).

3-4 Test Equipment List

Table 3-1 provides a list of the test equipment for the performance verification tests and adjustments. The test equipment setup is critical to making accurate measurements. In some cases, you may substitute test equipment having the same critical specifications as the test equipment indicated in the test equipment list (refer to “Measurement Uncertainty” on page 3-4).

Table 3-1. Test Equipment List (1 of 3)

Instrument	Critical Specification	Manufacturer/Model	Usage ^(a)
Computer running Windows XP	The following configuration must be dedicated during calibration and verification activities: Pentium 4 2.8 GHz 1 GB RAM 2 Serial ports CDROM Mouse Keyboard Monitor Network	Dell or other common source	C, P
National Instrument PCI GPIB card	PCI GPIB card for computer	National Instrument	C, P
Anritsu RF verification and calibration software	Requires the Mixer box and BNC low pass filters listed below.	Anritsu 2300-497	C, P
Spectrum Analyzer	Frequency: 100 kHz to 50 GHz Resolution bandwidth: 10 Hz	Agilent 8565EC	C, P
Phase noise measurement system	Frequency range: 5 MHz to 26.5 GHz	Aeroflex/Comstron PN9000 with: PN9060-00 Status Module PN9470-00 Noise Output Module PN9450-00 Lock Control Module PN9342-00 Phase Detector Module PN9530-00 Crystal Oscillator Module Agilent Phase Noise Station: Anritsu K222B Insertable F-F Anritsu 34NKF50 N Male to K Female Adapter Anritsu K241C Power Splitter Anritsu SC3855 3670K50-2 KM-KM flex cable Agilent E5052B Signal Source Analyzer Agilent E5053A Down Converter Two Anritsu K120MM-20CM Semi-rigid cables (will need to be bent on site to fit) Optical Mouse, PS2/USB for E5052B USB Keyboard for E5052B	P

Table 3-1. Test Equipment List (2 of 3)

Instrument	Critical Specification	Manufacturer/Model	Usage ^(a)
Power meter	Frequency: 100 kHz to 20 GHz Power range: -70 to +20 dBm	Anritsu model ML2437A/38A	C, P
Power sensor for power meter	Frequency: 0.01 to 40 GHz (K) Power range: -70 to +20 dBm	Anritsu model MA2474D	C, P
Power sensor for power meter	Frequency: 100 kHz to 18 GHz (N) Power range: -70 to +20 dBm	Anritsu model SC7400	C, P
Adapter for power sensor SC7400	N female to K adapter	Anritsu model 34NFK50	C, P
Adapter for power sensor calibration	N(m) to K(f)	Anritsu 34NKF50	C, P
Special AUX I/O cable assembly	Provides interface between the MG3702xA and the power meter	Anritsu PN: 806-97	P
Digital multimeter	Minimum 1% RMS ACV accuracy at 100 kHz	Agilent 34401A	P
Function generator	Frequency: 0.1 Hz to 15 MHz	Agilent 33120A	C, P
Digital sampling oscilloscope	Frequency: 50 GHz	Agilent 86100A with 83484A 50 GHz module	P
Frequency reference	Frequency: 10 MHz Accuracy: 5×10^{-12} parts/day	Symmetricom (Datum) Model 9390-6000	P
Measuring receiver ^(b)	Noise floor: < -140 dBm @ 500 MHz	Anritsu model ML2530A	C, P
Local oscillator ^(b)	Frequency: 0.01 to 20 GHz Power: >+13 dBm 10 MHz to 20 GHz	Anritsu Model MG3692C with: Options 3, 4, 16, and SM6191 (unit must not have options 15x, 22 or 2B)	C, P
One of the following ^(b) : Mixer Box (for low level calibration) ^(b) and Low Pass Filter (2 each) ^(b) or Mixer ^(b) and M to M Adapter ^(b)	Frequency Range: 0.01 to 40 GHz 1.9 GHz LPF or Frequency Range: 500MHz to 40 GHz Conversion loss: 10dBm (typical) K(m) to K(m)	Anritsu PN: T2579 and Anritsu PN: 1030-104 or Anritsu PN: 60-114 and Anritsu PN: K220B	C, P
Attenuator	Frequency range: DC to 40 GHz Attenuation: 3, 6, 10, and 20 dB (sizes and counts are determined depending on options and maximum output power of instrument)	Anritsu part number SC7879 K set of attenuators (41KC-3, 41KC-6, 41KC-10, 41KC-20) calibrated from 100 K to 40 GHz	C, P
BNC 50 Ω terminator		Any common source	C, P
BNC Tee connectors		Any common source	C, P
Generic 50 Ω BNC RF cables and connectors		Any common source	C, P
Generic GPIB cables		Any common source	C, P

Table 3-1. Test Equipment List (3 of 3)

Instrument	Critical Specification	Manufacturer/Model	Usage ^(a)
BNC to SMA adapter		Any common source	P
K(m) to K(m) flex cables or semi-rigid cables	K(m) to K(m) flex cables or Semi-rigid cables	Anritsu SC3855 3670K50-2 K(m) to K(m) flex cable or Anritsu K120mm-60CM custom semi-rigid cable	C, P
If the unit does not have a front panel, the following items are required: Monitor USB Keyboard USB Mouse	PC compatible	Any common source	C, P
BNC to Banana Adapter for DMM		Any common source	P
Inline BNC 6 dB attenuator		Any common source	P

a. P = Performance Verification Tests, C = Calibration, T = Troubleshooting

b. Only needed if option 2X is installed.

3-5 Measurement Uncertainty

In [Appendix A](#), all records are provided with a measurement uncertainty, which consists of the type-B¹ components. The error contributions are measurement method, test equipment, standards, and other correction factors (for example, calibration factors and mismatch error) per the prescribed test procedure. The statement(s) of compliance with specification² is based on a 95% coverage probability for the expanded uncertainty of the measurement results on which the decision of compliance is based. Other values of coverage probability for the expanded uncertainty may be reported, where practicable, for some of the measured values it is not possible to make a statement of compliance with specification²

1. BIPM JCGM 100:2008 Evaluation of measurement data- Guide to the expression of uncertainty in measurement.
2. LAC-G8:03/2009: Guidelines on the Reporting of Compliance with Specification.

3-6 Internal Time Base Aging Rate Test (Optional)

For the following test, refer to the test record table in [Appendix A, “Section 3-6 Internal Time Base Aging Rate Test \(Optional\)”](#).

The following test can be used to verify that the MG3702xA 100 MHz time base is within its aging specification. The instrument derives its frequency accuracy from an internal oven controlled 100 MHz crystal oscillator standard. An inherent characteristic of crystal oscillators is the effect of crystal aging within the first few days to weeks of operation. Typically, the frequency of the crystal oscillator increases slightly at first, then settles to a relatively constant value for the rest of its life.

Note Do not confuse crystal aging with other short term frequency instabilities, for example, noise and temperature. The internal time base of the instrument may not achieve its specified aging rate before the specified warm-up time of 7 to 30 days has elapsed; therefore, this performance test is optional.

For the greatest absolute frequency accuracy, allow the MG3702xA to warm up until its RF output frequency has stabilized (usually 7 to 30 days). Once stabilized, the change in reference oscillator frequency should remain within the aging rate if (1) the time base oven is not allowed to cool, (2) the instrument orientation with respect to the earth’s magnetic field is maintained, (3) the instrument does not sustain any mechanical shock, and (4) ambient temperature is held constant. This test should be performed upon receipt of the instrument and again after several days or weeks to fully qualify the aging rate.

Note Before performing this procedure ensure that all test equipment is calibrated. Refer to the manufacturer’s test equipment manual.

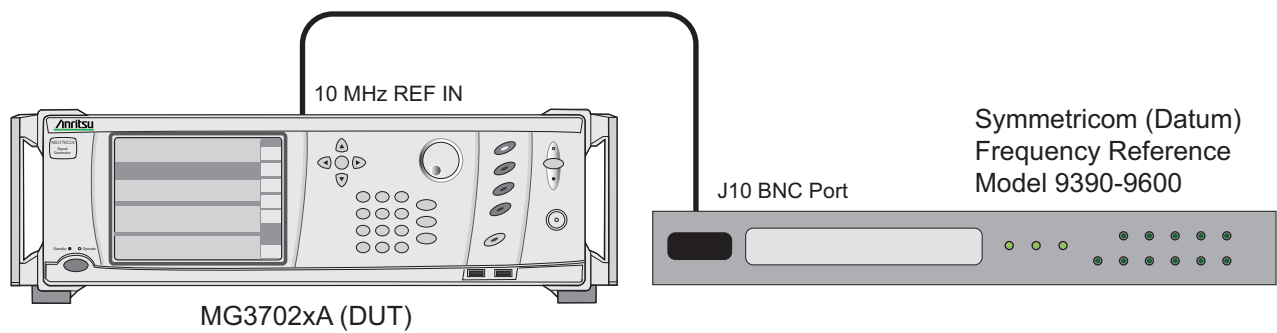

Figure 3-1. Equipment Setup for Internal Time Base Aging Rate Tests

Test Setup

Connect the MG3702xA rear panel 10 MHz REF OUT to the Symmetricom (Datum) model 9390-9600 frequency standard rear panel BNC connector labeled J10 using a BNC cable with 50 ohm termination and BNC tee. The frequency standard must be actively tracking at least three satellites, and the oscillator should be stabilized/locked. To confirm, the front panel TRACKING and LOCKED LEDs should be illuminated.

Procedure

1. Cycle the menu screen to the sixth screen (External Frequency Measurement) as shown below.

Row 1	EXT Freq: +0000E-14 / +0000E+00 SEC *
Row 2	<1>Enter Freq <2>ENABLE <3>DISABLE

2. On the keypad, press **1** followed by the number 10000000. This will input the test frequency of 10 MHz.

3. On the keypad, press **2** to ENABLE the external frequency measurement option. (Pressing **3** will DISABLE the option.)
4. Confirm that the external frequency measurement option is enabled and the unit is locked by observing an asterisk (*) in row 1, column 35 of the display. If “NOTLK” appears, the frequency standard is not locked and testing must be halted. If no asterisk (*) appears, the unit is not properly connected.
5. Confirm that the measurement count has started to change incrementally. This will be displayed in row 1, columns 20 through 29 of the display. Allow approximately 5 minutes for everything to stabilize.
6. On the test record, record the date and time of the test start and the frequency offset displayed in row 1, column 9 through 17 as the frequency error value.
7. After 24 hours, on the keypad, press **3** to disable the measurement. Note that the asterisk (*) will disappear.
8. On the test record, record the date and time of test completion, and the frequency offset displayed in row 1, column 9 through 17 as the frequency error value (after 24 hours).
9. The aging rate is the difference between frequency error value and frequency value (after 24 hours). Compare it to the upper limit and record the computed result in [Appendix A, “Section 3-6 Internal Time Base Aging Rate Test \(Optional\)”](#).

3-7 Spurious Signals Tests

For the following tests, refer to the test record table in [Appendix A, “Section 3-7 Harmonics and Harmonically Related Signals Test \(without Option 15\)”](#).

The following tests can be used to verify that the signal generator meets its spurious emissions specifications for RF output signals from 0.01 to 20 GHz.

The MG3702xA's CW RF output signal is fed directly into a spectrum analyzer. The CW frequency and power level is referenced and a peak search function on the spectrum analyzer is utilized to find any spurious signals above the specified limit.

Note Before performing this procedure ensure that all test equipment is calibrated. Refer to the manufacturer's test equipment manual.

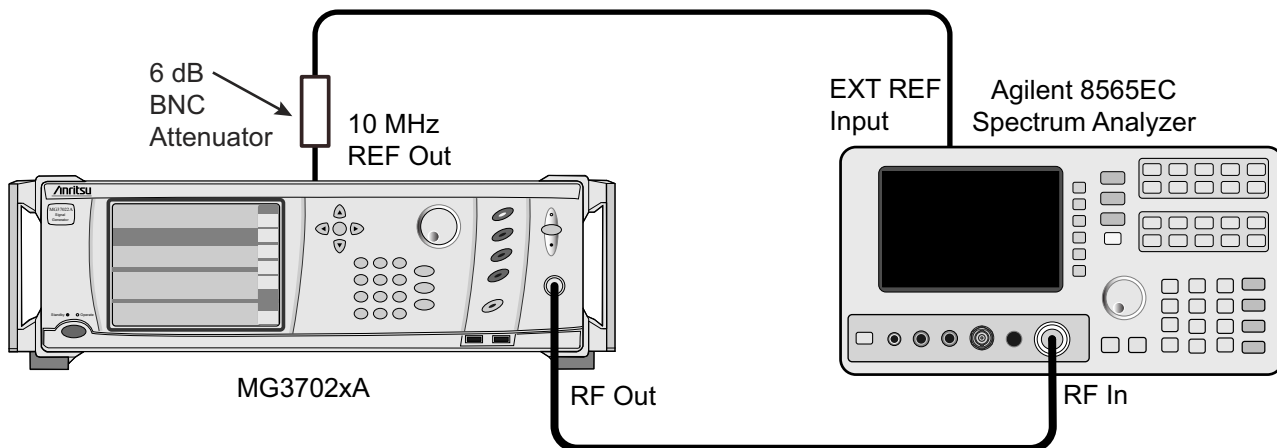

Figure 3-2. Equipment Setup for Spurious Signals Test

Harmonics and Harmonically Related Signals Test

Harmonic Test Setup

Connect the equipment shown in [Figure 3-2 on page 3-6](#), as follows:

1. Connect a BNC 6 dB pad to the MG3702xA rear panel 10 MHz REF OUT port.
2. Connect a BNC cable to the 6 dB pad on the MG3702xA rear panel 10 MHz REF OUT to the spectrum analyzer's external reference input.
3. Connect the MG3702xA RF Output to the spectrum analyzer RF input.

Note	Power line and fan rotation spurious emissions are tested as part of the single sideband phase noise test in Section 3-8 .
-------------	--

4. Set up the spectrum analyzer as follows:
 - a. Press the **PRESET** key.
 - b. Press **AUX CTRL**.
 - c. Press Rear Panel.
 - d. Press 10MHz and set to “EXT”.

Harmonic Test Procedure

1. Determine the first test frequency to test based on the test record, options and model number.
2. Set up the MG3702xA as follows:
 - a. Preset the instrument by pressing the **Preset** button. The CW menu is displayed.
 - b. Press **Edit Frequency** to open the current frequency parameter for editing and set F0 to the first appropriate test frequency (based on model and options) in the test record.
 - c. Press **Edit Level** to open the current power level parameter for editing.
 - d. Set L0 to +10 dBm or to the maximum specified power level, whichever is less. Refer to [Appendix B, “MG3702xA Technical Data Sheet”](#) for the maximum specified power levels. For the electronic version, refer to the MG3702xA Technical Data Sheet, PN: 11410-00429 on the Anritsu Internet site, <http://www.anritsu.com>.
3. Set up the spectrum analyzer as follows:
 - a. Press the **AMPLITUDE** key. Press **REF LVL** and enter the current power level setting (L0) of the MG3702xA.
 - b. Press the **FREQUENCY** key and enter the current frequency setting (F0) of the MG3702xA.
 - c. Press the **BW** key and press **MAN**. Set to the first appropriate test frequency RBW/VBW value (based on model and options) shown in the test record.
 - d. Press the **SPAN** key and set to the first appropriate test frequency SPAN value (based on model and options) shown in the test record.
4. Press the **PEAK SEARCH** key, then select **MARKER DELTA**.
5. Press the **FREQUENCY** key on the spectrum analyzer and enter next harmonic frequency listed in the test record.
6. Enter the reading from the spectrum analyzer in [Appendix A, “Section 3-7 Harmonics and Harmonically Related Signals Test \(without Option 15\)”](#).
7. Repeat [Step 5](#) through [Step 6](#) for each of the harmonic frequency listed in the test record.

8. On the MG3702xA, press **Edit Frequency** to open the current frequency parameter for editing and set F0 to the next appropriate test frequency (based on model and options) shown in the test record.
9. Determine if the power level for the MG3702xA and spectrum analyzer changes based on the new frequency or options and if so, adjust the MG3702xA LO and spectrum analyzer amplitude as needed.
10. Press the **SPAN** key and enter the value listed in the test record for the appropriate test frequency.
11. Press the **BW** key and enter the value listed in the test record for the appropriate test frequency.
12. On the MG3702xA, press **Edit Frequency** to open the current frequency parameter for editing and set F0 to the next appropriate test frequency (based on model and options) shown in the test record.
13. Repeat [Step 4](#) through [Step 12](#) for each of the test frequencies listed in the test record.

Non-Harmonic Signals Test

For the following test, refer to the test record tables in [Appendix A](#), “[Section 3-7 Non-Harmonic Signals Test \(Part 1\)](#)”.

Non-Harmonic Test Setup

Connect the equipment, shown in [Figure 3-2 on page 3-6](#).

1. Connect a BNC 6 dB pad to the MG3702xA rear panel 10 MHz REF OUT port.
2. Connect a BNC cable to the 6 dB pad on the MG3702xA rear panel 10 MHz REF OUT to the spectrum analyzer's EXT REF IN port.
3. Connect the MG3702xA RF Output to the spectrum analyzer's RF Input.

Note

Power line and fan rotation spurious emissions are tested as part of the single sideband phase noise test in [Section 3-8](#).

4. Set up the spectrum analyzer as follows:
 - a. Press the **PRESET** key.
 - b. Press **AUX CTRL**.
 - c. Press Rear Panel.
 - d. Press 10MHZ and set to “EXT”.

Non-Harmonic Test Procedure: Part 1

For the following test, refer to the test record table in [Appendix A](#), “[Section 3-7 Non-Harmonic Signals Test \(Part 1\)](#)”, “[Section 3-7 Non-Harmonic Signals Test \(Part 1\)](#)”.

1. Set up the MG3702xA as follows:
 - a. Preset the instrument by pressing the **Preset** button. The CW menu is displayed.
 - b. Press **Edit Frequency** to open the current frequency parameter for editing and set F0 to the first appropriate test frequency (based on model and options) in the test record.
 - c. Press **Edit Level** to open the current power level parameter for editing.
 - d. Set LO to +10 dBm or to the maximum specified power level, whichever is less. Refer to [Appendix B](#), “[MG3702xA Technical Data Sheet](#)” for the maximum specified power levels. For the electronic version, refer to the MG3702xA Technical Data Sheet, PN: 11410-00429 on the Anritsu Internet site, <http://www.anritsu.com>.

2. Set up the Spectrum Analyzer as follows:
 - a. Press the **AMPLITUDE** key.
 - b. Press REF LVL and enter the current power level setting (L0) of the MG3702xA.
 - c. Press the **FREQUENCY** key.
 - d. Press Start Freq.
 - e. Enter the current spectrum analyzer start frequency from the test record.
 - f. Press Stop Freq.
 - g. Enter the current spectrum analyzer stop frequency from the test record.
 - h. Press the **BW** key.
 - i. Press Res BW to MAN.
 - j. Enter the current spectrum analyzer RBW value from the test record.
3. Press the **PEAK SEARCH** key, and then select MARKER DELTA.
4. Set up the Spectrum Analyzer as follows:
 - a. Press the **FREQUENCY** key.
 - b. Press Start Freq.
 - c. Enter the next spectrum analyzer start frequency from the test record.
 - d. Press Stop Freq.
 - e. Enter the next spectrum analyzer stop frequency from the test record.
 - f. Press the **BW** key.
 - g. Press Res BW to MAN.
 - h. Enter the next Spectrum Analyzer RBW value from the test record.
5. Press **PEAK SEARCH**.
6. Record the reading from the Spectrum Analyzer Delta MKR reading in [Appendix A, “Section 3-7 Non-Harmonic Signals Test \(Part 1\)”](#), Part 1.
7. Repeat [Step 4](#) through [Step 6](#) for same specified MG3702xA frequency listed in the test record, part 1.
8. Repeat [Step 1](#) through [Step 7](#) for same each MG3702xA frequency groups listed in the test record, part 1.

Non-Harmonic Test Procedure: Part 2 (with option 004 installed)

For the following test, refer to the test record table in [Appendix A, “Section 3-7 Non-Harmonic Signals Test \(Part 1\)”](#), “Non-Harmonic Test Procedure: Part 2 (with option 004 installed)”.

1. Set up the MG3702xA as follows:
 - a. Press Edit Frequency to open the current frequency parameter for editing.
 - b. Set F0 to the appropriate test frequency (based on model and options) in the test record, part 2.
 - c. Press Edit Level to open the current power level parameter for editing.
 - d. Set L0 to +10 dBm or to the maximum specified power level, whichever is less. Refer to [Appendix B, “MG3702xA Technical Data Sheet”](#) for the maximum specified power levels. For the electronic version, refer to the MG3702xA Technical Data Sheet, PN: 11410-00429 on the Anritsu Internet site, <http://www.anritsu.com>.
2. Set up the spectrum analyzer as follows:
 - a. Press the **AMPLITUDE** key.

- b. Press REF LVL and enter the current power level setting (L1) of the MG3702xA.
 - c. Press the **FREQUENCY** key.
 - d. Press Center Freq.
 - e. Enter the current spectrum analyzer center frequency from the test record.
 - f. Press **SPAN**.
 - g. Enter the current spectrum analyzer span frequency from the test record.
 - h. Press the **BW** key.
 - i. Press Res BW to MAN.
 - j. Enter the current spectrum analyzer RBW value from the test record.
3. Press the **PEAK SEARCH** key, and then select MARKER DELTA, which sets the reference for the following measurements.
4. Set up the spectrum analyzer as follows:
 - a. Press the **FREQUENCY** key.
 - b. Press Center Freq.
 - c. Enter the next spectrum analyzer center frequency from the test record.
 - d. Press the **BW** key.
 - e. Press Res BW to MAN.
 - f. Enter the next spectrum analyzer RBW value from the test record.
5. Press **PEAK SEARCH**.
6. Record the reading from the spectrum analyzer Delta MKR reading in [Appendix A, “Section 3-7 Non-Harmonic Signals Test \(Part 1\)”](#), [“Section 3-7 Non-Harmonic Signals Test \(Part 2\)”](#) Part 2.
7. Repeat [Step 4](#) through [Step 6](#) for same specified MG3702xA frequency listed in the test record, part 2.

3-8 SSB Phase Noise Test

This section contains two different procedures depending on what test equipment is available:

- “[Procedure Using Agilent Equipment](#)”
- “[Procedure Using AeroFlex Equipment](#)”

Procedure Using Agilent Equipment

This section contains instructions to perform a SSB phase noise test using the Agilent E5052B Signal Source Analyzer and E5053A Down Converter. For the following test, refer to the test record table in [Appendix A](#), “[Section 3-8 SSB Phase Noise Test: Agilent Test Equipment](#)”.

Required Equipment

Table 3-2. Recommended Equipment List

Part Number	Quantity	Description	Vendor
K222B	1	Insertable F-F	Anritsu
34NKF50	1	N Male to K Female Adapter	Anritsu
K241C	1	Power Splitter	Anritsu
SC3855	1	3670K50-2 KM-KM flex cable	Anritsu
E5052B	1	Signal Source Analyzer	Agilent
E5053A	1	Down Converter	Agilent
K120MM-20CM	2	Semi-rigid cables K120MM-20CM (this will need to be bent on site to fit)	Anritsu
	1	Mouse, Optical, PS2/USB for E5052B	
	1	Keyboard, USB for E5052B	

MG3702xA Test Setup

Note

The MG3702xA, E5052B and the E5053A Down converter must be powered on for a minimum of 30 minutes before performing these measurements. The E5052B and E5053A must be installed and set up according to the instructions supplied with the instruments before continuing with this procedure.

The MG3702xA is setup as follows:

1. Preset the instrument by pressing **Preset**. The CW menu is displayed.
2. Press Edit Frequency to open the current frequency parameter for editing.
3. Set F0 to the CW frequency indicated in [Appendix A](#), “[Section 3-8 SSB Phase Noise Test: Agilent Test Equipment](#)”.
4. Press Edit Level to open the current power level parameter for editing. Set L0 to +10 dBm or the maximum leveled power of the instrument, whichever is lower.

Note

If you are not using the splitter, reduce L0 power level to +8 dBm.

5. Connect the MG3702xA as shown in [Figure 3-3 on page 3-12](#).
 - a. Connect the output of the MG3702xA to the input of the splitter.
 - b. Connect one of the outputs of the splitter to the RF input of the E5052B
 - c. Connect one of the outputs of the splitter to the RF input of the down converter.

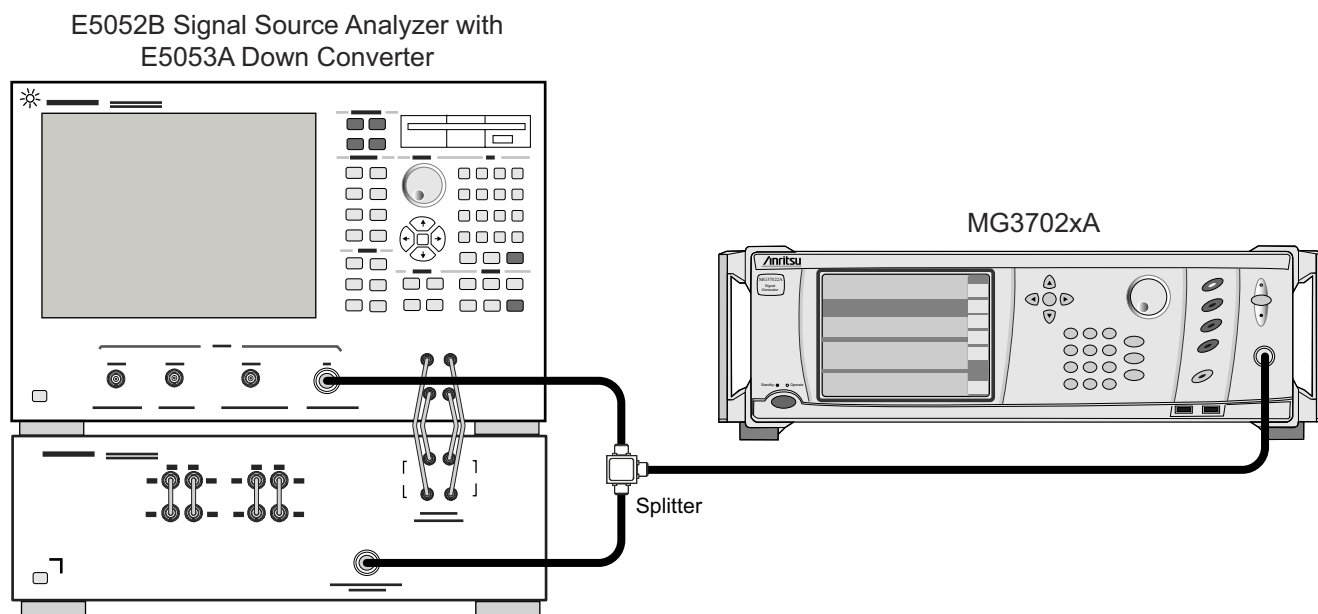

Figure 3-3. Equipment Setup for Single Sideband Phase Noise Test with E5052B and E5053A

Agilent E5052B and E5053A Setup

1. Press the green **Preset** button, then on the touchscreen press **Factory**.
2. Press **Measure/View**, then press **Phase Noise**.
3. Press **Window Max**.
4. Press **Start/Center**, then press 10 Hz.
5. Press **Stop/Span**, then press 1 MHz.
6. Press **Marker**, then:
 - a. Press **Marker 1**, enter 1, then press **X1** to obtain 10 Hz.
 - b. Press **Marker 2**, enter 100, then press **X1** to obtain 100 Hz.
 - c. Press **Marker 3**, enter 1, then press **k/M** to obtain 1 kHz.
 - d. Press **Marker 4**, enter 10, then press **k/M** to obtain 10 kHz.
 - e. Press **Marker 5**, enter 100, then press **k/m** to obtain 100 kHz.
 - f. Press **Marker 6**, enter 1, then press **M/u** to obtain 1 MHz.
7. Press **Avg/BW**, then press **Correlation** and set to 10.

Phase Noise Measurement

1. Refer to the section in [Appendix A](#), “[Section 3-8 SSB Phase Noise Test: Agilent Test Equipment](#)”.
2. Determine the test frequency.
3. Set the MG3702xA **F0** to the frequency called out in the test record.

Note

Frequencies from 10 MHz to 5 GHz are measured using the E5052B. Frequencies from 5 to 25 GHz are measured using the 5053A down converter and E5052B.

4. Press **Input** on the E5052B.

If the test frequencies are from 10 MHz to 5 GHz:

- a. Press **Downconverter**. This will present a choice between **RF Input** and **Downconverter**.
- b. Select **RF input**.
- c. Press **E5052B**. This selects the direct measurement into the E5052B.
- d. Press **Downconverter** and confirm it is **OFF**.

If the test frequencies are from > 5 GHz to 25 GHz:

- a. Press **Downconverter**. This will present a choice between **RF Input** and **Downconverter**.
- b. Select **Downconverter** and confirm it is **ON**.
- c. Press **RF input**.
- d. Press **Downconverter**. This selects the direct measurement into the downconverter.

Note There are different bands in the E5052B that need to be manually set as described in the next steps.
--

5. Press **Setup**.

6. Press **Frequency Band**.

- a. If the test frequencies are from 10 MHz to 40 MHz, press **10M - 41MHz**.
- b. If the test frequencies are from 39 MHz to 101 MHz, press **39M - 101MHz**.
- c. If the test frequencies are from 99 MHz to 1.5 GHz, press **99M - 1.5GHz**.
- d. If the test frequencies are from 250 MHz to 5 GHz, press **250M - 7GHz**.
- e. If the test frequencies are from > 5 GHz to 10 GHz (requires that downconverter is on and is the selected input), press **3G - 10GHz**.
- f. If the test frequencies are from 9 GHz to 26.5 GHz (requires that downconverter is on and is the selected input), press **9G - 26.5GHz**.

7. Set **IF Gain** to:

- a. 50 dB if the MG3702xA CW frequency < 5 GHz.
- b. 20 dB if the MG3702xA CW frequency ≥ 5GHz.

8. Press **Nominal Frequency** and enter the test frequency from the test record.

This is not performed in some cases.

9. Press **ATTN**.

- a. Set to 0 dB if DUT CW frequency is less than 5 GHz.
- b. Set to 10 dB if DUT CW frequency is greater than or equal to 5 GHz.

10. Press **Trigger**

- a. Press **Continuous**.
- b. Press **Single**.

At the upper right of the screen the E5052B should have the approximate test frequency displayed as shown in [Figure 3-4 on page 3-14](#).

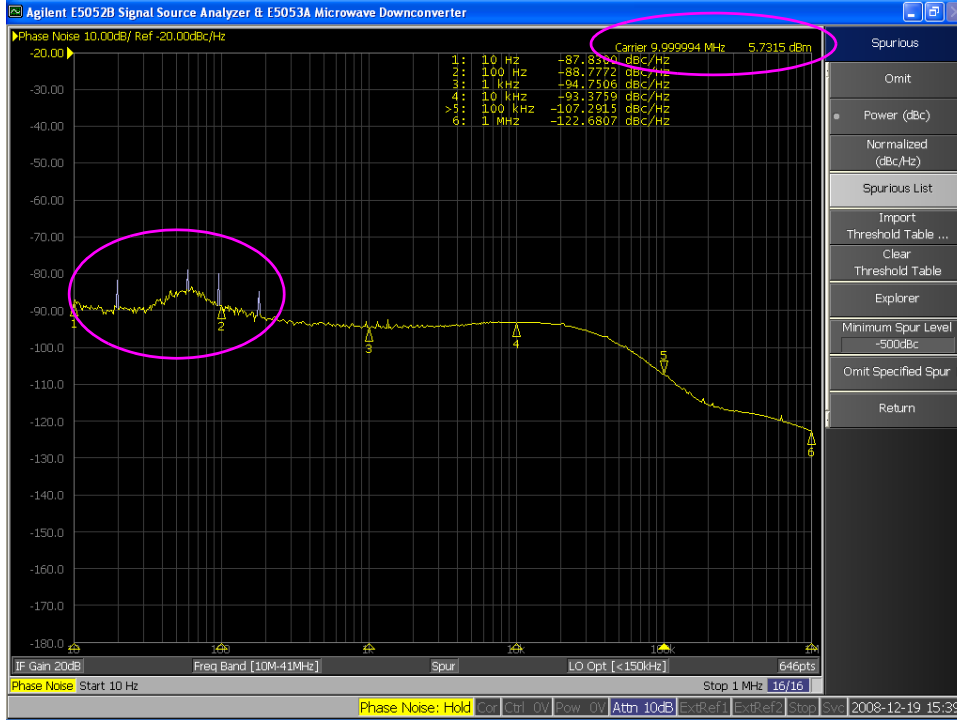

Figure 3-4. E5052B Display

11. Press **Trace/View**.

- a. Press **Spurious**.
- b. Press **Power (dBc)**.

Now white spikes may appear on the screen indicating spurs as shown in Figure 3-4.

- c. Press **Spurious List** and a new screen will appear.
- d. This screen gives the spurious signal’s frequency and power levels. The format is:
Frequency in hertz, Power level in dBc as shown in Figure 3-5.

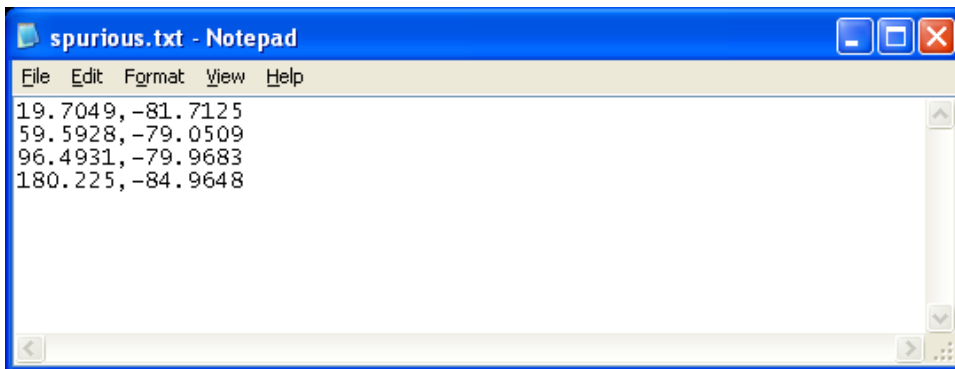

Figure 3-5. Spurious List

- 12. Compare these values to the appropriate frequency in Appendix A, “Section 3-8 SSB Phase Noise Test: Agilent Test Equipment”, “Power Line and Fan Rotation Emissions”. Record any values which are out of specification.

13. Close the Spurious List window.
14. Press **Trace/View** again.
 - a. Press **Spurious**
If this soft key is not visible, touch the down arrow at the bottom right of the screen to locate.
 - b. Press **OMIT**.



Figure 3-6. Phase Noise/Marker Values

15. Record the phase noise/marker values in the test record table in [Appendix A, “Section 3-8 SSB Phase Noise Test: Agilent Test Equipment”](#).
16. Refer to the next frequency in the Single Sideband Phase Noise Test.
17. Press **Trigger**, then press **Continuous**.
18. Go back to [Step 2](#) and repeat this until all test frequencies are verified for the particular model and option configuration under test.

Procedure Using AeroFlex Equipment

This section contains instructions to perform a SSB phase noise test using the AeroFlex PN9000 phase noise system. For the following test, refer to the test record table in [Appendix A, “Section 3-8 SSB Phase Noise Test: AeroFlex Test Equipment”](#).

The following test can be used to verify that the MG3702xA meets its single sideband phase noise specifications. For this test, an Anritsu MG3694A or B (with Options 3 and 4) signal generator is required to act as a local oscillator (LO). [Table 3-3](#) lists the single side band requirements for the local oscillator.

The CW RF output of the MG3702xA is mixed with the CW RF output from the MG3694B LO, which is offset by 100 MHz. Single sideband phase noise is measured at offsets of 10 Hz, 100 Hz, 1 kHz, 10 kHz, 100 kHz, and 1 MHz away from the resultant 100 MHz IF.

Table 3-3. Single Side Band Requirements for Local Oscillator

Frequency Range	Offset from Carrier					
	10 Hz	100 Hz	1 kHz	10 kHz	100 kHz	1 MHz
≥ 10 MHz to ≤ 15.625 MHz	-105	-126	-139	-142	-141	-145
> 15.625 MHz to ≤ 31.25 MHz	-99	-120	-134	-137	-137	-145
> 31.25 MHz to ≤ 62.5 MHz	-90	-114	-129	-136	-136	-144
> 62.5 MHz to ≤ 125 MHz	-88	-108	-127	-135	-133	-144
> 125 MHz to ≤ 250 MHz	-84	-102	-125	-132	-130	-143
> 250 MHz to ≤ 500 MHz	-77	-99	-123	-125	-124	-142
> 500 MHz to ≤ 1050 MHz	-71	-93	-118	-121	-119	-138
> 1050 MHz to ≤ 2200 MHz	-66	-86	-112	-115	-113	-135
> 2.2 GHz to ≤ 6 GHz	-54	-77	-104	-108	-107	-130
> 6 GHz to ≤ 10 GHz	-52	-73	-100	-107	-107	-128
> 10 GHz to ≤ 20 GHz	-45	-68	-94	-102	-102	-125
> 20 GHz to ≤ 40 GHz	-45	-63	-92	-98	-98	-119

Test Setup

The PN9000 software must be installed and set up according to the instructions supplied with the phase noise measurement system before continuing with this procedure.

Note Before performing this procedure ensure that all test equipment is calibrated. Refer to the manufacturer's test equipment manual.

Connect the equipment, shown in [Figure 3-7 on page 3-17](#), as follows:

1. Connect a GPIB interface cable from the PN9000 system to the MG3694B (LO) rear panel IEEE-488 GPIB connector.
2. Connect a GPIB interface cable from the PN9000 system to the MG3702xA (DUT) rear panel IEEE-488 GPIB connector.
3. Connect the MG3694B (LO) RF Output to the LO INPUT of the PN9000 phase detector module.
4. Connect the MG3702xA (DUT) RF Output to the RF INPUT of the PN9000 phase detector module.

5. On the PN9000 system, connect the Fc. 100 MHz OUTPUT of the crystal oscillator module to the 2nd LO INPUT of the phase detector module.
6. On the PN9000 system, connect the TUNE VOLTAGE OUTPUT of the lock control module to the Fc. TUNE INPUT of the crystal oscillator module.

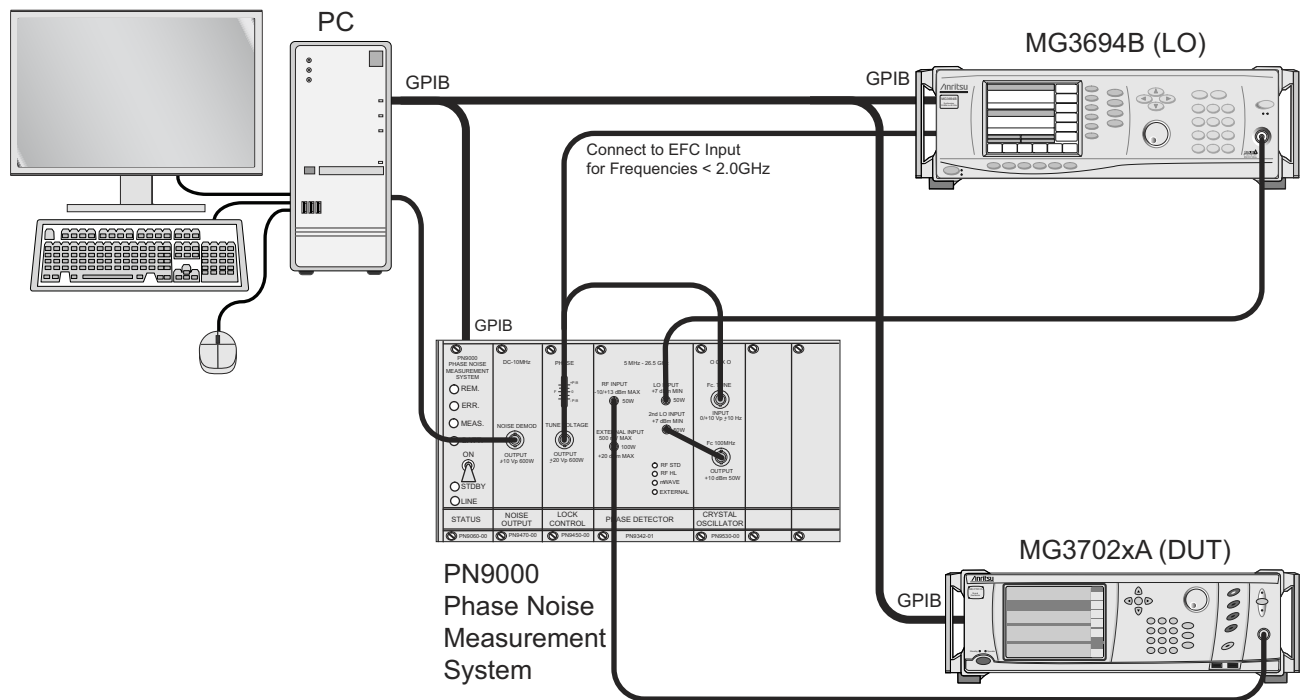

Figure 3-7. Equipment Setup for Single Sideband Phase Noise Test with Aeroflex PN9000 Phase Noise System

GPIB Address Setup

1. Set the MG3702xA GPIB address as follows:
 - a. Press **System**, then Config. The System Configuration menu is displayed.
 - b. Press the Remote tab to display the Configure GPIB menu.
 - c. Press Edit under GPIB Address to change the current address of the MG3702xA.
 - d. Enter a new address using the cursor control key or the data entry keypad and the Enter terminator key.
 - e. The new address will appear on the display. The entry must be between 1 and 30 to be valid.
2. Set the MG3694B (LO) GPIB address as follows. The GPIB address must be different from the one set for the MG3702xA in step 1.
 - a. Press **System**, then Config. The System Configuration menu is displayed.
 - b. Press GPIB to display the Configure GPIB menu.
 - c. Press GPIB Address to change the current address of the MG3702xA (DUT).
 - d. Enter a new address using the cursor control key or the data entry keypad and the Enter terminator key.
 - e. The new address will appear on the display. The entry must be between 1 and 30 to be valid.

PN9000 System Setup

1. Select the Measure/Graph menu on the PN9000:
 - a. Set Log. F_{\min} = 10 Hz
 - b. Set Log. F_{\max} = 1 MHz
 - c. Set Level max = -40 dB
 - d. Set Level min = -150 dB
2. Select the Status/Average menu:
 - a. Set Average = On
 - b. Set 10/100Hz = 10
 - c. Set 100/1kHz = 20
 - d. Set 1k/10kHz = 20
 - e. Set 10k/100kHz = 20
 - f. Set 100k/1MHz = 20
3. Set Vcontrol = 5 Volts (in the bottom status bar) by pressing the following on the keyboard:

Tab | Enter | 5 | Enter

This sets the “VCO-100MHz” frequency tune control to the middle of its range.

4. Select the Calib/Input menu:
 - a. Set Source RF driver to Wiltron 6700.
 - b. Set Source LO driver to Wiltron 6700.
 - c. Set Offset LO to the value stated in [Table 3-4 on page 3-20](#) for the current test frequency.
 - d. Set RF Phase Detection to the mode stated in [Table 3-4](#) for the current test frequency.
 - e. For test frequencies greater than 1.8 GHz, set RF Phase Detection = Transposition.
For test frequencies less than 1.8 GHz, set RF Phase Detection = Standard 5 dBm and connect the LO EFC to the PN9000 Tune Voltage using a BNC tee.

Note

When measuring frequencies less than 1.8 GHz, the Tune Voltage on the PN9000 must also be connected to the LO EFC input.

5. Select the Calib/RF menu:
 - a. Set Freq = to the frequency indicated in the test record.
 - b. Set Level = Value stated in [Table 3-4](#) for the current test frequency.
 - c. Set the GPIB address to the MG3702xA GPIB address.
6. Select the Calib/LO menu:
 - a. Set Freq = Frequency stated in [Table 3-4](#) for the current test frequency.
 - b. Set Level = Value stated in [Table 3-4](#) for the current test frequency.
When you exit the Calib/LO menu, the offset is automatically added to the LO frequency (displayed in the bottom status bar).
 - c. Set the GPIB address to the LO GPIB address.
7. Select the Calib/VCO menu:
 - a. For test frequencies greater than 1.8 GHz, set VCO1 = 100 MHz on.
 - b. For test frequencies less than 1.8 GHz, set VCO1 = Off.

8. Select the Calib/Fcounter menu:
 - a. Select Freq IF and press <Enter>.

A frequency close to the difference of the RF and LO frequencies is displayed in the menu item.
 - b. Press Esc to exit the menu.
9. Press the **CTRL + F** keys to obtain a frequency beat. A very low frequency beat (<10 Hz) should be obtained, indicating that the correct carrier frequency is programmed.

PN9000 Calibration and Lock

1. Select the Lock/Def. Loop menu:
 - a. Set Loop BW = Value stated in [Table 3-4](#) for the current frequency parameter.
 - b. Set Tune Slope = Value stated in [Table 3-4](#) for the current frequency parameter.
 - c. Set Maximum BW = Value stated in [Table 3-4](#) for the current frequency parameter.
2. Offset the frequency of the MG3702xA as follows:
 - a. Press Local to return the instrument to local control.
 - b. Offset the frequency by 1 kHz.
3. On the PN9000 system, select the Calib/Exec Cal menu, then select OK.
4. After calibration, remove the 1 kHz offset on the MG3702xA, then press <Enter> to continue.
5. For test frequencies greater 1.8 GHz, select the Lock/AutoLock menu:
 - a. Set Vmin = 0 V
 - b. Set Vmax = +10 V
 - c. Select OK MWAVE to perform the automatic locking process. The system will check that conditions for locking are met, measure the tune slope of the reference source, and look for the locking voltage.
 - d. When this process completes, press <Enter> to continue.

For test frequencies less than 1.8 GHz, select Lock/ExecLock to lock the PN9000 system.

Phase Noise Measurement

1. On the PN9000 system, select the Measure menu, then select OK to perform the measurement. When prompted for curve name, press N for no.
2. When the measurement completes, select the Process/Marker menu:
 - a. Set Marker = curveM
 - b. Set Type = Vert.line
 - c. Set Color = Green (or color of choice)
 - d. Select OK and press Esc.
3. Use the arrow keys on the keyboard to move the marker to the desired frequency offset (displayed on the lower right of the screen).

Note

For test frequencies less than 1.8 GHz, select Lock/Lock Off to turn off locking prior to testing the next test frequency.

4. Record the displayed phase noise levels at the following offsets from the carrier:
 - 10 Hz
 - 100 Hz

- 1 kHz
 - 10 kHz
 - 100 kHz
 - 1 MHz
5. Record any power line and fan rotation spurious emissions above the specified limits in the test record.
 6. Return to [“PN9000 System Setup” on page 3-18](#) and repeat the phase noise measurement for all frequencies listed in the test record.

Table 3-4. PN9000 Phase Noise Test

Test Freq	15 MHz	30 MHz	60 MHz	120 MHz	250 MHz	499 MHz	600 MHz	1.99 GHz	2.19 GHz	6.0 GHz	10 GHz	19.99 GHz
Notes	Option 004 Only											
CALIB/INPUT MENU												
LO Offset	0 Hz	0 Hz	0 Hz	0 Hz	0 Hz	0 Hz	0 Hz	100 MHz	0 Hz	-100 MHz	-100 MHz	-100 MHz
Phase Detection	Standard							Transposition				
CALIB/RF MENU:												
RF Freq	15 MHz	30 MHz	60 MHz	120 MHz	250 MHz	499 MHz	600 MHz	1.99 GHz	2.19 GHz	6.0 GHz	10 GHz	19.99 GHz
Power Level	10 dBm	10 dBm	10 dBm	10 dBm	10 dBm	10 dBm	10 dBm	10 dBm	The lesser of +10 dBm or maximum specified leveled output power			
CALIB/LO MENU:												
LO Frequency	15.1 MHz	30.1 MHz	60.1 MHz	120.1 MHz	250.1 MHz	499.1 MHz	600.1 MHz	2.09 GHz	2.09 GHz	6.0 GHz	10 GHz	19.99 GHz
Power Level	10 dBm	10 dBm	10 dBm	10 dBm	10 dBm	10 dBm	10 dBm	10 dBm	The lesser of +10 dBm or maximum specified leveled output power			
LOCK/DEFINE LOOP MENU:												
Loop BW	10 Hz	75 Hz	86 Hz	75 Hz	75 Hz	90 Hz	100 Hz	100 Hz	100 Hz	100 Hz	100 Hz	100 Hz
Tune Slope	40 Hz/V	40 Hz/V	86 Hz/V	172 Hz/V	172 Hz/V	333 Hz/V	420 Hz/V	210 Hz/V	210 Hz/V	210 Hz/V	210 Hz/V	210 Hz/V
Max BW	320 Hz	320 Hz	320 Hz	320 Hz	320 Hz	320 Hz	320 Hz	2 KHz	2 KHz	2 KHz	2 KHz	2 KHz

3-9 Power Level Accuracy and Flatness Tests

The following tests can be used to verify that the MG3702xA meets its power level specifications. Power level verifications are divided into four parts:

- Log conformity
- Power level accuracy (to -50 dBm)
- Power level accuracy (-50 dBm to -100 dBm)
- Power level flatness.

Note Accurate power level measurements below -100 dBm are not currently feasible.

Note Before performing this procedure ensure that all test equipment is calibrated. Refer to the manufacturer's test equipment manual.

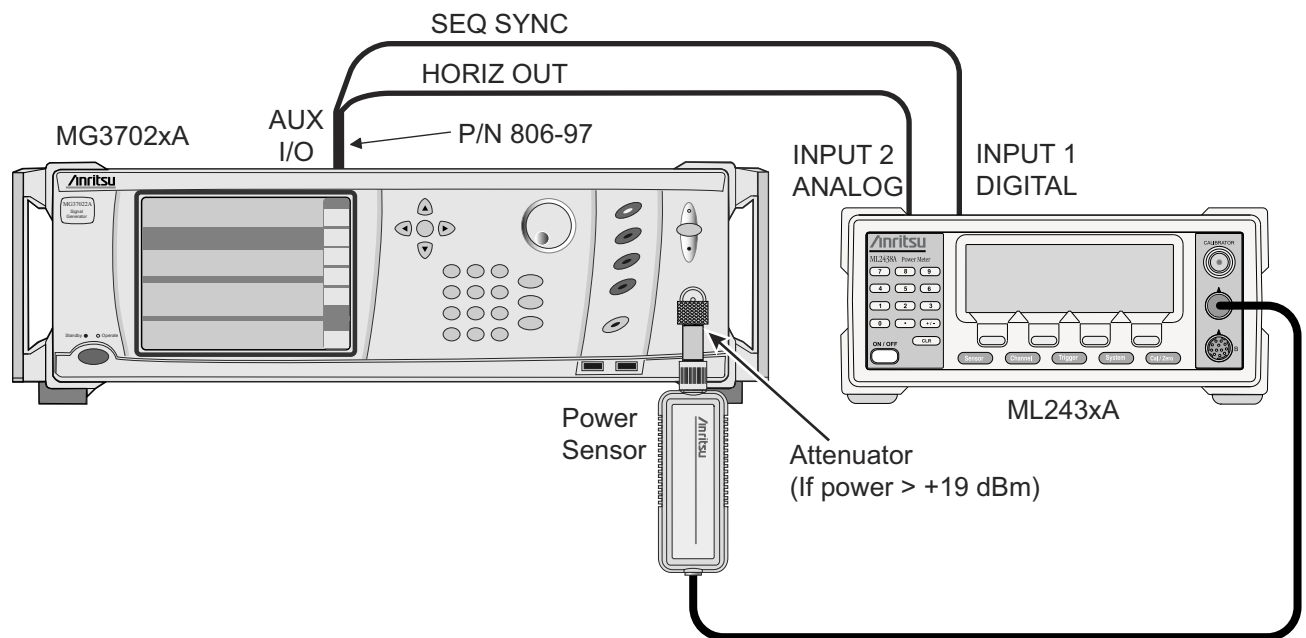

Figure 3-8. Equipment Setup for Power Level Accuracy and Flatness Tests Above -50 dBm

Test Setup

For all power level measurements above -50 dBm, connect the equipment, shown in [Figure 3-8](#), as follows:

Caution To prevent damage to the power sensor, use a fixed attenuator when measuring power levels above $+19$ dBm.

1. Calibrate the power meter with the appropriate power sensor.
2. Connect the power sensor to the RF Output of the MG3702xA (use a fixed attenuator when measuring power levels above $+19$ dBm).
3. Connect the special AUX I/O interface cable (Anritsu PN: 806-97) to the MG3702xA rear panel AUX I/O connector. Connect the cable BNC connectors as follows:
 - a. Connect the cable labeled SEQ SYNC to the power meter rear panel INPUT 1 DIGITAL connector.
 - b. Connect the cable labeled HORIZ OUT to the power meter rear panel INPUT 2 ANALOG connector.

Power Level Log Conformity

For the following test, refer to the test record table in [Appendix A, “Section 3-9 Power Level Accuracy and Flatness Tests”](#), “Power Level Log Conformity”.

The log conformity test verifies the dynamic range and level accuracy of the Automatic Level Control (ALC) loop. Power level log conformity is tested in both pulse (if equipped) and non-pulse modes by stepping the output power level down in 1 dB increments from its maximum rated power level and measuring the output power level at each step.

Power Meter setup

1. Reset the power meter by pressing:
System | Setup | -more- | PRESET | RESET
2. Configure the power meter to perform power measurements by pressing:
Sensor | Setup | MODE
Press MODE until Default is displayed in the Measurement MODE field.
3. Configure the power sensor's calibration factor source by pressing:
Sensor | CalFactor | SOURCE | V/GHz until V/GHz is displayed.
4. Setup the minimum V/GHz range by pressing:
Setup | Start F
5. Enter the minimum frequency of the MG3702xA under test or minimum of the power meter.
6. Setup the maximum V/GHz range by pressing:
Setup | Stop F
7. Enter the maximum frequency of the MG3702xA under test or maximum of the power meter.
8. Press any hard key to begin the measurement.

Caution

To prevent damage to the power sensor, use a fixed attenuator when measuring power levels above +19 dBm.

MG3702xA Setup and Test

1. Preset the instrument by pressing the green **PRESET** button. After preset, the CW menu is displayed.
2. If the MG3702xA has a step attenuator (Option 002):
 - a. Press **Level** to open the Level Control menu.
 - b. Press **Attenuation** to open the Attenuator Control menu.
 - c. Press **On** to decouple the attenuator from the ALC loop.
 - d. Ensure the Attenuation is set to 0 dB, as shown in [Figure 3-9](#). If not, press **Decrease Attenuation** until it reads 0 dB.

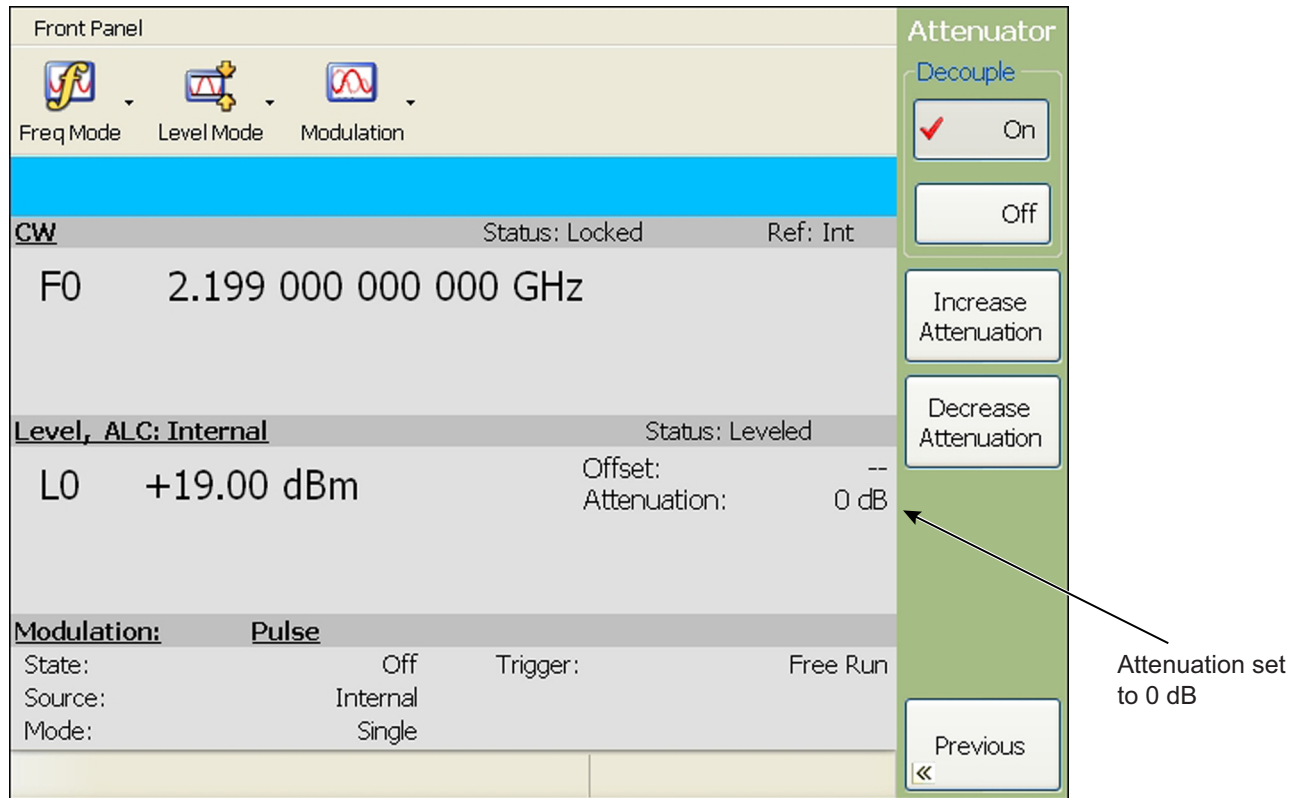

Figure 3-9. Ensuring 0dB attenuation setting

3. Press **Frequency** to open the current frequency parameter for editing.
4. Press Edit Frequency and set F0 to the CW frequency indicated in the test record.
5. Press Edit Level to open the current power level parameter for editing.
6. Set L0 to the first applicable power level indicated in the test record.
7. Measure the output power level with the power meter and record the reading in [Appendix A, "Section 3-9 Power Level Accuracy and Flatness Tests"](#).
8. On the MG3702xA, use the cursor control key (Arrow keys) to decrement L0 to the next test power level in the test record. Measure and record the power meter reading in the test record.
9. Repeat [Step 4](#) for each of the test power levels listed in the test record for the current CW frequency.
10. Repeat [Step 3](#) through [Step 9](#) for all CW frequencies listed in the test record.
11. For models with external pulse modulation:
 - a. Press **Modulation** to open the Pulse menu.
 - b. Select external pulse mode by pressing External, if required.
 - c. Turn the pulse mode on by pressing On/Off.
 - d. Repeat [Step 3](#) through [Step 10](#).

Power Level Accuracy (Models without Option 002)

For the following test, refer to the test record table in [Appendix A, “Section 3-9 Power Level Accuracy and Flatness Tests”](#), “Power Level Accuracy (Models without Option 002)”.

Power level accuracy for power levels of -50 dBm and above are tested by stepping the output power level down in 5 dB increments from its maximum rated power level and measuring the output power level using a power meter at each step.

Test Setup

For all power level flatness measurements connect the equipment, shown in [Figure 3-8 on page 3-21](#), as follows:

Caution To prevent damage to the power sensor, use a fixed attenuator when measuring power levels above +19 dBm.

1. Calibrate the power meter with the appropriate power sensor.
2. Connect the power sensor to the RF Output of the MG3702xA (use a fixed attenuator when measuring power levels above +19 dBm).

Caution Caution To prevent damage to the power sensor, use a fixed attenuator when measuring power levels above +19 dBm.

3. Connect the special AUX I/O interface cable (Anritsu Part No. 806-97) to the MG3702xA rear panel AUX I/O connector. Connect the cable BNC connectors as follows:
 - a. Connect the cable labeled SEQ SYNC to the power meter rear panel INPUT 1 DIGITAL connector.
 - b. Connect the cable labeled HORIZ OUT to the power meter rear panel INPUT 2 ANALOG connector.
4. Set up the power meter as follows:
 - a. Reset the power meter by pressing:
System | Setup | -more- | PRESET | RESET
 - b. Configure the power meter to perform power measurements by pressing:
Sensor | Setup | MODE
Press MODE until Default is displayed in the Measurement MODE field.
 - c. Configure the power sensor calibration factor source by pressing:
Sensor | CalFactor | SOURCE
Press SOURCE until V/GHz is displayed in the Cal Factor SOURCE field.
 - d. Setup the minimum V/GHz range by pressing:
Setup | Start F
 - e. Enter the minimum frequency of the MG3702xA under test or minimum of the power meter.
 - f. Setup the maximum V/GHz range by pressing:
Setup | Stop F
 - g. Enter the maximum frequency of the MG3702xA under test or maximum of the power meter.
 - h. Press any hard key to begin the measurement.
5. Set up the MG3702xA as follows:

- a. Preset the instrument by pressing the green **PRESET** button.
After preset, the CW menu is displayed.

Test Procedure

1. Set up the MG3702xA as follows:
 - a. Press **Frequency** to open the current frequency parameter for editing.
 - b. Press Edit Frequency and set F0 to the CW frequency indicated in the test record.
 - c. Press Edit Level to open the current power level parameter for editing.
 - d. Set L0 to the first applicable power level indicated in the test record.

Caution

To prevent damage to the power sensor, use a fixed attenuator when measuring power levels above +19 dBm.

2. Measure the output power level with the power meter and record the reading in the test record.
3. On the MG3702xA, use the cursor control key (Arrow keys) to decrement L0 to the next test power level in the test record. Measure and record the power meter reading in the test record.
4. Repeat [Step 3](#) for each of the test power levels listed in the test record (down to -50 dBm) for the current CW frequency.
5. Repeat [Step 1](#) through [Step 4](#) for all CW frequencies listed in the test record.

Power Level Accuracy (Models with Option 002)

For the following test, refer to the test record table in [Appendix A](#), “[Section 3-9 Power Level Accuracy and Flatness Tests](#)”, “[Power Level Accuracy \(Models with Option 002\)](#)”.

Power level accuracy for power levels below -50 dBm is tested in two methods:

- Measuring the MG3702xA’s RF output directly on a measuring receiver
- Down converting the MG3702xA’s RF output and measuring the down converted IF on a measuring receiver

In both cases, a reference power level is set on the measuring receiver and the output power level is stepped down in 5 dB increments. The relative output power level is then measured at each step.

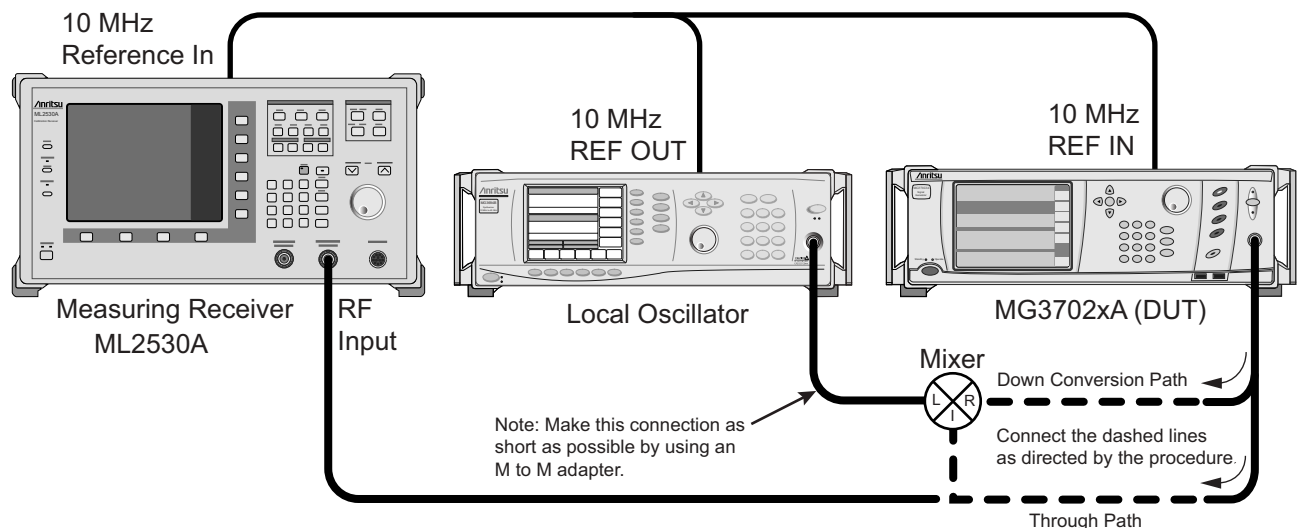

Figure 3-10. Equipment Setup for Power Level Accuracy and Flatness Tests Below -50 dBm

Test Setup Using a Mixer

For all power level measurements below -50 dBm, set up and connect the equipment shown in [Figure 3-10 on page 3-25](#), as follows:

1. Perform a Range Cal on the ML2530A with a bandwidth of 10 Hz at 8.51 MHz:
 - a. Set the Frequency to 8.51 MHz and Bandwidth to 10 Hz.
 - b. Press **Cal** | Range Cal | R1&R2.
 - c. Apply a 8.51 MHz signal that is approximately -30 dBm and choose **Execute**.
 - d. Wait for calibration to finish and then press R2&R3.
 - e. Apply a 8.51 MHz signal that is approximately -75 dBm and choose **Execute**.
 - f. Wait for calibration to finish.
 - g. Repeat the R1&R2 and R2&R3 calibrations for frequencies of 10 MHz, 15 MHz, 60 MHz, 500 MHz, 600 MHz, 1 GHz, and 2 GHz, all with a bandwidth of 10 Hz.
2. For RF frequencies below 2400 MHz, connect the MG3702xA RF Output directly to the RF input of the measuring receiver.
3. For RF frequencies above 2400 MHz:
 - a. Connect the RF Output of the LO and the MG3702xA to the mixer's (PN: 60-114) L-port and R-port, respectively, using low loss cables.
 - b. Connect the mixer's I-port to the RF input of the measuring receiver.
4. Using a BNC tee, connect the 10 MHz reference output from the measuring receiver to the MG3702xA and the local oscillator 10 MHz REF IN connectors.

Test Setup Using Anritsu T2579 Mixer Box

Use the following setup when using a T2579 box. See [Figure 3-11](#)

Note

When using the T2579 mixer box, moving the cables is not required because the T2579 box automatically connects to the proper locations.

1. Perform a Range Cal on the ML2530A with a bandwidth of 10 Hz at 8.51 MHz:
 - a. Set the Frequency to 8.51 MHz and Bandwidth to 10 Hz.
 - b. Press **Cal** | Range Cal | R1&R2.
 - c. Apply a 8.51 MHz signal that is approximately -30 dBm and choose **Execute**.
 - d. Wait for calibration to finish and then press R2&R3.
 - e. Apply a 8.51 MHz signal that is approximately -75 dBm and choose **Execute**.
 - f. Wait for calibration to finish.
 - g. Repeat the R1&R2 and R2&R3 calibrations for frequencies of 10 MHz, 15 MHz, 60 MHz, 500 MHz, 600 MHz, 1 GHz, and 2 GHz, all with a bandwidth of 10 Hz.
2. Connect the ML2530 Measuring receiver to the T2579 Mixer box connector labeled To ML2530.
3. Connect the MG3702xA DUT output to the T2579 Mixer box connector labeled DUT.
4. Connect the LO output to T2579 Mixer box connector labeled LO.
5. Connect a Low Pass Filter and BNC cable to the T2579 Mixer box connector labeled HI Band, then connect the other end to the Local Oscillator's rear panel BNC connector labeled HI Band.
6. Connect a Low Pass Filter and BNC cable to the T2579 Mixer box connector labeled Lo Band, then connect the other end to the Local Oscillator's rear panel BNC connector labeled Lo Band.

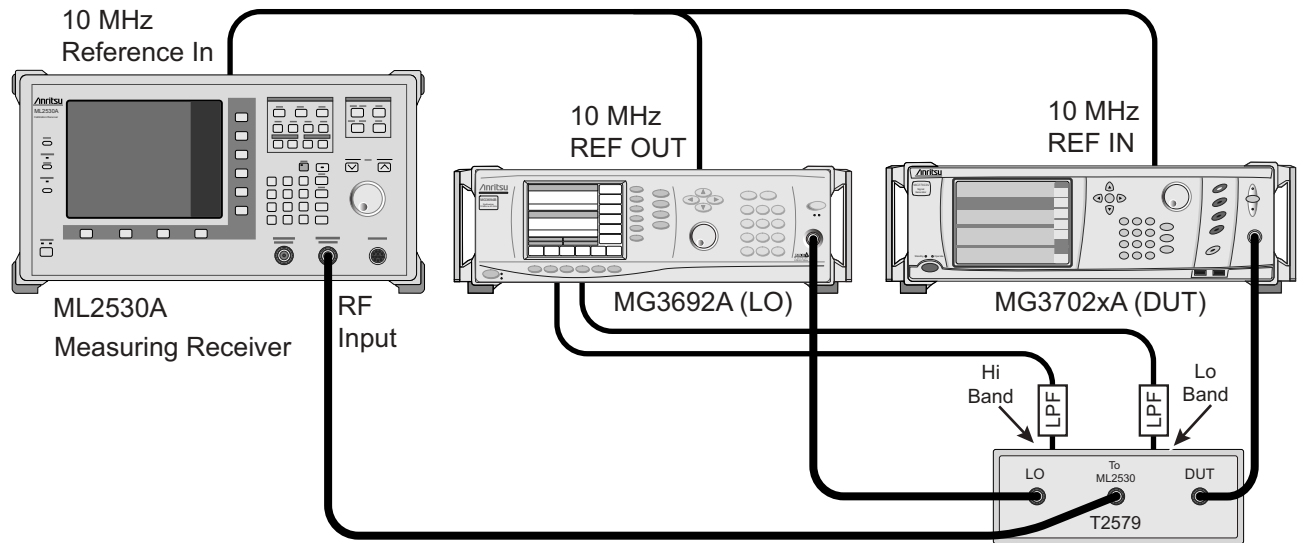

Figure 3-11. Equipment Setup for Power Level Accuracy and Flatness Tests Below -50 dBm Using T2579

Test Procedure

The following procedure verifies the power accuracy and flatness for all power level measurements below -50 dBm.

1. Setup the MG3702xA:
 - a. Preset the instrument by pressing **Preset**. After Preset, the CW menu is displayed.
2. Setup the LO:
 - a. Reset the instrument by pressing **System**, then **Reset**. After reset, the CW menu is displayed.
 - b. Press **Edit L1** to open the current power level parameter for editing.
 - c. Set L1 to $+13$ dBm.
3. Setup the Measurement Receiver:
 - a. Reset the receiver by pressing the **Preset** key.
 - b. Press the **Freq** key, then select Frequency Span and enter 10 kHz.
 - c. Press the **BW** key, then select Manual and enter 10 Hz.
4. Setup the MG3702xA as follows:
 - a. Press **Edit frequency** to open the current frequency parameter for editing.
 - b. Set F0 to the CW frequency indicated in the test record.
 - c. Press **Edit level** to open the current power level parameter for editing.
 - d. Set L0 to -40 dBm.
5. If measuring using the T2579 Mixer Box, skip to [Step 8](#).
6. If measuring frequencies below 2400 MHz, connect the MG3702xA RF Output directly to the measuring receiver's RF input and go to [Step 8](#).
7. If measuring frequencies above 2400 MHz, connect the MG3702xA RF Output to the mixer's R-input port and set up the LO as follows:
 - a. Press **Edit F1** to open the current frequency parameter for editing.

- b. Set F1 to the LO CW frequency indicated in the test record.
- c. Ensure Set L1 is set to +13 dB

Note When measuring frequencies above 2400 MHz, the measuring receiver, LO, and MG3702xA, should be connected to the mixer. The measuring receiver should be set to measure 8.51 MHz.

8. Set up the measuring receiver as follows:
 - a. Press the **Freq** key and enter the CW frequency listed in the test record.
 - b. Press the **Offset** key, select the offset value, enter 0.
 - c. Read the measured value and calculate the line and mixer loss offset as follows:
 - d. (Test record reading at -40 dBm for the current test frequency) – Receiver Reading = Offset
 - e. The offset value should be a positive number.
 - f. Press the **Offset** key and select **Offset On**.
 - g. Select **Offset Value** and enter the offset value that was calculated above. The displayed reading on the measuring receiver should be the test record reading at -40 dBm for the current test frequency. If not, repeat steps b through e.
9. On the MG3702xA, set L0 to the power level indicated in the test record starting with -55 dBm.

Note When making power level changes greater than 15 dB, the first measurement should be thrown out to allow for the measuring receiver to auto range.

10. Measure the relative output power level and record the reading in the test records.
11. Repeat [Step 9](#) and [Step 10](#) for each of the test power levels listed in the test record for the current CW frequency.

Note Depending on options and model numbers not all levels in the test records are tested. The lowest level measured is 100 dB below the maximum leveled power. In some cases measurement at or below -75 dBm is not required. Refer to the Technical Data Sheet for maximum leveled power specification and subtract 100 dB. This will determine the lowest value to measure.

12. Repeat [Step 4](#) through [Step 11](#) for all CW frequencies listed in the test record.

Power Level Flatness

For the following test, refer to the test record table in [Appendix A, “Section 3-9 Power Level Flatness”](#).

Power level flatness is tested by measuring the output power level variation during a full band sweep in the manual sweep mode.

Note

Before performing this procedure, ensure that all test equipment is calibrated. Refer to the manufacturer's test equipment manual.

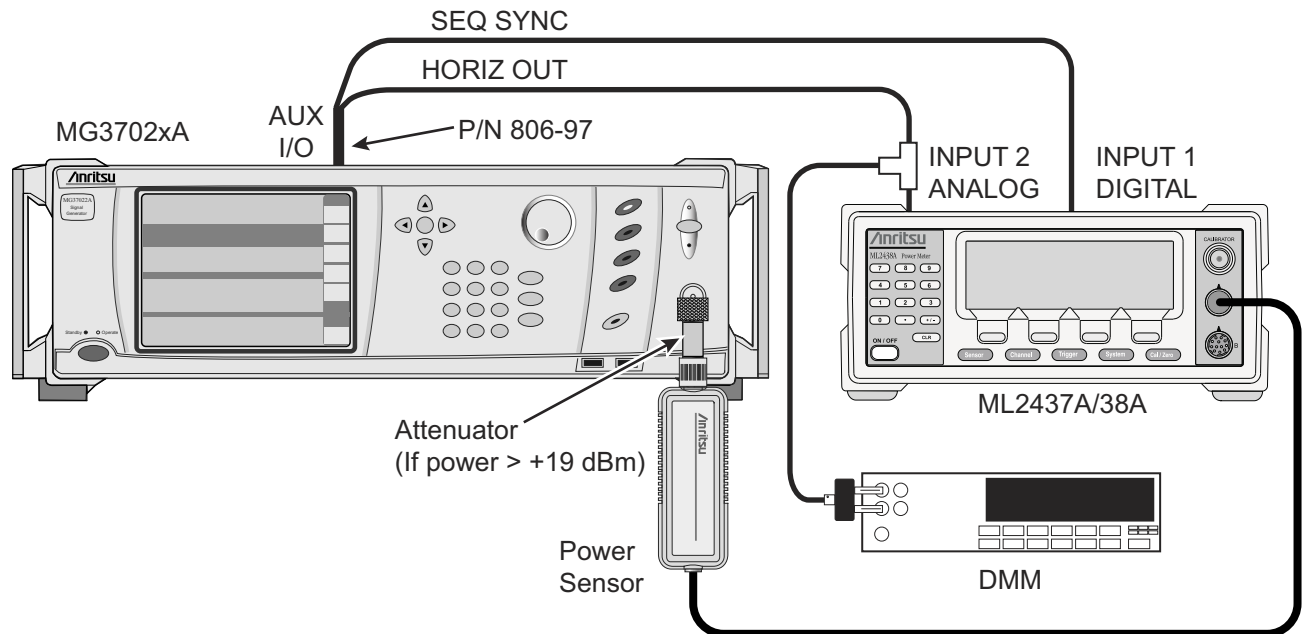

Figure 3-12. Equipment Setup for Flatness Tests and Maximum Levelled Power Test

Test Setup

1. Calibrate the power meter with the appropriate power sensor.
2. Connect the power sensor to the RF Output of the MG3702xA.
3. Connect the special AUX I/O interface cable (Anritsu Part No. 806-97) to the MG3702xA rear panel AUX I/O connector. Connect the cable BNC connectors as follows:
 - a. Connect the cable labeled “SEQ SYNC” to the power meter rear panel INPUT 1 DIGITAL connector.
 - b. Connect the cable labeled “HORIZ OUT” to the power meter rear panel INPUT 2 ANALOG connector.
 - c. Connect a BNC cable from the BNC tee on the INPUT 2 ANALOG connector to the DMM via a BNC to Banana adapter.
4. Set up the power meter as follows:
 - a. Reset the power meter by pressing:
System | Setup | -more- | PRESET | RESET
 - b. Configure the power meter to perform power measurements by pressing:
Sensor | Setup | MODE
until Default is displayed.

- c. Configure the power sensor's calibration factor source by pressing:
Sensor | CalFactor | SOURCE
until V/GHZ is displayed.
- d. Setup the minimum V/GHz range by pressing:
Setup | Start F
- e. Enter the lower frequency of the MG3702xA under test using the value in the frequency range column of the test record.
- f. Setup the maximum V/GHz range by pressing:
Setup | Stop F
- g. Enter the upper frequency of the MG3702xA under test using the value in the frequency range column of the test record.
- h. Press any hard key to begin the measurement.

MG3702xA Setup

1. Preset the instrument by pressing **Preset**. The CW menu is displayed.
2. Press **Level**.
3. Press **Edit Level** to open the current power level parameter for editing.
4. Set L0 to the power level indicated in the test record.
5. Press **Frequency**.
6. Press the **Freq Mode** (upper left hand corner of screen).
7. Press **Step Sweep** to place the instrument in the sweep frequency mode and to display the Step Sweep menu.
8. With the Step Sweep menu displayed, press **Edit Setup**.
9. Press **Single** to put the trigger into single sweep mode.
10. The minimum or maximum frequencies are based on the power sensor performance, model, options installed, and specifications.
 - a. Press **Edit F1**, enter the lower frequency of the MG3702xA under test using the next frequency range value in the test record.
 - b. Press **Edit F2**, enter the upper frequency of the MG3702xA under test using the next frequency range value in the test record.
 - c. Press **Dwell time** and set to 250ms.
 - d. Press **Num of Steps** to open the number-of-steps parameter for editing.
 - e. Enter the number of steps called out in the test records.

Test Procedure

Note	Be sure to use and calibrate the appropriate power sensor for the frequency being measured.
-------------	---

1. On the MG3702xA, press Trigger in the Step Sweep menu to start the sweep.
2. Monitor the power level and the DMM
 - a. On the power meter determine the Minimum and Maximum values.
 - b. Monitor the DMM which will be incrementing from approximately 0V to approximately 10V. When the DMM has reached approximately 10V the sweep is complete.
 - c. Repeat [Step 1](#) and [Step 2](#) until you have the Minimum and Maximum power reading. Then record the variation (difference between the maximum and minimum readings) in the test record. Verify that the variation does not exceed the specification noted in the test record.
3. Setup the power meter for the next measurement.
 - a. Configure the power sensor's calibration factor source by pressing:
Sensor | CalFactor | SOURCE
until V/GHZ is displayed.
 - b. Setup the minimum V/GHz range by pressing:
Setup | Start F
 - c. Enter the lower frequency of the MG3702xA under test using the next frequency range value in the test record.
 - d. Setup the maximum V/GHz range by pressing:
Setup | Stop F
 - e. Enter the upper frequency of the MG3702xA under test using the next frequency range value in the test record.
 - f. Press any hard key to begin the measurement.
4. Repeat the setup and test starting at [Step 2](#) of “MG3702xA Setup” on page 3-30 until all tests are completed in the test record.

Maximum Leveled Power

For the following test, refer to the test record table in [Appendix A](#), “Section 3-9 Maximum Leveled Power”.

Maximum leveled power is tested by measuring the output power level during a full band sweep in the manual sweep mode.

Test Setup

1. Calibrate the power meter with the appropriate power sensor.
2. Connect the equipment as shown in [Figure 3-12](#) on page 3-29.

Caution	To prevent damage to the power sensor, use a fixed attenuator when measuring power levels above +19dBm.
----------------	---

3. Connect the power sensor to the RF Output of the MG3702xA (use a fixed attenuator when measuring power levels above +19 dBm).
4. Connect the special AUX I/O interface cable (Anritsu PN: 806-97) to the MG3702xA rear panel AUX I/O connector. Connect the cable BNC connectors as follows:

- a. Connect the cable labeled “SEQ SYNC” to the power meter rear panel INPUT 1 DIGITAL connector.
 - b. Connect the cable labeled “HORIZ OUT” to the power meter rear panel INPUT 2 ANALOG connector.
 - c. Connect a BNC cable from the BNC tee on the INPUT 2 ANALOG connector to the DMM via a BNC to Banana adapter.
5. Set up the power meter as follows:
- a. Reset the power meter by pressing:
System | Setup | -more- | PRESET | RESET
 - b. Configure the power meter to perform power measurements by pressing:
Sensor | Setup | MODE
until Default is displayed.
 - c. Configure the power sensor's calibration factor source by pressing:
Sensor | CalFactor | SOURCE | V/GHz until V/GHz is displayed
 - d. Setup the minimum V/GHz range by pressing:
Setup | Start F
Enter the lower frequency of the MG3702xA under test using the value in the frequency range column of the test record.
 - e. Setup the maximum V/GHz range by pressing
Setup | Stop F
Enter the upper frequency of the MG3702xA under test using the value in the frequency range column of the test record.
 - f. Press any hard key to begin the measurement.

MG3702xA Setup

1. Preset the instrument by pressing **Preset**. The CW menu is displayed.
2. Press **Level**.

Caution To prevent damage to the power sensor, use a fixed attenuator when measuring power levels above +19 dBm.

3. Press **Edit Level** to open the current power level parameter for editing.
4. Set **L0** to the power level indicated in the test record.
5. Press **Frequency**.
6. Press **Freq Mode** (upper left hand corner of screen).
7. Press **Step Sweep** to place the instrument in the sweep frequency mode and to display the Step Sweep menu.
8. With the Step Sweep menu displayed, press **Edit Setup**.
9. Press **Single** to put the trigger into single sweep mode.
10. The minimum or maximum frequencies are based on the power sensor performance, model, options installed, and specifications.
 - a. Press **Edit F1**, enter the lower frequency of the MG3702xA under test using the next frequency range value in the test record.

- b. Press Edit F2, enter the upper frequency of the MG3702xA under test using the next frequency range value in the test record.
- c. Press Dwell time and set to 250ms.
- d. Press Num of Steps to open the number-of-steps parameter for editing.
- e. Enter the number of steps called out in the test records.

Note Be sure to use and calibrate the appropriate power sensor for the frequency being measured.

Test Procedure

1. On the MG3702xA, press Trigger in the Step Sweep menu to start the sweep.
2. Monitor the power level and the DMM.
 - a. On the power meter determine the Minimum power values.
 - b. Monitor the DMM which will be incrementing from approximately 0v to approximately 10V. When the DMM has reached approximately 10V the sweep is complete.
 - c. Repeat [Step 1](#) and [Step 2](#) until you have the Minimum power reading.
 - d. Add the attenuation value of the attenuator to the minimum power reading and record this value to the test record. Verify that the reading is above the specification noted in the test record.
3. Setup the power meter for the next measurement.
 - a. Configure the power sensor's calibration factor source by pressing:
Sensor | CalFactor | SOURCE
until V/GHZ is displayed.
 - b. Setup the minimum V/GHz range by pressing:
Setup | Start F
 - c. Enter the lower frequency of the MG3702xA under test using the next frequency range value in the test record.
 - d. Setup the maximum V/GHz range by pressing:
Setup | Stop F
 - e. Enter the upper frequency of the MG3702xA under test using the next frequency range value in the test record.
 - f. Press any hard key to begin the measurement.
4. Repeat the setup and test starting at [Step 2](#) of “MG3702xA Setup” on [page 3-32](#) until all tests are completed in the test record.

3-10 Pulse Modulation Tests

Pulse modulation tests are performed only if Option 26 or 37 is installed.

For the following test, refer to the test record table in [Appendix A](#), “Section 3-10 Pulse Modulation Tests”.

The pulse modulation tests verify the operation of the pulse modulation circuits in the MG3702xA. Rise time, fall time, overshoot, and power accuracy of the pulsed RF output are verified using a high speed digital sampling oscilloscope. The external power accuracy is also verified to insure the operation of the external pulse input. Pulse depth (on/off ratio) is measured using a Spectrum Analyzer.

Note

Before performing this procedure ensure that all test equipment is calibrated. Refer to the manufacturer’s test equipment manual.

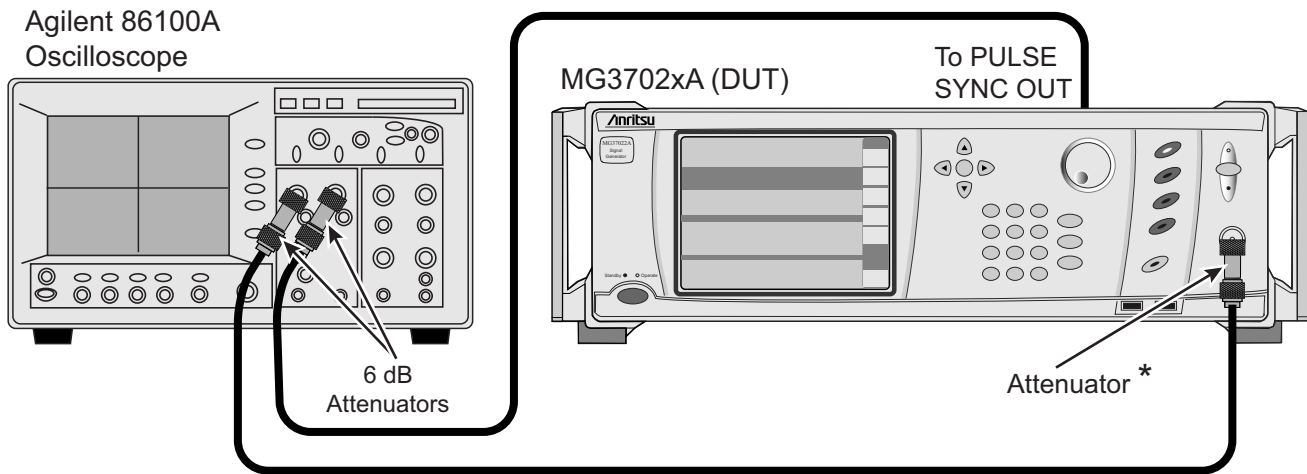

* Connect the proper value attenuator to the MG3702xA output as specified in the procedure.

Figure 3-13. Equipment Setup for Pulse Modulation Tests

Test Setup

1. Connect the equipment shown in [Figure 3-13](#), as follows:
2. Using the 2.4 mm (f) to K (f) adapters, connect a 6 dB fixed attenuator to the oscilloscope's Channel 1 and Trigger inputs.
3. Connect a RF coaxial cable to the 6 dB attenuator at the oscilloscope's Channel 1 input.
4. Use a BNC to SMA adapter to connect a 50Ω BNC cable from the MG3702xA's PULSE SYNC OUT to the 6 dB attenuator at the oscilloscope's Trigger input.
5. Set up the oscilloscope as follows:
 - a. Press the **Default Setup** key.
 - b. From the title bar, select:
Measure | Math | Function 1
 - c. Set the operator to MAX and turn on the Function 1 display.
 - d. Select Close to close the open window.
 - e. Select the Trigger Level button on the bottom of the display.
 - f. Set the trigger level to 500 mV.
 - g. Set the bandwidth to DC to 2.5 GHz.
 - h. Select rising edge triggering (soft key appears as a rising edge square wave).

- i. Select the left module as the source.
- j. Select Close to close the open window.
- k. Turn off channel 1 on the oscilloscope by pressing the **1** key above the module (LED off).

Pulse Rise Time, Fall Time and Overshoot

The following procedure describes the measurement of rise time, fall time, and overshoot of the MG3702xA's pulse modulated RF output.

Repeat the measurements of the pulse rise time, pulse fall time, and pulse overshoot based on the DUT frequencies according to “[Section 3-10 Pulse Modulation Tests](#)” in [Appendix A, “Test Records”](#).

Pulse Rise Time

1. Set up the MG3702xA as follows:
 - a. Preset the instrument by pressing **Preset**. After preset, the CW menu is displayed.
 - b. Turn RF output off.
 - c. Press **Edit Frequency** to open the current frequency parameter for editing.
 - d. Set F0 to the first/next applicable frequency in the test record.
 - e. Press **Edit Level** to open the current power level parameter for editing.
 - f. Set L0 to the maximum specified leveled output power level for the frequency and instrument being tested (refer to [Appendix B, “MG3702xA Technical Data Sheet”](#)).
 - g. Connect a fixed attenuator with the proper attenuation value (see [Table 3-5](#)) to the MG3702xA RF Output, then connect the RF coaxial cable from the Channel 1 input of the oscilloscope to the fixed attenuator.

Table 3-5. MG3702xA Attenuation

MG3702xA Rated Power	Required Attenuation
≥ 17 dBm	20 dB
≥ 13 dBm	10 dB
≥ 10 dBm	6 dB
≥ 8 dBm	3 dB
< 8 dBm	0 dB

- h. Turn **RF output ON**.
 - i. Press **Modulation | Internal** to select the Internal Pulse Status menu.
 - j. Press **PRI** and enter 4 μs.
 - k. Press **W1** and enter 1 μs.
 - l. Press **Enable** to **On** to turn the internal pulse mode on.
2. Set up the oscilloscope as follows:
 - a. Select the **Time/Delay** button on the bottom of the display.
 - b. Set the scale to 10 ns/div and the delay to 4 μs. Select **Close** to close the window.
 - c. Press the **Clear Display** key. Allow the oscilloscope to sample the signal and wait for a clearly defined waveform to appear on the display.
 - d. Select the (1) **Scale** button at the lower left corner of the display.

- e. Set the scale and offset voltages so that the positive peak of the pulse is centered and the amplitude is optimally displayed (typically a scale of 20mV/div and offset of 50 mV). Select **Close** to close the window.
 - f. Select the **Rise Time** button (on the left hand side of the display).
3. Read the measured result from the bottom of the display and enter the result in the test record.

Pulse Fall Time

4. Set up the oscilloscope as follows:
 - a. Select the **Time/Delay** button on the bottom of the display.
 - b. Set the delay time to 5 μ s. Select **Close** to close the window.
 - c. Press the **Clear Display** key. Allow the oscilloscope to sample the signal and wait for a clearly defined waveform to appear on the display.
 - d. Select the **Fall Time** button (on the left hand side of the display).
5. Read the measured result from the bottom of the display and enter the result in the test record.
6. Repeat pulse rise and fall time measurements for all frequencies listed by repeating [Step 1b](#) through [Step 5](#).

Overshoot

7. On the oscilloscope, select **Setup & Info** on bottom right of screen then put the cursor on top of **Rise Time** and select **Remove**.
8. On oscilloscope, select **Setup & Info** on bottom right of screen then put the cursor on top of **Fall Time** and select **Remove**.
9. Set up the MG3702xA as follows:
 - a. Turn RF output off.
 - b. Press **Edit Frequency** to open the current frequency parameter for editing.
 - c. Set **F0** to the first/next applicable frequency in the test record.
 - d. Press **Edit Level** to open the current power level parameter for editing.
 - e. Set **L0** to the maximum specified leveled output power level for the frequency and instrument being tested (refer to [Appendix B](#), “[MG3702xA Technical Data Sheet](#)”).
 - f. Connect a fixed attenuator with the proper attenuation value to the MG3702xA RF Output (refer to [Table 3-5 on page 3-35](#)), then connect the RF coaxial cable from the Channel 1 input of the oscilloscope to the fixed attenuator.
1. Turn RF output ON.
10. Set up the oscilloscope as follows:
 - a. Select the **Time/Delay** button on the bottom of the display.
 - b. Set the scale to 120 ns/div and the trigger to 4 μ s. Select **Close** to close the window.
 - c. Press the **Clear Display** key. Allow the oscilloscope to sample the signal and wait for a clearly defined waveform to appear on the display.
 - d. Select the **Amplitude** button, then the **Overshoot** button (on the left hand side of the display).
11. Read the measured result from the bottom of the display and record the result in the test record.
12. Repeat the overshoot test from [Step 9](#) through [Step 11](#) for each frequency listed in the test record.

Pulse Power Accuracy

The following procedure describes the measurement of the pulse power accuracy of the MG3702xA's pulse modulated RF Output. The accuracy is tested with a 1 μ s and a 0.5 μ s pulse width.

Test Setup

1. Disconnect the MG3702xA's RF coaxial cable from the front of the unit.
2. Set up the equipment as described in [Figure 3-13](#), then perform [Step 1](#) through [Step 5](#) in “Test Setup” on [page 3-34](#)“.

Test Procedure

1. Set up the MG3702xA as follows:
 - a. Preset the instrument by pressing **Preset**. After preset, the CW menu is displayed.
 - b. Turn RF output OFF.
 - c. Press **Edit Frequency** to open the current frequency parameter for editing.
 - d. Set F0 to the first applicable/next frequency in the test record.
 - e. Press **Edit Level** to open the current power level parameter for editing.
 - f. Set L0 to the maximum specified leveled output power level for the instrument being tested (refer to [Appendix B](#), “MG3702xA Technical Data Sheet”).
 - g. Connect a fixed attenuator with the proper attenuation value to the MG3702xA RF Output (refer to [Table 3-5 on page 3-35](#)), and then connect the RF coaxial cable from the Channel 1 Input of the Oscilloscope to the fixed attenuator.
 - h. Turn RF output ON.
 - i. Press **Modulation | Internal** to select the Internal source.
 - j. Press **PR1** and enter 4 μ s.
 - k. Press **W1** and enter 1 μ s (or 0.5 μ s for <1 μ s test).
 - l. Press **Off** to turn the internal pulse mode off.
2. Set up the oscilloscope as follows:
 - a. Press the **Source** button (near the trigger) until **Free Run** is illuminated.
 - b. Select the **Scale** button at the lower left corner of the display and set the scale to 20 mV/div.
 - c. Set the Offset so that the trace is centered on the display (typically 150mV), and select **Close**.
 - d. Select the **Amplitude** button and then the **Vavg** button (on the left hand side of the display), then touch **OK** to close.

Note Use the scroll bar to locate the V avg button.
--

3. Read the measured result on the display and record the result as V_{ref} in the test record.
4. On the MG3702xA, press **On** to turn pulse modulation ON.
5. On the oscilloscope, press the **Source** button (near the trigger) until **Left Module** is illuminated.
6. Set up the oscilloscope as follows:
 - a. Press the **Clear Display** key. Allow the oscilloscope to sample the signal and wait for a clearly defined waveform to appear on the display.

- b. Select Time Delay and scale so that only the positive peak portion of the pulse fills the display (typically set the scale to 90 ns/div and the delay time to 4.1 μ s for a 1 μ s pulse or set the scale to 40 μ s/div and the delay time to 4.1 μ s for a 500 μ s pulse). Press Close to close the window.
 - c. Read the measured result of V_{avg} on the display.
7. Record the result as V_{pulse} in the test record.
 8. Calculate the difference of the two voltages using the following equation, and then record the result in the test record as $P_{accuracy}$.

$$P_{accuracy} = 20 \times \log\left(\frac{V_{pulse}}{V_{ref}}\right)$$
 9. Repeat [Step 1: Step b](#) through [Step 8](#) for each frequency listed in the test record.
 10. For models with internal pulse, repeat [step 2: Step b](#) through [Step 8](#) using a pulse width of 0.5 μ s.

External Pulse Power Accuracy

The following procedure ensures the external pulse input to the MG3702xA is operational. The external pulse power accuracy is tested with a 1 μ s and a 0.5 μ s pulse width.

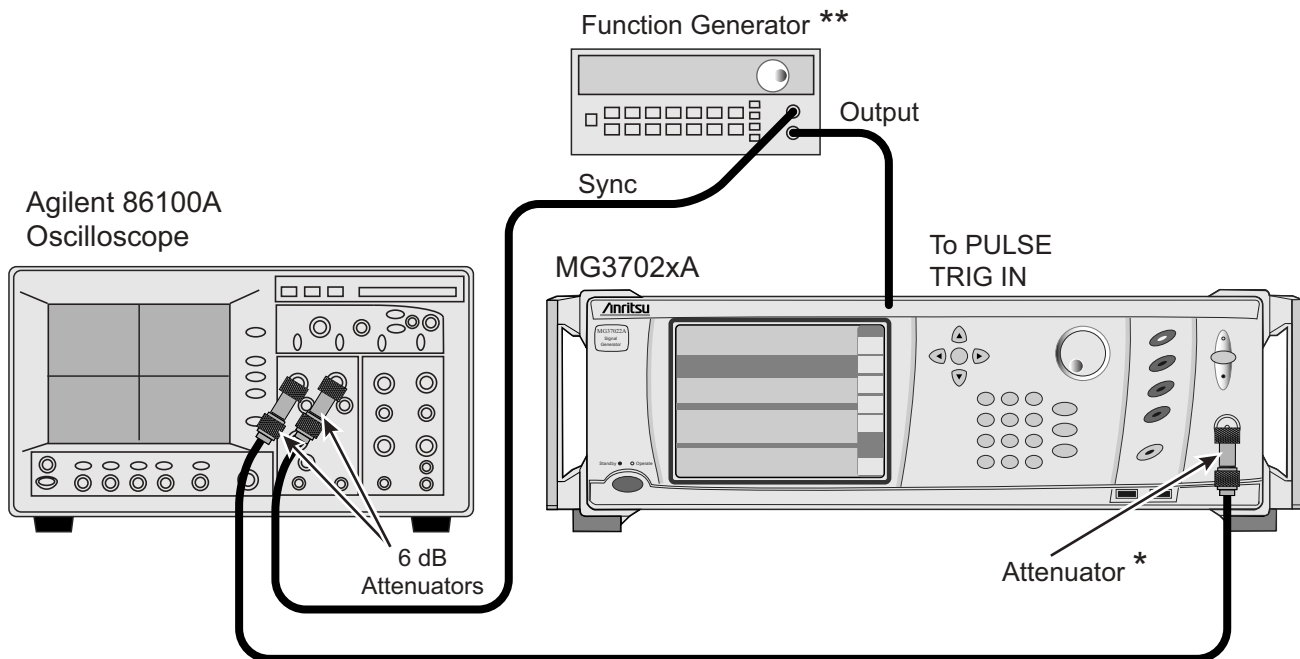

* Connect the proper value attenuator to the MG3702xA output as specified in the procedure.

** The function generator is only required if the MG37022A does not have Options 24 or 27.

Figure 3-14. External pulse verification setup

Test Setup

Connect the equipment shown in [Figure 3-14](#), as follows:

1. Disconnect the MG3702xA's RF coaxial cable from the front of the unit. Set up the equipment as shown in [Figure 3-14](#).

2. Using the 2.4 mm (f) to K (f) adapters, connect a 6 dB fixed attenuator to the oscilloscope's Channel 1 and Trigger inputs.
3. Connect a RF coaxial cable to the 6 dB attenuator at the oscilloscope's Channel 1 input.
4. Use a BNC to SMA adapter to connect a 50 Ω BNC cable from the Function Generator's SYNC to the 6 dB attenuator at the oscilloscope's Trigger input.
5. Connect a 50 Ω BNC cable from the Function Generator's signal output to the MG3702xA's rear panel PULSE TRIG IN connector.
6. Set up the oscilloscope as follows:
 - a. Press the **Default Setup** key.
 - b. From the title bar, select:
 - c. Measure | Math | Function 1
 - d. Set the operator to MAX and turn on the Function 1 display.
 - e. Select **Close** to close the open window.
 - f. Select the **Trigger Level** button on the bottom of the display.
 - g. Set the trigger level to 500 mV.
 - h. Set the bandwidth to DC to 2.5 GHz.
 - i. Select rising edge \uparrow triggering.
 - j. Select the left module as the source.
 - k. Select **Close** to close the open window.
 - l. Turn off channel 1 on the oscilloscope by pressing the **1** key above the module (LED off).
7. Set up the Function Generator as follows:
 - a. Turn the Function Generator off, then back on to reset the instrument.
 - b. Press the \square key to select the square wave function.
 - c. Press the **Freq** key, then the green **Enter Number** key and enter 250 kHz.
 - d. Press the blue **Shift** key, then the **%Duty Cycle** key and use the rotary knob to adjust the duty cycle to 25%.
 - e. Press the **Ampl** key, then the green **Enter Number** key and enter 2.2 Vp-p.
 - f. Press the **Offset** key, then the green **Enter Number** key and enter 1.1 VDC.

Test Procedure

1. Set up the MG3702xA as follows:
 - a. Preset the instrument by pressing **Preset**. After preset, the CW menu is displayed.
 - b. Turn RF output OFF.
 - c. Press **Edit Frequency** to open the current frequency parameter for editing.
 - d. Set F0 to the first applicable/next frequency in the test record.
 - e. Press **Edit Level** to open the current power level parameter for editing.
 - f. Set L0 to the maximum specified leveled output power level for the instrument being tested (refer to [Appendix B, "MG3702xA Technical Data Sheet"](#)).

- g. Connect a fixed attenuator with the proper attenuation value to the MG3702xA RF Output (refer to [Table 3-6](#)), then connect the RF coaxial cable from the Channel 1 input of the oscilloscope to the fixed attenuator.

Table 3-6. MG3702xA Attenuation

MG3702xA Rated Power	Required Attenuation
≥ 17 dBm	20 dB
≥ 13 dBm	10 dB
≥ 10 dBm	6 dB
≥ 8 dBm	3 dB
< 8 dBm	0 dB

- h. Turn RF output ON.
- i. Press **Modulation** | **External** to select the External Pulse Status menu.
- j. Ensure that the polarity is set to High RF.
- k. Press **Off** to turn the external pulse off.
2. Set up the oscilloscope as follows:
- Press the **Source** button (near the trigger) until Free Run is illuminated.
 - Select the **Scale** button at the lower left corner of the display and set the scale to 20 mV/div.
 - Set the Offset so that the trace is centered on the display (typically 150 mV), and select **Close**.
 - Select the **Amplitude** button, then the Vavg button (on the left hand side of the display) and press OK to close.

Note	Use the scroll bar to locate the Vavg button.
-------------	---

- Read the measured result on the display and record the result as V_{ref} in the test record.
- On the MG3702xA, press **On** to turn pulse modulation on
- On the oscilloscope, press the **Source** button (near the trigger) until Left Module is illuminated.
- Set up the oscilloscope as follows:
 - Select **Time Delay** and **Scale** so that only the positive peak portion of the pulse fills the display (typically set the scale to 90 ns/div and the delay time to 4.100μs). Press **Close** to close the window.
 - Press the **Clear Display** key. Allow the oscilloscope to sample the signal and wait for a clearly defined waveform to appear on the display.
 - Read the measured result of Vavg on the display.
- Record the result as V_{pulse} in the test record.
- Calculate the difference of the two voltages using the following equation, then record the result in the test record as $P_{accuracy}$.

$$P_{accuracy} = 20 \times \log\left(\frac{V_{pulse}}{V_{ref}}\right)$$

- Repeat steps [Step 1b](#) through [Step 7](#) for each frequency listed in the test record.

Pulse On/Off Ratio

The following procedure lets you measure the pulse on/off ratio of the MG3702xA's pulse modulated RF output.

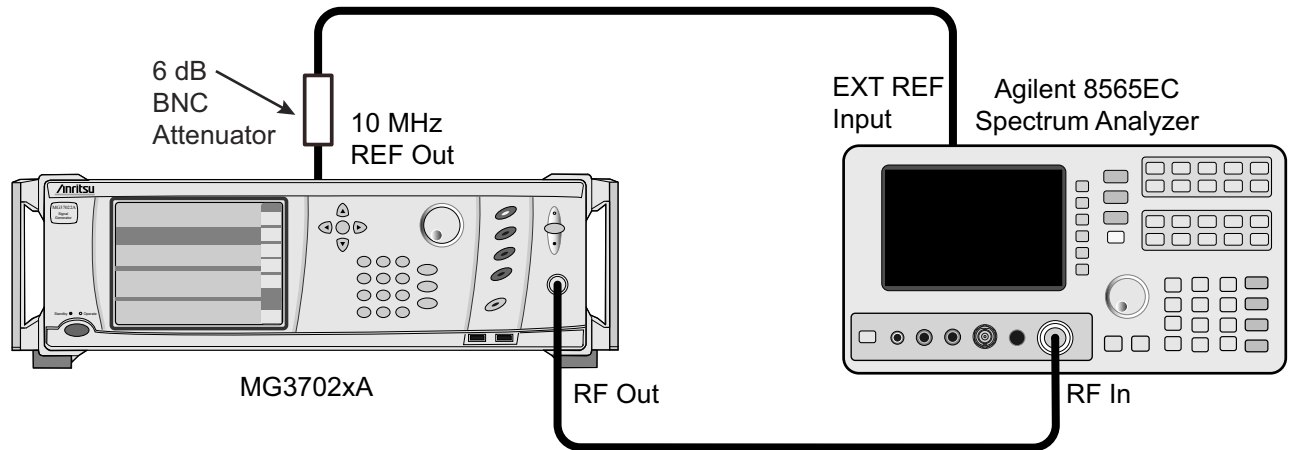

Figure 3-15. Equipment Setup for Pulse On/Off Ratio Tests

Test Setup

Set up the equipment shown in [Figure 3-15](#), as follows:

1. Connect a 6dB BNC pad to the MG3702xA 10 MHz reference output, then connect a BNC cable from the 6dB pad to the Spectrum Analyzer's External Reference input.
2. Connect the MG3702xA RF Output to the Spectrum Analyzer's RF Input.
3. Set up the Spectrum Analyzer as follows:
 - a. Press the **PRESET** key.
 - b. Press **AUX CTRL**.
 - c. Press the Rear Panel soft key.
 - d. Press the 10MHz soft key and set to “EXT”.

Test Procedure

Measure the pulse on/off ratio as follows:

1. Set up the MG3702xA as follows:
 - a. Preset the instrument by pressing **Preset**. After preset, the CW menu is displayed.
 - b. Press **Edit Frequency** to open the current frequency parameter for editing.
 - c. Set F0 to the first/next applicable frequency in the test record for the model being tested.
 - d. Press **Edit Level** to open the current power level parameter for editing.
 - e. Set L0 to the maximum specified leveled output power level for the instrument being tested (refer to [Appendix B](#), “MG3702xA Technical Data Sheet”).
 - f. Press **Modulation**, then **Pulse** to select the External Pulse Status menu.
 - g. Press **Low RF On** and ensure that the pulse mode is turned off.
2. Set up the Spectrum Analyzer as follows:
 - a. Press the **AMPLITUDE** key and enter the current power level setting of the MG3702xA.
 - b. Press the **FREQUENCY** key and enter the current frequency setting of the MG3702xA.

- c. Press the **SPAN** key and enter 100 kHz.
 - d. Press the **MKR** key, then select **MARKER DELTA** to set the marker reference.
3. On the MG3702xA's External Pulse Status menu, select On/Off to turn the pulse mode on.

Note

The signal level may drift slowly after the pulse mode is turned on. (Make the measurement as soon as possible after turning the pulse mode on.) This drift is the result of the Sample/Hold circuit not holding the level because of a very low pulse duty factor (time ratio of RF ON to RF OFF). This drift will not be present in normal pulse operation as the minimum pulse repetition rate is 100 Hz.

4. On the Spectrum Analyzer, read the marker delta value and record the value as P_{depth} in the test record.
5. Repeat steps [Step 1b](#) through [Step 4](#) for each frequency listed in the test record.

Chapter 4 — Adjustment

4-1 Introduction

This chapter contains procedures for calibrating the series MG3702xA Synthesized Signal Generators. These procedures are typically performed when out-of-tolerance conditions have been noted during performance verification testing ([Chapter 3](#)) or as a result of replacement of subassemblies or RF components.

Note	The adjustment procedures in this chapter support operating firmware version 1.7.0 and above. Anritsu recommends that you upgrade your instrument operating firmware to the latest available version prior to calibration.
-------------	--

4-2 Test Equipment List

[Table 4-1](#) provides a partial list of the test equipment for these adjustment procedures. The test equipment setup is critical to making accurate measurements. In some cases, you may substitute test equipment having the same critical specifications as the test equipment indicated in the test equipment list (refer to [“Measurement Uncertainty”](#) on page 3-4).

Table 4-1. Required Test Equipment

Instrument	Critical Specification	Manufacturer	Model / Part Number
PC, Monitor, Mouse, Keyboard	GPIB card installed, Anritsu Test Executive GPRG 57102 and Level Cal Software GPRG 57877 installed	Any	Any
10 MHz Frequency Reference	Frequency: 10 MHz Accuracy: $5E^{-12}$ parts/day	Symmetricom (Datum)	9390-9600
Local Oscillator	Frequency: 0.01 to 20 GHz Power: >+13 dBm 10 MHz to 20 GHz	Anritsu	MG3692C
Power Meter	Frequency: 0.01 GHz to 20 GHz Power Range: -70 dBm to +20 dBm	Anritsu	ML2437A/38A
Power Sensor	Frequency: 0.01 GHz to 20 GHz Power Range: -70 dBm to +20 dBm Connector: K(m)	Anritsu	MA2474D
10 dB Attenuator	Frequency: 0.01 GHz to 20 GHz Power Range: -70 dBm to +20 dBm Connector: K(m) to K(f)	Anritsu	41KC-10
Measuring Receiver	Noise Floor: < -140 dBm at 500 MHz	Anritsu	ML2530A
T2579 Mixer Fixture	N/A	Anritsu	T2579
Mini-Circuits Filter, Qty 2	N/A	Mini-Circuits Model BLP-1.9	Anritsu Part Number 1030-104

4-3 Test Records

A blank copy of a sample adjustment test record for each MG3702xA model is provided in [Appendix A, “Section 4-4 Adjustments after Subassembly Replacement”](#). It provides a means for maintaining an accurate and complete record of instrument adjustments. We recommend that you copy these pages and use them to record the adjustment of out-of-tolerance MG3702xA circuits or the adjustment of the MG3702xA following replacement of subassemblies or RF components.

4-4 Adjustments after Subassembly Replacement

Table 4-2 lists the calibrations that should be performed following the replacement of applicable MG3702xA subassemblies or RF components.

Table 4-2. Adjustment and Verifications Required after Subassembly Replacement (1 of 3)

Subassembly/RF Component Replaced	Perform the Following Adjustments and Verifications
Front Panel Assembly	Section 4-11 “Touch Screen Accuracy Adjustment”
A2 Microprocessor PCB	Section 4-6 “Utility DVM Adjustment” Section 4-7 “Frequency Reference Adjustment” Section 4-8 “Level Detector Tables and Level Flatness Adjustment” Section 4-9 “Level SWF Band Adjustment” Section 4-10 “Level ALC Adjustment” Section 4-11 “Touch Screen Accuracy Adjustment” Section 3-6 “Internal Time Base Aging Rate Test (Optional)” Section 3-7 “Spurious Signals Tests” Section 3-8 “SSB Phase Noise Test” Section 3-9 “Power Level Accuracy and Flatness Tests” Section 3-10 “Pulse Modulation Tests”
A3 Post Regulator PCB	None
A4 Auxiliary PCB	Section 4-6 “Utility DVM Adjustment” Section 3-10 “Pulse Modulation Tests”
A6 ALC PCB	Section 4-8 “Level Detector Tables and Level Flatness Adjustment” Section 4-9 “Level SWF Band Adjustment” Section 4-10 “Level ALC Adjustment” Section 3-9 “Power Level Accuracy and Flatness Tests” Section 3-10 “Pulse Modulation Tests”
A7 Coarse/Ref Loop PCB	Section 4-7 “Frequency Reference Adjustment” Section 3-7 “Spurious Signals Tests” Section 3-8 “SSB Phase Noise Test”
A8 Synthesizer Control PCB	Section 4-7 “Frequency Reference Adjustment”
A9 Output Fine Loop PCB	Section 3-9 “Power Level Accuracy and Flatness Tests” Section 4-7 “Frequency Reference Adjustment” Section 4-8 “Level Detector Tables and Level Flatness Adjustment” Section 4-9 “Level SWF Band Adjustment” Section 4-10 “Level ALC Adjustment”
A10 Rear Panel PCB	None
A11 Digital Down Converter PCB	Section 4-7 “Frequency Reference Adjustment” Section 4-8 “Level Detector Tables and Level Flatness Adjustment” Section 4-9 “Level SWF Band Adjustment” Section 4-10 “Level ALC Adjustment” Section 3-6 “Internal Time Base Aging Rate Test (Optional)” Section 3-7 “Spurious Signals Tests” Section 3-8 “SSB Phase Noise Test” Section 3-9 “Power Level Accuracy and Flatness Tests” Section 3-10 “Pulse Modulation Tests”

Table 4-2. Adjustment and Verifications Required after Subassembly Replacement (2 of 3)

Subassembly/RF Component Replaced	Perform the Following Adjustments and Verifications
A12 Switched Filter	Section 4-7 “Frequency Reference Adjustment” Section 4-8 “Level Detector Tables and Level Flatness Adjustment” Section 4-9 “Level SWF Band Adjustment” Section 4-10 “Level ALC Adjustment” Section 3-6 “Internal Time Base Aging Rate Test (Optional)” Section 3-7 “Spurious Signals Tests” Section 3-8 “SSB Phase Noise Test” Section 3-9 “Power Level Accuracy and Flatness Tests” Section 3-10 “Pulse Modulation Tests”
A16 40 GHz Diplex Switch	Section 4-7 “Frequency Reference Adjustment” Section 4-8 “Level Detector Tables and Level Flatness Adjustment” Section 4-9 “Level SWF Band Adjustment” Section 4-10 “Level ALC Adjustment” Section 3-6 “Internal Time Base Aging Rate Test (Optional)” Section 3-7 “Spurious Signals Tests” Section 3-8 “SSB Phase Noise Test” Section 3-9 “Power Level Accuracy and Flatness Tests” Section 3-10 “Pulse Modulation Tests”
Leveling Coupler, 40 GHz	Section 4-7 “Frequency Reference Adjustment” Section 4-8 “Level Detector Tables and Level Flatness Adjustment” Section 4-9 “Level SWF Band Adjustment” Section 4-10 “Level ALC Adjustment” Section 3-6 “Internal Time Base Aging Rate Test (Optional)” Section 3-7 “Spurious Signals Tests” Section 3-8 “SSB Phase Noise Test” Section 3-9 “Power Level Accuracy and Flatness Tests” Section 3-10 “Pulse Modulation Tests”
Output Connector, K(f)	Section 4-7 “Frequency Reference Adjustment” Section 4-8 “Level Detector Tables and Level Flatness Adjustment” Section 4-9 “Level SWF Band Adjustment” Section 4-10 “Level ALC Adjustment” Section 3-6 “Internal Time Base Aging Rate Test (Optional)” Section 3-7 “Spurious Signals Tests” Section 3-8 “SSB Phase Noise Test” Section 3-9 “Power Level Accuracy and Flatness Tests” Section 3-10 “Pulse Modulation Tests”
Power Supply	None
2 to 20 GHz Amplifier	Section 4-7 “Frequency Reference Adjustment” Section 4-8 “Level Detector Tables and Level Flatness Adjustment” Section 4-9 “Level SWF Band Adjustment” Section 4-10 “Level ALC Adjustment” Section 3-6 “Internal Time Base Aging Rate Test (Optional)” Section 3-7 “Spurious Signals Tests” Section 3-8 “SSB Phase Noise Test” Section 3-9 “Power Level Accuracy and Flatness Tests” Section 3-10 “Pulse Modulation Tests”

Table 4-2. Adjustment and Verifications Required after Subassembly Replacement (3 of 3)

Subassembly/RF Component Replaced	Perform the Following Adjustments and Verifications
Step Attenuator, 20 GHz	Section 4-7 “Frequency Reference Adjustment” Section 4-8 “Level Detector Tables and Level Flatness Adjustment” Section 4-9 “Level SWF Band Adjustment” Section 4-10 “Level ALC Adjustment” Section 3-6 “Internal Time Base Aging Rate Test (Optional)” Section 3-7 “Spurious Signals Tests” Section 3-8 “SSB Phase Noise Test” Section 3-9 “Power Level Accuracy and Flatness Tests” Section 3-10 “Pulse Modulation Tests”
All Other RF Components	Section 4-7 “Frequency Reference Adjustment” Section 4-8 “Level Detector Tables and Level Flatness Adjustment” Section 4-9 “Level SWF Band Adjustment” Section 4-10 “Level ALC Adjustment” Section 3-6 “Internal Time Base Aging Rate Test (Optional)” Section 3-7 “Spurious Signals Tests” Section 3-8 “SSB Phase Noise Test” Section 3-9 “Power Level Accuracy and Flatness Tests” Section 3-10 “Pulse Modulation Tests”

4-5 Calibration File Updates

The following table lists the adjustment procedures (detailed below), the corresponding calibration files that get updated, and whether the adjustments are done manually or by the Levels Cal Station.

Table 4-3. Adjustment List (1 of 2)

Calibration Adjustments	Calibration Files	Updated by Manual Calibration or Levels Calibration Station
Utility DVM Cal	Dvm.xml	Manual Calibration
	Dvm.log	Manual Calibration
Frequency Reference Cal	FrequencyRefCal.log	Manual Calibration
Level Detector Tables Cal	DetectorTableLowGain.xml	Levels Calibration Station
	DetectorTableMidGain.xml	Levels Calibration Station
	DetectorTableHighGain.xml	Levels Calibration Station
Level Flatness Cal	FlatnessTable00.xml	Levels Calibration Station
	FlatnessTable01.xml	Levels Calibration Station
	FlatnessTable02.xml	Levels Calibration Station
	FlatnessTable03.xml	Levels Calibration Station
	FlatnessTable04.xml	Levels Calibration Station
	FlatnessTable05.xml	Levels Calibration Station
	FlatnessTable06.xml	Levels Calibration Station
	FlatnessTable07.xml	Levels Calibration Station
	FlatnessTable08.xml	Levels Calibration Station
	FlatnessTable09.xml	Levels Calibration Station
	FlatnessTable10.xml	Levels Calibration Station
	FlatnessTable11.xml	Levels Calibration Station

Table 4-3. Adjustment List (2 of 2)

Calibration Adjustments	Calibration Files	Updated by Manual Calibration or Levels Calibration Station
Level SWF Band Cal	AlcBandwidth.xml	Manual Calibration
	AlcBandwidth.log	Manual Calibration
	AlcLimiter.xml	Manual Calibration
	AlcLimiter.log	Manual Calibration
Level ALC Cal	AlcBreakpoint.xml	Manual Calibration
	AlcBreakpoint.log	Manual Calibration
	AlcOffset.xml	Manual Calibration
	AlcOffset.log	Manual Calibration

4-6 Utility DVM Adjustment

This adjustment improves the accuracy of the internal DVM, which monitors internal system voltages. Since the DVM does not control instrument operations, this adjustment is considered optional if the unit appears to be operating normally. Perform this calibration if error messages regarding internal system voltages appear, or if the A4 PCB has been replaced.

Required Equipment

- None

Procedure

Adjust the internal DVM circuitry as follows:

1. Power on the MG3702XA and allow the unit to warm up for 1 hour.
2. Preset the unit by pressing the **Preset** hard key.
3. Press SYSTEM | Maint | **12345** | **Enter** | Calibration | Utility.
4. Press DVM | Run Cal | Next.
The +10 V and –10 V values are displayed on the screen.
5. Press Next.
6. Press Save to Nonvolatile.
7. Choose Yes to overwrite existing values.
8. The adjustment is complete, record as completed in the test record.

4-7 Frequency Reference Adjustment

This adjustment improves the frequency accuracy of the MG3702XA.

Required Equipment:

- Absolute Time Corp. Model 300, 10 MHz Frequency Reference

Equipment Setup

Connect the equipment as shown in [Figure 4-1](#).

Figure 4-1. Frequency Reference Adjustment

Adjust the Frequency Reference as follows:

1. Power on the MG3702XA and allow the unit to warm up for 1 hour.
2. Preset the unit by pressing the **Preset** hard key.
3. Press **System** | **Maint** | **12345** | **Enter** | **Calibration** | **Frequency**.
4. Press **Reference Cal**.
5. Connect the 10 MHz Output from the Frequency Reference to the 10 MHz REF IN connector at the rear panel of the MG3702XA.
6. Press **Run Cal** | **Next** to continue.
The values are displayed on the screen.
7. Press **Next**.
8. Press **Save to Nonvolatile**.
9. Choose **Yes** to overwrite existing values.
10. The adjustment is complete. Record as completed in the test record.

4. Enter Tester ID.
5. Choose Run Test.
6. Choose Level Calibration | Verification Wildfire | Next.
7. The software will auto detect the options installed and the MG3702xA serial number.
8. Choose Next.
9. Choose **Select All** to choose all of the following tests.
 - Log Table Calibration
 - Flatness Calibration
 - Maximum Leveled Power Verification
 - Log Conformity Verification
 - Level Accuracy Verification
 - Mixer Loss Calibration
10. Choose **Select All** to select all steps for Flatness Calibration.
11. Choose **Select All** to select all Log Conformity Verification tests.
12. Choose **Select All** to select all Level Accuracy Verification tests.
13. Select the power sensor model being used.
14. Connect the sensor to the power meter calibrator port and zero/cal the sensor.
15. Follow the directions on the monitor to perform the calibration and verification tests.

4-9 Level SWF Band Adjustment

This adjustment updates the SWF Band Calibration table.

Required Equipment:

- None

Procedure

1. Power on the MG3702xA and allow the unit to warm up for 1 hour.
2. Preset the unit by pressing the **Preset** hard key.
3. Press **System** | Maint | **12345** | **Enter** | Calibration | Level
4. Press SWF Band Cals
5. Press Run Cal
6. Press Next
7. When finished, press Next
8. Choose **Save to Nonvolatile**
9. Choose **Yes** to overwrite existing values
10. Switch from the Bandwidth tab to the Limiter tab
11. Press Run Cal | Next
12. When finished, press Next
13. Choose **Save to Nonvolatile**
14. Choose **Yes** to overwrite existing values
15. The adjustment is complete. Record as completed in the test record.

4-10 Level ALC Adjustment

This adjustment updates the ALC Calibration table.

Required Equipment

- Anritsu ML2438A Power Meter
- Anritsu MA2474D Power Sensor
- Anritsu 41KC-10 10 dB Attenuator

Equipment Setup

Connect the equipment as shown in [Figure 4-3](#)

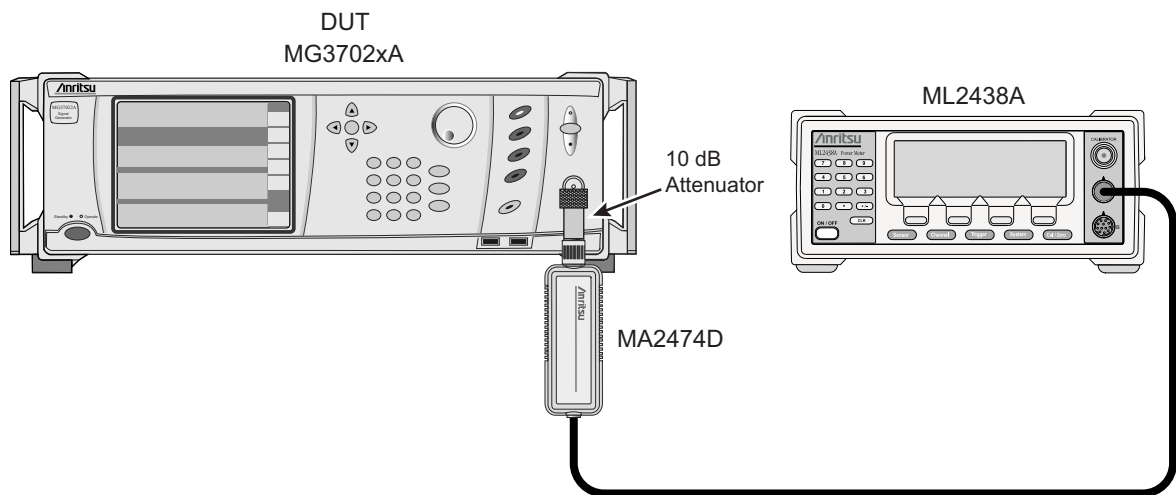

Figure 4-3. Level ALC Adjustment Setup

Procedure

1. Power on the MG3702XA and allow the unit to warm up for 1 hour.
2. Preset the unit by pressing the Preset hard key.
3. Press **System** | **Maint** | **12345** | **Enter** | **Calibration** | **Level**.
4. Press **ALC Cals**.
5. Cal/zero the power sensor and set the sensor cal factor to 1 GHz.
6. Connect the power sensor to a 10 dB attenuator and then connect the 10 dB attenuator directly to the RF Output of the MG3702XA.
7. Press **Run Cal** | **Next**.
8. Adjust the DAC value so the power meter reads -25.0 dBm, which is 10 dB below the desired level.
9. Press **Next**.
10. Adjust the DAC value so the power meter reads -15.0 dBm, which is 10 dB below the desired level.
11. Press **Next**.
12. Adjust the DAC value so the power meter reads -15.0 dBm, which is 10 dB below the desired Level.
13. Press **Next**.
14. When instructed to enter the DAC value for 1 dB less than the maximum power, increase the DAC until the power meter shows no increase in power.

Note this power level and then decrease the DAC value until the power level is 1 dB below the noted maximum power.

15. Press Next.
16. Adjust the DAC value so the power meter reads 10 dB below the desired level.
17. Press Next.
18. The adjustment may require another iteration. Press Next to continue and repeat [Step 8](#) through [Step 17](#) if another iteration is required.
19. Once Down Converter Detector is complete touch Next to start Main Band Detector Cal.
20. Repeat [Step 8](#) through [Step 18](#) to complete Main Band Detector Cal.
21. When the adjustment is complete, press Next to continue.
22. Press Save to Nonvolatile.
23. Choose Yes to overwrite.
24. Choose the tab called Log Amp Zero.
25. Press Run Cal | Next.
26. When adjustment is finished press Next
27. Press Save to Nonvolatile
28. Choose Yes to overwrite.
29. The calibration is complete. Record as completed in the test record.

4-11 Touch Screen Accuracy Adjustment

This process should be performed when the front panel or A2 Microprocessor PCB has been replaced. The adjustment improves the accuracy of presses on the touch screen as compared to the mouse pointer.

1. Enter the display configuration menu ([Figure 4-4](#)) by pressing **System** | Confi. | Display...

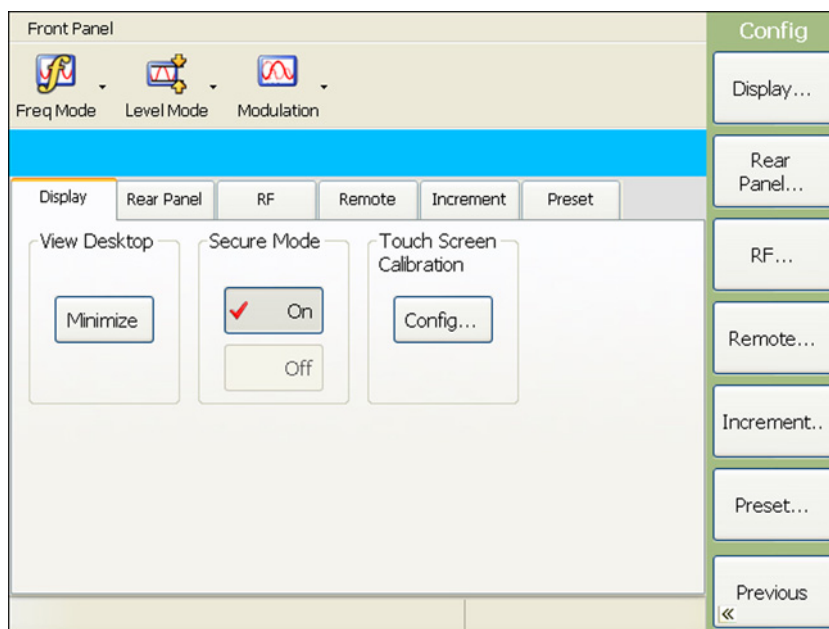

Figure 4-4. Display Configuration Menu

Note After initiating the touch-screen calibration, the calibration routine will count down and automatically start the calibration sequence.

2. Press the Touch Screen Calibration Config... button shown in [Figure 4-4](#) and follow the on-screen instructions found on the control panel ([Figure 4-5](#)) to start the automatic calibration function.

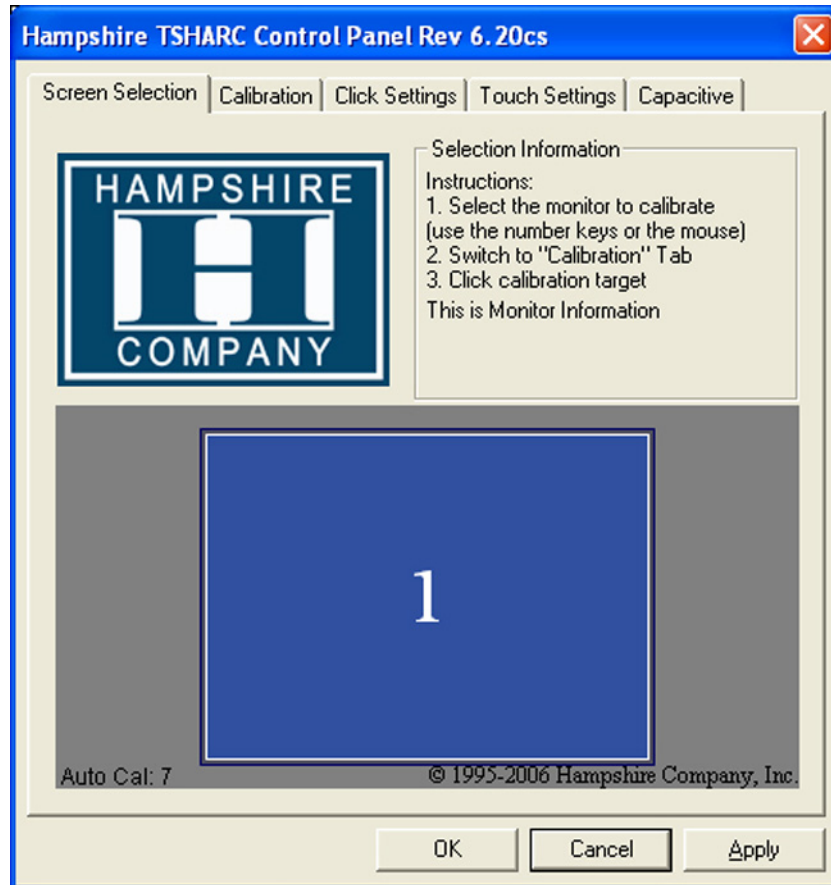

Figure 4-5. Touch Screen Control Panel

3. Select the Calibration tab before the countdown expires for manual calibration.

The screen shown in [Figure 4-6](#) is displayed, which offers additional calibration configurations and touch-screen tests:

- The Configure button sets the number of calibration points and the offset.
 - The Test button allows you to draw a line on the screen with your finger to test the calibration settings.
 - The Click Settings tab controls the touchscreen right-click and double-click settings.
 - The Touch Settings tab sets the touch screen sound feedback options.
 - The Capacitive tab is not used in calibration of the MG3702xA touch screen.
4. To continue with the manual touch-screen calibration, touch the calibration target
The calibration routine will continue as shown in [Figure 4-7](#) on page 4-12.
 5. Touch and hold the center of the target for each step of the calibration process as directed in the on-screen display.

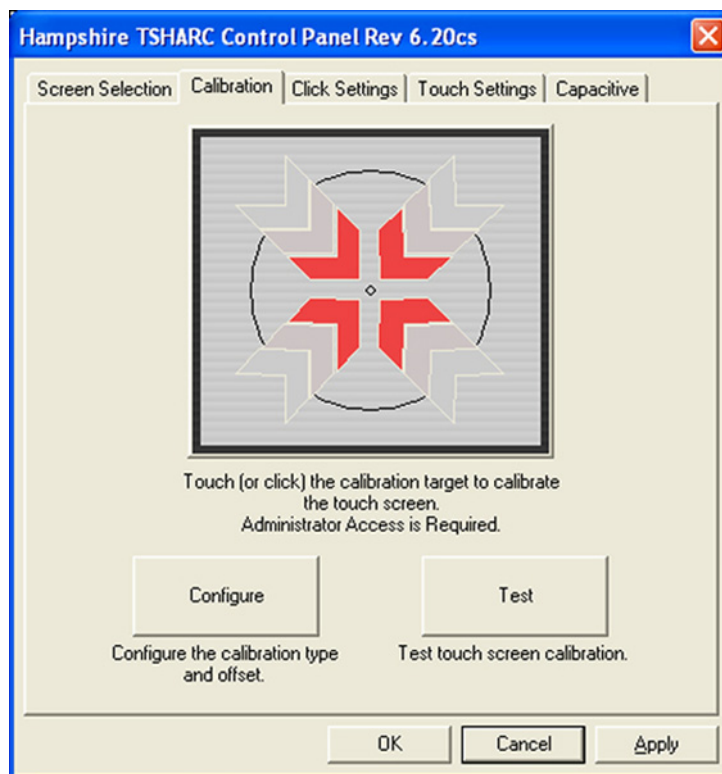

Figure 4-6. Touch Screen Control Panel

6. Now test the calibration by dragging the target around the screen as instructed.

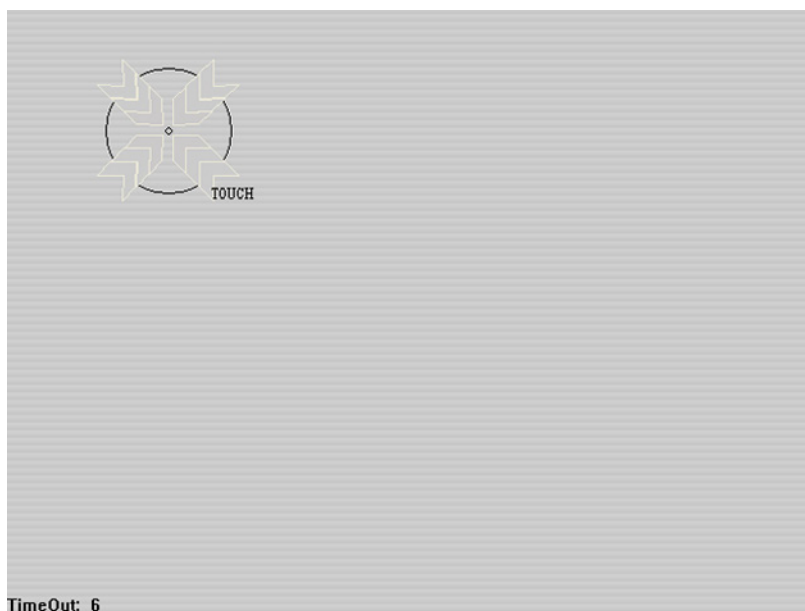

Figure 4-7. Touch Screen Calibration

Note

The calibration process has an automatic time-out feature to ensure that you are able to exit the calibration in the event of a problem.

Chapter 5 — Troubleshooting

Note

Troubleshooting procedures presented in this chapter may require the removal of the instrument's covers to gain access to the test points on the printed circuit boards and other subassemblies.

Danger



Hazardous voltages are exposed inside the MG3702xA whenever the power supply enclosure is open and the AC line power is connected. Turn off the instrument and remove the line cord before removing the power supply cover. Use extreme caution when troubleshooting with the power supply cover removed and the unit energized.

Troubleshooting or repair procedures should only be performed by qualified service personnel who are fully aware of the potential hazards.

Caution

ESD Requirements: The MG3702xA contains components that can be easily damaged by electrostatic discharge (ESD). An ESD safe work area and proper ESD handling procedures that conform to ANSI/ESD S20.20-1999 or ANSI/ESD S20.20-2007 is mandatory to avoid ESD damage when handling subassemblies or components found in the MG3702xA instrument. Repair of damage that is found to be caused by electrostatic discharge is not covered under warranty. Always observe proper static-sensitive component handling precautions.

5-1 Introduction

This chapter provides information for troubleshooting the MG3702xA. The troubleshooting procedures presented in this chapter support fault isolation to a replaceable subassembly or RF component. Remove and replace procedures for the subassemblies and RF components are found in [Chapter 6, “Removal and Replacement Procedures”](#). Required calibrations after assembly replacement are shown in [Table 4-2 on page 4-2](#).

All replaceable parts and assemblies and their locations are listed in [Chapter 6, “Removal and Replacement Procedures”](#).

Ensure you are familiar with the information in [Chapter 1, “General Information”](#) and [Chapter 2, “Functional Description”](#) before beginning any troubleshooting operations. Refer to important cautionary information in [Chapter 6, “Removal and Replacement Procedures”](#) before attempting to replace any internal items.

Unusual problems can often be caused by communication errors between external electronic equipment and the synthesizer or by powering down improperly (ensure that the unit is not being powered down using the rear panel switch).

Before attempting to troubleshoot any problem, disconnect all external equipment and perform a Master Reset:

1. Press **System** key
2. Press **Config**
3. Press the tab **Preset**
4. Locate **Master Reset** and then press **Reset**

A cursory inspection of the instrument exterior may show the presence of problems such as a damaged RF output connector, swapped side covers or other conditions causing reduced airflow, or evidence of the instrument being dropped.

Note Troubleshooting procedures in this chapter are intended to help identify and replace a failed part or assembly. The complex nature of this product may necessitate returning the MG3702xA to an Anritsu Service Center for some repairs and associated adjustments (calibrations).

5-2 Test Equipment List

The test equipment for the troubleshooting procedures presented in this chapter is listed in [Table 1-2 on page 1-6](#).

5-3 Error Messages

During normal operation, the MG3702xA generates error messages to indicate internal malfunctions, abnormal instrument operations, or invalid signal inputs or data entries. It also displays warning messages to alert the operator of conditions that could result in inaccurate MG3702xA output. In addition, status messages are displayed to remind the operator of current menu selections or settings.

System Self-Test

At power-on, the instrument performs a short self-test and reports errors that were encountered. A more comprehensive self-test performed under the System key (Self-Test / Run Self-Test) may be used for identifying system problems (excluding Windows-environment problems). The list of self-test errors and probable causes is found in [Table 5-1 on page 5-3](#). The error number will be displayed at the right of the screen, below is an example of an error.

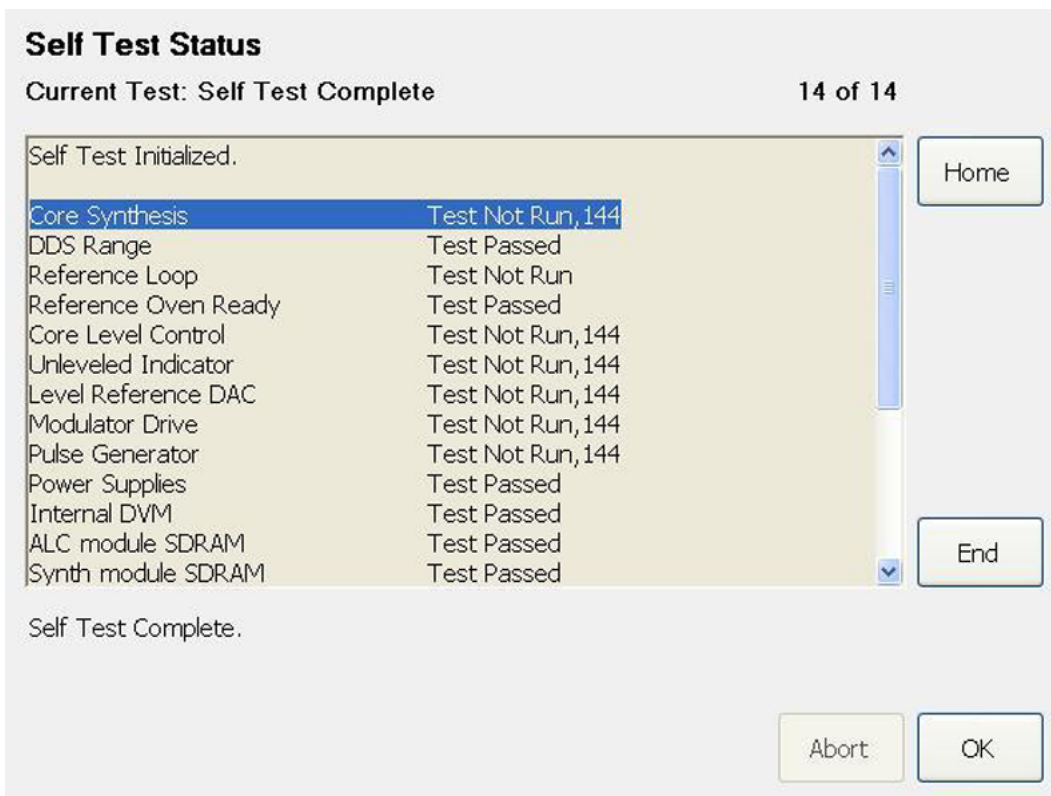

Figure 5-1. Failing Self Test Results

1. If failures appear after manually performing a self-test, select OK | Advanced.

2. To view the failure details, press the tab related to the failure (such as Frequency).
3. Highlight the failed test and activate the check mark under both Enabled and Verbose columns.
4. Select Selected Test Log to view the failure details.

You may chose to rerun only certain tests at this point. To do this:

5. Activate the checkmark(s) in the Enabled column for the desired test(s) and select Run Enabled.
The desired tests will be performed.

Self-test Definitions

- **Core** refers to the A7/A9 RF synthesis and associated PLL sections
- **Output Loop** refers to the A9 RF output
- **DDS Range** refers to the control circuit of the fine loop

Table 5-1. Self-Test Error Messages

Error Message	Troubleshooting Table	Page Number
Error 101 DVM Positive 10V Reference	Table 5-12	5-19
Error 102 DVM Negative 10V Reference	Table 5-12	5-19
Error 108 Crystal Oven Cold	Table 5-13	5-20
Error 109 The 100 MHz Reference is not Locked to the External Reference	Table 5-14	5-20
Error 121 Unleveled Indicator Failed	Table 5-15	5-20
Error 122 Level Reference Failed	Table 5-15	5-20
Error 144 RF was Off when Self-test started. Some tests were not performed.	Table 5-16	5-21
Error 148 Pulse 100 MHz reference circuitry failed	Table 5-17	5-21
Error 160 Core Synthesis	Table 5-18	5-21
Error 161 DDS Range (Fine loop controller failure)	Table 5-19	5-21
Error 162 Modulator Drive	Table 5-20	5-22
Error 163 A2 Digital Power	Table 5-21	5-22
Error 164 A2 Power Current	Table 5-21	5-22
Error 165 Synth RAM Data	Table 5-22	5-22
Error 166 Synth RAM Address	Table 5-22	5-22
Error 167 Synth RAM device	Table 5-22	5-22
Error 168 ALC Ram Data	Table 5-23	5-23
Error 169 ALC RAM Address	Table 5-23	5-23
Error 170 ALC RAM Device	Table 5-23	5-23
Error 171 Processor Battery	Table 5-24	5-23
Error 172 Core ALC	Table 5-25	5-23

Normal Operation Error and Warning/Status Messages

When an abnormal condition is detected during operation, the MG3702xA displays an error message to indicate that the output is abnormal or that a signal input or data entry is invalid. It also displays warning messages to alert you of conditions that could cause an inaccurate signal generator output. Status messages to remind you of current menu selections or settings are also generated.

Table 5-2 is a summary list of possible error messages that can be displayed during normal operations.

Table 5-2. Possible Error/Status Messages during Normal Operation

Error Message	Description
Locked	The RF output frequency is phase locked to the internal or external reference.
Error: Lock Error	The RF output frequency is not phase locked to the internal or external reference. The frequency accuracy and stability of the RF output is greatly reduced. This is usually caused by an internal component failure. Run self test to verify the malfunction.
Error: Sweep Setup	Displayed when the sweep setup is invalid. In this case, the last valid sweep is still occurring. Changing the sweep parameters to create a valid sweep setup. (10,000 points) should clear the error.
INT	The frequency reference is the internal 100 MHz reference oscillator.
EXT	The frequency reference is an external 10 MHz source (connected to the rear panel external reference input).
Leveled	The ALC is stable.
Unleveled	The ALC is unstable. Displayed when the RF output goes unleveled and is normally caused by exceeding the specified leveled power rating. Reducing the power level usually clears the error message.
ERROR	Displayed in the modulation mode title bar when a pulse parameter setting is invalid for the current pulse modulation state. The Pulse Period, Widths, and Delays must be set to conform as follows: $D1 + W1 + (D2 - W1) + W2 + (D3 - W2) + W3 + (D4 - W3) + W4$ should be \leq Period - 20 ns
Over Range Under Range	Displayed in the parameter editing area when the value entered is outside the range of the instrument. Entering valid values usually clears the error.

Error Log

The MG3702xA utilizes an error log to facilitate troubleshooting. The log displays problems encountered during self-test, potential hardware failures, normal operation errors, warning/status messages and remote devices that fail to initialize properly.

The log is accessed under the **System** key (press **Info**, then Error Log). The log holds a maximum of 100 errors, with most recent errors at the top of the list. Navigation controls are displayed above the log.

The error log displays the general error description, a number identifying the error type, and the date and time. Select **Details** to view the frequency, power level, temperature, and other internal conditions at the time of the error. The operator may recall the settings by selecting **Recall Error Setup** which places the MG3702xA into the same conditions when the error was logged.

To increase the operating speed of the unit under failing conditions, the error reporting may be disabled by pressing the **System** key, pressing **Maint**, and selecting OFF under Error Log.

To determine the probable failed assembly causing the error message(s), refer to the Error Tables (starting on table 5.13) and the circuit descriptions.

Note	The error “Unleveled” is often caused by an operator choosing a power setting that is above the capabilities of the instrument at the frequency chosen (and options installed). Refer to Appendix B, “MG3702xA Technical Data Sheet” for guaranteed level capabilities of this instrument.
-------------	--

5-4 No Error Message

The MG3702xA must be operating to run self-test. Therefore, malfunctions that cause the instrument to be non-operational do not produce error messages. These problems are generally a failure of the MG3702xA to power up properly or other start up issues. [Table 5-3](#) through [Table 5-11](#), beginning [on page 5-16](#), provides troubleshooting procedures for these malfunctions.

5-5 Troubleshooting Tables

This section provides procedures for troubleshooting common malfunctions encountered during operation of the signal generator. Included are procedures for troubleshooting faults that do not produce error messages, such as, failure to power up and unexpected shutdown.

[Table 5-12](#) through [Table 5-25](#), beginning [on page 5-19](#), provide procedures for isolating malfunctions (that are displayed as self-test errors) to a replaceable subassembly or RF component. In those cases where any of several subassemblies or RF components could have caused the problem, subassembly/RF component replacement is indicated. The recommended replacement order is to replace first the subassemblies/RF components that are most likely to have failed.

[Figure 5-2 on page 5-6](#) and [Figure 5-3 on page 5-7](#) show the locations of the MG3702xA connectors and test points that are called out in the troubleshooting procedures of [Table 5-3](#) through [Table 5-25](#).

Caution	Never remove or replace a subassembly or RF component with power applied. Always remove the power cord before disassembly and removal of any component or PCB. Serious damage to the instrument or personal injury may occur.
----------------	---

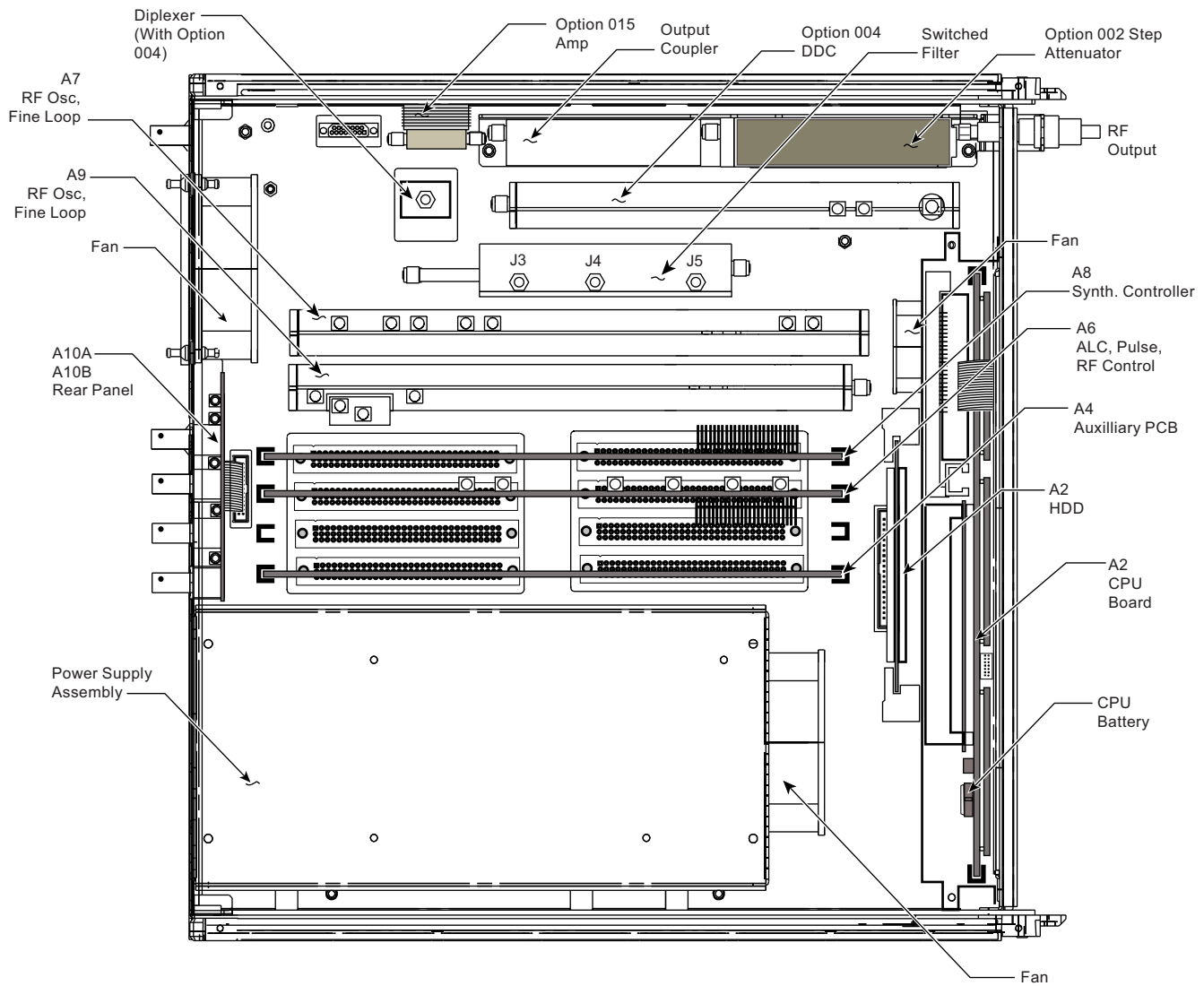

Figure 5-2. Top View of the MG3702xA Showing Connector and Test Point Locations

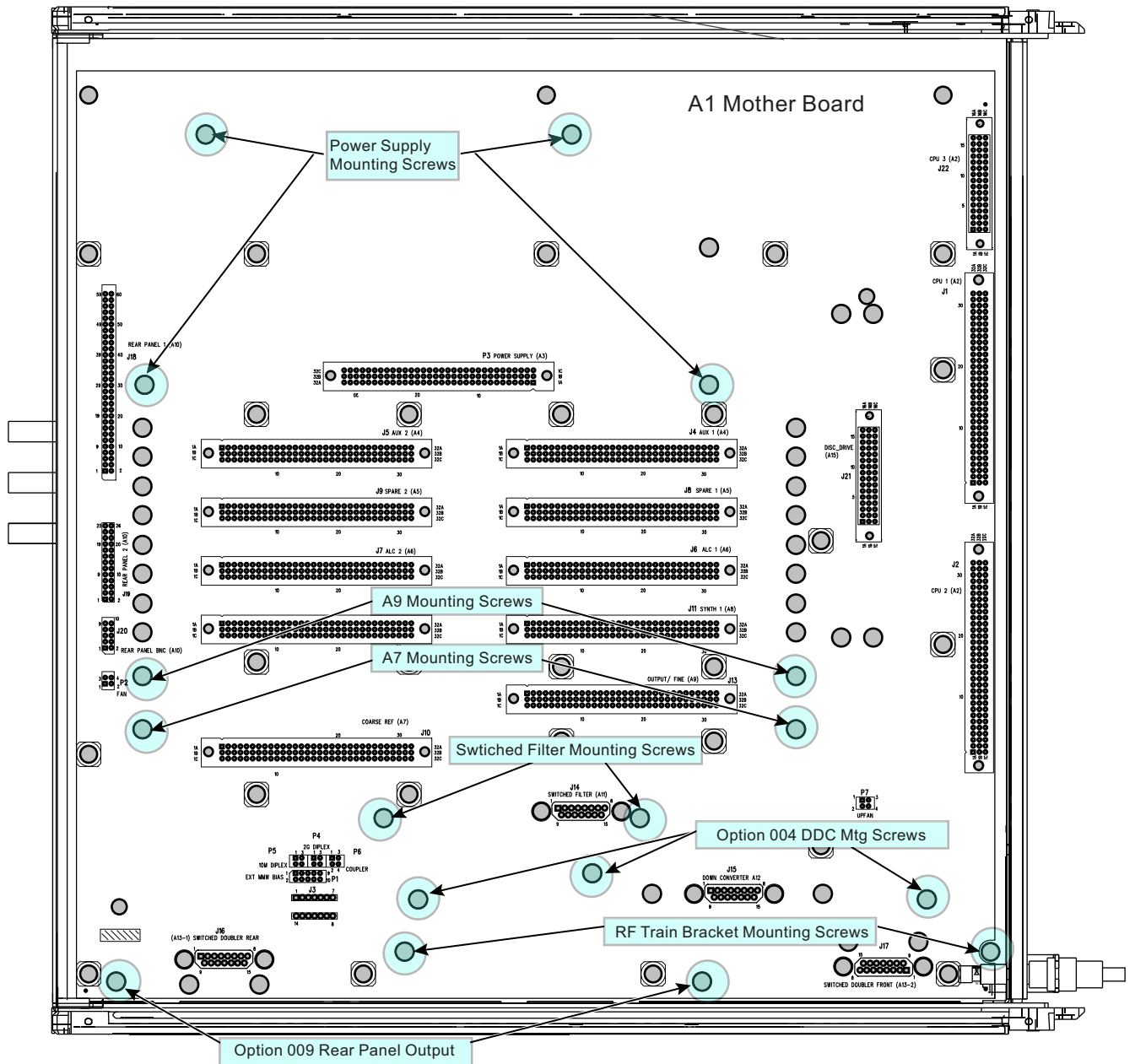

Figure 5-3. Bottom View of the MG3702xA Showing Connector and Test Point Locations

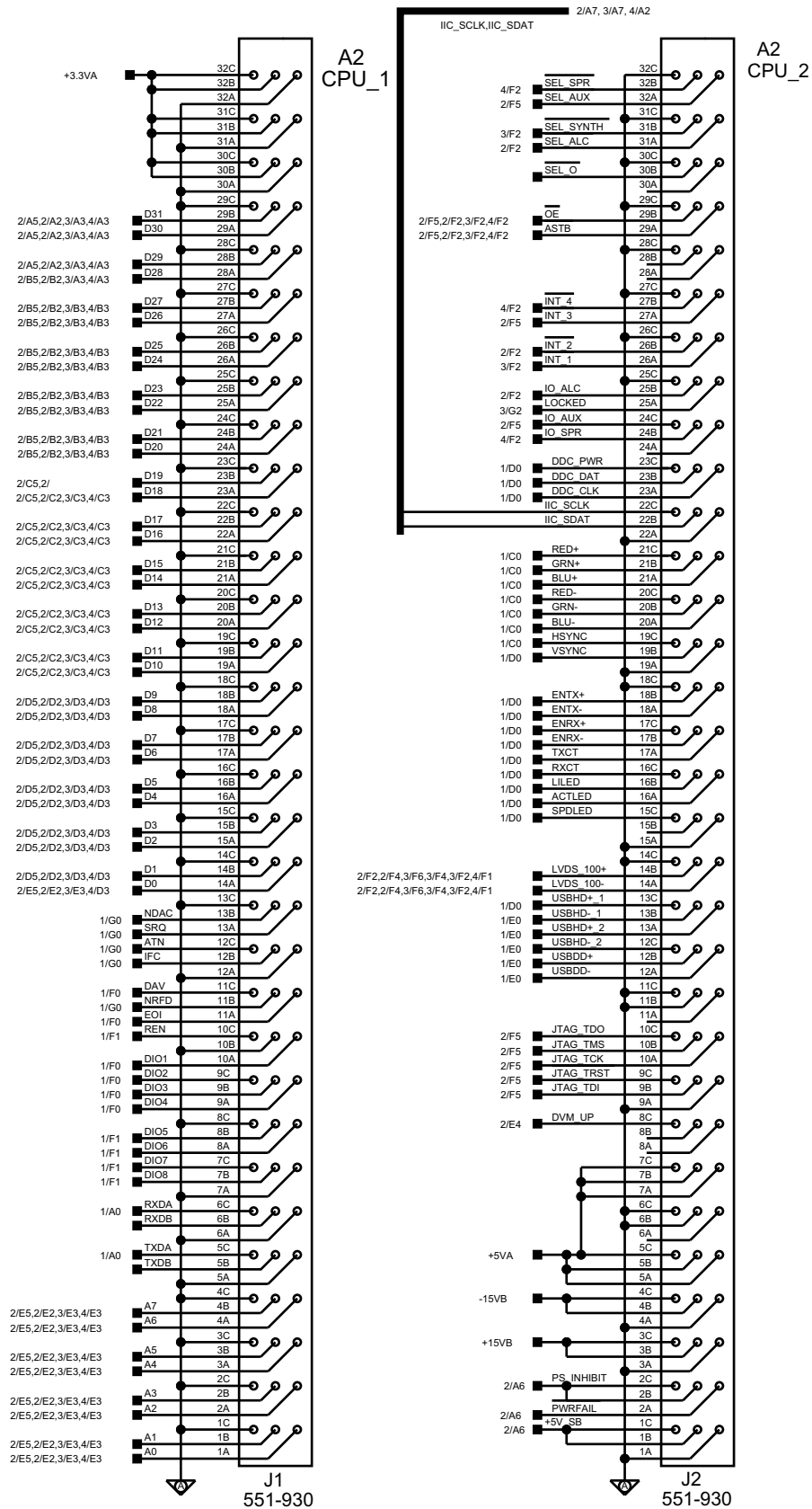

Figure 5-4. A2 CPU J1, J2 Connector Pinout Diagram

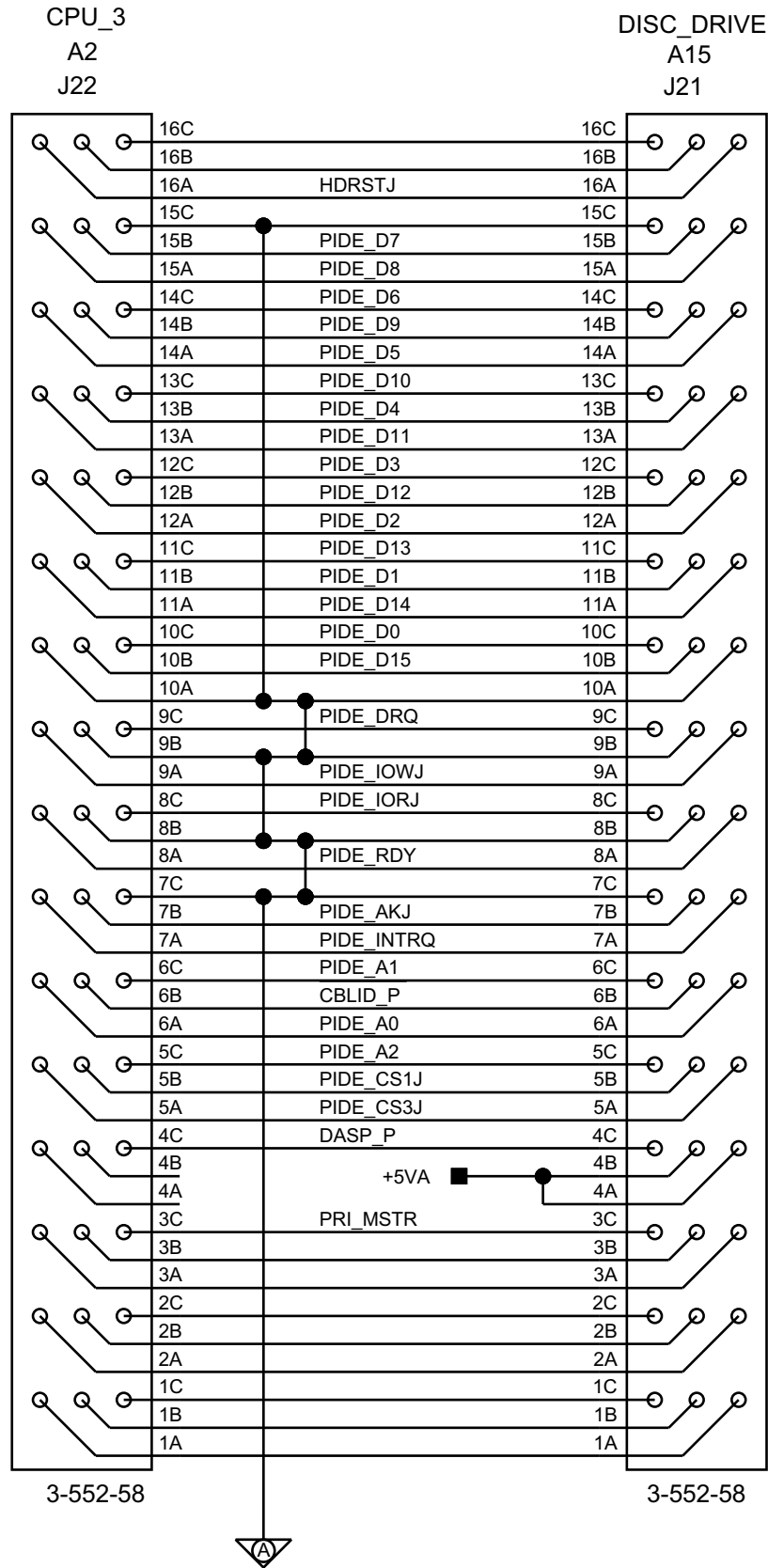

Figure 5-5. A2 CPU and Disc Drive J22, J21

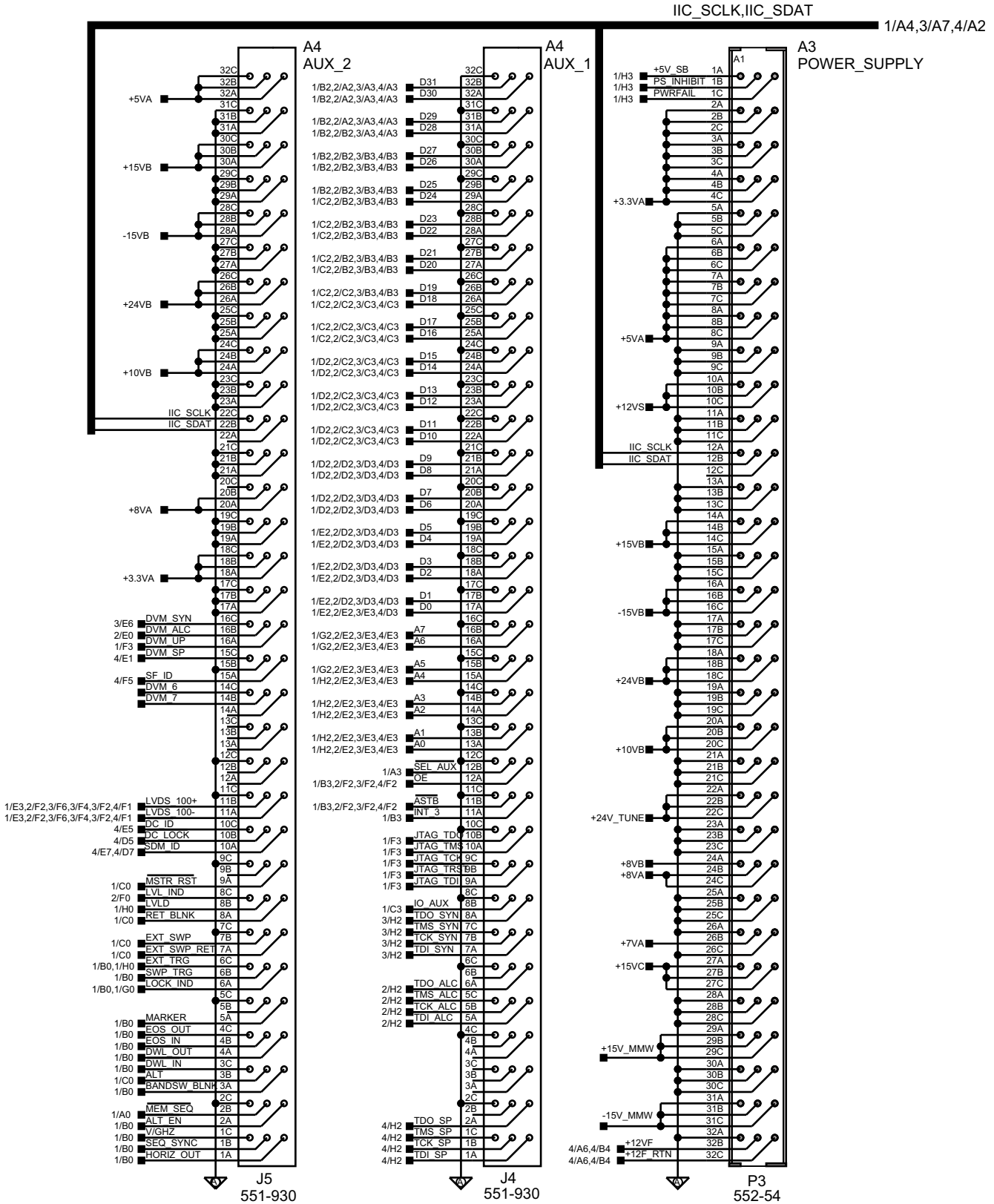

Figure 5-6. A3 Power Supply, A4 AUX1 and AUX2

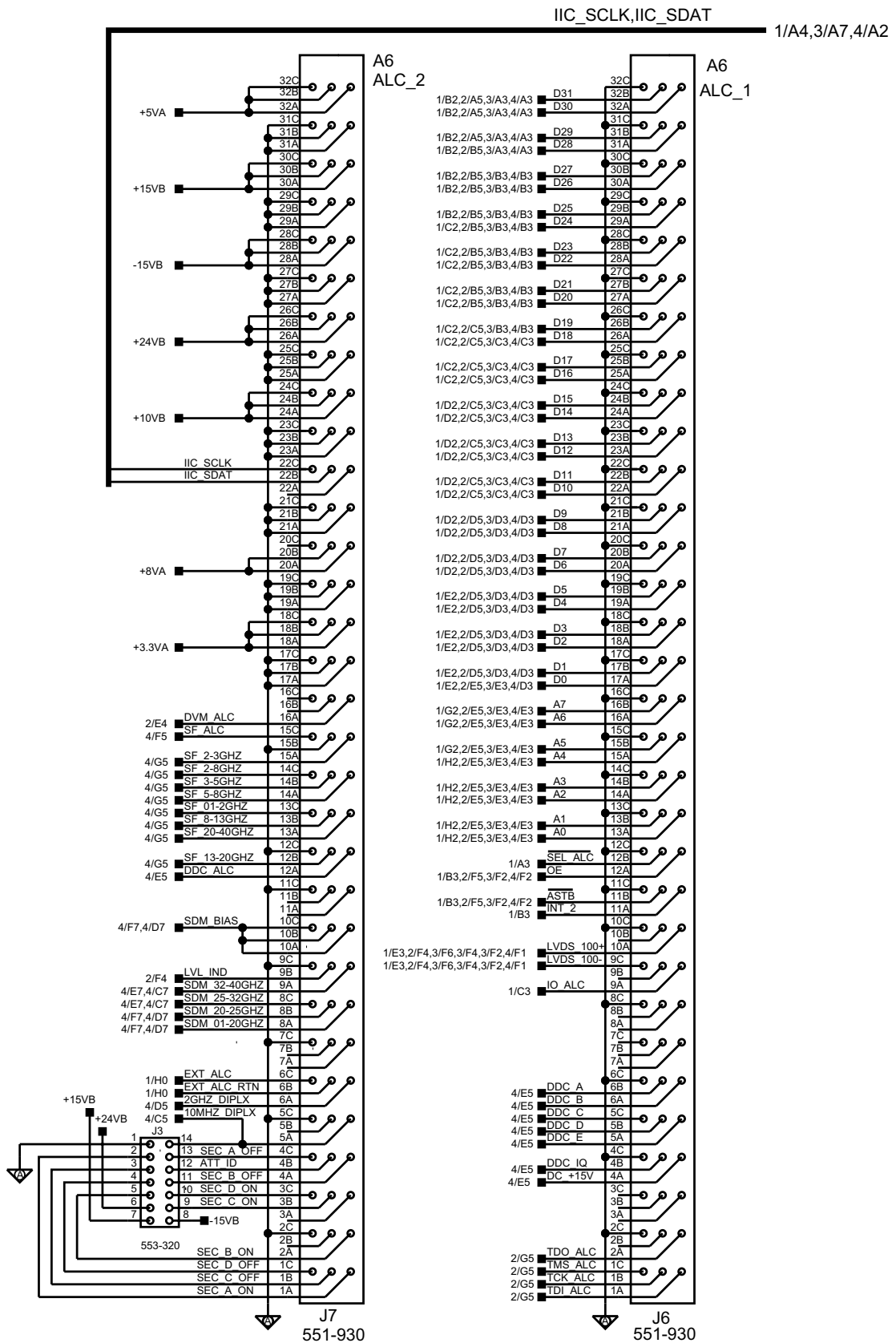

Figure 5-7. A6 ALC1 and ALC2

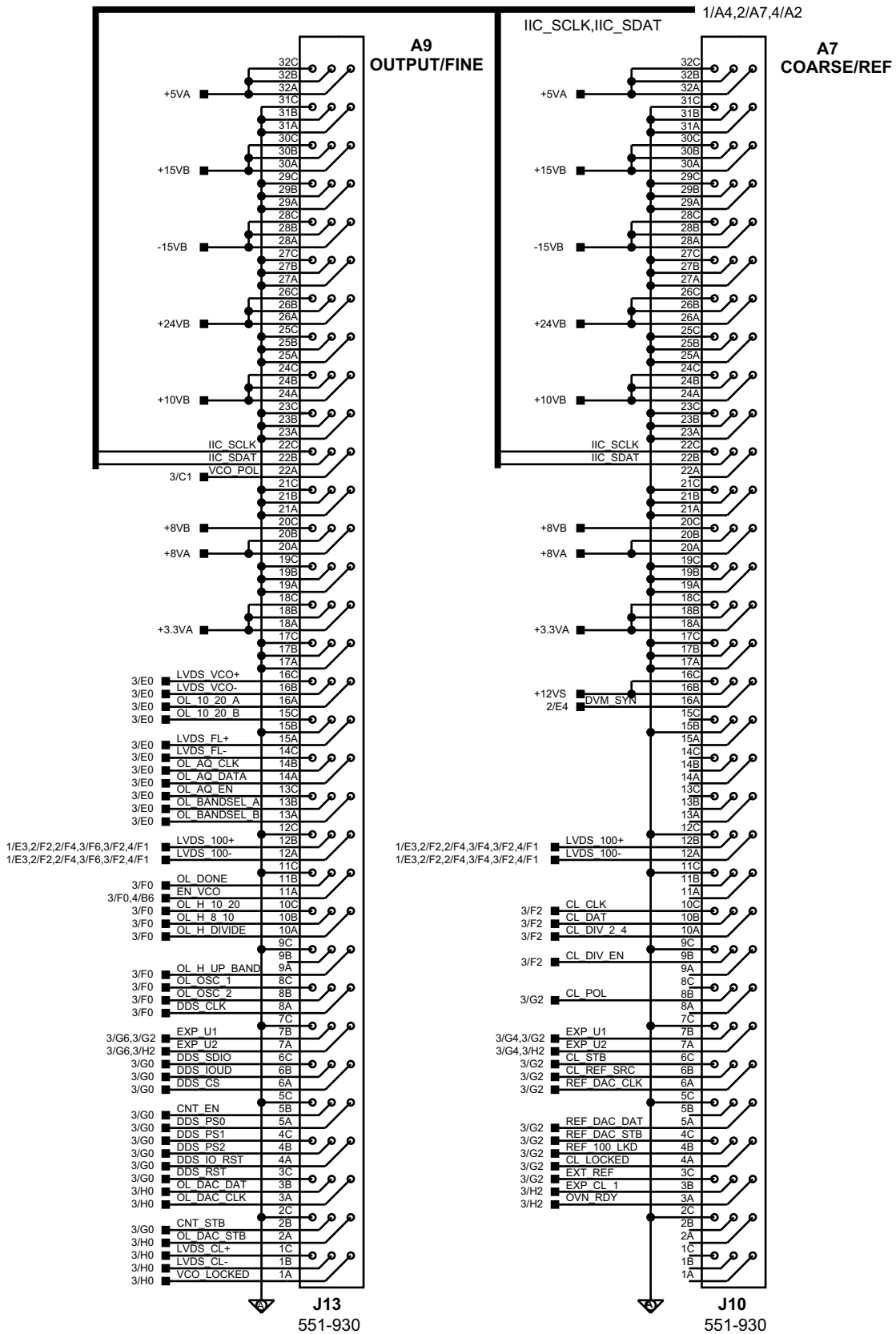

Figure 5-8. A7 Course/Ref, A9 Output/Fine

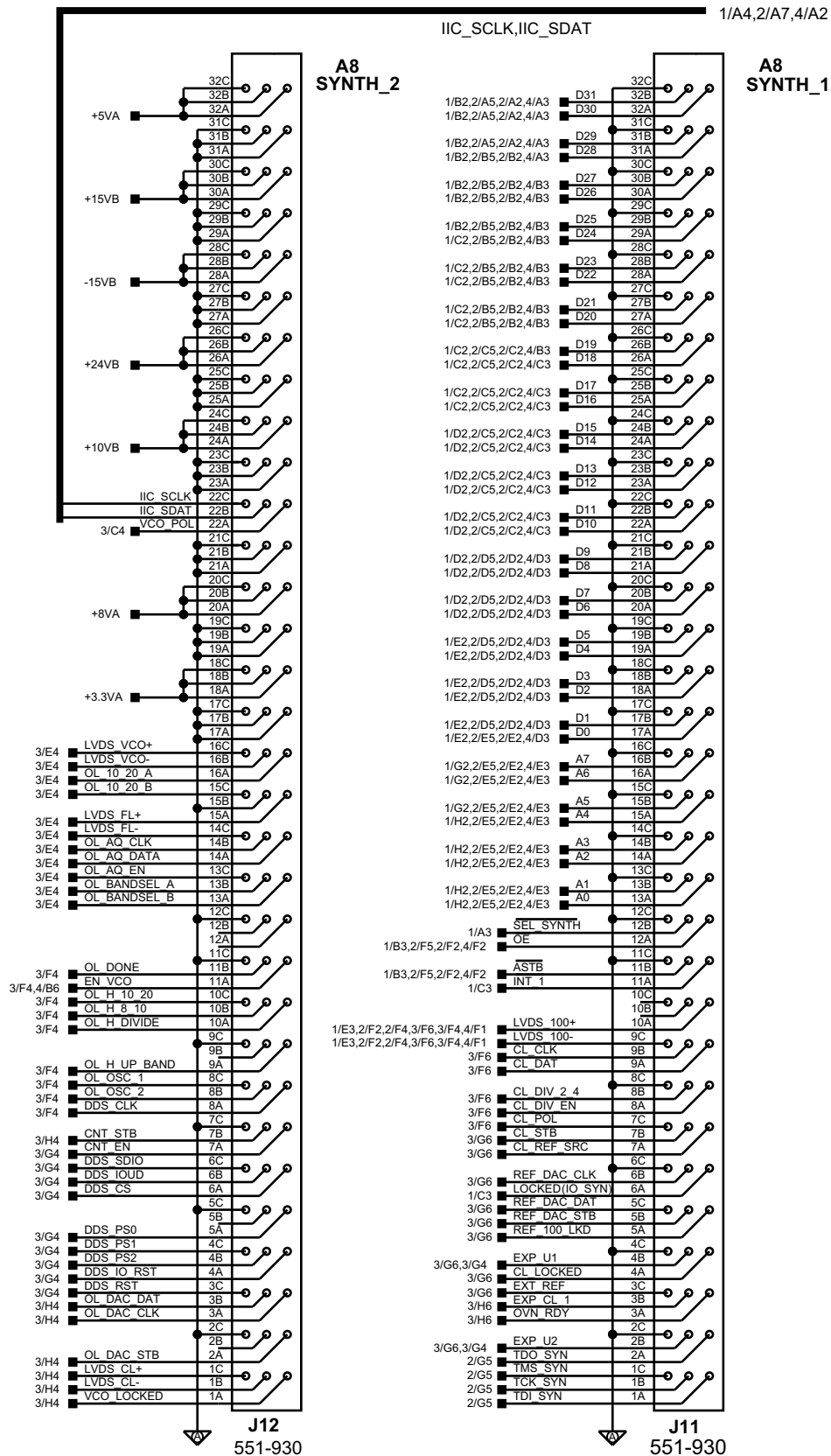

Figure 5-9. A8 Synth1, A8 Synth2

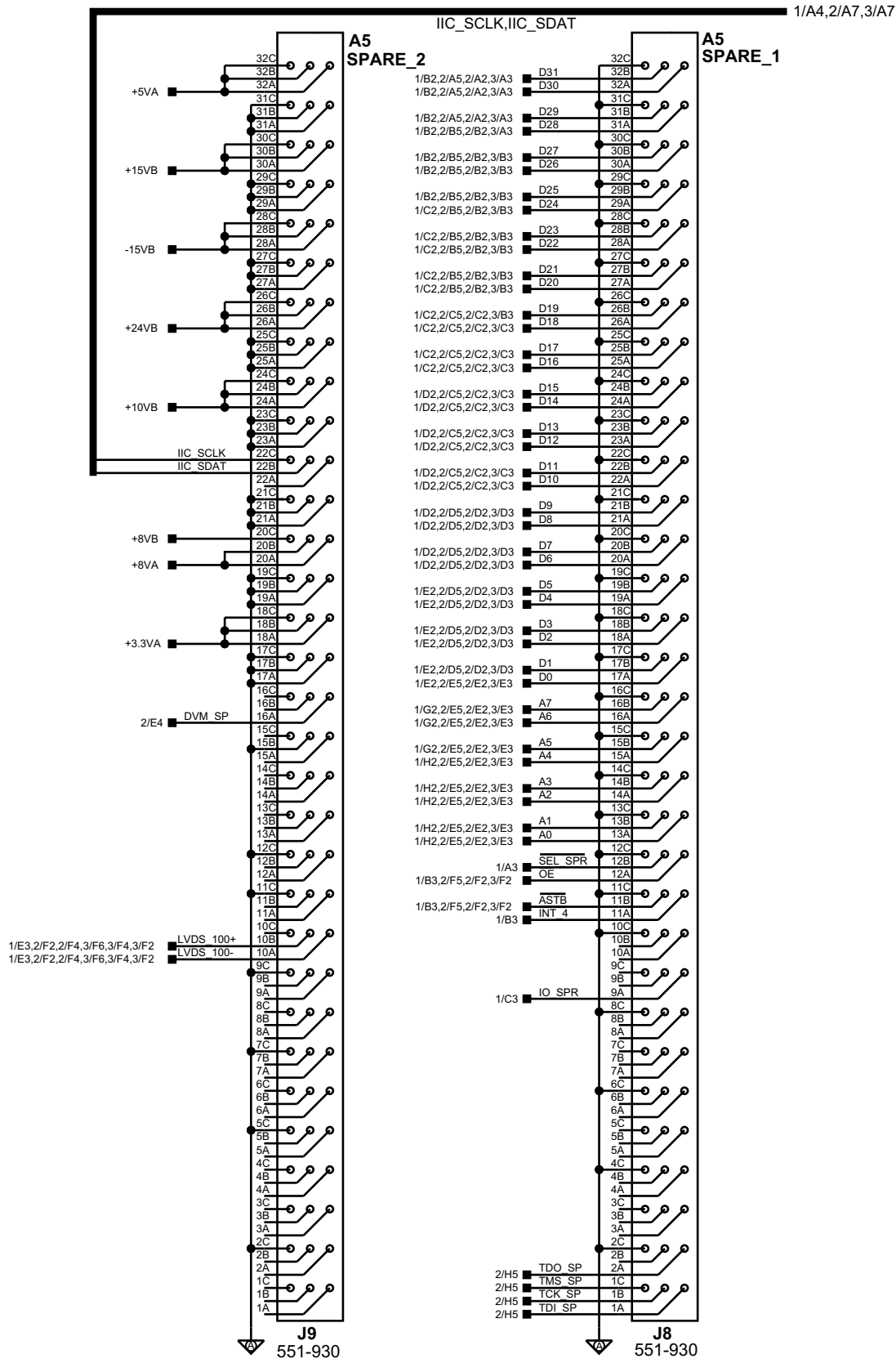

Figure 5-10. A5 Spare1 and Spare2

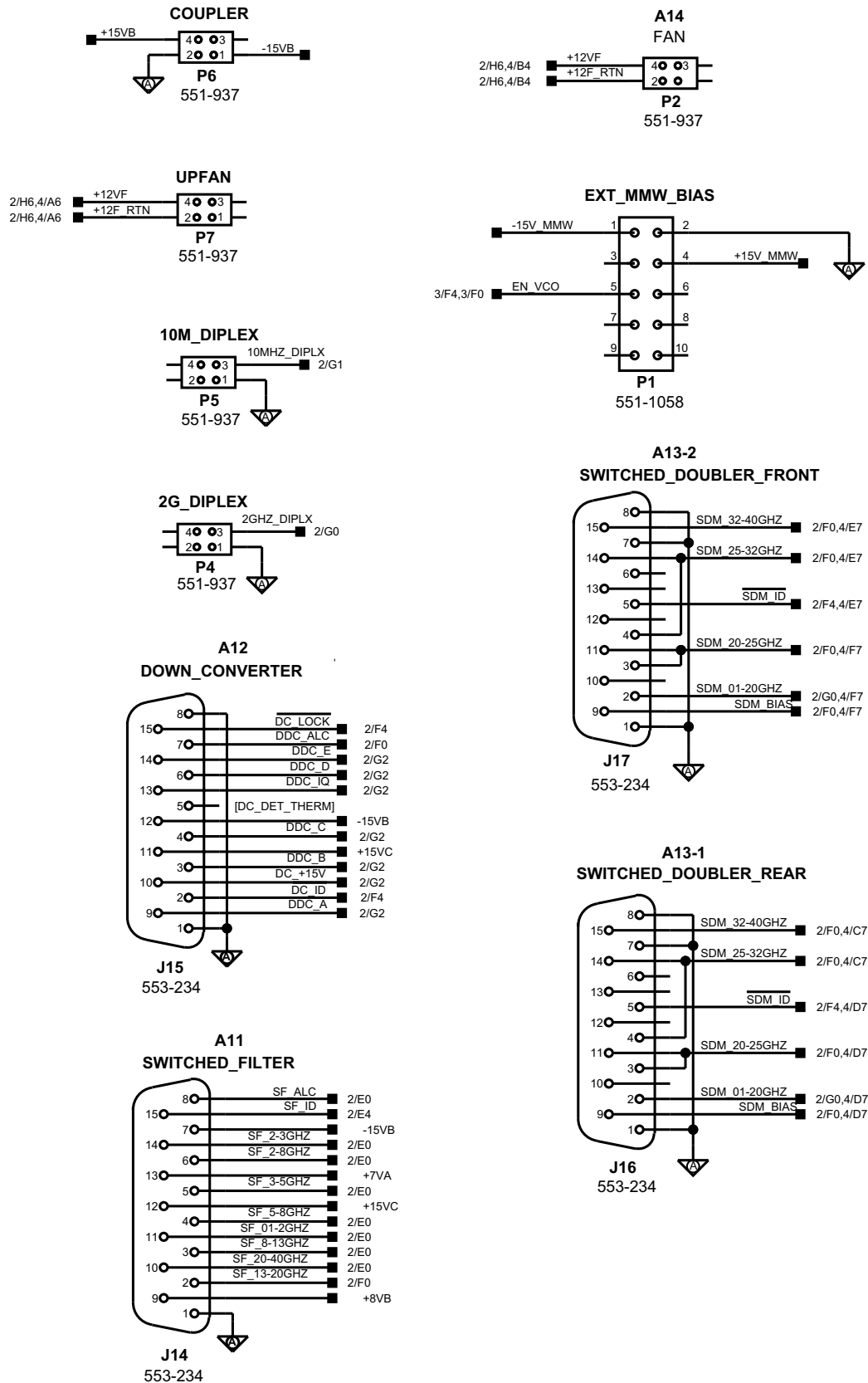

Figure 5-11. A11, A12, A13, A14 and Miscellaneous Connectors

Table 5-3. Malfunctions Not Displaying an Error Message 1**MG3702xA Will Not Turn On (OPERATE light and FAN are OFF)**

Normal Operation: When the MG3702xA is connected to the power source and the rear panel line switch is turned on, the OPERATE light should illuminate (green) and the instrument should power up. When the MG3702xA is set to standby mode, the fans should run slow and the STANDBY light should illuminate (yellow).

1. Disconnect the MG3702xA from the power source, then check the line fuses on the rear panel.
 - If the line fuses are good, go to [Step 2](#).
 - If the line fuses are defective, replace the fuses.
2. Apply power to the instrument.
 - If the instrument powers up, the problem is cleared.
 - If the instrument fails to power up, go to [Step 3](#).
3. Disconnect the MG3702xA from the power source, then remove the MG3702xA top cover.
4. Remove the four outer screws to the top cover of the power supply module and lift the cover with the main power supply attached. Refer to the R&R procedures in [Chapter 6, “Removal and Replacement Procedures”](#) as needed.
5. Inspect the AC line supply/switch block and the wiring to the main power supply and standby power supply for defects.
 - If a defect is found, replace as necessary.
 - If no defect is found, go to [Step 6](#).
6. Replace the standby and main power supplies.
 - If the instrument powers up, the problem is cleared.
 - If the instrument fails to power up, contact your local Anritsu service center for assistance.

Table 5-4. Malfunctions Not Displaying an Error Message 2**MG3702xA Will Not Turn On (OPERATE light is ON)**

Normal Operation: When the MG3702xA is connected to the power source and the rear panel line switch is turned on, the OPERATE light should illuminate and the instrument should power up. When the MG3702xA is set to standby mode, the fans should run slow and the STANDBY light should illuminate.

Checking DC Voltages

Manually check system DC voltages (see table 5-6) to ensure the supplies are close to the expected values.

Caution For safety reasons, do not take voltage measurements inside the power supply enclosure. Instead, take the measurements on P3 of the motherboard.

1. Remove the MG3702xA top and bottom cover.
2. Apply power and measure the regulated voltages at A1P3 according to [Table 5-5 on page 5-17](#).
 - If one or more, but not all of the related voltages are out of regulation, a malfunction of the regulation circuitry is indicated. Replace the A2 voltage regulator PCB.
 - If all of the related voltages are out of regulation, a malfunction of the regulator supply source is indicated. Replace the related supply source according to [Table 5-5](#).
3. Check for normal operation.
 - If the instrument powers up, the problem is cleared.

- If the instrument fails to power up, go to [Step 4](#).
4. Press the front panel **RF OUTPUT ON/OFF** button on and off.
 - If the yellow and green LEDs toggle, the malfunction may be caused by a failed front panel circuit. Replace the front panel assembly.
 - If the LEDs do not toggle or if both LEDs are lit, the problem may be caused by a CPU malfunction. Replace the A2 PCB.
 5. If the instrument fails to power up, contact your local Anritsu service center for assistance.

Table 5-5. Power Supply Module Regulated Outputs

A1 (A3) P3 Pin #	Regulator Output (V)	Related Source
32A	GRN REFERENCE	
1A	+5V_SB	Standby power supply
2A	+3.3VA	Main Power Supply (Positive V)
6A	+5VA	Main Power Supply (Positive V)
10A	+12VS	Standby power supply
14A	+15VB	Main Power Supply (Positive V)
16A	-15VB	Main Power Supply (Negative V)
18A	+24VB	Main Power Supply (Positive V)
20A	+10VB	Main Power Supply (Positive V)
22A	+24V_TUNE	Main Power Supply (Positive V)
24A	+8VB	Main Power Supply (Positive V)
24B	+8VA	Main Power Supply (Positive V)
26B	+7VA	Main Power Supply (Positive V)
27A	+15VC	Main Power Supply (Positive V)
29A	+15V_MMW	Main Power Supply (Positive V)
31A	-15V_MMW	Main Power Supply (Negative V)
32B	+12VF	Standby power supply for fan (+8V during standby)

Table 5-6. Malfunctions Not Displaying an Error Message 3

Description: Lights and fan operate when power button is pressed, but no display appears.

Normal operation: When the MG3702xA is connected to the power source and the rear panel line switch is turned on, the OPERATE light should illuminate and the instrument should power up. When the MG3702xA is set to standby mode, the fans should run slow and the STANDBY light should illuminate. During the boot process, the Windows XP boot process and eventually the MG3702xA options screen should be visible on the LCD screen.

1. Connect a PC-compatible display or monitor to the rear panel.
2. If the external display or monitor is OK, replace the MG3702xA front panel.
3. If the external display also has a problem, replace the A2 CPU PCB.
4. If this does not resolve the issue, contact your local Anritsu service center for assistance.

Table 5-7. Malfunctions Not Displaying an Error Message 4

Description: Window XP environment is not operational or error messages may be generated by the Windows operating system.

Normal operation: The unit boots into Windows and automatically starts up the MG3702xA application.

Errors generated by the Windows operating system should be researched using standard Windows-oriented technical documentation.

1. Power cycle the instrument to see if it clears the error.
2. If Windows-oriented errors cannot be solved using such XP documentation, replace the A2 PCB and disk drive.
3. If this does not resolve the issue contact your local Anritsu service center for assistance.

Table 5-8. Malfunctions Not Displaying an Error Message 5

Description: Problems with stability, accuracy, or signal purity (no error messages appear).

Normal operation: The unit is stable without error messages.

1. If the unit appears to operate normally when cold, but a problem appears after warm-up:
 - a. Ensure that the side covers are on correctly (perforated cover must be on left side).
 - b. Verify all three internal fans are functioning.
 - c. Verify that the fan filters are not blocked.
 - d. Check the condition of the RF output connector.
2. If none of the above problems are found, contact your local Anritsu service center for assistance.

Table 5-9. Error Messages after Entering the Synthesizer Application

Description: The unit stops the boot up process right after it enters into the MG3702xA application because the unit fails the short self test.

Normal operation: The unit runs the self test which passes and the unit completes the process of starting the MG3702xA application.

1. Review and log the failure.
2. Power cycle the instrument
3. If this clears the error, continue using the instrument.
4. If this does not resolve the issue, contact your local Anritsu service center for assistance.

Table 5-10. Instrument Shows Lock Error

Description: This error message is displayed in the frequency parameters area to indicate that the output frequency is not phase locked. This is normally caused by an internal component failure.

Normal operation: No error messages are displayed.

1. Perform a self test of the signal generator by pressing System | Self Test | Run Self Test.
2. If the self test does not result in an error message, resume normal operation.
3. Perform a master reset by pressing System | Config, then touch the tab preset and then reset.

Caution Performing a master reset clears all user settings and resets the instrument to factory default settings.

4. If an error message is displayed, contact your local Anritsu service center for assistance.

Table 5-11. Instrument Displays “Unleveled”

Description: This message is displayed to indicate that the RF output is unleveled.

Normal operation: No error messages are displayed.

1. Check that the output power does not exceed the specified leveled power rating and that the RF Output connector is terminated into a 50 ohm load.
2. Reduce the power level so it does not exceed the specified leveled power rating
3. Terminate the RF Output connector with a 50 ohm load.
4. Perform a master reset by pressing **System** | **Config**, then press the tab Preset and then reset.

Caution Performing a master reset clears all user settings and resets the instrument to factory default settings.

5. If the error message remains displayed, contact your local Anritsu service center for assistance.

Table 5-12. Error Messages 101 and 102

Internal DVM Tests

Error 101 DVM Positive 10V Reference, or Error 102 DVM Negative 10V Reference

Description: The DVM circuitry, located on the A4 auxiliary PCB, is calibrated using the ± 10 volts from the reference supplies on the A4 auxiliary PCB. The error messages indicate a calibration-related problem or a defective ± 10 volt reference.

1. Perform a manual DVM calibration (refer to “[Utility DVM Adjustment](#)” in [Chapter 4](#)).
2. Run self-test.
 - If no error message is displayed, the problem is cleared.
 - If any of the error messages, 100 or 101, are displayed, go to [Step 3](#).
3. Replace the A4 PCB, perform a manual DVM calibration and run self-test.
 - If no error message is displayed, the problem is cleared.
 - If any of the error messages, 100 and 101, are displayed, contact your local Anritsu service center for assistance.

Table 5-13. Error Message 108 Crystal Oven Cold

Description: Indicates that the 100 MHz crystal oven on the A7 Reference/Coarse loop PCB has not reached operating temperature. The MG3702xA is still operable, but frequency accuracy and stability may be degraded.

1. Allow a 30 minute warm up, then run self-test.
 - If error 108 is not displayed, the problem is cleared.
 - If error 108 is displayed, go to [Step 2](#).
2. Remove the bottom cover.
3. Measure the DC level on mother board on the A8 connector J11 pin 3A with a DVM.
4. If the level is above 3V then replace A8 PCB. Allow a 30 minute warm up, then run self-test.
 - If error 108 is not displayed, the problem is cleared.
 - If error 108 displays, go to [Step 6](#).
5. If the level is below 1V then replace A7 PCB. Allow a 30 minute warm up, then run self-test.
 - If error 108 is not displayed, the problem is cleared.
 - If error 108 displays, go to [Step 6](#).
6. If error 108 is displayed, contact your local Anritsu service center for assistance.

Table 5-14. Error Message 109 100MHz Reference is not Locked to the External Reference

Description: Indicates that the reference loop is not phase-locked to the external 10 MHz reference. The reference loop may phase-lock to the internal 100 MHz time base; consequently, the MG3702xA would continue to operate normally.

1. Using a coaxial cable with BNC connectors, connect the rear panel 10 MHz REF IN connector to the rear panel 10 MHz REF OUT connector.
2. Disconnect the MCX cable WF101 from A6J6.
3. Using an oscilloscope, verify the presence of a 10 MHz signal at the end of the MCX cable W158. The signal amplitude should be > 0.2 volts peak-to-peak (into 50 ohms).
 - If the signal is present, replace the A7 PCB.
 - If the signal is not present, replace the MCX cable W158 and inspect the BNC10 MHz REF IN connector.

Table 5-15. Error Messages 121 and 122

Error message 121: Unleveled Indicator Failed

Error message 122: Level Reference Failed

Description: These error messages indicate a failure of the leveled detector circuitry or the level reference circuitry. Each of the other error messages indicates a problem in the circuitry on the A6 ALC PCB that provides control of the RF output power level. Also, a warning message on the display may appear when the RF output is unleveled.

1. Replace the A6 PCB, and run self-test.
 - If no error message is displayed, the problem is cleared.
 - If error message 121 or 122 are displayed, contact your local Anritsu service center for assistance.

Table 5-16. Error Message 144 RF was Off when Self-test started. Some tests were not performed.

Description: Indicates that some self-tests were not performed because RF output was turned OFF on the MG3702xA front panel. Press the OUTPUT key to turn RF Output ON and run the self-test again.

1. Press the **OUTPUT** key on the front panel to turn the RF output ON.
2. Run self-test again. If error 144 is still displayed, contact your local Anritsu service center for assistance.

Table 5-17. Error Message 148 100 MHz reference circuitry failed

Description: Indicates that the 100 MHz signal from the A7 board not operating or connected to the input clock signal for A8 FPGA.

1. Using an oscilloscope, verify the presence of a 100 MHz at the rear panel of the unit BNC connector 100MHz out.
 - If present, replace the A8 PCB.
 - If not present, replace the A7 PCB.
2. Run self-test again. If error 148 is still displayed, contact your local Anritsu service center for assistance.

Table 5-18. Error Message 160 Core Synthesis

Description: Indicates a Lock error occurred while verifying Coarse Loop and Output Loop.

1. Replace the A7 board.
 - Perform the A7 PCB calibrations called out in [Table 4-2](#) in [Chapter 4](#).
 - Run self-test.
 - If no error message is displayed, the problem is cleared.
 - If error message 160 is displayed, go to [Step 2](#).
2. Replace the A9 board.
 - Perform the manual A9 PCB calibrations called out in [Table 4-2](#) in [Chapter 4](#).
 - Run self-test.
 - If no error message is displayed, the problem is cleared.
 - If error message 160 is displayed, contact your local Anritsu service center for assistance.

Table 5-19. Error message 161 DDS Range (Fine loop controller failure)

Description: Indicates fine loop frequency is not being working correctly.

1. Replace the A9 board.
 - Perform the manual A9 PCB calibration (Refer to Chapter 4).
 - Run self-test.
 - If error message 161 is displayed, then go to [Step 2](#).
2. Replace the A8 board.
 - Run self-test.
 - If no error message is displayed, the problem is cleared.
 - If error message 161 is displayed, contact your local Anritsu service center for assistance.

Table 5-20. Error message 162 Modulator Drive error

Description: Indicates ALC drive voltage for the modulator (located in the Switch Filter) is out of range or is incorrect.

1. Replace the A6 board.
 - Perform the manual A6 PCB calibration called out in [Table 4-2](#) in [Chapter 4](#).
 - Run self-test.
 - If error message 162 is displayed, go to [Step 2](#).
2. Replace the A8 board.
 - Run self-test.
 - If no error message is displayed, the problem is cleared.
 - If error message 162 is displayed, contact your local Anritsu service center for assistance.

Table 5-21. Error Messages 163 and 164 A2 power supply issues

Both of these errors are associated with the A2 power supply monitoring circuit.

Error message 163 Digital Power: Indicates digital power supply voltages on A2 Processor board are not in tolerance.

Error message 164 Power Current: Indicates current draw on 15V, 5V, 3.3V or 1.5V on A2 is out of tolerance.

Description: On the A2 board there is a switch which monitors the power supplies (+3.3V, +5V, +1.5V and +15V supplies). The output of the switch goes to the DVM bus which is read by the A4 Auxiliary board's DVM. Also on the A2 board are 4 current monitoring devices. These devices monitor +3.3V, +5V, +1.5V and +15V supply current. The output of these monitors is fed into the switch which is routed to the A4 board.

1. Replace the A2 board and run self-test.
 - If no error message is displayed, the problem is cleared.
 - If error message 163 or 164 is displayed, then go to [Step 2](#).
2. Replace the A4 board.
 - Perform a manual DVM calibration (refer to “[Utility DVM Adjustment](#)” in [Chapter 4](#)).
 - If no error message is displayed, the problem is cleared.
 - If error message 163 or 164 is displayed, contact your local Anritsu service center for assistance.

Table 5-22. Error Messages 165, 166 and 167

All of these errors are associated with the A8 RAM.

Error message 165 Synth RAM Data: Indicates failure while testing the data bus for the A8 RAM.

Error message 166 Synth RAM Address: Indicates failure while testing the address bus for the A8 RAM.

Error message 167 Synth RAM device: Indicates failure while testing the A8 RAM device.

Description: On the A8 board there are 2 RAMs (Program RAM and List RAM). These RAMs are used by the FPGA to run the synthesizer. These tests are to verify the data interface to these is operation.

1. Replace the A8 board, and run self-test.
 - If no error message is displayed, the problem is cleared.
 - If error messages 165, 166 or 167 are displayed, contact your local Anritsu service center for assistance.

Table 5-23. Error messages 168, 169 and 170

All of these errors are associated with the A6 RAM.

Error message 168 ALC RAM Data: Indicates failure while testing the data bus for the A6 RAM.

Error message 169 ALC RAM Address: Indicates failure while testing the address bus for the A6 RAM.

Error message 170 ALC RAM device: Indicates failure while testing the A6 RAM device.

Description: On the A6 board there is a List RAM. This List RAMs is used by the FPGA to run the store the user defined level sweep list. These tests verify the data interface to the List ram is operation.

1. Replace the A6 board, and run self-test.
 - If no error message is displayed, the problem is cleared.
 - If error messages 168, 169 or 170 are displayed, contact your local Anritsu service center for assistance.

Table 5-24. Error message 171 Processor Battery

Description: Indicates the RTC battery voltage on the A2 board is out of tolerance. The battery is monitored by the A4 AUX PCB DVM via the DVM bus on the mother board.

1. Remove the A2 board and locate the battery. The battery is a common CR2032.
2. Measure the battery voltage. Replace the battery if it is <3.0V.
3. Reinstall the A2 board and run self test.
 - If no error message is displayed, the problem is cleared.
 - If error message 171 is displayed, proceed to [Step 4](#).
4. Replace the A2 board, and run self-test.
 - If no error message is displayed, the problem is cleared.
 - If error message 171 is displayed, contact your local Anritsu service center for assistance.

Table 5-25. Error message 172 Core ALC

Description: Indicates that A6 Loop amp voltage is out of tolerance at a level 3 dB lower than the rated power or 12 dB lower than the rated power. This points to a problem in the circuitry on the A6 ALC PCB which provides control of the RF output power level. This measurement is done for several steps in each of the unit's frequency bands. For each of these steps the unit verifies it is leveled. If the unit is unleveled, error message 172 Core ALC is displayed.

1. Replace the A6 board, run the calibrations called out in [Table 4-2](#) in [Chapter 4](#), then run self-test.
 - If no error message is displayed, the problem is cleared.
 - If error message 172 is displayed, contact your local Anritsu service center for assistance.

Chapter 6 — Removal and Replacement Procedures

6-1 Introduction

This chapter provides a table of replaceable parts and procedures for gaining access to the major MG3702xA assemblies, subassemblies, and components for troubleshooting or replacement. Replacing most assemblies will require additional adjustments to the instrument. Refer to [Table 6-2 on page 6-3](#) for a calibration/verification rework guide.

Warning

Hazardous voltages are present inside the MG3702xA whenever AC line power is connected. Turn off the instrument and remove the line cord before removing any covers or panels. Troubleshooting and repair procedures should only be performed by service personnel who are fully aware of the potential hazards.

Caution

ESD Requirements: The MG3702xA contains components that can be easily damaged by electrostatic discharge (ESD). An ESD safe work area and proper ESD handling procedures that conform to ANSI/ESD S20.20-1999 or ANSI/ESD S20.20-2007 is mandatory to avoid ESD damage when handling subassemblies or components found in the S312D instrument. Repair of damage that is found to be caused by electrostatic discharge is not covered under warranty. Always observe proper static-sensitive component handling precautions.

Note

Many assemblies, subassemblies, and components within the MG3702xA family of instruments are type and model dependent. Before replacing an assembly, subassembly, or component, always verify the part number of the replacement item. Part numbers can be found in [Table 6-1 on page 6-2](#).
When replacing RF components with SMA, K or V connectors it is important to torque these to the proper value. In the MG3702xA unit that setting is 8 in/lbs. You can purchase a Anritsu torque wrench which is set to 8 in/lb. The Anritsu part number is 01-201.

Before servicing this instrument, ensure you are familiar with the information in [Chapter 1, “General Information”](#) and [Chapter 2, “Functional Description”](#) regarding exchange assemblies, instrument warranty, and other basic information. Note that replacement of many assemblies will require updating of Frequency Accuracy and/or Level Accuracy calibrations. Below are some other important reminders:

- Do not unsolder or cut wires or cables. All cables and wires should be unplugged.
- With the exception of replacing the processor (RTC) battery, never attempt to repair a defective assembly that is under warranty or is an exchange item.
- Installation of every replacement assembly is the opposite of removal.
- The system motherboard is not a field-replaceable item. Contact the factory regarding any problem with the system motherboard.

6-2 Replaceable Parts

Anritsu maintains an exchange assembly program for selected MG3702xA subassemblies and RF components. If one of these subassemblies malfunctions, the defective instrument can be exchanged. All exchange subassemblies and RF components are warranted for 90 days from the date of shipment, or for the balance of the original equipment warranty, whichever is longer.

Please have the exact model number and serial number of your instrument available when requesting this service, as the information about your instrument is filed according to the instrument's model and serial number. For more information about the program, contact your local sales representative or call your local Anritsu service center.

Table 6-1 lists most replaceable parts and assemblies found in the MG3702xA. All parts are exchange assemblies except fuses, fans, power supplies, EMI filters and front panel Model ID plates.

Table 6-1. MG3702xA Replaceable Subassemblies and Part Numbers (1 of 2)

ASSEMBLY NUMBER	SUBASSEMBLY OR PART NAME	MG3702xA Anritsu CS Part Number	Alternate Anritsu Part Number ^a	OPTION LIST
	Line Fuse (5 Amp Slow Blow)	631-33		
	AC Input Module with EMI Filter	260-23		
	Power Supply, Main	40-147	3-40-147	
	Power Supply, Standby	40-148	3-40-148	
	Fan Assembly, Power Supply Assy	ND68050		
	Fan Assembly, Rear Panel Assy	ND68051		
	Isolator, Fan, Vibration	790-581		
	Fan, DC, 60mmX60mm X 15mm, 22-26 VDC	650-54		
	Isolator, Vibration, Horiz	3-790-285		
	Fan Assembly, CPU Assy	ND73881		
	Processor CR2032 coin battery	3-633-43		
	Front Panel Assembly (excluding Model ID plate) ^b	ND68053	ND73881	
	MG3702xA Model ID Plate	63814-8	3-63814-8	
A2	Microprocessor PCB Assembly and Hard Drive with option 088	ND71077		With Option 088, Contact Anritsu
A2	Microprocessor PCB Assembly and Hard Drive without option 088	ND71076		Without Option 088, Contact Anritsu
A3	Post Regulator PCB Assembly	ND68055		
A4	Auxiliary PCB Assembly	ND68056		
A6	ALC PCB Assembly	ND68057		
A7	Coarse/Ref Loop PCB Assembly	ND68058		

Table 6-1. MG3702xA Replaceable Subassemblies and Part Numbers (2 of 2)

ASSEMBLY NUMBER	SUBASSEMBLY OR PART NAME	MG3702xA Anritsu CS Part Number	Alternate Anritsu Part Number ^a	OPTION LIST
A8	Synthesizer Control PCB Assembly	ND68059		
A8	Synthesizer Control PCB Assembly with option 088	ND71078		
A9	Output/fine loop PCB Assembly	ND68060		
A10	Rear Panel PCB Assembly BNC ITF	ND68066		
A10	Rear Panel PCB Assembly CPU ITF	ND68067		
A11	Digital Down Converter Assembly	ND55519		004
	Leveling Coupler, 40 GHz Assy	ND68062		
A12	Switched Filter HP	D45198		no 026 or no 015
A12	Switched Filter, Pulsed HP	D45200		026 and no 015
A12	Switched Filter, Pulsed	64539		015 and 026
A12	Switched Filter	64540		015, no 026
	Output Connector, KF	C27310		
	Step Attenuator, 20 GHz	D27152		002
	2 to 20 GHz Amplifier	61854		015
A16	40GHz DIPLEX.SWITCH ASSY	ND64379		If option 004 and 015 installed.

a. Alternate Anritsu part numbers are backward compatible.

b. The front panel is an integrated unit consisting of the casting, display, keypad parts, and knob. Order the front panel assembly and the Model ID plate when any of the front panel items is failing. The RF Out connector is a separate item and should be ordered separately.

6-3 Calibration and Verification after Subassembly Replacement

Replacing assemblies or components usually requires additional adjustments to the MG3702xA instrument. After replacing subassemblies or components, use [Table 6-2](#) to determine which calibrations and verifications must be performed.

Table 6-2. Adjustment and Verifications Required after Subassembly Replacement (1 of 4)

Subassembly/RF Component Replaced	Perform the Following Adjustments and Verifications
Front Panel Assembly	Section 4-11 “Touch Screen Accuracy Adjustment”

Table 6-2. Adjustment and Verifications Required after Subassembly Replacement (2 of 4)

Subassembly/RF Component Replaced	Perform the Following Adjustments and Verifications
A2 Microprocessor PCB	Section 4-6 "Utility DVM Adjustment" Section 4-7 "Frequency Reference Adjustment" Section 4-8 "Level Detector Tables and Level Flatness Adjustment" Section 4-9 "Level SWF Band Adjustment" Section 4-10 "Level ALC Adjustment" Section 4-11 "Touch Screen Accuracy Adjustment" Section 3-6 "Internal Time Base Aging Rate Test (Optional)" Section 3-7 "Spurious Signals Tests" Section 3-8 "SSB Phase Noise Test" Section 3-9 "Power Level Accuracy and Flatness Tests" Section 3-10 "Pulse Modulation Tests"
A3 Post Regulator PCB	None
A4 Auxiliary PCB	Section 4-6 "Utility DVM Adjustment" Section 3-10 "Pulse Modulation Tests"
A6 ALC PCB	Section 4-8 "Level Detector Tables and Level Flatness Adjustment" Section 4-9 "Level SWF Band Adjustment" Section 4-10 "Level ALC Adjustment" Section 3-9 "Power Level Accuracy and Flatness Tests" Section 3-10 "Pulse Modulation Tests"
A7 Coarse/Ref Loop PCB	Section 4-7 "Frequency Reference Adjustment" Section 3-7 "Spurious Signals Tests" Section 3-8 "SSB Phase Noise Test"
A8 Synthesizer Control PCB	Section 4-7 "Frequency Reference Adjustment"
A9 Output Fine Loop PCB	Section 4-7 "Frequency Reference Adjustment" Section 4-8 "Level Detector Tables and Level Flatness Adjustment" Section 4-9 "Level SWF Band Adjustment" Section 4-10 "Level ALC Adjustment"
A10 Rear Panel PCB	None
A11 Digital Down Converter PCB	Section 4-7 "Frequency Reference Adjustment" Section 4-8 "Level Detector Tables and Level Flatness Adjustment" Section 4-9 "Level SWF Band Adjustment" Section 4-10 "Level ALC Adjustment" Section 3-6 "Internal Time Base Aging Rate Test (Optional)" Section 3-7 "Spurious Signals Tests" Section 3-8 "SSB Phase Noise Test" Section 3-9 "Power Level Accuracy and Flatness Tests" Section 3-10 "Pulse Modulation Tests"
A12 Switched Filter	Section 4-7 "Frequency Reference Adjustment" Section 4-8 "Level Detector Tables and Level Flatness Adjustment" Section 4-9 "Level SWF Band Adjustment" Section 4-10 "Level ALC Adjustment" Section 3-6 "Internal Time Base Aging Rate Test (Optional)" Section 3-7 "Spurious Signals Tests" Section 3-8 "SSB Phase Noise Test" Section 3-9 "Power Level Accuracy and Flatness Tests" Section 3-10 "Pulse Modulation Tests"

Table 6-2. Adjustment and Verifications Required after Subassembly Replacement (3 of 4)

Subassembly/RF Component Replaced	Perform the Following Adjustments and Verifications
A16 40 GHz Diplex Switch	Section 4-7 “Frequency Reference Adjustment” Section 4-8 “Level Detector Tables and Level Flatness Adjustment” Section 4-9 “Level SWF Band Adjustment” Section 4-10 “Level ALC Adjustment” Section 3-6 “Internal Time Base Aging Rate Test (Optional)” Section 3-7 “Spurious Signals Tests” Section 3-8 “SSB Phase Noise Test” Section 3-9 “Power Level Accuracy and Flatness Tests” Section 3-10 “Pulse Modulation Tests”
Leveling Coupler, 40 GHz	Section 4-7 “Frequency Reference Adjustment” Section 4-8 “Level Detector Tables and Level Flatness Adjustment” Section 4-9 “Level SWF Band Adjustment” Section 4-10 “Level ALC Adjustment” Section 3-6 “Internal Time Base Aging Rate Test (Optional)” Section 3-7 “Spurious Signals Tests” Section 3-8 “SSB Phase Noise Test” Section 3-9 “Power Level Accuracy and Flatness Tests” Section 3-10 “Pulse Modulation Tests”
Output Connector, K(f)	Section 4-7 “Frequency Reference Adjustment” Section 4-8 “Level Detector Tables and Level Flatness Adjustment” Section 4-9 “Level SWF Band Adjustment” Section 4-10 “Level ALC Adjustment” Section 3-6 “Internal Time Base Aging Rate Test (Optional)” Section 3-7 “Spurious Signals Tests” Section 3-8 “SSB Phase Noise Test” Section 3-9 “Power Level Accuracy and Flatness Tests” Section 3-10 “Pulse Modulation Tests”
Power Supply	None
2 to 20 GHz Amplifier	Section 4-7 “Frequency Reference Adjustment” Section 4-8 “Level Detector Tables and Level Flatness Adjustment” Section 4-9 “Level SWF Band Adjustment” Section 4-10 “Level ALC Adjustment” Section 3-6 “Internal Time Base Aging Rate Test (Optional)” Section 3-7 “Spurious Signals Tests” Section 3-8 “SSB Phase Noise Test” Section 3-9 “Power Level Accuracy and Flatness Tests” Section 3-10 “Pulse Modulation Tests”
Step Attenuator, 20 GHz	Section 4-7 “Frequency Reference Adjustment” Section 4-8 “Level Detector Tables and Level Flatness Adjustment” Section 4-9 “Level SWF Band Adjustment” Section 4-10 “Level ALC Adjustment” Section 3-6 “Internal Time Base Aging Rate Test (Optional)” Section 3-7 “Spurious Signals Tests” Section 3-8 “SSB Phase Noise Test” Section 3-9 “Power Level Accuracy and Flatness Tests” Section 3-10 “Pulse Modulation Tests”

Table 6-2. Adjustment and Verifications Required after Subassembly Replacement (4 of 4)

Subassembly/RF Component Replaced	Perform the Following Adjustments and Verifications
All Other RF Components	Section 4-7 “Frequency Reference Adjustment” Section 4-8 “Level Detector Tables and Level Flatness Adjustment” Section 4-9 “Level SWF Band Adjustment” Section 4-10 “Level ALC Adjustment” Section 3-6 “Internal Time Base Aging Rate Test (Optional)” Section 3-7 “Spurious Signals Tests” Section 3-8 “SSB Phase Noise Test” Section 3-9 “Power Level Accuracy and Flatness Tests” Section 3-10 “Pulse Modulation Tests”

6-4 Removing the Instrument Covers

Troubleshooting procedures require removal of the top and bottom covers. Replacement of some MG3702xA assemblies and parts require removal of all covers. The following procedure describes this process.

<p>Danger</p> 	<p>Hazardous voltages are exposed inside the MG3702xA whenever the power supply enclosure is open and the AC line power is connected. Turn off the instrument and remove the line cord before removing the power supply cover. Use extreme caution when troubleshooting with the power supply cover removed and the unit energized.</p> <p>Troubleshooting or repair procedures should only be performed by qualified service personnel who are fully aware of the potential hazards.</p>
--	---

Tool Required

1 Phillips screwdriver

Preliminary

Disconnect the power cord from the instrument.

Procedure

Remove and replace the chassis covers as follows. Retain all screws for reinstallation.

<p>Warning</p>	<p>The screws with green heads have metric threads. When it becomes necessary to replace any of these screws, always use the exact replacement green-headed screws to avoid damage to the instrument. Anritsu PN: 905-8 (long); Z-951102 (short).</p>
-----------------------	---

1. Using a Phillips screwdriver, remove the screws and the front handle assemblies from the instrument (see [Figure 6-1](#)). For models not having front handles, remove the screws and the front top and bottom feet from the instrument.
2. Remove the 6 screws on the rear panel which secure the top and bottom covers (3 for the top cover, 3 for the bottom cover).
3. Remove the four feet and corners on the rear of the instrument.
4. At the rear of the instrument pull the top cover upwards about 1.5 inches then pull the cover towards the rear of the instrument while sliding the cover out along the grooves in the chassis.
5. Turn the instrument over so that the bottom cover is on top.
6. Remove the bottom cover the same way the top was removed.

7. To replace the instrument covers, reverse the procedure used to remove them.

Note It is necessary to remove the side covers only if the front panel must be removed in a later step.

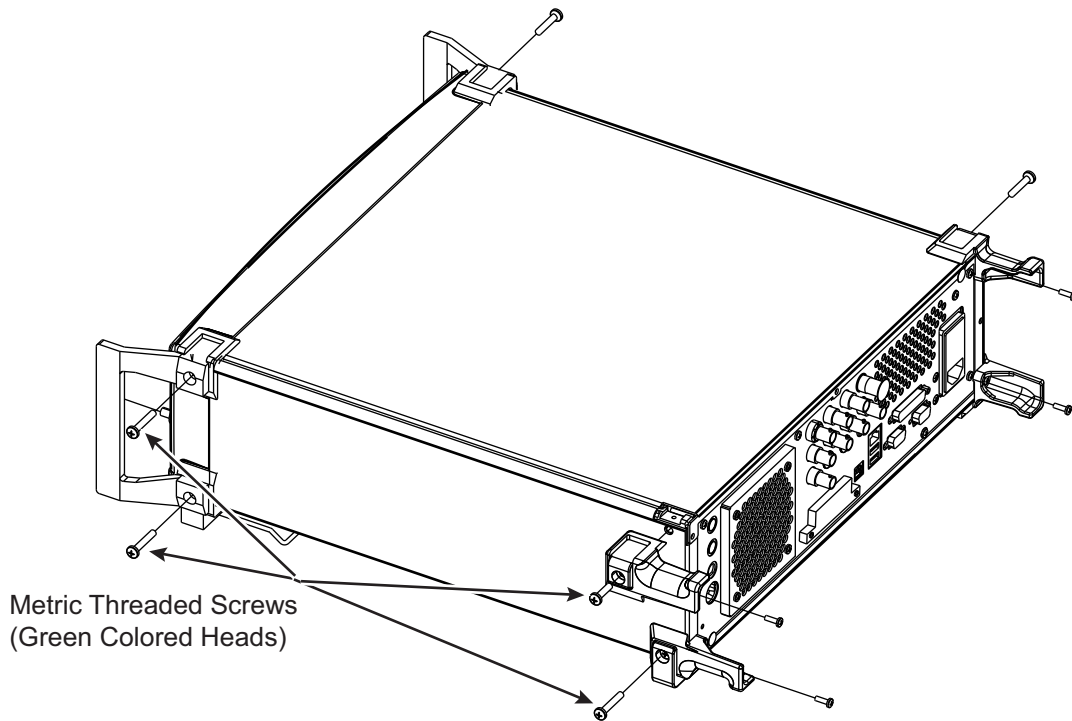

Figure 6-1. Front Handles, Rear Feet and Corners Removal

Caution When re-installing the side covers, ensure the perforated side cover (having air holes) is placed on the left side (as you face the front of the instrument).

8. If the side covers need to be removed, turn the instrument over to return it to the upright position.
9. Remove the screws that fasten the left and right side covers to the chassis. See [Figure 6-2](#).
10. Remove the side covers.
11. Remove the screw that fastens the right side cover to the chassis. See [Figure 6-2](#).
12. To replace the chassis covers, reverse the procedure used to remove them.

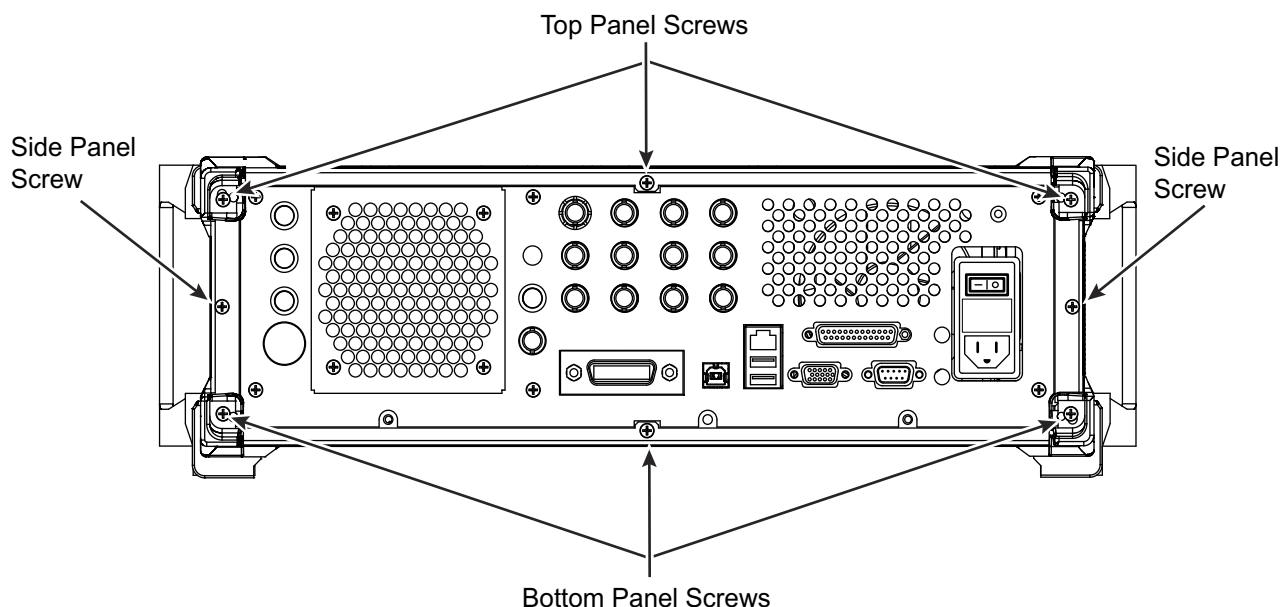

Figure 6-2. Rear Panel Retaining Screw Locations

6-5 Front Panel and RF Output Connector

This section provides instructions for removing and replacing the front panel assembly of the MG3702xA. The front panel assembly contains the A1 front panel PCB. Refer to [Figure 6-3](#) during this procedure.

The front panel is an integrated unit consisting of the casting, display, keypad parts, and knob. Replace the entire front panel assembly and the Model ID plate when any of these items have failed. The RF Out connector is separate from the front panel. However, the front panel must be removed to replace this connector.

Preliminary

Remove the front handles, rear feet, and chassis covers as described in [Section 6-4](#).

Procedure

1. With the front handles, feet, corners and chassis covers removed, place the MG3702xA on a flat surface, with the top side up.
2. Carefully pull the front panel away from the chassis to gain access to the ribbon cables that connect the front panel PCB assembly to the microprocessor PCB assembly. See [Figure 6-3](#).
3. Unplug the upper ribbon cable from the front panel.

Caution The lower ribbon cable is fragile. Use care when unplugging this cable.

4. To unplug the more delicate lower ribbon cable, use tweezers or another pointed tool to pull each small tab up (away from the PCB).

One tab is found at both ends of the connector.

After each tab has been moved out approximately 1-2 mm, the cable will be released and can be removed.

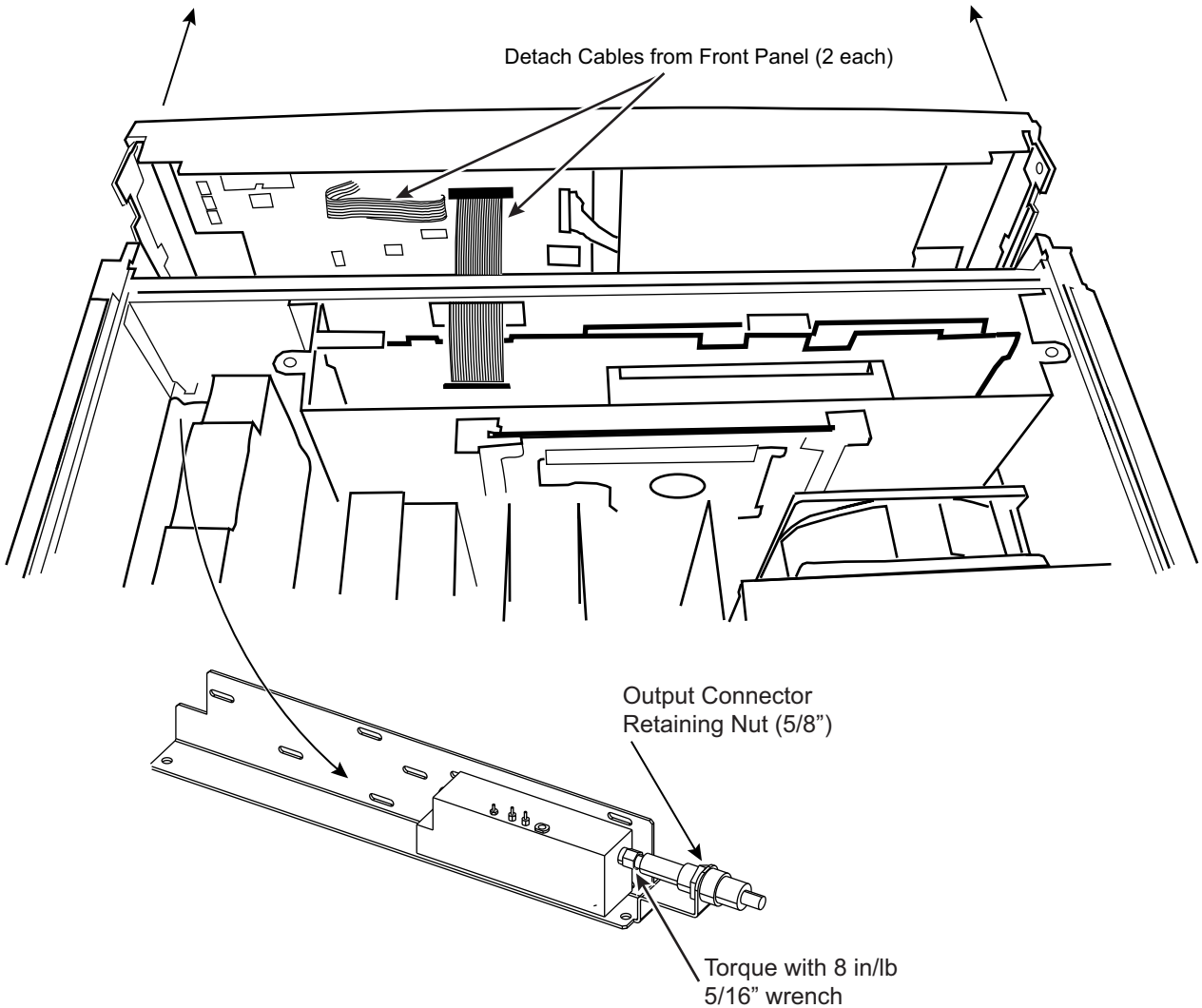

Figure 6-3. Front Panel Removal

5. Carefully pull the front panel assembly forward until it is clear of the RF OUTPUT connector. Set front panel aside.
6. If necessary, the RF output connector may be replaced:
 - a. Remove the output connector retaining nut with a 5/8 inch wrench.
 - b. Using a 5/16 inch wrench, disconnect the connector from the step attenuator or leveling coupler.
 - c. Remove the retaining nut from the new connector.
 - d. Slide the connector through the RF train bracket, then slip the retaining nut over the new connector before attaching to the output component.
 - e. Attach the output connector to the output component using a 5/16, 8in/lb torque wrench.
 - f. Tighten the retaining nut against the RF train bracket.
7. To replace the front panel assembly, reverse the removal process.
8. After replacement of the front panel RF connector, perform the Level Accuracy calibration.
9. After replacement of the front panel, recalibrate the touch screen using the procedure found in [Section 4-11](#) starting on page 4-10.

6-6 A2 CPU Assembly and Hard Drive

This section provides instructions for removing and replacing the A2 CPU Assembly and Hard Drive which are located under a metal cover directly behind the front panel. See [Figure 6-4](#). Instructions to replace the processor battery are included.

Note Because they are configured as a set, the A2 CPU assembly and the hard disk drive (HDD) must always be replaced together.

Preliminary

If possible, save the existing calibration data onto a flash drive by doing the following:

1. Insert USB flash drive into unit.
2. Copy the C:\Anritsu\MG37020A\Calibration directory to the USB flash drive.
3. Remove the Options.dat and SerialNumber.dat file from the USB flash drive.

Warning It's very important that the Options.dat and SerialNumber.dat files are *NOT* copied to the new A2 / Hard Drive in place of the existing files that come with the new exchange assembly. If this happens, the new exchange assembly will become inoperable.

4. Remove the front handles, rear feet, and chassis covers as described in [Section 6-4](#).
5. Remove the front panel assembly as described in [Section 6-5](#).

A2 and Hard Drive Replacement Procedure

Remove and replace the A2 CPU PCB as follows:

1. To gain access the A2 CPU, remove the two screws that secure the cover.
2. Rotate the 2 side catches up to raise the A2 assembly slightly.
3. Carefully unplug the upper ribbon cable from the PCB.

Caution The lower ribbon cable is fragile. Use care when unplugging this cable.

4. To disconnect the more delicate lower ribbon cable, use tweezers or another pointed tool to push down on the small tabs located at each end of the connector.
5. After a few pushes on each tab, the cable will be released.

After both cables are unplugged, remove the A2 assembly from the enclosure.

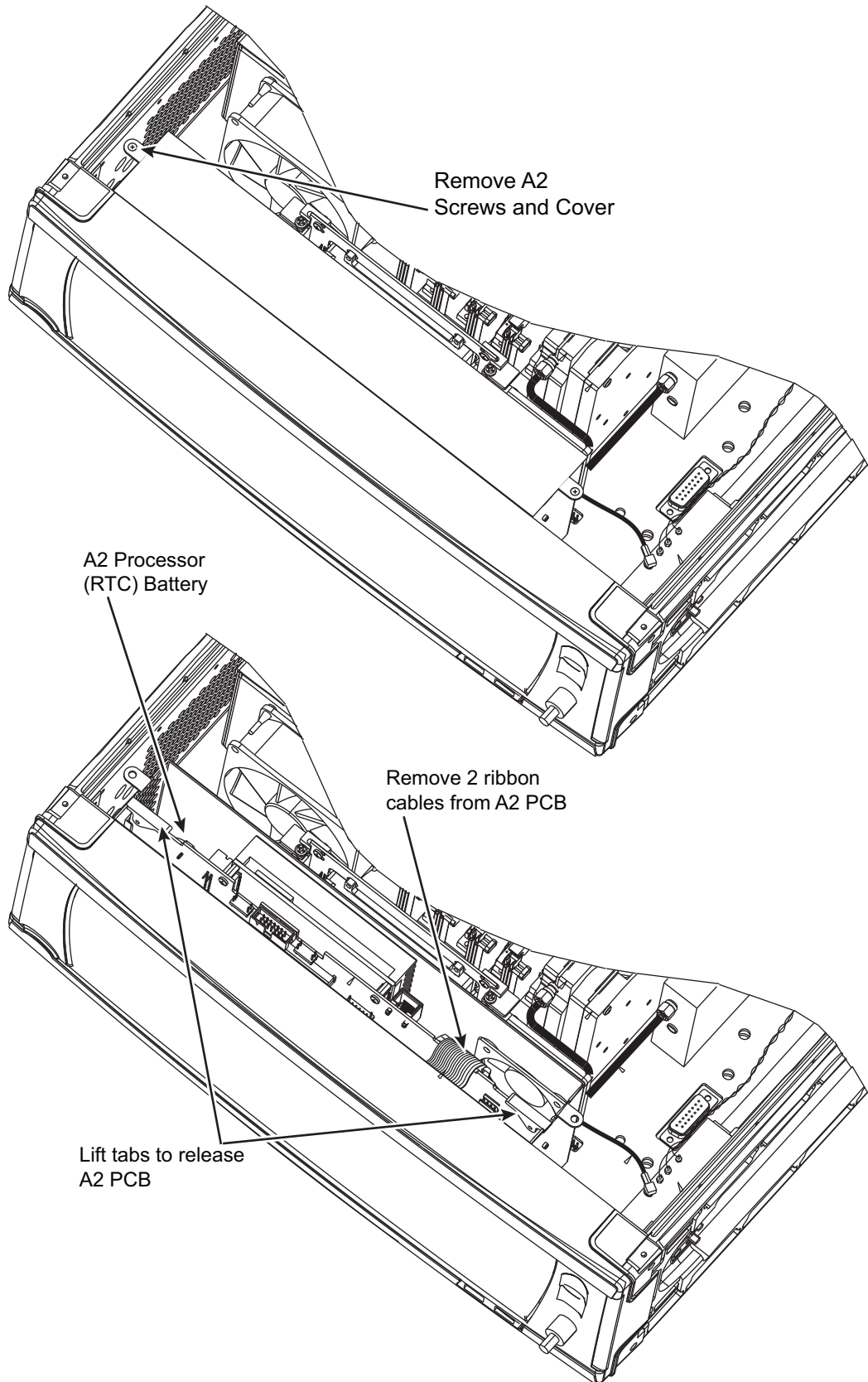

Figure 6-4. A2 Microprocessor PCB Removal

- Remove the 2 screws at the top of the PCB that attach the HDD carrier board to the vertical brackets. The PCB can be lifted up and removed.

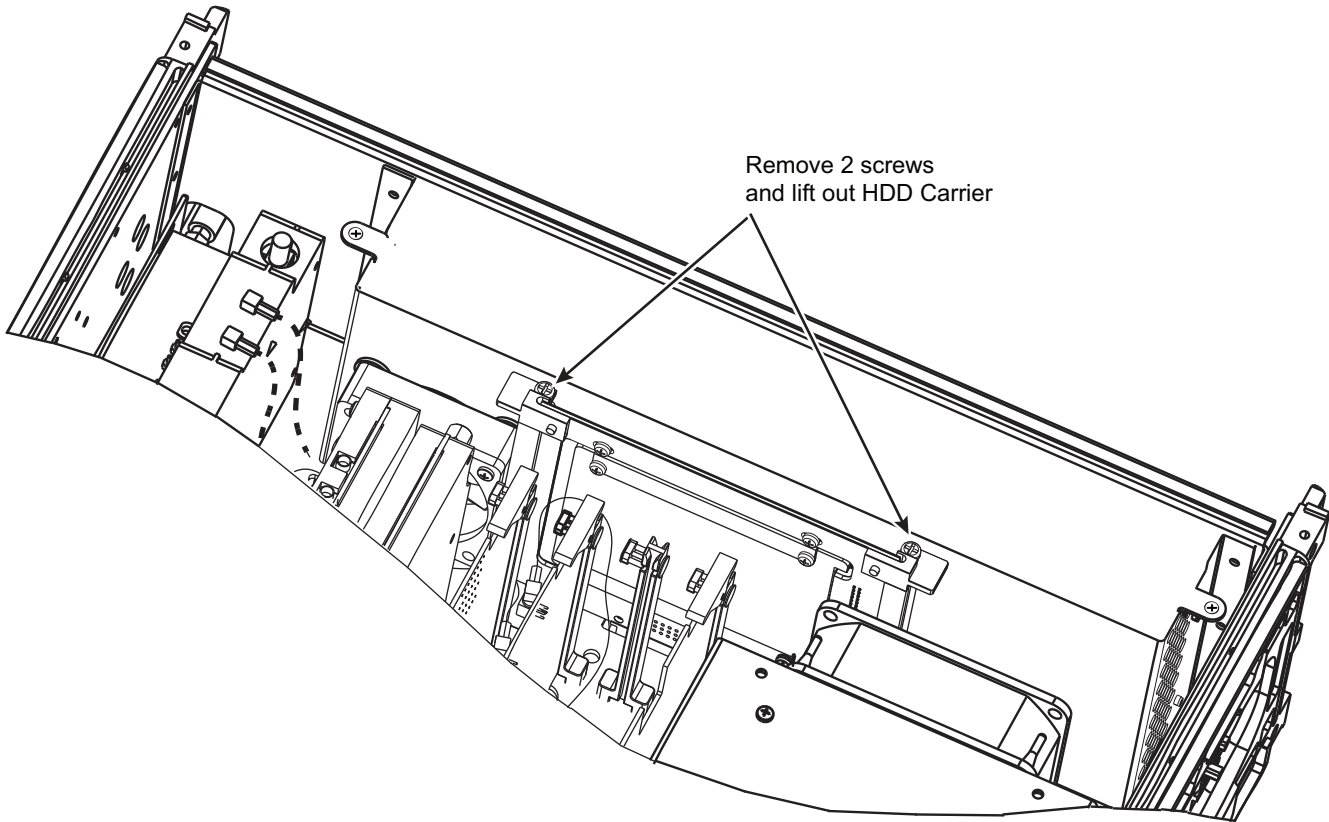

Figure 6-5. HDD Removal

- To install the A2 CPU PCB and HDD, reverse the removal process.

Note	When reconnecting the ribbon cable, the edge with the red stripe should be located to the right as seen from the front of the instrument.
-------------	---

- Copy all files from the USB Flash Drive Calibration directory to the C:\Anritsu\MG37020A\Calibration directory, making sure the Options.dat and SerialNumber.dat files *ARE NOT* overwritten or deleted.

If the calibration files were able to be saved and copied onto the new A2 CPU / HDD Exchange Assembly then only a full verification needs to be performed.

If the calibration files were not able to be saved and copied onto the new A2 CPU / HDD Exchange Assembly then a full calibration and verification needs to be performed.

Battery Replacement Procedure

See [Figure 6-6](#) below for the location of the processor battery (Anritsu part number 3-633-43 for CR2032 coin battery)

- Lift the tab over the battery to remove.

After battery replacement, apply 2 drops of RTV compound to attach the edge of the battery to the battery holder. This will ensure the battery cannot work loose during transport.

2. After replacement of the battery, enter the correct date and time in the Control Panel menu of Windows.

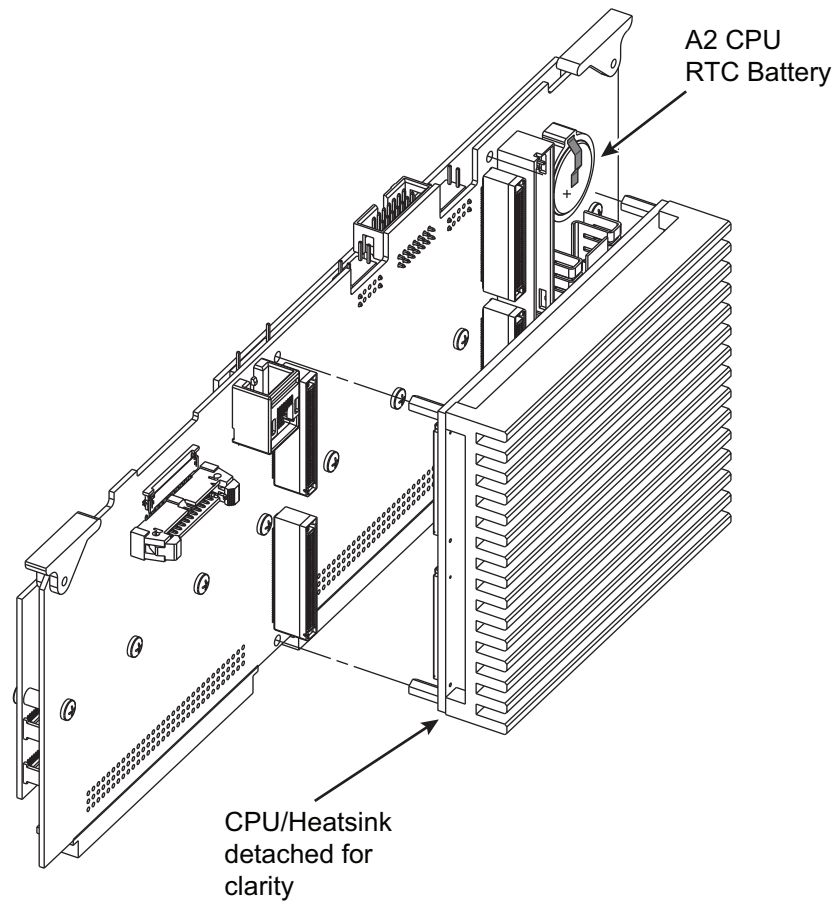

Figure 6-6. A2 Battery Replacement

3. To install the HDD board, reverse the removal process.

6-7 A7 or A9 PCB

Preliminary

Remove the front handles, rear feet, and chassis top and bottom covers as described in [Section 6-4](#).

Procedure

1. Unplug all snap-in (MCX) cables that are attached to the top of the A7 or A9 PCB assembly.
2. Using a 5/16 inch wrench, disconnect the semi-rigid cable that is attached between the A9 and the switched filter.
3. Remove the cover from the bottom of the instrument.
4. With the instrument standing on its side, hold the assembly to be removed in one hand while loosening the 2 screws (flathead type, captivated, with springs) that attach the assembly to the motherboard.
See [Figure 5-3 on page 5-7](#) for screw locations.
5. To install A7 or A9, reverse the removal procedure.
6. Refer to [Table 6-2 on page 6-3](#) for the adjustments and verifications needed after replacement.

6-8 A4, A6, A8 PCBs

These PCBs are secured by a locking catch on each end of the board. [Figure 6-7](#) shows the locked and unlocked positions of the catch. The PCB is unlocked when the circular tab is pushed inward.

Preliminary

Remove the front handles, rear feet, and chassis top and bottom covers as described in [Section 6-4](#).

Procedure

To release the A4, A6, or A8 PCB:

1. Unplug all cables that are attached to the top of the board.
2. Release the locking catches at both ends of the PCB.
3. Lift the release tabs on each end and pull the PCB straight up to remove from the unit.
4. To install the PCB, reverse the removal process.
5. Refer to [Table 6-2 on page 6-3](#) for the adjustments and verifications needed after replacement.

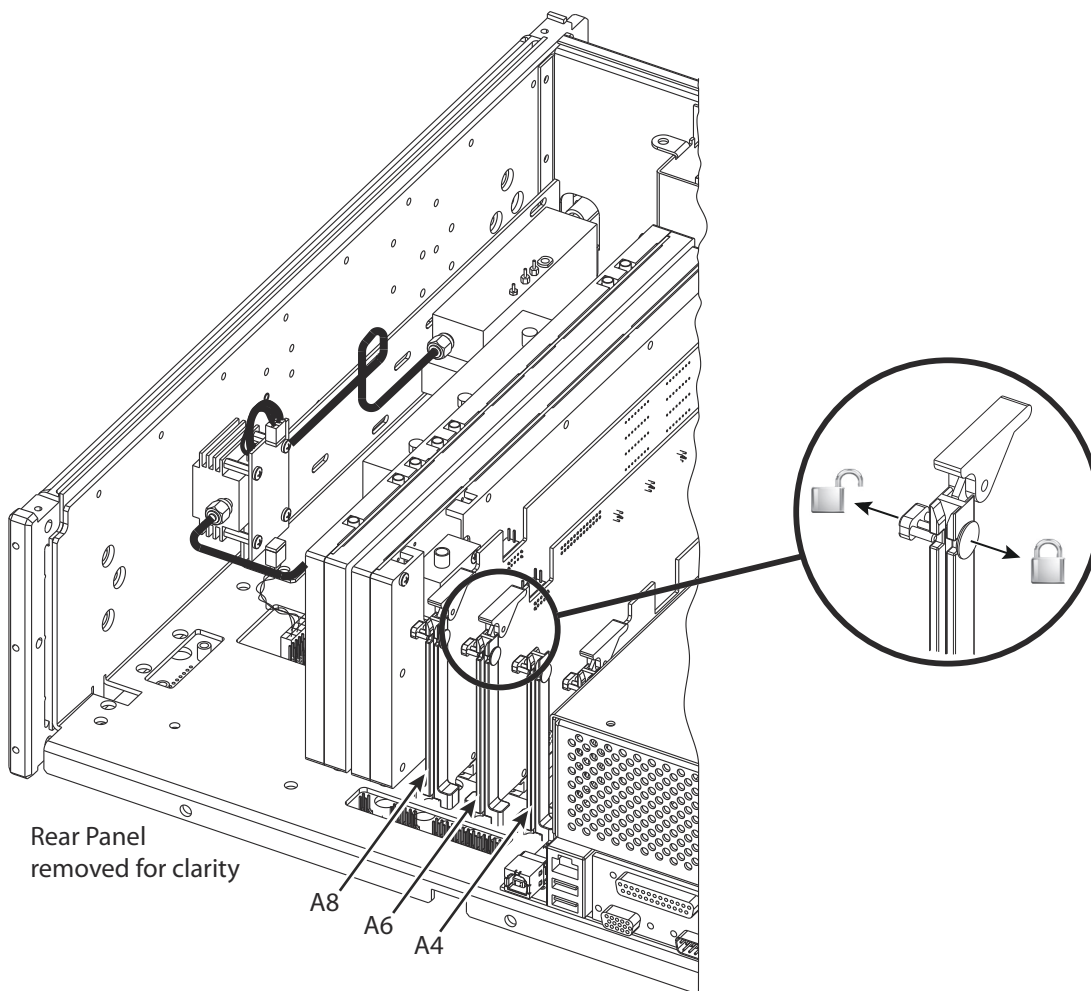

Figure 6-7. A4, A6, A8 PCB Locking Catch

6-9 Main Power Supply, Auxiliary Power Supply or Regulator PCB

The main supply, auxiliary (standby) supply and voltage regulator PCBs are found under the power supply cover as shown in [Figure 6-8](#).

Preliminary

Danger



Hazardous voltages are present inside the power supply assembly whenever the AC line power is connected. Turn off the instrument and remove the power line before proceeding with this section.

1. Remove the front handles, rear feet, and chassis covers as described in [Section 6-4](#).

Main Power Supply

To remove the power supply:

1. On the power supply cover, remove the 4 screws closest to the corners.

Note

The cover will feel heavy when lifted because the main power supply is mounted to the underside of the cover.

2. Unplug the connectors from both ends of the main power supply.
3. Release the main power supply from the cover by removing the 4 screws.
4. To install the power supply assembly, reverse the removal process.

Auxiliary Power Supply

The auxiliary (standby) power supply is a small PCB mounted on the larger voltage regulator PCB.

1. Unplug the connectors from the auxiliary PCB.
2. Remove the 4 screws that secure the auxiliary power supply to the regulator PCB.
3. To install the auxiliary power supply assembly, reverse the removal process.

A3 Regulator PCB

To remove the regulator PCB:

1. Unplug all connectors.
2. Remove the 6 screws that secure the regulator PCB.
3. To install regulator PCB, reverse the removal process.
4. Refer to [Table 6-2 on page 6-3](#) for the adjustments and verifications needed after replacement.

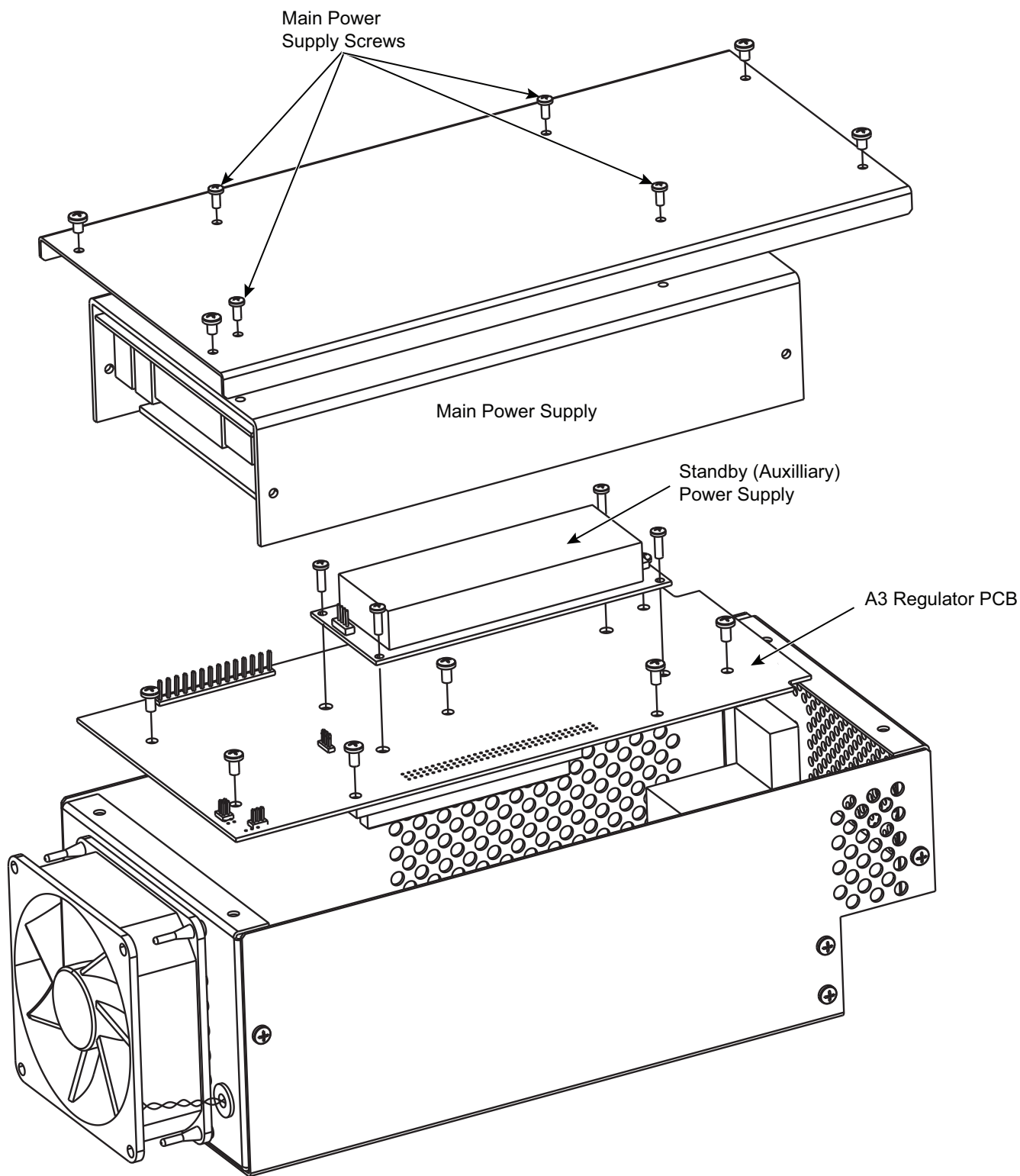

Figure 6-8. Power Supply Replacement

6-10 Rear Panel BNC Interface PCB

Preliminary

Remove the front handles, rear feet, and chassis covers as described in [Section 6-4](#).

Procedure

Refer to [Figure 6-9](#).

To replace the rear panel BNC interface:

1. Unplug the ribbon cable that attaches between the BNC PCB and the motherboard.
2. Unplug the snap-in MCX cables.
3. Using a T1451 socket, remove all exterior nuts from the BNC connectors.
4. The PCB is ready for removal.
5. To install the new BNC interface board, reverse the removal process.

No recalibrations are required after replacement of this item.

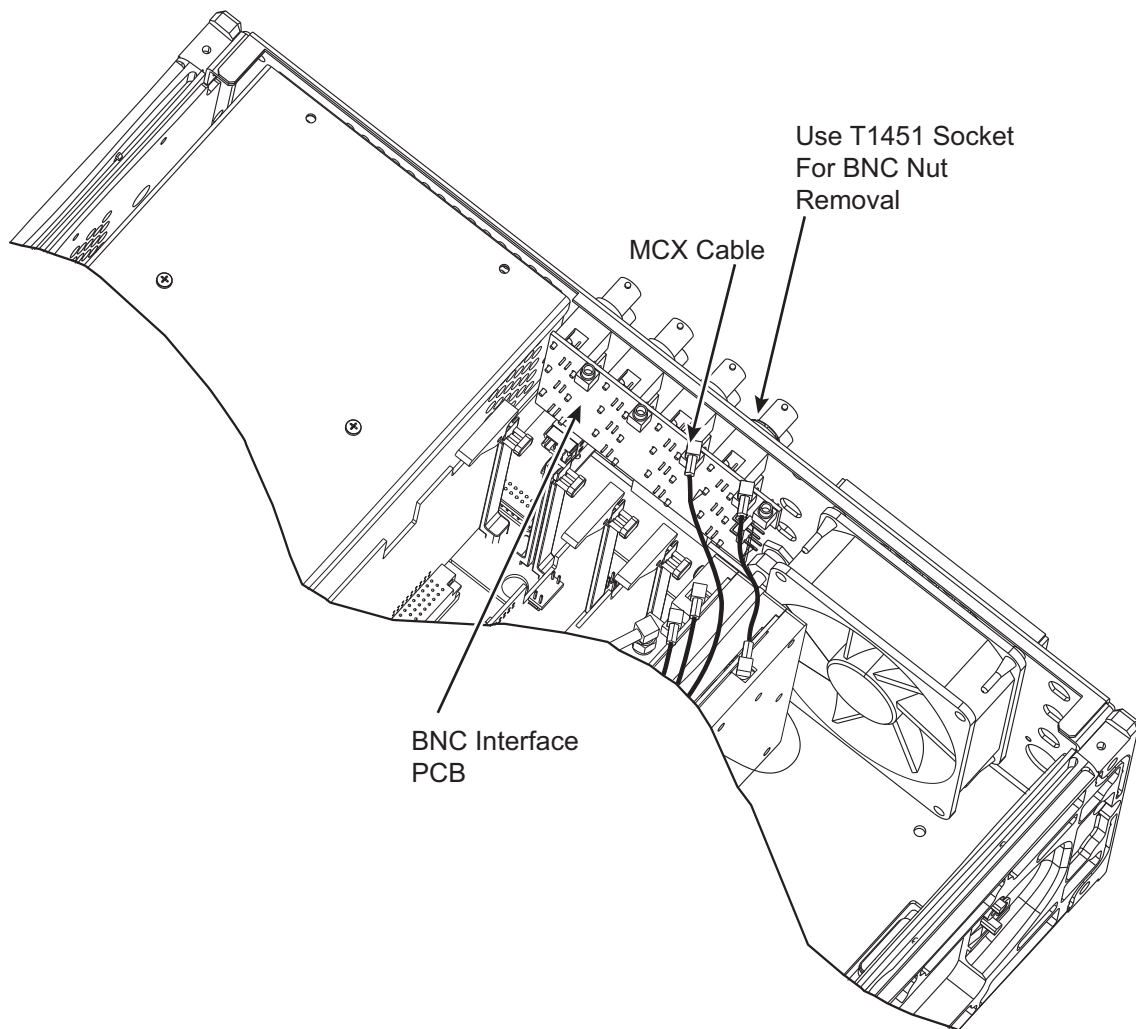

Figure 6-9. Rear Panel BNC Interface Replacement

6-11 Rear Panel Digital Interface PCB

Preliminary

Remove the front handles, rear feet, and chassis covers as described in [Section 6-4](#).

Procedure

To replace this PCB, the entire power supply enclosure must be removed. To remove the power supply enclosure, perform the following steps:

1. Loosen the 4 screws (flathead type, captivated) on the bottom of the instrument that are under the power supply. See [Figure 5-3 on page 5-7](#) for mounting screw locations.
2. Remove the 3 screws on the rear panel that are closest to the line input module (2 on left side, one above the line input module).
3. Remove the top cover of the power supply and lay the top cover gently to the side. (It is not necessary to remove the main power supply from the cover).
4. Grasp the front and rear of the power supply enclosure and lift the supply upwards and slide it toward the front of the instrument (the bottom of the supply has tabs that prevent it from being lifted straight up- Gently move the supply housing forward and upward until it is unplugged from the motherboard and can be removed.
5. Using a 3/16 inch wrench, remove the 6 nuts that secure the digital connectors on the outside of the instrument. Gently unplug the digital interface PCB from the motherboard.

No recalibrations are required after replacement of this item.

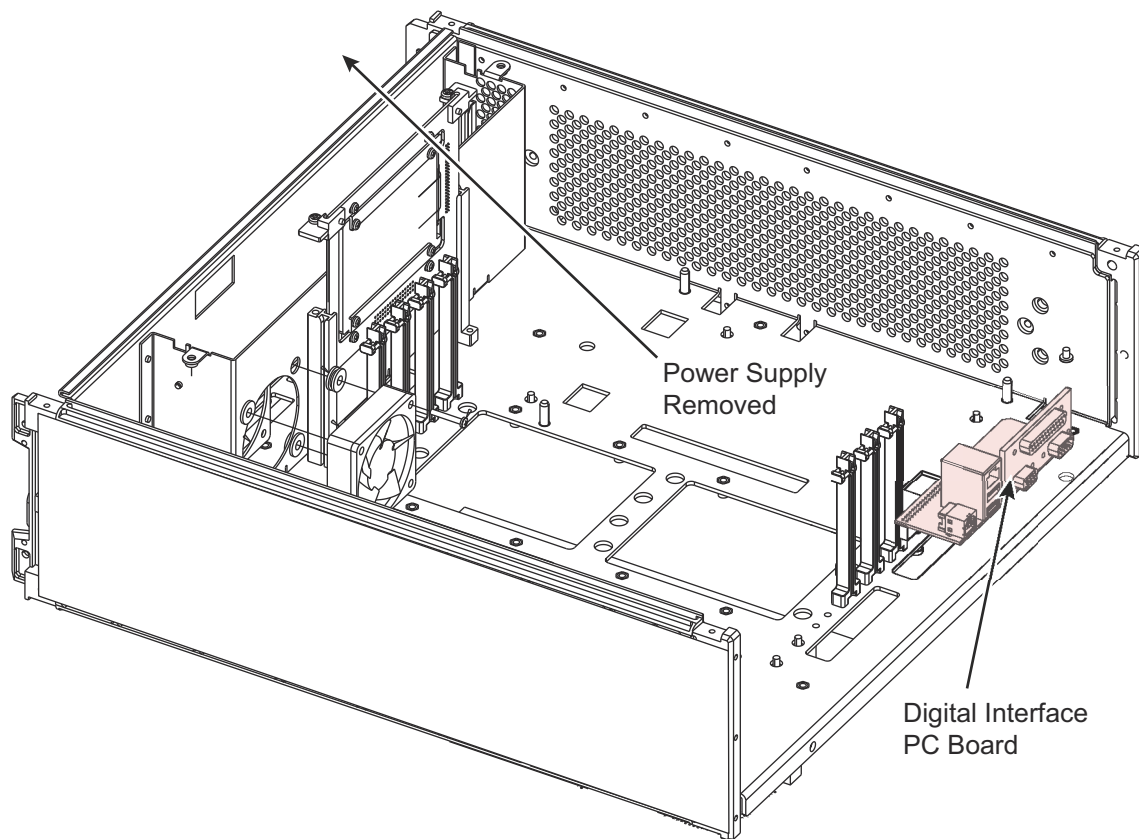

Figure 6-10. Rear Panel Digital Interface Replacement

6-12 Cooling Fans

The power supply fan and the main system fan are held in place by anti-vibration mounts, using no screws. The smaller A2 CPU fan is mounted using anti vibration rubber grommets and screws.

Main System Fan

Refer to [Figure 6-11](#).

1. Remove the front handles, rear feet, and chassis top and bottom covers as described in [Section 6-4](#).
2. Remove the fan filter cover and filter from the rear panel.
3. Disconnect the fan electrical connector from the mother board.
4. Remove the fan by pulling outward.

You may have to grasp and pull outward on the anti-vibration mounts to release the fan. Only a small amount of force is required. If this is not successful, cut the anti-vibration mounts.

Note The A7 and A9 PCBs may have to be removed if there is not enough clearance for fan removal. In this case, refer to [Section 6-7 “A7 or A9 PCB”](#) for PCB removal instructions.

5. Replace all damaged anti-vibration mounts (see [Table 6-1](#) for part number).
6. Install the new fan and attach the wired connector to P2 on the A1 mother board.
7. Reassemble the system.

No recalibrations are required after replacement of this item.

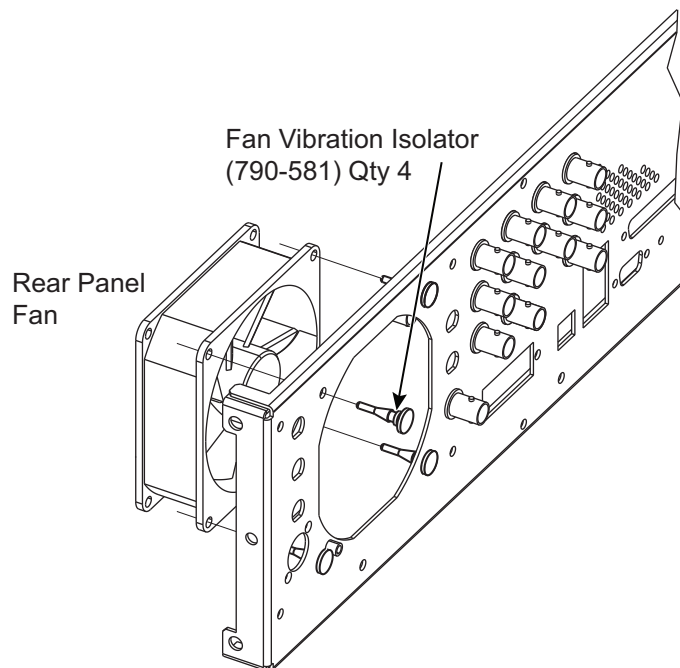

Figure 6-11. Rear Panel Cooling Fan Replacement

Power Supply Fan

Replacing the power supply fan requires removing the power supply cover.

Danger



Hazardous voltages are exposed inside the MG3702xA whenever the power supply enclosure is open and the AC line power is connected. Turn off the instrument and remove the line cord before removing the power supply cover. Use extreme caution when troubleshooting with the power supply cover removed and the unit energized.

Troubleshooting or repair procedures should only be performed by qualified service personnel who are fully aware of the potential hazards.

1. Remove the front handles, rear feet, and chassis top and bottom covers as described in [Section 6-4](#).
2. On the power supply cover, remove the 4 screws closest to the corners. See [Figure 6-12 on page 6-21](#).

Note The cover will feel heavy when lifted because the main power supply is mounted to the underside of the cover.

3. Lift the cover and the attached main power supply out of the way.
4. Detach the power connector from JP2 on the regulator board.
5. Remove the wires from the connector housing so the fan wires can be pulled from the housing.
6. Remove the fan by pulling outward.

You may have to grasp and pull outward on the anti-vibration mounts to release the fan. Only a small amount of force is required. If this is not successful, cut the anti-vibration mounts.

Note If the lower anti-vibration fan mounts are damaged or cut, the regulator PC assembly must be removed so new mounts can be installed. See [Section 6-9](#) for instructions.

7. Replace all damaged anti-vibration mounts (see [Table 6-1 on page 6-2](#) for part number).
8. If the regulator PC board was removed, install it now.

Note Before installing the new connector assembly, feed the fan wire ends through the rubber isolator.

9. Remove the fan wiring connector housing by pressing down on the metal tabs and gently pulling the contact from the housing.
10. Install the new fan. Pass the wires from the new fan through rubber isolator.
11. After the new fan wires are pulled into the power supply housing, reassemble the pins to the connector housing to the wires according to [Figure 6-12](#).

Caution Observe polarity during connector assembly to prevent the fan from running in the wrong direction.

12. Attach the fan electrical connector to its connector on the A3 regulator PC Board.
13. To reassemble the system, reverse the process.

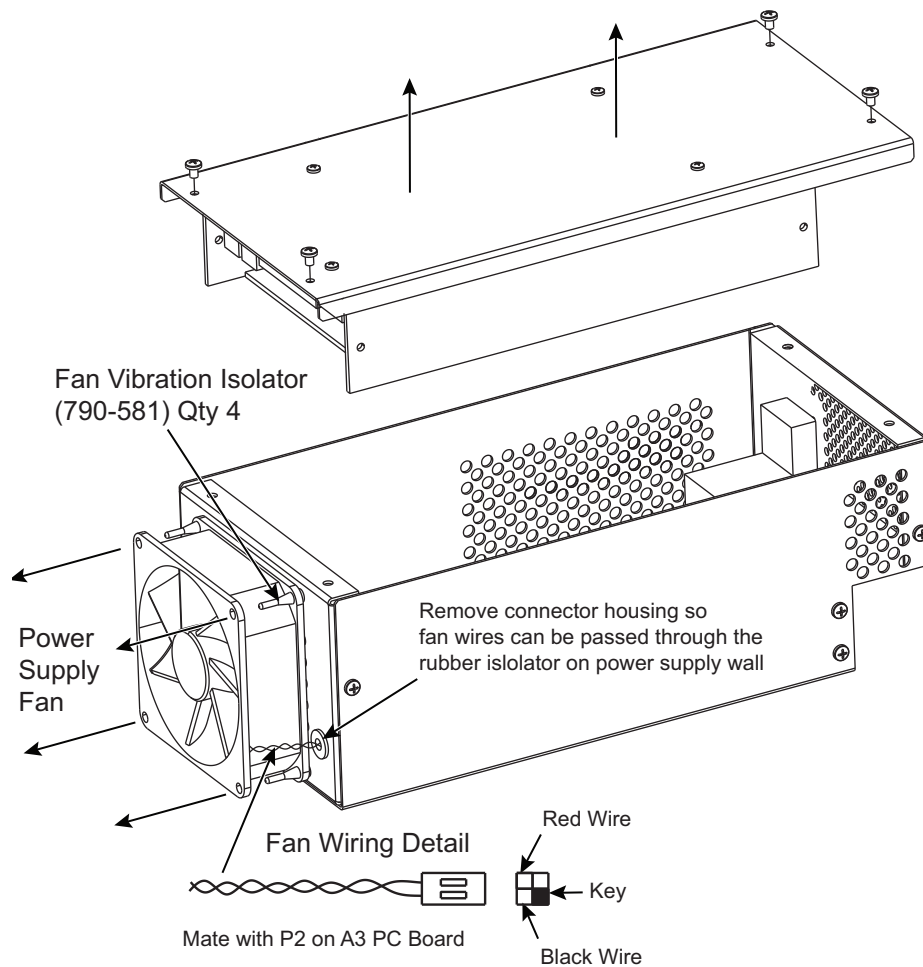

Figure 6-12. Power Supply Cooling Fan Replacement

A2 CPU Cooling Fan

Refer to [Figure 6-11](#).

1. Remove the front handles, rear feet, and chassis top and bottom covers as described in [Section 6-4](#).
2. Disconnect the fan electrical connector from the mother board.

Note The A7 and A9 PCBs may have to be removed if there is not enough clearance for fan removal. In this case, refer to [Section 6-7 “A7 or A9 PCB”](#) for PCB removal instructions.

3. Remove the four fan mounting screws.
4. Replace all damaged anti-vibration mounts (see [Table 6-1 on page 6-2](#) for part number).
5. Install the new fan and attach the wired connector to P7 on the A1 mother board.
6. Reassemble the system.

No recalibrations are required after replacement of this item.

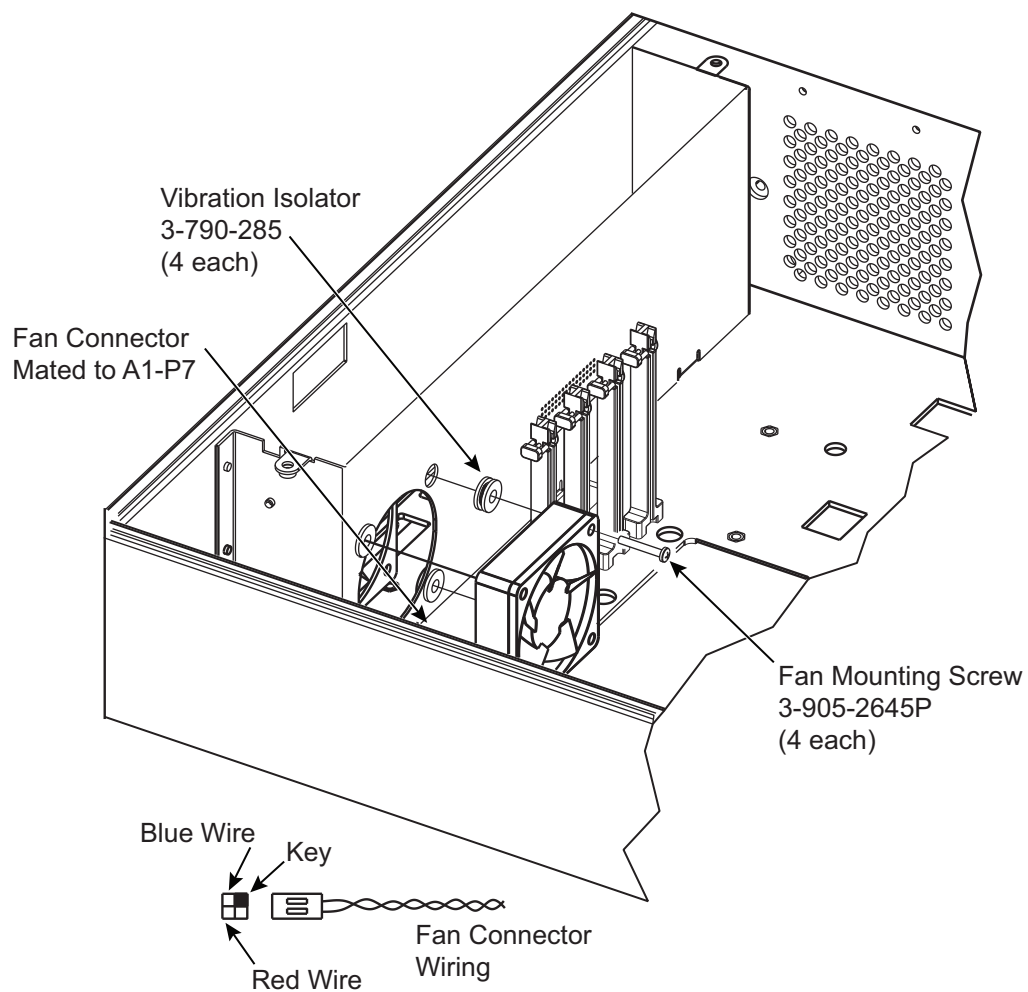

Figure 6-13. A2 CPU Fan Replacement

6-13 RF Components

Most RF components are secured by 2 screws (flathead type, captivated) which are accessed from the bottom of the instrument. See [Figure 5-3 on page 5-7](#) for screw locations. After loosening the screws (where present), the RF component can be removed by loosening the adjacent RF connectors and unplugging the bias wires from the motherboard connectors.

Note

It is often necessary to loosen all screws of all RF components in the entire line of components to allow movement during disconnection of the RF connectors.

Note

Never cut or unsolder wires.

Caution

When tightening component and cable RF connections, use a torque wrench (Anritsu part number 01-201). Failure to use a torque wrench can cause damage to RF connectors.

Caution

Use extreme caution when plugging the step attenuator cable into the motherboard connector. If inserted incorrectly, the step attenuator may be destroyed.

After the RF path has been broken, Level Accuracy verification should be performed, regardless of whether an RF component has been replaced. If an RF component has been replaced, the instrument Level Accuracy calibration must be performed.

Appendix A — Test Records

A-1 Introduction

This appendix provides tables for recording the results of the performance verification tests (Chapter 3) and the calibration procedures (Chapter 4). They jointly provide the means for maintaining an accurate and complete record of instrument performance.

Some test records are customized to cover particular MG3702xA options. These records contain references to frequency parameters and power levels that are applicable to the instrument with that option or set of options. When a test record is customized, it is labeled with the specific option list that it covers. Test records which are not customized do not specify an option list. These test records are generic and may contain specific references to frequency parameters and power levels that exceed the operational limits of the instrument being tested. When using generic test records, use only the parameters that fall within the operational limits of the instrument being tested.

A-2 Uncertainty Specifications

All test records are provided with a measurement uncertainty, which consists of the type-B¹ components. The error contributions are measurement method, test equipment, standards, and other correction factors (for example, calibration factors and mismatch error) per the prescribed test procedure. The statement(s) of compliance with specification² is based on a 95% coverage probability for the expanded uncertainty of the measurement results on which the decision of compliance is based. For some of the measured values it is not possible to make a statement of compliance with specification². Other values of coverage probability for the expanded uncertainty may be reported, where practicable.

A-3 Test Records

We recommend that you make a copy of the test record pages each time a test procedure is performed. By dating each test record copy, a detailed history of the instrument's performance can be accumulated.

Section 3-6 Internal Time Base Aging Rate Test (Optional)

All MG3702xA Models

	Date and Time	Measured Value	Upper Limit	Measurement Uncertainty
Frequency Error Value			N/A	N/A
Frequency Error Value (after 24 hours)			N/A	N/A
Computed Aging Rate	N/A	_____ per day	2×10^{-8} per day	2×10^{-12} per day

1. BIPM JCGM 100:2008 Evaluation of measurement data- Guide to the expression of uncertainty in measurement.
2. LAC-G8:03/2009: Guidelines on the Reporting of Compliance with Specification.

Model Number:

Firmware Revision:

Date:

Serial Number:

Options:

Operator:

Section 3-7 Harmonics and Harmonically Related Signals Test (without Option 15)**All MG3702xA Models without Option 15**

Power level: The power level changes based on frequency, model and options installed. Set L1 to the lesser of +10 dBm or to the maximum specified power level.

Refer to Appendix B the Technical Data Sheet, for the maximum specified power levels.

Test Frequency (MHz)	Spectrum Analyzer's Span (MHz)	Spectrum Analyzer BW/RBW/VBW (kHz)	2nd Harmonic Frequency (MHz)	Measured Value (dBc)	3rd Harmonic Frequency (MHz)	Measured Value (dBc)	1/2 Sub Harmonic (MHz)	Measured Value (dBc)	1/4 Sub Harmonic (MHz)	Measured Value (dBc)	3/4 Sub Harmonic (MHz)	Measured Value (dBc)	Harmonic Related Upper Limit (dBc)	Measurement Uncertainty (dB)
Frequencies: 10 MHz to ≤ 100 MHz (Models with Option 004 Only)														
10	1	10	20		30		N/A		N/A		N/A		-40	2.5
15	1	10	30		45		N/A		N/A		N/A		-40	2.5
60	1	10	120		180		N/A		N/A		N/A		-40	2.5
100	1	10	200		300		N/A		N/A		N/A		-40	2.5
Frequencies: > 100 MHz to ≤ 2.2 GHz (Models with Option 004 Only)														
100.1	1	10	200.2		300.3		N/A		N/A		N/A		-50	0.8
500	1	10	1000		1500		N/A		N/A		N/A		-50	0.8
1500	1	10	3000		4500		N/A		N/A		N/A		-50	0.8
2200	1	10	4400		6600		N/A		N/A		N/A		-50	0.8
Frequencies: 2 GHz to ≤ 20 GHz														
2000	1	10	4000		6000		N/A		N/A		N/A		-50	0.8
2201	1	10	4402		6603		N/A		N/A		N/A		-50	0.8
9990	1	10	19980		29970		N/A		N/A		N/A		-50	2.5
10001	1	10	20020		30030		N/A		N/A		N/A		-50	2.5
20000	1	10	40000		N/A		N/A		N/A		N/A		-50	2.5

Model Number:	Firmware Revision:	Date:
Serial Number:	Options:	Operator:

Section 3-7 Harmonics and Harmonically Related Signals Test (with Option 15)

All MG3702xA Models with Option 15

Power level: The power level changes based on frequency, model and options installed. Set L0 to the lesser of +10 dBm or to the maximum specified power level.

Refer to Appendix B the Technical Data Sheet, for the maximum specified power levels.

Test Frequency (MHz)	Spectrum Analyzer's Span (MHz)	Spectrum Analyzer's BW/RBW/VBW (kHz)	2nd Harmonic Frequency (MHz)	Measured Value (dBc)	3rd Harmonic Frequency (MHz)	Measured Value (dBc)	1/2 Sub Harmonic (MHz)	Measured Value (dBc)	1/4 Sub Harmonic (MHz)	Measured Value (dBc)	3/4 Sub Harmonic (MHz)	Measured Value (dBc)	Harmonic Related Upper Limit (dBc)	Measurement Uncertainty (dB)
Frequencies: 10 MHz to ≤ 100 MHz (Models with Option 004 Only)														
10	1	10	20		30		N/A		N/A		N/A		-40	2.5
15	1	10	30		45		N/A		N/A		N/A		-40	2.5
60	1	10	120		180		N/A		N/A		N/A		-40	2.5
100	1	10	200		300		N/A		N/A		N/A		-40	2.5
Frequencies: > 100 MHz to ≤ 2.2 GHz (Models with Option 004 Only)														
100.1	1	10	200.2		300.3		N/A		N/A		N/A		-50	0.8
500	1	10	1000		1500		N/A		N/A		N/A		-50	0.8
1500	1	10	3000		4500		N/A		N/A		N/A		-50	0.8
2000	1	10	4000		6000		N/A		N/A		N/A		-50	0.8
2200	1	10	4400		6600		N/A		N/A		N/A		-50	0.8

Model Number:

Firmware Revision:

Date:

Serial Number:

Options:

Operator:

Section 3-7 Non-Harmonic Signals Test (Part 1) (1 of 3)

MG3702xA Frequency (GHz)	MG3702xA Output Power Level ^(a)	Spectrum Analyzer Start Frequency (GHz)	Spectrum Analyzer Stop Frequency (GHz)	Spectrum Analyzer RBW (kHz)	Test Result (dBc)	Spec. (dBc)	Measurement Uncertainty
2.650	10dBm	2.649	2.651	30.000	n/a	n/a	n/a
2.650	10dBm	2.645	2.649	30.000		-40	2.26
2.650	10dBm	2.595	2.645	100.000		-40	2.34
2.650	10dBm	2.350	2.595	100.000		-40	2.34
2.650	10dBm	2.651	2.655	30.000		-40	2.26
2.650	10dBm	2.655	2.705	100.000		-40	2.34
2.650	10dBm	2.705	2.950	100.000		-40	2.93
2.650	10dBm	2.000	2.350	100.000		-40	2.34
2.650	10dBm	2.950	5.000	100.000		-40	2.93
2.650	10dBm	5.600	7.650	100.000		-40	3.33
2.650	10dBm	8.250	10.300	100.000		-40	3.33
2.650	10dBm	10.900	12.950	100.000		-40	3.33
2.650	10dBm	13.550	16.775	30.000		-40	3.24
2.650	10dBm	16.775	20.000	30.000		-40	3.24
4.400	10dBm	4.399	4.401	30.000	n/a	n/a	n/a
4.400	10dBm	4.395	4.399	30.000		-40	2.97
4.400	10dBm	4.345	4.395	100.000		-40	3.02
4.400	10dBm	4.100	4.345	100.000		-40	3.02
4.400	10dBm	4.401	4.405	30.000		-40	2.97
4.400	10dBm	4.405	4.455	100.000		-40	3.02
4.400	10dBm	4.455	4.700	100.000		-40	3.02
4.400	10dBm	2.500	3.000	100.000		-40	2.93
4.400	10dBm	3.600	4.100	100.000		-40	3.02
4.400	10dBm	4.700	8.500	100.000		-40	3.53
4.400	10dBm	9.100	12.900	100.000		-40	3.53
4.400	10dBm	13.500	17.300	30.000		-40	3.46
4.400	10dBm	17.900	20.000	30.000		-40	3.46
6.950	10dBm	6.949	6.951	30.000	n/a	n/a	n/a
6.950	10dBm	6.945	6.949	30.000		-40	3.66

Model Number:	Firmware Revision:	Date:
Serial Number:	Options:	Operator:

Section 3-7 Non-Harmonic Signals Test (Part 1) (2 of 3)

MG3702xA Frequency (GHz)	MG3702xA Output Power Level ^(a)	Spectrum Analyzer Start Frequency (GHz)	Spectrum Analyzer Stop Frequency (GHz)	Spectrum Analyzer RBW (kHz)	Test Result (dBc)	Spec. (dBc)	Measurement Uncertainty
6.950	10dBm	6.895	6.945	100.000		-40	3.69
6.950	10dBm	6.650	6.895	100.000		-40	3.69
6.950	10dBm	6.951	6.955	30.000		-40	3.66
6.950	10dBm	6.955	7.005	100.000		-40	3.69
6.950	10dBm	7.005	7.250	100.000		-40	3.69
6.950	10dBm	2.000	2.017	100.000		-40	3.33
6.950	10dBm	2.617	3.175	100.000		-40	3.53
6.950	10dBm	3.775	4.913	100.000		-40	3.53
6.950	10dBm	5.513	6.650	100.000		-40	3.69
6.950	10dBm	7.250	10.500	30.000		-40	3.66
6.950	10dBm	10.500	13.600	30.000		-40	3.78
6.950	10dBm	14.200	17.000	30.000		-40	3.75
6.950	10dBm	17.000	20.000	30.000		-40	3.75
10.950	10dBm	10.949	10.951	30.000	n/a	n/a	n/a
10.950	10dBm	10.945	10.949	30.000		-40	3.66
10.950	10dBm	10.895	10.945	30.000		-40	3.66
10.950	10dBm	10.650	10.895	30.000		-40	3.66
10.950	10dBm	10.951	10.955	30.000		-40	3.66
10.950	10dBm	10.955	11.005	30.000		-40	3.66
10.950	10dBm	11.005	11.250	30.000		-40	3.66
10.950	10dBm	2.000	3.350	30.000		-40	3.49
10.950	10dBm	3.950	5.175	30.000		-40	3.49
10.950	10dBm	5.775	7.913	30.000		-40	3.49
10.950	10dBm	8.512	10.650	30.000		-40	3.66
10.950	10dBm	11.250	15.500	10.000		-40	3.81
10.950	10dBm	15.500	20.000	10.000		-40	3.78
16.750	10dBm	16.749	16.751	30.000	n/a	n/a	n/a
16.750	10dBm	16.745	16.749	30.000		-40	3.59
16.750	10dBm	16.695	16.745	30.000		-40	3.59
16.750	10dBm	16.450	16.695	30.000		-40	3.59

Model Number:

Firmware Revision:

Date:

Serial Number:

Options:

Operator:

Section 3-7 Non-Harmonic Signals Test (Part 1) (3 of 3)

MG3702xA Frequency (GHz)	MG3702xA Output Power Level ^(a)	Spectrum Analyzer Start Frequency (GHz)	Spectrum Analyzer Stop Frequency (GHz)	Spectrum Analyzer RBW (kHz)	Test Result (dBc)	Spec. (dBc)	Measurement Uncertainty
16.750	10dBm	16.751	16.755	30.000		-40	3.59
16.750	10dBm	16.755	16.805	30.000		-40	3.59
16.750	10dBm	16.805	17.050	30.000		-40	3.59
16.750	10dBm	2.000	5.283	30.000		-40	3.46
16.750	10dBm	5.883	8.075	30.000		-40	3.75
16.750	10dBm	8.675	12.263	30.000		-40	3.75
16.750	10dBm	12.863	16.450	10.000		-40	3.78
16.750	10dBm	17.050	20.000	10.000		-40	3.63

a. All specifications apply at the lesser of +10 dBm output or Maximum specified leveled output power, unless otherwise noted.

Model Number:	Firmware Revision:	Date:
Serial Number:	Options:	Operator:

Section 3-7 Non-Harmonic Signals Test (Part 2)

Non-Harmonic Test Procedure: Part 2 (with option 004 installed)

MG3702xA Frequency (GHz)	MG3702xA Output Power Level ^(a)	Spectrum Analyzer Center Freq. (GHz)	Spectrum Analyzer Span	Spectrum Analyzer RBW	Test Result (dBc)	Specification (dBc)	Measurement Uncertainty	Exclusions
1.100000	10 dBm	1.100000	1 MHz	30 kHz	n/a	n/a	n/a	
1.100000	10 dBm	1.500000	1 MHz	30 kHz		-40 (opt. 4 units)	2.26	
1.100000	10 dBm	0.500000	1 MHz	30 kHz		-40 (opt. 4 units)	2.26	
1.100000	10 dBm	2.000000	1 MHz	30 kHz		-40 (opt. 4 units)	2.26	
1.100000	10 dBm	6.500000	1 MHz	30 kHz		-40 (opt. 4 units)	2.54	
1.100000	10 dBm	7.600000	1 MHz	30 kHz		-40 (opt. 4 units)	2.54	

a. All specifications apply at the lesser of +10 dBm output or Maximum specified leveled output power, unless otherwise noted.

Model Number:

Firmware Revision:

Date:

Serial Number:

Options:

Operator:

Section 3-8 SSB Phase Noise Test: Agilent Test Equipment**Power Line and Fan Rotation Emissions**

All MG3702xA Models (1 of 2)

Frequency Offset	Measured Value (dBc)	Upper Limit (dBc)	Measurement Uncertainty (dB)
Test Frequency: 15 MHz (Models with Option 004)			
< 300 Hz		-68	3.07
300 Hz to 1 kHz		-72	2.38
> 1 kHz		-72	2.0
Test Frequency: 30 MHz (Models with Option 004)			
< 300 Hz		-68	3.07
300 Hz to 1 kHz		-72	2.38
> 1 kHz		-72	2.0
Test Frequency: 60 MHz (Models with Option 004)			
< 300 Hz		-68	3.07
300 Hz to 1 kHz		-72	2.38
> 1 kHz		-72	2.0
Test Frequency: 120 MHz (Models with Option 004)			
< 300 Hz		-68	3.07
300 Hz to 1 kHz		-72	2.38
> 1 kHz		-72	2.0
Test Frequency: 250 MHz (Models with Option 004)			
< 300 Hz		-68	3.07
300 Hz to 1 kHz		-72	2.38
> 1 kHz		-72	2.0
Test Frequency: 499 MHz (Models with Option 004)			
< 300 Hz		-68	3.07
300 Hz to 1 kHz		-72	2.38
> 1 kHz		-72	2.0
Test Frequencies: 1.0 GHz (Models with Option 004)			
< 300 Hz		-62	3.07
300 Hz to 1 kHz		-72	2.38
> 1 kHz		-72	2.0
Test Frequency: 2.19 GHz (Models with Option 004)			

Model Number:

Firmware Revision:

Date:

Serial Number:

Options:

Operator:

Section 3-8 SSB Phase Noise Test: Agilent Test Equipment

Power Line and Fan Rotation Emissions

All MG3702xA Models (2 of 2)

Frequency Offset	Measured Value (dBc)	Upper Limit (dBc)	Measurement Uncertainty (dB)
< 300 Hz		-56	3.07
300 Hz to 1 kHz		-66	2.38
> 1 kHz		-66	2.0

Test Frequency: 6.0 GHz

< 300 Hz		-50	3.07
300 Hz to 1 kHz		-60	2.38
> 1 kHz		-60	2.0

Test Frequency: 10.0 GHz

< 300 Hz		-46	3.07
300 Hz to 1 kHz		-56	2.38
> 1 kHz		-60	2.0

Test Frequency: 19.99 GHz

< 300 Hz		-46	3.07
300 Hz to 1 kHz		-56	2.38
> 1 kHz		-60	2.0

Model Number:

Firmware Revision:

Date:

Serial Number:

Options:

Operator:

Section 3-8 SSB Phase Noise Test: Agilent Test Equipment

All MG3702xA Models Single Sideband Phase Noise (1 of 3)

Frequency Offset	Measured Value (dBc)	Upper Limit (dBc)	Measurement Uncertainty (dB)
Test Frequency: 15 MHz (Models with Option 004)			
10 Hz		-101	3.07
100 Hz		-126	2.38
1 kHz		-139	2.0
10 kHz		-142	2.0
100 kHz		-142	2.0
1 MHz		-145	2.0
Test Frequency: 30 MHz (Models with Option 004)			
10 Hz		-95	3.07
100 Hz		-121	2.38
1 kHz		-134	2.0
10 kHz		-139	2.0
100 kHz		-139	2.0
1 MHz		-145	2.0
Test Frequency: 60 MHz (Models with Option 004)			
10 Hz		-89	3.07
100 Hz		-116	2.38
1 kHz		-129	2.0
10 kHz		-135	2.0
100 kHz		-137	2.0
1 MHz		-142	2.0
Test Frequency: 120 MHz (Models with Option 004)			
10 Hz		-83	3.07
100 Hz		-110	2.38
1 kHz		-127	2.0
10 kHz		-129	2.0
100 kHz		-134	2.0
1 MHz		-138	2.0
Test Frequency: 250 MHz (Models with Option 004)			
10 Hz		-77	3.07

Model Number:	Firmware Revision:	Date:
Serial Number:	Options:	Operator:

Section 3-8 SSB Phase Noise Test: Agilent Test Equipment

All MG3702xA Models Single Sideband Phase Noise (2 of 3)

Frequency Offset	Measured Value (dBc)	Upper Limit (dBc)	Measurement Uncertainty (dB)
100 Hz		-104	2.38
1 kHz		-123	2.0
10 kHz		-123	2.0
100 kHz		-128	2.0
1 MHz		-132	2.0

Test Frequency: 499 MHz (Models with Option 004)

10 Hz		-71	3.07
100 Hz		-98	2.38
1 kHz		-117	2.0
10 kHz		-117	2.0
100 kHz		-122	2.0
1 MHz		-126	2.0

Test Frequency: 1.0 GHz (Models with Option 004)

10 Hz		-65	3.07
100 Hz		-92	2.38
1 kHz		-111	2.0
10 kHz		-111	2.0
100 kHz		-116	2.0
1 MHz		-120	2.0

Test Frequency: 2.19 GHz (Models with Option 004)

10 Hz		-59	3.07
100 Hz		-86	2.38
1 kHz		-105	2.0
10 kHz		-105	2.0
100 kHz		-110	2.0
1 MHz		-114	2.0

Model Number:

Firmware Revision:

Date:

Serial Number:

Options:

Operator:

Section 3-8 SSB Phase Noise Test: Agilent Test Equipment

All MG3702xA Models Single Sideband Phase Noise (3 of 3)

Frequency Offset	Measured Value (dBc)	Upper Limit (dBc)	Measurement Uncertainty (dB)
Test Frequency: 6.0 GHz			
10 Hz		-50	3.07
100 Hz		-77	2.38
1 kHz		-96	2.0
10 kHz		-96	2.0
100 kHz		-101	2.0
1 MHz		-105	2.0
Test Frequency: 10.0 GHz			
10 Hz		-46	3.07
100 Hz		-73	2.38
1 kHz		-92	2.0
10 kHz		-92	2.0
100 kHz		-100	2.0
1 MHz		-101	2.0
Test Frequency: 19.99 GHz			
10 Hz		-40	3.07
100 Hz		-67	2.38
1 kHz		-86	2.0
10 kHz		-86	2.0
100 kHz		-94	2.0
1 MHz		-95	2.0

Model Number:	Firmware Revision:	Date:
Serial Number:	Options:	Operator:

Section 3-8 SSB Phase Noise Test: AeroFlex Test Equipment

All MG3702xA Models (1 of 3)

Frequency Offset	Measured Value (dBc)	Upper Limit (dBc)	Measurement Uncertainty (dB)
Test Frequency: 15 MHz (Models with Option 004)			
10 Hz ^(a)		-101	3.07
100 Hz		-126	2.38
1 kHz		-139	2.0
10 kHz		-142	2.0
100 kHz		-142	2.0
1 MHz		-145	2.0
Test Frequency: 30 MHz (Models with Option 004)			
10 Hz		-95	3.07
100 Hz		-121	2.38
1 kHz		-134	2.0
10 kHz		-139	2.0
100 kHz		-139	2.0
1 MHz		-145	2.0
Test Frequency: 60 MHz (Models with Option 004)			
10 Hz		-89	3.07
100 Hz		-116	2.38
1 kHz		-129	2.0
10 kHz		-135	2.0
100 kHz		-137	2.0
1 MHz		-142	2.0
Test Frequency: 120 MHz (Models with Option 004)			
10 Hz		-83	3.07
100 Hz		-110	2.38
1 kHz		-127	2.0
10 kHz		-129	2.0
100 kHz		-134	2.0
1 MHz		-138	2.0
Test Frequency: 250 MHz (Models with Option 004)			
10 Hz		-77	3.07

Model Number:

Firmware Revision:

Date:

Serial Number:

Options:

Operator:

Section 3-8 SSB Phase Noise Test: AeroFlex Test Equipment

All MG3702xA Models (2 of 3)

Frequency Offset	Measured Value (dBc)	Upper Limit (dBc)	Measurement Uncertainty (dB)
100 Hz		-104	2.38
1 kHz		-123	2.0
10 kHz		-123	2.0
100 kHz		-128	2.0
1 MHz		-132	2.0

Test Frequency: 499 MHz (Models with Option 004)

10 Hz		-71	3.07
100 Hz		-98	2.38
1 kHz		-117	2.0
10 kHz		-117	2.0
100 kHz		-122	2.0
1 MHz		-126	2.0

Test Frequency: 1.0 GHz (Models with Option 004)

10 Hz		-65	3.07
100 Hz		-92	2.38
1 kHz		-111	2.0
10 kHz		-111	2.0
100 kHz		-116	2.0
1 MHz		-120	2.0

Test Frequency: 2.19 GHz (Models with Option 004)

10 Hz		-59	3.07
100 Hz		-86	2.38
1 kHz		-105	2.0
10 kHz		-105	2.0
100 kHz		-110	2.0
1 MHz		-114	2.0

Model Number:

Firmware Revision:

Date:

Serial Number:

Options:

Operator:

Section 3-8 SSB Phase Noise Test: AeroFlex Test Equipment

All MG3702xA Models (3 of 3)

Frequency Offset	Measured Value (dBc)	Upper Limit (dBc)	Measurement Uncertainty (dB)
Test Frequency: 6.0 GHz			
10 Hz		-50	3.07
100 Hz		-77	2.38
1 kHz		-96	2.0
10 kHz		-96	2.0
100 kHz		-101	2.0
1 MHz		-105	2.0
Test Frequency: 10.0 GHz			
10 Hz		-46	3.07
100 Hz		-73	2.38
1 kHz		-92	2.0
10 kHz		-92	2.0
100 kHz		-100	2.0
1 MHz		-101	2.0
Test Frequency: 19.99 GHz			
10 Hz		-40	3.07
100 Hz		-67	2.38
1 kHz		-86	2.0
10 kHz		-86	2.0
100 kHz		-94	2.0
1 MHz		-95	2.0

a. On some AeroFlex Test Stations, 10 Hz is not reported so use 10.23 Hz.

Model Number:

Firmware Revision:

Date:

Serial Number:

Options:

Operator:

Section 3-8 SSB Phase Noise Test: AeroFlex Test Equipment**Power Line and Fan Rotation Emissions**

All MG3702xA Models (1 of 2)

Frequency Offset	Measured Value (dBc)	Upper Limit (dBc)	Measurement Uncertainty (dB)
Test Frequency: 15 MHz (Models with Option 004)			
< 300 Hz		-68	3.07
300 Hz to 1 kHz		-72	2.38
> 1 kHz		-72	2.0
Test Frequency: 30 MHz (Models with Option 004)			
< 300 Hz		-68	3.07
300 Hz to 1 kHz		-72	2.38
> 1 kHz		-72	2.0
Test Frequency: 60 MHz (Models with Option 004)			
< 300 Hz		-68	3.07
300 Hz to 1 kHz		-72	2.38
> 1 kHz		-72	2.0
Test Frequency: 120 MHz (Models with Option 004)			
< 300 Hz		-68	3.07
300 Hz to 1 kHz		-72	2.38
> 1 kHz		-72	2.0
Test Frequency: 250 MHz (Models with Option 004)			
< 300 Hz		-68	3.07
300 Hz to 1 kHz		-72	2.38
> 1 kHz		-72	2.0
Test Frequency: 499 MHz (Models with Option 004)			
< 300 Hz		-68	3.07
300 Hz to 1 kHz		-72	2.38
> 1 kHz		-72	2.0
Test Frequencies: 1.0 GHz (Models with Option 004)			
< 300 Hz		-62	3.07
300 Hz to 1 kHz		-72	2.38
> 1 kHz		-72	2.0
Test Frequency: 2.19 GHz (Models with Option 004)			

Model Number:

Firmware Revision:

Date:

Serial Number:

Options:

Operator:

Section 3-8 SSB Phase Noise Test: AeroFlex Test Equipment

Power Line and Fan Rotation Emissions

All MG3702xA Models (2 of 2)

Frequency Offset	Measured Value (dBc)	Upper Limit (dBc)	Measurement Uncertainty (dB)
< 300 Hz		-56	3.07
300 Hz to 1 kHz		-66	2.38
> 1 kHz		-66	2.0

Test Frequency: 6.0 GHz

< 300 Hz		-50	3.07
300 Hz to 1 kHz		-60	2.38
> 1 kHz		-60	2.0

Test Frequency: 10.0 GHz

< 300 Hz		-46	3.07
300 Hz to 1 kHz		-56	2.38
> 1 kHz		-60	2.0

Test Frequency: 19.99 GHz

< 300 Hz		-46	3.07
300 Hz to 1 kHz		-56	2.38
> 1 kHz		-60	2.0

Model Number:

Firmware Revision:

Date:

Serial Number:

Options:

Operator:

Section 3-9 Power Level Accuracy and Flatness Tests**Power Level Log Conformity**

All MG3702xA Models (1 of 2)

Set L0 ^(a) to:	Set F0 to 2.199 GHz (Option 4) or skip if Opt. 4 not installed		Set F0 to 2.201 GHz (Option 4) or 2.001 GHz (All Others)		Specification (dBm)	Measurement Uncertainty (dB)
	Measured Power Non-pulse Mode (dBm)	Measured Power Pulse Mode (dBm)	Measured Power Non-pulse Mode (dBm)	Measured Power Pulse Mode (dBm)		
+23 dBm ^(b)					+22 to +24	0.44
+22 dBm ^(b)					+21 to +23	0.44
+21 dBm ^(b)					+20 to +22	0.44
+20 dBm ^(b)					+19 to +21	0.44
+19 dBm					+18 to +20	0.44
+18 dBm					+17 to +19	0.44
+17 dBm					+16 to +18	0.44
+16 dBm					+15 to +17	0.44
+15 dBm					+14 to +16	0.44
+14 dBm					+13 to +15	0.44
+13 dBm					+12 to +14	0.44
+12 dBm					+11 to +13	0.44
+11 dBm					+10 to +12	0.44
+10 dBm					+9 to +11	0.44
+9 dBm					+8 to +10	0.44
+8 dBm					+7 to +9	0.44
+7 dBm					+6 to +8	0.44
+6 dBm					+5 to +7	0.44
+5 dBm					+4 to +6	0.44
+4 dBm					+3 to +5	0.44
+3 dBm					+2 to +4	0.44
+2 dBm					+1 to +3	0.44
+1 dBm					+0 to +2	0.44
+0 dBm					-1 to +1	0.44
-1 dBm					-2 to +0	0.44
-2 dBm					-3 to -1	0.44

Model Number:

Firmware Revision:

Date:

Serial Number:

Options:

Operator:

Section 3-9 Power Level Accuracy and Flatness Tests

Power Level Log Conformity

All MG3702xA Models (2 of 2)

Set L0 ^(a) to:	Set F0 to 2.199 GHz (Option 4) or skip if Opt. 4 not installed		Set F0 to 2.201 GHz (Option 4) or 2.001 GHz (All Others)		Specification (dBm)	Measurement Uncertainty (dB)
	Measured Power Non-pulse Mode (dBm)	Measured Power Pulse Mode (dBm)	Measured Power Non-pulse Mode (dBm)	Measured Power Pulse Mode (dBm)		
-3 dBm					-4 to -2	0.44
-4 dBm					-5 to -3	0.44
-5 dBm					-6 to -4	0.44

- a. Start with the highest power level within instrument specification.
- b. Attenuator is required to prevent damaging power sensor.

Model Number:

Firmware Revision:

Date:

Serial Number:

Options:

Operator:

Section 3-9 Power Level Accuracy and Flatness Tests**Power Level Accuracy (Models without Option 002) (1 of 2)**

Set L0 ^(a) to:	Measured Power (dBm)	Measured Power (dBm)	Measured Power (dBm)	Specification ^(b) (dBm)	Measurement Uncertainty (dB)
	DUT F0: 10 MHz	DUT F0: 15 MHz			
+25 dBm ^(c)	N/A	N/A	N/A	+24 to +26	0.44
+20 dBm ^(c)	N/A	N/A	N/A	+19 to +21	0.44
+15 dBm			N/A	+14 to +16	0.44
+10 dBm			N/A	+9 to +11	0.44
+5 dBm			N/A	+4 to +6	0.44
+0 dBm			N/A	-1 to +1	0.44
-5 dBm			N/A	-6 to -4	0.44
	DUT F0: 60 MHz	DUT F0: 500 MHz	DUT F0: 600 MHz		
+25 dBm ^(c)				+24 to +26	0.44
+20 dBm ^(c)				+19 to +21	0.44
+15 dBm				+14 to +16	0.44
+10 dBm				+9 to +11	0.44
+5 dBm				+4 to +6	0.44
+0 dBm				-1 to +1	0.44
-5 dBm				-6 to -4	0.44
	DUT F0: 2.0 GHz	DUT F0: 4.0 GHz	DUT F0: 6.0 GHz		
+25 dBm ^(c)				+24 to +26	0.44
+20 dBm ^(c)				+19 to +21	0.44
+15 dBm				+14 to +16	0.44
+10 dBm				+9 to +11	0.44
+5 dBm				+4 to +6	0.44
+0 dBm				-1 to +1	0.44
-5 dBm				-6 to -4	0.44

Model Number:	Firmware Revision:	Date:
Serial Number:	Options:	Operator:

Section 3-9 Power Level Accuracy and Flatness Tests

Power Level Accuracy (Models without Option 002) (2 of 2)

Set L0 ^(a) to:	Measured Power (dBm)	Measured Power (dBm)	Measured Power (dBm)	Specification ^(b) (dBm)	Measurement Uncertainty (dB)
	DUT F0: 8.0 GHz	DUT F0: 10.0 GHz	DUT F0: 12.0 GHz		
+25 dBm ^(c)				+24 to +26	0.44
+20 dBm ^(c)				+19 to +21	0.44
+15 dBm				+14 to +16	0.44
+10 dBm				+9 to +11	0.44
+5 dBm				+4 to +6	0.44
+0 dBm				-1 to +1	0.44
-5 dBm				-6 to -4	0.44
	DUT F0: 14.0 GHz	DUT F0: 16.0 GHz	DUT F0: 18.0 GHz		
+25 dBm ^(c)				+24 to +26	0.44
+20 dBm ^(c)				+19 to +21	0.44
+15 dBm				+14 to +16	0.44
+10 dBm				+9 to +11	0.44
+5 dBm				+4 to +6	0.44
+0 dBm				-1 to +1	0.44
-5 dBm				-6 to -4	0.44
	DUT F0: 20.0 GHz				
+25 dBm ^(c)				+24 to +26	0.44
+20 dBm ^(c)				+19 to +21	0.44
+15 dBm				+14 to +16	0.44
+10 dBm				+9 to +11	0.44
+5 dBm				+4 to +6	0.44
+0 dBm				-1 to +1	0.44
-5 dBm				-6 to -4	0.44

- a. Start with the highest power level within instrument specification.
- b. Accuracy with high power Option 015 is ±1.5 dBm
- c. Attenuator is required to prevent damaging power sensor.

Model Number:

Firmware Revision:

Date:

Serial Number:

Options:

Operator:

Section 3-9 Power Level Accuracy and Flatness Tests**Power Level Accuracy (Models with Option 002) (1 of 6)**

LO ^(a) Setting	Measured Power (dBm)	Measured Power (dBm)	Measured Power (dBm)	Spec ^(b) (dBm)	Measurement Uncertainty (dB)
	DUT F0: 10 MHz Receiver: 10 MHz LO: N/A	DUT F0: 15 MHz Receiver: 15 MHz LO: N/A	DUT F0: 60 MHz Receiver: 60 MHz LO: N/A		
+25 dBm ^(c)				+24 to +26	0.44
+20 dBm ^(c)				+19 to +21	0.44
+15 dBm				+14 to +16	0.44
+10 dBm				+9 to +11	0.44
+5 dBm				+4 to +6	0.44
+0 dBm				-1 to +1	0.44
-5 dBm				-6 to -4	0.44
-10 dBm				-11 to -9	0.44
-15 dBm				-16 to -14	0.44
-20 dBm				-21 to -19	0.44
-25 dBm				-26 to -24	0.44
-30 dBm				-31 to -29	0.44
-35 dBm				-36 to -34	0.44
-40 dBm				-41 to -39	0.44
-45 dBm				-46 to -44	0.44
-50 dBm				-51 to -49	0.44
-55 dBm				-56 to -54	0.20
-60 dBm				-61 to -59	0.20
-65 dBm				-66 to -64	0.20
-70 dBm				-71 to -69	0.20
-75 dBm				-76 to -74	0.20
-80 dBm				-81 to -79	0.20
-85 dBm				-86 to -84	0.20
-90 dBm				-91 to -89	0.20
-95 dBm				-96 to -94	0.20

Model Number:	Firmware Revision:	Date:
Serial Number:	Options:	Operator:

Section 3-9 Power Level Accuracy and Flatness Tests

Power Level Accuracy (Models with Option 002) (2 of 6)

L0 ^(a) Setting	Measured Power (dBm)	Measured Power (dBm)	Measured Power (dBm)	Spec ^(b) (dBm)	Measurement Uncertainty (dB)
	DUT F0: 500 MHz Receiver: 500 MHz LO: N/A	DUT F0: 600 MHz Receiver: 600 MHz LO: N/A	DUT F0: 1.0 GHz Receiver: 1.0 GHz LO: N/A		
+25 dBm ^(c)				+24 to +26	0.44
+20 dBm ^(c)				+19 to +21	0.44
+15 dBm				+14 to +16	0.44
+10 dBm				+9 to +11	0.44
+5 dBm				+4 to +6	0.44
+0 dBm				-1 to +1	0.44
-5 dBm				-6 to -4	0.44
-10 dBm				-11 to -9	0.44
-15 dBm				-16 to -14	0.44
-20 dBm				-21 to -19	0.44
-25 dBm				-26 to -24	0.44
-30 dBm				-31 to -29	0.44
-35 dBm				-36 to -34	0.44
-40 dBm				-41 to -39	0.44
-45 dBm				-46 to -44	0.44
-50 dBm				-51 to -49	0.44
-55 dBm				-56 to -54	0.20
-60 dBm				-61 to -59	0.20
-65 dBm				-66 to -64	0.20
-70 dBm				-71 to -69	0.20
-75 dBm				-76 to -74	0.20
-80 dBm				-81 to -79	0.20
-85 dBm				-86 to -84	0.20
-90 dBm				-91 to -89	0.20
-95 dBm				-96 to -94	0.20

Model Number:

Firmware Revision:

Date:

Serial Number:

Options:

Operator:

Section 3-9 Power Level Accuracy and Flatness Tests**Power Level Accuracy (Models with Option 002) (3 of 6)**

L0 ^(a) Setting	Measured Power (dBm)	Measured Power (dBm)	Measured Power (dBm)	Spec ^(b) (dBm)	Measurement Uncertainty (dB)
	DUT F0: 2.0 GHz Receiver: 2.0 GHz LO: N/A	DUT F0: 4.0 GHz Receiver: 8.51 MHz LO: 3991.49 MHz			
+25 dBm ^(c)				+24 to +26	0.44
+20 dBm ^(c)				+19 to +21	0.44
+15 dBm				+14 to +16	0.44
+10 dBm				+9 to +11	0.44
+5 dBm				+4 to +6	0.44
+0 dBm				-1 to +1	0.44
-5 dBm				-6 to -4	0.44
-10 dBm				-11 to -9	0.44
-15 dBm				-16 to -14	0.44
-20 dBm				-21 to -19	0.44
-25 dBm				-26 to -24	0.44
-30 dBm				-31 to -29	0.44
-35 dBm				-36 to -34	0.44
-40 dBm				-41 to -39	0.44
-45 dBm				-46 to -44	0.44
-50 dBm				-51 to -49	0.44
-55 dBm				-56 to -54	0.20
-60 dBm				-61 to -59	0.20
-65 dBm				-66 to -64	0.20
-70 dBm				-71 to -69	0.20
-75 dBm				-76 to -74	0.20
-80 dBm				-81 to -79	0.20
-85 dBm				-86 to -84	0.20
-90 dBm				-91 to -89	0.20
-95 dBm				-96 to -94	0.20

Model Number:	Firmware Revision:	Date:
Serial Number:	Options:	Operator:

Section 3-9 Power Level Accuracy and Flatness Tests

Power Level Accuracy (Models with Option 002) (4 of 6)

L0^(a) Setting	Measured Power (dBm)	Measured Power (dBm)	Measured Power (dBm)	Spec^(b) (dBm)	Measurement Uncertainty (dB)
	DUT F0: 6.0 GHz Receiver: 8.51 MHz LO: 5991.49 MHz	DUT F0: 8.0 GHz Receiver: 8.51 MHz LO: 7991.49 MHz	DUT F0: 10.0 GHz Receiver: 8.51 MHz LO: 9991.49 MHz		
+25 dBm ^(c)				+24 to +26	0.44
+20 dBm ^(c)				+19 to +21	0.44
+15 dBm				+14 to +16	0.44
+10 dBm				+9 to +11	0.44
+5 dBm				+4 to +6	0.44
+0 dBm				-1 to +1	0.44
-5 dBm				-6 to -4	0.44
-10 dBm				-11 to -9	0.44
-15 dBm				-16 to -14	0.44
-20 dBm				-21 to -19	0.44
-25 dBm				-26 to -24	0.44
-30 dBm				-31 to -29	0.44
-35 dBm				-36 to -34	0.44
-40 dBm				-41 to -39	0.44
-45 dBm				-46 to -44	0.44
-50 dBm				-51 to -49	0.44
-55 dBm				-56 to -54	0.49
-60 dBm				-61 to -59	0.49
-65 dBm				-66 to -64	0.49
-70 dBm				-71 to -69	0.49
-75 dBm				-76 to -74	0.49
-80 dBm				-81 to -79	0.49
-85 dBm				-86 to -84	0.49
-90 dBm				-91 to -89	0.49
-95 dBm				-96 to -94	0.49

Model Number:

Firmware Revision:

Date:

Serial Number:

Options:

Operator:

Section 3-9 Power Level Accuracy and Flatness Tests**Power Level Accuracy (Models with Option 002) (5 of 6)**

L0 ^(a) Setting	Measured Power (dBm)	Measured Power (dBm)	Measured Power (dBm)	Spec ^(b) (dBm)	Measurement Uncertainty (dB)
	DUT F0: 12.0 GHz Receiver: 8.51 MHz LO: 11991.49 MHz	DUT F0: 14.0 GHz Receiver: 8.51 MHz LO: 13991.49 MHz	DUT F0: 16.0 GHz Receiver: 8.51 MHz LO: 15991.49 MHz		
+25 dBm ^(c)				+24 to +26	0.44
+20 dBm ^(c)				+19 to +21	0.44
+15 dBm				+14 to +16	0.44
+10 dBm				+9 to +11	0.44
+5 dBm				+4 to +6	0.44
+0 dBm				-1 to +1	0.44
-5 dBm				-6 to -4	0.44
-10 dBm				-11 to -9	0.44
-15 dBm				-16 to -14	0.44
-20 dBm				-21 to -19	0.44
-25 dBm				-26 to -24	0.44
-30 dBm				-31 to -29	0.44
-35 dBm				-36 to -34	0.44
-40 dBm				-41 to -39	0.44
-45 dBm				-46 to -44	0.44
-50 dBm				-51 to -49	0.44
-55 dBm				-56 to -54	0.49
-60 dBm				-61 to -59	0.49
-65 dBm				-66 to -64	0.49
-70 dBm				-71 to -69	0.49
-75 dBm				-76 to -74	0.49
-80 dBm				-81 to -79	0.49
-85 dBm				-86 to -84	0.49
-90 dBm				-91 to -89	0.49
-95 dBm				-96 to -94	0.49

Model Number:	Firmware Revision:	Date:
Serial Number:	Options:	Operator:

Section 3-9 Power Level Accuracy and Flatness Tests

Power Level Accuracy (Models with Option 002) (6 of 6)

L0^(a) Setting	Measured Power (dBm)	Measured Power (dBm)	Measured Power (dBm)	Spec^(b) (dBm)	Measurement Uncertainty (dB)
	DUT F0: 18.0 GHz Receiver: 8.51 MHz LO: 17991.49 MHz	DUT F0: 20.0 GHz Receiver: 8.51 MHz LO: 19991.49 MHz			
+25 dBm ^(c)				+24 to +26	0.44
+20 dBm ^(c)				+19 to +21	0.44
+15 dBm				+14 to +16	0.44
+10 dBm				+9 to +11	0.44
+5 dBm				+4 to +6	0.44
+0 dBm				-1 to +1	0.44
-5 dBm				-6 to -4	0.44
-10 dBm				-11 to -9	0.44
-15 dBm				-16 to -14	0.44
-20 dBm				-21 to -19	0.44
-25 dBm				-26 to -24	0.44
-30 dBm				-31 to -29	0.44
-35 dBm				-36 to -34	0.44
-40 dBm				-41 to -39	0.44
-45 dBm				-46 to -44	0.44
-50 dBm				-51 to -49	0.44
-55 dBm				-56 to -54	0.49
-60 dBm				-61 to -59	0.49
-65 dBm				-66 to -64	0.49
-70 dBm				-71 to -69	0.49
-75 dBm				-76 to -74	0.49
-80 dBm				-81 to -79	0.49
-85 dBm				-86 to -84	0.49
-90 dBm				-91 to -89	0.49
-95 dBm				-96 to -94	0.49

a. Start with the highest power level within instrument specification.

b. Accuracy with high power Option 015 is ± 1.5 dBm.

c. Attenuator is required to prevent damaging power sensor.

Model Number:

Firmware Revision:

Date:

Serial Number:

Options:

Operator:

Section 3-9 Power Level Flatness

All MG3702xA Models without Option 002

Set L0 to +17 dBm

Frequency Range	Power Sensor	# Of Steps	Maximum Power (dBm)	Minimum Power (dBm)	Variation (Max–Min) (dB)	Variation Spec. (dB)	Measurement Uncertainty (dB)
Minimum Frequency ^(a) to 10 GHz (no Opt. 015)	SC7400	100				≤1.60	0.289
10 GHz to 20 GHz (no Opt. 015)	MA2474D	100				≤1.60	0.539
Minimum Frequency ^(a) to 10 GHz (with Opt. 015)	SC7400	100				≤3.00	0.281
10 GHz to 20 GHz (with Opt. 015)	MA2474D	100				≤3.00	0.539

a. 2.0 GHz (or 10 MHz if Option 004 installed).

Section 3-9 Power Level Flatness

All MG3702xA Models with Option 002

Set L1 to +15 dBm

Frequency Range	Power Sensor	# Of Steps	Maximum Power (dBm)	Minimum Power (dBm)	Variation (Max–Min) (dB)	Variation Spec. (dB)	Measurement Uncertainty (dB)
Minimum Frequency ^(a) to 10 GHz (no Opt. 015)	SC7400	100				≤1.60	0.289
10 GHz to 20 GHz (no Opt. 015)	MA2474D	100				≤1.60	0.539
Minimum Frequency ^(a) to 10 GHz (with Opt. 015)	SC7400	100				≤3.00	0.281
10 GHz to 20 GHz (with Opt. 015)	MA2474D	100				≤3.00	0.539

a. 2.0 GHz (or 10 MHz if Option 004 installed).

Model Number:	Firmware Revision:	Date:
Serial Number:	Options:	Operator:

Section 3-9 Maximum Leveled Power

All MG3702xA Models without Option 015 and with or without Option 004

Set L0 to +30 dBm

Frequency Range (GHz)	Power Sensor	# of Steps	Minimum Measured Power (dBm)	Specification without Option 2 (dBm)	Specification with Option 2 (dBm)	Measurement Uncertainty (dB)
Minimum Frequency ^(a) to 10 GHz	SC7400	100		≥ +19.0	≥ +18.0	0.269
10.1 GHz to 20.0 GHz	MA2474D	100		≥ +17.0	≥ +15.0	0.539

a. 2.0 GHz (or 10 MHz if Option 004 installed).

Section 3-9 Maximum Leveled Power

All MG3702xA Models with Option 015 and without Option 004

Set L0 to +30 dBm

Frequency Range (GHz)	Power Sensor	# of Steps	Minimum Measured Power (dBm)	Specification without Option 2 (dBm)	Specification with Option 2 (dBm)	Measurement Uncertainty (dB)
2.0 GHz to ≤ 10.0 GHz	SC7400	100		≥ +23.0	≥ +21.0	0.269
10.1 GHz to ≤ 20.0 GHz	MA2474D	100		≥ +23.0	≥ +21.0	0.539

Section 3-9 Maximum Leveled Power

All MG3702xA Models with Option 015 and Option 004

Set L0 to +30 dBm

Frequency Range (GHz)	Power Sensor	# of Steps	Minimum Measured Power (dBm)	Specification without Option 2 (dBm)	Specification with Option 2 (dBm)	Measurement Uncertainty (dB)
10 MHz to 2.2 GHz	SC7400	50		≥ +19.0	≥ +18.0	0.268
2.3 GHz to 20.0 GHz	MA2474D	100		≥ +21.0	≥ +19.0	0.539

Model Number:

Firmware Revision:

Date:

Serial Number:

Options:

Operator:

Section 3-10 Pulse Modulation Tests

All MG3702xA Models with Option 026

Pulse Rise and Fall Times

DUT Frequency (GHz)	Rise Time (ns)	Fall Time (ns)	Specification (ns)	Measurement Uncertainty (\pm ns)
5.000 000 001			≤ 10	0.023
14.000 000 001			≤ 10	0.023

Pulse Overshoot

DUT Frequency (GHz)	Overshoot (%)	Specification (%)	Measurement Uncertainty (%)
0.500 000 001		≤ 10 (Option 4)	5
1.200 000 001		≤ 10 (Option 4)	5
1.900 000 001		≤ 10 (Option 4)	5
5.000 000 001		≤ 10	5
14.000 000 001		≤ 10	5

Pulse Power Accuracy (Pulse Width ≥ 1 μ s)

DUT Frequency (GHz)	V _{ref} (Volts)	V _{pulse} (Volts)	P _{accuracy} (dB)	Specification (dB)	Measurement Uncertainty (dB)
0.050 000 001				± 0.5	0.1
1.200 000 001				± 0.5	0.1
1.900 000 001				± 0.5	0.1
5.000 000 001				± 0.5	0.1
14.000 000 001				± 0.5	0.1

Pulse Power Accuracy (Pulse Width < 1 μ s)

DUT Frequency (GHz)	V _{ref} (Volts)	V _{pulse} (Volts)	P _{accuracy} (dB)	Specification (dB)	Measurement Uncertainty (dB)
2.200 000 001				± 1.0	0.1
5.000 000 001				± 1.0	0.1
14.000 000 001				± 1.0	0.1

Appendix A — Test Records

Model Number:	Firmware Revision:	Date:
Serial Number:	Options:	Operator:

External Pulse Power Accuracy (Pulse Width $\geq 1 \mu\text{s}$)

DUT Frequency (GHz)	V _{ref} (Volts)	V _{pulse} (Volts)	P _{accuracy} (dB)	Specification (dB)	Measurement Uncertainty (dB)
0.050 000 001				±0.5	0.1
1.200 000 001				±0.5	0.1
1.900 000 001				±0.5	0.1
5.000 000 001				±0.5	0.1
14.000 000 001				±0.5	0.1

Pulse On/Off Ratio

DUT Frequency (GHz)	P _{depth} (dB)	Specification (dB) ^(a)	Measurement Uncertainty (dB)
0.010		< -80	0.9
1.0		< -80	0.9
1.4		< -80	0.9
2.0		< -80	0.9
2.2		< -80	1.0
2.3		< -80	1.0
5.0		< -80	1.7
8.3		< -80	2.6
8.4		< -80	2.6
14.0		< -80	2.5
20.0		< -80	2.5

a. For models with Option 015, specification is <70 dB.

Section 4-4 Adjustments after Subassembly Replacement

Procedure Step	Step Completion
Utility DVM Adjustment	
Frequency Reference Adjustment	
Level Detector Tables and Level Flatness Adjustment	
Level SWF Band Adjustment	
Level ALC Adjustment	
Touch Screen Accuracy Adjustment	

Model Number:

Firmware Revision:

Date:

Serial Number:

Options:

Operator:

Appendix B — Performance Specifications

B-1 MG3702xA Technical Data Sheet

The latest version of the MG3702xA RF/Microwave Signal Generators Technical Data Sheet, Anritsu PN: 11410-00429, can be downloaded from the Anritsu Internet site:

<http://www.anritsu.com>

The data sheet provides performance specifications for all of the various models in the MG3702xA series.

Index

Numerics

100 MHz reference	
A7 PCB	2-7
error 109	5-3
error 148	5-21
error message INT	5-4
loop	2-4
option 036	1-3
2-20 GHz amplifier, part number	6-3

A

A10	
rear panel block diagram	2-12
rear panel BNC ITF part number	6-3
rear panel CPU ITF part number	6-3
rear panel inputs and outputs	2-7
replacement	6-17
switched filter	2-9
switched filter block diagram	2-2, 2-14, 2-15
A11	
adjustments	4-2, 6-4
down converter part number	6-3
A11 connector	5-15
A12	
switched filter adjustments	4-3, 6-4
switched filter HP part number	6-3
switched filter part number	6-3
switched filter part number, pulsed	6-3
switched filter, pulsed HP part number	6-3
A12 connector	5-15
A13 connector	5-15
A14 fan connector	5-15
A16	
adjustments	4-3, 6-5
part number	6-3
A2	
adjustment	4-2, 6-4
battery replacement	6-12
block diagram	2-12
connections	2-7
CPU pinout	5-9
DC voltage check	5-16
description	2-1
error 163	5-22
error 164	5-22
error 171	5-23
malfunction with no error message (3)	5-18
malfunction with no error message (4)	5-18
part number	6-2
pinout diagram	5-8

A3	
adjustment	4-2, 6-4
block diagram	2-2
description	2-5
outputs	5-17
part number	6-2
PCB voltage outputs	2-6
pinout diagram	5-10
replacement	6-15, 6-16
A4	
adjustment	4-2, 6-4
block diagram	2-14
description	2-5
error 101, error102 DVM	5-19
part number	6-2
part of ALC/pulse modulator	2-4
pinout diagram	5-10
replacement	6-14
A5 spare	
pinout diagram	5-14
A6	
adjustments	4-2, 6-4
ALC loop operation	2-9
ALC PCB	2-4
block diagram	2-14
description	2-4
part number	6-2
pinout diagram	5-11
pulse generator operation	2-10
replacement	6-14
replacement detail	6-14
troubleshooting	5-20, 5-22, 5-23
voltage input	2-6
A7	
adjustment	4-2, 6-4
block diagram	2-2
description	2-7
error 108	5-20
error109	5-20
error148	5-21
error160	5-21
main components	2-4
part number	6-2
part of frequency synthesis	2-4
pinout diagram	5-12
replacement	6-13
supply voltage	2-6
supply voltage 2	2-6

A8	adjustment	4-2, 6-4	DVM	adjustment	4-5
	block diagram	2-12		error 101, error 102	5-19
	description	2-1		error messages	5-3
	error 108	5-20		troubleshooting	5-19
	error 148	5-21		E	
	error 161	5-21		error messages	5-2
	error 162	5-22		ESD requirements	1-4, 5-1
	error 165, 166, 167	5-22		external leveling	2-10
	part number	6-3		F	
	part number with option 88	6-3		flatness test	3-21
	pinout diagram	5-13		frequency synthesis	2-4, 2-7
	replacement	6-14		front panel	
	replacement detail	6-14		description	2-4
A9	adjustments	4-2, 6-4		option 017	3-1
	as part of RF deck	2-5		part number	6-2
	description	2-8		switch	2-5
	error 160	5-21		test equip required with option 17	3-4
	error 161	5-21		touch screen adjustment	4-2, 4-10, 6-3
	frequency synthesis	2-4		troubleshooting	5-17, 5-18, 5-21
	main components	2-4		G	
	part number	6-3		GPIB	1-2
	pinout diagram	5-12		H	
	replacement	6-13		harmonic test	3-7
	voltage supply	2-6		I	
	voltage supply 2	2-6		instrument ID	1-1
ALC		2-9		instrument inputs and outputs	2-7
ALC loop operation		2-9		L	
ALC RAM address				level accuracy	3-21
error 169		5-3, 5-23		level flatness	3-29
ALC RAM data				level reference	
error 168		5-3, 5-23		DAC	2-9
ALC RAM device				error 122	5-3
error 170		5-3, 5-23		leveling coupler, part number	6-3
ALC-pulse modulator		2-4		M	
attenuator		2-11		maintenance levels	1-3
	C			measurement uncertainty	3-4
calibration				modulator drive	
test equipment		4-1		error 162	5-3, 5-22
core ALC				external mode	2-10
error 172		5-3, 5-23		motherboard interconnections	2-7
core synthesis				O	
error 160		5-3, 5-21		online manual	1-2
crystal oven				operation manual	1-2
error 108		5-3, 5-20		P	
	D			parts replacement	6-2
DDS range				phase noise	3-11
definition		5-3		power level accuracy	3-21
error 161		5-3, 5-21		power sweep	2-10
digital down converter		2-11		preventive maintenance	1-4

processor battery	
error 171	5-3, 5-23
replacement	6-10
programming manual	1-2
pulse 100 MHz	
error148	5-3
pulse generator	2-10
pulse modulation operation	2-10

R

related manuals	1-2
replaceable parts	6-2
required test equipment	4-1
RF deck	2-5, 2-10
RF output connector	
part number	6-3
replacement	6-8
RF signal filtering	2-11
RF signal flow	2-11

S

safety symbols	
for safety	Safety-2
in manuals	Safety-1
on equipment	Safety-1
SCPI programming manual	1-2
self test	
error 144	5-3
example	5-2
failure	5-18
lock error	5-4
signal filtering	2-11
step attenuator, part number	6-3
synth RAM address	
error 166	5-3, 5-22
synth RAM data	
error 165	5-3, 5-22
synth RAM device	
error 167	5-3, 5-22

T

test equipment required	4-1
test records	
power level accuracy test	A-20
testing/adjustment after parts replacement	4-2

U

uncertainty	3-4
unleveled indicator	
error 121, error 122	5-20
error121	5-3

Anritsu



 Anritsu utilizes recycled paper and environmentally conscious inks and toner.

Anritsu Company
490 Jarvis Drive
Morgan Hill, CA 95037-2809
USA
<http://www.anritsu.com>