



## Model RHS42

How to install, operate  
and maintain your Demand  
Controlled Water Softener

### PRODUCT AND WARRANTY REGISTRATION

Register your product  
online to validate and  
extend your warranty.  
See warranty page for  
details.

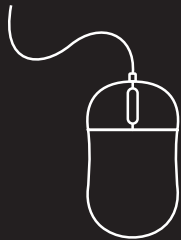

[www.rheemwatertreatment.com](http://www.rheemwatertreatment.com)

If you have any questions or concerns when  
installing, operating or maintaining your water  
softener, call our toll free number:

**1-800-754-7027**

or visit **[www.rheemwatertreatment.com](http://www.rheemwatertreatment.com)**

When you call, please be prepared to provide  
the model and serial number of your product,  
found on the rating decal inside the salt lid.

System tested and certified by NSF International  
against NSF/ANSI Standard 44  
for hardness reduction, efficiency and the  
reduction of barium and radium 226/228,  
and certified to NSF/ANSI Standard 372.



# Installation and Operation Manual

Manufactured and warranted by  
Water Channel Partners  
1890 Woodlane Drive  
Woodbury, MN 55125

7386473 (Rev. A 11/10/20)

# TABLE OF CONTENTS

	Page
Specifications & Performance Claims .....	3
Before You Start .....	4
Inspect Shipment .....	5
Water Conditioning Information .....	5
Installation Requirements .....	6-7
Installation Instructions .....	8-11
Programming the Water Softener .....	12-13
Controller Features .....	14-17
Bypass Blending Valve .....	18
Routine Maintenance .....	19-20
Troubleshooting .....	21-23
Exploded View & Parts List .....	24-27
Warranty .....	28

## Dimensions

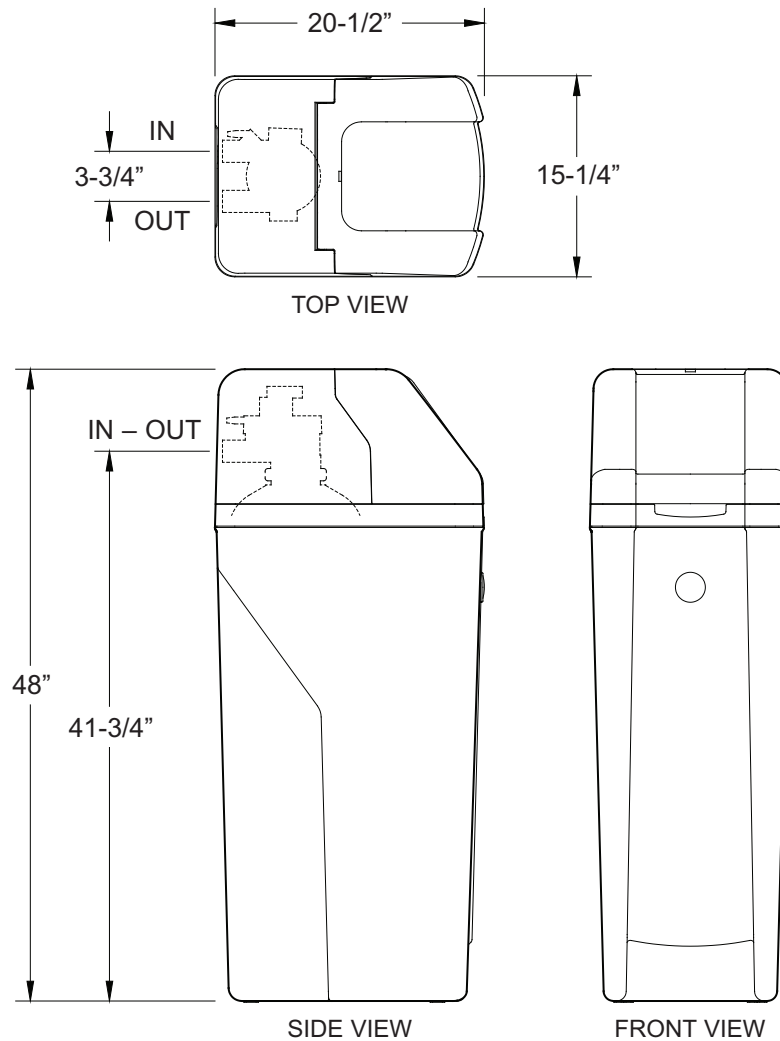

**FIG. 1**

# Specifications & Performance Claims

This model is efficiency rated. The efficiency rating is valid only at the minimum salt dose. This system has a demand initiated regeneration (D.I.R.) feature that complies with specific performance specifications intended to minimize the amount of regenerant brine and water used in their operation.

This water softener has a rated softener efficiency of not less than 3,350 grains of total hardness exchange per pound of salt (based on sodium chloride) and shall not deliver more salt than its listed rating or be operated at a sustained maximum service flow rate greater than its listed rating. This system has been proven to deliver soft water for at least ten continuous minutes at the rated service flow rate. The rated salt efficiency is measured by laboratory tests described in NSF/ANSI Standard 44. These tests represent the maximum possible efficiency that the system can achieve. Operational efficiency is the actual efficiency after the system has been installed. It is typically less than the rated efficiency, due to individual application factors including water hardness, water usage, and other contaminants that reduce a softener's capacity.

	<b>Model RHS42</b>
Model Code	rH42
Rated Softening Capacity (Grains @ Salt Dose)	12,400 @ 2.5 lbs. 29,900 @ 8.0 lbs. 42,400 @ 16.3 lbs.
Rated Efficiency (Grains/Pound of Salt @ Minimum Salt Dose)	5,010 @ 2.5 lbs.
Water Used During Regeneration @ Minimum Salt Dose	2.5 gallons / 1,000 grains
Total Water Used Per Regeneration @ Maximum Salt Dose	45.9 gallons
Rated Service Flow Rate	9.9 gpm
Amount of High Capacity Ion Exchange Resin	1.20 cu. ft.
Pressure Drop at Rated Service Flow	12.0 psig
Intermittent Flow Rate @ 30 psi*	22.4 gpm
Water Supply Max. Hardness	140 gpg
Water Supply Max. Clear Water Iron	11 ppm**
Water Pressure Limits (min. / max.)	20 - 125 PSI
Water and Ambient Temperature Limits (min. / max.)	40 - 120 °F
Minimum Water Supply Flow Rate	3 gpm
Maximum Drain Flow Rate	2.0 gpm

\*Intermittent flow rate does not represent the maximum service flow rate used for determining the softener's rated capacity and efficiency. Continuous operation at flow rates greater than the service flow rate may affect capacity and efficiency performance.

\*\*Capacity to reduce clear water iron is substantiated by laboratory test data. State of Wisconsin requires additional treatment if water supply contains clear water iron exceeding 5 ppm.

This system conforms to NSF/ANSI Standard 44 for the specific performance claims as verified and substantiated by test data.

**Variable Salt Dose:** The salt dose is selected by the electronic controls at regeneration time based on the amount needed.

**Questions? Call Toll Free 1-800-754-7027** or visit [www.rheemwatertreatment.com](http://www.rheemwatertreatment.com)

When you call, please be prepared to provide the model and serial number, found on the rating decal inside the salt lid.

---

## Before You Start

- The water softener requires a minimum water flow of 3 gallons per minute at the inlet. Maximum allowable inlet water pressure is 125 psi. If daytime pressure is over 80 psi, nighttime pressure may exceed the maximum. Use a pressure reducing valve if necessary (Adding a pressure reducing valve may reduce the flow). If your home is equipped with a back flow preventer, an expansion tank must be installed in accordance with local codes and laws.
- The water softener works on 24V DC electrical power, supplied by a direct plug-in power supply (included). Be sure to use the included power supply and plug it into a nominal 120V, 60 Hz household outlet that is in a dry location only, grounded and properly protected by an overcurrent device such as a circuit breaker or fuse.
- Do not use this system to treat water that is microbiologically unsafe or of unknown quality without adequate disinfection upstream or downstream of the system.



European Directive 2002/96/EC requires all electrical and electronic equipment to be disposed of according to Waste Electrical and Electronic Equipment (WEEE) requirements. This directive or similar laws are in place nationally and can vary from region to region. Please refer to your state and local laws for proper disposal of this equipment.

In the state of Massachusetts: The Commonwealth of Massachusetts plumbing code 248-CMR shall be adhered to. A licensed plumber shall be used for this installation.

In the state of California: You must turn the Salt Efficiency Feature setting to ON. This may initiate more frequent recharges. However, it will operate at 4,000 grains per pound of salt or higher. To turn on the Salt Efficiency Feature, follow the instructions in the "Salt Efficiency" section of this manual.

### **Do not return the water softener to store.**

If you have any questions, or there are missing parts or damage, please call **Toll Free 1-800-754-7027** or visit **[www.rheemwatertreatment.com](http://www.rheemwatertreatment.com)**

When you call, please be prepared to provide the model and serial number, found on the rating decal inside the salt lid.

# Inspect Shipment

The parts required to assemble and install the water softener are included with the unit. Thoroughly check the water softener for possible shipping damage and parts loss. Also inspect and note any damage to the shipping carton.

Remove and discard (or recycle) all packing materials. To avoid loss of small parts, we suggest you keep the small parts in the parts bag until you are ready to use them.

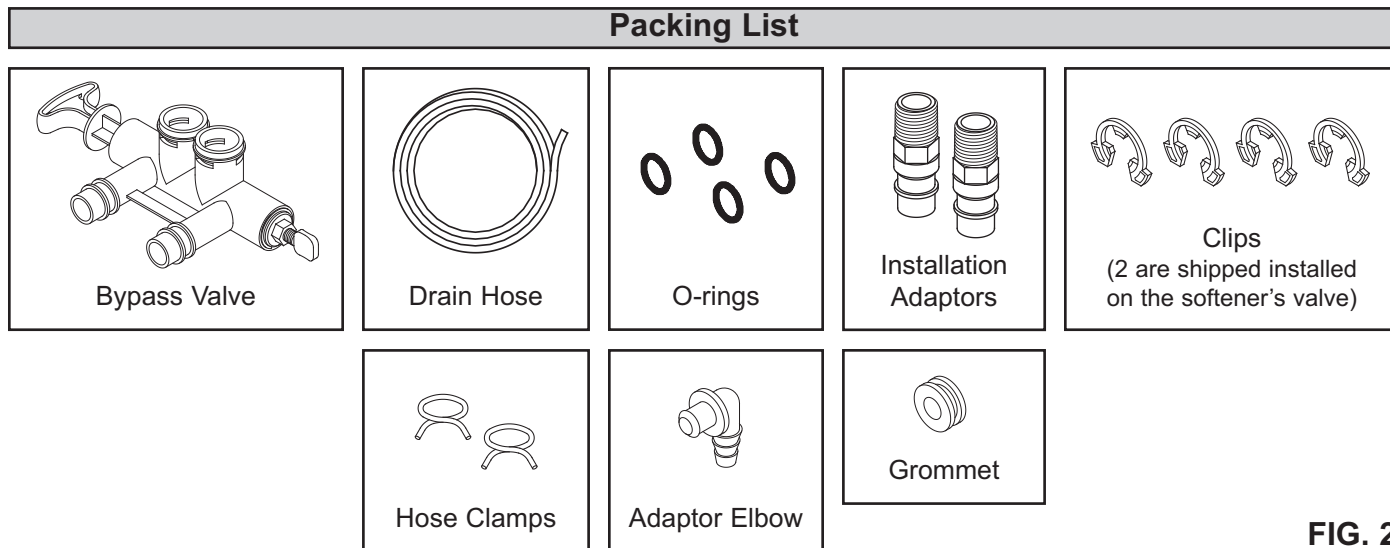

FIG. 2

## Water Conditioning Information

### IRON

Iron in water can cause stains on clothing and plumbing fixtures. It can negatively affect the taste of food, drinking water, and other beverages. Iron in water is measured in parts per million (ppm). The total\* ppm of iron, and type or types\*, is determined by chemical analysis. Four different types of iron in water are:

- Ferrous (clear water) iron
- Ferric (red water) iron
- Bacterial and organically bound iron
- Colloidal and inorganically bound iron (ferrous or ferric)

Ferrous (clear water) iron is soluble and dissolves in water. This water softener will reduce moderate amounts of this type of iron (see specifications).\*\*

Ferrous (clear water) iron is usually detected by taking a sample of water in a clear bottle or glass.

Immediately after taking, the sample is clear. As the water sample stands, it gradually clouds and turns slightly yellow or brown as air oxidizes the iron. This usually occurs in 15 to 30 minutes.

When using the softener to reduce Ferrous (clear water) iron, add 5 grains to the hardness setting for every 1 ppm of Ferrous (clear water) iron. See "Set Water Hardness Number" section.

Ferric (red water), and bacterial and organically bound irons are insoluble. This water softener will not remove ferric or bacterial iron. This iron is visible

immediately when drawn from a faucet because it has oxidized before reaching the home. It appears as small cloudy yellow, orange, or reddish suspended particles. After the water stands for a period of time, the particles settle to the bottom of the container. Generally these irons are removed from water by filtration. Chlorination is also recommended for bacterial iron.

Colloidal and inorganically bound iron is of ferric or ferrous form that will not filter or exchange out of water. This water softener will not remove colloidal iron. In some instances, treatment may improve colloidal iron water. Colloidal iron water usually has a yellow appearance when drawn. After standing for several hours, the color persists and the iron does not settle, but remains suspended in the water.

### SEDIMENT

Sediment is fine, foreign material particles suspended in water. This water softener will not remove sediment. This material is most often clay or silt. Extreme amounts of sediment may give the water a cloudy appearance. A sediment filter installed upstream of the water softener normally corrects this situation.

\* Water may contain one or more of the four types of iron and any combination of these. Total iron is the sum of the contents.

\*\* Capacity to reduce clear water iron is substantiated by laboratory test data.

# Installation Requirements

## LOCATION REQUIREMENTS

Consider all of the following when selecting an installation location for the water softener.

- Do not locate the water softener where freezing temperatures occur. Do not attempt to treat water over 120°F. Freezing temperatures or hot water damage voids the warranty.
- To condition all water in the home, install the water softener close to the water supply inlet, and upstream of all other plumbing connections, except outside water pipes. Outside faucets should remain on hard water to avoid wasting conditioned water and salt.
- A nearby drain is needed to carry away regeneration discharge (drain) water. Use a floor drain, laundry tub, sump, standpipe, or other options (check your local codes). See "Air Gap Requirements" and "Valve Drain Requirements" sections.
- The water softener works on 24V DC electrical power, supplied by a direct plug-in power supply (included). Provide nearby a 120V, 60Hz electrical outlet in accordance with NEC and local codes.
- Always install the water softener between the water inlet and water heater. Any other installed water conditioning equipment should be installed between the water inlet and water softener (See Figure 4 below).
- Avoid installing in direct sunlight. Excessive sun heat may cause distortion or other damage to non-metallic parts.
- Install on a flat, stable surface that evenly supports the weight of the water softener.

## PLUMBING CODES

All plumbing must be completed in accordance with national, state and local plumbing codes.

In the state of Massachusetts: The Commonwealth of Massachusetts plumbing code 248-CMR shall be adhered to. A licensed plumber shall be used for this installation.

## AIR GAP REQUIREMENTS

A drain is needed for the water discharged from the valve during the softener's regeneration cycle (See Figure 3). A floor drain, close to the water softener, is preferred. A laundry tub, standpipe, etc. are other drain options. Secure valve drain hose in place. Leave an air gap of 1-1/2" between the end of the hose and the drain. This gap is needed to prevent backflow of sewer water into the water softener. Do not put the end of the drain hose into the drain.

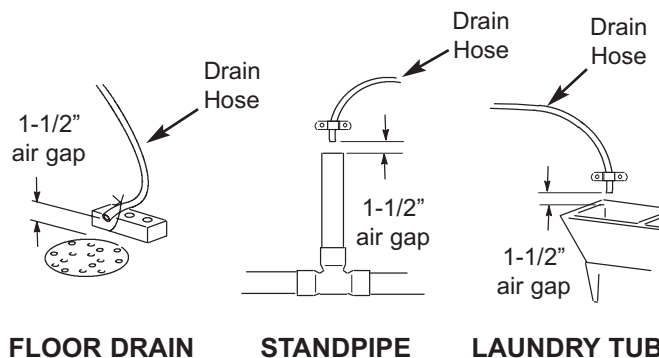

FIG. 3

## THE PROPER ORDER TO INSTALL WATER TREATMENT EQUIPMENT

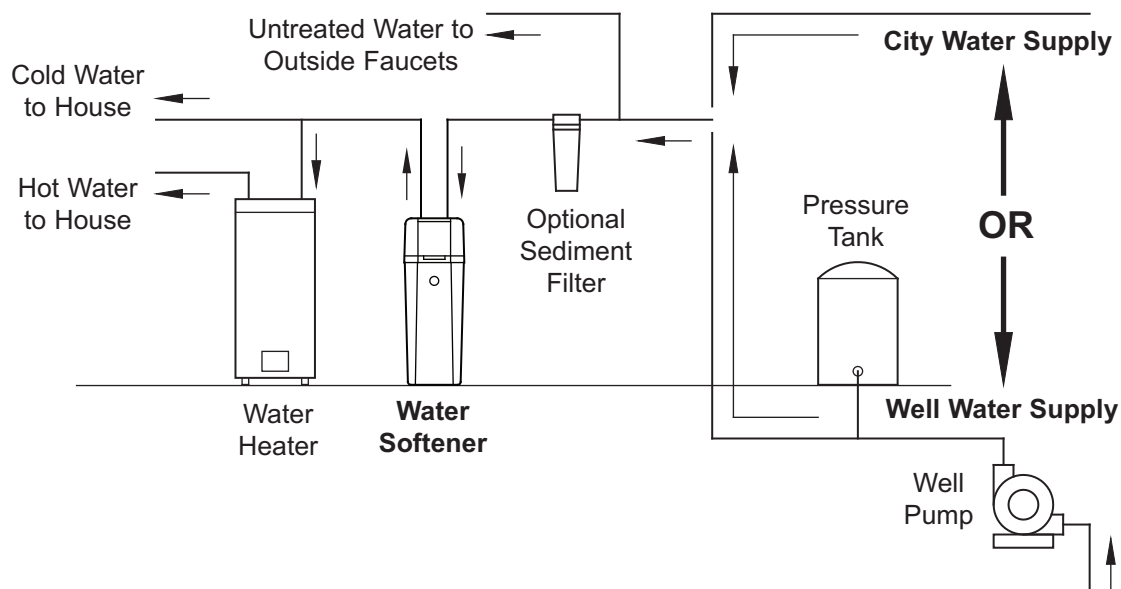

FIG. 4

# Installation Requirements

## VALVE DRAIN REQUIREMENTS

Using the flexible drain hose (included), measure and cut to the length needed. Flexible drain hose is not allowed in all localities (check your plumbing codes). If local codes do not allow use of a flexible drain hose, a rigid valve drain run must be used. Purchase a compression fitting (1/4 NPT x 1/2 in. minimum tube) and 1/2" tubing from your local hardware store. Plumb a rigid drain as needed (See Figure 6).

**NOTE:** Avoid drain hose runs longer than 30 feet. Avoid elevating the hose more than 8 feet above the floor. Make the valve drain line as short and direct as possible.

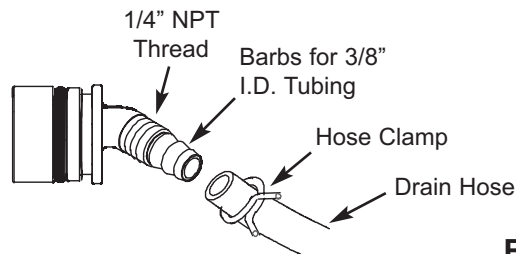

FIG. 5

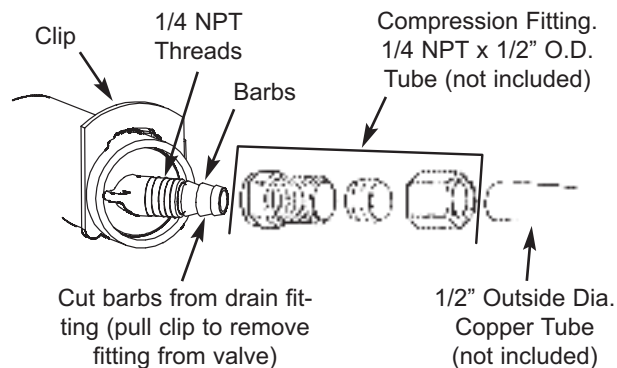

FIG. 6

## INLET / OUTLET PLUMBING OPTIONS

Always install either a single bypass valve (provided), as shown in Figure 7, or, if desired, parts for a 3 valve bypass system (not included) can be purchased and assembled, as shown in Figure 8. Bypass valves allow you to turn off water to the softener for maintenance if needed, but still have water in house pipes.

Use:

- Copper pipe
- Threaded pipe
- PEX (Crosslinked Polyethylene) pipe
- CPVC plastic pipe
- Other pipe approved for use with potable water

**IMPORTANT:** Do not solder with plumbing attached to installation adaptors and single bypass valve. Soldering heat will damage the adaptors and valve.

### SINGLE BYPASS VALVE

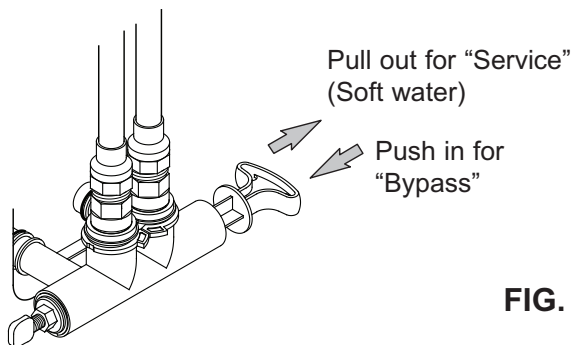

FIG. 7

### 3 VALVE BYPASS

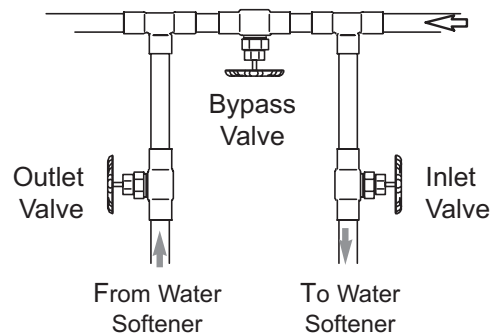

FIG. 8

# Installation Instructions

## TYPICAL INSTALLATION

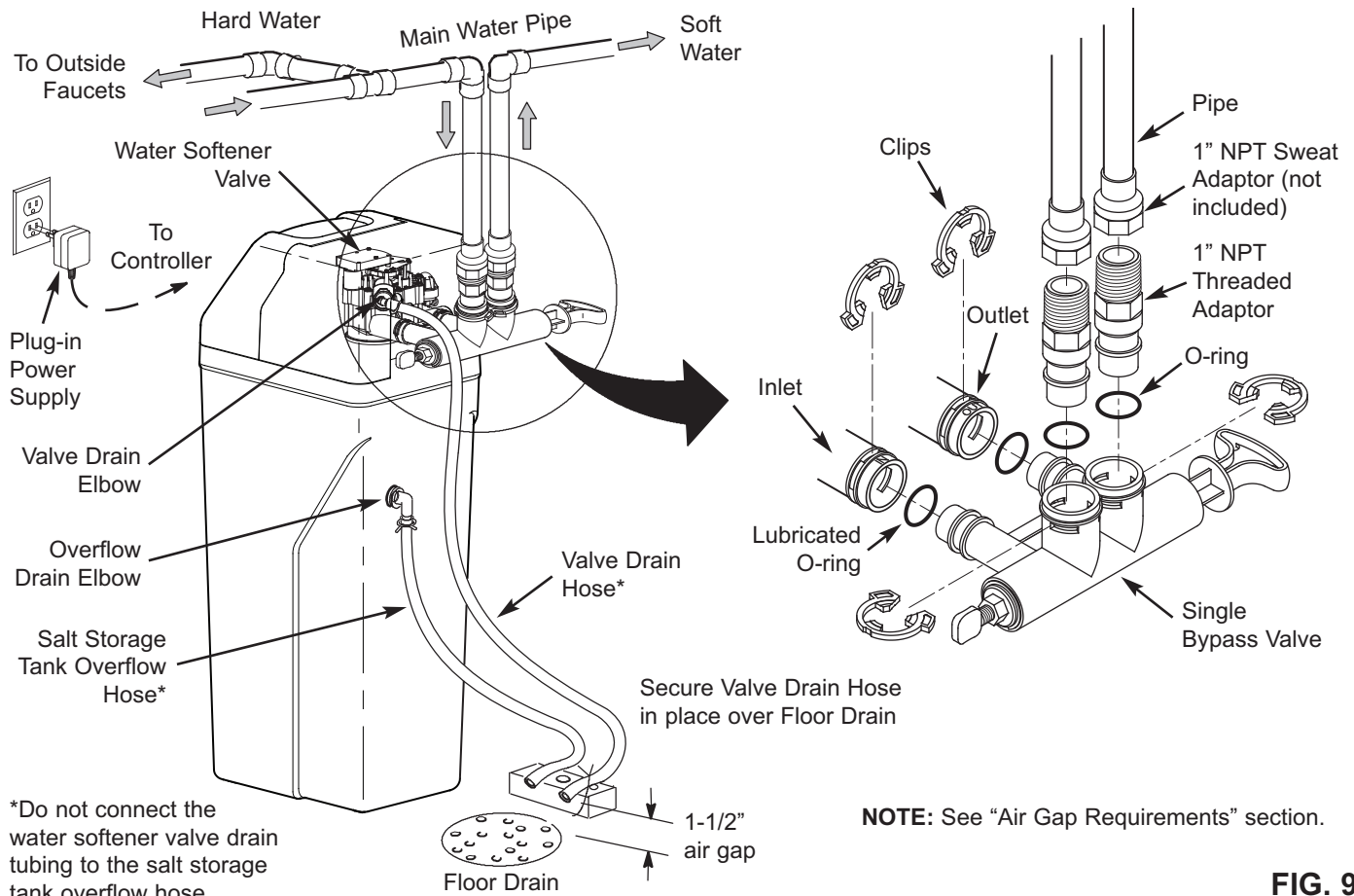

FIG. 9

### TURN OFF WATER SUPPLY

1. Close the main water supply valve, located near the well pump or water meter.
2. Shut off the electric or fuel supply to the water heater.
3. Open all faucets to drain all water from house pipes.

**NOTE:** Be sure not to drain water from the water heater, as damage to the water heater elements could result.

### ASSEMBLY

1. Rheem® models are factory assembled. During installation, unsnap and remove the top cover, together with the salt lid, to expose the softener valve assembly. Set them aside to prevent damage. Check the brinewell to be sure it is secured and vertical (See Figure 11).

2. Install the brine tank overflow grommet and elbow into the 13/16" diameter hole in the back of the salt storage tank wall.

### MOVE THE UNIT INTO PLACE

1. Move the water softener into the desired location. Set it on a solid, level surface.

**IMPORTANT:** Do not place shims directly under the salt storage tank to level the softener. The weight of the tank, when full of water and salt, may cause the tank to fracture at the shim.

continued on next page

# Installation Instructions

continued from previous page

2. Visually check and remove any debris from the water softener valve inlet and outlet ports.
3. Make sure the turbine assembly spins freely in the "out" port of the valve (See Figure 10).
4. If not already done, put a light coating of silicone grease on the single bypass valve o-rings.
5. Push the single bypass valve into the softener valve as far as it will go. Snap the two large holding clips into place, from the top down as shown in Figures 12 & 13.

**IMPORTANT:** Be sure the clips snap firmly into place so the single bypass valve will not pull out.

## COMPLETE INLET AND OUTLET PLUMBING

Measure, cut, and loosely assemble pipe and fittings from the main water pipe to the inlet and outlet ports of the water softener valve. Be sure to keep fittings fully together, and pipes squared and straight.

Be sure hard water supply pipe goes to the water softener valve inlet side.

**NOTE:** Inlet and outlet are marked on the water softener valve. Trace the water flow direction to be sure hard water is to inlet.

**IMPORTANT:** Be sure to fit, align and support all plumbing to prevent putting stress on the water softener valve inlet and outlet. Undue stress from misaligned or unsupported plumbing may cause damage to the valve.

Complete the inlet and outlet plumbing for the type of pipes you will be using.

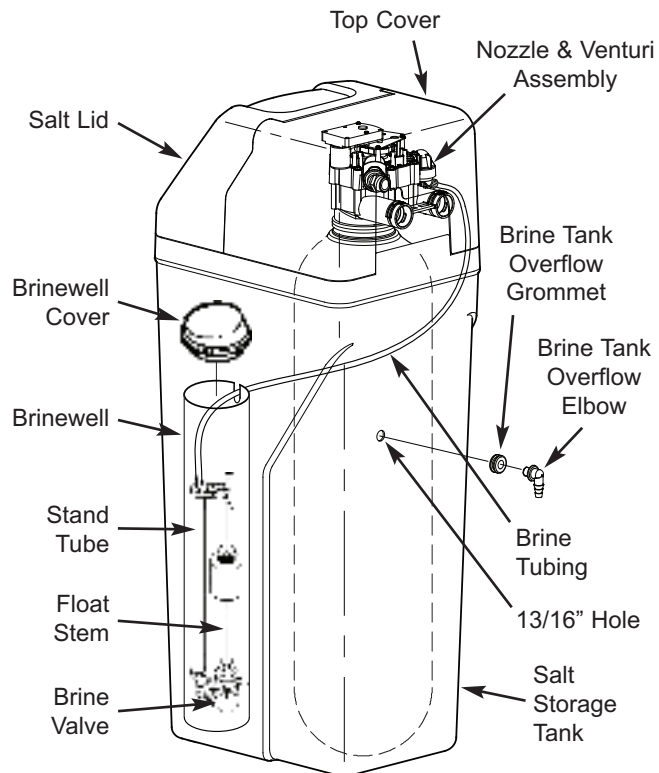

FIG. 11

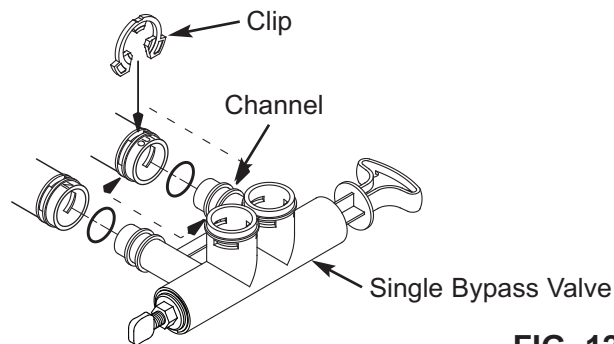

FIG. 12

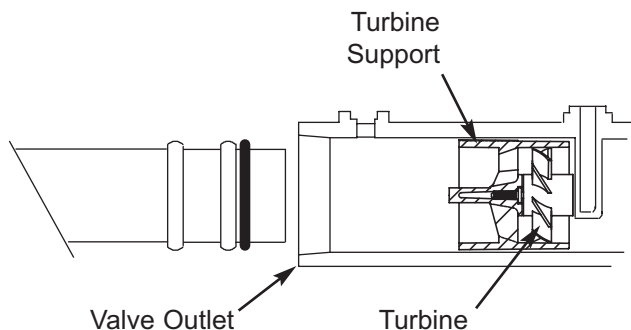

FIG. 10

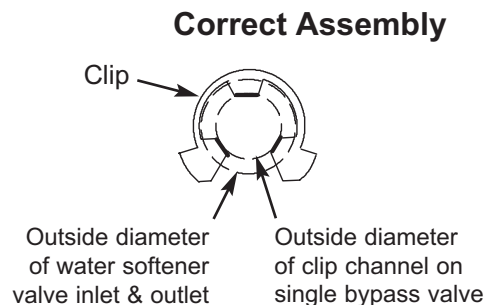

FIG. 13

**NOTE:** Be sure all 3 tabs of the clip go through the matching holes on the water softener valve inlet or outlet, and fully into the channel on the single bypass valve. Make sure that the tabs are fully seated.

# Installation Instructions

## COLD WATER PIPE GROUNDING

**CAUTION:** The house cold water pipe (metal only) is often used as a ground for the house electrical system. The 3-valve bypass type of installation, shown in Figure 8, will maintain ground continuity. If you use a plastic bypass valve at the unit, continuity is broken. To restore the ground, do the following:

1. Install a #4 copper wire across the removed section of main water pipe, securely clamping it at both ends (See Figure 14) - parts not included.

**NOTE:** Check local plumbing and electrical codes for proper installation of the ground wire. The installation must conform to them. In Massachusetts, plumbing codes of Massachusetts shall be conformed to. Consult with your licensed plumber.

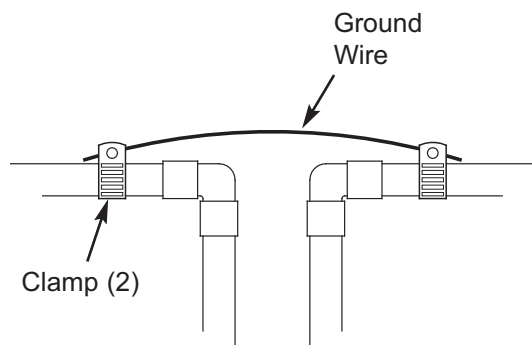

FIG. 14

## INSTALL VALVE DRAIN HOSE

**NOTE:** See valve drain options on pages 6 & 7.

1. Measure, cut to needed length and connect the 3/8" drain line (provided) to the water softener valve drain fitting. Use a hose clamp to hold the hose in place.

**IMPORTANT:** If codes require a rigid drain line see "Valve Drain requirements" section.

2. Run the drain hose (or a rigid line) to the floor drain. Secure drain hose. This will prevent "whipping" during regenerations. **Be sure to provide a 1-1/2" minimum air gap to prevent possible sewer water backup.** See "Air Gap Requirements" section.

**NOTE:** In addition to a floor drain, you can use a laundry tub or standpipe as a drain point for this hose.. Avoid long drain hose runs, or elevating the hose more than 8 feet above the floor.

## INSTALL SALT STORAGE TANK OVERFLOW HOSE

1. Measure, cut to needed length and connect the 3/8" drain line (provided) to the salt storage tank overflow elbow and secure in place with a hose clamp.
2. Route the hose to the floor drain, or other suitable drain point no higher than the drain fitting on the salt storage tank (This is a gravity drain). If the tank overfills with water, the excess water flows to the drain point. Cut the drain line to the desired length and route it neatly out of the way.

**IMPORTANT:** For proper operation of the water softener, do not connect the water softener valve drain tubing to the salt storage tank overflow hose.

## TEST FOR LEAKS

To prevent air pressure in the water softener and plumbing system, complete the following steps in order:

1. Fully open two or more softened cold water faucets close to the water softener, located downstream from the water softener.
2. Place the bypass valve (single or 3 valve) into the "bypass" position. See Figures 7 & 8 on Page 7.
3. Slowly open the main water supply valve. Run water until there is a steady flow from the opened faucets, with no air bubbles.
4. Place bypass valve(s) in "service" or soft water position as follows:
  - Single bypass valve: Slowly move the valve stem toward "service," pausing several times to allow the water softener to fill with water.
  - 3 valve bypass: Fully close the bypass valve and open the outlet valve. Slowly open the inlet valve, pausing several times to allow the water softener to fill with water.
5. After about three minutes, open a hot water faucet until there is a steady flow and there are no air bubbles, then close this faucet.
6. Close all cold water faucets and check for leaks at the plumbing connections that you made.
7. Check for leaks around clips at softener's inlet and outlet. If a leak occurs at a clip, depressurize the plumbing (turn off the water supply and open faucets) before removing clip. When removing clips at the softener's inlet or outlet, push the single bypass valve body toward the softener (See Figure 15). Improper removal may damage clips. Do not reinstall damaged clips.

# Installation Instructions

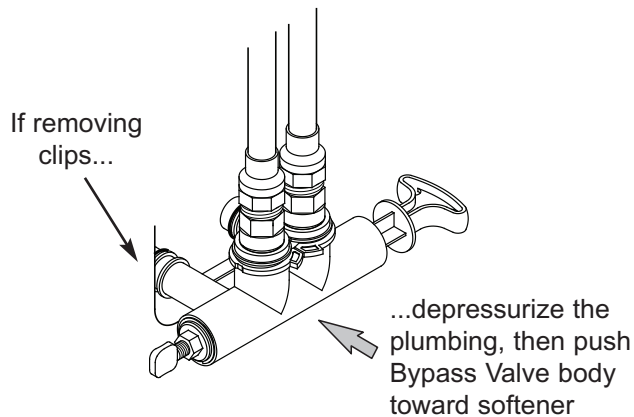

FIG. 15

## ADD WATER AND SALT TO THE SALT STORAGE TANK

1. Using a container, add about three gallons of clean water into the salt storage tank.
2. Add salt to the storage tank. Use nugget, pellet or coarse solar salts with less than 1% impurities.

## PLUG IN THE POWER SUPPLY

During installation, the water softener wiring may be moved or jostled from place. Check to be sure all leadwire connectors are secure on the back of the electronic board and be sure all wiring is away from the valve gear and motor area, which rotates during regenerations.

1. Plug the water softener's power supply into an electrical outlet that is not controlled by a switch and is approved by local codes.

**NOTE:** The water heater is filled with hard water and, as hot water is used, it will refill with conditioned water. In a few days, the hot water will be fully conditioned. To have fully conditioned hot water immediately, wait until the initial recharge is over. Then, drain the water heater (following instructions for water heater) until water runs cold.

## PROGRAM THE CONTROLLER

1. Install the softener's top cover and salt lid.
2. Complete the Programming Steps on Pages 12 & 13.

## SANITIZE THE WATER SOFTENER / SANITIZE AFTER SERVICE

Care is taken at the factory to keep your unit clean and sanitary. Materials used to make the unit will not infect or contaminate your water supply, and will not cause bacteria to form or grow. However, during shipping, storage, installation and operation, bacteria could get into the unit. For this reason, sanitizing as follows is suggested\* when installing.

1. Slide open the salt lid, remove the brinewell cover and pour about 3 oz. (6 tablespoons) of household bleach into the softener brinewell. Replace the brinewell cover.
2. Make sure the bypass valve(s) is in the "service" (open) position.
- 3 **Start a recharge:** Press the RECHARGE button and hold for 3 seconds, until "Recharge Now" begins to flash in the display. This recharge draws the sanitizing bleach into and through the water softener. Any air remaining in the unit is purged to the drain.
4. After the recharge has completed, fully open a cold water faucet, downstream from the softener, and allow 50 gallons of water to pass through the system. This should take at least 20 minutes. Close the faucet.

\*Recommended by the Water Quality Association. On some water supplies, the unit may need periodic disinfecting.

## RESTART THE WATER HEATER

1. Turn on the electricity or fuel supply to the water heater and relight the pilot, if applicable.

**NOTE:** The water heater is filled with hard water and, as hot water is used, it refills with conditioned water. In a few days, the hot water will be fully conditioned. To have fully conditioned hot water immediately, wait until the initial recharge (previous step) is over. Then, drain the water heater (following instructions for water heater) until water runs cold.

**Questions? Call Toll Free 1-800-754-7027** or visit [www.rheemwatertreatment.com](http://www.rheemwatertreatment.com)

When you call, please be prepared to provide the model and serial number, found on the rating decal inside the salt lid.

# Programming the Water Softener

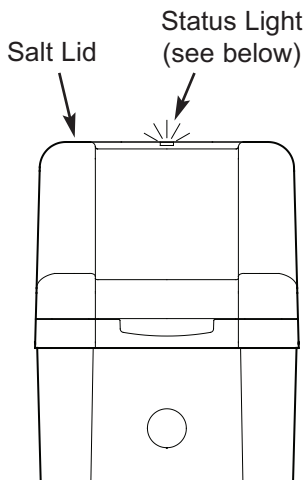

FIG. 16

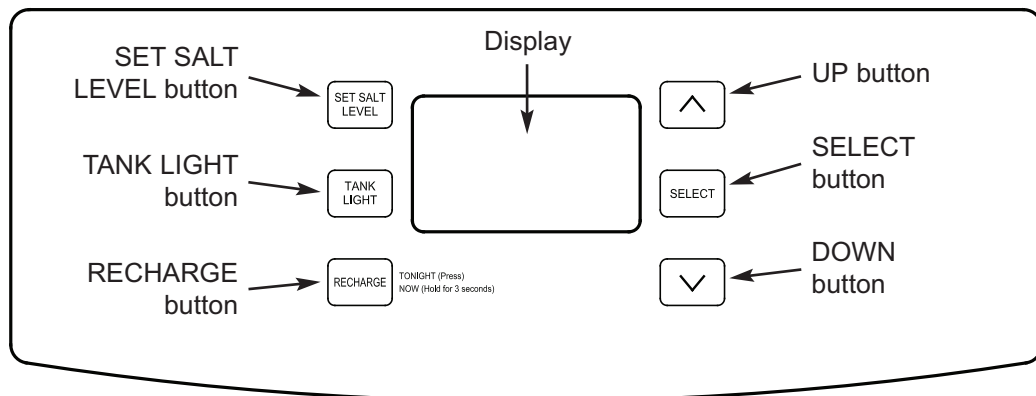

FIG. 18

## STATUS LIGHT / CLEAN REMINDER

When the water softener is connected to electrical power, the status light above the control panel will operate as follows:

Blue status light indication	Status
Flashing slowly	The salt monitor system indicates a low salt level and needs to be set. See "Salt Monitor System" on Page 14.
Flashing slowly, with "CLn" in the display (Fig. 17)	Four months have elapsed on the system's timer since start up or the last reset. See below.
Flashing rapidly, with "PRESENT TIME" in the display and the clock flashing slowly	The present time needs to be set, either during initial start up or after a long power outage. See "Set Present Time of Day", at right.
Flashing rapidly, with "Err" in the display	The electronic self-diagnostics have detected a problem. See "Troubleshooting" on Page 21.
On steady (not flashing)	The system has power and does not require any attention.

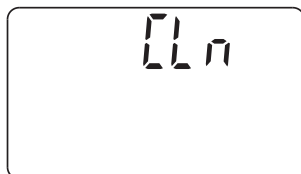

FIG. 17

This is a reminder to use **Rheem® RHWSC Water Softener Cleaner** (P/N RHWSC21) three times a year. To reset the timer, press any button on the control panel and the flashing words will disappear. The status light will stop flashing, unless the system is also low on salt.

## PROGRAM THE SOFTENER

When the power supply is plugged into the electrical outlet, the model code (rH42) and a software version number (example: J4.0), are briefly shown in the display. Then the words "PRESENT TIME" appear and "12:00 PM" begins to flash.

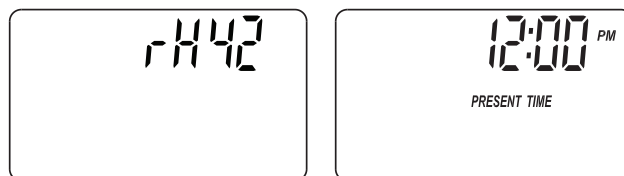

FIG. 19

### STEP 1. SET PRESENT TIME OF DAY

If the words "PRESENT TIME" do not show in the display, press the SELECT button a few times until they do.

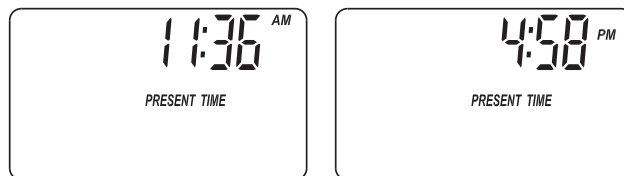

FIG. 20

1. Press the  $\Delta$  UP or  $\nabla$  DOWN buttons to set the present time. Up moves the display ahead; down sets the time back.

**NOTE:** Press buttons and quickly release to slowly advance the display. Hold the buttons down for fast advance.

2. When the correct time is displayed, press the SELECT button, and the display will change to show the "Hardness" screen.

continued on next page



# Controller Features

## EXTRA RECHARGE

Sometimes, a manually initiated recharge (regeneration) may be desired, or needed. Two examples are:

- You have used more water than usual (guests visiting) and you may run out of soft water before the next automatic regeneration.
- You did not add salt to the softener before it ran out. Add salt to the softener before regenerating.

You can start a regeneration immediately, or you can set the controller to regenerate at the next preset recharge time (2:00 AM, or as set).

## RECHARGE NOW

Press the RECHARGE button and hold for 3 seconds, until the words “RECHARGE”, “Serv” and “Fill” begin to flash in the display. The softener enters the fill cycle of regeneration immediately. This regeneration will take about 2 hours to complete. Then, you will have soft water again.

**NOTE:** If the “Clean Feature” is set ON, the normal regeneration cycle is preceded by a cleaning backwash and rinse. The words “CLEAN” and “Bkwhs” or “Rinse” flash in the display, along with the minutes of the clean cycle remaining.

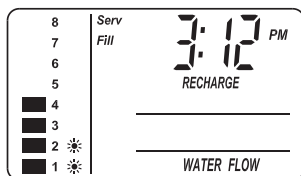

FIG. 25

## RECHARGE TONIGHT

Press and release (do not hold) the RECHARGE button. “RECHARGE TONIGHT” will begin flashing in the display, and the softener will begin regeneration at the next preset recharge time (2:00 AM, or as set). If you decide to cancel the regeneration before it starts, press and release the RECHARGE button once more. “RECHARGE TONIGHT” will stop flashing in the display.

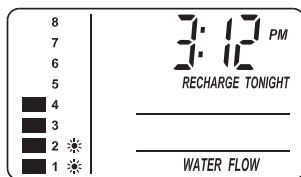

FIG. 26

## SALT MONITOR SYSTEM

The water softener has a status light to remind you to add salt to the storage tank.

**NOTE:** You must set salt level each time salt is added to the water softener.

**NOTE:** The salt monitor system estimates salt levels, and accuracy will vary with different salts.

**To set this monitor system:**

1. Lift the salt lid and level the salt in the storage tank.
2. The salt level scale, on the brinewell inside the tank, has numbers from 0 to 8 (see Fig. 27). Observe the highest number the leveled salt is at, or closest to.

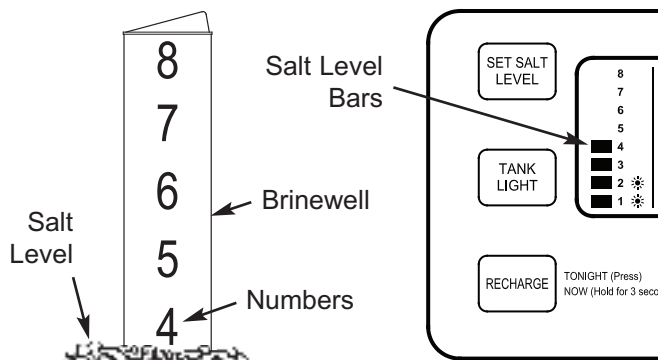

FIG. 27

3. Press the SET SALT LEVEL button as many times as necessary to make the salt level bars in the display (see Fig. 27) match the number on the brinewell. At level 2 or below, the status light will flash.
4. If you want to turn the salt monitor off, press the SET SALT LEVEL button past 8, until “OFF” shows in the display next to the number 8.

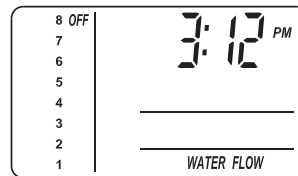

FIG. 28

# Controller Features

## OPTIONAL SETTINGS:

- SALT EFFICIENCY
- CLEAN FEATURE
- CLEAN FEATURE MINUTES
- MAXIMUM DAYS BETWEEN REGENERATIONS
- 12 / 24 HOUR CLOCK
- BACKWASH & FAST RINSE TIMES

1. To set any of these options, press and hold SELECT for 3 seconds until "000" shows in the display. Then press (do not hold) SELECT again to display one of the "Salt Efficiency" screens shown below.

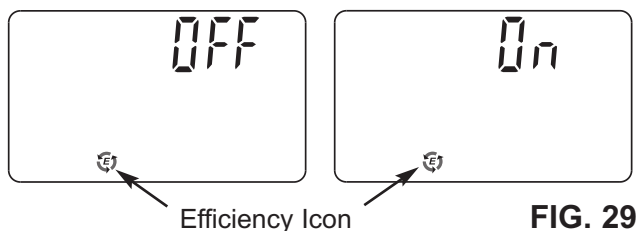

**SALT EFFICIENCY:** When this feature is ON, the water softener will operate at salt efficiencies of 4000 grains of hardness per pound of salt or higher. The softener may recharge more often using smaller salt dosage and less water. This softener is shipped with the efficiency feature set OFF. Use the  $\Delta$  UP or  $\nabla$  DOWN buttons to change between OFF and ON.

### California Efficiency Requirement

Your Rheem® Water Softener has a "High Efficiency" feature that can be set ON or OFF. This softener is shipped with the efficiency feature set OFF, which will utilize the maximum rated capacity while most often achieving maximum salt efficiencies. When installing this unit in the State of California, you **MUST** turn the efficiency feature ON. The softener may initiate more frequent recharges, but it will operate at 4000 grains per pound of salt or higher.

2. Press SELECT again to display one of the "Clean" screens shown below.

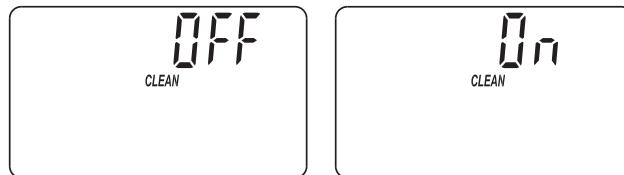

**CLEAN:** This feature is beneficial on water supplies containing iron and/or high amounts of sediments (sand, silt, dirt, etc.). When set to ON, a backwash and fast rinse cycle will occur first, preceding the normal regeneration sequence. This provides extra cleaning of the resin bed before it is regenerated with the salt brine. To conserve water, if your water supply does not contain iron or sediments, be sure this feature is set to OFF. The default is OFF. Use the  $\Delta$  UP or  $\nabla$  DOWN buttons to change between OFF and ON.

3. Press SELECT again to display the "Clean Time" screen shown below.

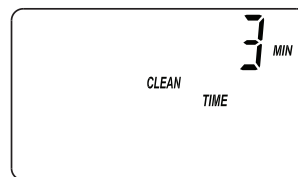

**CLEAN FEATURE MINUTES:** If you have set the Clean Feature ON, the length of the extra backwash cycle automatically is set to 3 minutes. However, you can adjust this time from 1 to 15 minutes in length. To change this cycle time, use the  $\Delta$  UP button to increase the time, or the  $\nabla$  DOWN button to shorten the time. If no change is desired, continue to next step.

continued on next page

# Controller Features

4. Press SELECT again to display the “Recharge Days” screen.

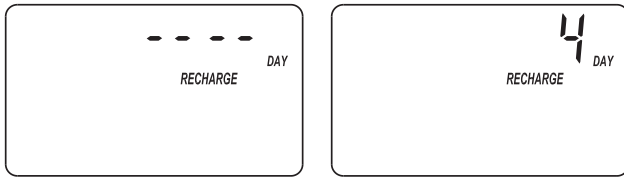

Default Display

Example:  
Set to 4 days maximum  
between regenerations

FIG. 32

### MAXIMUM DAYS BETWEEN RECHARGES:

The electronic controller automatically determines recharge frequency. This provides the greatest operating efficiency and, under most conditions this feature will be left in its default mode. However, you can set this feature to force a recharge every set number of days. You may want to do this if, for example, your water supply contains iron and you want the softener to recharge at least once every few days to keep the resin bed clean. Use the  $\Delta$  UP or  $\nabla$  DOWN buttons to change the number of days (up to 15).

5. Press SELECT again to display the “12 or 24 hr” screen.

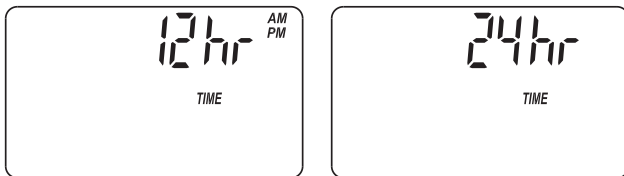

FIG. 33

**12 OR 24 HOUR CLOCK:** All time displays are shown in standard clock time (1 to 12 AM; and 1 to 12 PM) at the 12 hr default setting. If 24 hour time format is desired, set to 24 hr by pressing the  $\Delta$  UP button.

6. Press SELECT again to display the backwash time “Add” screen.

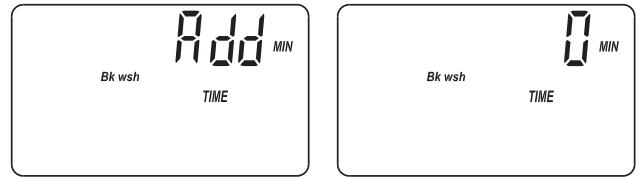

FIG. 34

**BACKWASH & FAST RINSE TIMES:** If you experience salty tasting water after recharge, you may need to increase the backwash and fast rinse times. The cycle times during recharge are determined by the softener’s electronic controller. However, you may increase the backwash and fast rinse times, in 1 minute increments.

If you wish to increase the backwash time, use the  $\Delta$  UP or  $\nabla$  DOWN buttons to add up to 15 minutes. Then press the OK button to display the fast rinse time “Add” screen.

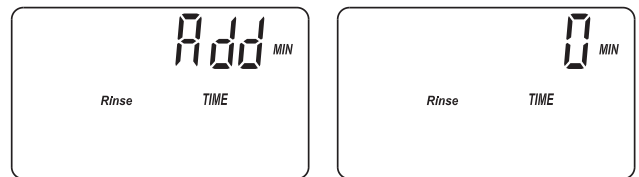

FIG. 35

If you wish to increase the fast rinse time, use the  $\Delta$  UP or  $\nabla$  DOWN buttons to add up to 15 minutes.\*

7. Press SELECT to return to the normal run (time of day) screen.

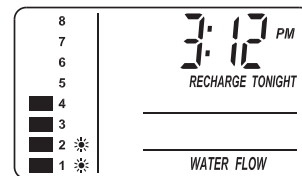

FIG. 36

\* Setting backwash and/or fast rinse times too low may result in salty tasting water after regeneration.

# Controller Features

## TANK LIGHT

To turn on the light inside the salt storage tank, press the TANK LIGHT button on the faceplate. Press this button again to turn the light off. It will also turn off automatically after 15 minutes.

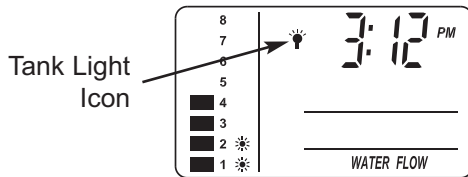

FIG. 37

## WATER FLOW THROUGH THE SOFTENER

If soft water is in use, the water flow bars continually scroll across the display. The bars scroll slowly when water flow is slow, and move faster as water flow increases. The flow bars do not show when all faucets and water using appliances are off.

Flow bars scroll when soft water is in use

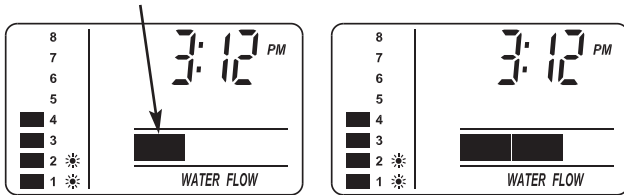

FIG. 38

## RECHARGE TIME REMAINING & VALVE POSITION INDICATORS

One of the valve position indicators (Serv, Fill, Brine, Bkwh, Rinse) is displayed while the softener is recharging. RECHARGE flashes in the display and, beginning with Brine, the minutes of recharge remaining before return to service appears in place of the present time. When the valve is moving from one cycle to another, both position indicators are flashing.

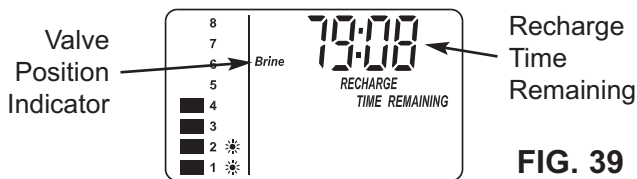

FIG. 39

## PROGRAM MEMORY

If electrical power to the softener goes off, the time display is blank but the electronic controller keeps the correct time for several hours. When electrical power comes on again, you will have to reset the present time only if the display is flashing. The HARDNESS and RECHARGE TIME never require resetting unless a change is desired. Even if the clock is incorrect after a long power outage, the softener works as it should to keep your water soft, however, regenerations may occur at the wrong time of day until you reset the clock to the correct time of day.

## CLEANSING FEATURE

The cleansing feature keeps larger particles of sediment from entering the home's plumbing system. As water passes through the softener, the larger sediment particles are collected in the integrated basket and then rinsed to the drain before each regeneration. The cleansing feature provides added protection for water using appliances by reducing the chance of larger particles entering the various products valves and screens. The "Clean Feature" may be turned ON to provide an extra backwash that will help keep the cleansing screen clean. The default is OFF.

**IMPORTANT:** The cleansing feature is not intended to replace pretreatment filtration. For problem water applications, additional sediment filtration is recommended.

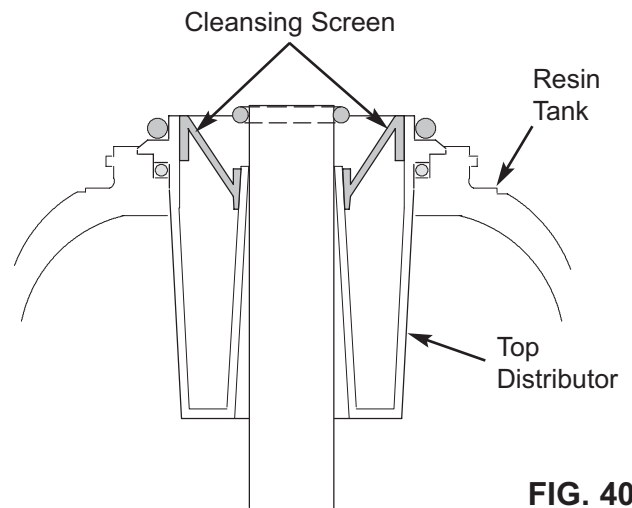

FIG. 40

Questions? Call Toll Free 1-800-754-7027 or visit [www.rheemwatertreatment.com](http://www.rheemwatertreatment.com)

When you call, please be prepared to provide the model and serial number, found on the rating decal inside the salt lid.

# Bypass Blending Valve

The bypass blending valve works as a typical push-pull bypass valve, but has the added ability to finely adjust hardness of the treated water leaving the water softener. If slightly harder water is desired than is normally output by the water softener, this bypass blending valve can divert a small stream of hard water before it enters the water softener and blend it with the exiting softened water. The amount of water diverted is controlled by turning a blend adjusting knob on the end cap of the valve stem (See Figure 41).

**IMPORTANT: Turn the blend adjusting knob by hand only. Do not overtighten.**

1. When the bypass valve is in service position (normal softener operation), with handle pulled all the way out (See Figure 41), **increase hardness** of treated water by turning the blend adjusting knob **counterclockwise** up to 6 turns from the fully closed position. Before turning the knob, unlock it, if necessary, by turning the hex nut counterclockwise. While adjusting the knob, hold the bypass valve handle to prevent the stem from rotating.
2. Do not continue to turn the knob counterclockwise beyond 6 turns from the fully closed position, as this would eventually pull the screw's internal o-rings out of their seat and water would leak from the bypass valve.
3. **Decrease hardness** of treated water by turning the blend adjusting knob **clockwise** while holding the bypass handle. Do not overtighten. When the knob is fully closed, hard water is not being blended with treated water.
4. Once the desired hardness is achieved, the adjustment knob may be locked in place by tightening the hex nut clockwise against the end cap using an adjustable wrench. Hold the bypass valve handle to prevent the stem from rotating, or else use another wrench to grip the stem on the flats between the end cap and the bypass valve body. Loosen the hex nut (turn it counterclockwise) before readjusting the hardness or closing the diversion path for servicing (see next step)
5. If the water softener is to be serviced or disconnected from the bypass valve, the blend adjusting knob must be closed to block the diversion path and prevent water leaking from the softener valve inlet of the bypass valve.

## SERVICE POSITION (Normal Softener Operation)

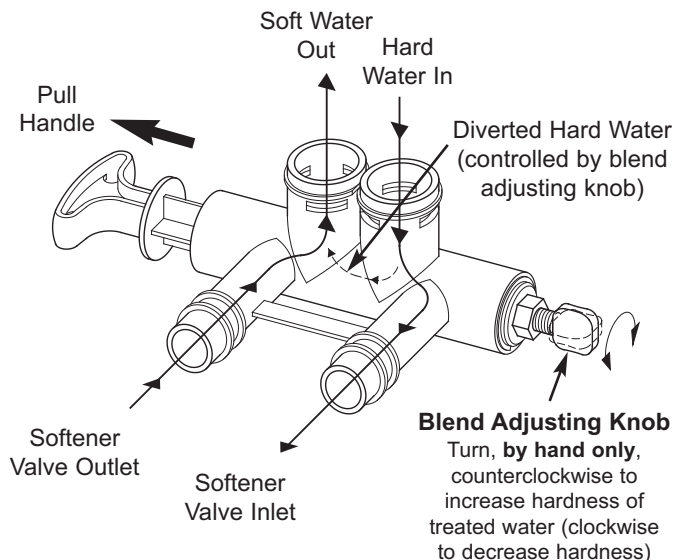

FIG. 41

## BYPASS POSITION

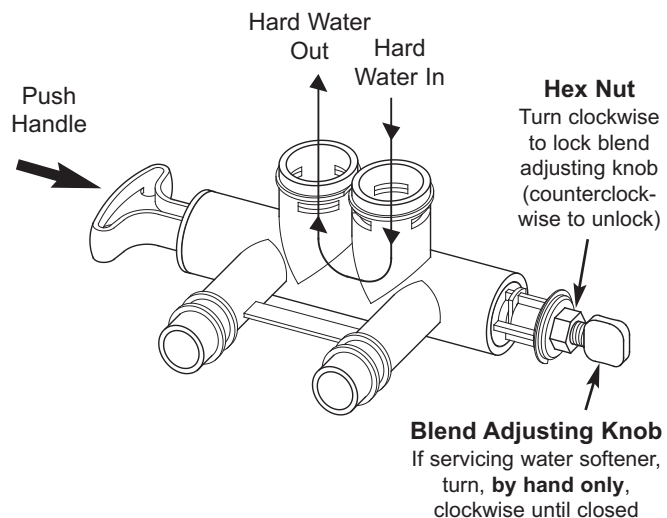

FIG. 42

# Routine Maintenance

## ADDING SALT

Lift the salt lid and check the salt storage level frequently. If the water softener uses all the salts before you refill it, you will experience hard water. Until you have established a refilling routine, check the salt every two or three weeks. Always add if less than 1/4 full. Be sure the brinewell cover is on.

**NOTE:** In humid areas, it is best to keep the salt storage level lower, and to refill more often to avoid salt “bridging”.

**Recommended Salt:** Nugget, pellet or coarse solar salts with less than 1% impurities.

**Salt Not Recommended:** Rock salt, high in impurities, block, granulated, table, ice melting, ice cream making salts, etc.

## BREAKING A SALT BRIDGE

Sometimes, a hard crust or salt “bridge” forms in the brine tank. It is usually caused by high humidity or the wrong kind of salt. When the salt “bridges,” an empty space forms between the water and the salt. Then, salt will not dissolve in the water to make brine. Without brine, the resin bed is not recharged and hard water will result.

If the storage tank is full of salt, it is difficult to tell if you have a salt bridge. A bridge may be underneath loose salt. Take a broom handle, or like tool, and hold it next to the water softener. Measure the distance from the floor to the rim of the water softener. Then, carefully push the broom handle straight down into the salt. If a hard object is felt before the pencil mark is even with the top, it is most likely a salt bridge. Carefully push into the bridge in several places to break it. Do not use any sharp or pointed objects as you may puncture the brine tank. Do not try to break the salt bridge by pounding on the outside of the salt tank. You may damage the tank.

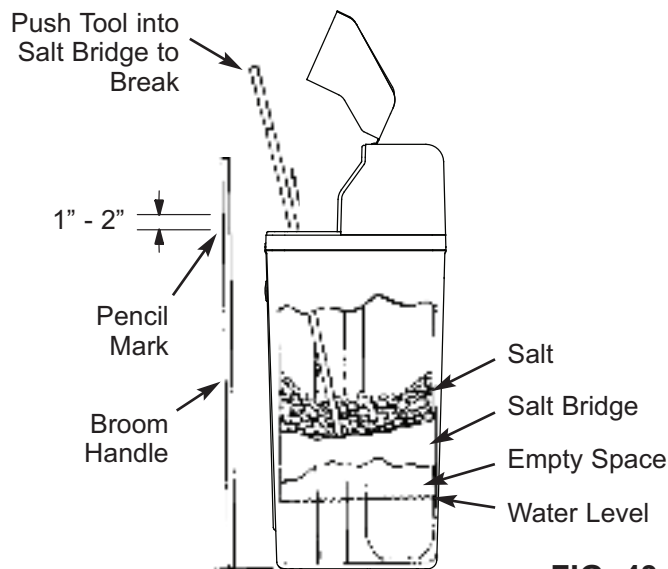

FIG. 43

Questions? Call Toll Free 1-800-754-7027 or visit [www.rheemwatertreatment.com](http://www.rheemwatertreatment.com)

When you call, please be prepared to provide the model and serial number, found on the rating decal inside the salt lid.

# Routine Maintenance

## CLEANING THE NOZZLE & VENTURI

A clean nozzle & venturi (See Figure 44) is a necessity for the water softener to work properly. This small component creates the suction to move brine from the brine tank, into the resin tank. If it should become plugged with sand, silt, dirt, etc., the water softener will not work, and hard water will result.

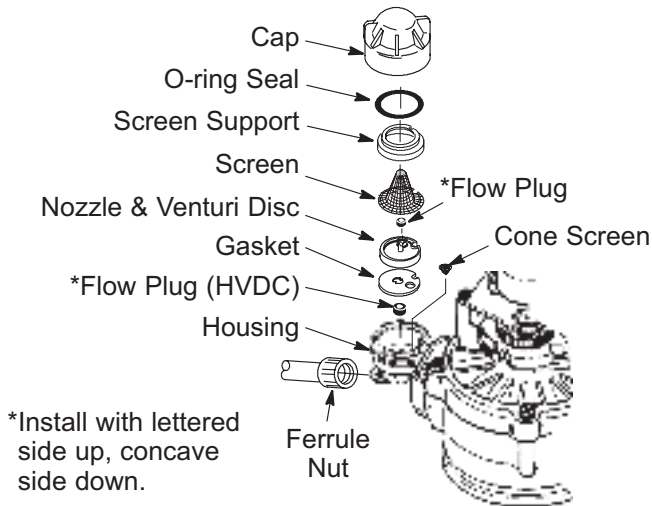

**IMPORTANT:** Be sure small hole in the gasket is centered directly over the small hole in the nozzle & venturi housing. Be sure the numbers are facing up.

**FIG. 44**

To get access to the nozzle & venturi, remove the water softener's top cover. Put the bypass valve(s) into the bypass position. Be sure the water softener is in soft water (service) cycle (no water pressure at nozzle & venturi). Then, holding the nozzle & venturi housing with one hand, unscrew the cap. Do not lose the o-ring seal. Lift out the screen support and screen. Then, remove the nozzle & venturi disc, gasket and flow plug(s). Wash the parts in warm, soapy water and rinse in fresh water. Be sure to clean both the top and bottom of the nozzle & venturi disc. If needed, use a small brush to remove iron or dirt. Do not scratch, misshape, etc., surfaces of the nozzle & venturi.

Carefully replace all parts in the correct order. Lubricate the o-ring seal with silicone grease and locate in place. Install and tighten the cap by hand, while supporting the housing. Overtightening may break the cap or housing. Put the bypass valve(s) into service (soft water) position.

Recharge the softener to reduce water level in the tank. This will also assure that the softener is completely recharged and ready to provide softened water again. Check the water level in the tank by looking down the brinewell. If the water level does not drop after a recharge, the problem has not been resolved. Call 1-800-754-7027.

## PROTECT THE WATER SOFTENER FROM FREEZING

If the softener is installed where it could freeze (summer cabin, lake home, etc.), you must drain all water from it to stop possible freeze damage. To drain the softener:

1. Close the shut-off valve on the house main water pipe, near the water meter or pressure tank.
2. Open a faucet in the soft water pipes to vent pressure in the softener.
3. Move the stem in the single bypass valve to bypass. Close the inlet and outlet valve in a 3 valve bypass system, and open the bypass valve. If you want water in the house pipes again, reopen the shut-off valve on the main water pipe.
4. Unplug the power supply at the wall outlet. Remove the softener's top cover, together with the salt lid. Take off both drain hoses if they will interfere with moving the softener into position over the drain.
5. Carefully remove the large holding clips at the softener inlet and outlet. Separate the softener from the plastic installation adaptors, or from the bypass valve.
6. Lay a piece of 2 inch thick board near the floor drain (See Figure 45).
7. Move the softener close to the drain. Slowly and gently, tip it over until the rim rests on the wood block with the inlet and outlet over the drain. Do not allow the softener's weight to rest on the inlet and outlet fittings or they may break.
8. Tip the bottom of the softener up a few inches and hold until all water has drained. Leave the softener laying like this until you are ready to use it. Plug the inlet and outlet with clean rags to keep dirt, bugs, etc. out.

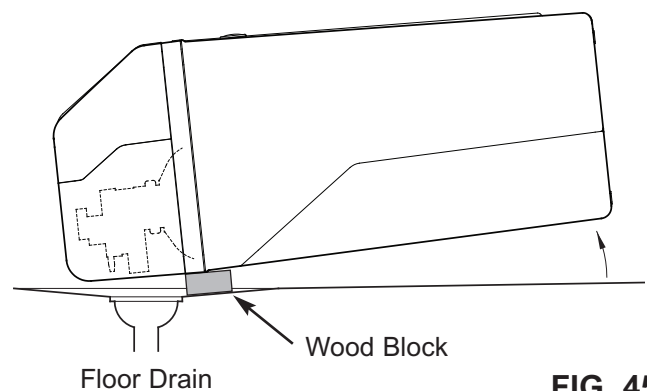

**FIG. 45**

# Troubleshooting Guide

PROBLEM	CAUSE	CORRECTION
<b>No soft water</b>	1. No salt in the storage tank.	Refill with salt and then use RECHARGE NOW feature.
<b>No soft water &amp; display is blank</b>	1. Power supply unplugged at wall outlet, or power cable disconnected from back of electronic board or power supply malfunction.	Check for loss of power and correct. Reset electronic controls and then use RECHARGE NOW feature.
	2. Fuse blown, circuit breaker popped, or circuit switched off (See "Program Memory" on Page 17).	Replace fuse, reset circuit breaker, or switch circuit on, and then use RECHARGE NOW feature.
	3. Electronic control board malfunction.	Replace electronic control board (See Page 25).
<b>No soft water &amp; salt level not dropping</b>	1. Salt storage tank "bridged".	Refer to "Breaking a Salt Bridge" section to break.
	2. Bypass valve(s) in "bypass" position.	Move bypass valve(s) to "service" position.
<b>No soft water &amp; salt storage tank full of water, water running to drain while unit is in the soft water cycle</b>	1. Dirty, plugged or damaged nozzle & venturi assembly	Take apart, clean and inspect nozzle & venturi (See "Cleaning the Nozzle & Venturi" section).
	2. Inner valve fault causing leak.	Replace seals and rotor.
	3. Valve drain hose is plugged.	Hose must not have any kinks, sharp bends or any water flow blockage (See "Valve Drain Requirements" section).
	4. Valve drain line and Salt Storage Tank overflow drain connected together by a tee.	Disconnect tee and run separate drain lines.
	5. Low or high system water pressure (low pressure may disrupt brine draw during recharge, high pressure may cause inner valve parts failure).	If pressure is low, increase well pump output to a minimum 20 psi. If daytime pressure is over 100 psi, add a pressure reducing valve in the supply pipe to the softener. Contact a licensed plumber.
	6. Brine float dirty or broken.	Clean or replace Brine Valve Float Assembly.
	7. Leak between valve and resin tank.	Replace o-rings between resin tank and valve.
<b>Water hard sometimes</b>	1. Incorrect time set.	Check and change time setting.
	2. Incorrect water hardness set.	Refer to "Set Water Hardness" section to set correctly.
	3. Incorrect model code programmed.	Refer to "Program the Water Softener" section to set correctly.
	4. Hot water being used when softener is regenerating.	Avoid using hot water while the softener is regenerating, as the water heater will fill with hard water.
	5. Possible increase in water hardness.	Test untreated water for hardness and iron, and program the water softener accordingly (See "Set Water Hardness") section to set.
	6. Leaking faucet or toilet valve. Excessive water usage.	A small leak can waste hundreds of gallons of water in a few days. Fix all leaks and always fully close faucets.
<b>Iron in water</b>	1. Clear water iron in water supply.	Test untreated water for hardness and iron, and program the water softener accordingly (See "Set Water Hardness") section to set.
	2. Iron in soft water.	Clean resin bed with Resin Bed Cleaner. Follow instructions on package.
	3. Bacterial or organic bound iron.	Cannot be treated by water softener.
<b>Resin in household plumbing</b>	1. Crack in distributor or riser tube.	Replace resin tank assembly.
<b>Salt storage tank leaking</b>	1. Crack in brine tank.	Replace salt storage tank assembly.
<b>Motor stalled or clicking</b>	1. Motor malfunction or internal valve fault causing high torque on motor.	a. Replace rotor/seal. b. Replace motor & switch.
<b>Error code E1, E3 or E4 appears</b>	1. Fault in wiring harness or connections to position switch.	Replace wiring harness or connections to position switch.
	2. Fault in switch.	Replace switch.
	3. Fault in valve causing high torque.	Replace rotor/seal.
	4. Motor inoperative.	Replace motor.
<b>Error code E5</b>	1. Electronic control malfunction.	Replace electronic control board.
<b>Status light off, but display is not blank</b>	1. Status light dislodged from its holder.	Remove top cover and reinsert status light into its holder.

# Troubleshooting

## MANUALLY INITIATED ELECTRONIC DIAGNOSTICS

1. To enter diagnostics, press the SELECT button and hold for three seconds. The display will change to show turbine count, valve cycle position, and position switch status (open or closed).

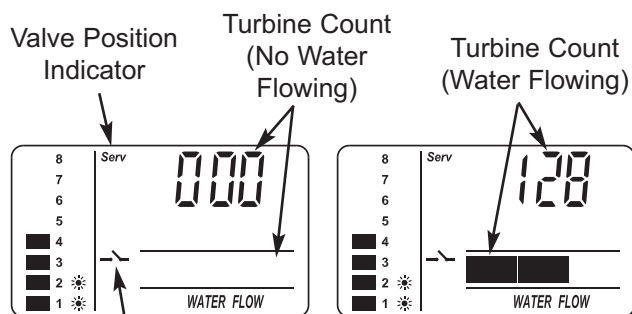

Position Switch Indicator (Open)

FIG. 46

**TURBINE OPERATION:** If no water is flowing through the softener, the turbine indicator displays three zeros. When water is flowing, a 000 to 140 count repeats for each gallon of water passing through the turbine. To check for positive operation of the turbine if zeros are shown, open a nearby soft water faucet and observe the turbine count. If you don't get a reading in the display with faucet open, pull the sensor housing from the valve outlet port (see Fig. 47). Pass a small magnet back and forth in front of the sensor. You should get a reading in the display. If you get a reading, unhook the inlet and outlet plumbing and check the turbine for binding.

**POSITION SWITCH STATUS:** With the valve in service, or any of the recharge cycle positions, the position switch indicator will show the switch open. While the valve is rotating from one position to another, the position switch indicator will show the switch closed. There is likely a problem if indications vary from this pattern.

**OTHER INFORMATION:** While in the diagnostics screen, the following information is available and may be beneficial for various reasons. This information is retained by the electronic controller from the first time electrical power is applied to the unit.

- Press and hold the  $\triangle$  UP button to display the number of days this controller has had electrical power applied.

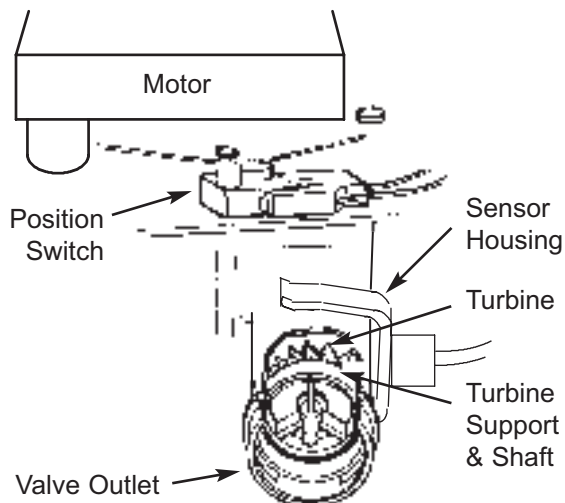

FIG. 47

- Press and hold the  $\nabla$  DOWN button to display the number of regenerations initiated by this controller since the model code number was entered.

**NOTE:** If the electronic controller is left in the diagnostic display (or a flashing display when setting times or hardness), the normal time of day display automatically returns if a button has not been pressed for 4 minutes. To return to the diagnostic display, repeat step 1, above.

## RESETTING TO FACTORY DEFAULTS

To reset the electronic controller to its factory default for all settings (time, hardness, etc.):

1. Press the SELECT button and hold it until the display changes twice to show the flashing model code.
2. Press the  $\triangle$  UP button to display a flashing "SoS".

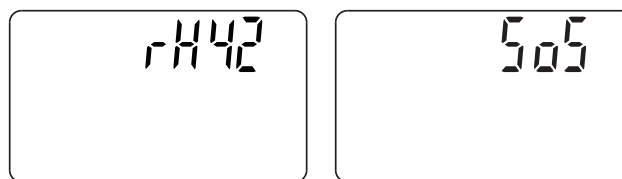

FIG. 48

3. Press the SELECT button, and the electronic controller will restart.
4. Set the present time, hardness, etc., as described on pages 12 & 13.

**Need help troubleshooting? Call Toll Free 1-800-754-7027 or visit [www.rheemwatertreatment.com](http://www.rheemwatertreatment.com)**

When you call, please be prepared to provide the model and serial number, found on the rating decal inside the salt lid.

# Troubleshooting

## MANUAL ADVANCE RECHARGE CHECK

This check verifies proper operation of the valve motor, brine tank fill, brine draw, recharge flow rates, and other controller functions. Always make the initial checks first, and perform the manually initiated electronic diagnostics.

**NOTE:** The display must show a steady time (not flashing). If an error code shows, first press the SELECT button to enter the diagnostic display.

1. Press the RECHARGE button and hold in for 3 seconds. "RECHARGE", "Serv" and "Fill" begin to flash in the display as the softener enters the fill cycle of regeneration.
2. When valve reaches "Fill" position, remove the brinewell cover and, using a flashlight, observe fill water entering the tank.
3. If water does not enter the tank, look for an obstructed nozzle, venturi, fill flow plug, brine tubing, or brine valve riser pipe.
4. After observing fill, press the RECHARGE button to move the softener into brining. A slow flow of water to the drain will begin. Verify brine draw from the brine tank by shining a flashlight into the brinewell and observing a noticeable drop in the liquid level.
5. If the softener does not draw brine:
  - nozzle and/or venturi dirty
  - nozzle and venturi not seated properly on gasket
  - restricted drain (check drain fitting and hose)
  - ineffective nozzle and venturi seal
  - other inner valve problem (rotor seal, rotor & disc, wave washer, etc.)

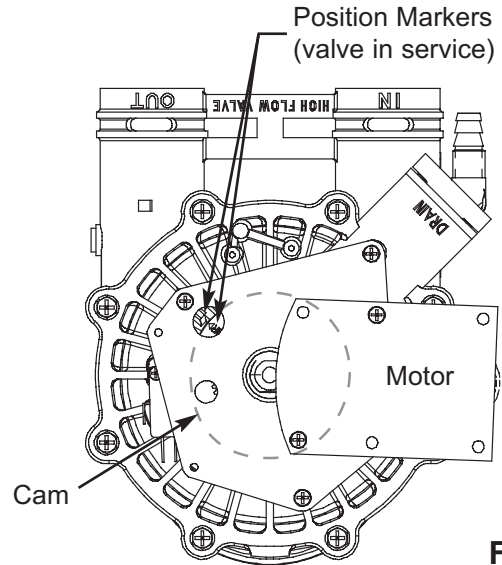

FIG. 49

**NOTE:** If water system pressure is low, an elevated drain hose may cause back pressure, stopping brine draw.

6. Again press RECHARGE to move the softener into backwash. Look for a fast flow of water from the drain hose.
7. An obstructed flow indicates a plugged top distributor, backwash flow plug or drain hose.
8. Press RECHARGE to move the softener into fast rinse. Again look for a fast drain flow. Allow the softener to rinse for a few minutes to flush out any brine that may remain in the resin tank from the brining cycle test.
9. To return the softener to service, press RECHARGE once more.

## WIRING SCHEMATIC

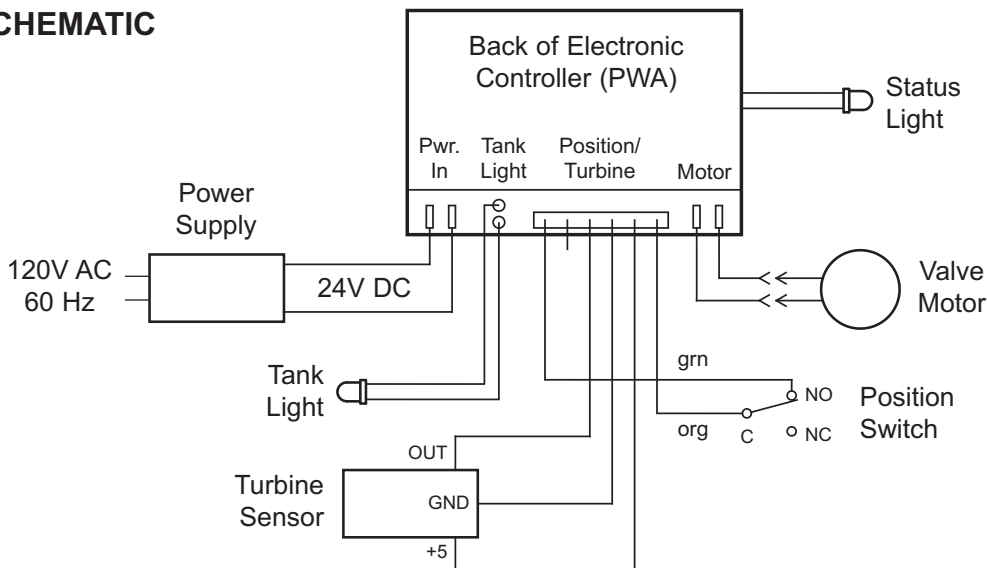
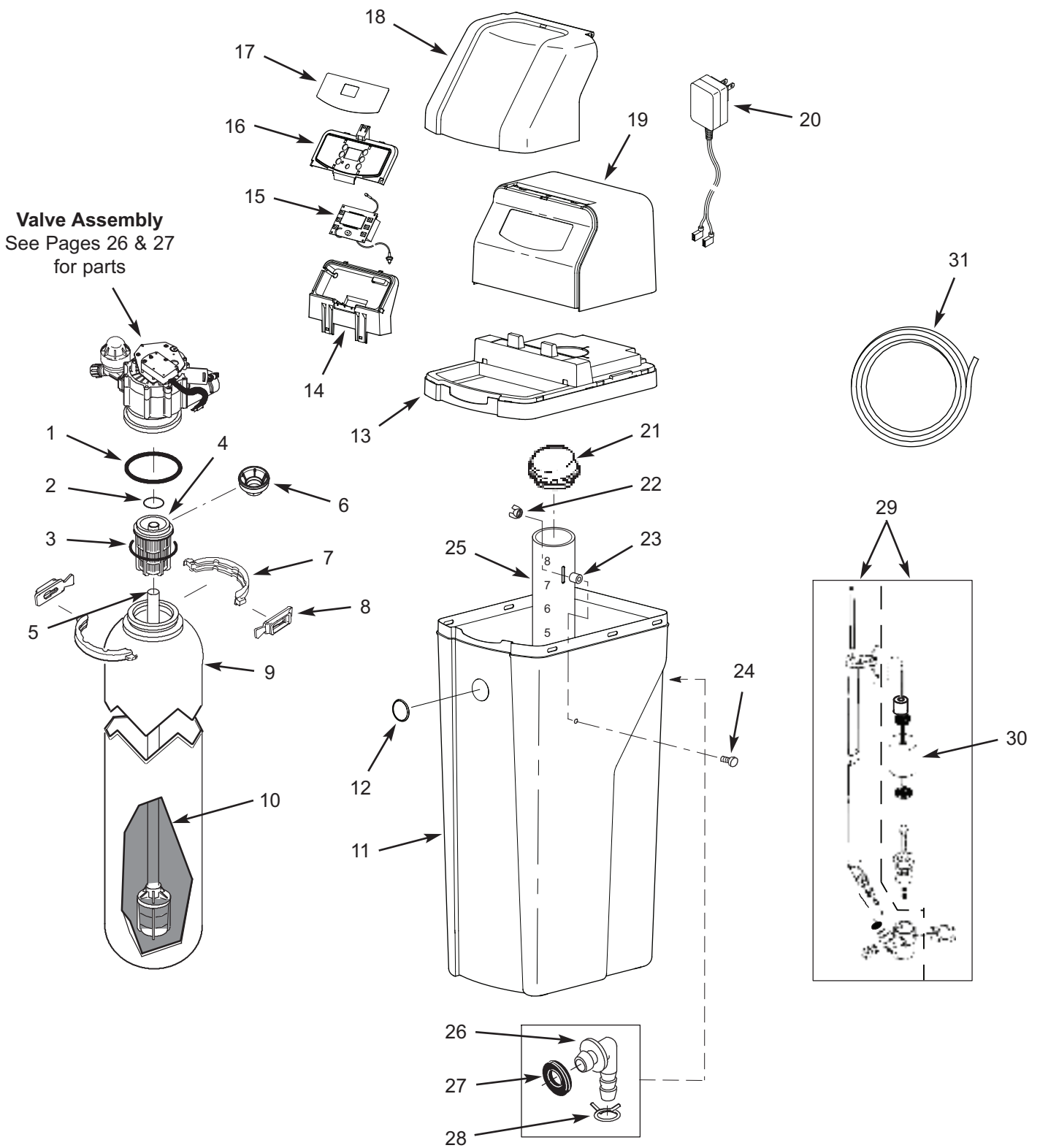

FIG. 50

# Softener Exploded View



# Softener Parts List

Key No.	Part No.	Description
–	7112963	Distributor O-Ring Kit (includes Key Nos. 1-3)
1	↑	O-Ring, 2-7/8" x 3-1/4"
2	↑	O-Ring, 13/16" x 1-1/16"
3	↑	O-Ring, 2-3/4" x 3"
4	7077870	Top Distributor
5	7327584	Repl. Bottom Distributor
6	7265025	Filter Screen
–	7331177	Tank Neck Clamp Kit (includes 2 ea. of Key Nos. 7 & 8)
7	↑	Clamp Section (2 req.)
8	↑	Retainer Clip (2 req.)
9	7247996	Repl. Resin Tank, 10" x 40"
10	0502272	Resin, 1 cu. ft.
11	7384659	Repl. Brine Tank (order badge below)
12	7386538	Badge, Rheem
13	7384641	Rim
14	7384633	Support, Faceplate
15	7386774	Repl. Electronic Control Board (PWA), including tank light & status light

Key No.	Part No.	Description
16	7385532	Faceplate (order decal below)
17	7385558	Faceplate Decal
18	7386839	Salt Lid (order decal below)
■	7386724	Instruction Decal
19	7386821	Top Cover
20	7351054	Power Supply, 24V DC
21	7386855	Cover, Brinewell
–	7386978	Brinewell Mounting Hardware Kit (includes Key Nos. 22-24)
22	↑	Wing Nut, 1/4-20
23	↑	Spacer, 3/4" long
24	↑	Screw, 1/4-20 x 1-1/2"
25	7214375	Brinewell
–	7331258	Overflow Hose Adaptor Kit (includes Key Nos. 26-28)
26	↑	Adaptor Elbow
27	↑	Grommet
28	↑	Hose Clamp
29	7310202	Repl. Brine Valve Assembly
30	7327568	Float, Stem & Guide Assembly
31	7139999	Drain Hose

■ Not illustrated.

To order repair parts call toll free 1-800-754-7027.

Manufactured and warranted by  
Water Channel Partners  
1890 Woodlane Drive  
Woodbury, MN 55125

**Questions? Call Toll Free 1-800-754-7027** or visit **[www.rheemwatertreatment.com](http://www.rheemwatertreatment.com)**

When you call, please be prepared to provide the model and serial number,  
found on the rating decal inside the salt lid.

# Valve Exploded View

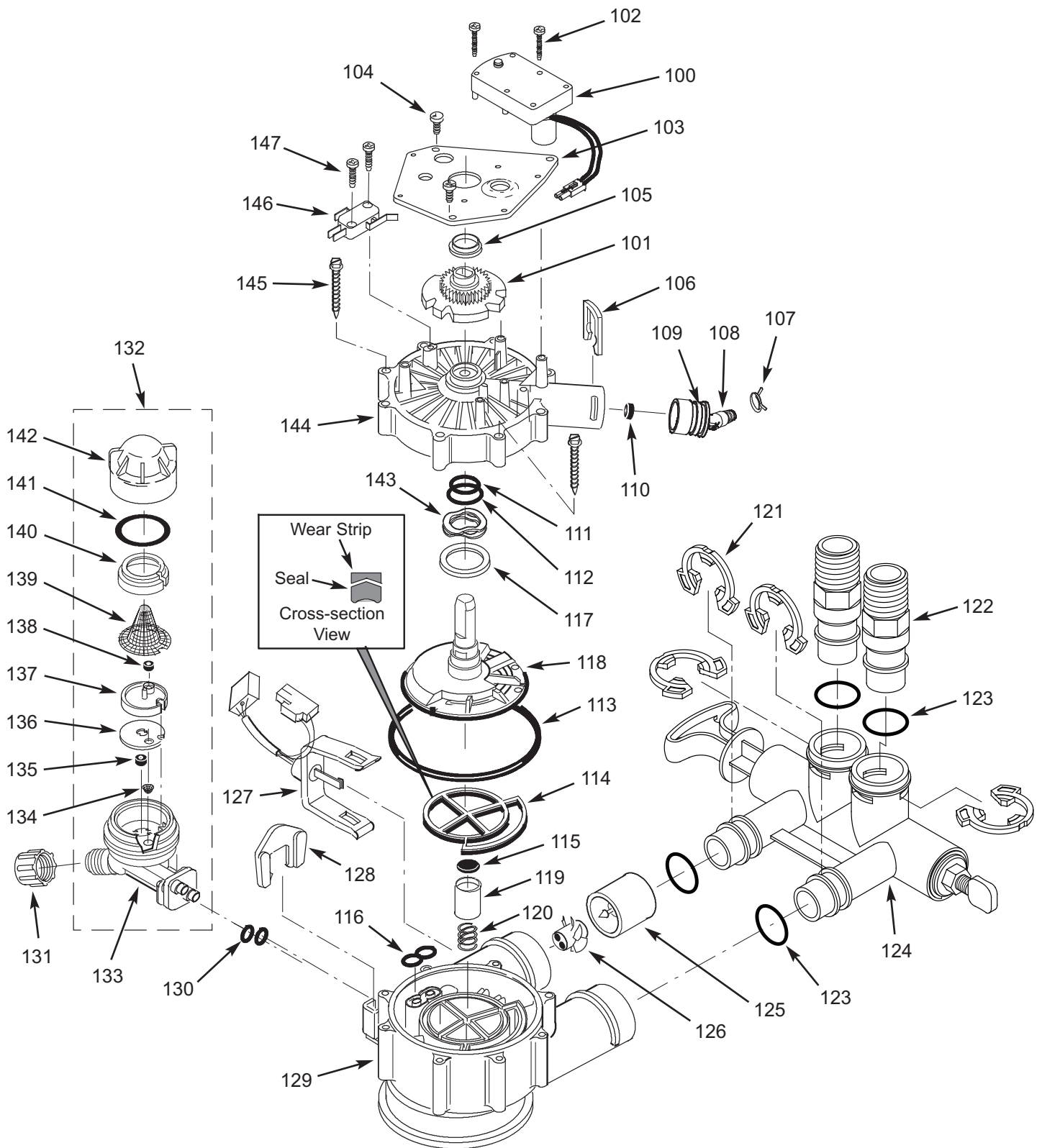

# Valve Parts List

Key No.	Part No.	Description
-	7384691	Motor, Cam & Gear Kit, 1" (includes Key Nos. 100-102)
100	↑	Motor
101	↑	Cam & Gear
102	7224087	Screw, #8-32 x 1" (2 req.)
103	7231393	Motor Plate
104	0900857	Screw, #6-20 x 3/8" (3 req.)
105	7171250	Bearing
-	7331169	Drain Hose Adaptor Kit (includes Key Nos. 106-110)
106	↑	Clip, Drain
107	↑	Hose Clamp
108	↑	Drain Hose Adaptor
109	↑	O-Ring, 15/16" x 1-3/16"
110	↑	Flow Plug, 2.0 gpm
-	7185487	Seal Kit (includes Key Nos. 111-116)
111	↑	O-Ring, 5/8" x 13/16"
112	↑	O-Ring, 1-1/8" x 1-1/2"
113	↑	O-Ring, 4-1/2" x 4-7/8"
114	↑	Rotor Seal
115	↑	Seal
116	↑	Seal, Nozzle & Venturi
117	7174313	Bearing, Wave Washer
118	7185500	Rotor & Disc
-	7342712	Drain Plug Kit, 1" (includes Key Nos. 115, 119 & 120)
119	↑	Plug, Drain Seal
120	↑	Spring
121	7337589	Clip, 1", pack of 4
122	7342704	Installation Adaptor, 1", pack of 2, including 2 ea. Clips & O-Rings (See Key Nos. 121 & 123)
123	7337597	O-Ring, 1-1/16" x 1-5/16", pack of 4

Key No.	Part No.	Description
124	7386986	Bypass Blending Valve Assembly, 1"
-	7290931	Turbine & Support Assembly, including 2 O-Rings (See Key No. 123) & 1 ea. of Key Nos. 125 & 126
125	↑	Turbine Support & Shaft
126	↑	Turbine
127	7309811	Wire Harness, Sensor
128	7081201	Retainer, Nozzle & Venturi
129	7171145	Valve Body
130	7342649	O-Ring, 1/4" x 3/8", pack of 2
131	1202600	Nut - Ferrule
132	7257454	Nozzle & Venturi Assembly (incl. Key Nos. 128, 130 & 133-142)
133	↑	Housing, Nozzle & Venturi
134	↑	Cone Screen
135	↑	Flow Plug, .3 gpm
136	↑	Gasket
137	↑	Nozzle & Venturi Disc, Blue
138	↑	Flow Plug, .15 gpm
139	↑	Screen
140	↑	Screen Support
141	↑	O-Ring, 1-1/8" x 1-3/8"
142	↑	Cap
■	7298913	Repl. Nozzle, Venturi & Gasket Kit (includes Key Nos. 130, 134, 136, 137, & 141)
143	7175199	Wave Washer
144	7171161	Valve Cover
145	7342681	Screw, #10-14 x 2-5/8", pack of 8
146	7305150	Switch
147	7140738	Screw, #4-24 x 3/4" (2 req.)

■ Not illustrated

To order repair parts call toll free 1-800-754-7027.

Manufactured and warranted by  
Water Channel Partners  
1890 Woodlane Drive  
Woodbury, MN 55125

**Questions? Call Toll Free 1-800-754-7027** or visit **www.rheemwatertreatment.com**

When you call, please be prepared to provide the model and serial number, found on the rating decal inside the salt lid.

---

**EXTEND YOUR WARRANTY:  
Use Rheem® RHWSC Water Softener Cleaner  
and register at [rheemwatertreatment.com](http://rheemwatertreatment.com)**

The factory warranty for your water softener is shown below. The one year full warranty period on parts and labor can be extended to five (5) years from the date of purchase if you use Rheem® RHWSC Water Softener Cleaner on your system, and register your purchase of Rheem® RHWSC Water Softener Cleaner at [rheemwatertreatment.com](http://rheemwatertreatment.com). Use one bottle of Rheem® RHWSC Water Softener Cleaner, as directed, every four months from the date of purchase of the water softener. Purchase of no more than three (3) bottles of Rheem® RHWSC Water Softener Cleaner in a 12 month period may be applied toward compliance with this warranty. Use of any water softener additive other than Rheem® RHWSC will not provide extended warranty coverage.

**WATER SOFTENER WARRANTY - MODEL RHS42**

**Warrantor: Water Channel Partners, 1890 Woodlane Drive, Woodbury, MN 55125**

Warrantor guarantees, to the original owner, that:

**One Year Full Warranty:**

- For a period of one (1) year from the date of purchase, all parts will be free from defects in materials and workmanship and will perform their normal functions.
- For a period of one (1) year from the date of purchase, labor to repair or replace any part deemed to be defective in materials or workmanship, will be provided at no additional cost.

**Limited Warranties:**

- For a period of ten (10) years from the date of purchase, the salt storage tank and fiberglass mineral tank will not rust, corrode, leak, burst, or in any other manner, fail to perform its proper functions.
- For a period of three (3) years from the date of purchase, the electronic control board will be free of defects in materials and workmanship and will perform its normal functions.

If, during such respective period, a part proves to be defective, Warrantor will ship a replacement part, directly to your home, without charge. After the first year, labor necessary to maintain this product is not covered by the product warranty. If you have questions regarding a warranted product, need assistance with installation or troubleshooting, wish to order a part or report a warranty issue, we are just a phone call away. SIMPLY DIAL 1-800-754-7027 for assistance.

**General Provisions**

The above warranties are effective provided the water softener is operated at water pressures not exceeding 125 psi, and at water temperatures not exceeding 120°F; provided further that the water softener is not subject to abuse, misuse, alteration, neglect, freezing, accident or negligence; and provided further that the water softener is not damaged as the result of any unusual force of nature such as, but not limited to, flood, hurricane, tornado or earthquake.

Warrantor is excused if failure to perform its warranty obligations is the result of strikes, government regulation, materials shortages, or other circumstances beyond its control.

**\*THERE ARE NO WARRANTIES ON THE WATER SOFTENER BEYOND THOSE SPECIFICALLY DESCRIBED ABOVE. ALL IMPLIED WARRANTIES, INCLUDING ANY IMPLIED WARRANTY OF MERCHANTABILITY OR OF FITNESS FOR A PARTICULAR PURPOSE, ARE DISCLAIMED TO THE EXTENT THEY MIGHT EXTEND BEYOND THE ABOVE PERIODS. THE SOLE OBLIGATION OF WARRANTOR UNDER THESE WARRANTIES IS TO REPLACE OR REPAIR THE COMPONENT OR PART WHICH PROVES TO BE DEFECTIVE WITHIN THE SPECIFIED TIME PERIOD, AND WARRANTOR IS NOT LIABLE FOR CONSEQUENTIAL OR INCIDENTAL DAMAGES. NO WARRANTOR DEALER, AGENT, REPRESENTATIVE, OR OTHER PERSON IS AUTHORIZED TO EXTEND OR EXPAND THE WARRANTIES EXPRESSLY DESCRIBED ABOVE.**

Some states do not allow limitations on how long an implied warranty lasts or exclusions or limitations of incidental or consequential damage, so the limitations and exclusions in this warranty may not apply to you. This warranty gives you specific legal rights, and you may have other rights which vary from state to state. This warranty applies to consumer-owned installations only.

**Rheem®, Rheem Preferred, Rheem Preferred Plus, and Rheem Preferred Platinum logos and product names are trademarks of Rheem Manufacturing Company, and are used under license. All rights reserved.**