

# SENSOR<sup>®</sup>3

---

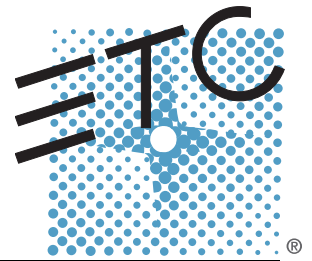

## CEM3 User Manual

Version 1.5.1

Copyright © 2014 Electronic Theatre Controls, Inc.  
All Rights reserved.  
Product information and specifications subject to change.  
Part Number: **7140M1200-1.5.1** Rev A  
Released: 2014-06

ETC<sup>®</sup> and Sensor<sup>®</sup> are either registered trademarks or trademarks of Electronic Theatre Controls, Inc. in the United States and other countries.

All other trademarks, both marked and not marked, are the property of their respective owners.

ETC intends this document, whether printed or electronic, to be provided in its entirety.

# Table of Contents

---

	Introduction . . . . .	1
	Using this Manual. . . . .	2
	Text Conventions. . . . .	2
	Help from ETC Technical Services . . . . .	3
<b>Chapter 1</b>	<b>Getting Started . . . . .</b>	<b>5</b>
	The User Interface . . . . .	6
	CEM3 face panel . . . . .	6
	Navigation . . . . .	6
	Performing a Quick Setup . . . . .	7
	Other Setup Functions. . . . .	8
<b>Chapter 2</b>	<b>System Reference . . . . .</b>	<b>9</b>
	Important Concepts . . . . .	10
	Advanced Features (AF) . . . . .	10
	Balanced (rack numbering) . . . . .	10
	Circuit. . . . .	11
	Configuration . . . . .	11
	Dimmer Doubling (UL/ 120V 60 Hz systems only) . . . . .	11
	Latch-Lock . . . . .	12
	Lug. . . . .	12
	Panic . . . . .	12
	Patch . . . . .	13
	Preset Functions . . . . .	13
	Redundant Tracking (ESR and FDX racks only) . . . . .	15
	Straight (rack numbering) . . . . .	16
	Menu Structure. . . . .	17
	Test . . . . .	17
	About . . . . .	17
	Setup . . . . .	18
	Dimmer Property Definitions . . . . .	19
	Rack Property Definitions. . . . .	22
	Dimmer Curves . . . . .	23
	Linear. . . . .	23
	Modified Linear (Mod-Linear). . . . .	25
	Square Law (Square). . . . .	25
	Modified Square Law (Mod-Square) . . . . .	26
	Sensor 2.0 . . . . .	26
	Stage 1 . . . . .	27
	Stage 2 . . . . .	27
	Fluor 1 . . . . .	28
	Fluor 2 . . . . .	28
	Andi . . . . .	29



VIP 90 .....	29
Dimmer Output Diagram .....	30

## **Chapter 3                      Common Tasks. . . . . 31**

Recording and Playing Back Presets .....	32
Preset Menu .....	32
Saving or Uploading Files and Firmware .....	33
Saving Configurations .....	33
Loading Configurations .....	33
Loading CEM3 Software .....	34
Setting Up Panic .....	35
Setting Up Patch .....	37
Automatic Patch .....	37
Manual Patch .....	38
Set Data Loss Behavior .....	38
Setting Up CEM3 on the Network .....	39
Network Setup for Redundant Tracking Racks .....	39
Working with an FTP Server .....	39
Setting Rack DIP Switches and Termination .....	40
DIPswitch settings .....	40
Termination Switches .....	41
Rack Maintenance and Cleaning .....	42
Cleaning Rack Air Filters .....	42
Vacuuming Dimmer Modules .....	43
Replacing AF Cards .....	44
Restore Rack Defaults .....	45

## **Appendix A                      Error Messages. . . . . 47**

## **Appendix B                      Using the CEM3 Web Interface . . . . . 49**

System .....	49
Dimmers .....	49
Set Levels .....	50
Setup .....	50
Files .....	50

## **Appendix C                      Redundant Tracking Systems. . . . . 51**

Redundant Tracking Switch .....	51
Automatic Control .....	52
Display Status .....	52
Configuration Management in Redundant Tracking Systems ..	53
Firmware Upgrades in Redundant Tracking Systems .....	53

<b>Appendix D</b>	<b>FDX 3000 Dimmer Racks . . . . .</b>	<b>55</b>
	Hardware . . . . .	55
	Regulatory Information . . . . .	57
	Initial Setup . . . . .	57
	Module Types . . . . .	57
	Advanced Features in FDX . . . . .	58
	FDX2000 vs. FDX3000 Dimmer Curve Comparison . . . . .	59





# Introduction

---

Welcome to your new CEM3 Power Control system!

This manual is designed to introduce you to the CEM3 user interface and the primary features and functions available to you in the setup and use of your CEM3 power control system.

For additional information you may also access our online CEM3 wiki page at <http://www.etcconnect.com/Sensor3help>. This wiki is updated regularly to reflect the most current information and may provide information on less commonly used features of your CEM3.

The introduction contains the following sections:

- ***Using this Manual*** .....2
- ***Text Conventions***.....2
- ***Help from ETC Technical Services***.....3



# Using this Manual

---

The following graphics and conventions are used throughout this manual to convey important information.



---

**Note:** *Notes are helpful hints and information that is supplemental to the main text.*

---



---

**CAUTION:** *A Caution statement indicates situations where there may be undefined or unwanted consequences of an action, potential for data loss or an equipment problem.*

---



---

**WARNING:** *A Warning statement indicates situations where damage may occur, people may be harmed, or there are serious or dangerous consequences of an action.*

---



---

**WARNING:** *RISK OF ELECTRIC SHOCK! This warning statement indicates situations where there is a risk of electric shock.*

---

## Text Conventions

Many of the procedures in this manual use a combination of text conventions to identify various types of inputs that are used to program your CEM3. Below is a list of commonly used conventions in this manual.

**Bold** is used to indicate a necessary action (such as a button press or menu path) in a procedure.

[Brackets] are used to indicate the press of a tactile button on the face of the CEM3 (such as [Setup], [Test], and [Enter]).

*Italics* are used to indicate a menu item listed in the display window.

Right angle bracket (>) is used to indicate a flow of button presses and menu selection options.

When used together, this instruction: **[Setup]>Panic>Record Panic Look>[Enter]** indicates you should, “Press [Setup], select *Panic* from the menu, select *Record Panic Look* from the menu, Press [Enter].”

## Advantages of Electronic Version

ETC's technical documentation is designed for printed or electronic use. However, there are many bonuses to using the electronic (.PDF) versions of our documents. Aside from having all of the benefits of a PDF (such as word find, bookmarks, and commenting tools) ETC documents include the ability to click headings in the Table of Contents or Index and jump to the desired page. Also, our cross-references (indicated in blue italics like this: [Introduction, page 1](#)) are links that may be clicked to jump to the specific part of the manual. And all of ETC's documents are available for free download from our website: [www.etconnect.com](http://www.etconnect.com).

You can download a .PDF copy of this manual directly from the USB port on the CEM3. See [About CEM3, page 17](#).

Please email comments about this manual to: [TechComm@etconnect.com](mailto:TechComm@etconnect.com)



# Help from ETC Technical Services

---

If you are having difficulties, your most convenient resources are the references given in this user manual. To search more widely, try the **ETC Web site** at [www.etconnect.com](http://www.etconnect.com) or the **Sensor3 Online Community Wiki** at <http://www.etconnect.com/Sensor3help>.

If none of these resources is sufficient, contact ETC Technical Services directly at one of the offices identified below. Emergency service is available from all ETC offices outside of normal business hours.

When calling for help, please have the following information handy:

- Product model and serial number (located on the bottom of the CEM3)
- Dimmer manufacturer and installation type
- Other components in your system (Unison®, other consoles, etc.)

## Americas

Electronic Theatre Controls Inc.  
Technical Services Department  
3031 Pleasant View Road  
Middleton, WI 53562  
800-775-4382 (USA, toll-free)  
+1-608 831-4116  
[service@etconnect.com](mailto:service@etconnect.com)

## United Kingdom

Electronic Theatre Controls Ltd.  
Technical Services Department  
26-28 Victoria Industrial Estate  
Victoria Road,  
London W3 6UU England  
+44 (0)20 8896 1000  
[service@etceurope.com](mailto:service@etceurope.com)

## Asia

Electronic Theatre Controls Asia, Ltd.  
Technical Services Department  
Room 1801, 18/F  
Tower 1, Phase 1 Enterprise Square  
9 Sheung Yuet Road  
Kowloon Bay, Kowloon, Hong Kong  
+852 2799 1220  
[service@etcasia.com](mailto:service@etcasia.com)

## Germany

Electronic Theatre Controls GmbH  
Technical Services Department  
Ohmstrasse 3  
83607 Holzkirchen, Germany  
+49 (80 24) 47 00-0  
[techserv-hoki@etconnect.com](mailto:techserv-hoki@etconnect.com)



# Chapter 1

## Getting Started

---

This chapter contains the following sections:

- ***The User Interface*** ..... 6
- ***Navigation*** ..... 6
- ***Performing a Quick Setup*** ..... 7

# The User Interface

This section will clarify the physical features of the hardware interface and the general functionality with the software.

## CEM3 face panel

These are the various components in the hardware interface. Familiarize yourself with these terms as they are used throughout this manual.

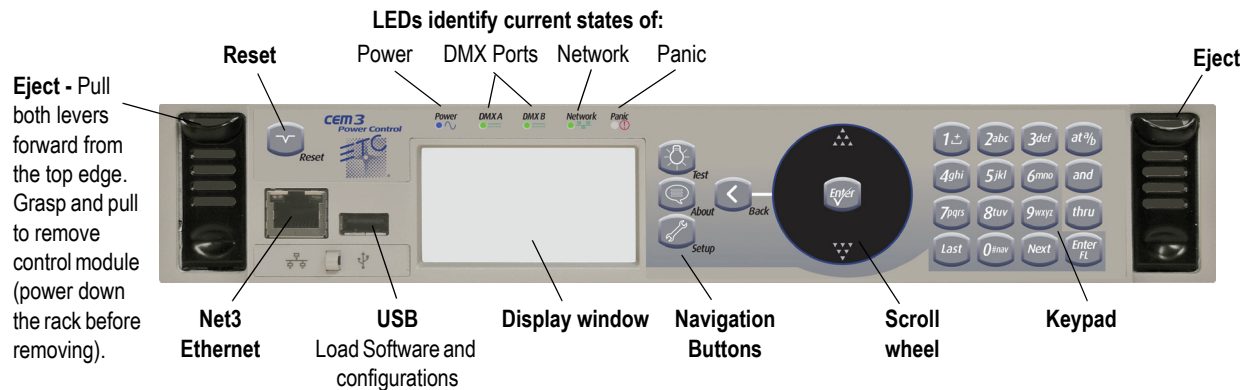

## Navigation

### Scroll Wheel

Use the scroll wheel and up/down arrows to move the selection cursor on any menu screen until the desired item is highlighted. You can also tap the top or bottom of the scroll wheel to move the display cursor up or down.

The scroll wheel also lets you scroll through number fields (such as circuit number) or through the available options for a selected item (such as Module Type).

The center button of the scroll wheel functions as [Enter]. Press [Enter] to select the highlighted item on the display window or to commit entered data.

### Keypad

Use keypad to enter values for any value fields in the display window. When setting levels you can select individual dimmers or ranges of dimmers using the [and] and [thru] buttons.

Both the center button of the scroll wheel and the bottom right keypad button function as [Enter]. Press [Enter] to select the highlighted item on the display window or to commit entered data.

The menu buttons ([Test], [About], [Setup]) and the [Back] button are integral in navigating the menu structure.

### Display Menus

The navigation buttons are used to navigate the menu structure.

Press the menu buttons ([Test], [About], [Setup]) to access features within that menu type (see [Menu Structure, page 17](#)).

Use the scroll wheel to navigate through menu items in the display window, using [Enter] to select desired items, entry fields, or access submenus.

Press [Back] to return to the previous screen on any menu.

# Performing a Quick Setup

---

Quick Setup is used to set up your rack using a minimum amount of data to achieve a basic configuration.



---

**Note:** *Prior to performing a Quick Setup, make sure that your rack DIP switch settings are set appropriately for your rack type. See [Setting Rack DIP Switches and Termination, page 40](#) for more information.*

---



---

**CAUTION:** *Quick rack setup will overwrite some of the data in your rack. Only perform a quick setup when you wish to reconfigure your system or are instructed to do so by ETC Technical Services.*

---

You can begin a quick setup by navigating to **[Setup]>Quick Setup>[Enter]**.

From this interface you can use the CEM3 interface to enter data in up to four fields to quickly establish your rack configuration: Rack Number, First Circuit, Numbering, and Dimmer Double (see below for field descriptions).

Once you have entered data in the desired fields, select [Go] and press **[Enter]** to save the setup changes.

## Rack Number

Enter a reference number between 1-999 to identify the rack. Default is 1.

## First Circuit

Enter the desired number for the first circuit in the rack. If this is your first or only rack, this number is typically 1. If this rack is one of many in your system, this number typically continues the numbering sequence from the previous rack. Default is 1.

## Numbering

Choose between “Straight” or “Balanced”. “Straight” results in circuit numbering that will proceed sequentially straight through the entire rack. See [Straight \(rack numbering\), page 16](#) for more information.

“Balanced” results in circuit numbering that will distribute the circuits evenly across the different power phases so that neighboring circuits do not place an uneven load on any phase. See [Balanced \(rack numbering\), page 10](#) for more information.

Default for Sensor3 installed racks (SR3) is “Balanced”. Default for Sensor3 portable racks (SP3) is “Straight.”

## Dimmer Double

Choose between “Yes” and “No” to activate or deactivate dimmer doubling for the rack. Default is “No” (see [Dimmer Doubling \(UL/ 120V 60 Hz systems only\), page 11](#)).

## Other Setup Functions

Once you have completed the quick setup, you may wish to proceed to these other common setup tasks:

Setting the module type in [Circuit Assignment, page 18](#).

[Setting Up Patch, page 37](#),

[Setting Up Panic, page 35](#),

or [Setting Up CEM3 on the Network, page 39](#).

# Chapter 2

## System Reference

---

Refer to this chapter for information about the general concepts behind the features of your CEM3, the general menu structure of the software, definitions of all dimmer properties, and illustrations of the various dimmer curves available in your system.

This chapter contains the following sections:

- ***Important Concepts*** .....10
- ***Menu Structure*** .....17
- ***Dimmer Property Definitions*** .....19
- ***Rack Property Definitions*** .....22
- ***Dimmer Curves*** .....23
- ***Dimmer Output Diagram*** .....30

# Important Concepts

---

This section introduces you to some of the primary concepts and their functionality, which you may encounter through your use of the CEM3 power control system. Topics are listed alphabetically.

## Advanced Features (AF)

Advanced Features (AF) allow you to receive feedback from your dimmer modules about their current state, including the amount of current being drawn on each circuit, whether the module is installed or not, and whether the circuit breaker on the module has tripped. This feedback information is available both at the front panel of the rack and at remote devices including ETC's Eos and Congo control systems, and other ACN capable devices.

Having Advanced Features also allows you to monitor circuit loads by recording and running a rig check (see [Rig Check, page 13](#)).

In order to use AF you need AF capable modules (denoted by having AF in the module name, for example D20AF or ED15AF), and also AF cards installed in the rack.

## Balanced (rack numbering)

Balanced rack numbering alternates dimmer numbering across phases in groups of two dimmers.

This table compares the circuit numbering of an SR3-6 filled with D20 modules when set to straight or balanced numbering:

Rack Phase	SR3-6 Straight Circuit Numbering	SR3-6 Balanced Circuit Numbering
A	1	1
	2	2
	3	7
	4	8
B	5	3
	6	4
	7	9
	8	10
C	9	5
	10	6
	11	11
	12	12

Racks can be set as balanced by [Performing a Quick Setup, page 7](#).



## Circuit

A circuit is a user assignable number, between 1 and 99999. the circuit is the reference number for that dimmer in the rack. Circuit numbers *must* be unique per space; it is possible to have multiple circuits of the same number, but they must be in different spaces.

## Configuration

The rack configuration is a collection of all of the data stored about the rack and all of its circuits. The configuration is stored automatically in the CEM3 whenever you make a change (for example, changing a circuit from switched to dimmed).

The configuration of any rack is automatically stored on both the CEM3 module and the CEM3 backplane. Therefore, you can remove a CEM3, replace it with a new, unconfigured CEM3, and the configuration from the backplane will be loaded to the new CEM3.

You can save and load rack configurations by connecting a USB removable media device to the USB port on the front of the module. Saving and loading are performed from the File Operations menu (see [File Operations, page 18](#)).

## Dimmer Doubling (UL/ 120V 60 Hz systems only)

ETC's Dimmer Doubler™ technology allows you to double the number of controllable circuits in your system without adding dimmer modules or running additional cable. The key to this feature is the Dimmer Doubler two-fer.

The Dimmer Doubler two-fer is installed between a Sensor dimmer module and two ETC Source Four 77 volt fixtures. It splits the output of a single dimmer into two, separately controlled outputs.

## Latch-Lock

Latch Lock is a control mode available to any dimmer circuit (see [Control](#), page 20). Similar to switched mode, Latch-Lock features an additional safeguard so that circuits can not be turned on or off as easily. The circuit only turns on when a *defined* control level range is held for a *specified* amount of time, and only turns off when a different control level range is held for another amount of time. Latch-lock is useful for avoiding accidental dowsing of arc lamps during shows (often caused by running the Grandmaster down). By requiring a level range and time, most master fades will not hover in a given range for long enough to trigger on or off.

The level ranges and times can be edited on a per dimmer basis (see [Dimmer Property Definitions](#), page 19). On and Off level ranges may not overlap.

**Diagram of How Latch-Lock is Applied to a Circuit**

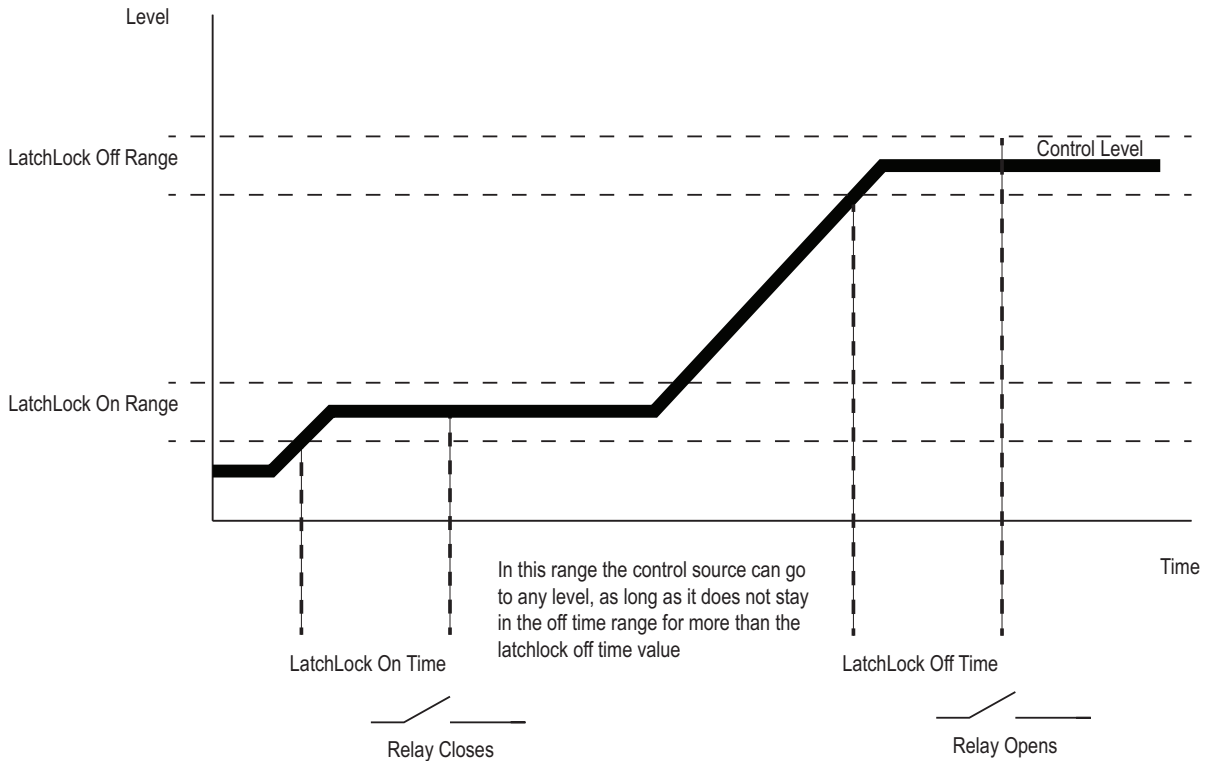

## Lug

“Lug” refers to a physical position in the rack. Lugs are always numbered counting downwards from the top of the rack, starting at “1.” Some modules may take up multiple lug positions in the rack.

## Panic

CEM3 offers a Panic capability that complies with UL 924 Panic functionality.

When a properly connected and enabled CEM3 has a panic “look” stored, when it receives a signal over the panic circuit it will automatically play the recorded look.

Panic can be enabled when a maintained (normally open or normally closed) contact closure is properly wired to the backplane (for more information, see the data termination guide or installation guide that was supplied with the rack).

For information on how to configure Panic on your CEM3, see [Setting Up Panic](#), page 35.

## Patch

Patching governs the relationship between control input sources (DMX A, DMX B, and sACN) and the control of circuits in the rack. This relationship can be edited to match the needs of your control sources and rack constraints. For information on patching, see [Setting Up Patch, page 37](#).

## Preset Functions

CEM3 supports a built-in preset control system allowing the recording and playback of preset looks. Preset looks can be played back either from the CEM3 face panel or using connected Echo preset stations. For more information on recording and playing back presets see [Recording and Playing Back Presets, page 32](#).

CEM3 allows the circuits within the rack to be divided up into spaces (performed in [Circuit Assignment, page 18](#)) with 64 presets available per space. Each space can only have one active preset at a time.

CEM3 includes default presets that include all circuits in the space. The default presets for any space start with 100% and then cycle through 75%, 50%, 25%, 100% and so on.

Sensor3's built-in EchoConnect power supply is limited to powering six racks or panels and six stations. An additional wall mounted or rack mounted power supply can be added to a system to support up to sixteen hosts and sixteen stations



---

**CAUTION:** *Do not activate "Station power" on more than one CEM3 on the same EchoConnect bus. Doing so may cause undesirable station function.*

---

Preset activation propagates across the Net3 network. So if a given preset is activated for Space 1, all CEM3s on the network will activate that preset for space 1.

### Rig Check

In Sensor3 racks with Advanced Features (see [Advanced Features \(AF\), page 10](#)) you can record a special preset called "Rig Check" which includes both circuit levels and the amount of load (current) expected on each circuit.

Once recorded, the rig check can be played back, either from the CEM3 face panel or remotely, and the CEM3 will post *load high*, *load low*, or *no load* messages based on how the load of the circuit has changed since you recorded the rig check preset. These messages will be available on the CEM3 display or on a connected console that monitors AF feedback.

Recording, running, and clearing a rig check can be performed from the Test menu ([See "Test" on page 17.](#))

## System Topology

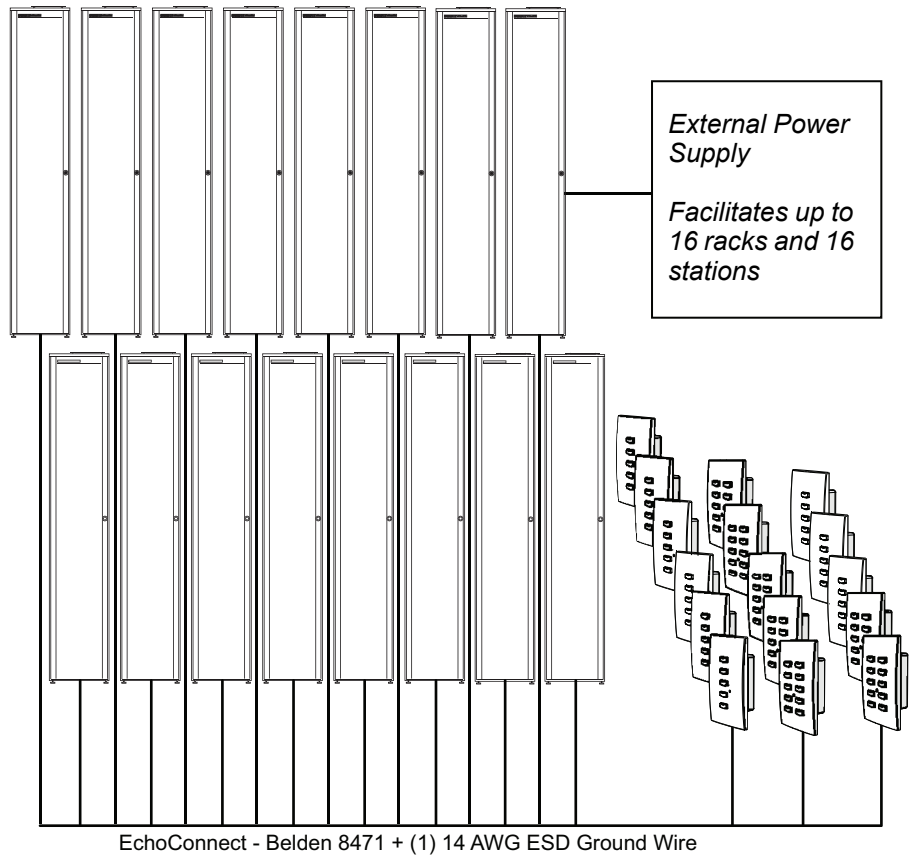
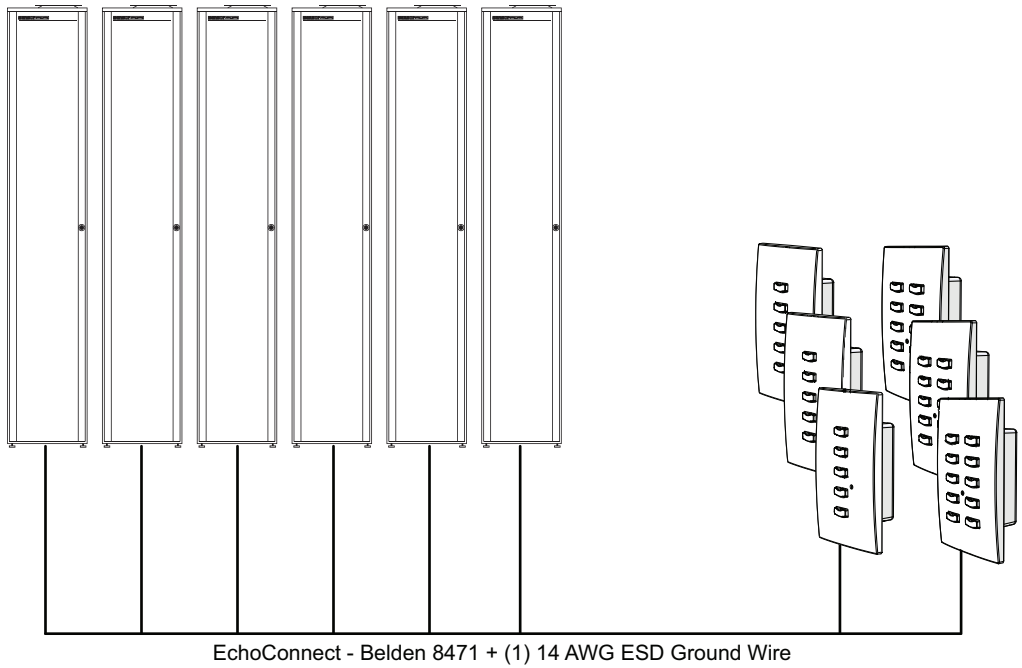

## Spaces

Spaces are logical divisions within a system (such as different rooms) that isolate station control (preset and sequence control) to the defined group of controllable outputs in that division. CEM3 supports separation of its controllable circuits into spaces.

## Station Functions

Presets can be played back from preset stations in the system.

- Press a preset station button to **activate** a preset.
- Press it again to **deactivate** the preset.
- Stations can be configured with an “Off” button. This option is performed at the station and should only be done by a qualified technician.
- The group of presets controlled by any station can be altered at the station. This should only be done by a qualified technician.

For more information see the *Echo Preset Station Installation Guide* available from the ETC web site.

## Zones

A space can be broken down further into zones. You can assign zone control to a preset station for direct control using that station’s buttons and fader knob. Multiple zones can exist within a space and a single zone can control multiple outputs across multiple racks.

A circuit’s control zone is a dimmer property and is assigned by accessing the dimmer setup menu (see “Arch Zone:” in [Dimmer Property Definitions, page 19](#)).

Each space can have up to 16 zones assigned (numbered 1-16). You can omit a circuit from zone control by setting the Arch Zone value to zero.

## **Redundant Tracking (ESR and FDX racks only)**

Redundant tracking provides extra security in the event of system failure, allowing a secondary CEM3 control module to immediately take control of the rack.

Redundant tracking is available in ESR and FDX racks only.

For more information, see [Redundant Tracking Systems, page 51](#).

## Straight (rack numbering)

Straight rack numbering assigns consecutive dimmer numbering vertically, from top of the rack to the bottom, regardless of phasing.

This table compares the circuit numbering of an SR3-6 filled with D20 modules when set to straight or balanced numbering:

Rack Phase	SR3-6 Straight Circuit Numbering	SR3-6 Balanced Circuit Numbering
<b>A</b>	1	1
	2	2
	3	7
	4	8
<b>B</b>	5	3
	6	4
	7	9
	8	10
<b>C</b>	9	5
	10	6
	11	11
	12	12

Racks can be set to straight through [Performing a Quick Setup, page 7](#).

# Menu Structure

---

This section lays out the entire menu structure for the software. Press the desired button to access the menu items below. Use the standard navigation method to select and enter options in the menus (see [Navigation, page 6](#)).

## Test



### Set Levels

Set levels for all circuits in a space.

### Dimmer Check

Quickly run through all circuits in a space to test their output at a given percentage.

### Release Set Levels

Release any active levels for a given space at once.

### Presets

Record or play back presets. See [Recording and Playing Back Presets, page 32](#).

### Record Rig Check

Records a rig check preset to facilitate AF reporting. See [Rig Check, page 13](#) and [Advanced Features \(AF\), page 10](#) for more information.

### Run Rig Check

Runs a rig check preset. You will be notified of any load inconsistencies found during the rig check.

### Clear Rig Check

Clears the recorded rig check from the CEM3.

## About



### Dimmers

View all properties for any circuit in a space. See [Dimmer Property Definitions, page 19](#).

### Rack

View all properties for the host Sensor rack. See [Rack Property Definitions, page 22](#).

### Errors

View any current errors or other status messages. See [Error Messages, page 47](#).

### Source Info

View the current control source (Highest-Takes-Precedence or "HTP") and related output level being received by all circuits in a space.

### About CEM3

Download a PDF of the CEM3 User Manual to a connected USB drive.

## Setup

Commonly used features found here include:

- changing dimmer, rack, and network settings
- enabling control ports
- changing operating mode
- upgrading software or backing up the rack configuration
- changing curve and firing mode

### Dimmers

View and alter the settings for any circuit in a space. See [Dimmer Property Definitions, page 19](#).

### Rack

View and alter the settings for the host Sensor3 rack. See [Rack Property Definitions, page 22](#).

### Circuit Assignment

Assign the space, circuit number, and module type for any circuit slot in the rack. You can auto assign or manually edit the options for any circuit.



---

**Note:**

*Single and half density modules such as the D20F need to be changed in the “Edit Circuit Layout” screen of Circuit Assignment to adjust circuit numbering prior to performing final patch updates.*

---

### Patching

Allows editing of the patch and functionality for any port (DMX or sACN). See [Setting Up Patch, page 37](#).

### Network

Allows setup and editing of network properties for the CEM3. See [Setting Up CEM3 on the Network, page 39](#).

### File Operations

Save configurations, load configurations, or upgrade CEM3 software using a USB memory device, or you can do this from a computer on the network or FTP server. See [Saving or Uploading Files and Firmware, page 33](#).

### Panic

Record a Panic look and set the specific details (such as fade and delay times) for when a Panic look is executed. See [Setting Up Panic, page 35](#).

### Time/Date

Allows you to set or alter the rack’s time and date or switch between automatic or manual time setting.

### Quick Setup

Allows for fast configuration of the rack. For more information see [Performing a Quick Setup, page 7](#).



## UI Preferences

Allows you to alter various settings regarding the user interface.

### **Backlight Mode**

This setting affects the backlight behind the display window. Choices are “On,” “Off,” and “Auto”. Auto will illuminate the window after a button press or boot up for the time specified in *Backlight Time*. Default is “Auto.”

### **Backlight Time**

Appears only when Backlight Mode is set to “Auto”. Specify the time in minutes and seconds (between 0:10 and 9:59) for the backlight to stay lit after a reboot or button press. Default is 3:00.

### **Contrast**

Adjusts the contrast of the display window. This can also be done from the home screen by holding the back arrow and using the scroll wheel.

### **Language**

Alters the display language for the display window. Default is English.

### **Temp Locale**

Alters the units used for the temperature display, Celsius (C) or Fahrenheit (F). Default is “F”.

### **sACN**

Determines the method of displaying sACN addresses: Universe/Channel (Uni/Ch) or absolute address (Abs). Default is Uni/Ch.

## Dimmer Property Definitions

---

Each dimmer has specific properties that dictate how the dimmer functions and how CEM3 will control it. These properties are accessible and editable for any dimmer by navigating to **[Setup]>Dimmers**.

Below is a list of the various dimmer properties in the order they appear on the display:

<b>Dimmer Property</b>	<b>Definition</b>
Cct:	Circuit Number. A user-assigned number for a unique circuit within a “space.” Typically the circuit number matches the labelling at the corresponding power outlet.
Lug:	Describes the physical location of a circuit in a rack. This field cannot be altered. Some module types may take up multiple lug positions in the rack. In this case, not all module “slots” will have a circuit number
Lvl:	The current level (0-100%) of the HTP source in control of the dimmer.
Module:	The type of module controlling the circuit. Defines module density, ratings, and features to ensure proper function of the connected equipment and power devices in the module.

Dimmer Property	Definition
Firing:	The firing mode of the dimmer module. Options are: <i>Normal</i> , <i>Dimmer Double</i> , or <i>Fluorescent</i> . Specific module types will also offer respectively: <i>Reverse Phase</i> , and <i>Thru-Power</i> .
Control:	<p>Determines the control mode of the dimmer. Possible settings are <i>Dimmable</i>, <i>Smoothing</i>, <i>Off</i>, <i>Always-On</i>, <i>Switched</i>, <i>Latch Lock</i>, <i>TPAuto</i>, and <i>TPDMX</i> (see individual definitions below).</p> <p><i>Dimmable</i> - Circuit dims according to curve within the minimum and maximum scaled voltages.</p> <p><i>Smoothing</i> - The dimmer adds a deliberately slow reaction time to changes in control level to “smooth out” dimming performance with loads that react quickly such as LEDs or low wattage lamps.</p> <p><i>Off</i> - Circuit ignores incoming levels and will not turn on even with local overrides.</p> <p><i>Always-On</i> - Circuit ignores incoming levels and will not turn off even with local overrides.</p> <p><i>Switched</i> - Circuit operates as a relay with output unregulated AC voltage when the control level is above the control threshold level.</p> <p><i>Latch-Lock</i> - similar to switched mode, Latch-Lock functions as a relay but features an additional safeguard so that circuits can not be turned on or off so easily. See <a href="#">Latch-Lock, page 12</a>.</p> <p><i>TPAuto</i> - For ThruPower modules. The control input to the circuit dims the circuit if it is between 0 and 99%. When the output is set to 100%, the relay of the ThruPower module closes.</p> <p><i>TPDMX</i> - For ThruPower modules. Two addresses (or three addresses when combined with 16-bit mode) control the dimmer and the relay of the ThruPower module. When the second address is below 50%, the first address acts as a relay control, turning the relay on at the threshold value. When the second address is above 50%, the first address acts as a dimmer in the normal manner, dimming the output.</p>
Curve:	The current operating curve for the dimmer. Options are: <i>Mod-Square</i> , <i>Square</i> , <i>Linear</i> , <i>Mod-Linear</i> , <i>Sensor 2.0</i> , and <i>Custom 1-5</i> . For more information curves see <a href="#">Dimmer Curves, page 23</a> .
Threshold%:	In switched mode the threshold value defines the control percentage at which the output turns on. In dimmed mode, the threshold defines the level at which preheat is applied. See <a href="#">Dimmer Output Diagram, page 30</a> for an illustration of how threshold works with other dimmer properties.
On-Level%:	<i>Latch-Lock only</i> - The control level range (as percentage) that causes the “On Time” to start counting down. Ranges available in 10% increments. Default is 41-50%. See <a href="#">Latch-Lock, page 12</a> .
Off-Level%:	<i>Latch-Lock only</i> - The control level range (as percentage) that causes the “Off Time” to start counting down. Ranges available in 10% increments. Default is 81-90%. See <a href="#">Latch-Lock, page 12</a> .
On Time (sec):	<i>Latch-Lock only</i> - The time that a level must be maintained before a circuit is switched on. Available range is 1-360 seconds. Default is 5 seconds. See <a href="#">Latch-Lock, page 12</a> .
Off Time (sec):	<i>Latch-Lock only</i> - The time that a level must be maintained before a circuit is switched off. Available range is 1-360 seconds. Default is 5 seconds. See <a href="#">Latch-Lock, page 12</a> .
DMX A:	The DMXA channel the circuit is patched to.

Dimmer Property	Definition
DMX A 16-Bit:	Determines if the circuit receives 16-Bit data from DMX A. Yes/No (Default = No)
DMX B	The DMXB channel the circuit is patched to.
DMX B 16-Bit:	Determines if the circuit receives 16-Bit data from DMX B. Yes/No (Default = No)
sACN:	The sACN channel the circuit is patched to. Displayed as either universe/channel or absolute, based on UI Preference settings (see <a href="#">UI Preferences, page 19</a> ).
sACN 16-Bit:	Determines if the circuit receives 16-Bit data from DMX A. Yes/No (Default = No)
Arch Zone:	Set the desired zone that the circuit will control. Range is from 0-16. Default is 1. Zero will exclude the circuit from zone control.
Scale Load:	The scale load setting allows hyper-accurate regulation of the voltage of the dimmer output. The scale load allows the CEM3 dimming engine to compensate for power losses occurring in the choke of the dimmer. The scale load is calculated as the load on the channel divided by the channel's capacity (in Amperes) and is expressed as a percentage. For example, a 5A load on a 20A channel would have a scale load of 25% ( $5A / 20A \times 100\% = 25\%$ ).
AF Enabled	Enables/disables advanced features for this circuit. Yes = AF enabled. This field is not available for circuits set to <i>Dimmer Double</i> .
Recorded Load:	<i>AF-Enabled only</i> - Displays the recorded load for this circuit.
Actual Load:	<i>AF-Enabled only</i> - Displays the current load for this circuit.
Min Scale (VAC):	Displays the minimum scale voltage of the circuit. See <a href="#">Dimmer Output Diagram, page 30</a> for an illustration relating to this property.
Max Scale (VAC):	Displays the maximum scale voltage of the circuit. See <a href="#">Dimmer Output Diagram, page 30</a> for an illustration relating to this property.
Regulation:	Displays whether voltage regulation is enabled for the circuit (Yes/No). Default is "Yes".
Preheat:	Displays whether the Preheat setting is on (Yes = On).
Time (sec):	Preheat Time value allows the preheat level to be sneaked back in after a blackout to allow rapid snap blackouts. This property specifies the length of time for the ramp back to preheat level. Default = 2 seconds.
DC Out Prevent:	If enabled, ensures that both positive and negative half cycles of the dimmer output are always equal. This setting is typically used for loads sensitive to DC for example transformers and electronic loads. Default is "No" (No = Off, Yes = On).
Inrush Protect:	Provides a soft start feature when lamps are turned on from "0" by ramping up the level over three mains cycles. Default is "No" (No = Off, Yes = On).
Allow in Panic:	Determines if this circuit should be included in the panic look.
Allow in Preset:	Determines if this circuit should be included in any presets that may be recorded in the future.

<b>Dimmer Property</b>	<b>Definition</b>
Reporting Mode:	<i>AF-Enabled only</i> - Defines the load reporting mode for this circuit. Options are: <i>Off</i> , <i>No-Load</i> , and <i>Load Change</i> . Default for AF modules is <i>Load Change</i> .
Sensitivity:	<i>AF-Enabled only</i> - Defines the threshold a load can be within before triggering a load error. Available in 0.5Amp increments. 2A is default.
AF Reaction:	<i>AF-Enabled only</i> - Determines the length of time for an AF reaction to occur. Default = 5 seconds.

## Rack Property Definitions

---

Each rack has specific properties that dictate how the rack is identified and functions. When selected in the Rack Setup display (**[Setup]>Rack**), the rack's properties are shown on the display window. Below is a list of the various rack properties in the order they appear on the display:

<b>Rack Property</b>	<b>Definition</b>
Rack Number:	Displays the current rack number, which you can change to be between 1-999.
System Number:	Displays the current system number, which you can change to be between 1-999. Default is 1.
DMX A:	Toggles the output of the DMX A port between "Enabled" and "Disabled." When disabled the respective "Priority" field is not visible and "Off" is displayed on the home screen. Default for DMX A is "Enabled".
Priority (DMX A):	Visible only when DMX A output is enabled. This field allows you to configure the priority of the DMX A output signal from the rack. Range is between 1-200 (200 = highest priority). Default is 100.
DMX B:	Toggles the output of the DMX B port between "Enabled" and "Disabled." When disabled the respective "Priority" field is not visible and "Off" is displayed on the home screen. Default for DMX B is "Disabled".
Priority (DMX B):	Visible only when DMX B output is enabled. This field allows you to configure the priority of the DMX B output signal from the rack. Range is between 1-200 (200 = highest priority). Default is 100.
sACN:	Toggles the output of the sACN port between "Enabled" and "Disabled." When disabled, "Off" displays on the home screen. Default for sACN is "Enabled".
Preset Priority	Set the priority for all outgoing preset levels. Range is between 1(lowest) - 200 (Highest). Default is 100.
Fan:	This is the length of time (in minutes) the rack fan will stay on after the last load in the rack has reached 0%. Range is between 30-180 minutes or can be set to "Always-on". Default is 30.
AF Enabled:	Displays whether the rack has Advanced Features (AF) enabled or not (Yes/No). Default is based on the backplane DIP switch setting.

Rack Property	Definition
Presets on Boot:	If enabled, and rack is rebooted when a preset (or presets) are active, then those same presets will be reactivated when the rack reboots.
Setup at Home:	Allows the “ <i>Quick Setup</i> ” shortcut menu option to be displayed on the home screen. Default is “Yes” for portable racks and “No” for install racks.
Voltage High Warn:	This setting defines the threshold to report an “over voltage” condition. Default is 140VAC for 100-120VAC systems and 250VAC for 230-240VAC systems.
Temp High Warn:	This setting defines the threshold to report an “over temperature” condition. The range is between 32-158°F (0-70°C). Default is 149°F (65°C)
Station Power:	This setting determines whether the preset station power supply for this CEM3 is turned on. Default is “Off” (see <a href="#">Preset Functions, page 13</a> for more information)
Remote Record	This setting determines whether presets can be remotely recorded from preset stations. Default is “No”.
Data Loss Behavior:	Opens the “Data Loss behavior” submenu (see <a href="#">Set Data Loss Behavior, page 38</a> ).

## Dimmer Curves

---

Dimmer curves determine how dimmers set voltage output in response to control signal input. To accommodate designer preferences and load response variations, Sensor3 offers several dimmer curves which can be applied to individual dimmers (see [Curve:, page 20](#)).

The available curves in CEM3 are as follows.

### Linear

The linear curve matches the control input percentage to Root Mean Squared (RMS) voltage output. Each percent increase in control level increases dimmer voltage output by

the same amount.

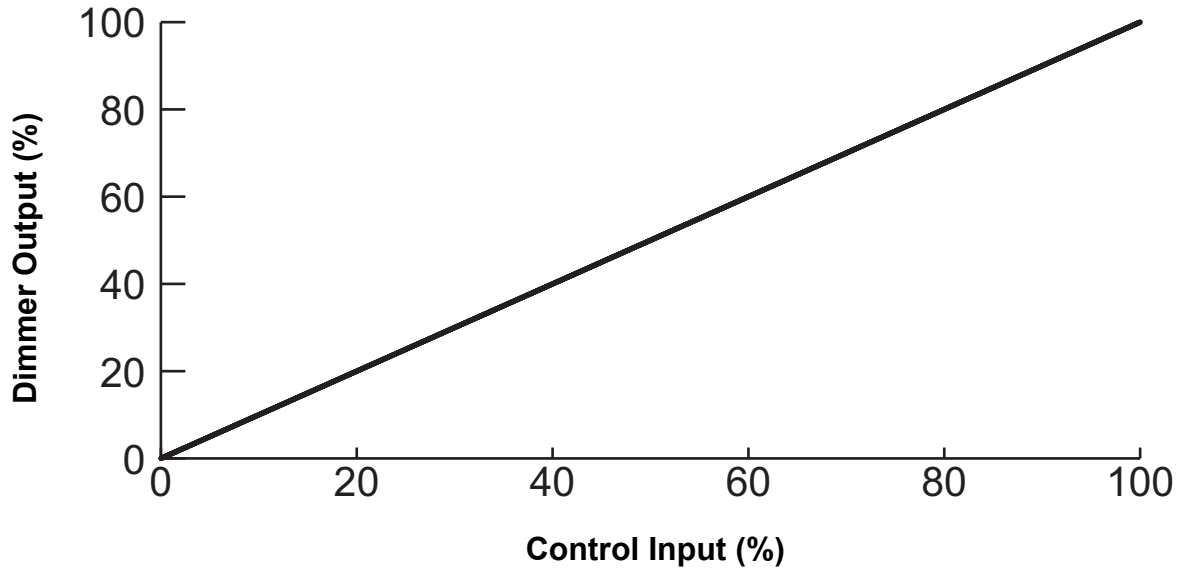

## Modified Linear (Mod-Linear)

A modified linear curve reduces the voltage change at low control levels for better performance in low-wattage fixtures.

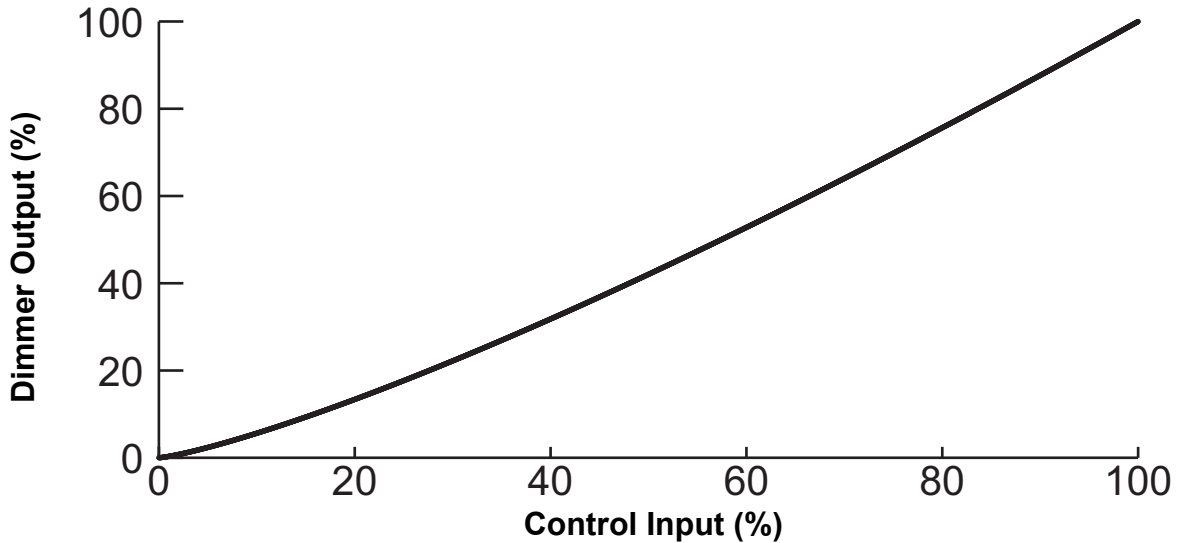

## Square Law (Square)

At low control levels, much of a traditional incandescent fixture's light output is in the invisible infrared spectrum. This results in poor visible response to low control levels. A square law curve applies a multiple derived from the square root of the control level (with full output equal to 1.00) to increase voltage response at low control levels to compensate for the infrared loss.

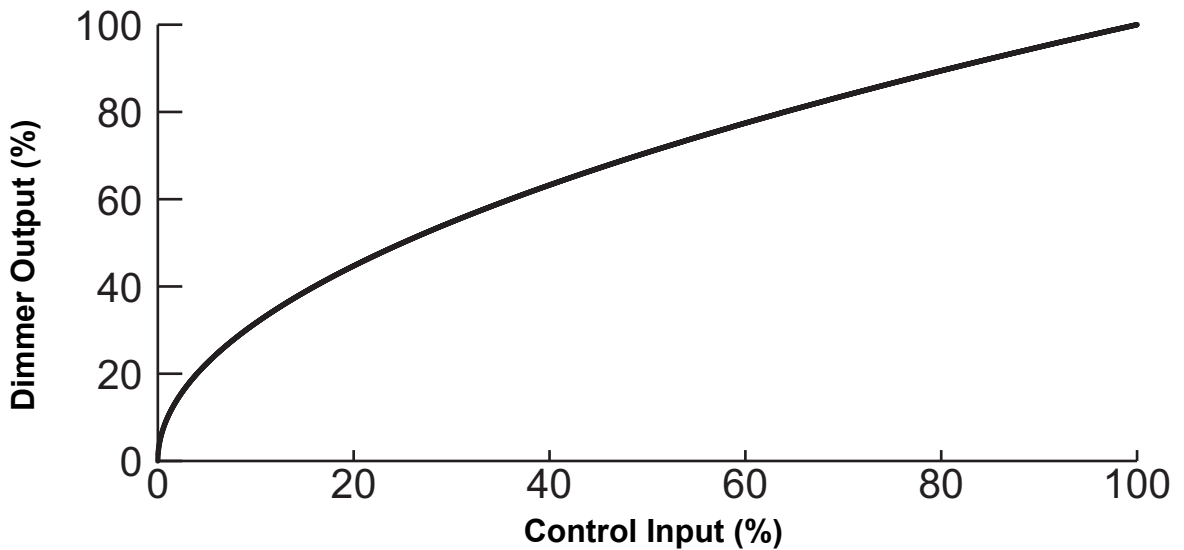

## Modified Square Law (Mod-Square)

A standard square law curve may overcompensate for infrared loss, resulting in “steppy” response to incremental control changes at low levels. ETC’s modified square law curve applies a second multiple to the standard square law curve for more uniform response to control levels changes across the entire range of dimmer output.

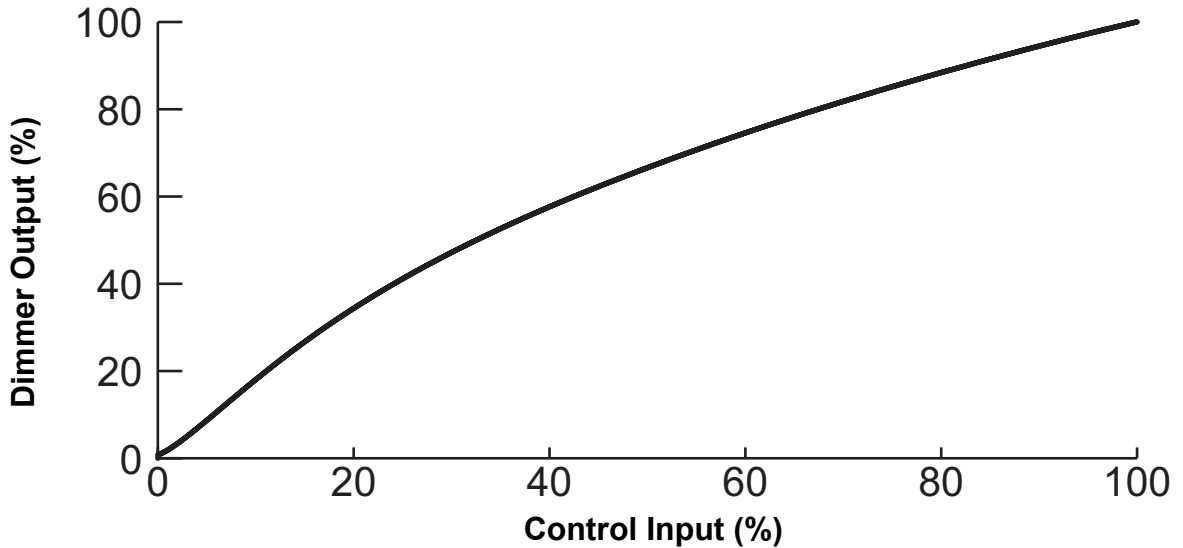

## Sensor 2.0

The Sensor 2.0 curve is the previous version of ETC’s modified square law curve. It provides backwards compatibility for shows created using earlier versions of ETC equipment and familiar response for designers who prefer the earlier version.

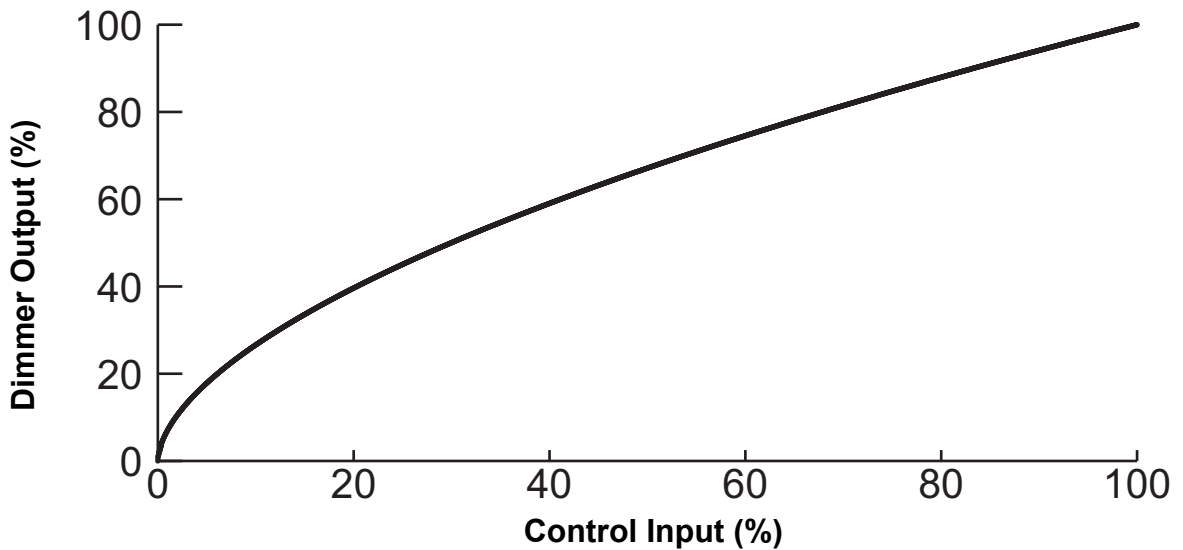



## Stage 1

This curve matches the stage curve of the Transtechnik PM90 dimming system.

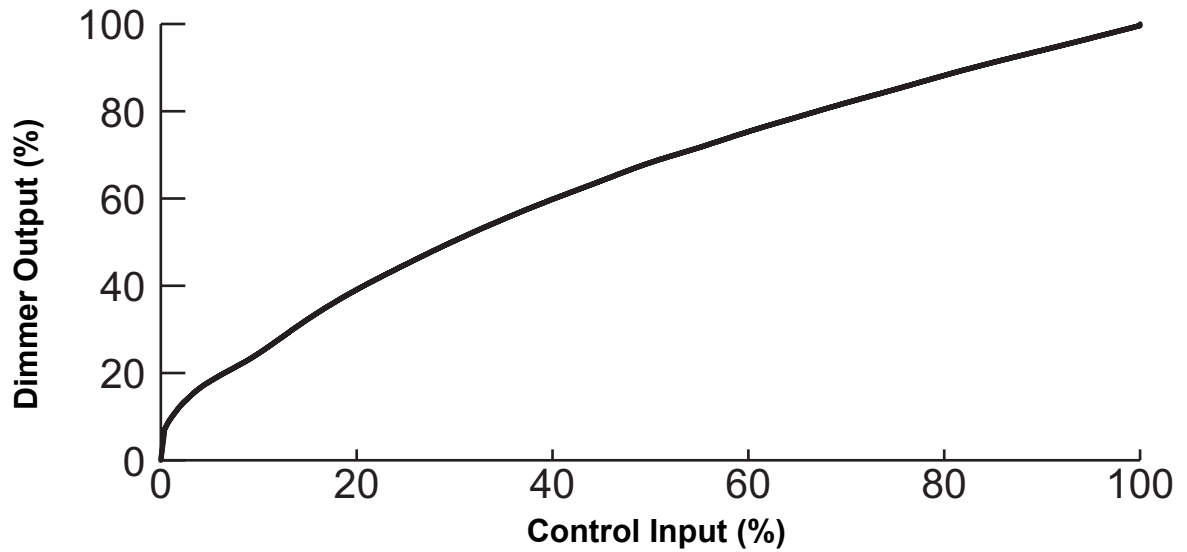

## Stage 2

This is a traditional German stage lighting curve.

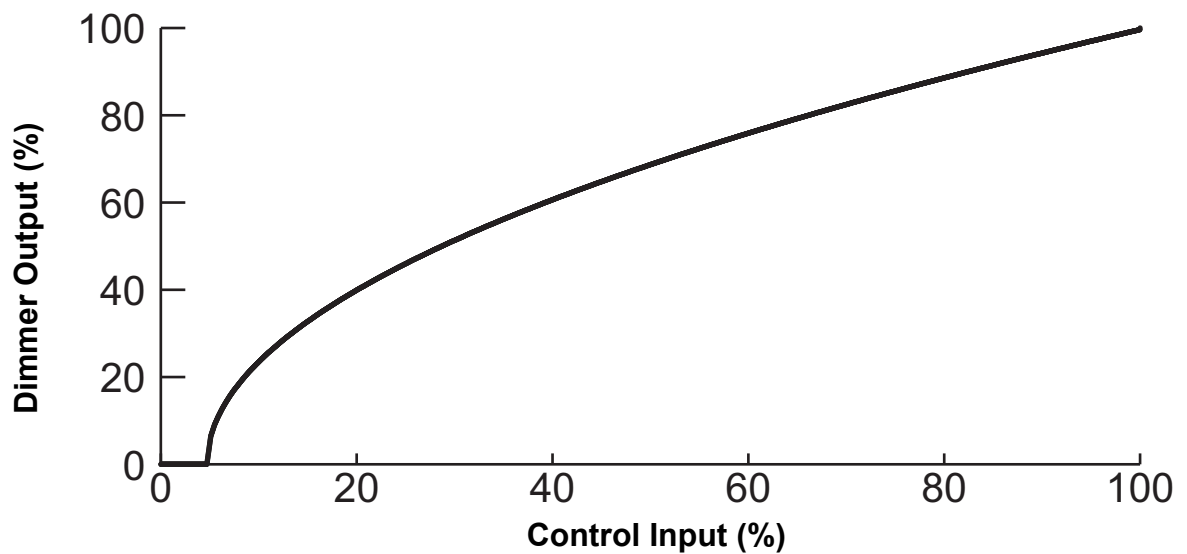

## Fluor 1

This curve is specifically for Nesys fluorescent devices.

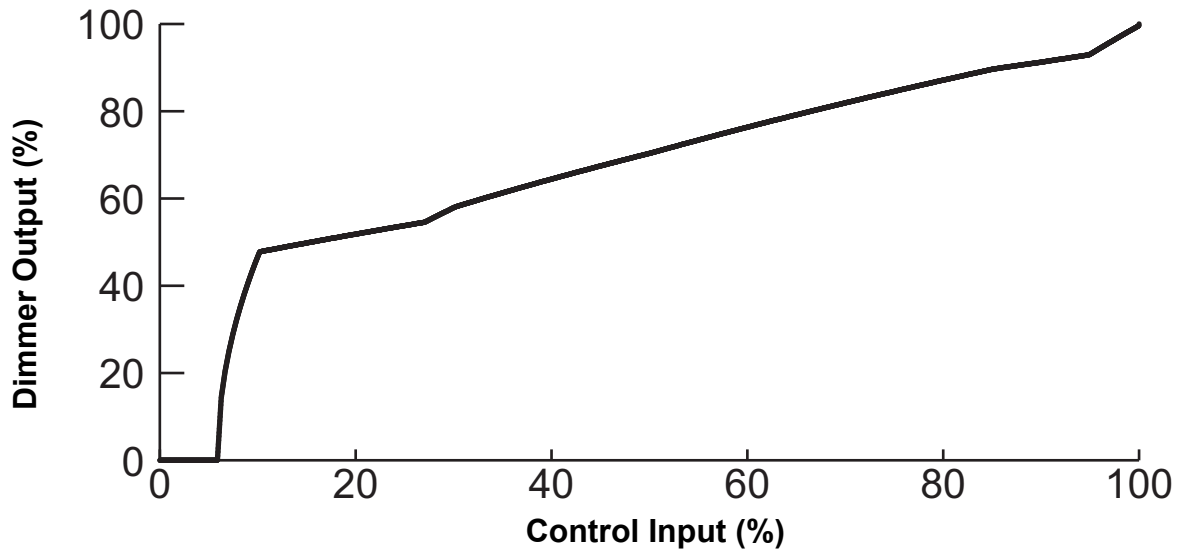

## Fluor 2

This curve is tuned to work with common 3-wire fluorescent ballasts.

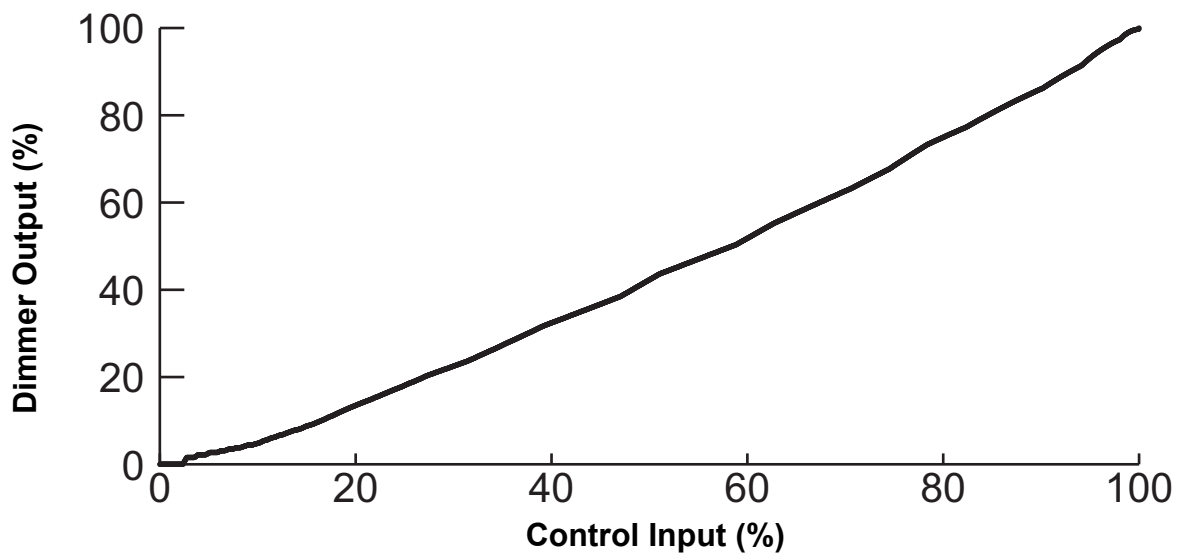

## Andi

This curve is tuned to match the curve of Strand ANDI dimmer systems.

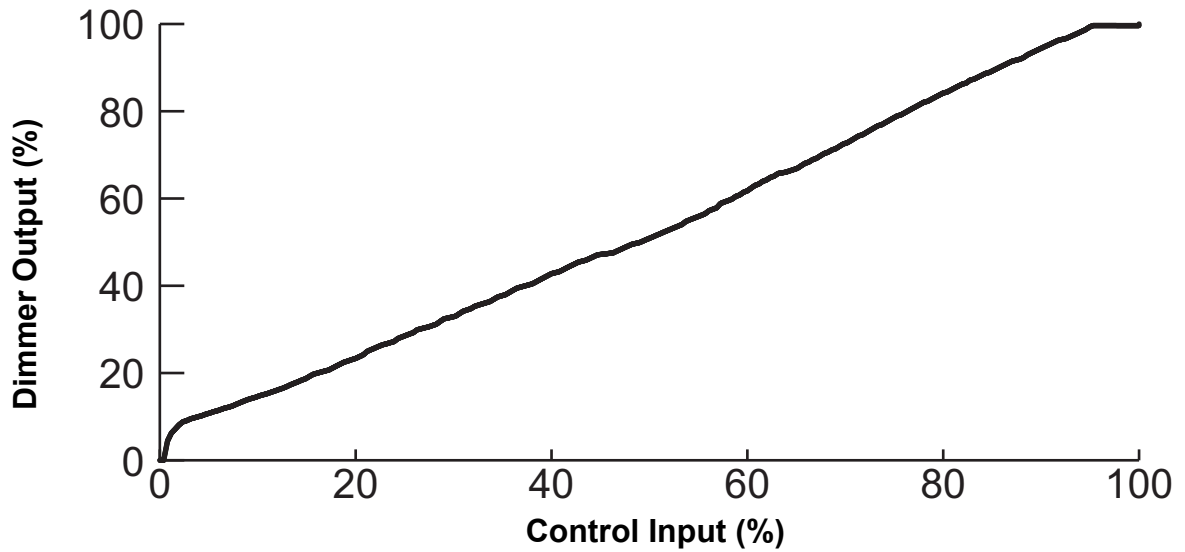

## VIP 90

VIP90 is a curve specifically tuned to produce good dimming performance with the VIP-90 fluorescent ballast from SE Light management AG, commonly used in European theatrical fluorescent luminaires.

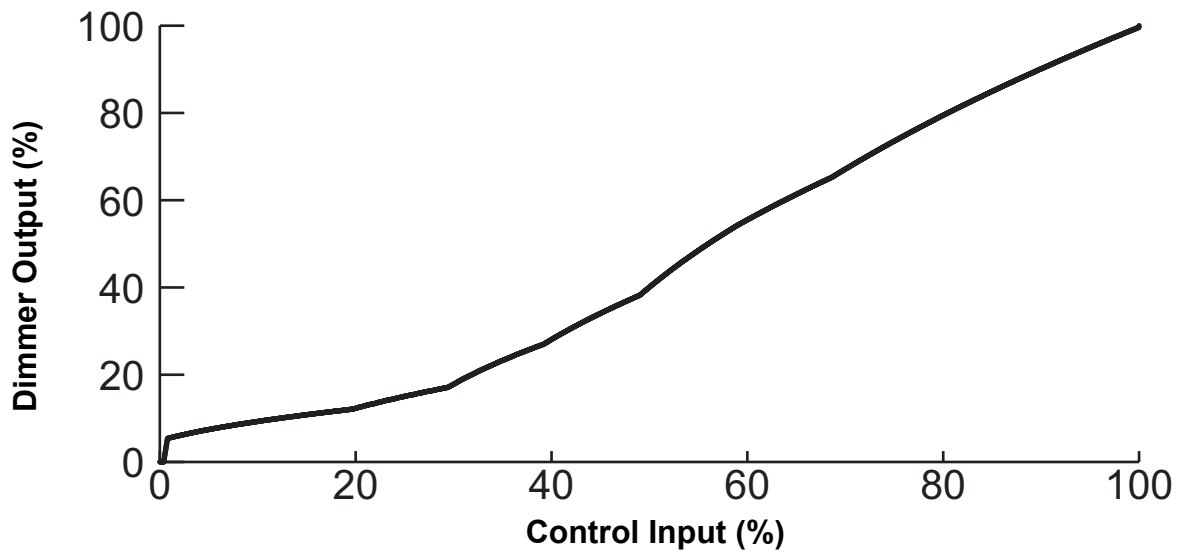

# Dimmer Output Diagram

This diagram illustrates the relationship between min scale, max scale, curve, threshold, and preheat for the dimmer output from a CEM3 channel.

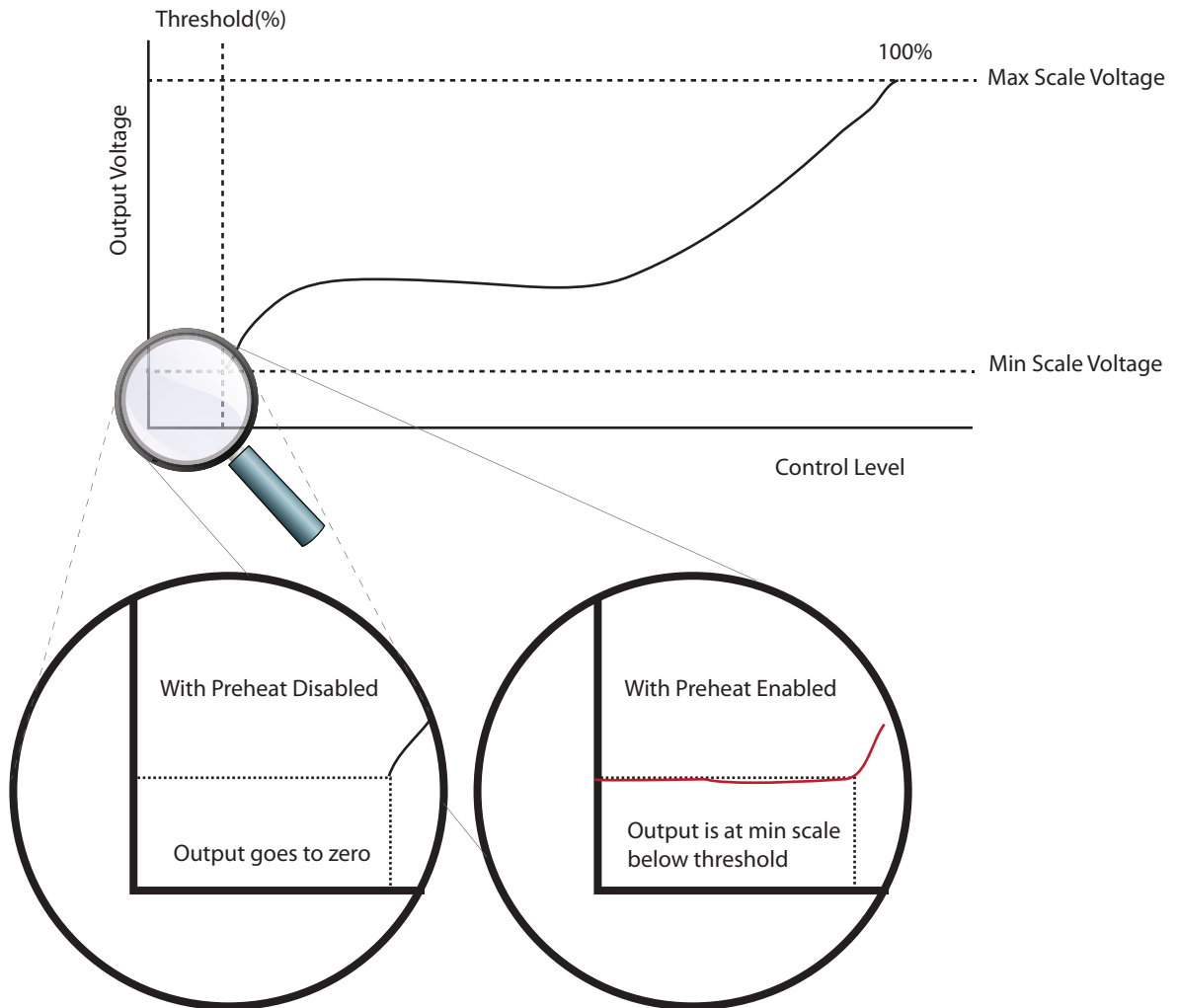

# Chapter 3

## Common Tasks

---

This chapter contains the following sections:

- [Recording and Playing Back Presets](#) ..... 32
- [Saving or Uploading Files and Firmware](#) ..... 33
- [Setting Up Panic](#) ..... 35
- [Setting Up Patch](#) ..... 37
- [Set Data Loss Behavior](#) ..... 38
- [Setting Up CEM3 on the Network](#) ..... 39
- [Setting Rack DIP Switches and Termination](#) ..... 40
- [Rack Maintenance and Cleaning](#) ..... 42
- [Replacing AF Cards](#) ..... 44

# Recording and Playing Back Presets

---

CEM3 has the ability to record and play back snapshot looks called “Presets.”

Presets can be recalled from the CEM3 or from any compatible Echo preset stations. For information on wiring preset stations, see the *Sensor3 CEM3 Data Terminations Guide* and the *Echo Preset Station Installation Guide*.

Up to 64 presets can be recorded for each space, numbered from 1-64. Only one preset can be active at a time in the same space.

## Preset Menu

Presets are recorded by taking a snapshot of the current levels for all circuits assigned to the space *that are set to be included in presets* (see [Allow in Preset; page 21](#)). If a circuit is not set to be included in presets, any level it is currently using will be withheld from the record action.

### To record or play back a preset:

- Step 1: Set the desired output levels for any dimmers in your rack using any method (methods include: “Set Levels” feature on CEM3, DMX device, or sACN device).
- Step 2: Using the CEM3 face panel, navigate to **[Test]>Presets**. The “Select Space” screen will appear (if multiple spaces exist).
- Step 3: Select the space you wish to record the preset for (if applicable) and then select **OK**. The Preset screen will open.
- Step 4: Select the preset (1-64) that you wish to record for the space. This will then give you access to the preset menu. From this menu you can now perform the following actions:
  - **[Activate/Deactivate]** - [Enter] toggles the preset between on and off.
  - **[Snapshot/Record]** - [Enter] records the current levels for the space to the selected preset.
  - **Fade Time**: set the desired time (in seconds) for the preset to fade in and out when activated/deactivated. Range is from 0-360 seconds. Default is 2 seconds.
- Step 5: Release the output levels (**[Test]>Release Set Levels**) or turn off the control source data.

# Saving or Uploading Files and Firmware

---

CEM3 allows you to save configurations to USB removable media, a computer connected to the network (using the CEM3 web interface), or an FTP server on the network.

You can also upload a configuration or update the CEM3 software using the same methods.

## Saving Configurations

### To USB media

- Step 1: Navigate to **[Setup]>File Operations>Save to USB**. The “Save As” screen will appear.
- Step 2: If desired, edit the name of the configuration using the scroll wheel and keypad.
  - a: Select the file name using the scroll wheel and press **[Enter]**. The first character of the rack name will be highlighted.
  - b: Use the keypad to alter the selected character. Keypad numbers have standard keypad text input letters. Multiple presses of any key will cycle through the number, lower case letters, and then upper case letters for that key.
  - c: When the desired character is displayed, use the scroll wheel to move to the next character in the rack name. If you want the name to be longer, press **[Next]** to add another character.
  - d: Repeat steps b-c until the desired rack name is displayed.
  - e: When the rack name is correct, press **[Enter]**.
- Step 3: Select “OK” and press **[Enter]**. The configuration will be saved to the device.

### To a computer

To save a configuration to a computer on the system network, see the appendix [Using the CEM3 Web Interface, page 49](#).

### To an FTP server

To save a configuration to an FTP server on the system network, see [Working with an FTP Server, page 39](#).

## Loading Configurations

### From USB media

- Step 1: Navigate to **[Setup]>File Operations>Load from USB**. The “Load cfg file” screen will appear.
- Step 2: Use the scroll wheel to navigate the file structure to the desired configuration file (the file name will end in “.etc”) and press **[Enter]**. The configuration will load.

### From a computer

To load a configuration from a computer on the system network, see the appendix [Using the CEM3 Web Interface, page 49](#).

### To an FTP server

To load a configuration from an FTP server on the system network, see [Working with an FTP Server, page 39](#).

## Loading CEM3 Software

You can upgrade your CEM3 software using the same methods as loading configurations (see above). CEM3 software can be obtained by contacting ETC Technical Services (see [page 3](#)).

### From USB media

- Step 1: Back up the rack configuration using the steps outlined in [Saving Configurations, page 33](#).
- Step 2: Navigate to **[Setup]>File Operations>Upgrade from USB**. The “software upgrade” screen will appear.
- Step 3: Use the scroll wheel to navigate the file structure to the desired configuration file (CEM3 software file names will end in “.bld”) and press **[Enter]**. A confirmation screen will appear.
- Step 4: Select “Yes” to continue. Select “No” abort the upgrade. The software upgrade process will take several minutes.

### From a computer

To load a configuration from a computer on the system network, see the appendix [Using the CEM3 Web Interface, page 49](#).

You can also use ETC’s Updaterator software to upgrade your CEM3. Updaterator can be downloaded from ETC’s website [www.etcconnect.com](http://www.etcconnect.com).

### To an FTP server

To load software from an FTP server on the system network, see [Working with an FTP Server, page 39](#).



# Setting Up Panic

---

To fully enable Panic functionality for your CEM3, the following criteria must be met:

- a maintained contact closure has been wired to the panic circuit on the CEM3 backplane (for more information, see the *Sensor3 CEM3 Data Terminations Guide* that ships with the Sensor3 rack),
- the “Emergency Contact” switch on the CEM3 backplane is the correct position for the contact closure type (normally open “NO” or normally closed “NC”),
- a snapshot of the desired Panic look has been recorded in the CEM3 software.



---

**Note:** *A Panic look can be recorded, regardless of if you have a wired Panic circuit.*

---

**To set the Emergency Contact switch on the CEM3 backplane:**



---

**WARNING:** *Power must be turned OFF when you perform this procedure. Before removing dimmer or control modules for service, de-energize main feed to dimmer rack and follow appropriate Lockout/Tagout procedures as described in NFPA Standard 70E. It is important to note that electrical equipment such as dimmer racks can present an arc flash safety hazard if improperly serviced. This is due to available large short circuit currents on the feeders of the equipment. Any work on energized equipment must comply with OSHA Electrical Safe Working Practices.*

---

- Step 1: Remove the CEM3 control module.
- Step 2: Move the switch labeled “EMERGENCY CONTACT” to the appropriate setting:
- “NC” - Use this setting if the emergency contact closure is a “Normally Closed” contact closure.
  - “Disabled” - This setting disables the Panic function for this CEM3 control module.
  - “NO” - Use this setting if the emergency contact closure is a “Normally Open” contact closure.

**To record a Panic look:**

- Step 1: Set the desired output levels for any dimmers in your rack using any method (methods include: Set Levels, DMX device, or sACN device).
- Step 2: Using the CEM3 face panel, navigate to **[Setup]>Panic>Record Panic Look>[Enter]**. If a panic look was already recorded, a confirmation screen will appear asking you if you wish to overwrite the Panic look.
- Select “Yes/Save” to overwrite the old Panic Look. The look will be saved.
  - Select “No/Cancel” to abort the record. The look will be aborted.

Once a Panic look is recorded, when the emergency contact closure is triggered the Panic look will be activated. When the contact closure is returned to its normal state, the Panic look will be deactivated.

## Other Panic Settings

From the Panic Setup menu (**[Setup]>Panic**) you have access to the following settings that will affect the manner of a Panic look activation:

- *In Delay (sec)* - This setting determines the length of time (in seconds) for the Panic look to delay before activating (default is 0).

- *Out Delay (sec)* - This setting determines the length of time (in seconds) for the Panic look to delay before deactivating (default is 0).
- *Fade In (sec)* - This setting determines the length of time (in seconds) for the Panic look to fade in when activated (default is 2).
- *Fade Out (sec)* - This setting determines the length of time (in seconds) for the Panic look to fade out when deactivated (default is 2).
- *Shed Other Loads* - This Yes/No setting determines if active levels at the moment of the Panic trigger should remain active or be forced off. Default is "N" (No).

The following graphic illustrates how these settings affect panic function:

## Panic Fade Diagram

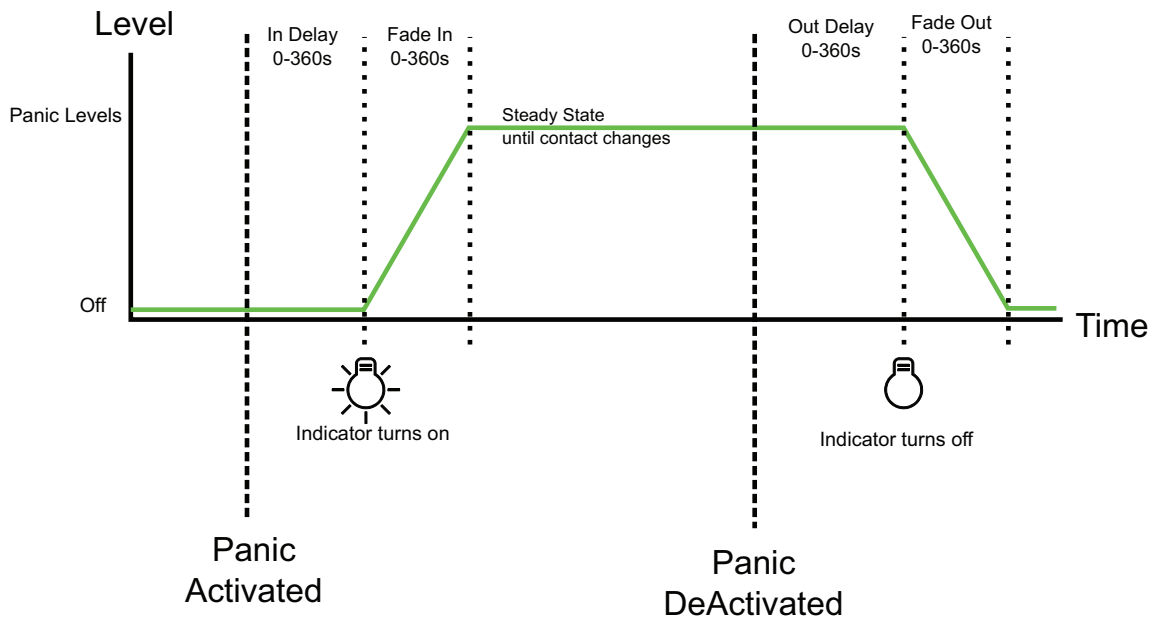

# Setting Up Patch

---

Patch governs the relationship between control sources (DMX A, DMX B, and sACN) and the rack's circuits and is editable from the CEM3 face panel. Typically, repatching is used in portable rack situations where the dimmer rack must adapt to different control sources and lighting systems. For permanent rack installs, altering your patch is rarely needed.

Racks with only one assigned space can have their patch edited through one of two methods: Manual or Automatic. Racks with multiple assigned spaces can only be edited manually. For racks edited using an automatic method, circuits will be numbered sequentially from the specified starting address following the designated "Straight" or "Balanced" setting in Quick Setup.

Any circuit set to a patch of "0" will render that circuit uncontrollable from the data source specified.

## Automatic Patch



---

**Note:** *Module density can affect patching. Prior to patching, make sure you set up the module type in [Setup]>Circuit Assignment.*

---

When you chose an automatic patching method the entire rack will be patched sequentially based on the criteria of the chosen option in *Quick Setup*. Only racks with one assigned space can use these methods.

If dimmer doubling is enabled, you will see additional fields for addressing dimmer doubled circuits.

There are three options offered for automatic patching: Simple, Split, and Independent.

### Simple

This patching method specifies the same starting circuit for all three data ports (DMX A, DMX B, and sACN) at once. Enter the starting number for the patch. Universe size is 512 dimmers (256 if dimmer doubling is enabled). If the patch count exceeds 512, the patch will "wrap" and start numbering again at 1 (257 for dimmer doubling).

### Split

This patching method should be used when a DMX universe will end part way through the rack's patch. Enter the starting number for the patch. If the patch sequence exceeds 512 (256 if dimmer doubling is enabled) DMX A will patch the rest of the circuits to "0" and DMX B will restart the patch numbers at 1 for those remaining circuits.

### Independent

This method allows you to specify different starting numbers for each data port in the patch (DMX A, DMX B, and sACN). Select a data port and assign the desired starting address for the rack. If the rack count then exceeds 512 (for DMX ports) the remainder of circuits in the rack will be patched to zero for that DMX port.

#### **To set an automatic patching method:**

- Step 1: Navigate to **[Setup]>Patching>Automatic: <choose method>**.
- Step 2: Enter or scroll to the desired starting channel number using the keypad. For Independent Mode, repeat for the other data ports.
- Step 3: Press **[Enter]** and confirm to save the changes.

## Manual Patch

Manual patching allows you to alter the patch on a circuit-by-circuit basis. There are two independent options for manual patch editing: DMX and sACN. Both can be set individually for your needs.

### To edit the patch manually:

- Step 1: Navigate to **[Setup]>[Patching]>[Edit DMX / sACN Patch]**
- Step 2: Press **[Enter]**. The Select Space screen will appear (if multiple spaces exist).
- Step 3: Select the desired space (if applicable) and then select **OK**. The Patch Table will open.
- Step 4: Use the scroll wheel or keypad to select the DMX port (A or B) or sACN universe and channel for the desired circuit.
- Step 5: Press **[Enter]**. The field will become editable.
- Step 6: Scroll to or enter the desired channel from the keypad.
- Step 7: Press **[Enter]**.
- Step 8: Repeat steps 4-7 for all desired circuits in the space.
- Step 9: Press **[Back]** when done. A confirmation dialog will open.
- Step 10: Select **[Yes/Save]** to save the changes. Press **[No/Cancel]** to abort. Press **[Continue Editing]** to edit further circuits.
- Step 11: Repeat steps 2-10 for any additional spaces.

## Set Data Loss Behavior

---

You can designate the rack's reaction to a loss of data from any of the three data ports (DMX A, DMX B, or sACN). For each of the ports you can select one of the following behaviors:

- **Crossfade** - On loss of data, the look will transition to a specified internal preset.
- **Wait & Fade** - On loss of data, the rack will wait for a specified amount of time and then fade to black over another specified time.
- **Hold Last Look** - On loss of data, no transition occurs. The levels will stay at the last known look until data is restored to the port. Resetting the processor will release the levels.

### To set the data loss behavior for any port:

- Step 1: Navigate to **[Setup]>Rack>Data Loss Behavior**. The Data Loss Behavior screen will be displayed.
- Step 2: Use the scroll wheel to highlight the desired port behavior (DMX A, DMX B, or sACN) and press **[Enter]**. The behavior will be highlighted.
- Step 3: Use the scroll wheel to select the desired behavior (see above) and press **[Enter]**.
  - a: Select "Fade Time" (if applicable) and set the desired time (range is 0-360 seconds).
  - b: Select "Wait Time" (if applicable) and set the desired time (range is 0-360 seconds).
  - c: Select "Preset Space" (Crossfade only) and select the space that contains

the desired crossfade preset.

- d: Select “Preset Number” (Crossfade only) and select the desired preset (1-64) for the crossfade.

Step 4: Repeat for the remaining data ports if desired.

## Setting Up CEM3 on the Network

---

Network setup allows editing of the CEM3 network properties to establish the rack’s IP, address. Three options for setting network characteristics are available: Link Local, DHCP, and custom. The default is DHCP.

You can access this menu by navigating to **[Setup]>Network>[Enter]**. After the desired method is set, a confirmation window will open asking you to confirm or abort the changes.

### Link Local

Choose Link Local if you work in a touring system where equipment changes frequently.

Link Local automatically assigns an IP address, in a special rang, with the IP being randomly generated.

### DHCP

Choose DHCP if your system includes a DHCP server (for example, an Eos console).

This setting will attempt to acquire an IP address from a DHCP server. If the request fails, CEM3 will acquire its address through Link-Local (see above) for this boot cycle only. If rebooted, the rack will attempt a DHCP request again.

### Custom

With this method you can directly set the IP address, Subnet, and Gateway manually using the keypad. ETC’s convention for IP address is to use 10.101.xxx.yy (“x” varies by ETC product line, “y” increments for products of the same type).

## Network Setup for Redundant Tracking Racks

The Redundant Tracking option is only available for ESR and FDX systems.

In a redundant tracking system, each processor has a separate network connection to which a separate IP address may be assigned. When working in a redundant tracking system CEM3 will prompt to select which processor (A or B) you wish to alter the IP settings for.

## Working with an FTP Server

CEM3 supports automatic or manual backup of the dimmer rack configuration to a server on an Ethernet network using the FTP (File Transfer Protocol) standard.

Before you can save to an FTP server you must first set one up from the CEM3 face panel.

### **To set up an FTP server from CEM3:**

Step 1: Navigate to **[Setup]>File Operations>Set Up Server**.

Step 2: Press enter to change enable to “yes”.

Step 3: Specify the IP address of the server.

Step 4: Specify the file name in “File”.

Step 5: Set AutoSave. When set to “Yes,” every time a change is applied to the

configuration it will be saved to the server. “No” means you will have to manually save.

To manually save a configuration to an FTP server, navigate to **[Setup]>File Operations>Save to Server**. You can edit the file name prior to saving using the scroll wheel and the keypad to enter letters.

To load a configuration from an FTP server, navigate to **[Setup]>File Operations>Load from Server** and choose the desired file from the list that appears (CEM3 configuration file names end in “.etc”).

To upgrade CEM3 software from an FTP server, navigate to **[Setup]>File Operations>Load from Server** and choose the desired file from the list that appears (CEM3 software file names end in “.bld”).

## Setting Rack DIP Switches and Termination

---



**WARNING:** *To avoid the possibility of electric shock, power must be turned OFF when you perform this procedure. Before removing dimmer or control modules, de-energize main feed to dimmer rack and follow appropriate Lockout/Tagout procedures as described in NFPA Standard 70E. It is important to note that electrical equipment such as dimmer racks can present an arc flash safety hazard if improperly serviced. This is due to available large short circuit currents on the feeders of the equipment. Any work on energized equipment must comply with OSHA Electrical Safe Working Practices.*

---

On the CEM3 backplane, located in the rack behind the CEM3 control module, there is a small bank of 8 DIP switches. The setting of these switches should be set to match the specific size, features, and desired behavior of your dimmer rack.

Generally, you should not need to alter these settings as they should have been set when your system was commissioned by an ETC technician. However in the event that you must replace your CEM3 control module or backplane, you will need to ensure these settings match the previous controller.

Use this section to determine the required settings for your dimmer rack. There is also a label on the underside of the CEM3 that explains the function of each switch.

When setting the DIP switches, you may also need to check the DMX A and DMX B termination settings for the rack. Reference the backplane label to determine the appropriate position of the termination switch.

### DIPswitch settings

The eight DIP switches relate to behavior, features, or the module size of the rack. In the descriptions below, switches set in the up position are “On” and switches set in the down position are “Off”.

#### DIP 1 - “DBM”

This switch disables the backplane memory so that the configuration is not stored on the rack itself. Default is “OFF”. If set to “ON”, a Rack Memory Error will be displayed on the CEM3.

### DIP 2 - “AF”

This switch should be set to “On” if your rack has Advanced Features (AF - see [Advanced Features \(AF\), page 10](#)).

### DIP 3 - “HSR 240V”

This switch should be set to “On” if your rack is an HSR rack intended for use with 240VAC power feeds.

### DIP 4 - “ESR 230V”

This switch should be set to “On” if your rack is an ESR rack intended for use with 230VAC power feeds.



---

**Note:** *For JSR dimmer racks, intended for use with 100VAC power feeds, both DIP 3 and DIP 4 should be set to “On”.*

---

### DIP 5 - “ND”

This switch should be set to “On” if your rack includes a neutral disconnect.

### DIPs 6-8

These DIP switches are used together to determine the number of module slots in your rack. Refer to the table below to find the desired settings for your rack size.

Rack size	DIP Number		
	6	7	8
6 module slots	Off	On	On
12 module slots	Off	On	Off
24 module slots	Off	Off	On
36 module slots	On	Off	Off
48 module slots	Off	Off	Off

## Termination Switches

DMX signal requires a signal termination at the end of a data run. If your rack is the last device on the data run for either DMX A or DMX B, set the termination switch for the appropriate run to “ON”. The switches are labeled “B” or “A” on the backplane label.

If the rack is not the last device on either data run, leave these set to “Off”.

# Rack Maintenance and Cleaning

---

Proper air flow is necessary for your Sensor3 rack to function properly and consistently. Perform the following procedures regularly to keep dust and foreign debris from impeding the proper function of your rack.

## Cleaning Rack Air Filters

Clean the air filter in the Sensor3 rack door a minimum of every six months, more often if your system operates in a dusty environment. This will also provide an opportunity to inspect the dimmer module air vents and clean them if necessary (see [Vacuuming Dimmer Modules, page 43](#)).

### To clean your rack air filter:

Step 1: Open the dimmer rack door. The air filter is mounted on the inside of the door, held in by a metal lip at the bottom of the door frame.



---

### **Note:**

*Sensor3 48-module racks have two filters, one stacked on top of the other with a retention bar in the middle of the rack. Remove the top filter screen before removing the bottom one.*

---

Step 2: Slide the filter upwards approximately 1/2 inch (1.25cm) until the base of the filter clears the top of the metal lip.

Step 3: Pull the bottom of the air filter out and away from the door far enough to clear the retaining lip and slide the filter downwards and out of the door frame.

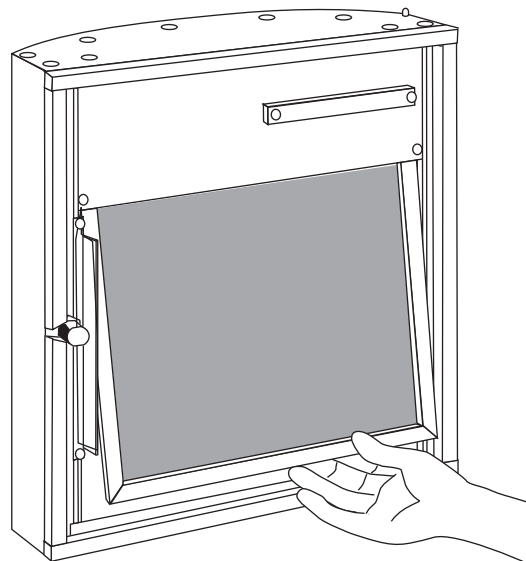

Step 4: In an area away from your dimmer rack and other dust-sensitive equipment, remove all dust or debris from the filter using either compressed air or a vacuum.



---

### **CAUTION:**

*You may rinse the filter under cold tap water, but it must be completely dry before you reinstall it.*

*Do not use soap or other chemical cleaners to clean the filter. They may damage the filter screen.*

---



- Step 5: Slide the top of the filter up into the slot at the top of the door until the base clears the metal retaining lip at the bottom.
- Step 6: Ease the filter back into the door frame and carefully let it drop back into place.



**Note:** For Sensor3 48-module racks, install the bottom filter first. The top filter rests on the top edge of the bottom filter.

## Vacuumping Dimmer Modules

As with cleaning the air filters, you should inspect the dimmer module air vents and SCR power cube inlets every six months and clean if necessary, more often if your system operates in a dusty environment.



**WARNING:** To avoid the possibility of electric shock, power must be turned OFF when you perform this procedure. Before vacuuming dimmer or control modules de-energize main feed to dimmer rack and follow appropriate Lockout/Tagout procedures as described in NFPA Standard 70E. It is important to note that electrical equipment such as dimmer racks can present an arc flash safety hazard if improperly serviced. This is due to available large short circuit currents on the feeders of the equipment. Any work on energized equipment must comply with OSHA Electrical Safe Working Practices.

**Do not remove dimmer modules when vacuuming. Phase voltages inside the rack can be deadly, therefore only qualified technicians should be allowed to remove modules and expose the inside of the dimmer rack.**

### To vacuum the dimmer module air inlets:

- Step 1: Open the rack door and inspect the air vents on the CEM3 and the air vents and SCR power cube air inlets on the dimmer modules for any collection of dust or other debris.
- Step 2: If necessary, use a vacuum cleaner and nozzle to remove any visible dust or other accumulated matter from the front of the modules **without removing them from the rack**. Most dust collects on the dimmer choke vents and SCR power cube air inlets of the modules (shown below).



**CAUTION:** Be careful not to push any foreign matter into the module.

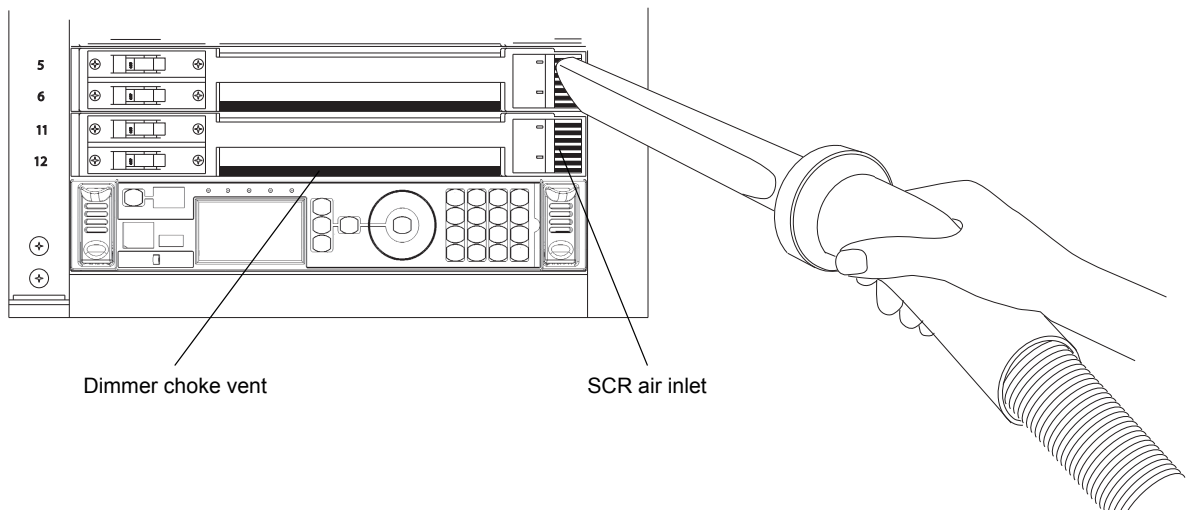

- Step 3: Close the rack door when you are finished vacuuming.

# Replacing AF Cards

AF cards are located on the right side of the dimmer module slot between the copper neutral busses and the dimming circuitry cards.



**WARNING:** *To avoid the possibility of electric shock, power must be turned OFF when you perform this procedure. Before removing modules or AF cards de-energize main feed to dimmer rack and follow appropriate Lockout/Tagout procedures as described in NFPA Standard 70E. It is important to note that electrical equipment such as dimmer racks can present an arc flash safety hazard if improperly serviced. This is due to available large short circuit currents on the feeders of the equipment. Any work on energized equipment must comply with OSHA Electrical Safe Working Practices.*

*Phase voltages inside the rack can be deadly, therefore only qualified technicians should be allowed to remove modules and expose the inside of the dimmer rack.*

## To replace the AF cards:

- Step 1: Note the module types and positions and remove the modules from the rack.
  - Step 2: Remove the old AF cards by flipping the white tab on the cards into the down position.
  - Step 3: Pull the old cards out of the slots.
  - Step 4: Set the DIP switches on the new cards according to the chart below. Only the first two DIP switches are used.
  - Step 5: Flip the white tab up to prevent it from interfering with the dimmer module.
  - Step 6: Slide the new AF cards completely into the vacant slots starting with card #1 in the top.
- The number of cards depends on rack size (see table below).

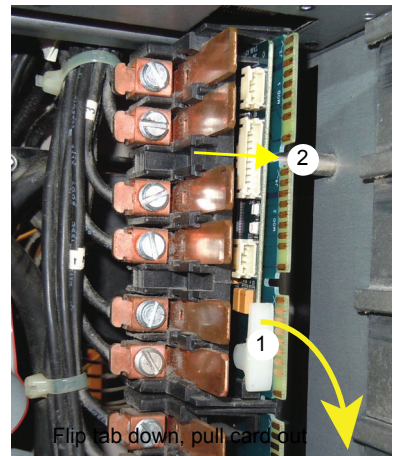

AF Card Addressing

			S	S	S	S
			W	W	W	W
			1	2	3	4
← 1	SR3-6	Card 1	ON	OFF	OFF	OFF
	(E)SR3-12	Card 2	OFF	ON	OFF	OFF
← 2	(E)SR3-24	Card 3	OFF	OFF	ON	OFF
		Card 4	OFF	OFF	OFF	ON
← 3	ESR3-36					
← 4	(E)SR3-48					

# Restore Rack Defaults

---

Restoring rack defaults is a fast way to completely reset all rack settings back to their original state. **This feature is only intended for users with touring or portable racks where a complete reset is a common requirement.**

Restoring defaults on an installed rack is not recommended unless you are expressly told to do so by ETC Technical Services.



---

**CAUTION:** *Restoring rack defaults will erase all rack data. Do not perform this procedure unless you absolutely intend to restore the rack back to its original factory settings.*

---

## To restore the factory defaults to your CEM3:

- Step 1: Save a backup of the rack configuration (see [Saving Configurations, page 33](#)).
- Step 2: Press and hold **[Setup]**.
- Step 3: Tap **[Reset]**, found in the upper left corner of the CEM3 interface.
- Step 4: Continue holding **[Setup]** until the “Deep Clear” screen appears.
- Step 5: Select “Yes” to clear all rack settings and restore the factory defaults. Select “No” to abort.



# Appendix A

## Error Messages

The table below lists all of the possible error/status messages that may be listed on the CEM3 display followed by the probably cause and any possible corrective action to remedy the error.

If you have any problems resolving errors, or do not feel comfortable performing them, contact ETC Technical Services (see [Help from ETC Technical Services, page 3](#)).



**WARNING:** *To avoid the possibility of electric shock, power must be turned OFF before removing dimmer or control modules. Prior to any action that involves removing any module, de-energize main feed to dimmer rack and follow appropriate Lockout/Tagout procedures as described in NFPA Standard 70E. It is important to note that electrical equipment such as dimmer racks can present an arc flash safety hazard if improperly serviced. This is due to available large short circuit currents on the feeders of the equipment. Any work on energized equipment must comply with OSHA Electrical Safe Working Practices.*

*Phase voltages inside the rack can be deadly, therefore only qualified technicians should be allowed to remove modules and expose the inside of the dimmer rack.*

Message	Cause	Possible Corrective Action
Ambient Temp High	The temperature detected at the CEM3 has exceeded the limit set under the "Temp High Warn" option in [Setup]->Rack	Decrease ambient temperature, or adjust temperature warning level. Ensure that fan is functioning properly.
CPU Temp Low	The temperature detected at the CEM3 is below 0C (32F)	Increase room temperature
DMX Error Port A	The DMX signal on port A is corrupt or invalid	Check DMX wiring and termination
DMX Error Port B	The DMX signal on port B is corrupt or invalid	Check DMX wiring and termination
No DMX Port A	No DMX signal is detected on port A	Check DMX wiring, termination or transceiver chip
No DMX Port B	No DMX signal is detected on port B	Check DMX wiring, termination or transceiver chip
Frequency Error	The power frequency is out the supported range of 47-63Hz	Check the incoming power supply to the rack. Contact a qualified electrician.
Phase A, B, or C Error	The power on the indicated phase could not be interpreted due to noise or interference	Check the incoming power supply to the rack. Contact a qualified electrician.
Phase A, B, or C Off	No power is detected on the indicated phase.	Check the incoming power supply to the rack. Contact a qualified electrician.
Temp Sensor Stuck	The temperature sensor is giving an invalid reading	Replace or service CEM3
Zero Cross Error	The dimming engine is unable to detect the power zero cross correctly	Check the incoming power supply/Service or replace CEM3. Power cycle the rack.
Phase A, B, or C Volts High	The power on the indicated phase is above the volts high warning level (in [Setup]->Rack)	Check the incoming power supply to the rack. Contact a qualified electrician.
Phase A, B, or C Volts Low	The voltage on the indicated phase is below the minimum required value for the CEM3	Check the incoming power supply to the rack. Contact a qualified electrician.
Phase A, B, or C Overvolts	The voltage on the indicated phase is above the maximum value for the CEM3	Check the incoming power supply to the rack. Contact a qualified electrician.
Rack Memory Error	The CEM3 is unable to communicate with the memory chip on the backplane	Check the CEM3 is seated correctly; Replace backplane

<b>Message</b>	<b>Cause</b>	<b>Possible Corrective Action</b>
Rack Detect Error	The CEM3 is unable to detect the rack type from the DIP switches on the backplane	Check the CEM3 is seated correctly; Replace the backplane
Fan Fail	The CEM3 detects that the rack fan is drawing current outside the expected value	Check the rack fan and fan fuse.
Config Rejected	A config was loaded that contained invalid data or values	Re-generate configuration; contact ETC Technical Services
AF Card Error 1, 2, 3, or 4	The CEM3 is unable to communicate with the indicated AF card.	Check the AF cards and CEM3 are seated correctly; Check rack hardware for damage. Check DIP switch settings.
AF Card 1, 2, 3, or 4 Loading	The indicated AF card is loading software	Wait until software load has completed
AF Dim Removed <Dimmer Nr>	AF detects that a dimmer has been removed	Re-insert dimmer; check dimmer module
AF Bkr Trip <Dimmer Nr>	AF detects that a dimmer circuit breaker has tripped	Re-set circuit breaker; check dimmer module
AF RCD Trip <Dimmer Nr>	AF detects that a dimmer circuit with RCD has tripped due to earth leakage	Re-set circuit breaker; check dimmer module and load
AF Load High <Dimmer Nr>	AF detects that the current load on a circuit is higher than the recorded load	Check load/lamps
AF Load Low <Dimmer Nr>	AF detects that the current load on a circuit is lower than the recorded load	Check load/lamps
AF No Load <Dimmer Nr>	AF detects that there is no load on a circuit	Check load/lamps
Dim Overtemp <Dimmer Nr>	An overtemperature condition has been detected on a dimmer module	Clear the error from the home screen and see if it returns. Check rack cooling fan is running and that room is in recommended temperature range. If normal temp, replace module.
Ambient Overtemp (FDX 3000 only)	The temperature detected at the CEM3 has exceeded the limit set under the "Temp High Warn" option in [Setup]->Rack	Decrease ambient temperature, or adjust temperature warning level. Ensure that fan is functioning properly.

# Appendix B

## Using the CEM3 Web Interface

---

CEM3 features a basic web interface accessible over the system network using any internet browser (such as Internet Explorer®, Firefox™, Safari®, or Chrome®) which allows you to view the system status, perform some basic functions, update software, and upload or download the rack configuration.

### To access the CEM3 over the network:

- Step 1: Connect an internet browsing device (such as a computer or mobile device) to the system network. You can connect using the network connector on the face of the CEM3.
- Step 2: Set the connected device to the proper IP address range if using a system of fixed IP addresses. If your system uses dynamically assigned addresses (DHCP), your address will be assigned from the system server.
- Step 3: Open an internet browser on the connected device.
- Step 4: In the browser address bar, enter the IP address of the CEM3 you wish to view. The address can be found by navigating to **[Setup]>Network** and noting the digits in the “IP:” field. The CEM3 “System” page will appear in the browser.

System	<b>ETC CEM3</b>	
Dimmers	<b>Software Versions</b>	
Set Levels	Software Version	1.4.0.1.0.17
Setup	DSP Version	1.4.0.0.0.20
Files	AF Card 1	
	AF Card 2	
	AF Card 3	
	AF Card 4	
	<b>Power Information</b>	
	Phase A	117 V
	Phase B	117 V
	Phase C	117 V
	Frequency	60 Hz
	<b>Errors</b>	

*Web Interface System Page*

The home page menu provides access to the five available pages of the interface: *System*, *Dimmers*, *Set Levels*, *Setup*, and *Files*.

### System

This page displays the software and power information for the rack, as well as any currently active error messages.

### Dimmers

This page allows you to view the current status of all circuits in the rack.

## Set Levels

This page allows you to set and release levels for any circuit in the rack.

You can use the displayed keypad or a connected keyboard to input commands into the green command window.

Once the command line reaches complete syntax it will be automatically entered as signified by a "\*" at the end of the command line.

- Select the desired space using the "Select Space" field at top (if applicable).
- Use "and" and "thru" to select multiple circuits or ranges of circuits.
- Use "A/B" to specify any dimmer doubled circuits (if applicable).
- Use "rel" to release channels.
- Use "Release All" to release all current levels.
- Use "Previous" and "Next" to cycle through successive channels.
- "Clear" clears the command line.

System
Dimmers
<b>Set Levels</b>
Setup
Files

Set Levels

Select Space :

```
1 thru 24 and 72 thru
78 at FL*
```

1	2	3	at
4	5	6	and
7	8	9	thru
A/B	0	rel	full
Previous		Next	
Release All		Clear	

[Keyboard Shortcuts](#)

[Set Levels Page](#)

## Setup

This page allows you to alter the "Control Mode" or "Curve" for any circuit in the rack. Click "Apply Changes" when you have completed all the desired changes.

## Files

This page allows you to upload CEM3 firmware or configurations as well as download the current rack configuration.

### To upload a file:

- Step 1: First select the file type (Configuration or Firmware) by clicking the appropriate box at top.
- Step 2: Use the "Browse" button to navigate to the desired file on your connected device.
- Step 3: Once the file is selected, click "Begin Upload".



# Appendix C

## Redundant Tracking Systems

CEM3 features the ability to support dual redundant controllers in ETC's ESR24, ESR36 and ESR48 rack types, as well as in the FDX3000 rack.

Redundant controllers provide extra security in the event of system failure, allowing a secondary processor to immediately take control of the rack.

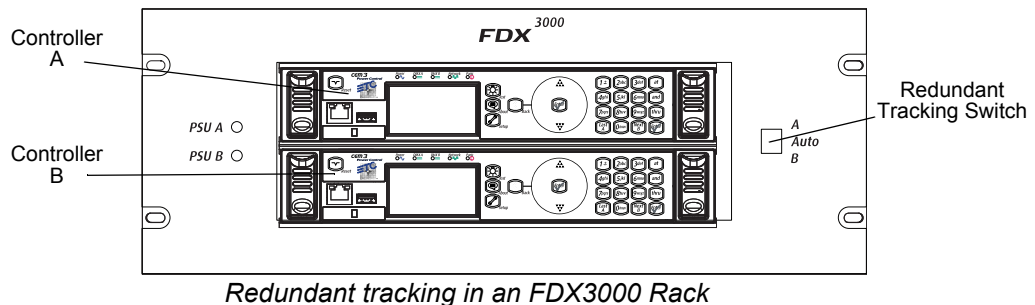
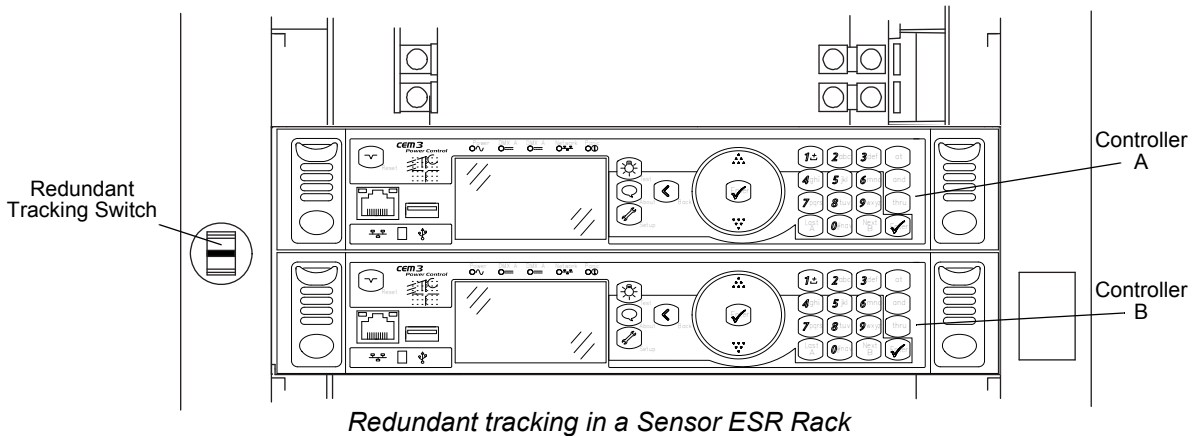

### Redundant Tracking Switch

The redundant tracking switch determines which controller runs the output to the dimmers. It has three positions.

- When the switch is set to A (upper position), the upper controller has control of the dimmers.
- When the switch is set to B (lower position), the lower controller has control of the dimmers.
- When the switch is set to Auto (center position), control is automatically allocated based on the health of the system (see below for details).

## Automatic Control

Typically, in a redundant tracking system, the switch should be left in the auto position. When the switch is set to auto, the A processor will have control by default. Control will switch to B when any of the following events occur.

### Loss of network

If network connectivity is lost to one processor but not the other, control will switch to the one which still has network connectivity.

### Loss of DMX

If DMX is lost by one processor but not the other, control will switch to the one still able to receive DMX (note that the DMX data line is interconnected between both, so this would only occur in the event of the failure of a DMX transceiver on the processor itself).

### Power errors

If one processor experiences power errors but the other does not, control will switch to the one that does not. Again, note that the same power is connected to both processors so this would only occur in the event of an internal failure in the processor.

### Total processor loss

If communication is completely lost to one processor but not the other, then control will switch to the processor which is still available.

## Display Status

When tracking is active and the A processor is in control, the displays will show as follows:

*Processor A*

```
Rack 1 - CEM3 Rack
System OK

DMXA: 1           DMXB: Off
sACN: 2 / 1

[Info]
```

*Processor B*

```
CEM3 Control

Backup Ready
```

When control switches to the B processor (either by automatic failover or manual control using the switch), the displays change to the following:

*Processor A*

```
CEM3 Control  
  
Backup Active
```

*Processor B*

```
Rack 1 - CEM3 Rack  
System OK  
  
DMXA: 1           DMXB: Off  
sACN: 2/1  
  
[Info]
```

The switchover from A to B for dimming happens instantaneously, so that control of lights is not lost. However, the switchover of the user interface has built in hysteresis to eliminate bounce in certain circumstances (for example, when DMX is lost, both processors may not see and account for the DMX loss at exactly the same time). For this reason it may sometimes appear to take a long time for the user interface of the backup unit to start up; however, bear in mind that dimming control always transfers near-instantaneously, however some hysteresis is required for the startup of the user interface.

## Configuration Management in Redundant Tracking Systems

In a tracking CEM3 system the two processors automatically communicate and synchronize their configurations through the backplane - no external Ethernet network is needed for the two processors to synchronize data.

Once you make a configuration change on one processor, that change is automatically transferred to the second processor.

When the system boots up, it is assumed that the A processor has the most recent configuration, so the configuration will be automatically transferred from A to B if B has a different configuration.

## Firmware Upgrades in Redundant Tracking Systems

When you upgrade firmware in a redundant system (either via the network or using a USB key), the firmware upgrade is automatically transferred to both processors. Once the firmware is transferred the upgrade will occur on both processors simultaneously. Therefore it is not necessary to update both processors independently in a rack.



# Appendix D

## FDX 3000 Dimmer Racks

CEM3 may be used as a control module in ETC's FDX3000 dimming system, providing networking facilities, dual redundant control modules, and precision 16-bit dimming. This appendix details information needed to work with CEM3 in an FDX3000 system, as well as outlining the hardware of your FDX3000 rack.

### Hardware

#### Front Panel

The FDX3000 carrier contains two CEM3 modules in a dual redundant configuration.

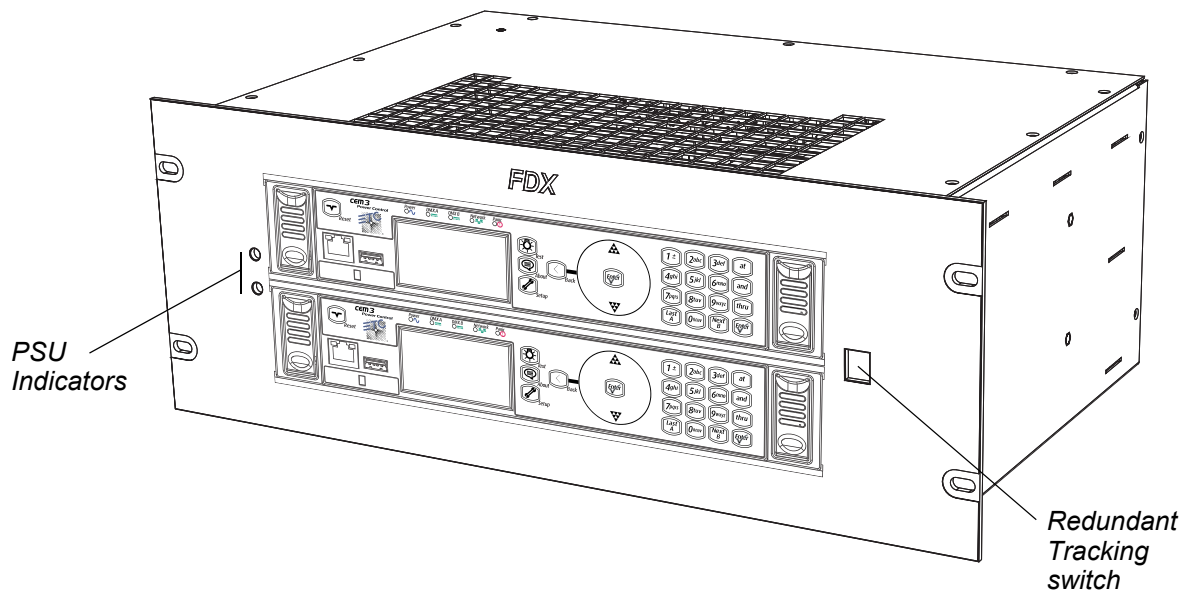

#### **PSU Indicators**

The PSU indicators show the status of the two internal power supplies which supply the 15VDC required by FDX dimmer modules.

The two indicators should be lit at all times. If either is not lit, this could indicate a failure of the internal power supply. If you see this condition, contact ETC Technical Services (see [page 3](#)).

#### **Redundant Tracking Switch**

The redundant tracking switch allows you to test the ability to switch from the upper (A) processor to the lower (B) processor. If it is set to the (A) or (B) position, the A or B processor will preferentially have control. In normal operation, the switch should be set to the center "Auto" position. This will ensure that A has control unless communication is lost to A, or certain hardware failures occur on A but not B (for example if A does not see DMX but B does).

## Rear Panel

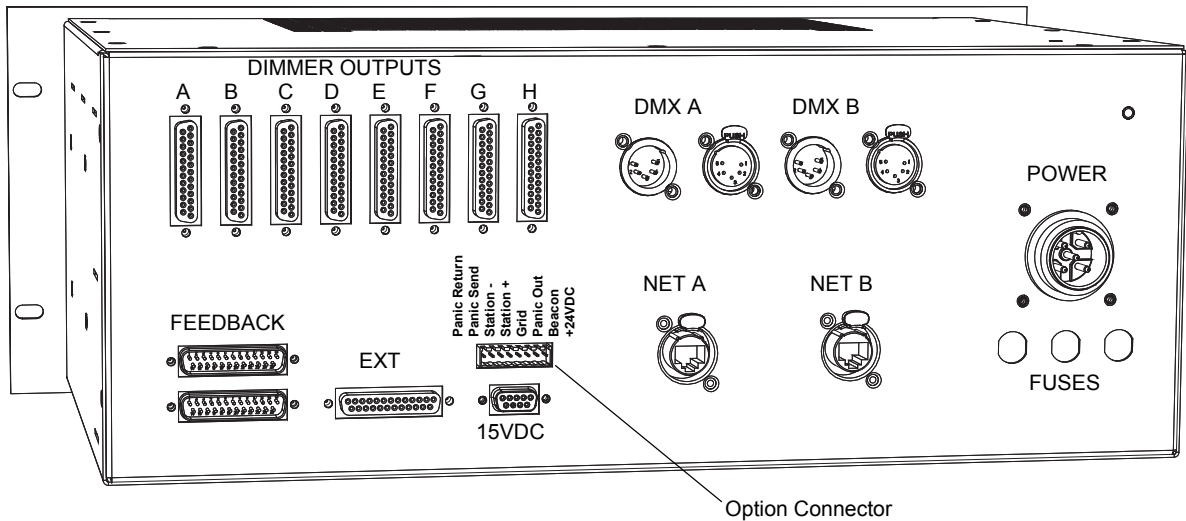

### **Dimmer Outputs**

The dimmer outputs connect from the FDX3000 processor to the dimmer module trays. They should generally be pre-configured from the factory. They are grouped in blocks of 12 dimmers, from A(1-12) through H(85-96).

### **Feedback**

The feedback connections allow the FDX3000 to determine the status of voltage and current for modules that support sensing. Again the two feedback connections should be made from the factory.

### **15VDC**

The 15VDC connection provides 15V power to the FDX dimmer modules.

### **Option Connector**

The option connector allows field connection of the rack options such as panic (see [page 35](#)), stations (see [page 15](#)), and a remote beacon. For information on these connections, see the termination markings on the rear of the FDX3000 carrier.

### **DMX Connections**

The FDX3000 processor features DMX In and Thru connections on two industry-standard 5 pin XLR connectors. The two DMX ports, A and B, are fed to both of the redundant processors.

### **Ethernet Connections**

Two Ethernet connections are provided using Neutrik Ethercon connectors, which may be either connected to a neutrik ethercon jack or a standard RJ45 connector. "Net A" connects to the A (upper) CEM3, and "Net B" connects to the lower. The CEM3s feature an internal switch allowing use of the rear and front panel Ethernet connections at the same time.

### **Power Input**

The power input connector is a three phase supply, fed from the supply in the rack. The FDX3000 processor will function regardless of any phase loss; as long as at least one phase is still active the processor will still dim any dimmers which still have power.

### **Fuses**

The power input has three panel-mount fuse holders to protect against internal failure. The fuses should only be replaced with the same type, 2.5A 20mm.

## Regulatory Information

The FDX3000 rack is certified to the following CE standards:

Safety: EN61439-1 (Low voltage Switchgear and Controlgear assemblies)

Electromagnetic Immunity: EN61547 (EMC Immunity for Lighting Systems)

## Initial Setup

### Module Count

The FDX3000 controller supports between 1 and 96 dimmers. The number of dimmers is configured using DIP switches on the backplane of the controller.

#### To configure or alter the number of modules configured in your FDX system:

- Step 1: Turn off power to the rack.
- Step 2: Remove the two CEM3 modules from the FDX3000 carrier.
- Step 3: Set the DIP switches in binary to the number of modules in your rack. The DIP switches are counted from left to right as follows:

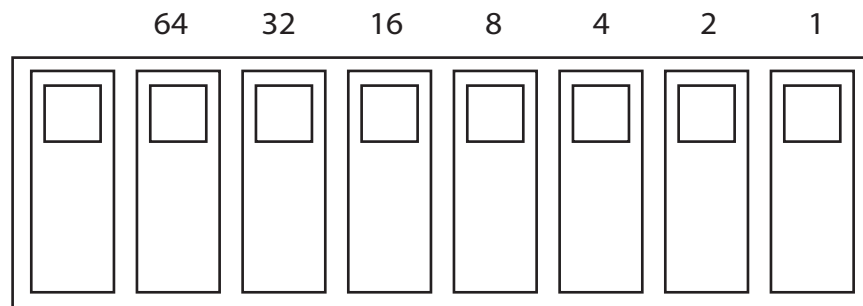

- Up indicates the DIP switch is on. So, for example to set the rack up for 96 modules, set DIP switches 32 and 64.

- Step 4: Reinstall the CEM3 modules.
- Step 5: Power up the rack.

## Module Types

The following module types are supported in FDX:

- **Blank** - Used where a blank plate is fitted; gives no control and no feedback
- **NoV-NoI** - A dimmer module with no current or voltage feedback.
- **V-NoI** - A dimmer module with voltage feedback but no current feedback.
- **NoV-I** - A dimmer module with current feedback but no voltage feedback.
- **V-I** - A dimmer module with voltage and current feedback.

## Advanced Features in FDX

FDX3000 supports all module types available in the FDX series of racks, including the DP90 and DP90S series of modules.

Advanced Features in an FDX rack allows modules which provide Voltage or Current feedback data to be monitored and to report errors both at the local UI and at ETC's console products and feedback software.

### Feedback Modes and Module Types

FDX modules may be set to one of the following module types:

Module Type	Purpose	Error Messages
NoV-NoI	Module provides no monitoring	No AF Error messages will be produced
NoV-I	Module monitors current, not voltage	"No Load" messages will be produced if the channel is turned
V-NoI	Module monitors voltage, not current	"Breaker Trip" messages will be produced if the channel is turned on with the breaker turned off.
V-I	Module monitors both voltage and current	Both "Breaker Trip" and "No Load" messages may be produced and the roasting short protecting feature will be enabled.

To configure the module type see [Dimmer Property Definitions, page 19](#).

### Roasting Short Protection

FDX3000 features a unique method for providing additional safety in the event of a roasting short situation. A roasting short can occur when a dimmer is at a low level and driven into a short circuit load with a long cable.

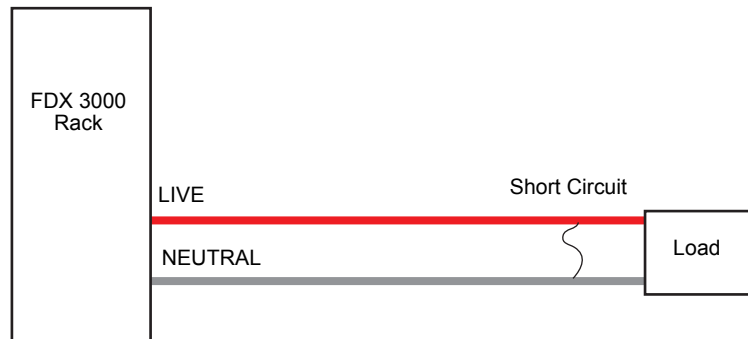

Because the dimmer is at a low level, the roasting short does not draw enough current to trip the circuit breaker, however it is still a dangerous condition as currents can flow at a high enough amperage to cause heat or, in extreme circumstances, fire.

The FDX3000 rack has the capability to detect this condition. When it is detected with a module set to V/I mode the dimmer is automatically driven to full, allowing the high current of the short circuit to trip the circuit breaker.

This facility is automatically enabled on any modules set to V/I mode.



## FDX2000 vs. FDX3000 Dimmer Curve Comparison

Curves in FDX3000 reference *voltage* rather than *power*. Therefore the following table will help to show the correlation between FDX2000 curve names and FDX3000 curve names.

FDX2000 Curve English / German	FDX3000 Curve English	Comment
1 = Linear (default)	Square	proportional to RMS power output (FDX2000 Linear)
2 = Stage1	Stage 1	Built to match an old Siemens curve
3 = Stage2	Stage 2	Built to match an old Siemens curve
4 = Log	Linear	proportional to RMS voltage output
5 = Fluor1	Fluor 1	
6 = Fluor2	Fluor 2	
7 = Pow/2	n.a.	obsolete
8 = 10%	n.a.	obsolete
9 = VIP90	VIP	
10 = ANDI	ANDI	
n.a	Mod-Square (Default)	
n.a	Mod-Linear	
n.a	Sensor 2.0	older mod square law



# Index

---

## A

About menu	17
About CEM3	17
dimmers	17
download manual	17
errors	17
rack	17
source info	17
Actual Load	
in dimmer properties	21
Advanced Features	
<i>definition</i>	10
see <i>AF</i>	
AF	
actual load	
in dimmer properties	21
AF reaction	
in dimmer properties	22
<i>definition</i>	10
recorded load	
in dimmer properties	21
reporting mode	
in dimmer properties	22
rig check	13
sensitivity	
in dimmer properties	22
AF Enabled	
in dimmer properties	21
in rack properties	22
AF Reaction	
in dimmer properties	22
air filter	
cleaning	42
Allow in Panic	
in dimmer properties	21
Allow in Preset	32
in dimmer properties	21
Andi curve	29
Arch Zone	
<i>definition</i>	21
in dimmer properties	21
assign	
circuit number	18
module type	18
space to circuit	18

automatic patch	37
-----------------	----

## B

backlight mode	19
backlight time	19
backplane	
DIP switches	40
termination switches	41
balanced (rack numbering)	10
bold text	
use of in procedures	2
brackets	
use of in procedures	2

## C

Cct	
see <i>Circuit</i>	
Celsius	19
Circuit	
assign to space	18
<i>definition</i>	11
in dimmer properties	19
Circuit Assignment	18
circuit number	
assign	18
cleaning	
dimmer modules	43
rack	42
rack air filters	42
configure rack	
<i>definition</i>	11
contact ETC technical services	3
contrast	19
control mode	20
Crossfade (data loss behavior)	38
Curve	
in dimmer properties	20
Curves	23–29
Andi	29
<i>definition</i>	23
Fluor 1	28
Fluor 2	28
Linear	23
Modified Square Law	26

Mod-Linear	25
Sensor 2.0	26
Square law	25
Stage 1	27
Stage 2	27
VIP 90	29
custom network settings	39

## D

Data Loss Behavior	
in rack properties	23
setting	38
Date	18
DC Out Prevent	
in dimmer properties	21
defaults	
restoring	45
DHCP	39
dimmer	
curves	23
Andi	29
Fluor 1	28
Fluor 2	28
Linear	23
Modified Square Law	26
Mod-Linear	25
Sensor 2.0	26
Square law	25
Stage 1	27
Stage 2	27
VIP 90	29
properties	
actual load	21
AF Enabled	21
AF reaction	22
allow in panic	21
allow in preset	21
arch zone	21
control mode	20
curve	20
DC out prevent	21
DMX A	20
DMX A 16-bit	21
DMX B	21
DMX B 16-bit	21
firing mode	20
inrush protect	21
max scale	21
min scale	21
module type	19
off time	20

off-level	20
on time	20
on-level	20
preheat	21
preheat time	21
recorded load (AF)	21
regulation	21
reporting mode	22
sACN	21
sACN 16-Bit	21
scale load	21
sensitivity	22
threshold	20
property definitions	19
dimmer check	17
dimmer doubling	
<i>definition</i>	11
dimmer modes	
Latch Lock	12
dimmer modules	
cleaning	43
dimmer output	
<i>diagram</i>	30
DIP switches	
setting	40
display	
backlight	19
contrast	19
language	19
sACN options	19
DMX	
setting priority	22
termination	41
DMX A	
in dimmer properties	20
in rack properties	22
DMX A 16-bit	
in dimmer properties	21
DMX B	
in dimmer properties	21
in rack properties	22
DMX B 16-bit	
in dimmer properties	21

## E

ETC Offices	3
ETC web site	3

## F

fade time	
in presets	32
Fahrenheit	19
Fan	
in rack properties	22
FDX dimmer racks	
Advanced Features in	58
dimmer curve comparison	59
module types	57
regulatory information	57
setup	57
using CEM3 with	55
filter	
cleaning	42
firing mode	20
Fluor 1 curve	28
Fluor 2 curve	28
FTP server	
network setup with	39

## H

Hold Last Look	38
----------------	----

## I

independent patch	37
Inrush Protect	
in dimmer properties	21
italics	
use of in procedures	2

## L

language	19
Latch Lock	
<i>definition</i>	12
off time	20
off-level	20
on time	20
on-level	20
LCD settings, see UI preferences	19
LCD window	
backlight	19
contrast	19
language	19
Level	
in dimmer properties	19

Linear curve	23
Link Local	39
Lug	
<i>definition</i>	12
in dimmer properties	19
Lvl	
see <i>Level</i>	19

## M

maintenance	
cleaning	42
rack	42
Manual	
downloading from CEM3	17
manual patch	38
Max Scale	
<i>diagram</i>	30
in dimmer properties	21
menu	
About	17
preset	32
structure	17
test	17
Min Scale	
<i>diagram</i>	30
in dimmer properties	21
Mod-Linear curve	25
Mod-Square curve	26
module type	19
assigning	18
modules	
cleaning	43

## N

network	
custom settings	39
DHCP	39
Link Local	39
set up with FTP server	39
setup	39
setup for redundant tracking	39

## O

Off Time	20
Off-Level	20
On Time	20

On-Level . . . . .	20
<b>P</b>	
Panic	
<i>definition</i> . . . . .	12
settings . . . . .	35
setup . . . . .	35
patch	
automatic . . . . .	37
<i>definition</i> . . . . .	13
independent . . . . .	37
manual . . . . .	38
setup . . . . .	37
simple . . . . .	37
split . . . . .	37
playback	
preset . . . . .	32
Preheat	
<i>diagram</i> . . . . .	30
in dimmer properties . . . . .	21
time	
in dimmer properties . . . . .	21
preset	
allow in . . . . .	32
<i>description</i> . . . . .	13
fade time . . . . .	32
menu . . . . .	32
play back . . . . .	32
priority . . . . .	22
record . . . . .	32
remote record function . . . . .	23
rig check . . . . .	13
spaces usable in . . . . .	32
station topology . . . . .	14
Preset stations	
general function . . . . .	15
Presets on Boot	
in rack properties . . . . .	23
Priority	
for presets . . . . .	22
in rack properties . . . . .	22
Priority (DMX A or B)	
in rack properties . . . . .	22
properties	
dimmer . . . . .	19
rack . . . . .	22

<b>Q</b>	
Quick Setup . . . . .	18
setup on home page . . . . .	23
<b>R</b>	
rack	
balanced numbering . . . . .	10
properties	
AF enabled . . . . .	22
data loss behavior . . . . .	23
DMX A . . . . .	22
DMX B . . . . .	22
fan . . . . .	22
preset priority . . . . .	22
priority . . . . .	22
remote record . . . . .	23
SACN . . . . .	22
setup at home . . . . .	23
station power . . . . .	23
system number . . . . .	22
temp high warn . . . . .	23
voltage high warn . . . . .	23
property definitions . . . . .	22
straight numbering . . . . .	16
rack configuration	
<i>definition</i> . . . . .	11
Rack Number	
in rack properties . . . . .	22
rack type	
set with DIP switches . . . . .	40
record	
preset . . . . .	32
Recorded Load (AF)	
in dimmer properties . . . . .	21
redundant tracking	
automatic control . . . . .	51, 52
<i>definition</i> . . . . .	15
firmware upgrades . . . . .	53
full feature description . . . . .	51
managing configurations . . . . .	53
network setup . . . . .	39
switch . . . . .	51
Regulation	
in dimmer properties . . . . .	21
release set levels . . . . .	17
Remote Record	
in rack properties . . . . .	23
Reporting Mode (AF)	
in dimmer properties . . . . .	22

restore defaults . . . . .	45
Rig check . . . . .	13, 17
<b>S</b>	
sACN	
display method . . . . .	19
in dimmer properties. . . . .	21
in rack properties . . . . .	22
sACN 16-Bit	
in dimmer properties. . . . .	21
Scale Load	
in dimmer properties. . . . .	21
Sensitivity (AF)	
in dimmer properties. . . . .	22
Sensor 2.0 curve. . . . .	26
set data loss behavior. . . . .	38
set levels . . . . .	17
settings	
panic. . . . .	35
setup . . . . .	18
network. . . . .	39
network for redundant tracking. . . . .	39
Panic . . . . .	35
patch. . . . .	37
Setup at Home	
in rack properties . . . . .	23
Setup menu . . . . .	18
Circuit Assignment . . . . .	18
Dimmers . . . . .	18
File Operations. . . . .	18
Network . . . . .	18
Panic . . . . .	18
Patching . . . . .	18
Quick Setup . . . . .	18
Rack . . . . .	18
Time/Date. . . . .	18
UI Preferences . . . . .	19
simple patch . . . . .	37
space	
assign to circuit. . . . .	18
usable for recording presets. . . . .	32
Spaces	
<i>definition</i> . . . . .	15
split patch . . . . .	37
Square curve . . . . .	25
Stage 1 curve . . . . .	27
Stage 2 curve . . . . .	27

Station Power	
in rack properties . . . . .	23
stations	
see <i>Preset stations</i> . . . . .	15
straight (rack numbering) . . . . .	16
support	
technical . . . . .	3
switches	
DIP settings . . . . .	40
termination . . . . .	41
System Number	
in rack properties . . . . .	22

<b>T</b>	
technical services . . . . .	3
Temp High Warn	
in rack properties . . . . .	23
temperature	
units . . . . .	19
termination	
DMX . . . . .	41
Test menu . . . . .	17
clear rig check. . . . .	17
Dimmer check . . . . .	17
presets . . . . .	17
record rig check . . . . .	17
release set levels . . . . .	17
run rig check . . . . .	17
set levels . . . . .	17
text conventions . . . . .	2
threshold . . . . .	20
<i>diagram</i> . . . . .	30
Time . . . . .	18
Time (sec)	
in dimmer properties. . . . .	21

<b>U</b>	
UI Preferences . . . . .	19
units	
temperature . . . . .	19
USB	
download manual from . . . . .	17
User Manual	
downloading from CEM3. . . . .	17



## V

VIP 90 curve . . . . .	29
Voltage High Warn in rack properties . . . . .	23

## W

Wait & Fade . . . . .	38
web site (ETC) . . . . .	3

## X-Z

Zones	
assigning to circuit . . . . .	21
<i>definition</i> . . . . .	15











**Corporate Headquarters** ■ 3031 Pleasant View Road, P.O. Box 620979, Middleton, Wisconsin 53562-0979 USA ■ Tel +608 831 4116 ■ Fax +608 836 1736  
**London, UK** ■ Unit 26-28, Victoria Industrial Estate, Victoria Road, London W3 6UU, UK ■ Tel +44 (0)20 8896 1000 ■ Fax +44 (0)20 8896 2000  
**Rome, IT** ■ Via Pieve Torina, 48, 00156 Rome, Italy ■ Tel +39 (06) 32 111 683 ■ Fax +44 (0) 20 8752 8486  
**Holzkirchen, DE** ■ Ohmstrasse 3, 83607 Holzkirchen, Germany ■ Tel +49 (80 24) 47 00-0 ■ Fax +49 (80 24) 47 00-3 00  
**Hong Kong** ■ Rm 1801, 18/F, Tower 1 Phase 1, Enterprise Square, 9 Sheung Yuet Road, Kowloon Bay, Kowloon, Hong Kong ■ Tel +852 2799 1220 ■ Fax +852 2799 9325  
**Service:** (Americas) [service@etcconnect.com](mailto:service@etcconnect.com) ■ (UK) [service@etc europe.com](mailto:service@etc europe.com) ■ (DE) [techserv-hoki@etcconnect.com](mailto:techserv-hoki@etcconnect.com) ■ (Asia) [service@etcasia.com](mailto:service@etcasia.com)  
**Web:** [www.etcconnect.com](http://www.etcconnect.com) ■ Copyright © 2014 ETC. All Rights Reserved. ■ Product information and specifications subject to change.  
7140M1200-1.5.1 ■ Rev A ■ Released 2014-06