

# *Owner's Manual*

*Diesel Generator*

**MDG25IF4**

SN \_\_\_\_\_ and higher

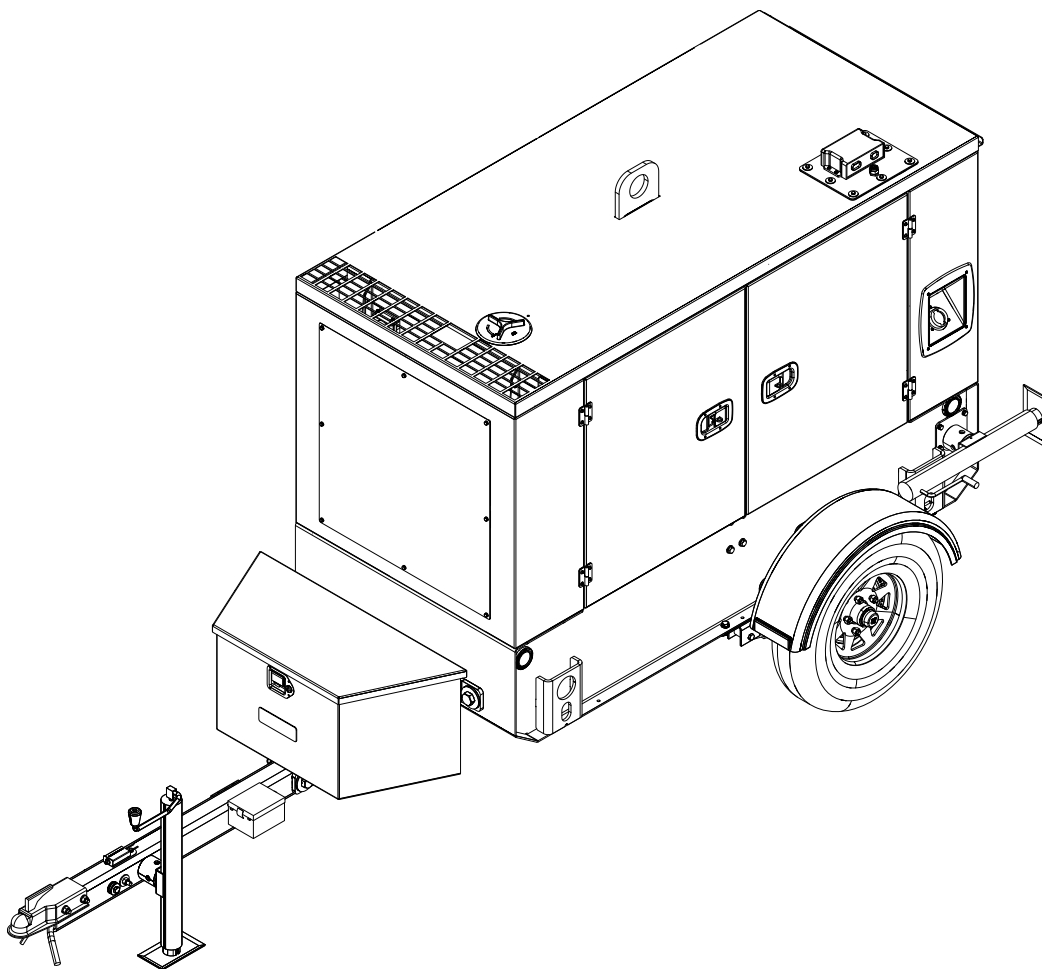

For technical assistance contact:

[www.generacmobileproducts.com](http://www.generacmobileproducts.com)

Technical Support

1-800-926-9768

***SAVE THIS MANUAL FOR FUTURE REFERENCE***

**Use this page to record important information about your unit.**

Unit Model No.	
Unit Serial No.	
Engine Model No.	
Engine Serial No.	
Generator Model No.	
Generator Serial No.	

Record the information found on your unit data label on this page. See unit serial number location (***Unit Serial Number Locations***). The label plate is affixed to the inside partition, to the left of the control panel console.

Engine and generator serial numbers are located on separate data plates affixed to the engine and generator.

When contacting a Generac Mobile Authorized Service Dealer (GMASD) about parts and service, supply the complete model number and serial number of the unit.

**Operation and Maintenance:** Proper maintenance and care of the unit ensures a minimum number of problems and keeps operating expenses at a minimum. It is the operator's responsibility to perform all safety checks, to verify that all maintenance for safe operation is performed promptly, and to have the equipment checked periodically by a GMASD. Normal maintenance, service and replacement of parts are the responsibility of the owner or operator and, as such, are not considered defects in materials or workmanship within the terms of the warranty. Individual operating habits and usage may contribute to the need for additional maintenance or service.

 **WARNING**

**CANCER AND REPRODUCTIVE HARM**

[www.P65Warnings.ca.gov](http://www.P65Warnings.ca.gov)

(000393a)

 **WARNING**

Breathing diesel engine exhaust exposes you to chemicals known to the State of California to cause cancer and birth defects or other reproductive harm.

- Always start and operate the engine in a well-ventilated area.
- If in an enclosed area, vent the exhaust to the outside.
- Do not modify or tamper with the exhaust system.
- Do not idle the engine except as necessary.

For more information go to

[www.P65Warnings.ca.gov/diesel](http://www.P65Warnings.ca.gov/diesel)

(000394)

# Table of Contents

## **Section 1: Introduction and Safety**

<b>Introduction</b> .....	1
Read This Manual Thoroughly .....	1
How to Obtain Service .....	1
<b>Safety Rules</b> .....	1
<b>Safety Symbols and Meanings</b> .....	1
<b>General Hazards</b> .....	2
<b>Trailer Hazards</b> .....	2
<b>Electrical Hazards</b> .....	3
<b>Battery Hazards</b> .....	4
<b>Fuel Hazards</b> .....	4
<b>Engine Safety</b> .....	4
<b>Operating Safety</b> .....	5
Positioning the Unit .....	5
<b>Towing Safety</b> .....	5
Hitch and Coupling .....	5
Safe Towing Techniques .....	5
<b>Reporting Trailer Safety Defects</b> .....	5
<b>Safety and Operating Decals</b> .....	6

## **Section 2: General Information**

<b>Specifications</b> .....	11
<b>Unit Dimensions</b> .....	12
<b>Unit and Serial Number Locations</b> .....	13
<b>Altitude and Temperature Limitations</b> .....	13
<b>Component Locations</b> .....	14
Exterior .....	14
Interior .....	15
<b>Connection Panel</b> .....	16
<b>Receptacle Panel</b> .....	17
<b>Control Panel</b> .....	18
<b>Genset Controller</b> .....	19
Controller Modes .....	21
Operator Pages .....	21
<b>Maintenance Alarms</b> .....	23
<b>Voltage Selector Switch</b> .....	24
Lockout Function .....	24

## **Section 3: Operation**

<b>Pre-start Checklist</b> .....	25
<b>Manually Starting the Unit</b> .....	25
<b>AUTO (Remote) Starting the Unit</b> .....	26
<b>Wet Stacking</b> .....	26

<b>Low Idle Switch</b> .....	27
<b>Cold Weather Operation</b> .....	27
<b>Using a Booster Battery or Charger (if equipped)</b> ..	28
Parallel: .....	28
<b>Generator Output Connections</b> .....	28
<b>Generator Cam Lock Connections (If Equipped)</b> ....	29
<b>Using the Voltage Selector Switch</b> .....	29
<b>Fine Voltage Adjustment</b> .....	30
<b>Voltage Regulator</b> .....	30
<b>Customer Convenience Receptacles</b> .....	30
<b>Main Circuit Breaker</b> .....	30
<b>Transfer Switch</b> .....	31
<b>Alternate Load Device (ALD)</b> .....	32
<b>Changing Exercise Timers</b> .....	32
<b>Shutting Down the Unit</b> .....	32
<b>Emergency Stop Switch</b> .....	32
<b>Using the ECU Override Switch</b> .....	33
<b>Positive Air Shutoff (PAS) Valves</b> .....	33
PAS Test Procedure .....	33
<b>Towing the Unit</b> .....	34
<b>Lifting the Unit</b> .....	34

## **Section 4: Maintenance**

<b>Emissions Information</b> .....	37
<b>Maintenance</b> .....	37
<b>Daily Walk Around Inspection</b> .....	37
<b>Belt Tensioners</b> .....	37
<b>General Maintenance</b> .....	37
<b>Engine Oil Recommendations</b> .....	38
<b>Coolant Recommendation</b> .....	38
<b>Basic Maintenance Schedule</b> .....	38
<b>Engine Break-In Requirements</b> .....	39
<b>Checking Generator Drive Plate Torque</b> .....	39
<b>ALD System Maintenance</b> .....	39
<b>Resetting Maintenance Alarms</b> .....	40
<b>Jack Maintenance</b> .....	40
Side-Wind Models .....	40
Top-Wind Models .....	40
<b>Trailer Wheel Bearings</b> .....	40

---

**Section 5: Troubleshooting**

General Troubleshooting .....	41
-------------------------------	----

**Section 6: Wiring Diagrams**

Controls .....	43
Control Box (1 of 2) .....	44
Control Box (2 of 2) .....	45
Generator Cabin (1 of 2) .....	46
Generator Cabin (2 of 2) .....	47
Generator Box—VFLEX (If Equipped) .....	48

# Section 1: Introduction and Safety

---

## Introduction

Thank you for purchasing a Generac Mobile product. This unit has been designed to provide high performance, efficient operation, and years of use when maintained properly.

The information in this manual is accurate based on products produced at the time of publication. The manufacturer reserves the right to make technical updates, corrections, and product revisions at any time without notice.

## Read This Manual Thoroughly



Consult Manual. Read and understand manual completely before using product. Failure to completely understand manual and product could result in death or serious injury. (000100a)

If any section of this manual is not understood, contact your nearest GMASD, or contact Generac Mobile Technical Service at 1-800-926-9768 or [www.generacmobileproducts.com](http://www.generacmobileproducts.com) with any questions or concerns.

The owner is responsible for proper maintenance and safe use of the equipment. Comply with regulations the Occupational Safety and Health Administration (OSHA) has established, or with equivalent standards. Also, verify that the unit is applied, used, and maintained in accordance with the manufacturer's instructions and recommendations. Do nothing that might alter safe application/usage and render the unit in noncompliance with the aforementioned codes, standards, laws, and regulations.

Save these instructions for future reference. This manual contains important instructions for the unit that should be followed during setup, operation and maintenance of the unit and battery. ALWAYS supply this manual to any individual that will use this machine.

## How to Obtain Service

When the unit requires servicing or repairs, contact a GMP ASD for assistance. Service technicians are factory-trained and are capable of handling all service needs. For assistance locating a dealer, go to <https://www.generacmobileproducts.com/parts-service/find-service>.

When contacting a GMP ASD about parts and service, always supply the complete model and serial number of the unit as given on the data decal located on the unit. Record the model and serial numbers in the spaces provided on the front cover of this manual.

## Safety Rules

The manufacturer cannot anticipate every possible circumstance that might involve a hazard. The warnings in this manual, and on tags and decals affixed to the unit are, therefore, not all inclusive. If using a procedure, work method or operating technique that the manufacturer does not specifically recommend, verify it is safe for others. Also make sure the procedure, work method or operating technique utilized does not render the equipment unsafe.

## Safety Symbols and Meanings

Throughout this publication, and on tags and decals affixed to the unit, DANGER, WARNING, CAUTION and NOTE blocks are used to alert personnel to special instructions about a particular operation that may be hazardous if performed incorrectly or carelessly. Observe them carefully. Their definitions are as follows:



Indicates a hazardous situation which, if not avoided, will result in death or serious injury.

(000001)



Indicates a hazardous situation which, if not avoided, could result in death or serious injury.

(000002)



Indicates a hazardous situation which, if not avoided, could result in minor or moderate injury.

(000003)

**NOTE:** Notes contain additional information important to a procedure and will be found within the regular text of this manual.

These safety alerts cannot eliminate the hazards that they indicate. Common sense and strict compliance with the special instructions while performing the action or service are essential to preventing accidents.

## General Hazards



**⚠ DANGER**

Asphyxiation. Running engines produce carbon monoxide, a colorless, odorless, poisonous gas. Carbon monoxide, if not avoided, will result in death or serious injury. (000103)



**⚠ DANGER**

Asphyxiation. Do not operate unit without a properly functioning exhaust system. Doing so will result in death or serious injury. (000340)



**⚠ WARNING**

Loss of life. This product is not intended to be used in a critical life support application. Failure to adhere to this warning could result in death or serious injury. (000209b)



**⚠ WARNING**

Hearing Loss. Hearing protection is recommended when using this machine. Failure to wear hearing protection could result in permanent hearing loss. (000107)



**⚠ WARNING**

Vision loss. Eye protection is required when operating unit. Failure to wear appropriate eye protection could result in vision loss or serious injury. (000407)



**⚠ WARNING**

Moving Parts. Keep clothing, hair, and appendages away from moving parts. Failure to do so could result in death or serious injury. (000111)



**⚠ WARNING**

Hot Surfaces. When operating machine, do not touch hot surfaces. Keep machine away from combustibles during use. Hot surfaces could result in severe burns or fire. (000108)

**⚠ WARNING**

Equipment damage. Do not attempt to start or operate a unit in need of repair or scheduled maintenance. Doing so could result in serious injury, death, or equipment failure or damage. (000291)

**⚠ WARNING**

Risk of injury. Do not operate or service this machine if not fully alert. Fatigue can impair the ability to service this equipment and could result in death or serious injury. (000215)

**⚠ WARNING**

Equipment damage. Only qualified service personnel may install, operate, and maintain this equipment. Failure to follow proper installation requirements could result in death, serious injury, and equipment or property damage. (000182a)

**⚠ CAUTION**

Equipment or property damage. Do not block air intake or restrict proper air flow. Doing so could result in unsafe operation or damage to unit. (000229)

## Trailer Hazards

**⚠ WARNING**

Personal injury. Trailer must be securely coupled to the hitch with the chains correctly attached. Uncoupled or unchained towing could result in death or serious injury. (000233a)

**⚠ WARNING**

Personal injury. Do not operate unit during transport. Doing so could result in death, serious injury, or property damage. (000231a)

**⚠ WARNING**

Crushing hazard. Verify unit is properly secured and on level ground. An unsecured unit can suddenly roll or move, causing death or serious injury. (000234a)

**⚠ WARNING**

Property or Equipment Damage. Tighten wheel lug nuts after first 50 miles to factory specifications. Failure to do so could result in death, serious injury, property or equipment damage. (000235)

## Electrical Hazards



### **⚠ DANGER**

Electrocution. In the event of electrical accident, immediately shut power OFF. Use non-conductive implements to free victim from live conductor. Apply first aid and get medical help. Failure to do so will result in death or serious injury. (000145)



### **⚠ DANGER**

Electrocution. Water contact with a power source, if not avoided, will result in death or serious injury.

(000104)



### **⚠ DANGER**

Electrocution. Contact with bare wires, terminals, and connections while generator is running will result in death or serious injury.

(000144)



### **⚠ DANGER**

Electrocution. Verify electrical system is properly grounded before applying power. Failure to do so will result in death or serious injury.

(000152)



### **⚠ DANGER**

Electrocution. Turn utility supply OFF before working on utility connections of the transfer switch. Failure to do so will result in death or serious injury.

(000123)



### **⚠ DANGER**

Electrocution. Never connect this unit to the electrical system of any building unless a licensed electrician has installed an approved transfer switch. Failure to do so will result in death or serious injury.

(000150)



### **⚠ WARNING**

Explosion. Batteries emit explosive gases. Always disconnect negative battery cable first to avoid spark. Failure to do so could result in death or serious injury.

(000238)

## Lifting Hazards



### **⚠ WARNING**

Personal injury. Failure to properly connect lifting cables, chains, or straps could result in death, serious injury, or property damage.

(000346)

### **⚠ WARNING**

Personal Injury. Do not use lifting eye if there are signs of damage or corrosion. Doing so could result in death, serious injury, or property damage.

(000433)

### **⚠ WARNING**

Personal Injury. Do not use lifting eye other than as directed. Doing so could result in death, serious injury, or property damage.

(000434)

### **⚠ WARNING**

Personal Injury. Verify all fasteners are properly tightened prior to lifting unit. Failure to do so could result in death, serious injury, or property damage.

(000351)

## Explosion and Fire Hazards



### **⚠ DANGER**

Explosion and Fire. Fuel and vapors are extremely flammable and explosive. Add fuel in a well ventilated area. Keep fire and spark away. Failure to do so will result in death or serious injury.

(000105)



### **⚠ WARNING**

Fire risk. Fuel and vapors are extremely flammable. Do not operate indoors. Doing so could result in death, serious injury, or property or equipment damage.

(000281)



### **⚠ WARNING**

Risk of Fire. Unit must be positioned in a manner that prevents combustible material accumulation underneath. Failure to do so could result in death or serious injury.

(000147)

## Battery Hazards



### ⚠ DANGER

Electrocution. Do not wear jewelry while working on this equipment. Doing so will result in death or serious injury.

(000188)



### ⚠ WARNING

Explosion. Batteries emit explosive gases while charging. Keep fire and spark away. Wear protective gear when working with batteries. Failure to do so could result in death or serious injury.

(000137a)



### ⚠ WARNING

Explosion. Do not dispose of batteries in a fire. Batteries are explosive. Electrolyte solution can cause burns and blindness. If electrolyte contacts skin or eyes, flush with water and seek immediate medical attention.

(000162)



### ⚠ WARNING

Risk of burn. Do not open or mutilate batteries. Batteries contain electrolyte solution which can cause burns and blindness. If electrolyte contacts skin or eyes, flush with water and seek immediate medical attention.

(000163a)

### ⚠ WARNING

Environmental Hazard. Always recycle batteries at an official recycling center in accordance with all local laws and regulations. Failure to do so could result in environmental damage, death, or serious injury.

(000228)

Always recycle batteries in accordance with local laws and regulations. Contact your local solid waste collection site or recycling facility to obtain information on local recycling processes. For more information on battery recycling, visit the Battery Council International website at: <http://batteryCouncil.org>

## Fuel Hazards



### ⚠ DANGER

Explosion and fire. Fuel and vapors are extremely flammable and explosive. No leakage of fuel is permitted. Keep fire and spark away. Failure to do so will result in death or serious injury.

(000192)



### ⚠ DANGER

Risk of fire. Allow fuel spills to completely dry before starting engine. Failure to do so will result in death or serious injury.

(000174)

- **DO NOT** fill fuel tank near an open flame, while smoking, or while engine is running. **DO NOT** fill tank in an enclosed area with poor ventilation.
- **DO NOT** operate with the fuel tank cap loose or missing.

## Engine Safety

Internal combustion engines present special hazards during operation and fueling. Failure to follow the safety guidelines described below could result in severe injury or death. Read and follow all safety alerts described in the engine operator's manual. A copy of this manual was supplied with the unit when it was shipped from the factory.

- **DO NOT** run engine indoors or in an area with poor ventilation. Verify engine exhaust cannot seep into closed rooms or ventilation equipment.
- **DO NOT** clean air filter with gasoline or other types of low flash point solvents.
- **DO NOT** operate the unit without a functional exhaust system.
- Shut the engine down if any of the following conditions exist during operation:
  - Abnormal change in engine speed.
  - Loss of electrical output.
  - Equipment connected to the unit overheats.
  - Sparking occurs.
  - Engine misfires or there is excessive engine/generator vibration.
  - Protective covers are loose or missing.
  - Ambient air temperature is above 120°F (49°C).



## Operating Safety

### Positioning the Unit



Crushing hazard. Verify unit is properly secured and on level ground. An unsecured unit can suddenly roll or move, causing death or serious injury.

(000234a)

- The area immediately surrounding the unit should be dry, clean, and free of debris.
- If the unit is equipped with a frame grounding stud, follow any local, state, and National Electrical Code (NEC) guidelines when connecting.

### Towing Safety

Towing a trailer requires care. Both the trailer and vehicle must be in good condition and securely fastened to each other to reduce the possibility of an accident. Some states require that large trailers be registered and licensed. Contact your local Department of Transportation office to check on license requirements for your particular unit.

### Hitch and Coupling

- Verify the hitch and coupling on the towing vehicle are rated equal to, or greater than, the trailer's Gross Vehicle Weight Rating (GVWR).
- Verify the trailer hitch and the coupling are compatible. Verify the coupling is securely fastened to the vehicle.
- **DO NOT** tow trailer using defective parts. Inspect the hitch and coupling for wear or damage.
- Connect safety chains in a crossing pattern under the tongue.
- Before towing the trailer, verify the weight of the trailer is equal across all tires. On trailers with adjustable height hitches, adjust the angle of the trailer tongue to keep the trailer as level as possible.

### Safe Towing Techniques

- Practice turning, stopping and backing up in an area away from heavy traffic prior to transporting the unit.
- Maximum recommended speed for highway towing is 45 mph (72 km/h). Recommended off-road towing speed is 10 mph (16 km/h) or less, depending on terrain.
- When towing, maintain extra space between vehicles and avoid soft shoulders, curbs and sudden lane changes.

## Reporting Trailer Safety Defects

If you believe your trailer has a defect which could cause a crash or could cause injury or death, you should immediately inform the National Highway Traffic Safety Administration (NHTSA) in addition to notifying Generac Mobile.

If NHTSA receives similar complaints, it may open an investigation; and if it finds that a safety defect exists in a group of vehicles, it may order a recall and remedy campaign. However, NHTSA cannot become involved in an individual problem between you, your GMP ASD, or Generac Mobile.

To contact NHTSA, you may either call the Auto Safety Hotline toll-free at 1-888-327-4236 (TTY:1-800-424-9153), go to <http://www.safercar.gov>; or write to:

Administrator  
NHTSA  
1200 New Jersey Avenue S.E.  
Washington, DC 20590

You can also obtain other information about motor vehicle safety from <http://www.safercar.gov>.

## Safety and Operating Decals

This unit features numerous safety and operating decals. These decals provide important operating instructions and warn of dangers and hazards. The following diagrams illustrate decal locations and descriptions.

Replace any missing or hard-to-read decals and use care when washing or cleaning the unit. Decal part numbers can be found in the parts manual at [www.generacmobileproducts.com](http://www.generacmobileproducts.com).

ID	Description	ID	Description
1	Lifting point	16	Connection terminal lugs
2	Coolant drain	17	Terminal connections (voltage selector switch)
3	Tie-down point	18	Electrical ground
4	Engine oil drain	19	Starting and stopping the generator
5	Do not open door with engine running	20	Electrical backfeed danger
6	Electrical shock hazard	21	Operating instructions
7	Ultra-low sulfur diesel	22	Read and understand owner's manual
8	Diesel fuel	23	Controller buttons
9	Towing instructions	24	Circuit breaker
10	Hot coolant under pressure, hot surface	25	Neutral bonded to frame
11	Do not remove guard—hazards	26	Remote start terminal connections
12	Secondary filter	27	Neutral
13	Primary filter	28	Cam lock connector
14	Warning: Generator can automatically start	29	Receptacle warning
15	Various hazards—read manual		

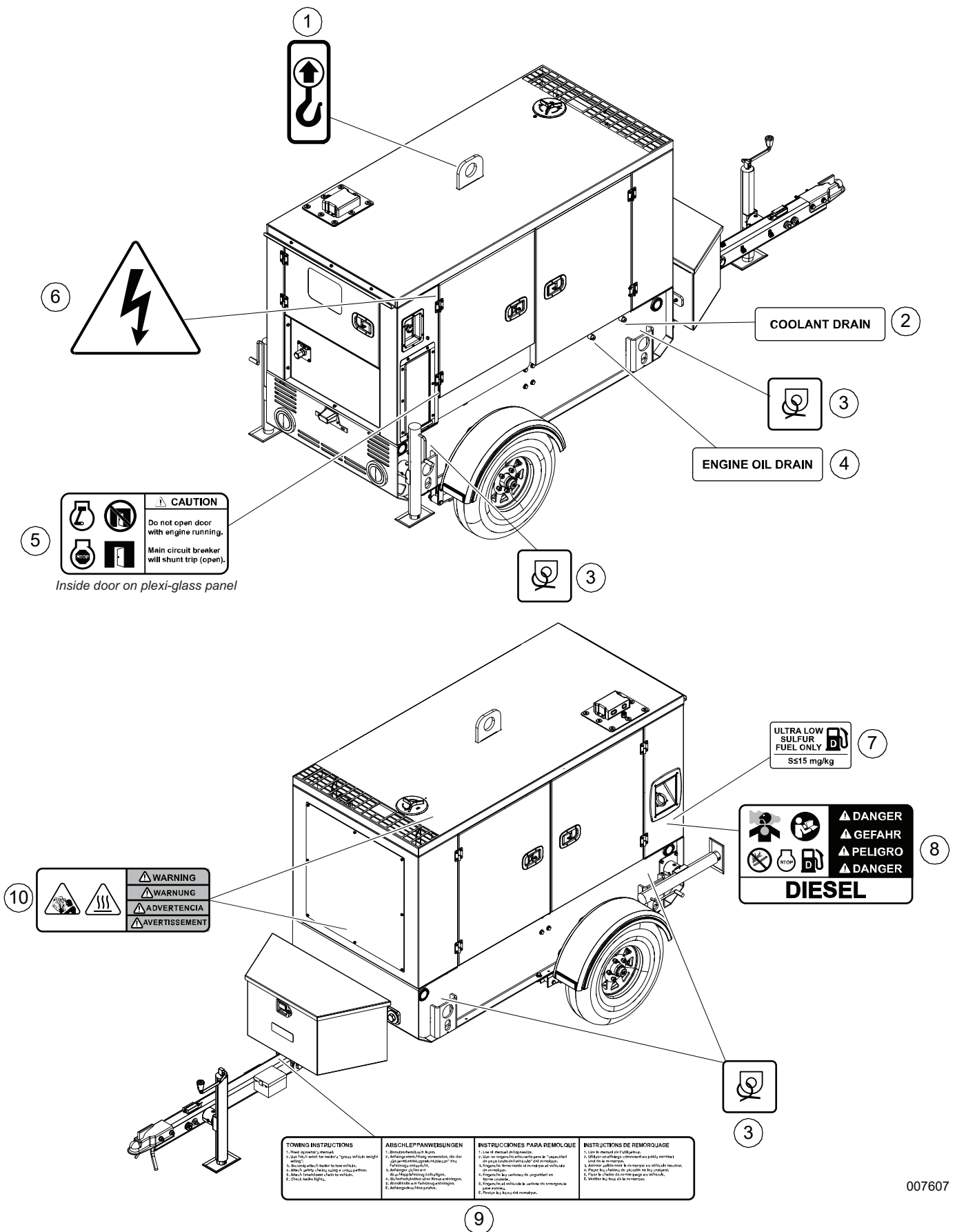

007607

Figure 1-1. Exterior Decals

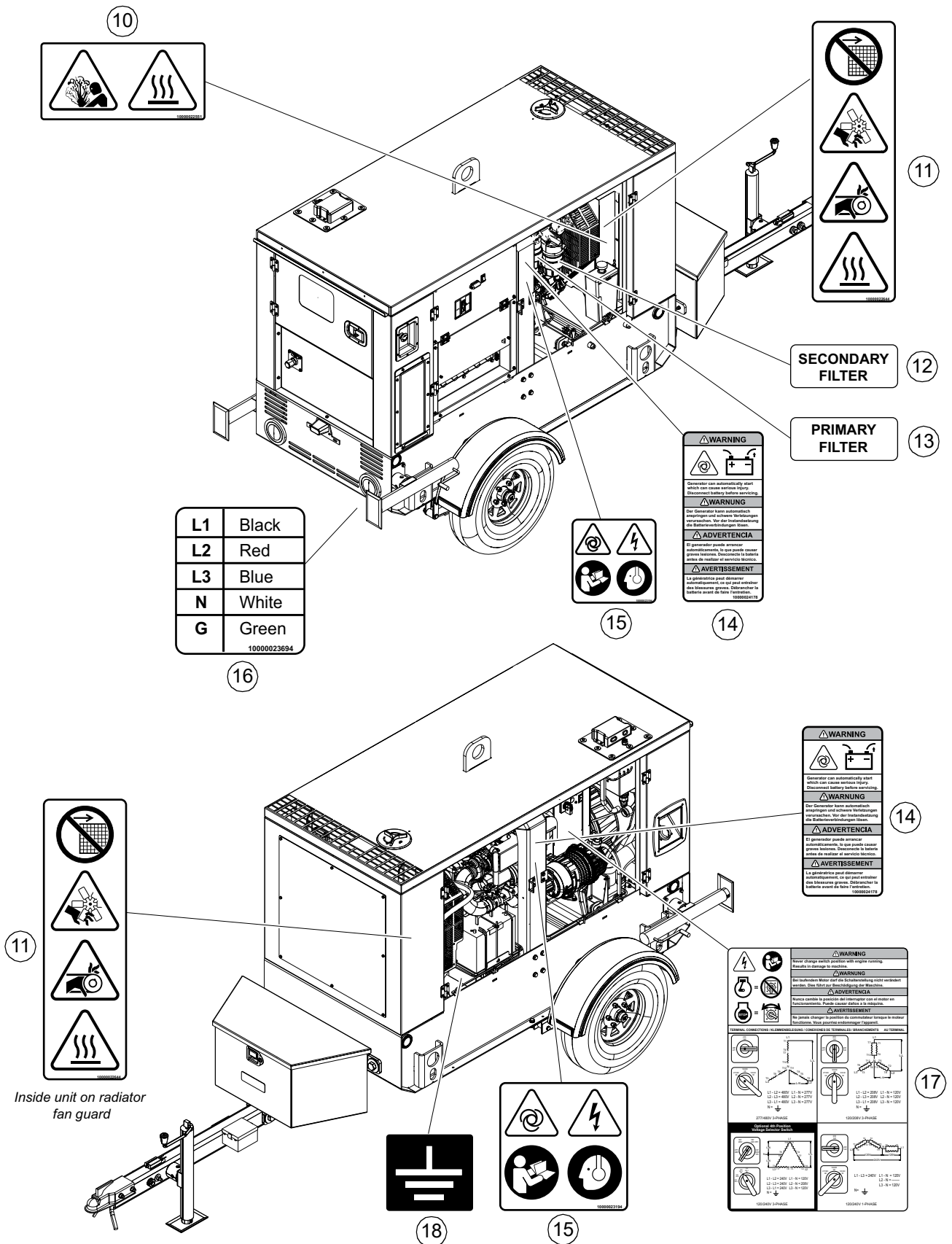

Figure 1-2. Interior Decals

011189

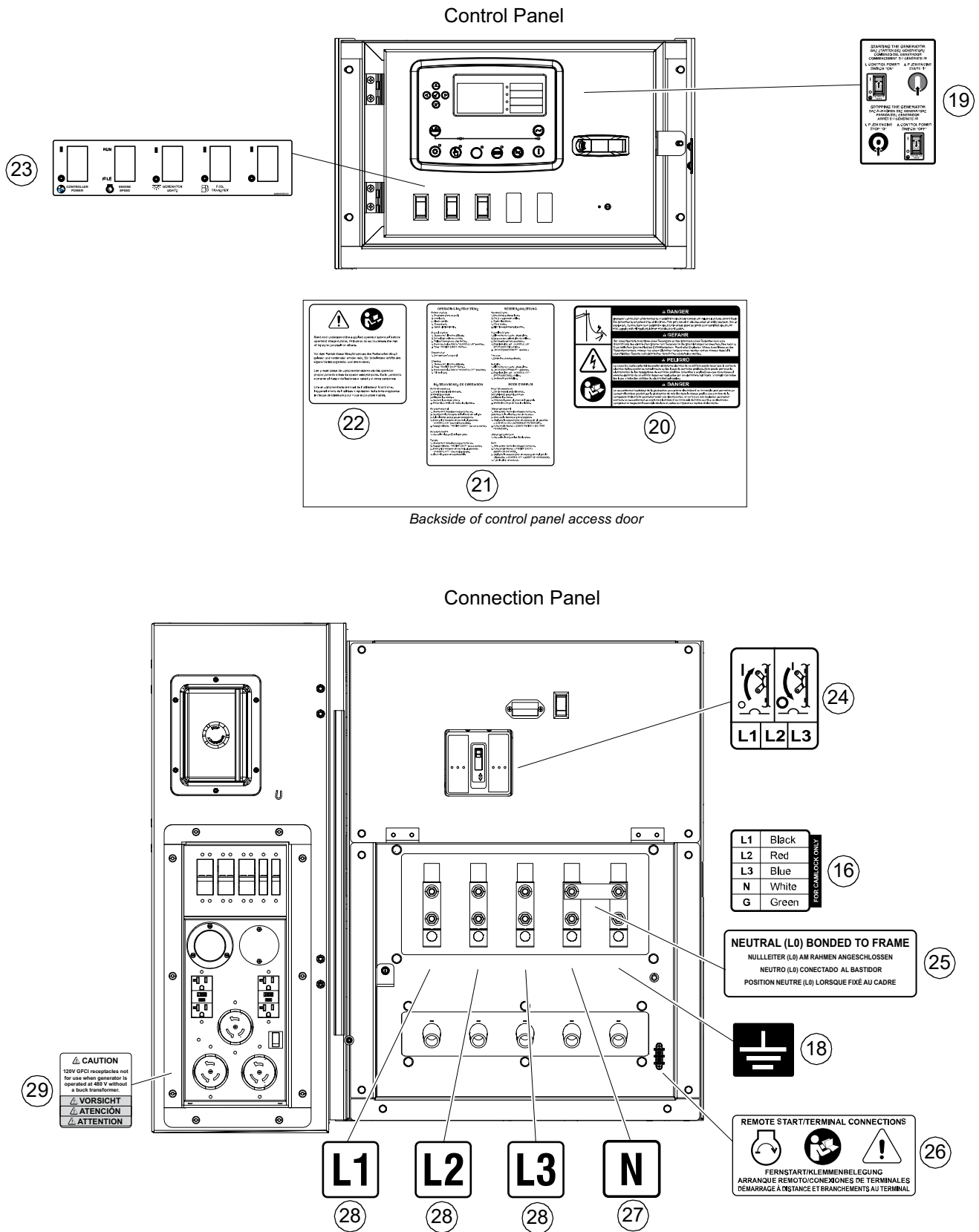

Figure 1-3. Control Panel and Connection Panel Decals

011190

**This page intentionally left blank.**

# Section 2: General Information

## Specifications

Description	UOM	MDG25IF4	With SUPERSTART®	With VFLEX
<b>Engine</b>				
Make (Model)	—	Isuzu® (4LE2T)	Isuzu (4LE2T)	Isuzu (4LE2T)
Rated Power Output	hp (kW)	40 (30)	40 (30)	40 (30)
Operating Speed	rpm	1,800	1,800	1,800
Fuel Consumption—100% load: <b>Standby, Prime</b>	gph (Lph)	2.3 (8.6), 2.0 (7.4)	2.3 (8.6), 2.0 (7.4)	2.3 (8.6), 2.0 (7.4)
Fuel Consumption—75% load: <b>Standby, Prime</b>	gph (Lph)	1.7 (6.5), 1.6 (6.1)	1.7 (6.5), 1.6 (6.1)	1.7 (6.5), 1.6 (6.1)
Fuel Consumption—50% load: <b>Standby, Prime</b>	gph (Lph)	1.2 (4.4), 1.1 (4.2)	1.2 (4.4), 1.1 (4.2)	1.2 (4.4), 1.1 (4.2)
EPA Emissions Certification	Tier	4 Final	4 Final	4 Final
Battery—Voltage (Qty of Batteries)	VDC (qty)	12 (1)	12 (1)	12 (1)
Battery—Rating	CCA	720	720	720
<b>Capacities</b>				
Fuel Tank—Usable	gal (L)	56 (211)	56 (211)	56 (211)
Maximum Run Time—Full Load	hr	28	28	28
Coolant—System	gal (L)	4.4 (16.7)	4.4 (16.7)	4.4 (16.7)
Oil—Crankcase	qt (L)	10.9 (10.4)	10.9 (10.4)	10.9 (10.4)
<b>Generator</b>				
Make (Model)	—	Marathon Electric® (282PSL1705)	SUPERSTART Marathon Electric (283PSL1707)	VFLEX Marathon Elec- tric (283PSL28106)
Insulation	Class	H	H	H
Poles	qty	4	4	4
Voltage Regulation	—	Standard, ±0.5%	Standard, ±0.5%	Standard, ±0.5%
Frequency	Hz	60	60	60
<b>Power Output</b>				
3∅ Standby	kW (kVA)	25 (31)	25 (31)	25 (31)
277/480 V	A	37	37	37
120/208 V	A	86	86	86
120/240 V	A	75*	75*	75*
346/600 V	A	NA	NA	29
3∅ Prime	kW (kVA)	20 (25)	20 (25)	20 (25)
277/480 V	A	30	30	30
120/208 V	A	70	70	70
120/240 V**	A	60	60	60
346/600 V	A	NA	NA	24
1∅ Standby	kW (kVA)	17.5 (17.5)	25 (25)	11 (11)
120/240 V	A	73	104	45
1∅ Prime	kW (kVA)	17.5 (17.5)	20 (20)	11 (11)
120/240 V	A	73	83	45
Power Factor: <b>3∅, 1∅</b>	—	0.8, 1.0	0.8, 1.0	0.8, 1.0
<b>AC Distribution</b>				
Circuit Breaker Size	A	125	125	125
<b>Trailer</b>				
Hitch—Standard	size, type	2 in (51 mm), ball	2 in (51 mm), ball	2 in (51 mm), ball
Maximum Tire Pressure	psi (kPA)	65 (448)	65 (448)	65 (448)
Tires	Size	ST185/80D13	ST185/80D13	ST185/80D13
Axle—GVWR	lb (kg)	3,500 (1,406)	3,500 (1,406)	3,500 (1,406)

Specifications continued on next page.

Description	UOM	MDG25IF4	With SUPERSTART®	With VFLEX
<b>Weight</b>				
Skid Mounted—Dry	lb (kg)	2,010 (911)	2,081 (944)	2,051 (930)
Skid Mounted—Operating	lb (kg)	2,450 (1,111)	2,521 (1,143)	2,491 (1,130)
Trailer Mounted—Dry	lb (kg)	2,247 (1,019)	2,318 (1,051)	2,288 (1,038)
Trailer Mounted—Operating	lb (kg)	2,771 (1,256)	2,842 (1,289)	2,812 (1,275)

Specifications are subject to change without notice.

\*Power rating achieved through use of optional 4-position phase switch.

## Unit Dimensions

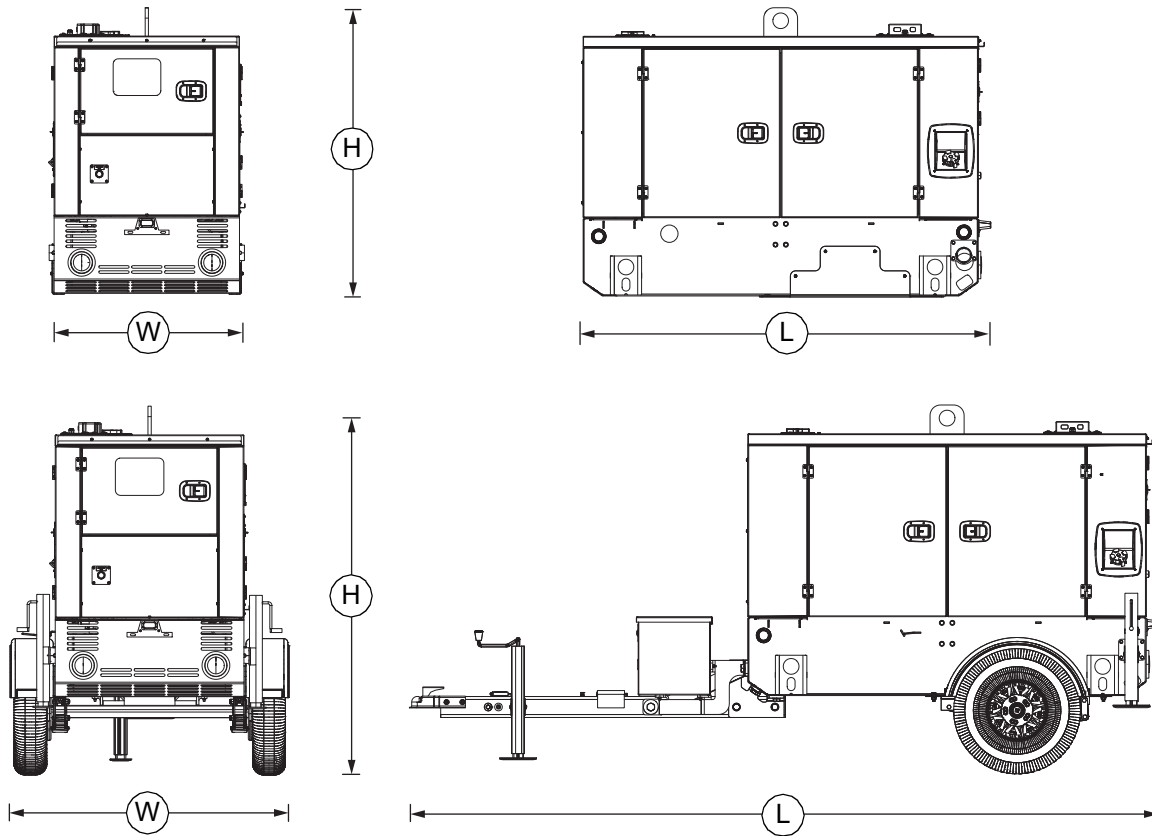

011143

**Figure 2-1. Unit Dimensions**

	L	W	H
Skid Mounted	76 in (1.93 m)	36.37 in (0.92 m)	53.5 in (1.35 m)
Trailer Mounted	139.25 in (3.53 m)	51.75 in (1.31 m)	64.75 in (1.64 m)



## Unit and Serial Number Locations

See [Figure 2-2](#) to locate the unit ID tag (A) and vehicle identification number (VIN) tag (B). Important information such as the unit model number, serial number, VIN, and tire loading information are listed on these tags. Record the information from these tags in the event the tags are lost or damaged. This information may be needed when ordering parts or requesting assistance.

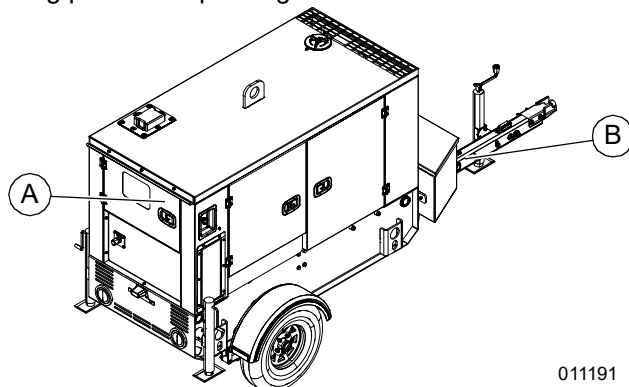

011191

**Figure 2-2. Unit and Serial Number Locations**

## Altitude and Temperature Limitations

All units are subject to derating for altitude and temperature. Derating reduces the available power for operating tools and accessories connected to the outlets. For the MDG25, the engine can provide full prime power up to an altitude of 10,000 ft (3,048 m).

Maximum Altitude		Maximum Air Temperature
Prime Power	Standby Power	
10,000 ft (3,048 m)	4,500 ft (1,371 m)	120 °F (49 °C)

If the unit is operated in an ambient condition above 120 °F (49 °C) at full power, the coolant temperature will exceed the maximum allowable limit of 203 °F (95 °C) and cause the engine to shut down.

## Component Locations

### Exterior

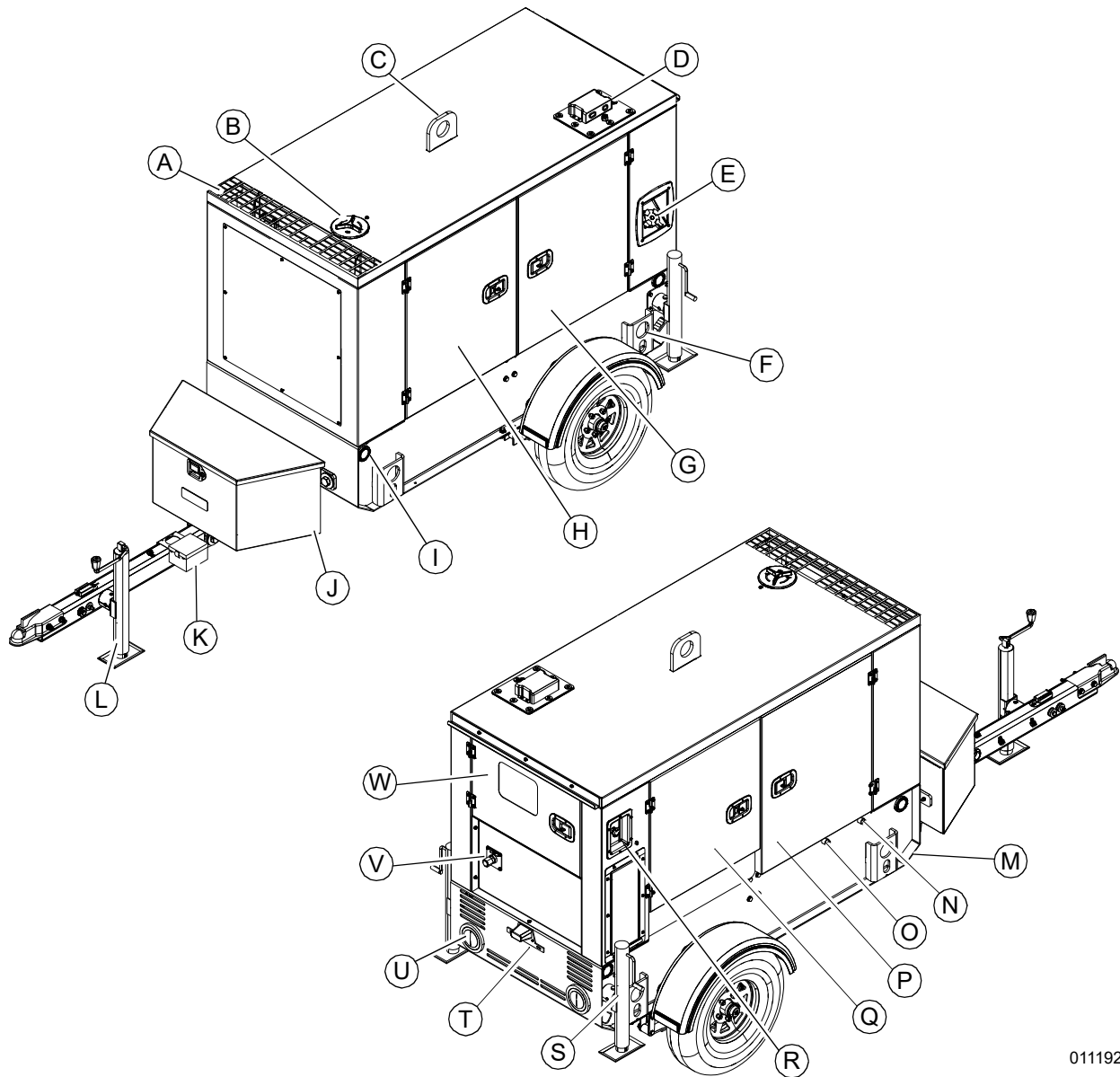

011192

**Figure 2-3. Exterior Components**

- |   |  |
|---|--|
| <b>A</b> Hot air/exhaust duct                       | <b>M</b> Fuel drain (unit underside)                 |
| <b>B</b> Coolant fill port                          | <b>N</b> Coolant drain                               |
| <b>C</b> Unit lift point                            | <b>O</b> Engine oil drain                            |
| <b>D</b> Telemetry (if equipped)                    | <b>P</b> Engine access door                          |
| <b>E</b> Fuel fill port                             | <b>Q</b> Breaker and connection panel access door    |
| <b>F</b> Tie-down point (4 locations)               | <b>R</b> Emergency stop switch                       |
| <b>G</b> Generator access door                      | <b>S</b> Stabilizer jack (2 locations) (if equipped) |
| <b>H</b> Engine access door                         | <b>T</b> License plate holder                        |
| <b>I</b> Side marker light (4 locations)            | <b>U</b> Tail light (2 locations)                    |
| <b>J</b> Tool box (if equipped)                     | <b>V</b> Auxiliary fuel inlet (if equipped)          |
| <b>K</b> Battery for breakaway brakes (if equipped) | <b>W</b> Control panel access door                   |
| <b>L</b> Tongue jack                                |  |

## Interior

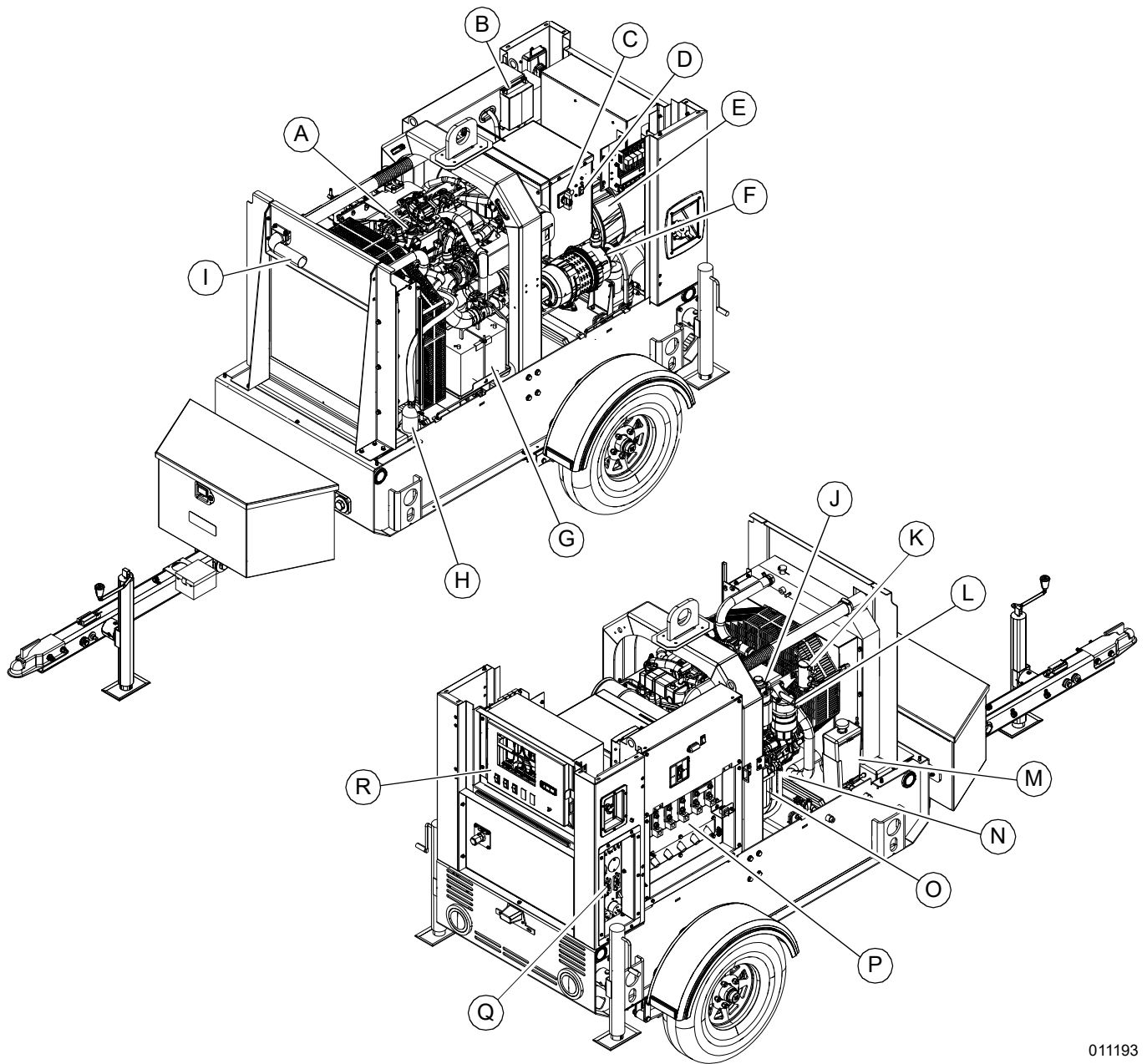

011193

**Figure 2-4. Interior Components**

- |  |                                     |
|--|-------------------------------------|
| <b>A</b> Engine oil fill               | <b>K</b> Fuel pump                  |
| <b>B</b> Battery charger (if equipped) | <b>L</b> Primary fuel filter        |
| <b>C</b> Generator phase switch        | <b>M</b> Coolant overflow container |
| <b>D</b> VFLEX switch (if equipped)    | <b>N</b> Battery disconnect switch  |
| <b>E</b> Generator                     | <b>O</b> Engine oil filter          |
| <b>F</b> Air filter                    | <b>P</b> Connection panel           |
| <b>G</b> Battery                       | <b>Q</b> Receptacle Panel           |
| <b>H</b> Block heater (if equipped)    | <b>R</b> Control panel              |
| <b>I</b> Engine exhaust                |                                     |
| <b>J</b> Secondary fuel filter         |                                     |

## Connection Panel

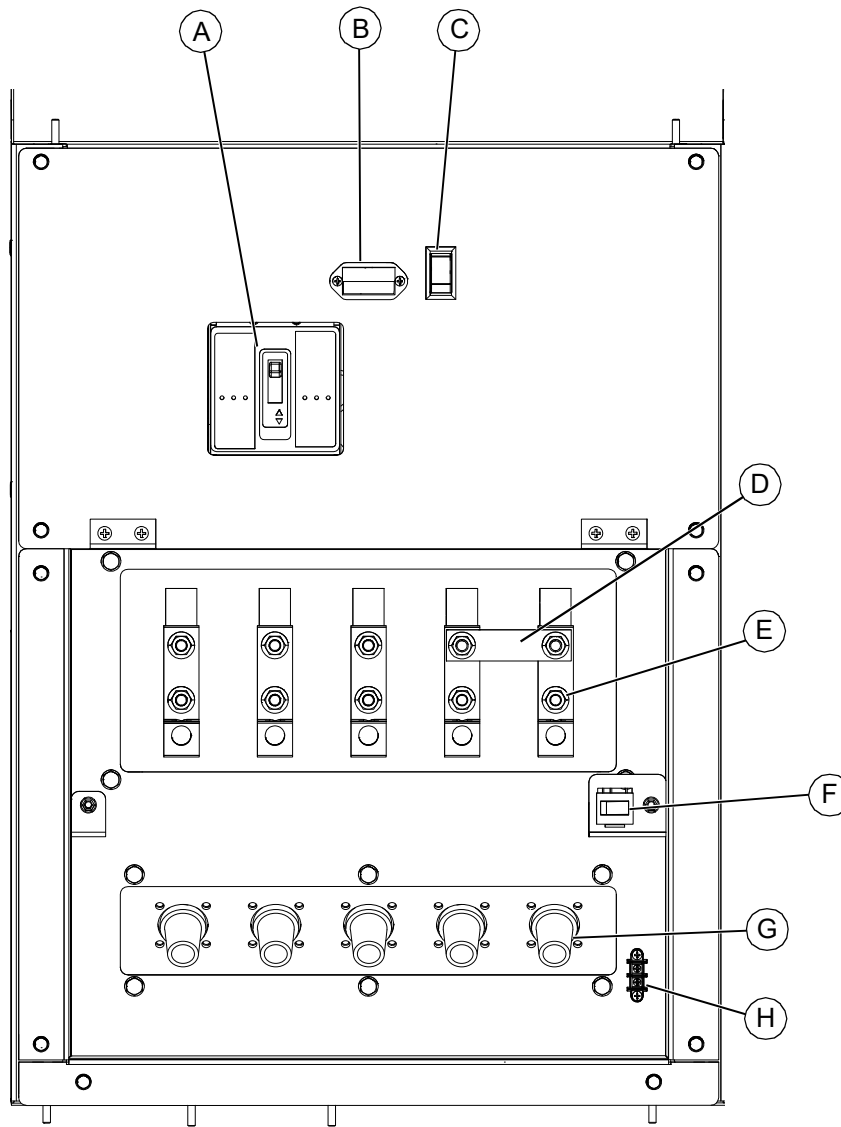

011194

**Figure 2-5. Connection Panel**

- |                                |  |
|--------------------------------|--|
| <b>A</b> Main circuit breaker  | <b>E</b> Connection lug (5 locations)                    |
| <b>B</b> Panel light           | <b>F</b> Safety shutoff switch                           |
| <b>C</b> Service lights switch | <b>G</b> Cam lock receptacle (5 locations) (if equipped) |
| <b>D</b> Neutral bonding bar   | <b>H</b> Remote start terminal block                     |

## Receptacle Panel

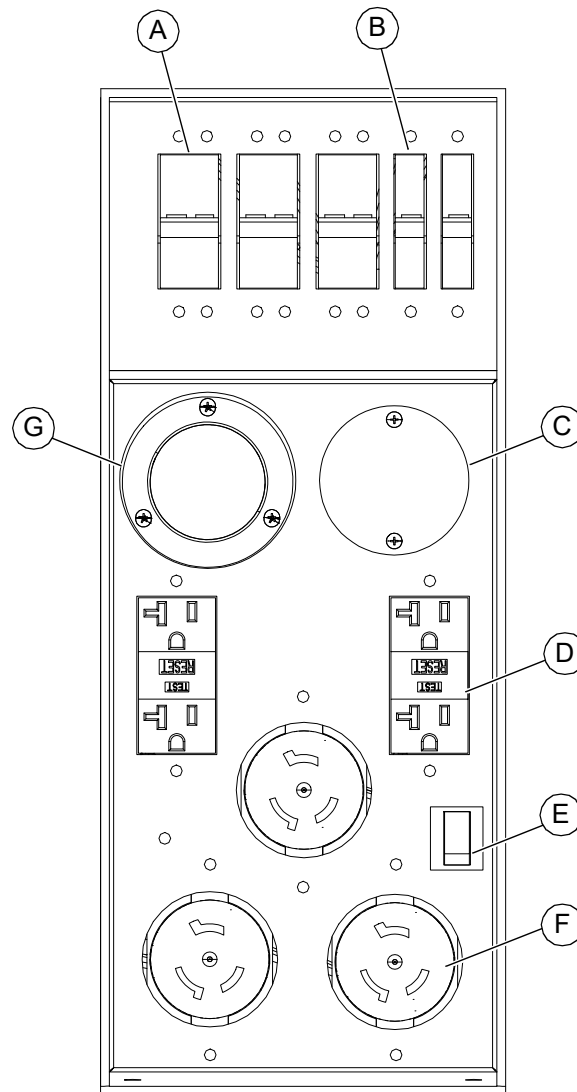

011195

**Figure 2-6. Receptacle Panel**

- |  |  |
|--|--|
| <b>A</b> 50 A circuit breaker (3 locations)      | <b>E</b> LED light switch                              |
| <b>B</b> 20 A circuit breaker (2 locations)      | <b>F</b> 120/240 V twist-lock receptacle (3 locations) |
| <b>C</b> Block heater power supply (if equipped) | <b>G</b> Battery charger power supply (if equipped)    |
| <b>D</b> 120 V GFCI receptacle (2 locations)     |  |

## Control Panel

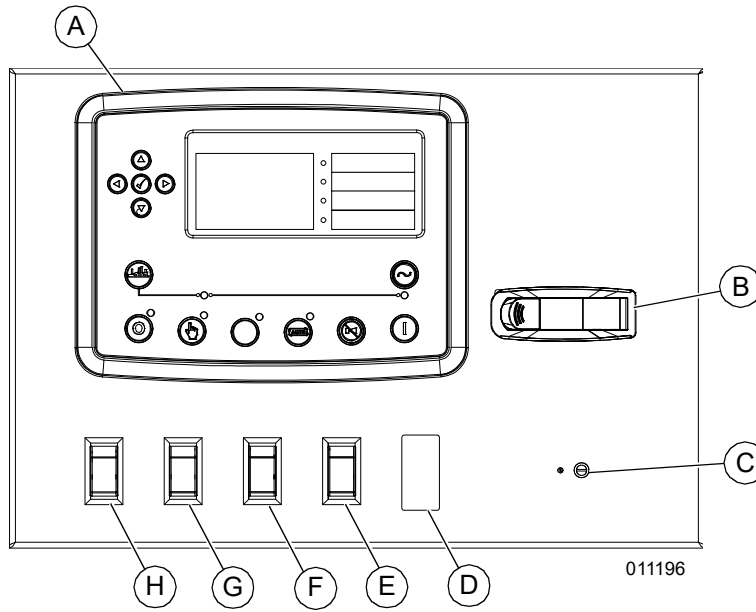

**Figure 2-7. Control Panel**

- |  |                                       |
|--|---------------------------------------|
| <b>A</b> Genset controller                       | <b>E</b> Fuel transfer pump switch    |
| <b>B</b> Door latch                              | <b>F</b> Interior cabin lights switch |
| <b>C</b> Voltage adjustment dial (potentiometer) | <b>G</b> Low idle switch              |
| <b>D</b> [not used]                              | <b>H</b> Controller power switch      |

## Genset Controller

See [Figure 2-8](#). The genset controller displays real-time operational data, monitors functions of the generator and engine, shuts down the unit for certain fault conditions, displays fault data, and retains up to 250 unit performance events.

The controller is programmable. It can automatically start and stop the genset according to schedule, fault condition, or load demand.

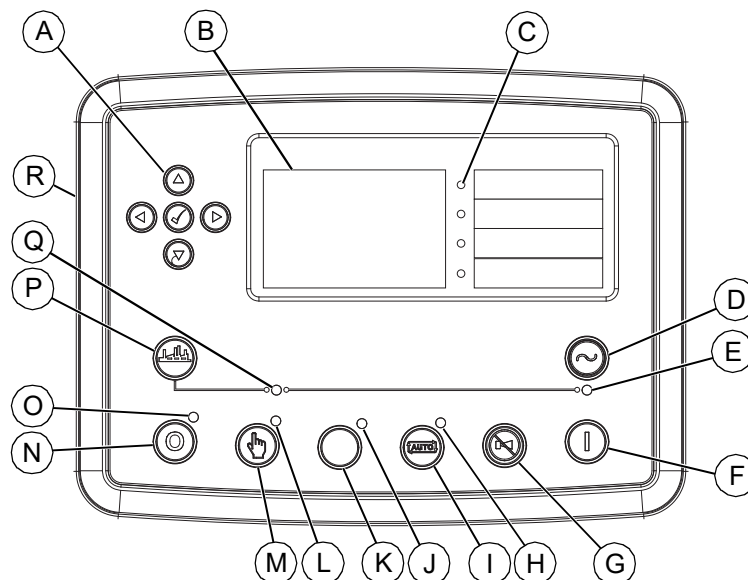

010417

**Figure 2-8. Genset Controller—Deep Sea® Model DSE7310 MKII**

- |  |   |
|--|---|
| <b>A</b> Navigation buttons              | <b>J</b> Positive air shutoff (PAS) valve test switch LED (if equipped) |
| <b>B</b> Screen                          | <b>K</b> PAS valve test switch (if equipped)                            |
| <b>C</b> Indicator LED (4 locations)     | <b>L</b> MANUAL Mode LED  |
| <b>D</b> Transfer to Generator button    | <b>M</b> MANUAL Mode button   |
| <b>E</b> Generator Available LED         | <b>N</b> Engine STOP/RESET Mode button                                  |
| <b>F</b> Engine START button             | <b>O</b> Engine STOP/RESET Mode LED                                     |
| <b>G</b> Alarm Mute and Lamp Test button | <b>P</b> Open Generator button  |
| <b>H</b> AUTO Mode LED                   | <b>Q</b> Open Generator LED   |
| <b>I</b> AUTO Mode button                | <b>R</b> RS232 serial port (not shown—controller backside)              |

**(A) Navigation Buttons**

See [Figure 2-9](#). Used to navigate the operator pages.

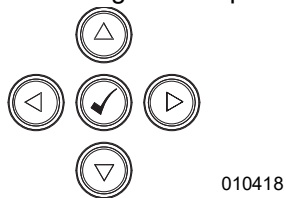

**Figure 2-9. Navigation Buttons**

Navigate the operator pages as follows.

- ▶ View next
- ◀ View previous
- ▲ Scroll up current
- ▼ Scroll down current
- ✓ Select highlighted item

**(B) Controller Screen**

The controller screen displays various operational data for unit monitoring, diagnosing, and troubleshooting. See [Operator Pages](#) for more information.

**(C) Indicator LEDs**

See [Figure 2-10](#). Each LED indicates a condition that impedes normal unit function.

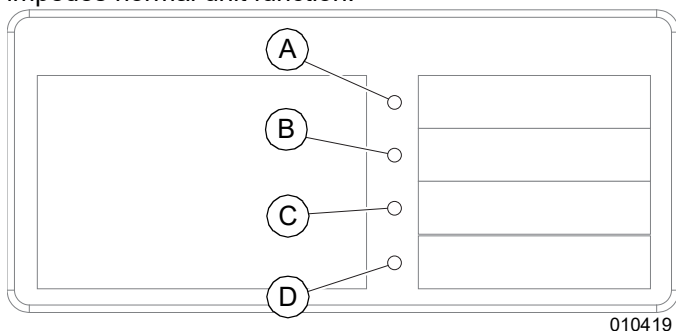

**Figure 2-10. Indicator LEDs**

If an indicator LED is illuminated, resolve the condition to restore normal unit function, as described in table below.

**NOTE:** When a condition is resolved, the corresponding indicator LED switches off.

- A *Low Load* indicator LED.
  - Indicates genset has operated at less than 30% capacity for more than 15 minutes.
  - Resolve by increasing electrical load. If unable to operate genset at more than 30% load, use a smaller generator.
- B *Lug Door Open* indicator LED.
  - Indicates lug-box door is open.
  - Resolve by closing lug-box door. If condition remains unresolved, inspect lug-box door safety switch for proper operation.

- C *Emergency Stop* indicator LED.
  - Indicates Emergency Stop switch is active (pushed in).
  - Resolve by deactivating (pulling out) Emergency Stop switch.
- D *Shutdown* indicator LED.
  - Indicates a shutdown alarm is present.
  - Resolve by resolving shutdown condition.

**NOTE:** If unable to resolve a condition as recommended, contact a GMASD.

**(D) Transfer to Generator Button**

Only applies to MANUAL mode.

Controls operation of generator load switch, when the generator is available.

**NOTE:** In units equipped with a manual breaker, limited function is available.

Status is indicated by the Close Generator LED.

**(E) Close Generator LED**

- When illuminated, cam locks and lugs are enabled.
- When not illuminated, cam locks and lugs are disabled.

**(F) Engine Start Button**

When STOP/RESET mode is active, the Engine Start button switches on the engine ECU but does not start the engine. Uses in this context are to check status of the CAN communication and to prime the engine.

When MANUAL mode is active, the Engine Start button starts the generator.

**NOTE:** In AUTO or STOP mode, the Engine Start button activates the ECU.

**(G) Alarm Mute and Lamp Test Button**

Stops the audible alarm and illuminates functional controller LEDs.

To test the LEDs, press and hold button. All LEDs illuminate. When button is released, the LEDs switch off.

**NOTE:** If an LED does not illuminate when button is pushed, the LED is not functioning.

**(H) AUTO Mode LED**

- When illuminated, AUTO mode is active.
- When not illuminated, AUTO mode is not active.

**(I) AUTO Mode Button**

Switches the mode to AUTO. See [Controller Modes](#) for important guidelines.

Status is indicated by the AUTO Mode LED.

**(J) PAS valve test switch LED (if equipped)**

When illuminated, PAS test is in progress.



**(K) PAS valve test switch (if equipped)**

When PAS test is active, the PAS is cycled to verify function.

**(L) MANUAL Mode LED**

- When illuminated, MANUAL mode is active.
- When not illuminated, MANUAL mode is not active.

**(M) MANUAL Mode Button**

Switches the mode to MANUAL. See [Controller Modes](#) for important guidelines.

Status is indicated by the MANUAL Mode LED.

**(N) Engine STOP/RESET Mode Button**

Switches the mode to STOP. See [Controller Modes](#) for important guidelines.

Status is indicated by the STOP/RESET Mode LED.

**(O) Engine STOP/RESET Mode LED**

- When illuminated, STOP mode is active.
- When not illuminated, STOP mode is not active.

**(P) Open Generator Button**

The Open Generator button is only active in the Manual Mode and allows the operator to open the generator load switch when a motorized breaker is used. Pressing the Open Generator button when the Generator is on load, the generator load switch is opened.

**NOTE:** In units equipped with a manual breaker, limited function is available.

Status is indicated by the Open Generator LED.

**(Q) Open Generator LED**

- When illuminated, cam locks and lugs are disabled.
- When not illuminated, cam locks and lugs are enabled.

**Controller Modes****MANUAL Mode**

MANUAL mode is distinguished by full operator control of unit start-up and shut-down functions, and by full operator control of generator load and unload functions.

**AUTO Mode**

AUTO mode is distinguished by automation of unit start-up and shut-down functions, and by automation of generator load and unload functions.

AUTO mode utilizes the remote start connections. For remote starting procedures, see [Section 3, Operation](#).

AUTO mode utilizes a programmed schedule, which can be modified.

**NOTE:** To modify the AUTO mode programmed schedule, use the Deep Sea Configuration Suite software.

**STOP/RESET Mode**

STOP/RESET mode is distinguished by the following:

- Unloads the generator.
- Clears active alarms—if alarm conditions have been resolved.
- Shuts down the unit.
- Deactivates the Engine Start button.
- Stops all AUTO mode automation (if applicable).
- Controller power remains ON.

**Switching Mode**

1. Verify controller is ON.

**NOTE:** The engine can be running but it is not required.

2. Stop drawing power from the unit: Stop using equipment plugged into receptacles, cam locks, and anything connected to the lugs.
3. See [Figure 2-8](#). Press the desired Mode button. The mode immediately changes.

**Operator Pages**

Operator pages display various data for unit monitoring, diagnosing, and troubleshooting. The pages are:

- Status page
- Engine page
- Generator page
- Alarm page
- ECU DTC page
- Event Log page
- Serial Port page
- Program File Information page
- About page

**NOTE:** Operator pages are available after normal unit start-up.

**NOTE:** Operator pages are view-only. No settings can be added, modified, or deleted.

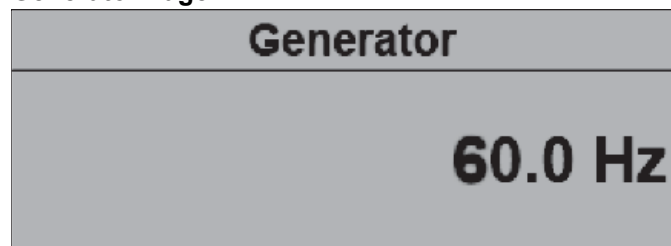
**Generator Page**

010422

**Figure 2-11. Generator Page**

The Generator page displays the following generator data, in real time (press ▲ or ▼ to scroll).

- Voltage (ph-N)
- Voltage (ph-ph)
- Frequency
- Current (A)
- Load ph-N (kW)
- Total load (kW)
- Load ph-N (kVA)
- Total load (kVA)
- Single phase power factors
- Power factor average
- Load ph-N (kvar)
- Total load (kvar)
- Accumulated load (kWh, kVAh, kvarh)
- Loading scheme
- Phase rotation
- Nominal
- Active configuration

**NOTE:** The list above varies, according to generator make, model, and features.

**NOTE:** As possible, distribute electrical loads equally among generator lines. Minor load imbalances (10% or less) usually do not cause problems. When loading generator, observe the load (amperage) on each line.

**Alarms Page**

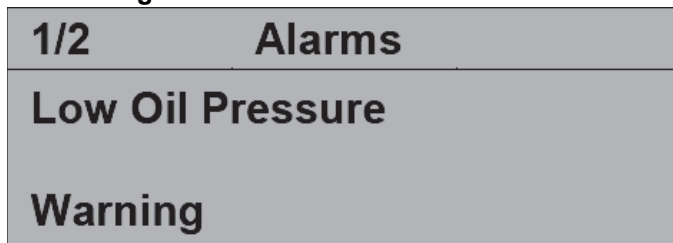

010423

**Figure 2-12. Alarm Page**

The Alarms page displays active warnings and active alarms, including engine DTCs.

**ECU DTC Page**

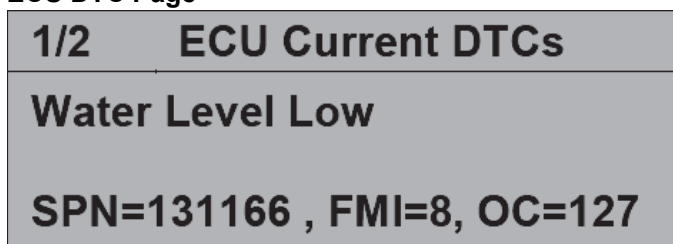

010424

**Figure 2-13. ECU DTC Page—Current DTCs**

The ECU Current DTC page displays active ECU DTCs. Press ► to view previous ECU DTCs.

**NOTE:** See engine manual for information on ECU DTCs.

**NOTE:** All DTCs display on the ECU DTC page. Some DTCs may also display in the Event Log, with similar descriptions as those displayed on the ECU DTC page.

**Event Log Page**

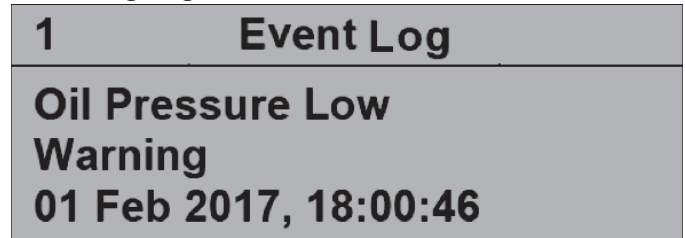

010425

**Figure 2-14. Event Log Page**

The Event Log page displays current and previous alarms.

- Event Log capacity is 250 alarm events. After 250 events are logged, each new event overwrites the oldest.
- Only alarms are logged.
- Newest event displays at top of log; oldest at bottom.

### Serial Port Page

The Serial Port page displays information about the RS232 serial port, which enables data transfers. If an external modem is connected to the serial port, modem information also displays.

**NOTE:** The Serial Port page display may vary, in accordance with controller configuration.

See [Figure 2-15](#). If a modem is connected to the controller, *Modem* displays, as illustrated.

Serial Port	
Baud	<b>9600</b>
SlaveID	<b>10</b>
	<b>Modem</b>

010426

**Figure 2-15. Serial Port Page. If modem is not connected, RS232 displays in place of Modem.**

See [Figure 2-16](#). When the controller can accept a data transfer, *Modem Ready* displays, as illustrated.

Serial Port	
	<b>Orange Modem Ready</b>

010427

**Figure 2-16. Serial Port Page—Modem Ready**

### Program File Information Page

<b>PROGRAM FILE INFORMATION</b>
<b>MDG25IF4 Mobile Generator</b>
<b>PRGMD CNTLR MDG25 NP 24</b>
<b>A0000xxxxxx.dse Revision A</b>

010428

**Figure 2-17. Program File Information Page**

The Program File Information page displays the following controller information.

- Controller model unit
- Program file name
- Program PN
- Program version

### About Page

About	
<b>Variant</b>	<b>7310</b>
<b>Application</b>	<b>V5.0.23</b>
<b>USB ID</b>	<b>6B248D0576</b>

About	
<b>Bootloader</b>	<b>V3.2.1</b>
<b>Analogue</b>	<b>V1.2.0</b>

About	
<b>Engine Type</b>	<b>Isuzu 4L</b>
<b>Version</b>	<b>V1.18.0</b>

010429

**Figure 2-18. About Page**

The About page displays various general information about the unit and controller, as illustrated.

### Maintenance Alarms

Maintenance alarms indicate a regular-maintenance service interval is expired. To resolve the condition, perform the indicated service, then re-set the corresponding service interval.

To re-set a service interval:

1. Display the Engine page.
2. Scroll (▲ or ▼) until the appropriate service interval is highlighted.

**NOTE:** The expired interval displays on the Alarm page.

3. Press and hold the Engine STOP/RESET Mode button until **###\* hr service** changes to **0 hr service**.

*\*A number displays. The value varies according to what service interval is highlighted.*

## Voltage Selector Switch



### ⚠ WARNING

Electric Shock. Never change the voltage selector switch while the engine is running or the controller is on. Doing so could result in death, serious injury or equipment damage.

(000302)

The voltage selector mechanically configures the generator main windings. The unit is equipped with either a 3- or a 4-position switch. Available configurations for each are shown in the table below.

	3-Position Switch	4-Position Switch
<b>Available Configurations</b>	<ul style="list-style-type: none"> <li>• Hi wye</li> <li>• Low wye</li> <li>• Zig zag</li> </ul>	<ul style="list-style-type: none"> <li>• Hi wye</li> <li>• Low wye</li> <li>• Zig zag</li> <li>• Delta</li> </ul>

### Lockout Function

The voltage selector switch is equipped with a lockout mechanism. When engaged, the switch is locked in place, preventing configuration changes. See [Using the Voltage Selector Switch](#) for instructions on switching the voltage.

**NOTE:** See [Using the Voltage Selector Switch](#) for more information

# Section 3: Operation

## Pre-start Checklist

All items in the pre-start checklist must be completed before starting the unit. This checklist applies to both manual and remote starting of the unit.



### ⚠️ WARNING

Consult Manual. Read and understand manual completely before using product. Failure to completely understand manual and product could result in death or serious injury. (000100a)

### ⚠️ WARNING

Equipment damage. Do not attempt to start or operate a unit in need of repair or scheduled maintenance. Doing so could result in serious injury, death, or equipment failure or damage. (000291)



### ⚠️ WARNING

Risk of Fire. Unit must be positioned in a manner that prevents combustible material accumulation underneath. Failure to do so could result in death or serious injury. (000147)

- Verify all maintenance procedures are up to date. For more information, see [General Maintenance](#) and [Basic Maintenance Schedule](#).
- Verify the unit is level.
- Verify there is no water inside, on, or near the unit; dry if needed.
- For grounding requirements, follow any local, state, or National Electrical Code (NEC) guidelines.
- Verify the control power switch is OFF (O).
- Verify all circuit breakers are OFF (O).
- Inspect all electrical cords; repair or replace any that are cut, worn, or bare.
- Verify oil, coolant, and fuel levels are correct, per the engine manufacturer's manual.
- Verify battery connections are secure.
- Turn the battery disconnect switch ON (if equipped).
- Verify engine fan belt tension and condition are within spec.
- Verify engine fan belt guard is installed and secure.
- Check engine exhaust system for loose or rusted components.
- Verify the radiator and surrounding shroud are clear of debris.
- Verify all covers are in place and secure.

- Verify all electrical connections at the connection lugs, if equipped, are tight and wired correctly.
- Verify the voltage selector switch is set to the desired voltage and locked.
- Verify the emergency stop switch is pulled out.
- Verify all doors on the unit are closed.

## Manually Starting the Unit



### ⚠️ DANGER

Asphyxiation. Running engines produce carbon monoxide, a colorless, odorless, poisonous gas. Carbon monoxide, if not avoided, will result in death or serious injury. (000103)



### ⚠️ WARNING

Fire risk. Fuel and vapors are extremely flammable. Do not operate indoors. Doing so could result in death, serious injury, or property or equipment damage. (000281)

Operating the unit in MANUAL mode allows the operator to start and stop the unit from the controller using the engine START and STOP buttons.

To start unit in MANUAL mode:

1. Set controller power to ON (I). The controller begins its boot sequence. When controller is ready, the Home page displays.

**NOTE:** The controller boots in STOP mode, as indicated at the top of the screen.

**NOTE:** If starting the unit in cold ambient temperatures, it is recommended to start the unit at low idle, and allow the engine to heat up the lubricating oil. For more information, see [Low Idle Switch](#).

**NOTE:** The controller can be started from any screen when it is in MANUAL mode.

2. Press engine START (I) button. The controller begins the engine startup sequence and starts the engine—provided no engine faults prevent starting.

**NOTE:** It takes several seconds for the engine to warm (run smoothly and reach its operating speed). During warming, the screen displays a different voltage than the voltage selector switch.

3. If the engine does not start within three crank attempts, the controller will display the failed start alarm. The starting sequence can be repeated after the starter has had a minimum of two minutes to

cool. Pressing the ENTER (✓) button will clear the alarm and reset the controller.

**NOTE:** Engine preheat is controlled by the ECU.

- When the engine starts, it accelerates to operating speed. If the Low Speed Idle switch is ON, the engine accelerates to the low idle speed set-point.

**IMPORTANT NOTE:** Allow the engine to warm for approximately 10 minutes. Failure to properly warm the engine prior to loading can cause premature engine wear or failure.

- When engine is warm, turn OFF the Low Idle Speed switch.
- Check the generator for excessive noise or vibration and any coolant, oil, or fuel leaks before applying any loads.
- Verify the AC output voltage is correct. See [Fine Voltage Adjustment](#).
- Verify generator frequency (Hz) is correct on the generator screen. The frequency should be the rating specified on the unit data tag.
- If all wiring connections have been made correctly, switch the main circuit breaker to ON (I), and then add any loads attached to the receptacles by switching the respective circuit breaker to the ON (I) position. A slight change in engine sound when a load is applied to the unit is normal.

## AUTO (Remote) Starting the Unit

AUTO mode allows the operator to start and stop the unit by closing the remote start contacts (on the lug panel), programming a schedule stop sequence in the controller, or through a telemetry signal (if equipped).

**NOTE:** When in AUTO mode, the STOP button can be pressed to stop the unit.

Review the [Pre-start Checklist](#) and [Manually Starting the Unit](#) before putting the unit in AUTO mode. Follow all safety warnings and review all information on isolating the generator with a transfer switch if the unit is to be used as a standby power supply. See [Shutting Down the Unit](#), then proceed as follows:

- Perform a manual start of the unit at least once to verify the engine and generator are operating correctly.
- To check the remote start circuit, remove the wires from the remote start terminal block. Press the AUTO button, and the display screen will show auto mode at the bottom of the screen.
- Attach a jumper wire (minimum 16 gauge) across the two terminals on the remote start terminal block. This applies a ground to the controller to close the starting circuit contacts. The engine will crank, start, and run.

- Remove the jumper wire from the remote start terminal block and the engine runs the stop sequence. Reconnect any necessary wires from the remote start switch (transfer switch) to the remote start terminal block.
- Verify the unit is in AUTO mode. The display screen should show AUTO mode at the top of the screen.
- Secure the unit by closing and locking all access doors.
- The unit is now ready for remote starting.

See [Figure 3-1](#). The remote start terminal block provides a connection for installation of a remote start switch which will allow the unit to be started by a remote dry-contact closure switch. For location of the remote start terminal block, see [Figure 2-5](#).

Before entering AUTO mode, verify the contacts on any remote switch linked to the unit are open. If the contacts on a remote switch are closed, the engine will crank and start when AUTO mode is entered. Attach the switch leads to the two unused terminals (A) on the unit's remote start terminal block.

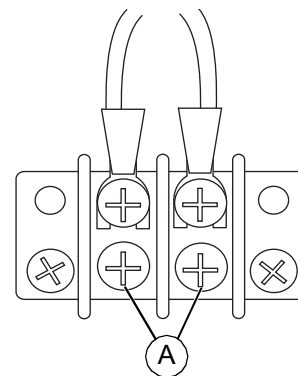

002806

**Figure 3-1. Remote Start Terminal Block**

## Wet Stacking

The unit is powered by a diesel engine. Diesel engines are susceptible to wet stacking if lightly loaded. Wet stacking occurs when an engine is run at less than 30% of its full load capacity, causing unburned fuel to accumulate in the exhaust system. Wet stacking can be detected by continuous black exhaust when the unit is under a constant load. It can also cause fouling of injectors and buildup on engine valves. Diesel engines operate properly when applied loads are between 30% and 100% capacity. Appropriate generator sizing is determined by the anticipated load.

## Low Idle Switch

Engine idle speed is 1,000 to 1,200 rpm. The engine will start at idle speed and run at idle for 15 seconds no matter what position the idle switch is in. After 15 seconds of running at idle, the unit will ramp up to 1,800 rpm if the idle switch is OFF. Otherwise the unit will continue to idle if the idle switch is ON.

When the engine is at idle speed (1,000 rpm), the voltage regulator will not function and the output voltage is dropped out by the voltage regulator.

**IMPORTANT NOTE:** Do not apply load to the unit when the engine is running at idle speed.

## Cold Weather Operation

This unit may be equipped with cold-weather starting aids such as coolant heater, oil pan heater, crankcase ventilation heater, battery heater, and fuel heater.

See [Figure 3-2](#). Starting aids are required below 32°F (0°C). They will enhance starting performance below these temperatures and may be needed to start applications that have high parasitic loads during cranking and start acceleration to idle. Other cold weather starting aids are required at temperatures below -13°F (-25°C) or at altitudes above 5,000 ft (1,500 m).

The use of correct grade oil is critical to achieving adequate cold weather cranking speed. Synthetic oils have improved flow at low temperatures.

**NOTE:** Contact a GMASD or refer to the applicable engine service manual for more information.

The oil pan heater, crankcase ventilation (CCV) heater, and fuel filter heater (if equipped); are activated with a thermostat and will turn on and off as needed. The block heater is powered by a shore power 120V electrical connection that can be found in the convenience receptacle. The CCV heater is powered by the generator and will stay on when the engine is operating in cold weather conditions. This heater is required for operation below 32 °F (0 °C).



**⚠ DANGER**

Explosion. Do not use ether when starting an engine equipped with glow plugs or an air intake heater. Doing so could cause an explosion, which will result in death or serious injury. (000583)

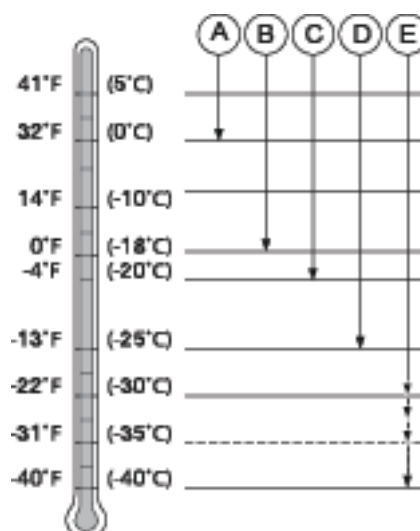

010913

**Figure 3-2. Cold Weather Starting Guidelines**

<b>A</b>	Fuel filter heaters
<b>B</b>	Fuel filter heaters, CCV heater
<b>C</b>	Fuel filter heaters, CCV heater, oil pan heater
<b>D</b>	Fuel filter heaters, CCV heater, oil pan heater, block heater
<b>E</b>	Fuel filter heaters, CCV heater, oil pan heater, block heater, 60/40 coolant

Use cold weather starting aids as needed according to [Figure 3-2](#). Follow supplier instructions for starting aids provided on engine. A booster battery can be connected if needed (see [Using a Booster Battery or Charger \(if equipped\)](#)).

**NOTE:** Turn key to ON but do not crank engine until Engine Preheat Indicator goes off.

**NOTE:** Additional information on cold weather operation is available from your local GMASD.

## Using a Booster Battery or Charger (if equipped)



### ⚠️ WARNING

Explosion. Batteries emit explosive gases while charging. Keep fire and spark away. Wear protective gear when working with batteries. Failure to do so could result in death or serious injury.

(000137a)



### ⚠️ WARNING

Risk of burns. Batteries contain sulfuric acid and can cause severe chemical burns. Wear protective gear when working with batteries. Failure to do so could result in death or serious injury.

(000138a)



### ⚠️ CAUTION

Equipment damage. Do not make battery connections in reverse. Doing so will result in equipment damage.

(000167a)

See [Figure 3-3](#). A 12 volt booster battery can be connected in parallel with batteries on the unit to aid in cold weather starting. ALWAYS use heavy-duty jumper cables.

### Parallel:

- Amps = Twice as a single battery
- Volts = Same as single battery

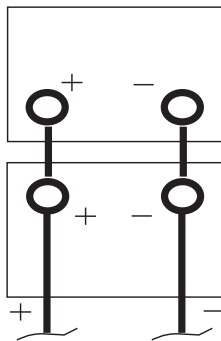

004508

**Figure 3-3. Parallel**

1. Connect booster battery or batteries to produce the required system current.

**NOTE:** To avoid sparks, do not allow the free ends of jumper cables to touch engine.

2. Connect one end of jumper cable to the POSITIVE (+) post of the booster battery.
3. Connect the other end of the jumper cable to the POSITIVE (+) post of battery connected to starter.
4. Connect one end of the other jumper cable to the NEGATIVE (-) post of the booster battery.

5. Complete the hookup by making the last connection of the NEGATIVE (-) cable to a good ground on the engine frame and away from the batteries.
6. Start the engine. Disconnect jumper cables immediately after engine starts. Always disconnect NEGATIVE (-) cable first.

## Generator Output Connections

### ⚠️ DANGER

Electrical backfeed. Use only approved switchgear to isolate generator from the normal power source. Failure to do so will result in death, serious injury, and equipment damage.

(000237)



### ⚠️ DANGER

Electrocution. Do not disable or modify the connection box door safety switch. Doing so will result in death or serious injury.

(000157)



### ⚠️ DANGER

Electrocution. Before connections are made to the unit, verify the main circuit breaker and battery disconnect switch are OFF. Failure to do so will result in death or serious injury.

(000156)

### ⚠️ WARNING

Electric shock. Only a trained and licensed electrician should perform wiring and connections to unit. Failure to follow proper installation requirements could result in death, serious injury, and equipment or property damage.

(000155a)

The installation should be in compliance with the national electrical code (NEC), state, and local regulations.

See [Figure 3-4](#). The unit is equipped with connection lugs (A), located on the lower portion of the control box behind the lug box door. The lugs provide connection points to attach external loads to the generator. A large decal on the inside of the connection lug door details the proper connections for selected voltages.

Connections to the lugs should be made by running the power cables up through the opening in the bottom of the box.

**IMPORTANT NOTE:** Do not make any connections directly to the lugs without routing the cables through the opening. Use a hex-wrench to tighten the cable connections.



The connection lug door is equipped with safety interlock switches that will trip the main circuit breaker and disable the voltage regulator if the door is opened while the unit is operating.

A ground connection (B) is located next to the connection lugs. The unit must be connected to ground for proper operating safety. The generator neutral is bonded to ground when it is shipped from the factory. The bonding plate must be removed when the generator is used as a standby power source.

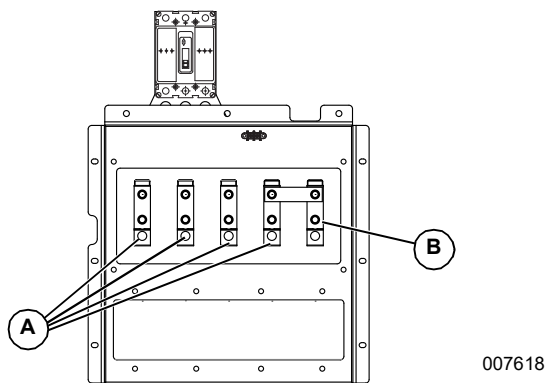

Figure 3-4. Generator Connection Lugs

## Generator Cam Lock Connections (If Equipped)



**⚠ DANGER**

Electrocution. Before connections are made to the unit, verify the main circuit breaker and battery disconnect switch are OFF. Failure to do so will result in death or serious injury.

(000156)

**⚠ DANGER**

Electrical backfeed. Use only approved switchgear to isolate generator from the normal power source. Failure to do so will result in death, serious injury, and equipment damage.

(000237)



**⚠ WARNING**

Electric Shock. Verify all connections to the cam lock receptacles are made to one side only. Failure to do so could result in death, serious injury and property damage.

(000308)

**⚠ WARNING**

Electric shock. Only a trained and licensed electrician should perform wiring and connections to unit. Failure to follow proper installation requirements could result in death, serious injury, and equipment or property damage.

(000155a)

See **Figure 3-5**. The unit may be equipped with cam lock connections (A), which are for powering external electrical loads. Decals below the receptacles display the proper connections for selected voltages.

L1	Black
L2	Red
L3	Blue
N (Neutral)	White
G (Ground)	Green

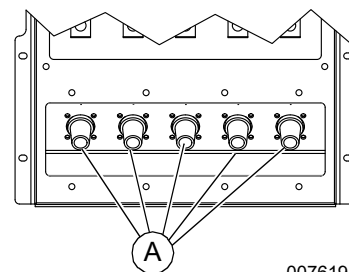

007619

Figure 3-5. Cam Lock Connections

Connections should be made by plugging power cables equipped with series 16 taper nose 400A/600V cam lock plugs into the cam lock receptacles. Secure the connection by rotating the plug 1/2 turn to the right.



**⚠ DANGER**

Electrocution. Do not disable or modify the connection box door safety switch. Doing so will result in death or serious injury.

(000157)

A ground connection is located on the far right of the cam lock panel. The unit must be connected to a good earthen ground for proper operating safety. The generator neutral is bonded to ground when it is shipped from the factory. The bonding plate must be removed when the generator is used as a standby power source. Installation should be in compliance with the National Electrical Code (NEC), state, and local regulations.

## Using the Voltage Selector Switch



**⚠ WARNING**

Electric Shock. Never change the voltage selector switch while the engine is running or the controller is on. Doing so could result in death, serious injury or equipment damage.

(000302)

1. Shut down the unit according to **Shutting Down the Unit**.
2. Remove padlock from voltage selector switch lockout device.
3. Move voltage selector switch to desired voltage.
4. Replace and lock padlock on voltage selector switch lockout device.
5. Start the unit according to **Manually Starting the Unit** or **AUTO (Remote) Starting the Unit**.

## Fine Voltage Adjustment

See [Figure 3-6](#). The potentiometer (A) allows manual voltage adjustment of  $\pm 10\%$ .

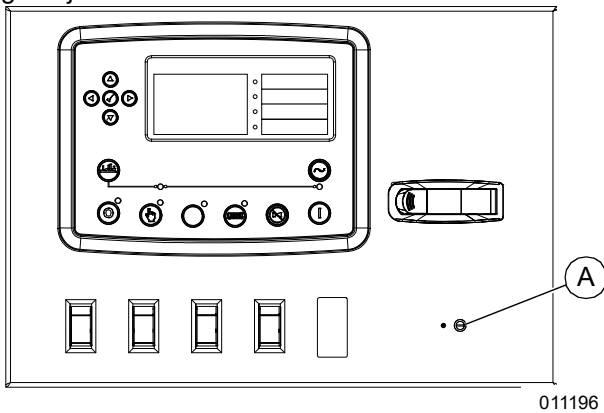

Figure 3-6. Potentiometer

## Voltage Regulator

The analog voltage regulator controls the output of the generator by regulating the current into the exciter field. The voltage regulator is adjusted before shipment from the factory. The regulator has four screwdriver adjustable potentiometers that may be adjusted for under frequency roll-off (U/F), U/F dip (DIP), stability (STAB), and voltage (VOLT). Contact a GMASD for additional information before attempting to adjust the voltage regulator.

**NOTE:** For units equipped with a Marathon DVR2000E+ automatic voltage regulator, see the Marathon operating manual provided with the unit.

## Customer Convenience Receptacles



Equipment Damage. Verify voltage application before making changes to factory settings. Incorrect voltage applied to a load could result in equipment damage. (000303)

See [Figure 3-7](#). The unit is equipped with five receptacles. The 240/120V twist-lock receptacles are rated at 50A each. The 120V GFCI receptacles are rated at 20A each, with ground fault circuit interrupt (GFCI) protection. The receptacles are not routed through the main circuit breaker. Each receptacle has its own circuit breaker, located directly above or next to the receptacle. Each breaker is sized to the maximum rating of the corresponding receptacle.

**NOTE:** Power to the receptacles is available any time the generator is running, even if the main circuit breaker is OFF (O). Verify equipment connected to the receptacles is turned OFF before turning the breakers ON (I).

**NOTE:** When the voltage selector switch is in position for 480/277V three-phase, voltage at the two GFCI receptacles is 139 volts and the voltage at the three twist-lock receptacles is 240/139 volts. Generac Mobile does not recommend using the receptacles in the 480V position. When the voltage selector switch is in position for 208/120V three-phase, voltage at the two twist-lock receptacles and the two GFCI receptacles is 208/120 volts.

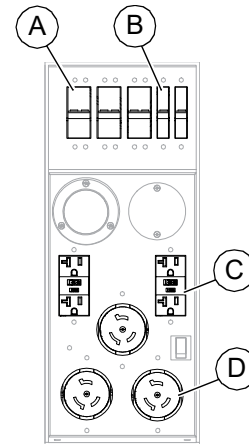

Figure 3-7. Customer Convenience Receptacles

<b>A</b>	50 A circuit breaker (3 locations)
<b>B</b>	20 A circuit breaker (2 locations)
<b>C</b>	120 V GFCI receptacle (2 locations)
<b>D</b>	120/240 V twistlock receptacle (3 locations)

## Main Circuit Breaker

The main circuit breaker is located on the main control panel. See [Figure 3-8](#). When the breaker is OFF (O), power is interrupted to the connection lugs and optional cam lock receptacles.

**IMPORTANT NOTE:** When the breaker is open, the generator is powered.

The breaker may be switched ON (I) once the connections have been made to the connection lugs or the optional cam lock receptacles, and the unit has been started and allowed to reach normal operating temperature.

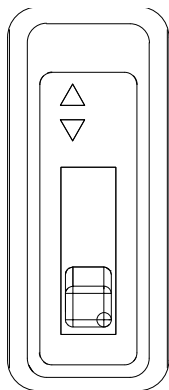

**Figure 3-8. Main Circuit Breaker**

010493

Reasons the main circuit breaker may trip:

- Overload of generator circuits to connection lugs or optional cam lock receptacles.
- Door covering connection lugs or optional cam lock receptacles is open.
- Unit is in idle.
- Emergency stop switch is active.
- Phase switch door is open.

Verify any problems that cause the main circuit breaker to trip are corrected before returning the switch to ON (I).

**NOTE:** The main circuit breaker only interrupts power to the connection lugs and the optional cam lock receptacles. The customer convenience receptacles have power even if the main circuit breaker is OFF (O). Use the individual circuit breakers located near each receptacle to disconnect power to these receptacles.

## Transfer Switch

### **⚠ DANGER**

Loss of life. Property damage. Installation must always comply with applicable codes, standards, laws and regulations. Failure to do so will result in death or serious injury. (000190)

### **⚠ DANGER**

Electrical backfeed. Use only approved switchgear to isolate generator from the normal power source. Failure to do so will result in death, serious injury, and equipment damage. (000237)

### **⚠ WARNING**

Electric shock. Only a trained and licensed electrician should perform wiring and connections to unit. Failure to follow proper installation requirements could result in death, serious injury, and equipment or property damage. (000155a)



### **⚠ WARNING**

Electric shock. Phase rotation must be compatible. Incompatible phase rotation could result in death, serious injury, or equipment damage. (000226b)

The installation should be in compliance with the National Electrical Code (NEC), state, and local regulations.

Before any connections are attempted, verify the main circuit breaker and the control power switch are in the OFF (O) position and that the negative (-) battery cable has been disconnected from the battery.

Installation of such devices must be performed by following all directions supplied by the manufacturer of the switch. If attaching the unit to a power supply normally serviced by a utility company, notify the utility company and check state and local regulations. Familiarize yourself with all instructions and warning labels supplied with the switch.

When the unit is used as a standby power supply, it must be equipped with a transfer switch that isolates it from the utility's distribution system. A transfer switch is designed to transfer electrical loads from the normal power source (utility) to the emergency power source (generator) when normal voltage falls below a prescribed level. The transfer switch automatically returns the load back to the normal source when power is restored back to operating levels.

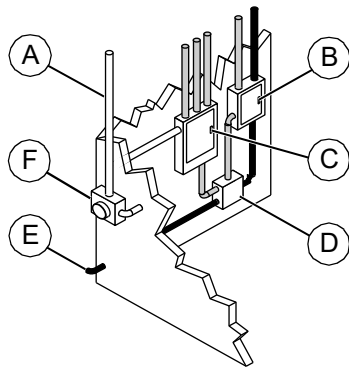

002807

**Figure 3-9. Transfer Switch Operation**

<b>A</b>	Incoming utility power
<b>B</b>	Emergency distribution panel (generator power)
<b>C</b>	Main distribution panel (utility power)
<b>D</b>	Transfer switch
<b>E</b>	Power from generator
<b>F</b>	Utility meter
<b>WHITE</b>	Incoming utility power
<b>GRAY</b>	Normal utility power circuit
<b>BLACK</b>	Emergency generator power circuit

### Alternate Load Device (ALD)

The ALD system mitigates wet-stack and low-load conditions by increasing engine load. It monitors generator load, activating when power capacity is under-utilized, and deactivating when generator is appropriately loaded—or as needed, to maintain appropriate engine temperature.

The ALD device is a fluid (coolant) shearing device, routing some coolant from the engine to the cylinder head. The device is belt driven, powered by the crankshaft pulley.

See [Maintenance](#) for maintenance requirements.

### Changing Exercise Timers

If exercise timers or scheduled runs are needed, contact a GMASD for assistance.

### Shutting Down the Unit

Prior to shutting down the unit, check with personnel using power supplied by the generator and let them know the power is going to be turned off. Verify the power shut

down will not create any hazards by accidentally turning off equipment that needs to be kept on (pumps, compressors, lights, etc.).

1. Remove all loads from the generator by opening all circuit breakers (turn OFF (O)).
2. Allow engine to run for approximately five minutes to allow it to cool down.
3. Press the red engine STOP (O) button on the controller. This will result in the generator going into the shutdown cycle. If the unit does not shut down within 15 seconds, a stop fail alarm will be displayed on the display screen.
4. After the unit shuts down, wait two minutes after engine shutdown for controller actuated actions to complete and then set the control power switch to OFF (O).

**NOTE:** Turning off the control panel before the controller finishes updating could cause a loss of data.

**NOTE:** For extended storage time, disconnect the battery. See the engine operator’s manual for extended storage requirements.

### Emergency Stop Switch



Equipment Damage. The emergency stop switch is not to be used to power down the unit under normal operating circumstances. Doing so could result in equipment damage. (000246b)

See [Figure 3-10](#). The unit is equipped with one emergency stop switch. The red button is clearly labeled EMERGENCY STOP. The switch can be accessed and activated with all doors closed and locked.

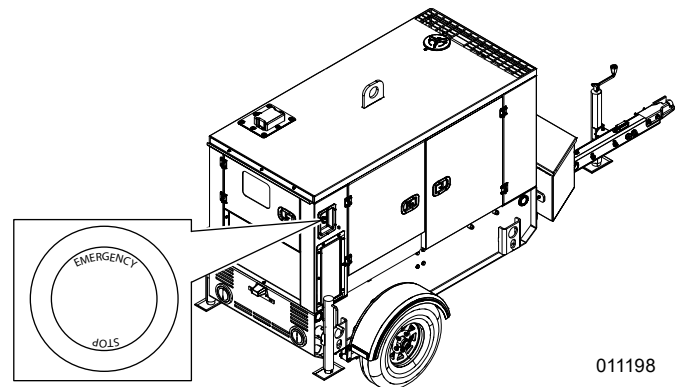

011198

**Figure 3-10. Emergency Stop Switch**

Activate the emergency stop switch by pushing the button in until it locks down. This trips the main circuit breaker which then opens the contact, disconnecting the load to the connection lugs. This will also open the fuel circuit, shutting down the engine. The emergency stop fault will be displayed on the control panel. The switch will remain closed until it is pulled out.

## Using the ECU Override Switch

### CAUTION

Equipment Damage. Do not start the engine with the Engine Control Unit (ECU) override switch ON. Doing so will damage the ECU.

(000305)

**IMPORTANT NOTE: Starting the engine with the ECU override switch ON will not allow the engine to shut down properly using the Engine STOP Button. This must only be used when the engine is OFF.**

See [Genset Controller](#) for location of the ECU override switch. This toggle switch powers up the ECU without having to start the engine. Use the ECU override switch to turn the ECU OFF. If the unit needs to be shut down immediately, use the emergency stop switch. See [Emergency Stop Switch](#).

## Positive Air Shutoff (PAS) Valves

Positive air shutoff (PAS) valves are offered as an option for the mobile diesel generators for industries that require them for specific job sites. The PAS valve will quickly starve the engine of air which will result in a safe and effective emergency shutdown of the engine and generator in the event of an engine over-speed situation. When installed, the PAS will be automatically activated via the generator controller logic when engine speed exceeds 2100 rpm. When activated, the valve will receive a signal from the controller to close and it will remain closed for 15 seconds. A message will also appear on the controller display "Positive Air Shutdown". This is to inform the operator that a PAS shutdown has occurred. When an emergency shutdown has been performed via the PAS, the engine should be inspected prior to a restart to verify if permanent damage or catastrophic failure has occurred.

If the unit is equipped with a PAS, a test function has also been incorporated into the controller to validate functional operation of the PAS. This may be required by inspectors on some customer job sites. The "Test" button (black) on the control panel can be used to perform this test. In order to perform the test, the outlined procedure can be followed:

## PAS Test Procedure

1. Make sure generator battery is connected.
2. Put Controller Power Switch in "ON" position, Insure the engine is not running.
3. See [Figure 3-11](#). Once the controller is at home screen, push and hold the black "Test" (A) button on the control panel until the message "Positive Air Shutdown" is visible on the display. The button can then be released.

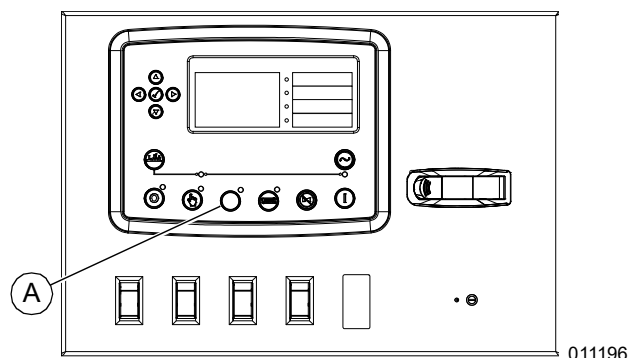

**Figure 3-11. PAS Test Button**

4. At that moment, the PAS valve will actuate and stay closed for 15 seconds. During this period, the engine cranking feature is disabled and cannot be started.
5. During the test sequence the visual indicator on the end of the PAS butterfly valve assembly shaft can be viewed for proof of functionality.
6. After the test is completed, the PAS valve will open back up assuming the button is no longer depressed.
7. The shutdown message will need to be cleared in the same manner as any other shutdown. The unit is now ready to operate.
8. You are not able to retest while in Shutdown state.

## Towing the Unit

### ⚠️ WARNING

Personal injury. Trailer must be securely coupled to the hitch with the chains correctly attached. Uncoupled or unchained towing could result in death or serious injury.

(000233a)

### ⚠️ WARNING

Personal injury. Do not operate unit during transport. Doing so could result in death, serious injury, or property damage.

(000231a)

### ⚠️ WARNING

Crushing hazard. Verify unit is properly secured and on level ground. An unsecured unit can suddenly roll or move, causing death or serious injury.

(000234a)

1. Verify the engine is OFF.
2. Use the tongue jack to raise or lower the trailer onto the hitch of the towing vehicle. Lock the hitch coupling and attach the safety chains or cables to the vehicle. Release the jack locking pin and rotate the jack into the travel position. Verify the locking pin snaps into place.

**NOTE:** A film of grease on the coupler will extend coupler life and eliminate squeaking. Wipe the coupler clean and apply fresh grease each time the unit is towed.

3. Lubricate the grease fittings located on the leveling jacks to verify proper operation of the jacks. See [Jack Maintenance](#). For maintenance interval information, see [Basic Maintenance Schedule](#).
4. Connect trailer wiring to the tow vehicle. Check for proper operation of the directional and brake lights.
5. Verify all doors and hoods are properly latched.
6. Check for proper inflation of the trailer tires. Proper inflation is specified in [Specifications](#).
7. Check the wheel lugs. Tighten or replace any lugs that are loose or missing. If a tire has been removed for axle service or replaced, tighten the lugs in the order shown in [Figure 3-12](#) to the following specifications:
  - a. Start all lug nuts by hand.
  - b. First pass tighten to 20–25 ft-lb (27–33 Nm).
  - c. Second pass tighten to 50–60 ft-lb (67–81 Nm).
  - d. Third pass tighten to 90–120 ft-lb (122–162 Nm).

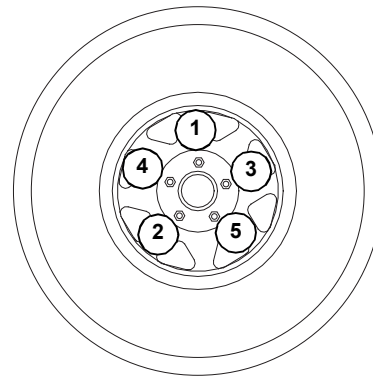

007620

**Figure 3-12. Lug Sequence**

### ⚠️ WARNING

Property or Equipment Damage. Tighten wheel lug nuts after first 50 miles to factory specifications. Failure to do so could result in death, serious injury, property or equipment damage.

(000235)

**NOTE:** Maximum recommended speed for highway towing is 45 mph (72 km/h). Recommended off-road towing speed is 10 mph (16 km/h), depending on the terrain.

## Lifting the Unit



### ⚠️ WARNING

Personal injury. Failure to properly connect lifting cables, chains, or straps could result in death, serious injury, or property damage.

(000346)

### ⚠️ WARNING

Personal Injury. Do not use lifting eye if there are signs of damage or corrosion. Doing so could result in death, serious injury, or property damage.

(000433)

### ⚠️ WARNING

Personal Injury. Do not use lifting eye other than as directed. Doing so could result in death, serious injury, or property damage.

(000434)

1. Verify the equipment being used to lift the unit is in good condition and has sufficient capacity. For approximate weights, see [Specifications](#).
2. Close and lock all hoods and doors.

**IMPORTANT NOTE:** Always remain aware of people and objects around the work site when moving or lifting the unit.

- See **Figure 3-13**. Use the unit lift point (A) according to guidelines below.

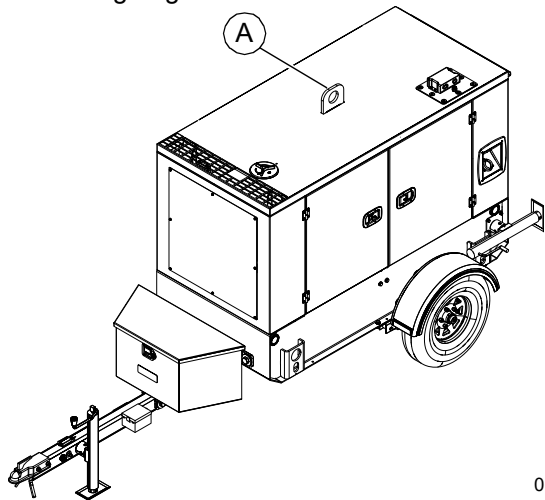

011188

**Figure 3-13. Unit Lift Point**

- Attach slings, chains, or hooks directly to the central lift point (A).

**NOTE:** This unit is not equipped with forklift pockets.

## Tying Down the Unit

When securing the unit for transportation, verify the equipment being used to fasten the unit is in good condition and has sufficient strength to hold the unit in place during transport.

See **Figure 3-14**. The unit is equipped with four tie-down points—two on each side (A).

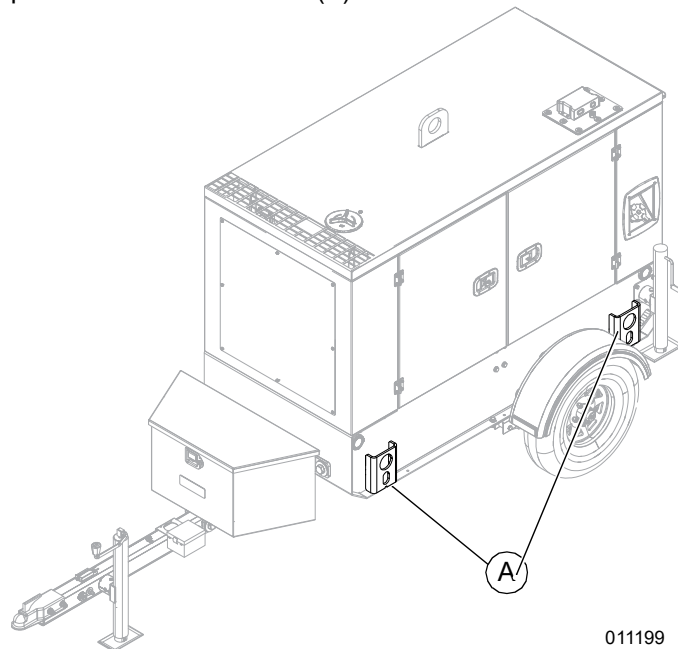

011199

**Figure 3-14. Tie-Down Points**

**This page intentionally left blank.**



# Section 4: Maintenance

---

## Emissions Information

For emissions information, see the OEM diesel engine manual.

## Maintenance

Regular maintenance will improve performance and extend engine/equipment life. Generac Mobile Products, LLC recommends that all maintenance work be performed by a Generac Mobile Authorized Service Dealer (GMASD). Regular maintenance, replacement, or repair of the emissions control devices and systems may be performed by any repair shop or person of the owner's choosing. To obtain emissions control warranty service free of charge, the work must be performed by a GMASD. See the emissions warranty.

## Daily Walk Around Inspection



Equipment Damage. Failure to perform a daily inspection could result in damage to the unit.

(000306)

Inspect for conditions that could hinder performance or safety, such as (but not limited to) oil, coolant, and fuel leakage, blocked vents, loose or missing hardware, and improper electrical connections.

Inspect the fan belt for signs of cracking, fraying, and stretching, and verify the belt is properly seated in the pulley grooves. Replace the belt according to the manufacturer's recommendations.

**NOTE:** At the 500 hour or 12 month service interval, it is recommended that the belt be removed and checked for wear. While the belt is removed, inspect pulleys and bearings. Rotate and feel for hard turning or unusual sounds. Contact the engine manufacturer if pulleys or bearings need replacement.

## Belt Tensioners

Isuzu engines use two types of belt tensioners: manual and automatic. Adjust the belt using the manual tensioner according to the manufacturer's specifications. The automatic tensioner cannot be adjusted or repaired and is designed to maintain proper tension over the belt's life. Units with an automatic belt tensioner must be inspected according to the manufacturer's specifications.

## General Maintenance

Poorly maintained equipment can become a safety hazard. Periodic maintenance and occasional repairs are necessary in order for the equipment to operate safely and properly over a long period of time. Never perform any routine service (oil and oil filter changes, cleaning, etc.) unless all electrical components are shut off. Before servicing the unit, always follow the instructions listed below.

- Verify the control power switch is turned OFF (O).
- Verify the circuit breakers are turned OFF (O).
- Activate (push in) the emergency stop switch.
- Disconnect the negative (-) terminal on the battery.
- Attach a DO NOT USE sign to the control panel. This signifies that the unit is being serviced and reduces the chance of someone inadvertently trying to start the unit.
- Do not wash the unit with a high pressure hose or with any kind of power washer.
- Do not wash the engine block or fuel tank with a power washer or steam cleaner. Water may enter the cabinet and collect in the generator windings or other electrical parts, causing damage.
- Inspect for water inside the cabinet and generator before each use if the unit is stored outside. If wet, dry the unit thoroughly before starting.
- Inspect condition of electrical cords. **DO NOT** use the unit if insulation is cut or worn through.
- Verify the condition of the air filter by viewing the level of the vacuum draw on the filter minder gauge. Replace the air filter when the yellow center bar reaches the red section on the gauge (20 in. H<sub>2</sub>O).
- Inspect wheel lugs. See [Towing the Unit](#).
- Inspect wheel bearings. See [Trailer Wheel Bearings](#).
- Inspect the wheel bearings for unusual wear.
- Inspect coolant level daily. See the engine operator's manual for coolant recommendations and proper mixture.
  - Visually inspect the level in the coolant overflow tank located near the radiator.
  - Normal operating level is between the FULL and ADD markings on the overflow jug.
  - When engine is stopped and completely cool, coolant may be added directly to the coolant overflow container.

- Check the oil level daily. See the engine operator’s manual for the proper viscosity grade of oil, including special operating conditions such as a change in season or climate.
  - **DO NOT** start the unit if the engine oil level is below the add mark on the dipstick.
  - Normal operating level is in the cross-hatch pattern between the FULL and ADD markings on the dipstick.
  - Add oil only if the oil level is below the ADD mark on the bottom of the cross-hatch pattern on the dipstick.
  - **DO NOT OVERFILL** the crankcase.
- Verify the fuel level.
- Verify the remote switch is also off and tagged if the unit is connected to a remote start or transfer switch.

**NOTE:** If the engine was run out of fuel, or the fuel tank was drained, it may be necessary to purge the fuel lines. See the engine operator’s manual supplied with the unit for more information.

### Engine Oil Recommendations

The engine oil should be serviced in accordance with the recommendations of this manual to maintain the product warranty.

The engine has been filled with factory engine oil of a grade recommended by the engine supplier.

Use a high quality detergent oil with an appropriate classification and viscosity for the engine type and ambient temperature conditions. Refer to [Figure 4-1](#) and [Figure 4-2](#)

**NOTE:** Contact a GMASD or refer to the applicable engine service manual for more information.

Temperature °C (°F)	-30 (-21)	-15 (5)	30 (86)
Engine oil viscosity	SAE 10W-30		
	SAE 10W-40		
	SAE 15W-40		

**Figure 4-1. Engine Oil Viscosity Recommendations**

Lubrication	Grade		
	API	ACEA	JASO
Diesel engine crankcase	CJ-4	E6 E9	DH-2

**Figure 4-2. Engine Oil Grade Recommendations**

### Coolant Recommendation



**DANGER**

Risk of poisoning. Do not use mouth to siphon coolant. Doing so will result in death or serious injury.

(000149)



**WARNING**

Risk of burns. Do not open coolant system until engine has completely cooled. Doing so could result in serious injury.

(000154)

**CAUTION**

Risk of overheating. Do not use any chromate base rust inhibitor with propylene glycol base antifreeze, boosters, or additives. Doing so will cause overheating and possible equipment damage.

(000165a)

Contact a GMASD or refer to the applicable engine service manual for engine coolant recommendations. See table below for mixtures:

Environmental Temperature—°F (°C)	-12 (-24)	-34 (-36)	-54 (-48)	-90 (-67)
Water (% Volume)	50	40	40	40
Antifreeze (% Volume)	50	60	60	60*

\* Maximum freeze protection is at 60%.

### Basic Maintenance Schedule

See the original equipment manufacturer’s operating manual for a complete list of maintenance requirements. Failure to comply with the procedures as described in the engine operator’s manual will nullify the warranty, decrease performance, and cause equipment damage or premature equipment failure. Maintenance records may be required to complete a warranty request.

**IMPORTANT NOTE:** Refer to the engine operator’s manual for additional maintenance information.

### Basic Maintenance Schedule

Item	Daily	First 50 Hr (Break-in Period)	Every 250 Hr	Every 500 Hr	Every 2,000 Hr	As Required
Check engine oil level	◆					
Check engine coolant level	◆					
Check fuel level	◆					
Drain fuel filter	◆					
Check tire pressure	◆					
Check all electrical connections	◆					
Clean battery	◆					
Check fan belt tension (replace if necessary)	◆					
Check ALD drive belt tension	◆					
Inspect radiator fins for debris; clean as required	◆					
Pre-heating condition check	◆					
Check engine starting and noise conditions	◆					
Check exhaust smoke condition	◆					
Perform <b>Daily Walk Around Inspection</b>	◆					
Replace engine oil		◆		◆		
Replace fuel filter elements				◆*		
Clean water sediment element				◆*		
Electromagnetic pump filter replacement or cleaning				◆*		
Oil filter element replacement		◆		◆		
Replace air filter element				◆		
Lubricate leveling jacks				◆		
<b>Checking Generator Drive Plate Torque</b>				◆		
Replace fan/ALD drive belt					◆	

\* If the unit is operated in a harsh environment or fuel quality is questioned, replace every 250 hours instead of every 500 hours.

## Engine Break-In Requirements

**NOTE:** During the first 20 hours of operation, avoid long periods of no load or sustained maximum load operation. If the generator is to run for longer than five minutes without a load, shut down the generator.

Operate the engine at heavy loads (60–90% of maximum) as much as possible. If the engine has spent significant time at idle, constant speed(s), or light load, or if makeup oil is required, a longer break in period may be needed. Refer to the engine operator's manual for a full description of necessary procedures on the addition of break-in oil and extension of the break-in period. For more information on regular maintenance intervals, refer to **Basic Maintenance Schedule**.

## Checking Generator Drive Plate Torque

1. Disconnect battery.
2. Remove generator fan guard.
3. Tighten each of the drive plate bolts to 27 ft-lbs (36 Nm).
4. Install generator fan guard.
5. Connect battery.

## ALD System Maintenance

See basic maintenance schedule, above, for ALD maintenance requirements.

## Resetting Maintenance Alarms

Maintenance alarms indicate a regular-maintenance service interval is expired. To resolve the condition, perform the indicated service, then re-set the corresponding service interval.

To re-set a service interval:

1. Display the Engine page.
2. Scroll (▲ or ▼) until the appropriate service interval is highlighted.

**NOTE:** The expired interval displays on the Alarm page.

3. Press and hold the Engine STOP/RESET Mode button until **###\* hr service** changes to **0 hr service**.

*\*A number displays. The value varies according to what service interval is highlighted.*

## Jack Maintenance

The following procedures should be performed annually.

### Side-Wind Models

- The internal gearing and bushings of the jack must be kept lubricated. Apply a small amount of automotive grease to the internal gearing by removing the jack cover, or if equipped, use a needle nose applicator or standard grease gun on the lubrication point on the side of the jack near the crank. Rotate the jack handle to distribute the grease evenly.
- A lightweight oil must be applied to the handle unit at both sides of the tube.
- If equipped, the axle bolt and nut assembly of the caster wheel must also be lubricated with the same lightweight oil.

### Top-Wind Models

- Apply a lightweight oil to the screw stem.

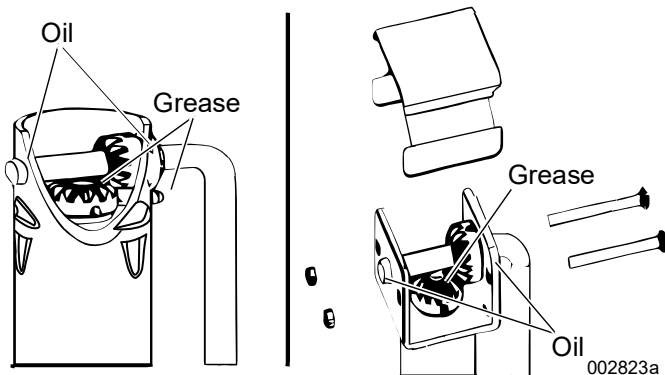

002823a

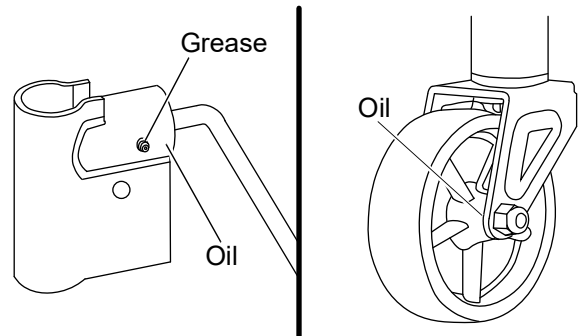

002824a

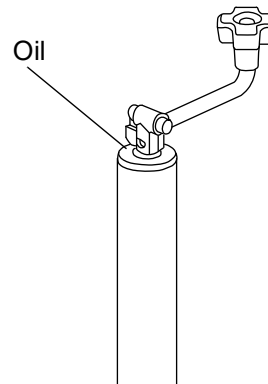

002825a

**Figure 4-3. Lubrication Points**

## Trailer Wheel Bearings

The trailer axles are equipped with a grease fitting to allow lubrication of the wheel bearings without needing to disassemble the axle hub. To lubricate the axle bearings, remove the small rubber plug on the grease cap, attach a standard grease gun fitting to the grease fitting, and pump grease into the fitting until new grease is visible around the nozzle of the grease gun. Use only a high quality grease made specifically for lubrication of wheel bearings. Wipe any excess grease from the hub with a clean cloth and replace the rubber plug when finished. The minimum recommended lubrication is every 12 months or 12,000 miles (19,312 km). More frequent lubrication may be required under extremely dusty or damp operating conditions.

# Section 5: Troubleshooting

## General Troubleshooting

This information is intended to be a check or verification for simple causes that can be located and fixed. It does not cover all types of problems. See the engine operator's

manual for additional troubleshooting information. Procedures that require in-depth knowledge or skills should be performed by a GMASD.

Problem	Possible Cause	Solution
Low fuel level shutdown	Low fuel level	Check fuel level in LCD window of controller.
	Unit not level	Confirm that unit is sitting level to ensure an accurate reading.
	Fuel tank leaking	Check tank for leaks.
	Damaged fuel sender or wiring	Check for continuity between sender and engine controller. (See <a href="#">Wiring Diagrams</a> .)
Low oil pressure shutdown	Low oil level	Check oil level on dipstick. Add oil, if needed.
	Oil leaking from engine	Visually inspect the engine for leaks. Restart unit and verify loss of pressure. Shut down immediately if pressure does not reach 5 psi (34 kPa) within five seconds.
	Oil pressure sender	See engine operator's manual to identify corrective action.
Low coolant level shutdown	Low coolant level	Allow engine to cool, then check coolant level in radiator. Add coolant, if needed.
	Coolant hoses leaking	Inspect hoses for leaks. Repair or replace as necessary.
	Engine block or water pump leaking	Visually inspect for leaks. Verify no coolant has mixed with the engine oil (oil will appear milky). See engine operator's manual for additional information.
High coolant temperature shutdown	Low coolant level	Allow engine to cool, then check coolant level in radiator. Add coolant if needed. Restart engine and check coolant temperature (on controller). Stop engine immediately if coolant temperature is 203 °F (95 °C) or higher.
	Blockage in radiator	Check radiator shroud and ducting for blockage and remove any foreign matter.
	Leakage in coolant hoses, engine block, or water pump	Inspect for visible leaks. Check tension of water pump serpentine drive belt. Remove load on generator and restart engine. Check coolant temperature and shut engine down immediately if it starts to overheat 210° F (99° C). See the engine operator's manual for additional information on engine overheating.
Overcrank shutdown	Fuel level low	Check fuel level in tank. Check fuel pump operation.
	Blocked air filter	Check air filter for blockage.  NOTE: See OEM engine manual for more information.

**This page intentionally left blank.**



# Control Box (1 of 2)

## GROUP G

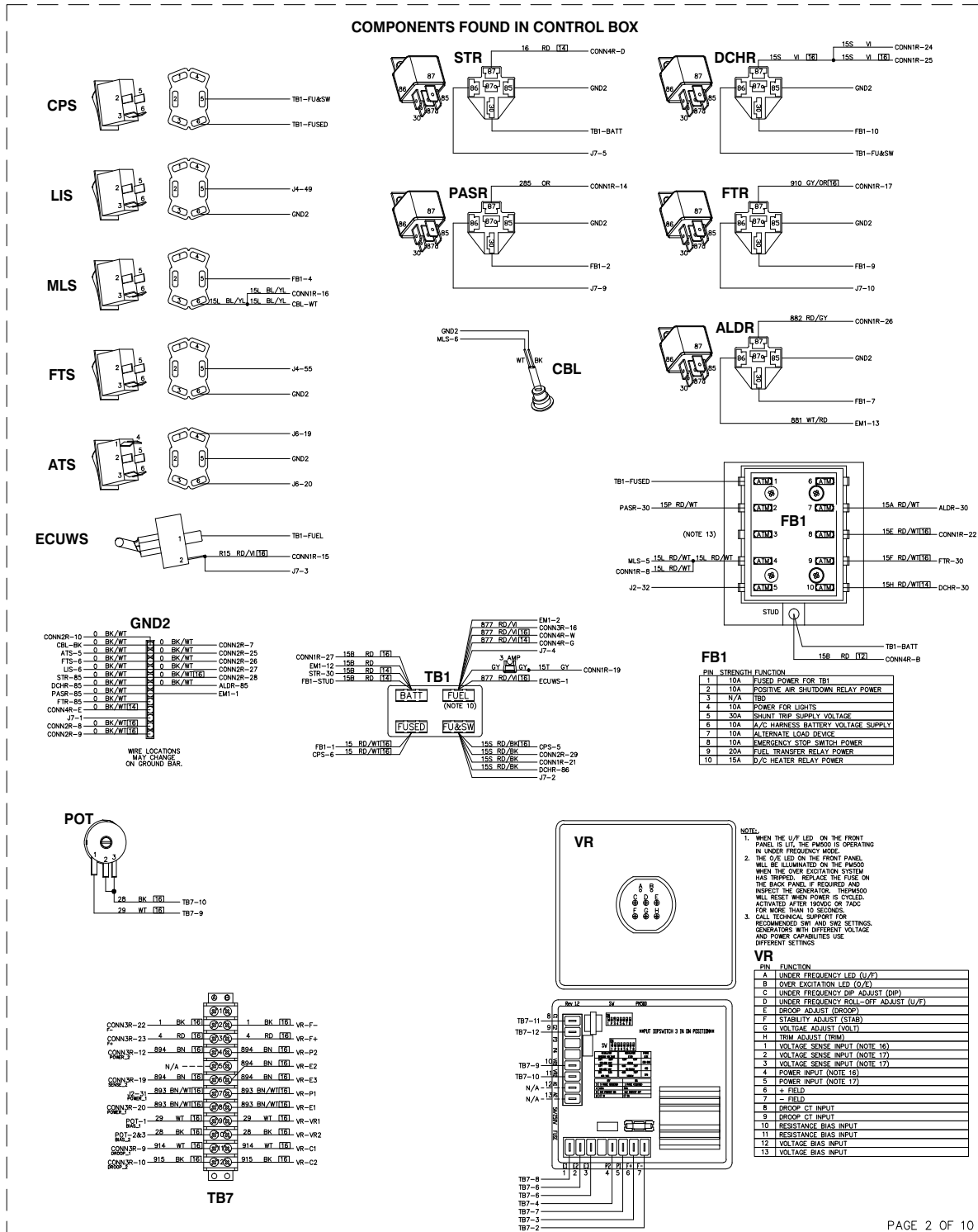



# Control Box (2 of 2)

## GROUP G

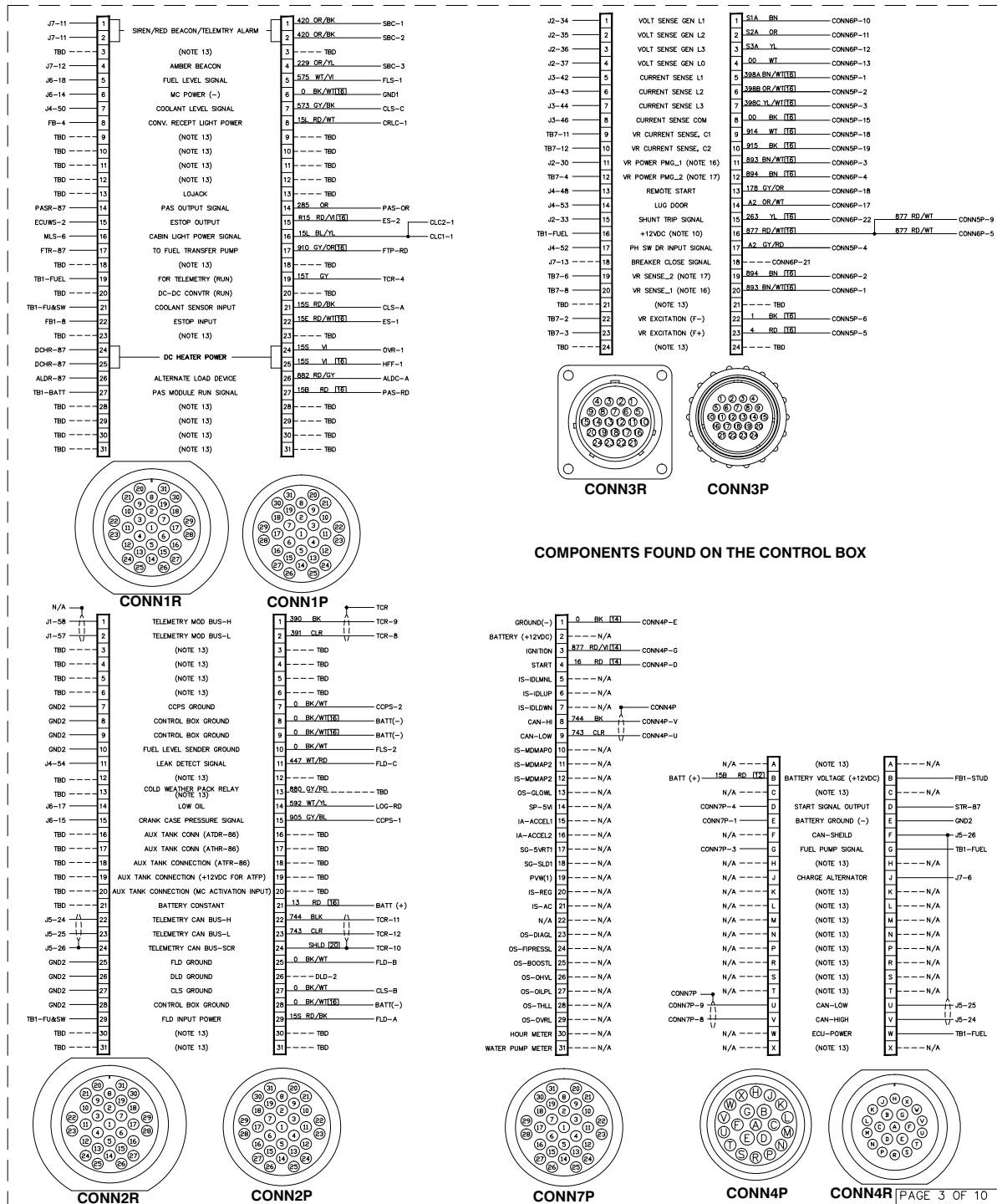

COMPONENTS FOUND ON THE CONTROL BOX

# Generator Cabin (1 of 2)

## GROUP G

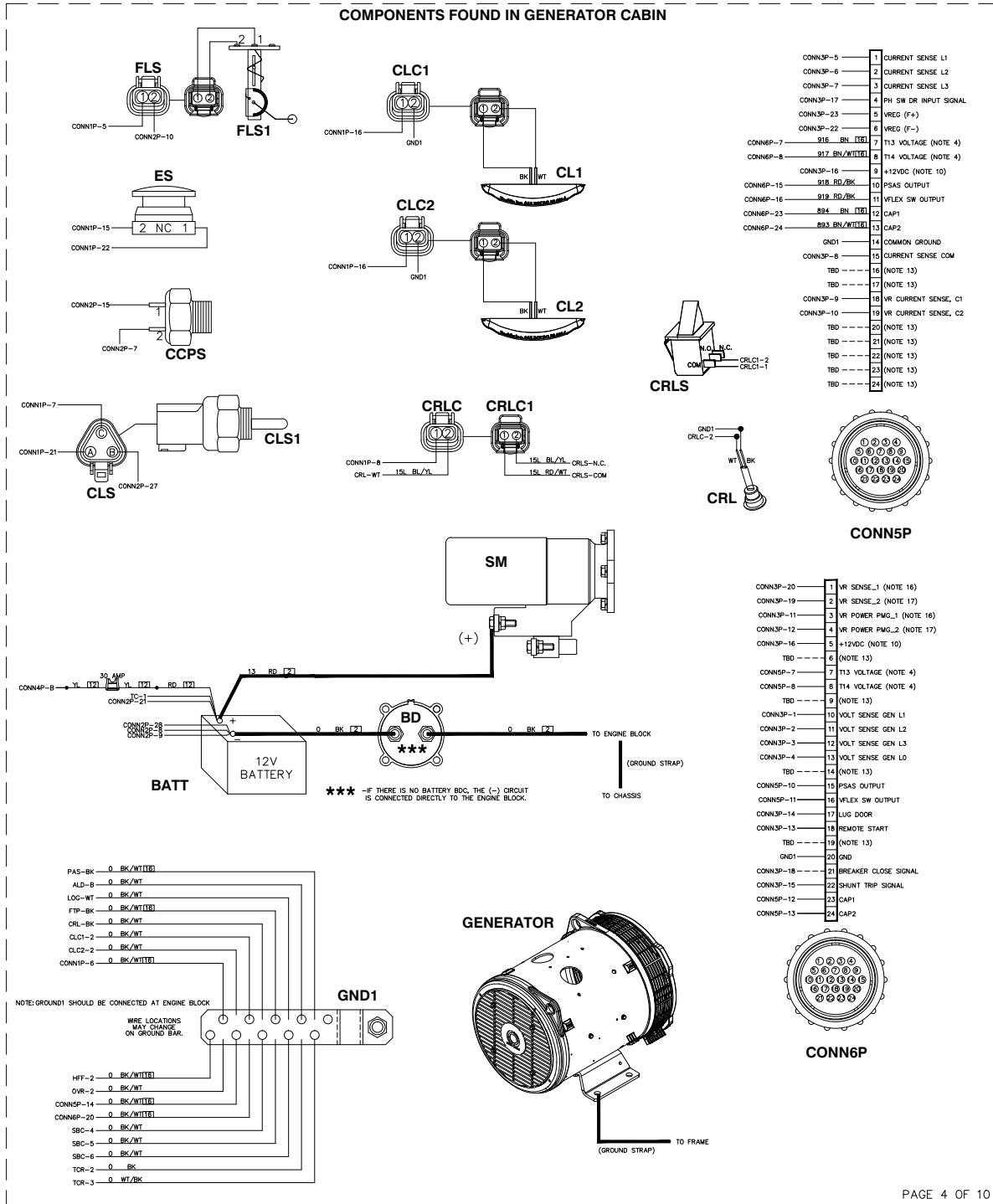

# Generator Cabin (2 of 2)

## GROUP G

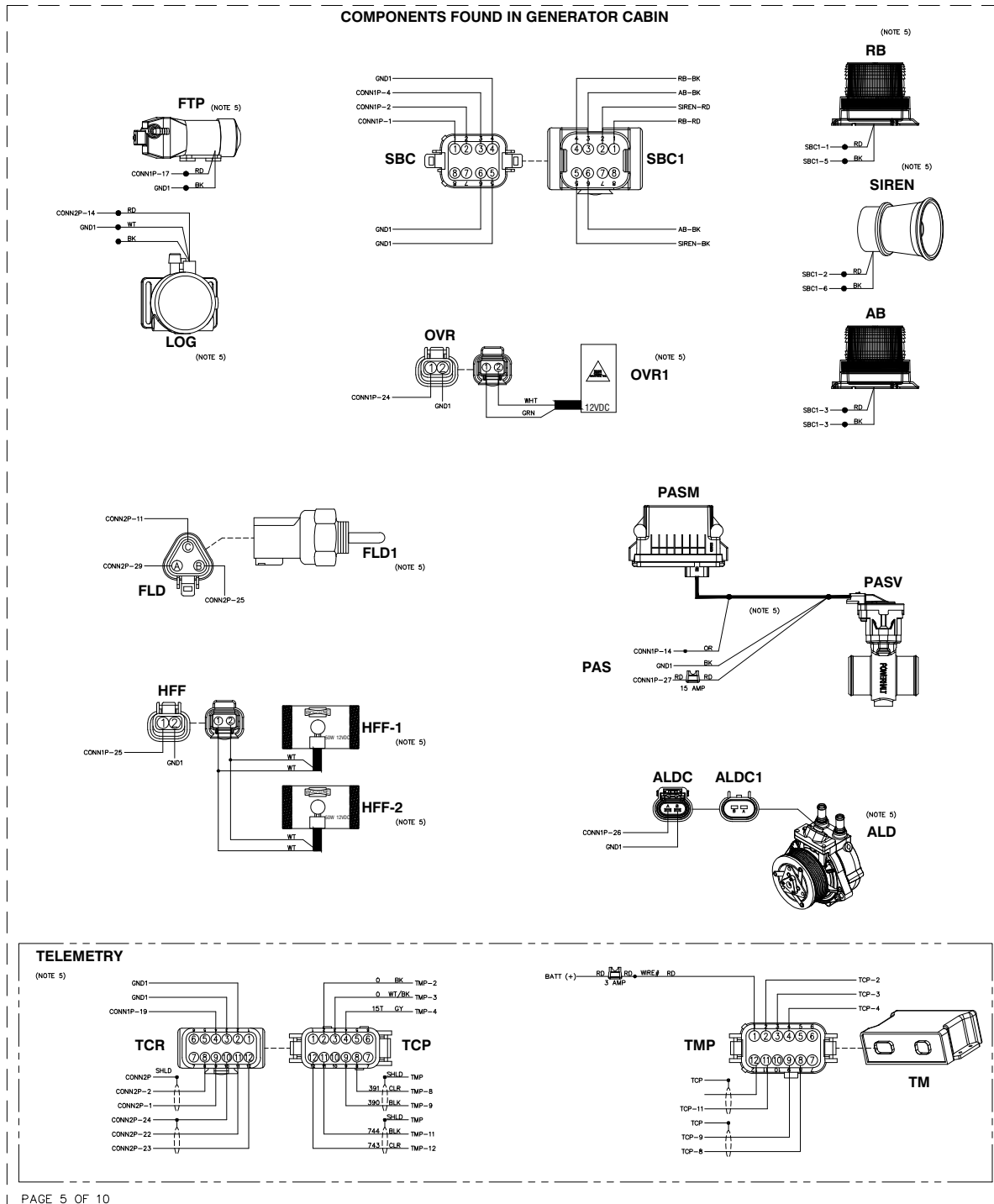

PAGE 5 OF 10

REVISION: B  
DATE: 4/17/2020

PAGE 5 OF 10

SCHEMATIC - DIAGRAM  
MDG251F4-STD3  
DRAWING #: A0000430348

# Generator Box—VFLEX (If Equipped)

GROUP G

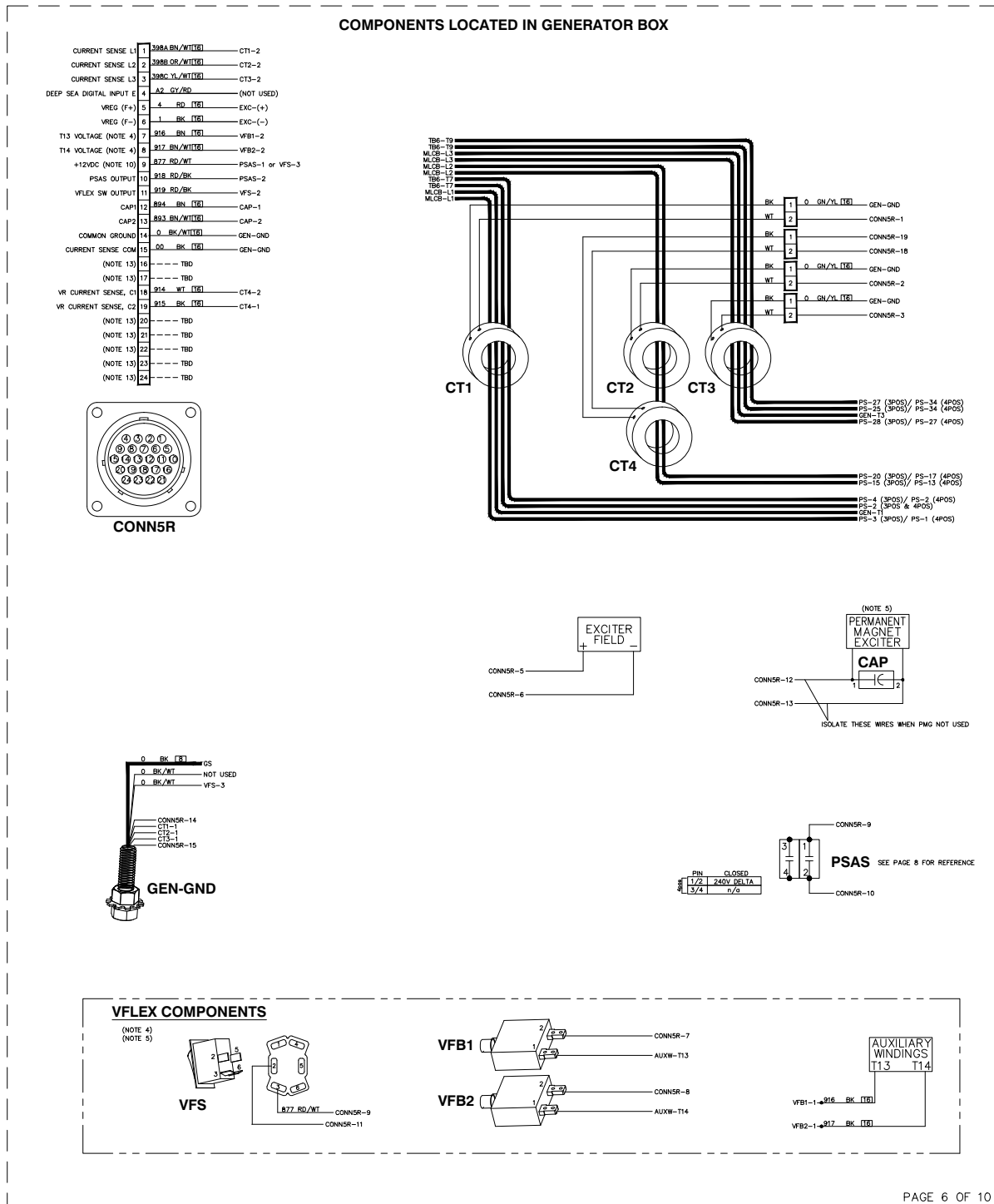

PAGE 6 OF 10

WIRING - DIAGRAM  
MDG25IF4-STD3

REVISION: B  
DATE: 4/17/2020

PAGE 6 OF 10

DRAWING #: A0000430348

GROUP G

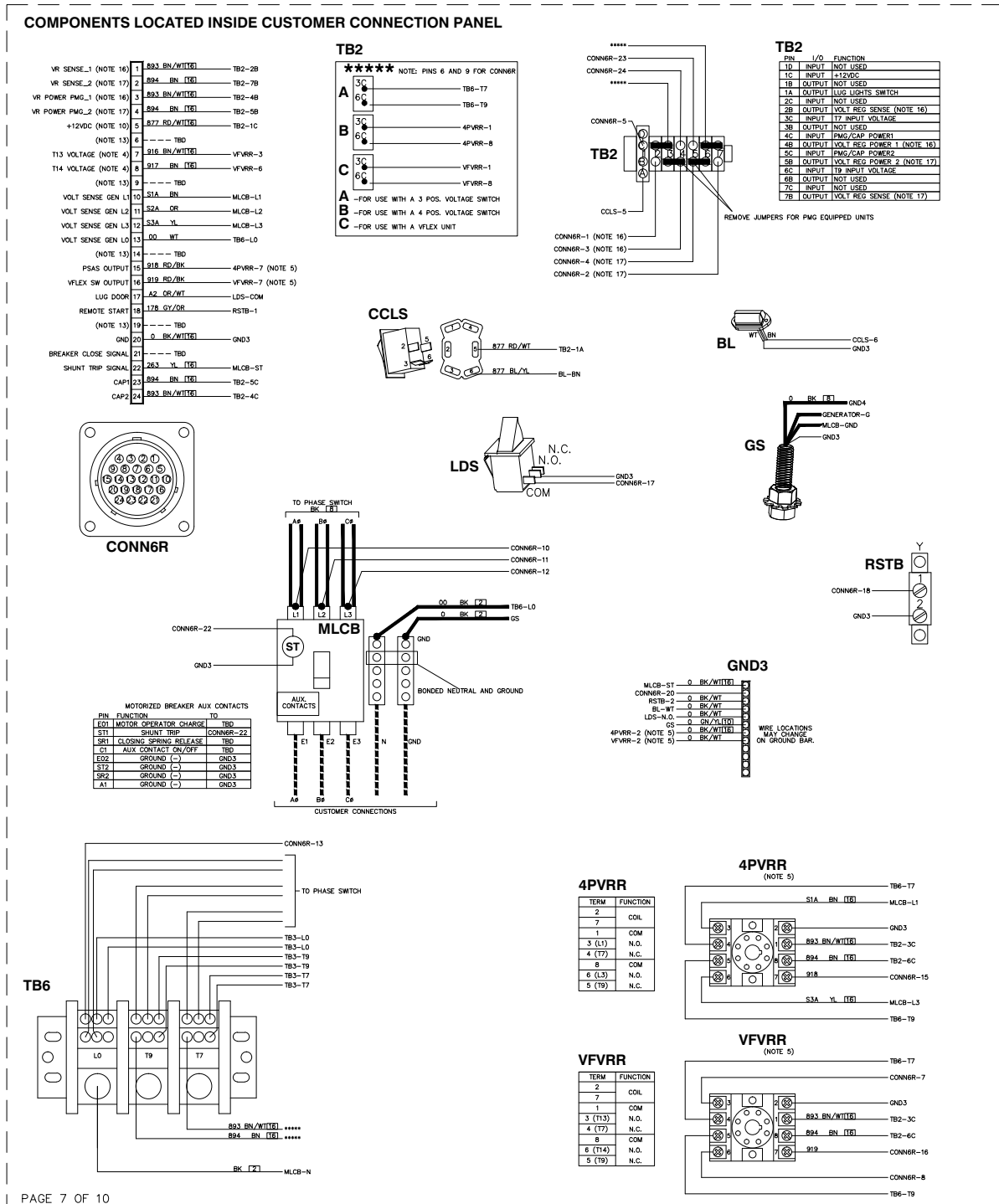

PAGE 7 OF 10

REVISION: B  
DATE: 4/17/2020

PAGE 7 OF 10

WIRING - DIAGRAM  
MDG25IF4-STD3  
DRAWING #: A0000430348

GROUP G

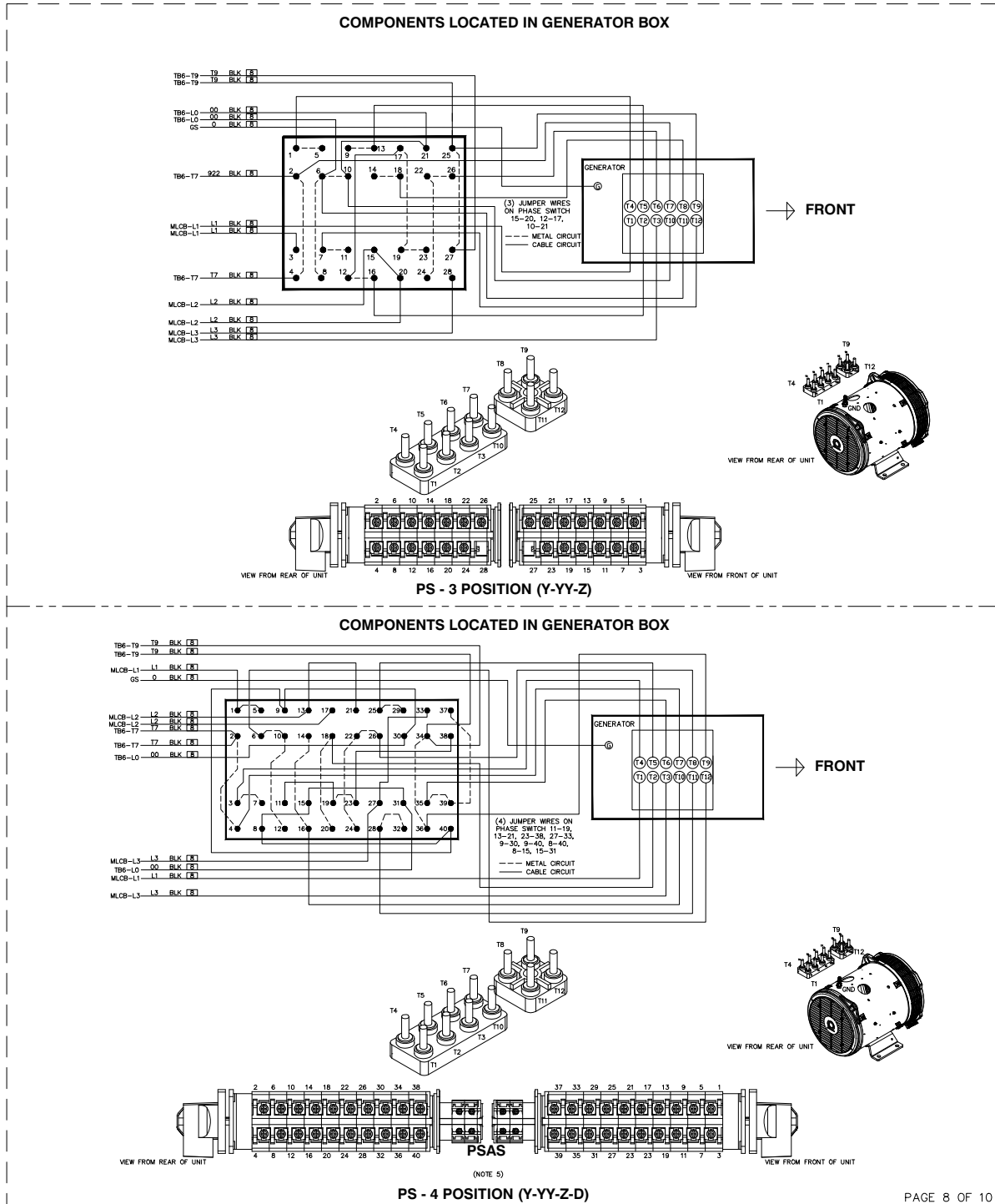

PAGE 8 OF 10

REVISION: B  
DATE: 4/17/2020

PAGE 8 OF 10

WIRING - DIAGRAM  
MDG25IF4-STD3  
DRAWING #: A0000430348

GROUP G

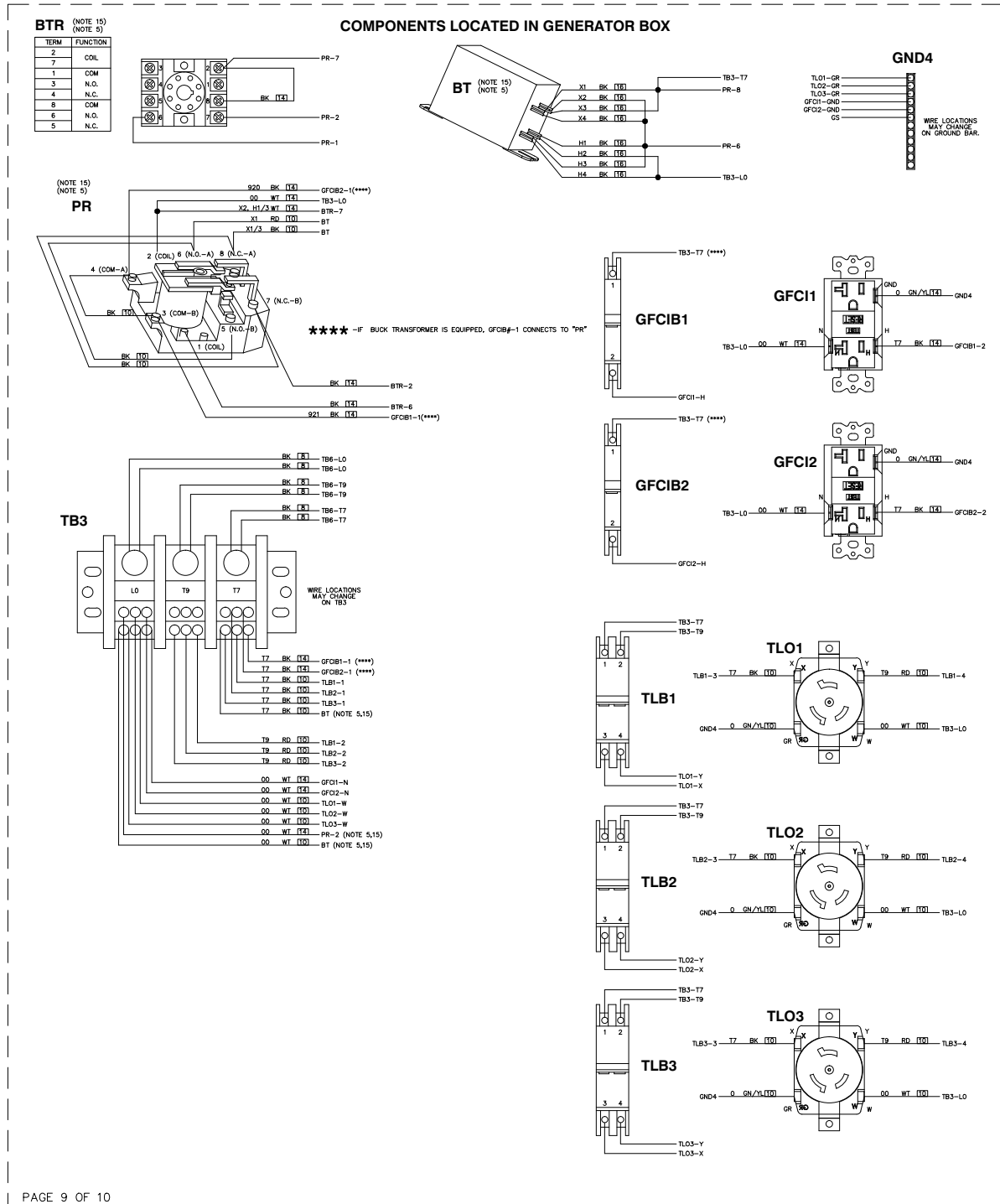

PAGE 9 OF 10

REVISION: B  
DATE: 4/17/2020

PAGE 9 OF 10

WIRING - DIAGRAM  
MDG251F4-STD3  
DRAWING #: A0000430348

GROUP G

COMPONENTS LOCATED IN GENERATOR CABIN

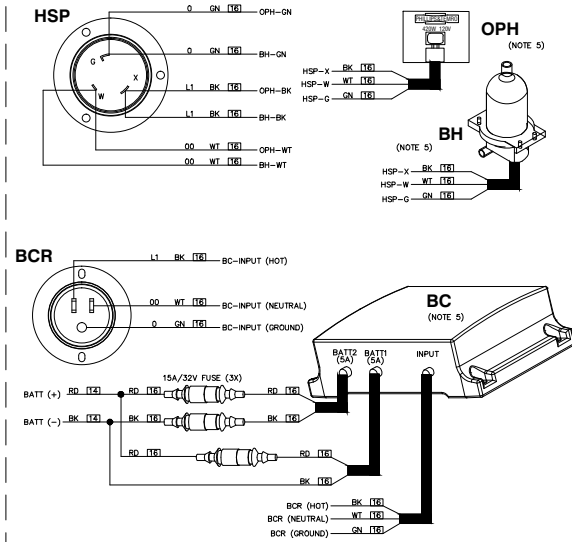

COMPONENTS LOCATED ON TRAILER AND TONGUE

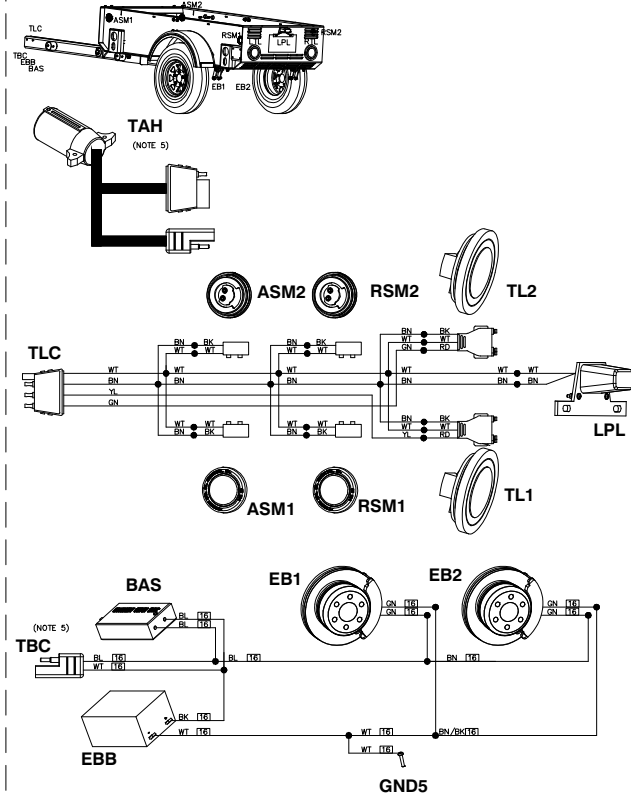

DRAWING NOTES:

- 1) WIRE# 0 IS CHASSIS GROUND (BATTERY-) UNLESS NOTED OTHERWISE.
- 2) WIRE# 13E IS FUSED AT THE ENGINE ECU FUSE BLOCK
- 3) WIRE# 877 IS FUSED +12VDC WHEN ENGINE FUEL PUMP IS RUNNING OR ECU SWITCH IS ON.
- 4) THESE COMPONENTS ARE ONLY AVAILABLE ON 600V CAPABLE UNITS (VFLEX)
- 5) THIS CIRCUIT IS PART OF AN OPTIONALLY EQUIPPED DEVICE.
- 6) N/A
- 7) THIS FUNCTION IS ONLY ACTIVE IF THE FT4 UNIT IS EQUIPPED WITH AUX. FUEL TANK OPTION.
- 8) BUS CABLE USED FOR DSE NET HIGH SPEED PERIPHERAL LINK COMMUNICATIONS
- 9) BUS CABLE USED FOR ENGINE ECU/ECM COMMUNICATION. USED WITH ZTR TELEMTRY.
- 10) VOLTAGE AT TB1-FUEL IS ONLY ACTIVE WHEN ENGINE FUEL PUMP IS RUNNING OR ECU SWITCH IS "ON".
- 11) BUS CABLE USED FOR MOD BUS COMMUNICATION. USED WITH ZTR TELEMTRY.
- 12) CIRCUIT ONLY USED WHEN A PMG IS EQUIPPED
- 13) NOT USED
- 14) EM1 ONLY USED IF UNIT IS EQUIPPED WITH "ALD" OPTION.
- 15) THIS EQUIPMENT IS ONLY AVAILABLE IF UNIT WAS EQUIPPED WITH A BUCK TRANSFORMER FOR GFCI OUTLETS IN ORDER TO OUTPUT 120VAC IN ANY VOLTAGE CONFIGURATION (HI/LOW-WYE, DELTA, ZIG-ZAG)
- 16) THIS CIRCUIT CONTAINS T7/L1/T13 VOLTAGE UNLESS JUMPER BETWEEN 3 AND 4 ON TB2 IS REMOVED AND A PMG IS EQUIPPED. IF A PMG IS EQUIPPED AND THE JUMPER IS NOT REMOVED, THE UNIT WILL NOT REGULATE VOLTAGE CORRECTLY AND A SHUTDOWN WILL OCCUR. IF THE PMG IS NOT EQUIPPED AND THE JUMPER IS NOT IN PLACE, THE UNIT WILL NOT REGULATE VOLTAGE CORRECTLY AND A SHUTDOWN WILL OCCUR.
- 17) THIS CIRCUIT CONTAINS T9/L3/T14 VOLTAGE UNLESS JUMPER BETWEEN 5 AND 6 ON TB2 IS REMOVED AND A PMG IS EQUIPPED. IF A PMG IS EQUIPPED AND THE JUMPER IS NOT REMOVED, THE UNIT WILL NOT REGULATE VOLTAGE CORRECTLY AND A SHUTDOWN WILL OCCUR. IF THE PMG IS NOT EQUIPPED AND THE JUMPER IS NOT IN PLACE, THE UNIT WILL NOT REGULATE VOLTAGE CORRECTLY AND A SHUTDOWN WILL OCCUR.
- 18) THIS CIRCUIT IS PLACED ON THE PHASE SWITCH TERMINAL BLOCK AND SHOULD BE LOCATED ON THE SAME POST, REGARDLESS OF WHICH PHASE SWITCH IS EQUIPPED.
- 19) WIRE #15B IS FUSED, DIRECT FROM BATTERY (30A)
- 20) WIRE #15B IS FUSED, DIRECT FROM BATTERY (30A)
- 21) WIRE #15P IS FUSED, POSITIVE AIR SHUTDOWN SUPPLY VOLTAGE.
- 22) WIRE #15A IS FUSED, ALTERNATE LOAD DEVICE SUPPLY VOLTAGE.
- 23) WIRE #15S IS FUSED, BATTERY POWER, SWITCHED.
- 24) WIRE #15E IS FUSED, EMERGENCY STOP SUPPLY VOLTAGE.
- 25) WIRE #15L IS FUSED, LED SUPPLY VOLTAGE.
- 26) WIRE #15F IS FUSED, FUEL TRANSFER PUMP SUPPLY VOLTAGE.
- 27) WIRE #15H IS FUSED, DC-HEATER SUPPLY VOLTAGE.
- 28) WIRE #15T IS FUSED, TELEMTRY SUPPLY VOLTAGE.
- 29) WIRE #15ST IS FUSED, SHUNT TRIP SUPPLY VOLTAGE.
- 30) WIRE #877 IS BATTERY VOLTAGE, ACTIVE WHEN ENGINE FUEL PUMP IS ACTIVE. THE ENGINE FUEL PUMP IS ACTIVE UPON PRE-START AND WHILE RUNNING, OR WHILE THE ECU SWITCH IS ON.
- 31) WIRE #877S IS BATTERY VOLTAGE, SWITCHED, ACTIVE WHEN THE ENGINE FUEL PUMP IS ACTIVE. SEE NOTE 30.

PAGE 10 OF 10

REVISION: B  
DATE: 4/17/2020

PAGE 10 OF 10

WIRING - DIAGRAM  
MDG25IF4-STD3  
DRAWING #: A0000430348



**This page intentionally left blank.**

**This page intentionally left blank.**



Part No. A0000214097 Rev. A 06/18/2020

©2020 Generac Mobile Products, LLC  
All rights reserved.  
Specifications are subject to change without notice.  
No reproduction allowed in any form without prior written  
consent from Generac Mobile Products, LLC.

**GENERAC** | **MOBILE**

Generac Mobile Products, LLC  
215 Power Drive, Berlin, WI 54923  
[GeneracMobileProducts.com](http://GeneracMobileProducts.com) | 800-926-9768 | 920-361-4442