



INTERFACE Cabling

System cabling and wiring interface

Wiring I/O modules with individual wires is an extremely time-consuming process. Wiring errors and tedious troubleshooting cannot be ruled out.

Interface Cabling reduces assembly costs by using plug-in components to carry out wiring quickly, clearly, and without errors.

The new interface modules in the **VIP - VARIOFACE Professional** series, which feature a modern housing design, offer the following advantages over previous solutions:

- **They save space**
- **Vibration-resistant up to 5 g thanks to metal feet**
- **Wide range of labeling options**

VIP modules are available for both product segments:

VARIOFACE system cabling is a cabling concept that has been specially developed to allow connection to the I/O modules of a wide range of automation devices.

The **VIP series** is rounded off by new front adapters with enclosed system cables for the Simatic S7 300.

VARIOFACE wiring interfaces are suitable for universal use. Various **VIP - VARIOFACE Professional** modules with a 1:1 connection from a high-pole connector to a different connection method are available. The enclosed system cables provide an effective and efficient means of establishing a connection to a control device with protection against polarity reversal.

A wide variety of potential distributors are available for splitting the control and operating voltage.

Product range overview

Introduction to VARIOFACE system cabling	200
Overview of VARIOFACE system cabling	202
Front adapter	
For ABB S800 I/O	204
For Allen-Bradley, ControlLogix, PLC 5, and SLC 500	206
For Emerson DeltaV	214
For GE Fanuc RX3i and Series 90-30	218
For Honeywell C300 Series CI/O and PlantScape	220
For Mitsubishi A1S and Q	222
For Omron CJ1, CS1, and C200H	223
For Phoenix Contact Axioline and Inline	224
For Schneider Electric MODICON®	226
VIP front adapter for Siemens SIMATIC® S7-300	228
For Siemens SIMATIC® S7-300 and S7-400	230
For Siemens SIMATIC® S5-S7 conversion	237
For Yokogawa CS3000 R3	244
Termination boards	
With passive transfer	248
With relay	268
PLC-INTERFACE via V8 adapter	
V8 adapter	262
Feed-through terminal block	264
Relay/solid-state relay	80
Cross-reference list	266
System cables	
With flat-ribbon cable and D-SUB connectors	278
Introduction to VARIOFACE wiring interface	
Overview of VIP - VARIOFACE Professional	
Passive interface modules	
VIP modules with flat-ribbon cable connectors	300
VIP modules with D-SUB connectors	306
VIP modules with high-density D-SUB connectors	313
With DIN strips	314
With ELCO connectors	316
With RJ45 connector	320
With COMBICON connection	321
VIP potential distributors	322
Active interface modules	
For relay couplers/optocouplers	324
For solid-state relays	327
Accessories (relays, optocouplers)	328

INTERFACE Cabling

VARIOFACE system cabling



A large part of the costs incurred in automation systems today results from the cabling for the actuators and signaling units. On top of this, machines and systems are becoming more and more complex, which means that the cabling costs for the input and output stations are also steadily on the increase. In addition to cabling material costs, the costs associated with planning, assembly, startup and documentation must also be considered.

VARIOFACE PLC system cabling is a system concept that reduces manufacturing costs by allowing fast, faultless, and uniform wiring of the input and output signals of a PLC.

The system configuration comprises three components:

- VARIOFACE front adapter
- VARIOFACE system cable
- VARIOFACE termination board

VARIOFACE system cabling is available for controllers from:

- **ABB**
- **Allen-Bradley**
- **Emerson**
- **Honeywell**
- **GE Fanuc**
- **Mitsubishi Electric**
- **OMRON**
- **Schneider Electric**
- **Siemens**
- **Yokogawa**
- **Phoenix Contact**

VIP - VARIOFACE Professional

The new front adapters with enclosed system cables for the S7 300 and new compact termination boards make the system cabling even more robust. VARIOFACE Professional means:

New front adapters

- **Optimized housing concept**
- **Power supplied via PCB terminal blocks**
- **Plug-in bridges for electrical isolation**
- **Directly connected system cables with enclosed connectors**

New termination boards

- **Space-saving**
- **Vibration-resistant up to 5 g**
- **Optional labeling**
- **New housing design**

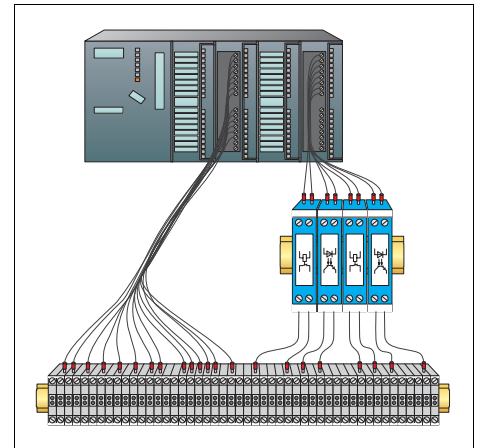

Figure 1: Example of control cabinet cabling with individual signal lines

The conventional method of wiring the input and output cards of programmable logic controllers is extremely time-consuming.

Signals are transmitted from the controller to modular terminal blocks or coupling modules such as relays or optocouplers by means of single conductor wiring (Figure 1).

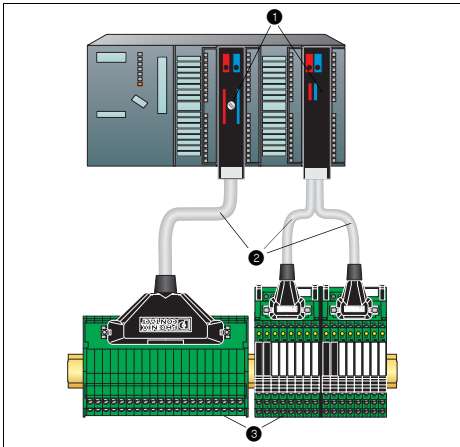

Figure 2: Example of control cabinet wiring with front adapters 1, pre-assembled system cables 2, and termination boards 3

This requires a complex wiring process. At the same time, wiring mistakes are always possible with this connection method. Errors in wiring are often only noticed during system startup, resulting in additional costs.

Wiring based on the system cabling concept reduces assembly time considerably and guarantees protection against polarity reversal (Figure 2).

Front adapters with an integrated pin strip (IEC 60603-13) are plugged onto the PLC I/O cards. They replace connection methods such as those involving a screw or crimp connection.

The termination boards are simply snapped onto the DIN rail instead of modular terminal blocks or coupling modules. They too have a high-pole pin strip on the control side.

The termination boards are connected to the front adapters using high-pole and pre-assembled system cables that can simply be plugged in.

Actuators and sensors from the field level are connected to the termination boards by means of screw or spring-cage connections, or knife disconnect terminal blocks. The termination boards are marked on the field side according to application, so that the signals can be clearly assigned.

These termination boards are available in a wide range of designs depending on the application:

- **Interface modules for 1:1 signal transfer with or without LED**
- **Initiator modules for the connection of PNP 3-wire initiators**
- **Active output modules and interfaces equipped with relays or optocouplers for electrical isolation, signal amplification or level adaptation**
- **Input modules and interfaces for various voltage ranges, feed-through and jumper modules**

The termination boards are connected to the PLC front adapter using the high-pole system round cables. The individual wires of the system cable can each be subjected to a load of 1 A.

The signals from 32-channel input and output cards (32 signals of 500 mA each) can be transmitted using a 50-pole system cable. Four single bytes are transmitted separately using one 14-pole system cable for each. The signals from 8-channel I/O cards (8 signals of 500 mA each) are also transmitted via a 14-pole system cable.

The supply voltage per byte is supplied through several free cores in the cable. This ensures that when 32 signals are transferred via a 50-pole cable, a total current of 2 A can flow.

If 8 signals are transmitted via a 14-pole cable, the total current is 3 A per byte. If a higher level of protection is required for the I/O cards, separate power terminals are available directly on the front adapter. The system components allow distribution of the coupling level even within a confined space.



The plug-in, standardized connection method not only simplifies the actual construction of the control cabinet and system startup thanks to fast and faultless wiring, but also planning and design.

The project planning cross-reference list (a quick reference guide to the VARIOFACE system components) is extremely useful when selecting the required components. What's more, matching components can be configured using the INTERFACE search wizard. See www.phoenixcontact.net/catalog.

VARIOFACE system cabling enables you to achieve greater efficiency:

- **Simple planning using the project planning cross-reference list or online selector**
- **Cost reductions thanks to time-saving wiring**
- **Fault minimization through protection against polarity reversal and**
- **Easy maintenance thanks to modular system components**

INTERFACE Cabling

VARIOFACE system cabling

Product overview of VARIOFACE system cabling

System component	Version	Controller						
		ABB	Allen-Bradley		Emerson	GE FANUC		
		S800 I/O	Control Logix	PLC 5	SLC 500	DeltaV	RX3i	90-30
		Page	Page	Page	Page	Page	Page	Page
Front adapter		Not required	206	208	210	Not required	218	219
System cables	Standard	290	282	282	282	284	282	282
	Controller-specific	205			212	214		
Termination boards	Passive, standard	248	248	248	248	248	248	248
	Passive, controller-specific	204	251		211	215		
	Active, standard	268	268	268	268	268	268	268
	V8 adapter/ feed-through terminal block	262	262	262	262	262	262	262
	Relay/optocoupler	80	80	80	80	80	80	80
	MINI Analog system adapter							
	MINI Analog							

	Honeywell		Mitsubishi	OMRON CJ1	Phoenix Contact	Schneider		Siemens			Yokogawa
	C300 Series CI/O	PlantScape	MELSEC A, A1S, Q	CS1, CQM1, C200H	Axioline Inline	TSX Qantum	M340	S7 300	S7 400	S5 to S7 conversion	Centum CS3000
	Page	Page	Page	Page	Page	Page	Page	Page	Page	Page	Page
	220	206	Not required	Not required	225	226	Not required	228	236	237	Not required
	290	282			282	282	227	282	282		
			222	223				233			244
	221	248	248	248	248	248	248	248	248		
						251		250	250		246
	268	268	268	268	268	268	268	268	268		
	262	262	262	262	262	262	262	262	262		262
	80	80	80	80	80	80	80	80	80		80
								374			374
								372			372

INTERFACE Cabling

VARIOFACE system cabling

ABB S800 I/O

Termination boards with knife disconnection

The ABB S800 I/O system offers the possibility of realizing the process wiring with D-SUB plug connectors. ABB TU 812 Compact MTU are available for this purpose.

The FLKM-D25SUB/B/KDS3-MT/... modules are connected to the I/O modules using assembled D-SUB cables (refer to chapter System cables).

In addition to screw connection with knife disconnection for every channel and ABB S800-specific labeling, the modules have the following features:

- Eight negative terminals with knife disconnection (TU810)
- Eight positive terminals with knife disconnection (TU810/P)
- For each channel, there is a positive and negative terminal with knife disconnection (TU830)

Passive interface modules can also be used for signal transmission (e.g., VIP-3/SC/D25SUB/F, 2315188), see page 307.

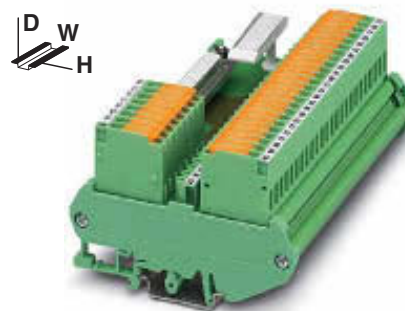

Interface module with knife disconnect terminal blocks

Technical data

Max. perm. operating voltage	50 V AC/DC
Max. perm. current (per branch)	2 A
Max. total current (voltage supply)	4 A (8 A L1-/L2-)
Rated surge voltage	1.4 kV
Ambient temperature (operation)	-20°C ... 50°C
Mounting position	Any
Standards / regulations	DIN EN 50178, IEC 62103
Connection method	Screw connection with disconnect knife
	Field level
	Control system level
Connection data solid / stranded / AWG	D-SUB socket 0.2 ... 4 mm ² / 0.2 ... 2.5 mm ² / 24 - 12
Dimensions	90 mm / 61 mm

Ordering data

Type	Order No.	Pcs. / Pkt.
FLKM-D25 SUB/B/KDS3-MT/TU810	2304513	1
FLKM-D25 SUB/B/KDS3-MT/TU810/P	2304539	1
FLKM-D25 SUB/B/KDS3-MT/TU830	2304526	1

Connectable I/O modules

Card type	FLKM-D25SUB...
Digital input	DI 810 DI 811 DI 814 DI 830 DI 831 DI 885
Digital output	DO 810 DO 814
Analog input	AI 810 AI 820 AI 830 AI 835
Analog output	AO 810 AO 820

Description	No. of poles	Module width W
VARIOFACE module, with knife disconnect terminal blocks for:		
- S800 I/O output modules	25	126.5 mm
- S800 I/O input modules	25	126.5 mm
- S800 I/O universal module	25	247.5 mm

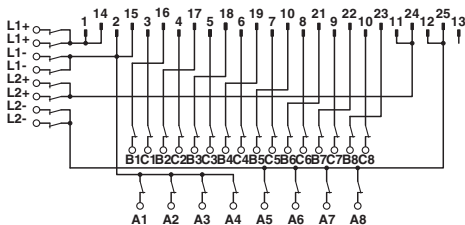

FLKM-D25 SUB/B/KDS3-MT/TU810 connection scheme

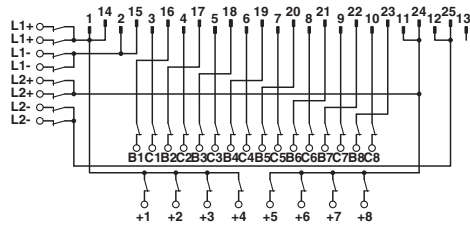

FLKM-D25 SUB/B/KDS3-MT/TU810/P connection scheme

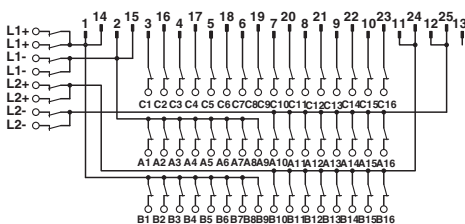

FLKM-D25 SUB/B/KDS3-MT/TU830 connection scheme

Explanation:

- Flat-ribbon cable strip
- Connection to I/O card
- Screw terminal blocks for separate supply

ABB S800 I/O
System cable

The ABB S800 I/O system offers the possibility of realizing the process wiring with D-SUB plug connectors. ABB TU 812 Compact MTU are available for this purpose.

The CABLE-D25SUB/B/2X14/.../TU812 system cables convert from a D-SUB socket strip to two flat-ribbon cable connectors. Therefore, all 8-channel controller boards of the system cabling can be connected to S800 I/O modules. Two controller boards are used per module.



System cable

Technical data

Max. perm. operating voltage	< 50 V AC / 60 V DC
Max. perm. current carrying capacitance per path	1 A
Ambient temperature (operation)	-20°C ... 50°C
Assembly	Insulation displacement, IEC 60352-4 / DIN EN 60352-4
Conductor cross section	AWG - / 0.14 mm ²
Conductor structure: stranded wires / material	7 / Cu tin-plated
Outside diameter	6.3 mm

25-pole

Ordering data

Description	No. of poles	Cable length	Type	Order No.	Pcs. / Pkt.
VARIOFACE system cable , for S800 I/O, with a 25-pole D-SUB socket strip and two 14-pole flat-ribbon cable connectors, in standard lengths	25	1 m	CABLE-D25SUB/B/2X14/100/TU812	2304649	1
	25	2 m	CABLE-D25SUB/B/2X14/200/TU812	2304652	1
	25	3 m	CABLE-D25SUB/B/2X14/300/TU812	2304665	1
	25	5 m	CABLE-D25SUB/B/2X14/500/TU812	2304678	1
VARIOFACE system cable for S800 I/O, with a 25-pole D-SUB socket strip and two 14-pole flat-ribbon cable connectors, in variable lengths	25		CABLE-D25SUB/B/2X14/TU812/...	2304681	1

Color code and pin assignment
CABLE-D25SUB/B/2X14...TU812

D-SUB connector 25-pos.	FLK 14 1. Connector	FLK 14 2. Connector	Conductor color
1	9		Gray
2	10		White
3	1		Black
4	3		Red
5	5		Yellow
6	7		Blue
7		1	Black
8		3	Red
9		5	Yellow
10		7	Blue
11		9	Orange
12		10	White
13	NC	NC	-
14	11		White-black
15	12		White-brown
16	2		Brown
17	4		Orange
18	6		Green
19	8		Violet
20		2	Brown
21		4	Orange
22		6	Green
23		8	Violet
24		11	White-black
25		12	White-brown

Ordering example for system cable:

- Cable for ABB S800, 12.75 m long

Quantity	Order No.	Length [m] ¹⁾
1	2304681	12.75

¹⁾ min. 0.20 m

INTERFACE Cabling

VARIOFACE system cabling

Allen-Bradley ControlLogix, Honeywell PlantScape Front adapter

I/O modules with 32 channels or with this design

The front adapters are pushed into the tall 1756-TBE covers (not supplied as standard, original accessories must be ordered directly from manufacturer) of the controller. 50-pole system cable can connect a maximum of 32 channels to the field level.

Perfectly-fitting VARIOFACE termination boards round off this system concept.

Notes:

Front adapters can also be used without a cover.

Suitable system cabling components can be configured in the INTERFACE search wizard. See www.phoenixcontact.net/catalog.



32-channel front adapter with 50-pole FLK strip



Technical data

Max. perm. operating voltage
Max. permissible current

< 50 V AC / 60 V DC
1 A (per path)
8 A (per connection, supply via separate power supply)

Ambient temperature (operation)
Ambient temperature (storage / transport)
Connection data solid / stranded / AWG
Standards / regulations

-20°C ... 50°C
-20°C ... 70°C
0.14 ... 1.5 mm² / 0.14 ... 1.5 mm² / 28 - 16
IEC 60664 / DIN EN 50178 / IEC 62103

Ordering data

Description	No. of poles
VARIOFACE front adapters, for ControlLogix:	
- A maximum of 1 x 32 channels can be connected	50
- IB 32 input board	50

Type	Order No.	Pcs. / Pkt.
FLKM 50-PA-AB/1756/EXTC	2302735	1
FLKM 50-PA-AB/1756/IN/EXTC	2302748	1

Front adapter for I/O modules of Allen Bradley ControlLogix and Honeywell PlantScape automation devices

Card type	FLKM 50-PA-AB/1756/EXTC
Digital input	1756-IA 16 I* or TC-TDK 161* 1756-IB 16 D* or TC-TDX 161* 1756-IB 16 I* or TC-TDJ 161* 1756-IH 16 I*
Digital output	1756-OB 32 or TC-ODD 321
Analog input	1756-IF 8* 1756-IF 16 I* or TC-IAH 161* 1756-IF 8H*
Counter	1756-HSC*
Servo	1756-M02 AE*
Card type	FLKM 50-PA-AB/1756/IN/EXTC
Digital input	1756-IB 32 or TC-IDD 321

* Only in conjunction with VIP-2/SC/FLK50/AB-1756, Order No.: 2322317.
There must be no voltage supply at the front adapter. Risk of short circuit!

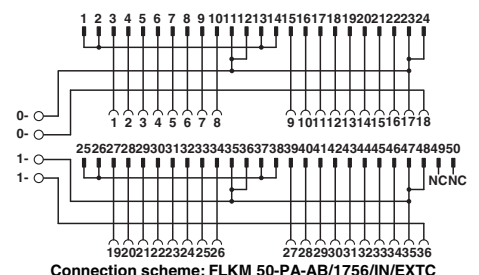
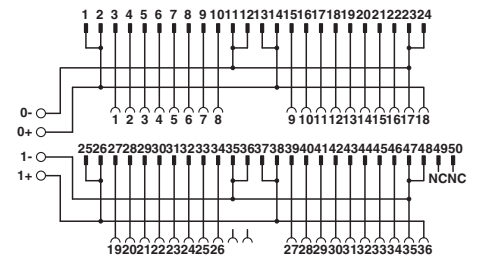

Explanation:

 Flat-ribbon cable strip
 Connection to I/O card
 Screw terminal blocks for separate supply

Allen-Bradley ControlLogix, Honeywell PlantScape Front adapter

I/O modules with 16 channels or with this design

The front adapters are pushed into the tall 1756-TBE covers (not supplied as standard, original accessories must be ordered directly from manufacturer) of the controller. Two 14-pole system cables are used to connect up to 2 x 8 channels to the field level.

Perfectly-fitting VARIOFACE termination boards round off this system concept.

Notes:

Front adapters can also be used without a cover.

Suitable system cabling components can be configured in the INTERFACE search wizard. See www.phoenixcontact.net/catalog.



16-channel front adapter with two 14-pole FLK strips



Technical data

Max. perm. operating voltage
Max. permissible current

< 50 V AC / 60 V DC
1 A (per path)
8 A (per connection, supply via separate power supply)

Ambient temperature (operation)
Ambient temperature (storage / transport)
Connection data solid / stranded / AWG
Standards / regulations

-20°C ... 50°C
-20°C ... 70°C
0.14 ... 1.5 mm² / 0.14 ... 1.5 mm² / 28 - 16
IEC 60664 / DIN EN 50178 / IEC 62103

Ordering data

Description	No. of poles
VARIOFACE front adapters , for ControlLogix:	
- Up to 2 x 8 channels can be connected	14
- IA 16, IB 16, IC 16, IN 16 input card	14
- IF6 I input card (only suitable for measuring current; no power terminals on adapter)	14

Type	Order No.	Pcs. / Pkt.
FLKM 14-PA-AB/1756/EXTC	2302861	1
FLKM 14-PA-AB/1756/IN/EXTC	2302874	1
FLKM 14-PA-AB/1756/IF6/EXTC	2901037	1

Front adapter for I/O modules of Allen Bradley ControlLogix and Honeywell PlantScape automation devices

Card type	FLKM 14-PA-AB/1756/EXTC
Digital input	1756-IA 8 D** or TC-IDX 081**
Digital output	1756-OB 16 E
Analog input	1756-IF 6 CIS** 1756-IF 6 I** or TC-IAH 061** 1756-IR 6 I** or TC-IXR 061** 1756-IT 6 I** or TC-IXL 061**
Analog output	1756-OF 4 I** 1756-OF 6 CI** or TC-OAH 061** 1756-OF 6 VI** or TC-OAV 061** 1756-OF 8** or TC-OAV 081** 1756-OF 8 H**
Switch	1756-PLS**

Card type	FLKM 14-PA-AB/1756/IN/EXTC
Digital input	1756-IN 16** 1756-IA 16 or TC-IDA 161** 1756-IB 16 1756-IC 16**

Card type	FLKM 14-PA-AB/1756/IF6/EXTC
Analog input	IF6I**

** Only in conjunction with VIP-2/SC/2FLK14/AB-1756, Order No.: 2322333.
There must be no voltage supply at the front adapter. Risk of short circuit!!

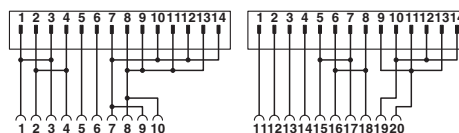

Connection scheme: FLKM 14-PA-AB/1756/IF6/EXTC

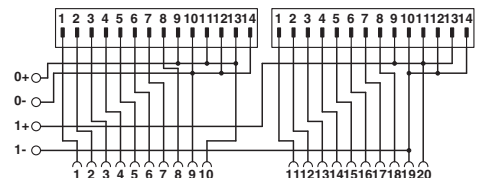

Connection scheme: FLKM 14-PA-AB/1756/EXTC

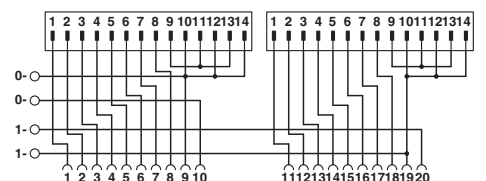

Connection scheme: FLKM 14-PA-AB/1756/IN/EXTC

Explanation:

- Flat-ribbon cable strip
- Connection to I/O card
- Screw terminal blocks for separate supply

INTERFACE Cabling

VARIOFACE system cabling

Allen-Bradley, PLC 5 series 1771 Front adapter

The front adapters mean that pre-assembled system cables can be directly connected to I/O modules.

Up to 32 channels are connected via 50-pole system cables.

Perfectly-fitting VARIOFACE termination boards with a variety of functions and connection possibilities round off this system concept.

Notes:

Suitable system cabling components can be configured in the INTERFACE search wizard. See www.phoenixcontact.net/catalog.



Front adapter for Allen-Bradley PLC 5, 1771



Technical data

Max. perm. operating voltage
Max. permissible current
Max. perm. total current

< 50 V AC / 60 V DC
1 A (per path)
2 A (per byte, for supply via connector)

Ambient temperature (operation)
Ambient temperature (storage / transport)
Standards / regulations

-20°C ... 50°C
-20°C ... 70°C
IEC 60664 / DIN EN 50178 / IEC 62103

Ordering data

Description	No. of poles
VARIOFACE front adapters, for Allen-Bradley PLC 5, 1771	
- IBN 32 channels input	50
- OBN 32 channels output	50

Type	Order No.	Pcs. / Pkt.
FLKM 50-PA-AB/IBN	2289816	2
FLKM 50-PA-AB/OBN	2289829	2

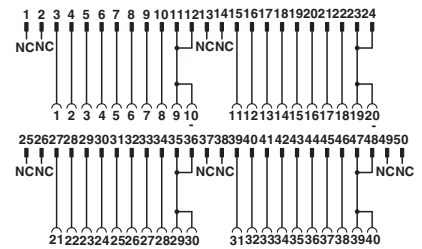

Connection scheme FLKM 50-PA-AB/IBN

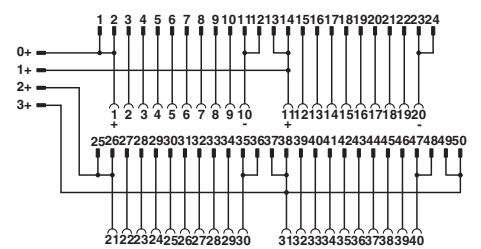

Connection scheme FLKM 50-PA-AB/OBN

Explanation:

- Flat-ribbon cable strip
- Connection to I/O card
- Screw terminal blocks for separate supply

INTERFACE Cabling

VARIOFACE system cabling

Allen-Bradley SLC 500 Front adapter

The front adapters mean that pre-assembled system cables can be directly connected to I/O modules.

- The FLKM 14-PA-SLC500... adapters connect max. 2 x 8 channels via two 14-pole system cables. Perfectly-fitting VARIOFACE termination boards with a variety of functions and connection possibilities round off this system concept.
- With the FLKM50-PA-SLC500 OUT/2A front adapters, the FLKM 50/16/SCL500 termination board and 50-pole system cables, the VARIOFACE system cabling can also be coupled to the OA16 and OW16 power output cards.

Notes:

Suitable system cabling components can be configured in the INTERFACE search wizard. See www.phoenixcontact.net/catalog.



Front adapter for SLC 500 1746, 2 x 8 channels can be connected



Technical data

FLKM 14-PA...	FLKM 50-PA...
< 50 V AC / 60 V DC	< 50 V AC / 60 V DC
1 A (per path)	2 A (per path)
2 A (per byte, for supply via connector)	7 A (per byte, for supply via connector)
-20°C ... 50°C	-20°C ... 50°C
-20°C ... 70°C	-20°C ... 70°C
Any	Any
IEC 60664 / DIN EN 50178 / IEC 62103	IEC 60664 / DIN EN 50178 / IEC 62103

Max. perm. operating voltage	
Max. permissible current	
Max. perm. total current	
Ambient temperature (operation)	
Ambient temperature (storage / transport)	
Mounting position	
Standards / regulations	

Ordering data

Description	No. of poles	Type	Order No.	Pcs. / Pkt.
VARIOFACE front adapter , 2 x 8 channels can be connected for Allen-Bradley SLC 500 for:				
- 1746 OB16, OV16, OG16, and IG16	14	FLKM 14-PA-SLC500/OUT	2293459	1
- 1746 IA16, IB16, ITB16, and IN16	14	FLKM 14-PA-SLC500/IN	2293462	1
- 1746 IV16 and IVT16	14	FLKM 14-PA-SLC500/IN/M	2293475	1
VARIOFACE front adapter , 1 x 16 channels can be connected for Allen-Bradley SLC 500 1746 OA16 and OW16	50	FLKM 50-PA-SLC500/OUT/2A	2293446	1

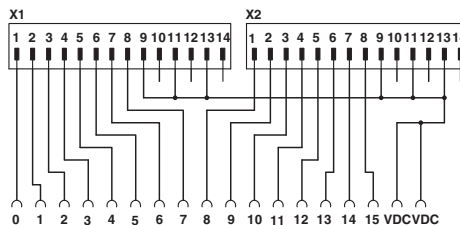

Connection scheme FLKM 14-PA-SLC500/IN/M

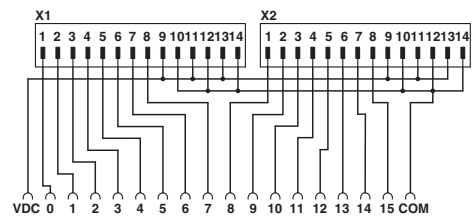

Connection scheme FLKM 14-PA-SLC500/OUT

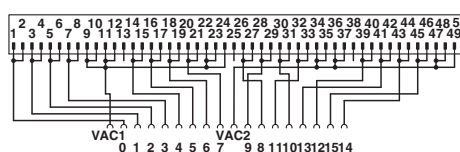

Connection scheme FLKM 50-PA-SLC500/OUT/2A

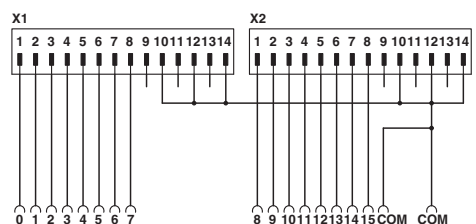

Connection scheme FLKM 14-PA-SLC500/IN

Explanation:

- Flat-ribbon cable strip
- Connection to I/O card
- Screw terminal blocks for separate supply

VIP termination board for Allen-Bradley SLC 500, 2 A output cards

The VIP - VARIOFACE Professional module VIP-2/SC/FLK50/16/SLC500 has been specially designed for the output modules OA16 and OW16. As regards the front adapter FLKM 50-PA-SLC500/OUT/2A, currents up to 2 A per channel can be transferred with the system cabling.

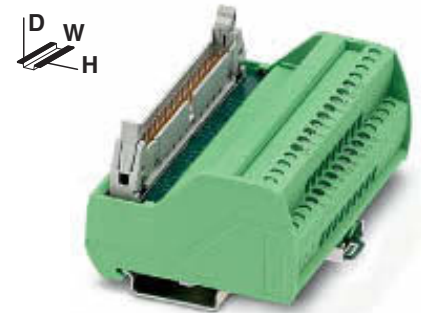

VARIOFACE controller board for 16 channels



Technical data

Max. perm. operating voltage	120 V AC/DC
Max. perm. current (per branch)	1 A
Max. total current (voltage supply)	2 A (per channel)
Rated surge voltage	-
Ambient temperature (operation)	-20°C ... 50°C
Mounting position	Any
Standards / regulations	IEC 60664, DIN EN 50178, IEC 62103
Connection method	Screw connection
	Field level
	Control system level
Connection data solid / stranded / AWG	0.2 ... 4 mm ² / 0.2 ... 2.5 mm ² / 24 - 12
Dimensions	H / D 65.5 mm / 56 mm

Ordering data

Description	No. of poles	Module width W	Type	Order No.	Pcs. / Pkt.
VARIOFACE controller board , for transfer of max. 16 channels, only in connection with FLKM 50-PA-SLC500 OUT/2A		90.8 mm	VIP-2/SC/FLK50/16/SLC500	2322320	1

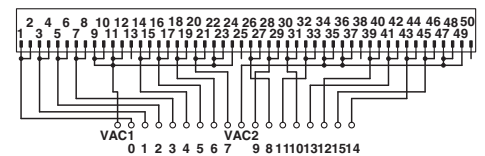

VIP-2/SC/FLK50/16/SLC500 connection scheme

Explanation:

- Flat-ribbon cable strip
- Connection to I/O card
- Screw terminal blocks for separate supply

INTERFACE Cabling

VARIOFACE system cabling

Allen-Bradley SLC 500 System cable for 32 channels

The 32-channel I/O cards of the SLC 500 are connected using 40-pole connectors (already integrated into the I/O modules). Passive interface modules (-3/SC/FLK40, etc.) are connected to the I/O cards using the **FLK 40/EZ-DR/.../SLC** system cables.

32 channels are split into 4x8 channels using the **FLK 40/4X14/EZ-DR/...** system cables.

The following 8-channel system cabling modules can be coupled:

- OB32 and IB32
passive and active modules plus V8 adapter
- OV32 and IV32
passive modules without status indicator

Notes:

Suitable system cabling components can be configured in the INTERFACE search wizard. See www.phoenixcontact.net/catalog.

Max. perm. operating voltage
Max. perm. current carrying capacitance per path
Ambient temperature (operation)
Assembly

Conductor cross section
Conductor structure: stranded wires / material
Outside diameter

40-pole



System cable for 32-channel I/O cards of the SLC 500 (OB32, OV32, IB32, IV32)



Technical data

< 50 V AC / 60 V DC
1 A
-20°C ... 50°C
Insulation displacement, IEC 60352-4 / DIN EN 60352-4

AWG 26 / 0.14 mm²
7 / Cu tin-plated

10 mm

Ordering data

Description	No. of poles	Cable length	Type	Order No.	Pcs. / Pkt.
Assembled round cables , with two 40-pole socket strips in fixed lengths (50 cm steps) for connection with 32-channel I/O cards of the SLC 500					
	40	0.5 m	FLK 40/EZ-DR/ 50/SLC	2294610	1
	40	1 m	FLK 40/EZ-DR/ 100/SLC	2294623	1
	40	1.5 m	FLK 40/EZ-DR/ 150/SLC	2294636	1
	40	2 m	FLK 40/EZ-DR/ 200/SLC	2294649	1
	40	3 m	FLK 40/EZ-DR/ 300/SLC	2294652	1
Round cable sets , for connection to Allen-Bradley SLC500, OB32 and IB32, with one 40-pole female connector and four 14-pole female connectors, for splitting max. 32 channels into 4 x 8 channels.					
for OB32	40	0.5 m			
	40	1 m			
	40	2 m			
	40	3 m			
for IB32	40	0.5 m			
	40	1 m			
	40	2 m			
	40	3 m			



System cable for splitting
max. 32 channels into 4 x 8 channels
(OB32, IB32)



Technical data

< 50 V AC / 60 V DC
 1 A
 -20°C ... 50°C
 Insulation displacement, IEC 60352-4 / DIN EN 60352-4

AWG 26 / 0.14 mm²
 7 / Cu tin-plated

7.8 mm

Ordering data

Type	Order No.	Pcs. / Pkt.
FLK 40/4X14/EZ-DR/ 50/OB32	2296786	1
FLK 40/4X14/EZ-DR/ 100/OB32	2298483	1
FLK 40/4X14/EZ-DR/ 200/OB32	2298522	1
FLK 40/4X14/EZ-DR/ 300/OB32	2298535	1
FLK 40/4X14/EZ-DR/ 50/IB32	2296812	1
FLK 40/4X14/EZ-DR/ 100/IB32	2296825	1
FLK 40/4X14/EZ-DR/ 200/IB32	2296838	1
FLK 40/4X14/EZ-DR/ 300/IB32	2296841	1

INTERFACE Cabling

VARIOFACE system cabling

Emerson DeltaV System cable

The DeltaV system allows you to install the process wiring through "mass termination blocks" (MTB) using flat-ribbon cable connectors. Besides the 10, 16, and 20-pole system cables of system cabling (refer to the System cables chapter), the following system-specific lines are also available:

- **FLK 16/14/DV-OUT/...**, for digital assemblies with 16-pos. MTB for connection with PLC-INTERFACE
- **FLK 16/14/DV-IN/...**, for digital modules with 16-pos. MTB for connection to PLC-INTERFACE
- **FLK 20/2FLK14/EZ-DR/...**, for digital assemblies with 40-pos. MTB for connection with PLC-INTERFACE
- **FLK 16/24/DV-AI/EZ-DR/...**, for analog assemblies with 24-pos. MTB
- **FLK 50/2FLK20/EZ-DR/.../DV** system cables are specifically designed for 32-channel I/O modules with 40-pin MTB for the purpose of connecting I/O modules with 32-channel VARIOFACE interface modules



System cable for DeltaV

		Technical data
Max. perm. operating voltage		< 50 V AC / 60 V DC
Max. perm. current carrying capacitance per path		1 A
Max. conductor resistance		0.16 Ω/m
Ambient temperature (operation)		-20°C ... 50°C
Conductor cross section		AWG 26 / 0.14 mm ²
Outside diameter	16-pole	6.8 mm
	20-pole	7.6 mm
	24-pole	6.5 mm
	20-pole	10.3 mm

Ordering data		
Description	No. of poles	Cable length
System cable , for 16-pos. "mass termination blocks" with a 16-pole and a 14-pole flat-ribbon cable connector for connection with PLC-INTERFACE		
	16	0.3 m
	16	0.5 m
	16	1 m
	16	2 m
	16	3 m
Variable cable length	16	
System cable , for 16-pos. "mass termination blocks" with a 16-pole and a 14-pos. flat-ribbon cable connector for connection with PLC-INTERFACE		
	16	0.5 m
	16	1 m
	16	2 m
	16	3 m
	16	4 m
Variable cable length	16	
System cable , for 40-pos. (2 x 20) "mass termination blocks" with a 20-pole and two 14-pole flat-ribbon cable connectors for connection with PLC-INTERFACE (two cables should be used per 32-channel I/O card)		
	20	1 m
	20	2 m
	20	3 m
Variable cable length	20	
System cable , for 24-pos. "mass termination blocks" with a 24-pole and a 16-pos. flat-ribbon cable connector for connection with UM-DELTA V/... modules		
	24	0.3 m
	24	0.5 m
	24	1 m
	24	2 m
	24	3 m
Variable cable length	24	
System cable , for 40-pos. "mass termination blocks" with two 20-pole and one 50-pole flat-ribbon cable plugs for connecting with 32-channel interface modules		
	20	0.5 m
	20	1 m
	20	2 m
	20	3 m
	20	6 m
	20	8 m
	20	10 m
Variable cable length	20	

Type	Order No.	Pcs. / Pkt.
FLK 16/14/DV-OUT/ 30	2304348	1
FLK 16/14/DV-OUT/ 50	2304351	1
FLK 16/14/DV-OUT/100	2300575	1
FLK 16/14/DV-OUT/200	2300588	1
FLK 16/14/DV-OUT/300	2304364	1
FLK 16-14-DV-OUT/...	2304377	1
FLK 16/14/DV-IN/ 50	2304393	1
FLK 16/14/DV-IN/100	2300559	1
FLK 16/14/DV-IN/200	2300562	1
FLK 16/14/DV-IN/300	2304403	1
FLK 16/14/DV-IN/400	2305185	1
FLK 16-14-DV-IN/...	2304416	1
FLK 20/2FLK14/EZ-DR/100/KONFEK	2298470	1
FLK 20/2FLK14/EZ-DR/200/KONFEK	2298438	1
FLK 20/2FLK14/EZ-DR/300/KONFEK	2300818	1
FLK 20/2FLK14/EZ-DR/...	2304487	1
FLK 16/24/DV-AI/EZ-DR/ 30	2304319	1
FLK 16/24/DV-AI/EZ-DR/ 50	2304296	1
FLK 16/24/DV-AI/EZ-DR/100	2301134	1
FLK 16/24/DV-AI/EZ-DR/200	2301545	1
FLK 16/24/DV-AI/EZ-DR/300	2304322	1
FLK 16-24-DV-AI-EZ-DR/...	2304335	1
FLK 50/2FLK20/EZ-DR/ 50/DV	2304872	1
FLK 50/2FLK20/EZ-DR/ 100/DV	2304898	1
FLK 50/2FLK20/EZ-DR/ 200/DV	2304908	1
FLK 50/2FLK20/EZ-DR/ 300/DV	2304911	1
FLK 50/2FLK20/EZ-DR/ 600/DV	2304937	1
FLK 50/2FLK20/EZ-DR/ 800/DV	2304940	1
FLK 50/2FLK20/EZ-DR/1000/DV	2304953	1
FLK 50-2FLK20-EZ-DR-DV/...	2304966	1



**Emerson DeltaV
Controller board for eight channels**

These system-specific interface modules for DeltaV assemblies are used in combination with the respective system cables. The controller board is connected to 8-channel modules through "mass termination blocks" with flat-ribbon cable connection.

FLKM 16/DV

- Universal module
- 1:1 connection

FLKM 16/AI/DV

- 1:1 connection
- Separate equipotential terminals per channel

FLKM 16/AO/SI/DV

- 1:1 connection
- Fuse 5 x 20, 50 mA T, IEC 60127-2/3 per channel

FLKM 16/DI/SI/LA/DV

- 1:1 connection
- Fuse 5 x 20, 50 mA T, IEC 60127-2/3 per channel
- LED status indicator per signal path

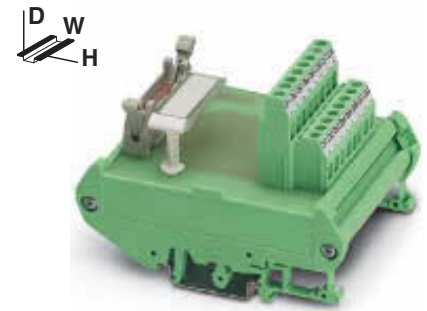

Interface module for 8 channels

Max. perm. operating voltage
Max. perm. current (per branch)

Rated surge voltage
Ambient temperature (operation)
Mounting position
Standards / regulations
Connection method

Connection data solid / stranded / AWG
Dimensions

Field level

Control system level

H / D

Technical data

FLKM 16/.../DV < 50 V AC 1 A (per signal path)	FLKM 16/.../SI.../DV < 50 V AC 50 mA (In delivered state, with one 50 mA fuse, max. 1 A permitted)
0.8 kV -20°C ... 50°C Any IEC 60664, DIN EN 50178, IEC 62103	0.8 kV -20°C ... 50°C Any IEC 60664, DIN EN 50178, IEC 62103
Screw connection	Screw connection
Flat-ribbon cable plug connector in acc. with IEC 60603-13	Flat-ribbon cable plug connector in acc. with IEC 60603-13
0.2 ... 4 mm ² / 0.2 ... 2.5 mm ² / 24 - 12	90 mm / 68 mm

Ordering data

Description	No. of poles	Module width W	Type	Order No.	Pcs. / Pkt.
Interface module, with 1:1 connection	16	45 mm	FLKM 16/DV	2304432	1
Interface module, with 1:1 connection and separate potential terminal blocks per channel	16	57 mm	FLKM 16/AI/DV	2304429	1
Interface module, with fuses per channel	16	90 mm	FLKM 16/AO/SI/DV	2304445	1
Interface module, with LED and fuses per channel	16	90 mm	FLKM 16/DI/SI/LA/DV	2304458	1

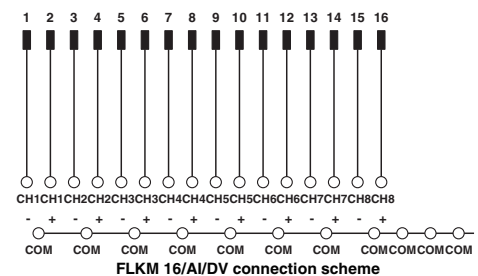
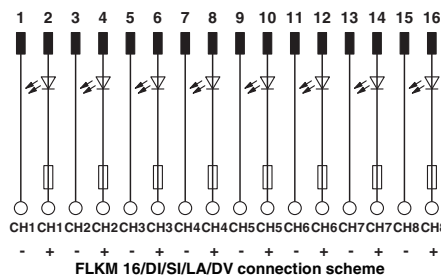
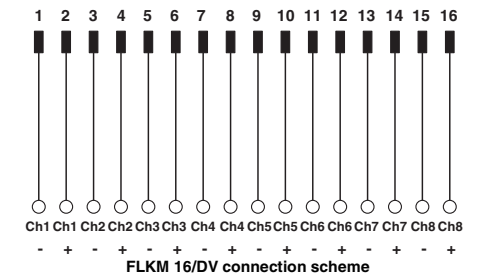
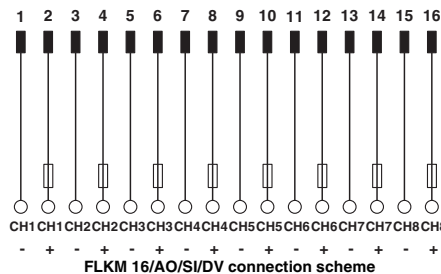

INTERFACE Cabling

VARIOFACE system cabling

Emerson DeltaV Controller board for 32 channels

These system-specific interface modules for DeltaV assemblies are used in combination with the FLK 50/2FLK20/EZ-DR/.../DV system cables. The controller board is connected to 32-channel modules through 40-pos. "mass termination blocks" with flat-ribbon cable connection.

FLKM 50/32M/DV

- Can be used for 32-channel input and output modules
- Two-wire connection with a separate negative terminal per channel

FLKM 50/32M/IN/LA/DV

- Can be used for 32-channel input modules
- LED status display per channel
- Two-wire connection with a separate negative terminal per channel (dry contact)

Max. perm. operating voltage
Max. perm. current (per branch)
Rated surge voltage
Ambient temperature (operation)
Mounting position
Standards / regulations
Connection method

Field level
Control system level

Connection data solid / stranded / AWG
Dimensions

H / D

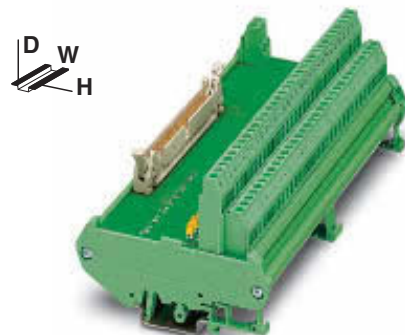

Interface module with two-wire connection method for DeltaV

Technical data

FLKM 50/32M/DV	FLKM 50/32M/IN/LA/DV
< 50 V AC	30 V DC
1 A	1 A
0.8 kV	0.8 kV
-20°C ... 50°C	-20°C ... 50°C
Any	Any
IEC 60664, DIN EN 50178, IEC 62103	
Screw connection	Screw connection
Flat-ribbon cable plug connector in acc. with IEC 60603-13	Flat-ribbon cable plug connector in acc. with IEC 60603-13

0.2 ... 4 mm² / 0.2 ... 2.5 mm² / 24 - 12
90 mm / 68 mm

Ordering data

Description	No. of poles	Module width W
VARIOFACE interface modules, for 32-channel I/O modules:		
- Input/Output	50	169 mm
- Input with LED per signal	50	169 mm

Type	Order No.	Pcs. / Pkt.
FLKM 50/32M/DV	2304869	1
FLKM 50/32M/IN/LA/DV	2304856	1

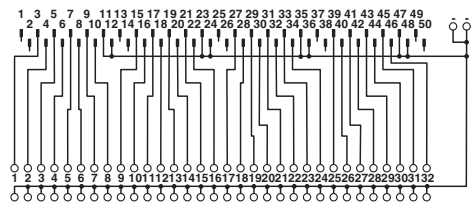

FLKM 50/32M/DV connection scheme

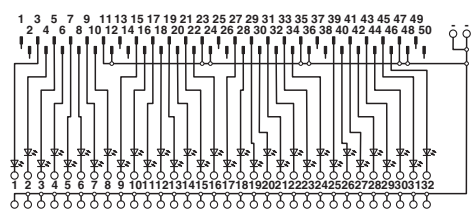

FLKM 50/32M/IN/LA/DV connection scheme

Emerson DeltaV Controller boards with fuses for 8 channels

These system-specific interface modules for DeltaV assemblies are used in combination with the respective system cables. The controller board is connected to 8-channel modules through 16-pos. or 24-pos. "mass termination blocks" with flat-ribbon cable connection.

UM-DELTA V/D/SI

- Fuse per channel
- Separate equipotential terminals per channel

UM-DELTA V/D/SI

- Fuse per channel
- Separate equipotential terminals per channel
- Knife disconnection for each channel

UM-DELTA V/D/SI/BFI/TP

- Fuse and LED status indicator per channel
- Separate equipotential terminals per channel

UM-DELTA V/D/SI

- Fuse and LED status indicator per channel
- Separate equipotential terminals per channel
- Knife disconnection for each channel

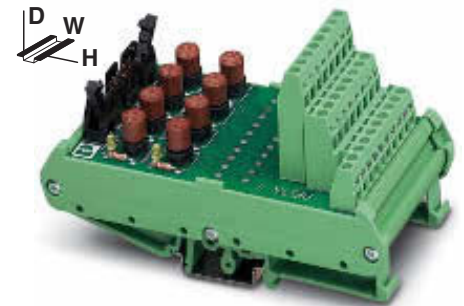

Interface module with fuses for 16-pos. and 24-pos. "mass termination blocks"



Technical data

Max. perm. operating voltage	24 V DC
Max. perm. current (per branch)	50 mA (in as-supplied state, with one 50 mA fuse, max. 1 A permitted)
Rated surge voltage	-
Ambient temperature (operation)	-20°C ... 50°C
Mounting position	Any
Standards / regulations	IEC 60664, DIN EN 50178, IEC 62103
Connection method	Screw connection
Field level	Flat-ribbon cable plug connector in acc. with IEC 60603-13
Control system level	
Connection data solid / stranded / AWG	0.2 ... 4 mm ² / 0.2 ... 2.5 mm ² / 24 - 12
Dimensions	126 mm / 71 mm

Ordering data

Description	No. of poles	Module width W	Type	Order No.	Pcs. / Pkt.
Interface modules for 16-pos. and 24-pos. "mass termination blocks" with:					
- Fuses	16	61 mm	UM-DELTA V/D/SI	5603255	1
- Fuses and knife disconnect terminal blocks	16	61 mm	UM-DELTA V/D/SI/BFI/TP	5603257	1
- Fuses and fuse failure display	16	61 mm	UM-DELTA V/A/SI	5603256	1
- Fuses, fuse failure display, and knife disconnect terminal blocks	16	61 mm	UM-DELTA V/A/SI/BFI/TP	5603258	1

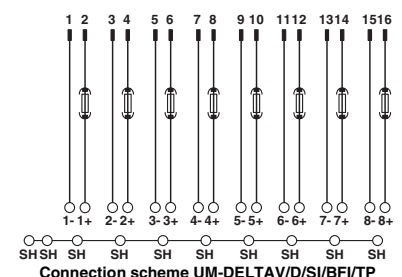
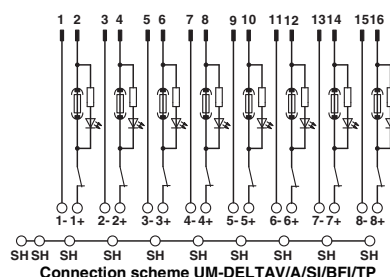
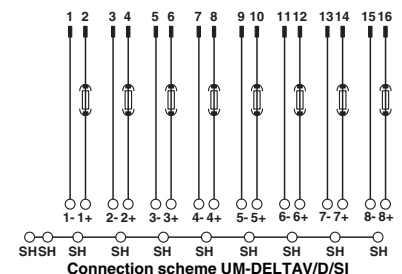
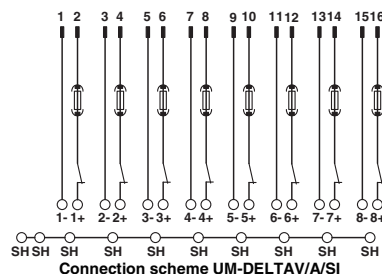

Explanation:

- Flat-ribbon cable strip
- Connection to I/O card
- Screw terminal blocks for separate supply

INTERFACE Cabling

VARIOFACE system cabling

GE Fanuc/RX3i Front adapters

The front adapters mean that pre-assembled system cables can be directly connected to I/O modules.

- Transfer of max. 32 channels over one 50-pole system cable
- Can be plugged onto I/O modules
- Connection via suitable VARIOFACE termination boards

Notes:

Suitable system cabling components can be configured in the INTERFACE search wizard. See www.phoenixcontact.net/catalog.



Front adapter for GE Fanuc RX3i

Max. perm. operating voltage
Max. permissible current

< 50 V AC / 60 V DC
1 A (per path)
8 A (per connection, supply via separate power supply)

Ambient temperature (operation)
Ambient temperature (storage / transport)
Mounting position
Standards / regulations

-20°C ... 50°C
-20°C ... 70°C
Any
IEC 60664 / DIN EN 50178 / IEC 62103

Technical data

Ordering data

Description	No. of poles
VARIOFACE front adapter , for PACSystems RX3i,	
For digital output and analog modules	50
For digital input modules	50

Type	Order No.	Pcs. / Pkt.
FLKM 50-PA-GE/TKFC/RXI	2321473	1
FLKM 50-PA-GE/TKFC/RXI/IN	2321486	1

Front adapter for I/O modules of RX3i series

Card type	FLKM 50-PA-GE/TKFC/RXI
Digital output	IC 694 MDL 754
Analog	IC 695 ALG 608* IC 695 ALG 616* IC 695 ALG 626* IC 695 ALG 629* IC 695 ALG 704* IC 695 ALG 708* IC 695 ALG 728*

Card type	FLKM 50-PA-GE/TKFC/RXI/IN
Digital input	IC 694 MDL 660

* Only in connection with VIP-3/SC/FLK50, Order No. 2315081. No voltage may be supplied through the slip-on connections on the front adapter.

Explanation:

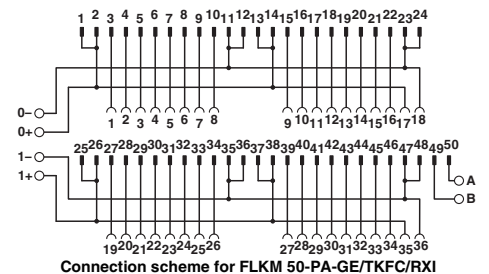

Connection scheme for FLKM 50-PA-GE/TKFC/RXI

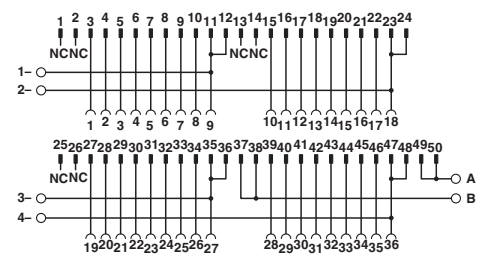

Connection scheme for FLKM 50-PA-GE/TKFC/RXI/IN

GE-FANUC, series 90-30 Front adapter

The front adapters mean that pre-assembled system cables can be directly connected to I/O modules.

Up to 2 x 8 channels are connected via two 14-pole system cables.

Perfectly-fitting VARIOFACE termination boards with a variety of functions and connection possibilities round off this system concept.

Notes:

Suitable system cabling components can be configured in the INTERFACE search wizard. See www.phoenixcontact.net/catalog.



Front adapter for GE-FANUC series 90-30



Technical data

Max. perm. operating voltage
Max. permissible current

< 50 V AC / 60 V DC
1 A (per path)
4 A (per connection, supply via separate power supply)

Max. perm. total current

3 A (per byte, for supply via connector)

Ambient temperature (operation)
Ambient temperature (storage / transport)
Mounting position
Standards / regulations

-20°C ... 50°C
-20°C ... 70°C
Any
IEC 60664 / DIN EN 50178 / IEC 62103

Ordering data

Description	No. of poles
VARIOFACE front adapter , for 90-30 series, max. 2 x 8 channels can be connected, digital output	14
VARIOFACE front adapter , for 90-30 series, max. 2 x 8 channels can be connected, digital input	14

Type	Order No.	Pcs. / Pkt.
FLKM 14-PA/GE/DO	2290009	2
FLKM 14-PA/GE/DI	2290038	5

Front adapter for 90-30 series I/O modules

Card type	FLKM 14-PA/GE/DO
Digital output	IC 693 MDL 732 IC 693 MDL 733* IC 693 MDL 740 IC 693 MDL 741* IC 693 MDL 742
Analog	IC 693 ALG 220* IC 693 ALG 221* IC 693 ALG 222* IC 693 ALG 223* IC 693 ALG 390* IC 693 ALG 391* IC 693 ALG 392* IC 693 ALG 442*

Card type	FLKM 14-PA/GE/DI
Digital input	IC 693 MDL 241 IC 693 MDL 634 IC 693 MDL 645 IC 693 MDL 646

* Only in conjunction with VIP-2/SC/2FLK14(1-20)/S7, Order No.: 2315230 and UM 45-2FLK14/ZFKDS/S7, Order No.: 2965156. All wire bridges (DR) on the adapter must be disconnected. There must be no voltage supply at the front adapter (flowing via the slip-on connections)!

Explanation:

- Flat-ribbon cable strip
- Connection to I/O card
- Screw terminal blocks for separate supply

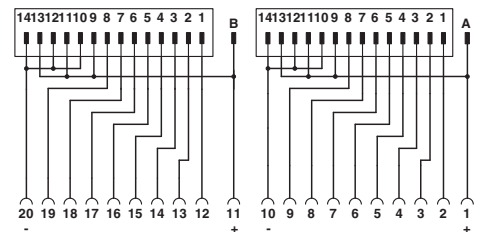

Connection scheme FLKM 14-PA/GE/DO

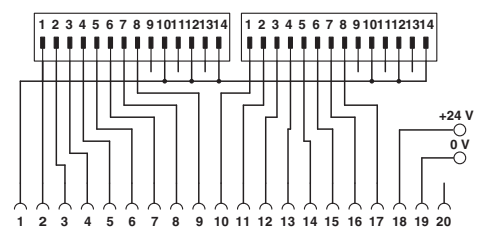

Connection scheme FLKM 14-PA/GE/DI

INTERFACE Cabling

VARIOFACE system cabling

Honeywell C300, series C I/O Front adapters

The front adapters mean that pre-assembled system cables can be directly connected to I/O modules.

FLKM-PA-D37/HW/C300

- Front adapter with D-SUB connector
- Connection of a maximum of 16 digital channels
- Terminal blocks for power supply
- Not for redundant digital I/O cards

FLKM-PA-D37/HW/DIO/C300

- Front adapter with D-SUB connector
- Connection of a maximum of 16 digital channels
- Specially designed for redundant digital I/O cards

FLKM-PA-D37/HW/AN/C300

- Front adapter with D-SUB connector
- Connection of analog modules

FLKM-PA-2D15/HW/DO/C300

- Front adapter with two 15-pole D-SUB connectors
- Connection of a maximum of 2 x 8 digital outputs

– Specially designed for coupling PLC-V8/D15.../OUT

Notes:

Matching system cable fitted with D-SUB female connector at both ends, see page 291.



Honeywell C300 front adapter

Technical data

Max. perm. operating voltage
Max. permissible current

< 50 V AC / 60 V DC
1 A (per path)
4 A (per connection, supply via separate power supply)

Ambient temperature (operation)
Ambient temperature (storage / transport)
Mounting position
Standards / regulations

-20°C ... 50°C
-20°C ... 70°C
Any
IEC 60664 / DIN EN 50178 / IEC 62103

Ordering data

Description	No. of poles
VARIOFACE front adapter for series C I/O, With D-SUB pin strip for digital I/O modules	37
With D-SUB pin strip for redundant digital I/O modules	37
With D-SUB pin strip for analog I/O modules	37
With two D-SUB pin strips for digital output modules	15

Type	Order No.	Pcs. / Pkt.
FLKM-PA-D37/HW/C300	2322029	1
FLKM-PA-D37/HW/DIO/C300	2901423	1
FLKM-PA-D37/HW/AN/C300	2900622	1
FLKM-PA-2D15/HW/DO/C300	2900924	1

Front adapter for I/O modules of the C300 series, C I/O series

Card type	FLKM-PA-D37/HW/C300
Digital input	TDIL 01*
Digital output	TDOB 01*

Card type	FLKM-PA-D37/HW/DIO/C300
Digital input	TDIL 11*
Digital output	TDOB 11*

Card type	FLKM-PA-D37/HW/AN/C300
Analog input	TAIX 01** TAIX 11**
Analog output	TAOX 01** TAOX 11**

Card type	FLKM-PA-2D15/HW/DO/C300
Digital output	TDOB 01* TDOB 11*

* Two front adapters are required for each module.

** For three-wire operation (channels 13 - 16) of input modules:
Only in conjunction with VIP-3/SC/D37SUB/M/HW/C300, Order No. 2900675.

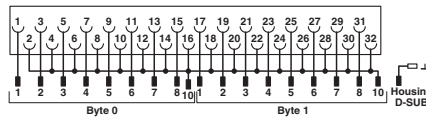

Connection scheme: FLKM-PA-2D15/HW/DO/C300

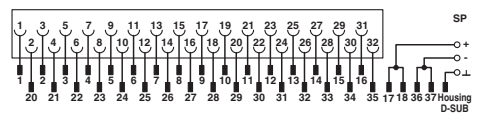

Connection scheme: FLKM-PA-D37/HW/C300

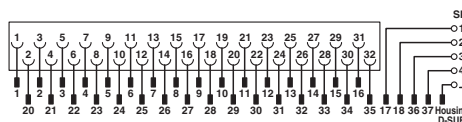

Connection scheme: FLKM-PA-D37/HW/AN/C300

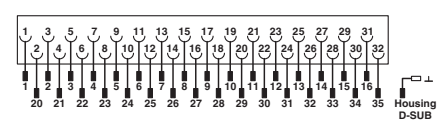

Connection scheme: FLKM-PA-D37/HW/DIO/C300

Explanation:

Honeywell C300, series C I/O Interface modules

These VARIOFACE modules are used in combination with the respective front adapters.

VIP-2/SC/D37SUB/M

- In conjunction with FLKM-PA-D37/HW/C300 or FLKM-PA-D37/HW/AN/C300 front adapter
- Universal module
- Field connection via double-level terminal blocks

VIP-2/SC/D37SUB/M/SO

- In conjunction with FLKM-PA-D37/HW/C300 front adapter
- System-specific labeling
- Field connection via double-level terminal blocks

VIP-3/SC/D37SUB/M/HW/C300

- In conjunction with FLKM-PA-D37/HW/AN/C300 front adapter
- System-specific labeling
- For TAIX01, TAIX11 analog input modules
- Field connection via three-level terminal blocks

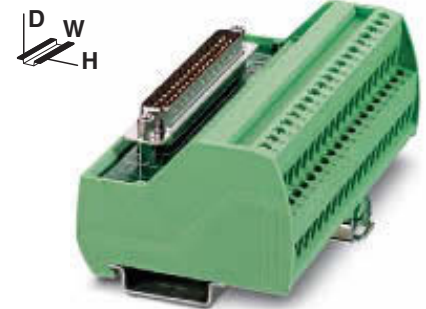

37 poles
with screw connection



Max. perm. operating voltage	
Max. perm. current (per branch)	
Ambient temperature (operation)	
Mounting position	
Standards / regulations	
Connection method	PCB connection
	D-SUB connection
Connection data solid / stranded / AWG	
Dimensions	H / D

Technical data	
VIP-2/SC...	VIP-3/SC...C300
125 V AC/DC	24 V DC
2 A	2 A
-20°C ... 50°C	-20°C ... 50°C
Any	Any
DIN EN 50178	
Screw connection	Screw connection
Male connector; 4-40 UNC thread	Male connector; 4-40 UNC thread
0.2 ... 4 mm ² / 0.2 ... 2.5 mm ² / 24 - 12	
45.5 mm / 65.5 mm	

Ordering data		
Type	Order No.	Pcs. / Pkt.
VIP-2/SC/D37SUB/M	2900676	1
VIP-2/SC/D37SUB/M/SO	2900786	1
VIP-3/SC/D37SUB/M/HW/C300	2900675	1

Description	No. of poles	Module width W
VARIOFACE interface modules with D-SUB pin strip,		
With universal labeling	37	101 mm
With system specific labeling	37	88 mm
For analog input modules	37	88 mm

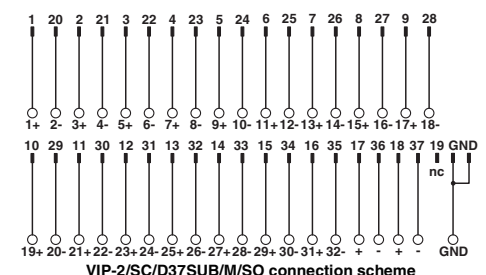
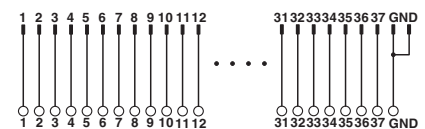
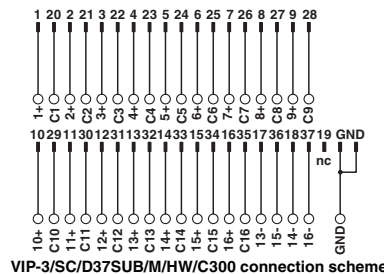

INTERFACE Cabling

VARIOFACE system cabling

Mitsubishi Electric MELSEC A, A1S, and Q System cable

For 32-/64-channel I/O boards with 37-pole D-SUB connectors. System cables are available for connecting 1 x 32 channels or 4 x 8 channels.

Notes:

Suitable system cabling components can be configured in the INTERFACE search wizard. See www.phoenixcontact.net/catalog.



**System cable,
D-SUB female connector on FLK,
number of poles: 37 on 50**



**Splitting cable,
D-SUB-female connector on FLK,
number of poles: 37 on 4 x 14**



Technical data	
Max. perm. operating voltage	< 50 V AC / 60 V DC
Max. perm. current carrying capacitance per path	1 A
Max. conductor resistance	0.16 Ω/m
Ambient temperature (operation)	-20°C ... 50°C
Conductor cross section	AWG 26 / 0.14 mm ²
Conductor structure: stranded wires / material	7 / Cu tin-plated
Outside diameter	10.5 mm



Technical data	
Max. perm. operating voltage	< 50 V AC / 60 V DC
Max. perm. current carrying capacitance per path	1 A
Max. conductor resistance	0.16 Ω/m
Ambient temperature (operation)	-20°C ... 50°C
Conductor cross section	AWG 26 / 0.14 mm ²
Conductor structure: stranded wires / material	7 / Cu tin-plated
Outside diameter	6.3 mm

Ordering data

Type	Order No.	Pcs. / Pkt.
FLK 50/EZ-DR/D37SUB/ 50/Y81P-O	2302599	1
FLK 50/EZ-DR/D37SUB/100/Y81P-O	2302609	1
FLK 50/EZ-DR/D37SUB/200/Y81P-O	2302612	1
FLK 50/EZ-DR/D37SUB/300/Y81P-O	2302638	1
FLK 50-EZ-DR-D37SUB-Y81P-O/...	2302625	1
FLK 50/EZ-DR/D37SUB/ 50/X81-I	2302641	1
FLK 50/EZ-DR/D37SUB/100/X81-I	2302654	1
FLK 50/EZ-DR/D37SUB/200/X81-I	2302667	1
FLK 50/EZ-DR/D37SUB/300/X81-I	2302670	1
FLK 50-EZ-DR-D37SUB-X81-I/...	2302683	1

Ordering data

Type	Order No.	Pcs. / Pkt.
CABLE-D37-M2,5/4X14/ 50/Y81P-O	2302476	1
CABLE-D37-M2,5/4X14/100/Y81P-O	2302489	1
CABLE-D37-M2,5/4X14/200/Y81P-O	2302492	1
CABLE-D37-M2,5/4X14/300/Y81P-O	2302502	1
CABLE-D37-M2,5-4X14-Y81P-O/...	2302696	1
CABLE-D37-M2,5/4X14/ 50/X81-I	2302515	1
CABLE-D37-M2,5/4X14/100/X81-I	2302528	1
CABLE-D37-M2,5/4X14/200/X81-I	2302531	1
CABLE-D37-M2,5/4X14/300/X81-I	2302544	1
CABLE-D37-M2,5-4X14-X81-I/...	2302706	1

Max. perm. operating voltage		
Max. perm. current carrying capacitance per path		
Max. conductor resistance		
Ambient temperature (operation)		
Conductor cross section		
Conductor structure: stranded wires / material		
Outside diameter		37-pole

Description	No. of poles	Cable length
Round cable (connection of 1 x 32 channels), for MELSEC Q Y81 P, MELSEC A1S Y81, and MELSEC A AY82EP, in standard lengths	37	0.5 m
	37	1 m
	37	2 m
	37	3 m
Round cable, same as before, however in variable lengths		
	37	
Round cable (connection of 4 x 8 channels), for MELSEC Q Y81 P, MELSEC A1S Y81, and MELSEC A AY82EP, in standard lengths	37	0.5 m
	37	1 m
	37	2 m
	37	3 m
Round cable, same as before, however in variable lengths		
	37	

Ordering example for system cable:

- Cable for MELSEC Q Y81P, 12.75 m long

Quantity	Order No.	Length [m]¹)
1	2302625	12.75

¹) min. 0.20 m

Ordering examples for splitting cable:

- Cable for MELSEC Q Y81P, 11.00 m long

Quantity	Order No.	Length [m]¹)
1	2302696	11.00

¹) min. 0.20 m

OMRON CJ1, CS1, CQM1, and C200H
System cable

These system cables are plugged onto the I/O cards that are connected using Fujitsu connectors.

FLK 50/EZ-DR/...

– Signal transmission of 32 channels

CABLE-FCN40...

– Splitting up 32 channels into 4 x 8 channels

CABLE-FCN24...

– Splitting up 16 channels into 2 x 8 channels



Connector Fujitsu FCN on flat-ribbon cable, number of poles: 40 on 50



Connector Fujitsu FCN on flat-ribbon cable, number of poles: 40 on 4 x 14 or 24 on 2 x 14



Technical data	
Max. perm. operating voltage	< 50 V AC / 60 V DC
Max. perm. current carrying capacitance per path	1 A
Max. conductor resistance	0.16 Ω/m
Ambient temperature (operation)	-20°C ... 50°C
Conductor cross section	AWG 26 / 0.14 mm ²
Conductor structure: stranded wires / material	7 / Cu tin-plated



Technical data	
Max. perm. operating voltage	< 50 V AC / 60 V DC
Max. perm. current carrying capacitance per path	1 A
Max. conductor resistance	0.16 Ω/m
Ambient temperature (operation)	-20°C ... 50°C
Conductor cross section	AWG - / 0.14 mm ²
Conductor structure: stranded wires / material	7 / Cu tin-plated

Ordering data

Type	Order No.	Pcs. / Pkt.
FLK 50/EZ-DR/FCN40/100/OMR-OUT	2304144	1
FLK 50/EZ-DR/FCN40/200/OMR-OUT	2304157	1
FLK 50-EZ-DR-FCN40-OMR-OUT/...	2302829	1
FLK 50/EZ-DR/FCN40/100/OMR-IN	2304160	1
FLK 50/EZ-DR/FCN40/200/OMR-IN	2304173	1
FLK 50-EZ-DR-FCN40-OMR-IN/...	2302803	1

Ordering data

Type	Order No.	Pcs. / Pkt.
CABLE-FCN40/4X14/100/OMR-OUT	2304186	1
CABLE-FCN40/4X14/200/OMR-OUT	2304199	1
CABLE-FCN40-4X14-OMR-OUT/...	2302832	1
CABLE-FCN40/4X14/100/OMR-IN	2304209	1
CABLE-FCN40/4X14/200/OMR-IN	2304212	1
CABLE-FCN40-4X14-OMR-IN/...	2302816	1
CABLE-FCN24/2X14/100/OMR-OUT	2304225	1
CABLE-FCN24/2X14/200/OMR-OUT	2304238	1
CABLE-FCN24-2X14-OMR-OUT/...	2302858	1
CABLE-FCN24/2X14/100/OMR-IN	2304241	1
CABLE-FCN24/2X14/200/OMR-IN	2304254	1
CABLE-FCN24-2X14-OMR-IN/...	2302845	1

Description	No. of poles	Cable length
Round cable in variable lengths for CJ1: OD231, OD261 CS1, C200H: OD218, OD219 CQM1: OD213	40	1 m
	40	2 m
Round cable , same as before, however in variable lengths	40	
Round cable in variable lengths for CJ1: ID231, ID261 CS1 and C200H: ID111, ID216, ID217, CQM1: ID213; ID214; ID112	40	1 m
	40	2 m
Round cable , same as before, however in variable lengths	40	
Round cable in variable lengths for CS1, C200H: OD215, MD115 (only output), MD215 (only output)	24	1 m
	24	2 m
Round cable , same as before, however in variable lengths	24	
Round cable in variable lengths for CS1, C200H: ID215, MD115 (only input), MD215 (only input)	24	1 m
	24	2 m
Round cable , same as before, however in variable lengths	24	

Ordering example for system cable:

– Cable for OMRON CJ1, ID231, 12.75 m long

Quantity **Order No.** **Length [m]¹⁾**

1	2302803	12.75
---	---------	-------

¹⁾ min. 0.20 m

INTERFACE Cabling

VARIOFACE system cabling

Phoenix Contact Axioline real-time I/O System cables

N

These cables have been specifically developed for connecting VARIOFACE termination boards to the Axioline realtime I/O system. The push-in technology on the I/O system ensures rapid connection.

The cables have the following features:

- 1:1 connection
- 14-pole connector, molded
- 8 pre-assembled open ends, for connection to the Axioline realtime I/O system
- Transmission of groups of 8 channels
- Labeling field on connector

Perfectly-fitting VARIOFACE termination boards round off this system concept.

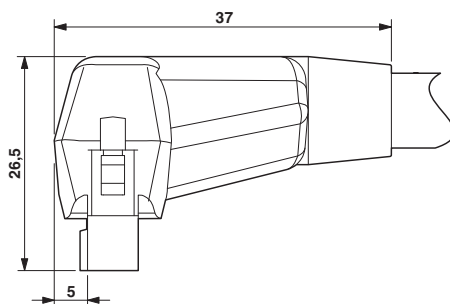

System cable for 8 channels

Notes:

The following modules cannot be coupled due to the larger outer contour of the molded connectors:
 UM 45-FLK14/8IM/ZFKDS/PLC, 2965211
 UM 45-8RM/MR-G24/1/PLC, 2962900

Max. perm. operating voltage
 Max. perm. current carrying capacitance per path
 Max. conductor resistance
 Ambient temperature (operation)
 Assembly

Conductor cross section
 Conductor structure: stranded wires / material
 Outside diameter

Technical data

< 50 V AC / 60 V DC
 1 A
 0.16 Ω/m
 -20°C ... 50°C
 Insulation displacement, IEC 60352-4 / DIN EN 60352-4

AWG 26 / 0.14 mm²
 7 / Cu tin-plated

14-pole 6.4 mm

Ordering data

Description	No. of poles	Cable length	Type	Order No.	Pcs. / Pkt.
Round cable with an open end (8 individual wires)					
	14	0.5 m	VIP-CAB-FLK14/AXIO/0,14/0,5M	2901604	1
	14	1 m	VIP-CAB-FLK14/AXIO/0,14/1,0M	2901605	1
	14	1.5 m	VIP-CAB-FLK14/AXIO/0,14/1,5M	2901606	1
	14	2 m	VIP-CAB-FLK14/AXIO/0,14/2,0M	2901607	1
	14	2.5 m	VIP-CAB-FLK14/AXIO/0,14/2,5M	2901608	1
	14	3 m	VIP-CAB-FLK14/AXIO/0,14/3,0M	2901609	1
	14	4 m	VIP-CAB-FLK14/AXIO/0,14/4,0M	2901610	1
	14	6 m	VIP-CAB-FLK14/AXIO/0,14/6,0M	2901611	1



Phoenix Contact Inline Front adapters

The front adapters are used to connect pre-assembled system cables directly to In-line. Front adapters are simply plugged into the relevant In-line modules. Three connection options are available:

- Transfer of 8 channels via a 14-pole system cable
- Transmission of 2 x 8 channels over two 14-pole system cables
- Transmission of 4 x 8 channels over four 14-pole system cables

Perfectly-fitting VARIOFACE termination boards round off this system concept.

Notes:

Suitable system cabling components can be configured in the INTERFACE search wizard. See www.phoenixcontact.net/catalog.



Front adapters for Inline



Max. perm. operating voltage
Max. permissible current
Ambient temperature (operation)
Ambient temperature (storage / transport)
Mounting position
Standards / regulations

< 50 V AC / 60 V DC
1 A (per path)
-20°C ... 50°C
-20°C ... 70°C
Any
IEC 60664 / DIN EN 50178 / IEC 62103

Technical data

Ordering data

Description	No. of poles
VARIOFACE front adapter , for 8-channel Inline modules	
Input: IB IL 24 D I8/HD-PAC Output: IB IL 24 DO 8/HD-PAC	
VARIOFACE front adapter , for 16-channel Inline modules	
Input: IB IL 24 DI 16 Output: IB IL 24 DO 16	
VARIOFACE front adapter , for 32-channel Inline modules	
Input: IB IL 24 DI 32/HD and Output: IB IL 24 DO 32/HD	

Type	Order No.	Pcs. / Pkt.
FLKM 14-PA-INLINE/DIO8	2900889	1
FLKM 14-PA-INLINE/IN16	2302751	1
FLKM 14-PA-INLINE/OUT16	2302764	1
FLKM 14-PA-INLINE/32	2302777	1

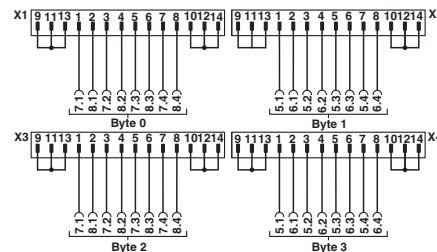

Connection scheme: FLKM 14-PA-INLINE/32

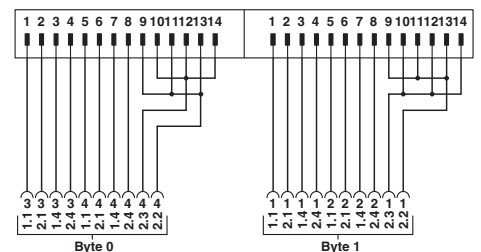

Connection scheme: FLKM 14-PA-INLINE/IN16

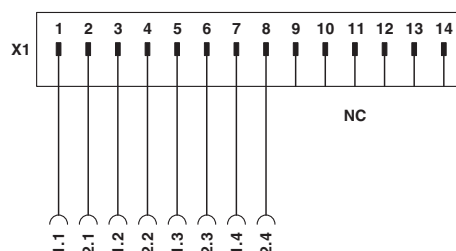

Connection scheme for FLKM 14-PA-INLINE/DIO8

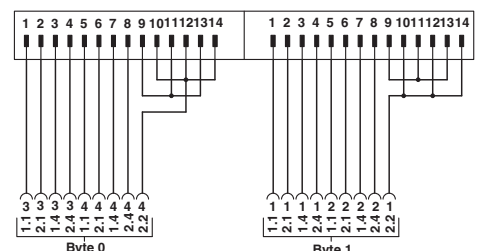

Connection scheme: FLKM 14-PA-INLINE/OUT16

Explanation:

- Flat-ribbon cable strip
- Connection to I/O card
- Screw terminal blocks for separate supply

INTERFACE Cabling

VARIOFACE system cabling

Schneider Electric MODICON® TSX Quantum Front adapter

The front adapters mean that pre-assembled system cables can be directly connected to I/O modules. There are two connection possibilities available:

- Transfer of max. 32 channels over one 50-pole system cable
- Transmission of 4 x 8 channels over four 14-pole system cables,

Perfectly-fitting VARIOFACE termination boards with a variety of functions and connection possibilities round off this system concept.

Notes:

Suitable system cabling components can be configured in the INTERFACE search wizard. See www.phoenixcontact.net/catalog.

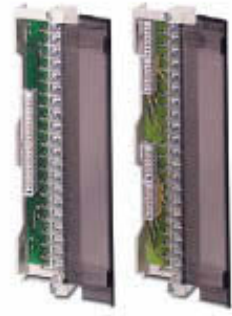

Front adapter for
MODICON TSX Quantum



Technical data

Max. perm. operating voltage
Max. permissible current

< 50 V AC / 60 V DC
1 A (per path)
4 A (per connection, supply via separate power supply)

Ambient temperature (operation)
Ambient temperature (storage / transport)
Mounting position
Standards / regulations

-20°C ... 50°C
-20°C ... 70°C
Any
IEC 60664 / DIN EN 50178 / IEC 62103

Front adapters for I/O modules of MODICON® TSX Quantum automation devices

Card type	FLKM 50-PA-MODI-TSX/Q
Digital input	DDI 353 DDI 841* DDI 853 DAI 340* DAI 353** DAI 440* DAI 453**
Digital output	DDO 353
Digital input/output	DDM 390*
Analog input	ACI 030* ACI 040* ATI 030* ARI 030* AVI 030*
Analog output	ACO 020* ACO 130* AVO 020*
Analog input/output	AMM 090*
Counter	ECH 105* EHC 202*

Description	No. of poles
VARIOFACE front adapter , for MODICON® TSX Quantum, 1 x 32 channels can be connected	50
VARIOFACE front adapter , for MODICON® TSX Quantum, 4 x 8 channels can be connected	14

Ordering data

Type	Order No.	Pcs. / Pkt.
FLKM 50-PA-MODI-TSX/Q	2294306	1
FLKM 50/ 4-FLK14/PA-MODI-TSX/Q	2294416	1

* Only in conjunction with VIP-2/SC/FLK50/MODI-TSX/Q,
Order No. 2322304.

** Only in conjunction with passive termination boards without LED.

Explanation:

- Flat-ribbon cable strip
- Connection to I/O card
- Screw terminal blocks for separate supply

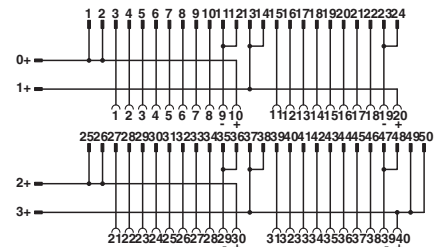

Connection scheme FLKM 50-PA-MODI-TSX/Q

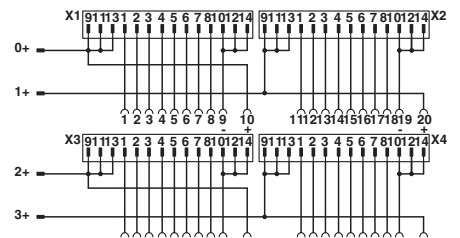

Connection scheme FLKM 50/ 4-FLK14/PA-MODI-TSX/Q

**Schneider Electric
MODICON® M340
System cable**

These system cables are plugged onto the I/O cards that are connected using Fujitsu connectors.

CABLE-FCN40/1X50/...

– Signal transmission of 32 channels

CABLE-FCN40/4X14/...

– Splitting up 32 channels into 4 x 8 channels

Notes:

Suitable system cabling components can be configured in the INTERFACE search wizard. See www.phoenixcontact.net/catalog.



Connector Fujitsu FCN on flat-ribbon cable, number of poles: 40 on 50



Connector Fujitsu FCN on flat-ribbon cable, number of poles: 40 on 4 x 14

			Technical data			Technical data		
Max. perm. operating voltage			< 50 V AC / 60 V DC			< 50 V AC / 60 V DC		
Max. perm. current carrying capacitance per path			1 A			1 A		
Max. conductor resistance			0.16 Ω/m			0.16 Ω/m		
Ambient temperature (operation)			-20°C ... 50°C			-20°C ... 50°C		
Conductor cross section			AWG 26 / 0.14 mm ²			AWG 26 / 0.14 mm ²		
Conductor structure: stranded wires / material			7 / Cu tin-plated			7 / Cu tin-plated		
Outside diameter			10.5 mm			6.3 mm		
			Ordering data			Ordering data		
Description	No. of poles	Cable length	Type	Order No.	Pcs. / Pkt.	Type	Order No.	Pcs. / Pkt.
Round cable in variable lengths for BMX DDI 3202K, BMX DDI 6402K, BMX DD0 3202K, BMX DD0 6402K, BMX DDM 3202K								
	40	0.5 m	CABLE-FCN40/1X50/ 0,5M/M340	2321635	1	CABLE-FCN40/4X14/ 0,5M/M340	2321716	1
	40	1 m	CABLE-FCN40/1X50/ 1,0M/M340	2321648	1	CABLE-FCN40/4X14/ 1,0M/M340	2321729	1
	40	2 m	CABLE-FCN40/1X50/ 2,0M/M340	2321651	1	CABLE-FCN40/4X14/ 2,0M/M340	2321732	1
	40	3 m	CABLE-FCN40/1X50/ 3,0M/M340	2321664	1	CABLE-FCN40/4X14/ 3,0M/M340	2321745	1
	40	4 m	CABLE-FCN40/1X50/ 4,0M/M340	2321677	1	CABLE-FCN40/4X14/ 4,0M/M340	2321758	1
	40	6 m	CABLE-FCN40/1X50/ 6,0M/M340	2321680	1	CABLE-FCN40/4X14/ 6,0M/M340	2321761	1
	40	8 m	CABLE-FCN40/1X50/ 8,0M/M340	2321693	1	CABLE-FCN40/4X14/ 8,0M/M340	2321774	1
	40	10 m	CABLE-FCN40/1X50/10,0M/M340	2321703	1	CABLE-FCN40/4X14/10,0M/M340	2321787	1

INTERFACE Cabling

VARIOFACE system cabling

VIP – VARIOFACE Professional front adapters for SIMATIC S7-300

Three connection options are available:

- Transfer of max. 32 channels via two 50-pole system cables (32-channel cards or this design)
- Transfer of 4 x 8 channels via two 14-pole system cables (32-channel cards or their type)
- Transfer of 2 x 8 channels via two 14-pole system cables (16-channel cards or their type)

The front adapters have the following features:

- Can be screwed with I/O module
 - Voltage supply via terminal blocks with spring-cage double connection
 - Encapsulated socket strips for module side
- Special lengths can be configured using separate order numbers.

Ordering example:

A front adapter with a connected 50-pole system cable (32-channel cards), 12.75 m in length:

1 pcs. 2900885/12,75

Notes:
The following modules cannot be coupled due to the larger outer contour of the molded connectors: UM 45-FLK14/ 8IM/ZFKDS/PLC, 2965211 UM 45-FLK50/32IM/ZFKDS/PLC, 2965224 UM 45- 8RM/MR-G24/1/PLC, 2962900 UM 45-16RM/MR-G24/1/PLC, 2962913
Suitable system cabling components can be configured in the INTERFACE search wizard. See www.phoenixcontact.net/catalog .

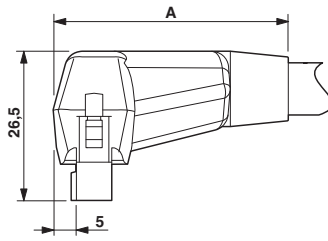

	A
...FLK14...	37
...FLK50...	42



Front adapter with system cable
1 x 32 channels can be connected

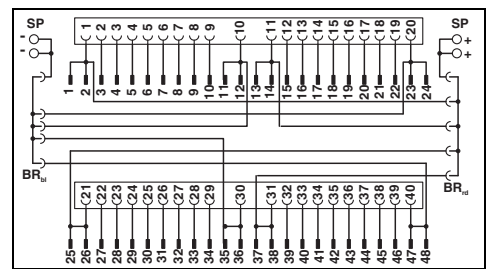

Technical data

Max. perm. operating voltage	< 50 V AC / 60 V DC
Max. perm. current carrying capacitance per path	1 A (per path)
Max. perm. current (separate power supply)	8 A
Rated surge voltage	0.8 kV
Max. conductor resistance	0.16 Ω/m
Conductor cross section	AWG 26 / 0.14 mm ²
Conductor structure: stranded wires / material	7 / Cu tin-plated
Outside diameter	10.3 mm
Ambient temperature range	-20°C ... 50°C
Standards / regulations	IEC 60664, IEC 62103, DIN EN 50178
Connection method	Front adapter: Can be plugged onto 40-pos. I/O modules / separate power supply through terminal blocks with spring-cage double connection System cable: Flat-ribbon cable plug connector in acc. with IEC 60603-13
Connection data solid / stranded / AWG	0.2 ... 2.5 mm ² / 0.2 ... 2.5 mm ² / 24 - 14

Ordering data

Description	Cable length	Type	Order No.	Pcs. / Pkt.
VIP VARIOFACE front adapter, with connected system cables for SIMATIC S7 300	0.5 m	VIP-PA-FLK50/ 0,5M/S7	2322443	1
	1 m	VIP-PA-FLK50/ 1,0M/S7	2322456	1
	1.5 m	VIP-PA-FLK50/ 1,5M/S7	2322469	1
	2 m	VIP-PA-FLK50/ 2,0M/S7	2321800	1
	2.5 m	VIP-PA-FLK50/ 2,5M/S7	2322472	1
	3 m	VIP-PA-FLK50/ 3,0M/S7	2322485	1
	4 m	VIP-PA-FLK50/ 4,0M/S7	2322498	1
	5 m	VIP-PA-FLK50/ 5,0M/S7	2322508	1
	6 m	VIP-PA-FLK50/ 6,0M/S7	2322511	1
	7 m	VIP-PA-FLK50/ 7,0M/S7	2322524	1
8 m	VIP-PA-FLK50/ 8,0M/S7	2322537	1	
10 m	VIP-PA-FLK50/10,0M/S7	2322540	1	
VIP VARIOFACE front adapter, as above, in variable lengths		VIP-PA-FLK50-S7/...	2900885	1

INTERFACE Cabling

VARIOFACE system cabling



Front adapter with system cable
4 x 8 channels can be connected



Front adapter with system cable
2 x 8 channels can be connected

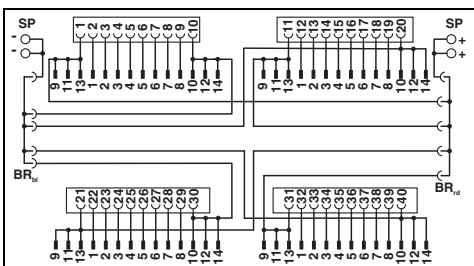

Technical data

< 50 V AC / 60 V DC
1 A (per path)
8 A

0.8 kV
0.16 Ω/m
AWG 26 / 0.14 mm²
7 / Cu tin-plated
6.4 mm
-20°C ... 50°C
IEC 60664, IEC 62103, DIN EN 50178
Can be plugged onto 40-pos. I/O modules / separate power supply through terminal blocks with spring-cage double connection

Flat-ribbon cable plug connector in acc. with IEC 60603-13

0.2 ... 2.5 mm² / 0.2 ... 2.5 mm² / 24 - 14

Ordering data

Type	Order No.	Pcs. / Pkt.
VIP-PA-FLK50/4X14/ 0,5M/S7	2322553	1
VIP-PA-FLK50/4X14/ 1,0M/S7	2322566	1
VIP-PA-FLK50/4X14/ 1,5M/S7	2322579	1
VIP-PA-FLK50/4X14/ 2,0M/S7	2321910	1
VIP-PA-FLK50/4X14/ 2,5M/S7	2322582	1
VIP-PA-FLK50/4X14/ 3,0M/S7	2322595	1
VIP-PA-FLK50/4X14/ 4,0M/S7	2322605	1
VIP-PA-FLK50/4X14/ 5,0M/S7	2322618	1
VIP-PA-FLK50/4X14/ 6,0M/S7	2322621	1
VIP-PA-FLK50/4X14/ 7,0M/S7	2322634	1
VIP-PA-FLK50/4X14/ 8,0M/S7	2322647	1
VIP-PA-FLK50/4X14/10,0M/S7	2322650	1
VIP-PA-FLK50-4X14-S7/...	2900886	1

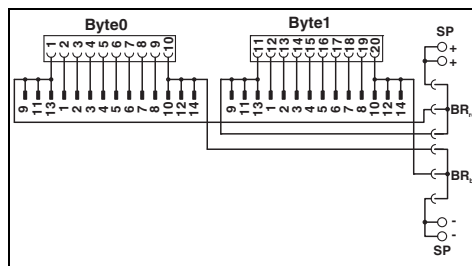

Technical data

< 50 V AC / 60 V DC
1 A (per path)
8 A

0.8 kV
0.16 Ω/m
AWG 26 / 0.14 mm²
7 / Cu tin-plated
6.4 mm
-20°C ... 50°C
IEC 60664, IEC 62103, DIN EN 50178
Can be plugged onto 20-pos. I/O modules / separate power supply through terminal blocks with spring-cage double connection

Flat-ribbon cable plug connector in acc. with IEC 60603-13

0.2 ... 2.5 mm² / 0.2 ... 2.5 mm² / 24 - 14

Ordering data

Type	Order No.	Pcs. / Pkt.
VIP-PA-FLK14/ 0,5M/S7	2322663	1
VIP-PA-FLK14/ 1,0M/S7	2322676	1
VIP-PA-FLK14/ 1,5M/S7	2322689	1
VIP-PA-FLK14/ 2,0M/S7	2321790	1
VIP-PA-FLK14/ 2,5M/S7	2322692	1
VIP-PA-FLK14/ 3,0M/S7	2322702	1
VIP-PA-FLK14/ 4,0M/S7	2322715	1
VIP-PA-FLK14/ 5,0M/S7	2322728	1
VIP-PA-FLK14/ 6,0M/S7	2322731	1
VIP-PA-FLK14/ 7,0M/S7	2322744	1
VIP-PA-FLK14/ 8,0M/S7	2322757	1
VIP-PA-FLK14/10,0M/S7	2322760	1
VIP-PA-FLK14-S7/...	2900887	1

Front adapter for 32-channel cards of
SIMATIC® S7-300

Card type	VIP-PA-FLK50/...M/S7
Digital input	6ES7 321-1BL00-0AA0
Digital output	6ES7 322-1BL00-0AA0
Digital input/output	6ES7 323-1BL00-0AA0
Analog input	6ES7 331-7PF01-0AB0* 6ES7 331-7PF11-0AB0* 6ES7 331-7NF00-0AB0* 6ES7 331-7NF10-0AB0* 6ES7 331-1KF01-0AB0*
Analog output	6ES7 332-5HF00-0AB0*
CPU	312C, 313C, 314C, 313C-2PiP 313C-2DP, 314C-2DP, 314C-2PiP
Other modules	6ES7 350-2AH01-0AE0* 6ES7 357-4AH01-0AE0*

Card type	VIP-PA-FLK50/4X14/...M/S7
Digital input	6ES7 321-1BL00-0AA0
Digital output	6ES7 322-1BL00-0AA0
Digital input/output	6ES7 323-1BL00-0AA0
CPU	313C, 314C, 313C-2PiP 313C-2DP, 314C-2DP, 314C-2PiP

* Only in conjunction with
VIP-2/SC/FLK50 (1-40)/S7, Order No.: 2315243,
UM 45-FLK50/ZFKDS/S7-300, Order No.: 2968111,
FLKM 50/KDS3-MT/PPA/S7-300, Order No.: 2304490.
All bridges (BR) at the adapter must be removed!

Front adapter for 16-channel cards of
SIMATIC® S7-300

Card type	VIP-PA-FLK14/...M/S7
Digital input	6ES7 321-1BH02-0AA0 6ES7 321-1BH10-0AA0 6ES7 321-1BH50-0AA0* 6ES7 321-7BH01-0AB0*
Digital output	6ES7 322-1BH01-0AA0 6ES7 322-1BH10-0AA0 6ES7 322-8BF00-0AB0*
Digital input/output	6ES7 323-1BH01-0AA0
Analog input	6ES7 331-7KF02-0AB0* 6ES7 331-7HF01-0AB0* 6ES7 331-7KB02-0AB0* 6ES7 331-7TF01-0AB0*
Analog output	6ES7 332-5HD01-0AB0* 6ES7 332-5HB01-0AB0* 6ES7 332-7ND02-0AB0*
Analog input/output	6ES7 334-0CE01-0AA0* 6ES7 334-0KE00-0AB0* 6ES7 335-7HG01-0AB0*
Other modules	6ES7 338-4BC01-0AB0* 6ES7 350-1AH03-0AE0* 6ES7 351-1AH01-0AE0* 6ES7 352-1AH02-0AE0* 6ES7 353-1AH01-0AE0* 6ES7 354-1AH01-0AE0* 6ES7 355-0VH10-0AE0* 6ES7 355-1VH10-0AE0*

* Only in conjunction with
IP-2/SC/2FLK14 (1-20)/S7, Order No.: 2315230
UM 45-2FLK14/ZFKDS/S7, Order No.: 2965156
FLKM-2FLK14/KDS 3-MT/PPA/S7, Order No.: 2295062
All bridges (BR) on the adapter must be disconnected.

Note:
The front adapters are non-isolated on delivery.
Removal of the bridges can achieve electrical isolation
(in groups of 8).

Explanation:
 Flat-ribbon cable strip
 Connection to I/O card

SP: Separate power terminals
BRbl: Blue plug-in bridge
BRrd: Red plug-in bridge

INTERFACE Cabling

VARIOFACE system cabling

Siemens-SIMATIC® S7-300 Front adapter

I/O modules with 32 channels or with this design

There are two connection possibilities available:

- Transfer of max. 32 channels over one 50-pole system cable
- Transmission of 4 x 8 channels over four 14-pole system cables,

Perfectly-fitting VARIOFACE termination boards with a variety of functions and connection possibilities round off this system concept.

Notes:

Suitable system cabling components can be configured in the INTERFACE search wizard. See www.phoenixcontact.net/catalog.



Front adapter for SIMATIC® S7-300, I/O cards with max. 32 channels



Technical data

Max. perm. operating voltage
Max. permissible current

< 50 V AC / 60 V DC
1 A (per path)
8 A (per connection, supply via separate power supply (2.8 x 0.8 mm))

Max. perm. total current

2 A (per byte, for supply via connector)
8 A (during supply via a separate bridged power supply)

Ambient temperature (operation)
Ambient temperature (storage / transport)
Standards / regulations
Connection method

-20°C ... 50°C
-20°C ... 70°C
IEC 60664 / DIN EN 50178 / IEC 62103
Flat-ribbon cable plug connector in acc. with IEC 60603-13

Front adapter for 32-channel cards of SIMATIC® S7-300

Card type	FLKM 50-PA-S300
Digital input	6ES7 321-1BL00-0AA0
Digital output	6ES7 322-1BL00-0AA0
Digital input/output	6ES7 323-1BL00-0AA0
Analog input	6ES7 331-7PF01-0AB0* 6ES7 331-7PF11-0AB0* 6ES7 331-7NF00-0AB0* 6ES7 331-7NF10-0AB0* 6ES7 331-1KF01-0AB0*
Analog output	6ES7 332-5HF00-0AB0*
CPU	312C, 313C, 314C, 313C-2PtP 313C-2DP, 314C-2DP, 314C-2PtP
Other modules	6ES7 350-2AH01-0AE0* 6ES7 357-4AH01-0AE0*

Card type	FLKM 50/4-FLK14/PA-S300
Digital input	6ES7 321-1BL00-0AA0
Digital output	6ES7 322-1BL00-0AA0
Digital input/output	6ES7 323-1BL00-0AA0
CPU	313C, 314C, 313C-2PtP 313C-2DP, 314C-2DP, 314C-2Pt

* Only in conjunction with VIP-2/SC/FLK50 (1-40)/S7, Order No.: 2315243, UM 45-FLK50/ZFKDS/S7-300, Order No.: 2968111, FLKM 50/KDS3-MT/PPA/S7-300, Order No.: 2304490. All wire bridges (DR) on the adapter must be disconnected! There must be no voltage supply at the front adapter (flowing via the slip-on connections)!

Note:
The front adapters are non-isolated on delivery. Removal of the bridges can achieve electrical isolation (in groups of 8).

Explanation:

- Flat-ribbon cable strip
- Connection to I/O card
- Screw terminal blocks for separate supply

Description	No. of poles
VARIOFACE front adapters, for SIMATIC® S7-300	
- 1 x 32 channels can be connected	50
- 4 x 8 channels can be connected	14

Ordering data

Type	Order No.	Pcs. / Pkt.
FLKM 50-PA-S300	2294445	1
FLKM 50/4-FLK14/PA-S300	2296281	1

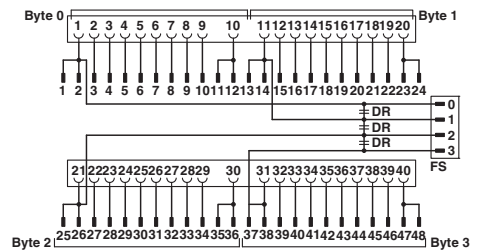

Connection scheme FLKM 50-PA-S300

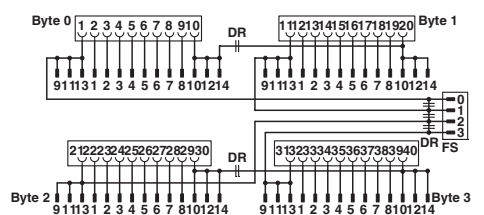

Connection scheme FLKM 50/4-FLK14/PA-S300

Siemens-SIMATIC® S7-300
Front adapter

I/O modules with 16 channels or with this design

– Up to 2 x 8 channels are connected via two 14-pole system cables

Perfectly-fitting VARIOFACE termination boards with a variety of functions and connection possibilities round off this system concept.

Notes:
Suitable system cabling components can be configured in the INTERFACE search wizard. See www.phoenixcontact.net/catalog.



Front adapter for SIMATIC® S7-300,
I/O cards with max. 16 channels



Technical data

Max. perm. operating voltage	< 50 V AC / 60 V DC
Max. permissible current	1 A (per path) 8 A (per connection, supply via separate power supply (2.8 x 0.8 mm))
Max. perm. total current	2 A (per byte, for supply via connector) 8 A (during supply via a separate bridged power supply)
Ambient temperature (operation)	-20°C ... 50°C
Ambient temperature (storage / transport)	-20°C ... 70°C
Standards / regulations	IEC 60664 / DIN EN 50178 / IEC 62103
Connection method	Flat-ribbon cable plug connector in acc. with IEC 60603-13

Ordering data

Type	Order No.	Pcs. / Pkt.
FLKM 14-PA-S300	2299770	1

Front adapter for 16-channel cards of SIMATIC® S7-300

Card type	FLKM 14-PA-S300
Digital input	6ES7 321-1BH02-0AA0 6ES7 321-1BH10-0AA0 6ES7 321-1BH50-0AA0* 6ES7 321-7BH01-0AB0*
Digital output	6ES7 322-1BH01-0AA0 6ES7 322-1BH10-0AA0 6ES7 322-8BF00-0AB0*
Digital input/output	6ES7 323-1BH01-0AA0
Analog input	6ES7 331-7KF02-0AB0* 6ES7 331-7HF01-0AB0* 6ES7 331-7KB02-0AB0* 6ES7 331-7TF01-0AB0*
Analog output	6ES7 332-5HD01-0AB0* 6ES7 332-5HB01-0AB0* 6ES7 332-7ND02-0AB0*
Analog input/output	6ES7 334-0CE01-0AA0* 6ES7 334-0KE00-0AB0* 6ES7 335-7HG01-0AB0*
Other modules	6ES7 338-4BC01-0AB0* 6ES7 350-1AH03-0AE0* 6ES7 351-1AH01-0AE0* 6ES7 352-1AH02-0AE0* 6ES7 353-1AH01-0AE0* 6ES7 354-1AH01-0AE0* 6ES7 355-0VH10-0AE0* 6ES7 355-1VH10-0AE0*

Description	No. of poles
VARIOFACE front adapters, for SIMATIC® S7-300	
- 2 x 8 channels can be connected	14

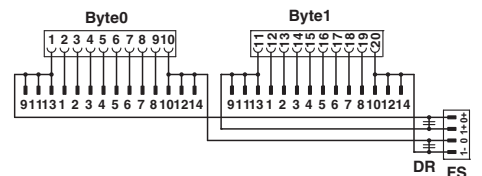

Connection scheme FLKM 14-PA-S300

* Only in conjunction with
VIP-2/SC/2FLK14 (1-20)/S7, Order No.: 2315230
UM 45-2FLK14/ZFKDS/S7, Order No.: 2965156
FLKM-2FLK14/KDS 3-MT/PPA/S7, Order No.: 2295062
All wire bridges (DR) on the adapter must be disconnected.
There must be no voltage supply at the front adapter (flowing via the slip-on connections)!

Note:
The front adapters are non-isolated on delivery.
Removal of the bridges can achieve electrical isolation (in groups of 8).

Explanation:
— Flat-ribbon cable strip
— Connection to I/O card
— Screw terminal blocks for separate supply

INTERFACE Cabling

VARIOFACE system cabling

Siemens SIMATIC® S7-300 Front adapter for failsafe modules

The front adapters are coupled using 50-pole system cables and convert the signals for passive modules.



Siemens SIMATIC S7-300 front adapter for failsafe I/O cards

Technical data

Max. perm. operating voltage	30 V DC
Max. permissible current	1 A (per path)
Max. perm. total current	2 A
Ambient temperature (operation)	-20°C ... 50°C
Ambient temperature (storage / transport)	-20°C ... 70°C
Standards / regulations	EN 50178
Connection method	Flat-ribbon cable plug connector in acc. with IEC 60603-13

Ordering data

Description	No. of poles	Type	Order No.	Pcs. / Pkt.
VARIOFACE front adapter for failsafe I/O cards				
6ES7 326-1BK02-0AB0 6ES7 326-1RF00-0AB0 6ES7 336-1HE00-0AB0	50	FLKM 50-PA-S300/SO167	2307662	1
VARIOFACE front adapter for failsafe I/O cards				
6ES7 326-2BF01-0AB0	50	FLKM 50-PA/DO326/S7-300	2321952	1

Front adapter for I/O modules of SIMATIC® S7-300

Card type	FLKM 50-PA-S300/SO167
Digital input	6ES7 326-1BK02-0AB0* 6ES7 326-1RF00-0AB0*1)
Analog input	6ES7 336-1HE00-0AB0*
Card type	FLKM 50-PA/DO326/S7-S300
Digital output	6ES7 326-2BF01-0AB0**

* Only in conjunction with
VIP-2/SC/FLK50 (1-40)/S7, Order No.: 2315243,
UM 45-FLK50/ZFKDS/S7-300, Order No.: 2968111,
FLKM 50/KDS3-MT/PPA/S7-300, Order No.: 2304490.

** Only in conjunction with
FLKM 50/DO326/S7-300, Order No.: 2312952.

1) Not suitable for signals from the Ex area.

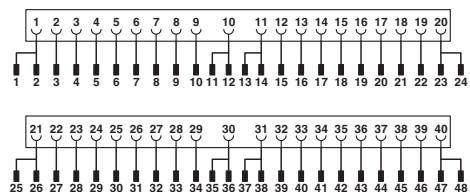

Connection scheme FLKM 50-PA-S300/SO167

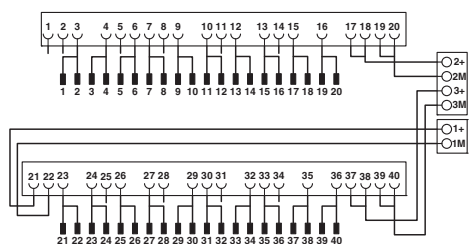

Connection scheme FLKM 50-PA/DO326/S7-300

Explanation:

Siemens SIMATIC S7 -300
System cables for 64-channel I/O cards

These system cables are plugged onto the 64-channel (2x32) I/O cards that are directly connected using connectors.

CABLE-FCN40/1X50/...

- Signal transmission of 1x32 channels
- System cable: 40-pole connector on 50-pole flat-ribbon cable strip

CABLE-FCN40/4X14/...

- Signal transmission of 4x8 channels
- Splitting cable: 40-pole connector on four 14-pole flat-ribbon cable strips



System cable



Splitting cable

			Technical data			Technical data			
Max. perm. operating voltage				< 50 V AC / 60 V DC			< 50 V AC / 60 V DC		
Max. perm. current carrying capacitance per path				1 A			1 A		
Max. conductor resistance				0.16 Ω/m			0.16 Ω/m		
Ambient temperature (operation)				-20°C ... 50°C			-20°C ... 50°C		
Conductor cross section				AWG 26 / 0.14 mm ²			AWG 26 / 0.14 mm ²		
Conductor structure: stranded wires / material				7 / Cu tin-plated			7 / Cu tin-plated		
Outside diameter				10 mm			6.3 mm		
			Ordering data			Ordering data			
Description	No. of poles	Cable length	Type	Order No.	Pcs. / Pkt.	Type	Order No.	Pcs. / Pkt.	
Round cable, for output module 6ES7 322-1BP00-0AA0 and 6ES7 322-1BP50-0AA0 (two cables per module)									
	40	0.5 m	CABLE-FCN40/1X50/ 0,5M/S7-OUT	2321017	1	CABLE-FCN40/4X14/ 0,5M/S7-OUT	2321172	1	
	40	1 m	CABLE-FCN40/1X50/ 1,0M/S7-OUT	2321020	1	CABLE-FCN40/4X14/ 1,0M/S7-OUT	2321185	1	
	40	2 m	CABLE-FCN40/1X50/ 2,0M/S7-OUT	2321033	1	CABLE-FCN40/4X14/ 2,0M/S7-OUT	2321198	1	
	40	3 m	CABLE-FCN40/1X50/ 3,0M/S7-OUT	2321046	1	CABLE-FCN40/4X14/ 3,0M/S7-OUT	2321208	1	
	40	4 m	CABLE-FCN40/1X50/ 4,0M/S7-OUT	2321059	1	CABLE-FCN40/4X14/ 4,0M/S7-OUT	2321211	1	
	40	6 m	CABLE-FCN40/1X50/ 6,0M/S7-OUT	2321062	1	CABLE-FCN40/4X14/ 6,0M/S7-OUT	2321224	1	
	40	8 m	CABLE-FCN40/1X50/ 8,0M/S7-OUT	2321075	1	CABLE-FCN40/4X14/ 8,0M/S7-OUT	2321237	1	
	40	10 m	CABLE-FCN40/1X50/10,0M/S7-OUT	2321088	1	CABLE-FCN40/4X14/10,0M/S7-OUT	2321240	1	
Round cable, for input module 6ES7 321-1BP00-0AA0 (two cables per module). Plus-reading operation (sinking mode) of the module									
	40	0.5 m	CABLE-FCN40/1X50/ 0,5M/S7-IN	2321091	1	CABLE-FCN40/4X14/ 0,5M/S7-IN	2321253	1	
	40	1 m	CABLE-FCN40/1X50/ 1,0M/S7-IN	2321101	1	CABLE-FCN40/4X14/ 1,0M/S7-IN	2321266	1	
	40	2 m	CABLE-FCN40/1X50/ 2,0M/S7-IN	2321114	1	CABLE-FCN40/4X14/ 2,0M/S7-IN	2321279	1	
	40	3 m	CABLE-FCN40/1X50/ 3,0M/S7-IN	2321127	1	CABLE-FCN40/4X14/ 3,0M/S7-IN	2321282	1	
	40	4 m	CABLE-FCN40/1X50/ 4,0M/S7-IN	2321130	1	CABLE-FCN40/4X14/ 4,0M/S7-IN	2321295	1	
	40	6 m	CABLE-FCN40/1X50/ 6,0M/S7-IN	2321143	1	CABLE-FCN40/4X14/ 6,0M/S7-IN	2321305	1	
	40	8 m	CABLE-FCN40/1X50/ 8,0M/S7-IN	2321156	1	CABLE-FCN40/4X14/ 8,0M/S7-IN	2321318	1	
	40	10 m	CABLE-FCN40/1X50/10,0M/S7-IN	2321169	1	CABLE-FCN40/4X14/10,0M/S7-IN	2321321	1	

INTERFACE Cabling

VARIOFACE system cabling

Siemens SIMATIC® S7-300 Front adapter for MINI MCR

This front adapter helps only in coupling the MINI MCR-SL-V8-FLK 16 A adapter. Changed analog standard signals can be transmitted with the help of these components.

Suitable isolators can be seen from page 352 on.

For suitable 16-pole system cable (FLK 16/EZ-DR/...), refer to page 284.



Front adapter for SIMATIC® S7-300,
20-pos. analog I/O boards



Technical data

FLKM 16-PA-S300/MINI-MCR
30 V AC/DC
50 mA (per path)
500 mA (per connection, supply via separate power supply)

-20°C ... 60°C
-20°C ... 70°C
DIN EN 50178 / IEC 62103

Max. perm. operating voltage
Max. permissible current

Ambient temperature (operation)
Ambient temperature (storage / transport)
Standards / regulations

Ordering data

Type	Order No.	Pcs. / Pkt.
FLKM 16-PA-S300/MINI-MCR	2314749	1

Accessories

FLK 16/EZ-DR/ 300/KONFEK	2299330	1
MINI MCR-SL-V8-FLK 16-A	2811268	1

Description	No. of poles
VARIOFACE front adapter, for SIMATIC® S7-300, only in connection with MINI MCR-SL-V8-FLK 16-A	16

Assembled round cable, with two 16-pole socket strips

System adapter, for MINI Analog modules with screw connection

Front adapter for analog cards of SIMATIC® S7-300

Card type	FLKM 16-PA-S300/MINI-MCR
Analog input	6ES7 331-7KF02-0AB0 6ES7 331-7KB02-0AB0 6ES7 331-7KB81-0AB0 6ES7 331-7TF00-0AB0
Analog output	6ES7 332-8TF01-0AB0

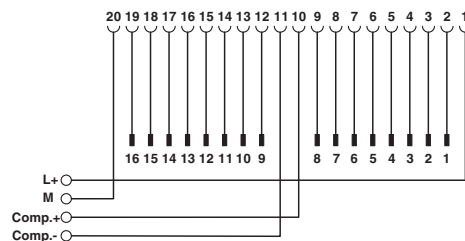

FLKM 16-PA-S300/MINI-MCR connection scheme

Explanation:

- Flat-ribbon cable strip
- Connection to I/O card
- Screw terminal blocks for separate supply

Siemens SIMATIC® S7-300
Front adapter for MINI Analog
system cabling

The FLKM 16-PA-331-1KF//MINI-MCR front adapter helps in system cabling in conjunction with the MINI Analog system adapter and a 16-pole system cable FLK 16/EZ-DR/.../KONFEK, refer to page 284.

Instead of the conventional front connector, screw terminal blocks are used to snap this component on to the analog module.

The DIP switches can be used to connect "M-" connections to each other and to the central ground of the system.

The front adapter supports **only current signals**.

The front adapter is suitable for the following analog input card:
 – 6ES7 331-1KF02-0AB0

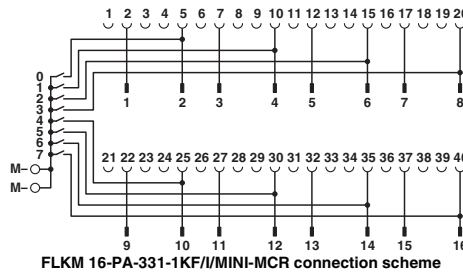

Max. perm. operating voltage
 Max. permissible current
 Rated surge voltage / insulation
 Ambient temperature (operation)
 Ambient temperature (storage / transport)
 Standards / regulations

30 V AC/DC
 50 mA (per path)
 0.5 kV / basic insulation
 -20°C ... 60°C
 -20°C ... 70°C
 DIN EN 50178 / IEC 62103



Front adapter for SIMATIC® S7-300,
6ES7 331-1KF02-0AB0 analog I/O board

Technical data

Ordering data

Description	No. of poles
VARIOFACE front adapter , for SIMATIC® S7-300, only in connection with MINI MCR-SL-V8-FLK 16-A	16

Type	Order No.	Pcs. / Pkt.
FLKM 16-PA- 331-1KF//MINI-MCR	2318237	1

Siemens SIMATIC® S7-300
Front adapter for MINI Analog
system cabling

The FLKM 16-PA-332-5HF//MINI-MCR front adapter helps in system cabling in conjunction with the MINI Analog system adapter and a 16-pole system cable FLK 16/EZ-DR/.../KONFEK, refer to page 284.

Instead of the conventional front connector, screw terminal blocks are used to snap this component on to the analog module.

The front adapter supports **only current signals**.

The front adapter is suitable for the following analog output cards:
 – 6ES7 332-5HF00-0AB0

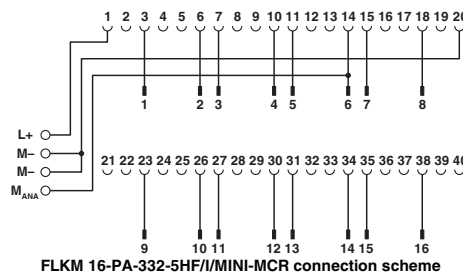

Max. perm. operating voltage
 Max. permissible current
 Rated surge voltage / insulation
 Ambient temperature (operation)
 Ambient temperature (storage / transport)
 Standards / regulations

30 V AC/DC
 50 mA (per path)
 500 mA (per connection, supply via separate power supply)
 0.5 kV / basic insulation
 -20°C ... 60°C
 -20°C ... 70°C
 DIN EN 50178 / IEC 62103



Front adapter for SIMATIC® S7-300,
6ES7 332-5HF00-0AB0 analog I/O board

Technical data

Ordering data

Description	No. of poles
VARIOFACE front adapter , for SIMATIC® S7-300, only in connection with MINI MCR-SL-V8-FLK 16-A	16

Type	Order No.	Pcs. / Pkt.
FLKM 16-PA- 332-5HF//MINI-MCR	2318240	1

INTERFACE Cabling

VARIOFACE system cabling

Siemens SIMATIC® S7-400

Front adapter

The front adapters mean that pre-assembled system cables can be directly connected to I/O modules.

FLKM 50-PA-S400

– Transmission of max. 32 digital channels over one 50-pole system cable

FLKM 50/4-FLK14/PA-S400

– Transmission of max. 32 digital channels via one 14-pole system cable

Perfectly-fitting VARIOFACE termination boards with a variety of functions and connection possibilities round off this system concept.

FLKM 50-PA-S400 (3-48)

– Analog channels are connected via a 50-pole system cable

The 1:1 connection of the adapter means that corresponding 1:1 interface modules are connected here.



Front adapter for SIMATIC® S7-400



Technical data

Max. perm. operating voltage
Max. permissible current

< 50 V AC / 60 V DC
1 A (per path)
8 A (per connection, supply via separate power supply)

Max. perm. total current

2 A (per byte, for supply via connector)
8 A (during supply via a separate bridged power supply)

Ambient temperature (operation)
Ambient temperature (storage / transport)
Mounting position
Standards / regulations

-20°C ... 50°C
-20°C ... 70°C
Any
IEC 60664 / DIN EN 50178 / IEC 62103

Ordering data

Front adapter for I/O modules of the Siemens automation equipment SIMATIC® S7-400

Card type	FLKM 50-PA-S400
Digital input	6ES7 421-1BL01-0AA0 6ES7 421-7BH01-0AB0* 6ES7 421-7DH00-0AB0*
Digital output	6ES7 422-1BL00-0AA0 6ES7 422-7BL00-0AB0
Card type	FLKM 50/4-FLK14/PA-S400
Digital input	6ES7 421-1BL01-0AA0
Digital output	6ES7 422-1BL00-0AA0 6ES7 422-7BL00-0AB0
Card type	FLKM 50-PA-S400 (3-48)
Analog input	6ES7 431-0HH00-0AB0** 6ES7 431-1KF00-0AB0** 6ES7 431-1KF10-0AB0** 6ES7 431-1KF20-0AB0** 6ES7 431-7KF00-0AB0** 6ES7 431-7KF10-0AB0** 6ES7 431-7QH00-0AB0**
Analog output	6ES7 432-1HF00-0AB0**

* Only in connection with VIP-2/SC/FLK50/S7/A-S400, Order No.: 2322359
All wire bridges (DR) on the adapter must be disconnected.

** Only in connection with VIP-3/SC/FLK50, Order No.: 2315081
UM 45-FLK 50/ZFKDS, Order No.: 2293585
UM 45-FLKS 50/ZFKDS, Order No.: 2968470
FLKM 50KDS3-MT/PPA/AN/PLC, Order No.: 2291587

Description	No. of poles
VARIOFACE front adapter, for - SIMATIC® S7-400, 1 x 32 channels can be connected	50
- SIMATIC® S7-400, 4 x 8 channels can be connected	14
- SIMATIC® S7-400, only analog	50

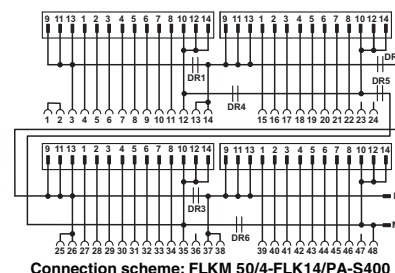
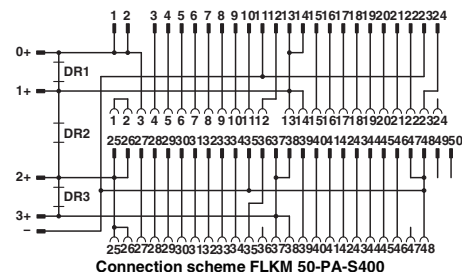
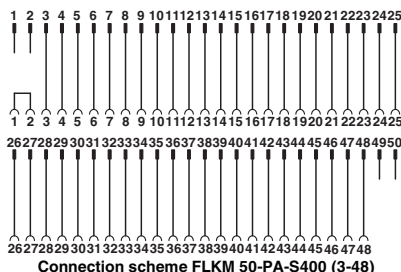

Explanation:

- Flat-ribbon cable strip
- Connection to I/O card
- Screw terminal blocks for separate supply

**Siemens SIMATIC® S7-400
Adapter for conversion from
S5-135/155 to S7-400**

The FLKM S135/... adapters connect a SIMATIC® S5 connector wired with individual conductors directly with the SIMATIC® S7-400 basic card.

The SIMATIC® S5 connector is plugged directly onto an S7-400 I/O card with the help of an FLKM S135/... intermediate adapter.

A new SIMATIC® S7-400 is installed in place of the SIMATIC® S5. The existing field wiring remains intact.

Attention:

The LEDs of the S7-400 module are hidden.



Adapter for Siemens SIMATIC® S5-135/S7-400



Max. perm. operating voltage
Max. permissible current

Test voltage (contact / contact)

Ambient temperature (operation)
Mounting position

Standards / regulations

Technical data			
①	②	③	④
24 V AC/DC	60 V DC	24 V DC	24 V AC/DC
4 A (per path)	2 A (per path)	4 A (per path)	4 A (per path)
500 V (50 Hz, 1 min.)	1.25 kV (50 Hz, 1 min.)	1.25 kV (50 Hz, 1 min.)	1.25 kV (50 Hz, 1 min.)
-20°C ... 50°C	-20°C ... 50°C	-20°C ... 50°C	-20°C ... 50°C
Any	Any	Any	Any

DIN EN 50178 / IEC 62103

Description	No. of poles
Digital IN 24 V from S5-135/155 to S7-400	
6ES5 420-4UA14 on 6ES7 421-1BL01-0AA0	①
6ES5 430-4UA14 on 6ES7 421-1BL01-0AA0	②
6ES5 431-4UA12 to 6ES7 421-7DH00-0AB0	③
6ES5 432-4UA12 on 6ES7 421-1BL01-0AA0	④

Ordering data		
Type	Order No.	Pcs. / Pkt.
FLKM S135/S400/SO120	2301723	1
FLKM S135/S400/SO121	2301736	1
FLKM S135-431-4UA/S400	2314846	1
FLKM S135/S400/SO122	2301749	1

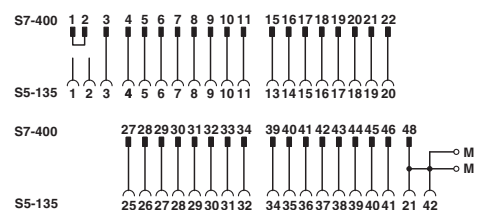
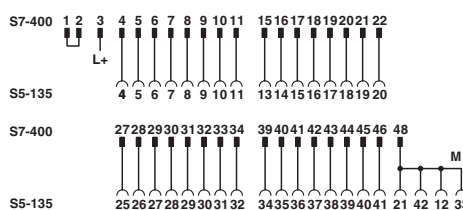
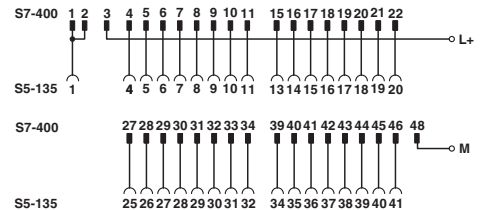
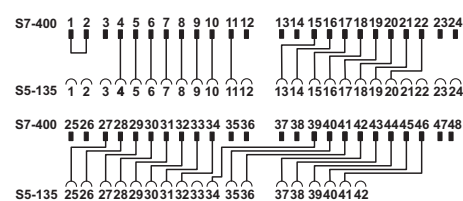

INTERFACE Cabling

VARIOFACE system cabling

Siemens SIMATIC® S7-400 Adapter for conversion from S5-135/155 to S7-400

The FLKM S135/... adapters connect a SIMATIC® S5 connector wired with individual conductors directly with the SIMATIC® S7-400 basic card.

The SIMATIC® S5 connector is plugged directly onto an S7-400 I/O card with the help of an FLKM S135/... intermediate adapter.

A new SIMATIC® S7-400 is installed in place of the SIMATIC® S5. The existing field wiring remains intact.

Attention:

The LEDs of the S7-400 module are hidden.



Front adapter for SIMATIC S5-135/S7-400

Max. perm. operating voltage	230 V AC/DC
Max. permissible current	4 A (per path)
Test voltage (contact / contact)	1.5 kV (50 Hz, 1 min.)
Ambient temperature (operation)	-20°C ... 50°C
Mounting position	Any

Technical data			
①	②	③	④
230 V AC/DC	24 V AC/DC	24 V DC	24 V DC
4 A (per path)	4 A (per path)	4 A (per path)	4 A (per path)
1.5 kV (50 Hz, 1 min.)	500 V (50 Hz, 1 min.)	1.25 kV (50 Hz, 1 min.)	500 V (50 Hz, 1 min.)
-20°C ... 50°C	-20°C ... 50°C	-20°C ... 50°C	-20°C ... 50°C
Any	Any	Any	Any

Standards / regulations

DIN EN 50178 / IEC 62103

Description	No. of poles
Digital IN 120/230 V UC from S5-135/155 to S7-400	
6ES5 436-4UA12 to 6ES7 421-1FH20-0AA0	①
Digital OUT 24 V from S5-135/155 to S7-400	
6ES5 441-4UA12 to 6ES7 422-1BL00-0AA0	②
6ES5 451-4UA14 to 6ES7 422-1BL00-0AA0	③
Digital OUT 24 V DC / 2 A from S5-135/155 to S7-400	
6ES5 453-4UA12 to 6ES7 422-1HH00-0AA0	④

Ordering data		
Type	Order No.	Pcs. / Pkt.
FLKM S135/S400/SO123	2301752	1
FLKM S135/S400/SO125	2301778	1
FLKM S135/S400/SO126	2301781	1
FLKM S135/S400/SO127	2301794	1

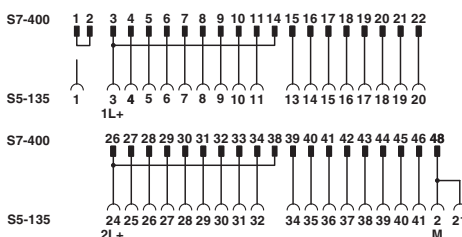

Connection scheme: FLKM S135/S400/SO126

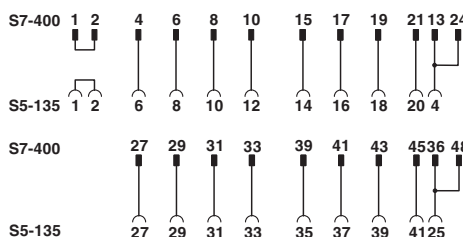

Connection scheme: FLKM S135/S400/SO123

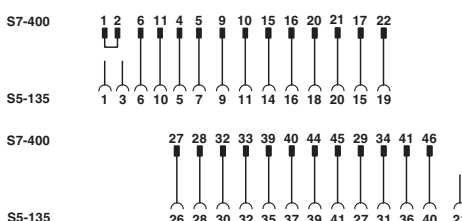

Connection scheme: FLKM S135/S400/SO127

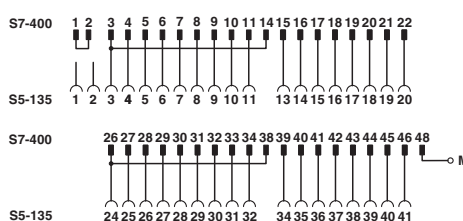

Connection scheme: FLKM S135/S400/SO125

Siemens SIMATIC® S7-400 Adapter for conversion from S5-135/155 to S7-400

The FLKM S135/... adapters connect a SIMATIC® S5 connector wired with individual conductors directly with the SIMATIC® S7-400 basic card.

The SIMATIC® S5 connector is plugged directly onto an S7-400 I/O card with the help of an FLKM S135/... intermediate adapter.

A new SIMATIC® S7-400 is installed in place of the SIMATIC® S5. The existing field wiring remains intact.

Attention:

The LEDs of the S7-400 module are hidden.



Adapter for Siemens SIMATIC® S5-135/S7-400

Max. perm. operating voltage	Max. permissible current
Test voltage (contact / contact)	
Ambient temperature (operation)	
Mounting position	
Standards / regulations	

Technical data			
①	②	③	④
24 V DC	230 V AC	24 V DC	24 V DC
4 A (per path)	4 A (per path)	4 A (per path)	4 A (per path)
1.25 kV (50 Hz, 1 min.)	1.5 kV (50 Hz, 1 min.)	500 V (50 Hz, 1 min.)	500 V (50 Hz, 1 min.)
-20°C ... 50°C	-20°C ... 50°C	-20°C ... 50°C	-20°C ... 50°C
Vertical	Vertical	Vertical	Vertical

DIN EN 50178 / IEC 62103

Description	No. of poles
Digital OUT 24 V DC / 2 A from S5-135/155 to S7-400	
6ES5 454-4UA14 to 6ES7 422-1BH11-0AA0	①
Digital OUT 230 V UC / 2 A from S5-135/155 to S7-400	
6ES5 456-4UA12 to 6ES7 422-1FH00-0AA0	②
Analog IN (only current measurement) from S5-135/155 to S7-400	
6ES5 460-4UA13 to 6ES7 431-1KF00-0AB0	③
Analog IN (only voltage measurement) from S5-135/155 to S7-400	
6ES5 460-4UA13 to 6ES7 431-1KF00-0AB0	④

Ordering data		
Type	Order No.	Pcs. / Pkt.
FLKM S135-454-4UA/S400	2314859	1
FLKM S135/S400/SO124	2301765	1
FLKM S135-460-4UA/I/S400	2314613	1
FLKM S135-460-4UA/U/S400	2314862	1

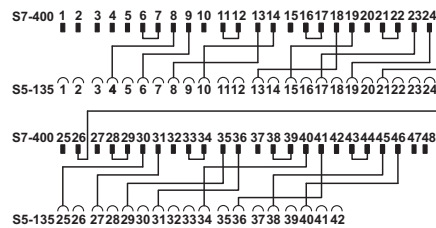

FLKM S135-460-4UA/I/S400 connection scheme

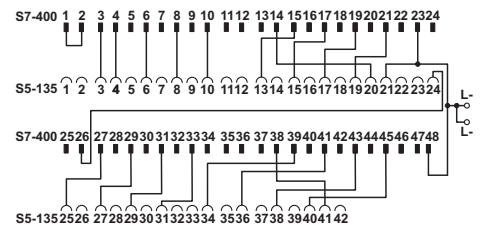

FLKM S135-454-4UA/S400 connection scheme

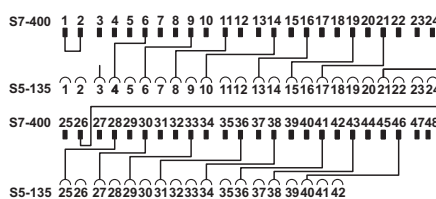

Connection scheme: FLKM S135-460-4UA/U/S400

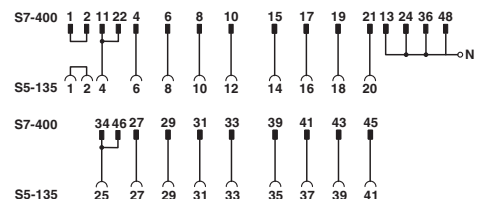

Connection scheme: FLKM S135/S400/SO124

INTERFACE Cabling

VARIOFACE system cabling

Siemens SIMATIC® S7-400 Adapter for conversion from S5-135/155 to S7-400

The FLKM S135/... adapters connect a SIMATIC® S5 connector wired with individual conductors directly with the SIMATIC® S7-400 basic card.

The SIMATIC® S5 connector is plugged directly onto an S7-400 I/O card with the help of an FLKM S135/... intermediate adapter.

A new SIMATIC® S7-400 is installed in place of the SIMATIC® S5. The existing wiring remains intact.

Attention:

The LEDs of the S7-400 module are hidden.



Adapter for Siemens SIMATIC® S5-135/S7-400

Max. perm. operating voltage	24 V DC
Max. permissible current	2 A (per path)
Test voltage (contact / contact)	500 V (50 Hz, 1 min.)
Ambient temperature (operation)	-20°C ... 50°C
Mounting position	Any

Standards / regulations

Technical data			
①	②	③	④
24 V DC	24 V DC	24 V DC	24 V DC
2 A (per path)	4 A (per path)	4 A (per path)	4 A (per path)
500 V (50 Hz, 1 min.)	500 V (50 Hz, 1 min.)	500 V (50 Hz, 1 min.)	500 V (50 Hz, 1 min.)
-20°C ... 50°C	-20°C ... 50°C	-20°C ... 50°C	-20°C ... 50°C
Any	Any	Any	Any

DIN EN 50178 / IEC 62103

Ordering data

Description	No. of poles
Analog IN (only Pt 100) from S5-135/155 to S7-400	
6ES5 465-4UA13 to 6ES7 431-7KF10-0AB0	①
Analog IN (only current and voltage measurement) from S5-135/155 to S7-400	
6ES5 465-4UA13 to 6ES7 431-0HH00-0AB0	②
6ES5 465-4UA13 to 6ES7 431-7QH00-0AB0	
Analog OUT (only current output) from S5-135/155 to S7-400	
6ES5 470-4UA13 to 6ES7 432-1HF00-0AB0	③
6ES5 470-4UC13 to 6ES7 432-1HF00-0AB0	
Analog OUT (only voltage output) from S5-135/155 to S7-400	
6ES5 470-4UA13 to 6ES7 432-1HF00-0AB0	④
6ES5 470-4UB13 to 6ES7 432-1HF00-0AB0	
6ES5 470-4UC13 to 6ES7 432-1HF00-0AB0	

Type	Order No.	Pcs. / Pkt.
FLKM S135-465-4UA/T/S400	2314875	1
FLKM S135-465-4UA/UI/S400	2314888	1
FLKM S135-470-4UC/I/S400	2314626	1
FLKM S135-470-4UC/U/S400	2314891	1

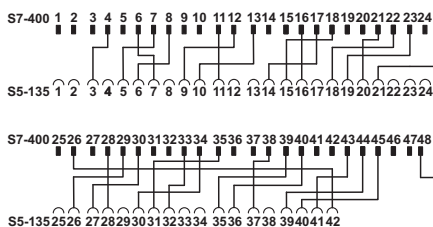

Connection scheme FLKM S135-470-4UC/I/S400

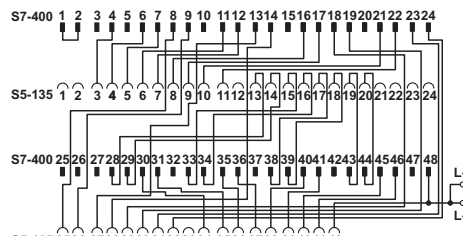

FLKM S135-465-4UA/T/S400 connection scheme

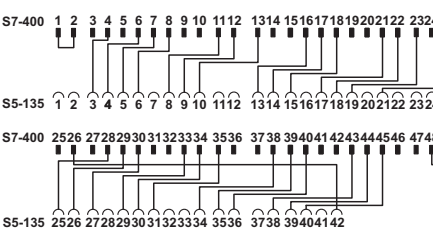

Connection scheme FLKM S135-470-4UC/U/S400

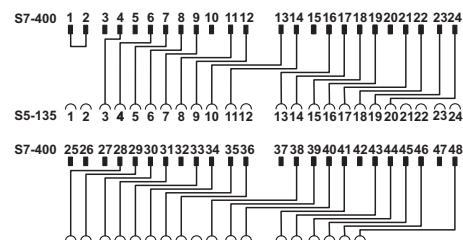

FLKM S135-465-4UA/UI/S400 connection scheme

**Siemens SIMATIC® S7-300
 Adapter for conversion from
 S5-135/155 to S7-300**

S5-S7 adapters connect the S5-135 front adapters wired with individual wires to the I/O modules of the S7.

With the help of the FLKM S135/S7/FLK50 converter module, the signals of the S5-135 front adapter can be converted to a 50-pole strip. A 50-pole system cable FLK 50/EZ-DR/.../KONFEK and a front adapter for the SIMATIC® S7 (FLKM 50-PA-S300) now connect the signals with the I/O module.

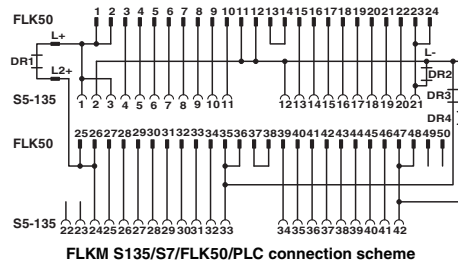

Converter for Siemens SIMATIC® S5-135 to 50-pole FLK strip

Technical data

Max. perm. operating voltage
 Max. permissible current
 Ambient temperature (operation)
 Ambient temperature (storage / transport)
 Mounting position
 Standards / regulations

50 V AC/DC
 1 A (per path)
 -20°C ... 50°C
 -20°C ... 70°C
 Any
 DIN EN 50178 / IEC 62103

Ordering data

Description
Digital IN or OUT 24 V DC from S5-135 to S7-300
IN 6ES5 420-4UA14 to 6ES7 321-1BL00-0AA0 6ES5 430-4UA14 to 6ES7 321-1BL00-0AA0
OUT 6ES5 441-4UA14 to 6ES7 322-1BL00-0AA0 6ES5 451-4UA14 to 6ES7 322-1BL00-0AA0

Type	Order No.	Pcs. / Pkt.
FLKM S135/S7/FLK50/PLC	2314736	1

Startup adapter for extending the existing S5-135/155 field wiring

All signals of the existing S5-135 wiring 3 or 5 are extended with the help of the universal commissioning adapters. The open cable end can be connected to various controllers such as S7-400 or S7-300. Therefore, the existing field wiring of S5-135 can communicate with the new controller for test purposes. Since the new control unit is temporarily arranged before the control cabinet, the original status of the system can be restored if required.

If the system functions with the new controller without problems, the S5-135 can now be replaced.

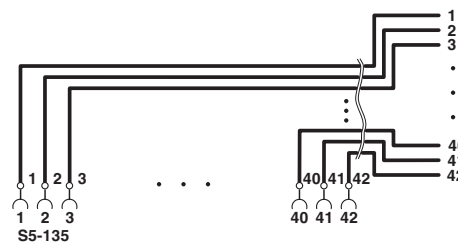

Technical data

Max. perm. operating voltage
 Max. permissible current
 Ambient temperature (operation)
 Ambient temperature (storage / transport)
 Mounting position
 Standards / regulations

250 V AC/DC
 6 A (per path)
 -20°C ... 50°C
 -20°C ... 80°C
 Any
 EN 60664-1

Ordering data

Description
Connection of all S5-135 connections (1 to 42) at the open cable end

Type	Order No.	Pcs. / Pkt.
FLKM S135/42X0,75/3,0M/OE	2315007	1
FLKM S135/42X0,75/5,0M/OE	2318017	1

INTERFACE Cabling

VARIOFACE system cabling

Siemens SIMATIC® S7-400 Adapter for conversion from S5-115 to S7-400

The FLKM S115/... adapters connect a SIMATIC® S5 connector wired with individual conductors directly with the SIMATIC® S7-400 basic card.

The SIMATIC® S5 connector is plugged directly onto an S7-400 I/O card with the help of an FLKM S115/... intermediate adapter.

A new SIMATIC® S7-400 is installed in place of the SIMATIC® S5. The existing field wiring remains intact.

Attention:

Due to the geometry, it is only possible to use every second slot. The LEDs of the S7-400 module are hidden by the S5-115 adapter.



Adapter for Siemens SIMATIC® S5-115/S7-400

Max. perm. operating voltage
Max. permissible current

24 V AC/DC
4 A (per path)
4 A (per connection, supply via separate power supply)

Ambient temperature (operation)
Ambient temperature (storage / transport)
Mounting position
Standards / regulations

-20°C ... 50°C
-20°C ... 70°C
Vertical
DIN EN 50178 / IEC 62103

Description
Digital IN or OUT 24 V DC from S5-115 to S7-400
IN 6ES5 420-7LA11 on 6ES7 421-1BL01-0AA0 6ES5 430-7LA11 on 6ES7 421-1BL01-0AA0
OUT 6ES5 441-7LA11 on 6ES7 422-1BL01-0AA0 6ES5 451-7LA11 on 6ES7 422-1BL01-0AA0
Digital OUT 24 V DC from S5-115 to S7-400
6ES5 454-7LA12 to 6ES7 422-1BH11-0AA0
Analog IN (only current and voltage measurement) from S5-115 to S7-400
6ES5 465-7LA13 to 6ES7 431-0HH00-0AB0 6ES5 465-7LA13 to 6ES7 431-7QH00-0AB0

Technical data

Ordering data

Type	Order No.	Pcs. / Pkt.
FLKM S115/S400/SO155	2307248	1
FLKM S115-454-7LA/S400	2314901	1
FLKM S115-465-7LA/UI/S400	2314914	1

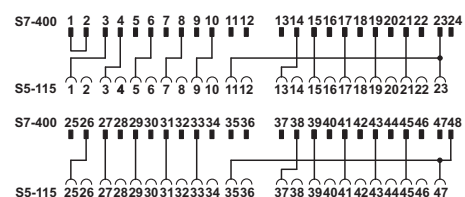
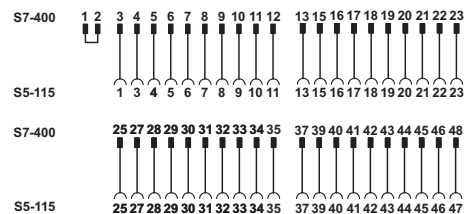

Siemens SIMATIC® S7-300
Adapter for conversion from
S5-115 to S7-300

S5-S7 adapters connect the S5-115 front adapters wired with individual wires to the I/O modules of S7-300.

With the aid of the FLKM S115/S7/FLK50/SO137 converter module, the signals of the S5-115 front adapter can be converted to a 50-pole strip. A 50-pole system cable FLK 50/EZ-DR/.../KONFEK and a front adapter for the SIMATIC® S7 (FLKM 50-PA-S300) now connect the signals with the I/O module.

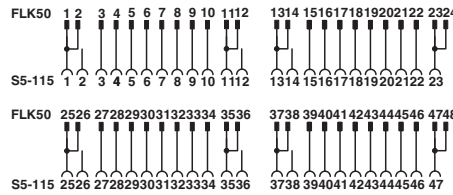

Connection scheme: FLKM S115/S7/FLK50/PLC/SO137



Converter for Siemens SIMATIC® S5-115 to 50-pole FLK strip

Technical data

Max. perm. operating voltage
 Max. permissible current
 Max. perm. total current
 Ambient temperature (operation)
 Ambient temperature (storage / transport)
 Standards / regulations

24 V AC/DC
 1 A (per path)
 2 A (per byte)
 -20°C ... 50°C
 -20°C ... 70°C
 DIN EN 50178 / IEC 62103

Ordering data

Description
Digital IN or OUT 24 V DC from S5-115 through converters, system cables and front adapters to S7-300
IN 6ES5 420-7LA11 on 6ES7 321-1BL00-0AA0 6ES5 430-7LA11 on 6ES7 321-1BL00-0AA0
OUT 6ES5 441-7LA11 on 6ES7 322-1BL00-0AA0 6ES5 451-7LA11 on 6ES7 322-1BL00-0AA0

Type	Order No.	Pcs. / Pkt.
FLKM S115/S7/FLK50/PLC/SO137	2306294	1

Commissioning adapters for extending the existing S5-115 field wiring

All signals of the existing S5-115 wiring 3 or 5 are extended with the help of the universal commissioning adapters. The open cable end can be connected to various controllers such as S7-400 or S7-300. Therefore, the existing field wiring of S5-115 can communicate with the new controller for test purposes. Since the new control unit is temporarily arranged before the control cabinet, the original status of the system can be restored if required.

If the system functions with the new controller without problems, the S5-115 can now be replaced.



Technical data

Max. perm. operating voltage
 Max. permissible current
 Ambient temperature (operation)
 Ambient temperature (storage / transport)
 Mounting position
 Standards / regulations

250 V AC/DC
 6 A (per path)
 -20°C ... 50°C
 -20°C ... 80°C
 Any
 EN 60664-1

Ordering data

Description
Connection of all S5-115 connections (1 to 23, 25 to 47) at the open cable end

Type	Order No.	Pcs. / Pkt.
FLKM S115/47X0,75/3,0M/OE	2314985	1
FLKM S115/47X0,75/5,0M/OE	2314998	1

INTERFACE Cabling

VARIOFACE system cabling

YOKOGAWA Centum CS3000 R3 System cable

These shielded system cables for digital (50-pole) and analog (40-pole) I/O modules are connected directly to the modules. An intermediate adapter is not required. Features:

- Molded plug connector
- Can be screwed
- Lateral cable outlet of the I/O module
- KS/AKB-compatible plug connectors on the module side



Technical data

Max. perm. operating voltage	30 V DC
Max. perm. current carrying capacitance per path	500 mA
Max. conductor resistance	0.16 Ω/m
Ambient temperature (operation)	-20°C ... 50°C
Conductor cross section	AWG 26 / 0.14 mm ²
Conductor structure: stranded wires / material	7 / Cu tin-plated
Outside diameter	50-pole 11 mm 40-pole 11 mm

Ordering data

Description	No. of poles	Cable length	Type	Order No.	Pcs. / Pkt.
50-pole YUC cables, for digital I/O modules					
	50	2 m	FLK 50-PA/EZ-DR/KS/ 200/YUC	2314299	1
	50	3 m	FLK 50-PA/EZ-DR/KS/ 300/YUC	2314309	1
	50	4 m	FLK 50-PA/EZ-DR/KS/ 400/YUC	2314312	1
	50	5 m	FLK 50-PA/EZ-DR/KS/ 500/YUC	2321499	1
	50	6 m	FLK 50-PA/EZ-DR/KS/ 600/YUC	2314927	1
	50	7 m	FLK 50-PA/EZ-DR/KS/ 700/YUC	2321509	1
	50	8 m	FLK 50-PA/EZ-DR/KS/ 800/YUC	2314930	1
	50	9 m	FLK 50-PA/EZ-DR/KS/ 900/YUC	2321512	1
	50	10 m	FLK 50-PA/EZ-DR/KS/1000/YUC	2314325	1
	50	11 m	FLK 50-PA/EZ-DR/KS/1100/YUC	2321389	1
	50	12 m	FLK 50-PA/EZ-DR/KS/1200/YUC	2321525	1
	50	13 m	FLK 50-PA/EZ-DR/KS/1300/YUC	2321392	1
	50	14 m	FLK 50-PA/EZ-DR/KS/1400/YUC	2321402	1
	50	15 m	FLK 50-PA/EZ-DR/KS/1500/YUC	2314338	1
	50	16 m	FLK 50-PA/EZ-DR/KS/1600/YUC	2321538	1
	50	17 m	FLK 50-PA/EZ-DR/KS/1700/YUC	2321541	1
	50	18 m	FLK 50-PA/EZ-DR/KS/1800/YUC	2321554	1
	50	19 m	FLK 50-PA/EZ-DR/KS/1900/YUC	2321567	1
	50	20 m	FLK 50-PA/EZ-DR/KS/2000/YUC	2314503	1
	50	25 m	FLK 50-PA/EZ-DR/KS/2500/YUC	2314516	1
	50	30 m	FLK 50-PA/EZ-DR/KS/3000/YUC	2314529	1
40-pole YUC cables, for analog I/O modules					
	40	1 m	FLK 40-PA/EZ-DR/KS/ 100/YUC	2322786	1
	40	2 m	FLK 40-PA/EZ-DR/KS/ 200/YUC	2314341	1
	40	3 m	FLK 40-PA/EZ-DR/KS/ 300/YUC	2314354	1
	40	4 m	FLK 40-PA/EZ-DR/KS/ 400/YUC	2314367	1
	40	5 m	FLK 40-PA/EZ-DR/KS/ 500/YUC	2321570	1
	40	6 m	FLK 40-PA/EZ-DR/KS/ 600/YUC	2314943	1
	40	7 m	FLK 40-PA/EZ-DR/KS/ 700/YUC	2321583	1
	40	8 m	FLK 40-PA/EZ-DR/KS/ 800/YUC	2314956	1
	40	9 m	FLK 40-PA/EZ-DR/KS/ 900/YUC	2321415	1
	40	10 m	FLK 40-PA/EZ-DR/KS/1000/YUC	2314370	1
	40	11 m	FLK 40-PA/EZ-DR/KS/1100/YUC	2321428	1
	40	12 m	FLK 40-PA/EZ-DR/KS/1200/YUC	2321431	1
	40	13 m	FLK 40-PA/EZ-DR/KS/1300/YUC	2321444	1
	40	14 m	FLK 40-PA/EZ-DR/KS/1400/YUC	2321457	1
	40	15 m	FLK 40-PA/EZ-DR/KS/1500/YUC	2314383	1
	40	16 m	FLK 40-PA/EZ-DR/KS/1600/YUC	2321596	1
	40	17 m	FLK 40-PA/EZ-DR/KS/1700/YUC	2321606	1
	40	18 m	FLK 40-PA/EZ-DR/KS/1800/YUC	2321619	1
	40	19 m	FLK 40-PA/EZ-DR/KS/1900/YUC	2321622	1
	40	20 m	FLK 40-PA/EZ-DR/KS/2000/YUC	2314532	1
	40	25 m	FLK 40-PA/EZ-DR/KS/2500/YUC	2314545	1
	40	30 m	FLK 40-PA/EZ-DR/KS/3000/YUC	2314558	1

YOKOGAWA Centum CS3000 R3
System cable

These system cables for digital I/O modules are connected directly to the modules. An intermediate adapter is not required.

Features:

- Lateral cable outlet of the I/O module
- Four 14-pole plug connectors on the module side for connection of four 8-channel VARIOFACE modules of the system cabling



			Technical data		
Max. perm. operating voltage			30 V DC		
Max. perm. current carrying capacitance per path			500 mA		
Max. conductor resistance			0.16 Ω/m		
Ambient temperature (operation)			-20°C ... 50°C		
Conductor cross section			AWG 26 / 0.14 mm ²		
Outside diameter					
	50-pole		11 mm		
			Ordering data		
Description	No. of poles	Cable length	Type	Order No.	Pcs. / Pkt.
System cable for digital I/O modules for coupling four 8-channel VARIOFACE modules					
	50	2 m	CABLE-50/4FLK14/ 2,0M/YUC	2314655	1
	50	4 m	CABLE-50/4FLK14/ 4,0M/YUC	2314671	1
	50	6 m	CABLE-50/4FLK14/ 6,0M/YUC	2318978	1
	50	10 m	CABLE-50/4FLK14/10,0M/YUC	2314684	1
	50	15 m	CABLE-50/4FLK14/15,0M/YUC	2322773	1
	50	20 m	CABLE-50/4FLK14/20,0M/YUC	2314778	1

YOKOGAWA Centum CS3000 R3
System cable for MINI Analog
system cabling

The Yokogawa system cable **CABLE-40/2FLK16/.../YUC** makes it possible to connect 16 MINI Analog modules to a Yokogawa control system. In conjunction with two MINI Analog system adapters MINI MCR-SL-V8-FLK-16-A, the Yokogawa system cable provides a simple and economical "Plug and Play" solution.

The system cable is plugged directly at the Yokogawa module. Two 16-pole flat-ribbon cable connectors are provided for connecting the module to the MINI Analog system adapters.

The system cable in conjunction with **4-wire measuring transducers** is suitable for the following analog cards:

- AAI 141
- AAI 143



			Technical data		
Max. perm. operating voltage			30 V DC		
Max. perm. current carrying capacitance per path			500 mA		
Max. conductor resistance			0.16 Ω/m		
Ambient temperature (operation)			-20°C ... 50°C		
Conductor cross section			AWG 26 / 0.14 mm ²		
Conductor structure: stranded wires / material			7 / Cu tin-plated		
Outside diameter					
	40-pole		11 mm		
			Ordering data		
Description	No. of poles	Cable length	Type	Order No.	Pcs. / Pkt.
System cable , for analog I/O modules for coupling two 8-channel MINI Analog system adapters					
	40	2 m	CABLE-40/2FLK16/ 2,0M/YUC	2321334	1
	40	4 m	CABLE-40/2FLK16/ 4,0M/YUC	2321347	1
	40	10 m	CABLE-40/2FLK16/10,0M/YUC	2321350	1
	40	15 m	CABLE-40/2FLK16/15,0M/YUC	2321376	1
	40	20 m	CABLE-40/2FLK16/20,0M/YUC	2321363	1

INTERFACE Cabling

VARIOFACE system cabling

YOKOGAWA Centum CS3000 R3 Controller boards

These modules are connected to the I/O modules through the YUC system cable.

FLKM-KS40/YCS:

- For analog modules
- Universal interface module with 40 connecting terminal blocks

For more cabling solutions for Yokogawa:
www.phoenixcontact.com

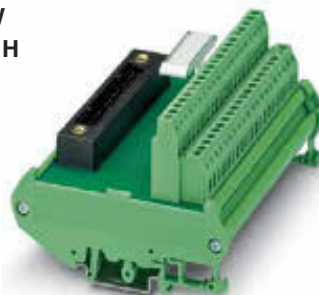

Passive interface modules

Technical data

Max. perm. operating voltage	24 V AC/DC ±10%
Max. perm. current (per branch)	1 A
Test voltage (contact / contact)	500 V (50 Hz, 1 min.)
Ambient temperature (operation)	-20°C ... 50°C
Mounting position	Any
Standards / regulations	DIN EN 50178
Connection method	Screw connection
	Field level
	Control system level
Connection data solid / stranded / AWG	Yokogawa KS-compatible
Dimensions	0.2 ... 4 mm ² / 0.2 ... 2.5 mm ² / 24 - 12
	H / D
	90 mm / 68 mm

Ordering data

Description	No. of poles	Module width W	Type	Order No.	Pcs. / Pkt.
Controller board, for analog I/O modules	40	112 mm	FLKM-KS40/YCS	2314642	1

YOKOGAWA Centum CS3000 R3 Controller boards

These modules are connected to the I/O modules through the YUC system cable.

FLKMS-KS50/32IM/YCS:

- For digital modules ADV 151 and ADV 551
- Three-wire connection (signal, plus, minus)
- Redundant voltage supply (fuse IEC 127-2, 5 x 20, 2 A)

For more cabling solutions for Yokogawa:
www.phoenixcontact.com

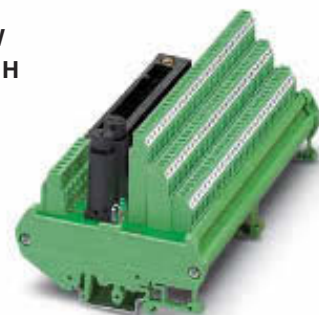

Passive interface modules

Technical data

Max. perm. operating voltage	24 V AC/DC ±10%
Max. perm. current (per branch)	1 A
Test voltage (contact / contact)	500 V (50 Hz, 1 min.)
Ambient temperature (operation)	-20°C ... 50°C
Mounting position	Any
Standards / regulations	DIN EN 50178
Connection method	Screw connection
	Field level
	Control system level
Connection data solid / stranded / AWG	Yokogawa KS-compatible
Dimensions	0.2 ... 4 mm ² / 0.2 ... 2.5 mm ² / 24 - 12
	H / D
	90 mm / 81 mm

Ordering data

Description	No. of poles	Module width W	Type	Order No.	Pcs. / Pkt.
Controller board, for digital I/O modules ADV 151 and ADV 551	50	174 mm	FLKMS-KS50/32IM/YCS	2314451	1

**YOKOGAWA Centum CS3000 R3
Controller boards**

These modules are connected to the analog I/O modules through the 40-pole YUC system cable.

The modules are designed for redundant signal transmission (two plug connectors in parallel). A separate connection to the HART multiplexer is possible.

FLKM-KS40/AO16/YCS

– For analog module AAI 543

FLKMS-KS40/SI/AI16/YCS

– For analog modules AAI 141 and AAI 143 (operation of modules in the 4-wire mode)

– Transfer of 16 channels with separate positive and negative connections
– 16 pluggable fuses (IEC 127-2, 5 x 20, 0.1 A) per positive supply and LED status indicator

– Redundant voltage supply (fuse IEC 127-2, 5 x 20, 2 A)

FLKMS-KS40/AI/YCS

– For analog modules AAI 141 and AAI 143 (operation of modules in the 4-wire mode)

– Transfer of 16 channels with separate positive and negative connections

– Redundant voltage supply (fuse IEC 127-2, 5 x 20, 2 A)

For more cabling solutions for Yokogawa:
www.phoenixcontact.com



Interface modules for analog I/O modules

Technical data

Max. perm. operating voltage	24 V DC ±10%
Max. perm. current (per branch)	100 mA
Test voltage (contact / contact)	500 V (50 Hz, 1 min.)
Ambient temperature (operation)	-20°C ... 50°C
Mounting position	Any
Standards / regulations	DIN EN 50178
Connection method	Screw connection
	Field level
	Control system level
Connection data solid / stranded / AWG	Yokogawa KS-compatible 0.2 ... 4 mm ² / 0.2 ... 2.5 mm ² / 24 - 12
Dimensions	H / D 126 mm / 68 mm

Ordering data

Description	No. of poles	Module width W	Type	Order No.	Pcs. / Pkt.
Controller board , for analog output modules AAI 543	40	108 mm	FLKM-KS40/AO16/YCS	2314260	1
Controller board , with fuses and LED, for analog input modules AAI 141 and AAI 143	40	214 mm	FLKMS-KS40/SI/AI16/YCS	2314273	1
Controller board , for analog input modules AAI 141 and AAI 143, without fuses and LED	40	214 mm	FLKMS-KS40/AI/YCS	2314286	1

INTERFACE Cabling

VARIOFACE system cabling

VIP termination boards

These VIP VARIOFACE Professional modules are used in combination with the respective front adapters.

Similar to the front adapters, the modules are connected through 14-pole system cables. The following module types are available:

VIP-2/SC/FLK14/PLC VIP-2/SC/FLK14/LED/PLC

- Byte-wise labeling
- Can be used for digital I/O modules
- Optionally with LED

Notes:

For marking systems and mounting material, see CLIPLINE catalog, part 2.



Passive interface modules for input/output of 8 channels



Technical data

	VIP-2/SC/FLK14/PLC	VIP-2/SC/FLK14/LED/PLC
Max. perm. operating voltage	60 V AC/DC	20 V DC (up to 26.5 V DC)
Max. perm. current (per branch)	1 A	1 A
Max. total current (voltage supply)	3 A	3 A
Rated surge voltage	0.6 kV	-
Ambient temperature (operation)	-20°C ... 50°C	-20°C ... 50°C
Mounting position	Any	Any
Standards / regulations	IEC 60664, DIN EN 50178, IEC 62103	
Connection method	Field level Screw connection	Screw connection
	Control system level	Flat-ribbon cable plug connector in acc. with IEC 60603-13
Connection data solid / stranded / AWG	0.2 ... 4 mm ² / 0.2 ... 2.5 mm ² / 24 - 12	
Dimensions	H / D 65.5 mm / 56 mm	

Ordering data

Description	No. of poles	Module width W	Type	Order No.	Pcs. / Pkt.
VARIOFACE interface module, for - eight channels	14	39.8 mm	VIP-2/SC/FLK14/PLC	2315214	1
VARIOFACE interface module, with light indicator for: - eight channels	14	39.8 mm	VIP-2/SC/FLK14/LED/PLC	2322249	1

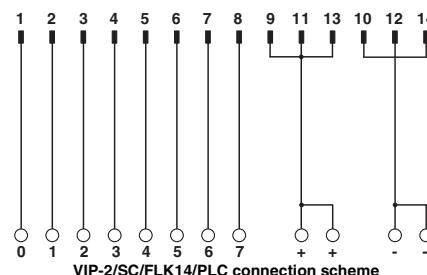
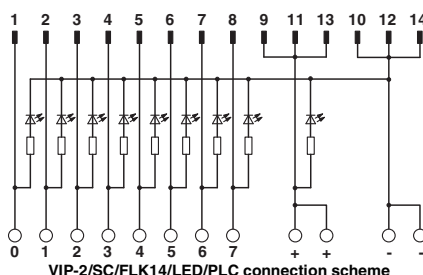

VIP termination boards

These VIP VARIOFACE Professional modules are used in combination with the respective front adapters.

Similarly to the front adapters, the modules are connected through 50-pole system cables. The following module types are available:

VIP-2/SC/FLK50/PLC VIP-2/SC/FLK50/LED/PLC

- Byte-wise labeling
- Can be used for digital I/O modules
- Optionally with LED.

Notes:

For marking systems and mounting material, see CLIPLINE catalog, part 2.

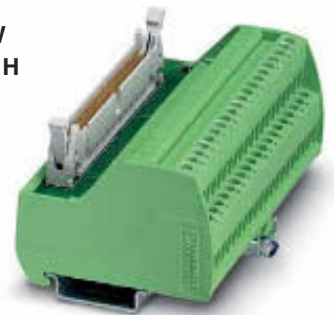

Passive interface modules for input/output of 32 channels



Technical data

Max. perm. operating voltage	VIP-2/SC/FLK50/PLC	VIP-2/SC/FLK50/LED/PLC
Max. perm. current (per branch)	60 V AC/DC	20 V DC (up to 26.5 V DC)
Max. total current (voltage supply)	1 A	1 A
Rated surge voltage	2 A	2 A (per byte)
Ambient temperature (operation)	0.6 kV	-
Mounting position	-20°C ... 50°C	-20°C ... 50°C
Standards / regulations	Any	Any
Connection method	IEC 60664, DIN EN 50178, IEC 62103	IEC 60664, DIN EN 50178, IEC 62103
	Field level	Control system level
	Screw connection	Flat-ribbon cable plug connector in acc. with IEC 60603-13
		Flat-ribbon cable plug connector in acc. with IEC 60603-13
Connection data solid / stranded / AWG	0.2 ... 4 mm ² / 0.2 ... 2.5 mm ² / 24 - 12	
Dimensions	H / D 65.5 mm / 56 mm	

Ordering data

Description	No. of poles	Module width W	Type	Order No.	Pcs. / Pkt.
VARIOFACE interface module, for - 32 channels	50	106.1 mm	VIP-2/SC/FLK50/PLC	2315227	1
VARIOFACE interface module, for - 32 channels	50	106.1 mm	VIP-2/SC/FLK50/LED/PLC	2322252	1

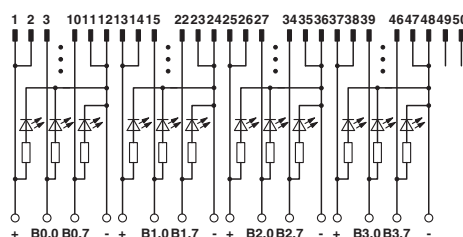

VIP-2/SC/FLK50/LED/PLC connection scheme

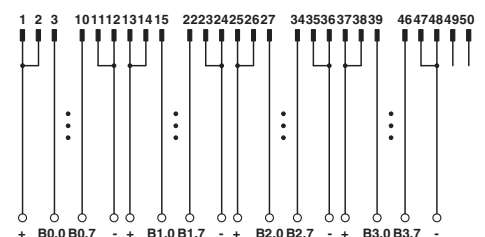

VIP-2/SC/FLK50/PLC connection scheme

INTERFACE Cabling

VARIOFACE system cabling

VIP termination boards for SIMATIC® S7

These VIP VARIOFACE Professional modules are used in combination with the respective front adapters for SIMATIC® S7.

Similarly to the front adapters, the modules are connected through 50-pole system cables. The following module types are available:

VIP-2/SC/FLK50 (1-40)/S7

- Numerical labeling (1-40)
- Specially for S7 300

VIP-2/SC/FLK50/S7/A-S400

- Numerical labeling (3-48)
- Specially for S7 400

Notes:

For marking systems and mounting material, see CLIPLINE catalog, part 2.

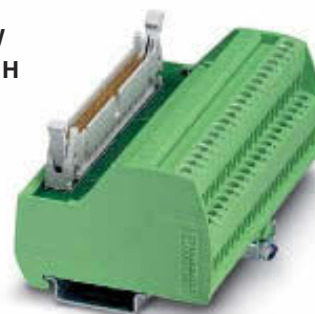

Passive interface modules for input/output of 32 channels, with SIMATIC®-specific labeling



Technical data

Max. perm. operating voltage	60 V AC/DC
Max. perm. current (per branch)	1 A
Rated surge voltage	0.6 kV
Ambient temperature (operation)	-20°C ... 50°C
Mounting position	Any
Standards / regulations	IEC 60664, DIN EN 50178, IEC 62103
Connection method	Screw connection
	Field level
	Control system level
Connection data solid / stranded / AWG	0.2 ... 4 mm ² / 0.2 ... 2.5 mm ² / 24 - 12
Dimensions	65.5 mm / 56 mm
	H / D

Ordering data

Description	No. of poles	Module width W	Type	Order No.	Pcs. / Pkt.
VARIOFACE interface module, for SIMATIC®S7-300, with SIMATIC®-specific labeling	50	106.1 mm	VIP-2/SC/FLK50 (1-40) /S7	2315243	1
VARIOFACE interface module, for SIMATIC®S7-400, with SIMATIC®-specific labeling	50	106.1 mm	VIP-2/SC/FLK50/S7/A-S400	2322359	1

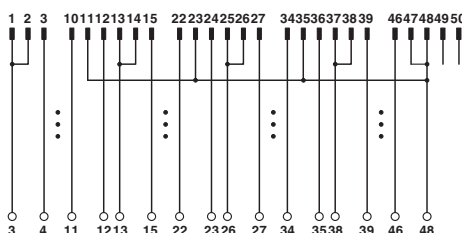

VIP-2/SC/FLK50/S7/A-S400 connection scheme

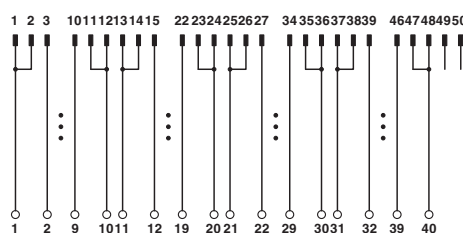

VIP-2/SC/FLK50 (1-40) /S7 connection scheme

VIP termination boards for MODICON® TSX Quantum and Allen-Bradley ControlLogix

These VIP VARIOFACE Professional modules are used in combination with the respective front adapters for MODICON® TSX Quantum.

Similar to the front adapters, the modules are connected through 50-pole system cables.

VIP-2/SC/FLK50/MODI-TSX/Q

- Numerical labeling (1-40)
- Specially for MODICON TSX Quantum

VIP-2/SC/FLK50/AB-1756

- Numerical labeling (1-36)
- Specially for ControlLogix

Notes:

For marking systems and mounting material, see CLIPLINE catalog, part 2.

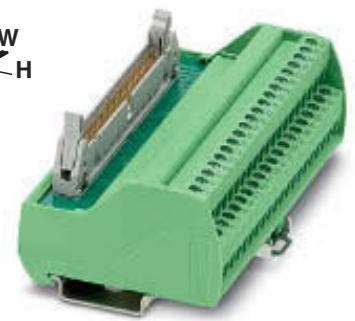

Passive interface modules for input/output of 32 channels



Technical data

Max. perm. operating voltage	60 V DC
Max. perm. current (per branch)	1 A
Rated surge voltage	-
Ambient temperature (operation)	-20°C ... 50°C
Mounting position	Any
Standards / regulations	IEC 60664, DIN EN 50178, IEC 62103
Connection method	Field level Control system level
	Screw connection
	Flat-ribbon cable plug connector in acc. with IEC 60603-13
Connection data solid / stranded / AWG	0.2 ... 4 mm ² / 0.2 ... 2.5 mm ² / 24 - 12
Dimensions	H / D 65.5 mm / 56 mm

Ordering data

Description	No. of poles	Module width W	Type	Order No.	Pcs. / Pkt.
VARIOFACE interface module , for MODICON® TSX Quantum, with MODICON®-specific labeling	50	106.1 mm	VIP-2/SC/FLK50/MODI-TSX/Q	2322304	1
VARIOFACE interface module for Allen-Bradley, with ControlLogix-specific labeling	50	95.9 mm	VIP-2/SC/FLK50/AB-1756	2322317	1

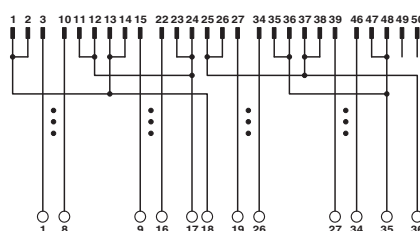

VIP-2/SC/FLK50/AB-1756 connection scheme

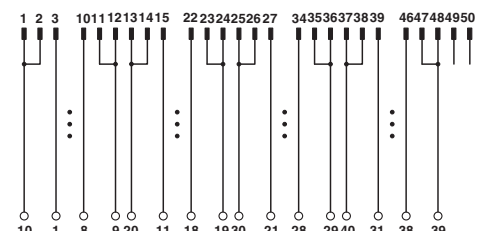

VIP-2/SC/FLK50/MODI-TSX/Q connection scheme

INTERFACE Cabling

VARIOFACE system cabling

VIP termination boards for Siemens SIMATIC® S7-300 and Allen-Bradley

These VIP VARIOFACE Professional modules are used in combination with the respective front adapters for Siemens SIMATIC® S7-300 and Allen-Bradley. The following modules are available:

VIP-2/SC/2FLK14 (1-20) /S7

- Screw or spring-cage connection
- Numerical labeling (1-20)
- Specially for S7 300.

VIP-2/SC/2FLK14/AB-1756

- Screw connection
- Numerical labeling (1-20)
- Specially for ControlLogix

Notes:

For marking systems and mounting material, see CLIPLINE catalog, part 2.

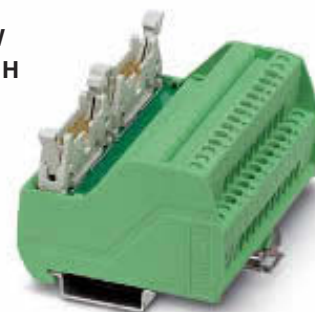

Passive interface modules for SIMATIC S7 300 and Allen-Bradley ControlLogix



Technical data

Max. perm. operating voltage	60 V AC/DC
Max. perm. current (per branch)	1 A
Rated surge voltage	0.6 kV
Ambient temperature (operation)	-20°C ... 50°C
Mounting position	Any
Standards / regulations	IEC 60664, DIN EN 50178, IEC 62103
Connection method	Screw connection
	Field level
	Control system level
Connection data solid / stranded / AWG	0.2 ... 4 mm ² / 0.2 ... 2.5 mm ² / 24 - 12
Dimensions	H / D 65.5 mm / 56 mm

Ordering data

Description	No. of poles	Module width W	Type	Order No.	Pcs. / Pkt.
VARIOFACE interface module , for SIMATIC®S7-300, with SIMATIC®-specific labeling					
With screw connection	14	80.6 mm	VIP-2/SC/2FLK14 (1-20) /S7	2315230	1
VARIOFACE interface module for Allen-Bradley, with ControlLogix-specific labeling					
With screw connection	14	80.6 mm	VIP-2/SC/2FLK14/AB-1756	2322333	1

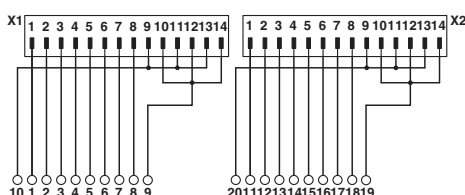

VIP-2/SC/2FLK14/AB-1756 connection scheme

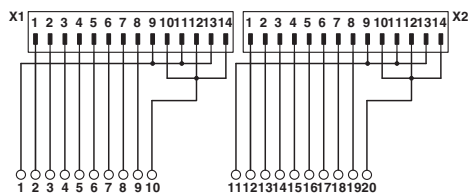

VIP-2/SC/2FLK14 (1-20) /S7 and UM 45-2FLK14/ZFKDS/S7

COMPACT-LINE

Controller boards with spring-cage connection

These VARIOFACE modules are used in combination with the respective front adapters. Like the front adapters, the modules are connected via 14-pole or 50-pole system cables. The following Compact-Line modules are available:

UM 45-FLK14.../PLC (for 8 channels) UM 45-FLK50.../PLC (for 32 channels)

- Byte-wise labeling
- Can be used for digital I/O modules
- Optionally with LED.

UM 45-FLK50/.../S7-300

- Numerical labeling (1-40)
- Specially for S7 300

UM 45-2FLK14/ZFKDS/S7

- Numerical labeling (1-20)
- Specially for S7 300
- Connection via two 14-pole system cables



Passive interface module for eight or 32 channels with a spring-cage connection



Technical data

... 14/PLC	... 50/PLC	... 14/LA/PLC	... 50/LA/PLC
60 V DC	60 V DC	20 V DC (up to 30 V DC)	20 V DC (up to 30 V DC)
1 A	1 A	1 A	1 A
3 A	2 A (per byte)	3 A	2 A (per byte)
No	No	LED	LED
0.8 kV	0.8 kV	0.8 kV	0.8 kV
-20°C ... 50°C			
Any			
IEC 60664, DIN EN 50178, IEC 62103			
Spring-cage connection			
Flat-ribbon cable plug connector in acc. with IEC 60603-13			
Connection data solid / stranded / AWG			
Dimensions			
0.2 ... 2.5 mm ² / 0.2 ... 1.5 mm ² / 24 - 14		45 mm / 50 mm	

Max. perm. operating voltage	
Max. perm. current (per branch)	
Max. total current (voltage supply)	
Status indication	
Rated surge voltage	
Ambient temperature (operation)	
Mounting position	
Standards / regulations	
Connection method	Field level Control system level

Connection data solid / stranded / AWG
Dimensions

H / D

Ordering data

Description	No. of poles	Module width W	Type	Order No.	Pcs. / Pkt.
VARIOFACE interface module for eight channels	14	59 mm	UM 45-FLK14/ZFKDS/PLC	2965172	1
VARIOFACE interface module for 32 channels	50	126 mm	UM 45-FLK50/ZFKDS/PLC	2965198	1
VARIOFACE interface module for eight channels, with light indicator	14	59 mm	UM 45-FLK14/LA/ZFKDS/PLC	2965334	1
VARIOFACE interface module for 32 channels, with light indicator	50	138 mm	UM 45-FLK50/LA/ZFKDS/PLC	2965347	1
VARIOFACE interface module, for SIMATIC® S7-300, with SIMATIC®-specific labeling	50	126 mm	UM 45-FLK50/ZFKDS/S7-300	2968111	1
VARIOFACE interface module, for SIMATIC® S7-300, with SIMATIC®-specific labeling and 2 FLK connectors	14	98 mm	UM 45-2FLK14/ZFKDS/S7	2965156	1

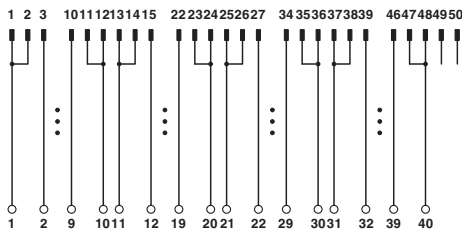

UM 45-FLK50/ZFKDS/S7-300 connection scheme

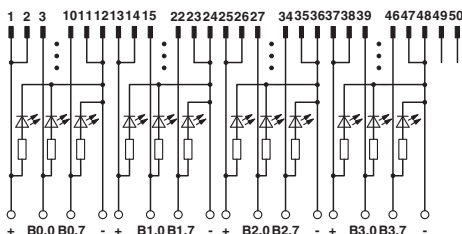

45-FLK50/LA/ZFKDS/PLC connection scheme

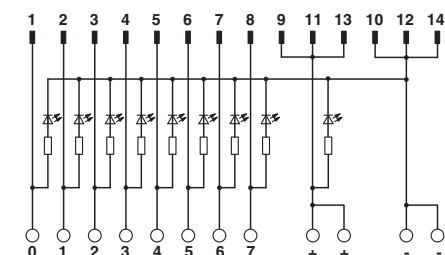

UM 45-FLK14/LA/ZFKDS/PLC connection scheme

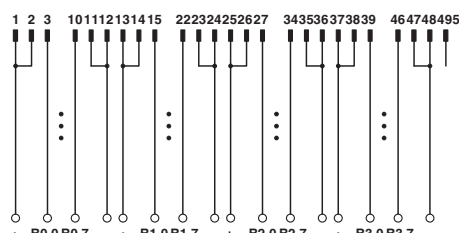

UM 45-FLK50/ZFKDS/PLC connection scheme

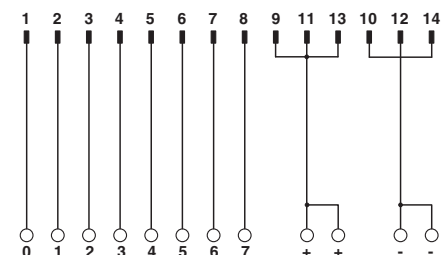

UM 45-FLK14/ZFKDS/PLC connection scheme

INTERFACE Cabling

VARIOFACE system cabling

VIP termination boards in 2-wire connection method

These VIP VARIOFACE modules are used in combination with the respective front adapters.

Similar to the front adapters, the modules are connected through 14-pole system cables. The following module types with the 2-wire connection method are available:

VIP-2/SC/FLK14/8M/PLC

- Byte-wise labeling
- Can be used for digital I/O modules
- Negative connection for each signal

VIP-2/SC/FLK14/8P/PLC

- Byte-wise labeling
- Can be used for digital I/O modules
- Positive connection per signal

Notes:

For marking systems and mounting material, see CLIPLINE catalog, part 2.



Passive interface modules for 8 channels



Technical data

Max. perm. operating voltage	60 V DC
Max. perm. current (per branch)	1 A
Max. total current (voltage supply)	3 A (per byte)
Rated surge voltage	-
Ambient temperature (operation)	-20°C ... 50°C
Mounting position	Any
Standards / regulations	IEC 60664, DIN EN 50178, IEC 62103
Connection method	Screw connection
	Field level
	Control system level
Connection data solid / stranded / AWG	0.2 ... 4 mm ² / 0.2 ... 2.5 mm ² / 24 - 12
Dimensions	H / D 65.5 mm / 56 mm

Ordering data

Description	No. of poles	Module width W	Type	Order No.	Pcs. / Pkt.
VARIOFACE interface module , for eight channels, each with an additional terminal block per signal for a common minus potential	14	50 mm	VIP-2/SC/FLK14/8M/PLC	2322281	1
VARIOFACE interface module , for eight channels, each with an additional terminal block per signal for a common plus potential	14	50 mm	VIP-2/SC/FLK14/8P/PLC	2322294	1

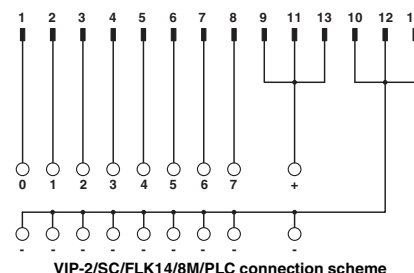
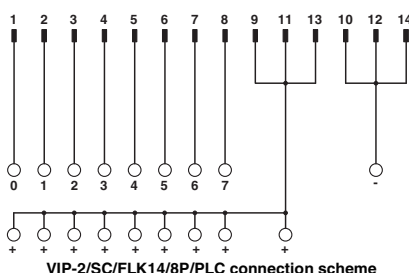

**Termination boards in
 2-wire connection method**

These VARIOFACE modules are used in combination with the respective front adapters.

Similar to the front adapters, the modules are connected through 50-pole system cables. The following module types with the 2-wire connection method are available:

FLKM 50/32M/PLC (for 32 channels)

- Byte-wise labeling
- Can be used for digital I/O modules
- Negative connection for each signal

FLKM50/32P/PLC (for 32 channels)

- Byte-wise labeling
- Can be used for all digital I/O modules
- Positive connection per signal

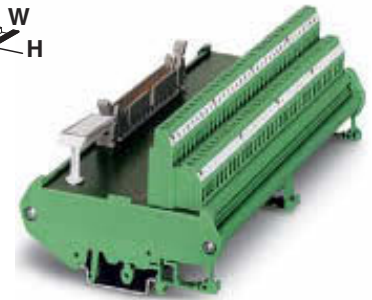

Passive interface modules for 32 channels



Technical data

Max. perm. operating voltage	60 V DC
Max. perm. current (per branch)	1 A
Max. total current (voltage supply)	8 A (per byte)
Rated surge voltage	0.8 kV
Ambient temperature (operation)	-20°C ... 50°C
Mounting position	Any
Standards / regulations	IEC 60664, DIN EN 50178, IEC 62103
Connection method	Field level Control system level
Connection data solid / stranded / AWG	0.2 ... 4 mm ² / 0.2 ... 2.5 mm ² / 24 - 12
Dimensions	H / D 90 mm / 68 mm

Ordering data

Description	No. of poles	Module width W	Type	Order No.	Pcs. / Pkt.
VARIOFACE interface module , for 32 channels, each with an additional terminal block per signal for a common minus potential	50	192 mm	FLKM 50/32M/PLC	2289719	1
VARIOFACE interface module , for 32 channels, each with an additional terminal block per signal for a common plus potential	50	192 mm	FLKM 50/32P/PLC	2291121	1

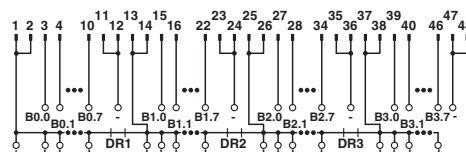

Connection scheme: FLKM 50/32P/PLC

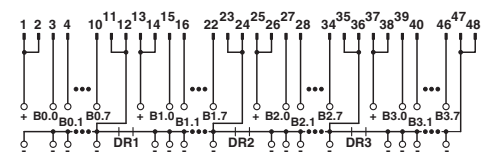

Connection scheme: FLKM 50/32M/PLC

INTERFACE Cabling

VARIOFACE system cabling

Termination boards with fuses in 2-wire connection method

These VARIOFACE modules are used in combination with the respective front adapters.

Like the front adapters, the modules are connected via 14-pole or 50-pole system cables. The following module types with fuses in the 2-wire and 4-wire connection method are available:

FLKM 14/8M/SI/PLC (for 8 channels) FLKM 50/32M/SI/PLC (for 32 channels)

- Byte-wise labeling
- Can be used for digital I/O modules
- Pluggable fuse (IEC 127-3, 1AF) per signal path (F1)
- Pluggable fuse (IEC 127-3, 2AF) per voltage supply (F2)
- Negative connection for each signal

Max. perm. operating voltage	
Max. perm. current (per branch)	
Max. total current (voltage supply)	
Rated surge voltage	
Ambient temperature (operation)	
Mounting position	
Standards / regulations	
Connection method	Field level

Control system level

Connection data solid / stranded / AWG	
Dimensions	H / D

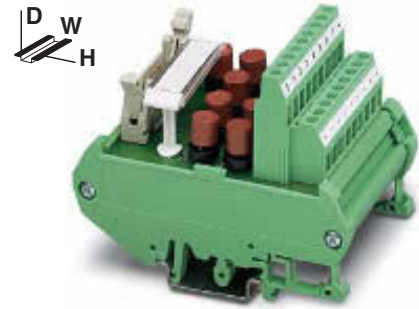

Passive fuse modules for 8 or 32 channels



Technical data

FLKM 14/8M/SI/PLC	FLKM 50/32M/PLC
60 V DC	60 V DC
1 A	1 A
2 A	2 A (per byte)
0.8 kV	0.8 kV
-20°C ... 50°C	-20°C ... 50°C
Any	Any
IEC 60664, DIN EN 50178, IEC 62103	IEC 60664, DIN EN 50178, IEC 62103
Screw connection	Screw connection
Flat-ribbon cable plug connector in acc. with IEC 60603-13	Flat-ribbon cable plug connector in acc. with IEC 60603-13

0.2 ... 4 mm² / 0.2 ... 2.5 mm² / 24 - 12
90 mm / 68 mm

Ordering data

Description	No. of poles	Module width W
VARIOFACE module , for eight channels, each with an additional terminal block and fuse per signal (common minus potential)	14	57 mm
VARIOFACE module , for 32 channels, each with an additional terminal block and fuse per signal (common minus potential)	50	192 mm

Type	Order No.	Pcs. / Pkt.
FLKM 14/8M/SI/PLC	2294487	1
FLKM 50/32M/SI/PLC	2294490	1

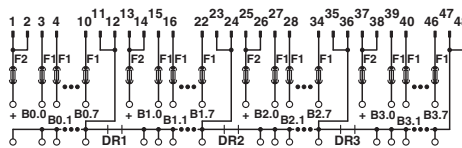

Connection scheme: FLKM 50/32M/SI/PLC

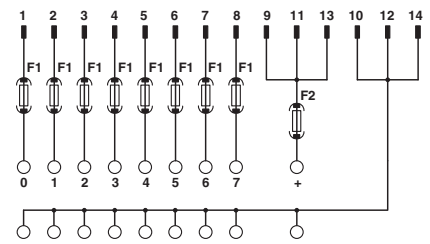

Connection scheme: FLKM 14/8M/SI/PLC

VIP initiator modules

These VIP VARIOFACE Professional modules are used in combination with the respective front adapters.

Similar to the front adapters, the modules are connected through 14-pole system cables. The following VIP initiator modules are available:

VIP-3/SC/FLK14/8IM/... (for 8 channels)

- Byte-wise labeling
- Can be used for digital I/O modules
- Positive and negative connection per signal
- Optionally with LED.

Notes:

For marking systems and mounting material, see CLIPLINE catalog, part 2.



Sensor modules for 8 channels



Technical data

Max. perm. operating voltage	60 V DC
Max. perm. current (per branch)	1 A
Max. total current (voltage supply)	3 A
Rated surge voltage	-
Ambient temperature (operation)	-20°C ... 50°C
Mounting position	Any
Standards / regulations	IEC 60664, DIN EN 50178, IEC 62103
Connection method	Screw connection
	Field level
	Control system level
Connection data solid / stranded / AWG	0.2 ... 4 mm ² / 0.2 ... 2.5 mm ² / 24 - 12
Dimensions	H / D 69 mm / 62 mm

Ordering data

Description	No. of poles	Module width W	Type	Order No.	Pcs. / Pkt.
VARIOFACE initiator module, for connection of eight PNP initiators					
	14	52.3 mm	VIP-3/SC/FLK14/8IM/PLC	2322278	1
	14	52.3 mm	VIP-3/SC/FLK14/8IM/LED/PLC	2322265	1

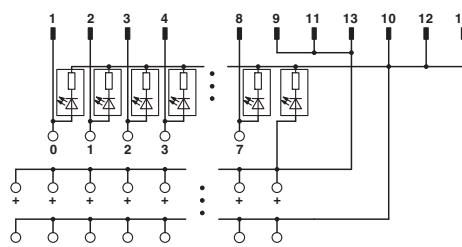

VIP-3/SC/FLK14/8IM/LED/PLC connection scheme

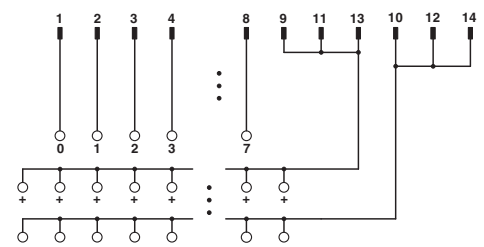

VIP-3/SC/FLK14/8IM/PLC connection scheme

INTERFACE Cabling

VARIOFACE system cabling

Sensor modules

These VARIOFACE modules are used in combination with the respective front adapters for digital I/O modules.

- For 32 channels
- Byte-wise labeling
- Positive and negative connection per signal
- Screw or spring-cage connection
- Optionally with LED

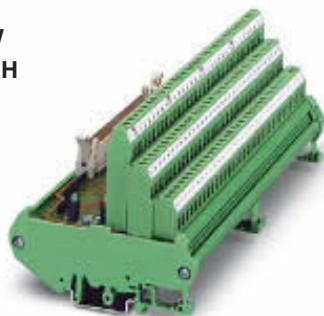

Initiator modules for 32 channels, with screw connection

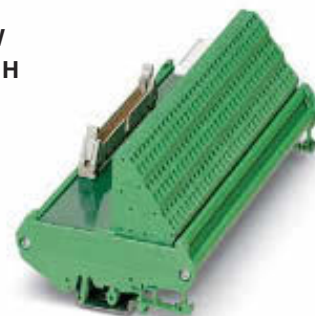

Initiator modules for 32 channels, with spring-cage connection



		Technical data		Technical data	
Max. perm. operating voltage		... 50/32 IM	... 50/32 IM/LA	60 V DC	60 V DC
Max. perm. current (per branch)		60 V DC	20 V DC (up to 30 V DC)	1 A	1 A
Max. total current (voltage supply)		1 A	1 A	2 A (per byte)	2 A (per byte)
Status indication		2 A (per byte)	2 A (per byte)	-	-
Rated surge voltage		No	LED	0.6 kV	0.6 kV
Ambient temperature (operation)		0.8 kV	0.8 kV	-20°C ... 50°C	-20°C ... 50°C
Mounting position		-20°C ... 50°C	-20°C ... 50°C	Any	Any
Standards / regulations		Any	Any	DIN EN 50178	DIN EN 50178
Connection method	Field level	IEC 60664, DIN EN 50178, IEC 62103	IEC 60664, DIN EN 50178, IEC 62103	Spring-cage connection	Spring-cage connection
	Control system level	Screw connection	Screw connection	Flat-ribbon cable plug connector in acc. with IEC 60603-13	Flat-ribbon cable plug connector in acc. with IEC 60603-13
Connection data solid / stranded / AWG		Flat-ribbon cable plug connector in acc. with IEC 60603-13	Flat-ribbon cable plug connector in acc. with IEC 60603-13	Flat-ribbon cable plug connector in acc. with IEC 60603-13	Flat-ribbon cable plug connector in acc. with IEC 60603-13
Dimensions	H / D	0.2 ... 4 mm ² / 0.2 ... 2.5 mm ² / 24 - 12	0.2 ... 4 mm ² / 0.2 ... 2.5 mm ² / 24 - 12	0.2 ... 2.5 mm ² / 0.2 ... 1.5 mm ² / 24 - 12	0.2 ... 2.5 mm ² / 0.2 ... 1.5 mm ² / 24 - 12
		90 mm / 81 mm	90 mm / 81 mm	90 mm / 73.5 mm	90 mm / 73.5 mm

			Ordering data			Ordering data		
Description	No. of poles	Module width W	Type	Order No.	Pcs. / Pkt.	Type	Order No.	Pcs. / Pkt.
VARIOFACE initiator module , for connection of 32 PNP initiators	50	180 mm	FLKMS 50/32IM/PLC	2284523	1			
VARIOFACE initiator module , same as before, however with light indicator	50	180 mm	FLKMS 50/32IM/LA/PLC	2284510	1			
VARIOFACE initiator module , for connection of 32 PNP initiators						FLKMS 50/32IM/ZFKDS/PLC	2901389	1

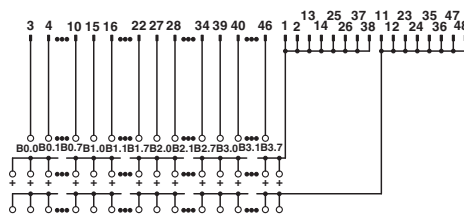

Connection scheme: FLKMS 50/32IM/PLC, ...50/32IM/ZFKDS/PLC

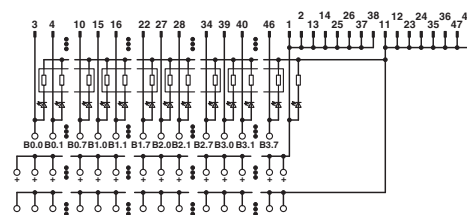

FLKMS 50/32IM/LA/PLC connection scheme

COMPACT-LINE initiator modules with spring-cage connection

These VARIOFACE modules are used in combination with the respective front adapters.

Like the front adapters, the modules are connected via 14-pole or 50-pole system cables. The following Compact-Line sensor modules are available:

UM 45-FLK14/8IM/.../PLC (for 8 channels)
UM 45-FLK 50/32IM/.../PLC (for 32 channels)

- Byte-wise labeling
- Can be used for digital I/O modules
- Positive and negative connection for every signal

Notes:

Due to the geometry, it is not possible to couple any molded FLK connectors (e.g., VIP-PA...S7).



Sensor modules for 8 or 32 channels With spring-cage connection



Technical data

	UM 45-FLK 14/.../PLC	UM 45-FLK 50/.../PLC
Max. perm. operating voltage	60 V DC	60 V DC
Max. perm. current (per branch)	1 A	1 A
Max. total current (voltage supply)	3 A	2 A (per byte)
Rated surge voltage	0.8 kV	0.8 kV
Ambient temperature (operation)	-20°C ... 50°C	-20°C ... 50°C
Mounting position	Any	Any
Standards / regulations	IEC 60664, DIN EN 50178, IEC 62103	IEC 60664, DIN EN 50178, IEC 62103
Connection method	Spring-cage connection	Spring-cage connection
Field level	Spring-cage connection	Spring-cage connection
Control system level	Flat-ribbon cable plug connector in acc. with IEC 60603-13	Flat-ribbon cable plug connector in acc. with IEC 60603-13
Connection data solid / stranded / AWG	0.2 ... 2.5 mm ² / 0.2 ... 1.5 mm ² / 24 - 14	
Dimensions	H / D 45 mm / 61 mm	

Ordering data

Description	No. of poles	Module width W	Type	Order No.	Pcs. / Pkt.
VARIOFACE-COMPACT-LINE initiator module , for connection of eight PNP initiators	14	75 mm	UM 45-FLK14/ 8IM/ZFKDS/PLC	2965211	1
VARIOFACE-COMPACT-LINE initiator module , for connection of 32 PNP initiators	50	197 mm	UM 45-FLK50/32IM/ZFKDS/PLC	2965224	1

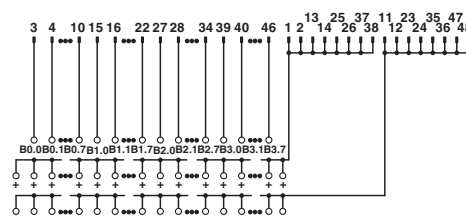

UM 45-FLK50/32IM/ZFKDS/PLC connection scheme

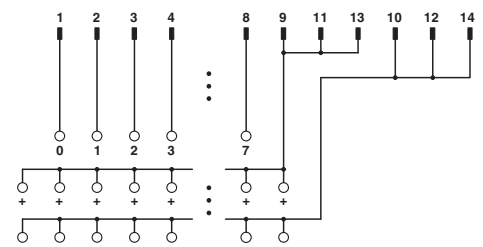

UM 45-FLK14/8IM/ZFKDS/PLC connection scheme

INTERFACE Cabling

VARIOFACE system cabling

Controller boards with knife disconnect terminal blocks

These VARIOFACE modules with knife disconnection and test connection for each signal (2 or 2.3 mm Ø test plug) are used in combination with the respective front adapters.

FLKM14/KDS3-MT/PPA/PLC

(for 8 channels)

FLKM 50/KDS3-MT/PPA/PLC

(for 32 channels)

- Byte-wise labeling
- Can be used for digital I/O modules

FLKM-2FLK14/KDS3-MT/PPA/S7

- Numerical labeling (1-20)
- Specially for S7-300 (in conjunction with the front adapter FLKM 14-PA-S300, Order No.: 2299770)

FLKM 50/KDS3-MT/PPA/7-300

- Numerical labeling (1-40)
- Specially for S7-300 (in conjunction with the front adapter FLKM 50-PA-S300, Order No.: 2294445)

FLKM 50/KDS3-MT/PPA/AN/PLC

- Numerical labeling (1-50)
- Specially for S7-400 (in conjunction with the front adapter FLKM 50-PA-S400 (3-48) Order No. 2294908)

Max. perm. operating voltage
 Max. perm. current (per branch)
 Max. total current (voltage supply)
 Rated surge voltage
 Ambient temperature (operation)
 Mounting position
 Standards / regulations
 Connection method

Field level

Control system level

Connection data solid / stranded / AWG

Dimensions

H / D

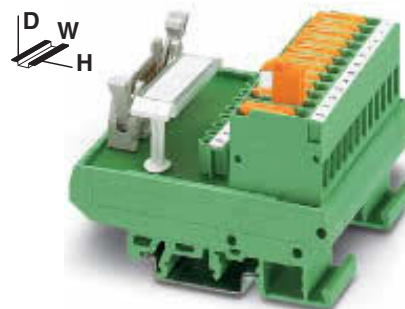

Passive interface modules for eight or 32 channels with knife disconnect terminal blocks



Technical data

FLKM...14/KDS 3-MT...	FLKM 50/KDS 3-MT...
60 V DC	60 V DC
1 A	1 A
3 A	2 A (per byte)
0.8 kV	0.8 kV
-20°C ... 50°C	-20°C ... 50°C
Any	Any
IEC 60664, DIN EN 50178, IEC 62103	
Screw connection with disconnect knife	Screw connection with disconnect knife
Flat-ribbon cable plug connector in acc. with IEC 60603-13	Flat-ribbon cable plug connector in acc. with IEC 60603-13

0.2 ... 4 mm² / 0.2 ... 2.5 mm² / 24 - 12
 77 mm / 61 mm

Ordering data

Description	No. of poles	Module width W	Type	Order No.	Pcs. / Pkt.
VARIOFACE interface module , for eight channels, with knife disconnect terminal blocks and test sockets to the field and the system	14	67 mm	FLKM 14/KDS3-MT/PPA/PLC	2290423	1
VARIOFACE interface module , for 32 channels, with knife disconnect terminal blocks and test sockets to the field and the system	50	214 mm	FLKM 50/KDS3-MT/PPA/PLC	2290614	1
VARIOFACE interface module , for SIMATIC S7-300 with SIMATIC-specific labeling (1-20), knife disconnect terminal blocks and test sockets to the field and the system	14	113 mm	FLKM-2FLK14/KDS3-MT/PPA/S7	2295062	1
VARIOFACE interface module , same as before, however, with SIMATIC-specific labeling (1-40)	50	214 mm	FLKM 50/KDS3-MT/PPA/S7-300	2304490	1
VARIOFACE interface module , same as before, however, for SIMATIC S7-400 with SIMATIC-specific labeling (3-48)	50	259 mm	FLKM 50/KDS3-MT/PPA/AN/PLC	2291587	1

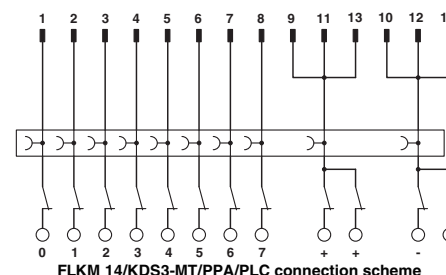
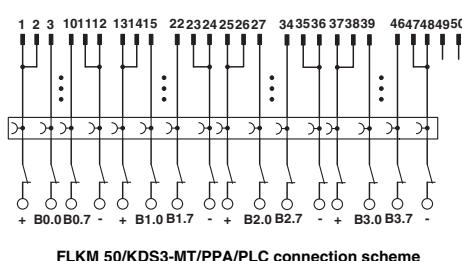
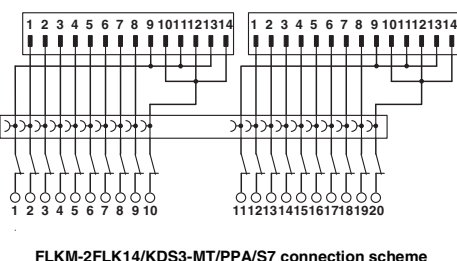
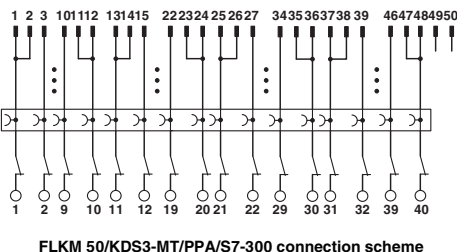
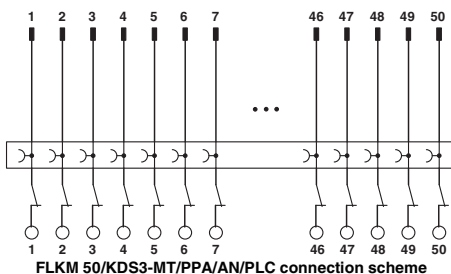

Simulation module with switches

These VARIOFACE modules enable simple simulation of the control and peripheral hardware for 8 signals.

The UM 45-DI/DO/S/LA/SIM8 switch module is assembled for signal transmission with COMBICON screw connector for single-wire wiring. Alternatively, connection to the PLC system cabling is established through a 14-pole flat-ribbon cable pin strip. Connection to the front adapters of the PLC system cabling is established through 14-pole system cables with socket strips.

Each signal path is allocated an LED which signals the "high active" signal state. The supply voltage to the modules is signaled via a green LED.

Notes:
Type of housing: Terminal blocks: Polyamide PA non-reinforced, color: Green. Housing: PVC
For marking systems and mounting material, see CLIPLINE catalog, part 2.

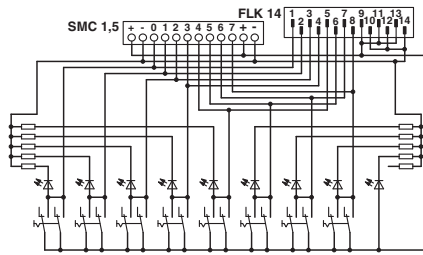

Switch module

Max. perm. operating voltage
Max. perm. current (per branch)
Max. total current (voltage supply)
Rated surge voltage
Ambient temperature (operation)
Mounting position
Standards / regulations
Connection data solid / stranded / AWG
Dimensions

24 V DC
1 A
8 A (+, - terminal block)
0.8 kV
-20°C ... 50°C
Any
IEC 60664, DIN EN 50178, IEC 62103
0.14 ... 1.5 mm² / 0.14 ... 1.5 mm² / 28 - 16
45 mm / 51 mm

Description	No. of poles	Module width W
VARIOFACE switch module, for simulation		75 mm

Technical data		
Ordering data		
Type	Order No.	Pcs. / Pkt.
UM 45-DI/DO/S/LA/SIM8	2968205	1

Simulation module for display

These VARIOFACE modules enable simple simulation of the control and peripheral hardware for 8 signals.

The UM 45-DO/LA/SIM8 display module is assembled for signal transmission with COMBICON screw connector for single-wire wiring. Alternatively, connection to the PLC system cabling is established through a 14-pole flat-ribbon cable pin strip. Connection to the front adapters of the PLC system cabling is established through 14-pole system cables with socket strips.

Each signal path is allocated an LED which signals the "high active" signal state. The supply voltage to the modules is signaled via a green LED.

Notes:
Type of housing: Terminal blocks: Polyamide PA non-reinforced, color: Green. Housing: PVC
For marking systems and mounting material, see CLIPLINE catalog, part 2.

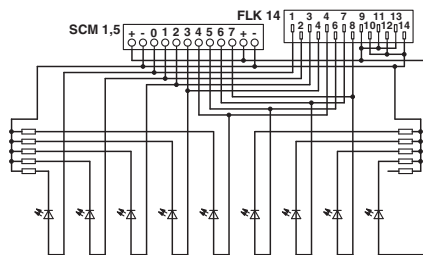

Indicator module

Max. perm. operating voltage
Max. perm. current (per branch)
Max. total current (voltage supply)
Rated surge voltage
Ambient temperature (operation)
Mounting position
Standards / regulations
Connection data solid / stranded / AWG
Dimensions

24 V DC
1 A
8 A (+, - terminal block)
0.8 kV
-20°C ... 50°C
Any
IEC 60664, DIN EN 50178, IEC 62103
0.14 ... 1.5 mm² / 0.14 ... 1.5 mm² / 28 - 16
45 mm / 51 mm

Description	No. of poles	Module width W
VARIOFACE display module, for simulation		75 mm

Technical data		
Ordering data		
Type	Order No.	Pcs. / Pkt.
UM 45-DO/LA/SIM8	2968195	1

INTERFACE Cabling

VARIOFACE system cabling

Adapter for PLC-INTERFACE (6.2 mm)

PLC-V8/... are the VARIOFACE adapters connecting the eight slim 6.2 mm PLC-INTERFACE modules to the VARIOFACE system cabling:

- Can be plugged into the bridge shafts of eight aligned PLC-INTERFACE modules
- Freely definable configuration with relays, optocouplers and passive feed-through terminal blocks
- With D-SUB connection as an option for universal connections

Notes:

Cross-reference list with matching PLC-INTERFACE modules, see page 266.



VARIOFACE adapter for 6.2 mm PLC-INTERFACE



Technical data

Max. perm. operating voltage	24 V DC ±25%
Max. perm. current (per branch)	1 A (per signal path)
Max. total current (voltage supply)	3 A
Rated surge voltage	0.8 kV
Ambient temperature (operation)	-40°C ... 70°C
Standards / regulations	IEC 60664, DIN EN 50178, IEC 62103
Connection method	Power supply Signal level Screw connection
Connection data solid / stranded / AWG	0.2 ... 4 mm ² / 0.2 ... 2.5 mm ² / 24 - 12
Dimensions	H / D 100 mm / 94 mm

Ordering data

Description	No. of poles	Module width W	Type	Order No.	Pcs. / Pkt.
V8 adapter, for 8 PLC interfaces (6.2 mm), with FLK connection, for PLC system cabling, positive switching					
OUTPUT	14	49.6 mm	PLC-V8/FLK14/OUT	2295554	1
INPUT	14	49.6 mm	PLC-V8/FLK14/IN	2296553	1
V8 adapter, for 8 PLC interfaces (6.2 mm), with FLK connection, for PLC system cabling, negative switching					
OUTPUT	14	49.6 mm	PLC-V8/FLK14/OUT/M	2304102	1
INPUT	14	49.6 mm	PLC-V8/FLK14/IN/M	2304115	1
V8 output adapter, for 8 PLC interfaces (6.2 mm), with 15-pole D-SUB connection					
Pin strip	15	49.6 mm	PLC-V8/D15S/OUT	2296058	1
Socket strip	15	49.6 mm	PLC-V8/D15B/OUT	2296061	1
V8 input adapter, for 8 PLC interfaces (6.2 mm), with 15-pole D-SUB connection					
Pin strip	15	49.6 mm	PLC-V8/D15S/IN	2296074	1
Socket strip	15	49.6 mm	PLC-V8/D15B/IN	2296087	1

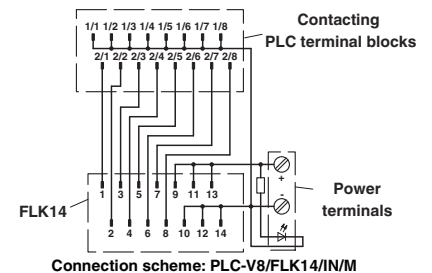
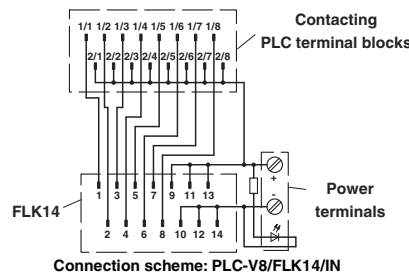
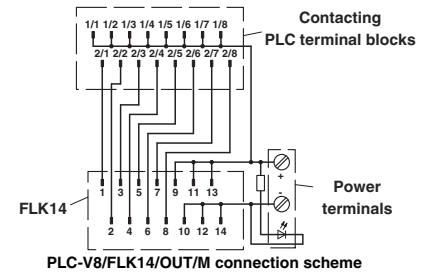
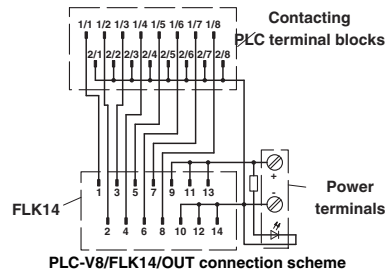

Adapter for PLC-INTERFACE (14 mm)

PLC-V8L/... are the VARIOFACE adapters connecting the eight 14 mm PLC-INTERFACE modules (2 PDT, HC, and IC types) to the system cabling:

- Can be plugged into the bridge shafts of eight aligned PLC-INTERFACE modules
- Freely selectable assembly with relays or optocouplers

Notes:

Cross-reference list with matching PLC-INTERFACE modules, see page 266.



VARIOFACE adapter for 14 mm PLC-INTERFACE



Applied for: UL / CUL

Technical data

Max. perm. operating voltage	24 V DC ±25%
Max. perm. current (per branch)	1 A (per signal path)
Max. total current (voltage supply)	3 A
Rated surge voltage	0.8 kV
Ambient temperature (operation)	-40°C ... 70°C
Mounting position	Any
Standards / regulations	IEC 60664, DIN EN 50178, IEC 62103
Connection method	Screw connection
Power supply	Flat-ribbon cable connector, in acc. with IEC 60603-13 (engagement catches based on IEC 60603-13)
Signal level	
Connection data solid / stranded / AWG	0.2 ... 4 mm ² / 0.2 ... 2.5 mm ² / 24 - 12
Dimensions	H / D 100 mm / 94 mm

Ordering data

Description	No. of poles	Module width W	Type	Order No.	Pcs. / Pkt.
V8 adapter , for 8 PLC interfaces (14 mm), with FLK connection, for PLC system cabling, positive switching	14	112.3 mm	PLC-V8L/FLK14/OUT	2299660	1
V8 adapter , for 8 PLC interfaces (14 mm), with FLK connection, for PLC system cabling, negative switching	14	112.3 mm	PLC-V8L/FLK14/OUT/M	2304306	1

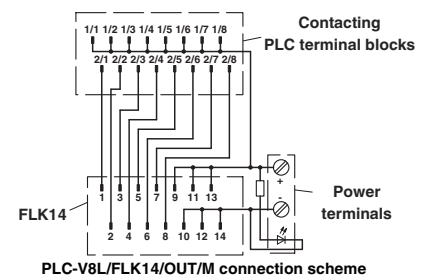
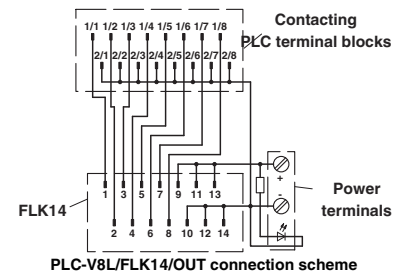

INTERFACE Cabling

VARIOFACE system cabling

Feed-through terminal blocks for PLC-INTERFACE

The VARIOFACE PLC-VT terminals are passive feed-through terminal blocks, with the same shape as the 6.2 mm slim relay and optocoupler interfaces PLC-INTERFACE. It is therefore possible to implement 8-channel interface blocks for the system cabling, which can be adapted to a bit for the particular application. For individual requirements, the relay, optocoupler or the PLC-VT terminal blocks for passive signal transmission can be combined as needed.

PLC-VT PLC-VT/LA

- Can be combined with PLC-INTERFACE universal series
- Signal path with additional potential level for free assignment (two-wire connection)
- Optionally with LED

Max. perm. operating voltage	
Max. perm. current (per branch)	
Ambient temperature (operation)	
Mounting position	
Standards / regulations	
Connection data solid / stranded / AWG	
Dimensions	H / D

Description	No. of poles	Module width W
VARIOFACE feed-through terminal block (two-wire connection), for PLC-INTERFACE universal series		6.2 mm
VARIOFACE feed-through terminal block , same as before, however, with 24 V DC light indicator		6.2 mm

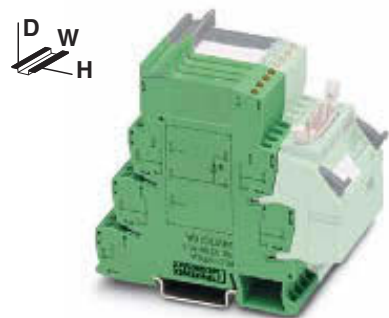

VARIOFACE feed-through terminal blocks for PLC-INTERFACE universal series



Technical data	
PLC-VT	PLC-VT/LA
Max. 250 V AC/DC	24 V DC
6 A (per signal conductor)	6 A (per signal conductor)
-40°C ... 70°C	-40°C ... 70°C
Any	Any
DIN EN 50178, IEC 62103	
0.2 ... 4 mm ² / 0.2 ... 2.5 mm ² / 24 - 12	
80 mm / 94 mm	

Ordering data		
Type	Order No.	Pcs. / Pkt.
PLC-VT	2296870	10
PLC-VT/LA	2296854	10



PLC-VT connection scheme

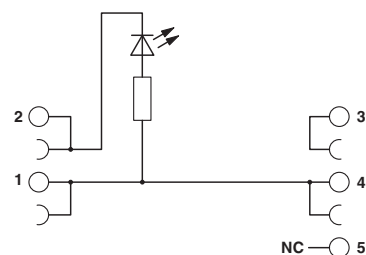

PLC-VT/LA connection scheme

Feed-through terminal blocks for PLC-INTERFACE

The VARIOFACE PLC-VT terminals are passive feed-through terminal blocks, with the same shape as the 6.2 mm slim relay and optocoupler interfaces PLC-INTERFACE. It is therefore possible to implement 8-channel interface blocks for the system cabling, which can be adapted to a bit for the particular application. For individual requirements, the relay, optocoupler or the PLC-VT terminal blocks for passive signal transmission can be combined as needed.

**PLC-VT/ACT
 PLC-VT/ACT/LA**

- Can be combined with PLC-INTERFACE actuator series
- Signal path with two additional potential levels for free assignment (three-wire connection)
- Optionally with LED

The system connection is made via the PLC-V8 adapter.

Max. perm. operating voltage	
Max. perm. current (per branch)	
Ambient temperature (operation)	
Mounting position	
Standards / regulations	
Connection data solid / stranded / AWG	
Dimensions	H / D

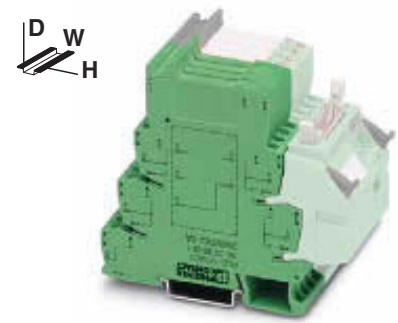

VARIOFACE feed-through terminal blocks for PLC-INTERFACE actuator series



Technical data	
PLC-VT/AKT	PLC-VT/AKT/LA
Max. 250 V AC/DC	24 V DC
6 A (per signal conductor)	6 A (per signal conductor)
-40°C ... 70°C	-40°C ... 70°C
Any	Any
DIN EN 50178, IEC 62103	
0.2 ... 4 mm ² / 0.2 ... 2.5 mm ² / 24 - 12	
80 mm / 94 mm	

Ordering data		
Type	Order No.	Pcs. / Pkt.
PLC-VT/ACT	2295567	10
PLC-VT/ACT/LA	2296867	10

Description	No. of poles	Module width W
VARIOFACE feed-through terminal block (three-wire connection), for PLC-INTERFACE actuator series		6.2 mm
VARIOFACE feed-through terminal block , same as before, however, with 24 V DC light indicator		6.2 mm

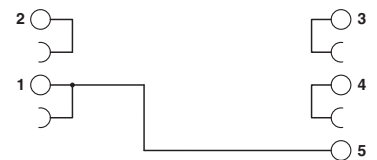

PLC-VT/ACT connection scheme

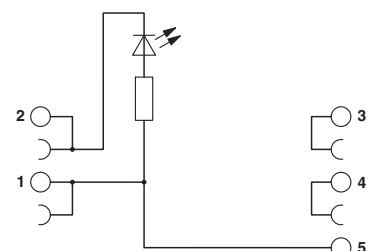

PLC-VT/ACT/LA connection scheme

Cross-reference list for PLC-V8 adapters with matching PLC-INTERFACE modules

Series



Function	Contact	Input	Output	Page	Spring-cage connection	Order No.:		
Relay	1 PDT	24 V DC	250 V AC/DC / 6 A	82	PLC-RSP-24DC/21	2966472		
		24 V DC	250 V AC/DC / 10 A	93	PLC-RSP-24DC/21HC	2912277		
		12 V DC	30 V AC/36 V DC / 50 mA	83	PLC-RSP-12DC/21AU	2967442		
		24 V DC	30 V AC/36 V DC / 50 mA	83	PLC-RSP-24DC/21AU	2966540		
		24 V AC/DC	30 V AC/36 V DC / 50 mA	83	PLC-RSP-24UC/21AU	2966553		
		48 V DC	30 V AC/36 V DC / 50 mA	83	PLC-RSP-48DC/21AU	2966566		
		60 V DC	30 V AC/36 V DC / 50 mA	83	PLC-RSP-60DC/21AU	2966579		
		120 V AC/DC	30 V AC/36 V DC / 50 mA	83	PLC-RSP-120UC/21AU	2966582		
		230 V AC/DC	30 V AC/36 V DC / 50 mA	83	PLC-RSP-230UC/21AU	2966647		
		120 V AC	30 V AC/36 V DC / 50 mA ¹⁾	94	PLC-BSP-120UC/21/SO46	2980351 ³⁾		
		230 V AC	30 V AC/36 V DC / 50 mA ¹⁾	94	PLC-BSP-230UC/21/SO46	2980377 ³⁾		
		Relay switch	2 PDT	24 V DC	250 V AC/DC / 6 A	83	PLC-RSP-24DC/21-21	2912507
				24 V DC	30 V AC/DC / 50 mA	83	PLC-RSP-24DC/21-21AU	2912578
		Relay switch	1 N/O contact	24 V AC/DC	250 V AC/DC / 6 A	110	PLC-RSP-24UC/1/S/H	2982249
24 V AC/DC	250 V AC/DC / 6 A			110	PLC-RSP-24UC/1/S/L	2834889		
Optocoupler	1 N/O contact, electronic	24 V DC	24 V DC / 3 A	85	PLC-OSP-24DC/24DC/2	2967471		
		24 V DC	24 V DC / 10 A	113	PLC-OSP-24DC/24DC/10/R	2982715		
		24 V DC	250 V AC / 0.75 A	85	PLC-OSP-24DC/230AC/1	2967895		
		24 V DC	300 V DC / 1 A	112	PLC-OSP-24DC/300DC/1	2980830		
		24 V DC	48 V DC / 100 mA	84	PLC-OSP-24DC/48DC/100	2967549		
		48 V DC	48 V DC / 100 mA	84	PLC-OSP-48DC/48DC/100	2967743		
		60 V DC	48 V DC / 100 mA	84	PLC-OSP-60DC/48DC/100	2967756		
		120 V AC/DC	48 V DC / 100 mA	84	PLC-OSP-120UC/48DC/100	2967552		
		230 V AC/DC	48 V DC / 100 mA	84	PLC-OSP-230UC/48DC/100	2967565		
		NAMUR	24 V DC / 50 mA	122	PLC-SP-EIK 1-SVN 24P/P	2982676		
		120 V AC	48 V DC / 100 mA ²⁾	94	PLC-BSP-120UC/21/SO46	2980351 ³⁾		
		230 V AC	48 V DC / 100 mA ²⁾	94	PLC-BSP-230UC/21/SO46	2980377 ³⁾		
1 PDT, electronic	24 V DC	48 V DC / 0.5 A	113	PLC-OSP-24DC/48DC/500/W	2980649			
Feed-through	-	250 V AC/DC	250 V AC/DC	264	-			
		24 V DC	24 V DC	264	-			
Relay	1 N/O contact	24 V DC	250 V AC/DC / 6 A	86	PLC-RSP-24DC/1/ACT	2967345		
		24 V DC	250 V AC/DC / 10 A (80 A; 20 ms)	92	PLC-RSP-24DC/11C/ACT	2912413		
		24 V DC	250 V AC/DC / 6 A	87	-			
	2 N/O contacts	24 V DC	250 V AC/DC / 6 A	87	-			
		24 V DC	250 V AC/DC / 6 A	87	-			
		24 V DC	250 V AC/DC / 6 A	87	-			
Optocoupler	1 N/O contact, electronic	24 V DC	24 V DC / 3 A	87	PLC-OSP-24DC/24DC/2/ACT	2967507		
		24 V DC	24 V DC / 5 A	88	-			
		24 V DC	250 V AC / 0.75 A	87	-			
		24 V DC	250 V AC / 2 A	88	-			
Feed-through	-	250 V AC/DC	250 V AC/DC	265	-			
		24 V DC	24 V DC	265	-			
Relay	1 N/O contact	24 V DC	30 V AC/36 V DC / 50 mA	90	PLC-RSP-24DC/1AU/SEN	2967374		
		120 V AC/DC	30 V AC/36 V DC / 50 mA	90	PLC-RSP-120UC/1AU/SEN	2967390		
		230 V AC/DC	30 V AC/36 V DC / 50 mA	90	PLC-RSP-230UC/1AU/SEN	2967413		
		120 V AC	30 V AC/36 V DC / 50 mA ¹⁾	95	PLC-BSP-120UC/1/SEN/SO46	2980364 ³⁾		
		230 V AC	30 V AC/36 V DC / 50 mA ¹⁾	95	PLC-BSP-230UC/1/SEN/SO46	2980380 ³⁾		
	Optocoupler	1 N/O contact, electronic	24 V DC	48 V DC / 100 mA	91	PLC-OSP-24DC/48DC/100/SEN	2967578	
			120 V AC/DC	48 V DC / 100 mA	91	PLC-OSP-120UC/48DC/100/SEN	2967581	
			230 V AC/DC	48 V DC / 100 mA	91	PLC-OSP-230UC/48DC/100/SEN	2967594	
			120 V AC	48 V DC / 100 mA ²⁾	95	PLC-BSP-120UC/1/SEN/SO46	2980364 ³⁾	
			230 V AC	48 V DC / 100 mA ²⁾	95	PLC-BSP-230UC/1/SEN/SO46	2980380 ³⁾	

1) Plug-in miniature relay insert: REL-MR-60DC/21AU, 2961134

2) Plug-in solid-state relay insert: OPT-60DC/48DC/100, 2966621

3) PLC-...SO46 is supplied as a basic terminal block with filter, but without relay or solid-state relay.

4) Cannot be combined with the universal series (within a byte)



Push-in connection



Screw connection

	Order No.:		Order No.:	PLC-V8...OUT(M)	PLC-V8...IN(M)	PLC-V8L...OUT
PLC-RPT-24DC/21	2900299	PLC-RSC-24DC/21	2966171	X		
PLC-RPT-24DC/21HC	2900291	PLC-RSC-24DC/21HC	2967620			X
PLC-RPT-12DC/21AU	2900317	PLC-RSC-12DC/21AU	2966919		X	
PLC-RPT-24DC/21AU	2900306	PLC-RSC-24DC/21AU	2966265	X	X	
PLC-RPT-24UC/21AU	2900307	PLC-RSC-24UC/21AU	2966278	X	X	
PLC-RPT-48DC/21AU	2900308	PLC-RSC-48DC/21AU	2966126		X	
PLC-RPT-60DC/21AU	2900309	PLC-RSC-60DC/21AU	2966142		X	
PLC-RPT-120UC/21AU	2900310	PLC-RSC-120UC/21AU	2966281		X	
PLC-RPT-230UC/21AU	2900311	PLC-RSC-230UC/21AU	2966294		X	
PLC-RPT-120UC/21/SO46	2900453 ³⁾	PLC-BSC-120UC/21/SO46	2980319 ³⁾		X	
PLC-RPT-230UC/21/SO46	2900455 ³⁾	PLC-BSC-230UC/21/SO46	2980335 ³⁾		X	
PLC-RPT-24DC/21-21	2900330	PLC-RSC-24DC/21-21	2967060			X
PLC-RPT-24DC/21-21AU	2900338	PLC-RSC-24DC/21-21AU	2967125			X
PLC-RPT-24UC/1/S/H	2900328	PLC-RSC-24UC/1/S/H	2982236	X		
PLC-RPT-24UC/1/S/L	2900327	PLC-RSC-24UC/1/S/L	2834876	X		
PLC-OPT-24DC/24DC/2	2900364	PLC-OSC-24DC/24DC/2	2966634	X		
PLC-OPT-24DC/24DC/10/R	2900398	PLC-OSC-24DC/24DC/10/R	2982702	X		
PLC-OPT-24DC/230AC/1	2900369	PLC-OSC-24DC/230AC/1	2967840	X		
PLC-OPT-24DC/300DC/1	2900383	PLC-OSC-24DC/300DC/1	2980678	X		
PLC-OPT-24DC/48DC/100	2900352	PLC-OSC-24DC/48DC/100	2966728	X	X	
PLC-OPT-48DC/48DC/100	2900353	PLC-OSC-48DC/48DC/100	2966993		X	
PLC-OPT-60DC/48DC/100	2900354	PLC-OSC-60DC/48DC/100	2967455		X	
PLC-OPT-120UC/48DC/100	2900355	PLC-OSC-120UC/48DC/100	2966744		X	
PLC-OPT-230UC/48DC/100	2900356	PLC-OSC-230UC/48DC/100	2966757		X	
PLC-PT-EIK 1-SVN 24/P	2900397	PLC-SC-EIK 1-SVN 24/P	2982663		X	
PLC-BPT-120UC/21/SO46	2900453 ³⁾	PLC-BSC-120UC/21/SO46	2980319 ³⁾		X	
PLC-BPT-230UC/21/SO46	2900455 ³⁾	PLC-BSC-230UC/21/SO46	2980335 ³⁾		X	
PLC-OPT-24DC/48DC/500/W	2900378	PLC-OSC-24DC/48DC/500/W	2980636	X		
-		PLC-VT	2296870	X	X	
-		PLC-VT/LA	2296854	X	X	
PLC-RPT-24DC/1/ACT	2900312	PLC-RSC-24DC/1/ACT	2966210	X		
PLC-RPT-24DC/1IC/ACT	2900298	PLC-RSC-24DC/1IC/ACT	2967604			X
-		PLC-RSC-24DC/1-1/ACT	2967109			X
PLC-OPT-24DC/24DC/2/ACT	2900376	PLC-OSC-24DC/24DC/2/ACT	2966676	X		
-		PLC-OSC-24DC/24DC/5/ACT	2982786			X
-		PLC-OSC-24DC/230AC/1/ACT	2967947	X		
-		PLC-OSC-24DC/230AC/2/ACT	2982760			X
-		PLC-VT/AKT	2295567	X		
-		PLC-VT/AKT/LA	2296867	X		
PLC-RPT-24DC/1AU/SEN	2900313	PLC-RSC-24DC/1AU/SEN	2966317		X	
PLC-RPT-120UC/1AU/SEN	2900314	PLC-RSC-120UC/1AU/SEN	2966320		X	
PLC-RPT-230UC/1AU/SEN	2900315	PLC-RSC-230UC/1AU/SEN	2966333		X	
PLC-BPT-120UC/1/SEN/SO46	2900456 ³⁾	PLC-BSC-120UC/1/SEN/SO46	2980322 ³⁾		X	
PLC-BPT-230UC/1/SEN/SO46	2900457 ³⁾	PLC-BSC-230UC/1/SEN/SO46	2980348 ³⁾		X	
PLC-OPT-24DC/48DC/100/SEN	2900358	PLC-OSC-24DC/48DC/100/SEN	2966773		X	
PLC-OPT-120UC/48DC/100/SEN	2900359	PLC-OSC-120UC/48DC/100/SEN	2966799		X	
PLC-OPT-230UC/48DC/100/SEN	2900361	PLC-OSC-230UC/48DC/100/SEN	2966809		X	
PLC-BPT-120UC/1/SEN/SO46	2900456 ³⁾	PLC-BSC-120UC/1/SEN/SO46	2980322 ³⁾		X	
PLC-BPT-230UC/1/SEN/SO46	2900457 ³⁾	PLC-BSC-230UC/1/SEN/SO46	2980348 ³⁾		X	

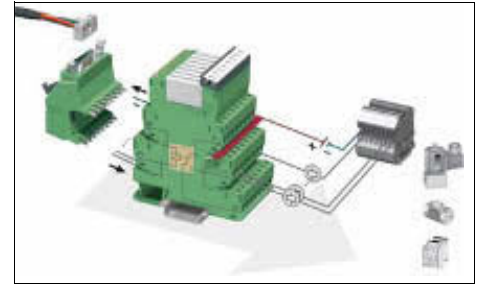

PLC universal series

The universal series of products can be used as either input or output interfaces. Each product consists of a basic terminal block with a plug-in miniature relay (PDT contact) or a plug-in solid-state relay.

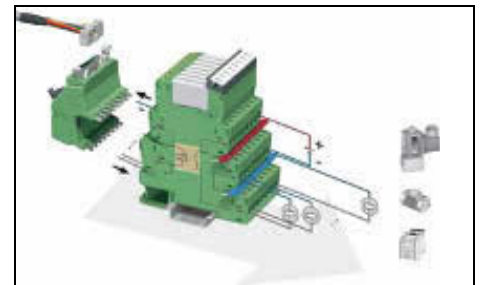

PLC actuator series

In applications involving an interface between the PLC and actuators (e.g., motors, contactors or solenoid valves) often only an N/O function is required. In such cases, the PLC...ACT output interface is used. All actuator connections, including the load return line, are connected directly. This eliminates the need for additional output terminal blocks.

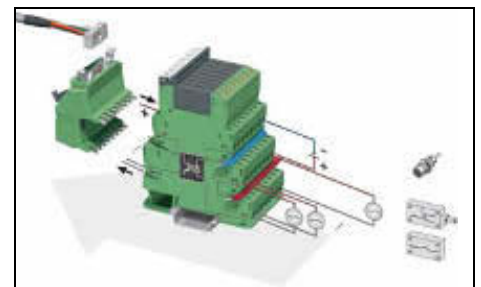

PLC sensor series

In applications involving an interface between the PLC and sensors (e.g., proximity switches, limit switches or auxiliary contacts), an N/O function is often required. In such cases, the PLC...SEN input interface is used. All sensor connections, including the supply voltage for the sensors/switches, are connected directly. This eliminates the need for additional modular terminal blocks.

INTERFACE Cabling

VARIOFACE system cabling

COMPACT-LINE output modules with relays, one N/O contact

These VARIOFACE Compact Line output modules are used in combination with the respective front adapters.

Like the front adapters, the modules are connected via 14-pole or 50-pole system cables. The following features characterize these relay modules:

- Pluggable miniature relays, each with an N/O contact
- Universal applications from 1 mA to 3 A continuous current through 2-layer double contact with hard gold plating
- Low construction height of only 45 mm
- LED status display for each signal path and supply voltage
- Free-wheeling and reverse polarity protection diode for each signal path

With the 32-channel version, the system cable is connected to the 16-channel base module UM 45-16RM/MR-G24/1/PLC. The output expansion module UM 45-16RM/MR-G24/1/E/PLC with a further 16 channels is coupled to the base module via a 20-pole flat-ribbon cable (length: 10 cm).

Notes:

The connecting cable between the base and the extension modules is delivered with the extension unit.

Due to the geometry, it is not possible to couple any molded FLK connectors (e.g., VIP-PA...S7).



Output module with eight miniature relays, one N/O contact

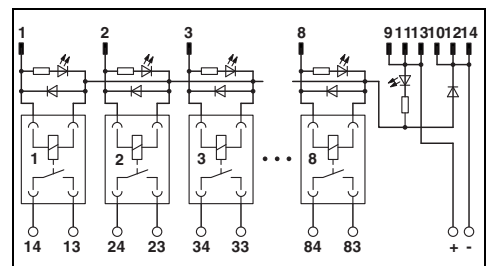

Technical data

Coil side		24 V DC
Operating voltage U_N		6.5 mA
Typ. input current at U_N		5 ms
Typ. response time at U_N		15 ms
Typ. release time at U_N		Free-wheeling diode, protection against polarity reversal
Input circuit		Yellow LED
Status display/channel		Flat-ribbon cable plug connector in acc. with IEC 60603-13
Connection method		
No. of poles		14
Contact side		
Contact type		1 N/O contact (double contact)
Contact material		AgNi, 5 μ m hard gold-plated
Max. switching voltage		250 V AC / 125 V DC
Min. switching voltage		5 V
Max. inrush current		5 A
Limiting continuous current		3 A
Min. switching current		1 mA
Max. interrupting rating:	24 V DC	72 W
	48 V DC	60 W
	60 V DC	50 W
	110 V DC	50 W
	250 V AC	750 VA
Connection method		Screw connection
Connection data solid / stranded / AWG		0.14 ... 1.5 mm ² / 0.14 ... 1.5 mm ² / 26 - 14
General data		
Test voltage		2 kV AC (50 Hz, 1 min.)
Ambient temperature (operation)		-20°C ... 50°C
Nominal operating mode		100% operating factor
Mechanical service life		2 x 10 ⁷ cycles
Standards / regulations		IEC 60664, DIN EN 50178, IEC 62103
Mounting position		Any
Mounting		In rows with zero spacing
Dimensions	H / D	45 mm / 50 mm

Ordering data

Description	Module width W	Type	Order No.	Pcs. / Pkt.
VARIOFACE COMPACT LINE output module, for 24 V DC (including relays)				
- With 8 miniature relays	103	UM 45- 8RM/MR-G24/1/PLC	2962900	1
- With 16 miniature relays	215			
VARIOFACE COMPACT LINE output expansion module, for 24 V DC (including relays)				
- With 16 miniature relays	200			

Accessories

Pluggable miniature relays	REL-MR-G 24/1	2961037	8
-----------------------------------	----------------------	----------------	----------

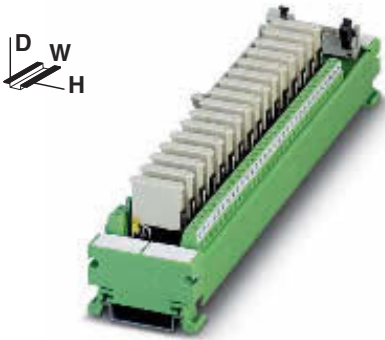

**Output base module with 16 miniature relays,
one N/O contact**

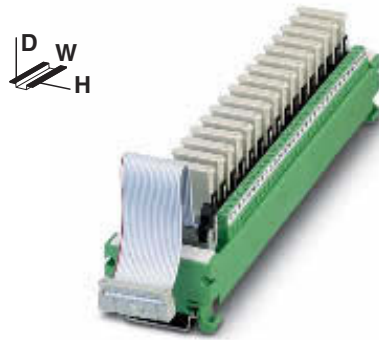

**Output extension module with 16 miniature relays,
one N/O contact**

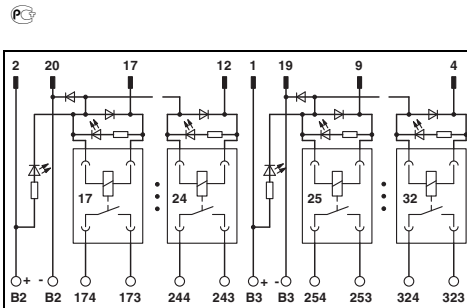
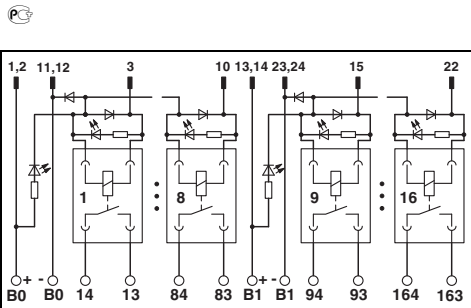

Technical data

24 V DC
6.5 mA
5 ms
15 ms
Free-wheeling diode, protection against polarity reversal
Yellow LED
Flat-ribbon cable plug connector in acc. with IEC 60603-13

50

1 N/O contact (double contact)
AgNi, 5 µm hard gold-plated
250 V AC / 125 V DC
5 V
5 A
3 A
1 mA
72 W
60 W
50 W
50 W
750 VA
Screw connection
0.14 ... 1.5 mm² / 0.14 ... 1.5 mm² / 26 - 14

2 kV (50 Hz, 1 min.)
-20°C ... 50°C
100% operating factor
2 x 10⁷ cycles
IEC 60664, DIN EN 50178, IEC 62103
Any
In rows with zero spacing
45 mm / 50 mm

Technical data

24 V DC
6.5 mA
5 ms
15 ms
Free-wheeling diode, protection against polarity reversal
Yellow LED
Flat-ribbon cable plug connector in acc. with IEC 60603-13

20

1 N/O contact (double contact)
AgNi, 5 µm hard gold-plated
250 V AC / 125 V DC
5 V
5 A
3 A
1 mA
72 W
60 W
50 W
50 W
750 VA
Screw connection
0.14 ... 1.5 mm² / 0.14 ... 1.5 mm² / 26 - 14

2 kV (50 Hz, 1 min.)
-20°C ... 50°C
100% operating factor
2 x 10⁷ cycles
IEC 60664, DIN EN 50178, IEC 62103
Any
In rows with zero spacing
45 mm / 50 mm

Ordering data

Type	Order No.	Pcs. / Pkt.
UM 45-16RM/MR-G24/1/PLC	2962913	1

Accessories

REL-MR-G 24/1	2961037	8
---------------	---------	---

Ordering data

Type	Order No.	Pcs. / Pkt.
UM 45-16RM/MR-G24/1/E/PLC	2962926	1

Accessories

REL-MR-G 24/1	2961037	8
---------------	---------	---

INTERFACE Cabling

VARIOFACE system cabling

Output modules with relays, one N/O contact

These VARIOFACE output modules are used in combination with the respective front adapters.

- Pluggable miniature relays, each with an N/O contact
- Universal applications from 1 mA to 3 A continuous current through 2-layer double contact with hard gold plating
- Slim construction widths of only 55 mm (8 channels) or 202 mm (32 channels)
- LED status display for each signal path and supply voltage
- Free-wheeling and reverse polarity protection diode for each signal path



Output module with eight miniature relays, one N/O contact

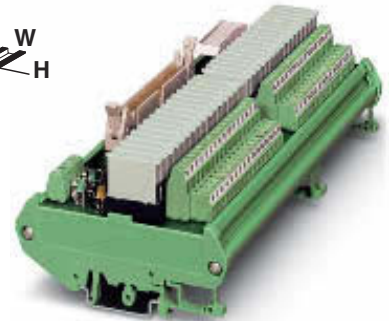

Output modules with 32 miniature relays, one N/O contact

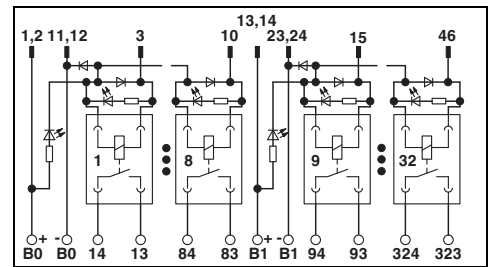
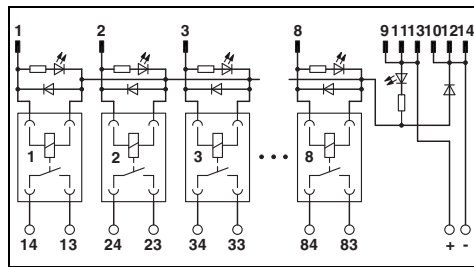

Technical data

Coil side	
Operating voltage U_N	24 V DC
Typ. input current at U_N	6.5 mA
Typ. response time at U_N	5 ms
Typ. release time at U_N	15 ms
Input circuit	Free-wheeling diode, protection against polarity reversal
Status display/channel	Yellow LED
Connection method	Flat-ribbon cable plug connector in acc. with IEC 60603-13
Contact side	
No. of poles	14
Contact type	1 N/O contact (double contact)
Contact material	AgNi, 5 μ m hard gold-plated
Max. switching voltage	250 V AC / 125 V DC
Min. switching voltage	5 V
Max. inrush current	5 A
Limiting continuous current	3 A
Min. switching current	1 mA
Max. interrupting rating:	24 V DC 72 W 48 V DC 60 W 60 V DC 50 W 110 V DC 50 W 250 V AC 750 VA
Connection method	Screw connection
Connection data solid / stranded / AWG	0.14 ... 1.5 mm ² / 0.14 ... 1.5 mm ² / 26 - 14
General data	
Test voltage	3 kV AC
Ambient temperature (operation)	-20°C ... 50°C
Nominal operating mode	100% operating factor
Mechanical service life	2 x 10 ⁷ cycles
Standards / regulations	IEC 60664, DIN EN 50178, IEC 62103
Mounting position	Any
Mounting	In rows with zero spacing
Dimensions	90 mm / 58 mm

Technical data

Coil side	
Operating voltage U_N	24 V DC
Typ. input current at U_N	6.5 mA
Typ. response time at U_N	5 ms
Typ. release time at U_N	15 ms
Input circuit	Free-wheeling diode, protection against polarity reversal
Status display/channel	Yellow LED
Connection method	Flat-ribbon cable plug connector in acc. with IEC 60603-13
Contact side	
No. of poles	50
Contact type	1 N/O contact (double contact)
Contact material	AgNi, 5 μ m hard gold-plated
Max. switching voltage	250 V AC / 125 V DC
Min. switching voltage	5 V
Max. inrush current	5 A
Limiting continuous current	3 A
Min. switching current	1 mA
Max. interrupting rating:	24 V DC 72 W 48 V DC 60 W 60 V DC 50 W 110 V DC 50 W 250 V AC 750 VA
Connection method	Screw connection
Connection data solid / stranded / AWG	0.14 ... 1.5 mm ² / 0.14 ... 1.5 mm ² / 26 - 16
General data	
Test voltage	3 kV AC
Ambient temperature (operation)	-20°C ... 50°C
Nominal operating mode	100% operating factor
Mechanical service life	2 x 10 ⁷ cycles
Standards / regulations	IEC 60664, DIN EN 50178, IEC 62103
Mounting position	Any
Mounting	In rows with zero spacing
Dimensions	90 mm / 58 mm

Ordering data

Description	Module width W
VARIOFACE output module, with eight miniature relays, plugged, for 24 V DC (incl. relays)	56
VARIOFACE output module, with 32 miniature relays, plugged in, for 24 V DC (including relays)	202

Type	Order No.	Pcs. / Pkt.
UMK- 8 RM/MR-G24/ 1/PLC	2979469	1

Ordering data

Type	Order No.	Pcs. / Pkt.
UMK-32 RM/MR-G24/1/PLC	2979472	1

Accessories

Pluggable miniature relays

REL-MR-G 24/1	2961037	8
---------------	---------	---

Accessories

REL-MR-G 24/1	2961037	8
---------------	---------	---

Output modules with relay, 1 PDT

These VARIOFACE output modules are used in combination with the respective front adapters.

Like the front adapters, the modules are connected via 14-pole or 50-pole system cables. The following features characterize these relay modules:

- Pluggable miniature relays, each with a PDT contact
- Slim construction widths of only 80 mm (8 channels) or 271 mm (32 channels)
- LED status display for each signal path and supply voltage
- Free-wheeling diode for each signal path



Output module with eight miniature relays, 1 PDT

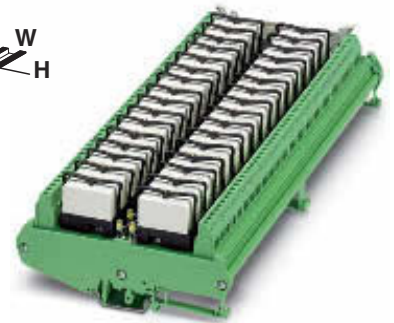

Output module with 32 miniature relays, 1 PDT

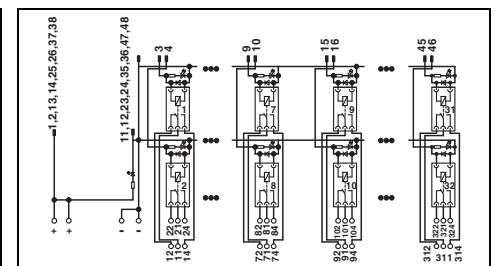
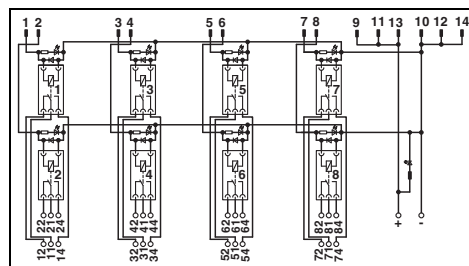

Technical data

Technical data

Coil side	
Operating voltage U_N	24 V DC
Typ. input current at U_N	18 mA
Typ. response time at U_N	8 ms
Typ. release time at U_N	10 ms
Input circuit	Free-wheeling diode
Status display/channel	Yellow LED
Connection method	Flat-ribbon cable plug connector in acc. with IEC 60603-13
No. of poles	14
Contact side	
Contact type	Single contact, 1 PDT
Contact material	AgNi
Max. switching voltage	250 V AC/DC
Min. switching voltage	12 V AC/DC
Limiting continuous current	5 A
Min. switching current	100 mA
Max. interrupting rating:	24 V DC 120 W 48 V DC 58 W 60 V DC 48 W 110 V DC 50 W 220 V DC 80 W 250 V AC 1250 VA
Connection method	Screw connection
Connection data solid / stranded / AWG	0.2 ... 4 mm ² / 0.2 ... 2.5 mm ² / 24 - 12
General data	
Test voltage	2.5 kV (50 Hz, 1 min.)
Ambient temperature (operation)	-20°C ... 50°C
Nominal operating mode	100% operating factor
Mechanical service life	3 x 10 ⁷ cycles
Standards / regulations	IEC 60664, DIN EN 50178, IEC 62103
Mounting position	Any
Mounting	In rows with zero spacing
Dimensions	123 mm / 68 mm

Coil side	
Operating voltage U_N	24 V DC
Typ. input current at U_N	18 mA
Typ. response time at U_N	8 ms
Typ. release time at U_N	10 ms
Input circuit	Free-wheeling diode
Status display/channel	Yellow LED
Connection method	Flat-ribbon cable plug connector in acc. with IEC 60603-13
No. of poles	50
Contact side	
Contact type	Single contact, 1 PDT
Contact material	AgNi
Max. switching voltage	250 V AC/DC
Min. switching voltage	12 V AC/DC
Limiting continuous current	5 A
Min. switching current	100 mA
Max. interrupting rating:	24 V DC 120 W 48 V DC 58 W 60 V DC 48 W 110 V DC 50 W 220 V DC 80 W 250 V AC 1250 VA
Connection method	Screw connection
Connection data solid / stranded / AWG	0.2 ... 4 mm ² / 0.2 ... 2.5 mm ² / 24 - 12
General data	
Test voltage	2.5 kV (50 Hz, 1 min.)
Ambient temperature (operation)	-20°C ... 50°C
Nominal operating mode	100% operating factor
Mechanical service life	3 x 10 ⁷ cycles
Standards / regulations	IEC 60664, DIN EN 50178, IEC 62103
Mounting position	Any
Mounting	In rows with zero spacing
Dimensions	123 mm / 68 mm

Ordering data

Ordering data

Description	Module width W	Type	Order No.	Pcs. / Pkt.
VARIOFACE output module, with eight miniature relays, plugged, for 24 V DC (incl. relays)	80	UM- 8 RM/RT-G24/21/PLC	2968386	1
VARIOFACE output module, with 32 miniature relays, plugged in, for 24 V DC (including relays)	271			

Description	Module width W	Type	Order No.	Pcs. / Pkt.
VARIOFACE output module, with 32 miniature relays, plugged in, for 24 V DC (including relays)	271	UM-32 RM/RT-G24/21/PLC	2968373	1

Accessories

Accessories

Pluggable miniature relays	REL-MR- 24DC/21HC	2961312	10
----------------------------	-------------------	---------	----

Pluggable miniature relays	REL-MR- 24DC/21HC	2961312	10
----------------------------	-------------------	---------	----

INTERFACE Cabling

VARIOFACE system cabling

Output modules with relay, 1 PDT

These VARIOFACE output modules are used in combination with the respective front adapters.

Like the front adapters, the modules are connected via 14-pole or 50-pole system cables. The following features characterize these relay modules:

- Plug-in miniature relays with one PDT each
- LED status display for each signal path and supply voltage
- Free-wheeling and reverse polarity protection diode for each signal path

With the 32-channel version, the system cable is connected to the base module with 16 channels UMK-16R.../KSR-G24/21/PLC. The output expansion module UMK-16R.../KSR-G24/21/E/PLC with a further 16 channels is coupled to the base module via a 20-pole flat-ribbon cable (length: 10 cm).

Notes:

The connecting cable between the base and the extension module is delivered with the extension unit.

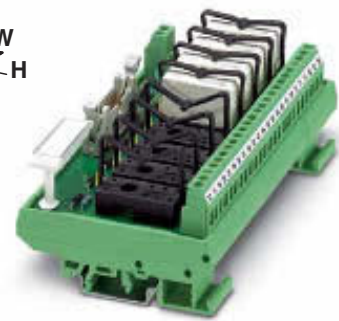

Output module with eight miniature relays, 1 PDT

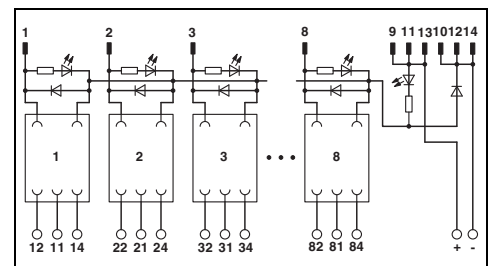

Technical data

Coil side	
Operating voltage U_N	24 V DC $\pm 10\%$
Input circuit	Free-wheeling diode, protection against polarity reversal
Operating voltage display	Green LED
Status display/channel	Yellow LED
Connection method	Flat-ribbon cable plug connector in acc. with IEC 60603-13
No. of poles	14
Contact side	
Contact type	1 PDT
Max. switching voltage	250 V AC/DC
Limiting continuous current	5 A
Connection method	Screw connection
Connection data solid / stranded / AWG	0.2 ... 4 mm ² / 0.2 ... 2.5 mm ² / 24 - 12
General data	
Test voltage	2.5 kV (50 Hz, 1 min.)
Ambient temperature (operation)	-20°C ... 50°C
Standards / regulations	IEC 60664, DIN EN 50178, IEC 62103
Mounting position	Any
Mounting	In rows with zero spacing
Dimensions	90 mm / 68 mm

Ordering data

Description	Module width W	Type	Order No.	Pcs. / Pkt.
VARIOFACE output module , with eight miniature relays, plugged, for 24 V DC (incl. relays)	135	UMK- 8 RM/KSR-G 24/21/PLC	2979485	1
VARIOFACE output module , with plug-in bases for eight miniature relays, for 24 V DC (without relays)	135	UMK- 8 RELS/KSR-G24/21/PLC	2974914	1
VARIOFACE output module , with 16 miniature relays, plugged, for 24 V DC (base module, including relays)	259			
VARIOFACE output module , with plug-in bases for 16 miniature relays, for 24 V DC (base module, without relays)	259			
VARIOFACE output extension module , with 16 miniature relays, plugged, for 24 V DC (including relays)	259			
VARIOFACE output extension module , with plug-in bases for 16 miniature relays, for 24 V DC (without relays)	259			

Accessories

Pluggable miniature relays	REL-MR- 24DC/21HC	2961312	10
-----------------------------------	--------------------------	----------------	----

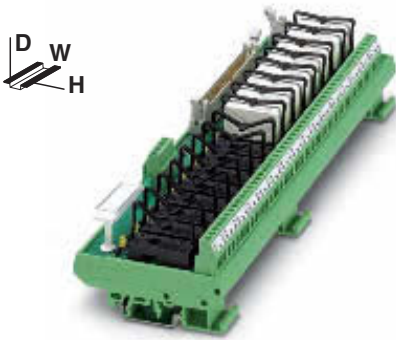

**Output base module with 16 miniature relays,
1 PDT**

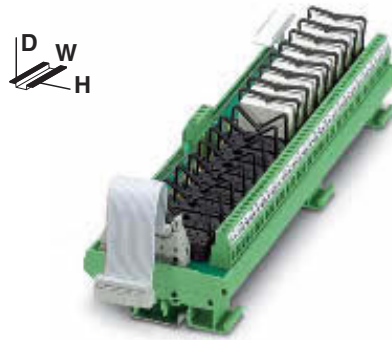

**Output extension module with 16 miniature relays,
1 PDT**

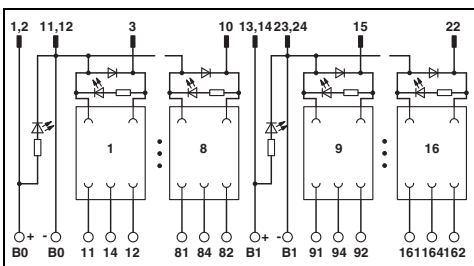

Technical data

24 V DC $\pm 10\%$
Free-wheeling diode, protection against polarity reversal
Green LED
Yellow LED
Flat-ribbon cable plug connector in acc. with IEC 60603-13

50
1 PDT
250 V AC/DC
5 A
Screw connection
0.2 ... 4 mm² / 0.2 ... 2.5 mm² / 24 - 12

2.5 kV (50 Hz, 1 min.)
-20°C ... 50°C
IEC 60664, DIN EN 50178, IEC 62103
Any
In rows with zero spacing
90 mm / 68 mm

Ordering data

Type	Order No.	Pcs. / Pkt.
UMK-16 RM/KSR-G 24/21/PLC	2979498	1
UMK-16 RELS/KSR-G24/21/PLC	2974901	1

Accessories

REL-MR- 24DC/21HC	2961312	10
-------------------	---------	----

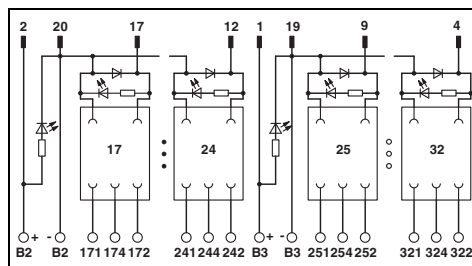

Technical data

24 V DC $\pm 10\%$
Free-wheeling diode, protection against polarity reversal
Green LED
Yellow LED
Flat-ribbon cable plug connector in acc. with IEC 60603-13

20
1 PDT
250 V AC/DC
5 A
Screw connection
0.2 ... 4 mm² / 0.2 ... 2.5 mm² / 24 - 12

2.5 kV (50 Hz, 1 min.)
-20°C ... 50°C
IEC 60664, DIN EN 50178, IEC 62103
Any
In rows with zero spacing
90 mm / 68 mm

Ordering data

Type	Order No.	Pcs. / Pkt.
UMK-16 RM/KSR-G 24/21/E/PLC	2979508	1
UMK-16 RELS/KSR-G24/21/E/PLC	2974891	1

Accessories

REL-MR- 24DC/21HC	2961312	10
-------------------	---------	----

INTERFACE Cabling

VARIOFACE system cabling

Output module for relays

- 2 PDTs
- 1 PDT with disconnect terminal blocks

These VARIOFACE output modules are used in combination with the respective front adapters.

8 channels are controlled via 14-pole cables. All modules feature the following:

- Plug-in miniature relays
- LED status indicator and free-wheeling diode per signal path
- Supply voltage indicator (LED)
- Polarity protection diode

With the 32-channel version (1 PDT with knife disconnect terminal blocks), the 50-pole system cable is connected to the base module with 16 channels.

The output expansion module with a further 16 channels is coupled to the base module via a 20-pole flat-ribbon cable (length: 10 cm).

Notes:

The connecting cable between the base and the extension modules is delivered with the extension unit.

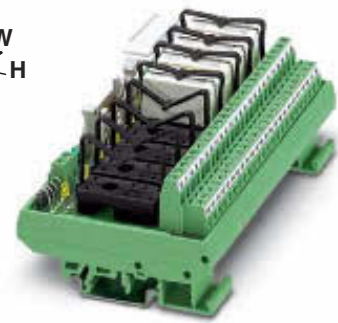

Output module for 8 miniature relays, 2 PDTs

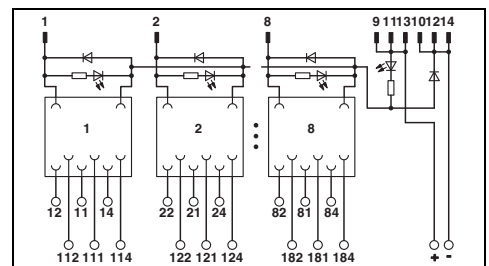

Technical data

Coil side	
Operating voltage U_N	24 V DC
Input circuit	Free-wheeling diode
Operating voltage display	Green LED
Status display/channel	Yellow LED
Connection method	Flat-ribbon cable plug connector in acc. with IEC 60603-13
No. of poles	14
Contact side	
Contact type	2 PDT
Max. switching voltage	250 V AC/DC
Limiting continuous current	3 A
Connection method	Screw connection
Connection data solid / stranded / AWG	0.14 ... 1.5 mm ² / 0.14 ... 1.5 mm ² / 26 - 14
General data	
Test voltage	2.5 kV AC
Ambient temperature (operation)	-20°C ... 50°C
Standards / regulations	IEC 60664, DIN EN 50178, IEC 62103
Mounting position	Any
Mounting	In rows with zero spacing
Dimensions	90 mm / 68 mm

Ordering data

Description	Module width W	Type	Order No.	Pcs. / Pkt.
VARIOFACE output module , with plug-in bases for eight miniature relays, for 24 V DC, each with two PDTs (without relays)	135	UMK- 8 RELS/KSR-G24/21-21/PLC	2976187	1
VARIOFACE output module , with plug-in bases for 8 miniature relays, for 24 V DC and knife disconnect terminal blocks, each with 1 PDT (without relays)	145			
VARIOFACE output module , with plug-in bases for 16 miniature relays, for 24 V DC and knife disconnect terminal blocks, each with 1 PDT (without relays)	285			
VARIOFACE output extension module , with plug-in bases for 16 miniature relays, for 24 V DC and knife disconnect terminal blocks, each with 1 PDT (without relays)	285			

Accessories

Pluggable miniature relays	REL-MR- 24DC/21-21	2961192	10
-----------------------------------	---------------------------	----------------	----



Output module for 8 miniature relays with knife/disconnect terminal blocks, 1 PDT

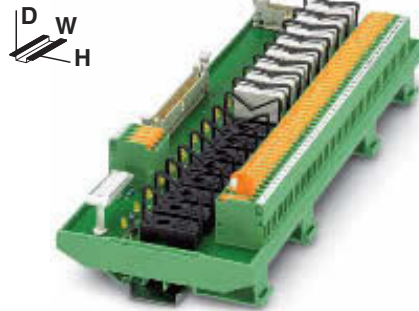

Output module for 16 miniature relays with knife/disconnect terminal blocks, 1 PDT

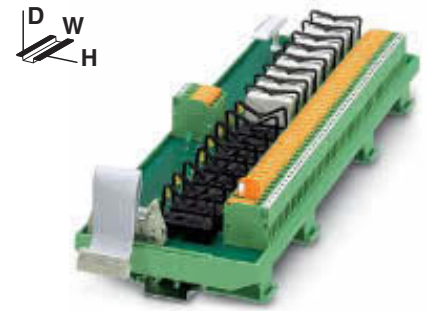

Output extension module for 16 miniature relays with knife/disconnect terminal blocks, 1 PDT

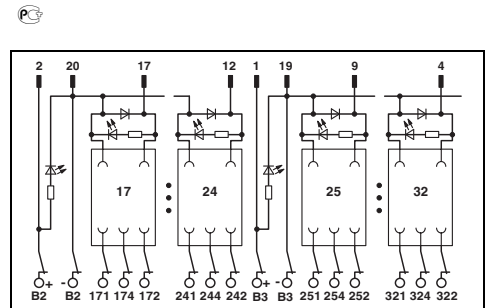
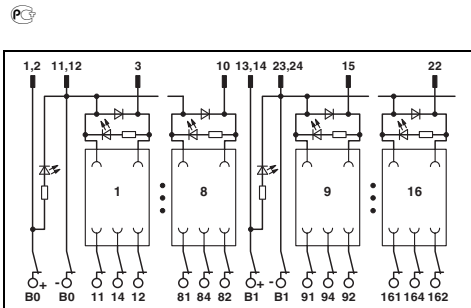
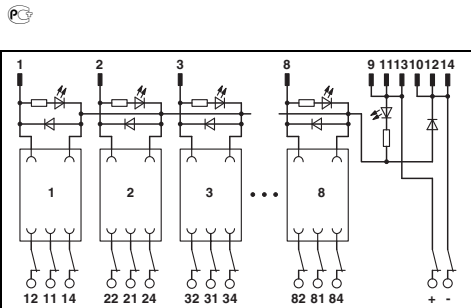

Technical data	
24 V DC	
Free-wheeling diode, protection against polarity reversal	
Green LED	
Yellow LED	
Flat-ribbon cable plug connector in acc. with IEC 60603-13	
14	
1 PDT	
250 V AC/DC	
5 A	
Screw connection with disconnect knife	
0.2 ... 4 mm ² / 0.2 ... 2.5 mm ² / 24 - 12	
2.5 kV (50 Hz, 1 min.)	
-20°C ... 50°C	
IEC 60664, DIN EN 50178, IEC 62103	
Any	
In rows with zero spacing	
111.5 mm / 59 mm	

Technical data	
24 V DC	
Free-wheeling diode	
Green LED	
Yellow LED	
Flat-ribbon cable plug connector in acc. with IEC 60603-13	
50	
1 PDT	
250 V AC/DC	
5 A	
Screw connection with disconnect knife	
0.2 ... 4 mm ² / 0.2 ... 2.5 mm ² / 24 - 12	
2.5 kV (50 Hz, 1 min.)	
-20°C ... 50°C	
IEC 60664, DIN EN 50178, IEC 62103	
Any	
In rows with zero spacing	
111.5 mm / 59 mm	

Technical data	
24 V DC	
Free-wheeling diode	
Green LED	
Yellow LED	
Flat-ribbon cable plug connector in acc. with IEC 60603-13	
20	
1 PDT	
250 V AC/DC	
5 A	
Screw connection with disconnect knife	
0.2 ... 4 mm ² / 0.2 ... 2.5 mm ² / 24 - 12	
2.5 kV (50 Hz, 1 min.)	
-20°C ... 50°C	
IEC 60664, DIN EN 50178, IEC 62103	
Any	
In rows with zero spacing	
111.5 mm / 59 mm	

Ordering data		
Type	Order No.	Pcs. / Pkt.
UM- 8 RELS/KSR-G24/21/MT/PLC	2962463	1

Ordering data		
Type	Order No.	Pcs. / Pkt.
UM-16 RELS/KSR-G24/21/MT/PLC	2962382	1

Ordering data		
Type	Order No.	Pcs. / Pkt.
UM-16 RELS/KSR-G24/21/E/MT/PLC	2962379	1

Accessories		
REL-MR- 24DC/21-21	2961192	10

Accessories		
REL-MR- 24DC/21-21	2961192	10

Accessories		
REL-MR- 24DC/21-21	2961192	10

INTERFACE Cabling

VARIOFACE system cabling

Output modules with relays, 1 PDT with detectable manual operation

These VARIOFACE output modules are used in combination with the respective front adapters.

The modules are connected via 14 or 50-pole system cable. These relay modules offer the following features:

- Plug-in miniature relays each with a PDT contact and detectable manual operation
- Slim design width of just 92 mm (8 channels) or 285 mm (32 channels)
- LED status indicator and free-wheeling diode per signal path (integrated in relay)
- Supply voltage indicator (LED)



Output module with 8 miniature relays, 1 PDT with detectable manual operation



Output module with 32 miniature relays, 1 PDT with detectable manual operation

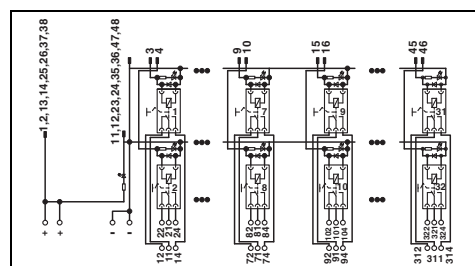
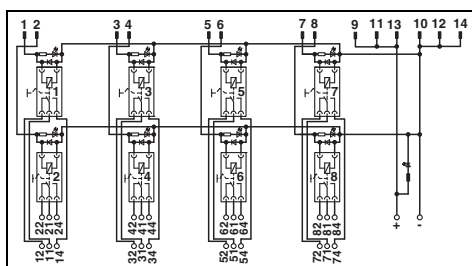

Coil side	
Operating voltage U_N	24 V DC
Typ. input current at U_N	18 mA
Typ. response time at U_N	9 ms
Typ. release time at U_N	6 ms
Input circuit	Free-wheeling diode (integrated in relay)
Status display/channel	Yellow LED (integrated in relay)
Connection method	Flat-ribbon cable plug connector in acc. with IEC 60603-13
Contact side	
No. of poles	14
General data	
Contact type	Single contact, 1 PDT
Contact material	AgNi
Max. switching voltage	250 V AC/DC
Min. switching voltage	12 V AC/DC
Limiting continuous current	5 A
Min. switching current	100 mA
Max. interrupting rating:	24 V DC 120 W 48 V DC 62 W 60 V DC 42 W 110 V DC 55 W 220 V DC 66 W 250 V AC 1250 VA
Connection method	Screw connection
Connection data solid / stranded / AWG	0.2 ... 4 mm ² / 0.2 ... 2.5 mm ² / 24 - 12
Rated insulation voltage	
Rated insulation voltage	260 V AC
Rated surge voltage	4 kV (basic insulation (safe isolation, reinforced insulation, and 6 kV between input and output))
Pollution degree / surge voltage category	
Pollution degree / surge voltage category	2 / III
Ambient temperature (operation)	-20°C ... 50°C
Nominal operating mode	100% operating factor
Mechanical service life	5 x 10 ⁶ cycles
Standards / regulations	DIN EN 50178
Mounting position	Any
Mounting	In rows with zero spacing
Dimensions	111 mm / 64 mm

Technical data		
Coil side		
Operating voltage U_N		
Typ. input current at U_N		
Typ. response time at U_N		
Typ. release time at U_N		
Input circuit		
Status display/channel		
Connection method		
Contact side		
No. of poles		
General data		
Contact type		
Contact material		
Max. switching voltage		
Min. switching voltage		
Limiting continuous current		
Min. switching current		
Max. interrupting rating:		
Connection method		
Connection data solid / stranded / AWG		
Rated insulation voltage		
Rated insulation voltage		
Rated surge voltage		
Pollution degree / surge voltage category		
Pollution degree / surge voltage category		
Ambient temperature (operation)		
Nominal operating mode		
Mechanical service life		
Standards / regulations		
Mounting position		
Mounting		
Dimensions		

Technical data		
Coil side		
Operating voltage U_N		
Typ. input current at U_N		
Typ. response time at U_N		
Typ. release time at U_N		
Input circuit		
Status display/channel		
Connection method		
Contact side		
No. of poles		
General data		
Contact type		
Contact material		
Max. switching voltage		
Min. switching voltage		
Limiting continuous current		
Min. switching current		
Max. interrupting rating:		
Connection method		
Connection data solid / stranded / AWG		
Rated insulation voltage		
Rated insulation voltage		
Rated surge voltage		
Pollution degree / surge voltage category		
Pollution degree / surge voltage category		
Ambient temperature (operation)		
Nominal operating mode		
Mechanical service life		
Standards / regulations		
Mounting position		
Mounting		
Dimensions		

Ordering data	
Description	Module width W
VARIOFACE output module, with 8 miniature relays, plugged in, for 24 V DC (including relays)	92
VARIOFACE output module, with 32 miniature relays, plugged in, for 24 V DC (including relays)	285

Ordering data		
Type	Order No.	Pcs. / Pkt.
UM- 8RM/KSR-G24/21/MS/PLC	2900890	1

Ordering data		
Type	Order No.	Pcs. / Pkt.
UM-32RM/KSR-G24/21/MS/PLC	2900891	1

Accessories	
Miniature relay with manual checking function	REL-MR- 24DC/21HC/MS

Accessories		
REL-MR- 24DC/21HC/MS	2987888	10

Accessories		
REL-MR- 24DC/21HC/MS	2987888	10

Output modules with relays, 1 PDT with or without manual operation and fuses

These VARIOFACE output modules are used in combination with the respective front adapters.

The modules are connected via 14-pole system cable. These relay modules offer the following features:

- Plug-in miniature relays each with a PDT contact with or without manual operation
- Fuse per output circuit as short-circuit protection
- Slim design width of just 127 mm
- LED status indicator and free-wheeling diode per signal path
- Supply voltage indicator (LED)
- Polarity protection diode



Output module with 8 miniature relays, 1 PDT and fuse per output circuit



Output module with 8 miniature relays, 1 PDT with detectable manual operation and fuse per output circuit

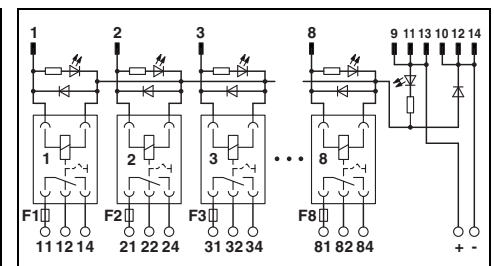
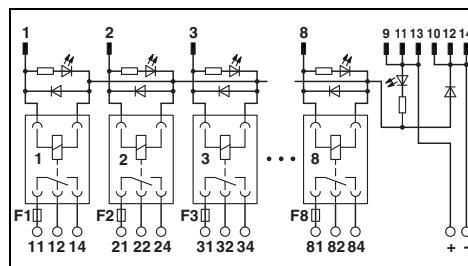

Technical data

Technical data

Coil side	
Operating voltage U_N	24 V DC
Typ. input current at U_N	17 mA
Typ. response time at U_N	8 ms
Typ. release time at U_N	10 ms
Input circuit	Free-wheeling diode
Status display/channel	Yellow LED
Connection method	Flat-ribbon cable plug connector in acc. with IEC 60603-13
No. of poles	
14	
Contact side	
Contact type	Single contact, 1 PDT
Contact material	AgNi
Max. switching voltage	250 V AC/DC
Min. switching voltage	12 V AC/DC
Output fuse	4 A 5x20 fuse (slow-blow)
Limiting continuous current	3.9 A (observe derating)
Min. switching current	100 mA
Max. interrupting rating:	24 V DC 48 V DC 60 V DC 110 V DC 220 V DC 250 V AC
Connection method	Screw connection
Connection data solid / stranded / AWG	0.2 ... 4 mm ² / 0.2 ... 2.5 mm ² / 24 - 12
General data	
Rated insulation voltage	260 V AC
Rated surge voltage	4 kV (basic insulation (safe isolation, reinforced insulation, and 6 kV between input and output))
Pollution degree / surge voltage category	2 / III
Ambient temperature (operation)	-20°C ... 50°C
Nominal operating mode	100% operating factor
Mechanical service life	3 x 10 ⁷ cycles
Standards / regulations	DIN EN 50178
Mounting position	Any
Mounting	In rows with zero spacing
Dimensions	111 mm / 60 mm

Technical data	
Operating voltage U_N	24 V DC
Typ. input current at U_N	18 mA
Typ. response time at U_N	9 ms
Typ. release time at U_N	6 ms
Input circuit	Free-wheeling diode (integrated in relay)
Status display/channel	Yellow LED (integrated in relay)
Connection method	Flat-ribbon cable plug connector in acc. with IEC 60603-13
No. of poles	
14	
Contact side	
Contact type	Single contact, 1 PDT
Contact material	AgNi
Max. switching voltage	250 V AC/DC
Min. switching voltage	12 V AC/DC
Output fuse	4 A 5x20 fuse (slow-blow)
Limiting continuous current	3.9 A (observe derating)
Min. switching current	100 mA
Max. interrupting rating:	93 W 62 W 42 W 55 W 66 W 975 VA
Connection method	Screw connection
Connection data solid / stranded / AWG	0.2 ... 4 mm ² / 0.2 ... 2.5 mm ² / 24 - 12
General data	
Rated insulation voltage	260 V AC
Rated surge voltage	4 kV (basic insulation (safe isolation, reinforced insulation, and 6 kV between input and output))
Pollution degree / surge voltage category	2 / III
Ambient temperature (operation)	-20°C ... 50°C
Nominal operating mode	100% operating factor
Mechanical service life	5 x 10 ⁶ cycles
Standards / regulations	DIN EN 50178
Mounting position	Any
Mounting	In rows with zero spacing
Dimensions	111 mm / 64 mm

Ordering data

Ordering data

Description	Module width W
VARIOFACE output module , with 8 miniature relays, plugged in, for 24 V DC (including relays)	127

Type	Order No.	Pcs. / Pkt.
UM-8RM/KSR-G24/21/SI/PLC	2900892	1

Type	Order No.	Pcs. / Pkt.
UM-8RM/KSR-G24/21/MS/SI/PLC	2900893	1

Accessories

Accessories

Pluggable miniature relays
REL-MR-24DC/21HC

Type	Order No.	Pcs. / Pkt.
REL-MR-24DC/21HC	2961312	10

Type	Order No.	Pcs. / Pkt.
REL-MR-24DC/21HC/MS	2987888	10

INTERFACE Cabling

VARIOFACE system cabling

VIP – VARIOFACE Professional system cables with flat-ribbon connectors

- 1:1 connection
- 10 to 20-pole
- Connectors as per IEC 60603-13
- In the desired lengths
- Individual serial number

Note:

Due to the enlarged outer contour of the molded connectors, module types with UM45 profile and three-level terminal blocks cannot be connected with the VIP-CAB-FLK... system cable.

The following module types (10 to 50-pole) can be connected.

- For example, for 20 poles:
- VIP-2/SC/FLK 20
- VIP-2/SC/FLK20/LED
- FLKM 20/ZFKDS
- UM45-FLK 20/ZFKDS (double-level connection)

The VIP-CAB-FLK... system cables are not suitable for front adapters (see the dimensional drawing).

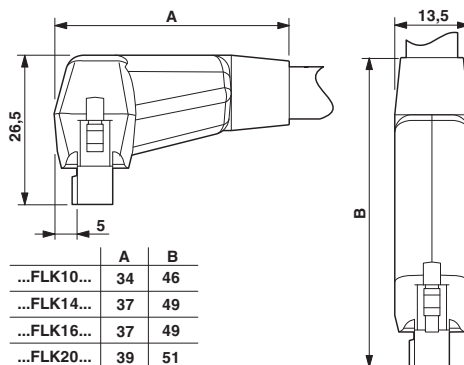

Not shielded



Max. perm. operating voltage
 Max. perm. current carrying capacitance per path
 Max. conductor resistance
 Ambient temperature (operation)
 Assembly

Conductor cross section
 Outside diameter

Technical data

< 50 V AC / 60 V DC
 1 A
 0.16 Ω/m
 -20°C ... 50°C
 Insulation displacement, IEC 60352-4 / DIN EN 60352-4

AWG 26 / 0.14 mm²

10-pole 6.1 mm
 14-pole 6.4 mm
 16-pole 6.8 mm
 20-pole 7.6 mm

Ordering data

Description	No. of poles	Cable length	Type	Order No.	Pcs. / Pkt.
Round cable, with two molded socket strips					
	10	0.5 m	VIP-CAB-FLK10/0,14/0,5M	2318305	1
	10	1 m	VIP-CAB-FLK10/0,14/1,0M	2318318	1
	10	1.5 m	VIP-CAB-FLK10/0,14/1,5M	2318321	1
	10	2 m	VIP-CAB-FLK10/0,14/2,0M	2318334	1
	10	3 m	VIP-CAB-FLK10/0,14/3,0M	2318347	1
	10	4 m	VIP-CAB-FLK10/0,14/4,0M	2318350	1
	10	6 m	VIP-CAB-FLK10/0,14/6,0M	2318363	1
Round cable, same as before, in variable lengths (minimum ordering quantity five pieces)					
	10		VIP-CAB-FLK10-0,14/...	2318376	1
Round cable, with two molded socket strips					
	14	0.5 m	VIP-CAB-FLK14/0,14/0,5M	2318389	1
	14	1 m	VIP-CAB-FLK14/0,14/1,0M	2318392	1
	14	1.5 m	VIP-CAB-FLK14/0,14/1,5M	2318402	1
	14	2 m	VIP-CAB-FLK14/0,14/2,0M	2318415	1
	14	3 m	VIP-CAB-FLK14/0,14/3,0M	2318428	1
	14	4 m	VIP-CAB-FLK14/0,14/4,0M	2318431	1
	14	6 m	VIP-CAB-FLK14/0,14/6,0M	2318444	1
Round cable, same as before, in variable lengths (minimum ordering quantity five pieces)					
	14		VIP-CAB-FLK14-0,14/...	2318457	1
Round cable, with two molded socket strips					
	16	0.5 m	VIP-CAB-FLK16/0,14/0,5M	2318460	1
	16	1 m	VIP-CAB-FLK16/0,14/1,0M	2318473	1
	16	1.5 m	VIP-CAB-FLK16/0,14/1,5M	2318486	1
	16	2 m	VIP-CAB-FLK16/0,14/2,0M	2318499	1
	16	3 m	VIP-CAB-FLK16/0,14/3,0M	2318509	1
	16	4 m	VIP-CAB-FLK16/0,14/4,0M	2318512	1
	16	6 m	VIP-CAB-FLK16/0,14/6,0M	2318525	1
Round cable, same as before, in variable lengths (minimum ordering quantity five pieces)					
	16		VIP-CAB-FLK16-0,14/...	2318538	1
Round cable, with two molded socket strips					
	20	0.5 m	VIP-CAB-FLK20/0,14/0,5M	2318541	1
	20	1 m	VIP-CAB-FLK20/0,14/1,0M	2318554	1
	20	1.5 m	VIP-CAB-FLK20/0,14/1,5M	2318567	1
	20	2 m	VIP-CAB-FLK20/0,14/2,0M	2318570	1
	20	3 m	VIP-CAB-FLK20/0,14/3,0M	2318583	1
	20	4 m	VIP-CAB-FLK20/0,14/4,0M	2318596	1
	20	6 m	VIP-CAB-FLK20/0,14/6,0M	2318606	1
Round cable, same as before, in variable lengths (minimum ordering quantity five pieces)					
	20		VIP-CAB-FLK20-0,14/...	2318619	1

Ordering example for system cable:

– 10-pos. cable, 7.6 m long

Quantity	Order No.	Length [m]
1	2318376	7.6
		Min. 0.5 m
		Max. 100.0 m
		Step width 0.1 m

VIP – VARIOFACE Professional system cables with flat-ribbon connectors

- 1:1 connection
- 26 to 50-pole
- Connectors as per IEC 60603-13
- In the desired lengths
- Individual serial number

Note:

Due to the enlarged outer contour of the molded connectors, module types with UM45 profile and three-level terminal blocks cannot be connected with the VIP-CAB-FLK... system cable.

The following module types (10 to 50-pole) can be connected.

For example, for 20 poles:

- VIP-2/SC/FLK 20
- VIP-2/SC/FLK20/LED
- FLKM 20/ZFKDS
- UM45-FLK 20/ZFKDS (double-level connection)

The VIP-CAB-FLK... system cables are not suitable for front adapters (see the dimensional drawing).

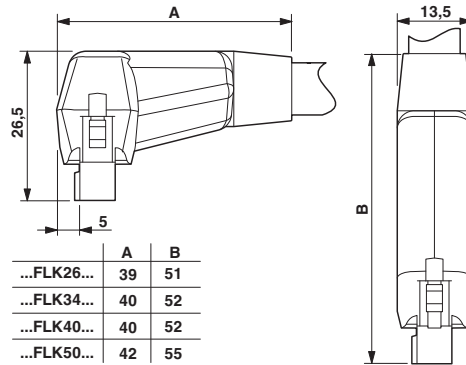

Not shielded



Max. perm. operating voltage
 Max. perm. current carrying capacitance per path
 Max. conductor resistance
 Ambient temperature (operation)
 Assembly

Conductor cross section
 Outside diameter

Technical data

< 50 V AC / 60 V DC
 1 A
 0.16 Ω/m
 -20°C ... 50°C
 Insulation displacement, IEC 60352-4 / DIN EN 60352-4
 AWG 26 / 0.14 mm²
 26-pole 8.3 mm
 34-pole 8.7 mm
 40-pole 9.9 mm
 50-pole 10.3 mm

Ordering data

Description	No. of poles	Cable length	Type	Order No.	Pcs. / Pkt.
Round cable, with two molded socket strips					
	26	0.5 m	VIP-CAB-FLK26/0,14/0,5M	2318622	1
	26	1 m	VIP-CAB-FLK26/0,14/1,0M	2318635	1
	26	1.5 m	VIP-CAB-FLK26/0,14/1,5M	2318648	1
	26	2 m	VIP-CAB-FLK26/0,14/2,0M	2318651	1
	26	3 m	VIP-CAB-FLK26/0,14/3,0M	2318664	1
	26	4 m	VIP-CAB-FLK26/0,14/4,0M	2318677	1
	26	6 m	VIP-CAB-FLK26/0,14/6,0M	2318680	1
Round cable, same as before, in variable lengths (minimum ordering quantity five pieces)					
	26		VIP-CAB-FLK26-0,14/...	2318693	1
Round cable, with two molded socket strips					
	34	0.5 m	VIP-CAB-FLK34/0,14/0,5M	2318703	1
	34	1 m	VIP-CAB-FLK34/0,14/1,0M	2318716	1
	34	1.5 m	VIP-CAB-FLK34/0,14/1,5M	2318729	1
	34	2 m	VIP-CAB-FLK34/0,14/2,0M	2318732	1
	34	3 m	VIP-CAB-FLK34/0,14/3,0M	2318745	1
	34	4 m	VIP-CAB-FLK34/0,14/4,0M	2318758	1
	34	6 m	VIP-CAB-FLK34/0,14/6,0M	2318761	1
Round cable, same as before, in variable lengths (minimum ordering quantity five pieces)					
	34		VIP-CAB-FLK34-0,14/...	2318774	1
Round cable, with two molded socket strips					
	40	0.5 m	VIP-CAB-FLK40/0,14/0,5M	2318787	1
	40	1 m	VIP-CAB-FLK40/0,14/1,0M	2318790	1
	40	1.5 m	VIP-CAB-FLK40/0,14/1,5M	2318800	1
	40	2 m	VIP-CAB-FLK40/0,14/2,0M	2318813	1
	40	3 m	VIP-CAB-FLK40/0,14/3,0M	2318826	1
	40	4 m	VIP-CAB-FLK40/0,14/4,0M	2318839	1
	40	6 m	VIP-CAB-FLK40/0,14/6,0M	2318842	1
Round cable, same as before, in variable lengths (minimum ordering quantity five pieces)					
	40		VIP-CAB-FLK40-0,14/...	2318855	1
Round cable, with two molded socket strips					
	50	0.5 m	VIP-CAB-FLK50/0,14/0,5M	2318868	1
	50	1 m	VIP-CAB-FLK50/0,14/1,0M	2318871	1
	50	1.5 m	VIP-CAB-FLK50/0,14/1,5M	2318884	1
	50	2 m	VIP-CAB-FLK50/0,14/2,0M	2318897	1
	50	3 m	VIP-CAB-FLK50/0,14/3,0M	2318907	1
	50	4 m	VIP-CAB-FLK50/0,14/4,0M	2318910	1
	50	6 m	VIP-CAB-FLK50/0,14/6,0M	2318923	1
Round cable, same as before, in variable lengths (minimum ordering quantity five pieces)					
	50		VIP-CAB-FLK50-0,14/...	2318936	1

Ordering example for system cable:

– 26-pos. cable, 12.6 m long

Quantity	Order No.	Length [m]
1	2318693	12.6
		Min. 0.5 m
		Max. 100.0 m
		Step width 0.1 m

INTERFACE Cabling

VARIOFACE system cabling

System cable with a flat-ribbon cable connector and an open end

- 1:1 connection
- 14- and 16-pole
- Connectors as per IEC 60603-13
- Open end at the other end

The individual wires at the open end are labeled (1, 2, 3, 4, ...) and equipped with a ferrule.



Molded connectors, not shielded



Not shielded

Notes:
In the case of molded connectors, please observe the dimensional drawing and note, see page 278.



	Technical data	Technical data
Max. perm. operating voltage	< 50 V AC / 60 V DC	< 50 V AC / 60 V DC
Max. perm. current carrying capacitance per path	1 A	1 A
Max. conductor resistance	0.16 Ω/m	0.16 Ω/m
Ambient temperature (operation)	-20°C ... 50°C	-20°C ... 50°C
Assembly	Insulation displacement, IEC 60352-4 / DIN EN 60352-4	Insulation displacement, IEC 60352-4 / DIN EN 60352-4
Conductor cross section	AWG 26 / 0.14 mm ²	AWG 26 / 0.14 mm ²
Conductor structure: stranded wires / material	7 / Cu tin-plated	7 / Cu tin-plated
Outside diameter	14-pole: 6.4 mm 16-pole: 6.5 mm	6.4 mm 6.5 mm

			Ordering data			Ordering data		
Description	No. of poles	Cable length	Type	Order No.	Pcs. / Pkt.	Type	Order No.	Pcs. / Pkt.
Round cable with an open end	14	0.5 m	VIP-CAB-FLK14/FR/OE/0,14/0,5M	2900122	1	CABLE-FLK14/OE/0,14/ 50	2305761	1
	14	1 m	VIP-CAB-FLK14/FR/OE/0,14/1,0M	2900123	1	CABLE-FLK14/OE/0,14/ 100	2305253	1
	14	1.5 m	VIP-CAB-FLK14/FR/OE/0,14/1,5M	2900125	1	CABLE-FLK14/OE/0,14/ 150	2305266	1
	14	2 m	VIP-CAB-FLK14/FR/OE/0,14/2,0M	2900126	1	CABLE-FLK14/OE/0,14/ 200	2305279	1
	14	2.5 m				CABLE-FLK14/OE/0,14/ 250	2305282	1
	14	3 m	VIP-CAB-FLK14/FR/OE/0,14/3,0M	2900127	1	CABLE-FLK14/OE/0,14/ 300	2305295	1
	14	4 m	VIP-CAB-FLK14/FR/OE/0,14/4,0M	2900128	1	CABLE-FLK14/OE/0,14/ 400	2305774	1
	14	6 m	VIP-CAB-FLK14/FR/OE/0,14/6,0M	2900129	1	CABLE-FLK14/OE/0,14/ 600	2305787	1
	14	8 m				CABLE-FLK14/OE/0,14/ 800	2305790	1
	14	10 m				CABLE-FLK14/OE/0,14/1000	2305800	1
Round cable , same as before, however in variable lengths	14					CABLE-FLK14/OE/0,14/...	2305732	1
Round cable with an open end	16	0.5 m	VIP-CAB-FLK16/FR/OE/0,14/0,5M	2900130	1	CABLE-FLK16/OE/0,14/ 0,5M	2318127	1
	16	1 m	VIP-CAB-FLK16/FR/OE/0,14/1,0M	2900131	1	CABLE-FLK16/OE/0,14/ 1,0M	2318130	1
	16	1.5 m	VIP-CAB-FLK16/FR/OE/0,14/1,5M	2900132	1	CABLE-FLK16/OE/0,14/ 1,5M	2318143	1
	16	2 m	VIP-CAB-FLK16/FR/OE/0,14/2,0M	2900133	1	CABLE-FLK16/OE/0,14/ 2,0M	2318156	1
	16	2.5 m				CABLE-FLK16/OE/0,14/ 2,5M	2318169	1
	16	3 m	VIP-CAB-FLK16/FR/OE/0,14/3,0M	2900134	1	CABLE-FLK16/OE/0,14/ 3,0M	2318172	1
	16	4 m	VIP-CAB-FLK16/FR/OE/0,14/4,0M	2900135	1	CABLE-FLK16/OE/0,14/ 4,0M	2318185	1
	16	6 m	VIP-CAB-FLK16/FR/OE/0,14/6,0M	2900136	1	CABLE-FLK16/OE/0,14/ 6,0M	2318198	1
	16	8 m				CABLE-FLK16/OE/0,14/ 8,0M	2318208	1
	16	10 m				CABLE-FLK16/OE/0,14/10,0M	2318211	1
Round cable , same as before, however in variable lengths	16					CABLE-FLK16/OE/0,14/...	2318224	1

System cable with a flat-ribbon cable connector and an open end

- 1:1 connection
- 20- and 50-pole
- Connectors as per IEC 60603-13
- Open end at the other end

The individual wires at the open end are labeled (1, 2, 3, 4, ...) and equipped with a ferrule.



Molded connectors, not shielded



Not shielded

Notes:
In the case of molded connectors, please observe the dimensional drawing and note, see page 278.



	Technical data	Technical data
Max. perm. operating voltage	< 50 V AC / 60 V DC	< 50 V AC / 60 V DC
Max. perm. current carrying capacitance per path	1 A	1 A
Max. conductor resistance	0.16 Ω/m	0.16 Ω/m
Ambient temperature (operation)	-20°C ... 50°C	-20°C ... 50°C
Assembly	Insulation displacement, IEC 60352-4 / DIN EN 60352-4	Insulation displacement, IEC 60352-4 / DIN EN 60352-4
Conductor cross section	AWG 26 / 0.14 mm ²	AWG 26 / 0.14 mm ²
Conductor structure: stranded wires / material	7 / Cu tin-plated	7 / Cu tin-plated
Outside diameter		
	20-pole	7.6 mm
	50-pole	10.3 mm

			Ordering data			Ordering data		
Description	No. of poles	Cable length	Type	Order No.	Pcs. / Pkt.	Type	Order No.	Pcs. / Pkt.
Round cable with an open end	20	0.5 m	VIP-CAB-FLK20/FR/OE/0,14/0,5M	2900138	1	CABLE-FLK20/OE/0,14/ 50	2305826	1
	20	1 m	VIP-CAB-FLK20/FR/OE/0,14/1,0M	2900139	1	CABLE-FLK20/OE/0,14/ 100	2305305	1
	20	1.5 m	VIP-CAB-FLK20/FR/OE/0,14/1,5M	2900141	1	CABLE-FLK20/OE/0,14/ 150	2305318	1
	20	2 m	VIP-CAB-FLK20/FR/OE/0,14/2,0M	2900142	1	CABLE-FLK20/OE/0,14/ 200	2305321	1
	20	2.5 m				CABLE-FLK20/OE/0,14/ 250	2305334	1
	20	3 m	VIP-CAB-FLK20/FR/OE/0,14/3,0M	2900143	1	CABLE-FLK20/OE/0,14/ 300	2305347	1
	20	4 m	VIP-CAB-FLK20/FR/OE/0,14/4,0M	2900144	1	CABLE-FLK20/OE/0,14/ 400	2305839	1
	20	6 m	VIP-CAB-FLK20/FR/OE/0,14/6,0M	2900145	1	CABLE-FLK20/OE/0,14/ 600	2305842	1
	20	8 m				CABLE-FLK20/OE/0,14/ 800	2305855	1
	20	10 m				CABLE-FLK20/OE/0,14/1000	2305868	1
Round cable, same as before, however in variable lengths	20					CABLE-FLK20/OE/0,14/...	2305745	1
Round cable with an open end	50	0.5 m	VIP-CAB-FLK50/FR/OE/0,14/0,5M	2900146	1	CABLE-FLK50/OE/0,14/ 50	2305871	1
	50	1 m	VIP-CAB-FLK50/FR/OE/0,14/1,0M	2900147	1	CABLE-FLK50/OE/0,14/ 100	2305350	1
	50	1.5 m	VIP-CAB-FLK50/FR/OE/0,14/1,5M	2900148	1	CABLE-FLK50/OE/0,14/ 150	2305363	1
	50	2 m	VIP-CAB-FLK50/FR/OE/0,14/2,0M	2900149	1	CABLE-FLK50/OE/0,14/ 200	2305376	1
	50	2.5 m				CABLE-FLK50/OE/0,14/ 250	2305389	1
	50	3 m	VIP-CAB-FLK50/FR/OE/0,14/3,0M	2900150	1	CABLE-FLK50/OE/0,14/ 300	2305392	1
	50	4 m	VIP-CAB-FLK50/FR/OE/0,14/4,0M	2900151	1	CABLE-FLK50/OE/0,14/ 400	2305884	1
	50	6 m	VIP-CAB-FLK50/FR/OE/0,14/6,0M	2900152	1	CABLE-FLK50/OE/0,14/ 600	2305897	1
	50	8 m				CABLE-FLK50/OE/0,14/ 800	2305907	1
	50	10 m				CABLE-FLK50/OE/0,14/1000	2305910	1
Round cable, same as before, however in variable lengths	50					CABLE-FLK50/OE/0,14/...	2305758	1

INTERFACE Cabling

VARIOFACE system cabling

System cable with flat-ribbon cable connector

Standard lengths

Round cable sets are used to connect the PLC front adapters to the corresponding VARIOFACE controller boards.

The following versions are available with 14 and 50 poles:

- Not shielded
- Shielded
- Halogen-free

Connector strips are fitted on both sides of the cables in accordance with IEC 60603-13/DIN 41651 (1:1 connection).

In case of shielded cables, a cable end with a ferrule is additionally provided as a shield connection (length: approx. 0.5 m; cable H05V-K 1 mm², black).

Special lengths are defined using an order key, refer to page 288.



Not shielded



Technical data

Max. perm. operating voltage
Max. perm. current carrying capacitance per path
Max. conductor resistance
Ambient temperature (operation)
Shield

< 50 V AC / 60 V DC
1 A
0.16 Ω/m
-20°C ... 50°C
-

Assembly

Insulation displacement, IEC 60352-4 / DIN EN 60352-4

Conductor cross section
Conductor structure: stranded wires / material
Outside diameter

AWG 26 / 0.14 mm²
7 / Cu tin-plated

14-pole 6.4 mm
50-pole 10.3 mm

Ordering data

Description	No. of poles	Cable length	Type	Order No.	Pcs. / Pkt.
Assembled round cables¹⁾ , with two 14-pole socket strips in fixed lengths, for transfer of eight channels among other things					
	14	0.3 m	FLK 14/EZ-DR/ 30/KONFEK	2295729	5
	14	0.5 m	FLK 14/EZ-DR/ 50/KONFEK	2288901	5
	14	1 m	FLK 14/EZ-DR/ 100/KONFEK	2288914	1
	14	1.5 m	FLK 14/EZ-DR/ 150/KONFEK	2288927	1
	14	2 m	FLK 14/EZ-DR/ 200/KONFEK	2288930	1
	14	2.5 m	FLK 14/EZ-DR/ 250/KONFEK	2288943	1
	14	3 m	FLK 14/EZ-DR/ 300/KONFEK	2288956	1
	14	3.5 m	FLK 14/EZ-DR/ 350/KONFEK	2288969	1
	14	4 m	FLK 14/EZ-DR/ 400/KONFEK	2288972	1
	14	4.5 m	FLK 14/EZ-DR/ 450/KONFEK	2290847	1
	14	5 m	FLK 14/EZ-DR/ 500/KONFEK	2290834	1
	14	5.5 m	FLK 14/EZ-DR/ 550/KONFEK	2290850	1
	14	6 m	FLK 14/EZ-DR/ 600/KONFEK	2290863	1
	14	7 m			
	14	8 m	FLK 14/EZ-DR/ 800/KONFEK	2299563	1
	14	10 m	FLK 14/EZ-DR/1000/KONFEK	2299576	1
Assembled round cables²⁾ , with two 50-pole socket strips in fixed lengths, for transfer of 32 channels among other things					
	50	0.5 m	FLK 50/EZ-DR/ 50/KONFEK	2289065	5
	50	1 m	FLK 50/EZ-DR/ 100/KONFEK	2289078	1
	50	1.5 m	FLK 50/EZ-DR/ 150/KONFEK	2289081	1
	50	2 m	FLK 50/EZ-DR/ 200/KONFEK	2289094	1
	50	2.5 m	FLK 50/EZ-DR/ 250/KONFEK	2289104	1
	50	3 m	FLK 50/EZ-DR/ 300/KONFEK	2289117	1
	50	3.5 m	FLK 50/EZ-DR/ 350/KONFEK	2289120	1
	50	4 m	FLK 50/EZ-DR/ 400/KONFEK	2289133	1
	50	4.5 m	FLK 50/EZ-DR/ 450/KONFEK	2289573	1
	50	5 m	FLK 50/EZ-DR/ 500/KONFEK	2289586	1
	50	5.5 m	FLK 50/EZ-DR/ 550/KONFEK	2289599	1
	50	6 m	FLK 50/EZ-DR/ 600/KONFEK	2289609	1
	50	6.5 m	FLK 50/EZ-DR/ 650/KONFEK	2289612	1
	50	7 m	FLK 50/EZ-DR/ 700/KONFEK	2289625	1
	50	7.5 m	FLK 50/EZ-DR/ 750/KONFEK	2289638	1
	50	8 m	FLK 50/EZ-DR/ 800/KONFEK	2289641	1
	50	8.5 m	FLK 50/EZ-DR/ 850/KONFEK	2289654	1
	50	9 m	FLK 50/EZ-DR/ 900/KONFEK	2289667	1
	50	9.5 m	FLK 50/EZ-DR/ 950/KONFEK	2289670	1
	50	10 m	FLK 50/EZ-DR/1000/KONFEK	2289683	1



Shielded



**Halogen-free
(only the cable)**



Applied for: UL / CUL

Technical data

< 50 V AC / 60 V DC
1 A
0.16 Ω/m
-20°C ... 50°C
Tinned copper-braided shield, approx. 85% covering

Insulation displacement, IEC 60352-4 / DIN EN 60352-4

AWG 26 / 0.14 mm²
7 / Cu tin-plated

6.7 mm
11 mm

Ordering data

Type	Order No.	Pcs. / Pkt.
FLK 14/EZ-DR/ 50/KONFEK/S	2296977	1
FLK 14/EZ-DR/ 100/KONFEK/S	2296980	1
FLK 14/EZ-DR/ 150/KONFEK/S	2296993	1
FLK 14/EZ-DR/ 200/KONFEK/S	2297002	1
FLK 14/EZ-DR/ 300/KONFEK/S	2299013	1
FLK 14/EZ-DR/ 400/KONFEK/S	2299026	1
FLK 14/EZ-DR/ 600/KONFEK/S	2299039	1
FLK 14/EZ-DR/ 800/KONFEK/S	2299042	1
FLK 14/EZ-DR/1000/KONFEK/S	2299055	1
FLK 50/EZ-DR/ 50/KONFEK/S	2299097	1
FLK 50/EZ-DR/ 100/KONFEK/S	2299107	1
FLK 50/EZ-DR/ 150/KONFEK/S	2299110	1
FLK 50/EZ-DR/ 200/KONFEK/S	2299123	1
FLK 50/EZ-DR/ 300/KONFEK/S	2299136	1
FLK 50/EZ-DR/ 400/KONFEK/S	2299149	1
FLK 50/EZ-DR/ 600/KONFEK/S	2299152	1
FLK 50/EZ-DR/ 800/KONFEK/S	2299165	1
FLK 50/EZ-DR/1000/KONFEK/S	2299178	1

Technical data

< 50 V AC / 60 V DC
1 A
0.16 Ω/m
-20°C ... 50°C
-

Insulation displacement, IEC 60352-4 / DIN EN 60352-4

AWG 26 / 0.14 mm²
7 / Cu tin-plated

6.4 mm
10.3 mm

Ordering data

Type	Order No.	Pcs. / Pkt.
FLK 14/EZ-DR/HF/ 50/KONFEK	2305952	1
FLK 14/EZ-DR/HF/ 100/KONFEK	2305965	1
FLK 14/EZ-DR/HF/ 150/KONFEK	2305978	1
FLK 14/EZ-DR/HF/ 200/KONFEK	2305981	1
FLK 14/EZ-DR/HF/ 250/KONFEK	2305994	1
FLK 14/EZ-DR/HF/ 300/KONFEK	2304759	1
FLK 14/EZ-DR/HF/ 400/KONFEK	2304762	1
FLK 14/EZ-DR/HF/ 500/KONFEK	2304717	1
FLK 14/EZ-DR/HF/ 600/KONFEK	2306003	1
FLK 14/EZ-DR/HF/ 700/KONFEK	2314011	1
FLK 14/EZ-DR/HF/ 800/KONFEK	2314024	1
FLK 14/EZ-DR/HF/1000/KONFEK	2314037	1
CABLE-FLK50/0,14/HF/ 0,5M	2314134	1
CABLE-FLK50/0,14/HF/ 1,0M	2314147	1
CABLE-FLK50/0,14/HF/ 1,5M	2314150	1
CABLE-FLK50/0,14/HF/ 2,0M	2314163	1
CABLE-FLK50/0,14/HF/ 2,5M	2314176	1
CABLE-FLK50/0,14/HF/ 3,0M	2314189	1
CABLE-FLK50/0,14/HF/ 4,0M	2314192	1
CABLE-FLK50/0,14/HF/ 5,0M	2314202	1
CABLE-FLK50/0,14/HF/ 6,0M	2314215	1
CABLE-FLK50/0,14/HF/ 7,0M	2314228	1
CABLE-FLK50/0,14/HF/ 8,0M	2314231	1
CABLE-FLK50/0,14/HF/10,0M	2314244	1

Color code of the system cables

No. of cores	PIN	Core color
	1	black
	2	brown
	3	red
	4	orange
	5	yellow
	6	green
	7	blue
	8	violet
	9	gray
10-pos.	10	white
	11	white-black
	12	white-brown
	13	white-red
14-pos.	14	white-orange
	15	white-yellow
16-pos.	16	white-green
	17	white-blue
	18	white-violet
	19	white-gray
20-pos.	20	brown-black
	21	brown-red
	22	brown-orange
	23	brown-yellow
	24	brown-green
	25	brown-blue
26-pos.	26	brown-violet
	27	brown-gray
	28	brown-white
	29	green-black
	30	green-brown
	31	green-red
	32	green-orange
	33	green-blue
34-pos.	34	green-violet
	35	green-gray
	36	green-white
	37	yellow-black
	38	yellow-brown
	39	yellow-red
40-pos.	40	yellow-orange
	41	yellow-blue
	42	yellow-violet
	43	yellow-gray
	44	yellow-white
	45	gray-black
	46	gray-brown
	39	gray-red
	48	gray-orange
	49	gray-yellow
50-pos.	50	gray-green

1) straight socket strips fitted at both ends.

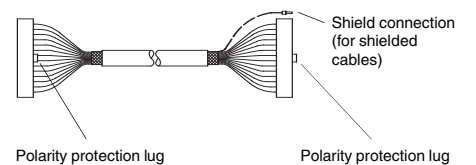

2) Socket strips fitted, straight at one end and angled at the other.

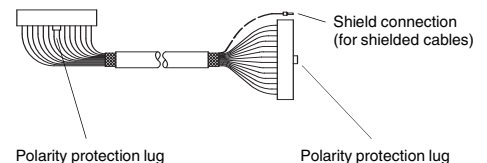

INTERFACE Cabling

VARIOFACE system cabling

System cable with flat-ribbon cable connector

Standard lengths

Pre-assembled round cables to couple the VARIOFACE interface modules.

Connector strips are fitted on both sides of the cables in accordance with IEC 60603-13/DIN 41651 (1:1 connection).

Special lengths are defined using an order key, refer to page 288.

Notes:	
Outside diameter of the cable	
10-pole:	6 mm
16-pole:	6.5 mm
20-pole:	7.6 mm
26-pole:	7.8 mm
34-pole:	10 mm



Not shielded



Applied for: UL / CUL

Technical data

Max. perm. operating voltage
Max. perm. current carrying capacitance per path
Max. conductor resistance
Ambient temperature (operation)
Assembly

< 50 V AC / 60 V DC
1 A
0.16 Ω/m
-20°C ... 50°C
Insulation displacement, IEC 60352-4 / DIN EN 60352-4

Conductor cross section
Conductor structure: stranded wires / material

AWG 26 / 0.14 mm²
7 / Cu tin-plated

Ordering data

Description	No. of poles	Cable length	Type	Order No.	Pcs. / Pkt.
Round cable¹⁾ , with two socket strips	10	0.5 m	FLK 10/EZ-DR/ 50/KONFEK	2299204	1
	10	1 m	FLK 10/EZ-DR/ 100/KONFEK	2299217	1
	10	1.5 m	FLK 10/EZ-DR/ 150/KONFEK	2299220	1
	10	2 m	FLK 10/EZ-DR/ 200/KONFEK	2299233	1
	10	3 m	FLK 10/EZ-DR/ 300/KONFEK	2299246	1
	10	4 m	FLK 10/EZ-DR/ 400/KONFEK	2299259	1
	10	6 m	FLK 10/EZ-DR/ 600/KONFEK	2299262	1
	10	8 m	FLK 10/EZ-DR/ 800/KONFEK	2299275	1
	10	10 m	FLK 10/EZ-DR/1000/KONFEK	2299288	1
	Round cable¹⁾ , with two socket strips	16	0.5 m	FLK 16/EZ-DR/ 50/KONFEK	2299291
16		1 m	FLK 16/EZ-DR/ 100/KONFEK	2299301	1
16		1.5 m	FLK 16/EZ-DR/ 150/KONFEK	2299314	1
16		2 m	FLK 16/EZ-DR/ 200/KONFEK	2299327	1
16		3 m	FLK 16/EZ-DR/ 300/KONFEK	2299330	1
16		4 m	FLK 16/EZ-DR/ 400/KONFEK	2299343	1
16		6 m	FLK 16/EZ-DR/ 600/KONFEK	2299356	1
16		8 m	FLK 16/EZ-DR/ 800/KONFEK	2299369	1
16		10 m	FLK 16/EZ-DR/1000/KONFEK	2299372	1
Round cable¹⁾ , with two socket strips		20	0.5 m	FLK 20/EZ-DR/ 50KONFEK	2296391
	20	1 m	FLK 20/EZ-DR/ 100KONFEK	2296401	1
	20	1.5 m	FLK 20/EZ-DR/ 150KONFEK	2296472	1
	20	2 m	FLK 20/EZ-DR/ 200KONFEK	2296485	1
	20	3 m	FLK 20/EZ-DR/ 300KONFEK	2296498	1
	20	4 m	FLK 20/EZ-DR/ 400KONFEK	2296508	1
	20	6 m	FLK 20/EZ-DR/ 600KONFEK	2296511	1
	20	8 m	FLK 20/EZ-DR/ 800KONFEK	2296524	1
	20	10 m	FLK 20/EZ-DR/1000KONFEK	2296537	1
	Round cable¹⁾ , with two socket strips	26	0.5 m	FLK 26/EZ-DR/ 50/KONFEK	2299385
26		1 m	FLK 26/EZ-DR/ 100/KONFEK	2299398	1
26		1.5 m	FLK 26/EZ-DR/ 150/KONFEK	2299408	1
26		2 m	FLK 26/EZ-DR/ 200/KONFEK	2299411	1
26		3 m	FLK 26/EZ-DR/ 300/KONFEK	2299424	1
26		4 m	FLK 26/EZ-DR/ 400/KONFEK	2299437	1
26		6 m	FLK 26/EZ-DR/ 600/KONFEK	2299440	1
26		8 m	FLK 26/EZ-DR/ 800/KONFEK	2299453	1
26		10 m	FLK 26/EZ-DR/1000/KONFEK	2299466	1
Round cable¹⁾ , with two socket strips		34	0.5 m	FLK 34/EZ-DR/ 50/KONFEK	2299479
	34	1 m	FLK 34/EZ-DR/ 100/KONFEK	2299482	1
	34	1.5 m	FLK 34/EZ-DR/ 150/KONFEK	2299495	1
	34	2 m	FLK 34/EZ-DR/ 200/KONFEK	2299505	1
	34	3 m	FLK 34/EZ-DR/ 300/KONFEK	2299518	1
	34	4 m	FLK 34/EZ-DR/ 400/KONFEK	2299521	1
	34	6 m	FLK 34/EZ-DR/ 600/KONFEK	2299534	1
	34	8 m	FLK 34/EZ-DR/ 800/KONFEK	2299547	1
	34	10 m	FLK 34/EZ-DR/1000/KONFEK	2299550	1

System cable with flat-ribbon cable connector

Standard lengths

Round cable sets are used to connect the PLC front adapters to the corresponding VARIOFACE controller boards.

Connector strips are fitted on both sides of the cables in accordance with IEC 60603-13/DIN 41651 (1:1 connection).

Special lengths are defined using an order key, refer to page 288.



Not shielded



Technical data

Max. perm. operating voltage	< 50 V AC / 60 V DC
Max. perm. current carrying capacitance per path	1 A
Max. conductor resistance	0.16 Ω/m
Ambient temperature (operation)	-20°C ... 50°C
Assembly	Insulation displacement, IEC 60352-4 / DIN EN 60352-4
Conductor cross section	AWG 26 / 0.14 mm ²
Conductor structure: stranded wires / material	7 / Cu tin-plated
Outside diameter	9.9 mm

40-pole

Ordering data

Description	No. of poles	Cable length	Type	Order No.	Pcs. / Pkt.
Round cable²⁾, with two socket strips					
	40	0.5 m	FLK 40/EZ-DR/ 50/KONFEK	2288985	5
	40	1 m	FLK 40/EZ-DR/ 100/KONFEK	2288998	1
	40	1.5 m	FLK 40/EZ-DR/ 150/KONFEK	2289007	1
	40	2 m	FLK 40/EZ-DR/ 200/KONFEK	2289010	1
	40	2.5 m	FLK 40/EZ-DR/ 250/KONFEK	2289023	1
	40	3 m	FLK 40/EZ-DR/ 300/KONFEK	2289036	1
	40	3.5 m	FLK 40/EZ-DR/ 350/KONFEK	2289049	1
	40	4 m	FLK 40/EZ-DR/ 400/KONFEK	2289052	1
	40	6 m	FLK 40/EZ-DR/ 600/KONFEK	2299589	1
	40	8 m	FLK 40/EZ-DR/ 800/KONFEK	2299592	1
	40	10 m	FLK 40/EZ-DR/1000/KONFEK	2299602	1

1) Straight socket strips fitted at both ends.

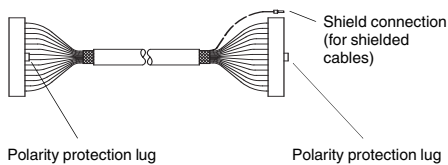

2) Socket strips fitted, straight at one end and angled at the other.

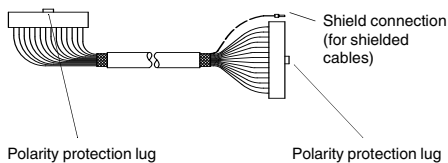

INTERFACE Cabling

VARIOFACE system cabling

System cable with flat-ribbon cable connector

The FLK 50... types are plugged onto the VARIOFACE front adapters for 32 channels and make it possible to split the channels into 4 x 8 channels. All 8-channel VARIOFACE modules and the PLC-V8 adapters for PLC-INTERFACE can therefore be connected.

In case of shielded cables, a cable end with a ferrule is additionally provided as a shield connection (length: approx. 0.5 m; cable H05V-K 1 mm², black).



Splitting cable unshielded
50 poles on 4 x 14



Splitting cable shielded
50 poles on 4 x 14



			Technical data			Technical data		
Max. perm. operating voltage			< 50 V AC / 60 V DC			< 50 V AC / 60 V DC		
Max. perm. current carrying capacitance per path			1 A			1 A		
Max. conductor resistance			0.16 Ω/m			0.16 Ω/m		
Ambient temperature (operation)			-20°C ... 50°C			-20°C ... 50°C		
Shield			-			Tinned copper-braided shield, approx. 85% covering		
Assembly			Insulation displacement, IEC 60352-4 / DIN EN 60352-4			Insulation displacement, IEC 60352-4 / DIN EN 60352-4		
Conductor cross section			AWG 26 / 0.14 mm ²			AWG 26 / 0.14 mm ²		
Conductor structure: stranded wires / material			7 / Cu tin-plated			7 / Cu tin-plated		
Number of connectors on the module side			4			4		
Outside diameter			6.3 mm			6.3 mm		
	50-pole							
			Ordering data			Ordering data		
Description	No. of poles	Cable length	Type	Order No.	Pcs. / Pkt.	Type	Order No.	Pcs. / Pkt.
Round cable sets , for connection to the VARIOFACE system cabling, with a 50-pole female connector and four 14-pole female connectors, for splitting max. 32 channels into 4 x 8 channels.								
	50	0.5 m	FLK 50/4X14/EZ-DR/ 50/KONFEK	2296689	1			
	50	1 m	FLK 50/4X14/EZ-DR/ 100/KONFEK	2296692	1			
	50	1.5 m	FLK 50/4X14/EZ-DR/ 150/KONFEK	2296702	1			
	50	2 m	FLK 50/4X14/EZ-DR/ 200/KONFEK	2296715	1			
	50	2.5 m	FLK 50/4X14/EZ-DR/ 250/KONFEK	2305402	1			
	50	3 m	FLK 50/4X14/EZ-DR/ 300/KONFEK	2296728	1			
	50	4 m	FLK 50/4X14/EZ-DR/ 400/KONFEK	2296731	1			
	50	6 m	FLK 50/4X14/EZ-DR/ 600/KONFEK	2296744	1			
	50	8 m	FLK 50/4X14/EZ-DR/ 800/KONFEK	2296757	1			
	50	10 m	FLK 50/4X14/EZ-DR/1000/KONFEK	2296773	1			
Assembled round cables , same as before, however in variable lengths	50		FLK50-4X14-EZ-DR ...	2302405	1			
Assembled round cables , same as before, however shielded and in variable lengths	50					FLK50-4X14-EZ-DR-S ...	2302447	1

Ordering example for system cable:

- Unshielded splitting cable 12.75 m long

Quantity	Order No.	Length [m] ¹⁾
1	2302405	12.75

¹⁾ min. 0.30 m

- Shielded splitting cable 11.00 m long

Quantity	Order No.	Length [m] ¹⁾
1	2302447	11.00

¹⁾ min. 0.30 m

INTERFACE Cabling

VARIOFACE system cabling

System cable with flat-ribbon cable connector

Special lengths

Pre-assembled **round cables** are used to connect the PLC front adapters to the corresponding VARIOFACE termination boards. Connector strips are fitted on both ends of the cables in accordance with IEC 60603-13/DIN 41651. In case of shielded cables, a cable end with a ferrule is additionally provided as a shield connection (length: Approx. 0.5 m; cable H05V-K 1 mm², black).

The order key for special lengths is defined by three features.

The features in the appropriate sequence are:

- Cable type
- Assembly,
- Length in meters.

There are two order keys, one for the non-shielded round cable FLK EZ-DR/.../.../... and one for the shielded round cable FLK EZ-DR-S/.../.../... The features necessary for clear identification of an order are described below:

Cable type

- The number of individual conductors of the cable is defined here.

Assembly

- None, the cable is not assembled at either end;
- socket strip at both ends, 10-pos., the cable is fitted at both ends with 10-pos. connectors (1:1 connection);
- socket strip at both ends, 14-pos., the cable is fitted at both ends with

14-pos. connectors (1:1 connection);

- socket strip at both ends, 50-pos., the cable is fitted at both ends with 50-pos. connectors (1:1 connection);
- socket strip at one end, 14-pos., socket strip at one end, 16-pos., the cable is fitted with a 14-pos. connector at one end and with a 16-pos. connector at the other (for SIMATIC S7; no 1:1 connection).

Features of permissible assemblies:

Cable type	Non-shielded round cables FLK EZ-DR-.../.../...								Shielded round cables FLK EZ-DR-S-.../.../...			
	10-pos.	14-pos.	16-pos.	20-pos.	26-pos.	34-pos.	40-pos.	50-pos.	14-pos.	16-pos.	40-pos.	50-pos.
no assembly	10U/C00/...	14U/C00/...	16U/C00/...	20U/C00/...	26U/C00/...	34U/C00/...	40U/C00/...	50U/C00/...	14S/C00/...	16S/C00/...	40S/C00/...	50S/C00/...
socket strip at both ends, 10-pos.	10U/C55/... ¹⁾											
socket strip at both ends, 14-pos.		14U/C23/... ¹⁾							14S/C23/... ¹⁾			
socket strip at both ends, 16-pos.			16U/C58/... ¹⁾							16S/C58/... ¹⁾		
socket strip at both ends, 20-pos.				20U/C61/... ¹⁾								
socket strip at both ends, 26-pos.					26U/C63/... ¹⁾							
socket strip at both ends, 34-pos.						34U/C65/... ¹⁾						
socket strip at both ends, 40-pos.							40U/C30/... ³⁾				40S/C30/... ³⁾	
socket strip at both ends, 50-pos.								50U/C38/... ²⁾				50S/C38/... ²⁾
socket strip at one end, 14-pos.; socket strip at one end, 16-pos.		14U/C52/... ¹⁾							14S/C52/... ¹⁾			

¹⁾ straight socket strips fitted at both ends.

²⁾ Socket strips fitted, straight at one end and angled at the other.

³⁾ Socket strips fitted, straight at one end and angled at the other.

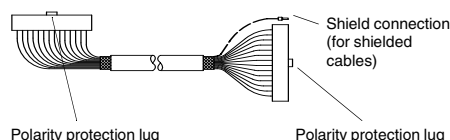
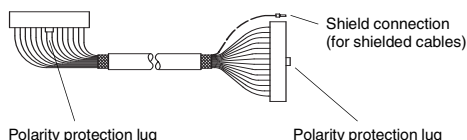
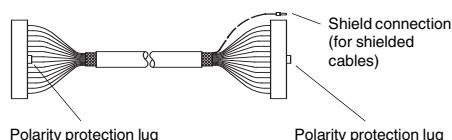

Sample order for round cable unshielded:

- Unshielded 50-position round cable sets with two 50-pos. socket strips and a length of 11.5 m

Quantity	Order No.	Cable type	Assembly	Length [m] ⁴⁾
1	2295059	50U 10U ≙ 10-pos. unshielded 14U ≙ 14-pos. unshielded 16U ≙ 16-pos. unshielded 20U ≙ 20-pos. unshielded 26U ≙ 26-pos. unshielded 34U ≙ 34-pos. unshielded 40U ≙ 40-pos. unshielded 50U ≙ 50-pos. unshielded	C38 C00 ≙ no assembly C55 ≙ 10-pos. socket strip at both ends C23 ≙ 14-pos. socket strip at both ends C52 ≙ 14-pos. socket strip at one end 16-pos. socket strip at one end (for S7) C58 ≙ 16-pos. socket strip at both ends C61 ≙ 20-pos. socket strip at both ends C63 ≙ 26-pos. socket strip at both ends C65 ≙ 34-pos. socket strip at both ends C30 ≙ 40-pos. socket strip at both ends C38 ≙ 50-pos. socket strip at both ends	11.50 ⁴⁾ min. 0.20 m

Sample orders for round cable shielded:

- Shielded 14-position round cable sets with two 14-pos. socket strips and a length of 12.75 m

Quantity	Order No.	Cable type	Assembly	Length [m] ⁴⁾
1	2295046	14S 14S ≙ 14-pos. shielded 16S ≙ 16-pos. shielded 40S ≙ 40-pos. shielded 50S ≙ 50-pos. shielded	C23 C00 ≙ no assembly C23 ≙ 14-pos. socket strip at both ends C52 ≙ 14-pos. socket strip at one end 16-pos. socket strip at one end (for S7) C58 ≙ 16-pos. socket strip at both ends C30 ≙ 40-pos. socket strip at both ends C38 ≙ 50-pos. socket strip at both ends	12.75 ⁴⁾ min. 0.20 m



Not shielded



Shielded



Max. perm. operating voltage
 Max. perm. current carrying capacitance per path
 Max. conductor resistance
 Ambient temperature (operation)
 Shield

< 50 V AC / 60 V DC
 1 A
 0.16 Ω/m
 -20°C ... 50°C
 -

Conductor cross section
 Conductor structure: stranded wires / material

AWG 26 / 0.14 mm²
 7 / Cu tin-plated

Technical data

< 50 V AC / 60 V DC
 1 A
 0.16 Ω/m
 -20°C ... 50°C
 Tinned copper-braided shield, approx. 85% covering

AWG 26 / 0.14 mm²
 7 / Cu tin-plated

Ordering data

Description	No. of poles	Cable length
Assembled round cables, with socket strips in variable lengths		

Type	Order No.	Pcs. / Pkt.
FLK EZ-DR.../.../...	2295059	1

Ordering data

Type	Order No.	Pcs. / Pkt.
FLK EZ-DR-S.../.../...	2295046	1

INTERFACE Cabling

VARIOFACE system cabling

System cable with D-SUB socket and pin strip

Standard lengths

Shielded round cable sets to connect the control level with the corresponding VARIOFACE interface modules.

Assembly with D-SUB strips as per IEC 60807-2/DIN 41652, (1:1 connection).

- D-SUB socket strip on one side and D-SUB pin strip on the other
- D-SUB socket strips on both sides
- D-SUB pin strips on both sides
- Cable exit: Straight
- Screw connection: 2 UNC 4-40 screws

Special lengths and assembly versions are defined using an order key, refer to page 292.



Socket at one end and pin strip at the other



Technical data

Max. perm. operating voltage	125 V AC/DC
Max. perm. current carrying capacitance per path	2 A
Max. conductor resistance	0.09 Ω/m
Ambient temperature (operation)	-20°C ... 50°C
Shield	Tinned copper-braided shield, approx. 85% covering
Insertion/withdrawal cycles	> 200
Conductor cross section	AWG 24 / 0.25 mm ²
Outside diameter	
	9-pole 7.5 mm
	15-pole 9 mm
	25-pole 10.5 mm
	37-pole 12.5 mm
	50-pole 13.5 mm

Ordering data

Description	No. of poles	Cable length	Type	Order No.	Pcs. / Pkt.
Shielded round cable, fitted with two D-SUB strips, various numbers of poles and lengths					
	9	0.5 m	CABLE-D 9SUB/B/S/ 50/KONFEK/S	2299987	1
	9	1 m	CABLE-D 9SUB/B/S/100/KONFEK/S	2299990	1
	9	1.5 m	CABLE-D 9SUB/B/S/150/KONFEK/S	2300009	1
	9	2 m	CABLE-D 9SUB/B/S/200/KONFEK/S	2302010	1
	9	3 m	CABLE-D 9SUB/B/S/300/KONFEK/S	2302023	1
	9	4 m	CABLE-D 9SUB/B/S/400/KONFEK/S	2302036	1
	9	6 m	CABLE-D 9SUB/B/S/600/KONFEK/S	2302049	1
	15	0.5 m	CABLE-D15SUB/B/S/ 50/KONFEK/S	2302052	1
	15	1 m	CABLE-D15SUB/B/S/100/KONFEK/S	2302065	1
	15	1.5 m	CABLE-D15SUB/B/S/150/KONFEK/S	2302078	1
	15	2 m	CABLE-D15SUB/B/S/200/KONFEK/S	2302081	1
	15	3 m	CABLE-D15SUB/B/S/300/KONFEK/S	2302094	1
	15	4 m	CABLE-D15SUB/B/S/400/KONFEK/S	2302104	1
	15	6 m	CABLE-D15SUB/B/S/600/KONFEK/S	2302117	1
	25	0.5 m	CABLE-D25SUB/B/S/ 50/KONFEK/S	2302120	1
	25	1 m	CABLE-D25SUB/B/S/100/KONFEK/S	2302133	1
	25	1.5 m	CABLE-D25SUB/B/S/150/KONFEK/S	2302146	1
	25	2 m	CABLE-D25SUB/B/S/200/KONFEK/S	2302159	1
	25	3 m	CABLE-D25SUB/B/S/300/KONFEK/S	2302162	1
	25	4 m	CABLE-D25SUB/B/S/400/KONFEK/S	2302175	1
	25	6 m	CABLE-D25SUB/B/S/600/KONFEK/S	2302188	1
	37	0.5 m	CABLE-D37SUB/B/S/ 50/KONFEK/S	2302191	1
	37	1 m	CABLE-D37SUB/B/S/100/KONFEK/S	2302201	1
	37	1.5 m	CABLE-D37SUB/B/S/150/KONFEK/S	2302214	1
	37	2 m	CABLE-D37SUB/B/S/200/KONFEK/S	2302227	1
	37	3 m	CABLE-D37SUB/B/S/300/KONFEK/S	2302230	1
	37	4 m	CABLE-D37SUB/B/S/400/KONFEK/S	2302243	1
	37	6 m	CABLE-D37SUB/B/S/600/KONFEK/S	2302256	1
	37	8 m			
	37	10 m			
	37	15 m			
	37	20 m			
	50	0.5 m	CABLE-D50SUB/B/S/ 50/KONFEK/S	2302269	1
	50	1 m	CABLE-D50SUB/B/S/100/KONFEK/S	2302272	1
	50	1.5 m	CABLE-D50SUB/B/S/150/KONFEK/S	2302285	1
	50	2 m	CABLE-D50SUB/B/S/200/KONFEK/S	2302298	1
	50	3 m	CABLE-D50SUB/B/S/300/KONFEK/S	2302308	1
	50	4 m	CABLE-D50SUB/B/S/400/KONFEK/S	2302311	1
	50	6 m	CABLE-D50SUB/B/S/600/KONFEK/S	2302324	1

INTERFACE Cabling

VARIOFACE system cabling



Socket strip at both ends



Male connector at both ends



Technical data

125 V AC/DC
2 A
0.09 Ω/m
-20°C ... 50°C
Tinned copper-braided shield, approx. 85% covering

> 200
AWG 24 / 0.25 mm²

7.5 mm
9 mm
10.5 mm
12 mm
13.5 mm



Technical data

125 V AC/DC
2 A
0.09 Ω/m
-20°C ... 50°C
Tinned copper-braided shield, approx. 85% covering

> 200
AWG 24 / 0.25 mm²

7.5 mm
9 mm
10.5 mm
12 mm
13.5 mm

Ordering data

Type	Order No.	Pcs. / Pkt.
CABLE-D 9SUB/B/B/100/KONFEK/S	2305415	1
CABLE-D 9SUB/B/B/200/KONFEK/S	2305428	1
CABLE-D 9SUB/B/B/300/KONFEK/S	2305431	1
CABLE-D15SUB/B/B/100/KONFEK/S	2305444	1
CABLE-D15SUB/B/B/200/KONFEK/S	2305457	1
CABLE-D15SUB/B/B/300/KONFEK/S	2305460	1
CABLE-D25SUB/B/B/100/KONFEK/S	2305473	1
CABLE-D25SUB/B/B/200/KONFEK/S	2305486	1
CABLE-D25SUB/B/B/300/KONFEK/S	2305499	1
CABLE-D37SUB/B/B/ 100/KONFEK/S	2305509	1
CABLE-D37SUB/B/B/ 200/KONFEK/S	2305512	1
CABLE-D37SUB/B/B/ 300/KONFEK/S	2305525	1
CABLE-D37SUB/B/B/ 400/KONFEK/S	2900759	1
CABLE-D37SUB/B/B/ 600/KONFEK/S	2900760	1
CABLE-D37SUB/B/B/ 800/KONFEK/S	2900761	1
CABLE-D37SUB/B/B/1000/KONFEK/S	2900762	1
CABLE-D37SUB/B/B/1500/KONFEK/S	2900763	1
CABLE-D37SUB/B/B/2000/KONFEK/S	2900764	1
CABLE-D50SUB/B/B/100/KONFEK/S	2305541	1
CABLE-D50SUB/B/B/200/KONFEK/S	2305554	1
CABLE-D50SUB/B/B/300/KONFEK/S	2305567	1

Ordering data

Type	Order No.	Pcs. / Pkt.
CABLE-D 9SUB/S/S/100/KONFEK/S	2305570	1
CABLE-D 9SUB/S/S/200/KONFEK/S	2305583	1
CABLE-D 9SUB/S/S/300/KONFEK/S	2305596	1
CABLE-D15SUB/S/S/100/KONFEK/S	2305606	1
CABLE-D15SUB/S/S/200/KONFEK/S	2305619	1
CABLE-D15SUB/S/S/300/KONFEK/S	2305622	1
CABLE-D25SUB/S/S/100/KONFEK/S	2305635	1
CABLE-D25SUB/S/S/200/KONFEK/S	2305648	1
CABLE-D25SUB/S/S/300/KONFEK/S	2305651	1
CABLE-D37SUB/S/S/100/KONFEK/S	2305664	1
CABLE-D37SUB/S/S/200/KONFEK/S	2305677	1
CABLE-D37SUB/S/S/300/KONFEK/S	2305680	1
CABLE-D50SUB/S/S/100/KONFEK/S	2305693	1
CABLE-D50SUB/S/S/200/KONFEK/S	2305703	1
CABLE-D50SUB/S/S/300/KONFEK/S	2305716	1

Color code of the system cables
CABLE-D...SUB/...

No. of cores	PIN	Core color
	1	white
	2	brown
	3	green
	4	yellow
	5	gray
	6	pink
	7	blue
	8	red
9-pos.	9	black
	10	violet
	11	gray-pink
	12	red-blue
	13	white-green
	14	brown-green
15-pos.	15	white-yellow
	16	yellow-brown
	17	white-gray
	18	gray-brown
	19	white-pink
	20	pink-brown
	21	white-blue
	22	brown-blue
	23	white-red
	24	brown-red
25-pos.	25	white-black
	26	brown-black
	27	gray-green
	28	yellow-gray
	29	pink-green
	30	yellow-pink
	31	green-blue
	32	yellow-blue
	33	green-red
	34	yellow-red
	35	green-black
37-pos.	36	yellow-black
	37	gray-blue
	38	pink-blue
	39	gray-red
	40	pink-red
	41	gray-black
	42	pink-black
	43	blue-black
	44	red-black
	45	white-brown-black
	46	yellow-green-black
	47	gray-pink-black
	48	blue-red-black
	49	white-green-black
50-pos.	50	green-brown-black

INTERFACE Cabling

VARIOFACE system cabling

System cable with D-SUB sockets and pin strip

Special lengths

Preassembled shielded **round cables** for connecting VARIOFACE termination boards. The cables are assembled with D-SUB strips in accordance with IEC 60807-2/DIN 41652.

The order key is defined by three features.

The features in the appropriate sequence are:

- Cable type
- Assembly
- Length in meters

There are three assembly variants of the shielded round cable:

- CABLE D-SUB-S/.../.../... D-SUB socket strip on one end and D-SUB pin strip on the other
- CABLE D-SUB-B-B-S/.../.../... D-SUB

- socket strip at both ends
 - CABLE D-SUB-S-S-S/.../.../... D-SUB pin strip at both ends
- The features necessary for clear identification of an order are described below:

Cable type

- The number of individual conductors of the cable is defined here.

Assembly

- (example for CABLE D-SUB-S/.../.../...)
- None, the cable is not assembled at either ends
- 9-pos. D-SUB socket strip at one end 9-pos. D-SUB pin strip at one end the cable connects (1:1) a 9-pos. D-SUB socket and pin strip

- 15-pos. D-SUB socket strip at one end 15-pos. D-SUB pin strip at one end the cable connects (1:1) a 15-pos. D-SUB socket and pin strip; or up to
- 50-pos. D-SUB socket strip at one end 50-pos. D-SUB pin strip at one end the cable connects (1:1) a 50-pos. D-SUB socket and pin strip.

Sample order for round cable set assembled with pin strip on one side and socket strip on one side

- unshielded 25-position round cable set, assembled with one 25-pos. D-SUB socket strip and one 25-pos. D-SUB pin strip, 11.5 mm long

Quantity	Order No.	Cable type	Assembly	Length [m] ¹⁾
1	2302340	25S 09S ≙ 9-pos. shielded 15S ≙ 15-pos. shielded 25S ≙ 25-pos. shielded 37S ≙ 37-pos. shielded 50S ≙ 50-pos. shielded	C36 C00 ≙ no assembly C01 ≙ 9-pos. D-SUB socket strip at one end 9-pos. D-SUB pin strip at one end C28 ≙ 15-pos. D-SUB socket strip at one end 15-pos. D-SUB pin strip at one end C36 ≙ 25-pos. D-SUB socket strip at one end 25-pos. D-SUB pin strip at one end C43 ≙ 37-pos. D-SUB socket strip at one end 37-pos. D-SUB pin strip at one end C49 ≙ 50-pos. D-SUB socket strip at one end 50-pos. D-SUB pin strip at one end	11.50 ¹⁾ min. 0.20 m

Sample order for round cable set assembled with socket strip at both ends

- Shielded 37-pos. round cable, assembled with two 37-pos. D-SUB socket strips, 12.75 m long

Quantity	Order No.	Cable type	Assembly	Length [m] ¹⁾
1	2302421	37S 09S ≙ 9-pos. shielded 15S ≙ 15-pos. shielded 25S ≙ 25-pos. shielded 37S ≙ 37-pos. shielded 50S ≙ 50-pos. shielded	C44 C00 ≙ no assembly C22 ≙ 9-pos. D-SUB socket strip at both ends C29 ≙ 15-pos. D-SUB socket strip at both ends C37 ≙ 25-pos. D-SUB socket strip at both ends C44 ≙ 37-pos. D-SUB socket strip at both ends C50 ≙ 50-pos. D-SUB socket strip at both ends	12.75 ¹⁾ min. 0.20 m

Sample order for round cable set assembled with pin strip at both ends

- Shielded 15-pos. round cable, assembled with two 15-pos. D-SUB pin strips, 8.5 m long

Quantity	Order No.	Cable type	Assembly	Length [m] ¹⁾
1	2302434	15S 09S ≙ 9-pos. shielded 15S ≙ 15-pos. shielded 25S ≙ 25-pos. shielded 37S ≙ 37-pos. shielded 50S ≙ 50-pos. shielded	C71 C00 ≙ no assembly C70 ≙ 9-pos. D-SUB pin strip at both ends C71 ≙ 15-pos. D-SUB pin strip at both ends C72 ≙ 25-pos. D-SUB pin strip at both ends C73 ≙ 37-pos. D-SUB pin strip at both ends C74 ≙ 50-pos. D-SUB pin strip at both ends	8.50 ¹⁾ min. 0.20 m



Shielded



Technical data

Max. perm. operating voltage	125 V AC/DC
Max. perm. current carrying capacitance per path	2 A
Max. conductor resistance	0.09 Ω/m
Ambient temperature (operation)	-20°C ... 50°C
Shield	Tinned copper-braided shield, approx. 85% covering
Insertion/withdrawal cycles	> 200
Conductor cross section	AWG 24 / 0.25 mm ²

Ordering data

Description	No. of poles	Cable length	Type	Order No.	Pcs. / Pkt.
Assembled round cables, in variable lengths, pin strip on one side and socket strip on one side			CABLE D-SUB-S/.../.../...	2302340	1
Assembled round cables, in variable lengths, socket strip on both sides			CABLE D-SUB-B-B-S/.../.../...	2302421	1
Assembled round cables, in variable lengths, pin strip on both sides			CABLE D-SUB-S-S-S/.../.../...	2302434	1

INTERFACE Cabling

VARIOFACE system cabling

System cable with D-SUB female connector or pin strip and one open end

- 1:1 connection
- D-SUB female connector or pin strip at one end
- Connector according to IEC 60807-2/DIN 41652
- Gland: 2 UNC 4-40 screws
- Open end at the other end
- Individual wire marking: 1, 2, 3, 4, etc.
- Individual wires fitted with ferrules
- Shield connection: H05V-K 1 mm² cable, black, 0.5 m in length



Female connector at one end and open end at the other



Pin strip at one end and open end at the other

	Technical data	Technical data
Max. perm. operating voltage	125 V AC/DC	125 V AC/DC
Max. perm. current carrying capacitance per path	2 A	2 A
Max. conductor resistance	0.09 Ω/m	0.09 Ω/m
Ambient temperature (operation)	-20°C ... 50°C	-20°C ... 50°C
Shield	Tinned copper-braided shield, approx. 85% covering	Tinned copper-braided shield, approx. 85% covering
Insertion/withdrawal cycles	> 200	> 200
Conductor cross section	AWG 24 / 0.25 mm ²	AWG 24 / 0.25 mm ²
Outside diameter		
	9-pole 7.5 mm	7.5 mm
	15-pole 9 mm	9 mm
	25-pole 10.5 mm	10.5 mm

			Ordering data			Ordering data		
Description	No. of poles	Cable length	Type	Order No.	Pcs. / Pkt.	Type	Order No.	Pcs. / Pkt.
Round cable with an open end	9	0.5 m	CABLE-D- 9SUB/F/OE/0,25/S/0,5M	2926014	1	CABLE-D- 9SUB/M/OE/0,25/S/0,5M	2926360	1
	9	1 m	CABLE-D- 9SUB/F/OE/0,25/S/1,0M	2926027	1	CABLE-D- 9SUB/M/OE/0,25/S/1,0M	2926373	1
	9	1.5 m	CABLE-D- 9SUB/F/OE/0,25/S/1,5M	2926030	1	CABLE-D- 9SUB/M/OE/0,25/S/1,5M	2926386	1
	9	2 m	CABLE-D- 9SUB/F/OE/0,25/S/2,0M	2926043	1	CABLE-D- 9SUB/M/OE/0,25/S/2,0M	2926399	1
	9	3 m	CABLE-D- 9SUB/F/OE/0,25/S/3,0M	2926056	1	CABLE-D- 9SUB/M/OE/0,25/S/3,0M	2926409	1
	9	4 m	CABLE-D- 9SUB/F/OE/0,25/S/4,0M	2926069	1	CABLE-D- 9SUB/M/OE/0,25/S/4,0M	2926412	1
	9	6 m	CABLE-D- 9SUB/F/OE/0,25/S/6,0M	2926072	1	CABLE-D- 9SUB/M/OE/0,25/S/6,0M	2926425	1
Round cable, same as before, however in variable lengths			CABLE-D- 9SUB-F-OE-0,25-S/...	2900903	1	CABLE-D- 9SUB-M-OE-0,25-S/...	2900909	1
Round cable with an open end	15	0.5 m	CABLE-D-15SUB/F/OE/0,25/S/0,5M	2926085	1	CABLE-D-15SUB/M/OE/0,25/S/0,5M	2926438	1
	15	1 m	CABLE-D-15SUB/F/OE/0,25/S/1,0M	2926098	1	CABLE-D-15SUB/M/OE/0,25/S/1,0M	2926441	1
	15	1.5 m	CABLE-D-15SUB/F/OE/0,25/S/1,5M	2926108	1	CABLE-D-15SUB/M/OE/0,25/S/1,5M	2926454	1
	15	2 m	CABLE-D-15SUB/F/OE/0,25/S/2,0M	2926111	1	CABLE-D-15SUB/M/OE/0,25/S/2,0M	2926467	1
	15	3 m	CABLE-D-15SUB/F/OE/0,25/S/3,0M	2926124	1	CABLE-D-15SUB/M/OE/0,25/S/3,0M	2926470	1
	15	4 m	CABLE-D-15SUB/F/OE/0,25/S/4,0M	2926137	1	CABLE-D-15SUB/M/OE/0,25/S/4,0M	2926483	1
	15	6 m	CABLE-D-15SUB/F/OE/0,25/S/6,0M	2926140	1	CABLE-D-15SUB/M/OE/0,25/S/6,0M	2926496	1
Round cable, same as before, however in variable lengths			CABLE-D-15SUB-F-OE-0,25-S/...	2900905	1	CABLE-D-15SUB-M-OE-0,25-S/...	2900910	1
Round cable with an open end	25	0.5 m	CABLE-D-25SUB/F/OE/0,25/S/0,5M	2926153	1	CABLE-D-25SUB/M/OE/0,25/S/0,5M	2926506	1
	25	1 m	CABLE-D-25SUB/F/OE/0,25/S/1,0M	2926166	1	CABLE-D-25SUB/M/OE/0,25/S/1,0M	2926519	1
	25	1.5 m	CABLE-D-25SUB/F/OE/0,25/S/1,5M	2926179	1	CABLE-D-25SUB/M/OE/0,25/S/1,5M	2926522	1
	25	2 m	CABLE-D-25SUB/F/OE/0,25/S/2,0M	2926182	1	CABLE-D-25SUB/M/OE/0,25/S/2,0M	2926535	1
	25	3 m	CABLE-D-25SUB/F/OE/0,25/S/3,0M	2926195	1	CABLE-D-25SUB/M/OE/0,25/S/3,0M	2926548	1
	25	4 m	CABLE-D-25SUB/F/OE/0,25/S/4,0M	2926205	1	CABLE-D-25SUB/M/OE/0,25/S/4,0M	2926551	1
	25	6 m	CABLE-D-25SUB/F/OE/0,25/S/6,0M	2926218	1	CABLE-D-25SUB/M/OE/0,25/S/6,0M	2926564	1
Round cable, same as before, however in variable lengths			CABLE-D-25SUB-F-OE-0,25-S/...	2900906	1	CABLE-D-25SUB-M-OE-0,25-S/...	2900911	1

Special lengths of D-SUB cable with open ends can be configured using separate order numbers.

Ordering example:

One system cable assembled with a 37-pole D-SUB female connector and one open end, 12.75 m in length:

1 pcs. 2900907/12,75



Female connector at one end and open end at the other end



Pin strip at one end and open end at the other end

			Technical data			Technical data		
Max. perm. operating voltage			125 V AC/DC			125 V AC/DC		
Max. perm. current carrying capacitance per path			2 A			2 A		
Max. conductor resistance			0.09 Ω/m			0.09 Ω/m		
Ambient temperature (operation)			-20°C ... 50°C			-20°C ... 50°C		
Shield			Tinned copper-braided shield, approx. 85% covering			Tinned copper-braided shield, approx. 85% covering		
Insertion/withdrawal cycles			> 200			> 200		
Conductor cross section			AWG 24 / 0.25 mm ²			AWG 24 / 0.25 mm ²		
Outside diameter								
	37-pole	12 mm				12 mm		
	50-pole	13.5 mm				13.5 mm		
			Ordering data			Ordering data		
Description	No. of poles	Cable length	Type	Order No.	Pcs. / Pkt.	Type	Order No.	Pcs. / Pkt.
Round cable with an open end								
	37	0.5 m	CABLE-D-37SUB/F/OE/0,25/S/0,5M	2926221	1	CABLE-D-37SUB/M/OE/0,25/S/0,5M	2926577	1
	37	1 m	CABLE-D-37SUB/F/OE/0,25/S/1,0M	2926234	1	CABLE-D-37SUB/M/OE/0,25/S/1,0M	2926580	1
	37	1.5 m	CABLE-D-37SUB/F/OE/0,25/S/1,5M	2926247	1	CABLE-D-37SUB/M/OE/0,25/S/1,5M	2926593	1
	37	2 m	CABLE-D-37SUB/F/OE/0,25/S/2,0M	2926250	1	CABLE-D-37SUB/M/OE/0,25/S/2,0M	2926603	1
	37	3 m	CABLE-D-37SUB/F/OE/0,25/S/3,0M	2926263	1	CABLE-D-37SUB/M/OE/0,25/S/3,0M	2926616	1
	37	4 m	CABLE-D-37SUB/F/OE/0,25/S/4,0M	2926276	1	CABLE-D-37SUB/M/OE/0,25/S/4,0M	2926629	1
	37	6 m	CABLE-D-37SUB/F/OE/0,25/S/6,0M	2926289	1	CABLE-D-37SUB/M/OE/0,25/S/6,0M	2926632	1
Round cable, same as before, however in variable lengths			CABLE-D-37SUB-F-OE-0,25-S/...	2900907	1	CABLE-D-37SUB-M-OE-0,25-S/...	2900912	1
Round cable with an open end								
	50	0.5 m	CABLE-D-50SUB/F/OE/0,25/S/0,5M	2926292	1	CABLE-D-50SUB/M/OE/0,25/S/0,5M	2926645	1
	50	1 m	CABLE-D-50SUB/F/OE/0,25/S/1,0M	2926302	1	CABLE-D-50SUB/M/OE/0,25/S/1,0M	2926658	1
	50	1.5 m	CABLE-D-50SUB/F/OE/0,25/S/1,5M	2926315	1	CABLE-D-50SUB/M/OE/0,25/S/1,5M	2926661	1
	50	2 m	CABLE-D-50SUB/F/OE/0,25/S/2,0M	2926328	1	CABLE-D-50SUB/M/OE/0,25/S/2,0M	2926674	1
	50	3 m	CABLE-D-50SUB/F/OE/0,25/S/3,0M	2926331	1	CABLE-D-50SUB/M/OE/0,25/S/3,0M	2926687	1
	50	4 m	CABLE-D-50SUB/F/OE/0,25/S/4,0M	2926344	1	CABLE-D-50SUB/M/OE/0,25/S/4,0M	2926690	1
	50	6 m	CABLE-D-50SUB/F/OE/0,25/S/6,0M	2926357	1	CABLE-D-50SUB/M/OE/0,25/S/6,0M	2926700	1
Round cable, same as before, however in variable lengths			CABLE-D-50SUB-F-OE-0,25-S/...	2900908	1	CABLE-D-50SUB-M-OE-0,25-S/...	2900913	1

INTERFACE Cabling

VARIOFACE wiring interface

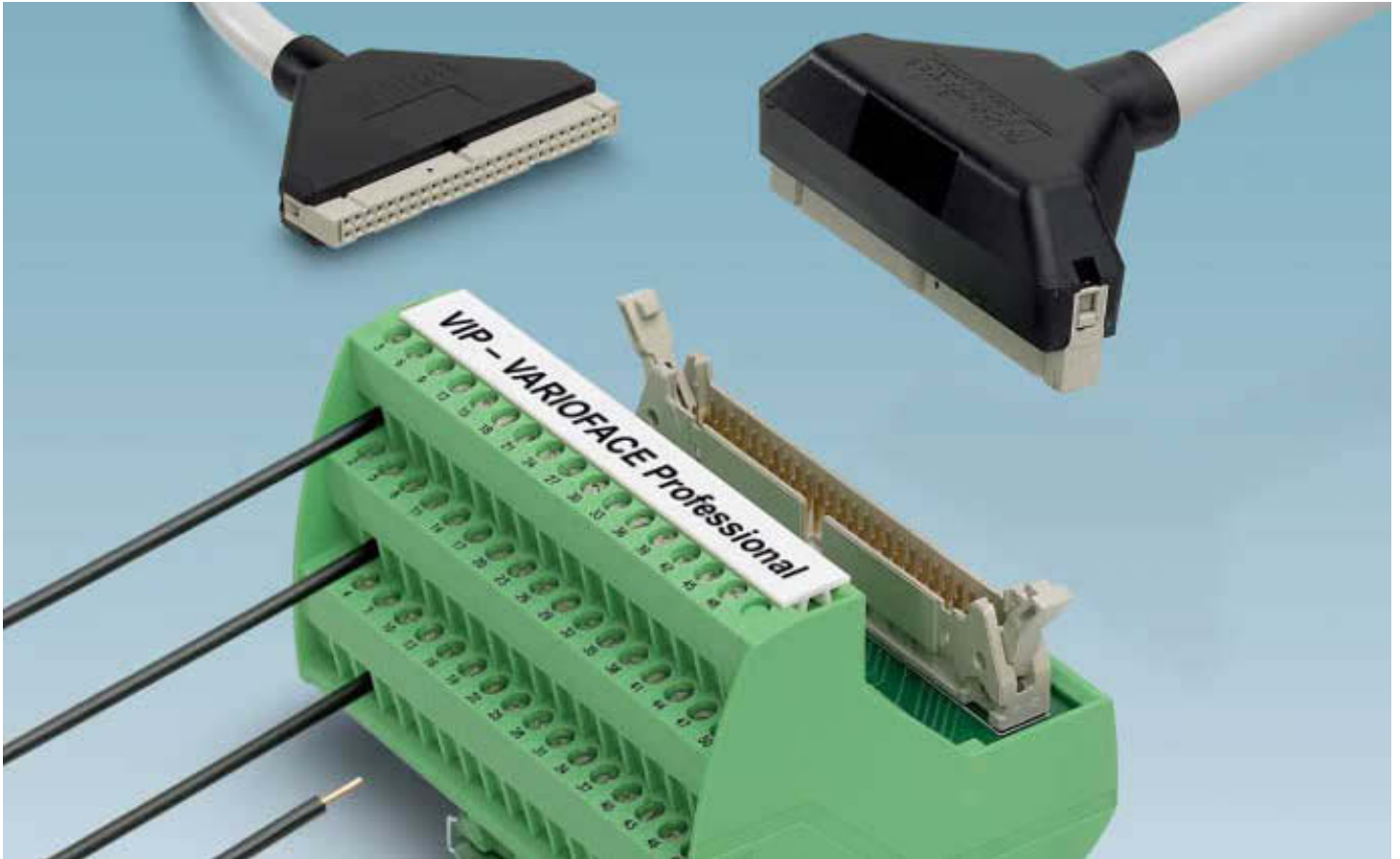

VIP – VARIOFACE Professional – Secure and reliable connections in even the tightest of spaces

Switch cabinet space is extremely valuable. That is why the I/Os of automation devices feature high-pole connectors. To enable the individual wires of the sensor/ actuator level to be connected to the automation interface in accordance with industry requirements, Phoenix Contact is now able to offer new interface modules and new system cables inside a professional and compact housing. Thanks to the enclosed system cables, the control and process levels can be connected securely and reliably within harsh industrial environments.

To allow all components to be supplied with power, potential distributors are available with the same housing design.

VARIOFACE Professional means:

New modules:

- Space-saving
- Vibration-resistant thanks to metal foot
- Optional labeling
- New housing design

New FLK system cables:

- Enclosed FLK connectors
- Professional strain relief
- Rugged design

VIP - VARIOFACE Professional interface modules

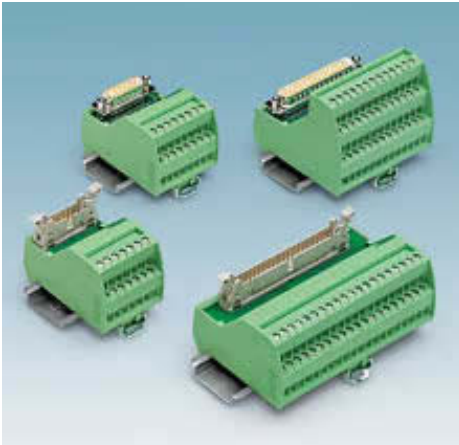

Interface modules with various connection methods and designs are available for the widely used FLK, D-SUB, and high-density D-SUB connectors. Modules with a status indicator can be selected for operation monitoring purposes.

Interface modules with ELCO or DIN connectors



Modules with ELCO connectors are available for tough environments or where increased safety requirements apply. Interface modules are also available for DIN strip types C, D, E, and F.

Relay/solid-state relay modules



The active modules are configured as a 4-channel, 8-channel or 16-channel interface. There is a choice of multi-channel modules for relays and signal/power optocouplers. This means that functions such as signal conditioning, electrical isolation, and power amplification can be supported.

System cables with enclosed FLK or D-SUB connectors



Ready-assembled FLK and D-SUB cables ensure a reliable connection between the automation equipment and the module. 1 A (FLK cable) and 2 A (D-SUB cable) currents can be transmitted on each signal path thanks to the large conductor cross sections.

VIP - VARIOFACE Professional potential distributors

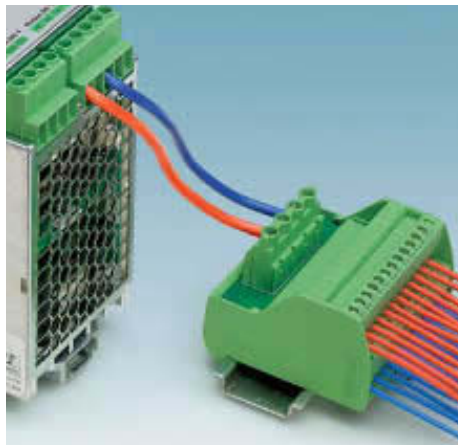









Designed for up to 250 V/30 V, the potential distributors are suitable for universal use – for both operating voltage and control voltage distribution. The screw or spring-cage connection method can be selected as required for the application concerned.

INTERFACE Cabling

VARIOFACE wiring interface

VIP - VARIOFACE Professional product overview

		Passive modules (connection method)				
		Flat-ribbon cable strip	D-SUB strip	DIN strip	ELCO strip	Potential distributor
Device series						
	Page	Page	Page	Page	Page	
VIP Line		300	306 313			322
Standard Line				314	318	
Slim Line		304	309			
Feed-through modules		305	310			
Cables		278	290			

COMBICON



Page

321

321

Device series

Standard Line



Accessories



Active modules (function)

Relays/solid-state relays



Page

324

Solid-state relays



Page

327

328

332

INTERFACE Cabling

VARIOFACE wiring interface

VIP – VARIOFACE Professional Modules with flat-ribbon cable connectors

- 1:1 connection
 - 10 to 64-pos.
 - Screw connection
 - Metal foot
 - As per IEC 60603-13
 - Optional with status indicator
- Low and high engagement latches are supplied with all modules.

Notes:

For marking systems and mounting material, see CLIPLINE catalog, part 2.



10 to 20 positions
with screw connection



Technical data

Operating voltage	60 V AC/DC
Max. perm. current (per branch)	1 A
Ambient temperature (operation)	-20°C ... 50°C
Mounting position	Any
Standards / regulations	IEC 60664, DIN EN 50178, IEC 62103
Connection data solid / stranded / AWG	0.2 - 4 mm ² / 0.2 - 2.5 mm ² / 24 - 12
Dimensions	65.5 mm / 56 mm

Ordering data

Description	No. of poles	Module width W	Type	Order No.	Pcs. / Pkt.
VARIOFACE module, with pin strip	10	34.70	VIP-2/SC/FLK10	2315010	1
	14	39.80	VIP-2/SC/FLK14	2315023	1
	16	45.00	VIP-2/SC/FLK16	2315036	1
	20	55.10	VIP-2/SC/FLK20	2315049	1
VARIOFACE module, with pin strip and light indicator	10	34.70			
	14	44.90			
	16	50.00			
	20	60.20			
VARIOFACE module, with pin strip	26	57.10			
	34	67.30			
	40	77.40			
	50	92.70			
	60	108.00			
	64	118.00			
VARIOFACE module, with pin strip and light indicator	26	57.40			
	34	67.60			
	40	77.80			
	50	93.10			
	60	113.50			
	64	118.60			

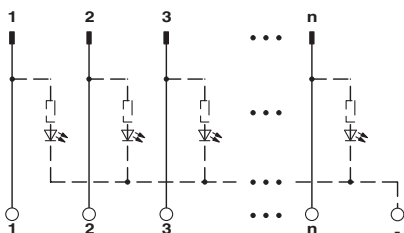



10 to 20 positions
with screw connection and light indicator



26 to 64 positions
with screw connection

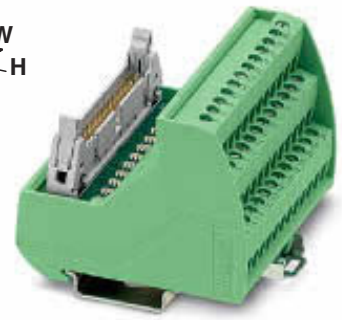

26 to 64 positions
with screw connection and light indicator



Technical data
24 V DC
1 A
-20°C ... 50°C
Any
IEC 60664, DIN EN 50178, IEC 62103
0.2 - 4 mm ² / 0.2 - 2.5 mm ² / 24 - 12
65.5 mm / 56 mm

Ordering data

Type	Order No.	Pcs. / Pkt.
VIP-2/SC/FLK10/LED	2322045	1
VIP-2/SC/FLK14/LED	2322058	1
VIP-2/SC/FLK16/LED	2322061	1
VIP-2/SC/FLK20/LED	2322074	1



Technical data
60 V AC/DC
1 A
-20°C ... 50°C
Any
IEC 60664, DIN EN 50178, IEC 62103
0.2 - 4 mm ² / 0.2 - 2.5 mm ² / 24 - 12
69 mm / 62 mm

Ordering data

Type	Order No.	Pcs. / Pkt.
VIP-3/SC/FLK26	2315052	1
VIP-3/SC/FLK34	2315065	1
VIP-3/SC/FLK40	2315078	1
VIP-3/SC/FLK50	2315081	1
VIP-3/SC/FLK60	2315094	1
VIP-3/SC/FLK64	2315104	1



Technical data
24 V DC
1 A
-20°C ... 50°C
Any
IEC 60664, DIN EN 50178, IEC 62103
0.2 - 4 mm ² / 0.2 - 2.5 mm ² / 24 - 12
69 mm / 62 mm

Ordering data

Type	Order No.	Pcs. / Pkt.
VIP-3/SC/FLK26/LED	2322087	1
VIP-3/SC/FLK34/LED	2322090	1
VIP-3/SC/FLK40/LED	2322100	1
VIP-3/SC/FLK50/LED	2322113	1
VIP-3/SC/FLK60/LED	2322126	1
VIP-3/SC/FLK64/LED	2322139	1

INTERFACE Cabling

VARIOFACE wiring interface

Modules with flat-ribbon cable connectors

The following VARIOFACE modules (1:1 connection) for flat-ribbon cable plug connectors (in accordance with IEC 60603-13/DIN 41651) are available with spring-cage connection:

- FLK modules with double-level terminal blocks with 10 to 64 positions
 - UM 45-FLK... modules with double-level terminal blocks with 10 to 64 positions
 - UM 45-FLKS... modules with double-level terminal blocks with 10 to 64 positions
- Low and high engagement latches are supplied with all modules.

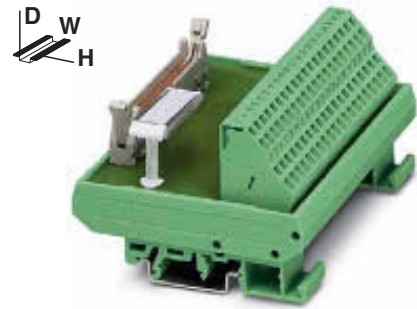

**10 to 64 positions
with spring-cage connection**

Operating voltage
Max. perm. current (per branch)
Ambient temperature (operation)
Mounting position
Standards / regulations
Connection data solid / stranded / AWG
Dimensions

Technical data

< 50 V AC / 60 V DC
1 A
-20°C ... 50°C
Any
IEC 60664, DIN EN 50178, IEC 62103
0.2 - 4 mm² / 0.2 - 2.5 mm² / 24 - 12
77 mm / 51 mm

Ordering data

Description	No. of poles	Module width W	Type	Order No.	Pcs. / Pkt.
VARIOFACE module, with pin strip					
	10	34.00	FLKM 10/ZFKDS	2302887	1
	14	45.00	FLKM 14/ZFKDS	2302890	1
	16	45.00	FLKM 16/ZFKDS	2302900	1
	20	57.00	FLKM 20/ZFKDS	2302913	1
	26	79.00	FLKM 26/ZFKDS	2302926	1
	34	90.00	FLKM 34/ZFKDS	2302939	1
	40	113.00	FLKM 40/ZFKDS	2302942	1
	50	135.00	FLKM 50/ZFKDS	2302955	1
	60	158.00	FLKM 60/ZFKDS	2302968	1
	64	169.00	FLKM 64/ZFKDS	2302971	1
VARIOFACE module, with pin strip					
	10	54.00			
	14	59.00			
	16	64.00			
	20	75.00			
	26	90.00			
	34	110.00			
	40	126.00			
	50	151.00			
	60	176.00			
	64	186.00			
VARIOFACE module, with pin strip					
	16	61.00			
	20	66.00			
	26	74.00			
	34	86.00			
	40	96.00			
	50	111.00			
	60	126.00			
	64	136.00			

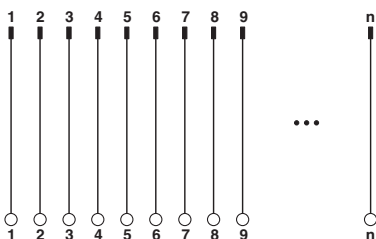

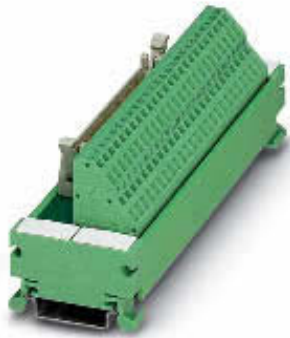

10 to 64 positions
with spring-cage connection



16 to 64 positions
with spring-cage connection



Technical data

< 50 V AC / 60 V DC
 1 A
 -20°C ... 50°C
 Any
 IEC 60664, DIN EN 50178, IEC 62103
 0.2 - 2.5 mm² / 0.2 - 1.5 mm² / 24 - 14
 45 mm / 50 mm



Technical data

< 50 V AC / 60 V DC
 1 A
 -20°C ... 50°C
 Any
 IEC 60664, DIN EN 50178, IEC 62103
 0.2 - 2.5 mm² / 0.2 - 1.5 mm² / 24 - 14
 45 mm / 61 mm

Ordering data

Type	Order No.	Pcs. / Pkt.
UM 45-FLK10/ZFKDS	2293514	1
UM 45-FLK14/ZFKDS	2293527	1
UM 45-FLK16/ZFKDS	2293530	1
UM 45-FLK20/ZFKDS	2293543	1
UM 45-FLK26/ZFKDS	2293556	1
UM 45-FLK34/ZFKDS	2293569	1
UM 45-FLK40/ZFKDS	2293572	1
UM 45-FLK50/ZFKDS	2293585	1
UM 45-FLK60/ZFKDS	2293598	1
UM 45-FLK64/ZFKDS	2293608	1

Ordering data

Type	Order No.	Pcs. / Pkt.
UM 45-FLKS16/ZFKDS	2968399	1
UM 45-FLKS20/ZFKDS	2968409	1
UM 45-FLKS26/ZFKDS	2968412	1
UM 45-FLKS34/ZFKDS	2968425	1
UM 45-FLKS40/ZFKDS	2968438	1
UM 45-FLKS50/ZFKDS	2968470	1
UM 45-FLKS60/ZFKDS	2968441	1
UM 45-FLKS64/ZFKDS	2968454	1

INTERFACE Cabling

VARIOFACE wiring interface

SLIM-LINE modules for flat-ribbon cable connectors

VARIOFACE SLIM-LINE modules connect flat-ribbon cable plug connectors in accordance with IEC 60603-13/DIN 41651 to front connecting terminal blocks.

The modules are provided with low and high engagement catches to protect the flat-ribbon cable connector against being accidentally released.



**20 and 26-pos.
with screw connection**



**34 to 50 positions
with screw connection**



Technical data

Operating voltage	< 50 V AC / 60 V DC
Max. perm. current (per branch)	0.8 A (data valid for 100% coincidence factor)
Ambient temperature (operation)	-10°C ... 50°C
Mounting position	Any
Standards / regulations	IEC 60664, DIN EN 50178, IEC 62103
Screw connection solid / stranded / AWG	0.2 ... 4 mm ² / 0.2 ... 2.5 mm ² / 24 - 12
Dimensions	45 mm / 25 mm



Technical data

Operating voltage	< 50 V AC / 60 V DC
Max. perm. current (per branch)	1 A (data valid for 100% coincidence factor)
Ambient temperature (operation)	-10°C ... 50°C
Mounting position	Any
Standards / regulations	IEC 60664, DIN EN 50178, IEC 62103
Screw connection solid / stranded / AWG	0.2 ... 4 mm ² / 0.2 ... 2.5 mm ² / 24 - 12
Dimensions	45 mm / 45 mm

Ordering data

Description	No. of poles	Module height H
VARIOFACE-SLIM-LINE module, with pin strip	20	177.00
	26	217.00
VARIOFACE-SLIM-LINE module, with pin strip	34	147.00
	40	167.00
	50	197.00

Type	Order No.	Pcs. / Pkt.
UM 25-FLK20/Front/Q	2959515	1
UM-25 FLK26/Front/Q	2959528	1

Ordering data

Type	Order No.	Pcs. / Pkt.
UM 45-FLK34/Front/Q	2959531	1
UM 45-FLK40/Front/Q	2959544	1
UM 45-FLK50/Front/Q	2959557	1

Panel feed-through modules for flat-ribbon cable connectors

VARIOFACE panel feed-through modules DFLK... connect the flat-ribbon cable connectors in accordance with IEC 60603-13/DIN 41651 to the screw connection terminal blocks.

These modules are suitable for mounting on a side panel with an appropriate housing cutout (see dimensioning table).

The modules are provided with low and high engagement catches to protect the flat-ribbon cable connector against being accidentally released.



16 to 50 positions with screw connection

Operating voltage
Max. perm. current (per branch)
Ambient temperature (operation)
Mounting position
Standards / regulations
Connection data solid / stranded / AWG

< 50 V AC / 60 V DC
1 A
-20°C ... 45°C
Any
IEC 60664, DIN EN 50178, IEC 62103
0.2 - 4 mm² / 0.2 - 2.5 mm² / 24 - 12

Technical data

Ordering data

Description	No. of poles	Module width W
VARIOFACE feed-through module, with pin strip		
	16	39.00
	20	39.00
	26	39.00
	34	39.00
	40	39.00
	50	39.00

Type	Order No.	Pcs. / Pkt.
DFLK 16	2280239	5
DFLK 20	2280242	5
DFLK 26	2280255	5
DFLK 34	2280268	5
DFLK 40	2280271	5
DFLK 50	2280284	5

Dimensioning of the housing cutout

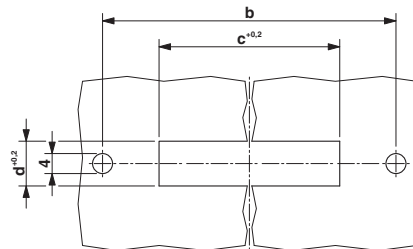

Type	a	b	c	d
DFLK 16	58.4	52.5	40.1 + 0.2	9 + 0.2
DFLK 20	68.4	62.5	45.2 + 0.2	9 + 0.2
DFLK 26	83.4	77.5	52.8 + 0.2	9 + 0.2
DFLK 34	103.4	97.5	63.0 + 0.2	9 + 0.2
DFLK 40	128.4	122.5	70.6 + 0.2	9 + 0.2
DFLK 50	143.4	137.5	83.3 + 0.2	9 + 0.2

Dimensional drawing DFLK:

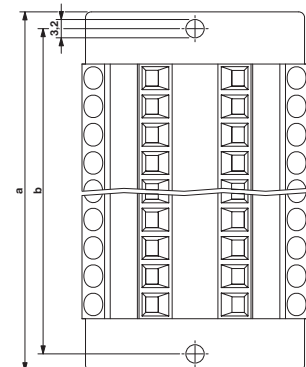
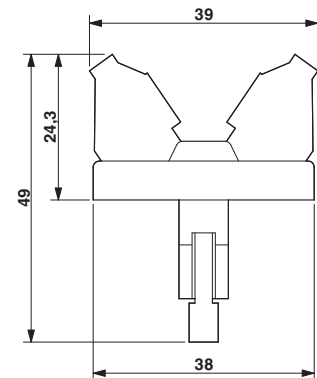

INTERFACE Cabling

VARIOFACE wiring interface

VIP – VARIOFACE Professional Modules with D-SUB connectors

- 1:1 connection
 - 9 to 50-pos.
 - Screw connection
 - Metal foot
 - As per IEC 60807-2
 - Optional with status indicator
- The D-SUB-4-40 UNC threads are led on to a connecting terminal block directly.

Notes:

For marking systems and mounting material, see CLIPLINE catalog, part 2.



9 to 15 positions
with screw connection



Technical data

Operating voltage	125 V AC/DC
Max. perm. current (per branch)	2 A
Ambient temperature (operation)	-20°C ... 50°C
Mounting position	Any
Standards / regulations	IEC 60664, DIN EN 50178, IEC 62103
Connection data solid / stranded / AWG	0.2 - 4 mm ² / 0.2 - 2.5 mm ² / 24 - 12
Dimensions	65.5 mm / 45.1 mm

Ordering data

Description	No. of poles	Module width W	Type	Order No.	Pcs. / Pkt.
VARIOFACE module, with D-Subminiature pin strip					
	9	34.70	VIP-2/SC/D 9SUB/M	2315117	1
	15	45.00	VIP-2/SC/D15SUB/M	2315120	1
VARIOFACE module, with D-Subminiature pin strip and light indicator					
	9	34.70			
	15	50.00			
VARIOFACE module, with D-Subminiature socket					
	9	34.70	VIP-2/SC/D 9SUB/F	2315162	1
	15	45.00	VIP-2/SC/D15SUB/F	2315175	1
VARIOFACE module, with D-Subminiature socket and light indicator					
	9	34.70			
	15	50.00			
VARIOFACE module, with D-Subminiature pin strip					
	25	57.40			
	37	72.70			
	50	98.20			
VARIOFACE module, with D-Subminiature pin strip and light indicator					
	25	57.40			
	37	72.70			
	50	98.20			
VARIOFACE module, with D-Subminiature socket					
	25	57.40			
	37	72.70			
	50	98.20			
VARIOFACE module, with D-Subminiature socket and light indicator					
	25	57.40			
	37	72.70			
	50	98.20			

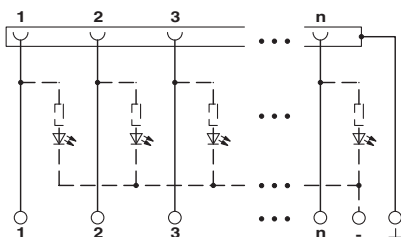



9 to 15 positions
with screw connection and light indicator



25 to 50 positions
with screw connection

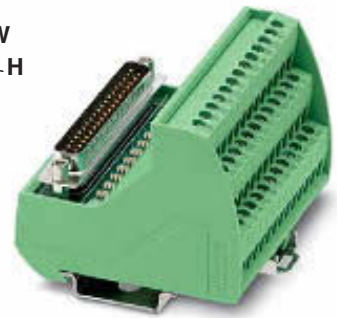

25 to 50 positions
with screw connection and light indicator



Technical data
24 V DC
2.5 A
-20°C ... 50°C
Any
IEC 60664, DIN EN 50178, IEC 62103
0.2 - 4 mm ² / 0.2 - 2.5 mm ² / 24 - 12
65.5 mm / 45.1 mm

Ordering data

Type	Order No.	Pcs. / Pkt.
VIP-2/SC/D 9SUB/M/LED	2322142	1
VIP-2/SC/D15SUB/M/LED	2322155	1
VIP-2/SC/D 9SUB/F/LED	2322197	1
VIP-2/SC/D15SUB/F/LED	2322207	1



Technical data
125 V AC/DC
2 A
-20°C ... 50°C
Any
IEC 60664, DIN EN 50178, IEC 62103
0.2 - 4 mm ² / 0.2 - 2.5 mm ² / 24 - 12
69 mm / 62 mm

Ordering data

Type	Order No.	Pcs. / Pkt.
VIP-3/SC/D25SUB/M	2315133	1
VIP-3/SC/D37SUB/M	2315146	1
VIP-3/SC/D50SUB/M	2315159	1
VIP-3/SC/D25SUB/F	2315188	1
VIP-3/SC/D37SUB/F	2315191	1
VIP-3/SC/D50SUB/F	2315201	1



Technical data
24 V DC
2.5 A
-20°C ... 50°C
Any
IEC 60664, DIN EN 50178, IEC 62103
0.2 - 4 mm ² / 0.2 - 2.5 mm ² / 24 - 12
69 mm / 62 mm

Ordering data

Type	Order No.	Pcs. / Pkt.
VIP-3/SC/D25SUB/M/LED	2322168	1
VIP-3/SC/D37SUB/M/LED	2322171	1
VIP-3/SC/D50SUB/M/LED	2322184	1
VIP-3/SC/D25SUB/F/LED	2322210	1
VIP-3/SC/D37SUB/F/LED	2322223	1
VIP-3/SC/D50SUB/F/LED	2322236	1

INTERFACE Cabling

VARIOFACE wiring interface

Modules for D-subminiature connectors

- 1:1 connection
- 9 to 50-pos.
- Spring-cage connection method
- As per IEC 60807-2

The D-SUB-4-40 UNC threads are led on to a connecting terminal block directly.

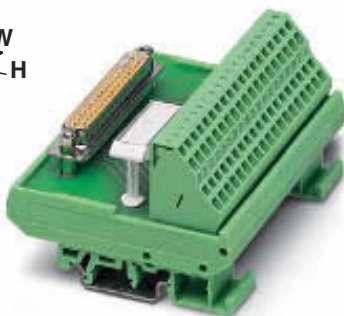

9 to 50 positions
with spring-cage connection

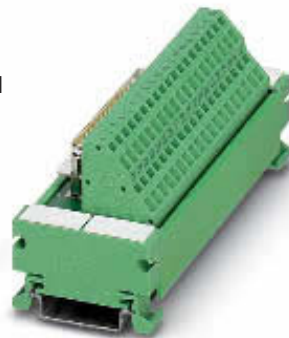

9 to 50 positions
with spring-cage connection



Technical data

Operating voltage	125 V AC/DC
Max. perm. current (per branch)	2.5 A
Ambient temperature (operation)	-20°C ... 50°C
Mounting position	Any
Standards / regulations	IEC 60664, DIN EN 50178, IEC 62103
Connection data solid / stranded / AWG	0.2 - 4 mm ² / 0.2 - 2.5 mm ² / 24 - 12
Dimensions	77 mm / 52 mm

Operating voltage	125 V AC/DC
Max. perm. current (per branch)	2.5 A
Ambient temperature (operation)	-20°C ... 50°C
Mounting position	Any
Standards / regulations	IEC 60664, DIN EN 50178, IEC 62103
Connection data solid / stranded / AWG	0.2 - 2.5 mm ² / 0.2 - 1.5 mm ² / 24 - 14
Dimensions	45 mm / 50 mm



Technical data

Operating voltage	125 V AC/DC
Max. perm. current (per branch)	2.5 A
Ambient temperature (operation)	-20°C ... 50°C
Mounting position	Any
Standards / regulations	IEC 60664, DIN EN 50178, IEC 62103
Connection data solid / stranded / AWG	0.2 - 2.5 mm ² / 0.2 - 1.5 mm ² / 24 - 14
Dimensions	45 mm / 50 mm

Ordering data

Description	No. of poles	Module width W
VARIOFACE module, with D-Subminiature pin strip		
	9	33.80
	15	45.00
	25	78.80
	37	101.30
	50	146.30
VARIOFACE module, with D-Subminiature socket		
	9	33.80
	15	45.00
	25	78.80
	37	101.30
	50	146.30
VARIOFACE COMPACT-LINE module, with D-Subminiature pin strip		
	9	54.00
	15	65.00
	25	90.00
	37	121.00
	50	156.00
VARIOFACE COMPACT-LINE module, with D-Subminiature socket		
	9	54.00
	15	65.00
	25	90.00
	37	121.00
	50	156.00

Ordering data

Type	Order No.	Pcs. / Pkt.
FLKM-D 9 SUB/S/ZFKDS	2302984	1
FLKM-D15 SUB/S/ZFKDS	2302997	1
FLKM-D25 SUB/S/ZFKDS	2303006	1
FLKM-D37 SUB/S/ZFKDS	2304018	1
FLKM-D50 SUB/S/ZFKDS	2304021	1
FLKM-D 9 SUB/B/ZFKDS	2304034	1
FLKM-D15 SUB/B/ZFKDS	2304047	1
FLKM-D25 SUB/B/ZFKDS	2304050	1
FLKM-D37 SUB/B/ZFKDS	2304063	1
FLKM-D50 SUB/B/ZFKDS	2304076	1

Ordering data

Type	Order No.	Pcs. / Pkt.
UM 45-D 9SUB/S/ZFKDS	2293611	1
UM 45-D15SUB/S/ZFKDS	2293624	1
UM 45-D25SUB/S/ZFKDS	2293637	1
UM 45-D37SUB/S/ZFKDS	2293640	1
UM 45-D50SUB/S/ZFKDS	2293653	1
UM 45-D 9SUB/B/ZFKDS	2293666	1
UM 45-D15SUB/B/ZFKDS	2293679	1
UM 45-D25SUB/B/ZFKDS	2293682	1
UM 45-D37SUB/B/ZFKDS	2293695	1
UM 45-D50SUB/B/ZFKDS	2293705	1

Accessories

Screwdriver
Blade: 0,4 x 2,5 x 75 mm, length: 156 mm

SZF 0-0,4X2,5	1204504	10
---------------	---------	----

Accessories

SZF 0-0,4X2,5	1204504	10
---------------	---------	----

SLIM-LINE modules for D-subminiature connectors

These VARIOFACE modules connect D-Sub strips with front connection terminal blocks in accordance with IEC 60807-2/DIN 41652.

To make the ground connection, the metallic plug shell (4-40 UNC thread) makes contact with a connecting terminal block.



**9 to 25 positions
with screw connection**



**37 to 50 positions
with screw connection**



Technical data

Operating voltage	125 V AC/DC
Max. perm. current (per branch)	2.5 A
Ambient temperature (operation)	-10°C ... 50°C
Mounting position	Any
Standards / regulations	IEC 60664, IEC 60664 A, DIN VDE 0110, DIN VDE 0160 (in parts)
Dimensions	45 mm / 25 mm

Operating voltage	125 V AC/DC
Max. perm. current (per branch)	2.5 A
Ambient temperature (operation)	-10°C ... 50°C
Mounting position	Any
Standards / regulations	IEC 60664, DIN EN 50178, IEC 62103
Dimensions	45 mm / 45 mm



Technical data

Operating voltage	125 V AC/DC
Max. perm. current (per branch)	2.5 A
Ambient temperature (operation)	-10°C ... 50°C
Mounting position	Any
Standards / regulations	IEC 60664, DIN EN 50178, IEC 62103
Dimensions	45 mm / 45 mm

Ordering data

Description	No. of poles	Module height H
VARIOFACE-SLIM-LINE module, with D-Subminiature pin strip	9	117.00
	15	147.00
	25	217.00
VARIOFACE-SLIM-LINE module, with D-Subminiature socket strip	9	117.00
	15	147.00
	25	217.00
VARIOFACE-SLIM-LINE module, with D-Subminiature pin strip	37	
	50	
	VARIOFACE-SLIM-LINE module, with D-Subminiature socket strip	37
50		

Type	Order No.	Pcs. / Pkt.
UM 25-D 9SUB/S/Front/Q	2959573	1
UM 25-D15SUB/S/Front/Q	2959599	1
UM 25-D25SUB/S/Front/Q	2959612	1
UM 25-D 9SUB/B/Front/Q	2959560	1
UM 25-D15SUB/B/Front/Q	2959586	1
UM 25-D25SUB/B/Front/Q	2959609	1

Ordering data

Type	Order No.	Pcs. / Pkt.
UM 45-D37SUB/S/Front/Q	2959638	1
UM 45-D50SUB/S/Front/Q	2959654	1
UM 45-D37SUB/B/Front/Q	2959625	1
UM 45-D50SUB/B/Front/Q	2959641	1

INTERFACE Cabling

VARIOFACE wiring interface

Panel feed-through modules for D-subminiature connectors

- 1:1 connection
- 9 to 50-pos.
- Screw connection
- As per IEC 60807-2
- D-SUB 4-40 UNC thread
- 9- to 37-pos.: Separate ground tap
- 50-pos.: No ground tap



With D-subminiature male connector



With D-subminiature female connector

Operating voltage
Max. perm. current (per branch)
Ambient temperature (operation)
Mounting position
Standards / regulations
Connection data solid / stranded / AWG

125 V AC/DC
2.5 A
-20°C ... 50°C
Any
0.2 - 4 mm² / 0.2 - 2.5 mm² / 24 - 12

125 V AC/DC
2.5 A
-20°C ... 50°C
Any
DIN EN 50178
0.2 - 4 mm² / 0.2 - 2.5 mm² / 24 - 12

Description	No. of poles	Module width W
VARIOFACE feed-through module, with D-subminiature male connector		
	9	39.00
	15	39.00
	25	39.00
	37	39.00
	50	39.00

Ordering data		
Type	Order No.	Pcs. / Pkt.
DFLK-D 9 SUB/S	2283870	5
DFLK-D15 SUB/S	2280297	5
DFLK-D25 SUB/S	2280310	5
DFLK-D37 SUB/S	2280336	5
DFLK-D50 SUB/S	2291286	5

Ordering data		
Type	Order No.	Pcs. / Pkt.
DFLK-D 9 SUB/B	2287135	5
DFLK-D15 SUB/B	2280307	5
DFLK-D25 SUB/B	2280323	5
DFLK-D37 SUB/B	2280349	5
DFLK-D50 SUB/B	2287669	5

Dimensioning of the housing cutout

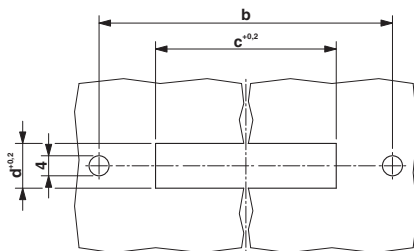

Type	a	b	c	d
DFLK-D 9 SUB/S	58.4	52.5	40.2 + 0.2	13 + 0.2
DFLK-D 15 SUB/S	58.4	52.5	40.2 + 0.2	13 + 0.2
DFLK-D 25 SUB/S	83.4	77.5	54.2 + 0.2	13 + 0.2
DFLK-D 37 SUB/S	128.4	122.5	70.6 + 0.2	13 + 0.2
DFLK-D 50 SUB/S	143.4	137.5	67.8 + 0.2	15.8 + 0.2
DFLK-D 9 SUB/B	58.4	52.5	40.2 + 0.2	13 + 0.2
DFLK-D 15 SUB/B	58.4	52.5	40.2 + 0.2	13 + 0.2
DFLK-D 25 SUB/B	83.4	77.5	54.2 + 0.2	13 + 0.2
DFLK-D 37 SUB/B	128.4	122.5	70.6 + 0.2	13 + 0.2
DFLK-D 50 SUB/B	143.4	137.5	67.8 + 0.2	15.8 + 0.2

Dimensional drawing: DFLK-D...SUB:

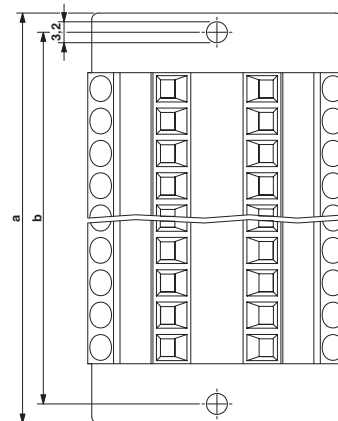
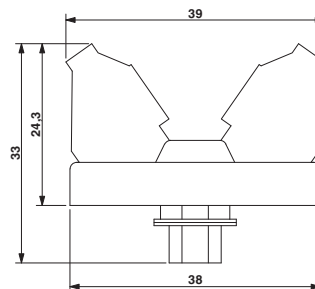

Feed-through module for high-density D-subminiature male connector with screw connection

- 1:1 connection
- 62-pole pin strip
- Screw connection
- As per IEC 60807-2
- D-SUB 4-40 UNC thread



With high-density D-subminiature pin strip

Operating voltage
 Max. perm. current (per branch)
 Ambient temperature (operation)
 Mounting position
 Standards / regulations
 Connection data solid / stranded / AWG

48 V AC/DC
 0.5 A
 -20°C ... 50°C
 Any
 DIN EN 50178
 0.2 - 4 mm² / 0.2 - 2.5 mm² / 24 - 12

Technical data

Ordering data

Description	No. of poles	Module width W
VARIOFACE feed-through module, with D-subminiature pin strip		
	62	40.40

Type	Order No.	Pcs. / Pkt.
DFLK-D62 SUBH/S	2300863	10

Dimensioning of the housing cutout

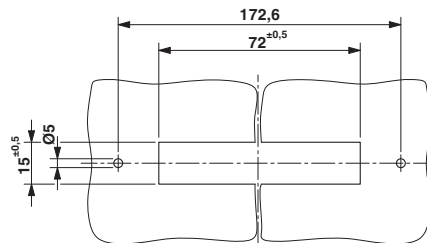

Dimensional drawing DFLK-D62 SUBH/S

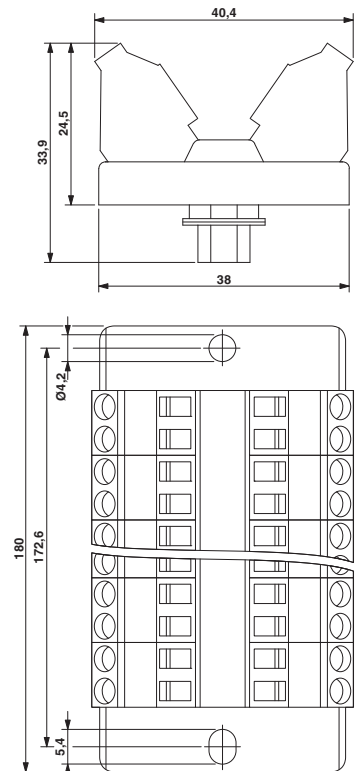

INTERFACE Cabling

VARIOFACE wiring interface

Feed-through module for high-density D-subminiature male connector with spring-cage connection

- 1:1 connection
- 62-pole pin strip
- Spring-cage connection with direct plug-in method
- As per IEC 60807-2
- D-SUB 4-40 UNC thread



With high-density D-subminiature pin strip

Technical data

Operating voltage	48 V DC
Max. perm. current (per branch)	0.5 A
Ambient temperature (operation)	-20°C ... 50°C
Mounting position	Any
Standards / regulations	DIN EN 50178, basic insulation
Connection data solid / stranded / AWG	0.2 - 1.5 mm ² / 0.2 - 1.5 mm ² / 24 - 16

Ordering data

Description	No. of poles	Module width W
VARIOFACE feed-through module, with D-subminiature pin strip	62	

Type	Order No.	Pcs. / Pkt.
DFLK-HD62SUB/M/PTDA-1,5	2900472	1

Dimensioning of the housing cutout

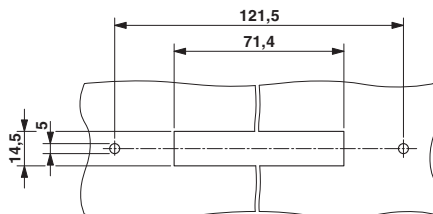

Dimensional drawing DFLK-HD62SUB/M/PTDA-1,5

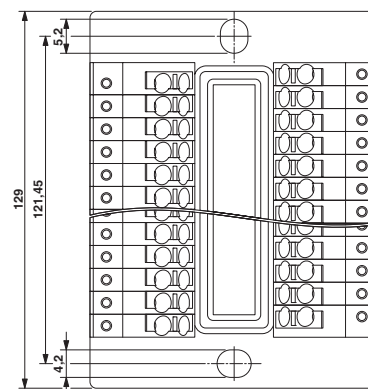
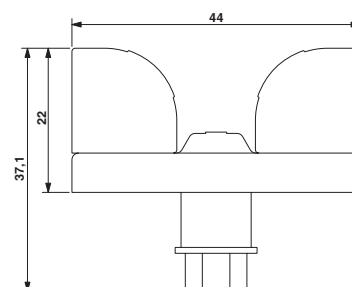

VIP – VARIOFACE Professional modules for high-density D-Subminiature plug connectors

These modules connect D subminiature male or female connectors with screw terminal blocks.

To make the ground connection, the metallic plug shell (4-40 UNC thread) makes contact with a connecting terminal block.

Notes:

For marking systems and mounting material, see CLIPLINE catalog, part 2.



15 to 62 positions with screw connection



Technical data

Operating voltage	125 V
Max. perm. current (per branch)	1 A
Ambient temperature (operation)	-20°C ... 50°C
Mounting position	Any
Connection data solid / stranded / AWG	0.2 - 4 mm ² / 0.2 - 2.5 mm ² / 24 - 12
Dimensions	H / D 69 mm / 62 mm

Ordering data

Description	No. of poles	Module width W	Type	Order No.	Pcs. / Pkt.
VARIOFACE module, with D-Subminiature pin strip					
Three-level terminal blocks	15	44.90	VIP-2/SC/HD15SUB/M	2322326	1
Three-level terminal blocks	26	52.30	VIP-3/SC/HD26SUB/M	2322375	1
Three-level terminal blocks	44	82.90	VIP-3/SC/HD44SUB/M	2322388	1
Three-level terminal blocks	62	113.50	VIP-3/SC/HD62SUB/M	2322391	1
VARIOFACE module, with D-Subminiature socket					
Three-level terminal blocks	15	44.90	VIP-2/SC/HD15SUB/F	2322401	1
Three-level terminal blocks	26	52.30	VIP-3/SC/HD26SUB/F	2322414	1
Three-level terminal blocks	44	82.90	VIP-3/SC/HD44SUB/F	2322427	1
Three-level terminal blocks	62	113.50	VIP-3/SC/HD62SUB/F	2322430	1

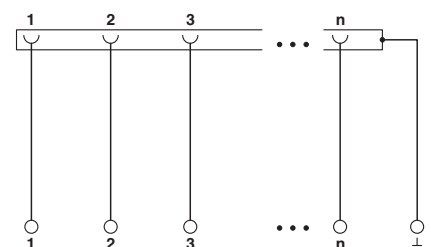

INTERFACE Cabling

VARIOFACE wiring interface

Modules for connectors IEC 60603/DIN 41612

These VARIOFACE interface modules connect high-pole plug connectors in acc. with IEC 60603/DIN 41612 to screw connection terminal blocks.

The following VARIOFACE modules are available:

- **UMK** modules with double-level connecting terminal blocks
- **UMKS** modules with three-level connecting terminal blocks

Notes:

Suitable cable housings, see the table on page 336

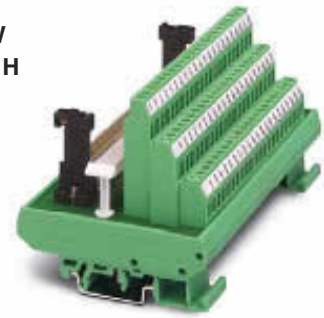

Design C, 64-position, a, c assembled



Technical data

Operating voltage	125 V AC/DC
Max. perm. current (per branch)	1 A
Ambient temperature (operation)	-20°C ... 50°C
Mounting position	Any
Standards / regulations	IEC 60664, DIN EN 50178, IEC 62103
Connection data solid / stranded / AWG	0.2 - 4 mm ² / 0.2 - 2.5 mm ² / 24 - 12
Dimensions	77 mm / 72 mm

Ordering data

Description	No. of poles	Module width W	Type	Order No.	Pcs. / Pkt.
VARIOFACE module, C 64-pos., screw-on cable housing, with:					
- Male connector	64	135.00	UMKS- C64M-VS	2970565	1
VARIOFACE module, E 48-pos., screw-on cable housing, with:					
- Male connector	48	123.80			
VARIOFACE module, F 48-pos., screw-on cable housing, with:					
- Male connector	48	112.50			
VARIOFACE module, F 48-pos., snap-on cable housing, with:					
- Male connector	48	112.50			
VARIOFACE module, D 32-pos., screw-on cable housing, with:					
- Male connector	32	135.00			

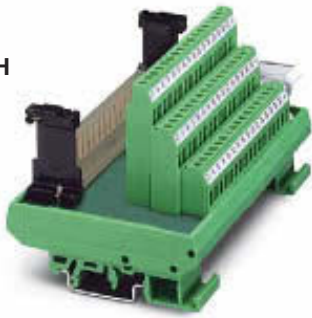

Design E, 48-position, a, c, e assembled

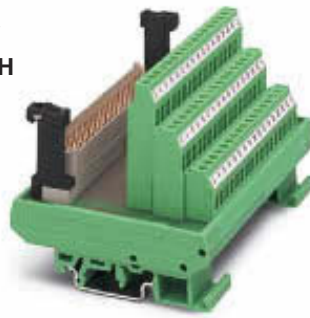

Design F, 48-position, z, b, d assembled

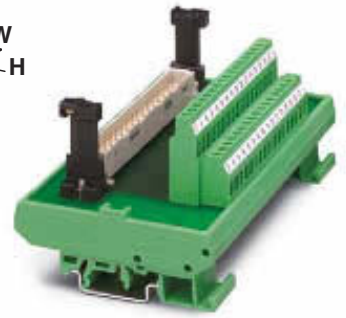

Design D, 32-position, a, c assembled



Technical data

125 V AC/DC
 4 A
 -20°C ... 50°C
 Any
 IEC 60664, DIN EN 50178, IEC 62103
 0.2 - 4 mm² / 0.2 - 2.5 mm² / 24 - 12
 77 mm / 72 mm

Ordering data

Type	Order No.	Pcs. / Pkt.
UMKS- E48M-VS	2970154	1



Technical data

250 V AC
 4 A
 -20°C ... 45°C
 Any
 IEC 60664, DIN EN 50178, IEC 62103
 0.2 - 4 mm² / 0.2 - 2.5 mm² / 24 - 12
 77 mm / 72 mm

Ordering data

Type	Order No.	Pcs. / Pkt.
UMKS- F48M-VS	2970714	1
UMKS- F48M-VR	2970167	1



Technical data

250 V AC/DC
 2 A
 -20°C ... 50°C
 Any
 IEC 60664, DIN EN 50178, IEC 62103
 0.2 - 4 mm² / 0.2 - 2.5 mm² / 24 - 12
 77 mm / 62.5 mm

Ordering data

Type	Order No.	Pcs. / Pkt.
UMK- D32M-VS	2970060	1

INTERFACE Cabling

VARIOFACE wiring interface

Modules for ELCO connectors

These modules can be used to connect ELCO plug connectors of the 8016 series to screw connection terminal blocks.

The diagonal position of the ELCO plug connector means that the wires leading out of the cable housing at the side can be led away without restricting neighboring modules.

Notes:

Dimensional drawings and pin assignments, see page 336.

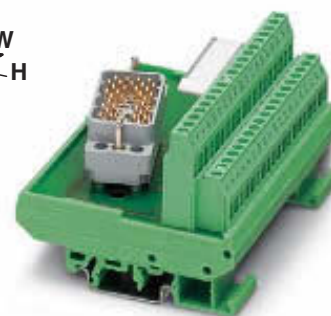

38-pos.



Technical data

Operating voltage	25 V AC / 60 V DC
Max. perm. current (per branch)	1.5 A
Total current	19 A (38 branches with 0.5 A each)
Ambient temperature (operation)	-20°C ... 40°C
Mounting position	Any
Standards / regulations	IEC 60664, DIN EN 50178, IEC 62103
Connection data solid / stranded / AWG	0.2 - 4 mm ² / 0.2 - 2.5 mm ² / 24 - 12
Dimensions	H / D 77 mm / 58.5 mm

Ordering data

Description	No. of poles	Module width W	Type	Order No.	Pcs. / Pkt.
VARIOFACE module, with:					
- Pin strip 8016 right	38	101.50	UMK- EC38/38-XOR	2976297	1
- Pin strip 8016 left	38	101.50	UMK- EC38/38-XOL	2976284	1
VARIOFACE module, with:					
- Pin strip 8016 right	56	157.50			
- Pin strip 8016 left	56	157.50			
VARIOFACE module, with:					
- Pin strip 8016 right	56	77.00			
- Pin strip 8016 left	56	77.00			
VARIOFACE module, with:					
- Pin strip 8016 right above	32	101.30			
- Pin strip 8016 right below	32	101.30			
- Pin strip 8016 left above	32	101.30			
- Pin strip 8016 left below	32	101.30			

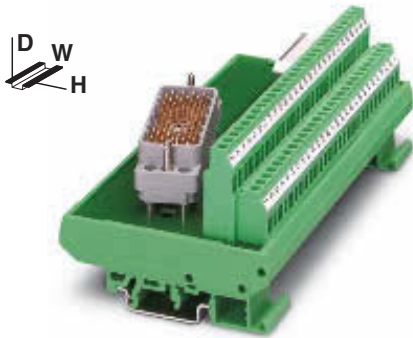

56-pos.



56-pos.,
with front connection terminal blocks

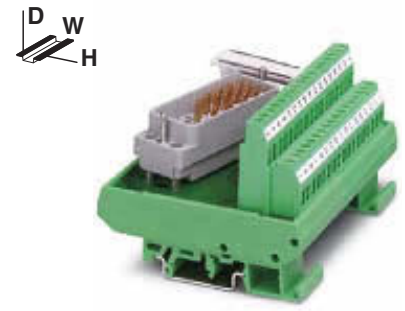

32-pos.



Technical data

125 V AC/DC
1.5 A
28 A (56 branches with 0.5 A each)
-20°C ... 50°C
Any
IEC 60664, DIN EN 50178, IEC 62103
0.2 - 4 mm² / 0.2 - 2.5 mm² / 24 - 12
77 mm / 58.5 mm

Ordering data

Type	Order No.	Pcs. / Pkt.
UMK- EC56/56-XOR	2975900	1
UMK- EC56/56-XOL	2975890	1



Technical data

< 25 V AC / 30 V DC
1.5 A
28 A (56 branches with 0.5 A each)
-20°C ... 50°C
Any
IEC 60664, DIN EN 50178, IEC 62103
0.2 - 2.5 mm² / 0.2 - 1.5 mm² / 26 - 16
146.3 mm / 47.5 mm

Ordering data

Type	Order No.	Pcs. / Pkt.
UMK- EC56/Front 2,5V/R	2976161	1
UMK- EC56/Front 2,5V/L	2976158	1



Technical data

25 V AC / 60 V DC
2 A
32 A (32 branches with 1 A each)
-20°C ... 40°C
Any
IEC 60664, DIN EN 50178, IEC 62103
0.2 - 4 mm² / 0.2 - 2.5 mm² / 24 - 12
77 mm / 58.5 mm

Ordering data

Type	Order No.	Pcs. / Pkt.
UMK- EC56/32-XOR	2975858	1
UMK- EC56/32-XUR	2975777	1
UMK- EC56/32-XOL	2975764	1
UMK- EC56/32-XUL	2975780	1

INTERFACE Cabling

VARIOFACE wiring interface

Modules for ELCO connectors for use in Ex i circuits

The VARIOFACE modules connect ELCO connectors of the 8016 series to screw connection terminal blocks. The modules for ELCO connectors can be used as simple electrical equipment for applications in intrinsically safe circuits as per EN 60079-14. They fulfill the requirements of the intrinsic safety as per EN 60079-11 (EN 50020) and can be used for various intrinsically safe circuits taking into account the pin configuration.

The voltage of an intrinsically safe circuit may not exceed 30 V. The voltage difference between two intrinsically safe circuits can be up to 60 V.

The modules are equipped with blue screw connection terminal blocks in order to clearly label intrinsically safe circuits.

The arrangement of angled ELCO connectors makes it possible to lead the lines led out from the cable housing away from the adjacent modules without any negative effects.

For the disconnection of intrinsically safe and non-intrinsically safe circuits, a distance of at least 50 mm should be kept between the connection points using partition plates or spaces.

Notes:

Dimensional drawings and pin assignments, see page 337.

Facts about explosion protection, see page 432.

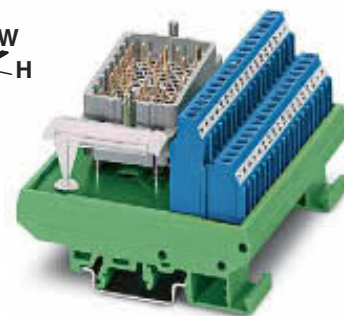

32-pos.

Operating voltage

Max. perm. current (per branch)

Ambient temperature (operation)

Mounting position

Standards / regulations

Connection data solid / stranded / AWG

Dimensions

H / D

Technical data

Max. 30 V DC (max. voltage between two intrinsically safe circuits: 60 V DC)

500 mA

-20°C ... 50°C

Any

0.2 - 4 mm² / 0.2 - 2.5 mm² / 24 - 12

77 mm / 58.5 mm

Ordering data

Description	No. of poles	Module width W
VARIOFACE module, with:		
- Pin strip 8016 right above	32	101.30
- Pin strip 8016 right below	32	101.30
- Pin strip 8016 left above	32	101.30
- Pin strip 8016 left below	32	101.30
VARIOFACE module, with:		
- Pin strip 8016 right	25	78.80
- Pin strip 8016 left	25	78.80
VARIOFACE module, with:		
- Pin strip 8016 right	25	77.00
- Pin strip 8016 left	25	77.00

Type	Order No.	Pcs. / Pkt.
UMK- EC90/32/EX-XOR	2900109	1
UMK- EC90/32/EX-XUR	2969068	1
UMK- EC90/32/EX-XOL	2900110	1
UMK- EC90/32/EX-XUL	2969071	1



25-pos.

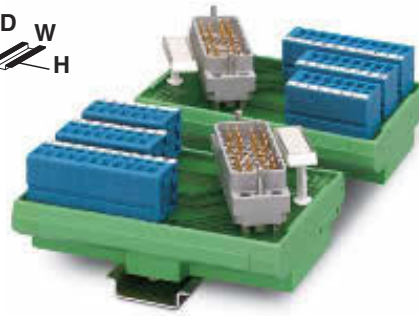

**25-pos.,
with front connection terminal blocks**

Technical data

Max. 30 V DC (max. voltage between two intrinsically safe circuits:
 60 V DC)
 500 mA
 -20°C ... 50°C
 Any

0.2 - 4 mm² / 0.2 - 2.5 mm² / 24 - 12
 77 mm / 58.5 mm

Technical data

Max. 30 V DC (max. voltage between two intrinsically safe circuits:
 60 V DC)
 500 mA
 -20°C ... 50°C
 Any

0.2 - 2.5 mm² / 0.2 - 2.5 mm² / 24 - 14
 112.5 mm / 52.5 mm

Ordering data

Type	Order No.	Pcs. / Pkt.
UMK- EC56/25/EX -R	2900112	1
UMK- EC56/25/EX -L	2900113	1

Ordering data

Type	Order No.	Pcs. / Pkt.
UMK- EC56/25/EX -FRONT 2,5V/R	2900114	1
UMK- EC56/25/EX -FRONT 2,5V/L	2900115	1

INTERFACE Cabling

VARIOFACE wiring interface

Modules with RJ45 connector

- 1:1 connection
- 8 positions, RJ45 connector
- Screw or spring-cage connection (direct plug-in method)
- Connector housing led to separate connection terminal blocks



8 positions
with screw connection

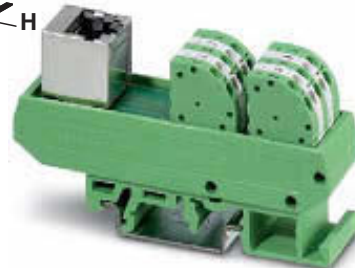

8 positions
with spring-cage connection

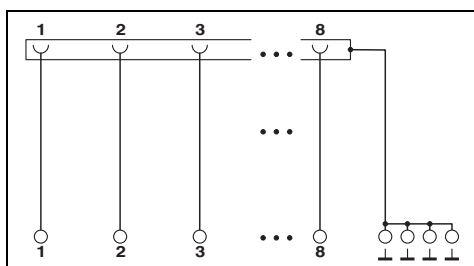

Technical data

48 V AC/DC
1 A
-20°C ... 50°C
Any
DIN EN 50178
0.2 - 4 mm² / 0.2 - 2.5 mm² / 24 - 12
62 mm / 69 mm

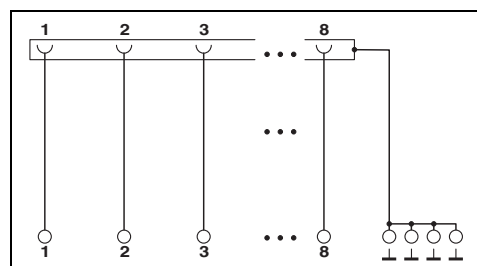

Technical data

48 V AC/DC
1 A
-20°C ... 50°C
Any
DIN EN 50178
0.2 - 1.5 mm² / 0.2 - 1.5 mm² / 24 - 16
91 mm / 51 mm

Operating voltage
Max. perm. current (per branch)
Ambient temperature (operation)
Mounting position
Standards / regulations
Connection data solid / stranded / AWG
Dimensions

H / D

Ordering data

Description	No. of poles	Module width W
VARIOFACE module , with RJ45 connector and screw connection terminal blocks		
RJ45	8	26.90
VARIOFACE module , with RJ45 connector and spring-cage connection (direct plug-in method)	8	25.00

Type	Order No.	Pcs. / Pkt.
VIP-3/SC/RJ45	2900701	1

Ordering data

Type	Order No.	Pcs. / Pkt.
UMK-RJ45/S/8PTDA	2900682	1

Modules with COMBICON connection

- The slim 10 and 18-pos. VARIOFACE SLIM-LINE modules connect the front connection terminal blocks to a COMBICON header. The corresponding COMBICON connectors (5.0 mm pitch) can be found in the COMBICON catalog PCB Connection Technique.
- The 32-pos. module UMK-32 MDSTB/MKKDS 3/R connects screw connection terminal blocks with coded COMBICON plug-in screw connectors.

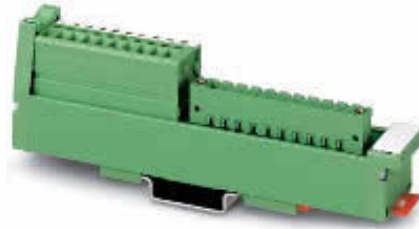

**10 and 18-pos.
with screw connection**

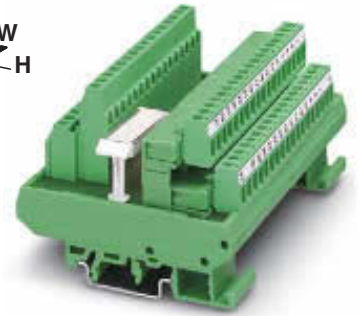

**32-pos.
with screw connection**

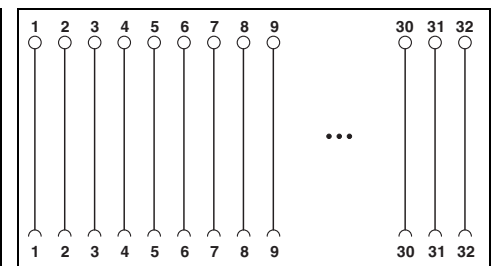
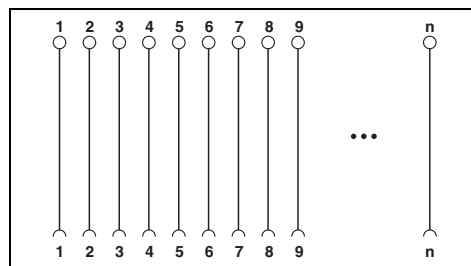

Operating voltage
 Max. perm. current (per branch)
 Ambient temperature (operation)
 Mounting position
 Standards / regulations
 Dimensions

D / W

Technical data	
250 V AC/DC	2.5 A
-10°C ... 50°C	Any
IEC 60664, DIN EN 50178, IEC 62103	45 mm / 25 mm

Technical data	
250 V AC/DC	3 A
-20°C ... 50°C	Any
IEC 60664, DIN EN 50178, IEC 62103	58.5 mm / 112.5 mm

Description	No. of poles	Module height H
VARIOFACE-SLIM-LINE module , with a COMBICON header (without a COMBICON connector)	10	137.00
	18	217.00
VARIOFACE module , with COMBICON plug connector, coded	32	77.00

Ordering data		
Type	Order No.	Pcs. / Pkt.
UM 25-10 MSTB/FRONT/Q	2959803	1
UM 25-18 MSTB/FRONT/Q	2959502	1

Ordering data		
Type	Order No.	Pcs. / Pkt.
UMK-32 MDSTB/MKKDS3/R	2970196	1

INTERFACE Cabling

VARIOFACE wiring interface

Modules as compact potential distributors

The VIP-2/SC/PDM... modules have the following features:

- Two potential levels
- Separate supply
- Consecutive labeling

The modules UMK-PVB and UMK-PVB 6 have three or six potential levels.

The modules UMK-PVB 2/.../ZFKDS are available as a variant with spring-cage connection.

Notes:

For marking systems and mounting material, see CLIPLINE catalog, part 2.



With screw connection and 2 potential levels

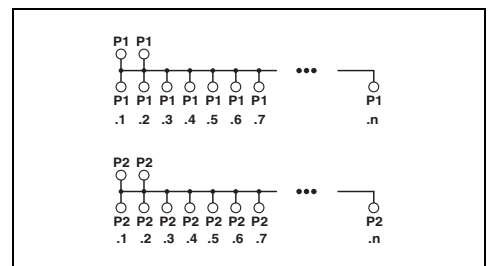

Operating voltage	
Max. perm. current (per branch)	
Total current	
Ambient temperature (operation)	
Mounting position	
Standards / regulations	
Supply connection data solid / stranded / AWG	
Distribution connection data solid / stranded / AWG	
Dimensions	H / D

250 V AC/DC
15 A
30 A (per potential)
-20°C ... 50°C
Any
IEC 60664, DIN EN 50178, IEC 62103
0.2 - 6 mm ² / 0.2 - 4 mm ² / 24 - 10
0.2 - 4 mm ² / 0.2 - 2.5 mm ² / 24 - 12
65.5 mm / 50 mm

Technical data

Ordering data

Description	No. of poles	Module width W
VARIOFACE module , with two busbars (P1, P2) for potential distribution, per potential:		
2 power terminal blocks/8 distributor terminal blocks		50.00
2 power terminal blocks/12 distributor terminal blocks		70.40
2 power terminal blocks/16 distributor terminal blocks		90.80
VARIOFACE module , with three busbars (+, -, PE) for potential distribution, per potential:		
(+) two power terminal blocks/48 distributor terminal blocks		168.80
(-) two power terminal blocks/24 distributor terminal blocks		
(PE) 2 power/72 distributor terminal blocks		
VARIOFACE module , with six busbars (P1 to P6) for potential distribution, per potential:		
2 power terminal blocks/12 distributor terminal blocks		123.80
VARIOFACE module , with two busbars (P1, P2) for potential distribution, per potential:		
2 power terminal blocks/8 distributor terminal blocks		45.00
2 power terminal blocks/12 distributor terminal blocks		67.50
2 power terminal blocks/16 distributor terminal blocks		90.00
2 power terminal blocks/24 distributor terminal blocks		135.00

Type	Order No.	Pcs. / Pkt.
VIP-2/SC/PDM-2/16	2315256	1
VIP-2/SC/PDM-2/24	2315269	1
VIP-2/SC/PDM-2/32	2315272	1

Accessories

Screwdriver
Blade: 0,6 x 3,5 x 100 mm, length: 181 mm

--	--	--

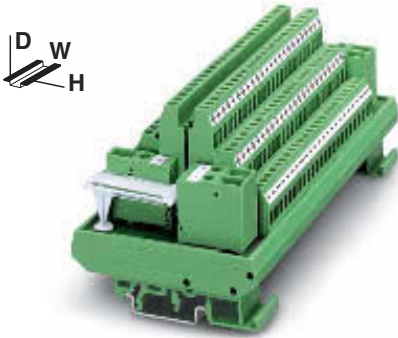

With screw connection and 3 potential levels

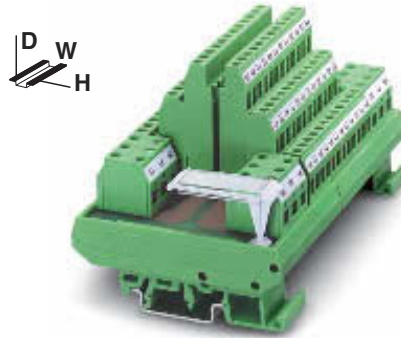

With screw connection and 6 potential levels

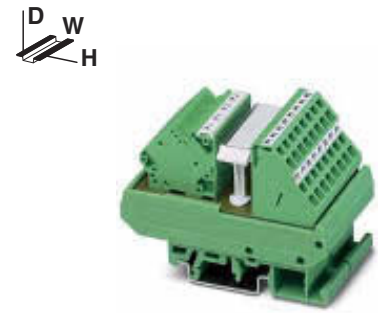

With spring-cage connection and 2 potential levels

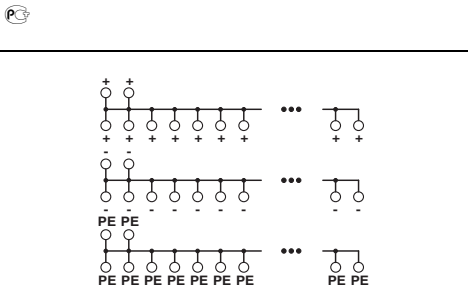

Technical data

250 V AC/DC
 16 A
 16 A (per potential)
 -20°C ... 50°C
 Any
 IEC 60664, DIN EN 50178, IEC 62103
 0.5 - 6 mm² / 0.5 - 4 mm² / 20 - 10
 0.2 - 4 mm² / 0.2 - 2.5 mm² / 24 - 12
 77 mm / 72 mm

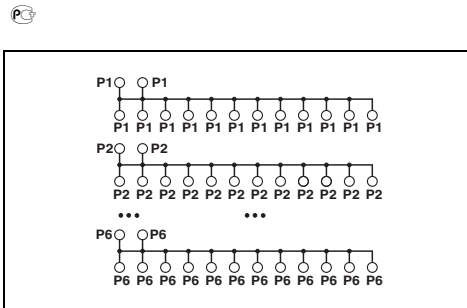

Technical data

250 V AC/DC
 16 A
 16 A (per potential)
 -20°C ... 50°C
 Any
 IEC 60664, DIN EN 50178, IEC 62103
 0.2 - 6 mm² / 0.2 - 4 mm² / 24 - 10
 0.2 - 4 mm² / 0.2 - 2.5 mm² / 24 - 12
 77 mm / 72 mm

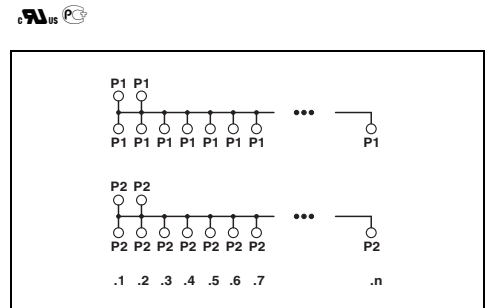

Technical data

250 V AC/DC
 17 A
 32 A (per potential)
 -20°C ... 50°C
 Any
 0.2 - 6 mm² / 0.2 - 4 mm² / 24 - 10
 0.2 - 4 mm² / 0.2 - 2.5 mm² / 24 - 12
 77 mm / 52 mm

Ordering data

Type	Order No.	Pcs. / Pkt.
UMK- PVB	2971302	1

Accessories

Ordering data

Type	Order No.	Pcs. / Pkt.
UMK- PVB 6	2972136	1

Accessories

Ordering data

Type	Order No.	Pcs. / Pkt.
UMK- PVB 2/16/ZFKDS	2302353	1
UMK- PVB 2/24/ZFKDS	2302366	1
UMK- PVB 2/32/ZFKDS	2302379	1
UMK- PVB 2/48/ZFKDS	2302382	1

Accessories

SZF 1-0,6X3,5	1204517	10
---------------	---------	----

INTERFACE Cabling

VARIOFACE wiring interface

VARIOFACE modules for pluggable miniature relays and/or miniature solid-state relays

The 4, 8, and 16-way relay and solid-state relay interfaces UMK-... RM provide four, eight or 16 slots for commercially available electromechanical relays (REL-MR...) or optoelectronic relays (SIM-EL...). The connections between the I/O module and the electronics, as well as the process cabling, are implemented via screw connection terminal blocks.



4-channel with bridge rectifier



4-channel for relays with a PDT contact

Notes:
For the protection of relay coils and contacts, inductive loads must be dampened with an efficient protective circuit.
Other input voltages on request.
1) Not with 230 V AC.
2) With 230 V AC glow lamp.
3) With 100 V DC and 230 V AC glow lamp.

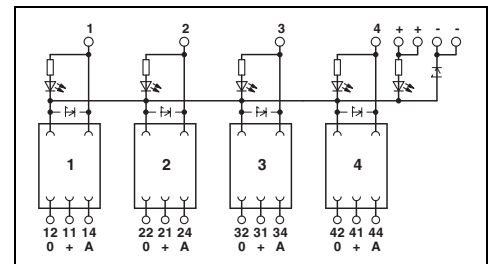
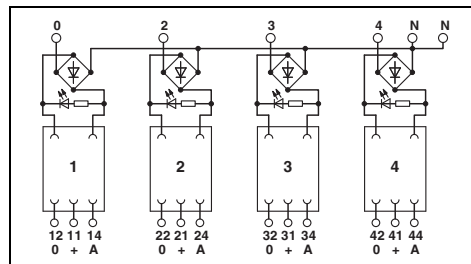

Coil side	
Tolerance of the input voltage	±10%
Input circuit	Bridge rectifier
Operating voltage display	-
Status display/channel	Yellow LED
Connection method	Screw connection
Connection data solid / stranded / AWG	0.2 ... 4 mm ² / 0.2 ... 2.5 mm ² / 24 - 12
Contact side	
Contact type	1 PDT
Max. switching voltage	250 V AC/DC
Limiting continuous current	6 A
Connection method	Screw connection
Connection data solid / stranded / AWG	0.2 ... 4 mm ² / 0.2 ... 2.5 mm ² / 24 - 12
General data	
Test voltage	2.5 kV (50 Hz, 1 min.)
Ambient temperature (operation)	-20°C ... 50°C
Standards / regulations	DIN VDE 0110
Mounting position	Any
Dimensions	W / H / D 67.5 mm / 77 mm / 59 mm

Technical data		
	±10%	
	Bridge rectifier	
	-	
	Yellow LED	
	Screw connection	
	0.2 ... 4 mm ² / 0.2 ... 2.5 mm ² / 24 - 12	
	1 PDT	
	250 V AC/DC	
	6 A	
	Screw connection	
	0.2 ... 4 mm ² / 0.2 ... 2.5 mm ² / 24 - 12	
	2.5 kV (50 Hz, 1 min.)	
	-20°C ... 50°C	
	DIN VDE 0110	
	Any	
	67.5 mm / 77 mm / 59 mm	

Technical data		
	±10%	
	Free-wheeling diode, protection against polarity reversal Yellow LED ¹⁾	
	Yellow LED ²⁾	
	Screw connection	
	0.2 ... 4 mm ² / 0.2 ... 2.5 mm ² / 24 - 24	
	1 PDT	
	250 V AC/DC	
	5 A (optocoupler-dependent)	
	Screw connection	
	0.2 ... 4 mm ² / 0.2 ... 2.5 mm ² / 24 - 12	
	2.5 kV (50 Hz, 1 min.)	
	-20°C ... 50°C	
	DIN VDE 0110	
	Any	
	67.5 mm / 77 mm / 59 mm	

Description	Input voltage
VARIOFACE module , for four pluggable miniature relays or miniature solid-state relays, with light indicator (without relays)	24 V AC/DC
VARIOFACE module , for pluggable miniature relays or miniature solid-state relays, with light indicator (without relay)	5 V DC 12 V DC 24 V DC 48 V DC 110 V DC 230 V AC

Ordering data		
Type	Order No.	Pcs. / Pkt.
UMK- 4 RM 24	2971344	1

Ordering data		
Type	Order No.	Pcs. / Pkt.
UMK- 4 RM 5DC	2972819	1
UMK- 4 RM 12DC	2972822	1
UMK- 4 RM 24DC	2972835	1
UMK- 4 RM 60DC	2972851	1
UMK- 4 RM110DC	2972864	1
UMK- 4 RM230AC	2972880	1

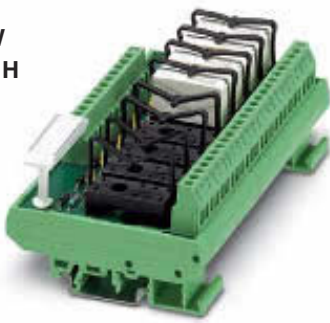

8-channel for relays with a PDT contact

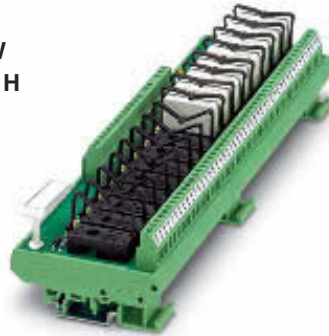

16-channel for relays with a PDT contact

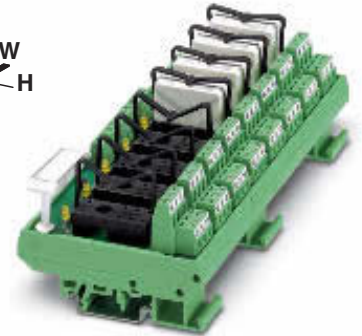

8-channel for relays with two PDT contacts

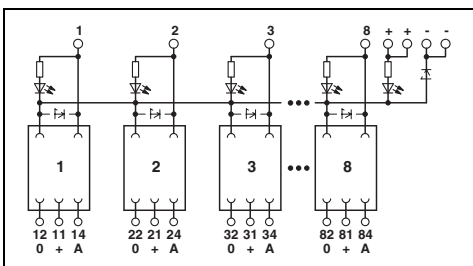

Technical data

±10%
Free-wheeling diode, protection against polarity reversal
Yellow LED³⁾

Yellow LED³⁾

Screw connection
0.2 ... 4 mm² / 0.2 ... 2.5 mm² / 24 - 24

1 PDT
250 V AC
5 A
Screw connection
0.2 ... 4 mm² / 0.2 ... 2.5 mm² / 24 - 12

2.5 kV (50 Hz, 1 min.)
-20°C ... 50°C
DIN VDE 0110
Any
135 mm / 77 mm / 59 mm

Ordering data

Type	Order No.	Pcs. / Pkt.
UMK- 8 RM 5DC/MKDS	2972893	1
UMK- 8 RM 12DC/MKDS	2972903	1
UMK- 8 RM24DC/MKDS	2972916	1
UMK- 8 RM 60DC/MKDS	2972932	1
UMK- 8 RM110DC/MKDS	2972945	1
UMK- 8 RM230AC/MKDS	2972961	1

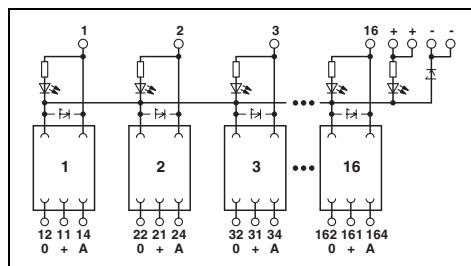

Technical data

±10%
Free-wheeling diode, protection against polarity reversal
Yellow LED²⁾

Yellow LED²⁾

Screw connection
0.2 ... 4 mm² / 0.2 ... 2.5 mm² / 24 - 24

1 PDT
250 V AC
5 A
Screw connection
0.2 ... 4 mm² / 0.2 ... 2.5 mm² / 24 - 12

2.5 kV (50 Hz, 1 min.)
-20°C ... 50°C
DIN VDE 0110
Any
259 mm / 77 mm / 59 mm

Ordering data

Type	Order No.	Pcs. / Pkt.
UMK-16 RM 5DC/MKDS	2972974	1
UMK-16 RM 12DC/MKDS	2972987	1
UMK-16 RM 24DC/MKDS	2972990	1
UMK-16 RM 60DC/MKDS	2973038	1
UMK-16 RM110DC/MKDS	2973041	1
UMK-16 RM230AC/MKDS	2973067	1

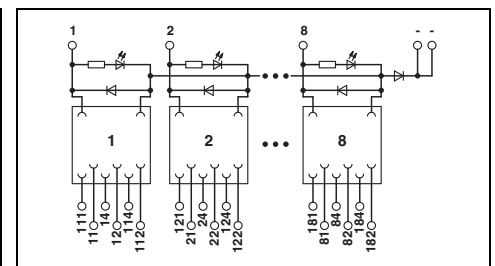

Technical data

±10%
Free-wheeling diode, protection against polarity reversal
-

Yellow LED

Screw connection
0.14 ... 1.5 mm² / 0.14 ... 1.5 mm² / 26 - 26

2 PDT
250 V AC
5 A
Screw connection
0.14 ... 1.5 mm² / 0.14 ... 1.5 mm² / 26 - 14

2.5 kV (50 Hz, 1 min.)
-20°C ... 50°C
DIN VDE 0110
Any
168.8 mm / 77 mm / 59 mm

Ordering data

Type	Order No.	Pcs. / Pkt.
UMK- 8 RELS/KSR-24/21/21	2975722	1

INTERFACE Cabling

VARIOFACE wiring interface

VARIOFACE modules as interface for pluggable solid-state relays or digital I/O modules

The 1, 4, 8 or 16-time INTERFACE modules are the wiring interface and the coupling level in one unit. The connection to the interface module is established using screw connection technology.

Properties of the single interface:

- Status indicator
- Protection against polarity reversal in input
- Surge protection in input
- Assembly option with solid-state relay for loads up to 350 V DC/1 A or 480 V AC/5 A

Properties of the 4, 8, and 16-time interfaces:

- Status indicator
- Integrated fuse for line protection
- Assembly option with solid-state relay or I/O modules

Notes:
Type of housing: Polyamide PA non-reinforced, color: Green.
For marking systems and mounting material, see CLIPLINE catalog, part 2.
For the protection of relay coils and contacts, inductive loads must be dampened with an efficient protective circuit.
Solid-state relays, see page 332.

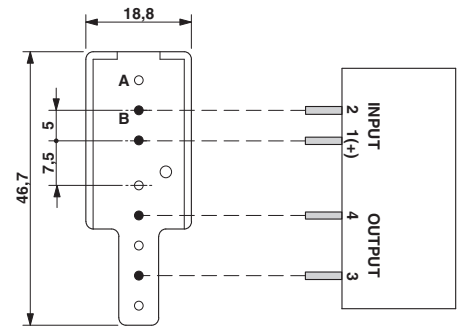

A = without metal
B = with metal

Input data	
Input voltage range	
Input circuit	
Status display/channel	
Connection method	
Connection data solid / stranded / AWG	
Output data	
Connection method	
Connection data solid / stranded / AWG	
General data	
Ambient temperature (operation)	
Standards / regulations	
Mounting position	
Mounting	
Dimensions	H / D

Description	Module width W
Interface module , with plug-in base for one solid-state relay, with locking clip	22.5
Interface module , with plug-in base for four solid-state relays, with locking clip	90
Microfuse: 250 V, 4 A	
Interface module , with plug-in base for eight digital I/O modules.	180
Microfuse: 250 V, 4 A	
Interface module , with plug-in base for eight solid-state relays, with locking clip	180
Microfuse: 250 V, 4 A	
Interface module , with plug-in base for 16 digital I/O modules.	326.5
Microfuse: 250 V, 4 A	
Interface module , with plug-in base for 16 solid-state relays, with locking clip	326.5
Microfuse: 250 V, 4 A	



With light indicator

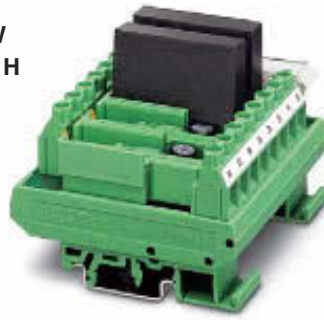

With light indicator and fuse,
control logic negative switching

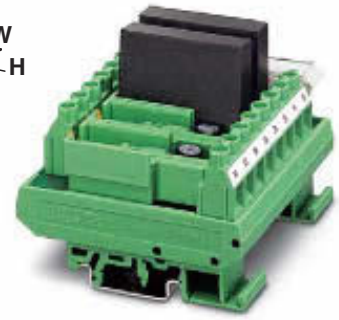

With light indicator and fuse,
control logic positive switching

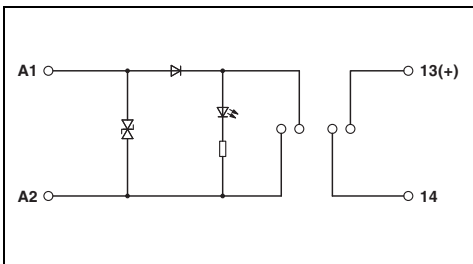

Technical data

4 V ... 32 V
Protection against polarity reversal, surge protection
Yellow LED
Screw connection
0.2 ... 4 mm² / 0.2 ... 2.5 mm² / 24 - 12

Screw connection
0.2 ... 6 mm² / 0.2 ... 4 mm² / 24 - 10

-20°C ... 60°C
DIN EN 50178

Any
In rows with zero spacing
77 mm / 72 mm

Ordering data

Type	Order No.	Pcs. / Pkt.
UMK- 1 OM-R/AMS	2983002	1

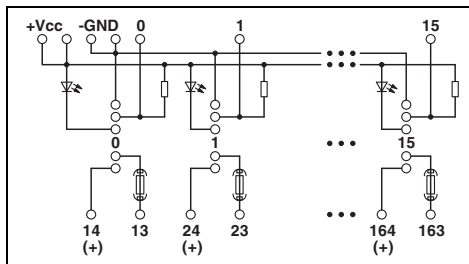

Technical data

4 V ... 32 V
Yellow LED
Screw connection
0.2 ... 4 mm² / 0.2 ... 2.5 mm² / 24 - 24

Screw connection
0.2 ... 6 mm² / 0.2 ... 4 mm² / 24 - 10

-20°C ... 55°C
DIN VDE 0110b, Gr. C for 250 V DC, DIN VDE 0160 (in relevant parts)

Any
In rows with zero spacing
77 mm / 72 mm

Ordering data

Type	Order No.	Pcs. / Pkt.
UMK- 4 OM-R/MF	2970882	1
UMK- 8 OM/MF/MKDS	2972712	1
UMK- 8 OM-R/MF/MKDS	2972738	1
UMK-16 OM/MF/MKDS	2972754	1
UMK-16 OM-R/MF/MKDS	2972770	1

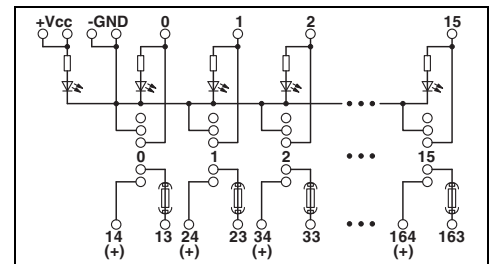

Technical data

4 V ... 32 V
Yellow LED
Screw connection
0.2 ... 4 mm² / 0.2 ... 2.5 mm² / 24 - 24

Screw connection
0.2 ... 6 mm² / 0.2 ... 4 mm² / 24 - 10

-20°C ... 55°C
DIN VDE 0110b, Gr. C for 250 V DC, DIN VDE 0160 (in relevant parts)

Any
In rows with zero spacing
77 mm / 72 mm

Ordering data

Type	Order No.	Pcs. / Pkt.
UMK- 4 OM-R/MF/P	2972673	1
UMK- 8 OM-R/MF/MKDS/P	2972699	1
UMK-16 OM-R/MF/MKDS/P	2972796	1

INTERFACE Cabling

VARIOFACE wiring interface

Miniature relay REL-MR

The robust relays are used as interface relays throughout process and production engineering.

The main features of these relays are their compact design, reliable electrical isolation, and compliance with the most important standards, as well as the number of variants.

Notes:

If the specified maximum values for multi-layer contact relays are exceeded, the gold plating is destroyed. The maximum values of the power contact relay are then valid. This can result in a shorter service life than with a pure power contact.

For diagrams of operating voltage ranges, see page 104.



Pluggable miniature relay
1 N/O contact (1)

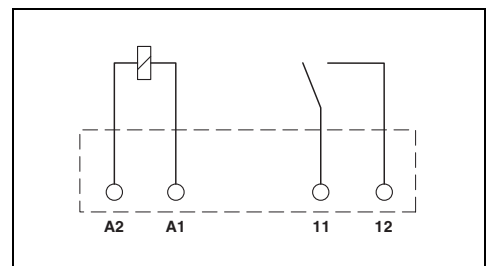

Technical data

Input data	②
Permissible range (with reference to U_N)	-
Permissible range (with reference to U_N)	0.8 - 1.1
Typ. input current at U_N [mA]	5
Typ. response time at U_N [ms]	5
Typ. response time at U_N (depending on phase relation) [ms]	-
Typ. release time at U_N [ms]	2
Typ. release time at U_N (depending on phase relation) [ms]	-
Output data	
Contact type	Double contact, 1 N/O contact
Contact material	AgNi 90/10, + 5 μ m hard gold-plated
Max. switching voltage	250 V AC / 125 V DC
Min. switching voltage	5 V DC
Limiting continuous current	3 A
Max. inrush current	5 A
Max. interrupting rating, ohmic load	-
	250 V AC
General data	
Test voltage (winding / contact)	2 kV AC (50 Hz, 1 min.)
Test voltage (contact / contact)	-
Ambient temperature (operation)	-40°C ... 85°C
Nominal operating mode	100% operating factor
Mechanical service life	Approx. 2×10^7 cycles
Standards / regulations	DIN VDE 0110, IEC 255 / DIN VDE 0435 (in relevant parts)
Mounting position / mounting	Any
Dimensions	W / H / D 5 mm / 23 mm / 17 mm

Ordering data

Description	Input voltage U_N	Type	Order No.	Pcs. / Pkt.
Pluggable miniature relays				
with power contact	① 12 V DC	REL-MR-G 24/1	2961037	8
with power contact	② 24 V DC			
with power contact	③ 48 V DC			
with power contact	④ 60 V DC			
with power contact	⑤ 110 V DC			
with power contact	⑥ 230 V AC			
Pluggable miniature relays				
with gold contact	① 12 V DC			
with gold contact	② 24 V DC			
with gold contact	③ 48 V DC			
with gold contact	④ 60 V DC			
with gold contact	⑤ 110 V DC			
with gold contact	⑥ 230 V AC			



1 PDT, for high continuous currents



2 PDT

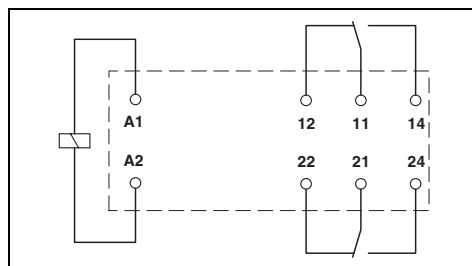
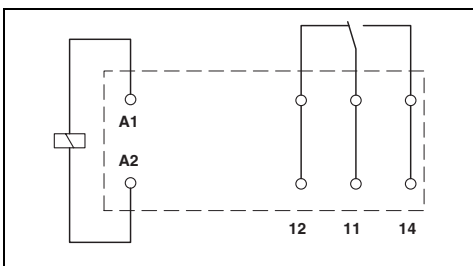

Technical data

① ② ③ ④ ⑤ ⑥
 Refer to the diagram

33	17	8.7	8.2	4.1	3
7	7	7	7	7	
					3 - 12
3	3	3	3	3	2 - 9

Single contact, 1 PDT AgNi 250 V AC/DC 12 V (at 10 mA) 16 A 30 A (300 ms)	Single contact, 1 PDT AgNi, hard gold-plated 30 V AC / 36 V DC 100 mV (at 10 mA) 50 mA 50 mA
4000 VA	-

5 kV AC (50 Hz, 1 min.)
 -
 -40°C ... 85°C
 100% operating factor
 3 x 10⁷ cycles
 IEC 60664, EN 50178, IEC 62103

Any / can be aligned without spacing (> 70°C ≥ 2.5 mm)

12.7 mm / 29 mm / 15.7 mm

Technical data

① ② ③ ④ ⑤ ⑥
 Refer to the diagram

33	17	8.7	8.2	4.1	3
7	7	7	7	7	
					3 - 12
3	3	3	3	3	2 - 9

Single contact, 2 PDT AgNi 250 V AC/DC 5 V (at 10 mA) 8 A 15 A (300 ms)	Single contact, 2 PDT AgNi, hard gold-plated 30 V AC / 36 V DC 100 mV (at 10 mA) 50 mA 50 mA
2000 VA	-

5 kV AC (50 Hz, 1 min.)
 2.5 kV AC (50 Hz, 1 min.)
 -40°C ... 85°C
 100% operating factor
 3 x 10⁷ cycles
 IEC 60664, EN 50178, IEC 62103

Any / can be aligned without spacing (> 70°C ≥ 2.5 mm)

12.7 mm / 29 mm / 15.7 mm

Ordering data

Type	Order No.	Pcs. / Pkt.
REL-MR- 12DC/21HC	2961309	10
REL-MR- 24DC/21HC	2961312	10
REL-MR- 48DC/21HC	2834821	10
REL-MR- 60DC/21HC	2961325	10
REL-MR-110DC/21HC	2961338	10
REL-MR-230AC/21HC	2961422	10
REL-MR- 12DC/21HC AU	2961532	10
REL-MR- 24DC/21HC AU	2961545	10
REL-MR-110DC/21HC AU	2961561	10
REL-MR-230AC/21HC AU	2961529	10

Ordering data

Type	Order No.	Pcs. / Pkt.
REL-MR- 12DC/21-21	2961257	10
REL-MR- 24DC/21-21	2961192	10
REL-MR- 48DC/21-21	2834834	10
REL-MR- 60DC/21-21	2961273	10
REL-MR-110DC/21-21	2961202	10
REL-MR-230AC/21-21	2961451	10
REL-MR- 12DC/21-21AU	2961299	10
REL-MR- 24DC/21-21AU	2961215	10
REL-MR- 48DC/21-21AU	2834847	10
REL-MR- 60DC/21-21AU	2961286	10
REL-MR-110DC/21-21AU	2961228	10
REL-MR-230AC/21-21AU	2961480	10

INTERFACE Cabling

VARIOFACE wiring interface

Miniature solid-state relay SIM-EI

The SIM-EI miniature solid-state relays have connections compatible with commercially available miniature switching relays and are of the same shape.

The modules are used for floating conditioning of process signals as an alternative to electromechanical relays. Substituting mechanical relays for solid-state ones opens new possibilities for solving interface problems in a user-friendly way. The compatibility of the pins with the mechanical relay permits use of solid-state relays without any changes in the layout. The output of the solid-state relay is "high active" and designed as a 2 or 3-wire output.



With DC voltage output, max. = 100 mA

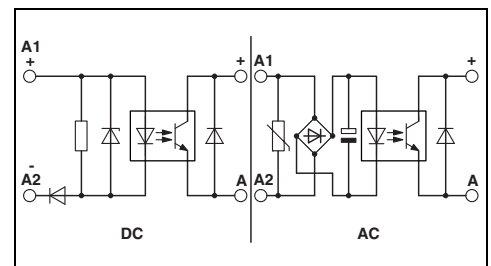

Input data	
Permissible range (with reference to U_N)	
Switching level with reference to U_N	1 signal ("H") 0 signal ("L")
Typ. input current at U_N	[mA]
Transmission frequency f_{limit}	[Hz]
Input circuit AC	
Input circuit DC	
Output data	
Operating voltage range	
Limiting continuous current	
Residual voltage drop at "H"	
Max. inrush current	
Output circuit	
Output protection	
General data	
Test voltage input/output	
Ambient temperature (operation)	
Standards / regulations	
Mounting position / mounting	
Dimensions	W / H / D

Technical data							
①	②	③	④	⑤	⑥	⑦	⑧
0.9 - 1.1	0.9 - 1.1	0.9 - 1.1	0.9 - 1.1	0.9 - 1.1	0.9 - 1.1	0.9 - 1.1	0.9 - 1.1
≥ 0.8	≥ 0.8	≥ 0.8	≥ 0.8	≥ 0.8	≥ 0.8	≥ 0.8	≥ 0.8
≤ 0.35	≤ 0.4	≤ 0.4	≤ 0.25	≤ 0.4	≤ 0.4	≤ 0.4	≤ 0.4
5.4	5.7	5.1	6.8	2.4	2.6	2.1	2.1
600	600	600	600	300	300	3	3
Protection against polarity reversal, surge protection							
Protection against polarity reversal							
8 V DC ... 48 V DC							
100 mA							
1 V							
-							
2-wire, floating							
Protection against polarity reversal							
2.5 kV (50 Hz, 1 min.)							
-20°C ... 50°C							
DIN VDE 0110							
Any / can be aligned with 2 mm spacing							
13 mm / 29 mm / 25 mm							

Description	Input voltage U_N
Solid-state relay , with protective circuit in the input and output circuit	① 5 V DC
	② 12 V DC
	③ 24 V DC
48 V DC ... 60 V DC	④ 60 V DC
	⑤ 110 V DC
	⑥ 220 V DC
	⑦ 120 V AC
	⑧ 230 V AC

Ordering data		
Type	Order No.	Pcs. / Pkt.
SIM-EI- 5DC/48DC/100	2271057	10
SIM-EI- 12DC/48DC/100	2271060	10
SIM-EI- 24DC/48DC/100	2271073	10
SIM-EI- 60DC/48DC/100	2271086	10
SIM-EI-110DC/48DC/100	2271099	10
SIM-EI-220DC/48DC/100	2271109	10
SIM-EI-120AC/48DC/100	2271112	10
SIM-EI-230AC/48DC/100	2271125	10

Accessories		
Type	Order No.	Pcs. / Pkt.
SIM-ERSN	2271484	100
SIM-ERSN-HB-KSR	2271468	10
SIM-ERSN-HB-KSR/MET	2271497	10
SIM-ERSN-HB-MR	2271471	10
SIM-ERSN-HB-MR/MET	2271510	10

Plug-in base , for plug-in miniature relays or miniature solid-state relays, for soldering onto the printed circuit board.
Retaining bracket , for miniature solid-state relay
- Plastic
- Metal
Retaining bracket , for miniature relay
- Plastic
- Metal

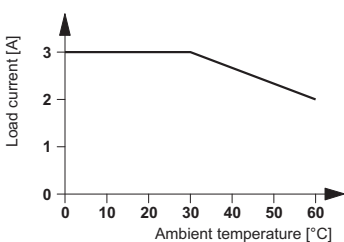

Derating curve for SIM-EI-OV-24 DC/24 DC/3



With TTL logic level output,
max. = 100 mA



With DC voltage output,
max. = 100 mA, RC element in input



With DC voltage output,
max. = 3 A

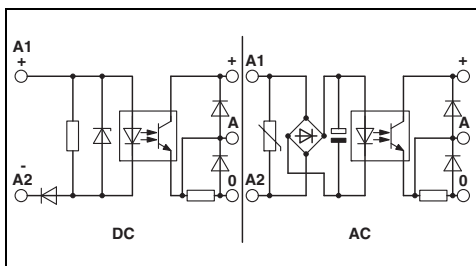

Technical data

①	②	③	④	⑤	⑥	⑦	⑧
0.9 - 1.1	0.9 - 1.1	0.9 - 1.1	0.9 - 1.1	0.9 - 1.1	0.9 - 1.1	0.9 - 1.1	0.9 - 1.1
≥ 0.8	≥ 0.8	≥ 0.8	≥ 0.8	≥ 0.8	≥ 0.8	≥ 0.8	≥ 0.8
≤ 0.35	≤ 0.4	≤ 0.4	≤ 0.25	≤ 0.4	≤ 0.4	≤ 0.4	≤ 0.4
5.4	5.7	5.1	4.7	2.4	2.6	2.1	2.1
4000	4000	4000	4000	1000	1000	3	3

Protection against polarity reversal, surge protection
Protection against polarity reversal

3 V DC ... 5.25 V DC
100 mA

0.3 V
-

3-wire, ground-referenced
Protection against polarity reversal, free running

2.5 kV (50 Hz, 1 min.)
-20°C ... 50°C
DIN VDE 0110
Any / can be aligned with 2 mm spacing
13 mm / 29 mm / 25 mm

Ordering data

Type	Order No.	Pcs. / Pkt.
SIM-EI-5DC/TTL/100	2271138	10
SIM-EI-12DC/TTL/100	2271141	10
SIM-EI-24DC/TTL/100	2271154	10
SIM-EI-60DC/TTL/100	2271167	10
SIM-EI-110DC/TTL/100	2271170	10
SIM-EI-220DC/TTL/100	2271183	10
SIM-EI-120AC/TTL/100	2271196	10
SIM-EI-230AC/TTL/100	2271206	10

Accessories

Type	Order No.	Pcs. / Pkt.
SIM-ERSN	2271484	100
SIM-ERSN-HB-KSR	2271468	10
SIM-ERSN-HB-KSR/MET	2271497	10
SIM-ERSN-HB-MR	2271471	10
SIM-ERSN-HB-MR/MET	2271510	10

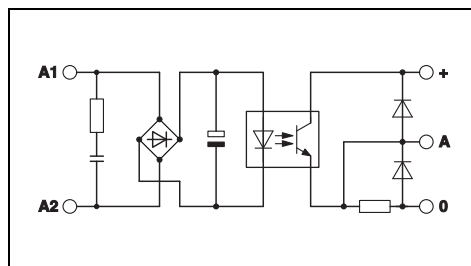

Technical data

⑦	⑧
0.9 - 1.1	0.9 - 1.1
≥ 0.8	≥ 0.8
≤ 0.4	≤ 0.4
2.2	2.5
3	3

RC element

8 V DC ... 48 V DC
100 mA

1 V
-
2-wire, floating
Protection against polarity reversal

2.5 kV (50 Hz, 1 min.)
-20°C ... 50°C
DIN VDE 0110
Any / can be aligned with 2 mm spacing
13 mm / 29 mm / 25 mm

Ordering data

Type	Order No.	Pcs. / Pkt.
SIM-EI-120AC/48DC/100/RC	2271439	10
SIM-EI-230AC/48DC/100/RC	2271426	10

Accessories

Type	Order No.	Pcs. / Pkt.
SIM-ERSN	2271484	100
SIM-ERSN-HB-KSR	2271468	10
SIM-ERSN-HB-KSR/MET	2271497	10
SIM-ERSN-HB-MR	2271471	10
SIM-ERSN-HB-MR/MET	2271510	10

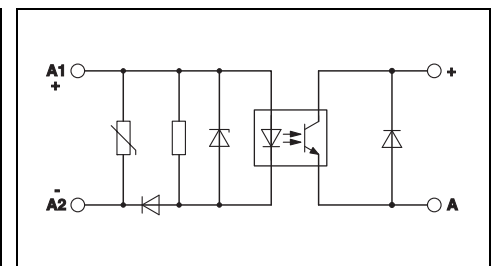

Technical data

③
0.8 - 1.2
≥ 0.8
≤ 0.4
7
300

Protection against polarity reversal, surge protection

3 V DC ... 33 V DC
3 A (see derating curve)

≤ 200 mV
15 A (10 ms)
2-wire, floating
Protection against polarity reversal, surge protection

2.5 kV (50 Hz, 1 min.)
-20°C ... 60°C
DIN VDE 0110
Any / can be aligned with 2 mm spacing
13 mm / 29 mm / 25 mm

Ordering data

Type	Order No.	Pcs. / Pkt.
SIM-EI-OV-24DC/24DC/3	2300096	10

Accessories

Type	Order No.	Pcs. / Pkt.
SIM-ERSN	2271484	100
SIM-ERSN-HB-KSR	2271468	10
SIM-ERSN-HB-KSR/MET	2271497	10
SIM-ERSN-HB-MR	2271471	10
SIM-ERSN-HB-MR/MET	2271510	10

INTERFACE Cabling

VARIOFACE wiring interface

Solid-state relay OV

Solid-state relays for electrical isolation can be mounted directly on the printed circuit board as interfaces or plugged in using the solder-in socket SIM-AMS.

The solid-state relays are suitable for switching ohmic, capacitive or inductive loads. Relays for switching AC circuits have a zero voltage switch to switch the load on in the zero voltage crossing. It is switched off in the zero current crossing. The integrated RC element permits operation up to $\cos \phi = 0.5$.

Inductive DC loads must be equipped with a fast-acting free-wheeling diode for semiconductor relay protection.

- Switching capacity up to 350 V DC/1 A, 60 V DC/4 A or 480 V AC/5 A
- No wear and tear, even with high switching frequencies
- No contact bounce – no movable parts
- No electromagnetic interference
- Electrically insulated housings
- Small dimensions
- High test voltage of 4 kV between control and load circuits

Notes:
For derating curves see page 338.
For suitable bases, see page 334.
1) Turn-on/off time at U_N : Max. ½ period



With DC voltage output, max. = 1 A

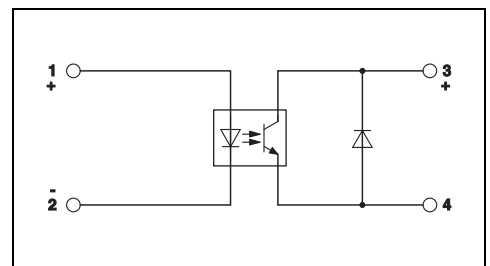

Technical data

Input data	①
Input voltage range	4.25 V DC ... 32 V DC
Switching level	3.3
	1 signal ("H") [V DC] \geq
	0 signal ("L") [V DC] \leq
Typ. input current at U_N	[mA] 15
Typ. switch-on time at U_N	[μ s] 100
Typ. switch-off time at U_N	[μ s] 250
Transmission frequency f_{limit}	[Hz] 100
Output data	
Operating voltage range	1 V DC ... 350 V DC
Periodic peak reverse voltage	-
Limiting continuous current	1 A (see derating curve)
Min. load current	1 mA
Surge current	20 A ($t_p = 1$ s)
Residual voltage drop at "H"	0.5 V
Leakage current in off state	100 μ A
Phase angle ($\cos \phi$)	-
Max. load value	-
Output protection	Protection against polarity reversal
General data	
Test voltage input/output	4 kV (50 Hz, 1 min.)
Ambient temperature (operation)	-20°C ... 80°C
Standards / regulations	EN 61000-4-2, EN 61000-4-3, EN 61000-4-4, EN 55011
Mounting position / mounting	Any / can be aligned with > 9 mm spacing
Dimensions	W / H / D 10.5 mm / 43 mm / 25.4 mm

Ordering data

Description	Input voltage U_N	Type	Order No.	Pcs. / Pkt.
Solid-state relay for signal amplification and electrical isolation of the control and load circuits, pluggable in the solder-in plug-in base SIM-AMS or with PCB connection for direct mounting onto the PCB Input: DC voltage Output: DC voltage	① 24 V DC	OV-24DC/350DC/1	2982634	10
Solid-state relay , same as before, however Input: DC voltage Output: AC voltage	① 24 V DC			



With DC voltage output,
max. = 4 A



With alternating voltage output,
max. = 5 A

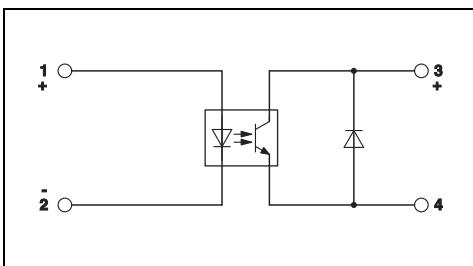

Technical data

①
 4.25 V DC ... 32 V DC
 3.3
 1
 15
 100
 250
 100

1 V DC ... 60 V DC
 -
 4 A (see derating curve)
 1 mA
 25 A (tp = 1 s)
 0.5 V
 100 µA
 -
 -
 Protection against polarity reversal

4 kV (50 Hz, 1 min.)
 -20°C ... 80°C
 EN 61000-4-2, EN 61000-4-3, EN 61000-4-4, EN 55011

Any / can be aligned with > 20 mm spacing
 10.5 mm / 43 mm / 25.4 mm

Ordering data

Type	Order No.	Pcs. / Pkt.
OV-24DC/ 60DC/4	2982647	10

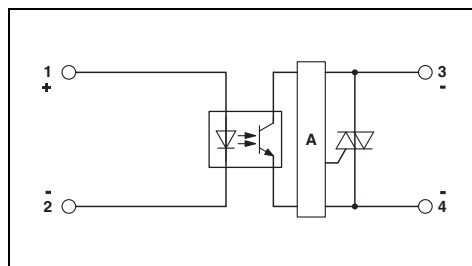

Technical data

①
 4 V DC ... 32 V DC
 3.5
 1.2
 10
 1)
 1)
 25

12 V AC ... 530 V AC (45/65 Hz)
 1000 V
 5 A (see derating curve)
 20 mA
 80 A (tp = 20 ms)
 1.2 V
 < 1 mA
 0.5
 50 A²s
 -

4 kV (50 Hz, 1 min.)
 -20°C ... 70°C
 EN 61000-4-2, EN 61000-4-3, EN 61000-4-4, EN 61000-4-5,
 EN 61000-4-6

Any / can be aligned with > 20 mm spacing
 10.5 mm / 43 mm / 25.4 mm

Ordering data

Type	Order No.	Pcs. / Pkt.
OV-24DC/480AC/5	2982650	10

INTERFACE Cabling

VARIOFACE wiring interface

Solder-in socket for solid-state relays and I/O modules

Modern interface solutions for computer and electronic controls are increasingly being designed as I/O systems which are system independent and individually mountable. Electrical isolation and signal conditioning are carried out using standard I/O modules. These are produced by various manufacturers in pin-compatible versions for different functions. The I/O modules are either soldered directly into the PCB or plugged into component sockets for quick interchanging.

SIM sockets facilitate the plugging of I/O modules considerably. All standard I/O modules and solid-state relays with up to eight connections can be plugged into the solder-in plug-in socket.

The I/O modules are securely fixed to the socket using fastening screws which are specific to the module. They are thereby protected against being accidentally released. Optocouplers, now also available in pluggable versions, are secured using the latch which is attached to the socket and which can be labeled. For better identification, each module plug position has its own marking panel on the socket.

The SIM socket has been designed so that it can be used on existing printed circuit boards without any layout modifications. Peripheral components such as LEDs or fuse resistors remain accessible to the user.

Notes:
Type of housing: Polyamide PA non-reinforced, color: Green.
For marking systems and mounting material, see CLIPLINE catalog, part 2.
For dimensional drawings and pin assignments, see page 338.
¹⁾ Applies only to the sockets SIM-AMS 1, SIM-AMS 1-R, and SIM-AMSC in connection with the standard I/O modules with the corresponding AC voltage output.

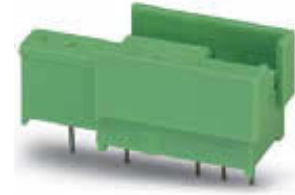

Plug-in base for solid-state relays

Operating voltage

Nominal current
Standards / regulations



Technical data

250 V AC / 380 V AC¹⁾

5 A
DIN VDE 0110b, Gr. C for 250 V DC

Ordering data

Description	No. of poles	Module width W
Plug-in base , for solid-state relay and I/O modules, with different numbers of contacts, can be labeled with marker pins BN or BNB		
Partial assembly Complete assembly		
Plug-in base , as above, however, with locking clips for fastening		
Partial assembly Complete assembly		
Plug-in base , for standard I/O modules of generation 4 of the company Opto 22, can be labeled using marker pins BN or BNB		

Type	Order No.	Pcs. / Pkt.
SIM-AMS 1	2271015	10
SIM-AMS 2	2271028	10

Accessories

Marker pin , made of white plastic, lettering area 7.5 x 4 mm, unprinted for self-marking with B-STIFT
Marker pen, not refillable , for manual labeling, line thickness 0.5 mm

BN-TRK	2701404	100
B-STIFT	1051993	10



Plug-in base for solid-state relays with locking clip



Plug-in base for I/O modules



Technical data

250 V AC / 380 V AC¹⁾
 5 A
 DIN VDE 0110b, Gr. C for 250 V DC

Ordering data

Type	Order No.	Pcs. / Pkt.
SIM-AMS 1-R	2271031	10
SIM-AMS 2-R	2271044	10

Accessories

BN-TRK	2701404	100
B-STIFT	1051993	10



Technical data

250 V AC / 380 V AC¹⁾
 5 A
 DIN VDE 0110b, Gr. C for 250 V DC

Ordering data

Type	Order No.	Pcs. / Pkt.
SIM-AMSC1	2271390	50

Accessories

BN-TRK	2701404	100
B-STIFT	1051993	10

INTERFACE Cabling

VARIOFACE wiring interface

Modules for IEC 60603/DIN 41612 connectors

Cable housings suitable for snap-lock mechanism:

Manufacturer	Type F, 32- and 48-pos.
HARTING	Types "B" and "D"

Cable housings suitable for screw locking:

Manufacturer	Type C, 64-pos.	Type D, 32-pos.
ERNI	KSG 173...	KSG 173...
AMP	826196-1	826196-1

Cable housings suitable for screw locking:

Manufacturer	Type E, 48-pos.	Type F, 32- and 48-pos.
ERNI	KSG 173...	KSG 203...
AMP	-	826198-1

Modules for ELCO connectors

Dimensional drawing for UMK-EC38/38-XOL

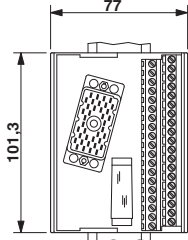

Dimensional drawing for UMK-EC38/38-XOR

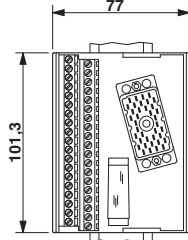

Dimensional drawing for UMK-EC56/56-XOL

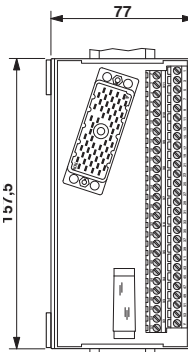

Dimensional drawing for UMK-EC56/56-XOR

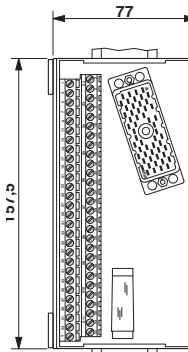

Dimensional drawing for UMK-EC56/FRONT 2,5V/R

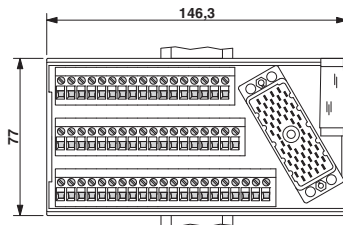

Dimensional drawing for UMK-EC56/FRONT 2,5V/L

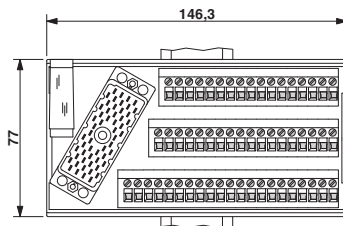

Dimensional drawing for UMK-EC56/32-XOL

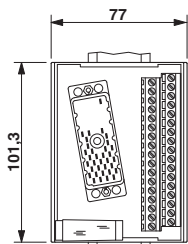

Dimensional drawing for UMK-EC56/32-XOR

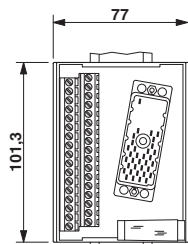

Pin assignment UMK-EC38/38...

Terminal	Pin strip
1	A
2	B
3	C
4	D
5	E
6	F
7	H
8	J
9	K
10	L
11	M
12	N
13	P
14	R
15	S
16	T
17	U
18	V
19	W
20	X
21	Y
22	Z
23	AA
24	BB
25	DD
26	EE
27	FF
28	HH
29	JJ
30	KK
31	LL
32	MM
33	NN
34	PP
35	RR
36	SS
37	CC
CC	CC

Pin assignment UMK-EC56/56...

Terminal	Pin strip
Z	Z
1	A
2	B
3	C
4	D
5	E
6	F
7	H
8	J
9	K
10	L
11	M
12	N
13	P
14	R
15	S
16	T
17	U
18	V
19	W
20	X
21	a
22	b
23	c
24	d
25	e
26	f
27	h
28	j
29	k
30	l
31	m
32	n
33	p
34	r
35	s
36	t
37	u
38	v
39	w
40	x
41	y
42	z
43	AA
44	BB
45	CC
46	DD
47	EE
48	FF
49	HH
50	JJ
51	KK
52	LL
53	MM
54	NN
Y	Y (shield)

Modules for ELCO connectors with Ex i protection type

Pin assignment
 UMK-EC56/FRONT 2,5V/...

Terminal	ELCO connector
X	N.C.
1	A
2	B
3	C
4	D
5	E
6	F
7	H
8	J
9	K
10	L
11	M
12	N
13	P
14	R
15	S
16	T
17	U
18	V
19	W
20	X
21	a
22	b
23	c
24	d
25	e
26	f
27	h
28	j
29	k
30	l
31	m
32	n
33	p
34	r
35	s
36	t
37	u
38	v
39	w
40	x
41	y
42	z
43	AA
44	BB
45	CC
46	DD
47	EE
48	FF
49	HH
50	JJ
51	KK
52	LL
53	MM
54	NN
Y	Y (shield)

Pin assignment
 UMK-EC56/32-...

Terminal	ELCO connector
1	A
2	B
3	C
4	D
5	E
6	F
7	H
8	J
9	K
10	L
11	M
12	N
13	P
14	R
15	S
16	T
17	U
18	V
19	W
20	X
21	Z
22	a
23	b
24	c
25	d
26	e
27	f
28	h
29	j
30	k
31	l
32	m
Y	NN + Y

Dimensional drawing for
 UMK-EC90/32/EX-XUL

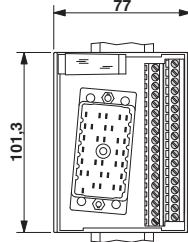

Dimensional drawing for
 UMK-EC90/32/EX-XUR

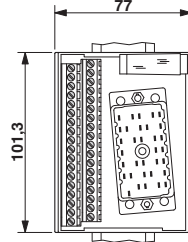

Dimensional drawing for
 UMK-EC56/25/EX-L

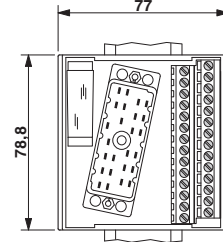

Dimensional drawing for
 UMK-EC56/25/EX-R

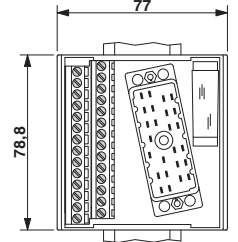

Dimensional drawing for
 UMK-EC90/32/EX-XOL

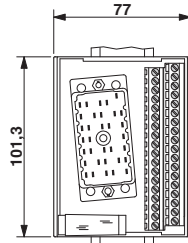

Dimensional drawing for
 UMK-EC90/32/EX-XOR

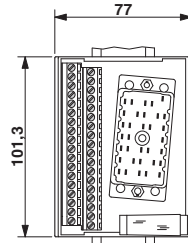

Dimensional drawing for UMK-EC 56/25/EX/FRONT 2,5 V/L

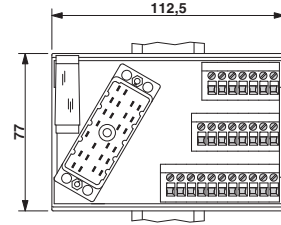

Dimensional drawing for UMK-EC 56/25/EX/FRONT 2,5 V/R

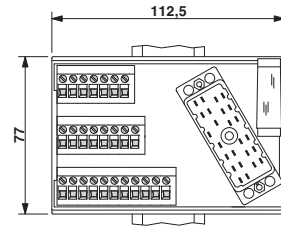

Pin assignment
 UMK-EC90/32/EX-...

Terminal	Pin strip	Channel
1	H	
2	J	1
3	L	
4	M	2
5	P	
6	X	3
7	Z	
8	AA	4
9	AC	
10	AD	5
11	AM	
12	AN	6
13	AR	
14	AS	7
15	AU	
16	BC	8
17	AZ	
18	BA	9
19	BJ	
20	BK	10
21	BM	
22	BN	11
23	BR	
24	BY	12
25	CA	
26	CB	13
27	CD	
28	CE	14
29	CN	
30	CP	15
31	CS	
32	CT	16
Y	DB	

Pin assignment
 UMK-EC 56/25/EX/...

Terminal	Pin strip	Channel
1	C	
2	D	1
3	E	
4	F	2
5	N	
6	P	3
7	R	
8	S	4
9	a	
10	b	5
11	d	
12	j	6
13	k	
14	l	7
15	s	
16	t	8
17	u	
18	v	9
19	BB	
20	CC	10
21	DD	
22	EE	11
23	MM	
24	NN	12
Y	Y	

INTERFACE Cabling

VARIOFACE wiring interface

OV solid-state relays

Load current as a function of ambient temperature
Operating time: 100% OT

OV-24DC/350DC/1

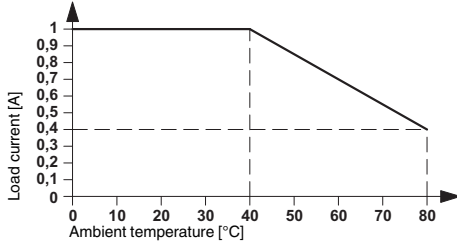

OV-24DC/60DC/4

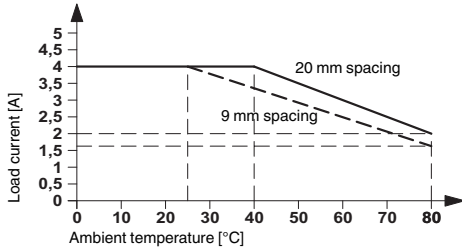

OV-24DC/480AC/5

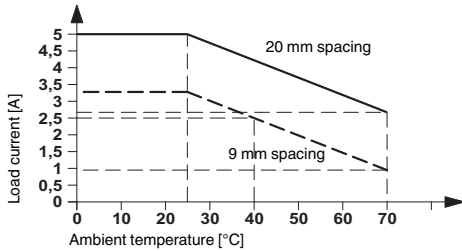

Solder-in SIM-AMS plug-in bases for solid-state relays and I/O modules

Dimensional drawing for SIM-AMS:

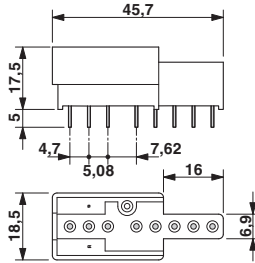

Dimensional drawing for SIM-AMSC:

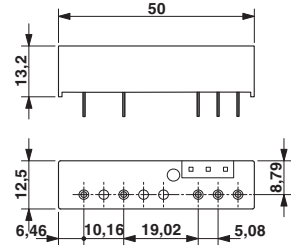

Dimensional drawing for SIM-AMS...R:

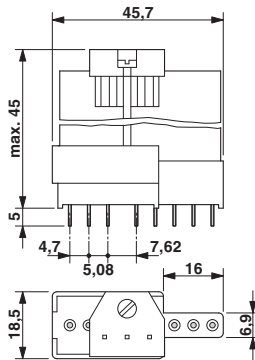

Contacts in the SIM-AMSC plug-in base:



- With metal
- Without metal

Note:
4th generation optocoupler, available from Opto 22.

Contacts in the SIM-AMS plug-in base

1. Partial mounting for standard I/O modules

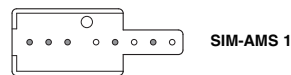

2. Complete mounting for analog I/O modules, for example

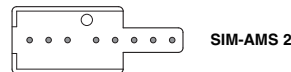

- With metal
- Without metal