

ARGUS[®]

Cordex 48-1kW 19" Shelf, Flush Mounting For Systems Up To 6000W

030-828-B2
(030-707-20 pre-RoHS)



Visit us at www.argus.ca

Power

This page intentionally left blank.

Cordex 48-1kW 19" Shelf, Flush Mounting For Systems Up To 6000W

030-828-B2
(030-707-20 pre-RoHS)

The following documents and drawings are included in this manual to provide the necessary information required for installation, operation and fault diagnosis of the unit:

- **Specifications, 19" Shelf, Flush Mounting:** 030-828-B1
- **Specifications, Rectifier:** 010-606-B1 (010-566-20 pre-RoHS)
- **CSA/NRTL Equivalence:** 048-554-10
- **Installation and Operation Instructions:** 030-827-C0
- **Schematic:** 030-707-05 (RoHS: 030-828-20)
- **Outline Drawing, 19" Shelf, Flush Mounting:** 030-707-06 (RoHS: 030-828-20)
- **Customer Connections:** 030-707-08 (RoHS: 030-828-20)
- **Warranty and Service Information:** 048-700-10
- **Service Centers:** 048-693-10

Specifications for Argus' Cordex 48-1kW 19" Shelf, Flush Mounting, System

Basic Unit, Shelf

Output:	111A @ 54Vdc nominal (124.8A maximum @ 48V)
Recommended Feeder Breaker	
Single Phase:	15A, #12AWG, 90 deg.C wire at 30 deg. C ambient (per rectifier) [refer also to AC Feeder Protection/Sizing section of the manual]

Mechanical

Dimensions*:	177.3mm H x 444.5mm W x 303.4mm D (rectifier front panel 18.8mm D) [6.98" H x 17.50" W x 11.95" D (rectifier front panel 0.74" D)]
Mounting*:	19" flush
Weight:	7.5 kg (16.5 lb.)

Connections*

AC Input:	#6-32 screw terminal blocks
Chassis ground:	1/4-20 stud
Communications:	CAN (bus), in and out, RJ-12 offset; Ethernet RJ-45
DC Output:	1/4-20 x 5/8" studs
Signal wiring:	Terminal blocks 0.75 to 0.14mm ² (#18 to #26 AWG)

Safety

CSA	C22.2 No. 60950-1
UL	60950-1
CE	EN 60950, CB Scheme 73/23/EEC Low Voltage Directive with amendment 93/68/EEC
EN 60950	Rectifier output shall be rated SELV suitable for connection to TNV-1 circuits

* See drawings at the rear of this manual.

Basic Unit, CXCM

Input Voltage:	17 to 65Vdc within rated limits
Current:	<100mA @ 48Vdc <200mA @ 24Vdc
MTBF:	>430,000 hours @ 30°C (86°F)
EMC:	The unit meets requirements of: ICES-003 Class B EN 55022 Class B (CISPR 22) EN 61000-4-2 ESD EN 61000-4-3 Radiated Immunity EN 61000-4-4 EFT /Burst EN 61000-4-6 Conducted Immunity FCC Part 15 Class B, FCC Part 68

In accordance with FCC requirements, we provide the following statement as specified in the FCC guidelines for conformance to Part 15, Class B:

NOTE: *This equipment has been tested and found to comply with the limits for a Class B digital device, pursuant to part 15 of the FCC Rules. These limits are designed to provide reasonable protection against harmful interference in a residential installation. This equipment generates, uses, and can radiate radio frequency energy and, if not installed and used in accordance with the instructions, may cause harmful interference to radio communications. However, there is no guarantee that interference will not occur in a particular installation. If this equipment does cause harmful interference to radio or television reception, which can be determined by turning the equipment off and on, the user is encouraged to try to correct the interference by one or more of the following measures:*

- Reorient or relocate the receiving antenna.
- Increase the separation between the equipment and receiver.
- Connect the equipment into an outlet on a circuit different from that to which the receiver is connected.
- Consult the dealer or an experienced radio/TV technician for help.

Any changes or modifications to this equipment not expressly described in this manual could void the FCC compliance.

Environmental

Temperature:	-40 to 65°C standard @ 3000m derate to 55°C @ 4000m (-40 to 149°F derate to 131°F @ 13124ft)
Humidity:	0 to 95% non-condensing
Elevation:	-500 to +4000m (-1640 to 13124 ft)

Hardware Specifications, CXCM

CPU:	Coldfire
RAM:	8MB
Flash:	4MB standard, 8MB optional
Display:	160 x 160 pixel grayscale LCD
Front Panel Controls:	Reset button and touch panel (display and input device)
LED's:	System OK (Green) Power System Minor Alarm (Yellow) Power System Major Alarm / Controller Fail (Red)
Audio:	Built-in speaker for alarm and popup message tones
Dimensions:	177mm H x 74mm W x 255mm D (6.9" H x 2.9" W x 10" D)
Weight:	2.2 kg (5 lb.)
Mounting*:	Modular on Cordex 4RU series 1kW shelves
Relay Outputs*:	Eight (8) Form C, 60Vdc 1A maximum
Digital Inputs*:	Three (3), 0 to 60Vdc
Analog Inputs and System Signals*: [standard for List 120]	Two (2) DC voltage -LVD1 (K1), Form C relay, 60Vdc 1A maximum -Load Voltage (V1), 0 to 100Vdc One (1) current, $\pm 50\text{mV}$ Two (2) temperature, 0 to 20Vdc with power source One (1) bi-voltage

* See drawings at the rear of this manual.

The above information is valid at the time of publication. Consult factory for up-to-date ordering information. Specifications are subject to change without notice.

Specifications for Argus' Switched Mode Rectifier Cordex 48-1kW

Power Module Output

Voltage:	40.5 to 58Vdc within rated limits
Current:	18.5A @ 54Vdc nominal (20.8A maximum @ 48V)
Maximum Power:	1000W continuous/module
Static Load Regulation:	Better than $\pm 0.5\%$ for any load change within rated limits
Dynamic Load Regulation:	Better than $\pm 2\%$ for 10% - 90% load step (output shall recover to static limits within 2ms)
Static Line Regulation:	Better than $\pm 0.1\%$ for any change in input voltage within rated limits
Dynamic Line Regulation:	Better than $\pm 1\%$ for any change in input voltage within rated limits (output voltage shall recover to static limits within 2ms)
Hold-up Time:	10ms
Time Stability:	$\leq 0.2\%$ per year
Temperature Stability:	$\leq 100\text{ppm}/^\circ\text{C}$ over the operating range
Heat Dissipation:	$< 340\text{BTU}$ per hour (per rectifier module)
Electrical Noise:	$< 26\text{dBnC}$ (voice band) without battery $\leq 22\text{dBnC}$ (voice band) with battery $< 5\text{mVrms}$ to 100MHz (wideband) $< 100\text{mVp-p}$ to 100MHz $< 2\text{mV}$ (psophometric)
Acoustic Noise:	$< 55\text{dBa}$ @ 1m (3ft.) @ 30°C (86°F) [individual module] $< 55\text{dBa}$ @ 1m (3ft.) @ 30°C (86°F) [four modules]
EMI:	The unit meets requirements of EN55022 (see Standards for more EMC)

In accordance with FCC requirements, we provide the following statement as specified in the FCC guidelines for conformance to Part 15, Class B:

NOTE: *This equipment has been tested and found to comply with the limits for a Class B digital device, pursuant to part 15 of the FCC Rules. These limits are designed to provide reasonable protection against harmful interference in a residential installation. This equipment generates, uses, and can radiate radio frequency energy and, if not installed and used in accordance with the instructions, may cause harmful interference to radio communications. However, there is no guarantee that interference will not occur in a particular installation. If this equipment does cause harmful interference to radio or television reception, which can be determined by turning the equipment off and on, the user is encouraged to try to correct the interference by one or more of the following measures:*

- Reorient or relocate the receiving antenna.
- Increase the separation between the equipment and receiver.
- Connect the equipment into an outlet on a circuit different from that to which the receiver is connected.
- Consult the dealer or an experienced radio/TV technician for help.

Any changes or modifications to this equipment not expressly described in this manual could void the FCC compliance.

Specifications for Argus' Switched Mode Rectifier Cordex 48-1kW Continued

Power Module Input

Voltage:	208 to 240Vac nominal
Extended Operation:	Low: 150 to 90Vac (power de-rated linearly to 40% output) High: 176 to 320Vac (de-rated power factor above 265Vac)
Frequency:	50/60Hz nominal (45 to 66Hz)
Current:	5.3 to 4.6A (nominal Vac) 7.4A maximum @ 150Vac
Power Factor:	>0.99 at nominal conditions and 50-100% load; >0.98 at nominal conditions and 30-100% load
Protection:	10kA-interrupting capacity fuses in active and neutral lines
Efficiency:	>91% at nominal conditions and 50-100% load
Inrush Current:	≤ full load steady state current of the rectifier within rated limits
Start-up Ready Time:	<5 seconds (excluding soft start) to complete inrush limit routine and ac measurement (for OK signal)
Start-up Delay:	Programmable up to 120 seconds to enable stagger-start of multiple rectifiers and to minimize the effect on a supply source
Soft Start:	User adjustable to at least 5 seconds (not including start-up delay time) and is determined by output current limit ramp-up
T.H.D. (Current):	<5% at 100% load
Input Transient Suppression:	Meets ANSI/IEEE C62.41 Category B3
Input Leakage Current:	<3.5mA @ 265Vac 60Hz

Miscellaneous

MTBF:	>400,000 hours
Dimensions:	177mm H x 71mm W x 250mm D (excluding connector) [6.9" H x 2.8" W x 9.8" D]
Weight:	2.9 kg (6.4 lb.)

Environmental

Temperature Operating:	-40 to +50°C (-40 to 122°F)
Extended:	400W @ +65°C (149°F)
Storage:	-50 to +85°C (-58 to 185°F)
Humidity:	0 to 95% non-condensing
Elevation:	-500 to +4000m; derate @ -4°C/1000m above sea level (-1640 feet to 13124 feet; derate @ -7.2°F/3281 feet above sea level)

Specifications for Argus' Switched Mode Rectifier Cordex 48-1kW Continued

Referenced Standards

EN 300 386-2	EMC and ERM; Telecommunication Network Equipment
EN 55022 (CISPR 22): 1998	Information Technology Equipment – Radio Disturbance Characteristics – Limits and Methods of Measurement
EN 61000-3-2:2000	Harmonic Current Emissions
EN 61000-3-3:1995	Voltage Fluctuations and Flicker
EN 61000-4-2	ESD Immunity
EN 61000-4-3	Radiated Electromagnetic Immunity
EN 61000-4-4	Electrical Fast Transient/Burst Immunity
EN 61000-4-5	Power Line Surge Immunity
EN 61000-4-6	Conducted Electromagnetic Immunity
EN 61000-4-11	Voltage Dips, Short Interruptions and Variations
ETS 300 019-1-1	Environmental Conditions; Storage
ETS 300 019-1-2	Environmental Conditions; Transportation
ETS 300 132-2	Power Supply Interface at the Input to Telecommunications Equipment; Operated by Direct Current (DC)
ETS 300 753	Acoustic Noise Emissions
IEC 60950	Safety of Information Technology Equipment, Including Electrical Business Equipment (UL/CSA 60950)

The above information is valid at the time of publication. Consult factory for up-to-date ordering information. Specifications are subject to change without notice.

CSA/NRTL — MARKS — BACKGROUND

What are the CSA and NRTL?

CSA (Canadian Standards Association also known as CSA International) was established in 1919 as an independent testing laboratory in Canada. CSA received its recognition as an NRTL (Nationally Recognized Testing Laboratory) in 1992 from OSHA (Occupational Safety and Health Administration) in the United States of America (Docket No. NRTL-2-92). This was expanded and renewed in 1997, 1999, and 2001. The specific notifications were posted on OSHA's official website as follows:

- Federal Register #: 59:40602 - 40609 [08/09/1994]
- Federal Register #: 64:60240 - 60241 [11/04/1999]
- Federal Register #: 66:35271 - 35278 [07/03/2001]

When these marks appear with the indicator "C and US" or "NRTL/C" it means that the product is certified for both the US and Canadian markets, to the applicable US and Canadian standards. (1)

Argus rectifier and power system products, bearing the aforementioned CSA marks, are certified to CSA C22.2 No. 950 and UL 1950, or CSA/UL 60950.

As part of the reciprocal, US/Canada agreement regarding testing laboratories, the Standards Council of Canada (Canada's national accreditation body) granted Underwriters Laboratories (UL) authority to certify products for sale in Canada. (2)

Only Underwriters Laboratories may grant a licence for the use of this mark, which indicates compliance with both Canadian and US requirements. (3)

What are NRTLs and what do they do?

NRTLs are third party organizations recognized by OSHA, US Department of Labor, under the NRTL program.

The testing and certifications are based on product safety standards developed by US based standards developing organizations and are often issued by the American National Standards Institute (ANSI). (4)

The NRTL determines that a product meets the requirements of an appropriate consensus-based product safety standard either by successfully testing the product itself, or by verifying that a contract laboratory has done so, and the NRTL certifies that the product meets the requirements of the product safety standard. (4)

When was the NRTL started and who governs it?

In 1983, in a suit brought on by an independent testing laboratory, OSHA was court ordered to remove specific references to UL (Underwriters Laboratories) and FMRC (Factory Mutual Research Corporation) from its regulations.

In 1988, OSHA revised its regulations to remove those references and the NRTL program was established.

The NRTL Program is both national and international in scope with foreign labs permitted.

References:

Information in this document has been developed from the official websites of the respective organizations.

- (1) www.csa-international.org
- (2) www.scc.ca
- (3) www.ulc.ca
- (4) www.osha.gov



The product on which either of these marks appear has been certified by CSA as meeting applicable Canada/US standards.



The product on which this mark appears has been certified by UL as meeting applicable Canada/US standards.

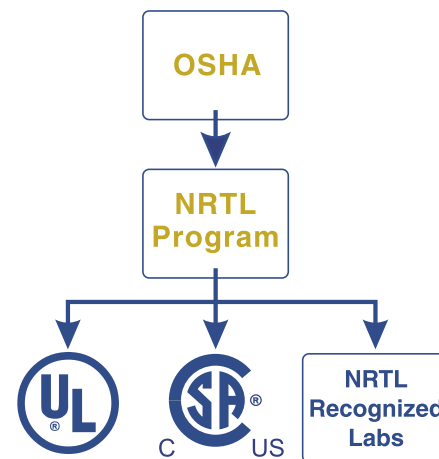

IMPORTANT SAFETY INSTRUCTIONS

SAVE THESE INSTRUCTIONS

1. Please read this manual prior to use to become familiar with the product's numerous features and operating procedures. To obtain a maximum degree of safety, follow the sequences as outlined.
2. This manual provides warnings and special notes for the user:
 - a. Points that are vital to the proper operation of the product or the safety of the operator are indicated by the heading: **WARNING**.
 - b. A notation that is in ***Bold Italic*** typeface covers points that are important to the performance or ease of use of the product.
3. Before using the product, read all instructions and cautionary markings on the product and any equipment connected to the product.
4. Do not expose the product to rain or snow; install only in a clean, dry environment.
5. **CAUTION** – Unless otherwise noted, use of an attachment not recommended or sold by the product manufacturer may result in a risk of fire, electric shock, or injury to persons.
6. **CAUTION** – Do not operate the product if it has received a sharp blow, it has been dropped, or otherwise damaged in any way – return it to a qualified service center for repair.
7. **CAUTION** – Do not disassemble the product – call our qualified service centers for servicing. Incorrect reassembling may result in a risk of electrical shock or fire.

TABLE OF CONTENTS

1	INTRODUCTION	1
1.1	Scope of the Manual	1
1.2	Product Overview	1
1.3	Part Numbers and List Options	2
2	RECTIFIER FEATURES.....	3
2.1	Front Panel.....	3
2.2	Rear Panel	4
2.3	True Module Fail Alarm.....	4
2.4	Heat Dissipation	4
2.5	Over Temperature Protection	4
2.6	Wide AC Range	5
2.7	AC Inrush/Transient Suppression	5
2.8	Soft Start	5
2.9	Start Delay	5
2.10	Current Limit/Short Circuit Protection	5
2.11	Power Limiting.....	5
2.12	High Voltage Shutdown (HVSD)	5
2.13	Battery Eliminator Operation.....	5
3	CXCM FEATURES.....	6
3.1	Front Panel.....	6
3.2	Analog Input Channels.....	7
3.3	Digital Input Channels	8
3.4	Alarm and Control Output Relays	8
3.5	System Fail Alarm/Relay.....	8
3.6	Network Connection and Remote Communications	8
4	INSPECTION.....	9
4.1	Packing Materials.....	9
4.2	Check for Damage	9
5	INSTALLATION	10
5.1	Safety Precautions	10
5.2	Shelf Preparation/Mounting	10
5.3	Module Insertion/Removal	10
6	WIRING AND CONNECTIONS	11
6.1	Safety Precautions	11
6.2	Tools Required.....	11
6.3	Power System Chassis Ground	12
6.4	AC Feeder Protection/Sizing.....	12
6.5	AC Input Connections	12
6.6	Calculating Output Wire Size Requirements.....	12
6.7	DC Output Connections	13
6.8	CAN Serial Ports	13
6.9	Network Connection and Remote Communications via CXC.....	15
6.10	Alarm and Signal Wiring Connections for CXCM	16
7	OPERATION.....	20

7.1	Main Rectifier States	20
7.2	Main Rectifier Modes	21
7.3	Can Bus Communications.....	21
7.4	Factory Ranges and Defaults	22
8	SYSTEM STARTUP	23
8.1	Check System Connections.....	23
8.2	Verify AC and Power the Shelf	23
8.3	Check Battery Polarity and Connect.....	23
8.4	CXC Reset	23
9	MAINTENANCE	24
10	ARGUS CONVENTIONS.....	25
10.1	Numbering System.....	25
10.2	Acronyms and Definitions	25

This page intentionally left blank.

1 Introduction

1.1 Scope of the Manual

This instruction manual explains the installation and interconnection of Argus Technologies' Cordex 48-1kW 19" Shelf for Systems up to 6000W.

NOTE: *To aid the user with installation, frequent reference is made to drawings located at the rear of this manual.*

For systems ordered with the Cordex CXC System Controller option, separate documentation will be provided detailing the software features, setup and operation.

1.2 Product Overview

A complete Cordex rectifier system consists of a CXC and one or more power modules in a common shelf enclosure. The shelf has connections for AC inputs, DC output, and system communications.

Cordex rectifier modules use a high frequency, switched mode conversion technique to provide a fully regulated and isolated DC output from the AC mains. The rectifier input is wide range to allow use on 208/220/240 50/60 Hz electrical service. Rectifier power modules are "hot swappable" meaning they can be inserted or removed from the shelf without cutting power to or from the system or the load. Additional power modules can be included with the system at the time of ordering or added after the shelf has been installed.

The shelf (and rectifier system) is designed to operate with the Argus Cordex System Controller (CXC); in particular, the optional CXCM (modular version of the CXC controller) plugs directly into the rectifier system shelf. See Figure 1 below.

Details for installation and wiring are provided in the respective chapters of this documentation package.

There are also rack (CXCR) and panel (CXCP) mount versions of the system controller that communicate with the shelf via offset RJ-12 shelf connectors.

See manual #018-587-B2 (pre-RoHS #018-557-B2).

The CXC allows the user to set up, control and monitor the entire power system and ancillary components from one central, easy-to-use source.

Details of controller operation are provided in the current version software manual.



Figure 1—Cordex 5000W system with CXCM

1.3 Part Numbers and List Options

This product is available to order under the following part numbers and list options:

Description	Part Number/List Option
Cordex 48-1kW 19" Shelf for Systems up to 6000W (030-706-20 pre-RoHS)	030-827-20
[equipped to receive one CXCM controller and up to five CXRC 48-1kW rectifiers (Figure 1)]	*List 0
208/220/240Vac input	List 6
19" rack, mid-mounting	List 19
23" rack, mid-mounting	List 23
23" rack, flush mounting	List 25
Temperature sensor, 1/4" lug, 12 ft.	List 72
Temperature sensor, 3/8" lug, 12 ft.	List 75
Six 1kW rectifier module positions, dual feed ac input, no CXCM (Figure 2)	*List 81
DC output adapters, dual 2-position, 5/8" centers	List 85
Power module blank plate	List 50,90
Cordex 48-1kW 19" Shelf for Systems up to 6000W, flush mounting only (030-707-20 pre-RoHS)	030-828-20
[equipped to receive one CXCM controller and up to five CXRC 48-1kW rectifiers (Figure 1)]	*List 0
208/220/240Vac input	List 6
Temperature sensor, 1/4" lug, 12 ft.	List 72
Temperature sensor, 3/8" lug, 12 ft.	List 75
Six 1kW rectifier module positions, dual feed ac input, no CXCM (Figure 2)	*List 81
Six 1kW rectifier module positions, three feed ac input, no CXCM (Figure 2)	List 82
DC output adapters, dual 2-position, 5/8" centers	List 85
Power module blank plate	List 50,90
Cordex 48-1kW rectifier power module	010-566-20
Basic module	*List 0
Gray finish with blue silkscreen	*List 50

* Default option

The above information is valid at the time of publication. Consult factory for up-to-date ordering information.



Figure 2—Cordex 6000W system (no CXCM)

2 Rectifier Features

2.1 Front Panel



Figure 3–Cordex 48-1kW rectifier

2.1.1 LEDs

The front panel LEDs provide:

- Rectifier status summary,
- Rectifier software upgrade in progress indication,
- Locate module pattern.

Rectifier status summary will show the rectifier alarm status, communication fail status and rectifier on/off status.

2.1.1.1 AC ON

The top LED (green) is on when AC is within valid range. The LED will flash (~2Hz) when AC is outside the nominal range – **AC voltage is invalid if the AC Mains Low or AC Mains High alarm is active**. The LED turns off when AC has failed.

2.1.1.2 DC ON

The middle LED (green) is on when the rectifier is delivering power to the load. The LED will flash when communication is lost. The LED turns off when the rectifier is off; e.g., when commanded via the CXC.

2.1.1.3 ALARM

The bottom LED (red) is on continuously in the event of an active Module Fail alarm. The LED will flash (~2Hz) when a minor alarm is detected. The LED remains off in the absence of an alarm.

2.1.1.4 LED Activity During Software Upload

When a rectifier software upload is in progress, the LEDs will behave in a distinctly different way to indicate new rectifier software is being transferred from the CXC.

When a rectifier data transfer is in progress, all three LEDs will flash in a sequence lasting 1.5 seconds. When the last LED is lit, the sequence is repeated beginning at the first LED.

2.1.1.5 LED Activity During 'Locate Module' Command from CXC

When the 'locate module' command has been received from the CXC, the LEDs will behave in another distinct fashion so that the rectifier is easier to visually identify among adjacent rectifiers.

This state is entered when commanded via the CXC. The LEDs will flash in a ping-pong pattern repeating every 2 seconds.

The ping-pong pattern lights each LED sequentially. After the last LED is lit, each LED is lit in reverse sequence. When the first LED is lit, the pattern repeats. The effect makes it appear as if the light is bouncing between the first and last LED.

2.1.2 Mechanical

A thumbscrew is provided to secure the rectifier into the shelf. During normal operation the rectifier shall be locked into position. A handle (or grip) is incorporated into the front panel to facilitate the removal of the rectifier from the shelf. No special tools are required.

2.2 Rear Panel

Located on the rear panel of the rectifier are connectors for shelf power and communications.

2.3 True Module Fail Alarm

The power modules have a "true" fail alarm. This provides a true indication of the power module's ability to source current. When the module's output current drops below 2.5% of the rated output a low output current condition is detected and the Module Fail detection circuit is activated. This circuit momentarily ramps up the output voltage to determine if the module will source current. If no increase in current is detected, the Module Fail alarm is activated. The module will test once every 60 seconds for the condition until current is detected. Output voltage ramping will cease upon detection of current¹. A minimum 2.5% load is required to avoid the Ramp Test Fail alarm; this can typically be provided with the parallel system battery. Activation of this alarm could indicate a failed module or a failed load.

NOTE: *For Cordex rectifier systems without batteries (or with a very light load; below 2.5% of rated output) it is recommended that the ramp test be disabled to avoid nuisance alarms. The Ramp Test feature is enabled/disabled via the CXC menu item: Rectifiers, Configure Settings.*

2.4 Heat Dissipation

Heat dissipation is achieved through natural (bottom to top) convection cooling.

NOTE: *Some rectifier shelves incorporate fan aided cooling to increase the temperature rating of the module. See shelf manual supplied with your system.*

2.5 Over Temperature Protection

Each module is protected in the event of an excessive increase in temperature due to component failure or cooling airflow blockage. During over temperature conditions, the rectifier limits the output power as well as the output current. **At 65°C output power and current limit are reduced to 70%.** If temperature continues to increase, a shutdown of the rectifier is initiated. The rectifier shall restart automatically if the temperature has returned to a safe level.

¹ A battery connected to the output of the rectifier will draw current when the voltage ramp occurs. Therefore the rectifier fail alarm will not be generated with a battery connected.

2.6 Wide AC Range

A minor alarm is generated when the AC input voltage drops below 180Vac. Output power is reduced linearly below 150Vac to 40% of the rated output power. At a lower voltage the module will shut down and will not restart until the AC is greater than or equal to 150Vac.

For voltages above 276Vac, power factor and total harmonic distortion may be derated. For voltages between 277Vac and 320Vac, the rectifier may not be operational but shall not suffer any damage.

2.7 AC Inrush/Transient Suppression

The modules' inrush current is limited to less than one times the nominal peak line current to prevent surge on the AC line. Modules are also protected from input lightning and transient surges in accordance with IEEE/ANSI C62.41 Category B3.

2.8 Soft Start

To eliminate an instantaneous demand on the AC source, a soft start feature is employed. Soft Start, sometimes referred to as "current walk-in", works by gradually (up to five seconds) ramping the current limit up from zero to the actual or defined customer setting. The output voltage is ramped up from the minimum voltage to the float voltage.

2.9 Start Delay

The modules are equipped with a delay timer in order to stagger start a series of modules to prevent excessive loading of generators upon start up. The built-in timer delays the turn on of the module depending on the value selected (up to 120 seconds) via the CXC. A minimum one-second delay is preset to allow charging of the input capacitors.

2.10 Current Limit/Short Circuit Protection

The current limit function determines the maximum output current limit of the module, regardless of output voltage or power. Maximum output current is limited to a constant value down to short circuit condition. Current limiting can be used to mate the rectifier output current ampacity to the needs of the load and parallel battery to minimize excessive battery recharge current.

The rectifier will sustain a short circuit at the output terminals indefinitely. The maximum short circuit current shall not exceed 105% of the rated full load current.

2.11 Power Limiting

Each module is designed to limit power output to the module specification. This enables more current to be supplied at lower output voltages, and allows matching of output to the demand of constant power loads, normally seen with telecom equipment.

This feature may also be used for a faster recharge of flooded batteries paralleled with the load.

NOTE: *Current limiting overrides the power-limiting feature.*

2.12 High Voltage Shutdown (HVSD)

This feature provides protection to the load from over voltage conditions originating from the rectifiers. It operates by shutting down the offending rectifier module when a high output voltage condition occurs. Indication is through the red Alarm (Module Fail) LED. Modules will restart automatically; however, if more than three over voltage conditions occur in one minute, the module will latch off and remain shut down until it is reset via the CXC.

2.13 Battery Eliminator Operation

Modules maintain all specifications (except where indicated) with or without a battery attached in parallel to the output; however, if a battery or another module supplying DC voltage in parallel is not present, there will be no monitoring or control activity if there is an AC power failure or input fuse failure.

3 CXCM Features

The optional CXCM (Cordex Controller, Modular) can be mounted in the rectifier system shelf and brings advanced monitoring technology to the Cordex series of rectifiers. This compact 4RU system controller is designed for seamless operation and set up of Argus power systems and is equipped with the complete range of Cordex software features, including the following:

- Designed to communicate directly with Cordex rectifiers
- Includes battery temperature compensation charging
- Battery performance diagnostics
- Provides local and remote communications
- User definable alarms
- Daily logging of power system events and system statistics.

Behind the CXCM's front panel lies the main controller motherboard, which contains a microprocessor, memory, as well as numerous other electronic components.

The CXCM includes a web server providing easy set up and monitoring using an Internet connection with the standard Windows® Internet Explorer browser.

The data logging feature allows the user to capture data from multiple inputs, for AC/DC voltages, load/battery current, cell voltages & temperatures (automatically for up to 16 user defined logs). Typical applications of the CXCM logging include power system details, thermal performance of outdoor enclosures, battery cell specifics, or mains variations captured by an AC voltage watchdog.

A built-in audio speaker sounds an intermittent tone during active alarms.

The input/output (I/O) board houses a series of terminal connections; located at the back of the system shelf.

3.1 Front Panel

3.1.1 Display

Located on the front panel is a 160 x 160-pixel graphical LCD with touch screen similar to those used in PDAs. This graphical user interface (GUI) allows the operator to interact with screen selectable items using a fingertip.



Figure 4–Cordex CXCM model system controller front panel

3.1.2 LEDs

The CXCM has three LEDs located on the front panel. These are used to display the alarm status of the power system, CXCM progress and status during startup, and file transfers.

3.1.2.1 Alarm Conditions

The CXCM illuminates the LED that corresponds to the system alarm status. The following show the corresponding alarm status for each LED color:

Green – OK, no alarms present

Yellow – Minor alarm is present (no major alarms)

Red – Major alarm is present.

Only one LED is illuminated at a time during alarm conditions.

3.1.2.2 Progress and Status Indication

The LEDs are also used in the following situations:

Base unit validation – all three LEDs are on at the same time.

File transfer – when recovering from invalid firmware application – the red LED is illuminated.

3.1.3 Reset

A reset button is located on the front panel for restarting the CXCM's microprocessor. It takes approximately 15 seconds before the display reappears after pressing the reset button.

NOTE: *Refer also to the software manual – always select the shutdown menu item before pressing the reset button.*

3.1.4 Ethernet Port

The Ethernet port is designed for CXCM connection to a user supplied network (TCP/IP secured by user) via a rear panel RJ-45 jack and a standard network cable.

Local access (e.g. laptop computer) is also possible from the Ethernet port connection using a standard network crossover cable.

3.1.5 RS-232 Serial (Craft) Port

Local access to the CXCM is possible through a front panel RS-232 serial port; using a null modem cable. The communication protocol supports a web interface (via Microsoft® Internet Explorer 6 or greater). The remote screen display is an enhanced version of the CXC's front panel display.

3.2 Analog Input Channels

The CXCM has analog input channels for voltage, current, and temperature.

3.2.1 Voltage Inputs

Two voltage input channels, V1 and V2, provide monitoring of discharge and charge voltage. The CXCM software is pre-configured to monitor V2 for both load and battery voltage. V2 is used as the system reference for rectifier float voltage, low voltage disconnect (LVD), system high voltage alarm, and system low voltage alarm. V1 is available for additional voltage measurements.

3.2.2 Current Inputs

The CXCM software is pre-configured to monitor I1 for load current using an external 50mV current shunt.

3.2.3 General-Purpose

A set of terminals are provided to monitor a bi-voltage signal that may vary in either polarity from zero; e.g., +/-60Vdc.

3.2.4 Temperature Inputs

Two temperature input channels, T1 and T2, provide monitoring of battery temperature and temperature compensation (temp comp) or room/ambient temperature. A voltage is supplied to these terminals to power the temperature sensors.

3.3 Digital Input Channels

The CXCM can accommodate up to three channels and can monitor digital alarm/control signals from rectifiers, converters and many other types of equipment.

3.4 Alarm and Control Output Relays

The CXCM contains eight Form C digital alarm output relays to extend alarms and control external apparatus. Each internally generated alarm or control signal may be mapped to any one of the relays, or, several signals may be mapped to just one relay or none at all.

3.4.1 LVD Control (External Option)

The LVD Control functions can be hardwired directly from the assigned relay output to an optional LVD override control and distribution alarm card. This provides a safety measure to protect against load disconnect during CXCM reset or replacement; e.g. when the controller is off-line. Operators may also perform test and maintenance procedures on the CXCM without disturbing the load.

3.5 System Fail Alarm/Relay

The CXCM system fail alarm (K0) activates because of a major internal failure. During such a condition, the unit will attempt to reset, but if this fails, an alarm condition will be extended to a relay and the red LED on the front panel will illuminate. This is a fail-safe signal to the remote monitoring equipment; i.e. alarm will be extended even if power to the unit is interrupted.

3.6 Network Connection and Remote Communications

The Cordex system can be set up, monitored and tested via Ethernet 10/100 Base-T serial data connection. The communication protocol supports a web interface. All alarming and control of Cordex rectifiers is accomplished with a CXC via a CAN bus.

A step-by-step connection wizard – provided to establish remote communications with your CXC – is available via the Argus website (www.argusdcpower.com).

4 Inspection

4.1 Packing Materials

All Argus products are shipped in rugged, double walled boxes and suspended via solid inserts to minimize shock that may occur during transportation. Packaging assemblies and methods are tested to International Safe Transit Association standards.

Products are also packaged with Cortex. This plastic wrap contains a corrosive-inhibitor that protects the product from corrosion for up to two years.

4.1.1 Returns for Service

Save the original shipping container. If the product needs to be returned for service, it should be packaged in its original shipping container. If the original container is unavailable, make sure the product is packed with at least three inches of shock-absorbing material to prevent shipping damage.

NOTE: *Argus Technologies is not responsible for damage caused by the improper packaging of returned products.*

4.2 Check for Damage

Prior to unpacking the product, note any damage to the shipping container. Unpack the product and inspect the exterior for damage. If any damage is observed contact the carrier immediately.

Continue the inspection for any internal damage. In the unlikely event of internal damage, please inform the carrier and contact Argus Technologies for advice on the impact of any damage.



Verify that you have all the necessary parts per your order for proper assembly.

5 Installation

This chapter is provided for qualified personnel to install the product, which shall be mounted in a clean and dry environment.

NOTE: *To aid the user with installation, frequent reference is made to drawings located at the rear of this manual.*

5.1 Safety Precautions



WARNING

Hazardous voltages are present at the input of power systems. The DC output from the rectifiers and battery system has a high short circuit current capacity that may cause severe burns and electrical arcing.

Before working with any live battery or power system/distribution center, follow these precautions:

- Remove all metallic jewelry; e.g., watches, rings, metal rimmed eyeglasses, necklaces.
- Wear safety glasses with side shields (and prescription lenses if necessary) at all times during installation.

The installer should follow all applicable local rules and regulations for electrical and battery installations; e.g., CSA, UL, CEC, NEC, OSHA, and local fire codes.

Use OSHA approved insulated hand tools.

5.2 Shelf Preparation/Mounting

For 030-706-20, the shelf has been designed for mounting in a standard EIA 19" rack (19" shelf option only) or 23" relay rack. See drawing 030-706-06.

For 030-707-20, the shelf has been designed for flush mounting only (in a standard EIA 19" rack). See drawing 030-707-06.

NOTE: *The shelf shall be mounted in a clean and dry environment. Allow at least 1.75" of free space above and below the unit for unrestricted convection cooling airflow.*

Mounting brackets accommodate either 1" or 1-3/4" rack spacing. The shelf should be mounted to the rack using at least two #12 – 24 x 1/2" screws in each bracket. Philips-type screws and screwdriver should be used to eliminate the possibility of slippage and scratching of the unit's exterior. Washers (such as internal tooth) or special screws that are designed to cut through the painted surface should be used to ensure a good chassis ground.

5.3 Module Insertion/Removal

Insert by placing the module on the shelf bottom and sliding the module into the rear connectors (inside of the shelf). Apply pressure on the handles to engage the rear connector in the shelf receptacle. Tighten the screw on the bottom of the faceplate to secure the module to the shelf.

NOTE: *Do not force a module into position if it does not seat properly. All modules are keyed to ensure that the correct module type is used.*

To remove modules, loosen the screw on the bottom of the faceplate. Grasp handle and pull out, sliding the module away from the rear connectors and out of the shelf.

6 Wiring and Connections

This chapter provides cabling details and notes on cable sizing for DC applications with respect to the shelf.

NOTE: Refer also to drawings located at the rear of this manual.

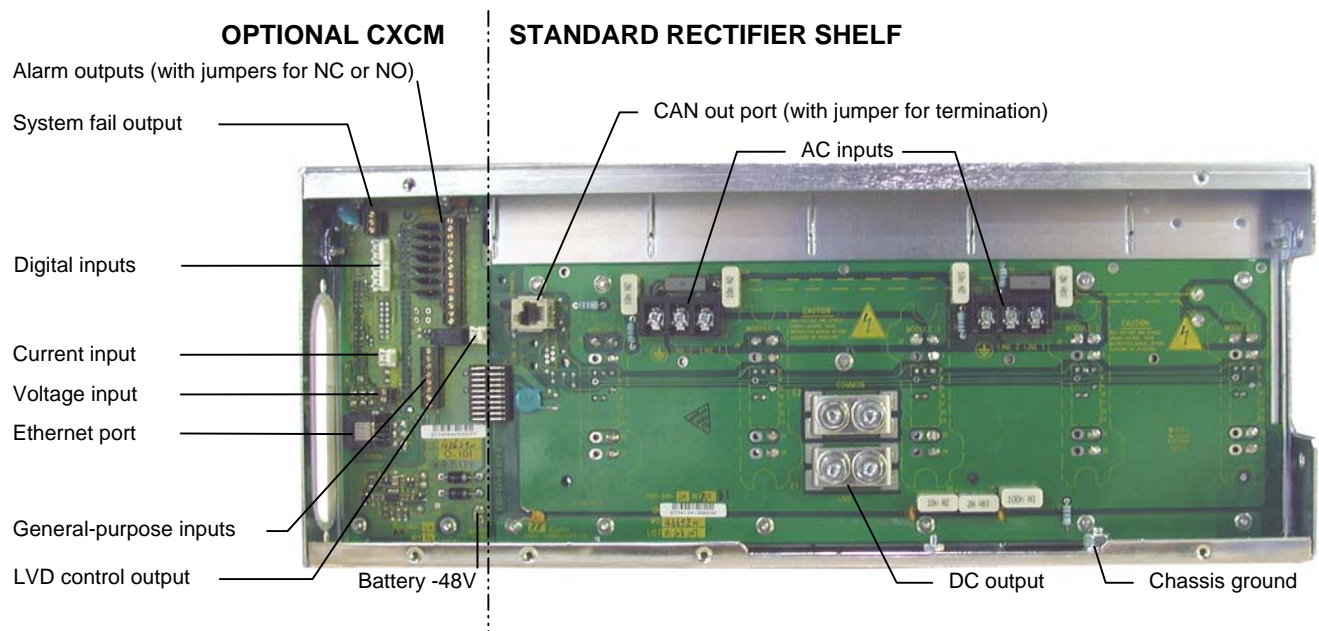

Figure 5–Rear view of shelf showing all system connections

6.1 Safety Precautions



WARNING

Hazardous AC voltages may be present. Ensure power at the AC service panel is off before attempting work on the AC connections. Use a voltmeter to verify the absence of voltage. Clearly mark the correct polarity of the battery leads before commencing work on DC connections.

Refer to the previous (Installation) chapter for additional safety precautions.

6.2 Tools Required

Various tools are essential for product installation. Use this list as a guide:

- Slot head screwdrivers (blade sizes: 1/4", 1/8", 1/16")
- Philips head screwdriver, #2 (tip size 3/16")
- Digital voltmeter equipped with test leads
- Adjustable 48Vdc load (optional)
- Cutters and wire strippers
- Crimping tool (optional for large gauge wire)
- Socket and ratchet set (Imperial measure)
- Anti-static wrist strap
- Computer (laptop) with Microsoft® Internet Explorer 6 or greater
- Crossover cable RJ-45 (for access using the Ethernet port).

6.3 Power System Chassis Ground

WARNING

For safety reasons, ensure the system is properly bonded to the building's ground grid.

Both the shelf chassis ground (via power system chassis ground) and common return shall be connected to the site ground to ensure correct operation of the system and to prevent drifting floating analog (especially current) readings.

6.4 AC Feeder Protection/Sizing

To maximize system reliability, a dual AC feed divides the rectifiers into two groups to be supplied by two separate feeds. A three feed option divides the rectifiers into three groups to be supplied by three separate feeds.

It is recommended for each feed to use a dedicated protection feeder breaker located at the AC distribution panel. The feeder breaker can also act as the disconnect device for the connected modules.

Number of Rectifiers on AC Feed	Circuit Breaker Exact Value to Use (A)	90 deg. C Wire Gauge to use at 30 deg. C ambient (AWG)
1	15	12
2	20	12
3	30	10

Table A–Recommended AC supply configuration

6.5 AC Input Connections

CAUTION: AC input wires should be routed in flexible or rigid conduit as far away as possible from the DC power wires to minimize EMI disturbances.

Remove the metal cover from the rear of the shelf to expose the wireway for input terminal blocks.

The wireway is designed for two customer-supplied 1" conduit fittings for AC supply located on the left side of the shelf and two 3/4" conduit fittings on the rear.

Attach the conduit retainers to the wireway hole(s) and route the AC cables through. Secure the wires to the AC input and chassis ground terminals as required. Tighten the cable connector to the AC cable (conduit similar).

Replace rear cover once all connections have been completed.

6.6 Calculating Output Wire Size Requirements

Wire size is calculated by first determining the appropriate maximum voltage drop requirement. Using the formula below calculate the CMA wire size requirement. Determine the size and number of conductors required to satisfy the CMA requirement.

$CMA = (A \times LF \times K) / AVD$, where:

CMA = Cross section of wire in circular MIL area

A = Ultimate drain in amps

LF = Conductor loop feet

K = 11.1 constant factor for commercial (TW type) copper wire

AVD = Allowable voltage drop

Check again that the ampacity rating of the cable meets the requirement for the installation application. Consult local electrical codes (NEC, CEC, etc.) for guidelines. If required, increase the size of the cable to meet the code.

6.7 DC Output Connections



WARNING

Leave cables or bus bars disconnected at battery and verify output polarity using a voltmeter. Make battery connections only after all other wiring is completed.

DC output wire shall be UL approved XHHW or RHH/RHW (for Canadian users, RW90 Type). Control and sense wires shall be UL approved Style 1015 (for Canadian users, TEW type).

Connect DC output cables at the side of the shelf. Without the distribution option, the side DC access is made toward the rear of the shelf.

Terminate cable leads with appropriate crimp lugs. Secure the positive and negative to the shelf output post of the correct polarity; i.e., +V_{cable} to +V_{post}. Ensure the washers are on the bolts in the same order in which they were shipped from the factory. Tighten the bolts as per Customer Connections drawing at the rear of this manual.

The common output leg of the rectifier system should be connected to ground. This is typically done at the load common termination point.

Replace rear cover once all connections have been completed.

6.8 CAN Serial Ports

Connect Cordex equipment and set jumpers as shown:



Serial ports, for communications with Argus' Cordex rectifiers and other CAN-enabled equipment, are located on the backplane.

Daisy-chain from shelf to shelf as necessary and ensure that the last shelf is terminated with the jumper (below).



List 0 (system equipped for CXCM) has one CAN OUT port.



List 81 (equipped for six rectifiers and no CXCM) has one CAN IN port and one CAN OUT port.

The jumper (P1) allows setting of the CAN OUT to be open to next shelf or TERMINATED if last shelf on CAN bus, as shown here:

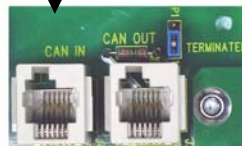

Figure 6—CAN ports for multiple shelf connections with CXCM



Serial ports, for communications with Argus' Cordex rectifiers and other CAN-enabled equipment, are located on the backplane.

Daisy-chain from shelf to shelf as necessary and ensure that the last shelf is terminated with the jumper (below).



System equipped with CXCP or CXCR has one CAN OUT port.



List 81 (shelf equipped for six rectifiers and no CXCM) has one CAN IN port and one CAN OUT port.

The jumper (P1) allows setting of the CAN OUT to be open to next shelf or TERMINATED if last shelf on CAN bus, as shown here:

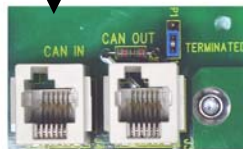

Figure 7–CAN ports for multiple shelf connections with CXCP (CXCR typical)

6.9 Network Connection and Remote Communications via CXC

The Cordex 48-1kW system can be set up, monitored and tested via Ethernet 10/100 Base-T or with RS-232 serial data connection. The communication protocol supports a web interface.

NOTE: Pinouts are shown in drawings 030-706-08 and 030-707-08.

Some standard scenarios are described below:

6.9.1 Ethernet Port for Network Connection (Standard Network Cable)

The Ethernet port is designed for CXC connection to a user supplied network (TCP/IP secured by user) via a rear panel RJ-45 jack. Connect to the Cordex shelf using a standard network cable.

6.9.2 Ethernet Port for Local Connection (Crossover Cable)

Local access (e.g. laptop computer) is also possible from the Ethernet port connection using a standard network crossover cable.

6.9.3 RS-232 Serial (Craft) Port for Local Connection

Local access to the CXC is possible through the front panel RS-232 serial port using a null modem cable. See Figure 8.

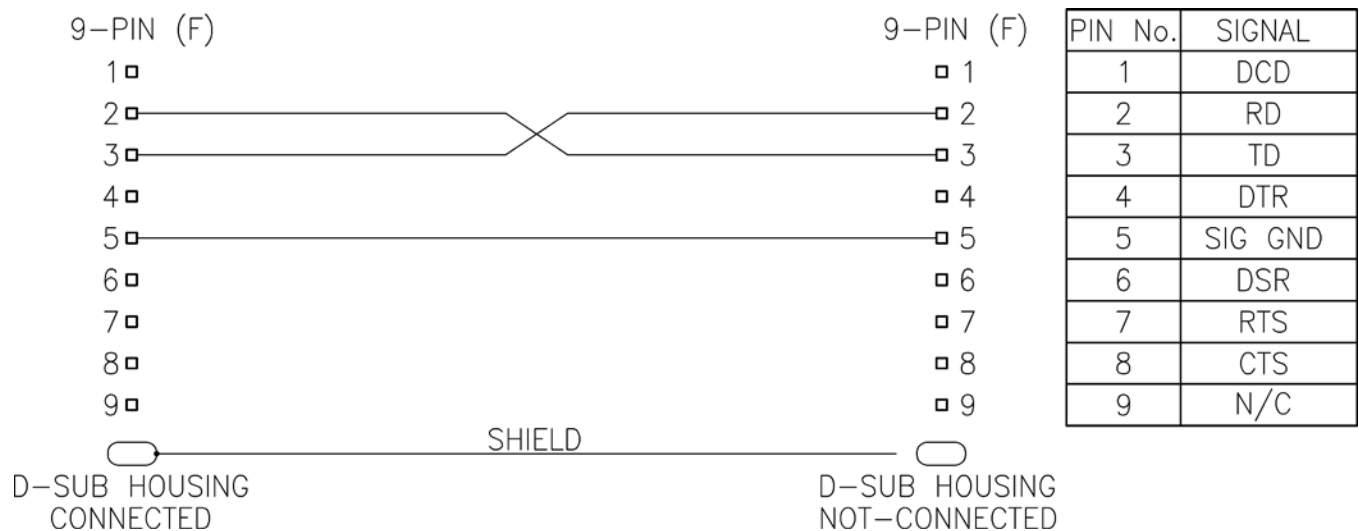

Figure 8–NULL modem pinouts

6.10 Alarm and Signal Wiring Connections for CXCM

For terminal block connections, the recommended wire sizes are 0.75 to 0.14mm² (#18 to #26 AWG) for the temperature range of 0 to 50 deg. C (as per UL/CSA).

For insulation displacement receptacles, the recommended wire size is 0.75mm² (#18 AWG).



CAUTION: to reduce risk of fire, use only 0.129mm² (#26 AWG) or larger wire.

Terminal	Description	Signal Type	Range
Alarm Outputs – Can be configured to de-energize on alarm (DOA) or energize on alarm (EOA).			
#2-21,22(common)	K2, LVD2	NC/COM/NO (JP2)	60Vdc / 1A
#3-19,20(common)	K3, LVD3	NC/COM/NO (JP3)	60Vdc / 1A
#4-17,18(common)	K4, System Minor	NC/COM/NO (JP4)	60Vdc / 1A
#5-15,16(common)	K5, System Major	NC/COM/NO (JP5)	60Vdc / 1A
#6-13,14(common)	K6, AC Mains Hi-Low	NC/COM/NO (JP6)	60Vdc / 1A
#7-11,12(common)	K7, Not assigned	NC/COM/NO (JP7)	60Vdc / 1A
#8-9,10(common)	K8, Not assigned	NC/COM/NO (JP8)	60Vdc / 1A
#0-25,24,23	K0, System Fail Output*	NC/COM/NO	60Vdc / 1A
Digital Inputs – See Table B for definitions of logic and system			
P5-1,2	D1, Distribution Fuse (Alarm)	Pos (+) or Neg (-)	0–60Vdc
P5-3, P6-1	D2, Distribution CB (Alarm)	Pos (+) or Neg (-)	0–60Vdc
P6-2,3	D3, Battery CB (Alarm)	Pos (+) or Neg (-)	0–60Vdc
Analog Inputs and System Signals			
E1	Battery -48V**	Neg (-)	20–60Vdc
J3	Ethernet port	N/A	N/A
P1-2,1	K1, LVD1	Pos (+) / Neg (-)	0–60Vdc / 1A
P7-2,1	V1, Load Voltage	Pos (+) / Neg (-)	0–100Vdc
P8-2,1	I1, Load Current	Pos (+) / Neg (-)	±50mV
– for List 120, add the following:			
1-2	T1 (GP1), Temp Probe 1	Pos (+) / Neg (-)	0–20Vdc, with power source
3-4	T2 (GP2), Temp Probe 2	Pos (+) / Neg (-)	0–20Vdc, with power source
5-6	GP3, General Input 3	Pos (+) / Neg (-)	Not used
7-8	GP4, General Input 4	Pos (+) / Neg (-)	±60V, bi-polar voltage
– for List 124, consult the factory to add the following:			
1-2	V3 (GP1), Voltage Input 3	Pos (+) / Neg (-)	0–60Vdc
3-4	V4 (GP2), Voltage Input 4	Pos (+) / Neg (-)	0–60Vdc
5-6	V5 (GP3), Voltage Input 5	Pos (+) / Neg (-)	0–60Vdc
7-8	T1 (GP4), General Input 4	Pos (+) / Neg (-)	0–20Vdc, with power source

Table B–Signal wiring connections for CXCM

* System Fail output relay is fail-safe and will de-energize during an alarm condition.

** Battery –48V: connect to battery only when using a battery disconnect device

NOTE: To aid the user with installation, frequent reference is made to drawings located at the rear of this manual. Custom configurations may be detailed within the Argus power system documentation package.

6.10.1 Alarm (Relay) Outputs

Terminals provide contacts for extending various alarm or control signals. Each relay output can be wired (jumper selectable) for NO or NC operation during an alarm or control condition. See Figure 9.

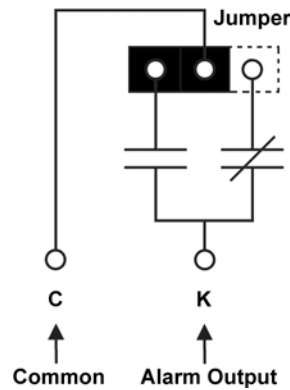

Figure 9—Showing relay connections

Relays can be programmed to energize or de-energize during an alarm condition (see CXC Software manual). When the CXCM reset button is pressed or power is lost, all relays de-energize.

These relays could be used for additional external LVD contactor control; however, this would not provide the redundant LVD control as with the assigned output pins described below.

6.10.1.1 LVD Control

The LVD Control functions can be hardwired directly from the assigned output pins (+ and -) to an external LVD contactor (or panel). See Controls Menu Defaults in the CXC Software manual.

Redundant LVD Control Circuit

The shelf backplane² provides circuitry to override the LVD Control function. This is a safety measure to protect against accidental load disconnect should the CXCM be removed from the shelf. This protection is also necessary during CXCM reset.

The OUT voltage is 46V and the IN voltage is 51V. Ensure the CXCM LVD voltages are set outside of this range. **NOTE: Controller Relay 1 must be set to ENERGIZED for the LVD to operate properly.**

6.10.1.2 System Fail Output

Terminals (#0) provide connections for a system controller fail relay (K0). This is a fail-safe relay and will de-energize during an alarm condition. Both NO and NC contacts are available for this particular relay.

² Argus #707-340-20 for the CXCM. See Customer Connections drawing at the rear of this manual.

6.10.2 Digital Inputs

The digital input channels are used to monitor various alarm and control signals. All input channels are voltage activated and accept a bipolar (i.e. negative or positive) DC signal directly.

6.10.2.1 Connection Method

Typical Argus systems use the “reset with Hot and trigger with Ground” connection. The digital input is wired in such a way that the Hot is wired directly into one of the input terminals; e.g., negative input for –48V systems. The other input terminal is wired to the Ground (common) of the system through a relay (dry contact – usually located on the equipment requiring monitoring). This method (see Figure 10) allows the digital input to receive (or not receive) a Ground signal on an alarm.

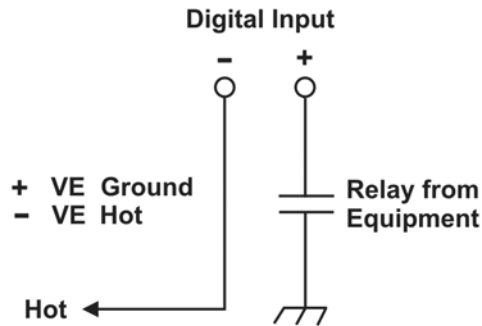

Figure 10–Showing connection method

6.10.2.2 Programming the Digital Input

The digital input channels can be programmed for “active high” or “active low.” Active high indicates “alarm on the presence of a ground signal” and active low indicates “alarm on the removal of a ground signal.” See CXC Software manual for detailed instruction on programming.

Voltage Range (VDC)	Voltage Level (VDC) Considered As “0” (Off)	Voltage Level (VDC) Considered As “1” (On)
0—60 (system voltage setting)	0—3	18—60

Table C–Voltage level definitions for digital inputs

6.10.3 Battery –48V

The Battery -48V should be connected at the battery system voltage terminal for CXCM reference when a battery disconnect device is used. It is critical to CXCM operation as it ensures a source of power to the CXCM should the disconnect device open the circuit. A 1/4" spade (quick connect) connector is provided on the CXCM portion of the shelf backplane. #18AWG wire is recommended.

6.10.4 Analog Inputs

CAUTION: Ensure the correct polarity is used for all input cable terminations.

The analog input channels are used to monitor various types of electrical signals. Some of the analog channels are reserved for specific signals, while others are designated as general-purpose inputs, which accommodate various types of analog signals. The input cables should be bundled together and routed through the entry holes of the shelf, if applicable.

6.10.4.1 Voltage

Voltage Input #1 (discharge voltage per CXC software) terminals on the shelf provide connections to an optional secondary voltage input. For example, this can be terminated to the load side of an LVD contactor to monitor load voltage.

Voltage Input #2 (charge voltage per CXC software) is wired internally to the rectifier output voltage of the shelf. This is used as the reference for system alarming (such as high voltage) and control (such as low voltage disconnect).

6.10.4.2 Current

Current Input #1 terminals provide connections (factory-installed) to the system current shunt used to monitor discharge (load) current.

6.10.4.3 General-Purpose

Terminals provide connection pairs for various analog inputs such as temperature sensors. These are configured at the time of ordering. The configuration determines whether the signals allowed are to be bipolar (may vary in either polarity from zero; e.g., +/-60VDC) or unipolar (may vary positive from zero; e.g., 0 to +60VDC).

NOTE: *The CXC software is pre-configured to monitor converter voltage through input channel GP1.*

Temperature Sensor

Terminals, of the general purpose grouping, may be configured as temperature input channels and provide connections for up to two temperature sensors. A voltage is supplied to these terminals for sensor measurements.

7 Operation

7.1 Main Rectifier States

Rectifier operation can be broken up into five main states:

1. Off,
2. Start delay,
3. Soft start,
4. Normal operation,
5. Turning off.

Each state is characterized as being distinct and necessary for the operation of the rectifier. These states are briefly described below.

7.1.1 Off State

The rectifier will be in the Off state immediately after power is applied to the rectifier or after a rectifier shutdown. The shutdown source may be remote or local shutdown, AC shutdown, OVP or thermal shutdown.

When the rectifier is in this state the DC-DC converter is turned off and the CXC will be monitoring its inputs for the proper conditions to begin the start up sequence.

When the conditions have been met for the rectifier to start up, it will transition to the Start Delay state.

7.1.2 Start Delay State

When the rectifier is in the Start Delay state, the DC-DC converter is held off and still not sourcing power and is waiting for a given amount of time before transitioning to the next state.

When in this state, the CXC continues to monitor its inputs.

After the Start Delay state the rectifier will transition to the Soft Start state.

NOTE: *Soft start, or current walk-in, gradually increases the voltage and current output of the rectifier upon startup. This is done to reduce the instantaneous load on the AC source.*

7.1.3 Soft Start State

When the Soft Start state is entered, the rectifier will be turned on and the output voltage and output current will be gradually increased. If a load is present, the rectifier will begin to source power.

When the voltage and current limit ramps have finished, the rectifier will transition to the Normal Operation state.

7.1.4 Normal Operation State

The Normal Operation state is the state that the rectifier will be in performing all of the rectifier functions and features specified herein.

From this state, the only valid transition is to the Turning Off state. This transition will happen if the rectifier is required to shut down.

7.1.5 Turning Off State

The Turning Off state is entered because a short delay is required before the rectifier actually turns off to take care of any initialization requirements.

When this short delay has elapsed, a transition to the Off state is made.

7.2 Main Rectifier Modes

In addition to Main Rectifier States, there is a set of Main Rectifier Modes. These modes can be divided into two categories as follows:

7.2.1 Output Voltage Modes

Voltage modes can be thought of as modes that, under software control, can directly adjust the output voltage. The qualification of 'under software control' is made because there are processes that occur in the rectifier that can change the output voltage that do not adjust the output voltage directly (such as the rectifier being in current limit).

The following table lists the five Output Voltage Modes and a description of when they are active:

Output Voltage Modes	Active when...
Float	Output voltage is set to the float voltage setting.
Equalize	Output voltage is set to the equalize voltage setting.
Battery Test	Output voltage is set to the battery test voltage setting.
Safe	Output voltage is set to the safe mode voltage setting.
Manual Test	Output voltage can be manually adjusted outside of the standard adjustment ranges.

Table D–Output voltage modes

7.2.2 Output Current/Power Modes

These modes directly affect the output current and power.

The following table lists the four Output Current/Power Modes and a description of when they are active:

Output Current/Power Mode	Active when...
Temperature foldback mode	Output current and power limit have been reduced due to high temperature of the heatsink or internal ambient temperature sensor.
AC foldback mode	Output current and power limit have been reduced due to low AC input voltage. <i>Note: this will reduce the risk of tripping an AC breaker due to increased AC current draw as the AC voltage decreases.</i>
Short circuit foldback mode	Output current limit has been reduced due to a short circuit at the output.
Internal fault foldback mode	Output current limit has been reduced due to an internal fault.

Table E–Output current/power modes

7.3 Can Bus Communications

The CAN bus is used for communication between the rectifier and CXC.

The communication between the rectifier and CXC consists of commands and data transfer that are used during the operation of the power system to configure the rectifier with system settings and to monitor rectifier status.

7.4 Factory Ranges and Defaults

The following table lists the rectifier settings/ranges/defaults; changes are made via the CXC:

Setting	Range (minimum to maximum)	Default
Float (FL) Voltage	47.5 – 58.2V	54V
Equalize (EQ) Voltage	49.8 – 60.2V	55V
Battery Test (BT) Voltage	44 – 52V	46V
OVP	See note below – 63V	57V
Current Limit (CL)	23 – 100%	100%
Power Limit (PL)	0 – 100%	100%
Module Start Delay	0 – 250s	1s
System Start Delay	0 – 600s	0s
Low Voltage Alarm (LVA)	42 – 52V	44V
High Voltage Alarm (HVA)	52 – 63V	55.5V
EQ Timeout	1 – 2399h	30h
BT Timeout	1 – 250h	8h
Softstart Ramp-rate	Normal/Fast	Normal
CL/PL Alarm	Enable/Disable	Enable
Remote Shutdown	Enable/Disable	Enable
Ramp Test	Enable/Disable	Enable

Table F–Cordex 48-1kW rectifier factory ranges and defaults

NOTE: OVP cannot be set below the present system/FL/EQ/BT voltage setting or the safe mode voltage of 51.4V.

8 System Startup

After completing the shelf wiring and installation, perform the following startup and test procedure to ensure proper operation:

8.1 Check System Connections

- Ensure AC is off, battery is disconnected
- Ensure CXCM (if equipped) and all power modules are removed from the shelf.
- Triple check the polarity of all connections.

8.2 Verify AC and Power the Shelf

- Install one power module.
- Verify AC input voltage is correct and turn on the corresponding AC input feeder breaker.
- The power module OK LED should illuminate after a preset start delay.
- Using the CXC (CXCM if equipped), test functionality of various module alarms and controls.

8.3 Check Battery Polarity and Connect

- Verify correct battery polarity using a voltmeter (ensuring no cells or batteries are reversed).
- Connect battery as required to the output of the system or turn on battery breaker.
- Install remaining power modules.
- In the adjustments menu of the CXC, set Float and Equalize voltage to the levels specified by the battery manufacturer.
- Using the CXC, test functionality of various module alarms and controls. In addition, perform a load test with the system using a resistive load box as needed.

8.4 CXC Reset

A reset button is located on the front panel of the CXC for restarting the microprocessor. It takes approximately 15 seconds before the display reappears after pressing the reset button. To protect against accidental load disconnect, see 6.10.1.1.

9 Maintenance

Although very little maintenance is required with Argus systems, routine checks and adjustments are recommended to ensure optimum system performance. Qualified service personnel should do repairs.

The following table lists a few maintenance procedures for this system. These procedures should be performed at least once a year.



WARNING: HIGH VOLTAGE AND SHOCK HAZARD.

Use extreme care when working inside the shelf while the system is energized. Do not make contact with live components or parts.

Circuit cards, including RAM chips, can be damaged by static electricity. Always wear a grounded wrist strap when handling or installing circuit cards.

Procedure	Date Completed
Clean ventilation openings	
Inspect all system connections (re-torque as necessary)	
Verify alarm/control settings	
Verify alarm relay operation	

Table G—Sample maintenance log

NOTE: *There are no field replaceable parts.*

10 Argus Conventions

10.1 Numbering System

Argus Technologies uses an eight-digit drawing number system, which is broken into three blocks. The first three digits describe the category of the product; e.g., rectifier or fuse panel. The next three digits indicate the sequence in which the product number was allocated in a particular category. The last two digits indicate the type of drawing, for example:

"-05"	Schematic
"-06"	Outline Drawing
"-20"	Main Assembly

Argus uses an eight-digit part numbering system for all components and sub assemblies. Each part is covered by its own unique number. Due to the quantity, categories will not be listed within this manual.

10.2 Acronyms and Definitions

AC	Alternating current
AWG	American wire gauge
CAN	Controller Area Network
CEC	Canadian Electrical Code
CSA	Canadian Standards Association
CX	Cordex series; e.g., CXC for Cordex™ System Controller
DC	Direct current
EIA	Electronic Industries Alliance
HVSD	High voltage shutdown
LED	Light emitting diode
LVD	Low voltage disconnect
NC	Normally closed
NEC	National Electrical Code (for the USA)
NO	Normally open
OSHA	Occupational Safety & Health Administration
OVP	Over voltage protection
RAM	Random access memory
UL	Underwriters Laboratories

REVISION		DATE	APPD
LTR	DESCRIPTION		
A	REVISED PER EOs A9,10	05/02	

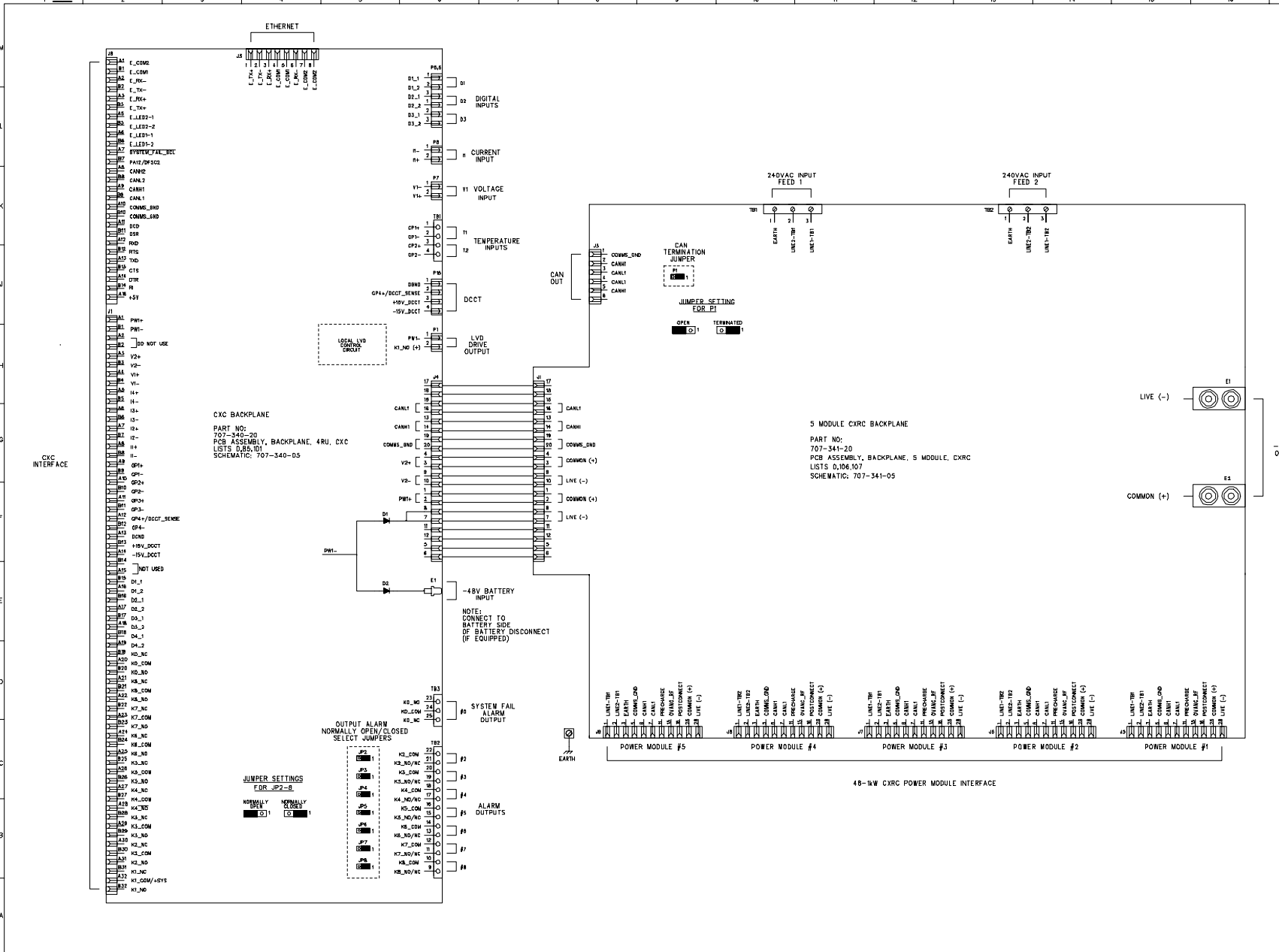

LISTS SHOWN: 0,6

ARGUS
TECHNOLOGIES

THESE DESIGNS AND SPECIFICATIONS ARE THE PROPERTY OF ARGUS TECHNOLOGIES AND SHALL NOT BE COPIED OR USED FOR MANUFACTURING WITHOUT ITS WRITTEN CONSENT.

DESIGN	WES	2003/09	MATERIAL
DRAWN	J.K.	2003/10	
CHECKED	J.K.	2003/10	
APPROVED	WES	2003/10	FINISH

TOLERANCES SCALE N/A

TITLE SCHEMATIC, CAB, 19" FLUSH MNT, 5 MDL W/ CXRC OR 6 MDL, 48-1kW CXRC

ISSUE DATE SHEET 1 of 3

SIZE	DWG NO.	REV
B	S3 030-707-05	B

REVISION			
LTR	DESCRIPTION	DATE	APPD

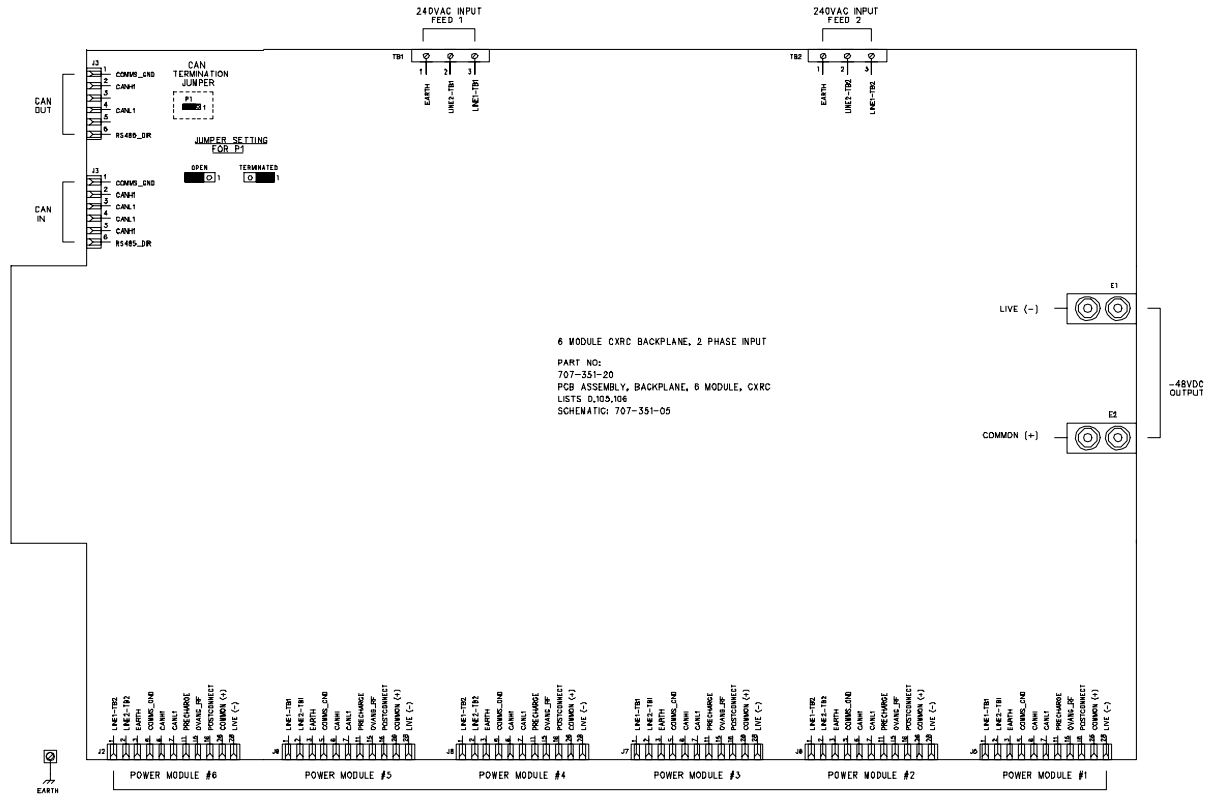

48-1kW CXRC POWER MODULE INTERFACE

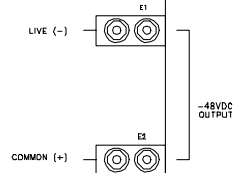

LISTS SHOWN: 0,6,8,1

THESE DESIGNS AND SPECIFICATIONS ARE THE PROPERTY OF ARGUS TECHNOLOGIES AND SHALL NOT BE COPIED OR USED FOR MANUFACTURING WITHOUT ITS WRITTEN CONSENT.

DESIGN	WES	2003/09	MATERIAL
DRAWN	J.K.	2003/10	
CHECKED	J.K.	2003/10	
APPROVED	WES	2003/10	FINISH

TOLERANCES SCALE N/A

TITLE SCHEMATIC, CAB, 19" FLUSH MNT, 5 MDL W/ CXRC OR 6 MDL, 48-1kW CXRC

ISSUE DATE	DWG NO. 030-707-05		SHEET 2 of 3
SIZE B	S3	REV B	

REVISION			
LTR	DESCRIPTION	DATE	APPD

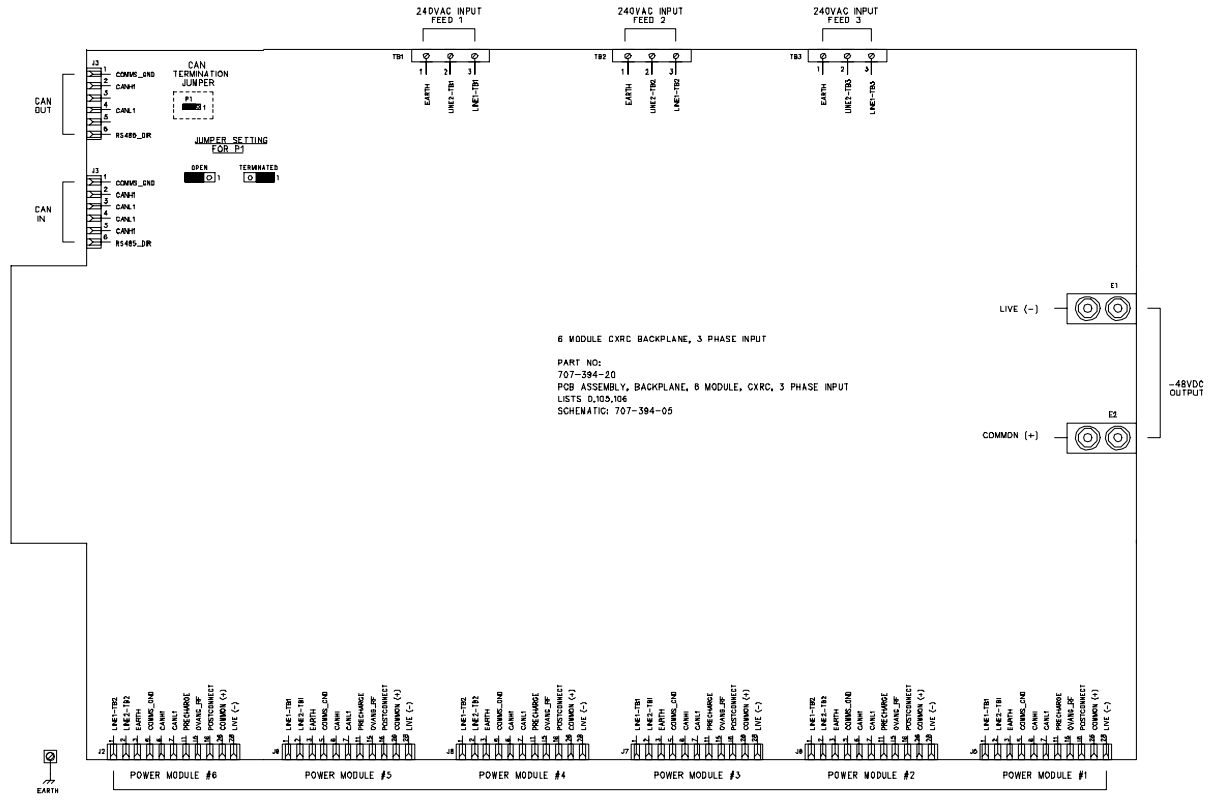

LISTS SHOWN: 0,6,82

THESE DESIGNS AND SPECIFICATIONS ARE THE PROPERTY OF ARGUS TECHNOLOGIES AND SHALL NOT BE COPIED OR USED FOR MANUFACTURING WITHOUT ITS WRITTEN CONSENT.

DESIGN	WES	2003/09	MATERIAL
DRAWN	J.K.	2003/10	
CHECKED	J.K.	2003/10	
APPROVED	WES	2003/10	FINISH

TOLERANCES SCALE N/A
 TITLE SCHEMATIC, CAB, 19" FLUSH MNT, 5 MDL W/ CXRC OR 6 MDL, 48-1kW CXRC

ISSUE DATE	SHEET 3 of 3
SIZE B	DWG NO. 030-707-05 REV B

REVISIONS				
LTR	DESCRIPTION	REV BY	DATE	APPD

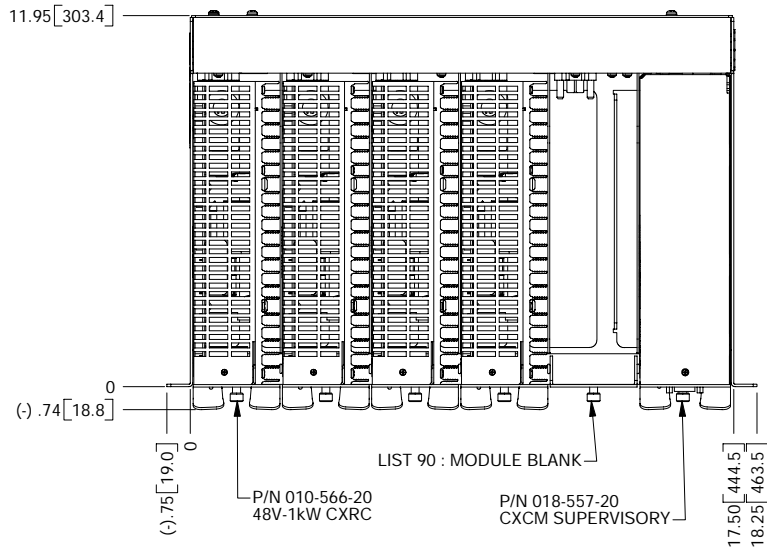

TOP VIEW

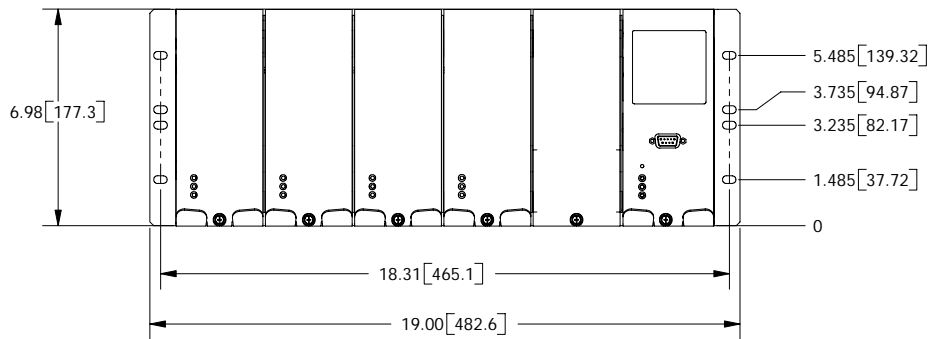

PLAN VIEW

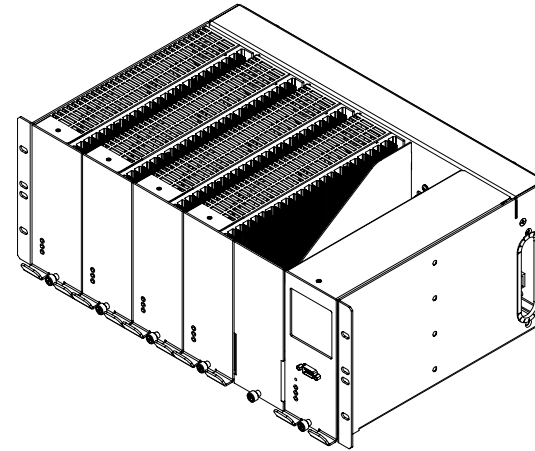

FRONT ISOMETRIC VIEW

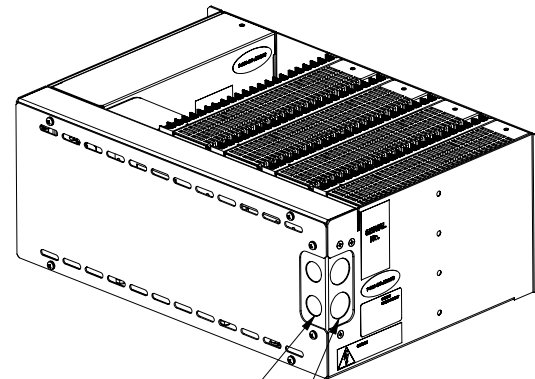

875 K.O ACCEPTS 3/4" CONDUIT

1.125 K.O. ACCEPTS 1" CONDUIT

REAR ISOMETRIC VIEW

© 2003 ARGUS TECHNOLOGIES

DIMENSIONS ARE IN INCHES WITH METRIC [mm] IN BRACKETS: INCHES [mm]

ARGUS [®]			
THESE DESIGNS AND SPECIFICATIONS ARE THE PROPERTY OF ARGUS TECHNOLOGIES AND SHALL NOT BE COPIED OR USED FOR MANUFACTURING WITHOUT ITS WRITTEN CONSENT.			
DESIGN	DGW	2003/11	MATERIAL
DRAWN	DGW	2003/11	
CHECKED			
APPROVED			FINISH
TOLERANCES			PER P.O. and Doc. 070-024-83
X.X	±0.04"	[X] ±1mm	
X.XX	±0.02"	[X.X] ±0.5mm	
X.XXX	±0.01"	[X.XX] ±0.25mm	SCALE NTS
TITLE			
OUTLINE, 19 FLUSH MOUNT CABINET 5 MDL w CXCM SUP. OR 6 MDL 48-1kW CXRC			
ISSUE	DATE	SHEET	1 of 1
SIZE	TYPE	DWG NO.	REV
B	D2	030-707-06	A

REVISIONS				
LTR	DESCRIPTION	REV BY	DATE	APPD
B	ADDED PG3, LIST0.9.82, 3 FEEDS	DGW	2004/12	GS
C	UPDATED AC I/P TERM BLOCK	SDW		

LIST 0,6 : 5 MODULE WITH CXC CONTROLLER

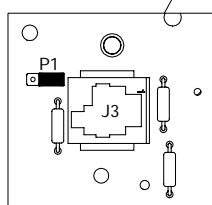
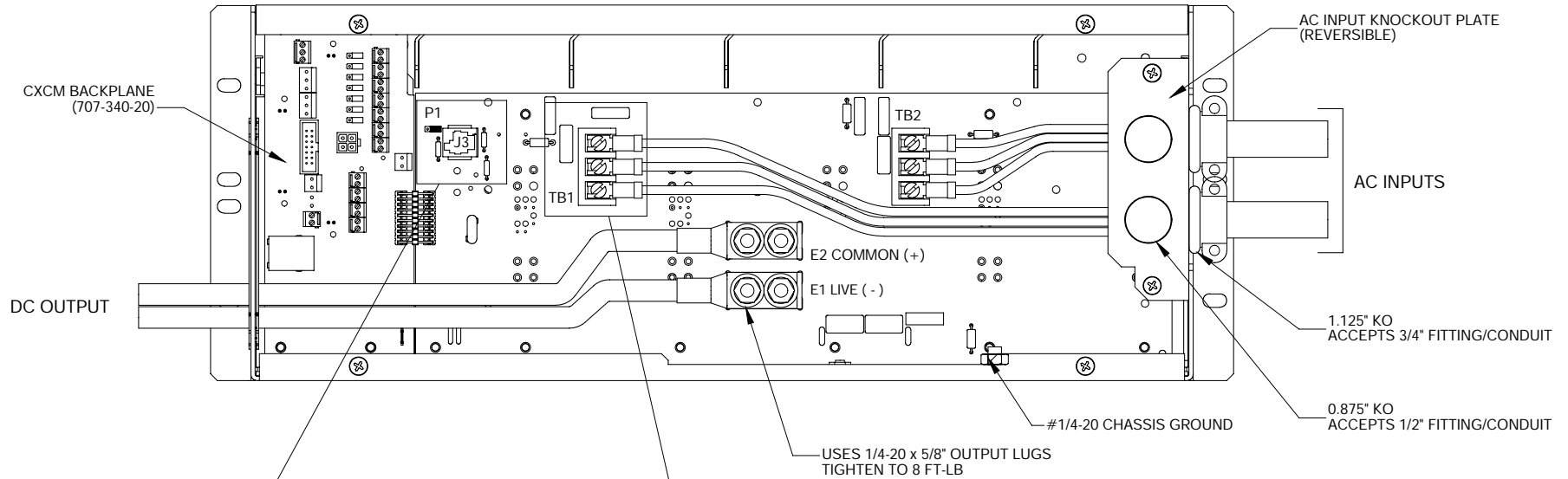

CAN OUT RJ12 OFFSET PIN OUT (J3)

1. GND
2. CAN H
3. NOT CONNECTED
4. CAN L
5. NOT CONNECTED
6. NOT CONNECTED

JUMPER SETTING FOR P1

- CAN TERMINATED
- CAN UNTERMINATED

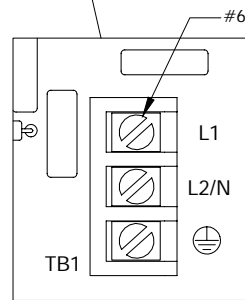

TYPICAL AC INPUT TERMINAL BLOCK (TB1 SHOWN)

TB1 FEEDS RECTIFIERS 1,3,5
TB2 FEEDS RECTIFIERS 2,4

ARGUS[®]

THESE DESIGNS AND SPECIFICATIONS ARE THE PROPERTY OF ARGUS TECHNOLOGIES AND SHALL NOT BE COPIED OR USED FOR MANUFACTURING WITHOUT ITS WRITTEN CONSENT.

DESIGN	DGW	2004/05	MATERIAL
DRAWN	DGW	2004/05	
CHECKED	JK	2004/05	
APPROVED	WES	2004/05	FINISH
TOLERANCES			PER P.O. and Doc. 070-024-83
X.X	±0.04"	[X]	±1mm
X.XX	±0.02"	[X.X]	±0.5mm
X.XXX	±0.01"	[X.XXX]	±0.25mm
TITLE			SCALE NTS
CUSTOMER CONNECTION, 6 MOD OR 5 MOD w CXC SUP. 48-1kW CXRC 19" FLUSH MNT			
ISSUE DATE	SHEET 1 of 4		REV
SIZE TYPE DWG NO.	030-707-08		REV C

© 2004 ARGUS TECHNOLOGIES

DIMENSIONS ARE IN INCHES WITH METRIC (mm) IN BRACKETS: INCHES [mm]

LIST 0,6,81 - 6 MODULE , DUAL FEEDS

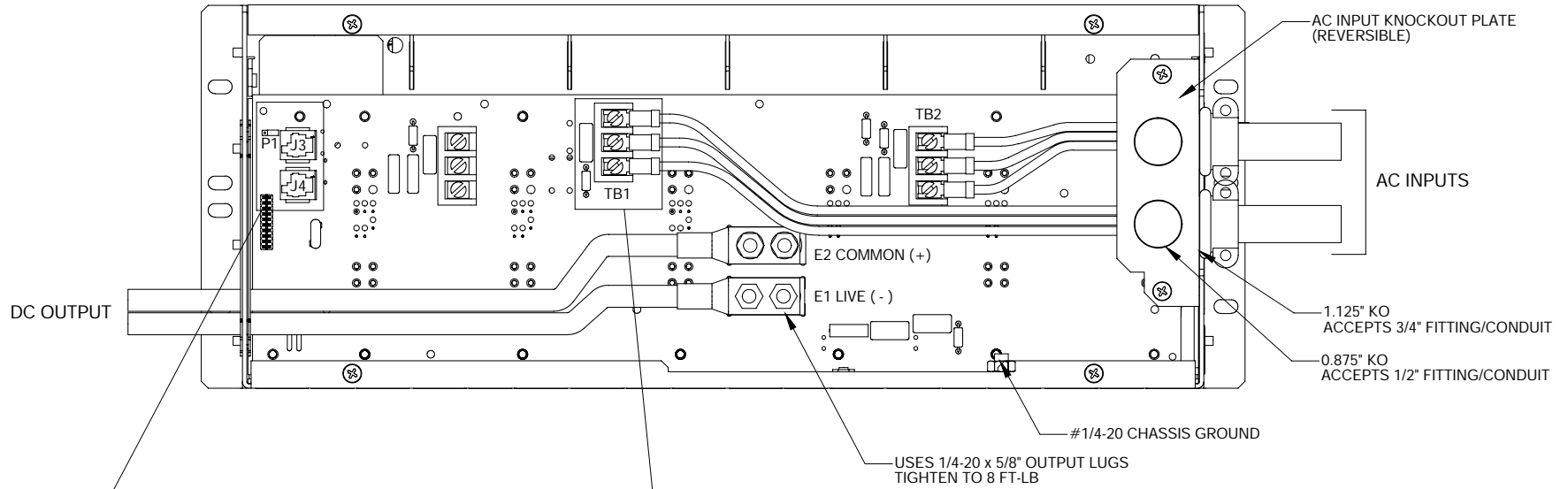

JUMPER SETTING FOR P1

- CAN TERMINATED
- CAN UNTERMINATED

CAN OUT RJ12 OFFSET
PIN OUT (J3)

1. GND
2. CAN H
3. NOT CONNECTED
4. CAN L
5. NOT CONNECTED
6. NOT CONNECTED

CAN IN RJ12 OFFSET
PIN OUT (J4)

1. GND
2. CAN H
3. NOT CONNECTED
4. CAN L
5. NOT CONNECTED
6. NOT CONNECTED

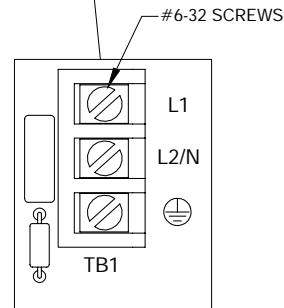

TYPICAL AC INPUT TERMINAL BLOCK
(TB1 SHOWN)

TB1 FEEDS RECTIFIERS 1, 3, 5
TB2 FEEDS RECTIFIERS 2, 4, 6

ARGUS [®]	
THESE DESIGNS AND SPECIFICATIONS ARE THE PROPERTY OF ARGUS TECHNOLOGIES AND SHALL NOT BE COPIED OR USED FOR MANUFACTURING WITHOUT ITS WRITTEN CONSENT.	
SCALE NTS	
TITLE CUSTOMER CONNECTION, 6 MOD OR 5 MOD w CXG SUP. 48-1kW CXRC 19" FLUSH MNT	
ISSUE DATE	SHEET 2 OF 4
SIZE TYPE DWG NO.	REV C
B D2	030-707-08

© 2004 ARGUS TECHNOLOGIES

DIMENSIONS ARE IN INCHES WITH METRIC (mm) IN BRACKETS: INCHES [mm]

LIST 0,9,82 - 6 MODULE ,THREE FEEDS

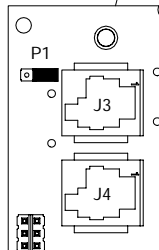
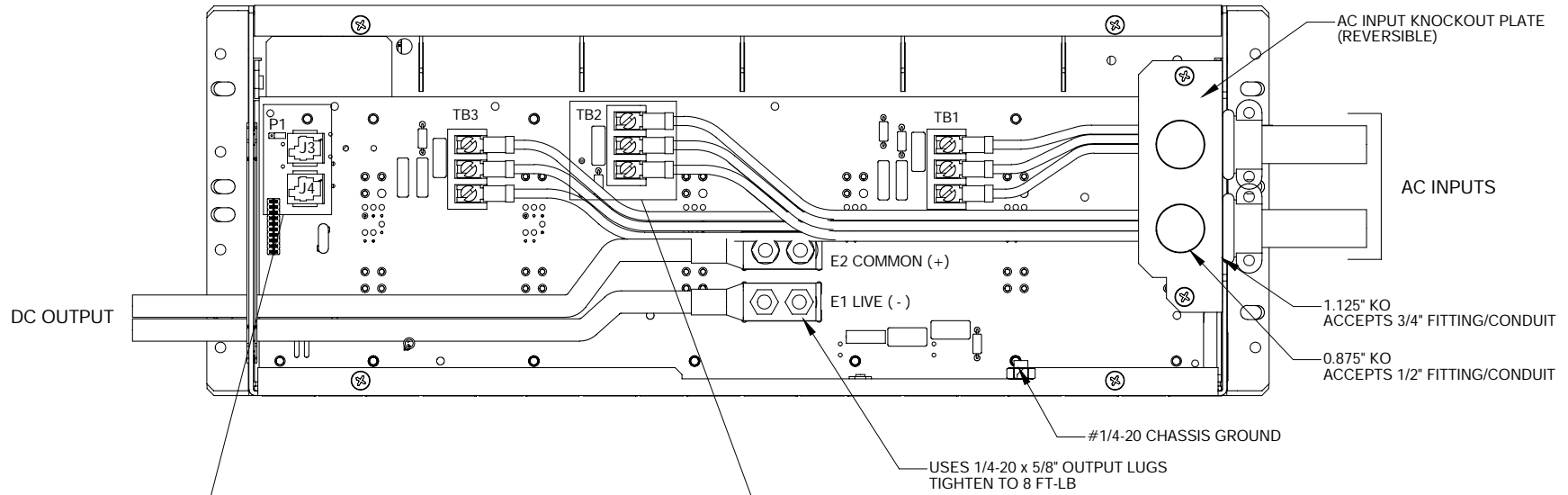

- JUMPER SETTING FOR P1**
- CAN TERMINATED
 - CAN UNTERMINATED
- | | |
|---|--|
| <p>CAN OUT RJ12 OFFSET PIN OUT (J3)</p> <ol style="list-style-type: none"> 1. GND 2. CAN H 3. NOT CONNECTED 4. CAN L 5. NOT CONNECTED 6. NOT CONNECTED | <p>CAN IN RJ12 OFFSET PIN OUT (J4)</p> <ol style="list-style-type: none"> 1. GND 2. CAN H 3. NOT CONNECTED 4. CAN L 5. NOT CONNECTED 6. NOT CONNECTED |
|---|--|

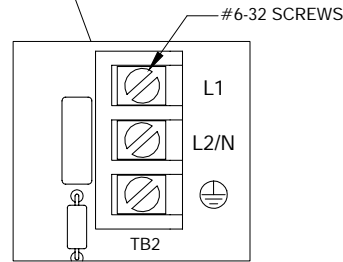

TYPICAL AC INPUT TERMINAL BLOCK (TB2 SHOWN)

- TB1 FEEDS RECTIFIERS 1, 2
- TB2 FEEDS RECTIFIERS 3, 4
- TB3 FEEDS RECTIFIERS 5, 6

ARGUS [®]	
<small>THESE DESIGNS AND SPECIFICATIONS ARE THE PROPERTY OF ARGUS TECHNOLOGIES AND SHALL NOT BE COPIED OR USED FOR MANUFACTURING WITHOUT ITS WRITTEN CONSENT.</small>	
SCALE	NTS
TITLE CUSTOMER CONNECTION, 6 MOD OR 5 MOD w CXC SUP. 48-1KW CXRC 19" FLUSH MNT	
ISSUE DATE	SHEET 3 of 4
SIZE TYPE DWG NO.	REV C
B D2	030-707-08

JUMPER SETTINGS FOR JP2-8



LIST 0 : 5 MDL e/w CXC

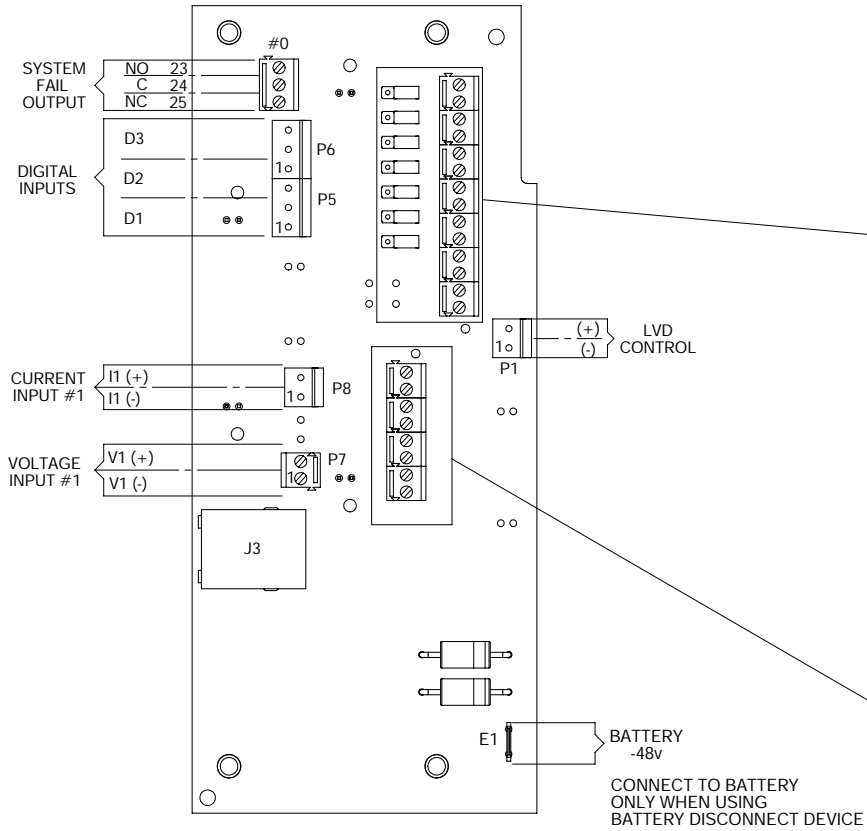

TOP VIEW - CXC BACKPLANE
(707-340-20)

SOME DETAILS OMITTED

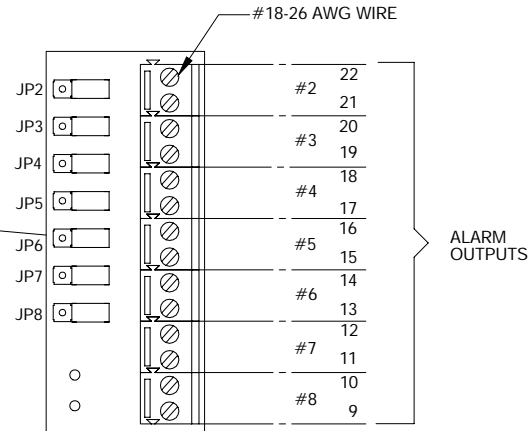

ETHERNET RJ45
PINOUT (J3)

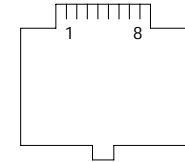

- 1. TX+
- 2. TX-
- 3. RX+
- 4. COM1
- 5. COM2
- 6. RX-
- 7. COM1
- 8. COM2

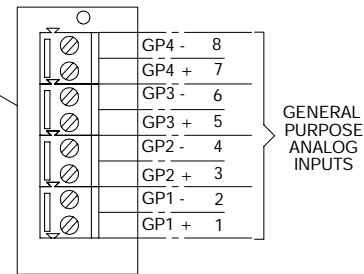

GENERAL PURPOSE ANALOG INPUTS

GENERAL PURPOSE CONFIGURATION TABLE		
INPUT	CXC LIST OPTION	
	LIST 120	LIST 124
GP4	±60V	TEMP
GP3	N/A	0 - 60V
GP2	TEMP	0 - 60V
GP1	TEMP	0 - 60V

DIMENSIONS ARE IN INCHES WITH METRIC (mm) IN BRACKETS: INCHES [mm]

© 2004 ARGUS TECHNOLOGIES

ARGUS[®]

THESE DESIGNS AND SPECIFICATIONS ARE THE PROPERTY OF ARGUS TECHNOLOGIES AND SHALL NOT BE COPIED OR USED FOR MANUFACTURING WITHOUT ITS WRITTEN CONSENT.

TITLE	SCALE
CUSTOMER CONNECTION, 6 MOD OR 5 MOD w CXC SUP. 48-1kW CXRC 19" FLUSH MNT	NTS
ISSUE DATE	SHEET 4 OF 4
SIZE TYPE DWG NO.	REV
B D2 030-707-08	C

This page intentionally left blank.

WARRANTY AND SERVICE INFORMATION

Technical Support

Technical support staff are available for answering general questions related to installation, operation and maintenance of Argus products. In Canada and the USA, call Argus toll free at +1-888-GO-ARGUS (+1-888-462-7487) 7:30 am to 5:00 pm Pacific Standard Time.

For emergencies, call +1-888-GO-ARGUS (+1-888-462-7487) 24 hours a day, seven days a week. Customers outside Canada and the USA, call +1-604-436-5547 for technical support.

Factory Repair and Servicing

All service, beyond initial adjustments, should be carried out by qualified factory service personnel. For these procedures, please contact Argus Technologies at the locations listed in the Service Centers document.

Warranty Policy

Argus Technologies Ltd. warrants all equipment manufactured by it to be free from defects in parts and labor, excluding third party OEM materials (example: air conditioners, batteries), for a period of two years from the date of shipment from the factory. For third party products the OEM's warranty shall apply. The liability of Argus applies solely to repairing, replacing or issuing credit (at Argus' sole discretion) for any equipment manufactured by it and returned by the customer during the warranty period. The terms of the warranty are Ex Works (EXW) from Argus' factory service location.

Argus reserves the right to void the warranty if:

- (1) identification marks or serial numbers are removed or altered in any way,
- (2) invoice is unpaid, or
- (3) defect is the result of misuse, neglect, improper installation, environmental conditions, non-authorized repair, alteration or accident.

Argus shall not be liable to the customer or other parties for any loss of profits, loss of use, costs for removal or installation of defective equipment, damages or consequential damages based upon equipment failure during or after the warranty period. There shall be no other obligations either expressed or implied. Argus will not honor warranties for batteries and other third party products without prior written Argus authorization.

Customer is responsible for all shipping and handling charges (COD and freight collect will not be accepted without prior approval from Argus Technologies).

Payment terms (North America) are net 30 days subject to prior credit approval. All other orders require payment before shipping.

Payment terms (International) are subject to prior approval and are typically through Tele-Transfer.

Return Material Policy

Our return policy is designed to ensure prompt, efficient and high quality factory service. A service request order (SRO) number must be obtained before products can be accepted for servicing by the Argus factory. For returns to an authorized service center (refer to the Service Centers document), please consult the individual service center for specific return policies and instructions.

To obtain an SRO number for a factory return, customers must call the appropriate location with the product serial and model number, as well as a brief description of the problem, shipment instructions and billing details.

The original packing container should be used whenever possible. The box should be completely enclosed and constructed of wood or double-wall, corrugated cardboard. At least 3" of foam or shock absorbing packing material must surround the unit. Both the shipping documents and the outside of the box must have the SRO # clearly marked and the product shipped prepaid to the Argus factory service center. Argus will endeavor to repair products within five working days of receipt. Repairs to the returned product are warranted for a period of six months. A service charge may be applied if no fault is found in the returned product. Argus will not accept products without an SRO number.

Service Centers

Factory Service Centers

Canada and International

Argus Technologies Ltd.
ATTN: RMA Returns
7033 Antrim Avenue
Burnaby, BC, V5J 4M5 Canada
Tel: +1 604 436 5900
Fax: +1 604 436 1233
Email: returns@argusdcpower.com

USA

Argus Technologies Inc.
ATTN: RMA Returns
3116 Mercer Avenue
Bellingham, WA, 98225 USA
Tel: +1-360 756 4904
Fax: +1-360 647 0498
Email: returns-usa@argusdcpower.com

Asia-Pacific

PCM Electronics (Dong Guan) Co., Ltd.
Hongli Industrial Area, Miaobian,
Liaobu Town, Dongguan City,
Guangdong Province, 523400 China
Tel: +86 755 8895 3310
Fax: +86 755 8895 3307

Authorized Service Center

Argentina

Argus Technologies de Argentina
Belen 315, Capital Federal, Buenos
Aires,
14071 Argentina
Tel: +54 (11) 4672 4821
Fax: +54 (11) 4504 4698
Cell: +54 9 (11) 4993 9996
Email: lkleiman@argus.ca

Asia

Argus Technologies Asia Pte Ltd
Blk 6 Tagore Lane #160
Singapore 787570
Tel: +65 6458 8900
Fax: +65 6458 2122

Australia

CPS National
8/376 Newbridge Rd
Moorebank, NSW, 2170 Australia
Tel: +61 02 9822 8977
Fax: +61 02 9822 8077

Australia/New Zealand

Alpha Power Systems Pty Ltd.
Unit 3, 30 Heathcote Road
Moorebank, NSW, 2170 Australia
Tel: +61 02 9602 8331
Fax: +61 02 9602 9180

Century Yuasa

37 - 65 Colbalt Street
Carole Park QLD 4300
Australian Sales & Service
Tel: +61 07 3361 6587
Fax: +61 07 3361 6705
New Zealand Sales & Service
Tel: +64 9 978 6689
Fax: +64 9 978 6677

Brazil

Argus Brasil Serviços e Comércio Ltda
Rua: Constituição, 145/147 - Santos
São Paulo – Brasil 11015-471
Tel: +55 (13) 3234 2469
Fax: +55 (13) 3234 2469
Cell: +55 (13) 7806 1438
Email: argusbrasil@bignet.com.br

Canada

Compower Systems Inc.
118 Tiffield Road
Toronto, ON, M1V 5N2 Canada
Tel: +1 416 293 3088
Fax: +1 416 293 0671

Europe

Alpha Technologies Europe Ltd.
Cartel Business Estate
Edinburgh Way
Harlow, Essex, CM20 2DU UK
Tel: +44 1279 422110
Fax: +44 1279 423355

Mexico & Central America

Technologies Argus First De Mexico
SA de CV
Anatole France No. 17
Col. Polanco
Mexico City, 11560 Mexico
Tel: +52 55 5280 6990
Fax: +52 55 5280 6585

Romania

Alphapower SRL
Str. Paul Constantinescu nr.5
Timisoara, Romania
Tel: +40 21 569 1214
Cell: +40 31 816 1491

South America

Argus Technologies Argentina
Santo Tome 2573, Capital Federal
Buenos Aires, 1416 Argentina
Tel: +54 11 4504 4698
Cell: +54 9 11 4993 9996
E-pager: 541149939996@nextel.net.ar

Turkey

IPC Enerji Elk San ve TIC AS
Inonu cad. Kanarya sok. No:20
Yenisahra - Kadikoy
Istanbul, Turkey
Tel: +90 216 317 41 42
Fax: +90 216 472 90 66