

The Best Way  
To Go  
About Your  
Business

**TAYLOR-DUNN<sup>®</sup>**



*Models: B5-440-36  
B5-440-48*

**BIGFOOT**

## **MANUAL MB-440-01**

*Operation, Troubleshooting and  
Replacement Parts Manual*

Serial numbers:

Starting: 193200

Ending: See Introduction Chapter

## **My Vehicle information**

Serial Number: \_\_\_\_\_.

Date Purchased: \_\_\_\_\_.

Date Delivered: \_\_\_\_\_.

Dealer Purchased From: \_\_\_\_\_.

Salesman Name: \_\_\_\_\_.

Your satisfaction is our #1 goal. If you have questions or concerns with your vehicle, please contact your sales Representative or Service Advisor at your local dealership.

Taylor-Dunn has a worldwide dealer and distribution network to provide replacement parts and service for our vehicles.

Refer to our web site, [www.taylor-dunn.com](http://www.taylor-dunn.com), for a dealer lookup application.

Originally Published 9/30/2014

Revision A, 9/30/2014, contents subject to change without notice

Taylor-Dunn® Mfg.

2114 W. Ball Rd.

Anaheim, CA 92804

(800)-688-8680

(714) 956-4040

(FAX) (714) 956-0504

Visit our Web site: [www.taylor-dunn.com](http://www.taylor-dunn.com)

### **Taylor-Dunn Contact information**

*Service, Parts, Sales:*

*Taylor-Dunn has a network of dealers distributed around the globe to support our vehicles. Information regarding vehicle sales, replacement parts, or service should be obtained through your local dealer. A dealer locator can be found on the Taylor-Dunn website at [www.taylor-dunn.com](http://www.taylor-dunn.com).*

*If you do not have access to the internet, you can call the factory direct at:*

*01 (714) 956-4040*

*Feedback regarding this or any Taylor-Dunn vehicle manual can be sent to:*

*Taylor-Dunn Manufacturing*

*Attn: Tech Writer*

*2114 West Ball Road*

*Anaheim, CA 92804*



**The Taylor-Dunn Corporation:**  
Leading Provider of Commercial & Industrial Vehicles since 1949



**Taylor-Dunn Manufacturing:**

From the day we shipped our first vehicle in 1949, we have pursued a singular goal: to build tough, rugged, dependable vehicles to help our customers move personnel, equipment, and materials. It's that simple. For over sixty years, our standard and custom vehicles - Burden Carriers, Personnel Carriers, Stock Chasers, Electric Carts, Tow Tractors & more - have been the leading solution for customers in a broad range of industrial, commercial, and ground-support markets.

Decades of experience are an invaluable asset, and it is an asset we cherish and protect. Our guiding principle is to provide application-specific solutions, which are reliable, efficient, and economical.

Our domestic and international network of quality Taylor-Dunn Dealers and Parts & Service Support keeps our customers moving.

**Tiger Tractor:**

Tiger manufacturing has become a leading manufacturer of internal combustion industrial tractors and ground support equipment. With tractor capacities ranging from 3,000 - 12,000 pounds drawbar pull, they are ideal for industrial applications as well as aircraft ground support. As with all Taylor-Dunn vehicles; quality, service, support and reliability are built into all Tiger Tractor products.

*Shown below is just a small sample of what Taylor-Dunn has to offer to keep your business moving:*



Note: Each section title page contains a section table of contents

## Master Table of Contents

Introduction.....	7
Service/Maintenance Guidelines.....	13
Special Tool List .....	17
Lubrication .....	21
Front Axle.....	25
Drive Axle-GT.....	33
Steering .....	43
Brakes.....	51
Motor.....	59
Tires & Wheels.....	65
Motor Controller .....	71
Suspension .....	75
Batteries .....	77
Wire Diagram .....	83
Hardware Information .....	85
Replacement Parts .....	91





## Table of Contents

### Introduction

About This Manual .....	8
Who Should Read This Manual .....	8
Replacement Parts .....	8
How To Use This Manual .....	8
Conventions .....	9
Signal Words and Their Definitions: .....	9
Responsibilities .....	10
How to Identify Your Vehicle .....	11
Web Site Registration .....	11

### **WARNING**

This section is one section of a complete service manual. Before starting any procedure, read all warnings and instructions that are located in the Service Guidelines chapter.



## **ABOUT THIS MANUAL**

The purchase of this vehicle shows a belief in high quality products manufactured in the USA. Taylor-Dunn®, a leading manufacturer of electric burden and personnel carriers since 1949, wants to be sure this vehicle provides years of reliable service. Please continue to read this manual and enjoy this high quality Taylor-Dunn® vehicle.

This manual is to serve as a guide for the service, repair, and operation of Taylor-Dunn® vehicles and is not intended as a training guide. Taylor-Dunn® has made every effort to include as much information as possible about the operation and maintenance of this vehicle.

Before servicing, operating, training or performing maintenance on this or any other Taylor-Dunn® vehicle, read the appropriate Taylor-Dunn® manual.

Each Taylor-Dunn® manual references the applicable models and serial numbers on the front cover.

Please, be aware of all cautions, warnings, instructions, and notes contained in this manual.

## **WHO SHOULD READ THIS MANUAL**

This manual is intended for use by anyone who is going to operate, own, perform maintenance on, service, or order parts for this Taylor-Dunn® vehicle. Each person shall be familiar with the parts of this manual that apply to their use of this vehicle.

## **REPLACEMENT PARTS**

To maintain peak performance, only use original Taylor-Dunn replacement parts intended for use on your vehicle.

Taylor-Dunn components are designed and tested for use on specific Taylor-Dunn model vehicles. Only use the correct Taylor-Dunn replacement components for your Taylor-Dunn vehicle.

Electrical components not tested by Taylor-Dunn (or intended for use on other Taylor-Dunn vehicles) may have unanticipated interaction and/or interference with the vehicles control system resulting in unsafe operation or damage to the electrical system.

Mechanical components not tested by Taylor-Dunn (or from other model Taylor-Dunn vehicles) may have an undesirable affect on the operation of the vehicle, result in additional frame stress, or stress other components resulting in premature failure or an unsafe condition.

Due to the unknown properties of non-Taylor-Dunn tested components or from components not originally equipped on the vehicle, we cannot approve their use in a Taylor-Dunn vehicle.

## **HOW TO USE THIS MANUAL**

This manual is organized into three main sections:

### **Introduction**

This section describes how to use this service manual and how to identify your vehicle.

### **Maintenance, Service, and Repair**

This section gives specific information on the servicing of the vehicle and a schedule for maintenance checks.

This manual is for mechanical repairs only and does not include electrical diagnosis procedures. Electrical diagnosis procedures are included in a separate manual.

### **Replacement Parts**

This section provides an illustrated view of various assemblies. The illustrations are accompanied by tables identifying the parts.





**Conventions**

Symbols and/or words used to define Dangers, Warnings, Cautions, and Notices are found throughout this manual. The “Words” in this context will be referred to as “Signal words.” The words defined here as “signal words” may be used elsewhere in the text of this document without being a signal word. When used as a signal word, the signal word will be enclosed in a solid rectangle with white background (example below).

**Signal Words and Their Definitions:**

**DANGER:** This signal word will be accompanied by the safety alert symbol (see below). “DANGER” will indicate a hazard that, if not avoided, **WILL** result in death or serious bodily injury to yourself, the operator or passengers of the vehicle, or people in the immediate area of the vehicle.

**WARNING:** This signal word will be accompanied by the safety alert symbol (see below). “WARNING” will indicate a hazard that, if not avoided, may result in death or serious bodily injury to yourself, the operator or passengers of the vehicle, or people in the immediate area of the vehicle.

**CAUTION:** This signal word will be accompanied by the safety alert symbol (see below). “CAUTION” will indicate a hazard that, if not avoided, may result in minor or moderate injury to yourself, the operator or passengers of the vehicle, or people in the immediate area of the vehicle.

**NOTICE:** This signal word will not be accompanied by the safety alert symbol. “NOTICE” will indicate a condition that if not avoided may result in property damage. “Property” is defined as the vehicle, components in the vehicle and/or the surrounding area such as buildings, other vehicles, etc.

**Safety Messages**

Important information notifying you of any conditions that may result in hazards to yourself, persons nearby, and/or hazards to the vehicle will be presented in a text box with a black border and may include a signal word (see above). To the right is an example of a safety message.

The safety message may include additional warning icons representing the type of hazard. The following is a list of these icons and what they represent. These icons may also be included on the various warning and information decals applied to the vehicle.





**This is an example of a safety alert message. This message will contain information about a hazard and/or instructions on avoiding a hazard. The actual size and location of this warning box may vary.**

 Safety alert symbol (see above).

 Represents a high voltage hazard.

 Represents an explosion hazard.

 Represents a corrosive chemical hazard.

 Represents a fire hazard.

 Represents a poisonous chemical hazard.

Some of the decals applied to the vehicle will have icons representing their function. The icons and their definitions are listed below:

 Read the operators manual.

 Read the maintenance manual.

 Keep arms and legs inside the vehicle.

 Parking brake ON.

 Parking brake OFF.

 Do not get wet.

 Do not spray wash.

**Responsibilities****Of the Owner...**

The owner of this or any Taylor-Dunn vehicle is responsible for the overall maintenance and repairs of the vehicle, as well as the training of operators.

The owner is also responsible for operator training per the following federal regulations:

- ANSI/ITSDF 56.8-2006 Personnel and Burden Carriers: Part II, Paragraph 6.2a.
- ANSI/ITSDF 56.9 – 2007 Safety Standard for Operator Controlled Industrial Tow Tractors: Part II, paragraph 4.11.
- Code of Federal Regulations (CFR) Title 29, Subtitle B, Chapter Xvii OSHA, Part 1910.178 Powered Industrial Trucks (2011): 1910.178, Section (I).

Per OSHA Regulation, 29 CFR 1910.178 Powered Industrial Truck Operator Training, the owner must keep a record of conducted training and maintenance performed on the vehicle.

**Of the Service Personnel...**

The service personnel are responsible for the service and maintenance of the vehicle. At no time shall a service person allow any untrained personnel to service or repair this or any Taylor-Dunn® vehicle. For the purposes of training, a qualified service person may oversee the repairs or services being made to a vehicle by an individual in training. At no time shall an untrained individual be allowed to service or repair a vehicle without supervision. This manual is not a training guide.

Personnel performing service and repair shall have knowledge of:

- Basic standard automotive repair procedures
- Basic DC and AC electrical theory
- AC motor speed control operation
- Use of digital and analog multi-meters
- Lead acid batteries

Personnel performing maintenance shall have basic knowledge of standard automotive maintenance procedures and lead acid batteries.

 **WARNING**

To maintain peak performance, always use original Taylor-Dunn replacement parts intended for use on your vehicle. Taylor-Dunn components are designed and tested for use on specific Taylor-Dunn model vehicles. Only use the correct Taylor-Dunn replacement components for your Taylor-Dunn vehicle.

Do not modify your vehicle:  
**Modifications to this vehicle may have an undesirable affect on the operation of the vehicle, result in additional frame stress, or stress other components resulting in premature failure or an unsafe condition and may lead to an accident resulting in serious injury or death.**

 **WARNING**

The only personnel authorized to repair, modify, or adjust any part of this or any Taylor-Dunn vehicle is a factory authorized service technician. Repairs made by unauthorized personnel may result in damage to the vehicles systems which could lead to an unsafe condition resulting in severe bodily injury and/or property damage. Unauthorized repairs may also void the vehicles warranty.

**Of the Operator...**

A vehicle shall not be operated until the operator has successfully completed an operator training course provided by the owner of the vehicle.

The operator is responsible to be sure that the vehicle is operated only on authorized roads, highways, and installations.

The operator is responsible to confirm that all passengers are properly seated and properly using the available restraints.

The operator is responsible for the safe operation of the vehicle, preoperational and operational checks on the vehicle, and the reporting of any problems to service and repair personnel.

**Of the Passengers...**

The passengers are responsible to remain fully seated, keeping their hands, arms, and legs inside the vehicle at all times. Each passenger shall be fully aware of the vehicle's operation. All forms of recklessness are to be avoided. Do not engage in horseplay.

## ***HOW TO IDENTIFY YOUR VEHICLE***

This manual is valid only for the serial numbers listed on the front cover. If the ending serial number is blank, then this manual was for current production vehicles when printed. If you did not receive this manual with the vehicle, you should confirm this manual is valid for your serial number at the Taylor-Dunn web site.

The locations of the model and serial numbers are shown in the illustrations below:

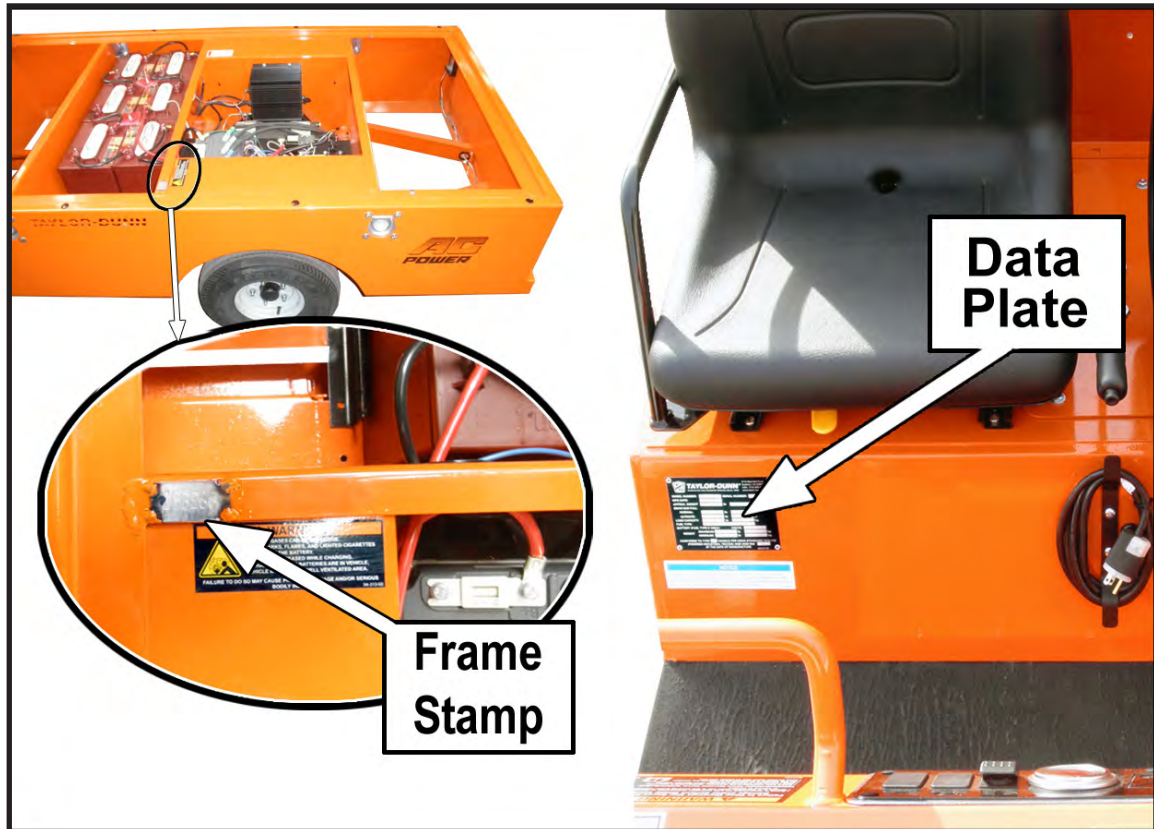

## ***WEB SITE REGISTRATION***

Registering on the Taylor-Dunn web site will give you access to a wealth of information about your vehicle and the entire Taylor-Dunn line of vehicles. Your contact information will remain confidential and will not be shared outside of the Taylor-Dunn corporation.

Once registered on the Taylor-Dunn web site, you will have access to:

- Additional Taylor-Dunn product information.
- Worldwide Taylor-Dunn dealer contacts
- Vehicle Service, Maintenance, Operator, Troubleshooting, and Parts manuals.
- Replacement part number lookup utility

***[www.taylor-dunn.com](http://www.taylor-dunn.com)***



## Table of Contents

### **Service/Maintenance Guidelines**

Read Me First - Maintenance Guidelines and General instructions .....	14
Vehicle Modifications .....	15
Using Non-OEM Replacement Components:.....	15

#### **WARNING**

This section is one section of a complete service manual. Before starting any procedure, read all warnings and instructions that are located in the Service Guidelines chapter.

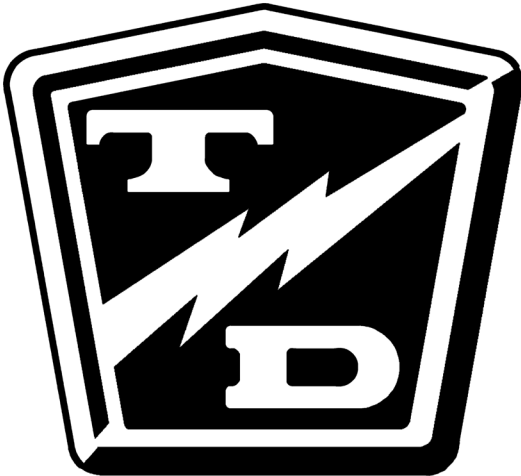

# Service/Maintenance Guidelines

## **READ ME FIRST - MAINTENANCE GUIDELINES AND GENERAL INSTRUCTIONS**

### **WARNING**

Read and follow all of the guidelines listed below. Failure to follow these guidelines may result in severe bodily injury and/or property damage.

- Read the operator's manual before operating this vehicle.
- Avoid fire hazards and have fire protection equipment present in the work area.
- Conduct vehicle performance checks in an authorized area where safe clearance exists.
- Ventilate the work area properly.
- Regularly inspect and maintain the following systems in a safe working condition: brakes, steering mechanisms, speed and directional control mechanisms, warning devices, lights, governors, guards, and safety devices.
- Inspect and maintain battery limit switches, protective devices, electrical conductors, and connections in conformance with Taylor-Dunn's® recommended procedures.
- Keep the vehicle in clean condition to minimize fire hazards and facilitate detection of loose or defective parts.
- Do not use an open flame to check level or leakage of battery electrolyte.
- Do not use open pans of fuel or flammable fluids for cleaning parts.
- Only properly trained and authorized technicians should perform maintenance or repairs to this vehicle.

### **WARNING**

The only personnel authorized to repair, modify, or adjust any part of this or any Taylor-Dunn vehicle is a factory authorized service technician. Repairs made by unauthorized personnel may result in damage to or improper operation of the vehicles systems which could lead to an unsafe condition resulting in severe bodily injury and/or property damage.

Unauthorized repairs may also void the vehicles warranty.

### **WARNING**

Periodic maintenance and service must be performed on this vehicle. Failure to complete these scheduled maintenance and service procedures can result in severe bodily injury and/or property damage. It is the owner and/or operators responsibility to ensure that proper service and maintenance is performed on the vehicle, described in this manual.

### **WARNING**

The vehicle may operate at any time while performing control system test procedures.

All tests must be performed with the drive wheels off of the ground and the vehicle supported with jack stands.

Testing with drive wheels on the ground may result in vehicle movement causing severe bodily injury and/or property damage.

### **WARNING**

#### **BEFORE STARTING ANY REPAIRS**

- 1) Make sure the start switch is in the "OFF" position, then remove the key.
- 2) Place the forward-reverse switch in the center "OFF" position.
- 3) **Set the park brake or confirm the brake is set when equipped with an automatic brake.**
- 4) Place blocks under the front or rear wheels to prevent vehicle movement.
- 5) Disconnect the main positive and negative cables at the batteries.

### **WARNING**

When lifting the vehicle, always use a hoist with lifting strap, or a jack of adequate capacity. Use jack stands to support the vehicle before starting any repairs. Failure to use lifting and support devices of rated load capacity may result in severe bodily injury.

### **WARNING**

On a three wheel vehicle: When raising both rear wheels, the front end of the vehicle must be supported to prevent tipping. The rear of the vehicle should be raised by a means so that the left and right side are raised equally, such as a hoist with fixed length chains attached to the left and right side of the vehicle. Failure to properly support the vehicle may result in the vehicle tipping over causing severe bodily injury and/or property damage.

## **VEHICLE MODIFICATIONS**

Taylor-Dunn vehicles are designed and manufactured in accordance with ANSI/ITSDF and OSHA regulations. Per ANSI/ITSDF and OSHA, modifications to the vehicle must be approved by the manufacturer. Listed below are the specific regulations:

### **ANSI/ITSDF 56.8-2006 Personnel and Burden Carriers:**

#### Paragraph 8.2q:

Modifications and additions which affect capacity and safe machine operation shall not be performed by the customer or user without manufacture's prior written authorization; where authorized modifications have been made, the user shall ensure that capacity, operation, warning, and maintenance instructions plates, tags, or decals are changed accordingly.

#### Paragraph 8.2r:

Care shall be taken to ensure that all replacement parts are interchangeable with the original parts and of a quality at least equal to that provided in the original equipment.

### **ANSI/ITSDF 56.9 – 2007 Safety Standard for Operator Controlled Industrial Tow Tractors:**

#### Paragraph 6.2.14:

Modifications and additions which affect capacity and safe tow tractor operation shall not be performed without manufacture's prior written approval. Capacity, operation, and maintenance instructions plates, tags, or decals are changed accordingly.

### **Code of Federal Regulations (CFR) Title 29, Subtitle B, Chapter XVII OSHA, Part 1910.178 Powered Industrial Trucks (2011)**

#### 1910.178(a)(4)

Modifications and additions which affect capacity and safe operation shall not be performed by the customer or user without manufacturers prior written approval. Capacity, operation, and maintenance instruction plates, tags, or decals shall be changed accordingly.

#### 1910.178(q)(6)

Industrial trucks shall not be altered so that the relative positions of the various parts are different from what they were when originally received from the manufacturer, nor shall they be altered either by the addition of extra parts not provided by the manufacturer or by the elimination of any parts, except as provided in paragraph (q)(12) of this section. Additional counterweighting of fork trucks shall not be done unless approved by the truck manufacturer.

### **Using Non-OEM Replacement Components:**

To maintain peak performance, always use original Taylor-Dunn replacement parts intended for use on your vehicle.

Taylor-Dunn components are designed and tested for use on specific Taylor-Dunn model vehicles. Only use the correct Taylor-Dunn replacement components for your Taylor-Dunn vehicle.

#### Electrical Components:

Electrical components not tested by Taylor-Dunn (or intended for use on other Taylor-Dunn vehicles) may have unanticipated interaction and/or interference with the vehicles control system resulting in unsafe operation or damage to the electrical system.

#### Mechanical Components:

Mechanical components not tested by Taylor-Dunn (or from other model Taylor-Dunn vehicles) may have an undesirable affect on the operation of the vehicle, result in additional frame stress, or stress other components resulting in premature failure or an unsafe condition.

Due to the unknown properties of non-Taylor-Dunn tested components or from components not originally equipped on the vehicle, we cannot approve their use in a Taylor-Dunn vehicle.







## Table of Contents

### Special Tool List

Tool List .....	18
Controller Programming: .....	18
Troubleshooting Guide .....	20

#### **WARNING**

This section is one section of a complete service manual. Before starting any procedure, read all warnings and instructions that are located in the Service Guidelines chapter.

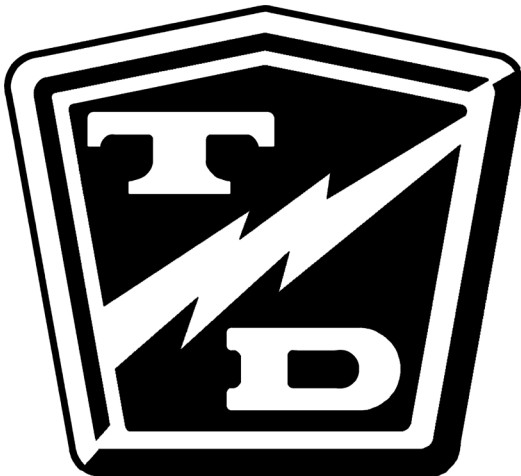

# Special Tool List

**TOOL LIST**

The tools shown here are generic for servicing Taylor-Dunn vehicles. Not all tools will be required for servicing this vehicle.



62-027-32: Throttle Module Analyzer  
Tests the throttle module in or out of the vehicle



75-089-00: Throttle Module Test Harness  
Used in conjunction with a volt meter to test the throttle module. The module must be installed in a working control system.  
*Note: Part # 62-027-31 includes instructions.*



62-027-00: Test Light  
Used for testing electrical circuits. Switchable for 12, 24, 36, 48 volt systems.  
Required to complete troubleshooting provided in the vehicle service manuals.



41-532-50: Chain Case Centering Tool  
Used to center the chain case cover on all vehicles equipped with the Power Traction primary reduction and a pinion brake or speed sensor. Includes instructions.



43-201-50: Pinion Seal Installation Tool  
Used to install the pinion seal on all vehicles equipped with the Power Traction primary reduction and a pinion brake or speed sensor.

**Controller Programming:**

Sevcon: 62-027-63 "PCpaK Cable lead and application."

Curtis AC: 62-027-66 "1314 PC Programming Station"



62-027-61 and 62-027-62: Sevcon System Handset  
Diagnostics and adjustments (-62 only) of the Sevcon Power Pak and Micro Pak control systems.



62-027-56 and 62-027-57: Sevcon AC System Handset  
Diagnostics and adjustments of the Sevcon AC control system.



62-027-64 and 62-027-65: Curtis AC System Handset  
Diagnostics and adjustments (-65 only) of the Curtis AC control system.



96-500-43: PMT/C Meter Reset Module  
Required to reset the PMT/C maintenance meter (special order option).



41-350-13: Disc Brake Boot Installation Tool  
Assists in installing the rubber boot onto the disc brake piston.



70-440-55: Pin Removing Tool  
Removes pin from Amp circular harness connectors.



77-200-00: Hydrometer  
Used for testing battery electrolyte. Illustration is of a typical hydrometer, actual hydrometer type may vary.



77-201-00: Battery Filler  
Used to safely add water to batteries. Equipped with splash guard and auto-shutoff when cell is full.



Extension Not Included

96-500-48: GT Drive Oil Fill Plug Tool  
Used to remove the oil fill plug on GT drives. It is used with a 3/8" drive extension (not included).



**Molex-.062 pin**

**11-0300-02**

Molex # 11-300-02: Pin Removing Tool  
Removes 0.062 diameter pins from Molex rectangular harness connectors. Not available from Taylor-Dunn. Purchase from any local electronics distributor.



**Molex-.093 pin**

**11-0300-06**

Molex # 11-300-06: Pin Removing Tool  
Removes 0.093 diameter pins from Molex rectangular harness connectors. Not available from Taylor-Dunn. Purchase from any local electronics distributor.



75-442-55: Pin Removing Tool  
Removes pins from Molex Mini-Fit harness connectors.

## TROUBLESHOOTING GUIDE

This is a general troubleshooting guide for various mechanical faults. Refer to the electrical troubleshooting chapter for checking the electronic motor control system.

This list is provided as a guide only. It is not all inclusive of causes that may result in a specific symptom.

<b>Symptom</b>	<b>Suspect Component or System</b>	<b>Action</b>
Steering Pulls Left or Right	Front end out of alignment	Realign front end
	Low tire pressure	Inspect tire pressure
Difficult Steering	Lack of lubrication	Lubricate steering linkages
	Damaged or worn steering components	Inspect all steering components
	Low tire pressure	Inspect tire pressure
Excessive Play in Steering	Damaged or worn steering linkages	Inspect steering linkages
	Loose steering linkages	Tighten all hardware
	Loose steering wheel	Inspect steering wheel nut
	Loose front spring hardware	Tighten all hardware
Soft and/or Low Brake Pedal	Air in brake lines	Bleed brake system
	Master cylinder fluid level low	Fill master cylinder and bleed system
	Brake pedal linkage out of adjustment	Adjust linkages
Hard Brake Pedal	Faulty master cylinder	Inspect master cylinder
Lack of Braking Power	Contaminated brake pads	Replace brake pads
	Worn brakes	Replace brakes
	Air in brake lines	Bleed brake system
Brakes Dragging	Brake pedal linkage out of adjustment	Adjust linkages
	Faulty master cylinder	Inspect master cylinder
	Faulty brake caliper	Inspect brake calipers
	Debris in brakes	Inspect brakes
	Parking brake applied	Release parking brake, inspect linkage
Low Power or Running Slow	Faulty or discharged battery	Test battery and charge
	Brakes dragging	Inspect brake system
	Fault in motor control system	Refer to motor control fault codes
Noise, Front End	Loose wheel nuts	Tighten all hardware
	Damaged or worn wheel bearings	Inspect wheel bearings
	Damaged, worn, or debris in brakes	Inspect brakes
	Loose components	Tighten all hardware
	Damaged or worn suspension mounts	Inspect suspension
Noise, Rear End	Loose wheel nuts	Tighten all hardware
	Damaged or worn internal transaxle components	Inspect transaxle
	Damaged or worn suspension mounts	Inspect suspension

*Note: This list is provided as a guide only. It is not all inclusive of causes that may result in a specific symptom.*

## Table of Contents

### Lubrication

Lubrication and Fluids Chart.....	22
Hazardous Waste Disposal.....	22
Lubrication Diagram.....	23
Wheel Bearings .....	24

### **WARNING**

This section is one section of a complete service manual. Before starting any procedure, read all warnings and instructions that are located in the Service Guidelines chapter.

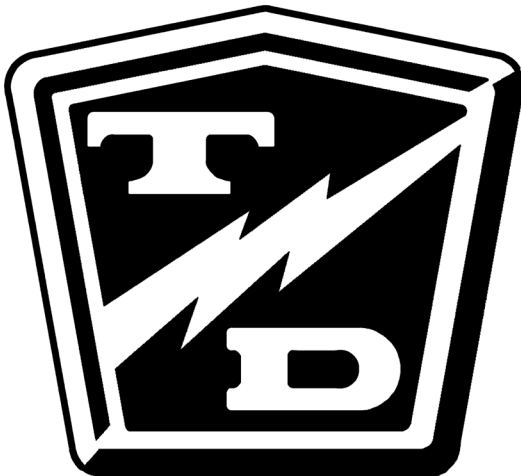

**LUBRICATION AND FLUIDS CHART**

---

Assembly	Component	# of Locations	Capacity	Lubricant
<b><u>Front Axle:</u></b>				
	3: Wheel Bearings	2	-	NLGI Grade 2 lithium high temp Bearing Grease
	> Refer to procedure later in this section			
	4: King Pin	4	-	NLGI Grade 2 lithium multi-purpose grease
<b><u>Suspension:</u></b>				
	5: Rear spring eyes	6		NLGI Grade 2 lithium multi-purpose grease
<b><u>Steering:</u></b>				
	1: Steering Rack	1		NLGI Grade 2 lithium multi-purpose grease
	2: 90° Steering Gear	1		NLGI Grade 2 lithium multi-purpose grease
	6: Collapsible steering shaft	1		NLGI Grade 2 lithium multi-purpose grease
<b><u>Brake Fluid:</u></b>				
	Master Cylinder	1		DOT 3, Meets or exceeds SAE J1703
<b><u>Linkages:</u></b>				
	Park brake handle	1	-	Multi-purpose spray lubricant
<b><u>Rear Transaxle:</u></b>				
	7: Drain Plug (ref)			
	8: Level Plug (ref)			
	9: Fill Plug	1	1.4-1.9 Liters	SAE 80W90 Gear Oil
	10: Motor Coupler	1		Part # 94-421-34 Moly Paste Grease

**HAZARDOUS WASTE DISPOSAL**

---

This vehicle contains various components and/or fluids that may be classified as hazardous waste.

This includes but is not limited to Lead, Acid, Oil, Grease.

The brake linings originally installed by the factory do not contain asbestos. However, since it is possible that asbestos brake linings were installed as replacement parts, brake linings should be handled as hazardous waste.

The requirements for disposal of hazardous waste vary by location. Consult your local regulations regarding the proper disposal of hazardous waste products.

**LUBRICATION DIAGRAM**

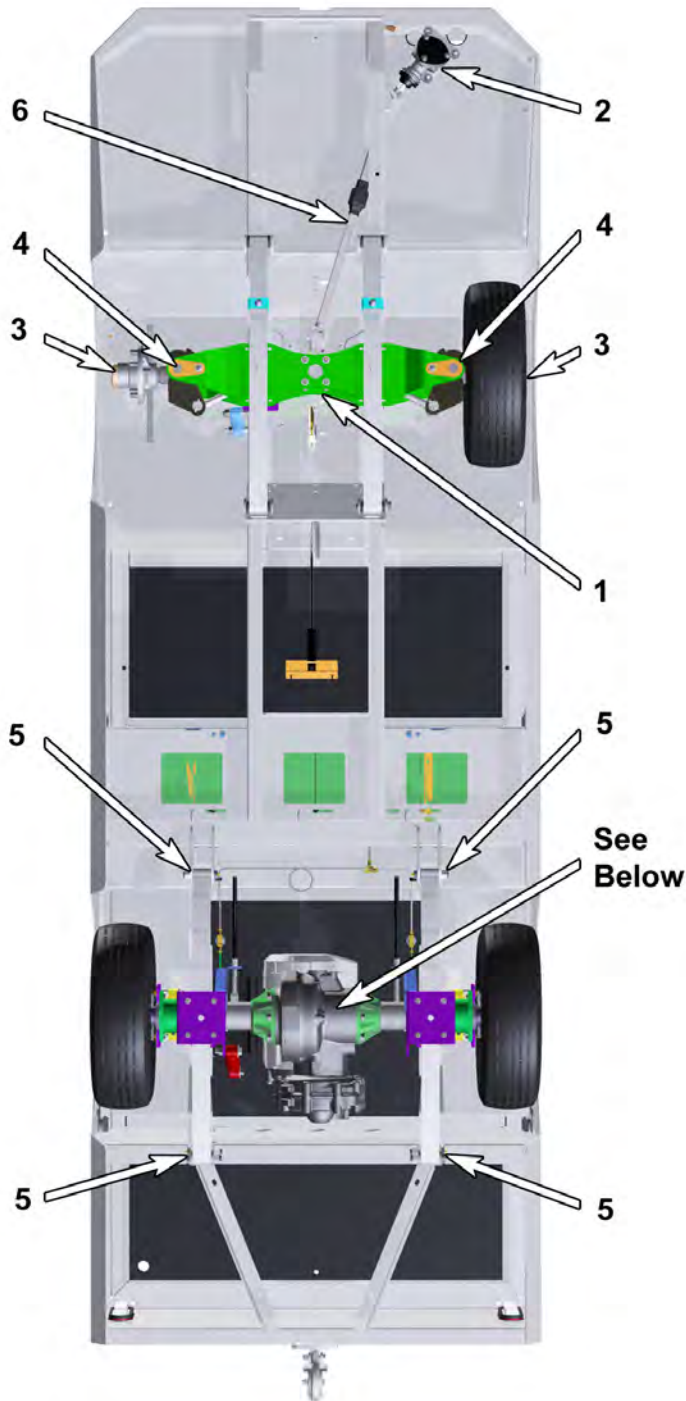

*Note: The transaxle is mounted at an angle in the vehicle. The transaxle must be level when checking oil level. This will require raising the rear of the vehicle until the transaxle is level with the ground. Refer to Drive Axle service section.*

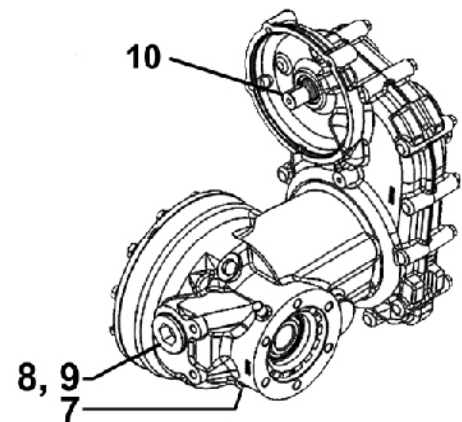

*Drive Axle Lubrication*

## Wheel Bearings

The Bigfoot is available with or without front brakes. There are two different lube procedures depending on whether your vehicle has front brakes.

Refer to the lubrication chart for grease specification.

### Front Axle without Brakes

There is a grease fitting located on the inside face of the hub.

- 1: Clean the exterior of the grease fitting so that debris is not injected into the bearings.
- 2: Remove the bearing cap.
- 3: Inject grease until a small amount is extruded through the outer bearing.
- 4: Reinstall the bearing cap.
- 5: Using a tool similar to the one shown below, slide it under the seal so that it is between the seal lip and the spindle. This will allow grease to slip through the seal so that the pressure does not pop the seal out of the hub.
- 6: Inject grease until a small amount is extruded through the lip around the tool.
- 7: Wipe off any excess grease.

### Front Axle with Brakes

- 1: Remove the hub from the spindle. Refer to the front axle section for information on how to remove and install the hub.
- 2: Remove the grease seal and discard.
- 3: Remove and thoroughly clean the inner and outer bearings.
- 4: Thoroughly clean the inside of the hub and bearing cap.
- 5: Pack the inner and outer bearing with grease.
- 6: Insert the inner bearing into the hub and install a new grease seal.
- 7: Reinstall the hub on the spindle.

## **WARNING**

Incorrect lubrication of the front wheel bearings may result in contamination of the brake pads and rotor. **This will significantly increase stopping distance and may result in severe bodily injury and/or property damage.**

**If the brake pads have been contaminated they should be replaced.**

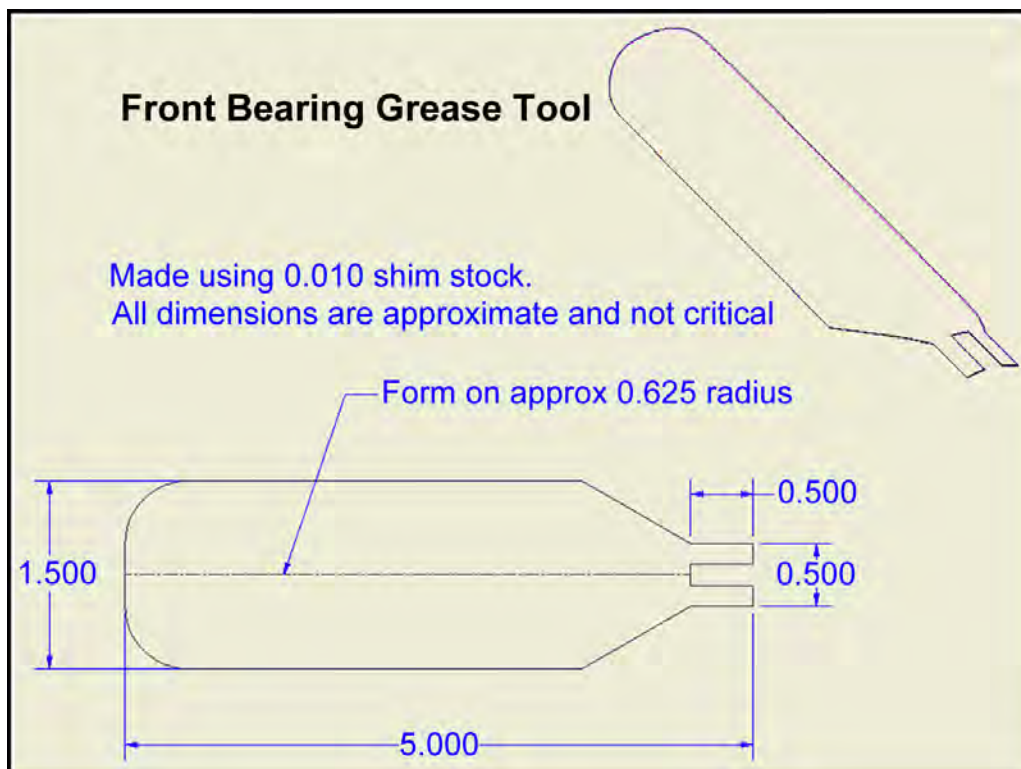
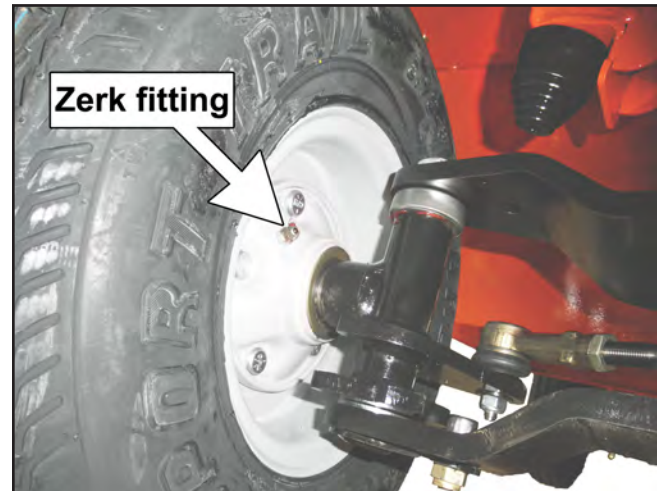



## Table of Contents

### Front Axle

Remove.....	26
Install .....	26
Assemble Complete Axle.....	27
Inspect Front Wheel Bearings.....	28
Adjust Front Wheel Bearings .....	28
Front Wheel Alignment .....	29
Replace Steering Knuckle .....	30
Replace King Pin/Bushings.....	31
Replace Front Wheel Bearings.....	31
Service Limits and Specifications .....	32
King Pin Bushings .....	32
Toe In.....	32
Hardware Torque .....	32

### **WARNING**

This section is one section of a complete service manual. Before starting any procedure, read all warnings and instructions that are located in the Service Guidelines chapter.

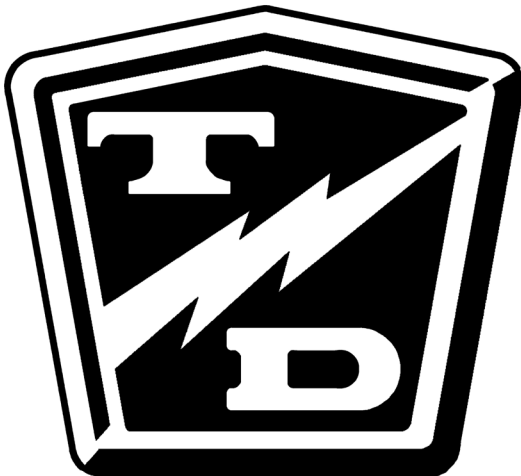

**REMOVE****⚠ WARNING**

This section is one section of a complete service manual. Before starting any procedure, read all warnings and instructions that are located in the Service Guidelines chapter.

**NOTICE**

If vehicle is equipped with front brakes, you will need to disconnect the front brakes and bleed the brake lines.

- 1: Raise the front of the vehicle and support with jack stands.
- 2: Remove both front wheels.
- 3: Remove the 8 spring mounting bolts, spacers, and 2 lower spring mounting plates.
- 4: Remove the coupler pinch bolt and discard the bolt and nut.
- 5: Remove the coupler from the steering rack input shaft.

*Note: Vehicles up to serial number 193269: You will have to move the axle back about 1 inch for clearance to remove the coupler.*

- 6: Lift the axle up over the spring centering bolts and slide the axle assembly over the springs out of the left or right side of the vehicle.

**INSTALL****⚠ WARNING**

This section is one section of a complete service manual. Before starting any procedure, read all warnings and instructions that are located in the Service Guidelines chapter.

**NOTICE**

If vehicle is equipped with front brakes, you will need to disconnect the front brakes and bleed the brake lines.

- 1: Raise the front of the vehicle and support with jack stands.
- 2: Slide the axle assembly through the left or right side and position on the spring centering bolts.
- 3: Loosen the 4 steering rack mounting bolt nuts DO NOT REMOVE.
- 4: Install the 8 spring mounting bolts, spacers, and 2 lower spring mounting plates.
- 5: Tighten the steering rack mounting bolt nuts.
- 6: Install the steering coupler to the steering rack.
- 7: Install a new coupler pinch bolt and tighten per torque listed in the Hardware Torque table at the end of this section.
- 8: Install new pinch bolt jam nut.
- 9: Install the wheels and test drive.

## ASSEMBLE COMPLETE AXLE

### **WARNING**

This section is one section of a complete service manual. Before starting any procedure, read all warnings and instructions that are located in the Service Guidelines chapter.

*Note: Thrust bearings should be packed with grease before assembly.*

*Note: The steering rack and spring hardware should not be fully tightened until the assembly is installed in the vehicle.*

- 1: Securely clamp the lower axle beam to a work surface.
- 2: Install the king pins up through the beam. Install locking bolt and hand thread the nut to the bolt.
- 3: Install flat washer onto each king pin.
- 4: Install steering knuckles.
- 5: Inspect the thrust bearing bronze washer. Replace if any grooves are worn flat.
- 6: Assemble, grease, and install thrust bearings. Make sure they are orientated correctly.
- 7: Place the steering rack assembly onto the lower beam and install ball joints.
- 8: Tighten ball joint nuts to torque specified at the end of this section.
- 9: Place the upper axle beam onto the assembly.
- 10: Tighten the kingpin nuts so that there is no vertical play in the knuckle but it still turns freely.
- 11: Place the beam spacers into the assembly and drop the 8 mounting bolts/washers (do not install nuts) through the two beams.
- 12: Install the springs, spring plates, and nuts/washers but do not fully tighten the hardware at this time.
- 13: Drop the 4 steering rack mounting bolts/washers through the two beams. Install the washers and nuts but do not fully tighten at this time.
- 14: Install the axle/spring assembly into the vehicle and then tighten the 8 axle beam mounting nuts and 4 steering rack mounting nuts.

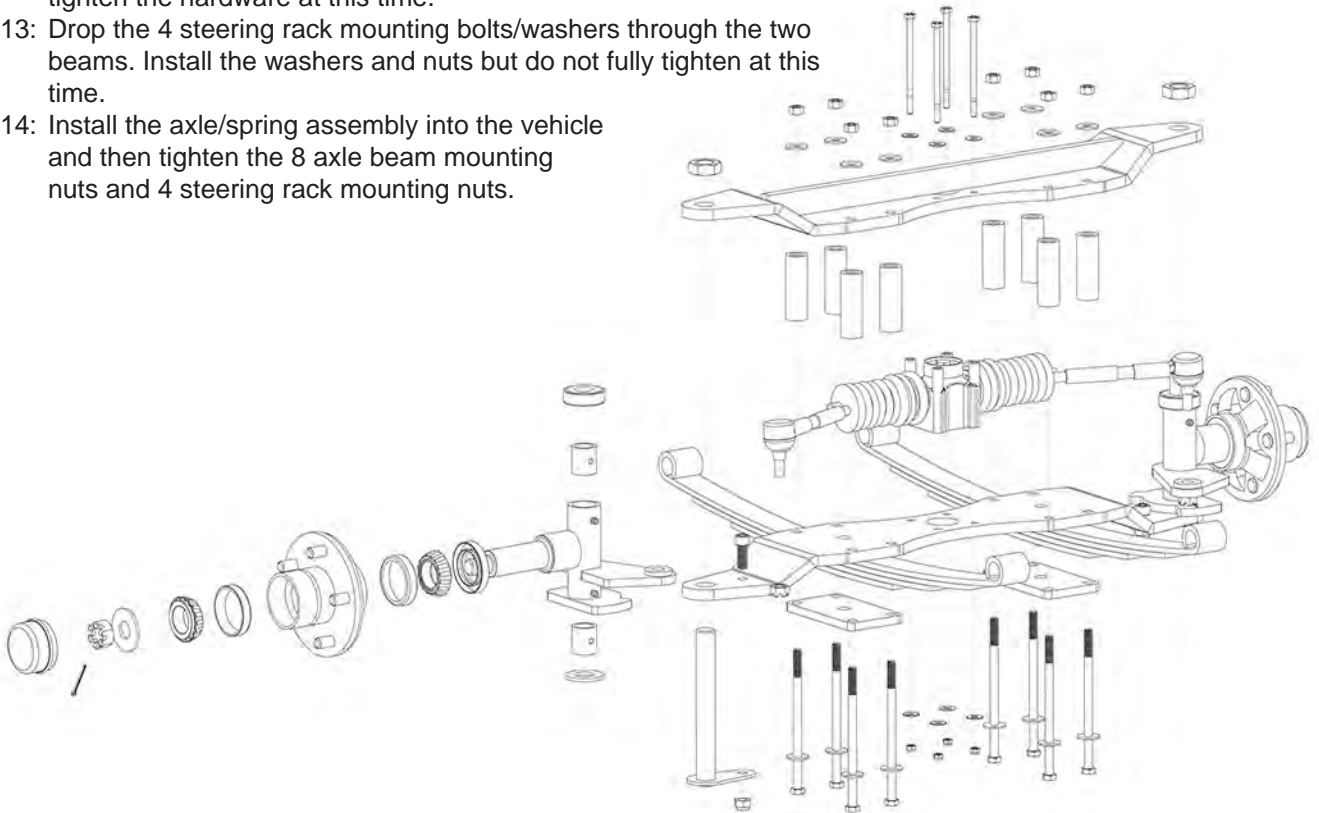

## INSPECT FRONT WHEEL BEARINGS

### **WARNING**

This section is one section of a complete service manual. Before starting any procedure, read all warnings and instructions that are located in the Service Guidelines chapter.

- 1: Raise the front of the vehicle and support with jack stands.
- 2: Grab the top and bottom of the tire/wheel assembly. Feel for any movement or play while pulling and pushing on the top and bottom of the tire. Any movement or play is indication of loose wheel bearings. 
- 3: Spin the front wheel(s) by hand. The wheel should stop spinning in no more than 2-revolutions. A wheel that continues to spin freely is an indication of a loose wheel bearing.
 

*Note: Refer to the Adjust Front Wheel Bearings section for detailed information regarding the proper adjustment of the wheel bearings.*
- 4: Spin the wheel(s) and listen for any grinding noise. Any noise may be an indication of worn or damaged wheel bearings.
 

*Note: Refer to the Replace Front Wheel Bearings section for information regarding the replacement of the wheel bearings.*
- 5: Lower the vehicle.
- 6: Reconnect the batteries.
- 7: Remove the blocks from behind the wheels.
- 8: Release the park brake and test drive the vehicle.



3-Wheel vehicle front fork shown for illustration purposes only

## ADJUST FRONT WHEEL BEARINGS

### **WARNING**

This section is one section of a complete service manual. Before starting any procedure, read all warnings and instructions that are located in the Service Guidelines chapter.

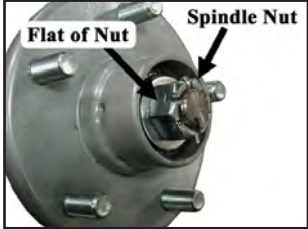
- The bearings must be lubricated before performing this procedure.
- 1: Raise the front wheel(s) off of the ground and support with jack stands.
  - 2: **While rotating the wheel**, tighten the front axle nut until the wheel is difficult to rotate.
  - 3: Continue to rotate the wheel for 5 complete revolutions.
  - 4: Attach a rope to the tire and wrap around the tire with 1 foot remaining hanging in the air.
  - 5: Tie a weight (see table and illustration below) to the end of the rope.
  - 6: Slowly loosen the axle nut until the hanging weight rotates the wheel then rotate to the nearest flat and install a new cotter pin. 
  - 7: Remove the rope and weight.
  - 8: Spin the wheel and listen for any grinding noise. Any grinding noise may be an indication of worn or damaged wheel bearings.
 

*Note: Refer to the Replace Front Wheel Bearings section for information regarding the replacement of the wheel bearings.*
  - 9: Lower the vehicle.
  - 10: Reconnect the main positive and negative cables at the batteries.
  - 11: Remove the blocks from behind the wheels.
  - 12: Release the park brake and test drive the vehicle.

Tire Size	Weight NEW (pounds / kg)	Weight USED (pounds / kg)
4.80 x 8	2.15 / 0.975	1.00 / 0.454
5.70 x 8/	1.99 / 0.902	0.93 / 0.422
4.00 x 8	2.15 / 0.975	1.01 / 0.485
5.00 x 8	1.99 / 0.902	0.93 / 0.422
8.50 x 8	2.02 / 0.916	0.94 / 0.426
8 x 2.50	4.23 / 1.919	1.97 / 0.894
10 x 3.5	3.38 / 1.533	1.56 / 0.708

NEW: Weight = 16.931 / Radius

USED: Weight = 7.875 / Radius

## FRONT WHEEL ALIGNMENT

### **WARNING**

This section is one section of a complete service manual. Before starting any procedure, read all warnings and instructions that are located in the Service Guidelines chapter.

*Note: Only Toe In can be set. Both Caster and Camber are not adjustable.*

- 1: Raise the front of the vehicle and support with jack stands.
- 2: Remove both ball joints from the steering arms.
- 3: Turn the steering wheel all the way to the left.
- 4: Turn the steering wheel all the way back to the right, counting the number of rotations.
- 5: Turn back to the left 1/2 the number of turns and tie the steering wheel in position so that it cannot rotate.
- 6: Reinstall the ball joints and tighten nut to torque specified at the end of this section.
- 7: Loosen the steering link jam nuts.
- 8: Remove the left front wheel.
- 9: Clamp a straight edge across the face of the wheel hub.
- 10: Adjust the driver left side steering link so that the straight edge is parallel to the center line of the vehicle.
- 11: Remove the straight edge and reinstall the wheel.
- 12: Using a piece of chalk, mark a line around the center line of both front tires.
- 13: Measure the distance between the chalk lines at the front of the tires and at the rear of the tires.
- 14: Adjust the right side steering link so that the toe in is within specification listed at the end of this section.
- 15: Tighten both steering link jam nuts to torque specified at the end of this section.



## REPLACE STEERING KNUCKLE

### **WARNING**

This section is one section of a complete service manual. Before starting any procedure, read all warnings and instructions that are located in the Service Guidelines chapter.

### **Remove**

- 1: Raise the front of the vehicle and support with jack stands.
- 2: Remove the tire/wheel assembly. Refer to Tires and Wheels section for information regarding removing the tire/wheel assembly.
- 3: Remove the hub bearing cap, cotter pin and nut, then remove the hub from the steering knuckle.

### **WARNING**

Do not allow the brake body or caliper to hang by the brake hose. Hanging by the brake hose may damage the brake hose resulting in loss of brakes which may cause serious bodily injury and/or property damage.

*Note: If equipped with front brake option you must remove the brake body before removing the hub. Refer to the Brakes section for information regarding the removal of the brake body. Do not remove the hydraulic brake line from the brake body. If the brake line is removed then it will be necessary to bleed the brakes.*

- 4: Remove the ball joint from the steering arm.
- 5: Remove the steering stop bolt.
- 6: Remove the king pin nut.
- 7: Using a large brass drift punch, drive the king pin out of the axle and remove the steering knuckle and thrust bearing.

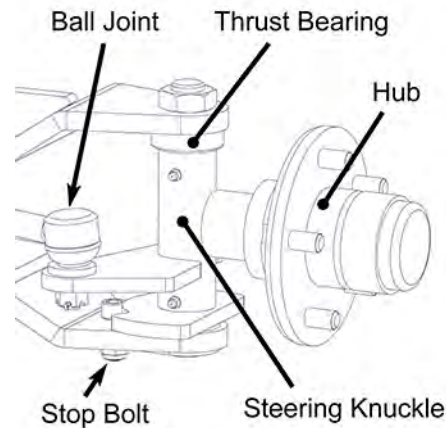

### **Install**

- 1: Thoroughly clean the kingpin, thrust bearing, knuckle, wheel bearings, and hub.
- 2: Inspect the thrust bearing bronze washer. Replace if any grooves worn flat. 
- 3: Pack the thrust bearing with grease.
- 4: Lightly coat the kingpin bushings with grease.
- 5: Place the thrust bearing on top of the steering knuckle with the inner race facing down.
- 6: Insert the knuckle bearing assembly into the axle and insert the kingpin up from the bottom mounting flange.
- 7: Install the steering stop bolt.
- 8: Tighten the kingpin nut so that there is no vertical play in the knuckle but it still turns freely.
- 9: Install the ball joint and tighten nut to torque specified at the end of this section.
- 10: Pack wheel bearings with grease.
- 11: Install the rear bearing and new grease seal.
- 12: Install the hub onto the spindle and adjust the bearing preload per procedure in the section.
- 13: Install a new cotter pin and bearing cap.
- 14: Grease the bushings.
- 15: Install the wheel, remove the blocks from behind the wheels and test drive the vehicle.



**REPLACE KING PIN/BUSHINGS****⚠ WARNING**

This section is one section of a complete service manual. Before starting any procedure, read all warnings and instructions that are located in the Service Guidelines chapter.

*Note: Bronze bushings must be reamed or broached to the proper diameter after they are pressed into the axle beam or steering knuckle.*

*Note: It is recommended that the thrust bearings should be replaced whenever replacing the king pin bushings or king pins. Refer to the Replacement Parts section for the orientation of the thrust bearing.*

- 1: Remove the steering knuckle. Refer to Replace the Steering Knuckle for information regarding removing the steering knuckle.
- 2: Press the bushings out from the steering knuckle.
- 3: Discard the bushings, king pins, and thrust bearings.
- 4: Thoroughly clean the knuckle.

**NOTICE**

**Before pressing bushing: Make sure that the holes in the bushings are lined up with the grease fittings in the spindle sleeve.**

- 5: Press new bushings into steering knuckle flush with the end of the sleeve.
- 6: If equipped with bronze bushings, ream or broach the bushings per specification listed at the end of this chapter.
- 7: Reassemble in reverse order using new king pins and thrust bearings.

*Note: Refer to Replace the Steering Knuckle for information on installing the steering knuckle.*

- 8: Grease the bushings.
- 9: Lower the vehicle, and test drive.

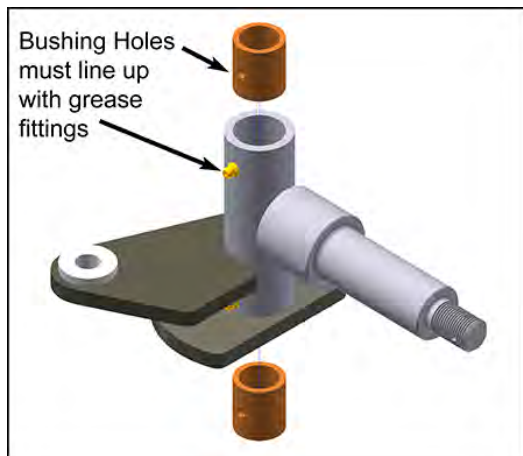
**REPLACE FRONT WHEEL BEARINGS****⚠ WARNING**

This section is one section of a complete service manual. Before starting any procedure, read all warnings and instructions that are located in the Service Guidelines chapter.

- 1: Set the park brake.
- 2: Disconnect the batteries.
- 3: Raise the front of the vehicle and support with jack stands.
- 4: Remove the tire/wheel assembly from the hub. Refer to the Tire/Wheel section for information regarding removing the tire/wheel assembly.
- 5: Remove the hub dust cap, cotter pin, and spindle nut.
- 6: Remove the hub from the steering knuckle.

**⚠ WARNING**

**Do not allow the brake body or caliper to hang by the brake hose. Hanging by the brake hose may damage the brake hose resulting in loss of brakes which may cause serious bodily injury and/or property damage.**

*Note: For a front disc brake option you must remove the brake body before removing the hub. Refer to the Brakes section for information regarding the removal of the brake body.*

- 7: Thoroughly clean all grease from the inside of the hub and the bearings.
- 8: Inspect and replace the races and bearings as a set.

*Note: It is recommended to replace all four bearings and races in the left and right wheels as a set.*

- 9: Assemble in reverse order using new grease seals.
  - a. Lube the bearings (refer to Lubrication section).
  - b. Adjust the bearing preload per specifications in the Adjust Front Wheel Bearing procedure.
  - d. Install a new cotter pin.
- 10: Install the hub dust cap.
- 11: Reinstall the brake body. Refer to the Brakes section for information regarding the installation of the brake body.
- 12: Reinstall the tire/wheel. Refer to the Tire/Wheel section for information regarding installing the tire/wheel assembly.
- 13: Lower the vehicle.
- 14: Reconnect the batteries.
- 15: Remove the blocks from behind the wheels.
- 16: Release the park brake and test drive.





## Table of Contents

<b>Drive Axle-GT</b>	
Check Oil Level.....	34
Change Oil.....	34
<b>Axle Assembly .....</b>	<b>35</b>
Remove .....	35
Install .....	35
<b>Axle Shaft .....</b>	<b>36</b>
Remove .....	36
Install .....	36
<b>Rear Hub, Rotor &amp; Bearings .....</b>	<b>37</b>
<b>Motor, Remove.....</b>	<b>37</b>
<b>Primary Gear Case .....</b>	<b>38</b>
<b>Secondary Gear Case .....</b>	<b>39</b>
Disassemble.....	39
Assemble.....	39
<b>Pinion Bearing Preload .....</b>	<b>41</b>
Pinion Gear Shimming Instructions .....	41
Set Pinion Bearing Preload .....	41
<b>Hardware Torque .....</b>	<b>42</b>

### **WARNING**

This section is one section of a complete service manual. Before starting any procedure, read all warnings and instructions that are located in the Service Guidelines chapter.

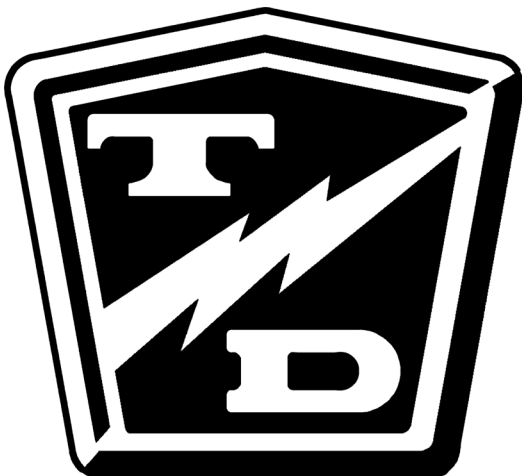

**CHECK OIL LEVEL****! WARNING**

This section is one section of a complete service manual. Before starting any procedure, read all warnings and instructions that are located in the Service Guidelines chapter.

Fluid type and capacities are listed in the Lubrication chapter.

*Note: The oil flows freely between the main gear case (3rd member) and the primary reduction gear case. It is only necessary to check the oil level of the 3rd member.*

- 1: Park the vehicle on a level surface and block the front wheels.
- 2: Disconnect the batteries.
- 3: Place a level on top of the motor.
- 4: Raise the rear of the vehicle until the level indicates that the drive is level with the ground.
- 5: Place an oil drain pan underneath the 3rd member.
- 6: Remove the fill/level plug.
- 7: The oil level should be very close to the bottom of the level plug opening.
  - a. If the oil level is below the bottom of the opening, add oil as required until level with the bottom of the opening. Refer to the Lube Chart section for information regarding type of oil.
  - b. If oil comes out of the opening, allow to drain until level with the bottom of the opening.
- 8: Replace the fill/level plug.
- 9: Reconnect the batteries.
- 10: Remove the blocks from the wheels.

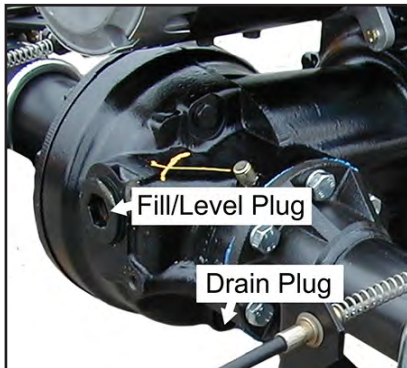
**CHANGE OIL****! WARNING**

This section is one section of a complete service manual. Before starting any procedure, read all warnings and instructions that are located in the Service Guidelines chapter.

Fluid type and capacities are listed in the Lubrication section in the General Maintenance chapter.

- 1: Raise the rear of the vehicle and support with jack stands.
- 2: Place a four quart drain pan under the axle assembly center section.
- 3: Remove the drain plugs from the differential case and gear case.
- 4: Replace the drain plugs once the oil has drained.
- 5: Remove the differential gear case fill/level plug and fill with oil. Refer to Check Oil Level procedure for proper oil level.
- 6: Replace the fill plug.
- 7: Reconnect the batteries.
- 8: Remove the blocks from the wheels.



*Primary reduction case drain plug*

**AXLE ASSEMBLY****⚠ WARNING**

This section is one section of a complete service manual. Before starting any procedure, read all warnings and instructions that are located in the Service Guidelines chapter.

**Remove**

- 1: Disconnect the wiring from the motor.
- 2: Disconnect the hydraulic brake hoses from the left and right brake lines.
- 3: Disconnect the parking brake cables from the left and right rear calipers and cable mounts.
- 4: If equipped with shocks, remove the lower shock bolts.
- 5: Remove the nuts only from the lower spring hangers and the frame spring eye.
- 6: Slowly raise the frame until the spring bolts can be removed, then raise the frame high enough to roll the axle assembly out from under the vehicle.
- 7: Lower the frame to the ground or leave supported on jack stands.

**Install**

- 1: Install in reverse order of removal. The wheels should be already installed.
- 2: Lower the frame and install the suspension stops and shocks.
- 3: Adjust the parking brake. Refer to procedure in "Brake Service" section.
- 4: Bleed the rear brakes. Refer to procedure in "Brake Service" section.
- 5: Lubricate the spring bolts.
- 6: Tighten the motor wire terminals per torque listed in the Hardware Torque table at the end of this section.
- 7: Reconnect the battery, remove the blocks from behind the wheels and test drive the vehicle.



**AXLE SHAFT****⚠ WARNING**

This section is one section of a complete service manual. Before starting any procedure, read all warnings and instructions that are located in the Service Guidelines chapter.

**⚠ WARNING**

The axle retaining plate bolts have a pre-applied thread locking compound. They are intended for one time use only. If removed they must be replaced. Reusing the original bolts could cause loss of brakes resulting in severe bodily injury and/or property damage.

The oil level in the housing is above the bottom of the axle flange. To minimize oil spills, raise the side of the vehicle high enough so that the oil level is below the bottom of the axle flange. If both axles have to be removed at the same time then all oil must be drained from the housing.

*Note: This procedure does not require that the rear end or drive assembly be removed from the vehicle.*

*Note: The axle hub bolt has a special thread locking compound applied to the threads. If this bolt is removed, it must be replaced.*

*Note: The hub or rotor does not have to be removed but if they are to be replaced, then remove them before removing the axle from the housing.*

**Remove**

- 1: Disconnect the batteries.
- 2: If required, drain the oil. Refer to Change Oil Procedure.
- 3: Raise the rear of the vehicle and support with jack stands.
- 4: Release the park brake.
- 5: Remove the tire and wheel assembly. Refer to Tires and Wheels section for information regarding removing the tire and wheel assembly.
- 6: Remove the four bolts attached to the axle retaining plate.
- 7: Remove the axle retaining plate and brake body assembly as one unit.
- 8: Secure the brake body assembly, do not let it hang by the brake hose.
- 9: Pull the axle out of the housing.
- 10: Inspect all bearings for roughness or play, replace as needed.

**Install**

- 11: Install in reverse order of removal
  - a. Lubricate the bearing external O-ring.
  - b. Use new bolts for the axle retaining plate.
  - c. If the wheel hub was removed, install the hub and rotor. Torque the hub bolt to the specification listed in the table at the end of this section.
- 12: Fill with oil to the level of the fill plug threads. Refer to Check Oil Level procedure.
- 13: Set the park brake.
- 14: Lower the vehicle.
- 15: Reconnect the batteries.
- 16: Remove the blocks from behind the wheels.
- 17: Release the park brake and test drive.

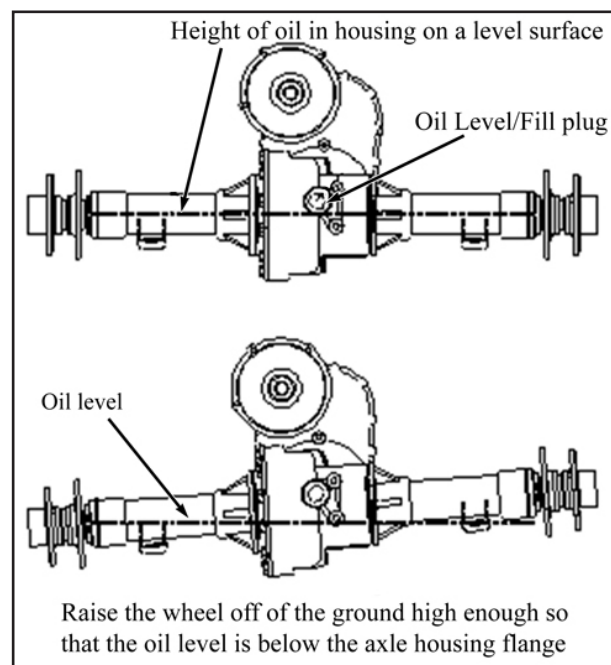

**REAR HUB, ROTOR & BEARINGS****⚠ WARNING**

This section is one section of a complete service manual. Before starting any procedure, read all warnings and instructions that are located in the Service Guidelines chapter.

**⚠ WARNING**

The axle retaining plate bolts have a pre-applied thread locking compound. They are intended for one time use only. If removed they must be replaced. Reusing the original bolts could cause loss of brakes resulting in severe bodily injury and/or property damage.

*Note: The axle hub bolt has a special thread locking compound applied to the threads. If this bolt is removed, it must be replaced.*

- 1: Disconnect the batteries.
- 2: Raise the wheel off of the ground.
- 3: Release the park brake.
- 4: Remove the tire/wheel assembly, Refer to Tires and Wheels section for information regarding removing the tire/wheel assembly.
- 5: Remove the axle hub bolt and washer and remove the hub from the axle.
- 6: Remove the outer brake pad. Refer to section Brake Service for information regarding removing the brake pads.
- 7: Remove the rotor.
- 8: If also replacing the bearing, the axle shaft must be removed from the housing. Refer to Axle Shaft procedure for information on removing and installing the axle shaft.
- 9: Install in reverse order.
  - a. Thoroughly clean the threads in the axle shaft.
  - b. Lightly grease the hub splines.
  - c. Refer to Brakes section for information regarding installing the brake pads.
  - d. Using a new bolt, torque the axle hub bolt to the specification listed in the table at the end of this section.
  - e. Refer to Tires and Wheels section for information regarding installing the tire/wheel assembly.
- 10: Set the park brake.
- 11: Lower the wheel to the ground.
- 12: Reconnect the batteries.
- 13: Remove the blocks from behind the wheels, release the park brake and test drive.

**MOTOR, REMOVE**

*Note: Some applications will require removing the drive assembly from the vehicle to remove the motor. Refer to Removing and Installing the Drive Assembly for information on removing the drive assembly.*

- 1: Disconnect the batteries
- 2: Remove the wires from the motor.

*Note: Label the motor wires with the number of the motor terminal before they are removed from the motor.*

- 3: Remove the motor support bracket U-bolt (only used on larger motors).
- 4: Remove the motor mounting bolts and slide the motor off of the input shaft.
- 5: Install the motor in reverse order. Make sure that the motor coupler o-ring is properly installed on the transmission input shaft. Refer to the torque table in the motor section for tightening the motor terminals.
- 6: Apply a light coating of moly paste grease part number 94-421-34 to the splines on the transmission input shaft only.
- 7: Reconnect the batteries.
- 8: Remove the blocks from behind the wheels.
- 9: Release the park brake and test drive.



*Transmission input shaft*

**PRIMARY GEAR CASE**

**⚠ WARNING**

This section is one section of a complete service manual. Before starting any procedure, read all warnings and instructions that are located in the Service Guidelines chapter.

- 1: Disconnect the batteries.
- 2: Raise the rear of the vehicle and support with jack stands.
- 3: Place a drain pan under the gear case that is capable of holding 4 liters (4 quarts) of oil and drain the oil from the front gear case.
- 4: If required, remove the drive assembly from the vehicle. Refer to Remove assembly procedure.
- 5: Remove the motor only if the entire drive is to be disassembled. Refer to Motor procedure.
- 6: Remove the cover retaining bolts.
- 7: Remove the cover plate and let the remaining oil drain from the housing.
- 8: Remove the circlip from the idler gear.
- 9: Remove the input shaft/bearing assembly and idler gear/bearing assembly from the gear case cover at the same time.
- 10: Remove the pinion nut from the output gear and remove the output gear from the pinion shaft.

*Note: If necessary, remove the seal from the input shaft bore at this time.*

- 11: Mark the gear case position in relation to the 3rd member housing so that it will be reassembled in the same position.
- 12: Remove the six retaining bolts holding the gear case to the 3rd member housing.
- 13: Remove the gear case housing from the 3rd member housing.
- 14: Inspect all parts for signs of wear or damage.
- 15: Assemble the gear case in reverse order.
  - a. Apply gasket sealer (#94-430-05) to the front flange on the 3rd member and gear case cover.
  - b. Pack the motor seal with non-acetic based grease.
  - c. Torque the drain plug, gear case to 3rd member bolts, and pinion nut per torque listed in the Hardware Torque table at the end of this section.
- 16: Fill the differential with oil. Refer to Check Oil Level for information on filling the drive with oil.
- 17: Lower the vehicle.
- 18: Reconnect the batteries.
- 19: Remove the blocks from behind the wheels.
- 20: Test drive the vehicle.

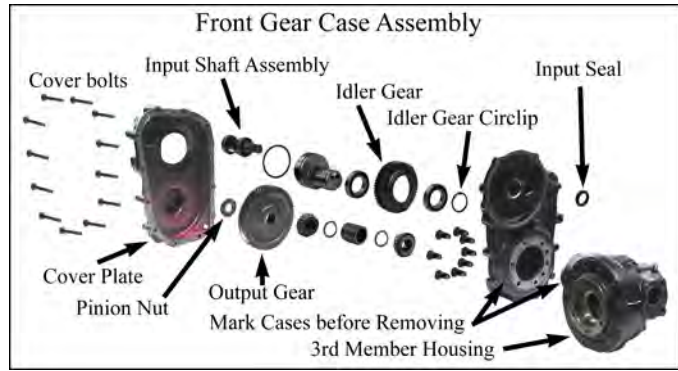

*Idler Gear Circlip*



*Remove Idler & Input Assy.*

## SECONDARY GEAR CASE

### **WARNING**

This section is one section of a complete service manual. Before starting any procedure, read all warnings and instructions that are located in the Service Guidelines chapter.

### Disassemble

- 1: Remove the transaxle assembly from the vehicle. Refer to Remove in this section.
- 2: Place a drain pan under the gear case that is capable of holding 4 liters (4 quarts) of oil and drain the oil from the front and secondary gear case.
- 3: Place the axle assembly on an appropriate stand.
- 4: Remove the axle shafts and tubes as an assembly by removing the six axle tube flange bolts on each axle tube.
- 5: Remove the primary reduction gear case. Refer to Primary Gear Case for information on removing the gear case.
- 6: Remove the 12 side plate bolts, then remove the side plate.
- 7: Remove the carrier bearing adjusting nut roll pin and adjusting nut from the side plate.
- 8: Turn the side plate over and remove the carrier bearing race from the side plate.
- 9: Remove the differential assembly.
- 10: Remove the carrier bearing adjusting nut roll pin from the carrier housing, then remove the carrier adjusting nut.
- 11: Remove the carrier bearing race from the 3rd member housing.
- 12: Remove the front bearing from the pinion gear shaft.

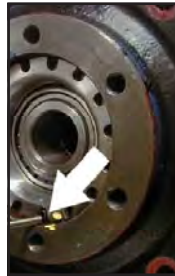

Roll Pin

*Note: The pinion gear may have to be driven out to perform this procedure.*

- 13: Remove the pinion gear shims and spacer.
- 14: Remove the pinion gear from the carrier housing.
- 15: Remove the front and rear pinion bearing races.
- 16: Inspect all parts for signs of wear or damage.
- 17: Thoroughly clean all parts.

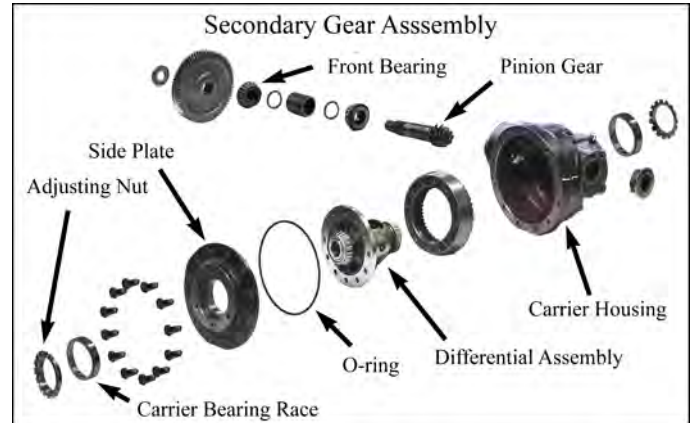

### Assemble

- 1: Temporarily install the pinion gear (hand tighten only).
- 2: Install the carrier bearing race adjusting nuts into the housing and cover.
- 3: Install the carrier bearing races into the housing and cover.
- 4: Place the differential assembly into the housing.
- 5: Tighten the housing carrier bearing race adjusting nut so that the ring gear is not in binding against the pinion gear.
- 6: Remove the differential assembly.  
*Note: Do not allow the ring nut to rotate.*
- 7: Remove the pinion gear and then reinstall the differential assembly.
- 8: Install the cover onto the housing using 4-bolts in a cross pattern and torque per torque listed in the Hardware Torque table at the end of this section.
- 9: Pre set the carrier bearing preload by tightening the housing carrier bearing race adjusting nut until it requires 2.1 - 4.7 Nm (1.5 to 3.3 foot pounds) to rotate the differential assembly.  
*Note: Rotate the carrier assembly whenever adjusting the ring nuts.*
- 10: Mark the position of each carrier bearing adjusting nut in relation to the drive housing and cover and then remove the differential assembly, do not allow the nuts to rotate.
- 11: Install the pinion gear. Re-shim if required. Refer to Pinion Bearing Preload procedure.

- 12: Install the pinion gear holding tool (96-500-42) and tighten the pinion nut enough to keep the pinion gear from rotating.

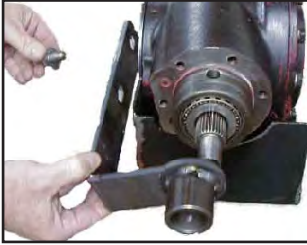

*Pinion Holding Tool*

- 13: Install the differential assembly.  
14: Install the cover and all of the cover bolts. Torque per torque listed in the Hardware Torque table at the end of this section.  
15: Check the gear lash between the ring and pinion gears. The gear lash should be 0.127-0.178 mm (0.005 to 0.007 inches).  
16: Adjust the gear lash if needed by tightening or loosening the carrier bearing race adjusting nuts. The two ring nuts must be turned equally in opposite directions.

*Note: To move the ring gear closer to the pinion: Loosen the housing carrier bearing race ring nuts and tighten the cover carrier bearing race ring nut equally.*

*Note: To move the ring gear away from the pinion: Loosen the cover carrier bearing race ring nut and tighten the housing carrier race ring nut equally.*

- 17: Install the locking roll pins into the housing and cover to lock the adjusting nuts in place.  
18: Remove the pinion gear holding tool.  
19: Install the primary reduction gear case, axles and housings, motor, and install the complete drive onto the vehicle.  
20: Fill the drive with oil. Refer to the Lube Chart section for information regarding type of oil. Refer to Check Oil Level procedure for information regarding the proper oil level..  
21: Lower the vehicle.  
22: Reconnect batteries  
23: Remove the blocks from behind the wheels and test drive.





## PINION BEARING PRELOAD

### **WARNING**

This section is one section of a complete service manual. Before starting any procedure, read all warnings and instructions that are located in the Service Guidelines chapter.

### Pinion Gear Shimming Instructions

*Note: This procedure is required only when replacing the front or rear pinion bearings and races or the ring and pinion gears.*

*Note: To perform this procedure, all parts must be clean and the bearings lightly lubricated.*

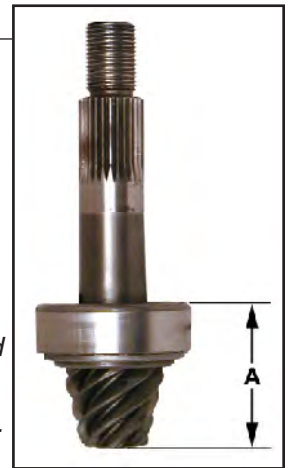

### Setting the Pinion Gear Depth

This formula is used to calculate the amount of shims required to properly set the depth:

$C - B - A + (DV) = \text{Pinion Shim (mm)}$  where,

**DV** = The number on the face of the pinion gear.

**A** = The distance in millimeters from the face of the pinion gear to the top of the inner pinion bearing race (see illustration)

**B** = 54.

**C** = The number on the edge of the differential side plate closest to the input shaft (see illustration, next page).

**D** = The number on the edge of the differential side plate farthest from the input shaft (see illustration, see next page).

**E** = The distance in millimeters from the rear of the drive housing to the face of the pinion gear (see illustration).

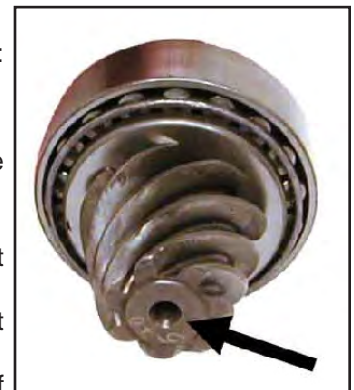

DV: On face of pinion gear

Once a shim has been selected and the pinion gear is installed, confirm that:  $E - D = B + (DV)$

### Set Pinion Bearing Preload

*Note: The pinion gear depth must be set before the preload. Refer to Setting the Pinion Gear Depth.*

- 1: Install the pinion gear, spacer, and shims into the housing.
- 2: Install the outer pinion bearing.
- 3: Install the main gear onto the pinion shaft and torque the pinion nut to 220-241 Nm (154-169 foot pounds).
- 4: Measure the torque required to rotate the pinion shaft in the housing.
- 5: The torque required to rotate the pinion shaft should be between 1.57-4.14 Nm (1.1 and 2.9 foot pounds). If the torque is not within specifications then add or subtract from the total shim thickness and repeat this procedure until the proper preload is obtained.

*Note: Add shims to decrease torque.*

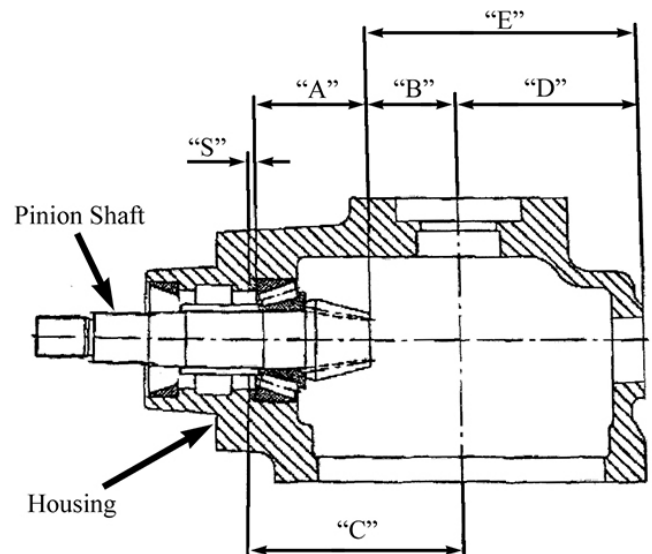

**HARDWARE TORQUE**

If hardware is not listed here, refer to standard torque values in the appendix.

Description	Foot Pounds	Newton Meters
Pinion nut	154-169	209229
Drain plug	21-25	28.4-33
Gear case to 3rd member	18-20	24.4-27
3rd Member cover bolts	40-50	54-67.5
Axle hub bolt	275	392

**Note: Special Washers**

The washers for the primary gear case housing and carrier housing side plate are in the shape of a cone referred to as conical or belleville washers.

This type of washer is designed to maintain tension in bolted assemblies.

Belleville washers must be orientated correctly to function properly. See illustration.

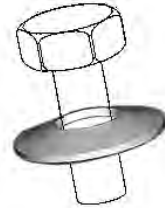

*NOTE: Values shown are for reference only*

# Steering

## Table of Contents

### Steering

Inspect Ball Joints.....	44
Front Wheel Alignment .....	44
Replace Ball Joint.....	44
Replace Upper Steering Shaft.....	45
Remove .....	45
Install .....	45
Replace Lower Steering Shaft.....	46
Inspect.....	46
Remove .....	46
Install .....	46
Replace Boot.....	46
Replace 90° Steering Gear.....	47
Inspect.....	47
Remove .....	47
Install .....	47
Replace Steering Rack.....	48
Inspect.....	48
Remove .....	48
Install .....	48
Replace Steering Wheel.....	49
Remove .....	49
Install .....	49
Hardware Torque .....	50

### **WARNING**

This section is one section of a complete service manual. Before starting any procedure, read all warnings and instructions that are located in the Service Guidelines chapter.

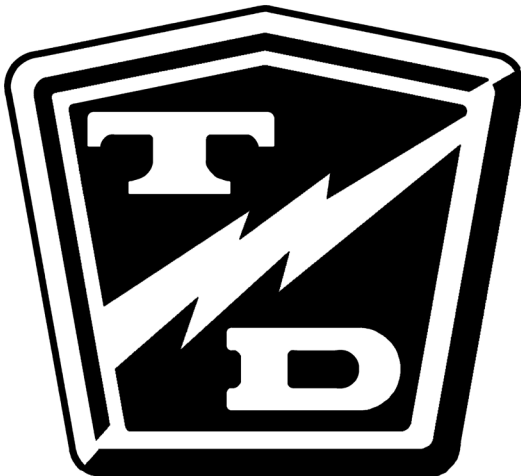

## INSPECT BALL JOINTS

### **WARNING**

This section is one section of a complete service manual. Before starting any procedure, read all warnings and instructions that are located in the Service Guidelines chapter.

*Note: A set of ball joints and/or rod ends will wear at the same rate. If a ball joint and or rod end is worn out, then all should be replaced as a set.*

- 1: Tie off the front wheels so that they cannot turn.
- 2: While watching the ball joints, rapidly rotate the steering wheel to the left and right.
- 3: If the housing moves up or down on the shaft then the ball joint is worn out and should be replaced. Refer to section Replace Ball Joint for information regarding replacing ball joints.
- 4: Untie the front wheels.
- 5: Reconnect the main positive and negative cables at the batteries.
- 6: Remove the blocks from behind the wheels.
- 7: Release the parking brake and test drive.



*Ball Joint*

## FRONT WHEEL ALIGNMENT

Refer to the Front Axle section for front wheel alignment procedure.

## REPLACE BALL JOINT

### **WARNING**

This section is one section of a complete service manual. Before starting any procedure, read all warnings and instructions that are located in the Service Guidelines chapter.

*Note: In many cases the removal of a ball joint may cause damage to the ball joint. It is recommended that if a ball joint is removed then it should be replaced.*

- 1: Raise the front of the vehicle and support with jack stands.
- 2: Loosen the ball joint jam nut.
- 3: Remove the ball joint nut.
- 4: Using a ball joint separator or pickle fork, remove the ball joint from the steering arm.
- 5: Remove the ball joint from the tie rod.
- 6: Install the new ball joint into the steering sleeve.
- 7: Install the ball joint into the steering arm. Tighten the ball joint nut per torque listed in the Hardware Torque table at the end of this section.
- 8: Realign the front wheels. Refer to the Front Axle section for information regarding realignment of the front wheels.
- 9: Lower the vehicle.
- 10: Reconnect the main positive and negative cables at the batteries.
- 11: Release the park brake and test drive.



*Typical Pickle Fork*



*Typical Ball Joint Separator*

**REPLACE UPPER STEERING SHAFT****⚠ WARNING**

This section is one section of a complete service manual. Before starting any procedure, read all warnings and instructions that are located in the Service Guidelines chapter.

**Remove**

- 1: Remove the steering wheel. Refer to Replace the Steering Wheel procedure for information regarding removing the steering wheel.
- 2: Remove the steering coupler pinch bolt and nut and discard.
- 3: Using a soft face hammer, tap the coupler up and off of the steering shaft.

*Note: If too tight, drive a small wedge into the coupler slot to spread it slightly apart.*

- 4: Remove the 4 bolts holding the column housing to the frame and lift the housing/shaft assembly out of the frame.
- 5: Pull the shaft down and out of the housing.
- 6: If required, remove both the upper and lower steering shaft bushings from the housing.

**Install**

- 1: Thoroughly clean all components
- 2: If bushings were removed, install the upper and lower steering shaft bushings into the housing.
- 3: *Lightly* grease the two bushings.
- 4: Insert the shaft up into the housing
- 5: Install the housing/shaft assembly into the frame sliding the coupler down onto the steering gear shaft.
- 6: Using a new pinch bolt and nut, tighten the coupler pinch bolt per torque listed in the Hardware Torque table at the end of this section.
- 7: Install the steering wheel. Refer to Replace the Steering Wheel procedure for information regarding installing the steering wheel.
- 8: Test drive the vehicle

**⚠ WARNING**

Do not use the original pinch bolt and nut. Failure to replace the pinch bolt and nut may result in failure of the steering causing loss of control of the vehicle. This could lead to severe bodily injury and/or property damage.

Make sure that the pinch bolt is not aligned with the flat on the steering shaft. Aligning the bolt with the flat could result in failure of the steering and loss of control of the vehicle. This could lead to severe bodily injury and/or property damage.

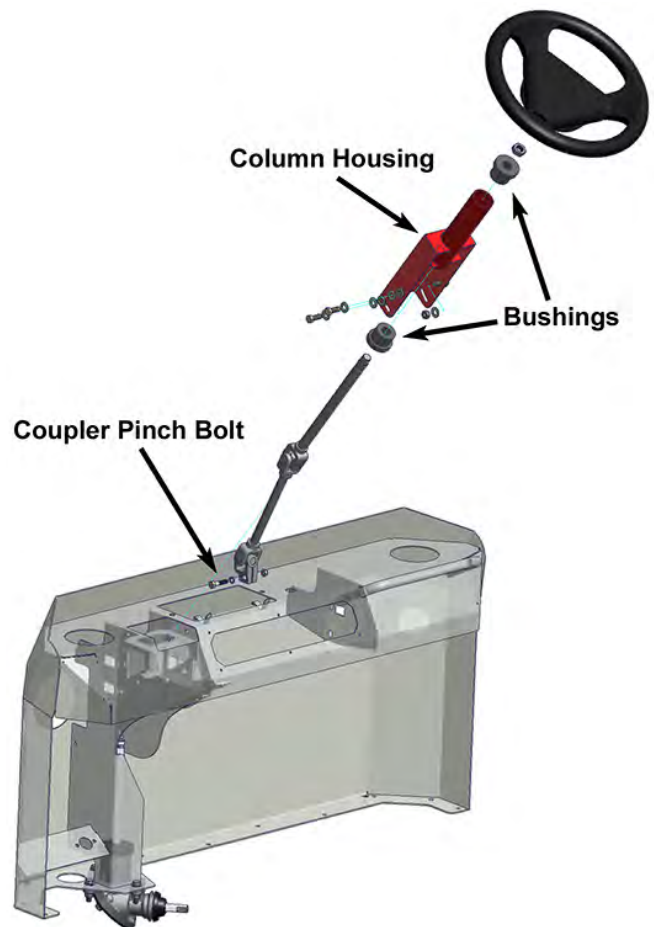

## REPLACE LOWER STEERING SHAFT

### **⚠ WARNING**

This section is one section of a complete service manual. Before starting any procedure, read all warnings and instructions that are located in the Service Guidelines chapter.

### **Inspect**

If there is any play between the inner and outer shafts then the steering shaft should be replaced.

If the boot is torn then it should be replaced.

### **Remove**

- 1: Remove the front and rear steering coupler pinch bolts and nuts and discard.
- 2: Vehicles up to serial number 193269 only: Remove the 8 bolts holding the axle assembly to the front springs and lift the axle up off of the spring locating bolts.
- 3: Using a soft face hammer, tap the couplers off of the 90° gear shaft and rack shaft.

*Note: If too tight, drive a small wedge into the coupler slot to spread it slightly apart.*

### **Install**

- 1: Thoroughly clean the couplers and shafts.
- 2: Position the front wheels in the straight ahead position.
- 3: Position the steering wheel in the straight ahead position.
- 4: Install the coupler onto the 90° gear output shaft aligning the machined flat on the shaft with the slot in the coupler.
- 5: Install the coupler on the steering rack input shaft so that the bolt holes line up with the groove in the shaft.
- 6: Vehicles up to serial number 193269 only: Install the front axle over the spring locating bolts and install mounting hardware.
- 7: Install new coupler pinch bolts and tighten to torque listed in the Hardware Torque table at the end of this section.
- 8: Install new pinch bolt jam nuts.
- 9: Test drive the vehicle.

### **Replace Boot**

- 1: The steering shaft must be removed from the vehicle. Refer to removal procedure for info on how to properly remove the shaft.
- 2: Cut the plastic ties holding the boot.
- 3: Clamp one end of the shaft assembly in a vise.
- 4: Pull on the other end until the two shafts separate.
- 5: Remove the boot.
- 6: Thoroughly clean both shafts (in and out).
- 7: Lightly grease the inside of the shaft.
- 8: Install the new boot and slide the two shafts together.
- 9: Install new plastic ties on the boot.

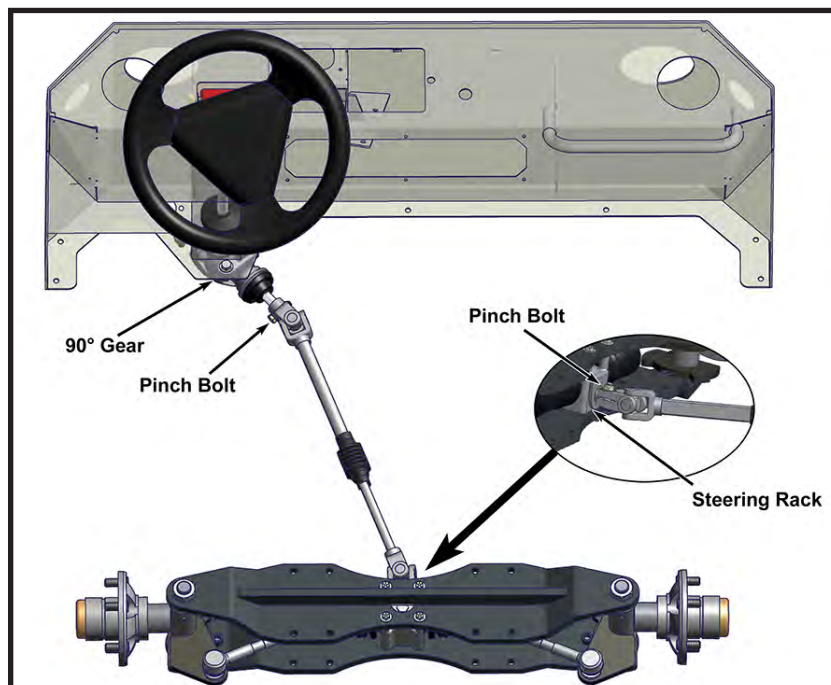

## **REPLACE 90° STEERING GEAR**

---

### **WARNING**

This section is one section of a complete service manual. Before starting any procedure, read all warnings and instructions that are located in the Service Guidelines chapter.

There are no internal components available for the 90° steering gear. If worn out it must be replaced.

### **Inspect**

- 1: Clamp the lower steering shaft so that it cannot rotate.
- 2: Turn upper steering shaft and measure degrees of free play.
- 3: If more than 2° free play then gear box should be replaced.

### **Remove**

- 1: Remove the pinch bolt from the gear input shaft coupler and discard the bolt and nut.
- 2: Raise the front of the vehicle and support with jack stands
- 3: Remove the pinch bolt from the gear output shaft coupler and discard the bolt and nut.
- 4: Remove the 3 gear mounting bolts.
- 5: Using a soft face hammer, tap the upper coupler off of the input shaft and drop the gear down out of the frame.
- 6: Using a soft face hammer, tap the lower coupler off of the output shaft.

*Note: If couplers too tight, drive a small wedge into the coupler slot to spread it slightly apart.*

### **Install**

- 1: Thoroughly clean all components.
- 2: Position the front wheels in the straight ahead position.
- 3: Position the steering wheel in the straight ahead position and tie in place so that it cannot rotate.
- 4: Insert the gear output shaft into the lower steering shaft coupler.
- 5: Put the gear up into the frame inserting the output shaft into the steering shaft.
- 6: Install the gear mounting bolts.
- 7: Install new coupler pinch bolts and tighten to torque listed in the Hardware Torque table at the end of this section.
- 8: Install new pinch bolt jam nuts.
- 9: Untie the steering wheel.
- 10: Test drive the vehicle.

## REPLACE STEERING RACK

---

### **WARNING**

This section is one section of a complete service manual. Before starting any procedure, read all warnings and instructions that are located in the Service Guidelines chapter.

There are no internal components available for the steering rack. If worn out it must be replaced.

### **Inspect**

- 1: Raise the front of the vehicle and support with jack stands.
- 2: Tie both front wheels in place so that they cannot turn.
- 3: While watching the two rods and the input to the steering rack, rotate the steering wheel back and forth.
- 4: There should be no gear lash. If you can see the input shaft rotate and the tie rods do not move then the steering rack should be replaced.

### **Remove**

- 1: Raise the front of the vehicle and support with jack stands
- 2: Remove the front wheels
- 3: Remove the ball joints from the steering arms.
- 4: Remove the coupler pinch bolt and discard the bolt and nut.
- 5: Loosen (do not remove) the 8 spring mounting bolts but do not remove.
- 6: Remove the 4 steering rack mounting bolts.
- 7: Using a soft face hammer, tap on the rack to push it out of the steering coupler.  
*Note: If too tight, drive a small wedge into the coupler slot to spread it slightly apart.*
- 8: Remove the steering rack from the axle assembly

### **Install**

- 1: Thoroughly clean all components.
- 2: Place the steering rack into the axle assembly with the input shaft closest to the bottom plate.
- 3: Place the steering wheel in the straight ahead position and tie in place so that it cannot rotate.
- 4: Confirm the steering rod is centered and center the steering rack.
- 5: Slide the rack between the upper and lower axle plates and into the coupler
- 6: Install the 4 rack mounting bolts.
- 7: Install a new coupler pinch bolt and tighten to torque listed in the Hardware Torque table at the end of this section.
- 8: Install new pinch bolt jam nut and tighten to torque listed in the Hardware Torque table at the end of this section.
- 9: Tighten the 8 spring mounting bolts.
- 10: Install the ball joints to the steering arms and tighten to torque listed in the Hardware Torque table at the end of this section.
- 11: Install the front wheels.
- 12: Realign the front end. Refer to Front Wheel Alignment procedure in the Front Axle section.
- 13: Test drive the vehicle.



**REPLACE STEERING WHEEL****⚠ WARNING**

This section is one section of a complete service manual. Before starting any procedure, read all warnings and instructions that are located in the Service Guidelines chapter.

*Note: The steering wheel is on a tapered shaft and may be damaged when it is removed.*

**Remove**

- 1: Remove the steering wheel hub cover.
- 2: Remove the steering wheel nut.
- 3: Using a steering wheel puller, remove the steering wheel.

**Install**

- 1: Check wheel alignment before installing steering wheel.
- 2: Position the front wheels in the straight ahead position.
- 3: Lightly grease the steering wheel splines and install the replacement steering wheel orientated as shown in the illustration.
- 4: Tighten the steering wheel nut to torque listed in the Hardware Torque table at the end of this section.
- 5: Reinstall the horn switch (if equipped).
- 6: Reconnect the main positive and negative cables at the batteries.
- 7: Remove the blocks from behind the wheels.
- 8: Release the parking brake and test drive.





## Table of Contents

<b>Brakes</b>	
<b>General Guidelines and Safety</b> .....	<b>52</b>
<b>Front Brake</b> .....	<b>53</b>
Service Limits .....	53
Inspection .....	53
Replace Pads .....	53
<b>Rear Brake</b> .....	<b>54</b>
Service Limits .....	54
Inspection .....	54
Replace Pads .....	54
<b>Rebuild Disc Brake Body</b> .....	<b>55</b>
<b>Bleed System</b> .....	<b>56</b>
<b>Flush System</b> .....	<b>56</b>
<b>Master Cylinder</b> .....	<b>57</b>
Add Fluid .....	57
<b>Parking Brake</b> .....	<b>57</b>
Adjust .....	57
<b>Service Limits</b> .....	<b>58</b>
<b>Hardware Torque</b> .....	<b>58</b>

### **WARNING**

This section is one section of a complete service manual. Before starting any procedure, read all warnings and instructions that are located in the Service Guidelines chapter.

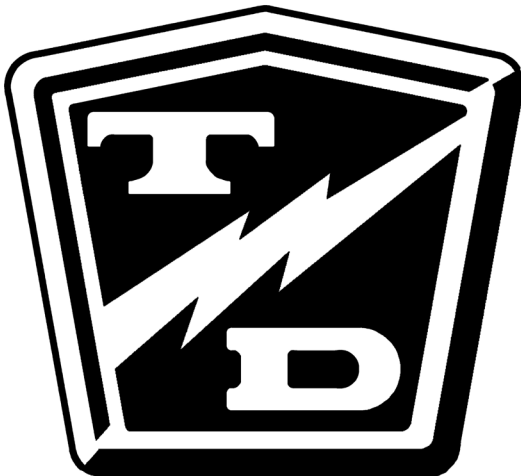

**GENERAL GUIDELINES AND SAFETY****⚠️ WARNING**

This section is one section of a complete service manual. Before starting any procedure, read all warnings and instructions that are located in the Service Guidelines chapter.

**⚠️ WARNING**

**Do not ingest brake fluid or allow contact with skin or eyes. Always wear protective clothing and a face shield when working with or around brake fluid.**

**SKIN CONTACT:**

Flush area immediately with water for several minutes. If a rash or skin irritation develops, get medical attention immediately.

**EYE CONTACT:**

**Immediately flush the eye with water for 15 minutes and call physician.**

**INGESTION:**

Get medical attention immediately.

**⚠️ WARNING**

Hydraulic brake system components must be kept clean. Make sure your work area is free from dirt and debris and will contain any brake fluid spills. Any debris or contaminants left in the brake system could lead to brake failure and result in property damage and/or severe bodily injury.

**⚠️ WARNING****When replacing or adding brake fluid:**

- Only use DOT 3 brake fluid from a new sealed container.
- DOT 3 brake fluid is corrosive, will damage paint finishes and may damage electrical components.
- Dispose of brake fluid in accordance with local state and federal regulations.
- Read and follow all warnings on the brake fluid container.

**⚠️ WARNING**

Taylor-Dunn does not currently supply asbestos fiber-brake pads/shoes with any vehicle. However, there is the possibility that the original brake pads/shoes were replaced with aftermarket pads/shoes containing asbestos. Since this possibility does exist, the brake pads/shoes should be handled as if they do contain asbestos.

Never use compressed air or dry brush to clean the brake assemblies. Use an OSHA approved vacuum cleaner or any alternate method approved by OSHA to minimize the hazard caused by airborne asbestos fibers and brake dust.

Do not grind, sand, break, or chisel the brake pads/shoes, as this will cause unnecessary dust, possibly releasing asbestos fibers in the air.

Always wear protective clothing and a respirator when working on the brake pads/shoes or their associated components.

**Inhaled asbestos fibers have been found to cause cancer and respiratory diseases.**

Do not drive the vehicle if any worn or broken part is detected in any part of the brake system. The cause of the damage must be repaired immediately.



## FRONT BRAKE

### WARNING

This section is one section of a complete service manual. Before starting any procedure, read all warnings and instructions that are located in the Service Guidelines chapter.

### Service Limits

Refer to the table at the end of this section

### Inspection

*Note: Service Limits are listed in a table at the end of this section.*

- 1: Raise the front of the vehicle and support with jack stands.
- 2: Remove the front wheels.
- 3: Measure the brake lining (not including the metal backing plate) of each pad at it's thinnest point. If any one of the brake pads are equal to or less that the service limit then all pads should be replaced.
- 4: Measure the rotor thickness in three places. If the rotor thickness is less than the service limit then the rotor must be replaced.
- 5: Measure the rotor runout. If the runout exceeds the service limit, then the rotor must be resurfaced. After resurfacing the rotor, measure the rotor thickness. If the rotor thickness is less than the service limit, then the rotor must be replaced.
- 6: Lower the vehicle.
- 7: Reconnect the battery, remove the blocks from behind the wheels and test drive.

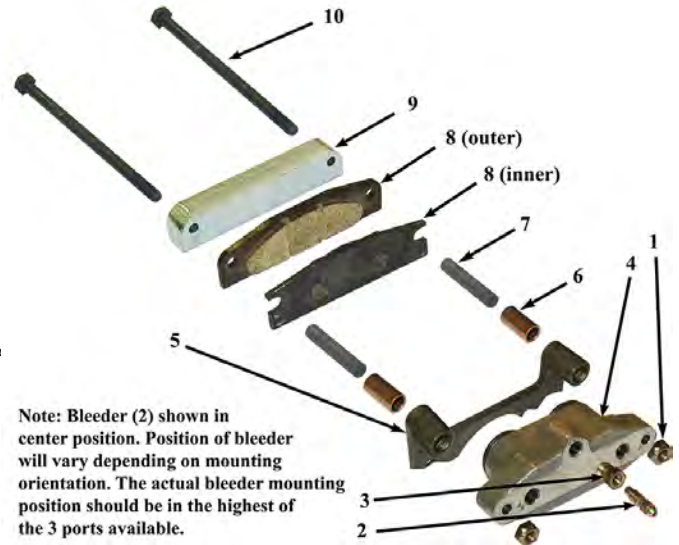

### Replace Pads

*Note: Installing new brake pads will raise the brake fluid level in the master cylinder.*

- 1: Thoroughly clean the area around the master cylinder cap.
- 2: Remove fluid from the master cylinder until it is 1/2 full.
- 3: Raise the front of the vehicle and support with jack stands.
- 4: Remove the tire/wheel assembly. Refer to Tires and Wheels section for information on removing the tire and wheel assembly.

*Note: Refer to the illustration for the following steps.*

- 5: Remove the brake body bolts (10) and discard the lock nuts (1) and brake pads (8).
- 6: Remove the spacer bushings (6) from the mounting bracket (5) and discard the bushings.
- 7: Inspect the brake rotor. See Inspect the Service Brakes section for information regarding inspecting the brake rotor.
- 8: Inspect the spacers (7) and replace if any wear or damage is found.
- 9: Install new spacer bushings in the mounting bracket.
- 10: Install new brake pads and assemble the caliper in reverse order. Torque the brake body per specification at the end of this section.
- 11: Install the tire/wheel assembly onto the hub and lower the vehicle to the ground.
- 12: Fill the master cylinder to the proper level. Refer to Check Master Cylinder Fluid section for information on the proper master cylinder fluid level.
- 13: Reconnect the battery, remove the blocks from behind the wheels and test drive.

## REAR BRAKE

### **⚠ WARNING**

This section is one section of a complete service manual. Before starting any procedure, read all warnings and instructions that are located in the Service Guidelines chapter.

### **Service Limits**

Refer to the table at the end of this section

*Note: Service Limits are listed in a table at the end of this section.*

### **Inspection**

- 1: Raise the front of the vehicle and support with jack stands.
- 2: Remove the front wheels.
- 3: Measure the brake lining (not including the metal backing plate) of each pad at its thinnest point. If any one of the brake pads are equal to or less than the service limit then all pads should be replaced.
- 4: Measure the rotor thickness in three places. If the rotor thickness is less than the service limit then the rotor must be replaced.
- 5: Measure the rotor runout. If the runout exceeds the service limit, then the rotor must be resurfaced. After resurfacing the rotor, measure the rotor thickness. If the rotor thickness is less than the service limit, then the rotor must be replaced.
- 6: Lower the vehicle.
- 7: Reconnect the battery, remove the blocks from behind the wheels and test drive.

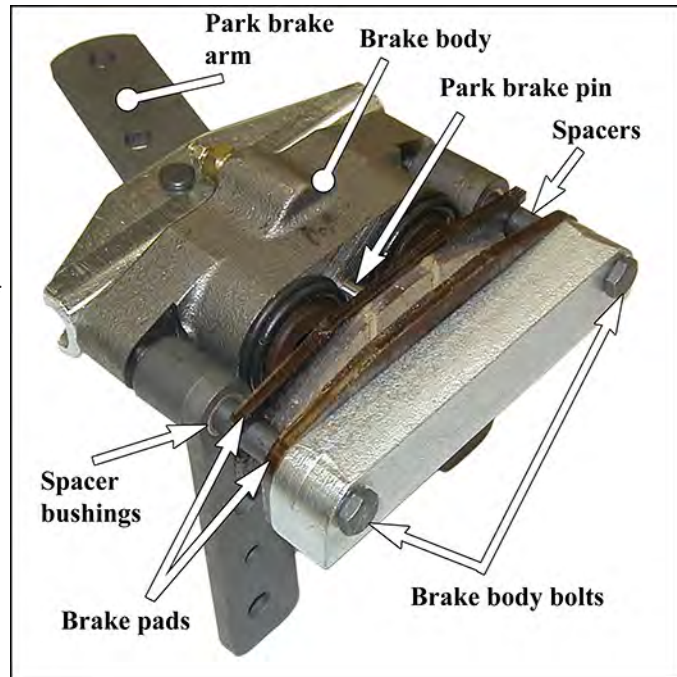

### **Replace Pads**

*Note: Installing new brake pads will raise the brake fluid level in the master cylinder.*

- 1: Thoroughly clean the area around the master cylinder cap.
- 2: Remove fluid from the master cylinder until it is 1/2 full.
- 3: Raise the rear of the vehicle and support with jack stands.
- 4: Remove the tire/wheel assembly. Refer to Tires and Wheels section for information on removing the tire and wheel assembly.
- 5: Remove the brake body bolts and discard the lock nuts and brake pads.
- 6: Remove the spacer bushings from the mounting bracket and discard.
- 7: Inspect the brake rotor. Refer to Inspect the Service Brake section for information regarding inspecting the brake rotor.
- 8: Inspect the spacers and replace if any wear or damage is found.
- 9: Inspect the park brake pin. Should slide freely inside the brake body. Clean or replace the pin and bushing if required.
- 10: Install new spacer bushings in the mounting bracket.
- 11: Back off the parking brake adjustment.
- 12: Install new brake pads in reverse order. Torque the brake body per specification at the end of this section.
- 13: Repeat this procedure for the other wheel.
- 14: Install the tire/wheel assembly and lower the vehicle to the ground.
- 15: Fill the master cylinder to the proper level. Refer to Check Master Cylinder Fluid section for information regarding the correct master cylinder fluid level.
- 16: Reconnect the battery, remove the blocks from behind the wheels and test drive.

**REBUILD DISC BRAKE BODY****⚠ WARNING**

This section is one section of a complete service manual. Before starting any procedure, read all warnings and instructions that are located in the Service Guidelines chapter.

This procedure assumes that the component has been removed from the vehicle. Refer to the component assembly removal instructions for details and warnings regarding the removal and installation procedure.

**⚠ WARNING**

The pistons are very fragile. If the piston is damaged it must be replaced. Failure to replace a damaged piston could lead to brake failure and result in property damage and/or severe bodily injury.

- 1: Pull the pistons out of the brake body.
- 2: Remove the piston rubber boot.
- 3: Remove the piston o-ring from inside of the brake body.
- 4: Inspect and replace parts as required.
- 5: Lubricate the brake parts with clean brake fluid from a sealed container.
- 6: Install the O-rings into the brake body. Make sure that the O-rings are installed into the second groove and that they are not twisted (Fig 1).
- 7: Using tool #41-350-13 (optional), slide the rubber boots onto the pistons as shown. The boot should be hanging off of the end of the piston (Fig 2).
- 8: Insert the rubber boot/piston into the brake body making sure that the boot is properly seated in the groove (Fig 3).
- 9: Press the pistons all the way down into the brake body making sure that the boot seats properly into the upper groove on the piston.
- 10: Install any fittings or plugs that were removed from the brake body using teflon tape thread sealant.
- 11: If the brake body assembly is not to be immediately installed onto a vehicle, plug the brake hose fitting hole to prevent any contaminates from entering the brake body.

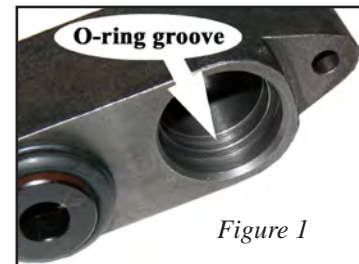
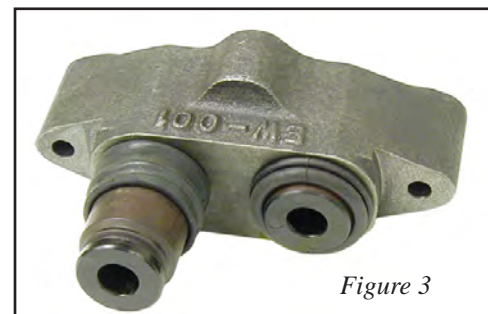
*Figure 1**Figure 2**Figure 3*

**BLEED SYSTEM****⚠ WARNING**

This section is one section of a complete service manual. Before starting any procedure, read all warnings and instructions that are located in the Service Guidelines chapter.

*Note: Start this procedure at the wheel furthest from the master cylinder, then work toward the wheel closest to the master cylinder. The rear bleeder valves can be accessed through the center rear inspection cover.*

- 1: Thoroughly clean the area around the master cylinder cap and remove the cap.
- 2: Add brake fluid from a new sealed container to the master cylinder. Fill to 1/4" from the top of the master cylinder chamber.
- 3: The master cylinder fluid level will drop as the brakes are bled. Periodically check and fill the master cylinder during this procedure. Do not allow the fluid level in the master cylinder to drop too low as this will allow air into the brake lines.
- 4: Attach a clear hose to the bleeder valve on the brake cylinder that is to be bled. Route the hose into a clear container for waste brake fluid.
- 5: Pump the brake pedal a few times and then press and hold light pressure to the brake pedal.
- 6: Open the brake bleeder valve.
- 7: Depress the foot pedal to the floor and then close the bleeder valve. Do not release pressure on the brake pedal until the bleeder valve is closed.
- 8: Slowly release the foot pedal, allowing it to return to its released position.

*Note: Check and fill the master cylinder frequently during the bleeding process. Do not allow the fluid level in the master cylinder to drop low enough to allow air to enter the brake lines. If air enters the brake lines during the bleeding process, then you will have to start again from the beginning.*

- 9: Repeat the above steps until you are sure that all of the air is expelled from the brake line. Any air bubbles that can be seen in the clear hose attached to the bleeder is an indication that there is still air in the brake lines.
- 10: Repeat this process with each of the other wheels.

*Note: When finished, top off the master cylinder with fluid. See Check Master Cylinder Fluid for information on filling the master cylinder.*

- 11: Reconnect the battery, remove the blocks from behind the wheels and test drive.

**FLUSH SYSTEM**

- 1: Raise the rear wheels off of the ground and support with jack stands.
- 2: If equipped with front brakes, raise the front wheels off of the ground and support with jack stands.
- 3: Release the park brake.
- 4: Remove both rear wheels and, if equipped with front brakes, the front wheels. Refer to Tires and Wheels section for information regarding removing the wheels.
- 5: Remove the wheel cylinders from each axle. Refer to Replace the Wheel Cylinder section for information regarding removing the wheel cylinder.
- 6: Attach a clear hose to the bleeder valve on each of the wheel cylinders and route the hoses into a container for waste brake fluid.
- 7: Position the wheel cylinders so that the bleeder screw is pointing to the ground and open all bleeder screws.
- 8: Pump the master cylinder until all fluid has been pumped from the brake lines and all wheel cylinders.
- 9: Close all bleeder screws.
- 10: Fill the master cylinder with fluid.
- 11: Open one of the bleeder screws and pump the master cylinder until all fluid has been pumped from the master cylinder and close the bleeder screw.
- 12: Repeat the above two steps for each wheel cylinder.
- 13: Reinstall the wheel cylinders and bleed the brakes. Refer to Bleed the Brakes for information regarding bleeding the brakes.
- 14: Set the park brake.
- 15: Install the wheels and lower the vehicle to the ground.
- 16: Reconnect the battery, remove the blocks from behind the wheels and test drive.

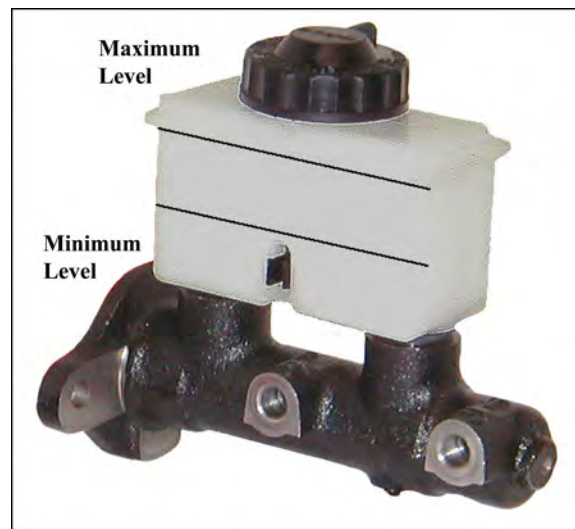



## MASTER CYLINDER

### **WARNING**

This section is one section of a complete service manual. Before starting any procedure, read all warnings and instructions that are located in the Service Guidelines chapter.

There are no internally serviceable components in the master cylinder. If the master cylinder is faulty, it must be replaced.

### **Add Fluid**

- 1: Thoroughly clean the area around the master cylinder cap and remove the cap.
- 2: Add brake fluid from a new sealed container to the master cylinder until it is at the maximum level line molded in the reservoir.

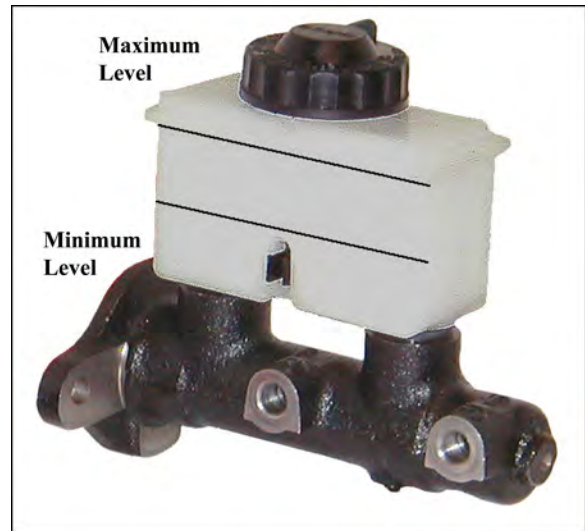

Level lines are highlighted in the illustration for clarity. They are not black.

## PARKING BRAKE

### **WARNING**

This section is one section of a complete service manual. Before starting any procedure, read all warnings and instructions that are located in the Service Guidelines chapter.

The brake pads and rotor should be inspected anytime the park brake requires adjustment.

### **Adjust**

- 1: Block the rear wheels.
- 2: Release the park brake.
- 3: Loosen the jam nut on the park brake equalizer cable.
- 4: Pull on the equalizer to remove all slack from the brake cables.
- 5: Tighten the cable until it is difficult to rotate the clevis pin and then loosen 1 turn.

*Note: If there is no more cable adjustment, then move the brake arm extension to the next hole on the brake arm.*

- 6: Check for brake drag. If there is noticeable drag, then loosen cable 1/2 turn and recheck.
- 7: Tighten the equalizer cable jam nut on the park brake linkage.
- 8: Set the park brake.
- 9: Reconnect the battery, remove the blocks from behind the wheels and test drive.

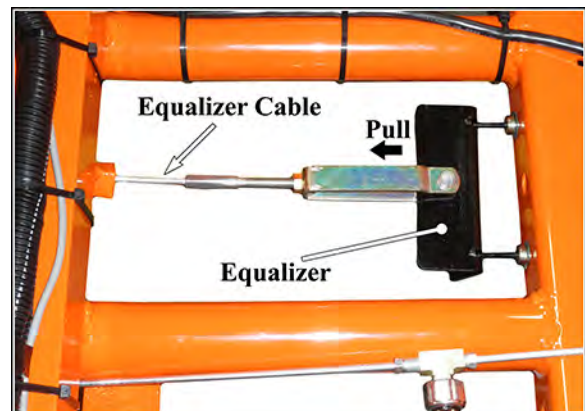
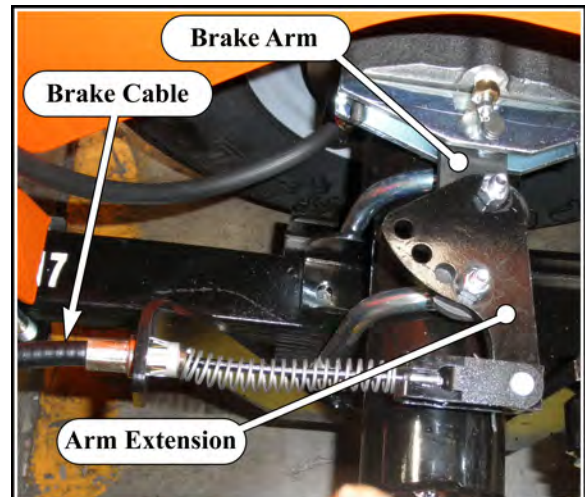



## Table of Contents

<b>Motor</b>	
Motor Identification .....	60
Remove/Install .....	60
Inspect/Testing .....	60
Bearing .....	60
Electrical Testing.....	60
Disassemble.....	61
Assemble.....	62
Hardware Torque .....	64

### **WARNING**

This section is one section of a complete service manual. Before starting any procedure, read all warnings and instructions that are located in the Service Guidelines chapter.

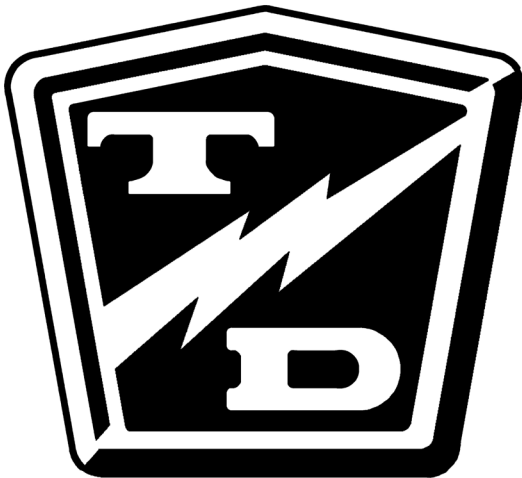

## MOTOR IDENTIFICATION

Shown below is a typical motor specification decal that is applied to the motor.

The specification number on this illustration is for reference only. Use the motor specification number on your motor for parts and service information.

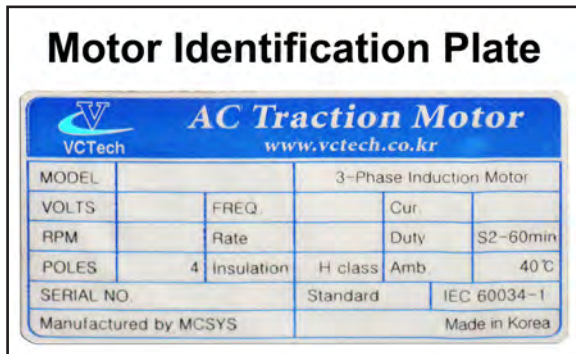
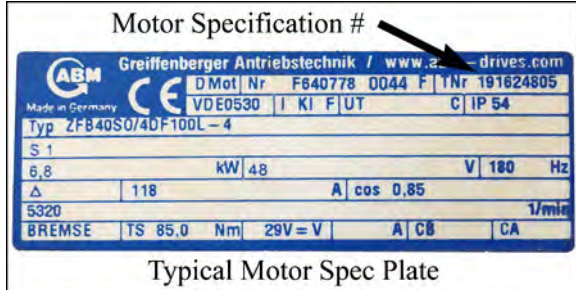

## REMOVE/INSTALL

Refer to the Drive Axle section for information regarding removing the motor.

## INSPECT/TESTING

### Bearing

*Note: The bearing in Motor spec DLGF112150-4 consists of a combination bearing and armature rotation sensor.*

### Bearing

*Note: An "experienced ear" will be required to use this procedure. If you are not familiar with the normal sounds that emanate from a drive axle, then the motor must be disassembled to inspect the bearing.*

Raise the rear wheels off of the ground and support with jack stands.

Place a mechanics stethoscope on the rear motor housing and listen to the bearing noise.

A faulty bearing will typically sound like a high pitch grinding noise or squeal.

### Electrical Testing

Electrical testing for the motor is included in the Electrical Troubleshooting manual. Contact your Taylor-Dunn representative for information on obtaining a copy of the manual.



**DISASSEMBLE****⚠ WARNING**

This section is one section of a complete service manual. Before starting any procedure, read all warnings and instructions that are located in the Service Guidelines chapter.

*Refer to illustration of exploded motor (found later in this section)*

- 1: Mark where the front end housing (3), rear motor housing (4), and the stator (2) are aligned in relation to each other.
- 2: Remove the three screws (24) from the sensor cover plate (7).
- 3: Remove the four bolts (22) from the speed sensor (9).
- 4: Remove the wire clamps (18/19) and terminal block hardware (26).
- 5: Remove the six drive end bolts (21) from the front motor housing (3).

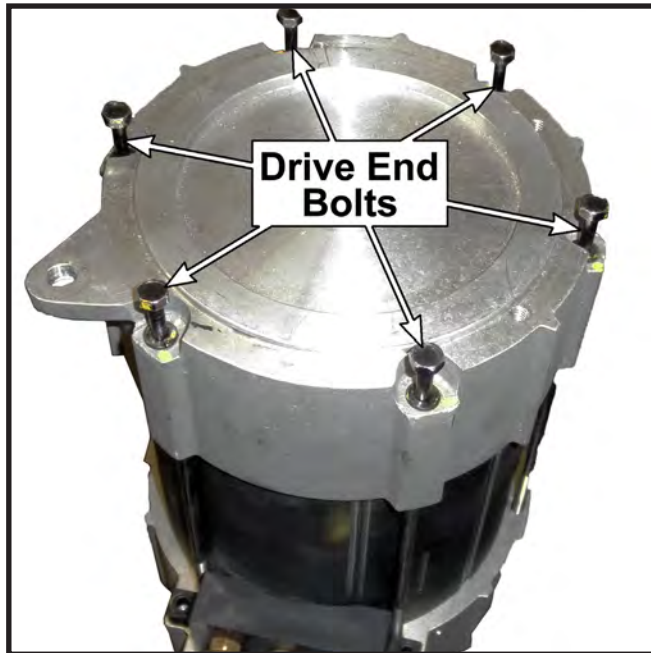

- 6: Using a soft face hammer, gently tap on the front motor housing (3) to remove.

*Note: Do not lose the wave washer (15).*

**NOTICE**

**For specific torque values please refer to Hardware Torque table found at the end of this chapter.**

- 7: Remove the armature (1).
  - a: Remove the motor encoder (9) by removing the bolts (23).
  - b: Gently tap the armature using a soft faced hammer and 1" hollow pipe around the armature magnet (see illustration).
  - c: Reinstall the motor encoder (9) by installing the bolts (23).

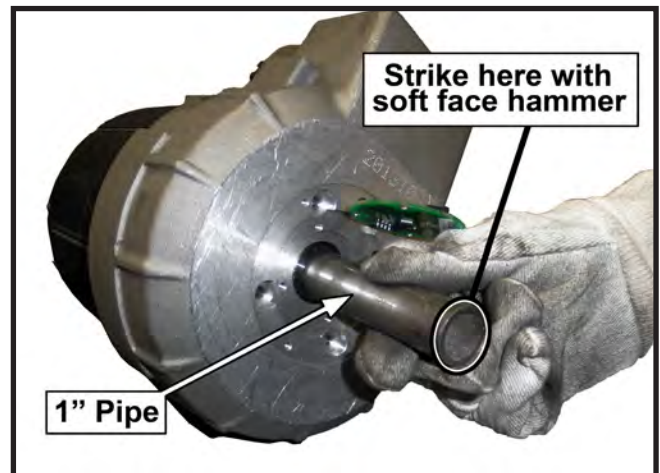
**NOTICE**

Use **CAUTION** when removing rear motor housing to prevent wire damage



- 8: Using a soft face hammer tap on the rear motor housing (4) to separate it from the stator (2).

**ASSEMBLE****⚠ WARNING**

This section is one section of a complete service manual. Before starting any procedure, read all warnings and instructions that are located in the Service Guidelines chapter.

Refer to illustration of exploded motor (found later in this section)

- 1: Set the armature (1) into the rear end housing (4).

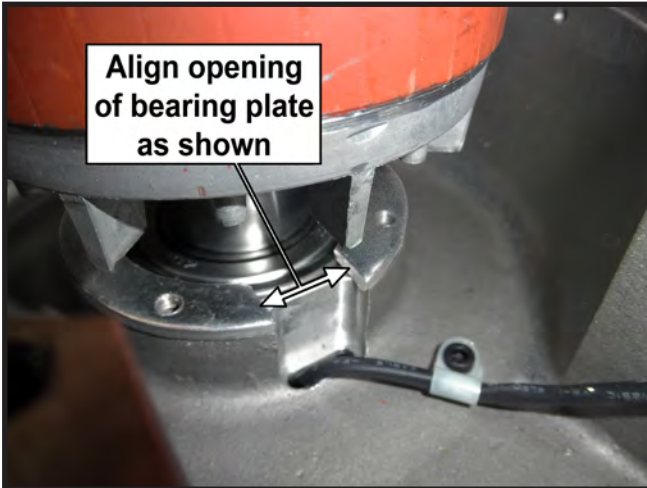

- 2: Thread a long 10/32 screw through the rear housing (4) and into the bearing plate (6) to temporarily hold in place.
- 3: Install three of the bearing plate bolts (22). Do not fully tighten.
- 4: Remove long screw and replace with remaining bearing plate bolt (22). Then tighten all bolts (22).

**NOTICE**

To prevent wire damage, line up the wires to the opening on rubber seal (11) and insert the rubber seal (see illustration).

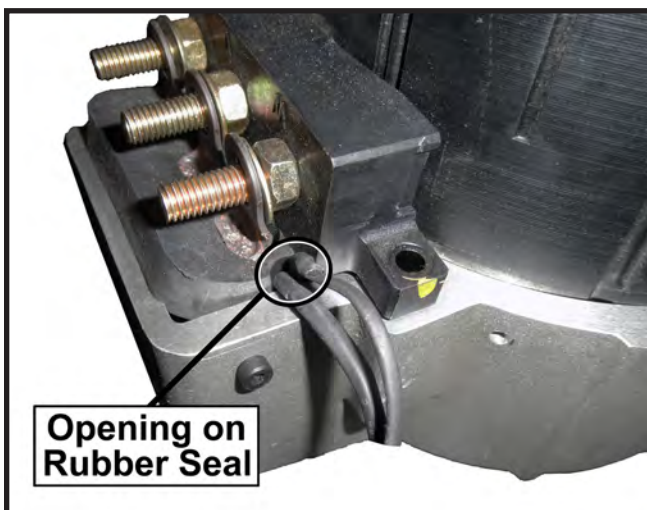
**NOTICE**

For specific torque values please refer to Hardware Torque table found at the end of this chapter.

- 5: Set the stator (2) into the rear housing (4).  
*Note: Be sure the parts are properly aligned using previously made marks on both the housing ends and side of the stator.*
- 6: Install two terminal block bolts (26) onto the terminal block (12).
- 7: Place the wave washer (15) on top of armature bearing (14) and place the front motor housing (3) on the stator (2) /armature (1).  
*Note: Be sure the parts are properly aligned using previously made marks on both housing ends and side of the stator.*  
*Note: If necessary, use a soft face hammer to tap around the perimeter of the front end housing (4) onto the thermal sensor kit.*
- 8: Install the bolts (21) through the front end housing (3) to the rear end housing (4).
- 9: Place the gasket cover (8) on the rear end housing (4).
- 10: Install cover (7) to rear end housing using the three cover bolts (24).
- 11: Reattach the wires and the wire clamps (18/19) to the rear end housing (4).

**NOTICE**

- Do not place armature on magnet head.
- Do not apply excessive pressure or force to the top of armature.
- Do not apply any magnetized material to the magnet on armature.

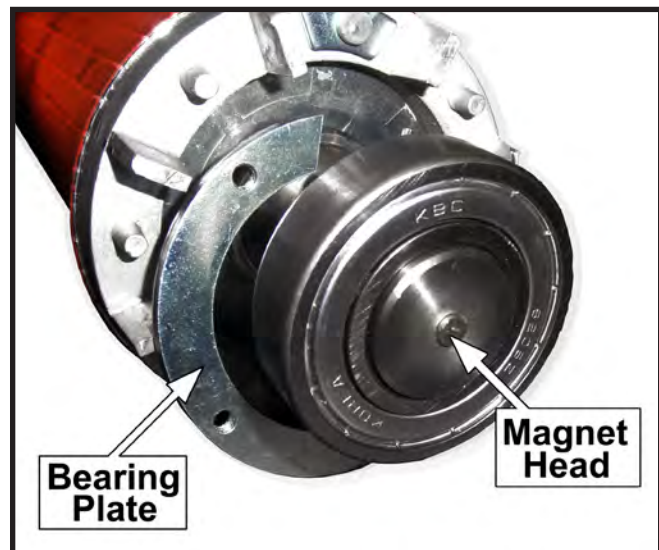

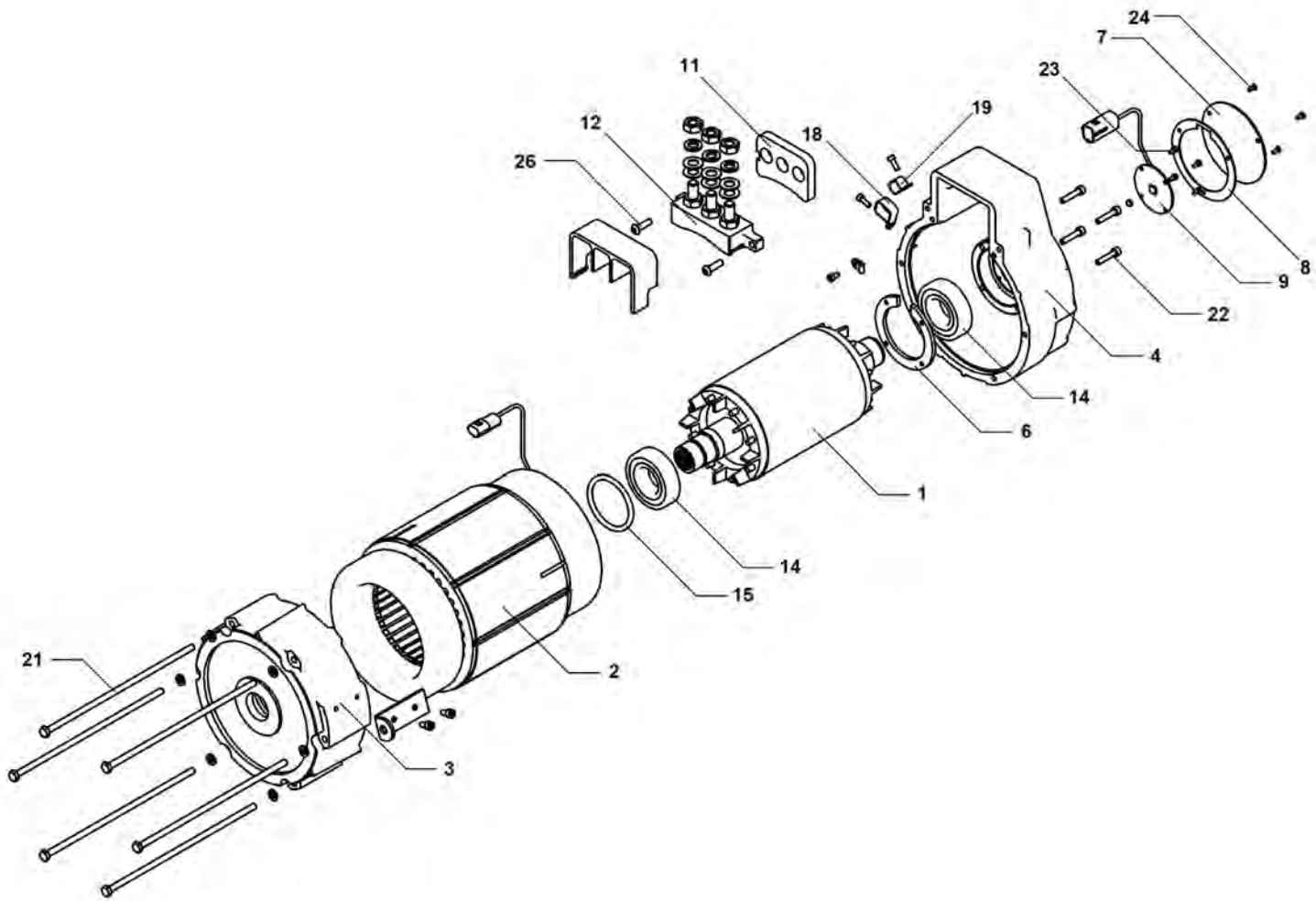





# Tires & Wheels

## Table of Contents

### Tires & Wheels

Inflation.....	66
Air pressure .....	66
Tread Wear .....	67
Rotation .....	67
Changing Tire/Wheel Assembly .....	68
Replace the Tire (pneumatic) .....	68
Repair the Tire (pneumatic).....	69
Hardware Torque .....	69

### **WARNING**

This section is one section of a complete service manual. Before starting any procedure, read all warnings and instructions that are located in the Service Guidelines chapter.

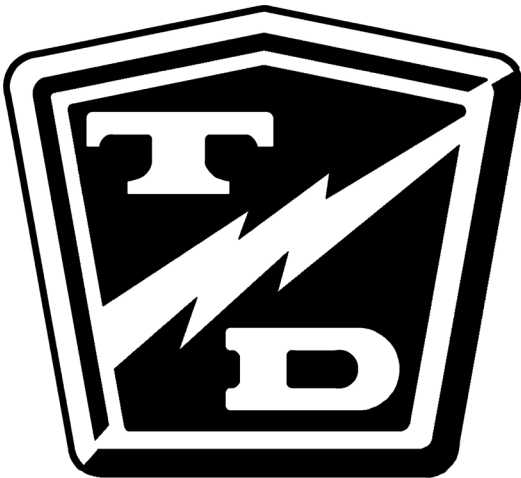

## ***INFLATION***

### **! WARNING**

This section is one section of a complete service manual. Before starting any procedure, read all warnings and instructions that are located in the Service Guidelines chapter.

### **! WARNING**

**Incorrect tire inflation can result in sudden failure of the tire and/or braking / steering problems leading to loss of control of the vehicle.**

**Never exceed the maximum pressure as indicated on the side wall of the tire. Exceeding the maximum pressure may cause explosive failure of the tire resulting in severe personal injury.**

### **Air pressure**

Maintaining the correct tire pressure is important to the safe operation of the vehicle as well as ensuring long tread life.

Under inflated tires result in:

- Excessive tire side wall flexing that can result in sudden tire failure.
- Excessive tread wear resulting in shortened tire life.

### **Over inflated tires result in:**

- Tire explosion due to excessive pressure.
- Reduced road surface traction.
- Increased vibration from the road surface.
- Excessive tread wear resulting in shortened tire life.

### **Unequal tire inflation may result in:**

- Uneven braking and loss of control of the vehicle.
- Steering pulling to the left or right.

Only check the tire pressure when the tire is cold. When checking tire pressure, you must check all tires including your spare tire.

The correct tire size and pressure can be found in the specifications list in the manual.

*Note: The front and rear tires may have a different tire pressure specification.*

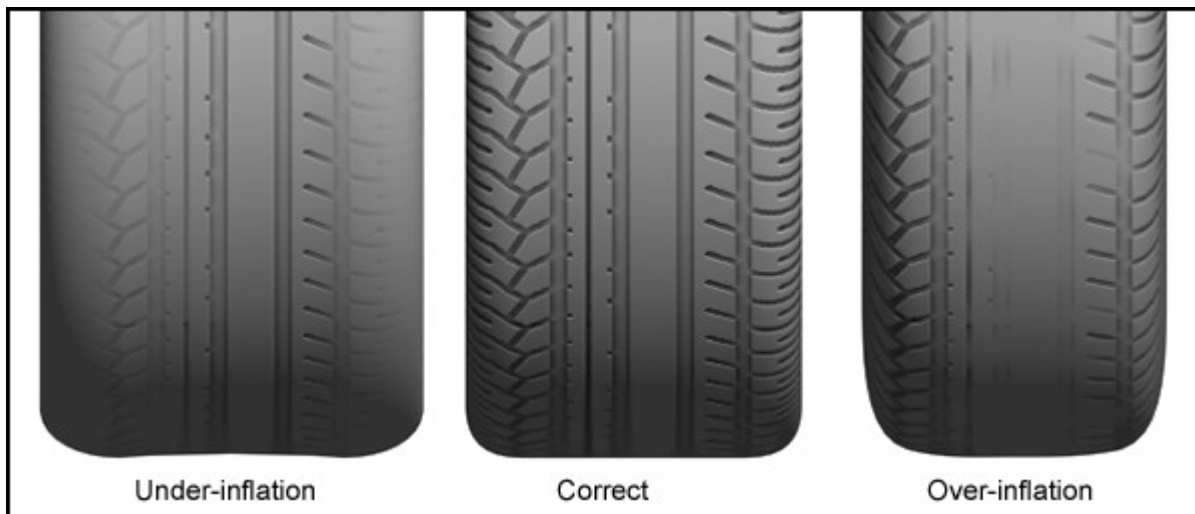

**TREAD WEAR**

**! WARNING**

This section is one section of a complete service manual. Before starting any procedure, read all warnings and instructions that are located in the Service Guidelines chapter.

It is important to periodically inspect each tires tread for wear. Driving with inadequate tread increases the risk of loosing control of the vehicle due to hydroplaning on a wet road surface. It also increases the risk of a flat tire due to road debris. Extreme tire wear can result in sudden tire failure and loss of control of the vehicle.

Refer to the maintenance schedule in this manual for the recommended interval.

Minimum recommended tread depth is 1/16 inch (1.6 mm). There are a series of tread depth wear indicators around the circumference of the tire. They will appear as approximately 1/2 inch (12 mm) bands across the tread as the tire approaches its wear limit (see illustration). The tire should be replaced if any tread depth indicator can be seen or any part of the tread depth is 1/16 inch (1.6 mm) or less.

**! WARNING**

DO NOT operate a vehicle if the cord is visible on any tire (see illustration). A tire in this conditions may suddenly fail at any time and cause loss of control of the vehicle.



**ROTATION**

**! WARNING**

This section is one section of a complete service manual. Before starting any procedure, read all warnings and instructions that are located in the Service Guidelines chapter.

Front and rear tires as well as left and right tires can wear at different rates. It is important to periodically rotate your ties to extend your tire life. Refer to the maintenance schedule in this manual for the recommended interval.

Use the pattern below for a vehicle with no spare tire:

- Right Rear to Right Front
- Right Front to Left Rear
- Left Rear to Left Front
- Left Front to Right Rear

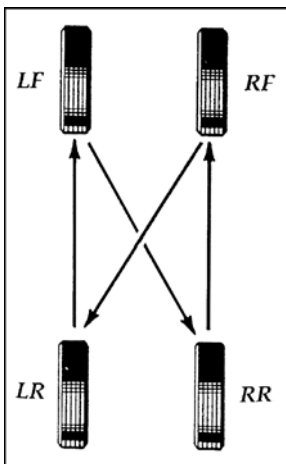

Use the pattern shown below for a vehicle with spare tire:

- Right Rear to Right Front
- Right Front to Left Rear
- Left Rear to Spare
- Spare to Left Front
- Left Front to Right Rear

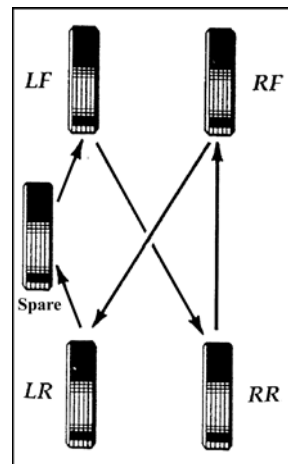

## CHANGING TIRE/WHEEL ASSEMBLY

### **WARNING**

This section is one section of a complete service manual. Before starting any procedure, read all warnings and instructions that are located in the Service Guidelines chapter.

*Note: A spare tire, jack, or lug wrench is not attached to the vehicle.*

- 1: Loosen the wheel nuts (do not remove) before raising the tire off of the ground.
- 2: Raise the tire to be changed off of the ground and support with a jack stand.
- 3: Remove the wheel nuts and tire/wheel assembly.
- 4: Install the replacement tire/wheel assembly.
- 5: Install the wheel nuts and cross tighten to torque specified in table.
- 6: Check the tire for proper inflation.
- 7: Lower the vehicle to the ground and remove the blocks from the wheels.
- 8: Check wheel nuts for tightness after 100 miles.

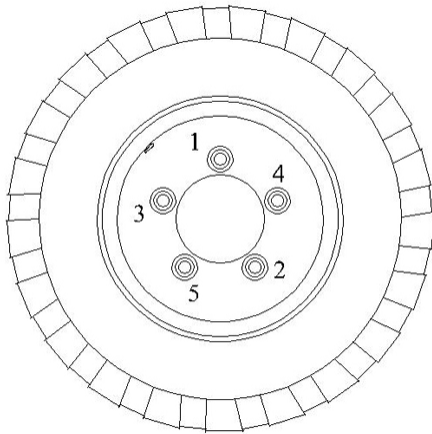

5-Bolt Pattern

## REPLACE THE TIRE (PNEUMATIC)

### **WARNING**

This section is one section of a complete service manual. Before starting any procedure, read all warnings and instructions that are located in the Service Guidelines chapter.

*Note: To replace the tire, the tire/wheel assembly must be removed from the vehicle. Refer to Replace the Tire/Wheel section for information on removing the tire/wheel assembly.*

Tire replacement should only be performed by personnel trained in tire replacement.

The tire replacement procedure will be unique to the type of replacement equipment being used. Refer to the instructions provided with your equipment.

Always use a new valve stem when replacing a tire.

- 1: Remove the tire from the wheel.
- 2: Cut the old valve stem off of the wheel.
- 3: Remove the valve stem cap from the new valve stem.
- 4: Lubricate the valve stem with liquid soap.
- 5: Install a new valve stem using a valve stem tool.

*Note: The valve stem tool is available at most auto repair shops.*

- 6: Install the tire onto the wheel following the instructions provided with your tire replacement equipment.
- 7: Inflate the tire to the proper pressure and check for leaks.
- 8: Install the valve stem cap.

***REPAIR THE TIRE (PNEUMATIC)***

**⚠ WARNING**

**Improper assembly or disassembly of a split rim wheel can result in tire explosion causing severe injury. Refer tire/wheel repair to a qualified tire supplier.**

*Note: To properly repair a puncture, the tire must be removed from the wheel. Refer to Replace the Tire section for information on removing the tire from the wheel.*

It is recommended to repair a tire with a combination vulcanized plug and internal patch.

Tire repairs should only be performed by personnel trained in tire repair.

The tire repair procedure will be unique to the type of repair equipment or repair components used. Refer to the instructions provided with your equipment or repair components.

***HARDWARE TORQUE***

If hardware is not listed here, refer to standard torque values in the appendix.

Description	Foot Pounds	Newton Meters
Wheel nut	85	115





## Table of Contents

**Motor Controller**  
Remove/Install .....72  
Inspect .....72  
    Receptacles.....72  
    Base Plate .....72  
    Terminal Ends.....72  
**Troubleshooting** .....72  
**Repair/Programming** .....73  
    Programming.....73  
**Hardware Torque** .....73



**⚠ WARNING**

This section is one section of a complete service manual. Before starting any procedure, read all warnings and instructions that are located in the Service Guidelines chapter.

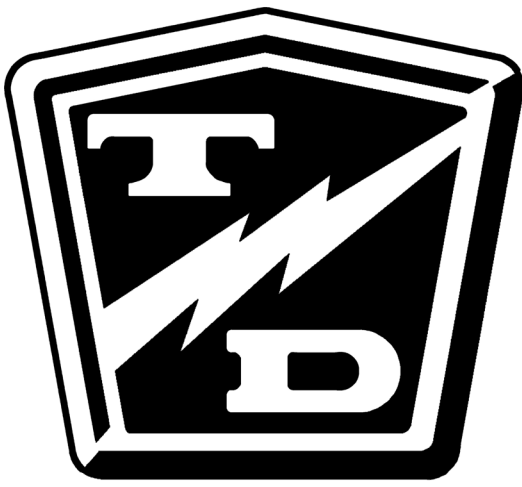

## REMOVE/INSTALL

### **WARNING**

This section is one section of a complete service manual. Before starting any procedure, read all warnings and instructions that are located in the Service Guidelines chapter.

### **NOTICE**

Do not allow the wires to rotate while removing terminal hardware.

Internal electrical connection will be damaged if the terminal stud rotates.

It may be required to remove the control panel from the vehicle for this procedure.

### **Remove**

- 1: Turn the start switch OFF.
- 2: Disconnect the batteries.
- 3: While holding the wires so that they do not rotate, remove the terminal bolts.
- 4: Disconnect the logic connector.
- 5: Remove the four bolts holding the controller to the panel and remove the controller.

*Note: If a heat sink is installed, then these bolts may also hold the heat sink to the panel.*

### **Install**

- 1: Thoroughly clean the controller base, mounting plate, and heat sink.
- 2: Apply thermal transfer compound to the controller base and heat sink.
- 3: Install the controller to the mounting plate.
- 4: Attach the wires to the studs and torque per specification listed in the table at the end of this section.

*Note: DO NOT allow the wires to rotate while torquing the bolts (see notice above).*

- 5: Install silicon dielectric grease (94-422-10, 5.3 ounce tube) into the harness receptacle and reconnect to the controller.
- 6: Reconnect the batteries and test drive.

### **WARNING**

The motor controllers are programmed to match the vehicle configuration.

DO NOT move a control to another vehicle unless the vehicle configurations are identical.

Any changes to the vehicle configuration may require reprogramming the controller.

Installing a controller programmed with improper settings may result in damage to the controller or electrical system which may lead to unsafe vehicle operation causing severe bodily injury and/or property damage.

## INSPECT

### **Receptacles**

The inside of each receptacle should be clean and free of any debris. Use aerosol electrical cleaner if required.

### **Base Plate**

The base plate should be flat. If required, sand with 150 wet sandpaper to remove any raised areas.

### **Terminal Ends**

The wire insulation at each terminal should be smooth and free of any sign of heat. Any indication of heat is a result of a loose connection at the terminal. This could have been a loose bolt or a faulty crimp. It is recommend to replace the cable terminal end.

*Note: A loose bolt could result in damaging the terminal crimp.*

## TROUBLESHOOTING

Troubleshooting control system is not included in this manual.

All electrical troubleshooting information is included in a separate manual "Troubleshooting Electric Vehicles".

This manual was provided on the original vehicle CD. A hard copy can be purchased from your authorized Taylor-Dunn distributor or can be downloaded from the Taylor-Dunn web site.





**REPAIR/PROGRAMMING**

**⚠ WARNING**

This section is one section of a complete service manual. Before starting any procedure, read all warnings and instructions that are located in the Service Guidelines chapter.

**Repairs**

There are no internally serviceable components in the motor speed controllers. If a controller is faulty then it must be replaced.

*Note: Opening or disassembling a controller will void the controller warranty.*

**Programming**

Must refer to supplementary instructions that were included with Sevcon Gen4™ AC Handsets before attempting to program any settings.

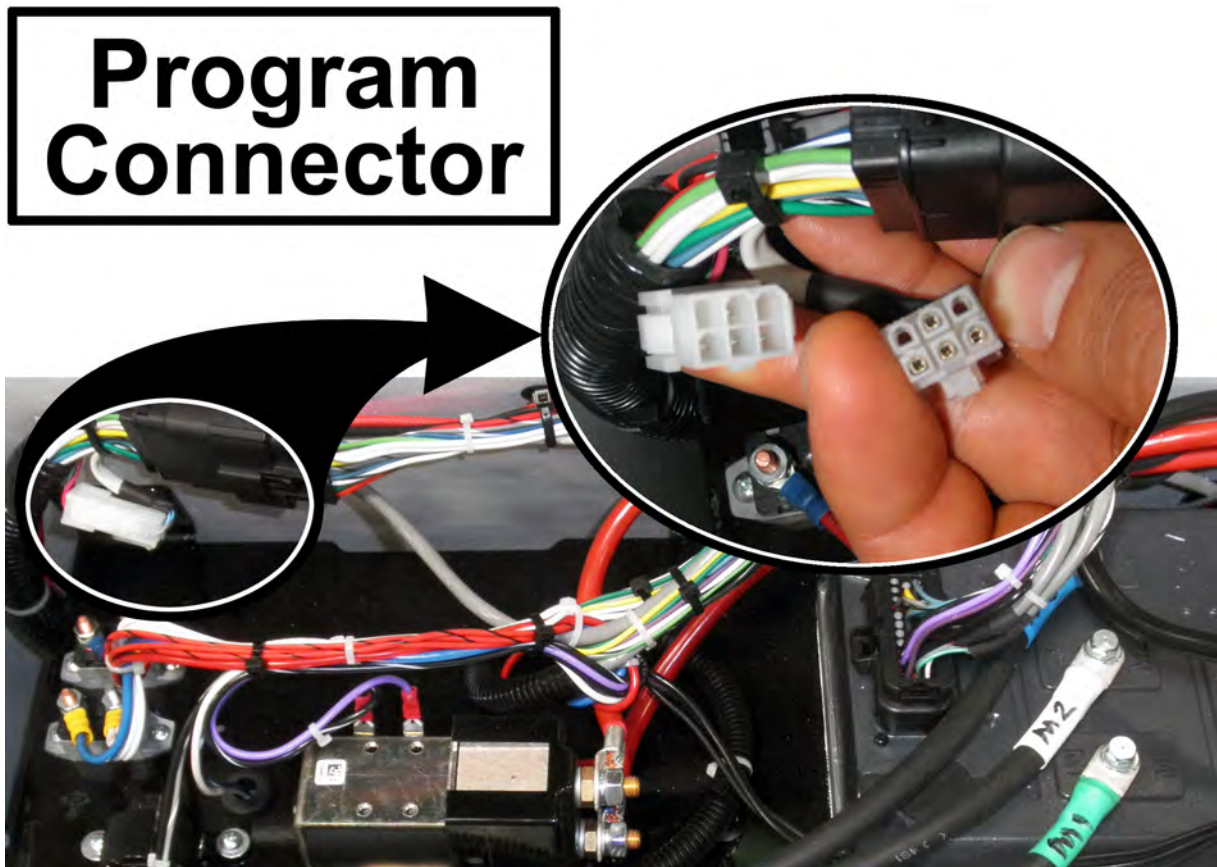

*Program Connector is located under the rear deckboard on the Motor Speed Control Panel*

**HARDWARE TORQUE**

If hardware is not listed here, refer to standard torque values in the appendix.

Description	Inch Pounds	Newton Meters
Terminal stud	85	9.6



# Suspension

## Table of Contents

### Suspension

<b>Front Springs</b> .....	<b>76</b>
Remove.....	76
Install.....	76
<b>Rear Springs</b> .....	<b>76</b>
Remove.....	76
Install.....	76

### **WARNING**

This section is one section of a complete service manual. Before starting any procedure, read all warnings and instructions that are located in the Service Guidelines chapter.

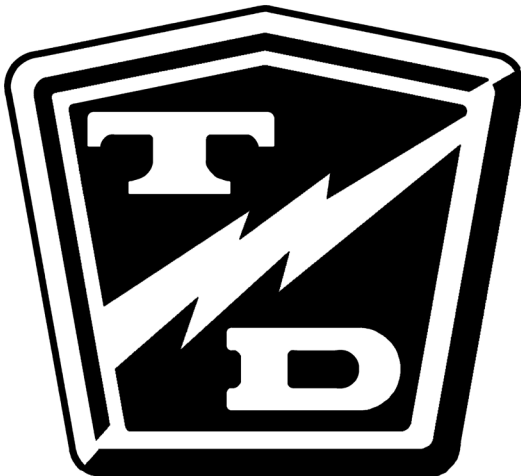

## FRONT SPRINGS

### **WARNING**

This section is one section of a complete service manual. Before starting any procedure, read all warnings and instructions that are located in the Service Guidelines chapter.

*Note: If a left or right side spring is replaced, it is recommended to replace the opposite side at the same time.*

*Note: All spring bushing should be replaced when replacing a spring.*

*Note: When replacing the springs, replace one side and then the other to avoid dropping the axle out of the vehicle.*

### **Remove**

- 1: Raise the front end and support with jack stands.
- 2: Remove the 4 spring mounting bolt nuts and discard.
- 3: Raise the axle up and off of the spring and securely tie in place.

### **NOTICE**

**Do not over torque the spring bolts on elliptical spring hangers. The spring hangers must be allowed to pivot.**

- 4: Remove the 2 spring eye bolts and discard the nuts.
- 5: Remove the spring from the vehicle.
- 6: Remove the spring hanger bolt and discard the nut.
- 7: Discard all spring eye and hanger bushings.

### **Install**

- 1: Inspect the spring hangers for damage and replace as needed.
- 2: Using new nuts and bushings, install the hangers and spring in the frame.
- 3: Tighten the spring to frame mounting hardware until there is no axial play in the bolt then 1/4 turn more.
- 4: Untie the axle and lower down into the spring making sure that the spring locating stud is in the hole on the lower axle beam.
- 5: Using new nuts, install the spring plate.
- 6: Repeat Remove and Install procedures for the other side.
- 7: Test drive the vehicle.

## REAR SPRINGS

### **NOTICE**

**When the vehicle is carrying a full load, the bumpstops will be against the frame. This will not cause harm to your vehicle as this is an active part of the suspension system.**

*Note: If a left or right side spring is replaced, it is recommended to replace the opposite side at the same time.*

*Note: All spring bushing should be replaced when replacing a spring.*

*Note: When replacing the springs, replace one side and then the other to avoid dropping the axle out of the vehicle.*

*Note: The rubber bumper on the axle is an active suspension component. It is not a bump stop and is normal for the spring to contact the bumper.*

### **Remove**

- 1: Raise the side of the vehicle so that the wheel is no more than 1 inch (25 mm) off of the ground and support with a jack stand.
- 2: Remove the wheel.
- 3: Remove the nuts from the axle mounting U-bolts and discard the nuts.
- 4: Place the jack under the axle hub (not rotor) and raise so that the axle rubber suspension bumper is pushing up on the frame. Do not lift so high that the frame comes off of the jack stand.
- 5: Remove the 2 spring eye bolts and discard the nuts.
- 6: Remove the spring from the vehicle.
- 7: Remove the spring hanger bolt and discard the nut.
- 8: Discard all spring eye and hanger bushings.

### **Install**

- 1: Inspect the spring hangers for damage and replace as needed.
- 2: Using new nuts and bushings, install the hangers and spring in the frame.
- 3: Tighten the spring to frame mounting hardware until there is no axial play in the bolt then 1/4 turn more.
- 4: Untie the axle and lower down into the spring making sure that the spring locating stud is in the hole on the lower axle beam.
- 5: Using new nuts, install the spring plate.
- 6: Install the wheel
- 7: Repeat Remove and Install procedures for the other side.
- 8: Test drive the vehicle.

## Table of Contents

<b>Batteries</b>	
General Guidelines and Safety.....	78
Cleaning .....	79
Charging.....	79
Watering .....	79
Testing.....	80
Specific Gravity .....	80
<b>Storing.....</b>	<b>80</b>
Storage.....	80
Returning to Service.....	80
<b>Remove/Install .....</b>	<b>81</b>
Industrial Battery or Lift Out Battery Pack .....	81
Individual Batteries .....	81
<b>Hardware Torque .....</b>	<b>81</b>

### **WARNING**

This section is one section of a complete service manual. Before starting any procedure, read all warnings and instructions that are located in the Service Guidelines chapter.

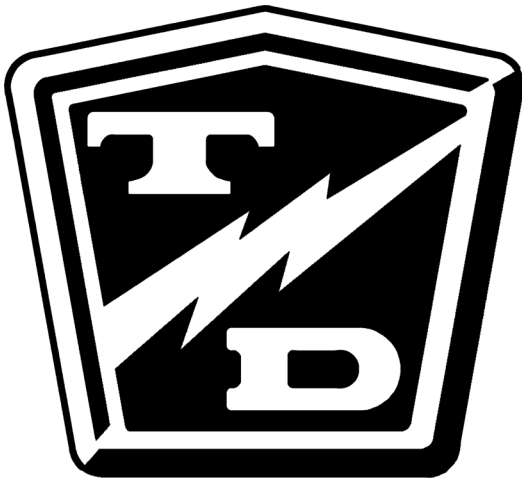

**GENERAL GUIDELINES AND SAFETY****⚠ WARNING**

This section is one section of a complete service manual. Before starting any procedure, read all warnings and instructions that are located in the Service Guidelines chapter.

**NOTICE**

Battery electrolyte will stain and corrode most surfaces. Immediately and thoroughly clean any surface outside of the battery that the battery electrolyte comes in contact with. Failure to clean may result in property damage.

**⚠ WARNING**

- Explosive mixtures of Hydrogen gas are present within battery cells at all times. Do not work with or charge battery in an area where open flames (including gas furnace or water heater pilots), sparks, cigarettes, or any other sources of combustion are present. Always provide ample ventilation in rooms where batteries are being charged. Failure to do so may result in severe bodily injury and/or property damage.
- A battery is a live electrical source. It cannot be disconnected or neutralized. Do not drop any tool or conductive object onto the battery. A conductive object that comes in contact with the battery terminals will initiate a short circuit of the battery. This could cause the battery to explode resulting in severe bodily injury and/or property damage.
- Battery electrolyte is poisonous and dangerous. It contains sulfuric acid. Avoid contact with skin eyes or clothing. Wear rubber gloves and safety glasses while servicing batteries. **DO NOT INGEST!** This may result in severe bodily injury.



## CLEANING

### **WARNING**

This section is one section of a complete service manual. Before starting any procedure, read all warnings and instructions that are located in the Service Guidelines chapter and beginning of this section..

Disconnect the batteries before cleaning.

Dry dirt can be readily blown off with low-pressure air or brushed off.

*Note: Wetness or wet dirt on the top of the battery indicates battery acid boil over or excessive gassing.*

Using a nonmetallic brush with flexible bristles, wash the battery off with a strong solution of baking soda and hot water mixed with a ratio of one pound of soda to one gallon of water (0.5 kg / 3.7 liters). Continue until all fizzing stops, which indicates that the acid has been neutralized. Then rinse thoroughly with clear water. DO NOT get any of the solution into the battery cells.



## WATERING

### **WARNING**

This section is one section of a complete service manual. Before starting any procedure, read all warnings and instructions that are located in the Service Guidelines chapter and beginning of this section..

### **NOTICE**

**DO NOT attempt to add electrolyte to a sealed battery. Removing the caps of a sealed battery will damage the battery resulting in premature failure.**

*Note: The electrolyte level in a battery rises while charging and will be close to its highest level after the end of a charging cycle. It is recommended to fill the battery at the end of a charging cycle. If the electrolyte is below the top of the battery plates then fill just enough to cover the plates and then top off when the charging cycle is complete.*

Clean the battery. Refer to Cleaning section for information on cleaning the battery.

Check the electrolyte level in all battery cells. If low, fill to the correct level (see illustration) with distilled water using part number 77-201-00 battery filler, never add additional battery electrolyte to the batteries.

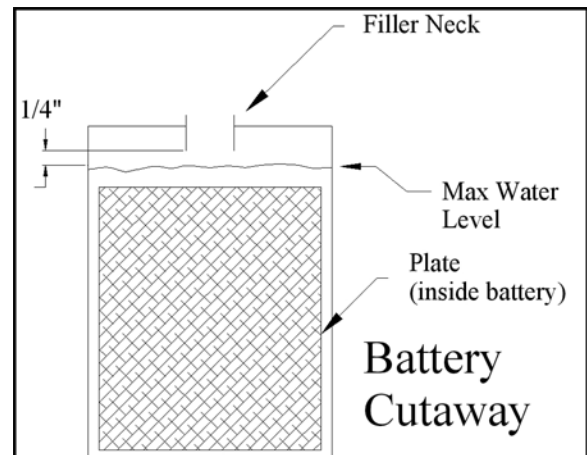

## CHARGING

Refer to the Operator manual for information regarding charging the battery.

**TESTING**

**⚠ WARNING**

This section is one section of a complete service manual. Before starting any procedure, read all warnings and instructions that are located in the Service Guidelines chapter and beginning of this section..

**NOTICE**

**DO NOT attempt to test the specific gravity of a sealed battery. Removing the caps of a sealed battery will damage the battery resulting in premature failure.**

**Specific Gravity**

*Note: The battery must be fully charged before performing this test.*

The specific gravity of a cell is an indication of the actual state of charge of the cell. A fully charged cell should have a reading of 1275 to 1300 (see the illustration below). A discharged cell will read 1100. Ideally, all cells in a battery will have the same reading. Any cells in a battery that vary by more than 25 points may be an indication of a bad or weak cell.

Clean the battery. Refer to Cleaning section for information on cleaning the battery.

Using part number 77-200-00 hydrometer or equivalent graduated type hydrometer, test and record the specific gravity of each cell in the battery.

Use the highest reading to compare to all other cells. A cell with a reading above (highest reading – 25 points) should be suspected as being a bad cell.

If, after charging, none of the cells exceed a hydrometer reading of 1250 then there may be a fault in the charging system. If the charging system checks OK then the battery pack is no longer accepting a charge and should be replaced.

It may be possible to replace Individual cells in industrial batteries. Contact the battery manufacturer for details.



*Typical  
Hydrometer  
Float*

**STORING**

**⚠ WARNING**

This section is one section of a complete service manual. Before starting any procedure, read all warnings and instructions that are located in the Service Guidelines chapter and beginning of this section..

**Storage**

Thoroughly clean the battery and battery compartment. Refer to Cleaning in this section for information regarding cleaning the battery.

Check the electrolyte level and charge the battery. Refer to Watering in this section for information regarding checking the electrolyte level.

Store the vehicle or battery (if removed) in a cool, dry, well ventilated area.

If storing for more than one month, the battery should be charged per the table below.

**Returning to Service**

Thoroughly clean the battery and battery compartment. Refer to Cleaning in this chapter for information regarding cleaning the battery.

Check the electrolyte level and charge the battery. Refer to Watering in this chapter for information regarding checking the electrolyte level.

Test the battery. Refer to Testing section for information on testing the battery.

The battery is now ready to be put back into service.

Storage Temperature (F)	Charging Interval (months)
Over 60	1
Between 40 and 60	2
Below 40	6



**REMOVE/INSTALL**

**⚠ WARNING**

This section is one section of a complete service manual. Before starting any procedure, read all warnings and instructions that are located in the Service Guidelines chapter and beginning of this section..

**⚠ WARNING**

Do not allow the loose battery cables to contact any other parts of the vehicle as this could cause in a short circuit resulting severe bodily injury or damage to the vehicle.

**Industrial Battery or Lift Out Battery Pack**

- 1: Thoroughly clean the battery and battery compartment. Refer to Cleaning in this section for information regarding cleaning the batteries.
- 2: Using a hoist or forklift equipped with a proper battery lifting device (see illustration), slowly raise the battery out of the vehicle.
- 3: Inspect the battery compartment for signs of corrosion.
- 4: If minimal signs of corrosion are seen, then the damaged paint should be stripped off and the entire battery compartment cleaned and repainted.
- 5: If there are excessive signs of corrosion, then it may be necessary to replace some of the frame members or completely rebuild the battery compartment.
- 6: Inspect the battery cables and terminals. If any of the cables or terminals show signs of corrosion, then they must be repaired or replaced.
- 7: Install the battery in reverse order.
- 8: Remove the blocks from the wheels and test drive.

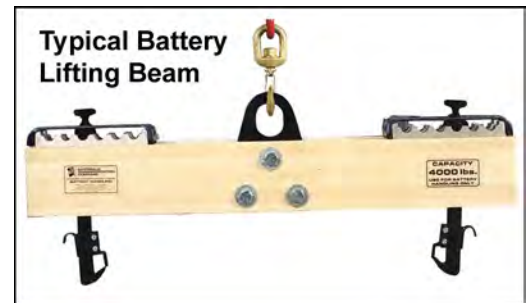
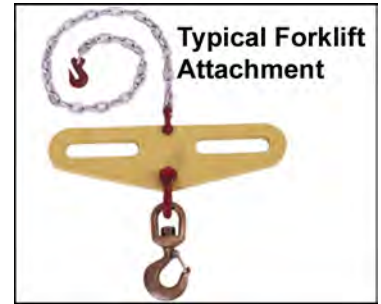

**⚠ WARNING**

Individual batteries can weigh up to 80 pounds or more. To avoid injury, use proper lifting techniques or a hoist to remove the battery.

**Individual Batteries**

- 1: Using an insulated wrench, disconnect the cables from the battery to be removed.
- 2: Using a battery lifting strap, remove the battery from the vehicle.
- 3: Inspect the battery compartment for corrosion. If there is significant corrosion, all batteries should be removed and the compartment cleaned and painted.
- 4: Install the battery and torque the battery terminal hardware per torque listed in the Hardware Torque table at the end of this section.



**HARDWARE TORQUE**

If hardware is not listed here, refer to standard torque values in the appendix.

Description	Inch Pounds	Newton Meters
Battery terminal, Trojan bolt	95-105	11-12
Battery terminal, Trojan stud	95-105	11-12
Battery terminal, T/D bolt	168	19



## Table of Contents

### Wire Diagram

Diagram Part Numbers.....84

# Wire Diagram

#### **WARNING**

This section is one section of a complete service manual. Before starting any procedure, read all warnings and instructions that are located in the Service Guidelines chapter.

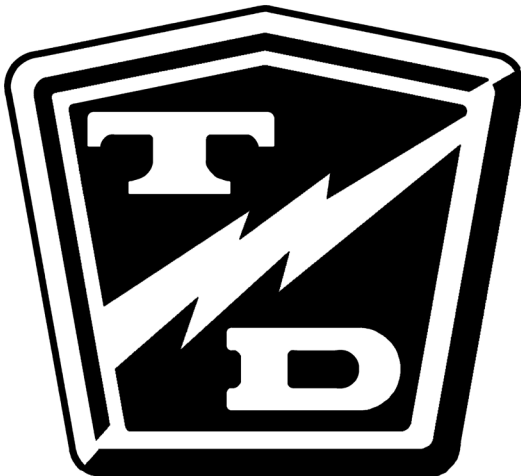

## DIAGRAM PART NUMBERS

Wire diagrams are too large to be legible when printed at this size. The wire diagram for this vehicle is included on the Vehicle Documentation CD provided with the vehicle.

The diagram # for this vehicle: SCH-00071

This vehicle diagram as well as other Taylor-Dunn vehicle diagrams can be downloaded from the Taylor-Dunn web site at [www.taylor-dunn.com](http://www.taylor-dunn.com).

Listed below are the available diagrams as of the revision date of this manual.

SCH-00001	B4K4560, VEHICLE
SCH-00002	R380, VEHICLE
SCH-00004	T48, VEHICLE
SCH-00005	PAR-KAN, VEHICLE
SCH-00006	P249, VEHICLE, EV-1
SCH-00007	B248AC, VEHICLE
SCH-00008	B248AC, VEHICLE, W/DC CONV
SCH-00009	SEVCON POWERPAK, TYPICAL
SCH-00010	SEVCON MICROPAC, TYPICAL
SCH-00011	SPECIAL, KBG-C48-074
SCH-00012	R380, VEHICLE, GT-PMC
SCH-00013	R380, VEHICLE, F2-PMC
SCH-00014	SC159/SC-90, VEHICLE
SCH-00015	G150, VEHICLE, OIL LIGHT
SCH-00016	G150, VEHICLE, OIL KILL
SCH-00017	B210, VEHICLE, PMC
SCH-00018	T48, VEHICLE, F2, 2 PC CHARGE
SCH-00019	T48, VEHICLE, F2, 1 PC CHARGE
SCH-00020	ET3000, VEHICLE
SCH-00021	T48AC/R-380AC, VEHICLE
SCH-00022	ET150, VEHICLE, PMC
SCH-00023	TT316, VEHICLE
SCH-00024	B42500, VEHICLE TO 163333
SCH-00025	B42500, VEHICLE 164796 TO
SCH-00026	CURTIS PMC, TYPICAL
SCH-00027	VEHICLE, SEVCON W/HYD DUMP
SCH-00028	ET150AC, VEHICLE
SCH-00029	C426AC, VEHICLE, FED EX
SCH-0003	C426, VEHICLE, FED EX, SEVCON
SCH-00030	SC-100, VEHICLE, FED EX
SCH-00031	SS, VEHICLE, STARTING 97450
SCH-00032	MX600, VEHICLE, STARTING 113277
SCH-00033	TC50, CHASSIS, FED EX
SCH-00034	ENGINE, PSI 3.0L
SCH-00035	TRAM, FEDEX
SCH-00036	TIGER TRACTOR, TYPICAL
SCH-00037	TC-50E, VEHICLE
SCH-00038	TC50, CHASSIS, FEDEX FORD
SCH-00039	ENGINE, FORD DSG
SCH-0004	C426AC, VEHICLE

SCH-00040	SEVCON, TYPICAL WITH DC CONV
SCH-00041	TT316, VEHICLE, STARTING 178410
SCH-00042	T48, VEHICLE, DC CONVERTER
SCH-00043	TRIDENT, VEHICLE
SCH-00044	TC30/60, VEHICLE, CAN-BUSS
SCH-00045	C425, DASH (SEVCON)
SCH-00046	C425, CONTROL PANEL (SEVCON)
SCH-00047	B248, VEHICLE, DC CONVERTER
SCH-00048	CHARGER, LESTER E-SERIES
SCH-00049	TYPICAL SEVCON, HARDWIRED DASH
SCH-00050	R-380, RHEOSTAT
SCH-0005	426AC, VEHICLE
SCH-00051	POWER-TRON, POT MODULE
SCH-00052	POWER-TRON, SS MODULE
SCH-00053	TC-3060 CHASSIS, CUMMINS B3.3
SCH-00054	ENGINE, FORD MSG-425
SCH-00055	CURTIS PMC, TYPICAL NO TAP
SCH-00056	G-150, KOHLER TH16 ENGINE
SCH-00057	TYPICAL PMC, 12V TAP DC CNVRTR
SCH-00058	ENGINE INTERFACE, FORD MSG/DSG
SCH-00059	ENGINE INTERFACE, FORD MSG/DSG
SCH-0006	C426AC, VEHICLE, FED EX
SCH-00060	B-210 AC SYSTEM W/12V TAP
SCH-00061	B-210 AC SYSTEM W/DC-DC
SCH-00070	BA-RT0-48 AC SYSTEM
SCH-00071	B5-440 BIGFOOT

## Table of Contents

### Hardware Information

<b>Torque Guidelines for Standard Hardware ...</b>	<b>86</b>
Hardware Identification.....	86
Hex Nuts.....	87
Hex Lock Nuts (stover).....	87
Other Nuts.....	87
Generic Torque Values.....	88
<b>Replacing Hardware.....</b>	<b>90</b>

 **WARNING**

This section is one section of a complete service manual. Before starting any procedure, read all warnings and instructions that are located in the Service Guidelines chapter.

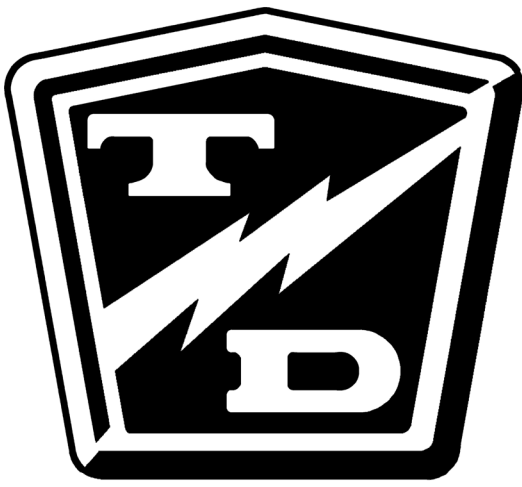

## **TORQUE GUIDELINES FOR STANDARD HARDWARE**

*Note: Torque values specified are for clean dry threads.*

*Note: Torque value used should be for lowest grade of hardware used. If a grade 2 nut is used on a grade 8 bolt, use grade 2 torque value.*

### **Hardware Identification**

#### **Hex Head Bolts and Screws**

The grade of SAE bolts and screws are identified by markings on the head as illustrated to the right.

The grade of a metric hex head bolt or screw is cast directly on the head. Below is an example of a 10.9. The location and style of the text will vary.

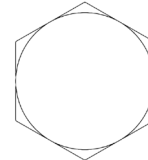

SAE Grade 2



SAE Grade 5

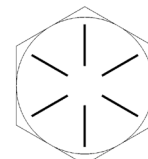

SAE Grade 8

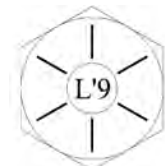

SAE Grade 9

#### **Other types of bolts and screws**



Truss Head, Grade 2



Carriage Bolt, Grade 2

**Hex Nuts**

*Nuts with no markings are to be treated as S.A.E. Grade 2*

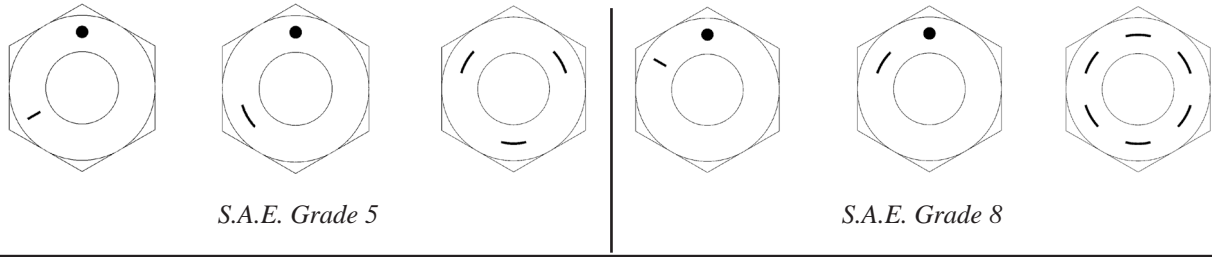

*S.A.E. Grade 5*

*S.A.E. Grade 8*

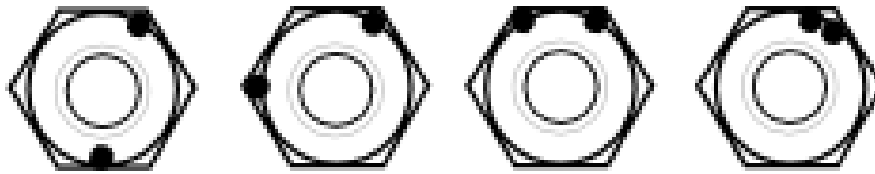

5.8

8.8

10.9

12.9

*Metric Nuts*

**Hex Lock Nuts (stover)**

Lock nuts use a letter to indicate the grade of the nut. Grade 'A' locknuts would be the equivalent of Grade '2' hex nuts, Grade 'B' as Grade '5' and Grade 'C' as Grade '8'.

*NOTE: Nuts with no markings are to be treated as S.A.E. Grade A*

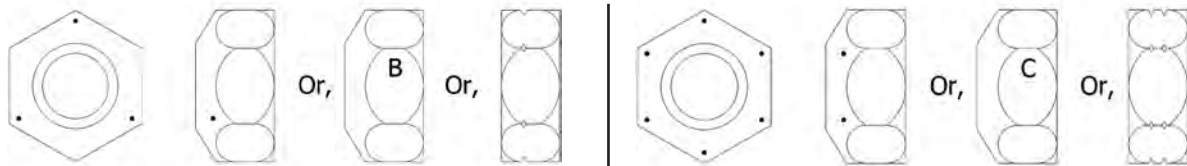

*S.A.E. Grade B*

*S.A.E. Grade C*

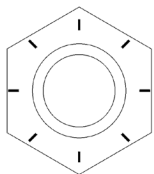

*Grade L'9*

**Other Nuts**

*Other nuts used by Taylor-Dunn® should be treated as S.A.E. grade A*

## Generic Torque Values

All torque values are for clean dry zinc plated threads in noncritical steel assemblies of the same hardness specification. Reduce torque approximately 10-15% for lubricated threads.

Refer to the service section assembly procedure for critical torque values.

Imperial (inch), Foot Pounds					
Dia.	Pitch	Grade, SAE			
		2	5	8	L9
#4	40	*	*	*	*
#6	32	*	*	*	*
#8	32	*	*	*	*
#10	32	*	*	*	*
#12	32	*	*	*	*
1/4	20	5.5	8.5	12.5	11
	28	6.5	10.5		
5/16	18	12.0	17.5	24.5	22
	24	12.5	19.0	*	*
3/8	16	20	30	43	40
	24	22.5	33	50	45
7/16	14	27	50	70	65
	20	36	55	77	70
1/2	13	49	75	106	95
	20	55	85	120	110
9/16	12	70	109	153	140
	18	78	121	171	160
5/8	11	97	150	212	195
	18	110	170	240	225
3/4	10	172	275	376	350
	16	192	297	420	390
7/8	9	278	429	593	565
	14	306	473	818	625
1	8	416	644	909	850
	14	466	721	1018	930
1-1/8	7	590	794	1287	1700
	12	662	891	1444	1850
1-1/4	7	832	1120	1817	2950
	12	922	1241	2012	3330

Imperial (inch), Newton Meters					
Dia.	Pitch	Grade, SAE			
		2	5	8	L9
#4	40	*	*	*	*
#6	32	*	*	*	*
#8	32	*	*	*	*
#10	32	*	*	*	*
#12	32	*	*	*	*
1/4	20	7.4	11.5	16.9	14.9
	28	8.8	14.2		
5/16	18	16.2	23.7	33.2	29.8
	24	16.9	25.8	*	*
3/8	16	27.1	41	58	54
	24	30.5	45	68	61
7/16	14	37	68	95	88
	20	49	75	104	95
1/2	13	66	102	144	129
	20	75	115	163	149
9/16	12	95	148	614	190
	18	106	164	232	217
5/8	11	132	203	287	264
	18	149	230	325	305
3/4	10	233	373	510	475
	16	260	403	569	529
7/8	9	377	582	804	766
	14	415	641	1109	847
1	8	564	873	1232	1152
	14	632	978	1380	1261
1-1/8	7	800	1076	1744	2304
	12	897	1208	2364	2508
1-1/4	7	1128	1518	2463	4000
	12	1250	1682	2727	4514

### Conversion Formulas:

- 1: Foot Pounds = Newton Meters x 0.737562149
- 2: Newton meters = Foot Pounds x 1.355817948



All torque values are for clean dry zinc plated threads in noncritical steel assemblies of the same hardness specification. Reduce torque approximately 10-15% for lubricated threads.

Refer to the service section assembly procedure for critical torque values.

Metric, Newton Meters					
Dia.	Pitch	Grade, N-m			
		4.6	8.8	10.9	12.9
3	0.50	0.51	*	*	*
4	0.70	0.95	3.1	*	*
5	0.80	2.28	6.1	*	*
6	1.00	3.92	10.4	15.5	*
8	1.00	*	27.0	*	*
	1.25	9.48	25.0	37.0	*
10	1.00	*	57.0	*	*
	1.25	*	54.0	*	*
	1.50	19.1	51.0	75.0	*
12	1.25	*	96.0	*	*
	1.50	*	92.0	*	*
	1.75	32.6	87.0	160	*
14	1.50	*	150	*	*
	2.00	51.9	140	205	*
16	1.50	*	*	*	*
	2.00	79.9	215	310	*
18	1.50	*	*	*	*
	2.00	*	*	*	*
	2.50	110	300	*	*
20	1.50	*	*	*	*
	2.00	*	*	*	*
	2.50	156	430	*	*
22	1.50	*	*	*	*
	2.00	*	*	*	*
	2.50	211	580	*	*
24	2.00	*	*	*	*
	3.00	270	740	*	*
27	3.00	*	*	*	*
	3.00	398	*	*	*
30	2.00	*	*	*	*
	3.50	540	*	*	*

Metric, Foot Pounds					
Dia.	Pitch	Grade, N-m			
		4.6	8.8	10.9	12.9
3	0.50	0.38	*	*	*
4	0.70	0.7	2.3	*	*
5	0.80	1.7	4.5	*	*
6	1.00	2.9	7.7	11.4	*
8	1.00	*	19.9	*	*
	1.25	7	18.4	27.3	*
10	1.00	*	42	*	*
	1.25	*	40	*	*
	1.50	14.1	38	55	*
12	1.25	*	71	*	*
	1.50	*	68	*	*
	1.75	24	64	118	*
14	1.50	*	111	*	*
	2.00	38	103	151	*
16	1.50	*	*	*	*
	2.00	60	158	229	*
18	1.50	*	*	*	*
	2.00	*	*	*	*
	2.50	81	221	*	*
20	1.50	*	*	*	*
	2.00	*	*	*	*
	2.50	115	317	*	*
22	1.50	*	*	*	*
	2.00	*	*	*	*
	2.50	156	428	*	*
24	2.00	*	*	*	*
	3.00	199	524	*	*
27	3.00	*	*	*	*
	3.00	293	*	*	*
30	2.00	*	*	*	*
	3.50	398	*	*	*

Conversion Formulas:

- 1: Foot Pounds = Newton Meters x 0.737562149
- 2: Newton meters = Foot Pounds x 1.355817948

## REPLACING HARDWARE

---

### **WARNING**

This section is one section of a complete service manual. Before starting any procedure, read all warnings and instructions that are located in the Service Guidelines chapter.

### **WARNING**

Failure to follow the following guidelines may result in failure of the hardware resulting in severe bodily injury or property damage:

- **Many assemblies require specific torque settings for some hardware. Refer to the appropriate assembly procedure for information regarding proper hardware torque.**
- All hardware should be inspected for thread damage or corrosion prior to reassembly. If any evidence of damage is found then the hardware should be replaced.
- Battery hardware should always be replaced when installing new batteries.
- Never reuse cotter pins or safety locking wire. Never use a wire, nail, or any other material to substitute for a cotter pin.
- The locking force of a locknut is diminished when it is removed. Locknuts should be replaced whenever removed.
- Some hardware may requires the use of a thread locking compound. Always thoroughly clean both male and female threads when applying thread locking compounds.



---

## TABLE OF CONTENTS

---

### Replacement Parts

Ordering Parts for Your Vehicle .....	92
Taylor-Dunn Web Site Information.....	92
Axle Assembly, Front .....	94
Axle Shaft Assembly, Rear .....	96
TransAxle Assembly, Rear.....	98
Battery .....	100
Brakes, Brake Lines .....	102
Brakes, Front Axle.....	104
Brakes, Rear Axle .....	105
Charger, Signet.....	106
Charger, X-Series.....	107
Control System, Motor Speed .....	108
Control System, Instrument Panel.....	110
Decals.....	111
Electrical, Miscellaneous .....	112
Frame and Body (P1).....	114
Frame and Body (P2).....	116
Frame and Body, Drop Sides.....	118
Hitches.....	120
Lights.....	121
Motor.....	122
Steering Linkage.....	124
Suspension, Front .....	126
Suspension, Rear .....	127
Wheels and Tires .....	128

### **WARNING**

This section is one section of a complete service manual. Before starting any procedure, read all warnings and instructions that are located in the Service Guidelines chapter.



*Note: Your vehicle may have been ordered with special order options. These options typically start with the letter "K". Refer to your vehicle sales order for information.*

*Replacement part numbers for special order options are not included in the standard manual.*

**ORDERING PARTS FOR YOUR VEHICLE** **WARNING**

The only personnel authorized to repair, modify, or adjust any part of this or any Taylor-Dunn vehicle is a factory authorized service technician. Repairs made by unauthorized personnel may result in damage to the vehicles systems which could lead to an unsafe condition resulting in severe bodily injury and/or property damage. Unauthorized repairs may also void the vehicles warranty.

 **WARNING**

To maintain peak performance, always use original Taylor-Dunn replacement parts intended for use on your vehicle. Taylor-Dunn components are designed and tested for use on specific Taylor-Dunn model vehicles. Only use the correct Taylor-Dunn replacement components for your Taylor-Dunn vehicle.

Do not modify your vehicle:

**Modifications to this vehicle may have an undesirable affect on the operation of the vehicle, result in additional frame stress, or stress other components resulting in premature failure or an unsafe condition and may lead to an accident resulting in serious injury or death.**

This section contains a comprehensive parts list that includes all of the typical replacement parts available as of the published date of this manual. This parts list should be used as a guide only.

This parts list does not include special order options that may have been ordered for your vehicle. To identify special order options, refer to the original vehicle sales order. Any special order options will have a 'K' letter prefix in the option number. The vehicle option list is also available on the Taylor-Dunn web site. The serial number of the vehicle is required to obtain the option list.

Only use original Taylor-Dunn parts purchased from an authorized Taylor-Dunn distributor. Refer to the Taylor-Dunn web site to locate your local distributor or call the factory direct at (714) 956-4040 for referral to a local dealer.

When contacting your dealer, always include the serial number of the vehicle to ensure obtaining the correct replacement parts. The Taylor-Dunn web site includes a parts lookup utility. By using this utility you can obtain the most current parts list for your vehicle. The serial number of the vehicle is required to use the lookup utility.

**TAYLOR-DUNN WEB SITE INFORMATION**

Registering on the Taylor-Dunn web site will give you access to a wealth of information about your vehicle and the entire Taylor-Dunn line of vehicles. Your contact information will remain confidential and will not be shared outside of the Taylor-Dunn corporation.

Once registered on the Taylor-Dunn web site, you will have access to:

- Additional Taylor-Dunn product information.
- Worldwide Taylor-Dunn dealer contacts
- Vehicle Service, Maintenance, Operator, and Parts manuals.
- Replacement part number lookup utility

***www.taylor-dunn.com***

My Vehicle information

Serial Number: \_\_\_\_\_

Date Purchased: \_\_\_\_\_

Date Delivered: \_\_\_\_\_

Dealer Purchased From: \_\_\_\_\_

Salesman Name: \_\_\_\_\_

My local Parts Dealer: \_\_\_\_\_

*Notes:*

---

---

---

---

---

---

---

---

---

---

---

---



**TAYLOR-DUNN®**

*The best way to go about your business*  
**Commercial and Industrial Vehicles Since 1949**

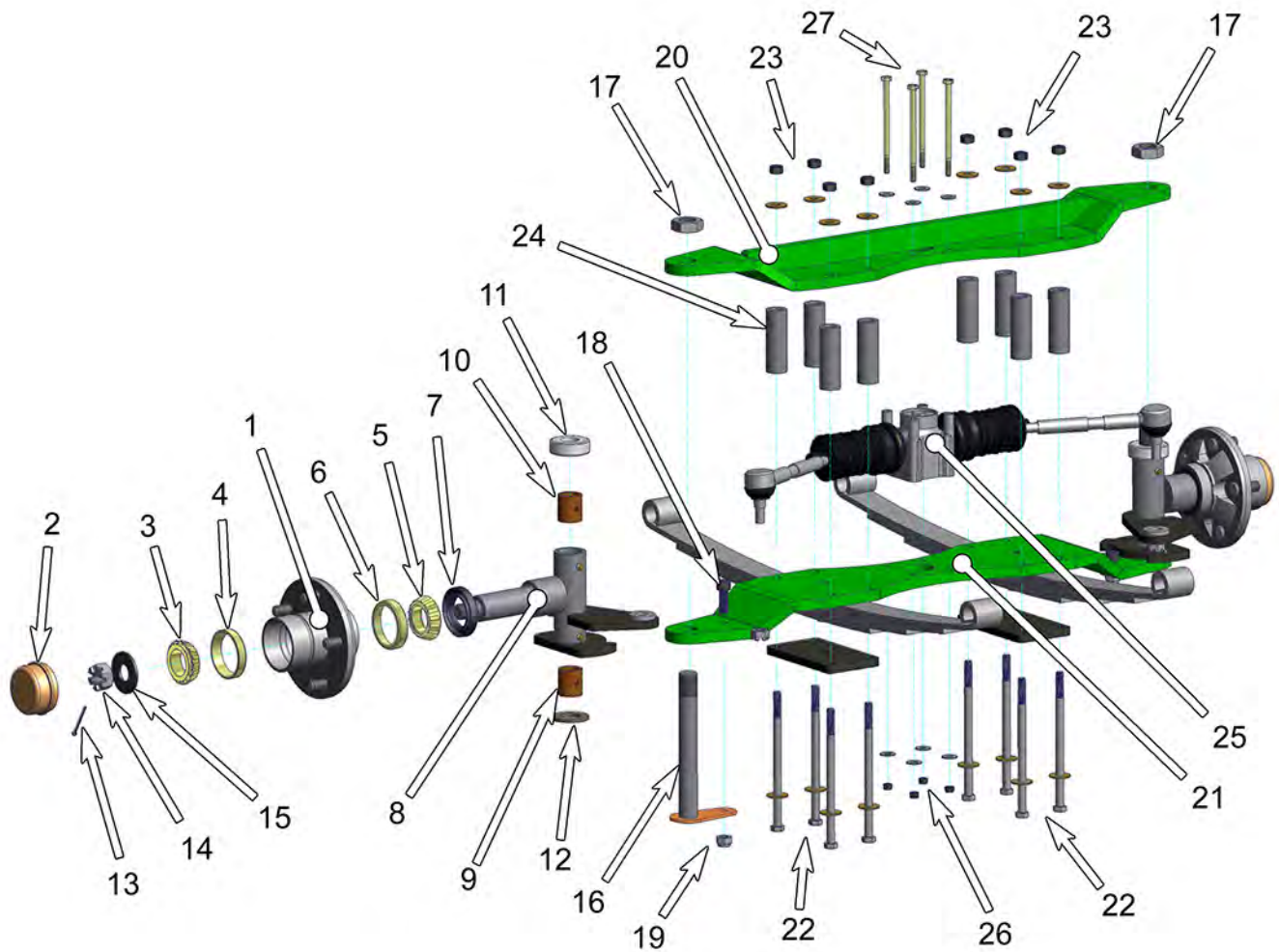

<b>Axle Assembly, Front</b>			
Item No.	Part No.	Description	Qty
1	12-115-10	Hub, With Disc (includes items 4, 5, 6 & 7)	2
	12-115-00	Hub, Without Disc (includes items 4, 5, 6 & 7)	2
2	92-105-00	Dust Cap	2
3	80-011-00	Bearing, Cone	2
4	80-102-00	Race	2
5	PKIT-00050	Includes 3, 4, 5, 6, 7, and 13 (1 hub)	-
6	PKIT-00050	Includes 3, 4, 5, 6, 7, and 13 (1 hub)	-
7	45-304-00	Seal (included in PKIT-00050)	2
Note:	Steering knuckles include bushings for king pin and brake		-
8	14-010-09	Steering Knuckle, Front Brake, Left	0 or 1
	14-010-08	Steering Knuckle, Front Brake, Right	0 or 1
	14-010-10	Steering Knuckle, Left, No brakes	0 or 1
	14-010-11	Steering Knuckle, Right, No brakes	0 or 1
9 / 10	PKIT-00051	Kit, King Pins and Bushings	2
11	PKIT-00051	Thrust Bearing	2
12	PKIT-00051	7/8 SAE Flat Washer	2
13	88-527-14	Cotter Pin, 1/8 X 1-1/2	2
14	88-239-85	3/4 NF Hex Slotted Nut	2
15	88-228-60	3/4 Cut Washer	2
16	PKIT-00051	King Pin	2
17	PKIT-00051	7/8NF Thin Hex Locknut Grade 5	2
18	PKIT-00051	7/16 X 1-1/8 NC Socket Head Cap Screw	2
19	PKIT-00051	7/16 NC Grade 9 Locknut	2
20	14-010-00	Front Axle Plate, Top	1
21	14-010-01	Front Axle Plate, Bottom	1
22	88-401-57	3/8 X 6-1/2 NC Grade 8 Hex Head Screw	8
23	88-109-82	3/8-NC Lock Nut, Grade C	8
	88-401-95	3/8 Flat Washer, Grade 8	16
24	14-010-02	Spacer	8
25	See Steering	Steering Rack	1
26	88-069-82	1/4 NC Hex Locknut, Grade 8	4
	88-400-90	1/4 Flat Washer Grade 8	8
27	88-060-27	1/4 X 4-1/2NC Hex Head Cap Screw, Grade 8	4

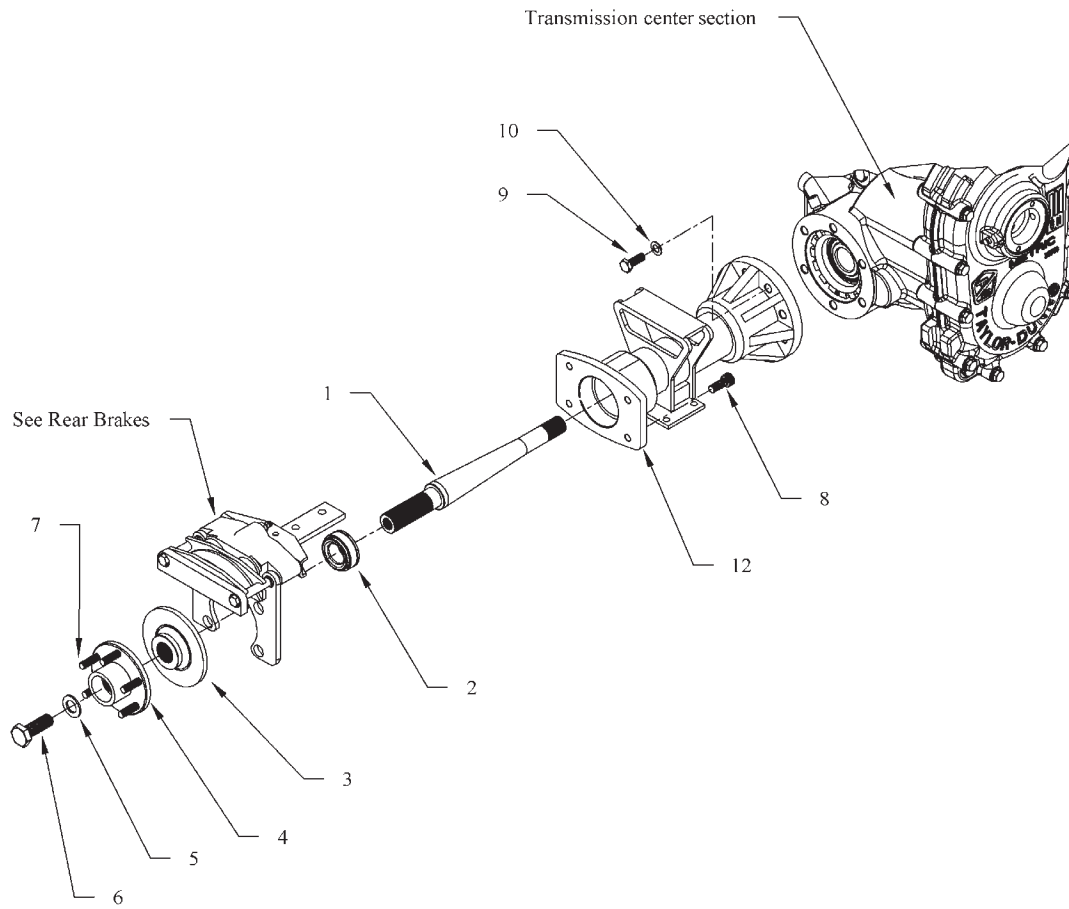



<b>Axle Shaft Assembly, Rear</b>			
Item No.	Part No.	Description	Qty
1	41-154-20	Axle shaft	2
2	80-505-20	Bearing	2
3	41-490-11	Disc brake rotor	2
4	41-172-21	Hub	2
5	88-268-63	Flat washer	2
6	*88-268-30	7/8-14 x 1.5 Bolt, grade 5	2
7	96-329-10	Wheel stud	10
8	96-327-10	3/8 X 3/4NF, Grade 5 with thread lock	8
9	89-113-30	M12 x 1.75 x 30mm Hex bolt	12
10	89-113-60	M12 Split lock washer	12
12	41-290-91	Axle housing	2
<hr/>			
Not Shown			
	92-104-10	Hub cover	2

*\* Bolt (88-268-30) should be replaced whenever it is removed.*

**TRANSAXLE ASSEMBLY, REAR**

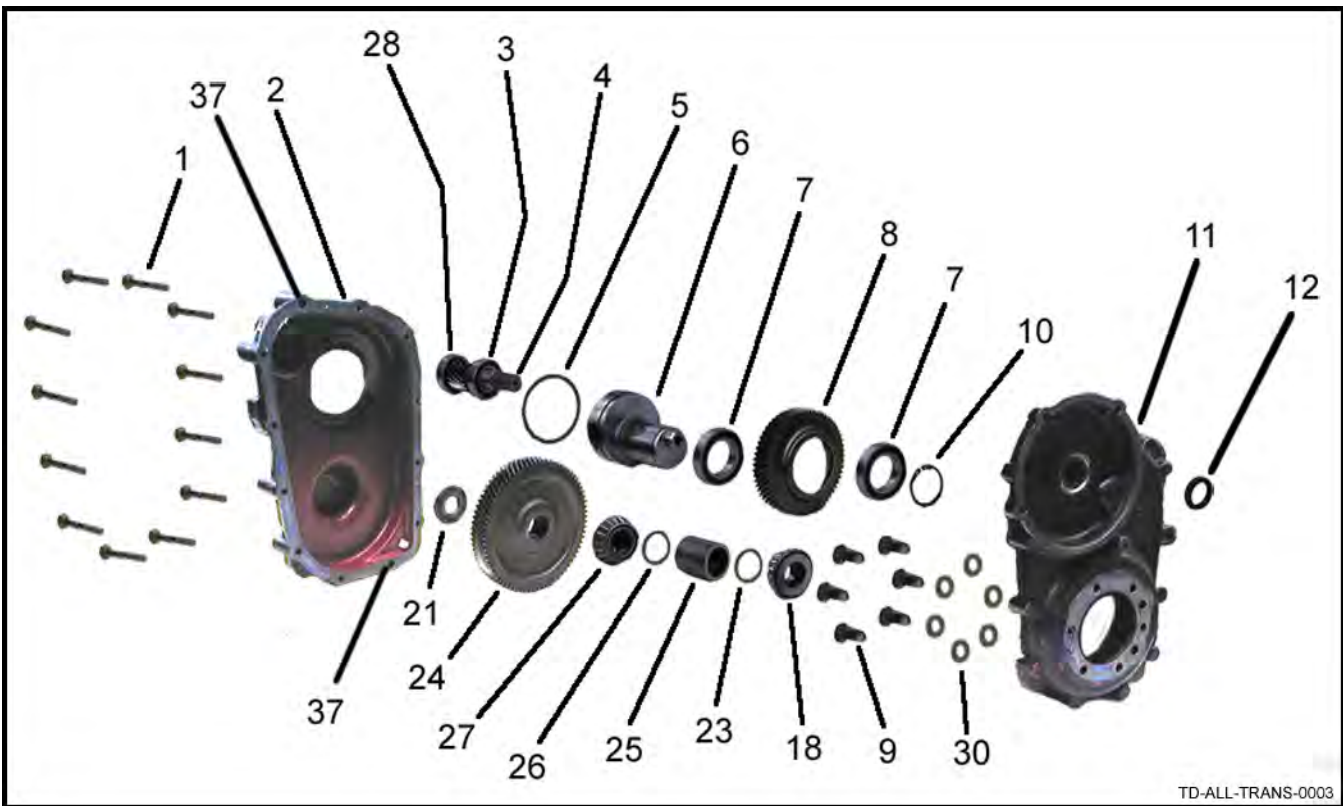

TD-ALL-TRANS-0003

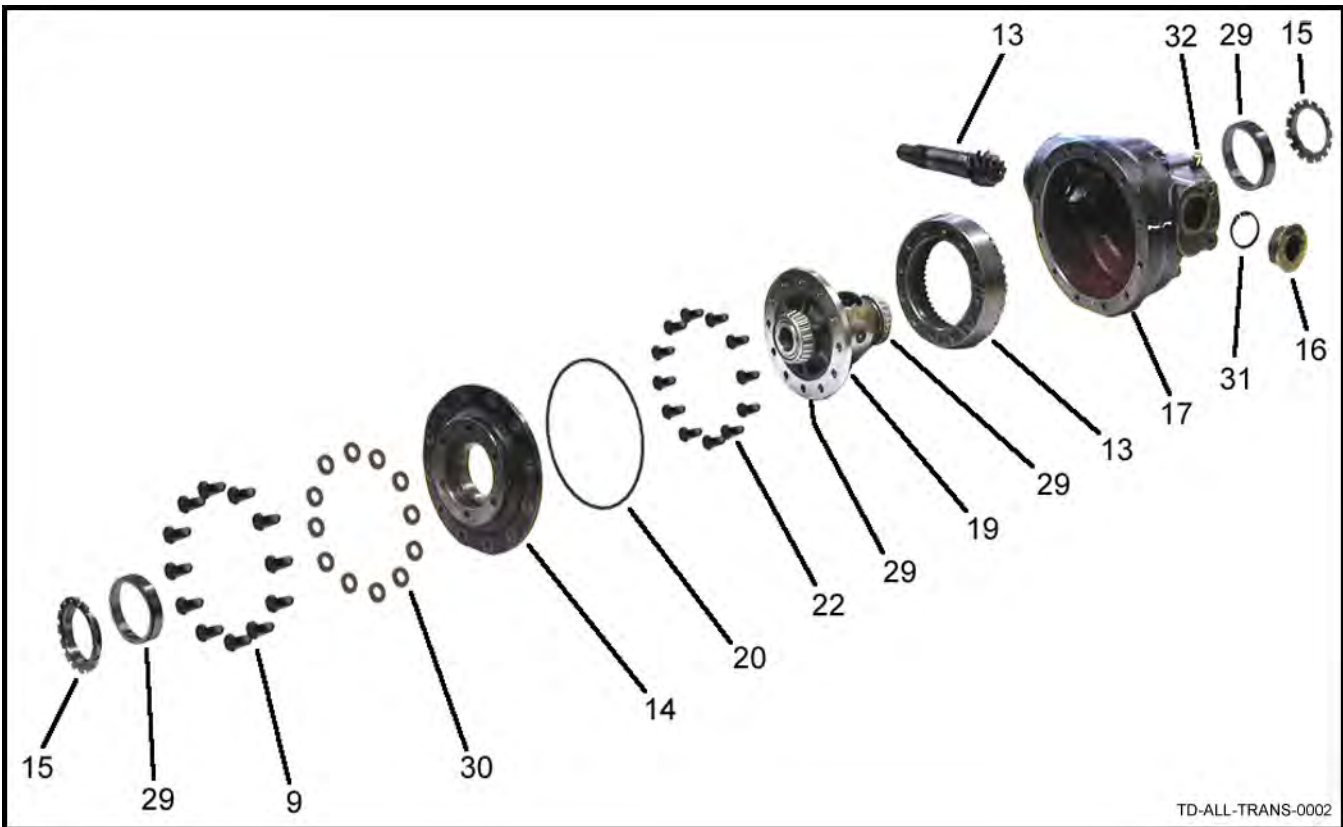

TD-ALL-TRANS-0002

*Note: Spacer 23 is available in increments of .05mm starting at 3.9mm. 3.9mm spacer is part number GT-3287213. Add 10 to the part number for every 0.05mm over 3.9. For example, if 4.55mm is needed:  $4.55 - 3.9 = .65\text{mm over}$ ,  $0.65 / .05 = 13$ ,  $13 * 10 = 130$ . Part number for 4.5mm spacer is  $3287213 + 130 = 3287343$ .*

<b>Axle Assembly, Rear</b>			
Item No.	Part No.	Description	Qty
1	GT-71682	M8 x 60 bolt	12
2	GT-3287563	Gear case cover	1
3	GT-71259	Bearing	1
4	GT-3287513	Input shaft, 30:1	0 or 1
	GT-3287523	Input shaft, 24:1	0 or 1
	GT-3287533	Input shaft, 18:1	0 or 1
5	GT-71982	O-ring	1
6	GT-3287503	Eccentric shaft	1
7	GT-72005	Bearing	2
8	GT-3287493	Idler gear	1
9	GT-70302	M10 x 30 Bolt	18
10	GT-71715	Snap ring	1
11	GT-3287553	Gear case housing	1
12	GT-72019	Seal	1
13	GT-3287183	Ring and pinion gear set	1
14	GT-3297193	Differential case cover	1
15	GT-3287133	Adjusting ring	2
16	GT-70417	Fill/Level plug	1
17	GT-3287113	Differential housing	1
18	GT-71979	Bearing	1
19	GT-3287143	Differential case	1
20	GT-72013	O-ring	1
21	GT-3273633	Pinion nut	1
22	GT-71896	M10 x 25 Bolt	12
23	See Note previous page		
24	GT-3287453	Output gear, 30:1	0 or 1
	GT-3287463	Output gear, 24:1	0 or 1
	GT-3287473	Output gear, 18:1	0 or 1
25	PKIT-00018	Shim/Spacer kit	
26	PKIT-00018	Shim/Spacer kit	
27	GT-71068	Bearing	1
28	GT-72022	Bearing	1
29	GT-71978	Bearing and race	2
30	GT-70299	10mm Washer	18
31	GT-71881	Seal	1
32	GT-70052	Vent	1
37	GT-3252633	Dowel pin	2

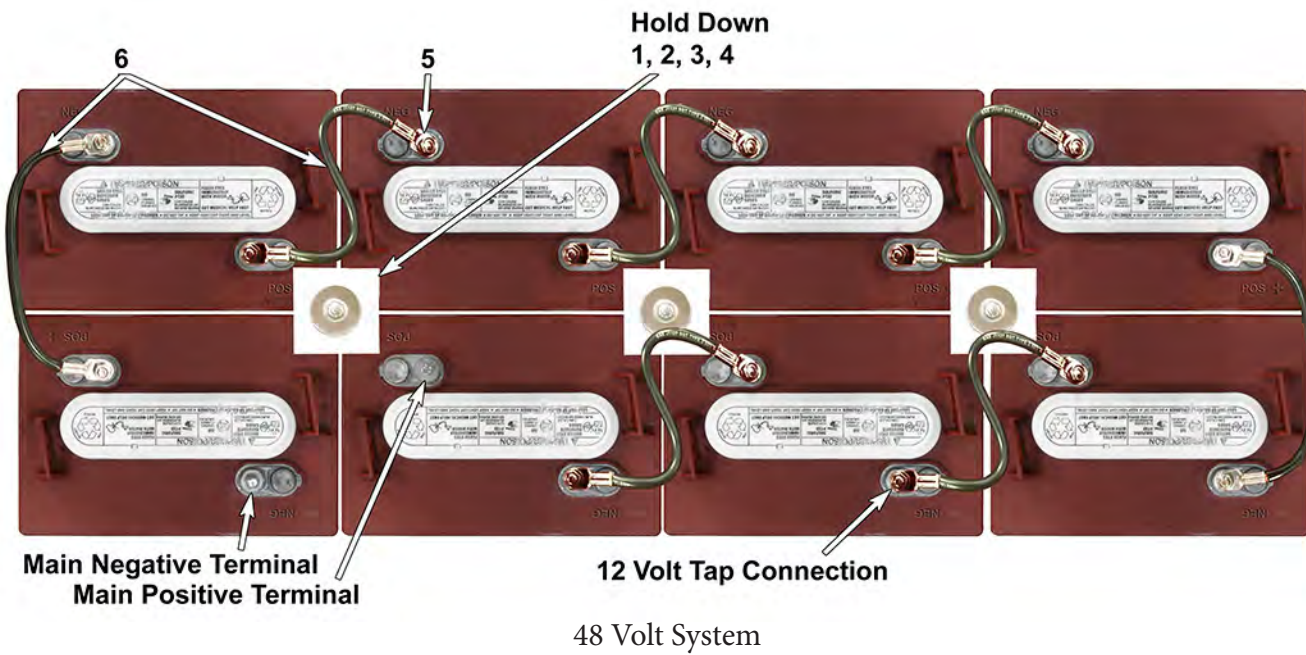
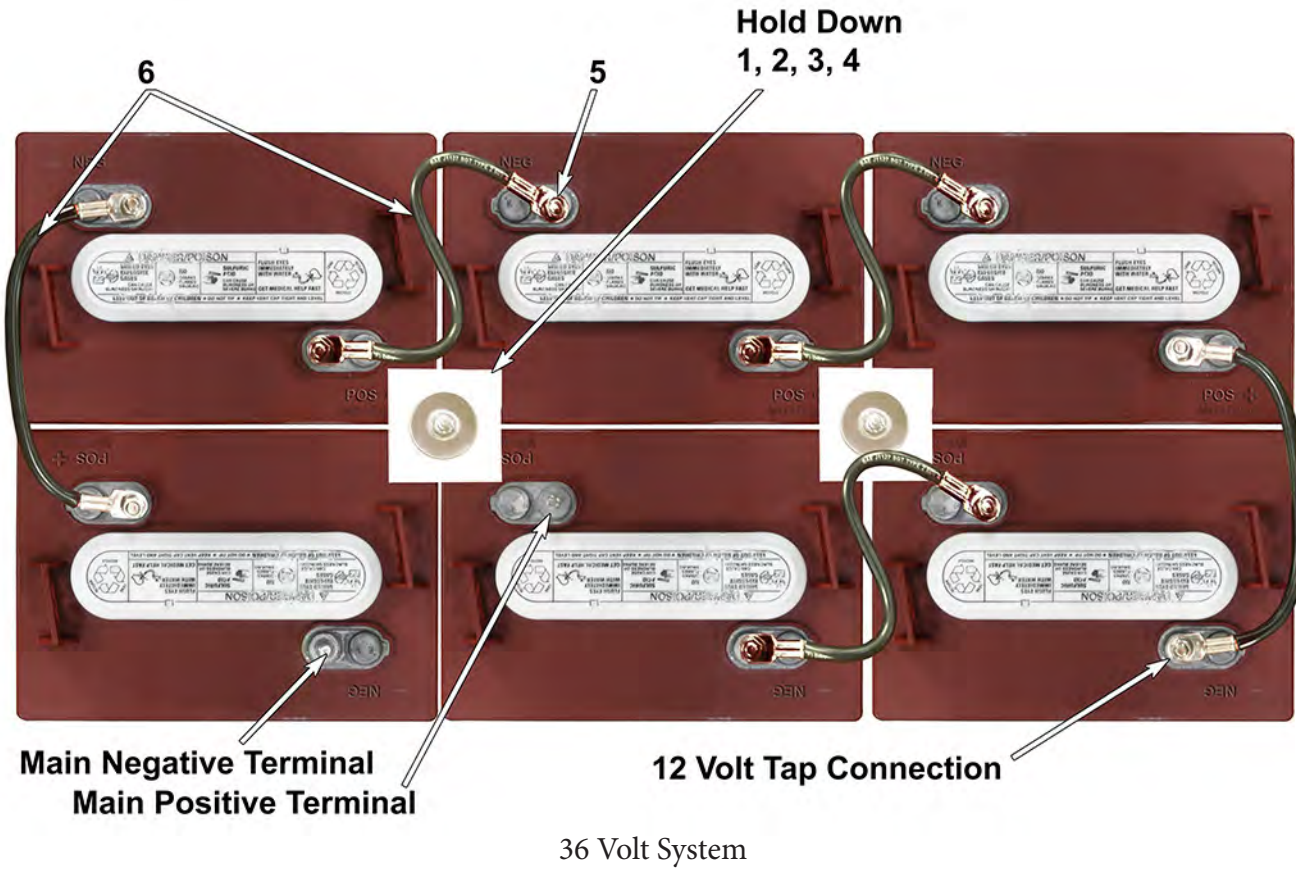

Item No.	Part No.	Description	Qty
1	See kits below	Battery rod	*
2	See kits below	Battery hold down	*
3	See kits below	Flat washer, tin/lead plated	*
4	See kits below	1/4NC Nylon lock nut	*
5	See kits below	5/16NC Hex nut, stainless steel, 36V 5/16 Split lock washer, stainless steel, 36V	* *
6	See kits below	Battery jumper	*
<b>Battery</b>			
-	77-042-00	225AH, T-105	*
-	77-043-00	210AH, T-605	*
-	77-044-10	195AH, Maintenance free (Note: requires special charger)	*
-	77-047-00	260H, T-145	*
-	77-047-80	260H, T-145 Moist charge (dry)	*
-	77-051-00	160AH Gel (Note: requires special charger)	*
<b>Not Shown</b>			
-	77-201-71	Watering System, 36V, TROJAN Kit w/ Pump (optional)	
-	77-201-73	Watering System, 48V, TROJAN Kit w/Pump (optional)	
-	77-201-75	Water Fill System, TROJAN, Hose (optional)	
-	01-534-43	Battery locator (angle in bottom of battery box, 72 v only)	
-	00-500-04	Angle, Battery locator (front)	
-	PKIT-00052	Battery Hold Down, 36v	
-	PKIT-00055	Battery Hold Down, 48v	
-	PKIT-00053	Battery Cables, 36v	
-	PKIT-00054	Battery Cables, 48v	
*	Quantities depend on voltage configuration of vehicle.		

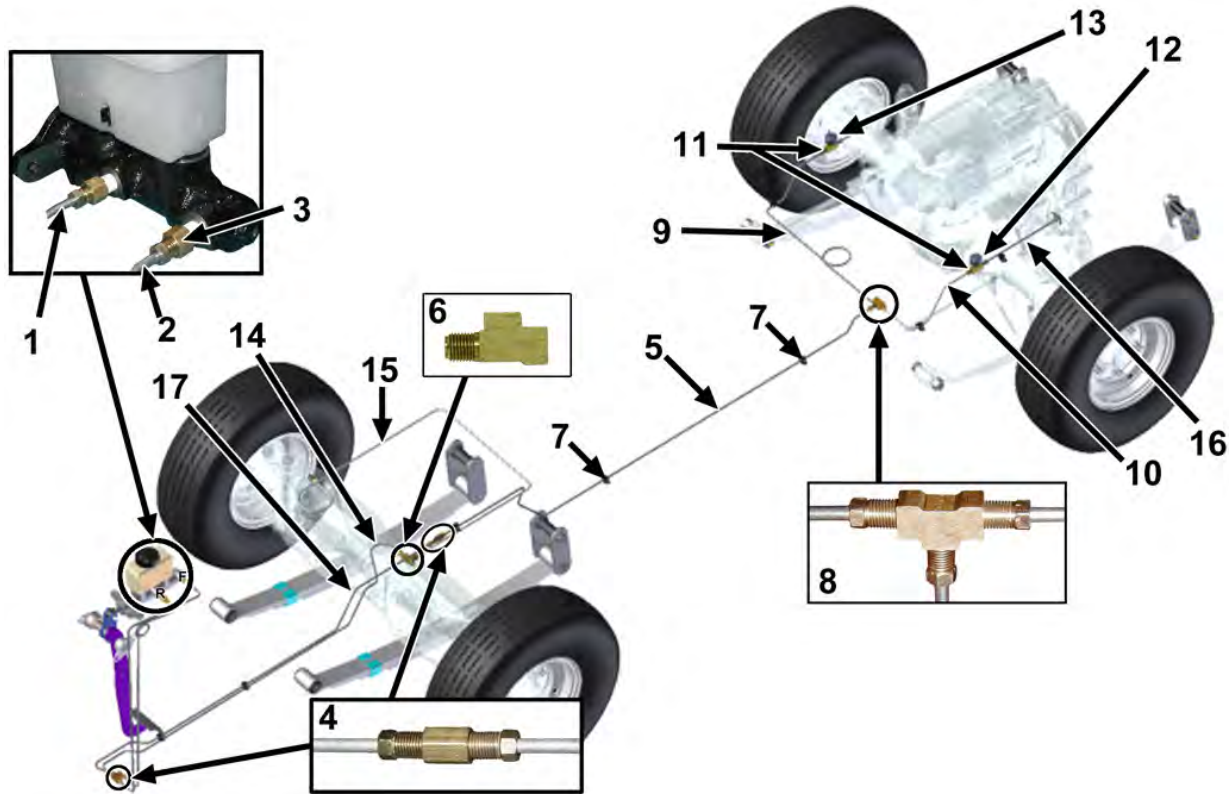

Item No.	Part No.	Description	Qty
1	99-605-83	Brake Line	1
2	99-605-84	Brake Line (only with front brakes)	1
3	99-575-32	Adapter, 3/16T x M10-1.0	2
4	99-575-00	Coupler	3
5	99-607-11	Brake Line, Mid to Rear	1
6	99-559-00	T-Fitting	1
7	96-640-00	Brake Line Clip	2 or 11
8	99-564-00	Union T, 3/16	1
9	99-605-12	Brake Line, Rear Right	1
10	99-603-20	Brake Line, Rear Left	1
11	99-591-00	Tee, 3/16 x 18 pipe	2
12	500552	Switch, Brake Regen	1
13	71-110-00	Switch, Brake Lights	1
14	99-606-06	Brake Line (front brake only)	1
15	99-606-51	Brake Line, Front Right	1
16	99-601-01	Brake Line, Straight	2
17	99-606-05	Brake Line	1
-	99-580-10	Brake hose, Front	2
-	99-575-10	Adaptor, Brake hose to brake body	2
-	99-580-20	Brake Hose Rear	2
-	99-576-00	Clip, Brake Hose	
-	99-598-00	Plug, Master Cylinder Port (vehicles without front brakes)	1

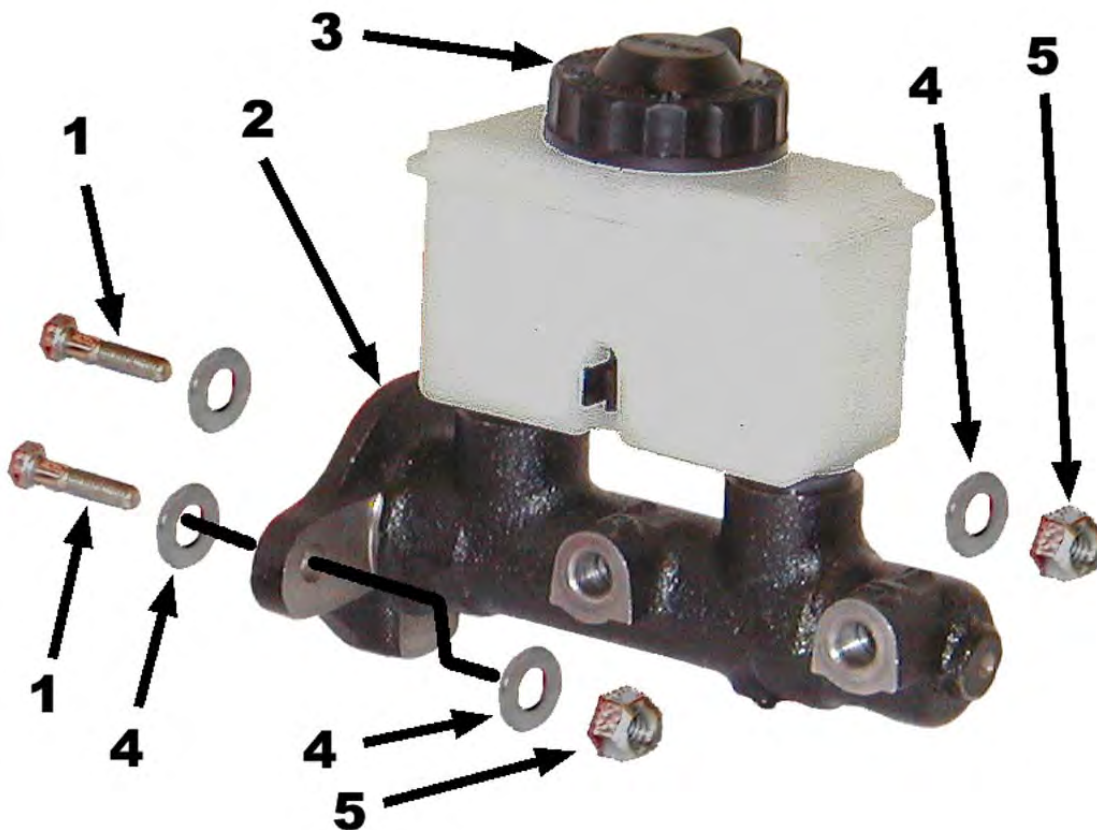

**Brake Lines, Master Cylinder**

Item No.	Part No.	Description	Qty
1	88-080-14	Bolt, 5/16" X 1-1/2" NC, Hex Head	2
2	99-511-20	Master Cylinder (includes item #3)	1
3	99-511-52	Cap Seal, Master Cylinder	1
	99-511-53	Cap, Master Cylinder	1
4	88-088-61	Washer, 5/16"	4
5	88-089-81	Locknut, 5/16"	2
Not Shown			
	99-511-51	Rubber Boot, Master Cylinder	1

**BRAKES, FRONT AXLE**

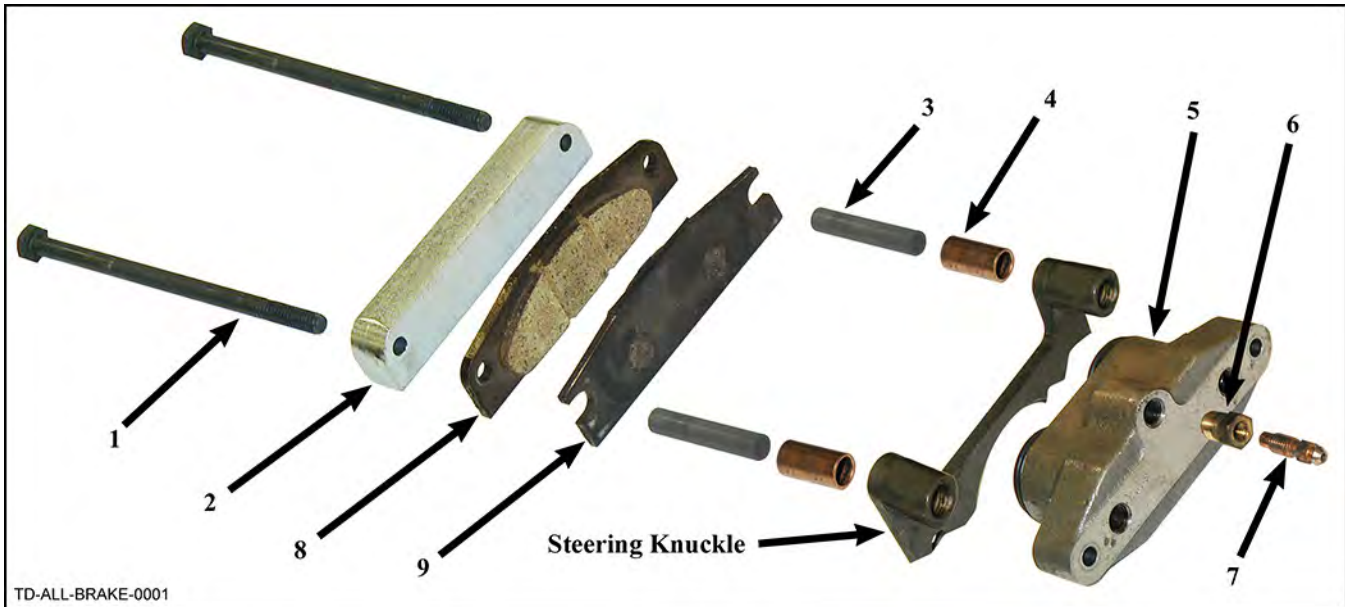

TD-ALL-BRAKE-0001

Item No.	Part No.	Description	Qty
	41-351-35	Complete Brake Assembly	
1	88-067-29	Bolt	4
2	41-350-91	Plate, Secondary	2
3	41-348-58	Spacer	4
4	32-208-01	Bushing (included in rebuild kit)	4
5	*	Brake Body (all parts on this list)	2
6	99-588-01	Bleeder adaptor	2
7	99-588-00	Bleeder valve	2
8	See rebuild kit	Brake pad, Inner	2
9	See rebuild kit	Brake pad, Outer	2
<b>Not Shown</b>			
	41-886-00	Plug, 1/8 Pipe, Hex Socket	2
	88-069-82	Nut, Brake bolt	4
	41-348-61	Brake rebuild kit, 1 axle front or rear, includes #3, 4, 8, 9, and brake bolt nuts	

\* - Not available separately, order complete caliper assembly

**Park Brake**

Item No.	Part No.	Description	Qty
	51-344-80	Park Brake lever	1
	96-813-00	Cable Assembly	1
	01-204-32	Equalizer, Park Brake	1
	00-500-09	Handbrake Mount	1



**BRAKES, REAR AXLE**

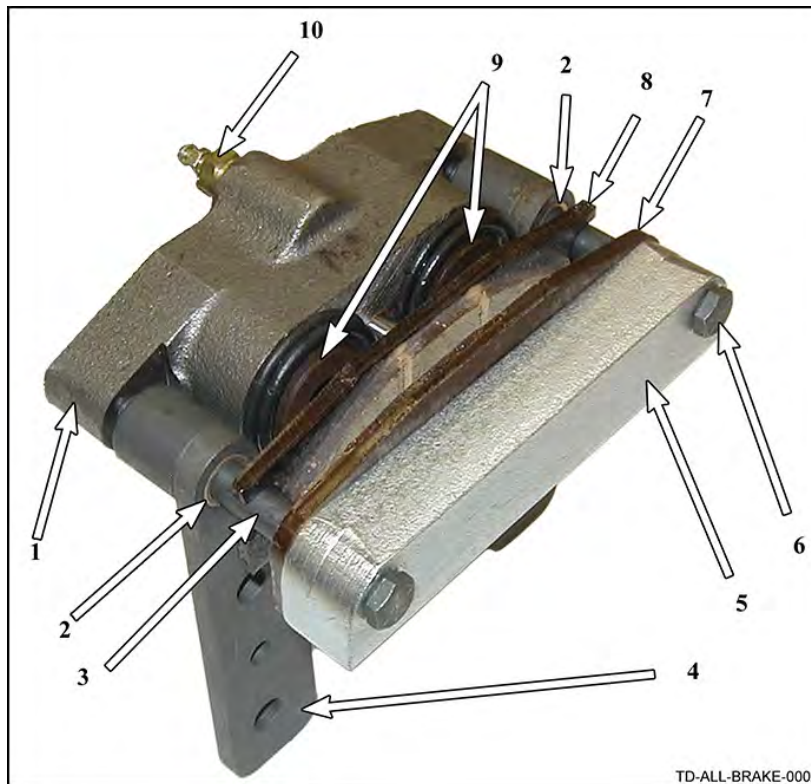

**Brakes, Rear Axle**

Item No.	Part No.	Description	Qty
-	41-351-80	Complete caliper assembly (left)	1
-	41-351-81	Complete caliper assembly (right)	1
1	*	Brake body	1
2	32-208-01	Bushing (included in rebuild kit)	2
3	41-348-58	Spacer (included in rebuild kit)	4
4	41-350-28-1	Mounting Bracket	2
5	41-350-91	Secondary Plate	2
6	88-067-21	Bolt	4
	88-069-82	Nut	4
7	See rebuild kit	Brake pad, Outer	2
8	See rebuild kit	Brake pad, Inner	2
9	-	-	-
10	99-588-00	Bleeder valve	2
	99-588-01	Bleeder adaptor	2
<b>Not Shown</b>			
	41-886-00	PLUG, 1/8 PIPE, HEX SOCKET	2
	41-348-61	Brake rebuild kit, 1 axle front or rear, includes #2, 3, 6 (nut), 7, 8	
* - Not available separately, order complete caliper assembly			

**CHARGER, SIGNET**



- Note: There are no user serviceable components inside the charger
- Note: The charger AC cord is an integral part of the charger. When replacing the charger, do not cut and splice the AC cord. **Cutting the AC cord will void the charger warranty.**
- Note: The Signet model HBS series charger replaces all previous Signet models.
- Note: The harness connectors and AC plug are not included with the charger.

AC input Voltage Range	Charger Model	System Voltage
DC output		
<b>MODEL</b>	<b>HBS1000-36</b>	
<b>PART No.</b>	<b>79-303-40</b>	
<b>INPUT</b>	AUTO SELECTABLE DUAL AC INPUT 100-240V ~ 50/60Hz 13A	
<b>OUTPUT</b>	36V $\pm$ 20A 1000W	
<b>Manufacturer SIGNET SYSTEMS INC.</b>		

Model HBS Charger			
Type	24 Volt	36 Volt	48 Volt
Flooded	*	79-303-41	79-309-42
Gel	*	79-303-42	79-309-43
Model HB Charger			
Type	24 Volt	36 Volt	48 Volt
Flooded	79-302-20	79-303-40	79-309-40
Gel	*	K4G-CH-003	79-309-41

Standard Single Phase AC wire Color Codes as of 2010.  
 Note: Older systems may use a alternate color code.

Refer high voltage wiring repairs to a qualified technician

**United States / Canada**

- Neutral: White
- Hot: Black or Red
- Ground: Green

**IEC (Europe) and United Kingdom**

- Neutral: Blue
- Hot: Brown
- Ground: Green/Yellow

QTY	PART #	DESCRIPTION
2	75-318-20	Butt splice
2	75-320-51	Knife connector
1	76-200-00	AC plug, 115 volt 

**CHARGER, X-SERIES**



Item No.	Part No.	Description	Qty
	79-303-48	Charger Assembly, X-Series, 48 volt Built In	0 or 1
	79-303-36	Charger Assembly, X-Series, 36 volt Built In	0 or 1
	79-309-05	Charger Assembly, X-Series, 48 volt Portable	0 or 1
	79-303-37	Charger Assembly, X-Series, 36 volt Portable	0 or 1
	75-107-10	Harness, Portable Charger	0 or 1
	JF3-86181-00-00	Receptacle, Portable Charger	0 or 1
	98507-05035-00	Screw	2
	90157-05M19-00	Screw	2
	92907-05600-00	Flat Washer	4
	92907-05100-00	Lock Washer	4
	95-917-00	Hole Plug (BI AC Cord)	1
	79-831-00	Fuse	
	79-809-61	Relay board assembly, 48v	
	79-809-61	Relay board assembly, 36v	
	*	Control board assembly	
	79-749-14	SCR assembly	
	79-840-02	Circuit breaker	
	79-849-00	Ammeter	
	79-810-01	Switch kit (start/stop, low voltage, self diagnostic)	
	79-809-50	Interlock relay	
	79-722-03	Wiring kit (includes LED's)	
	00-500-05	Splash Guard	1
	79-580-03	Junction Box, AC Cord	1

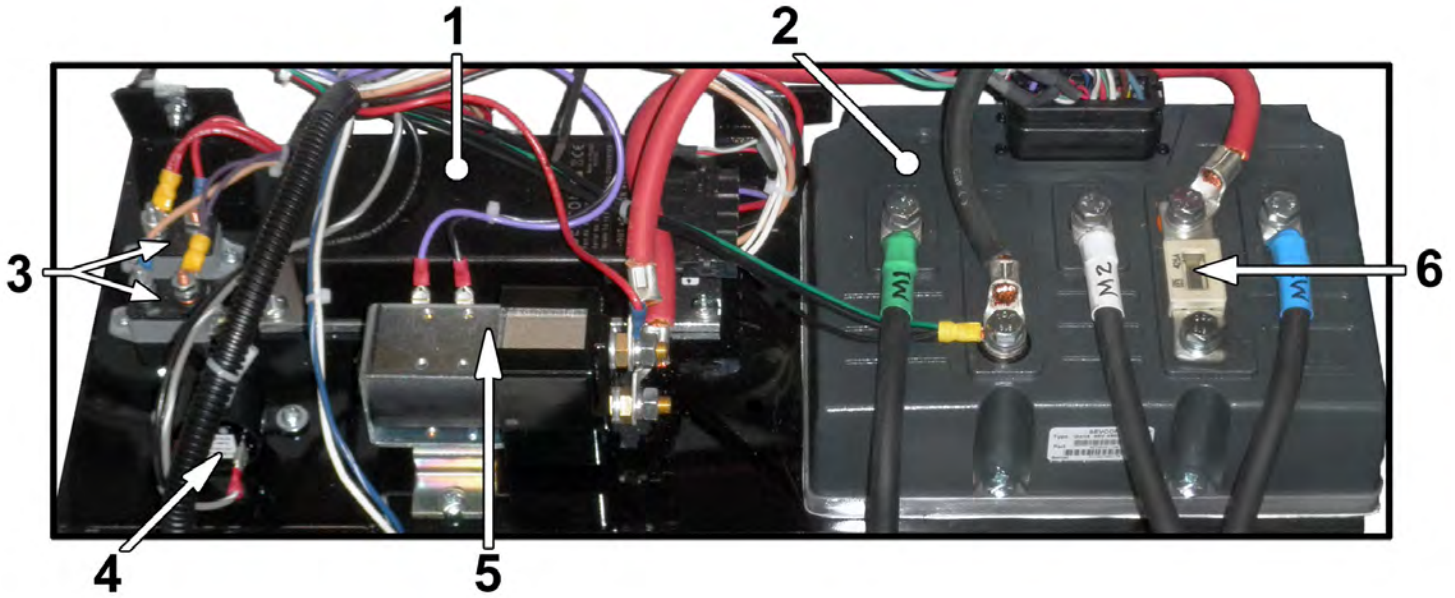

62-400-38 AC Controller, 24/48V, 300A  
 79-829-15 Fuse, 330A System



62-400-47 AC Controller, 36/48V, 450A  
 79-829-10 Fuse, 500A System

<b>Speed Control Panel</b>			
Item No.	Part No.	Description	Qty
1	73-012-33	DC-DC Converter, 36-48V (Optional)	1
	88-838-06	#14X1/2 PN Head Screw	4
2	62-400-38	AC Controller, 24/48V, 300A	0 or 1
	62-400-47	AC Controller, 36/48V, 450A	0 or 1
	88-065-11	1/4X1 NC Phillips Truss Head GR2	4
	88-069-81	1/4NC Nylon Locknut GR2	4
	88-068-61	1/4 SAE Washer GR2	4
3	79-840-20	Circuit Breaker, 20A	2
	88-818-06	#8X1/2 PN Head Screw	4
4	73-005-01	Alarm, Pulse, Panel Mount, 10-50V	1
	88-048-61	Washer, #10 SAE	2
	88-818-06	#8X1/2 PN Head Screw	2
5	71-300-02	Line Contactor, SW180-140, 24V	1
	71-300-01	Bracket, Mounting, SW180 SERIES	1
	88-838-06	#14X1/2 PN Head Screw	2
6	79-829-15	Fuse, 330A System	0 or 1
	79-829-10	Fuse, 500A System	0 or 1
<b>Harnesses</b>			
	75-153-90	Harness, Chassis	1
	75-153-91	Harness, Control Panel, No DC Converter	0 or 1
	75-153-94	Harness, Control Panel, With DC Converter	0 or 1
	75-153-92	Harness, Power Wires, 330A, No DC Converter	0 or 1
	75-153-95	Harness, Power Wires, 330A, With DC Converter	0 or 1
	75-153-96	Harness, Power Wires, 500A, With DC Converter	0 or 1
<b>Not Shown</b>			
-	97-211-20	U-NUT, 1/4-20 X .150 MAX	3
-	01-200-02	Plate, Controller Panel	1
-	01-200-69	Plate, Heatsink	1
-	94-422-21	Heatsink 340 PASTE, 13.5OZ	-
-	62-400-16	Heatsink	1
-	98-618-00	Grommet, Wire	1
-	75-152-90	Smart View Cable	1

**CONTROL SYSTEM, INSTRUMENT PANEL**

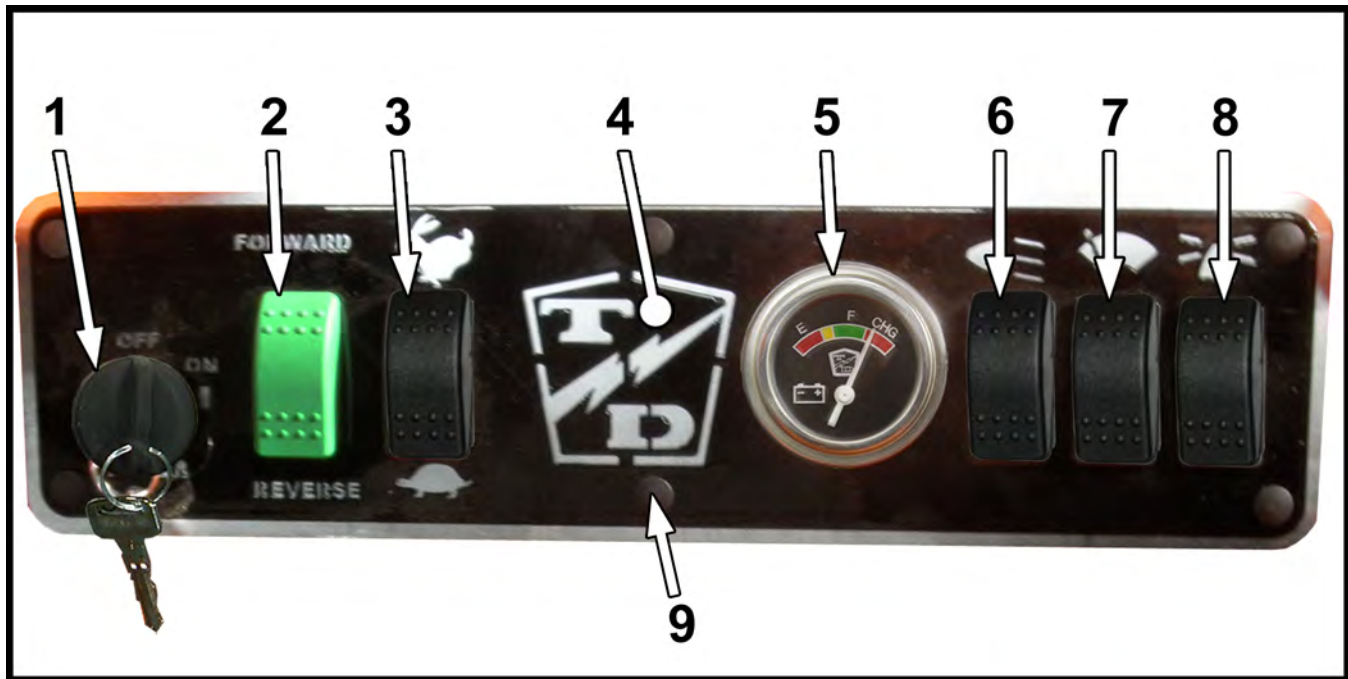

**Instrument Panel**

Item No.	Part No.	Description	Qty
1	71-120-10 71-121-20	Start switch (key) Key Switch	1
2	71-039-02	Forward / Reverse Switch	1
3	71-039-11	High / Low speed Switch	1
4	94-305-24 94-305-25	Dash Panel Backing Plate	1 1
5	74-009-00 74-010-00	Battery Status Indicator (pictured) SmartView Gauge (optional)	1 1
6	71-039-11	Light Switch	1
7	71-039-11	Windshield Wiper Switch (Optional)	1
8	71-039-11	Strobe Light Switch (Optional)	1
9	88-607-00	Rivet, push-in	6
Not Shown			
-	71-039-21	Plug, Switch hole	-
-	75-153-93	Harness	1

**DECALS**

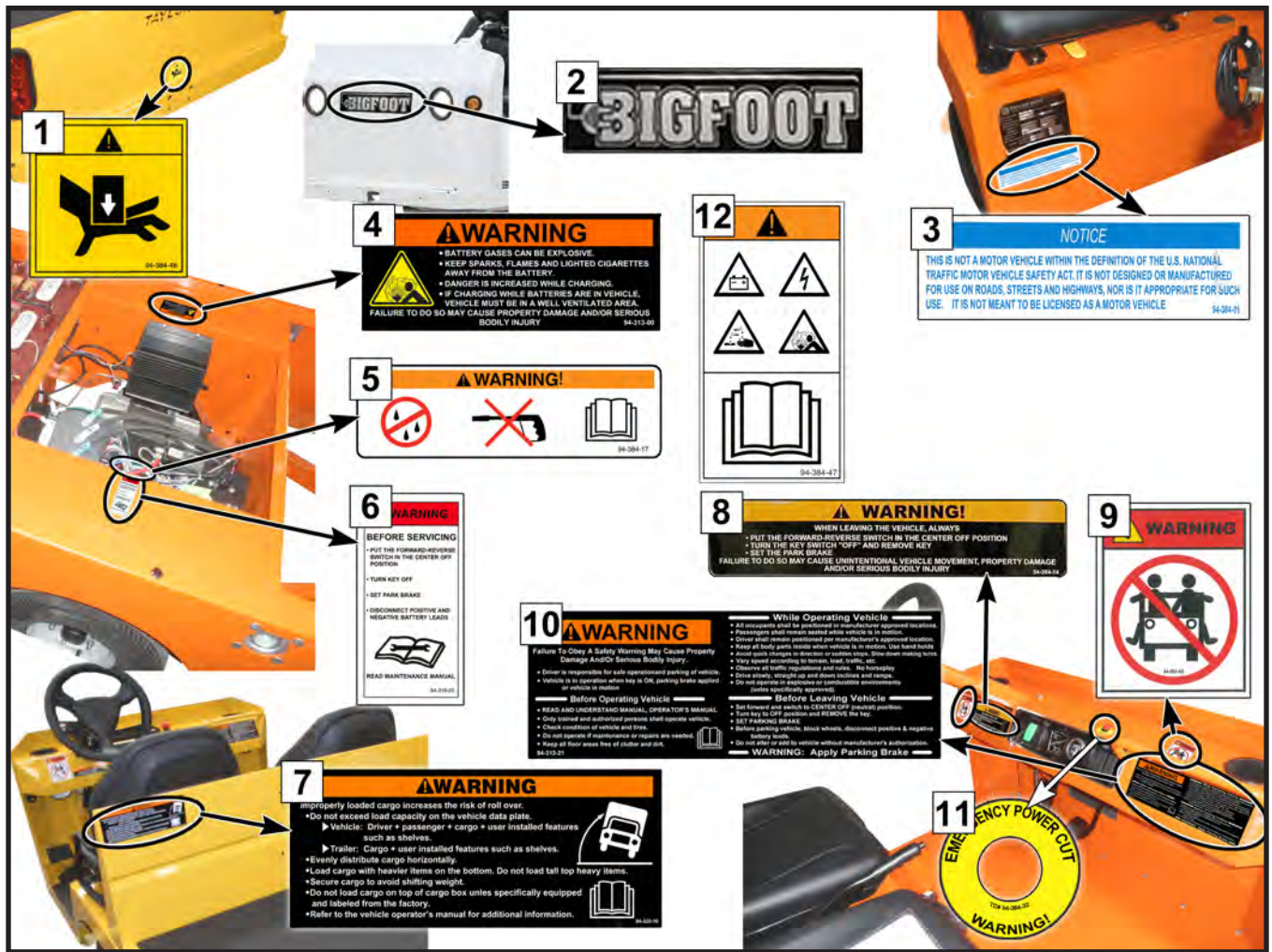

**Decals**

Item No.	Part No.	Description	Qty
1	94-384-48	Fingers Crushed WARNING	1
2	94-301-45	Bigfoot DECAL	1
3	94-384-01	Not a motor vehicle (White/Blue)	1
4	94-313-00	Battery WARNING	1
5	94-384-17	Do Not Spray WARNING	1
6	94-319-00	Battery Disconnect	1
7	94-320-10	Roll Over WARNING	1
8	94-384-14	When leaving vehicle WARNING	1
9	94-301-42	Arms and Legs	2
10	94-313-21	Safety WARNING	1
11	94-384-32	Emergency Power Cut	1
Not Shown			
	94-301-19	AC Power (Black Letter)	2
	94-301-41	DOT 3 Brake Fluid	1
	94-384-47	Battery WARNING	1
	94-301-57	Door WARNING (Cab Option)	2

**ELECTRICAL, MISCELLANEOUS**

ILLUSTRATIONS ARE NOT TO SCALE



1



2



3



4



5



6

TD-ALL-CLAMPS-0001

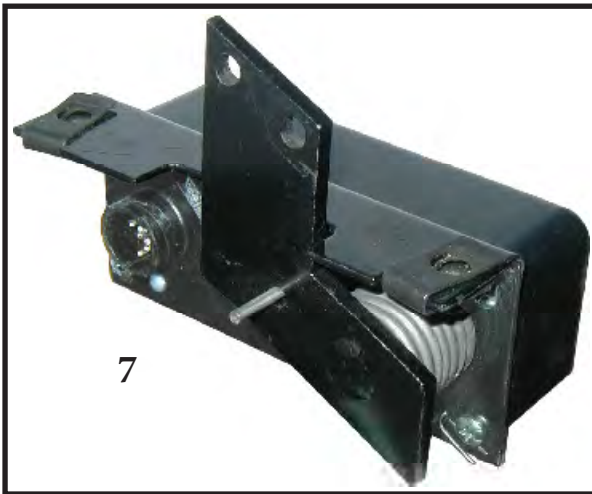

7



<b>Electrical</b>			
Item No.	Part No.	Description	Qty
1	96-624-00	Clamp, 1/4 Jiffy Clip	
	96-625-00	Clamp, 5/16 Jiffy Clip	
2	96-626-00	Clamp, 7/8 Jiffy Clip	
3	96-640-00	Clamp, 3/16 Push Mount	
4	96-642-00	Wire harness Clip, push mount	
5	96-650-01	Wire Harness Clip, stick on	
6	96-629-80 (not shown)	Clamp, Rubber Lined 3/16 ID	
	96-630-00 (not shown)	Clamp, Rubber Lined 5/8 ID	
	96-630-50 (not shown)	Clamp, Rubber Lined 5/8 ID (.265 mounting hole)	
	96-631-00 (not shown)	Clamp, Rubber Lined 3/4 ID	
	96-631-10 (shown)	Clamp, Rubber Lined 1.0 ID	
	96-631-15 (not shown)	Clamp, Rubber Lined 1-1/2 ID	
7	62-034-90	Throttle Module	1
<b>Not Shown</b>			
	98-599-15	Plastic grommet for 1.75 hole	
	98-599-20	Plastic Grommet for 2.5 hole	
	98-603-00	Grommet, Rubber, 3/8 X 0.625 X 0.188	
	98-618-00	Rubber Grommet, 5/8 ID X 7/8	
	75-107-10	Portable Charger Harness	1
	78-321-10	Ground Strap (optional)	1
	71-122-00	Horn Switch	1
	90-160-95	Operator Presence Switch	1
	96-642-00	Mount, Cable Tie	
	98-599-15	BUSHING, SNAP, PLASTIC, 1.75 HOLE	
	98-599-17	BUSHING, SNAP, PLASTIC, 2.00 HOLE	
	98-599-20	BUSHING, SNAP, PLASTIC, 2.5 HOLE	
	71-120-14	Emergency Stop Switch	1

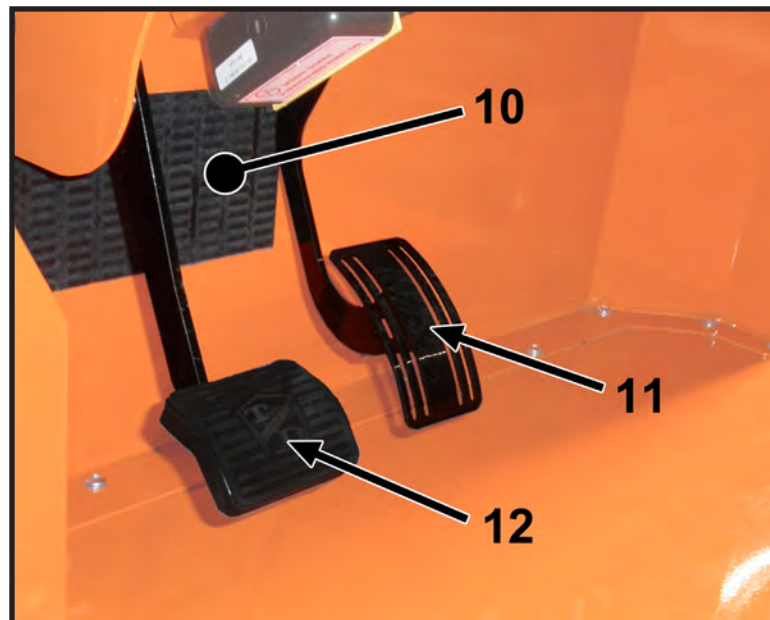
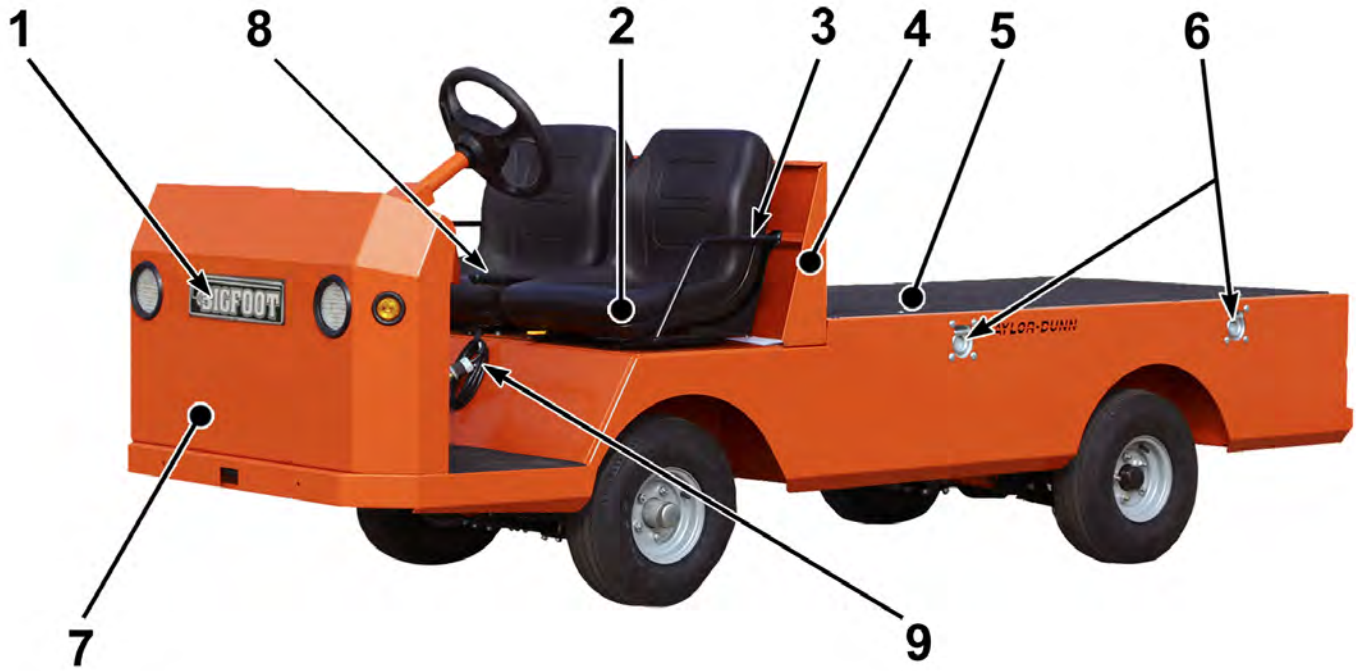

Item No.	Part No.	Description	Qty
1	See Decals	BIGFOOT Decal	1
2	90-160-96	Seat, 6" Adjustable	2
	01-500-14	Panel, Seat Base	1
3	90-160-97	Hip Restraint, Driver	1
	90-160-98	Hip Restraint, Passenger	1
4	01-500-28	Seat Back	1
5	90-444-05	Deckboard, 75-1/4 X 41	1
	88-065-14	1/4 X 1-1/2NC TRUSS HD SCR GR2	4
	88-068-61	1/4 SAE Washer GR2	4
	97-211-20	U-NUT, 1/4-20 X .150 MAX	4
6	96-000-15	Tie Down, Zinc Plate	4
7	00-500-02	Front Cowl	1
8	See Brakes, Parking	Park Brake Lever	
9	79-511-00	Cord Holder	1
	79-530-00	Bushing, AC Cord	
	79-575-09	Charger AC Cord** (X-Series charger only)	1
10	98-017-80	Rubber Mat, Brake/Accelerator Pedal	1
11	00-500-08	Pedal, Throttle	1
12	41-310-00	Brake Pedal	1
	80-410-20	Bearing, Brake pedal	2
	85-295-00	Spring, Pedal Return	1
	41-310-01	Push rod, Master Cylinder	1
<b>Not Shown</b>			
	01-500-68	Cover, Access/Tray	1
	98-240-04	Tape, Non-Slip (applied to dead pedal)	60 foot roll
	78-321-10	Static Ground Strap (optional)	0 or 1
	98-105-00	Cup Holder	2

\*\* - AC cord has integral NEMA plug.

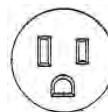



<b>Cab</b>			
Item No.	Part No.	Description	Qty
1	74-055-04	Wiper Arm	1
	74-055-06	Wiper Blade, Curved, 26"	1
	74-055-11	Wiper Motor	1
	74-055-17	Pigtail, 2-Speed Wiper Motor	1
2	90-821-00	Curved Windshield	1
3	92-150-23	Mirror, Left Side	1
	92-150-24	Mirror, Right Side	1
	00-500-12	Mirror, Spacer	2
4	90-821-10	Door Window (Left)	1
	90-821-11	Door Window (Right)	1
5	91-050-14	Side Window	2
6	00-020-05	Mount, Mirror	1
	92-206-51	Mirror, Inside, 2-1/4 X 8"	1
7	91-051-00	Door, Left	1
	91-052-00	Door, Right	1
8	91-050-00	Cab	1
Not Shown			
	90-850-10	Rear Window	1

<b>Visor (optional with cab)</b>			
Item No.	Part No.	Description	Qty
-	88-069-81	1/4 Locknut GR2	6
-	90-821-03	Plate, Visor Anchor	2
-	90-821-04	Block, Visor Anchor	2
-	88-068-61	1/4 Washer	8
-	88-065-11	1/4X1 NC PHILLIPS TRUSS HD GR2	4
-	88-065-13	1/4X1-1/4NC PHIL TRUSS HD GR2	4
-	90-821-05	Clip, Sun Visor	2
-	98-602-11	Grommet, Rubber, 1/4ID, 5/8OD, 3/8 HOLE	2
-	90-821-01	Sun Visor	1
-	90-821-02	Rod, Sun Visor	1

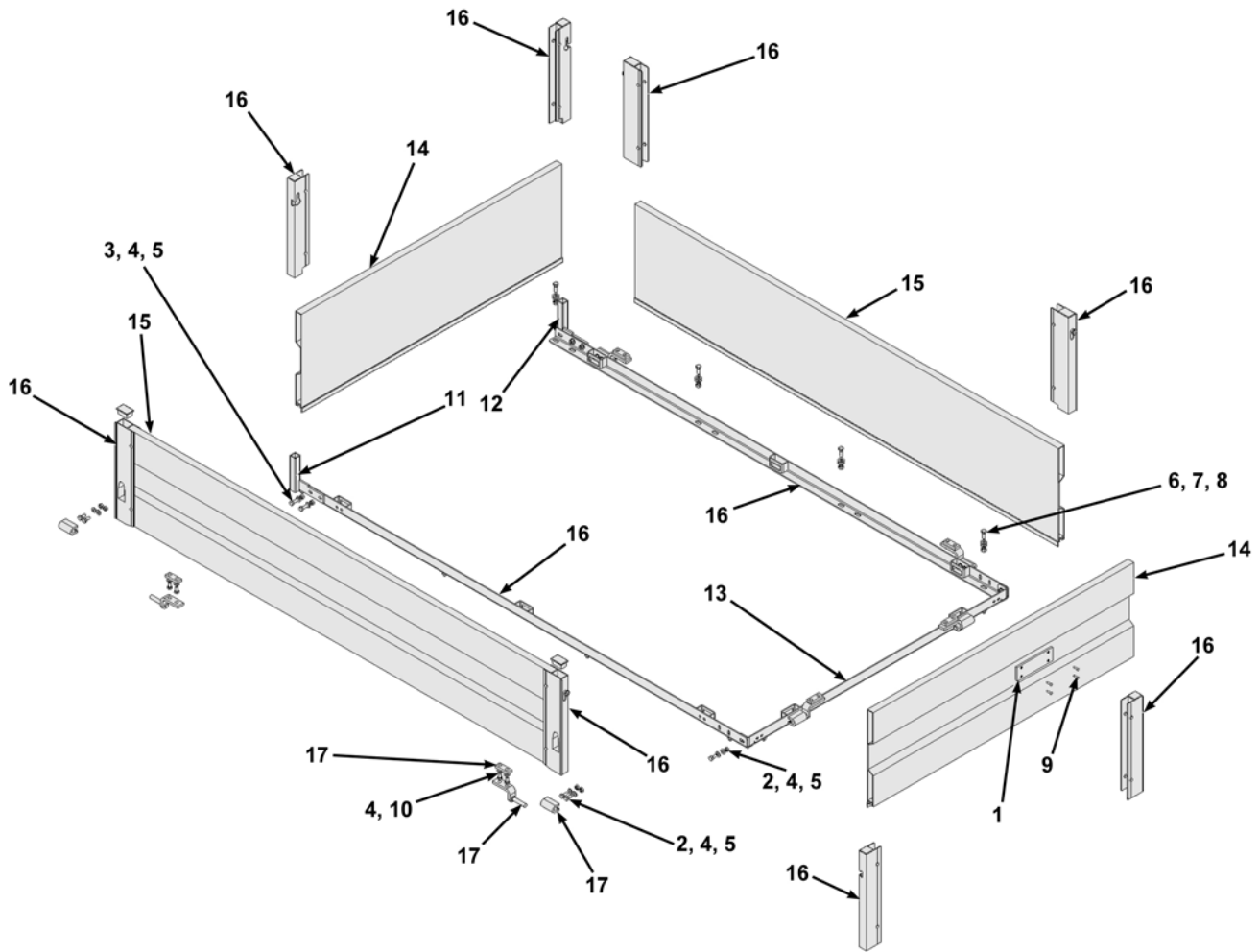

Item No.	Part No.	Description	Qty
1	02-204-43	Hitch Pad	1
2	88-080-09	Screw, 5/16 X 3/4	14
3	88-080-11	Screw, 5/16 X 1	4
4	88-088-61	Washer	36
5	88-089-81	Lock Nut	18
6	88-100-11	Screw, 3/8 X1	10
7	88-108-61	Flat Washer	20
8	88-109-81	Lock Nut	10
9	88-737-08	Pop Rivit	4
10	89-080-16	Hex Bolt	12
11	90-556-06	Peg, Left	1
12	90-556-07	Peg, Right	1
13	90-556-52	Rear Rail	1
14	90-556-53	Gate, Front/Rear	2
15	90-556-54	Gate, Side	2
16	90-556-55	Rail, Side	2
17	90-556-60-M	Hardware Kit	1

**HITCHES**

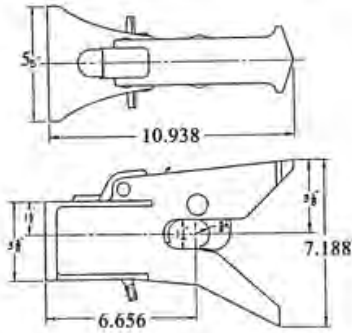

**97-808-00**  
Automatic Coupling Hitch

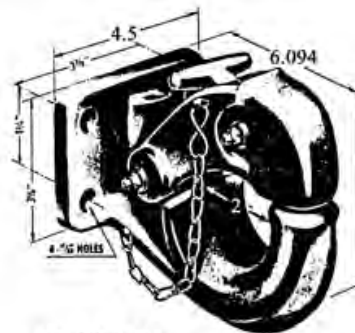

**97-804-01**  
Pintle Hitch

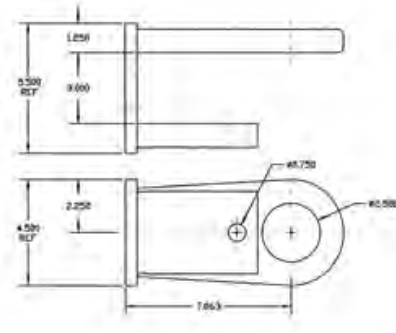

**Hook Pin and Eye Hitch**  
97-809-00

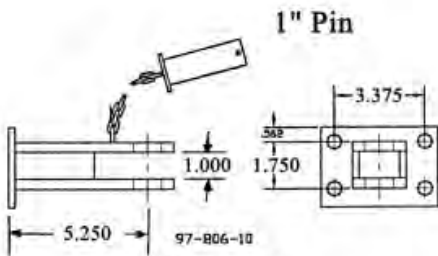

**97-806-10**  
Pin and Clevis Hitch



**Ball Hitch Mount**  
97-805-00 (1-7/8")  
97-807-00 (2")

**Mounting Hardware**

Item No.	Part No.	Description	Qty
	97-800-69	Backing Plate (installed on inside of frame)	1
	88-140-14	1/2NC x 1-1/2 Hex bolt	4
	88-148-61	1/2 Flat Washer (on all hitch options)	4
	88-148-62	1/2 Split lock washer	4
	88-149-80	1/2NC Hex nut	4
Not Shown			
	97-811-10	Hitch, 1-7/8 Inch Ball, 1" Pin	1
	97-821-00	Hitch, 2 lynch Ball	1



**LIGHTS**

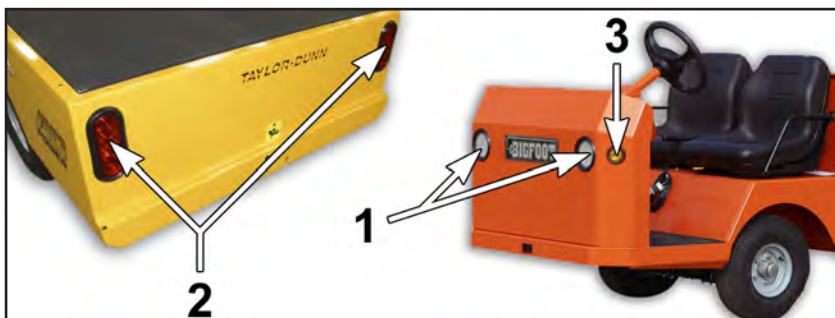

Item No.	Part No.	Description	Qty
1	72-005-22	Headlight, LED W/ Grommet & Connector (Cowl only)	0 or 2
	72-005-13	Headlight, Single Beam (Cab only)	0 or 2
	00-020-19	Headlight Cover (cab only)	0 or 2
2	72-022-04	Stop/Tail Light, LED	2
	72-022-53	LED Tail Light, Pigtail	2
3	72-005-15	Light, Marker (Cab only)	0 or 2
	72-005-08	Light, Marker, LED (cowl only)	0 or 2
	71-650-18	Reflector, Amber, (cowl only)	0 or 2
	72-005-09	2" Light Grommet	2
Not Shown			
	71-900-40	Electronic Flasher for LED, 12 V	1
	71-141-23	Turn Signal Switch	1
	98-330-50	Insulator, Turn Signal Switch	1
	502143	Reflector, Amber (Cab only, on front bumper)	2
Inside Cab (Option)			
-	00-020-18	Dome Light mount	1
-	72-402-10	LED Dome Light	1
-	71-030-60	Switch, Dome Light	1

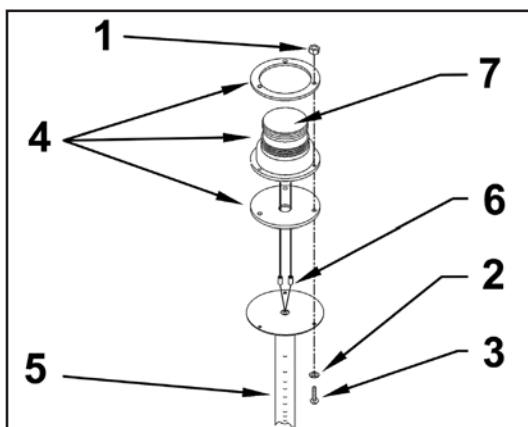

**Strobe Light (optional)**

Item No.	Part No.	Description	Qty
1	88-029-80	8-32 Hex Nut	3
2	88-028-62	Lock Washer, #8	3
3	88-025-10	8-32 X 7/8 Machine Screw	3
4	72-023-59	Strobe assembly (amber)	1
5	72-023-30	Mounting pole	1
6	75-152-08	Harness	1
7	72-023-22	Lens, Amber	1
	72-023-23	Lens, Red	

**MOTOR**

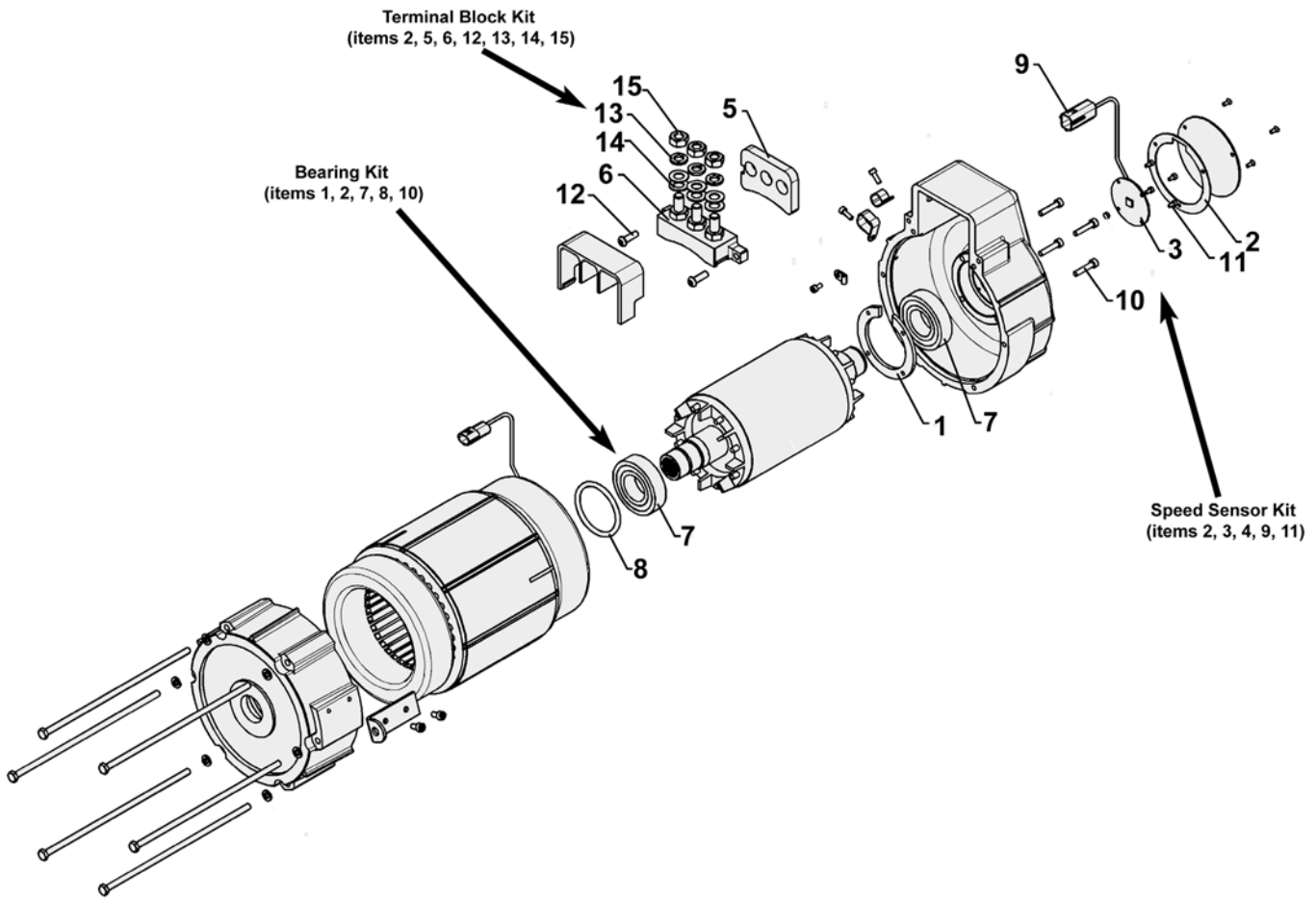

Motor P/N 70-058-41

<b>Motor (70-058-41)</b>			
Item No.	Part No.	Description	Qty
1	Order kit	Bearing Plate	1
2	70-058-41-08	Cover Gasket	1
3	Order kit	Speed Sensor	-
4	-	-	-
5	70-058-41-11	Rubber Insulator	1
6	Order kit	Terminal Block, W/Cover	-
7	Order kit	Bearing	-
8	70-058-41-15	Wave Washer	1
9	70-058-41-16	Connector, Speed Sensor	1
10	70-058-41-22	Bolt, Bearing Plate	4
11	70-058-41-23	Bolt, Speed Sensor	4
12	70-058-41-26	Bolt, Terminal Block	2
13	70-058-41-30	Spring Washer, Terminal Block	3
14	70-058-41-31	Washer, Terminal Block	6
15	70-058-41-32	Nut, Terminal Block	3
<b>KITS</b>			
	PKIT-00041	Bearing Kit (Includes items 1, 2, 7, 8, 10)	
	PKIT-00044	Terminal Block Kit (Includes items 2, 5, 6, 12, 13, 14, 15)	
	PKIT-00045	Speed Sensor Kit (Includes items 2, 3, 9, 11)	

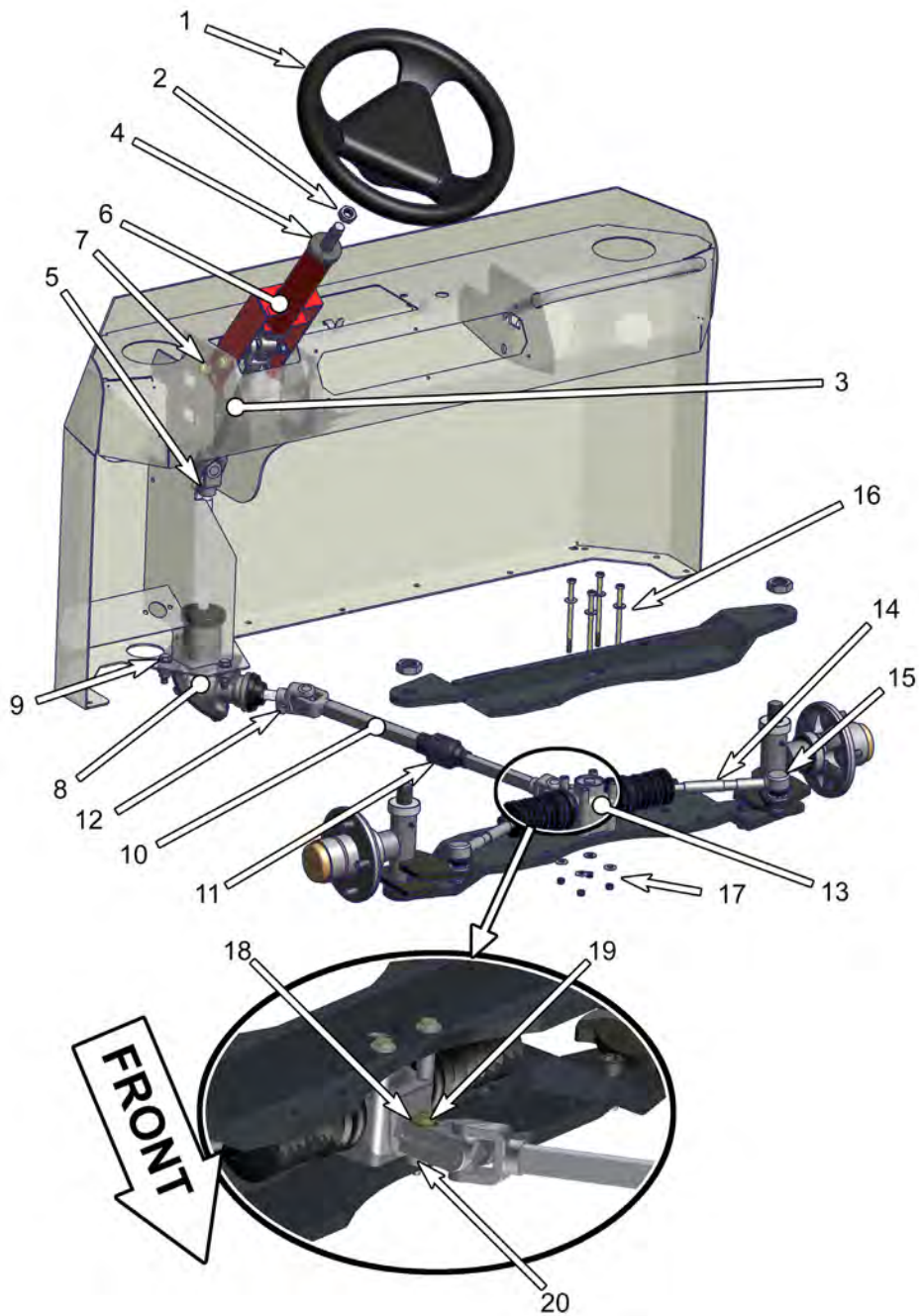

<b>Steering Linkage</b>			
Item No.	Part No.	Description	Qty
1	19-011-30	Steering Wheel	1
	19-011-35	Steering Wheel Cover	1
2	88-199-82	5/8 NF Hex Head Jam Nut GR 2	1
3	18-058-92	Steering Shaft Assembly	1
4	32-248-20	Steering Bushing	2
5	89-080035K-C-00	Bolt	1
	89-080000K-C-04	M8x1.25 Metal Locknut, 10.9	1
6	00-500-03	Steering Column	1
7	88-100-11	5/16 X 1 Nc Hex Head Cap Screw Grade 2	6
	88-108-61	Flat Washer	12
	88-109-81	Nut	4
8	18-058-95	90 Degree Steering Gearbox	1
9	88-100-14	3/8 X 1-1/2 NC Hex Head Screw Grade 2	3
10	18-058-94	Steering Sleeve (includes 11)	1
11	*	Steering Sleeve Boot	
12	89-080035K-C-00	M8X1.25X35,Hex Head Bolt,10.9	1
	89-0800000-A-07	M8, Lock Washer,Split Ring	1
	89-080000K-C-04	M8X1.25 Metal Locknut, 10.9	1
13	86-501-07	Steering Rack (includes 14 and 15)	1
14	*	Tie Rod	-
15	*	Rod End	-
16	See front Axle	1/4X4-1/2 NC HEX Head Cap Screw, Grade 8	4
17	See Front Axle	1/4 NC Hex Lock Nut, GR 8	4
	See Front Axle	1/4 FLW Thru-Hard, GR 8	8
??	89-080-20	M8 Shoulder Screw, 20MM	1
	89-080000K-C-04	M8X1.25 Metal Locknut, 10.9	1
	88-406-60	M8 Flat Washer	1

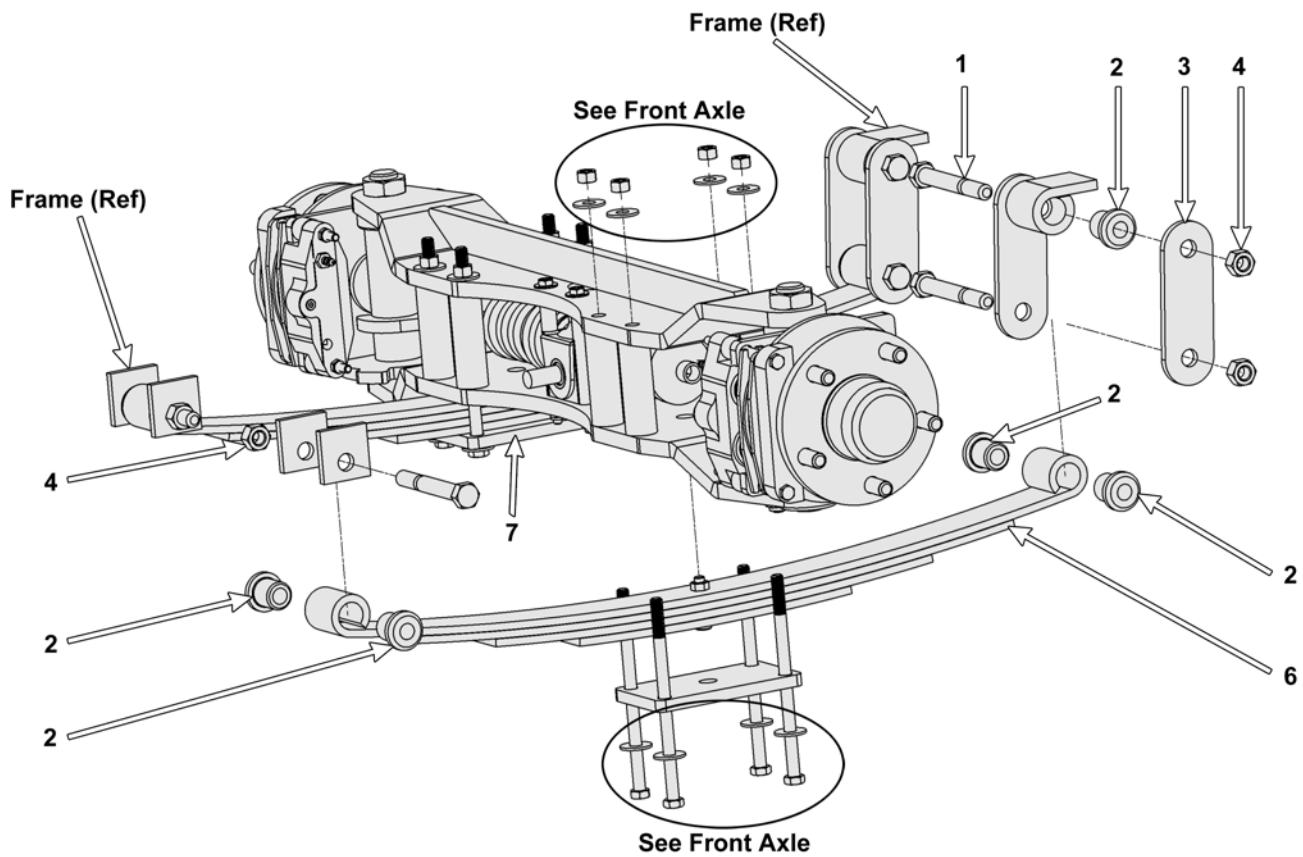

**Front Suspension**

Item No.	Part No.	Description	Qty
1	96-240-00	Spring Bolt	6
2	32-214-50	Bushing	12
3	16-871-04	Spring Hanger	4
4	88-149-81	1/2 NC LOCK NUT GR5	3
5	-	-	-
6	85-498-00	Leaf Spring	2
7	14-010-07	Spring plate	2
Not Shown			
	98-753-15	Bump Stop	2

**SUSPENSION, REAR**

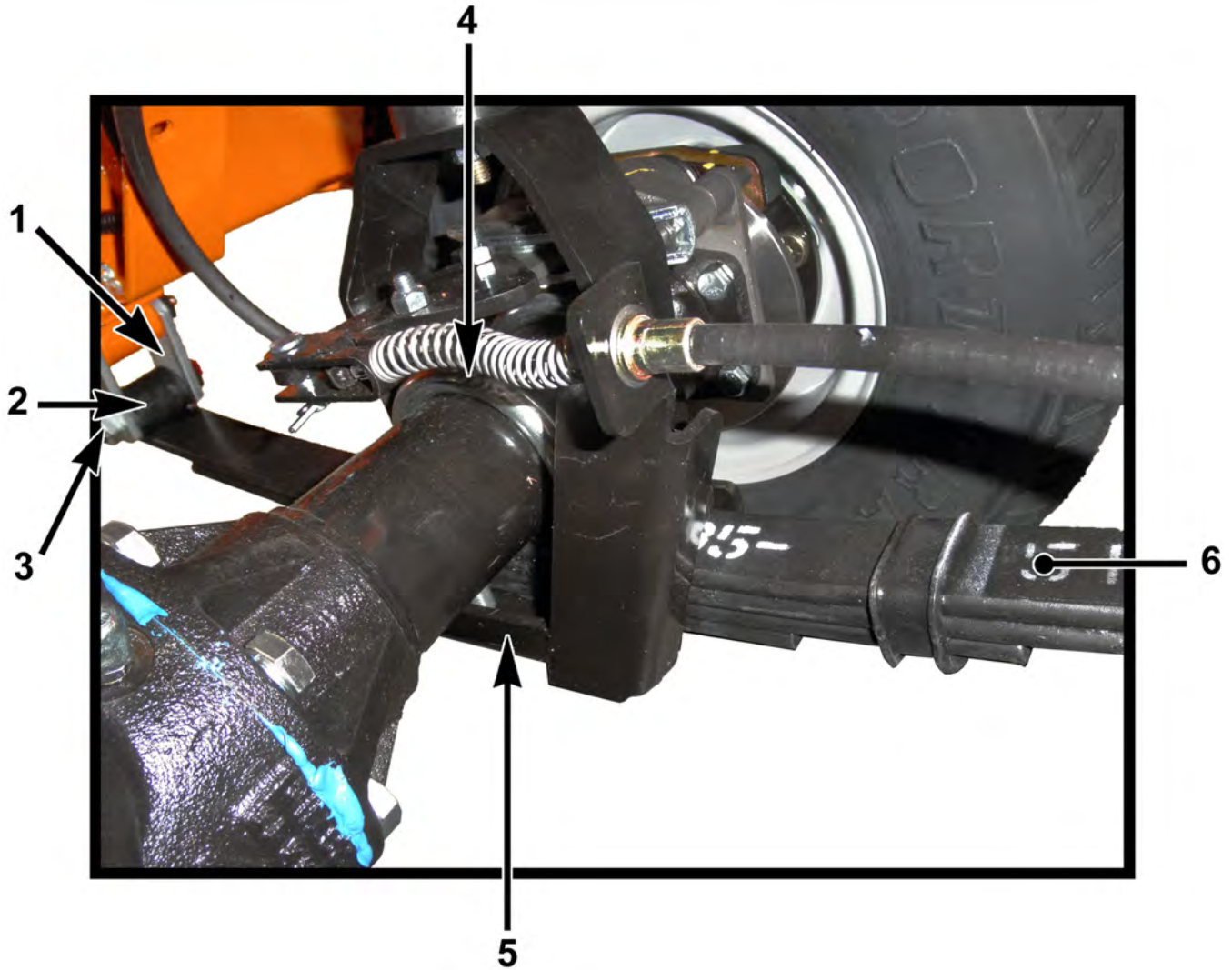

Item No.	Part No.	Description	Qty
1	16-870-10	Spring Hanger	4
2	32-213-00	Bushing, Spring Eye	6
3	96-248-01	BOLT, SPRING, W/GRS FITNG GR5	6
	88-169-82	9/16 NFLOCK NUT, GRADE C	6
4	96-114-00	UBOLT,RD,1/2NFX2.78X6 L GR5	4
	88-159-84	LOCKNUT,NY-LOCK, 1/2-20 NF GR2	4
5	40-500-00	Plate, Spring Mounting	2
6	85-512-40	Spring	2
Not Shown			
	98-753-15	Bump Stop	2

**WHEELS AND TIRES**

---

Item No.	Part No.	Description	Qty
-	13-746-13 10-092-00	Tire, Wheel, 18.5 X 8.5 X 8, Load Range-C 8.50 x 8 LR C (replacement tire)	4
-	13-742-35 12-012-00	Tires, 5 X 8 Monomatic, Solid	4
-	13-742-13 10-083-00	Tire,Wheel, 5.7 X 8 Load Range-C	4
-	13-742-12	Tires, 5.7 X 8.0, Load Range-C, Split Rims	4
-	13-742-50 10-086-00	Tire, 5X8,Soft shoe, NonMark 5.00 x 8 Man-Toters with lugs (soft solid)	4
-	94-423-20	FLAT OUT, Tire Seal Treatment	4
-	97-236-00	Wheel Nut	-
-	13-989-00	Valve stem, tubeless tire only	-
	11-041-00	8.50 x 8 Tube	-
	11-040-00	5.70 x 8 Tube	-



 **WARNING**

**CALIFORNIA**

**Proposition 65 Warning**

**Engine exhaust and some of its constituents are known to the state of California to cause cancer, birth defects, and other reproductive harm.**

**There are chemicals contained in the operating systems of this vehicle that are known to the state of California to cause cancer, birth defects, and other reproductive harm**



Taylor-Dunn® Manufacturing.

2114 West Ball Road.

Anaheim, CA 92804

(800)-688-8680

(714) 956-4040

FAX: (714) 956-0504

Visit our Website: [www.taylor-dunn.com](http://www.taylor-dunn.com)