

Use this QR link to our
Sleep Apnea page
for more information.



YOUR APRIA SLEEP THERAPY USER GUIDE

For the Philips Respironics DreamStation® 2



WELCOME.

Thank you for choosing Apria Healthcare as your home medical provider. You are receiving this package because your doctor has diagnosed you with sleep apnea and prescribed Positive Airway Pressure therapy. Positive Airway Pressure therapy—also known as PAP therapy or sleep therapy—helps millions of users feel more energized and refreshed.

We are excited to accompany you on your journey to a better night's sleep!

Responsive. On Time. Apria Delivers.

With over 275 branch locations in the U.S., **Apria is ready to support patients every day and in times of need**, with well-established emergency preparedness protocols in place. Apria has the knowledge, experience, and ability to provide excellent home health and equipment delivery services in all types of environments.

- **MOBILIZED EFFORTS:** Trained staff members available around the clock to coordinate urgent and after-hours orders and carry out emergency services
- **24/7 DELIVERY SERVICES:** Deliveries to homes, shelters and other areas pre- and post-catastrophic events
- **275+ LOCATIONS NATIONWIDE:** Local branches with teams ready to serve patients, day or night
- **EXTENSIVE INVENTORY:** Home oxygen therapy and respiratory services, sleep therapy and supply refills, non-invasive ventilation therapy, and negative pressure wound therapy

Care is just around the corner.

Make sure your home address can be easily seen from the street during both day and night.

If you are expecting a night delivery or visit, turn on the porch light. Check to see that your address numbers are easy to spot and read from the street. This will allow all Apria Healthcare and emergency services to locate your residence easily.

Follow Emergency and Natural Disaster Instructions

In the event of an emergency or natural disaster, follow the radio or television instructions of your local authorities.

Overview

Your doctor has prescribed PAP therapy because you have been diagnosed with sleep apnea. Sleep apnea occurs when a person repeatedly stops breathing for 10 or more seconds at a time while sleeping. These events may occur hundreds of times throughout the night, causing oxygen levels in the blood to drop, putting stress on the heart. If left untreated, sleep apnea is linked to many other serious conditions like high blood pressure, diabetes, heart disease and stroke.

This guide contains easy step-by-step instructions for using your PAP equipment, and is designed to help you benefit from therapy as soon as your equipment arrives. Please watch the sleep apnea video on the enclosed DVD and review the manufacturer's user guides along with the other educational materials that were included with your equipment. The sleep apnea video can also be found on Apria Healthcare's website at www.apria.com/resource-center in the "Video Library" section located at the bottom of the screen. Additional information is also available at www.apria.com/sleep-apnea.

Your Device and Settings

A licensed Apria clinician has programmed your PAP machine with the settings prescribed by your physician. If your doctor recommends changes to your PAP settings, please notify Apria Healthcare immediately, so that the clinician can make any necessary adjustments.

GET STARTED.

Start your therapy tonight so you can feel refreshed in the morning.



Please watch the sleep apnea video on the DVD and review the manufacturer's user guides and other materials that were included with your equipment. The sleep apnea video can also be found at www.apria.com/resource-center in the "Video Library" section located at the bottom of the screen.



1. Supply power
Power cord can be routed in either direction. White light ring indicates power.



2. Remove tank
Press indent on lid to release tank. Slide tank away from heater plate.



3. Remove lid and fill tank with water
Lift latch on lid and pull up. Fill to line with distilled water.



4. Reattach tank
Align lid hooks with tank tabs and snap into place. On flat surface, slide tank onto heater plate until it clicks.



5. Connect tubing
Slide onto air outlet port. If using heated tube, align pin connections and push until there is a click.



6. Press Therapy button to start
Blue light ring indicates therapy is running.

GET FAMILIAR WITH YOUR PAP EQUIPMENT.

If your doctor prescribed a specific mask and size, follow the fitting instructions provided by the manufacturer, then proceed to Step 3. If you received a mask with multiple cushions, follow the instructions below and on the next page.

There is a mask cushion currently attached to the frame of your mask. This size fits most patients. Once you begin therapy, if your mask is leaking or feels uncomfortable, try removing the existing cushion and replacing it with a different size cushion. If you are between sizes, it is best to use the larger cushion. Use the Fitting Template (for nasal mask and full face mask) and/or the manufacturer's instructions included with your mask for help.





Nasal Mask

1. Release the lower strap magnets from the frame of the mask. Make sure the logo on the headgear is facing outward. While holding the mask against your face, pull the headgear over your head.
2. Position the lower straps so they both sit below the ears. Bring each of the magnets up to meet their corresponding clips on the frame.
3. Adjust the fastening tabs on the upper straps until the mask feels even and stable. Do not over-tighten. Reattach the fastening tabs.
4. Repeat Step 3 with the lower straps. Reattach the fastening tabs.
5. Connect the hose to the front of the mask. Ensure that the nasal mask fits securely over your nose. It is normal to feel some air escaping through the small air vents on the elbow of the hose.

Please refer to the manufacturer's instructions for additional information on topics, such as:

- How to properly remove your mask
- How to remove and change the mask cushion
- How to adjust the length of the mask straps



Nasal Pillow Mask

1. Hold the pillows away from your nose with the left (L) and right (R) indicators correctly facing towards you.
2. Guide the nasal pillows into your nostrils.
3. Pull the headgear over your head by holding the bottom strap and stretching it around the back of your head.
4. Adjust the top and bottom straps. The top strap should fit comfortably on the top of your head.
5. Ensure that the nasal pillows fit securely into your nostrils with both pillows positioned upright. If not, move the mask away from your face and then place it back again.
6. To achieve a comfortable fit, adjust the straps. Spread the straps apart to loosen, or draw them closer together to tighten.



Please refer to the manufacturer's instructions for additional information on topics, such as:

- How to properly remove your mask
- How to remove and change the mask cushion
- How to adjust the length of the mask straps



Full Face Mask

1. Twist and pull both magnetic clips away from the frame. With the logo on the headgear facing outward, hold the mask against your face and pull the headgear over your head.
2. Bring the lower straps below your ears and attach the magnetic clip to the frame.
3. Undo the fastening tabs on the upper headgear straps. Pull the straps evenly until the mask is stable and positioned as shown in the illustrations. Reattach the fastening tabs.
4. Undo the fastening tabs on the lower headgear straps. Pull the straps evenly until the mask sits firmly on the chin and reattach the fastening tabs.
5. Connect the air tubing from your device to the elbow. Attach the elbow to the mask by pressing the side buttons and pushing the elbow into the mask.
6. To achieve a comfortable fit, readjust the straps. Evenly, apply only enough tension so that a seal is achieved.

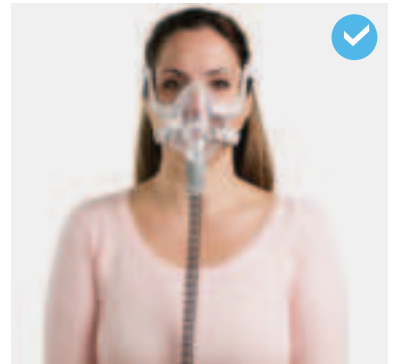

Please refer to the manufacturer's instructions for additional information on topics, such as:

- How to properly remove your mask
- How to remove and change the mask cushion
- How to adjust the length of the mask straps

Heated Elements

Heated Humidifier — The heated humidifier is used to control the desired temperature and humidification of the air that is delivered to you from your PAP device.

Heated Tubing — Heated tubing is designed to maintain the temperature of the humidified air as it passes through the tube to improve comfort. Keeping the air temperature in the tube at a constant level ensures that rainout is avoided even if the temperature in the room drops during the night.

1. To connect heated tubing (shown), line up the pin connectors on the heated tube with the bottom of the air outlet port on the device. The clips at the end of the tubing should be aligned to the sides of the port and will click into place.

If you are using standard tubing (not shown), simply slide the tubing over the air outlet port

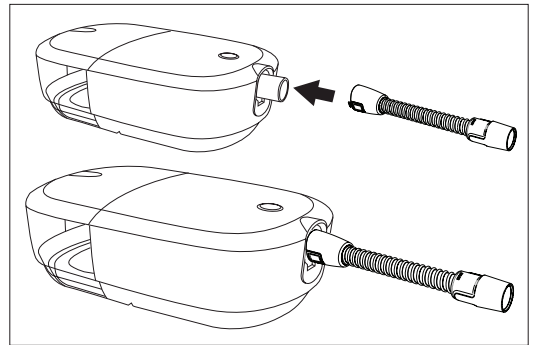

2. Connect the tubing to the mask. For proper placement and positioning, refer to the instructions that came with your mask.
3. Attach the headgear to the mask if necessary. Refer to the instructions that came with your headgear.

Using Oxygen with Heated Tubing

1. Attach heated tubing circuit to the device outlet (shown above).
2. Attach pressure valve to the to the other end of the heated wire tubing (the opposite end of the pressure valve connection and the end closest to the mask).
See diagram of pressure valve placement on page 10.
3. Attach the O2 tee adaptor to the open end of the pressure valve.
4. Attach the O2 tee adaptor to mask hose.

Attach oxygen tubing here

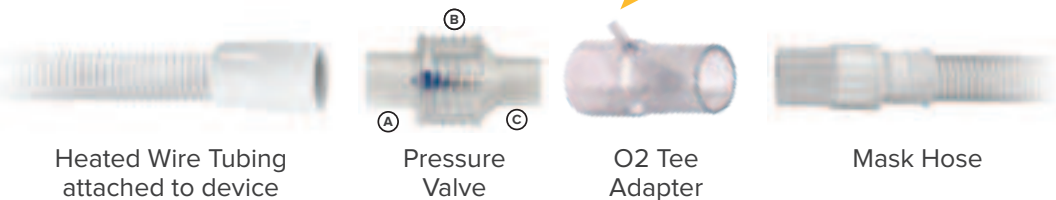

Heated Wire Tubing attached to device

Pressure Valve

O2 Tee Adapter

Mask Hose

IMPORTANT SAFETY NOTE: If you are using prescribed oxygen with your PAP device, be sure to observe all the fire and safety rules associated with the use of oxygen. Make sure to follow this sequence of steps when turning your oxygen on and off. **1.** Always turn your PAP machine ON before turning ON the oxygen flow from your oxygen source. **2.** Always turn OFF the oxygen flow from your oxygen source before turning OFF the PAP machine.

Using Oxygen with Non-Heated Tubing

1. Attach the pressure valve to the machine outlet.
2. Attach the O2 tee adaptor to the open end of the pressure valve.
3. Attach the large-bore PAP tubing to the small end of the O2 tee adaptor.
4. Attach the other end of large-bore tubing to mask hose.

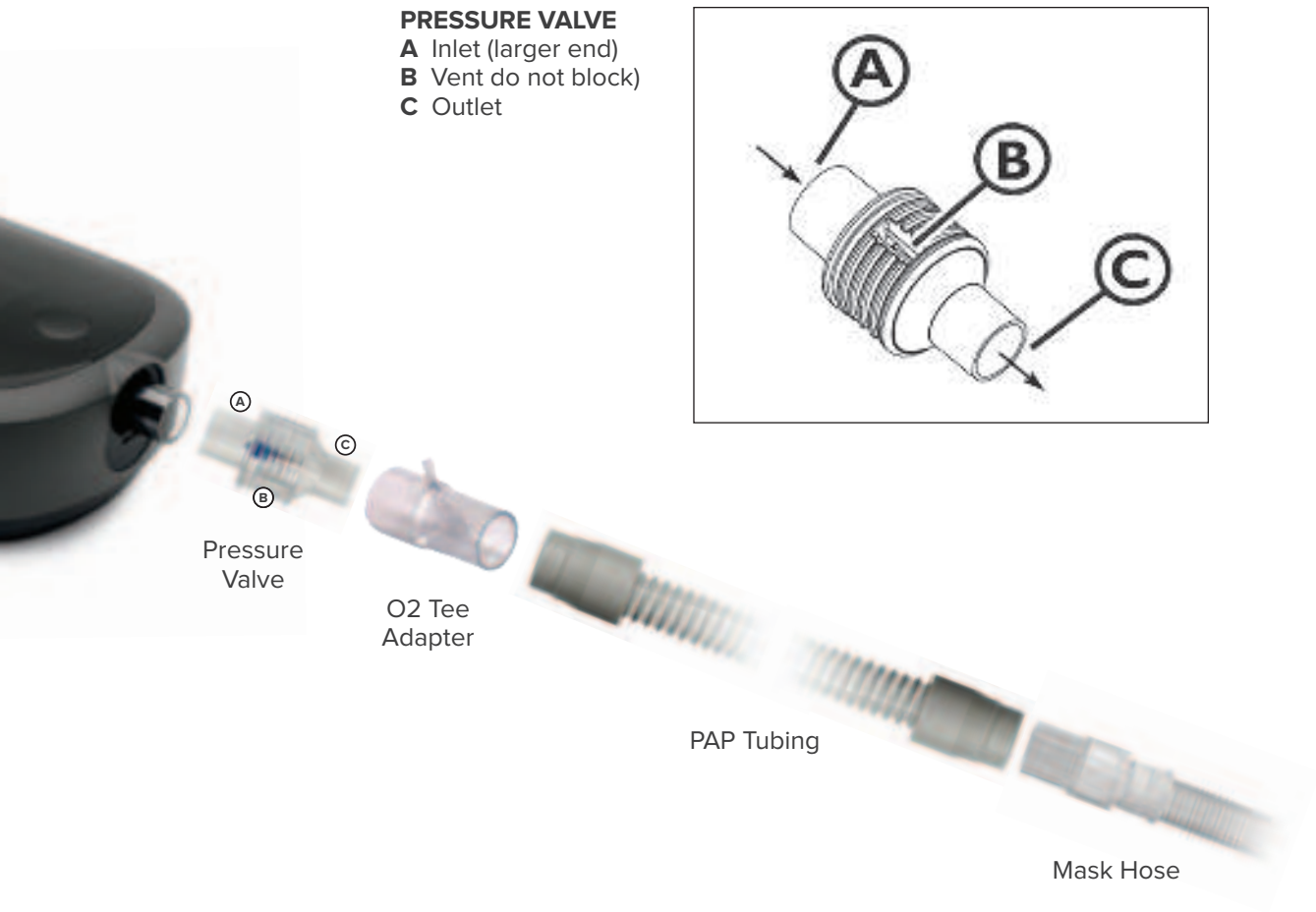

IMPORTANT: When using supplemental oxygen, you must attach a pressure valve device in all cases. If you use oxygen and did not receive a pressure valve and/or oxygen tee adapter with your PAP device, please contact Apria.

START YOUR PAP MACHINE.

1. Ensure power is supplied to the device as indicated by a white ring around the therapy button.
2. Put on your mask assembly. Refer to the instructions supplied with the mask. A small amount of mask leak is normal and acceptable. Correct large amount of mask leaks or eye irritation by adjusting your mask headgear. Tips for managing mask leaks are provided on the next page
3. Press the Therapy button on top of the device to turn on airflow and begin therapy. The Therapy button ring will illuminate blue.

Note: If your home care provider has enabled the Automatic On feature, the device will automatically turn the airflow on when you put on your mask and breathe.

4. Press the Therapy button again to turn off the therapy. The Therapy button ring will illuminate white.

Note: If your home care provider has enabled the Automatic Off feature, the device will automatically turn the airflow off when you take off your mask and the device recognizes inactivity.



Helpful Tips

For Nasal and Full Face Masks

- To resolve leaks at the upper part of the mask, adjust the upper headgear straps.
- For leaks at the lower part, adjust the lower headgear straps.
- When adjusting straps, loosen or tighten both the left and right straps so that adjustments are made evenly.
- Adjust only enough for a comfortable seal.
- The upper strap adjustment is the key to seal and comfort.
- Do not over-tighten the lower straps. They mainly serve to keep the cushion in position.

For Nasal Pillows Masks

- Position the pillow cushion tips into your nostrils so they sit comfortably under your nose without any gaps. Pull the mask away from your face, then place it back to get a comfortable fit.
- Adjust the side straps evenly by pulling downwards; the mask should feel secure and comfortable against your face. Do not over-tighten.
- If leaks persist, try the next larger set of cushions.
- If the pillow is not staying in place in your nostrils, try the next smaller cushion size.

Hand washing Technique

Thorough hand washing must be done prior to all procedures. Contaminated, dirty hands are one of the most common sources of infection.

1. Wet your hands thoroughly with warm water.
2. Use soap.
3. Scrub hands for 20 seconds using a rotary motion and friction. Wash:
 - Back and palm of each hand
 - Between all fingers
 - Fingernails

Need a timer? Hum the “Happy Birthday” song from beginning to end twice.

4. Rinse your hands under the running water.
5. Dry on clean towel or with a paper towel.

For additional good health habits, visit our patient education section on apria.com.

GET COMFORTABLE WITH YOUR THERAPY.



Use your PAP therapy during all hours of sleep, including during naps. Some people may need up to one or two weeks to adjust to PAP therapy, but the benefits are well worth it.

Ways to help you adjust:

- Try watching TV or reading while wearing your mask and headgear. Turn on the PAP device for short periods of time while wearing your mask to get used to the pressure.
- Use your equipment every night.
- Keep the device turned on for as long as you can tolerate, building up each night until you have reached at least 4 hours per night.
- Keep practicing until you are using PAP therapy during all hours of sleep, including during naps.

THERAPY ON DISPLAY.

The UI on this device allows you to adjust the device settings and view information about your therapy. The UI consists of the display screen with touch capability.

While the device is delivering therapy, the pressure setting is displayed. You can also view and adjust humidification, heated tube temperature, and RAMP PLUS settings.

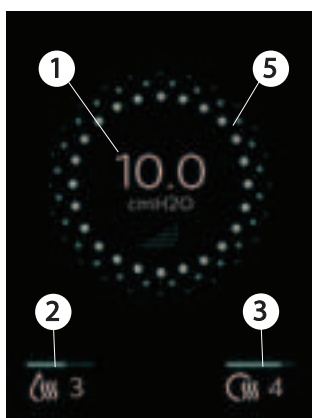

1. Therapy pressure (cmH2O)
2. Adjustable humidifier setting (if available)
3. Heated tube temperature (if available)
4. RAMP PLUS (Ramp+)
5. Ramp indicator
6. Ramp indicator
7. Oximetry connection

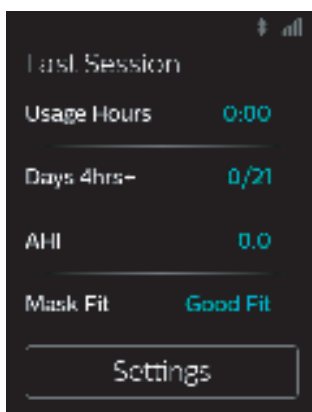

Therapy Off display

A summary of your therapy displays on the UI when therapy is turned off. You can view additional details about your therapy or perform a mask fit check. From here you can tap “Settings” to adjust Comfort and Device settings if enabled by your provider.

TRACK YOUR PROGRESS.

You can track your progress by registering for Philips Respironics DreamMapper at www.philips.com/mydreammapper. You can track your previous night's results, create goals and get feedback. You can also access other helpful information, like tips to help you stay motivated in adhering to your PAP therapy.



Do you have a dry nose or throat, or a runny nose?

Increase the temperature or humidity level.

Are there droplets of water or condensation inside your nose, mask, or tubing?

Decrease the temperature or humidity level.

Is the air pressure making it difficult for you to fall asleep?

Tap the Ramp Plus icon, then tap the - or + icons until the desired starting pressure is displayed.

Do you have sore or dry eyes?

Adjust your mask or headgear. It may need to be repositioned. Refer to the instructions provided in the manufacturer's user guide for your mask. Also review Steps 2 and 3 in this guide.

Are you experiencing redness on your face where the mask touches the skin?

Your mask may be too tight. Try adjusting your headgear. If redness persists, contact Apria Healthcare.

Do you have nasal, sinus or ear pain?

You may have a sinus or ear infection. Stop using your machine and contact your doctor.

This information is intended for your general knowledge only and is not a substitute for medical advice or treatment for a specific medical condition. Should you have any healthcare-related questions, please consult your doctor.

CLEANING, MAINTENANCE AND REPLACEMENT

1. Oil from your face and ingredients in facial products can cause the PAP mask cushions to wear down and decrease the useful life of the mask. Get in the habit of wiping down your mask each day, especially the areas that come in contact with your skin. **Clean your mask and headgear weekly according to the instructions in the mask user guide.**
2. Wash the water chamber and air tubing in warm water, using a mild detergent. **Hand wash only.** Do not wash in a dishwasher, as it can deteriorate the plastic.
3. When needed, wipe the exterior of the machine with a dry cloth.
4. Your device has an automatic air filter reminder. Refer to the manufacturers's instructions for information on how to replace the filter.

REPLACE SUPPLIES REGULARLY

Replace your sleep supplies regularly. This helps to ensure a good mask seal and reduce buildup of bacteria, viruses, and allergens.¹ Ordering fresh, clean supplies to replace your old items helps improve the comfort of your mask and maintains the overall effectiveness of your therapy.

Recommended Replacement Schedule

Twice Monthly	Once Monthly	Every 3 Months	Every 6 Months
<ul style="list-style-type: none">• Nasal mask cushions and nasal pillows• Disposable filters	<ul style="list-style-type: none">• Full-face mask cushions	<ul style="list-style-type: none">• Mask frame• Tubing (standard or heated)	<ul style="list-style-type: none">• Headgear and chin straps• Humidifier water chamber• Non-disposable filters

Please note that the frequency of resupply and your insurance's coverage of supplies will be governed by your insurance plan and may differ from the schedule provided above.

Source:

1. Horowitz A, Horowitz S, Chun C. CPAP Masks are Sources of Microbial Contamination. SleepHealth Centers, Div. of Sleep Medicine, Brigham and Women's Hospital, Harvard Medical School, Boston. APSS Poster; 2009.

CONVENIENT ORDERING OPTIONS

When ordering fresh supplies through Apria, **shipping is always free**, and we verify and bill your insurance for you.

Enroll in Apria's Continuous Sleep Resupply Program*

Determine if you want fresh PAP supplies shipped to your front door every three or six months, and let Apria do the rest. Visit apria.com/papresupply to access the online form or call a Sleep Resupply Expert at **877.265.2426** and select option 2.

Order Online

Apria.com/PAPResupply — Register for the PAP Patient Portal with your Apria Patient ID, and place an order when you need new supplies.

ApriaDirect.com — Order supplies anytime on the retail (non-insurance) website.

Call Our Automated System

Dial **800.436.5657** to use Apria's automated phone system available 24/7 to place your order.

Speak with an Apria Sleep Resupply Expert

Dial **877.265.2426** and select option 2 to order supplies with an Apria Sleep Resupply Expert. Monday-Friday: 8 a.m. to 9 p.m. EST or Saturday: 8 a.m. to 7 p.m. EST

Note: If you decide not to participate in the PAP Resupply Program, you will receive convenient, automated calls from Apria to remind you that it is time to order replacement sleep supplies.

* This Continuous Sleep Resupply Program is not available to all Sleep patients. Patients with certain payors, such as Medicare, Medicaid, Managed Medicaid or TRICARE, are not eligible.



We are here for you! With Apria's Premium Care Sleep™ program, you can rest assured that you will receive the support you need to achieve a better night's sleep. It's not uncommon to experience some discomfort during the first several days.

Remember that regular use will help improve your overall quality of life so you can look forward to:

- **Increased energy and alertness**
- **Improved blood pressure**
- **Improved glucose tolerance**

Data from your PAP machine is securely communicated to Apria Healthcare using cloud-based software. If you register for Philips Respironics DreamMapper, you will get feedback on your progress.

One of Apria's Premium Care Sleep Experts will reach out to you during the first few days of therapy to see how you are adjusting. If you are struggling with therapy or have questions about your equipment, please call us right away. We are here to help you.

Remember to use your PAP therapy anytime you sleep, including during naps. Compliant use is defined as at least 4 hours per night for at least 70% of the days.

If you have questions about PAP therapy, please contact Apria's Premium Care Sleep Experts. Dial the number below and select option 4.

877.265.2426

Monday - Friday: 8 a.m. - 10 p.m. EST

Saturday and Sunday: 11 a.m. - 7:30 p.m. EST

If you have any questions, or need help setting up your device and getting started, please call a member of Apria's Premium Care Sleep Expert team. Dial the number below and select option 4.

877.265.2426

Monday - Friday: 8 a.m. - 10 p.m. EST
Saturday and Sunday: 11 a.m. - 7:30 p.m. EST

Apria is committed to safe, quality patient care. We encourage you to report any concerns to your local Apria Healthcare branch. If your concern is not resolved, please contact the Patient Satisfaction team at the number listed below.

800.260.8808



DreamStation is a registered trademark of Philips Respironics.

©2021 Apria Healthcare Group LLC SLP-4323 05/21_v3