

Inspecting LP-Gas Regulators

Introduction

LP-Gas regulators are very durable pieces of equipment that are able to automatically supply gas, year in and year out, and thus it's easy to take the regulator for granted. Oftentimes, the regulator receives minimal, if any, attention from the owner, marketer or the bobtail driver, who probably sees the regulator installation the most. A program to replace, inspect, and maintain regulators can prevent accidents. This bulletin lists some simple, common sense replacement considerations and installation/inspection procedures that can lessen the likelihood of an LP-Gas system being the cause of accident that could result in personal injury or property damage.

When to Replace A Regulator

Regulator service life depends upon the regulator's use and environment, and some environments are much more unfavorable than other environments. Some of the many variables in addition to daily operation that can diminish a regulator's service life include:

- Climatic conditions
- Flooding
- Air pollution
- Contaminants in the LP-Gas
- Installation location such as underground tanks or coastal areas
- Proper installation in all locations
- If the regulator has been periodically inspected, tested, and maintained.

Emerson Process Management Regulator Technologies Inc. recommends that most regulators, be replaced at 15 years from the date of manufacture. For the R600 Series, Types R122H, R222, and R232 regulators, we recommend that they are not be kept in service over 20 years from the date of manufacture. Regulators installed in underground tank domes or in coastal areas may need to be replaced sooner than the recommended period. In our experience,

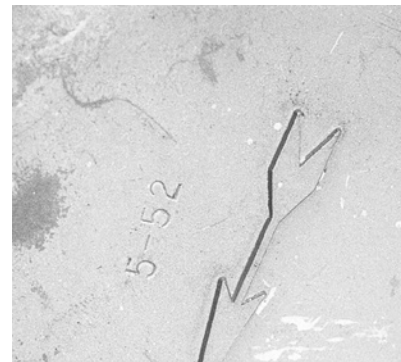

Figure 1. Date Stamping Examples

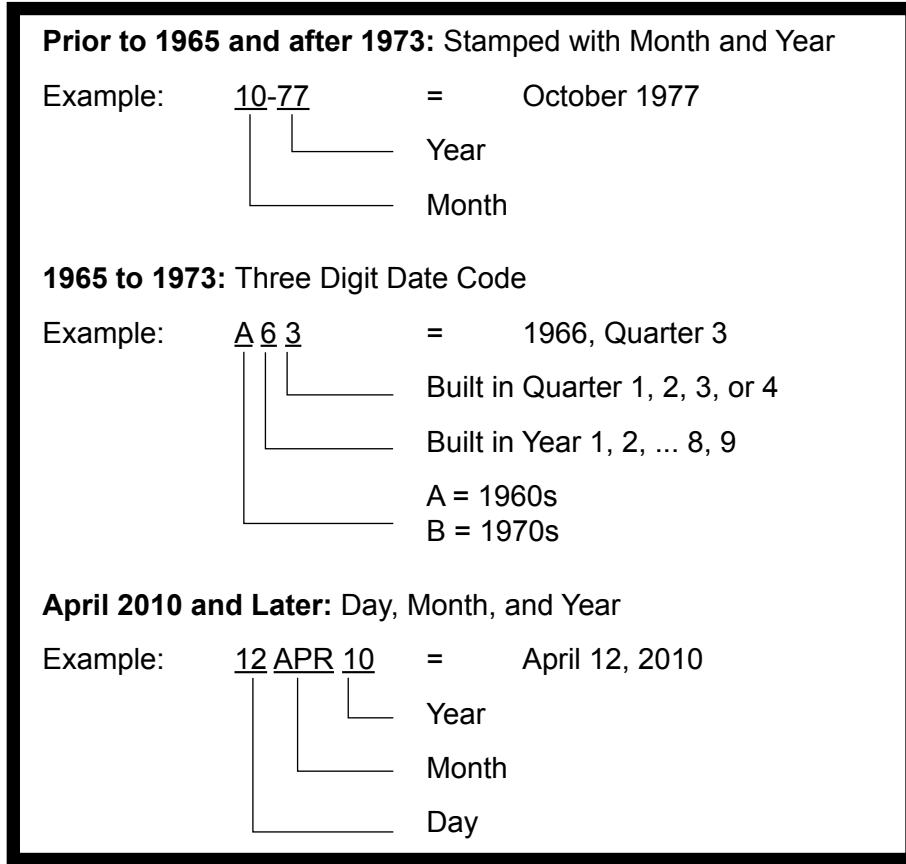

Figure 2. Date Coding Example

the majority of regulators that suddenly no longer control pressure occur in units that are over 15 years old. Replacing old regulators is probably the biggest single step that can be taken in helping to reduce accidents associated with LP-Gas regulators.

A 15-year-old regulator may have more years of life left in it, but exactly how many more years it will continue to work without causing problems is difficult to establish. To prevent an accident, replace the regulator before it wears out. Establishing a preventative inspection and maintenance program for regulators and propane systems will help find potential problems in operation, changes to the environment around the installation that may need to be addressed, or other areas that may impact the propane system operation. Refer to the section at the end of this article titled "Questions to Ask About the Regulator Installation."

Fisher® stamps the regulator's date of manufacture usually in one of four places:

- The closing cap
- Between the flange screws on the spring case
- The bottom of the regulator body
- On a nameplate when provided

Starting April 1, 2010 Fisher regulator date stamping is in the form of a day, month, and year designation.

12APR10 indicating April 12, 2010.

Previously, Fisher stamped the date of manufacture by month and year such as 10-77 for October 1977.

And for a period from 1965 through approximately 1973, a date code was used such as A63.

First Character	A = 1960's B = 1970's
Second Character	6 in the example = year, so A6 is 1966. B2 would be 1972
Third Character	Quarter in which product was made 1 = 1st Quarter of year 2 = 2nd Quarter of year 3 = 3rd Quarter of year 4 = 4th Quarter of year

So A63 means the regulator was made in the 3rd Quarter, 1966. See Figure 2.

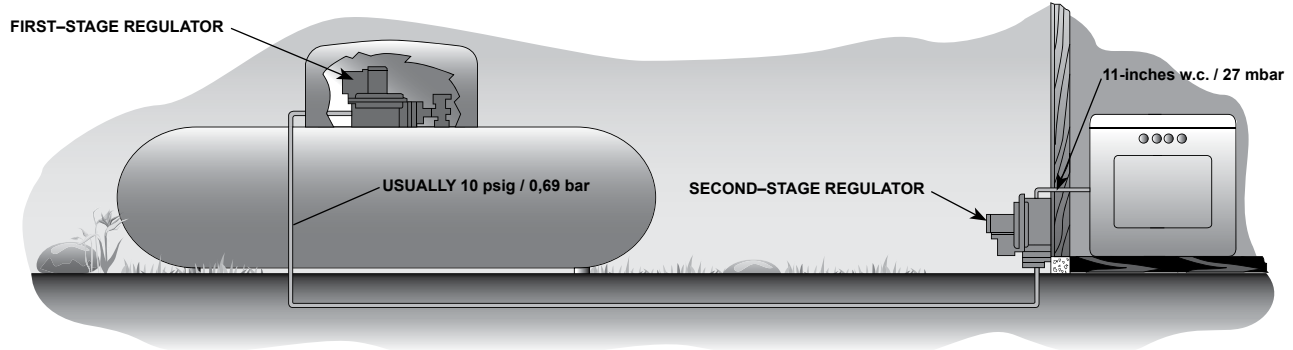

Figure 3. Two-Stage Regulation, One at Tank and One at Building, Reducing Pressure Down to Burner Pressure (11-inches w.c. / 27 mbar)

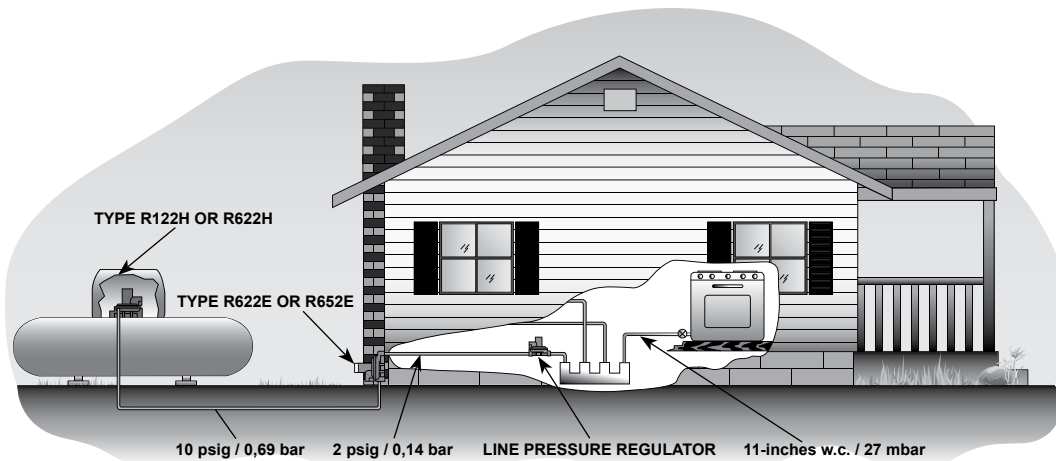

Figure 4. Typical 2-PSI Installation

Proper Regulator Installation

Proper regulator installation is vital for a regulator to function correctly for long periods of time. Therefore, the following information assumes that the regulator is on a vapor system and has been installed per NFPA 58, state or local regulations, and the manufacturer's instructions.

Wrong Regulator or No Regulator in the System

There are numerous types of LP-Gas systems—Single-Stage, Two-Stage including Integral regulators, 2 psig / 0,14 bar systems, and large commercial/ industrial installations. Not having a pressure regulator (it has happened) in the system or a pressure regulator that is not suitable for the installation, high-pressure regulator instead of low-pressure regulator for example, can be disastrous.

A Two-Stage System (Figure 3) includes a first-stage regulator at the container and a second-stage regulator at the building or appliance. A first-stage regulator can feed more than 1 second-stage regulator. If the container is small so that it can be placed closer to the building, an integral two-stage regulator may be installed only at the container. The integral two-stage regulator combines a first-stage and second-stage regulator in one unit.

A 2-Psig System (Figure 4) is similar to a Two-Stage System, except that there are actually 3 regulators in the system. A first-stage regulator, typically set at 10 psi / 0,69 bar, is located at the tank; a second regulator, set at 2 psi / 0,14 bar, is typically located at the house; and finally a line pressure regulator set at 11-inches w.c. / 27 mbar is installed inside the building or at each appliance. The line pressure regulator, per ANSI Z21.80 / CSA6.22 Line Pressure

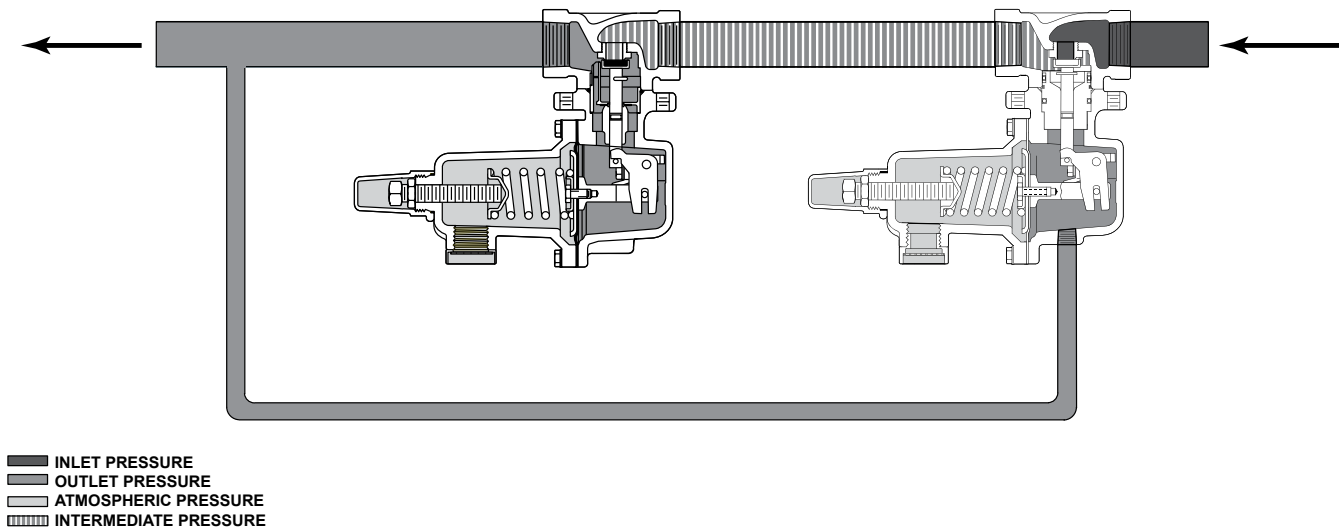

Figure 5. Type 627 Direct-Operated Monitor Operational Schematic

Regulators standard, reduces 2 psig / 0,14 bar pressure to appliance pressure. It is rare to see an integral regulator in a 2 psig / 0,14 bar system, but integral 2 psi regulators that combine the first-stage and 2 psi (second regulator in the system) into a single unit can be used and are installed at the tank.

While **Single-Stage Systems** cannot be installed on new 0.50 psig / 0,03 bar fixed pipe gas pressure systems, they do still exist on older installations and therefore need to be inspected. NFPA 58 does not allow a new single stage regulator to be installed after June 30, 1997. Since it has been almost 15 years since a new single stage system could be installed, most existing single stage systems are probably over 15 years of age, and therefore need to be upgraded to a new two-stage regulator system that complies with the current NFPA 58 regulations. A single-stage regulator is installed at the container. Oftentimes the single-stage regulator can be replaced with an integral two-stage regulator resulting in minimal piping changes. If the container is far from the house, both a first and second-stage regulator will have to be installed.

Commercial and Industrial Systems also have to comply with NFPA 58 requirements for two-stage systems if they supply low-pressure gas to appliances. In some instances a high-pressure regulator that supplies more than 10 psi / 0,69 bar may be installed between the container and the first-stage regulator if needed to meet flow or piping demands. In some instances, additional external overpressure protection will be required between the high-pressure regulator and the first-stage regulator.

Regulators used as second-stage regulators in these systems may not have internal relief protection or if they do, the relief valve may have limited capacity so that it may not meet the 2 psig / 0,14 bar relief pressure requirement. Therefore, additional external relief devices or other means of overpressure protection may be required depending upon the regulator construction used as a second-stage regulator. Monitor systems are being used more as another means of overpressure protection. A monitor system provides a “back up” regulator in the event the working regulator no longer controls pressure. Monitor systems do not vent gas to the atmosphere like an internal or external relief valve will do when the relief valve activates. Therefore, monitor systems need to be inspected annually to validate their continued proper operation. Commercial and industrial regulators, monitor regulators, and the external relief devices have to be installed properly and the information discussed in this article would apply equally to these systems along with the recommendations found in the product’s instruction manuals. See Figures 5 and 6.

Vent Orientation and/or Protection from Vent Blockage

Regulators must have an open vent in order to control pressure properly and have adequate flow area for the internal relief valve. Ice, mud, insects, dense snow, and paint covering the screened vent are few things that can cause a blocked vent. A blocked vent can cause overpressure at the appliances, resulting in the possibility of a serious accident. Since 1974 Underwriters Laboratories (UL) 144 “Standard for

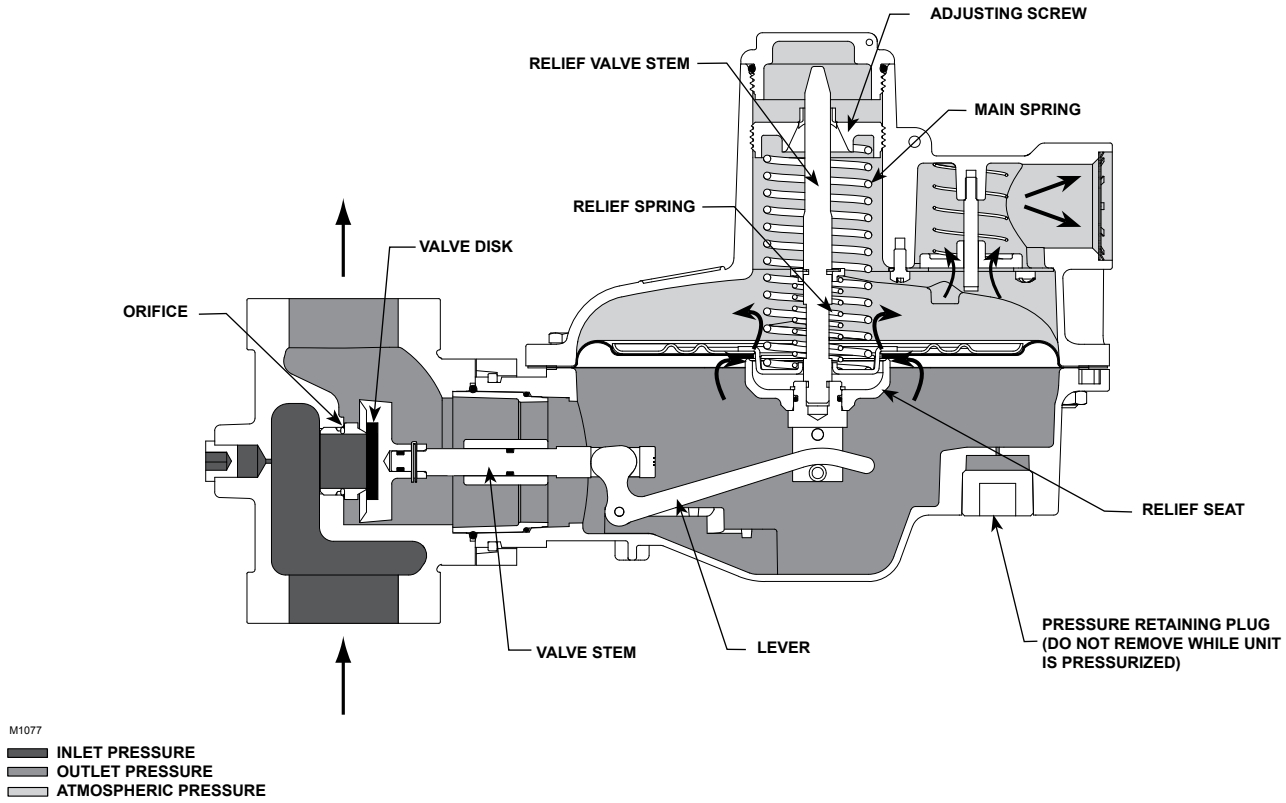

Figure 6. Type CS400IR Internally Registered Regulator with Internal Relief Operational Schematic

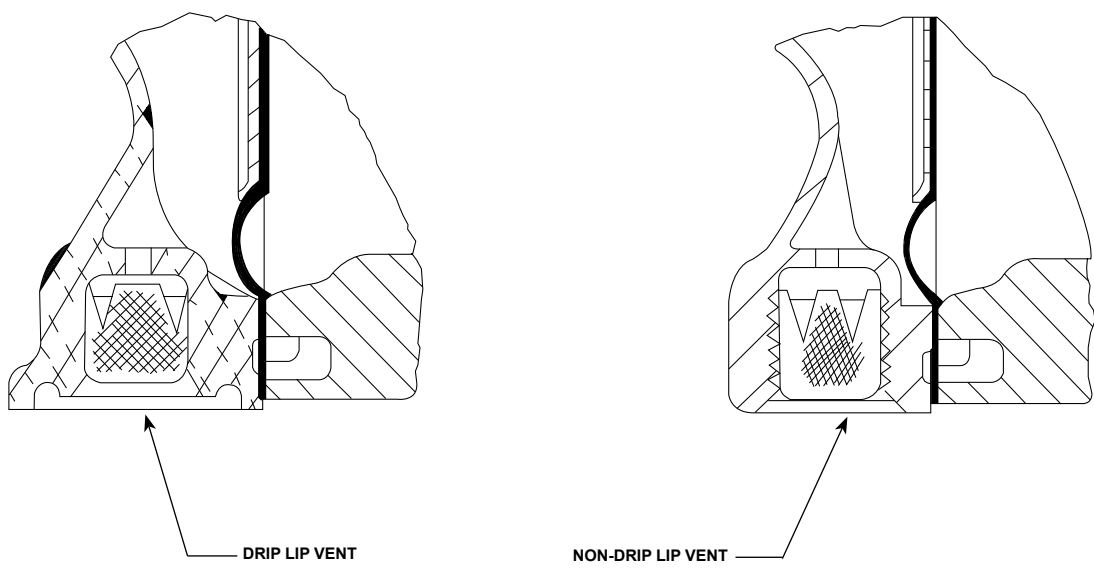

Figure 7. 1/4 NPT Regulator Vents with and without Drip Lip Design

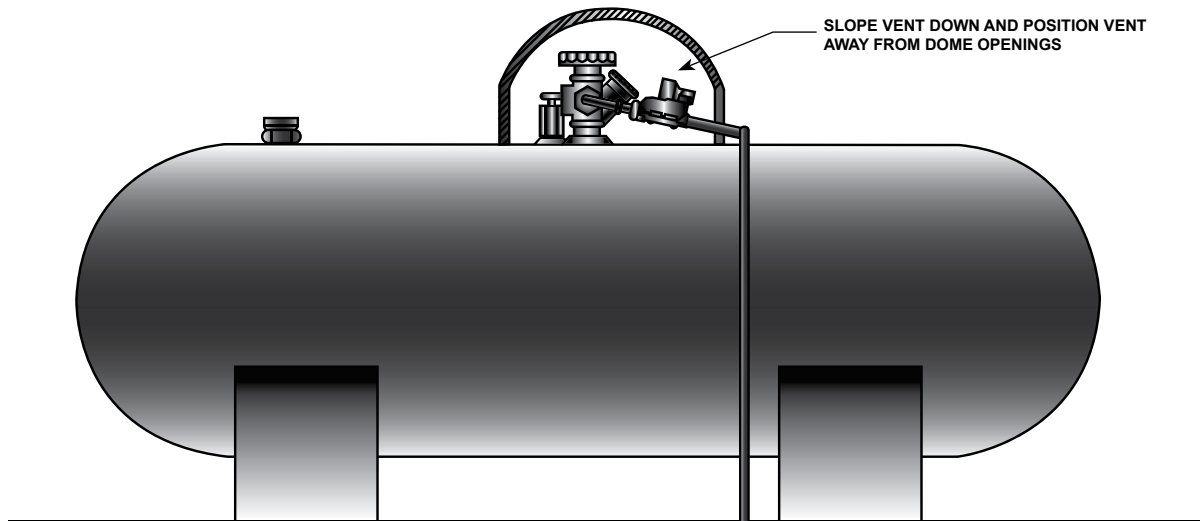

Figure 8. Tank Installation

LP-Gas Regulators” has called for a regulator’s vent to be a drip lip vent design, see Figure 7. If the vent is not a drip lip design, the regulator manufacturer must label the unit with **“CAUTION: For outdoor use, install under a protective cover.”**

Regulators, even with the drip lip vent, installed in a horizontal position must be under a protective cover or the container dome. Position the vent far enough away from any opening in the cover so that water cannot get into the regulator through the vent or freezing rain, sleet and snow can freeze across the vent screen.

If the regulator vent is oriented so that water can collect inside a regulator’s spring case, that water can freeze in the winter. When the water freezes across the diaphragm surface, the diaphragm can no longer move up or down with changes in load demands. Likewise, the ice will prevent the internal relief from opening. When a load change decreases, the pressure in the downstream piping will increase because the disc cannot close and the relief valve will not open.

The effect of condensation on internal parts can be greatly reduced by installing the regulator so that the vent is pointing down or sloping downward when the regulator is installed under the container dome or under a protective cover. This minimizes corrosion on the pusher post and relief valve parts by keeping them out of the water as well as allowing the water to drain out the vent if heavy condensation occurs. See Figure 8.

Make sure all regulators installed outdoors have the drip lip construction. Drip lip vents are extremely

resistant to blockage by freezing rain (the most common cause for vent blockage) when properly installed outdoors with the vent pointing vertically down. 1/4 NPT regulator vents with drip lip design are much more resistant to freeze-ups than old style vents when installed pointing down. ***If the drip lip vent is not pointing vertically down, the “drip lip feature” will not keep the vent from freezing over with ice.*** The regulator vent or vent assembly on the end of a vent discharge line (from a regulator installed inside a building) should always be

- Pointed vertically down or
- Installed under a protective cover.

Regulators without a drip lip vent should have either an auxiliary vent assembly (Figure 9) installed in the vent or have a protective hood installed over the regulator.

Regulators should never be installed with the

- Vent pointing up (water can collect inside the regulator and freeze or cause corrosion problems).
- Vent pointing horizontal unless the regulator is covered with a protective cover or vent shelter. Without a protective cover, water could get inside the regulator and freeze or cause corrosion of internal parts. See Figure 10.

Drip lip vents and/or protective covers do not eliminate the need for periodic inspection of the vent. Insects like mud daubers are apt to build nests in small openings, and they have caused vent blockage in the past. Mud has also caused problems on recreational vehicles when the regulator is exposed

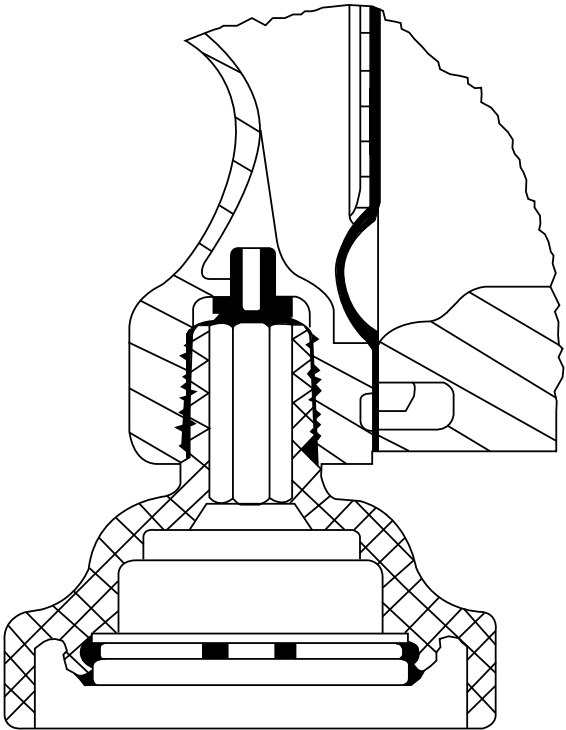

Figure 9. *Drip Lip Protection Added through an Auxiliary Vent*

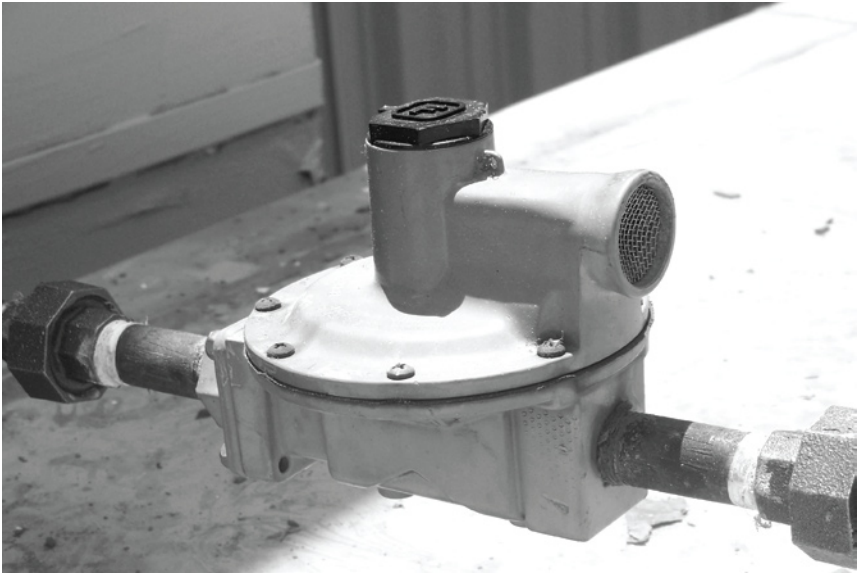

Figure 10. *Improper Installation: Horizontal Regulator Installation Without Vent Cover*

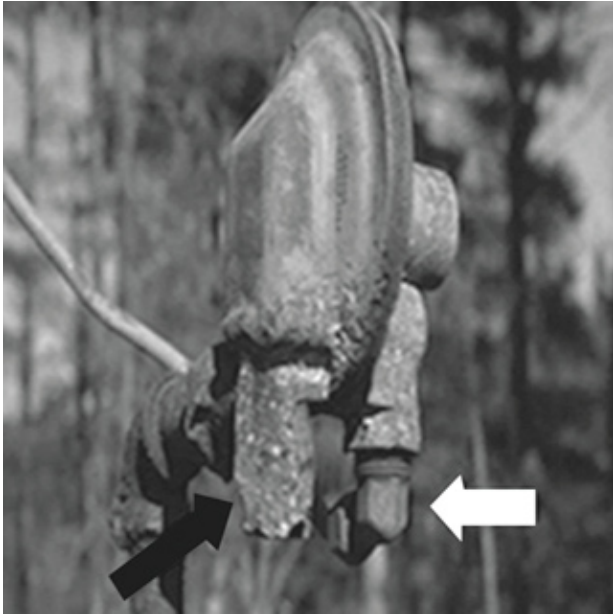

Figure 11. Corrosion due to Below Ground Level Installation

to road splatter. For more information on Drip Lip Vents, see Fisher® **Bulletin LP-18, Tests Show How Drip Lips Can Prevent Regulator Freeze-Ups.**

Regulator Installed Above Ground Level

Regulators installed outdoors should be located at least 18-inches / 457 mm above the ground. This minimizes the amount of “splash back” that can bounce back up onto the screened vent area and either block the vent with ice (in the winter) or enter the regulator and create corrosion problems. This distance also keeps the regulator out of the dirt which can also cause corrosion issues.

Regulators should not be buried in the ground. Refer to Figure 11. This regulator was partially buried in the ground. The external corrosion (pitting) extended up onto the back of the lower casing. Inlet pipe boss (Black Arrow) broke away from the actuator. The 3/4-inch NPT vent (White Arrow) was piped away but with a 3/8-inch / 9,5 mm copper tube which restricts the flow through the vent from the internal relief valve.

Regulators should not be installed under a house eave or valley that allows water runoff and snow melt or ice and snow from a roof to fall directly onto the regulator. If the regulator has to be installed in such locations,

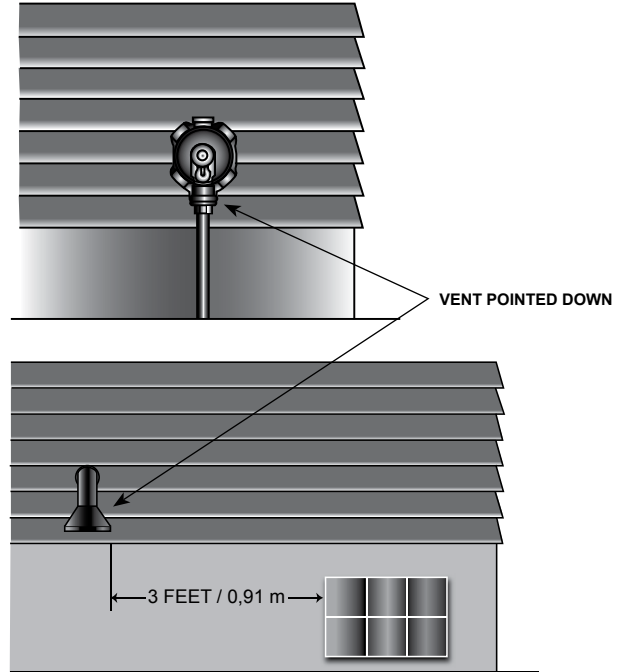

Figure 12. Vent Installation Away from Windows, Basement Air Intakes, and other Openings

then additional protection is required such as installing a vent line with an auxiliary vent piped to a better location, hoods, covers or shelters should be installed over the regulator. See the two sections in this article titled **INSTALLED AWAY FROM WINDOWS, BASEMENTS, AIR INTAKES, AND OTHER OPENINGS** and **REGULATORS INSTALLED INSIDE BUILDINGS** for additional information on installing vent lines and auxiliary vents. Refer to Figure 12.

Installed Away From Windows, Basements, Air Intakes, and Other Openings

NFPA 58 requires that the regulator(s) be installed so that the relief valve discharge from the regulator vent is

- At least 3-feet / 0,91 m horizontally away from any building opening below the level of the relief valve vent discharge
- Not beneath any building unless well ventilated and not enclosed for more than 50% of its perimeter
- Not less than 5-feet / 1,5 m in any direction from ignition sources openings in to direct vent appliances or mechanical ventilation air intakes

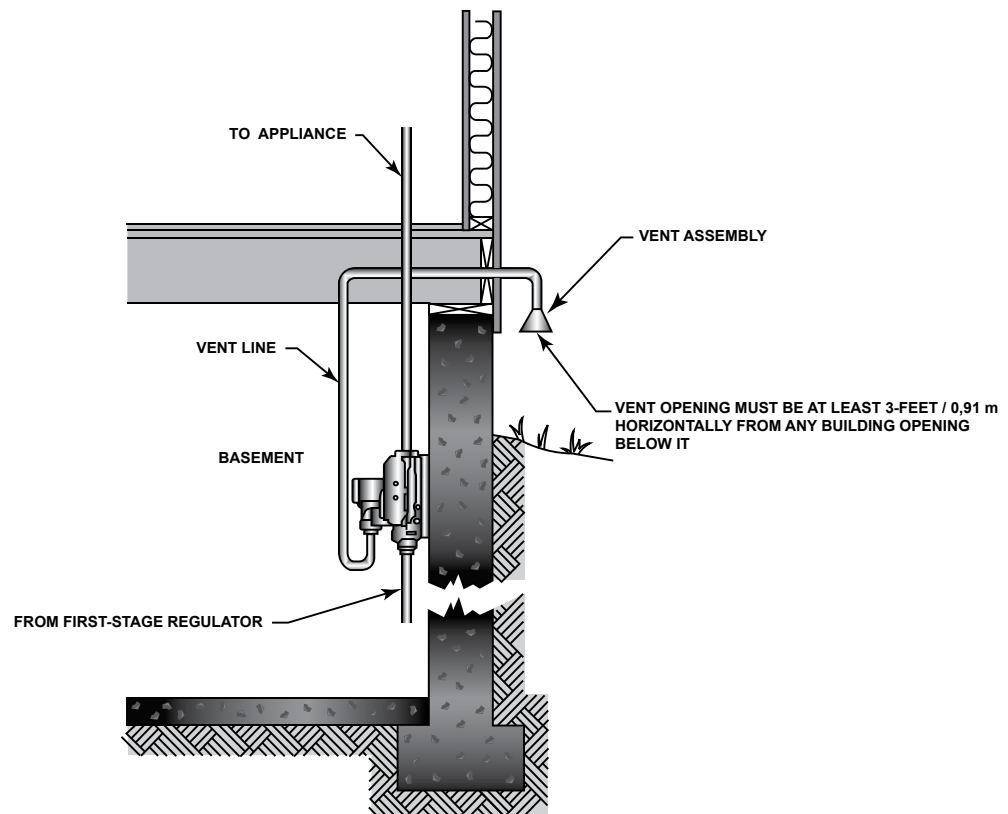

T14445

Figure 13. *Basement or Indoor Installation*

If the regulator cannot be moved to comply with these requirements, then a vent line will have to be installed and the end of the vent line terminated at a place where it will comply with the requirements. The end of the vent line must also comply with the vent orientation and protection requirements discussed earlier.

Regulators Installed Inside Buildings

Regulators are sometimes installed inside a building because of long piping runs to one or more gas appliances. See Figures 12 and 13. Regulators inside buildings have some special conditions that have to be met in order to comply with NFPA 58 requirements. Some of those requirements include:

- No liquid LP-Gas piped into buildings except under certain conditions.
- No vapor pressure in excess of 20 psi / 1,4 bar except under certain conditions. Note also that second-stage regulators are limited to 10 psi / 0,69 bar maximum inlet pressure. So if 20 psi / 1,4 bar is piped into the building, an additional first-stage pressure regulator will have to be installed to maintain 10 psi / 0,69 bar to the second-stage regulators.
- The regulator vent must be piped to the atmosphere outside the building.
- The end of the vent discharge line must comply with the distance requirements from building openings and the vent orientation and protection requirements discussed earlier.
- The vent discharge piping must be the same nominal pipe size as the vent connection piping so as not to restrict the relief capacity and performance of the regulator. Long vent discharge lines may actually require increased pipe sizes to account for piping line loss.
- Vent discharge piping must be
 - Metal pipe or tubing as allowed by the code or
 - PVC material per UL 651, Schedule 40 or 80 Rigid PVC Conduit
- If more than one regulator is installed indoors, separate vent lines must be run from each regulator, or special piping manifolds have to be designed so that discharge from one regulator relief valve will not backpressure the other regulator spring case through the vent connected to the same manifold.



Figure 14. *Is your Second-Stage Regulator under a Snow Bank?*

Regulators Installed in Heavy Snow Areas

Providing a snow shelter over the regulator is a good practice. A snow shelter provides protection for a regulator:

- that is subjected to large and frequent snow falls,
- from accumulation of snow, or drifting snow,
- installed under a roof eave where snow and/or ice may slide off the roof and onto the regulator covering the regulator with snow,
- or even physically fracturing the regulator, inlet or outlet piping and shut-off valve below the regulator.

The snow shelter provides protection from heavy, wet snow that can damage the regulator or piping if it falls onto the regulator. A snow shelter could include any of the following:

- A protective cover manufactured or built to go over the regulator. The protective cover can either be home made or commercially available.
- Installing the regulator high above the snow accumulation or drift; it may be up under the eave (support and protect the inlet and outlet piping).
- Installed indoors and the vent piped to the outside (protect the external vent).

The snow shelter provides protection for the regulator vent so that snow does not drift under and up onto the vent screen. A shelter can provide a larger area, free of snow and ice, in which the regulator is installed. This larger open area allows space for the regulator to breathe or vent gas if the relief valve discharges.

There are many types of snow conditions. Some snow conditions are more porous and allow the regulator to breathe under the snow. But a dense heavy snow can actually block the regulator vent. Thawing and refreezing also produces ice both over the snow surface and potentially around the regulator so that the regulator may actually become incased in ice, again blocking the regulator vent.

Mark the regulator location with a long stick and flag so that the regulator can be located quickly if needed. See Figure 14.

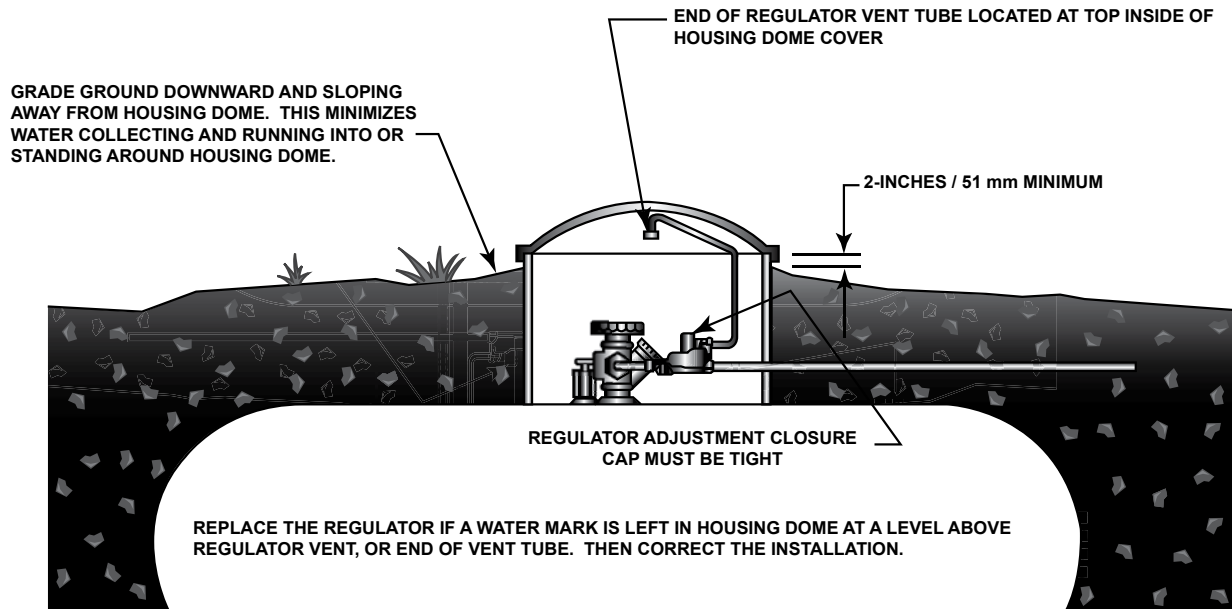

T14448

Figure 15. *Underground Installation*

Regulators Installed in an Underground Container Dome

Regulators, normally a first stage but sometimes an integral two-stage, installed in the dome of an underground container are subjected to a pretty harsh environment -- water, fertilizers, and dirt. These elements can cause excessive corrosion both internally and externally to the regulator. Therefore, ***underground installations should be inspected more often for corrosion and signs of water inside or having covered the regulator.*** Proper installation will minimize the damaging effects while still allowing the regulator to control pressure.

A vent line is required for each regulator vent—one vent on a first-stage regulator and 2 vents on an integral regulator. The vent line should be installed tightly in the vent and terminate in the top of the dome above the water line in the dome. The vent line should have a “U” bend and be screened at the end. See Figure 15.

The closing cap should be on tightly to keep water from seeping into the regulator spring case. If the cap is on tight and water still enters, a gasket or sealing material will have to be used to keep water out.

If water is found inside the regulator, the regulator should be replaced.

If extensive corrosion is visible on the casings, the regulator should be replaced.

Flooded Regulators

A regulator that has been in a flood must be replaced. Not only does water get into the regulator, but so do mud and other debris. Also, floating logs, limbs, and other items can physically hit the regulator causing physical damage that may lead to leakage. The water can cause corrosion as previously discussed. The mud can block the internal relief valve opening and also cause the diaphragm to rot and eventually to leak. These things may not cause problems immediately but will create problems months or years after the event.

Internal and External Corrosion

Corrosion problems are particularly acute on regulators installed near coastlines, around large bodies of water and in buried containers. Regulator models, which have worked for many years in a dry climate, will fail sooner when they were submerged in water from time to time or located in coastal areas.

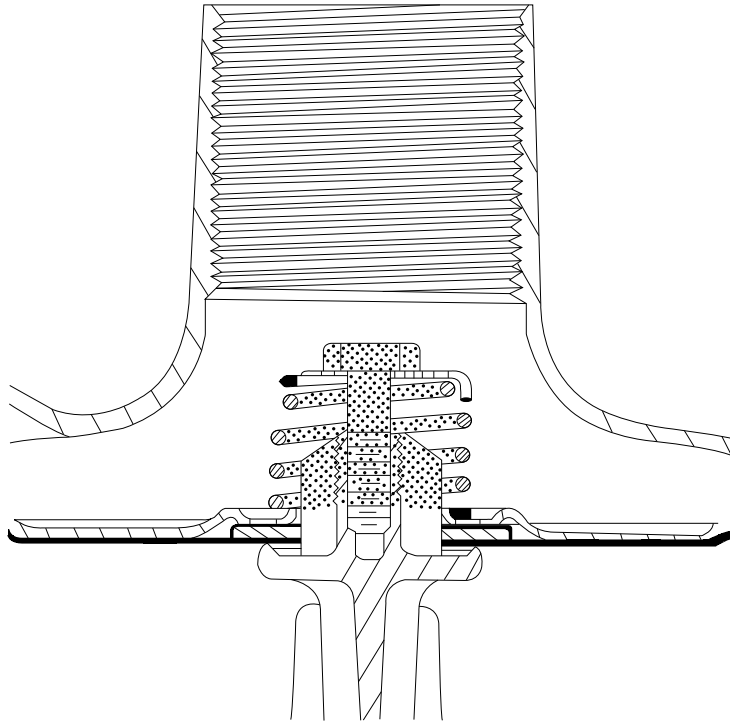

Figure 16. Signs of Corrosion in the Pusher Post and Internal Relief Valve Assembly (shaded area)

A brief visual inspection of the regulator is sufficient to spot signs of external corrosion. External corrosion is normally found on flange screws and fittings. Normally this is more cosmetic in nature than functionally dangerous.

It takes a more inspection time to find internal corrosion and it is internal corrosion that leads to sudden loss of pressure control. Water accumulating inside the spring case can cause corrosion of internal parts. Eventually the pusher post or internal springs can be destroyed, making it impossible for the regulator to operate. For many regulators, it is possible to inspect for internal corrosion without removing the regulator from service.

To inspect a regulator internally:

1. Remove the closing cap and look down into the spring case. A flashlight may be needed for the inspection.
2. Most adjusting screws have a large hole through the middle so that the relief valve area can be seen. If the adjusting screw does not allow you to see the relief valve parts, then it will be necessary to shut down the system to remove the adjusting screw and spring.
3. Look for visible corrosion or watermarks on the shaded area in Figure 16.

4. Replace the regulator if signs of internal corrosion are present.
5. Observe normal start-up precautions for lighting pilots and system pressure tightness when turning the system back on and adjusting the regulator.

Chips and Foreign Material

Pipe scale, dirt, and chips of foreign material can also cause regulator problems. These chips sometimes become trapped between the regulator's orifice and seat disc, refer to Figure 17, preventing the regulator from locking up (shutting off completely). Pressure then becomes too high downstream when the appliances are shut off. The regulator's internal relief valve then opens to prevent a hazardous pressure condition caused by chips and disc wear, but only if the regulator vent is open.

Chips are most likely to be encountered on new installations where there can be foreign material in the pipe or tubing. Another possible problem area is on weekend or summer homes where gas is shut off for a time and then turned back on; the sudden flow surge in the line could dislodge piping scale.

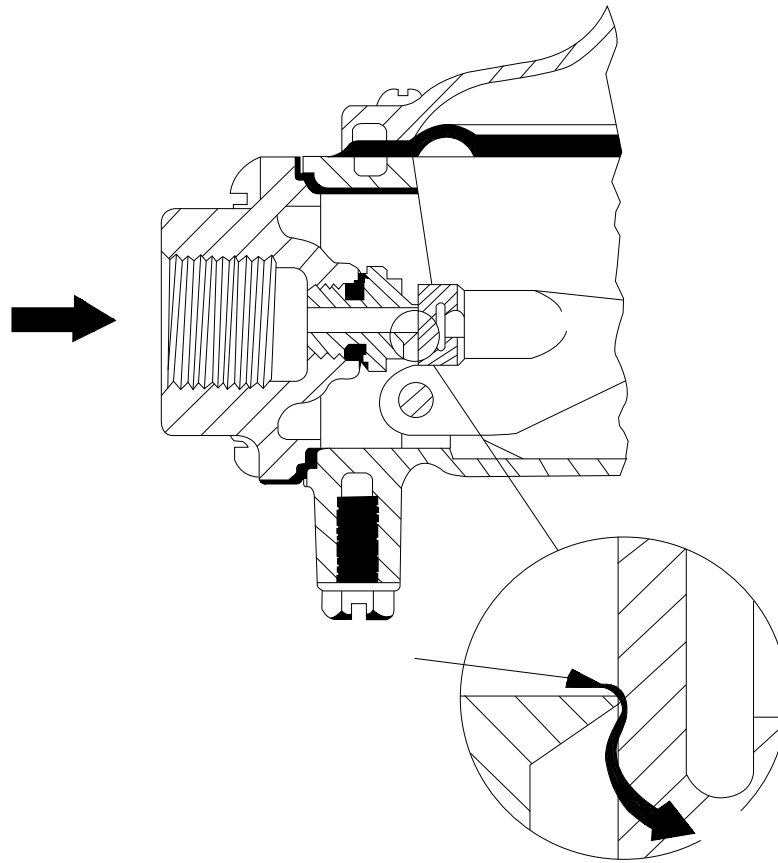

Figure 17. Dirt Preventing Seat Disc from Moving Close Enough to the Orifice

The best approach is to minimize the effect of chips. Blow out pipe and tubing fittings before installing a regulator or when a cylinder is changed out. Don't reuse old copper pigtailed when making new installations because the old copper tube may be brittle or contain scale. Installing second-stage regulators with the inlet pointing down makes it more difficult for chips to enter the regulator inlet and orifice disc interface.

Seat disc indentation can eventually cause pressure variations, but it usually takes a number of years for the disc to become indented enough to give high-pressure difficulties.

If chips or seat indentation damages the regulator's seat disc, the disc has to be replaced. Repaired regulators should be visually inspected and completely tested by qualified personnel before they are returned to service. After the regulator is put back in service, a recheck of the entire system should be conducted.

Regulator Testing

Most regulators can be tested and repaired. A complete regulator test or replacement of parts such as disc, diaphragm, gaskets, or springs will require that the regulator be removed from the gas system. However, a lock-up test, setpoint test, and even a limited flow test can be performed while the regulator is installed on the system without taking the regulator out of service. These tests will give an indication if further testing or regulator replacement or repair is needed because of performance issues.

Most new model regulators have pressure taps that allow easy installation of pressure measuring devices. Use these pressure taps or other pressure tap locations in the system when doing lock-up, setpoint, or a limited flow test.

Refer to your company policy and procedures or contact the factory for additional information on testing regulators.

Setpoint Test

A setpoint test establishes the regulator's setting with a small amount of gas load. Adjust the regulator with a small load (approximately 50,000 BTUs) for a second-stage regulator with a diaphragm casing of about 4 to 5 inches / 102 to 127 mm in diameter. If the setpoint is adjusted with a pilot light load, the accuracy of the setting will vary as the setpoint is too near lock-up. If the setting is made with full load (all appliances are on at one time), the lock-up value during the lock-up test may be too high. Record the pressure gauge reading on the regulator outlet. This is your setpoint.

Lock-up Test

Lock-up is the pressure required to stop flow through the regulator when there is no flow out of the gas system (through an appliance). After adjusting the setpoint, turn off all gas appliances and pilot lights. Record the pressure gauge reading on the regulator outlet. This is your lock-up pressure. The pressure gauge should eventually stop rising. If the pressure continues to increase after about 1 minute, there is a lock-up issue that needs to be fixed.

Limited Flow Test

The limited flow test will tell you the gas delivery pressure with all appliances and gas loads on at the same time. This test is "limited" in that the regulator you are testing is probably capable of supplying 3 or 4 times more gas than the gas system can demand, therefore the term "limited flow test". Record the pressure gauge reading on the regulator outlet. This is your delivery pressure with a high flow rate.

Regulator Repair

In the current economic environment, regulator repair can fall into the realm of diminishing returns. The cost to replace a regulator may be less than the cost for parts, labor, and equipment investment required to repair regulators. Thus, it becomes a company by company decision on repair versus replacing the regulator.

If the regulator is 15 years old or older, just replace the regulator.

Gas Check and/or Other Similar Preventative Maintenance Program

It is imperative that a marketer has a Preventative Maintenance Program for both company owned and customer owned regulators. A Preventative Maintenance Program should schedule the periodic inspection, repair and/or replacement of a regulator prior to its maximum service life or sooner if conditions so dictate. **The PERC Gas Check® program** or another similar Preventative Maintenance Program that inspects, tests and documents the regulator's performance, condition, surroundings and age will be invaluable in preventing a potentially hazardous situation from ever taking place.

It's not very difficult for a serviceperson to make a survey of customer regulators to find the oldest unit. These older units should be inspected for corrosion and aging problems. Regulators of various ages should be examined to get an idea of just how quickly corrosion can become a problem in the particular climate. By doing this a LP-Gas dealer can then identify regulators that need to be replaced.

Questions to Ask About the Regulator Installation

While the following questions may seem obvious and one would think that the situation the question implies could never happen, almost every one of these conditions has occurred. So it is important to reexamine an installation periodically to insure that conditions around the regulator have not changed.

Regulator System Questions

- What type of regulator system is installed?
- Is vapor being piped to the regulator?
- Is there a regulator in the system and is it appropriate for the application?
- Is the final-stage regulator a low-pressure (not a high-pressure or first-stage) regulator?
- For a two-stage or integral regulator system, is there a first-stage and a second-stage regulator?
- If there is only one regulator in the two-stage system, is it an integral regulator that combines both first and second-stage regulators into one construction?
- If this is a 2 psig / 0,14 bar system, is there a first-stage regulator at the tank, a 2 psig / 0,14 bar regulator at the house and a line pressure regulator inside the house?

- On commercial and industrial applications, is the regulator properly sized and does the installation have adequate relief protection?
- Are external relief valve discharge openings open to the atmosphere and protected from the elements?

Regulator Questions

- If the vent is not pointing vertically down, is the regulator covered with a protective cover?
- Does the regulator have a drip lip vent construction?
- If the regulator vent does not have a drip lip design, is an auxiliary vent installed to create a drip lip vent?
- Is the regulator vent or vent line end located at the appropriate distance away from various openings near the regulator?
- Is the line pressure regulator vented properly?
- Is it piped to the outside of the house or does it contain a vent limiter device?
- Is the vent screen in place?
- Is the vent screen plugged with insect remains or insect nests such as mud daubers or wasps?
- Has the vent screen mesh been painted over with paint?
- Has the regulator been covered with dirt from flowerbeds or fill material?
- Has the regulator been enclosed or covered by a building addition such as a porch or new room? If so, does the regulator need to be moved or a vent line added?

- Is the regulator installed under a roof valley or directly under the drip line of a roof overhang or eave?
- Can snow and ice slide off the roof and cause damage to the regulator?
- Does the regulator need additional protection from the elements such as from excessive snow depths?
- Has the regulator been marked so that it can be found when covered by snow?
- Is the regulator 18-inches / 457 mm above the ground level?
- Is the regulator installed in an area prone to flooding?
- Has the regulator been flooded? If so, replace it.

Indoor Regulator/Vent Tube Questions

- Is the regulator inside a building and if so is there a vent line to the outside open air and is that vent line protected with a screened drip lip vent assembly?
- Is the vent line the same size or larger than the regulator vent pipe connection?
- Does the vent line end have an auxiliary vent assembly that is screened, points down, contains a drip lip construction and does not restrict the relief capacity of the regulator's internal relief valve?

Underground Installations

- Is the closing cap in place and on tight?
- On underground tank regulators, does the regulator have a vent line?
- Does the vent line keep water out of the regulator?
- Does it extend up above the water level?

LP-Gas Equipment

Emerson Process Management Regulator Technologies, Inc.

USA - Headquarters
McKinney, Texas 75069-1872, USA
Telephone: +1 800 558 5853
Telephone: +1 972 548 3574

For further information visit www.fisherregulators.com

The Emerson logo is a trademark and service mark of Emerson Electric Co. All other marks are the property of their prospective owners. Fisher is a mark owned by Fisher Controls, Inc., a business of Emerson Process Management.

The contents of this publication are presented for informational purposes only, and while every effort has been made to ensure their accuracy, they are not to be construed as warranties or guarantees, express or implied, regarding the products or services described herein or their use or applicability. We reserve the right to modify or improve the designs or specifications of such products at any time without notice.

Emerson Process Management does not assume responsibility for the selection, use or maintenance of any product. Responsibility for proper selection, use and maintenance of any Emerson Process Management product remains solely with the purchaser.