



Acuvim II Series Power Meter AXM WEB2 User's Manual



Copyright © 2021 V1.13

This manual may not be altered or reproduced in whole or in part by any means without the expressed written consent of Accuenergy.



The information contained in this document is believed to be accurate at the time of publication, however, Accuenergy assumes no responsibility for any errors which may appear here and reserves the right to make changes without notice. Please ask the local representative for latest product specifications before ordering.

Please read this manual carefully before installation, operation and maintenance of the Acuvim II series meter. The following symbols in this manual are used to provide warning of danger or risk during the installation and operation of the meters.



Electric Shock Symbol: Carries information about procedures which must be followed to reduce the risk of electric shock and danger to personal health.



Safety Alert Symbol: Carries information about circumstances which if not considered may result in injury or death.

Prior to maintenance and repair, the equipment must be de-energized and grounded. All maintenance work must be performed by qualified, competent accredited professionals who have received formal training and have experience with high voltage and current devices. Accuenergy shall not be responsible or liable for any damages or injuries caused by improper meter installation and/or operation.

Table of Contents

Chapter 1: Introduction to Ethernet.....	6
1.1 Introduction to Ethernet.....	6
1.1.1 IPv6.....	6
Chapter 2 - Functional Description of the Ethernet module	7
Chapter 3 - Appearance and Dimensions	8
Chapter 4 - Installation Method	9
4.1 Definition of RJ45	10
Chapter 5 - Initializing the Ethernet module.....	11
5.1 Cable.....	19
Chapter 6 - Connection Method.....	20
6.1 Direct Connect to a Computer	20
6.2 Direct Connect to a Router/Switch	24
6.3 Connect through WiFi.....	24
6.4 Description of Modbus-TCP Protocol	24
6.4.1 Protocol	24
a. Data Frame Format	24
b. Modbus Application Header (MBA Header) Field	24
c. Function Field.....	26
d. Data Field	26
6.4.2 Format of communication.....	27
Explanation of frame	27
1) Read Status of Relay (Function code 01)	28
2) Read Status of DI (Function Code 02)	29
3) Read Data (Function Code 03).....	30
4) Control Relay (Function Code05).....	31
5) Preset/Reset Multi-Register (Function Code 16).....	32
Chapter 7 - User Management.....	33
7.1 User Access Login.....	33
7.1.1 User Configuration.....	34
7.2.1 Role Configuration.....	35

7.3.1 Password Policy	36
7.3.1 Password Management	37
7.3.1 API Token Management	37

Chapter 8 - Web Interface Readings and Parameter Settings.....38

8.1 Dashboard	38
8.2 Metering web page	38
8.2.1 Basic Metering	39
8.2.2 Power & Energy	40
8.2.3 Min/Max.....	41
8.2.4 THD.....	41
8.2.5 Harmonics	42
8.2.6 Phase Angles	42
8.2.7 Sequence	43
8.2.8 I/O.....	44
8.3 Logs	45
8.3.1 Trend Log.....	46
8.3.1.1 Realtime	46
8.3.1.2 Energy	47
8.3.1.3 Data Preview	48
8.3.2 Trendlog Management	48
8.3.2.1 Clear Logs	50
8.3.3 Data log.....	51
8.3.3.1 Deleting Data Logs.....	51
8.3.4 Alarm Log	52
8.3.5 SOE Log.....	53
8.3.6 Waveform Log.....	53
8.3.6.1 COMTRADE	56
8.3.7 Event Log	57
8.4 About	57
8.5 Settings.....	58
8.5.1 Meter Settings.....	58

8.5.1.1 General Settings	58
8.5.1.2 IO Settings	65
8.5.1.3 Alarm Settings.....	72
8.5.1.4 Custom Read.....	74
8.5.1.5 Waveform Settings.....	76

Chapter 9 - Communications.....78

9.1 Network	78
9.1.1 RSTP Protocol.....	78
9.1.2 VLAN.....	79
9.1.3 Network Settings	80
9.1.4 Default Routing Interface (Outbound Traffic).....	84
9.2 IPv6	85
9.3 Certificate Management	86
9.4 Access Control	87
9.5 Email	88
9.6 Time/Date	91
9.7 Data Log	93
9.7.1 50ms Fast Log	97
9.7.2 100ms Fast Log.....	99
9.8 Post Channel.....	100
9.9 Waveform Post.....	102
9.10 AcuCloud	103
9.11 BACnet/IP	105
9.12 SNMP	106
9.13 DNP	107
9.14 IEC61850.....	110
9.15 EtherNet/IP	112
9.16 MQTT	112
9.16.1 MQTT General Settings.....	112
9.16.2 MQTT Authentication.....	113
9.16.3 MQTT Encryption.....	114

9.16.4 Last Will & Testament	114
9.16.5 Top and Parameter Selection	115
9.17 Remote Access	117
9.18 Config Management	118
9.18.1 Backup Configuration	120
9.18.2 Export/Apply Configuration	121
9.18.3 Import Configuration	122
Chapter 10 - Management	123
10.1 Parameter Reset	123
10.2 Reboot Meter & Communications Module	123
10.3 Reset to Factory	124
10.4 SSH	124
10.5 Debug Diagnostic	124
10.6 Diagnostic File	125
Chapter 11 - Network Diagnostic.....	126
11.1 Network Status	126
11.2 Host Lookup	127
11.3 Connection Test	127
Chapter 12 Firmware Update.....	128
12.1 Module Firmware Update.....	128
12.1.1 Auto Firmware Update	128
12.1.2 Manual Update	129
12.1.3 Remote Update.....	130
12.2 Meter Firmware Update.....	132
12.2.1 Manual Update	132
12.2.2 Remote Update.....	134
12.3 Emergency Mode	136
Step 1:.....	137
Step 2:.....	138
Step 3:.....	139

Chapter 1: Introduction to Ethernet

The AXM-WEB2 module provides a dual Ethernet and WiFi communication channel for Acuvim II series power meters. Users will be able to use both Ethernet ports and WiFi simultaneously with different networks and data acquisition systems.

This communications module provides users with an industry leading 100ms and 40ms response rate via Modbus TCP that allows users to attain real time updates to key parameters such as voltage, current and power from the Acuvim II Series meter.

1.1 Introduction to Ethernet

Ethernet was originally developed by Xerox and then further developed by DEC and Intel. This networking technology uses Carrier Sense Multiple Access with Collision Detection (CDSM/CD) protocol and provides transmission speeds up to 100Mbps.

Ethernet is not a network but more of a standard. It is the most current communication standard Local Area Network(LAN). This standard defines the type of cable that is used and the method of Signal Processing. The AXM-WEB2 module supports two Ethernet channels.

1.1.1 IPv6

The AXM-WEB2 module also supports IPv6 which is the latest version for the internet protocol. The protocol uses 128-bit addressing in comparison to IPv4 which uses 32-bit addressing. The difference for addressing allows for more devices to be connected using IPv6 as opposed to the IPv4 protocol. The protocol is more efficient and provides more secure routing over the internet.

Chapter 2: Functional Description of the Ethernet module

The AXM-WEB2 module supports a wide range of communication protocols. Some of the more commonly used protocols are briefly explained below.

This module supports the Modbus-TCP protocol. When connected to the Acuvim II series meter, it is a slave device that can only respond to queries. The default value for the Modbus Port is 502. The user defined range is 2000~5999.

The AXM-WEB2 grants users the ability to send emails based on a time interval or when there is a triggered event using the SMTP protocol. It can send mail from encrypted servers and servers that use different SMTP ports.

The AXM-WEB2 protocol supports HTTPS protocol. It is used as an HTTPS server and where the default value of the protocol port is 443. Using the HTTPS protocol, the AXM-WEB2 can send post requests to both HTTP and HTTPS servers.

The following are all the protocols supported by the AXM-WEB2 module:

- Modbus TCP
- IPv6
- RSTP
- BACnet-IP
- SNMP V3
- DNP 3.0 V2
- IEC 61850 2nd Edition
- SMTP, NTP, SNTP
- HTTP/HTTPs
- FTP
- sFTP
- WiFi WPA, WPA2 Enterprise
- Ethernet/IP
- MQTT

Chapter 3: Appearance and Dimensions

The dimensions in the following diagram are in millimeters.

Dimensions listed in the brackets are inches.

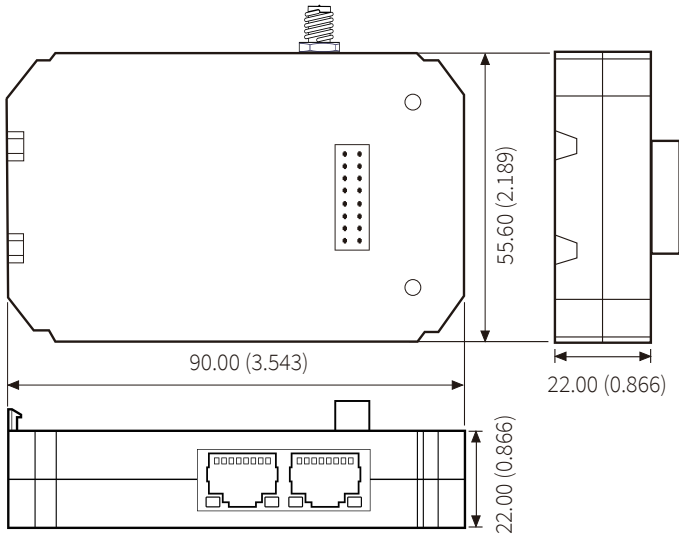

Chapter 4: Installation Method

The AXM-WEB2 module is linked to the Acuvim II series meter by a communication plug. Other extended modules such as the IO modules can be linked to the Acuvim II series meter through the AXM-WEB2.

- 1) Remove cover from the back of the Acuvim II series meter which will expose the socket.
- 2) Insert the installation clips to the grooves in the Acuvim II series meter and then press the AXM-WEB2 module lightly to establish a linking between meter and module.
- 3) Tighten the installation screws.

NOTE: Installation with power to the meter is forbidden. The module must be installed/uninstalled while the meter is powered off.

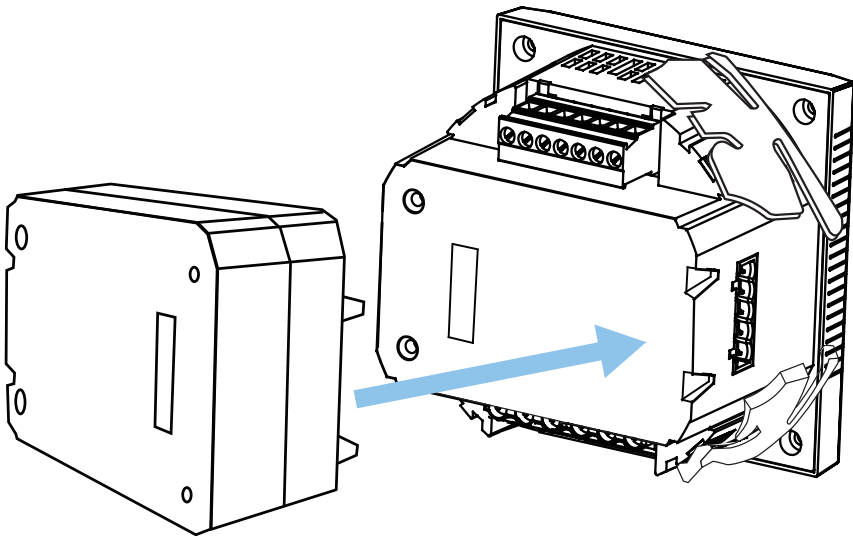

4.1 Definition of RJ45

The AXM-WEB2 uses two standard RJ45 connectors to access the Ethernet network. The mechanical and electrical characteristics of the connector are consistent with the requirements of IEC 603-7.

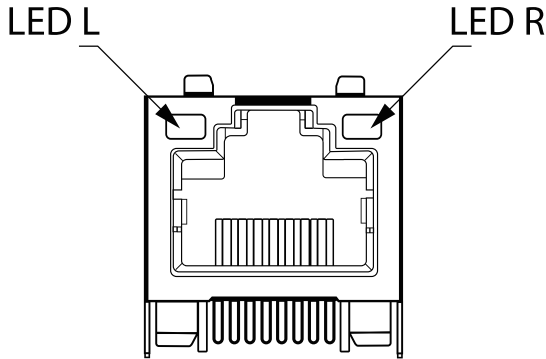

Top View

Pin number	Name	Description
1	TX+	Tranceive Data+
2	TX-	Tranceive Data-
3	RX+	Receive Data+
4	n/c	Not connected
5	n/c	Not connected
6	RX-	Receive Data-
7	n/c	Not connected
8	n/c	Not connected

LED_L (Yellow): Displays the speed status. When the LED is on it indicates 100Mbps, while an off LED represents a speed of 10Mbps.

LED_R (Green): Displays the link and activity status. When the LED is on it indicates the link status. When the LED is flashing it indicates that there is activity.

Chapter 5: Initializing the Ethernet module

The default settings in the Acuvim II series meter are as followed:

Ethernet 1 (Static IP address)

IP Address (192.168.1.254)

Subnet Mask (255.255.255.0)

Gateway (192.168.1.1)

DNS Server 1 (8.8.8.8)

DNS Server 2 (8.8.4.4)

Modbus Port 502

Ethernet 2 (Dynamic IP address)

By default Ethernet 2 is configured for DHCP, meaning the network will dynamically assign its network properties. In order to view the Ethernet 2 IP address from the meters display the Acuvim II meter must be configured to the WEB2 protocol. The following explains how to change the meters protocol settings to work with the WEB2 module:

- Press the 'H' and 'V/A' buttons simultaneously on the Acuvim II series. Release the buttons and the meter will enter the meter selecting mode, as indicated by the flashing 'Meter' cursor.

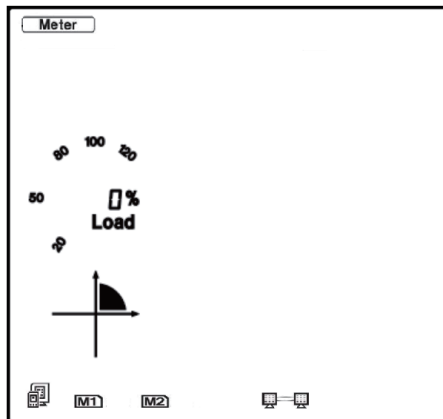

AXM-WEB2 for Acuvim II Series Power Meter

- Press the 'P' or 'E' button to move the cursor to 'Setting'. Press 'V/A' button to enter the parameter setting mode. The device address page is the first page of the 'Setting' mode. It will show the Modbus address of the meter for a second before prompting for the password of the device.
- You will be required to type in a password in the 'PASSWORD' screen. Leave the password as default '0000' and press 'V/A' to enter the parameter selection Mode.

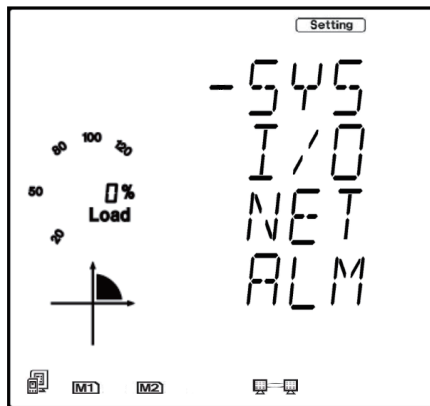
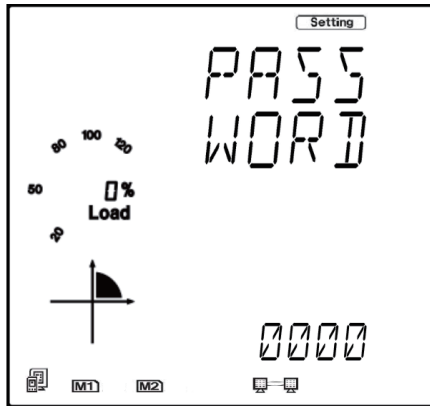

- The cursor will be on 'SYS'. Press 'V/A' on this screen to get to the system settings. This will show screen 'S01 ADDR'.

- Press the 'E' button until you get to 'S34 PROTOCOL 2'. Select the 'WEB2' protocol.
 - Press 'V/A' to modify the setting; the cursor should now flash.
 - Press 'P' or 'E' to select 'WEB2'.
 - Press 'V/A' to confirm the change.

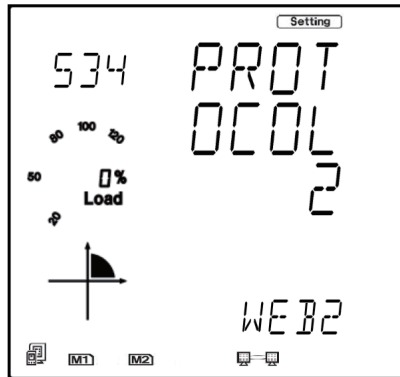

Once the protocol 2 setting of the Acuvim II meter is configured for WEB2, users can now view all necessary settings in the meters NET settings.

Press the 'H' button to exit the system setting, you will be directed to the parameter selection screen.

Press the 'P' or 'E' button to move the cursor to 'NET' and press the 'V/A' button to enter the Ethernet module settings.

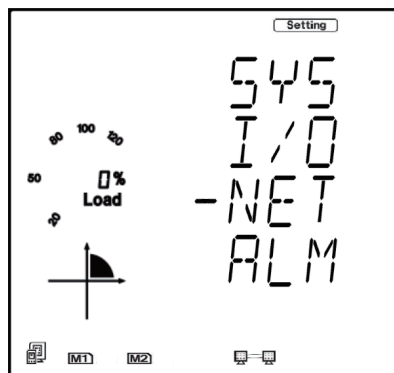

AXM-WEB2 for Acuvim II Series Power Meter

- The first page of the NET Settings will be the N01 DHCP setting. By default this is configured to Manual. Setting this configuration to Auto will allow the router to assign the meter with an IP address, while Manual will allow the user to configure the IP address. Press the 'V/A' button to enter edit mode. Press 'P' or 'E' to change the setting and press 'V/A' to confirm.

NOTE: If the DHCP is selected as Auto, the Ethernet module needs to be rebooted before it can be assigned with the new IP address.

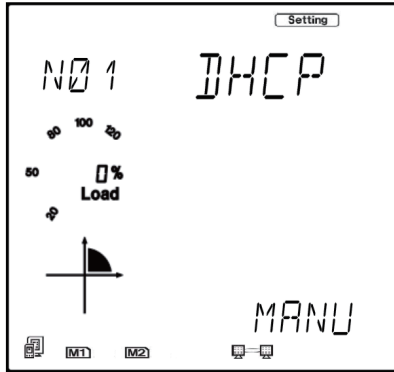

- Press 'P' to get to "N02 IP address". This is the IP address for Ethernet 1 and can be used to access the web interface of the module. Users can configure the IP address if the DHCP is configured to Manual. Press 'V/A' to configure the IP address. The cursor of the first digit will begin to flash. Press the 'H' button to scroll through the digits, press the 'P' or 'E' to change the value of the flashing cursor and press 'V/A' to confirm.



- Press 'P' to get to "N03 Subnet Mask". Press 'V/A' to configure the subnet address. The cursor of the first digit will begin to flash. Press the 'H' button to scroll through the digits, press the 'P' or 'E' to change the value of the flashing cursor and press 'V/A' to confirm.

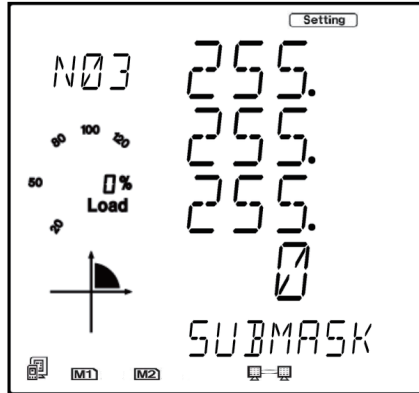

- Press 'P' to get to "N04 Gateway". Press 'V/A' to configure the gateway IP address. The cursor of the first digit will begin to flash. Press the 'H' button to scroll through the digits, press the 'P' or 'E' to change the value of the flashing cursor and press 'V/A' to confirm.

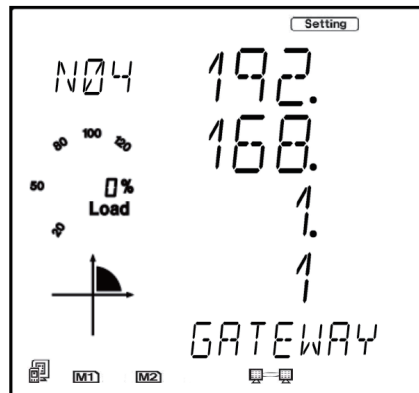

- Press 'P' to get to "N05 DNS Primary Server". Press 'V/A' to configure the DNS address. The cursor of the first digit will begin to flash. Press the 'H' button to scroll through the digits, press the 'P' or 'E' to change the value of the flashing cursor and press 'V/A' to confirm. The DNS parameters must be set correctly to use the SMTP, FTP/HTTP Post and AcuCloud functions.

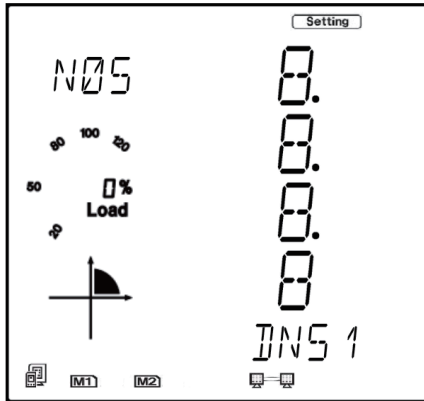

- Press 'P' to get to "N06 DNS Secondary Server". Press 'V/A' to configure the DNS address. The cursor of the first digit will begin to flash. Press the 'H' button to scroll through the digits, press the 'P' or 'E' to change the value of the flashing cursor and press 'V/A' to confirm.

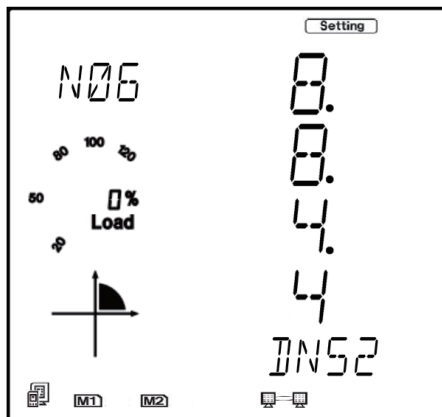

- Press 'P' to get to "N07 Modbus Port". Press 'V/A' to configure the Modbus Port. The cursor of the first digit will begin to flash. Press the 'H' button to scroll through the digits, press the 'P' or 'E' to change the value of the flashing cursor and press 'V/A' to confirm.

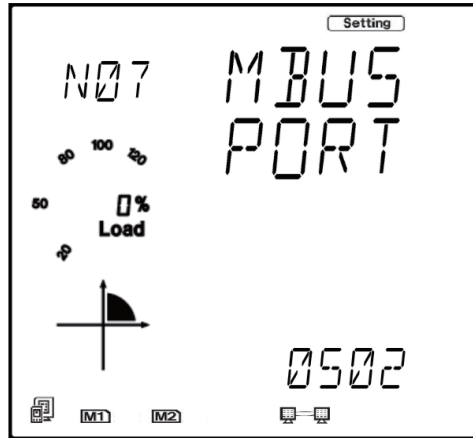

- Press 'P' to get to "N08 HTTP Port". Press 'V/A' to configure the HTTP Port. The cursor of the first digit will begin to flash. Press the 'H' button to scroll through the digits, press the 'P' or 'E' to change the value of the flashing cursor and press 'V/A' to confirm.



AXM-WEB2 for Acuvim II Series Power Meter

- Press 'P' to get to "N09 NET REST". After making any changes to the NET settings, users must reboot the Ethernet module from this page for the settings to take effect. Press 'V/A' to reboot the module, the cursor will begin to flash. Press the 'P' or 'E' button to change the setting to 'Reset' and press 'V/A' to confirm. The cursor will return to 'No' once the module has successfully reset.

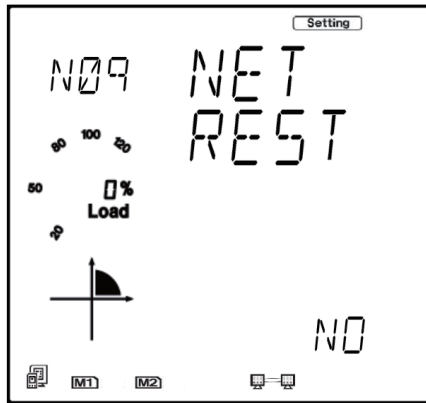

- Press 'P' to get to "N10 PASSREST". Press 'V/A' to configure the password reset. The cursor of the first digit will begin to flash. Press the 'P' or 'E' button to change the setting to 'Reset' and press 'V/A' to confirm. The cursor will return to 'No' once successful.



- Press 'P' to get to "N11 WiFi" This is the IP address of WiFi and will be the IP address to access the web interface of the module by using WiFi connection. This IP address cannot be modified from the meters display, it can only be configured on the meters web server.

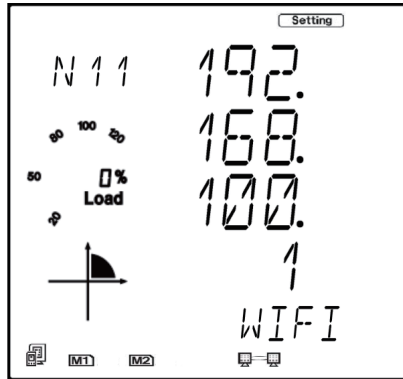

- Press 'P' to get to 'N12 IP2'. This is the IP address for Ethernet port 2, it is preset as dynamic DHCP. A new IP address will be assigned to it when it is connected to the internet via Ethernet port 2.

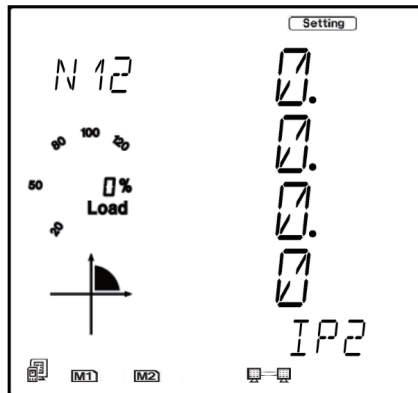

5.1 Cable

An RJ45 cable is needed to connect the meter to the network.

A shielded twisted pair cable(standard 568A or standard 568B) is recommended as reference to the EIA/TIA standard.

Chapter 6: Connection Method

6.1 Direct Connect to a Computer

The AXM-WEB2 can be connected to a computer using a crossover cable(standard 568A). The AXM-WEB2 module supports Modbus-TCP and HTTPS Functions for this method of connection.

To connect meter directly to the computer, the computers IP must be within the same subnet as the meters IP address. The following steps outline how to change the computers IP using a computer running the Windows OS:

- Manually connect the meter via Ethernet cable to the computer
- Right click on the connection icon
- Select "Open Network Sharing Center"

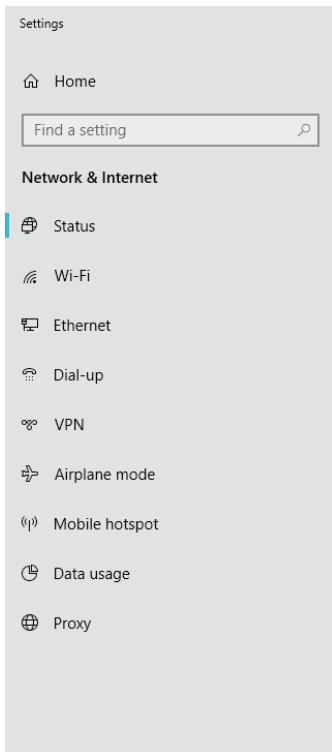

Status

Network status

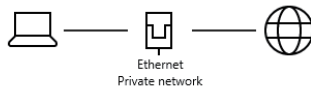

You're connected to the Internet

If you have a limited data plan, you can make this network a metered connection or change other properties.

[Change connection properties](#)

[Show available networks](#)

Change your network settings

 **Change adapter options**
View network adapters and change connection settings.

 **Sharing options**
For the networks you connect to, decide what you want to share.

 **Network troubleshooter**
Diagnose and fix network problems.

[View your network properties](#)

[Windows Firewall](#)

- Click on Change adapter options

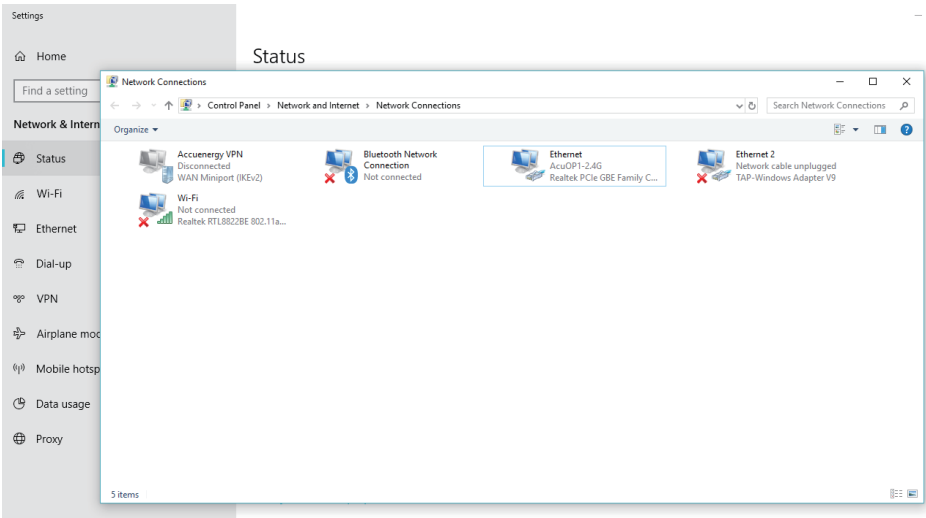

- Once there, right click on the local area connection icon and select properties.

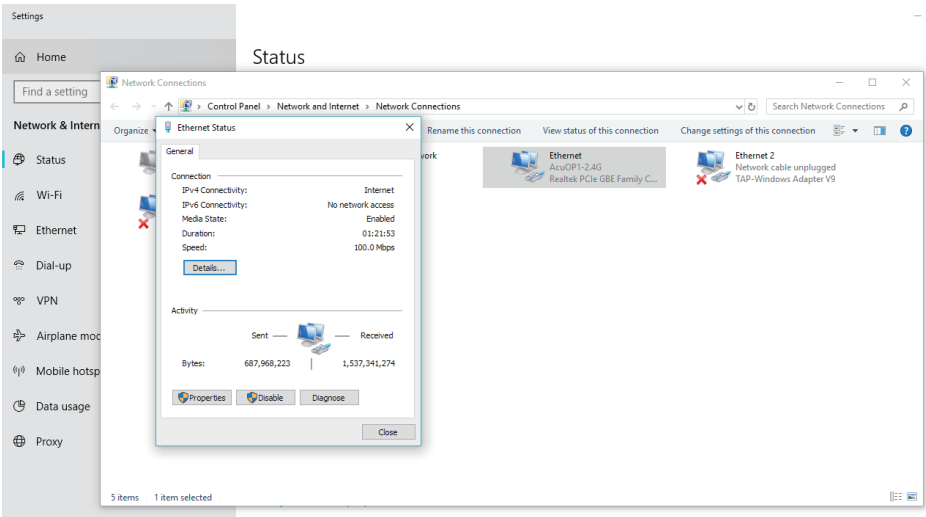

AXM-WEB2 for Acuvim II Series Power Meter

- Select the icon that says Internet Protocol Version 4 TCP/IP

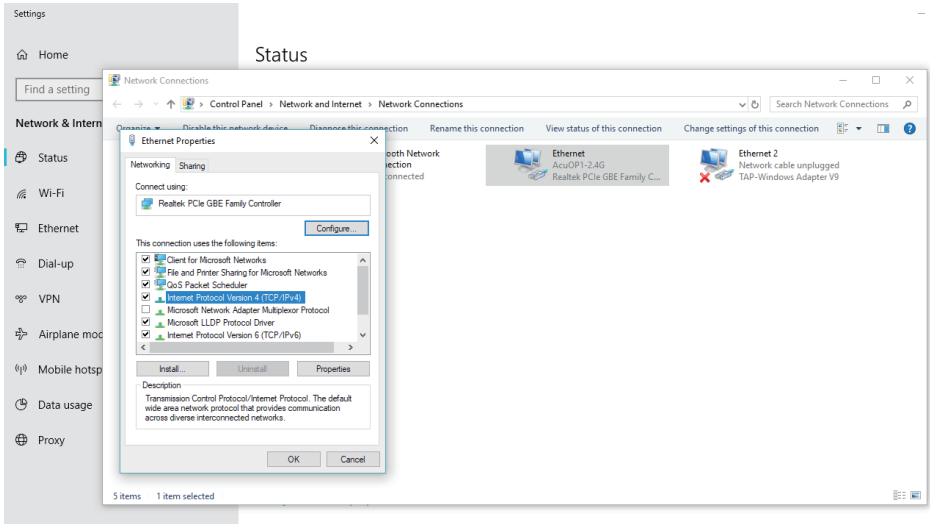

- The Internet Protocol Version 4(TCP/IP) Properties box will pop up

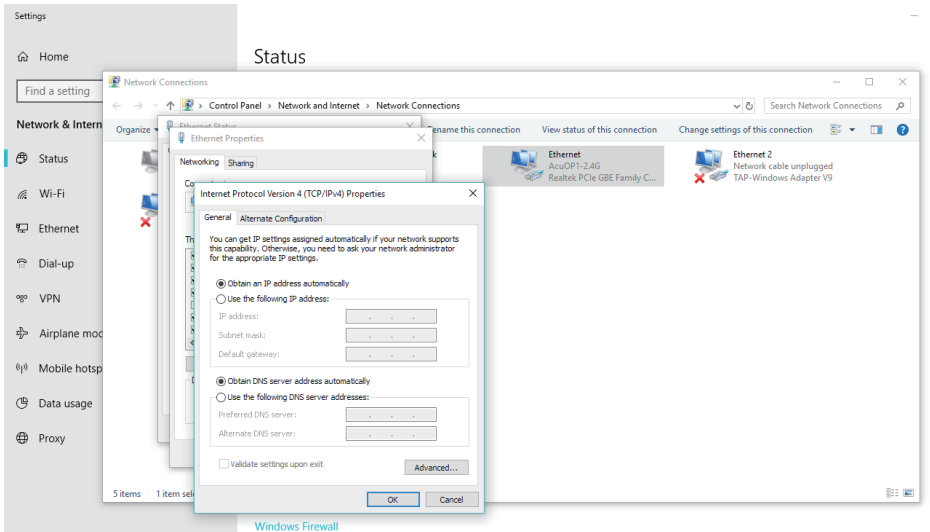

- Click on "Use the following IP address" and enter in an IP number so that meter and computer are in the same local network range. For example, if the meter has IP address of 192.168.1.254, then the computer must be assigned with an IP 192.168.1.xxx, where xxx can be any number but cannot be the same as the value the meter has.

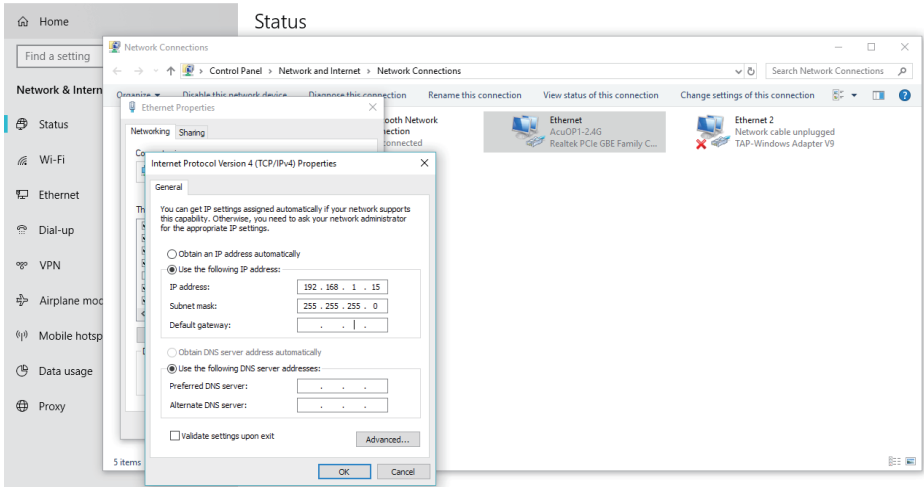

- Once you have entered in the IP address, press the Tab key on your keyboard until you hit the bottom and click OK
- Before selecting the OK button make note of the IP address you have assigned to the meter and then press OK.

NOTE: The meter and computer cannot have the same IP address, they must be different.

6.2 Direct Connect to a Router/Switch

The AXM-WEB2 can be connected to a router or switch using a patch cable. The DHCP can be configured to Auto to have the router assign the meter with an IP address or the DHCP can be configured to Manual to set an IP address and network settings manually.

AXM-WEB 2 has two Ethernet ports, Ethernet 1 is set to have the static DHCP, and Ethernet 2 is set to have the dynamic DHCP. Both of the Ethernet ports have the same functionalities, you can use either of them according to the requirement.

6.3 Connect through WiFi

The AXM-WEB2 can be connected through WiFi network.

By default the AXM-WEB2 will be in Access Point mode with default IP address of 192.168.100.1. Ensure the device connecting to the AXM-WEB2 has DHCP enabled or it should be in the same subnet as the AXM-WEB2. The module will appear in the WiFi network as AXM-WEB2-WIFI-(serial number of module) as the SSID or name of the wireless network. By default, the network key or password will be "accuenergy".

- Once connected to the network, open an internet browser and type in the IP address of the WIFI module: **192.168.100.1**
- Log in at Admin access level, using the default password of '**admin**'.

6.4 Description of Modbus-TCP Protocol

The Modbus-TCP protocol is used as one of the communication protocols in the AXM-WEB2. The protocol establishes a master and slave connection in Ethernet. The master device(client) first sets up a TCP-IP link with slave device(server). The master device then sends a request to the slave device and the slave device in return sends a response to the master device. Figure below shows how the Modbus-TCP protocol works.

6.4.1 Protocol

a. Data Frame Format

MBAP Header	Function	Data
7x8 bits	8-bits	Nx8 bits

b. Modbus Application Header (MBA Header) Field

Modbus application header field is the start of the data frame, and consists of seven bytes.



Field	Length	Description
Transaction Identifier	2 Bytes	Identification of a Modbus Request/Response transaction
Protocol Identifier	2 Bytes	Modbus Protocol = 0
Length	2 Bytes	Number of following bytes
Unit Identifier	1 Byte	Slave address, in the range of 0-247 decimal

c. Function Field

The function code field of a message frame contains eight bits. Valid codes are in the range of 1-255. When a message is sent from a client to a server device, the function code field tells the server what kinds of action to perform.

Code	Meaning	Data
01	Read Relay Output Status	Obtain current status of Relay Output
02	Read Digital Input (DI) Status	Obtain current status of Digital Input
03	Read Data	Obtain current binary value in one or more registers
05	Control Single Relay Output	Force Relay to a state of ON or OFF
16	Write Multiple Registers	Place specific value into a series of consecutive multiple registers

d. Data Field

The data field is constructed using sets of two hexadecimal digits, in the range of 00 to FF. The data field of messages sent from a master to slave contains additional information which the slave must use to take the action defined by the function code. This can include information such as the register addresses, the quantity of registers to query and the count of the actual number of data bytes. For example, if the master requests a slave to read a group of holding registers(function code 03), the data field specifies the starting register and how many registers are to be read.

If the master needs to write data(function code 10 hexadecimal) to a group of registers in the slave, the data field specifies the starting register, how many registers to write, the count of data bytes to follow in the data field and the data to be written into the registers.

6.4.2 Format of communication

Explanation of frame

Transaction identifier hi	Transaction identifier lo	Protocol identifier hi	Protocol identifier lo	Length hi	Length lo	Unit identifier
00H	00H	00H	00H	00H	06H	01H

Function Code	Data start register hi	Data start register lo	Data # of registers hi	Data # of registers lo
03H	40H	00H	00H	48H

The meaning of each abbreviated field above is:

Transaction identifier hi: High byte of transaction identifier

Transaction identifier lo: Low byte of transaction identifier

Protocol identifier hi: High byte of protocol identifier

Protocol identifier low: Low byte of protocol identifier

Length hi: High byte of length

Length lo: Low byte of length

Unit identifier: Slave address

Fun: Function code

Data start register hi: High byte of starting register address

Data start register lo: Low byte of starting register address

Data #of registers hi: High byte of number of registers

Data #of registers lo: Low byte of number of registers

1) Read Status of Relay (Function code 01)

Function Code 1

This function code is used to read the relay output status in the Acuvim II series meter.

1=On 0=Off

There are 8 relay outputs in the Acuvim II series meter and they start at address 0000H.

The following query is to read 2 relay output status of the Acuvim II series address 1.

Query

Transaction identifier hi	Transaction identifier lo	Protocol identifier hi	Protocol identifier lo	Length hi	Length lo	Unit identifier
00H	00H	00H	00H	00H	06H	01H

Fun	Data start register hi	Data start register lo	Data # of registers hi	Data # of registers lo
01H	00H	00H	00H	02H

Response

The Acuvim II series meter responds back with the MBAP header, function code, quantity of data bytes and the data.

An example of response to read the status of the first 2 relay outputs starting at 0000H is shown below. The status of relay output 1 and 2 is corresponds to the last 2 bits of data.

Relay 1: bit0 Relay 2: bit1

Transaction identifier hi	Transaction identifier lo	Protocol identifier hi	Protocol identifier lo	Length hi	Length lo	Unit identifier
00H	00H	00H	00H	00H	04H	01H

Fun	Byte count	Data
01H	01H	02H

The content of the data is,

7	6	5	4	3	2	1	0
0	0	0	0	0	0	1	0

MSB

LSB

(Relay 1 = OFF, Relay 2 = ON)

2) Read Status of DI (Function Code 02)

Function Code 2

1=On

0=Off

There are 28 DIs in the Acuvim II series meter starting at address 0000H.

The following query is to read 4 DI statuses of AXM-IO1 module with logic address of 1 in the Acuvim II series meter.

Query

Transaction identifier hi	Transaction identifier lo	Protocol identifier hi	Protocol identifier lo	Length hi	Length lo	Unit identifier
00H	00H	00H	00H	00H	06H	01H

Fun	Data start register hi	Data start register lo	Data # of registers hi	Data # of registers lo
02H	00H	00H	00H	04H

Response

The response includes the MBAP header, function code, quantity of data characters and the data.

An example response from the meter to read the status of 4 DIs(DI1-On, DI2=On, DI3=On, DI4=On) is shown below. The status of each corresponds to the last 4 bits of the data.

D11: bit0		D12: bit1		D13: bit2		D14: bit3
Transaction identifier hi	Transaction identifier lo	Protocol identifier hi	Protocol identifier lo	Length hi	Length lo	Unit identifier
00H	00H	00H	00H	00H	04H	01H

Fun	Byte count	Data
02H	01H	0FH

The content of the data is,

7	6	5	4	3	2	1	0
0	0	0	0	1	1	1	1

MSB

LSB

3) Read Data (Function Code 03)

Function Code 3

Query

This function allows the user to obtain the measurement results of the Acuvim II series meter.

Below is an example to read 6 registers corresponding to the device clock of the meter, starting at 1040H.

Transaction identifier hi	Transaction identifier lo	Protocol identifier hi	Protocol identifier lo	Length hi	Length lo	Unit identifier
00H	00H	00H	00H	00H	06H	01H

Fun	Data start reg hi	Data start reg lo	Data #of reg hi	Data #of reg lo
03H	10H	40H	00H	06H

An example response is provided to read the time (2006-12-18 14:15:20).

Transaction identifier hi	Transaction identifier lo	Protocol identifier hi	Protocol identifier lo	Length hi	Length lo	Unit identifier
00H	00H	00H	00H	00H	0FH	01H

Fun	Byte count	Data1 hi	Data1 lo	Data2 hi	Data2 lo	Data3 hi	Data3 lo	Data4 hi	Data4 lo	Data5 hi	Data5 lo	Data6 hi	Data6 lo
03H	0CH	07H	D6H	00H	0CH	00H	12H	00H	0EH	00H	0FH	00H	14H

4) Control Relay (Function Code05)

Function Code 5

Query

This function code enables the control of a single relay output in the Acuvim II series meter. Any relay output in the Acuvim II series meter can be controlled on or off starting at 0000H.

Sending the data 'FF00H' will set they relay output on and sending '0000H' will turn it off; all other values are illegal and will not affect they relay output status.

The example below is a request to a Acuvim II series meter to turn on relay output 1.

Transaction identifier hi	Transaction identifier lo	Protocol identifier hi	Protocol identifier lo	Length hi	Length lo	Unit identifier
00H	00H	00H	00H	00H	06H	01H

Fun	Data start reg hi	Data start reg lo	Data #of reg hi	Data #of reg lo
05H	00H	00H	FFH	00H

Response

The normal response to the command request is to retransmit the message as received after the relay output status has been altered.

Transaction identifier hi	Transaction identifier lo	Protocol identifier hi	Protocol identifier lo	Length hi	Length lo	Unit identifier
00H	00H	00H	00H	00H	06H	01H

Fun	Data start reg hi	Data start reg lo	Value hi	Value lo
05H	00H	00H	FFH	00H

5) Preset/Reset Multi-Register (Function Code 16)

Function Code 16

Query

This function code allows the user to modify the contents of a register. The example below is a request to an Acuvim II series meter with device address 1 to preset the CT1(500) and CT2(5) registers. The CT1 data address is 1008H and CT2 is at 1009H.

Transaction identifier hi	Transaction identifier lo	Protocol identifier hi	Protocol identifier lo	Length hi	Length lo	Unit identifier
00H	00H	00H	00H	00H	0BH	01H

Fun	Data start reg hi	Data start reg lo	Data #of reg hi	Data #of reg lo	Byte count	Value1 hi	Value1 lo	Value2 hi	Value2 lo
10H	10H	08H	00H	02H	04H	01H	F4H	00H	05H

Response

The normal response to a preset Multi-Register request including the MBAP Header, function code, data start register and the number of registers is shown below.

Transaction identifier hi	Transaction identifier lo	Protocol identifier hi	Protocol identifier lo	Length hi	Length lo	Unit identifier
00H	00H	00H	00H	00H	06H	01H

Fun	Data start reg hi	Data start reg lo	Data #of reg hi	Data #of reg lo
10H	10H	08H	00H	02H

Chapter 7: User Management

The AXM-WEB2 module supports the HTTPS protocol to allow for the use of a web interface. The user will need to access the AXM-WEB2 web interface to configure the module and use its functions. The web interface allows for remote initial setup of the Acuvim II meter.

The AXM-WEB2 web interface allows for different user access levels where multiple users and role configurations can be made.

To access the web interface the IP address for the WEB2 either Ethernet 1, Ethernet 2 or a WiFi IP address must be known.

7.1 User Access Login

Enter the correct IP address of the module in the search bar of the internet browser to access the web interface of the AXM-WEB2. The user will be redirected to a web page prompting to enter the User Name and the appropriate password for that user. It is recommended that no more than 5 users are logged in at the same time for this level to ensure optimal performance of web interface.

The default User Name is **admin** and the default password for this user name is also **admin**.

User Name: **admin**

Password: **admin**

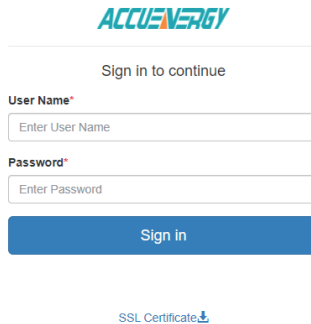

ACCUENERGY

Sign in to continue

User Name*
Enter User Name

Password*
Enter Password

Sign in

SSL Certificate 

7.1.1 User Configuration

The AXM-WEB2 supports the creation of different users for the web interface. Each user can have different roles where the role configuration determines what permission and functions users will have when logged in. To access the User configuration page click on the **User Management** tab and select **User Configuration**.

The user configuration table provides information regarding the access level, such as the register date, expiration date and last login time. If the correct permission is available on the account, users have the option to lock an account, and also edit and delete users.

NOTE: Users cannot lock or delete an account while they are logged into that particular user account.

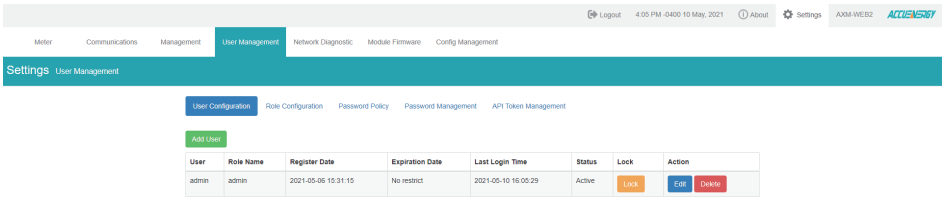

New users can be added where a user name, password, role, and option to override the password policy is available. The role determines the type of access the user will have on the user level created. Users have the option to override the password policy which is a set of rules for allowable passwords on the AXM-WEB2 interface, this includes length and complexity of the password (capital letters, number, special characters, etc.).

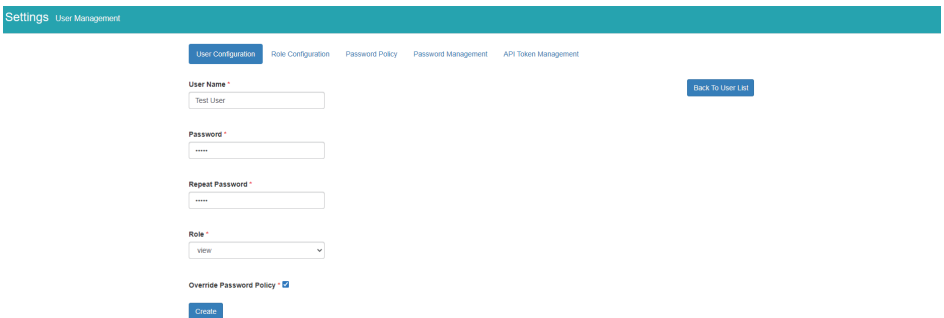

7.2.1 Role Configuration

The role configuration allows users to configure and create different roles for user levels. These roles determine whether the user has edit, view or no access to certain features on the web interface. By default there are two roles on the module, Admin and View. The admin role allows the user to view and configure all settings where as the view role allows users to only view meter readings.

The screenshot shows the 'Role Configuration' page in the AccuEnergy web interface. The page includes a navigation bar with 'Settings' and 'User Management' tabs. Under 'User Management', there are sub-tabs for 'User Configuration', 'Role Configuration', 'Password Policy', 'Password Management', and 'API Token Management'. The 'Role Configuration' sub-tab is active, showing a table with columns: Role Name, Readings Permission, Configuration Permission, Maintenance Permission, User Configuration Permission, and Action. There are two rows: 'view' and 'admin'.

Role Name	Readings Permission	Configuration Permission	Maintenance Permission	User Configuration Permission	Action
view	View	N/A	N/A	N/A	Edit Delete
admin	Edit	Edit	Edit	Edit	Edit Delete

Reading Permissions: Allows users to either edit or view the meter readings, this includes all readings such as real time, energy, harmonics, demand, etc. This also includes access to data logs, trend logs, alarm logs and SOE logs.

Configuration Permissions: Allows users to edit or view the meter configurations such as the CT/PT ratio, alarms, and communication settings.

Maintenance Permissions: Allows users to access Firmware updates, both module and meter firmware update options.

Maintenance Permissions: Allows users to access Firmware updates, both module and meter firmware update options.

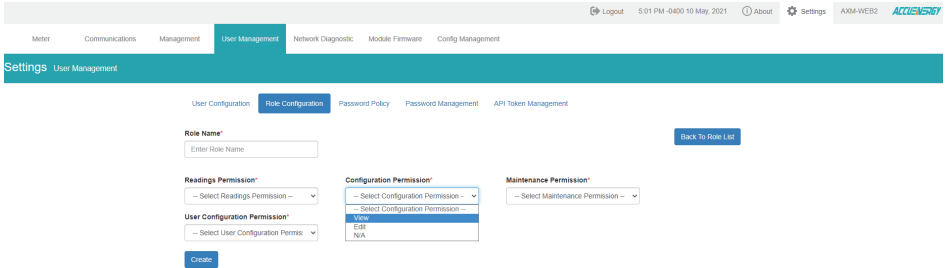

7.3.1 Password Policy

The password policy provides users with a method in ensuring that all passwords created follow specific criteria. The password policy lists specific details relating to the password that some users may find beneficial for security purposes. When creating a user password there is an option to override the password policy if desired.

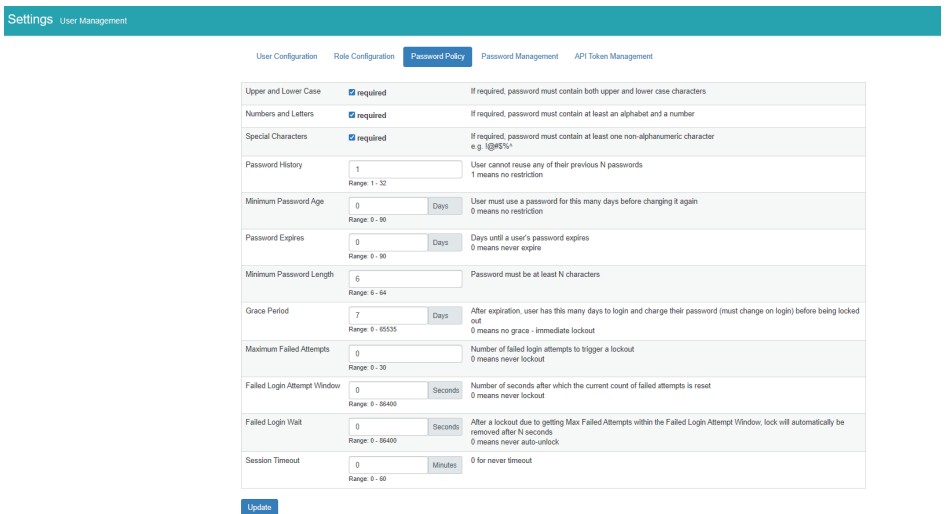

7.3.1 Password Management

The password management page allows users to change the password for the different user levels created.

The screenshot shows the 'User Management' section with the 'Password Management' tab selected. Below the navigation tabs, there is a table with the following data:

User	Role Name	Register Date	Expiration Date	Last Login Time	Status	Action
admin	admin	2021-05-06 15:31:15	No restrict	2021-05-10 16:59:23	Active	Edit
Test	Test Role	2021-05-10 16:48:13	No restrict	2021-05-10 16:58:46	Active	Edit
Test2	Test Role	2021-05-10 16:59:08	No restrict	2021-05-10 16:59:15	Active	Edit

7.3.1 API Token Management

Provides users with the API token for the web interface. This token can be reset and a new one will be generated.

The screenshot shows the 'API Token Management' tab selected. Below the navigation tabs, there is a table with the following data:

Live API Token	Reset API Token
a5e08e32-ef64-d6ba-780e-97673ad3205a	Reset API Token

Chapter 8: Web Interface Readings and Parameter Settings

8.1 Dashboard

In the dashboard, the user will find the tabs to access different pages in the web interface such as **'Metering', 'Logs', and 'Settings'**. The dashboard is the first page the user will see once they have successfully logged in to the meters web interface.

The dashboard displays selected parameters from the different groups of metering parameters such as **'Basic Metering', 'Power & Energy', 'THD'** and **'Max Demand'**. By clicking on "Full report" under any one of these four metering parameter groups the user will be redirected to the web page which contains all the parameters supported by that metering parameter group.

The dashboard also displays how long the AXM-WEB2 module has been connected to the network since the last reboot of the module in the bottom left corner of the page.

The parameters on this page are updated every 5 sec.

The screenshot shows the AXM-WEB2 dashboard interface. At the top, there is a navigation bar with 'Dashboard', 'Metering', and 'Logs' tabs. The main content area is divided into four sections: 'Basic Metering', 'THD', 'Power & Energy', and 'Max Demand'. Each section contains a table of parameters and a 'Full Report' link.

Basic Metering	
Average Voltage	119.977 V
Average Line Voltage	201.067 V
Average Current	1.947 A
Frequency	49.990 Hz
Full Report	

THD	
THD Voltage Average	43.070 %
THD Current Average	0.000 %
Full Report	

Power & Energy	
Total Power Factor	0.917 PF
Total Active Power	0.642 kW
Total Apparent Power	0.701 kVA
Import Active Energy	0.100 kWh
Full Report	

Max Demand	
Maximum Apparent Power Demand	0.700 kVA
Maximum Active Power Demand	0.700 kW
Full Report	

Module up since Mon May 27 2019 16:56:42 GMT+0800 (Eastern Daylight Time)

8.2 Metering web page

Click on the 'Metering' tab to select the different kinds of parameter readings. There are eight kinds of metering parameter web pages including "Basic Metering", "Power & Energy", "Min/Max", "THD", "Harmonics", "Phase Angles", "Sequence" and "I/O". Each web page shows data from the Acuvim II series meter.

Logout 5:03 PM -0400 27 May, 2019
About Settings AXM-WEB2
ACCUENERGY

Dashboard
Metering
Logs
WEB2-TE5

Basic Metering

- Basic Metering Power & Energy
- THD
- Min/Max
- Harmonics
- Phase Angles
- Sequence
- IO

Basic Metering Power & Energy	
Average Voltage	119.974 V
Average Line Voltage	201.048 V
Average Current	1.947 A
Frequency	49.990 Hz
Full Report	

THD	
THD Voltage Average	43.100 %
THD Current Average	0.000 %
Full Report	

Power & Energy	
Total Power Factor	0.917 PF
Total Active Power	0.642 KW
Total Apparent Power	0.701 KVA
Import Active Energy	0.100 KWH
Full Report	

Max Demand	
Maximum Apparent Power Demand	0.700 KVA
Maximum Active Power Demand	0.700 KW
Full Report	

Module up since Mon May 27 2019 16:56:42 GMT-0400 (Eastern Daylight Time)

8.2.1 Basic Metering

The Basic Metering webpage includes the data of real-time parameters for the Acuvim II series meter. This includes the Line Voltages, Phase Voltages, Current, Neutral Current, Active, Reactive and Apparent Power, Power Factor, Frequency and Load type.

The parameters on this page are updated every 1 sec.

The values displayed in this webpage will depend on the wiring configuration mode of the meter. For example, if the meter is configured as '2LL' or '3LL' then the metering webpage will not display the phase readings, only the total values will be shown.

Logout 5:04 PM -0400 27 May, 2019
About Settings AXM-WEB2
ACCUENERGY

Dashboard
Metering
Logs

Metering

- Basic Metering

Parameter	Phase A	Phase B	Phase C	Average	Total
Line-to-Neutral Voltage V	120.027	119.892	120.005	119.975	-
Line-to-Line Voltage V	202.291	200.876	199.779	200.982	-
Current A	1.925	1.890	2.027	1.947	-
Neutral Current A	-	-	-	-	0.000
Active Power kW	0.205	0.210	0.227	-	0.642
Reactive Power kvar	-0.011	-0.005	-0.007	-	-0.023
Apparent Power kva	0.231	0.226	0.243	-	0.700
Power Factor	0.889	0.927	0.935	-	0.917
Frequency Hz	49.990				
Load Type	C				

8.2.2 Power & Energy

The Power & Energy webpage shows the energy data for the Acuvim II series meter such as the Active and Reactive energy that is consumed and delivered as well as the total and per phase Apparent energy. This page also shows the different demand types measured by the Acuvim II meter such as the Active, Reactive, Apparent Power as well as the three phase Current demands.

The parameters in this webpage are updated every 5 sec.

Metering Power & Energy

Manual Edit

Energy by Consumption/Generation

Parameter	Import	Export	Total	Net
Active Energy kWh	154178.7	18886.0	203064.7	165292.7
Reactive Energy kVarh	6363.1	232272.9	258636.0	-245889.8
Apparent Energy kVAh	-	-	-	346178.1

Energy by Phase

Parameter	Phase A	Phase B	Phase C
Import Active Energy kWh	61403.7	61588.0	61162.5
Export Active Energy kWh	9427.8	9458.5	0.3
Import Reactive Energy kVarh	3182.9	3189.2	0.1
Export Reactive Energy kVarh	83960.2	84195.9	84095.3
Apparent Energy kVAh	120652.4	120989.9	104801.6

Demand

Parameter	Phase A	Phase B	Phase C	Total
Active Power Demand kW	-	-	-	7.933
Reactive Power Demand kVar	-	-	-	-10.847
Apparent Power Demand kVA	-	-	-	13.439
Current Demand A	37.430	37.447	37.437	-

From the Power & Energy page user have the option to edit and write new Energy values. Simply click on the 'Manual Edit' button to edit the energy values.

This will be useful for users who want to start and monitor energy accumulation at a certain kilowatt-hour reading. All energy parameters including individual phase, total, import, export, and net for the real, reactive and apparent energies support this feature.

Metering Power & Energy

Manual Edit

Energy by Consumption/Generation

Parameter	Import	Export	Total	Net
Active Energy kWh	154178.7	18886.0	203064.7	165292.7
Reactive Energy kVarh	6363.1	232272.9	258636.0	-245889.2
Apparent Energy kVAh	-	-	-	346178.6

Energy by Phase

Parameter	Phase A	Phase B	Phase C
Import Active Energy kWh	61403.9	61588.1	61162.6
Export Active Energy kWh	9427.8	9458.5	0.3
Import Reactive Energy kVarh	3182.9	3189.2	0.1
Export Reactive Energy kVarh	83960.4	84200.0	84095.4
Apparent Energy kVAh	120652.5	120990.0	104801.8

Demand

Parameter	Phase A	Phase B	Phase C	Total
Active Power Demand kW	-	-	-	7.933
Reactive Power Demand kVar	-	-	-	-10.847
Apparent Power Demand kVA	-	-	-	13.439
Current Demand A	37.430	37.447	37.437	-

Enter new value for Export Active Energy kWh - Phase C

Save Cancel

8.2.3 Min/Max

The Min/Max page shows the maximum and minimum statistics that the meter has recorded since the lifetime of the meter or from the last reset of the min/max statistics. The timestamps they were recorded at is also displayed on this page.

The parameters in this web page are updated every 10 sec.

Parameter	Min	Min Timestamp	Max	Max Timestamp
Phase A Voltage V	0.000	2019-05-23 16:00:25	160.100	2019-05-24 15:58:45
Phase B Voltage V	0.000	2019-05-23 16:00:25	170.000	2019-05-24 12:27:01
Phase C Voltage V	0.000	2019-05-23 16:00:25	173.000	2019-05-24 12:20:30
Line Voltage AB V	0.000	2019-05-23 16:00:25	277.700	2019-05-24 12:27:01
Line Voltage BC V	0.000	2019-05-23 16:00:25	277.800	2019-05-24 12:27:01
Line Voltage CA V	0.000	2019-05-23 16:00:25	277.300	2019-05-24 15:58:45
Phase A Current A	0.000	2019-05-23 16:00:25	235.000	2019-05-24 15:59:09
Phase B Current A	0.000	2019-05-23 16:00:25	225.000	2019-05-23 16:47:58
Phase C Current A	0.000	2019-05-23 16:00:25	225.000	2019-05-24 15:59:09
Active Power kW	-80.000	2019-05-24 15:59:10	70.000	2019-05-23 13:07:30
Reactive Power kvar	0.000	2019-05-23 13:07:30	0.000	2019-05-23 13:07:30
Apparent Power kva	0.000	2019-05-23 16:00:25	80.000	2019-05-24 15:59:10
Power Factor	-1.000	2019-05-23 16:48:19	1.000	2019-05-23 13:07:30
Frequency Hz	0.000	2019-05-23 16:00:25	60.000	2019-05-23 13:07:30
Active Power Demand kW	-70.000	2019-05-23 17:02:27	70.000	2019-05-23 13:22:24
Reactive Power Demand kvar	0.000	2019-05-23 13:07:30	0.000	2019-05-23 13:07:30
Apparent Power Demand kva	0.000	2019-05-23 13:07:30	70.000	2019-05-23 13:22:24
Voltage Unbalance %	0.000	2019-05-23 13:07:30	12.300	2019-05-27 16:53:12
Current Unbalance %	0.000	2019-05-23 13:07:30	100.000	2019-05-27 16:47:26
Phase A Voltage THD %	0.000	2019-05-23 16:00:25	51.140	2019-05-27 16:54:48
Phase B Voltage THD %	0.000	2019-05-23 16:00:25	40.690	2019-05-27 16:54:04
Phase C Voltage THD %	0.000	2019-05-23 13:07:30	37.790	2019-05-27 16:55:40
Phase A Current THD %	0.000	2019-05-23 13:07:30	0.000	2019-05-23 13:07:30

8.2.4 THD

The THD web page shows the power quality data such as the THD, THFF, Crest, and K Factor for both the voltage and current.

The parameters in this web page are updated every 15 sec.

Parameter	Phase A	Phase B	Phase C
THD Voltage %	50.960	40.560	37.690
THD Current %	0.000	0.000	0.000
THD Odd Line Voltage %	26.090	27.480	26.150
THD Even Line Voltage %	43.790	29.670	27.150
Crest Factor Line Voltage	3.570	3.179	3.325
THFF Line Voltage %	27.620	43.690	26.010
THD Odd Current %	0.000	0.000	0.000
THD Even Current %	0.000	0.000	0.000
K Factor Current	0.000	0.000	0.000

8.2.5 Harmonics

The Harmonics web page will show the harmonics of the voltage and the current waveform being measured. It will display the harmonics of each phase in graphical and tabular format. Select between voltage and current to view their respective harmonics as well as between 2nd - 31st harmonics or 32nd - 63rd from the drop-down list.

The parameters in this web page are updated every 15 sec.

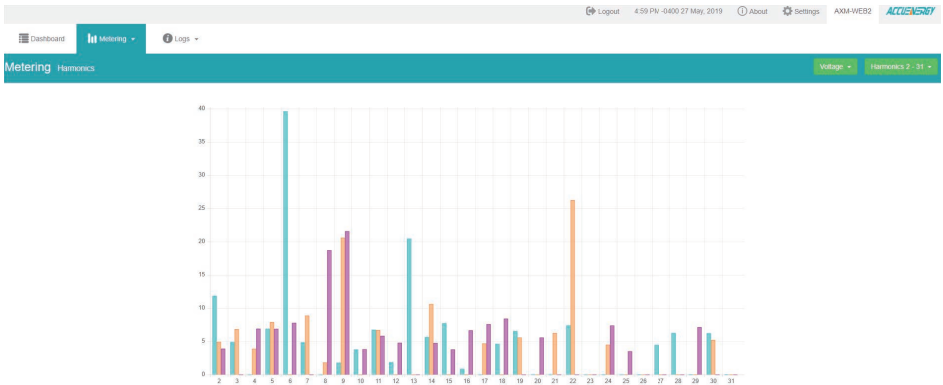

8.2.6 Phase Angles

The Phase Angles web page will show the phase angles of the voltage and current waveform being measured which can be used for remote troubleshooting. This page provides a visual diagram of the phase angles with respect to the voltage connected to the Phase A voltage input.

The parameters in this web page are updated every 10 sec.

Dashboard | Metering | Log In | 5:15 PM 04/27 May, 2019 | About | Settings | AXAMWEB2 | ACCUENERGY

Metering Phase Angles

Parameter	Phase A	Phase B	Phase C
Voltage Phase Angle	0.000	120.000	239.900
Current Phase Angle	357.000	116.600	239.600

All phase angles relative to Phase A

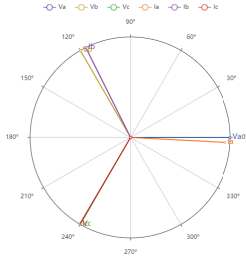

8.2.7 Sequence

The Sequence web page will show the positive, negative and zero components of the voltage and current waveform being measured.

The parameters in this web page are updated every 10 sec.

Metering **sequence**

Sequence			
Parameter	Positive	Negative	Zero
Voltage	109.500	1.612	1.530
Real Voltage	109.500	-1.600	-1.500
Imaginary Voltage	0.000	-0.200	0.300
Current	0.019	0.000	0.000
Real Current	0.019	0.000	0.000
Imaginary Current	0.000	0.000	0.000

Unbalance	
Voltage Unbalance Factor %	1.458
Current Unbalance factor %	0.000

Positive Sequence
 Negative Sequence
 Zero Sequence

Va Vb Vc Ia Ib Ic

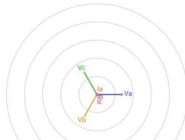

Phase V: $109.5 + 0j$
 Phase I: $0.019 + 0.000j$
 Vrms: 109.5v
 I rms: 0.019A
 ϕ value: 0.0°

8.2.8 I/O

The I/O web page displays the status of the I/O modules that are connected and their values depending on the model of the module that is connected to the meter. I.E. The AXM-IO11 module will display the Relay Output status(on/off), DI status/counter. The I/O module can be configured in the general settings section of the web interface which is discussed later in the manual.

The parameters in this web page are updated every 5 sec.

From the IO readings page, users can perform the following functions depending on the IO module being used:

IO Module	Functions
AXM-IO1-1/2	<ul style="list-style-type: none"> • Read Digital Input Status or Digital Input Count value depending on the mode configured (Channels 1-6) • Read the Relay Output Channel 1 and 2 Status ON/OFF • Toggle Relay Output Channels 1 and 2 ON/OFF <p>NOTE: Relay must be configured for Control Mode for toggle function to work</p> <ul style="list-style-type: none"> • Reset DI Counter back to 0 (Counters 1-6)
AXM-IO2-1/2	<ul style="list-style-type: none"> • Read Digital Input Status or Digital Input Count value depending on the mode configured (Channels 1-4) • Read value of the Analog Output Channels 1 and 2, either 4-20mA, 0-20mA, 0-5V, 1-5V signals • Reset DI Counter back to 0 (counters (1-4)
AXM-IO3-1/2	<ul style="list-style-type: none"> • Read Digital Input Status or Digital Input Count value depending on the mode configured (Channels 1-4) • Read the Relay Output Channel 1 and 2 Status ON/OFF • Toggle Relay Output Channels 1 and 2 ON/OFF <p>NOTE: Relay must be configured for Control Mode for toggle function to work</p> <ul style="list-style-type: none"> • Read Analog Input Channels 1 and 2, either 4-20mA, 0-20mA, 0-5V, 1-5V signals • Reset DI Counter back to 0 (Counters 1-4)

The screenshots show the configuration pages for four AXM modules:

- AXM-IO1-1 Module:** Shows Relay Output (RO1, RO2) with toggle switches, and Digital Input (DI1-DI6) counters. A 'Reset DI Counter' button is present.
- AXM-IO1-2 Module:** Shows Relay Output (RO1, RO2) with toggle switches, and Digital Input (DI1-DI6) counters. A 'Reset DI Counter' button is present.
- AXM-IO2-1 Module:** Shows Analog Output (AO1, AO2) with voltage readings (2.500V) and Digital Input (DI1-DI4) status indicators. A 'Reset DI Counter' button is present.
- AXM-IO3-2 Module:** Shows Analog Output (AO1, AO2) with voltage readings (2.500V) and Digital Input (DI1-DI4) status indicators. A 'Reset DI Counter' button is present.

8.3 Logs

Click on the 'Logs' tab to visit the metering logs web pages.

There are six kinds of logs that can be viewed, they are "Trend Log", "Trendlog Management", "Data Log", "Alarm Log", "SOE Log", "Event Log" and "Waveform Log" (Only available in Acuvim IIW model).

The screenshot shows the main dashboard with the 'Logs' menu open. The menu options are:

- Trend Log
- Trend Log Management
- Data Log
- Alarm Log
- SOE Log
- Waveform Log
- Event Log

The dashboard displays the following data:

Basic Metering	
Average Voltage	118.831 V
Average Line Voltage	0.000 V
Average Current	10.986 A
Frequency	60.020 Hz
Full Report	

Power & Energy	
Total Power Factor	0.600 PF
Total Active Power	2.350 KW
Total Apparent Power	3.915 KVA
Import Active Energy	3257.2 KWh
Full Report	

THD	
THD Voltage Average	2.500 %
THD Current Average	120.710 %
Full Report	

Max Demand	
Maximum Apparent Power Demand	4.410 KVA
Maximum Active Power Demand	2.340 KW
Full Report	

Module up since Fri Dec 04 04:20:20 21:37:51 GMT+0500 (Eastern Standard Time)

8.3.1 Trend Log

The Trend Log web page includes the real-time and energy trend diagram. The real-time trend log diagram can be selected to show the following parameters phase voltage, line voltage, current, active power, reactive power, apparent power and power factor for each phase as well as the totals. The energy trend log shows the imported and exported active energy, reactive energy, total energy, net energy and apparent energy.

The data of the trend log can be previewed and downloaded as a .csv file by clicking the 'Data Review' and 'Data' icons on the right top side of the diagram. The trend log diagram can also be saved as an image by clicking the 'Image' icon.

8.3.1.1 Realtime

The real time parameters can be trended at different time intervals depending on the Time Frame selected. Listed below are the time intervals for each possible time frame setting:

Time Frame	Time Intervals
Last 10 minutes	1 second 15 seconds 1 minute
Last 1 Hour	1 minute
Today	15 minutes 1 hour
Yesterday	15 minutes 1 hour
Last 7 days	15 minutes 1 hour 1 day
Last 30 days	1 hour 1 day
Last Month	1 hour 1 day
Custom Range	Dependent on range specified

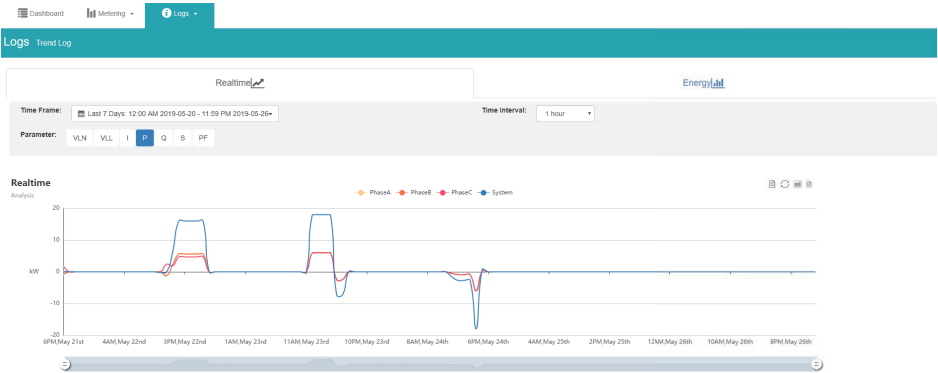

8.3.1.2 Energy

Similarly the energy parameters can be trended at different time intervals depending on the Time Frame selected. The table below displays the time intervals:

Time Frame	Time Intervals
Last 10 minutes	15 seconds 1 minute
Last 1 Hour	1 minute
Today	15 minutes 1 hour
Yesterday	15 minutes 1 hour
Last 7 days	15 minutes 1 hour 1 day
Last 30 days	1 hour 1 day
Last Month	1 hour 1 month
Custom Range	Dependent on range specified

AXM-WEB2 for Acuvim II Series Power Meter

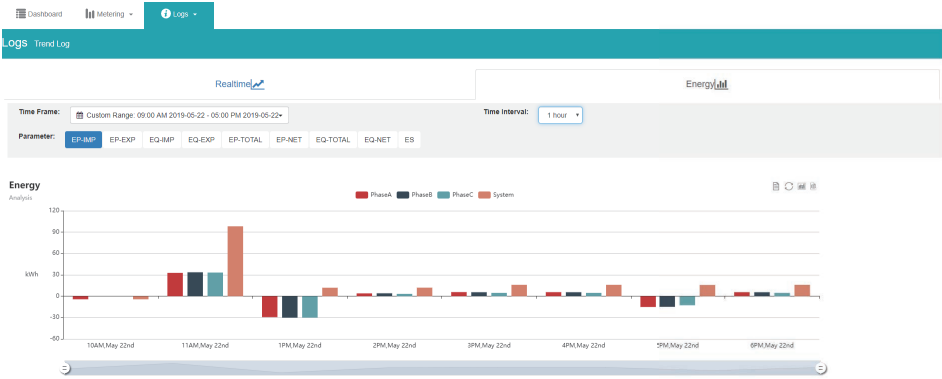

8.3.1.3 Data Preview

The data preview allows the user to view the graphical data in tabular form.

User can also download this data into a csv file for further examination.

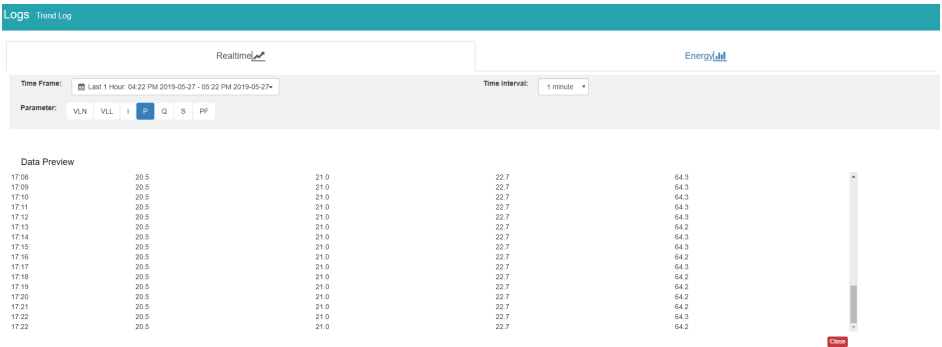

8.3.2 Trendlog Management

The trendlog management page allows the user to download data from the meters data base.

The trendlog management page acts as a back up to the data logs for users.

Log Param Type: Users can select which data they want to download from the meter. In the drop down menu there is a timestamp range to show the available data.

NOTE: Energy data will remain in meter data base for up to years, whereas all other metering data will remain in the meter data base for up to 1 month before overriding.

Log Param Type Detail: This setting allows users to modify what values they see in the data log. Users can select the following parameter details:

- Instantaneous
- Minimum
- Maximum
- Average

Only the 'Real-time' and 'Demand' parameters support the minimum, maximum and average parameter type details. All other parameter types such as Energy, Power Quality, and IO only support the instantaneous values displayed in the the data log.

The log file will be downloaded as a .gz file and will need to be unzipped in order to view the csv file.

TrendLog Management

Log Param Type

Real-Time (2019-08-06 - 2019-12-16) ▼

Not selected

Selected

- Line-to-Neutral Voltage
- Line-to-Line Voltage
- Line Current
- Neutral Current
- Active Power
- Reactive Power
- Apparent Power
- Power Factor
- Frequency
- Load Type

>

<

All

Clear

Log Param Type Detail

Instantaneous Value

Minimum Value

Maximum Value

Average Value

Start Time 2019-08-06

End Time 2019-12-16

Log Interval

Trend log file is ready. (Generating new file will delete current file)

Filename: AN20190502-2019-12-10T15-14-45-0500-5min.csv.gz ✖

Note: File size is 112.82 KB, delete file to free up disk space.

8.3.2.1 Clear Logs

The clear logs function allows the user to clear and remove all metering data stored on the module database. This will allow users to clear all readings and historical data without resetting all features and functions. Users can clear the logs by clicking on the button at the bottom of the Trendlog page.

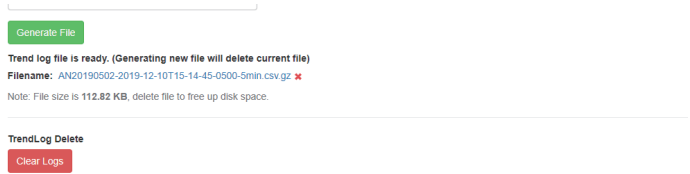

To clear the logs click on "Clear Logs", a warning message is displayed notifying users that this action is irreversible once done.

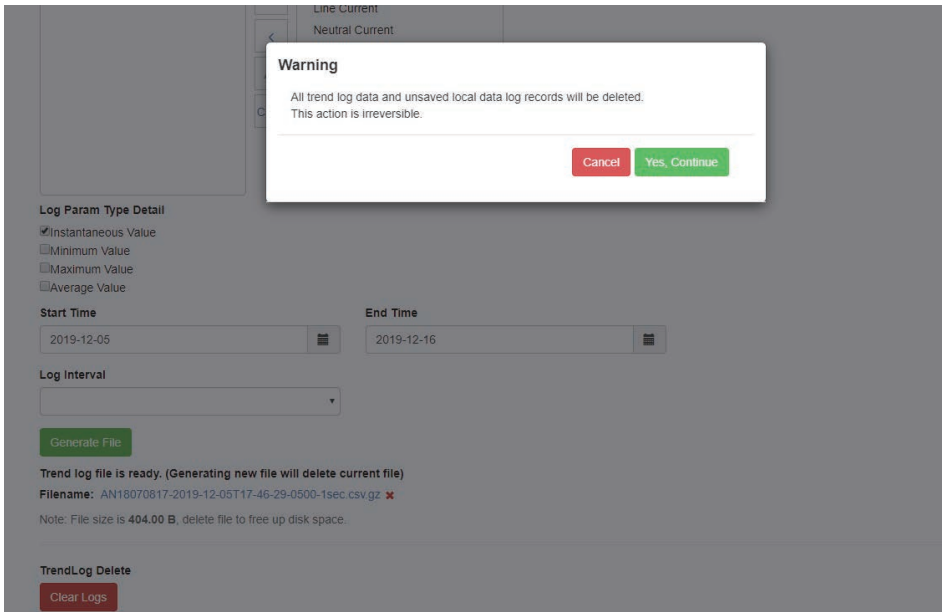

NOTE: This cannot be undone, once the trend log is cleared all data in meter database is cleared.

8.3.3 Data log

The data log web page includes all the data log files for the three different loggers, Acucloud, and 50/100ms loggers.

You can select the different loggers by clicking the logger tab. After the logger is selected, the log file for this logger will show on the screen with the update time and file size. To download the file, click on the download icon to save the file in the computer. The data log will be saved as a compressed csv file.

Select All	Files	Updated at	Size
<input type="checkbox"/>	ANZ0096925-kogger1-2021-04-01T11:00:00-0400-1sec-backup.csv.gz	2021-04-01 11:00:37	18 KB
<input type="checkbox"/>	ANZ0096925-kogger1-2021-04-01T14:00:00-0400-1sec-backup.csv.gz	2021-04-01 14:00:37	18 KB
<input type="checkbox"/>	ANZ0096925-kogger1-2021-04-01T13:00:00-0400-1sec-backup.csv.gz	2021-04-01 13:00:33	18 KB
<input type="checkbox"/>	ANZ0096925-kogger1-2021-04-01T12:00:00-0400-1sec-backup.csv.gz	2021-04-01 12:00:37	17 KB
<input type="checkbox"/>	ANZ0096925-kogger1-2021-04-01T10:00:00-0400-1sec-backup.csv.gz	2021-04-01 10:00:39	18 KB
<input type="checkbox"/>	ANZ0096925-kogger1-2021-04-01T09:00:00-0400-1sec-backup.csv.gz	2021-04-01 09:00:34	18 KB
<input type="checkbox"/>	ANZ0096925-kogger1-2021-04-01T08:00:00-0400-1sec-backup.csv.gz	2021-04-01 08:00:36	18 KB
<input type="checkbox"/>	ANZ0096925-kogger1-2021-04-01T07:00:00-0400-1sec-backup.csv.gz	2021-04-01 07:00:32	18 KB
<input type="checkbox"/>	ANZ0096925-kogger1-2021-04-01T06:00:00-0400-1sec-backup.csv.gz	2021-04-01 06:00:32	18 KB
<input type="checkbox"/>	ANZ0096925-kogger1-2021-04-01T05:00:00-0400-1sec-backup.csv.gz	2021-04-01 05:00:39	18 KB
<input type="checkbox"/>	ANZ0096925-kogger1-2021-04-01T04:00:00-0400-1sec-backup.csv.gz	2021-04-01 04:00:35	18 KB
<input type="checkbox"/>	ANZ0096925-kogger1-2021-04-01T03:00:00-0400-1sec-backup.csv.gz	2021-04-01 03:00:36	18 KB
<input type="checkbox"/>	ANZ0096925-kogger1-2021-04-01T02:00:00-0400-1sec-backup.csv.gz	2021-04-01 02:00:37	18 KB
<input type="checkbox"/>	ANZ0096925-kogger1-2021-04-01T01:00:00-0400-1sec-backup.csv.gz	2021-04-01 01:00:36	18 KB
<input type="checkbox"/>	ANZ0096925-kogger1-2021-04-01T00:00:00-0400-1sec-backup.csv.gz	2021-04-01 00:01:01	18 KB
<input type="checkbox"/>	ANZ0096925-kogger1-2021-03-31T23:00:00-0400-1sec-backup.csv.gz	2021-03-31 23:00:33	18 KB

8.3.3.1 Deleting Data Logs

To delete the data logs users can check the box next to the data log file and click on the 'Delete Selected' button at the bottom of the page.

Users will be prompted by a window asking to confirm the data log delete.

NOTE: *Deleting the data log is permanent, this cannot be undone once deleted.*

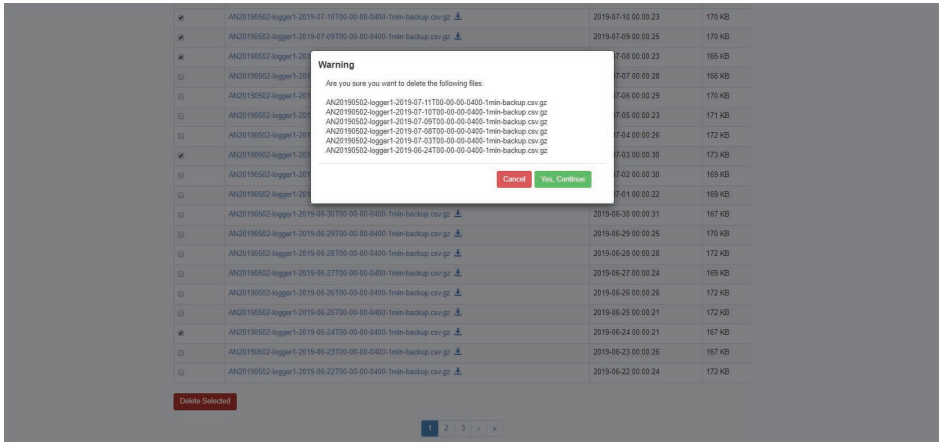

8.3.4 Alarm Log

The Alarm Log web page provides the user with a summary of the alarm events that have occurred with the meter. It will show the status of up to 16 alarm events indicating the alarm ID, status, parameter, value that exceeded or went below the threshold and the timestamp of the alarm event.

Once all 16 alarm events are full, the newest alarm event will then wrap around to alarm 1. The parameters in the alarm status web page are updated every 10 seconds.

Dashboard Metering **Logs** Alarm Log

Logout 12:59 PM -0400 27 Aug, 2019 About Settings AXM-WEB2 ACCUENERGY

Timestamp	Alarm ID	Parameter	Value	Status
2019-08-27 12:56:44.839	4	Phase A Voltage	118.900V	Alarm
2019-08-27 12:56:44.839	5	Total Active Power	7.800kW	Alarm
2019-08-27 12:56:44.839	15	Phase A Reactive Power	-3.300kvar	Alarm
2019-07-22 10:13:28.939	1	Frequency	59.970Hz	Cleared
2019-07-22 07:30:17.390	1	Frequency	59.950Hz	Alarm
0000-00-00 00:00:00.000	0	Frequency	0.000Hz	Cleared
0000-00-00 00:00:00.000	0	Frequency	0.000Hz	Cleared
0000-00-00 00:00:00.000	0	Frequency	0.000Hz	Cleared
0000-00-00 00:00:00.000	0	Frequency	0.000Hz	Cleared
0000-00-00 00:00:00.000	0	Frequency	0.000Hz	Cleared
0000-00-00 00:00:00.000	0	Frequency	0.000Hz	Cleared
0000-00-00 00:00:00.000	0	Frequency	0.000Hz	Cleared
0000-00-00 00:00:00.000	0	Frequency	0.000Hz	Cleared
0000-00-00 00:00:00.000	0	Frequency	0.000Hz	Cleared
0000-00-00 00:00:00.000	0	Frequency	0.000Hz	Cleared
0000-00-00 00:00:00.000	0	Frequency	0.000Hz	Cleared
0000-00-00 00:00:00.000	0	Frequency	0.000Hz	Cleared

8.3.5 SOE Log

The SOE web page will display the Sequence of Event log for the enabled I/O module that is attached to the Acuvim II series meter with timestamps and will display the DI status for up to 20 SOE events.

The SOE log parameters are updated every 10 sec.

Group	DI1 Status	DI2 Status	DI3 Status	DI4 Status	DI5 Status	DI6 Status	Timestamp
Group 1	OK	OK	OK	OK	OK	OK	2018-12-19 17:46:28
Group 2	OK	OK	OK	OK	OK	OK	2018-12-19 17:46:34
Group 3	OK	OK	OK	OK	OK	OK	2018-12-19 17:46:34
Group 4	OK	OK	OK	OK	OK	OK	2018-12-20 08:46:50
Group 5	OK	OK	OK	OK	OK	OK	2018-12-20 08:46:57
Group 6	OK	OK	OK	OK	OK	OK	2018-12-20 10:32:41
Group 7	OK	OK	OK	OK	OK	OK	2018-12-20 10:32:41
Group 8	OK	OK	OK	OK	OK	OK	2018-12-20 10:32:41
Group 9	OK	OK	OK	OK	OK	OK	2018-12-20 10:32:49
Group 10	OK	OK	OK	OK	OK	OK	2018-12-13 13:22:03
Group 11	OK	OK	OK	OK	OK	OK	2018-12-13 08:50:12
Group 12	OK	OK	OK	OK	OK	OK	2018-12-13 08:50:22
Group 13	OK	OK	OK	OK	OK	OK	2000-00-00 00:00:00
Group 14	OK	OK	OK	OK	OK	OK	2018-12-17 08:53:36
Group 15	OK	OK	OK	OK	OK	OK	2018-12-17 08:53:42
Group 16	OK	OK	OK	OK	OK	OK	2018-12-17 15:18:14
Group 17	OK	OK	OK	OK	OK	OK	2018-12-17 15:18:21
Group 18	OK	OK	OK	OK	OK	OK	2018-12-19 17:45:17
Group 19	OK	OK	OK	OK	OK	OK	2018-12-19 17:45:26
Group 20	OK	OK	OK	OK	OK	OK	2018-12-19 17:46:24

8.3.6 Waveform Log

The waveform log is available only on Acuvim I1W models of the Acuvim II series meter. This meter supports a waveform capture function that allows users to capture and record 10 cycles before and after the triggering point whether it be a voltage sag, swell, or over current. The waveform log on the web interface allows users to view these waveforms whenever a power quality event has occurred. The log displays is a table that includes the waveform files, the time the waveform is updated at, and the size of the file. The waveform file name includes the timestamp when the event occurred as well as the parameter name/event name that triggered the power quality event.

AXM-WEB2 for Acuvim II Series Power Meter

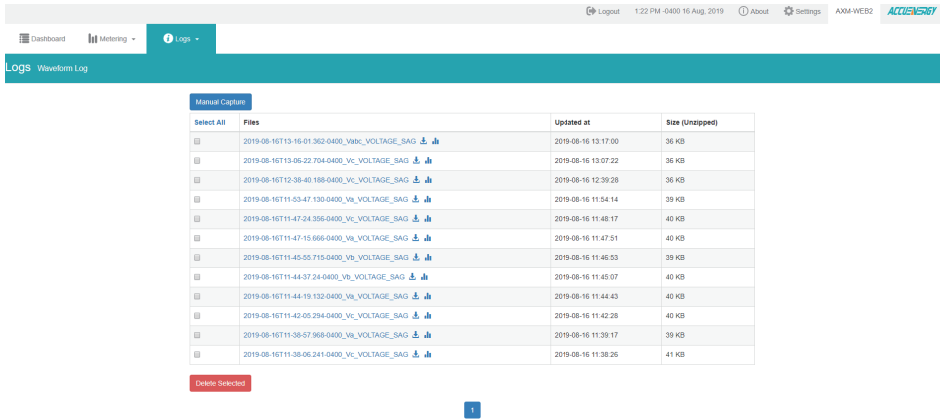

To view the waveform click on the icon. Users can select which voltage or current phase they want to view on the graph during the power quality event.



An image of the graph can be downloaded by clicking on the button.



Users can zoom into the graph for further detail by clicking on the. The graph can be reset back by double clicking the button.



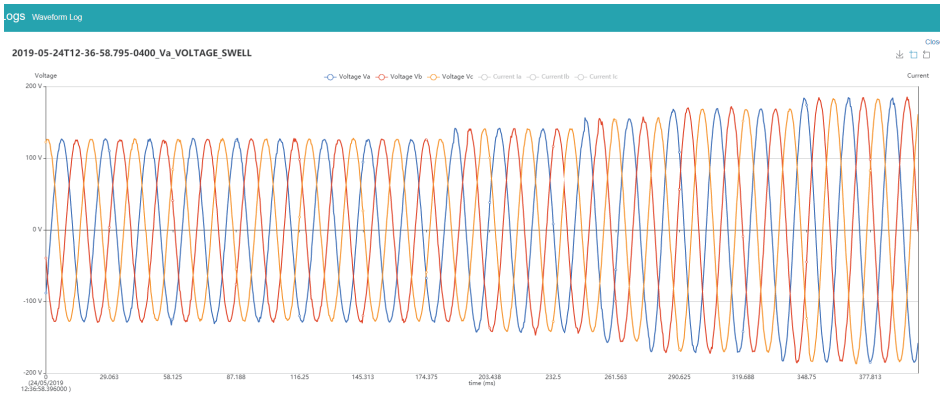

Users can select 'Close' to close the waveform and navigate back to the waveform Log.

Users can perform a manual waveform capture by clicking on 'Manual Capture'. This will manually capture voltage and current waveforms of the system being monitored. Once the waveform is captured it will take approximately 1-2 minutes to appear in the waveform log.















The screenshot shows the 'Manual Capture' button in the top left. A 'Success' dialog box is centered on the screen, with the text: 'Success. Capture waveform successful, it may take 1 to 2 minutes for waveform to appear in list.' and an 'OK' button. Below the dialog is a table of captured waveforms. The table has columns for 'Files', 'Size (Unzipped)', and 'Delete Selected'.

Select All	Files	Size (Unzipped)
<input type="checkbox"/>	2019-08-16T13-16-01-363-0400_Va_VOLTAGE_SWELL	36 KB
<input type="checkbox"/>	2019-08-16T13-05-22-704-0400_Vc_VOLTAGE_SAG	36 KB
<input type="checkbox"/>	2019-08-16T12-36-40-188-0400_Vc_VOLTAGE_SAG	36 KB
<input type="checkbox"/>	2019-08-16T11-53-47-130-0400_Vb_VOLTAGE_SAG	39 KB
<input type="checkbox"/>	2019-08-16T11-47-24-356-0400_Vc_VOLTAGE_SAG	40 KB
<input type="checkbox"/>	2019-08-16T11-47-15-666-0400_Va_VOLTAGE_SAG	40 KB
<input type="checkbox"/>	2019-08-16T11-45-55-715-0400_Vb_VOLTAGE_SAG	39 KB
<input type="checkbox"/>	2019-08-16T11-44-37-24-0400_Vb_VOLTAGE_SAG	40 KB
<input type="checkbox"/>	2019-08-16T11-44-19-132-0400_Va_VOLTAGE_SAG	40 KB
<input type="checkbox"/>	2019-08-16T11-42-05-294-0400_Vc_VOLTAGE_SAG	40 KB
<input type="checkbox"/>	2019-08-16T11-38-57-968-0400_Va_VOLTAGE_SAG	39 KB
<input type="checkbox"/>	2019-08-16T11-38-06-241-0400_Vc_VOLTAGE_SAG	41 KB



















The file name for the manually captured waveform will include the timestamp the capture occurred and the reason will say 'MANUAL' at the end of the file.

Logs Waveform Log

Manual Capture

Select All	Files	Updated at	Size (Unzipped)
<input type="checkbox"/>	2019-08-16T13-25-51.531-0400_Vc_VOLTAGE_SAG  	2019-08-16 13:26:39	36 KB
<input type="checkbox"/>	2019-08-16T13-25-48.979-0400_MANUAL  	2019-08-16 13:26:15	37 KB
<input type="checkbox"/>	2019-08-16T13-16-01.382-0400_Vabc_VOLTAGE_SAG  	2019-08-16 13:17:00	36 KB
<input type="checkbox"/>	2019-08-16T13-06-22.704-0400_Vc_VOLTAGE_SAG  	2019-08-16 13:07:22	36 KB
<input type="checkbox"/>	2019-08-16T12-38-40.188-0400_Va_VOLTAGE_SAG  	2019-08-16 12:39:28	36 KB
<input type="checkbox"/>	2019-08-16T11-53-47.130-0400_Va_VOLTAGE_SAG  	2019-08-16 11:54:14	39 KB
<input type="checkbox"/>	2019-08-16T11-47-24.356-0400_Vc_VOLTAGE_SAG  	2019-08-16 11:48:17	40 KB

In the waveform log page, users also have the option to select and delete waveform files. Simply click on the check box next to the file to select it, alternatively users can click on the 'Select All' button. Once all files are selected click on delete to remove the files from the waveform log.

<input type="checkbox"/>	2019-07-11T11-42-00.799-0400_Vabc_VOLTAGE_SAG  	2019-07-11 11:42:18	34 KB
<input type="checkbox"/>	2019-07-09T14-11-24.915-0400_Vabc_VOLTAGE_SWELL  	2019-07-09 14:12:15	43 KB
<input type="checkbox"/>	2019-07-01T08-41-34.407		43 KB
<input type="checkbox"/>	2019-06-25T18-32-33.355		40 KB
<input type="checkbox"/>	2019-06-25T18-04-17.755		35 KB
<input type="checkbox"/>	2019-06-12T16-32-56.225		43 KB
<input type="checkbox"/>	2019-06-12T16-16-31-17.255		35 KB
<input type="checkbox"/>	2019-06-12T16-27-41.525		43 KB
<input type="checkbox"/>	2019-06-11T12-05-43.901		43 KB
<input type="checkbox"/>	2019-06-10T09-25-26.675-0400_Vabc_VOLTAGE_SWELL  	2019-06-10 09:26:14	43 KB
<input type="checkbox"/>	2019-06-05T14-36-59.542-0400_Vabc_VOLTAGE_SWELL  	2019-06-06 14:37:48	43 KB
<input checked="" type="checkbox"/>	2019-06-05T14-03-36.155-0400_Vabc_VOLTAGE_SWELL  	2019-06-05 14:04:24	43 KB
<input checked="" type="checkbox"/>	2019-06-05T11-43-30.609-0400_Vabc_VOLTAGE_SWELL  	2019-06-05 11:44:19	43 KB
<input checked="" type="checkbox"/>	2019-06-05T11-40-47.519-0400_Vabc_VOLTAGE_SWELL  	2019-06-05 11:41:35	43 KB
<input type="checkbox"/>	2019-06-05T11-10-33.931-0400_Vabc_VOLTAGE_SWELL  	2019-06-05 11:11:19	43 KB
<input type="checkbox"/>	2019-06-03T18-45-20.791-0400_Vabc_VOLTAGE_SWELL  	2019-06-03 18:46:09	43 KB

Warning

Are you sure you want to delete the following files:

- 2019-07-11T12-47-19.887-0400_Vabc_VOLTAGE_SWELL
- 2019-06-05T14-03-38.155-0400_Vabc_VOLTAGE_SWELL
- 2019-06-05T11-43-30.609-0400_Vabc_VOLTAGE_SWELL
- 2019-06-05T11-40-47.519-0400_Vabc_VOLTAGE_SWELL

Delete Selected

1 2 3 4 >

8.3.6.1 COMTRADE

The AXM-WEB2 allows users to download the waveform data as a COMTRADE file. COMTRADE is a file format for storing waveform data related to transient power system disturbances.

The file can be downloaded from the waveform log by clicking on the file name or by clicking on the button. Once downloaded the file can be read using a COMTRADE file reader where users can further analyze the waveform data provided from the meter.



8.3.7 Event Log

The AXM-WEB2 provide the event log page for the user to track the activities of the module.

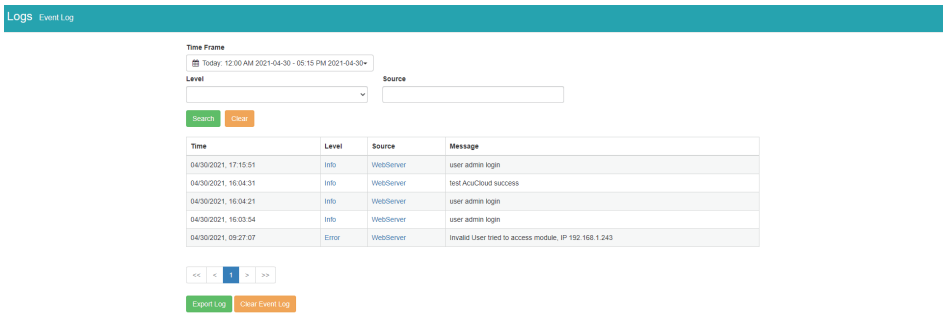

The screenshot shows the 'Event Log' page. At the top, there is a 'Time Frame' dropdown set to 'Today, 12:00 AM 2021-04-30 - 05:15 PM 2021-04-30'. Below this is a 'Level' dropdown menu and a 'Source' text input field. There are 'Search' and 'Clear' buttons. A table displays the event log entries:

Time	Level	Source	Message
04/30/2021, 17:15:51	Info	WebServer	user admin login
04/30/2021, 16:04:31	Info	WebServer	test AcuCloud success
04/30/2021, 16:04:21	Info	WebServer	user admin login
04/30/2021, 16:03:54	Info	WebServer	user admin login
04/30/2021, 09:27:07	Error	WebServer	Invalid User tried to access module, IP: 192.168.1.243

Below the table is a pagination control with '<<', '<', '1', '>', and '>>' buttons. At the bottom are 'Export Log' and 'Clear Event Log' buttons.

The user is able to specify the event level and source by choosing the level and the source type.

To clear the event logs, click “Clear Event Log”. Then click “Yes” to continue. Users can also export the Event log where it can be exported as a .csv file.

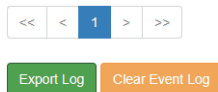

8.4 About

The About tab located at the top right corner of the web interface allows users to view the Device Information page. This page provides users with information about the Acuvim II series meter and the AXM-WEB2 module. The Device Information contains the model of the Acuvim II meter, serial number, firmware version and the meter addresses. It also contains the serial number, firmware version, hardware version and the MAC addresses of the AXM-WEB2 module.

The disk usage field at the bottom of the device information page allows users to view the percentage of the memory that is used on the AXM-WEB2 module.

Setting	Value
Meter Model	AcuvimIIW-D-5A
Meter Serial Number	AH17061888
Meter Firmware Version	v4.20
Device Description	
Module Model	AXM-WEB2
Module Serial Number	AN18070834
Module Hardware Version	v1.00
Module Firmware Version	v1.17
Ethernet 1 MAC Address	EC C3 8A 20 29 FD
Ethernet 2 MAC Address	EC C3 8A 20 29 FE
WiFi MAC Address	00 25 CA 38 BC 67
Meter Channel 1 Address	1
Meter Channel 2 Address	1
Seals Status	Open
Meter Boot Version	
Disk Usage	38.503%

8.5 Settings

8.5.1 Meter Settings

8.5.1.1 General Settings

The basic metering settings needed for installation and commissioning can be done from the web interface. To access these settings users can click on Settings and select the 'Meter' tab. On the metering tab users will see the 'General' tab selected and the following page presented.

Meter
Settings

Meter
Save

General
IO Alarm Custom Read Power Quality

Device Description

Motor Load
Maximum 15 characters

Wiring

Voltage Wiring

3LN-Three Phase Four Wire Y --- Compatible with 3CT only

Current Wiring

3CT --- Compatible with 2LL, 3LL & 3LN only

PT and CT Ratios

PT1

400.0
Default: 400; Range: 50-1,000,000

CT1

1000
Default: 5; Range: 1-50,000

PT2

400.0
Default: 400; Range: 50-400

CT2

5A

The general page allows users to configure the following settings:

Device Description: A description for the meter can be provided in this field which will display on the Dashboard page.

Voltage Wiring: Select the type of wiring that the meter will be monitoring from the modes in the drop down list.

Current Wiring: Select the number of CT's that will be connected to the meter to measure the current.

PT1: Enter the rated input of the potential transformer that is connected to the meter. Possible range is from 50 to 1,000,000V. By default PT1 is 400.

PT2: Enter the rated output of the potential transformer. Possible range is from 50 to 400V. The default PT2 setting is 400.

NOTE: *If the voltage input is connected directly to the meter and there are no PTs (Potential Transformers) stepping down the voltage to the meters voltage input then the PT1 and PT2 settings can be left as the default of 400.*

CT1: Enter the rated input of the current transformer that is used with the meter. Possible ranges for the CT1 are from 1 to 50000A.

The default settings for CT1 are dependent on the current input type of the Acuvim II meter. The following table displays the default CT1 values for the different Current input options.

Acuvim II Current Input	Default CT1 Value
1A	1
5A	5
80mA/100mA/200mA	1
333mV	1
RCT	1000

CT2: Select the rated output of the current transformer from the drop down list. By default this setting is already configured.

NOTE: *CT2 is configurable only for 5A and mA current inputs, 5A can be either 5A or 1A and mA can be either 80mA, 100mA or 200mA.*

Real time Reading: Select the mode of the readings for the meter when it is polled through Modbus. By default the meter is in Secondary mode which will require some parameters to be scaled by a relationship. Configuring the meter in Primary mode does not require any scaling.

I A Direction: Represents the flow of direction for the Phase A current being measured, configure this setting to troubleshoot issues related to incorrect polarity of readings such as real power, Power Factor and etc.

I B Direction: Represents the flow of direction for the Phase B current being measured, configure this setting to troubleshoot issues related to incorrect polarity of readings such as real power, Power Factor and etc.

I C Direction: Represents the flow of direction for the Phase C current being measured, configure this setting to troubleshoot issues related to incorrect polarity of readings such as real power, Power Factor and etc.

Demand Settings

Sliding Window: This setting refers to the demand type. There are 4 demand types that are supported by the Acuvim II series meter, users can choose one of the following:

- 1. Fixed Window** - The demand is calculated based on selecting the calculation period between 1-30min. The meter will calculate and update the demand values at the end of each calculation period.
- 2. Sliding Window** - The demand is calculated by selecting the calculation period between 1-30 min. The meter will average the energy accumulated within this period of time and the demand value is updated every minute.
- 3. Thermal** - The demand is calculated based on thermal response, used in thermal demand meters. This method uses a sliding window to update the demand value at the end of each calculation period.
- 4. Rolling Window** - The demand is based on selecting a calculation period between 1-30min, a subinterval(Demand Calculation Slip Time) and the demand value is updated at each subinterval. The subinterval must be a factor of the calculation period. For example, with a calculation period of 15min, the subinterval can be configured as 5min.

Sub Interval: The sub interval setting is only relevant if the Rolling Window Method is selected, this method requires a sub-interval time that must be a factor of the demand calculation period. the range for this setting is from 1-30 minutes.

Average Interval: The average interval window is the calculation period of the demand, and can be set from 1-30 minutes.

On-board RS485

Protocol: Select the protocol for the Acuvim II RS485 port, the protocol can be set to Modbus or DNP 3.

Address: Select the RS485 address for the meter, the range for this setting is from 1-247.

Baud Rate: The baud rate is the communication speed of the RS485 data transfer, this ranges from 1200-38400.

Parity: Select the parity bit setting for communication.

Realtime Reading		<input checked="" type="radio"/> Primary	<input type="radio"/> Secondary
I A Direction	<input checked="" type="radio"/> Positive	<input type="radio"/> Negative	
I B Direction	<input checked="" type="radio"/> Positive	<input type="radio"/> Negative	
I C Direction	<input checked="" type="radio"/> Positive	<input type="radio"/> Negative	
Demand			
Sliding Window	Sub-Interval	Averaging Interval Window	
Fixed Window Demand	1 mins	15 mins	
	Range: 1-30	Range: 1-30	
On-board RS485			
Protocol	Address	Baud Rate	Parity
Modbus	1	19200	None 1
	Range: 1-247		

Display

Current Password: This password relates to the four digit password used to access the meter settings from the display of the meter. By default it is 0000, the range for this setting is 0000-9999.

New Password: Enter in a new four digit password.

Repeat Password: Repeat the new password configured in the previous setting

AXM-WEB2 for Acuvim II Series Power Meter

Backlight: This setting refers to how long back light on the meters display is on for, the range is from 0-120 minutes, where 0 would disable to back light from turning off.

Rated Load: The rated load can be represented in terms of either power or current.

- If current is selected the rated current that is used would be the CT1 setting value in the PT and CT ratio settings section of the web page. For example if CT1 is set for 1000A, and the average current the meter is monitoring is 500A, the load percentage would be 50% (500/1000A).
- If power is selected the rated primary power would be used in the load percentage calculation. The max primary power can be calculated as follows:

Max Primary Power without using PTs = $3 * (480) * (CT1)$

Max Primary Power using PTs = $3 * (PT1) * (CT1)$

The max primary power would be the power that is entered in this setting.

The load percentage is displayed on the front of the Acuvim II meter display. The load percentage is calculated based on the following equation:

Load Percentage = $(\text{Active System Power} / ((5A \text{ or } 1A) * \text{User Setting})) * 100\%$, where the meter will have either a 5A or 1A current input. If users have Acuvim II meters with Rogowski Coil (RCT), 333mV and mA type Current Inputs then they would use 1A in this equation.

For example if the max primary power of your system is 576000W (or 576kW), your system is currently using 211kW and the meters current input type is 5A, then the load percentage would be calculated as follows:

Load Percentage = $(211kW / (5 * 576kW)) * 100 = 7\%$

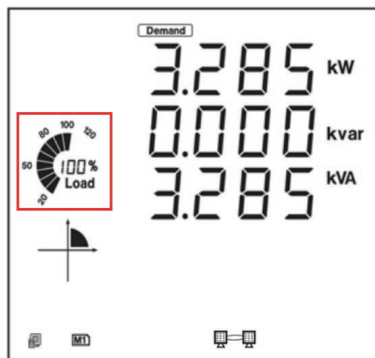

Display ▾

Current Password <input type="text" value="0000"/> <small>Must be length 4</small>	New Password <input type="text" value="1234"/> <small>Must be length 4</small>	Repeat New Password <input type="text" value="1234"/> <small>Passwords must match</small>
<div style="display: flex; justify-content: space-between;"> Update Password Hide password </div>		
Backlight <input type="text" value="12"/> mins <small>Range 0-120, 0 to disable backlight</small>		
Rated Load <div style="display: flex; align-items: center;"> <div style="border: 1px solid #ccc; padding: 2px; margin-right: 5px;">Power</div> <input style="width: 150px;" type="text" value="576000"/> Watt <small>Range 8000-115200000</small> </div>		

Advanced

Energy Type: The energy type can either be selected as Fundamental or Fundamental+Harmonics

Energy Reading: This can be set to either Primary or Secondary, where Primary displays the energy accumulation in terms of the Primary and Secondary will display the energy accumulation in terms of the secondary with resolution of up to 1Wh.

NOTE: When the energy reading mode is changed the energy will reset to 0 on the meter.

VAR/PF Convention: The VAR/PF convention can either be set to IEEE or IEC.

IEC the power factor is dependent on the direction of the real power flow

IEEE the power factor is dependent on the nature of the load, i.e. capacitive, inductive.

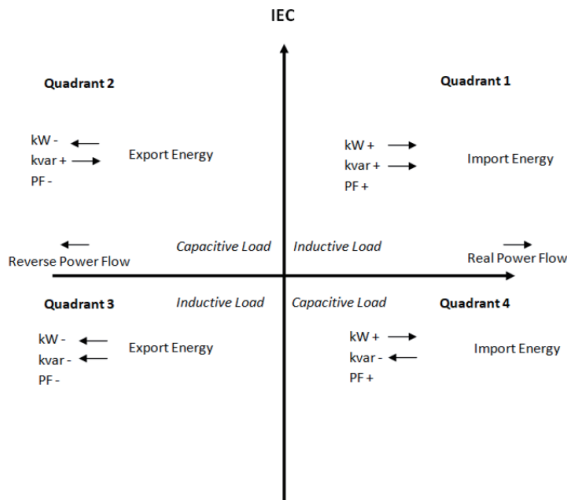

VAR Calculation Method: Can be selected as either True or Generalized

- True Method - Uses the Budeanu Concept to calculate the 'True' reactive power. This method generally takes the harmonic components to do the calculation instead of using the power vector triangle method. This method can be defined by the following expression for single phase circuit:
- Generalized Method - Uses Fryze's concept to calculate the 'Generalized' reactive power. This method separates instantaneous current into two components, active and reactive currents.

Active current is calculated as:

and reactive current as:

Active and reactive powers are:

where I_a and I_r represents RMS values of instantaneous active and reactive currents.

$$P = V_{\text{RMS}} \cdot I_a$$

$$Q_f = V_{\text{RMS}} \cdot I_r$$

$$i_r(t) = i(t) - i_a(t).$$

$$i_a(t) = \frac{P}{V_{\text{RMS}}^2} v(t)$$

Optional Seal Configurations: Users can choose to seal the following parameters from this setting:

- Device Run Time
- DI Counters
- Communication Channel 1
- Communication Channel 2

Once all settings have been configured users can click on save and then perform a module reboot in order for the settings to be saved to the meter.

Advanced

Energy Type: Fund. + Harm.

var:PF Convention: IEC

Energy Reading: Primary

Note: Changing this option will reset energy.

var Calculation Method: Generalized

Optional Seal Configurations:

- Device Run-Time
- DI Counters
- Communication Channel 1
- Communication Channel 2

Save

8.5.1.2 IO Settings

The Acuvim II supports 3 different I/O expansion modules that allow users add Digital Inputs, Digital Outputs, Relay Outputs, Analog Inputs, and Analog Outputs. There can be a max two of the same I/O module per meter, and will be represented by the I/O logic address 1 or 2. From the AXM-WEB2 interface users can configure the settings for these I/O modules.

AXM-IO1-1/2

The AXM-IO1 module supports 6 Digital Input channels, 2 Relay Output channels, and has a built in 24Vdc supply.

- Digital Input - Can be configured as either digital status or pulse counter.
 - DI Pulse Constant - If the DI is configured as pulse counter, then the DI pulse constant will represent how many pulses equals one count, i.e pulse constant is 2 that means that every 2 pulses the inputs reads the counter is increased by 1.
 - DI1-6 Name - Users can assign a name for each Digital Input, this name is used for either Counter or Status mode.
 - DI1-6 On/Off Name - A custom label when the DI status is on/off can be configured
 - DI1-6 Unit - Unit can be assigned to the DI counter reading
 - DI1-6 Ratio - Users can configure a scaling ratio for the DI counter reading
- Relay Output - Can be configured as Relay Control or Alarm Mode
 - Control Mode Output Mode - Can be configured as Latch or Momentary where users can manually turn on/off relay

- Latch - Manually turn on/off relay
- Momentary - Manually turn on relay for a short moment of time, the RO On time range is from 50-3000ms
- Alarm Mode - The relay can be configured to trigger based on the alarm settings of the meter.

The screenshot shows the configuration page for the AXM-IO1-1 module. It includes settings for six Digital Input (DI) channels and the Relay Control Output (RO) mode.

DI 1 Type	DI 2 Type	DI 3 Type	DI 4 Type	DI 5 Type	DI 6 Type
<input type="radio"/> Status <input checked="" type="radio"/> Counter	<input type="radio"/> Status <input checked="" type="radio"/> Counter	<input type="radio"/> Status <input checked="" type="radio"/> Counter	<input type="radio"/> Status <input checked="" type="radio"/> Counter	<input type="radio"/> Status <input checked="" type="radio"/> Counter	<input type="radio"/> Status <input checked="" type="radio"/> Counter

RO Type: Relay Control Alarm

RO Relay Control Output Mode: Latch Momentary

RO ON Time: 5000 ms

DI Pulse Constant: 1

DI 1 Name	DI 2 Name	DI 3 Name	DI 4 Name
Counter	Energy Counter	Water	
DI 5 Name	DI 6 Name	DI 1 On Name	DI 2 On Name
	Gas Meter	High	Alarm
DI 3 On Name	DI 4 On Name	DI 5 On Name	DI 6 On Name
DI 1 Off Name	DI 2 Off Name	DI 3 Off Name	DI 4 Off Name
Low	No Alarm		
DI 5 Off Name	DI 6 Off Name	DI 1 Unit	DI 2 Unit
		IN3	KWH
DI 3 Unit	DI 4 Unit	DI 5 Unit	DI 6 Unit
L	US GAL	M3	IMP GAL
DI 1 Ratio	DI 2 Ratio	DI 3 Ratio	DI 4 Ratio
1.5	0.102	5.151	10
DI 5 Ratio	DI 6 Ratio		
0.000	2		

AXM-IO2-1/2

The AXM-IO2 module supports 4 Digital Input channels, 2 Digital Output channels, and 2 Analog Output channels.

- Digital Input - Can be configured as either digital status or pulse counter.
 - DI Pulse Constant - If the DI is configured as pulse counter, then the DI pulse constant will represent how many pulses equals one count, i.e pulse constant is 2 that means that every 2 pulses the inputs reads the counter is increased by 1.
 - DI1-4 Name - Users can assign a name for each Digital Input, this name is used for either Counter or Status mode.
 - DI1-4 On/Off Name - A custom label when the DI status is on/off can be configured
 - DI1-4 Unit - Unit can be assigned to the DI counter reading
 - DI1-4 Ratio - Users can configure a scaling ratio for the DI counter reading

AXM-IO2-1
Enabled

DI 1 Type <input checked="" type="radio"/> Status <input type="radio"/> Counter	DI 2 Type <input type="radio"/> Status <input checked="" type="radio"/> Counter	DI 3 Type <input checked="" type="radio"/> Status <input type="radio"/> Counter	DI 4 Type <input checked="" type="radio"/> Status <input type="radio"/> Counter
--	--	--	--

DI Pulse Constant
 Pulse = 1

The DI name, on/off name, unit, and ratio settings can be found at the bottom of the page under the Analog Output 2 settings.

DI 1 Name <input type="text" value="Water Meter"/>	DI 2 Name <input type="text"/>	DI 3 Name <input type="text"/>	DI 4 Name <input type="text"/>
DI 1 On Name <input type="text"/>	DI 2 On Name <input type="text" value="HIGH"/>	DI 3 On Name <input type="text" value="HIGH"/>	DI 4 On Name <input type="text"/>
DI 1 Off Name <input type="text"/>	DI 2 Off Name <input type="text" value="LOW"/>	DI 3 Off Name <input type="text" value="LOW"/>	DI 4 Off Name <input type="text"/>
DI 1 Unit <input type="text" value="L"/>	DI 2 Unit <input type="text" value="N/A"/>	DI 3 Unit <input type="text" value="N/A"/>	DI 4 Unit <input type="text" value="N/A"/>
DI 1 Ratio <input type="text" value="0.125"/>	DI 2 Ratio <input type="text" value="0.000"/>	DI 3 Ratio <input type="text" value="0.000"/>	DI 4 Ratio <input type="text" value="0.000"/>

- Digital Output - Can be configured for Pulse or Alarm mode.
 - DO 1 Output - Users can select the type of energy pulse outputted from DO Channel 1
 - DO 2 Output - Users can select the type of energy pulse outputted from DO Channel 2
 - There are 4 types of energy that can be used for Energy Pulse Output:
 1. System Import Active Energy
 2. System Export Active Energy
 3. System Import Reactive Energy
 4. System Export Reactive Energy
 - Pulse Width - Users can configure the Energy pulse width, the range is from 20-1000ms
 - DO Active Energy Pulse Constant - Select the Pulse Constant for Active Energy Pulse, the range is from 1-60000
 - DO Reactive Energy Pulse Constant - Select the Pulse Constant for Reactive Energy Pulse, the range is from 1-60000.

DO Type
 Energy Pulse
 Alarm

DO 1 Output

DO 2 Output

Pulse Width ms

DO Active Energy Pulse Constant Range 1-60000

DO Reactive Energy Pulse Constant Range 1-60000

Pulse Constant Calculator

The pulse constant calculator allows users to determine the pulse constant value based on the amount of energy per pulse required. Users would first need to input the maximum primary power which is the CT1 value multiplied by the PT1 value.

Once entered in, users can then scroll down to the 'Primary 1 Pulse =' and enter the value that one pulse would represent, i.e. 1 pulse = 1 kWh. Once this is configured, a secondary pulse value will be populated which is the required pulse constant value. Users can import this value to the pulse constant setting by clicking on the 'Set as Active Energy Constant' or 'Set as Reactive Energy Constant' buttons.

Calculate Pulse Constant

kW(kvar)
 Range: 0.001 - 400

PT1 V
 CT1 A
 PT2 V
 CT2

Secondary Maximum Power kW(kvar)
 Output Energy Pulse Width ms
 Minimum Interval ms
 Must be larger than 80

Secondary DO Constant
 Max: 1 kWh(kvarh) = Pulse
 Min: 1 kWh(kvarh) = Pulse

Primary DO Constant
 Max: 1 Pulse = kWh(kvarh)
 Min: 1 Pulse = kWh(kvarh)

Max: 1 kWh(kvarh) = Pulse
 Min: 1 kWh(kvarh) = Pulse

Primary 1 Pulse = kWh(kvarh)
 Range: 0.017888888888888888 - 1000

Primary 1 kWh(kvarh) = Pulse
 Range: 0.001 - 55.900621118012424

Secondary 1kWh(kvarh) = Pulse

Range: 1 - 55901

- Analog Output - There are two analog output channels that users can configure.
 - AO1 Slope - select the slope value, the range is from 1-3
 - AO 1 Input Range 1 - Enter in the starting range for the Analog Output
 - AO 1 Input Range 2/3/4 - Enter in the ending range for the Analog Output
 - AO 1 Output Range 1 - Enter in the analog output signal
 - AO 1 Output Range 2/3/4 - Enter in the ending analog output signal.

NOTE: The analog output range can be a 4-20mA, 0-20mA, 0-5V, 1-5V signal depending on the model of the I/O, either voltage or current model.

AO 1 Channel: Phase A Line-to-Neutral Voltage (V) | AO 2 Channel: Phase A Line Current (A) | AO Type: 4 ~ 20mA

AO 1 Slope: 1

AO 1 Input Range 1: 0.000 | AO 1 Input Range 2: 0 | AO 1 Input Range 3: 0 | AO 1 Input Range 4: 100.000

AO 1 Output Range 1: 3.999 | AO 1 Output Range 2: 0 | AO 1 Output Range 3: 0 | AO 1 Output Range 4: 20.000

Input	Output
0	4
20	7
40	10
60	13
80	16
100	20

The interface displays a graph for the Analog output signal Range according to the input range that has been configured.

Similar to Analog Output channel 1, the second analog output channel can also be configured in the same manner from the web interface.

AXM-IO3-1/2

The AXM-IO3 module supports 4 Digital Input channels, 2 Relay Output channels, and 2 Analog Input channels.

- Digital Input - Can be configured as either digital status or pulse counter.
 - DI Pulse Constant - If the DI is configured as pulse counter, then the DI pulse constant will represent how many pulses equals one count, i.e pulse constant is 2 that means that every 2 pulses the inputs reads the counter is increased by 1.
 - DI1-4 Name - Users can assign a name for each Digital Input, this name is used for either Counter or Status mode.
 - DI1-4 On/Off Name - A custom label when the DI status is on/off can be configured
 - DI1-4 Unit - Unit can be assigned to the DI counter reading
 - DI1-4 Ratio - Users can configure a scaling ratio for the DI counter reading
- Relay Output - Can be configured as Relay Control or Alarm Mode
 - Control Mode Output Mode - Can be configured as Latch or Momentary where users can manually turn on/off relay
 - Latch - Manually turn on/off relay
 - Momentary - Manually turn on relay for a short moment of time, the RO On time range is from 50-3000ms
 - Alarm Mode - The relay can be configured to trigger based on the alarm settings of the meter.
- Analog Input - There are two analog input channels, users can select the type based on the type of module they have.
 - The AI types are:
 - 4-20mA
 - 0-20mA

1-5V

0-5V

- AI1-2 Name - Users can assign the analog input channels a name
- AI1-2 Unit - A unit can be configured for the AI
- AI1-2 Ratio - A scaling ratio can be applied and configured for the AI
- AI1-2 Offset - An offset can be applied and configured for the AI

The screenshot shows the configuration page for the AXM-IO3-1 module. The page is organized into several sections:

- DI 1 Type, DI 2 Type, DI 3 Type, DI 4 Type:** Each has radio buttons for Status and Counter. All are currently set to Counter.
- DI Pulse Constant:** A dropdown menu showing the value '1'.
- RO Type:** Radio buttons for Relay Control (selected) and Alarm.
- RO Relay Control Output Mode:** Radio buttons for Latch and Momentary (selected).
- RO ON Time:** A text input field with '3000' and a unit dropdown set to 'ms'.
- AI Type:** A dropdown menu showing '4 - 20mA'.
- DI 1-4 Parameters:** Each channel (DI 1, 2, 3, 4) has fields for Name, On Name, Off Name, Unit, Ratio, and Offset.
- AI 1-2 Parameters:** Each channel (AI 1, 2) has fields for Name, Unit, Ratio, and Offset.

IO Logic Address

From the WEB2 interface users have the option to change the logic addresses for the AXM-IO1 and AXM-IO3 modules. This is useful when users have two modules with the same logic address. For example if the user has two AXM-IO1-1 and attaches them both to the meter, the meter will only recognize one of the modules. This function allows the user to change the logic number from 1 to 2 where the user would then have one AXM-IO1-1 module and one AXM-IO1-2 module.

To change the logic address the module must be attached and installed on the back of the meter after the WEB2 communications module. Simply click on the drop down menu and select the corresponding logic address.

NOTE: The meter be physically power cycled in order for the logic address change to take effect.

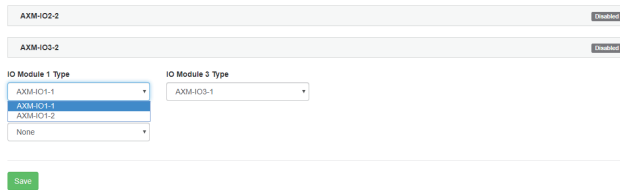

The screenshot shows a configuration interface for the AXM-WEB2 power meter. It features two dropdown menus for selecting IO Module types. The first dropdown, labeled 'IO Module 1 Type', has three options: 'AXM-IO1-1', 'AXM-IO1-2', and 'None'. The second dropdown, labeled 'IO Module 3 Type', has one option: 'AXM-IO3-1'. Below the dropdowns is a green 'Save' button.

8.5.1.3 Alarm Settings

The Acuvim II meters supports over/under alarms for different metering parameters. From the WEB2 interface users can configure these alarms and can find these settings by clicking on 'Settings' and selecting the 'Alarm' tab.

The meter supports up to 16 Alarm channels that users can monitor when the configured parameter goes over or under the alarm threshold. If users have extended I/O modules attached to the meter, digital outputs (DO) and relay outputs (RO) can be triggered upon alarm condition and used to activate external devices such as a buzzer, light, etc.

Alarm Enable: The alarm function can be enabled or disabled

Backlight Flash Trigger: If enabled, when an alarm is triggered the backlight of the Acuvim II meter display will flash during the alarm event.

Steps to setup alarm channels:

- To configure an alarm channel, enable the preferred alarm channel(s).
- Select the required parameter for the alarm channel under the 'Parameter' column.
- Choose the required setpoint and then select the condition for the alarm, i.e greater than (>), less than (<), or equal to (=).
- Users have the ability to set a delay for the alarm trigger, the range is from 0-30000 ms.
- Users can use the 'AND' function to trigger an alarm event when two conditions have been met.

Chapter 8: Web Interface Readings and Parameter Settings

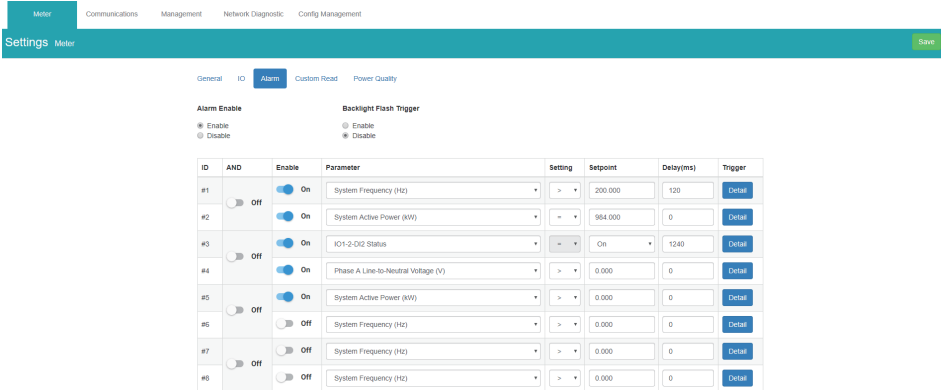

The screenshot shows the 'Alarm' configuration page. At the top, there are navigation tabs: 'General', 'IO', 'Alarm', 'Custom Read', and 'Power Quality'. The 'Alarm' tab is active. Below the tabs, there are two sections: 'Alarm Enable' and 'Backlight Flash Trigger'. The 'Alarm Enable' section has radio buttons for 'Enable' and 'Disable'. The 'Backlight Flash Trigger' section has radio buttons for 'Enable' and 'Disable'. Below these sections is a table with columns: ID, AND, Enable, Parameter, Setting, Setpoint, Delay(ms), and Trigger. The table contains 8 rows of alarm configurations.

ID	AND	Enable	Parameter	Setting	Setpoint	Delay(ms)	Trigger
#1		On	System Frequency (Hz)	> >	200.000	120	Detail
#2	Off	On	System Active Power (kW)	= >	984.000	0	Detail
#3	Off	On	IO1-2-DO2 Status	= >	On	1240	Detail
#4	Off	On	Phase A Line-to-Neutral Voltage (V)	> >	0.000	0	Detail
#5	Off	On	System Active Power (kW)	= >	0.000	0	Detail
#6	Off	Off	System Frequency (Hz)	= >	0.000	0	Detail
#7	Off	Off	System Frequency (Hz)	= >	0.000	0	Detail
#8	Off	Off	System Frequency (Hz)	= >	0.000	0	Detail

If extended IO modules are being used, users can click on the detail tab to configure the digital output and relay outputs to be triggered when an alarm is triggered.

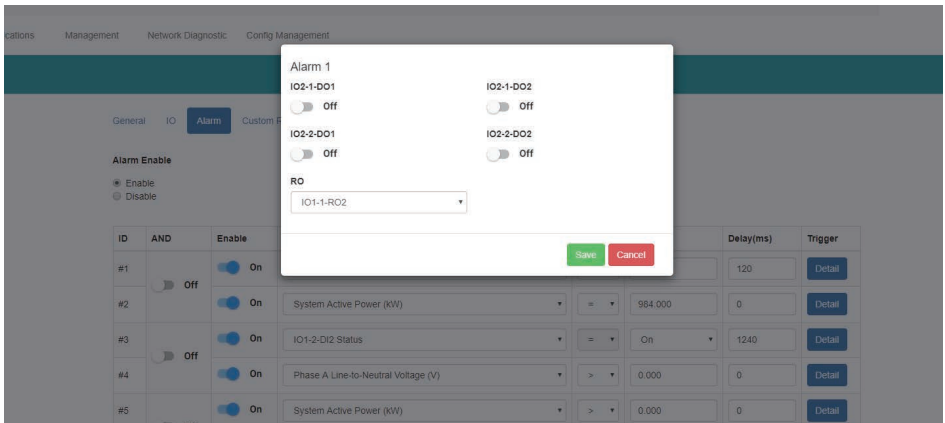

The screenshot shows the 'Alarm 1' configuration dialog box. The dialog box has a title 'Alarm 1' and several sections: 'IO2-1-DO1', 'IO2-2-DO1', 'IO2-1-DO2', 'IO2-2-DO2', and 'RO'. Each section has a toggle switch. The 'RO' section has a dropdown menu showing 'IO1-1-RO2'. At the bottom of the dialog box, there are 'Save' and 'Cancel' buttons. The background shows the 'Alarm' configuration page with the 'Alarm 1' row selected.

Once all alarm settings are configured, user must click on 'Save' and then reboot the communications module in order for the settings to be saved.

8.5.1.4 Custom Read

The Acuvim II meter supports a custom read function which allows users to customize a block of Modbus registers within the Acuvim II meter. Within this custom block different parameters (i.e. Basic metering, THD, Energy, etc) can be configured as well as different data types for the parameters (i.e. Int, float, etc). There is a total of 64 bytes that users have to create their customized register block.

NOTE: *The Custom Read Function is only available in meters with firmware version 3.51 and higher.*

The window on the left under 'Not Selected' are the list of parameters available for the custom read block. Users can choose between different parameters by clicking on the drop down menu under 'Parameter Type'. The available parameter types include:

- Real-Time Metering
- Demand
- Energy
- THD
- Sequence
- Phase Angles
- DI Counter
- AO/AI value

Each of these parameter types are available in different data types, such as integer (int), float, and double-word. Users may select the data type for each parameter from this drop down menu.

Users can select the parameters and click on the '>' button to add the parameters to the 'Selected' window. The parameters can be removed from the register block by clicking on the '<' button, and can clear the entire block by selecting the 'Clear' button.

As users add and remove parameters, there is a 'Bytes Used' and 'Bytes Remaining' value that lets users know how much space is left in the customized register block.

Chapter 8: Web Interface Readings and Parameter Settings

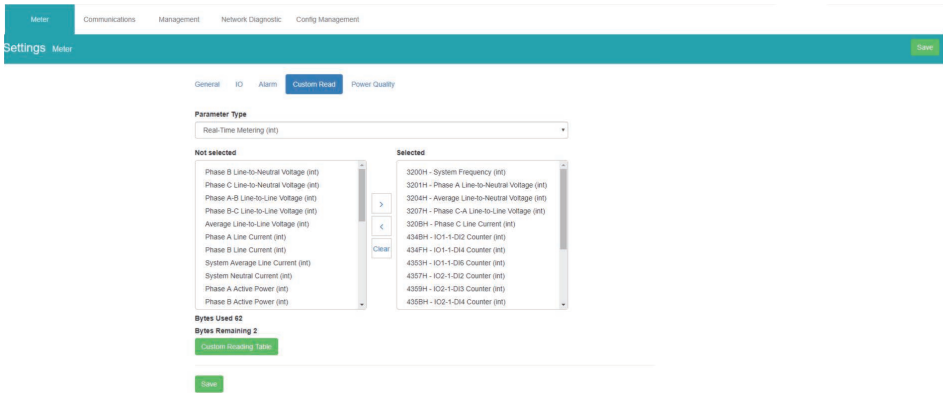

Once the block is configured, users can click on 'Save'.

A copy of the custom read register block can be viewed by selecting 'Custom Reading Table'. The table can be downloaded as a csv file by clicking on 'Export Table'.

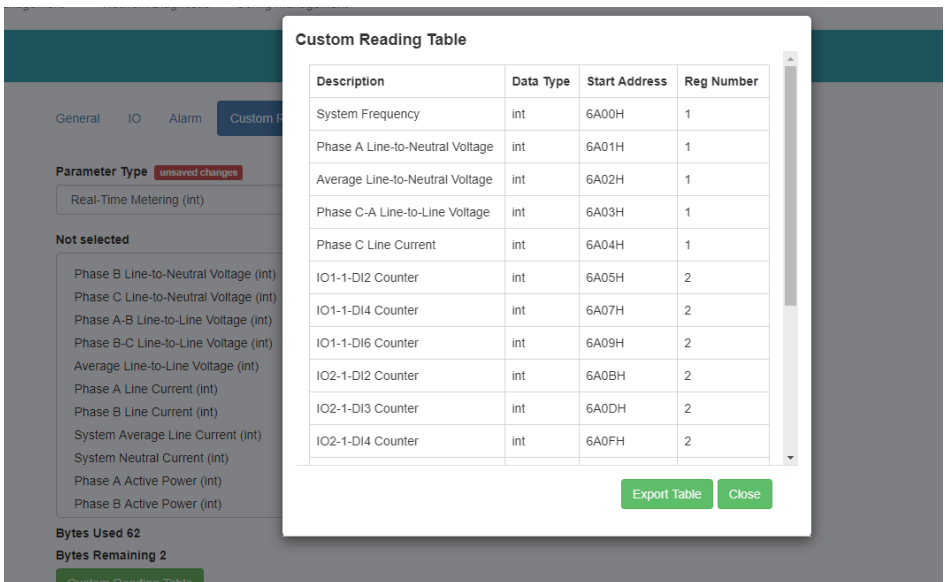

8.5.1.5 Waveform Settings

The Acuvim IIV meters support a waveform capture feature where users can capture waveforms based on power quality events such as voltage sags, voltage swells and over currents. From the WEB2 interface, users can configure these settings by clicking on the 'Settings' tab and then selecting the 'Waveform' tab.

Rated Voltage: The rated voltage of the system should be entered here, the range is from 50-400V for wye systems or 50-690V for delta systems.

Voltage Swell

- Triggering Waveform Capture - Select enable to capture voltage swell events
- Threshold - Enter in the percentage of the voltage swell to be captured, the range is from 50-140%. For example if the rated voltage is 277V, and the voltage swell threshold is set for 110%. The swell event would be captured when the voltage is 110% above 277V, which is roughly 304V.

Voltage Sag

- Triggering Waveform Capture - Select enable to capture voltage sag events
- Threshold - Enter in the percentage of the voltage sag to be captured, the range is from 20-100%. For example if the rated voltage is 277V, and the voltage sag threshold is set for 50%. The sag event would be captured when the voltage drops 50% below 277V, which is roughly 138V.
- Half-cycle Threshold - Enter in the half cycle threshold for the sag event, the range is from 4-200 half cycles.

Rated Current: The rated current for the over current should be entered here, the range will be dependent on the CT1 value configured on the meter. The rated current range will be from 50-100% of the CT1 value. For example if CT1 is configured as 1000A, then the rated current range for the Power Quality event is from 500A to 1000A.

Over Current

- Triggering Waveform Capture - Select enable to capture over current events
- Threshold - Enter in the percentage of the over current to be captured, the range is from 50-150%. For example if the rated current is 1000A, and the over current threshold is set

for 50%. The over current event would be captured when the current is 50% of the rated current, which is 500A.

Settings Meter

General IO Alarm Custom Read **Power Quality**

Rated Voltage
 V
 Range 50 to 400

Voltage Swell

Threshold > <input type="text" value="130"/> % Range 50 to 140	Triggering Waveform Capture <input type="radio"/> Disable <input checked="" type="radio"/> Enable
---	--

Voltage Sag

Threshold < <input type="text" value="20"/> % Range 20 to 100	Half-cycle Threshold <input type="text" value="10"/> Half-cycle Range 4 to 200	Triggering Waveform Capture <input type="radio"/> Disable <input checked="" type="radio"/> Enable
--	---	--

Rated Current
 A
 Range 500 to 1000

Over Current

Threshold > <input type="text" value="100"/> % Range 50 to 150	Triggering Waveform Capture <input type="radio"/> Disable <input checked="" type="radio"/> Enable
---	--

If user are using external I/O modules, the waveform capture can be triggered by the Digital Inputs Status. The DI can trigger the waveform by the following:

- From Status Off to On
- From Status On to Off
- Any Change

The DI triggering can be disabled is users do not require it to trigger the waveform capture.

DI Trigger Waveform Capture

IO1-1-DI1 Disabled From Off to On From On to Off Any Change	IO1-1-DI2 Disabled	IO1-1-DI3 Disabled	IO1-1-DI4 Disabled
IO2-1-DI1 Disabled	IO2-1-DI2 Disabled	IO2-1-DI3 Disabled	IO2-1-DI4 Disabled
IO3-1-DI1 Disabled	IO3-1-DI2 Disabled	IO3-1-DI3 Disabled	IO3-1-DI4 Disabled

Chapter 9: Communications

9.1 Network

The first page the user will see after selecting the Communications option under the Settings tab is the Network page. The network settings allow users to configure all network related settings including both Ethernet 1 and Ethernet 2 as well as WiFi.

9.1.1 RSTP Protocol

The AXM-WEB2 supports the RSTP protocol where users can daisy chain the Ethernet ports on the AXM-WEB2 module to a network switch.

Users can configure the meters IP manually or by setting the DHCP set as Auto.

NOTE: When the RSTP is enabled users will not be able to configure Ethernet 1 and Ethernet 2, there is only 1 IP per meter using RSTP protocol.

Network Topology

Users can daisy chain up to 32 devices using the RSTP protocol. This can cut down the amount of network switches required in different applications and allows the use of 1 network switch/router to be used with up to 32 devices. Each device can be accessed by configuring a unique IP address or having the IP addresses assigned automatically by the network.

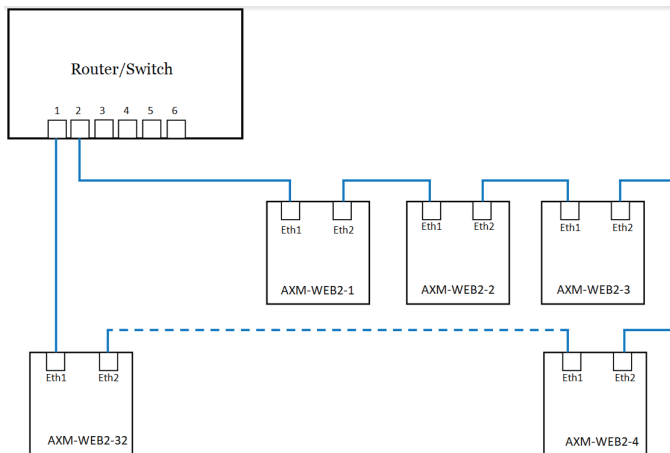

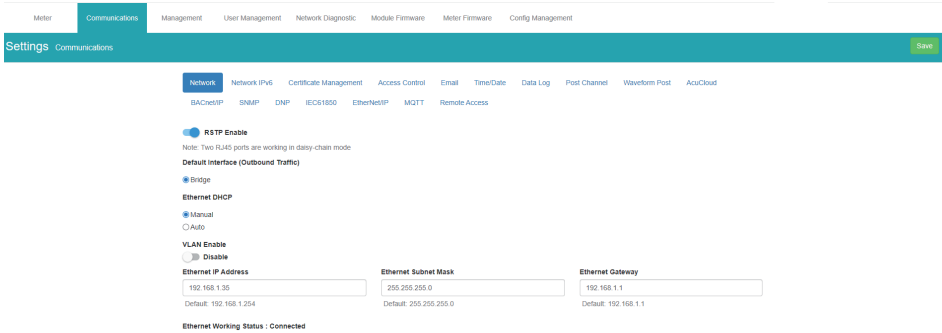

9.1.2 VLAN

Virtual Local Area Network (VLAN) allows devices under the same physical network to be grouped (by VLAN ID) and act as if they are in separate networks. VLANs are isolated from one another where traffic stays private in the same VLAN.

When VLAN of an interface is enabled, it allows the AXM-WEB2 module to communicate with other devices under the same VLAN without a VLAN switch, via this interface. In other words, the module can parse IEEE 802.1Q-tagged Ethernet VLAN frames by itself.

Users can enable VLAN from the web interface under either the Ethernet 1 or Ethernet 2 settings, once enabled a VLAN ID is required.

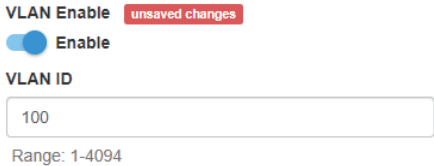

One of the common uses is when RSTP is enabled, the module can be put between two VLAN switches, where both ETH1 and ETH2 ports connecting to switches' trunk ports. In this method, the module can still forward all traffic between the switches; while other devices in the same VLAN can have access to the module, and no additional switch is required.

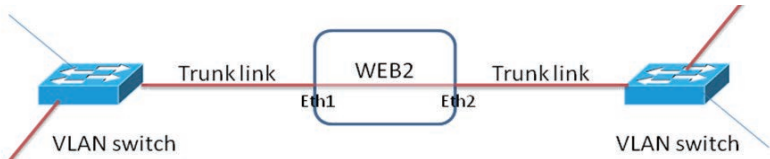

9.1.3 Network Settings

The settings for the Ethernet 1 and Ethernet 2 are as followed:

Ethernet 1 DHCP: Select 'Manual' to manually configure the IP address to access the meter. If set to 'Manual', you'll also need to set the Subnet Mask and Gateway. By default the IP address for ETH1 will be 192.168.1.254

Select 'Auto' to have the meter assigned a IP address automatically. With this selection the Subnet Mask, and Gateway will also be automatically assigned.

Note: After changing DHCP to Auto, check the display of the meter(N02 NET Settings) to obtain the new IP address that has been assigned. The new IP address will be displayed only after a module reboot is performed and completed.

IP Address: If the DHCP is configured to Manual, the IP address can be configured from this page. Default is 192.168.1.254

Subnet Mask: If the DHCP is configured to Manual, the Subnet Mask can be configured from this page. Default is 255.255.255.0

Gateway: If the DHCP is configured to Manual, the Gateway can be configured from this web page. Default is 192.168.1.1

The status of the Ethernet 1 port will display if it is connected or disconnected.

Ethernet 2 DHCP: By default the Ethernet 2 port is configured to have its DHCP set to 'Auto'. If configured to 'Manual' the default Manual IP address is 192.168.1.253. Users can configure the IP address to any IP once the DHCP is configured for 'Manual', users will also need to set the Subnet Mask and Gateway if using this method.

NOTE: The IP address of the Ethernet 2 can be found page N12 of the NET Settings. The Acuvim II protocol setting must be configured to WEB2 to view this from the meters NET settings.

IP Address: By default the IP address is configured by DHCP, this field will be grayed out. If the DHCP is configured to Manual, the IP address can be configured from this page.

Subnet Mask: If the DHCP is configured to Manual, the Subnet Mask can be configured from this page.

Gateway: If the DHCP is configured to Manual, the Gateway can be configured from this web page.

The status of the Ethernet 2 port will display if it is connected or disconnected.

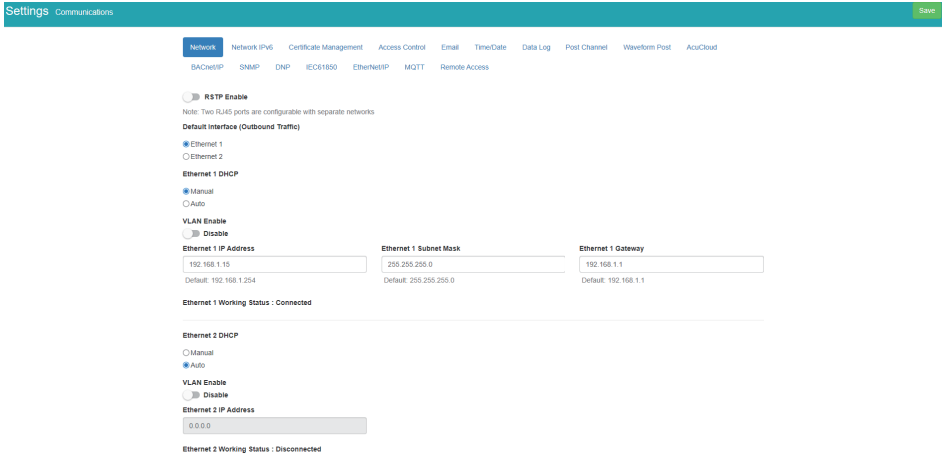

WiFi Enabled: Select the Enable or Disable communication through WiFi.

WiFi Mode: The WiFi can be configured to work in two modes just like any other WiFi device. It can be configured as either Access Point(AP) or Station mode.

Access Point: Default configuration for AXM-WEB2. The AXM-WEB2 will act as a wireless access point and will allow other wireless devices to connect and access the AXM-WEB2.

- In Access Point mode, users can configure the SSID, Network Key and IP of the AXM-WEB2 module as well as the DHCP DNS servers.

Station: The AXM-WEB2 will behave like a wireless client and bridge to another wireless network that is available.

- In Station mode, users can select the Wireless network to connect to under the "Connect to SSID" setting. Click on "Select from Available Networks" and enter the Network Key for the wireless network that the AXM-WEB2 will bridge to.
- If users are connecting to an open Wireless network that is not password protection, the password field can be left blank.
- The AXM-WEB2 also supports Enterprise WiFi, where users can connect using an enterprise level WiFi network which is common in many colleges/universities, hospitals, etc. When attempting to connect to an enterprise level WiFi network the interface will show options to connect to the network with a username and password.

AXM-WEB2 for Acuvim II Series Power Meter

WiFi Enable
 Disable
 Enable

WiFi Mode
Station

Connect to SSID [Select from available networks](#)
ASUS
Note: Maximum 32 characters

WPA/WPA2-Enterprise

Username
test
Note: Maximum 32 characters

Network Key
.....
Note: Minimum 8 characters and maximum 63 characters

WiFi DHCP
 Manual

WiFi IP Address **WiFi Subnet Mask** **WiFi Gateway**
192.168.0.89 255.255.255.0 192.168.0.1

WiFi Working Status : Connected [Connect](#)

In station Mode the DHCP can configured as either manual or auto.

- If manual, users can configure the IP, Subnet Mask and Gateway and DNS Servers.
- If auto, users can check the meter's display to get the IP address and all other network configurations assigned by the wireless network. The user can also configure the DNS servers if the DHCP is set to Auto.

NOTE: The WiFi IP address for the AXM-WEB2 will be in parameter N11 of the NET settings. The Acuvim II protocol setting must be configured to WEB2 to view this from the meters NET settings.

The AXM-WEB2 supports a connection test to the WIFI network, users can use this test to manually connect to the WIFI network.

Enable

WiFi Mode
Station

Connect to SSID [Select from available networks](#)
ASUS
Note: Maximum 32 characters

WPA/WPA2-Enterprise

Username
chi
Note: Maximum 32 characters

Network Key
.....
Note: Minimum 8 characters and maximum 63 characters

WiFi DHCP
 Auto

WiFi IP Address
192.168.2.152

WiFi Working Status : Connected [Connect](#)

DNS Server 1 **DNS Server 2**
8.8.8.8 8.8.4.4
Default: 8.8.8.8 Default: 8.8.4.4

Confirmation

WiFi Connect Successfully!

[OK](#)

DNS Server 1: Enter the address of DNS server 1 in this field.

DNS Server 2: Enter the address of DNS server 2 in this field.

HTTPS Port: Enter the HTTPS port number of the meter. By default, this setting is configured to 443. The range can be from 6000 to 9999.

Meter Channel 2 Address (Modbus TCP): Enter the Modbus TCP address of the meter. By default, the address is 1.

NOTE: This setting should never be configured to 80. Enable the HTTP Enable configuration to access the web interface at port 80.

HTTP Enable: Enable HTTP so the the AXM-WEB2 cab be accessed through the HTTP protocol, by default the HTTP port is 80 but it can be configured from 6000-9999.

Modbus TCP Port: Enter the Modbus port number of the meter. By default, this setting is configured to 502. The range can be from 2000 to 5999.

The screenshot shows a configuration interface with the following fields and options:

- DNS Server 1:** Text input field containing "8.8.8.8". Below it, "Default: 8.8.8.8".
- DNS Server 2:** Text input field containing "8.8.4.4". Below it, "Default: 8.8.4.4".
- HTTP Enable:** Radio button options: "Disable" (selected) and "Enable".
- HTTPS Port:** Text input field containing "443". Below it, "Default: 443, Range 6000-9999".
- Meter Channel 2 Address (Modbus TCP):** Text input field containing "1". Below it, "Range 1-247".
- Modbus TCP Port:** Text input field containing "502". Below it, "Default: 502, Range 2000-5999".

Fast Read Mode Enable: Selecting Enable allows the user to read the real time parameters at 100ms.

- Frequency Adjustment: Allows users to control the rate of change of frequency. The range can be set from 1.00-5.00 Hz/s, by default this is set for 1 Hz/s.
- The minimum range is 45Hz and the max range is 65Hz, any frequency outside of the range will not have the frequency adjustment applied.

NOTE: Frequency Adjustment is only available when the meter is in Fast Read Mode.

NOTE: When Fast Read mode is enabled, all functions except Modbus and the Web server are disabled.

Fast Read Mode Enable

Disable
 Enable

The meter will run into Fast Read Mode after reboot
All functions except modbus reading will be disabled

Frequency Adjustment

Disable
 Enable

Change Rate

Hz/s
Range: 0.01-5.00

Minimum Adjustment Value

Hz
Range: 45-65

Maximum Adjustment Value

Hz
Range: 45-65

Proxy Server Enable: Select enable to allow for forwarding of data log files to pass through the Proxy server first and then the data post server. IE. AcuCloud.

HTTP Proxy Enable

Disable
 Enable

HTTP Proxy Server URL

HTTP Proxy Server Port

Range: 1-65535

After making any changes on the network settings page, click 'Save'. Users will be prompted to reboot the AXM-WEB2 immediately or later. If later is chosen the AXM-WEB2 will need to be rebooted from the 'Management' page in order for the settings to take effect.

9.1.4 Default Routing Interface (Outbound Traffic)

The AXM-WEB2 supports a routing default interface setting which allows users to configure which port to use for primary routing to external networks. Since there are multiple ways the user can connect such as Ethernet1/2, WIFI, RSTP, this setting will establish which one is used for the main routing interface. The other interfaces can be used for local routing if being used.

Users can select the default routing interface as:

- Ethernet 1
- Ethernet 2
- WIFI - only valid if WIFI is configured for station mode
- Bridge (RSTP) - only valid if RSTP is enabled

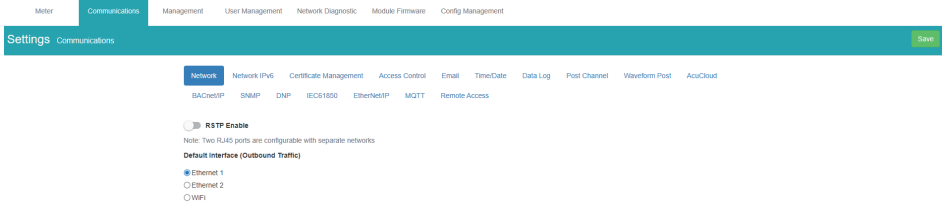

9.2 IPv6

The AXM-WEB2 module supports IPv6 communication where users can use IPv6 to access the web interface as well as connect via SNMP protocol. The settings for IPv6 can be accessed by clicking on Settings and selecting the Communications tab. On the Communications page select the IPv6 tab to configure the settings.

IPv6 Enable: Enable to access the settings for IPv6

Ethernet DHCP: This can be set to manual or auto.

- When set to Manual, users must configure the IPv6 address, the Subnet Prefix Length, and the Gateway.
- When set to Auto, the network will assign an IPv6 address automatically.

Ethernet Link Local Address: Is an IPv6 address that is automatically configured on the device with prefix 'fe80' followed by the MAC address of the module.

Ethernet Status: Displays whether there is an Ethernet cable connected or disconnected.

AXM-WEB2 for Acuvim II Series Power Meter

Settings Communications Save

Network **Network IPv6** Certificate Management Access Control Email Time/Date Data Log Post Channel Waveform Post AcuCloud

BACnet/IP SNMP DNP IEC61850 EtherNet/IP MQTT Remote Access

Note: Only webserver & SNMP server support IPv6

IPv6 Enable

Disabled

Enabled

Ethernet 1

Manual

Auto

Ethernet 1 IPv6 Link-local Address

fe80::ec3:3aff:fe20:29fd

Ethernet 1 IPv6 Address

Ethernet 1 Working Status : Connected

Ethernet 2

Manual

Auto

Ethernet 2 IPv6 Link-local Address

Ethernet 2 IPv6 Address

Ethernet 2 Working Status : Disconnected

9.3 Certificate Management

From the AXM-WEB2 web interface, there is a certificate management section that allows users to view the web page certificate details. Users can also generate a new self signed certificate, generate a certificate signed request, and import/export the certificates.

Meter Communications Management User Management Network Diagnostic Module Firmware Config Management

Settings Communications Save

Network **Network IPv6** **Certificate Management** Access Control Email Time/Date Data Log Post Channel Waveform Post AcuCloud

BACnet/IP SNMP DNP IEC61850 EtherNet/IP MQTT Remote Access

Import **Generate New Self-Signed Certificate** **Generate CSR** **Export**

Certificate Issuer	
Common Name	AN19070834
Company Name	Accuenergy (CANADA) Inc.
City	Toronto
State	CN
Country Code	CA

Certificate Subject	
Common Name	AN19070834
Company Name	Accuenergy (CANADA) Inc.
City	Toronto
State	CN
Country Code	CA

9.4 Access Control

The AXM-WEB2 supports the access control function, also known as the IP whitelist.

When enabled, only the selected IP addresses can access the meter’s web interface. Users can enter in an IPv4 or IPv6 address along with a description for the address. There is a maximum of 20 IP addresses that can be added to the IP Whitelist.

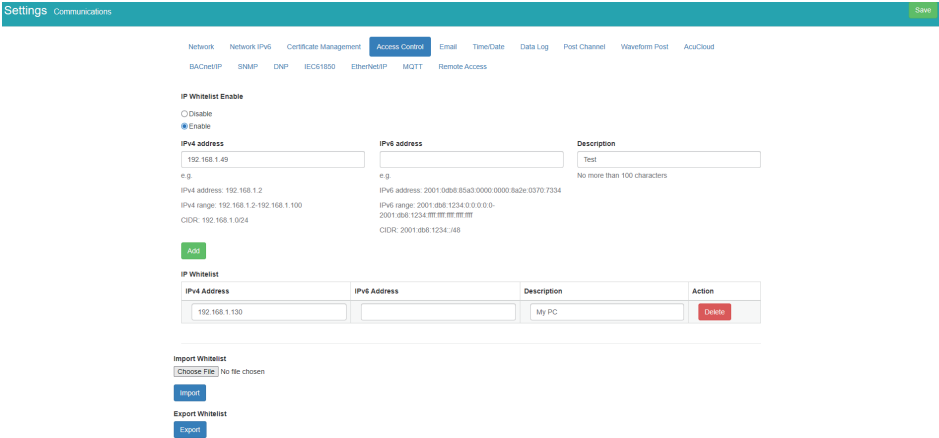

Users can import the IP whitelist or export an existing IP whitelist.

Click “Choose File” to import an whitelist, it should be an CSV file looks like below.

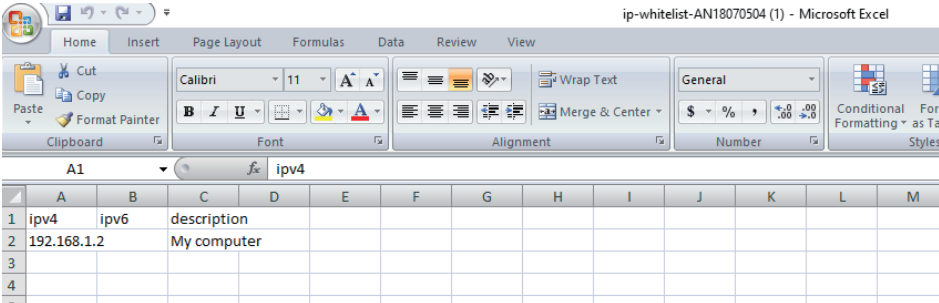

To export the IP whitelist, simply add the IP addresses and click “Export”. A CSV file will be downloaded automatically.

9.5 Email

The AXM-WEB2 supports the SMTP protocol where users can set up the email function to enable the meter to send emails based on a specific time interval or whenever there is an alarm or SOE event or a combination of both. The Email configuration page can be accessed by clicking on the 'Email' tab on the settings page. Users must know their SMTP server provider and details regarding their SMTP server, which can be provided by users' IT personnel.

There are three modes available for sending emails that the user can enable.

The first mode is **'Triggered Sending'** where emails are sent immediately when there is a new alarm, SOE, or waveform event.

The second mode is **'Timed Sending'** where users can receive emails at a certain period of time based on the time interval configured. The email will include the data that is selected to be sent.

The third mode is when both of the above are enabled.

To use this function the following settings need to be configured:

SMTP Enabled: Select 'Enable' to enable and to further configure the settings related to the SMTP function.

Start Time to Send Email: Select the date and time for when the emails should begin to send.

- Click on the icon to configure the time and date.



- Click on the icon in the bottom right to clear the time and date.



Start Time to Send Email

Input field: |

Calendar view for May 2019:

Su	Mo	Tu	We	Th	Fr	Sa
28	29	30	1	2	3	4
5	6	7	8	9	10	11
12	13	14	15	16	17	18
19	20	21	22	23	24	25
26	27	28	29	30	31	1
2	3	4	5	6	7	8

Bottom right icons: [Clear] [OK]

SMTP Server: Enter the URL of a valid SMTP server. I.E. mail.accuenergy.com or smtp.gmail.com

SMTP Port: Enter the port number associated with the SMTP server.

SMTP From: Enter a name or phrase which will appear to let you know who the mail is from. I.E. 'Technical Support'

SMTP Subject: Enter a subject line for the emails

Authentication: Users can have email authentication on or off. If authentication is on users will need to provide the SMTP username and password.

SMTP Username: Enter the SMTP user name for the SMTP server set above.

SMTP Password: Enter the SMTP user password for the username set above.

TLS/SSL: Users have the option to send emails using TLS/SSL protocols

Authentication

- On
- Off

SMTP Username

note: maximum 40 characters

SMTP Password

note: maximum 32 characters

TLS/SSL

- On
- Off

SMTP To Address 1;2;3: Enter up to three recipients that you wish to have the email sent to in 'SMTP To Address 1', 'SMTP To Address 2' and 'SMTP To Address 3'.

Test Address 1,2,3: Test the if the email can be sent to 'SMTP To Address 1', 'SMTP To Address 2', 'SMTP To Address 3'.

NOTE: If the test address function fails, users can view the email post failure by clicking on the 'Details' option from the test post screen.

After configuring the above settings, the next step is to select the content for the emails.

Settings Communications Save

Network Network IPv6 Certificate Management Access Control **Email** Time/Date Data Log Post Channel Waveform Post AcuCloud

BACnet/IP SNMP DNP IEC61850 EtherNet/IP MQTT Remote Access

SMTP Enable

Disable
 Enable

Start Time to Send Email 4:38 PM -0400 3 May, 2021

SMTP Server test@accuenergy.com

SMTP Port 587

Note: Maximum 40 characters

SMTP From test@accuenergy.com

Note: Maximum 40 characters

SMTP Subject Email Alert

Note: Maximum 30 characters

Authentication

On
 Off

SMTP Username test@accuenergy.com

Note: Maximum 40 characters

SMTP Password

Note: Maximum 32 characters

TLS/SSL

On
 Off

SMTP To Address 1 test@accuenergy.com

Note: Maximum 40 characters

SMTP To Address 2

Note: Maximum 40 characters

SMTP To Address 3

Note: Maximum 40 characters

The content of the emails can either be time based triggered or event based triggered.

For receiving emails on a time based under Enable Periodic Email Reporting:

Enter a time between 5-1440 mins in the Set time interval

Check off the box beside the parameters for the content the user should receive.

- **Metering Data:** Report on Real-time voltage, current, power and etc.
- **Energy Data:** Report on energy parameters.
- **Harmonics Data:** Report on the voltage and current harmonics from 2nd to 63rd.
- **Sequence & Phase Angles:** Report on the positive, negative and zero components of the voltage and current waveform.
- **Min/Max:** Report on the maximum and minimum statistics that the meter has recorded since the lifetime of the meter or from the last reset of the min/max statistics.
- **Alarm:** Report of the alarm log.
- **SOE Record:** Report of the SOE log.
- **Waveform:** Report of the waveform log.

The user will receive an email with csv file attachment.

For receiving emails on a event based select either Alarm Event, SOE Record or Waveform Data under the Enable Real-time Email Reporting.

NOTE: Waveform Data is only available for Acuvim IIW model.

The user will receive an email with csv file attachment corresponding to the triggered event selected.

Enable Periodic Email Reporting	Set time interval <input type="text" value="5"/> Range 5 - 1440
Include in the Periodic Email	
<input checked="" type="checkbox"/> Metering Data	<input checked="" type="checkbox"/> Min/Max
<input checked="" type="checkbox"/> Energy Data	<input checked="" type="checkbox"/> Alarms
<input checked="" type="checkbox"/> Harmonics Data	<input checked="" type="checkbox"/> SOE Records
<input checked="" type="checkbox"/> Sequence & Phase Angles	
Enable Real-time Email Reporting	
<input checked="" type="checkbox"/> Include Alarm Event	
<input checked="" type="checkbox"/> Include SOE Records	
<input type="checkbox"/> Include WaveForm Data	

9.6 Time/Date

The device clock of the Acuvim II series meter can be set through the web interface of the AXM-WEB2 module. The AXM-WEB2 module supports the NTP (Network Time Protocol) protocol so that the module can update the meter's device clock by synchronizing with a time server.

The module can sync with up to 3 time servers. If a time server is down, the module will synchronize with the second or third time server if they are configured.

The settings for the time and date can be found by clicking on the 'Settings' and selecting the 'Communications' tab. Users can select 'Time/Date' to configure the time settings.

The following must be configured to set the time/date and NTP settings:

NTP Enabled: Select enable to further configure the settings related to the NTP (Network Time Protocol) function

Device Clock: Configure the date and time on the meter

- Click on the icon to configure the date and time.



- Click on the icon in the bottom right to clear the time and date.

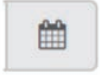

Sync Time: Click on Force Update to have the AXM-WEB2 sync its time with the NTP server

NTP Type: Select the NTP type from NTP or SNTP. SNTP should be selected when using the IEC61850 protocol.

NTP Server 1;2;3: Enter up to 3 NTP servers in the "NTP Server 1", "NTP Server 2" and "NTP Ser

0.us.pool.ntp.org

1.us.pool.ntp.org

2.us.pool.ntp.org

3.us.pool.ntp.org

For more NTP servers based on region, visit the following site:

<http://www.pool.ntp.org/en/>

Time Zone: Select the time zone the meter is in or the time zone in which you would like the meter's time to be synchronized to from the drop down list. Users can also select the timezone by clicking on the region in the map.

Click 'Save' after configuring the time settings. Users will be prompted to reboot the AXM-WEB2 immediately or later. If later is chosen the AXM-WEB2 must be rebooted from the 'Management' page in order for the settings to take effect.

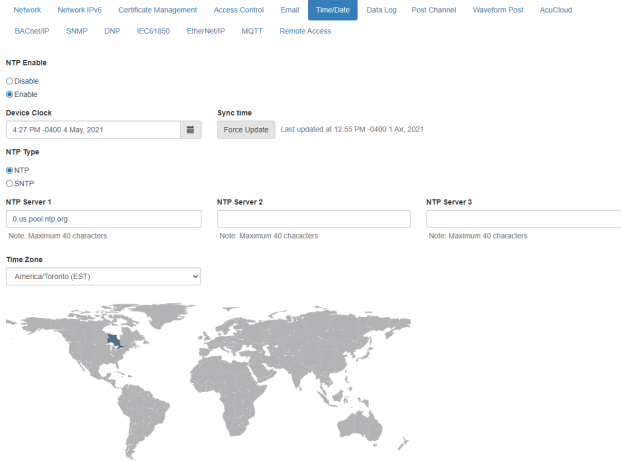

9.7 Data Log

The AXM-WEB2 supports logging data onto its on board memory, which has a capacity of 8GB. The module supports three loggers for different parameters and requirements. The data can be downloaded as a .csv file from the datalog page in the logs section or by using a HTTP/FTP client.

Logger Enable: To use the data log function to log the data onto the module, select 'Enable' to view and configure the settings that are applicable.

Post Channel: Select the channel to push the datalog to. Only an enabled post channel can be selected here. A post channel can be enabled in the 'Post Channel' tab on the settings page.

Log Param Type: Users can select the type of parameters they wish to log into logger.

Users can use the '>' button to add selected parameters into the data log, and use the '<' button to remove selected parameters from the data log. Users can also use the 'All' or 'Clear' buttons to add all or clear all parameters to and from the data log. The supported parameter types include real-time readings, energy readings, demand readings, power quality readings and I/O readings.

Log File Format: Users can select the log file format at either JSON or CSV.

NOTE: JSON format is only supported via HTTP/FTP/MQTT posting and is not supported when logging data locally to the module memory. Only CSV file format is supported for local log files.



The image shows a web interface element titled "Log File Format". It is a dropdown menu with a light blue border. The current selection is "csv", which is highlighted in a grey background. Below the dropdown, the options "csv" and "json" are listed in a plain font.

Timestamp Format: Select the format of the timestamp for the data that is logged. The format for the timestamp can be based on the Local Time (not available for JSON format), UTC Seconds or based on ISO8601 Format.

Log File Name Format: Select the format of the log file name for the data that is logged. The format for the log file name can be based on the UTC timestamp or based on Time Interval Format.

Log Interval: Select how frequently the meter will log data to the file that will be uploaded to the server from the drop down list. The logging interval can be from 1 second to 1 month. The minimum time interval option is according to the selected parameter.

- The Real-time & IO's min Log Interval is 1 sec
- The Energy's min Log Interval is 15 sec
- The Demand & Power Quality's min Log Interval is 1 min

NOTE: If selected parameters are Real-time and I/O, the min log interval is 1 sec. If selected parameters are Real-time and Energy, the min log interval is 15 sec.

Post File Length: Select how frequently the log file will be uploaded to the HTTP/FTP server from the drop down list. The log file length can be from 1 minute to 1 month.

Log File Name Prefix: Provide a name for the log file posted to post channel which will be

AXM-WEB2 for Acuvim II Series Power Meter

appended to the beginning of the log file if "Time Interval Format" is selected as the Post File Name Format. By default "logger1" will be appended to the beginning of the log file.

Local Log File Length: Select the length of the local log file as 1 hour, 1 day, 7 days or 1 month of data from the drop down list. The log file will appear at the end of the log file length interval, for example if set for 1 day users will not see the local logs until the next day at 12AM. See the table below for more details.

Local Long File Length	Date Configured	Date log file will appear in module
1 hour	November 11th 2020 at 1:00PM	November 11th 2020 at 2PM
1 day	November 11th 2020 at 1PM	November 12th 2020 at 12AM
7 days	November 11th 2020 at 1PM	November 18th 2020 at 12AM
1 month	November 11th 2020 at 1PM	December 11th 2020 at 12AM

Local Log File Name Prefix: Provide a name for the local log file which will be appended to the beginning of the log file if "Time Interval Format" is selected as the Post File Name Format. By default "logger1" will be appended to the beginning of the log file.

NOTE: The Post File Length and Local Log File Length must be less than or equal to the log interval selected.

SFTP Enable: To download the logged data from the module using a FTP client, select Enable. The log file will then be available to be downloaded using a FTP client using the following credentials:

Host: sftp://IPaddressofthemet

Username: sftpuser

SFTP Password: accuenergy

Port: 22

By default the password for retrieving the backup log files is **accuenergy**. The user can configure any password or can reset to the default of accuenergy by clicking on the "Reset SFTP Password".

NOTE: After enabling the SFTP function the user must reboot the communication module in order to access the data logs with the default password of 'accuenergy'.

Click 'Save' after changing any settings. Users will be prompted to reboot the AXM-WEB2 immediately or later. If later is chosen the AXM-WEB2 must be rebooted from the 'Management' page in order for the changes to take effect.

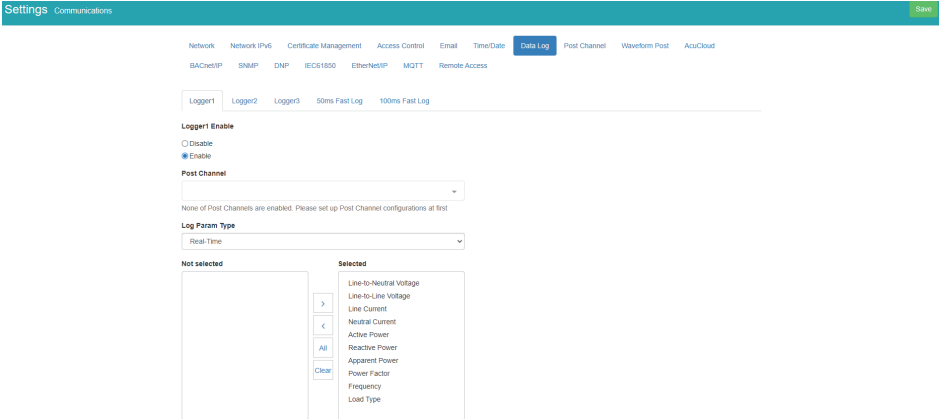

9.7.1 50ms Fast Log

There is a 50ms fast logger supported on the AXM-WEB2 module, this logger allows users to log Frequency and active power data at 50ms. No other parameters besides these two are supported on the 50ms logger.

NOTE: The 50ms fast logger is only supported on Acuvim II meters with firmware version 4.12 and higher. In order to use the fast logger mode the baud rate 2 setting in the meter is required to be 115200.

Users can configure the log file length and log file name prefix for the fast logger. Once enabled, all other protocols supported on the AXM-WEB2 are disabled except for Modbus TCP. Users will still have access to the meters network settings, however all other protocol related settings such as BACnet, MQTT, etc are disabled when the fast logger is enabled.

AXM-WEB2 for Acuvim II Series Power Meter

Settings Communications Save

[Network](#)
[Network IPv6](#)
[Certificate Management](#)
[Access Control](#)
[Email](#)
[Time/Date](#)
[Data Log](#)
[Post Channel](#)
[Waveform Post](#)
[AcuCloud](#)

[BACnetIP](#)
[SNMP](#)
[DNP](#)
[IEC61850](#)
[EthernetMMS](#)
[MQTT](#)
[Remote Access](#)

[Logger1](#)
[Logger2](#)
[Logger3](#)
[50ms Fast Log](#)
[100ms Fast Log](#)

50ms Fast Log Enable

Disable
 Enable

Note:
 * 50ms Fast Log will disable all protocols except Modbus TCP
 * 2 parameters: Frequency and Active Power will be logged at 50ms rate

Log File Length **Log File Name Prefix**

e.g., fastlog-1004519143-50ms.csv

SFTP Enable

Disable
 Enable

SFTP Port **SFTP Password**
 [Reset SFTP Password](#)
Note: Setup SFTP Port Note: Maximum 12 characters, Default: accuenergy

[Save](#)

After all settings have been saved and the module is rebooted from the web interface, the AXM-WEB2 will be in Fast Log Mode. When logging into the web interface during fast log mode, users will observe that the dashboard will only display frequency and total active power.

Logout 4:49 PM -0400 4 May, 2021 [About](#) [Settings](#) AXM-WEB2 **ACCUENERGY**

Dashboard [Logs](#) Test Meter

Parameter	Phase A	Phase B	Phase C	Average	Total
Active Power kW	-	-	-	-	1,300
Frequency Hz	50.005				

Module up since Tue May 04 2021 16:45:49 GMT-0400 (Eastern Daylight Time)

The fast log files can be downloaded under the logs menu.

Logout 5:16 PM -0400 4 May, 2021 [About](#) [Settings](#) AXM-WEB2 **ACCUENERGY**

Dashboard [Logs](#)

Logs [Data Log](#)

Select All	Files	Updated at	Size
<input type="checkbox"/>	fastlog-1620165600-50ms.csv ↓	2021-05-04 17:15:56	773 KB
<input type="checkbox"/>	fastlog-1620162000-50ms.csv ↓	2021-05-04 17:00:00	501 KB

[Delete Selected](#)

1

9.7.2 100ms Fast Log

When the meter is in Fast Read mode users can enable the 100ms Fast Log on the AXM-WEB2. This logger allows users to log real time data such as voltage, current, power, etc at 100ms intervals.

NOTE: This can only be enabled if the meter is in fast read mode, the 100ms logger cannot be enabled during normal mode.

The screenshot shows the 'Settings' page for 'Communications'. Under the 'Data Log' tab, the '100ms Fast Log Enable' section has 'Enable' selected. Below it, 'Log File Length' is set to '5 minutes' and 'Log File Name Prefix' is 'fastlog'. The 'SFTP Enable' section also has 'Enable' selected, with 'SFTP Port' set to '22' and a 'SFTP Password' field. A 'Save' button is at the bottom left of the settings area.

The data log files for the 100ms logger can be downloaded under the logs menu.

The screenshot shows the 'Logs' page with a table of log files. The table has columns for 'Select All', 'Files', 'Updated at', and 'Size'. The files listed are all for 'Logger 100ms' and have names starting with 'fastlog-'. The 'Updated at' column shows various timestamps, and the 'Size' column shows file sizes ranging from 1637 KB to 176 KB.

Select All	Files	Updated at	Size
<input type="checkbox"/>	fastlog-1620164400-100ms.csv	2021-05-04 17:43:00	683 KB
<input type="checkbox"/>	fastlog-1620164100-100ms.csv	2021-05-04 17:33:00	176 KB
<input type="checkbox"/>	fastlog-1617131700-100ms.csv	2021-03-30 15:08:30	165 KB
<input type="checkbox"/>	fastlog-1617130800-100ms.csv	2021-03-30 15:03:00	1637 KB
<input type="checkbox"/>	fastlog-1617129900-100ms.csv	2021-03-30 14:43:00	1637 KB
<input type="checkbox"/>	fastlog-1617129000-100ms.csv	2021-03-30 14:33:00	1637 KB
<input type="checkbox"/>	fastlog-1617128100-100ms.csv	2021-03-30 14:15:00	1637 KB
<input type="checkbox"/>	fastlog-1617127200-100ms.csv	2021-03-30 14:00:00	1637 KB
<input type="checkbox"/>	fastlog-1617126300-100ms.csv	2021-03-30 13:43:00	1637 KB
<input type="checkbox"/>	fastlog-1617125400-100ms.csv	2021-03-30 13:30:00	1637 KB
<input type="checkbox"/>	fastlog-1617124500-100ms.csv	2021-03-30 13:15:00	1637 KB
<input type="checkbox"/>	fastlog-1617123600-100ms.csv	2021-03-30 13:03:00	1637 KB
<input type="checkbox"/>	fastlog-1617122700-100ms.csv	2021-03-30 12:41:00	1637 KB
<input type="checkbox"/>	fastlog-1617121800-100ms.csv	2021-03-30 12:33:00	1637 KB

9.8 Post Channel

The AXM-WEB2 supports the HTTP and FTP Post functions to send data from the meter to a HTTP/FTP server. The AXM-WEB2 can post .csv/.json files to three different HTTP or FTP servers using HTTP Post or FTP Post.

In the case when there is no connection to the server, the AXM-WEB2 will store the posts and send it out after the connection is restored. The module can store up to 3GB of cache post files. The Clear Post Channel Logs button will allow users to clear the buffered files on meter.

NOTE: *If the disk usage exceeds 85% the module will begin to delete some older backup/post cached files.*

The AXM-WEB2 can post data to a server at intervals of time ranging from 1 minute to 1 month.

The settings for configuring the post channels to post the data can be found by clicking on 'Settings' and then selecting 'Communications' tab. Click "Post Channels" to configure any of the three post channels.

Post Channel 1/2/3 Enable: Enable the Post Channel 1 in order to configure the settings needed to post data via the HTTP(S)/FTP post functions

Post Method: Select the method for posting the files, the user can choose HTTP/HTTPS or FTP

Post Name Fixed: This configuration needs to be enabled in order for user to control the name of the file that will be posted. Otherwise file name will be based on the Log File Name Format configuration from the Data Log settings

Post File Name: Users can enter a name for the file that will be posted as if 'Post Name Fixed' is enabled

If the HTTP/HTTPS post method is selected:

Need Authorization: If the HTTP server requires some sort of password/authorization in order to send files users can enter that under the token field.

Default authorization: requires a password/token to be entered for the server

Basic authentication: requires a user name and password for the server

HTTP/HTTPS URL: Enter the URL for the HTTP/HTTPS server. The URL needs to begin with the prefix http:// or (https://)

HTTP/HTTPS Port: Enter the port number the server will be listening on

HTTP/HTTPS Meter ID: Enter a name or description for the meter to be identified on the server

Settings Communications Save

Network Network IPv6 Certificate Management Access Control Email Time/Date Data Log **Post Channel** Waveform Post AcuCloud

BACnet/IP SNMP DNP IEC61850 EtherNet/IP MQTT Remote Access

Post Channel 1 Post Channel 2 Post Channel 3

Post Channel 1 Enable

Disable
 Enable

Post Method
HTTP / HTTPS

Post Name Prefix
 Disable
Post file name need to be provided

Post File Name
Note: Maximum 20 characters

Need Authorize
 Disable
 Enable

HTTP/HTTPS Authentication Method
Basic Authentication

User Name
admin

Password
admin

HTTP / HTTPS URL
https://testserver.ca
URL begins with http:// or https://

HTTP / HTTPS Port
80
Range: 0-65535

HTTP / HTTPS Meter ID
Test

[Test Post Channel](#) [Clear Post Channel 1 Log](#)

Save

If the FTP post method is selected:

FTP URL: Enter the URL for the FTP server. The URL needs to begin with the prefix ftp://

FTP Port: Enter the port number the server will be listening on

FTP Username: Enter the username required to log into the FTP server

FTP Password: Enter the password required to log into the FTP server

Settings Communications Save

Network Network IPv6 Certificate Management Access Control Email Time/Date Data Log **Post Channel** Waveform Post AcuCloud

BACnet/IP SNMP DNP IEC61850 EtherNet/IP MQTT Remote Access

Post Channel 1 Post Channel 2 Post Channel 3

Post Channel 1 Enable

Disable
 Enable

Post Method
FTP

FTP URL
ftp://testftpserver.ca
URL begins with ftp://

FTP Port
21
Range: 0-65535

FTP Username
admin

FTP Password
admin

[Test Post Channel 1](#) [Clear Post Channel 1 Log](#)

Save

AXM-WEB2 for Acuvim II Series Power Meter

Click 'Save' after changing any settings. Users will be prompted to reboot the AXM-WEB2 immediately or later. If later is chosen the AXM-WEB2 must be rebooted from the 'Management' page in order for the settings to take effect.

The test post button can be used to test the connection to the server. This should only be used after saving the HTTP/FTP post settings, otherwise a failed message will be observed. If a failed message is observed the "test post details" will provide users with a description of why the test failed.

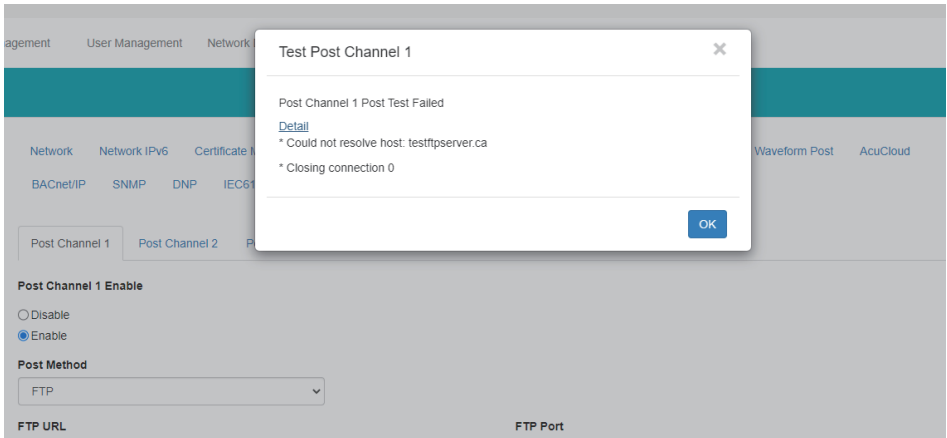

9.9 Waveform Post

The AXM-WEB2 supports a waveform post function that allows users to send waveform data to an HTTP/FTP server. The AXM-WEB2 will send Comtrade (.cfg and .dat) files to either an HTTP or FTP whenever a power quality event has occurred. The settings for the Waveform Post can be found by clicking on the 'Settings' tab and selecting 'Communications', from the Communications page click on the 'Waveform Post' tab.

NOTE: This function is only available on Acuvim I1W models which support the Waveform Capture Function, all other models will not have this feature available.

Waveform Post Enable: Select Enable to enable the waveform post and configure the settings further.

Scan Interval: Users can configure a scan interval where the AXM-WEB2 module scans at the Acuvim II meter to check whether there are any power quality events that occurred during the selected scan interval. For example if the scan interval is set for 15 minutes the module will scan

for all the power quality events that occurred within 15 minutes and post it to the server. The scan interval ranges from 15 seconds to 1 month.

File Name Prefix: Users can configure the file name prefix for the Comtrade file that is sent to the server.

Post Method: From the drop down menu select either FTP or HTTP/HTTPS

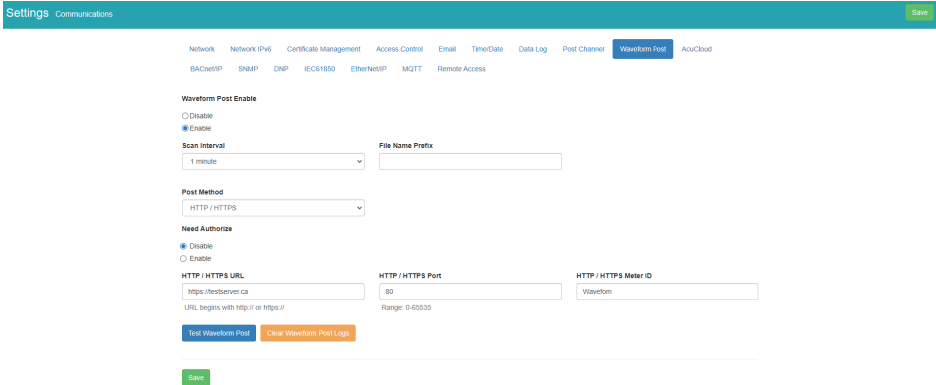

NOTE: The 'Test Waveform Post' button should only be utilized after clicking the 'Save' button otherwise a fail response will be observed. If the test post fails users can view the test post details by clicking on the 'Details' option from the test post screen.

Similar to the Post Channel function discussed earlier, in the case when there is no connection to the server the AXM-WEB2 will store the posts and send it out after the connection is restored. A maximum of 3000 files will be buffered on module. The 'Clear Waveform Post Channel Logs' button will allow users to clear the buffered waveform files on meter.

There is no interval setting for sending the waveform data using the waveform post, the data will post directly to the FTP/HTTP server when a power quality event has occurred.

9.10 AcuCloud

The AXM-WEB2 module can directly interface with the Accuenergy Cloud software AcuCloud. The AXM-WEB2 will post data to the cloud software every five minutes.

AXM-WEB2 for Acuvim II Series Power Meter

AcuCloud will require the serial number of the AXM-WEB2 module which will then provide a token that will be used to configure the AXM-WEB2 so it can send its data to AcuCloud.

The settings for the AcuCloud post function can be found by clicking on the 'Settings' tab and selecting 'Communications'. Select 'AcuCloud' to access the settings to configure the AXM-WEB2 to send data to the cloud.

AcuCloud Enable: Select 'Enable' to enable the function and to further configure the settings related to AcuCloud.

AcuCloud Token: Copy and paste the token provided by the AcuCloud software into this field.

The screenshot shows the 'Settings' page for 'Communications'. The 'AcuCloud' tab is selected. Under 'AcuCloud Enable', the 'Enable' radio button is selected. The 'Module Serial Number' is AN20090924. The 'AcuCloud Token' is 0074a1c0-c2b5-4749-bc16-a25f521f6017. There are buttons for 'Test AcuCloud', 'Clear AcuCloud Post Logs', and 'Save'.

NOTE: The "TEST AcuCloud" button should only be utilized after clicking the 'Save' button otherwise a fail response will be observed. If a fail response occurs after clicking 'Save', please double check the serial number entered in AcuCloud, the token pasted in the web page as well viewing the test post details by clicking on the 'Details' option.

Users can use the 'Link to AcuCloud' to access the cloud software and configure the required settings on that platform. Users must have sufficient access to add devices on their account in order to correctly configure the meter on the software. For inquiries on creating your AcuCloud account please contact Accuenergy Technical Support.

Click 'Save' after changing any settings. Users will be prompted to reboot the AXM-WEB2 immediately or later. If later is chosen the AXM-WEB2 must be rebooted from the 'Management' page for the settings to take effect.

The AXM-WEB2 will post the data continuously every 5 minutes after the reboot.

9.11 BACnet/IP

The AXM-WEB2 module supports the BACnet/IP protocol. The settings for the BACnet/IP protocol can be found on the web by clicking on the 'Settings' tab and selecting 'Communications'. Once on the communications page select "BACnet/IP" to access the settings to configure the AXM-WEB2 to communicate with a BACnet client.

BACnet Enabled: Select Enable to enable the BACnet protocol.

BACnet Port: Enter the BACnet or UDP port number. Default port is 47808.

Device Instance: Enter the instance number for the device in the BACnet system. It must be unique within the system.

Device Name: Enter a name for the device to distinguish it from other devices within the network.

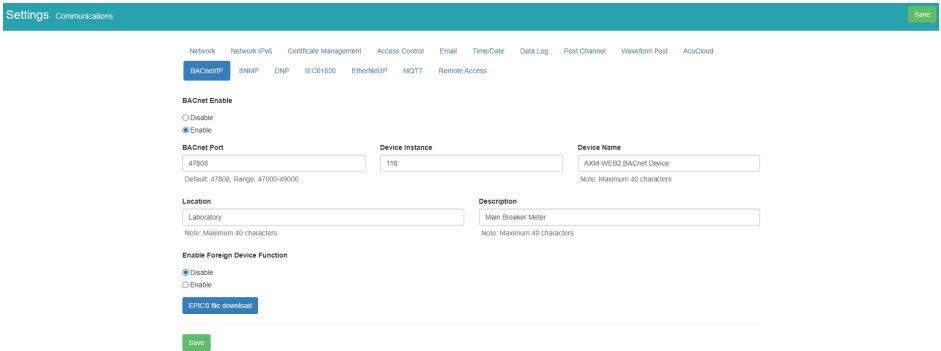

Under the "Enable Foreign Device Function", select 'Enable' to communicate with a BACnet device from another subnet.

- Enter the IP of the BACnet Broadcast Management Device(BBMD) under the 'BBMD IP' field for the device which will receive broadcast messages on one subnet and forward them to another subnet.
- Enter BACnet Port of the BBMD in "BBMD Port"
- Enter a value between 5-1440 min in the "Time To Live" for how often the foreign device will register in the BBMD's foreign device table.

Click 'Save' after changing any settings. Users will be prompted to reboot the AXM-WEB2 immediately or later. If later is chosen the AXM-WEB2 must be rebooted from the 'Management' page in order for the settings to take effect.

Enable Foreign Device Function unsaved changes

Disable
 Enable

BBMD IP

BBMD Port

Time To Live
Enter time in minutes

[EPICIS file download](#)

[Save](#)

9.12 SNMP

The AXM-WEB2 module supports the Simple Network Management Protocol(SNMP) protocol for reporting the metering data to the management station. The AXM-WEB2 uses a public community string for read-only access. By default the module will communicate using SNMP port 161. The AXM-WEB2 also supports 'traps' to send unsolicited messages to up to four management stations.

The settings for the SNMP protocol can be found by clicking on the 'Settings' tab and selecting 'Communications'. From the communications page select the 'SNMP' tab to access the settings to configure the AXM-WEB2 for communication with a SNMP management station.

SNMP Enable: Select 'Enable' to enable the function and to further configure the settings related to the SNMP protocol.

SNMP Version: Users can select the SNMP version, the WEB2 module supports SNMPv2c and SNMPv3.

SNMP Port: By default the SNMP Port is configured to 161. The SNMP Port can be any value from ranging from 16100 to 16199.

Read Only Community: By default the community string is Public, this configuration is similar to a password which allows only authorized users to access the meters data.

Trap Enable: Select 'Enable' so that the meter will send a message to the management station when an event is triggered. The event could be a change in Digital Input Status. The notification can then be sent to up to 4 stations.

Trap Target 1: Enter the IP address and port number of station number 1 that should be notified when there is an event.

Trap Target 2: Enter the IP address and port number of station number 2 that should be notified when there is an event.

Trap Target 3: Enter the IP address and port number of station number 3 that should be notified when there is an event.

Trap Target 4: Enter the IP address and port number of station number 4 that should be notified when there is an event.

Report Buffer Size: Enter the size of the buffer for the amount of notifications will be stored before being sent to the management station. A maximum of 30 notifications can be stored.

Report Hold Time: Enter the time in seconds for how long the notification will be in queue before it gets sent to the management station. By default, this setting is configured to 0 so the notification will be sent immediately after an event occurs. This setting could be configured from 0-30 seconds.

Click 'Save' after changing any settings. Users will be prompted to reboot the AXM-WEB2 immediately or later. If later is chosen the AXM-WEB2 must be rebooted from the 'Management' page in order for the settings to take effect.

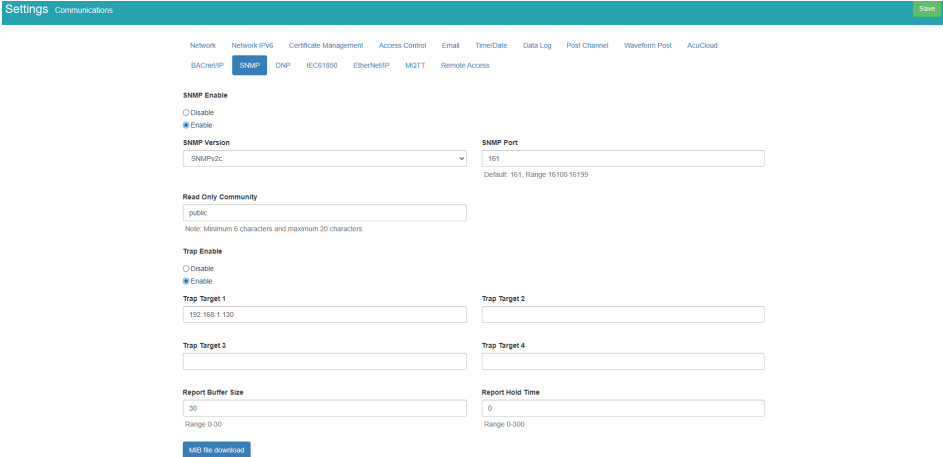

9.13 DNP

The AXM-WEB2 supports the DNP communications protocol. The Distributed Network Protocol (DNP) is an open protocol used in the electric utility industry for communication and interoperability among substation computers, Remote Terminal Units (RTUs), Intelligent Electronic Devices (e.g. meters), and master stations.

AXM-WEB2 for Acuvim II Series Power Meter

The settings for the DNP protocol can be found by clicking on the 'Settings' tab and selecting 'Communications'. Select 'DNP' to access the settings to configure the AXM-WEB2 to communicate with a DNP master.

DNP Enable: Select 'Enable' to enable the function and to further configure the settings related to the DNP function.

TCP/IP Mode: By default the TCP/IP is set as TCP&UDP, it can be changed to TCP dual endpoint mode or UDP only.

Local TCP Port: Enter the port number for the local TCP server.

Local UDP Port: Enter the port number for the local UDP server.

Destination IP address: The default IP address is set as *.*.*.* to allow all incoming requests.

Dual endpoint IP port: Enter the port number for the endpoint IP server.

Destination UDP port for initial unsolicited null responses: Enter the port number of the destination UDP server for the initial unsolicited null responses.

Destination UDP port for response: Enter the port number of the destination UDP server for response.

Link address: Enter the address number of the slave device.

Master link address: Enter the address number of the master device.

Source address validation: By default the validation is disabled, select 'Enable' to enable the destination address validation.

Supports Unsolicited Reporting: Select 'Enable' to enable the function and further configure the settings related to the unsolicited report.

Number of Unsolicited Retries: Number of retries can be selected as '0', '10' and 'infinite'.

Unsolicited response trigger Condition(Num of class # events): Enter the number of events for each class to setup the trigger point. The unsolicited response will be triggered once the number the class events reaches the configured triggering number. The range is from 0-255.

Unsolicited response trigger Condition(Hold time after class # events): Enter the threshold holding time for each class, the unsolicited response will be triggered once the event holding time is longer or equal to the threshold time. The range is from 0-86400000 milliseconds.

Support for broadcast functionality: In DNP there three broadcasting addresses that are supported. Enabling this setting would allow the module to respond to requests (from the client) sending them to the broadcasting addresses.

File Transfer: The DNP function in the AXM-WEB2 allows for file transfer, where users can send and transfer data. This transfer requires a username and password which is user configurable, the default username/password is **accuenergy**.

Unsolicited response trigger Condition: Num of class 1 events	<input type="text" value="0"/>	Range: 0-255
Unsolicited response trigger Condition: Num of class 2 events	<input type="text" value="0"/>	Range: 0-255
Unsolicited response trigger Condition: Num of class 3 events	<input type="text" value="0"/>	Range: 0-255
Unsolicited response trigger Condition: Hold time after class 1 events	<input type="text" value="0"/>	Range: 0-86400000 (milliseconds)
Unsolicited response trigger Condition: Hold time after class 2 events	<input type="text" value="0"/>	Range: 0-86400000 (milliseconds)
Unsolicited response trigger Condition: Hold time after class 3 events	<input type="text" value="0"/>	Range: 0-86400000 (milliseconds)

Support for broadcast functionality Disable Enable

File Transfer Class: User Name: Password:

DNP3 Point Configuration

Users can assign certain parameters to either class 1, class 2 or class 3. The scale factor is a multiplier that can be applied to a certain parameter when viewing the readings. An offset can be applied to the reading. The dead band can be set for each parameter, where if the value of the parameter exceeds the dead band value a DNP event will occur.

DNP3 Point Configuration		Class 1	Class 2	Class 3	Scale Factor	Scale Offset	Deadband
<div style="border: 1px solid black; padding: 2px;"> Analog Input: Realtime <input checked="" type="checkbox"/> Not Selected Analog Input: Realtime Analog Input: Energy Analog Input: Demand Analog Input: THD Analog Input: V01 Harmonics Analog Input: Current Harmonics Analog Input: AI & AG Binary Input: DI Status Binary Input: Virtual Input Counter: DI Counter Binary Output: Relay Output Binary Output: Virtual Relay </div>							
4	AverageLine-to-NeutralVoltage	<input checked="" type="checkbox"/>	<input checked="" type="checkbox"/>	<input checked="" type="checkbox"/>	1	0	0
5	PhaseA-Line-to-LineVoltage	<input checked="" type="checkbox"/>	<input checked="" type="checkbox"/>	<input checked="" type="checkbox"/>	1	0	0
6	PhaseB-Line-to-LineVoltage	<input checked="" type="checkbox"/>	<input checked="" type="checkbox"/>	<input checked="" type="checkbox"/>	1	0	0
7	PhaseC-Line-to-LineVoltage	<input checked="" type="checkbox"/>	<input checked="" type="checkbox"/>	<input checked="" type="checkbox"/>	1	0	0
8	AverageLine-to-LineVoltage	<input checked="" type="checkbox"/>	<input checked="" type="checkbox"/>	<input checked="" type="checkbox"/>	1	0	0
9	PhaseA-LineCurrent	<input checked="" type="checkbox"/>	<input checked="" type="checkbox"/>	<input checked="" type="checkbox"/>	1	0	0
10	PhaseB-LineCurrent	<input checked="" type="checkbox"/>	<input checked="" type="checkbox"/>	<input checked="" type="checkbox"/>	1	0	0
11	PhaseC-LineCurrent	<input checked="" type="checkbox"/>	<input checked="" type="checkbox"/>	<input checked="" type="checkbox"/>	1	0	0
12	AverageLineCurrent	<input checked="" type="checkbox"/>	<input checked="" type="checkbox"/>	<input checked="" type="checkbox"/>	1	0	0
13	SystemNeutralCurrent	<input checked="" type="checkbox"/>	<input checked="" type="checkbox"/>	<input checked="" type="checkbox"/>	1	0	0
14	PhaseActivePower	<input checked="" type="checkbox"/>	<input checked="" type="checkbox"/>	<input checked="" type="checkbox"/>	1	0	0
15	PhaseBActivePower	<input checked="" type="checkbox"/>	<input checked="" type="checkbox"/>	<input checked="" type="checkbox"/>	1	0	0
16	PhaseCActivePower	<input checked="" type="checkbox"/>	<input checked="" type="checkbox"/>	<input checked="" type="checkbox"/>	1	0	0
17	SystemActivePower	<input checked="" type="checkbox"/>	<input checked="" type="checkbox"/>	<input checked="" type="checkbox"/>	1	0	0

AXM-WEB2 for Acuvim II Series Power Meter

Users can use the 'Batch Modify' button to apply certain settings to all parameters instead of individually configuring each point. Once the configuration in the batch modify is complete click on 'save changes'.

DNP3 Point Configuration

Analog-Input: Realtime

Batch Modify x

Description	Class 1	Class 2	Class 3	Scale Factor	Scale Offset	Deadband
	<input type="checkbox"/>	<input checked="" type="checkbox"/>	<input type="checkbox"/>	100	10	2

Close
Save changes

Batch Modify

Point Number	Description	Class 1	Class 2	Class 3	Scale Factor	Scale Offset	Deadband
0	SystemFrequency	<input type="checkbox"/>	<input checked="" type="checkbox"/>	<input type="checkbox"/>	100	10	2
1	PhaseALine-to-NeutralVoltage	<input type="checkbox"/>	<input checked="" type="checkbox"/>	<input type="checkbox"/>	100	10	2
2	PhaseBLine-to-NeutralVoltage	<input type="checkbox"/>	<input checked="" type="checkbox"/>	<input type="checkbox"/>	100	10	2
3	PhaseCLine-to-NeutralVoltage	<input type="checkbox"/>	<input checked="" type="checkbox"/>	<input type="checkbox"/>	100	10	2
4	AverageLine-to-NeutralVoltage	<input type="checkbox"/>	<input checked="" type="checkbox"/>	<input type="checkbox"/>	100	10	2
5	PhaseA-BLine-to-LineVoltage	<input type="checkbox"/>	<input checked="" type="checkbox"/>	<input type="checkbox"/>	100	10	2
6	PhaseB-CLine-to-LineVoltage	<input type="checkbox"/>	<input checked="" type="checkbox"/>	<input type="checkbox"/>	100	10	2
7	PhaseC-ALine-to-LineVoltage	<input type="checkbox"/>	<input checked="" type="checkbox"/>	<input type="checkbox"/>	100	10	2
8	AverageLine-to-LineVoltage	<input type="checkbox"/>	<input checked="" type="checkbox"/>	<input type="checkbox"/>	100	10	2

After all DNP settings are complete, click on 'Save'. Users will be prompted to reboot the AXM-WEB2 immediately or later. If later is chosen the AXM-WEB2 must be rebooted from the 'Management' page in order for the settings to take effect.

9.14 IEC61850

The AXM-WEB2 supports IEC 61850 which is a standard for Ethernet communication among IEDs (intelligent Electronic Devices) in substations.

The settings for IEC 61850 can be found by clicking on the 'Settings' tab and selecting 'Communications'. Select 'IEC61850' to access the settings to configure the AXM-WEB2 to communicate using the standard.

IEC61850 Enable: Select 'Enable' to enable the function and to further configure the settings related to the IEC61850 function.

IEC61850 Port: By default the IEC61850 Port is configured to 102. The IEC61850 Port can be any value from 10200 to 10299.

CID File: The CID file is the configuration file that holds the meter settings pertaining to the IEC 61850 standard. This file can be downloaded from this page and altered by the user in order to meet their requirements.

Select CID File: Users can upload their own CID configuration file by selecting 'Choose File' and then selecting 'Upload' once the correct file is chosen.

Restore to Default: At any point the user can divert back to the original CID file by selecting this button.

Users can download the CID file for the module, where both Edition 1 and Edition 2 of the protocol is supported. Either edition CID file can be downloaded from the web interface.

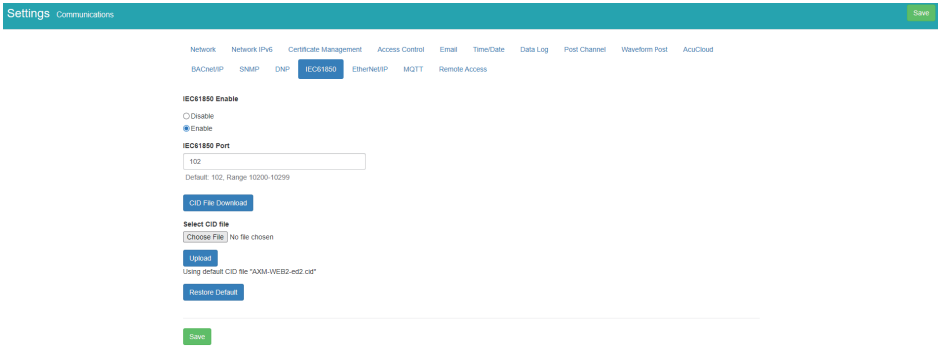

NOTE: CID file in v1.13 and lower are not compatible with firmware v1.14 and higher. If communicating with the meter using IEC61850 protocol and then update to firmware v1.14 or higher, users will need to restore to default to use the compatible CID file.

Once all settings are entered in correctly click on 'Save' and reboot the communications module. If the user decides to reboot the module later, users will have to perform the reboot manually from the 'Management' page in order for the settings to take effect.

9.15 EtherNet/IP

The AXM-WEB2 module supports the Ethernet/IP protocol which is an industrial based network protocol that uses standard Ethernet and TCP/IP technology.

EtherNet/IP Enable: Select Enable to enable the EtherNet/IP protocol

EtherNet/IP Explicit Exchanges Port: Users can configure the EtherNet/IP port, the default port is 44818 and the port number ranges from 44800-44899.

EtherNet/IP Implicit Exchange Interface: Users can select Ethernet 1 or Ethernet 2 for communication.

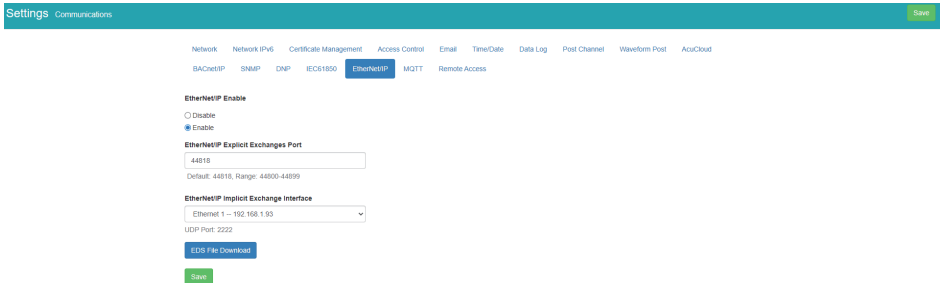

9.16 MQTT

The AXM-WEB2 supports the MQTT protocol where the meter can publish device data to a subscriber using an MQTT broker. The MQTT broker is a central server where all MQTT clients would connect to. The broker/server manages all message topics and updates new messages to all clients that are subscribed to a particular topic (Acuvim II). All related MQTT settings can be configured in the MQTT page under the Communications tab.

9.16.1 MQTT General Settings

Under the **General** tab in the MQTT page, users can enable the MQTT protocol and configure the broker settings.

Enable MQTT: Select Enable to use MQTT protocol

Broker Address: Enter the broker address of the MQTT server

Broker Port: Enter the port number for the MQTT Broker

Client ID: Enter the Client ID for the Acuvim II; must be a unique ID number

Keep Alive: The client communicates a time interval in seconds to the broker, "Keep-Alive" is the maximum length of time in seconds that the broker and the client cannot communicate with each other.

Clean Session: If selected as Yes the session data is cleared all offline data is lost, if selected as No messages are queued are received up reconnection.

Once all settings are configured click Save. The connection to the broker can be tested by using the Test MQTT button.

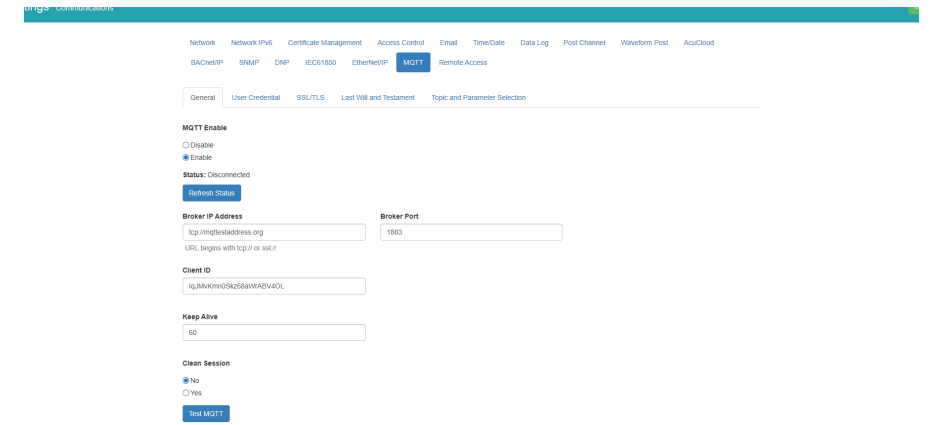

9.16.2 MQTT Authentication

The **User Credential** tab allows users to configure a User Name and Password authentication if the broker is able to support it.

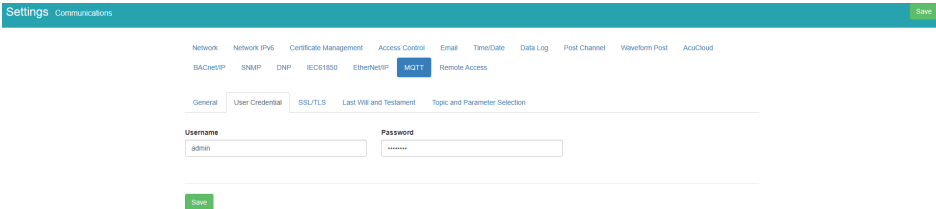

9.16.3 MQTT Encryption

The **SSL/TLS** tab allows users to use the MQTT protocol with encryption.

In this page users will be able to upload the required certificate and key files.

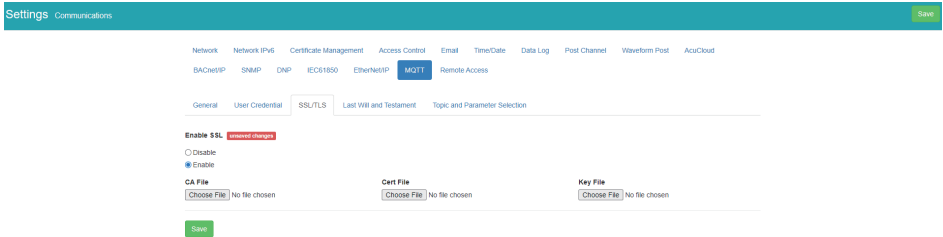

9.16.4 Last Will & Testament

The AXM-WEB2 supports Last Will and Testament messages via the MQTT protocol. These settings can be configured under the Last Will & Testament tab.

The last will and testament message is used to notify other clients regarding other disconnected clients. The message is an MQTT message that contains a topic, a QoS level and a payload.

Topic: Refers to the path used to access the MQTT message.

QoS: Stands for Quality of Service and refers to the reliability of the message delivery between the publisher and subscriber. There are three types of quality of service:

1. QoS 0 - is the lowest level, and is defined as “at most once” delivery. This level has the fastest message delivery but the success rate of delivery is not reliable.
2. QoS 1 - is defined as “at least once” delivery. These types of messages are reliable and are guaranteed, however the message may be sent as duplicates several times.
3. QoS 2 - Is the highest level, and is defined as “exactly once” delivery. These messages are more reliable and are guaranteed to be sent once without any duplicates. This type of messaging sends the most reliable message however it has a slower message delivery. Each client can optionally specify its own LWT message when it connects to a broker. The broker stores this message so that if the client disconnects ungracefully, the broker will send the disconnected client’s LWT message to all the other clients that are subscribed to that last will message topic.

Retained: Users have the option retain messages or not. If a client retains messages that was published to topic, a second client that is subscribed to the same topic will be able to see the retained message.

The screenshot shows the 'Settings Communications' interface. The 'MQTT' tab is selected. Under the 'Last Will and Testament' sub-tab, the 'Enable Last Will' section has the 'Enable' radio button selected. The 'Topic' field contains 'AXM-WEB2'. The 'QoS' dropdown is set to 'QoS 0'. In the 'Retained' section, the 'Yes' radio button is selected. A green 'Save' button is located at the bottom left of the configuration area.

9.16.5 Top and Parameter Selection

Under the **Topic and Parameter Selection** tab users can configure the sending interval and devices data they want to publish to the broker.

Topic: Users will enter in the Topic used to read all devices.

QoS: Users can configure the quality of service level, where Qos 0 is the lowest level and Qos 2 is the highest level.

Retained: Users have the option retain messages or not. If a client retains messages that was published to topic, a second client that is subscribed to the same topic will be able to see the retained message.

Interval: Users can select the publishing interval, the range is from 10-600 seconds.

Parameter Type: Users can select different parameter types, i.e Real Time, Energy, Demand.

Parameter Selected/Not Selected: Users can click and select different parameters from the not selected panel and add them over to the selected panel using the right arrow button. Users can use the left arrow button to remove parameters from the selected panel. The All and Clear buttons are used to add All parameters or Clear all parameters from the selection box.

Once all settings are configured, click on Save and perform a reboot in order for the settings to be saved.

AXM-WEB2 for Acuvim II Series Power Meter

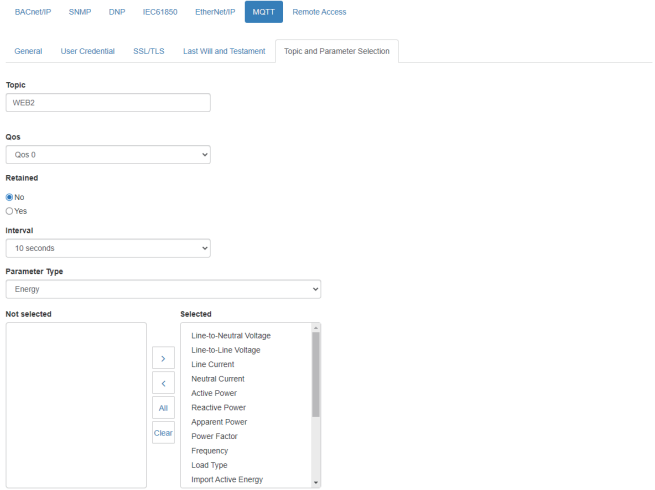

Once configured, you can verify on your MQTT server if the data is being received. The data is received in JSON format.

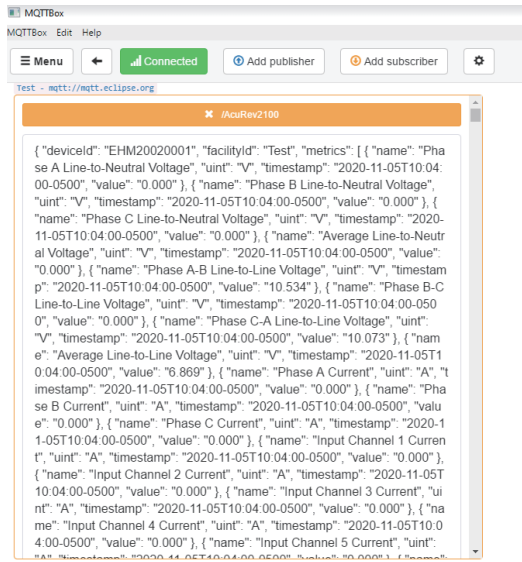

9.17 Remote Access

The AXM-WEB2 has a remote access function. This will allow users to provide other users with remote access to the meters web interface. Users will have full functionality and access to all meter readings and settings with this function.

Remote Access Enable: Select 'Enable' to enable the function and allow for Remote Access.

Current Status: Will provide user with a status of the Remote Access on whether it is 'Registered' or 'Unregistered'.

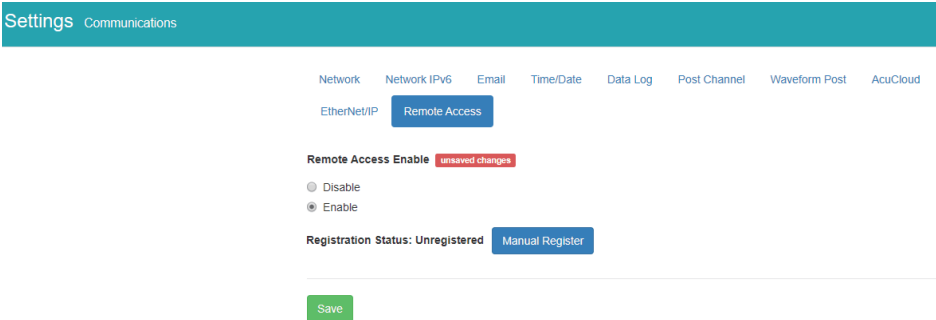

Users can click on the 'Manual Register' button to register the remote access. The following page will be displayed.

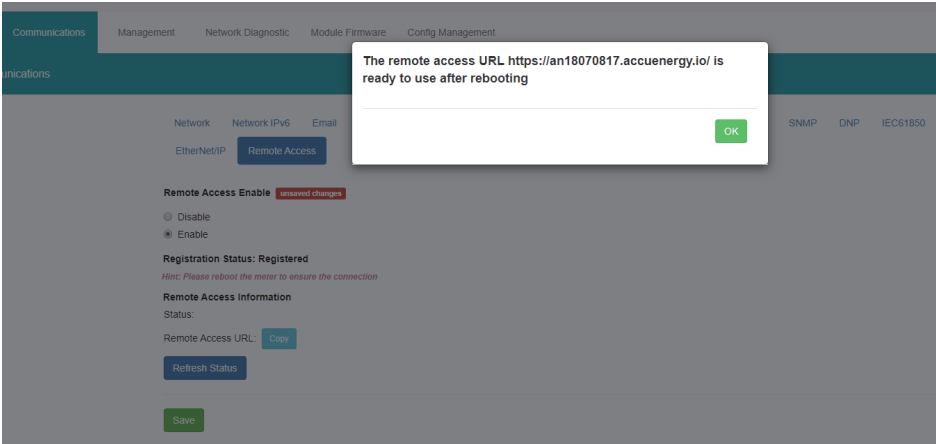

NOTE: The module must be rebooted in order for the remote access connection to work properly.

Registration Status: Displays the status as 'Registered' or 'Unregistered'

Remote Access Information: Lets users know if the remote access status is online or offline.

Remote Access URL: The URL used to access the meters web server remotely. This URL can be copied and shared with all users that require the remote access.

Remote Access Deregister:

The user can reset the remote access link by deregistering the remote access if there is an issue.

Click "Deregister" and the URL will be reset. the user can reboot the meter or re-register the remote access to re-enable the link.

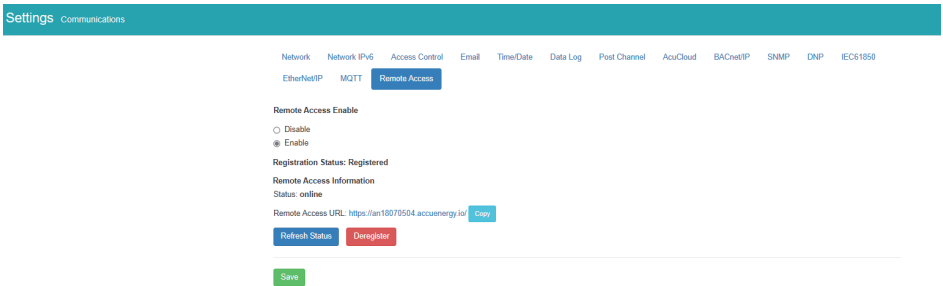

9.18 Config Management

The AXM-WEB2 module has a configuration management page that allows users to save all web settings with the exception of a certain settings into a configuration file. This is useful if users have more than one meter that needs to be programmed with the same settings, and eliminates any error when trying to configure another WEB2 module.

The following settings are saved in the configuration file:

- All Meter settings (General, IO, Alarm, Custom Read, Waveform)
- Network settings (Only DNS1, DNS2, Modbus TCP Port, HTTP Proxy)
- All Email settings

- All Time/Date settings
- All Data Log settings
- All Post Channel settings
- All BACnet settings
- All SNMP settings
- All DNP settings (Point configuration will also be applied)
- All IEC61850 settings (CID file will also be applied)
- Management settings (the View and Admin Access Level passwords, SSH, and Debug Configuration)

The settings that are not included or effected by the Config Management file is:

Most Network settings (RSTP, DHCP, IP, Submask, Gateway, HTTP Port for both Ethernet 1 and 2. All WiFi settings, Fast Read Mode, HTTP enable, and HTTPS port are not changed)

- IPv6
- AcuCloud
- Access Control (IP Whitelist)
- Remote Access

The Config Management page can be accessed by clicking on the **Settings** tab and selecting **Config Management**.

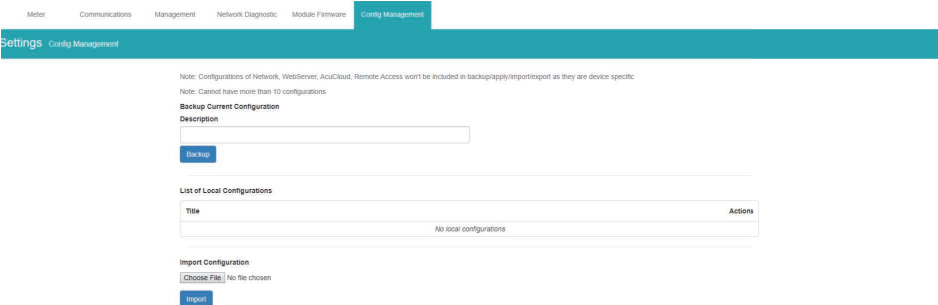

9.18.1 Backup Configuration

Users can create a backup of the current configurations on the WEB2 interface.

Backup Current Configuration Description: Enter in a description for the backup configuration file.

Once the description is entered in click on the 'Backup' button.

The backup is displayed in the List of Local Configurations. The file has a file format that includes the module serial number, module firmware version, and time stamp that the file was created.

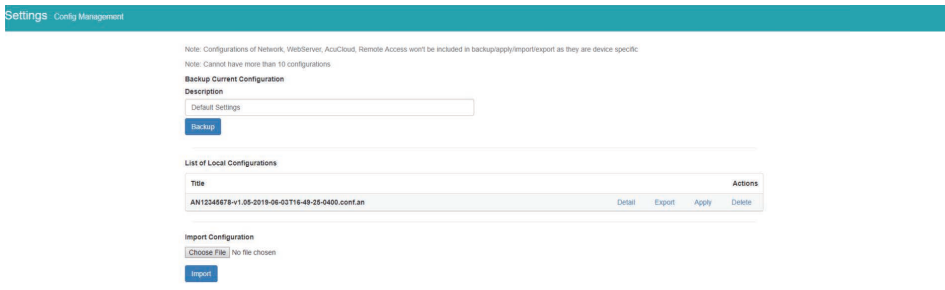

NOTE: Users cannot have more than 10 configurations in the List of Local Configurations.

Users can click on Detail to view the description of the configuration file. The details include the Model name, serial number, time created, firmware version and the description entered when the backup was created. Users can remove any of the configuration files from the list at any time by selecting Delete.

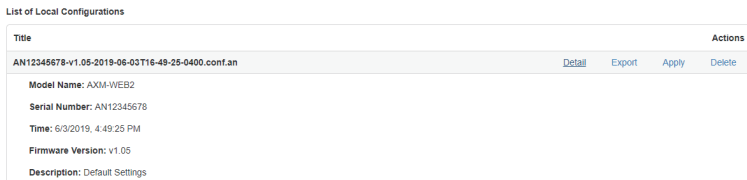

9.18.2 Export/Apply Configuration

Users can export the configuration file and use it on other WEB2 modules. The file is downloaded as a .an file.

To implement the configuration file click on **Apply**. A prompt warning the user that the existing .conf.an file will be overwritten is shown. Click **Yes** to continue.

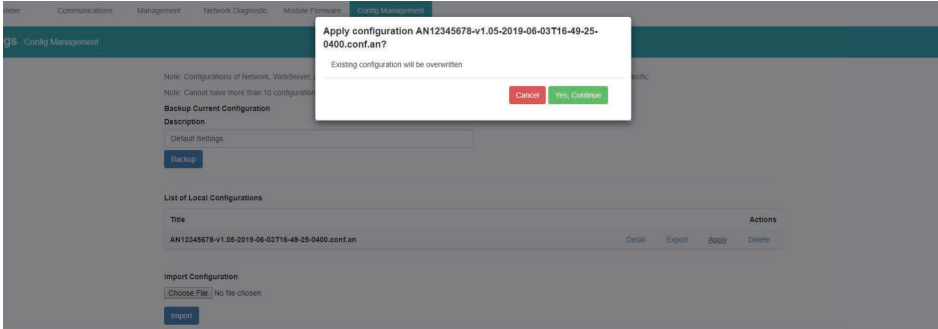

A module reboot is required for the configuration to take effect. If users decided to reboot later the reboot must be performed from the Management page in order for the settings to take effect on the device.

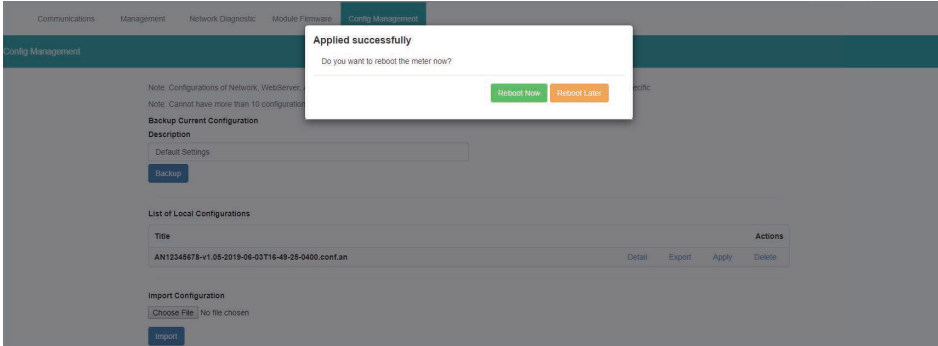

9.18.3 Import Configuration

Import Configuration: Users can import a configuration file (.conf.an file format) to the WEB2 module.

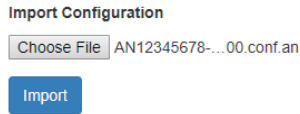

Click on **Import** to upload the configuration file to the WEB2 module.

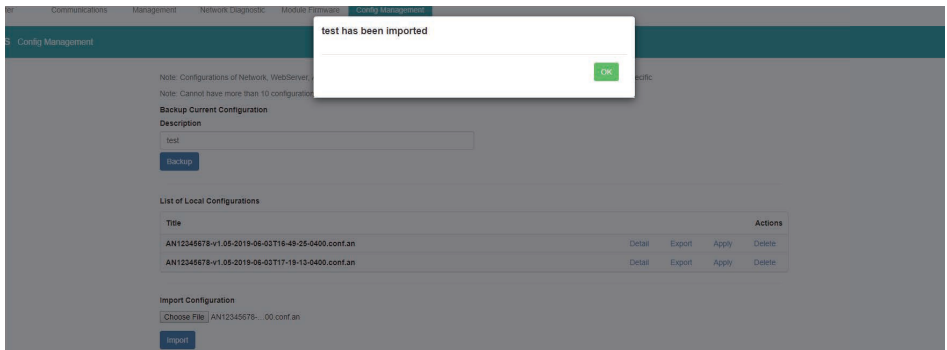

The newly imported file will now appear in the List of Local Configurations

List of Local Configurations				
Title				Actions
AN12345678-v1.05-2019-06-03T16-49-25-0400.conf.an				Detail Export Apply Delete
AN12345678-v1.05-2019-06-03T17-19-13-0400.conf.an				Detail Export Apply Delete

NOTE: Users cannot import a file that already exists on the local configurations, when the list already contains 10 config files, and cannot import a config file that has been exported from a WEB2 module with a higher firmware version.

Chapter 10: Management

10.1 Parameter Reset

The Management web page allows the user to clear and reset certain parameters in the meter. The following parameters can be reset from the Management page:

- Demand
- Energy
- Max and Min
- Alarm Record
- Device Run Time

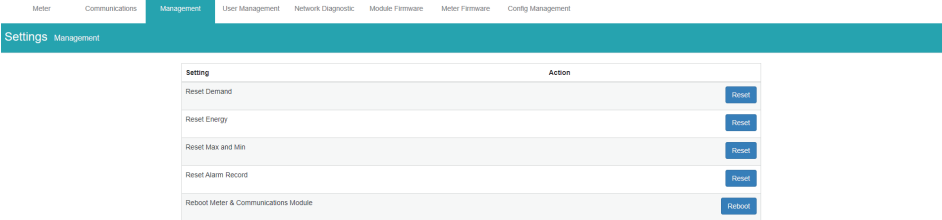

10.2 Reboot Meter & Communications Module

Users can also reboot the web module and meter which is required after any communication or meter setting is changed, if a module reboot is not performed the settings will not be saved to the meter and will go back to its default settings. This not only resets the communication module, it also performs a soft reboot on the Acuvim II meter.

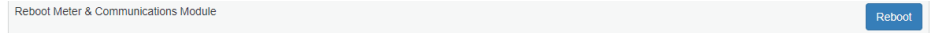

10.3 Reset to Factory

The AXM-WEB2 supports a reset to factory function where if reset the module settings would be configured back to its default factory settings. This impacts all configurations and logs stored on the module.

NOTE: This setting is permanent and cannot be undone!

Reset to Factory Defaults

Reset

10.4 SSH

The WEB2 module supports the SSH which can be enabled to allow users to remotely log into the meter using the SSH protocol. When enabled the status will show 'On', when disabled the status will show 'Off'.

SSH
current status: Off

Enable

10.5 Debug Diagnostic

The debug diagnostic allows the user to enable or disable the debug logs. The current status will say 'All off' if disabled, 'All On' if enabled.

Users can click on the advanced link, to turn on or off specific debug logs. If certain debug logs are enabled the current status will show 'Partial On'.

NOTE: The system performance may be affected by enabling the debug logs.

Setting	Status
RtuServer	Debug OFF
AppSuperVisor	Debug OFF
AppConfig	Debug OFF
TimeConfigurator	Debug OFF
Meter	Debug OFF
WaveForm	Debug OFF
ReadingSource	Debug OFF
Database	Debug OFF
Web Server	Debug OFF
DataLog	Debug OFF
DataPost	Debug OFF
Email	Debug OFF
Mudp	Debug OFF
Modbus Server	Debug OFF
Bacnet	Debug OFF
Smp	Debug OFF
Dnp	Debug OFF
Common	Debug OFF
Mqtt	Debug OFF

10.6 Diagnostic File

There is a diagnostic file on the WEB2 module that users can download which can be used to analyze the modules diagnostics.

NOTE: Please send the diagnostic file to Accuenergy Technical Support (support@accuenergy.com) for analysis.

The screenshot shows the 'Management' section of the Accuenergy interface. The navigation bar includes 'Meter', 'Communications', 'Management', 'User Management', 'Network Diagnostic', 'Module Firmware', 'Meter Firmware', and 'Config Management'. The 'Management' section is active, showing a table of settings and actions.

Setting	Action
Reset Demand	Reset
Reset Energy	Reset
Reset Max and Min	Reset
Reset Alarm Record	Reset
Reboot Meter & Communications Module	Reboot
Device Clock	11:24 AM -0400 10 May, 2021
Reset Device Run Time	Reset
Reset to Factory Defaults	Reset
SSH current status: Off	Enable
Debug Diagnostic current status: All Off Link to advanced settings	Enable Disable

[Download diagnostic file](#)

11.2 Host Lookup

In the **Host Lookup** tab users can utilize the 'ping' function to test the reach-ability to other networks. Users can also use the **ping6** function to ping an IPv6 address.

Settings Network Diagnostic

Networking Status **Host Lookup** Connection Test

Name of system or domain name to lookup

Valid IPv4/IPv6 or domain name

mstockup
 ping
 ping6
 traceroute

Lookup

```

Ping
PING www.google.com (172.217.1.164) 56(84) bytes of data:
64 bytes from yy130804-lr-f4-1a100.net (172.217.1.164): icmp_seq=1 ttl=54 time=4.08 ms
64 bytes from yy130804-lr-f4-1a100.net (172.217.1.164): icmp_seq=2 ttl=54 time=4.10 ms
64 bytes from yy130804-lr-f4-1a100.net (172.217.1.164): icmp_seq=3 ttl=54 time=4.43 ms
64 bytes from yy130804-lr-f4-1a100.net (172.217.1.164): icmp_seq=4 ttl=54 time=4.54 ms
64 bytes from yy130804-lr-f4-1a100.net (172.217.1.164): icmp_seq=5 ttl=54 time=4.05 ms

--- www.google.com ping statistics ---
5 packets transmitted, 5 received, 0% packet loss, time 400ms
rtt min/avg/max/mdev = 4.051/4.252/4.948/0.109 ms
  
```

11.3 Connection Test

User can also use the **Connection Test** function to test the local network that the module connected to. The test result will show **SUCCESS** and **PASS** if there is no issues found.

Meter Communications Management **Network Diagnostic** Module Firmware Config Management

Settings Network Diagnostic

Networking Status Host Lookup **Connection Test**

This diagnostic page will attempt a connection to the specified network nodes.
 In the process, all network settings will be tested and a report will be given with detailed results of these tests.

Begin Test

```

# Loop Back Address #
PING 127.0.0.1 SUCCESS
# Gateway #
PING 192.168.1.1 SUCCESS
# DNS 1 #
PING 8.8.8.8 SUCCESS
# DNS 2 #
PING 8.8.4.4 SUCCESS
TEST COMPLETE 4/4 PASS
  
```

Chapter 12 Firmware Update

12.1 Module Firmware Update

The Module Firmware web page is used for updating the firmware version on the AXM-WEB2 module. The user can check if the module they are using is up to date and update the module if needed using the remoter firmware update. Users can also manually update the firmware by uploading the firmware file. The current version of the firmware will be displayed on the Module firmware update page and can also be viewed on the 'Device Information' page of the web interface.

There is an Auto Firmware Update feature available also, this allows users to update the module automatically without manually going into the web server and performing the update.

NOTE: Users can also contact Accuenergy Technical Support for latest firmware.

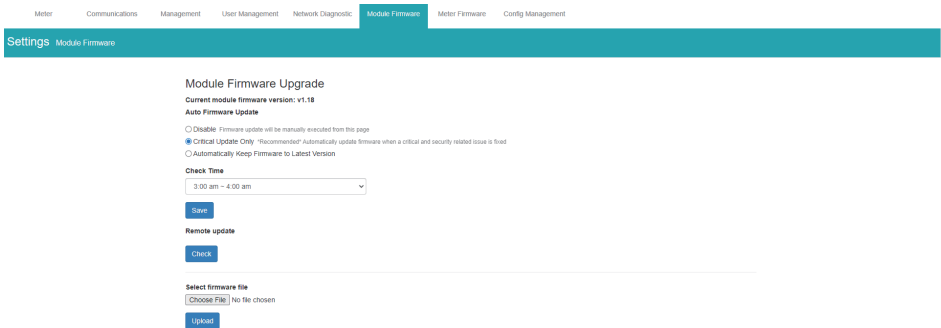

12.1.1 Auto Firmware Update

The auto firmware update allows users to select three different updating options.

- Disable - Disables the auto firmware update function
- Critical Update Only - Updates the module to the latest critical firmware
- Automatically keep firmware to Latest - Updates the module to the latest firmware

If users select critical or latest firmware update options, the time for the update can be configured. By default the update time is set for 3 am-4 am.

NOTE: The one hour time block means that the update will occur anytime within the hour.

After the automatic firmware update, when users log in to the web interface for the first time after the update they will see a message displayed, which shows the time and date the module was updated at as well as the firmware version updated to.

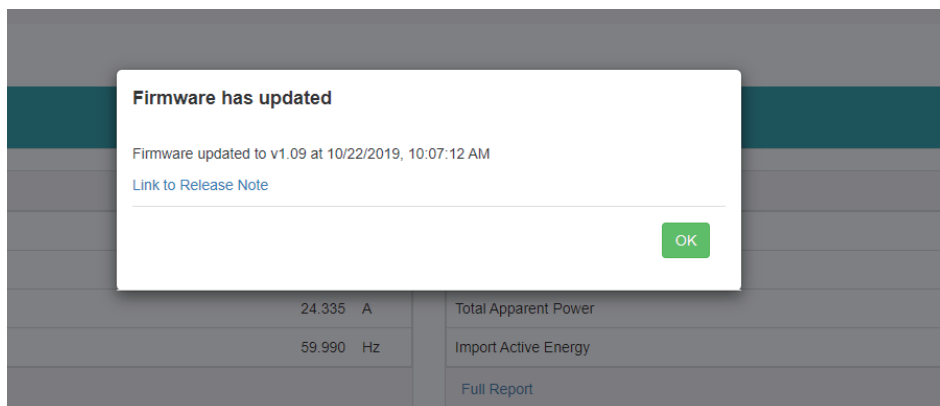

12.1.2 Manual Update

Select and upload the AXM-WEB2 firmware file, it is a .aup file extension.

Select firmware file

AXM-WEB2-v1.18.a2up

Once the upload was successfully uploaded you will see the following page confirming that the file was uploaded.

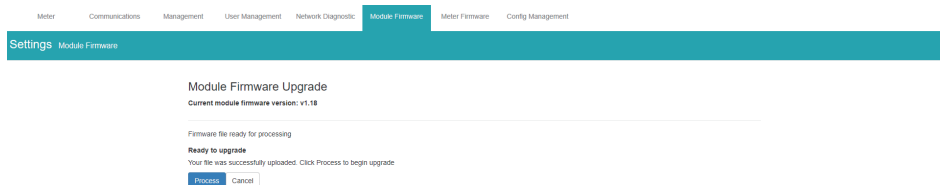

Click 'Process' to begin the update.

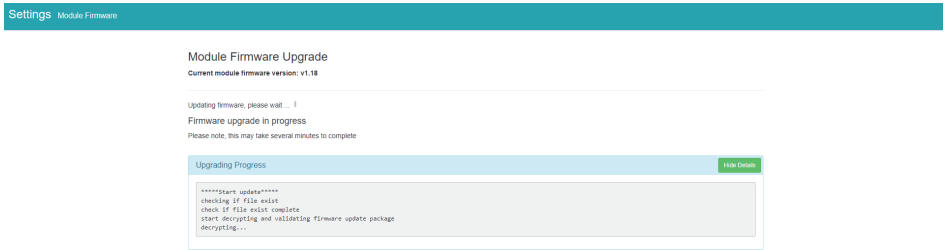

Click 'OK' to log out the web interface and wait for 1-2 minutes to complete the reboot.

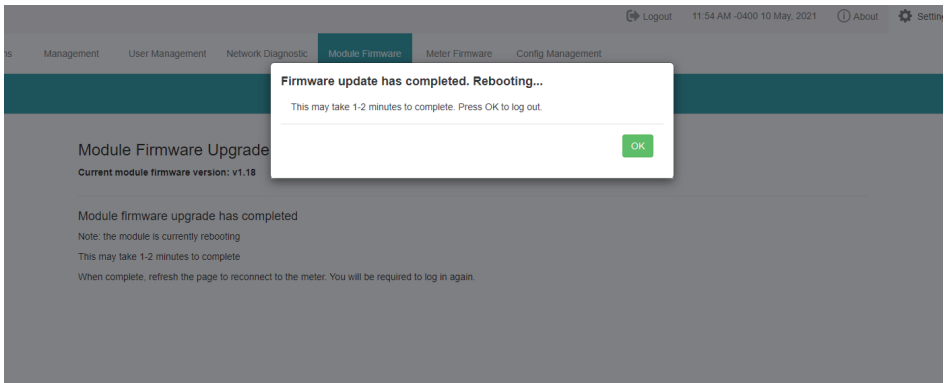

Login to the web interface of AXM-WEB2 after the reboot is complete, and go to the 'About' page to check if the module firmware version is updated.

12.1.3 Remote Update

Users can also use the remote firmware server to update the module firmware. Click on 'Check' to verify if there is a firmware update available.

Update available!

Latest version: v136

Update detail: <https://www.accuenergy.com/firmware>

Proceed

If there is a update available users can proceed to download the firmware.

Update available!

Latest version: v136

Update detail: <https://www.accuenergy.com/firmware>



Downloading firmware...

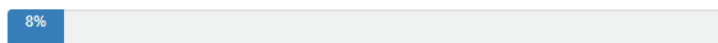

Once the download is complete the updating process will begin.

Settings Module Firmware

Module Firmware Upgrade

Current module firmware version: v1.18

Updating firmware, please wait...
Firmware upgrade in progress
Please note, this may take several minutes to complete

Upgrading Progress 100 Done

```
*****Start upgrade*****  
checking if file exist  
check if file exist complete  
start decrypting and validating firmware update package  
decrypting...
```

When the firmware update is complete, the module will reboot. The rebooting process will take 1-2 minutes to complete.

Management User Management Network Diagnostic **Module Firmware** Meter Firmware Config Management

Logout 11:54 AM -0400 10 May, 2021 About Settings

Firmware update has completed. Rebooting...
This may take 1-2 minutes to complete. Press OK to log out.

OK

Module Firmware Upgrade

Current module firmware version: v1.18

Module firmware upgrade has completed
Note: the module is currently rebooting
This may take 1-2 minutes to complete
When complete, refresh the page to reconnect to the meter. You will be required to log in again.

After the module reboots, users will be able to log back into the web interface. When logged in click on the 'About' tab located on the top right corner of the web page to view the 'Device Information' page. From the Device Information page users can ensure that the meter was updated correctly to the right firmware version.

12.2 Meter Firmware Update

The AXM WEB2 allows users to update the meters firmware from its web server. The meters firmware can be updated manually by uploading the required firmware file or by connecting to our remote firmware server.

NOTE: The meter firmware update option is only available on meters that are firmware version 3.69 and above.

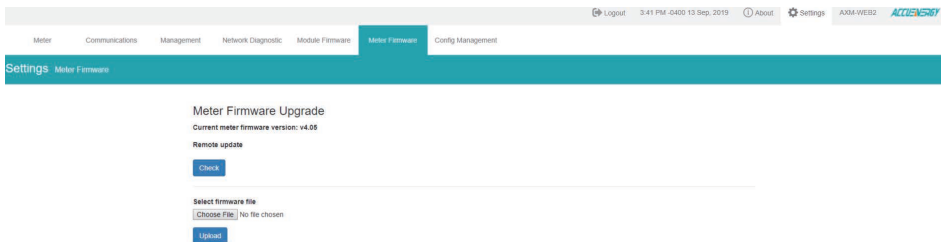

12.2.1 Manual Update

Users can update the meter firmware manually by loading the firmware file to the web server. Click on 'Choose File' and upload the correct file. All firmware files are .abin type files.

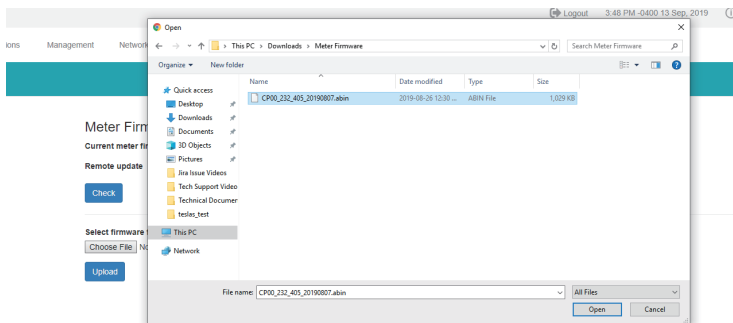

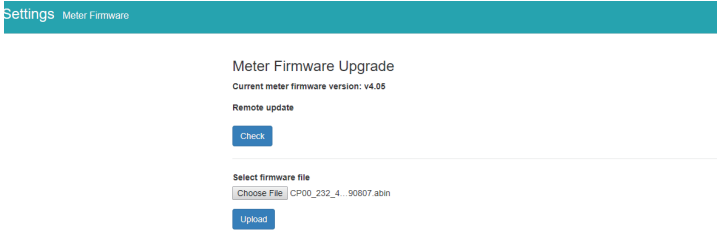

Once the file is selected click on 'Upload'.

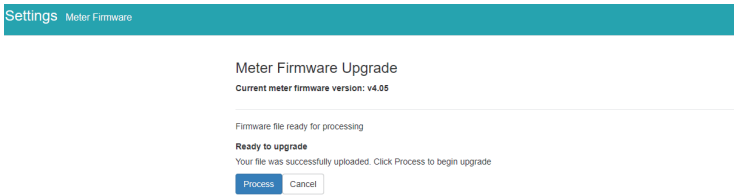

After the firmware has uploaded to the web server, click on 'Process'.
The firmware update will take approximately 5-10 minutes to complete.

Meter Firmware Upgrade

Current meter firmware version: v4.05

Updating firmware, please wait ... ●

Firmware upgrade in progress

Please note, this may take several minutes to complete

Notice: Please do not refresh or leave the page until the upgrade is complete

Notice: Rebooting or disconnecting the meter can cause upgrade failure and activate Emergency Mode, in which repeat the process to recover

Upgrading Progress

Hide Details

```
parseFirmware 0, _mbInLen 0x100000
status 0, numFailure 0
rebootModbusSlave 0
status 1, numFailure 0
configSerial to 9600 bps 0
doCmdRequestToProgram 0
configSerial to 38400 bps 0
doCmdSetupConnection 0
status 2, numFailure 0
write firmware file 16.00%
```

AXM-WEB2 for Acuvim II Series Power Meter

When the firmware update is complete, the module will reboot. The rebooting process will take 1-2 minutes to complete.

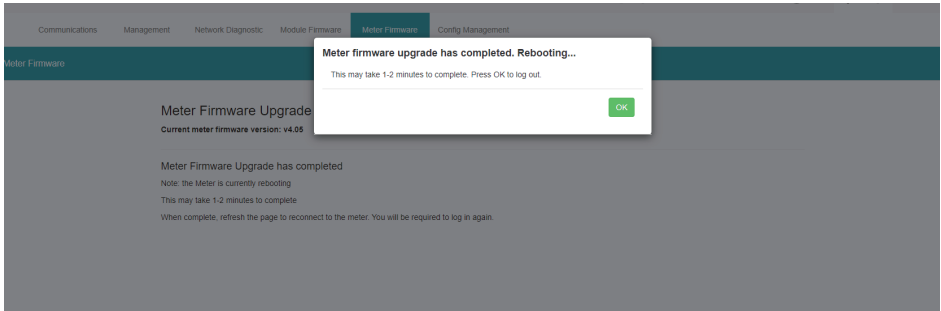

After the meter reboots, users will be able to log back into the web interface. When logged in click on the 'About' tab located on the top right corner of the web page to view the 'Device Information' page. From the Device Information page users can ensure that the meter was updated correctly to the right firmware version.

12.2.2 Remote Update

Users also have the option to use the remote firmware server to update the meters firmware. Click on 'Check' to verify if there is a firmware update available.

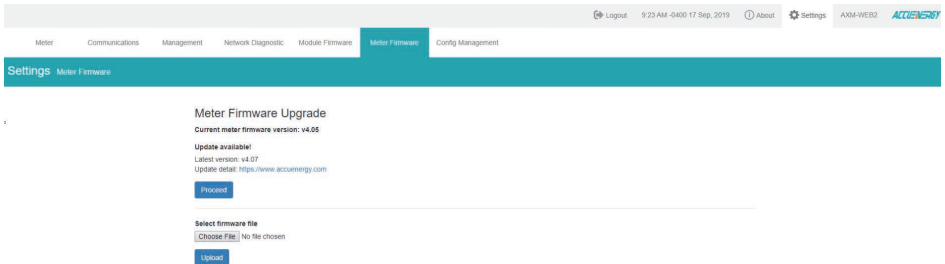

If there is a update available users can proceed to download the firmware. Once the download is complete the updating process will begin.



Meter Firmware Upgrade

Current meter firmware version: v4.05

Updating firmware, please wait ...

Firmware upgrade in progress

Please note, this may take several minutes to complete

Notice: Please do not refresh or leave the page until the upgrade is complete

Notice: Rebooting or disconnecting the meter can cause upgrade failure and activate Emergency Mode, in which repeat the process to recover

Users can click on 'Show Details' to view the update percentage of the firmware.



Meter Firmware Upgrade

Current meter firmware version: v4.05

Updating firmware, please wait ...

Firmware upgrade in progress

Please note, this may take several minutes to complete

Notice: Please do not refresh or leave the page until the upgrade is complete

Notice: Rebooting or disconnecting the meter can cause upgrade failure and activate Emergency Mode, in which repeat the process to recover

Upgrading Progress

Hide Details

```
parseFirmware 0, _mBinLen 0x100000
status 0, numFailure 0
rebootModbusSlave 0
status 1, numFailure 0
configSerial to 9600 bps 0
doCndRequestToProgram 0
configSerial to 38400 bps 0
doCndSetupConnection 0
status 2, numFailure 0
write firmware file 4.33%
```

When the firmware update is complete, the module will reboot. The rebooting process will take 5-10 minutes to complete.

After the meter reboots, users will be able to log back into the web interface. When logged in click on the 'About' tab located on the top right corner of the web page to view the 'Device Information' page. From the Device Information page users can ensure that the meter was updated correctly to the right firmware version.

12.3 Emergency Mode

During the meter firmware update process if the meter loses power or connectivity to the web interface the meter will run in emergency mode. In this mode the next time the user logs into the web interface instead of seeing the dashboard the following screen will be displayed.

It lets users know that the meter firmware update process has failed and to try updating the meter firmware again. The meter will stay in this mode until the meters firmware has been updated successfully.

Users can update the meters firmware manually or through the remote server while the meter is in Emergency mode. After the update is complete the meter will come out of emergency mode and users will be able to see the web server in its normal mode.

NOTE: The meter will only go into emergency mode if the Meter firmware update fails, emergency mode is not applicable if the Module firmware update fails.

Setting	Value
Meter Model	AcuWIIW-D-RCT
Meter Serial Number	AH1905262
Meter Firmware Version	v4.12
Device Description	test meter
Module Model	AXM-WEB2
Module Serial Number	AN2009525
Module Hardware Version	v1.03
Module Firmware Version	v1.16
Ethernet 1 MAC Address	EC:C3:8A:20:90:84
Ethernet 2 MAC Address	EC:C3:8A:20:90:88
WiFi MAC Address	06:25:CA:39:84:65
Meter Channel 1 Address	1
Meter Channel 2 Address	1
Serial Status	Open
Meter Bld Version	FP90203310
Disk Usage	13.406%

While in emergency mode users can still view the meters network settings under the Communications tab. From here all the network related settings can be viewed and configured for the meter.

Also in the communications tab users can enable remote access, and configure the IPv6 and Access control settings.

NOTE: Remote access is still accessible when the meter is in Emergency Mode.

The screenshot shows the 'Settings' page in 'Emergency Mode'. The 'Communications' tab is active. Under the 'Network' sub-tab, the 'Enable SSH' option is checked and has an 'Enable' button. The 'RSTP Enable' option is unchecked. A note states: 'Note: Two RJ45 ports are configurable with separate networks'. The 'Default Interface (Outbound Traffic)' is set to 'Ethernet 1'. Under 'Ethernet 1 DHCP', 'Manual' is selected. 'VLAN Enable' is set to 'Disable'. The 'Ethernet 1 IP Address' is '192.168.1.17' (Default: 192.168.1.254). The 'Ethernet 1 Subnet Mask' is '255.255.255.0' (Default: 255.255.255.0). The 'Ethernet 1 Gateway' is '192.168.1.1' (Default: 192.168.1.1). The status at the bottom indicates 'Ethernet 1 Working Status : Connected'.

There is a three step process to ensure that users can save all data and meter configuration before completing the update.

Step 1:

In step one of emergency mode users can export the module configuration, this allows users to save all module settings which can be imported to any WEB2 module. Also in the meters diagnostic file can be downloaded, this file will provide detailed analysis of any errors that occur within the AXM-WEB2 module and should be provided to Accuenergy Technical Support for further analysis. Only provide the file if you are experiencing issues with the AXM-WEB2 communications module.

The screenshot shows the 'Settings' page in 'Emergency Mode'. The 'Emergency Mode' tab is active. The 'Network Diagnostic' sub-tab is selected. The page displays a three-step process: 'Step 1' (highlighted), 'Step 2', and 'Step 3'. Under 'Step 1', there are two main actions: 'Export Config' with an 'Export' button, and 'Download Diagnostic File' with a 'Download Diagnostic File' button. A 'Next Step' button is located at the bottom of the Step 1 section.

AXM-WEB2 for Acuvim II Series Power Meter

Step 2:

In step two of emergency mode users can export and download data from the data loggers. If all three data loggers have been configured users can export or reset the data on the module. The AcuCloud data can also be exported and deleted from this page, this data will only be deleted from the module and will still be available on the cloud server.

The Clear Trendlog option allows users to reset and delete all existing data on the module.

Users may find it useful to clear the trend logs and all data logs if the module disk space is full. Users can check the disk usage under the Emergency mode tab in the device information table.

The screenshot shows the 'Emergency Mode' tab selected in a navigation menu. Below the menu, the 'Settings' section is active, and the 'Emergency Mode' sub-section is highlighted. The main content area displays a three-step process, with 'Step 2' currently selected. Under 'Step 2', there are four sections for data loggers: 'Export Logger 1', 'Export Logger 2', 'Export Logger 3', and 'Export Logger AcuCloud'. Each section shows 'Available Files: 0' and provides 'Export' and 'Reset' buttons. The 'Export Logger AcuCloud' section shows 'Available Files: 3' and includes a note: '*Export local AcuCloud data logs (unsuccessful posts) before restoring meter to factory default'. Below these sections is a 'Clear Trendlog' section with a 'Reset' button. At the bottom of the step, there is a 'Next Step' button.

Step 3:

In step three of emergency mode, users can update the module/meter firmware and can also perform soft reboots to both meter/module as well.

Users can reset the entire module back to its factory settings,

NOTE: When resetting the module back to factory while in emergency mode the meters network settings will go back to its default setting.

Updating the module firmware while in emergency mode will keep the meter in emergency mode. The only way for the meter to exit emergency mode is to update the meter firmware successfully. The meter firmware can be updated either remotely or by manual upload.

Step 1
Step 2
Step 3

Module Firmware Upgrade

Current module firmware version: v1.18

Remote update

Check

Select firmware file

Choose File No file chosen

Upload

Meter Firmware Upgrade

Current meter firmware version: v4.12

Remote update

Check

Select firmware file

Choose File No file chosen

Upload

Reset To Factory Default

Warning: Reset to Factory Default will change Ethernet 1 IP to 192.168.1.254 and Ethernet 2 IP obtained from DHCP server.

Reset

Reboot Meter

Reboot

Reboot Module

Reboot

Next Step



MAKE ENERGY USAGE SMARTER

ACCUEENERGY (CANADA) INC.

2 Lansing Square, Suite 700
Toronto, ON M2J 4P8, Canada

TF: 1-877-721-8908
INT: +1-416-497-4100
FAX: +1-416-497-4130
E: marketing@accuenergy.com

ACCUEENERGY SOUTH AFRICA (PTY) LTD

Castle Walk Corporate Park,
Block B, Cnr. Nossob & Swakop Street
Erasmuskloof, Pretoria, 0181
South Africa

TF: +27 (0) 87 802 6136



Revision Date: May 2021