

Disclaimer and Warning

USER RESPONSIBILITY - IMPROPER SELECTION, USE OR MAINTENANCE OF THE SYSTEM, PRODUCTS OR COMPONENTS DESCRIBED IN THIS CATALOG MAY CAUSE OR RESULT IN DEATH, PERSONAL INJURY AND/OR PROPERTY DAMAGE.

This document and other information from Eaton Corporation, its subsidiaries and authorized distributors provide product or system options for users having technical expertise. This product is not intended for users who do not have technical expertise.

The user, through its own analysis and testing, is solely responsible for making the final selection of the system and components and assuring that all performance, endurance, maintenance, safety and warning requirements of the application are met. The user must analyze all aspects of the application, follow applicable industry standards, and follow the information concerning the product in the current product catalog and in any other materials provided from Eaton or its subsidiaries or authorized distributors.

To the extent that Eaton or its subsidiaries or authorized distributors provide component or system options based upon data or specifications provided by the user, the user is responsible for determining that such data and specifications are suitable and sufficient for all applications and all reasonable foreseeable uses of the components or systems.

Table of Contents

Feature	4
How to order	5
Model code	6
NZ Standard Mounting Styles	8

Mounting Style & Installation Dimensions

NZ01 Side Lug Mounts	10
NZ02 Side Tapped Mounts	12
NZ03 End Lug Mounts	14
NZ04 Keyed Side Lug Mounts	16
NZ05 Keyed Tapped Mounts	18
NZ07 Head Rectangular Flange Mounts	20
NZ08 Head Square Flange Mounts	22
NZ09 Head Rectangle Mounts	24
NZ10 Cap Fixed Clevis Mounts	26
NZ11 Cap Spherical Bearing Mounts	28
NZ12 Cap Rectangular Flange Mounts	30
NZ13 Cap Square Flange Mounts	32
NZ14 Cap Rectangle Mounts	34
NZ15 Intermediate Trunnion Mounts	36
NZ16 Cap Trunnion Mounts	38
NZ17 Head Trunnion Mounts	40
NZ19 Center Lug Mounts	42
NZ21 Cap End Extended Tie Rod Mounts	44
NZ22 Head End Extended Tie Rod Mounts	46
NZ23 Both End Extended Tie Rod Mounts	48
NZ24 No Mounts	50
NZ25 Double Rod Side Lug Mounts	52
NZ47 Cap Fixed Mono Clevis Mounts	54
NZ48 Cap Detachable Eye Mounts	56
NZ50 Cap Detachable Mounts	58

Technical Data

Accessories	60
Rod End Couplings	64
Self Aligning Coupler	65
Rod End Types	66
Port type and size	68
Port Selections	70
Port Locations	71
Sealing system	72
Proximity switch	74
Bore Rod & Diameter, Cylinder Size Selection	77
Maximum Allowable Push Stroke	78
Technical Data, Cushion	79

Features

1. Rod Cartridge Assembly:

Machined to maximum bearing support and wear resistance. Unitized, thread-less assembly is pilot-fitted into the head on a precision bored diameter to assure true concentricity.

2. Special Wearbands:

Metal-to-metal contact is eliminated, providing superior wearability, increased load carrying capability, and prolonged cylinder life.

3. Piston Sealing System:

This system offers not only a selection of highly efficient seal materials, but also an extra wide wearband that rides smoothly within the precision-honed cylinder body to provide extended piston seal life.

4. Square Head Tie-Rod Design:

Suitable for nominal working pressure up to 3000 psi.

5. Piston Rod:

Hard chrome plated piston rod in a variety of diameters between 1 and 5 1/2 inches provides maximum durability and extends seal life. Case hardened rods are standard up to 4 inches, and are an option for 4 1/2 inch and larger rods.

6. Captive Screws:

Inadvertent removal of cushion screws is prevented, while still allowing a full range of adjustment.

7. Fully Adjustable Cushioning System:

This design has been engineered to provide the ability to tune the cushion performance for an optimized deceleration profile. Our patented floating ring cushion seal or an alternate ball check design allows maximum acceleration. This excellent acceleration profile translates into faster cycle times and increased machine production.

8. Global Design:

Engineered for ANSI B93.15/ NFPA interchangeability with the durability required for heavy-duty applications.

9. SureSeal Sealing System:

Carefully selected wiper and seal combinations are mated with a hard chrome plated piston rod to deliver exceptional all-around performance and durability.

10. Full Range of Ports:

Including SAE, BSPP, and metric to ISO 6149 and DIN standard 3852 to provide the broadest piping flexibility.

11. Teflon Tube Seals:

Superior design to prevent leakage Compatible with virtually all fluids Operating temperatures to 500°F

12. Bore Size Range:

Cylinder bores available between 1-1/2 and 8 inches.

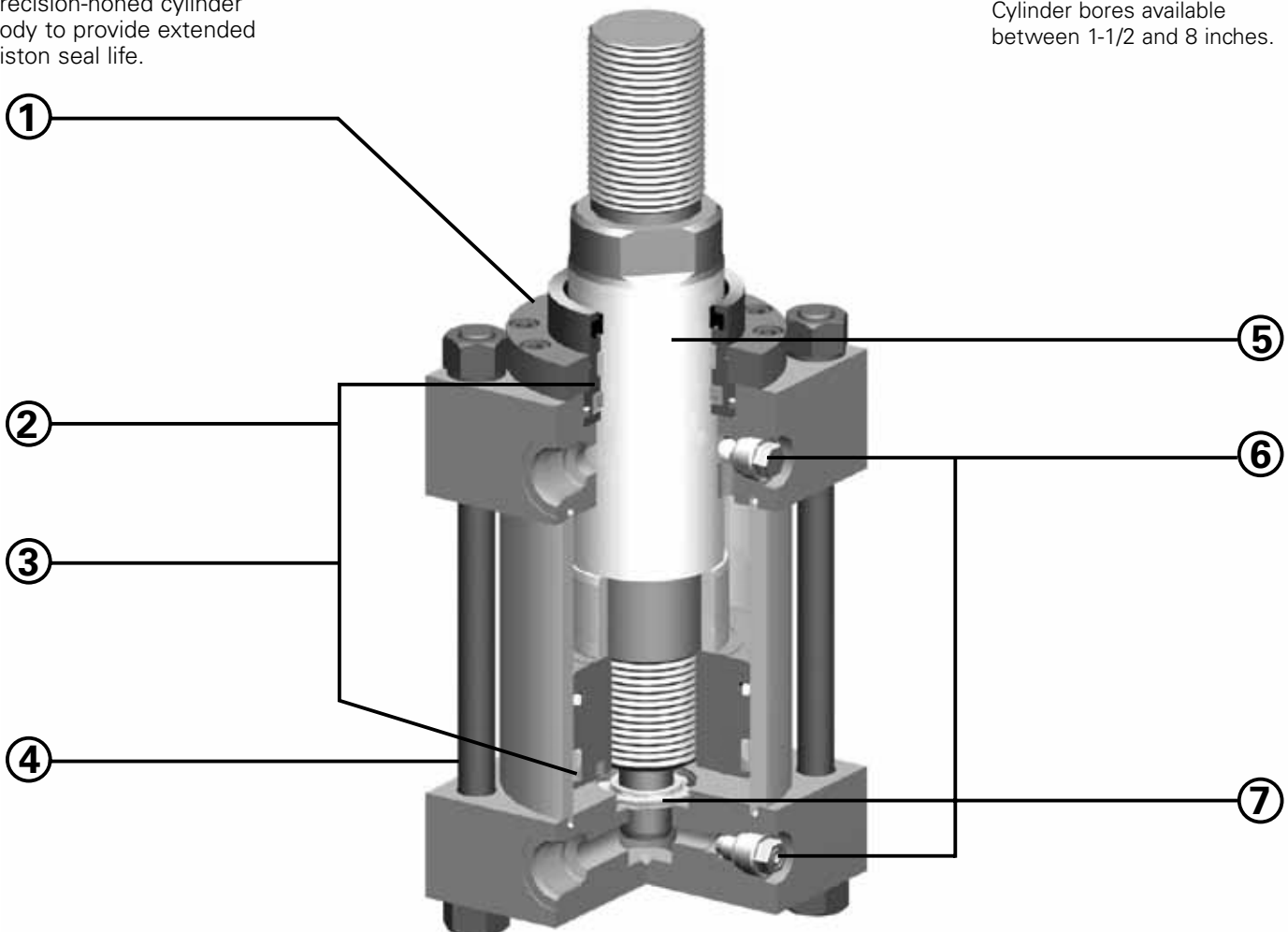

How To Order

Standard Cylinders

Eaton has created an easy system for ordering Vickers™ Series NZ cylinders, developed to improve our service to you. The Standard model code consists of sixteen alpha-numeric digits which fully describe the most common standard options offered on Series NZ cylinders.

To specify your Series NZ cylinder, review the following pages for a full description of each option available and select the desired code.

This model code system will:

Simplify the re-order process.

Each Vickers™ Series NZ cylinder is assigned a sixteen digit model code. That code is unique to a particular cylinder description. That way, when you re-order your Series NZ cylinder, you're assured of exactly the same top quality cylinder design.

Improve identification.

Every Series NZ cylinder has its sixteen digit model code clearly marked on the product, impression stamped in the metal head or cap. Each sixteen digit code completely describes a specific cylinder. This allows seals and replacement components to be easily identified in the field.

Facilitate communications.

This fully descriptive model code system allows you to work directly with your local Eaton sales engineer to identify and service your Vickers cylinder.

NOTE

See pages 6 and 7 for a summary of model code options.

Custom Cylinders

New Cylinders

Although the model code has been arranged to cover the vast majority of available options, there will be occasions when you require an option which cannot be coded.

When specifying such an option, enter an "X" for the appropriate item in the sixteen digit model code, then describe your requirements. For example, if you have an application which requires a custom thread on the end of the piston rod, enter an "X" for item 7. Then add a full description at the end of the model code, such as "With 3.25 inch total rod projection and M22 x 1,5 thread 1.375 inches long." The cylinder will then be given a unique six digit design number on receipt of order (as explained below).

If more than one of the available options represented in items 15 and 16 are required, add the appropriate codes as a suffix. The cylinder will then be given a unique six digit design number on receipt of order (as explained below).

Replacement Cylinders

Every custom Eaton cylinder is assigned a unique design number. A Custom cylinder will have 22 digits vs. 16 for the standard cylinder. The design number is contained in the last six digits of the model code, and position 17 is always an alpha character. In other words, the design number begins after position 16. When ordering a replacement cylinder, simply give the model code or the six digit design number to your local Eaton Cylinder Sales representative.

Replacement Parts

Each design number is stored in a quick retrieval computerized storage system. This gives our field sales representatives rapid access to assist you in identifying and specifying genuine Eaton replacement parts.

WARNING

It is the user's responsibility to select the correct system, product or components.

Model Codes

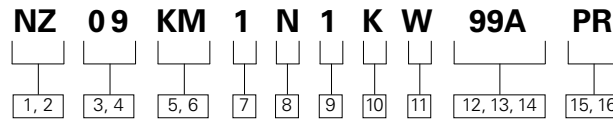

1, 2 Series

NZ – ANSI B93.15/NFPA Interchangeable Hydraulic cylinder

3, 4 Mounting Styles

01 – Side Lug	MS2
02 – Side Tapped	MS4
03 – End Lug Mount	MS7
04 – Keyed Side Lug	
05 – Keyed Tapped	
07 – Head Rectangular Flange	MF1
08 – Head Square Flange	MF5
09 – Head Rectangular	ME5
10 – Clevis	MP1
11 – Spherical Bushing	MP5
12 – Cap Rectangular Flange	MF2
13 – Cap Square Flange	MF6
14 – Cap Rectangular	ME6
15 – Intermediate Trunnion	MT4
16 – Cap Trunnion	MT2
17 – Head Trunnion	MT1
19 – Centerline Lug	MS3
21 – Cap End Extended Tie Rod	MX2
22 – Head End Extended Tie Rod	MX3
23 – Both Ends Extended Tie Rod	MX1
24 – No Mount	-
25 – Double Rod, Side Lug	-
26 – Double Rod, Tapped	-
27 – Double Rod, End Lug	-
28 – Double Rod, Keyed Side Lug	-
29 – Double Rod, Keyed Tapped	-
31 – Double Rod, Rectangular Flange	-
32 – Double Rod, Square Flange	-
33 – Double Rod, Head Rectangular	-
34 – Double Rod, Intermediate Trunnion	-
35 – Double Rod, Head Trunnion	-

37 – Double Rod, Centerline Lug	-
39 – Double Rod, Extended Tie Rod	-
40 – Double Rod, Both Ends Extended Tie Rod	-
41 – Double Rod, No Mount	-
47 – Cap Fixed Eye	MP3
48 – Detachable Eye	MP4
50 – Detachable Clevis	MP2

5, 6 Bore and Rod Size Combinations

Code	Bore(in)	Rod(in)
CC	1-1/2	5/8
CE	1-1/2	1
DE	2	1
DH	2	1-3/8
EE	2-1/2	1
EH	2-1/2	1-3/8
EL	2-1/2	1-3/4
GH	3-1/4	1-3/8
GL	3-1/4	1-3/4
GM	3-1/4	2
HL	4	1-3/4
HM	4	2
HP	4	2-1/2
KM	5	2
KP	5	2-1/2
KU	5	3
KV	5	3-1/2
LP	6	2-1/2
LU	6	3
LV	6	3-1/2
LW	6	4
MU	7	3
MV	7	3-1/2
MW	7	4
MY	7	4-1/2
MZ	7	5
NV	8	3-1/2
NW	8	4
NY	8	4-1/2
NZ	8	5
N1	8	5-1/2

7 Rod End Type

Code	Type
1	Short Female Metric Thd.
2	Short Female UN Thd.
5	Small Male UN Thd.
6	Plain No Attachment
7	Small Male Metric Thd.
9	Intermediate Male UN Thd.
0	Intermediate Male Metric
G	Grooved End
K	Extended Small Male UN Thd.
L	Extended Small Male Metric Thd.
M	Extended Intermediate Male UN Thd.
N	Extended Intermediate Male Metric Thd.
R	Studded Small Male UN Thd.

8 Seal Options

N – Normal
L – Low Friction
T – High Temperature
C – Normal with Cast Iron Piston Rings
R – High Temperature with Cast Iron Piston Rings

9 Port Options

1 – Standard NPTF*
2 – Oversize NPTF*
3 – SAE/UN O-ring
4 – Oversize SAE/UN
5 – NFPA Standard SAE/UN
6 – SAE 4-Bolt Flange
7 – BSPP
8 – Oversize BSPP
9 – Metric
0 – Oversize Metric
A – ISO 6149
B – Oversize ISO 6149
K – Undersize ISO 6149
C – Undersize 4-Bolt Flange
D – Undersize NPTF*
G – Undersize Metric
M – Standard Manifold

* Not recommended for maximum

reliability on new applications.

10 Port Locations

Ports are located as shown in Rod end type section when viewing cylinder from head end (mounting end of double rod cylinders).

Code	Head	Cap
K	1	1
L	1	2
M	1	3
N	1	4
P	2	1
R	2	2
S	2	3
T	2	4
U	3	1
V	3	2
W	3	3
Y	3	4
1	4	1
2	4	2
3	4	3
4	4	4
5	1	5
6	2	5
7	3	5
8	4	5

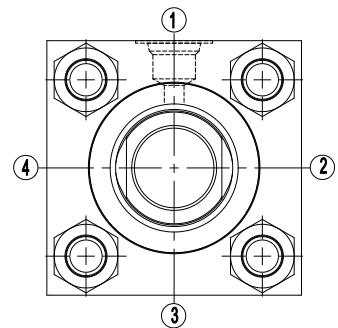

Model Codes

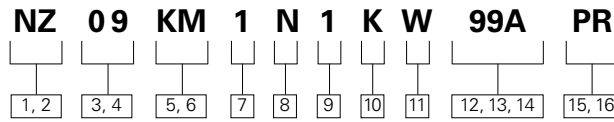

11 Cushion Location

Cushions are located as shown in Rod end type section when viewing cylinder from head end (mounting end of double rod cylinders). “-” in table indicates no cushion.

Code	Head	Cap
A	-	-
B	-	1
C	-	2
D	-	3
E	-	4
F	1	-
G	2	-
H	3	-
J	4	-
K	1	1
L	1	2
M	1	3
N	1	4
P	2	1
R	2	2
S	2	3
T	2	4
U	3	1
V	3	2
W	3	3
Y	3	4
1	4	1
2	4	2
3	4	3
4	4	4

Double Rod Cylinders:
 “Head” = “Mounting End”
 “Cap” = Non-mounting End

12, 13, 14 Cylinder Stroke

Items 12 and 13 indicate stroke length from 00 inches through 99 inches. Item 14 indicates fraction of an inch per the following codes:

Code	Fraction	Code	Fraction
0	0	8	1/2
1	1/16	9	9/16
2	1/8	A	5/8
3	3/16	B	11/16
4	1/4	C	3/4
5	5/16	D	13/16
6	3/8	E	7/8
7	7/16	F	15/16

15, 16 Extra Rod Projection

Item 15 indicates inches from 0 thru 9.
 Item 16 indicates fraction of an inch per the following codes:

_____ OR _____

Proximity Switch, Gland Drain, Air Bleeder / flats / rod material / Limit switch / stop tube / keyed piston

Code	No. of A/C Flat*
F4	4
F6	6

* Only upto 3.5” Rod.

Gland Drain

Code	Head	Cap
* GB	-	1
* GC	-	2
* GD	-	3
* GE	-	4
GF	1	-
GG	2	-
GH	3	-
GJ	4	-
* GK	1	1
* GG	1	2
* GM	1	3
* GN	1	4
* GP	2	1
* GR	2	2
* GS	2	3
* GT	2	4
* GU	3	1
* GV	3	2
* GW	3	3
* GY	3	4
* G1	4	1
* G2	4	2
* G3	4	3
* G4	4	4

* Codes applicable to Double Rods only

Proximity/Positions

Code	Head	Cap
PB	-	1
PC	-	2
PD	-	3
PE	-	4
PF	1	-

PG	2	-
PH	3	-
PJ	4	-
PK	1	1
PL	1	2
PM	1	3
PN	1	4
PP	2	1
PR	2	2
PS	2	3
PT	2	4
PU	3	1
PV	3	2
PW	3	3
PY	3	4
P1	4	1
P2	4	2
P3	4	3
P4	4	4

** P5	1	5
** P6	2	5
** P7	3	5
** P8	4	5

** Applicable for Single rods, Except 1.50” Bore Cushioned option

Air Bleed/Positions

Code	Head	Cap
HB	-	1
HC	-	2
HD	-	3
HE	-	4
HF	1	-
HG	2	-
HH	3	-
HJ	4	-
HK	1	1
HL	1	2
HM	1	3
HN	1	4
HP	2	1
HR	2	2
HS	2	3
HT	2	4
HU	3	1
HV	3	2
HW	3	3
HY	3	4
H1	4	1
H2	4	2
H3	4	3
H4	4	4

Double Rod Cylinders:

“Head” = “Mounting End”
 “Cap” = Non-mounting End

Stop Tube/Positions

Code	Length in inches
S1	1
S2	2
S3	3
S4	4
S5	5
S6	6
S7	7
S8	8
S9	9
S0	10
SA	11
SB	12
SC	13
SD	14
SE	15
SF	16
SG	17
SH	18
SJ	19
SK	20

Keyed Piston to Rod

Code	Type
KG	Grub Screw
KS	Weld Piston to rod

Rod Material Options

Code	Type
* RP	Thick Chrome Plate
RS	Stainless Steel 17-4
** RT	Stainless Steel 303

* .002 Chrome thickness

** Consult factory for pressure Rating

Mounting Styles

Available Mountings

The variety of standard ANSI/NFPA mountings available in the Series NZ gives you a broad selection to match the proper mount to your application. Eaton offers rigid mounts (including side lug mounts, flange mounts, and extended tie rod mounts) and swivel mounts (including clevis mounts and trunnion mounts). For custom mounts, enter "XX"

for model code item 2, and give a detailed description with drawings. Series NZ cylinders are available in all mounting styles listed.

Selecting the Proper Mounting

Just as the cylinder bore must be sized to provide the proper force for an application, a cylinder mounting that can absorb these application forces must also be specified.

CAUTION

In the mounting information, some mounts have been downrated to minimize deflection. For appli-

cations where the motion is linear and parallel to the cylinder rod motion, a rigid mount is recommended. For curvilinear motion, a swivel mount should be chosen. The specifics of each application dictate the correct mounting style it is the user's responsibility to make the correct determination.

NZ01

Side lug
ANSI MS2

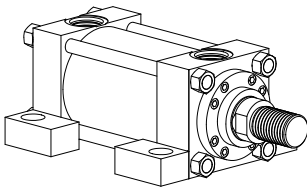

NZ02

Side Tapped
ANSI MS4

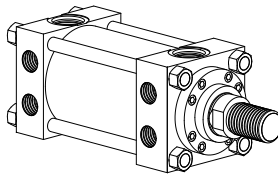

NZ03

End lug
ANSI MS7

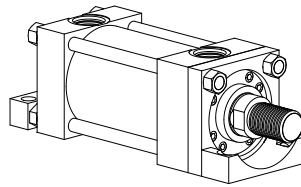

NZ04

Keyed Side Lug

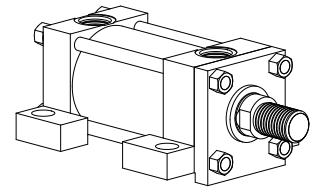

NZ05

Keyed Side Tapped

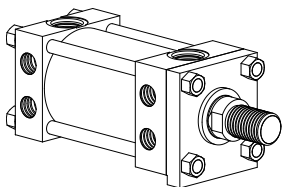

NZ07

Head Rectangular flange
ANSI MF1
(Maximum working pressure
800 PSI)

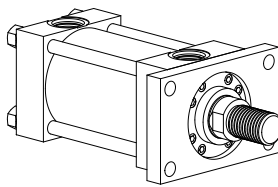

NZ08

Head Square flange
ANSI MF5
(Maximum working pressure
1500 PSI)

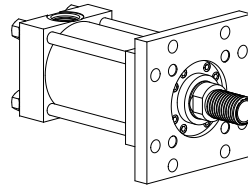

NZ09

Head Rectangular
ANSI ME5

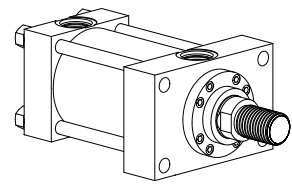

NZ10

Cap Clevis
ANSI MP1

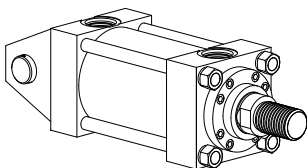

NZ11

Cap Spherical bearing
(Maximum working pressure
per Bore on page 28.)

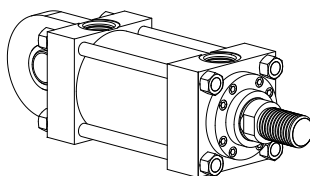

NZ12

Cap Rectangular flange
ANSI MF2
(Maximum working pressure
800 PSI)

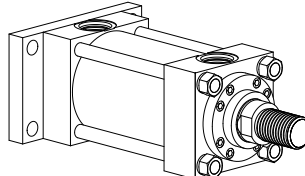

NZ13

Cap Square flange
ANSI MF6
(Maximum working pressure
1500 PSI)

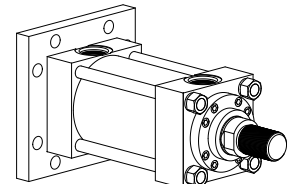

Mounting Styles

NZ14
Cap Rectangular
ANSI ME6

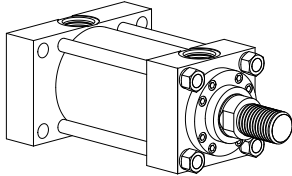

NZ15
Intermediate Trunnion
ANSI MT4

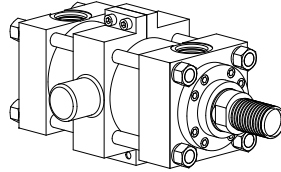

NZ16
Cap Trunnion
ANSI MT2

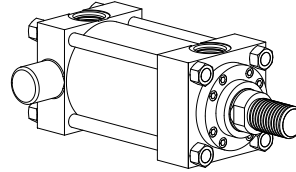

NZ17
Head Trunnion
ANSI MT1

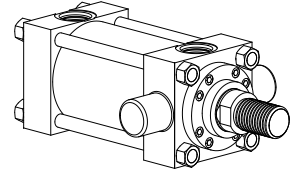

NZ19
Center Lug
ANSI MS3

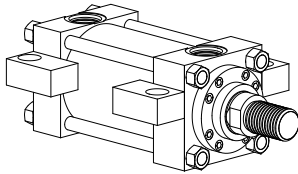

NZ21
Cap Extended Tie rod
ANSI MX2

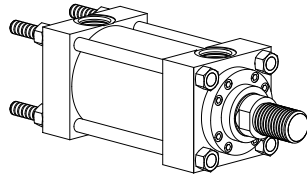

NZ22
Head Extended Tie rod
ANSI MX3

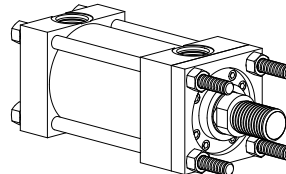

NZ23
Both Ends Extended Tie rod
ANSI MX1

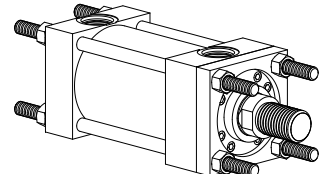

NZ24
No Mount

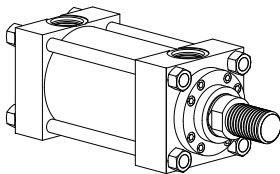

NZ25
Double rod, Side Lug

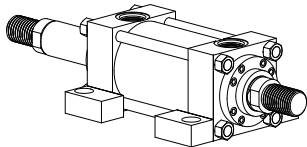

NZ47
Cap Fixed Eye
ANSI MP3

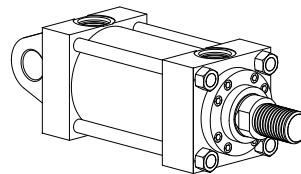

NZ48
Cap Detachable Eye
ANSI MP4

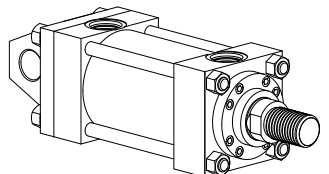

NZ50
Cap Detachable Clevis
ANSI MP2

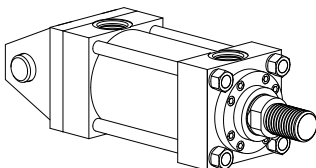

Mounting Style and Installation

Dimensions – NZ01 Side Lug Mount

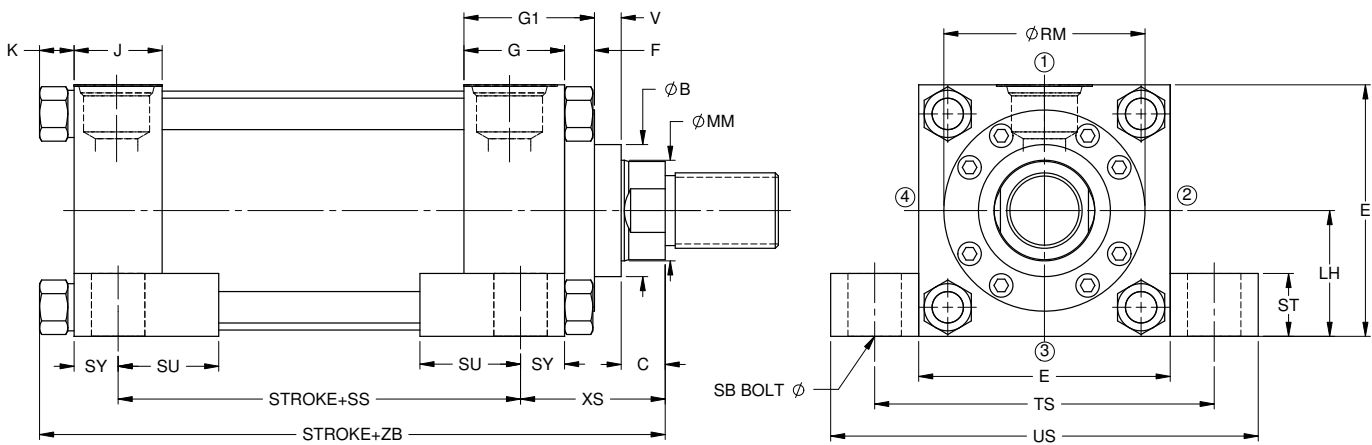

Bore	Rod Dia MM	B +0.000/- .002	C	E	G	J	F	V	RM	LH ±.002	SB
1.50	0.63	1.124	0.38	2.50	1.75	1.50	0.38	0.25	-	1.243	0.38
	1.00	1.499	0.50	2.50	1.75	1.50	0.38	0.50	-	1.243	0.38
2.00	1.00	1.499	0.50	3.00	1.75	1.50	0.63	0.25	-	1.493	0.50
	1.38	1.999	0.63	3.00	1.75	1.50	0.63	0.38	-	1.493	0.50
2.50	1.00	1.499	0.50	3.50	1.75	1.50	0.50	0.38	2.63	1.743	0.75
	1.38	1.999	0.63	3.50	1.75	1.50	0.63	0.38	-	1.743	0.75
	1.75	2.374	0.75	3.50	1.75	1.50	0.63	0.50	-	1.743	0.75
3.25	1.38	1.999	0.63	4.50	2.00	1.75	0.59	0.41	3.25	2.243	0.75
	1.75	2.374	0.75	4.50	2.00	1.75	0.75	0.38	-	2.243	0.75
	2.00	2.624	0.88	4.50	2.00	1.75	0.75	0.38	-	2.243	0.75
4.00	1.75	2.374	0.75	5.00	2.00	1.75	0.59	0.53	3.88	2.493	1.00
	2.00	2.624	0.88	5.00	2.00	1.75	0.59	0.53	4.00	2.493	1.00
	2.50	3.124	1.00	5.00	2.00	1.75	0.59	0.66	4.44	2.493	1.00
5.00	2.00	2.624	0.88	6.50	2.00	1.75	0.59	0.53	4.00	3.243	1.00
	2.50	3.124	1.00	6.50	2.00	1.75	0.59	0.66	4.44	3.243	1.00
	3.00	3.749	1.00	6.50	2.00	1.75	0.72	0.53	5.25	3.243	1.00
	3.50	4.249	1.00	6.50	2.00	1.75	0.72	0.53	5.63	3.243	1.00
6.00	2.50	3.124	1.00	7.50	2.25	2.25	0.59	0.66	4.44	3.743	1.25
	3.00	3.749	1.00	7.50	2.25	2.25	0.72	0.53	5.25	3.743	1.25
	3.50	4.249	1.00	7.50	2.25	2.25	0.72	0.53	5.63	3.743	1.25
	4.00	4.749	1.00	7.50	2.25	2.25	0.88	0.38	6.44	3.743	1.25
7.00	3.00	3.749	1.00	8.50	2.75	2.75	0.72	0.53	5.25	4.243	1.50
	3.50	4.249	1.00	8.50	2.75	2.75	0.72	0.53	5.63	4.243	1.50
	4.00	4.749	1.00	8.50	2.75	2.75	0.88	0.38	6.44	4.243	1.50
	4.50	5.249	1.00	8.50	2.75	2.75	0.88	0.38	7.13	4.243	1.50
	5.00	5.749	1.00	8.50	2.75	2.75	0.88	0.38	7.56	4.243	1.50
8.00	3.50	4.249	1.00	9.50	3.00	3.00	0.72	0.53	5.63	4.743	1.50
	4.00	4.749	1.00	9.50	3.00	3.00	0.88	0.38	6.44	4.743	1.50
	4.50	5.249	1.00	9.50	3.00	3.00	0.88	0.38	7.13	4.743	1.50
	5.00	5.749	1.00	9.50	3.00	3.00	0.88	0.38	7.56	4.743	1.50
	5.50	6.249	1.00	9.50	3.00	3.00	0.88	0.38	8.38	4.743	1.50

+ Plus Stroke

† For Port and Switch at position 2 & 4 please refer page 71, Mounting Holes requires counter Bore

Mounting Style and Installation

Dimensions – NZ01 Side Lug Mount

Side lug mounts are for moving loads along a flat guided surface as in a carriage along rails. The mounting surface should be flat and parallel to the centerline of the piston rod. The load should be guided to traverse along the centerline of the piston rod.

The frame on which the cylinder is mounted *must* be sufficiently rigid to resist bending moments.

NOTE

Limit operating pressure to 2320 psi for minimum deflec-

tion on 6, 7 and 8 inch bores. For strokes in excess of 30 inches, see "Stop tube selection" on page 77.

WARNING

With unsupported loads, the bearing must absorb more force. For these applications, the larger available rod is recommended, and stop tubes should be considered.

Use high tensile socket head cap screws or hex head bolts tightened to the manufacturer's recommended torque.

For high shock applications, dowel pins or shear keys

should be incorporated in the mounting design. For these applications, consider a keyed side lug mount, NZ04.

For severe side load applications, consult your local Eaton sales engineer.

WARNING

Failure to mount the cylinder correctly on the frame may result in death, bodily injury and/or property damage.

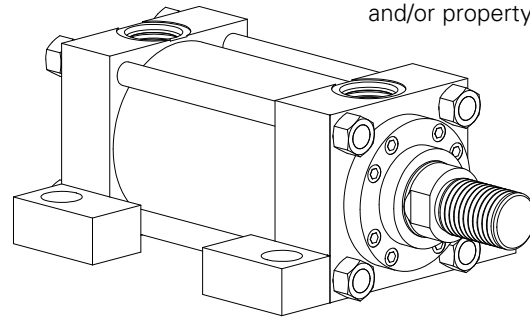

Bore	Rod Dia MM	SS+	ST	SU	SY	TS	US	XS	ZB+ Max	Piston Thick.	K Max
1.50	0.63	3.88	0.50	0.91	0.38	3.25	4.00	1.38	6.13	1.38	0.41
	1.00	3.88	0.50	0.91	0.38	3.25	4.00	1.75	6.50	1.38	0.41
2.00	1.00	3.63	0.75	1.24	0.50	4.00	5.00	1.88	6.66	1.38	0.55
	1.38	3.63	0.75	1.24	0.50	4.00	5.00	2.13	6.92	1.38	0.55
2.50	1.00	3.38	1.00	1.56	0.69	4.88	6.25	2.06	6.78	1.50	0.55
	1.38	3.38	1.00	1.56	0.69	4.88	6.25	2.31	7.04	1.50	0.55
	1.75	3.38	1.00	1.56	0.69	4.88	6.25	2.56	7.28	1.50	0.55
3.25	1.38	4.13	1.00	1.55	0.69	5.88	7.25	2.31	7.91	1.75	0.67
	1.75	4.13	1.00	1.55	0.69	5.88	7.25	2.56	8.16	1.75	0.67
	2.00	4.13	1.00	1.55	0.69	5.88	7.25	2.69	8.29	1.75	0.67
4.00	1.75	4.00	1.25	2.00	0.88	6.75	8.50	2.75	8.40	2.00	0.78
	2.00	4.00	1.25	2.00	0.88	6.75	8.50	2.88	8.53	2.00	0.78
	2.50	4.00	1.25	2.00	0.88	6.75	8.50	3.13	8.78	2.00	0.78
5.00	2.00	4.50	1.25	2.00	0.88	8.25	10.00	2.88	9.32	2.50	0.92
	2.50	4.50	1.25	2.00	0.88	8.25	10.00	3.13	9.57	2.50	0.92
	3.00	4.50	1.25	2.00	0.88	8.25	10.00	3.13	9.56	2.50	0.92
	3.50	4.50	1.25	2.00	0.88	8.25	10.00	3.13	9.56	2.50	0.92
6.00	2.50	5.13	1.50	2.50	1.13	9.75	12.00	3.38	10.80	2.88	1.03
	3.00	5.13	1.50	2.50	1.13	9.75	12.00	3.38	10.80	2.88	1.03
	3.50	5.13	1.50	2.50	1.13	9.75	12.00	3.38	10.80	2.88	1.03
	4.00	5.13	1.50	2.50	1.13	9.75	12.00	3.38	10.80	2.88	1.03
7.00	3.00	5.75	1.75	2.88	1.38	11.25	14.00	3.63	12.09	3.00	1.17
	3.50	5.75	1.75	2.88	1.38	11.25	14.00	3.63	12.09	3.00	1.17
	4.00	5.75	1.75	2.88	1.38	11.25	14.00	3.63	12.09	3.00	1.17
	4.50	5.75	1.75	2.88	1.38	11.25	14.00	3.63	12.09	3.00	1.17
	5.00	5.75	1.75	2.88	1.38	11.25	14.00	3.63	12.09	3.00	1.17
8.00	3.50	6.75	1.75	2.88	1.38	12.25	15.00	3.63	13.18	3.50	1.26
	4.00	6.75	1.75	2.88	1.38	12.25	15.00	3.63	13.18	3.50	1.26
	4.50	6.75	1.75	2.88	1.38	12.25	15.00	3.63	13.18	3.50	1.26
	5.00	6.75	1.75	2.88	1.38	12.25	15.00	3.63	13.18	3.50	1.26
	5.50	6.75	1.75	2.88	1.38	12.25	15.00	3.63	13.18	3.50	1.26

+ Plus Stroke

See Mount 24 on page 50 for Port Dimensions

Mounting Style and Installation

Dimensions – NZ02 Side Tapped

Mounts ANSI MS4

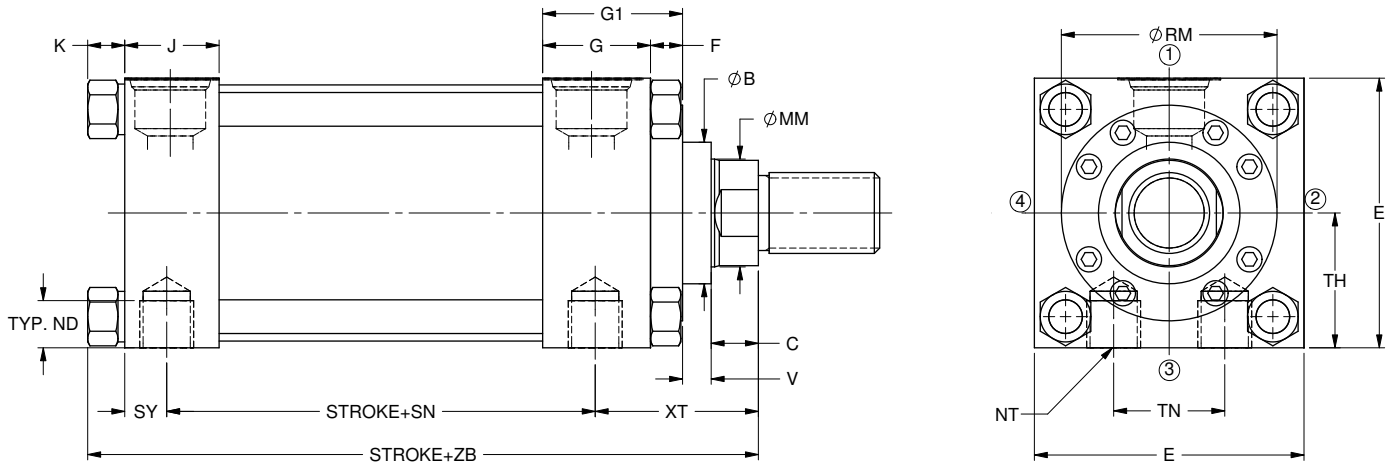

Bore	Rod Dia MM	B +.000/-0.002	C	E	G	J	F	V	RM	TH ±.002
1.50	0.63	1.124	0.38	2.50	1.75	1.50	0.38	0.25	-	1.243
	1.00	1.499	0.50	2.50	1.75	1.50	0.38	0.50	-	1.243
2.00	1.00	1.499	0.50	3.00	1.75	1.50	0.63	0.25	-	1.493
	1.38	1.999	0.63	3.00	1.75	1.50	0.63	0.38	-	1.493
2.50	1.00	1.499	0.50	3.50	1.75	1.50	0.50	0.38	2.63	1.743
	1.38	1.999	0.63	3.50	1.75	1.50	0.63	0.38	-	1.743
	1.75	2.374	0.75	3.50	1.75	1.50	0.63	0.50	-	1.743
3.25	1.38	1.999	0.63	4.50	2.00	1.75	0.59	0.41	3.25	2.243
	1.75	2.374	0.75	4.50	2.00	1.75	0.75	0.38	-	2.243
	2.00	2.624	0.88	4.50	2.00	1.75	0.75	0.38	-	2.243
4.00	1.75	2.374	0.75	5.00	2.00	1.75	0.59	0.53	3.88	2.493
	2.00	2.624	0.88	5.00	2.00	1.75	0.59	0.53	4.00	2.493
	2.50	3.124	1.00	5.00	2.00	1.75	0.59	0.66	4.44	2.493
5.00	2.00	2.624	0.88	6.50	2.00	1.75	0.59	0.53	4.00	3.243
	2.50	3.124	1.00	6.50	2.00	1.75	0.59	0.66	4.44	3.243
	3.00	3.749	1.00	6.50	2.00	1.75	0.72	0.53	5.25	3.243
	3.50	4.249	1.00	6.50	2.00	1.75	0.72	0.53	5.63	3.243
6.00	2.50	3.124	1.00	7.50	2.25	2.25	0.59	0.66	4.44	3.743
	3.00	3.749	1.00	7.50	2.25	2.25	0.72	0.53	5.25	3.743
	3.50	4.249	1.00	7.50	2.25	2.25	0.72	0.53	5.63	3.743
	4.00	4.749	1.00	7.50	2.25	2.25	0.88	0.38	6.44	3.743
7.00	3.00	3.749	1.00	8.50	2.75	2.75	0.72	0.53	5.25	4.243
	3.50	4.249	1.00	8.50	2.75	2.75	0.72	0.53	5.63	4.243
	4.00	4.749	1.00	8.50	2.75	2.75	0.88	0.38	6.44	4.243
	4.50	5.249	1.00	8.50	2.75	2.75	0.88	0.38	7.13	4.243
	5.00	5.749	1.00	8.50	2.75	2.75	0.88	0.38	7.56	4.243
8.00	3.50	4.249	1.00	9.50	3.00	3.00	0.72	0.53	5.63	4.743
	4.00	4.749	1.00	9.50	3.00	3.00	0.88	0.38	6.44	4.743
	4.50	5.249	1.00	9.50	3.00	3.00	0.88	0.38	7.13	4.743
	5.00	5.749	1.00	9.50	3.00	3.00	0.88	0.38	7.56	4.743
	5.50	6.249	1.00	9.50	3.00	3.00	0.88	0.38	8.38	4.743

+ Plus Stroke

Mounting Style and Installation

Dimensions – NZ02 Side Tapped Mounts ANSI MS4

Tapped mounts are for moving loads along a flat guided surface as in a carriage along rails.

The mounting surface should be flat and parallel to the centerline of the piston rod.

The load should be guided to traverse along the centerline of the piston rod.

The frame on which the cylinder is mounted *must* be sufficiently rigid to resist bending moments.

NOTE

For strokes in excess of 30 inches, see “Stop tube selection” on page 77.

WARNING

With unsupported loads, the bearing must absorb more force. For these applications, the larger available rod is recommended, and stop tubes should be considered.

Use high tensile socket head cap screws or hex head bolts tightened to the manufacturer’s recommended torque.

For high shock applications, dowel pins or shear keys should be incorporated in the

mounting design. For these applications, consider a keyed side lug mount, NZ04.

For severe side load applications, consult your local Eaton sales engineer.

WARNING

Failure to mount the cylinder correctly on the frame may result in death, bodily injury and/or property damage.

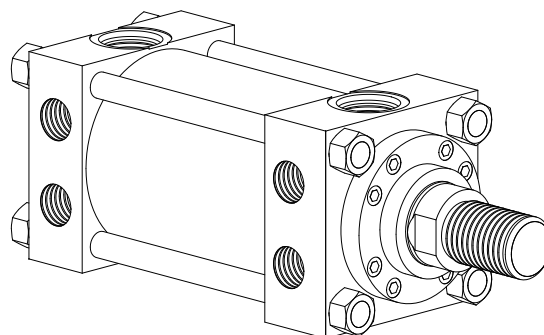

Bore	Rod Dia MM	ND	NT (Tap)	SN+	TN	SY	XT	ZB+ Max	Piston Thick.	K
1.50	0.63	0.56	0.375-16	2.88	0.75	0.75	2.00	6.04	1.38	0.41
	1.00	0.50	0.375-16	2.88	0.75	0.75	2.38	6.41	1.38	0.41
2.00	1.00	0.50	0.500-13	2.88	0.94	0.75	2.38	6.56	1.38	0.55
	1.38	0.50	0.500-13	2.88	0.94	0.75	2.63	6.82	1.38	0.55
2.50	1.00	0.81	0.625-11	3.00	1.31	0.75	2.38	6.68	1.50	0.55
	1.38	0.61	0.625-11	3.00	1.31	0.75	2.63	6.94	1.50	0.55
	1.75	0.61	0.625-11	3.00	1.31	0.75	2.88	7.18	1.50	0.55
3.25	1.38	0.75	0.750-10	3.50	1.50	0.88	2.75	7.80	1.75	0.67
	1.75	0.75	0.750-10	3.50	1.50	0.88	3.00	8.05	1.75	0.67
	2.00	0.75	0.750-10	3.50	1.50	0.88	3.13	8.18	1.75	0.67
4.00	1.75	1.00	1.000-8	3.75	2.06	0.88	3.00	8.40	2.00	0.78
	2.00	0.75	1.000-8	3.75	2.06	0.88	3.13	8.53	2.00	0.78
	2.50	0.69	1.000-8	3.75	2.06	0.88	3.38	8.78	2.00	0.78
5.00	2.00	1.13	1.000-8	4.25	2.94	0.88	3.13	9.18	2.50	0.92
	2.50	1.13	1.000-8	4.25	2.94	0.88	3.38	9.43	2.50	0.92
	3.00	1.13	1.000-8	4.25	2.94	0.88	3.38	9.42	2.50	0.92
	3.50	1.00	1.000-8	4.25	2.94	0.88	3.38	9.42	2.50	0.92
6.00	2.50	1.31	1.250-7	5.13	3.31	1.00	3.50	10.66	2.88	1.03
	3.00	1.31	1.250-7	5.13	3.31	1.00	3.50	10.80	2.88	1.03
	3.50	1.31	1.250-7	5.13	3.31	1.00	3.50	10.80	2.88	1.03
	4.00	1.25	1.250-7	5.13	3.31	1.00	3.50	10.81	2.88	1.03
7.00	3.00	2.13	1.500-6	5.88	3.75	1.06	3.81	11.92	3.00	1.17
	3.50	2.13	1.500-6	5.88	3.75	1.06	3.81	11.92	3.00	1.17
	4.00	1.75	1.500-6	5.88	3.75	1.06	3.81	11.92	3.00	1.17
	4.50	1.50	1.500-6	5.88	3.75	1.06	3.81	11.92	3.00	1.17
	5.00	1.13	1.500-6	5.88	3.75	1.06	3.81	11.92	3.00	1.17
8.00	3.50	1.56	1.500-6	6.63	4.25	1.19	3.94	13.00	3.50	1.26
	4.00	1.56	1.500-6	6.63	4.25	1.19	3.94	13.00	3.50	1.26
	4.50	1.56	1.500-6	6.63	4.25	1.19	3.94	13.00	3.50	1.26
	5.00	1.56	1.500-6	6.63	4.25	1.19	3.94	13.00	3.50	1.26
	5.50	1.38	1.500-6	6.63	4.25	1.19	3.94	13.00	3.50	1.26

+ Plus Stroke

See Mount 24 on page 50 for Port Dimensions

Mounting Style and Installation

Dimensions – NZ03 End Lug

Mounts ANSI MS7

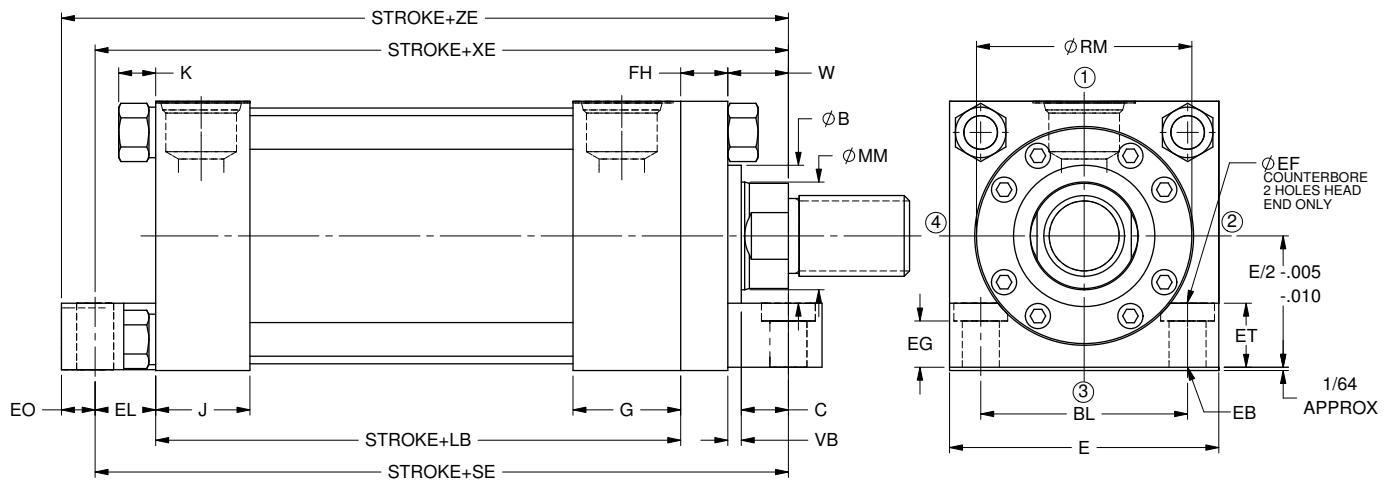

Bore	Rod Dia MM	B +.000/-.002	C	E	G	J	FH	VB	W	EB	SE+
1.50	0.63	1.124	0.38	2.50	1.75	1.50	0.38	0.25	0.63	0.38	6.75
	1.00	1.499	0.50	2.50	1.75	1.50	0.38	0.50	1.00	0.38	6.75
2.00	1.00	1.499	0.50	3.00	1.75	1.50	0.63	0.25	0.75	0.50	7.13
	1.38	1.999	0.63	3.00	1.75	1.50	0.63	0.38	1.01	0.50	7.13
2.50	1.00	1.499	0.50	3.50	1.75	1.50	0.63	0.25	0.75	0.50	7.25
	1.38	1.999	0.63	3.50	1.75	1.50	0.63	0.38	1.01	0.50	7.25
	1.75	2.374	0.75	3.50	1.75	1.50	0.63	0.50	1.25	0.50	7.25
3.25	1.38	1.999	0.63	4.50	2.00	1.75	0.75	0.25	0.88	0.63	8.50
	1.75	2.374	0.75	4.50	2.00	1.75	0.75	0.38	1.13	0.63	8.50
	2.00	2.624	0.88	4.50	2.00	1.75	0.75	0.38	1.26	0.63	8.50
4.00	1.75	2.374	0.75	5.00	2.00	1.75	0.88	0.25	1.00	0.63	8.88
	2.00	2.624	0.88	5.00	2.00	1.75	0.88	0.25	1.13	0.63	8.88
	2.50	3.124	1.00	5.00	2.00	1.75	0.88	0.38	1.38	0.63	8.88
5.00	2.00	2.624	0.88	6.50	2.00	1.75	0.88	0.25	1.13	0.88	10.13
	2.50	3.124	1.00	6.50	2.00	1.75	0.88	0.38	1.38	0.88	10.13
	3.00	3.749	1.00	6.50	2.00	1.75	0.88	0.38	1.38	0.88	10.13
	3.50	4.249	1.00	6.50	2.00	1.75	0.88	0.38	1.38	0.88	10.13
6.00	2.50	3.124	1.00	7.50	2.25	2.25	1.00	0.25	1.25	1.00	11.75
	3.00	3.749	1.00	7.50	2.25	2.25	1.00	0.25	1.25	1.00	11.75
	3.50	4.249	1.00	7.50	2.25	2.25	1.00	0.25	1.25	1.00	11.75
	4.00	4.749	1.00	7.50	2.25	2.25	1.00	0.25	1.25	1.00	11.75
7.00	3.00	3.749	1.00	8.50	2.75	2.75	1.00	0.25	1.25	1.13	13.13
	3.50	4.249	1.00	8.50	2.75	2.75	1.00	0.25	1.25	1.13	13.13
	4.00	4.749	1.00	8.50	2.75	2.75	1.00	0.25	1.25	1.13	13.13
	4.50	5.249	1.00	8.50	2.75	2.75	1.00	0.25	1.25	1.13	13.13
	5.00	5.749	1.00	8.50	2.75	2.75	1.00	0.25	1.25	1.13	13.13
8.00	3.50	4.249	1.00	9.50	3.00	3.00	1.00	0.25	1.25	1.25	14.50
	4.00	4.749	1.00	9.50	3.00	3.00	1.00	0.25	1.25	1.25	14.50
	4.50	5.249	1.00	9.50	3.00	3.00	1.00	0.25	1.25	1.25	14.50
	5.00	5.749	1.00	9.50	3.00	3.00	1.00	0.25	1.25	1.25	14.50
	5.50	6.249	1.00	9.50	3.00	3.00	1.00	0.25	1.25	1.25	14.50

+ Plus Stroke

† Port at Position 3 not available on 1.50", 2.00", 2.50", 3.25" and 4.00"

Mounting Style and Installation

Dimensions – NZ03 End Lug Mounts ANSI MS7

End lug mounts are for moving loads along a flat guided surface as in a carriage along rails.

The mounting surface should be flat and parallel to the centerline of the piston rod.

The load should be guided to traverse along the centerline of the piston rod.

The frame on which the cylinder is mounted *must* be sufficiently rigid to resist bending moments.

NOTE

Port at position 3 not available on 1.50" 2.00" 2.50" 3.25" and 4.00" diameter bores.

WARNING

With unsupported loads, the bearing must absorb more force.

For these applications, the larger available rod is recommended, and stop tubes should be considered.

Use high tensile socket head cap screws or hex head bolts tightened to the manufacturer's recommended torque.

For high shock applications, dowel pins or shear keys should be incorporated in the mounting design. For these applications, consider a keyed side lug mount, NZ04.

For severe side load applications, consult your local Eaton sales engineer.

WARNING

Failure to mount the cylinder correctly on the frame may result in death, bodily injury and/or property damage.

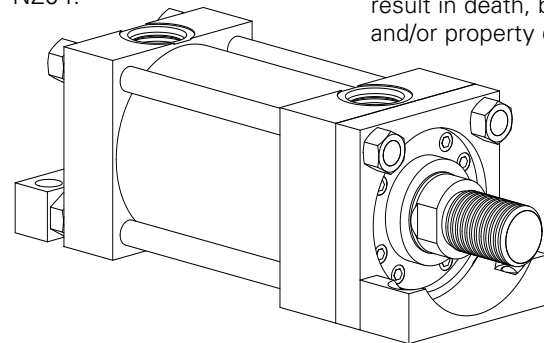

Bore	Rod Dia MM	ET	EG	EL	EF	BL	XE+	LB+	E0	ZE+ Max	Piston Thick.	K
1.50	0.63	0.88	0.69	0.88	0.63	1.63	6.51	4.63	0.38	6.89	1.38	0.41
	1.00	0.88	0.69	0.88	0.63	1.63	6.88	4.63	0.38	7.26	1.38	0.41
2.00	1.00	1.00	0.75	0.94	0.81	2.07	6.94	4.63	0.50	7.44	1.38	0.55
	1.38	1.00	0.75	0.94	0.81	2.07	7.20	4.63	0.50	7.70	1.38	0.55
2.50	1.00	1.00	0.75	0.94	0.81	2.56	7.07	4.75	0.50	7.57	1.50	0.55
	1.38	1.00	0.75	0.94	0.81	2.56	7.33	4.75	0.50	7.83	1.50	0.55
	1.75	1.00	0.75	0.94	0.81	2.56	7.57	4.75	0.50	8.07	1.50	0.55
3.25	1.38	1.25	1.06	1.13	1.00	3.27	8.26	5.50	0.63	8.88	1.75	0.67
	1.75	1.25	1.06	1.13	1.00	3.27	8.51	5.50	0.63	9.13	1.75	0.67
	2.00	1.25	1.06	1.13	1.00	3.27	8.64	5.50	0.63	9.26	1.75	0.67
4.00	1.75	1.25	0.88	1.13	1.00	3.84	8.75	5.75	0.63	9.38	2.00	0.78
	2.00	1.25	0.88	1.13	1.00	3.84	8.88	5.75	0.63	9.51	2.00	0.78
	2.50	1.25	0.88	1.13	1.00	3.84	9.13	5.75	0.63	9.76	2.00	0.78
5.00	2.00	1.50	1.25	1.50	1.38	4.95	9.76	6.25	0.75	10.51	2.50	0.92
	2.50	1.50	1.25	1.50	1.38	4.95	10.01	6.25	0.75	10.76	2.50	0.92
	3.00	1.50	1.25	1.50	1.38	4.95	10.01	6.25	0.75	10.76	2.50	0.92
	3.50	1.50	1.25	1.50	1.38	4.95	10.01	6.25	0.75	10.76	2.50	0.92
6.00	2.50	1.75	1.50	1.69	1.63	5.74	11.31	7.38	0.88	12.19	2.88	1.03
	3.00	1.75	1.50	1.69	1.63	5.74	11.31	7.38	0.88	12.19	2.88	1.03
	3.50	1.75	1.50	1.69	1.63	5.74	11.31	7.38	0.88	12.19	2.88	1.03
	4.00	1.75	1.50	1.69	1.63	5.74	11.31	7.38	0.88	12.19	2.88	1.03
7.00	3.00	2.00	1.50	1.81	1.63	6.58	12.56	8.50	1.00	13.56	3.00	1.17
	3.50	2.00	1.50	1.81	1.63	6.58	12.56	8.50	1.00	13.56	3.00	1.17
	4.00	2.00	1.50	1.81	1.63	6.58	12.56	8.50	1.00	13.56	3.00	1.17
	4.50	2.00	1.50	1.81	1.63	6.58	12.56	8.50	1.00	13.56	3.00	1.17
	5.00	2.00	1.50	1.81	1.63	6.58	12.56	8.50	1.00	13.56	3.00	1.17
8.00	3.50	2.00	1.75	2.00	2.09	7.51	13.75	9.50	1.13	14.88	3.50	1.26
	4.00	2.00	1.75	2.00	2.09	7.51	13.75	9.50	1.13	14.88	3.50	1.26
	4.50	2.00	1.75	2.00	2.09	7.51	13.75	9.50	1.13	14.88	3.50	1.26
	5.00	2.00	1.75	2.00	2.09	7.51	13.75	9.50	1.13	14.88	3.50	1.26
	5.50	2.00	1.75	2.00	2.09	7.51	13.75	9.50	1.13	14.88	3.50	1.26

+ Plus Stroke

See Mount 24 on page 50 for Port Dimensions

Mounting Style and Installation Dimensions – NZ04 Keyed Side Lug Mounts

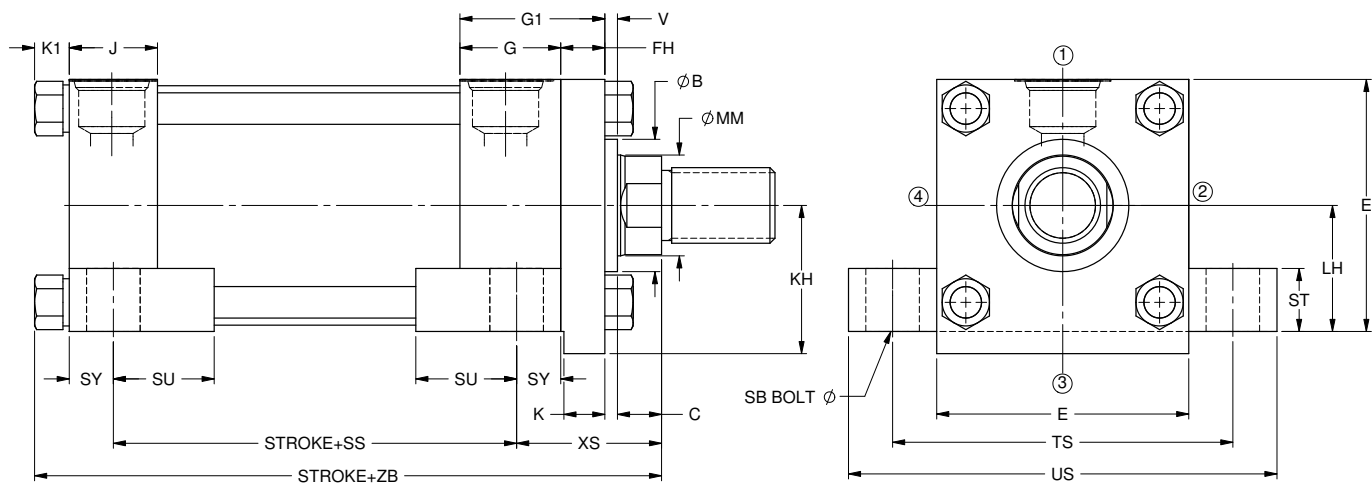

Bore	Rod Dia MM	B +0.000/- .002	C	E	G1	J	FH	K +0.000 /-.002	Max KH	LH ± 0.002	V
1.50	0.63	1.124	0.38	2.50	2.13	1.50	0.38	0.362	1.44	1.243	0.25
	1.00	1.499	0.50	2.50	2.13	1.50	0.38	0.362	1.43	1.243	0.50
2.00	1.00	1.499	0.50	3.00	2.38	1.50	0.63	0.612	1.81	1.493	0.25
	1.38	1.999	0.63	3.00	2.38	1.50	0.63	0.612	1.81	1.493	0.38
2.50	1.00	1.499	0.50	3.50	2.38	1.50	0.63	0.612	2.06	1.743	0.25
	1.38	1.999	0.63	3.50	2.38	1.50	0.63	0.612	2.06	1.743	0.38
	1.75	2.374	0.75	3.50	2.38	1.50	0.63	0.612	2.06	1.743	0.50
3.25	1.38	1.999	0.63	4.50	2.75	1.75	0.75	0.737	2.63	2.243	0.25
	1.75	2.374	0.75	4.50	2.75	1.75	0.75	0.737	2.63	2.243	0.38
	2.00	2.624	0.88	4.50	2.75	1.75	0.75	0.737	2.63	2.243	0.38
4.00	1.75	2.374	0.75	5.00	2.88	1.75	0.88	0.862	2.94	2.493	0.25
	2.00	2.624	0.88	5.00	2.88	1.75	0.88	0.862	2.94	2.493	0.25
	2.50	3.124	1.00	5.00	2.88	1.75	0.88	0.862	2.94	2.493	0.38
5.00	2.00	2.624	0.88	6.50	2.88	1.75	0.88	0.862	3.68	3.243	0.25
	2.50	3.124	1.00	6.50	2.88	1.75	0.88	0.862	3.68	3.243	0.38
	3.00	3.749	1.00	6.50	2.88	1.75	0.88	0.862	3.68	3.243	0.38
	3.50	4.249	1.00	6.50	2.88	1.75	0.88	0.862	3.68	3.243	0.38
6.00	2.50	3.124	1.00	7.50	3.25	2.25	1.00	0.987	4.25	3.743	0.25
	3.00	3.749	1.00	7.50	3.25	2.25	1.00	0.987	4.25	3.743	0.25
	3.50	4.249	1.00	7.50	3.25	2.25	1.00	0.987	4.25	3.743	0.25
	4.00	4.749	1.00	7.50	3.25	2.25	1.00	0.987	4.25	3.743	0.25
7.00	3.00	3.749	1.00	8.50	3.75	2.75	1.00	0.987	4.75	4.243	0.25
	3.50	4.249	1.00	8.50	3.75	2.75	1.00	0.987	4.75	4.243	0.25
	4.00	4.749	1.00	8.50	3.75	2.75	1.00	0.987	4.75	4.243	0.25
	4.50	5.249	1.00	8.50	3.75	2.75	1.00	0.987	4.75	4.243	0.25
8.00	5.00	5.749	1.00	8.50	3.75	2.75	1.00	0.987	4.75	4.243	0.25
	3.50	4.249	1.00	9.50	4.00	3.00	1.00	0.987	5.25	4.743	0.25
	4.00	4.749	1.00	9.50	4.00	3.00	1.00	0.987	5.25	4.743	0.25
	4.50	5.249	1.00	9.50	4.00	3.00	1.00	0.987	5.25	4.743	0.25
	5.00	5.749	1.00	9.50	4.00	3.00	1.00	0.987	5.25	4.743	0.25

+ Plus Stroke

† For Port and Switch at position 2 & 4 please refer page 71, Mounting Holes requires counter Bore

Mounting Style and Installation Dimensions – NZ04 Keyed Side Lug Mounts

Keyed side lug mounts are for moving loads along a flat guided surface as in a carriage along rails.

The mounting surface should be flat and parallel to the centerline of the piston rod.

The load should be guided to traverse along the centerline of the piston rod.

The frame on which the cylinder is mounted *must* be sufficiently rigid to resist bending moments.

NOTE

For strokes in excess of 30 inches, see "Stop tube selection" on page 77.

WARNING

With unsupported loads, the bearing must absorb more force.

For these applications, the larger available rod is recommended, and stop tubes should be considered.

Use high tensile socket head cap screws or hex head bolts tightened to the manufacturer's recommended torque.

For severe side load applications, consult your local Eaton sales engineer.

WARNING

Failure to mount the cylinder correctly on the frame may result in death, bodily injury and/or property damage.

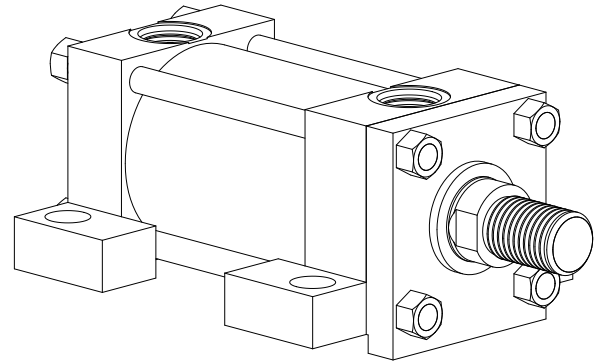

Bore	Rod Dia MM	SB	SS+	ST	SU	SY	TS	US	XS	ZB+ Max	Piston Thick.	K1
1.50	0.63	0.38	3.88	0.50	0.91	0.38	3.25	4.00	1.38	6.04	1.38	0.41
	1.00	0.38	3.88	0.50	0.91	0.38	3.25	4.00	1.75	6.41	1.38	0.41
2.00	1.00	0.50	3.63	0.75	1.24	0.50	4.00	5.00	1.88	6.56	1.38	0.55
	1.38	0.50	3.63	0.75	1.24	0.50	4.00	5.00	2.13	6.82	1.38	0.55
2.50	1.00	0.75	3.38	1.00	1.56	0.69	4.88	6.25	2.06	6.68	1.50	0.55
	1.38	0.75	3.38	1.00	1.56	0.69	4.88	6.25	2.31	6.94	1.50	0.55
	1.75	0.75	3.38	1.00	1.56	0.69	4.88	6.25	2.56	7.18	1.50	0.55
3.25	1.38	0.75	4.13	1.00	1.55	0.69	5.88	7.25	2.31	7.80	1.75	0.67
	1.75	0.75	4.13	1.00	1.55	0.69	5.88	7.25	2.56	8.05	1.75	0.67
	2.00	0.75	4.13	1.00	1.55	0.69	5.88	7.25	2.69	8.18	1.75	0.67
4.00	1.75	1.00	4.00	1.25	2.00	0.88	6.75	8.50	2.75	8.40	2.00	0.78
	2.00	1.00	4.00	1.25	2.00	0.88	6.75	8.50	2.88	8.53	2.00	0.78
	2.50	1.00	4.00	1.25	2.00	0.88	6.75	8.50	3.13	8.78	2.00	0.78
5.00	2.00	1.00	4.50	1.25	2.00	0.88	8.25	10.00	2.88	9.18	2.50	0.92
	2.50	1.00	4.50	1.25	2.00	0.88	8.25	10.00	3.13	9.43	2.50	0.92
	3.00	1.00	4.50	1.25	2.00	0.88	8.25	10.00	3.13	9.43	2.50	0.92
	3.50	1.00	4.50	1.25	2.00	0.88	8.25	10.00	3.13	9.43	2.50	0.92
6.00	2.50	1.25	5.13	1.50	2.50	1.13	9.75	12.00	3.38	10.66	2.88	1.03
	3.00	1.25	5.13	1.50	2.50	1.13	9.75	12.00	3.38	10.66	2.88	1.03
	3.50	1.25	5.13	1.50	2.50	1.13	9.75	12.00	3.38	10.66	2.88	1.03
	4.00	1.25	5.13	1.50	2.50	1.13	9.75	12.00	3.38	10.66	2.88	1.03
7.00	3.00	1.50	5.75	1.75	2.88	1.38	11.25	14.00	3.63	11.92	3.00	1.17
	3.50	1.50	5.75	1.75	2.88	1.38	11.25	14.00	3.63	11.92	3.00	1.17
	4.00	1.50	5.75	1.75	2.88	1.38	11.25	14.00	3.63	11.92	3.00	1.17
	4.50	1.50	5.75	1.75	2.88	1.38	11.25	14.00	3.63	11.92	3.00	1.17
	5.00	1.50	5.75	1.75	2.88	1.38	11.25	14.00	3.63	11.92	3.00	1.17
8.00	3.50	1.50	6.75	1.75	2.88	1.38	12.25	15.00	3.63	13.00	3.50	1.26
	4.00	1.50	6.75	1.75	2.88	1.38	12.25	15.00	3.63	13.00	3.50	1.26
	4.50	1.50	6.75	1.75	2.88	1.38	12.25	15.00	3.63	13.00	3.50	1.26
	5.00	1.50	6.75	1.75	2.88	1.38	12.25	15.00	3.63	13.00	3.50	1.26
	5.50	1.50	6.75	1.75	2.88	1.38	12.25	15.00	3.63	13.00	3.50	1.26

+ Plus Stroke

See Mount 24 on page 50 for Port Dimensions

Mounting Style and Installation

Dimensions – NZ05 Keyed Tapped Lug Mounts

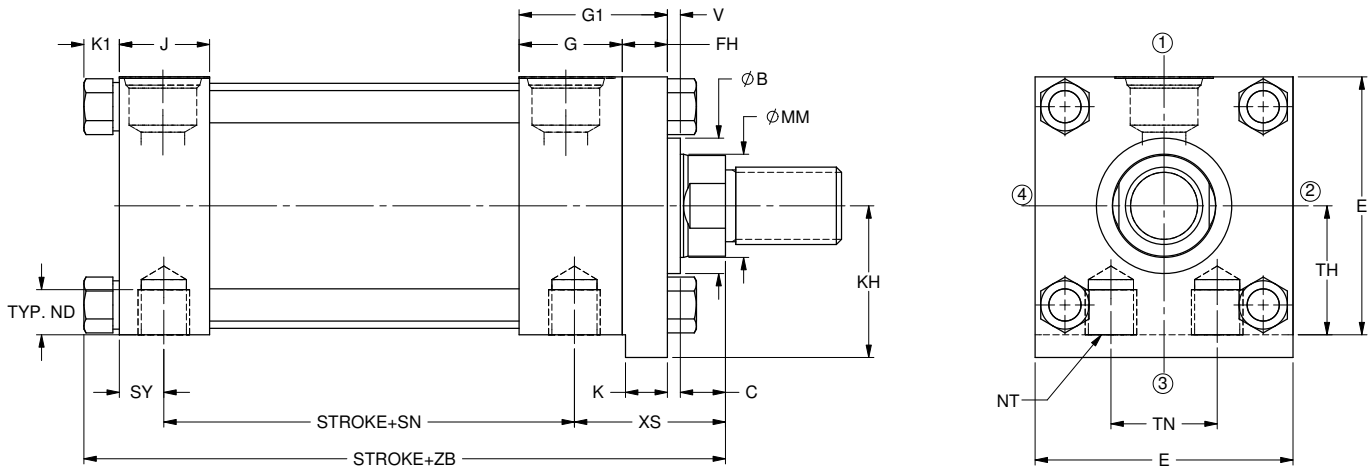

Bore	Rod MM	B +.000/--.002	C	E	G1	J	FH	K +.000/- .002	Max KH	V	TH ±.002
1.50	0.63	1.124	0.38	2.50	2.13	1.50	0.38	0.362	1.44	0.25	1.243
	1.00	1.499	0.50	2.50	2.13	1.50	0.38	0.362	1.44	0.50	1.243
2.00	1.00	1.499	0.50	3.00	2.38	1.50	0.63	0.612	1.81	0.25	1.493
	1.38	1.999	0.63	3.00	2.38	1.50	0.63	0.612	1.81	0.38	1.493
2.50	1.00	1.499	0.50	3.50	2.38	1.50	0.63	0.612	2.06	0.25	1.743
	1.38	1.999	0.63	3.50	2.38	1.50	0.63	0.612	2.06	0.38	1.743
	1.75	2.374	0.75	3.50	2.38	1.50	0.63	0.612	2.06	0.50	1.743
3.25	1.38	1.999	0.63	4.50	2.75	1.75	0.75	0.737	2.63	0.25	2.243
	1.75	2.374	0.75	4.50	2.75	1.75	0.75	0.737	2.63	0.38	2.243
	2.00	2.624	0.88	4.50	2.75	1.75	0.75	0.737	2.63	0.38	2.243
4.00	1.75	2.374	0.75	5.00	2.88	1.75	0.88	0.862	2.94	0.25	2.493
	2.00	2.624	0.88	5.00	2.88	1.75	0.88	0.862	2.94	0.25	2.493
	2.50	3.124	1.00	5.00	2.88	1.75	0.88	0.862	2.94	0.38	2.493
5.00	2.00	2.624	0.88	6.50	2.88	1.75	0.88	0.862	3.68	0.25	3.243
	2.50	3.124	1.00	6.50	2.88	1.75	0.88	0.862	3.68	0.38	3.243
	3.00	3.749	1.00	6.50	2.88	1.75	0.88	0.862	3.68	0.38	3.243
	3.50	4.249	1.00	6.50	2.88	1.75	0.88	0.862	3.68	0.38	3.243
6.00	2.50	3.124	1.00	7.50	3.25	2.25	1.00	0.987	4.25	0.25	3.743
	3.00	3.749	1.00	7.50	3.25	2.25	1.00	0.987	4.25	0.25	3.743
	3.50	4.249	1.00	7.50	3.25	2.25	1.00	0.987	4.25	0.25	3.743
	4.00	4.749	1.00	7.50	3.25	2.25	1.00	0.987	4.25	0.25	3.743
7.00	3.00	3.749	1.00	8.50	3.75	2.75	1.00	0.987	4.75	0.25	4.243
	3.50	4.249	1.00	8.50	3.75	2.75	1.00	0.987	4.75	0.25	4.243
	4.00	4.749	1.00	8.50	3.75	2.75	1.00	0.987	4.75	0.25	4.243
	4.50	5.249	1.00	8.50	3.75	2.75	1.00	0.987	4.75	0.25	4.243
	5.00	5.749	1.00	8.50	3.75	2.75	1.00	0.987	4.75	0.25	4.243
8.00	3.50	4.249	1.00	9.50	4.00	3.00	1.00	0.987	5.25	0.25	4.743
	4.00	4.749	1.00	9.50	4.00	3.00	1.00	0.987	5.25	0.38	4.743
	4.50	5.249	1.00	9.50	4.00	3.00	1.00	0.987	5.25	0.38	4.743
	5.00	5.749	1.00	9.50	4.00	3.00	1.00	0.987	5.25	0.38	4.743
	5.50	6.249	1.00	9.50	4.00	3.00	1.00	0.987	5.25	0.38	4.743

+ Plus Stroke

Mounting Style and Installation Dimensions – NZ05 Keyed Tapped Lug Mounts

Tapped mounts are for moving loads along a flat guided surface as in a carriage along rails.

The mounting surface should be flat and parallel to the centerline of the piston rod.

The load should be guided to traverse along the centerline of the piston rod.

The frame on which the cylinder is mounted *must* be sufficiently rigid to resist bending moments.

NOTE

For strokes in excess of 30 inches, see “Stop tube selection” on page 77.

WARNING

With unsupported loads, the bearing must absorb more force.

For these applications, the larger available rod is recommended, and stop tubes should be considered.

Use high tensile socket head cap screws or hex head bolts tightened to the manufacturer’s recommended torque.

For high shock applications, dowel pins or shear keys should be incorporated in the mounting design. For these applications, consider a keyed side lug mount, NZ04.

For severe side load applications, consult your local Eaton sales engineer.

WARNING

Failure to mount the cylinder correctly on the frame may result in death, bodily injury and/or property damage.

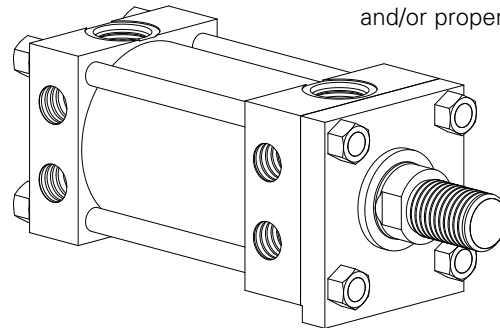

Bore	Rod MM	ND	NT (Tap)	SN+	TN	SY	XS	ZB+ Max	Piston Thick.	K1
1.50	0.63	0.56	0.375-16	2.88	0.75	0.75	2.00	6.04	1.38	0.41
	1.00	0.50	0.375-16	2.88	0.75	0.75	2.38	6.41	1.38	0.41
2.00	1.00	0.50	0.500-13	2.88	0.94	0.75	2.38	6.56	1.38	0.55
	1.38	0.50	0.500-13	2.88	0.94	0.75	2.63	6.82	1.38	0.55
2.50	1.00	0.81	0.625-11	3.00	1.31	0.75	2.38	6.68	1.50	0.55
	1.38	0.61	0.625-11	3.00	1.31	0.75	2.63	6.94	1.50	0.55
	1.75	0.61	0.625-11	3.00	1.31	0.75	2.88	7.18	1.50	0.55
3.25	1.38	0.75	0.750-10	3.50	1.50	0.88	2.75	7.80	1.75	0.67
	1.75	0.75	0.750-10	3.50	1.50	0.88	3.00	8.05	1.75	0.67
	2.00	0.75	0.750-10	3.50	1.50	0.88	3.13	8.18	1.75	0.67
4.00	1.75	1.00	1.000-8	3.75	2.06	0.88	3.00	8.40	2.00	0.78
	2.00	0.75	1.000-8	3.75	2.06	0.88	3.13	8.53	2.00	0.78
	2.50	0.69	1.000-8	3.75	2.06	0.88	3.38	8.78	2.00	0.78
5.00	2.00	1.13	1.000-8	4.25	2.94	0.88	3.13	9.18	2.50	0.92
	2.50	1.13	1.000-8	4.25	2.94	0.88	3.38	9.43	2.50	0.92
	3.00	1.13	1.000-8	4.25	2.94	0.88	3.38	9.43	2.50	0.92
	3.50	1.00	1.000-8	4.25	2.94	0.88	3.38	9.43	2.50	0.92
6.00	2.50	1.31	1.250-7	5.13	3.31	1.00	3.50	10.66	2.88	1.03
	3.00	1.31	1.250-7	5.13	3.31	1.00	3.50	10.66	2.88	1.03
	3.50	1.31	1.250-7	5.13	3.31	1.00	3.50	10.66	2.88	1.03
	4.00	1.25	1.250-7	5.13	3.31	1.00	3.50	10.66	2.88	1.03
7.00	3.00	2.13	1.500-6	5.88	3.75	1.06	3.81	11.92	3.00	1.17
	3.50	2.13	1.500-6	5.88	3.75	1.06	3.81	11.92	3.00	1.17
	4.00	1.75	1.500-6	5.88	3.75	1.06	3.81	11.92	3.00	1.17
	4.50	1.50	1.500-6	5.88	3.75	1.06	3.81	11.92	3.00	1.17
	5.00	1.13	1.500-6	5.88	3.75	1.06	3.81	11.92	3.00	1.17
8.00	3.50	1.56	1.500-6	6.63	4.25	1.19	3.94	13.00	3.50	1.26
	4.00	1.56	1.500-6	6.63	4.25	1.19	3.94	13.00	3.50	1.26
	4.50	1.56	1.500-6	6.63	4.25	1.19	3.94	13.00	3.50	1.26
	5.00	1.56	1.500-6	6.63	4.25	1.19	3.94	13.00	3.50	1.26
	5.50	1.38	1.500-6	6.63	4.25	1.19	3.94	13.00	3.50	1.26

+ Plus Stroke

See Mount 24 on page 50 for Port Dimensions

Mounting Style and Installation

Dimensions – NZ07 Head

Rectangular Flange Mount

ANSI MF1

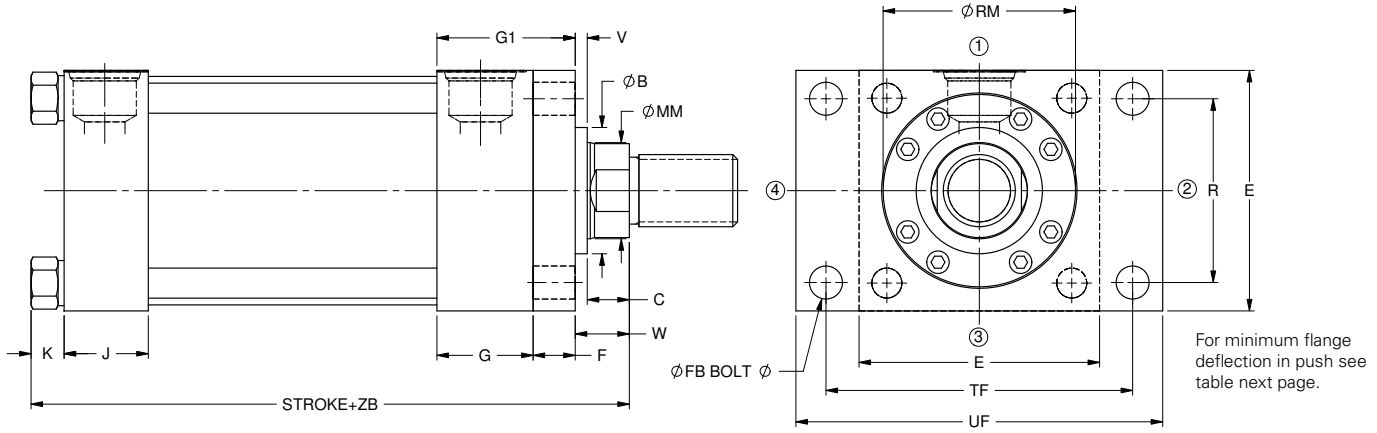

Bore	Rod Dia MM	B +.000/ -.002	C	E	G1	J	F	V	RM	W
1.50	0.63	1.124	0.38	2.50	2.13	1.50	0.38	0.25	-	0.63
	1.00	1.499	0.50	2.50	2.13	1.50	0.38	0.50	-	1.00
2.00	1.00	1.499	0.50	3.00	2.38	1.50	0.63	0.25	-	0.75
	1.38	1.999	0.63	3.00	2.38	1.50	0.63	0.38	-	1.00
2.50	1.00	1.499	0.50	3.50	2.38	1.50	0.63	0.25	2.63	0.75
	1.38	1.999	0.63	3.50	2.38	1.50	0.63	0.38	-	1.00
	1.75	2.374	0.75	3.50	2.38	1.50	0.63	0.50	-	1.25
3.25	1.38	1.999	0.63	4.50	2.75	1.75	0.75	0.25	3.25	0.88
	1.75	2.374	0.75	4.50	2.75	1.75	0.75	0.38	-	1.13
	2.00	2.624	0.88	4.50	2.75	1.75	0.75	0.38	-	1.25
4.00	1.75	2.374	0.75	5.00	2.88	1.75	0.88	0.25	3.88	1.00
	2.00	2.624	0.88	5.00	2.88	1.75	0.88	0.25	4.00	1.13
	2.50	3.124	1.00	5.00	2.88	1.75	0.88	0.38	4.44	1.38
5.00	2.00	2.624	0.88	6.50	2.88	1.75	0.88	0.25	4.00	1.13
	2.50	3.124	1.00	6.50	2.88	1.75	0.88	0.38	4.44	1.38
	3.00	3.749	1.00	6.50	2.88	1.75	0.88	0.38	5.25	1.38
	3.50	4.249	1.00	6.50	2.88	1.75	0.88	0.38	5.63	1.38
6.00	2.50	3.124	1.00	7.50	3.25	2.25	1.00	0.25	4.44	1.25
	3.00	3.749	1.00	7.50	3.25	2.25	1.00	0.25	5.25	1.25
	3.50	4.249	1.00	7.50	3.25	2.25	1.00	0.25	5.63	1.25
	4.00	4.749	1.00	7.50	3.25	2.25	1.00	0.25	6.44	1.25
7.00	3.00	3.749	1.00	8.50	3.75	2.75	1.00	0.25	5.25	1.25
	3.50	4.249	1.00	8.50	3.75	2.75	1.00	0.25	5.63	1.25
	4.00	4.749	1.00	8.50	3.75	2.75	1.00	0.25	6.44	1.25
	4.50	5.249	1.00	8.50	3.75	2.75	1.00	0.25	7.13	1.25
	5.00	5.749	1.00	8.50	3.75	2.75	1.00	0.25	7.56	1.25
8.00	3.50	4.249	1.00	9.50	4.00	3.00	1.00	0.25	5.63	1.25
	4.00	4.749	1.00	9.50	4.00	3.00	1.00	0.25	6.44	1.25
	4.50	5.249	1.00	9.50	4.00	3.00	1.00	0.25	7.13	1.25
	5.00	5.749	1.00	9.50	4.00	3.00	1.00	0.25	7.56	1.25
	5.50	6.249	1.00	9.50	4.00	3.00	1.00	0.25	8.38	1.25

+ Plus Stroke

Mounting Style and Installation

Dimensions – NZ07 Head

Rectangular Flange Mount

ANSI MF1

These mounts are ideal for straight line force transfer applications in which the cylinder is used in tension (pulling). The mounting surface should be flat, and the rod end cartridge should be piloted into it.

The frame on which the cylinder is mounted *must* be sufficiently rigid to resist bending moments.

NOTE

For strokes in excess of 30 inches, see "Stop tube selection" on page 77.

The force of the load should be perpendicular to the mounting surface and parallel to the centerline of the piston rod. For eccentric loads, the larger of the two available rods in each bore size is recommended. Stop tubes should also be considered.

The head rectangular mounts (NZ09) is recommended for heavy duty applications. Refer the table for recommended pressure ratings in push stroke. Use

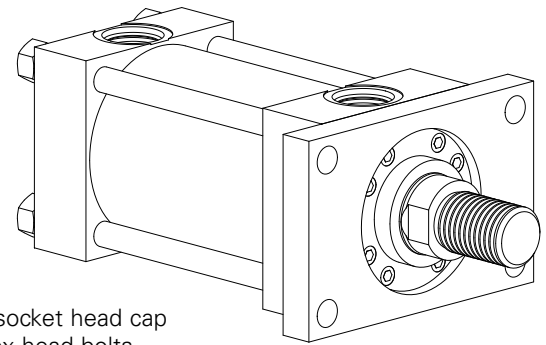

high tensile socket head cap screws or hex head bolts tightened to the manufacturer's recommended torque.

Bore Size	Recommended Pressure Rating in Push Stroke
1.50 to 4.00	3000 psi
5.00	1440 psi
6.00	1440 psi
7.00	1040 psi
8.00	800 psi

Bore	Rod Dia MM	FB	R	TF	UF	ZB+ Max	Piston Thick.	K
1.50	0.63	0.38	1.63	3.44	4.25	6.04	1.38	0.41
	1.00	0.38	1.63	3.44	4.25	6.41	1.38	0.41
2.00	1.00	0.50	2.05	4.13	5.13	6.56	1.38	0.55
	1.38	0.50	2.05	4.13	5.13	6.82	1.38	0.55
2.50	1.00	0.50	2.55	4.63	5.63	6.68	1.50	0.55
	1.38	0.50	2.55	4.63	5.63	6.94	1.50	0.55
	1.75	0.50	2.55	4.63	5.63	7.18	1.50	0.55
3.25	1.38	0.63	3.25	5.88	7.13	7.80	1.75	0.67
	1.75	0.63	3.25	5.88	7.13	8.05	1.75	0.67
	2.00	0.63	3.25	5.88	7.13	8.18	1.75	0.67
4.00	1.75	0.63	3.82	6.38	7.63	8.40	2.00	0.78
	2.00	0.63	3.82	6.38	7.63	8.53	2.00	0.78
	2.50	0.63	3.82	6.38	7.63	8.78	2.00	0.78
5.00	2.00	0.88	4.95	8.19	9.75	9.18	2.50	0.92
	2.50	0.88	4.95	8.19	9.75	9.43	2.50	0.92
	3.00	0.88	4.95	8.19	9.75	9.43	2.50	0.92
	3.50	0.88	4.95	8.19	9.75	9.43	2.50	0.92
6.00	2.50	1.00	5.73	9.44	11.25	10.66	2.88	1.03
	3.00	1.00	5.73	9.44	11.25	10.66	2.88	1.03
	3.50	1.00	5.73	9.44	11.25	10.66	2.88	1.03
	4.00	1.00	5.73	9.44	11.25	10.66	2.88	1.03
7.00	3.00	1.13	6.58	10.63	12.63	11.92	3.00	1.17
	3.50	1.13	6.58	10.63	12.63	11.92	3.00	1.17
	4.00	1.13	6.58	10.63	12.63	11.92	3.00	1.17
	4.50	1.13	6.58	10.63	12.63	11.92	3.00	1.17
	5.00	1.13	6.58	10.63	12.63	11.92	3.00	1.17
8.00	3.50	1.25	7.50	11.81	14.00	13.00	3.50	1.26
	4.00	1.25	7.50	11.81	14.00	13.00	3.50	1.26
	4.50	1.25	7.50	11.81	14.00	13.00	3.50	1.26
	5.00	1.25	7.50	11.81	14.00	13.00	3.50	1.26
	5.50	1.25	7.50	11.81	14.00	13.00	3.50	1.26

+ Plus Stroke

See Mount 24 on page 50 for Port Dimensions

Mounting Style and Installation

Dimensions – NZ08 Head Square

Flange Mount ANSI MF5

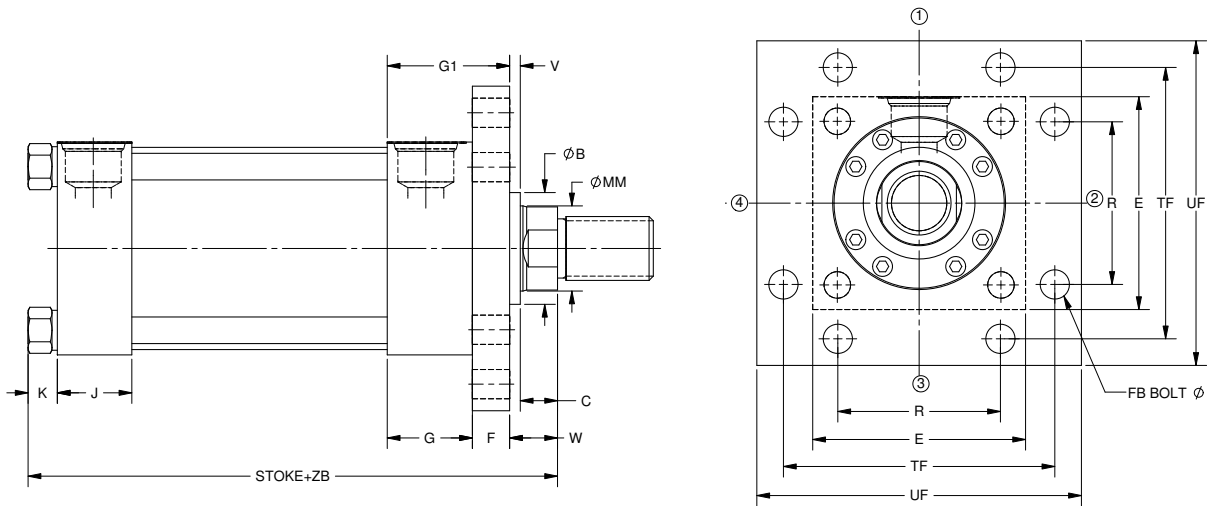

Bore	Rod Dia MM	B +0.000/-0.002	C	E	G1	J	F	V
1.50	0.63	1.124	0.38	2.50	2.13	1.50	0.38	0.25
	1.00	1.499	0.50	2.50	2.13	1.50	0.38	0.50
2.00	1.00	1.499	0.50	3.00	2.38	1.50	0.63	0.25
	1.38	1.999	0.63	3.00	2.38	1.50	0.63	0.38
2.50	1.00	1.499	0.50	3.50	2.38	1.50	0.63	0.25
	1.38	1.999	0.63	3.50	2.38	1.50	0.63	0.38
	1.75	2.374	0.75	3.50	2.38	1.50	0.63	0.50
3.25	1.38	1.999	0.63	4.50	2.75	1.75	0.75	0.25
	1.75	2.374	0.75	4.50	2.75	1.75	0.75	0.38
	2.00	2.624	0.88	4.50	2.75	1.75	0.75	0.38
4.00	1.75	2.374	0.75	5.00	2.88	1.75	0.88	0.25
	2.00	2.624	0.88	5.00	2.88	1.75	0.88	0.25
	2.50	3.124	1.00	5.00	2.88	1.75	0.88	0.38
5.00	2.00	2.624	0.88	6.50	2.88	1.75	0.88	0.25
	2.50	3.124	1.00	6.50	2.88	1.75	0.88	0.38
	3.00	3.749	1.00	6.50	2.88	1.75	0.88	0.38
	3.50	4.249	1.00	6.50	2.88	1.75	0.88	0.38
6.00	2.50	3.124	1.00	7.50	3.25	2.25	1.00	0.25
	3.00	3.749	1.00	7.50	3.25	2.25	1.00	0.25
	3.50	4.249	1.00	7.50	3.25	2.25	1.00	0.25
	4.00	4.749	1.00	7.50	3.25	2.25	1.00	0.25
7.00	3.00	3.749	1.00	8.50	3.75	2.75	1.00	0.25
	3.50	4.249	1.00	8.50	3.75	2.75	1.00	0.25
	4.00	4.749	1.00	8.50	3.75	2.75	1.00	0.25
	4.50	5.249	1.00	8.50	3.75	2.75	1.00	0.25
	5.00	5.749	1.00	8.50	3.75	2.75	1.00	0.25
8.00	3.50	4.249	1.00	9.50	4.00	3.00	1.00	0.25
	4.00	4.749	1.00	9.50	4.00	3.00	1.00	0.25
	4.50	5.249	1.00	9.50	4.00	3.00	1.00	0.25
	5.00	5.749	1.00	9.50	4.00	3.00	1.00	0.25
	5.50	6.249	1.00	9.50	4.00	3.00	1.00	0.25

+ Plus Stroke

Mounting Style and Installation Dimensions – NZ08 Head Square Flange Mount ANSI MF5

These mounts are ideal for straight line force transfer applications in which the cylinder is used in tension (pulling).

The mounting surface should be flat, and the rod end cartridge should be piloted into it.

The frame on which the cylinder is mounted *must* be sufficiently rigid to resist bending moments.

NOTE

For strokes in excess of 30 inches, see “Stop tube selection” on page 77.

WARNING

The force of the load should be perpendicular to the mounting surface and parallel to the centerline of the piston rod. For eccentric loads, the larger of the two available rods in each bore size is recommended. Stop tubes should also be considered.

The head rectangular mounts (NZ09) is recommended for heavy duty applications.

Use high tensile socket head cap screws or hex head bolts tightened to the manufacturer’s recommended torque.

WARNING

Failure to mount the cylinder correctly on the frame may result in death, bodily injury and/or property damage.

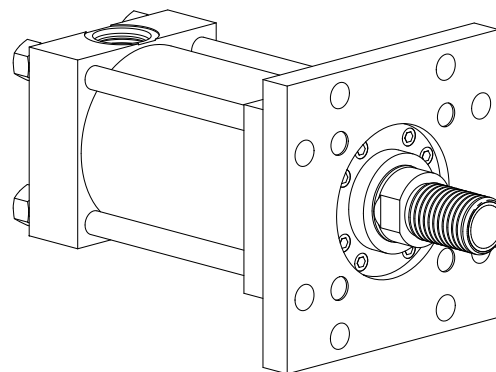

Bore	Rod Dia MM	W	FB	R	TF	UF	ZB+ Max	Piston Thick.	K
1.50	0.63	0.63	0.38	1.63	3.44	4.25	6.04	1.38	0.41
	1.00	1.00	0.38	1.63	3.44	4.25	6.41	1.38	0.41
2.00	1.00	0.75	0.50	2.05	4.13	5.13	6.56	1.38	0.55
	1.38	1.00	0.50	2.05	4.13	5.13	6.82	1.38	0.55
2.50	1.00	0.75	0.50	2.55	4.63	5.63	6.68	1.50	0.55
	1.38	1.00	0.50	2.55	4.63	5.63	6.94	1.50	0.55
	1.75	1.25	0.50	2.55	4.63	5.63	7.18	1.50	0.55
3.25	1.38	0.88	0.63	3.25	5.88	7.13	7.80	1.75	0.67
	1.75	1.13	0.63	3.25	5.88	7.13	8.05	1.75	0.67
	2.00	1.25	0.63	3.25	5.88	7.13	8.18	1.75	0.67
4.00	1.75	1.00	0.63	3.82	6.38	7.63	8.40	2.00	0.78
	2.00	1.13	0.63	3.82	6.38	7.63	8.53	2.00	0.78
	2.50	1.38	0.63	3.82	6.38	7.63	8.78	2.00	0.78
5.00	2.00	1.13	0.88	4.95	8.19	9.75	9.18	2.50	0.92
	2.50	1.38	0.88	4.95	8.19	9.75	9.43	2.50	0.92
	3.00	1.38	0.88	4.95	8.19	9.75	9.43	2.50	0.92
	3.50	1.38	0.88	4.95	8.19	9.75	9.43	2.50	0.92
6.00	2.50	1.25	1.00	5.73	9.44	11.25	10.66	2.88	1.03
	3.00	1.25	1.00	5.73	9.44	11.25	10.66	2.88	1.03
	3.50	1.25	1.00	5.73	9.44	11.25	10.66	2.88	1.03
	4.00	1.25	1.00	5.73	9.44	11.25	10.66	2.88	1.03
7.00	3.00	1.25	1.13	6.58	10.63	12.63	11.92	3.00	1.17
	3.50	1.25	1.13	6.58	10.63	12.63	11.92	3.00	1.17
	4.00	1.25	1.13	6.58	10.63	12.63	11.92	3.00	1.17
	4.50	1.25	1.13	6.58	10.63	12.63	11.92	3.00	1.17
	5.00	1.25	1.13	6.58	10.63	12.63	11.92	3.00	1.17
8.00	3.50	1.25	1.25	7.50	11.81	14.00	13.00	3.50	1.26
	4.00	1.25	1.25	7.50	11.81	14.00	13.00	3.50	1.26
	4.50	1.25	1.25	7.50	11.81	14.00	13.00	3.50	1.26
	5.00	1.25	1.25	7.50	11.81	14.00	13.00	3.50	1.26
	5.50	1.25	1.25	7.50	11.81	14.00	13.00	3.50	1.26

+ Plus Stroke

See Mount 24 on page 50 for Port Dimensions

Mounting Style and Installation

Dimensions – NZ09 Head

Rectangular Mount ANSI ME5

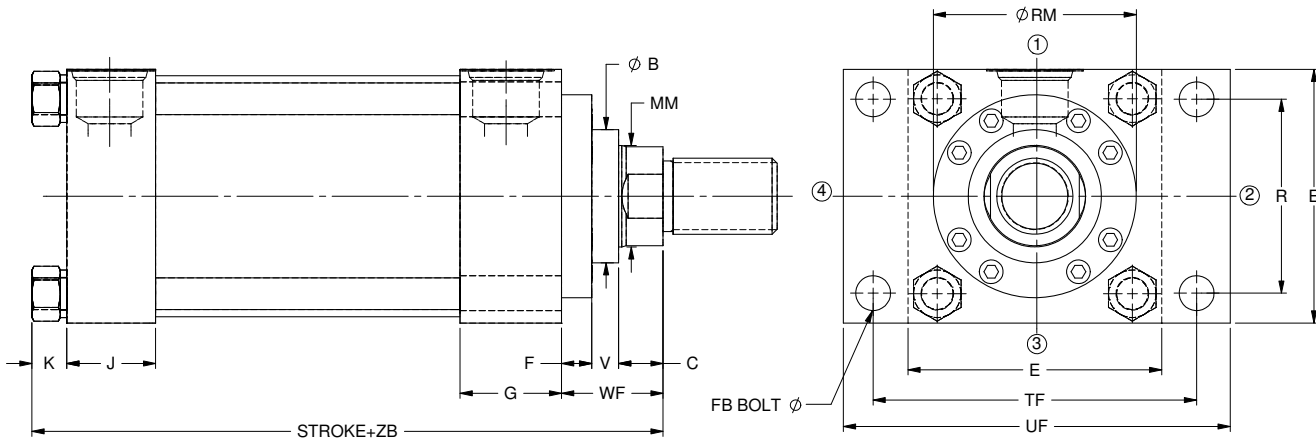

Bore	Rod Dia MM	B +.000/-.002	C	E	G	J	F Max	V	WF
1.50	0.63	1.124	0.38	2.50	1.75	1.50	0.34	0.28	1.00
	1.00	1.499	0.50	2.50	1.75	1.50	0.50	0.38	1.38
2.00	1.00	1.499	0.50	3.00	1.75	1.50	0.50	0.38	1.38
	1.38	1.999	0.63	3.00	1.75	1.50	0.59	0.41	1.63
2.50	1.00	1.499	0.50	3.50	1.75	1.50	0.50	0.38	1.38
	1.38	1.999	0.63	3.50	1.75	1.50	0.59	0.41	1.63
	1.75	2.374	0.75	3.50	1.75	1.50	0.59	0.54	1.88
3.25	1.38	1.999	0.63	4.50	2.00	1.75	0.59	0.41	1.63
	1.75	2.374	0.75	4.50	2.00	1.75	0.59	0.54	1.88
	2.00	2.624	0.88	4.50	2.00	1.75	0.59	0.53	2.00
4.00	1.75	2.374	0.75	5.00	2.00	1.75	0.59	0.54	1.88
	2.00	2.624	0.88	5.00	2.00	1.75	0.59	0.53	2.00
	2.50	3.124	1.00	5.00	2.00	1.75	0.59	0.66	2.25
5.00	2.00	2.624	0.88	6.50	2.00	1.75	0.59	0.53	2.00
	2.50	3.124	1.00	6.50	2.00	1.75	0.59	0.66	2.25
	3.00	3.749	1.00	6.50	2.00	1.75	0.72	0.53	2.25
	3.50	4.249	1.00	6.50	2.00	1.75	0.72	0.53	2.25
6.00	2.50	3.124	1.00	7.50	2.25	2.25	0.59	0.66	2.25
	3.00	3.749	1.00	7.50	2.25	2.25	0.72	0.53	2.25
	3.50	4.249	1.00	7.50	2.25	2.25	0.72	0.53	2.25
	4.00	4.749	1.00	7.50	2.25	2.25	0.88	0.38	2.25
7.00	3.00	3.749	1.00	8.50	2.75	2.75	0.72	0.53	2.25
	3.50	4.249	1.00	8.50	2.75	2.75	0.72	0.53	2.25
	4.00	4.749	1.00	8.50	2.75	2.75	0.88	0.38	2.25
	4.50	5.249	1.00	8.50	2.75	2.75	0.88	0.38	2.25
	5.00	5.749	1.00	8.50	2.75	2.75	0.88	0.38	2.25
8.00	3.50	4.249	1.00	9.50	3.00	3.00	0.72	0.53	2.25
	4.00	4.749	1.00	9.50	3.00	3.00	0.88	0.38	2.25
	4.50	5.249	1.00	9.50	3.00	3.00	0.88	0.38	2.25
	5.00	5.749	1.00	9.50	3.00	3.00	0.88	0.38	2.25
	5.50	6.249	1.00	9.50	3.00	3.00	0.88	0.38	2.25

+ Plus Stroke

Mounting Style and Installation

Dimensions – NZ09 Head

Rectangular Mount ANSI ME5

These mounts are ideal for straight line force transfer applications in which the cylinder is used in tension (pulling). The mounting surface should be flat, and the rod end cartridge should be piloted into it.

The frame on which the cylinder is mounted *must* be sufficiently rigid to resist bending moments.

NOTE

For strokes in excess of 30 inches, see "Stop tube

selection" on page 77.

WARNING

The force of the load should be perpendicular to the mounting surface and parallel to the centerline of the piston rod. For eccentric loads, the larger of the two available rods in each bore size is recommended. Stop tubes should also be considered.

The head rectangular mounts (NZ09) is recommended for heavy duty applications. Use high tensile socket head cap screws or hex head bolts

tightened to the manufacturer's recommended torque.

WARNING

Failure to mount the cylinder correctly on the frame may result in death, bodily injury and/or property damage.

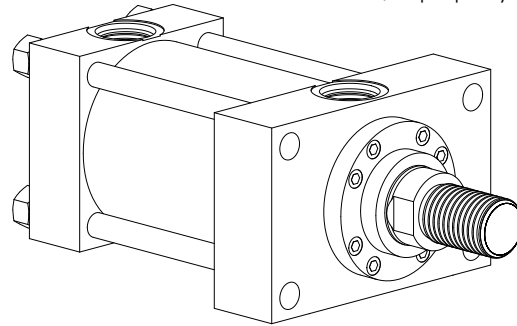

Bore	Rod Dia MM	RM	FB	R	TF	UF	ZB+ Max	Piston Thick.	K
1.50	0.63	2.38	0.38	1.63	3.44	4.25	6.04	1.38	0.41
	1.00	2.63	0.38	1.63	3.44	4.25	6.41	1.38	0.41
2.00	1.00	2.63	0.50	2.05	4.13	5.13	6.56	1.38	0.55
	1.38	3.25	0.50	2.05	4.13	5.13	6.82	1.38	0.55
2.50	1.00	2.63	0.50	2.55	4.63	5.63	6.68	1.50	0.55
	1.38	3.25	0.50	2.55	4.63	5.63	6.94	1.50	0.55
	1.75	3.88	0.50	2.55	4.63	5.63	7.18	1.50	0.55
3.25	1.38	3.25	0.63	3.25	5.88	7.13	7.80	1.75	0.67
	1.75	3.88	0.63	3.25	5.88	7.13	8.05	1.75	0.67
	2.00	4.00	0.63	3.25	5.88	7.13	8.18	1.75	0.67
4.00	1.75	3.88	0.63	3.82	6.38	7.63	8.40	2.00	0.78
	2.00	4.00	0.63	3.82	6.38	7.63	8.53	2.00	0.78
	2.50	4.44	0.63	3.82	6.38	7.63	8.78	2.00	0.78
5.00	2.00	4.00	0.88	4.95	8.19	9.75	9.18	2.50	0.92
	2.50	4.44	0.88	4.95	8.19	9.75	9.43	2.50	0.92
	3.00	5.25	0.88	4.95	8.19	9.75	9.43	2.50	0.92
	3.50	5.63	0.88	4.95	8.19	9.75	9.43	2.50	0.92
6.00	2.50	4.44	1.00	5.73	9.44	11.25	10.66	2.88	1.03
	3.00	5.25	1.00	5.73	9.44	11.25	10.66	2.88	1.03
	3.50	5.63	1.00	5.73	9.44	11.25	10.66	2.88	1.03
	4.00	6.44	1.00	5.73	9.44	11.25	10.66	2.88	1.03
7.00	3.00	5.25	1.13	6.58	10.63	12.63	11.92	3.00	1.17
	3.50	5.63	1.13	6.58	10.63	12.63	11.92	3.00	1.17
	4.00	6.44	1.13	6.58	10.63	12.63	11.92	3.00	1.17
	4.50	7.13	1.13	6.58	10.63	12.63	11.92	3.00	1.17
	5.00	7.56	1.13	6.58	10.63	12.63	11.92	3.00	1.17
8.00	3.50	5.63	1.25	7.50	11.81	14.00	13.00	3.50	1.26
	4.00	6.44	1.25	7.50	11.81	14.00	13.00	3.50	1.26
	4.50	7.13	1.25	7.50	11.81	14.00	13.00	3.50	1.26
	5.00	7.56	1.25	7.50	11.81	14.00	13.00	3.50	1.26
	5.50	8.38	1.25	7.50	11.81	14.00	13.00	3.50	1.26

+ Plus Stroke

See Mount 24 on page 50 for Port Dimensions

Mounting Style and Installation

Dimensions – NZ10 Cap Fixed

Clevis Mount ANSI MP1

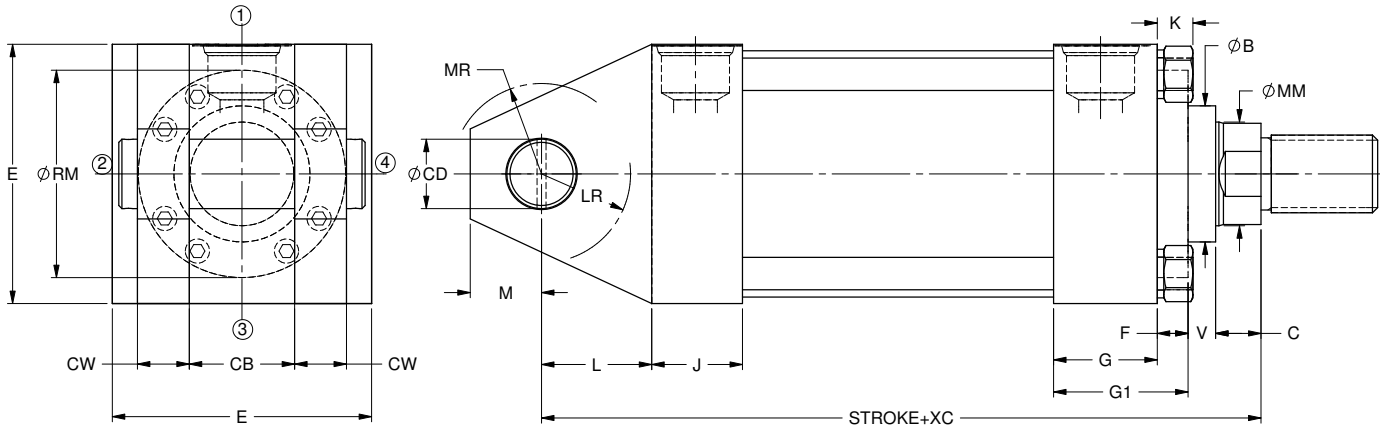

Bore	Rod Dia MM	B +0.000/-0.002	C	E	G	J	F	V	RM	L
1.50	0.63	1.124	0.38	2.50	1.75	1.50	0.38	0.25	-	0.75
	1.00	1.499	0.50	2.50	1.75	1.50	0.38	0.50	-	0.75
2.00	1.00	1.499	0.50	3.00	1.75	1.50	0.63	0.25	-	1.25
	1.38	1.999	0.63	3.00	1.75	1.50	0.63	0.38	-	1.25
2.50	1.00	1.499	0.50	3.50	1.75	1.50	0.50	0.38	2.63	1.25
	1.38	1.999	0.63	3.50	1.75	1.50	0.63	0.38	-	1.25
	1.75	2.374	0.75	3.50	1.75	1.50	0.63	0.50	-	1.25
3.25	1.38	1.999	0.63	4.50	2.00	1.75	0.59	0.41	3.25	1.50
	1.75	2.374	0.75	4.50	2.00	1.75	0.75	0.38	-	1.50
	2.00	2.624	0.88	4.50	2.00	1.75	0.75	0.38	-	1.50
4.00	1.75	2.374	0.75	5.00	2.00	1.75	0.59	0.53	3.88	2.13
	2.00	2.624	0.88	5.00	2.00	1.75	0.59	0.53	4.00	2.13
	2.50	3.124	1.00	5.00	2.00	1.75	0.59	0.66	4.44	2.13
5.00	2.00	2.624	0.88	6.50	2.00	1.75	0.59	0.53	4.00	2.25
	2.50	3.124	1.00	6.50	2.00	1.75	0.59	0.66	4.44	2.25
	3.00	3.749	1.00	6.50	2.00	1.75	0.72	0.53	5.25	2.25
	3.50	4.249	1.00	6.50	2.00	1.75	0.72	0.53	5.63	2.25
6.00	2.50	3.124	1.00	7.50	2.25	2.25	0.59	0.66	4.44	2.50
	3.00	3.749	1.00	7.50	2.25	2.25	0.72	0.53	5.25	2.50
	3.50	4.249	1.00	7.50	2.25	2.25	0.72	0.53	5.63	2.50
	4.00	4.749	1.00	7.50	2.25	2.25	0.88	0.38	6.44	2.50
7.00	3.00	3.749	1.00	8.50	2.75	2.75	0.72	0.53	5.25	3.00
	3.50	4.249	1.00	8.50	2.75	2.75	0.72	0.53	5.63	3.00
	4.00	4.749	1.00	8.50	2.75	2.75	0.88	0.38	6.44	3.00
	4.50	5.249	1.00	8.50	2.75	2.75	0.88	0.38	7.13	3.00
	5.00	5.749	1.00	8.50	2.75	2.75	0.88	0.38	7.56	3.00
8.00	3.50	4.249	1.00	9.50	3.00	3.00	0.72	0.53	5.63	3.25
	4.00	4.749	1.00	9.50	3.00	3.00	0.88	0.38	6.44	3.25
	4.50	5.249	1.00	9.50	3.00	3.00	0.88	0.38	7.13	3.25
	5.00	5.749	1.00	9.50	3.00	3.00	0.88	0.38	7.56	3.25
	5.50	6.249	1.00	9.50	3.00	3.00	0.88	0.38	8.38	3.25

+ Plus Stroke

Mounting Style and Installation

Dimensions – NZ10 Cap Fixed Clevis Mount ANSI MP1

These mounts are for applications in which the machine member travels in a curved path within one plane.

These mounts can be used both in compression (push) and tension (pull). Care *must* be exercised to prevent rod buckling in compression applications with long strokes. See page 80 for stroke limitations.

NOTE

For strokes in excess of 24 inches, see “Stop tube selection” on page 77.

WARNING

The centerline of the machine member that attaches to the swivel pin must be perpendicular to the centerline of the piston rod and the curved path must be in one plane only. Any misalignment will cause excess side loading on the bearing and piston. This will lead to premature failure.

For applications with small amounts of misalignment, consider the spherical bearing mount, as shown in the NZ11

WARNING

Failure to mount the cylinder correctly on the frame may result in death, bodily injury and/or property damage.

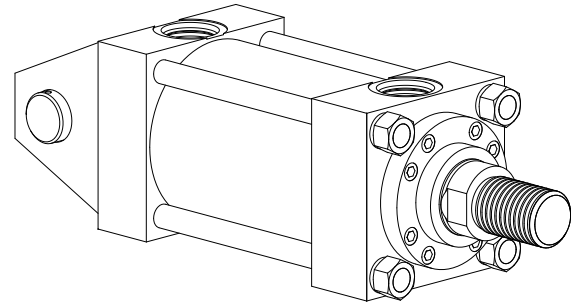

Bore	Rod Dia MM	M	CB	CD	CW	LR	MR	XC+	Piston Thick.	K
1.50	0.63	0.50	0.75	0.50	0.50	0.56	0.56	6.38	1.38	0.41
	1.00	0.50	0.75	0.50	0.50	0.56	0.56	6.75	1.38	0.41
2.00	1.00	0.75	1.25	0.75	0.63	1.06	1.06	7.25	1.38	0.55
	1.38	0.75	1.25	0.75	0.63	1.06	1.06	7.50	1.38	0.55
2.50	1.00	0.75	1.25	0.75	0.63	1.06	1.06	7.38	1.50	0.55
	1.38	0.75	1.25	0.75	0.63	1.06	1.06	7.63	1.50	0.55
	1.75	0.75	1.25	0.75	0.63	1.06	1.06	7.88	1.50	0.55
3.25	1.38	1.00	1.50	1.00	0.75	1.25	1.13	8.63	1.75	0.67
	1.75	1.00	1.50	1.00	0.75	1.25	1.13	8.88	1.75	0.67
	2.00	1.00	1.50	1.00	0.75	1.25	1.13	9.00	1.75	0.67
4.00	1.75	1.38	2.00	1.38	1.00	1.88	1.75	9.75	2.00	0.78
	2.00	1.38	2.00	1.38	1.00	1.88	1.75	9.88	2.00	0.78
	2.50	1.38	2.00	1.38	1.00	1.88	1.75	10.13	2.00	0.78
5.00	2.00	1.75	2.50	1.75	1.25	1.94	1.88	10.50	2.50	0.92
	2.50	1.75	2.50	1.75	1.25	1.94	1.88	10.75	2.50	0.92
	3.00	1.75	2.50	1.75	1.25	1.94	1.88	10.75	2.50	0.92
	3.50	1.75	2.50	1.75	1.25	1.94	1.88	10.75	2.50	0.92
6.00	2.50	2.00	2.50	2.00	1.25	2.06	2.13	12.13	2.88	1.03
	3.00	2.00	2.50	2.00	1.25	2.06	2.13	12.13	2.88	1.03
	3.50	2.00	2.50	2.00	1.25	2.06	2.13	12.13	2.88	1.03
	4.00	2.00	2.50	2.00	1.25	2.06	2.13	12.13	2.88	1.03
7.00	3.00	2.50	3.00	2.50	1.50	2.56	2.50	13.75	3.00	1.17
	3.50	2.50	3.00	2.50	1.50	2.56	2.50	13.75	3.00	1.17
	4.00	2.50	3.00	2.50	1.50	2.56	2.50	13.75	3.00	1.17
	4.50	2.50	3.00	2.50	1.50	2.56	2.50	13.75	3.00	1.17
	5.00	2.50	3.00	2.50	1.50	2.56	2.50	13.75	3.00	1.17
8.00	3.50	2.75	3.00	3.00	1.50	2.69	2.75	15.00	3.50	1.26
	4.00	2.75	3.00	3.00	1.50	2.69	2.75	15.00	3.50	1.26
	4.50	2.75	3.00	3.00	1.50	2.69	2.75	15.00	3.50	1.26
	5.00	2.75	3.00	3.00	1.50	2.69	2.75	15.00	3.50	1.26
	5.50	2.75	3.00	3.00	1.50	2.69	2.75	15.00	3.50	1.26

+ Plus Stroke

See Mount 24 on page 50 for Port Dimensions

Mounting Style and Installation

Dimensions – NZ11 Cap Spherical Bearing Mount

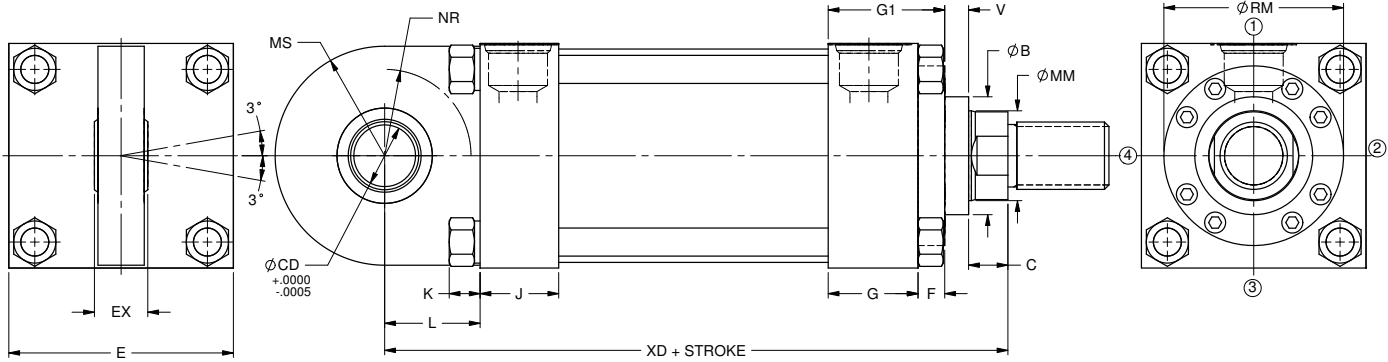

Max. operating pressure

Bore	PSI
1.50	1650
2.00	2000
2.50	1400
3.25	1500
4.00	1750
5.00	1900
6.00	1700

Bore	Rod Dia MM	B +0.000/-0.002	C	E	G	J	F	V
1.50	0.63	1.124	0.38	2.50	1.75	1.50	0.38	0.25
	1.00	1.499	0.50	2.50	1.75	1.50	0.38	0.50
2.00	1.00	1.499	0.50	3.00	1.75	1.50	0.63	0.25
	1.38	1.999	0.63	3.00	1.75	1.50	0.63	0.38
2.50	1.00	1.499	0.50	3.50	1.75	1.50	0.50	0.38
	1.38	1.999	0.63	3.50	1.75	1.50	0.63	0.38
	1.75	2.374	0.75	3.50	1.75	1.50	0.63	0.50
3.25	1.38	1.999	0.63	4.50	2.00	1.75	0.59	0.41
	1.75	2.374	0.75	4.50	2.00	1.75	0.75	0.38
	2.00	2.624	0.88	4.50	2.00	1.75	0.75	0.38
4.00	1.75	2.374	0.75	5.00	2.00	1.75	0.59	0.53
	2.00	2.624	0.88	5.00	2.00	1.75	0.59	0.53
	2.50	3.124	1.00	5.00	2.00	1.75	0.59	0.66
5.00	2.00	2.624	0.88	6.50	2.00	1.75	0.59	0.53
	2.50	3.124	1.00	6.50	2.00	1.75	0.59	0.66
	3.00	3.749	1.00	6.50	2.00	1.75	0.72	0.53
	3.50	4.249	1.00	6.50	2.00	1.75	0.72	0.53
6.00	2.50	3.124	1.00	7.50	2.25	2.25	0.59	0.66
	3.00	3.749	1.00	7.50	2.25	2.25	0.72	0.53
	3.50	4.249	1.00	7.50	2.25	2.25	0.72	0.53
	4.00	4.749	1.00	7.50	2.25	2.25	0.88	0.38

+ Plus Stroke

Mounting Style and Installation Dimensions – NZ11 Cap Spherical Bearing Mount

This mount is for applications in which the machine member travels in a curved path in one plane where some misalignment is unavoidable. The amount of allowable misalignment can be calculated. This mount can be used both in compression (push) and tension (pull) applications. Care *must* be exercised to prevent rod buckling in compression applications with long strokes.

NOTE

For strokes in excess of 24 inches, see “Stop tube selection” on page 77.

WARNING

Maximum radial static and dynamic bearing loads must not exceed the recommended ratings shown in the following table. Angle Z is the recommended maximum angle of misalignment.

To find the maximum recommended X distance, multiply the distance between pivot mounting holes (see NZ11 dimensional drawing) by the tangent of angle Z.

WARNING

Failure to mount the cylinder correctly on the frame may result in death, bodily injury and/or property damage.

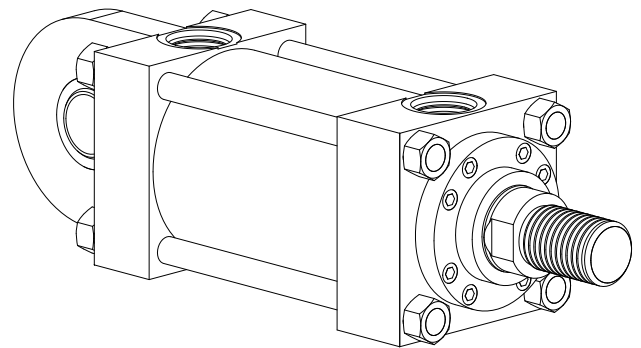
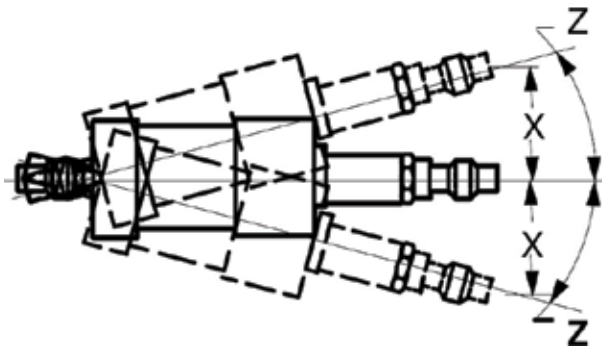

Bore	Rod Dia MM	RM	L	CD +.0000 -.0005	EX	NR	MS	XD+	Piston Thick.	K
1.50	0.63	-	0.75	0.5000	0.44	0.63	0.94	6.38	1.38	0.41
	1.00	-	0.75	0.5000	0.44	0.63	0.94	6.75	1.38	0.41
2.00	1.00	-	1.25	0.7500	0.66	1.00	1.38	7.25	1.38	0.55
	1.38	-	1.25	0.7500	0.66	1.00	1.38	7.50	1.38	0.55
2.50	1.00	2.63	1.25	0.7500	0.66	1.00	1.38	7.38	1.50	0.55
	1.38	-	1.25	0.7500	0.66	1.00	1.38	7.63	1.50	0.55
	1.75	-	1.25	0.7500	0.66	1.00	1.38	7.88	1.50	0.55
3.25	1.38	3.25	1.50	1.0000	0.88	1.25	1.69	8.63	1.75	0.67
	1.75	-	1.50	1.0000	0.88	1.25	1.69	8.88	1.75	0.67
	2.00	-	1.50	1.0000	0.88	1.25	1.69	9.00	1.75	0.67
4.00	1.75	3.88	2.13	1.3750	1.19	1.63	2.44	9.75	2.00	0.78
	2.00	4.00	2.13	1.3750	1.19	1.63	2.44	9.88	2.00	0.78
	2.50	4.44	2.13	1.3750	1.19	1.63	2.44	10.13	2.00	0.78
5.00	2.00	4.00	2.25	1.7500	1.53	2.06	2.88	10.50	2.50	0.92
	2.50	4.44	2.25	1.7500	1.53	2.06	2.88	10.75	2.50	0.92
	3.00	5.25	2.25	1.7500	1.53	2.06	2.88	10.75	2.50	0.92
	3.50	5.63	2.25	1.7500	1.53	2.06	2.88	10.75	2.50	0.92
6.00	2.50	4.44	2.50	2.0000	1.75	2.38	3.31	12.13	2.88	1.03
	3.00	5.25	2.50	2.0000	1.75	2.38	3.31	12.13	2.88	1.03
	3.50	5.63	2.50	2.0000	1.75	2.38	3.31	12.13	2.88	1.03
	4.00	6.44	2.50	2.0000	1.75	2.38	3.31	12.13	2.88	1.03

+ Plus Stroke

See Mount 24 on page 50 for Port Dimensions

Mounting Style and Installation

Dimensions – NZ12 Cap

Rectangular Flange Mount

ANSI MF2

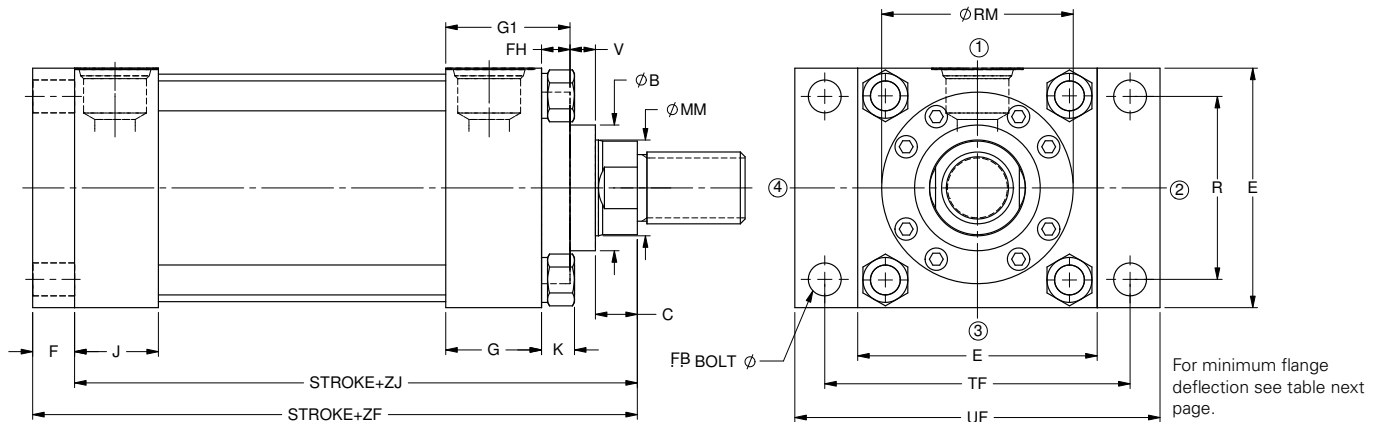

Bore	Rod Dia MM	B +.000/- .002	C	E	G	J	FH	RM	V	F
1.50	0.63	1.124	0.38	2.50	1.75	1.50	0.38	-	0.25	0.38
	1.00	1.499	0.50	2.50	1.75	1.50	0.38	-	0.50	0.38
2.00	1.00	1.499	0.50	3.00	1.75	1.50	0.63	-	0.25	0.63
	1.38	1.999	0.63	3.00	1.75	1.50	0.63	-	0.38	0.63
2.50	1.00	1.499	0.50	3.50	1.75	1.50	0.50	2.63	0.38	0.63
	1.38	1.999	0.63	3.50	1.75	1.50	0.63	-	0.38	0.63
	1.75	2.374	0.75	3.50	1.75	1.50	0.63	-	0.50	0.63
3.25	1.38	1.999	0.63	4.50	2.00	1.75	0.59	3.25	0.41	0.75
	1.75	2.374	0.75	4.50	2.00	1.75	0.75	-	0.38	0.75
	2.00	2.624	0.88	4.50	2.00	1.75	0.75	-	0.38	0.75
4.00	1.75	2.374	0.75	5.00	2.00	1.75	0.59	3.88	0.53	0.88
	2.00	2.624	0.88	5.00	2.00	1.75	0.59	4.00	0.53	0.88
	2.50	3.124	1.00	5.00	2.00	1.75	0.59	4.44	0.66	0.88
5.00	2.00	2.624	0.88	6.50	2.00	1.75	0.59	4.00	0.53	0.88
	2.50	3.124	1.00	6.50	2.00	1.75	0.59	4.44	0.66	0.88
	3.00	3.749	1.00	6.50	2.00	1.75	0.72	5.25	0.53	0.88
	3.50	4.249	1.00	6.50	2.00	1.75	0.72	5.63	0.53	0.88
6.00	2.50	3.124	1.00	7.50	2.25	2.25	0.59	4.44	0.66	1.00
	3.00	3.749	1.00	7.50	2.25	2.25	0.72	5.25	0.53	1.00
	3.50	4.249	1.00	7.50	2.25	2.25	0.72	5.63	0.53	1.00
	4.00	4.749	1.00	7.50	2.25	2.25	0.88	6.44	0.38	1.00
7.00	3.00	3.749	1.00	8.50	2.75	2.75	0.72	5.25	0.53	1.00
	3.50	4.249	1.00	8.50	2.75	2.75	0.72	5.63	0.53	1.00
	4.00	4.749	1.00	8.50	2.75	2.75	0.88	6.44	0.38	1.00
	4.50	5.249	1.00	8.50	2.75	2.75	0.88	7.13	0.38	1.00
	5.00	5.749	1.00	8.50	2.75	2.75	0.88	7.56	0.38	1.00
8.00	3.50	4.249	1.00	9.50	3.00	3.00	0.72	5.63	0.53	1.00
	4.00	4.749	1.00	9.50	3.00	3.00	0.88	6.44	0.38	1.00
	4.50	5.249	1.00	9.50	3.00	3.00	0.88	7.13	0.38	1.00
	5.00	5.749	1.00	9.50	3.00	3.00	0.88	7.56	0.38	1.00
	5.50	6.249	1.00	9.50	3.00	3.00	0.88	8.38	0.38	1.00

+ Plus Stroke

Mounting Style and Installation

Dimensions – NZ12 Cap

Rectangular Flange Mount

ANSI MF2

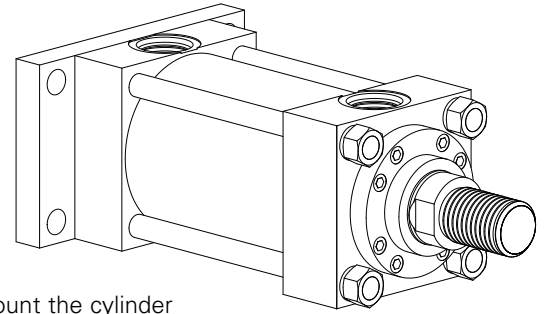

These mounts are ideal for straight line force transfer applications in which the cylinder is used in compression (pushing), as in push presses.

For tension applications (pulling), a head rectangular mount is more appropriate.

NOTE

For strokes in excess of 30 inches, see "Stop tube selection" on page 77.

WARNING

The frame on which the cylinder is mounted must be sufficiently rigid to resist bending moments.

The cap rectangular mounts (NZ14) is recommended for heavy duty applications. Refer to the table for recommended pressure ratings in pull stroke.

Use high tensile socket head cap screws or hex head bolts tightened to the manufacturer's recommended torque.

WARNING

Failure to mount the cylinder correctly on the frame may result in death, bodily injury and/or property damage.

Bore Size	Recommended Pressure Rating in Pull Stroke
1.50 to 4.00	3000 psi
5.00	1800 psi
6.00	1800 psi
7.00	1300 psi
8.00	1000 psi

Bore	Rod Dia MM	FB	R	TF	UF	ZF+ Max	ZJ+ Max	Piston Thick.	K
1.50	0.63	0.38	1.63	3.44	4.25	6.00	5.63	1.38	0.41
	1.00	0.38	1.63	3.44	4.25	6.38	6.00	1.38	0.41
2.00	1.00	0.50	2.05	4.13	5.13	6.63	6.00	1.38	0.55
	1.38	0.50	2.05	4.13	5.13	6.88	6.26	1.38	0.55
2.50	1.00	0.50	2.55	4.63	5.63	6.75	6.13	1.50	0.55
	1.38	0.50	2.55	4.63	5.63	7.00	6.38	1.50	0.55
	1.75	0.50	2.55	4.63	5.63	7.25	6.63	1.50	0.55
3.25	1.38	0.63	3.25	5.88	7.13	7.88	7.13	1.75	0.67
	1.75	0.63	3.25	5.88	7.13	8.13	7.38	1.75	0.67
	2.00	0.63	3.25	5.88	7.13	8.25	7.50	1.75	0.67
4.00	1.75	0.63	3.82	6.38	7.63	8.50	7.63	2.00	0.78
	2.00	0.63	3.82	6.38	7.63	8.63	7.75	2.00	0.78
	2.50	0.63	3.82	6.38	7.63	8.88	8.00	2.00	0.78
5.00	2.00	0.88	4.95	8.19	9.75	9.13	8.25	2.50	0.92
	2.50	0.88	4.95	8.19	9.75	9.38	8.50	2.50	0.92
	3.00	0.88	4.95	8.19	9.75	9.38	8.50	2.50	0.92
	3.50	0.88	4.95	8.19	9.75	9.38	8.50	2.50	0.92
6.00	2.50	1.00	5.73	9.44	11.25	10.63	9.63	2.88	1.03
	3.00	1.00	5.73	9.44	11.25	10.63	9.63	2.88	1.03
	3.50	1.00	5.73	9.44	11.25	10.63	9.63	2.88	1.03
	4.00	1.00	5.73	9.44	11.25	10.63	9.63	2.88	1.03
7.00	3.00	1.13	6.58	10.63	12.63	11.75	10.75	3.00	1.17
	3.50	1.13	6.58	10.63	12.63	11.75	10.75	3.00	1.17
	4.00	1.13	6.58	10.63	12.63	11.75	10.75	3.00	1.17
	4.50	1.13	6.58	10.63	12.63	11.75	10.75	3.00	1.17
	5.00	1.13	6.58	10.63	12.63	11.75	10.75	3.00	1.17
8.00	3.50	1.25	7.50	11.81	14.00	12.75	11.75	3.50	1.26
	4.00	1.25	7.50	11.81	14.00	12.75	11.75	3.50	1.26
	4.50	1.25	7.50	11.81	14.00	12.75	11.75	3.50	1.26
	5.00	1.25	7.50	11.81	14.00	12.75	11.75	3.50	1.26
	5.50	1.25	7.50	11.81	14.00	12.75	11.75	3.50	1.26

+ Plus Stroke

See Mount 24 on page 50 for Port Dimensions

Mounting Style and Installation

Dimensions – Flange Mount

ANSI MF6

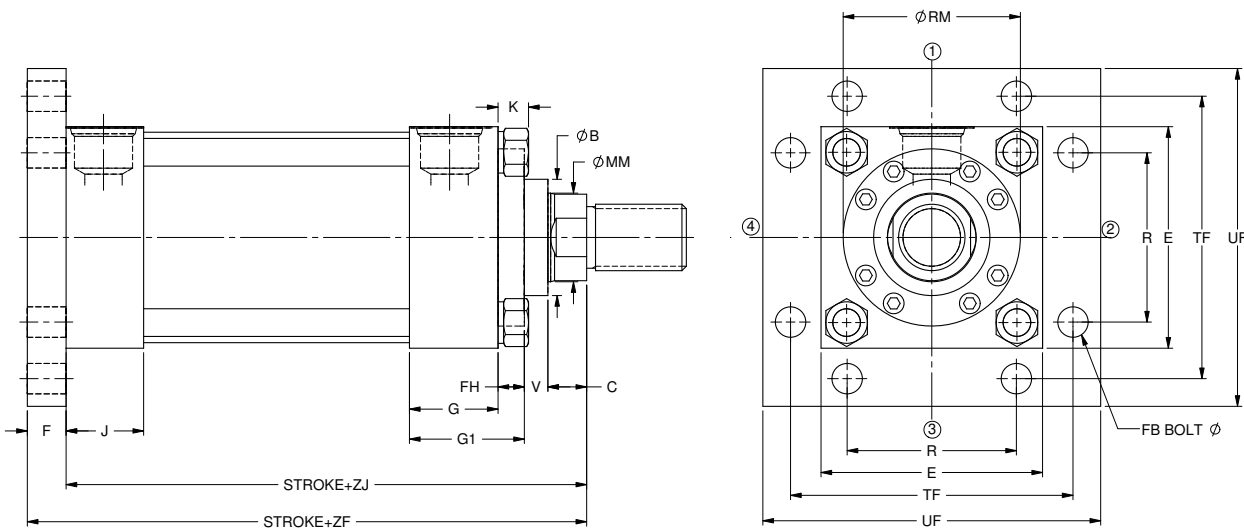

Bore	Rod Dia MM	B +0.00/-0.02	C	E	G	J	FH	RM	V	F
1.50	0.63	1.124	0.38	2.50	1.75	1.50	0.38	-	0.25	0.38
	1.00	1.499	0.50	2.50	1.75	1.50	0.38	-	0.50	0.38
2.00	1.00	1.499	0.50	3.00	1.75	1.50	0.63	-	0.25	0.63
	1.38	1.999	0.63	3.00	1.75	1.50	0.63	-	0.38	0.63
2.50	1.00	1.499	0.50	3.50	1.75	1.50	0.50	2.63	0.38	0.63
	1.38	1.999	0.63	3.50	1.75	1.50	0.63	-	0.38	0.63
	1.75	2.374	0.75	3.50	1.75	1.50	0.63	-	0.50	0.63
3.25	1.38	1.999	0.63	4.50	2.00	1.75	0.59	3.25	0.41	0.75
	1.75	2.374	0.75	4.50	2.00	1.75	0.75	-	0.38	0.75
	2.00	2.624	0.88	4.50	2.00	1.75	0.75	-	0.38	0.75
4.00	1.75	2.374	0.75	5.00	2.00	1.75	0.59	3.88	0.53	0.88
	2.00	2.624	0.88	5.00	2.00	1.75	0.59	4.00	0.53	0.88
	2.50	3.124	1.00	5.00	2.00	1.75	0.59	4.44	0.66	0.88
5.00	2.00	2.624	0.88	6.50	2.00	1.75	0.59	4.00	0.53	0.88
	2.50	3.124	1.00	6.50	2.00	1.75	0.59	4.44	0.66	0.88
	3.00	3.749	1.00	6.50	2.00	1.75	0.72	5.25	0.53	0.88
	3.50	4.249	1.00	6.50	2.00	1.75	0.72	5.63	0.53	0.88
6.00	2.50	3.124	1.00	7.50	2.25	2.25	0.59	4.44	0.66	1.00
	3.00	3.749	1.00	7.50	2.25	2.25	0.72	5.25	0.53	1.00
	3.50	4.249	1.00	7.50	2.25	2.25	0.72	5.63	0.53	1.00
	4.00	4.749	1.00	7.50	2.25	2.25	0.88	6.44	0.38	1.00
7.00	3.00	3.749	1.00	8.50	2.75	2.75	0.72	5.25	0.53	1.00
	3.50	4.249	1.00	8.50	2.75	2.75	0.72	5.63	0.53	1.00
	4.00	4.749	1.00	8.50	2.75	2.75	0.88	6.44	0.38	1.00
	4.50	5.249	1.00	8.50	2.75	2.75	0.88	7.13	0.38	1.00
	5.00	5.749	1.00	8.50	2.75	2.75	0.88	7.56	0.38	1.00
8.00	3.50	4.249	1.00	9.50	3.00	3.00	0.72	5.63	0.53	1.00
	4.00	4.749	1.00	9.50	3.00	3.00	0.88	6.44	0.38	1.00
	4.50	5.249	1.00	9.50	3.00	3.00	0.88	7.13	0.38	1.00
	5.00	5.749	1.00	9.50	3.00	3.00	0.88	7.56	0.38	1.00
	5.50	6.249	1.00	9.50	3.00	3.00	0.88	8.38	0.38	1.00

+ Plus Stroke

Mounting Style and Installation Dimensions – NZ13 Cap Square Flange Mount ANSI MF6

These mounts are ideal for straight line force transfer applications in which the cylinder is used in compression (pushing), as in push presses.

For tension applications (pulling), a head rectangular mount is more appropriate.

NOTE

For strokes in excess of 30 inches, see "Stop tube selection" on page 77.

WARNING

The frame on which the cylinder is mounted must be sufficiently rigid to resist bending moments. The cap rectangular mounts (NZ14) is recommended for heavy duty applications.

Use high tensile socket head cap screws or hex head bolts tightened to the manufacturer's recommended torque.

WARNING

Failure to mount the cylinder correctly on the frame may result in death, bodily injury and/or property damage.

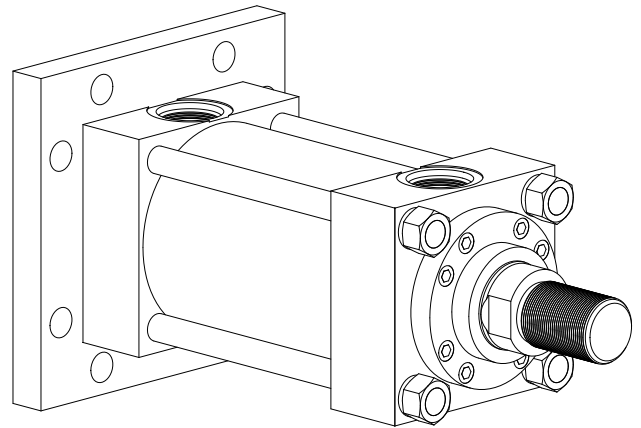

Bore	Rod Dia MM	FB	R	TF	UF	ZF+ Max	ZJ+ Max	Piston Thick.	K
1.50	0.63	0.38	1.63	3.44	4.25	6.00	5.63	1.38	0.41
	1.00	0.38	1.63	3.44	4.25	6.38	6.00	1.38	0.41
2.00	1.00	0.50	2.05	4.13	5.13	6.63	6.00	1.38	0.55
	1.38	0.50	2.05	4.13	5.13	6.88	6.26	1.38	0.55
2.50	1.00	0.50	2.55	4.63	5.63	6.75	6.13	1.50	0.55
	1.38	0.50	2.55	4.63	5.63	7.00	6.38	1.50	0.55
	1.75	0.50	2.55	4.63	5.63	7.25	6.63	1.50	0.55
3.25	1.38	0.63	3.25	5.88	7.13	7.88	7.13	1.75	0.67
	1.75	0.63	3.25	5.88	7.13	8.13	7.38	1.75	0.67
	2.00	0.63	3.25	5.88	7.13	8.25	7.50	1.75	0.67
4.00	1.75	0.63	3.82	6.38	7.63	8.50	7.63	2.00	0.78
	2.00	0.63	3.82	6.38	7.63	8.63	7.75	2.00	0.78
	2.50	0.63	3.82	6.38	7.63	8.88	8.00	2.00	0.78
5.00	2.00	0.88	4.95	8.19	9.75	9.13	8.25	2.50	0.92
	2.50	0.88	4.95	8.19	9.75	9.38	8.50	2.50	0.92
	3.00	0.88	4.95	8.19	9.75	9.38	8.50	2.50	0.92
	3.50	0.88	4.95	8.19	9.75	9.38	8.50	2.50	0.92
6.00	2.50	1.00	5.73	9.44	11.25	10.63	9.63	2.88	1.03
	3.00	1.00	5.73	9.44	11.25	10.63	9.63	2.88	1.03
	3.50	1.00	5.73	9.44	11.25	10.63	9.63	2.88	1.03
	4.00	1.00	5.73	9.44	11.25	10.63	9.63	2.88	1.03
7.00	3.00	1.13	6.58	10.63	12.63	11.75	10.75	3.00	1.17
	3.50	1.13	6.58	10.63	12.63	11.75	10.75	3.00	1.17
	4.00	1.13	6.58	10.63	12.63	11.75	10.75	3.00	1.17
	4.50	1.13	6.58	10.63	12.63	11.75	10.75	3.00	1.17
	5.00	1.13	6.58	10.63	12.63	11.75	10.75	3.00	1.17
8.00	3.50	1.25	7.50	11.81	14.00	12.75	11.75	3.50	1.26
	4.00	1.25	7.50	11.81	14.00	12.75	11.75	3.50	1.26
	4.50	1.25	7.50	11.81	14.00	12.75	11.75	3.50	1.26
	5.00	1.25	7.50	11.81	14.00	12.75	11.75	3.50	1.26
	5.50	1.25	7.50	11.81	14.00	12.75	11.75	3.50	1.26

+ Plus Stroke

See Mount 24 on page 50 for Port Dimensions

Mounting Style and Installation

Dimensions – NZ14 Cap Rectangle

Mount ANSI ME6

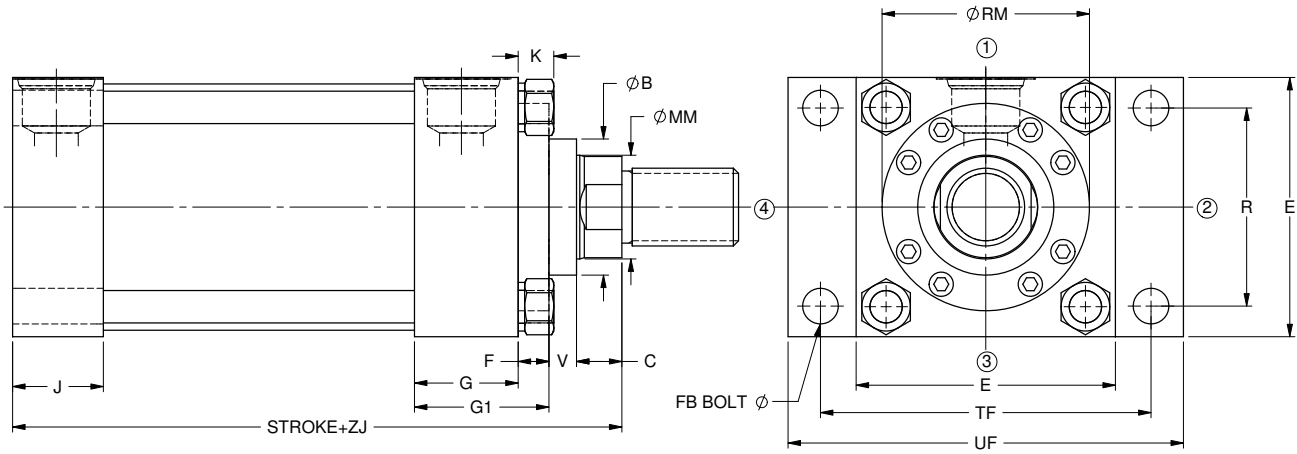

Bore	Rod Dia MM	B +.000/- .002	C	E	G	J	F	V	RM
1.50	0.63	1.124	0.38	2.50	1.75	1.50	0.38	0.25	-
	1.00	1.499	0.50	2.50	1.75	1.50	0.38	0.50	-
2.00	1.00	1.499	0.50	3.00	1.75	1.50	0.63	0.25	-
	1.38	1.999	0.63	3.00	1.75	1.50	0.63	0.38	-
2.50	1.00	1.499	0.50	3.50	1.75	1.50	0.50	0.38	2.63
	1.38	1.999	0.63	3.50	1.75	1.50	0.63	0.38	-
	1.75	2.374	0.75	3.50	1.75	1.50	0.63	0.50	-
3.25	1.38	1.999	0.63	4.50	2.00	1.75	0.59	0.41	3.25
	1.75	2.374	0.75	4.50	2.00	1.75	0.75	0.38	-
	2.00	2.624	0.88	4.50	2.00	1.75	0.75	0.38	-
4.00	1.75	2.374	0.75	5.00	2.00	1.75	0.59	0.53	3.88
	2.00	2.624	0.88	5.00	2.00	1.75	0.59	0.53	4.00
	2.50	3.124	1.00	5.00	2.00	1.75	0.59	0.66	4.44
5.00	2.00	2.624	0.88	6.50	2.00	1.75	0.59	0.53	4.00
	2.50	3.124	1.00	6.50	2.00	1.75	0.59	0.66	4.44
	3.00	3.749	1.00	6.50	2.00	1.75	0.72	0.53	5.25
	3.50	4.249	1.00	6.50	2.00	1.75	0.72	0.53	5.63
6.00	2.50	3.124	1.00	7.50	2.25	2.25	0.59	0.66	4.44
	3.00	3.749	1.00	7.50	2.25	2.25	0.72	0.53	5.25
	3.50	4.249	1.00	7.50	2.25	2.25	0.72	0.53	5.63
	4.00	4.749	1.00	7.50	2.25	2.25	0.88	0.38	6.44
7.00	3.00	3.749	1.00	8.50	2.75	2.75	0.72	0.53	5.25
	3.50	4.249	1.00	8.50	2.75	2.75	0.72	0.53	5.63
	4.00	4.749	1.00	8.50	2.75	2.75	0.88	0.38	6.44
	4.50	5.249	1.00	8.50	2.75	2.75	0.88	0.38	7.13
	5.00	5.749	1.00	8.50	2.75	2.75	0.88	0.38	7.56
8.00	3.50	4.249	1.00	9.50	3.00	3.00	0.72	0.53	5.63
	4.00	4.749	1.00	9.50	3.00	3.00	0.88	0.38	6.44
	4.50	5.249	1.00	9.50	3.00	3.00	0.88	0.38	7.13
	5.00	5.749	1.00	9.50	3.00	3.00	0.88	0.38	7.56
	5.50	6.249	1.00	9.50	3.00	3.00	0.88	0.38	8.38

+ Plus Stroke

Mounting Style and Installation

Dimensions – NZ14 Cap Rectangle Mount ANSI ME6

These mounts are for straight line force transfer applications in which the cylinder is used in compression (pushing) and tension (pulling) applications.

The mounting surface should be flat and perpendicular to the force of the load.

The frame on which the cylinder is mounted *must* be sufficiently rigid to resist bending moments.

The cap rectangular mount (NZ14) is recommended for heavy duty applications.

NOTE

For strokes in excess of 30 inches, see "Stop tube selection" on page 77.

WARNING

Use high tensile socket head cap screws or hex head bolts tightened to the manufacturer's recommended torque value.

WARNING

Failure to mount the cylinder correctly on the frame may result in death, bodily injury and/or property damage.

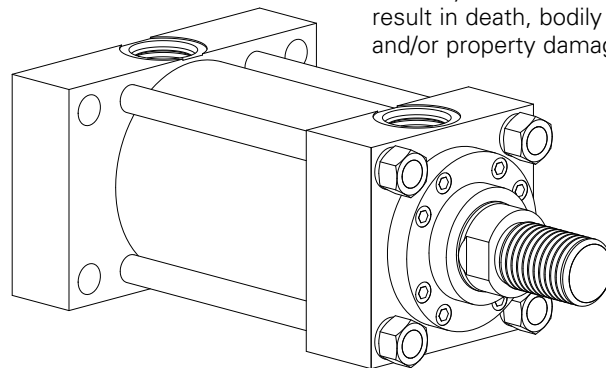

Bore	Rod Dia MM	FB	R	TF	UF	ZJ+ Max	Piston Thick.	K
1.50	0.63	0.38	1.63	3.44	4.25	5.63	1.38	0.41
	1.00	0.38	1.63	3.44	4.25	6.00	1.38	0.41
2.00	1.00	0.50	2.05	4.13	5.13	6.00	1.38	0.55
	1.38	0.50	2.05	4.13	5.13	6.25	1.38	0.55
2.50	1.00	0.50	2.55	4.63	5.63	6.13	1.50	0.55
	1.38	0.50	2.55	4.63	5.63	6.38	1.50	0.55
	1.75	0.50	2.55	4.63	5.63	6.63	1.50	0.55
3.25	1.38	0.63	3.25	5.88	7.13	7.13	1.75	0.67
	1.75	0.63	3.25	5.88	7.13	7.38	1.75	0.67
	2.00	0.63	3.25	5.88	7.13	7.50	1.75	0.67
4.00	1.75	0.63	3.82	6.38	7.63	7.63	2.00	0.78
	2.00	0.63	3.82	6.38	7.63	7.75	2.00	0.78
	2.50	0.63	3.82	6.38	7.63	8.00	2.00	0.78
5.00	2.00	0.88	4.95	8.19	9.75	8.25	2.50	0.92
	2.50	0.88	4.95	8.19	9.75	8.50	2.50	0.92
	3.00	0.88	4.95	8.19	9.75	8.50	2.50	0.92
	3.50	0.88	4.95	8.19	9.75	8.50	2.50	0.92
6.00	2.50	1.00	5.73	9.44	11.25	9.63	2.88	1.03
	3.00	1.00	5.73	9.44	11.25	9.63	2.88	1.03
	3.50	1.00	5.73	9.44	11.25	9.63	2.88	1.03
	4.00	1.00	5.73	9.44	11.25	9.63	2.88	1.03
7.00	3.00	1.13	6.58	10.63	12.63	10.75	3.00	1.17
	3.50	1.13	6.58	10.63	12.63	10.75	3.00	1.17
	4.00	1.13	6.58	10.63	12.63	10.75	3.00	1.17
	4.50	1.13	6.58	10.63	12.63	10.75	3.00	1.17
	5.00	1.13	6.58	10.63	12.63	10.75	3.00	1.17
8.00	3.50	1.25	7.50	11.81	14.00	11.75	3.50	1.26
	4.00	1.25	7.50	11.81	14.00	11.75	3.50	1.26
	4.50	1.25	7.50	11.81	14.00	11.75	3.50	1.26
	5.00	1.25	7.50	11.81	14.00	11.75	3.50	1.26
	5.50	1.25	7.50	11.81	14.00	11.75	3.50	1.26

+ Plus Stroke

See Mount 24 on page 50 for Port Dimensions

Mounting Style and Installation

Dimensions – NZ15 Intermediate Trunnion Mounts NFPA MT4 Mount

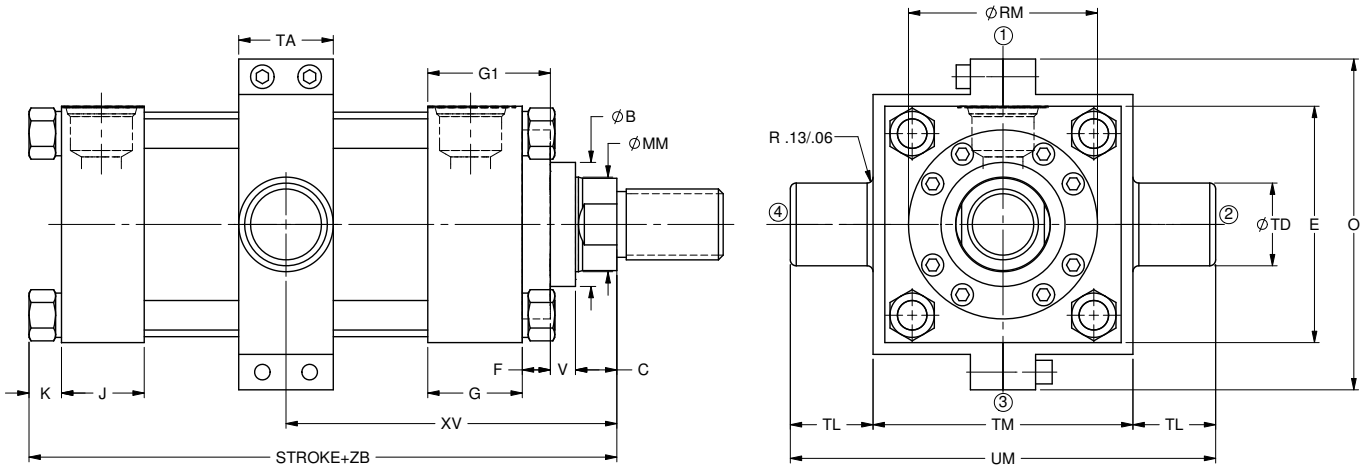

Bore	Rod Dia MM	B +.000/- .002	C	E	G	J	F	V	RM	TD +.000/- .001	TL
1.50	0.63	1.124	0.38	2.50	1.75	1.50	0.38	0.25	-	1.000	1.00
	1.00	1.499	0.50	2.50	1.75	1.50	0.38	0.50	-	1.000	1.00
2.00	1.00	1.499	0.50	3.00	1.75	1.50	0.63	0.25	-	1.375	1.38
	1.38	1.999	0.63	3.00	1.75	1.50	0.63	0.38	-	1.375	1.38
2.50	1.00	1.499	0.50	3.50	1.75	1.50	0.50	0.38	2.63	1.375	1.38
	1.38	1.999	0.63	3.50	1.75	1.50	0.63	0.38	-	1.375	1.38
	1.75	2.374	0.75	3.50	1.75	1.50	0.63	0.50	-	1.375	1.38
3.25	1.38	1.999	0.63	4.50	2.00	1.75	0.59	0.41	3.25	1.750	1.75
	1.75	2.374	0.75	4.50	2.00	1.75	0.75	0.38	-	1.750	1.75
	2.00	2.624	0.88	4.50	2.00	1.75	0.75	0.38	-	1.750	1.75
4.00	1.75	2.374	0.75	5.00	2.00	1.75	0.59	0.53	3.88	1.750	1.75
	2.00	2.624	0.88	5.00	2.00	1.75	0.59	0.53	4.00	1.750	1.75
	2.50	3.124	1.00	5.00	2.00	1.75	0.59	0.66	4.44	1.750	1.75
5.00	2.00	2.624	0.88	6.50	2.00	1.75	0.59	0.53	4.00	1.750	1.75
	2.50	3.124	1.00	6.50	2.00	1.75	0.59	0.66	4.44	1.750	1.75
	3.00	3.749	1.00	6.50	2.00	1.75	0.72	0.53	5.25	1.750	1.75
	3.50	4.249	1.00	6.50	2.00	1.75	0.72	0.53	5.63	1.750	1.75
6.00	2.50	3.124	1.00	7.50	2.25	2.25	0.59	0.66	4.44	2.000	2.00
	3.00	3.749	1.00	7.50	2.25	2.25	0.72	0.53	5.25	2.000	2.00
	3.50	4.249	1.00	7.50	2.25	2.25	0.72	0.53	5.63	2.000	2.00
	4.00	4.749	1.00	7.50	2.25	2.25	0.88	0.38	6.44	2.000	2.00
7.00	3.00	3.749	1.00	8.50	2.75	2.75	0.72	0.53	5.25	2.500	2.50
	3.50	4.249	1.00	8.50	2.75	2.75	0.72	0.53	5.63	2.500	2.50
	4.00	4.749	1.00	8.50	2.75	2.75	0.88	0.38	6.44	2.500	2.50
	4.50	5.249	1.00	8.50	2.75	2.75	0.88	0.38	7.13	2.500	2.50
	5.00	5.749	1.00	8.50	2.75	2.75	0.88	0.38	7.56	2.500	2.50
8.00	3.50	4.249	1.00	9.50	3.00	3.00	0.72	0.53	5.63	3.000	3.00
	4.00	4.749	1.00	9.50	3.00	3.00	0.88	0.38	6.44	3.000	3.00
	4.50	5.249	1.00	9.50	3.00	3.00	0.88	0.38	7.13	3.000	3.00
	5.00	5.749	1.00	9.50	3.00	3.00	0.88	0.38	7.56	3.000	3.00
	5.50	6.249	1.00	9.50	3.00	3.00	0.88	0.38	8.38	3.000	3.00

+ Plus Stroke

Mounting Style and Installation

Dimensions – NZ15 Intermediate Trunnion Mounts NFPA MT4 Mount

The Intermediate Trunnion Mount is for longer stroke applications in which the machine member travels in a curved path in one plane.

On special orders, the trunnion can be located anywhere along the body.

This mount can be used both in compression (push) and tension (pull) applications.

NOTE

For strokes in excess of 24 inches, see “Stop tube selection” on page 77.

WARNING

It is recommended that rigidly mounted pillow blocks with bearings at least as long as the trunnion pins be used. The pillow blocks should be installed as close to the shoulder of the trunnion as possible.

WARNING

Failure to mount the cylinder correctly on the frame may result in death, bodily injury and/or property damage.

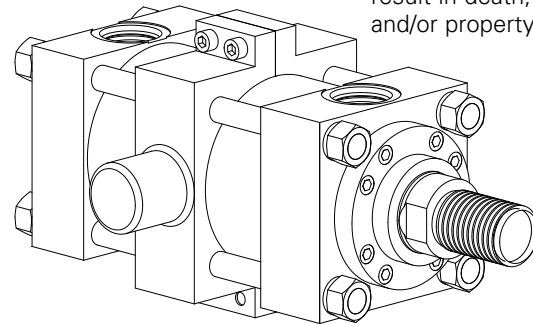

Bore	Rod Dia MM	UM	TM	TA	Max. O	XV Std *	ZB+ Max	Piston Thick.	K	Minimum stroke Required
1.50	0.63	5.00	3.00	1.50	-	3.44	6.04	1.38	0.41	0.25
	1.00	5.00	3.00	1.50	-	3.81	6.41	1.38	0.41	0.25
2.00	1.00	6.25	3.50	1.50	-	3.81	6.56	1.38	0.55	0.25
	1.38	6.25	3.50	1.50	-	4.19	6.82	1.38	0.55	0.25
2.50	1.00	6.75	4.00	1.50	-	3.88	6.68	1.50	0.55	0.13
	1.38	6.75	4.00	1.50	-	4.14	6.94	1.50	0.55	0.13
	1.75	6.75	4.00	1.50	-	4.38	7.18	1.50	0.55	0.13
3.25	1.38	8.50	5.00	2.00	-	4.50	7.80	1.75	0.67	0.38
	1.75	8.50	5.00	2.00	-	4.76	8.05	1.75	0.67	0.38
	2.00	8.50	5.00	2.00	-	4.89	8.18	1.75	0.67	0.38
4.00	1.75	9.00	5.50	2.00	-	4.88	8.40	2.00	0.78	0.13
	2.00	9.00	5.50	2.00	-	5.00	8.53	2.00	0.78	0.13
	2.50	9.00	5.50	2.00	-	5.25	8.78	2.00	0.78	0.13
5.00	2.00	10.50	7.00	2.50	-	5.25	9.18	2.50	0.92	0.13
	2.50	10.50	7.00	2.50	-	5.50	9.43	2.50	0.92	0.13
	3.00	10.50	7.00	2.50	-	5.50	9.43	2.50	0.92	0.13
	3.50	10.50	7.00	2.50	-	5.50	9.43	2.50	0.92	0.13
6.00	2.50	12.50	8.50	3.00	9.50	5.94	10.66	2.88	1.03	0.25
	3.00	12.50	8.50	3.00	9.50	5.94	10.66	2.88	1.03	0.25
	3.50	12.50	8.50	3.00	9.50	5.94	10.66	2.88	1.03	0.25
	4.00	12.50	8.50	3.00	9.50	5.94	10.66	2.88	1.03	0.25
7.00	3.00	14.75	9.75	3.00	11.50	6.50	11.92	3.00	1.17	0.13
	3.50	14.75	9.75	3.00	11.50	6.50	11.92	3.00	1.17	0.13
	4.00	14.75	9.75	3.00	11.50	6.50	11.92	3.00	1.17	0.13
	4.50	14.75	9.75	3.00	11.50	6.50	11.92	3.00	1.17	0.13
	5.00	14.75	9.75	3.00	11.50	6.50	11.92	3.00	1.17	0.13
8.00	3.50	17.00	11.00	3.50	13.25	7.13	13.00	3.50	1.26	-
	4.00	17.00	11.00	3.50	13.25	7.13	13.00	3.50	1.26	-
	4.50	17.00	11.00	3.50	13.25	7.13	13.00	3.50	1.26	-
	5.00	17.00	11.00	3.50	13.25	7.13	13.00	3.50	1.26	-
	5.50	17.00	11.00	3.50	13.25	7.13	13.00	3.50	1.26	-

+ Plus Stroke

*XV = XV std + 1/2 Stroke

See Mount 24 on page 50 for Port Dimensions

Mounting Style and Installation

Dimensions – NZ16 Trunnion

Mounts NFPA MT2 Mount

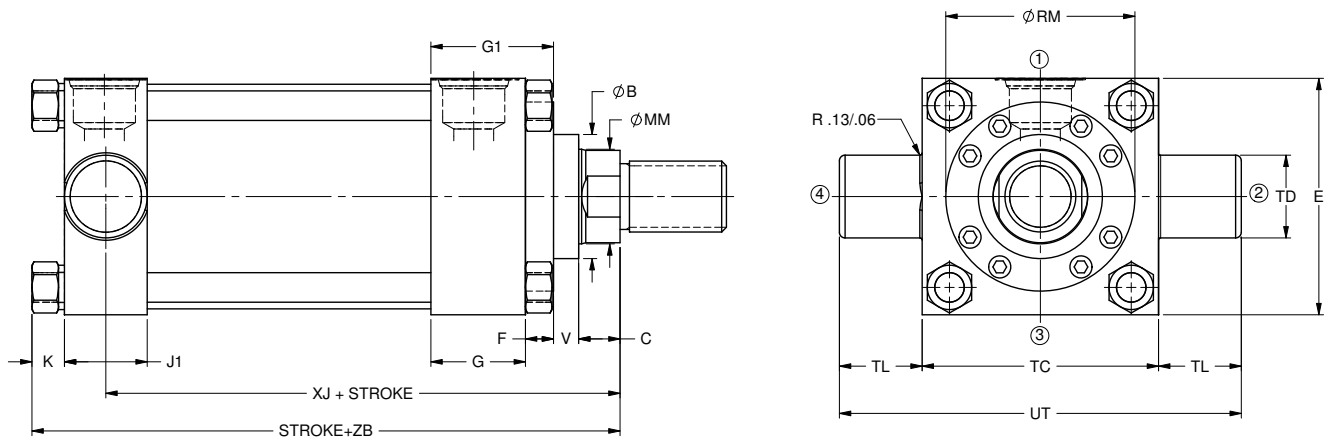

Bore	Rod Dia MM	B +.000/--.002	C	E	G	J1	F	V	RM
1.50	0.63	1.124	0.38	2.50	1.75	1.50	0.38	0.25	-
	1.00	1.499	0.50	2.50	1.75	1.50	0.38	0.50	-
2.00	1.00	1.499	0.50	3.00	1.75	1.50	0.63	0.25	-
	1.38	1.999	0.63	3.00	1.75	1.50	0.63	0.38	-
2.50	1.00	1.499	0.50	3.50	1.75	1.50	0.50	0.38	2.63
	1.38	1.999	0.63	3.50	1.75	1.50	0.63	0.38	-
	1.75	2.374	0.75	3.50	1.75	1.50	0.63	0.50	-
3.25	1.38	1.999	0.63	4.50	2.00	1.75	0.59	0.41	3.25
	1.75	2.374	0.75	4.50	2.00	1.75	0.75	0.38	-
	2.00	2.624	0.88	4.50	2.00	1.75	0.75	0.38	-
4.00	1.75	2.374	0.75	5.00	2.00	1.75	0.59	0.53	3.88
	2.00	2.624	0.88	5.00	2.00	1.75	0.59	0.53	4.00
	2.50	3.124	1.00	5.00	2.00	1.75	0.59	0.66	4.44
5.00	2.00	2.624	0.88	6.50	2.00	1.75	0.59	0.53	4.00
	2.50	3.124	1.00	6.50	2.00	1.75	0.59	0.66	4.44
	3.00	3.749	1.00	6.50	2.00	1.75	0.72	0.53	5.25
	3.50	4.249	1.00	6.50	2.00	1.75	0.72	0.53	5.63
6.00	2.50	3.124	1.00	7.50	2.25	2.25	0.59	0.66	4.44
	3.00	3.749	1.00	7.50	2.25	2.25	0.72	0.53	5.25
	3.50	4.249	1.00	7.50	2.25	2.25	0.72	0.53	5.63
	4.00	4.749	1.00	7.50	2.25	2.25	0.88	0.38	6.44
7.00	3.00	3.749	1.00	8.50	2.75	2.75	0.72	0.53	5.25
	3.50	4.249	1.00	8.50	2.75	2.75	0.72	0.53	5.63
	4.00	4.749	1.00	8.50	2.75	2.75	0.88	0.38	6.44
	4.50	5.249	1.00	8.50	2.75	2.75	0.88	0.38	7.13
	5.00	5.749	1.00	8.50	2.75	2.75	0.88	0.38	7.56
8.00	3.50	4.249	1.00	9.50	3.00	3.00	0.72	0.53	5.63
	4.00	4.749	1.00	9.50	3.00	3.00	0.88	0.38	6.44
	4.50	5.249	1.00	9.50	3.00	3.00	0.88	0.38	7.13
	5.00	5.749	1.00	9.50	3.00	3.00	0.88	0.38	7.56
	5.50	6.249	1.00	9.50	3.00	3.00	0.88	0.38	8.38

+ Plus Stroke

Mounting Style and Installation Dimensions – NZ16 Trunnion Mounts NFPA MT2 Mount

These mounts are for applications in which the machine member travels in a curved path in one plane.

Either mount can be used both in compression (push) and tension (pull) applications. When used in compression

applications, head trunnion mounts provide a longer maximum stroke than cap trunnion mounts.

NOTE

For strokes in excess of 24 inches, see “Stop tube selection” on page 77.

The trunnion pins are an integral part of the head and can be sleeved to provide an extremely tight fit to the mating machine member and permit curvilinear motion.

It is recommended that rigidly mounted pillow blocks with bearings at least as long as the trunnion pins be used.

The pillow blocks should be installed as close to the shoulder of the trunnion as possible.

WARNING

Failure to mount the cylinder correctly on the frame may result in death, bodily injury and/or property damage.

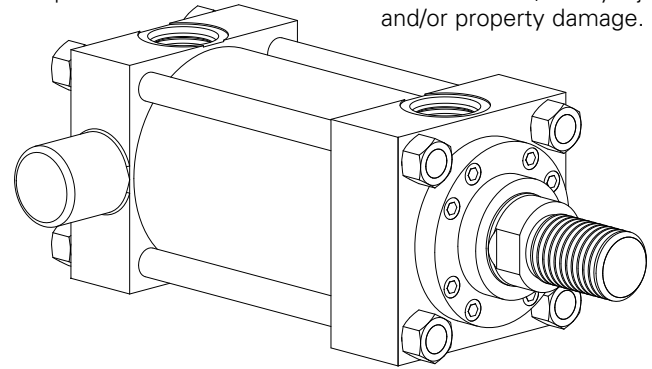

Bore	Rod Dia MM	TD +.000/- .001	TL	TC	UT	XJ+	ZB+ Max	Piston Thick.	K
1.50	0.63	1.000	1.00	2.50	4.50	4.88	6.04	1.38	0.41
	1.00	1.000	1.00	2.50	4.50	5.25	6.41	1.38	0.41
2.00	1.00	1.375	1.38	3.00	5.75	5.25	6.56	1.38	0.55
	1.38	1.375	1.38	3.00	5.75	5.50	6.82	1.38	0.55
2.50	1.00	1.375	1.38	3.50	6.25	5.38	6.68	1.50	0.55
	1.38	1.375	1.38	3.50	6.25	5.63	6.94	1.50	0.55
	1.75	1.375	1.38	3.50	6.25	5.88	7.18	1.50	0.55
3.25	1.38	1.750	1.75	4.50	8.00	6.25	7.80	1.75	0.67
	1.75	1.750	1.75	4.50	8.00	6.50	8.05	1.75	0.67
	2.00	1.750	1.75	4.50	8.00	6.63	8.18	1.75	0.67
4.00	1.75	1.750	1.75	5.00	8.50	6.75	8.40	2.00	0.78
	2.00	1.750	1.75	5.00	8.50	6.88	8.53	2.00	0.78
	2.50	1.750	1.75	5.00	8.50	7.13	8.78	2.00	0.78
5.00	2.00	1.750	1.75	6.50	10.00	7.38	9.18	2.50	0.92
	2.50	1.750	1.75	6.50	10.00	7.63	9.43	2.50	0.92
	3.00	1.750	1.75	6.50	10.00	7.63	9.43	2.50	0.92
	3.50	1.750	1.75	6.50	10.00	7.63	9.43	2.50	0.92
6.00	2.50	2.000	2.00	7.50	11.50	8.38	10.66	2.88	1.03
	3.00	2.000	2.00	7.50	11.50	8.38	10.66	2.88	1.03
	3.50	2.000	2.00	7.50	11.50	8.38	10.66	2.88	1.03
	4.00	2.000	2.00	7.50	11.50	8.38	10.66	2.88	1.03
7.00	3.00	2.500	2.50	8.50	13.50	9.38	11.92	3.00	1.17
	3.50	2.500	2.50	8.50	13.50	9.38	11.92	3.00	1.17
	4.00	2.500	2.50	8.50	13.50	9.38	11.92	3.00	1.17
	4.50	2.500	2.50	8.50	13.50	9.38	11.92	3.00	1.17
	5.00	2.500	2.50	8.50	13.50	9.38	11.92	3.00	1.17
8.00	3.50	3.000	3.00	9.50	15.50	10.25	13.00	3.50	1.26
	4.00	3.000	3.00	9.50	15.50	10.25	13.00	3.50	1.26
	4.50	3.000	3.00	9.50	15.50	10.25	13.00	3.50	1.26
	5.00	3.000	3.00	9.50	15.50	10.25	13.00	3.50	1.26
	5.50	3.000	3.00	9.50	15.50	10.25	13.00	3.50	1.26

+ Plus Stroke

See Mount 24 on page 50 for Port Dimensions

Mounting Style and Installation

Dimensions – NZ17 Head Trunnion

Mounts NFPA MT1 Mount

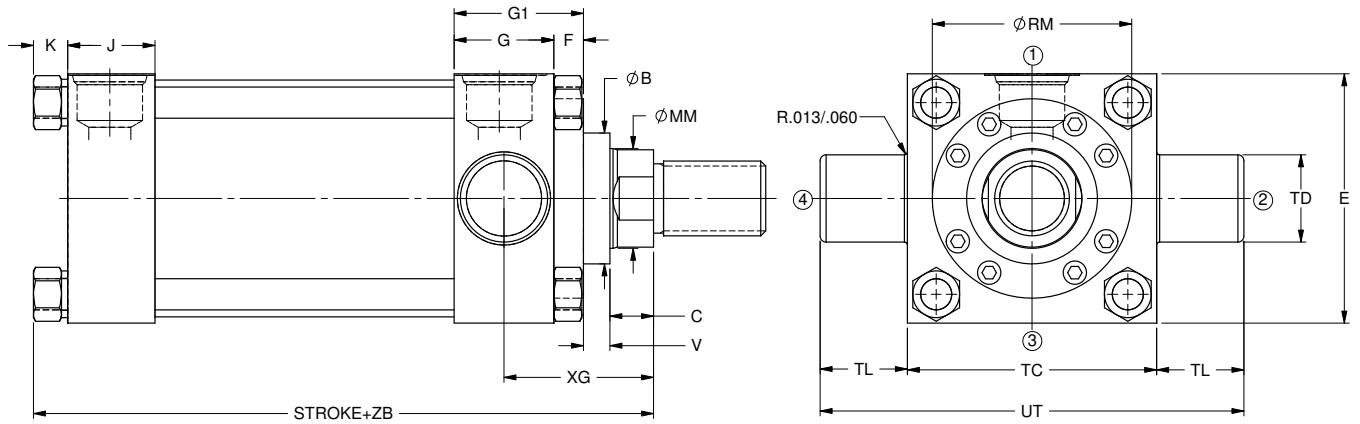

Bore	Rod Dia MM	B +.000/- .002	C	E	G	J	F	V	RM
1.50	0.63	1.124	0.38	2.50	1.75	1.50	0.38	0.25	-
	1.00	1.499	0.50	2.50	1.75	1.50	0.38	0.50	-
2.00	1.00	1.499	0.50	3.00	1.75	1.50	0.63	0.25	-
	1.38	1.999	0.63	3.00	1.75	1.50	0.63	0.38	-
2.50	1.00	1.499	0.50	3.50	1.75	1.50	0.50	0.38	2.63
	1.38	1.999	0.63	3.50	1.75	1.50	0.63	0.38	-
	1.75	2.374	0.75	3.50	1.75	1.50	0.63	0.50	-
3.25	1.38	1.999	0.63	4.50	2.00	1.75	0.59	0.41	3.25
	1.75	2.374	0.75	4.50	2.00	1.75	0.75	0.38	-
	2.00	2.624	0.88	4.50	2.00	1.75	0.75	0.38	-
4.00	1.75	2.374	0.75	5.00	2.00	1.75	0.59	0.53	3.88
	2.00	2.624	0.88	5.00	2.00	1.75	0.59	0.53	4.00
	2.50	3.124	1.00	5.00	2.00	1.75	0.59	0.66	4.44
5.00	2.00	2.624	0.88	6.50	2.00	1.75	0.59	0.53	4.00
	2.50	3.124	1.00	6.50	2.00	1.75	0.59	0.66	4.44
	3.00	3.749	1.00	6.50	2.00	1.75	0.72	0.53	5.25
	3.50	4.249	1.00	6.50	2.00	1.75	0.72	0.53	5.63
6.00	2.50	3.124	1.00	7.50	2.25	2.25	0.59	0.66	4.44
	3.00	3.749	1.00	7.50	2.25	2.25	0.72	0.53	5.25
	3.50	4.249	1.00	7.50	2.25	2.25	0.72	0.53	5.63
	4.00	4.749	1.00	7.50	2.25	2.25	0.88	0.38	6.44
7.00	3.00	3.749	1.00	8.50	2.75	2.75	0.72	0.53	5.25
	3.50	4.249	1.00	8.50	2.75	2.75	0.72	0.53	5.63
	4.00	4.749	1.00	8.50	2.75	2.75	0.88	0.38	6.44
	4.50	5.249	1.00	8.50	2.75	2.75	0.88	0.38	7.13
	5.00	5.749	1.00	8.50	2.75	2.75	0.88	0.38	7.56
8.00	3.50	4.249	1.00	9.50	3.00	3.00	0.72	0.53	5.63
	4.00	4.749	1.00	9.50	3.00	3.00	0.88	0.38	6.44
	4.50	5.249	1.00	9.50	3.00	3.00	0.88	0.38	7.13
	5.00	5.749	1.00	9.50	3.00	3.00	0.88	0.38	7.56
	5.50	6.249	1.00	9.50	3.00	3.00	0.88	0.38	8.38

+ Plus Stroke

Mounting Style and Installation

Dimensions – NZ17 Head Trunnion

Mounts NFPA MT1 Mount

These mounts are for applications in which the machine member travels in a curved path in one plane.

Either mount can be used both in compression (push) and tension (pull) applications. When used in compression applications, head trunnion mounts provide a longer maximum stroke than cap trunnion mounts.

NOTE

For strokes in excess of 24 inches, see “Stop tube selection” on page 77.

tion” on page 77.

The trunnion pins are an integral part of the head and can be sleeved to provide an extremely tight fit to the mating machine member and permit curvilinear motion.

It is recommended that rigidly mounted pillow blocks with bearings at least as long as the trunnion pins be used. The pillow blocks should be installed as close to the shoulder of the trunnion as possible.

WARNING

Failure to mount the cylinder correctly on the frame may result in death, bodily injury and/or property damage.

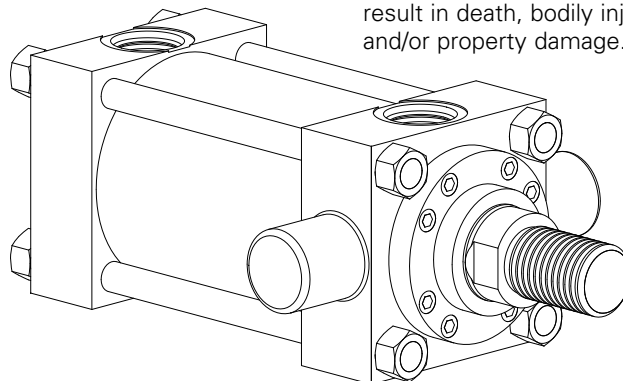

Bore	Rod Dia MM	TD +.000/- .001	TL	TC	UT	XG+	ZB+ Max	Piston Thick.	K
1.50	0.63	1.000	1.00	2.50	4.50	1.88	6.04	1.38	0.41
	1.00	1.000	1.00	2.50	4.50	2.25	6.41	1.38	0.41
2.00	1.00	1.375	1.38	3.00	5.75	2.25	6.56	1.38	0.55
	1.38	1.375	1.38	3.00	5.75	2.50	6.82	1.38	0.55
2.50	1.00	1.375	1.38	3.50	6.25	2.25	6.68	1.50	0.55
	1.38	1.375	1.38	3.50	6.25	2.50	6.94	1.50	0.55
	1.75	1.375	1.38	3.50	6.25	2.75	7.18	1.50	0.55
3.25	1.38	1.750	1.75	4.50	8.00	2.63	7.80	1.75	0.67
	1.75	1.750	1.75	4.50	8.00	2.88	8.05	1.75	0.67
	2.00	1.750	1.75	4.50	8.00	3.00	8.18	1.75	0.67
4.00	1.75	1.750	1.75	5.00	8.50	2.88	8.40	2.00	0.78
	2.00	1.750	1.75	5.00	8.50	3.00	8.53	2.00	0.78
	2.50	1.750	1.75	5.00	8.50	3.25	8.78	2.00	0.78
5.00	2.00	1.750	1.75	6.50	10.00	3.00	9.18	2.50	0.92
	2.50	1.750	1.75	6.50	10.00	3.25	9.43	2.50	0.92
	3.00	1.750	1.75	6.50	10.00	3.25	9.43	2.50	0.92
	3.50	1.750	1.75	6.50	10.00	3.25	9.43	2.50	0.92
6.00	2.50	2.000	2.00	7.50	11.50	3.38	10.66	2.88	1.03
	3.00	2.000	2.00	7.50	11.50	3.38	10.66	2.88	1.03
	3.50	2.000	2.00	7.50	11.50	3.38	10.66	2.88	1.03
	4.00	2.000	2.00	7.50	11.50	3.38	10.66	2.88	1.03
7.00	3.00	2.500	2.50	8.50	13.50	3.63	11.92	3.00	1.17
	3.50	2.500	2.50	8.50	13.50	3.63	11.92	3.00	1.17
	4.00	2.500	2.50	8.50	13.50	3.63	11.92	3.00	1.17
	4.50	2.500	2.50	8.50	13.50	3.63	11.92	3.00	1.17
	5.00	2.500	2.50	8.50	13.50	3.63	11.92	3.00	1.17
8.00	3.50	3.000	3.00	9.50	15.50	3.75	13.00	3.50	1.26
	4.00	3.000	3.00	9.50	15.50	3.75	13.00	3.50	1.26
	4.50	3.000	3.00	9.50	15.50	3.75	13.00	3.50	1.26
	5.00	3.000	3.00	9.50	15.50	3.75	13.00	3.50	1.26
	5.50	3.000	3.00	9.50	15.50	3.75	13.00	3.50	1.26

+ Plus Stroke

See Mount 24 on page 50 for Port Dimensions

Mounting Style and Installation

Dimensions – NZ19 Center Lug

Mounts ANSI MS3

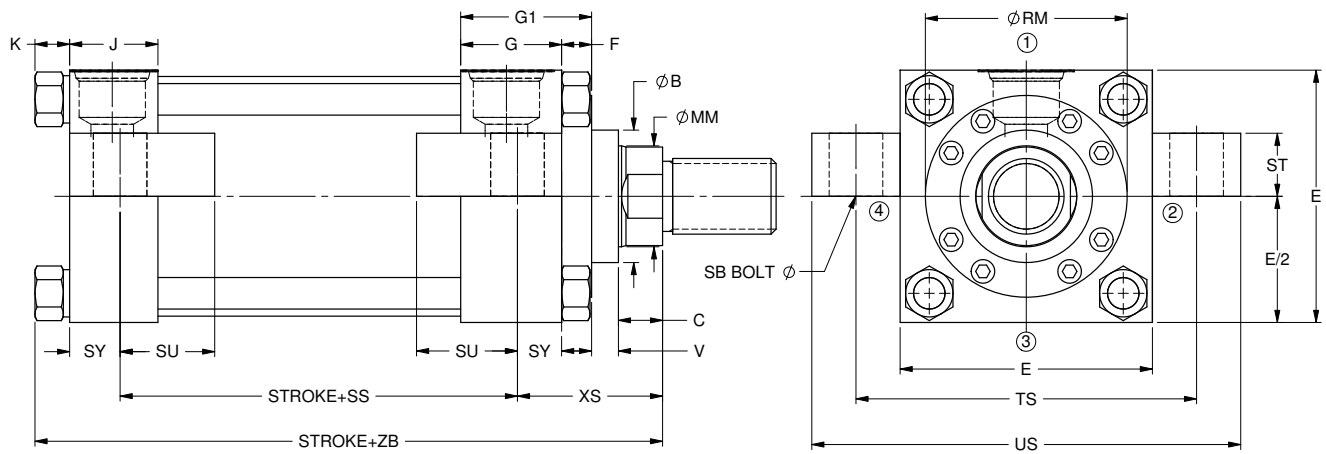

Bore	Rod Dia MM	B +.000/- .002	C	E	G	J	F	V	RM	SB	SS+
1.50	0.63	1.124	0.38	2.50	1.75	1.50	0.38	0.25	-	0.38	3.88
	1.00	1.499	0.50	2.50	1.75	1.50	0.38	0.50	-	0.38	3.88
2.00	1.00	1.499	0.50	3.00	1.75	1.50	0.63	0.25	-	0.50	3.63
	1.38	1.999	0.63	3.00	1.75	1.50	0.63	0.38	-	0.50	3.63
2.50	1.00	1.499	0.50	3.50	1.75	1.50	0.50	0.38	2.63	0.75	3.38
	1.38	1.999	0.63	3.50	1.75	1.50	0.63	0.38	-	0.75	3.38
	1.75	2.374	0.75	3.50	1.75	1.50	0.63	0.50	-	0.75	3.38
3.25	1.38	1.999	0.63	4.50	2.00	1.75	0.59	0.41	3.25	0.75	4.13
	1.75	2.374	0.75	4.50	2.00	1.75	0.75	0.38	-	0.75	4.13
	2.00	2.624	0.88	4.50	2.00	1.75	0.75	0.38	-	0.75	4.13
4.00	1.75	2.374	0.75	5.00	2.00	1.75	0.59	0.53	3.88	1.00	4.00
	2.00	2.624	0.88	5.00	2.00	1.75	0.59	0.53	4.00	1.00	4.00
	2.50	3.124	1.00	5.00	2.00	1.75	0.59	0.66	4.44	1.00	4.00
5.00	2.00	2.624	0.88	6.50	2.00	1.75	0.59	0.53	4.00	1.00	4.50
	2.50	3.124	1.00	6.50	2.00	1.75	0.59	0.66	4.44	1.00	4.50
	3.00	3.749	1.00	6.50	2.00	1.75	0.72	0.53	5.25	1.00	4.50
	3.50	4.249	1.00	6.50	2.00	1.75	0.72	0.53	5.63	1.00	4.50
6.00	2.50	3.124	1.00	7.50	2.25	2.25	0.59	0.66	4.44	1.25	5.13
	3.00	3.749	1.00	7.50	2.25	2.25	0.72	0.53	5.25	1.25	5.13
	3.50	4.249	1.00	7.50	2.25	2.25	0.72	0.53	5.63	1.25	5.13
	4.00	4.749	1.00	7.50	2.25	2.25	0.88	0.38	6.44	1.25	5.13
7.00	3.00	3.749	1.00	8.50	2.75	2.75	0.72	0.53	5.25	1.50	5.75
	3.50	4.249	1.00	8.50	2.75	2.75	0.72	0.53	5.63	1.50	5.75
	4.00	4.749	1.00	8.50	2.75	2.75	0.88	0.38	6.44	1.50	5.75
	4.50	5.249	1.00	8.50	2.75	2.75	0.88	0.38	7.13	1.50	5.75
	5.00	5.749	1.00	8.50	2.75	2.75	0.88	0.38	7.56	1.50	5.75
8.00	3.50	4.249	1.00	9.50	3.00	3.00	0.72	0.53	5.63	1.50	6.75
	4.00	4.749	1.00	9.50	3.00	3.00	0.88	0.38	6.44	1.50	6.75
	4.50	5.249	1.00	9.50	3.00	3.00	0.88	0.38	7.13	1.50	6.75
	5.00	5.749	1.00	9.50	3.00	3.00	0.88	0.38	7.56	1.50	6.75
	5.50	6.249	1.00	9.50	3.00	3.00	0.88	0.38	8.38	1.50	6.75

+ Plus Stroke

Mounting Style and Installation Dimensions – NZ19 Center Lug Mounts ANSI MS3

Centerline lug mounts are for moving loads along a flat guided surface as in a carriage along rails.

The mounting surface should be flat and parallel to the centerline of the piston rod.

The load should be guided to traverse along the centerline of the piston rod.

The frame on which the cylinder is mounted *must* be sufficiently rigid to resist bending moments.

NOTE

Limit operating pressure to 1500 psi for minimum deflection. For strokes in excess of 30 inches, see "Stop tube selection" on page 77.

WARNING

With unsupported loads, the bearing must absorb more force. For these applications, the larger available rod is recommended, and stop tubes should be considered.

Use high tensile socket head cap screws or hex head bolts tightened to the manufacturer's recommended torque.

For high shock applications, dowel pins or shear keys should be incorporated in the mounting design.

For severe side load applications, consult your local Eaton sales engineer.

WARNING

Failure to mount the cylinder correctly on the frame may result in death, bodily injury and/or property damage.

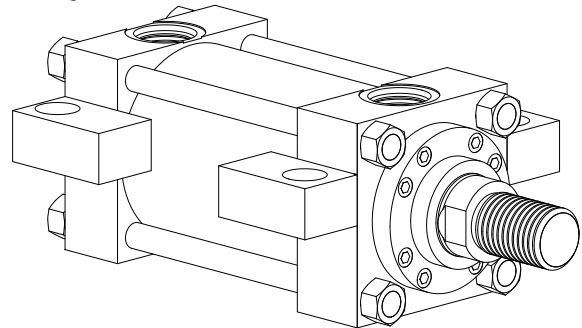

Bore	Rod Dia MM	ST	SU	SY	TS	US	XS	ZB+ Max	Piston Thick.	K
1.50	0.63	0.50	0.91	0.38	3.25	4.00	1.38	6.04	1.38	0.41
	1.00	0.50	0.91	0.38	3.25	4.00	1.75	6.41	1.38	0.41
2.00	1.00	0.75	1.24	0.50	4.00	5.00	1.88	6.56	1.38	0.55
	1.38	0.75	1.24	0.50	4.00	5.00	2.13	6.82	1.38	0.55
2.50	1.00	1.00	1.56	0.69	4.88	6.25	2.06	6.68	1.50	0.55
	1.38	1.00	1.56	0.69	4.88	6.25	2.31	6.94	1.50	0.55
	1.75	1.00	1.56	0.69	4.88	6.25	2.56	7.18	1.50	0.55
3.25	1.38	1.00	1.55	0.69	5.88	7.25	2.31	7.80	1.75	0.67
	1.75	1.00	1.55	0.69	5.88	7.25	2.56	8.05	1.75	0.67
	2.00	1.00	1.55	0.69	5.88	7.25	2.69	8.18	1.75	0.67
4.00	1.75	1.25	2.00	0.88	6.75	8.50	2.75	8.40	2.00	0.78
	2.00	1.25	2.00	0.88	6.75	8.50	2.88	8.53	2.00	0.78
	2.50	1.25	2.00	0.88	6.75	8.50	3.13	8.78	2.00	0.78
5.00	2.00	1.25	2.00	0.88	8.25	10.00	2.88	9.18	2.50	0.92
	2.50	1.25	2.00	0.88	8.25	10.00	3.13	9.43	2.50	0.92
	3.00	1.25	2.00	0.88	8.25	10.00	3.13	9.43	2.50	0.92
	3.50	1.25	2.00	0.88	8.25	10.00	3.13	9.43	2.50	0.92
6.00	2.50	1.50	2.50	1.13	9.75	12.00	3.38	10.66	2.88	1.03
	3.00	1.50	2.50	1.13	9.75	12.00	3.38	10.66	2.88	1.03
	3.50	1.50	2.50	1.13	9.75	12.00	3.38	10.66	2.88	1.03
	4.00	1.50	2.50	1.13	9.75	12.00	3.38	10.66	2.88	1.03
7.00	3.00	1.75	2.88	1.38	11.25	14.00	3.63	11.92	3.00	1.17
	3.50	1.75	2.88	1.38	11.25	14.00	3.63	11.92	3.00	1.17
	4.00	1.75	2.88	1.38	11.25	14.00	3.63	11.92	3.00	1.17
	4.50	1.75	2.88	1.38	11.25	14.00	3.63	11.92	3.00	1.17
	5.00	1.75	2.88	1.38	11.25	14.00	3.63	11.92	3.00	1.17
8.00	3.50	1.75	2.88	1.38	12.25	15.00	3.63	13.00	3.50	1.26
	4.00	1.75	2.88	1.38	12.25	15.00	3.63	13.00	3.50	1.26
	4.50	1.75	2.88	1.38	12.25	15.00	3.63	13.00	3.50	1.26
	5.00	1.75	2.88	1.38	12.25	15.00	3.63	13.00	3.50	1.26
	5.50	1.75	2.88	1.38	12.25	15.00	3.63	13.00	3.50	1.26

+ Plus Stroke

See Mount 24 on page 50 for Port Dimensions

Mounting Style and Installation

Dimensions – NZ21 Cap End

Extended Tie Rod Mounts NFPA

MX2 Mount

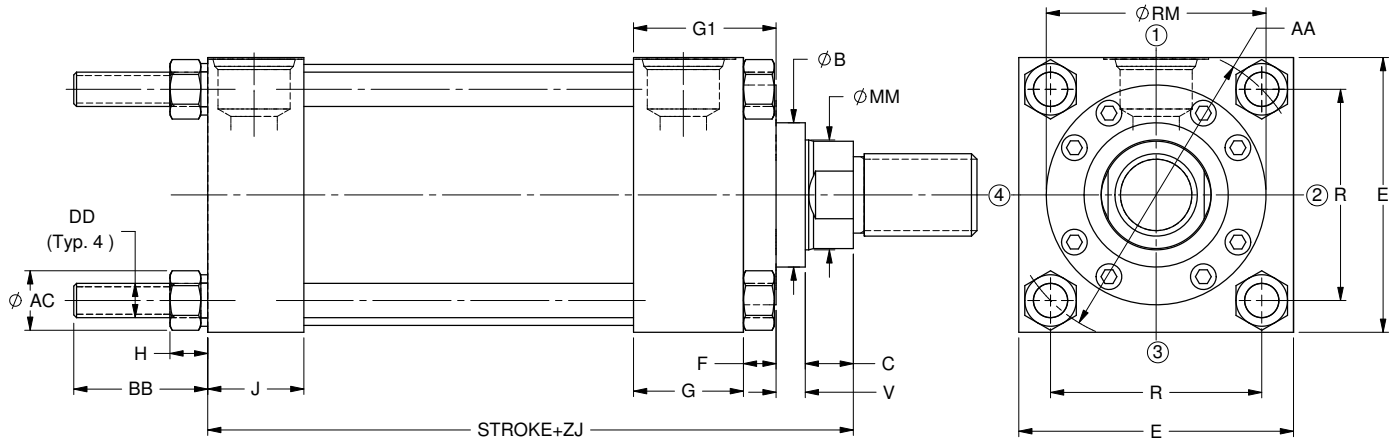

Bore	Rod Dia MM	B +0.000/-0.002	C	E	G	J	F	V	RM
1.50	0.63	1.124	0.38	2.50	1.75	1.50	0.38	0.25	-
	1.00	1.499	0.50	2.50	1.75	1.50	0.38	0.50	-
2.00	1.00	1.499	0.50	3.00	1.75	1.50	0.63	0.25	-
	1.38	1.999	0.63	3.00	1.75	1.50	0.63	0.38	-
2.50	1.00	1.499	0.50	3.50	1.75	1.50	0.50	0.38	2.63
	1.38	1.999	0.63	3.50	1.75	1.50	0.63	0.38	-
	1.75	2.374	0.75	3.50	1.75	1.50	0.63	0.50	-
3.25	1.38	1.999	0.63	4.50	2.00	1.75	0.59	0.41	3.25
	1.75	2.374	0.75	4.50	2.00	1.75	0.75	0.38	-
	2.00	2.624	0.88	4.50	2.00	1.75	0.75	0.38	-
4.00	1.75	2.374	0.75	5.00	2.00	1.75	0.59	0.53	3.88
	2.00	2.624	0.88	5.00	2.00	1.75	0.59	0.53	4.00
	2.50	3.124	1.00	5.00	2.00	1.75	0.59	0.66	4.44
5.00	2.00	2.624	0.88	6.50	2.00	1.75	0.59	0.53	4.00
	2.50	3.124	1.00	6.50	2.00	1.75	0.59	0.66	4.44
	3.00	3.749	1.00	6.50	2.00	1.75	0.72	0.53	5.25
	3.50	4.249	1.00	6.50	2.00	1.75	0.72	0.53	5.63
6.00	2.50	3.124	1.00	7.50	2.25	2.25	0.59	0.66	4.44
	3.00	3.749	1.00	7.50	2.25	2.25	0.72	0.53	5.25
	3.50	4.249	1.00	7.50	2.25	2.25	0.72	0.53	5.63
	4.00	4.749	1.00	7.50	2.25	2.25	0.88	0.38	6.44
7.00	3.00	3.749	1.00	8.50	2.75	2.75	0.72	0.53	5.25
	3.50	4.249	1.00	8.50	2.75	2.75	0.72	0.53	5.63
	4.00	4.749	1.00	8.50	2.75	2.75	0.88	0.38	6.44
	4.50	5.249	1.00	8.50	2.75	2.75	0.88	0.38	7.13
	5.00	5.749	1.00	8.50	2.75	2.75	0.88	0.38	7.56
8.00	3.50	4.249	1.00	9.50	3.00	3.00	0.72	0.53	5.63
	4.00	4.749	1.00	9.50	3.00	3.00	0.88	0.38	6.44
	4.50	5.249	1.00	9.50	3.00	3.00	0.88	0.38	7.13
	5.00	5.749	1.00	9.50	3.00	3.00	0.88	0.38	7.56
	5.50	6.249	1.00	9.50	3.00	3.00	0.88	0.38	8.38

+ Plus Stroke

Mounting Style and Installation Dimensions – NZ21 Cap End Extended Tie Rod Mounts NFPA MX2 Mount

These mounts are for straight line force transfer applications. The cap extended tie rod mount is recommended for compression (pushing) applications.

The mounting surface should be flat and the frame on which the cylinder is mounted *must* be sufficiently rigid to resist bending moments.

Once fitted into the application framework, mounting nuts should be torqued to the values listed in the table (right).

Tie Rod Torque Values

Torque values in the following table apply to all mounting styles.

Bore	Tie Rod Torque	
	Ft-Lb	Nm
1.50	30	41
2.00	40	54
2.50	80	108
3.25	190	258
4.00	190	258
5.00	550	746
6.00	700	949
7.00	750	1017
8.00	1250	1695

NOTE

For strokes in excess of 30 inches, see "Stop tube selection" on page 77.

WARNING

Failure to mount the cylinder correctly on the frame may result in death, bodily injury and/or property damage.

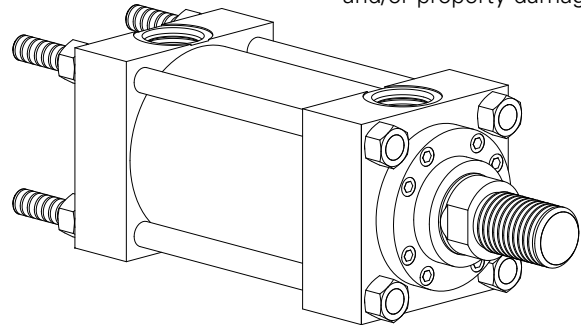

Bore	Rod Dia MM	R	AA	Max AC	BB	(UN) DD	ZJ+	Piston Thick.	Max H
1.50	0.63	1.63	2.30	0.69	1.38	.375-24	5.63	1.38	0.38
	1.00	1.63	2.30	0.69	1.38	.375-24	6.00	1.38	0.38
2.00	1.00	2.05	2.90	0.88	1.81	.500-20	6.00	1.38	0.50
	1.38	2.05	2.90	0.88	1.81	.500-20	6.26	1.38	0.50
2.50	1.00	2.55	3.60	0.88	1.81	.500-20	6.13	1.50	0.50
	1.38	2.55	3.60	0.88	1.81	.500-20	6.38	1.50	0.50
	1.75	2.55	3.60	0.88	1.81	.500-20	6.63	1.50	0.50
3.25	1.38	3.25	4.60	1.12	2.31	.625-18	7.13	1.75	0.63
	1.75	3.25	4.60	1.12	2.31	.625-18	7.38	1.75	0.63
	2.00	3.25	4.60	1.12	2.31	.625-18	7.51	1.75	0.63
4.00	1.75	3.82	5.40	1.12	2.31	.625-18	7.63	2.00	0.63
	2.00	3.82	5.40	1.12	2.31	.625-18	7.75	2.00	0.63
	2.50	3.82	5.40	1.12	2.31	.625-18	8.00	2.00	0.63
5.00	2.00	4.95	7.00	1.56	3.19	.875-14	8.26	2.50	0.81
	2.50	4.95	7.00	1.56	3.19	.875-14	8.50	2.50	0.81
	3.00	4.95	7.00	1.56	3.19	.875-14	8.50	2.50	0.81
	3.50	4.95	7.00	1.56	3.19	.875-14	8.50	2.50	0.81
6.00	2.50	5.73	8.10	1.75	3.63	1.000-14	9.63	2.88	0.94
	3.00	5.73	8.10	1.75	3.63	1.000-14	9.63	2.88	0.94
	3.50	5.73	8.10	1.75	3.63	1.000-14	9.63	2.88	0.94
	4.00	5.73	8.10	1.75	3.63	1.000-14	9.63	2.88	0.94
7.00	3.00	6.58	9.30	2.00	4.13	1.125-12	10.75	3.00	1.06
	3.50	6.58	9.30	2.00	4.13	1.125-12	10.75	3.00	1.06
	4.00	6.58	9.30	2.00	4.13	1.125-12	10.75	3.00	1.06
	4.50	6.58	9.30	2.00	4.13	1.125-12	10.75	3.00	1.06
	5.00	6.58	9.30	2.00	4.13	1.125-12	10.75	3.00	1.06
8.00	3.50	7.50	10.60	2.19	4.50	1.250-12	11.75	3.50	1.12
	4.00	7.50	10.60	2.19	4.50	1.250-12	11.75	3.50	1.12
	4.50	7.50	10.60	2.19	4.50	1.250-12	11.75	3.50	1.12
	5.00	7.50	10.60	2.19	4.50	1.250-12	11.75	3.50	1.12
	5.50	7.50	10.60	2.19	4.50	1.250-12	11.75	3.50	1.12

+ Plus Stroke

See Mount 24 on page 50 for Port Dimensions

Mounting Style and Installation

Dimensions – NZ22 Head End

Extended Tie Rod Mounts NFPA

MX3 Mount

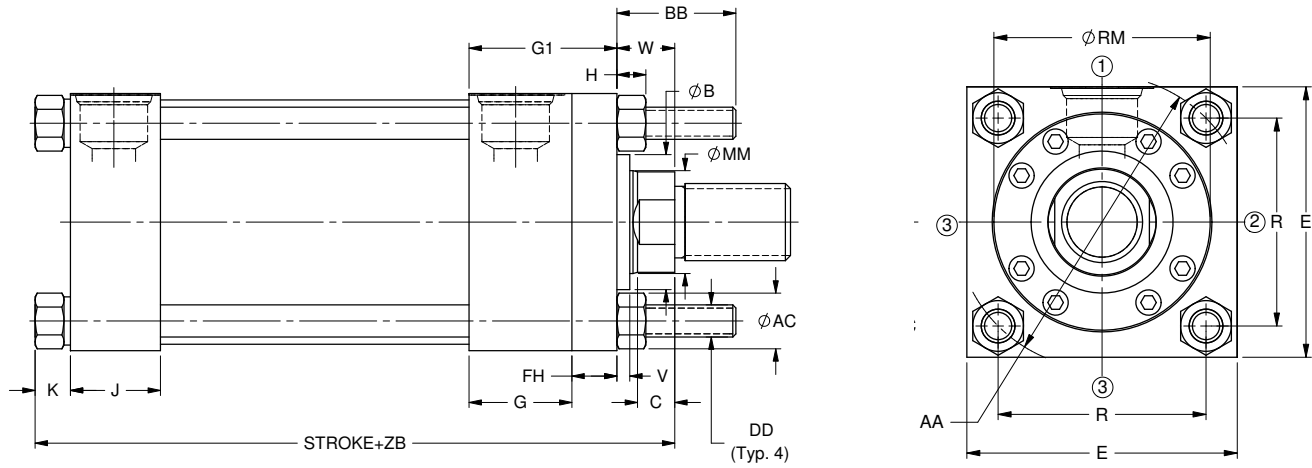

Bore	Rod Dia MM	B +.000/-.002	C	E	G	J	FH	V	R
1.50	0.63	1.124	0.38	2.50	1.75	1.50	0.38	0.25	1.63
	1.00	1.499	0.50	2.50	1.75	1.50	0.38	0.50	1.63
2.00	1.00	1.499	0.50	3.00	1.75	1.50	0.63	0.25	2.05
	1.38	1.999	0.63	3.00	1.75	1.50	0.63	0.38	2.05
2.50	1.00	1.499	0.50	3.50	1.75	1.50	0.63	0.25	2.55
	1.38	1.999	0.63	3.50	1.75	1.50	0.63	0.38	2.55
	1.75	2.374	0.75	3.50	1.75	1.50	0.63	0.50	2.55
3.25	1.38	1.999	0.63	4.50	2.00	1.75	0.75	0.25	3.25
	1.75	2.374	0.75	4.50	2.00	1.75	0.75	0.38	3.25
	2.00	2.624	0.88	4.50	2.00	1.75	0.75	0.38	3.25
4.00	1.75	2.374	0.75	5.00	2.00	1.75	0.88	0.25	3.82
	2.00	2.624	0.88	5.00	2.00	1.75	0.88	0.25	3.82
	2.50	3.124	1.00	5.00	2.00	1.75	0.88	0.38	3.82
5.00	2.00	2.624	0.88	6.50	2.00	1.75	0.88	0.25	4.95
	2.50	3.124	1.00	6.50	2.00	1.75	0.88	0.38	4.95
	3.00	3.749	1.00	6.50	2.00	1.75	0.88	0.38	4.95
	3.50	4.249	1.00	6.50	2.00	1.75	0.88	0.38	4.95
6.00	2.50	3.124	1.00	7.50	2.25	2.25	1.00	0.25	5.73
	3.00	3.749	1.00	7.50	2.25	2.25	1.00	0.25	5.73
	3.50	4.249	1.00	7.50	2.25	2.25	1.00	0.25	5.73
	4.00	4.749	1.00	7.50	2.25	2.25	1.00	0.25	5.73
7.00	3.00	3.749	1.00	8.50	2.75	2.75	1.00	0.25	6.58
	3.50	4.249	1.00	8.50	2.75	2.75	1.00	0.25	6.58
	4.00	4.749	1.00	8.50	2.75	2.75	1.00	0.25	6.58
	4.50	5.249	1.00	8.50	2.75	2.75	1.00	0.25	6.58
	5.00	5.749	1.00	8.50	2.75	2.75	1.00	0.25	6.58
8.00	3.50	4.249	1.00	9.50	3.00	3.00	1.00	0.25	7.50
	4.00	4.749	1.00	9.50	3.00	3.00	1.00	0.25	7.50
	4.50	5.249	1.00	9.50	3.00	3.00	1.00	0.25	7.50
	5.00	5.749	1.00	9.50	3.00	3.00	1.00	0.25	7.50
	5.50	6.249	1.00	9.50	3.00	3.00	1.00	0.25	7.50

+ Plus Stroke

Mounting Style and Installation

Dimensions – NZ22 Head End

Extended Tie Rod Mounts NFPA

MX3 Mount

These mounts are for straight line force transfer applications. The head extended tie rod mount is recommended for tension (pulling) applications.

The mounting surface should be flat and the frame on which the cylinder is mounted *must* be sufficiently rigid to resist bending moments.

On head mount applications, the cartridge provides a pilot diameter to align the rod in the mounting frame.

Once fitted into the application framework, mounting nuts should be torqued to the values listed in the table on page 45.

NOTE

For strokes in excess of 30 inches, see "Stop tube selection" on page 77.

WARNING

The force on the rod should be perpendicular to the mounting surface and coincide with the centerline of the piston rod. For eccentric

loads, the larger of the two available rods in each bore size is recommended. Stop tubes should also be considered.

WARNING

Failure to mount the cylinder correctly on the frame may result in death, bodily injury and/or property damage.

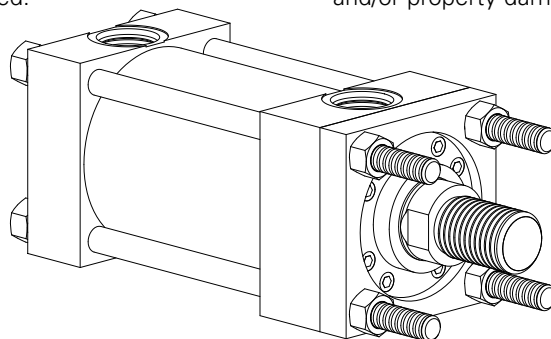

Bore	Rod Dia MM	AA	Max AC	BB	(UN) DD	Max H	ZB+ Max	Piston Thick.	K
1.50	0.63	2.30	0.69	1.38	.375-24	0.34	6.04	1.38	0.41
	1.00	2.30	0.69	1.38	.375-24	0.34	6.41	1.38	0.41
2.00	1.00	2.90	0.88	1.81	.500-20	0.45	6.56	1.38	0.55
	1.38	2.90	0.88	1.81	.500-20	0.45	6.82	1.38	0.55
2.50	1.00	3.60	0.88	1.81	.500-20	0.45	6.68	1.50	0.55
	1.38	3.60	0.88	1.81	.500-20	0.45	6.94	1.50	0.55
	1.75	3.60	0.88	1.81	.500-20	0.45	7.18	1.50	0.55
3.25	1.38	4.60	1.12	2.31	.625-18	0.56	7.80	1.75	0.67
	1.75	4.60	1.12	2.31	.625-18	0.56	8.05	1.75	0.67
	2.00	4.60	1.12	2.31	.625-18	0.56	8.18	1.75	0.67
4.00	1.75	5.40	1.12	2.31	.625-18	0.56	8.40	2.00	0.78
	2.00	5.40	1.12	2.31	.625-18	0.56	8.53	2.00	0.78
	2.50	5.40	1.12	2.31	.625-18	0.56	8.78	2.00	0.78
5.00	2.00	7.00	1.56	3.19	.875-14	0.78	9.18	2.50	0.92
	2.50	7.00	1.56	3.19	.875-14	0.78	9.43	2.50	0.92
	3.00	7.00	1.56	3.19	.875-14	0.78	9.43	2.50	0.92
	3.50	7.00	1.56	3.19	.875-14	0.78	9.43	2.50	0.92
6.00	2.50	8.10	1.75	3.63	1.000-14	0.89	10.66	2.88	1.03
	3.00	8.10	1.75	3.63	1.000-14	0.89	10.66	2.88	1.03
	3.50	8.10	1.75	3.63	1.000-14	0.89	10.66	2.88	1.03
	4.00	8.10	1.75	3.63	1.000-14	0.89	10.66	2.88	1.03
7.00	3.00	9.30	2.00	4.13	1.125-12	1.00	11.92	3.00	1.17
	3.50	9.30	2.00	4.13	1.125-12	1.00	11.92	3.00	1.17
	4.00	9.30	2.00	4.13	1.125-12	1.00	11.92	3.00	1.17
	4.50	9.30	2.00	4.13	1.125-12	1.00	11.92	3.00	1.17
	5.00	9.30	2.00	4.13	1.125-12	1.00	11.92	3.00	1.17
8.00	3.50	10.60	2.19	4.50	1.250-12	1.09	13.00	3.50	1.26
	4.00	10.60	2.19	4.50	1.250-12	1.09	13.00	3.50	1.26
	4.50	10.60	2.19	4.50	1.250-12	1.09	13.00	3.50	1.26
	5.00	10.60	2.19	4.50	1.250-12	1.09	13.00	3.50	1.26
	5.50	10.60	2.19	4.50	1.250-12	1.09	13.00	3.50	1.26

+ Plus Stroke

See Mount 24 on page 50 for Port Dimensions

Mounting Style and Installation

Dimensions – NZ23 Both End

Extended Tie Rod Mounts NFPA

MX1 Mount

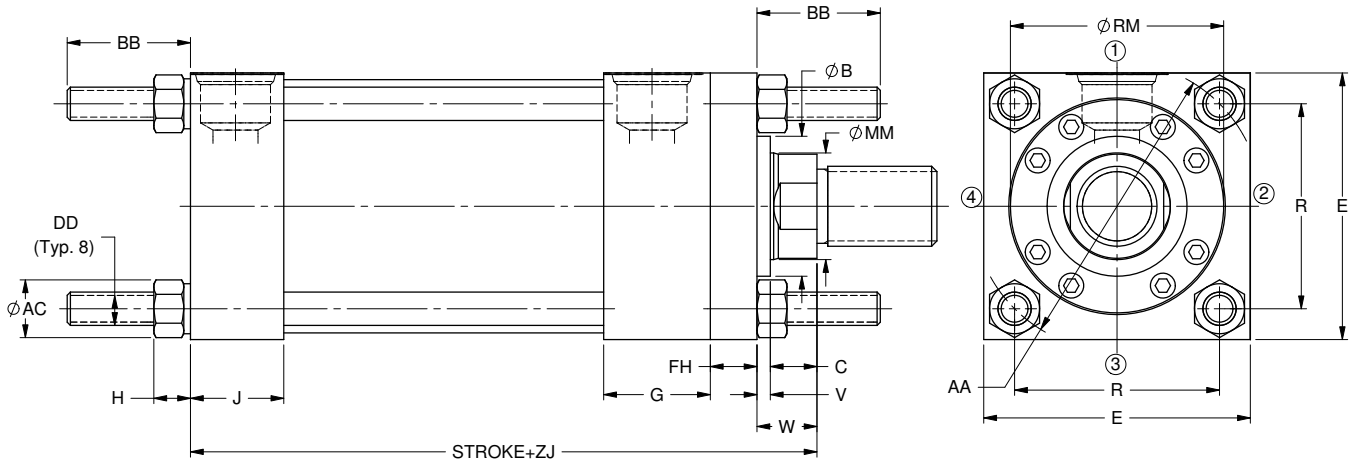

Bore	Rod Dia MM	B +0.000/-0.002	C	E	G	J	FH	V	W
1.50	0.63	1.124	0.38	2.50	1.75	1.50	0.38	0.25	0.63
	1.00	1.499	0.50	2.50	1.75	1.50	0.38	0.50	1.00
2.00	1.00	1.499	0.50	3.00	1.75	1.50	0.63	0.25	0.75
	1.38	1.999	0.63	3.00	1.75	1.50	0.63	0.38	1.01
2.50	1.00	1.499	0.50	3.50	1.75	1.50	0.63	0.25	0.75
	1.38	1.999	0.63	3.50	1.75	1.50	0.63	0.38	1.01
	1.75	2.374	0.75	3.50	1.75	1.50	0.63	0.50	1.25
3.25	1.38	1.999	0.63	4.50	2.00	1.75	0.75	0.25	0.88
	1.75	2.374	0.75	4.50	2.00	1.75	0.75	0.38	1.13
	2.00	2.624	0.88	4.50	2.00	1.75	0.75	0.38	1.26
4.00	1.75	2.374	0.75	5.00	2.00	1.75	0.88	0.25	1.00
	2.00	2.624	0.88	5.00	2.00	1.75	0.88	0.25	1.13
	2.50	3.124	1.00	5.00	2.00	1.75	0.88	0.38	1.38
5.00	2.00	2.624	0.88	6.50	2.00	1.75	0.88	0.25	1.13
	2.50	3.124	1.00	6.50	2.00	1.75	0.88	0.38	1.38
	3.00	3.749	1.00	6.50	2.00	1.75	0.88	0.38	1.38
	3.50	4.249	1.00	6.50	2.00	1.75	0.88	0.38	1.38
6.00	2.50	3.124	1.00	7.50	2.25	2.25	1.00	0.25	1.25
	3.00	3.749	1.00	7.50	2.25	2.25	1.00	0.25	1.25
	3.50	4.249	1.00	7.50	2.25	2.25	1.00	0.25	1.25
	4.00	4.749	1.00	7.50	2.25	2.25	1.00	0.25	1.25
7.00	3.00	3.749	1.00	8.50	2.75	2.75	1.00	0.25	1.25
	3.50	4.249	1.00	8.50	2.75	2.75	1.00	0.25	1.25
	4.00	4.749	1.00	8.50	2.75	2.75	1.00	0.25	1.25
	4.50	5.249	1.00	8.50	2.75	2.75	1.00	0.25	1.25
	5.00	5.749	1.00	8.50	2.75	2.75	1.00	0.25	1.25
8.00	3.50	4.249	1.00	9.50	3.00	3.00	1.00	0.25	1.25
	4.00	4.749	1.00	9.50	3.00	3.00	1.00	0.25	1.25
	4.50	5.249	1.00	9.50	3.00	3.00	1.00	0.25	1.25
	5.00	5.749	1.00	9.50	3.00	3.00	1.00	0.25	1.25
	5.50	6.249	1.00	9.50	3.00	3.00	1.00	0.25	1.25

+ Plus Stroke

Mounting Style and Installation Dimensions – NZ23 Both End Extended Tie Rod Mounts NFPA MX1 Mount

These mounts are for straight line force transfer applications. Both ends extended tie rod mounts are suited for tension and compression applications or applications where additional hardware is to be attached to cylinders.

The mounting surface should be flat and the frame on which the cylinder is mounted *must* be sufficiently rigid to resist bending moments.

Once fitted into the application framework, mounting nuts should be torqued to the values listed in the table on page 46.

NOTE

For strokes in excess of 30 inches, see "Stop tube selection" on page 77.

WARNING

The force on the rod should be perpendicular to the mounting surface and coincide with the centerline of the

piston rod. For eccentric loads, the larger of the two available rods in each bore size is recommended. Stop tubes should also be considered.

WARNING

Failure to mount the cylinder correctly on the frame may result in death, bodily injury and/or property damage.

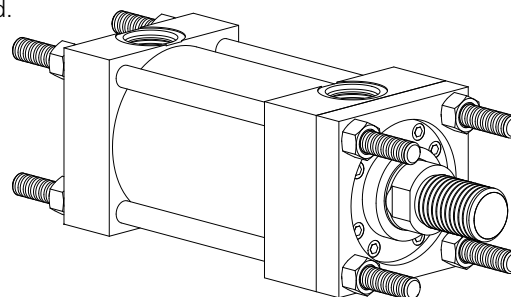

Bore	Rod Dia MM	R	AA	Max AC	BB	(UN) DD	ZJ+ Max	Piston Thick.	Max H
1.50	0.63	1.63	2.30	0.69	1.38	.375-24	5.63	1.38	0.34
	1.00	1.63	2.30	0.69	1.38	.375-24	6.00	1.38	0.34
2.00	1.00	2.05	2.90	0.88	1.81	.500-20	6.00	1.38	0.45
	1.38	2.05	2.90	0.88	1.81	.500-20	6.26	1.38	0.45
2.50	1.00	2.55	3.60	0.88	1.81	.500-20	6.13	1.50	0.45
	1.38	2.55	3.60	0.88	1.81	.500-20	6.38	1.50	0.45
	1.75	2.55	3.60	0.88	1.81	.500-20	6.63	1.50	0.45
3.25	1.38	3.25	4.60	1.12	2.31	.625-18	7.13	1.75	0.56
	1.75	3.25	4.60	1.12	2.31	.625-18	7.38	1.75	0.56
	2.00	3.25	4.60	1.12	2.31	.625-18	7.51	1.75	0.56
4.00	1.75	3.82	5.40	1.12	2.31	.625-18	7.63	2.00	0.56
	2.00	3.82	5.40	1.12	2.31	.625-18	7.76	2.00	0.56
	2.50	3.82	5.40	1.12	2.31	.625-18	8.00	2.00	0.56
5.00	2.00	4.95	7.00	1.56	3.19	.875-14	8.26	2.50	0.78
	2.50	4.95	7.00	1.56	3.19	.875-14	8.50	2.50	0.78
	3.00	4.95	7.00	1.56	3.19	.875-14	8.50	2.50	0.78
	3.50	4.95	7.00	1.56	3.19	.875-14	8.50	2.50	0.78
6.00	2.50	5.73	8.10	1.75	3.63	1.000-14	9.63	2.88	0.89
	3.00	5.73	8.10	1.75	3.63	1.000-14	9.63	2.88	0.89
	3.50	5.73	8.10	1.75	3.63	1.000-14	9.63	2.88	0.89
	4.00	5.73	8.10	1.75	3.63	1.000-14	9.63	2.88	0.89
7.00	3.00	6.58	9.30	2.00	4.13	1.125-12	10.75	3.00	1.00
	3.50	6.58	9.30	2.00	4.13	1.125-12	10.75	3.00	1.00
	4.00	6.58	9.30	2.00	4.13	1.125-12	10.75	3.00	1.00
	4.50	6.58	9.30	2.00	4.13	1.125-12	10.75	3.00	1.00
	5.00	6.58	9.30	2.00	4.13	1.125-12	10.75	3.00	1.00
8.00	3.50	7.50	10.60	2.19	4.50	1.250-12	11.75	3.50	1.09
	4.00	7.50	10.60	2.19	4.50	1.250-12	11.75	3.50	1.09
	4.50	7.50	10.60	2.19	4.50	1.250-12	11.75	3.50	1.09
	5.00	7.50	10.60	2.19	4.50	1.250-12	11.75	3.50	1.09
	5.50	7.50	10.60	2.19	4.50	1.250-12	11.75	3.50	1.09

+ Plus Stroke

See Mount 24 on page 50 for Port Dimensions

Mounting Style and Installation Dimensions – NZ24 No Mounts

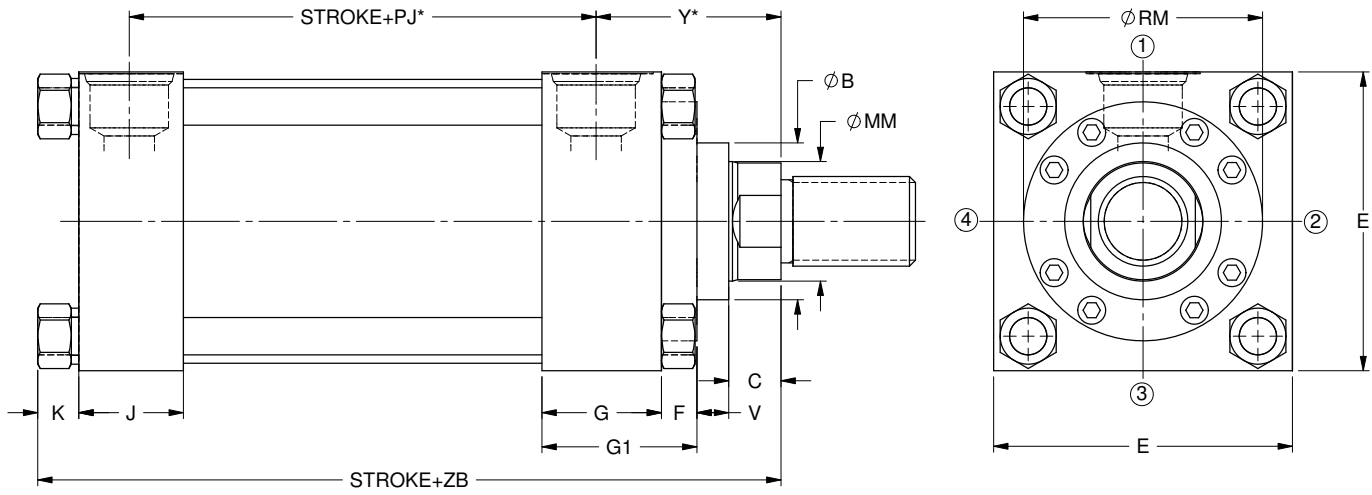

Bore	Rod Dia MM	B +0.00/ -0.02	C	E	G	J	F	V	Y	PJ+	RM	ZB+ Max	Piston Thick. K	
1.50	0.63	1.124	0.38	2.50	1.75	1.50	0.38	0.25	2.47	2.69	-	6.04	1.38	0.41
	1.00	1.499	0.50	2.50	1.75	1.50	0.38	0.50	2.47	2.69	-	6.41	1.38	0.41
2.00	1.00	1.499	0.50	3.00	1.75	1.50	0.63	0.25	2.47	2.69	-	6.56	1.38	0.55
	1.38	1.999	0.63	3.00	1.75	1.50	0.63	0.38	2.72	2.69	-	6.82	1.38	0.55
2.50	1.00	1.499	0.50	3.50	1.75	1.50	0.50	0.38	2.47	2.81	2.63	6.68	1.50	0.55
	1.38	1.999	0.63	3.50	1.75	1.50	0.63	0.38	2.72	2.81	-	6.94	1.50	0.55
	1.75	2.374	0.75	3.50	1.75	1.50	0.63	0.50	2.97	2.81	-	7.18	1.50	0.55
3.25	1.38	1.999	0.63	4.50	2.00	1.75	0.59	0.41	2.72	3.56	3.25	7.80	1.75	0.67
	1.75	2.374	0.75	4.50	2.00	1.75	0.75	0.38	2.97	3.56	-	8.05	1.75	0.67
	2.00	2.624	0.88	4.50	2.00	1.75	0.75	0.38	3.09	3.56	-	8.18	1.75	0.67
4.00	1.75	2.374	0.75	5.00	2.00	1.75	0.59	0.53	2.97	3.81	3.88	8.40	2.00	0.78
	2.00	2.624	0.88	5.00	2.00	1.75	0.59	0.53	3.09	3.81	4.00	8.53	2.00	0.78
	2.50	3.124	1.00	5.00	2.00	1.75	0.59	0.66	3.34	3.81	4.44	8.78	2.00	0.78
5.00	2.00	2.624	0.88	6.50	2.00	1.75	0.59	0.53	3.09	4.31	4.00	9.18	2.50	0.92
	2.50	3.124	1.00	6.50	2.00	1.75	0.59	0.66	3.34	4.31	4.44	9.43	2.50	0.92
	3.00	3.749	1.00	6.50	2.00	1.75	0.72	0.53	3.34	4.31	5.25	9.43	2.50	0.92
	3.50	4.249	1.00	6.50	2.00	1.75	0.72	0.53	3.34	4.31	5.63	9.43	2.50	0.92
6.00	2.50	3.124	1.00	7.50	2.25	2.25	0.59	0.66	3.59	4.69	4.44	10.66	2.88	1.03
	3.00	3.749	1.00	7.50	2.25	2.25	0.72	0.53	3.59	4.69	5.25	10.66	2.88	1.03
	3.50	4.249	1.00	7.50	2.25	2.25	0.72	0.53	3.59	4.69	5.63	10.66	2.88	1.03
	4.00	4.749	1.00	7.50	2.25	2.25	0.88	0.38	3.59	4.69	6.44	10.66	2.88	1.03
7.00	3.00	3.749	1.00	8.50	2.75	2.75	0.72	0.53	3.94	5.13	5.25	11.92	3.00	1.17
	3.50	4.249	1.00	8.50	2.75	2.75	0.72	0.53	3.94	5.13	5.63	11.92	3.00	1.17
	4.00	4.749	1.00	8.50	2.75	2.75	0.88	0.38	3.94	5.13	6.44	11.92	3.00	1.17
	4.50	5.249	1.00	8.50	2.75	2.75	0.88	0.38	3.94	5.13	7.13	11.92	3.00	1.17
	5.00	5.749	1.00	8.50	2.75	2.75	0.88	0.38	3.94	5.13	7.56	11.92	3.00	1.17
8.00	3.50	4.249	1.00	9.50	3.00	3.00	0.72	0.53	4.06	5.88	5.63	13.00	3.50	1.26
	4.00	4.749	1.00	9.50	3.00	3.00	0.88	0.38	4.06	5.88	6.44	13.00	3.50	1.26
	4.50	5.249	1.00	9.50	3.00	3.00	0.88	0.38	4.06	5.88	7.13	13.00	3.50	1.26
	5.00	5.749	1.00	9.50	3.00	3.00	0.88	0.38	4.06	5.88	7.56	13.00	3.50	1.26
	5.50	6.249	1.00	9.50	3.00	3.00	0.88	0.38	4.06	5.88	8.38	13.00	3.50	1.26

+ Plus Stroke

* Port dimensions for standard ports only. Consult Eaton for flange, manifold and special ports.

Mounting Style and Installation Dimensions – NZ24 No Mounts

No mounts are for moving loads on a flat guided surface such as carriage rails.

Mounting surface should be flat and parallel to centerline of the piston rod.

The load should be guided to traverse along the centerline of the piston rod.

The frame on which the cylinder is mounted *must* be sufficiently rigid to resist bending moments.

NOTE

For strokes in excess of 30 inches, see "Stop tube selection" on page 77.

WARNING

With unsupported loads, the bearing must absorb more force.

For these applications, the larger available rod is recommended, and stop tubes should be considered.

External clamping mechanism on head and cap is required to hold cylinder in place during operation.

Use high tensile socket head cap screws or hex head bolts tightened to the manufacturer's recommended torque in clamping.

For high shock applications, dowel pins or shear keys should be incorporated in the mounting design. For these applications, consider a keyed side lug mount, NZ04.

For severe side load applications, consult your local Eaton sales engineer.

WARNING

Failure to mount the cylinder correctly on the frame may result in death, bodily injury and/or property damage.

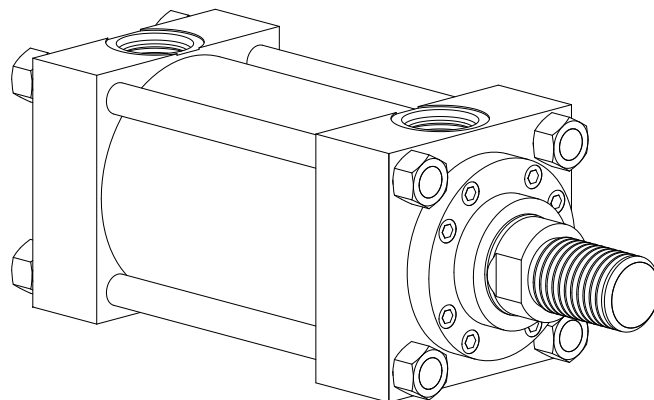

Mounting Style and Installation

Dimensions – NZ25 Double Rod

Side Lug Mount NFPA MS7 Mount

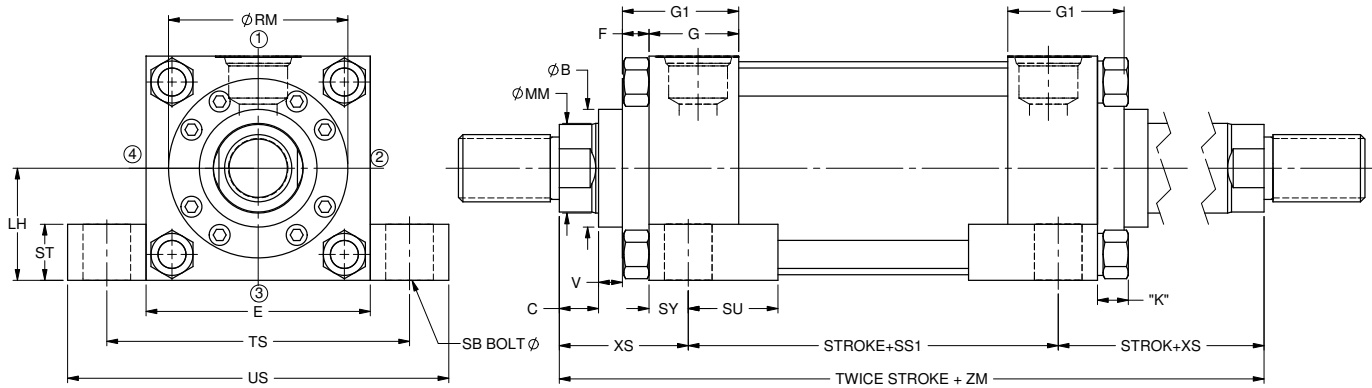

Bore	Rod Dia MM	B +.000/- .002	C	E	G	F	V	RM	LH ±.002	SS1+
1.50	0.63	1.124	0.38	2.50	1.75	0.38	0.25	-	1.243	4.13
	1.00	1.499	0.50	2.50	1.75	0.38	0.50	-	1.243	4.13
2.00	1.00	1.499	0.50	3.00	1.75	0.63	0.25	-	1.493	3.88
	1.38	1.999	0.63	3.00	1.75	0.63	0.38	-	1.493	3.88
2.50	1.00	1.499	0.50	3.50	1.75	0.50	0.38	2.63	1.743	3.63
	1.38	1.999	0.63	3.50	1.75	0.63	0.38	-	1.743	3.63
	1.75	2.374	0.75	3.50	1.75	0.63	0.50	-	1.743	3.63
3.25	1.38	1.999	0.63	4.50	2.00	0.59	0.41	3.25	2.243	4.38
	1.75	2.374	0.75	4.50	2.00	0.75	0.38	-	2.243	4.38
	2.00	2.624	0.88	4.50	2.00	0.75	0.38	-	2.243	4.38
4.00	1.75	2.374	0.75	5.00	2.00	0.59	0.53	3.88	2.493	4.25
	2.00	2.624	0.88	5.00	2.00	0.59	0.53	4.00	2.493	4.25
	2.50	3.124	1.00	5.00	2.00	0.59	0.66	4.44	2.493	4.25
5.00	2.00	2.624	0.88	6.50	2.00	0.59	0.53	4.00	3.243	4.75
	2.50	3.124	1.00	6.50	2.00	0.59	0.66	4.44	3.243	4.75
	3.00	3.749	1.00	6.50	2.00	0.72	0.53	5.25	3.243	4.75
	3.50	4.249	1.00	6.50	2.00	0.72	0.53	5.63	3.243	4.75
6.00	2.50	3.124	1.00	7.50	2.25	0.59	0.66	4.44	3.743	5.13
	3.00	3.749	1.00	7.50	2.25	0.72	0.53	5.25	3.743	5.13
	3.50	4.249	1.00	7.50	2.25	0.72	0.53	5.63	3.743	5.13
	4.00	4.749	1.00	7.50	2.25	0.88	0.38	6.44	3.743	5.13
7.00	3.00	3.749	1.00	8.50	2.75	0.72	0.53	5.25	4.243	5.75
	3.50	4.249	1.00	8.50	2.75	0.72	0.53	5.63	4.243	5.75
	4.00	4.749	1.00	8.50	2.75	0.88	0.38	6.44	4.243	5.75
	4.50	5.249	1.00	8.50	2.75	0.88	0.38	7.13	4.243	5.75
	5.00	5.749	1.00	8.50	2.75	0.88	0.38	7.56	4.243	5.75
8.00	3.50	4.249	1.00	9.50	3.00	0.72	0.53	5.63	4.743	6.75
	4.00	4.749	1.00	9.50	3.00	0.88	0.38	6.44	4.743	6.75
	4.50	5.249	1.00	9.50	3.00	0.88	0.38	7.13	4.743	6.75
	5.00	5.749	1.00	9.50	3.00	0.88	0.38	7.56	4.743	6.75
	5.50	6.249	1.00	9.50	3.00	0.88	0.38	8.38	4.743	6.75

+ Plus Stroke

Mounting Style and Installation

Dimensions – NZ25 Double Rod

Side Lug Mount NFPA MS7 Mount

Double rod cylinders are specified when equal displacement is desired on both sides of the piston, or when the application is such that another function can be performed simultaneously with a second rod. The single rod mount application data is also applicable to double rod cylinders. Rod and pilot related dimensions are typical for both ends.

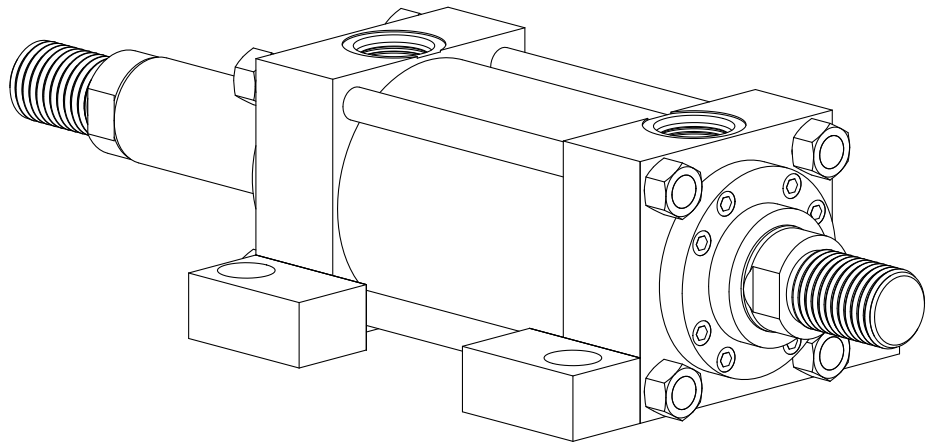

WARNING

Failure to mount the cylinder correctly on the frame may result in death, bodily injury and/or property damage.

Bore	Rod Dia MM	ST	SU	SY	TS	US	SB	XS	ZM+	Piston Thick.	K
1.50	0.63	0.50	0.91	0.38	3.25	4.00	0.38	1.38	6.88	1.38	0.41
	1.00	0.50	0.91	0.38	3.25	4.00	0.38	1.75	7.63	1.38	0.41
2.00	1.00	0.75	1.24	0.50	4.00	5.00	0.50	1.88	7.63	1.38	0.55
	1.38	0.75	1.24	0.50	4.00	5.00	0.50	2.13	8.13	1.38	0.55
2.50	1.00	1.00	1.56	0.69	4.88	6.25	0.75	2.06	7.75	1.50	0.55
	1.38	1.00	1.56	0.69	4.88	6.25	0.75	2.31	8.25	1.50	0.55
	1.75	1.00	1.56	0.69	4.88	6.25	0.75	2.56	8.75	1.50	0.55
3.25	1.38	1.00	1.55	0.69	5.88	7.25	0.75	2.31	9.00	1.75	0.67
	1.75	1.00	1.55	0.69	5.88	7.25	0.75	2.56	9.50	1.75	0.67
	2.00	1.00	1.55	0.69	5.88	7.25	0.75	2.69	9.75	1.75	0.67
4.00	1.75	1.25	2.00	0.88	6.75	8.50	1.00	2.75	9.75	2.00	0.78
	2.00	1.25	2.00	0.88	6.75	8.50	1.00	2.88	10.00	2.00	0.78
	2.50	1.25	2.00	0.88	6.75	8.50	1.00	3.13	10.50	2.00	0.78
5.00	2.00	1.25	2.00	0.88	8.25	10.00	1.00	2.88	10.50	2.50	0.92
	2.50	1.25	2.00	0.88	8.25	10.00	1.00	3.13	11.00	2.50	0.92
	3.00	1.25	2.00	0.88	8.25	10.00	1.00	3.13	11.00	2.50	0.92
	3.50	1.25	2.00	0.88	8.25	10.00	1.00	3.13	11.00	2.50	0.92
6.00	2.50	1.50	2.50	1.13	9.75	12.00	1.25	3.38	11.88	2.88	1.03
	3.00	1.50	2.50	1.13	9.75	12.00	1.25	3.38	11.88	2.88	1.03
	3.50	1.50	2.50	1.13	9.75	12.00	1.25	3.38	11.88	2.88	1.03
	4.00	1.50	2.50	1.13	9.75	12.00	1.25	3.38	11.88	2.88	1.03
7.00	3.00	1.75	2.88	1.38	11.25	14.00	1.50	3.63	13.00	3.00	1.17
	3.50	1.75	2.88	1.38	11.25	14.00	1.50	3.63	13.00	3.00	1.17
	4.00	1.75	2.88	1.38	11.25	14.00	1.50	3.63	13.00	3.00	1.17
	4.50	1.75	2.88	1.38	11.25	14.00	1.50	3.63	13.00	3.00	1.17
	5.00	1.75	2.88	1.38	11.25	14.00	1.50	3.63	13.00	3.00	1.17
8.00	3.50	1.75	2.88	1.38	12.25	15.00	1.50	3.63	14.00	3.50	1.26
	4.00	1.75	2.88	1.38	12.25	15.00	1.50	3.63	14.00	3.50	1.26
	4.50	1.75	2.88	1.38	12.25	15.00	1.50	3.63	14.00	3.50	1.26
	5.00	1.75	2.88	1.38	12.25	15.00	1.50	3.63	14.00	3.50	1.26
	5.50	1.75	2.88	1.38	12.25	15.00	1.50	3.63	14.00	3.50	1.26

+ Plus Stroke

See Mount 24 on page 50 for Port Dimensions

Mounting Style and Installation

Dimensions – NZ47 Cap Fixed Eye

Mount ANSI MP3

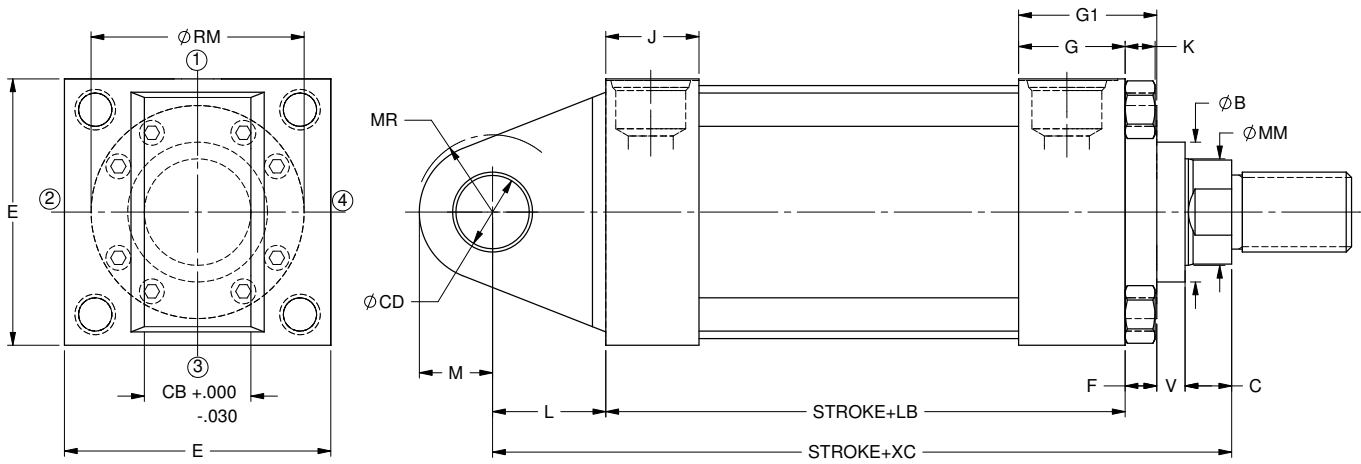

Bore	Rod Dia MM	B +0.000/-0.002	C	E	G	J	F	V	RM
1.50	0.63	1.124	0.38	2.50	1.75	1.50	0.38	0.25	-
	1.00	1.499	0.50	2.50	1.75	1.50	0.38	0.50	-
2.00	1.00	1.499	0.50	3.00	1.75	1.50	0.63	0.25	-
	1.38	1.999	0.63	3.00	1.75	1.50	0.63	0.38	-
2.50	1.00	1.499	0.50	3.50	1.75	1.50	0.50	0.38	2.63
	1.38	1.999	0.63	3.50	1.75	1.50	0.63	0.38	-
	1.75	2.374	0.75	3.50	1.75	1.50	0.63	0.50	-
3.25	1.38	1.999	0.63	4.50	2.00	1.75	0.59	0.41	3.25
	1.75	2.374	0.75	4.50	2.00	1.75	0.75	0.38	-
	2.00	2.624	0.88	4.50	2.00	1.75	0.75	0.38	-
4.00	1.75	2.374	0.75	5.00	2.00	1.75	0.59	0.53	3.88
	2.00	2.624	0.88	5.00	2.00	1.75	0.59	0.53	4.00
	2.50	3.124	1.00	5.00	2.00	1.75	0.59	0.66	4.44
5.00	2.00	2.624	0.88	6.50	2.00	1.75	0.59	0.53	4.00
	2.50	3.124	1.00	6.50	2.00	1.75	0.59	0.66	4.44
	3.00	3.749	1.00	6.50	2.00	1.75	0.72	0.53	5.25
	3.50	4.249	1.00	6.50	2.00	1.75	0.72	0.53	5.63
6.00	2.50	3.124	1.00	7.50	2.25	2.25	0.59	0.66	4.44
	3.00	3.749	1.00	7.50	2.25	2.25	0.72	0.53	5.25
	3.50	4.249	1.00	7.50	2.25	2.25	0.72	0.53	5.63
	4.00	4.749	1.00	7.50	2.25	2.25	0.88	0.38	6.44
7.00	3.00	3.749	1.00	8.50	2.75	2.75	0.72	0.53	5.25
	3.50	4.249	1.00	8.50	2.75	2.75	0.72	0.53	5.63
	4.00	4.749	1.00	8.50	2.75	2.75	0.88	0.38	6.44
	4.50	5.249	1.00	8.50	2.75	2.75	0.88	0.38	7.13
	5.00	5.749	1.00	8.50	2.75	2.75	0.88	0.38	7.56
8.00	3.50	4.249	1.00	9.50	3.00	3.00	0.72	0.53	5.63
	4.00	4.749	1.00	9.50	3.00	3.00	0.88	0.38	6.44
	4.50	5.249	1.00	9.50	3.00	3.00	0.88	0.38	7.13
	5.00	5.749	1.00	9.50	3.00	3.00	0.88	0.38	7.56
	5.50	6.249	1.00	9.50	3.00	3.00	0.88	0.38	8.38

+ Plus Stroke

Mounting Style and Installation Dimensions – NZ47 Cap Fixed Eye Mount ANSI MP3

These mounts are for applications in which the machine member travels in a curved path within one plane.

These mounts can be used both in compression (push) and tension (pull). Care must be exercised to prevent rod buckling in compression applications with long strokes. See page 81 for stroke limitations.

NOTE

For strokes in excess of 24 inches, see “Stop tube selection” on page 77.

WARNING

The centerline of the machine member that attaches to the swivel pin must be perpendicular to the centerline of the piston rod and the curved path must be in one plane only. Any misalignment will cause excess side loading on the bearing and piston. This will lead to premature failure.

For applications with small amounts of misalignment, consider the spherical bearing mount NZ11.

WARNING

Failure to mount the cylinder correctly on the frame may result in death, bodily injury and/or property damage.

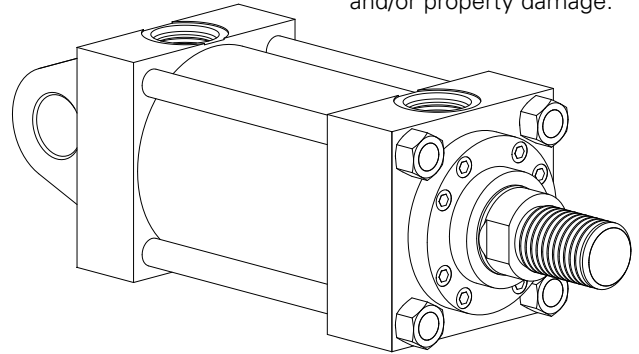

Bore	Rod Dia MM	L	M	CB	CD	MR	LB+	XC+	Piston Thick.	K
1.50	0.63	0.75	0.50	0.75	0.500	0.56	4.63	6.38	1.38	0.41
	1.00	0.75	0.50	0.75	0.500	0.56	4.63	6.75	1.38	0.41
2.00	1.00	1.25	0.75	1.25	0.750	1.06	4.63	7.25	1.38	0.55
	1.38	1.25	0.75	1.25	0.750	1.06	4.63	7.50	1.38	0.55
2.50	1.00	1.25	0.75	1.25	0.750	1.06	4.75	7.38	1.50	0.55
	1.38	1.25	0.75	1.25	0.750	1.06	4.75	7.63	1.50	0.55
	1.75	1.25	0.75	1.25	0.750	1.06	4.75	7.88	1.50	0.55
3.25	1.38	1.50	1.00	1.50	1.000	1.13	5.50	8.63	1.75	0.67
	1.75	1.50	1.00	1.50	1.000	1.13	5.50	8.88	1.75	0.67
	2.00	1.50	1.00	1.50	1.000	1.13	5.50	9.00	1.75	0.67
4.00	1.75	2.13	1.38	2.00	1.375	1.75	5.75	9.75	2.00	0.78
	2.00	2.13	1.38	2.00	1.375	1.75	5.75	9.88	2.00	0.78
	2.50	2.13	1.38	2.00	1.375	1.75	5.75	10.13	2.00	0.78
5.00	2.00	2.25	1.75	2.50	1.750	1.88	6.25	10.50	2.50	0.92
	2.50	2.25	1.75	2.50	1.750	1.88	6.25	10.75	2.50	0.92
	3.00	2.25	1.75	2.50	1.750	1.88	6.25	10.75	2.50	0.92
	3.50	2.25	1.75	2.50	1.750	1.88	6.25	10.75	2.50	0.92
6.00	2.50	2.50	2.00	2.50	2.000	2.13	7.38	12.13	2.88	1.03
	3.00	2.50	2.00	2.50	2.000	2.13	7.38	12.13	2.88	1.03
	3.50	2.50	2.00	2.50	2.000	2.13	7.38	12.13	2.88	1.03
	4.00	2.50	2.00	2.50	2.000	2.13	7.38	12.13	2.88	1.03
7.00	3.00	3.00	2.50	3.00	2.500	2.50	8.50	13.75	3.00	1.17
	3.50	3.00	2.50	3.00	2.500	2.50	8.50	13.75	3.00	1.17
	4.00	3.00	2.50	3.00	2.500	2.50	8.50	13.75	3.00	1.17
	4.50	3.00	2.50	3.00	2.500	2.50	8.50	13.75	3.00	1.17
	5.00	3.00	2.50	3.00	2.500	2.50	8.50	13.75	3.00	1.17
8.00	3.50	3.25	2.75	3.00	3.000	2.75	9.50	15.00	3.50	1.26
	4.00	3.25	2.75	3.00	3.000	2.75	9.50	15.00	3.50	1.26
	4.50	3.25	2.75	3.00	3.000	2.75	9.50	15.00	3.50	1.26
	5.00	3.25	2.75	3.00	3.000	2.75	9.50	15.00	3.50	1.26
	5.50	3.25	2.75	3.00	3.000	2.75	9.50	15.00	3.50	1.26

+ Plus Stroke

See Mount 24 on page 50 for Port Dimensions

Mounting Style and Installation

Dimensions – NZ48 Cap

Detachable Eye Mount ANSI MP4

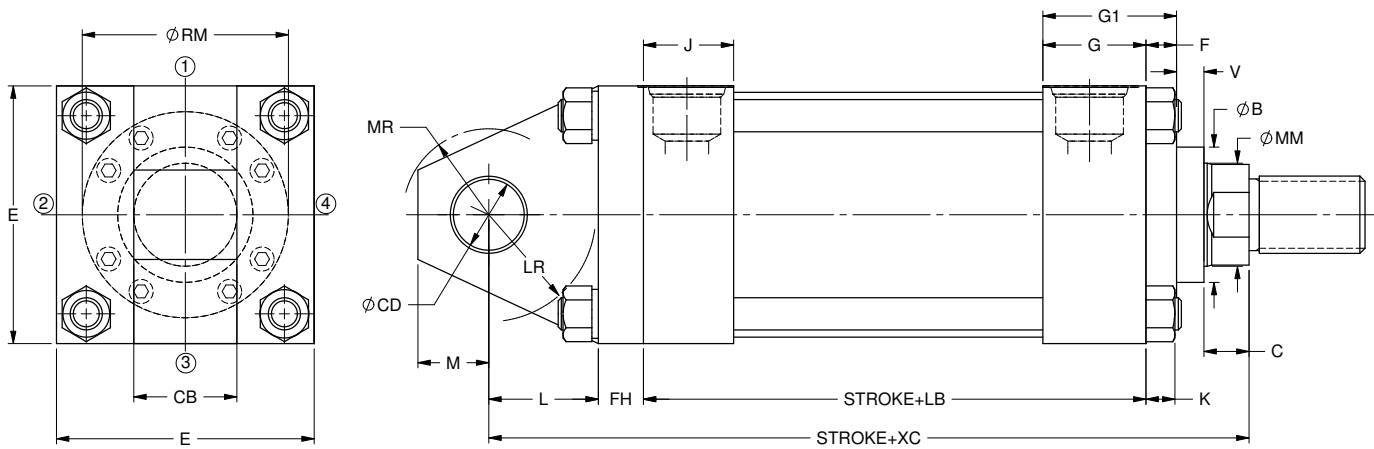

Bore	Rod Dia MM	B +0.000/-0.002	C	E	G	J	F	V	RM	L
1.50	0.63	1.124	0.38	2.50	1.75	1.50	0.38	0.25	-	0.75
	1.00	1.499	0.50	2.50	1.75	1.50	0.38	0.50	-	0.75
2.00	1.00	1.499	0.50	3.00	1.75	1.50	0.63	0.25	-	1.25
	1.38	1.999	0.63	3.00	1.75	1.50	0.63	0.38	-	1.25
2.50	1.00	1.499	0.50	3.50	1.75	1.50	0.50	0.38	2.63	1.25
	1.38	1.999	0.63	3.50	1.75	1.50	0.63	0.38	-	1.25
	1.75	2.374	0.75	3.50	1.75	1.50	0.63	0.50	-	1.25
3.25	1.38	1.999	0.63	4.50	2.00	1.75	0.59	0.41	3.25	1.50
	1.75	2.374	0.75	4.50	2.00	1.75	0.75	0.38	-	1.50
	2.00	2.624	0.88	4.50	2.00	1.75	0.75	0.38	-	1.50
4.00	1.75	2.374	0.75	5.00	2.00	1.75	0.59	0.53	3.88	2.13
	2.00	2.624	0.88	5.00	2.00	1.75	0.59	0.53	4.00	2.13
	2.50	3.124	1.00	5.00	2.00	1.75	0.59	0.66	4.44	2.13
5.00	2.00	2.624	0.88	6.50	2.00	1.75	0.59	0.53	4.00	2.25
	2.50	3.124	1.00	6.50	2.00	1.75	0.59	0.66	4.44	2.25
	3.00	3.749	1.00	6.50	2.00	1.75	0.72	0.53	5.25	2.25
	3.50	4.249	1.00	6.50	2.00	1.75	0.72	0.53	5.63	2.25
6.00	2.50	3.124	1.00	7.50	2.25	2.25	0.59	0.66	4.44	2.50
	3.00	3.749	1.00	7.50	2.25	2.25	0.72	0.53	5.25	2.50
	3.50	4.249	1.00	7.50	2.25	2.25	0.72	0.53	5.63	2.50
	4.00	4.749	1.00	7.50	2.25	2.25	0.88	0.38	6.44	2.50
7.00	3.00	3.749	1.00	8.50	2.75	2.75	0.72	0.53	5.25	3.00
	3.50	4.249	1.00	8.50	2.75	2.75	0.72	0.53	5.63	3.00
	4.00	4.749	1.00	8.50	2.75	2.75	0.88	0.38	6.44	3.00
	4.50	5.249	1.00	8.50	2.75	2.75	0.88	0.38	7.13	3.00
	5.00	5.749	1.00	8.50	2.75	2.75	0.88	0.38	7.56	3.00
8.00	3.50	4.249	1.00	9.50	3.00	3.00	0.72	0.53	5.63	3.25
	4.00	4.749	1.00	9.50	3.00	3.00	0.88	0.38	6.44	3.25
	4.50	5.249	1.00	9.50	3.00	3.00	0.88	0.38	7.13	3.25
	5.00	5.749	1.00	9.50	3.00	3.00	0.88	0.38	7.56	3.25
	5.50	6.249	1.00	9.50	3.00	3.00	0.88	0.38	8.38	3.25

+ Plus Stroke

Mounting Style and Installation Dimensions – NZ48 Cap Detachable Eye Mount ANSI MP4

These mounts are for applications in which the machine member travels in a curved path within one plane.

These mounts can be used both in compression (push) and tension (pull). Care must be exercised to prevent rod buckling in compression applications with long strokes. See page 80 for stroke limitations.

NOTE

For strokes in excess of 24 inches, see “Stop tube selection” on page 77.

WARNING

The centerline of the machine member that attaches to the swivel pin must be perpendicular to the centerline of the piston rod and the curved path must be in one plane only. Any misalignment will cause excess side loading on the bearing and piston. This will lead to premature failure.

For applications with small amounts of misalignment, consider the spherical bearing mount NZ11.

WARNING

Failure to mount the cylinder correctly on the frame may result in death, bodily injury and/or property damage.

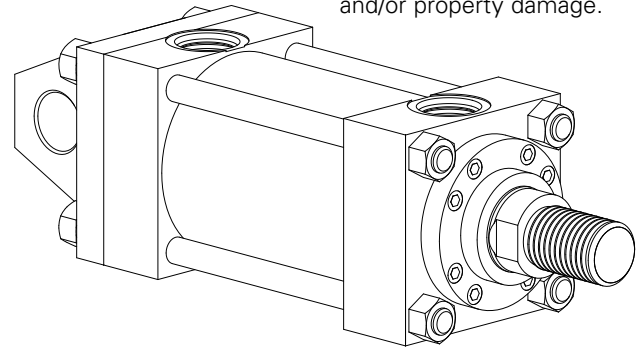

Bore	Rod Dia MM	M	CB	CD	MR	LB+	FH	XC+	Piston Thick.	K
1.50	0.63	0.50	0.75	0.500	0.56	4.63	0.38	6.75	1.38	0.41
	1.00	0.50	0.75	0.500	0.56	4.63	0.38	7.13	1.38	0.41
2.00	1.00	0.75	1.25	0.750	1.06	4.63	0.63	7.88	1.38	0.55
	1.38	0.75	1.25	0.750	1.06	4.63	0.63	8.13	1.38	0.55
2.50	1.00	0.75	1.25	0.750	1.06	4.75	0.63	8.00	1.50	0.55
	1.38	0.75	1.25	0.750	1.06	4.75	0.63	8.25	1.50	0.55
	1.75	0.75	1.25	0.750	1.06	4.75	0.63	8.50	1.50	0.55
3.25	1.38	1.00	1.50	1.000	1.13	5.50	0.75	9.38	1.75	0.67
	1.75	1.00	1.50	1.000	1.13	5.50	0.75	9.63	1.75	0.67
	2.00	1.00	1.50	1.000	1.13	5.50	0.75	9.75	1.75	0.67
4.00	1.75	1.38	2.00	1.375	1.75	5.75	0.88	10.63	2.00	0.78
	2.00	1.38	2.00	1.375	1.75	5.75	0.88	10.75	2.00	0.78
	2.50	1.38	2.00	1.375	1.75	5.75	0.88	11.00	2.00	0.78
5.00	2.00	1.75	2.50	1.750	1.88	6.25	0.88	11.38	2.50	0.92
	2.50	1.75	2.50	1.750	1.88	6.25	0.88	11.63	2.50	0.92
	3.00	1.75	2.50	1.750	1.88	6.25	0.88	11.63	2.50	0.92
	3.50	1.75	2.50	1.750	1.88	6.25	0.88	11.63	2.50	0.92
6.00	2.50	2.00	2.50	2.000	2.13	7.38	1.00	13.13	2.88	1.03
	3.00	2.00	2.50	2.000	2.13	7.38	1.00	13.13	2.88	1.03
	3.50	2.00	2.50	2.000	2.13	7.38	1.00	13.13	2.88	1.03
	4.00	2.00	2.50	2.000	2.13	7.38	1.00	13.13	2.88	1.03
7.00	3.00	2.50	3.00	2.500	2.50	8.50	1.00	14.75	3.00	1.17
	3.50	2.50	3.00	2.500	2.50	8.50	1.00	14.75	3.00	1.17
	4.00	2.50	3.00	2.500	2.50	8.50	1.00	14.75	3.00	1.17
	4.50	2.50	3.00	2.500	2.50	8.50	1.00	14.75	3.00	1.17
	5.00	2.50	3.00	2.500	2.50	8.50	1.00	14.75	3.00	1.17
8.00	3.50	2.75	3.00	3.000	2.75	9.50	1.00	16.00	3.50	1.26
	4.00	2.75	3.00	3.000	2.75	9.50	1.00	16.00	3.50	1.26
	4.50	2.75	3.00	3.000	2.75	9.50	1.00	16.00	3.50	1.26
	5.00	2.75	3.00	3.000	2.75	9.50	1.00	16.00	3.50	1.26
	5.50	2.75	3.00	3.000	2.75	9.50	1.00	16.00	3.50	1.26

+ Plus Stroke

See Mount 24 on page 50 for Port Dimensions

Mounting Style and Installation

Dimensions – NZ50 Cap

Detachable Clevis Mount ANSI MP2

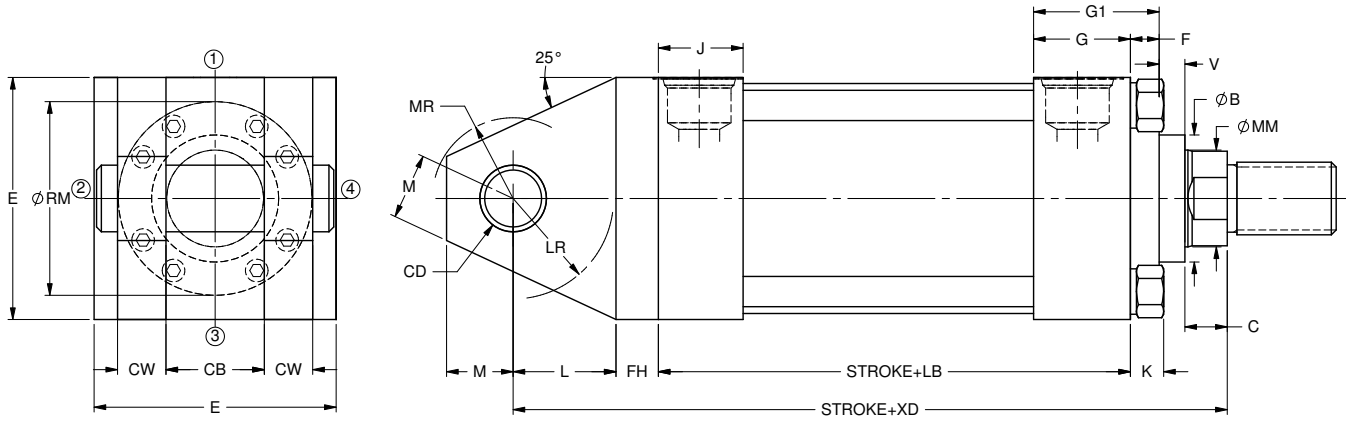

Bore	Rod Dia MM	B +.000/- .002	C	E	G	J	F	V	RM	FH	L
1.50	0.63	1.124	0.38	2.50	1.75	1.50	0.38	0.25	-	0.38	0.75
	1.00	1.499	0.50	2.50	1.75	1.50	0.38	0.50	-	0.38	0.75
2.00	1.00	1.499	0.50	3.00	1.75	1.50	0.63	0.25	-	0.63	1.25
	1.38	1.999	0.63	3.00	1.75	1.50	0.63	0.38	-	0.63	1.25
2.50	1.00	1.499	0.50	3.50	1.75	1.50	0.50	0.38	2.63	0.63	1.25
	1.38	1.999	0.63	3.50	1.75	1.50	0.63	0.38	-	0.63	1.25
	1.75	2.374	0.75	3.50	1.75	1.50	0.63	0.50	-	0.63	1.25
3.25	1.38	1.999	0.63	4.50	2.00	1.75	0.59	0.41	3.25	0.75	1.50
	1.75	2.374	0.75	4.50	2.00	1.75	0.75	0.38	-	0.75	1.50
	2.00	2.624	0.88	4.50	2.00	1.75	0.75	0.38	-	0.75	1.50
4.00	1.75	2.374	0.75	5.00	2.00	1.75	0.59	0.53	3.88	0.88	2.13
	2.00	2.624	0.88	5.00	2.00	1.75	0.59	0.53	4.00	0.88	2.13
	2.50	3.124	1.00	5.00	2.00	1.75	0.59	0.66	4.44	0.88	2.13
5.00	2.00	2.624	0.88	6.50	2.00	1.75	0.59	0.53	4.00	0.88	2.25
	2.50	3.124	1.00	6.50	2.00	1.75	0.59	0.66	4.44	0.88	2.25
	3.00	3.749	1.00	6.50	2.00	1.75	0.72	0.53	5.25	0.88	2.25
	3.50	4.249	1.00	6.50	2.00	1.75	0.72	0.53	5.63	0.88	2.25
6.00	2.50	3.124	1.00	7.50	2.25	2.25	0.59	0.66	4.44	1.00	2.50
	3.00	3.749	1.00	7.50	2.25	2.25	0.72	0.53	5.25	1.00	2.50
	3.50	4.249	1.00	7.50	2.25	2.25	0.72	0.53	5.63	1.00	2.50
	4.00	4.749	1.00	7.50	2.25	2.25	0.88	0.38	6.44	1.00	2.50
7.00	3.00	3.749	1.00	8.50	2.75	2.75	0.72	0.53	5.25	1.00	3.00
	3.50	4.249	1.00	8.50	2.75	2.75	0.72	0.53	5.63	1.00	3.00
	4.00	4.749	1.00	8.50	2.75	2.75	0.88	0.38	6.44	1.00	3.00
	4.50	5.249	1.00	8.50	2.75	2.75	0.88	0.38	7.13	1.00	3.00
	5.00	5.749	1.00	8.50	2.75	2.75	0.88	0.38	7.56	1.00	3.00
8.00	3.50	4.249	1.00	9.50	3.00	3.00	0.72	0.53	5.63	1.00	3.25
	4.00	4.749	1.00	9.50	3.00	3.00	0.88	0.38	6.44	1.00	3.25
	4.50	5.249	1.00	9.50	3.00	3.00	0.88	0.38	7.13	1.00	3.25
	5.00	5.749	1.00	9.50	3.00	3.00	0.88	0.38	7.56	1.00	3.25
	5.50	6.249	1.00	9.50	3.00	3.00	0.88	0.38	8.38	1.00	3.25

+ Plus Stroke

Mounting Style and Installation

Dimensions – NZ50 Cap

Detachable Clevis Mount ANSI MP2

These mounts are for applications in which the machine member travels in a curved path within one plane.

These mounts can be used both in compression (push) and tension (pull). Care must be exercised to prevent rod buckling in compression applications with long strokes. See page 80 for stroke limitations.

NOTE

For strokes in excess of 24 inches, see “Stop tube selection” on page 77.

WARNING

The centerline of the machine member that attaches to the swivel pin must be perpendicular to the centerline of the piston rod and the curved path must be in one plane only. Any misalignment will cause excess side loading on the bearing and piston. This will lead to premature failure.

For applications with small amounts of misalignment, consider the spherical bearing mount NZ11.

WARNING

Failure to mount the cylinder correctly on the frame may result in death, bodily injury and/or property damage.

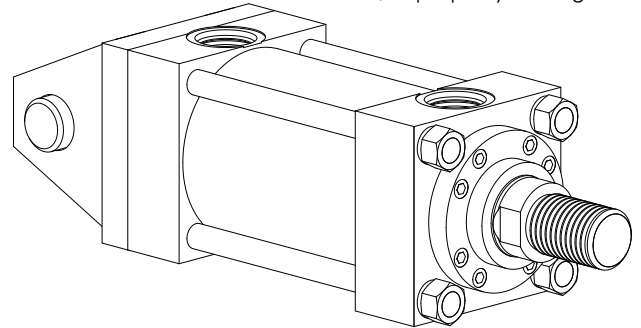

Bore	Rod Dia		CB	CD+.000/ -.002		LR	MR	LB+	XD+	Piston	
	MM	M		CW						Thick.	K
1.50	0.63	0.50	0.75	0.500	0.50	0.56	0.56	4.63	6.75	1.38	0.41
	1.00	0.50	0.75	0.500	0.50	0.56	0.56	4.63	7.13	1.38	0.41
2.00	1.00	0.75	1.25	0.750	0.63	1.06	1.06	4.63	7.88	1.38	0.55
	1.38	0.75	1.25	0.750	0.63	1.06	1.06	4.63	8.13	1.38	0.55
2.50	1.00	0.75	1.25	0.750	0.63	1.06	1.06	4.75	8.00	1.50	0.55
	1.38	0.75	1.25	0.750	0.63	1.06	1.06	4.75	8.25	1.50	0.55
	1.75	0.75	1.25	0.750	0.63	1.06	1.06	4.75	8.50	1.50	0.55
3.25	1.38	1.00	1.50	1.000	0.75	1.25	1.13	5.50	9.38	1.75	0.67
	1.75	1.00	1.50	1.000	0.75	1.25	1.13	5.50	9.63	1.75	0.67
	2.00	1.00	1.50	1.000	0.75	1.25	1.13	5.50	9.75	1.75	0.67
4.00	1.75	1.38	2.00	1.375	1.00	1.88	1.75	5.75	10.63	2.00	0.78
	2.00	1.38	2.00	1.375	1.00	1.88	1.75	5.75	10.75	2.00	0.78
	2.50	1.38	2.00	1.375	1.00	1.88	1.75	5.75	11.00	2.00	0.78
5.00	2.00	1.75	2.50	1.750	1.25	1.94	1.88	6.25	11.38	2.50	0.92
	2.50	1.75	2.50	1.750	1.25	1.94	1.88	6.25	11.63	2.50	0.92
	3.00	1.75	2.50	1.750	1.25	1.94	1.88	6.25	11.63	2.50	0.92
	3.50	1.75	2.50	1.750	1.25	1.94	1.88	6.25	11.63	2.50	0.92
6.00	2.50	2.00	2.50	2.000	1.25	2.06	2.13	7.38	13.13	2.88	1.03
	3.00	2.00	2.50	2.000	1.25	2.06	2.13	7.38	13.13	2.88	1.03
	3.50	2.00	2.50	2.000	1.25	2.06	2.13	7.38	13.13	2.88	1.03
	4.00	2.00	2.50	2.000	1.25	2.06	2.13	7.38	13.13	2.88	1.03
7.00	3.00	2.50	3.00	2.500	1.50	2.56	2.50	8.50	14.75	3.00	1.17
	3.50	2.50	3.00	2.500	1.50	2.56	2.50	8.50	14.75	3.00	1.17
	4.00	2.50	3.00	2.500	1.50	2.56	2.50	8.50	14.75	3.00	1.17
	4.50	2.50	3.00	2.500	1.50	2.56	2.50	8.50	14.75	3.00	1.17
	5.00	2.50	3.00	2.500	1.50	2.56	2.50	8.50	14.75	3.00	1.17
8.00	3.50	2.75	3.00	3.000	1.50	2.69	2.75	9.50	16.00	3.50	1.26
	4.00	2.75	3.00	3.000	1.50	2.69	2.75	9.50	16.00	3.50	1.26
	4.50	2.75	3.00	3.000	1.50	2.69	2.75	9.50	16.00	3.50	1.26
	5.00	2.75	3.00	3.000	1.50	2.69	2.75	9.50	16.00	3.50	1.26
	5.50	2.75	3.00	3.000	1.50	2.69	2.75	9.50	16.00	3.50	1.26

+ Plus Stroke

See Mount 24 on page 50 for Port Dimensions

Technical Data

WARNING

All rod accessories must be torqued against the rod shoulder.

Mounting brackets, rod clevises, and rod eyes for all NZ cylinders are available from Eaton. These accessories are detailed below showing part numbers and all pertinent dimensional data. Make sure the rod end type selected has threads that match the threads of any required accessory. Dimensions are in inches unless otherwise noted. When ordering, please specify the part name and part number. It is user's responsibility to select the correct accessory.

WARNING

Failure to mount the cylinder correctly on the frame may result in death, bodily injury and/or property damage.

Accessories

Rod Eye

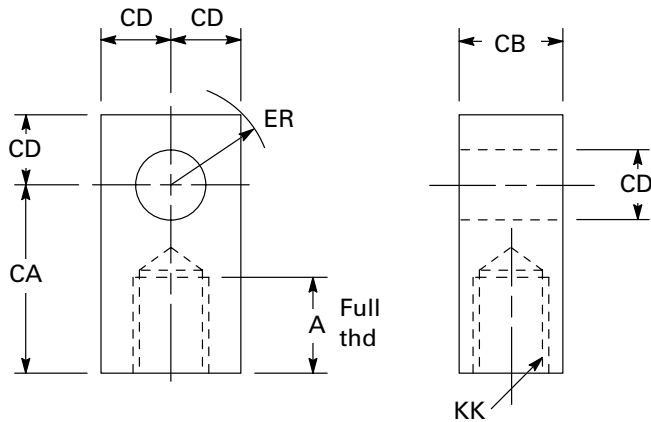

* Recommended torque values using MoS₂ lubricant with 0.12 co-efficient of friction.

Bore	KK	Torque* (ft-lb)	Part Number	Weight (lbs)	A	CA	CB	CD	ER
1.50	7/16-20 UNF-2B	36	FRE-0437	0.38	0.75	1.50	0.75	0.50	0.63
2.00	3/4-16 UNF-2B	125	FRE-0750	1.25	1.13	2.06	1.25	0.75	0.88
2.50	3/4-16 UNF-2B	125	FRE-0750	1.25	1.13	2.06	1.25	0.75	0.88
3.25	1-14 NS-2B	250	FRE-1000	2.5	1.63	2.81	1.50	1.00	1.18
4.00	1 1/4-12 UNF-2B	460	FRE-1250	5.94	2.00	3.44	2.00	1.38	1.56
5.00	1 1/2-12 UNF-2B	663	FRE-1500	11.4	2.25	4.00	2.50	1.75	2.00
6.00	1 7/8-12 UNF-2B	944	FRE-1875	15.1	3.00	5.00	2.50	2.00	2.25
7.00	2 1/4-12 UNF-2B	1315	FRE-2250	27	3.50	5.81	3.00	2.50	2.81
8.00	2 1/2-12 UNF-2B	5050	FRE-2500	35	3.50	6.12	3.00	3.00	3.25

WARNING

It is the user's responsibility to select the correct accessory.

WARNINGS – Piston Rods

Cylinder users must always make sure that the piston rod is securely attached to the machine member.

Piston rods are not normally designed to absorb bending moments or loads which are perpendicular to the axis of piston rod motion. These additional loads can cause the piston rod end to fail. If these types of additional loads are expected to be imposed on the piston rods, their magnitude should be made known to our Engineering Department so they may be properly addressed.

On occasion, cylinders are ordered with double rods. In some cases, a stop is threaded onto one of the piston rods and used as an external stroke adjuster. This type of

usage may result in a potential safety hazard and can also lead to premature piston rod failure. The external stop will create a pinch point. As a result, the cylinder user must use guards.

Furthermore, if an external stop is not parallel to the final contact surface, it will place a bending moment on the piston rod. An external stop will also negate the effect of a cushion and will subject the piston rod to an impact loading. These two (2) conditions can cause premature piston rod failure. The use of external stroke adjusters should be reviewed with our Engineering Department.

WARNINGS – Mounting & Accessories

The cylinder user should avoid severe vibration and high impact load. Severe vibration can cause joints to become loose. A high impact load can reduce the fatigue life of the

piston rod, rod end, accessories and other components. Consult the Eaton Engineering Department if there is severe vibration or a high impact load.

Proper selection and installation of the mounting style options and accessories will improve cylinder performance and extend service life. Cylinders are capable of generating a very high force, so proper selection and maintenance is necessary. It is the user's responsibility to ensure proper selection and installation.

The failure to select the correct mounting options and accessories, the failure to mount the cylinder correctly and/or the failure to install the piston rod, rod ends, accessories and other components correctly may cause or result in Death, Bodily Injury and/or Property Damage.

Accessories

Pivot Pin

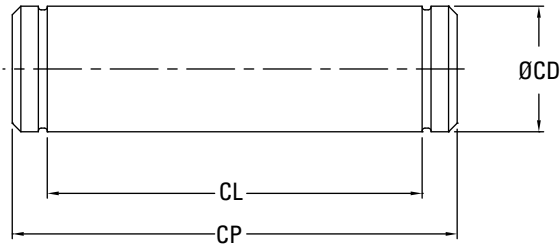

Bore	Part Number	CD	CL	CP
1.50	SVPIN-050-10	0.500	1.88	2.10
2.00	SVPIN-075-10	0.750	2.63	2.89
2.50	SVPIN-075-10	0.750	2.63	2.89
3.25	SVPIN-100-10	1.000	3.13	3.39
4.00	SVPIN-138-10	1.375	4.16	4.47
5.00	SVPIN-175-10	1.750	5.16	5.56
6.00	SVPIN-200-10	2.000	5.16	5.56
7.00	SVPIN-250-10	2.500	6.16	6.64
8.00	SVPIN-300-10	3.000	6.19	6.77

1. Pivot pins are furnished with clevis mounted cylinders.
2. Pivot pins supplied with retainer clips.

Mounting Eye Bracket

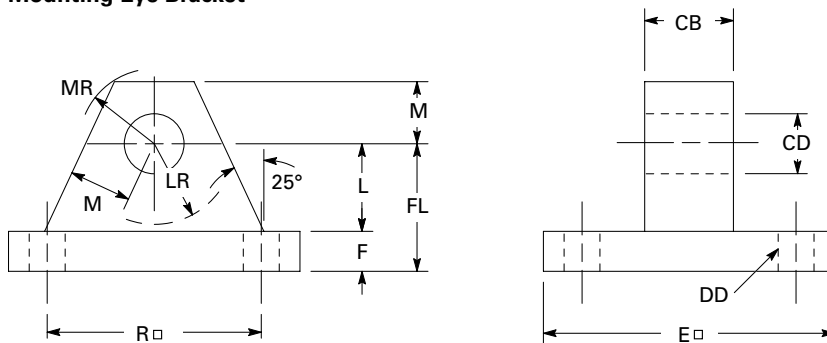

Bore	Part Number	Weight (lbs)	E	F	L	M	R	CB	CD	DD	FL	LR	MR
1.50	SEB-0500	0.94	2.50	0.38	0.75	0.50	1.63	0.75	0.50	0.38	1.13	0.50	0.56
2.00	SEB-0750	3.19	3.50	0.63	1.25	0.75	2.55	1.25	0.75	0.50	1.88	1.00	1.06
2.50	SEB-0750	3.19	3.50	0.63	1.25	0.75	2.55	1.25	0.75	0.50	1.88	1.00	1.06
3.25	SEB-1000	7.17	4.50	0.88	1.50	1.00	3.25	1.50	1.00	0.63	2.38	1.00	1.13
4.00	SEB-1375	11.7	5.00	0.88	2.13	1.38	3.82	2.00	1.38	0.63	3.00	1.13	1.75
5.00	SEB-1750A	22	6.50	1.13	2.25	1.75	4.95	2.50	1.75	0.88	3.38	1.75	1.88
6.00	SEB-2000A	34.5	7.50	1.50	2.50	2.00	5.73	2.50	2.00	1.00	4.00	2.00	2.13
7.00	SEB-2500A	55.4	8.50	1.75	3.00	2.50	6.58	3.00	2.50	1.13	4.75	2.50	2.50
8.00	SEB-3000	72.5	9.50	2.00	3.25	2.75	7.50	3.00	3.00	1.25	5.25	2.75	2.75

Rod Clevis

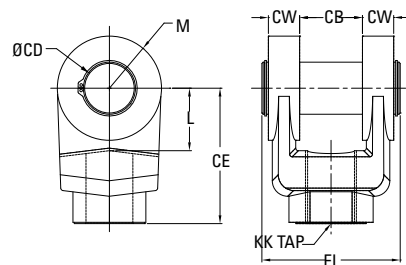

Bore	KK	Part Number	Weight (lbs)	L	M	CB	CD	CE	CW	EL
1.50	7/16-20 UNF-2B	NZ-162-10	0.56	0.75	0.50	0.75	0.50	1.50	0.50	2.38
2.00	3/4-16 UNF-2B	NZ-262-10	1.56	1.25	0.75	1.25	0.75	2.38	0.63	3.13
2.50	3/4-16 UNF-2B	NZ-262-10	1.56	1.25	0.75	1.25	0.75	2.38	0.63	3.13
3.25	1-14 NS-2B	NZ-362-10	3.31	1.50	1.00	1.50	1.00	3.13	0.75	3.75
4.00	1 1/4-12 UNF-2B	NZ-462-10	9.25	2.13	1.38	2.00	1.38	4.13	1.00	4.75
5.00	1 1/2-12 UNF-2B	NZ-562-10	14.62	2.25	1.75	2.50	1.75	4.50	1.25	6.03
6.00	1 7/8-12 UNF-2B	NZ-662-10	21	2.50	2.00	2.50	2.00	5.50	1.25	6.03
7.00	2 1/4-12 UNF-2B	NZ-762-10	36	3.00	2.50	3.00	2.50	6.50	1.50	7.03
8.00	2 1/2-12 UNF-2B	NZ-862-10	43	3.25	2.75	3.00	3.00	6.75	1.50	7.13

Accessories

Clevis Bracket

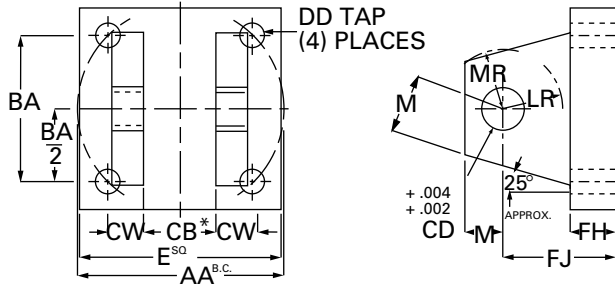

Bore	Part No.	AA	BA	CB	CD	CW	DD	E	FH	FJ	LR	M	MR
1.50	ECB-0500	2.30	1.63	0.78	0.500	0.50	3/8-24	2.50	0.38	1.38	0.50	0.50	0.56
2.00	ECB-0750	2.90	2.06	0.59	0.750	0.63	1/2-20	3.00	0.63	1.88	1.00	0.75	0.69
2.50	ECB-0750A	3.60	2.56	0.59	0.750	0.63	1/2-20	3.50	0.63	1.88	1.06	0.75	0.69
3.25	ECB-1000	4.60	3.25	1.53	1.000	0.75	5/8-18	4.50	0.75	2.25	1.25	1.00	1.13
4.00	ECB-1380	5.40	3.81	2.03	1.375	1.00	5/8-18	5.00	0.88	3.00	1.88	1.38	1.75
5.00	ECB-1750	7.00	4.94	2.53	1.750	1.25	7/8-14	6.50	0.88	3.13	2.00	1.75	1.88
6.00	ECB-2000	8.10	5.75	2.53	2.000	1.25	1-14	7.50	1.00	3.50	2.13	2.00	2.13
7.00	ECB-2500	9.30	6.59	3.03	2.500	1.50	1 1/8-12	8.50	1.00	4.00	2.63	2.50	2.50
8.00	ECB-3000	10.60	7.50	3.03	3.000	1.50	1 1/4-12	9.50	1.00	4.25	2.88	2.75	2.75

Spherical Rod Eye

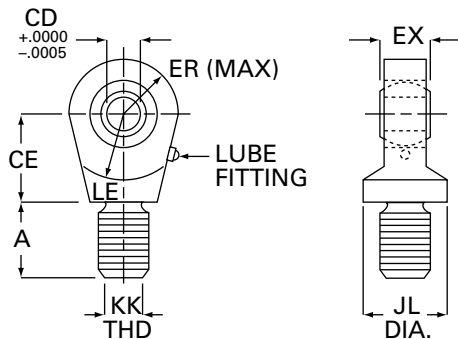

Bore	KK	Part No.	A	CD +.0000 -.0005	CE	EX	ER	JL	LE	Load Capacity (lbs)
1.50	7/16-20	BRE-0437	0.69	0.5000	0.88	0.44	0.88	0.88	0.75	2600
2.00	3/4-16	BRE-0750	1.00	0.7500	1.25	0.66	1.25	1.31	1.06	9400
2.50	3/4-16	BRE-0750	1.00	0.7500	1.25	0.66	1.25	1.31	1.06	9400
3.25	1-14	BRE-1000	1.50	1.0000	1.88	0.88	1.38	1.50	1.44	16800
4.00	1 1/4-12	BRE-1250	2.00	1.3750	2.13	1.19	1.81	2.00	1.88	28600
5.00	1 1/2-12	BRE-1500	2.13	1.7500	2.50	1.53	2.19	2.25	2.13	43000
6.00	1 7/8-12	BRE-1875	2.88	2.0000	2.75	1.75	2.63	2.75	2.50	70000

Accessories – For Spherical Bushing Mounted Cylinder

Spherical Clevis Bracket

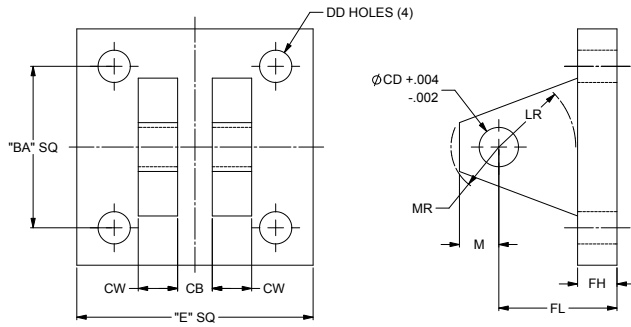

Bore	Part No.	BA	CB	CD	CW	DD	E	FH	FL	LR	M	MR
1.50	SCB-0500	2.05	0.44	0.500	0.50	0.41	3.00	0.50	1.50	0.94	0.50	0.62
2.00	SCB-0750	2.76	0.66	0.750	0.62	0.53	3.75	0.62	2.00	1.38	0.88	1.00
2.50	SCB-0750	2.76	0.66	0.750	0.62	0.53	3.75	0.62	2.00	1.38	0.88	1.00
3.25	SCB-1000	4.10	0.88	1.000	0.75	0.53	5.50	0.75	2.50	1.69	1.00	1.19
4.00	SCB-1380	4.95	1.19	1.375	1.00	0.66	6.50	0.88	3.50	2.44	1.38	1.62
5.00	SCB-1750	6.58	1.53	1.750	1.25	0.91	8.50	1.25	4.50	2.88	1.75	2.06
6.00	SCB-2000	7.92	1.75	2.000	1.50	0.91	10.62	1.50	5.00	3.31	2.00	2.38

Pivot Pin - for Spherical Bearing

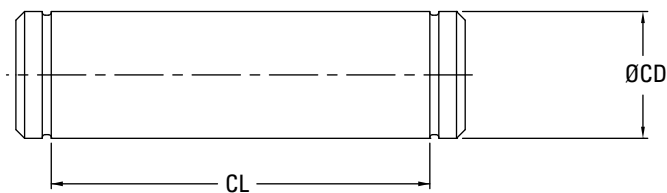

Bore	Part No.	CD	CL
1.50	SBPIN-050-10	0.500	1.56
2.00	SBPIN-075-10	0.750	2.03
2.50	SBPIN-075-10	0.750	2.03
3.25	SBPIN-100-10	1.000	2.50
4.00	SBPIN-138-10	1.375	3.31
5.00	SBPIN-175-10	1.750	4.22
6.00	SBPIN-200-10	2.000	4.94

1. Pivot pins supplied with retainer clips.

Rod End Couplings

Used with the Vickers style G Rod End, the Vickers Rod End Coupling provides for close lateral alignment between the rod end and machine member. The two-piece steel coupling features high tensile strength socket head cap screws (with safety factor designed to take full load), permits quick assembly/disassembly for fast and easy installation and servicing.

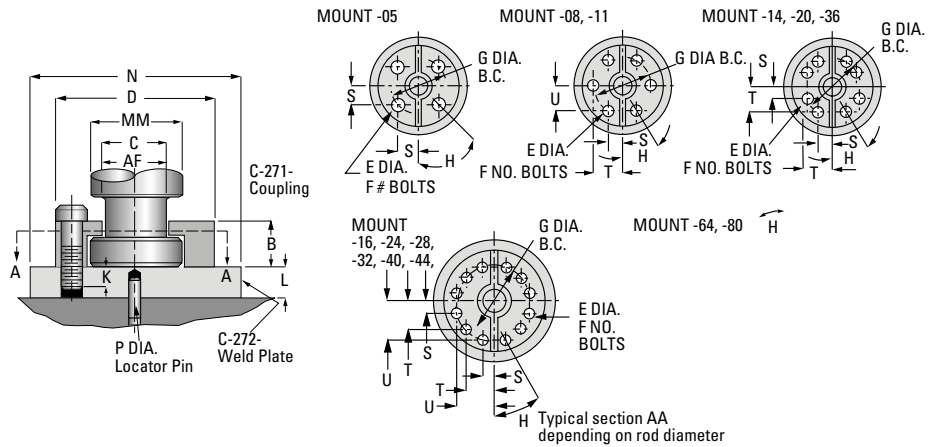
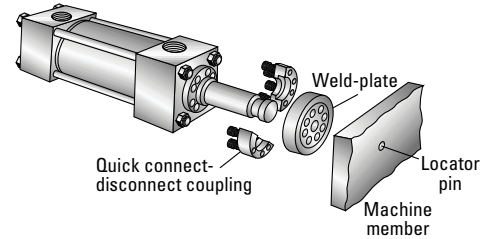

Coupling and Weld plate Assembly	Coupling NZ-271-	Rod Dia (MM)	AF	B	C	D	E	F	G	H	K
NZ-275-05	NZ-271-05	0.63	0.38	0.44	0.41	1.50	0.22	4.00	1.12	45°	0.44
NZ-275-08	NZ-271-08	1.00	0.69	0.62	0.75	2.00	0.28	6.00	1.50	30°	0.38
NZ-275-11	NZ-271-11	1.38	0.88	0.69	0.94	2.50	0.34	6.00	2.00	30°	0.56
NZ-275-14	NZ-271-14	1.75	1.12	0.88	1.18	3.00	0.41	8.00	2.38	22° 30'	0.62
NZ-275-16	NZ-271-16	2.00	1.38	1.25	1.44	3.50	0.41	12.00	2.69	15°	0.75
NZ-275-20	NZ-271-20	2.50	1.75	1.38	1.88	4.25	0.53	8.00	3.44	22° 30'	0.88
NZ-275-24	NZ-271-24	3.00	2.25	1.88	2.38	5.00	0.53	12.00	4.00	15°	0.88
NZ-275-28	NZ-271-28	3.50	2.50	2.00	2.62	5.88	0.66	12.00	4.69	15°	1.00
NZ-275-32	NZ-271-32	4.00	3.00	2.00	3.12	6.38	0.66	12.00	5.18	15°	1.00
NZ-275-36	NZ-271-36	4.50	3.50	2.38	3.62	6.88	0.78	8.00	5.69	22° 30'	1.12
NZ-275-40	NZ-271-40	5.00	3.88	2.50	4.00	7.38	0.66	12.00	6.18	15°	1.25
NZ-275-44	NZ-271-44	5.50	4.38	3.12	4.50	8.25	0.78	12.00	6.88	15°	1.38

Weld Plate	L	N	P	Scs. Hd. Cap Screws	Bolt Torq. Ft. lb.	S	T	U	X
WP-05	0.50	2.00	0.25	#10-24x.88	5	0.40	-	-	-
WP-08	0.50	2.50	0.25	1/4"-20x1.0	14	0.38	0.75	0.65	-
WP-11	0.62	3.00	0.25	5/16"-18x1.25	30	0.50	1.00	0.87	-
WP-14	0.75	3.50	0.25	3/8"-16x1.5	52	0.45	1.10	-	-
WP-16	0.88	4.00	0.38	3/8"-16x2.0	52	0.35	0.95	1.30	-
WP-20	1.00	5.00	0.38	1/2"-13x2.25	128	0.66	1.59	-	-
WP-24	1.00	5.50	0.38	1/2"-13x2.75	128	0.52	1.41	1.93	-
WP-28	1.12	6.50	0.38	5/8"-11x3.0	255	0.61	1.66	2.26	-
WP-32	1.12	7.00	0.38	5/8"-11x3.0	255	0.67	1.83	2.51	-
WP-36	1.25	7.50	0.38	3/4"-10x3.5	450	1.09	2.63	-	-
WP-40	1.38	8.00	0.38	5/8"-11x3.75	255	0.80	2.19	2.99	-
WP-44	1.50	9.00	0.38	3/4"-10x4.5	450	0.89	2.43	3.32	-

Self-Aligning Coupler

Lateral movement (on push only) and radial movement provide precision alignment between cylinder and machine. Couplers preset with proper clearances and completely lubricated at factory before shipping.

Note

When ordering oversize and 2:1 rod cylinders, specify modification to suit standard rod diameter's coupler.

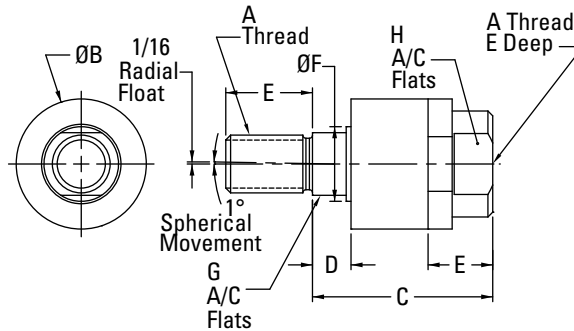

SAC-0312 Thru SAC-2000, SAC-4000

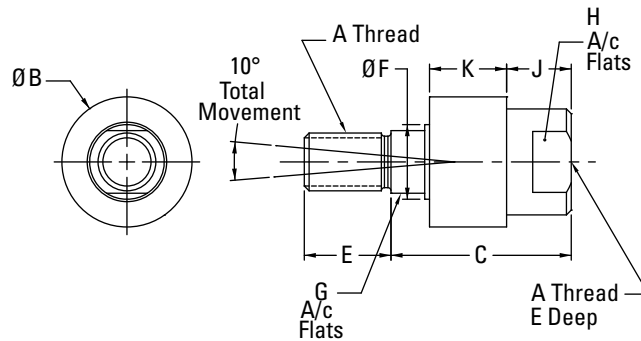

SAC-2250 Thru SAC-3250, SAC-4250

Part No.	"A" Thread	B	C	D	E	F	G	H	J	K	M° of Movement	Load Rating Max Pull at Yield (lbs)
SAC-0312	5/16-24	0.88	1.25	0.25	0.63	0.31	0.25	0.81	-	-	1	4,000
SAC-0375	3/8-24	0.88	1.25	0.25	0.63	0.37	0.31	0.81	-	-	1	5,000
SAC-0437	7/16-20	1.25	2.00	0.50	0.75	0.63	0.56	1.13	-	-	1	10,000
SAC-0500	1/2-20	1.25	2.00	0.50	0.75	0.63	0.56	1.13	-	-	1	14,000
SAC-0625	5/8-18	1.25	2.00	0.50	0.75	0.63	0.50	1.13	-	-	1	14,000
SAC-0750	3/4-16	1.75	2.31	0.31	1.13	0.97	0.88	1.50	-	-	1	34,000
SAC-0875	7/8-14	1.75	2.31	0.31	1.13	0.97	0.88	1.50	-	-	1	34,000
SAC-1000	1-14	2.50	2.94	0.50	1.63	1.38	1.25	2.25	-	-	1	64,000
SAC-1250	1-1/4-12	2.50	2.94	0.50	1.63	1.38	1.25	2.25	-	-	1	64,000
SAC-1500	1-1/2-12	3.25	4.38	0.81	2.25	1.75	1.50	3.00	-	-	1	120,000
SAC-1750	1-3/4-12	3.25	4.38	0.81	2.25	1.75	1.50	3.00	-	-	1	120,000
SAC-1875	1-7/8-12	3.75	5.44	0.69	3.00	2.25	1.88	3.50	-	-	1	240,000
SAC-2000	2-12	3.75	5.44	0.69	3.00	2.25	1.88	3.50	-	-	1	240,000
SAC-2250	2-1/4-12	6.75	6.38	-	3.50	2.75	2.38	2.88	1.63	3.38	10	397,000
SAC-2500	2-1/2-12	7.00	6.50	-	3.50	3.25	2.88	3.38	1.63	3.88	10	495,000
SAC-2375	2-3/4-12	7.00	6.50	-	3.50	3.25	2.88	3.38	1.63	3.88	10	603,800
SAC-3000	3-12	7.00	6.50	-	3.50	3.25	2.88	3.38	1.63	3.88	10	723,040
SAC-3250	3-1/4-12	9.25	8.50	-	4.50	4.00	3.38	4.50	2.00	5.50	10	853,800
SAC-4000	4-12	7.25	9.38	1.00	5.50	5.47	*	1.88	-	-	1	750,010
SAC-4250	4-1/4-12	12.88	11.25	-	4.50	5.50	4.88	7.00	1.50	8.75	10	1,483,400

Rod End Types

In addition to selecting the correct bore, you must specify the appropriate rod size and rod ends configuration for your application.

Twelve different inch and Metric rod ends configurations are available. If a custom design is required con-

tact your local Eaton sales engineer and we will build to your requirements.

Table on page 80 gives maximum allowable push length at various operating pressures for available rod diameters. Rod ends on rigid mount should be supported.

Longer strokes allowable for pull only applications.

Contact your local Eaton sales engineer for application assistance if necessary

Note: Code 0, 1, and N threads are to ISO 4395 and are based on the metric fine pitch series. Rod end acces-

series locknuts, tooling and gauges are available. These threads are also specified in ISO 6020-2 (160 Bar compact) cylinder series. Code 7 and L threads are based on the closest metric threads to the UN series and are recommended for replacement only.

Inch Rod Ends

Code 2		For rod sizes 3 1/2" thru 5 1/2"	
Code 5		Code K	
Code 6		Code G	
Code 9		Code M	

Rod Ø MM	UN(F) Thread											
	A	C	D	AC	AD	AE	AF	AX	DC	CC	KK	NA
0.625	0.75	0.38	0.50	1.13	0.63	0.38	0.25	1.13	-	1/2-10	7/16-20	0.585
1.000	1.13	0.50	0.88	1.50	0.94	0.69	0.38	1.69	-	7/8-14	3/4-16	0.968
1.375	1.63	0.63	1.13	1.75	1.06	0.88	0.38	2.44	-	1 1/4-12	1-14	1.343
1.750	2.00	0.75	1.50	2.00	1.31	1.13	0.50	3.00	-	1 1/2-12	1 1/4-12	1.718
2.000	2.25	0.88	1.75	2.63	1.69	1.38	0.63	3.38	-	1 3/4-12	1 1/2-12	1.953
2.500	3.00	1.00	2.13	3.25	1.94	1.75	0.75	4.50	-	2 1/4-12	1 7/8-12	2.437
3.000	3.50	1.00	2.63	3.63	2.44	2.25	0.88	5.25	-	2 3/4-12	2 1/4-12	2.937
3.500	3.50	1.00	3.00	4.38	2.69	2.50	1.00	5.25	-	3 1/4-12	2 1/2-12	3.437
4.000	4.00	1.00	-	4.50	2.69	3.00	1.00	6.00	0.50	3 3/4-12	3-12	3.906
4.500	4.50	1.00	-	5.25	3.19	3.50	1.50	6.75	0.50	4 1/4-12	3 1/4-12	4.406
5.000	5.00	1.00	-	5.38	3.19	3.88	1.50	7.50	0.50	4 3/4-12	3 1/2-12	4.906
5.500	5.50	1.00	-	6.25	3.94	4.38	1.88	8.25	0.50	5 1/4-12	4-12	5.406

* Dimensions are in Inches

Rod End Types

Metric Rod Ends

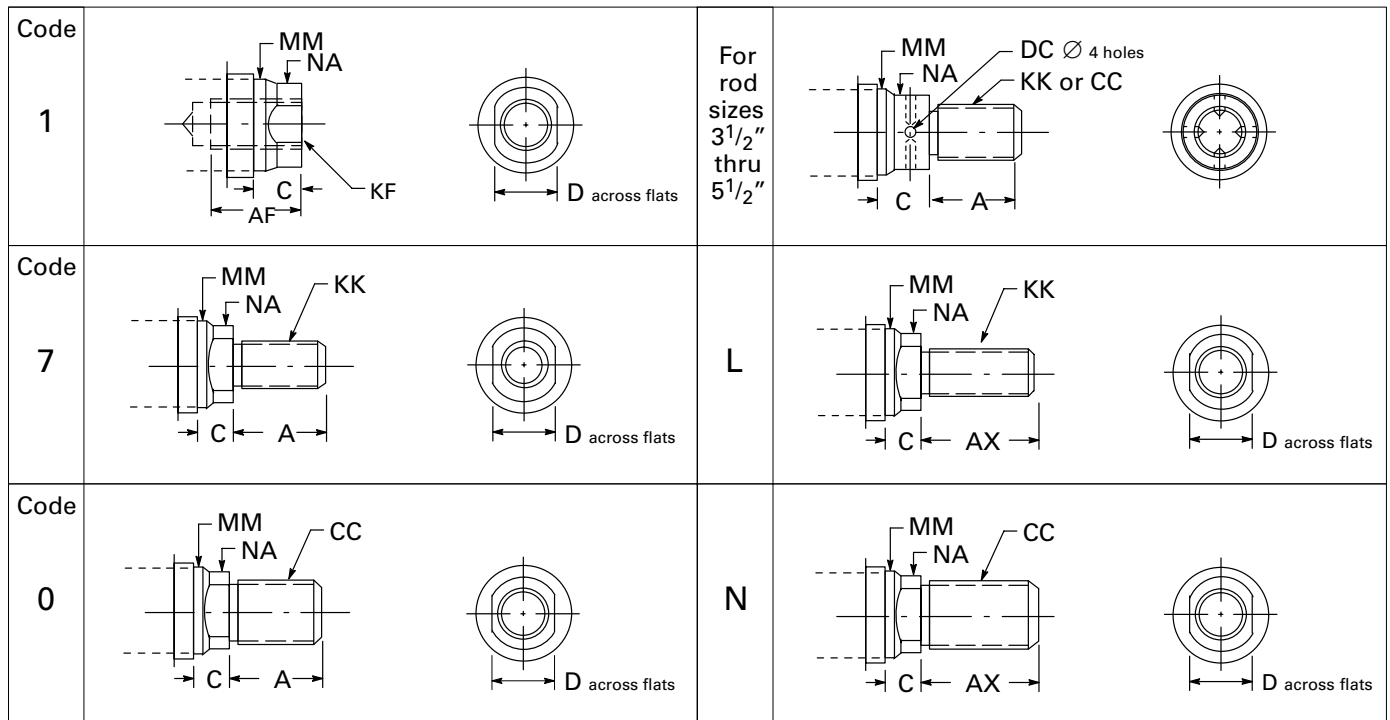

Rod Dia MM (in)	A	C	D	AF	AX	DC	Metric Thread			
							CC (ISO 4395)	KF (ISO 4395)	KK (ISO 261)	NA
0.625	16	9,5	13	19,0	24	–	M12 x 1,25	M10 x 1,25	M10 x 1,5	14.86
1	28	12,7	22	28,6	40	–	*	M20 x 1,5	M20 x 1,5	24.59
1.375	36	15,9	30	41,3	54	–	M27 x 2	M27 x 2	M26 x 1,5	34.11
1.75	45	19,0	36	50,8	66	–	*	M33 x 2	M33 x 2	43.64
2	56	22,2	41	57,1	84	–	M42 x 2	M42 x 2	M39 x 2	49.61
2.5	63	25,4	55	76,2	96	–	*	M48 x 2	M48 x 2	61.90
3	85	25,4	65	88,9	128	–	M64 x 3	M58 x 2	M58 x 2	74.60
3.5	85	25,4	75	88,9	128	9,52	M64 x 3	M64 x 3	M64 x 2	87.30
4	95	25,4	–	101,6	140	11,11	M80 x 3	M80 x 3	M76 x 2	99.21
4.5	106	25,4	–	114,3	158	11,11	M90 x 3	M90 x 3	M80 x 2	111.91
5	112	25,4	–	139,7	168	12,70	M100 x 3	M100 x 3	M90 x 2	124.61
5.5	112	25,4	–	139,7	168	12,70	M100 x 3	M100 x 3	M100 x 2	137.31

* Intermediate male metric thread not available for 1, 1 3/4, and 2 1/2 inch rod sizes. Use codes 7 or L.
Note: Dimensions in millimeters.

Port Type and Size

Available Ports

Series NZ cylinders are available with SAE straight thread O-ring ports and the alternate ports listed below. The table

below lists the port types and sizes available for each bore diameter. The table on the next page lists the maximum piston velocities obtainable

with each bore diameter and port type combination. Some mounting styles have port location restrictions. Check the port location table on page

71 for your particular mounting style. Where a port or port boss interferes with cylinder mounting, mounting should take precedence.

CODE 3, 4, 5,

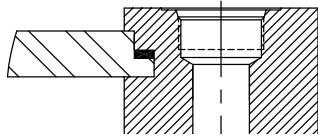

CODE D,1,2

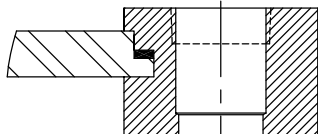

CODE 2 with*

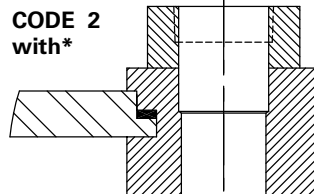

CODE H,7, 8, G, 9, 0, K, A, B

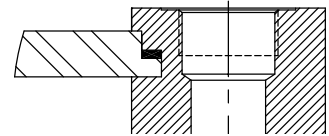

Port Code

		3	4	5	D	1	2	H	7	8	C	6		
		SAE J1926 / UN O-ring			NPTF † Pipe		BSPP † ISO 228-1		BSPP † ISO 228-1		SAE 518 Code 61 Flange			
Bore	Rod	Std	Over size	NFPA Std	Under Size	Std	Head	Cap	Under Size	Std	Head	Cap	Under Size	Std
1.50	0.63	# 6	# 10	# 8	3/8	1/2	3/4	3/4	G 3/8	G 1/2	G 3/4*	G 3/4*	NA	NA
	1.00	# 6	# 10	# 8	3/8	1/2	3/4*	3/4	G 3/8	G 1/2	G 3/4*	G 3/4*	NA	NA
2.00	1.00	# 6	# 10	# 8	3/8	1/2	3/4	3/4	G 3/8	G 1/2	G 3/4*	G 3/4*	NA	NA
	1.38	# 6	# 10	# 8	3/8	1/2	3/4*	3/4	G 3/8	G 1/2	G 3/4*	G 3/4*	NA	NA
2.50	1.00	# 6	# 10	# 8	3/8	1/2	3/4	3/4	G 3/8	G 1/2	G 3/4*	G 3/4*	NA	0.50 **
	1.38	# 6	# 10	# 8	3/8	1/2	3/4	3/4	G 3/8	G 1/2	G 3/4*	G 3/4*	NA	0.50 **
	1.75	# 6	# 10	# 8	3/8	1/2	3/4*	3/4	G 3/8	G 1/2	G 3/4*	G 3/4*	NA	NA
3.25	1.38	# 10	# 14	# 12	1/2	3/4	1	1	G 1/2	G 3/4	G1	G 1	.50	0.75 **
	1.75	# 10	# 14	# 12	1/2	3/4	1	1	G 1/2	G 3/4	G1	G 1	.50	0.75 **
	2.00	# 10	# 14	# 12	1/2	3/4	1	1	G 1/2	G 3/4	G1	G 1	.50	0.75 **
4.00	1.75	# 10	# 14	# 12	1/2	3/4	1	1	G 1/2	G 3/4	G 1	G 1	.50	0.75 **
	2.00	# 10	# 14	# 12	1/2	3/4	1	1	G 1/2	G 3/4	G1	G 1	.50	0.75 **
	2.50	# 10	# 14	# 12	1/2	3/4	1	1	G 1/2	G 3/4	G1	G 1	.50	0.75 **
5.00	2.00	# 10	# 14	# 12	1/2	3/4	1	1	G 1/2	G 3/4	G 1	G 1	.50	0.75
	2.50	# 10	# 14	# 12	1/2	3/4	1	1	G 1/2	G 3/4	G1	G 1	.50	0.75
	3.00	# 10	# 14	# 12	1/2	3/4	1	1	G 1/2	G 3/4	G1	G 1	.50	0.75
	3.50	# 10	# 14	# 12	1/2	3/4	1	1	G 1/2	G 3/4	G1	G 1	.50	0.75
6.00	2.50	# 12	# 20	# 16	3/4	1	1 1/4	1 1/4	G 3/4	G 1	G 1 1/4	G 1 1/4	.75	1.00
	3.00	# 12	# 20	# 16	3/4	1	1 1/4	1 1/4	G 3/4	G 1	G 1 1/4	G 1 1/4	.75	1.00
	3.50	# 12	# 20	# 16	3/4	1	1 1/4	1 1/4	G 3/4	G 1	G 1 1/4*	G 1 1/4	.75	1.00
	4.00	# 12	# 20	# 16	3/4	1	1 1/4	1 1/4	G 3/4	G 1	G 1 1/4*	G 1 1/4	.75	1.00
7.00	3.00	# 16	# 24	# 20	1	1 1/4	1 1/2	1 1/2	G 1	G 1 1/4	G 1 1/2	G 1 1/2	1.00	1.25
	3.50	# 16	# 24	# 20	1	1 1/4	1 1/2	1 1/2	G 1	G 1 1/4	G 1 1/2	G 1 1/2	1.00	1.25
	4.00	# 16	# 24	# 20	1	1 1/4	1 1/2	1 1/2	G 1	G 1 1/4	G 1 1/2	G 1 1/2	1.00	1.25
	4.50	# 16	# 24	# 20	1	1 1/4	1 1/2	1 1/2	G 1	G 1 1/4	G 1 1/2	G 1 1/2	1.00	1.25
	5.00	# 16	# 24	# 20	1	1 1/4	1 1/2	1 1/2	G 1	G 1 1/4	G 1 1/2	G 1 1/2	1.00	1.25
8.00	3.50	# 16	# 20	# 24	1 1/4	1 1/2	2	2	G 1	G 1 1/4	G 1 1/2	G 1 1/2	1.25	1.50
	4.00	# 16	# 20	# 24	1 1/4	1 1/2	2	2	G 1	G 1 1/4	G 1 1/2	G 1 1/2	1.25	1.50
	4.50	# 16	# 20	# 24	1 1/4	1 1/2	2	2	G 1	G 1 1/4	G 1 1/2	G 1 1/2	1.25	1.50
	5.00	# 16	# 20	# 24	1 1/4	1 1/2	2	2	G 1	G 1 1/4	G 1 1/2	G 1 1/2	1.25	1.50
	5.50	# 16	# 20	# 24	1 1/4	1 1/2	2	2	G 1	G 1 1/4	G 1 1/2	G 1 1/2	1.25	1.50

* With Port Boss

† NPTF and BSPP ports are not recommended for maximum reliability on new application

Following notes applies to 01,04 mounts

* Port Boss required for port position 1 and 3, These ports are not feasible for port position 2 & 4

** Port is not feasible for port position 2 and 4

Port at position 3 not available on 1.50", 2.00", 2.50", 3.25" and 4.00" for 03 mount

Port Type and Size

CODE C,6

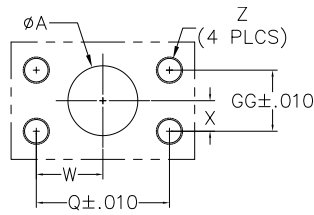

Dimensions in inches

Flange Size	A	Q	W	X	GG	Z
3/4 (-12)	0.75	1.875	0.94	0.44	0.875	3/8 (-16)
1 (-16)	1.00	2.062	1.03	0.52	1.031	3/8 (-16)
1 1/4 (-20)	1.25	2.312	1.16	0.59	1.118	7/16 (-14)
1 1/2 (-24)	1.50	2.750	1.38	0.70	1.406	1/2 (-13)

CODE M

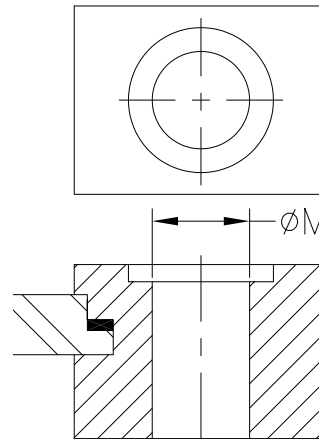

CODE H,7,8, G, 9, 0, K, A, B with*

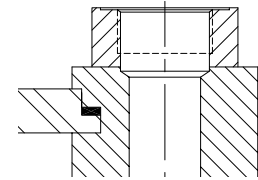

Port Code

G	9	0	K	A	B	M
DIN 3852 Form X Metric			ISO 6149-1		Manifold	
Bore	Rod	Under Size		OverSize		Std Φ M
		Std	Head	Cap	Std	
1.50	0.63	M20 x 1.5	M22 x 1.5	M27 x 2*	M27 x 2*	9/16
	1.00	M20 x 1.5	M22 x 1.5	M27 x 2*	M27 x 2*	9/16
2.00	1.00	M20 x 1.5	M22 x 1.5	M27 x 2*	M27 x 2*	9/16
	1.38	M20 x 1.5	M22 x 1.5	M27 x 2*	M27 x 2*	9/16
2.50	1.00	M20 x 1.5	M22 x 1.5	M27 x 2*	M27 x 2*	9/16
	1.38	M20 x 1.5	M22 x 1.5	M27 x 2*	M27 x 2*	9/16
	1.75	M20 x 1.5	M22 x 1.5	M27 x 2*	M27 x 2*	9/16
3.25	1.38	M22 x 1.5	M27 x 2	M33 x 2*	M33 x 2*	3/4
	1.75	M22 x 1.5	M27 x 2	M33 x 2*	M33 x 2*	3/4
	2.00	M22 x 1.5	M27 x 2	M33 x 2*	M33 x 2*	3/4
4.00	1.75	M22 x 1.5	M27 x 2	M33 x 2	M33 x 2	3/4
	2.00	M22 x 1.5	M27 x 2	M33 x 2	M33 x 2	3/4
	2.50	M22 x 1.5	M27 x 2	M33 x 2	M33 x 2	3/4
5.00	2.00	M22 x 1.5	M27 x 2	M33 x 2	M33 x 2	3/4
	2.50	M22 x 1.5	M27 x 2	M33 x 2	M33 x 2	3/4
	3.00	M22 x 1.5	M27 x 2	M33 x 2	M33 x 2	3/4
	3.50	M22 x 1.5	M27 x 2	M33 x 2	M33 x 2	3/4
6.00	2.50	M27 x 1.5	M33 x 2	M42 x 2	M42 x 2	1
	3.00	M27 x 1.5	M33 x 2	M42 x 2	M42 x 2	1
	3.50	M27 x 1.5	M33 x 2	M42 x 2	M42 x 2	1
	4.00	M27 x 1.5	M33 x 2	M42 x 2*	M42 x 2	1
7.00	3.00	M33 x 2	M42 x 2	M48 x 2	M48 x 2	1 3/8
	3.50	M33 x 2	M42 x 2	M48 x 2	M48 x 2	1 3/8
	4.00	M33 x 2	M42 x 2	M48 x 2	M48 x 2	1 3/8
	4.50	M33 x 2	M42 x 2	M48 x 2	M48 x 2	1 3/8
	5.00	M33 x 2	M42 x 2	M48 x 2	M48 x 2	1 3/8
8.00	3.50	M42 x 2	M48 x 2	NA	NA	1 5/8
	4.00	M42 x 2	M48 x 2	NA	NA	1 5/8
	4.50	M42 x 2	M48 x 2	NA	NA	1 5/8
	5.00	M42 x 2	M48 x 2	NA	NA	1 5/8
	5.50	M42 x 2	M48 x 2	NA	NA	1 5/8

Port Selections

Use this table to determine which bore diameter, rod diameter and port combination will provide the piston velocity required for your application.

Bore ∅ in	Rod ∅ in	Fluid Required per Inch of stroke		Port Codes 1,5,6,9 & A		Port Codes 2,4,0 & B		Port Code 3		Port Code 7		Port Code 8		
		(gal)	(in ³)	Flow (gpm)	Piston Velocity (In/sec)	Flow (gpm)	Piston Velocity (In/sec)	Flow (gpm)	Piston Velocity (In/sec)	Flow (gpm)	Piston Velocity (In/sec)	Flow (gpm)	Piston Velocity (In/sec)	
1.50	Cap	0.008	1.767	6.0	13.1	9.2	20.0	6.0	13.1	3.4	7.4	9.2	20.0	
		0.63	0.006	1.460	6.0	15.8	9.2	24.3	6.0	15.8	3.4	9.0	9.2	24.3
		1.00	0.004	0.982	6.0	23.5	9.2	36.1	6.0	23.5	3.4	13.3	9.2	36.1
2.00	Cap	0.014	3.142	6.0	7.4	9.2	11.3	6.0	7.4	3.4	4.2	9.2	11.3	
		1.00	0.010	2.356	6.0	9.8	9.2	15.0	6.0	9.8	3.4	5.6	9.2	15.0
		1.38	0.007	1.657	6.0	13.9	9.2	21.4	6.0	13.9	3.4	7.9	9.2	21.4
2.50	Cap	0.021	4.909	6.0	4.7	9.2	7.2	6.0	4.7	3.4	2.7	9.2	7.2	
		1.00	0.018	4.123	6.0	5.6	9.2	8.6	6.0	5.6	3.4	3.2	9.2	8.6
		1.38	0.015	3.424	6.0	6.7	9.2	10.3	6.0	6.7	3.4	3.8	9.2	10.3
		1.75	0.011	2.503	6.0	9.2	9.2	14.1	6.0	9.2	3.4	5.2	9.2	14.1
3.25	Cap	0.036	8.296	14.5	6.7	20.2	9.4	14.5	6.7	9.2	4.3	27.9	12.9	
		1.38	0.029	6.811	14.5	8.2	20.2	11.4	14.5	8.2	9.2	5.2	27.9	15.8
		1.75	0.026	5.891	14.5	9.5	20.2	13.2	14.5	9.5	9.2	6.0	27.9	18.2
		2.00	0.022	5.154	14.5	10.8	20.2	15.1	14.5	10.8	9.2	6.9	27.9	20.8
4.00	Cap	0.054	12.566	14.5	4.4	20.2	6.2	14.5	4.4	9.2	2.8	27.9	8.5	
		1.75	0.044	10.161	14.5	5.5	20.2	7.7	14.5	5.5	9.2	3.5	27.9	10.6
		2.00	0.041	9.425	14.5	5.9	20.2	8.3	14.5	5.9	9.2	3.8	27.9	11.4
		2.50	0.033	7.658	14.5	7.3	20.2	10.2	14.5	7.3	9.2	4.6	27.9	14.0
5.00	Cap	0.085	19.635	14.5	2.8	20.2	4.0	14.5	2.8	9.2	1.8	27.9	5.5	
		2.00	0.071	16.493	14.5	3.4	20.2	4.7	14.5	3.4	9.2	2.1	27.9	6.5
		2.50	0.064	14.726	14.5	3.8	20.2	5.3	14.5	3.8	9.2	2.4	27.9	7.3
		3.00	0.054	12.566	14.5	4.4	20.2	6.2	14.5	4.4	9.2	2.8	27.9	8.5
		3.50	0.043	10.014	14.5	5.6	20.2	7.8	14.5	5.6	9.2	3.5	27.9	10.7
6.00	Cap	0.122	28.274	27.9	3.8	45.5	6.2	27.9	3.8	14.5	2.0	45.5	6.2	
		2.50	0.101	23.366	27.9	4.6	45.5	7.5	27.9	4.6	14.5	2.4	45.5	7.5
		3.00	0.092	21.206	27.9	5.1	45.5	8.3	27.9	5.1	14.5	2.6	45.5	8.3
		3.50	0.081	18.653	27.9	5.8	45.5	9.4	27.9	5.8	14.5	3.0	45.5	9.4
		4.00	0.068	15.708	27.9	6.8	45.5	11.2	27.9	6.8	14.5	3.6	45.5	11.2
7.00	Cap	0.167	38.485	45.5	4.6	67.4	6.7	45.5	4.6	27.9	2.8	67.4	6.7	
		3.00	0.136	31.416	45.5	5.6	67.4	8.3	45.5	5.6	27.9	3.4	67.4	8.3
		3.50	0.125	28.863	45.5	6.1	67.4	9.0	45.5	6.1	27.9	3.7	67.4	9.0
		4.00	0.112	25.918	45.5	6.8	67.4	10.0	45.5	6.8	27.9	4.1	67.4	10.0
		4.50	0.098	22.580	45.5	7.8	67.4	11.5	45.5	7.8	27.9	4.8	67.4	11.5
		5.00	0.082	18.850	45.5	9.3	67.4	13.8	45.5	9.3	27.9	5.7	67.4	13.8
8.00	Cap	0.218	50.266	67.4	5.2	45.5	3.5	45.5	3.5	27.9	2.1	67.4	5.2	
		3.50	0.176	40.644	67.4	6.4	45.5	4.3	45.5	4.3	27.9	2.6	67.4	6.4
		4.00	0.163	37.699	67.4	6.9	45.5	4.6	45.5	4.6	27.9	2.8	67.4	6.9
		4.50	0.149	34.361	67.4	7.6	45.5	5.1	45.5	5.1	27.9	3.1	67.4	7.6
		5.00	0.133	30.631	67.4	8.5	45.5	5.7	45.5	5.7	27.9	3.5	67.4	8.5
		5.50	0.115	26.507	67.4	9.8	45.5	6.6	45.5	6.6	27.9	4.1	67.4	9.8

Note : Under size port velocities are not shown

Port Locations

Port locations are identified by viewing the cylinder from the head end (or from the mounting end of double rod cylinders). The location num-

bers are shown here. Certain Port locations cannot be specified with some mounting styles. The table

below indicates which of the head and cap port locations are available for each Series NZ mounting style.

Bore	J	D
1.50	0.625	0.22
2.00	0.812	0.38
2.50	1.188	0.7
3.25	1.188	0.44
4.00	1.562	0.66
5.00	1.562	0.062
6.00	2.00	-
7.00	2.312	0.31
8.00	2.312	-

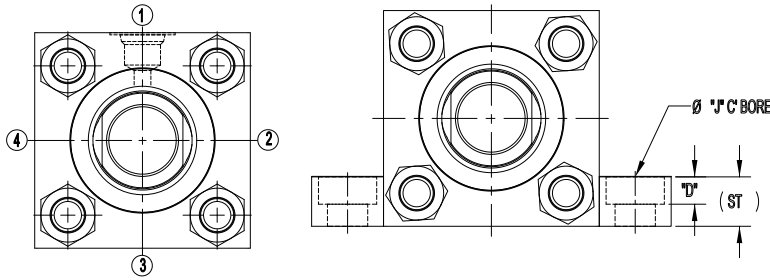

Mounting Style code	Description	Head location				Cap location				
		1	2	3	4	1	2	3	4	5
01	Side Lug	A	W	A	W	A	W	A	W	A
02	Side Tapped	A	A	N	A	A	A	N	A	A
03	End Lug Mount	A	A	N	A	A	A	N	A	A
04	Keyed Side Lug	A	W	A	W	A	W	A	W	A
05	Keyed Tapped	A	A	N	A	A	A	N	A	A
07	Head Rectangular Flange	A	W	A	W	A	A	A	A	A
08	Head Square Flange	W	W	W	W	A	A	A	A	A
09	Head Rectangular	A	A	A	A	A	A	A	A	A
10	Clevis	A	A	A	A	A	A	A	A	N
11	Spherical Bushing	A	A	A	A	A	A	A	A	N
12	Cap Rectangular Flange	A	A	A	A	A	W	A	W	N
13	Cap Square Flange	A	A	A	A	W	W	W	W	N
14	Cap Rectangular	A	A	A	A	A	A	A	A	N
15	Intermediate Trunnion	A	A	A	A	A	A	A	A	A
16	Cap Trunnion	A	A	A	A	A	N	A	N	A
17	Head Trunnion	A	N	A	N	A	A	A	A	A
19	Centerline Lug	A	N	A	N	A	N	A	N	A
21	Cap End Extended Tie Rod	A	A	A	A	A	A	A	A	A
22	Head End Extended Tie Rod	A	A	A	A	A	A	A	A	A
23	Both Ends Extended Tie Rod	A	A	A	A	A	A	A	A	A
24	No Mount	A	A	A	A	A	A	A	A	A
25	Double Rod, Side Lug	A	A	A	A					
26	Double Rod, Tapped	A	A	N	A					
27	Double Rod, End Lug	A	A	N	A					
28	Double Rod, Keyed Side Lug	A	W	A	W					
29	Double Rod, Keyed Tapped	A	A	N	A					
31	Double Rod, Rectangular Flange	A	W	A	W					
32	Double Rod, Square Flange	W	W	W	W					
33	Double Rod, Head Rectangular	A	A	A	A					
34	Double Rod, Intermediate Trunnion	A	A	A	A					
35	Double Rod, Head Trunnion	A	N	A	N					
37	Double Rod, Centerline Lug	A	N	A	N					
39	Double Rod, Extended Tie Rod	A	A	A	A					
40	Double Rod, Both Ends Extended Tie Rod	A	A	A	A					
41	Double Rod, No Mount	A	A	A	A					
47	Cap Fixed Eye	A	A	A	A	A	A	A	A	N
48	Cap Detachable Eye	A	A	A	A	A	A	A	A	N
50	Cap Detachable Clevis	A	A	A	A	A	A	A	A	N

A - Available
 N - Not available
 W - Port is available without port Boss only
 Refer Page 68 for port Boss requirements, refer Page 74 for switch availability

Sealing system

Four different sealing systems are available in Series NZ cylinders.

Determine the correct seal code for your application, then enter it as item 8 in the model code.

Code	Fluid	Temperature (°F)	Max. Speed (ft/s)	Application
N	Mineral oil, petroleum base	-31 to 176	2.25	Normal, typical industrial
	Automotive transmission fluid			
L	Mineral oil	-31 to 248	15	Low friction servo
	Water glycol (HFC)	50 to 158	3	Fire retardant fluids
	Oil-in-water emulsions (HFA)			
	Water-in-oil emulsions (HFB)			
T	Mineral oil	-13 to 392	15	High temperature
	Phosphate esters, petroleum oil blends	32 to 392	15	Fire retardant fluids
	Fyrquel 220, 550, 1000			
	Hought-O-Safe 1340			
	Pydraul 200, 230C, 280, 312C, 540C, A200			
C	Mineral oil, petroleum base	-31 to 176	2.25	Normal, typical industrial
	Automotive transmission fluid			

Rod Seal Configuration

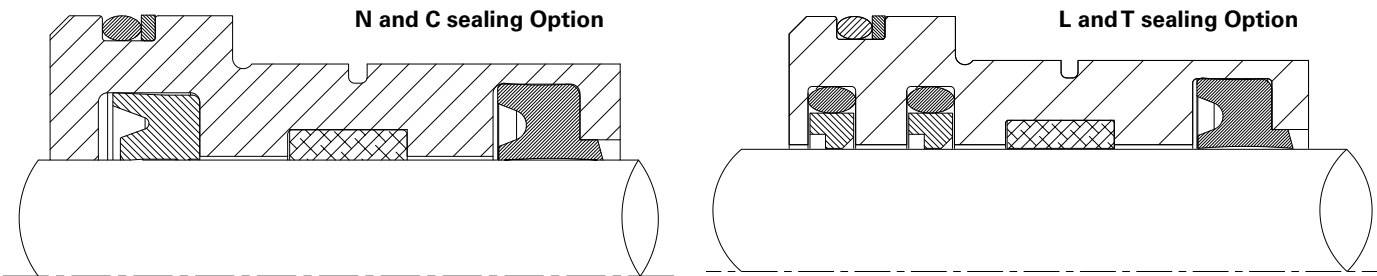

Piston Seal Configuration

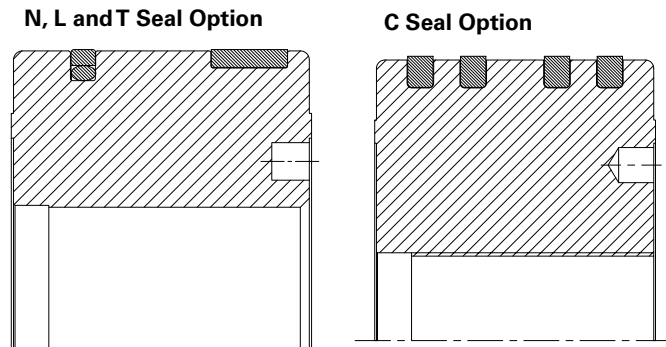

Gland drains/Air bleeds

Gland Drain Option

Gland drains are primarily used for long stroke cylinders (over 30 inches) and when extended speed exceeds retract speed.

The gland drain is used to return any accumulated fluid, between the rod seal and wiper, to tank. This is used in servo applications, for ultra-low leakage requirements, or for remote visual monitoring of rod seal leakage for preventive maintenance purposes.

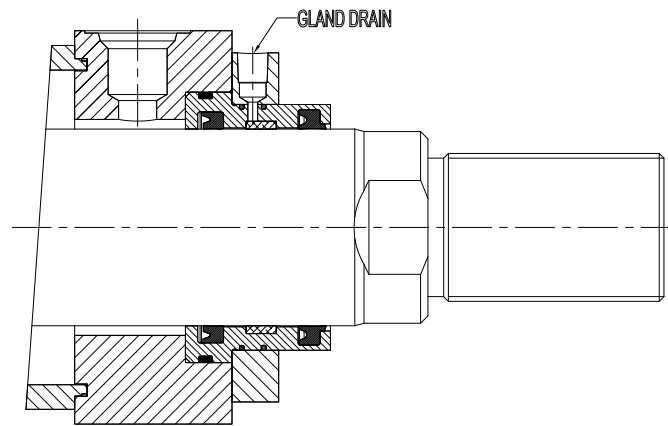

Air Bleed Option

Usually cylinders will bleed themselves of air when ports are vertical, on top. Bleed ports are often desirable to remove entrapped air, when the ports are on the bottom. High performance and high speed or heavy load applications are a few examples where air bleeds are desirable.

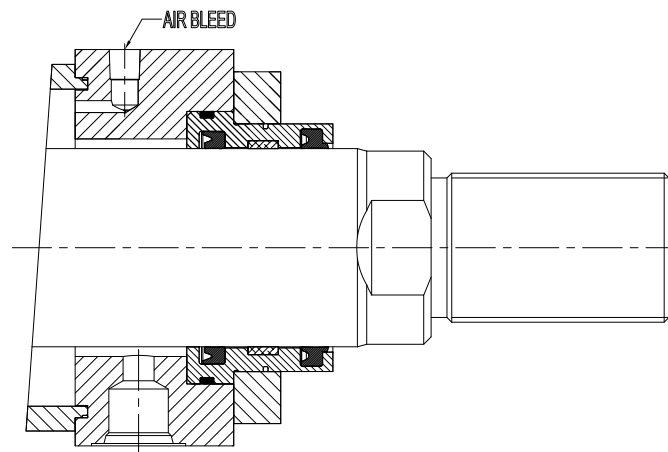

Technical Data Proximity Switches

Proximity switches for series NZ cylinder are inductive type switches with sensing probe that "looks" at the cushion collar or button to provide extended or retracted indication. Since the probe is inside the cylinder, harsh external environments don't affect sensing. The 2-wire circuit will operate on AC or DC and works as

reliably as a programmable controller. Proximity switches will meet UL requirements for 3000-psi (210 bar) hydraulic cylinder.

Switch will allow 304° rotations. Short Circuit protection is standard feature on Proximity proximity switch. SCP protects the switch from shorts in load or line. Upon sensing short condi-

tion, the switch assumes a non-conducting mode. The fault condition *must* be removed and power turned off in order to reset the switch.

This feature prevents unintended automatic restarts. The switch indicated when it is in SCP mode by flashing both leads.

Torque ¼-20 mounting screws to 15 ft-lb (20 Nm)

Balluff

Pressure	3000 PSI
Sensing Range	0.08 in ± 10 %
Sensing distance from End of stroke	0.25" - 0.38" stroke to go
Operating temperature range	-13° to +158° F
Repeatability	0.001 in
Switching differential	≤ 15%
Supply Voltage	20 - 250 V AC / DC
Voltage drop	≤ 6 V
Load Current capacity @ 25° C	5-400 mA
Inrush current	≤ 3A (t ≤ 20ms)
Indicating LED's (Standard)	1 lit: Power on non-conducting 2 lit: Target present (both flashing = SCP mode)

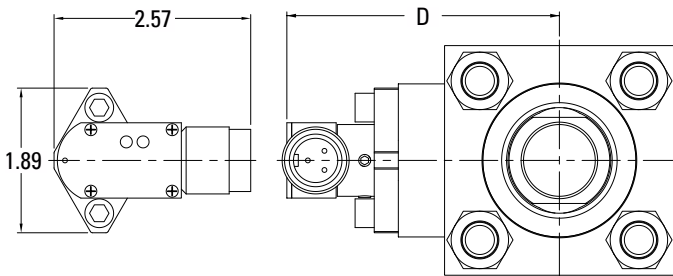

Note : NA - Not available

Proximity switch for 1.50" at postion 2 & 4 is not available for 07 Mount at Head end, 12 Mount at Cap end

Proximity Switch for "1.50" is unavailable for 08 Mount at Head end, 13 Mount at Cap end

Proximity Switch for "7.00 & 8.00" is unavailable for 14 Mount at Cap end

BORE	ROD	"D" Max.	"D" Max.	"D" Max.
			09 mounts Pos. 2 & 4	14 mounts Pos. 2 & 4
1.50	0.63	2.99	4.03	2.99
	1.00	3.12	4.16	3.12
	CAP	2.99	2.99	3.80
2.00	1.00	3.37	5.00	3.37
	1.38	3.30	4.34	3.30
	CAP	3.08	3.08	4.73
2.50	1.00	3.35	5.00	3.35
	1.38	3.53	5.15	3.53
	1.75	3.49	4.53	3.49
	CAP	3.92	3.92	4.73
3.25	1.38	4.40	5.22	4.40
	1.75	4.59	5.40	4.59
	2.00	3.82	5.47	3.82
	CAP	4.03	4.03	5.75
4.00	1.75	4.59	5.41	4.59
	2.00	4.78	5.59	4.78
	2.50	4.07	5.72	4.07
	CAP	4.84	4.84	5.74
5.00	2.00	5.59	6.49	5.59
	2.50	5.03	6.74	5.03
	3.00	5.28	6.99	5.28
	3.50	5.40	7.12	5.40
	CAP	5.03	5.03	6.72
6.00	2.50	5.84	7.53	5.84
	3.00	6.09	7.78	6.09
	3.50	5.38	7.11	5.38
	4.00	5.66	7.37	5.66
	CAP	6.18	6.18	7.41
7.00	3.00	6.09	8.22	6.09
	3.50	6.34	8.03	6.34
	4.00	6.47	8.15	6.47
	4.50	6.03	8.53	6.03
	5.00	6.19	8.68	6.19
8.00	CAP	6.18	6.18	NA
	3.50	6.32	NA	6.32
	4.00	6.47	8.60	6.47
	4.50	6.84	8.97	6.84
	5.00	7.00	8.68	7.00
	5.50	6.47	8.96	6.47
CAP	6.21	6.21	NA	

Application Engineering Data

Transducer Options

A wide variety of precision cylinder position sensing and feedback devices are available. These packaged cylinder systems can handle virtually any application requiring feedback throughout the cylinder stroke with or without velocity monitoring and with resolutions of ± 0.001 or better. Cylinders can be manufactured prepared for transducer or with transducer already installed.

Two different protective cover options are available for rugged environments to protect the electronics.

Transducer Cover

Rugged aluminum casting cover protects the transducer from minor wear and tear, yet is easily removable to service the transducer.

False Stage Cover

Transducer is protected by a tie-rod cylinder body and end cap for the best protection short of the encapsulated HLT II design. Utilize this design when you need heavy duty protection for the transducer, yet need output options not available in the HLT II.

Eaton HLT II

The Eaton HLT II is a linear displacement transducers are precise, durable, cost-effective measurement devices. Well protected within the core of the cylinder, the HLT II not only measures the position of the moving elements of the cylinder, but also remains untouched, and unaffected by even the harshest elements. HLT II also is an ideal choice, with its compact design, when overall cylinder length is a concern. The innovative encapsulated design and engineering along with the rugged construction of Eaton HLT II transducer guarantee the best reliability, precision and durability in even the toughest industrial environment.

Additional Probe Options

Eaton has years of experience providing cylinders with a variety of transducer feedback options. From the common mangetostriptive type transducers to solid state transducers, Eaton can provide a solution for your feedback needs regardless of application or condition. Eaton can also provide a cylinder "prepared" for a transducer if you prefer to provide your own feedback. Please contact your Eaton representative with your requirements and we can provide a cylinder solution.

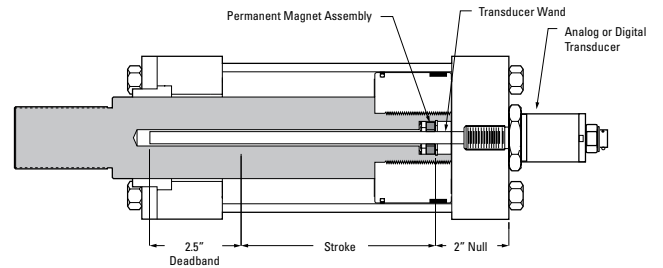
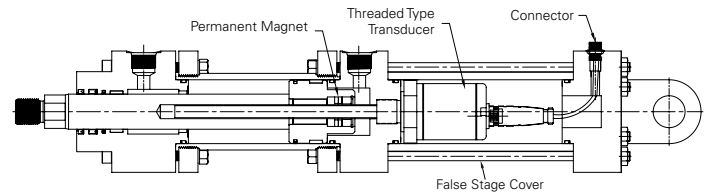
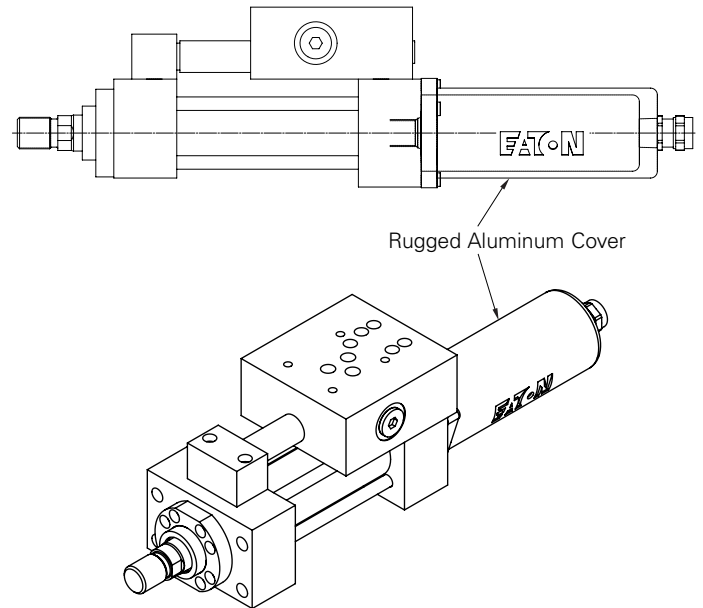

Typical Probe Design Threaded in Cap

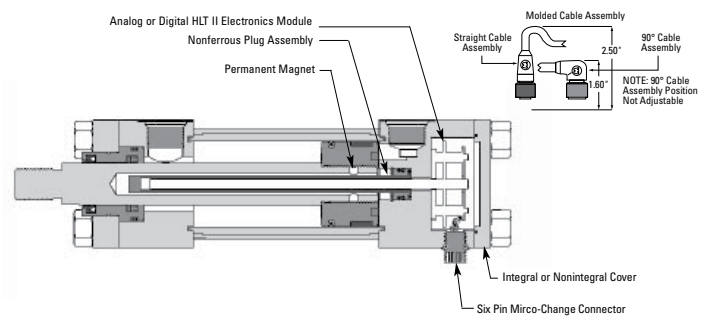

HLT II

Application/Engineering Data

Manifold Options

Eaton cylinders can be specified to include hydraulic manifolds and plumbing to simplify the integration of the cylinder with a control valve. Eaton offers standard hydraulic manifold options for valve interfaces of CETOP D03, D05 and SM4-20. Other manifolds can be designed as a special and incorporated with or without feedback.

Customer Requirements

Eaton has been an industry pioneer incorporating positioning systems into industrial cylinders, and can design systems for any application. If a specific type of system is required and not covered here, we can work with you to create a cylinder configuration incorporating your needs.

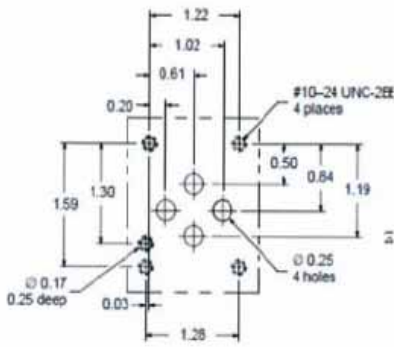

CETOP 3

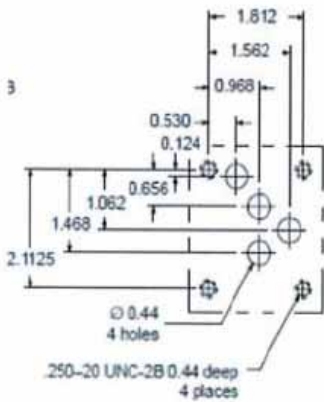

CETOP 5

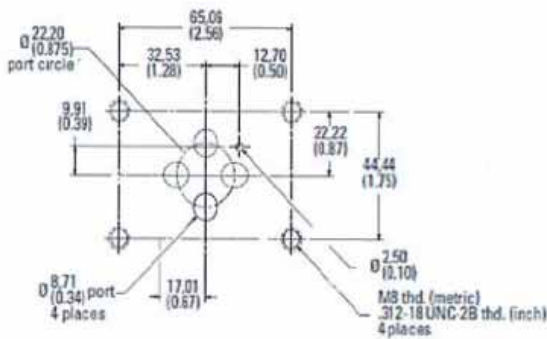

SM4-20(.875 PORT CIRCLE)

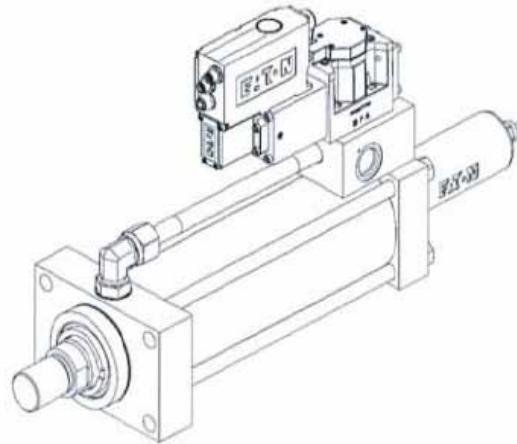
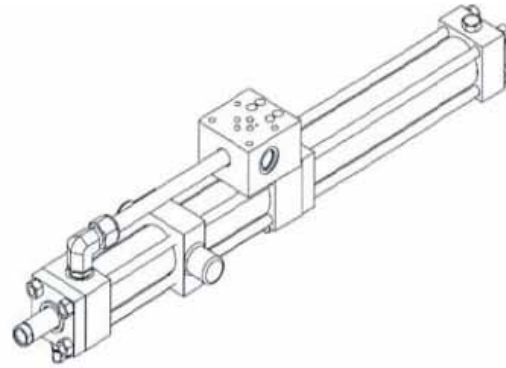

Technical Data

Stop Tubes

Stop tubes are located between the piston and the rod shoulder on the head end of the cylinder. Bearing loading is reduced by separating the piston and the rod bushing. Bearing wear and tendency to buckle is reduced.

To determine if a stop tube is required and the length of stop tube needed, use the following procedure:

Determine the value of D with the piston rod in the fully extended position. If the value of D is under 40", no stop tube is needed.

If D is greater than 40", one inch of stop tube is recommended for each 10", or fraction thereof, beyond 40".

Special Note

When specifying stroke and stop tube lengths, please

include net working stroke plus stop tube length.

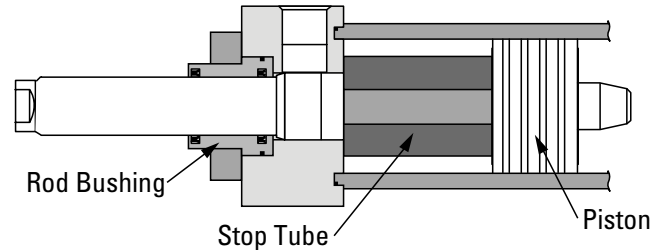

<p>$D = 4S$ Unsupported Rod End</p>	<p>$D = S$ Supported Rod End</p>	<p>$D = 0.5S$ Firmly Guided Rod End</p>	<p>$D = 4S$ Unsupported Rod End</p>
<p>Cap Clevis or Trunnion</p>	<p>Intermediate Trunnion</p>	<p>Head Trunnion</p>	<p>$D = S$ Supported Rod End</p>
			<p>$D = 0.5S$ Firmly Guided Rod End</p>

Stop Tubes

There are two stop tube designs depending on the length required.

Design A

The standard stop tube design for lengths under 10".

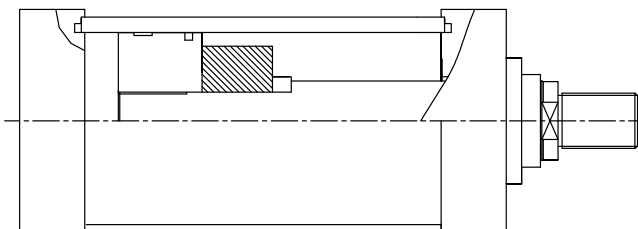

Design B

The standard stop tube design for lengths over 10". Note that the piston's effective bearing area is doubled, in addition to gaining the normal increased minimum distance between bearing points.

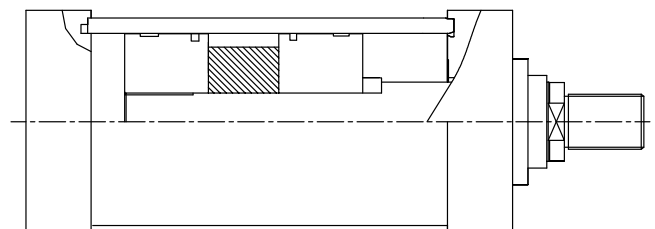

Technical Data

Tie rod Spacers and Center supports

A tie rod spacer or center support should be applied when the stroke length exceeds 20 times the bore diameter.

Tie rod spacer

Tie rod spacers and center supports are used to improve the structural rigidity of long

stroke tie rod cylinders. The spacers have through holes for the tie rods and are held in place on the cylinder barrel with a small tack weld or set screw. The spacer keeps the tie rod in the proper position around the centerline of the cylinder and acts much like a truss in preventing excessive deflection in a long stroke cylinder that is not rigidly mounted (clevis mount, etc.).

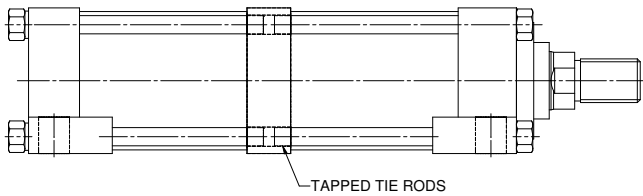
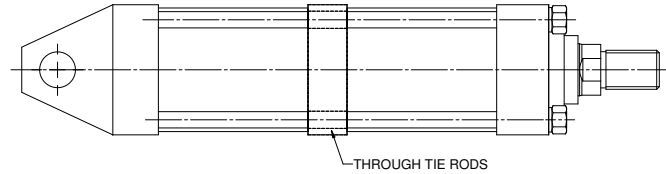

Tie rod center support

The center support has side mounting lugs similar to side lug mount heads and serves as an additional mounting location. The tie rods are threaded into the center support and it becomes a load-carrying component of the cylinder assembly.

The exact location of the tie rod center support is generally optional, which greatly increases the flexibility in mounting a long stroke cylinder.

Bore & Rod Diameter – Cylinder Size Selection

To choose the proper size of cylinder for your application, first determine the maximum push or pull force required to do the job. Then use the below table to select the cylinder that will provide that force.

Remember that force capabilities derived from charts and formulas may be therotically correct, but other factor must be considered. Be sure to allow for pressure drop between pump outlet and

cylinder port. Also some of a cylinder force is used up over-coming seal friction and lesser extent the inertia of the piston itself.

WARNING

It is the user's responsibility to select the correct cylinder size.

Bore φ in	Rod φ in	Work Area (in ²)	Maximum Force (lbf) At working pressure(psi)					
			500 (psi)	750 (psi)	1000 (psi)	1500 (psi)	2000 (psi)	3000 (psi)
1.50	-	1.767	884	1325	1767	2651	3534	5301
	0.625	1.460	730	1095	1460	2191	2921	4381
	1	0.982	491	736	982	1473	1964	2945
2.00	-	3.142	1571	2356	3142	4712	6283	9425
	1	2.356	1178	1767	2356	3534	4712	7069
	1.375	1.657	828	1243	1657	2485	3313	4970
2.50	-	4.909	2454	3682	4909	7363	9817	14726
	1	4.123	2062	3093	4123	6185	8247	12370
	1.375	3.424	1712	2568	3424	5136	6848	10272
	1.75	2.503	1252	1878	2503	3755	5007	7510
3.25	-	8.296	4148	6222	8296	12444	16592	24887
	1.375	6.811	3405	5108	6811	10216	13622	20433
	1.75	5.891	2945	4418	5891	8836	11781	17672
	2	5.154	2577	3866	5154	7731	10308	15463
4.00	-	12.566	6283	9425	12566	18850	25133	37699
	1.75	10.161	5081	7621	10161	15242	20322	30483
	2	9.425	4712	7069	9425	14137	18850	28274
	2.5	7.658	3829	5743	7658	11486	15315	22973
5.00	-	19.635	9817	14726	19635	29452	39270	58905
	2	16.493	8247	12370	16493	24740	32987	49480
	2.5	14.726	7363	11045	14726	22089	29453	44179
	3	12.566	6283	9425	12566	18850	25133	37699
	3.5	10.014	5007	7510	10014	15021	20028	30042
6.00	-	28.274	14137	21206	28274	42412	56549	84823
	2.5	23.366	11683	17524	23366	35048	46731	70097
	3	21.206	10603	15904	21206	31809	42412	63617
	3.5	18.653	9327	13990	18653	27980	37307	55960
	4	15.708	7854	11781	15708	23562	31416	47124
7.00	-	38.485	19242	28863	38485	57727	76969	115454
	3	31.416	15708	23562	31416	47124	62832	94248
	3.5	28.863	14432	21648	28863	43295	57727	86590
	4	25.918	12959	19439	25918	38877	51836	77755
	4.5	22.580	11290	16935	22580	33870	45161	67741
	5	18.850	9425	14137	18850	28274	37699	56549
8.00	-	50.266	25133	37699	50266	75398	100531	150797
	3.5	40.644	20322	30483	40644	60967	81289	121933
	4	37.699	18850	28274	37699	56549	75398	113098
	4.5	34.361	17181	25771	34361	51542	68723	103084
	5	30.631	15315	22973	30631	45946	61261	91892
	5.5	26.507	13254	19880	26507	39761	53015	79522

Maximum Allowable Push Stroke (Recommended "L")

In Push application, a cylinder acts as loaded column.

To use the side table first go to section for your mounting style. Then locate the column which is closest to, but not below, your application's operating pressure. The intersection of operating pressure and Bore /rod size represents the allowable length (L) in full extended condition.

The maximum allowable length "L" is based on column spelling analysis only and does not consider side loading, stop tube requirements or other cylinder stroke limitations.

For pressure above 3000 PSI Consult your local Eaton representative.

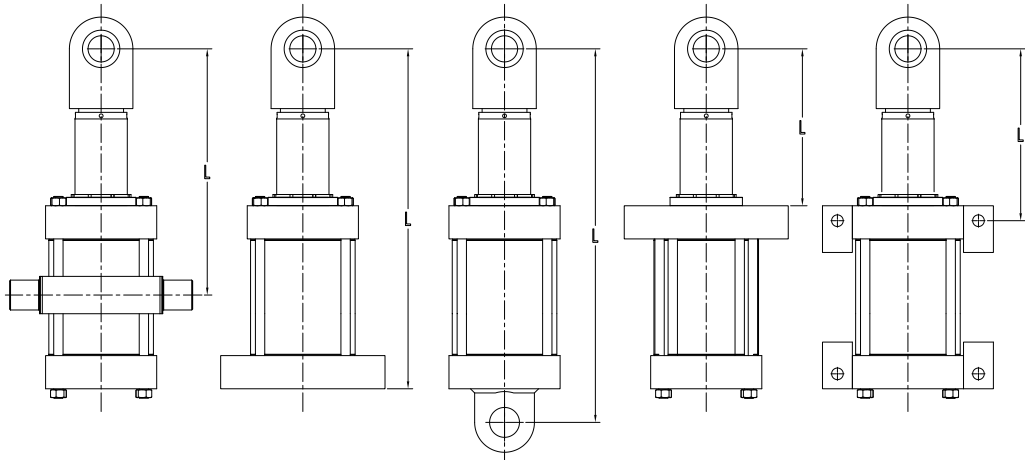

Maximum Length L (in) at Working Pressure (psi) (Length L in full extend condition)

Bore φ in	Rod φ in	Rigid Mount (01,02,04,05,07,08,09,12, 13,14,19,21,22,23,24)								Swivel Mount (10,11,15,16,17,47,48,50)							
		3000	2000	1500	1000	750	500	250	3000	2000	1500	1000	750	500	250		
		psi	psi	psi	psi	psi	psi	psi	psi	psi	psi	psi	psi	psi	psi		
1.50	0.63	14	19	22	27	31	38	54	10	13	15	19	22	27	38		
	1.00	40	48	56	69	79	97	137	28	34	40	48	56	69	97		
2.00	1.00	30	36	42	51	59	73	103	21	26	30	36	42	51	73		
	1.38	56	69	79	97	112	137	194	40	49	56	69	79	97	137		
2.50	1.00	20	19	34	41	47	58	82	14	19	24	29	34	41	58		
	1.38	45	55	63	78	90	110	156	32	39	45	55	63	78	110		
	1.75	73	89	103	126	145	178	252	51	63	73	89	103	126	178		
3.25	1.38	32	42	49	60	69	85	120	23	30	35	42	49	60	85		
	1.75	56	69	79	97	112	137	194	40	48	56	69	79	97	137		
	2.00	73	89	103	127	146	179	253	52	63	73	89	103	127	179		
4.00	1.75	43	56	64	79	91	111	157	31	39	45	56	64	79	111		
	2.00	59	73	84	103	119	145	206	42	51	59	73	84	103	145		
	2.50	93	114	131	161	186	227	321	66	80	93	114	131	161	227		
5.00	2.00	40	38	67	82	95	116	165	28	27	47	58	67	82	116		
	2.50	74	91	105	129	148	182	257	52	64	74	91	105	129	182		
	3.00	107	131	151	185	214	262	370	76	93	107	131	151	185	262		
	3.50	145	178	206	252	291	356	504	103	126	145	178	206	252	356		
6.00	2.50	56	76	87	107	124	151	214	40	54	62	76	87	107	151		
	3.00	89	109	126	154	178	218	308	63	77	89	109	126	154	218		
	3.50	121	148	171	210	242	297	420	86	105	121	148	171	210	297		
	4.00	158	194	224	274	317	388	548	112	137	158	194	224	274	388		
7.00	3.00	72	93	108	132	153	187	264	51	66	76	93	108	132	187		
	3.50	104	127	147	180	208	254	360	73	90	104	127	147	180	254		
	4.00	136	166	192	235	271	332	470	96	118	136	166	192	235	332		
	4.50	172	210	243	297	344	421	595	121	149	172	210	243	297	421		
	5.00	212	260	300	367	424	519	735	150	184	212	260	300	367	519		
8.00	3.50	87	111	129	157	182	223	315	62	79	91	111	129	157	223		
	4.00	119	145	168	206	237	291	411	84	103	119	145	168	206	291		
	4.50	150	184	213	260	301	368	521	106	130	150	184	213	260	368		
	5.00	186	227	262	321	371	454	643	131	161	186	227	262	321	454		
	5.50	224	275	317	389	449	550	778	159	194	224	275	317	389	550		

Calculation according to Euler

$$P = \frac{C\pi^2 EI}{FL^2} \quad \frac{L}{k} > \left[\frac{2C\pi^2 E}{S_y} \right]$$

Calculation according to Jb Johnson

$$P = \frac{AS_y}{F} \left[1 - \frac{S_y L^2}{4C\pi^2 Ek^2} \right] \quad \frac{L}{k} \leq \left[\frac{2C\pi^2 E}{S_y} \right]$$

End conditions for above chart
 Mount Condition
 Rigid Mounts Fixed-Guided
 Swivel Mounts Pin-Pin

F Safety factor,
 P Critical load, Lb
 E Modulus of elasticity, 30000000 psi
 L Length, in
 I Moment of inertia, in⁴
 C End condition
 Fixed-Guided 2
 Fixed-Fixed 4
 Pin-Pin 1
 A Rod area, in²
 k Radius of gyration, in

Technical Data Cushion Formulas and Factors

Cushions are recommended when piston speed is in excess of 20-25 feet per minute. Cushions decelerate the piston and rod assembly at the end of the stroke, lessening the noise and shock

and increasing cylinder life. Heavy loads attached to the piston and rod assembly should be stopped by external means, such as shock absorbers, springs, decelerating valves, etc.

Use the information below, along with the examples on page 83 to determine if standard cushioning is sufficient for your application.

Force Factor Terminology

Force Factor Chart

Force Factors ($a = \sqrt{2} \times .001294$)

(continued)

Piston	Velocity
ips	a
1	0.001
2	0.005
3	0.012
4	0.021
5	0.032
6	0.047
7	0.063
8	0.083
9	0.105
10	0.129
11	0.157
12	0.186
13	0.219
14	0.254
15	0.291
16	0.331
17	0.374
18	0.419
19	0.467
20	0.518
21	0.571
22	0.626
23	0.685
24	0.745
25	0.809

General Formulas

Horizontal motion	$F_{acc} \text{ or } F_{dec} = W \times \frac{a}{s}$
Vertical motion, decelerating downward or accelerating upward	$F_{acc} \text{ or } F_{dec} = (W \times \frac{a}{s}) + W$
Vertical motion, decelerating upward or accelerating downward	$F_{acc} \text{ or } F_{dec} = (W \times \frac{a}{s}) - W$
Frictional force	$F_f = u \times W$
Total cushioning force (+ F_f if load accelerating, - F_f if load decelerating)	$F_t = F_{acc} \text{ or } F_{dec} + F_p \pm F_f$
Contained pressure	$P_c = F_t/A_{cc} \text{ or } F_t/A_{hc}$

Acceleration and Deceleration Forces

The a force factors shown are used to determine the forces required to accelerate or decelerate a weight through a given distance, s (Refer to **Force Factor Chart**).

- If the motion of the load is horizontal, use the general formula $F_{acc} \text{ or } F_{dec} = W \times \frac{a}{s}$.
- If the motion of the load is vertical and is being decelerated downward or accelerated upward, use the general formula $F_{acc} \text{ or } F_{dec} = (W \times \frac{a}{s}) + W$.
- If the motion of the load is vertical and is being decelerated upward or accelerated downward, use the general formula $F_{acc} \text{ or } F_{dec} = (W \times \frac{a}{s}) - W$.

- Friction due to load motion affects F_t . Add F_f to F_t if the load is accelerating. Subtract F_f from F_t if the load is decelerating.
- Cylinder friction is negligible.

Note

The contained cushioning pressure must not exceed 5000 psi. If the standard cushion results in a too high pressure, then a longer cushion spud must be specified.

Technical Data

How to Calculate Cushion Requirements

Hydraulic Examples

Example A

Horizontal deceleration

NZ series cylinder, 3 1/4" bore, 1 3/8" rod (standard), cushioning at cap.

A weight of 3000 lbs., moving at 25 ips, and driven by a pump pressure of 1000 psi should be stopped in 1 1/4". Assume the coefficient of friction to be .15.

1. $F_f = u \times W$
 $= .15 \times 3000 \text{ lbs.}$
 $F_f = 450 \text{ lbs.}$
2. $F_p = A_h \times P_p$
 $A_h = A_b - \text{rod area}$
 $= 8.45 \text{ sq. in.} - 1.49 \text{ sq. in.}$
 $A_h = 6.96 \text{ sq. in.}$
 $F_p = 6.96 \text{ sq. in.} \times 1000 \text{ psi}$
 $F_p = 6960 \text{ lbs.}$
3. $F_{dec} = W \times a/s$
 $= 3000 \text{ lbs.} \times .809/1.25 \text{ in.}$
 $F_{dec} = 1942 \text{ lbs.}$
4. $F_t = F_{dec} + F_p - F_f$
 $= 1942 + 6960 - 450$
 $F_t = 8452 \text{ lbs.}$
5. $P_c = F_t / Acc$
 $= 8452 \text{ lbs.} / 7.85 \text{ sq. in.}$
 $P_c = 1077 \text{ psi}$

This figure does not exceed the pressure capability of the cylinder, therefore, the standard cushion is acceptable.

Example B

Horizontal deceleration

NZ series cylinder, 6" bore, 2 1/2" rod (standard), cushioning at head. The cylinder is mounted vertical rod down, with a 2000 lb. load attached to the rod end. Pump pressure is 750 psi, the load is moving at 40 ips, and must be stopped in 1 3/8". There is no load friction.

1. $F_p = P_p \times A_b$
 $= 750 \text{ psi} \times 28.56 \text{ sq. in.}$
 $F_p = 21,420 \text{ lbs.}$
3. $F_{dec} = (W \times a/s) + W$
 $= (2000 \text{ lbs.} \times 2.07/1.375 \text{ in.}) + 2000 \text{ lbs.}$
 $F_{dec} = 5011 \text{ lbs.}$
4. $F_t = F_p + F_{dec}$
 $= 21,420 + 5011 \text{ lbs.}$
 $F_t = 26,431 \text{ lbs.}$
5. $P_c = F_t / A_{hc}$
 $= 26,431 \text{ lbs.} / 22.07 \text{ sq. in.}$
 $P_c = 1198 \text{ psi}$

This does not exceed the pressure capability of the cylinder, therefore, the standard cushion is acceptable.

Note

If your calculations show you need a longer cushion than standard, longer cushions are available in 1/4 inch increments.

Bore Size	Rod Dia	Cushion Length (in.)		Effective Cushion Area (in. ²)	
		Head	Cap	Head (A _{hc})	Cap (A _{cc})
1.50	0.63	1.13	1.81	1.24	1.70
	1.00	1.13	1.81	0.73	1.70
2.00	1.00	1.13	1.13	2.13	2.91
	1.38	1.13	1.13	1.17	2.90
2.50	1.00	1.13	1.13	3.92	4.77
	1.38	1.13	1.13	2.96	4.77
	1.75	1.13	1.13	1.89	4.77
3.25	1.38	1.38	1.25	6.38	7.85
	1.75	1.38	1.25	5.31	7.85
	2.00	1.38	1.25	4.02	7.85
	2.50	1.38	1.25	8.33	12.16
4.00	1.75	1.38	1.25	9.62	12.16
	2.00	1.38	1.25	8.33	12.16
	2.50	1.38	1.25	6.27	12.16
5.00	2.00	1.38	1.25	15.44	18.64
	2.50	1.38	1.25	13.38	18.64
	3.00	1.31	1.25	10.93	18.64
	3.50	1.31	1.25	8.08	18.64
6.00	2.50	1.38	1.50	22.07	26.16
	3.00	1.31	1.50	19.62	26.16
	3.50	1.31	1.50	16.77	26.16
	4.00	1.50	1.50	15.20	26.16
7.00	3.00	2.00	2.00	29.88	36.42
	3.50	2.00	2.00	27.03	36.42
	4.00	2.00	2.00	25.46	36.42
	4.50	2.00	2.00	19.29	36.42
	5.00	2.00	2.00	17.70	36.42
	5.50	2.00	2.00	17.70	36.42
8.00	3.50	2.00	2.00	38.85	48.24
	4.00	2.00	2.00	37.28	48.24
	4.50	2.00	2.00	31.11	48.24
	5.00	2.00	2.00	29.52	48.24
	5.50	2.00	2.00	29.52	48.24

Eaton Cylinder Application Data Sheet

Customer Name:			
Customer P/N	Rev	Machine	Function
Contact	Ph	Fax	e-mail
Cylinder Description			
Series	Mtg Style	Bore	Stroke
Cushions: None <input type="checkbox"/> Rod End <input type="checkbox"/> Pos: Blind End <input type="checkbox"/> Pos:			
Weight Connected to Rod (lbs):			
How is Cylinder Mounted			
Horizontal <input type="checkbox"/>	Vertical Rod Up <input type="checkbox"/>	Rod Down <input type="checkbox"/>	Angle <input type="checkbox"/> Degrees Vertical
Rod End Connection	Firmly Guided <input type="checkbox"/> Supported <input type="checkbox"/> Unsupported <input type="checkbox"/> Know Side Load(lbs)		
How is Cylinder Used			
Operating Fluid:		Fluid Temp @ Cylinder: $^{\circ}$ F	
Pressure Setting Extend:		Pressure Setting Retract:	
Stop Internal Ext <input type="checkbox"/>	Stop Internal Ret <input type="checkbox"/>	Stop External Ext <input type="checkbox"/>	Stop External Ret <input type="checkbox"/>
Force Ext lb f	Force Ret lb f	Velocity Ext:	Velocity Ret:
Cycle Rate:	Cycle Life of Cylinder:	Cycle Life Seals:	
Environmental Conditions			
Standard Factory <input type="checkbox"/> Very Dirty <input type="checkbox"/> Outdoors <input type="checkbox"/> Other:			
Application Sketch		Special Requirements	
Prepared By	Date	Reviewed By	Date

ext = cylinder extends ret = cylinder retracts

Eaton
Hydraulics Group USA
14615 Lone Oak Road
Eden Prairie, MN 55344
USA
Tel: 952-937-9800
Fax: 952-294-7722
www.eaton.com/hydraulics

Eaton
Hydraulics Group Europe
Route de la Longeraie 7
1110 Morges
Switzerland
Tel: +41 (0) 21 811 4600
Fax: +41 (0) 21 811 4601

Eaton
Hydraulics Group Asia Pacific
Eaton Building
No.7 Lane 280 Linhong Road
Changning District, Shanghai
200335 China
Tel: (+86 21) 5200 0099
Fax: (+86 21) 2230 7240