

Propeller Upblast Roof Fans Models RBU, RBUMO and RDU

Direct Drive and Belt Drive



BUILDING VALUE IN AIR.

 **GREENHECK**
Building Value in Air.

November
2011

Contents

Model Comparison	3-4	RBUMO - Belt Drive - Motor out of airstream . . .12	
Basics of Fan Selection	5	Sizes 20-60	
Construction Features/Details	6-7	Capacities to 62,000 cfm and 1.0 in. wg	
Service	8	RDU - Direct Drive Fans13
Accessories	8-9	Sizes 18-48	
High Temperature Options.10	Capacities to 43,000 cfm and 1.0 in. wg	
Electrical11	Selection Guide14
Dimensional Data		Model Number Codes15
RBU - Belt Drive - Motor in airstream12	Performance Direct Drive	16-17
Sizes 20-60		Performance Belt Drive	18-27
Capacities to 64,000 cfm and 1.0 in. wg		Specifications28
		Warranty28



Greenheck Fan Corporation certifies that the RBU, RBUMO and RDU models shown herein are licensed to bear the AMCA seal. The ratings shown are based on tests and procedures performed in accordance with AMCA Publication 211 and AMCA Publication 311 and comply with the requirements of the AMCA Certified Ratings Program.



RDU, RBU, RBUMO models are Listed for electrical (UL/cUL 705) File No. E40001

RBUMO model is Listed for Emergency Smoke Control Systems File No. MH17511



Enjoy Greenheck's extraordinary service, before, during and after the sale.

Greenheck offers added value to our wide selection of top performing, energy-efficient products by providing several unique Greenheck service programs.

- Our Quick Delivery Program ensures shipment of our in-stock products within 24 hours of placing your order. Our Quick Build made-to-order products can be produced in 1-3-5-10-15- or 25-day production cycles, depending upon their complexity.
- Greenheck's free Computer Aided Product Selection program (CAPS), rated by many as the best in the industry, helps you conveniently and efficiently select the right products for the challenge at hand.
- Greenheck has been Green for a long time! Our energy-saving products and ongoing corporate commitment to sustainability can help you qualify for LEED credits.
- Our 3D service allows you to download, at no charge, easy-to-use AutoDesk™ Revit™ 3D drawings for many of our ventilation products.

Find out more about these special Greenheck services at greenheck.com

Model Comparison																										
Model	Location		Mounting					Airflow				Application						Drive Type		Impeller Type			Performance		Relative Cost	
	Outdoor	Indoor	Roof Curb	Base/Floor	Hanging	Wall	Ceiling Mounted	Exhaust	Supply	Reversible	Recirculate	General/Clean Air	Contaminated Air	Spark Resistant	Grease (UL 762)	Smoke Control (UL)	High Wind (150 mph)	High Temp (above 200°F)	Belt	Direct	Centrifugal	Propeller/Axial	Mixed Flow	Maximum Volume (cfm)		Maximum Static Pressure (in. wg)
RDU	✓		✓					✓				✓	✓	✓						✓		✓		43,400	.75	\$
RBU	✓		✓					✓				✓	✓						✓			✓		64,300	1.0	\$
RBUMO	✓		✓					✓				✓	✓		✓		✓		✓			✓		61,800	1.0	\$\$

Greenheck upblast propeller fans are designed to discharge contaminants up and away from the building for most commercial jobs and many industrial applications. These roof exhaust fans are available in both belt and direct drives with steel or aluminum blades. Drive frames and panels are constructed to match the level of duty and motor size.

- Wide range of construction and performance capabilities provide for the most complete upblast propeller fan line available.
- Regardless of fan size, performance or duty level, all upblast propeller roof fans are built to perform with the same high standards of reliability and durability.
- Greenheck subjects these products to extensive life testing, assuring you that the fans will provide years of reliable performance.
- Performance as cataloged is assured. All RBU, RBUMO and RDU models are tested in our AMCA accredited laboratory and all are licensed to bear the AMCA Sound and Air Performance seal.

Direct Drive RDU

- Preferred for jobs where maintenance access is difficult.
- Maintenance costs are generally lower; no belts or bearings to replace, no pulleys to adjust.

Belt Drive RBU and RBUMO

- RBU has the motor in the airstream.
- RBUMO has the motor out of the airstream, allowing for high temperature air to be exhausted.
- Fan speed can be adjusted for system balancing.
- Models offer flexibility in speeds and motor selections.



RDU



RBU



RBUMO



Direct Drive Fan Selection

These models are designed and constructed for applications with static pressure ranges up to 1 in. wg. Propellers are cast aluminum. For low sound applications, it is best to select the largest fan with the lowest RPM to meet the performance requirements. This ensures the tip speeds will be as low as possible.

Construction Levels	Model Performance Pages	Size Range Diameter	Performance	Propeller	
Level 3	Cast aluminum airfoil blades	RDU pages 16-17	18 to 48 inch (508 to 1372 mm)	Up to 43,500 cfm (78,155 m ³ /hr) and up to 0.75 in. wg (249 Pa)	

Belt Drive Fan Selection Propeller Types

Application requirements for sound and static pressure determine propeller type. Propellers are available in fabricated steel, fabricated aluminum or cast aluminum.

Construction Levels	Model Performance Pages	Size Range Diameter	Performance	Propellers	
Level 1	Galvanized steel blades riveted to the hub	pages 18-20 and 23-25	20 to 36 inch (508 to 1372 mm)	Up to 16,500 cfm (50,970 m ³ /hr) and up to 5/8 in. wg (156 Pa)	
Level 2		page 18	20 and 24 inch (508 and 610 mm)	Up to 8070 cfm (23,711 m ³ /hr) and up to 1/2 in. wg (124 Pa)	
Level 2	Gusseted galvanized steel blades riveted to the hub	pages 19-27	30 to 54 inch (762 to 1524 mm)	Up to 46,000 cfm (90,048 m ³ /hr) and up to 3/4 in. wg (190 Pa)	
Level 3	Fully welded and gusseted steel blades	pages 18-27	24 to 60 inch (610 to 1829 mm)	Up to 64,000 cfm (149,513 m ³ /hr) and up to 1 in. wg (249 Pa)	

Belt Drive Blade Designs



H Type Propeller:

Straight, moderately pitched blade. It is designed for applications where static pressures are above 0.5 in. wg (125 Pa). These propellers typically run at higher RPMs and generate slightly higher sound levels than the “L” propellers.



L Type Propeller:

Swept, steeply pitched blade design. These propellers typically run at lower RPMs and generate low sound levels making them the best selection for sound critical applications or applications requiring the best combination of both air and sound performance. Typically used when the static pressure is 0.5 in. wg (125 Pa) or less.

The first consideration in any fan selection is the amount of air to be moved and the resistance to this air movement. With specific performance and application criteria in mind, propeller fan selections typically require decisions based on the following criteria.

Belt Drive vs. Direct Drive

Belt drive fans offer the ability to adjust fan speed for system balancing if necessary. They also offer more flexibility in speeds and motor selections. In a cost comparison, belt drive fans are typically less costly than comparable size direct drive fans with low speed motors.

Direct drive fans are often preferred for jobs where maintenance access is difficult. Maintenance costs are generally lower with direct drive fans since there are no belts or bearings to replace and no pulleys to adjust.

Larger Fans vs. Smaller Fans

In most applications, several fans may meet the specified airflow and pressure requirements. Just as larger fans tend to turn slower and generate less sound, they also tend to have higher initial costs but lower operating costs. Smaller fans have more stable performance curves, lower initial costs, higher sound levels and higher operating costs because of their higher speeds.

Low Sound vs. High Static Pressure

Fans selected for high static pressures run at higher speeds and produce higher tip speeds resulting in higher sound levels. Conversely, in low pressure applications fans generally run at lower speeds, produce lower sound levels and are recommended for sound sensitive applications.

How Accessories Affect Static Pressure

All accessory losses must be accounted for when calculating the static pressure load for a fan. This means upblast propeller roof fans can be specified with low pressure capabilities, below 3/8 in. wg (93 Pa), when used in conjunction with properly applied accessories (as within our installation recommendations).

When fans are over-specified to compensate for losses that do not actually exist, both cost and sound levels can be higher than necessary. This most commonly results from larger motors and higher tip speeds.

Motor Service Factor

Upblast roof fan motors (except for the model RBUMO) are cooled by the airstream. With an uninterrupted flow of cooling air, motors may be operated in their service factor range (up to 20% above the motor nameplate horsepower) without damage due to overheating. Lesser overloads are recommended for applications using totally enclosed or explosion resistant motors.

Belt drive performance tables in this catalog show RPM selections for each propeller type (L or H) at a given motor horsepower. The first selection is a 1.0 motor service factor. The second speed selection is at 1.2 motor service factor. Direct drive performance tables show Bhp levels with motor service factors ranging up to 1.2. When a selection using the motor service factor is not desirable for the application, specify the next higher motor horsepower.

Propeller Fan Rotation Guide

The propeller blade should cup and throw the air when rotating in the correct rotation as shown below.

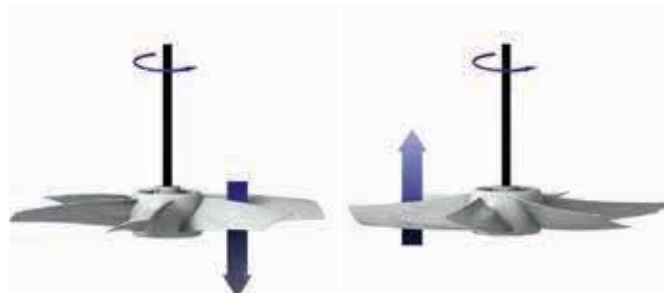

Construction Features

Models RBU, RBUMO and RDU

- 1 **Windband** is heavy-gauge galvanized (or painted) steel construction with bolted seams. Edges are reinforced for added strength and have built-in damper stops.
- 2 **Curb Caps** are constructed of galvanized steel in sizes 18-48. Sizes 54 and 60 are constructed of painted steel. Curb caps include an integral venturi inlet and prepunched mounting holes.
- 3 **Drive Frames** are die-formed, galvanized structural steel to provide a rigid platform for motors, shafts, bearings and drives.
- 4 **Adjustable Motor Plate** for belt tensioning.
- 5 **Drive Assembly** belts, pulleys and keys are sized for 150% of driven horsepower.
- 6 **Variable Pitch Motor Pulley** allows for fan speed adjustments of 10-15%. Size 42 and larger have fixed pulleys.
- 7 **Belts** are static-resistant and oil free.
- 8 **Bearings** are 100% factory tested and designed specifically for air handling applications with a minimum L₁₀ life in excess of 100,000 hours (L₅₀ life of 500,000 hours).
 - Level 1: Stamped steel pillow block bearings.
 - Level 2 and 3: Cast iron pillow block bearings with grease fittings (on RBU and RBUMO).
- 9 **Fan Shaft** is precisely sized, ground and polished so the first critical speed is at least 25% over the maximum operating speed. Where the shaft makes contact with bearings, close tolerances result in longer bearing life.
- 10 **Fasteners** are corrosion-resistant.
- 11 **Aluminum Butterfly Dampers** provide weather protection and prevent backdrafts when the fan is not in operation. Standard damper blade construction is aluminum with galvanized steel construction optional.
- 12 **Fan Base** and motor cover is constructed of galvanized steel.
- 13 **Windband Mounting Brackets** are designed to also be used as **Lifting Lugs** for ease when lifting unit to the roof deck.

Propellers

Level 1: Galvanized steel, riveted blades.

Level 2: Reinforced galvanized steel, riveted blades.

Level 3: RBU and RBUMO - Heavy-duty, welded reinforced, steel blades.
 RDU - Heavy-duty, cast aluminum blades, all with keyed hubs.

Note: Construction features are standard on all models in this catalog. Various Models are shown on this page.

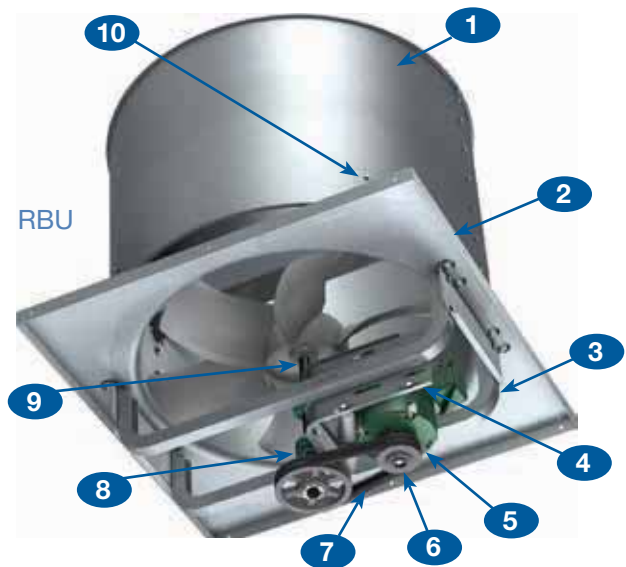

Motors

Motors are heavy-duty ball bearing type.

Motor Sheaves

Adjustable for system balancing (sizes 42 and larger are fixed pitch).

Construction Details

Models RBU, RBUMO and RDU



LEVEL 1	Material Gauges						Belt Drive Shaft Size*	Max Motor Frame Size	
	Fan Size	Windband (galv)	Curb Cap (galv)	Butterfly Damper		RBUMO Housing (galv)			Drive Frame Channel
				Galv.	Alum.				
20	20	16	24	0.040	18	14	3/4 (19)	56	
24	20	16	24	0.040	18	14	3/4 (19)	56	
30	20	16	24	0.040	18	11	3/4 (19)	56	
36	20	16	20	0.051	18	11	3/4 (19)	145T	
LEVEL 2	20	20	16	24	0.040	18	14	3/4 (19)	145T
	24	20	16	24	0.040	18	14	3/4 (19)	145T
	30	20	16	24	0.040	18	11	1 (25)	184T
	36	20	16	20	0.051	18	11	1 (25)	184T
	42	20	14	20	0.064	18	11	1 1/4 (32)	184T
	48	20	14	20	0.064	18	11	1 1/4 (32)	184T
	54	18	14	18	0.080	16	11	1 1/4 (32)	184T

*Approximate weight does not include accessories. *Dimensions in inches (millimeters) and weight. lbs (kg).

LEVEL 3	Material Gauges							Belt Drive Shaft Size*	Max Motor Frame Size		
	Fan Size	Windband (galv)	Curb Cap (galv)	Butterfly Damper		RBUMO Housing (galv)	Drive Frame Channel		Belt Drive	Direct Drive	
				Galv.	Alum.		Belt				Direct
18	20	18	24	0.040	-	-	12	-	-	56	
20	20	18	24	0.040	-	-	12	-	-	143T	
24	20	16	24	0.040	18	14	11	3/4 (19)	145T	182T	
30	20	16	24	0.040	18	11	11	1 (25)	184T	184T	
36	20	16	20	0.051	18	11	8	1 1/4 (32)	184T	215T	
42	20	14	20	0.064	18	11	8	1 1/2 (38)	215T	254T	
48	20	14	20	0.064	18	11	8	1 1/2 (38)	215T	256T	
54	18	14	18	0.080	16	11	-	1 1/2 (38)	254T	-	
60	18	14	18	0.080	16	11	-	1 3/4 (44)	256T	-	

*Approximate weight does not include accessories. *Dimensions in inches (millimeters) and weight. lbs (kg).

Service Features

NOTE: To service RBU and RDU fans, it is recommended the fan be accessed from below (looking up). If this is not possible, the fan may be serviced by taking off the removable windband.



RBUMO (pictured)

- 1 Removable Windband**
The windband can be lifted off by removing the bolts from the four windband mounting brackets. When the windband is removed, access to the fan can be made through the butterfly dampers. For specific details on this procedure, please refer to the Installation Operation and Maintenance Manual for this model found on greenheck.com
- 2 Motor out of Airstream**
Model RBUMO simplifies inspection and servicing with the “motor out of the airstream” design.
- 3 Removable Motor Cover**
Enables quick and easy access to the motor, belt and drives from the roof deck.

Accessories

- 1 Outlet Screen**
Screen is constructed of heavy-gauge steel mesh and is available to shield the fan discharge and dampers from debris. Outlet screens cannot be used in conjunction with motorized butterfly dampers.
- 2 Steel Butterfly Dampers**
For installations where standard aluminum construction is not desired. Refer to notes on performance pages for the minimum airflow volumes to open dampers.
- 3 Magnetic Damper Latches**
Available to minimize damper flutter when the fan is not in operation.
- 4 Fusible Link Damper Lifters**
Available to automatically open the butterfly dampers when the air temperature below the damper blades exceeds 165°F (74°C). Fusible links for higher temperatures are also available. The damper blades are held open to provide smoke and heat relief with no electrical power required.
- 5 Roof Curbs**
Roof curbs reduce installation time and costs by ensuring compatibility between the fan, the curb and the roof opening. All curbs are lined with fiberglass insulation to prevent condensation and reduce sound levels. See Greenheck’s roof curb catalog for complete details.

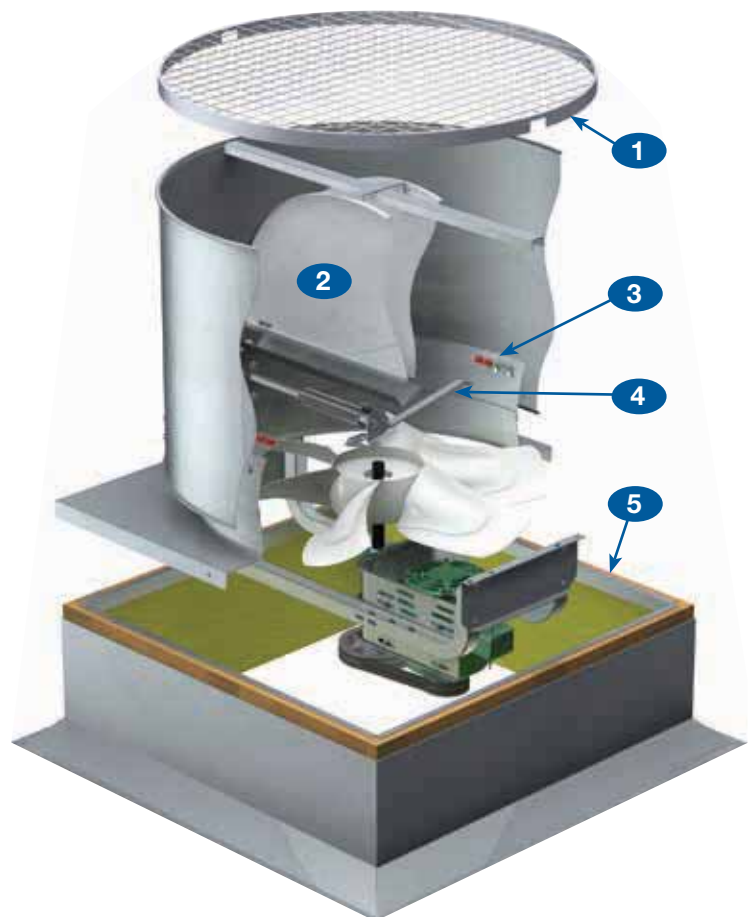

Accessories

Aluminum Propellers

Available for spark resistance.

Extended Lube Lines

For belt driven fans—lubrication lines with grease fittings that extend from the shaft bearings to the exterior of the fan base. Extended lube lines allow for bearing lubrication from the rooftop without disassembling the fan.

Inlet Guards

Model RBUMO fans are available with protective guards for mounting to the fan inlet. For models RBU and RDU, protective guards are available when mounted within a base extension.

NOTE: When an inlet guard is not ordered with the fan, it should be provided by the installer.

Motorized Butterfly Dampers

Available for low CFM applications that insufficiently open the butterfly dampers and for use with 2-speed motors at low speed.

Coatings

Decorative and protective coatings are offered to protect the fan from harsh atmospheres where galvanized steel is not sufficient. Decorative coatings are available in a variety of colors to match existing building fixtures.

Belt Tube

Available on model RBUMO to isolate the drive components from airstream contaminants.

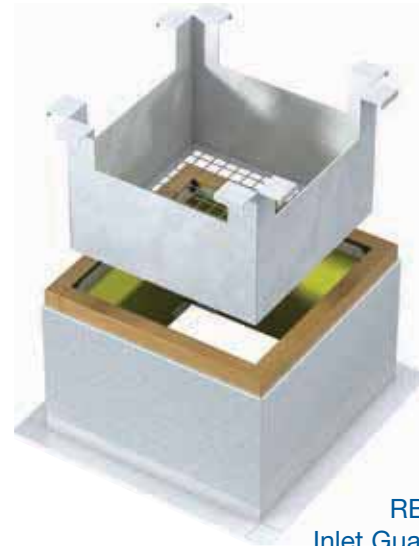

RBU
Inlet Guard

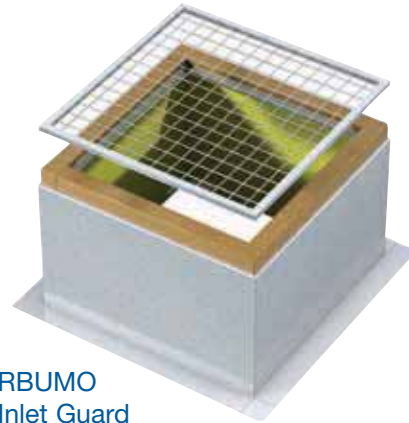

RBUMO
Inlet Guard



Belt Tube

High Temperature Option

500°F (260°C) for a minimum of 4 hours

1000°F (538°C) for a minimum of 15 minutes

This construction meets specifications for IRI requirements of 500°F (260°C) air for a minimum of 4 hours and the SBCCI “Standard Fire Prevention Code” requirements of 1000°F (538°C) for a minimum of 15 minutes in emergency smoke removal applications. In addition, this construction exceeds British Standards 7346 Class B (250°C for 2 hours), Class C (300°C for 30 minutes) and Class D (300°C for 1 hour) temperature requirements. Temperature ratings are tested in accordance to UL smoke control systems.

High Temperature Option - UL Listed

(Construction Levels 2 and 3 only)

500°F (260°C) for a minimum of 4 hours

1000°F (538°C) for a minimum of 15 minutes

Snow Load Test for butterfly dampers in UL 793

This construction meets specifications for UL Listed “Power Ventilators for Smoke Control Systems”. This includes the IRI requirements of 500°F for a minimum of 4 hours, the SBCCI “Standard Fire Prevention Code” requirements of 1000°F for a minimum of 15 minutes and the Snow Load Test for butterfly dampers (10 pounds of lifting per square foot) in UL 793. In addition, this construction exceeds British Standards 7346 Class B (250°C for 2 hours), Class C (300°C for 30 minutes) and Class D (300°C for 1 hour) temperature requirements.

NOTE: Model RBUMO accommodates airstream temperatures up to 180°F (82°C) without high temperature features. For continuous high temperature operation from 180°F (82°C) to 500°F (260°C), use Greenheck model TAUB with its corresponding high temperature option.



Emergency Smoke Removal

Greenheck model RBUMO can be equipped for emergency smoke removal applications by specifying a high temperature option. The table shows the construction features included with high temperature options that enable the exhaust of heat and smoke at 500°F (260°C) for a minimum of 4 hours or 1000°F (538°C) for a minimum of 15 minutes.

High temperature testing was conducted at Greenheck’s research and design facility with airstream temperatures in excess of 1000°F (538°C). Temperatures were monitored at the following critical locations throughout the tests: bearings, bearing compartment, belt tube, motor, motor compartment, airstream and fan housing.

Features	High Temperature Option	High Temperature Option with UL/cUL 793*
165°F (74°C) Fusible link damper lifters	✓	
165°F (74°C) Fusible link damper lifters that will lift 10 pounds per square foot		✓
Belt tube with heat shield	✓	✓
Dual drives	✓	✓
High temperature bearings	✓	✓
UL label (Power ventilators for smoke control systems)		✓

* Construction Level 2 and Level 3 only

Wiring

Wiring from the motor to the disconnect box is provided when a fan is ordered with a mounted disconnect.

UL/cUL 705

All model RBU and selected model RDU fans with totally enclosed motors are available with the UL/cUL 705 Listing for electrical. The UL/cUL 705 Listing is available on Model RBUMO fans with open and totally enclosed motors.



RDU, RBU, RBUMO models are Listed for electrical (UL/cUL 705)
File No. E40001

Motor Selection

Motor frame size, enclosure type and fan size limit the available standard motor selections. Consult your local Greenheck representative or the factory for motor availability.

Disconnect Switches

Toggle type and heavy-duty disconnect switches are available for positive electrical shut-off and safety when servicing fans. The following switches are available to meet individual electrical requirements and can be factory mounted or shipped loose for field mounting.

Heavy Duty	Toggle	
		<ul style="list-style-type: none"> • NEMA-3R Rain-Resistant • NEMA-4 Watertight • NEMA-3R and NEMA-4 Heavy-Duty • NEMA-7 and 9 for Class 1 and Class 2 hazardous locations.
NEMA-3R and 4	NEMA-3R	

Disconnect Wiring Options *Note:* Conduit and wiring by others

Typical Installation

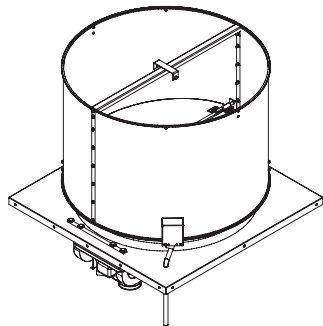

Disconnect Installation
RBU with NEMA-3R

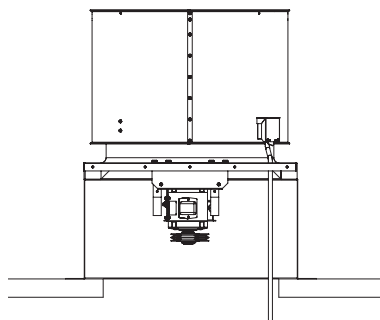

RBU on a GPI Curb with NEMA-3R

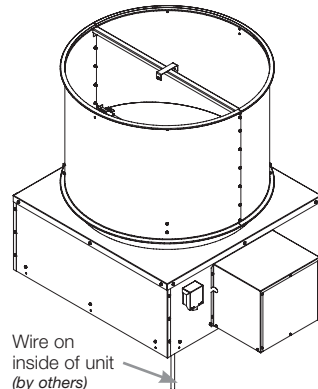

Disconnect Installation
RBUMO with NEMA-3R

Not recommended for high temperature exhaust

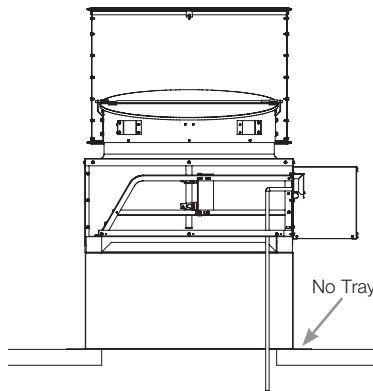

RBUMO with GPI and NEMA-3R

High Temperature Installation

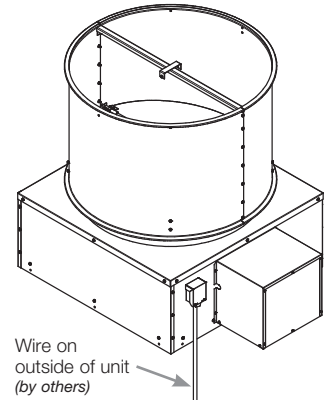

Disconnect Installation
RBUMO with NEMA-3R

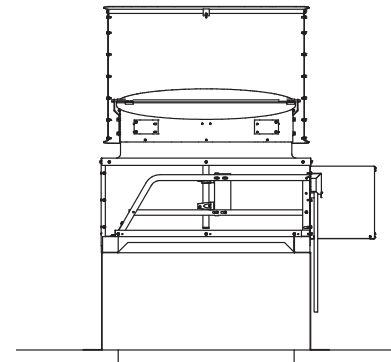

RBUMO with GPI and NEMA-3R

Dimensional Data

Level 1, 2 and 3 Models RBU and RBUMO

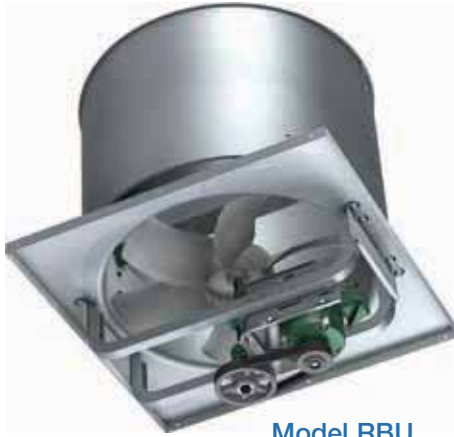

Model RBU

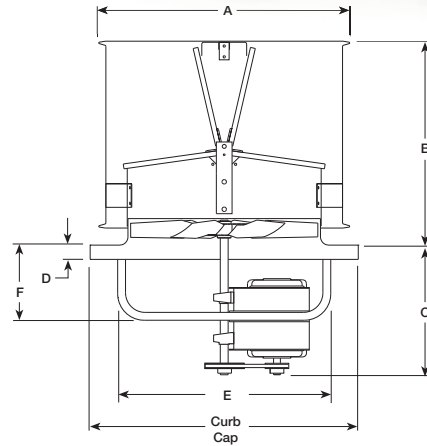

Model RBU - Belt Drive									Maximum Recommended Roof Opening
Model Size	A	B	C*		D	E	F	Curb Cap (Inside)	
			Level						
			1, 2	3					
20	27 ¹ / ₄ (692)	24 (610)	15 (381)	—	1 ¹ / ₄ (44)	23 ¹ / ₄ (591)	9 ¹ / ₃₂ (229)	30 (762)	26 ¹ / ₂ (673)
24	31 ¹ / ₈ (791)	26 (660)	15 ¹ / ₂ (394)	16 ³ / ₄ (425)	1 ¹ / ₄ (44)	27 ³ / ₈ (695)	9 ⁷ / ₁₆ (240)	34 (864)	30 ¹ / ₂ (775)
30	37 ³ / ₈ (999)	30 (762)	15 ¹ / ₂ (394)	16 ³ / ₄ (425)	1 ¹ / ₄ (44)	34 ³ / ₄ (883)	9 ⁷ / ₈ (251)	40 (1016)	36 ¹ / ₂ (927)
36	43 ¹ / ₂ (1105)	33 (838)	16 ³ / ₄ (425)	16 ³ / ₄ (425)	1 ¹ / ₄ (44)	40 ⁷ / ₈ (1038)	9 ⁷ / ₈ (251)	46 (1168)	42 ¹ / ₂ (1080)
42	49 ⁵ / ₈ (1245)	38 (965)	19 ³ / ₈ (492)	23 ³ / ₈ (606)	1 ¹ / ₄ (44)	46 ³ / ₄ (1187)	11 ³ / ₄ (298)	52 (1321)	48 ¹ / ₂ (1232)
48	56 (1422)	40 (1016)	19 ³ / ₈ (492)	23 ³ / ₈ (606)	1 ¹ / ₄ (44)	52 ³ / ₄ (1340)	11 ³ / ₄ (298)	58 (1473)	54 ¹ / ₂ (1384)
54	62 ⁵ / ₈ (1591)	45 (1143)	19 ¹ / ₄ (489)	26 ³ / ₈ (683)	1 ¹ / ₄ (44)	61 ¹ / ₄ (1556)	11 ¹ / ₂ (292)	66 ¹ / ₂ (1689)	63 (1600)
60	68 ³ / ₄ (1746)	48 (1219)	21 ¹ / ₄ (540)	27 (686)	1 ¹ / ₄ (44)	66 ¹ / ₄ (1683)	15 (381)	72 ¹ / ₂ (1842)	69 (1753)

All dimensions are in inches (millimeters). *Dimension may vary depending on motor.



Model RBUMO

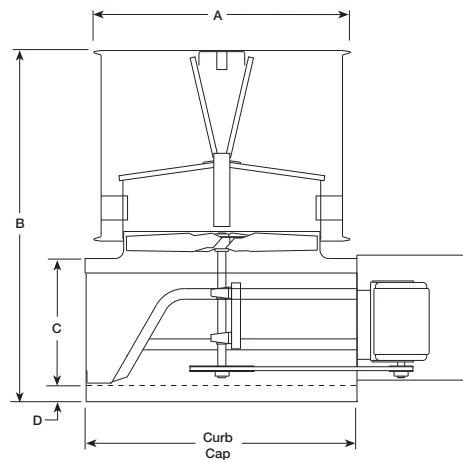

Model RBUMO - Belt Drive						Maximum Recommended Roof Opening
Model Size	A	B ⁺	C*	D	Curb Cap (Inside)	
20	27 ¹ / ₄ (692)	43 ¹ / ₂ (1105)	19 ³ / ₄ (502)	2 ¹ / ₄ (57)	29 ¹ / ₂ (749)	26 (660)
24	31 ¹ / ₈ (791)	45 ⁵ / ₈ (1143)	17 ¹ / ₂ (438)	2 ¹ / ₄ (57)	33 ¹ / ₂ (851)	30 (762)
30	37 ³ / ₈ (949)	51 ³ / ₄ (1314)	19 ¹ / ₂ (495)	2 ¹ / ₄ (57)	39 ¹ / ₂ (1003)	36 (914)
36	43 ¹ / ₂ (1105)	55 (1397)	19 ¹ / ₂ (495)	2 ¹ / ₄ (57)	45 ¹ / ₂ (1156)	42 (1067)
42	49 ⁵ / ₈ (1245)	59 ⁵ / ₈ (1503)	19 ¹ / ₂ (498)	2 ¹ / ₄ (57)	51 ¹ / ₂ (1308)	48 (1219)
48	56 (1422)	63 ⁵ / ₈ (1600)	21 ³ / ₄ (552)	2 ¹ / ₄ (57)	57 ¹ / ₂ (1461)	54 (1372)
54	62 ⁵ / ₈ (1591)	70 ⁵ / ₈ (1794)	22 ³ / ₄ (578)	2 ¹ / ₄ (57)	66 (1676)	62 ¹ / ₂ (1588)
60	68 ³ / ₄ (1746)	75 (1905)	23 (584)	2 ¹ / ₄ (57)	72 (1829)	68 ¹ / ₂ (1740)

All dimensions shown in inches (millimeters). *Sizes greater than 36 with high temperature option will be 5 inches larger. *Dimension may vary depending on motor.

Dimensional Data

Model RDU

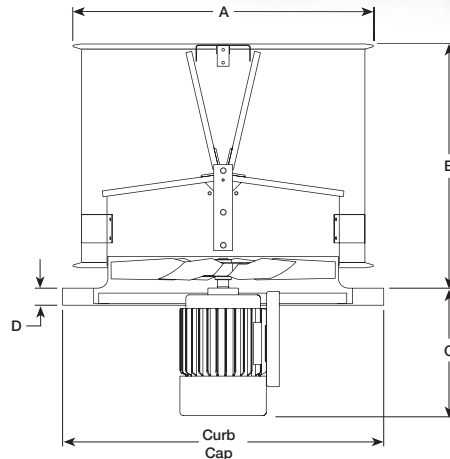

Model RDU - Direct Drive						Maximum Recommended Roof Opening
Model Size	A	B	C*	D	Curb Cap (Inside)	
18	25 (635)	22 (559)	8 ³ / ₈ (218)	1 ³ / ₄ (44)	28 (711)	24 ¹ / ₂ (622)
20	27 ¹ / ₄ (692)	24 (610)	9 ³ / ₄ (235)	1 ³ / ₄ (44)	30 (762)	26 ¹ / ₂ (673)
24	31 ¹ / ₈ (791)	26 (660)	13 ¹ / ₂ (343)	1 ³ / ₄ (44)	34 (864)	30 ¹ / ₂ (775)
30	37 ³ / ₈ (949)	30 (762)	13 ¹ / ₈ (333)	1 ³ / ₄ (44)	40 (1016)	36 ¹ / ₂ (927)
36	43 ¹ / ₂ (1105)	33 (838)	12 ¹⁵ / ₁₆ (329)	1 ³ / ₄ (44)	46 (1168)	42 ¹ / ₂ (1080)
42	49 ⁵ / ₈ (1245)	38 (965)	18 ¹ / ₂ (470)	1 ³ / ₄ (44)	52 (1321)	48 ¹ / ₂ (1232)
48	56 (1422)	40 (1016)	18 ¹ / ₂ (470)	1 ³ / ₄ (44)	58 (1473)	54 ¹ / ₂ (1384)

All dimensions shown in inches (millimeters). *Dimension may vary depending on motor.

Weights

Level 1, 2 and 3 Models RBU and RBUMO

Model Size	Approximate Weights*						
	Level 1		Level 2		Level 3		
	RBU	RBUMO	RBU	RBUMO	RBU	RBUMO	RDU
18	-	-	-	-	-	-	122 (55)
20	144 (65)	217 (98)	144 (65)	217 (98)	-	-	141 (64)
24	170 (77)	248 (112)	174 (79)	254 (115)	178 (81)	262 (119)	200 (91)
30	232 (105)	335 (152)	242 (110)	346 (157)	273 (124)	368 (167)	218 (99)
36	267 (121)	385 (175)	292 (132)	410 (186)	327 (148)	440 (200)	288 (131)
42	-	-	411 (186)	535 (243)	418 (190)	542 (246)	351 (159)
48	-	-	555 (252)	703 (319)	602 (273)	750 (340)	484 (220)
54	-	-	705 (320)	848 (385)	717 (325)	915 (415)	-
60	-	-	-	-	817 (371)	1063 (482)	-

*Approximate weight does not include accessories. *Weight. lbs (kg).

Using The Performance Table

Shown below is a portion of a typical performance table used in this catalog. Performance data shown, offers the best selections for each propeller type (“L” or “H”) relative to sound, RPM and static pressure.

Most applications can be met with the “L” type propeller. When using the performance tables, look first at the “L” selections, because they offer the lowest speed and sound levels.

Model Number	Motor HP	Fan RPM	Max Bhp	*Sones	Volume (CFM) / Static Pressure (in wg)													
					0.00	0.10	0.125	0.15	0.20	0.25	0.30	0.375	0.50	0.625	0.75	1.00		
Level 1 Performance		Max RPM	L - 1085	H - 1221	Max Motor Frame Size - 56						TS = RPM x 5.235							
RBU-1L20-4	1/4	705	0.17	11.6	3606	2836	2451											CFM values shown in black are the most efficient selections. Values shown in gray are not recommended.
		810	0.25	13.3	4143	3510	3325	3084										
		861	0.30	14.3	4404	3795	3672	3455										
RBU-1H20-4	1/4	773	0.17	11.1	2987	2453	2293	2112	1596	924	676	304						
		892	0.27	14.1	335	2987	2873	2744	2436	2011	1409	886	348					
		953	0.30	16.2	3581	3247	3148	3034	2769	2469	2002	1160	657					
RBU-1L20-3	1/3	889	0.33	14.9	4547	3950	3830	3655	3067									
		947	0.40	16.1	4844	4271	4156	4044	3648									
		998	0.37	16.7	3750	3636	3342	3244	3006	2727	2398	1588	873	393				
RBU-1H20-3	1/3	1039	0.40	17.2	3904	3638	3517	3427	3212	2954	2676	2037	1064	603				
		1021	0.50	17.0	5222	4675	4566	4461	4181	3747								
		1085	0.60	17.9	5550	5021	4919	4817	4621	4269	3712							
RBU-1L20-5	1/2	1107	0.50	18.0	4159	3885	3805	3720	3534	3315	3065	2599	1368	935	502			
		1221	0.60	20	4587	4339	4277	4203	4049	3873	3675	3333	2514	1456	1064			

“L” type
Low pressure propeller

“H” type
High pressure propeller

Shows level of construction based on fan RPM and motor frame size.

Note that each max. Bhp is cataloged at a 1.0 and 1.2 motor service factor. See page 5 for more details.

Optimum selection range for the “L” type propeller.

Optimum selection range for the “H” type propeller.

Model Number Codes

Model Number Code - Direct Drive

The model number code is designed to completely identify the fan. A detailed explanation of the RDU model number is shown below.

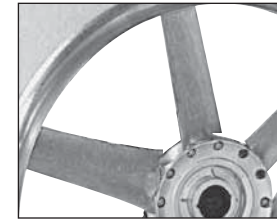
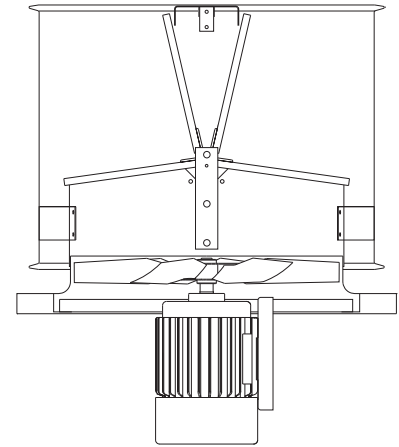
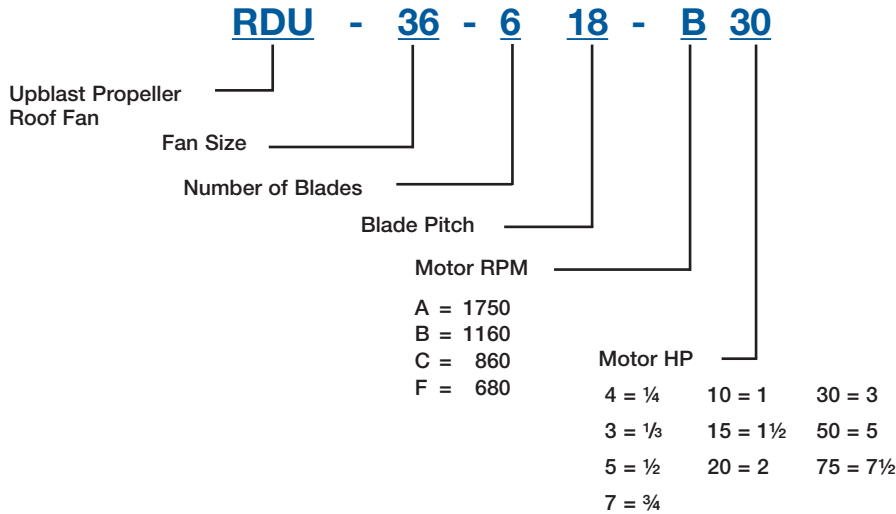

All propellers for model RDU fans are cast aluminum construction.

Model Number Code - Belt Drive

The model number system is designed to completely identify the fan. The correct code letters must be specified to designate motor in airstream or motor out of airstream. The remainder of the model number is determined by the size and performance selected from the following pages. A detailed explanation of the model number code is shown below.

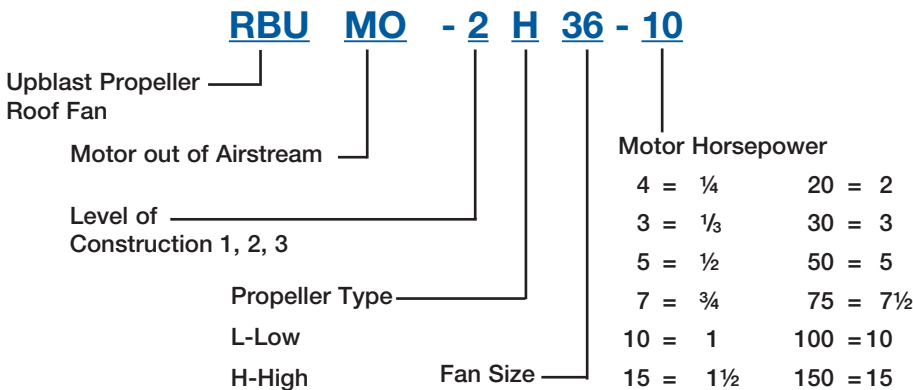
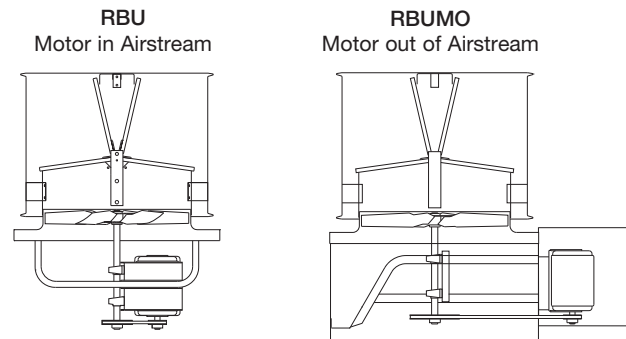

RDU-18 – 24 Direct Drive



Model Number	Motor HP	Fan RPM	Max Bhp	*Sones	Volume (CFM) / Static Pressure (in. wg)														
					0.000	0.100	0.125	0.150	0.200	0.250	0.300	0.375	0.500	0.625	0.750	1.000			
RDU-18-635-B3	1/3	1140	0.37	19.1	3178	2812													
RDU-18-317-A4	1/4	1725	0.31	23	3101	2858	2796												
RDU-18-416-A3	1/3	1725	0.39	26	3274	3070	3013	2956	2839										
RDU-18-620-A5	1/2	1725	0.62	28	3792	3598	3550	3502	3404	3304	3198	3014							
RDU-18-432-A7	3/4	1725	0.87	32	4248	3992	3930	3868	3739	3601	3444								
RDU-18-632-A10	1	1725	1.20	32	4755	4528	4471	4414	4301	4163	4015								
RDU-20-425-B4	1/4	1140	0.28	19.7	3554														
RDU-20-625-B3	1/3	1140	0.37	21	3831	3497	3401	3302											
RDU-20-635-B5	1/2	1140	0.56	24	4316	3944	3857	3740											
RDU-20-313-A3	1/3	1725	0.40	27	3940	3643	3569	3494	3333	3171									
RDU-20-320-A5	1/2	1725	0.57	28	4505	4195	4120	4046	3892	3732	3561	3273							
RDU-20-618-A7	3/4	1725	0.86	34	4943	4743	4693	4640	4523	4402	4280	4086							
RDU-20-430-A10	1	1725	1.19	35	5746	5455	5382	5311	5168	5018	4867	4626	4064						
RDU-24-622-C4	1/4	860	0.27	15.2	4720	4111													
RDU-24-628-C3	1/3	860	0.36	15.5	5293	4670	4470	4266											
RDU-24-411-B4	1/4	1140	0.23	21	4372														
RDU-24-416-B3	1/3	1140	0.36	22	5248	4737	4594	4446	4102										
RDU-24-620-B5	1/2	1140	0.58	24	6055	5643	5517	5391	5120	4861	4578								
RDU-24-628-B7	3/4	1140	0.85	26	7016	6577	6454	6330	6044	5739	5429								
RDU-24-635-B10	1	1140	1.13	28	7661	7152	7019	6886	6576										
RDU-24-304-A3	1/3	1725	0.35	32	4632	4207	4086	3964											
RDU-24-309-A5	1/2	1725	0.54	34	5844	5443	5341	5238	5018	4777	4495	4022							
RDU-24-411-A7	3/4	1725	0.81	38	6617	6306	6220	6123	5929	5740	5553	5209	4509						
RDU-24-613-A10	1	1725	1.21	43	7271	7024	6962	6899	6764	6628	6493	6282	5889						
RDU-24-617-A15	1½	1725	1.67	44	8422	8148	8080	8011	7873	7734	7595	7364	6956	6505	5713				
RDU-24-622-A20	2	1725	2.15	47	9469	9206	9141	9075	8937	8770	8603	8346	7894	7412	6867				
RDU-24-630-A30	3	1725	3.19	54	10952	10631	10551	10471	10311	10152	9993	9748	9267	8756					

Minimum CFM required to open dampers
Aluminum Dampers: 2750
Steel Dampers: 3520

Minimum CFM required to open dampers
Aluminum Dampers: 3170
Steel Dampers: 4090

Minimum CFM required to open dampers
Aluminum Dampers: 3950
Steel Dampers: 5220

Performance certified is for Model RDU exhaust for installation type A: free inlet, free outlet. Performance ratings do not include appurtenances (accessories). The sound ratings shown are loudness values in fan sones at 5 ft. (1.5m) in a hemispherical free field calculated per AMCA Standard 301. Values are for installation type A: free inlet hemispherical sone levels. The AMCA Certified Ratings Sound Seal applies to sone ratings only.

RDU-30 – 48 Direct Drive



Model Number	Motor HP	Fan RPM	Max Bhp	*Sones	Volume (CFM) / Static Pressure (in. wg)														
					0.000	0.100	0.125	0.150	0.200	0.250	0.300	0.375	0.500	0.625	0.750	1.000			
RDU-30-416-C3	1/3	860	0.38	18.9	7927	7927	6810	6462	6094										
RDU-30-618-C5	1/2	860	0.57	21	8669	7729	7498	7266	6699										
RDU-30-625-C7	3/4	860	0.85	21	10393	9494	9232	8923	8272	7591									
RDU-30-632-C10	1	860	1.15	24	11515	10497	10245	9891	9115	8329									
RDU-30-307-B3	1/3	1140	0.38	40	7386	6463	6212												
RDU-30-315-B5	1/2	1140	0.63	25	9321	8409	8158	7895	7254	6544									
RDU-30-416-B7	3/4	1140	0.89	32	10507	9722	9512	9287	8783	8227	7695	6656							
RDU-30-422-B10	1	1140	1.18	35	11647	10816	10580	10347	9893	9394	8826	7751							
RDU-30-430-B15	1½	1140	1.70	37	13067	12049	11781	11486	10876	10355	9768	8637							
RDU-30-628-B20	2	1140	2.28	36	14530	13816	13655	13493	13171	12743	12100	11265							
RDU-36-414-F3	1/3	680	0.38	16.6	9917	7934													
RDU-36-615-F5	1/2	680	0.59	19.0	11433	9917	9459	8949	7673										
RDU-36-622-F7	3/4	680	0.85	19.9	13216	11603	11061	10511	9213										
RDU-36-629-F10	1	680	1.15	22	14378	12427	11758	11166											
RDU-36-308-C3	1/3	860	0.40	21	9872	8056													
RDU-36-313-C5	1/2	860	0.54	25	11220	9523	9028	8468											
RDU-36-414-C7	3/4	860	0.76	24	12543	11115	10700	10239	9200	7727									
RDU-36-615-C10	1	860	1.19	27	14459	13327	13018	12683	11962	11146	10158	8083							
RDU-36-622-C15	1½	860	1.72	28	16715	15553	15206	14844	13988	13118	12105								
RDU-36-628-C20	2	860	2.22	31	18062	16604	16260	15831	14876	13917	12722								
RDU-36-303-B5	1/2	1140	0.57	34	10004	8726	8364	8020											
RDU-36-308-B10	1	1140	0.94	33	13087	11802	11461	11068	10324	9409	8240								
RDU-36-318-B15	1½	1140	1.72	37	16515	15146	14768	14407	13675	12863	11797	10059							
RDU-36-612-B20	2	1140	2.26	44	17601	16764	16541	16311	15852	15353	14830	13955	12254	10056					
RDU-36-618-B30	3	1140	3.47	49	21168	20299	20082	19853	19392	18931	18376	17466							
RDU-36-629-B50	5	1140	5.41	54	24105	23042	22776	22508	21972	21368	20507	19378	17312						
RDU-42-318-F7	3/4	680	0.90	26	15873	12993	12062												
RDU-42-326-F10	1	680	1.18	28	17693	13919	12889	11677											
RDU-42-430-F15	1½	680	1.78	31	20266	16909	15982	14977	12230										
RDU-42-628-F20	2	680	2.38	36	22335	19964	19209	18361	16704	15083	13007								
RDU-42-605-C10	1	860	1.24	34	14640	13254	12891	12556	11886	11297									
RDU-42-318-C15	1½	860	1.83	35	20075	17913	17294	16677	15253	13365	11434								
RDU-42-326-C20	2	860	2.39	36	22377	19401	18665	17914	16299	14329	11788								
RDU-42-430-C30	3	860	3.60	45	25630	22907	22278	21640	20210	18568	16592	12434							
RDU-48-407-F7	3/4	680	0.87	30	17727	15062	14400	13708											
RDU-48-411-F10	1	680	1.16	31	20823	18292	17571	16813	15029	12918									
RDU-48-613-F15	1½	680	1.79	33	23068	21326	20829	20332	19185	17878	16327	13330							
RDU-48-617-F20	2	680	2.31	36	26328	24480	23979	23477	22269	20873	19170	15473							
RDU-48-625-F30	3	680	3.53	37	32294	29875	29316	28758	27277	25313	22864	18864							
RDU-48-306-C10	1	860	1.21	39	20430	17957	17317	16677	15166	13454									
RDU-48-311-C15	1½	860	1.81	39	24974	22700	22090	21397	19872	18138	16088								
RDU-48-316-C20	2	860	2.44	39	28517	25985	25197	24406	22786	20954	18705	14253							
RDU-48-417-C30	3	860	3.49	46	31630	29602	29019	28435	27152	25731	24060	21100	14269						
RDU-48-621-C50	5	860	5.86	52	37854	36010	35553	35121	34257	33393	32340	30675	26552	20719	12453				
RDU-48-630-C75	7½	860	8.83	55	43433	41386	40786	40100	38727	37353	35980	33238	28482	18414	12755				

Minimum CFM required to open dampers
Aluminum Dampers: 6050
Steel Dampers: 7130

Minimum CFM required to open dampers
Aluminum Dampers: 7620
Steel Dampers: 10980

Minimum CFM required to open dampers
Aluminum Dampers: 11050
Steel Dampers: 13550

Minimum CFM required to open dampers
Aluminum Dampers: 12820
Steel Dampers: 16420

Performance certified is for Model RDU exhaust for installation type A: free inlet, free outlet. Performance ratings do not include appurtenances (accessories). The sound ratings shown are loudness values in fan sones at 5 ft. (1.5m) in a hemispherical free field calculated per AMCA Standard 301. Values are for installation type A: free inlet hemispherical sone levels. The AMCA Certified Ratings Sound Seal applies to sone ratings only.

RBU-30 Belt Drive



Model Number	Motor HP	Fan RPM	Max Bhp	*Sones	Volume (CFM) / Static Pressure (In. wg)															
					0.000	0.100	0.125	0.150	0.200	0.250	0.300	0.375	0.500	0.625	0.750	1.000				
Level 1 Performance		Max RPM			L - 695	H - 963	Max Motor Frame Size - 56					TS = RPM x 7.854								
RBU-1L30-3	1/3	454	0.25	10.7	7256															
RBU-1L30-3	1/3	499	0.33	11.7	7975	6266	6266													
RBU-1L30-3	1/3	531	0.40	12.6	8487	6888	6472													
RBU-1H30-3	1/3	572	0.25	11.7	6499															
RBU-1H30-3	1/3	626	0.33	13.2	7113	6094														
RBU-1H30-3	1/3	669	0.40	14.2	7602	6659	6401	6131												
RBU-1L30-5	1/2	571	0.50	13.7	9126	7622	7262	6875												
RBU-1L30-5	1/2	607	0.60	14.8	9701	8268	7951	7593												
RBU-1H30-5	1/2	720	0.50	16.5	8181	7316	7079	6839	6300											
RBU-1H30-5	1/2	764	0.60	17.6	8681	7875	7653	7428	6955	6419										
RBU-1L30-7	3/4	654	0.75	16.4	10452	9097	8803	8507	7831											
RBU-1L30-7	3/4	695	0.90	18.0	11108	9822	9534	9257	8651	7844										
RBU-1H30-7	3/4	824	0.75	19.0	9363	8628	8422	8216	7797	7329	6824									
RBU-1H30-7	3/4	875	0.90	22	9942	9261	9067	8873	8481	8081	7613	6874								
RBU-1H30-10	1	908	1.00	25	10317	9666	9481	9294	8918	8538	8108	7415								
RBU-1H30-10	1	963	1.20	27	10942	10328	10165	9989	9637	9279	8918	8280	7021							
Level 2 Performance		Max RPM			L - 964	H - 1213	Max Motor Frame Size - 184T					TS = RPM x 7.854								
RBU-2L30-10	1	720	1.00	19.1	11507	10270	9974	9707	9142	8511										
RBU-2L30-10	1	765	1.20	21	12227	11068	10765	10508	10006	9433	8692									
RBU-2H30-10	1	908	1.00	23	10317	9666	9481	9294	8918	8538	8108	7415								
RBU-2H30-10	1	963	1.20	26	10942	10328	10165	9989	9637	9279	8918	8280	7021							
RBU-2L30-15	1½	824	1.50	23	13170	12102	11820	11543	11077	10591	10054									
RBU-2L30-15	1½	876	1.81	25	14001	13003	12739	12474	12004	11566	11083	10270								
RBU-2H30-15	1½	1039	1.50	29	11806	11236	11094	10938	10612	10284	9951	9418	8408							
RBU-2H30-15	1½	1102	1.80	30	12522	11985	11851	11716	11409	11101	10790	10320	9408	8414						
RBU-2L30-20	2	907	2.00	27	14496	13537	13281	13026	12551	12128	11686	10955								
RBU-2L30-20	2	964	2.41	30	15407	14512	14272	14031	13551	13148	12750	12089								
RBU-2H30-20	2	1143	2.00	31	12988	12470	12341	12211	11923	11627	11328	10875	10030	9095						
RBU-2H30-20	2	1213	2.40	34	13783	13295	13173	13051	12795	12515	12235	11811	11071	10226	9315					
Level 3 Performance		Max RPM			L - 1154	H - 1471	Max Motor Frame Size - 184					TS = RPM x 7.854								
RBU-3L30-20	2	862	1.50	29	13255	12275	12006	11737	11181	10523										
RBU-3L30-20	2	949	2.01	29	14592	13722	13477	13232	12740	12233	11639									
RBU-3L30-20	2	1008	2.40	31	15500	14684	14463	14232	13772	13300	12822									
RBU-3H30-20	2	1099	1.50	34	12302	11703	11554	11415	11143	10872	10591	10164	9307	8153	5836					
RBU-3H30-20	2	1209	2.00	36	13533	12989	12853	12717	12466	12220	11973	11589	10912	10090	9046					
RBU-3H30-20	2	1285	2.40	39	14384	13872	13744	13616	13371	13138	12906	12554	11946	11238	10414	7066				
RBU-3L30-30	3	1086	3.01	37	16699	15942	15753	15540	15112	14685	14242	13577								
RBU-3L30-30	3	1154	3.61	38	17745	17032	16854	16669	16267	15864	15457	14831								
RBU-3H30-30	3	1384	3.00	45	15492	15017	14898	14779	14542	14323	14107	13784	13228	12660	11965	10175				
RBU-3H30-30	3	1471	3.60	50	16466	16019	15907	15795	15572	15355	15152	14848	14335	13804	13225	11816				

Minimum CFM required to open dampers
Aluminum Dampers: 6050
Steel Dampers: 7130

CFM values shown in black are the most efficient selections. Values shown in gray are not recommended.

Performance certified is for Model RBU exhaust for installation type A: free inlet, free outlet. Power rating (Bhp) does not include transmission losses. Performance ratings do not include appurtenances (accessories). The sound ratings shown are loudness values in fan sones at 5 ft. (1.5m) in a hemispherical free field calculated per AMCA Standard 301. Values are for installation type A: free inlet hemispherical sone levels. The AMCA Certified Ratings Sound Seal applies to sone ratings only.

*Sones shown apply to the highest cataloged CFM in black type at each fan RPM. For selections at other CFM and static pressure points, refer to the CAPS program.

RBU-36 Belt Drive



Model Number	Motor HP	Fan RPM	Max Bhp	*Sones	Volume (CFM) / Static Pressure (in. wg)														
					0.000	0.100	0.125	0.150	0.200	0.250	0.300	0.375	0.500	0.625	0.750	1.000			
Level 1 Performance		Max RPM			L - 551	H - 806				Max Motor Frame Size - 145T				TS = RPM x 9.424					
RBU-1L36-5	1/2	357	0.30	10.7	9954														
RBU-1L36-5	1/2	410	0.50	12.8	11432	9148	8431												
RBU-1L36-5	1/2	435	0.60	14.0	12129	10040	9378	8604											
RBU-1H36-5	1/2	458	0.33	13.0	9342														
RBU-1H36-5	1/2	526	0.50	14.9	10729	9149	8603	7986											
RBU-1H36-5	1/2	561	0.60	16.1	11443	10005	9555	9000											
RBU-1L36-7	3/4	468	0.75	15.6	13049	11190	10573	9959											
RBU-1L36-7	3/4	497	0.90	17.3	13857	12181	11600	11019	9696										
RBU-1H36-7	3/4	602	0.75	17.7	12279	10984	10571	10132	9055										
RBU-1H36-7	3/4	639	0.90	19.4	13034	11803	11470	11076	10145	9049									
RBU-1L36-10	1	515	1.00	18.4	14359	12768	12227	11665	10504										
RBU-1L36-10	1	551	1.23	20	15364	13924	13461	12937	11891										
RBU-1H36-10	1	663	1.00	20	13523	12330	12047	11667	10817	9809									
RBU-1H36-10	1	704	1.20	22	14360	13224	12966	12662	11941	11048	10041								
RBU-1H36-15	1½	760	1.50	25	15502	14433	14195	13956	13335	12611	11784								
RBU-1H36-15	1½	806	1.80	28	16440	15419	15194	14969	14454	13829	13081	11825							
Level 2 Performance		Max RPM			L - 693	H - 1014				Max Motor Frame Size - 184T				TS = RPM x 9.424					
RBU-2L36-15	1½	589	1.50	23	16423	15126	14702	14249	13267	12291									
RBU-2L36-15	1½	626	1.80	25	17454	16283	15884	15485	14579	13658	12653								
RBU-2H36-15	1½	760	1.50	25	15502	14433	14195	13956	13335	12611	11784								
RBU-2H36-15	1½	806	1.80	27	16440	15419	15194	14969	14454	13829	13081	11825							
RBU-2L36-20	2	649	2.01	27	18096	16996	16611	16226	15382	14491	13606								
RBU-2L36-20	2	689	2.40	29	19211	18194	17865	17503	16756	15917	15081	13659							
RBU-2H36-20	2	836	2.01	29	17052	16059	15842	15625	15175	14572	13910	12761							
RBU-2H36-20	2	889	2.40	32	18133	17184	16980	16776	16368	15867	15300	14286	12176						
RBU-2L36-30	3	693	2.44	29	19323	18312	17991	17630	16893	16058	15226	13839							
RBU-2H36-30	3	956	3.00	38	19500	18611	18408	18218	17839	17460	16948	16134	14446						
RBU-2H36-30	3	1014	3.60	41	20683	19845	19636	19458	19100	18742	18349	17603	16144	14425					
Level 3 Performance		Max RPM			L - 976	H - 1401				Max Motor Frame Size - 184T				TS = RPM x 9.424					
RBU-3L36-30	3	677	2.01	25	18205	16889	16573	16257	15391	14466									
RBU-3L36-30	3	774	3.00	31	20814	19650	19372	19096	18543	17787	16953	15800							
RBU-3L36-30	3	823	3.61	34	22132	21037	20769	20509	19988	19426	18641	17506							
RBU-3H36-30	3	971	2.00	35	16514	15825	15625	15471	14977	14480	13961	13208	11941	9760					
RBU-3H36-30	3	1108	3.00	42	18844	18240	18089	17938	17613	17180	16747	16073	14975	13923	12474				
RBU-3H36-30	3	1181	3.61	47	20086	19519	19377	19235	18952	18589	18182	17568	16500	15518	14414	9248			
RBU-3L36-50	5	918	5.00	42	24686	23705	23460	23218	22751	22285	21819	20768	19095						
RBU-3L36-50	5	976	6.01	61	26246	25323	25092	24862	24418	23979	23540	22727	21093						
RBU-3H36-50	5	1315	5.01	60	22365	21856	21728	21601	21347	21092	20771	20223	19292	18333	17453	15377			
RBU-3H36-50	5	1401	6.00	66	23827	23350	23230	23111	22872	22633	22394	21893	21036	20140	19259	17598			

Minimum CFM required to open dampers
Aluminum Dampers: 7620
Steel Dampers: 10980

CFM values shown in black are the most efficient selections. Values shown in gray are not recommended.

Performance certified is for Model RBU exhaust for installation type A: Free inlet, Free outlet. Power rating (Bhp) does not include transmission losses. Performance ratings do not include appurtenances (accessories). The sound ratings shown are loudness values in fan sones at 5 ft. (1.5m) in a hemispherical free field calculated per AMCA Standard 301. Values are for installation type A: free inlet hemispherical sone levels. The AMCA Certified Ratings Sound Seal applies to sone ratings only.

*Sones shown apply to the highest cataloged CFM in black type at each fan RPM. For selections at other CFM and static pressure points, refer to the CAPS program.

RBUMO-30 Belt Drive



Model Number	Motor HP	Fan RPM	Max Bhp	*Sones	Volume (CFM) / Static Pressure (in. wg)														
					0.000	0.100	0.125	0.150	0.200	0.250	0.300	0.375	0.500	0.625	0.750	1.000			
Level 1 Performance		Max RPM			L - 696	H - 929				Max Motor Frame Size - 56				TS = RPM x 7.854					
RBUMO-1L30-3	1/3	481	0.30	11.3	6936														
RBUMO-1L30-3	1/3	496	0.33	11.6	7153														
RBUMO-1L30-3	1/3	512	0.36	12.1	7383														
RBUMO-1H30-3	1/3	603	0.30	12.6	6634														
RBUMO-1H30-3	1/3	623	0.34	13.2	6854														
RBUMO-1H30-3	1/3	640	0.36	13.7	7041														
RBUMO-1L30-5	1/2	570	0.50	13.7	8220	6787	6349												
RBUMO-1L30-5	1/2	588	0.55	14.2	8480	7097	6696	6238											
RBUMO-1H30-5	1/2	719	0.50	16.8	7910	6915	6669	6422											
RBUMO-1H30-5	1/2	735	0.55	17.5	8086	7113	6871	6630											
RBUMO-1L30-7	3/4	652	0.75	17.2	9403	8180	7842	7486											
RBUMO-1L30-7	3/4	673	0.82	17.9	9705	8529	8202	7875	7064										
RBUMO-1H30-7	3/4	814	0.75	21	8956	8082	7857	7639	7194	6644									
RBUMO-1H30-7	3/4	844	0.82	23	9286	8445	8228	8015	7594	7088									
RBUMO-1L30-10	1	696	0.91	18.0	10038	8806	8593	8276	7542										
RBUMO-1H30-10	1	897	1.00	25	9869	9081	8877	8672	8276	7857	7358								
RBUMO-1H30-10	1	929	1.10	26	10221	9462	9265	9068	8683	8300	7830								
Level 2 Performance		Max RPM			L - 933	H - 1167				Max Motor Frame Size - 184T				TS = RPM x 7.854					
RBUMO-2L30-10	1	718	1.00	19.0	10354	9263	8962	8656	7973										
RBUMO-2L30-10	1	741	1.10	20	10686	9634	9346	9049	8417	7594									
RBUMO-2H30-10	1	897	1.00	24	9869	9081	8877	8672	8276	7857	7358								
RBUMO-2H30-10	1	929	1.10	25	10221	9462	9265	9068	8683	8300	7830								
RBUMO-2L30-15	1½	822	1.50	23	11854	10925	10667	10409	9873	9287	8593								
RBUMO-2L30-15	1½	848	1.65	24	12229	11335	11085	10835	10319	9785	9149								
RBUMO-2H30-15	1½	1029	1.50	29	11321	10642	10464	10286	9931	9585	9240	8613							
RBUMO-2H30-15	1½	1066	1.65	30	11728	11075	10904	10732	10388	10052	9719	9153							
RBUMO-2L30-20	2	904	2.00	27	13037	12211	11977	11743	11266	10779	10241	9206							
RBUMO-2L30-20	2	933	2.20	28	13455	12662	12435	12208	11751	11279	10796	9930							
RBUMO-2H30-20	2	1137	2.00	32	12509	11897	11741	11580	11257	10937	10624	10156	9183						
RBUMO-2H30-20	2	1167	2.20	32	12839	12243	12092	11935	11621	11307	11002	10546	9632						
Level 3 Performance		Max RPM			L - 1109	H - 1420				Max Motor Frame Size - 184T				TS = RPM x 7.854					
RBUMO-3L30-20	2	853	1.50	30	12059	11008	10740	10485	9979	9171									
RBUMO-3L30-20	2	939	2.01	29	13275	12324	12081	11837	11374	10897	10141								
RBUMO-3L30-20	2	969	2.20	30	13699	12779	12543	12307	11853	11408	10750	9296							
RBUMO-3H30-20	2	1092	1.50	35	11707	11118	10955	10785	10444	10096	9745	9194	8246	6997					
RBUMO-3H30-20	2	1202	2.00	37	12886	12351	12218	12068	11758	11449	11132	10654	9809	8943	7779				
RBUMO-3H30-20	2	1240	2.20	39	13293	12775	12646	12507	12207	11907	11603	11139	10331	9496	8523				
RBUMO-3L30-30	3	1074	3.00	35	15183	14357	14145	13933	13507	13103	12701	11830							
RBUMO-3L30-30	3	1109	3.30	36	15678	14878	14675	14469	14056	13569	13270	12533							
RBUMO-3H30-30	3	1376	3.01	47	14751	14284	14168	14051	13796	13526	13255	12844	12148	11409	10657				
RBUMO-3H30-30	3	1420	3.30	49	15223	14771	14657	14544	14306	14044	13782	13387	12712	12008	11284				

Minimum CFM required to open dampers
Aluminum Dampers: 6050
Steel Dampers: 7130

CFM values shown in black are the most efficient selections. Values shown in gray are not recommended.

Performance certified is for Model RBUMO exhaust for installation type A: free inlet, free outlet. Power rating (Bhp) does not include transmission losses. Performance ratings do not include appurtenances (accessories). The sound ratings shown are loudness values in fan sones at 5 ft. (1.5m) in a hemispherical free field calculated per AMCA Standard 301. Values are for installation type A: free inlet hemispherical sone levels. The AMCA Certified Ratings Sound Seal applies to sone ratings only.

*Sones shown apply to the highest cataloged CFM in black type at each fan RPM. For selections at other CFM and static pressure points, refer to the CAPS program.

RBUMO-36 Belt Drive



Model Number	Motor HP	Fan RPM	Max Bhp	*Sones	Volume (CFM) / Static Pressure (in. wg)															
					0.000	0.100	0.125	0.150	0.200	0.250	0.300	0.375	0.500	0.625	0.750	1.000				
Level 1 Performance		Max RPM			L - 551	H - 784				Max Motor Frame Size - 145T				TS = RPM x 9.424						
RBUMO-1L36-5	1/2	355	0.33	10.7	9535															
RBUMO-1L36-5	1/2	408	0.50	12.8	10958	8903	8176													
RBUMO-1L36-5	1/2	421	0.55	13.3	11308	9343	8665	7961												
RBUMO-1H36-5	1/2	418	0.33	13.0	9075															
RBUMO-1H36-5	1/2	528	0.50	14.9	10439	8778	8321	7853												
RBUMO-1H36-5	1/2	546	0.55	15.8	10795	9198	8762	8309												
RBUMO-1L36-7	3/4	467	0.75	15.6	12543	10864	10322	9708												
RBUMO-1L36-7	3/4	482	0.82	16.4	12946	11350	10825	10261	9031											
RBUMO-1H36-7	3/4	603	0.75	17.8	11922	10502	10111	9717	8897											
RBUMO-1H36-7	3/4	623	0.82	18.8	12318	10943	10575	10193	9406	8277										
RBUMO-1L36-10	1	514	1.00	18.3	13806	12331	11881	11389	10264											
RBUMO-1L36-10	1	530	1.10	19.3	14234	12800	12402	11925	10866											
RBUMO-1H36-10	1	664	1.00	21	13128	11839	11514	11156	10430	9646										
RBUMO-1H36-10	1	685	1.10	22	13543	12294	11981	11642	10945	10224	9153									
RBUMO-1L36-15	1½	551	1.24	20	14800	13414	13080	12620	11645	10569										
RBUMO-1H36-15	1½	760	1.50	25	15026	13900	13618	13336	12725	12094	11444	10035								
RBUMO-1H36-15	1½	784	1.65	27	15501	14410	14136	13863	13283	12677	12048	10846								
Level 2 Performance		Max RPM			L - 693	H - 988				Max Motor Frame Size - 184T				TS = RPM x 9.424						
RBUMO-2L36-15	1½	588	1.50	23	15793	14484	14178	13826	12965	11978	10970									
RBUMO-2L36-15	1½	607	1.65	24	16304	15029	14733	14437	13603	12686	11709									
RBUMO-2H36-15	1½	760	1.50	25	15026	13900	13618	13336	12725	12094	11444	10035								
RBUMO-2H36-15	1½	784	1.65	26	15501	14410	14136	13863	13283	12677	12048	10846								
RBUMO-2L36-20	2	647	2.00	26	17378	16171	15893	15615	14926	14143	13229									
RBUMO-2L36-20	2	668	2.20	28	17942	16767	16498	16229	15610	14852	14010	12679								
RBUMO-2H36-20	2	838	2.00	29	16569	15548	15292	15036	14521	13954	13382	12498								
RBUMO-2H36-20	2	868	2.20	31	17162	16177	15930	15683	15188	14653	14106	13256								
RBUMO-2L36-30	3	693	2.46	29	18614	17474	17215	16955	16418	15687	14926	13643								
RBUMO-2H36-30	3	958	3.00	38	18941	18049	17826	17602	17154	16706	16217	15473	14185							
RBUMO-2H36-30	3	988	3.30	39	19534	18669	18453	18236	17802	17368	16908	16187	14947	13188						
Level 3 Performance		Max RPM			L - 943	H - 1343				Max Motor Frame Size - 184T				TS = RPM x 9.424						
RBUMO-3L36-30	3	673	2.00	25	17382	16106	15785	15464	14730	13897	12837									
RBUMO-3L36-30	3	770	3.00	31	19887	18774	18494	18213	17625	17013	16336	15016								
RBUMO-3L36-30	3	795	3.30	32	20533	19455	19184	18912	18369	17782	17126	15947								
RBUMO-3H36-30	3	959	2.00	34	16023	15406	15251	15079	14580	14083	13597	12850	11447	9259						
RBUMO-3H36-30	3	1095	3.00	41	18296	17755	17620	17484	17179	16742	16305	15662	14568	13377	11856					
RBUMO-3H36-30	3	1131	3.30	44	18897	18374	18243	18112	17850	17434	17011	16384	15349	14222	12896					
RBUMO-3L36-50	5	913	5.00	42	23580	22642	22407	22172	21699	21226	20753	19904	18230							
RBUMO-3L36-50	5	943	5.50	49	24355	23447	23219	22992	22534	22076	21618	20835	19334							
RBUMO-3H36-50	5	1299	5.00	57	21704	21248	21134	21020	20793	20565	20243	19690	18779	17881	16919	14710				
RBUMO-3H36-50	5	1343	5.51	61	22439	21999	21888	21778	21558	21337	21076	20541	19655	18786	17884	15849				

Minimum CFM required to open dampers
Aluminum Dampers: 7620
Steel Dampers: 10980

CFM values shown in black are the most efficient selections. Values shown in gray are not recommended.

Performance certified is for Model RBUMO exhaust for installation type A: free inlet, free outlet. Power rating (Bhp) does not include transmission losses. Performance ratings do not include appurtenances (accessories). The sound ratings shown are loudness values in fan sones at 5 ft. (1.5m) in a hemispherical free field calculated per AMCA Standard 301. Values are for installation type A: free inlet hemispherical sone levels. The AMCA Certified Ratings Sound Seal applies to sone ratings only.

*Sones shown apply to the highest cataloged CFM in black type at each fan RPM. For selections at other CFM and static pressure points, refer to the CAPS program.

Specifications

BELT DRIVE

Belt driven, axial type upblast propeller roof exhaust fans shall be provided as follows:

Propellers shall be constructed with fabricated steel, fabricated aluminum or cast aluminum blades and hubs. Propellers shall be securely attached to fan shafts. All propellers shall be statically and dynamically balanced. Motors shall be heavy-duty type, matched to the fan load and furnished at the specified voltage, phase and enclosure. Ground and polished steel fan shafts shall be mounted in ball bearing pillow blocks. Bearings shall be selected for a minimum L_{10} life in excess of 100,000 hours (L_{50} average life of 500,000 hours) at maximum cataloged operating speeds. Drives shall be sized for a minimum of 150% of driven horsepower. Pulleys shall be of the fully-machined cast iron type, keyed and securely attached to the wheel and motor shafts. Motor sheaves shall be adjustable for final system balancing (Sizes 42 and larger have fixed drives). Drive frame assemblies shall be galvanized steel or painted steel. Drive frames shall have formed channels and fan panels shall have a deep formed inlet venturi. Windbands shall be constructed of heavy-gauge galvanized steel with reinforced edges and bolted seams. Curb caps shall be constructed of galvanized steel in sizes 20-48 (sizes 54 and 60 constructed of painted steel). The axial belt drive upblast propeller roof fans shall bear the AMCA Certified Rating Seal for both Sound and Air Performance.

For RBUMO models, fans shall meet the following additional requirements: Motors shall be mounted out of the airstream. Motor covers shall be vented for motor cooling.

For high temperature applications, insert the appropriate option shown below.

HIGH TEMPERATURE OPTION

This construction meets specifications for IRI requirements of 500°F (260°C) air for a minimum of 4 hours and the SBCCI "Standard Fire Prevention Code" requirements of 1000°F (538°C) for a minimum of 15 minutes in emergency smoke removal applications.

In addition, this construction exceeds British Standards 7346 Class B 482°F (250°C for 2 hours), Class C 572°F (300°C for 30 minutes), and Class D 572°F (300°C for 1 hour) temperature requirements. Temperature ratings tested in accordance to UL smoke control systems.

HIGH TEMPERATURE OPTION - UL LISTED

This construction meets specifications for UL Listed "Power Ventilators for Smoke Control Systems". This includes the IRI requirements of 500°F (260°C) for a minimum of 4 hours, the SBCCI "Standard Fire Prevention Code" requirements of 1000°F (538°C) for a minimum of 15 minutes, and the Snow Load Test for butterfly dampers in UL 793. In addition, this construction exceeds British Standards 7346 Class B 482°F (250°C for 2 hours), Class C 572°F (300°C for 30 minutes), and Class D 572°F (300°C for 1 hour) temperature requirements.

Fans shall be Model RBU/RBUMO as manufactured by Greenheck Fan Corporation, in Schofield, Wisconsin.

DIRECT DRIVE

Direct driven, axial type upblast propeller roof exhaust fans shall be provided as follows:

Propeller construction shall be cast aluminum airfoil design. A tapered bushing shall lock the propeller to the motor shaft. Propellers shall be statically and dynamically balanced for vibration-free operation. Motors shall be heavy-duty type, matched to the fan load and furnished at the specified voltage, phase and enclosure. Motor, drive frame and fan panel/curb cap assemblies shall be galvanized steel or painted steel. Drive frames shall have formed channels and fan panel/curb cap shall have a deep formed inlet venturi. Windbands shall be constructed of heavy gauge galvanized steel with reinforced edges and bolted seams. The axial direct drive upblast propeller roof fans shall bear the AMCA Certified Rating Seal for both Sound and Air Performance.

Fans shall be Model RDU as manufactured by Greenheck Fan Corporation, in Schofield, Wisconsin.



Our Commitment

As a result of our commitment to continuous improvement, Greenheck reserves the right to change specifications without notice.

Specific Greenheck product warranties are located on greenheck.com within the product area tabs and in the Library under Warranties.



Prepared to Support
Green Building Efforts