

LD1500 & LD2100

Helps Eliminate High Humidity False Alarms



LD2100



LD1500

Together with the SC or SC-C sensing cable, the LD1500 and LD2100 panels detect and report the presence and location of the cable-specific fluid. When the fluid comes in contact with the patented cable, the monitoring panel quickly pinpoints the location of the leak, triggering an alarm and displaying the location.

SPECIFICATIONS

Input Power	24 Vac@600 mA max., 50/60 Hz
INPUTS	
Water Leak Detection Cable	Requires 15 ft. (4.5 m) leader cable kit (LC-KIT or LC-KIT-M)
Maximum Length	LD1500: 1500 ft. (457 m); LD2100: 2000 ft. (609 m)
Detection Accuracy	± 2 ft (0.6 m) + 0.5% of the cable length
Detection Repeatability	± 2 ft (0.6 m) + 0.25% of the cable length
Detection Response Time	5 to 995 sec \pm 2 sec, configure in 5 steps
OUTPUTS	
Relay (LD2100 only)	1 A@24 Vdc, 0.5 A resistive@120 Vac
COMMUNICATIONS PORTS	
RS-232	9600 baud, No parity, 8 data bits, 1 stop bit
RS-485	1200, 2400, 9600, or 19200 baud (selectable); No parity, 8 data bits, 1 stop bit
PROTOCOLS	
Terminal Emulation: RS-232	VT100 compatible
Modbus RS-485	Slave; RTU Mode; Supports function codes 03, 04, 06, and 16; Johnson N2 (LD2100 only)
EXPANDED PROTOCOLS	
TCP/IP, HTML, TFTP	IPv4.0
SNMP	V1: V2C MIB-2 compliant; NMS Manageable with Get, Set, Traps
SMTP email, LD2100 only	Supports client authentication (plain and login); compatible with ESMTP servers
Modbus TCP/IP	Modbus slave; TCP/IP transmission protocol
BACnet/IP	ASHRAE Std 135-2004 Annex J
ALARM NOTIFICATION	
Audible Alarm: LD2100	70 dBA@2 ft. (0.6 m); re-sound configurable (disabled, 0 to 24 hours, integer values only)

High detection accuracy

Adjustable leak and contamination alarm thresholds reduce false alarms due to high humidity... high detection accuracy

PC configuration

Summary alarm relay output... fast response

Visual Alarm: LD1500 LD2100	Red, 4-digit; 7 segment LED display; bi-color status LED Bi-color status LED
Email LD1500/LD2100	4 email recipients; email sent on Alarm and Return to Normal
SNMP Traps LD1500, LD2100	4 community strings

LOGGING CAPABILITIES

Event Log LD1500 LD2100	Last 10 events Last 500 events
Trend Log LD2100	Cable current level every day, for the last 288 days

LOGIN SECURITY

Display Access	1 Administrator (password for configuration, no password required to view panel status)
----------------	---

FRONT PANEL INTERFACE

Display LD2100	Green alphanumeric dot matrix
Push Buttons LD2100	Test/Reset
LED Indicator LD1500 LD2100	1 tri-color Power/Status (green = power on; red = alarm; yellow = cable fault) 1 bi-color Power/Status (green=power on, red=alarm)

OPERATING ENVIRONMENT

Temperature	0 to 50 °C (32 to 122 °F)
Humidity	5 to 95% RH non-condensing
Altitude	15000 ft. (4572 m) max.
Mounting	Vertical wall mount (DIN rail mounting option available on LD2100 only)

WARRANTY

Limited Warranty	2 years
------------------	---------

AGENCY APPROVALS

Agency Approvals	CE*; ETL listed: conforms to UL 61010-1, EN 61010-1; CSA C22.2; RoHS compliant
------------------	--



*The CE mark indicates RoHS2 compliance. Please refer to the CE Declaration of Conformity for additional details.



LD1500/LD2100 BASIC SC INSTALLATION

Wiring Diagram

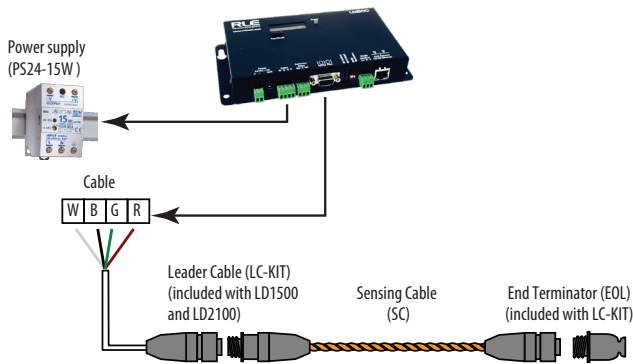

LD1500

Dimensional Drawing

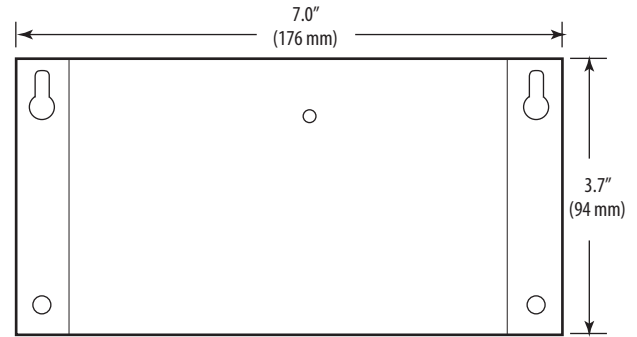

LD1500/LD2100 BASIC SC-C INSTALLATION

Wiring Diagram

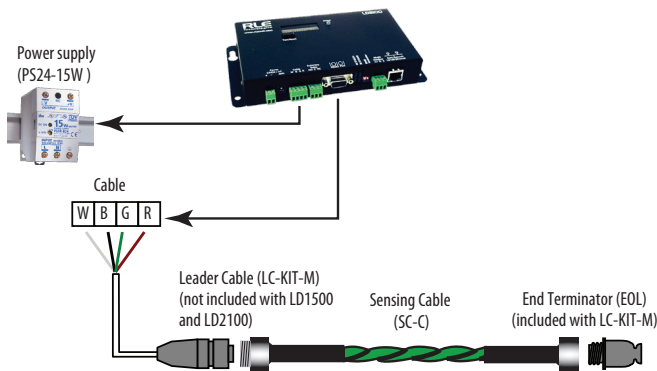

LD2100

Dimensional Drawing

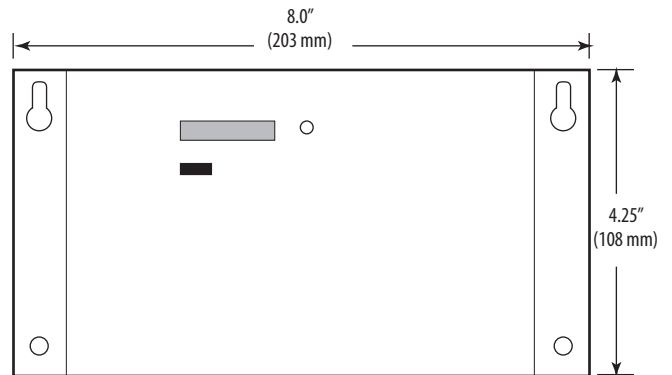

ORDERING INFORMATION

MODEL	MANUF. PART #	DESCRIPTION
U006-0038*	LD1500*	Leak Panel, 1500' Distance Read, Modbus, BACnet, SNMP, SMTP, and relay outputs
U006-0047*	LD2100*	Leak Panel, 2000' Distance Read, Modbus, BACnet, SNMP, SMTP, and relay outputs
U006-0035**	LC-KIT**	Leader cable kit for SC cables (connects from leak panel to SC or NSC cable)
U006-0061***	LC-KIT-M***	Leader cable kit for SC-C cables (connects from leak panel to SC-C cable)
U006-0004	FM1114	Reference map, framed (11" x 14")

* Power supply not included. Use LD-ENC (U006-0045) wall mount enclosure with built-in power supply or Veris PS24-15W power supply or equivalent.

** Included with LD1500 and LD2100.

*** Not included with LD1500 or LD2100. Required for installation of SC-C cables.