Section 31. DMA Controller

HIGHLIGHTS

This section of the manual contains the following major topics:

31.1	Introduction	31-2
31.2	Status and Control Registers	31-6
31.3	Modes of Operation	31-29
31.4	Channel Control	31-40
31.5	Interrupts	31-44
31.6	Operation in Power-Saving and Debug Modes	31-46
31.7	Effects of Various Resets	31-46
31.8	Related Application Notes	31-47
31.9	Revision History	31-48

Note: This family reference manual section is meant to serve as a complement to device data sheets. Depending on the device, this manual section may not apply to all PIC32 devices.

Please consult the note at the beginning of the “**Direct Memory Access (DMA) Controller**” chapter in the current device data sheet to check whether this document supports the device you are using.

Device data sheets and family reference manual sections are available for download from the Microchip Worldwide Web site at: <http://www.microchip.com>

31.1 INTRODUCTION

The Direct Memory Access (DMA) controller is a bus master module that is useful for data transfers between different peripherals without intervention from the CPU. The source and destination of a DMA transfer can be any of the memory-mapped modules included in the PIC32 family of devices. For example, memory, or one of the Peripheral Bus (PB) devices such as the SPI or UART, among others.

Key features of the DMA module include:

- Depending on the device, up to eight identical channels are available, including:
 - Auto-Increment Source and Destination Address registers
 - Source and Destination Pointers
- Depending on the device, uninterrupted data transfers of up to 64 Kbytes are supported
- Flexible data transfer, featuring the following:
 - Transfer granularity down to byte level
 - Bytes need not be word-aligned at source and destination
- Fixed priority channel arbitration
- Flexible DMA channel operating modes, including:
 - Manual (software) or automatic (interrupt) DMA requests
 - One-Shot or Auto-Repeat Block Transfer modes
 - Channel-to-channel chaining
- Flexible DMA requests, featuring:
 - A DMA request can be selected from any of the peripheral interrupt sources
 - Each channel can select any interrupt as its DMA request source
 - A DMA transfer abort can be selected from any of the peripheral interrupt sources
 - Automatic transfer termination upon a data pattern match
- Multiple DMA channel status interrupts, supplying:
 - DMA channel block transfer complete
 - Source empty or half-empty
 - Destination full or half-full
 - DMA transfer aborted due to an external event
 - Invalid DMA address generated
- DMA debug support features, including:
 - Most recent address accessed by a DMA channel
 - Most recent DMA channel to transfer data
- CRC Generation module, featuring:
 - CRC module can be assigned to any of the available channels
 - Data read from the source can be reordered on some devices
 - CRC module is highly configurable
 - CRC calculation

These features are also available in the DMA controller:

- Different source and destination sizes
- Memory-to-memory transfers
- Memory-to-peripheral transfers
- Channel auto-enable
- Events start/stop
- Pattern match detection
- Channel chaining

31.1.1 DMA Operation

A DMA channel transfers data from a source to a destination without CPU intervention. The source and destination start addresses define the start address of the source and destination, respectively.

Both the source and destination have independently configurable sizes and the number of the transferred bytes is independent of the source and destination sizes.

A transfer is initiated either by software or by an interrupt request. The user can select any interrupt on the device to start a DMA transfer.

Upon transfer initiation, the DMA controller will perform a cell transfer (defined by the cell size register) and the channel remains enabled until all bytes of a block (the larger of source size or destination size) transfer is complete. When a channel is disabled, further transfers will be prohibited until the channel is re-enabled.

The DMA channel uses separate pointers to keep track of the current word locations at the source and destination.

Interrupts can be generated when the source/destination pointer is half of the source/destination size, or when the source/destination counter reaches the end of the source/destination.

A DMA transfer can be aborted by the software, by a pattern match or by an interrupt event. The transfer will also stop when an address error is detected.

Figure 31-1 shows a typical DMA transfer. The block transfer size is set by setting the Source size (DCHxSSIZ) and Destination size (DCHxDSIZ) to 4 and 2 bytes (block size is 4). The source (DCHxSSA) and destination (DCHxDSA) registers are then given starting address locations. The source address is the physical SRAM location of an array named buffer. The destination address is the physical PMDIN (PMP output buffer) memory location. The cell size (DCHxCSIZ) is also set to 2. This means the 4 byte block transfer will take two 2 byte cell transfers to be completed. The transfer event for the DMA is set to be a PMP write, which means when a PMP write occurs, a cell transfer will be initiated. Notice the DMA channel can be auto-enabled by setting the CHAEN bit to '1' in the DCHxCON register. A DMA transfer can also be forced by writing a '1' to the CFORCE bit in the DCHXECON register. If the channel is auto-enabled, at the end of a block transfer all channel registers reset to their initial set state before the initial cell transfer. If not, the DMA channel becomes disabled.

Figure 31-1: Typical DMA Source to Destination Transfer Diagram

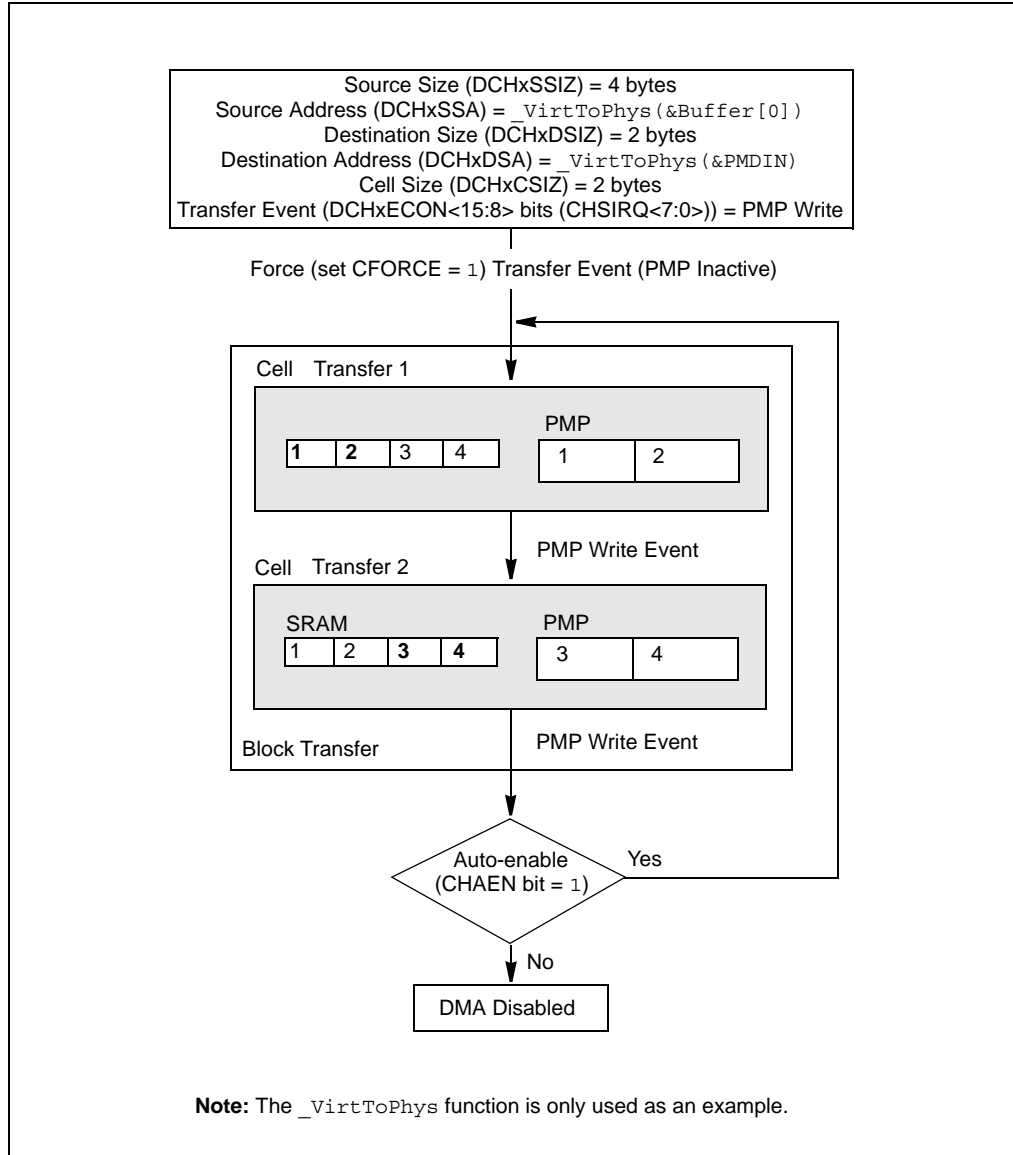
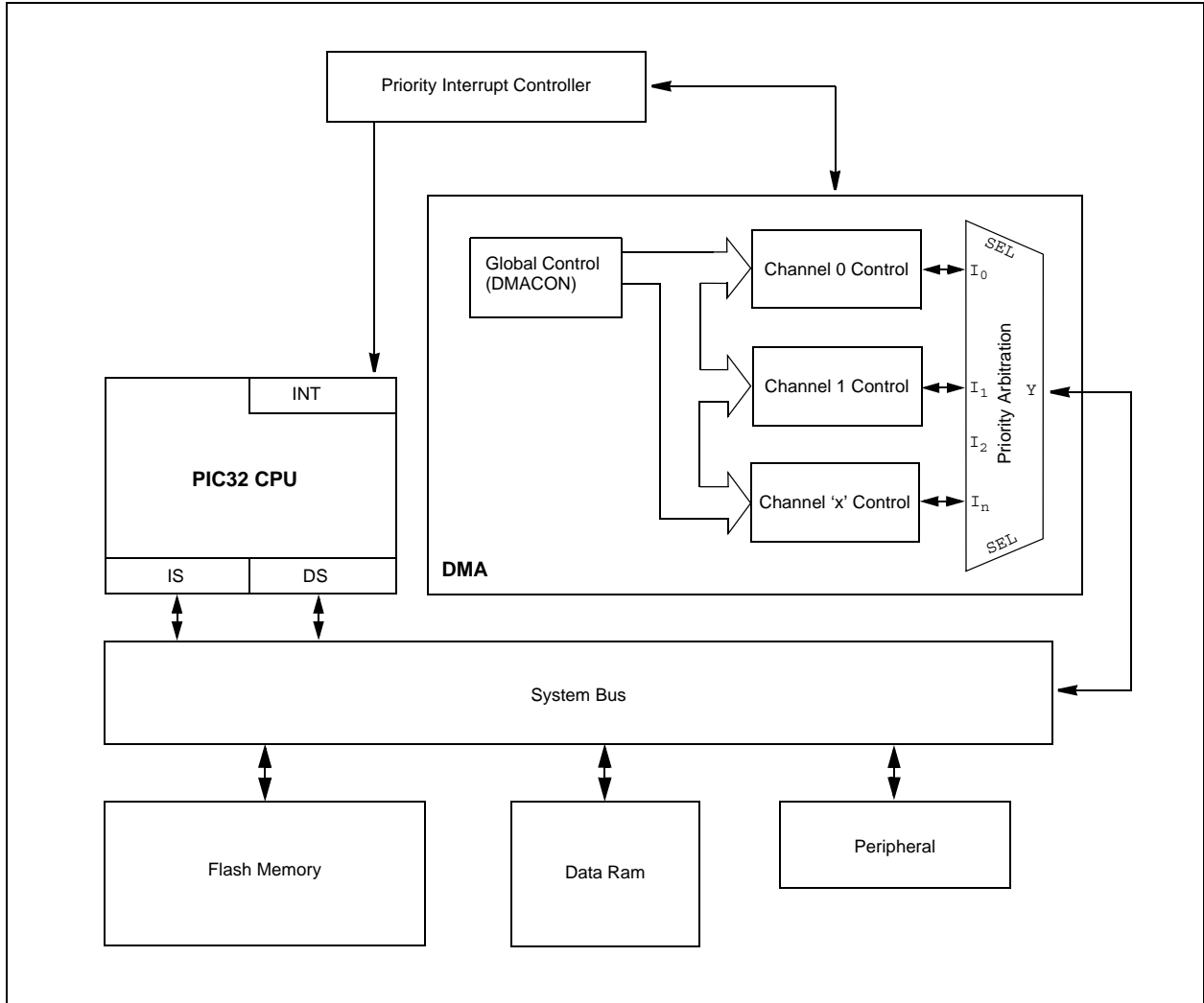

Figure 31-2: DMA Module Block Diagram



31.2 STATUS AND CONTROL REGISTERS

Note: A PIC32 device may have one or more DMA channels. An 'x' used in the names of Control/Status bits and registers denotes the particular channel. Refer to the “**Direct Memory Access Controller**” chapter of the specific device data sheet for more details.

The DMA module consists of the following Special Function Registers (SFRs):

- **DMACON: DMA Controller Control Register**
This register configures the corresponding DMA channel.
- **DMASTAT: DMA Status Register**
This register contains the status of the last read or write transfer that occurred.
- **DMAADDR: DMA Address Register**
This register contains the address of the most recent DMA transfer.
- **DCRCCON: DMA CRC Control Register**
This register controls the CRC of the DMA and how it will function.
- **DCRCDATA: DMA CRC Data Register**
This register sets the initial value of the CRC generator. Writing to this register will seed the CRC generator. Reading from this register will return the current value of the CRC.
- **DCRCXOR: DMA CRCXOR Enable Register**
This register provides a description of the generator polynomial for CRC calculation.
- **DCHxCON: DMA Channel 'x' Control Register**
This register controls the configuration of a specific DMA channel.
- **DCHxECON: DMA Channel 'x' Event Control Register**
This register controls the event for a specific DMA channel.
- **DCHxINT: DMA Channel 'x' Interrupt Control Register**
This register controls the DMA interrupt for a specific DMA channel.
- **DCHxSSA: DMA Channel 'x' Source Start Address Register**
This register configures the source start address for a specific DMA channel.
- **DCHxDSA: DMA Channel 'x' Destination Start Address Register**
This register configures the destination start address for a specific DMA channel.
- **DCHxSSIZ: DMA Channel 'x' Source Size Register**
This register configures the source size for a specific DMA channel.
- **DCHxDSIZ: DMA Channel 'x' Destination Size Register**
This register configures the destination size for a specific DMA channel.
- **DCHxSPTR: DMA Channel 'x' Source Pointer Register**
This register contains the address of the current location of the source for a specific DMA channel.
- **DCHxDPTR: DMA Channel 'x' Destination Pointer Register**
This register contains the address of the current location of the destination for a specific DMA channel.
- **DCHxCSIZ: DMA Channel 'x' Cell Size Register**
This register configures how many transfers can occur per event for a specific DMA channel.
- **DCHxCPTR: DMA Channel 'x' Cell Pointer Register**
This register counts how many transfers have occurred since the last event for a specific DMA channel.
- **DCHxDAT: DMA Channel 'x' Pattern Data Register**
This register contains data to be matched to allow a terminate on match for a specific DMA channel.

Table 31-1 provides a brief summary of the related DMA module registers. Corresponding register tables appear after the summary, that include a detailed description of each bit.

Table 31-1: DMA Register Summary

Name	Bit Range	Bit 31/15	Bit 30/14	Bit 29/13	Bit 28/12	Bit 27/11	Bit 26/10	Bit 25/9	Bit 24/8	Bit 23/7	Bit 22/6	Bit 21/5	Bit 20/4	Bit 19/3	Bit 118/2	Bit 17/1	Bit 16/0	
DMACON ⁽¹⁾	31:15	—	—	—	—	—	—	—	—	—	—	—	—	—	—	—	—	
	15:0	—	—	—	—	—	—	—	—	ON	—	—	SUSPEND	DMABUSY ⁽²⁾	—	—	—	
DMASTAT	31:16	RDWR ⁽²⁾	—	—	—	—	—	—	—	—	—	—	—	—	—	—	—	
	15:0	—	—	—	—	—	—	—	—	—	—	—	—	RDWR ⁽²⁾	DMACH<2:0> ⁽²⁾			
DMAADDR	31:16	DMAADDR<31:16>																
	15:0	DMAADDR<15:0>																
DCRCCON ⁽¹⁾	31:16	—	—	BYTO<1:0> ⁽²⁾		WBO ⁽²⁾	—	—	BITO ⁽²⁾	—	—	—	—	—	—	—	—	
	15:0	—	—	—	PLEN<4:0> ⁽²⁾				CRCCEN	CRCCAPP	CRCTYP ⁽²⁾	—	—	CRCCH<2:0> ⁽²⁾				
DCRCDATA ⁽¹⁾	31:16	DCRCDATA<31:16> ⁽²⁾																
	15:0	DCRCDATA<15:0> ⁽²⁾																
DCRCXOR ⁽¹⁾	31:16	DCRCXOR<31:16> ⁽²⁾																
	15:0	DCRCXOR<15:0> ⁽²⁾																
DCHxCON ⁽¹⁾	31:16	CHPIGN<7:0>										—	—	—	—	—	—	—
	15:0	CHBUSY ⁽²⁾	—	CHPIGNEN ⁽²⁾	—	CHPATLEN ⁽²⁾	—	—	CHCHNS	CHEN	CHAED	CHCHN	CHAEN	—	CHEDET	CHPRI<1:0>		
DCHxECON ⁽¹⁾	31:16	—	—	—	—	—	—	—	—	CHAIRQ<7:0>								
	15:0	CHSIRQ<7:0>								CFORCE	CABORT	PATEN	SIRQEN	AIRQEN	—	—	—	
DCHxINT ⁽¹⁾	31:16	—	—	—	—	—	—	—	—	CHSDIE	CHSHIE	CHDDIE	CHDHIE	CHBCIE	CHCCIE	CHTAIE	CHERIE	
	15:0	—	—	—	—	—	—	—	—	CHSDIF	CHSHIF	CHDDIF	CHDHIF	CHBCIF	CHCCIF	CHTAIF	CHERIF	
DCHxSSA ⁽¹⁾	31:16	CHSSA<31:16>																
	15:0	CHSSA<15:0>																
DCHxDSA	31:16	CHDSA<31:16>																
	15:0	CHDSA<15:0>																
DCHxSSIZ ⁽¹⁾	31:16	—	—	—	—	—	—	—	—	—	—	—	—	—	—	—	—	
	15:0	CHSSIZ<15:0> ⁽²⁾																
DCHxDSIZ ⁽¹⁾	31:16	—	—	—	—	—	—	—	—	—	—	—	—	—	—	—	—	
	15:0	CHDSIZ<15:0> ⁽²⁾																
DCHxSPTR	31:16	—	—	—	—	—	—	—	—	—	—	—	—	—	—	—	—	
	15:0	CHSPTR<15:0>																

Legend: — = unimplemented, read as '0'. Address offset values are shown in hexadecimal.

- Note 1:** This register has an associated Clear, Set, and Invert register at an offset of 0x4, 0x8, and 0xC bytes, respectively. These registers have the same name with CLR, SET, and INV appended to the end of the register name (e.g., DMACONCLR). Writing a '1' to any bit position in the Clear, Set, or Invert register will clear valid bits in the associated register. Reads from these registers should be ignored.
- Note 2:** This bit is not available on all devices. Refer to the "Direct Memory Access (DMA) Controller" chapter in the specific device data sheet for availability.

Table 31-1: DMA Register Summary (Continued)

Name	Bit Range	Bit 31/15	Bit 30/14	Bit 29/13	Bit 28/12	Bit 27/11	Bit 26/10	Bit 25/9	Bit 24/8	Bit 23/7	Bit 22/6	Bit 21/5	Bit 20/4	Bit 19/3	Bit 118/2	Bit 17/1	Bit 16/0
DCHxDPTR	31:16	—	—	—	—	—	—	—	—	—	—	—	—	—	—	—	—
	15:0	CHDPTR<15:0> ⁽²⁾															
DCHxCSIZ ⁽¹⁾	31:16	—	—	—	—	—	—	—	—	—	—	—	—	—	—	—	—
	15:0	CHCSIZ<15:0> ⁽²⁾															
DCHxCPTR	31:16	—	—	—	—	—	—	—	—	—	—	—	—	—	—	—	—
	15:0	CHCPTR<15:0> ⁽²⁾															
DCHxDAT ⁽¹⁾	31:16	—	—	—	—	—	—	—	—	—	—	—	—	—	—	—	—
	15:0	CHPDAT<15:8> ⁽²⁾									CHPDAT<7:0>						

Legend: — = unimplemented, read as '0'. Address offset values are shown in hexadecimal.

- Note 1:** This register has an associated Clear, Set, and Invert register at an offset of 0x4, 0x8, and 0xC bytes, respectively. These registers have the same name with CLR, SET, and INV appended to the end of the register name (e.g., DMACONCLR). Writing a '1' to any bit position in the Clear, Set, or Invert register will clear valid bits in the associated register. Reads from these registers should be ignored.
- 2:** This bit is not available on all devices. Refer to the “Direct Memory Access (DMA) Controller” chapter in the specific device data sheet for availability.

Register 31-1: DMACON: DMA Controller Control Register

Bit Range	Bit 31/23/15/7	Bit 30/22/14/6	Bit 29/21/13/5	Bit 28/20/12/4	Bit 27/19/11/3	Bit 26/18/10/2	Bit 25/17/9/1	Bit 24/16/8/0
31:24	U-0	U-0	U-0	U-0	U-0	U-0	U-0	U-0
	—	—	—	—	—	—	—	—
23:16	U-0	U-0	U-0	U-0	U-0	U-0	U-0	U-0
	—	—	—	—	—	—	—	—
15:8	R/W-0	U-0	U-0	R/W-0	R/W-0	U-0	U-0	U-0
	ON	—	—	SUSPEND	DMABUSY ⁽¹⁾	—	—	—
7:0	U-0	U-0	U-0	U-0	U-0	U-0	U-0	U-0
	—	—	—	—	—	—	—	—

Legend:

R = Readable bit

W = Writable bit

U = Unimplemented bit, read as '0'

-n = Value at POR

'1' = Bit is set

'0' = Bit is cleared

x = Bit is unknown

bit 31-16 **Unimplemented:** Read as '0'bit 15 **ON:** DMA On bit

1 = DMA module is enabled

0 = DMA module is disabled

When using the 1:1 PBCLK divisor, the user's software should not read/write the peripheral's SFRs in the SYSCLK cycle immediately following the instruction that clears the module's ON bit.

bit 14-13 **Unimplemented:** Read as '0'bit 12 **SUSPEND:** DMA Suspend bit

1 = DMA transfers are suspended to allow CPU uninterrupted access to data bus

0 = DMA operates normally

bit 11 **DMABUSY:** DMA Module Busy bit⁽¹⁾

1 = DMA module is active

0 = DMA module is disabled and not actively transferring data

bit 10-0 **Unimplemented:** Read as '0'**Note 1:** This bit is not available on all devices. Refer to the "Direct Memory Access (DMA) Controller" chapter in the specific device data sheet for availability.

PIC32 Family Reference Manual

Register 31-2: DMASTAT: DMA Status Register

Bit Range	Bit 31/23/15/7	Bit 30/22/14/6	Bit 29/21/13/5	Bit 28/20/12/4	Bit 27/19/11/3	Bit 26/18/10/2	Bit 25/17/9/1	Bit 24/16/8/0
31:24	R-0	U-0	U-0	U-0	U-0	U-0	U-0	U-0
	RDWR	—	—	—	—	—	—	—
23:16	U-0	U-0	U-0	U-0	U-0	U-0	U-0	U-0
	—	—	—	—	—	—	—	—
15:8	U-0	U-0	U-0	U-0	U-0	U-0	U-0	U-0
	—	—	—	—	—	—	—	—
7:0	U-0	U-0	U-0	U-0	R-0	R-0	R-0	R-0
	—	—	—	—	RDWR	DMACH<2:0>		

Legend:

R = Readable bit W = Writable bit U = Unimplemented bit, read as '0'
-n = Value at POR '1' = Bit is set '0' = Bit is cleared x = Bit is unknown

- bit 31 **RDWR:** Read/Write Status bit
 1 = Last DMA bus access when an error that was detected was a read
 0 = Last DMA bus access when an error that was detected was a write
- bit 30-4 **Unimplemented:** Read as '0'
- bit 3 **RDWR:** Read/Write Status bit
 1 = Last DMA bus access when an error that was detected was a read
 0 = Last DMA bus access when an error that was detected was a write
- bit 2-0 **DMACH<2:0>:** DMA Channel bits
 These bits contain the value of the most recent active DMA channel when an error was detected.

Note: Not all bits in register are available on all devices. Refer to the **“Direct Memory Access (DMA) Controller”** chapter in the specific device data sheet for availability.

Register 31-3: DMAADDR: DMA Address Register

Bit Range	Bit 31/23/15/7	Bit 30/22/14/6	Bit 29/21/13/5	Bit 28/20/12/4	Bit 27/19/11/3	Bit 26/18/10/2	Bit 25/17/9/1	Bit 24/16/8/0
31:24	R-0	R-0	R-0	R-0	R-0	R-0	R-0	R-0
DMAADDR<31:24>								
23:16	R-0	R-0	R-0	R-0	R-0	R-0	R-0	R-0
DMAADDR<23:16>								
15:8	R-0	R-0	R-0	R-0	R-0	R-0	R-0	R-0
DMAADDR<15:8>								
7:0	R-0	R-0	R-0	R-0	R-0	R-0	R-0	R-0
DMAADDR<7:0>								

Legend:

R = Readable bit

W = Writable bit

U = Unimplemented bit, read as '0'

-n = Value at POR

'1' = Bit is set

'0' = Bit is cleared

x = Bit is unknown

bit 31-0 DMAADDR<31:0>: DMA Module Address bits

Note: This register contains the address of the most recent DMA access.

PIC32 Family Reference Manual

Register 31-4: DCRCCON: DMA CRC Control Register

Bit Range	Bit 31/23/15/7	Bit 30/22/14/6	Bit 29/21/13/5	Bit 28/20/12/4	Bit 27/19/11/3	Bit 26/18/10/2	Bit 25/17/9/1	Bit 24/16/8/0
31:24	U-0	U-0	R/W-0	R/W-0	R/W-0	U-0	U-0	R/W-0
	—	—	BYTO<1:0> ⁽¹⁾		WBO ^(1,2)	—	—	BITO ⁽¹⁾
23:16	U-0	U-0	U-0	U-0	U-0	U-0	U-0	U-0
	—	—	—	—	—	—	—	—
15:8	U-0	U-0	U-0	R/W-0	R/W-0	R/W-0	R/W-0	R/W-0
	—	—	—	PLEN<4:0> ⁽²⁾				
7:0	R/W-0	R/W-0	R/W-0	U-0	U-0	R/W-0	R/W-0	R/W-0
	CRCCEN	CRCCAPP ⁽²⁾	CRCTYP ⁽¹⁾	—	—	CRCCH<2:0> ⁽¹⁾		

Legend:

R = Readable bit W = Writable bit U = Unimplemented bit, read as '0'
 -n = Value at POR '1' = Bit is set '0' = Bit is cleared x = Bit is unknown

bit 31-30 **Unimplemented:** Read as '0'

bit 29-28 **BYTO<1:0>**: CRC Byte Order Selection bits⁽¹⁾

- 11 = Endian byte swap on half-word boundaries (i.e., source half-word order with reverse source byte order per half-word)
- 10 = Swap half-words on word boundaries (i.e., reverse source half-word order with source byte order per half-word)
- 01 = Endian byte swap on word boundaries (i.e., reverse source byte order)
- 00 = No swapping (i.e., source byte order)

bit 27 **WBO**: CRC Write Byte Order Selection bit^(1,2)

- 1 = Source data is written to the destination re-ordered as defined by BYTO<1:0>
- 0 = Source data is written to the destination unaltered

bit 26-25 **Unimplemented:** Read as '0'

bit 24 **BITO**: CRC Bit Order Selection bit⁽²⁾

- 1 = The checksum/CRC is calculated Least Significant bit (LSb) first (i.e., reflected)
- 0 = The checksum/CRC is calculated Most Significant bit (MSb) first (i.e., not reflected)

bit 23-13 **Unimplemented:** Read as '0'

bit 12-8 **PLEN<4:0>**: Polynomial Length bits⁽²⁾

When CRCTYP (DCRCCON<15>) = 1 (CRC module is in IP Header mode):
 These bits are unused.

When CRCTYP (DCRCCON<15>) = 0 (CRC module is in LFSR mode):
 Denotes the length of the polynomial – 1.

bit 7 **CRCCEN**: CRC Enable bit

- 1 = CRC module is enabled and channel transfers are routed through the CRC module
- 0 = CRC module is disabled and channel transfers proceed normally

bit 6 **CRCCAPP**: CRC Append Mode bit⁽²⁾

- 1 = The DMA transfers data from the source into the CRC but NOT to the destination. When a block transfer completes the DMA writes the calculated CRC value to the location given by CHxDSA
- 0 = The DMA transfers data from the source through the CRC obeying WBO as it writes the data to the destination

Note 1: Not all bits are available on all devices. Refer to the “Direct Memory Access (DMA) Controller” chapter in the specific device data sheet for availability.

2: When WBO = 1, unaligned transfers are not supported and the CRCCAPP bit cannot be set.

Register 31-4: DCRCCON: DMA CRC Control Register (Continued)

- bit 5 **CRCTYP**: CRC Type Selection bit⁽¹⁾
1 = The CRC module will calculate an IP header checksum
0 = The CRC module will calculate a LFSR CRC
- bit 4-3 **Unimplemented**: Read as '0'
- bit 2-0 **CRCCH<2:0>**: CRC Channel Select bits⁽¹⁾
111 = CRC is assigned to Channel 7
110 = CRC is assigned to Channel 6
101 = CRC is assigned to Channel 5
100 = CRC is assigned to Channel 4
011 = CRC is assigned to Channel 3
010 = CRC is assigned to Channel 2
001 = CRC is assigned to Channel 1
000 = CRC is assigned to Channel 0

- Note 1:** Not all bits are available on all devices. Refer to the “**Direct Memory Access (DMA) Controller**” chapter in the specific device data sheet for availability.
- 2:** When $WBO = 1$, unaligned transfers are not supported and the CRCAPP bit cannot be set.

PIC32 Family Reference Manual

Register 31-5: DCRCDATA: DMA CRC Data Register

Bit Range	Bit 31/23/15/7	Bit 30/22/14/6	Bit 29/21/13/5	Bit 28/20/12/4	Bit 27/19/11/3	Bit 26/18/10/2	Bit 25/17/9/1	Bit 24/16/8/0
31:24	R/W-0	R/W-0	R/W-0	R/W-0	R/W-0	R/W-0	R/W-0	R/W-0
DCRCDATA<31:24>								
23:16	R/W-0	R/W-0	R/W-0	R/W-0	R/W-0	R/W-0	R/W-0	R/W-0
DCRCDATA<23:16>								
15:8	R/W-0	R/W-0	R/W-0	R/W-0	R/W-0	R/W-0	R/W-0	R/W-0
DCRCDATA<15:8>								
7:0	R/W-0	R/W-0	R/W-0	R/W-0	R/W-0	R/W-0	R/W-0	R/W-0
DCRCDATA<7:0>								

Legend:

R = Readable bit

W = Writable bit

U = Unimplemented bit, read as '0'

-n = Value at POR

'1' = Bit is set

'0' = Bit is cleared

x = Bit is unknown

bit 31-0 **DCRCDATA<31:0>**: CRC Data Register bits

Writing to this register will seed the CRC generator. Reading from this register will return the current value of the CRC. Bits greater than the PLEN<4:0> bits (DCRCCON<12:8>) will return '0' on any read.

When CRCTYP (DCRCCON<15>) = 1 (CRC module is in IP Header mode):

Only the lower 16 bits contain IP header checksum information. The upper 16 bits are always '0'. Data written to this register is converted and read back in 1's complement form (i.e., current IP header checksum value).

When CRCTYP (DCRCCON<15>) = 0 (CRC module is in LFSR mode):

Bits greater than the PLEN<4:0> bits (DCRCCON<12:8>) will return '0' on any read.

Note: Not all bits in this register are available on all devices. Refer to the “**Direct Memory Access (DMA) Controller**” chapter in the specific device data sheet for availability.

Register 31-6: DCRCXOR: DMA CRCXOR Enable Register

Bit Range	Bit 31/23/15/7	Bit 30/22/14/6	Bit 29/21/13/5	Bit 28/20/12/4	Bit 27/19/11/3	Bit 26/18/10/2	Bit 25/17/9/1	Bit 24/16/8/0
31:24	R/W-0	R/W-0	R/W-0	R/W-0	R/W-0	R/W-0	R/W-0	R/W-0
DCRCXOR<31:24>								
23:16	R/W-0	R/W-0	R/W-0	R/W-0	R/W-0	R/W-0	R/W-0	R/W-0
DCRCXOR<23:16>								
15:8	R/W-0	R/W-0	R/W-0	R/W-0	R/W-0	R/W-0	R/W-0	R/W-0
DCRCXOR<15:8>								
7:0	R/W-0	R/W-0	R/W-0	R/W-0	R/W-0	R/W-0	R/W-0	R/W-0
DCRCXOR<7:0>								

Legend:

R = Readable bit

W = Writable bit

U = Unimplemented bit, read as '0'

-n = Value at POR

'1' = Bit is set

'0' = Bit is cleared

x = Bit is unknown

bit 31-0 **DCRCXOR<31:0>**: CRC XOR Register bitsWhen **CRCTYP (DCRCCON<15>) = 1** (CRC module is in IP Header mode):

This register is unused.

When **CRCTYP (DCRCCON<15>) = 0** (CRC module is in LFSR mode):

1 = Enable the XOR input to the Shift register

0 = Disable the XOR input to the Shift register; data is shifted in directly from the previous stage in the register

Note: Not all bits in this register are available on all devices. Refer to the “**Direct Memory Access (DMA) Controller**” chapter in the specific device data sheet for availability.

PIC32 Family Reference Manual

Register 31-7: DCHxCON: DMA Channel 'x' Control Register

Bit Range	Bit 31/23/15/7	Bit 30/22/14/6	Bit 29/21/13/5	Bit 28/20/12/4	Bit 27/19/11/3	Bit 26/18/10/2	Bit 25/17/9/1	Bit 24/16/8/0
31:24	R/W-x	R/W-x	R/W-x	R/W-x	R/W-x	R/W-x	R/W-x	R/W-x
CHPIGN<7:0> ⁽¹⁾								
23:16	U-0	U-0	U-0	U-0	U-0	U-0	U-0	U-0
	—	—	—	—	—	—	—	—
15:8	R/W-0	U-0	R/W-0	U-0	R/W-0	U-0	U-0	R/W-0
	CHBUSY ⁽¹⁾	—	CHPIGNEN ⁽¹⁾	—	CHPATLEN ⁽¹⁾	—	—	CHCHNS ⁽²⁾
7:0	R/W-0	R/W-0	R/W-0	R/W-0	U-0	R-0	R/W-0	R/W-0
	CHEN ⁽³⁾	CHAED	CHCHN	CHAEN	—	CHEDET	CHPRI<1:0>	

Legend:

R = Readable bit W = Writable bit U = Unimplemented bit, read as '0'
-n = Value at POR '1' = Bit is set '0' = Bit is cleared x = Bit is unknown

bit 31-24 **CHPIGN<7:0>**: Channel Register Data bits⁽¹⁾

Pattern Terminate mode:

Any byte matching these bits during a pattern match may be ignored during the pattern match determination when the CHPIGNEN bit is set. If a byte is read that is identical to this data byte, the pattern match logic will treat it as a “don't care” when the pattern matching logic is enabled and the CHPIGNEN bit is set.

bit 23-16 **Unimplemented**: Read as '0'

bit 15 **CHBUSY**: Channel Busy bit⁽¹⁾

- 1 = Channel is active or has been enabled
- 0 = Channel is inactive or has been disabled

bit 14 **Unimplemented**: Read as '0'

bit 13 **CHPIGNEN**: Enable Pattern Ignore Byte bit⁽¹⁾

- 1 = Treat any byte that matches the CHPIGN<7:0> bits as a “don't care” when pattern matching is enabled
- 0 = Disable this feature

bit 12 **Unimplemented**: Read as '0'

bit 11 **CHPATLEN**: Pattern Length bit⁽¹⁾

- 1 = 2 byte length
- 0 = 1 byte length

bit 8 **CHCHNS**: Chain Channel Selection bit⁽²⁾

- 1 = Chain to channel lower in natural priority (CH1 will be enabled by CH2 transfer complete)
- 0 = Chain to channel higher in natural priority (CH1 will be enabled by CH0 transfer complete)

bit 7 **CHEN**: Channel Enable bit⁽³⁾

- 1 = Channel is enabled
- 0 = Channel is disabled

bit 6 **CHAED**: Channel Allow Events If Disabled bit

- 1 = Channel start/abort events will be registered, even if the channel is disabled
- 0 = Channel start/abort events will be ignored if the channel is disabled

bit 5 **CHCHN**: Channel Chain Enable bit

- 1 = Allow channel to be chained
- 0 = Do not allow channel to be chained

Note 1: This bit is not available on all devices. Refer to the “Direct Memory Access (DMA) Controller” chapter in the specific device data sheet for availability.

2: The chain selection bit takes effect when chaining is enabled (i.e., CHCHN = 1).

3: When the channel is suspended by clearing this bit, the user application should poll the CHBUSY bit (if available on the device) to see when the channel is suspended, as it may take some clock cycles to complete a current transaction before the channel is suspended.

Register 31-7: DCHxCON: DMA Channel 'x' Control Register (Continued)

- bit 4 **CHAEN:** Channel Automatic Enable bit
 1 = Channel is continuously enabled, and not automatically disabled after a block transfer is complete
 0 = Channel is disabled on block transfer complete
- bit 3 **Unimplemented:** Read as '0'
- bit 2 **CHEDET:** Channel Event Detected bit
 1 = An event has been detected
 0 = No events have been detected
- bit 1-0 **CHPRI<1:0>:** Channel Priority bits
 11 = Channel has priority 3 (highest)
 10 = Channel has priority 2
 01 = Channel has priority 1
 00 = Channel has priority 0

- Note 1:** This bit is not available on all devices. Refer to the “Direct Memory Access (DMA) Controller” chapter in the specific device data sheet for availability.
- 2:** The chain selection bit takes effect when chaining is enabled (i.e., CHCHN = 1).
- 3:** When the channel is suspended by clearing this bit, the user application should poll the CHBUSY bit (if available on the device) to see when the channel is suspended, as it may take some clock cycles to complete a current transaction before the channel is suspended.

PIC32 Family Reference Manual

Register 31-8: DCHxECON: DMA Channel 'x' Event Control Register

Bit Range	Bit 31/23/15/7	Bit 30/22/14/6	Bit 29/21/13/5	Bit 28/20/12/4	Bit 27/19/11/3	Bit 26/18/10/2	Bit 25/17/9/1	Bit 24/16/8/0
31:24	U-0	U-0	U-0	U-0	U-0	U-0	U-0	U-0
	—	—	—	—	—	—	—	—
23:16	R/W-1	R/W-1	R/W-1	R/W-1	R/W-1	R/W-1	R/W-1	R/W-1
	CHAIRQ<7:0>							
15:8	R/W-1	R/W-1	R/W-1	R/W-1	R/W-1	R/W-1	R/W-1	R/W-1
	CHSIRQ<7:0>							
7:0	S-0	S-0	R/W-0	R/W-0	R/W-0	U-0	U-0	U-0
	CFORCE	CABORT	PATEN	SIRQEN	AIRQEN	—	—	—

Legend:	S = Settable bit	U = Unimplemented bit, read as '0'
R = Readable bit	W = Writable bit	'0' = Bit is cleared
-n = Value at POR	'1' = Bit is set	x = Bit is unknown

bit 31-24 **Unimplemented:** Read as '0'

bit 23-16 **CHAIRQ<7:0>:** Channel Transfer Abort IRQ bits

11111111 = Interrupt 255 will abort any transfers in progress and set CHAIF flag

-
-
-

00000001 = Interrupt 1 will abort any transfers in progress and set CHAIF flag

00000000 = Interrupt 0 will abort any transfers in progress and set CHAIF flag

bit 15-8 **CHSIRQ<7:0>:** Channel Transfer Start IRQ bits

11111111 = Interrupt 255 will initiate a DMA transfer

-
-
-

00000001 = Interrupt 1 will initiate a DMA transfer

00000000 = Interrupt 0 will initiate a DMA transfer

bit 7 **CFORCE:** DMA Forced Transfer bit

1 = A DMA transfer is forced to begin when this bit is written to a '1'

0 = This bit always reads '0'

bit 6 **CABORT:** DMA Abort Transfer bit

1 = A DMA transfer is aborted when this bit is written to a '1'

0 = This bit always reads '0'

bit 5 **PATEN:** Channel Pattern Match Abort Enable bit

1 = Abort transfer and clear CHEN on pattern match

0 = Pattern match is disabled

bit 4 **SIRQEN:** Channel Start IRQ Enable bit

1 = Start channel cell transfer if an interrupt matching CHSIRQ occurs

0 = Interrupt number CHSIRQ is ignored and does not start a transfer

bit 3 **AIRQEN:** Channel Abort IRQ Enable bit

1 = Channel transfer is aborted if an interrupt matching CHAIRQ occurs

0 = Interrupt number CHAIRQ is ignored and does not terminate a transfer

bit 2-0 **Unimplemented:** Read as '0'

Register 31-9: DCHxINT: DMA Channel 'x' Interrupt Control Register

Bit Range	Bit 31/23/15/7	Bit 30/22/14/6	Bit 29/21/13/5	Bit 28/20/12/4	Bit 27/19/11/3	Bit 26/18/10/2	Bit 25/17/9/1	Bit 24/16/8/0
31:24	U-0	U-0	U-0	U-0	U-0	U-0	U-0	U-0
	—	—	—	—	—	—	—	—
23:16	R/W-0	R/W-0	R/W-0	R/W-0	R/W-0	R/W-0	R/W-0	R/W-0
	CHSDIE	CHSHIE	CHDDIE	CHDHIE	CHBCIE	CHCCIE	CHTAIE	CHERIE
15:8	U-0	U-0	U-0	U-0	U-0	U-0	U-0	U-0
	—	—	—	—	—	—	—	—
7:0	R/W-0	R/W-0	R/W-0	R/W-0	R/W-0	R/W-0	R/W-0	R/W-0
	CHSDIF	CHSHIF	CHDDIF	CHDHIF	CHBCIF	CHCCIF	CHTAIF	CHERIF

Legend:

R = Readable bit

W = Writable bit

U = Unimplemented bit, read as '0'

-n = Value at POR

'1' = Bit is set

'0' = Bit is cleared

x = Bit is unknown

bit 31-24 **Unimplemented:** Read as '0'bit 23 **CHSDIE:** Channel Source Done Interrupt Enable bit

- 1 = Interrupt is enabled
- 0 = Interrupt is disabled

bit 22 **CHSHIE:** Channel Source Half Empty Interrupt Enable bit

- 1 = Interrupt is enabled
- 0 = Interrupt is disabled

bit 21 **CHDDIE:** Channel Destination Done Interrupt Enable bit

- 1 = Interrupt is enabled
- 0 = Interrupt is disabled

bit 20 **CHDHIE:** Channel Destination Half Full Interrupt Enable bit

- 1 = Interrupt is enabled
- 0 = Interrupt is disabled

bit 19 **CHBCIE:** Channel Block Transfer Complete Interrupt Enable bit

- 1 = Interrupt is enabled
- 0 = Interrupt is disabled

bit 18 **CHCCIE:** Channel Cell Transfer Complete Interrupt Enable bit

- 1 = Interrupt is enabled
- 0 = Interrupt is disabled

bit 17 **CHTAIE:** Channel Transfer Abort Interrupt Enable bit

- 1 = Interrupt is enabled
- 0 = Interrupt is disabled

bit 16 **CHERIE:** Channel Address Error Interrupt Enable bit

- 1 = Interrupt is enabled
- 0 = Interrupt is disabled

bit 15-8 **Unimplemented:** Read as '0'bit 7 **CHSDIF:** Channel Source Done Interrupt Flag bit

- 1 = Channel Source Pointer has reached end of source (CHSPTR = CHSSIZ)
- 0 = No interrupt is pending

bit 6 **CHSHIF:** Channel Source Half Empty Interrupt Flag bit

- 1 = Channel Source Pointer has reached midpoint of source (CHSPTR = CHSSIZ/2)
- 0 = No interrupt is pending

bit 5 **CHDDIF:** Channel Destination Done Interrupt Flag bit

- 1 = Channel Destination Pointer has reached end of destination (CHDPTR = CHDSIZ)
- 0 = No interrupt is pending

PIC32 Family Reference Manual

Register 31-9: DCHxINT: DMA Channel 'x' Interrupt Control Register (Continued)

- bit 4 **CHDHIF**: Channel Destination Half Full Interrupt Flag bit
1 = Channel Destination Pointer has reached midpoint of destination (CHDPTR = CHDSIZ/2)
0 = No interrupt is pending
- bit 3 **CHBCIF**: Channel Block Transfer Complete Interrupt Flag bit
1 = A block transfer has been completed (the larger of CHSSIZ/CHDSIZ bytes has been transferred), or a pattern match event occurs
0 = No interrupt is pending
- bit 2 **CHCCIF**: Channel Cell Transfer Complete Interrupt Flag bit
1 = A cell transfer has been completed (CHCSIZ bytes have been transferred)
0 = No interrupt is pending
- bit 1 **CHTAIF**: Channel Transfer Abort Interrupt Flag bit
1 = An interrupt matching CHAIRQ has been detected and the DMA transfer has been aborted
0 = No interrupt is pending
- bit 0 **CHERIF**: Channel Address Error Interrupt Flag bit
1 = A channel address error has been detected
 Either the source or the destination address is invalid.
0 = No interrupt is pending

Register 31-10: DCHxSSA: DMA Channel 'x' Source Start Address Register

Bit Range	Bit 31/23/15/7	Bit 30/22/14/6	Bit 29/21/13/5	Bit 28/20/12/4	Bit 27/19/11/3	Bit 26/18/10/2	Bit 25/17/9/1	Bit 24/16/8/0
31:24	R/W-0	R/W-0	R/W-0	R/W-0	R/W-0	R/W-0	R/W-0	R/W-0
	CHSSA<31:24>							
23:16	R/W-0	R/W-0	R/W-0	R/W-0	R/W-0	R/W-0	R/W-0	R/W-0
	CHSSA<23:16>							
15:8	R/W-0	R/W-0	R/W-0	R/W-0	R/W-0	R/W-0	R/W-0	R/W-0
	CHSSA<15:8>							
7:0	R/W-0	R/W-0	R/W-0	R/W-0	R/W-0	R/W-0	R/W-0	R/W-0
	CHSSA<7:0>							

Legend:

R = Readable bit	W = Writable bit	U = Unimplemented bit, read as '0'
-n = Value at POR	'1' = Bit is set	'0' = Bit is cleared x = Bit is unknown

bit 31-0 **CHSSA<31:0>** Channel Source Start Address bits
 These bits define the channel source start address.

Note: The value of this register must be the physical address of the source.

Register 31-11: DCHxDSEA: DMA Channel 'x' Destination Start Address Register

Bit Range	Bit 31/23/15/7	Bit 30/22/14/6	Bit 29/21/13/5	Bit 28/20/12/4	Bit 27/19/11/3	Bit 26/18/10/2	Bit 25/17/9/1	Bit 24/16/8/0
31:24	R/W-0	R/W-0	R/W-0	R/W-0	R/W-0	R/W-0	R/W-0	R/W-0
	CHDSA<31:24> ⁽¹⁾							
23:16	R/W-0	R/W-0	R/W-0	R/W-0	R/W-0	R/W-0	R/W-0	R/W-0
	CHDSA<23:16> ⁽¹⁾							
15:8	R/W-0	R/W-0	R/W-0	R/W-0	R/W-0	R/W-0	R/W-0	R/W-0
	CHDSA<15:8> ⁽¹⁾							
7:0	R/W-0	R/W-0	R/W-0	R/W-0	R/W-0	R/W-0	R/W-0	R/W-0
	CHDSA<7:0> ⁽¹⁾							

Legend:

R = Readable bit	W = Writable bit	U = Unimplemented bit, read as '0'
-n = Value at POR	'1' = Bit is set	'0' = Bit is cleared x = Bit is unknown

bit 31-0 **CHDSA<31:0>**: Channel Destination Start Address bits
 These bits define the channel destination start address.

Note: The value of this register must be the physical address of the destination.

PIC32 Family Reference Manual

Register 31-12: DCHxSSIZ: DMA Channel 'x' Source Size Register

Bit Range	Bit 31/23/15/7	Bit 30/22/14/6	Bit 29/21/13/5	Bit 28/20/12/4	Bit 27/19/11/3	Bit 26/18/10/2	Bit 25/17/9/1	Bit 24/16/8/0
31:24	U-0	U-0	U-0	U-0	U-0	U-0	U-0	U-0
	—	—	—	—	—	—	—	—
23:16	U-0	U-0	U-0	U-0	U-0	U-0	U-0	U-0
	—	—	—	—	—	—	—	—
15:8	R/W-0	R/W-0	R/W-0	R/W-0	R/W-0	R/W-0	R/W-0	R/W-0
	CHSSIZ<15:8>							
7:0	R/W-0	R/W-0	R/W-0	R/W-0	R/W-0	R/W-0	R/W-0	R/W-0
	CHSSIZ<7:0>							

Legend:

R = Readable bit

W = Writable bit

U = Unimplemented bit, read as '0'

-n = Value at POR

'1' = Bit is set

'0' = Bit is cleared

x = Bit is unknown

bit 31-16 **Unimplemented:** Read as '0'

bit 15-0 **CHSSIZ<15:0>**: Channel Source Size bits

11111111111111111111 = 65,535 byte source size

-
-
-

0000000000000010 = 2 byte source size

0000000000000001 = 1 byte source size

0000000000000000 = 65,536 byte source size

Note: Not all bits in this register are available on all devices. Refer to the “**Direct Memory Access (DMA) Controller**” chapter in the specific device data sheet for availability.

Register 31-13: DCHxDSIZ: DMA Channel 'x' Destination Size Register

Bit Range	Bit 31/23/15/7	Bit 30/22/14/6	Bit 29/21/13/5	Bit 28/20/12/4	Bit 27/19/11/3	Bit 26/18/10/2	Bit 25/17/9/1	Bit 24/16/8/0
31:24	U-0	U-0	U-0	U-0	U-0	U-0	U-0	U-0
	—	—	—	—	—	—	—	—
23:16	U-0	U-0	U-0	U-0	U-0	U-0	U-0	U-0
	—	—	—	—	—	—	—	—
15:8	R/W-0	R/W-0	R/W-0	R/W-0	R/W-0	R/W-0	R/W-0	R/W-0
	CHDSIZ<15:8>							
7:0	R/W-0	R/W-0	R/W-0	R/W-0	R/W-0	R/W-0	R/W-0	R/W-0
	CHDSIZ<7:0>							

Legend:

R = Readable bit

W = Writable bit

U = Unimplemented bit, read as '0'

-n = Value at POR

'1' = Bit is set

'0' = Bit is cleared

x = Bit is unknown

bit 31-16 **Unimplemented:** Read as '0'bit 15-0 **CHDSIZ<15:0>**: Channel Destination Size bits

1111111111111111 = 65,535 byte destination size

-
-
-

0000000000000010 = 2 byte destination size

0000000000000001 = 1 byte destination size

0000000000000000 = 65,536 byte destination size

Note: Not all bits in this register are available on all devices. Refer to the “Direct Memory Access (DMA) Controller” chapter in the specific device data sheet for availability.

PIC32 Family Reference Manual

Register 31-14: DCHxSPTR: DMA Channel 'x' Source Pointer Register

Bit Range	Bit 31/23/15/7	Bit 30/22/14/6	Bit 29/21/13/5	Bit 28/20/12/4	Bit 27/19/11/3	Bit 26/18/10/2	Bit 25/17/9/1	Bit 24/16/8/0
31:24	U-0	U-0	U-0	U-0	U-0	U-0	U-0	U-0
	—	—	—	—	—	—	—	—
23:16	U-0	U-0	U-0	U-0	U-0	U-0	U-0	U-0
	—	—	—	—	—	—	—	—
15:8	R-0	R-0	R-0	R-0	R-0	R-0	R-0	R-0
	CHSPTR<15:8>							
7:0	R-0	R-0	R-0	R-0	R-0	R-0	R-0	R-0
	CHSPTR<7:0>							

Legend:

R = Readable bit	W = Writable bit	U = Unimplemented bit, read as '0'
-n = Value at POR	'1' = Bit is set	'0' = Bit is cleared x = Bit is unknown

bit 31-16 **Unimplemented:** Read as '0'

bit 15-0 **CHSPTR<15:0>:** Channel Source Pointer bits⁽¹⁾

1111111111111111 = Points to byte 65,535 of the source

-
-
-

0000000000000001 = Points to byte 1 of the source

0000000000000000 = Points to byte 0 of the source

Note 1: When in Pattern Detect mode, this register is Reset on a pattern detect.

Register 31-15: DCHxDPTR: DMA Channel 'x' Destination Pointer Register

Bit Range	Bit 31/23/15/7	Bit 30/22/14/6	Bit 29/21/13/5	Bit 28/20/12/4	Bit 27/19/11/3	Bit 26/18/10/2	Bit 25/17/9/1	Bit 24/16/8/0
31:24	U-0	U-0	U-0	U-0	U-0	U-0	U-0	U-0
	—	—	—	—	—	—	—	—
23:16	U-0	U-0	U-0	U-0	U-0	U-0	U-0	U-0
	—	—	—	—	—	—	—	—
15:8	R-0	R-0	R-0	R-0	R-0	R-0	R-0	R-0
	CHDPTR<15:8>							
7:0	R-0	R-0	R-0	R-0	R-0	R-0	R-0	R-0
	CHDPTR<7:0>							

Legend:

R = Readable bit	W = Writable bit	U = Unimplemented bit, read as '0'
-n = Value at POR	'1' = Bit is set	'0' = Bit is cleared x = Bit is unknown

bit 31-16 **Unimplemented:** Read as '0'

bit 15-0 **CHDPTR<15:0>:** Channel Destination Pointer bits

1111111111111111 = Points to byte 65,535 of the destination

-
-
-

0000000000000001 = Points to byte 1 of the destination

0000000000000000 = Points to byte 0 of the destination

Note: Not all bits in this register are available on all devices. Refer to the “**Direct Memory Access (DMA) Controller**” chapter in the specific device data sheet for availability.

PIC32 Family Reference Manual

Register 31-16: DCHxCSIZ: DMA Channel 'x' Cell Size Register

Bit Range	Bit 31/23/15/7	Bit 30/22/14/6	Bit 29/21/13/5	Bit 28/20/12/4	Bit 27/19/11/3	Bit 26/18/10/2	Bit 25/17/9/1	Bit 24/16/8/0
31:24	U-0	U-0	U-0	U-0	U-0	U-0	U-0	U-0
	—	—	—	—	—	—	—	—
23:16	U-0	U-0	U-0	U-0	U-0	U-0	U-0	U-0
	—	—	—	—	—	—	—	—
15:8	R/W-0	R/W-0	R/W-0	R/W-0	R/W-0	R/W-0	R/W-0	R/W-0
	CHCSIZ<15:8>							
7:0	R/W-0	R/W-0	R/W-0	R/W-0	R/W-0	R/W-0	R/W-0	R/W-0
	CHCSIZ<7:0>							

Legend:

R = Readable bit W = Writable bit U = Unimplemented bit, read as '0'
 -n = Value at POR '1' = Bit is set '0' = Bit is cleared x = Bit is unknown

bit 31-16 **Unimplemented:** Read as '0'

bit 15-0 **CHCSIZ<15:0>**: Channel Cell-Size bits

11111111111111111111 = 65,535 bytes transferred on an event
 •
 •
 •
 0000000000000010 = 2 bytes transferred on an event
 0000000000000001 = 1 byte transferred on an event
 0000000000000000 = 65,536 bytes transferred on an event

Note: Not all bits in this register are available on all devices. Refer to the “Direct Memory Access (DMA) Controller” chapter in the specific device data sheet for availability.

Register 31-17: DCHxCPTR: DMA Channel 'x' Cell Pointer Register

Bit Range	Bit 31/23/15/7	Bit 30/22/14/6	Bit 29/21/13/5	Bit 28/20/12/4	Bit 27/19/11/3	Bit 26/18/10/2	Bit 25/17/9/1	Bit 24/16/8/0
31:24	U-0	U-0	U-0	U-0	U-0	U-0	U-0	U-0
	—	—	—	—	—	—	—	—
23:16	U-0	U-0	U-0	U-0	U-0	U-0	U-0	U-0
	—	—	—	—	—	—	—	—
15:8	R-0	R-0	R-0	R-0	R-0	R-0	R-0	R-0
	CHCPTR<15:8>							
7:0	R-0	R-0	R-0	R-0	R-0	R-0	R-0	R-0
	CHCPTR<7:0>							

Legend:

R = Readable bit	W = Writable bit	U = Unimplemented bit, read as '0'
-n = Value at POR	'1' = Bit is set	'0' = Bit is cleared x = Bit is unknown

bit 31-16 **Unimplemented:** Read as '0'

bit 15-0 **CHCPTR<15:0>:** Channel Cell Progress Pointer bits

1111111111111111 = 65,535 bytes have been transferred since the last event

•
•
•

0000000000000001 = 1 byte has been transferred since the last event

0000000000000000 = 0 bytes have been transferred since the last event

- Note 1:** Not all bits in this register are available on all devices. Refer to the “**Direct Memory Access (DMA) Controller**” chapter in the specific device data sheet for availability.
- 2:** When in Pattern Detect mode, this register is Reset on a pattern detect.

PIC32 Family Reference Manual

Register 31-18: DCHxDAT: DMA Channel 'x' Pattern Data Register

Bit Range	Bit 31/23/15/7	Bit 30/22/14/6	Bit 29/21/13/5	Bit 28/20/12/4	Bit 27/19/11/3	Bit 26/18/10/2	Bit 25/17/9/1	Bit 24/16/8/0
31:24	U-0	U-0	U-0	U-0	U-0	U-0	U-0	U-0
	—	—	—	—	—	—	—	—
23:16	U-0	U-0	U-0	U-0	U-0	U-0	U-0	U-0
	—	—	—	—	—	—	—	—
15:8	R/W-0	R/W-0	R/W-0	R/W-0	R/W-0	R/W-0	R/W-0	R/W-0
	CHPDAT<15:8> ⁽¹⁾							
7:0	R/W-0	R/W-0	R/W-0	R/W-0	R/W-0	R/W-0	R/W-0	R/W-0
	CHPDAT<7:0> ⁽¹⁾							

Legend:

R = Readable bit	W = Writable bit	U = Unimplemented bit, read as '0'
-n = Value at POR	'1' = Bit is set	'0' = Bit is cleared x = Bit is unknown

bit 31-16 **Unimplemented:** Read as '0'

bit 15-0 **CHPDAT<15:0>:** Channel Data Register bits⁽¹⁾

Pattern Terminate mode:

Data to be matched must be stored in this register to allow terminate on match.

All other modes:

Unused.

Note 1: These bits are not available on all devices. Refer to specific device data sheet for availability.

31.3 MODES OF OPERATION

The DMA module offers the following operating modes:

- Basic Transfer mode
- Pattern Match mode
- Channel Chaining mode
- Channel Auto-Enable mode
- Special Function Module (SFM) mode: LFSR CRC, IP header checksum

These operation modes are not mutually exclusive, but can be simultaneously operational. For example, the DMA controller can perform CRC calculation using chained channels and terminating the transfer upon a pattern match.

The following terminology is used while describing the various operational modes of the DMA Controller:

- **Event:** Any system event that can initiate or abort a DMA transfer
- **Transaction:** A single word transfer (up to 4 bytes), consisting of read and write operations
- **Cell Transfer:** The number of bytes transferred when a DMA channel has a transfer initiated before waiting for another event (given by the DCHxCSIZ register). A cell transfer is comprised of one or more transactions.
- **Block Transfer:** Defined as the number of bytes transferred when a channel is enabled. The number of bytes is the larger of either DCHxSSIZ or DCHxDSIZ. A block transfer is comprised of one or more cell transfers.

Note: To avoid cache coherency issues on devices with L1 cache, all buffers that are accessed by the DMA module must be allocated in KSEG1 and/or KSEG3 (uncached) segments.

31.3.1 Basic Transfer Mode

A DMA channel will transfer data from a source to a destination without CPU intervention. The Channel Source Start Address register (DCHxSSA) defines the physical start address of the source. The Channel Destination Start Address register (DCHxDSA) defines the physical start address of the destination. Both the source and destination are independently configurable using the DCHxSSIZ and DCHxDSIZ registers.

A cell transfer is initiated in one of two ways:

- Software can initiate a transfer by setting the channel CFORCE bit (DCHxECON<7>)
- Interrupt event occurs on the device that matches the CHSIRQ interrupt and SIRQEN = 1 (DCHxECON<4>). The user can select any interrupt on the device to start a DMA transfer.

A DMA transfer will transfer DCHxCSIZ (cell transfer) bytes when a transfer is initiated (an event occurs). The channel remains enabled until the DMA channel has transferred the larger of DCHxSSIZ and DCHxDSIZ (i.e., block transfer is complete). If DCHxCSIZ is greater than the larger of DCHxSSIZ and DCHxDSIZ, then the larger of DCHxSSIZ and DCHxDSIZ bytes will be transferred. When the channel is disabled, further transfers will be prohibited until the channel is re-enabled (CHEN is set to '1').

Each channel keeps track of the number of words transferred from the source and destination using the pointers DCHxSPTR and DCHxDPTR. Interrupts are generated when the source or Destination Pointer is half of the size (DCHxSSIZ/2 or DCHxDSIZ/2), or when the source or destination counter reaches the end. These interrupts are CHSHIF (DCHxINT<6>), CHDHIF (DCHxINT<4>), CHSDIF (DCHxINT<7>) or CHDDIF (DCHxINT<5>), respectively.

A DMA transfer request can be reset by the following:

- Writing the CABORT (DCHxECON<6>) bit, as described in [31.4.6 “Resetting the Channel”](#)
- Pattern match occurs if pattern match is enabled as described in [31.3.2 “Pattern Match Termination Mode”](#), provided that Channel Auto-Enable mode bit, CHAEN (DCHxCON<4>), is not set
- Interrupt event occurs on the device that matches the CHAIRQ <7:0> (DCHxECON<23:16>) bits interrupt if enabled by the AIRQEN (DCHxECON<3>) bit
- Detection of an address error

- Completion of a cell transfer
- A block transfer completes and the Channel Auto-Enable mode (CHAEN) is not set

When a channel abort interrupt occurs, the Channel Transfer Abort Interrupt Flag bit, CHTAIF (DCHxINT<1>), is set. This allows the user to detect and recover from an aborted DMA transfer. When a transfer is aborted, any transaction currently underway will be completed.

The Source and Destination Pointers are updated as a transfer progresses. These pointers are read-only. The pointers are reset under the following conditions:

- If the channel source address (DCHxSSA) is updated, the Source Pointer (DCHxSPTR) will be reset
- Similar updates to the destination address (DCHxDSA) will cause the Destination Pointer (DCHxDPTR) to be reset
- A channel transfer is aborted by writing the CABORT (DCHxECON<6>) bit

Note: Refer to [Table 31-2](#) for more detailed information about the channel event behavior.

Example 31-1: DMA Channel Initialization for Basic Transfer Mode Code Example

```
/* This code example illustrates the DMA channel 0 configuration for a data transfer. */
IEC1CLR=0x00010000;           // disable DMA channel 0 interrupts
IFS1CLR=0x00010000;           // clear existing DMA channel 0 interrupt flag

DMACONSET=0x00008000;         // enable the DMA controller
DCH0CON=0x3;                  // channel off, priority 3, no chaining
DCH0ECON=0;                   // no start or stop IRQs, no pattern match

// program the transfer
DCH0SSA=VirtToPhys(flashBuff); // transfer source physical address
DCH0DSA=VirtToPhys(ramBuff);   // transfer destination physical address
DCH0SSIZ=200;                  // source size 200 bytes
DCH0DSIZ=200;                  // destination size 200 bytes
DCH0CSIZ=200;                  // 200 bytes transferred per event
DCH0INTCLR=0x00ff00ff;        // clear existing events, disable all interrupts
DCH0CONSET=0x80;              // turn channel on

// initiate a transfer
DCH0ECONSET=0x00000080;       // set CFORCE to 1

// do something else
// poll to see that the transfer was done

while(TRUE)
{
    register int pollCnt;      // use a poll counter.
                               // continuously polling the DMA controller in a tight
                               // loop would affect the performance of the DMA transfer

    int dmaFlags=DCH0INT;
    if( (dmaFlags&0xb)
        {
            // one of CHERIF (DCHxINT<0>), CHTAIF (DCHxINT<1>)
            // or CHBCIF (DCHxINT<3>) flags set
            break;             // transfer completed
        }
    pollCnt=100;               // use an adjusted value here
    while(pollCnt--);         // wait before reading again the DMA controller
}
// check the transfer completion result
```

31.3.1.1 Interrupt and Pointer Updates

The Source and Destination Pointers are updated after every transaction. Interrupts will also be set or cleared at this time. If a pointer passes the halfway point during a transaction, the interrupt will be updated accordingly.

Pointers are reset when any of the following occurs:

- On any device Reset
- When the DMA is turned off (ON (DMACON<15>) bit is '0')
- A block transfer completes, regardless of the state of CHAEN (DCHxCON<4>) bit
- A pattern match terminates a transfer, regardless of the state of CHAEN (DCHxCON<4>) bit
- The CABORT (DCHxECON<6>) bit flag is written
- Source or destination start addresses are updated

31.3.2 Pattern Match Termination Mode

Pattern Match Termination mode allows the user to end a transfer if data written during a transaction matches a specific pattern, as defined by the DCHxDAT register. A pattern match is treated the same way as a block transfer complete, where the CHBCIF bit (DCHxINT<3>) is set and the CHEN bit (DCHxCON<7>) is cleared.

This feature is useful in applications where a variable data size is required and eases the setup of the DMA channel. The UART module is a good example of where this feature can be effectively used.

Assuming a system has a series of messages that are routinely transmitted to an external host and it has a maximum message size of 86 characters, the user would set the following parameters on the channel:

- DCHxSSIZ to 87 bytes – If something unexpected occurs, the CPU program will be interrupted when the buffer overflows and can take the appropriate action
- DCHxDSIZ set to 1 byte
- The destination address is set to the UART TXREG
- The DCHxDAT is set to 0x00, which will stop the transfer on a NULL character in any byte lane
- The CHSIRQ<7:0> bits (DCHxECON<15:8>) are set to the UART “transmit buffer empty” IRQ
- The SIRQEN bit (DCHxECON<4>) is set to enable the channel to respond to the start interrupt event
- The start address is set to the start address of the message to be transferred
- The channel is enabled, CHEN (DCHxCON<7>) = 1
- The user will then force a cell transfer through CFORCE bit (DCHxECON<7>) and the first byte transmission by the UART
- Each time a byte is transmitted by the UART, the transmit buffer empty interrupt will initiate the following byte transfer from the source to the UART
- When the DMA channel detects a NULL character in any of the byte lanes of the channel, the transaction will be completed and the channel disabled

Pattern matching is independent of the byte lane of the source data. If ANY byte in the source buffer matches DCHxDAT, a pattern match is detected. The transaction will be completed and the data read from the source will be written to the destination.

31.3.2.1 PATTERN MATCH IGNORE MODE

In devices with a CHPATLEN bit, a pattern can either be 8 bits or 16 bits wide. This pattern length is defined by the CHPATLEN bit in the DCHxCON register. If the CHPATLEN bit is set to a '1', the Pattern Match Ignore mode can be used. If the Enable Pattern Ignore Byte bit (CHPIGNEN) is set, and when the value in the Channel Register Data bits, CHPIGN<7:0>, is met, the data being transferred is treated as a “don't care” when trying to find a termination pattern during a cell transfer. An example of this condition is when there are space characters found between the end of a line and a carriage return. If an end of line is known as an 'X' and a carriage return is known as a 'Y' and the CHPIGN<7:0> bits are set to ' _ ', when 'X _ Y' is transferred during a DMA cell transfer, a pattern match termination would be detected since the zeroes in between would be ignored by the SFM when detecting a Pattern Match.

Example 31-2: DMA Channel Initialization in Pattern Match Transfer Mode Code Example

```
/* This code example illustrates the DMA channel 0 configuration for data transfer with pattern
match enabled. Transfer from the UART1 a <CR> ended string, at most 200 characters long */

IEC1CLR=0x00010000;          // disable DMA channel 0 interrupts
IFS1CLR=0x00010000;          // clear any existing DMA channel 0 interrupt flag

DMACONSET=0x00008000;        // enable the DMA controller
DCH0CON=0x03;                // channel off, priority 3, no chaining

DCH0ECON=(27 <<8) | 0x30;    // start irq is UART1 RX, pattern match enabled
DCH0DAT='\r';                // pattern value, carriage return

                                // program the transfer
DCH0SSA=VirtToPhys(&U1RXREG); // transfer source physical address
DCH0DSA=VirtToPhys(ramBuff); // transfer destination physical address
DCH0SSIZ=1;                  // source size is 1 byte
DCH0DSIZ=200;                // destination size at most 200 bytes
DCH0CSIZ=1;                  // one byte per UART transfer request

DCH0INTCLR=0x00ff00ff;       // clear existing events, disable all interrupts
DCH0INTSET=0x00090000;       // enable Block Complete and error interrupts

IPC9CLR=0x0000001f;          // clear the DMA channel 0 priority and sub-priority
IPC9SET=0x00000016;          // set IPL 5, sub-priority 2
IEC1SET=0x00010000;          // enable DMA channel 0 interrupt

DCH0CONSET=0x80;             // turn channel on
```

31.3.3 Channel Chaining Mode

Channel chaining is an enhancement to the DMA channel operation. A channel (slave channel) can be chained to an adjacent channel (master channel). The slave channel will be enabled when a block transfer of the master channel completes (i.e., CHBCIF (DCHxINT<3>) bit is set).

At this point, any event on the slave channel will initiate a cell transfer. If the channel has an event pending, a cell transfer will begin immediately.

The master channel will set its interrupt flags normally, CHBCIF bit (DCHxINT<3>) and has no knowledge of the “chain” status of the slave channel. The master channel is still able to cause interrupts at the end of a DMA transfer if one of the CHSDIE/CHDDIE/CHBCIE (DCHxINT<23/21/19>) bits is set.

In the channels natural priority order, channel 0 has the highest priority. The channel higher or lower in natural priority, that can enable a specific channel, is selected by CHCHNS bit (DCHxCON<8>), provided that channel chaining is enabled, CHCHN (DCHxCON<5>) = 1.

A feature of the DMA module is the ability to allow events while the channel is disabled using the CHAED bit (DCHxCON<6>). This bit is particularly useful in Chained mode, in which the slave channel needs to be ready to start a transfer as soon as the channel is enabled by the master channel.

The following examples demonstrate situations in which chaining may be useful:

1. Transferring data in one peripheral (e.g., from UART1, DMA channel 0, at 9600 baud, to SRAM) to another peripheral (e.g., from SRAM to UART2, DMA channel 1, at 19200 baud).

In this example, CHAED will be set in both channels; with UART2 setting the event detect, CHEDET bit (DCHxCON<2>), on channel 1 when the last byte has been transmitted. As soon as channel 0 completes a transfer, channel 1 is enabled and the data is transferred immediately.

2. ADC module transfers data to one buffer (connected to channel 0).

When the destination buffer 0 is full (block transfer completes), channel 1 is enabled and further conversions are transferred to buffer 1. In this case, CHAED will not be enabled. If it were, the last word transferred by channel 0 would be transferred a second time by channel 1 (because the ADC interrupt event would have set the event detect flag CHEDET in both channels).

Example 31-3: DMA Channel Initialization in Chaining Mode Code Example

```
/* This code example illustrates the DMA channel 0 configuration for data transfer with pattern
match enabled. DMA channel 0 transfer from the UART1 to a RAM buffer while DMA channel 1
transfers data from the RAM buffer to UART2. Transferred strings are at most 200 characters
long. Transfer on UART2 starts as soon as the UART1 transfer is completed. */
```

```
    unsigned char myBuff<200>;    // transfer buffer

    IEC1CLR=0x00010000;           // disable DMA channel 0 interrupts
    IFS1CLR=0x00010000;           // clear any existing DMA channel 0 interrupt flag

    DMACONSET=0x00008000;         // enable the DMA controller

    DCH0CON=0x3;                  // channel 0 off, priority 3, no chaining
    DCH1CON=0x62;                 // channel 1 off, priority 2
                                    // chain to higher priority
                                    // (channel 0), enable events detection while disabled

    DCH0ECON=(27 <<8) | 0x30;     // start IRQ is UART1 RX, pattern enabled
    DCH1ECON=(42 <<8) | 0x30;     // start IRQ is UART1 TX, pattern enabled

    DCH0DAT=DCH1DAT='\r';        // pattern value, carriage return

                                    // program channel 0 transfer
    DCH0SSA=VirtToPhys(&U1RXREG); // transfer source physical address
    DCH0DSA=VirtToPhys(myBuff);  // transfer destination physical address
    DCH0SSIZ=1;                   // source size is 1 byte
    DCH0DSIZ=200;                 // dst size at most 200 bytes
    DCH0CSIZ=1;                   // one byte per UART transfer request

                                    // program channel 1 transfer
    DCH1SSA=VirtToPhys(myBuff);  // transfer source physical address
    DCH1DSA=VirtToPhys(&U2TXREG); // transfer destination physical address
    DCH1SSIZ=200;                 // source size at most 200 bytes
    DCH1DSIZ=0;                   // dst size is 1 byte
    DCH1CSIZ=1;                   // one byte per UART transfer request

    DCH0INTCLR=0x00ff00ff;       // DMA0: clear events, disable interrupts
    DCH1INTCLR=0x00ff00ff;       // DMA1: clear events, disable interrupts
    DCH1INTSET=0x00090000;       // DMA1: enable Block Complete and error interrupts

    IPC9CLR=0x00001f1f;          // clear the DMA channels 0 and 1 priority and
                                    // sub-priority
    IPC9SET=0x00000b16;          // set IPL 5, sub-priority 2 for DMA channel 0
                                    // set IPL 2, sub-priority 3 for DMA channel 1
    IEC1SET=0x00020000;          // enable DMA channel 1 interrupt

    DCH0CONSET=0x80;             // turn channel on
```

31.3.4 Channel Auto-Enable Mode

The channel auto-enable can be used to keep a channel active, even if a block transfer completes or pattern match occurs. This prevents the user from having to re-enable the channel each time a block transfer completes. To use this mode the user will configure the channel, setting the CHAEN bit (DCHxCON<4>) before enabling the channel (i.e., setting the CHEN bit (DCHxCON<7>)). The channel will behave as normal except that normal termination of a transfer will not result in the channel being disabled.

Normal block transfer completion is defined as:

- Block transfer complete
- Pattern match detect

As before, the Channel Pointers will be reset. This mode is useful for applications that do repeated pattern matching.

Note: The CHAEN bit prevents the channel from being automatically disabled once it has been enabled. The channel will still have to be enabled by the software.

31.3.5 Special Function Module (SFM) Mode

The DMA module has one integrated Special Function Module (SFM) shared by all channels.

As illustrated in [Figure 31-3](#), the SFM has the following blocks:

- Linear Feedback Shift Register (LFSR) CRC
- IP header checksum
- Byte reordering
- Bit reordering

Figure 31-3: Special Function Module (SFM)

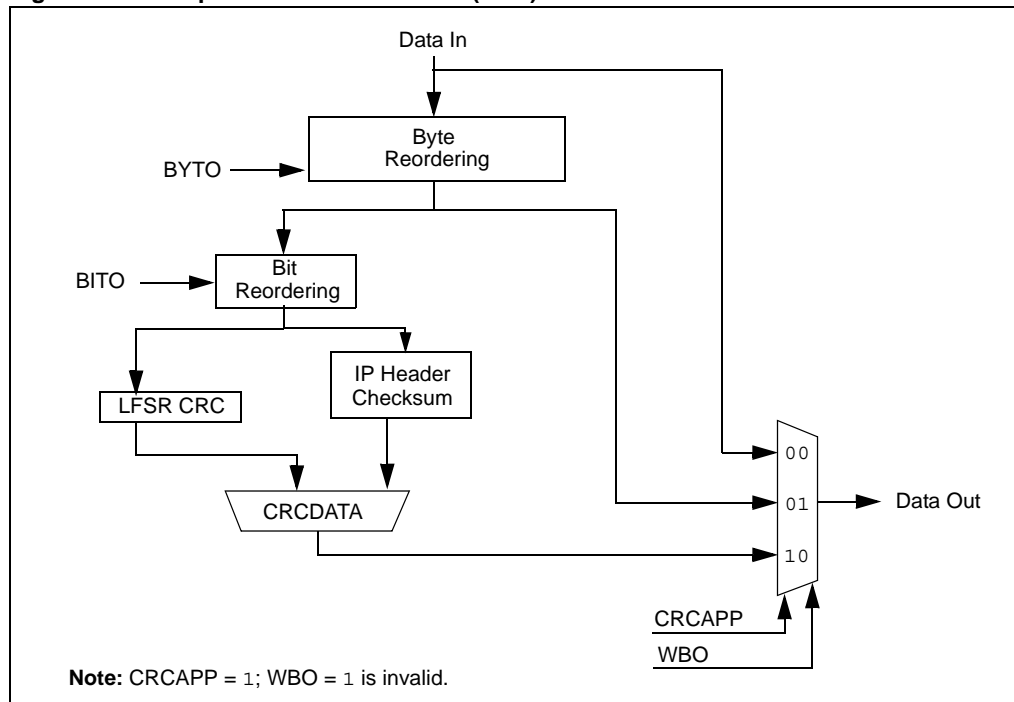

Depending on the device, the SFM is a highly configurable, 16-bit or 32-bit CRC generator. The SFM can be assigned to any available DMA channel by setting the CRCCH<2:0> bit (DCRCCON<2:0>). The SFM is enabled by setting the CRGEN bit (DCRCCON<7>).

The data from the source can be optionally subjected to byte reordering using the WBO bit. The data is then optionally passed to the LFSR CRC or IP header checksum blocks based on the setting of the CRCTYP bit (DCRCCON<15>), as illustrated in [Figure 31-3](#).

Further, the SFM modifies the behavior of the DMA channel associated with the SFM. The behavior of the channel is selected by the CRCAPP bit (DCRCCON<6>), resulting in the following two modes:

- Background mode: CRC is calculated in the background, with normal DMA behavior maintained (see 31.3.5.1 “CRC Background Mode (CRCAPP = 0)”).
- Append mode: Data read from the source is not written to the destination, but the CRC data is accumulated in the CRC data register. The accumulated CRC is written to the location given by the DCHxDSA register when a block transfer completes (see 31.3.5.2 “CRC Append Mode (CRCAPP = 1)”).

The order in which data is written to the destination can be selected using the WBO bit (DCRCCON<27>). If the WBO bit is cleared, the writes to the destination are unaltered. If the WBO bit is set, the writes to the destination are reordered as defined by the CRC Byte Order Selection bits, BYTO<1:0> (DCRCCON<29:28>).

Note: This feature is not available on all devices. Refer to the “Direct Memory Access (DMA) Controller” chapter in the specific device data sheet for availability.

The SFM generator can be seeded by writing to the DCRCDATA register before enabling the channel.

When in IP Header Checksum mode (CRCTYP (DCRCCON<15>) = 1), data written reads back as the 1’s complement form as this is the current value of the checksum.

The CRC value in DCRCDATA can be read at any time during the CRC generation, but is only valid once the transfer completes.

Note 1: If a DMA Transfer is aborted while a CRC calculation is in progress, the DMA channel should be reset before the next CRC calculation is started. Alternatively, the same channel or another unused channel can be configured to transfer two or more bytes. The transfer should then be initiated and allowed to complete. The CRC module is then ready for the next CRC calculation.

2: If a DMA channel is disabled (CHEN (DCHxCON<7>) = 0) when a CRC calculation is in progress, the value in the DCRCDATA register is not updated. The same channel or another unused channel can be configured to transfer two or more bytes. The transfer should then be initiated and allowed to complete. When the transfer is complete, the DCRCDATA value will be correct for the number of byte processed prior to the stop being issued. The DMA address register can be inspected to determine the address range of the current CRC value.

31.3.5.1 CRC BACKGROUND MODE (CRCAPP = 0)

In this mode, the behavior of the DMA channel is maintained. The DMA reads the data from the source, passes it through the CRC module and writes it to the destination. Writes to the destination obey the WBO selection. In this mode, the calculated CRC is left in the DCRCDATA register at the end of the block transfer.

This mode can be used to calculate a CRC as data is moved from a source address to a destination address. The data source can be either a memory buffer or a FIFO in a peripheral. Likewise, the destination can be either a memory buffer or a FIFO. When the data transfer completes, the user can read the calculated CRC value and either append it to the transmitted data or verify the received CRC data.

Background mode potentially ties up the CRC module for extended periods of time. For instance, when assigned to a UART data stream, the SFM cannot be used by another channel until the UART data stream completes.

PIC32 Family Reference Manual

Example 31-4: DMA LFSR CRC Calculation in Background Mode Code Example

```
/* This code example illustrates a DMA calculation using the CRC background mode. Data is
transferred from a 200 bytes Flash buffer to a RAM buffer and the CRC is calculated while the
transfer takes place. */

unsigned int blockCrc;           // CRC of the Flash block

IEC1CLR=0x00010000;           // disable DMA channel 0 interrupts
IFS1CLR=0x00010000;           // clear any existing DMA channel 0 interrupt flag

DMACONSET=0x00008000;         // enable the DMA controller

DCRCDATA=0xffff;              // seed the CRC generator
DCRCXOR=0x1021;               // Use the standard CCITT CRC 16 polynomial: X^16+X^12+X^5+1
DCRCCON=0x0f80;               // CRC enabled, polynomial length 16, background mode
                                // CRC attached to the DMA channel 0.

DCH0CON=0x03;                 // channel off, priority 3, no chaining
DCH0ECON=0;                   // no start irq's, no match enabled

                                // program channel transfer
DCH0SSA=VirtToPhys(flashBuff); // transfer source physical address
DCH0DSA=VirtToPhys(ramBuff);   // transfer destination physical address
DCH0SSIZ=200;                  // source size
DCH0DSIZ=200;                  // destination size
DCH0CSIZ=200;                  // 200 bytes per event

DCH0INTCLR=0x00ff00ff;        // DMA0: clear events, disable interrupts

DCH0CONSET=0x80;              // channel 0 on

                                // initiate a transfer
DCH0ECONSET=0x00000080;       // set CFORCE to 1

                                // do something else while the transfer takes place
                                // poll to see that the transfer was done

BOOL error=FALSE;
while(TRUE)
{
    register int pollCnt;      // don't poll in a tight loop
    int dmaFlags=DCH0INT;
    if( (dmaFlags& 0x3)
    {
        error=TRUE;           // CHERIF (DCHxINT<0>) or CHTAIF (DCHxINT<1>) set
        break;                // error or aborted...
    }
    else if (dmaFlags&0x8)
    {
        break;                // CHBCIF (DCHxINT<3>) set
                                // transfer completed normally
    }
    pollCnt=100;              // use an adjusted value here
    while(pollCnt--);         // wait before polling again
}

if(!error)
{
    blockCrc=DCRCDATA;        // read the CRC of the transferred Flash block
}
else
{
                                // process error
}
}
```

31.3.5.2 CRC APPEND MODE (CRCAPP = 1)

In this mode, the DMA only feeds source data to the CRC module; it does not write source data to the destination address. However, when the block transfer completes or a pattern match occurs, the DMA writes the CRC value to the destination address.

The following usage information applies to CRC Append mode:

- Only the source buffer is viewed when considering whether a block transfer is complete, the destination address (DCHxDSA) is only used as the location to write the generated CRC value.
- The destination size (DCHxDSIZ) can be a maximum of 4.
 - If DCHxDSIZ is greater than four, only 4 bytes are written
 - If DCHxDSIZ is less than four, only DCHxDSIZ bytes of the CRC are written
 - PLEN<4:0> bits have no effect on the number of CRC bytes or bits written
- After the write, the channel is disabled.
- Any abort (i.e., abort IRQ asserts) prevents the CRC value from being written
- Reordering is not supported in Append mode if the WBO bit is set to '0'.

Example 31-5: CRC Calculation in Append Mode Code Example

```

/* This code example illustrates a DMA calculation using the CRC append mode. The CRC of a 256
bytes Flash buffer is calculated without performing any data transfer. As soon as the CRC
calculation is completed the CRC value of the Flash buffer is available in a local variable for
further use. */

unsigned int blockCrc;           // CRC of the Flash block

IEC1CLR=0x00010000;           // disable DMA channel 0 interrupts
IFS1CLR=0x00010000;           // clear any existing DMA channel 0 interrupt flag

DMACONSET=0x00008000;         // enable the DMA controller

DCRCDATA=0xffff;              // seed the CRC generator
DCRCXOR=0x1021;               // Use the standard CCITT CRC 16 polynomial: X^16+X^12+X^5+1
DCRCCON=0x0fc0;               // CRC enabled, polynomial length 16, append mode
                                // CRC attached to the DMA channel 0.

DCH0CON=0x03;                 // channel off, priority 3, no chaining
DCH0ECON=0;                    // no start irqs, no match enabled

                                // program channel transfer
DCH0SSA=VirtToPhys(flashBuff); // transfer source physical address
DCH0DSA=VirtToPhys(&blockCrc); // transfer destination physical address
DCH0SSIZ=200;                  // source size
DCH0DSIZ=200;                  // dst size
DCH0CSIZ=200;                  // 200 bytes transferred per event

DCH0INTCLR=0x00ff00ff;        // DMA0: clear events, disable interrupts
DCH1INTCLR=0x00ff00ff;        // DMA1: clear events, disable interrupts

DCH0CONSET=0x80;              // channel 0 on

                                // initiate a transfer
DCH0ECONSET=0x00000080;       // set CFORCE to 1

                                // do something else while the CRC calculation takes place
                                // poll to see that the transfer was done

BOOL error=FALSE;
while(TRUE)
{
    register int pollCnt;       // don't poll in a tight loop
    int dmaFlags=DCH0INT;
    if( (dmaFlags& 0x3)
        {
            error=TRUE;         // CHERIF (DCHxINT<0>) or CHTAIF (DCHxINT<1>) set
            break;              // error or aborted...
        }
        else if (dmaFlags&0x8)
        {
            break;              // CHBCIF (DCHxINT<3>) set
                                // transfer completed normally
        }
    pollCnt=100;                // use an adjusted value here
    while(pollCnt--);           // wait before polling again
}

if(error)
{
    // process error
}

```

31.3.5.3 DATA ORDER

Data read from the source can be reordered to allow for variations in the byte order of the source data, such as endianness. The reordered source data is written to the channel destination when $WBO = 1$. The unaltered source data is written to the destination when $WBO = 0$.

The $BYTO<1:0>$ bits control the byte order of the data being processed by the module. [Figure 31-4](#) shows the different byte order settings and the effect on data reads. A $BYTO<1:0>$ value of '01' is useful for reordering bytes within words. $BYTO<1:0>$ values of '10' and '11' are useful for reordering bytes within half-words.

It is important to note that the data is reordered as it is read. This means that data that is not word-aligned may not be reordered correctly.

When using the LFSR CRC mode or IP Header Checksum mode of the SFM, the bit order (either MSB or LSB) can be changed by using the $BITO$ ($DCRCCON<24>$) bit.

Figure 31-4: Byte Order for BYTO Values

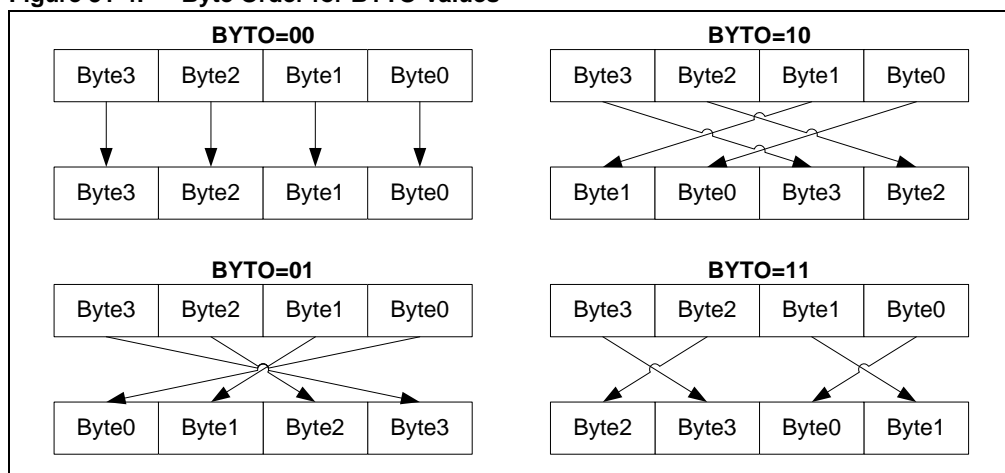

31.3.5.4 LFSR CRC

The CRC generator will take one system clock to process each byte of data read from the source. This implies that if 32 bits of data are read from the source, the CRC generation will take four system clocks to process the data.

When the $CRYTYP$ bit is cleared, the SFM is set to LFSR CRC mode and calculates the LFSR CRC.

Note: This feature is not available on all devices. Refer to the “**Direct Memory Access (DMA) Controller**” chapter in the specific device data sheet for availability.

The implementation of the CRC module is software configurable. The terms of the polynomial and its length can be programmed using the $DCRCXOR<31:0>$ bits and the $PLEN<4:0>$ bits ($DCRCCON<12:8>$), respectively.

[Example 31-6](#) and [Example 31-7](#) show the polynomials for the 16-bit and 32-bit CRC. The bit values that include an 'x' are considered a “don't care” as they are always XORed.

Example 31-6: 16-bit CRC Polynomial

$$x^{16} + x^{12} + x^5 + 1$$

$PLEN<4:0> = \text{'b01111}$
 $DCRCXOR<15:0> = \text{'bx001 0000 0010 000x}$

Example 31-7: 32-bit CRC Polynomial

$$x^{32} + x^{26} + x^{23} + x^{22} + x^{16} + x^{12} + x^{11} + x^{10} + x^8 + x^7 + x^5 + x^4 + x^2 + x + 1$$

$PLEN<4:0> = \text{'b11111}$
 $DCRCXOR<31:0> = \text{'bx000 0100 1100 0001 0001 1101 1011 011x}$

The PLEN<4:0> bits (DCRCCON<12:8>) in the CRC generator are used to select which bit is used as the feedback point of the CRC. For a 16-bit CRC example, if PLEN<4:0> = 00110, bit 6 of the Shift register is fed into the XOR gates of all bits set in the CRCXOR register.

The CRCXOR feedback points are specified using the DCRCXOR register. Setting the Nth bit in the DCRCXOR register will enable the input to the Nth bit of the CRC Shift register to be XORed with the (PLEN + 1)th bit of the CRC Shift register. Bit 0 and bit 15 of the CRC generator is always XORed.

31.3.5.5 CALCULATING THE IP HEADER CHECKSUM

When the CRCTYP bit (DCRCCON<15>) bit is set, the SFM calculates the IP header checksum. Use the following procedure to calculate the IP header checksum:

1. Configure a channel to point to the IP header.
2. Configure CRCCON to enable the SFM and select the channel being used.
3. Set the CRCTYP bit, which selects IP Header checksum.
4. Set DCRCDATA to '0000'.
5. Start the transfer.
6. When the transfer completes, read the data out of the DCRCDATA register.

Note: This feature is not available on all devices. Refer to the “**Direct Memory Access (DMA) Controller**” chapter in the specific device data sheet for availability.

31.4 CHANNEL CONTROL

31.4.1 Channel Enable

Each channel has an enable bit, CHEN (DCHxCON<7>), which can be used to enable or disable the channel in question. When this bit is set, the channel transfer requests are serviced by the DMA controller.

When the CHEN bit is clear, the state of the channel is preserved (this allows the channel to be suspended once a transfer has begun).

The CHEN bit will be cleared by hardware under the following conditions:

- A block transfer is complete, the pointer to the larger of the source or destination matches the size (only if the CHAEN (DCHxCON<4>) bit is clear)
- A pattern match occurs in Pattern Match mode (only if the CHAEN bit is clear)
- An abort interrupt occurs
- The user writes the CABORT (DCHxECON<6>) bit

31.4.2 Channel Transfer Behavior

Once a channel has been enabled, CHEN = 1, any event that starts a cell transfer will transfer the CHCSIZ<15:0> (DCHxCSIZ<15:0>) bytes of data. This will require one or more transactions. Once the cell transfer is complete the channel will return to an inactive state, and will wait for another channel start event to occur before starting another cell transfer.

When the larger of CHSSIZ<15:0> (DCHxSSIZ<15:0>) or CHDSIZ<15:0> (DCHxDSIZ<15:0>) bytes are transferred, a block transfer completes, the channel transfer will be halted and the channel will be disabled (i.e., CHEN set to '0' by hardware, and pointers are reset).

31.4.2.1 CHANNEL EVENT TRANSFER INITIATION

A given channel transfer can be initiated by:

- Writing the CFORCE bit (DCHxECON<7>)
- An interrupt occurs that matches the value of CHSIRQ<7:0> (DCHxECON<15:8>) if it is enabled by SIRQEN bit (DCHxECON<4>)

Channel events are registered if the channel is enabled (CHEN = 1), or if "Allow Event If Disabled" is set (i.e., CHAED (DCHxCON<6>) = 1)

31.4.2.2 CHANNEL EVENT TRANSFER TERMINATION

Channel transfer is terminated in any of the following cases:

- A transfer is aborted as described in [31.4.6 "Resetting the Channel"](#)
- A cell transfer (CHCSIZ<15:0> bytes (DCHxCSIZ<15:0> transferred)) completes
- The DMA has transferred the larger of CHSSIZ<15:0> or CHDSIZ<15:0> bytes (block transfer complete), the channel is disabled in hardware and must be re-enabled by user software before the channel will respond to channel events
- A pattern match occurs if enabled
- An abort interrupt, CHAIRQ<7:0> (DCHxECON<23:16>), occurs if abort interrupts are enabled by AIRQEN bit (DCHxECON<3>)
- An address error occurs

An example of how to use the abort interrupt would be a transfer from a UART channel to the memory. While the UART Receive Data Available interrupt can be used to start the transfer, the UART Error interrupt can abort the transfer. This way, whenever an error occurs on the communication channel (a framing/parity error or even an overrun), the transfer is stopped and the user code gets control in an ISR (if the abort interrupt is enabled for the DMA controller).

A summary of the status flags affected by channel transfer initiation or termination is provided in [Table 31-2](#). Channel abort events are allowed if the channel is enabled, CHEN = 1, or if the user elects to allow events while the channel is disabled, CHAED = 1.

Table 31-2: Channel Event Behavior

Event	Description and Function	Registers Affected
Events Initiating Transfers		
System Interrupt Matching CHSIRQ<7:0> ^(1,2)	The channel event detect will be set.	CHEDET = 1
Channel Chain Event	This will enable the channel if not already set. If an event detect is pending, a channel transfer will begin immediately.	CHEN = 1
User Writes the CFORCE bit ⁽¹⁾	The channel event detect will be set.	CHEDET = 1
Events Terminating Transfers		
System Interrupt Matching CHAIRQ<7:0> ^(1,2)	The channel event detect will be reset and the channel turned off. The abort interrupt flag is set.	CHEDET = 0 CHEN = 0 CHAIF = 1
Pattern Match Terminate ⁽¹⁾	This occurs when any byte of data written in a transaction matches the data in CHPDAT. The channel event detect is reset. The channel is turned off if CHAEN = 0. This event is treated as a completed block transfer. Pointers are reset.	CHEDET = 0 CHEN = 0 CHBCIF = 1 CHSPTR = 0 CHDPTR = 0 CHCPTR = 0
Cell Transfer is Complete	This occurs when CHCSIZ bytes have been transferred. The transfer event detect is reset and the channel remains enabled pending the next event.	CHEDET = 0 CHCCIF = 1
Block Transfer is Complete	The channel event detect is reset. The channel is turned off if CHAEN = 0. This event is treated as a completed transfer. Pointers are reset.	CHEDET = 0 CHEN = 0 CHBCIF = 1 CHSPTR = 0 CHDPTR = 0 CHCPTR = 0
User Writes the CABORT bit	The channel is turned off and the channel event detect is reset. The pointers are reset.	CHEDET = 0 CHEN = 0 CHSPTR = 0 CHDPTR = 0 CHCPTR = 0
Address Error is Detected	The channel is turned off and the event detect is reset. The address error interrupt flag is set.	CHEDET = 0 CHEN = 0 CHERIF = 1

Note 1: Events are allowed only when the channel is enabled, or the user allows events while disabled (CHEN = 1 or CHAED = 1).

- 2:** The DMA Controller maintains its own flags for detecting start and abort interrupt requests (IRQs) in the system, and is completely independent of the INT Controller IES/IFS flags. Once the start or abort IRQ system events are triggered, they will be detected automatically by the DMA controller internal logic, without the need for user intervention.

31.4.3 Channel IRQ Detection

The DMA Controller maintains its own flags for detecting the start and abort IRQ in the system and is completely independent of the INT Controller and IESx/IFSx flags. The corresponding IRQ does not have to be enabled before a transfer can take place, nor cleared at the end of a DMA transfer.

After the start or abort IRQ system events are triggered, they will be detected automatically by the DMA controller internal logic, without the need for user intervention.

31.4.4 Channel Abort Interrupt

A channel can elect to abort a cell transfer if an interrupt event occurs. The interrupt is selected by the channel's abort IRQ, CHAIRQ<7:0> (DCHxECON<23:16>). Any one of the device interrupt events can cause a channel abort. An abort only occurs if enabled by the AIRQEN bit (DCHxECON<3>).

If this occurs (often a timer time-out or a module error flag), the channel's status flags will indicate the external abort event on the channel in question by setting its CHTAIF bit (DCHxINT<1>). The Source and Destination Pointers are not reset, allowing the user to recover from the error.

31.4.5 DMA Suspend

DMA transactions are suspended immediately if the SUSPEND bit (DMACON<12>) is set. The current read or write will be completed. If the suspend comes during the read portion of the transaction, the transaction will be suspended and the write will be put on hold. If the suspend comes during the write portion of the transaction, the write will complete and the pointers updated as normal. Any transactions that were in process will continue where they left off when the SUSPEND bit is cleared.

Depending on the device, when the DMA module is suspended by setting the SUSPEND bit, the user application should poll the DMABUSY bit (DMACON<11>) to determine when the module is completely suspended following the completion of the current transaction.

Note: The DMABUSY bit is not available on all device. Refer to the “Direct Memory Access (DMA) Controller” chapter in the specific device data sheet for availability.

Example 31-8: DMA Controller Suspension

```
/* This code example will suspend the DMA Controller. */  
  
DMACONSET=0x00001000;      // suspend the DMA controller  
  
while(!(DMACONbits.busy)); // wait for the transfer to be suspended  
  
                          // let the CPU have complete control of the bus  
  
DMACONCLR=0x00001000;     // clear the suspend mode and let the DMA  
                          // operate normally. From now on, the CPU and  
                          // DMA controller share the bus access
```

Individual channels may be suspended using the CHEN bit (DCHxCON<7>). If a DMA transfer is in progress and the CHEN bit is cleared, the current transaction will be completed and further transactions on the channel will be suspended.

Depending on the device, when the channel is suspended by clearing the CHEN bit, the user application should poll the CHBUSY bit (DCHxCON<15>) to determine when the channel is completely suspended following completion of the current transaction.

Clearing the enable bit, CHEN, will not affect the Channel Pointers or the transaction counters. While a channel is suspended, the user can elect to continue to receive events (abort interrupts, etc.) by setting the CHAED bit (DCHxCON<6>).

31.4.6 Resetting the Channel

The channel logic will be reset on any device Reset. The channel is also reset when the channel bit, CABORT (DCHxECON<6>), is set. This will turn off the channel bit, CHEN = 0, clear the Source and Destination Pointers, and reset the event detector. When the CABORT bit is set, the current transaction in progress (if any) will complete before the channel is reset, but any remaining transactions will be aborted.

The user should modify the channel registers only while the channel is disabled (CHEN = 0). Modifying the Source and Destination registers will reset the corresponding pointer registers (DCHxSPTR or DCHxDPTR).

Note: The channel size must be changed while the channel is disabled.

31.4.7 Channel Priority and Selection

The DMA controller has a natural priority associated with each of the channels. Channel 0 has the highest natural priority. A channel priority can be changed by the CHPRI<1:0> bits (DCHxCON<1:0>). These bits identify the channel's priority where a value of zero is the lowest. If no priority is set, the DMA controller will use the natural priority associated with each channel. When multiple channels have transfers pending, the next channel to transmit data will be selected as follows:

- Channels with the highest priority will complete all cell transfers before moving onto channels with a lower priority (see PRI3 transfers, in [Figure 31-5](#)).
- If multiple channels have the same priority (identical CHPRI), the controller will cycle through all channels at that priority. Each channel with a cell transfer in progress at the highest priority will be allowed a single transaction of the active cell transfer before the controller allows a single transaction by the next channel at that priority level (see PRI2 transfers between markers C and B, in [Figure 31-5](#)).
- If a channel with a higher priority requests a transfer while another channel of lower priority has a transaction in process, the transaction will complete before moving to the channel with the higher priority (see events at marker A in [Figure 31-5](#)).

Figure 31-5: Channel Priority Behavior

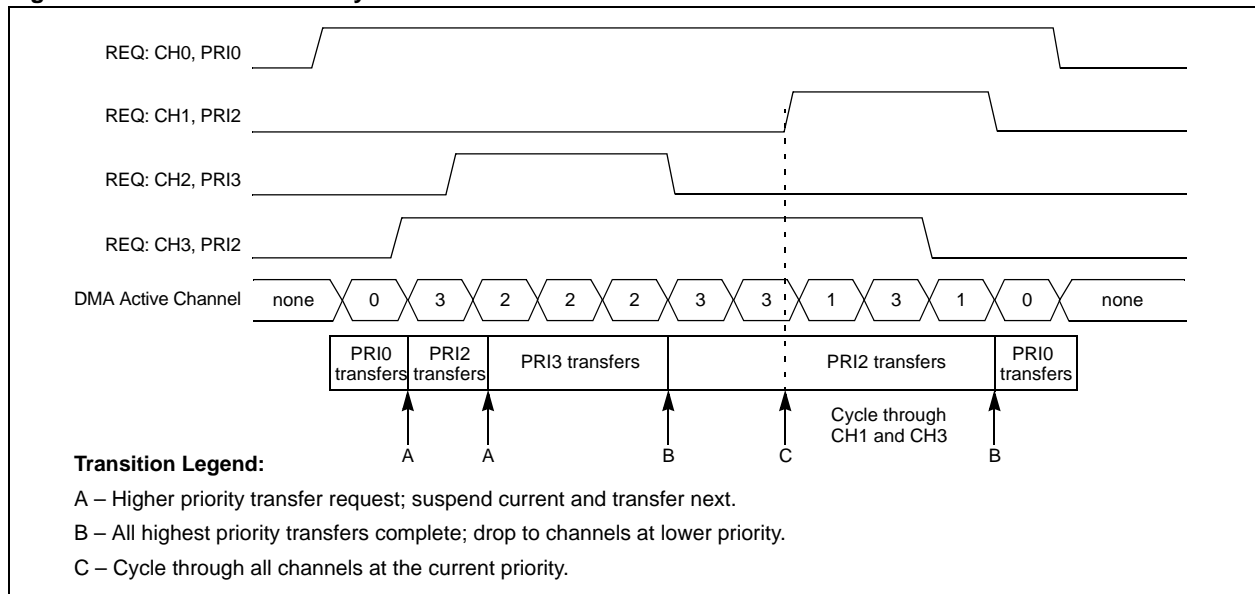

31.4.8 Byte Alignment

The byte alignment feature of the DMA controller relieves the user from aligning the source and destination addresses. The read portion of a transaction will read the maximum number of bytes that are available to be read in a given word. For example, if the Source Pointer is $N > 4$ bytes from the source size, 4 bytes will be read if the Source Pointer points to byte 0, 3 bytes if the Source Pointer points to byte 1, etc. If the number of bytes remaining in the source is $N < 4$, only the first N bytes are read. This is important when the read includes registers that are updated on a read.

The Source Pointer and Destination Pointers are updated after every write, with the number of bytes that have been written. The user should note that in cases where a transfer is aborted, before a transaction is complete, the Source Pointer will not necessarily reflect the reads that have taken place.

31.4.9 Address Error

If the address (either source or destination) occurring during a transfer is an illegal address, the channel's address error interrupt flag CHERIF bit (DCHxINT<0>) will be set. The channel will be disabled (i.e., the CHEN bit will be reset by hardware).

The channel status is unaffected to aid in the debug of the problem.

31.5 INTERRUPTS

The DMA device has the ability to generate interrupts reflecting the events that occur during the channel's data transfer:

- Error interrupts, signaled by each channel's CHERIF bit (DCHxINT<0>) and enabled using the CHERIE bit (DCHxINT<16>). This event occurs when there is an address error occurred during the channel transfer operation.
- Abort interrupts, signaled by each channel's CHTAIF bit (DCHxINT<1>) and enabled using the CHTAIE bit (DCHxINT<17>). This event occurs when a DMA channel transfer gets aborted because of a system event (interrupt) matching the CHAIRQ<7:0> bits (DCHxECON<23:16>) when the abort interrupt request is enabled, AIRQEN (DCHxECON<3>) = 1.
- Block complete interrupts, signaled by each channel's CHBCIF bit (DCHxINT<3>) and enabled using the CHBCIE bit (DCHxINT<19>). This event occurs when a DMA channel block transfer is completed.
- Cell complete interrupts, signaled by each channel's CHCCIF bit (DCHxINT<2>) and enabled using the CHCCIE bit (DCHxINT<18>). This event occurs when a DMA channel cell transfer is completed.
- Source Address Pointer activity interrupts: either when the Channel Source Pointer reached the end of the source, signaled by the CHSDIF bit (DCHxINT<7>) and enabled by CHSDIE bit (DCHxINT<23>), or when the Channel Source Pointer reached midpoint of the source, signaled by the CHSHIF bit (DCHxINT<6>) and enabled by the CHSHIE bit (DCHxINT<22>).
- Destination Address Pointer activity interrupts: either when the Channel Destination Pointer reached the end of the destination, signaled by the CHDDIF bit (DCHxINT<5>) and enabled by the CHDDIE bit (DCHxINT<21>), or when the Channel Destination Pointer reached midpoint of the destination, signaled by the CHDHIF bit (DCHxINT<4>) and enabled by the CHDHIE bit (DCHxINT<20>).

All the interrupts belonging to a DMA channel map to the corresponding channel interrupt vector.

Note: Not all DMA channels are available on all devices. Refer to the “**Interrupts**” chapter in the specific device data sheet for availability.

31.5.1 Interrupt Configuration

Each DMA channel internally has multiple interrupt flags (CHSDIF, CHSHIF, CHDDIF, CHDHIF, CHBCIF, CHCCIF, CHTAIF, CHERIF) and corresponding enable interrupt control bits (CHSDIE, CHSHIE, CHDDIE, CHDHIE, CHBCIE, CHCCIE, CHTAIE, CHERIE).

However, for the interrupt controller, there is just one dedicated interrupt flag bit per channel, DMAxIF, and the corresponding interrupt enable/mask bits, DMAxIE.

Note: Depending on the device, up to eight (i.e., 0 through 7) interrupt flags and interrupt enable/mask bits are available. Refer to the “**Interrupts**” chapter in the specific device data sheet for availability.

Therefore, note that all of the interrupt conditions for a specific DMA channel share just one interrupt vector. Each DMA channel can have its own priority level independent of other DMA channels.

Example 31-9: DMA Channel Initialization with Interrupts Enabled Code Example

```

/* This code example illustrates a DMA channel 0 interrupt configuration. When the DMA channel
0 interrupt is generated, the CPU will jump to the vector assigned to DMA0 interrupt. */

    IEC1CLR=0x00010000;           // disable DMA channel 0 interrupts
    IFS1CLR=0x00010000;           // clear any existing DMA channel 0 interrupt flag

    DMACONSET=0x00008000;         // enable the DMA controller
    DCH0CON=0x03;                 // channel off, priority 3, no chaining

    DCH0ECON=0;                   // no start or stop irq's, no pattern match

                                   // program the transfer
    DCH0SSA=VirtToPhys(flashBuff); // transfer source physical address
    DCH0DSA=VirtToPhys(ramBuff);   // transfer destination physical address
    DCH0SSIZ=200;                 // source size 200 bytes
    DCH0DSIZ=200;                 // destination size 200 bytes
    DCH0CSIZ=200;                 // 200 bytes transferred per event

    DCH0INTCLR=0x00ff00ff;        // clear existing events, disable all interrupts
    DCH0INTSET=0x00090000;        // enable Block Complete and error interrupts

    IPC9CLR=0x0000001f;          // clear the DMA channel 0 priority and sub-priority
    IPC9SET=0x00000016;          // set IPL 5, sub-priority 2
    IEC1SET=0x00010000;          // enable DMA channel 0 interrupt

    DCH0CONSET=0x80;             // turn channel on
                                   // initiate a transfer
    DCH0ECONSET=0x00000080;       // set CFORCE to 1

```

Example 31-10: DMA Channel 0 ISR Code Example

```

/*This code example demonstrates a simple Interrupt Service Routine for DMA channel 0
interrupts. The user's code at this vector should perform any application specific operations
and must clear the DMA0 interrupt flags before exiting. */

void __ISR(_DMA_0_VECTOR, ipl5) __DMA0Interrupt(void)
{
    int dmaFlags=DCH0INT&0xff;    // read the interrupt flags

    /*
    perform application specific operations in response to any interrupt flag set
    */

    DCH0INTCLR=0x000000ff;        // clear the DMA channel interrupt flags
    IFS1CLR = 0x00010000;         // Be sure to clear the DMA0 interrupt flags
                                   // before exiting the service routine.
}

```

Note: The DMA ISR code example shows MPLAB® C32 C compiler specific syntax. Refer to your compiler manual regarding support for ISRs.

31.6 OPERATION IN POWER-SAVING AND DEBUG MODES

31.6.1 DMA Operation in Sleep Mode

When the device enters Sleep mode, the system clock is disabled. No DMA activity can occur in this mode.

31.7 EFFECTS OF VARIOUS RESETS

31.7.1 Device Reset

All DMA registers are forced to their reset states upon a device Reset. When the asynchronous Reset input goes active, the DMA logic:

- Resets all fields in DMACON, DMASTAT, DMAADDR, DCRCCON, DCRCDATA and DCRCXOR
- Sets the appropriate values in each channel's register fields: DCHxCON, DCHxECON, DCHxINT, DCHxSSIZ, DCHxDSIZ, DCHxSPTR, DCHxDPTR, DCHxCSIZ, DCHxCPTR and DCHxDAT
- Registers DCHxSSA and DCHxDSA have random values after a reset
- Aborts any ongoing data transfers

31.7.2 Power-on Reset

All DMA registers are forced to their reset states upon a Power-on Reset.

31.7.3 Watchdog Timer Reset

All DMA registers are forced to their reset states upon a Watchdog Timer Reset.

31.8 RELATED APPLICATION NOTES

This section lists application notes that are related to this section of the manual. These application notes may not be written specifically for the PIC32 device family, but the concepts are pertinent and could be used DMA Controller with modification and possible limitations. The current application notes related to the Direct Memory Access (DMA) module are:

Title	Application Note #
No related application notes at this time	N/A

Note: Visit the Microchip web site (www.microchip.com) for additional application notes and code examples for the PIC32 family of devices.

31.9 REVISION HISTORY

Revision A (October 2007)

This is the initial released version of the document.

Revision B (October 2007)

Updated document to remove Confidential status.

Revision C (April 2008)

Revised status to Preliminary; Revised U-0 to r-x; Revised Table 31-1; Revised Table 31-2 (DCHxCON, bit 3), deleted Note 1; Revised Registers 31-19, 31-39, 31-43, 31-47, 31-48, 31-49, 31-53; Revise Sections 31.3, 31.3.2; Revised Examples 31-1, 31-3, 31-4, 31-6, 31-7, 31-8; Delete Example 31-2 and renumber examples; Delete Section 31.3.3 and renumber sections; Revised Section 31.3.20.7.

Revision D (June 2008)

Revised Registers 31-58 to 31-60, Footnote; Revised Example 31-8; Change Reserved bits "Maintain as" to "Write"; Added Note to ON bit (DMACON Register).

Revision E (August 2009)

This revision introduces new bits and functionality that are only available on certain devices. The following details the resulting changes:

- DMA Register Summary (Table 31-1)
 - Added the BUSY, BYTO1, BYTO0, WBO, BITO, CRCTYP and CHBUSY bits
 - Removed references to the IEC1, IPC9 and IFS1 registers
 - Added the Address Offset column to the DMA Register Summary
 - Added Notes 1, 2 and 3, which describe the Clear, Set and Invert registers
 - Added Notes 4 and 5 regarding the availability of certain bits and ranges of bits depending on the device
- Added Notes describing the Clear, Set and Invert registers to the following registers:
 - DMACON (Register 31-1)
 - DMASTAT (Register 31-2)
 - DMAADDR (Register 31-3)
 - DCRCCON (Register 31-4)
 - DCRCDATA (Register 31-5)
 - DCRCXOR (Register 31-6)
 - DCHxCON (Register 31-7)
 - DCHxECON (Register 31-8)
 - DCHxINT (Register 31-9)
 - DCHxSSA (Register 31-10)
 - DCHxDSA (Register 31-11)
 - DCHxSSIZ (Register 31-12)
 - DCHxDSIZ (Register 31-13)
 - DCHSPTR (Register 31-14)
 - DCHxDPTR (Register 31-15)
 - DCHxCSIZ (Register 31-16)
 - DCHxCPTR (Register 31-17)
 - DCHxDAT (Register 31-18)
- Removed these registers: IFS1, IEC1 and IPC9
- Added the BUSY bit (DMACON<11>) and Note 1 regarding availability of the SIDL and BUSY bits to Register 31-1

Revision E (August 2009) (Continued)

- Updated the DMACH bit (DMASTAT<2:0>) and added Note 2 regarding the availability of all bits in Register 31-2
- Added the BYTO1, BYTO0, WBO, BITO and CRCTYP bits, updated bits PLEN<4:0> and CRCCH<2:0>, and added Notes 1 and 2 to Register 31-4
- Updated DCRCDATA bits and added Note 1 to Register 31-5
- Updated DCRCXOR bits and added Note 1 to Register 31-6
- Added CHBUSY bit (DCHxCON<15>) and added Note 1 to Register 31-7
- Updated DCHxSSIZ bits and added Note 1 to Register 31-12
- Updated DCHxDSIZ bits and added Note 1 to Register 31-13
- Updated DCHxSPTR bits and added Note 2 to Register 31-14
- Updated DCHxDPTR bits and added Note 1 to Register 31-15
- Updated DCHxCSIZ bits and added Note 1 to Register 31-16
- Updated DCHxCPTR bits and added Note 2 to Register 31-17
- Updated the lowest priority channel number and added a related note to the fourth paragraph in **31.3.4 “Channel Chaining Mode”**
- Added information on suspending the DMA module and a related Note to **31.3.7 “Suspending Transfers”** and **31.3.19 “DMA Suspend”**
- Updated **31.3.6 “Special Function Module (SFM) Mode”** to differentiate between the 16-bit and 32-bit CRC
- Added **31.3.6.5 “Calculating the IP Header Checksum”**
- Added DMA channel interrupt flags, enable bits and priority-level bits to **31.4 “Interrupts”**
- Added DMA interrupt vectors (DMA4-DMA7) to Table 31-6
- Updated **31.5.1 “DMA Operation in Idle Mode”**

Revision F (October 2010)

This revision includes the following updates:

- Added a note at the beginning of this section, which provides information on complementary documentation
- Changed all occurrences of “**Reserved:** Write ‘0’; ignore read” to “**Unimplemented:** Read as ‘0’”, and updated the default POR definitions in all registers
- Added Notes 1, 2 and 3, which describe the Clear, Set and Invert registers to the following:
 - Table 31-1: DMA Register Summary
 - Register 31-1: DMACON: DMA Controller Control Register
 - Register 31-4: DCRCCON: DMA CRC Control Register
 - Register 31-5: DCRCDATA: DMA CRC Data Register
 - Register 31-6: DCRCXOR: DMA CRCXOR Enable Register
 - Register 31-7: DCHxCON: DMA Channel ‘x’ Control Register
 - Register 31-8: DCHxECON: DMA Channel ‘x’ Event Control Register
 - Register 31-9: DCHxINT: DMA Channel ‘x’ Interrupt Control Register
 - Register 31-10: DCHxSSA: DMA Channel ‘x’ Source Start Address Register
 - Register 31-12: DCHxSSIZ: DMA Channel ‘x’ Source Size Register
 - Register 31-13: DCHxDSIZ: DMA Channel ‘x’ Destination Size Register
 - Register 31-16: DCHxCSIZ: DMA Channel ‘x’ Cell Size Register
 - Register 31-18: DCHxECON: DMA Channel ‘x’ Event Control Register
- Removed all Clear, Set and Invert registers
- Removed all Interrupt registers
- Changed the name of the BUSY bit to DMABUSY in Register 31-1 and in Table 31-1
- Added a note box just after the last paragraph of **31.3.6 “Special Function Module (SFM) Mode”**
- Minor formatting and text updates have been incorporated throughout the document

Revision G (April 2012)

This revision includes the following updates:

- Updated the Typical DMA Source to Destination Transfer Diagram (see Figure 31-1)
- Updated the DMA Module Block Diagram (see Figure 31-2)
- Removed the CRC Implementation Details (Figure 31-3)
- Updated the register definitions in 31.2 “Status and Control Registers”
- Removed the FRZ bit from the DMACON register (see Register 31-1)
- Added the CMAWCH<2:0> bits in the DMASTAT register (see Register 31-2)
- Added the CHPIGN<7:0>, CHPIGNEN, and CHPATLEN bits to the DCHxCON register (see Register 31-7)
- Added the CHPDAT<15:8> bits to the DCHxDAT register (see Register 31-18)
- Added 31.3.2.1 “Pattern Match Ignore Mode”
- Created the new section, 31.4 “Channel Control”, from existing content
- Removed Source and Destination Point Updates Examples 1 and 2 (Table 31-3 and Table 31-4)
- Removed 31.3.17 “Channel Abort”
- Removed 31.5.3 “DMA Operation in Debug Mode”
- Removed 31.6.1 “DMA Operation in Idle Mode”
- Formatting updates to all registers and minor text updates have been incorporated throughout the document

Revision H (November 2013)

This revision includes the following updates:

- All references to BMX and Bus Matrix were updated to: System Bus
- Note 3 was removed and the Note 2 references were updated in the DMA Register Summary (see [Table 31-1](#))
- An additional RDWR bit was added, and the DMAWCH<2:0> and DMARCH<2:0> bits were removed in the DMASTAT register (see [Table 31-1](#) and [Register 31-2](#))
- Minor updates to text and formatting were incorporated throughout the document

Note the following details of the code protection feature on Microchip devices:

- Microchip products meet the specification contained in their particular Microchip Data Sheet.
- Microchip believes that its family of products is one of the most secure families of its kind on the market today, when used in the intended manner and under normal conditions.
- There are dishonest and possibly illegal methods used to breach the code protection feature. All of these methods, to our knowledge, require using the Microchip products in a manner outside the operating specifications contained in Microchip's Data Sheets. Most likely, the person doing so is engaged in theft of intellectual property.
- Microchip is willing to work with the customer who is concerned about the integrity of their code.
- Neither Microchip nor any other semiconductor manufacturer can guarantee the security of their code. Code protection does not mean that we are guaranteeing the product as "unbreakable."

Code protection is constantly evolving. We at Microchip are committed to continuously improving the code protection features of our products. Attempts to break Microchip's code protection feature may be a violation of the Digital Millennium Copyright Act. If such acts allow unauthorized access to your software or other copyrighted work, you may have a right to sue for relief under that Act.

Information contained in this publication regarding device applications and the like is provided only for your convenience and may be superseded by updates. It is your responsibility to ensure that your application meets with your specifications. MICROCHIP MAKES NO REPRESENTATIONS OR WARRANTIES OF ANY KIND WHETHER EXPRESS OR IMPLIED, WRITTEN OR ORAL, STATUTORY OR OTHERWISE, RELATED TO THE INFORMATION, INCLUDING BUT NOT LIMITED TO ITS CONDITION, QUALITY, PERFORMANCE, MERCHANTABILITY OR FITNESS FOR PURPOSE. Microchip disclaims all liability arising from this information and its use. Use of Microchip devices in life support and/or safety applications is entirely at the buyer's risk, and the buyer agrees to defend, indemnify and hold harmless Microchip from any and all damages, claims, suits, or expenses resulting from such use. No licenses are conveyed, implicitly or otherwise, under any Microchip intellectual property rights.

Trademarks

The Microchip name and logo, the Microchip logo, dsPIC, FlashFlex, KEELOQ, KEELOQ logo, MPLAB, PIC, PICmicro, PICSTART, PIC³² logo, rPIC, SST, SST Logo, SuperFlash and UNI/O are registered trademarks of Microchip Technology Incorporated in the U.S.A. and other countries.

FilterLab, Hampshire, HI-TECH C, Linear Active Thermistor, MTP, SEEVAL and The Embedded Control Solutions Company are registered trademarks of Microchip Technology Incorporated in the U.S.A.

Silicon Storage Technology is a registered trademark of Microchip Technology Inc. in other countries.

Analog-for-the-Digital Age, Application Maestro, BodyCom, chipKIT, chipKIT logo, CodeGuard, dsPICDEM, dsPICDEM.net, dsPICworks, dsSPEAK, ECAN, ECONOMONITOR, FanSense, HI-TIDE, In-Circuit Serial Programming, ICSP, Mindi, MiWi, MPASM, MPF, MPLAB Certified logo, MPLIB, MPLINK, mTouch, Omniscient Code Generation, PICC, PICC-18, PICDEM, PICDEM.net, PICkit, PICtail, REAL ICE, rLAB, Select Mode, SQI, Serial Quad I/O, Total Endurance, TSHARC, UniWinDriver, WiperLock, ZENA and Z-Scale are trademarks of Microchip Technology Incorporated in the U.S.A. and other countries.

SQTP is a service mark of Microchip Technology Incorporated in the U.S.A.

GestIC and ULPP are registered trademarks of Microchip Technology Germany II GmbH & Co. KG, a subsidiary of Microchip Technology Inc., in other countries.

All other trademarks mentioned herein are property of their respective companies.

© 2007-2013, Microchip Technology Incorporated, Printed in the U.S.A., All Rights Reserved.

 Printed on recycled paper.

ISBN: 978-1-62077-642-1

**QUALITY MANAGEMENT SYSTEM
CERTIFIED BY DNV
= ISO/TS 16949 =**

Microchip received ISO/TS-16949:2009 certification for its worldwide headquarters, design and wafer fabrication facilities in Chandler and Tempe, Arizona; Gresham, Oregon and design centers in California and India. The Company's quality system processes and procedures are for its PIC[®] MCUs and dsPIC[®] DSCs, KEELOQ[®] code hopping devices, Serial EEPROMs, microperipherals, nonvolatile memory and analog products. In addition, Microchip's quality system for the design and manufacture of development systems is ISO 9001:2000 certified.



MICROCHIP

Worldwide Sales and Service

AMERICAS

Corporate Office
2355 West Chandler Blvd.
Chandler, AZ 85224-6199
Tel: 480-792-7200
Fax: 480-792-7277
Technical Support:
<http://www.microchip.com/support>
Web Address:
www.microchip.com

Atlanta
Duluth, GA
Tel: 678-957-9614
Fax: 678-957-1455

Austin, TX
Tel: 512-257-3370

Boston
Westborough, MA
Tel: 774-760-0087
Fax: 774-760-0088

Chicago
Itasca, IL
Tel: 630-285-0071
Fax: 630-285-0075

Cleveland
Independence, OH
Tel: 216-447-0464
Fax: 216-447-0643

Dallas
Addison, TX
Tel: 972-818-7423
Fax: 972-818-2924

Detroit
Novi, MI
Tel: 248-848-4000

Houston, TX
Tel: 281-894-5983

Indianapolis
Noblesville, IN
Tel: 317-773-8323
Fax: 317-773-5453

Los Angeles
Mission Viejo, CA
Tel: 949-462-9523
Fax: 949-462-9608

New York, NY
Tel: 631-435-6000

San Jose, CA
Tel: 408-735-9110

Canada - Toronto
Tel: 905-673-0699
Fax: 905-673-6509

ASIA/PACIFIC

Asia Pacific Office
Suites 3707-14, 37th Floor
Tower 6, The Gateway
Harbour City, Kowloon
Hong Kong
Tel: 852-2401-1200
Fax: 852-2401-3431

Australia - Sydney
Tel: 61-2-9868-6733
Fax: 61-2-9868-6755

China - Beijing
Tel: 86-10-8569-7000
Fax: 86-10-8528-2104

China - Chengdu
Tel: 86-28-8665-5511
Fax: 86-28-8665-7889

China - Chongqing
Tel: 86-23-8980-9588
Fax: 86-23-8980-9500

China - Hangzhou
Tel: 86-571-2819-3187
Fax: 86-571-2819-3189

China - Hong Kong SAR
Tel: 852-2943-5100
Fax: 852-2401-3431

China - Nanjing
Tel: 86-25-8473-2460
Fax: 86-25-8473-2470

China - Qingdao
Tel: 86-532-8502-7355
Fax: 86-532-8502-7205

China - Shanghai
Tel: 86-21-5407-5533
Fax: 86-21-5407-5066

China - Shenyang
Tel: 86-24-2334-2829
Fax: 86-24-2334-2393

China - Shenzhen
Tel: 86-755-8864-2200
Fax: 86-755-8203-1760

China - Wuhan
Tel: 86-27-5980-5300
Fax: 86-27-5980-5118

China - Xian
Tel: 86-29-8833-7252
Fax: 86-29-8833-7256

China - Xiamen
Tel: 86-592-2388138
Fax: 86-592-2388130

China - Zhuhai
Tel: 86-756-3210040
Fax: 86-756-3210049

ASIA/PACIFIC

India - Bangalore
Tel: 91-80-3090-4444
Fax: 91-80-3090-4123

India - New Delhi
Tel: 91-11-4160-8631
Fax: 91-11-4160-8632

India - Pune
Tel: 91-20-3019-1500

Japan - Osaka
Tel: 81-6-6152-7160
Fax: 81-6-6152-9310

Japan - Tokyo
Tel: 81-3-6880-3770
Fax: 81-3-6880-3771

Korea - Daegu
Tel: 82-53-744-4301
Fax: 82-53-744-4302

Korea - Seoul
Tel: 82-2-554-7200
Fax: 82-2-558-5932 or
82-2-558-5934

Malaysia - Kuala Lumpur
Tel: 60-3-6201-9857
Fax: 60-3-6201-9859

Malaysia - Penang
Tel: 60-4-227-8870
Fax: 60-4-227-4068

Philippines - Manila
Tel: 63-2-634-9065
Fax: 63-2-634-9069

Singapore
Tel: 65-6334-8870
Fax: 65-6334-8850

Taiwan - Hsin Chu
Tel: 886-3-5778-366
Fax: 886-3-5770-955

Taiwan - Kaohsiung
Tel: 886-7-213-7830

Taiwan - Taipei
Tel: 886-2-2508-8600
Fax: 886-2-2508-0102

Thailand - Bangkok
Tel: 66-2-694-1351
Fax: 66-2-694-1350

EUROPE

Austria - Wels
Tel: 43-7242-2244-39
Fax: 43-7242-2244-393

Denmark - Copenhagen
Tel: 45-4450-2828
Fax: 45-4485-2829

France - Paris
Tel: 33-1-69-53-63-20
Fax: 33-1-69-30-90-79

Germany - Dusseldorf
Tel: 49-2129-3766400

Germany - Munich
Tel: 49-89-627-144-0
Fax: 49-89-627-144-44

Germany - Pforzheim
Tel: 49-7231-424750

Italy - Milan
Tel: 39-0331-742611
Fax: 39-0331-466781

Italy - Venice
Tel: 39-049-7625286

Netherlands - Druenen
Tel: 31-416-690399
Fax: 31-416-690340

Poland - Warsaw
Tel: 48-22-3325737

Spain - Madrid
Tel: 34-91-708-08-90
Fax: 34-91-708-08-91

Sweden - Stockholm
Tel: 46-8-5090-4654

UK - Wokingham
Tel: 44-118-921-5800
Fax: 44-118-921-5820

10/28/13