

POLARIS[®]
The Way Out.



RANGER[®] Diesel

Owner's Manual
for Maintenance and Safety

 WARNING

Read, understand, and follow all of the instructions and safety precautions in this manual and on all product labels.

Failure to follow the safety precautions could result in serious injury or death.

 WARNING

The engine exhaust from this product contains chemicals known to the State of California to cause cancer, birth defects or other reproductive harm.



The text is printed on 100% recycled
with 40% post-consumer waste (PCW).

WARNING

Improper vehicle use can result in SEVERE INJURY or DEATH.

NEVER Operate:

- At speeds too fast for your skills or the conditions.
- After or while using Alcohol or Drugs.
- On hills steeper than 15 degrees $\leq 15^\circ$
- On public roads. A collision can occur with another vehicle.
- With more than two passengers, or with passengers under age twelve or who cannot comfortably reach the floor and hand holds.
- On paved surfaces - pavement may seriously affect handling and control.
- With non-Polaris approved accessories - they may seriously affect stability.

ALWAYS:

- Wear your seat belt. Vehicle rollover could cause severe injury or death.
- Wear a helmet and eye protection and keep hands and feet in vehicle at all times. Use the cab nets.
- Reduce speed and use extra caution when carrying passengers.
- Avoid sharp turns or turns while applying heavy throttle.
- Operate slowly in reverse - avoid sharp turns or sudden braking.
- Make sure passenger reads and understands all safety labels.
- Watch for branches or other hazards that could enter vehicle.

**READ OWNER'S MANUAL.
FOLLOW ALL INSTRUCTIONS AND WARNINGS.**



POLARIS
The Way Out.

For your nearest Polaris dealer,
call 1-800-POLARIS
or visit www.polarisindustries.com
Polaris Sales Inc.,
2100 Hwy. 55, Medina, MN 55340
Phone 1-888-704-5290
Part No. 9923138 Rev 01
Printed in USA



WELCOME

Thank you for purchasing a POLARIS vehicle, and welcome to our world-wide family of POLARIS owners. We proudly produce an exciting line of utility and recreational products.

- Snowmobiles
- All-terrain vehicles (ATVs)
- *RANGER*® utility vehicles
- Victory Motorcycles®
- Low Emission Vehicles (LEVs)

We believe POLARIS sets a standard of excellence for all utility and recreational vehicles manufactured in the world today. Many years of experience have gone into the engineering, design, and development of your POLARIS vehicle, making it the finest machine we've ever produced.

For safe and enjoyable operation of your vehicle, be sure to follow the instructions and recommendations in this owner's manual. Your manual contains instructions for minor maintenance, but information about major repairs is outlined in the POLARIS Service Manual and should be performed only by a Factory Certified Master Service Dealer® (MSD) Technician.

Your POLARIS dealer knows your vehicle best and is interested in your total satisfaction. Be sure to return to your dealership for all of your service needs during, and after, the warranty period.

We also take great pride in our complete line of apparel, parts and accessories, available through our online store at www.purepolaris.com. Have your accessories and clothing delivered right to your door!



POLARIS®
The Way Out.

POLARIS, THE WAY OUT and RANGER are registered trademarks of POLARIS Industries Inc.

Copyright 2010 POLARIS Sales Inc. All information contained within this publication is based on the latest product information at the time of publication. Due to constant improvements in the design and quality of production components, some minor discrepancies may result between the actual vehicle and the information presented in this publication. Depictions and/or procedures in this publication are intended for reference use only. No liability can be accepted for omissions or inaccuracies. Any reprinting or reuse of the depictions and/or procedures contained within, whether whole or in part, is expressly prohibited.

The original instructions for this vehicle are in English. Other languages are provided as translations of the original instructions.

Printed in U.S.A.

2011 *RANGER* Diesel Owner's Manual

P/N 9923138

TABLE OF CONTENTS

Introduction	4
Safety	7
Features and Controls	20
Operation	37
Emission Control Systems	63
Maintenance	64
Specifications	108
POLARIS Products	110
Troubleshooting	111
Declaration of Conformity	114
Warranty	115
Maintenance Log	124
Index	126

INTRODUCTION

The *RANGER* is an off-road vehicle. Familiarize yourself with all laws and regulations concerning the operation of this vehicle in your area.

The following signal words and symbols appear throughout this manual and on your vehicle. Your safety is involved when these words and symbols are used. Become familiar with their meanings before reading the manual.



The safety alert symbol indicates a potential personal injury hazard.

WARNING

A WARNING indicates a hazardous situation which, if not avoided, may result in death or serious injury.

CAUTION

A CAUTION indicates a hazardous situation which, if not avoided, may result in minor or moderate injury.

NOTICE

A NOTICE indicates a situation that may result in property damage.



The Prohibition Safety Sign indicates an action NOT to take in order to avoid a hazard.



The Mandatory Action Sign indicates an action that NEEDS to be taken to avoid a hazard.

INTRODUCTION

WARNING

Failure to follow the warnings contained in this manual can result in severe injury or death.

A POLARIS *RANGER* is not a toy and can be hazardous to operate. This vehicle handles differently than other vehicles, such as motorcycles and cars. A collision or rollover can occur quickly, even during routine maneuvers like turning, or driving on hills or over obstacles, if you fail to take proper precautions.

- Read this owner's manual. Understand all safety warnings, precautions and operating procedures before operating the vehicle. Keep this manual with the vehicle.
- This vehicle is an **ADULT VEHICLE ONLY**. NEVER operate this vehicle if you are under age 16 and NEVER operate without a valid driver's license.
- No person under the age of 12 may ride as a passenger in this vehicle. Any passenger must be able to comfortably reach the floor and hand holds.
- Never permit a guest to operate this vehicle unless the guest has read this manual and all product labels.
- Always use the cab nets while riding in this vehicle.
- Always keep hands and feet inside the vehicle at all times.

INTRODUCTION

Vehicle Identification Numbers

Record your vehicle's identification numbers and key number in the spaces provided. Remove the spare key and store it in a safe place. An ignition key can be duplicated only by ordering a POLARIS key blank (using your key number) and mating it with one of your existing keys. The ignition switch must be replaced if all keys are lost.



VIN

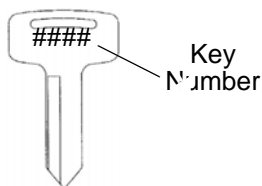

Engine Serial Number

Vehicle Model Number: _____

Frame VIN: _____

Engine Serial Number: _____

Key Number _____

Safety Labels and Locations

Warning labels have been placed on the vehicle for your protection. Read and follow the instructions of the labels on the vehicle carefully. If any of the labels depicted in this manual differ from the labels on your vehicle, always read and follow the instructions of the labels *on the vehicle*.

If any label becomes illegible or comes off, contact your POLARIS dealer to purchase a replacement. Replacement *safety* labels are provided by POLARIS at no charge. The part number is printed on the label.

Container/Passenger/Tire Pressure Warning

WARNING

Remove flammable material containers from box before filling.

WARNING

- Passengers can be thrown off. This can cause serious injury or death.
- Never carry passengers in cargo box.

WARNING

Maximum 4X4 Box Load 1000 lbs. (455 kg)

WARNING

IMPROPER TIRE PRESSURE OR OVERLOADING can cause loss of control resulting in SEVERE INJURY OR DEATH.

TIRE PRESSURE IN PSI (KPa):

RANGER - 4X4 FRONT 10 (69) REAR 10 (69)

MAXIMUM WEIGHT CAPACITY INCLUDES WEIGHT OF OPERATOR, PASSENGER, CARGO, AND ACCESSORIES.

RANGER 4X4 is 1500 LBS. (682 KG)

Reduce speed and allow greater distance for braking when carrying cargo. Overloading or carrying tall, off-center, or unsecured loads will increase your risk of losing control. Loads should be centered and carried as low as possible in box. For stability on rough or hilly terrain, reduce speed and cargo. Be careful if load extends over the side of the box.

Read Owner's Manual for more detailed loading information.

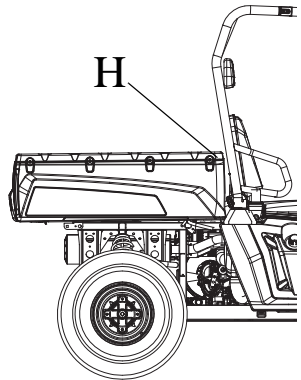

7176334

SAFETY

Safety Labels and Locations

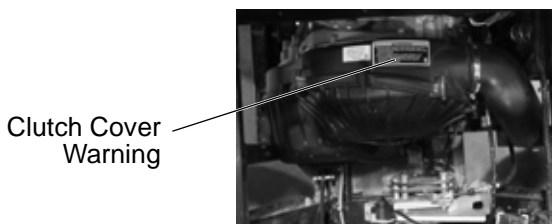
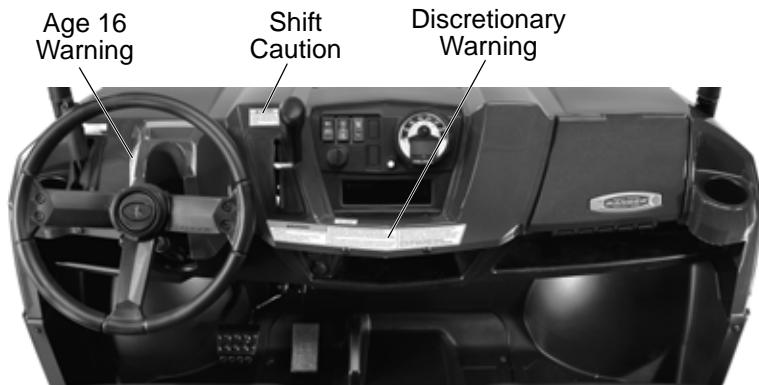

Clutch Cover Warning

WARNING

- Moving parts hazard under belt-clutch guard. To prevent serious injury, do not operate vehicle with guard removed.
- Do not modify engine or clutch. Doing so can cause part failure, possible imbalance, and excessive engine RPM which can result in serious injury or death.

7175488

Age 16 Warning

WARNING

NO OPERATOR UNDER 16

Operating this vehicle if you are under the age of 16 increases your chance of severe injury or death.

NEVER operate this vehicle if you are under age 16 and NEVER operate this vehicle without a valid driver's license.

7175566

Shift Caution

CAUTION

To avoid transmission damage, shift only when vehicle is stationary and at idle.

7172674

Safety Labels and Locations Discretionary Warning

WARNING

Improper vehicle use can result in Severe Injury or Death.

NEVER Operate:

- At speeds too fast for your skills or the conditions.
- After or while using Alcohol or Drugs.
- On hills steeper than 15 degrees $\leq 15^\circ$.
- On public roads, a collision can occur with a another vehicle.
- With more than two passengers, or passengers under age twelve or who cannot comfortably reach the floor and hand holds.
- On paved surfaces - pavement may seriously affect handling and control.
- With non-POLARIS approved accessories - they may seriously affect stability.

ALWAYS:

- Wear your seat belt. Vehicle rollover could cause severe injury or death.
- Secure cab nets and keep hands and feet in vehicle at all times.
- Wear a helmet and eye protection.
- Reduce speed and use extra caution when carrying passengers.
- Avoid sharp turns or turns while applying heavy throttle.
- Operate slowly in reverse - avoid sharp turns or sudden braking.
- Make sure passenger reads and understands all safety labels.

LOCATE AND READ OWNER'S MANUAL. FOLLOW ALL INSTRUCTIONS AND WARNINGS.

7176128

SAFETY

Operator Safety

WARNING

Serious injury or death can result if you do not follow these instructions and procedures, which are outlined in further detail within your owner's manual.

- Read this manual and all labels carefully. Follow the operating procedures described.
- Never allow anyone under age 16 to operate this vehicle and never allow anyone without a valid driver's license to operate this vehicle.
- Do not carry passengers until you have at least two hours of driving experience with this vehicle.
- No person under the age of 12 may ride as a passenger in this vehicle. Any passenger must be able to comfortably reach the floor and hand holds.
- The driver and all passengers must wear helmet, eye protection and seat belt at all times.
- Always use the cab nets while riding in this vehicle.
- Always keep hands and feet inside the vehicle at all times.
- Always keep both hands on the steering wheel and both feet on the floorboards of the vehicle during operation.
- Never permit a guest to operate this vehicle unless the guest has read this manual and all product labels.
- To reduce tipover risk, be especially careful when encountering obstacles and slopes and when braking on hills or during turns.
- This vehicle is for off road use only. Never operate on public roads. Always avoid paved surfaces.
- Never consume alcohol or drugs before or while operating this vehicle.
- Never operate at excessive speeds. Always travel at a speed proper for the terrain, visibility and operating conditions, and your experience.
- Never attempt jumps or other stunts.

Operator Safety

- Always inspect the vehicle before each use to make sure it's in safe operating condition. Always follow the inspection procedures described in this manual.
- Always travel slowly and use extra caution when operating on unfamiliar terrain. Be alert to changing terrain.
- Never operate on excessively rough, slippery or loose terrain.
- Always follow proper procedures for turning. Practice turning at slow speeds before attempting to turn at faster speeds. Never turn at excessive speeds.
- Always have this vehicle checked by an authorized POLARIS dealer if it has been involved in an accident.
- Never operate this vehicle on hills too steep for the vehicle or for your abilities. Practice on smaller hills before attempting larger hills.
- Always follow proper procedures for climbing hills as described in this manual. Check the terrain carefully before attempting to climb a hill. Never climb hills with excessively slippery or loose surfaces. Never open the throttle suddenly or make sudden gear changes. Never go over the top of a hill at high speed.
- Always follow the proper procedures outlined in this manual for traveling downhill and for braking on hills. Check the terrain carefully before descending a hill. Never travel downhill at high speed. Avoid going downhill at an angle, which would cause the vehicle to lean sharply to one side. Travel straight down the hill where possible.
- Always check for obstacles before operating in a new area. Never attempt to operate over large obstacles such as rocks or fallen trees. Always follow the proper procedures outlined in this manual when operating over obstacles.
- Always be careful of skidding or sliding. On slippery surfaces such as ice, travel slowly and exercise caution to reduce the chance of skidding or sliding out of control.

SAFETY

Operator Safety

- Never operate your vehicle in fast-flowing water or in water deeper than that specified in this manual. Wet brakes may have reduced stopping ability. Test your brakes after leaving water. If necessary, apply them lightly several times to let friction dry out the pads.
- Always be sure there are no obstacles or people behind your vehicle when operating in reverse. When it's safe to proceed in reverse, move slowly. Avoid turning at sharp angles in reverse.
- Always use the proper size and type of tires specified in this manual. Always maintain proper tire pressure as specified on safety labels.
- Never modify this vehicle through improper installation or use of accessories.
- Never exceed the stated load capacity for this vehicle. Cargo should be properly distributed and securely attached. Reduce speed and follow the instructions in this manual for hauling cargo or pulling a trailer. Allow a greater distance for braking.
- Always engage the park brake before getting out of the vehicle. See page 23.
- Always apply the brakes before engaging or releasing the park brake.
- Always stop the engine before refueling. Remove flammable material containers from the box before filling them with fuel. Make sure the refueling area is well ventilated and free of any source of flame or sparks. Fuel is extremely flammable. See page 43 for fuel safety warnings.
- Always remove the ignition key when the vehicle is not in use to prevent unauthorized use or accidental starting.

**FOR MORE INFORMATION ABOUT SAFETY, call POLARIS at
1-800-342-3764.**

Operator Safety

Equipment Modifications

We strongly recommend that consumers do not install on a POLARIS *RANGER* any equipment that may increase the speed or power of the vehicle, or make any other modifications to the vehicle for these purposes. Any modifications to the original equipment of the vehicle create a substantial safety hazard and increase the risk of bodily injury.

The warranty on your POLARIS *RANGER* is terminated if any equipment has been added to the vehicle, or if any modifications have been made to the vehicle, that increase its speed or power.

The addition of certain accessories, including (but not limited to) mowers, blades, tires, sprayers, or large racks, may change the handling characteristics of the vehicle. Use only POLARIS-approved accessories, and familiarize yourself with their function and effect on the vehicle.

SAFETY

Operator Safety

▲ WARNING

Failure to operate the *RANGER* properly can result in a collision, loss of control, accident or overturn, which may result in serious injury or death. Heed all safety warnings outlined in this section of the owner's manual. See the OPERATION section of the owner's manual for proper operating procedures.

Age Restrictions

This vehicle is an **ADULT VEHICLE ONLY**. NEVER operate this vehicle if you are under age 16 and NEVER operate without a valid driver's license.

No person under the age of 12 may ride as a passenger in this vehicle. Any passenger must be able to comfortably reach the floor and hand holds.



Cab Nets

Riding in this vehicle without using the cab nets increases the risk of serious injury or death in the event of an accident or overturn. Always use the cab nets while riding in this vehicle. Always keep hands and feet inside the vehicle at all times.

Operating Without Instruction

Operating this vehicle without proper instruction increases the risk of an accident. The operator must understand how to operate the vehicle properly in different situations and on different types of terrain.

All operators must read and understand the Owner's Manual and all warning and instruction labels before operating the vehicle.

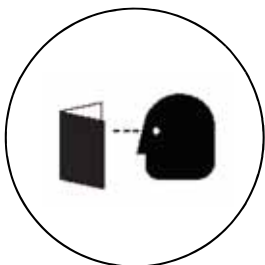

Using Alcohol or Drugs

Operating the vehicle after consuming alcohol or drugs could adversely affect operator judgment, reaction time, balance and perception.

Never drink alcohol or use drugs or medications before or while operating this vehicle.



Operator Safety

Seat Belts

Riding in this vehicle without wearing the seat belt increases the risk of serious injury in the event of an accident or sudden stop. Riders *must* wear seat belts at all times. Seat belts reduce the severity of injury in the event of a sudden stop or accident. Always make sure the seat belts are secured for both the operator and passengers before riding.

Failure to Inspect Before Operating

Failure to inspect and verify that the vehicle is in safe operating condition before operating increases the risk of an accident.

Always inspect your *RANGER* before each use to make sure it's in safe operating condition.

Always follow all inspection and maintenance procedures and schedules described in the owner's manual.

SAFETY

Operator Safety

Exposure to Exhaust

Engine exhaust fumes are poisonous and can cause loss of consciousness or death in a short time. Never start the engine or let it run in an enclosed area.

The engine exhaust from this product contains chemicals known to cause cancer, birth defects or other reproductive harm. Operate this vehicle only outdoors or in well-ventilated areas.

Operating a Damaged Vehicle

Operating a damaged vehicle can result in an accident. After any overturn or accident, have a qualified service dealer inspect the entire machine for possible damage, including (but not limited to) brakes, throttle and steering systems.

Operating at Excessive Speeds

Operating this vehicle at excessive speeds increases the operator's risk of losing control. Always operate at a speed that's appropriate for the terrain, the visibility and operating conditions, your skills and your passengers' skills.

Operating on Pavement

This vehicle's tires are designed for off-road use only, not for use on pavement. Operating this vehicle on paved surfaces (including sidewalks, paths, parking lots and driveways) may adversely affect the handling of the vehicle and could result in loss of control and accident or overturn.

Avoid operating the vehicle on pavement. If it's unavoidable, travel slowly and avoid sudden turns or stops.

Operator Safety

Operating on Public Roads

Operating this vehicle on public streets, roads or highways could result in a collision with another vehicle.

Never operate this vehicle on any public street, road or highway, including dirt and gravel roads. In some areas it's unlawful to operate this vehicle on public streets, roads and highways.

Turning Improperly

Turning improperly could cause loss of traction, loss of control, accident or overturn. Always follow proper procedures for turning. Never turn abruptly or at sharp angles. Never turn at high speeds. Practice turning at slow speeds before attempting to turn at faster speeds.

Jumps and Stunts

Attempting wheelies, jumps and other stunts increases the risk of an accident or overturn. Never attempt wheelies, jumps, or other stunts. Avoid exhibition driving.

Operating in Unfamiliar Terrain

Failure to use extra caution when operating on unfamiliar terrain could result in an accident or overturn. Unfamiliar terrain may contain hidden rocks, bumps, or holes that could cause loss of control or overturn.

Travel slowly and use extra caution when operating on unfamiliar terrain. Always be alert to changing terrain conditions.

SAFETY

Operator Safety

Operating on Slippery Terrain

Failure to use extra caution when operating on excessively rough, slippery or loose terrain could cause loss of traction, loss of control, accident or overturn.

Do not operate on excessively slippery surfaces.

Always reduce speed and use additional caution when operating on slippery surfaces.

Improper Hill Climbing

Climbing hills improperly can cause loss of control or vehicle overturn. Always follow proper procedures for climbing hills as described in the owner's manual. See page 51.

Stalling While Climbing a Hill

Stalling or rolling backwards while climbing a hill could cause an overturn. Always maintain a steady speed when climbing a hill.

If all forward speed is lost:

- Apply the brakes.
- Place the transmission in reverse and slowly allow the vehicle to roll straight downhill while applying light brake pressure to control speed.

If you begin rolling downhill:

- Never apply engine power.
- Apply the brakes gradually until the vehicle is fully stopped.
- Place the transmission in reverse and slowly allow the vehicle to roll straight downhill while applying light brake pressure to control speed.

Operator Safety

Improper Tire Maintenance

Operating this vehicle with improper tires or with improper or uneven tire pressure could cause loss of control or accident.

Always use the size and type of tires specified for your vehicle.

Always maintain proper tire pressure as described in the owner's manual and on safety labels.

Operating on Frozen Bodies of Water

Severe injury or death can result if the vehicle and/or the operator fall through the ice. Never operate the vehicle on a frozen body of water unless you have first verified that the ice is sufficiently thick to support the weight and moving force of the vehicle, you and your passengers, and your cargo, together with any other vehicles in your party. Always check with local authorities and residents to confirm ice conditions and thickness over your entire route. Vehicle operators assume all risk associated with ice conditions on frozen bodies of water.

Unauthorized Use of the Vehicle

Leaving the keys in the ignition can lead to unauthorized use of the vehicle, which could result in an accident or overturn. Always remove the ignition key when the vehicle is not in use.

Hot Exhaust Systems

Exhaust system components are very hot during and after use of the vehicle. Hot components can cause burns and fire. Do not touch hot exhaust system components. Always keep combustible materials away from the exhaust system. Use caution when traveling through tall grass, especially dry grass.

FEATURES AND CONTROLS

Component Locations

Your vehicle is equipped with cab nets on both sides of the vehicle. Cab nets must be used by both operator and passengers at all times. The vehicle illustrated below is shown without cab nets only to allow component identification. Always use the cab nets.

Not all models come with all features. Refer to the specifications section beginning on page 108.

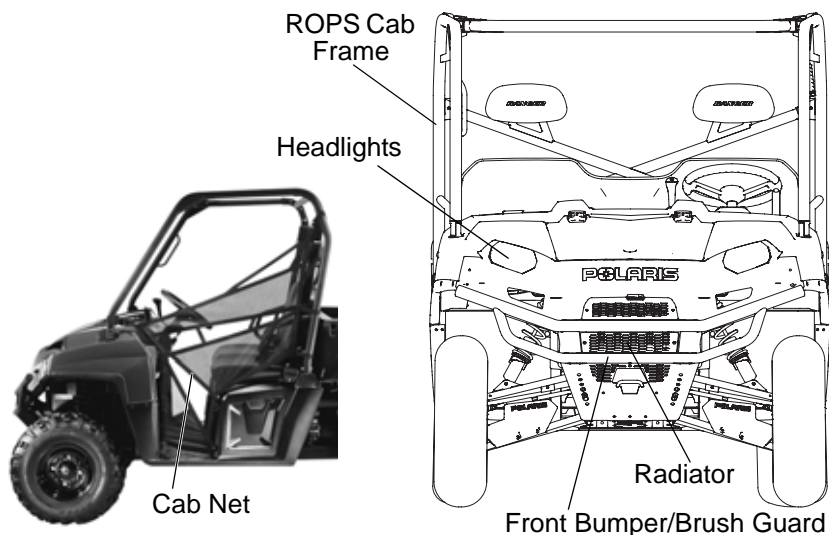
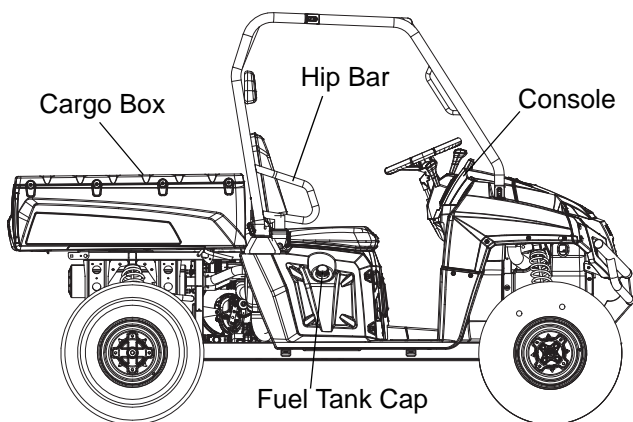

FEATURES AND CONTROLS

Component Locations

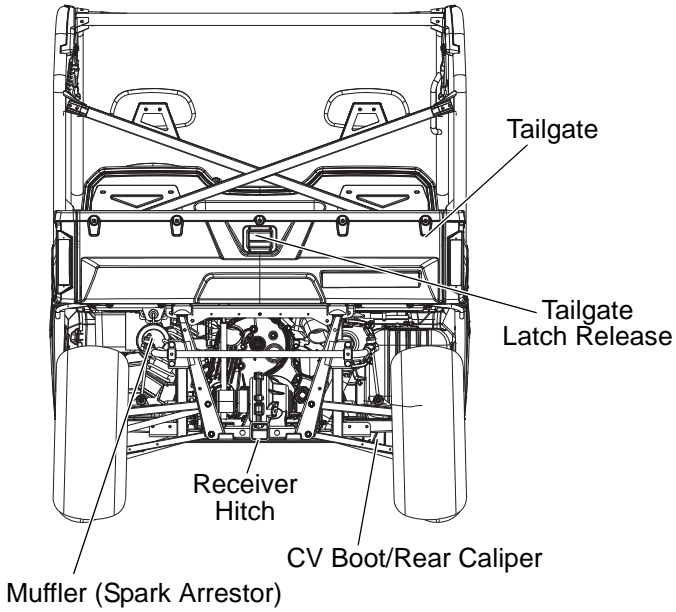
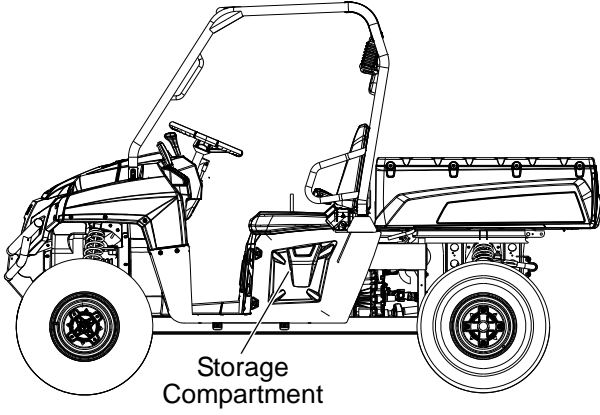

FEATURES AND CONTROLS

Console

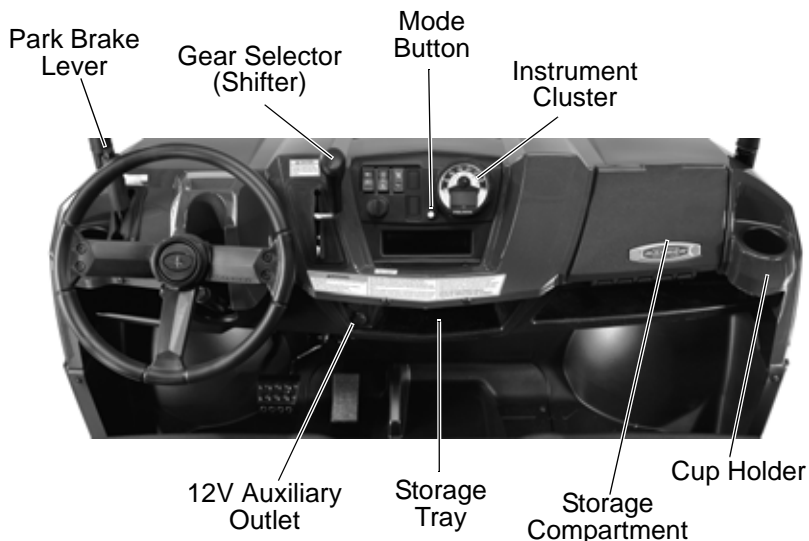

Auxiliary Outlet

The 12-volt receptacles have spade connections on the back that may be used to power an auxiliary light or other optional accessories or lights. The connections are behind the console, under the dash.

Mode Button

The yellow button located near the instrument cluster is used to toggle through mode options. See pages 31-36.

Gear Selector

Use the gear selector to shift gears. Low gear is the primary driving range for the *RANGER*. High gear is intended for use on hard-packed surfaces with light loads. To shift gears, brake to a complete stop. When the engine is idling, move the lever to the desired gear.

NOTICE: Shifting gears with the engine speed above idle or while the vehicle is moving could cause transmission damage. Always shift when the vehicle is stationary and the engine is at idle.

Tip: Maintaining shift linkage adjustment is important to assure proper transmission function. See your dealer if you experience any shifting problems.

FEATURES AND CONTROLS

Console

Park Brake Lever

To help prevent the vehicle from rolling, engage the park brake when parking the vehicle. When the park brake is fully engaged, the park brake indicator will be illuminated.

If the vehicle is in any gear other than neutral with the park brake engaged, “BRAKE” flashes in the rider information display. If throttle is applied and engine speed reaches 1200 RPM, an alarm will sound to alert the operator.

Tip: This feature will not operate properly if the park brake connector or switch (under the hood) malfunctions or becomes disconnected, or if the switch has moved. Check for disconnection, then see your dealer promptly if this feature fails to operate properly.

Inspect and adjust park brake cable tension after the first 25 hours of operation and every 100 hours thereafter to ensure proper cable tension. See page 92.

Always apply the service brakes before engaging or releasing the park brake.

1. Apply the brakes.
2. Pull the park brake lever downward as far as possible.
3. To release the park brake, apply the brakes. Press the park brake release inward and move the lever upward as far as possible.

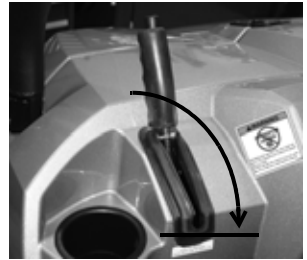

WARNING! Operating the vehicle while the park brake is engaged could cause loss of control and result in serious injury or death. Always disengage the park brake before operating the vehicle.

FEATURES AND CONTROLS

Switches and Indicator Lights

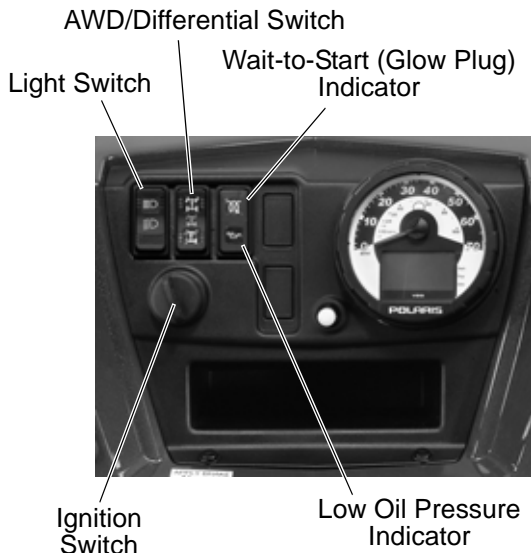

Ignition Switch

The ignition switch is a three-position, key-operated switch. The key can be removed from the switch in the OFF position.

OFF	The engine is off. Electrical circuits are off, except Acc, 12V.
ON	Electrical circuits are on. Electrical equipment can be used.
START	After the wait-to-start indicator turns off, turn the key to the START position to engage the electric starter. The key returns to the ON position when released.

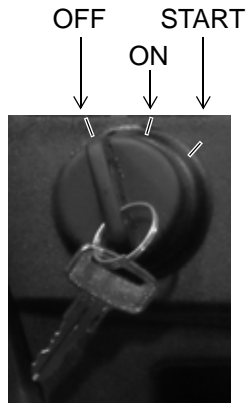

FEATURES AND CONTROLS

Switches and Indicator Lights

Light Switch

The ignition switch must be in the ON position to operate the headlights.

Press the top of the rocker switch toward the dash to place the headlights on high beam.

Move the rocker switch to the center position to place the headlights on low beam.

Press the bottom of the rocker switch to turn off the headlights.

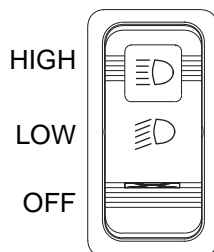

AWD/Differential Lock Switch

The AWD/Differential Switch has three positions:

- All Wheel Drive (AWD)
- Differential Lock (2WD)
- Differential Unlock

Press the top of the rocker switch to engage All Wheel Drive (AWD). See page 61 for operating instructions.

Move the rocker switch to the center position to lock the differential and operate in rear wheel drive. Press the bottom of the switch to unlock the differential and allow the two rear drive wheels to operate independently. See page 62 for differential lock operating instructions.

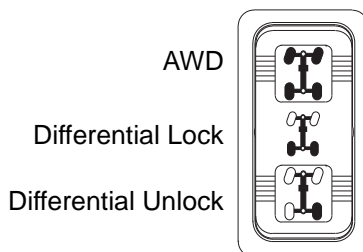

Wait-to-Start (Glow Plug) Indicator

When the key is turned to the ON position, the glow plug system activates and the wait-to-start indicator illuminates. *Do not crank the engine until this indicator light turns off.* See page 46 for engine starting procedures.

Low Oil Pressure Indicator

If the low oil pressure indicator remains on when the engine is running, stop the engine immediately to avoid engine damage. Check the oil level and add oil as necessary to bring the level within the safe operating range. See page 71. If the oil level is adequate, see your POLARIS dealer for service.

FEATURES AND CONTROLS

Trailer Hitch Bracket

This vehicle is equipped with a receiver hitch bracket for a trailer hitch. To avoid injury and property damage, always heed the warnings and towing capacities outlined on pages 57-59.

Brake Pedal

Depress the brake pedal to slow or stop the vehicle. Apply the brakes while starting the engine.

Throttle Pedal

Push the throttle pedal down to increase engine speed. Spring pressure returns the pedal to the rest position when released. Always check that the throttle pedal returns normally before starting the engine. Make sure there's adequate throttle pedal freeplay. See page 89 for throttle pedal adjustment procedures.

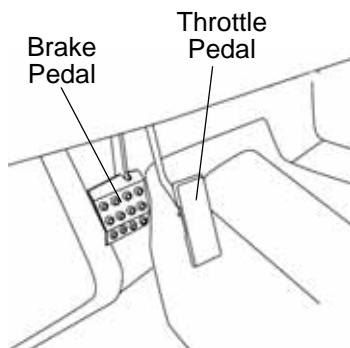

Adjustable Steering Wheel

The steering wheel can be tilted upward or downward for rider preference.

Lift and hold the adjustment lever toward you while moving the steering wheel upward or downward. Release the lever when the steering wheel is at the desired position.



FEATURES AND CONTROLS

Cab Nets

Riding in this vehicle without using the cab nets increases the risk of serious injury or death in the event of an accident or overturn. Cab nets must be used by operator and passengers at all times. Make sure all latches are secure before operating the vehicle.

Always inspect cab nets for tightness, wear and damage before each use of the vehicle. Use the strap adjusters to tighten any loose straps. Promptly replace worn or damaged cab nets with new cab nets, available from your authorized Polaris dealer.

Securing a Net

1. After entering the vehicle, insert the lower net rod into the net mount on the floor. Make sure the ball at the end of the rod is properly secured in the slot at the base of the mount.
2. Connect the latch at the top edge of the net to the receiver latch mounted on the front frame.

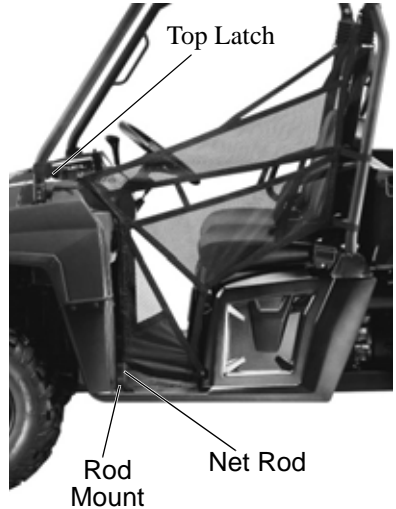

Opening a Net

1. To exit the vehicle, release the top front latch.
2. Rotate the net rearward and slide the lower net rod out of the mount to remove it.
3. Allow the net to hang freely outside the vehicle while dismounting.



FEATURES AND CONTROLS

Seat Belts

This POLARIS vehicle is equipped with three-point lap and diagonal seat belts on all external seats. The center seat is equipped with a lap-style seat belt. Always make sure the seat belts are secured for all riders before operating.

WARNING! Falling from a moving vehicle could result in serious injury or death. Always fasten your seat belt securely before operating or riding in the *RANGER*.

To wear the seat belt properly, follow this procedure:

1. For 3-point belts, pull the seat belt latch downward and across your chest toward the buckle at the inner edge of the seat. The belt should fit snugly across your hips and diagonally across your chest. Make sure the belt is not twisted. For lap style belts, place the belt across your lap as low on your hips as possible. Make sure that the belt is not twisted.
2. Push the latch plate into the buckle until it clicks.
3. Release the strap, it will self-tighten.

Tip: The center belt must be tightened manually by pulling on the strap.

4. To release the seat belt, press the square red button in the buckle's center.

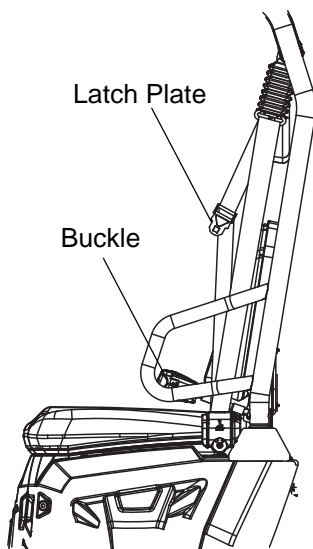

FEATURES AND CONTROLS

Seat Belts

Seat Belt Inspection

Inspect all seat belts for proper operation before each use of the vehicle.

1. Push the latch plate into the buckle until it clicks. The latch plate must slide smoothly into the buckle. A click indicates that it's securely latched.
2. Push the red release latch in the middle of the buckle to make sure it releases freely.
3. Pull each seat belt completely out and inspect the full length for any damage, including cuts, wear, fraying or stiffness. If any damage is found, or if the seat belt does not operate properly, have the seat belt system checked and/or replaced by an authorized POLARIS dealer.
4. To clean dirt or debris from the seat belts, sponge the straps with mild soap and water. Do not use bleach, dye or household detergents.

Seat Removal

Pull up on the front of the seat and slide it toward the front of the vehicle. Install the seat by sliding the tabs into the rear of the seat base. Push down firmly on the front of the seat until the pins are fully seated into the grommets.

FEATURES AND CONTROLS

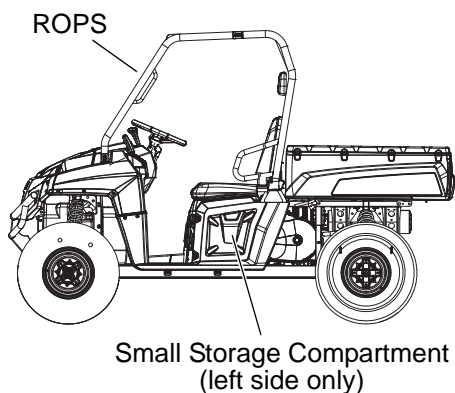

Rollover Protective Structure (ROPS)

The Rollover Protective Structure (ROPS) on this vehicle meets OSHA 1928.53 rollover performance requirements. Always have your authorized POLARIS dealer thoroughly inspect the ROPS if it ever becomes damaged in any way.

No device can assure occupant protection in the event of a rollover. Always follow all safe operating practices outlined in this manual to avoid vehicle rollover.

WARNING! Vehicle rollover could cause severe injury or death. Always avoid operating in a manner that could result in vehicle rollover.

Storage Compartments

A storage compartment is located under the driver's seat.

FEATURES AND CONTROLS

Instrument Cluster

Your vehicle is equipped with an instrument cluster that senses vehicle speed from the transmission. In addition to showing vehicle speed, the speedometer needle flashes when a warning condition exists.

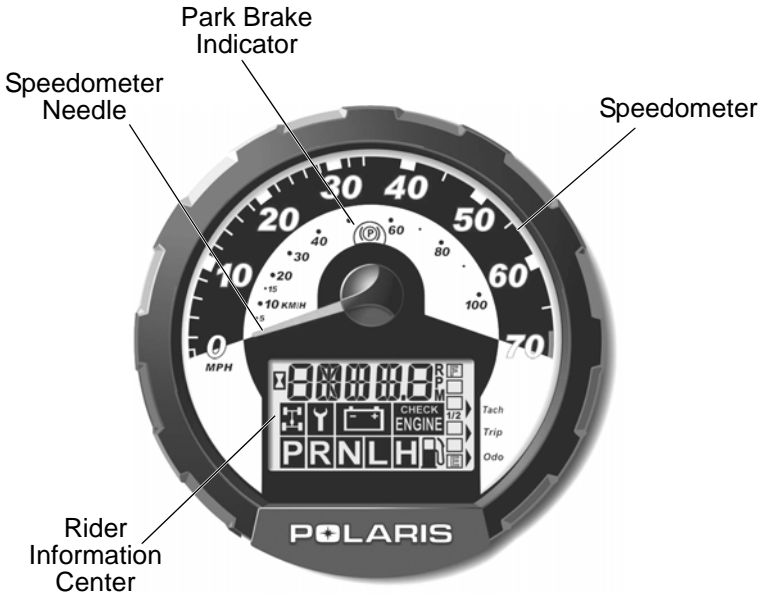

NOTICE: High water pressure may damage components. Wash the vehicle by hand or with a garden hose using mild soap.

Certain products, including insect repellents and chemicals, will damage the instrument cluster lens and other plastic surfaces. Do not use alcohol to clean the instrument cluster. Do not allow insect sprays to contact the lens. Immediately clean off any fuel that splashes on the instrument cluster.

FEATURES AND CONTROLS

Instrument Cluster

Rider Information Center

The rider information center is located in the instrument cluster. All segments will briefly light up and “HOT” may display at start-up. If the instrument cluster fails to illuminate, a battery over-voltage may have occurred and the instrument cluster may have shut off to protect the electronic speedometer. If this occurs, take the vehicle to your Polaris dealer for proper diagnosis.

1. **Gear Indicator** - This indicator displays gear shifter position.
H = High Gear
L = Low Gear
N = Neutral
R = Reverse Gear

2. **AWD Indicator** - This indicator illuminates when the AWD switch is on AWD.

3. **Engine Hour Display Indicator**

4. **Service Interval/Diagnostic Mode Indicator**

5. **Low Battery and Over Voltage** - This warning usually indicates that the vehicle is operating at an RPM too low to keep the battery charged. It may also occur when the engine is at idle and high electrical load (lights, cooling fan, accessories) is applied. Drive at a higher RPM or recharge the battery to clear the warning.

6. **Odometer/Tachometer/Tripmeter/Hour Meter/Engine Overheat** - If “HOT” displays in this area, the engine is overheating. Check and clean the radiator screen and core and the engine exterior. If the display continues, see your dealer for service.

7. **Fuel Gauge** - The segments of the fuel gauge show the level of fuel in the fuel tank. When the last segment clears, a low fuel warning is activated. All segments will flash, FUEL will display in the LCD, and the speedometer needle will blink. Refuel immediately.

8. **Check Engine Warning Indicator** - This indicator is not active for this model.

9. **Mode Indicator**

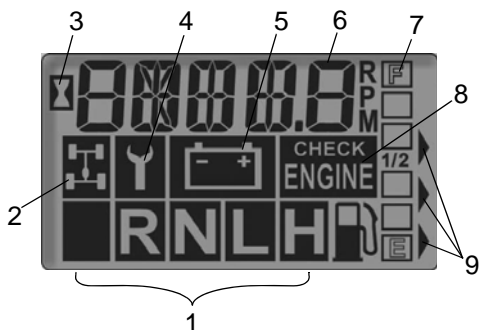

FEATURES AND CONTROLS

Instrument Cluster

Rider Information Center

Standard Modes

Use the MODE button to toggle through the mode options.

Odometer Mode

The odometer records the miles traveled by the vehicle.

Trip Meter Mode

The trip meter records the miles traveled by the vehicle on each trip if it's reset before each trip. To reset the trip meter, select the trip meter mode. Press and hold the MODE button until the total changes to 0. In the Rider Information Center, the trip meter display contains a decimal point, but the odometer displays without a decimal point.

Hour Meter Mode

This mode logs the total hours the engine has been in operation.

Tachometer Mode

The engine RPM is displayed digitally. Small fluctuations in the RPM from day to day may be normal because of changes in humidity, temperature and elevation.

FEATURES AND CONTROLS

Instrument Cluster

Rider Information Center

Diagnostic Mode

The wrench icon will display when the gauge is in the diagnostic mode. To exit the diagnostic mode, turn the ignition switch off and on. Any movement of the tires will also cause the gauge to exit the diagnostic mode.

To enter the diagnostics mode:

1. Turn the ignition switch off and wait 10 seconds.
2. Lock the parking brake.
3. Place the transmission in neutral.
4. Hold the MODE button and turn the key switch on. Release the switch as soon as the display is activated.
5. Use the MODE button to toggle through the diagnostic screens.

FEATURES AND CONTROLS

Instrument Cluster

Rider Information Center

Diagnostic Mode

Battery Voltage Screen

View this screen to check battery voltage level.

Tachometer Screen

View the tachometer to check engine speed.

AWD Diagnostic Screen

The gauge indicates whether or not current is flowing through the all-wheel-drive coil. This screen is for informational purposes only. Please see your dealer for all major repairs.

Gear Circuit Diagnostic Screen

This screen displays the resistance value (in ohms) being read at the gear switch input of the gauge. This screen is for informational purposes only. Please see your dealer for all major repairs.

Programmable service interval

When the hours of engine operation equal the programmed service interval setting, the wrench icon will flash for 5 seconds each time the engine is started. When this feature is enabled, it provides a convenient reminder to perform routine maintenance. See page 36.

Tip: The first service interval is programmed at 50 hours at the factory.

FEATURES AND CONTROLS

Instrument Cluster

Rider Information Center

Diagnostic Mode

Programmable service interval

To enable or disable the service interval:

1. Enter the diagnostic mode.
2. Toggle to the service interval screen.
3. Press and hold the MODE button for about 7 seconds, until either ON or OFF appears in the Rider Information Center, depending on your preference.

To reset the service interval:

1. Enter the diagnostic mode.
2. Toggle to the service interval screen.
3. Press and hold the MODE button for 2-3 seconds, until the wrench icon flashes. Release the button.
4. Press and release the MODE button once to advance the setting by one hour. Press and *hold* the MODE button to advance the hours quickly.
5. If you scroll past the intended number, press and hold the button until the hours cycle back to zero.
6. When the desired setting is displayed, wait until the wrench icon stops flashing. The new service interval is now programmed.

Miles/Kilometers toggle

The display in the tripmeter and odometer can be changed to display either standard or metric units of measurement.

1. Enter the diagnostic mode.
2. Toggle to the screen that displays either kilometers (KM) or miles (MP).
3. Press and hold the MODE button until the letters flash, then press and release the button once. When the display stops flashing, the mode has been set.

WARNING

Failure to operate the vehicle properly can result in a collision, loss of control, accident or overturn, which may result in serious injury or death. Read and understand all safety warnings outlined in this owner's manual.

Break-In Period

The break-in period for your new vehicle is the first 50 hours of operation. No single action on your part is as important as a proper break-in period. Careful treatment of a new engine will result in more efficient performance and longer life for the engine.

New Engine Break-In

1. Fill the fuel tank with the recommended fuel. See page 39.
2. On the initial engine start-up, allow the engine to idle for approximately 15 minutes. Check for proper engine oil pressure, diesel fuel leaks, engine oil leaks, coolant leaks and proper operation of the indicators and gauges.
3. During the first hour of operation, vary engine speed and the load on the engine. Short periods of maximum engine speed and load are desirable. Avoid prolonged operation at minimum or maximum engine speeds and loads for the next 4 to 5 hours.
4. During the break-in period, carefully observe the engine oil pressure and engine temperature.
5. Check the engine oil and coolant levels frequently during the break-in period. Perform regular checks on areas outlined on the daily pre-ride inspection checklist. See page 38.
6. Change both the oil and the filter at 50 hours.
7. Inspect and adjust park brake cable tension after the first 25 hours of operation and every 100 hours thereafter. See page 92.

PVT Break-in (Clutches/Belt)

A proper break-in of the clutches and drive belt will ensure a longer life and better performance. Break in the clutches and belt by operating at slower speeds during the break-in period as recommended. Pull only light loads. Avoid aggressive acceleration and high speed operation during the break-in period.

OPERATION

Pre-Ride Inspection

Failure to inspect and verify that the vehicle is in safe operating condition before operating increases the risk of an accident. Always inspect the vehicle before each use to make sure it's in safe operating condition.

Item	Remarks	Page
Brake system/pedal travel	Ensure proper operation	26 90
Brake fluid	Ensure proper level	90
Front suspension	Inspect, lubricate if necessary	69
Rear suspension	Inspect, lubricate if necessary	69
Steering	Ensure free operation	92
Tires	Inspect condition and pressure	94
Wheels/fasteners	Inspect, ensure fastener tightness	94
Frame nuts, bolts, fasteners	Inspect, ensure tightness	-
Fuel and oil	Ensure proper levels	43 71
Coolant level	Ensure proper level	80 81
Coolant hoses	Inspect for leaks	-
Throttle	Ensure proper operation	88
Indicator lights/switches	Ensure operation	24
Air filter, pre-filter	Inspect, clean	86
Air box sediment tube	Drain deposits whenever visible	86
Headlamp	Check operation, apply POLARIS dielectric grease when lamp is replaced	96
Brake light/tail lamp	Check operation, apply POLARIS dielectric grease when lamp is replaced	96
Seat Belts	Check length of belt for damage, check latches for proper operation	29
Cab Nets	Check for wear or damage, ensure proper installation	27

Fuel Recommendations

NOTICE: For the best engine performance, to prevent engine damage and to comply with EPA/CARB warranty requirements, use **ONLY** the recommended diesel fuels. Use only **CLEAN** diesel fuel.

POLARIS recommends the following diesel fuels for use in this vehicle:

- Low Sulfur
- Ultra Low Sulfur #2
- #1 Diesel Fuel containing no more than 5% bio-diesel (see page 40)

See page 44 for cold weather fuel blend recommendations. For more information about recommended diesel fuels and the consequences of using bio-diesel fuel exceeding 5% bio-diesel, see *Additional Technical Fuel Requirements* below.

Diesel fuel should comply with the following world-wide specifications.

Diesel Fuel Specification	Location
ASTM D975 No. 1D S15, S500 No. 2D S15, S500	USA
EN590:96	European Union
ISO 8217 DMX	International
BS 2869-A1 or A2	United Kingdom
JIS K2204 Grade No. 2	Japan
KSM-2610	Korea
GB252	China

Additional Technical Fuel Requirements

- The fuel cetane number should be equal to 45 or higher.
- The sulfur content must not exceed 0.5% by volume. Less than 0.5% is preferred. Especially in the U.S.A. and Canada, Low Sulfur (300 to 500 ppm (mg/kg) or Ultra Low Sulfur fuel should be used.
- Bio-Diesel fuels: see pages 40-42.
- NEVER mix kerosene, used engine oil or residual fuels with diesel fuel.
- Water and sediment in the fuel should not exceed 0.05% by volume.
- Keep the fuel tank and fuel-handling equipment clean at all times.

(continued on next page)

OPERATION

Fuel Recommendations

Additional Technical Fuel Requirements

- Poor quality fuel can reduce engine performance and/or cause engine damage.
- Fuel additives are not recommended. Some fuel additives may cause poor engine performance.
- Ash content must not exceed 0.01% by volume.
- Carbon residue content must not exceed 0.35% by volume. Less than 0.1% is preferred.
- Total aromatics content should not exceed 35% by volume. Less than 30% is preferred.
- PAH (polycyclic aromatic hydrocarbons) content should be below 10% by volume.
- Metal content of Na, Mg, Si and Al should be equal to or lower than 1 mass ppm (test analysis method JPI-5S-44-95).
- Lubricity: Wear mark of WS1.4 should be Max. 0.018 in. (460 μ m) at HFRR test.

Bio-Diesel Fuels

In Europe and in the United States, as well as some other countries, non-mineral oil based fuel resources such as RME (Rapeseed Methyl Ester) and SOME (Soybean Methyl Ester), collectively known as FAME (Fatty Acid Methyl Esters), are being used as extenders for mineral oil derived diesel fuels.

YANMAR approves the use of bio-diesel fuels that do not exceed a blend of 5% (by volume) of FAME with 95% (by volume) of approved mineral oil derived diesel fuel. Such bio-diesel fuels are known in the marketplace as B5 diesel fuels.

These B5 diesel fuels must meet certain requirements:

1. The bio-fuels must meet the minimum specifications for the country in which they are used.
 - In Europe, bio-diesel fuels must comply with the European Standard EN14214.
 - In the United States, bio-diesel fuels must comply with the American Standard ASTM D-6751.2.
2. Bio-fuels should be purchased only from recognized and authorized diesel fuel suppliers.

Fuel Recommendations

Bio-Diesel Fuels

Precautions and concerns regarding the use of bio-fuels:

1. Free methanol in FAME may result in corrosion of aluminum and zinc FIE components.
2. Free water in FAME may result in plugging of fuel filters and increased bacterial growth.
3. High viscosity at low temperatures may result in fuel delivery problems, injection pump seizures and poor injection nozzle spray atomization.
4. FAME may have adverse effects on some elastomers (seal materials) and may result in fuel leakage and dilution of the engine lubricating oil.
5. Even bio-diesel fuels that comply with a suitable standard as delivered will require additional care and attention to maintain the quality of the fuel in the equipment or other fuel tanks. It is important to maintain a supply of clean, fresh fuel. Regular flushing of the fuel system and/or fuel storage containers may be necessary.
6. The use of bio-diesel fuels that do not comply with the standards as agreed to by the diesel engine manufacturers and the diesel fuel injection equipment manufacturers, or bio-diesel fuels that have degraded as per the precautions and concerns above, may affect the warranty coverage of your engine.

OPERATION

Fuel Recommendations

Bio-Diesel Fuels

B6 To B20 Bio-diesel Fuel Blend Usage:

B6 to B20 bio-diesel is not approved for this POLARIS application.

Approved Engines

Only the YANMAR TNM engine series listed below may operate with bio-diesel fuel concentrations up to B5 for POLARIS applications.

NOTICE: Do not exceed bio-diesel fuel blend B5 for this POLARIS application.

- 3TNM72

Approved Fuel

NOTICE: Raw pressed vegetable oils are not considered bio-diesel, and are unacceptable for use as fuel in any concentration in YANMAR engines.

Bio-diesel fuel blends up to B5 must comply with the following standards:

- EN14214 (European standard) and/or ASTM D-6751 (American standard).
- All applicable engines may operate with bio-diesel fuel up to a maximum B5 (5% bio-diesel blend) concentration.

Operating Conditions with B5 Bio-diesel Fuel Blends

Engine Warranty

Damages, performance or service concerns determined to be caused by the use of bio-diesel fuel not meeting the specifications outlined above are not considered to be defects in material or factory workmanship and are not covered under warranty. The same applies to damages or other concerns induced by not complying with the recommended operating conditions of YANMAR engines with bio-diesel fuel.

Fuel Recommendations

Handling Fuel

WARNING! Diesel fuel is flammable and explosive under certain conditions.

- NEVER refuel with the engine running.
- Always refuel outdoors or in a well ventilated area.
- Fill the fuel tank with diesel fuel **ONLY**. Filling the fuel tank with gasoline may result in a fire and will damage the engine.
- Remove flammable material containers from the box before filling them with fuel.
- Do not smoke or allow open flames or sparks in or near the area where refueling is performed or where fuel is stored.
- Wipe up all spills immediately.
- Keep sparks, open flames or any other form of ignition (match, cigarette, static electricity source) well away when refueling.
- NEVER remove the fuel cap while the engine is running.
- NEVER overfill the fuel tank. Do not fill the tank neck.
- If fuel spills on your skin or clothing, immediately wash it off with soap and water and change clothing.

Refueling

The fuel tank filler cap is located on the right side of the vehicle near the passenger seat.

Remove the cap and add the recommended fuel to the bottom of the filler neck. Do not overfill.



OPERATION

Cold Weather Operation

Cold weather operation can result in fuel gelling if the incorrect fuel type is used. Use the following fuel blending guideline to prevent this from occurring.

Fuel Blending Guideline		
Temperature	No. 2	No. 1
+15° F (9° C)	100%	0%
Down to -20° F (-29° C)	50%	50%
Below -20° F (-29° C)	0%	100%

Block Heater Use

If this vehicle will be operated when temperatures are in the +5° to -25° F. (-15° to -32° C) range, a block heater must be installed. Please see your dealer to purchase a block heater kit.

Bio-Diesel Blended Fuel

NOTICE: Never use bio-diesel blended fuel containing more than 5% bio-diesel in this vehicle. See page 40.

Bio-diesel blended fuel has unique qualities that should be considered before using it in this vehicle:

- Cold weather conditions can lead to plugged fuel system components and hard starting.
- Bio-diesel blended fuel is an excellent medium for microbial growth and contamination which can cause corrosion and plugging of fuel system components.
- Use of bio-diesel blended fuel may result in premature failure of fuel system components, such as plugged fuel filters and deteriorated fuel lines.
- Shorter maintenance intervals may be required, such as cleaning the fuel system and replacing fuel filters and fuel lines.
- Using bio-diesel blended fuels containing more than five percent (5%) bio-diesel can affect engine life and cause deterioration of hoses, tubes, injectors, injector pump and seals.

Cold Weather Operation Bio-Diesel Blended Fuel

Use the following guidelines if bio-diesel blended fuel is used:

- Never use bio-diesel blended fuel containing more than 5% bio-diesel in this vehicle.
- Ensure the fuel tank is as full as possible at all times to prevent moisture from collecting in the fuel tank.
- Ensure that the fuel tank cap is securely tightened.
- Clean up any spilled fuel immediately to prevent damage to painted surfaces.
- Drain all water from the fuel filter daily before operating the vehicle.
- Do not exceed the engine oil change interval. Extended intervals can result in engine damage.
- Before vehicle storage, drain the fuel tank, refill with 100% petroleum diesel fuel, add fuel stabilizer and run the engine for at least 30 minutes.

NOTICE: Bio-diesel blended fuel does not have long term stability and should not be stored for more than three months.

Operating Conditions

NOTICE: Observe the following environmental operating conditions to maintain engine performance and avoid premature engine wear.

- Avoid operating in the presence of chemical gases or fumes.
- Avoid operating in a corrosive atmosphere such as salt water spray.
- NEVER operate the engine in a floodplain unless proper precautions are taken to avoid being subject to a flood.
- NEVER expose the engine to the rain.
- The standard range of ambient temperatures for the normal operation of YANMAR engines is from +5° F (-15° C) to +104° F (+40° C).
- If the ambient temperature exceeds +104° F (+40° C), the engine may overheat and cause the engine oil to break down.
- If the ambient temperature is between +5° F (-15° C) and -25° F (-32° C), POLARIS recommends the use of a block heater. See page 44.

OPERATION

Starting the Engine

NOTICE: NEVER use an engine starting aid such as ether. Engine damage will result.

Before operating this vehicle in cold weather, review the cold weather operation information beginning on page 44.

Always wait for the wait-to-start indicator light to turn off before cranking the engine.

1. Always start the engine outdoors or in a well-ventilated area.
2. Sit in the driver's seat and fasten the seat belt. Secure the cab nets.
3. Apply the brakes. Engage the park brake.
4. Shift the transmission to neutral.
5. Turn the ignition switch to the ON position and wait for the wait-to-start indicator light to turn off before cranking the engine.
6. Turn the ignition switch past the ON position to START. Engage the starter for a maximum of five seconds. Release the key when the engine starts.
7. If the engine does not start within five seconds, release the ignition switch and wait five seconds. Repeat steps 6 and 7 until the engine starts.
8. Vary the engine RPM slightly with the throttle to aid in warm up until the engine idles smoothly.

NOTICE: Operating the vehicle immediately after starting could cause engine damage. Allow the engine to warm up for several minutes before operating the vehicle.

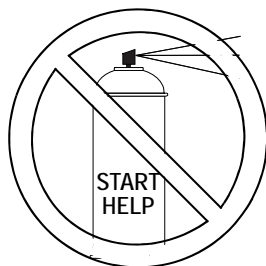

Stopping the Engine

For maximum engine life, allow the engine to idle, without load, for 5 minutes. This will allow the engine components that operate at high temperatures, such as the exhaust system, to cool slightly before the engine is shut down.

1. Release the throttle pedal completely and brake to a complete stop.
2. Turn the engine off.
3. Engage the park brake.

WARNING! A rolling vehicle can cause serious injury. Always engage the park brake after stopping the engine.

Braking

1. Release the throttle pedal completely.
2. Press on the brake pedal evenly and firmly.
3. Practice starting and stopping (using the brakes) until you're familiar with the controls.

Tip: When the throttle pedal is released completely and the engine speed drops near an idle, the vehicle has no engine braking.

OPERATION

Driving Procedure

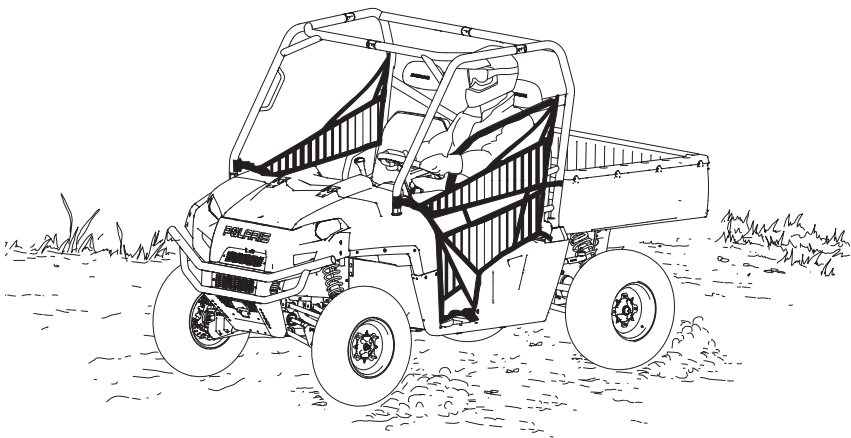

1. Wear a helmet and eye protection.
2. Perform the pre-ride inspection. See page 38.
3. Sit in the driver's seat and fasten the seat belt.
4. Always use the cab nets while riding in this vehicle.
5. Start the engine and allow it to warm up.
6. Apply the service brakes and shift the transmission into gear.
7. Check your surroundings and determine your path of travel.
8. Release the park brake.
9. Keeping both hands on the steering wheel, slowly release the brakes and depress the throttle with your right foot to begin driving.
10. Drive slowly. Practice maneuvering and using the throttle and brakes on level surfaces.
11. Do not carry a passenger until you have at least two hours of driving experience with this vehicle.

Driving with a Passenger

1. Perform the pre-ride inspection. See page 38.
2. Make sure all passengers are at least 12 years of age and tall enough to comfortably and safely sit in a passenger seat with the seat belt secured, put both feet on the floor and grasp the hand hold.
3. Make sure all passengers are wearing an approved helmet and eye protection.
4. Make sure all passengers secure their seat belt.
5. Make sure all cab nets are properly secured.
6. Do not carry more than two passengers in the 4X4 vehicle.
7. Allow a passenger to ride only in a passenger seat.
8. Slow down. Always travel at a speed appropriate for your skills, your passengers' skills, and operating conditions. Avoid unexpected or aggressive maneuvers that could cause discomfort or injury to a passenger.
9. Vehicle handling may change with a passenger and/or cargo on board. Allow more time and distance for braking.
10. Always follow all operating guidelines as outlined on safety labels and in this manual.

OPERATION

Driving on Slippery Surfaces

⚠ WARNING

Skidding or sliding can cause loss of control or overturn (if tires regain traction unexpectedly). When operating on slippery surfaces such as ice or loose gravel, reduce speed and use extra caution to reduce the chance of skidding or sliding out of control. Do not operate on excessively slippery surfaces.

Whenever riding on slippery surfaces such as wet trails or loose gravel, or during freezing weather, follow these precautions:

1. Do not operate on excessively rough, slippery or loose terrain.
2. Slow down before entering slippery areas.
3. Maintain a high level of alertness, reading the trail and avoiding quick, sharp turns, which can cause skids.
4. Engage all-wheel drive before wheels begin to lose traction.

NOTICE: Severe damage to the drive train may occur if the AWD is engaged while the wheels are spinning. Always allow the wheels to stop spinning before engaging AWD.

5. Correct a skid by turning the steering wheel in the direction of the skid. *Never apply the brakes during a skid.*

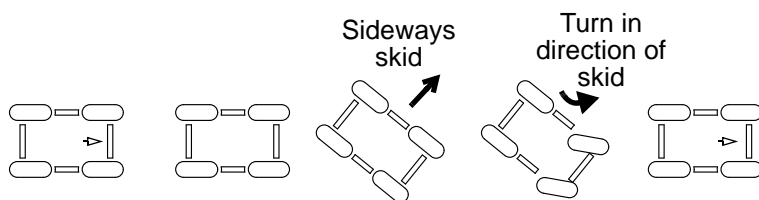

Driving Uphill

Whenever traveling uphill, follow these precautions:

1. Always travel straight uphill.
2. Avoid steep hills (15° maximum).
3. Keep both feet on the floor.
4. Always check the terrain carefully before ascending any hill.
5. Never climb hills with excessively slippery or loose surfaces.
6. Proceed at a steady rate of speed and throttle opening. Never open the throttle suddenly.
7. Never go over the crest of a hill at high speed. An obstacle, a sharp drop, or another vehicle or person could be on the other side of the hill.

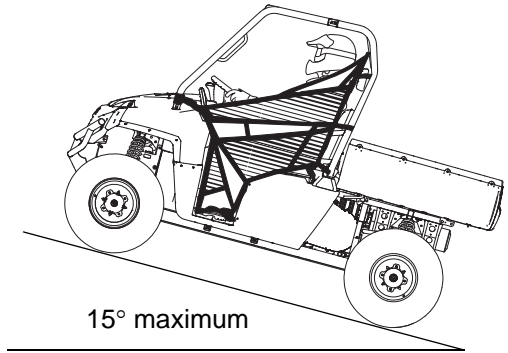

OPERATION

Driving on a Sidehill (Sidehilling)

Driving on a sidehill is not recommended. Improper procedure could cause loss of control or overturn. Avoid crossing the side of any hill unless absolutely necessary.

If crossing a sidehill is *unavoidable*, follow these precautions:

1. Slow down.
2. Exercise extreme caution.
3. Avoid crossing the side of a steep hill (15° maximum).

Driving Downhill

When driving downhill, follow these precautions:

1. Avoid steep hills (15° maximum).
2. Drive straight downhill. Avoid descending a hill at an angle, which would cause the vehicle to lean sharply to one side. Travel straight downhill when possible.
3. Slow down.
4. Apply the brakes *slightly* to aid in slowing.

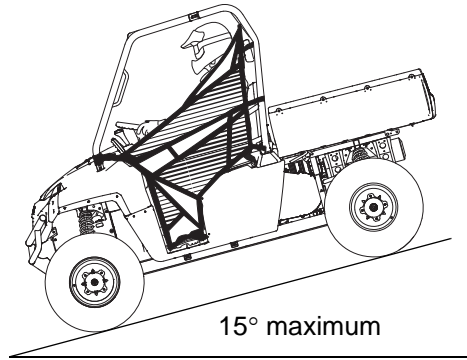

Driving Through Water

Your POLARIS *RANGER* can operate through water up to a maximum recommended depth equal to the floorboards.

NOTICE: Driving through water deeper than the floorboards will cause engine damage and will also void the engine warranty.

NOTICE: Immersion can result in major damage if the vehicle isn't serviced correctly and promptly. After immersion, always take the vehicle to a your dealer for service. Do not start the engine! If it's impossible to bring the vehicle to your dealer before starting the engine, perform the service outlined on page 84, and take the vehicle to your dealer at the first opportunity.

Follow these procedures when operating through water:

1. Determine water depths and current before entering water.
2. Choose a crossing where both banks have gradual inclines.
3. Proceed slowly, avoiding rocks and obstacles.
4. Avoid operating through deep or fast-flowing water.

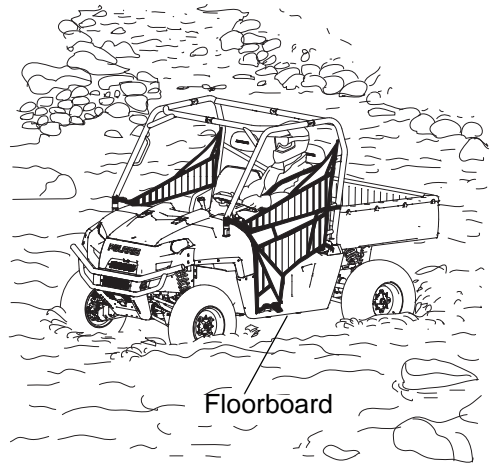

WARNING! The large tires on your *RANGER* may cause the vehicle to float in deep or fast-flowing water, which could result in loss of control and lead to serious injury or death. Never cross deep or fast-flowing water with your *RANGER*.

5. After leaving water, always dry the brakes by applying light pressure to the pedal repeatedly until braking action is normal.

NOTICE: After operating the vehicle in water, it's critical that you perform the services outlined in the Periodic Maintenance Chart beginning on page 64. Give special attention to engine oil, transmission oil, all gearcase fluids and all grease fittings.

OPERATION

Driving Over Obstacles

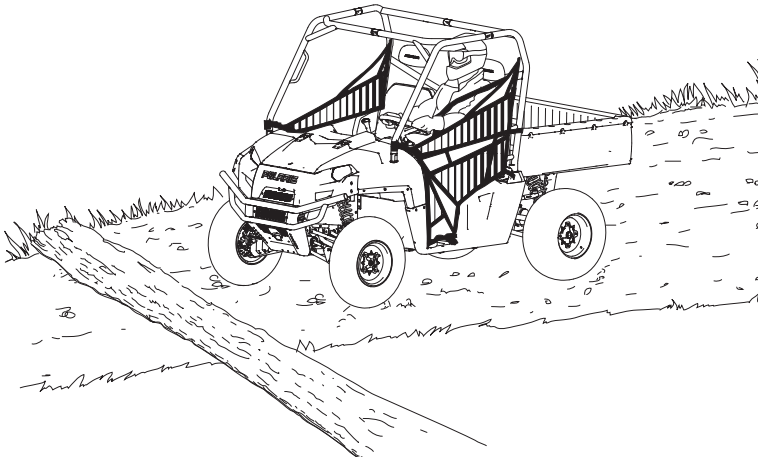

Follow these precautions when operating over obstacles:

1. Always check for obstacles before operating in a new area.
2. Look ahead and learn to read the terrain. Be constantly alert for hazards such as logs, rocks and low hanging branches.
3. Travel slowly and use extra caution when operating on unfamiliar terrain. Not all obstacles are immediately visible.

Driving in Reverse

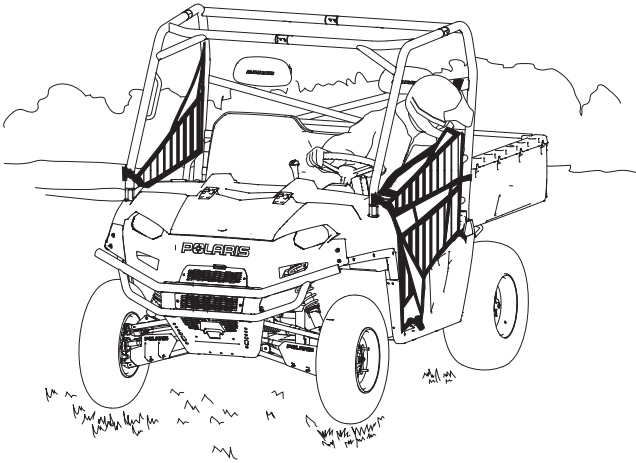

Follow these precautions when operating in reverse:

1. Always check for obstacles or people behind the vehicle. Always inspect left and right fields of vision before backing.
2. Always avoid backing downhill.
3. Back slowly.
4. Apply the brakes *lightly* for stopping.
5. Avoid turning at sharp angles.
6. Never open the throttle suddenly.

OPERATION

Parking the Vehicle

1. Apply the brakes. Stop the vehicle on a level surface.
2. When parking inside a garage or other structure, be sure that the structure is well ventilated and that the vehicle is not close to any source of flame or sparks, including any appliance with pilot lights.
3. Turn the engine off.
4. Engage the park brake.
5. Remove the ignition switch key to prevent unauthorized use.

Parking on an Incline

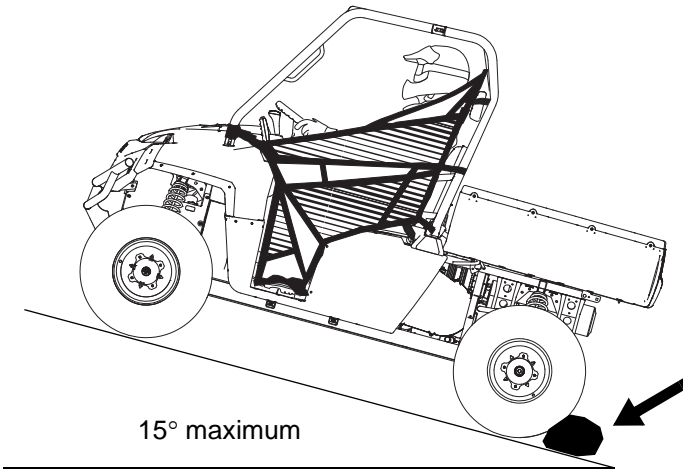

Avoid parking on an incline if possible. If it's unavoidable, follow these precautions:

1. Apply the brakes.
2. Place the transmission in gear.
3. Engage the park brake.
4. Turn the engine off.
5. Block the rear wheels on the downhill side.

Hauling Cargo

▲ WARNING

Hauling cargo improperly can alter vehicle handling and may cause loss of control or brake instability, which can result in serious injury or death. Always follow these precautions when hauling cargo:

Never exceed the maximum weight capacity of the vehicle. When determining the weight you are adding to the vehicle, include the weight of the operator, passenger, accessories, loads in the rack or box and the load on the trailer tongue. The combined weight of these items must not exceed the maximum weight capacity.

REDUCE SPEED AND ALLOW GREATER DISTANCES FOR BRAKING WHEN HAULING CARGO.

Always load the cargo box with the load as far forward and as low as possible.

When operating over rough or hilly terrain, reduce speed and cargo to maintain stable driving conditions.

Always operate the vehicle with extreme care when hauling or towing loads.

Slow down and drive in the lowest gear available.

SECURE ALL LOADS BEFORE OPERATING. Unsecured loads can create unstable operating conditions, which could result in loss of control of the vehicle.

OPERATE ONLY WITH STABLE AND SAFELY ARRANGED LOADS. When handling off-centered loads that cannot be centered, securely fasten the load and operate with extra caution. Always attach the tow load to the hitch point designated for your vehicle.

HEAVY LOADS CAN CAUSE BRAKING AND CONTROL PROBLEMS. Use extreme caution when applying brakes with a loaded vehicle. Avoid terrain or situations that may require backing downhill.

USE EXTREME CAUTION when operating with loads that extend over the rack sides. Stability and maneuverability may be adversely affected, causing the vehicle to overturn.

DO NOT TRAVEL FASTER THAN THE RECOMMENDED SPEEDS. Vehicle should never exceed 10 mph (16 kph) while towing a load on a level grass surface. Vehicle speed should never exceed 5 mph (8 kph) when towing loads in rough terrain, while cornering, or while ascending or descending a hill.

OPERATION

Hauling Cargo

The *RANGER* has been designed to carry or tow specific capacities. Always read and understand the load distribution warnings listed on the warning labels. The total load (operator, passenger, accessories, cargo and weight on hitch) must not exceed the maximum weight capacity of the vehicle. Never exceed the following capacities.

Model	Maximum Total Weight Capacity (Level Ground)	Maximum Cargo Box Weight Capacity
<i>RANGER</i> Diesel	1500 lbs. (681 kg)	1000 lbs. (454 kg)

WARNING! Driving with passengers in the cargo box can result in severe injury or death. Never allow passengers to ride in the cargo box. Passengers must always ride in the cab with seat belts fastened securely.

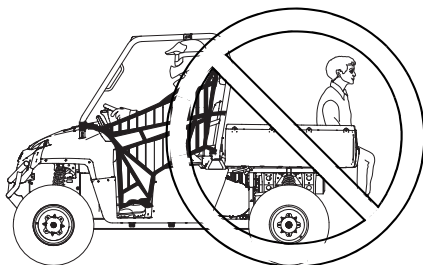

Towing Loads

Towing improperly can alter vehicle handling and may cause loss of control or brake instability. Always follow these precautions when towing:

1. Never load more than 150 lbs. (68.1 kg) tongue weight on the towing bracket.
2. Use low range. Do not operate the vehicle faster than 10 mph (16 km/h) when towing. See page 57. Towing a trailer increases braking distance.
3. Do not tow more than the recommended weight for the vehicle. See the towing capacity chart below and the specifications charts beginning on page 108.
4. Attach a trailer to the trailer hitch bracket only. Do not attach a trailer to any other location or you may lose control of the vehicle.
5. Never tow a trailer on a grade steeper than 15°.

Model	Total Towed Load Weight (Level Ground)	Total Towed Load Weight (15° grade)	Total Hitch Vertical Weight	Maximum Towing Speed
<i>RANGER Diesel</i>	2000 lbs. (907 kg)	850 lbs. (386 kg)	150 lbs. (68.1 kg)	10 mph (16 kph)

Belt Life

To extend belt life, use the lowest gear possible when hauling or towing heavy cargo.

OPERATION

Dumping the Cargo Box

1. Select a level site to dump the cargo box. Do not attempt to dump or unload the vehicle while parked on an incline.
2. Apply the brakes.
3. Place the transmission in gear.
4. Engage the park brake.
5. Dismount the vehicle.
6. Ensure that the cargo is positioned evenly or toward the front of the cargo box.
7. Release the tailgate by pulling up on the tailgate latch.



WARNING! If the weight distribution on the box is located toward the rear of the box when the release lever is pulled forward, the box may dump unexpectedly and cause serious injury to the operator or bystanders. Never operate the dump lever without ensuring that the load is positioned evenly or at the front of the box.

8. Stand clear and pull up on the cargo box release lever.
9. Lift the front of the cargo box to dump the cargo.
10. Lower the cargo box and push down securely to latch.

WARNING! Operating the vehicle while the cargo box is raised could result in severe injury. The box could close unexpectedly and cause injury to the driver or passenger. The rear tires will also catch the rear of a raised box, damaging the vehicle and creating hazardous driving conditions. Never operate this vehicle with the cargo box in the raised position.

All Wheel Drive (AWD)

Engaging AWD

Press the top of the rocker switch to engage All Wheel Drive (AWD). The illuminated amber AWD switch indicates that the vehicle is in AWD.

When the AWD switch is on, the front wheels will automatically engage any time the rear wheels lose traction. When the rear wheels regain traction, the front wheels will automatically disengage. There is no limit to the length of time the vehicle may remain in AWD.

Tip: The AWD switch may be turned on or off while the vehicle is moving.

Engage the AWD before getting into conditions where front wheel drive may be needed. If the rear wheels are spinning, release the throttle before switching to AWD.

NOTICE: Switching to AWD while the rear wheels are spinning may cause severe drive shaft and clutch damage. Always switch to AWD while the rear wheels have traction or are at rest.

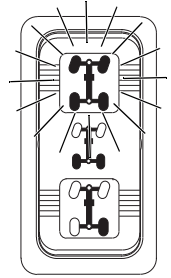

Disengaging AWD

Move the AWD switch to the center or bottom position to disengage AWD. If the switch is turned off while the front hubs are driving, they will not release until the rear wheels regain traction.

In some situations, the front gearcase may remain locked after turning the AWD switch off. If this occurs, you may notice increased steering effort and some vehicle speed restriction. Perform the following procedure to unlock the front gearcase.

1. Stop the vehicle.
2. Operate in reverse for at least 10 feet (3 m).
3. Stop completely.
4. Shift into low gear and drive forward.
5. If the front gearcase remains locked after following these instructions, see your dealer for service.

OPERATION

All Wheel Drive (AWD)

Locking the Differential

NOTICE: Damage to the differential can occur if it is engaged while the vehicle is traveling at high speeds or while the rear wheels are spinning. Slow the vehicle to nearly stopped before engaging the differential.

Locking the differential in slippery or low traction conditions helps improve traction. Move the rocker switch to the center position (2WD) to lock the differential and operate in rear wheel drive.

Press the bottom of the switch to unlock the differential and allow the rear drive wheels to operate independently. This mode of operation is well suited to turf driving or whenever aggressive traction is not required.

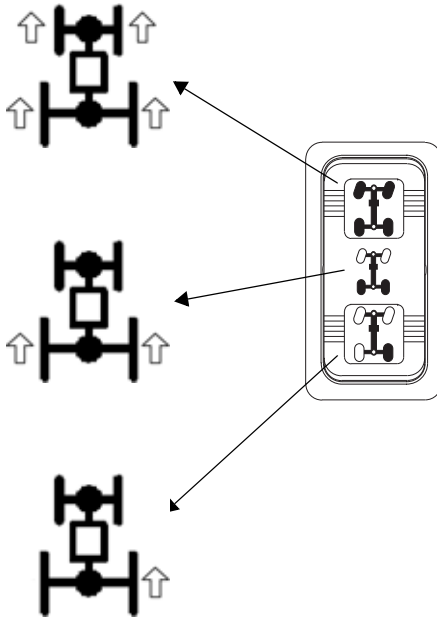

EMISSION CONTROL SYSTEMS

Noise Emission Control System

Do not modify the engine, intake or exhaust components, as doing so may affect compliance with U.S.A. EPA noise control requirements (40 CFR 205) and local noise level requirements.

Operation on Public Lands in the U.S.A.

Your POLARIS vehicle has a spark arrestor that was tested and qualified to be in accordance with the USFS standard 5100-1c. Federal law requires that this spark arrestor be installed and functional when the vehicle is operated on public lands.

Operation of off-road vehicles on public lands in the U.S.A. is regulated by 43 CFR 420. Violations are subject to monetary penalties. Federal regulations can be viewed online at www.gpoaccess.gov/ecfr/.

Exhaust Emission Control System

California-certified, new off-road compression-ignition engines must be designed, built and equipped to meet the state's stringent anti-smog standards. In the remaining forty nine (49) states, new off-road compression-ignition engines must be designed, built and equipped to meet the United States EPA emissions standards.

Your engine is designed to operate on low sulfur or ultra low sulfur diesel fuel only. Use of any other fuel may result in your engine no longer operating in compliance with CARB and EPA emissions requirements.

Electromagnetic Interference

This vehicle complies with the EMC requirements of European directives 97/24/EC and 2004/108/EC.

Non-ionizing Radiation

This vehicle emits some electromagnetic energy. People with active or non-active implantable medical devices (such as heart monitoring or controlling devices) should review the limitations of their device and the applicable electromagnetic standards that apply to this vehicle.

MAINTENANCE

Periodic Maintenance Chart

Careful periodic maintenance will help keep your vehicle in the safest, most reliable condition. Inspection, adjustment and lubrication of important components are explained in the periodic maintenance chart.

Inspect, clean, lubricate, adjust and replace parts as necessary. When inspection reveals the need for replacement parts, use genuine POLARIS parts available from your POLARIS dealer.

Record maintenance and service in the Maintenance Log beginning on page 124.

Tip: Service and adjustments are important for proper vehicle operation. If you're not familiar with safe service and adjustment procedures, have a qualified dealer perform these operations.

Maintenance intervals in the following chart are based upon average riding conditions and an average vehicle speed of approximately ten (10) miles per hour. Vehicles subjected to severe use must be inspected and serviced more frequently.

Severe Use Definition

- Frequent immersion in mud, water or sand
- Frequent or prolonged operation in dusty environments
- Racing or race-style high RPM use
- Prolonged low speed, heavy load operation
- Extended idle
- Short trip cold weather operation

Pay special attention to the oil level. A rise in oil level during cold weather can indicate contaminants collecting in the oil sump or crankcase. Change oil immediately if the oil level begins to rise. Monitor the oil level, and if it continues to rise, discontinue use and determine the cause or see your dealer.

Periodic Maintenance Chart

Maintenance Chart Key

► Perform these operations more often for vehicles subjected to severe use.

E Emission-related service (Failure to conduct this maintenance will not void the emissions warranty but may affect emissions.)

n Have an authorized POLARIS dealer perform these services.

WARNING! Improperly performing the procedures marked with a **n** could result in component failure and lead to serious injury or death. Have an authorized POLARIS dealer perform these services.

MAINTENANCE

Periodic Maintenance Chart

Perform all services at whichever maintenance interval is reached first.

Item		Maintenance Interval (whichever comes first)			Remarks
		Hours	Calendar	Miles (Km)	
n	Steering	-	Pre-Ride	-	Make adjustments as needed. See Pre-Ride Checklist on page 38.
▶	Front suspension	-	Pre-Ride	-	
▶	Rear suspension	-	Pre-Ride	-	
	Tires	-	Pre-Ride	-	
▶	Brake fluid level	-	Pre-Ride	-	
▶	Brake pedal travel				
	Brake system	-	Pre-Ride	-	
	Wheels/fasteners	-	Pre-Ride	-	
	Frame fasteners	-	Pre-Ride	-	
▶	Engine oil level	-	Pre-Ride	-	
▶ E	Air filter, pre-filter	-	Daily	-	Inspect; clean often; replace as needed
▶	Fuel filter/water separator	-	Daily	-	Inspect
	Coolant (if applicable)	-	Daily	-	Check level daily, change coolant every 2 years
	Radiator	-	Daily	-	Clean dust/dirt from external surfaces daily
	Headlamp/tail lamp	-	Daily	-	Check operation; apply dielectric grease if replacing
▶ E	Air filter, main element	-	Weekly	-	Inspect; replace every 150 hours (or more often)
▶ n	Brake pad wear	10 H	Monthly	-	Inspect periodically
	Battery	20 H	Monthly	-	Check terminals; clean; test
▶	Front Gearcase Oil (if equipped)	25 H	Monthly	-	Inspect level; change yearly
▶	Middle Gearcase Oil (if equipped)	25 H	Monthly	-	Inspect level; change yearly
▶	Rear gearcase oil (if equipped)	25 H	Monthly	-	Inspect level; change yearly
▶	Transmission oil	25 H	Monthly	-	Inspect level; change yearly

▶ Perform these procedures more often for vehicles subjected to severe use.

E Emission-Related Service

n Have an authorized POLARIS dealer perform these services.

MAINTENANCE

Periodic Maintenance Chart

Item		Maintenance Interval (whichever comes first)			Remarks
		Hours	Calendar	Miles (Km)	
	Park brake cable tension	25 H	1 M	-	Check tension, adjust
▶	Engine oil change	50 H	-	-	Perform break-in oil change, then change oil and filter every 100 hours
▶	General lubrication	50 H	3 M	-	Lubricate all fittings, pivots, cables, etc.
▶	Fuel filter/water separator	50 H	3 M	-	Drain water
	Shift Linkage	50 H	6 M	-	Inspect, lubricate, adjust
n	Steering	50H	6 M	-	Lubricate
▶	Front Suspension	50 H	6 M	-	Lubricate
▶	Rear Suspension	50 H	6 M	-	Lubricate
nE	Throttle cable/ ETC switch	50 H	6 M	-	Inspect; adjust; lubricate; replace if necessary
E	Throttle body air intake ducts/flange	50 H	6 M	-	Inspect duct for proper sealing/air leaks
	Drive belt	50 H	6 M	-	Inspect; adjust; replace as needed
	Cooling system (if applicable)	50 H	6 M	-	Inspect coolant strength seasonally; pressure test system yearly
	Park brake cable tension	100 H	6 M	-	Check tension, adjust
▶	Engine oil change	100 H	-	-	After break-in oil change at 50 hours, change oil and filter every 100 hours
▶	Oil filter change	100 H	-	-	Replace with oil change

▶ Perform these procedures more often for vehicles subjected to severe use.

E Emission-Related Service

n Have an authorized POLARIS dealer perform these services.

MAINTENANCE

Periodic Maintenance Chart

Item		Maintenance Interval (whichever comes first)			Remarks
		Hours	Calendar	Miles (Km)	
■ E	Fuel system	100 H	12 M	-	Check for leaks at tank cap, lines, fuel valve, filter, pump, throttle body; replace lines every 2 years
▶	Radiator (in applicable)	100 H	12 M	-	Inspect; clean external surfaces
▶	Cooling Hoses	100 H	12 M	-	Inspect for leaks
▶	Engine mounts	100 H	12 M	-	Inspect
	Exhaust muffler/ pipe	100 H	12 M	-	Inspect
▶	Wiring	100 H	12 M	-	Inspect for wear, routing, security; apply dielectric grease to connectors subjected to water, mud, etc.
■ ▶	Clutches (drive and driven)	100 H	12 M	-	Inspect; clean; replace worn parts
■	Front wheel bearings	100 H	12 M	-	Inspect; replace as needed
▶ E	Air filter, main element	150 H		-	Replace
■	Fuel filter/water separator	150 H	12 M	-	Replace
■	Brake fluid	200 H	24 M	-	Change every two years
■	Fuel system	200 H	24 M	-	Replace lines every 2 years
	Spark arrestor	300 H	36 M	-	Clean out
■	Toe adjustment	-			Inspect periodically; adjust when parts are replaced
■ ▶	Auxiliary brake (if equipped)	-			Inspect daily; adjust as needed
	Headlight aim	-			Adjust as needed

▶ Perform these procedures more often for vehicles subjected to severe use.

E Emission-Related Service

■ Have an authorized POLARIS dealer perform these services

MAINTENANCE

Lubrication Recommendations

Check and lubricate all components at the intervals outlined in the Periodic Maintenance Chart beginning on page 64, or more often under severe use, such as wet or dusty conditions. Items not listed in the chart should be lubricated at the general lubrication interval.

Item	Lube	Method
Engine Oil		See page 71.
Brake Fluid	DOT 4	Maintain level between fill lines. See page 90.
Main Gearcase Oil (Transmission)	AGL PLUS Transmission Fluid	See page 74.
Front Gearcase Oil	Demand Drive PLUS Fluid	See page 76.
Front Prop Shaft Yoke	POLARIS Premium U- Joint Lube	Locate fittings and grease (3 pumps maximum).

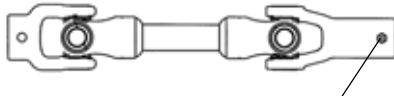

Prop Shaft Grease Zerk

MAINTENANCE

Engine Oil

Always check the oil level *daily*. Change the engine oil at the intervals outlined in the Periodic Maintenance Chart beginning on page 64.

Always change the oil filter whenever changing oil.

WARNING! Vehicle operation with insufficient, deteriorated or contaminated engine oil will cause accelerated wear and may result in engine seizure, accident and injury. Always perform the maintenance procedures as outlined in the Periodic Maintenance Chart.

Oil Recommendations

NOTICE: Use of a non-recommended engine oil may cause serious engine damage.

POLARIS recommends the use of POLARIS Diesel Oil (SAE CI-4) for this vehicle. Always use the the correct viscosity grade based on the ambient temperature expected during operation. See the chart below.

Oil Viscosity/Ambient Air Temperature Chart

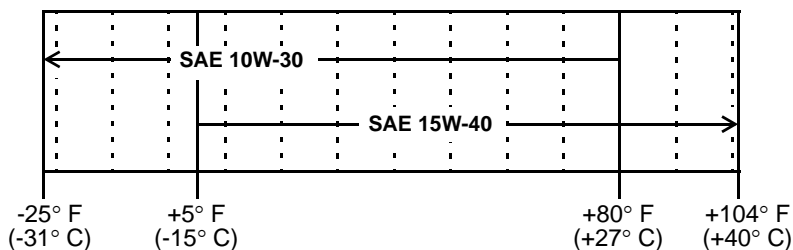

Engine Oil

Always check and change the oil at the intervals outlined in the Periodic Maintenance Chart beginning on page 64. Always use the recommended engine oil.

Oil Check

The oil dipstick is located on the engine under the passenger seat.

1. Position the vehicle on a level surface.
2. Stop the engine.
3. Remove the seat.
4. Remove the dipstick. Wipe it dry with a clean cloth.
5. Reinstall the dipstick, then remove it and check the oil level. Maintain the oil level in the safe range. Do not overfill.

Tip: Due to the dipstick entry angle into the crankcase, the oil level will read higher on the bottom side of the dipstick. Always read the level on the upper surface of the dipstick.

Dipstick

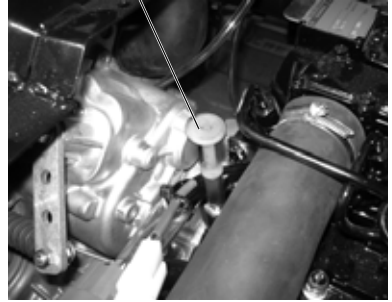

Check Level on Top Side

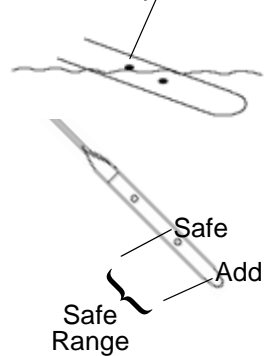

MAINTENANCE

Engine Oil

Oil and Filter Change

Always change the oil and filter at the intervals outlined in the Periodic Maintenance Chart beginning on page 64. Always change the oil filter whenever changing oil.

1. Position the vehicle on a level surface.
2. Run the engine for two to three minutes until warm. Stop the engine.
3. Clean the area around the drain plug.
4. Place a drain pan beneath the engine crankcase.

CAUTION! Hot oil can cause burns to skin. Do not allow hot oil to contact skin.

5. Remove the drain plug. Allow the oil to drain completely.
6. Reinstall the sealing washer on the drain plug. The sealing surfaces on drain plug and crankcase should be clean and free of burrs, nicks or scratches.
7. Reinstall the drain plug. Torque to 25 ft. lbs. (34 Nm).
8. Place shop towels beneath the oil filter. Using an oil filter wrench, turn the filter counter-clockwise to remove it.
9. Using a clean dry cloth, clean the filter sealing surface on the crankcase.
10. Lubricate the o-ring on the new filter with a film of fresh engine oil. Check to make sure the o-ring is in good condition.
11. Install the new filter and turn by hand until the filter gasket contacts the sealing surface, then turn an additional 1/2 turn.

Engine Oil Oil and Filter Change

12. Remove the oil fill cap and add 1.8 quarts (1.7 l) of the recommended oil.

Tip: An additional fill cap is located on the side of the engine on the crankcase. Use the most convenient location for adding oil.

13. Reinstall the oil fill cap.
14. Shift the transmission to neutral.
15. Apply the brakes. Engage the park brake.
16. Start the engine. Allow it to idle for one to two minutes.
17. Stop the engine. Inspect for leaks.
18. Check the oil level on the dipstick and add oil as necessary to bring the level to the upper mark on the dipstick.
19. Dispose of used filter and oil properly.

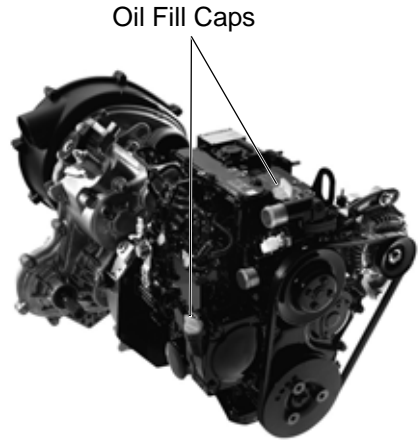

MAINTENANCE

Gearcases

Gearcase Specification Chart

<i>RANGER Diesel Gearcase Specifications</i>				
Gearcase	Lubricant	Capacity	Fill Plug Torque	Drain Plug Torque
Main Gearcase (Transmission)	AGL PLUS Transmission Fluid	34 oz. (1000 ml)	12 ft. lbs. (16.3 Nm)	12 ft. lbs. (16.3 Nm)
Front Gearcase	Demand Drive PLUS Fluid	6.75 oz. (200 ml)	8-10 ft. lbs. (11-13.6 Nm)	11 ft. lbs. (15 Nm)
Rear Gearcase	ATV Angle Drive Fluid (or GL5 80-90 weight gear lube)	20 oz. (591 ml)	20-30 ft. lbs. (27-40 Nm)	30-45 in. lbs. (.2-.3 Nm)

Gearcases

Transmission (Main Gearcase)

Always check and change the transmission oil at the intervals outlined in the Periodic Maintenance Chart beginning on page 64. Maintain the oil level even with the bottom of the fill plug hole threads.

Refer to the Gearcase Specifications Chart on page 74 for recommended lubricants, capacities and torque specifications. See page 110 for the part numbers of POLARIS products.

Oil Check

The fill plug is located on the right side of the transmission. Access the fill plug from the rear right-hand side of the vehicle.

1. Position the vehicle on a level surface.
2. Remove the fill plug.
3. Check the oil level. Add the recommended oil as needed.
4. Reinstall the fill plug. Torque to specification.

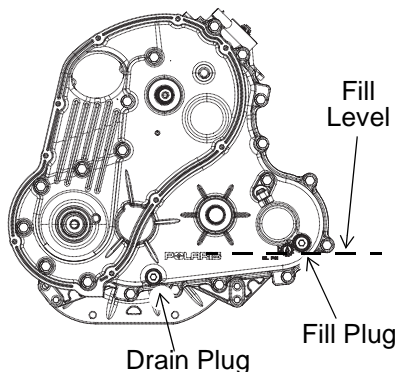

Transmission (Main Gearcase)

Oil Change

The drain plug is located on the right side of the transmission. Access the drain plug from the rear right-hand side of the vehicle.

1. Remove the fill plug.
2. Place a funnel into the skid plate hole and under the transmission drain plug. Place a drain pan under the vehicle at the location of the funnel.
3. Remove the drain plug. Allow the oil to drain completely.
4. Clean and reinstall the drain plug with a new sealing washer. Torque to specification.
5. Add the recommended oil.
6. Reinstall the fill plug. Torque to specification.
7. Check for leaks. Dispose of used oil properly.

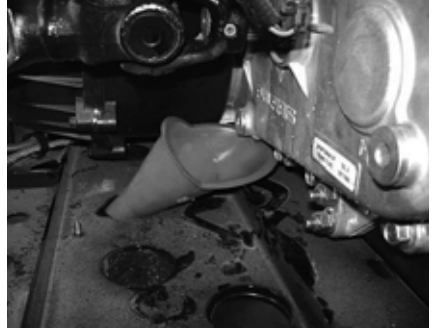

MAINTENANCE

Gearcases

Front Gearcase

Always check and change the front gearcase oil at the intervals outlined in the Periodic Maintenance Chart beginning on page 64. Maintain the oil level even with the bottom thread of the fill plug hole.

Refer to the Gearcase Specifications Chart on page 74 for recommended lubricants, capacities and torque specifications. See page 110 for the part numbers of POLARIS products.

Oil Check

The front gearcase fill plug is located on the right side of the front gearcase.

1. Position the vehicle on a level surface.
2. Remove the fill plug. Check the oil level.
3. Add the recommended oil as needed.
4. Reinstall the fill plug. Torque to specification.

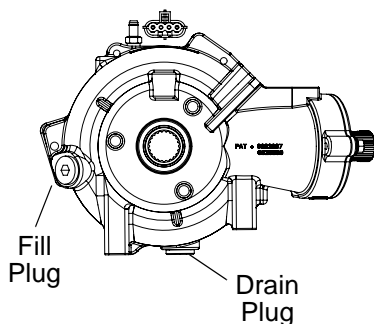

Oil Change

1. Support the vehicle securely with a jackstand.
2. Remove the front tire on the driver's side.
3. Remove the fill plug.
4. Place a drain pan under the drain plug on the bottom right-hand side.
5. Remove the drain plug. Allow the oil to drain completely.
6. Clean and reinstall the drain plug. Torque to specification.
7. Add the recommended oil.
8. Reinstall the fill plug. Torque to specification.
9. Check for leaks. Dispose of used oil properly.

Gearcases

Rear Gearcase

Always check and change the rear gearcase oil at the intervals outlined in the Periodic Maintenance Chart beginning on page 64. Maintain the fluid level at the bottom of the fill hole threads. Do not overfill.

Refer to the Gearcase Specifications Chart on page 74 for recommended lubricants, capacities and torque specifications.

The fill plug is located on the rear of the gearcase. The drain plug is located on the bottom of the gearcase.

Oil Check

1. Position the vehicle on a level surface.
2. Remove the fill plug. Check the oil level.
3. Add the recommended oil as needed. *Do not overfill.*
4. Reinstall the fill plug. Torque to specification.

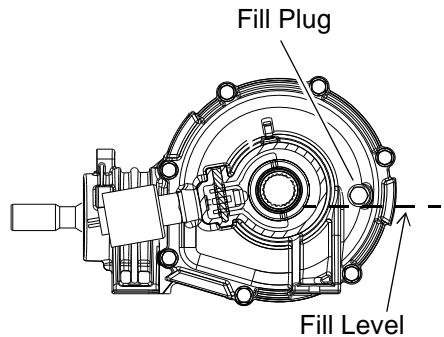

MAINTENANCE

Gearcases

Rear Gearcase

Oil Change

1. Position the vehicle on a level surface.
2. Place a drain pan under the drain plug.
3. Remove the drain plug. Allow the oil to drain completely.
4. Clean and reinstall the drain plug with a new sealing washer. Torque to specification.
5. Remove the fill plug. Add the proper amount of the recommended oil. *Do not overfill.*
6. Reinstall the fill plug. Torque to specification.
7. Check for leaks.
8. Dispose of used oil properly.

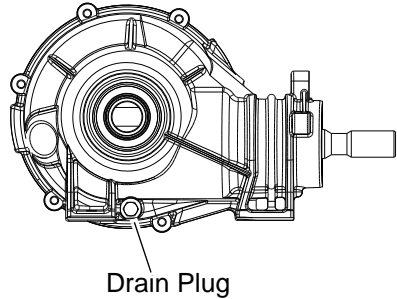

Cooling System

The engine coolant level is controlled or maintained by the recovery system. The recovery system components are the overflow bottle, radiator filler neck, radiator pressure cap and connecting hose.

As coolant operating temperature increases, the expanding (heated) excess coolant is forced out of the radiator, past the pressure cap, and into the overflow bottle. As engine coolant temperature decreases, the contracting (cooled) coolant is drawn back up from the tank, past the pressure cap, and into the radiator.

Some coolant level drop on new vehicles is normal as the system is purging itself of trapped air. Observe coolant levels and maintain as recommended by adding coolant to the overflow bottle.

Adding or Changing Coolant

To ensure that the coolant maintains its ability to protect the engine, we recommend that the system be completely drained every two years and a fresh mixture of antifreeze and water added.

NOTICE: Do not mix different types of coolant in the cooling system when adding coolant. Mixing types can result in damage to the cooling system.

POLARIS recommends the use of POLARIS Premium 60/40 anti-freeze/coolant or a 50/50 mixture of high quality aluminum compatible anti-freeze/coolant and distilled water. POLARIS Premium 60/40 is already premixed and ready to use. Do not dilute with water.

Always follow the manufacturer's mixing recommendations for the freeze protection required in your area.

Any time the cooling system has been drained for maintenance or repair, replace the coolant. If the recovery bottle has run dry, the level in the radiator should be inspected. Add coolant as needed.

MAINTENANCE

Cooling System

Radiator and Cooling Fan

Always check and clean the screen and radiator fins at the intervals outlined in the Periodic Maintenance Chart beginning on page 64. Do not obstruct or deflect air flow through the radiator by installing unauthorized accessories in front of the radiator or behind the cooling fan. Interference with the radiator air flow can lead to overheating and consequent engine damage.

NOTICE: Washing the vehicle with a high-pressure hose could damage the radiator fins and impair the radiator's effectiveness. Using a high-pressure system is not recommended.

Overflow Bottle Coolant Level

Always check and change the coolant at the intervals outlined in the Periodic Maintenance Chart beginning on page 64. Maintain the coolant level between the minimum and maximum marks on the bottle (when the fluid is cool).

The overflow bottle is located under the hood.

1. Position the vehicle on a level surface.
2. View the coolant level in the overflow bottle.
3. If the coolant level is below the safe operating range, lift the hood and locate the overflow bottle lid. Remove the cap and use a funnel to add coolant through the filler opening. Reinstall the cap.

Tip: If coolant must be added often, or if the overflow bottle runs completely dry, there may be a leak in the system. Have the cooling system inspected by your POLARIS dealer.

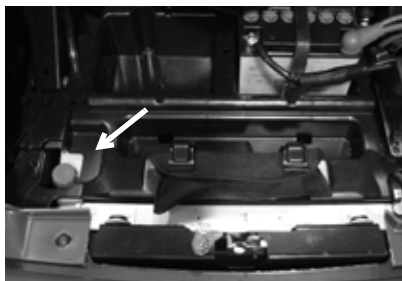

Cooling System Radiator Coolant Level

1. Lift the hood.

CAUTION! Escaping steam can cause burns. Never remove the pressure cap while the engine is warm or hot. Always allow the engine to cool before removing the pressure cap.

2. Slowly remove the radiator cap.
3. View the coolant level through the opening.
4. Use a funnel and slowly add coolant as needed.

Tip: This procedure is required only if the cooling system has been drained for maintenance and/or repair. But if the overflow bottle has run dry, the level in the radiator should also be inspected.

5. Reinstall the pressure cap. Use of a non-standard pressure cap will not allow the recovery system to function properly. See your dealer for the correct replacement part.



MAINTENANCE

POLARIS Variable Transmission (PVT) System

▲ WARNING

Failure to comply with the instructions in this warning can result in severe injury or death.

Do not modify any component of the PVT system. Doing so may reduce its strength so that a failure may occur at a high speed. The PVT system has been precision balanced. Any modification will cause the system to be out of balance, creating vibration and additional loads on components.

The PVT system rotates at high speeds, creating large amounts of force on clutch components. Extensive engineering and testing has been conducted to ensure the safety of this product. However, as the owner, you have the following responsibilities to make sure this system remains safe:

- Always follow all recommended maintenance procedures. See your dealer as outlined in the owner's manual.
- This PVT system is intended for use on POLARIS products only. Do not install it in any other product.
- Always make sure the PVT housing is securely in place during operation.

When To Use Low Range and High Range

Belt slip is responsible for creating excessive heat that destroys belts, wears clutch components and causes outer clutch covers to fail. Switch to low range while operating at slower speeds to extend the life of the PVT components (belt, cover, etc.).

Condition	Range to Use
Operating at speeds less than 7 MPH (11 km/h)	Low
Towing	Low
Operating in rough terrain (swamps, mountains, etc.)	Low
Operating at speeds greater than 7 MPH (11 km/h)	High

PVT System

PVT Drying

There may be some instances when water is accidentally ingested into the PVT system. Use the following instructions to dry it out before operating.

NOTICE: Do not attempt to start the engine if water is present in the air box.

1. Position the vehicle on a level surface.
2. Remove the drain plug. Allow the water to drain completely. Reinstall the drain plug.
3. Apply the brakes. Start the engine.
4. Engage the park brake.
5. Shift the transmission to neutral.
6. Apply varying throttle for 10-15 seconds to expel the moisture and air-dry the belt and clutches. Do not hold the throttle wide open for more than 10 seconds.
7. Allow the engine RPM to settle to idle speed. Apply the service brakes. Release the park brake and shift the transmission to the lowest available range.
8. Test for belt slippage. If the belt slips, repeat the process.
9. Take the vehicle to your dealer for service as soon as possible.

MAINTENANCE

Vehicle Immersion

NOTICE: If your vehicle becomes immersed, major engine damage can result if the machine is not thoroughly inspected. Take the vehicle to your dealer before starting the engine.

If it's impossible to take your *RANGER* to a dealer before starting it, follow the steps outlined below.

1. Move the vehicle to dry land or at the very least, to water below the floorboards.
2. Inspect the air box for water.

NOTICE: Do not attempt to start the engine if water is present in the air box. Engine damage will result. Take the vehicle to your dealer before starting the engine.

3. If the air box is wet but has no visible water, dry the air box.
4. Thoroughly dry the air pre-cleaner located under the hood.
5. Take the vehicle to your dealer for service as soon as possible, whether you succeed in starting it or not.
6. If water has been ingested into the PVT follow the procedure on page 83 for drying.

Fuel Filter/Water Separator

The fuel filter/water separator is located under the seat on the right side of the vehicle, between the engine and fuel tank.

Inspect the separator *daily* for leaks. Drain water and replace the separator at the intervals outlined in the Periodic Maintenance Chart beginning on page 64. Service the separator more frequently if the vehicle is operated with inferior fuel.

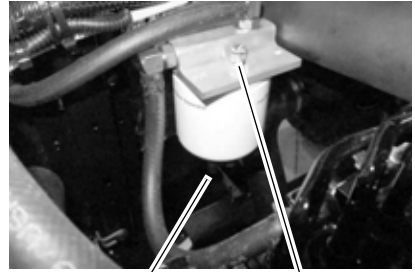

Drain Valve

Bleed Screw

CAUTION! Both fuel and water will drain from the separator during the following procedure. Use caution and observe all fuel safety precautions when handling fuel.

1. Remove the seat. Disconnect the battery.
2. Place an appropriate container under the fuel filter drain to catch fluids (water and fuel).
3. Slightly loosen the bleed screw to relieve fuel pressure in the filter. Do not tighten the screw at this time.
4. Reach under the fuel filter and slightly loosen the drain valve until the fluids drain from the drain hole. Do not completely unscrew the drain valve.
5. When fluids stop draining from the valve, tighten the valve firmly (by hand only).
6. Reconnect the battery.
7. Turn the ignition key on to engage the fuel pump. Leave the key on only until fuel begins to spit from the bleed screw, then tighten the screw.
8. Clean up any spilled fuel and soiled shop towels properly.
9. Cycle the key switch from OFF to ON six times, waiting three seconds at each "ON" cycle to allow the fuel pump to cycle.
10. Start the engine and check for fuel leaks.
11. Reinstall the seat.

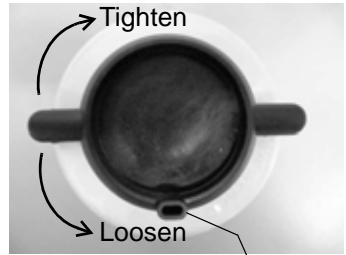

Drain Hole
(viewed from bottom)

MAINTENANCE

Air Filter

Always change the air filter at the intervals outlined in the Periodic Maintenance Chart beginning on page 64. Service the air filter more frequently if the vehicle is operated in wet or dusty conditions or at high throttle openings for extended periods.

1. Lift the cargo box to access the air box.
2. Release the four air box cover clips. Remove the air box cover and inspect the gasket. It should adhere tightly to the cover.
3. Remove the air filter assembly with a pulling and twisting motion. Use care to avoid damaging the filter element.
4. Remove debris from the filter using low pressure compressed air. Lightly blow from the inside out.

NOTICE: Operating a diesel engine with a soiled or damaged air filter can result in engine damage. Do not attempt to wash the filter. Always replace a soiled or damaged filter with a new filter.

5. Clean any oil or water deposits from the air box.
6. Apply a small amount of all-purpose grease to the sealing edges of the filter. Make sure the plastic ring is installed.
7. Reinstall the filter into the air box. Make sure it fits tightly.
8. Align the tab and notch of the air box cover and secure the cover clips.



Air Box

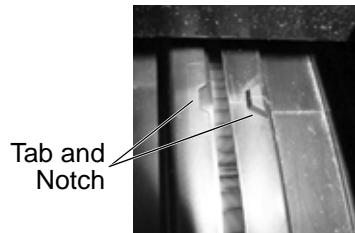
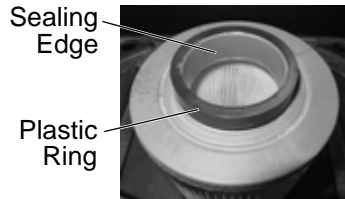
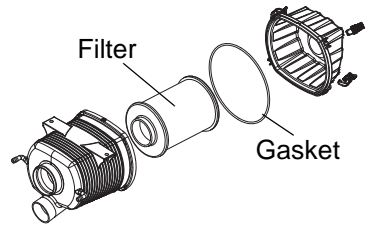

Spark Arrestor

▲ WARNING

Failure to heed the following warnings while servicing the spark arrestor could result in serious injury or death.

Do not perform service on the spark arrestor while the system is hot. Exhaust system temperatures can reach 1000° F. Allow components to cool sufficiently before proceeding.

Remove any combustible materials from the area.

Wear eye protection and gloves.

Do not stand behind or in front of the vehicle while purging.

Never run the engine in an enclosed area. Exhaust can cause loss of consciousness or death in a very short time.

Never go under the vehicle while it's inclined.

Use the following procedure to periodically purge accumulated carbon from the exhaust pipe.

1. Remove the arrestor clean-out plug located on the bottom of the muffler.
2. Place the transmission in neutral. Engage the park brake. Start the engine.
3. Purge accumulated carbon from the system by momentarily revving the engine several times.
4. If carbon is expelled, *partially* cover the exhaust outlet and rap on the pipe around the clean-out plug while revving the engine several more times.
5. If particles are still suspected to be in the muffler, elevate the rear of the vehicle one foot higher than the front. Block the wheels.
6. Repeat steps 3 and 4 until no more particles are expelled when the engine is revved.
7. Stop the engine. Allow the arrestor to cool.
8. Reinstall the arrestor plug and remove the partial outlet cover.

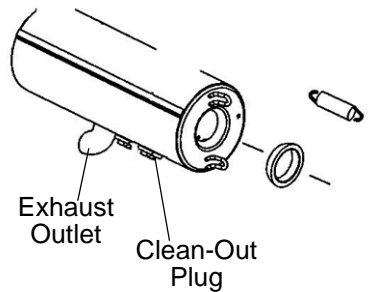

MAINTENANCE

Throttle System

⚠ WARNING

Failure to check or maintain proper operation of the throttle system can result in an accident and lead to serious injury or death if the throttle pedal sticks during operation.

Always check the pedal for free movement and return before starting the engine and occasionally during operation. Never start or operate this vehicle if it has a sticking or improperly operating throttle pedal. Immediately contact your dealer for service if throttle problems arise.

Throttle Freeplay

If the throttle pedal has excessive play due to cable stretch or mis-adjustment, it will cause a delay in throttle response, especially at low engine speed. The throttle may also not open fully. If the throttle pedal has no freeplay, the throttle may be hard to control, and the idle speed may be erratic.

Check the throttle pedal freeplay at the intervals outlined in the Periodic Maintenance Chart beginning on page 64. Adjust the freeplay if necessary.

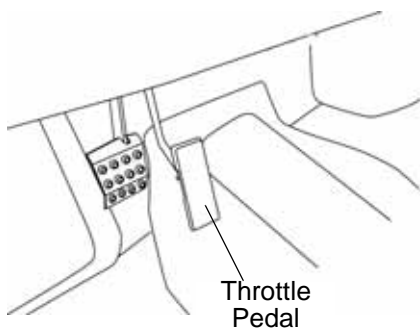

Throttle Freeplay Inspection

1. Apply the brakes.
2. Engage the park brake. Shift the transmission to neutral.
3. Start the engine. Allow it to warm up thoroughly.
4. Measure the distance the throttle pedal moves before the engine begins to pick up speed. Freeplay should be 1/16 to 1/8 inches (1.6-3.2 mm).

Throttle System Idle RPM

Idle RPM is preset by the manufacturer. If the engine idle speed is not satisfactory, please see your POLARIS dealer for adjustment.

Throttle Freeplay Adjustment

1. Remove the seat.
2. Locate the throttle cable adjuster.
3. Squeeze the end of the rubber boot and slide it far enough to expose the end of the inline cable adjuster.
4. Loosen the adjuster lock nut.
5. Rotate the boot to turn the adjuster until $1/16''$ to $1/8''$ (1.5-3 mm) of freeplay is achieved at the throttle pedal. See page 88.

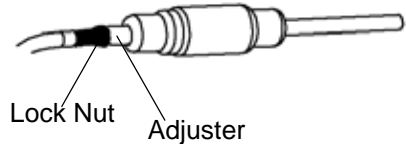
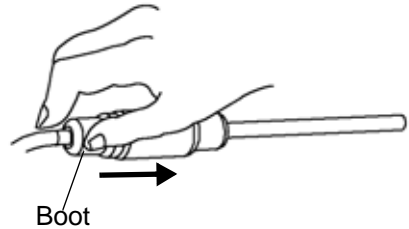

Tip: While adjusting, lightly flip the throttle pedal up and down.

6. Tighten the lock nut.
7. Squeeze the end of the rubber boot and slide it over the cable adjuster to its original position.

MAINTENANCE

Brakes

The front and rear brakes are hydraulic disc type brakes activated by the brake pedal. See page 26.

Brake Fluid

Inspect the brake system routinely. Inspect the level of the brake fluid before each operation.

WARNING! After opening a bottle of brake fluid, always discard any unused portion. Never store or use a partial bottle. Brake fluid is hygroscopic, meaning it rapidly absorbs moisture from the air. The moisture causes the boiling temperature of the brake fluid to drop, which can lead to early brake fade and the possibility of accident or severe injury.

Change the brake fluid every two years and any time the fluid becomes contaminated, the fluid level is below the minimum, or if the type and brand of the fluid in the reservoir are unknown.

1. Position the vehicle on a level surface.
2. View the brake fluid level at the reservoir in the driver's side wheel well.
3. The level should be between the upper (MAX) and lower (MIN) level lines.
4. If the fluid level is lower than the upper level line, add brake fluid to the upper (MAX) line.
5. Apply the brake forcefully for a few seconds and check for fluid leakage around the fittings.

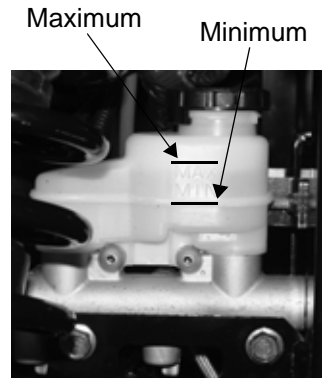

Brakes

Brake Inspection

1. Check the brake system for fluid leaks.
2. Check the brake pedal for excessive travel or a spongy feel.
3. Check the friction pads for wear, damage and looseness.
4. Inspect the brake disc spline and pad wear surface for excessive wear.
5. Change pads when worn to $3/64''$ (1 mm).

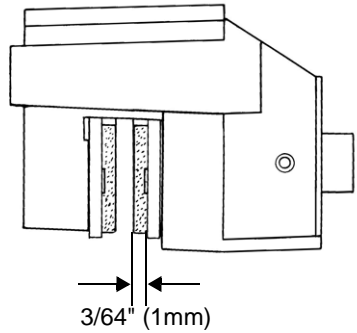

Park Brake Inspection

1. Apply the brakes.
2. Pull the park brake lever downward as far as possible.
3. Check the vehicle for movement. The vehicle should not roll while parked. If the vehicle moves, adjust the park brake.

Park Brake Release

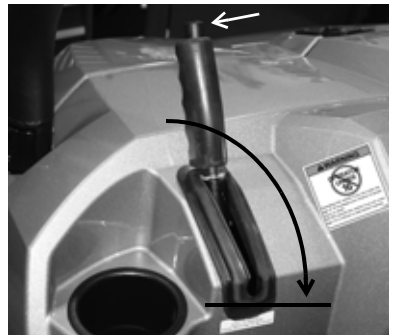

MAINTENANCE

Brakes

Park Brake Adjustment

Inspect and adjust park brake cable tension after the first 25 hours of operation and every 100 hours thereafter to ensure proper cable tension. Loss of tension in the park brake cable may cause illumination of the park brake light and activation of the limiting feature. If this occurs, move the park brake lever to the forward-most position, then inspect and adjust park brake cable tension.

Tip: If performing this service is difficult due to conditions or location, open the hood and temporarily disconnect the park brake connector. This will inactivate the limiting function. Reconnect the connector as soon as possible, and adjust the park brake cable to proper tension.

1. Position the vehicle on a level surface.
2. Shift the transmission to neutral.
3. Loosen or tighten the nuts on the lever end of the park brake cable as needed.

Steering Wheel Inspection

Check the steering wheel for specified freeplay and smooth operation at the intervals outlined in the Periodic Maintenance Chart beginning on page 64.

1. Position the vehicle on level ground.
2. Lightly turn the steering wheel left and right.
3. There should be 0.8"-1.0" (20-25 mm) of freeplay.
4. If there is excessive freeplay or strange noises, or the steering feels rough or "catchy," have the steering system inspected by an authorized POLARIS dealer.

Suspension Adjustments

The front and rear suspensions can be adjusted to provide a stiffer suspension, if necessary.

1. Remove the top shock mounting bolts from the inside mounting holes.
2. Reposition the shocks to the outside mounting holes.
3. Reinstall the shock mounting bolts. Torque to 30 ft. lbs. (40 Nm).

Spring Adjustment

Adjust the front and rear shock absorber springs by rotating the adjustment cam either clockwise or counterclockwise to increase or decrease spring tension.

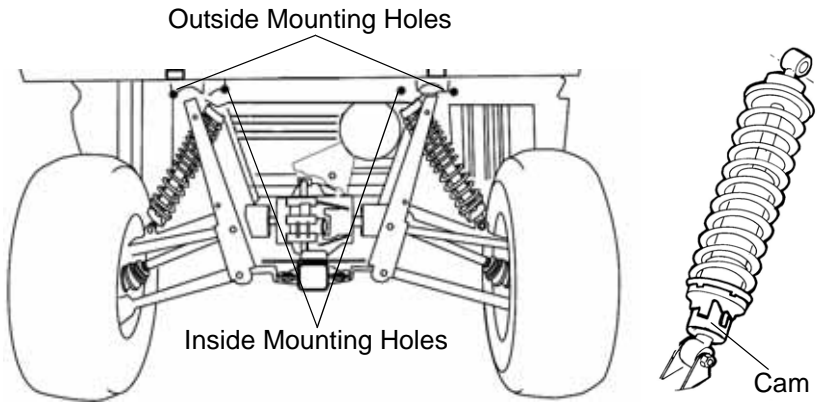

Rear Suspension Shown
Adjustment is similar for Front Suspension

MAINTENANCE

Tires

⚠ WARNING

Operating your vehicle with worn tires, improperly inflated tires, non-standard tires or improperly installed tires will affect vehicle handling and could cause an accident resulting in serious injury or death. Always follow all tire maintenance procedures as outlined in this manual and on the labels on the vehicle. Always use original equipment size and type when replacing tires.

Tire Tread Depth

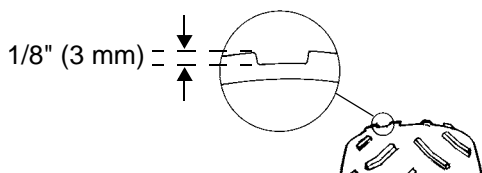

Always replace tires when tread depth is worn to 1/8" (3 mm) or less.



Axle and Wheel Nut Torque Specifications

Inspect the following items occasionally for tightness, and if they've been loosened for maintenance service.

Do not lubricate the stud or the lug nut.

Nut Type	Location	Nut Torque
Lug Nut (Aluminum Wheels) 	Front and Rear	30 ft. lbs. (41 Nm) PLUS 1/4 TURN
Nut and Washer (Steel Wheels) 	Front and Rear	35 ft. lbs. (47 Nm)
Spindle Nut	Front	70 ft. lbs. (95 Nm)
Hub Retaining Nuts	Center and Rear	110 ft. lbs. (150 Nm)

Tires

Wheel Removal

1. Apply the brakes.
2. Engage the park brake.
3. Stop the engine. Place the transmission in gear.
4. Loosen the wheel nuts slightly.
5. Elevate the side of the vehicle by placing a suitable stand under the frame.
6. Remove the wheel nuts and washers. Remove the wheel.

Wheel Installation

1. Apply the brakes.
2. Place the transmission in gear.
3. Engage the park brake.
4. Place the wheel in the correct position on the wheel hub. Be sure the valve stem is toward the outside and rotation arrows on the tire point toward forward rotation.

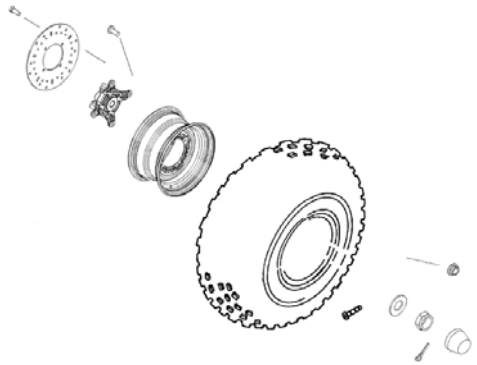

WARNING! Improperly installed wheels can adversely affect tire wear and vehicle handling, which can result in serious injury or death. Always ensure that all nuts are torqued to specification. Do not service axle nuts that have a cotter pin installed. See your POLARIS dealer.

5. Attach the wheel nuts and washers and finger tighten.
6. Carefully lower the vehicle to the ground.
7. Torque the wheel nuts to specification. See page 94.

MAINTENANCE

Lights

Poor lighting can result in reduced visibility when driving. Headlight and taillight lenses become dirty during normal operation. Clean lights frequently and replace burned out lamps promptly. Always make sure lights are adjusted properly for best visibility.

When servicing a halogen lamp, don't touch the lamp with bare fingers. Oil from your skin leaves a residue, causing a hot spot that will shorten the life of the lamp.

Headlight Lamp Replacement

1. Open the hood.

CAUTION! Hot components can cause burns to skin. Allow lamps to cool before servicing.

2. Unplug the headlamp from the wiring harness. Be sure to pull on the connector, not on the wiring.
3. Turn the lamp counterclockwise to remove it.
4. Install the new lamp.

Tip: Make sure the tab on the lamp locates properly in the housing.

5. Reinstall the harness assembly into the headlight assembly.

Brake Lights

When the brake pedal is depressed, the console brake light comes on. Check the brake light before each ride.

1. Turn the ignition switch to the ON position.
2. Depress the brake pedal. The brake light should come on after about 10 mm (0.4 in.) of pedal travel. If the light doesn't come on, check the bulb.

Lights

Headlight Beam Adjustment

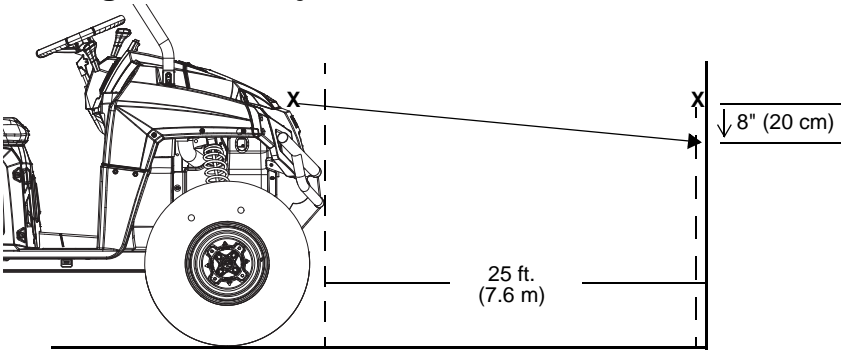

1. Place the vehicle on a level surface with the headlight approximately 25 ft. (7.6 m) from a wall.
2. Place the transmission in gear. Engage the park brake.
3. Measure the distance from the floor to the center of the headlight and make a mark on the wall at the same height.
4. Apply the brakes. Start the engine. Turn on the headlights.
5. Observe the headlight aim. The most intense part of the headlight beam should be aimed 8" (20 cm) below the mark placed on the wall. Include the weight of a rider on the seat while performing this step.
6. If a headlight needs adjustment, locate the adjustment screw at the back of the headlight.
7. Loosen the screw, adjust the headlight, and tighten the screw.
8. Repeat steps 5-7 until the lamp is properly adjusted.

MAINTENANCE

Fuses

If the engine stops or will not start, or if you experience other electrical failures, a fuse may need replacement. Locate and correct any short circuits that may have caused the blown fuse, then replace the fuse. Spare fuses are provided in the fuse box.

If you suspect that a fuse or relay may not be working properly, please see your POLARIS dealer.

Tip: The 120 ohm resistor (if equipped) is used by your POLARIS dealer for power steering diagnostics.

START RELAY	SPARE 30A	SPARE 20A	SPARE 10A
	FUEL PULL 30A		UNSWITCH 10A
PARK BRAKE RELAY	GLOW PLUG 30A		AUX. LIGHTING 20A
	DRIVE 20A	ACCESSORY 20A	LIGHTS 20A

7177049

	FAN RELAY	FUEL PULL RELAY
CHASSIS RELAY	GLOW PLUG RELAY	ATTACH RELAY

7176368



Battery

▲ WARNING

Improperly connecting or disconnecting battery cables can result in an explosion and cause serious injury or death. When removing the battery, always disconnect the negative (black) cable first. When reinstalling the battery, always connect the negative (black) cable last.

Your vehicle is equipped with a sealed battery, which requires little maintenance. Always keep battery terminals and connections free of corrosion. If cleaning is necessary, remove corrosion with a stiff wire brush. Wash with a solution of one tablespoon baking soda and one cup water. Rinse well with tap water and dry off with clean shop towels. Coat the terminals with dielectric grease or petroleum jelly.



Battery Removal

1. Remove the front seat.
2. Disconnect the black (-) battery cable first.
3. Disconnect the red (+) battery cable last.
4. Remove the battery hold-down strap.
5. Lift the battery out of the vehicle.

Battery Installation

Using a new battery that has not been fully charged can damage the battery and result in a shorter life. It can also hinder vehicle performance. Follow the battery charging instructions on page 100 before installing the battery.

1. Ensure that the battery is fully charged.
2. Place the battery in the battery holder. Install the battery hold-down strap.
3. Coat the terminals with dielectric grease or petroleum jelly.
4. Connect and tighten the red (+) cable first.
5. Connect and tighten the black (-) cable last.

MAINTENANCE

Battery

Battery Storage

Whenever the vehicle is not used for a period of three months or more, remove the battery from the vehicle, ensure that it's fully charged, and store it out of the sun in a cool, dry place. Check battery voltage each month during storage and recharge as needed to maintain a full charge.

POLARIS recommends maintaining battery charge by using a POLARIS Battery Tender charger or by charging about once a month to make up for normal self-discharge. Battery Tender can be left connected during the storage period, and will automatically charge the battery if the voltage drops below a pre-determined point. See page 110 for the part numbers of POLARIS products.

Battery Charging

The following battery charging instructions apply only to the installation of a sealed battery. Read all instructions before proceeding with the installation of this battery.

The sealed battery is already filled with electrolyte and has been sealed and *fully charged* at the factory. *Never* pry the sealing strip off or add any other fluid to this battery.

The single most important thing about maintaining a sealed battery is to keep it fully charged. Since the battery is sealed and the sealing strip cannot be removed, you must use a voltmeter or multimeter to measure DC voltage.

Battery

Battery Charging

WARNING! An overheated battery may explode, causing severe injury or death. Always watch charging times carefully. Stop charging if the battery becomes very warm to the touch. Allow it to cool before resuming charging.

For a refresh charge, follow all instructions carefully.

1. Check the battery voltage with a voltmeter or multimeter. A fully charged battery will register 12.8 V or higher.
2. If the voltage is less than 12.8 volts, recharge the battery at 1.2 amps or less until battery voltage is 12.8 or greater.
3. When using an automatic charger, refer to the charger manufacturer's instructions for recharging. When using a constant current charger, use the guidelines on the next page for recharging.

Always verify battery condition before and 1-2 hours after the end of charging.

State of Charge	Voltage	Action	Charge Time (Using constant current charger @ standard amps specified on top of battery)
100%	12.8-13.0 volts	None, check at 3 mos. from date of manufacture	None required
75%-100%	12.5-12.8 volts	May need slight charge, if no charge given, check in 3 months	3-6 hours
50%-75%	12.0-12.5 volts	Needs charge	5-11 hours
25%-50%	11.5-12.0 volts	Needs charge	At least 13 hours, verify state of charge
0%-25%	11.5 volts or less	Needs charge with desulfating charger	At least 20 hours

MAINTENANCE

Cleaning and Storage

Washing the Vehicle

Keeping your POLARIS vehicle clean will not only improve its appearance but it can also extend the life of various components.

NOTICE: High water pressure may damage components. POLARIS recommends washing the vehicle by hand or with a garden hose, using mild soap.

NOTICE: Certain products, including insect repellents and chemicals, will damage plastic surfaces. Do not allow these types of products to contact the vehicle.

The best and safest way to clean your POLARIS vehicle is with a garden hose and a pail of mild soap and water.

1. Use a professional-type washing cloth, cleaning the upper body first and the lower parts last.
2. Rinse with clean water frequently.
3. Dry surfaces with a chamois to prevent water spots.

Washing Tips

- Avoid the use of harsh cleaners, which can scratch the finish.
- Do not use a power washer to clean the vehicle.
- Do not use medium to heavy duty compounds on the finish.
- Always use clean cloths and pads for cleaning and polishing. Old or reused cloths and pads may contain dirt particles that will scratch the finish.

Cleaning and Storage

Washing the Vehicle

If a high pressure water system is used for cleaning (not recommended), exercise extreme caution. The water may damage components and could remove paint and labels. Avoid directing the water stream at the following items:

- Engine
- Air Intake
- Wheel bearings
- Radiator
- Transmission seals
- Brakes
- Cab and body panels
- Labels and decals
- Switches and controls
- Electrical components and wiring

If an informational or graphic label becomes illegible or comes off, contact your POLARIS dealer to purchase a replacement. Replacement *safety* labels are provided by POLARIS at no charge.

Grease all zerk fittings immediately after washing. Allow the engine to run for a while to evaporate any water that may have entered the engine or exhaust system.

Polishing the Vehicle

POLARIS recommends the use of common household aerosol furniture polish for polishing the finish on your POLARIS vehicle. Follow the instructions on the container.

Polishing Tips

- Avoid the use of automotive products, some of which can scratch the finish of your vehicle.
- Always use clean cloths and pads for cleaning and polishing. Old or reused cloths and pads may contain dirt particles that will scratch the finish.

MAINTENANCE

Cleaning and Storage

Chrome Wheel Care (if equipped)

Proper maintenance will protect chrome wheels from corrosion, preserve wheel life and ensure a “like new” appearance for many years. Chrome wheels exposed to road salt (or salt in the air in coastal areas) are more susceptible to corrosion if not properly cleaned. Clean chrome wheels more often if they're exposed to salt or other corrosive elements.

1. Wash chrome wheels frequently. Use a mild detergent. Never use abrasive cleaners on plated or painted surfaces.
2. Rinse well with clear water. Soap, detergents, salt, dirt, mud and other elements can cause corrosion.
3. Polish the clean chrome wheels periodically. Use an automotive grade chrome polish.
4. Routinely and liberally apply a weather resistant wax to each polished chrome wheel. Choose a product suitable for chrome finishes. Read and follow the product labels and instructions.

Removing Corrosion

If light rust is found on the chrome finish, use steel wool (#0000-OTT grade) to remove it. Gently rub the affected areas with the steel wool until the corrosion has been removed. Clean and polish the wheel as outlined above.

Cleaning and Storage

Storage Tips

Clean the Exterior

Make any necessary repairs and clean the vehicle as recommended. See page 102.

Oil and Filter

Change the oil and filter. See page 72.

Air Filter / Air Box

1. Inspect and clean or replace the pre-cleaner and air filter. See page 86.
2. Clean the air box, including sediment plugs.

Inspect and Lubricate

Inspect all cables and lubricate all areas of the vehicle as recommended in the Periodic Maintenance Chart beginning on page 64.

Battery Maintenance

See pages 100-101 for storage and charging procedures.

MAINTENANCE

Cleaning and Storage

Storage Tips

Fluid Levels

Inspect the fluid levels. Add or change fluids as recommended in the Periodic Maintenance Chart beginning on page 64.

- Front gearcase fluid
- Rear gearcase fluid
- Transmission fluid
- Brake fluid (change every two years and any time the fluid looks dark or contaminated)
- Coolant (test strength/fill)

Storage Area/Covers

Be sure the storage area is well ventilated. Cover the vehicle with a genuine POLARIS cover. Do not use plastic or coated materials. They do not allow enough ventilation to prevent condensation, and may promote corrosion and oxidation.

Removal from Storage

1. Charge the battery if necessary. Install it in the vehicle.
2. Fill the fuel tank with fuel.
3. Check all the points listed in the Daily Pre-Ride Inspection section on page 38. *Tightness of the bolts, nuts and other fasteners should be checked by an authorized POLARIS dealer.*
4. Lubricate at the intervals outlined in the Periodic Maintenance Chart beginning on page 64.

Transporting the *RANGER*

Follow these procedures when transporting the vehicle.

1. Apply the brakes.
2. Engage the park brake.
3. Stop the engine.
4. Place the transmission in gear.
5. Secure the fuel cap, oil cap and seat.
6. Always tie the frame of the *RANGER* to the transporting unit securely with suitable straps or rope. Do not attach tie straps to the front A-arm bolt pockets.
7. Remove the key to prevent loss during transporting.

SPECIFICATIONS

RANGER Diesel	
Maximum Weight Capacity	1500 lbs. (681 kg) (includes weight of operator, passenger, cargo, accessories)
Dry Weight	1435 lbs. (651 kg)
Fuel Capacity	8.8 gal. (33.3 l)
Engine Oil Capacity	1.8 qts. (1.7 l)
Coolant Capacity (Radiator)	190 oz. (5.6 l)
Coolant Capacity (Overflow)	7.5 oz. (222 ml)
Towing Capacity	2000 lbs. (907 kg)
Hitch Tongue Capacity	150 lbs. (68 kg)
Max. Cargo Box Load	1000 lbs. (454 kg)
Overall Length	114 in. (289.6 cm)
Overall Width (box)	60 in. (152.4 cm)
Overall Width (tires)	58 in. (147.3 cm)
Overall Height	76 in. (193 cm)
Wheelbase	76 in. (193 cm)
Cargo Box Dimensions (Inside)	36.5 x 54 x 11.5 in. (93 x 137 x 29 cm)
Ground Clearance	12 in. (30.5 cm)
Min. Turning Radius	158 in. (401 cm)
Engine	YANMAR 3-Cylinder Inline Diesel
Displacement	904 cc
Bore x Stroke	72mm x 74mm
Alternator Output	12V DC 55A
Compression Ratio	23.5:1
Starting System	Electric
Fuel System	Indirect Injection
Front Suspension	Dual A-arm w/9.6 in. (24.4 cm) of travel
Rear Suspension	Independent w/9 in. (23 cm) of travel

SPECIFICATIONS

RANGER Diesel

Lubrication System	Pressurized Wet Sump
Driving System Type	PVT, 4-wheel independent shaft, lockable differential
Shift Type	Single Lever (H/L/N/R)
Gear Reduction - Low	5.77:1
Gear Reduction - Reverse	5.17:1
Gear Reduction - High	2.72:1
Drive Ratio - Front:	3.818:1
Drive Ratio - Rear	3.70:1
Tire Size - Front	25 x 8 - 12
Tire Size - Rear	25 x 11 - 12
Tire Pressure - Front	8-12 psi (69 KPa)
Tire Pressure - Rear	8-12 psi (69 KPa)
Brakes, Front/Rear	Foot Activated, 4 wheel hydraulic disc
Brake, Park	Hand activated, mechanical
Hood Headlight	60/55W High/Low Halogen
Taillights	10 L.E.D. (.28W)
Brake Light	10 L.E.D. (3.1W)
Indicator Light	1.0 W

Clutching

See your POLARIS dealer for clutching specifications.

POLARIS PRODUCTS

Part Number	Description
Engine Lubricant	
2878473	15W-40 Diesel Oil, Summer (2 qt./1.9 l)
2878474	10W-30 Diesel Oil, Winter (2 qt./1.9 l)
2878471	Diesel Oil Change Kit, Summer
2878472	Diesel Oil Change Kit, Winter
Gearcase / Transmission Lubricants	
2878068	AGL PLUS Transmission Fluid (qt./95 l)
2878069	AGL PLUS Transmission Fluid (gal./3.8 l)
2877922	Demand Drive Plus Fluid (qt./95 l)
2877923	Demand Drive Plus Fluid (gal./3.8 l)
2871653	Premium ATV Angle Drive Fluid (8 oz./237 ml)
2872276	Premium ATV Angle Drive Fluid (2.5 gal./9.5 l)
2870465	Pump for Gallon (3.8 l) Jug
Coolant	
2871323	60/40 Coolant (gal./3.8 l)
2871534	60/40 Coolant (qt./95 l)
Grease / Specialized Lubricants	
2871312	Grease Gun Kit, Premium All Season
2871322	Premium All Season Grease (3 oz./89 ml cartridge)
2871423	Premium All Season Grease (14 oz./414 ml cartridge)
2871460	Starter Drive Grease
2871515	Premium U-Joint Lube (3 oz./89 ml cartridge)
2871551	Premium U-Joint Lube (14 oz./414 ml cartridge)
2871329	Dielectric Grease (Nyogel™)
Additives / Miscellaneous	
2872189	DOT 4 Brake Fluid
2871956	Loctite™ 565 Thread Sealant
2871076	POLARIS Battery Tender™ Charger

TROUBLESHOOTING

Drive Belt Wear/Burn

Possible Cause	Solution
Driving onto a pickup or tall trailer in high range	Use low range during loading.
Starting out going up a steep incline	Use low range. See warnings on page 51.
Driving at low RPM or ground speed (3-7 MPH)	Drive at a higher speed or use low range more frequently. See page 82.
Insufficient warm-up at low ambient temperatures	Warm the engine at least 5 minutes. With the transmission in neutral, advance the throttle to about 1/8 throttle in short bursts, 5 to 7 times. The belt will become more flexible and prevent belt burning.
Slow/easy clutch engagement	Use the throttle quickly and effectively.
Towing/pushing at low RPM/low ground speed	Use low range only.
Utility use/plowing	Use low range only.
Stuck in mud or snow	Shift the transmission to low range and carefully use fast, aggressive throttle application to engage clutch. WARNING: Excessive throttle may cause loss of control and vehicle overturn.
Climbing over large objects from a stopped position	Shift the transmission to low range and carefully use fast, brief, aggressive throttle application to engage clutch. WARNING: Excessive throttle may cause loss of control and vehicle overturn.
Belt slippage from water or snow ingestion into the PVT system	Dry out the PVT. See page 83. Inspect clutch seals for damage if repeated leaking occurs.
Clutch malfunction	See your POLARIS dealer.
Poor engine performance	Check for clogged air filter, clogged fuel filter, water in the fuel or foreign material in fuel tank or fuel lines. See your dealer.
Slippage from failure to warm up belt	Always warm up the belt by operating below 30 mph for one mile (5 miles or more when temperature is below freezing).
Wrong or missing belt	Install the recommended belt.
Improper break-in	Always break in a new belt and/or clutch. See pages 37 and 82.

TROUBLESHOOTING

Park Brake Alarm Fails to Turn Off

Possible Cause	Solution
Park brake is not completely disengaged	Ensure lever is in forward-most position
Park brake connector malfunction or switch movement or failure	Disconnect the connector if temporary continued operation is necessary, see your dealer promptly for service

Engine Doesn't Turn Over

Possible Cause	Solution
Low battery voltage	Recharge the battery to 12.8 VDC
Loose battery connections	Check all connections and tighten
Loose solenoid connections	Check all connections and tighten
Loose electronic control box connections	Inspect, clean, reinstall connectors

Engine Turns Over, Fails to Start

Possible Cause	Solution
Out of fuel	Refuel
Clogged fuel filter/water separator	Replace
Clogged air filter	Replace
Water is present in fuel	Drain the fuel system and refuel, replace fuel filter/water separator
Old or non-recommended fuel	Replace with fresh recommended fuel
Water or fuel in crankcase	Immediately see your POLARIS dealer
Low battery voltage	Recharge the battery to 12.8 VDC
Mechanical failure	See your dealer
Defective glow plug	Inspect and replace
Defective stop solenoid	Replace
Defective fuel pump	Replace

Engine Backfires

Possible Cause	Solution
Old or non-recommended fuel	Replace with fresh recommended fuel
Loose ignition connections	Check all connections and tighten
Water present in fuel	Replace with fresh recommended fuel

TROUBLESHOOTING

Engine Runs Irregularly, Stalls or Misfires

Possible Cause	Solution
Poor fuel quality or incorrect fuel	Replace with recommended fuel
Low fuel level	Refuel
Clogged fuel filter	Replace
Clogged air filter	Replace
Loose ignition connections	Check all connections and tighten
Water present in fuel	Replace with new fuel
Kinked or plugged fuel tank vent line	Inspect and replace
Other mechanical failure	See your dealer

Engine Stops or Loses Power

Possible Cause	Solution
Poor fuel quality or incorrect fuel	Replace with recommended fuel
Clogged fuel filter	Replace
Clogged air filter	Replace
Loose ignition connections	Check all connections and tighten
Water present in fuel	Replace with new fuel
Kinked or plugged fuel tank vent line	Inspect and replace
Other mechanical failure	See your dealer
Out of fuel	Refuel
Low battery voltage	Recharge the battery to 12.8 VDC
Overheated engine	Clean radiator screen and core, clean engine exterior, operate at lower load, see your dealer

DECLARATION OF CONFORMITY

POLARIS Industries Inc.,
2100 Hwy 55, Medina, MN 55340 U.S.A.
Telephone 763-542-0500
April 22, 2010



We, Polaris Industries Inc., declare that the vehicles listed below conform to the essential health and safety requirements applicable to off-road all-terrain vehicles.

APPLICABLE EUROPEAN DIRECTIVES	TEST / EVALUATION METHODS	
2006/42/EC as amended (Machinery Directive)	EN 1050 hazard analysis prEN 15997 driver-perceived noise level prEN 15997 vibration	
2004/108/EC as amended (EMC Directive)	CISPR 12:2009 CAN/CSA-C108.4-M92	EN 55012:2007 EN 61000-6-2:2005

PRODUCT IDENTIFICATION

VEHICLE SERIES	TRADE NAME	MODEL YEARS
__KA05__ / __KA09__	OUTLAW 50 / 90	2008, 2009, 2010, 2011
__FA09__	SPORTSMAN 90	2008, 2009, 2010, 2011
__VA17__	RZR 170	2009, 2010, 2011
__PB20__	PHOENIX 200	2008, 2009, 2010, 2011
__BA32__ , __NA32__	TRAIL BLAZER 330	2008, 2009, 2010, 2011
__CA32__ , __EA32__	TRAIL BOSS 330	2008, 2009, 2010, 2011
__BA50__ , __BG50__	SCRAMBLER 500	2008, 2009, 2010, 2011
__GJ45__	OUTLAW 450	2008, 2009, 2010, 2011
__GJ52__ , __GP52__	OUTLAW 525 / 525 S	2008, 2009, 2010, 2011
__LH46__	SPORTSMAN 400	2008, 2009, 2010, 2011
__MH50__	SPORTSMAN 500 HO	2008, 2009, 2010, 2011
__DH50__	SPORTSMAN 500 HO TOURING	2010, 2011
__ZN55__ , __ZX55__	SPORTSMAN 550 EFI	2009, 2010, 2011
__TN55__ , __TX55__	SPORTSMAN 550 X2	2010, 2011
__DN55__ , __DX55__	SPORTSMAN 550 TOURING	2010, 2011
__MN76__	SPORTSMAN 800	2008, 2009, 2010, 2011
__CL76__ , __CF76__	SPORTSMAN 800 6X6	2009, 2010, 2011
__ZN85__ , __ZX85__	SPORTSMAN 850 EFI	2009, 2010, 2011
__TN85__ , __TX85__	SPORTSMAN 850 X2	2010, 2011
__DN85__ , __DX85__	SPORTSMAN 850 TOURING	2010, 2011
__RH45__	RANGER 400 / 450	2010, 2011
__RH50__	RANGER 500 4X4	2010, 2011
__TH76__	RANGER 800 EFI 4X4	2010, 2011
__WH50__	RANGER 500 CREW	2011
__WH76__	RANGER 800 EFI CREW	2010, 2011
__HR76__	RANGER 800 6X6	2010, 2011
__HY76__ , __TY76__	RANGER HD 800 4X4	2010, 2011
__TH90__	RANGER DIESEL	2011
__VH76__ , __VY76__	RANGER RZR / RZR S	2008, 2009, 2010, 2011
__XH76__	RANGER RZR 4	2011

European Community Person Authorized to Compile the Technical File: Ross Clifford, General Manager Polaris Britain Ltd Forge Mills Park, Station Road Coleshill, Warwickshire B46 1HT	Authorized Manufacturer Signatory Empowered to Draw up the EC Declaration of Conformity: Lawrence E. Keller, Product Compliance Manager 7290 East Viking Blvd. Wyoming, MN 55092
--	---

WARRANTY

LIMITED WARRANTY

POLARIS Sales Inc., 2100 Highway 55, Medina, MN 55340, gives a SIX MONTH LIMITED WARRANTY on all components of the POLARIS *RANGER* against defects in material or workmanship. POLARIS also gives a 12-month/1000-hours of engine operation limited warranty on the engine of this vehicle for failure due to defects. This warranty covers the parts and labor charges for repair or replacement of defective parts which are covered by this warranty. This warranty begins on the date of purchase. This warranty is transferable to another consumer during the warranty period through a POLARIS dealer.

REGISTRATION

At the time of sale, the Warranty Registration Form must be completed by your dealer and submitted to POLARIS within ten days. Upon receipt of this registration, POLARIS will record the registration for warranty. No verification of registration will be sent to the purchaser as the copy of the Warranty Registration Form will be the warranty entitlement. If you have not signed the original registration and received the customer copy, please contact your dealer immediately. **NO WARRANTY COVERAGE WILL BE ALLOWED UNLESS YOUR VEHICLE IS REGISTERED WITH POLARIS.**

Initial dealer preparation and set-up of your vehicle is very important in ensuring trouble-free operation. Purchasing a machine in the crate or without proper dealer set-up will void your warranty coverage.

WARRANTY COVERAGE AND EXCLUSIONS: LIMITATIONS OF WARRANTIES AND REMEDIES

The POLARIS limited warranty excludes any failures that are not caused by a defect in material or workmanship. This warranty does not cover accidental damage, normal wear and tear, abuse or improper handling. This warranty also does not cover any vehicle that has been altered structurally, modified, neglected, improperly maintained, used for racing, or used for purposes other than for which it was manufactured, or for any damages which occur during trailer transit or as a result of unauthorized service or the use of unauthorized parts. In addition, this warranty does not cover physical damage to paint or finish, stress cracks, tearing or puncturing of upholstery material, corrosion, or defects in parts, components or the vehicle due to fire, explosions or any other cause beyond POLARIS' control.

Warranty does not apply to parts exposed to friction surfaces, stresses, environmental conditions and/or contamination for which they were not designed or not intended, including but not limited to the following items:

- Wheels and tires
- Suspension components
- Brake components
- Seat components
- Clutches and components
- Steering components
- Batteries
- Light bulbs/Sealed beam lamps
- Finished and unfinished surfaces
- Carburetor/Throttle body components
- Engine components
- Drive belts
- Hydraulic components
- Circuit breakers/Fuses
- Electronic components

WARRANTY

LIMITATIONS OF WARRANTIES AND REMEDIES

Warranty applies to the product only and does not allow for coverage of personal loss. Some items are considered "consumable," meaning they are considered part of normal maintenance or part of completing an effective repair. The following items are excluded from warranty coverage in the event of a warranty claim:

- Spark Plugs
- Filters
- Fuel
- Sealants
- Hotel fees
- Towing charges
- Mileage
- Rentals/Loss of product use
- Lubricants such as oil, grease, etc.
- Batteries (unless defective)
- Cosmetic damage/repair
- Coolants
- Meals
- Shipping/ handling fees
- Product pick-up/delivery
- Loss of vacation/personal time

This warranty also excludes failures resulting from improper lubrication; improper engine timing; improper fuel; surface imperfections caused by external stress, heat, cold or contamination; operator error or abuse; improper component alignment, tension, adjustment or altitude compensation; failure due to snow, water, dirt or other foreign substance ingestion/contamination; improper maintenance; modified components; use of aftermarket components resulting in failure; unauthorized repairs; repairs made after the warranty period expires or by an unauthorized repair center; use of the product in competition or for commercial purposes. Warranty will not apply to any product which has been damaged by abuse, accident, fire or any other casualty not determined a defect of materials or workmanship.

This warranty does not cover the use of unauthorized lubricants, chemicals, or fuels that are not compatible with the vehicle. The exclusive remedy for breach of this warranty shall be, at POLARIS' exclusive option, repair or replacement of any defective materials, or components or products. **THE REMEDIES SET FORTH IN THIS WARRANTY ARE THE ONLY REMEDIES AVAILABLE TO ANY PERSON FOR BREACH OF THIS WARRANTY. POLARIS SHALL HAVE NO LIABILITY TO ANY PERSON FOR INCIDENTAL, CONSEQUENTIAL OR SPECIAL DAMAGES OF ANY DESCRIPTION, WHETHER ARISING OUT OF EXPRESS OR IMPLIED WARRANTY OR ANY OTHER CONTRACT, NEGLIGENCE, OR OTHER TORT OR OTHERWISE. THIS EXCLUSION OF CONSEQUENTIAL, INCIDENTAL, AND SPECIAL DAMAGES IS INDEPENDENT FROM AND SHALL SURVIVE ANY FINDING THAT THE EXCLUSIVE REMEDY FAILED OF ITS ESSENTIAL PURPOSE.** Some states do not permit the exclusion or limitation of incidental or consequential damages or implied warranties, so the above limitations or exclusions may not apply to you if inconsistent with controlling state law.

WARRANTY

LIMITATIONS OF WARRANTIES AND REMEDIES

ALL IMPLIED WARRANTIES (INCLUDING BUT NOT LIMITED TO THE IMPLIED WARRANTIES OF MERCHANTABILITY AND FITNESS FOR A PARTICULAR PURPOSE) ARE LIMITED IN DURATION TO THE ABOVE SIX MONTH WARRANTY PERIOD. POLARIS FURTHER DISCLAIMS ALL EXPRESS WARRANTIES NOT STATED IN THIS WARRANTY. Some states do not allow limitations on how long an implied warranty lasts, so the above limitation may not apply to you if inconsistent with controlling state law.

12-MONTH / 1000-HOUR ENGINE OPERATION LIMITED ENGINE WARRANTY TERMS AND EXCLUSIONS

How long is the engine warranty period?

The standard limited warranty on the engine of this vehicle runs for a period of twelve (12) months or 1000 engine operation hours, whichever occurs first. The warranty period on the engine (by duration or operation hours) begins on the date of delivery to the original retail purchaser and is valid only until the applicable warranted duration has passed or the operation hours are exceeded, whichever comes first.

What is NOT covered by this warranty?

This warranty does not cover parts affected by or damaged by any reason other than defective materials or workmanship including, but not limited to, accident, misuse, abuse, "Acts of God", neglect, improper installation, improper maintenance, improper storage, the use of unsuitable attachments or parts, the use of contaminated fuels, the use of fuels, oils, lubricants or fluids other than those recommended in this manual, unauthorized alterations or modifications, ordinary wear and tear, and rust or corrosion.

This warranty does not cover the cost of parts and/or labor required to perform normal scheduled maintenance on your engine. This warranty does not cover consumable parts such as, but not limited to, filters, belts, hoses, fuel injector nozzles, lubricants and cleaning fluids. This warranty does not cover the cost of shipping the product to or from your POLARIS dealership.

WARRANTY

HOW TO OBTAIN WARRANTY SERVICE

If your vehicle requires warranty service, you must take it to a POLARIS Servicing Dealer. When requesting warranty service you must present your copy of the Warranty Registration form to the dealer. (THE COST OF TRANSPORTATION TO AND FROM THE DEALER IS YOUR RESPONSIBILITY). POLARIS suggests that you use your original selling dealer; however, you may use any POLARIS Servicing Dealer to perform warranty service.

Please work with your dealer to resolve any warranty issues. Should your dealer require any additional assistance they will contact the appropriate person at POLARIS.

This warranty gives you specific legal rights, and you may also have other rights which vary from state to state.

If any of the above terms are void because of state or federal law, all other warranty terms will remain in effect.

Lubricants

1. Mixing oil brands or using non-recommended oil may cause engine damage. We recommend the use of POLARIS engine oil.
2. Damage resulting from the use of non-recommended lubricants may not be covered by warranty.

SPARK ARRESTOR

POLARIS warrants that the spark arrestor in this vehicle will meet the efficiency requirements of USFS standard 5100-1c for at least 1000 hours when subjected to normal use and when maintenance and installation are in accordance with POLARIS recommendations.

EXPORTED VEHICLES

EXCEPT WHERE SPECIFICALLY REQUIRED BY LAW, THERE IS NO WARRANTY OR SERVICE BULLETIN COVERAGE ON THIS VEHICLE IF IT IS SOLD OUTSIDE THE COUNTRY OF THE SELLING DEALER'S AUTHORIZED LOCATION.

This policy does not apply to vehicles that have received authorization for export from POLARIS Industries. Dealers may not give authorization for export. You should consult an authorized dealer to determine this vehicle's warranty or service bulletin coverage if you have any questions.

This policy does not apply to vehicles registered to government officials or military personnel on assignment outside the country of the selling dealer's authorized location.

This policy does not apply to Safety Bulletins.

EXPORTED VEHICLES

How to Get Service

In the Country where your vehicle was purchased:

Warranty or Service Bulletin repairs must be done by an authorized POLARIS dealer. If you move or are traveling within the country where your vehicle was purchased, Warranty or Service Bulletin repairs may be requested from any authorized POLARIS dealer who sells the same line as your vehicle.

Outside the Country where your vehicle was purchased:

If you are traveling temporarily outside the country where your vehicle was purchased, you should take your vehicle to an authorized POLARIS dealer. You must show the dealer photo identification from the country of the selling dealer's authorized location as proof of residence. Upon residence verification, the servicing dealer will be authorized to perform the warranty repair.

If You Move:

If you move to another country, be sure to contact POLARIS Customer Assistance and the customs department of the destination country before you move. Vehicles importation rules vary considerably from country to country. You may be required to present documentation of your move to POLARIS Industries in order to continue your warranty coverage. You may also be required to obtain documentation from POLARIS Industries in order to register your vehicle in your new country. You should warranty register your vehicle at a local POLARIS dealer in your new country immediately after you move to continue your warranty coverage and to ensure that you receive safety information and notices regarding your vehicle.

If Purchased From A Private Party:

If you purchase a POLARIS product from a private citizen, to be kept and used outside of the country in which the vehicle was originally purchased, all warranty coverage will be denied. You must nonetheless warranty register your vehicle under your name and address with a local POLARIS dealer in your country to ensure that you receive safety information and notices regarding your vehicle.

Notice

If your vehicle is registered outside of the country where it was purchased, and you have not followed the procedure set out above, your vehicle will no longer be eligible for warranty or service bulletin coverage of any kind, other than *safety* bulletins. (Vehicles registered to Government officials or military personnel on assignment outside of the country where the vehicle was purchased will continue to be covered by the basic warranty.)

For questions call POLARIS Customer Assistance:

United States: 1-888-704-5290

Canada: 1-204-925-7100

WARRANTY

Your POLARIS dealer is authorized to perform all warranty and service repairs on your diesel engine. Contact POLARIS Customer Assistance or an authorized POLARIS dealer.

In this emission control limited warranty, the term "Manufacturer" means Yanmar Co., Ltd. (Yanmar) as the holder of the U.S. Environmental Protection Agency (U.S. EPA) Certificate of Conformity and California Executive Order for the vehicle. The emission control limited warranty is in addition to the standard limited warranty for your vehicle.

EMISSION CONTROL SYSTEM WARRANTY

Your Warranty Rights and Obligations:

The California Air Resources Board (CARB), the United States Environmental Protection Agency (EPA) and Yanmar Co., Ltd., hereafter referred to as the Manufacturer, are pleased to explain the **emission control system warranty** on your 2007 and subsequent model year industrial compression-ignition engine. California-certified, new off-road compression-ignition engines must be designed, built and equipped to meet the State's stringent anti-smog standards. In the remaining forty nine (49) states, new off-road compression-ignition engines must be designed, built and equipped to meet the United States EPA emissions standards. The Manufacturer must warrant the emission control system on your engine for the periods of time listed below provided there has been no abuse, neglect or improper maintenance of your engine.

Your emission control system may include parts such as the fuel injection system and the air induction system. Also included may be hoses, belts, connectors and other emission-related assemblies.

Where a warrantable condition exists, the Manufacturer will repair your off-road compression-ignition engine at no charge to you including diagnosis, parts and labor.

EMISSION CONTROL SYSTEM WARRANTY

Manufacturer's Warranty Period:

2007 and subsequent model year off-road compression-ignition engines are warranted for the periods listed below. If any emission-related part on your engine is found to be defective during the applicable warranty period, the part will be repaired or replaced by the Manufacturer.

Engine Type	Warranty Period by Number of Years or Hours of Operation
Constant speed engines rated at or above 37 kW	The warranty period is five (5) years or 3,000 hours of use, whichever occurs first. In the absence of a device to measure the hours of use, the engine has a warranty period of five (5) years.
Constant speed engines rated under 37 kW with rated speeds greater than or equal to 3,000 rpm	The warranty period is two (2) years or 1,500 hours of use, whichever occurs first. In the absence of a device to measure the hours of use, the engine has a warranty period of two (2) years.
Engines rated at or above 19 kW	The warranty period is five (5) years or 3,000 hours of use, whichever occurs first. In the absence of a device to measure the hours of use, the engine has a warranty period of five (5) years.
Engines rated under 19 kW	The warranty period is two (2) years or 1,500 hours of use, whichever occurs first. In the absence of a device to measure the hours of use, the engine has a warranty period of two (2) years.

WARRANTY

EMISSION CONTROL SYSTEM WARRANTY

Warranty Coverage:

This warranty is transferable to each subsequent purchaser for the duration of the warranty period. Repair or replacement of any warranted part will be performed at an authorized dealer.

Warranted parts not scheduled for replacement as required maintenance in the owner's manual shall be warranted for the warranty period. Warranted parts scheduled for replacement as required maintenance in the owner's manual are warranted for the period of time prior to the first scheduled replacement. Any warranted parts scheduled for replacement as required maintenance that are repaired or replaced under warranty shall be warranted for the remaining period of time prior to the first scheduled replacement. Any part not scheduled for replacement that is repaired or replaced under warranty shall be warranted for the remaining warranty period.

During the warranty period, the Manufacturer is liable for damages to other engine components caused by the failure of any warranted part during the warranty period.

Any replacement part which is functionally identical to the original equipment part in all respects may be used in the maintenance or repair of your engine, and shall not reduce the Manufacturer warranty obligations. Add-on or modified parts that are not exempted may not be used. The use of any non-exempted add-on or modified parts shall be grounds for disallowing a warranty.

Warranted Parts:

This warranty covers engine components that are a part of the emission control system of the engine as delivered by Yanmar to the original retail purchaser. Such components may include the following:

- A. Fuel injection system
- B. Cold start enrichment system
- C. Intake manifold
- D. Turbocharger systems
- E. Exhaust manifold
- F. Positive crankcase ventilation system
- G. Charge Air Cooling systems
- H. Exhaust Gas Recirculation (EGR) systems
- I. Electronic Controls
- J. Hoses, belts, connectors and assemblies associated with emission control systems

Since emissions-related parts may vary slightly between models, certain models may not contain all of these parts and other models may contain the functional equivalents.

EMISSION CONTROL SYSTEM WARRANTY

Exclusions:

Failures other than those arising from defects in material or workmanship are not covered by this warranty. The warranty does not extend to the following: malfunctions caused by abuse, misuse, improper adjustment, modification, alteration, tampering, disconnection, improper or inadequate maintenance, or use of non-recommended fuels and lubricating oils, accident-caused damage and replacement of expendable items made in connection with scheduled maintenance. The Manufacturer disclaims any responsibility for incidental or consequential such as loss of time, inconvenience, loss of use of equipment/engine or commercial loss.

Owner's Warranty Responsibilities:

As the off-road compression-ignition engine owner, you are responsible for the performance of the required maintenance listed in your owner's manual. The Manufacturer recommends that you retain all documentation, including receipts, covering maintenance on your off-road compression-ignition engine, but the Manufacturer cannot deny warranty solely for the lack of receipts or for your failure to ensure the performance of all scheduled maintenance.

The Manufacturer may deny your warranty coverage if your off-road compression-ignition engine or a part has failed due to abuse, neglect, improper maintenance or unapproved modifications.

Your engine is designed to operate on diesel fuel only. Use of any other fuel may result in your engine no longer operating in compliance with CARB and EPA emissions requirements.

You are responsible for initiating the warranty process. You must present your engine to an authorized dealer as soon as a problem exists. The warranty repairs should be completed by the dealer as expeditiously as possible. If you have any questions regarding your warranty rights and responsibilities, or would like information on the nearest dealer or authorized service center, you should contact the department indicated in the vehicle standard warranty statement.

INDEX

A

Accessory Outlets	22
Air Filter	86
All Wheel Drive	61-62
Disengaging AWD	61
Engaging AWD	61
Locking the Differential	62
All Wheel Drive Switch	25
Auxiliary Outlets	22
Axle Nut Inspection	94
Axle Nut Torque	94

B

Battery	99-101
Charging	100-101
Installation	99
Removal	99
Storage	100
Battery Warnings	99
Belt Burning	111
Belt Life	59
Belt Wear	111
Bio-Diesel Fuels	40-42
Blended Fuel	44-45
Block Heater Use	44
Brake Fluid	90
Brake Inspection	91
Brake Light Inspection	96
Brake Pedal	26
Brake, Park	23
Brake, Park, Adjustment	92
Brake, Park, Inspection	91
Brakes	90-92
Braking	47
Break-In Period	37

C

Cab Frame, ROPS	30
Cab Nets	27
Capacity, Weight	58
Cargo	57-58
Cargo Box, Dumping	60
Chrome Wheel Care	104
Cleaning and Storage	102-106
Clutching	109
Cold Weather Operation	44-45
Component Locations	20-21

C

Console	22-23
Coolant Level, Overflow Bottle	80
Coolant Level, Radiator	81
Coolant, Adding or Changing	79
Cooling Fan	80
Cooling System	79-81
Corrosion Removal, Chrome	104

D

Differential Lock Switch	25
Differential Locking	62
Disengaging AWD	61
Drive Belt Wear	111
Driving Downhill	52
Driving in Reverse	55
Driving on a Sidehill	52
Driving on Slippery Surfaces	50
Driving Over Obstacles	54
Driving Procedure	48
Driving Through Water	53
Driving Uphill	51
Driving with a Passenger	49
Driving, After Driving in Water	83
Drying the Transmission	83
Dumping the Cargo Box	60

E

Engaging AWD	61
Engine Oil	70-73
Engine Starting	46
Engine Stopping	47
Equipment Modifications	13
Exhaust System Purging	87

F

Fan, Cooling	80
Filter, Air	86
Filter, Fuel	85
Fluid, Brake	90
Fluid Change	
Engine Oil	72-73
Front Gearcase	76
Main Gearcase	75
Rear Gearcase	78
Transmission	75

INDEX

F

Fluid Level	
Engine Oil	71
Front Gearcase	76
Main Gearcase	74
Rear Gearcase	77
Transmission	74
Fluid Levels During Storage	106
Fluid Part Numbers	110
Front Gearcase	76
Fuel Filter	85
Fuel Handling	43
Fuel Recommendations	39-43
Fuel Requirements	39-40
Fuel Safety	43
Fuel, Adding	43
Fuels, Bio-Diesel	40-42
Fuses	98

G

Gear Selector	22
Gearcase Specification Chart	74
Gearcase, Front	76
Gearcase, Rear	77-78
Gearcases	74-78
Gears, Shifting	22

H

Hauling Cargo	57-58
Headlight Beam Adjustment	97
Headlight Lamp Replacement	96
Hitch	26
Hitch Weight	59

I

Idle RPM	89
Ignition Switch	24
Indicator Lights	24-25
Inspection, Pre-Ride	38
Instrument Cluster	31-36
Interference, Electromagnetic	63

K

Key, Periodic Maintenance Chart	65
---------------------------------	----

L

Lamp Replacement, Headlight	96
Light Switch	25
Lights	96-97
Load Capacity	58
Low Oil Pressure Indicator	25
Lubrication Recommendations	69

M

Maintenance Log	124-126
Maintenance, Periodic	64-68
Mode Button	22
Modifications to Vehicle	13

N

Noise Emission Control System	63
-------------------------------	----

O

Obstacles	54
-----------	----

Oil

Engine	70-73
Transmission	74-75

Oil and Filter Care During Storage	105
------------------------------------	-----

Oil Change

Engine	72-73
Front Gearcase	76
Main Gearcase	75
Rear Gearcase	78
Transmission	75

Oil Level

Engine	71
Front Gearcase	76
Main Gearcase	74
Rear Gearcase	77
Transmission	74

Oil Recommendation, Engine	70
----------------------------	----

Operation on Public Lands	63
---------------------------	----

Operator Safety	10-19
-----------------	-------

Outlets, Auxiliary	22
--------------------	----

P

Park Brake	23
------------	----

Park Brake Adjustment	92
-----------------------	----

Park Brake Inspection	91
-----------------------	----

Parking on an Incline	56
-----------------------	----

Parking the Vehicle	56
---------------------	----

INDEX

P

Periodic Maintenance Chart	64-68
Plug, Accessory	22
Polaris Products	110
Polishing the Vehicle	103
Pre-Ride Inspection	38
Public Lands	63
PVT Break-In	37
PVT Drying	83
PVT System	82
PVT Warning	82

R

Radiator	80
Radiator Coolant Level	81
Rear Gearcase	77-78
Rear Suspension Adjustment	93
Receiver Hitch	26
Refueling	43
Removing the Vehicle from Storage	107
Reverse Operation	55
Rider Information Center	32-36
ROPS Cab Frame	30

S

Safety Labels	7-9
Seat Belts	28-29
Seat Removal	29
Service Interval Programming	36
Severe Use Definition	64
Shifter	22
Shifting Gears	22
Shock Spring Adjustment	93
Spark Arrestor Purging	87
Specifications	108-109
Specifications, Gearcase	74
Speed, Towing	59
Speedometer	31
Spring, Shock, Adjustment	93
Starting the Engine	46
Steering Wheel Inspection	92
Steering Wheel, Adjustment	26
Stopping the Engine	47
Storage	102-106
Storage Compartments	30
Storage, Battery	100
Storage, Fluid Levels	106

S

Storage, Oil and Filter	105
Suspension Adjustment, Rear	93
Switches	24-25
AWD Switch	25
Differential Lock Switch	25
Ignition	24
Light	25

T

Throttle Freeplay	88
Throttle Freeplay Adjustment	89
Throttle Freeplay Inspection	88
Throttle Pedal	26
Throttle System	88-89
Tilt Steering	26
Tire Tread Depth	94
Tires	94-95
Torque, Axle Nuts	94
Torque, Wheel Nut	94
Towing Loads	59
Towing Speed	59
Trailer Hitch	26
Transmission	74-75
Transmission Operation	82
Transmission System	82-83
Transmission Warning	82
Transmission, Drying	83
Transporting the Vehicle	107
Tread Depth	94

V

Vehicle Identification Numbers	6
Vehicle Immersion	84
Vehicle Transport	107

W

Wait-to-Start Indicator	25
Warning Symbols	4
Warning, Transmission Modification	82
Washing the Vehicle	102-103
Water Separator	85
Water, Immersion of Vehicle	84
Weight Capacity	58
Wheel Installation	95
Wheel Nut Inspection	94
Wheel Nut Torque	94
Wheel Removal	95