

**DIAGNOSTIC  
REPAIR  
MANUAL**

**GENERAC®**

**QuietPact® 40G & 40LP**



MODELS:

4700

4701

4709

**RECREATIONAL VEHICLE GENERATORS**

## **SAFETY**

Throughout this publication, “DANGER!” and “CAUTION!” blocks are used to alert the mechanic to special instructions concerning a particular service or operation that might be hazardous if performed incorrectly or carelessly. **PAY CLOSE ATTENTION TO THEM.**



**DANGER! UNDER THIS HEADING WILL BE FOUND SPECIAL INSTRUCTIONS WHICH, IF NOT COMPLIED WITH, COULD RESULT IN PERSONAL INJURY OR DEATH.**



**CAUTION! Under this heading will be found special instructions which, if not complied with, could result in damage to equipment and/or property.**

These “Safety Alerts” alone cannot eliminate the hazards that they signal. Strict compliance with these special Instructions plus “common sense” are major accident prevention measures.

### ***NOTICE TO USERS OF THIS MANUAL***

This SERVICE MANUAL has been written and published by Generac to aid our dealers’ mechanics and company service personnel when servicing the products described herein.

It is assumed that these personnel are familiar with the servicing procedures for these products, or like or similar products manufactured and marketed by Generac. That they have been trained in the recommended servicing procedures for these products, including the use of common hand tools and any special Generac tools or tools from other suppliers.

Generac could not possibly know of and advise the service trade of all conceivable procedures by which a service might be performed and of the possible hazards and/or results of each method. We have not undertaken any such wide evaluation. Therefore, anyone who uses a procedure or tool not recommended by Generac must first satisfy himself that neither his nor the products safety will be endangered by the service procedure selected.

All information, illustrations and specifications in this manual are based on the latest product information available at the time of publication.

When working on these products, remember that the electrical system and engine ignition system are capable of violent and damaging short circuits or severe electrical shocks. If you intend to perform work where electrical terminals could be grounded or touched, the battery cables should be disconnected at the battery.

Any time the intake or exhaust openings of the engine are exposed during service, they should be covered to prevent accidental entry of foreign material. Entry of such materials will result in extensive damage when the engine is started.

During any maintenance procedure, replacement fasteners must have the same measurements and strength as the fasteners that were removed. Metric bolts and nuts have numbers that indicate their strength. Customary bolts use radial lines to indicate strength while most customary nuts do not have strength markings. Mismatched or incorrect fasteners can cause damage, malfunction and possible injury.

### ***REPLACEMENT PARTS***

Components on Generac recreational vehicle generators are designed and manufactured to comply with Recreational Vehicle Industry Association (RVIA) Rules and Regulations to minimize the risk of fire or explosion. The use of replacement parts that are not in compliance with such Rules and Regulations could result in a fire or explosion hazard. When servicing this equipment, It is extremely important that all components be properly installed and tightened. If Improperly Installed and tightened, sparks could Ignite fuel vapors from fuel system leaks.

**SAFETY ..... INSIDE FRONT COVER**

**SECTION 1:  
GENERATOR FUNDAMENTALS .....3-6**

MAGNETISM ..... 3  
 ELECTROMAGNETIC FIELDS ..... 3  
 ELECTROMAGNETIC INDUCTION ..... 3  
 A SIMPLE AC GENERATOR ..... 4  
 A MORE SOPHISTICATED AC GENERATOR ..... 4  
 FIELD BOOST ..... 6  
 GENERATOR AC CONNECTION SYSTEM ..... 6

**SECTION 2:  
MAJOR GENERATOR COMPONENTS .....7-9**

ROTOR ASSEMBLY ..... 7  
 STATOR ASSEMBLY ..... 7  
 BRUSH HOLDER ..... 7  
 BATTERY CHARGE COMPONENTS ..... 8  
 EXCITATION CIRCUIT COMPONENTS ..... 8  
 BREATHER ASSEMBLY ..... 9

**SECTION 3:  
INSULATION RESISTANCE TESTS ..... 10-12**

EFFECTS OF DIRT AND MOISTURE ..... 10  
 INSULATION RESISTANCE TESTERS ..... 10  
 DRYING THE GENERATOR ..... 10  
 CLEANING THE GENERATOR ..... 10  
 STATOR INSULATION RESISTANCE ..... 11  
 TESTING ROTOR INSULATION ..... 12  
 THE MEGOHMMETER ..... 12

**SECTION 4:  
MEASURING ELECTRICITY ..... 13-15**

METERS ..... 13  
 THE VOM ..... 13  
 MEASURING AC VOLTAGE ..... 13  
 MEASURING DC VOLTAGE ..... 13  
 MEASURING AC FREQUENCY ..... 14  
 MEASURING CURRENT ..... 14  
 MEASURING RESISTANCE ..... 14  
 ELECTRICAL UNITS ..... 15  
 OHM'S LAW ..... 15

**SECTION 5:  
ENGINE DC CONTROL SYSTEM ..... 16-24**

INTRODUCTION ..... 16  
 OPERATIONAL ANALYSIS ..... 16  
 ENGINE CONTROLLER CIRCUIT BOARD ..... 22  
 BATTERY ..... 22  
 7.5 AMP FUSE ..... 23  
 FUEL PRIMER SWITCH ..... 23  
 START-STOP SWITCH ..... 23  
 STARTER CONTACTOR & MOTOR ..... 24

**SECTION 6:  
TROUBLESHOOTING FLOWCHARTS ..... 25-35**

IF PROBLEM INVOLVES AC OUTPUT ..... 25  
 PROBLEM 1 –  
 VOLTAGE & FREQUENCY ARE BOTH  
 HIGH OR LOW ..... 25  
 PROBLEM 2 –  
 GENERATOR PRODUCES ZERO VOLTAGE OR  
 RESIDUAL VOLTAGE (5-12 VAC) ..... 26  
 PROBLEM 3 –  
 NO BATTERY CHARGE OUTPUT ..... 27  
 PROBLEM 4 –  
 EXCESSIVE VOLTAGE/FREQUENCY DROOP  
 WHEN LOAD IS APPLIED ..... 28  
 PROBLEM 5 –  
 PRIMING FUNCTION DOES NOT WORK ..... 28  
 PROBLEM 6 –  
 ENGINE WILL NOT CRANK ..... 29  
 PROBLEM 7 –  
 ENGINE CRANKS BUT WILL NOT START ..... 30-31  
 PROBLEM 8 –  
 ENGINE STARTS HARD AND RUNS ROUGH ..... 32-33  
 PROBLEM 9 –  
 ENGINE STARTS THEN SHUTS DOWN ..... 34  
 PROBLEM 10 –  
 7.5 AMP (F1) FUSE BLOWING ..... 35

**SECTION 7:  
DIAGNOSTIC TESTS ..... 36-60**

TEST 1 –  
 Check No-Load Voltage And Frequency ..... 36  
 TEST 2 –  
 Check Engine Governor..... 36  
 TEST 3 –  
 Test Excitation Circuit Breaker ..... 37  
 TEST 4 –  
 Fixed Excitation Test/Rotor Amp Draw ..... 37  
 TEST 5 –  
 Wire Continuity ..... 38  
 TEST 6 –  
 Check Field Boost..... 38  
 TEST 7 –  
 Test Stator DPE Winding ..... 39  
 TEST 8 –  
 Check Sensing Leads/Power Windings ..... 40  
 TEST 9 –  
 Check Brush Leads ..... 41  
 TEST 10 –  
 Check Brushes & Slip Rings..... 41  
 TEST 11 –  
 Check Rotor Assembly ..... 41  
 TEST 12 –  
 Check Main Circuit Breakers ..... 42  
 TEST 13 –  
 Check Load Voltage & Frequency..... 42

## Table of Contents

TEST 14 – Check Load Watts & Amperage.....	42	TEST 38 – Check Engine / Cylinder Leak Down Test / Compression Test .....	58
TEST 15 – Check Battery Charge Output.....	43	TEST 39 – Check Oil Pressure Switch .....	59
TEST 16 – Check Battery Charge Rectifier .....	43	TEST 40 – Check Oil Temperature Switch .....	59
TEST 17 – Check Battery Charge Windings/ Battery Charge Resistor .....	43	TEST 41 – Test Choke Heater .....	60
TEST 18 – Try Cranking the Engine .....	44	Test 42 – Check LPG Fuel Solenoid .....	60
TEST 19 – Test Primer Switch .....	44	<b>SECTION 8: ASSEMBLY .....</b>	<b>63</b>
TEST 20 – Check Fuel Pump .....	45	MAJOR DISASSEMBLY .....	63
TEST 21 – Check 7.5 Amp Fuse .....	46	Enclosure/Panels .....	63
TEST 22 – Check Battery & Cables.....	46	Rotor/Stator Removal .....	63
TEST 23 – Check Power Supply to Circuit Board .....	47	Flywheel/Ignition Coil Removal.....	63
TEST 24 – Check Start-Stop Switch.....	47	<b>SECTION 9: EXPLODED VIEWS / PART NUMBERS .....</b>	<b>64-85</b>
TEST 25 – Check Power Supply to Wire 56.....	48	ENCLOSURE DRAWING (LP UNITS) .....	64
TEST 26 – Check Starter Contactor .....	48	GENERATOR DRAWING (LP UNITS) .....	66
TEST 27 – Check Starter Motor.....	49	CONTROL PANEL DRAWING (LP UNITS) .....	68
TEST 28 – Check Fuel Supply.....	50	GN-220 H/SH ENGINE DRAWING (LP UNITS) ....	70-73
TEST 29 – Check Wire 14 Power Supply.....	51	GAS REGULATOR ASSEMBLY (LP UNITS) .....	74
TEST 30 – Check Wire 18 .....	52	ENCLOSURE DRAWING (GASOLINE UNITS) .....	76
TEST 31 – Check Fuel Solenoid.....	52	GENERATOR DRAWING (GASOLINE UNITS) .....	78
TEST 32 – Check Ignition Spark.....	53	CONTROL PANEL DRAWING (GASOLINE UNITS) .....	80
TEST 33 – Check Spark Plug .....	53	GN-220 H/SH ENGINE DRAWING (GASOLINE UNITS) .....	82-85
TEST 34 – Check Ignition Coil.....	54	<b>SECTION 10: SPECIFICATIONS &amp; CHARTS .....</b>	<b>86-89</b>
TEST 35 – Check Valve Adjustment .....	55	MAJOR FEATURES AND DIMENSIONS .....	86-87
TEST 36 – Check Carburetion .....	55	COMPARTMENT FLOOR CUTOUT .....	88
TEST 37 – Check Choke Solenoid .....	56	GENERATOR SPECIFICATIONS .....	90
		NOMINAL RESISTANCES OF GENERATOR WINDINGS AT 68°F .....	90
		ENGINE SPEEDS AND VOLTAGE SPECIFICATIONS .....	90
		TORQUE SPECIFICATIONS .....	91
		<b>SECTION 11: ELECTRICAL DATA.....</b>	<b>92-93</b>
		ELECTRICAL SCHEMATIC AND WIRING DIAGRAM .....	92-93

### MAGNETISM

Magnetism can be used to produce electricity and electricity can be used to produce magnetism.

Much about magnetism cannot be explained by our present knowledge. However, there are certain patterns of behavior that are known. Application of these behavior patterns has led to the development of generators, motors and numerous other devices that utilize magnetism to produce and use electrical energy.

See Figure 1-1. The space surrounding a magnet is permeated by magnetic lines of force called "flux". These lines of force are concentrated at the magnet's north and south poles. They are directed away from the magnet at its north pole, travel in a loop and re-enter the magnet at its south pole. The lines of force form definite patterns which vary in intensity depending on the strength of the magnet. The lines of force never cross one another. The area surrounding a magnet in which its lines of force are effective is called a "magnetic field".

Like poles of a magnet repel each other, while unlike poles attract each other.

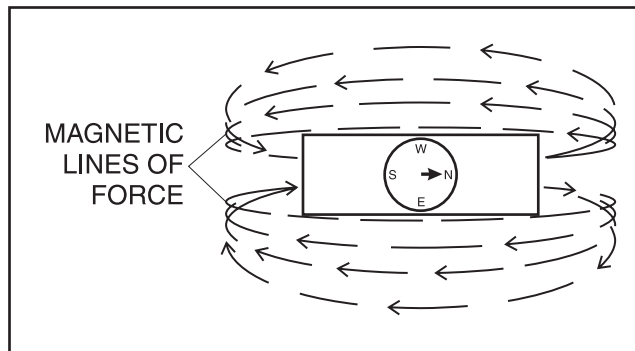

Figure 1-1. – Magnetic Lines of Force

### ELECTROMAGNETIC FIELDS

All conductors through which an electric current is flowing have a magnetic field surrounding them. This field is always at right angles to the conductor. If a compass is placed near the conductor, the compass needle will move to a right angle with the conductor. The following rules apply:

- The greater the current flow through the conductor, the stronger the magnetic field around the conductor.
- The increase in the number of lines of force is directly proportional to the increase in current flow and the field is distributed along the full length of the conductor.
- The direction of the lines of force around a conductor can be determined by what is called the "right hand rule". To apply this rule, place your right hand around the conductor with the thumb pointing in the direction of current flow. The fingers will then be pointing in the direction of the lines of force.

**NOTE:** The "right hand rule" is based on the "current flow" theory which assumes that current flows from positive to negative. This is opposite the "electron" theory, which states that current flows from negative to positive.

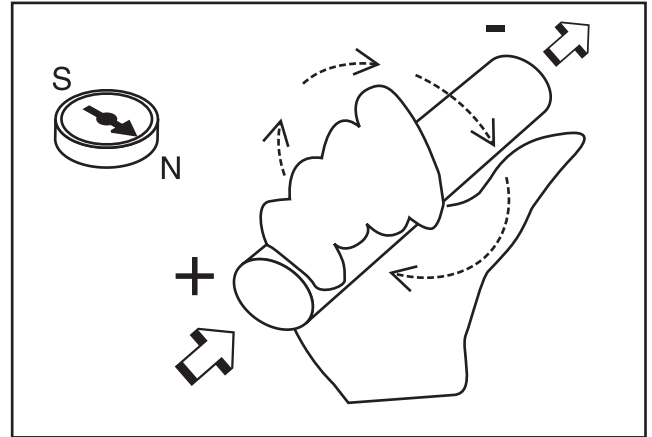

Figure 1-2. – The Right Hand Rule

### ELECTROMAGNETIC INDUCTION

An electromotive force (EMF) or voltage can be produced in a conductor by moving the conductor so that it cuts across the lines of force of a magnetic field.

Similarly, if the magnetic lines of force are moved so that they cut across a conductor, an EMF (voltage) will be produced in the conductor. This is the basic principle of the revolving field generator.

Figure 1-3, below, illustrates a simple revolving field generator. The permanent magnet (Rotor) is rotated so that its lines of magnetic force cut across a coil of wires called a Stator. A voltage is then induced into the Stator windings. If the Stator circuit is completed by connecting a load (such as a light bulb), current will flow in the circuit and the bulb will light.

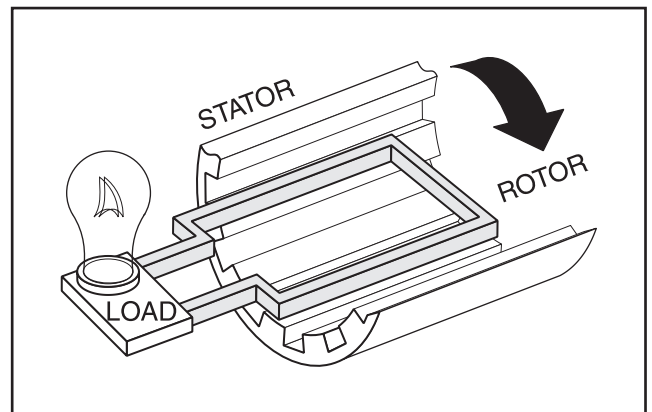

Figure 1-3. – A Simple Revolving Field Generator

# Section 1

## GENERATOR FUNDAMENTALS

### A SIMPLE AC GENERATOR

Figure 1-4 shows a very simple AC Generator. The generator consists of a rotating magnetic field called a ROTOR and a stationary coil of wire called a STATOR. The ROTOR is a permanent magnet which consists of a SOUTH magnetic pole and a NORTH magnetic pole.

As the ROTOR turns, its magnetic field cuts across the stationary STATOR. A voltage is induced into the STATOR windings. When the magnet's NORTH pole passes the STATOR, current flows in one direction. Current flows in the opposite direction when the magnet's SOUTH pole passes the STATOR. This constant reversal of current flow results in an alternating current (AC) waveform that can be diagrammed as shown in Figure 1-5.

The ROTOR may be a 2-pole type having a single NORTH and a single SOUTH magnetic pole. Some ROTORS are 4-pole type with two SOUTH and two NORTH magnetic poles. The following apply:

1. The 2-pole ROTOR must be turned at 3600 rpm to produce an AC frequency of 60 Hertz, or at 3000 rpm to deliver an AC frequency of 50 Hertz.
2. The 4-pole ROTOR must operate at 1800 rpm to deliver a 60 Hertz AC frequency or at 1500 rpm to deliver a 50 Hertz AC frequency.

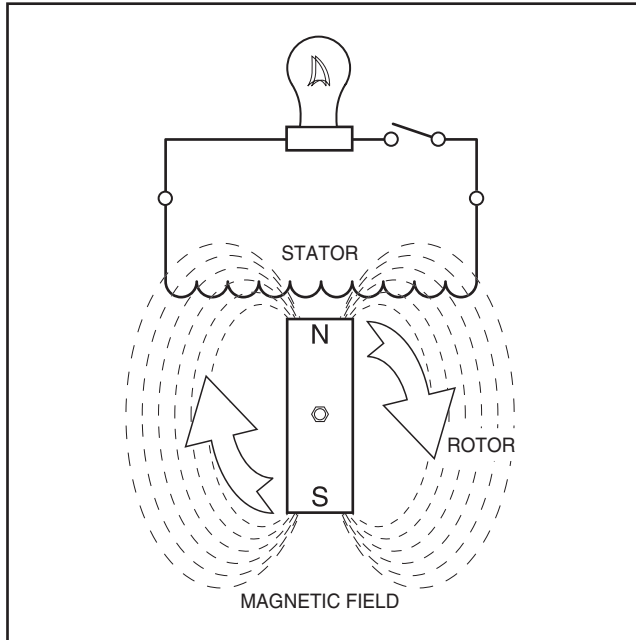

Figure 1-4. – A Simple AC Generator

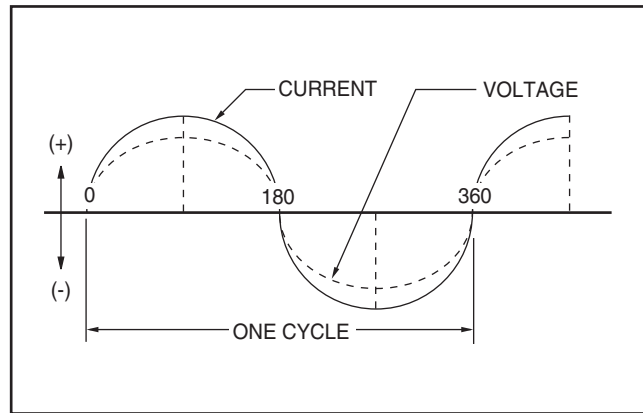

Figure 1-5. – Alternating Current Sine Wave

### A MORE SOPHISTICATED AC GENERATOR

Figure 1-6 represents a more sophisticated generator. A regulated direct current is delivered into the ROTOR windings via carbon BRUSHES AND SLIP RINGS. This results in the creation of a regulated magnetic field around the ROTOR. As a result, a regulated voltage is induced into the STATOR. Regulated current delivered to the ROTOR is called "EXCITATION" current.

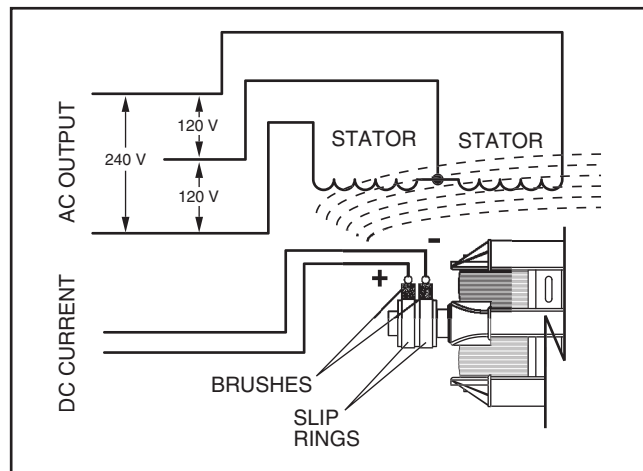

Figure 1-6. – A More Sophisticated Generator

See Figure 1-7 (next page). The revolving magnetic field (ROTOR) is driven by the engine at a constant speed. This constant speed is maintained by a mechanical engine governor. Units with a 2-pole rotor require an operating speed of 3600 rpm to deliver a 60 Hertz AC output. Engine governors are set to maintain approximately 3720 rpm when no electrical loads are connected to the generator.

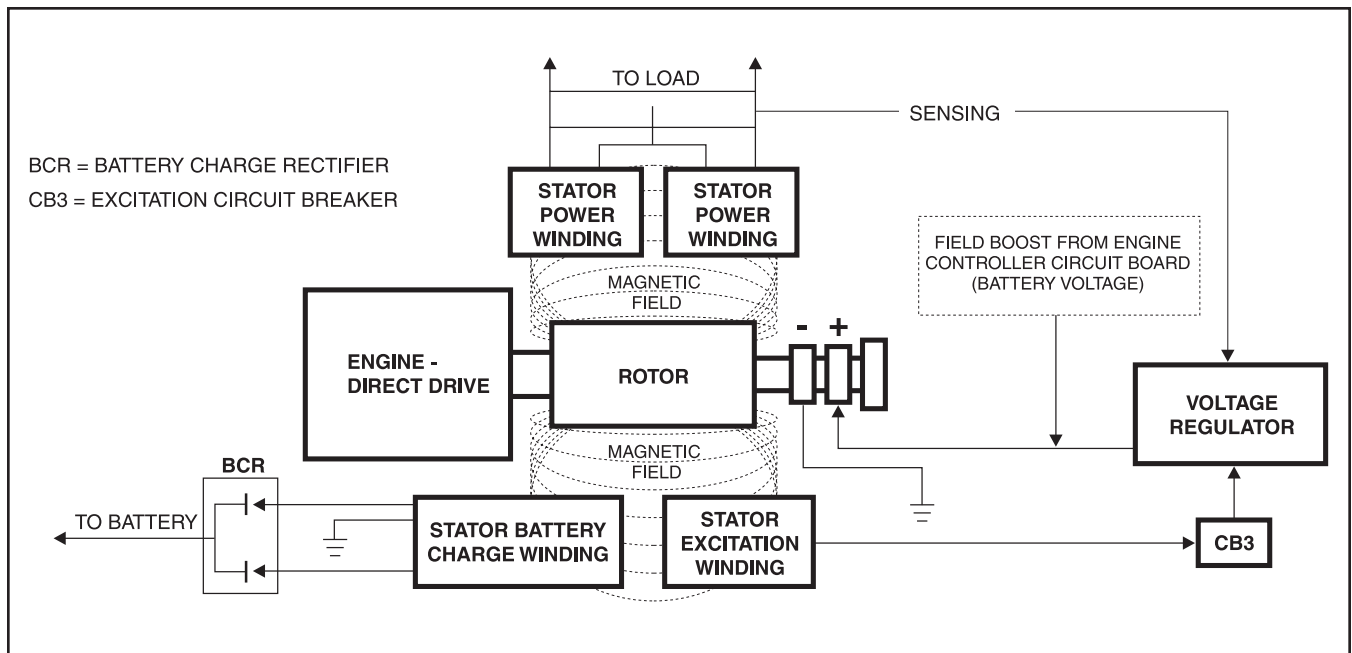

Figure 1-7. – Generator Operating Diagram

**NOTE: AC output frequency at 3720 rpm will be about 62 Hertz. The “No-Load” is set slightly high to prevent excessive rpm, frequency and voltage drop under heavy electrical loading.**

Generator operation may be described briefly as follows:

1. Some “residual” magnetism is normally present in the Rotor and is sufficient to induce approximately 7 to 12 volts AC Into the STATOR’s AC power windings.
2. During startup, an engine controller circuit board delivers battery voltage to the ROTOR, via the brushes and slip rings.
  - a. The battery voltage is called “Field Boost”.
  - b. Flow of direct current through the ROTOR increases the strength of the magnetic field above that of “residual” magnetism alone.
3. “Residual” plus “Field Boost” magnetism induces a voltage into the Stator excitation (DPE), battery charge and AC Power windings.
4. Excitation winding unregulated AC output is delivered to an electronic voltage regulator, via an excitation circuit breaker.
  - a. A “Reference” voltage has been preset into the Voltage Regulator.
  - b. An “Actual” (“sensing”) voltage is delivered to the Voltage Regulator via sensing leads from the Stator AC power windings.
  - c. The Regulator “compares” the actual (sensing) voltage to its pre-set reference voltage.

(1) If the actual (sensing) voltage is greater than the pre-set reference voltage, the Regulator will decrease the regulated current flow to the Rotor.

(2) If the actual (sensing) voltage is less than the pre-set reference voltage, the Regulator will increase the regulated current flow to the Rotor.

(3) In the manner described, the Regulator maintains an actual (sensing) voltage that is equal to the pre-set reference voltage.

**NOTE: The Voltage Regulator also changes the Stator excitation windings alternating current (AC) output to direct current (DC).**

5. When an electrical load is connected across the Stator power windings, the circuit is completed and an electrical current will flow.
6. The Rotor’s magnetic field also induces a voltage into the Stator battery charge windings.
  - a. Battery charge winding AC output is delivered to a battery charge rectifier (BCR) which changes the AC to direct current (DC).
  - b. The rectified DC is then delivered to the unit battery, to maintain the battery in a charged state.
  - c. A 1 ohm, 25 watt Resistor is installed in series with the grounded side of the battery charge circuit.

## Section 1 GENERATOR FUNDAMENTALS

### FIELD BOOST

When the engine is cranked during startup, the engine's starter contactor is energized closed. Battery current is then delivered to the starter motor and the engine cranks.

Closure of the starter contactor contacts also delivers battery voltage to Pin 13 of an Engine Controller circuit board. The battery current flows through a 47 ohm, 2 watt resistor and a field boost diode, then to the Rotor via brushes and slip rings. This is called "Field Boost" current.

Field boost current is delivered to the Rotor only while the engine is cranking. The effect is to "flash the field" every time the engine is cranked. Field boost current helps ensure that sufficient "pickup" voltage is available on every startup to turn the Voltage Regulator on and build AC output voltage.

**NOTE: Loss of the Field Boost function may or may not result in loss of AC power winding output. If Rotor residual magnetism alone is sufficient to turn the Regulator on loss of Field Boost may go unnoticed. However, If residual magnetism alone is not enough to turn the Regulator on, loss of the Field Boost function will result in loss of AC power winding output to the load. The AC output voltage will then drop to a value commensurate with the Rotor's residual magnetism (about 7-12 VAC).**

### GENERATOR AC CONNECTION SYSTEM

#### 120 VAC OUTPUT:

The Stator AC power winding consists of two windings connected in parallel, with each winding capable of supplying 120 volts AC.

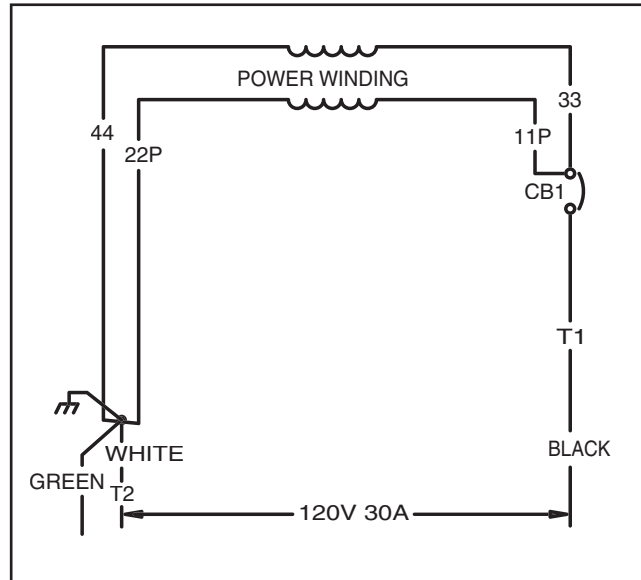
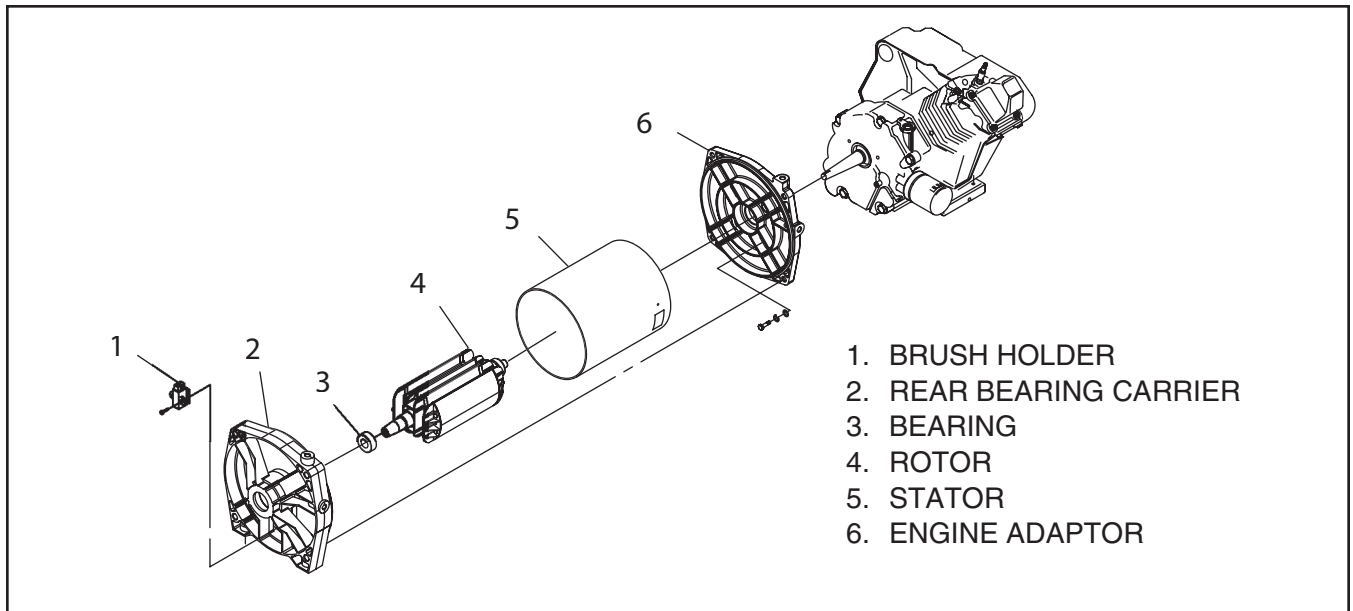

Figure 1-8. – Power Winding Output





*Figure 2-1. Exploded View of Generator*

### **ROTOR ASSEMBLY**

The Rotor is sometimes called the “revolving field”, since it provides the magnetic field that induces a voltage into the stationary Stator windings. Slip rings on the Rotor shaft allow excitation current from the voltage regulator to be delivered to the Rotor windings. The Rotor is directly coupled to the engine crankshaft.

All generator models in this manual utilize a 2-pole Rotor, i.e., one having a single north and a single south pole. This type of Rotor must be driven at 3600 rpm for a 60 Hertz AC output, or at 3000 rpm for a 50 Hertz output.

Slip rings may be cleaned. If dull or tarnished, clean them with fine sandpaper (a 400 grit wet sandpaper is recommended). **DO NOT USE ANY METALLIC GRIT OR ABRASIVE TO CLEAN SLIP RINGS.**

### **STATOR ASSEMBLY**

The Stator is “sandwiched” between the engine adaptor and rear bearing carrier and retained in that position by four Stator studs. Windings Included in the Stator assembly are (a) dual AC power windings, (b) an excitation or DPE winding, and (c) a battery charge winding. A total of eleven (11) leads are brought out of the Stator as follows:

1. Four (4) Stator power winding output leads (Wires No. 11P, 22P, 33 and 44). These leads deliver power to connected electrical loads.
2. Stator Power winding “sensing” leads (11S and 22S). These leads deliver an “actual voltage signal to the electronic Voltage Regulator.

3. Two excitation winding output leads (No. 2 and 6). These leads deliver unregulated excitation current to the voltage regulator.
4. Three (3) battery charge output leads (No. 55, 66 and 77).

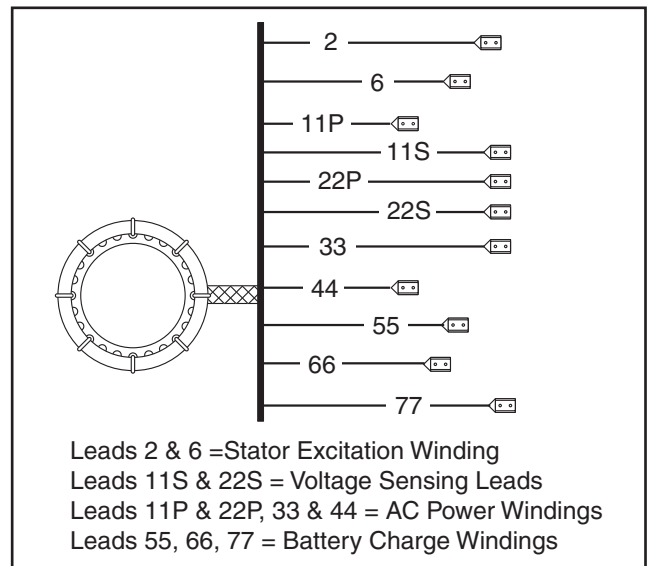

*Figure 2-2. – Stator Output Leads*

### **BRUSH HOLDER**

The brush holder is retained in the rear bearing carrier by two M5 screws. It retains two brushes, which contact the Rotor slip rings and allow current flow from stationary parts to the revolving Rotor. The positive (+) brush is located nearest the Rotor bearing.

## Section 2 MAJOR GENERATOR COMPONENTS

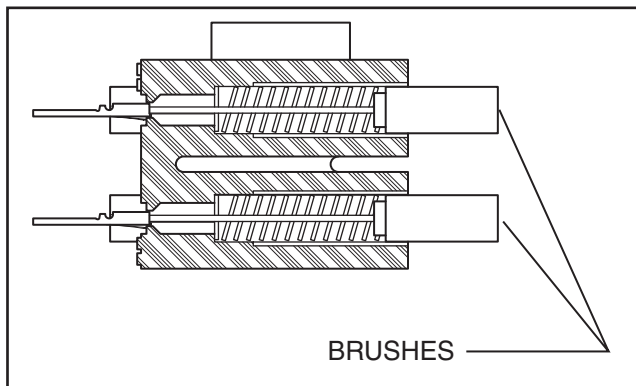

Figure 2-3. – Brush Holder

### BATTERY CHARGE COMPONENTS

The Stator incorporates dual battery charge windings. A battery charge rectifier (BCR) changes the AC output of these windings to direct current (DC). Battery charge winding output is delivered to the unit battery via the rectifier, a 7.5 amp fuse and Wire No. 13. A 1 ohm, 25 watt resistor is connected in series with the grounded side of the circuit.

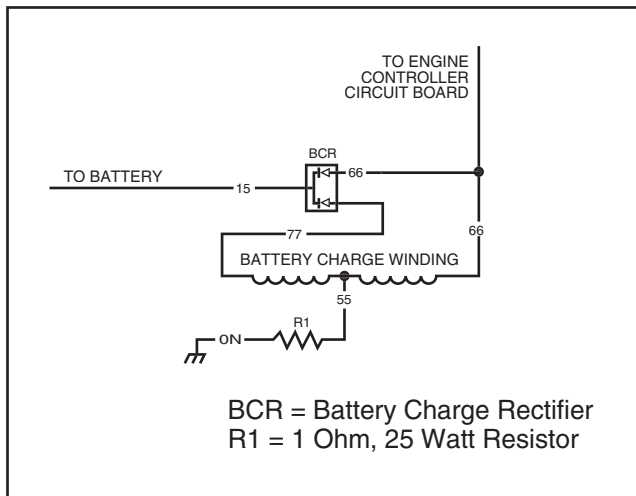

Figure 2-4. – Battery Charge Circuit

### EXCITATION CIRCUIT COMPONENTS

#### GENERAL:

During operation, the Rotor's magnetic field induces a voltage and current flow into the Stator excitation winding. The resultant AC output is delivered to a voltage regulator via an excitation circuit breaker (CB3).

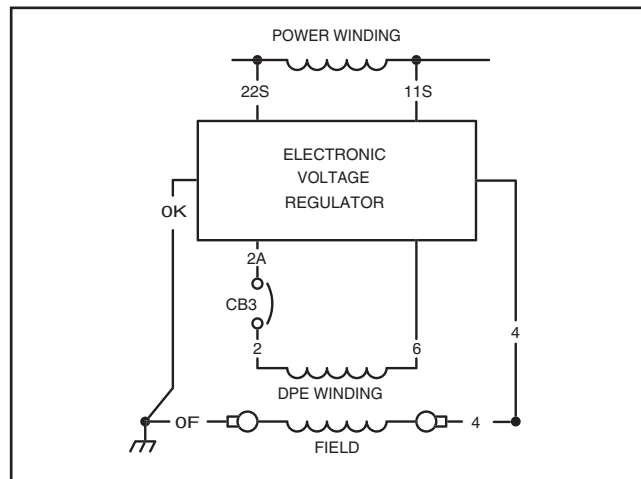

Figure 2-5. – Schematic- Excitation Circuit

#### EXCITATION CIRCUIT BREAKER:

The excitation circuit breaker (CB3) is self-resetting and cannot be reset manually. Should the breaker open for any reason, excitation current flow to the Rotor will be lost. The unit's AC output voltage will then drop to a value commensurate with the Rotor's residual magnetism (about 7-12 VAC).

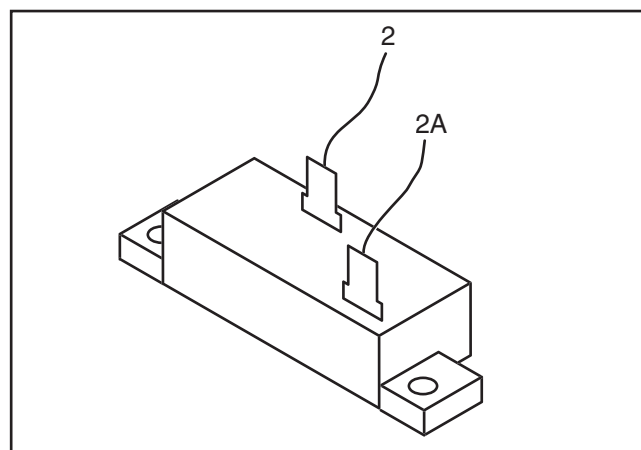
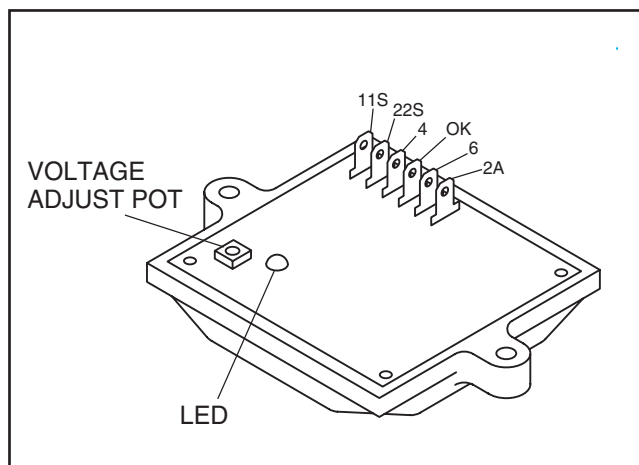

Figure 2-6. – Excitation Circuit Breaker

#### VOLTAGE REGULATOR:

Six (6) leads are connected to the voltage regulator as follows:

- Two (2) SENSING leads deliver ACTUAL AC output voltage signals to the regulator. These are Wires No. 11S and 22S.
- Two (2) leads (No. 2A and 6) deliver Stator excitation winding AC output to the regulator.
- Two (2) leads (0K and 4) deliver the regulated direct current to the Rotor, via brushes and slip rings.



*Figure 2-7. – Voltage Regulator*

The regulator mounts a “VOLTAGE ADJUST” potentiometer, used for adjustment of the pre-set REFERENCE voltage. A lamp (LED) will turn on to indicate that SENSING voltage is available to the regulator and the regulator is turned on.

The regulator mounts a “VOLTAGE ADJUST” potentiometer, used for adjustment of the pre-set REFERENCE voltage. A lamp (LED) will turn on to indicate that SENSING voltage is available to the regulator and that the regulator is turned on.

**VOLTAGE ADJUSTMENT PROCEDURE:**

With the frequency set at 62.5 Hertz and no load on the generator, slowly turn the voltage adjust pot on the voltage regulator until 124 VAC is measured. If voltage is not adjustable, proceed to Section 6 - Troubleshooting; Problem 2.

**NOTE: If, for any reason, sensing voltage to the regulator is lost, the regulator will shut down and excitation output to the Rotor will be lost. The AC output voltage will then drop to a value that is commensurate with Rotor residual magnetism (about 7-12 VAC). Without this automatic shutdown feature, loss of sensing (actual) voltage to the regulator would result in a “full field” or “full excitation” condition and an extremely high AC output voltage.**

**NOTE: Adjustment of the regulator’s “VOLTAGE ADJUST” potentiometer must be done only when the unit is running at its correct governed no-load speed. Speed is correct when the unit’s no-load AC output frequency is about 62.5 Hertz. At the stated frequency, AC output voltage should be about 124 volts.**

**BREATHER ASSEMBLY**

**DESCRIPTION:**

A crankcase breather is located in the rocker arm cover of horizontal crankshaft engines (Figure 2-8). The breather serves to maintain a reduced pressure in the engine crankcase, to prevent oil from being forced past the oil seals, gaskets or piston rings.

The CHECK VALVE allows excess pressure to be vented out of the crankcase and to atmosphere through the BREATHER TUBE. Two small DRAIN HOLES allow condensed oil vapors to return to the crankcase.

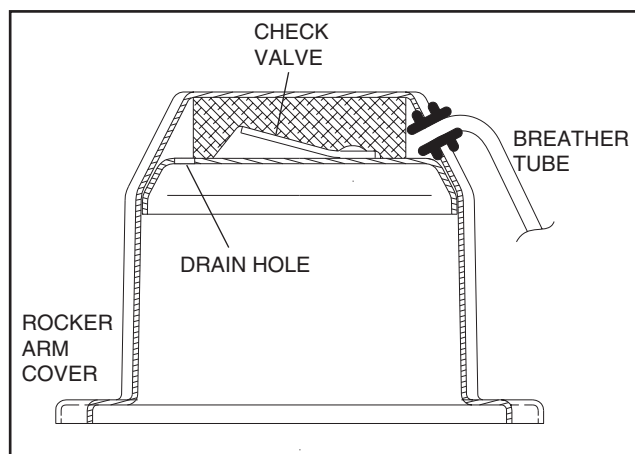

*Figure 2-8. – Crankcase Breather*

**INSPECTION:**

1. Remove the breather tube. Check tube for cracks, hardening or other damage. Replace if necessary.
2. Clean the rocker arm cover in commercial solvent.
3. Make sure the two small drain holes are open. If necessary, use a length of wire to open the holes.
4. Check the rivets that retain the check valve, make sure they are tight.
5. The breather plate is retained in the rocker arm cover with a continuous bead of Type 103 black RTV sealant. This sealant must not leak. Test the sealant for leakage as follows:
  - a. Seal all holes on the breather plate.
  - b. Apply air pressure of 5 psi (0.352 kg/cm ) through the breather hose hole. No leakage must be observed.
  - c. If necessary, reseal the plate with Type 103 black RTV sealant.

## Section 3

### INSULATION RESISTANCE TESTS

#### EFFECTS OF DIRT AND MOISTURE

Moisture and dirt are detrimental to the continued good operation of any generator set.

If moisture is allowed to remain in contact with the Stator and Rotor windings, some of the moisture will be retained in voids and cracks of the winding insulation. This will result in a reduced Insulation resistance and, eventually, the unit's AC output will be affected.

Insulation used in the generator is moisture resistant. However, prolonged exposure to moisture will gradually reduce the resistance of the winding insulation.

Dirt can make the problem worse, since it tends to hold moisture into contact with the windings. Salt, as from sea air, contributes to the problem since salt can absorb moisture from the air. When salt and moisture combine, they make a good electrical conductor.

Because of the detrimental affects of dirt and moisture, the generator should be kept as clean and as dry as possible. Rotor and Stator windings should be tested periodically with an insulation resistance tester (such as a megohmmeter or hi-pot tester).

If the Insulation resistance is excessively low, drying may be required to remove accumulated moisture. After drying, perform a second insulation resistance test. If resistance is still low after drying, replacement of the defective Rotor or Stator may be required.

#### INSULATION RESISTANCE TESTERS

Figure 3-1 shows one kind of hi-pot tester. The tester shown has a "Breakdown" lamp that will glow during the test procedure to indicate an insulation breakdown in the winding being tested.

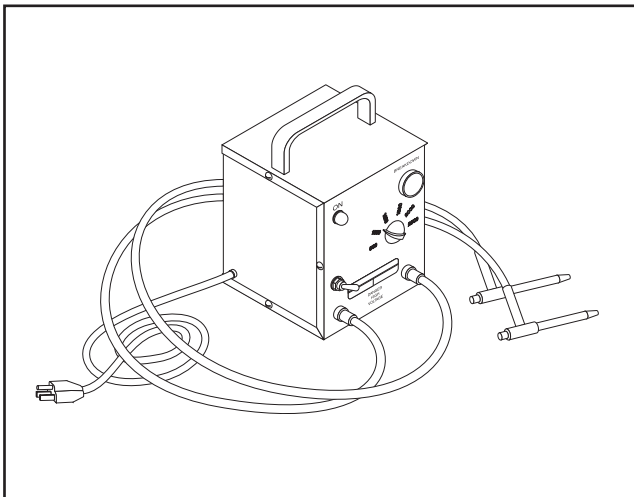

Figure 3-1. – One Type of Hi-Pot Tester



**DANGER!: INSULATION RESISTANCE TESTERS SUCH AS HI-POT TESTERS AND MEGOHMMETERS ARE A SOURCE OF HIGH AND DANGEROUS ELECTRICAL VOLTAGE. FOLLOW THE TESTER MANUFACTURER'S INSTRUCTIONS CAREFULLY. USE COMMON SENSE TO AVOID DANGEROUS ELECTRICAL SHOCK**

#### DRYING THE GENERATOR

##### GENERAL:

If tests indicate the insulation resistance of a winding is below a safe value, the winding should be dried before operating the generator. Some recommended drying procedures include (a) heating units and (b) forced air.

##### HEATING UNITS:

If drying is needed, the generator can be enclosed in a covering. Heating units can then be installed to raise the temperature about 15°-18° F. (8°-10° C.) above ambient temperature.

##### FORCED AIR:

Portable forced air heaters can be used to dry the generator. Direct the heated air into the generator's air intake openings. Remove the voltage regulator and run the unit at no-load. Air temperature at the point of entry into the generator should not exceed 150° F. (66° C.).

#### CLEANING THE GENERATOR

##### GENERAL:

The generator can be cleaned properly only while it is disassembled. The cleaning method used should be determined by the type of dirt to be removed. Be sure to dry the unit after it has been cleaned.

**NOTE: A shop that repairs electric motors may be able to assist you with the proper cleaning of generator windings. Such shops are often experienced in special problems such as a sea coast environment, marine or wetland applications, mining, etc.**

##### USING SOLVENTS FOR CLEANING:

If dirt contains oil or grease a solvent is generally required. Only petroleum distillates should be used to clean electrical components. Recommended are safety type petroleum solvents having a flash point greater than 100° F. (38° C.).



**CAUTION!:** Some generators may use epoxy or polyester base winding varnishes. Use solvents that will not attack such materials.

Use a soft brush or cloth to apply the solvent. Be careful to avoid damage to wire or winding insulation. After cleaning, dry all components thoroughly using moisture-free, low-pressure compressed air.



**DANGER!: DO NOT ATTEMPT TO WORK WITH SOLVENTS IN ANY ENCLOSED AREA. PROVIDE ADEQUATE VENTILATION WHEN WORKING WITH SOLVENTS. WITHOUT ADEQUATE VENTILATION, FIRE, EXPLOSION OR HEALTH HAZARDS MAY EXIST. WEAR EYE PROTECTION. WEAR RUBBER GLOVES TO PROTECT THE HANDS.**

CLOTH OR COMPRESSED AIR:

For small parts or when dry dirt is to be removed, a dry cloth may be satisfactory. Wipe the parts clean, then use low pressure air at 30 psi (206 Kpa) to blow dust away.

BRUSHING AND VACUUM CLEANING:

Brushing with a soft bristle brush followed by vacuum cleaning is a good method of removing dust and dirt. Use the soft brush to loosen the dirt, then remove it with the vacuum.

### ***STATOR INSULATION RESISTANCE***

GENERAL:

Insulation resistance is a measure of the Integrity of the insulating materials that separate electrical windings from the generator's steel core. This resistance can degrade over time due to the presence of contaminants, dust, dirt, grease and especially moisture).

The normal Insulation resistance for generator windings is on the order of "millions of ohms" or "megohms".

When checking the insulation resistance, follow the tester manufacturer's Instructions carefully. Do NOT exceed the applied voltages recommended in this manual. Do NOT apply the voltage longer than one (1) second.



**CAUTION!: DO NOT CONNECT THE HI-POT TESTER OR MEGOHMMETER TEST LEADS TO ANY LEADS THAT ARE ROUTED INTO THE GENERATOR CONTROL PANEL. CONNECT THE TESTER LEADS TO THE STATOR OR ROTOR LEADS ONLY.**

STATOR SHORT-TO-GROUND TESTS:

See Figure 3-2. To test the Stator for a short-to-ground condition, proceed as follows:

1. Disconnect and Isolate all Stator leads as follows:
  - a. Disconnect sensing leads 11S and 22S from the voltage regulator.
  - b. Disconnect excitation winding lead No. 6 from the voltage regulator.
  - c. Disconnect excitation lead No. 2 from the excitation circuit breaker (CB3).
  - d. Disconnect battery charge winding leads No. 66 and 77 from the battery charge rectifier (BCR).
  - e. Disconnect battery charge winding lead No. 55 from the battery charge resistor (R1).
  - f. At the main circuit breakers, disconnect AC power leads No. 11P and 33.
  - g. At the 4-tab ground terminal (GT), disconnect Stator power leads No. 22P and 44.
2. When all leads have been disconnected as outlined in Step 1 above, test for a short-to-ground condition as follows:
  - a. Connect the terminal ends of all Stator leads together (11S, 22S, 11P, 22P, 33, 44, 2,6, 55, 66, 77).
  - b. Follow the tester manufacturer's instructions carefully. Connect the tester leads across all Stator leads and to frame ground on the Stator can. Apply a voltage of 1500 volts. Do NOT apply voltage longer than one (1) second.

If the test Indicates a breakdown in Insulation, the Stator should be cleaned, dried and re-tested. If the winding fails the second test (after cleaning and drying), replace the Stator assembly.

TEST BETWEEN ISOLATED WINDINGS:

1. Follow the tester manufacturer's instructions carefully. Connect the tester test leads across Stator leads No. 11P and 2. Apply a voltage of 1500 volts- DO NOT EXCEED 1 SECOND.
2. Repeat Step 1 with the tester leads connected across the following Stator leads:
  - a. Across Wires No. 33 and 2.
  - b. Across Wires No. 11P and 66.
  - c. Across Wires No. 33 and 66.
  - d. Across Wires No. 2 and 66.

If a breakdown in the insulation between isolated windings is indicated, clean and dry the Stator. Then, repeat the test. If the Stator fails the second test, replace the Stator assembly.

## Section 3 INSULATION RESISTANCE TESTS

### TEST BETWEEN PARALLEL WINDINGS:

Connect the tester leads across Stator leads No. 11P and 33. Apply a voltage of 1500 volts. If an insulation breakdown is indicated, clean and dry the Stator. Then, repeat the test between parallel windings. If the Stator fails the second test, replace it.

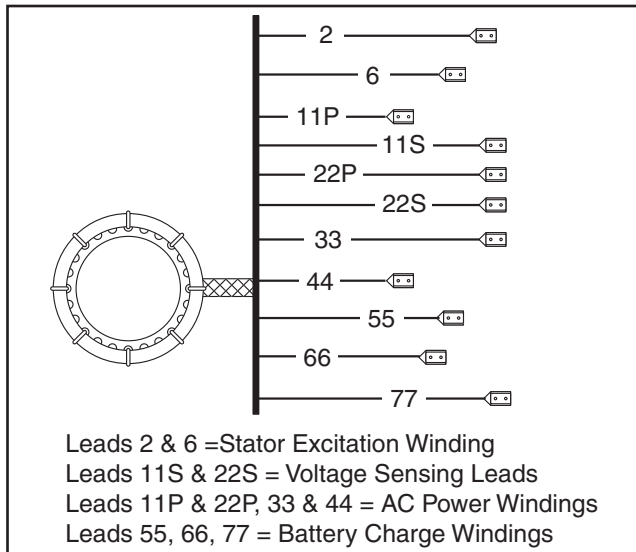

Figure 3-2. – Stator Leads

### TESTING ROTOR INSULATION

To test the Rotor for insulation breakdown, proceed as follows:

1. Disconnect wires from the Rotor brushes or remove the brush holders with brushes.
2. Connect the tester positive (+) test lead to the positive (+) slip ring (nearest the Rotor bearing). Connect the tester negative (-) test lead to a clean frame ground (like the Rotor shaft).

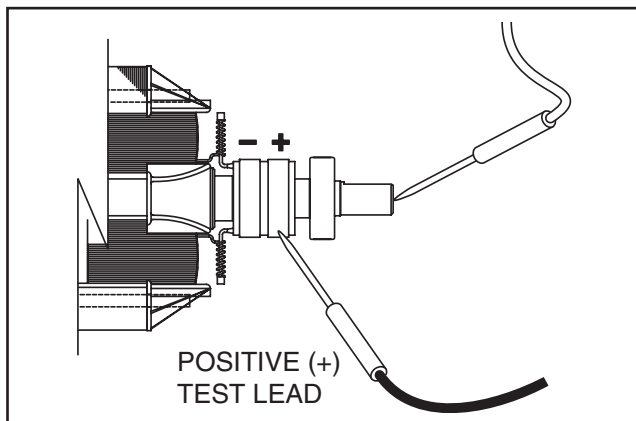

Figure 3-3. – Rotor Test Points

3. Apply 1000 volts. DO NOT APPLY VOLTAGE LONGER THAN 1 SECOND.

If an insulation breakdown is indicated, clean and dry the Rotor then repeat the test. Replace the Rotor if it fails the second test (after cleaning and drying).

## THE MEGOHMMETER

### GENERAL:

A megohmmeter, often called a “megger”, consists of a meter calibrated in megohms and a power supply. Use a power supply of 1500 volts when testing Stators; or 1000 volts when testing the Rotor. DO NOT APPLY VOLTAGE LONGER THAN ONE (1) SECOND.

### TESTING STATOR INSULATION:

All parts that might be damaged by the high megger voltages must be disconnected before testing. Isolate all Stator leads (Figure 3-2) and connect all of the Stator leads together. FOLLOW THE MEGGER MANUFACTURER’S INSTRUCTIONS CAREFULLY.

Use a megger power setting of 1500 volts. Connect one megger test lead to the junction of all Stator leads, the other test lead to frame ground on the Stator can. Read the number of megohms on the meter.

The MINIMUM acceptable megger reading for Stators may be calculated using the following formula:

$$\frac{\text{MINIMUM INSULATION RESISTANCE (in "Megohms")}}{1000} = \frac{\text{GENERATOR RATED VOLTS}}{1000} + 1$$

**EXAMPLE: Generator is rated at 120 volts AC. Divide “120” by “1000” to obtain “0.12”. Then add “1” to obtain “1.12” megohms. Minimum Insulation resistance for a 120 VAC Stator is 1.12 megohms.**

If the Stator insulation resistance is less than the calculated minimum resistance, clean and dry the Stator. Then, repeat the test. If resistance is still low, replace the Stator.

Use the Megger to test for shorts between isolated windings as outlined “Stator Insulation Resistance”.

Also test between parallel windings. See “Test Between Parallel Windings” on this page.

### TESTING ROTOR INSULATION:

Apply a voltage of 1000 volts across the Rotor positive (+) slip ring (nearest the rotor bearing), and a clean frame ground (i.e. the Rotor Shaft). DO NOT EXCEED 1000 VOLTS AND DO NOT APPLY VOLTAGE LONGER THAN 1 SECOND. FOLLOW THE MEGGER MANUFACTURER’S INSTRUCTIONS CAREFULLY.

### ROTOR MINIMUM INSULATION RESISTANCE:

1.5 megohms

### METERS

Devices used to measure electrical properties are called meters. Meters are available that allow one to measure (a) AC voltage, (b) DC voltage, (c) AC frequency, and (d) resistance in ohms. The following apply:

- To measure AC voltage, use an AC voltmeter.
- To measure DC voltage, use a DC voltmeter.
- Use a frequency meter to measure AC frequency in “Hertz” or “cycles per second”..
- Use an ohmmeter to read circuit resistance, in “ohms”.

### THE VOM

A meter that will permit both voltage and resistance to be read is the “volt-ohm-milliammeter” or “VOM”.

Some VOM’s are of the “analog” type (not shown). These meters display the value being measured by physically deflecting a needle across a graduated scale. The scale used must be interpreted by the user.

“Digital” VOM’s (Figure 4-1) are also available and are generally very accurate. Digital meters display the measured values directly by converting the values to numbers.

**NOTE: Standard AC voltmeters react to the AVERAGE value of alternating current. When working with AC, the effective value is used. For that reason a different scale is used on an AC voltmeter. The scale is marked with the effective or “rms” value even though the meter actually reacts to the average value. That is why the AC voltmeter will give an incorrect reading if used to measure direct current (DC).**

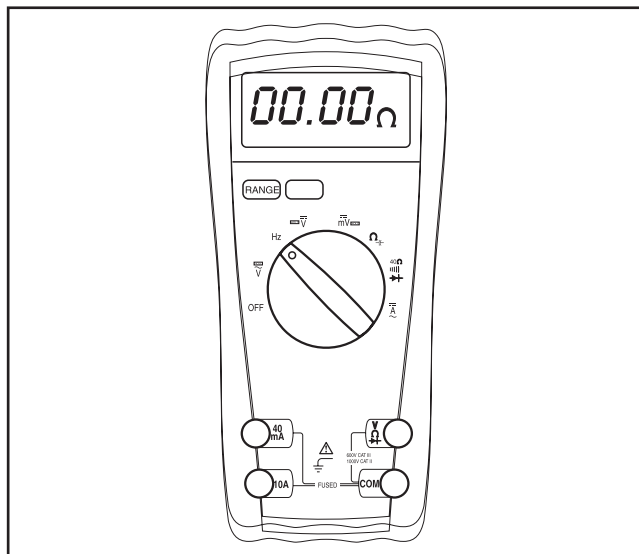

Figure 4-1. – Digital VOM

### MEASURING AC VOLTAGE

An accurate AC voltmeter or a VOM may be used to read the generator’s AC output voltage. The following apply:

1. Always read the generator’s AC output voltage only at the unit’s rated operating speed and AC frequency.
2. The generator’s voltage regulator can be adjusted for correct output voltage only while the unit is operating at its correct rated speed and frequency.
3. Only an AC voltmeter may be used to measure AC voltage. DO NOT USE A DC VOLTMETER FOR THIS PURPOSE.



**DANGER!: RV GENERATORS PRODUCE HIGH AND DANGEROUS VOLTAGES. CONTACT WITH HIGH VOLTAGE TERMINALS WILL RESULT IN DANGEROUS AND POSSIBLY LETHAL ELECTRICAL SHOCK.**

### MEASURING DC VOLTAGE

A DC voltmeter or a VOM may be used to measure DC voltages. Always observe the following rules:

1. Always observe correct DC polarity.
  - a. Some VOM’s may be equipped with a polarity switch.
  - b. On meters that do not have a polarity switch, DC polarity must be reversed by reversing the test leads.
2. Before reading a DC voltage, always set the meter to a higher voltage scale than the anticipated reading. if in doubt, start at the highest scale and adjust the scale downward until correct readings are obtained.
3. The design of some meters is based on the “current flow” theory while others are based on the “electron flow” theory.
  - a. The “current flow” theory assumes that direct current flows from the positive (+) to the negative (-).
  - b. The “electron flow” theory assumes that current flows from negative (-) to positive (+).

**NOTE: When testing generators, the “current flow” theory is applied. That is, current is assumed to flow from positive (+) to negative (-).**

## Section 4 MEASURING ELECTRICITY

### MEASURING AC FREQUENCY

The generator's AC output frequency is proportional to Rotor speed. Generators equipped with a 2-pole Rotor must operate at 3600 rpm to supply a frequency of 60 Hertz. Units with 4-pole Rotor must run at 1800 rpm to deliver 60 Hertz.

Correct engine and Rotor speed is maintained by an engine speed governor. For models rated 60 Hertz, the governor is generally set to maintain a no-load frequency of about 62 Hertz with a corresponding output voltage of about 124 volts AC line-to-neutral. Engine speed and frequency at no-load are set slightly high to prevent excessive rpm and frequency droop under heavy electrical loading.

### MEASURING CURRENT

To read the current flow, in AMPERES, a clamp-on ammeter may be used. This type of meter indicates current flow through a conductor by measuring the strength of the magnetic field around that conductor. The meter consists essentially of a current transformer with a split core and a rectifier type instrument connected to the secondary. The primary of the current transformer is the conductor through which the current to be measured flows. The split core allows the Instrument to be clamped around the conductor without disconnecting it.

Current flowing through a conductor may be measured safely and easily. A line-splitter can be used to measure current in a cord without separating the conductors.

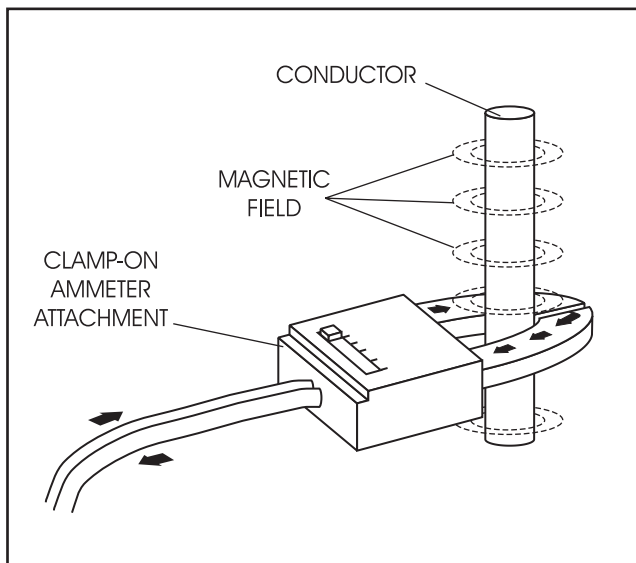

Figure 4-2. – Clamp-On Ammeter

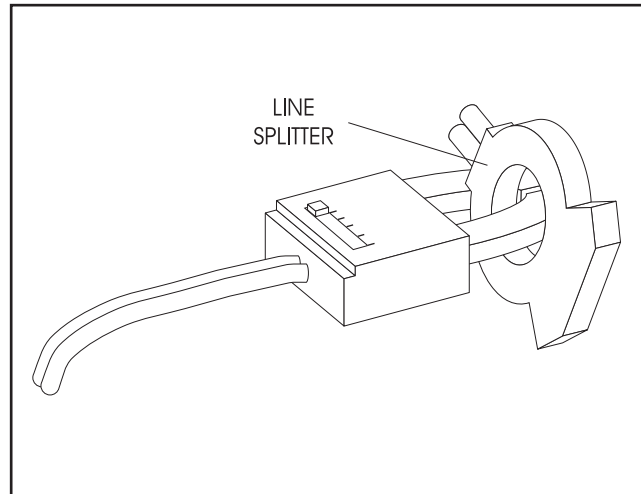

Figure 4-3. – A Line-Splitter

**NOTE:** If the physical size of the conductor or ammeter capacity does not permit all lines to be measured simultaneously, measure current flow in each individual line. Then, add the individual readings.

### MEASURING RESISTANCE

The volt-ohm-milliammeter may be used to measure the resistance in a circuit. Resistance values can be very valuable when testing coils or windings, such as the Stator and Rotor windings.

When testing Stator windings, keep in mind that the resistance of these windings is very low. Some meters are not capable of reading such a low resistance and will simply read "continuity".

If proper procedures are used, the following conditions can be detected using a VOM:

- A "short-to-ground" condition in any Stator or Rotor winding.
- Shorting together of any two parallel Stator windings.
- Shorting together of any two isolated Stator windings.
- An open condition in any Stator or Rotor winding.

Component testing may require a specific resistance value or a test for "infinity" or "continuity." Infinity is an OPEN condition between two electrical points, which would read as no resistance on a VOM. Continuity is a closed condition between two electrical points, which would be indicated as very low resistance or "ZERO" on a VOM.



**ELECTRICAL UNITS**

**AMPERE:**

The rate of electron flow in a circuit is represented by the AMPERE. The ampere is the number of electrons flowing past a given point at a given time. One AMPERE is equal to just slightly more than six thousand million billion electrons per second.

With alternating current (AC), the electrons flow first in one direction, then reverse and move in the opposite direction. They will repeat this cycle at regular intervals. A wave diagram, called a "sine wave" shows that current goes from zero to maximum positive value, then reverses and goes from zero to maximum negative value. Two reversals of current flow is called a cycle. The number of cycles per second is called frequency and is usually stated in "Hertz".

**VOLT:**

The VOLT is the unit used to measure electrical PRESSURE, or the difference in electrical potential that causes electrons to flow. Very few electrons will flow when voltage is weak. More electrons will flow as voltage becomes stronger. VOLTAGE may be considered to be a state of unbalance and current flow as an attempt to regain balance. One volt is the amount of EMF that will cause a current of 1 ampere to flow through 1 ohm of resistance.

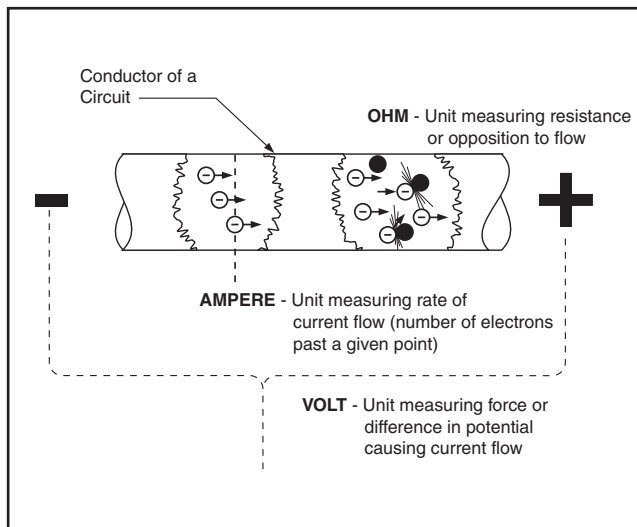

Figure 4-4. – Electrical Units

**OHM:**

The OHM is the unit of RESISTANCE. In every circuit there is a natural resistance or opposition to the flow of electrons. When an EMF is applied to a complete circuit, the electrons are forced to flow in a single direction rather than their free or orbiting pattern. The resistance of a conductor depends on (a) its physical makeup, (b) its cross-sectional area, (c) its length, and (d) its temperature. As the conductor's temperature increases, its resistance increases in direct proportion. One (1) ohm of resistance will permit one (1) ampere of current to flow when one (1) volt of electromotive force (EMF) is applied.

**OHM'S LAW**

A definite and exact relationship exists between VOLTS, OHMS and AMPERES. The value of one can be calculated when the value of the other two are known. Ohm's Law states that in any circuit the current will increase when voltage increases but resistance remains the same, and current will decrease when resistance increases and voltage remains the same.

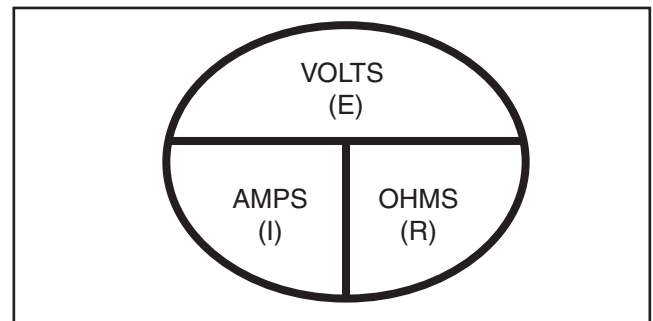

Figure 4-5.

If AMPERES is unknown while VOLTS and OHMS are known, use the following formula:

$$\text{AMPERES} = \frac{\text{VOLTS}}{\text{OHMS}}$$

If VOLTS is unknown while AMPERES and OHMS are known, use the following formula:

$$\text{VOLTS} = \text{AMPERES} \times \text{OHMS}$$

If OHMS is unknown but VOLTS and AMPERES are known, use the following:

$$\text{OHMS} = \frac{\text{VOLTS}}{\text{AMPERES}}$$

# Section 5 ENGINE DC CONTROL SYSTEM

## INTRODUCTION

The engine DC control system includes all components necessary for the operation of the engine. Operation includes rest, priming, cranking, starting, running and shutdown. The system is shown schematically on Pages 16-21.

## OPERATIONAL ANALYSIS

### CIRCUIT CONDITION- REST:

Battery voltage is available to the engine controller circuit board (PCB) from the unit BATTERY and via (a) the RED battery cable, Wire 13, a 7.5 amp FUSE (F1), Wire 15 and circuit board Terminal J3. However, circuit board action is holding the circuit open and no action can occur.

Battery output is available to the contacts of a STARTER CONTACTOR (SC), but the contacts are open.

Battery voltage is also delivered to the FUEL PRIMER SWITCH (SW2). The switch is open and the circuit is incomplete.

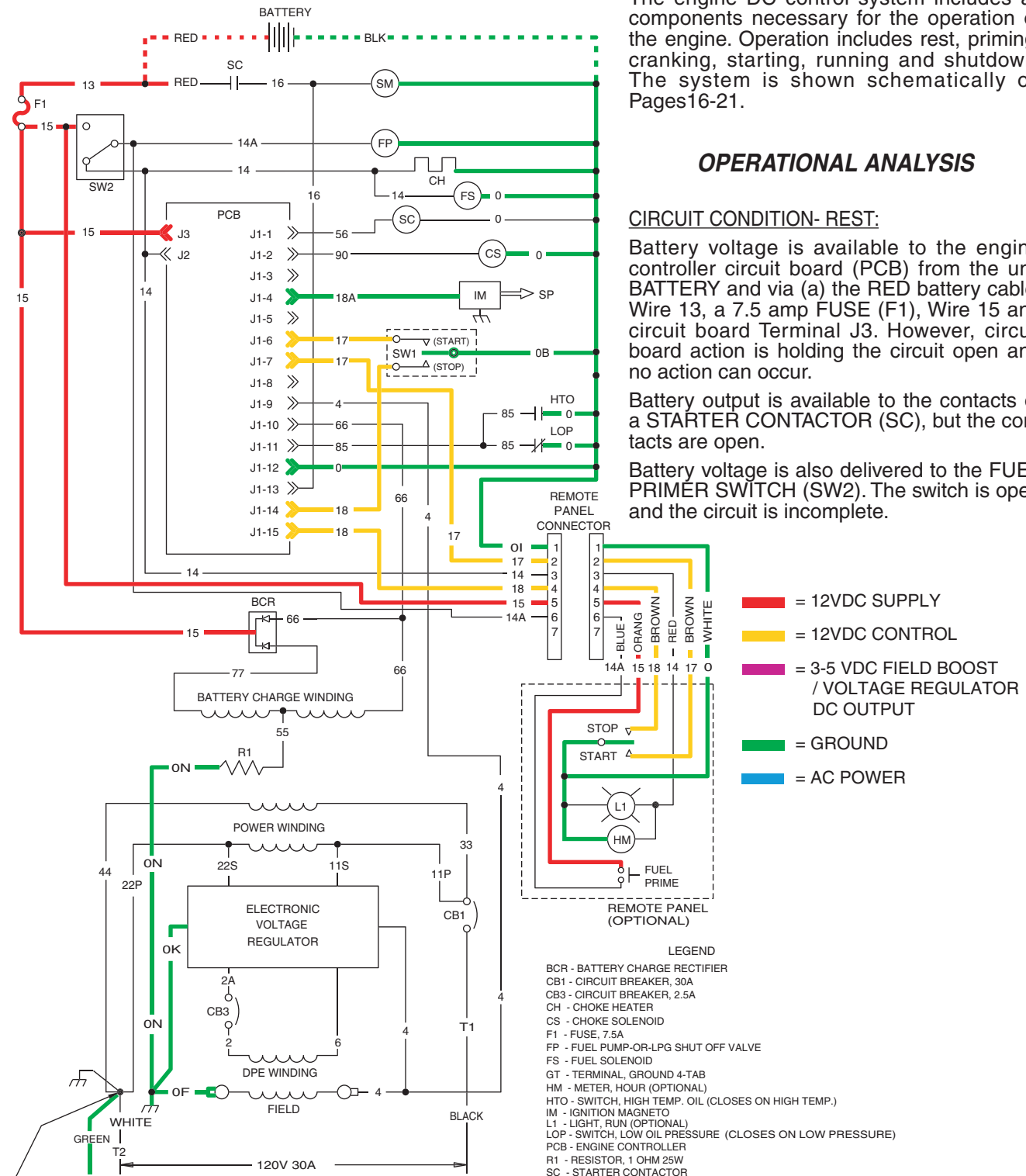

# Section 5 ENGINE DC CONTROL SYSTEM

## CIRCUIT CONDITION- PRIMING:

When the FUEL PRIMER SWITCH (SW2) is closed by the operator, battery voltage is delivered across the closed switch contacts and to the FUEL PUMP (FP) via Wire 14A. The FUEL SOLENOID (FS) will be energized open via Wire 14 during cranking and running.

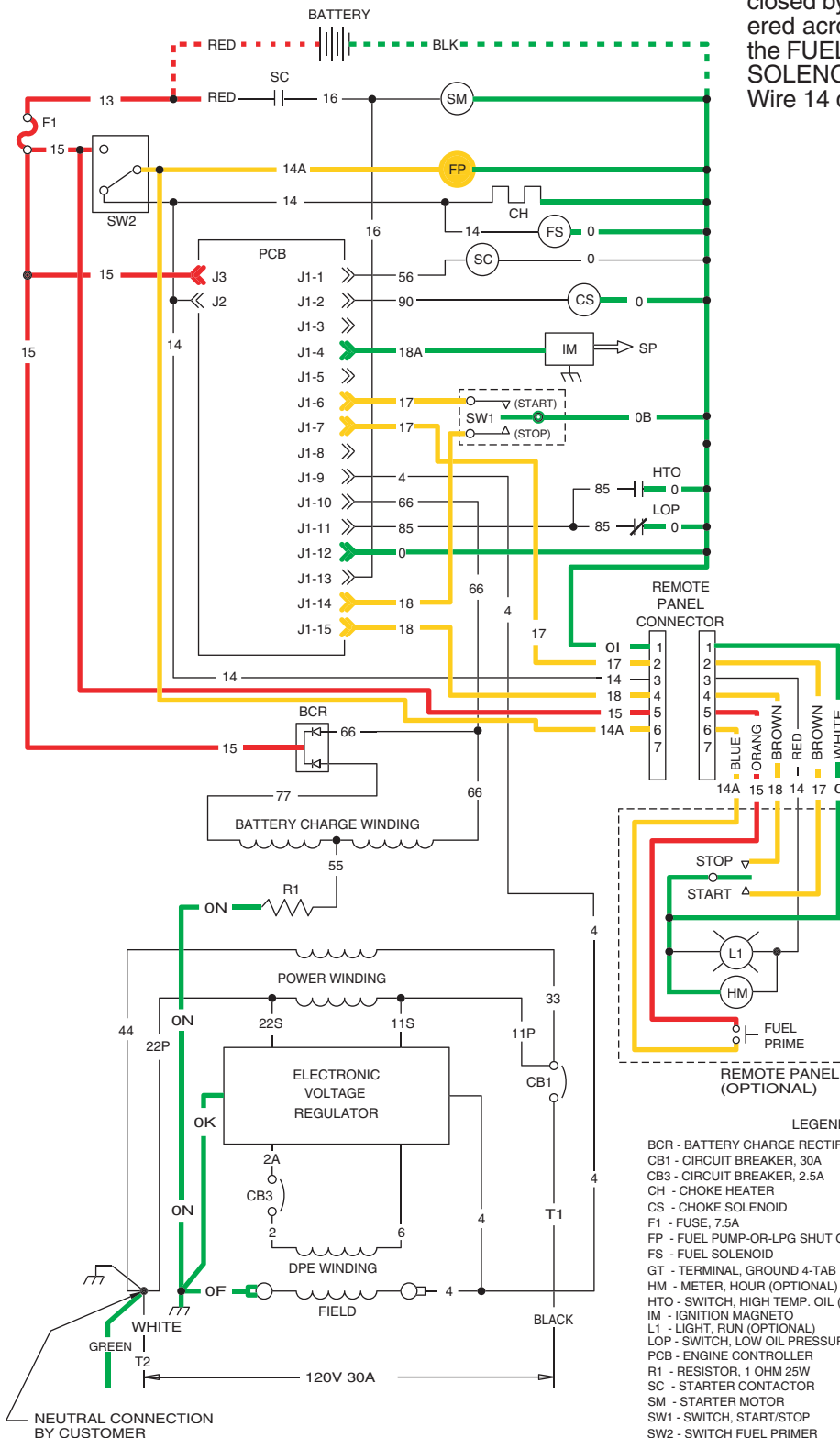

- █ = 12VDC SUPPLY
- █ = 12VDC CONTROL
- █ = 3-5 VDC FIELD BOOST / VOLTAGE REGULATOR DC OUTPUT
- █ = GROUND
- █ = AC POWER

- LEGEND
- BCR - BATTERY CHARGE RECTIFIER
  - CB1 - CIRCUIT BREAKER, 30A
  - CB3 - CIRCUIT BREAKER, 2.5A
  - CH - CHOKE HEATER
  - CS - CHOKE SOLENOID
  - F1 - FUSE, 7.5A
  - FP - FUEL PUMP-OR-LPG SHUT OFF VALVE
  - FS - FUEL SOLENOID
  - GT - TERMINAL, GROUND 4-TAB
  - HM - METER, HOUR (OPTIONAL)
  - HTO - SWITCH, HIGH TEMP. OIL (CLOSES ON HIGH TEMP.)
  - IM - IGNITION MAGNETO
  - L1 - LIGHT, RUN (OPTIONAL)
  - LOP - SWITCH, LOW OIL PRESSURE (CLOSES ON LOW PRESSURE)
  - PCB - ENGINE CONTROLLER
  - R1 - RESISTOR, 1 OHM 25W
  - SC - STARTER CONTACTOR
  - SM - STARTER MOTOR
  - SW1 - SWITCH, START/STOP
  - SW2 - SWITCH FUEL PRIMER
  - SP - SPARK PLUG
  - TC - TERMINAL, CONN. 4-TAB

# Section 5 ENGINE DC CONTROL SYSTEM

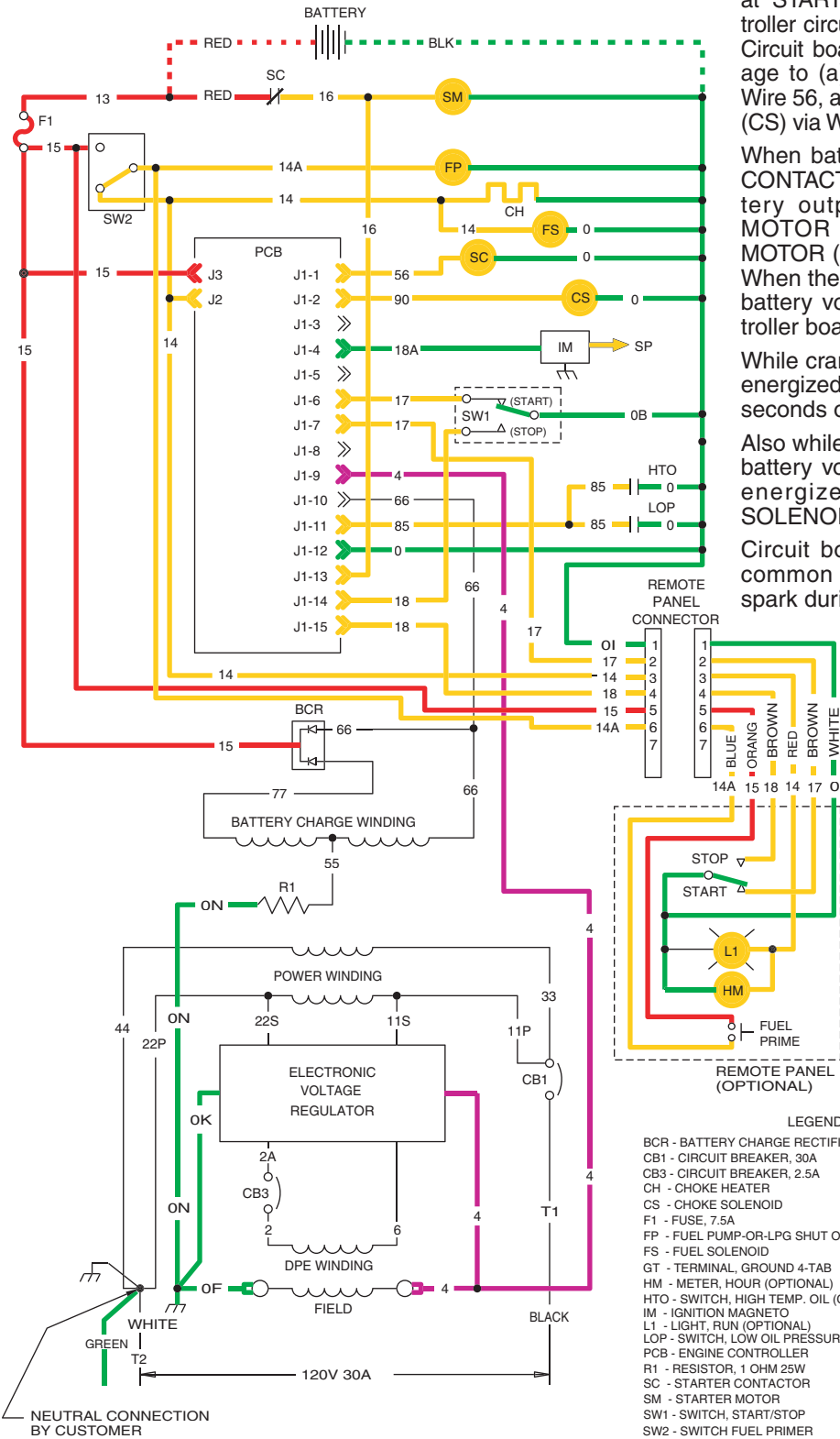

## CIRCUIT CONDITION- CRANKING:

When the START-STOP SWITCH (SW1) is held at "START" position, Wire 17 from the engine controller circuit board is connected to frame ground. Circuit board action will then deliver battery voltage to (a) a STARTER CONTACTOR (SC) via Wire 56, and to an automatic CHOKE SOLENOID (CS) via Wire 90.

When battery voltage energizes the STARTER CONTACTOR (SC), its contacts close and battery output is delivered to the STARTER MOTOR (SM) via Wire 16. The STARTER MOTOR (SM) energizes and the engine cranks. When the STARTER CONTACTOR (SC) closes, battery voltage is delivered to the engine controller board for field boost.

While cranking, the CHOKE SOLENOID (CS) is energized cyclically by circuit board action (two seconds on, two seconds off).

Also while cranking, circuit board action delivers battery voltage to the Wire 14/14A circuit. This energizes the FUEL PUMP (FP), FUEL SOLENOID (FS) and CHOKE HEATER (CH).

Circuit board action holds open Wire 18A to common ground. The Magneto will induce a spark during cranking.

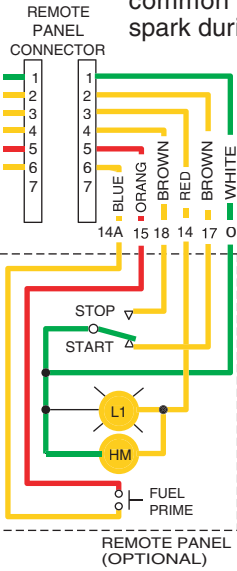

- LEGEND**
- BCR - BATTERY CHARGE RECTIFIER
  - CB1 - CIRCUIT BREAKER, 30A
  - CB3 - CIRCUIT BREAKER, 2.5A
  - CH - CHOKE HEATER
  - CS - CHOKE SOLENOID
  - F1 - FUSE, 7.5A
  - FP - FUEL PUMP-OR-LPG SHUT OFF VALVE
  - FS - FUEL SOLENOID
  - GT - TERMINAL, GROUND 4-TAB
  - HM - METER, HOUR (OPTIONAL)
  - HTO - SWITCH, HIGH TEMP. OIL (CLOSES ON HIGH TEMP.)
  - IM - IGNITION MAGNETO
  - L1 - LIGHT, RUN (OPTIONAL)
  - LOP - SWITCH, LOW OIL PRESSURE (CLOSES ON LOW PRESSURE)
  - PCB - ENGINE CONTROLLER
  - R1 - RESISTOR, 1 OHM 25W
  - SC - STARTER CONTACTOR
  - SM - STARTER MOTOR
  - SW1 - SWITCH, START/STOP
  - SW2 - SWITCH FUEL PRIMER
  - SP - SPARK PLUG
  - TC - TERMINAL, CONN. 4-TAB

# Section 5 ENGINE DC CONTROL SYSTEM

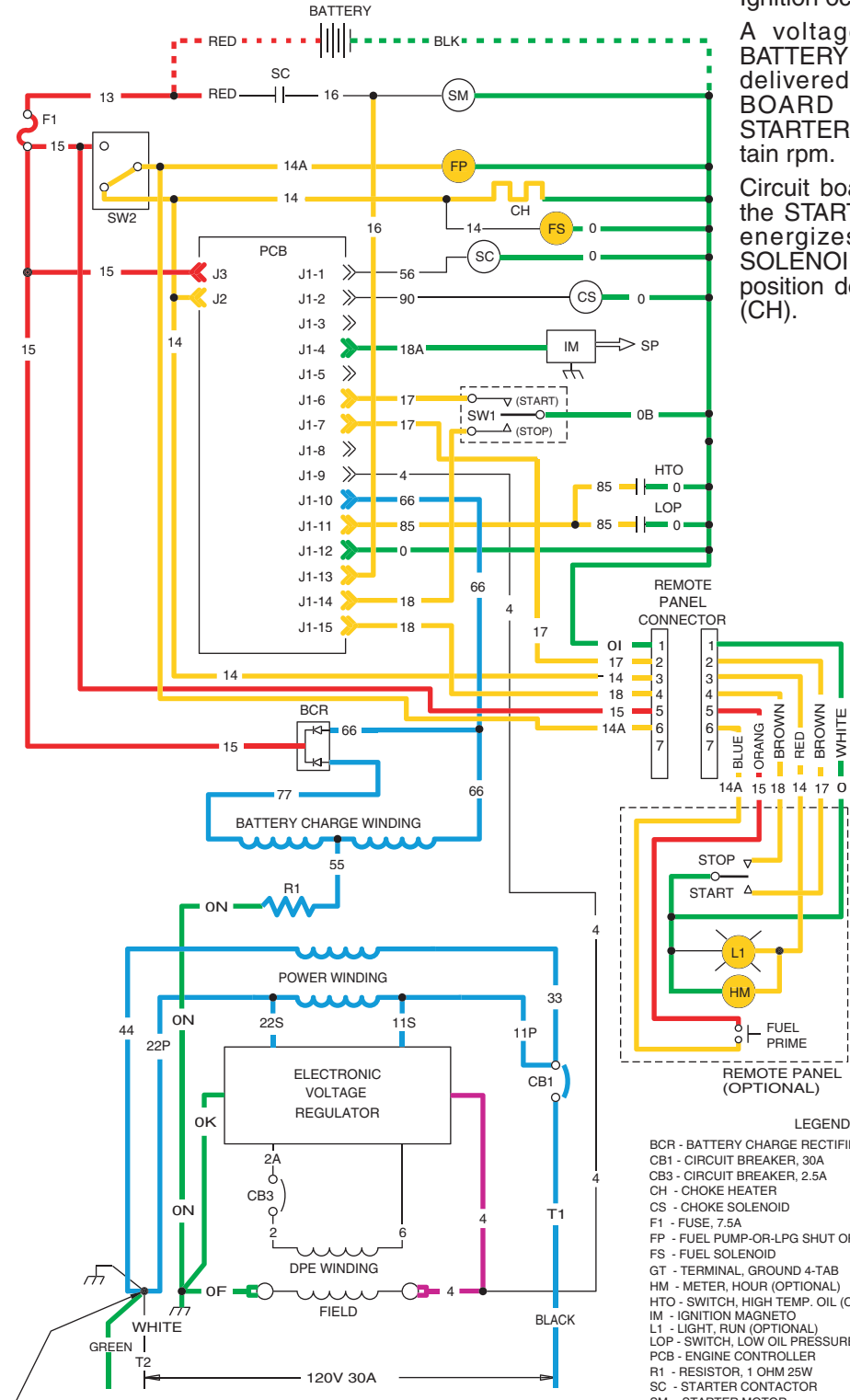

**CIRCUIT CONDITION-RUNNING:**

With the FUEL PUMP (FP) operating and Ignition occurring, the engine should start.

A voltage is induced into the Stator's BATTERY CHARGE WINDING. This voltage is delivered to the ENGINE CONTROLLER BOARD (PCB) via Wire 66 to prevent STARTER MOTOR engagement above a certain rpm.

Circuit board action terminates DC output to the STARTER CONTACTOR, which then de-energizes to end cranking and CHOKE SOLENOID operation. The choke will go to a position determined by the CHOKE HEATER (CH).

- █ = 12VDC SUPPLY
- █ = 12VDC CONTROL
- █ = 3-5 VDC FIELD BOOST / VOLTAGE REGULATOR DC OUTPUT
- █ = GROUND
- █ = AC POWER

- LEGEND**
- BCR - BATTERY CHARGE RECTIFIER
  - CB1 - CIRCUIT BREAKER, 30A
  - CB3 - CIRCUIT BREAKER, 2.5A
  - CH - CHOKE HEATER
  - CS - CHOKE SOLENOID
  - F1 - FUSE, 7.5A
  - FP - FUEL PUMP-OR-LPG SHUT OFF VALVE
  - FS - FUEL SOLENOID
  - GT - TERMINAL, GROUND 4-TAB
  - HM - METER, HOUR (OPTIONAL)
  - HTO - SWITCH, HIGH TEMP. OIL (CLOSES ON HIGH TEMP.)
  - IM - IGNITION MAGNETO
  - L1 - LIGHT, RUN (OPTIONAL)
  - LOP - SWITCH, LOW OIL PRESSURE (CLOSES ON LOW PRESSURE)
  - PCB - ENGINE CONTROLLER
  - R1 - RESISTOR, 1 OHM 25W
  - SC - STARTER CONTACTOR
  - SM - STARTER MOTOR
  - SW1 - SWITCH, START/STOP
  - SW2 - SWITCH FUEL PRIMER
  - SP - SPARK PLUG
  - TC - TERMINAL, CONN. 4-TAB

# Section 5 ENGINE DC CONTROL SYSTEM

## CIRCUIT CONDITION- SHUTDOWN:

Setting the START-STOP SWITCH (SW1) to its "STOP" position connects the Wire 18 circuit to frame ground. Circuit board action then closes the circuit to Wire 18A, grounding the ignition coil. Circuit board action opens the circuit to Wire 14. Ignition and fuel flow terminate and the engine shuts down.

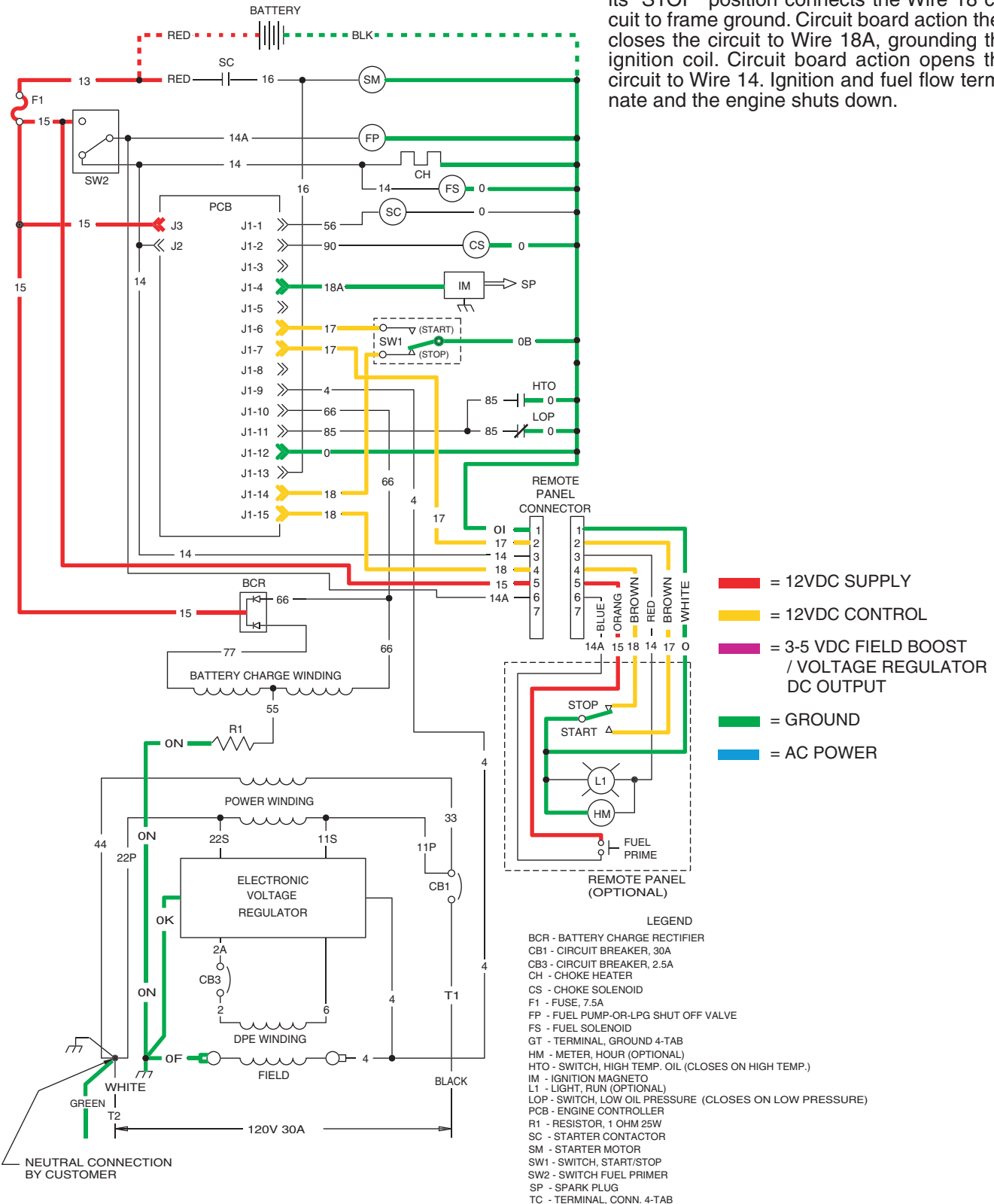

## Section 5 ENGINE DC CONTROL SYSTEM

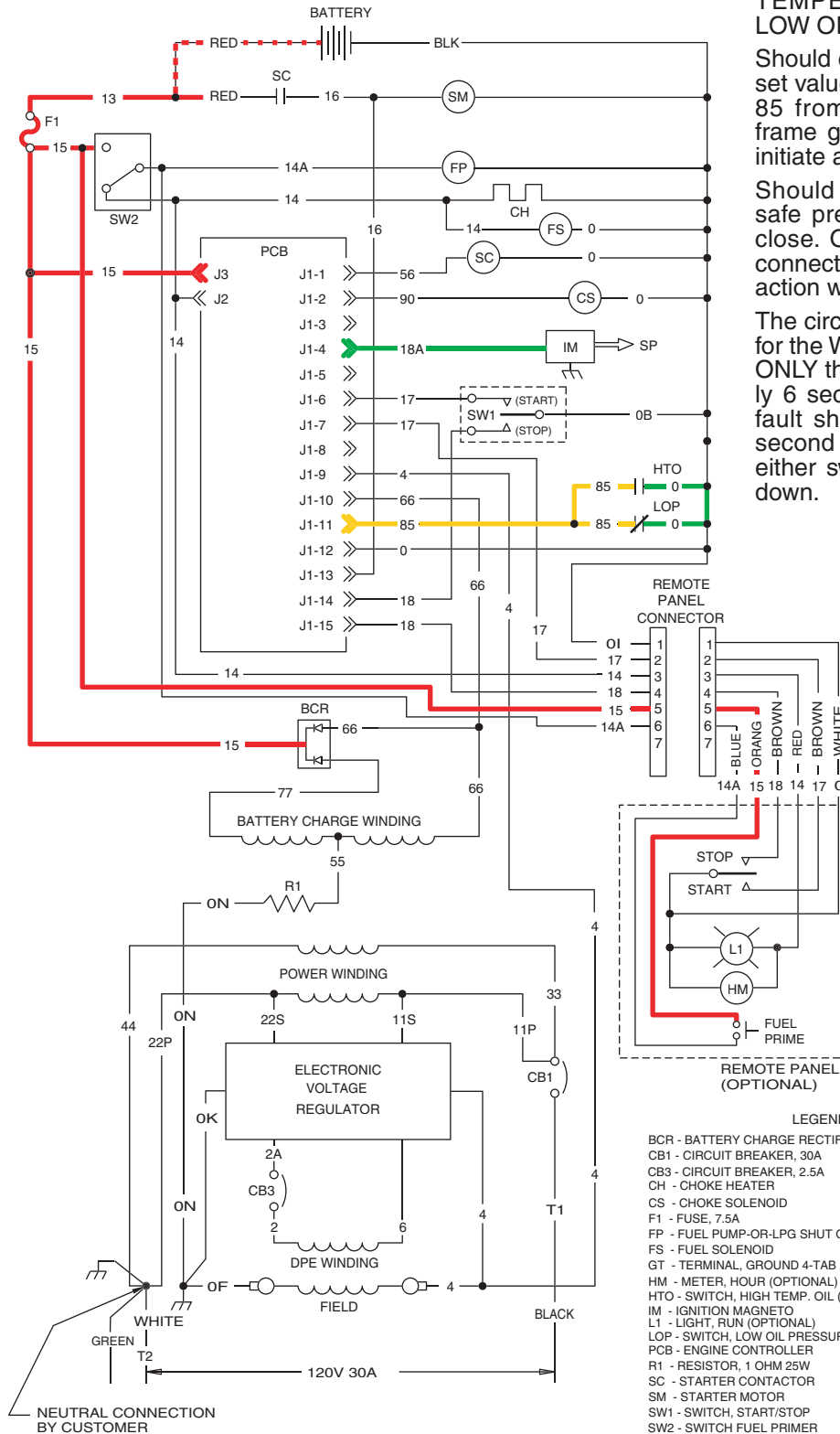

**CIRCUIT CONDITION- FAULT SHUTDOWN:**  
The engine mounts a HIGH OIL TEMPERATURE SWITCH (HTO) and a LOW OIL PRESSURE SWITCH (LOP).

Should engine oil temperature exceed a pre-set value, the switch contacts will close. Wire 85 from the circuit board will connect to frame ground. Circuit board action will then initiate a shutdown.

Should engine oil pressure drop below a safe pre-set value, the switch contacts will close. On contact closure, Wire 85 will be connected to frame ground and circuit board action will initiate an engine shutdown.

The circuit board has a time delay built into it for the Wire 85 fault shutdowns. At STARTUP ONLY the circuit board will wait approximately 6 seconds before looking at the Wire 85 fault shutdowns. Once running after the 6 second time delay, grounding Wire 85 thru either switch will cause an immediate shutdown.

- █ = 12VDC SUPPLY
- █ = 12VDC CONTROL
- █ = 3-5 VDC FIELD BOOST / VOLTAGE REGULATOR DC OUTPUT
- █ = GROUND
- █ = AC POWER

- LEGEND
- BCR - BATTERY CHARGE RECTIFIER
  - CB1 - CIRCUIT BREAKER, 30A
  - CB3 - CIRCUIT BREAKER, 2.5A
  - CH - CHOKE HEATER
  - CS - CHOKE SOLENOID
  - F1 - FUSE, 7.5A
  - FP - FUEL PUMP-OR-LPG SHUT OFF VALVE
  - FS - FUEL SOLENOID
  - GT - TERMINAL, GROUND 4-TAB
  - HM - METER, HOUR (OPTIONAL)
  - HTO - SWITCH, HIGH TEMP. OIL (CLOSES ON HIGH TEMP.)
  - IM - IGNITION MAGNETO
  - L1 - LIGHT, RUN (OPTIONAL)
  - LOP - SWITCH, LOW OIL PRESSURE (CLOSES ON LOW PRESSURE)
  - PCB - ENGINE CONTROLLER
  - R1 - RESISTOR, 1 OHM 25W
  - SC - STARTER CONTACTOR
  - SM - STARTER MOTOR
  - SW1 - SWITCH, START/STOP
  - SW2 - SWITCH FUEL PRIMER
  - SP - SPARK PLUG
  - TC - TERMINAL, CONN. 4-TAB

## Section 5 ENGINE DC CONTROL SYSTEM

### ENGINE CONTROLLER CIRCUIT BOARD

#### GENERAL:

The engine controller board is responsible for cranking, startup, running and shutdown operations. The board interconnects with other components of the DC control system to turn them on and off at the proper times. It is powered by fused 12 VDC power from the unit battery.

#### CIRCUIT BOARD CONNECTIONS:

The circuit board mounts a 15-pin receptacle (J1) and two single pin terminals (J2 and J3, see Figure 5.3). Figure 5-2 shows the 15-pin receptacle (J1), the associated wires and the function(s) of each pin and wire.

In addition to the 15-pin receptacle (J1), the circuit board is equipped with two single pin terminals (J2 and J3). These terminals may be identified as follows:

PIN	WIRE	FUNCTION
1	56	Delivers 12 VDC to Starter Contactor (SC) while cranking only.
2	90	Delivers 12 VDC to Choke Solenoid coil while cranking only. (Two seconds ON, Two seconds OFF)
3	—	Not used.
4	18A	Grounds Magneto for Shutdown.
5	—	Not used.
6	17	To Start-Stop switch. When wire is grounded by setting Start-Stop switch to "START", engine will crank.
7	17	To Start-Stop switch on optional Remote Panel.
8	—	Not used.
9	4	Field Boost DC to Voltage Regulator and to Rotor windings.
10	66	Starter Lockout. Prevents cranking while engine is running.
11	85	Fault shutdown circuit. When grounded by closure of High Oil Temperature or Low Oil Pressure Switch engine will shut down.
12	0	Common Ground.
13	16	12 VDC Input to Field Boost circuit while cranking only.
14	18	To Start-Stop switch. When grounded by setting Switch to "STOP" engine shuts down.
15	18	To Start-Stop Switch on optional Remote Panel.

Figure 5-2. – Receptacle J1

1. Wire 14 connects to Terminal J2. During cranking and running, the circuit board delivers battery voltage to the Wire 14 circuit for the following functions:

- To operate the electric Fuel Pump (FP).
- To energize the Fuel Solenoid.

- To operate the Choke Heater.
- To the Remote Wire Harness to operate an hourmeter or a light.

2. Wire 15 connects to Terminal J3. This is the power supply (12 VDC) for the circuit board and the DC control system.

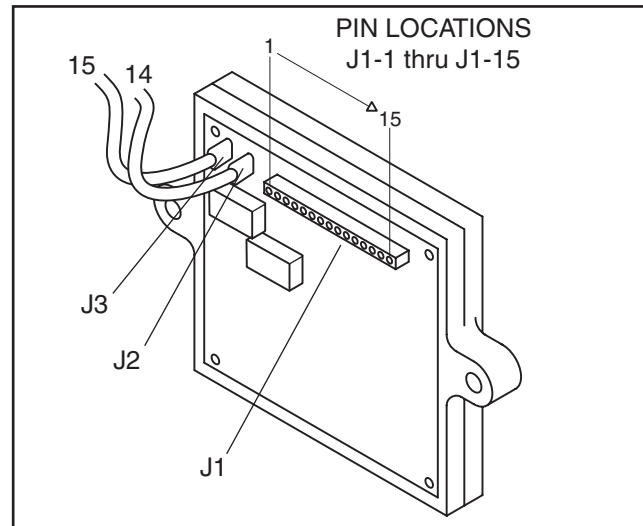

Figure 5-3. – Engine Controller Circuit Board

### BATTERY

#### RECOMMENDED BATTERY:

When anticipated ambient temperatures will be consistently above 32° F. (0° C.), use a 12 volts automotive type storage battery rated 70 amp-hours and capable of delivering at least 400 cold cranking amperes.

If ambient temperatures will be below 32° (0° C.), use a 12 volt battery rated 95 amp-hours and having a cold cranking capacity of 400 amperes.

#### BATTERY CABLES:

Use of battery cables that are too long or too small in diameter will result in excessive voltage drop. For best cold weather starting, voltage drop between the battery and starter should not exceed 0.12 volt per 100 amperes of cranking current.

Select the battery cables based on total cable length and prevailing ambient temperature. Generally, the longer the cable and the colder the weather, the larger the required cable diameter.

The following chart applies:

CABLE LENGTH (IN FEET)	RECOMMENDED CABLE SIZE
0-10	No. 2
11-15	No. 0
16-20	No. 000



**EFFECTS OF TEMPERATURE:**

Battery efficiency is greatly reduced by a decreased electrolyte temperature. Such low temperatures have a decided numbing effect on the electrochemical action. Under high discharge rates (such as cranking), battery voltage will drop to much lower values in cold temperatures than in warmer temperatures. The freezing point of battery electrolyte fluid is affected by the state of charge of the electrolyte as indicated below:

SPECIFIC GRAVITY	FREEZING POINT
1.220	-35° F. (-37° C.)
1.200	-20° F. (-29° C.)
1.160	0° F. (-18° C.)

**ADDING WATER:**

Water is lost from a battery as a result of charging and discharging and must be replaced. If the water is not replaced and the plates become exposed, they may become permanently sulfated. In addition, the plates cannot take full part in the battery action unless they are completely immersed in electrolyte. Add only DISTILLED WATER to the battery. DO NOT USE TAP WATER.

**NOTE: Water cannot be added to some “maintenance-free” batteries.**

**CHECKING BATTERY STATE OF CHARGE:**

Use an automotive type battery hydrometer to test the battery state of charge. Follow the hydrometer manufacturer’s instructions carefully. Generally, a battery may be considered fully charged when the specific gravity of its electrolyte is 1.260. If the hydrometer used does not have a “Percentage of Charge” scale, compare the readings obtained with the following:

SPECIFIC GRAVITY	PERCENTAGE OF CHARGE
1.260	100%
1.230	75%
1.200	50%
1.170	25%

**CHARGING A BATTERY:**

Use an automotive type battery charger to recharge a battery. Battery fluid is an extremely corrosive, sulfuric acid solution that can cause severe burns. For that reason, the following precautions must be observed:

- The area in which the battery is being charged must be well ventilated. When charging a battery, an explosive gas mixture forms in each cell.
- Do not smoke or break a live circuit near the top of the battery. Sparking could cause an explosion.
- Avoid spillage of battery fluid. If spillage occurs, flush the affected area with clear water immediately.
- Wear eye protection when handling a battery.

**7.5 AMP FUSE**

This panel-mounted Fuse protects the DC control circuit against overload and possible damage. If the Fuse has melted open due to an overload, neither the priming function nor the cranking function will be available.

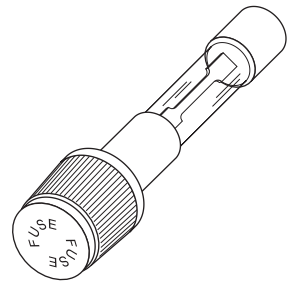

Figure5-4

**FUEL PRIMER SWITCH**

Following generator installation and after the unit has been idle for some time, the fuel supply line may be empty. This condition will require a long cranking period before fuel can reach the carburetor. The Fuel Primer Switch, when actuated to its “PRIME” position will deliver battery voltage across the closed switch contacts to the Fuel Pump (FP) to turn the Pump on. Pump action will then draw fuel from the supply tank to prime the fuel lines and carburetor.

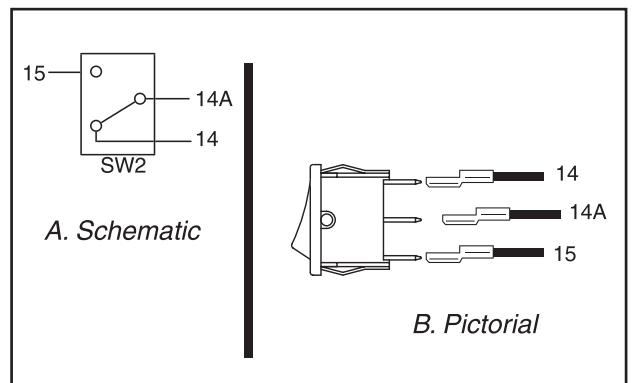

Figure 5-5. – Primer Switch

**START-STOP SWITCH**

The Start-Stop Switch allows the operator to control cranking, startup and shutdown. The following wires connect to the Start-Stop Switch:

1. Wire No. 17 from the Engine Controller circuit board. This is the CRANK and START circuit. When the Switch is set to “START”, Wire 17 is connected to frame ground via Wire OB.
  - a. With Wire 17 grounded, a Crank Relay on the circuit board energizes and battery voltage is delivered to the Starter Contactor via Wire 56. The Starter contactor energizes, its contacts close and the engine cranks.

## Section 5 ENGINE DC CONTROL SYSTEM

- b. With Wire 17 grounded, a Run Relay on the circuit board energizes and battery voltage is delivered to the Wire 14 circuit. Battery voltage is delivered to the Fuel Pump, Fuel Solenoid, Choke Heater and the Remote Harness.

2. Wire 18 from the Engine Controller board. This is the ENGINE STOP circuit. When the Start-Stop Switch is set to "STOP", Wire 18 is connected to frame ground via Wire No. 0B. Circuit board action then opens the circuit to Wire 14, and grounds Wire 18A. Fuel flow to the carburetor and ignition are terminated.

3. Wire 0B connects the Switch to frame ground.

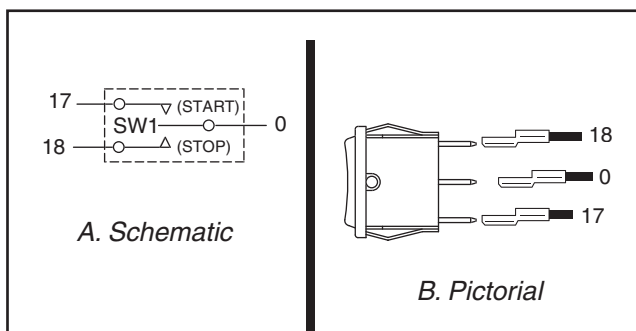

Figure 5-6. – Start-Stop Switch

### STARTER CONTACTOR & MOTOR

The positive (+) battery cable (13) attaches to one of the large lugs of the Contactor along with Wire 13 for DC supply to the Fuse (F1). The Starter cable (16) attaches to the second large lug, along with Wire 16 for the Field Boost Circuit. Attached to the two small lugs are Wires 56 and 0.

When the Start-Stop switch is set to "START", the circuit board delivers battery voltage to the Contactor

coil via Wire 56. The Contactor energizes and its contacts close. Battery voltage is then delivered from the positive battery cable, across the closed contacts and to the Starter Motor via Wire 16.

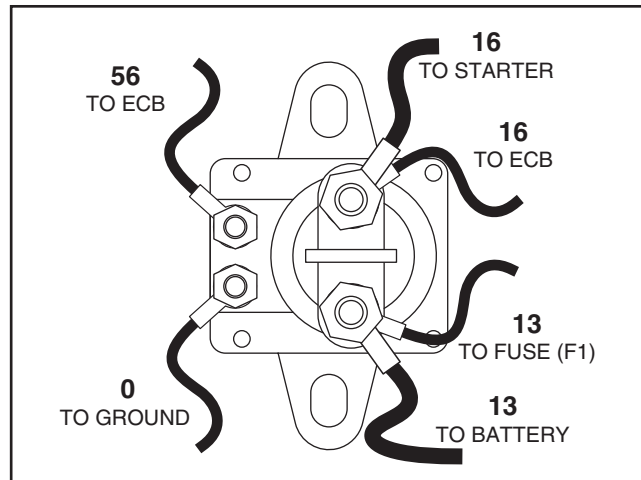

Figure 5-7. – Starter Contactor

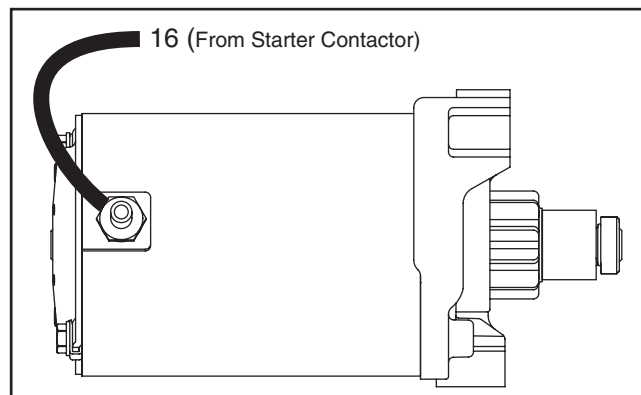

Figure 5-8. – Starter Motor

**INTRODUCTION**

The "Flow Charts" in this section may be used in conjunction with the "Diagnostic Tests" of Section 7. Numbered tests in the Flow Charts correspond to identically numbered tests of Section 7.

Problems 1 through 5 apply to the AC generator only. Beginning with Problem 6, the engine DC control system is dealt with.

**If Problem Involves AC Output**

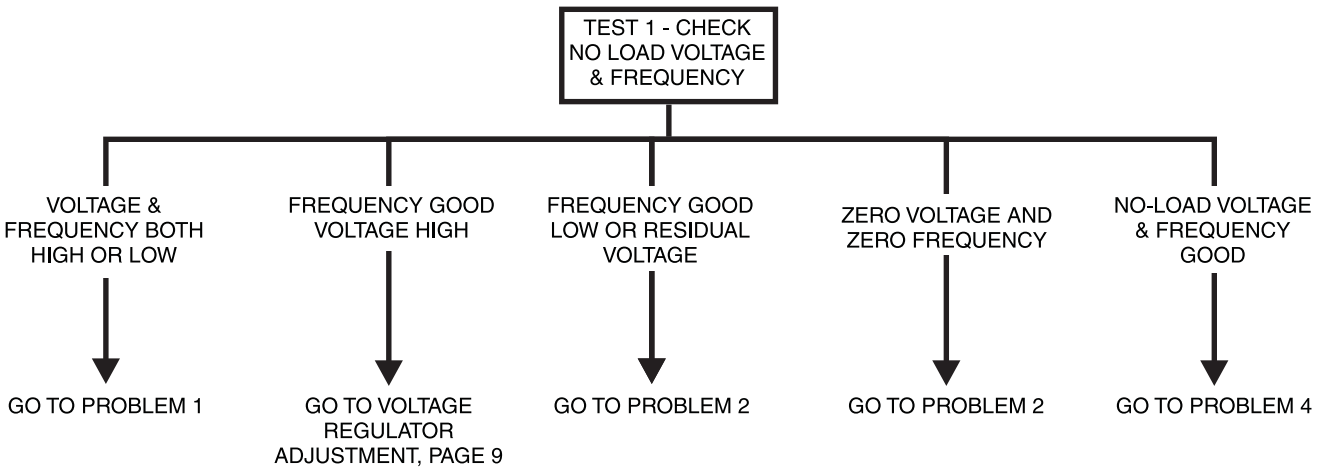

**Problem 1 - Voltage & Frequency Are Both High or Low**

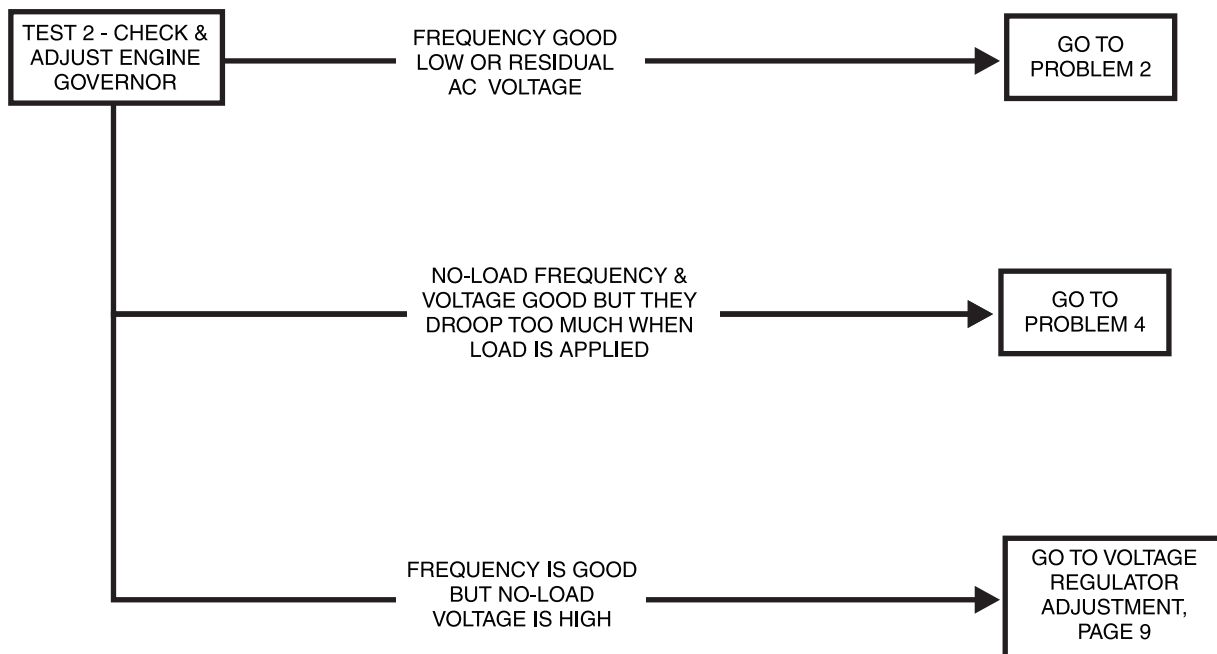

**Section 6**  
**TROUBLESHOOTING FLOWCHARTS**

**Problem 2 - Generator Produces Zero Voltage or Residual Voltage (5-12 VAC)**

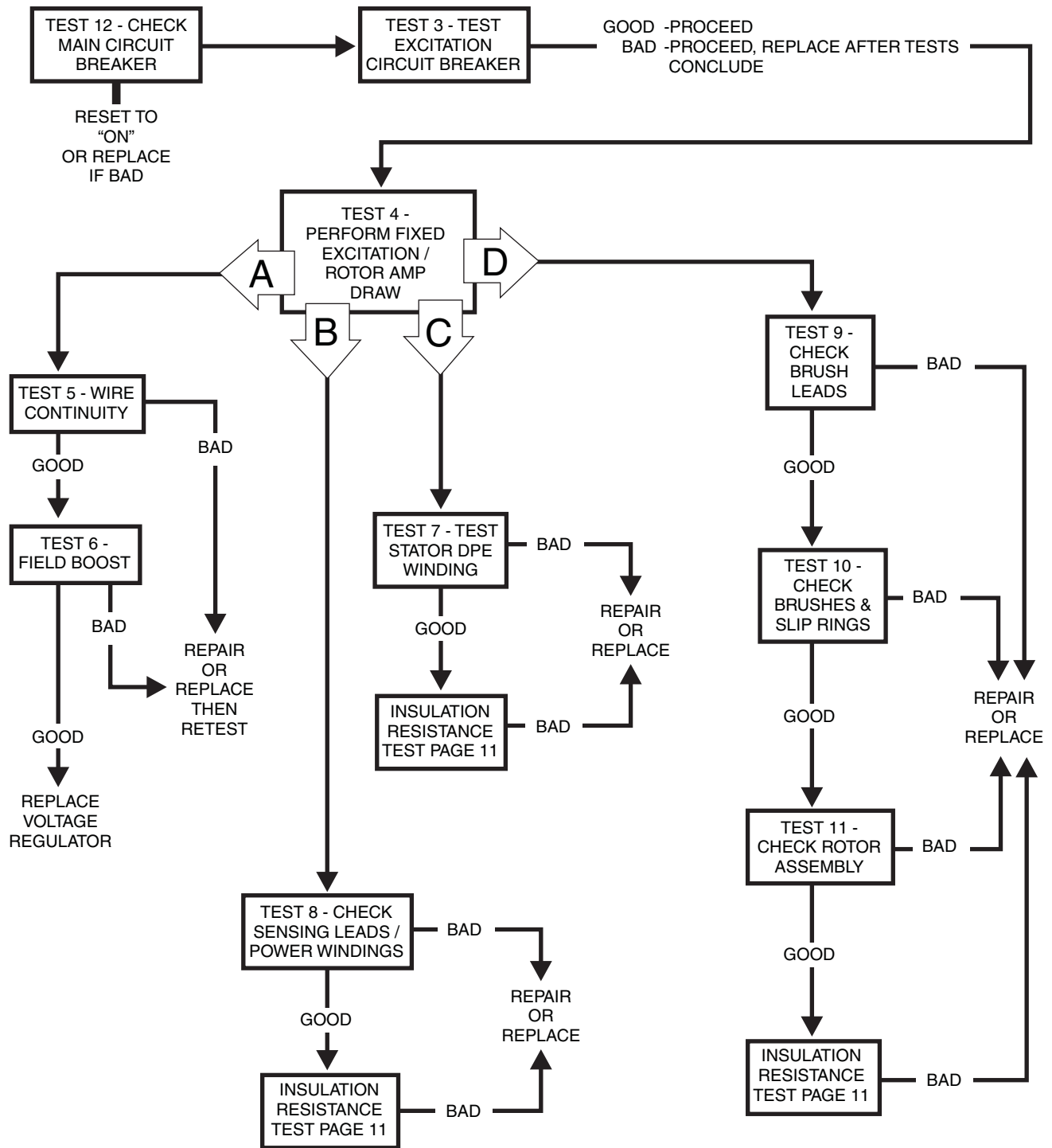

**Problem 2 - Generator Produces Zero Voltage or Residual Voltage (5-12 VAC)  
(continued)**

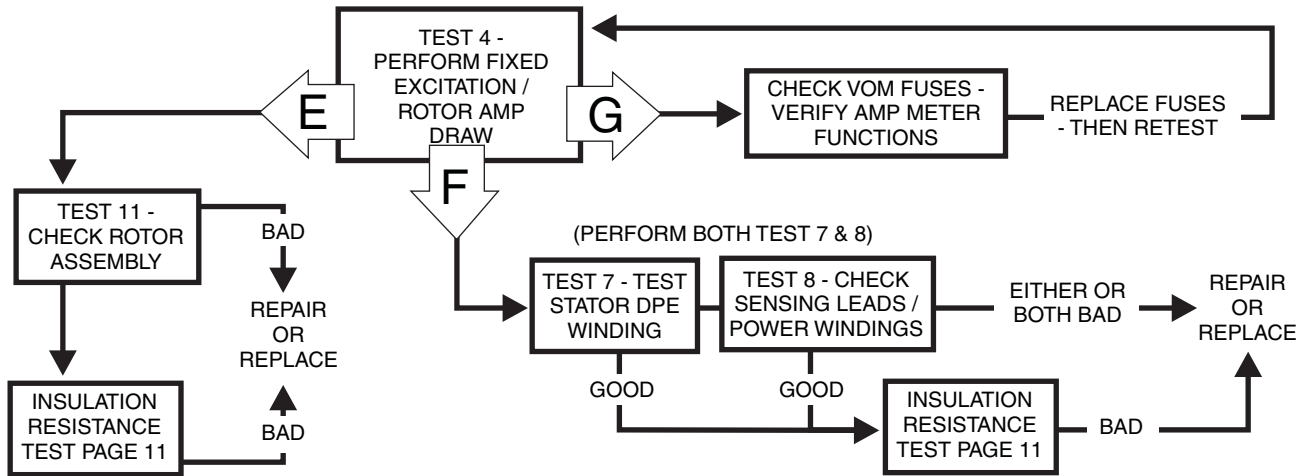

**Problem 3 - No Battery Charge Output**

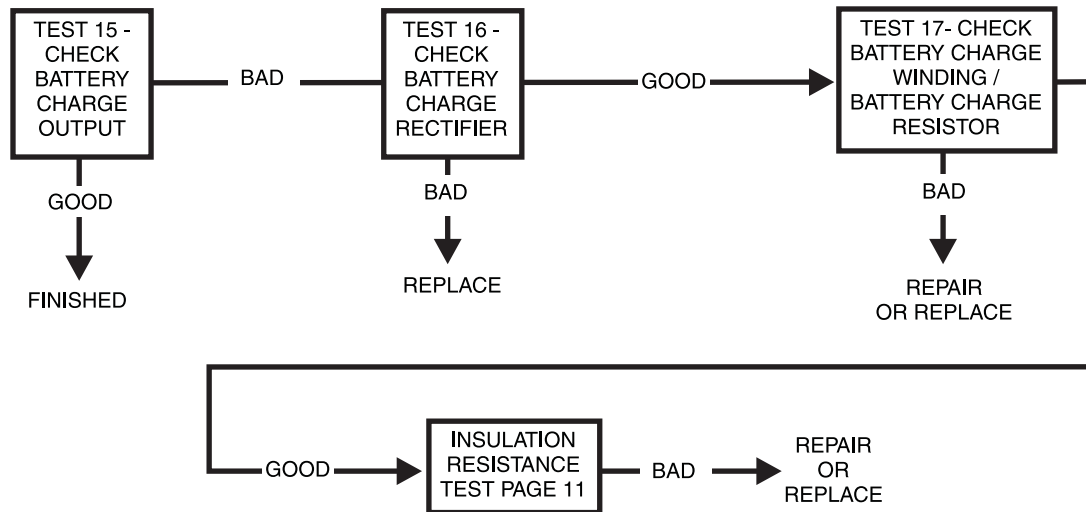

**Section 6**  
**TROUBLESHOOTING FLOWCHARTS**

**Problem 4 - Excessive Voltage/Frequency Droop When Load is Applied**

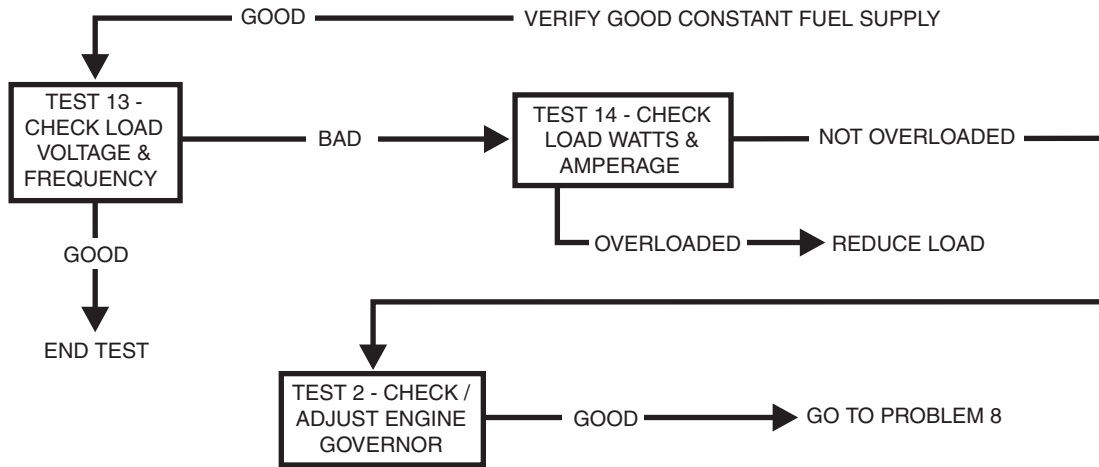

**Problem 5 - Priming Function Does Not Work (Gasoline Units)**

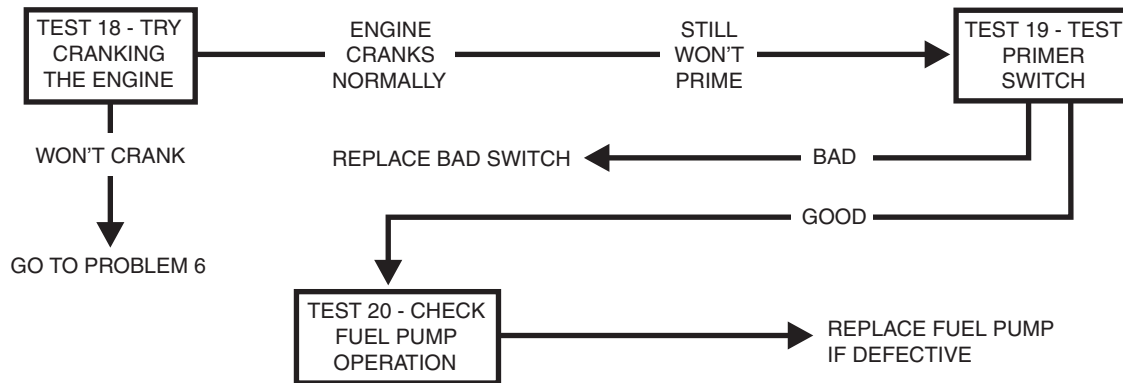

**Problem 6 - Engine Will Not Crank**

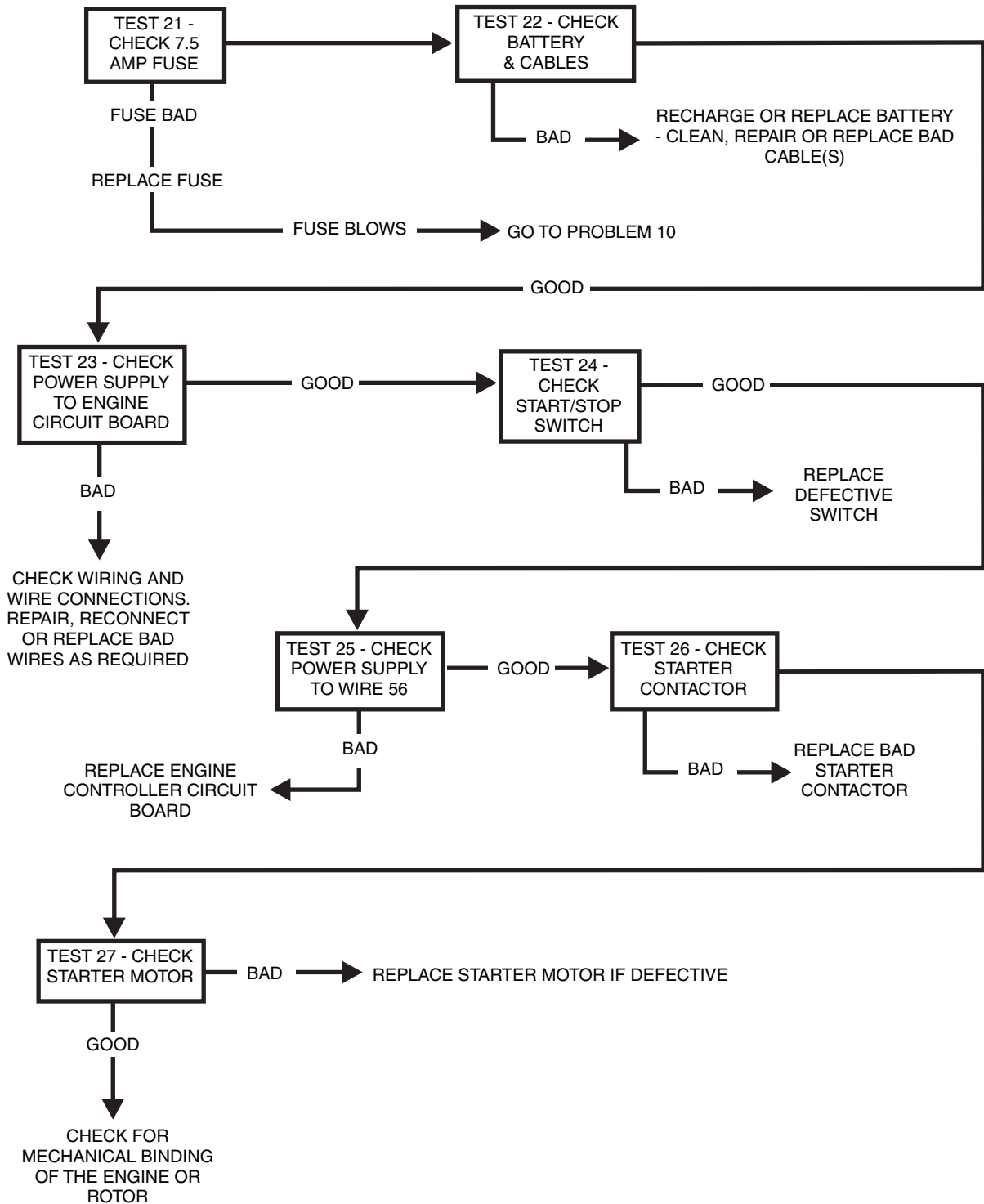

# Section 6 TROUBLESHOOTING FLOWCHARTS

## Problem 7 - Engine Cranks But Will Not Start (Gasoline Units)

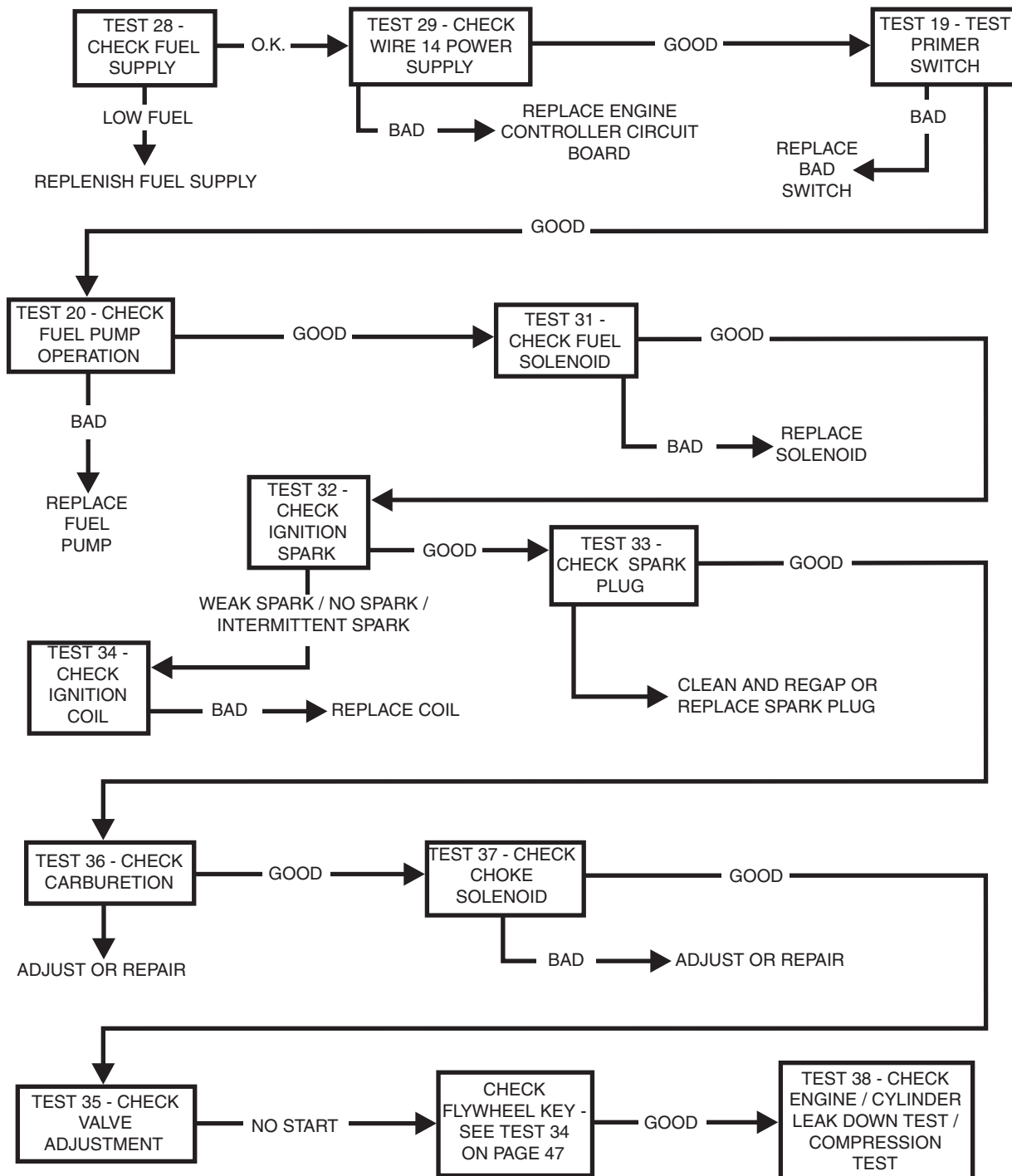



**Problem 7 - Engine Cranks But Will Not Start (LP Units)**

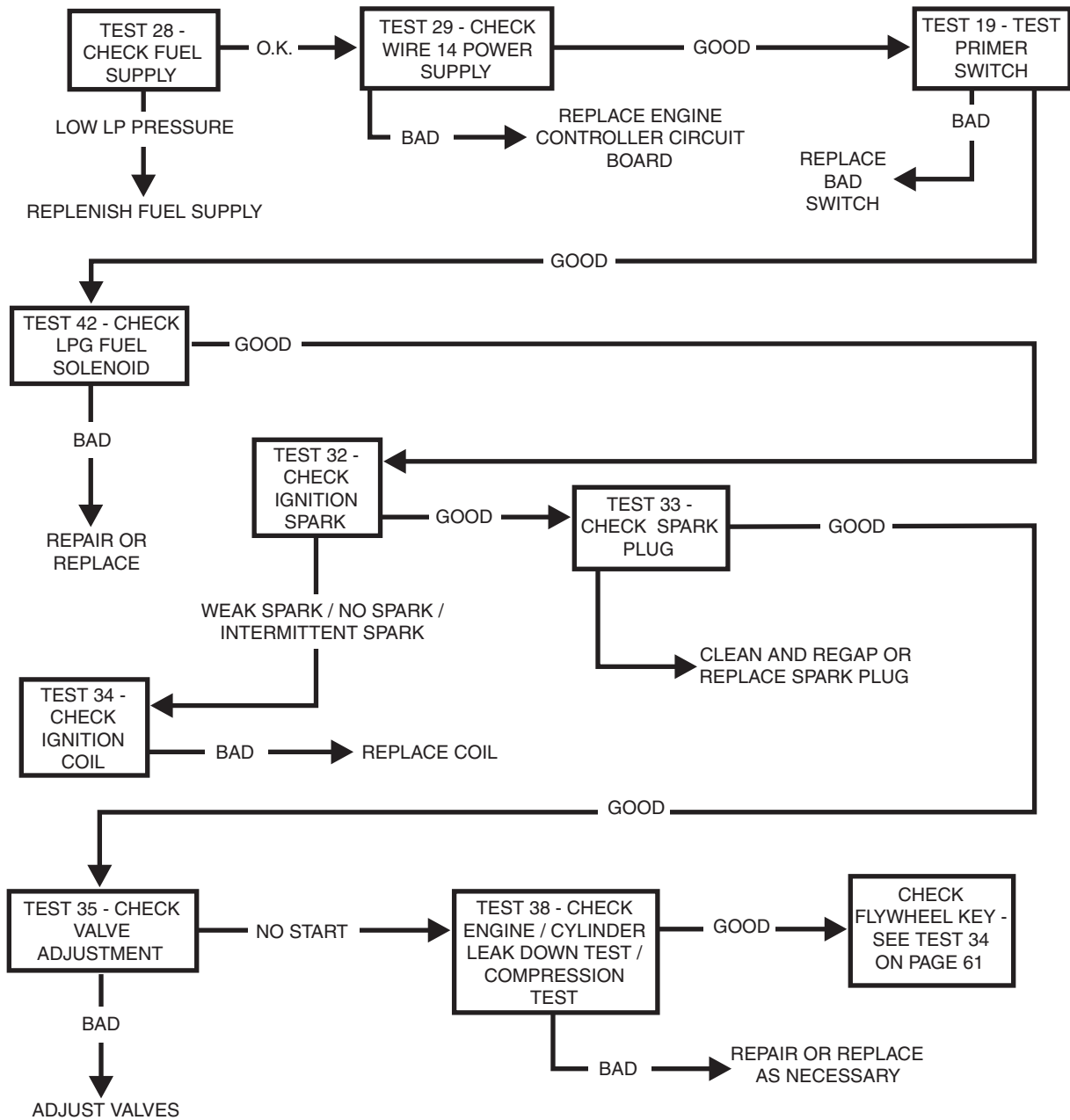

**Section 6**  
**TROUBLESHOOTING FLOWCHARTS**

**Problem 8 - Engine Starts Hard and Runs Rough (Gasoline Units)**

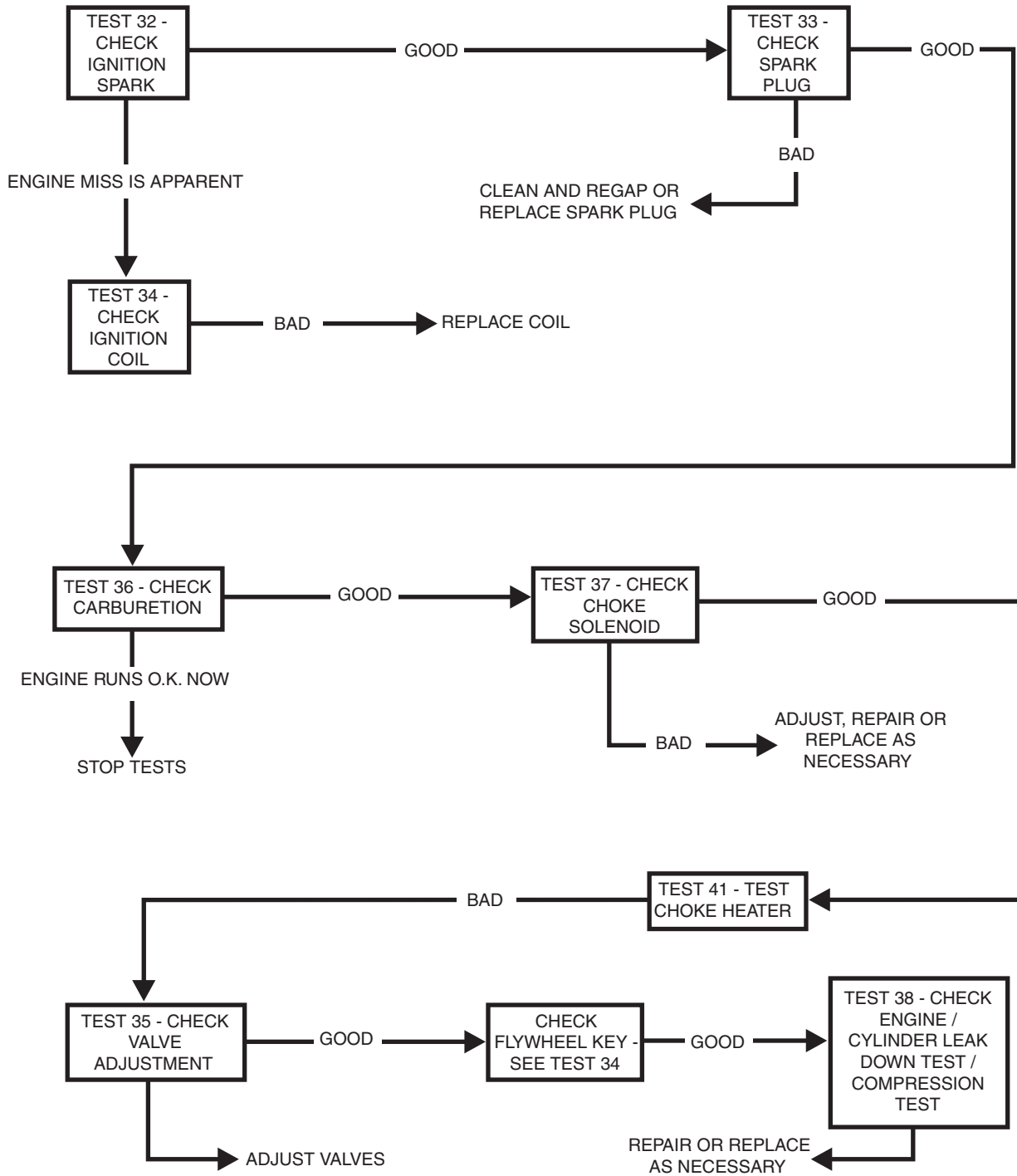

**Problem 8 - Engine Starts Hard and Runs Rough (LP Units)**

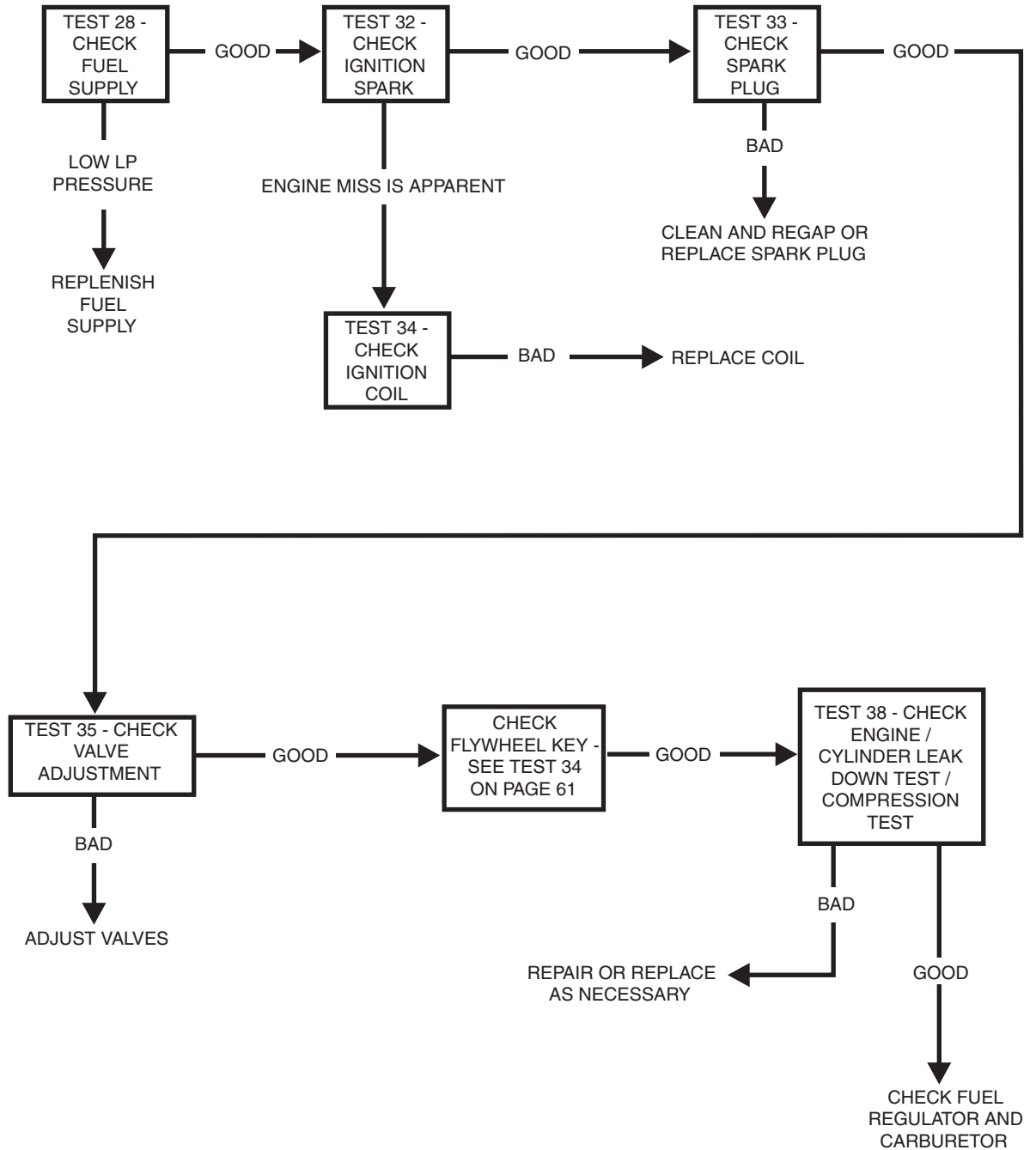

**Section 6**  
**TROUBLESHOOTING FLOWCHARTS**

***Problem 9 - Engine Starts Then Shuts Down***

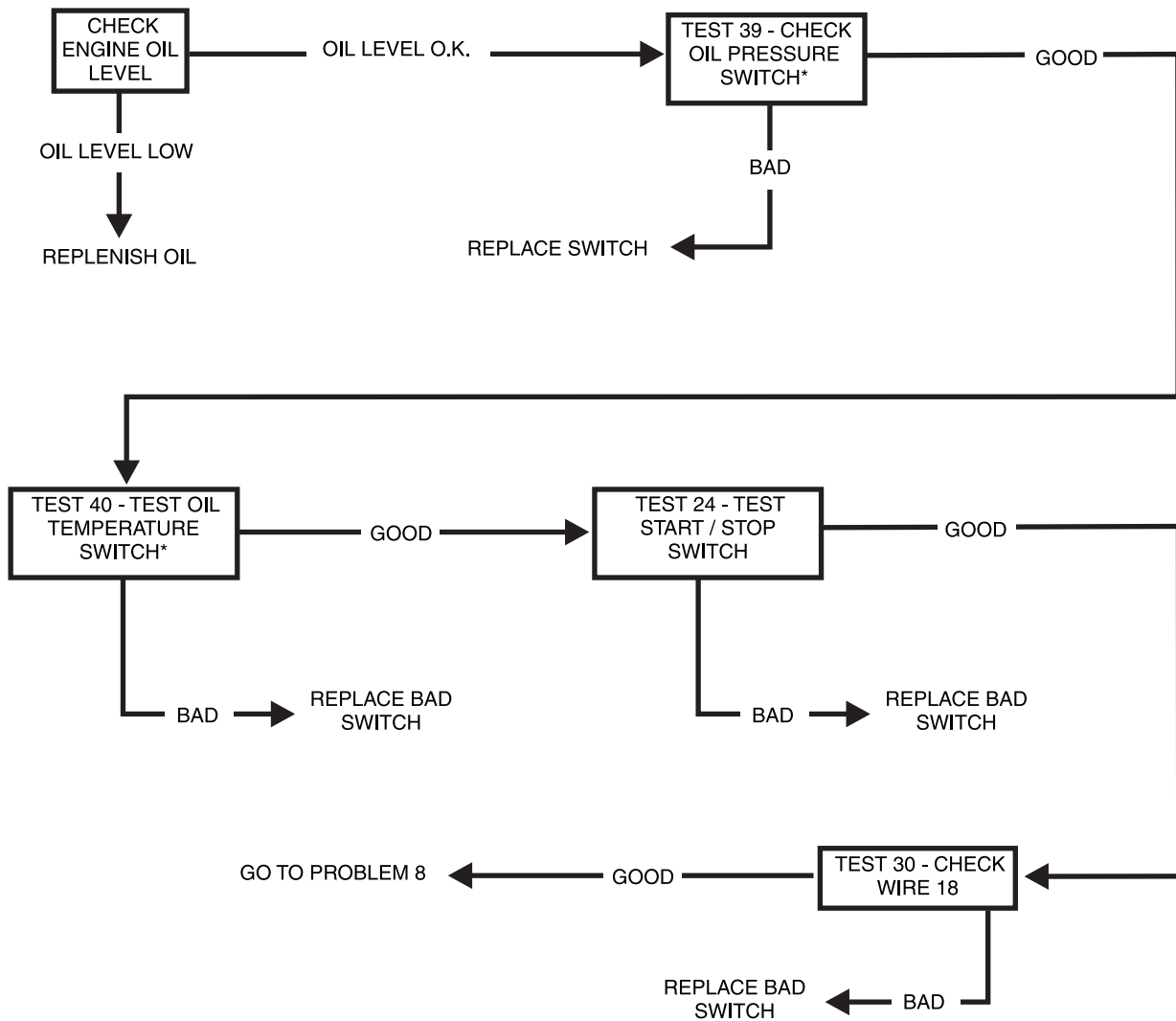

\*NOTE: IF OIL PRESSURE IS LOW, FIND THE CAUSE AND CORRECT.  
 IF OIL TEMPERATURE IS HIGH, DETERMINE THE CAUSE AND CORRECT.

**Problem 10 - 7.5A (F1) Fuse Blowing**

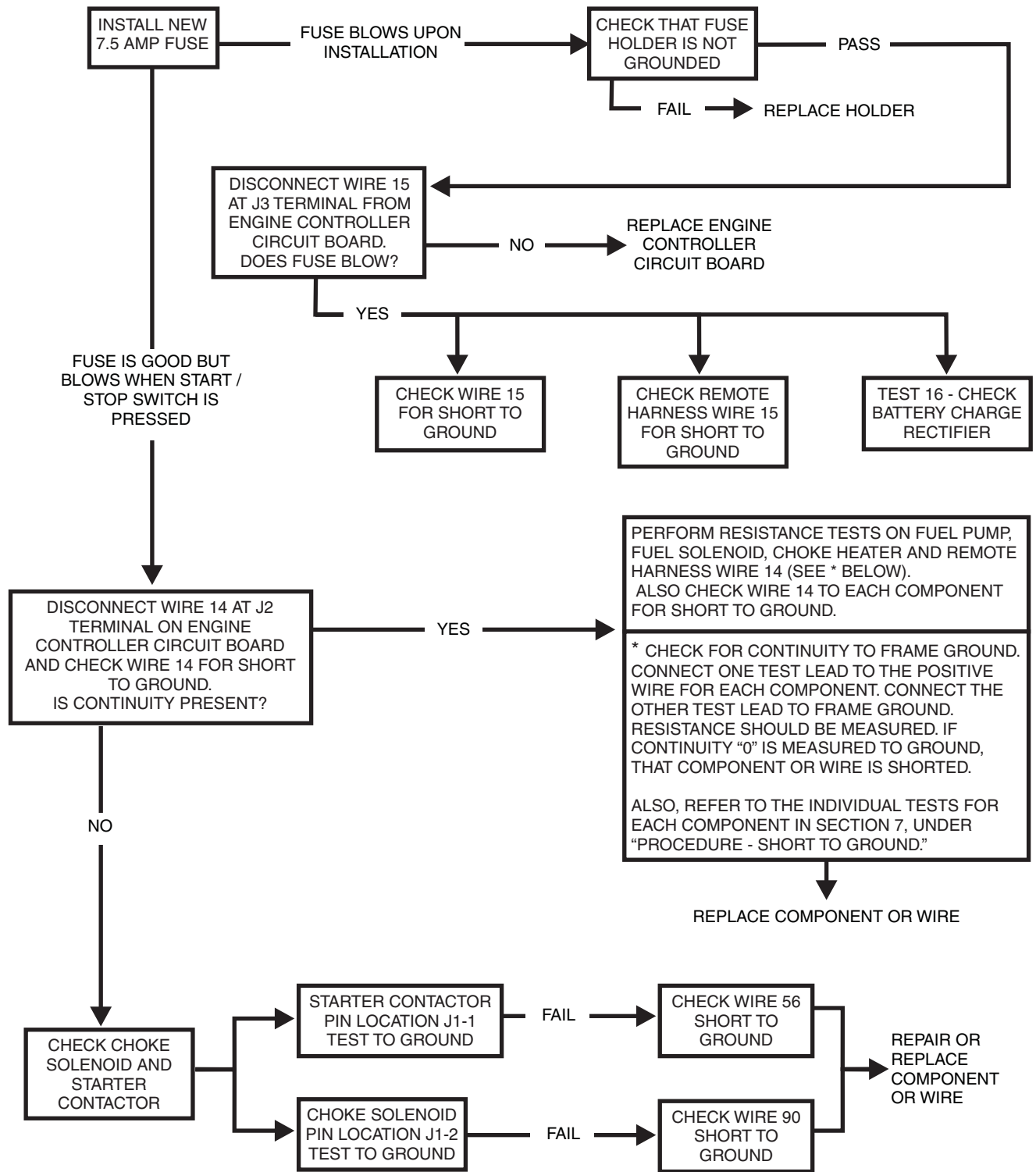

## Section 7 DIAGNOSTIC TESTS

### INTRODUCTION

The “Diagnostic Tests” in this chapter may be performed in conjunction with the “Flow Charts” of Section 6. Test numbers in this chapter correspond to the numbered tests in the “Flow Charts”.

Tests 1 through 17 are procedures involving problems with the generator’s AC output voltage and frequency (Problems 1 through 4 in the “Flow Charts”).

Tests 18 through 40 are procedures involving problems with engine operation (Problems 5 through 9 in the “Troubleshooting Flow Charts”).

You may wish to read Section 4, “Measuring Electricity”.

**NOTE: Test procedures in this Manual are not necessarily the only acceptable methods for diagnosing the condition of components and circuits. All possible methods that might be used for system diagnosis have not been evaluated. If you use any diagnostic method other than the method presented in this Manual, you must ensure that neither your safety nor the product’s safety will be endangered by the procedure or method you have selected.**

### TEST 1 – CHECK NO-LOAD VOLTAGE AND FREQUENCY

#### DISCUSSION:

The first step in analyzing any problem with the AC generator is to determine the unit’s AC output voltage and frequency. Once that has been done, you will know how to proceed with specific diagnostic tests.

#### PROCEDURE:

1. Set a volt-ohm-milliammeter (VOM) to read AC voltage. Connect the meter test leads across customer connection leads T1 (Red) and T2 (White).
2. Disconnect or turn OFF all electrical loads. Initial checks and adjustments are accomplished at no-load.
3. Start the engine, let it stabilize and warm up.
4. Read the AC voltage.
5. Connect an AC frequency meter across AC output leads T1 (Black) and T2 (White). Repeat the above procedure.

#### RESULTS:

For units rated 60 Hertz, no-load voltage and frequency should be approximately 122-126 VAC and 61-63 Hertz respectively.

1. If AC voltage and frequency are BOTH correspondingly high or low, go to Test 2.
2. If AC frequency is good but low or residual voltage is indicated, go to Test 3.

3. If AC output voltage and frequency are both “zero”, go to Test 12.
4. If the no-load voltage and frequency are within the stated limits, go to Test 13.

**NOTE: The term “low voltage” refers to any voltage reading that is lower than the unit’s rated voltage. The term “residual voltage” refers to the output voltage supplied as a result of Rotor residual magnetism (approximately 5-12 VAC).**

### TEST 2 – CHECK ENGINE GOVERNOR

#### DISCUSSION:

Rotor operating speed and AC output frequency are proportional. The generator will deliver a frequency of 60 Hertz at 3600 Rotor rpm or 62 Hertz at 3720 Rotor rpm.

The Voltage Regulator should be adjusted to deliver 120 VAC (line-to-neutral) at a frequency of 60 Hertz or 124 VAC (line-to-neutral) at 62 Hertz. It is apparent that, if governed speed is high or low, AC frequency and voltage will be correspondingly high or low. Governed speed at no-load is usually set slightly above the rated speed of 60 Hertz (to 62 Hertz), to prevent excessive rpm, frequency and voltage droop under heavy electrical loading.

#### GOVERNOR ADJUSTMENT

1. Loosen the GOVERNOR CLAMP BOLT.
2. Push Spring end of GOVERNOR LEVER clockwise to wide open throttle position of lever.
  - a. Hold the GOVERNOR LEVER at wide open throttle and, with a pair of pliers, rotate the GOVERNOR SHAFT fully clockwise (CW). Use a minimum amount of force against the governor shaft.
  - b. While holding the GOVERNOR SHAFT fully clockwise and the GOVERNOR LEVER at wide open throttle, tighten the GOVERNOR CLAMP BOLT to 70 inch-pounds (8 N-m).

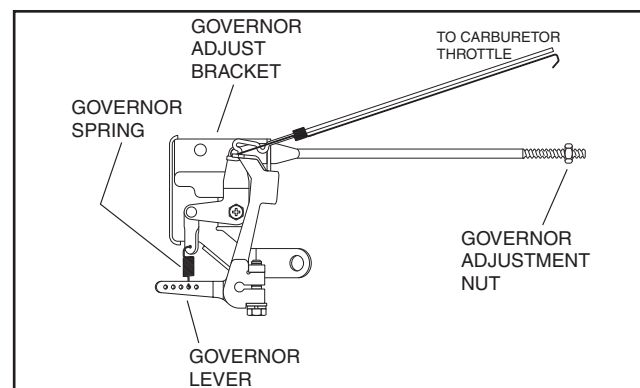

Figure 7-1. – Governor Adjustment

3. Start engine, let it stabilize and warm up at no-load.
4. Turn the ADJUSTER NUT to obtain a frequency reading of 62 Hertz.
5. Determine if the GOVERNOR SPRING is properly located in the slot of the GOVERNOR LEVER as shown in Figure 7-1 on the previous page.
6. After repositioning the SPRING on a LEVER slot, recheck frequency reading and, if necessary, readjust ADJUSTER NUT to obtain 62 Hertz at no-load.
7. When frequency is correct at no-load, check the AC voltage reading. If voltage is incorrect, the voltage regulator may require adjustment. See "VOLTAGE ADJUSTMENT PROCEDURE", Page 9.

### **TEST 3 – TEST EXCITATION CIRCUIT BREAKER**

**DISCUSSION:**

This circuit breaker (CB3) is normally closed and self-resetting. It will open in the event of excessive current from the Stator excitation (DPE) winding. The circuit breaker should re-close or reset automatically after it cools down (takes approximately two minutes).

When the breaker (CB3) is open, excitation current to the Regulator (and to the Rotor) will be lost. The unit's AC output voltage will then drop to a value that is commensurate with the Rotor's residual magnetism (about 5-12 volts AC). This test will determine if the breaker has failed in its open position.

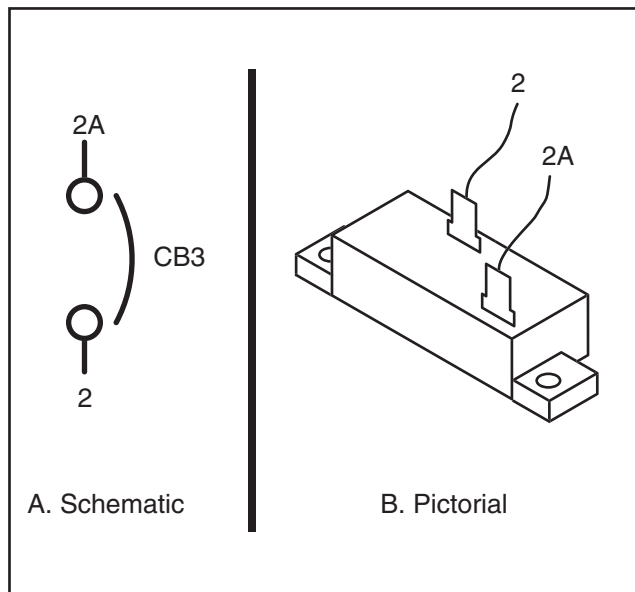

*Figure 7-2. – Excitation "DPE" Circuit Breaker*

**PROCEDURE:**

**Note: After running the unit, allow two minutes for the breaker to reset.**

1. Set a volt-ohm-milliammeter (VOM) to its "Rx1" scale and zero the meter.
2. In the generator panel, locate the excitation circuit breaker. Disconnect Wires No. 2 and 2A from the breaker terminals.
3. Connect the meter test leads across the two circuit breaker (CB3) terminals. The meter should indicate "continuity".

**RESULTS:**

1. If the meter did NOT read "continuity", replace the excitation (DPE) circuit breaker (CB3), and go to Test 4.
2. If "continuity" was indicated, go to Test 4.

### **TEST 4 – FIXED EXCITATION TEST/ROTOR AMP DRAW**

**DISCUSSION:**

The fixed excitation test consists of applying battery voltage (12 VDC) to the Rotor windings. This allows that portion of the excitation circuit between the Voltage Regulator and the Rotor (including the Rotor itself) to be checked as a possible cause of the problem. When battery voltage is applied to the Rotor, the resulting magnetic field around the Rotor should induce a Stator power winding voltage equal to about one-half the unit's rated output voltage.

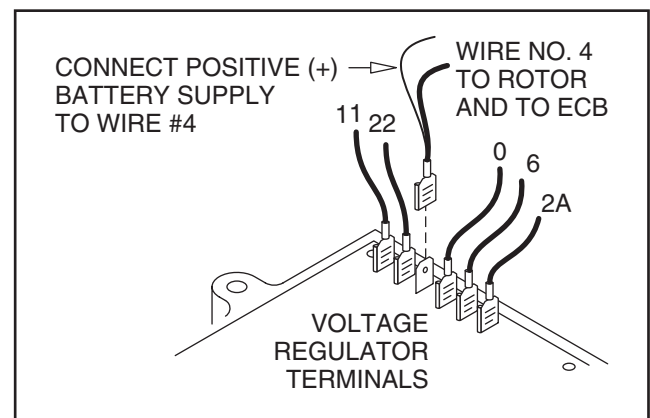

*Figure 7-3. – Fixed Excitation Test*

**PROCEDURE:**

1. Disconnect Wire #4 from the voltage regulator (VR). (Third terminal from the top of VR).
2. Connect a jumper wire to Wire #4 and to the 12 volt fused battery positive supply Wire #15 (Wire #15 located at fuse (F1) holder).

## Section 7

### DIAGNOSTIC TESTS

#### TEST 4 RESULTS

	A	B	C	D	E	F	G
VOLTAGE RESULTS WIRE 2 & 6 EXCITATION WINDING	ABOVE 60 VAC	ABOVE 60 VAC	BELOW 60 VAC	ZERO OR RESIDUAL VOLTAGE (5-12 VAC)	BELOW 60 VAC	BELOW 60 VAC	ABOVE 60 VAC
VOLTAGE RESULTS WIRE 11 & 22 POWER WINDING SENSE LEADS	ABOVE 60 VAC	BELOW 60 VAC	ABOVE 60 VAC	ZERO OR RESIDUAL VOLTAGE (5-12 VAC)	BELOW 60 VAC	BELOW 60 VAC	ABOVE 60 VAC
ROTOR AMP DRAW	1.0 - .85 A ± 20%	1.0 - .85 A ± 20%	1.0 - .85 A ± 20%	ZERO CURRENT DRAW	ABOVE 1.2 A	1.0 - .85 A ± 20%	ZERO CURRENT DRAW

(MATCH RESULTS WITH LETTER AND REFER TO FLOW CHART – Problem 2 on Pages 26 & 27)

- Set the VOM to measure AC voltage.
- Disconnect Wire #2 from the DPE breaker (CB3) and connect one test lead to that wire. Disconnect Wire #6 from the Voltage Regulator and connect the other test lead to that wire. Start the generator and measure the AC voltage. It should be above 60 volts. Record the results and stop the generator.
- Re-connect Wire #2 to the DPE Circuit Breaker (CB3) and re-connect Wire #6 to the Voltage Regulator.
- Disconnect Wire #11 from the Voltage Regulator (VR) and connect one test lead to that wire. Disconnect Wire #22 from the Voltage Regulator (VR) and connect the other test lead to that wire. Start the generator and measure the AC voltage. It should be above 60 volts. Record the results and stop the generator.
- Re-connect Wire #11 and Wire #22 to the Voltage Regulator (VR).
- Remove the jumper wire between Wire #4 and 12 volt supply.
- Set the VOM to measure DC amps.
- Connect one test lead to the 12 volt fused battery supply Wire #15, and connect the other test lead to Wire #4 (should still be disconnected from the VR).
- Start the generator. Measure the DC current. Record the rotor amp draw.
- Stop the generator. Re-connect Wire #4 to the Voltage Regulator.

#### TEST 5 – WIRE CONTINUITY

##### DISCUSSION:

The Voltage Regulator receives unregulated alternating current from the Stator Excitation Winding via Wires 2, 6 and 2A. It also receives voltage sensing from the Stator AC Power Windings via Wires 11 and 22. The regulator rectifies the AC from the Excitation Winding and, based on the sensing signals, regulates

that DC current flow to the Rotor. The rectified and regulated current flow is delivered to the Rotor Brushes via Wires 4 (+) and 0 (-). This test will verify the integrity of Wires No. 0 and 2A.

##### PROCEDURE:

- Set a VOM to its "Rx1" scale.
- Remove Wire No. 0 from the Voltage Regulator, fourth terminal from the top. The Voltage Regulator is labeled next to terminal(-).
- Connect one test lead to Wire No. 0 and the other test lead to a clean frame ground. The meter should read continuity.
- Disconnect Wire No. 2A from the Voltage Regulator, sixth terminal from the top. Disconnect the other end of this wire from the Excitation Circuit Breaker (CB3). Connect one test lead to one end of Wire No. 2A and the other test lead to the other end of the same wire. The meter should read continuity.

##### RESULTS:

If continuity was NOT measured across each wire, repair or replace the wires as needed.

If continuity WAS measured, proceed to Test 6.

#### TEST 6 – CHECK FIELD BOOST

##### DISCUSSION:

Field boost current is delivered to the Rotor only while the engine is being cranked. This current helps ensure that adequate "pickup" voltage is available to turn the Voltage Regulator on and build AC output voltage.

Loss of the field boost function may or may not result in a problem with AC output voltage. If the Rotor's residual magnetism is sufficient to turn the Regulator on, loss of the function may go unnoticed. However, if the Rotor's residual magnetism is not enough to turn the Regulator on, loss of field boost can result in failure of the unit to generate an output voltage.



**PROCEDURE:**

1. Set VOM to measure DC voltage.
2. Disconnect Wire No. 4 from the Voltage Regulator and connect the positive (+) test lead to it. Connect the negative (-) test lead to a clean frame ground.
3. Set the Start-Stop switch to "Start." During cranking only, measure DC voltage. It should read 3-5 VDC. Reconnect Wire No. 4 to the Voltage Regulator. If voltage is measured, it can be assumed that the Field Boost is working. Stop testing. If voltage is not measured, proceed to Step 4.
4. Connect the positive (+) test lead to Wire No. 16 at pin location J1-13 on the PCB (see Figure 7-4) (J1, J2 & J3 connectors remain connected to PCB). Connect the negative(-) test lead to a clean frame ground.
5. Set the Start-Stop switch to "Start." During cranking only, battery voltage should measure 11-12 VDC.
6. Connect the positive (+) test lead to Wire No. 4 at pin location J1-9 on the PCB (see Figure 7-4) (J1, J2 & J3 connectors remain connected to PCB). Connect the negative(-) test lead to a clean frame ground.
7. Set the Start-Stop switch to "Start." During cranking only measure the DC voltage. It should measure 3-5 VDC.

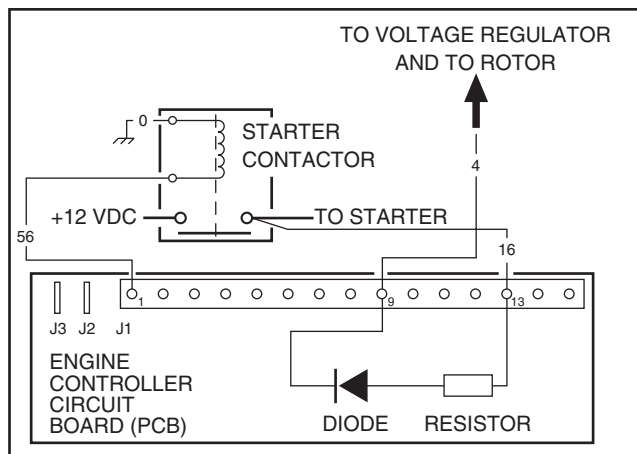

*Figure 7-4. – The Field Boost Circuit*

**RESULTS:**

1. If battery voltage was not measured in Step 5, repair or replace Wire No. 16 between the Starter Contactor and PCB.
2. If field boost voltage was measured in Step 7 but not measured in Step 3, repair or replace Wire No. 4 between PCB and Voltage Regulator.
3. If battery voltage was measured in Step 5 but field boost voltage was not measured in Step 7, replace PCB.

**TEST 7 – TEST STATOR DPE WINDING**

**DISCUSSION:**

An open circuit in the Stator excitation windings will result in a loss of unregulated excitation current to the Voltage Regulator. The flow of regulated excitation current to the Rotor will then terminate and the unit's AC output voltage will drop to a value that is commensurate with the rotor's residual magnetism (about 5 - 12 VAC).

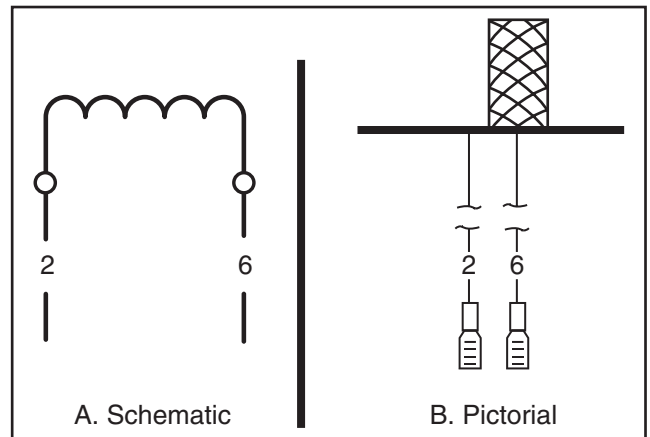

*Figure 7-5. – Stator Excitation Winding*

**PROCEDURE:**

1. Disconnect Wire No. 2 from the excitation circuit breaker.
2. Disconnect Wire No. 6 from the Voltage Regulator.
3. Set a VOM to its "Rx1" scale and zero the meter.
4. Connect the VOM test leads across the terminal ends of Wires No. 2 and 6. The VOM should indicate the resistance of the Stator excitation (DPE) windings.

**NOMINAL RESISTANCE OF  
STATOR EXCITATION "DPE" WINDINGS\***  
**2.168 - 2.510 OHMS**

- \* Resistance values in ohms at 20° C. (68° F.). Actual readings may vary depending on ambient temperature. A tolerance of plus or minus 5% is allowed.
5. Now, set the meter to its "Rx1 K" or "Rx10,000" scale and zero the meter. Test for a "short-to-ground" condition as follows:
    - a. Connect one meter test lead to Stator lead No. 2, the other test lead to a clean frame ground.
    - b. The meter should read "infinity". Any other reading indicates a "short-to-ground" condition and the Stator should be replaced.
  6. Test for a short between windings as follows:
    - a. Meter should be set to its "Rx1 K" or "Rx10,000" scale.

## Section 7 DIAGNOSTIC TESTS

- b. Connect one meter test lead to Stator Wire No. 2, the other test lead to Stator lead No. 11. The meter should read "Infinity".
- c. Connect one VOM test lead to Stator lead No. 2 the other test lead to Stator lead No. 33. "Infinity" should be indicated.
- d. Connect one VOM test lead to Stator lead No. 2 and connect the other test lead to Stator lead No. 66. "Infinity" should be indicated.

### RESULTS:

1. If the Stator excitation (DPE) windings are open or shorted, replace the Stator assembly.
2. If the excitation windings are good, perform "Insulation Resistance Test", page 11.

### TEST 8 – CHECK SENSING LEADS / POWER WINDINGS

#### DISCUSSION:

The Voltage Regulator "regulates" excitation current flow to the Rotor by electronically comparing sensing voltage to a pre-set reference voltage. The sensing voltage is delivered to the Regulator via Wires 11S and 22S.

If an open circuit exists in sensing leads 11S or 22S, the normal reaction of an unprotected Regulator would be to Increase the excitation current to the Rotor in an effort to increase the actual AC output voltage. This would result in a "full field" condition and an extremely high AC output voltage.

To protect the system against such a high AC output voltage, the Voltage Regulator will shut down if sensing voltage signals are lost.

If the regulator shuts down, the generator's AC output voltage will decrease to a value that is commensurate with the Rotor's residual magnetism (about 5-12 VAC).

#### PROCEDURE:

Gain access to the generator control panel interior. Test the Stator power windings, as follows:

1. From main breaker, disconnect Wires 11 P and 33.
2. Also disconnect Wires 22P and 44 from the ground terminal.
3. Disconnect Wires 11S and 22S from the Voltage Regulator.
4. Set a VOM to its "Rx1" scale and zero the meter.
5. Connect the meter test leads across Stator leads 11P and 22P. Normal power winding resistance should be read.

6. Connect the meter test leads across Stator leads 33 and 44. Normal power winding resistance should be read.
7. Connect the meter test leads across Stator leads 11S and 22S. Normal Power Winding resistance should be read.

#### AC POWER WINDING RESISTANCE (Ohms at 20° C.)

ACROSS WIRES:	OHMS
11P & 22P	0.468Ω - 0.542Ω
11S & 22S	0.468Ω - 0.542Ω
33 & 44	0.468Ω - 0.542Ω

8. Now, set the VOM to its "Rx1 K" or "Rx10,000" scale and zero the meter.
9. Connect the meter test leads across Stator lead 11P and frame ground. "Infinity" should be read.
10. Connect the meter test leads across Stator lead 33 and frame ground. The reading should be "infinity".
11. Connect the meter test leads across Stator leads Wire 11P and Wire 33. The reading should be "infinity."
12. Connect the meter test leads across Stator leads Wire 11P and Wire 66. The reading should be "infinity."
13. Connect the meter test leads across Stator leads Wire 33 and Wire 66. The reading should be "infinity."

#### RESULTS:

1. If the Stator passes all steps except Step 7, repair, re-connect or replace Sensing leads 11S and 22S.
2. Replace the Stator if it's power windings fail the test. (Note Result No. 1).
3. If the Power Windings test good, perform the "Insulation Resistance Test" on Page 11.

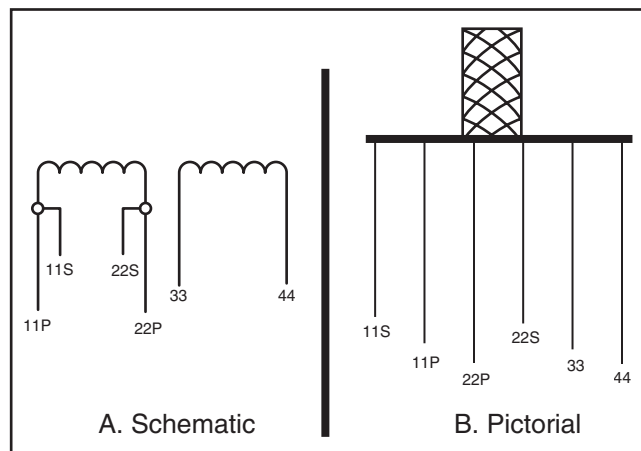

Figure 7-6. – Stator Power Winding Leads

### **TEST 9 – CHECK BRUSH LEADS**

#### DISCUSSION:

In Test 4, if application of battery voltage to the Rotor did NOT result in an output of about one-half rated voltage, the brush leads could be one possible cause of the problem. This test will check Wires 4 and OK for an open circuit condition.

#### PROCEDURE:

1. Set a VOM to its “Rx1” scale and zero the meter.
2. Disconnect Wire No. 4 from the Voltage Regulator and from the Rotor brush terminal.
3. Connect the VOM test leads across each end of the wire. The meter should read “continuity”.
4. Disconnect Wire OF from the Rotor Brush Terminal. Connect one meter test lead to Wire OF. Connect the other test lead to a clean frame ground. The meter should read continuity.

#### RESULTS:

1. Repair, reconnect or replace any defective wire(s).
2. If wires check good, go to Test 10.

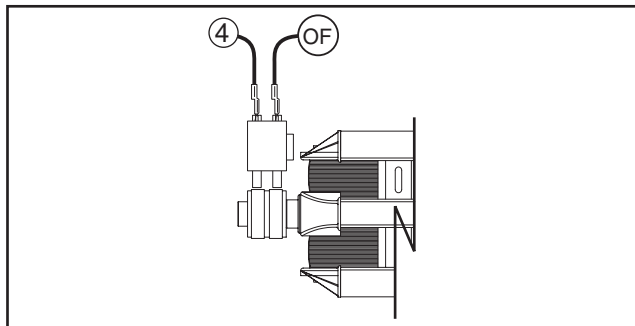

Figure 7-7. – Brush Leads

### **TEST 10 – CHECK BRUSHES & SLIP RINGS**

#### DISCUSSION:

Brushes and slip rings are made of special materials that will provide hundreds of hours of service with little wear. However, when the generator has been idle for some time, an oxide film can develop on the slip rings. This film acts as an insulator and impedes the flow of excitation current to the Rotor.

If Test 4 resulted in less than one-half rated output voltage, it is possible that the brushes and slip rings are at fault.

#### PROCEDURE:

1. Gain access to the brushes and slip rings.
2. Remove Wire No. 4 from the positive (+) brush terminal.
3. Remove the ground wire (OF) from the negative (-) brush.
4. Remove the brush holder, with brushes.
5. Inspect the brushes for excessive wear, damage, cracks, chipping, etc.
6. Inspect the brush holder, replace if damaged.
7. Inspect the slip rings.
  - a. If slip rings appear dull or tarnished they may be cleaned and polished with fine sandpaper. **DO NOT USE ANY METALLIC GRIT TO CLEAN SLIP RINGS.** (A 400 grit wet sandpaper is recommended).
  - b. After cleaning slip rings, blow away any sandpaper residue.

#### RESULTS:

1. Replace bad brushes. Clean slip rings, if necessary.
2. If brushes and rings are good, go to Test 11.

### **TEST 11 – CHECK ROTOR ASSEMBLY**

#### DISCUSSION:

During the “Fixed Excitation Test” (Test 4), if AC output voltage did not come up to about one-half rated volts, one possible cause might be a defective Rotor. The Rotor can be tested for an open or shorted condition using a volt-ohm-milliammeter (VOM).

Also see Chapter Three, “INSULATION RESISTANCE TESTS”.

#### PROCEDURE:

Gain access to the brushes and slip rings. Disconnect Wire No. 4 and Wire OF from their respective brushes and remove the brush holder. Then, test the Rotor as follows:

1. Set a VOM to its “Rx1” scale and zero the meter.
2. Connect the positive (+) meter test lead to the positive (+) slip ring (nearest the Rotor bearing). Connect the common (-) test lead to the negative (-) slip ring. Read the resistance of the Rotor windings, in OHMS.

**ROTOR RESISTANCE**  
**(Ohms at 20° C. / 68° F):**  
**12.72Ω - 14.73Ω**

3. Set the VOM to its “Rx1 K” or “Rx10,000” scale and zero the meter.
4. Connect the positive (+) meter test lead to the positive (+) slip ring, the common (-) test lead to a clean frame ground (such as the Rotor shaft). The meter should read “infinity”.

## Section 7 DIAGNOSTIC TESTS

### RESULTS:

1. Replace the Rotor if it fails the test.
2. If Rotor checks good, perform "Insulation Resistance Test," on Page 11.

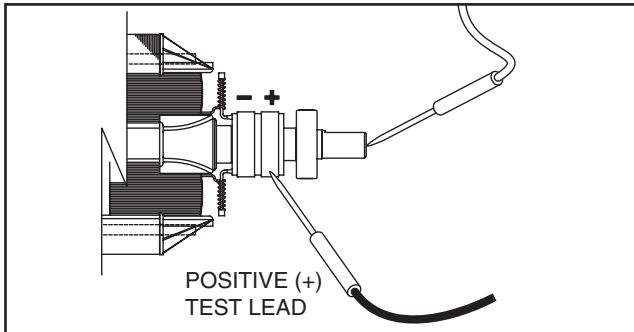

Figure 7-8. – Rotor Assembly

### TEST 12 – CHECK MAIN CIRCUIT BREAKER

#### DISCUSSION:

The main circuit breaker on the generator panel must be closed or no output to the load will be available. A defective breaker may not be able to pass current even though it is in the "ON" position.

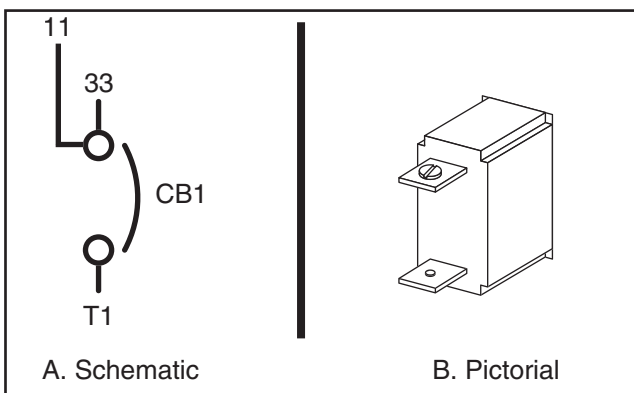

Figure 7-9. – Main Breaker (Typical)

#### PROCEDURE:

Set the coach main breaker to its "OFF" position. Check that the appropriate main breaker on the generator panel is set to its "ON" (closed) position. Set a VOM to measure resistance and use it to check for "continuity" across the breaker terminals.

### RESULTS:

1. If breaker is "ON" and continuity is measured, go to Test 3.
2. If breaker is "OFF", reset to the "ON" position and check for AC output.
3. If breaker is "ON" and continuity is not measured, replace the defective circuit breaker.

### TEST 13 – CHECK LOAD VOLTAGE & FREQUENCY

#### DISCUSSION:

If engine speed appears to drop off excessively when electrical loads are applied to the generator, the load voltage and frequency should be checked.

#### PROCEDURE:

Perform this test in the same manner as Test 1, but apply a load to the generator equal to its rated capacity. With load applied check voltage and frequency.

Frequency should not drop below about 58 Hertz with the load applied.

Voltage should not drop below about 115 VAC with load applied.

#### RESULTS:

1. If voltage and/or frequency drop excessively when the load is applied, go to Test 14.
2. If load voltage and frequency are within limits, end tests.

### TEST 14 – CHECK LOAD WATTS & AMPERAGE

#### DISCUSSION:

This test will determine if the generator's rated wattage/ampere capacity has been exceeded.

Continuous electrical loading should not be greater than the unit's rated capacity.

#### PROCEDURE:

Add up the wattages or amperages of all loads powered by the generator at one time. If desired, a clamp-on ammeter may be used to measure current flow. See "Measuring Current" on Page 14.

#### RESULTS:

1. If the unit is overloaded, reduce the load.
2. If load is within limits, but frequency and voltage still drop excessively, complete Test 2, "Check/Adjust Engine Governor". If governor adjustment does not correct the problem, go to Problem 8.

### **TEST 15 – CHECK BATTERY CHARGE OUTPUT**

#### DISCUSSION:

The Battery Charge system consists of a center tap Battery Charge Winding, a Battery Charge Rectifier, and a Battery Charge Resistor. During normal operation the battery charge output will vary between 1 to 2 amps, depending on the load applied to the generator. Battery Charge Winding Stator Lead Wire No. 66 is tapped at the Battery Charge Rectifier and connected to the Engine Control Circuit Board at Pin location J1-10, and is used as a signal for Starter lockout.

#### PROCEDURE:

1. Disconnect Wire No. 15 from the Battery Charge Rectifier (center terminal). Wire No. 15 is the fused battery supply.
2. Set your VOM to measure DC Amps. Connect the positive (+) test lead to the center terminal of the Battery Charge Rectifier. Connect the negative (-) test lead to Wire No. 15 previously disconnected.
3. Start the generator. The amp reading on the VOM should be approximately 0.8 Amps. Apply full load to the generator. The amp reading should increase to approximately 2 Amps.

#### RESULTS:

1. If amperage was measured between 0.8 to 2 Amps in Step 2 and Step 3, the charging system is working.
2. If no amperage was measured, check the VOM fuses and verify the functioning of the Amp Meter. Verify that the generator fuse F1 is not blown. If the fuse is bad, replace the fuse and retest. If meter and fuse are both good, go to Test 16.

### **TEST 16 – CHECK BATTERY CHARGE RECTIFIER**

#### DISCUSSION:

The Battery Charge Rectifier (BCR) is a full wave rectifier.

#### PROCEDURE:

1. Disconnect Wire No. 66, Wire No. 15 and Wire No. 77 from the Battery Charge Rectifier.
2. Set the VOM to the Diode Test range. Connect the negative (-) test lead to the center terminal of the BCR. Connect the positive (+) test lead to an outer terminal. The meter should measure approximately 0.5 volts. Now connect the positive test lead to the other outer terminal. Again, the meter should measure approximately 0.5 volts.
3. Connect the positive (+) test lead to the center terminal of the BCR. Connect the negative (-) test lead to an outer terminal. The meter

should measure "Infinity." Connect the negative test lead to the other outer terminal. Infinity should once again be measured.

Short to Ground:

4. Set the VOM to measure resistance. Connect the positive (+) test lead to the case housing of the BCR. Connect the negative (-) test lead to an outer terminal. "Infinity" should be measured. Now connect the negative test lead to the BCR center terminal. Infinity should be measured. Next, connect the negative test lead to the remaining outer BCR terminal. Once again "Infinity" should be measured.

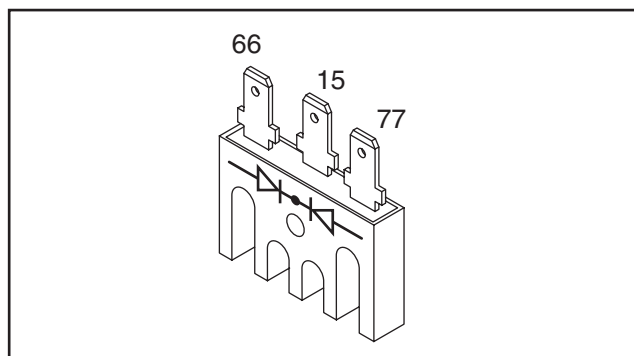

*Figure 7-10. – Battery Charge Rectifier*

#### RESULTS:

1. If any of the previous steps has failed, replace the Battery Charge Rectifier.
2. If the BCR tests good, go to Test 17.

### **TEST 17 – CHECK BATTERY CHARGE WINDINGS / BATTERY CHARGE RESISTOR**

#### DISCUSSION:

The Battery Charge Winding (BCW) produces AC voltage that is delivered to the Battery Charge Rectifier. The Battery Charge Winding is a center tapped winding consisting of the following Stator Leads: Wire No. 66, Wire No. 77 and Wire No. 55. The Battery Charge Resistor is used as a current limiting resistor.

#### PROCEDURE:

1. Disconnect the Stator Leads (Wire No. 66 and Wire No. 77) from the Battery Charge Rectifier. (Be sure to disconnect Stator Lead Wire No. 66 "Black" from Wire No. 66 "Blue" connector for this test). Disconnect the Stator Lead Wire No. 55 from the Battery Charge Resistor.
2. Set the VOM to measure resistance at the "R x 1" scale. Connect one test lead to Stator Lead Wire No. 66. Connect the

## Section 7

### DIAGNOSTIC TESTS

- other test lead to Stator Lead Wire No. 55. Normal Battery Charge Winding resistance should be measured.
3. Connect one test lead to Stator Lead Wire No. 77. Connect the other test lead to Stator Lead Wire No. 55. Normal Battery Charge Winding resistance should be measured.
  4. Connect one test lead to Stator Lead Wire No. 55. Connect the other test lead to Stator Leads Wire No. 11 & 33 at the back of CB1. "Infinity" should be measured.
  5. Connect one test lead to Stator Lead Wire No. 55. Disconnect Stator Lead Wire No. 2 from the DPE circuit breaker (CB3) and connect the other test lead to Wire No. 2. "Infinity" should be measured.
  6. Connect one test lead to Stator Lead Wire No. 55. Connect the other test lead to frame ground. "Infinity" should be measured.
  7. Connect one test lead to the Battery Charge Resistor terminal that Wire No. 55 was removed from. Connect the other test lead to frame ground. One (1) ohm should be measured. If 1 ohm was not measured, remove Wire No. 0 from the Battery Charge Resistor. Connect one test lead to Wire No. 0 and the other test lead to frame ground. Continuity should be measured. Repair or replace Wire No. 0 if defective and retest the Battery Charge Resistor.

**BATTERY CHARGE WINDING RESISTANCE:**  
**0.140 - 0.174  $\Omega$**

#### RESULTS:

1. For Steps 2 & 3, keep in mind that the resistance values are very low. Depending upon the quality of the VOM, it may read continuity across these winding. Exercise good judgement with these values.
2. If Steps 2, 3, 4, 5 & 6 fail any test, replace the Stator.
3. In Step 7, if Wire No. 0 reads continuity, but resistor does not measure 1 ohm, replace the Battery Charge Resistor.
4. If all of the Steps in this test pass, perform "Insulation Resistance Test" on page 11.

### TEST 18 – TRY CRANKING THE ENGINE

#### DISCUSSION:

If the Fuel Primer Switch on the generator panel is actuated, but the Fuel Pump does not run (priming function doesn't work), perhaps battery voltage is not available.

#### PROCEDURE:

Hold the Start-Stop Switch at "START". The engine should crank and start.

#### RESULTS:

1. If the engine cranks normally, but the priming function still doesn't work, go to Test 19.
2. If engine will not crank, go to Test 21. Refer to Problem 6 of Section 6.
3. If engine cranks but won't start, go to Problem 7 of Section 6.
4. If engine starts hard and runs rough, go to Problem 8 of Section 6.

### TEST 19 – TEST PRIMER SWITCH

#### DISCUSSION:

A defective primer switch can prevent the priming function from occurring.

Switch failure can also prevent the engine from starting, since the switch is in series with the Wire 14 circuit. (Also see "Fuel Primer Switch," page 23).

#### PROCEDURE:

1. Set a VOM to read battery voltage (12 VDC).
2. Connect the positive (+) meter test lead to the Wire 15 terminal of the Primer Switch (leave Wire 15 connected to the switch). Connect the negative (-) meter test lead to frame ground. The meter should indicate battery voltage.

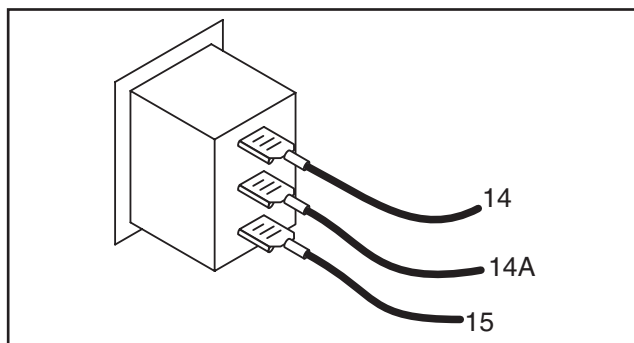
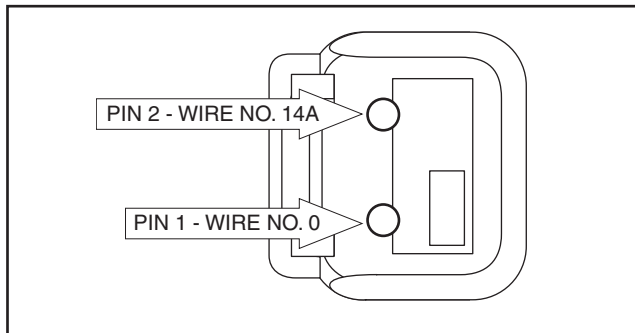

Figure 7-11. – Primer Switch

3. Connect the positive (+) meter test lead to the Wire 14 terminal of the Primer Switch (leave Wire 14 connected to the switch). Connect the negative (-) meter test lead to a clean frame ground. Set the Start-Stop switch to "START". The engine should crank and battery voltage should be measured.
4. Connect the positive (+) meter test lead to the Wire 14A terminal of the Primer Switch, the negative (-) meter test lead to frame ground.
  - a. With the Primer Switch NOT actuated, no voltage should be indicated.

- b. Actuate the switch to its “PRIME” position and the meter should read battery voltage.
5. For gasoline models, disconnect Connector 2 at the Fuel Pump. Connect the VOM positive (+) test lead to Wire 14A, (Pin 2 of Connector 2) going up to the Control Panel (see Figure 7-12). Connect the VOM negative(-) test lead to frame ground. Repeat Steps 4a and 4b. Battery Voltage should be measured when the Primer Switch is activated.



*Figure 7-12. – Harness End of Connector 2*

6. For LPG models, disconnect Wire 14A from the LPG Fuel Solenoid (FS)(see Figure 7-13). Connect the VOM positive (+) test lead to Wire 14A. Connect the VOM negative(-) test lead to frame ground. Repeat Steps 4a and 4b. Battery Voltage should be measured when the Primer Switch is activated.
7. Set the VOM to measure resistance at the “Rx1” scale and zero the meter.
- Disconnect Wire 14 from the Primer Switch.
  - Connect the meter test leads across the Wires 14 and 14A terminals of the switch.
  - With the switch NOT actuated, the meter should read “Continuity”.

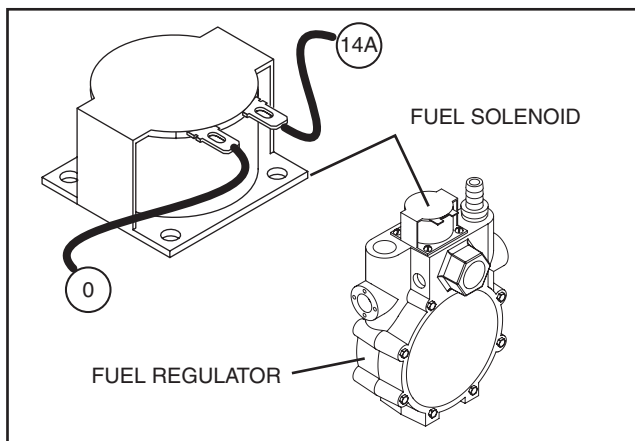

*Figure 7-13. – The LPG Fuel Solenoid (FS)*

**RESULTS:**

- If battery voltage is not indicated in Step 2, check Wire 15 between the Primer Switch and the 7.5 amp fuse for an open condition.
- If battery voltage is indicated in Step 2 but not in Step 4, replace the Primer Switch. If battery voltage is NOT indicated in Step 3 repair or replace Wire 14 between the 4-tab Terminal Connector (TC) and the Fuel Primer Switch (SW2).
- If battery voltage was indicated in Step 4 but not in Step 5:
  - For gasoline models repair or replace Wire 14A between the Primer Switch (SW2) and Fuel Pump Connector 2.
  - For LPG models repair or replace Wire 14A between the Fuel Prime Switch (SW2) and the LPG Fuel Solenoid (FS).
- If the meter reads anything other than “Continuity” in Step 7, replace the Primer Switch.
- If the Primer Switch checks good, go to Test 20 for Gasoline models. For LPG models, go to Test 42.

**TEST 20 – CHECK FUEL PUMP**

**DISCUSSION:**

An inoperative Fuel Pump will (a) prevent the priming function from working and (b) prevent the engine from starting.

**PROCEDURE:**

- Remove Fuel Filter and verify that filter is not clogged. Replace filter if necessary.
- Verify that fuel is available to Fuel Filter inlet. Use an alternative fuel supply if questionable.
- Remove air filter access panel and air filter. Remove fuel hose from pump. Place a suitable container to catch fuel from fuel pump line. Activate fuel primer switch. Pump should operate and fuel should flow. If pump does not operate, proceed to Step 4.
- In Test 19, Battery Voltage was checked at Connector 2. This step will test the ground wire. Disconnect Connector 2 at the Fuel Pump. Set the VOM to measure resistance. Connect one test lead to Wire No. 0, (Pin 1 of Connector 2) that goes to the Control Panel. Connect the other test lead to a clean frame ground. Continuity should be measured.
- To test for an open fuel pump coil, connect one test lead to the Red Wire (Pin 2 of Connector 2) going to the fuel pump. Connect the other test lead to the Black Wire (Pin 1 of Connector 2) going to the Fuel Pump. The VOM should indicate Fuel Pump coil resistance of about 29.5 kΩ. (Current draw of the pump at nominal voltage is approximately 1.4 amperes MAXIMUM).

## Section 7 DIAGNOSTIC TESTS

Short to Ground:

- To test for a shorted fuel pump coil, connect one test lead to the Red Wire (Pin 2 of Connector 2). Connect the other test lead to the fuel pump housing. "Infinity" should be measured.

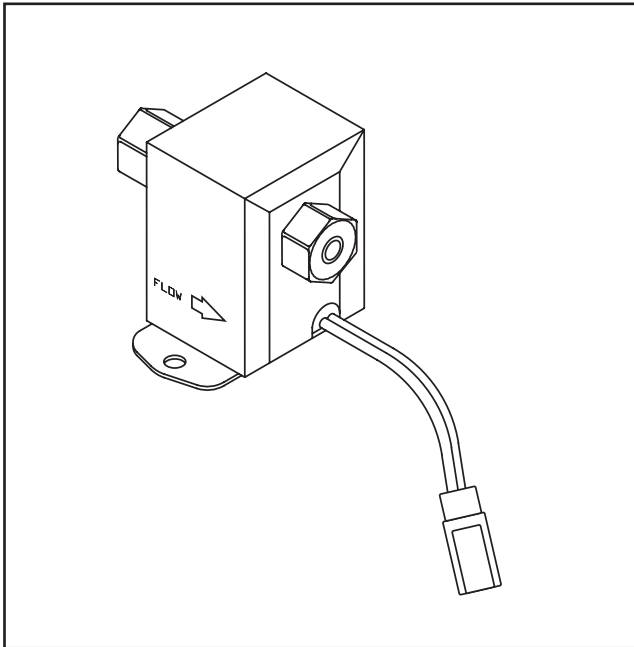

Figure 7-14. – Electric Fuel Pump

### RESULTS:

- If "Continuity" was not measured in Step 4, repair or replace Wire No. 0 between Connector 2 and the ground terminal.
- If "Continuity" is measured in Step 4, but pump does not operate in Step 3, replace the Fuel Pump.
- If the pump fails Step 5 or Step 6, replace the Fuel Pump.

**Note: If desired, a pressure gauge can be attached to the pumps outlet side. Pump outlet pressure should be 2.0 to 3.5 psi.**

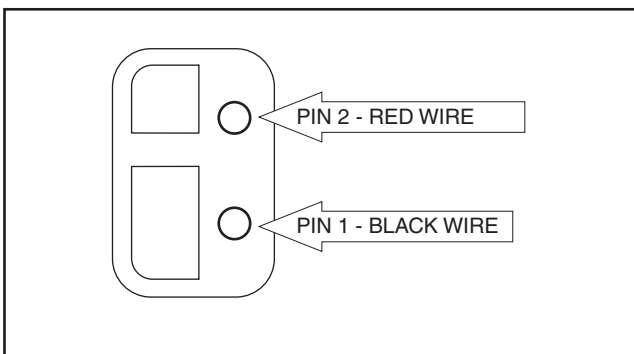

Figure 7-15. – Harness to Fuel Pump

## TEST 21 – CHECK 7.5 AMP FUSE

### DISCUSSION:

If the panel-mounted 7.5 amp fuse (F1) has blown, engine cranking will not be possible.

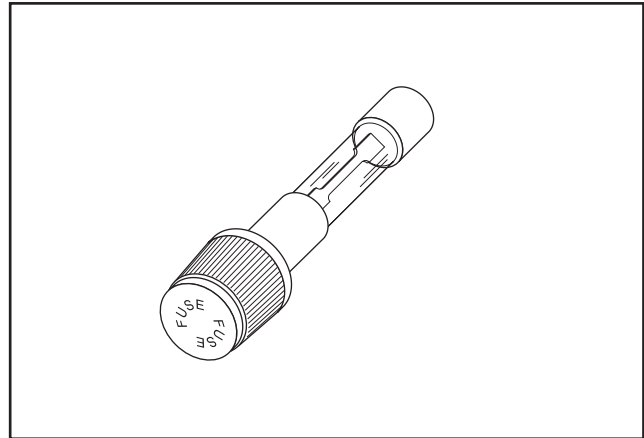

Figure 7-16. – 7.5 Amp Fuse

### PROCEDURE:

Push In on fuse holder cap and turn counterclockwise. Then, remove the cap with fuse. Inspect the Fuse.

### RESULTS:

If the Fuse element has melted open, replace the Fuse. If Fuse is good, go to Test 22.

## TEST 22 – CHECK BATTERY & CABLES

### DISCUSSION:

If the engine won't crank or cranks too slowly, the battery may be weak or discharged. See "Battery" on Page 22.

### PROCEDURE:

- Inspect the battery cables and battery posts or terminals for corrosion, tightness. Measure the voltage at the terminal of the starter contactor and verify 11-12 volts DC is available to the generator during cranking. If voltage is below 11 volts DC, measure at the battery terminals during cranking. If battery voltage is below 11 volts DC, recharge/replace battery. If battery voltage is above 11 volts DC, check for proper battery cable sizing (see "BATTERY CABLES" on Page 22). If battery or cables are still suspected, connect an alternate battery and cables to the generator and retest.
- Use a battery hydrometer to test the battery for (a) state of charge and (b) condition. Follow the hydrometer manufacturer's instructions carefully.



**RESULTS:**

1. Clean battery posts and cables as necessary. Make sure battery cables are tight.
2. Recharge the battery, if necessary.
3. Replace the battery, if necessary.
4. If battery is good, but engine will not crank, go to Test 23.

**TEST 23 – CHECK POWER SUPPLY TO  
CIRCUIT BOARD**

**DISCUSSION:**

If battery voltage is not available to the circuit board, engine cranking and running will not be possible.

If battery voltage is available to the board, but no DC output is delivered to the board's Wire 56 terminal while attempting to crank, either the circuit board is defective or the Start-Stop Switch has failed.

This test will determine if battery voltage is available to the Engine Controller circuit board. Test 24 will check the Start-Stop Switch. Test 25 will check the DC power supply to the circuit board's Wire 56 terminal (Receptacle J1, Pin 1).

**PROCEDURE:**

1. On the Engine Controller circuit board, locate Terminal J3 to which Wire 15 connects.
2. Set a VOM to read battery voltage. Connect the meter test leads across circuit board Terminal J3 and frame ground. The meter should read battery voltage.
3. Set the VOM to measure resistance ("Rx1" scale). Connect one meter test lead to Wire No. 0, Pin location J1-12 on the Engine Controller Circuit Board. Connect the other test lead to a clean frame ground. Continuity should be measured.

**RESULTS:**

1. If battery voltage is NOT indicated in Step 1, check Wire 13 between Starter Contactor and 7.5 amp Fuse, Wire 15 between the Fuse and the Battery Charge Rectifier, and Wire 15 between the Battery Charge Rectifier and the Engine Controller circuit board. Repair, reconnect or replace bad wiring as necessary.
2. If battery voltage is indicated but engine will not crank, go to Test 24.
3. If continuity was not measured in Step 3, repair or replace Wire No. 0 between the Engine Controller Circuit Board and the Ground Terminal.

**TEST 24 – CHECK START-STOP SWITCH**

**DISCUSSION:**

Engine cranking and startup is initiated when Wire 17 from the Engine Controller board is connected to frame ground by setting the Start-Stop Switch to "START".

Engine shutdown occurs when circuit board Wire 18 is connected to frame ground by the Start-Stop Switch.

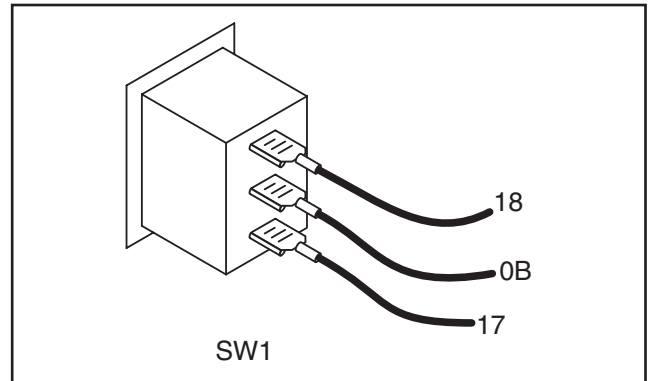

*Figure 7-17. – Start-Stop Switch*

A defective Start-Stop Switch can result in (a) failure to crank when the switch is set to "START", and/or (b) failure to shut down when the Switch is set to "STOP".

**PROCEDURE:**

1. Set a VOM to its "Rx1" scale and zero the meter.
2. Inspect the ground Wire 0B, between the Start-Stop Switch and the grounding terminal. Connect one meter test lead to Wire No. 0B on SW1. Connect the other test lead to a clean frame ground. Continuity should be measured.
3. Disconnect Wire 17 from its Switch terminal and connect it to frame ground. The engine should crank.
4. Remove the 7.5 amp fuse. Disconnect Wire No. 18, Wire No. 0B and Wire No. 17 from the start-stop switch (SW1).
5. Connect one test lead to the center terminal of SW1. Connect the other test lead to an outer terminal of SW1. Infinity should be measured. Remove the test lead from the outer terminal of SW1 and connect it to the opposite outer terminal. Infinity should be measured.
6. Leave the test lead connected to the center terminal of SW1 from Step 5. Connect the other test lead to an outer terminal. Depress the switch away from the terminal being tested (see Figure 7-18). Continuity should be measured. Repeat the procedure with the test lead connected to the other outer terminal. Continuity should be measured.

## Section 7 DIAGNOSTIC TESTS

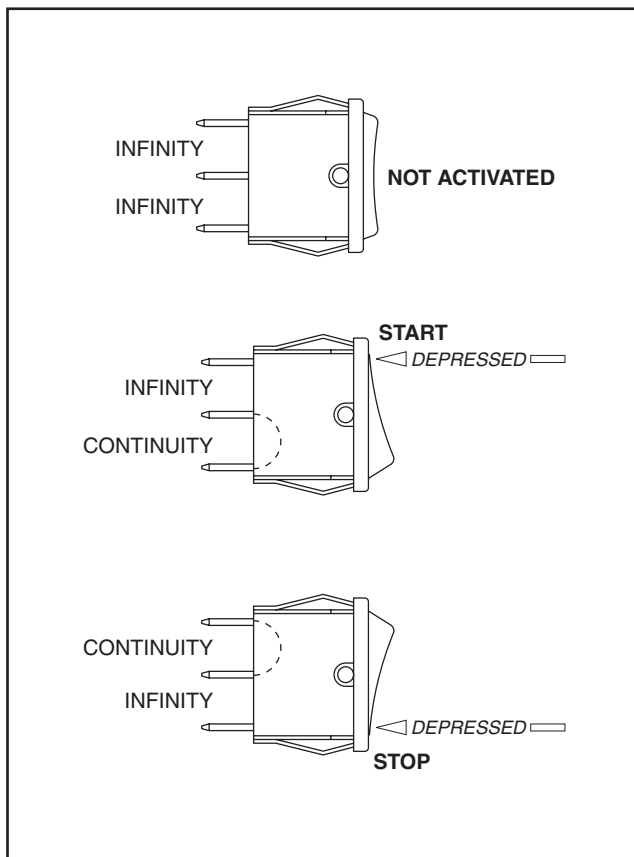

Figure 7-18. – Test 24, Step 6

### RESULTS:

1. If continuity is not measured in Step 2, repair, reconnect or replace Wire 0B (between Start-Stop Switch and ground terminal) as necessary.
2. If engine cranks in Step 3 when Wire 17 is grounded, but will not crank when the Switch is set to “START”, replace the Start-Stop switch.
3. If the Start-Stop Switch (SW1) failed any part of Steps 5 or 6, replace the switch.
4. If engine will not crank when Wire 17 is grounded, proceed as follows:
  - a. Use a jumper wire to connect the circuit board's Wire 17 (pin location J1-6) to ground. If engine does NOT crank, proceed to Test 25.
  - b. If engine cranks now, but would not crank in Step 3 of the procedure, check Wire 17 for continuity between the circuit board and Start-Stop Switch. If continuity is not measured, repair or replace Wire No. 17 between the engine control board and the Start-Stop switch.

## TEST 25 – CHECK POWER SUPPLY TO WIRE 56

### DISCUSSION:

If battery voltage is available to the Engine Controller board in Test 23, then DC voltage should be delivered to Wire 56 when the Start Switch is set to “START” (Test 24). This test will check to see if the circuit board is delivering battery voltage to the Wire 56 terminal.

### PROCEDURE:

1. Set a VOM to measure DC voltage (12 VDC).
2. Disconnect Wire 56 from its Starter Contactor terminal.
3. Connect the meter positive (+) test lead to Wire 56, just disconnected. Connect the other test lead to frame ground. No voltage should be indicated.
4. Actuate the Start-Stop Switch to its “START” position. The meter should indicate battery voltage. If battery voltage is present, stop the procedure.
5. Connect the VOM positive (+) test lead to Wire No. 56 (Pin Location J1-1) at the Engine Controller Circuit Board. Connect the other test lead to frame ground.
6. Actuate the Start-Stop Switch to the “START” position. The meter should indicate battery voltage.

### RESULTS:

1. If battery voltage was measured in Step 6, but not in Step 4, repair or replace Wire No. 56 between the Engine Controller Circuit Board and Starter Contactor.
2. If battery voltage was not available in Step 6, replace the Engine Controller Circuit Board.
3. If battery voltage is available in Step 4 but engine does not crank, go to Test 26.

## TEST 26 – CHECK STARTER CONTACTOR

### DISCUSSION:

If battery voltage is available to the Wire 56 circuit, but engine won't crank, one possible cause of the problem is a failed Starter Contactor.

### PROCEDURE:

1. Set the VOM to measure resistance (“R x 1” scale). Connect one test lead to Wire No. 0 on the Starter Contactor terminal. Connect the other test lead to frame ground. Continuity should be measured.
2. Momentarily connect a suitable **jumper cable** across the two large terminal studs of the Starter Contactor. The engine should crank.

**SHORT TO GROUND:**

3. Set the VOM to measure resistance. Disconnect Wire No. 56 from the Starter Contact terminal. Connect one meter test lead to the Starter Contact terminal from which Wire No. 56 was just removed. Connect the other meter test lead to a clean frame ground. A Starter Contactor coil resistance of 3.9 ohms should be measured. If continuity is measured, a short to ground exists. (Current draw of the Starter Contactor coil at nominal voltage is approximately 3.2 amps).

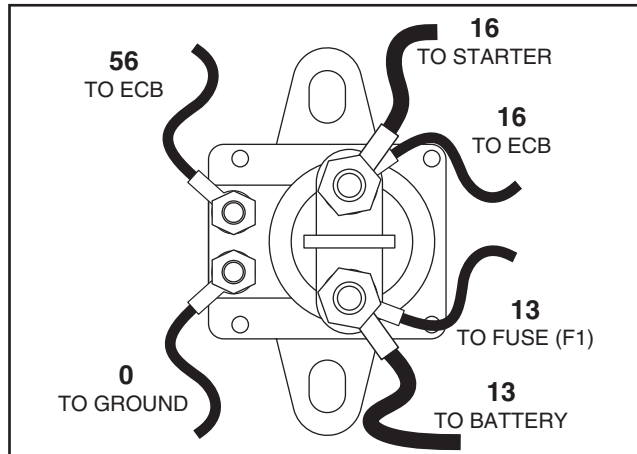

Figure 7-19. – Starter Contactor

**RESULTS:**

1. If continuity is not measured in Step 1, repair or replace Wire No. 0 between the Starter Contactor and the ground terminal.
2. If engine cranks during Step 2, but would not crank in Test 25, remove and replace the Starter Contactor.
3. If engine does not crank in this test, go to Test 27.

**TEST 27 – CHECK STARTER MOTOR**

**DISCUSSION:**

If the engine will not crank, the Starter Motor may have failed. This test will check that possibility.

**PROCEDURE:**

The battery should have been checked prior to this test and should be fully charged.

Set a VOM to measure DC voltage (12 VDC). Connect the meter positive (+) test lead to the cable connection on the Starter Motor. Connect the common (-) test lead to the Starter Motor frame.

Set the Start-Stop Switch to its “START” position and observe the meter. Meter should indicate battery voltage, Starter Motor should operate and engine should crank.

**RESULTS:**

1. If battery voltage is indicated on the meter but Starter Motor did not operate, remove and bench test the Starter Motor (see following test).
2. If battery voltage was indicated and the starter motor tried to engage (bendix came up), but engine did not crank, check for mechanical binding of the engine or rotor.

If engine turns over slightly, go to Test 35 “Check Valve Adjustment.” Compression release may not be working, or mechanical binding is occurring.

**TESTING THE STARTER MOTOR**

**CHECKING THE PINION:**

When the starter motor is activated, the pinion gear should move and engage the flywheel ring gear. If the pinion does not move normally, inspect the large spiral threads of the sleeve and pinion for binding or sticking.

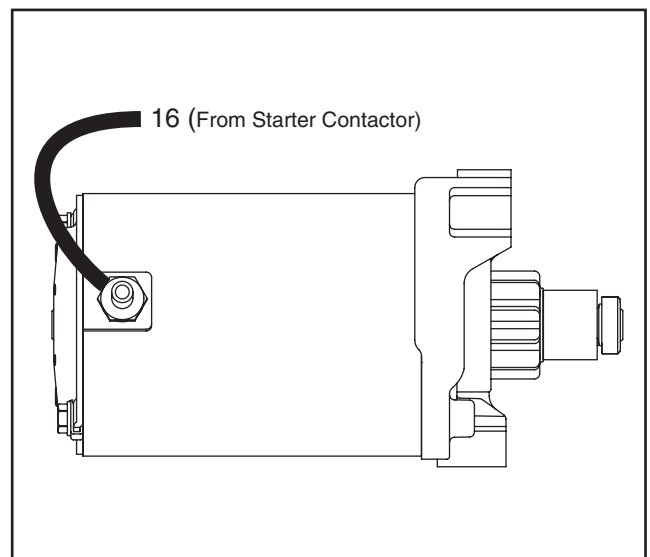

Figure 7-20. – Starter Motor

**TOOLS FOR STARTER PERFORMANCE TEST:**

The following equipment may be used to complete a performance test of the starter motor:

- A digital multimeter (VOM).
- A tachometer capable of reading up to 1,500 rpm.
- A fully charged 12-volt battery.

**STARTER PERFORMANCE TEST:**

1. Set the meter to read DC amps.
2. Connect the starter motor, battery and VOM as shown in Figure 7-21.

## Section 7 DIAGNOSTIC TESTS

3. Insert the tachometer at end of the pinion gear and activate the starter motor. A starter motor in good condition will be within the following specifications:

### STARTER MOTOR PERFORMANCE SPECIFICATIONS AT 12 VOLTS DC:

**MINIMUM MOTOR RPM = 800**  
**MAXIMUM AMPS = 9**

If the starter does not perform satisfactorily, it should be replaced.

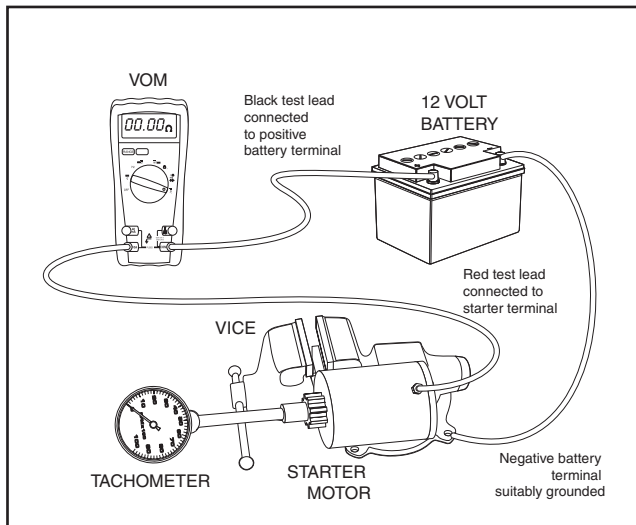

Figure 7-21 – Starter Performance Test

### TEST 28 – CHECK FUEL SUPPLY

#### DISCUSSION (GASOLINE MODELS):

If the engine cranks but won't start, don't overlook the obvious. The fuel supply may be low. Many RV generator installations "share" the fuel tank with the vehicle engine. When such is the case, the Installer may have used a generator fuel pickup tube that is shorter than the vehicle engine's pickup tube. Thus, the generator will run out of gas before the vehicle engine.

#### PROCEDURE:

Check fuel level in the supply tank. Attach a fresh fuel supply if necessary and restart. Fuel may be stale, causing a hard start.

#### RESULTS:

1. If necessary, replenish fuel supply.
2. If fuel is good, go to Test 29.

#### DISCUSSION (LPG MODELS):

LP gas is stored in pressure tanks as a liquid. The gas systems used with these generators were designed

only for vapor withdrawal type systems. Vapor withdrawal systems use the gas vapors that form above the liquid fuel in the tank. Do NOT attempt to use the generator with any liquid withdrawal type system.

Gas pressure delivered to the solenoid valve must be properly regulated by means of a primary gas regulator. Mount the primary regulator at the gas tank outlet or in the supply line from the gas tank. The following rules apply:

- For best results, the primary regulator supplies gaseous fuel to the secondary regulator at 11 inches water column. Do NOT exceed 14 inches water column.
- The installer must be sure the primary regulator is rated at sufficient gas flow to operate the generator plus all other gas appliances in the circuit.

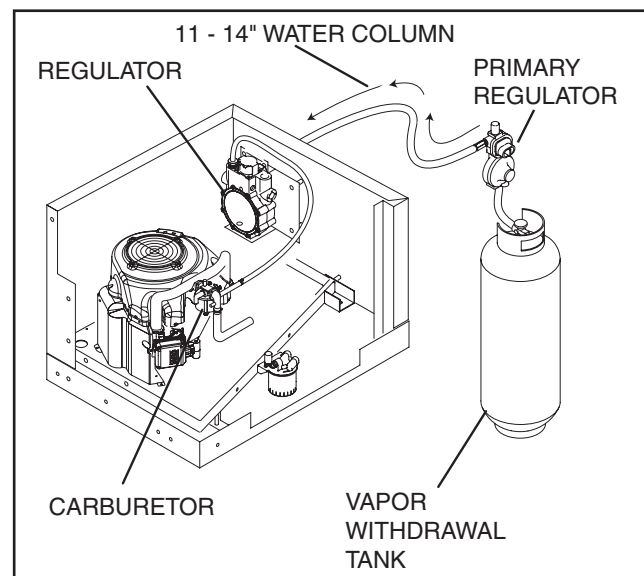

Figure 7-22 – Typical Propane Gas Fuel System

**NOTE: Recommended MINIMUM gas flow rate for all air-cooled QUIETPACT series generators is 67 cubic feet per hour.**

**If an existing primary gas regulator does not have a sufficient flow capacity for the generator and other gas appliances in the circuit, (a) install a primary regulator with adequate flow rate, or (b) install a separate regulator only and rated at least 67 cubic feet per hour. The inlet side of any primary regulator that supplies the generator must connect directly to a gas pressure tank. Do NOT tee the generator line into a gas circuit feeding other areas.**



**CAUTION!: Use only approved components in the fuel supply system. All components must be properly installed in accordance with applicable codes. Improper installation or use of unauthorized components may result in fire**

**or an explosion. Follow approved methods to test the system for leaks. No leakage is permitted. Do not allow fuel vapors to enter the vehicle interior.**

LP gas vapors should be supplied to the secondary regulator inlet at about 11 inches water column (positive pressure). The engine pistons draw air in during the intake stroke (Figure 7-23). This air passes through a carburetor venturi, which creates a low pressure that is proportional to the quantity of air being pumped. The low pressure from the carburetor venturi acts on the regulator diaphragm to pull the diaphragm toward the source of low pressure. A lever attached to the diaphragm opens a valve to permit gas flow through the carburetor.

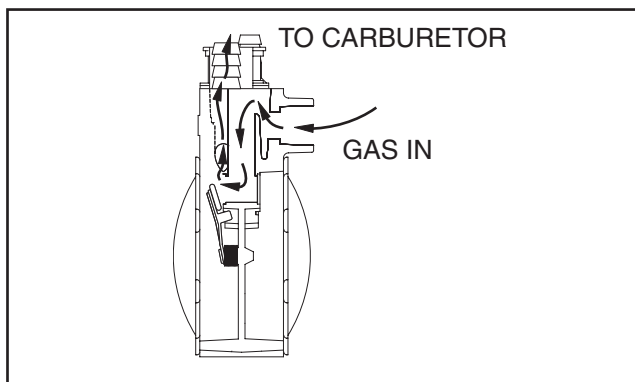

*Figure 7-23 – LP Gas Carburetion Diagram*

The greater the airflow through the carburetor venturi, the lower the pressure at the venturi throat. The lower the pressure at the venturi throat, the greater the diaphragm movement, and the greater the movement of the regulator valve. The more the regulator valve opens, the greater the gas flow that is proportional to airflow through the generator.

The following facts about the secondary regulator must be emphasized:

- The regulator must be sensitive to venturi throat pressure changes throughout the operating range.
- The regulator must be properly adjusted so it will stop the flow of gas when the engine is not running (no air flow through the carburetor).
- The slightest airflow (and vacuum in the venturi throat) should move the regulator valve off its seat and permit gas to flow.

**PROCEDURE:**

A water manometer or a gauge that is calibrated in “ounces per square inch” may be used to measure the fuel pressure. Fuel pressure at the inlet side of the LPG Shut Off Valve should be between 11-14 inches water column as measured with a manometer. The LP system must be able to maintain 11-14 inches water column under all load requirements.

1. Turn LP supply to generator off.
2. Remove the Gas Pressure Tap from the fuel regulator and install manometer to this port.
3. Turn LP supply to generator on, the gauge should read 11-14 inches water column.
4. For Problem 8 only (Section 6), start the engine and the gauge should read 11-14 inches water column.

**RESULTS:**

1. If the LP gas pressure is less than 11-14 inches water column the fuel supply system must be corrected in order to maintain 11-14 inches water column.
2. If the LP gas pressure is between 11-14 inches water Column, proceed to Test 29 for Problem 7 (Section 6). Proceed to Test 32 for Problem 8 (Section 6).

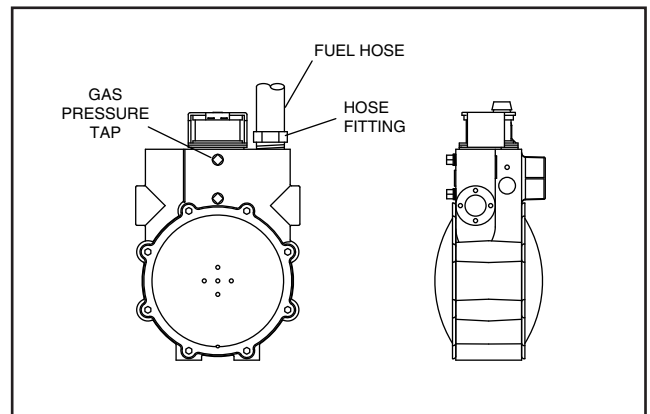

*Figure 7-24. – Fuel Regulator*

**TEST 29 – CHECK WIRE 14 POWER SUPPLY**

**DISCUSSION:**

When the engine is cranked, Engine Controller circuit board action must deliver battery voltage to the Wire 14 circuit or the engine will not start. This is because the Wire 14 circuit operates the Fuel Pump and Fuel Solenoid.

**PROCEDURE:**

Inside the generator panel, locate the 4-tab terminal connector (Figure 7-25). Then, proceed as follows:

1. Set a VOM to read battery voltage (12 VDC).
2. Connect the meter positive (+) test lead to the 4-tab terminal connector, the common (-) test lead to frame ground.
3. Crank the engine and the meter should read battery voltage. If battery voltage is not measured, proceed to Step 4.

## Section 7

### DIAGNOSTIC TESTS

4. Connect the positive (+) meter test lead to Terminal J2 on the Engine Controller Circuit Board. Connect the negative (-) test lead to a clean frame ground.
5. Crank the engine. The meter should indicate battery voltage.

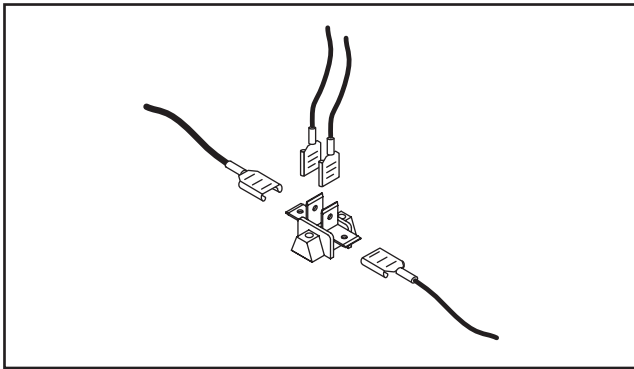

Figure 7-25. – The 4-tab Connector

#### RESULTS:

1. If the meter indicated battery voltage, go to Test 30.
2. If battery voltage was NOT indicated in Step 3 but is indicated in Step 5, check Wire 14 between the 4-tab connector and the Engine Controller circuit board.
  - a. Repair, reconnect or replace Wire 14 as necessary.
3. If battery voltage was not indicated in Step 5, replace the Engine Controller Circuit Board.

### TEST 30 – CHECK WIRE 18

#### DISCUSSION:

Wire No. 18 controls sending the STOP signal to the Engine Controller Circuit Board. If Wire No. 18 contacts ground it will initiate a shutdown. Coach manufacturers sometimes install a 15 to 30 foot remote harness. A ground on Wire No. 18 in a remote harness can also cause a shutdown.

#### PROCEDURE:

1. Remove the remote harness connector from the generator and re-test. If generator continues to run, a short is present in the remote harness. Repair or replace the remote harness.
2. Remove the J1 connector from the Engine Controller Circuit Board. Set the VOM to measure resistance. Connect one test lead to Pin Location J1-14. Connect the other test lead to a clean frame ground. Infinity should be measured.
3. Connect one test lead to Pin Location J1-15. Connect the other test lead to a clean frame ground. Infinity should be measured.

#### RESULTS:

1. If continuity is measured in Step 2, repair or replace shorted Wire No. 18 between J1 Connector and Start-Stop Switch.
2. If continuity was measured in Step 3, repair or replace shorted Wire No. 18 between J1 Connector and remote panel connector.

### TEST 31 – CHECK FUEL SOLENOID (GASOLINE UNITS)

#### DISCUSSION:

If the Fuel Solenoid fails to open, the engine will not start.

#### PROCEDURE:

Set the Start-Stop Switch to “START”. The Fuel Solenoid should actuate.

1. Remove the Control Panel cover to access the back side of the Fuel Primer Switch.
2. Place a hand on the Fuel Solenoid located at the base of the carburetor bowl.
3. Connect a jumper between the top and bottom terminals of the fuel primer switch. This will activate the fuel pump and fuel solenoid. The fuel solenoid should energize and you should be able to feel and hear it. If the Fuel Solenoid does not operate, proceed to Step 4.

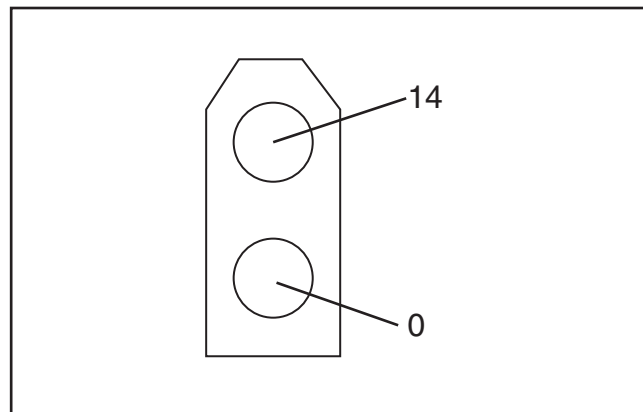

Figure 7-26. – Connector 3, Fuel Solenoid to Panel

4. Set the VOM to measure DC voltage. Disconnect Connector 3 from the Fuel Solenoid. Connect the positive (+) meter test lead to Wire No. 14 (Connector 3, Pin 2) that goes to the control panel. Connect the other test lead to a clean frame ground. Set the Start-Stop Switch to “START.” Battery voltage should be measured.
5. Set the VOM to measure resistance. Disconnect Connector 3 from the Fuel Solenoid. Connect one test lead to Wire No. 0

(Connector 3, Pin 1) that goes to the control panel. Connect the other test lead to a clean frame ground. Continuity should be measured.

Short to Ground:

6. Set the VOM to measure resistance. Disconnect Connector to the Fuel Solenoid. Connect one meter test lead to one pin on the Fuel Solenoid. Connect the other meter test lead to the Fuel Solenoid housing. Infinity should be measured. If continuity is measured, a short to ground exists. (Fuel Solenoid coil resistance is approximately 30.1 ohms. Current draw of the Fuel Solenoid at nominal voltage is approximately 418 milliamps or 0.418 amps).

**RESULTS:**

1. If the Fuel Solenoid passes Steps 4 & 5 but does NOT operate in Step 3, replace or repair Fuel Solenoid.
2. If battery voltage is not measured in Step 4, repair or replace Wire No. 14 between Connector 3 and the 4-tab terminal.
3. If continuity is not measured in Step 5, repair or replace Wire No. 0 between the Fuel Solenoid and ground terminal.
4. If the Fuel Solenoid operates, proceed to Test 32.

**TEST 32 – CHECK IGNITION SPARK**

**DISCUSSION:**

A problem in the engine Ignition system can cause any of the following:

- Engine will not start.
- Engine starts hard, runs rough.

A commercially available spark tester may be used to test the engine ignition system. One can also be purchased from Generac Power Systems (Part No. 0C5969).

**PROCEDURE:**

1. Disconnect the high tension lead from the spark plug.
2. Attach the high tension lead to the spark tester terminal.
3. Ground the spark tester clamp by attaching to the cylinder head.
4. Crank the engine rapidly. Engine must be cranking at 350 rpm or more. If spark jumps the tester gap, you may assume the ignition system is working properly.
5. To determine if an engine miss is ignition related, connect the spark tester in series with the high tension lead and the spark plug. Then, start the engine. If spark jumps the tester gap at regular Intervals, but the engine miss continues, the problem may be in the spark plug or fuel system. Proceed to Test 33.

6. If spark jumps the tester gap intermittently, the problem may be in the Ignition Coil. Proceed to Test 34.

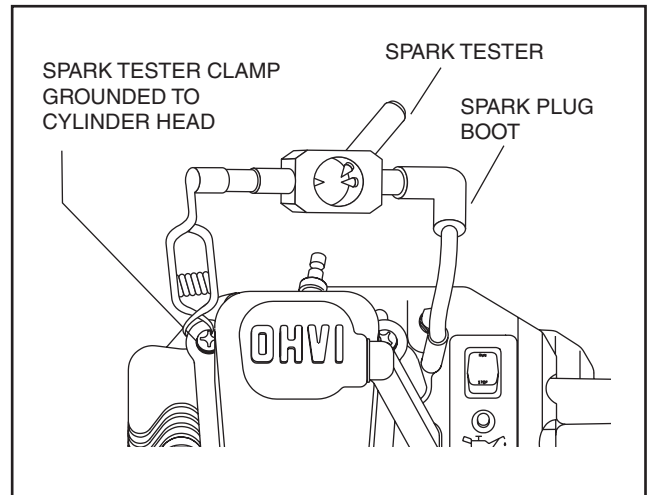

*Figure 7-27. – Testing Ignition System*

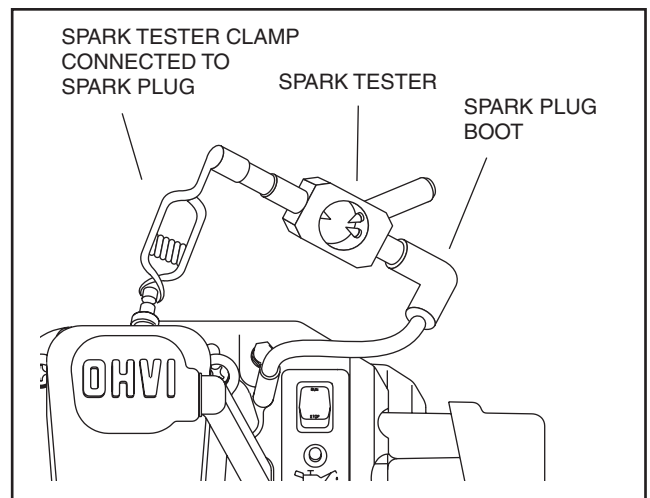

*Figure 7-28. – Checking Engine Miss*

**RESULTS:**

1. If no spark or if engine miss is apparent, go to Test 34.
2. If ignition spark is good, go to Test 33.

**TEST 33 – CHECK SPARK PLUG**

**DISCUSSION:**

During Test 32, if spark jumped the tester gap, the ignition system must be functioning properly. However, if the engine misses the spark plug itself may be fouled.

## Section 7 DIAGNOSTIC TESTS

### PROCEDURE:

Remove spark plug. Clean with a commercial solvent. **DO NOT BLAST CLEAN SPARK PLUGS.** Replace spark plug if badly fouled, if ceramic is cracked, or if badly worn or damaged. Set gap to 0.030 inch (0.76mm). Use a Champion RC14YC (or equivalent) replacement spark plug.

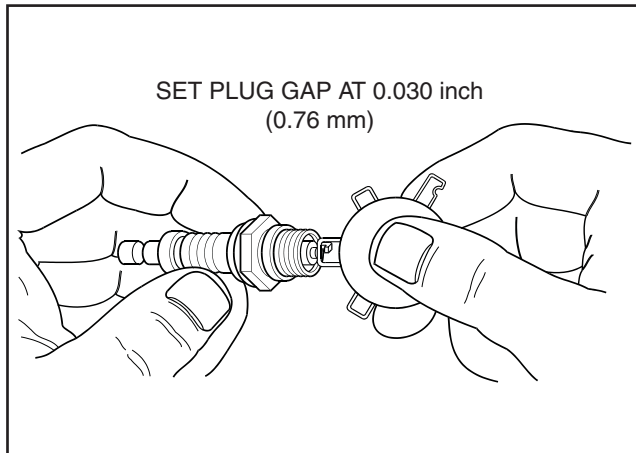

Figure 7-29. – Setting Spark Plug Gap

### RESULTS:

1. Clean and regap or replace spark plug as necessary.
2. If spark plug is good, go to Test 36.

## TEST 34 – CHECK IGNITION COIL

### DISCUSSION:

The ignition system used on GH-220 engines is a solid-state (breakerless) type. The system utilizes a magnet on the engine flywheel to induce a relatively low voltage into an ignition coil assembly. Ignition coil internal components increase the voltage and deliver the resulting high voltage across the spark plug gap.

The ignition coil houses a solid state-circuit board that controls ignition timing. Timing is fixed, air gap is non-adjustable and spark advance is automatic.

Major components of the ignition system include (a) the ignition coil assembly, (b) the spark plug, (c) the engine control board and (d) the engine flywheel.

Solid-state components encapsulated in the ignition coil are not accessible and cannot be serviced. If the coil is defective, the entire assembly must be replaced. The air gap between the coil and the flywheel magnet is fixed and non-adjustable.

The ignition coil assembly (Figure 7-30) consists of (a) ignition coil, (b) spark plug high tension lead and (c) spark plug boot.

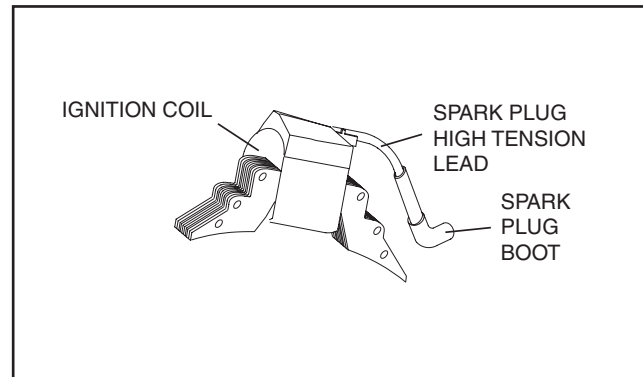

Figure 7-30 – Ignition Coil Assembly

### PROCEDURE:

1. Disconnect Wire No. 18A at the Bullet Connector. Repeat Test 32.
2. If unit now produces spark, disconnect J1 Connector from ECB (Engine Control Board). Set the VOM to measure resistance. Connect one test lead to Wire No. 18A (Pin Location J1-4). Connect the other test lead to a clean frame ground. Infinity should be measured.
3. If Step 1 produced spark and Step 2 tested good, set the VOM to measure DC voltage. Connect one test lead to Wire No. 15 (J3 Terminal) on ECB. Connect the other test lead to frame ground. Battery voltage should be measured. Verify that Wire No. 15 is connected to J3 and that Wire No. 14 is connected to J2; if reversed the unit will produce no spark.
4. Set the VOM to measure resistance. Connect the negative (-) test lead to Wire No. 18A, which goes to the coil. Connect the positive (+) test lead to frame ground. Approximately 1.5 k $\Omega$  should be measured.
5. Set the VOM to measure resistance. Disconnect the high tension lead from the spark plug. Connect one test lead to the high tension lead. Connect the other test lead to frame ground. Approximately 16 k $\Omega$  should be measured.

### RESULTS:

1. If infinity is not measured in Step 2, repair or replace grounded Wire No. 18 between ECB and bullet connector.
2. If battery voltage is not measured in Step 3, reconnect Wire No. 15 and Wire No. 14 to the correct terminal locations.
3. If the Ignition Coil fails Step 4 or Step 5 by a high margin, replace the Ignition Coil.
4. If the coil passes Step 4 and Step 5, but there is still no spark, replace the Ignition Coil.

**Note: Before replacing the Ignition Coil, check the Flywheel Magnet.**



**CHECKING FLYWHEEL MAGNET:**

The flywheel magnet rarely loses its magnetism. If you suspect a magnet might be defective, a rough test can be performed as follows:

1. Place the flywheel on a wooden surface.
2. Hold a screwdriver at the extreme end of its handle and with its point down.
3. Move the tip of the screwdriver to about 3/4 inch (19mm) from the magnet. The screwdriver blade should be pulled in against the magnet.

**FLYWHEEL KEY:**

In all cases, the flywheel's taper is locked on the crankshaft taper by the torque of the flywheel nut. A keyway is provided for alignment only and theoretically carries no load.

If the flywheel key becomes sheared or even partially sheared, ignition timing can change. Incorrect timing can result in hard starting or failure to start.

**TEST 35 – CHECK VALVE ADJUSTMENT**

**DISCUSSION:**

The valve lash must be adjusted correctly in order to provide the proper air/fuel mixture to the combustion chamber.

**ADJUSTING VALVE CLEARANCE:**

Adjust valve clearance with the engine at room temperature. The piston should be at top dead center (TDC) of its compression stroke (both valves closed).

An alternative method is to turn the engine over and position the intake valve fully open (intake valve spring compressed) and adjust the exhaust valve clearance. Turn the engine over and position the exhaust valve fully open (exhaust valve spring compressed) and adjust the intake valve clearance.

Correct valve clearance is given below, in INCHES (MILLIMETERS).

<b>Intake Valve</b>	<b>0.001-0.0022 (0.03-0.056)</b>
<b>Exhaust Valve</b>	<b>0.0018-0.003 (0.046-0.07)</b>

1. Loosen the rocker arm jam nut. Use an 8mm allen wrench to turn the pivot ball stud while checking the clearance between the rocker arm and valve stem with a feeler gauge (see Figure 7-31).
2. When clearance is correct, hold the pivot ball stud with the allen wrench and tighten the rocker arm jam nut to the specified torque with a crow's foot. After tightening the jam nut, recheck valve clearance to make sure it did not change.



**TORQUE SPECIFICATION**  
**ROCKER ARM JAM NUT**  
**72 inch-pounds**

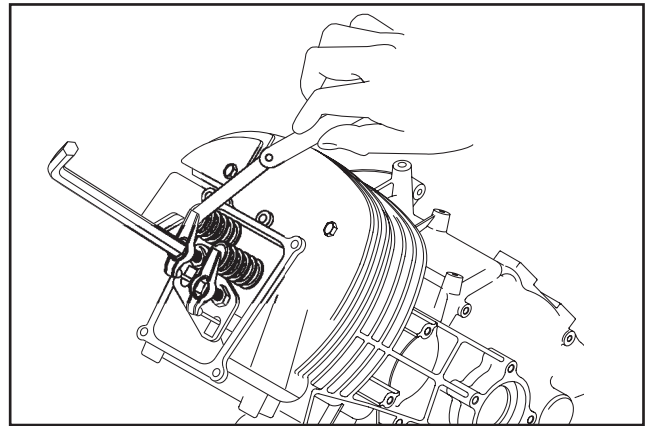

*Figure 7-31 – Adjusting Valve Clearance*

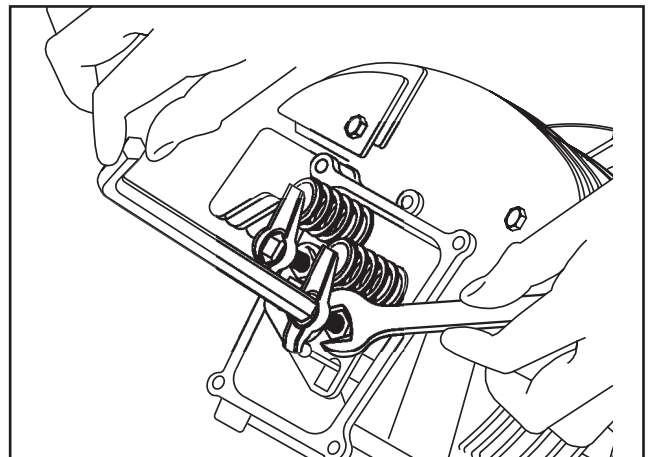

*Figure 7-32 – Tightening the Jam Nut*

**INSTALL ROCKER ARM COVER:**

1. Use a new rocker arm cover gasket. Install the rocker arm cover and retain with four screws.
2. Install oil breather tube.

**RESULTS:**

Adjust valves to specification and retest.

**TEST 36 – CHECK CARBURETION**

**DISCUSSION:**

If the engine cranks but will not start, one possible cause of the problem might be the carburetion system.

**PROCEDURE:**

Before making a carburetion check, be sure the fuel supply tank has an ample supply of fresh, clean gasoline.

Check that all shutoff valves are open and fuel flows freely through the fuel line.

## Section 7

### DIAGNOSTIC TESTS

---

Make sure the automatic choke operates properly.

If the engine will not start, remove and inspect the spark plug. If the spark plug is wet, look for the following:

- Overchoking.
- Excessively rich fuel mixture.
- Water in fuel.
- Intake valve stuck open.
- Needle/float stuck open.

If the spark plug is dry look for the following:

- Leaking carburetor mounting gaskets.
- Intake valve stuck closed.
- Inoperative fuel pump.
- Plugged fuel filter(s).
- Varnished carburetor

If the engine starts hard or will not start, look for the following:

- Physical damage to the AC generator. Check the Rotor for contact with the Stator.
- Starting under load. Make sure all loads are disconnected or turned off before attempting to crank and start the engine.
- Check that the automatic choke is working properly.

#### RESULTS:

If problem has not been solved, go to Test 37. If carburetor is varnished, clean or replace.

1. Remove fuel line at carburetor and ensure that there is an adequate amount of fuel entering the carburetor.
2. Remove the float bowl and check to see if there is any foreign matter in bottom of carburetor bowl..
3. The float is plastic and can be removed for access to the needle so it can be cleaned.
4. With all this removed you can use carburetor cleaner to clean the rest of the carburetor before reassembly.
5. After cleaning carburetor with an approved carburetor cleaner blow dry with compressed air and reassemble.

Shelf life on gasoline is 30 days. Proper procedures need to be taken for carburetors so that the fuel doesn't varnish over time. You must use a fuel stabilizer at all times in order to ensure that the fuel is fresh at all times.

### **TEST 37 – CHECK CHOKE SOLENOID**

#### DISCUSSION:

The automatic choke is active only during cranking. When the Start-Stop Switch is held at "START", a crank relay on the Engine Controller circuit board is energized closed to (a) crank the engine and (b) deliver a cyclic voltage to the Choke Solenoid via Wire No. 90. The Choke Solenoid will be pulled in for about two

seconds, then deactivate for about two seconds. This cyclic choking action will continue as long as the engine is being cranked.

**NOTE: LP units do not use a Wire #14 or BI-METAL HEATER ASSEMBLY.**

#### PROCEDURE:

1. Operational Check: Crank the engine. While cranking, the choke solenoid should pull in about every 2 seconds (2 seconds ON, 2 seconds OFF). If the choke solenoid does not pull in, try adjusting the choke as follows.
2. Pre-Choke Adjustment: With the CHOKE SOLENOID not actuated, the carburetor CHOKE PLATE should be approximately 1/8 Inch from its full open position. Verify choke is completely open once engine is warmed up. If not, power will be down and emissions will be up. Adjust position of BI-METAL HEATER ASSEMBLY by loosening screws until unit starts when cold and the choke is fully open when engine is up to temperature. Tighten the screws to complete the adjustment (see Figure 7-36).
3. Choke Solenoid Adjustment: Loosen the screws that retain the CHOKE SOLENOID to its bracket.
  - a. Using a screw driver or similar tool, lift the choke solenoid at the retaining clip as shown in Figure 7-33. Do NOT lift at the BI-METAL HEATER ASSEMBLY .
  - b. The solenoid is in the correct position when Edge A of the carburetor throttle shaft is lined up parallel to Edge B of the carburetor body as shown in Figure 7-34.
  - c. Tighten the screws that retain the CHOKE SOLENOID to its bracket.
  - d. Verify that the BI-METAL HEATER ASSEMBLY operates as described in Step 2. Re-adjust as necessary.
4. Disconnect Connector 1: Set the VOM to measure DC voltage. Connect the positive (+) test lead to Wire No. 90 (Pin 2) of Connector 1 going to the control panel. Connect the negative (-) test lead to frame ground. Activate the Start-Stop switch to "START." During cranking, battery voltage should be measured cyclically every two seconds.
5. If battery voltage was not measured in Step 4, check at J1 Connector: Connect positive (+) test lead to Pin Location J1-2 at the engine control board. Connect the negative (-) test lead to frame ground. Activate the Start-Stop switch to "START." During cranking, battery voltage should be measured cyclically every two seconds.
6. Set the VOM to measure resistance. Disconnect Connector 1 from the Choke Solenoid. Connect one test lead to Wire No. 0 (Pin 1) of Connector 1, going to the control panel. Connect the other test lead to frame ground. Continuity should be measured.

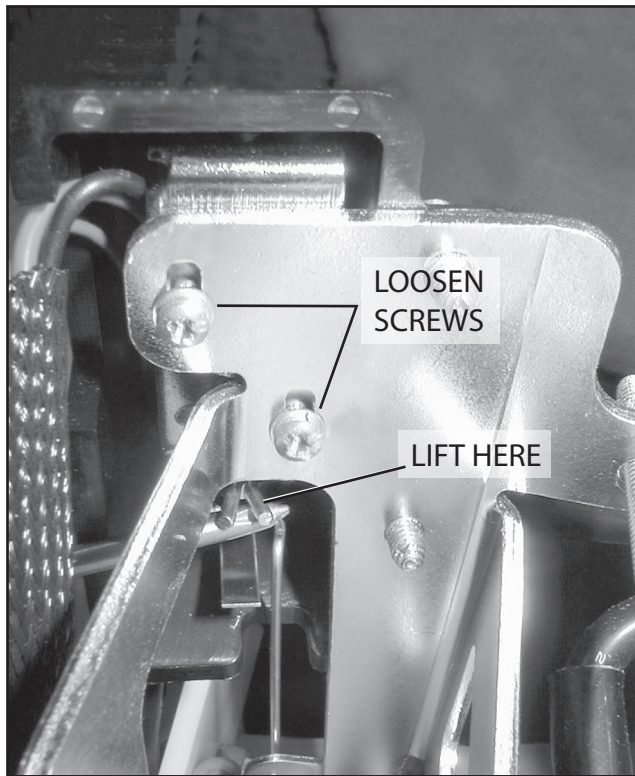

Figure 7-33. – Choke Assembly Adjustment

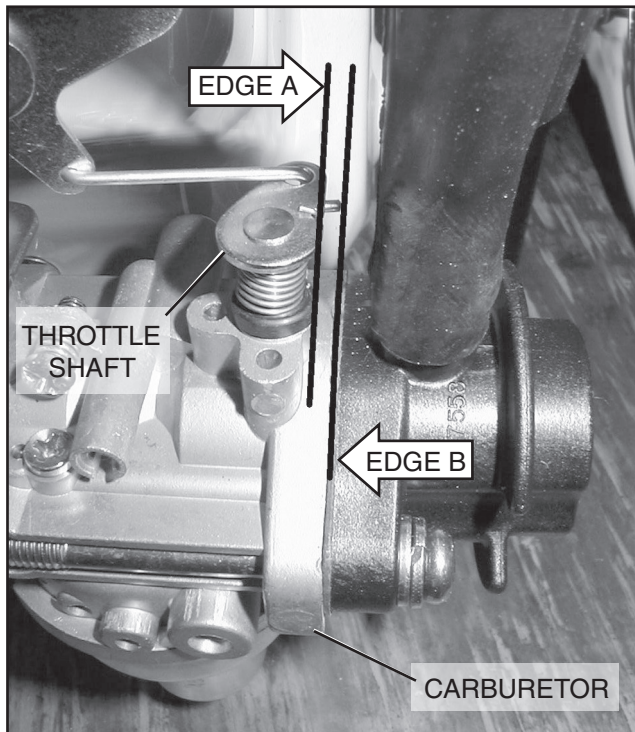

Figure 7-34. – Final Choke Adjustment

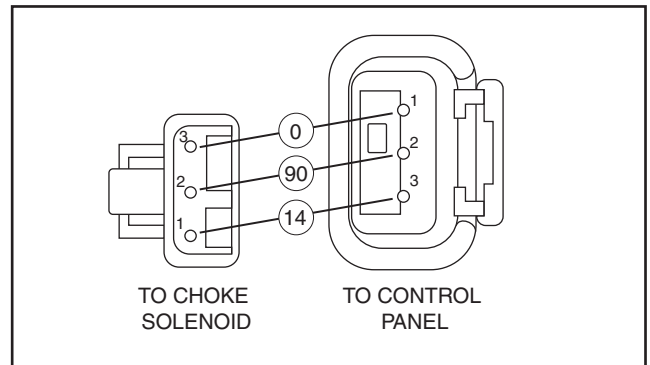

Figure 7-35. – Connector 1

- Set the VOM to measure resistance. Disconnect Connector 1. Connect one meter test lead to Wire No. 90 (Connector 1, Pin 2) going to the Choke Solenoid. Connect the other meter test lead to Wire No. 0 (Connector 1, Pin 1). Approximately 3.7 ohms should be measured. (Current draw of Choke Solenoid at nominal voltage is 3.4 amps).

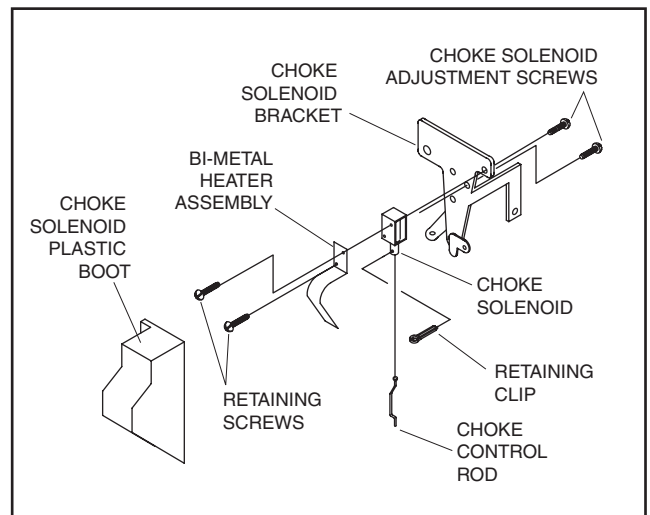

Figure 7-36. – Exploded View of Choke Assembly

Short to Ground:

- Set the VOM to measure resistance. Disconnect Connector 1. Connect one meter test lead to Wire No. 90 (Connector 1, Pin 2). Connect the other meter test lead to the metal Choke Solenoid housing. Infinity should be measured. If continuity is measured, a short to ground exists.

**RESULTS:**

- If Choke operation is good, go to Test 35 for Problem 7, "Engine Cranks but Won't Start." Go to Test 41 for Problem 8, "Engine Starts Hard and Runs Rough."

## Section 7

### DIAGNOSTIC TESTS

- If battery voltage was measured in Step 5 but not measured in Step 4, repair or replace Wire No. 90 between ECB and Connector 1.
- If battery voltage is not measured in Step 5 during engine cranking, replace Engine Control Board.
- If continuity is not measured in Step 6, repair or replace Wire No. 0 between the ground terminal and Connector 1.
- If Choke Solenoid coil resistance is not measured or is incorrect in Step 7, replace the Choke Solenoid.

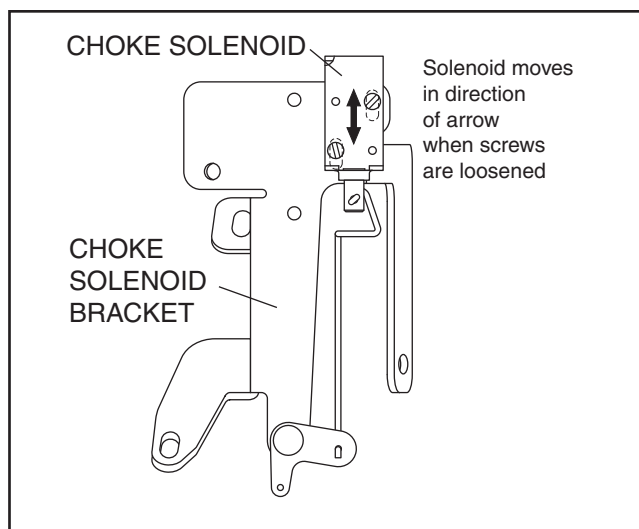

Figure 7-37. – Automatic Choke Assembly

### TEST 38 – CHECK ENGINE / CYLINDER LEAK DOWN TEST / COMPRESSION TEST

#### GENERAL:

Most engine problems may be classified as one or a combination of the following:

- Will not start.
- Starts hard.
- Lack of power.
- Runs rough.
- Vibration.
- Overheating.
- High oil consumption.

#### DISCUSSION:

The Cylinder Leak Down Tester checks the sealing (compression) ability of the engine by measuring air leakage from the combustion chamber. Compression loss can present many different symptoms. This test is designed to detect the section of the engine where the fault lies before disassembling the engine.

#### PROCEDURE:

1. Remove the spark plug.
2. Gain access to the flywheel. Remove the valve cover.
3. Rotate the engine crankshaft until the piston reaches top dead center (TDC). Both valves should be closed.
4. Lock the flywheel at top dead center.
5. Attach cylinder leak down tester adapter to spark plug hole.
6. Connect an air source of at least 90 psi to the leak down tester.
7. Adjust the regulated pressure on the gauge to 80 psi.
8. Read the right hand gauge on the tester for cylinder pressure. 20 percent leakage is normally acceptable. Use good judgement, and listen for air escaping at the carburetor, the exhaust, and the crankcase breather. This will determine where the fault lies.

#### RESULTS:

- Air escapes at the carburetor – check intake valve.
- Air escapes through the exhaust – check exhaust valve.
- Air escapes through the breather – check piston rings.
- Air escapes from the cylinder head – the head gasket should be replaced.

#### CHECK COMPRESSION:

To check engine compression, remove the spark plug. Insert an automotive type compression gauge into the spark plug hole. Crank the engine until there is no further increase in pressure. The highest reading obtained is the engine compression pressure.

#### MINIMUM ALLOWABLE COMPRESSION PRESSURE COLD ENGINE – GH-220 60 psi

If compression is poor, look for one or more of the following causes:

- Loose cylinder head bolts.
- Failed cylinder head gasket.
- Burned valves or valve seats.
- Insufficient valve clearance.
- Warped cylinder head.
- Warped valve stem.
- Worn or broken piston ring(s).
- Worn or damaged cylinder bore.
- Broken connecting rod.
- Worn valve seats or valves.
- Worn valve guides.

**NOTE: Refer to Engine Service manual No. 0C1103 for further engine service information.**

### **TEST 39 – CHECK OIL PRESSURE SWITCH**

#### DISCUSSION:

Also see “Operational Analysis” on Page 16. The Low oil Pressure Switch is normally-closed, but is held open by engine oil pressure during cranking and start-up. Should oil pressure drop below a safe level, the switch contacts will close to ground the Wire 85 circuit. Engine controller board action will then initiate an automatic shutdown.

If the switch fails closed, the engine will crank and start, but will then shut down after a few seconds.

If the switch fails open, low oil pressure will not result in automatic shutdown.

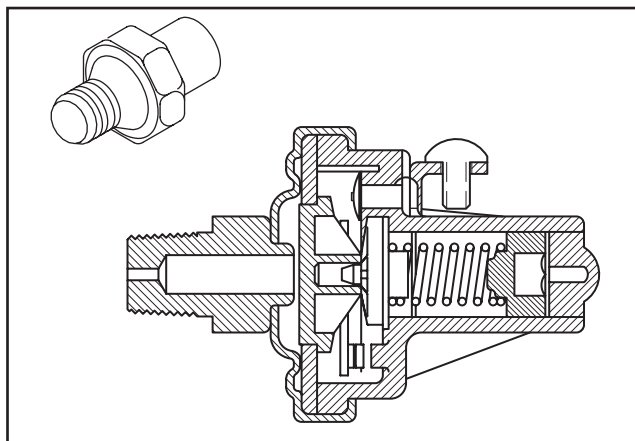

*Figure 7-38. – Oil Pressure Switch*

#### PROCEDURE:

1. Check engine oil level. If necessary, replenish oil level to the dipstick “FULL” mark.
2. Set a VOM to its “Rx1” scale and zero the meter.
3. Connect the meter test leads across the switch terminals, with engine shut down. The meter should read “continuity”. A small amount of resistance is acceptable.
4. Crank the engine. Oil pressure should open the switch contacts at some point while cranking and starting. Meter should then indicate “infinity”.
5. If the contacts did not open in Step 5, remove the low oil pressure switch and connect an oil pressure gauge in its place. Start the engine and measure oil pressure. Pressure should be above 10 psi.

#### RESULTS:

1. In Step 4, if “continuity” is not indicated, replace the switch.
2. If oil pressure checked good in Step 6, but Step 5 measured “infinity,” replace the low oil pressure switch.

3. If oil pressure is below 10 psi, determine cause of low oil pressure. Refer to Engine Service manual No. 0C1103 for further engine service information. Verify that the oil is the proper viscosity for the climate and season.

### **TEST 40 – TEST OIL TEMPERATURE SWITCH**

#### DISCUSSION:

If the engine cranks, starts and then shuts down, one possible cause of the problem may be a high oil temperature condition. Protective shutdown is a normal occurrence if the oil temperature switch exceeds approximately 305°F (151°C).

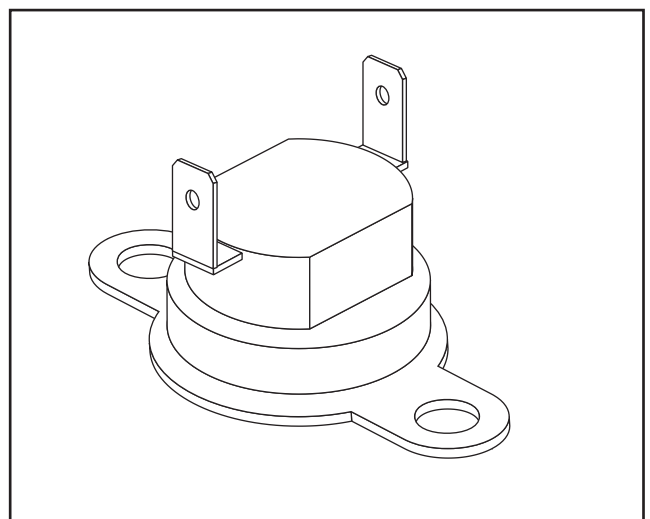

*Figure 7-39. – Oil Temperature Switch*

#### PROCEDURE:

1. Remove Wire No. 85 from Oil Temperature Switch terminal and start the generator. If engine starts and runs now, but shuts down when Wire 85 is connected to the switch terminal, the following possibilities exist:
  - a. Oil temperature is too high.
  - b. The oil temperature switch has failed closed or is shorted to ground.
2. Remove the switch and place its sensing tip into oil (Figure 7-40). Place a thermometer into the oil.
3. Connect the test leads of a VOM across the switch terminals. The meter should read “infinity”.
4. Heat the oil. When oil temperature reaches approximately 305°F (151°C), the switch contacts should close and the meter should read “continuity”.

## Section 7 DIAGNOSTIC TESTS

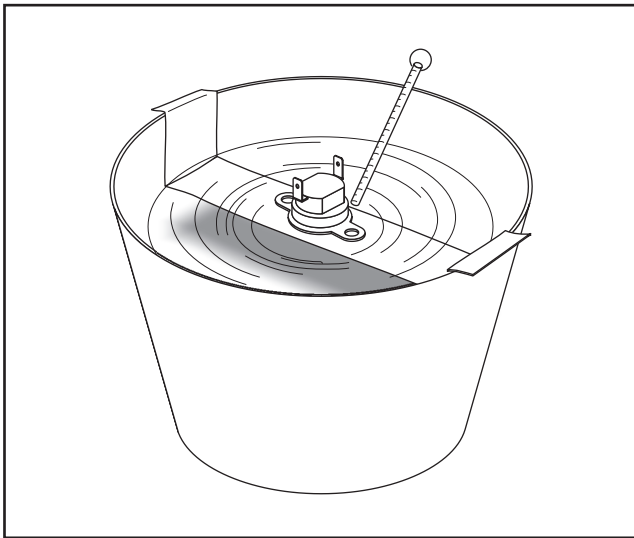

Figure 7-40. – Testing Oil Temperature Switch

### RESULTS:

1. If the Oil Temperature Switch fails Step 3 or Step 4, replace the Oil Temperature Switch.
2. If the Oil Temperature Switch is good, an overheat condition may be occurring. Verify that the installation of the generator is within specified tolerances. The generator must receive the proper amount of incoming air, and also be able to exhaust the cooling air with NO RESTRICTIONS. Check to be sure that the exhaust pipe is not under the air intake. Refer to the Owner's and Installation Manual for proper installation specifications.

### **TEST 41 – TEST CHOKE HEATER**

#### DISCUSSION:

The Choke Heater is a sensitive heating element wrapped around a temperature sensitive Bi-Metal strip. The Bi-Metal strip positions the Choke Plate during startup. Once running, the Bi-Metal strip will also allow the Choke Plate to fully open. Power for the heater element is supplied from Wire No. 14 to assist the Bi-Metal strip in opening the Choke Plate after starting. Failure of the Choke Plate to open will cause an excessively rich fuel-air mixture and engine performance will suffer.

#### PROCEDURE:

1. Verify that the Choke Plate on the carburetor is mechanically free to move and is not binding. If the engine runs rough, check the operation of the Bi-Metal strip. Allow the engine to run for five minutes, then inspect the choke position. The Bi-Metal strip should have been heated by the Choke Heater and should have expanded to allow the Choke Plate to open fully.

2. If the Choke Plate did not open in Step 1, check the Choke Heater. Set the VOM to measure DC voltage. Disconnect Connector 1 at the Choke Assembly. Connect the positive (+) meter test lead to Wire No. 14 (Connector 1, Pin 3) going to the control panel. Connect the negative (-) meter test lead to a clean frame ground. Set the Start-Stop switch to "START." Battery voltage should be measured.
3. If battery voltage was not measured in Step 2, set the VOM to measure resistance. Disconnect Connector 1 at the Choke Assembly. Connect one meter test lead to Wire No. 14 (Connector 1, Pin 3) going to the control panel. Connect the other meter test lead to the 4-tab terminal for Wire No. 14 in the control panel. Continuity should be measured.
4. Set the VOM to measure resistance. Connect one meter test lead to Wire No. 14 (Connector 1, Pin 3) going to the Choke Heater. Connect the other meter test lead to the exposed steel portion of the Choke Heater/Bi-Metal strip. Approximately 37 ohms ( $\pm 20\%$ ) should be measured. (Current draw of the Choke Heater at nominal voltage is approximately 340 milliamps or 0.340 amps). If continuity is present the Choke Heater has a short to ground.

### RESULTS:

1. If Choke Plate is binding in Step 1, repair or replace binding Choke Plate. If Choke Heater tests good, go to Test 35.
2. If battery voltage was not measured in Step 2 and continuity was measured in Step 3, go to Test 29.
3. If continuity was not measured in Step 3, repair or replace Wire No. 14 between the 4-tab Terminal and Connector 1.
4. If the resistance value is incorrect in Step 4 or the Bi-Metal strip does not function with voltage present, replace the Choke Heater.

### **TEST 42 – CHECK LPG FUEL SOLENOID**

#### DISCUSSION:

IF THE LPG FUEL SOLENOID (FS) FAILS TO OPEN, FUEL WILL NOT BE AVAILABLE TO THE ENGINE AND IT WILL NOT START. PROCEDURE:

1. Place one hand on the top of the LPG Fuel Solenoid. Activate the Fuel Prime Switch. You should be able to feel as well as hear the solenoid energize. If solenoid energizes discontinue testing.
2. Set VOM to measure resistance. Disconnect Wire 0 from the LPG Fuel Solenoid. Connect one meter test lead to Wire 0. Connect the other test lead to a clean frame ground. "Continuity" should be measured. Reconnect Wire 0 to LPG shut off valve.

SHORT TO GROUND:

Set VOM to measure resistance. Disconnect Wire 14A from the LPG Fuel Solenoid. Connect one meter test lead to LPG Fuel Solenoid terminal that Wire 14A was just removed from. Connect the other meter test lead to a clean frame ground. LPG Fuel Solenoid coil resistance of approximately 30-32 ohms should be measured. Current draw of the LPG Fuel Solenoid at nominal voltage is approximately 380 milliamps or 0.380 amps.

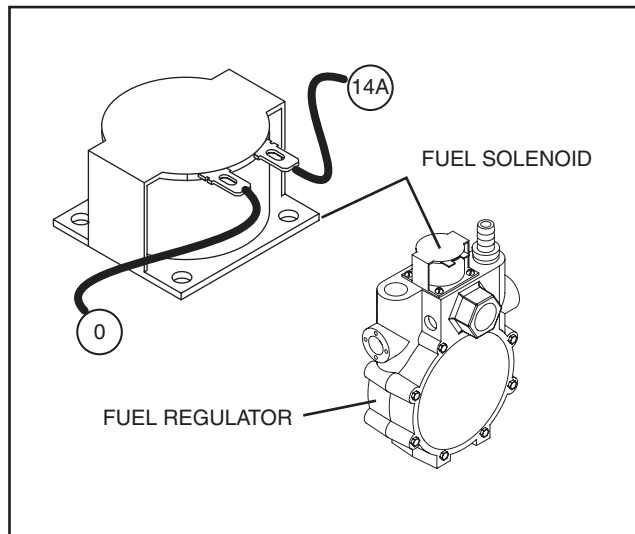

*Figure 7-41. – Fuel Solenoid*

RESULTS:

1. If the solenoid energized in Step 1, proceed to Test 32.
2. If "Continuity" was not measured in Step 2 repair or replace Wire 0 between the LPG Fuel Solenoid (FS) and the Ground Terminal (GT) in the control panel.
3. If "Continuity" was measured in Step 2, repair or replace the Fuel Solenoid (FS).

## NOTES

---



### ***MAJOR DISASSEMBLY***

#### ENCLOSURE/PANELS:

1. Remove enclosure door.
2. Remove the six (6) top cover bolts from the perimeter of the top cover. Remove top cover. (A 10mm socket is required).
3. Remove top two nuts attaching muffler shield to back enclosure panel. Move muffler shield up and over back panel to gain access to two remaining muffler shield nuts. (A 10mm socket is required).
4. Remove four (4) inside nuts from side panel studs. Remove three (3) outer side panel bolts. Remove one inside top corner bolt from side panel. (A 10mm socket is required).
5. Remove one bottom nut from panel divider, and two side nuts attached to back enclosure. (A 10mm socket is required).
6. Remove rotor/fan bolt (a 13mm socket is required). Remove fan and panel divider.
7. Remove two starter contactor mounting nuts. Remove seven (7) outer back enclosure bolts. Remove two inside nuts attached to front panel divider (a 10mm socket is required). Remove customer AC connections. Remove four (4) remote harness bolts (a 7mm socket is required). Remove one nut inside air filter area (a 10mm socket is required).
8. Remove three (3) hold down nuts to base. Remove two front panel divider bolts. Remove fuel pump and fuel line. Gently move control panel out of the way.

#### ROTOR/STATOR REMOVAL:

1. Remove enclosure (Steps 1 through 6 of previous procedure).
2. Remove four (4) muffler hold down bolts (a 10mm socket is required). Remove one 13mm nut and one M8 socket capscrew from cylinder head (using an 8mm allen wrench cut short). Remove muffler.
3. Remove two alternator bracket mounting bolts (using a 13mm socket). Pry up alternator bracket and place a socket underneath to gain clearance. Remove two bolts holding the alternator bracket to the rear carrier (using a 10mm wrench). Remove socket from underneath bracket. Disconnect stator leads from control panel. Disconnect brush leads from brush block. Remove brush assembly using a 1/4 inch socket. Remove four (4) stator hold down bolts. Remove rear carrier. Remove rotor. Remove two alternator air duct bolts. Remove stator assembly.

#### ENGINE REMOVAL:

1. Remove enclosure, Steps 1 through 8.
2. Disconnect Wire No. 16 from starter terminal. Disconnect Wire No. 18 bullet connector. Disconnect Wire No. 0 and Wire No. 4 from brush assembly. Disconnect Connector 1 from the choke assembly. Disconnect Wire No. 85 and Wire No. 0 from low oil pressure switch and high oil temperature switch. Move harness out of way.
3. Remove air filter. Remove fuel hose from fuel pump and pull through panel divider.
4. Remove two safety hold nuts from studs going through alternator mounting bracket and engine mounting bracket (using a 14mm wrench).
5. Remove four (4) mounting nuts from alternator mounting bracket and engine mounting bracket (using a 13mm socket).
6. Remove engine/alternator assembly. Follow rotor/stator removal procedure to remove generator from engine.

#### FLYWHEEL/IGNITION COIL REMOVAL:

1. Remove enclosure, Steps 1 through 8.
2. Remove governor spring. Remove governor bracket adjustor assembly (one 8mm socket and one 10mm socket). Disconnect Connector 1 to the choke assembly. Remove three (3) bolts from the choke assembly bracket (8mm socket). Remove choke linkage. Remove both assemblies.
3. Remove four (4) remaining blower housing bolts (using an 8mm socket). Remove housing.
4. Remove two magneto hold down bolts (using an 8mm socket).
5. Remove flywheel nut (using a 24mm socket). Use flywheel puller to remove flywheel. Use two M8 x 1.25 bolts supplied with puller for threads in flywheel. Remove flywheel.

# Section 9 Exploded Views

Enclosure, LP Units – Drawing No. 0F4589-B

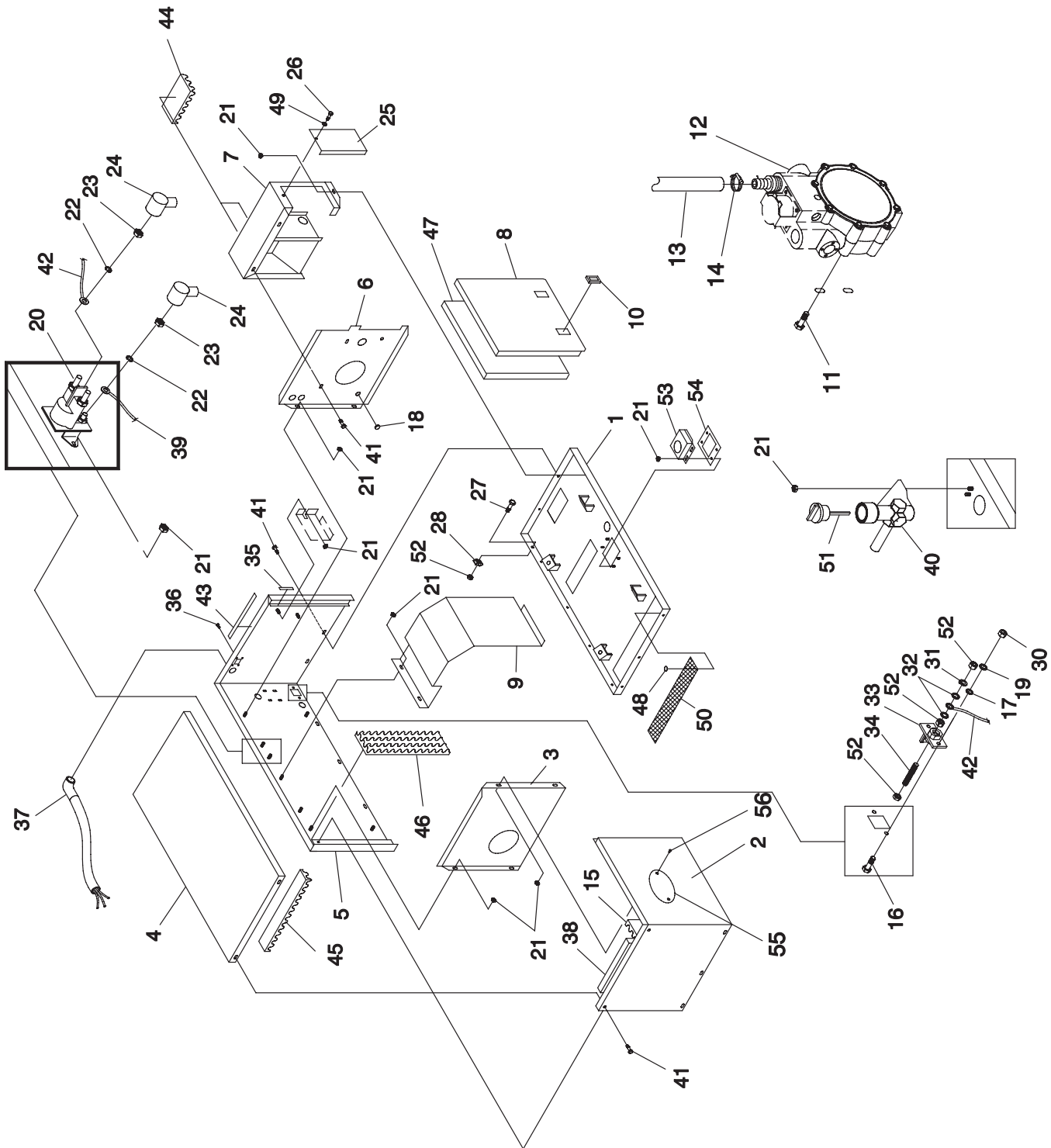

**Section 9**  
**Exploded Views**

ITEM	QTY.	DESCRIPTION
1	1	TRAY, ENCLOSURE
2	1	PANEL, ENCLOSURE SIDE
3	1	PANEL, REAR DIVIDER
4	1	PANEL, ENCLOSURE ROOF
5	1	PANEL, ENCLOSURE BACK
6	1	PANEL, FRONT DIVIDER
7	1	COMPARTMENT, AIR INTAKE
8	1	PANEL, ENCLOSURE DOOR
9	1	SHIELD, MUFFLER
10	2	SLIDE LATCH, FLUSH
11	4	SCREW HHTT M4-0.7 X 10mm
12	1	LP REGULATOR
13	1	HOSE 3/8" I.D. SINGLE BRAID 33" LONG
14	1	HOSE CLAMP BAND 3/8"
15	1	FOAM, FRONT AIR OUT COMPARTMENT
16	2	SCREW HHC M6-1.0 X 16
17	2	WASHER FLAT 1/4"
18	1	BUSHING, 1.09" SNAP
19	2	WASHER LOCK M6-1/4"
20	1	CONTACTOR, STARTER
21	22	NUT FLANGE M6-1.0 NYLOK
22	2	WASHER LOCK M8-5/16"
23	2	NUT HEX 5/16"-18
24	2	BOOT BATTERY CABLE
25	1	PANEL AIR BOX COVER
26	1	SCREW, M6-1.00 x 20mm WING
27	1	BOLT CARR 3/8"-16 X 1" BRASS
28	1	3/8" SPECIAL L/WASHER

ITEM	QTY.	DESCRIPTION
30	2	NUT HEX M6 X 1.0
31	1	WASHER LOCK 3/8"
32	2	WASHER FLAT 3/8-M10"
33	1	BLOCK, TERMINAL BATTERY POST
34	1	STUD 3/8"-16 X 2"-1/4" BRASS
35	2.1'	TAPE FOAM 1/8" x 1/2"
36	4	SCREW HHTT M5-0.8 X 10
37	1	CUSTOMER CONNECTION HARNESS
38	1	FOAM, AIR OUT COMPARTMENT SIDE
39	1	CABLE, STARTER
40	1	ASSEMBLY OIL DRAIN
41	20	SCREW SWT 1/4-20 X 5/8 W/W
42	1	CABLE, BATTERY CONNECTION
43	8.75'	FOAM TAPE 1/16" X 1/2"
44	2	FOAM, AIR INTAKE COMPARTMENT
45	1	FOAM, ROOF AIR OUT COMPARTMENT
46	1	FOAM, BACK COMPARTMENT
47	1	FOAM, DOOR PANEL
48	4	WASHER SELF LOCKING 1"
49	1	WASHER NYLON .250"
50	1	HARDWARE CLOTH COMPARTMENT AIR OUT
51	1	ASSEMBLY, CAP & DIPSTICK
52	4	NUT HEX JAM 3/8"-16 BRASS
53	1	BOX, MUFFLER TAIL PIPE
54	1	GASKET, MUFFLER TAIL PIPE BOX
55	1	LOGO, QP
56	2	RIVET, POP

# Section 9 Exploded Views

Generator, LP Units – Drawing No. 0F4590-C

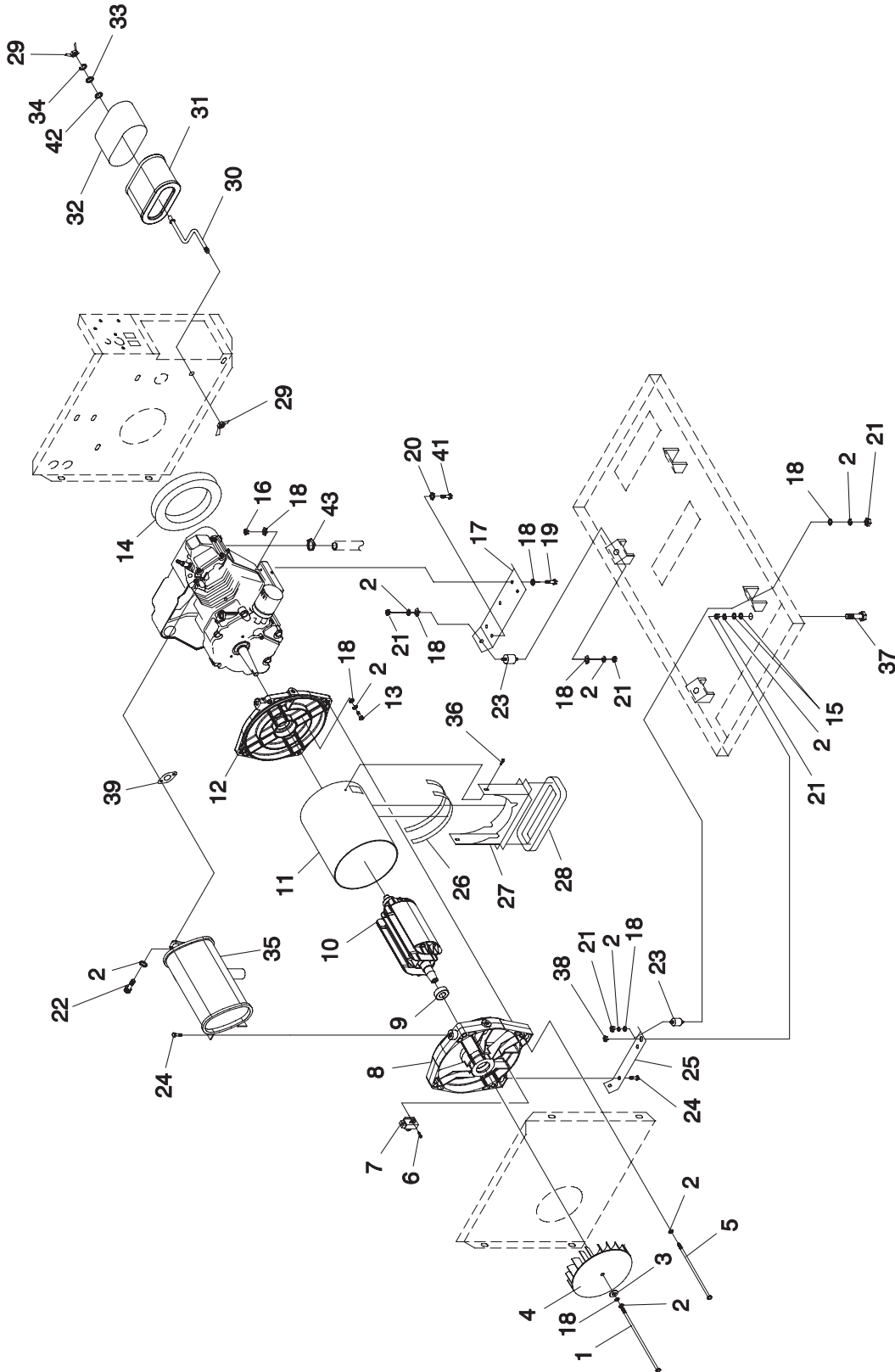

**Section 9**  
**Exploded Views**

ITEM	QTY.	DESCRIPTION
1	1	SCREW IHHC 5/16"-24 X 11-1/4" G5
2	22	WASHER LOCK M8-5/16"
3	1	WASHER FLAT .406" I.D. X 1.62" O.D.
4	1	FAN, 8" CURVE BLADE, 16.5MM I.D.
5	4	SCREW IHHC M8-1.25 X 260MM
6	2	SCREW HHTT M5-0.8 X 16
7	1	ASSEMBLY, BRUSH HOLDER
8	1	CARRIER, REAR BEARING
9	1	BEARING
10	1	ROTOR
11	1	STATOR
12	1	ADAPTOR, ENGINE
13	4	SCREW HHC 5/16"-24 X 3/4"
14	1	GASKET, FRONT DIVIDER
15	4	WASHER FLAT 3/8"-M10
16	4	NUT LOCK HEX 5/16"-18 NYLON INSERT
17	1	BRACKET, ENGINE MOUNTING
18	18	WASHER FLAT 5/16"
19	3	SCREW HHC 5/16"-18 X 1-1/2"
20	1	5/16" SPECIAL LOCK WASHER
21	10	NUT HEX 5/16"-18
22	2	SCREW SHC M8-1.25 X 18MM

ITEM	QTY.	DESCRIPTION
23	4	VIBRATION MOUNT
24	6	SCREW HHTT M8-1.2 X 16MM
25	1	BRACKET, ALTERNATOR MOUNTING
26	2.14'	TAPE ELEC. UL FOAM 1/8" X 1/2"
27	1	DUCT, ALTERNATOR AIR
28	1	GASKET, ALTERNATOR DUCT
29	2	NUT WING M6-1.0
30	1	STUD, M6-1.0 OFFSET
31	1	ELEMENT, AIR FILTER
32	1	PRECLEANER, AIR
33	1	WASHER FLAT .281" I.D. X 1.50" O.D.
34	1	WASHER LOCK M6-1/4"
35	1	MUFFLER
36	2	SCREW HHTT M6-1.0 X 12MM
37	2	BOLT CARR 5/16"-18 X 2"
38	2	NUT FLANG 5/16"-18 LOCK
39	1	GASKET, EXHAUST
41	1	SCREW HHC 5/16"-18 X 1-3/4"
42	1	FILTER GASKET RV
43	1	HOSE CLAMP 3/8"

# Section 9 Exploded Views

Control Panel, LP Units – Drawing No. 0F4591-A

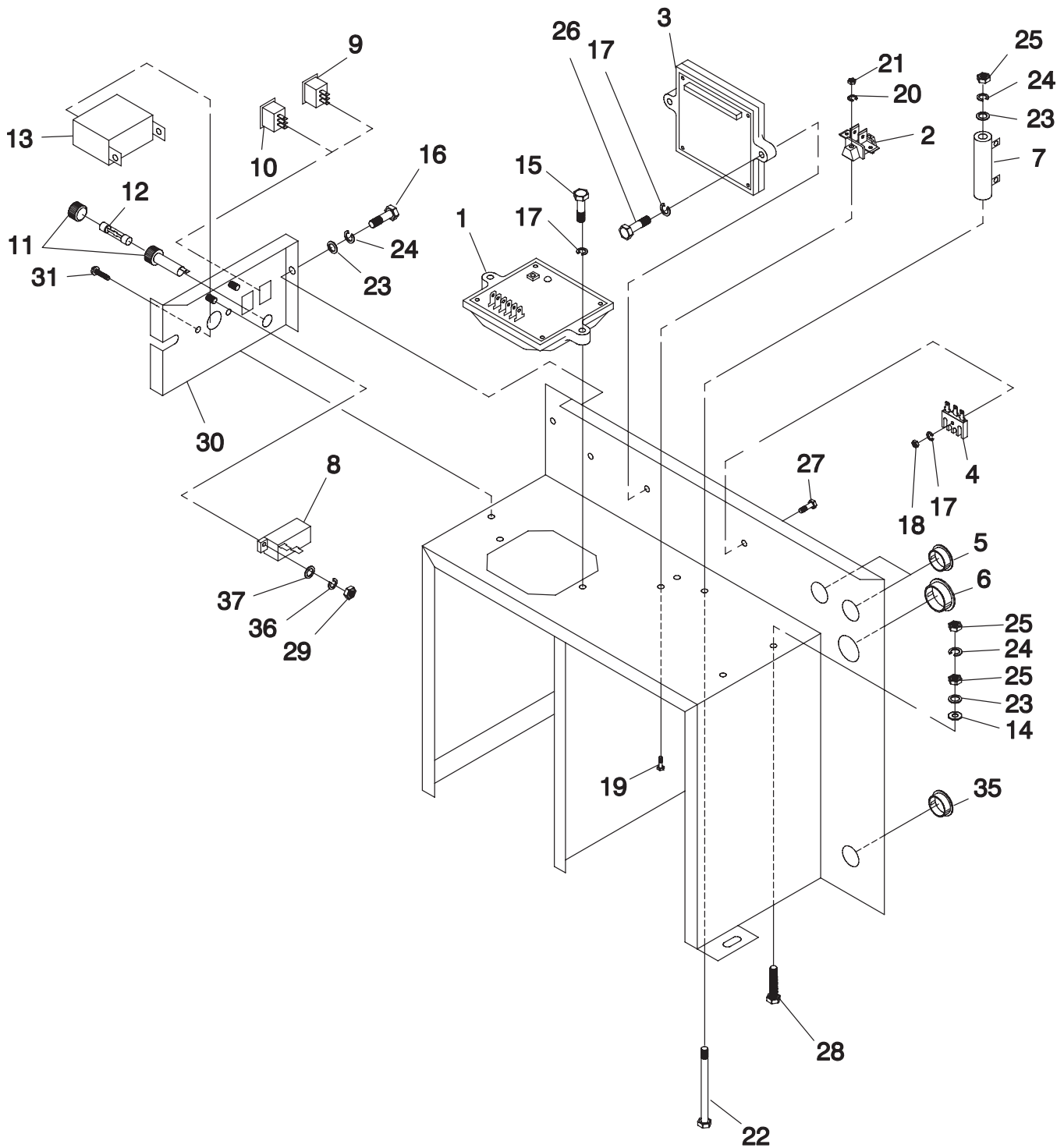

**Section 9**  
**Exploded Views**

ITEM	QTY.	DESCRIPTION
1	1	REGULATOR VOLTAGE
2	1	TERMINAL BLOCK
3	1	CONTROLLER P.C.B.
4	1	BATTERY CHARGER RECTIFIER
5	2	BUSHING SNAP 1"
6	1	BUSHING SNAP 1-1/4"
7	1	RESISTOR, 1 OHM 25W
8	1	CIRCUIT BREAKER 2.0 AMP (60HZ)
	1	CIRCUIT BREAKER 3.0 AMP (50HZ)
9	1	SWITCH S.P.D.T.
10	1	SWITCH S.P.D.T. ON-MOM-ON
11	1	HOLDER FUSE
12	1	FUSE 7.5A
13	1	CIRCUIT BREAKER, 30 X 1 (60HZ)
	1	CIRCUIT BREAKER, 15A 2 POLE (50HZ)
14	2	LOCK WASHER SPECIAL
15	2	SCREW HHC M5-0.8 X 30MM
16	2	SCREW HHC M6-1.0 X 16MM
17	5	WASHER LOCK M5
18	1	NUT HEX M5-0.8

ITEM	QTY.	DESCRIPTION
19	2	SCREW PPHM M4-0.7 X 16MM
20	2	WASHER LOCK #8-M4
21	4	NUT HEX M4-0.7
22	1	SCREW HHC M6-1.0 X 65MM
23	5	WASHER FLAT 1/4"
24	4	WASHER LOCK M6-1/4"
25	4	NUT HEX M6-1.0
26	2	SCREW HHC M5-0.8 X 25MM
27	1	SCREW HHC M5-0.8 X 16MM
28	2	SCREW HHC M6-1.0 X 30MM
29	2	NUT, HEX M3-0.5
30	1	PANEL CONTROL
31	2	SCREW RHM #6-32 X 1/4" SIMS
32	2	TIE WRAP UL 4" (NOT SHOWN)
33	1	DECAL (NOT SHOWN)
34	1	HARNESS (NOT SHOWN)
35	1	BUSHING, SNAP 1.09"
36	2	WASHER LOCK M3
37	2	WASHER FLAT M3

# Section 9 Exploded Views

GN-220 H/SH Engine, LP Units – Drawing No. 0F5791-G Page 1

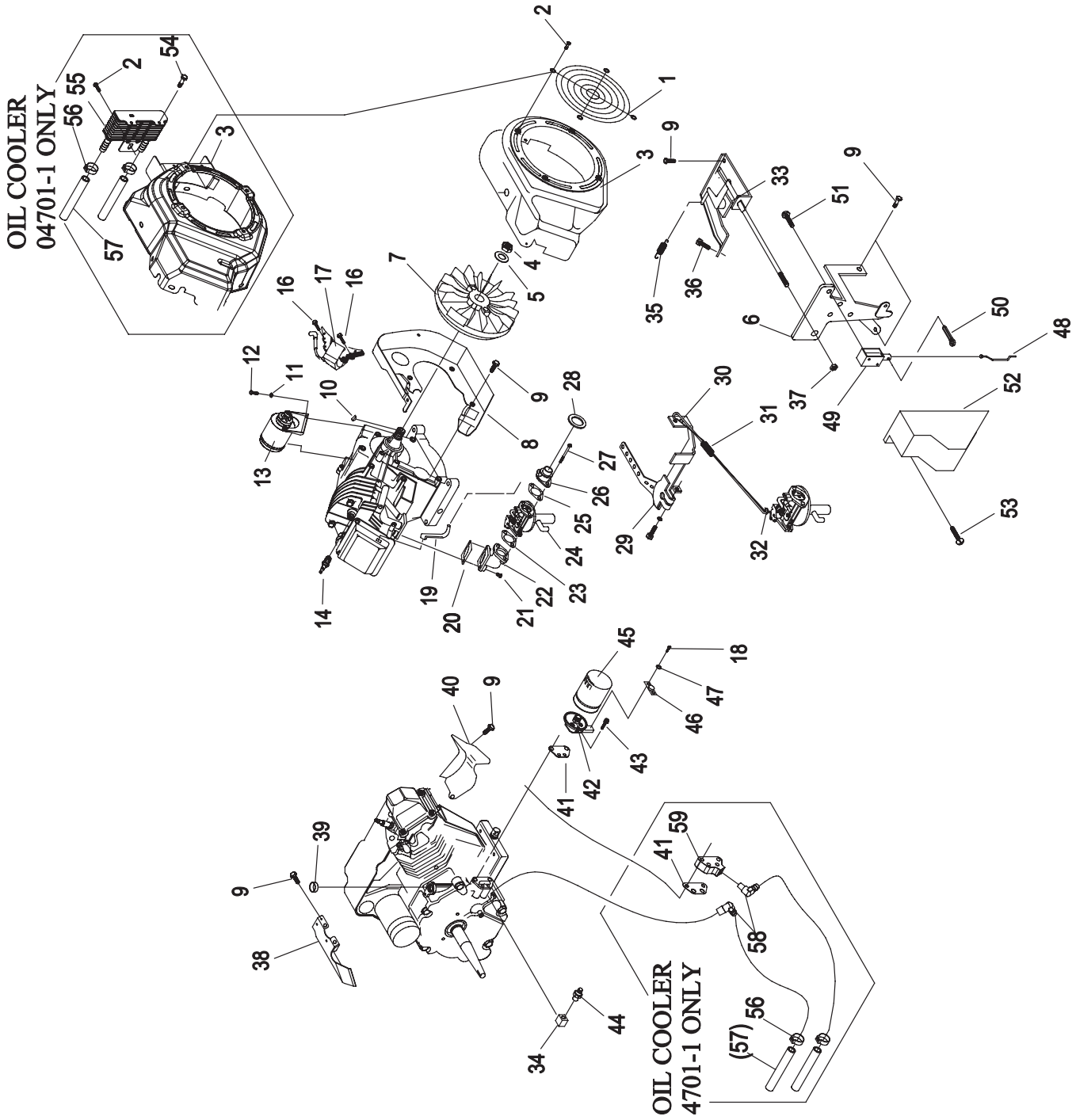



**Section 9**  
**Exploded Views**

ITEM	QTY.	DESCRIPTION
1	1	GUARD, FAN
2	10	SCREW, HHTT M6-1.0 X 8mm
	11	(04701-1 ONLY)
3	1	BLOWER HOUSING
	1	BLOWER HOUSING (04701-1 ONLY)
4	1	NUT, HEX M16-1.5
5	1	WASHER, M16 CONICAL
6	1	ASSY, CHOKE SOLENOID BRACKET
7	1	FLYWHEEL, WITH RING GEAR
8	1	BACKPLATE, ELECTRIC START
9	10	SCREW HHTT M6-1.0 X 10mm
10	1	KEY, WOODRUFF 4 x 19D
11	2	5/16"-M8 LOCK WASHER
12	2	SCREW SHC M8-1.25 X 40mm
13	1	STARTER ASSEMBLY
14	1	SPARKPLUG
15		
16	2	TAPTITE, M6-1.0 x 30mm
17	1	ASSY, IGNITION COIL ADV. W/DIODE
18	2	SCREW PPHM M3-0.5 X 8mm
19	1	BREATHER TUBE
20	1	GASKET, MANIFOLD/ HEAD
21	2	SCREW HHFC M6-1.0 X 30mm
22	1	INTAKE MANIFOLD
23	1	GASKET CARBURETOR/MANIFOLD
24	1	CARBURETOR LP WITH CHOKE NO IDLE PORT
25	1	GASKET, CARB/ ADAPTOR
26	1	ADAPTOR, CARB
27	2	BOLT, CARB MOUNT M6-1.0 x 75mm
28	1	GASKET, CARB TO AIRBOX
29	1	ASSEMBLY, GOVERNOR LEVER
30	1	ROD, GOVERNOR

ITEM	QTY.	DESCRIPTION
31	1	SPRING, ANTI LASH
32	1	WASHER, CARB WEAR
33	1	ASSY BRACKET GOVERNOR ADJUST
34	1	ELBOW 90D STREET 1/8NPT
35	1	SPRING, GOVERNOR
36	1	SCREW HHTT M8-1.2 x 16mm
37	1	NUT HEX LOCK M5-0.8 NYLOCK
38	1	TOP WRAPPER
39	1	PLUG, EXPANSION
40	1	LOWER WRAPPER
41	1	GASKET, OIL PSI PAD
	2	(04701-1 ONLY)
42	1	ADAPTER, OIL FILTER
43	2	SCREW SHC M6-1.0 X 22mm
	2	SCREW SHC M6-1.0 X 35MM G12.9 (04701-1 ONLY)
44	1	SWITCH, OIL- 5 PSI
45	1	FILTER, OIL
46	1	THERMAL SWITCH 305F
47	2	WASHER LOCK M3
48	1	ROD, CHOKE CONTROL
49	1	SOLENOID, CHOKE
50	1	PIN, COTTER
51	2	SCREW PRHMS #4-40 x 1-1/8" LONG
52	1	COVER, CHOKE COIL
53	2	SCREW TAP-R #10-32 X 9/16"
54	2	SCREW HHTT M4-0.7 X 8 BP
55	1	OIL COOLER 220
56	4	CLAMP, HOSE OETIKER STEPLESS 17
57	2	HOSE 3/8" X 16.25" BRAID-WRAP
58	2	BARBED EL 90 1/8 NPT X 3/8
59	1	OIL FILTER SPACER 220RV

# Section 9 Exploded Views

GN-220 H/SH Engine, LP Units – Drawing No. 0F5791-G Page 2

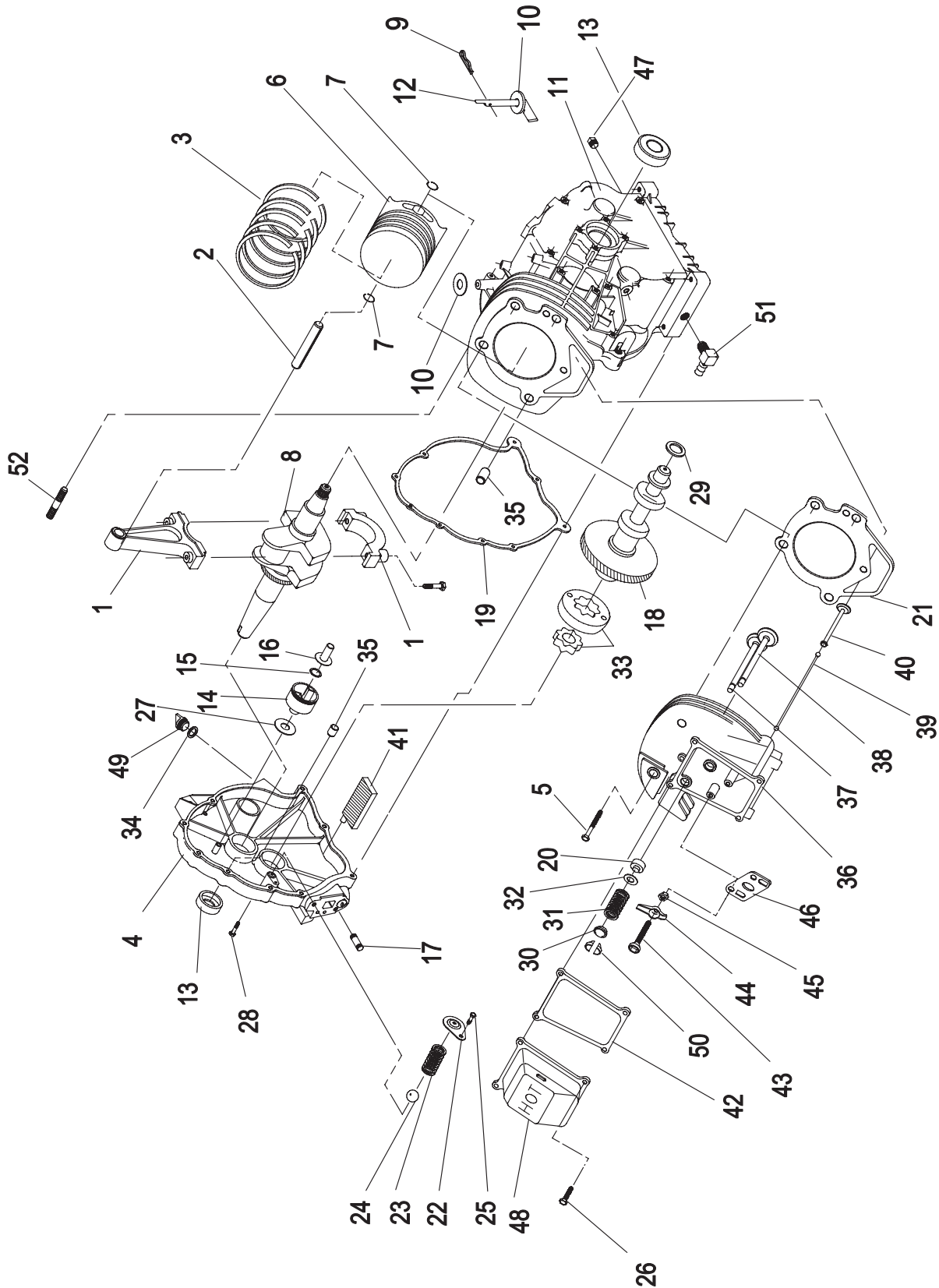

**Section 9**  
**Exploded Views**

ITEM	QTY.	DESCRIPTION
1	1	CONNECTING ROD ASSEMBLY
2	1	PISTON PIN
3	1	RING SET, PISTON DIA 75
4	1	GEAR COVER ASSEMBLY
5	5	M8 x 56mm HEAD BOLT
6	1	PISTON, COATED DIA 75
7	2	PIN RETAINER RING
8	1	ASSY, CRANKSHAFT GH220 TAPER
9	1	GOVERNOR "R" PIN
10	2	WASHER FLAT 1/4, .015 THK
11	1	CRANKCASE ASSEMBLY
12	1	GOVERNOR ARM
13	2	OIL SEAL
14	1	GOVERNOR GEAR ASSEMBLY
15	1	GOVERNOR GEAR C-RING
16	1	GOVERNOR SPOOL
17	1	1/8" NPT PIPE PLUG
18	1	CAMSHAFT ASSEMBLY
19	1	CRANKCASE GASKET
20	1	VALVE STEM SEAL
21	1	CYLINDER HEAD GASKET
22	1	OIL PRESSURE RELIEF COVER
23	1	OIL PRESSURE SPRING
24	1	11/32" BALL
25	1	M5 FORM SCREW
26	4	M6-1.0 x 12mm SCREW

ITEM	QTY.	DESCRIPTION
27	1	GOVERNOR GEAR THRUST WASHER
28	6	SCREW, HHFC M8-1.25 X 35mm
29	1	SPRING WASHER
30	2	VALVE RETAINER
31	2	VALVE SPRING
32	2	VALVE SPRING WEAR WASHER
33	1	GEROTER SET
34	1	"O" RING
35	4	SLEEVE, SEAM DWL
36	1	CYLINDER HEAD ASSEMBLY
37	1	EXHAUST VALVE
38	1	INTAKE VALVE
39	2	PUSH ROD
40	2	TAPPET
41	1	OIL PICK-UP ASSEMBLY
42	1	ROCKER COVER GASKET
43	2	PIVOT BALL STUD
44	2	GN- 191/220 ROCKER ARM
45	2	ROCKER ARM JAM NUT
46	1	PUSH ROD GUIDE PLATE
47	1	1/4" NPT PIPE PLUG
48	1	ROCKER COVER ASSEMBLY
49	1	PLASTIC OIL FILL PLUG
50	4	VALVE SPRING KEEPER
51	1	BARBED ELBOW 90 1/4" NPT X 3/8"
52	1	STUD M8-1.25 / 10mm X 30mm

# Section 9 Exploded Views

Gas Regulator Assembly, LP Units – Drawing No. 0F5819

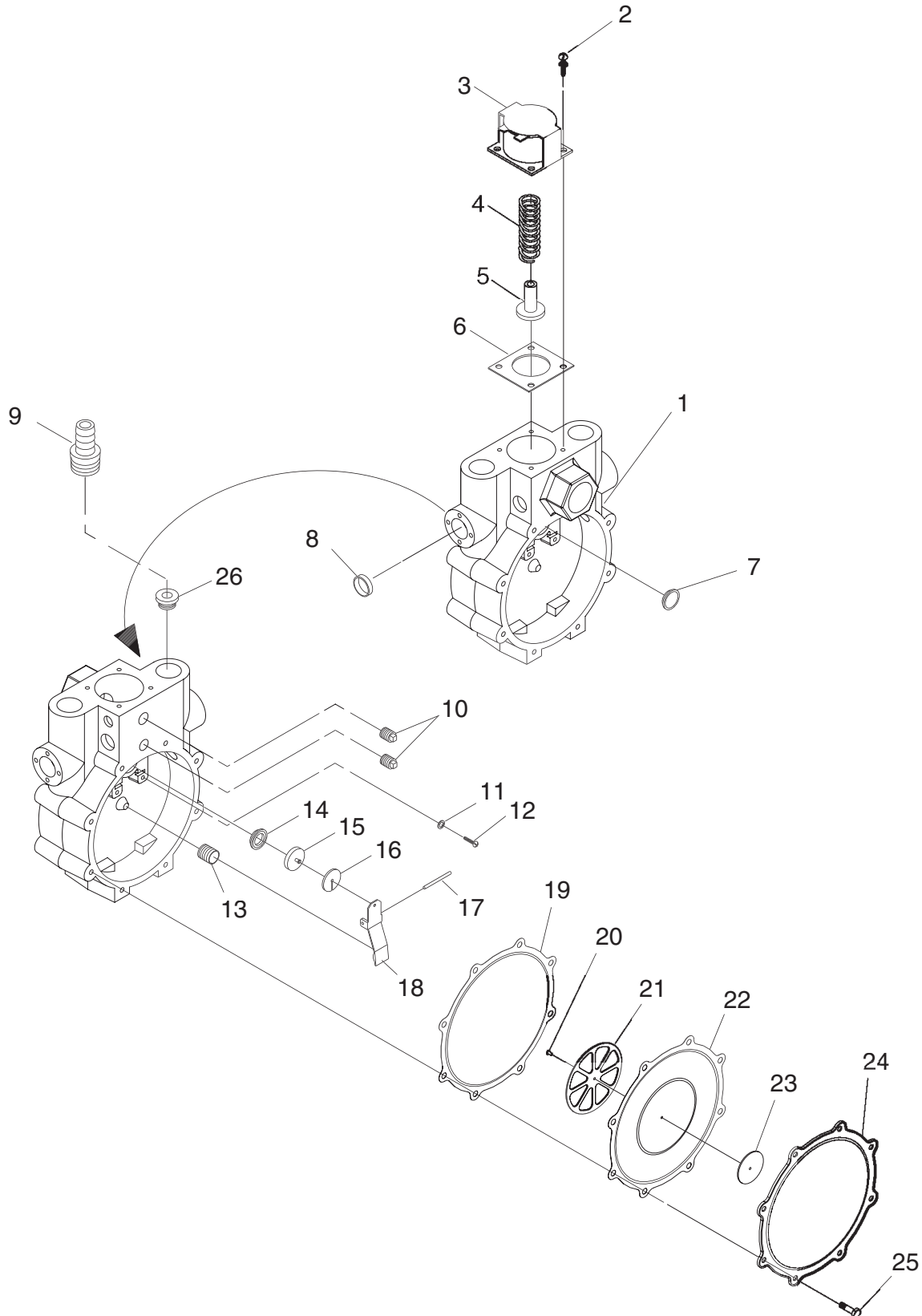

**Section 9**  
**Exploded Views**

<b>ITEM</b>	<b>QTY.</b>	<b>DESCRIPTION</b>
1	1	CASTING, TWIN REGULATOR HOUSING
2	4	SCREW PPHM SEMS M4-0.7 X 10
3	1	SOLENOID COIL, 12VDC
4	1	SPRING-SOLENOID PLUNGER
5	1	PLUNGER LP REG. ASSY
6	1	GASKET, SOLENOID
7	1	INLET, TWIN REGULATOR NO HOLE
8	1	PLUG, EXPANSION 16MM TWINREG
9	1	BARBED STR 1/2NPT X 3/8" W/VS
10	2	PLUG STD PIPE 1/8 STEEL SQ HD
11	2	WASHER FLAT 3.2MM ID X 10MM OD
12	2	SCREW PFILHM M3-0.5 X 5
13	1	SPRING, REGULATOR
14	1	INLET, TWIN REG 11.11 DIA.
15	1	SEAL, INLET REGULATOR
16	1	SUPPORT, INLET SEAL
17	1	PIN, PIVOT ARM
18	1	LEVER, REGULATOR
19	1	GASKET, DIAPHRAGM
20	1	RIVET .118 X .125 ALUMINUM
21	1	SUPPORT, DIAPHRAGM
22	1	DIAPHRAGM, TWIN REGULATOR
23	1	CAP, DIAPHRAGM SUPPORT
24	1	COVER, TWIN REGULATOR
25	8	SCREW HHTT M4-0.7 X 8 BP
26	1	JET LP

# Section 9 Exploded Views

Enclosure, Gasline Units – Drawing No. 0D8352-M

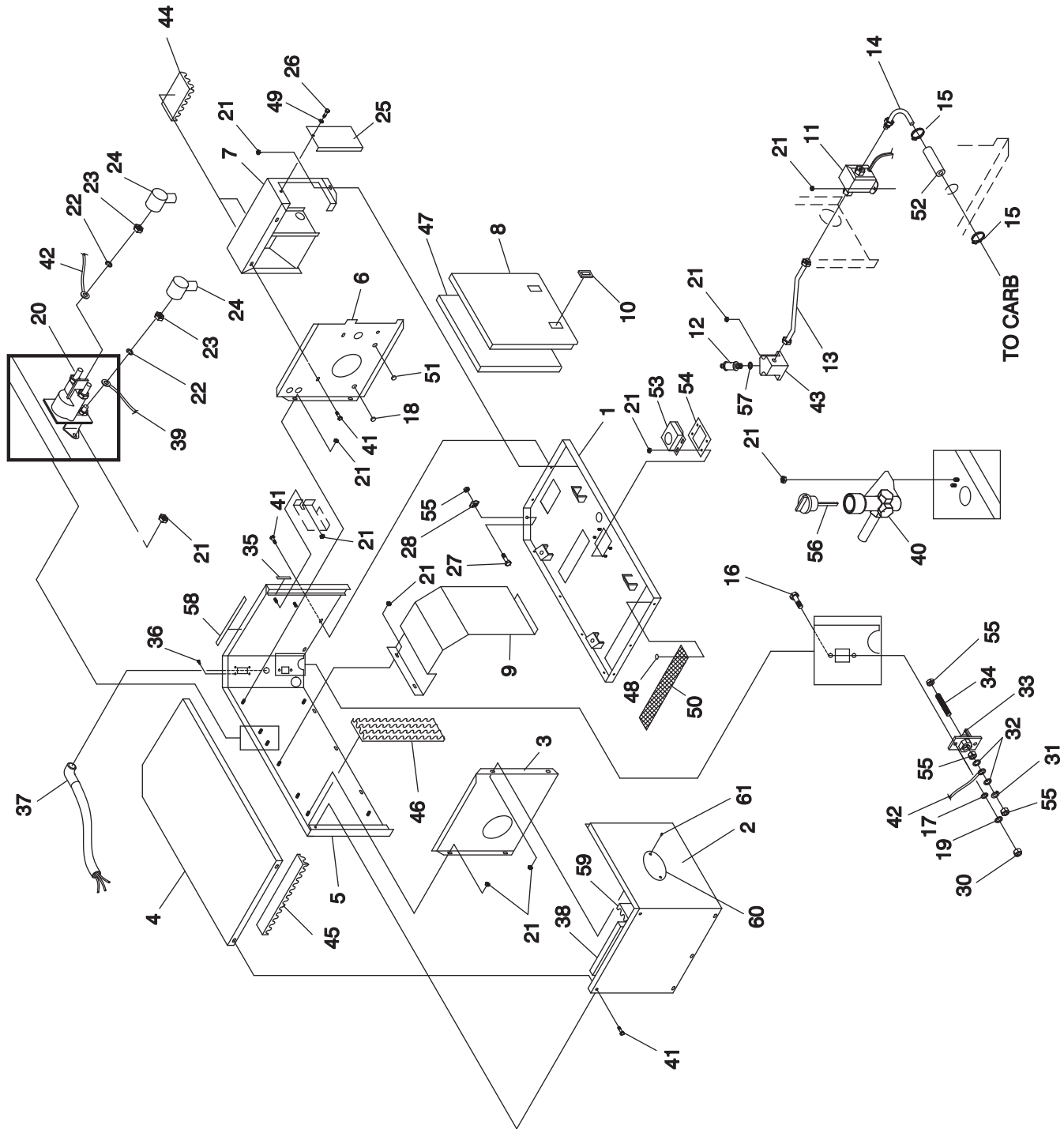

**Section 9**  
**Exploded Views**

ITEM	QTY.	DESCRIPTION
1	1	TRAY, ENCLOSURE
2	1	PANEL, ENCLOSURE SIDE
3	1	PANEL, REAR DIVIDER
4	1	PANEL, ENCLOSURE ROOF
5	1	PANEL, ENCLOSURE BACK
6	1	PANEL, FRONT DIVIDER
7	1	COMPARTMENT, AIR INTAKE
8	1	PANEL, ENCLOSURE DOOR
9	1	SHIELD, MUFFLER
10	2	SLIDE LATCH, FLUSH
11	1	PUMP, FUEL
12	1	FILTER, FUEL
13	1	FUEL LINE, FILTER TO PUMP
14	1	FUEL LINE, PUMP TO CARB
15	2	CLAMP,HOSE WORM GEAR
16	2	SCREW HHC M6-1.0 X 16
17	2	WASHER FLAT ¼"
18	1	BUSHING, 1.09" SNAP
19	2	WASHER LOCK M6-1/4"
20	1	CONTACTOR, STARTER
21	24	NUT FLANGE M6-1.0 NYLOK
22	2	WASHER LOCK M8-5/16"
23	2	NUT HEX 5/16"-18
24	2	BOOT BATTERY CABLE
25	1	PANEL AIR BOX COVER
26	1	SCREW, M6-1.00 X 20MM WING
27	1	BOLT CARR 3/8"-16 X 1"
28	1	3/8" SPECIAL L/WASHER
30	2	NUT HEX M6 X 1.0
31	1	WASHER LOCK 3/8"
32	2	WASHER FLAT 3/8-M10"
33	1	BLOCK, TERMINAL BATTERY POST

ITEM	QTY.	DESCRIPTION
34	1	STUD 3/8"-16 X 2"-1/4" BRASS
35	2.1'	TAPE FOAM 1/8" X ½"
36	4	SCREW HHTT M5-0.8 X 10
37	1	CUSTOMER CONNECTION HARNESS
38	1	FOAM, AIR OUT COMPARTMENT SIDE
39	1	CABLE, STARTER
40	1	ASSEMBLY OIL DRAIN
41	18	SCREW SWT 1/4-20 X 5/8 W/W
42	1	CABLE, BATTERY CONNECTION
43	1	MOUNT, FUEL FILTER SUPPORT
44	2	FOAM, AIR INTAKE COMPARTMENT
45	1	FOAM, ROOF AIR OUT COMPARTMENT
46	1	FOAM, BACK COMPARTMENT
47	1	FOAM, DOOR PANEL
48	4	WASHER SELF LOCKING 1"
49	1	WASHER NYLON .250"
50	1	HARDWARE CLOTH COMPARTMENT AIR OUT
51	1	BUSHING, 0.50" SNAP
52	8.5"	HOSE, 1/4" ID
53	1	BOX, MUFFLER TAIL PIPE
54	1	GASKET, MUFFLER TAIL PIPE BOX
55	4	NUT HEX JAM 3/8"-16 BRASS
56	1	ASSEMBLY, CAP & DIPSTICK
57	1	FILTER GASKET
58	8.75'	FOAM TAPE 1/16" X ½"
59	1	FOAM, FRONT AIR OUT COMPARTMENT
60	1	LOGO. QP
61	2	RIVET, POP

# Section 9 Exploded Views

Generator, Gasoline Units – Drawing No. 0D8353-M

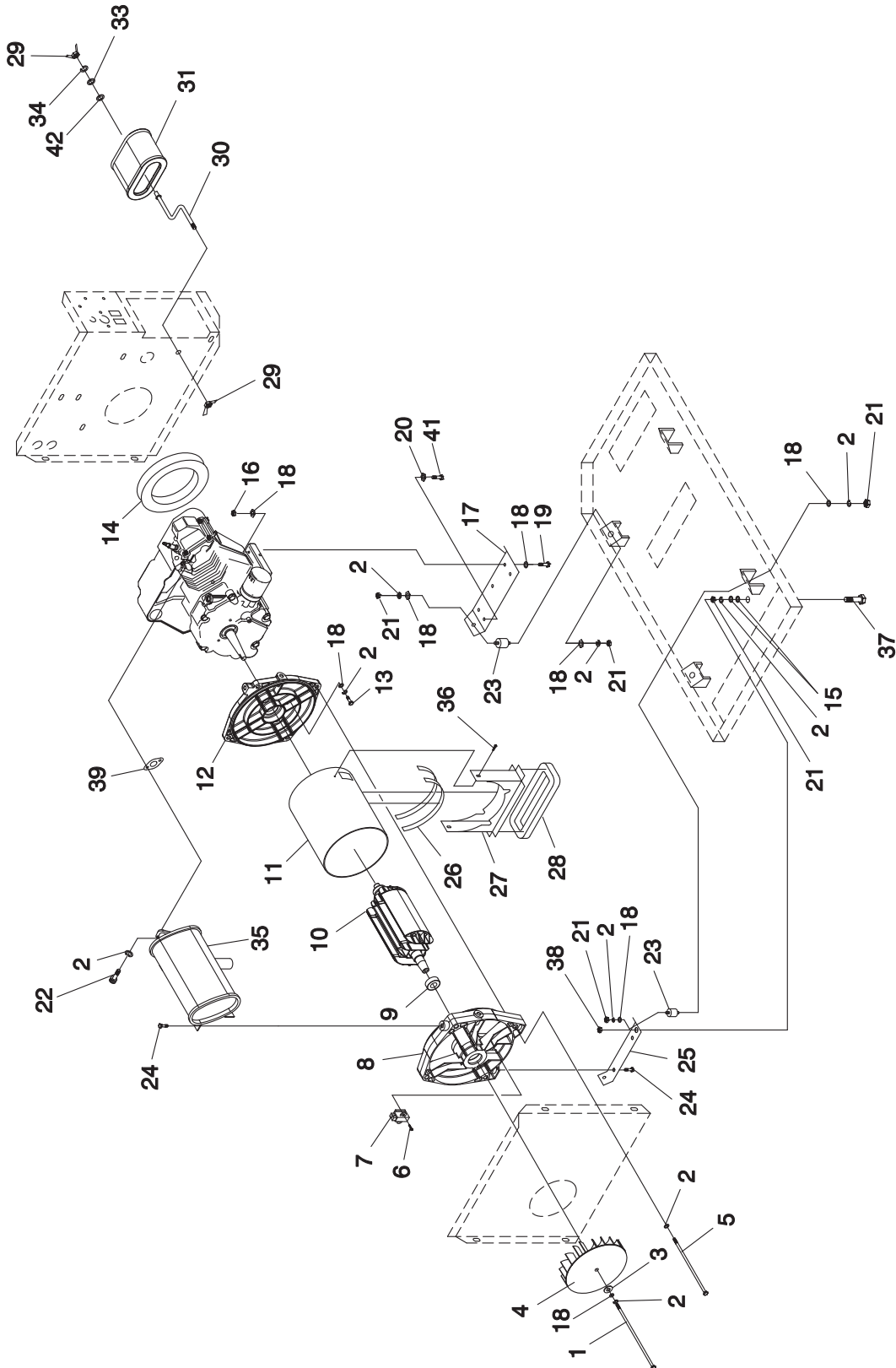



**Section 9**  
**Exploded Views**

ITEM	QTY.	DESCRIPTION
1	1	SCREW IHHC 5/16"-24 X 11-1/4" G5
2	22	WASHER LOCK M8-5/16"
3	1	WASHER FLAT .406" I.D. X 1.62" O.D.
4	1	FAN, 8" CURVE BLADE, 16.5MM I.D.
5	4	SCREW IHHC M8-1.25 X 260MM
6	2	SCREW HHTT M5-0.8 X 16
7	1	ASSEMBLY, BRUSH HOLDER
8	1	CARRIER, REAR BEARING
9	1	BEARING
10	1	ROTOR
11	1	STATOR
12	1	ADAPTOR, ENGINE
13	4	SCREW HHC 5/16"-24 X 3/4"
14	1	GASKET, FRONT DIVIDER
15	4	WASHER FLAT 3/8"-M10
16	4	NUT LOCK HEX 5/16"-18 NYLON INSERT
17	1	BRACKET, ENGINE MOUNTING
18	18	WASHER FLAT 5/16"
19	3	SCREW HHC 5/16"-18 X 1-1/2"
20	1	5/16" SPECIAL LOCK WASHER

ITEM	QTY.	DESCRIPTION
21	10	NUT HEX 5/16"-18
22	2	SCREW SHC M8-1.25 X 18MM
23	4	VIBRATION MOUNT
24	6	SCREW HHTT M8-1.2 X 16MM
25	1	BRACKET, ALTERNATOR MOUNTING
26	2.14'	TAPE ELEC. UL FOAM 1/8" X 1/2"
27	1	DUCT, ALTERNATOR AIR
28	1	GASKET, ALTERNATOR DUCT
29	2	NUT WING M6-1.0
30	1	STUD, M6-1.0 OFFSET
31	1	ELEMENT, AIR FILTER
32		
33	1	WASHER FLAT .281" I.D. X 1.50" O.D.
34	1	WASHER LOCK M6-1/4"
35	1	MUFFLER W/ CATALYST
36	2	SCREW HHTT M6-1.0 X 12MM
37	2	BOLT CARR 5/16"-18 X 2"
38	2	NUT FLANG 5/16"-18 LOCK
39	1	GASKET, EXHAUST
41	1	SCREW HHC 5/16"-18 X 1-3/4"
42	1	FILTER GASKET RV

# Section 9 Exploded Views

Control Panel, Gasoline Units – Drawing No. 0D8354-M

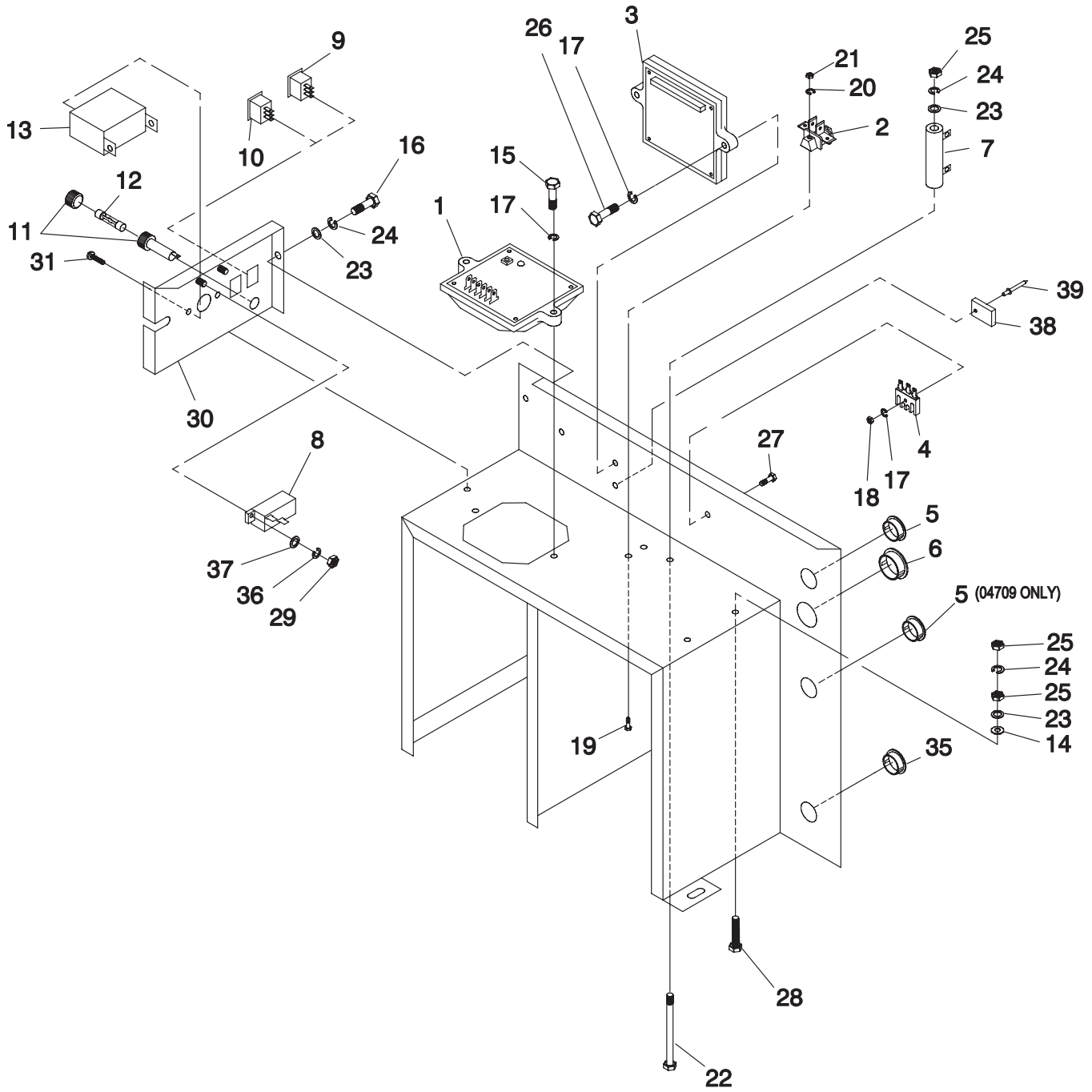

**Section 9**  
**Exploded Views**

ITEM	QTY.	DESCRIPTION
1	1	REGULATOR VOLTAGE
2	1	TERMINAL BLOCK
3	1	CONTROLLER P.C.B.
4	1	BATTERY CHARGER RECTIFIER
5	1	BUSHING SNAP 1"
	2	BUSHING SNAP 1" (04709 ONLY)
6	1	BUSHING SNAP 1-1/4"
7	1	RESISTOR, 1 OHM 25W
8	1	CIRCUIT BREAKER 2.0 Amp (60Hz)
	1	CIRCUIT BREAKER 3.0 Amp (50Hz)
9	1	SWITCH S.P.D.T.
10	1	SWITCH S.P.D.T. ON-MOM-ON
11	1	HOLDER FUSE
12	1	FUSE 7.5A
13	1	CIRCUIT BREAKER, 30 X 1 (60HZ)
	1	CIRCUIT BREAKER, 15A 2 POLE (50HZ)
14	2	LOCK WASHER SPECIAL
15	2	SCREW HHC M5-0.8 x 30mm
16	2	SCREW HHC M6-1.0 X 16mm
17	5	WASHER LOCK M5
18	1	NUT HEX M5-0.8

ITEM	QTY.	DESCRIPTION
19	2	SCREW PPHM M4-0.7 x 16mm
20	2	WASHER LOCK #8-M4
21	4	NUT HEX M4-0.7
22	1	SCREW HHC M6-1.0 x 65mm
23	5	WASHER FLAT 1/4"
24	4	WASHER LOCK M6-1/4"
25	4	NUT HEX M6-1.0
26	2	SCREW HHC M5-0.8 X 25mm
27	1	SCREW HHC M5-0.8 X 16mm
28	2	SCREW HHC M6-1.0 X 30mm
29	2	NUT, HEX M3-0.5
30	1	PANEL CONTROL
31	2	SCREW RHM #6-32 X 1/4" SIMS
32	2	TIE WRAP UL 4" (NOT SHOWN)
33	1	DECAL (NOT SHOWN)
34	1	HARNESS (NOT SHOWN)
35	1	BUSHING, SNAP 1.09"
36	2	WASHER LOCK M3
37	2	WASHER FLAT M3
38	1	DEUTSCH, MOUNTING CLIP
39	1	RIVET POP 0.125" LARGE FLANGE

# Section 9 Exploded Views

GN-220 H/SH Engine, Gasoline Units – Drawing No. 0D8355-AD Page 1 of 2

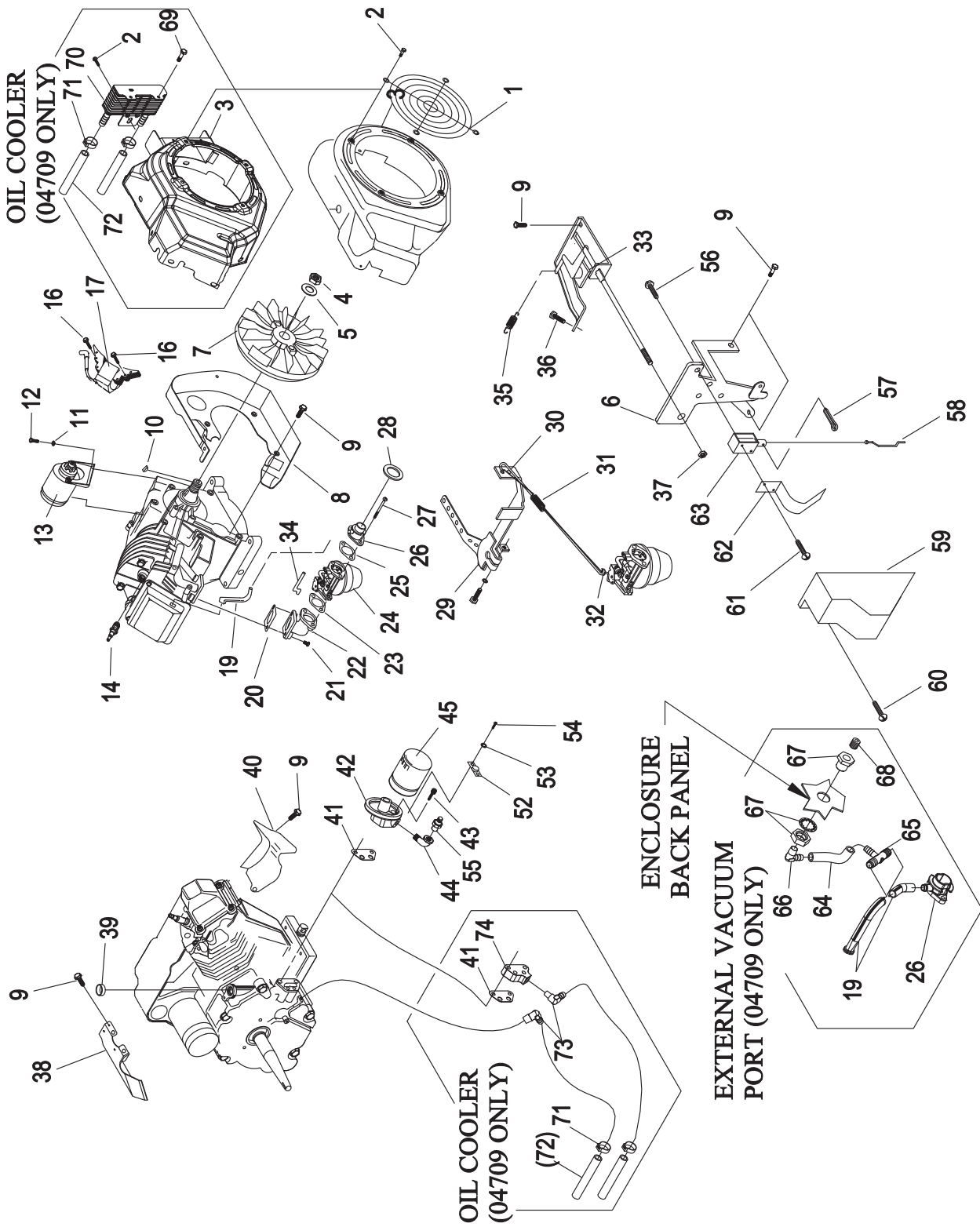

**Section 9**  
**Exploded Views**

ITEM	QTY.	DESCRIPTION
1	1	GUARD, FAN
2	11	SCREW, HHTT M6-1.0 X 8MM
3	1	BLOWER HOUSING
4	1	NUT, HEX M16-1.5
5	1	WASHER, M16 CONICAL
6	1	ASSY CHOKE SOLENOID BRACKET
7	1	FLYWHEEL, WITH RING GEAR
8	1	BACKPLATE, ELECTRIC START
9	9	SCREW HHTT M6-1.0 X 10MM
10	1	KEY, WOODRUFF 4 X 19D
11	2	5/16"-M8 LOCK WASHER
12	2	SCREW SHC M8-1.25 X 40MM
13	1	ASSY, STARTER
14	1	SPARK PLUG, CHAMPION RC14YC
15		
16	2	TAPTITE, M6-1.0 X 25 ZINC
17	1	ASSY, IGNITION COIL ADV. W/DIODE
19	1	BREATHER TUBE
20	1	GASKET, MANIFOLD/ HEAD
21	2	SCREW HHFC M6-1.0 X 30MM
22	1	INTAKE MANIFOLD
23	1	GASKET CARBURETOR/MANIFOLD
24	1	CARBURETOR
25	1	GASKET, CARB/ ADAPTOR
26	1	ADAPTOR, CARB
27	2	BOLT, CARB MOUNT M6-1.0 X 75MM
28	1	GASKET, CARB TO AIRBOX
29	1	ASSEMBLY, GOVERNOR LEVER
30	1	ROD, GOVERNOR
31	1	SPRING, ANTI LASH
32	1	WASHER, CARB WEAR
33	1	ASSY BRACKET GOVERNOR ADJUST
34	1	ROD, CHOKE LINKAGE
35	1	SPRING, GOVERNOR

ITEM	QTY.	DESCRIPTION
36	1	SCREW, HHTT 5/16" X 1/2" SEMI-GIMLET
37	1	NUT, M5-0.8 LOCK
38	1	TOP WRAPPER
39	1	PLUG, EXPANSION
40	1	LOWER WRAPPER
41	2	GASKET, OIL PSI PAD
42	1	ADAPTER, OIL FILTER
43	2	SCREW SHC M6-1.0 X 20MM G12.9
44	1	SWITCH, OIL- 5 PSI
45	1	FILTER, OIL
52	1	SWITCH, THERMAL 305F
53	2	WASHER LOCK M3
54	2	SCREW PPHM M3-0.5 X 6MM
55	1	ELBOW 90D STREET 1/8NPT
56	2	RHMS #4-40 X 5/16" SEMS
57	1	COTTER PIN
58	1	ROD, CHOKE CONTROL
59	1	BOOT CHOKE SOLENOID PLASTIC
60	2	SCREW TAP-R #10-32 X 9/16"
61	2	RHMS #4-40 X 1/4" SEMS
62	1	ASSEMBLY, BI-METAL/HEATER
63	1	SOLENOID, CHOKE
64	21"	FUEL HOSE 3/8 LO-PERM
65	1	BARBED TEE 1/2X3/8X1/2
66	1	BARBED EL 90 1/4NPT X 3/8
67	1	BULKHEAD ADAPTOR FITTING
68	1	PLUG STD PIPE 1/4 COUNTERSUNK
69	2	SCREW HHTT M4-0.7 X 8 BP
70	1	OIL COOLER 220
71	4	CLAMP,HOSE OETIKER STEPLESS 17
72	2	HOSE 3/8" X 16.25" BRAID-WRAP
73	2	BARBED EL 90 1/8NPT X 3/8
74	1	OIL FILTER SPACER 220RV

# Section 9 Exploded Views

GN-220 H/SH Engine, Gasoline Units – Drawing No. 0D8355-AD Page 2 of 2

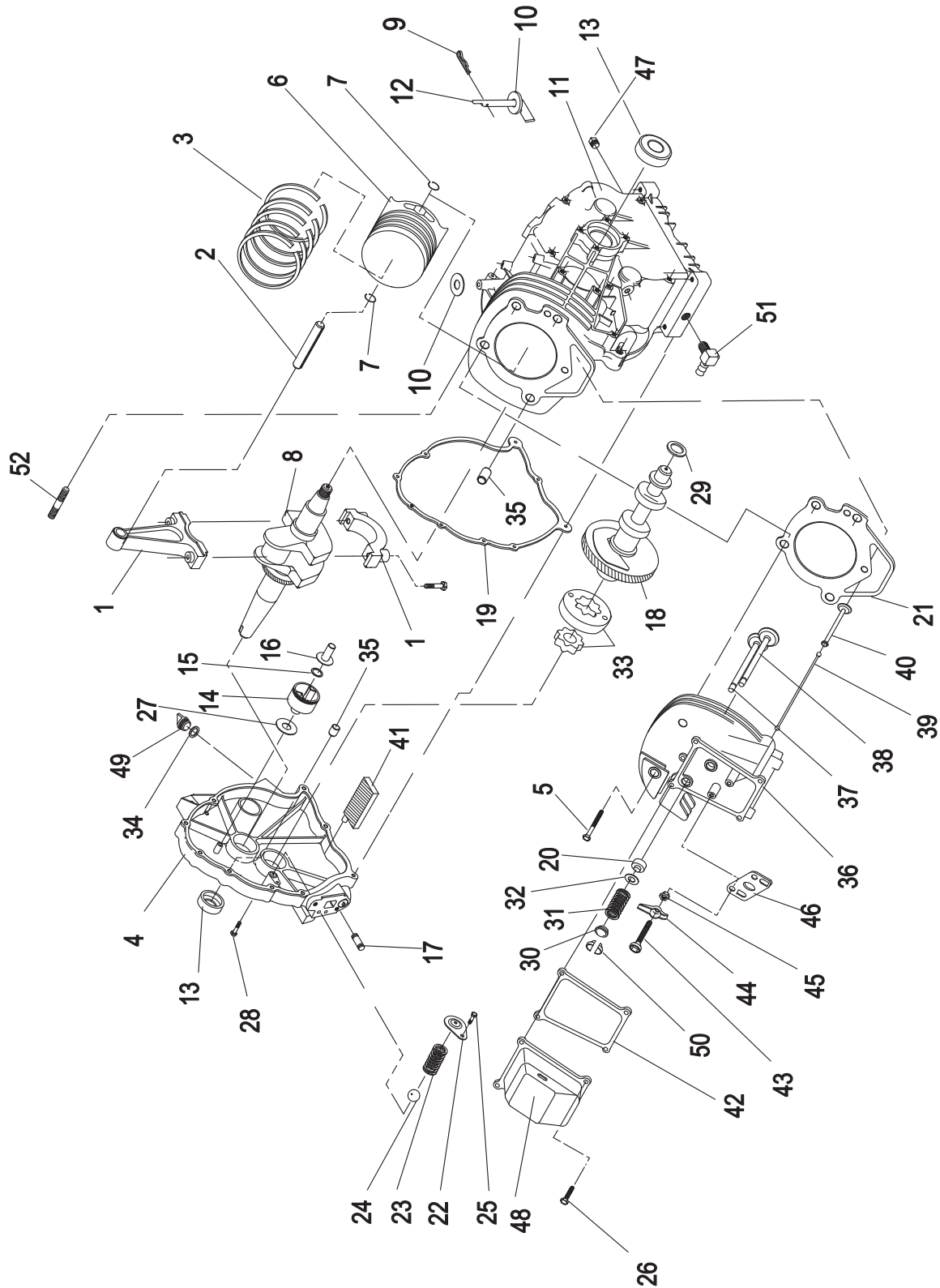

**Section 9**  
**Exploded Views**

ITEM	QTY.	DESCRIPTION
1	1	CONNECTING ROD ASSEMBLY
2	1	PISTON PIN
3	1	PISTON RING SET DIA 75
4	1	GEAR COVER ASSEMBLY
5	5	M8 X 56MM HEAD BOLT
6	1	PISTON, COATED DIA 75
7	2	PIN RETAINER RING
8	1	ASSY, CRANKSHAFT GH220 TAPER
9	1	GOVERNOR "R" PIN
10	2	WASHER FLAT 1/4, .015 THK
11	1	CRANKCASE ASSEMBLY
12	1	GOVERNOR ARM
13	2	OIL SEAL
14	1	GOVERNOR GEAR ASSEMBLY
15	1	GOVERNOR GEAR C-RING
16	1	GOVERNOR SPOOL
17	1	1/8" NPT PIPE PLUG
18	1	CAMSHAFT ASSEMBLY
19	1	CRANKCASE GASKET
20	1	VALVE STEM SEAL
21	1	CYLINDER HEAD GASKET
22	1	OIL PRESSURE RELIEF COVER
23	1	OIL PRESSURE SPRING
24	1	11/32" BALL
25	1	M5 FORM SCREW
26	4	M6-1.0 X 12MM SCREW

ITEM	QTY.	DESCRIPTION
27	1	GOVERNOR GEAR THRUST WASHER
28	6	SCREW, HHFC M8-1.25 X 35MM
29	1	SPRING WASHER
30	2	VALVE RETAINER
31	2	VALVE SPRING
32	2	VALVE SPRING WEAR WASHER
33	1	GEROTER SET
34	1	"O" RING
35	4	SLEEVE, SEAM DWL
36	1	CYLINDER HEAD ASSEMBLY
37	1	EXHAUST VALVE
38	1	INTAKE VALVE
39	2	PUSH ROD
40	2	TAPPET
41	1	OIL PICK-UP ASSEMBLY
42	1	ROCKER COVER GASKET
43	2	PIVOT BALL STUD
44	2	GN- 191/220 ROCKER ARM
45	2	ROCKER ARM JAM NUT
46	1	PUSH ROD GUIDE PLATE
47	1	1/4" NPT PIPE PLUG
48	1	ROCKER COVER ASSEMBLY
49	1	PLASTIC OIL FILL PLUG
50	4	VALVE SPRING KEEPER
51	1	BARBED ELBOW 90 1/4" NPT X 3/8"
52	1	STUD M8-1.25 / 10MM X 30MM

# Section 10 SPECIFICATIONS & CHARTS

## Major Features and Dimensions (Gasoline Units)– Drawing No. 0D8716 Rev. G

VIEW FROM TOP

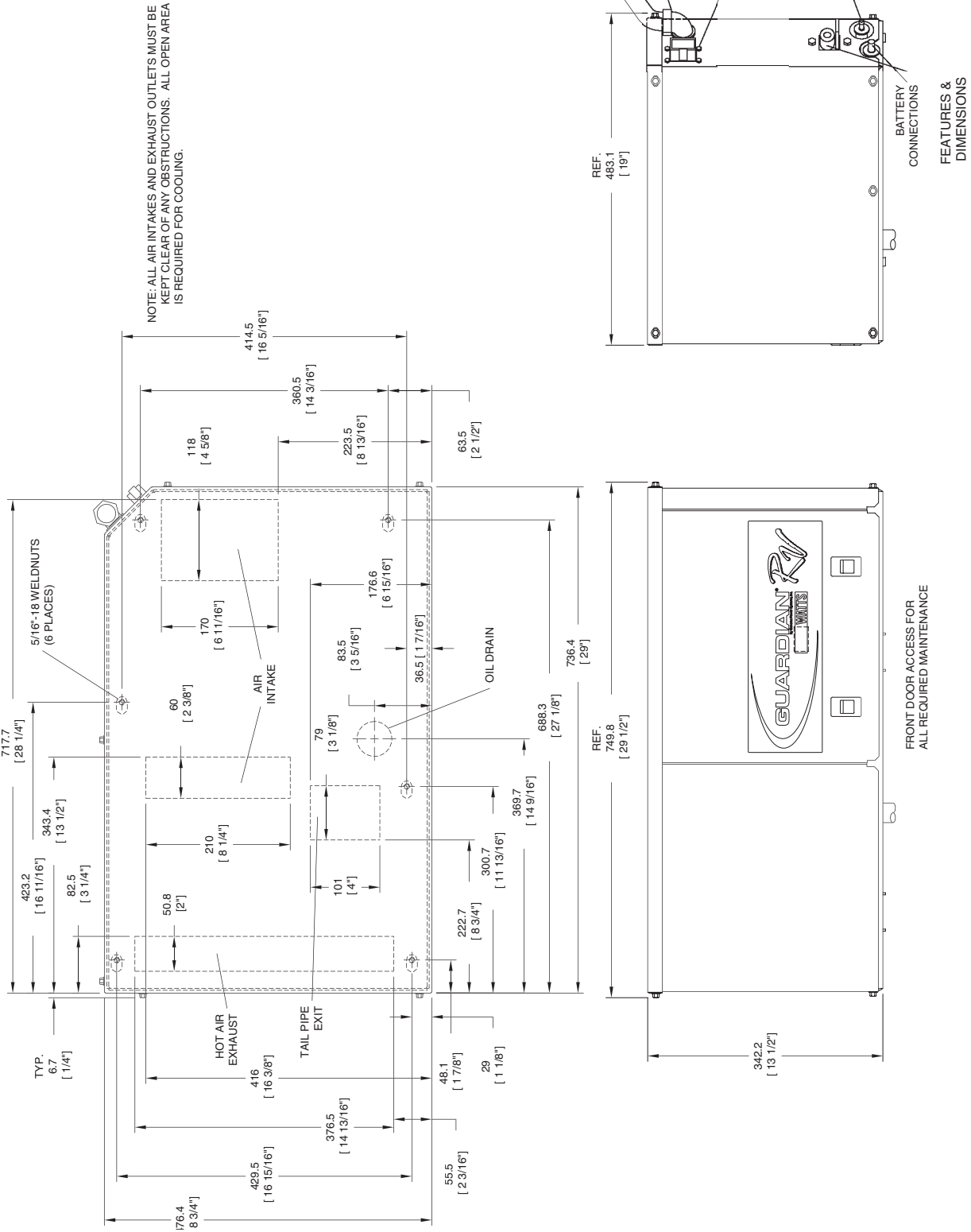



Major Features and Dimensions (LP Units) – Drawing No. 0F4610

VIEW FROM TOP

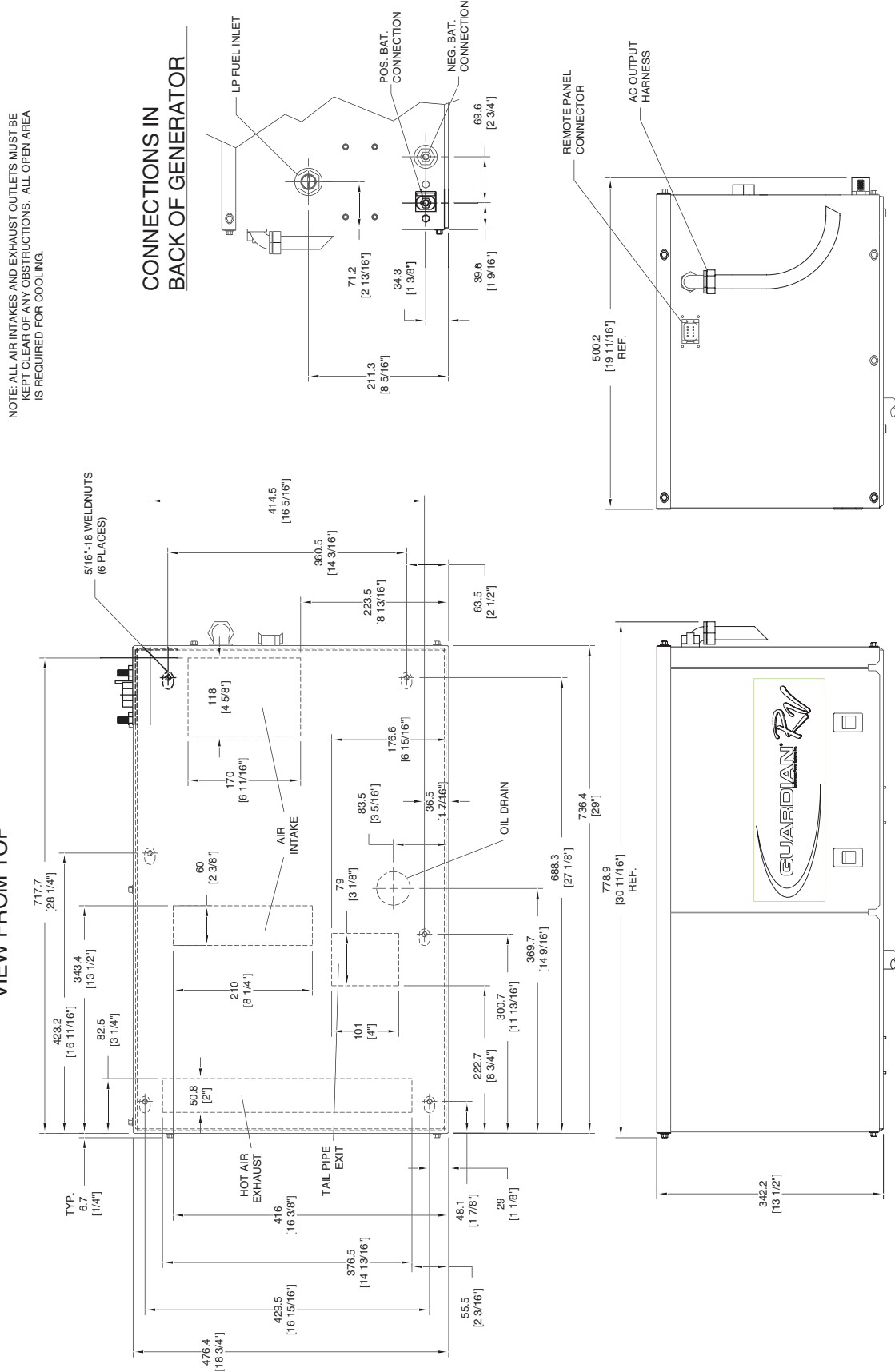

NOTE: ALL AIR INTAKES AND EXHAUST OUTLETS MUST BE KEPT CLEAR OF ANY OBSTRUCTIONS. ALL OPEN AREA IS REQUIRED FOR COOLING.

FEATURES & DIMENSIONS

# Section 10 SPECIFICATIONS & CHARTS

## Compartment Floor Cutout – Drawing No. 0G3723-A

VIEW FROM TOP

DIMENSIONS ARE IN MM [ INCHES ]

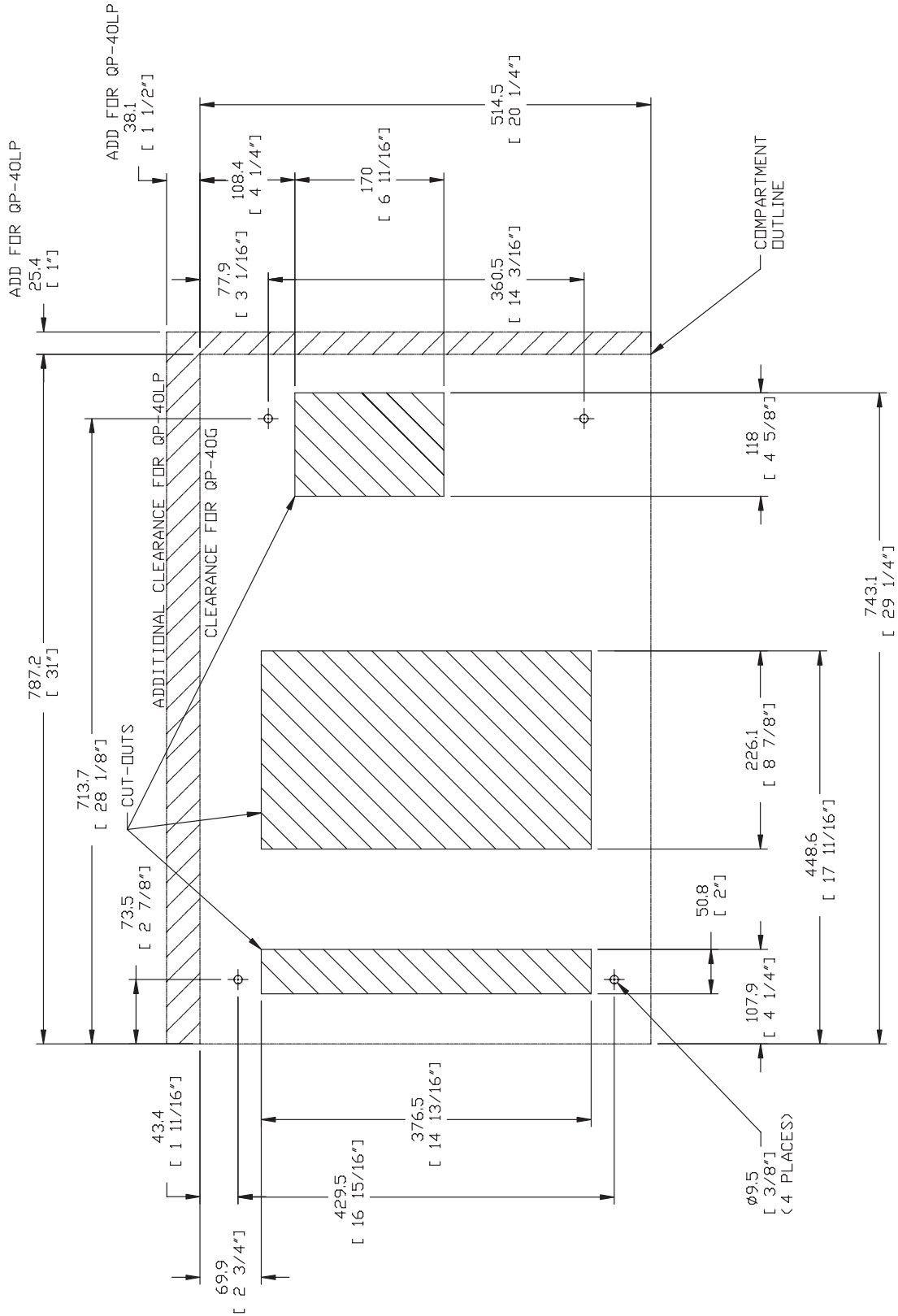

CONTACT GUARDIAN RV SALES:  
RVtemplates@generac.com  
FOR A FULL SIZE  
INSTALLATION TEMPLATE

NOTE: ALL AIR INTAKES AND EXHAUST OUTLETS MUST BE  
KEPT CLEAR OF ANY OBSTRUCTIONS. ALL OPEN AREA  
IS REQUIRED FOR COOLING.



**Section 10**  
**SPECIFICATIONS & CHARTS**

**GENERATOR SPECIFICATIONS**

TYPE	QUIETPACT 40 G	QUIETPACT 40 LP
MODEL	4700/4709	4701
WEIGHT	170 pounds	170 pounds
TYPE OF ROTOR	Two-pole	Two-pole
RATED WATTS	3600	3400
RATED VOLTS	120	120
PHASE	1-Phase	1-Phase
RATED MAXIMUM LOAD AMPERES	30.0	28.3
RATED FREQUENCY	60 Hz	60
OPERATING SPEED	3600 rpm	3600 rpm
ENGINE MODEL	GH-220	GH-220
TYPE OF ENGINE	Horizontal Shaft	Horizontal Shaft
FUEL SYSTEM	Gasoline	LP Vapor
COOLING SYSTEM	Air-Cooled	Air-Cooled
OIL SYSTEM	Pressurized with Filter	Pressurized with Filter
OIL PUMP	Trochoid Type	Trochoid Type
AIR CLEANER	Paper element w/foam pre-cleaner	Paper element w/foam pre-cleaner
STARTER	12 VDC electric	12 VDC electric
IGNITION SYSTEM	Solid State	Solid State
SPARK PLUG	Champion RC14YC (or equivalent)	Champion RC14YC (or equivalent)
SPARK PLUG GAP	0.030 inch (0.76mm)	0.030 inch (0.76mm)

**NOTE 1: Engine speed will vary between approximately 2400-4000 rpm, depending on the load and load voltage.**

**NOMINAL RESISTANCES OF GENERATOR WINDINGS AT 68°F**

Stator Power Windings	
11 & 22	0.468 to 0.542 ohm
33 & 44	0.468 to 0.542 ohm
Rotor Winding	
Slip Ring to Slip Ring	12.72 to 14.73 ohms

Stator Battery Charge Windings	
Lead 55 to 77	0.150 to 0.174 ohm
Lead 55 to 66	0.150 to 0.174 ohm
Excitation "DPE" Winding	
Lead 2 to 6	2.168 to 2.510 ohm

**ENGINE SPEEDS AND VOLTAGE SPECIFICATIONS**

Listed below are normal running voltages, load voltages and frequency ranges.

LOAD %	VOLTAGE (VAC)	FREQUENCY (Hz)
0	123-126	62-62.5
50	118-121	61-59
100	112.5-116.5	57-60

**TORQUE SPECIFICATIONS**

<b>LONG BLOCK TORQUE REQUIREMENTS</b>	
HEAD BOLTS	22 ft-lbs (±5%)
GEAR COVER BOLTS	18 ft-lbs
CONNECTING ROD CAP BOLTS	10 ft-lbs
VALVE COVER BOLTS	48 in-lbs
ROCKER ARM JAM NUTS	96 in-lbs
OIL PRESSURE RELIEF COVER BOLT	50 in-lbs
OIL FILTER ADAPTER	9 ft-lbs
<b>TRIM TORQUE REQUIREMENTS</b>	
M3-.5 PHILLIPS PAN HEAD SCREW INTO ALUMINUM	50 in-lbs
M6-1 TAPTITE SCREW INTO ALUMINUM	96 in-lbs
M6-1 TAPTITE SCREW INTO WELDNUT	96 in-lbs
M8-1.25 TAPTITE SCREW INTO ALUMINUM	18 ft-lbs
STARTER BRACKET TO BLOCK	18 ft-lbs
GOVERNOR LEVER PINCH BOLT	108 in-lbs
FLYWHEEL NUT	82 ft-lbs
SPARK PLUG	15 ft-lbs
<b>RV TORQUE REQUIREMENTS</b>	
EXHAUST OUTLET BOLTS	18 ft-lbs
ROTOR BOLT	19 ft-lbs
ALTERNATOR ADAPTOR BOLTS	12 ft-lbs
STATOR BOLTS	12 ft-lbs
M6-1 TAPTITE SCREW INTO PIERCED HOLE	96 in-lbs

# Section 11 ELECTRICAL DATA

Electrical Schematic and Wiring Diagram – Drawing No. 0D8063-D

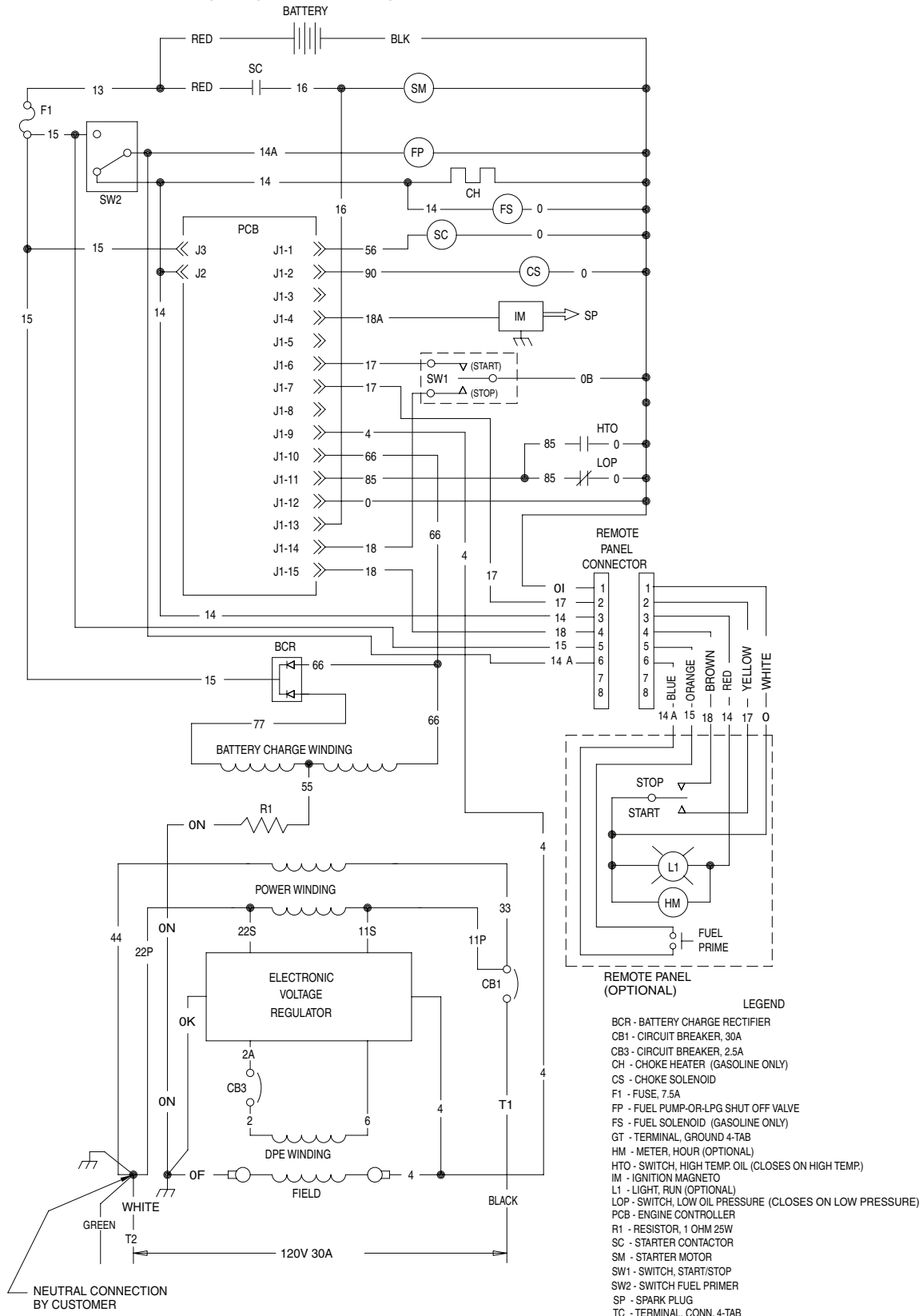



## Notes

---





