



Refrigerated Showcases

Models RS-CN-0120-B, 0200-B, 0120-S, 0200-S
Items 50077, 50078, 50079, 50080
Instruction Manual



Revised - 05/20/2021



Toll Free: 1-800-465-0234
Fax: 905-607-0234
Email: service@omcan.com
www.omcan.com

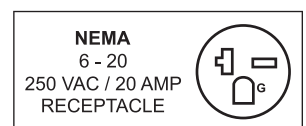

Table of Contents

Model RS-CN-0120-B / Model RS-CN-0200-B
Model RS-CN-0120-S / Model RS-CN-0200-S

Section	Page
Disclaimer -----	3
General Information -----	4 - 5
Safety and Warranty -----	5 - 6
Technical Specifications -----	7
Installation and Operation -----	7 - 8
Maintenance -----	8 - 10
Troubleshooting -----	10 - 11
Parts Breakdown -----	12 - 17
Electrical Schematics -----	18
Warranty Registration -----	19

Disclaimer

OMCAN IS NOT RESPONSIBLE FOR ANY DAMAGES DUE TO WATER LEAKS. WARRANTY FOR WATER LEAKS IS VOID IF THE AMBIENT ROOM TEMPERATURE EXCEEDS 75°F AND 55% RELATIVE HUMIDITY, AND THE APPLIANCE DRAIN IS NOT CONNECTED DIRECTLY TO A FLOOR DRAIN.

General Information

Omcman Manufacturing and Distributing Company Inc., Food Machinery of America, Inc. dba Omcman and Omcman Inc. are not responsible for any harm or injury caused due to any person's improper or negligent use of this equipment. The product shall only be operated by someone over the age of 18, of sound mind, and not under the influence of any drugs or alcohol, who has been trained in the correct operation of this machine, and is wearing authorized, proper safety clothing. Any modification to the machine voids any warranty, and may cause harm to individuals using the machine or in the vicinity of the machine while in operation.

CHECK PACKAGE UPON ARRIVAL

Upon receipt of an Omcman shipment please inspect for external damage. If no damage is evident on the external packaging, open carton to ensure all ordered items are within the box, and there is no concealed damage to the machine. If the package has suffered rough handling, bumps or damage (visible or concealed), please note it on the bill of lading before accepting the delivery and contact Omcman within 24 hours, so we may initiate a claim with the carrier. A detailed report on the extent of the damage caused to the machine must be filled out within three days, from the delivery date shown in the shipping documents. Omcman has no recourse for damaged products that were shipped collect or third party.

Before operating any equipment, always read and familiarize yourself with all operation and safety instructions.

Omcman would like to thank you for purchasing this machine. It's of the utmost importance to save these instructions for future reference. Also save the original box and packaging for shipping the equipment if servicing or returning of the machine is required.

Omcman Fabrication et distribution Compañie Limité et Food Machinery d'Amerique, dba Omcman et Omcman Inc. ne sont pas responsables de tout dommage ou blessure causé du fait que toute personne ait utilisé cet équipement de façon irrégulière. Le produit ne doit être exploité que par quelqu'un de plus de 18 ans, saine d'esprit, et pas sous l'influence d'une drogue ou d'acohol, qui a été formé pour utiliser cette machine correctement, et est vêtu de vêtements de sécurité approprié. Toute modification de la machine annule toute garantie, et peut causer un préjudice à des personnes utilisant la machine ou des personnes à proximité de la machine pendant son fonctionnement.

VÉRIFIEZ LE COLIS DÈS RÉCEPTION

Dès réception d'une expédition d'Omcman veuillez inspecter pour dommages externes. Si aucun dommage n'est visible sur l'emballage externe, ouvrez le carton afin de s'assurer que tous les éléments commandés sont dans la boîte, et il n'y a aucun dommage dissimulé à la machine. Si le colis n'a subi aucune mauvaises manipulations, de bosses ou de dommages (visible ou cachée), notez-le sur le bond de livraison avant d'accepter la livraison et contactez Omcman dans les 24 heures qui suivent, pour que nous puissions engager une réclamation auprès du transporteur. Un rapport détaillé sur l'étendue des dommages causés à la machine doit être rempli dans un délai de trois jours, à compter de la date de livraison indiquée dans les documents d'expédition. Omcman n'a aucun droit de recours pour les produits endommagés qui ont été expédiées ou cueilli par un tiers transporteur.



General Information

Avant d'utiliser n'importe quel équipement, toujours lire et vous familiariser avec toutes les opérations et les consignes de sécurité.

Omcan voudrais vous remercier d'avoir choisi cette machine. Il est primordial de conserver ces instructions pour une référence ultérieure. Également conservez la boîte originale et l'emballage pour l'expédition de l'équipement si l'entretien ou le retour de la machine est nécessaire.

Omcan Empresa De Fabricacion Y Distribucion Inc. Y Maquinaria De Alimentos De America, Inc. dba Omcan y Omcan Inc. no son responsables de ningun daño o perjuicio causado por cualquier persona inadecuada o el uso descuidado de este equipo. El producto solo podra ser operado por una persona mayor de 18 años, en su sano juicio y no bajo alguna influencia de droga o alcohol, y que este ha sido entrenado en el correcto funcionamiento de esta máquina, y ésta usando ropa apropiada y autorizada. Cualquier modificación a la máquina anula la garantía y puede causar daños a las personas usando la máquina mientras esta en el funcionamiento.

REVISE EL PAQUETE A SU LLEGADA

Tras la recepcion de un envio Omcan favor inspeccionar daños externos. Si no hay daños evidentes en el empaque exterior, Habra el carton para asegurarse que todos los articulos solicitados estén dentro de la caja y no encuentre daños ocultos en la máquina. Si el paquete ha sufrido un manejo de poco cuidado, golpes o daños (visible o oculto) por favor anote en la factura antes de aceptar la entrega y contacte Omcan dentro de las 24 horas, de modo que podamos iniciar una reclamación con la compañía. Un informe detallado sobre los daños causados a la máquina debe ser llenado en el plazo de tres días, desde la fecha de entrega que se muestra en los documentos de envío. Omcan no tiene ningun recurso por productos dañados que se enviaron a recoger por terceros.

Antes de utilizar cualquier equipo, siempre leer y familiarizarse con todas las instrucciones de operación y seguridad.

Omcan quisiera darles las gracias por la compra de esta máquina. Es de la máxima importancia para guardar estas instrucciones para referencias en el futuro. También guarde la caja original y el embalaje para envío del equipo si el mantenimiento o la devolución de la máquina es necesaria.

Safety and Warranty

WHEN USING ELECTRICAL APPLIANCES BASIC SAFETY PRECAUTIONS SHOULD BE FOLLOWED:

- This cooler must be properly installed and located in accordance with the installation service representative.
- Do not allow children to climb, stand or hang on the shelves in the cooler. They could damage the unit and seriously injure themselves.
- Do not store or use gasoline or other flammable vapors and liquids in the vicinity of this or any other appliance.

Safety and Warranty

- Unplug the unit from the electrical outlet before cleaning or making repairs.
- Do not touch the cold surfaces in the refrigerator compartment when hands are damp or wet. Skin may stick to these extremely cold surfaces.

NOTE: It is strongly recommended that any servicing be performed by an authorized instructions before it is used.

- When the refrigerator is installed or used, all the packaging (including cardboard and plastic wrap) should be removed.
- Keep the refrigerator stable to avoid vibration and noise.
- The refrigerator should be installed in a place with good ventilation and a space of at least 4" should be allowed between the surrounding walls and the cabinet wall for air circulation.
- Unit should be placed far from any heating source to avoid decrease of refrigeration efficiency.
- Install the refrigerator in a dry place to prevent rust from forming on the compartment body, which may affect the electrical insulation.

RESIDENTIAL USERS: Vendor assumes no liability for parts or labor coverage for component failure or other damages resulting from installation in non-commercial or residential applications. The right is reserved to deny shipment for residential usage; if this occurs, you will be notified as soon as possible.

1 YEAR PARTS AND LABOR WARRANTY

Within the warranty period, contact Omcan Inc. at 1-800-465-0234 to schedule an Omcan authorized service technician to repair the equipment locally.

Unauthorized maintenance will void the warranty. Warranty covers electrical and part failures, not improper use.

Please see <https://omcan.com/disclaimer> for complete info.

WARNING:

The packaging components are classified as normal solid urban waste and can therefore be disposed of without difficulty.

In any case, for suitable recycling, we suggest disposing of the products separately (differentiated waste) according to the current norms.

DO NOT DISCARD ANY PACKAGING MATERIALS IN THE ENVIRONMENT!



Technical Specifications

Model	RS-CN-0120-B	RS-CN-0120-S	RS-CN-0200-B	RS-CN-0200-S
Type	Black	Stainless Steel	Black	Stainless Steel
Temperature Range	0 - 6°C / 32 - 43°F			
Max Ambient Temp Rating	32°C / 90°F			
Power	1/4+ HP		3/4 HP	
Electrical	115V / 60Hz / 1			
Current	2.6A		5.9A	
Capacity	508 L / 18 cu.ft.		903 L / 32 cu.ft.	
Refrigerant	R290			
Dimensions	47" x 32.5" x 43" / 1200 x 825 x 1089mm		82" x 32.5" x 43" / 2082 x 825 x 1089mm	
Packaging Dimensions	52" x 37" x 49" / 1320 x 940 x 1240mm		86.8" x 37" x 49" / 2202 x 940 x 1240mm	
Weight	319 lbs. / 145 kgs.		506 lbs. / 230 kgs.	
Packaging Weight	429 lbs. / 195 kgs.		638 lbs. / 290 kgs.	
Item Number	50077	50079	50078	50080

Installation and Operation

To ensure that your unit works properly from the first day, it must be installed properly. We highly recommend a trained refrigeration mechanic and electrician install your equipment.

- Remove the outer packaging, inspect for concealed damage. Again, immediately file a claim with the freight carrier if there is damage.
- Remove the wood frame and pallet.
- Place the refrigerator on a flat surface and remove to the final location. Be sure there is adequate ventilation in your room. Under extreme heat conditions, (100°F+, 38°C+), you may want to install an exhaust fan.

ELECTRICAL

Do not under any circumstances cut or remove the grounding prong from the power cord. For safety this appliance must be properly grounded at all times.

- The power cord of this cooler is equipped with a grounding plug which mates with a standard grounding wall outlet to minimize the possibility of electric shock hazard.
- If the outlet is a standard 2-prong outlet, it must be replaced with the properly grounded wall outlet. NEVER USE AN ADAPTER PLUG!
- Have the wall outlet and circuit checked by a qualified electrician to make sure the outlet is properly grounded. Check the incoming voltage with a voltmeter.

Installation and Operation

- DO NOT USE EXTENSION CORDS. The use of extension cords to connect the cooler will void warranty. The unit must be close enough to the electrical supply so that extension cords are never used.
- The cooler should always be plugged into its own dedicated circuit with a voltage rating that matches the rating plate. This provides the best performance and also prevents overloading wiring circuits which could become a fire hazard from overheated wires.
- Never unplug your cooler by pulling on the power cord. Always grip the plug firmly and pull straight out from the outlet.
- Repair or replace immediately all power cords that have become frayed or otherwise damaged. Do not use a power cord that has cracks or abrasion damage along its length or at either of its ends.
- When removing the cooler away from the wall be careful not to run over or damage the power cord.

NOTE: Wiring diagram can be referenced by removing the front louvered grill, and looking on the inside cabinet wall.

PLUG IN THE COOLER AND THE COMPRESSOR IS READY TO OPERATE.

- Excessive tampering with the control could lead to service difficulties. Should it ever become necessary to replace the temperature control it should be ordered from your dealer or recommended service agent.

LIGHT SWITCH LOCATION:

The light switch is located at the left side of rear grille.

NOTE: If the unit is disconnected or shut off, wait five (5) minutes before re-starting unit.

RECOMMENDATION: Before loading product the unit should be run for 2 to 3 hours. This allows confirmation that the electrical wiring and installation are correct and no shipping damage has occurred.

Maintenance

Condensers accumulate dirt and dust and require cleaning every 30 days. Dirty condensers result in compressor failure, product loss, and lost sales -- which are not covered by warranty.

Air is pulled through the condenser continuously along with dust, lint, grease, etc. If you keep the condenser clean you will minimize your service expense and lower your electrical costs. The condenser requires scheduled cleaning every days or as needed. A dirty condenser can result in non-warranted part and compressor failures and product loss.

Proper cleaning involves removing debris from the condenser by using a soft brush or vacuuming the condenser with a shop vacuum or using CO₂, nitrogen or pressurized air.

If you cannot remove the debris adequately please call your refrigeration service company.

CLEANING THE CONDENSER COIL

REQUIRED TOOLS

- Phillips screwdriver.
- Stiff bristle brush.
- Adjustable wrench.

WHEN USING ELECTRICAL APPLIANCES BASIC SAFETY PRECAUTIONS SHOULD BE FOLLOWED.

- Disconnect power to unit.
- Take off front grill assembly by removing all screws.
- Remove bolts anchoring compressor assembly to frame rails and carefully slide out --tube connections are flexible.
- Clean off accumulated dirt from condensing coil with the stiff bristle brush.
- Lift cardboard cover above fan at plastic plugs and carefully clean condenser coil and fan blades.
- After brushing condenser coil, vacuum dirt from coil and interior floor.
- Replace cardboard cover, carefully slide compressor assembly back into position and replace bolts.
- Reinstall front grille assembly onto unit with appropriate fasteners and clips. Tighten all screws.
- Connect unit to power and check to see if condenser is running.

STAINLESS STEEL CARE AND CLEANING

RECOMMENDED CLEANERS FOR STAINLESS STEEL

- Soap, ammonia and detergent medallion applied with a soft cloth or sponge for routine cleaning.
- Arcal 20, Loc-O-Nu Eco shine provide a barrier film for fingerprints and smears.
- Cameo, Talc, Zud First Impression is for stubborn stains and discoloration. Rub in direction of polish lines.
- Easy-off and De-Grease It oven aid are excellent for removals on all finishes for grease-fatty acids, blood and burnt-on foods.
- Any good commercial detergent can be applied with a sponge or soft cloth to remove grease and oil.
- Benefit, Super Sheen, Sheila Shine are good for restoration/passiveness.

CAUTION: Do not use any steel wool, abrasive or chlorine based products to clean stainless steel surfaces.

STAINLESS STEEL ENEMIES

There are three basic items that can break down stainless steel's passivity layer and allow corrosion to occur.

- Scratches from wire brushes, metal scrapers and steel pads are just a few examples of items that can be abrasive to stainless steel's surface.
- Deposits left on stainless steel can leave spots. Hard water can leave spots. Hard water that is heated can leave deposits if left to sit for too long. These deposits can cause the passive layer to break down and rust stainless steel. All deposits left from food prep or service should be removed as quickly as possible.
- Chlorides are present in table salt, food and water. Household and industrial cleaners are the worst type of chlorides to use.

8 STEPS THAT CAN HELP PREVENT RUST ON STAINLESS STEEL

- Use the correct cleaning tools. Use non-abrasive tools when cleaning your stainless steel products. The

Maintenance

stainless steel's passive layer will not be harmed by soft cloths and plastic scouring pads.

- Clean along the polish lines. Polish lines or grain are visible on some stainless steel. Always scrub parallel to visible lines. Use a plastic scouring pad or soft cloth when grain is not visible.
- Use alkaline, alkaline chlorinated or non-chloride containing cleaners. While many traditional cleaners are loaded with chlorides, the industry is providing an ever increasing choice of non-chloride cleaners. If unsure of chloride content contact the cleaner supplier. If present cleaner contains chlorides, ask for an alternative. Avoid cleaners containing quaternary salts as they can attack stainless steel causing pitting and rusting.
- Water treatment. To reduce deposits, use soft water whenever possible. Installation of certain filters can be an advantage. Contact a treatment specialist about proper water treatment.
- Maintain cleanliness of food equipment. Use cleaners at recommended strength(alkaline, alkaline chlorinated or non-chloride). Avoid buildup of hard stains by cleaning frequently.
- When using chlorinated cleaners you must rinse and wipe dry immediately. It is better to wipe standing cleaning agents and water as soon as possible. All stainless steel equipment to air dry. Oxygen helps maintain the passivity film on stainless steel.
- Hydrochloric acid (muriatic acid) should never be used on stainless steel.
- Regularly restore/passiveness stainless steel.

Troubleshooting

Before requesting any service on your unit, please check the following points. Please note that this guide serves only as a reference for solutions to common problems.

SYMPTOM	POSSIBLE CAUSE	CORRECTIVE ACTION
Compressor not running.	Fuse blown or circuit breaker tripped.	Replace fuse or reset circuit breaker.
	Power cord unplugged.	Plug in power cord.
	Thermostat set too high.	Set thermostat to lower temperature.
	Cabinet in defrost cycle.	Wait for defrost cycle to finish.

Troubleshooting

Condensing unit runs for long periods of time.	Excessive amount of warm product placed in cabinet.	Allow adequate time for product to cool down.
	Prolonged door opening or door ajar.	Ensure doors are closed when not in use. Avoid opening doors for long periods of time.
	Door gasket(s) not sealing properly.	Ensure gaskets are snapped in completely. Remove gasket and wash with soap and water. Check condition of gasket and replace if necessary.
	Dirty condenser coil.	Clean the condenser coil.
	Evaporator coil iced over.	Unplug unit and allow coil to defrost. Make sure thermostat is not set too cold. Ensure that door gasket(s) are sealing properly.
Cabinet temperature is too warm.	Thermostat set too warm.	Set thermostat to lower temperature.
	Blocking air flow.	Re-arrange product to allow for proper air flow. Make sure there is at least four inches of clearance from evaporator.
	Excessive amount of warm product placed in cabinet.	Allow adequate time for product to cool down.
	Fuse blown or circuit breaker tripped.	Replace fuse or reset circuit breaker.
	Dirty condenser coil.	Clean the condenser coil.
	Prolonged door opening or door ajar.	Ensure doors are closed when not in use. Avoid opening doors for long periods of time.
	Evaporator coil iced over.	Unplug unit and allow coil to defrost. Make sure thermostat is not set too cold. Ensure that door gasket(s) are sealing properly.
Cabinet is noisy.	Loose part(s).	Locate and tighten loose part(s).
	Tubing vibration.	Ensure tubing is free from contact with other tubing or components.

Parts Breakdown

Model RS-CN-0120-B 50077

Model RS-CN-0120-S 50079

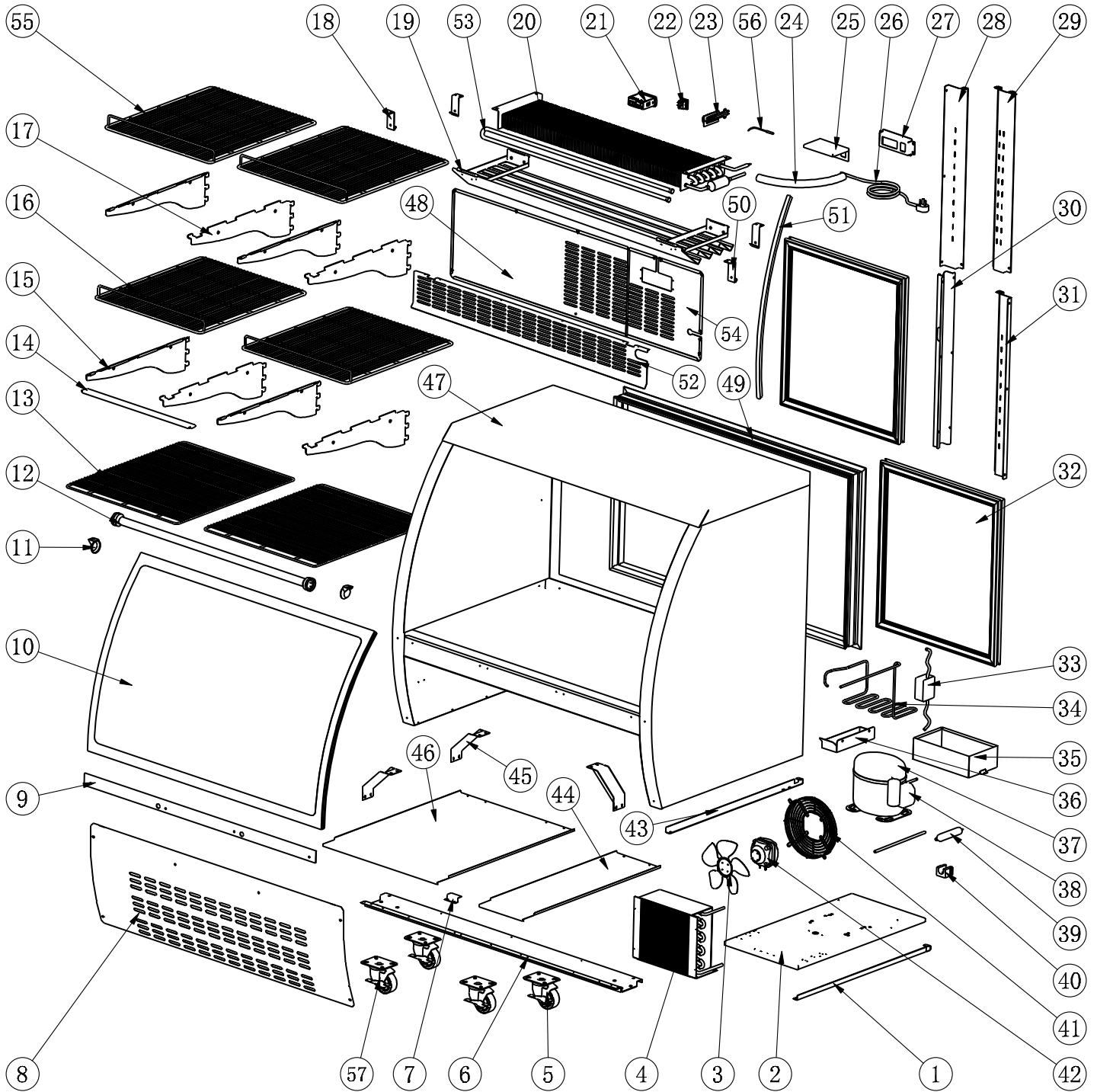

Parts Breakdown

Model RS-CN-0120-B 50077

Item No.	Description	Position	Item No.	Description	Position	Item No.	Description	Position
AB607	Right Track of Installation Board for 50077	1	AB582	Thermostat for 50077	21	AA249	Condenser Fan Motor Cover for 50077	41
AB634	Installation Board of Compressor for 50077	2	AA124	Power Switch for 50077	22	AA984	Condenser Fan Motor for 50077	42
AA248	Condenser Fan Blade for 50077	3	AA378	Temperature Probe Fixer for 50077	23	AB657	Left Track of Installation Board for 50077	43
AA250	Condenser for 50077	4	AA528	Drain Hose for 50077	24	AB658	Cover Board of Machine Room for 50077	44
26247	Caster without Brake for 50077	5	AA214	Thermostat Water Proof Cover for 50077	25	AB659	Support Holder of Cabinet for 50077	45
AB635	Support Board of Leveling Feet for 50077	6	AA135	Power Cord for 50077	26	AB660	Cover Board of Machine Room for 50077	46
AB973	Limited Block for Installation Board for 50077	7	AE984	Thermostat Installation Cover for 50077	27	AB661	Cabinet for 50077	47
AB637	Front Grill for 50077	8	AB649	Right Bracket for 50077	28	AB662	Back Grill for 50077	48
AB638	Fixed Board of Curve Glass for 50077	9	AB650	Middle Bracket for 50077	29	AB663	Framework of Door Track for 50077	49
AB639	Curve Glass for 50077	10	AB651	Air Pipe Protection Board for 50077	30	AB772	Left Hanger of Grill for 50077	50
AG538	LED Light and Socket for 50077	11, 12	AB652	Left Bracket for 50077	31	AB604	Sealing Rubber Strip for 50077	51
AG539	Bottom Shelf for 50077	13	AB653	Glass Door for 50077	32	AB665	Baffle for Evaporator for 50077	52
AB641	Shelf Support Board Connector for 50077	14	AA711	LED Power Supply for 50077	33	AB666	Defrost Heater for 50077	53
AB642	Right Shelf Support Board for 50077	15	AB589	Coiled Copper Pipe of Outer Drain Pan for 50077	34	AB667	Thermostat Mounting Plate for 50077	54
AG540	Middle Shelf for 50077	16	AB590	Outer Drain Pan for 50077	35	AG543	Upper Shelf for 50077	55
AB644	Left Shelf Support Board for 50077	17	AG542	Inner Drain Pipe for 50077	36	AB084	Evaporator Temperature Sensor for 50077	56
AB769	Right Hanger of Grill for 50077	18	AE876	Compressor for 50077	37	26246	Caster with Brake for 50077	57
AB646	Grill Components for 50077	19	AB594	Filter for 50077	39			
AG541	Evaporator for 50077	20	AB595	Filter Fixer for 50077	40			

Parts Breakdown

Model RS-CN-0120-S 50079

Item No.	Description	Position	Item No.	Description	Position	Item No.	Description	Position
AB607	Right Track of Installation Board for 50079	1	AB582	Thermostat for 50079	21	AA249	Condenser Fan Motor Cover for 50079	41
AB634	Installation Board of Compressor for 50079	2	AA124	Power Switch for 50079	22	AA984	Condenser Fan Motor for 50079	42
AA248	Condenser Fan Blade for 50079	3	AA378	Temperature Probe Fixer for 50079	23	AB657	Left Track of Installation Board for 50079	43
AA250	Condenser for 50079	4	AA528	Drain Hose for 50079	24	AB658	Cover Board of Machine Room for 50079	44
26247	Caster without Brake for 50079	5	AA214	Thermostat Water Proof Cover for 50079	25	AB659	Support Holder of Cabinet for 50079	45
AB635	Support Board of Leveling Feet for 50079	6	AA135	Power Cord for 50079	26	AB660	Cover Board of Machine Room for 50079	46
AB973	Limited Block for Installation Board for 50079	7	AE984	Thermostat Installation Cover for 50079	27	AB690	Cabinet for 50079	47
AB672	Front Grill for 50079	8	AB649	Right Bracket for 50079	28	AB662	Back Grill for 50079	48
AB638	Fixed Board of Curve Glass for 50079	9	AB650	Middle Bracket for 50079	29	AB663	Framework of Door Track for 50079	49
AB639	Curve Glass for 50079	10	AB651	Air Pipe Protection Board for 50079	30	AB772	Left Hanger of Grill for 50079	50
AG538	LED Light and Socket for 50079	11, 12	AB652	Left Bracket for 50079	31	AB604	Sealing Rubber Strip for 50079	51
AG539	Bottom Shelf for 50079	13	AB653	Glass Door for 50079	32	AB665	Baffle for Evaporator for 50079	52
AB641	Shelf Support Board Connector for 50079	14	AA711	LED Power Supply for 50079	33	AB666	Defrost Heater for 50079	53
AB642	Right Shelf Support Board for 50079	15	AB589	Coiled Copper Pipe of Outer Drain Pan for 50079	34	AB667	Thermostat Mounting Plate for 50079	54
AG540	Middle Shelf for 50079	16	AB590	Outer Drain Pan for 50079	35	AG543	Upper Shelf for 50079	55
AB644	Left Shelf Support Board for 50079	17	AG542	Inner Drain Pipe for 50079	36	AB084	Evaporator Temperature Sensor for 50079	56
AB769	Right Hanger of Grill for 50079	18	AE876	Compressor for 50079	37	26246	Caster with Brake for 50079	57
AB646	Grill Components for 50079	19	AB594	Filter for 50079	39			
AG541	Evaporator for 50079	20	AB595	Filter Fixer for 50079	40			

Parts Breakdown

Model RS-CN-0200-B 50078

Model RS-CN-0200-S 50080

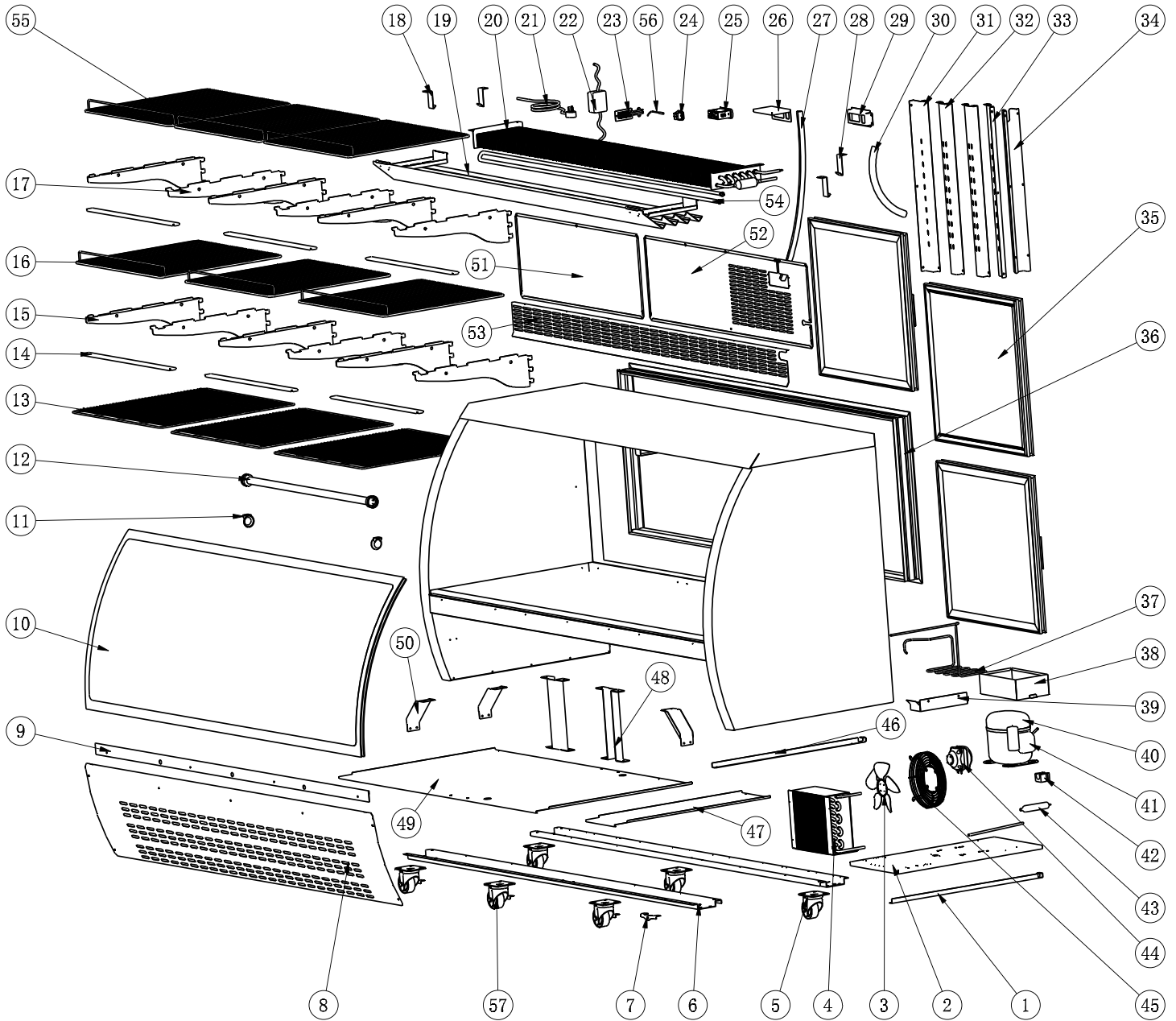

Parts Breakdown

Model RS-CN-0200-B 50078

Item No.	Description	Position	Item No.	Description	Position	Item No.	Description	Position
AB607	Right Track of Installation Board for 50078	1	AA135	Power Cord for 50078	21	AB719	Compressor for 50078	40
AB634	Installation Board of Compressor for 50078	2	AA711	LED Power Supply for 50078	22	AB595	Filter Fixer for 50078	42
AA248	Condenser Fan Blade for 50078	3	AA378	Temperature Probe Fixer for 50078	23	AB594	Filter for 50078	43
AA300	Condenser for 50078	4	AA124	Power Switch for 50078	24	AA984	Condenser Fan Motor for 50078	44
26247	Caster without Brake for 50078	5	AB582	Thermostat for 50078	25	AA249	Condenser Fan Motor Cover for 50078	45
AB759	Support Board of Leveling Feet for 50078	6	AA214	Thermostat Water Proof Cover for 50078	26	AB657	Left Track of Installation Board for 50078	46
AB973	Limited Block of Installation Board for 50078	7	AB604	Sealing Rubber Strip for 50078	27	AB658	Cover Board of Machine Room for 50078	47
AB761	Front Grill for 50078	8	AB772	Left Hanger of Grill for 50078	28	AB784	Support Board of Machine Room for 50078	48
AB762	Fixed Board of Curve Glass for 50078	9	AE984	Thermostat Installation Cover for 50078	29	AB785	Cover Board of Machine Room (Big) for 50078	49
AB763	Curve Glass for 50078	10	AA528	Drain Hose for 50078	30	AB659	Support Holder of Cabinet for 50078	50
AG538	LED Light and Socket for 50078	11, 12	AB652	Left Bracket for 50078	31	AB787	Right Back Grill for 50078	51
AG544	Bottom Shelf for 50078	13	AB650	Middle Bracket for 50078	32	AB667	Thermostat Mounting Plate for 50078	52
AB765	Shelf Support Board Connector for 50078	14	AB649	Right Bracket for 50078	33	AB789	Baffle for Evaporator for 50078	53
AB642	Right Shelf Support Board for 50078	15	AB651	Air Pipe Protection Board for 50078	34	AB790	Defrost Heater for 50078	54
AG545	Middle Shelf for 50078	16	AB778	Glass Door for 50078	35	AG547	Upper Shelf for 50078	55
AB644	Left Shelf Support Board for 50078	17	AB779	Framework of Glass Door for 50078	36	AB084	Evaporator Temperature Sensor for 50078	56
AB769	Right Hanger of Grill for 50078	18	AB589	Coiled Copper Pipe of Outer Drain Pan for 50078	37	26246	Caster with Brake for 50078	57
AB770	Grill Components for 50078	19	AB590	Outer Drain Pan for 50078	38			
AG546	Evaporator for 50078	20	AG542	Inner Drain Pipe for 50078	39			

Parts Breakdown

Model RS-CN-0200-S 50080

Item No.	Description	Position	Item No.	Description	Position	Item No.	Description	Position
AB607	Right Track of Installation Board for 50080	1	AA135	Power Cord for 50080	21	AB719	Compressor for 50080	40
AB634	Installation Board of Compressor for 50080	2	AA711	LED Power Supply for 50080	22	AB595	Filter Fixer for 50080	42
AA248	Condenser Fan Blade for 50080	3	AA378	Temperature Probe Fixer for 50080	23	AB594	Filter for 50080	43
AA300	Condenser for 50080	4	AA124	Power Switch for 50080	24	AA984	Condenser Fan Motor for 50080	44
26247	Caster without Brake for 50080	5	AB582	Thermostat for 50080	25	AA249	Condenser Fan Motor Cover for 50080	45
AB759	Support Board of Leveling Feet for 50080	6	AA214	Thermostat Water Proof Cover for 50080	26	AB657	Left Track of Installation Board for 50080	46
AB973	Limited Block of Installation Board for 50080	7	AB604	Sealing Rubber Strip for 50080	27	AB658	Cover Board of Machine Room for 50080	47
AB795	Front Grill for 50080	8	AB772	Left Hanger of Grill for 50080	28	AB784	Support Board of Machine Room for 50080	48
AB762	Fixed Board of Curve Glass for 50080	9	AE984	Thermostat Installation Cover for 50080	29	AB785	Cover Board of Machine Room (Big) for 50080	49
AB763	Curve Glass for 50080	10	AA528	Drain Hose for 50080	30	AB659	Support Holder of Cabinet for 50080	50
AG538	LED Light and Socket for 50080	11, 12	AB652	Left Bracket for 50080	31	AB787	Right Back Grill for 50080	51
AG544	Bottom Shelf for 50080	13	AB650	Middle Bracket for 50080	32	AB667	Thermostat Mounting Plate for 50080	52
AB765	Shelf Support Board Connector for 50080	14	AB649	Right Bracket for 50080	33	AB789	Baffle for Evaporator for 50080	53
AB642	Right Shelf Support Board for 50080	15	AB651	Air Pipe Protection Board for 50080	34	AB790	Defrost Heater for 50080	54
AG545	Middle Shelf for 50080	16	AB778	Glass Door for 50080	35	AG547	Upper Shelf for 50080	55
AB644	Left Shelf Support Board for 50080	17	AB779	Framework of Glass Door for 50080	36	AB084	Evaporator Temperature Sensor for 50080	56
AB769	Right Hanger of Grill for 50080	18	AB589	Coiled Copper Pipe of Outer Drain Pan for 50080	37	26246	Caster with Brake for 50080	57
AB770	Grill Components for 50080	19	AB590	Outer Drain Pan for 50080	38			
AG546	Evaporator for 50080	20	AG542	Inner Drain Pipe for 50080	39			

Electrical Schematics

Model RS-CN-0120-B 50077

Model RS-CN-0200-B 50078

Model RS-CN-0120-S 50079

Model RS-CN-0200-S 50080

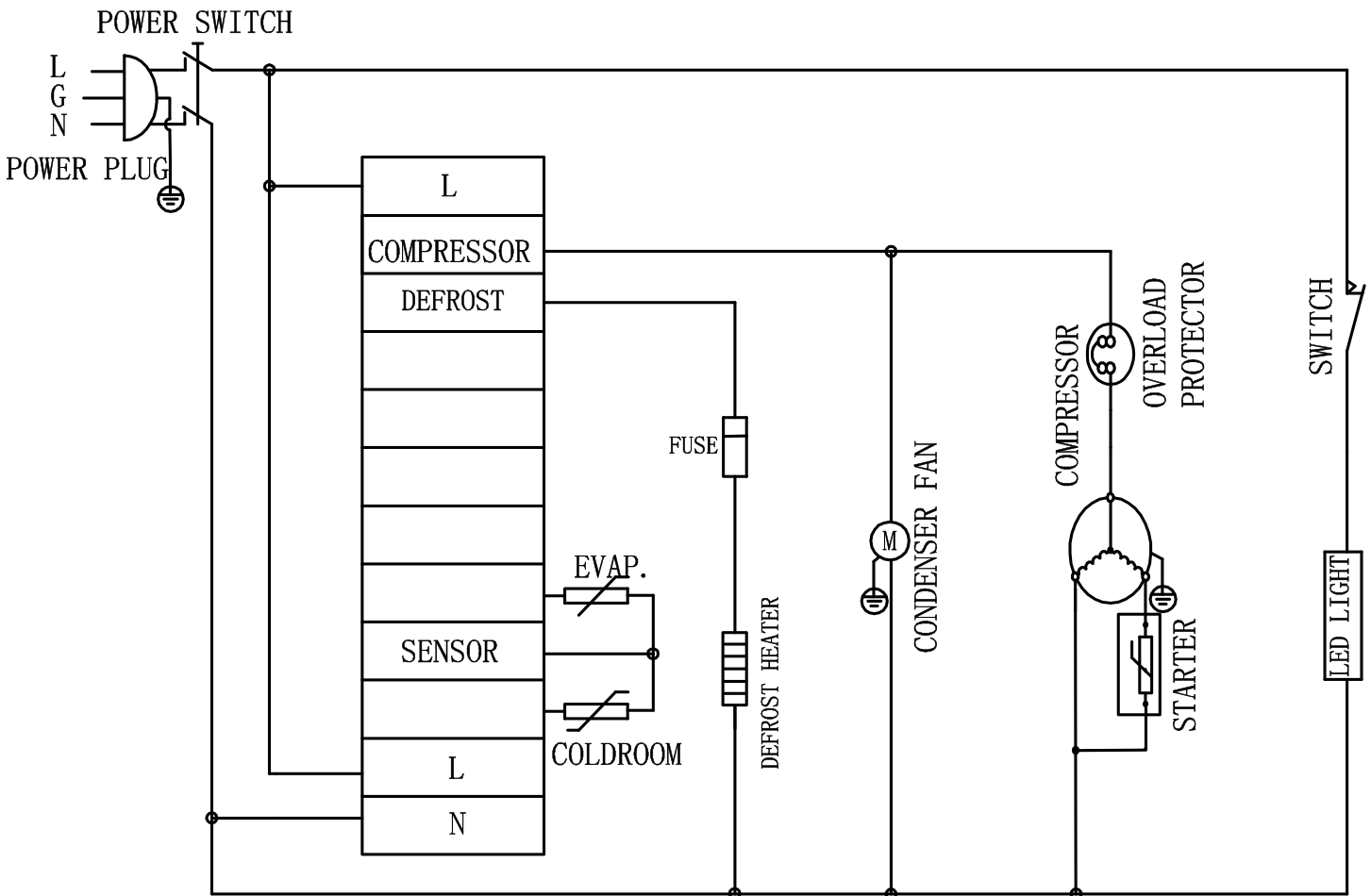



Warranty Registration

Thank you for purchasing an Omcan product. To register your warranty for this product, complete the information below, tear off the card at the perforation and then send to the address specified below. You can also register online by visiting:

Merci d'avoir acheté un produit Omcan. Pour enregistrer votre garantie pour ce produit, complétez les informations ci-dessous, détachez la carte au niveau de la perforation, puis l'envoyer à l'adresse spécifiée ci-dessous. Vous pouvez également vous inscrire en ligne en visitant:

Gracias por comprar un producto Omcan usted. Para registrar su garantía para este producto, complete la información a continuación, cortar la tarjeta en la perforación y luego enviarlo a la dirección indicada a continuación. También puede registrarse en línea en:

<https://omcan.com/warranty-registration/>

For mailing in Canada

Pour postale au Canada

Por correo en Canadá

OMCAN

PRODUCT WARRANTY REGISTRATION

3115 Pepper Mill Court,

Mississauga, Ontario

Canada, L5L 4X5

For mailing in the US

Pour diffusion aux États-Unis

Por correo en los EE.UU.

OMCAN

PRODUCT WARRANTY REGISTRATION

4450 Witmer Industrial Estates, Unit 4,

Niagara Falls, New York

USA, 14305

or email to: service@omcan.com



Purchaser's Information

Name: _____

Address: _____

City: _____ Province or State: _____ Postal or Zip: _____

Country: _____

Dealer from which Purchased: _____

Dealer City: _____ Dealer Province or State: _____

Invoice: _____

Model Name: _____ Model Number: _____

Machine Description: _____

Date of Purchase (MM/DD/YYYY): _____

Would you like to extend the warranty? Yes No

Company Name: _____

Telephone: _____

Email Address: _____

Type of Company:

Restaurant Bakery Deli

Butcher Supermarket Caterer

Institution (*specify*): _____

Other (*specify*): _____

Serial Number: _____

Date of Installation (MM/DD/YYYY): _____

Thank you for choosing Omcan | Merci d'avoir choisi Omcan | Gracias por elegir Omcan



Since 1951 Omcan has grown to become a leading distributor of equipment and supplies to the North American food service industry. Our success over these many years can be attributed to our commitment to strengthen and develop new and existing relationships with our valued customers and manufacturers. Today with partners in North America, Europe, Asia and South America, we continually work to improve and grow the company. We strive to offer customers exceptional value through our qualified local sales and service representatives who provide convenient access to over 5,000 globally sourced products.

Depuis 1951 Omcan a grandi pour devenir un des “leaders” de la distribution des équipements et matériel pour l’industrie des services alimentaires en Amérique du Nord. Notre succès au cours de ces nombreuses années peut être attribué à notre engagement à renforcer et à développer de nouvelles et existantes relations avec nos clients et les fabricants de valeur. Aujourd’hui avec des partenaires en Amérique du Nord, Europe, Asie et Amérique du Sud, nous travaillons continuellement à améliorer et développer l’entreprise. Nous nous efforçons d’offrir à nos clients une valeur exceptionnelle grâce à nos ventes locales qualifiées et des représentants de service qui offrent un accès facile à plus de 5000 produits provenant du monde entier.

Desde 1951 Omcan ha crecido hasta convertirse en un líder en la distribución de equipos y suministros de alimentos en América del Norte industria de servicios. Nuestro éxito en estos años se puede atribuir a nuestro compromiso de fortalecer y desarrollar nuevas relaciones existentes con nuestros valiosos clientes y fabricantes. Hoy con socios de América del Norte, Europa, Asia y América del Sur, que trabajan continuamente para mejorar y crecer la empresa. Nos esforzamos por ofrecer a nuestros clientes valor excepcional a través de nuestro local de ventas y representantes de los servicios que proporcionan un fácil acceso a más de 5,000 productos con origen a nivel mundial.

