

A952V

PRODUCT SPECIFICATIONS

2-STAGE VARIABLE SPEED GAS FURNACE

FORM NO. A952V-100 (04/2016)



HEAT EXCHANGER DESIGN

- 409 Stainless steel primary heat exchanger material
- AL29-4C Stainless steel secondary heat exchanger
- Non-welded crimped S-curve primary heat exchanger design for maximum durability

BURNERS

- Aluminized steel in shot burners for smooth ignition
- Isolated burner enclosure for quiet operation

CABINET CONSTRUCTION

- Compact 33" height
- Standardized widths for easy coil fit
- Unitized construction for cabinet integrity
- Heat exchanger compartment and blower compartment insulated to increase efficiency and reduce sound levels
- Baked on prepainted steel cabinet finish

AIR DELIVERY SYSTEM

- Efficient ECM variable speed blower motor
- Motor features "soft start" and "soft stop" for quiet operation
- Active and passive dehumidification feature
- Easily removable slide-out blower design
- Dynamically balanced blower wheel with resilient motor mounts for smooth and quiet operation

CONTROLS

- Two stage gas valve
- Integrated ignition and fan control
- System Sentry™ control retains last five (5) fault codes with push button memory recall, regardless of power interruption
- Hot surface ignition system uses silicon nitride ignitor
- Control features 120 volt electronic air cleaner and humidifier terminals
- Control circuit is fuse protected
- Color coded control wiring
- Compatible with single or two stage thermostats for heating
- Two stage thermostat is recommended when installed with two stage cooling unit.

VENTING

- 2-speed induced draft motor with stainless steel shaft, steel ball bearings, and fan cooled for long life
- Vent materials for Canadian applications must comply with ULC S636
- Certified for direct vent (2-pipe) and in-direct (1-pipe) applications.

INSTALLATION FEATURES

- Left or right gas and electric entry
- Zero step horizontal conversion
- Removable floor base (upflow/horizontal units) for bottom return air
- All models comply with California's South Coast Air
- Quality Management district Low NOx requirements

WARRANTY

10 year limited parts warranty / lifetime heat exchanger warranty available. See limited warranty document for details.



MODEL NUMBER GUIDE

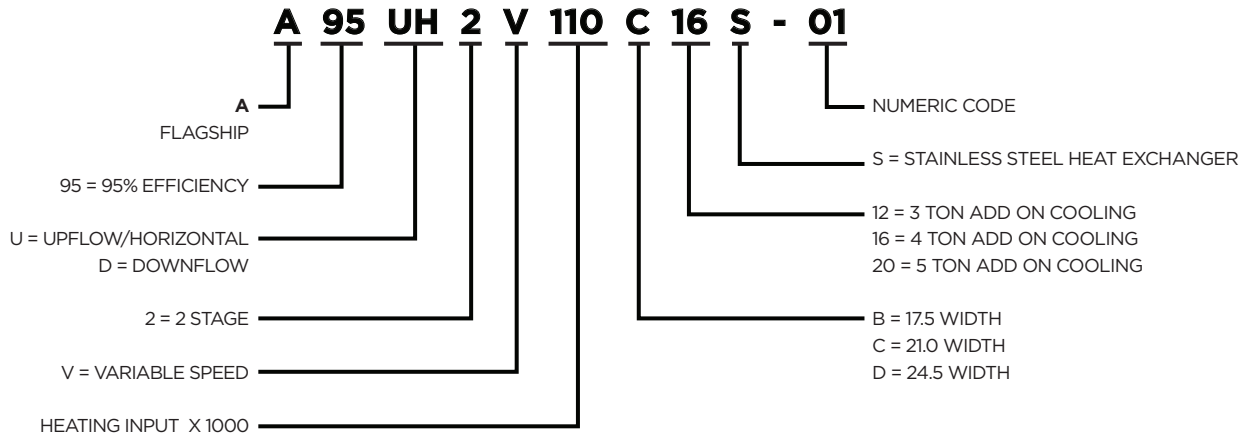

PHYSICAL AND ELECTRICAL DATA

	Model	1st Stage		2nd Stage		AFUE (ICS)	Nominal Cooling Capacity	Gas Inlet (in.)	Volts/Hz/Phase	Max. Time Delay Breaker or Fuse	Nominal F.L.A.	Trans. (V.A.)	Aprox. Shipping Weight (lbs.)
		Input (Btuh)	Output* (Btuh)	Input (Btuh)	Output* (Btuh)								
UPFLOW/HORIZONTAL	A95UH2V045B12S	29,000	28,000	44,000	42,000	95.0	3	1/2	120-60-1	15	7.7	40	130
	A95UH2V070B12S	43,000	41,000	66,000	62,000	95.0	3	1/2	120-60-1	15	7.7	40	138
	A95UH2V090C12S	57,000	55,000	88,000	84,000	95.0	3	1/2	120-60-1	15	7.7	40	154
	A95UH2V090C16S	57,000	55,000	88,000	85,000	95.0	4	1/2	120-60-1	15	10.1	40	165
	A95UH2V090C20S	57,000	55,000	88,000	85,000	95.0	5	1/2	120-60-1	20	12.8	40	166
	A95UH2V110C16S	72,000	70,000	110,000	105,000	95.0	4	1/2	120-60-1	15	10.1	40	173
	A95UH2V110C20S	72,000	70,000	110,000	106,000	95.0	5	1/2	120-60-1	20	12.8	40	174
	A95UH2V135D20S	88,000	84,000	132,000	126,000	95.0	5	1/2	120-60-1	20	12.8	40	188
DOWNFLOW	A95DF2V045B12S	29,000	28,000	44,000	43,000	95.0	3	1/2	120-60-1	15	7.7	40	131
	A95DF2V070B16S	43,000	42,000	66,000	64,000	95.0	4	1/2	120-60-1	15	10.1	40	138
	A95DF2V090C20S	57,000	56,000	88,000	85,000	95.0	5	1/2	120-60-1	20	12.8	40	166
	A95DF2V110C20S	72,000	70,000	110,000	106,000	95.0	5	1/2	120-60-1	20	12.8	40	176

Note: For vent length and clearances to combustibles, please reference installation instructions.
 * Outputs shown are High Fire, 100% rate, Low Fire is 67% of shown output.

FILTER REQUIREMENT DATA

1. The Airflow Descriptor is the two digits following the "B", "C", or "D" in the model number; e.g. "20" is the Airflow Descriptor.
 2. Areas shown for permanent filters are based on filters rated at 600 feet per minute face velocity.

Airflow Descriptor	Disposable Filters	Cleanable Filters
	Minimum Area (sq. in.)	Minimum Area (sq.in.)
12	576	288
16	768	384
20	960	480

BLOWER PERFORMANCE DATA

UPFLOW / HORIZONTAL	Model	Motor Size (hp)	Blower Size	Heating Temp. Rise (°F)	Heating CFM @ .10" - .80" w.c.				Cooling Stage	Cooling CFM @ .10" - .80" w.c.				Speed Adj.
					Cooling "D"	Cooling "C"	Cooling "B"	Cooling "A"		Cooling "D"	Cooling "C"	Cooling "B"	Cooling "A"	
A95UH2V045B12S	1/2	10x9	35-65 High Fire	745	875	990	1005	2nd Stage	905	1075	1210	1370	+	
				685	765	895	910		815	980	1120	1255	Norm	
				610	695	785	810		720	885	1020	1135	-	
			20-50 Low Fire	685	765	895	910	1st Stage	595	760	865	980	+	
				620	705	800	820		540	660	785	890	Norm	
				545	625	715	725		485	600	695	790	-	
A95UH2V070B12S	1/2	10x9	50-80 High Fire	965	1130	1255	1400	2nd Stage	860	1060	1215	1365	+	
				880	990	1140	1295		810	960	1130	1265	Norm	
				810	890	1030	1170		705	840	1005	1140	-	
			25-55 Low Fire	940	1070	1195	1345	1st Stage	600	740	840	970	+	
				830	965	1100	1235		555	665	770	855	Norm	
				755	840	975	1130		500	600	680	790	-	
A95UH2V090C12S	1/2	10x9	60-90 High Fire	1060	1135	1240	1430	2nd Stage	875	1040	1210	1360	+	
				960	1040	1120	1310		800	945	1100	1245	Norm	
				830	935	980	1175		720	840	970	1115	-	
			35-65 Low Fire	960	1040	1120	1310	1st Stage	625	710	830	950	+	
				875	945	995	1195		565	670	760	860	Norm	
				790	840	920	1080		520	610	685	785	-	
A95UH2V090C16S	3/4	11x11	45-75 High Fire	1230	1310	1360	1605	2nd Stage	1165	1375	1580	1770	+	
				1115	1195	1255	1455		1075	1265	1440	1645	Norm	
				1005	1070	1130	1335		935	1145	1320	1465	-	
			30-60 Low Fire	1165	1250	1315	1520	1st Stage	840	1005	1155	1315	+	
				1075	1140	1195	1405		780	915	1045	1190	Norm	
				935	1030	1065	1285		690	835	955	1070	-	
A95UH2V090C20S	1	11x11	40-70 High Fire	1450	1565	1725	1865	2nd Stage	1385	1595	1820	2020	+	
				1310	1450	1585	1690		1225	1465	1645	1885	Norm	
				1155	1305	1450	1545		1065	1320	1504	1675	-	
			30-60 Low Fire	1120	1265	1420	1520	1st Stage	935	1055	1275	1465	+	
				965	1120	1285	1395		835	980	1120	1335	Norm	
				865	950	1120	1235		740	870	1010	1150	-	
A95UH2V110C16S	3/4	11x11	60-90 High Fire	1210	1275	1385	1620	2nd Stage	1100	1325	1530	1760	+	
				1100	1160	1255	1455		1025	1205	1405	1565	Norm	
				1015	1055	1135	1335		920	1080	1260	1440	-	
			35-65 Low Fire	1210	1275	1385	1620	1st Stage	810	980	1085	1235	+	
				1100	1160	1255	1455		760	875	1010	1135	Norm	
				1015	1055	1135	1335		695	805	905	1040	-	
A95UH2V110C20S	1	11x11	45-75 High Fire	1560	1760	1905	2080	2nd Stage	1310	1560	1745	1955	+	
				1415	1610	1740	1930		1220	1405	1570	1795	Norm	
				1285	1485	1560	1745		1075	1270	1430	1635	-	
			35-65 Low Fire	1155	1325	1420	1565	1st Stage	935	1065	1245	1405	+	
				1055	1200	1310	1480		865	970	1145	1280	Norm	
				935	1075	1170	1315		790	890	1025	1165	-	
A95UH2V135D20S	1	11x11	55-85 High Fire	1650	1845	2000	2195	2nd Stage	1395	1640	1840	2055	+	
				1495	1660	1880	1985		1290	1480	1660	1905	Norm	
				1360	1500	1670	1850		1170	1330	1500	1705	-	
			40-70 Low Fire	1300	1435	1630	1715	1st Stage	1015	1160	1330	1480	+	
				1190	1325	1465	1620		940	1085	1200	1345	Norm	
				1095	1190	1340	1430		870	965	1110	1225	-	

BLOWER PERFORMANCE DATA

Model	Motor Size (hp)	Blower Size	Heating Temp. Rise (°F)	Heating CFM @ .10" - .80" w.c.				Cooling Stage	Cooling CFM @ .10" - .80" w.c.				Speed Adj.
				Cooling "D"	Cooling "C"	Cooling "B"	Cooling "A"		Cooling "D"	Cooling "C"	Cooling "B"	Cooling "A"	
				DOWNFLOW									
A95DF2V045B12S	1/2	10x9	35-65 High Fire	735	830	1015	1210	2nd Stage	895	1050	1210	1360	+
				680	750	930	1070		805	965	1105	1250	Norm
				625	695	835	1000		735	865	1000	1130	-
			20-50 Low Fire	705	780	975	1110	1st Stage	640	755	850	975	+
				655	730	890	1055		580	695	780	880	Norm
				595	670	790	960		545	645	720	795	-
A95DF2V070B16S	3/4	11x10	35-65 High Fire	1110	1305	1430	1700	2nd Stage	1110	1340	1575	1800	+
				995	1175	1315	1520		995	1230	1420	1650	Norm
				880	1055	1170	1365		880	1085	1290	1460	-
			25-55 Low Fire	860	1020	1140	1340	1st Stage	740	915	1055	1255	+
				795	910	1030	1230		660	820	940	1120	Norm
				680	825	910	1085		575	735	850	995	-
A95DF2V090C20S	1	11x11	40-70 High Fire	1395	1555	1695	1825	2nd Stage	1335	1600	1750	1980	+
				1275	1395	1585	1670		1225	1450	1630	1830	Norm
				1145	1265	1405	1525		1120	1270	1450	1660	-
			30-60 Low Fire	1130	1230	1365	1475	1st Stage	955	1115	1265	1450	+
				1040	1130	1250	1340		855	1005	1150	1285	Norm
				910	1025	1130	1210		750	890	1060	1170	-
A95DF2V110C20S	1	11x11	45-75 High Fire	1595	1795	1955	2140	2nd Stage	1335	1585	1790	2010	+
				1450	1615	1795	1975		1220	1440	1630	1865	Norm
				1290	1460	1610	1795		1100	1275	1475	1680	-
			35-65 Low Fire	1165	1305	1465	1625	1st Stage	920	1095	1265	1440	+
				1055	1185	1315	1475		830	965	1130	1290	Norm
				930	1070	1180	1320		735	860	1035	1155	-

DIMENSIONS

	Model	A	B	C	D
UPFLOW/HORIZONTAL	A95UH2V045B12S	17-1/2	16-3/8	16	7-5/8
	A95UH2V070B12S	17-1/2	16-3/8	16	7-5/8
	A95UH2V090C12S	21	19-7/8	19-1/2	9-3/8
	A95UH2V090C16S	21	19-7/8	19-1/2	9-3/8
	A95UH2V090C20S	21	19-7/8	19-1/2	9-3/8
	A95UH2V110C16S	21	19-7/8	19-1/2	9-3/8
	A95UH2V110C20S	21	19-7/8	19-1/2	9-3/8
	A95UH2V135D20S	24-1/2	23-3/8	23	11-1/8
DOWNFLOW	A95DF2V045B12S	17-1/2	16-3/8	16	15-1/2
	A95DF2V070B16S	17-1/2	16-3/8	16	15-1/2
	A95DF2V090C20S	21	19-7/8	19-1/2	19
	A95DF2V110C20S	21	19-7/8	19-1/2	19

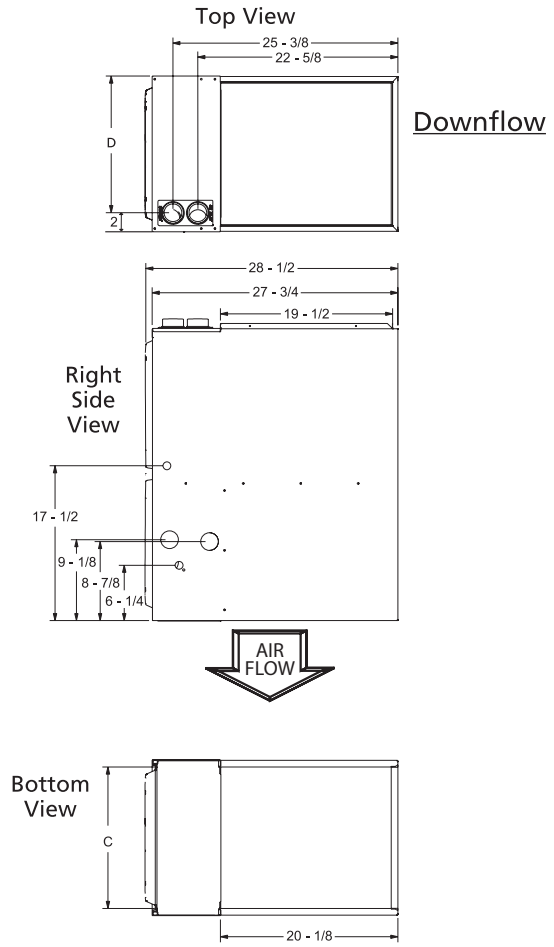
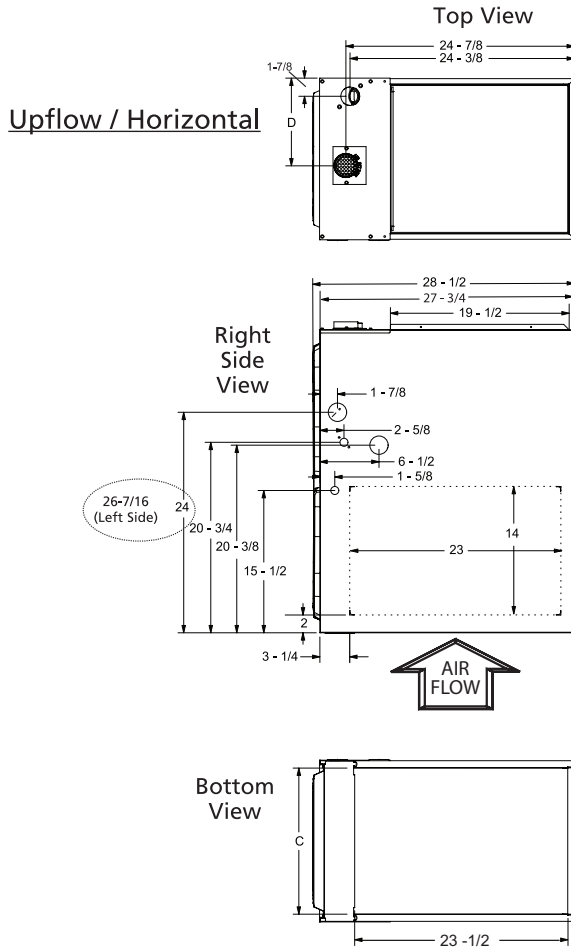
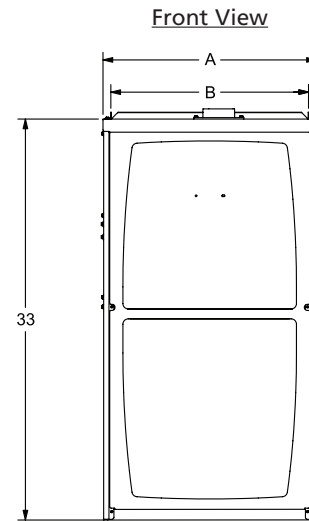

ACCESSORY LIST

CATALOG NUMBER	DESCRIPTION
External Filter Rack kits	
1.841018	1 pack (16 x 25)
1.841039	10 pack (16 x 25)
Natural to LP kits	
68W76	for -1 models
77W08	for -2 models
LP to Natural kits	
73W32	for -1 models
77W10	for -2 models
Return Air Base	
68W61	Return Air Base 14.5 Inch, A Width
68W62	Return Air Base 17.5 Inch, B Width
68W63	Return Air Base 21.0 Inch, C Width
Night Service Kit	
89W54	Two-Stage
Horizontal Suspension Kit	
51W10	80% & 90% Kit
Combustible Floor Base	
11M59	14.5 Inch, A Width
11M60	17.5 Inch, B Width
11M61	21.0 Inch, C Width

Note: For vent length and clearances to combustibles, please reference installation instructions.



1-800-448-5872

All specifications and illustrations subject to change without notice and without incurring obligations.