



Count on it.

Form No. 16228SL Rev B

Service Manual

Workman® GTX Electric & Lithium

Reader Comments

The Toro Company Technical Assistance Center maintains a continuous effort to improve the quality and usefulness of its publications. To do this effectively, we encourage user feedback. Please comment on the completeness, accuracy, organization, usability, and readability of this manual by an e-mail to servicemanuals@toro.com

or Mail to:

**Technical Publication Manager, Commercial
The Toro Company
8111 Lyndale Avenue South
Bloomington, MN 55420-1196
Phone: +1 952-887-8495s**



Workman[®] GTX Electric & Lithium

Service Manual

Preface

The purpose of this publication is to provide the service technician with information for troubleshooting, testing and repair of major systems and components on the Workman GTX Electric vehicle.

REFER TO THE OPERATOR'S MANUAL FOR OPERATING, MAINTENANCE AND ADJUSTMENT INSTRUCTIONS. For reference, insert a copy of the Operator's Manual and Parts Catalog for your machine into Chapter 2 of this service manual. Additional copies of the Operator's Manual and Parts Catalog are available on the internet at www.Toro.com.

The Toro Company reserves the right to change product specifications or this publication without notice.



This safety symbol means DANGER, WARNING or CAUTION, PERSONAL SAFETY INSTRUCTION. When you see this symbol, carefully read the instructions that follow. Failure to obey the instructions may result in personal injury.

NOTE: A NOTE will give general information about the correct operation, maintenance, service, testing or repair of the machine.

IMPORTANT: The IMPORTANT notice will give important instructions which must be followed to prevent damage to systems or components on the machine.



This page is intentionally blank.

Table Of Contents

Chapter 1 - Safety

Safety Instructions	1 - 2
Jacking and Other Instructions	1 - 4
Safety and Instruction Decals	1 - 5

Chapter 2 - Product Records and Maintenance

Product Records	2 - 1
Maintenance	2 - 1
Equivalents and Conversions	2 - 2
Torque Specifications	2 - 3

Chapter 3A - Electrical System

General Information	3A - 2
Vehicle Operation	3A - 4
Special Tools	3A - 5
Troubleshooting	3A - 8
Adjustments	3A - 11
Component Testing	3A - 12
Service and Repairs	3A - 32

Chapter 3B - Electrical System-Lithium

General Information	3B - 2
Vehicle Operation	3B - 5
Special Tools	3B - 11
Troubleshooting	3B - 13
Component Testing	3B - 24
Service and Repairs	3B - 48

Chapter 4 - Transaxle

General Information	4 - 2
Specifications	4 - 3
Service and Repairs	4 - 4

Chapter 5 - Chassis

General Information	5 - 2
Specifications	5 - 3
Special Tools	5 - 4
Troubleshooting	5 - 6
Adjustments	5 - 9
Service and Repairs	5 - 11

Chapter 6 - Electrical Drawings

Electrical Drawing Designations	6 - 2
Electrical Schematic	6 - 3
Electrical Circuit Drawings	6 - 6
Wire Harness Drawings	6 - 9

Safety

Product Records
and Maintenance

Electrical
System

Transaxle

Chassis

Electrical
Drawings

This page is intentionally blank.



Table of Contents

SAFETY INSTRUCTIONS	2
Supervisor's Responsibilities	2
Before Operating	2
While Operating	2
Maintenance and Service	3
JACKING AND OTHER INSTRUCTIONS	4
Jacking Vehicle	4
Towing Vehicle	4
Transporting Vehicle	4
SAFETY AND INSTRUCTION DECALS	5

Safety Instructions

The Workman GTX Electric is designed and tested to offer safe service when operated and maintained properly. Although hazard control and accident prevention are partially dependent upon the design and configuration of the machine, these factors are also dependent upon the awareness, concern and proper training of the personnel involved in the operation, transport, maintenance and storage of the machine. Improper use or maintenance of the machine can result in injury or death. To reduce the potential for injury or death, comply with the following safety instructions.

Read and understand the contents of the Operator's Manual before starting and operating the machine. Become familiar with all controls and know how to stop it quickly. Additional copies of the Operator's Manual are available on the internet at www.Toro.com.

This safety symbol means DANGER, WARNING, or CAUTION, PERSONAL SAFETY INSTRUCTION. When you see this symbol, carefully read the instructions that follow. Failure to obey the instructions may result in personal injury.

 WARNING
To reduce the potential for injury or death, comply with the following safety instructions.

 WARNING
The Workman GTX Electric is an off-highway vehicle only. It is not designed, equipped or manufactured for use on public streets, roads or highways.

Supervisor's Responsibilities

1. Make sure operators are thoroughly trained and familiar with the Operator's Manual and all labels on the vehicle.
2. Be sure to establish your own special procedures and work rules for unusual operating conditions (e.g. slopes too steep for vehicle operation).

Before Operating

1. Read and understand the contents of the Operator's Manual and Operator's DVD before starting and operating the vehicle. Become familiar with the controls and know how to stop the vehicle and engine quickly. Additional copies of the Operator's Manual are available on the internet at www.Toro.com.
2. Keep all shields, safety devices and decals in place. If a shield, safety device or decal is defective, illegible or damaged, repair or replace it before operating the vehicle. Also, tighten any loose nuts, bolts or screws to ensure vehicle is in safe operating condition.

While Operating

1. Sit on the operator seat when starting and operating the vehicle.
2. Before starting the vehicle:
 - A. Make sure that the AC power supply cord (extension cord) is disconnected from the vehicle onboard charger receptacle.
 - B. Engage the parking brake.
 - C. Make sure accelerator pedal is not depressed.
 - D. Check position of direction selector switch and supervision speed limit switch.
3. Before getting off the operator seat:
 - A. Stop vehicle, turn key switch to OFF and remove key from switch.
 - B. Apply the parking brake.
4. If vehicle is parked on incline, chock or block the wheels after getting off the vehicle.

Maintenance and Service

1. Before servicing or making adjustments to the vehicle, stop vehicle, turn key switch to OFF, engage parking brake and remove key from the key switch.
2. Make sure machine is in safe operating condition by keeping all nuts, bolts and screws tight.
3. Do not use open pans of flammable cleaning fluids for cleaning vehicle parts.
4. Keep battery area free of excessive grease, grass, leaves and dirt.
5. As the first step in any electrical system repair, open the battery circuit by disconnecting the conductors between the battery pack and vehicle components (see Opening Battery Circuit in the General Information section of Chapter 3 – Electrical System). Take care during repairs, however, to not allow tools or vehicle components to complete the battery circuit that was opened. Connect the conductors between the battery pack and vehicle components as the last step in the repair.
6. When using metal, uninsulated tools around batteries, do not allow tools to contact both positive and negative battery terminals simultaneously.
7. Remove jewelry and watches before servicing electrical components of the vehicle.
8. Battery acid is poisonous and can cause burns. Avoid battery acid contact with skin, eyes and clothing. Protect your face, eyes and clothing when working with batteries.
9. Battery gases can explode. Keep cigarettes, sparks and flames away from the batteries. Always service, store and charge the vehicle batteries in a well ventilated area.
10. When connecting the AC power supply cord (extension cord) to the vehicle onboard battery charger, connect the power supply cord to the vehicle charger receptacle before plugging the supply cord into an AC outlet (electrical supply for charger). After charging the vehicle batteries, unplug the supply cord from the outlet before disconnecting the supply cord from the vehicle charger receptacle.
11. If major repairs are ever needed or assistance is desired, contact an Authorized Toro Distributor.
12. To assure optimum performance and continued safety of the machine, use genuine Toro replacement parts and accessories. Replacement parts and accessories made by other manufacturers may result in non-conformance with safety standards and the warranty may be voided.
13. When raising the machine to change tires or to perform other service, use correct blocks, hoists and jacks. Make sure machine is parked on a solid level surface such as a concrete floor. Prior to raising the machine, remove any attachments that may interfere with the safe and proper raising of the machine. Always chock or block wheels that remain on the ground for vehicle stability. Use jack stands to support the raised machine. If the machine is not properly supported by jack stands, the machine may move or fall, which may result in personal injury (see Jacking Instructions in the Operator's Manual and in this Chapter).
14. Make sure to dispose potentially harmful waste (e.g. batteries, oil) in an environmentally safe manner. Follow all local codes and regulations when recycling or disposing of waste.

Jacking and Other Instructions

Jacking Vehicle



DANGER

POTENTIAL HAZARD

- A vehicle that is not properly supported may become unstable.

WHAT CAN HAPPEN

- The vehicle may move or fall. Personal injury or damage to the machine may result.

HOW TO AVOID THE HAZARD

- Make sure vehicle is parked on a solid level surface, such as a concrete floor.
- Make sure key switch is OFF and key is removed from the switch before getting off the vehicle.
- Before raising the vehicle, remove any attachments that may interfere with the safe and proper raising of the vehicle.
- Always chock or block wheels to prevent the vehicle from rolling.
- Make sure proper hoists and jack stands are used to raise and support the vehicle.

Jacking Locations

1. Jack front of the vehicle on the front of the frame behind the towing tongue (Fig. 1).
2. Jack rear of the vehicle under each rear axle tube. Do not jack vehicle below the transaxle case (Fig. 2).

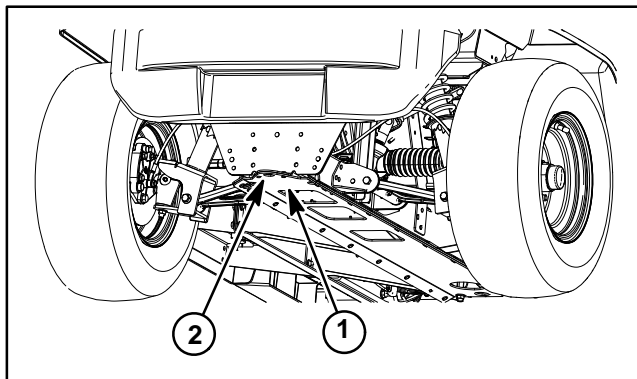

Figure 1

1. Front of frame
2. Towing tongue

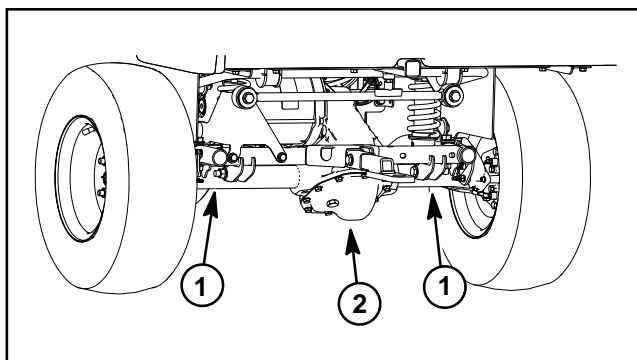

Figure 2

1. Rear axle tube
2. Transaxle case

Towing Vehicle

IMPORTANT: Frequent or long distance towing of the Workman GTX Electric is not recommended.

In case of emergency, the vehicle can be towed for a **short** distance. See Operator's Manual for towing information.

IMPORTANT: If vehicle is towed, make sure that key switch is in the OFF position, parking brake is released and key is removed from switch.

Transporting Vehicle

When moving the vehicle long distances, use a trailer or flatbed truck. Make sure vehicle is secured to the trailer properly. Also, make sure to secure seats to vehicle during transport. See Operator's Manual for transport information.

Safety and Instruction Decals

There are several safety and instruction decals attached to your Workman vehicle. If any decal becomes illegible or damaged, install a new decal. Part numbers are listed in the Parts Catalog. Order replacement decals from your Authorized Toro Distributor.

This page is intentionally blank.



Product Records and Maintenance

Product Records and Maintenance

Table of Contents

PRODUCT RECORDS 1
MAINTENANCE 1
EQUIVALENTS AND CONVERSIONS 2
 Decimal and Millimeter Equivalents 2
 U.S. to Metric Conversions 2
TORQUE SPECIFICATIONS 3
 Fastener Identification 3
 Using a Torque Wrench with an Offset Wrench .. 3
 Standard Torque for Dry, Zinc Plated and
 Steel Fasteners (Inch Series) 4
 Standard Torque for Dry, Zinc Plated and
 Steel Fasteners (Metric Fasteners) 5
 Other Torque Specifications 6
 Conversion Factors 6

Product Records

Insert Operator’s Manual and Parts Catalog for your Workman vehicle at the end of this chapter. Additionally, if any optional equipment or accessories have been installed to your Workman, insert the Installation Instructions, Operator’s Manuals and Parts Catalogs for those options at the end of this chapter.

Maintenance

Maintenance procedures and recommended service intervals for the Workman GTX Electric are covered in the Operator’s Manual. Refer to that publication when performing regular vehicle maintenance.

Equivalents and Conversions

Decimal and Millimeter Equivalents

Fractions	Decimals	mm	Fractions	Decimals	mm
	1/64	0.015625	—	0.397	
	1/32	0.03125	—	0.794	
	3/64	0.046875	—	1.191	
1/16	—	0.0625	—	1.588	
	5/64	0.078125	—	1.984	
	3/32	0.09375	—	2.381	
	7/64	0.109275	—	2.778	
1/8	—	0.1250	—	3.175	
	9/64	0.140625	—	3.572	
	5/32	0.15625	—	3.969	
	11/64	0.171875	—	4.366	
3/16	—	0.1875	—	4.762	
	13/64	0.203125	—	5.159	
	7/32	0.21875	—	5.556	
	15/64	0.234375	—	5.953	
1/4	—	0.2500	—	6.350	
	17/64	0.265625	—	6.747	
	9/32	0.28125	—	7.144	
	19/64	0.296875	—	7.541	
5/16	—	0.3125	—	7.938	
	21/64	0.328125	—	8.334	
	11/32	0.34375	—	8.731	
	23/64	0.359375	—	9.128	
3/8	—	0.3750	—	9.525	
	25/64	0.390625	—	9.922	
	13/32	0.40625	—	10.319	
	27/64	0.421875	—	10.716	
7/16	—	0.4375	—	11.112	
	29/64	0.453125	—	11.509	
	15/32	0.46875	—	11.906	
	31/64	0.484375	—	12.303	
1/2	—	0.5000	—	12.700	
	1 mm = 0.03937 in.			0.001 in. = 0.0254 mm	
				33/64	0.515625
				17/32	0.53125
				35/64	0.546875
			9/16	—	0.5625
				37/64	0.578125
				19/32	0.59375
				39/64	0.609375
			5/8	—	0.6250
				41/64	0.640625
				21/32	0.65625
				43/64	0.671875
			11/16	—	0.6875
				45/64	0.703125
				23/32	0.71875
				47/64	0.734375
			3/4	—	0.7500
				49/64	0.765625
				25/32	0.78125
				51/64	0.796875
			13/16	—	0.8125
				53/64	0.828125
				27/32	0.84375
				55/64	0.859375
			7/8	—	0.8750
				57/64	0.890625
				29/32	0.90625
				59/64	0.921875
			15/16	—	0.9375
				61/64	0.953125
				31/32	0.96875
				63/64	0.984375
			1	—	1.000

U.S. to Metric Conversions

	To Convert	Into	Multiply By
Linear Measurement	Miles	Kilometers	1.609
	Yards	Meters	0.9144
	Feet	Meters	0.3048
	Feet	Centimeters	30.48
	Inches	Meters	0.0254
	Inches	Centimeters	2.54
	Inches	Millimeters	25.4
Area	Square Miles	Square Kilometers	2.59
	Square Feet	Square Meters	0.0929
	Square Inches	Square Centimeters	6.452
	Acre	Hectare	0.4047
Volume	Cubic Yards	Cubic Meters	0.7646
	Cubic Feet	Cubic Meters	0.02832
	Cubic Inches	Cubic Centimeters	16.39
Weight	Tons (Short)	Metric Tons	0.9078
	Pounds	Kilograms	0.4536
	Ounces (Avdp.)	Grams	28.3495
Pressure	Pounds/Sq. In.	Kilopascal	6.895
	Pounds/Sq. In.	Bar	0.069
Work	Foot-pounds	Newton-Meters	1.356
	Foot-pounds	Kilogram-Meters	0.1383
	Inch-pounds	Kilogram-Centimeters	1.152144
Liquid Volume	Quarts	Liters	0.9463
	Gallons	Liters	3.785
Liquid Flow	Gallons/Minute	Liters/Minute	3.785
Temperature	Fahrenheit	Celsius	1. Subtract 32°
			2. Multiply by 5/9

Torque Specifications

Recommended fastener torque values are listed in the following tables. For critical applications, as determined by Toro, either the recommended torque or a torque that is unique to the application is clearly identified and specified in this Service Manual.

These Torque Specifications for the installation and tightening of fasteners shall apply to all fasteners which do not have a specific requirement identified in this Service Manual. The following factors shall be considered when applying torque: cleanliness of the fastener, use of a thread sealant (e.g. Loctite), degree of lubrication on the fastener, presence of a prevailing torque feature (e.g. Nylock nut), hardness of the surface underneath the fastener's head or similar condition which affects the installation.

As noted in the following tables, torque values should be **reduced by 25% for lubricated fasteners** to achieve the similar stress as a dry fastener. Torque values may also have to be reduced when the fastener is threaded into aluminum or brass. The specific torque value should be determined based on the aluminum or brass material strength, fastener size, length of thread engagement, etc.

The standard method of verifying torque shall be performed by marking a line on the fastener (head or nut) and mating part, then back off fastener 1/4 of a turn. Measure the torque required to tighten the fastener until the lines match up.

Fastener Identification

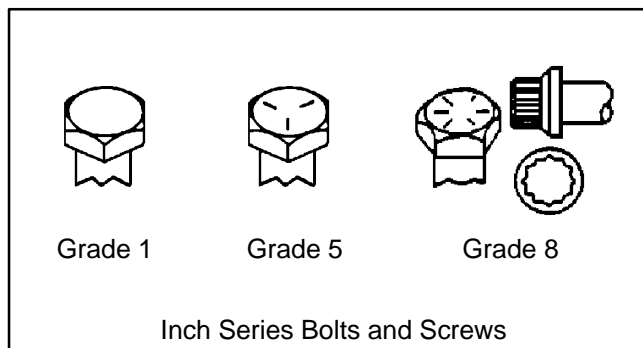

Figure 1

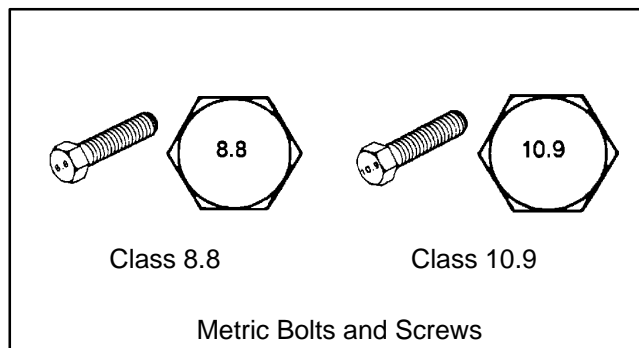

Figure 2

Using a Torque Wrench with an Offset Wrench

Use of an offset wrench (e.g. crowfoot wrench) will affect torque wrench calibration due to the effective change of torque wrench length. When using a torque wrench with an offset wrench, multiply the listed torque recommendation by the calculated torque conversion factor (Fig. 3) to determine proper tightening torque. Tightening torque when using a torque wrench with an offset wrench will be lower than the listed torque recommendation.

Example: The measured effective length of the torque wrench (distance from the center of the handle to the center of the square drive) is 18".

The measured effective length of the torque wrench with the offset wrench installed (distance from the center of the handle to the center of the offset wrench) is 19".

The calculated torque conversion factor for this torque wrench with this offset wrench would be $18 / 19 = 0.947$.

If the listed torque recommendation for a fastener is from 76 to 94 ft-lb, the proper torque when using this torque wrench with an offset wrench would be from 72 to 89 ft-lb.

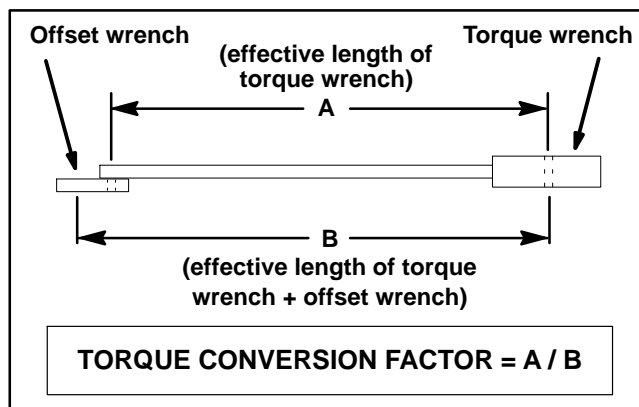

Figure 3

Standard Torque for Dry, Zinc Plated and Steel Fasteners (Inch Series)

Thread Size	Grade 1, 5 & 8 with Thin Height Nuts	SAE Grade 1 Bolts, Screws, Studs & Sems with Regular Height Nuts (SAE J995 Grade 2 or Stronger Nuts)		SAE Grade 5 Bolts, Screws, Studs & Sems with Regular Height Nuts (SAE J995 Grade 2 or Stronger Nuts)		SAE Grade 8 Bolts, Screws, Studs & Sems with Regular Height Nuts (SAE J995 Grade 5 or Stronger Nuts)	
	in-lb	in-lb	N-cm	in-lb	N-cm	in-lb	N-cm
# 6 – 32 UNC	10 ± 2	13 ± 2	147 ± 23	15 ± 2	169 ± 23	23 ± 3	262 ± 34
# 6 – 40 UNF				17 ± 2	192 ± 23	25 ± 3	282 ± 34
# 8 – 32 UNC	13 ± 2	25 ± 5	282 ± 30	29 ± 3	328 ± 34	41 ± 5	463 ± 56
# 8 – 36 UNF				31 ± 4	350 ± 45	43 ± 5	486 ± 56
# 10 – 24 UNC	18 ± 2	30 ± 5	339 ± 56	42 ± 5	475 ± 56	60 ± 6	678 ± 68
# 10 – 32 UNF				48 ± 5	542 ± 56	68 ± 7	768 ± 79
1/4 – 20 UNC	48 ± 7	53 ± 7	599 ± 79	100 ± 10	1130 ± 113	140 ± 15	1582 ± 169
1/4 – 28 UNF	53 ± 7	65 ± 10	734 ± 113	115 ± 12	1299 ± 136	160 ± 17	1808 ± 192
5/16 – 18 UNC	115 ± 15	105 ± 15	1186 ± 169	200 ± 25	2260 ± 282	300 ± 30	3390 ± 339
5/16 – 24 UNF	138 ± 17	128 ± 17	1446 ± 192	225 ± 25	2542 ± 282	325 ± 33	3672 ± 373
	ft-lb	ft-lb	N-m	ft-lb	N-m	ft-lb	N-m
3/8 – 16 UNC	16 ± 2	16 ± 2	22 ± 3	30 ± 3	41 ± 4	43 ± 5	58 ± 7
3/8 – 24 UNF	17 ± 2	18 ± 2	24 ± 3	35 ± 4	47 ± 5	50 ± 6	68 ± 8
7/16 – 14 UNC	27 ± 3	27 ± 3	37 ± 4	50 ± 5	68 ± 7	70 ± 7	95 ± 9
7/16 – 20 UNF	29 ± 3	29 ± 3	39 ± 4	55 ± 6	75 ± 8	77 ± 8	104 ± 11
1/2 – 13 UNC	30 ± 3	48 ± 7	65 ± 9	75 ± 8	102 ± 11	105 ± 11	142 ± 15
1/2 – 20 UNF	32 ± 4	53 ± 7	72 ± 9	85 ± 9	115 ± 12	120 ± 12	163 ± 16
5/8 – 11 UNC	65 ± 10	88 ± 12	119 ± 16	150 ± 15	203 ± 20	210 ± 21	285 ± 28
5/8 – 18 UNF	75 ± 10	95 ± 15	129 ± 20	170 ± 18	230 ± 24	240 ± 24	325 ± 33
3/4 – 10 UNC	93 ± 12	140 ± 20	190 ± 27	265 ± 27	359 ± 37	375 ± 38	508 ± 52
3/4 – 16 UNF	115 ± 15	165 ± 25	224 ± 34	300 ± 30	407 ± 41	420 ± 43	569 ± 58
7/8 – 9 UNC	140 ± 20	225 ± 25	305 ± 34	430 ± 45	583 ± 61	600 ± 60	813 ± 81
7/8 – 14 UNF	155 ± 25	260 ± 30	353 ± 41	475 ± 48	644 ± 65	667 ± 66	904 ± 89

NOTE: Reduce torque values listed in the table above by 25% for lubricated fasteners. Lubricated fasteners are defined as threads coated with a lubricant such as engine oil or thread sealant such as Loctite.

NOTE: Torque values may have to be reduced when installing fasteners into threaded aluminum or brass. The specific torque value should be determined based on the fastener size, the aluminum or base material strength, length of thread engagement, etc.

NOTE: The nominal torque values listed above for Grade 5 and 8 fasteners are based on 75% of the minimum proof load specified in SAE J429. The tolerance is approximately ± 10% of the nominal torque value. Thin height nuts include jam nuts.

Standard Torque for Dry, Zinc Plated and Steel Fasteners (Metric Series)

Thread Size	Class 8.8 Bolts, Screws and Studs with Regular Height Nuts (Class 8 or Stronger Nuts)		Class 10.9 Bolts, Screws and Studs with Regular Height Nuts (Class 10 or Stronger Nuts)	
M5 X 0.8	57 ± 6 in-lb	644 ± 68 N-cm	78 ± 8 in-lb	881 ± 90 N-cm
M6 X 1.0	96 ± 10 in-lb	1085 ± 113 N-cm	133 ± 14 in-lb	1503 ± 158 N-cm
M8 X 1.25	19 ± 2 ft-lb	26 ± 3 N-m	28 ± 3 ft-lb	38 ± 4 N-m
M10 X 1.5	38 ± 4 ft-lb	52 ± 5 N-m	54 ± 6 ft-lb	73 ± 8 N-m
M12 X 1.75	66 ± 7 ft-lb	90 ± 10 N-m	93 ± 10 ft-lb	126 ± 14 N-m
M16 X 2.0	166 ± 17 ft-lb	225 ± 23 N-m	229 ± 23 ft-lb	310 ± 31 N-m
M20 X 2.5	325 ± 33 ft-lb	440 ± 45 N-m	450 ± 46 ft-lb	610 ± 62 N-m

Product Records and Maintenance

NOTE: Reduce torque values listed in the table above by 25% for lubricated fasteners. Lubricated fasteners are defined as threads coated with a lubricant such as engine oil or thread sealant such as Loctite.

NOTE: The nominal torque values listed above are based on 75% of the minimum proof load specified in SAE J1199. The tolerance is approximately ± 10% of the nominal torque value.

NOTE: Torque values may have to be reduced when installing fasteners into threaded aluminum or brass. The specific torque value should be determined based on the fastener size, the aluminum or base material strength, length of thread engagement, etc.

Other Torque Specifications

SAE Grade 8 Steel Set Screws

Thread Size	Recommended Torque	
	Square Head	Hex Socket
1/4 – 20 UNC	140 ± 20 in-lb	73 ± 12 in-lb
5/16 – 18 UNC	215 ± 35 in-lb	145 ± 20 in-lb
3/8 – 16 UNC	35 ± 10 ft-lb	18 ± 3 ft-lb
1/2 – 13 UNC	75 ± 15 ft-lb	50 ± 10 ft-lb

Wheel Bolts and Lug Nuts

Thread Size	Recommended Torque**	
7/16 – 20 UNF Grade 5	65 ± 10 ft-lb	88 ± 14 N-m
1/2 – 20 UNF Grade 5	80 ± 10 ft-lb	108 ± 14 N-m
M12 X 1.25 Class 8.8	80 ± 10 ft-lb	108 ± 14 N-m
M12 X 1.5 Class 8.8	80 ± 10 ft-lb	108 ± 14 N-m

** For steel wheels and non-lubricated fasteners.

Thread Cutting Screws (Zinc Plated Steel)

Type 1, Type 23 or Type F	
Thread Size	Baseline Torque*
No. 6 – 32 UNC	20 ± 5 in-lb
No. 8 – 32 UNC	30 ± 5 in-lb
No. 10 – 24 UNC	38 ± 7 in-lb
1/4 – 20 UNC	85 ± 15 in-lb
5/16 – 18 UNC	110 ± 20 in-lb
3/8 – 16 UNC	200 ± 100 in-lb

Thread Cutting Screws (Zinc Plated Steel)

Thread Size	Threads per Inch		Baseline Torque*
	Type A	Type B	
No. 6	18	20	20 ± 5 in-lb
No. 8	15	18	30 ± 5 in-lb
No. 10	12	16	38 ± 7 in-lb
No. 12	11	14	85 ± 15 in-lb

* Hole size, material strength, material thickness and finish must be considered when determining specific torque values. All torque values are based on non-lubricated fasteners.

Conversion Factors

$$\text{in-lb} \times 11.2985 = \text{N-cm}$$

$$\text{ft-lb} \times 1.3558 = \text{N-m}$$

$$\text{N-cm} \times 0.08851 = \text{in-lb}$$

$$\text{N-m} \times 0.7376 = \text{ft-lb}$$



Electrical System

Table of Contents

GENERAL INFORMATION	2	SERVICE AND REPAIRS	32
Operator's Manual	2	Battery Service	32
Electrical Drawings	2	Battery Specifications	32
Rear Frame Panel Cover	2	Battery Removal	33
Opening Battery Circuit	3	Battery Installation	33
VEHICLE OPERATION	4	Battery Inspection and Maintenance	34
SPECIAL TOOLS	5	Battery Testing	35
TROUBLESHOOTING	8	Battery Charging	36
General Run Problems	8	Battery Storage	36
Battery Charger Operation	10	Traction Motor	38
Battery Charger Problems	11	Traction Motor Service	42
COMPONENT TESTING	12	Controller	46
Key Switch	12	On-board Battery Charger	48
Fuses	13		
Battery Discharge Indicator	14		
Light Switch	15		
Direction Selector Switch	16		
Status Indicator Light	17		
Supervision Speed Limit Switch	18		
Parking Brake Switch	19		
USB Charge Port	20		
Main Contactor (48 VDC)	21		
Accelerator Pedal	22		
Traction Motor	23		
On-board Battery Charger	24		
Controller	26		
Diode Assembly	30		
Reverse Audio Alarm (if Equipped)	31		

Electrical System

General Information

The Workman GTX Electric uses a 48 VDC electrical system that is an isolated circuit. The vehicle frame is not used for any ground connections.

The vehicle controller monitors operator and vehicle inputs to determine voltage to the traction motor. If a problem exists that will prevent normal vehicle operation, an LED on the controller and the status indicator light on the dash panel will flash a fault code to assist in identifying the problem.

After performing any repair on electrical components on the vehicle, make sure that wiring is routed and secured so as to prevent abrasion or contact with moving vehicle parts.

Operator's Manual

The Operator's Manual provides information regarding the operation, general maintenance and maintenance intervals for your Workman vehicle. Refer to the Operator's Manual for additional information when servicing the machine.

Electrical Drawings

The electrical schematic and other electrical drawings for the Workman GTX Electric are located in Chapter 6 - Electrical Drawings.

Rear Frame Panel Cover

A panel cover is secured to the top of the rear frame behind the seats to prevent debris entry to the front of the swing arm area. The cover can easily be removed by releasing the latches and lifting the cover from the rear frame.

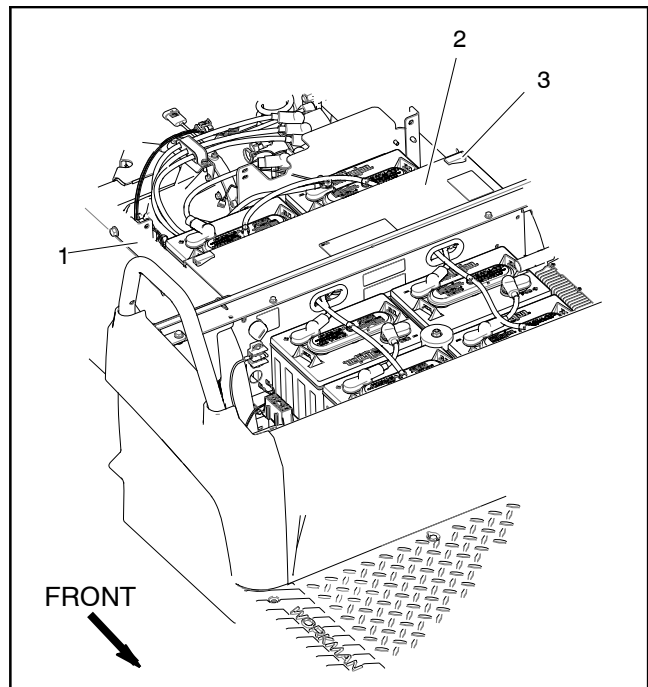

Figure 1

- 1. Rear frame
- 2. Panel cover
- 3. Latch (2 used)

Opening Battery Circuit

To prevent allowing a current path through tools used during vehicle electrical circuit repairs, disconnect the conductors between the battery pack and vehicle components as the first step in any electrical system repair.

Battery pack cable routing is shown in Figure 2.

Before working on the vehicle electrical system, remove battery conductors as follows (Fig. 2):

1. Park vehicle on a level surface, turn key switch to OFF, engage the parking brake and remove key from the key switch. Make sure that the vehicle battery charger is not connected to an electrical outlet.

2. Raise and support cargo bed to allow access to battery pack.

3. Remove hex nut from negative terminal on the left, rear battery that secures the negative cable from the vehicle controller, the wire harness ground conductor and the negative (black and white) conductors from the battery charger. Remove all of the conductors from the negative battery terminal.

4. Remove hex nut from the positive terminal on the right, rear battery that secures the positive cable to the vehicle main contactor and the positive (red) conductor from the battery charger. Remove the conductors from the positive battery terminal.

5. Make sure that disconnected conductors are positioned away from the battery terminals.

6. Service electrical system on the vehicle as required. Take care during repairs, however, to not allow tools or vehicle components to complete the battery circuit that was opened with the cable removal.

After working on the vehicle electrical system, attach battery conductors as follows (Fig. 2):

1. Make sure that key is removed from the key switch.

2. Install the positive cable from the vehicle main contactor and the positive conductor (red charger wire) from the battery charger onto the positive terminal on the right, rear battery. Secure conductors to battery with hex nut and torque nut from **95 to 105 in-lb (10.8 to 11.8 N-m)**.

3. Install the negative cable from the vehicle controller, the wire harness ground conductor and the negative conductors (black and white charger wires) from the battery charger onto the negative terminal on the left, rear battery. Secure conductors to battery with hex nut and torque nut from **95 to 105 in-lb (10.8 to 11.8 N-m)**.

4. Apply battery terminal protector (see Special Tools in this chapter) to the connections after the conductors have been secured to the battery terminals. Also, make sure that boot is positioned over positive terminal of the right, rear battery.

5. Lower and secure cargo bed.

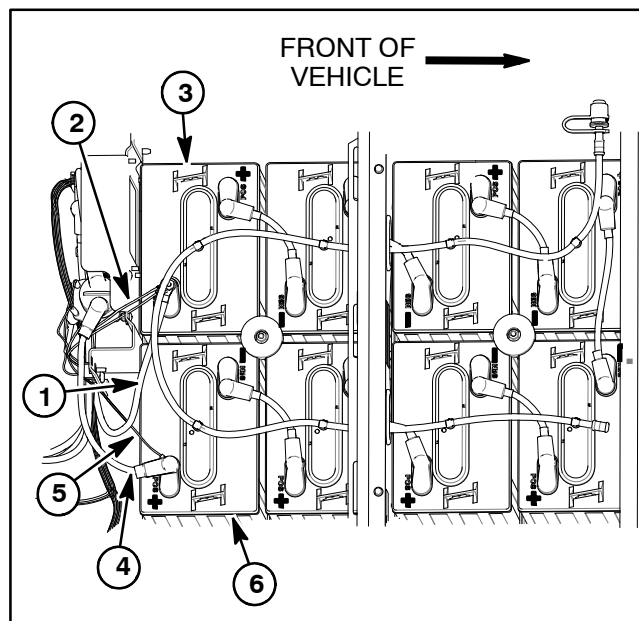

Figure 2

1. Negative cable to controller
2. Negative conductors from charger and harness
3. Left, rear battery
4. Positive cable to main contactor
5. Positive conductor from charger
6. Right, rear battery

Vehicle Operation

The Workman GTX Electric electrical system uses a 48 volt battery pack, an electric traction motor, a vehicle controller and numerous other electrical components to allow vehicle operation.

Eight, 6 volt, advanced deep cycle batteries that are connected in series provide current for a 48V, brushless, high torque, AC inductive traction motor, the vehicle controller and vehicle accessories. The batteries are discharged as the vehicle is used so charging the batteries after using the vehicle is necessary. A battery discharge indicator on the dash provides the operator with information on battery charge level. Demands on the vehicle during use (speed, payload, incline use), battery condition (age, charge level), ambient temperature and vehicle condition will all put constraints on how long a vehicle can be used before the batteries are in need of recharging.

IMPORTANT: When connecting the battery pack in the 48 VDC system, make sure that battery polarity is carefully checked. System damage can occur if batteries are not connected correctly.

The Workman GTX electrical system is an isolated system so the vehicle frame is not used for any ground connections. Before performing any electrical service, it is recommended to open the vehicle battery circuit by disconnecting the conductors between the battery pack and vehicle components (see Opening Battery Circuit in the General Information section of this chapter). This will prevent unexpected component operation when performing service on the vehicle.

The electric traction motor directly drives a double reduction, high torque transaxle with integral differential. Operator inputs for forward/reverse, supervision speed limit switch position and accelerator pedal position are used by the controller to determine needed electrical power for the traction motor.

The traction motor is protected from overheating by a thermistor (thermally sensitive resistor) that resides in the motor housing. If unsafe motor temperature is sensed by the thermistor, the controller will limit vehicle speed and torque until the motor temperature reduces to a normal level.

The vehicle controller is a sealed electronic logic device that uses inputs from several vehicle components to control motor speed and direction. These inputs include several switches (key, direction selector, supervision speed limit, parking brake), the traction motor thermistor (temperature), the traction motor encoder (speed sensor), the accelerator pedal and the vehicle main contactor (solenoid). The controller also provides regenerative braking to assist in slowing the vehicle whenever the accelerator pedal is released. The controller has fault detection capabilities to help identify system problems. Battery current is available to the controller whenever the key switch is ON which energizes the main contactor. A high current fuse mounted to the controller protects the 48 VDC circuits.

The Workman controller also limits roll away speed in instances when the vehicle begins to move (roll away) after being stopped. On an incline and with the key switch in the ON position, if the vehicle starts moving, regenerative braking will limit vehicle speed.

Vehicle accessories (headlights, USB charge port, optional reverse alarm and optional lights) are operated by a 12 VDC system that is powered by a 48 VDC to 12 VDC converter mounted under the dash panel. These vehicle accessories receive current for operation when the key switch is ON. The 10 amp fuse in the fuse block provides circuit protection for the components in this 12 VDC system. Ground wires used for 12 VDC circuits have black insulation.

An on-board, fully automatic, high efficiency 1kW smart charger with 85 - 265 VAC global input is attached to the vehicle for charging the battery pack. The vehicle controller prevents the vehicle from operating while charging the batteries. Charger activity can be monitored at the indicator LED near the battery charge receptacle on the left side of the vehicle.

Testing and service information about components used in the Workman GTX electrical system is included in the Component Testing and Service and Repairs sections of this chapter.

Special Tools

Order special tools from your Toro Distributor. Some tools may also be available from a local supplier.

Multimeter

The multimeter can test electrical components and circuits for current, resistance or voltage.

NOTE: Toro recommends the use of a DIGITAL Volt-Ohm-Amp multimeter when testing electrical circuits. The high impedance (internal resistance) of a digital meter in the voltage mode will make sure that excess current is not allowed through the meter. This excess current can cause damage to circuits not designed to carry it.

NOTE: Workman GTX Electric vehicles use a 48 volt, DC electrical system. If multimeter is not of the auto-range type, make sure to properly set multimeter range before performing any voltage test.

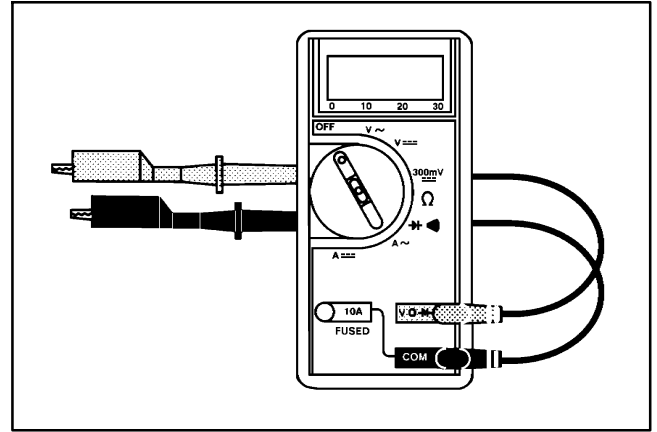

Figure 3

Electrical System

Battery Terminal Protector

Aerosol spray that should be used on battery terminals, ring terminals and fork terminals to reduce corrosion problems. Apply terminal protector to the connection after the battery cable, ring terminal or fork terminal has been secured.

Toro Part Number: **107-0392**



Figure 4

Dielectric Gel

Dielectric gel should be used to prevent corrosion of unsealed connection terminals. To ensure complete coating of terminals, liberally apply gel to both component and wire harness connector, plug connector to component, unplug connector, reapply gel to both surfaces and reconnect harness connector to component. Connectors should be thoroughly packed with gel for effective results.

Do not use dielectric gel on sealed connection terminals as the gel can unseat connector seals during assembly.

Toro Part Number: **107-0342**



Figure 5

Hand Pump Hose Assembly

Use the hand pump hose assembly when adding distilled water to vehicle batteries through the single port fill system. The hand pump hose coupler attaches to the fill port coupler on the Workman vehicle.

Toro Part Number: **131-8522**

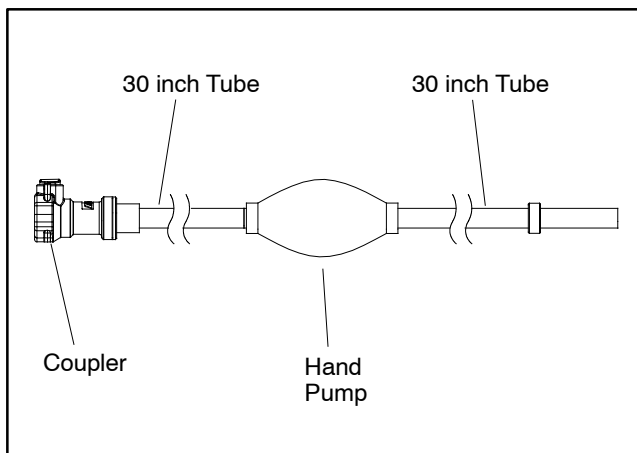

Figure 6

Battery Lift Strap

Use the battery lift strap to remove and install batteries from the vehicle. Lift strap allows use of case loops on battery tops as safe battery lifting points. Obtain battery lift strap locally.



Figure 7

Battery Hydrometer

Use the battery hydrometer when measuring specific gravity of battery electrolyte. Obtain hydrometer locally.



Figure 8

36/48 Volt Battery Discharge Unit

The 36/48 Volt Battery Discharge Unit is recommended for quick and accurate load testing for the batteries on a Workman GTX Electric vehicle. This tool is used to determine the capacity of the Workman battery pack and also for finding a faulty battery (or batteries) in the battery pack.

Toro Part Number: **TOR4106**



Figure 9

Troubleshooting



CAUTION

Remove all jewelry, especially rings and watches, before doing any electrical troubleshooting or testing. Before working on the vehicle electrical system, open the battery circuit by disconnecting the conductors between the battery pack and vehicle components (see Opening Battery Circuit in the General Information section of this chapter). Connect the battery circuit if a test procedure requires battery voltage.

For effective troubleshooting and repairs, there must be a good understanding of the electrical circuits and components used on this vehicle (see Electrical Schematic and wire harness drawings in Chapter 6 - Electrical Drawings).

If the vehicle has any switches by-passed, they must be reconnected for proper vehicle operation, troubleshooting and safety.

General Run Problems

NOTE: Check status indicator light on dash panel or controller LED for possible faults whenever diagnosing vehicle electrical circuit problems (see Controller in the Component Testing section of this chapter).

Problem	Possible Causes
Main contactor clicks, but vehicle will not operate.	<p>Battery charge is low (check battery discharge indicator on dash).</p> <p>Battery cables are loose, corroded or damaged.</p> <p>Cable connection(s) at main contactor is/are loose or corroded.</p> <p>Cable connection(s) at controller is/are loose or corroded.</p> <p>Cable connection(s) at traction motor is/are loose or corroded.</p> <p>Traction motor is faulty (check status indicator light on dash or LED on controller for possible fault).</p> <p>Controller is faulty (check status indicator light on dash or LED on controller for possible fault).</p>

General Run Problems (Continued)

Problem	Possible Causes
Nothing happens when key switch is turned to ON.	<p>Battery charge is extremely low (check battery discharge indicator on dash).</p> <p>Battery cables are loose, corroded or damaged.</p> <p>Cable connection(s) at main contactor is/are loose or corroded.</p> <p>10 ampere fuse to the key switch is loose or faulty.</p> <p>Cable connection(s) at controller is/are loose or corroded.</p> <p>425 ampere fuse on controller is loose or faulty.</p> <p>Main contactor or circuit wiring is faulty (check status indicator light on dash or LED on controller for possible fault).</p> <p>The key switch or circuit wiring is faulty.</p> <p>Controller is faulty (check status indicator light on dash or LED on controller for possible fault).</p>
Traction motor stops during operation.	<p>Battery charge is extremely low (check battery discharge indicator on dash).</p> <p>Wiring to the traction motor components (e.g. main contactor, controller, traction motor) is loose, corroded or damaged (refer to Electrical Schematic in Chapter 6 - Electrical Diagrams).</p> <p>Battery cables are loose, corroded or damaged.</p> <p>Traction motor is overheated (check status indicator light on dash or LED on controller for possible fault).</p> <p>Controller is overheated (check status indicator light on dash or LED on controller for possible fault).</p> <p>Traction motor is faulty (check status indicator light on dash or LED on controller for possible fault).</p> <p>Brake problem exists (see Brakes in the Troubleshooting section of Chapter 5 - Chassis).</p> <p>Transaxle problem exists (see Chapter 4 - Transaxle).</p>

General Run Problems (Continued)

Problem	Possible Causes
Vehicle runs slowly.	<p>The supervision speed limit switch is in the slow position.</p> <p>Tire pressure is low (see Check Tire Pressure in the Service and Repairs section of Chapter 5 - Chassis).</p> <p>The parking brake is improperly adjusted (see Adjust Parking Brake in the Adjustments section of Chapter 5 - Chassis).</p> <p>Brakes are worn or faulty (see Brakes in the Troubleshooting section of Chapter 5 - Chassis).</p> <p>Battery charge is extremely low (check battery discharge indicator on dash).</p> <p>Controller is overheated (check status indicator light on dash or LED on controller for possible fault).</p> <p>Traction motor is overheated (check status indicator light on dash or LED on controller for possible fault).</p>
Vehicle movement is erratic or jerky.	<p>Accelerator pedal movement is dirty preventing smooth pedal operation.</p> <p>Accelerator pedal is worn or faulty (check status indicator light on dash or LED on controller for possible fault).</p> <p>A brake system problem exists (see Brakes in the Troubleshooting section of Chapter 5 - Chassis).</p> <p>A transaxle problem exists (see Chapter 4 - Transaxle).</p>

Battery Charger Operation

Light Status	Indicates
Green light on battery charger is illuminated (not flashing).	Batteries is fully charged. Vehicle ready to operate.
Green light on battery charger is flashing.	<p>Slow flash (once per second): Batteries being charged (batteries less than 80% charged). Continue charging.</p> <p>Rapid flash (four times per second): Batteries being charged (batteries more than 80% charged). Continue charging.</p>
Red light on battery charger is flashing.	<p>Rapid flash: Charger timer shutoff has occurred after 20 hours of charging.</p> <p>Slow flash: No current to charger. Check AC outlet (electrical supply for charger) and AC power supply cord (extension cord).</p>

Battery Charger Problems

NOTE: Check battery charger diagnostic LED for possible faults whenever diagnosing on-board battery charger problems (see On-board Battery Charger in the Component Testing section of this chapter).

Problem	Possible Causes
Battery charger does not turn on.	<p>AC outlet (electrical supply for charger) circuit breaker or fuse is tripped or blown.</p> <p>AC outlet (electrical supply for charger) is faulty.</p> <p>AC power supply cord (extension cord) is faulty.</p> <p>Vehicle wiring is loose or damaged (see electrical schematic in Chapter 6 - Electrical Diagrams).</p> <p>Vehicle charger receptacle or circuit wiring is damaged.</p> <p>On-board battery charger is faulty (check charger diagnostic LED on charger for possible fault).</p>
Battery charger does not turn off.	<p>NOTE: Charging new batteries or charging batteries in cold temperatures may require extended charge time to achieve full charge.</p> <p>On-board battery charger is faulty (check charger diagnostic LED on charger for possible fault).</p>
The AC outlet (electrical supply for charger) circuit breaker or fuse is tripped or blown when using the battery charger.	<p>Overloaded AC circuit (electrical supply for charger).</p> <p>On-board battery charger is faulty (check charger diagnostic LED on charger for possible fault).</p>

Component Testing

For accurate resistance and/or continuity checks, electrically disconnect the component being tested from the circuit (e.g. disconnect the harness wire connectors from the vehicle key switch before doing a continuity check on the key switch).

**CAUTION**

When testing electrical components for continuity with a multimeter (ohms setting), make sure that power to the circuit has been disconnected.

Key Switch

The Workman GTX Electric key switch has two (2) positions (OFF and ON) and three (3) switch terminals on the back of the switch. The key switch is located on the dash panel.

NOTE: Only key switch terminals B1 and 3 are used on the Workman GTX Electric vehicle.

NOTE: The Workman GTX Electric key switch circuit is a 48 VDC circuit.

Testing

**CAUTION**

When testing the key switch for continuity with a multimeter (ohms setting), make sure that power to the circuit has been disconnected.

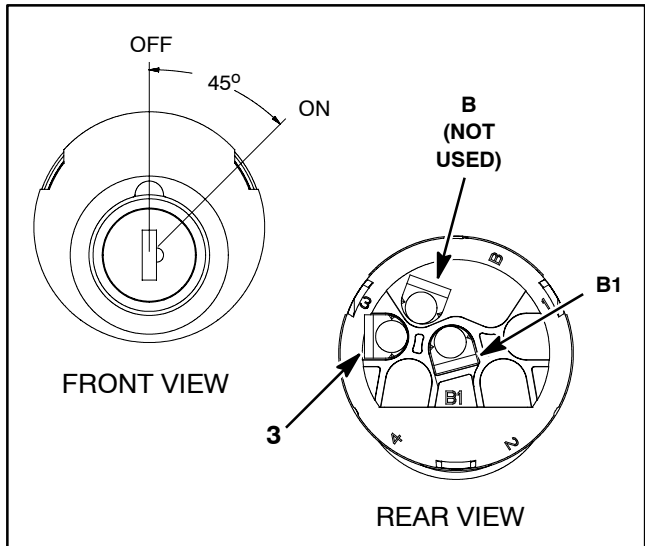

Figure 10

1. Park vehicle on a level surface, turn key switch to OFF, engage the parking brake and remove key from the key switch.
2. Make sure that vehicle battery charger IS NOT connected to electrical outlet. Open the battery circuit by disconnecting the conductors between the battery pack and vehicle components (see Opening Battery Circuit in the General Information section of this chapter).
3. Raise hood to allow access to wire harness connections for switches mounted in dash.
4. Label and disconnect wire harness connectors from the key switch.
5. With the use of a multimeter (ohms setting), the key switch functions may be tested to determine whether continuity exists between the B1 and 3 terminals for each switch position. The key switch terminals are marked as shown in Figure 10.

- A. When the key switch is in the OFF position, **no continuity** (infinite ohms) should exist between switch terminals B1 and 3.
- B. In the ON position, **continuity** (zero ohms) should exist between switch terminals B1 and 3.
6. Replace key switch if testing determines that the switch is faulty.
7. If key switch tests correctly and circuit problem still exists, check wire harness for possible problems (see electrical schematic and wire harness drawing in Chapter 6 – Electrical Drawings).
8. After key switch testing is complete, connect wire harness connectors to the switch.
9. Connect the conductors between the battery pack and vehicle components (see Opening Battery Circuit in the General Information section of this chapter). Make sure to torque hex nuts on battery terminals from **95 to 105 in-lb (10.8 to 11.8 N-m)**.
10. Lower and secure front hood.

Fuses

The Workman fuse block is located under the seat assembly (Fig. 11). All fuse block fuses are rated at 80 VDC.

The fuse location in the fuse block is shown in Figure 12. The fuses protect circuits as follows:

The front 10 amp (80 VDC) fuse protects the power supply to the key switch and all switched circuits. The battery charge indicator is also protected by the front fuse.

The second fuse position is used to protect the optional cargo bed lift circuit. When equipped with the bed lift kit, a 15 amp fuse (80 VDC) will be in the fuse block.

The third fuse position is used to protect the optional horn circuit. When equipped with the horn kit, a 30 amp (80 VDC) fuse will be in the fuse block.

The fourth fuse position is used for other optional kits, if equipped.

An additional fuse is attached to the controller (Fig. 13). This fuse is rated at 425 amperes continuous and protects the 48VDC vehicle power supply circuit. If this fuse has failed, vehicle operation will not occur.

IMPORTANT: If fuse replacement is necessary on your Workman GTX Electric vehicle, make sure that new fuses have the correct specifications (voltage and amperage).

Fuse Testing



CAUTION

When testing fuses for continuity with a multimeter (ohms setting), make sure that fuse is removed from circuit.

IMPORTANT: Before removing fuse from controller (425 Amp) for testing, open the battery circuit by removing one of the battery cables (see Opening Battery Circuit in the General Information section of this chapter).

Make sure key switch is turned OFF. Remove fuse to check continuity. The test meter should read **less than 1 ohm** if a fuse is functional. Replace the fuse if faulty.

If fuse was removed from controller, torque the nuts that secure the fuse from **89 to 106 in-lb (10 to 12 N-m)**.

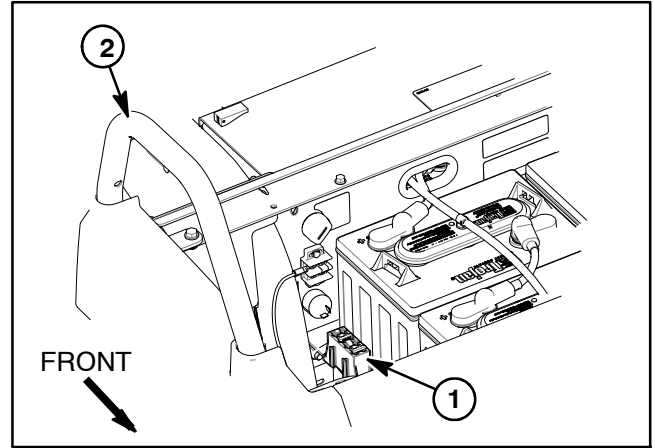

Figure 11

1. Fuse block
2. Passenger hand hold

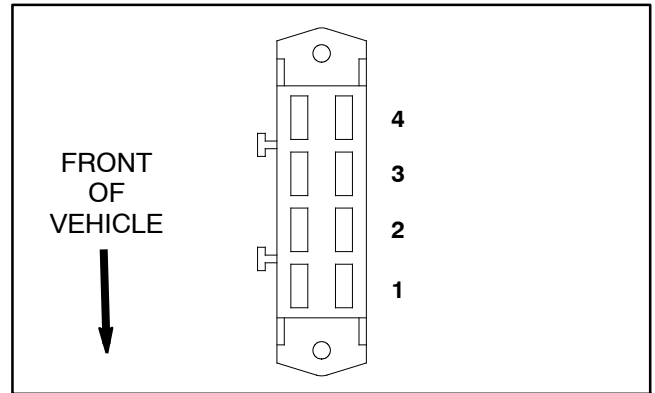

Figure 12

1. 10 Amp (front fuse)
2. 15 Amp (bed lift kit)
3. 30 Amp (horn kit)
4. Optional kit

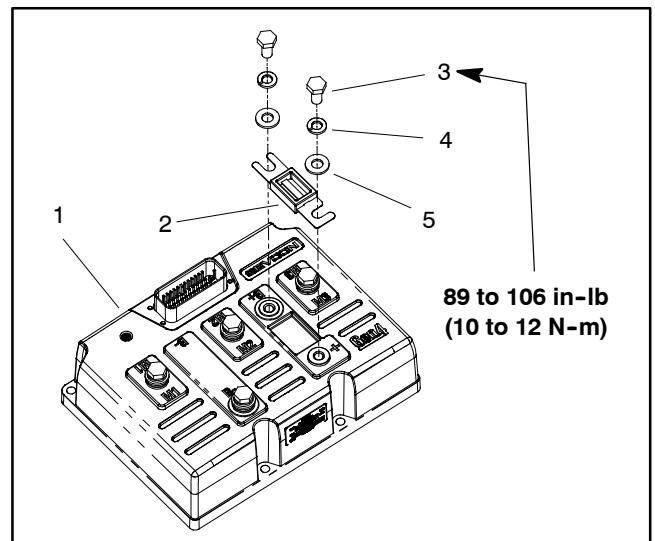

Figure 13

1. Controller
2. Fuse (425 A)
3. Screw (2 used)
4. Lock washer (2 used)
5. Flat washer (2 used)

Battery Discharge Indicator

The battery discharge indicator identifies the battery pack state of charge and is located on the dash panel (Fig. 14).

The discharge indicator reads full (10 indicator bars) after the battery pack has been fully charged (approximately 51 volts). As battery pack voltage decreases with vehicle use, fewer battery indicator bars are shown on the indicator.

When the discharge indicator reaches two (2) indicator bars due to diminished battery pack charge, the remaining two (2) bars will blink to identify that the battery charge level is extremely low. At this point or before, the batteries should be charged for best battery durability.

If the vehicle continues to be used after the battery discharge indicator reaches two (2) bars, the remaining two (2) bars will alternatively flash. At this point, the batteries should be charged to prevent serious battery damage.

IMPORTANT: To obtain maximum battery life, always charge the batteries when there are two (2) or more bars remaining on the battery discharge indicator. Regularly depleting the batteries to lower than two (2) bars will reduce the life of the batteries in your Workman GTX Electric vehicle. Also, when only two (2) bars remain on the indicator, the vehicle may enter a reduced speed mode. This reduced speed helps to protect the batteries and acts as a notice that the batteries should be charged.

NOTE: It should be noted that very high or very low ambient temperatures may affect the operation of the battery discharge indicator.

The back of the discharge indicator is shown in Figure 16. A wire harness connector plugs into the indicator. Refer to Chapter 6 - Electrical Diagrams for electrical schematic and wire harness information.

If the battery discharge indicator proves to be inaccurate, the meter should be replaced.

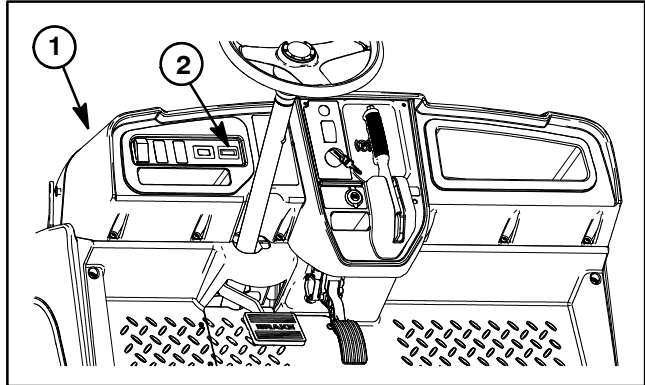

Figure 14

- 1. Dash panel
- 2. Discharge indicator

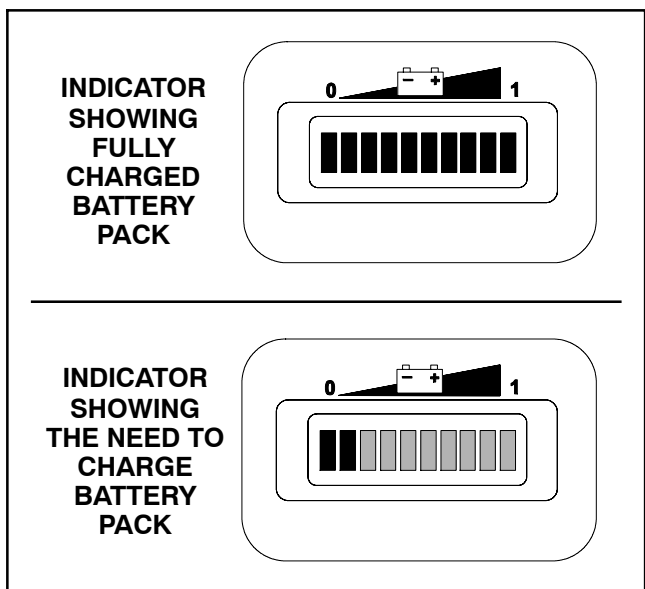

Figure 15

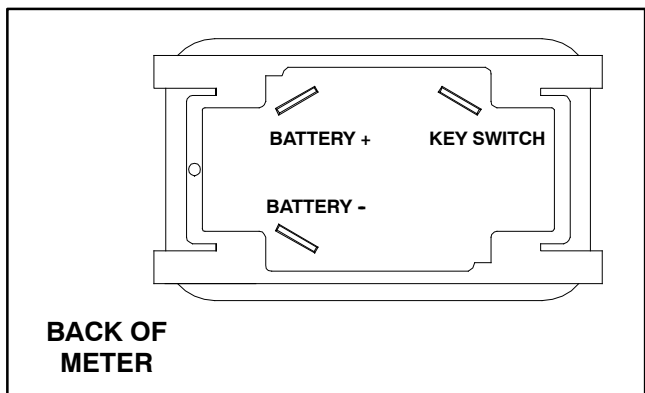

Figure 16

Light Switch

The light switch allows the headlights to be turned ON and OFF. This rocker switch is located on the dash panel (Fig. 17).

NOTE: The Workman GTX Electric headlight circuit is a 12 VDC circuit.

Testing

1. Park vehicle on a level surface, turn key switch to OFF, engage the parking brake and remove key from the key switch.
2. Raise hood to allow access to wire harness connections for switches mounted in dash.
3. Disconnect wire harness connector from the light switch.
4. With the use of a multimeter (ohms setting), the switch functions may be tested to determine whether continuity exists between the various terminals for each light switch position. The light switch terminals are marked as shown in Figure 18. The circuitry of this switch is shown in the chart below. Verify continuity between switch terminals.

SWITCH POSITION	NORMAL CIRCUITS	OTHER CIRCUITS
ON	2 + 3	5 + 6
OFF	1 + 2	4 + 5

5. Replace light switch if testing determines that the switch is faulty.
6. If light switch tests correctly and circuit problem still exists, check fuse, headlights and wire harness for possible problems (see electrical schematic and wire harness drawing in Chapter 6 - Electrical Drawings).
7. After light switch testing is complete, connect wire harness connector to the light switch. Lower and secure front hood.

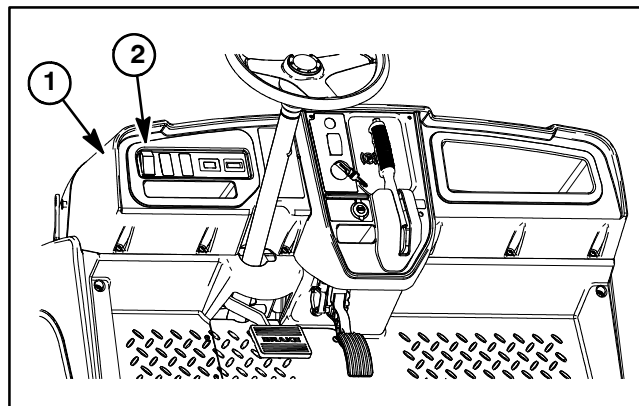

Figure 17

1. Dash panel 2. Light switch

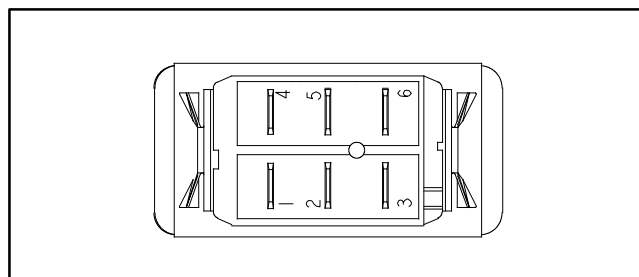

Figure 18

Direction Selector Switch

The direction selector switch allows the direction (forward/neutral/reverse) of the vehicle to be changed by the operator and is one of several inputs for the vehicle controller. The direction selector switch is located on the dash panel (Fig. 19).

NOTE: Direction selector switch terminals 1, 2 and 3 are used on all Workman GTX Electric vehicles to change the direction of the vehicle. On vehicles with a reverse alarm (12 VDC circuit), switch terminals 4 and 5 are also used to activate the alarm when the selector switch is in the reverse direction.

NOTE: The Workman GTX Electric direction selector circuit is a 48 VDC circuit.

Testing

1. Park vehicle on a level surface, turn key switch to OFF, engage the parking brake and remove key from the key switch.
2. Raise hood to allow access to wire harness connections to the direction selector switch.
3. Disconnect wire harness connector from the direction selector switch.
4. With the use of a multimeter (ohms setting), the switch functions may be tested to determine whether continuity exists between the various terminals for each direction switch position. The direction switch terminals are marked as shown in Figure 20. The circuitry of this switch is shown in the chart below. Verify continuity between switch terminals.

SWITCH POSITION	NORMAL CIRCUITS	OTHER CIRCUITS
FORWARD	2 + 3	5 + 6
NEUTRAL	NONE	NONE
REVERSE	2 + 1	5 + 4

5. Replace direction selector switch if testing determines that the switch is faulty.
6. If direction selector switch tests correctly and circuit problem still exists, check wire harness for possible problems (see electrical schematic and wire harness drawing in Chapter 6 - Electrical Drawings).
7. After direction selector switch testing is complete, connect wire harness connector to the selector switch. Lower and secure front hood.

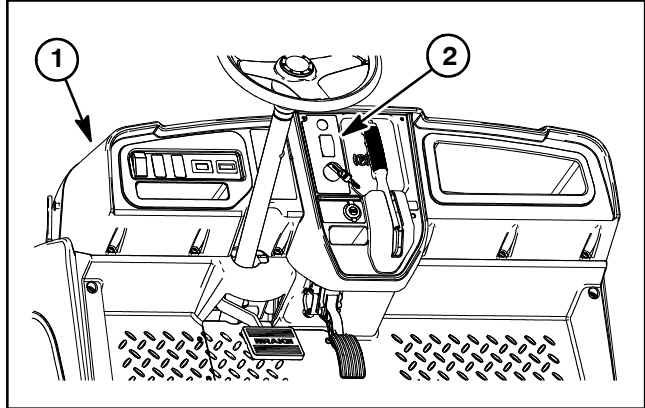

Figure 19

1. Dash panel

2. Selector switch

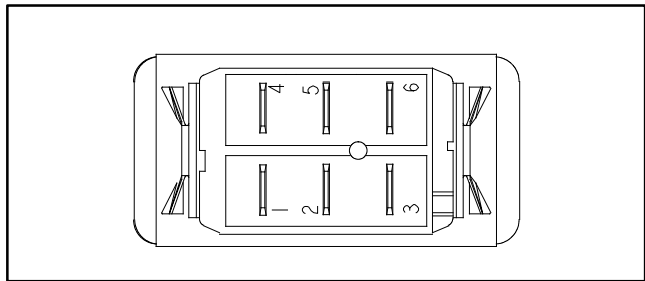

Figure 20

Status Indicator Light

The status indicator light is located on the control panel next to the parking brake lever (Fig. 21). During normal operation, the status indicator light should be continuously illuminated. A vehicle electrical problem will be identified by a flashing status indicator light.

The status indicator and LED on the vehicle controller should have the same condition (off, illuminated or flashing). If the status indicator does not illuminate when the key switch is turned ON, check the LED on the vehicle controller to make sure it is illuminated. If the controller LED is illuminated and the status indicator light is not illuminated, check the status indicator light and circuit wiring.

See Controller (in this section) and your Operator's Manual for information on a flashing status indicator light.

Testing

1. Park vehicle on a level surface, turn key switch to OFF, engage the parking brake and remove key from the key switch.
2. Raise hood to allow access to wire harness connections to the status indicator light.
3. Disconnect wire harness connectors from status indicator light.

IMPORTANT: The status indicator light is a 48 VDC component. To test the light, use jumper wires from the vehicle battery pack (48 VDC).

4. The two (2) terminals for the light are shown in Figure 22. Use appropriate jumper wires to connect a 48 VDC source to the status indicator light terminals.
5. Status indicator light should illuminate as long as the jumper leads are connected to the light.
6. Remove voltage source from the light. Replace light if testing determines that it is faulty.
7. When status indicator light testing is completed, connect wire harness connectors to light.
8. Lower and secure hood.

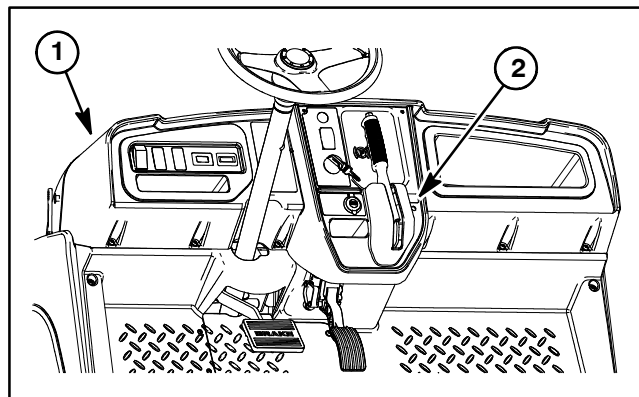

Figure 21

1. Dash panel 2. Status indicator light

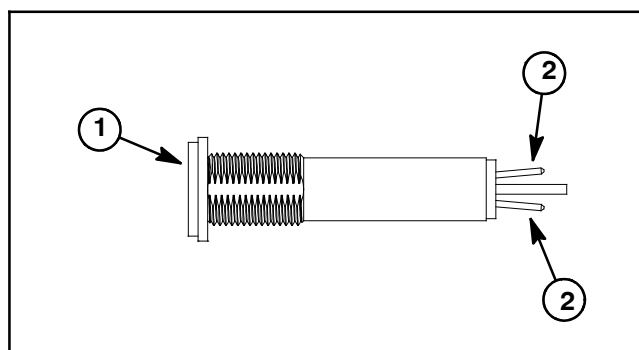

Figure 22

1. Indicator light lens 2. Terminal

Supervision Speed Limit Switch

The supervision speed limit switch allows the maximum speed of the vehicle to be set to either performance (16 mph/26 kph) or economy (12 mph/19 kph). The speed limit switch is one of several inputs for the vehicle controller and is located under the seat assembly (Fig. 23).

The supervision speed limit switch is open in the performance position (key vertical) and closed in the economy position (key rotated clockwise).

NOTE: Only speed limit switch terminals A and D are used on the Workman GTX Electric vehicle.

NOTE: The Workman GTX Electric supervision speed limit circuit is a 48 VDC circuit.

Testing



CAUTION

When testing the key switch for continuity with a multimeter (ohms setting), make sure that power to the circuit has been disconnected.

1. Park vehicle on a level surface, turn key switch to OFF, engage the parking brake and remove key from the key switch.
2. Remove seat assembly to allow access to supervision speed limit switch.
3. Disconnect wire harness connector from the supervision speed limit switch.
4. With the use of a multimeter (ohms setting), the speed limit switch functions may be tested to determine whether continuity exists between the A and D terminals for each switch position. The speed limit switch terminals are identified as shown in Figure 24.

A. When the speed limit switch is in the performance position (vertical), **no continuity** (infinite ohms) should exist between switch terminals A and D.

B. In the economy position (key rotated clockwise), **continuity** (zero ohms) should exist between switch terminals A and D.

5. Replace the speed limit switch if testing determines that the switch is faulty.

6. If the speed limit switch tests correctly and circuit problem still exists, check wire harness for possible problems (see electrical schematic and wire harness drawing in Chapter 6 - Electrical Drawings).

7. After speed limit switch testing is complete, plug wire harness connector to the switch. Install seat assembly.

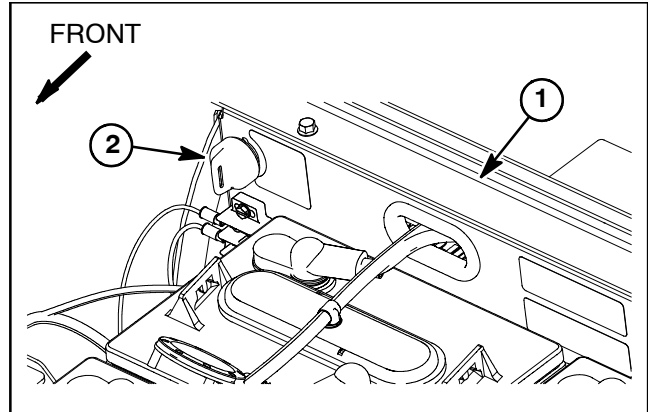

Figure 23

1. Seat base support 2. Speed limit switch

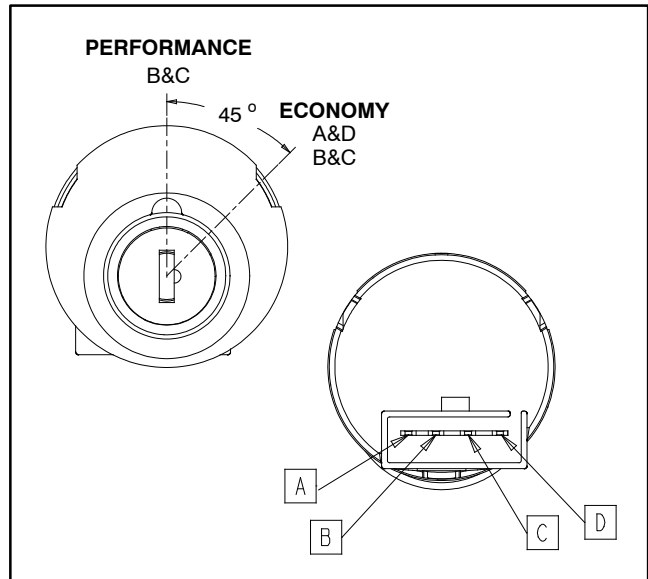

Figure 24

Parking Brake Switch

The parking brake switch is used as an input for the vehicle controller to identify when the parking brake is applied. The parking brake switch is attached to the parking brake mount behind the dash (Fig. 25).

A normally closed contact in the switch is opened when the parking brake is released. When the parking brake is applied, the switch is in its normally closed state. Only two (2) of the switch terminals are used in the parking brake switch circuit.

If the direction selector switch is in either the forward or reverse direction and the parking brake is applied, the status indicator light on the dash should blink two (2) times.

Testing

1. Park vehicle on a level surface, turn key switch to OFF, engage the parking brake and remove key from the key switch.
2. To access the parking brake switch, remove dash (see Dash in the Service and Repairs section of Chapter 5 - Chassis).
3. Disconnect wire harness electrical connector from the brake switch (Fig. 25).
4. Connect a multimeter (ohms setting) across the common and normally closed (NC) terminals of the brake switch (Fig. 26).
5. With the parking brake released (not applied), the washer on the parking brake lever should be depressing the lever on the brake switch. In this switch position, there **should not be continuity** (infinite ohms) between the common and normally closed (NC) switch terminals.
6. With the parking brake applied, the washer on the parking brake lever should not be depressing the lever on the brake switch. In this switch position, there **should be continuity** (zero ohms) between the common and NC switch terminals.

NOTE: The normally open (NO) switch terminal is not used in the parking brake circuit.

7. If testing determines that the brake switch is faulty, replace switch.

8. If the brake switch tests correctly and a circuit problem still exists, check wire harness for problems (see electrical schematic and wire harness drawing in Chapter 6 - Electrical Drawings).

9. After brake switch testing is completed, connect wire harness electrical connector to the switch.

10. Carefully position and secure dash to vehicle (see Dash in the Service and Repairs section of Chapter 5 - Chassis).

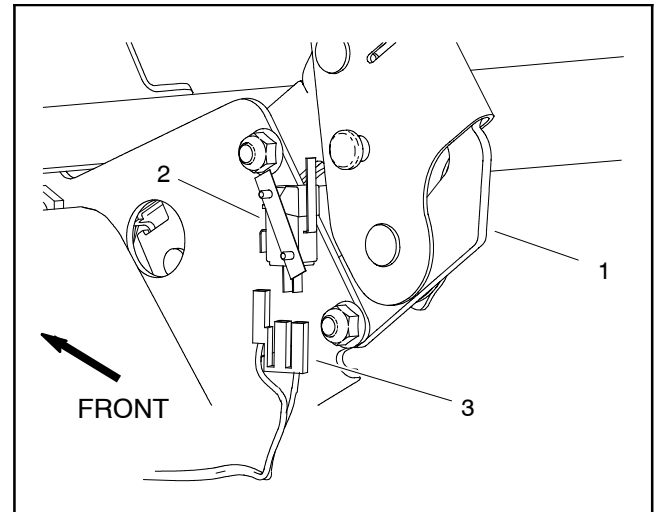

Figure 25

1. Parking brake lever
2. Parking brake switch
3. Wire harness connector

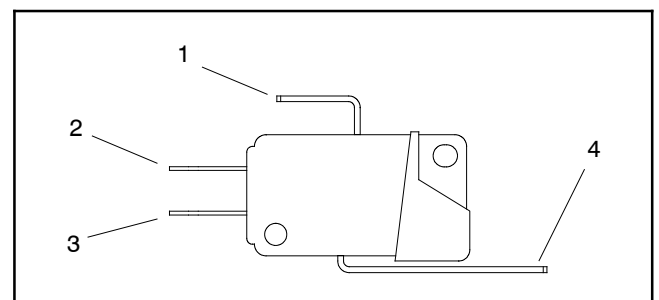

Figure 26

1. Common terminal
2. NO terminal
3. NC terminal
4. Switch lever

USB Charge Port

The USB charge port can be used to charge or power electrical devices that use a USB port. The charge port has a 5 VDC output and is mounted to the dash (Fig. 27).

If the vehicle wire harness is to be disconnected from the charge port, note the wire harness connections at the charge port for assembly purposes. The white wire harness lead should be connected to the positive (+) terminal on the charge port and the black wire harness lead should be connected to the negative (-) terminal on the charge port (Fig. 28).

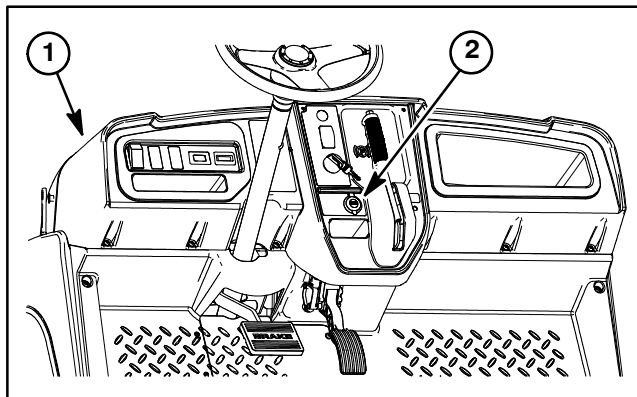

Figure 27

- 1. Dash panel
- 2. USB charge port

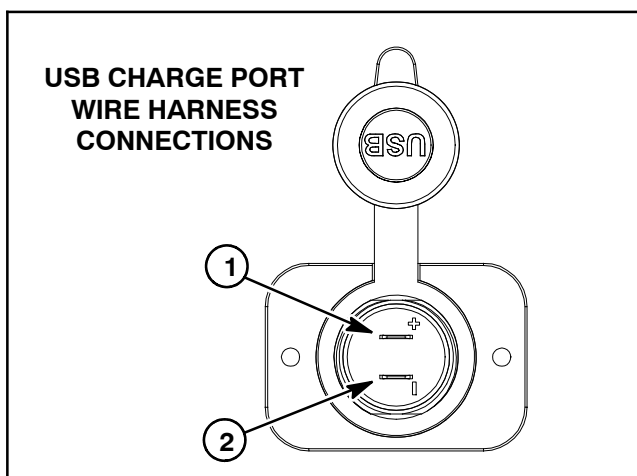

Figure 28

- 1. Positive (+) terminal
- 2. Negative (-) terminal

Main Contactor (48 VDC)

The main contactor provides provides current to the 48 VDC system circuits (e.g. controller, traction motor) and is energized by the controller when the key switch is ON. The main contactor is mounted to the controller bracket beneath the cargo bed (Fig. 29).

NOTE: If main contactor is faulty, a fault may be displayed at the status indicator light on dash and LED on controller (see Controller in this section).

Testing

NOTE: Prior to taking small resistance readings with a digital multimeter, short the meter test leads together. The meter will display a small resistance value (usually 0.5 ohms or less) that is due to the internal resistance of the meter and test leads. Subtract this value from the measured value of the component you are testing.

1. Park vehicle on a level surface, turn key switch to OFF, engage the parking brake and remove key from the key switch. Raise and support cargo bed to access the main contactor.

2. Make sure that vehicle battery charger IS NOT connected to electrical outlet. Open the battery circuit by disconnecting the conductors between the battery pack and vehicle components (see Opening Battery Circuit in the General Information section of this chapter).

3. Locate main contactor. Disconnect all vehicle wire harness connectors from contactor. Note wire connector locations on contactor for assembly purposes.

4. Using jumper wires, apply 48 VDC directly across the contactor coil posts (Fig. 30). The contactor should click as voltage is applied. With the contactor coil energized, resistance across the main contact posts should be less than **1 ohm**.

5. Remove voltage from contactor coil posts. The contactor should click as voltage is removed. With the contactor coil not energized, resistance across the main contact posts should be **infinite ohms**.

6. With voltage removed from contactor coil posts, measure resistance across the coil posts (Fig. 30). The resistance should be approximately **126 ohms**.

7. Replace main contactor if testing determines that it is faulty.

8. When contactor testing is completed, connect wire harness connectors to contactor. Torque tighten the nuts to **45 to 55 in-lb (5 to 6.2 N-m)**.

9. Connect the conductors between the battery pack and vehicle components (see Opening Battery Circuit in the General Information section of this chapter). Make sure to torque hex nuts on battery terminals from **95 to 105 in-lb (10.8 to 11.8 N-m)**.

10. Lower and secure cargo bed.

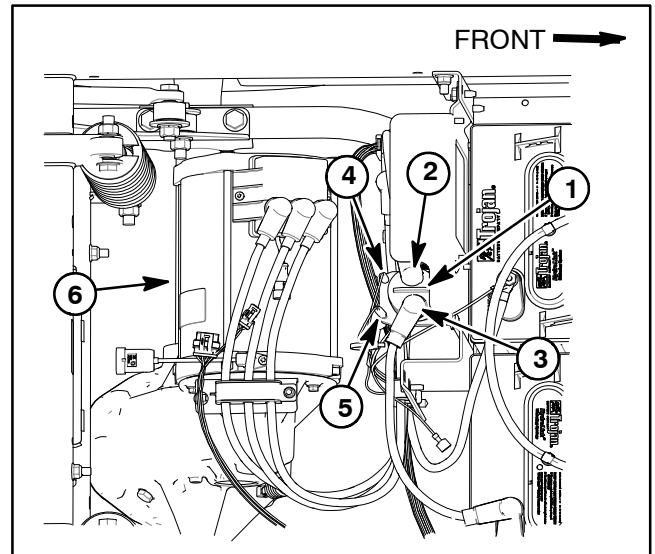

Figure 29

- | | |
|---------------------------|---------------------------|
| 1. Main contactor | 4. Wire harness connector |
| 2. Cable to controller B+ | 5. Wire harness connector |
| 3. Positive battery cable | 6. Traction motor |

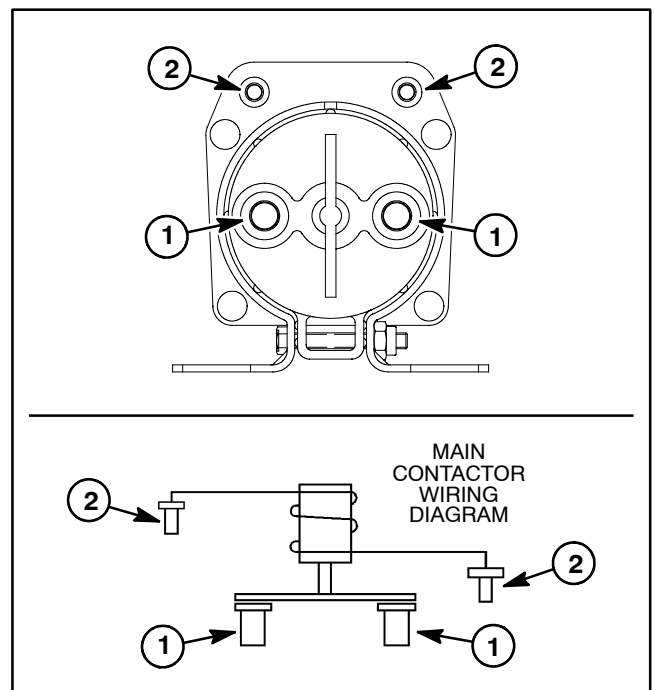

Figure 30

- | | |
|-----------------------|-------------------------|
| 1. Main contact posts | 2. Contactor coil posts |
|-----------------------|-------------------------|

Accelerator Pedal

The accelerator pedal is attached to the foot board under the dash (Fig. 31). This pedal is used as one of the inputs for the vehicle controller to determine vehicle speed. The electronic control incorporated in the accelerator pedal is a non-contact, rotary hall effect sensor that varies output voltage based on the pedal position. When the operator presses or releases the accelerator pedal, the voltage from the pedal sensor changes. Output voltage from the pedal is used by the controller to determine appropriate current flow to the traction motor.

If the accelerator pedal is thought to be faulty, consider the following before replacing the pedal:

1. Make sure that the accelerator pedal moves smoothly through its entire range of motion.
2. Check the vehicle controller for any existing faults that indicate a problem with the accelerator pedal (see Controller in this section of this chapter).
3. The wire harness connector and accelerator pedal connector should be inspected for corrosion or connector pin damage.

NOTE: No internal parts are available for the acceleration pedal.

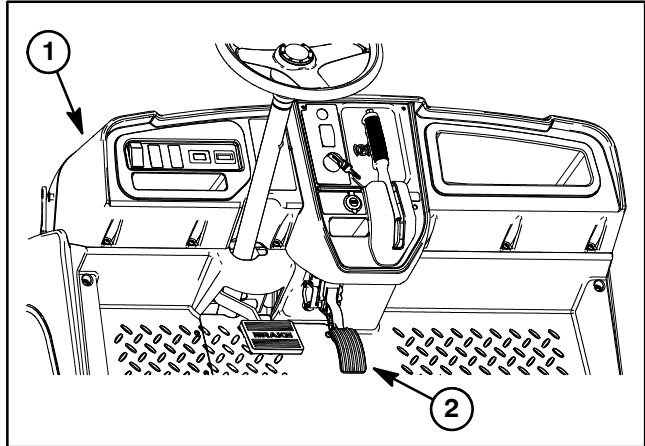

Figure 31

1. Dash panel

2. Accelerator pedal

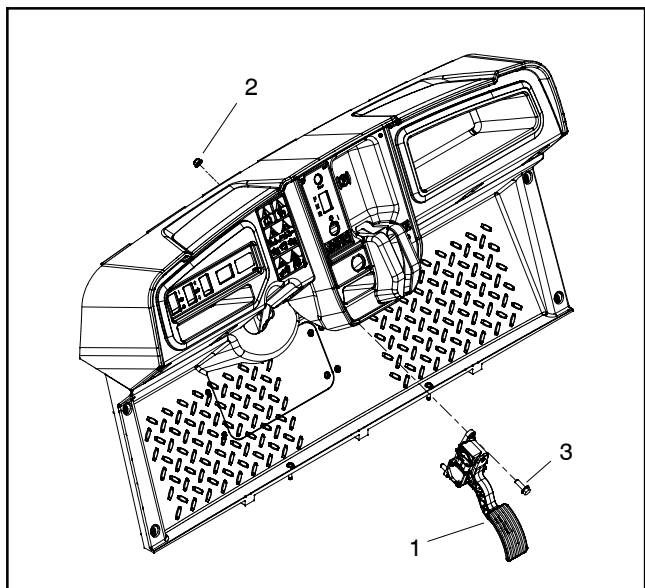

Figure 32

1. Accelerator pedal

2. Flange nut (3 used)

3. Flange screw (3 used)

Traction Motor

The traction motor stator winding, thermistor (temperature) and encoder (speed sensor) can be tested with the motor attached to the transaxle. Test connection points for the traction motor are shown in Fig. 33.

If a traction motor component is faulty, there should likely be a fault code displayed on the controller LED and the status indicator light. Before disconnecting electrical connections on the motor, check for existing fault codes that suggest a problem with the motor. See Controller in this section for additional information regarding faults.

Before disconnecting any electrical connections from the traction motor, open the vehicle battery circuit by disconnecting the conductors between the battery pack and vehicle components (see Opening Battery Circuit in the General Information section of this chapter). When installing cables to motor terminals, torque jam nuts at terminals from **72 to 88 in-lb (8 to 9 N-m)** (Fig. 37). Apply Toro battery terminal protector (see Special Tools) to motor connections after tightening nuts.

Refer to Traction Motor and Traction Motor Service in the Service and Repairs section of this chapter for traction motor removal, installation, disassembly and assembly information.

Stator Winding Testing

Use a multimeter to measure resistance (ohms) between motor terminals (U, V and W). There should be very low (not zero) resistance between pairs of terminals (U and V, V and W and U and W). Also, measure resistance between each terminal and the motor drive end bracket. There should be infinite resistance between each terminal and the drive end bracket.

If resistance between terminals is either very high or zero, the stator is damaged. The stator is also faulty if resistance between any terminal and the drive end bracket is not infinite. If stator is damaged, replacement of the traction motor is necessary.

Thermistor (Thermally Sensitive Resistor) Testing

Use a multimeter to measure resistance (ohms) between the pins in the thermistor connector. The measured resistance at 77F (25°) (motor temperature) should be approximately **600 ohms**. If resistance testing determines a short circuit (low resistance) or an open circuit (infinite resistance), the thermistor or thermistor wiring is damaged and the motor must be replaced. The thermistor is an integral component of the traction motor stator.

Encoder (Speed Sensor) Testing

If encoder problems exist, the vehicle controller should determine that a problem exists and a fault code should be displayed on the controller LED and the status indicator light. See Controller in this section for additional information regarding encoder faults.

NOTE: If a traction motor armature problem exists in the motor (e.g. worn bearing in rear end bracket, missing retaining ring on rear of armature shaft, loose or damaged tone ring on armature), an encoder fault could be generated due to the armature issue.

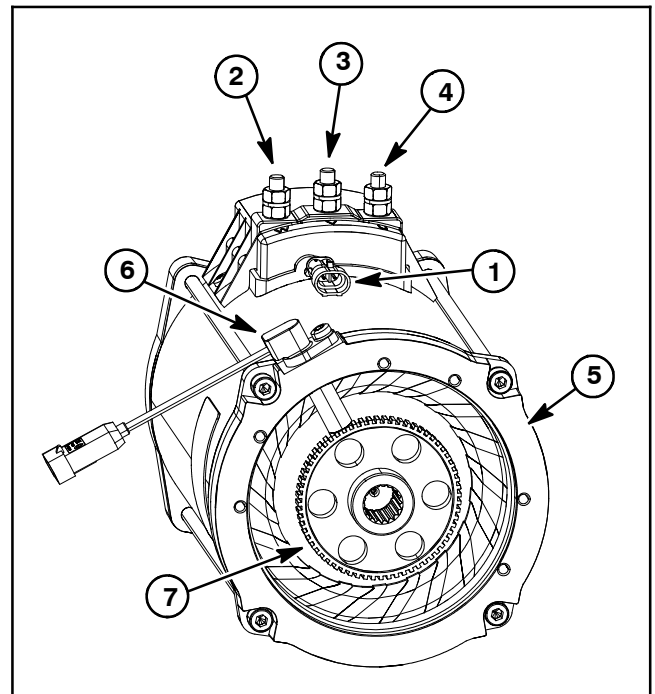

Figure 33

- | | |
|-------------------------|-----------------------|
| 1. Thermistor connector | 5. Drive end bracket |
| 2. Terminal U | 6. Encoder |
| 3. Terminal V | 7. Armature tone ring |
| 4. Terminal W | |

On-board Battery Charger

The Workman GTX Electric on-board battery charger is attached to the left side of the vehicle under the operator seat.

Power input to the charger is provided at the charging receptacle by an AC power supply cord. A four (4) wire output cable with three (3) connectors is used to connect the charger to the vehicle electrical system. The connectors include battery positive (red wire), battery negative (black and white wires) and charging lock out (green wire). The output cable connector for the battery negative (black and white wires) includes a thermistor (thermally sensitive resistor) used by the charger to identify battery temperature. Because of the solid state circuitry built into the charger, there is no method to test the charger directly (e.g. using a multimeter).

The battery pack charging operation is fully automated. While connected to an AC power supply, charger activity can be monitored at the charger diagnostic LED located near the battery charger charge port on the left side of the vehicle. Use the table below to identify charger activity based on the LED color and flash rate. The vehicle controller prevents the vehicle from operating while charging the batteries.

IMPORTANT: To obtain maximum battery life, always charge the batteries when there are 2 or more bars visible on the dash mounted battery charge indicator. Regularly depleting the batteries to lower than 2 bars will reduce the life of the batteries.

NOTE: In high-ambient temperature environments, remove the seat assembly for optimal charging time. If the battery charger is too hot, it may not charge properly. In cold temperatures, it may take a longer for the batteries to charge.

After charging the vehicle battery pack, make sure that the water level in all batteries is checked and adjusted as necessary.

NOTE: Refer to On-board Battery Charger in the Service and Repairs section of this chapter for battery charger removal and installation information.

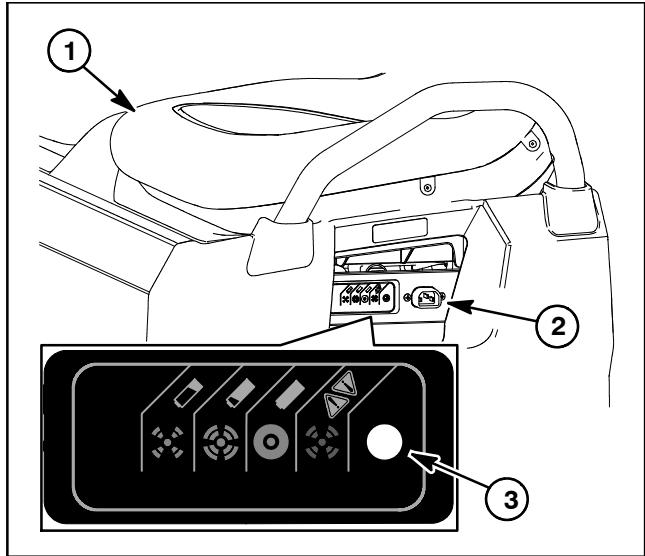

Figure 34

1. Operator seat
2. Charging receptacle
3. Charger diagnostic LED

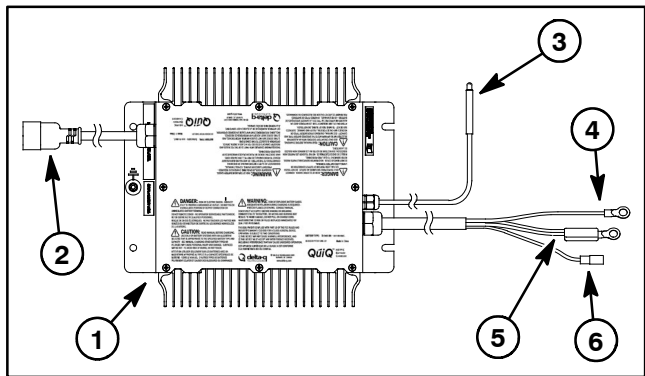

Figure 35

1. Battery charger
2. AC input
3. Charger diagnostic LED
4. Wire to battery + (red wire)
5. Wires to battery - (black and white wires)
6. Charger lock out wire (green wire)

LED Pattern	Cause	Necessary Action
Green LED is always on (not flashing)	Battery pack is fully charged.	None required. Vehicle is ready for operation.
Green LED has short flash (0.1 second ON and 0.9 second OFF)	Batteries are less than 80% charged.	Continue charging batteries.
Green LED has long flash (0.5 second ON and 0.5 second OFF)	Batteries are more than 80% charged.	Continue charging batteries.

LED Pattern	Cause	Necessary Action
Amber LED is flashing	Reduced-power mode: Low AC voltage or high internal charger temperature.	<p>Make sure that electrical outlet is providing adequate voltage for charger.</p> <p>Remove operator seat assembly to allow additional cooling air to on-board battery charger. Also, make sure that charger cooling fins are clean.</p> <p>Make sure that extension cord that is being used has suitable gauge size and length if not using the cord that was provided with your Workman.</p>
Red LED is flashing	Internal charger error (fault) or battery pack problem.	Reset charger by unplugging extension cord from vehicle charging receptacle, waiting for 15 seconds and then plugging extension cord back into the receptacle. If charger does not reset and red LED is still flashing, count the number of flashes between pauses and use information below to identify problem.
1 red LED flash between pauses	Battery voltage is excessive.	Check battery size and condition. Fault should clear when battery voltage is corrected.
2 red LED flashes between pauses	Battery voltage is low.	Check battery size and condition. Fault should clear when battery voltage is corrected.
3 red LED flashes between pauses	<p>Charge timeout was caused by battery pack not reaching required voltage.</p> <p>Charger output was reduced due to high temperatures</p>	<p>Check battery connections.</p> <p>Operate charger at a lower ambient temperature. In elevated ambient temperatures, remove operator seat assembly to allow additional cooling air to on-board battery charger. Also, make sure that charger cooling fins are clean.</p> <p>Reset charger by unplugging extension cord from vehicle charging receptacle, waiting for 15 seconds and then plugging extension cord back into the receptacle.</p>
4 red LED flashes between pauses	Battery charging could not be fully completed.	<p>Reset charger by unplugging extension cord from vehicle charging receptacle, waiting for 15 seconds and then plugging extension cord back into the receptacle. If same red LED flash pattern exists after reset, check battery pack.</p> <p>Check for damaged cells in one of more of the batteries.</p>
5 red LED flashes between pauses	Charger shut down due to high internal temperature.	<p>Ensure that cooling air flow in charger area is sufficient. Remove operator seat assembly to allow additional cooling air to on-board battery charger. Also, make sure that charger cooling fins are clean.</p> <p>Reset charger by unplugging extension cord from vehicle charging receptacle, waiting for 15 seconds and then plugging extension cord back into the receptacle. If same red LED flash pattern exists after reset, allow charger to cool before continuing with charging process.</p>
6 red LED flashes between pauses	Internal charger fault.	Reset charger by unplugging extension cord from vehicle charging receptacle, waiting for 15 seconds and then plugging extension cord back into the receptacle. If same red LED flash pattern exists after reset, charger replacement may be necessary.

Controller

The Workman controller is secured to the rear frame beneath the cargo box (Fig. 36). The controller uses inputs from several vehicle components to accurately control vehicle speed, direction (forward and reverse) and regenerative braking. Controller inputs include key switch, direction selector switch (forward/reverse), accelerator pedal, supervision speed limit switch, traction motor thermistor (temperature), traction motor encoder (speed sensor) and battery charger lockout. A single wire harness connection and five (5) cables are used to connect the controller to the vehicle electrical system.

A fuse that is rated at 425 amperes continuous is attached to the controller and protects the 48VDC vehicle power supply circuit. If this fuse has failed, vehicle operation will not occur.

Cable connections for the controller are as follows:

- Terminal B-: Negative (-) battery cable from the left, rear battery
- Terminal B+: Positive (+) cable from the main contactor post
- Terminal M1: Cable to traction motor terminal W
- Terminal M2: Cable to traction motor terminal V
- Terminal M3: Cable to traction motor terminal U

Because of the solid state circuitry built into the controller, there is no method to test it directly (e.g. using a multimeter). A LED exists on the controller to identify normal operation or faults that will prevent the vehicle from operating correctly. The status indicator light on the dash panel should display the same information as the LED on the controller. See chart below for light pattern fault codes identified by the controller LED and status indicator light.

NOTE: If the controller LED and status indicator light are flashing, attempt to reset the controller by turning the key switch to OFF, waiting several seconds and then turning the switch to ON. If the controller LED and status indicator light continue flashing after the reset attempt, proceed with fault code identification and necessary action.

Before removing any electrical connections from the controller, open the vehicle battery circuit by disconnecting the conductors between the battery pack and vehicle components (see Opening Battery Circuit in the General Information section of this chapter). When installing cables to controller, torque screws at all controller terminals from **89 to 106 in-lb (10 to 12 N-m)** (Fig. 37). Apply Toro battery terminal protector (see Special Tools) to controller connections after tightening terminal screws. Refer to Controller in the Service and Repairs section of this chapter for controller removal and installation information.

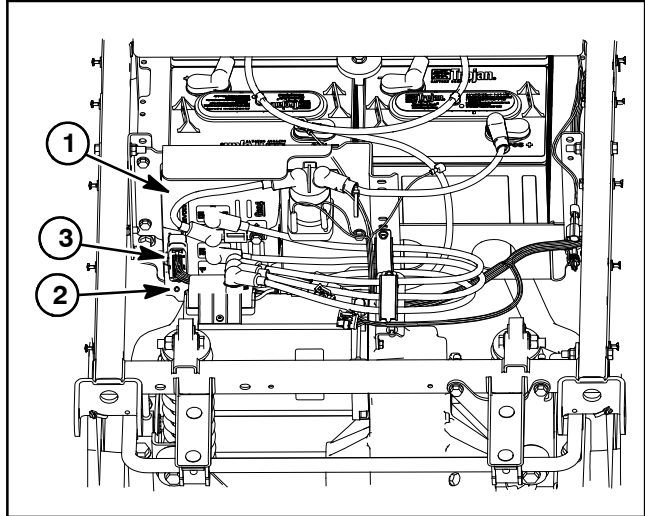

Figure 36

- 1. Controller
- 2. Controller LED
- 3. Wire harness connector

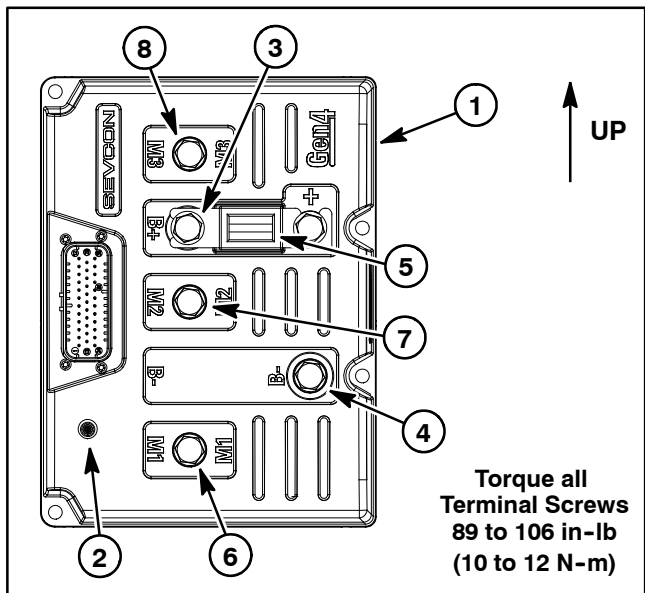

Figure 37

- 1. Controller
- 2. Controller LED
- 3. B+ terminal (+ cable from main contactor)
- 4. B- terminal (- cable from left, rear battery)
- 5. Fuse (425 A)
- 6. M1 terminal (cable to motor terminal W)
- 7. M2 terminal (cable to motor terminal V)
- 8. M3 terminal (cable to motor terminal U)

**Torque all Terminal Screws
89 to 106 in-lb
(10 to 12 N-m)**

Light Pattern	Cause	Necessary Action
Always on (not flashing)	System functioning normally.	None required.
Always off	System inoperable. No electrical power to the controller. Status indicator light on dash is faulty. The controller has failed.	Check for low battery voltage, faulty fuse(s), loose battery cable connections, damaged battery cables and/or faulty main contactor. If batteries, cables and other electrical components are in good condition, controller replacement may be needed. If necessary, contact your Authorized Toro Distributor for assistance.
1 Flash	System inoperable. There is a controller configuration fault	Turn key switch OFF, wait several seconds and turn key switch ON. If controller does not reset correctly, controller replacement may be required. If necessary, contact your Authorized Toro Distributor for assistance.
2 Flashes	The parking brake is engaged while in the FORWARD or REVERSE position. This fault could also be caused by a problem with accelerator pedal operation.	Release the parking brake if it is applied. If controller does not reset correctly, parking brake switch or circuit wiring may be faulty. Turn key switch OFF, wait several seconds and turn key switch ON. If controller does not reset correctly, check accelerator pedal operation (see Accelerator Pedal in this section). Also, if necessary, inspect the circuit wires between the accelerator pedal and the controller (see Electrical Schematic and Wire Harness Drawings in Chapter 6 - Electrical Drawings).
3 Flashes	System inoperable. The motor current exceeded the controller rated maximum. There is an internal controller power component fault.	Turn key switch OFF, wait several seconds and turn key switch ON. If controller does not reset correctly, check battery pack voltage and all battery cable connections. Check all batteries and high current controller connections. Controller replacement may be required. If the condition continues, contact your Authorized Toro Distributor for assistance.
4 Flashes	Main contactor malfunction.	Turn key switch OFF, wait several seconds and turn key switch ON. If controller does not reset correctly, inspect main contactor (see Main Contactor in this section). Check main contactor wire and cable connections.
5 Flashes	Exceeded the maximum motor speed.	Turn key switch OFF, wait several seconds and turn key switch ON. If controller does not reset correctly, inspect traction motor encoder (speed sensor) (see Traction Motor in this section). Inspect the circuit wires between the traction motor encoder and the controller (see Electrical Schematic and Wire Harness Drawings in Chapter 6 - Electrical Drawings).

Light Pattern	Cause	Necessary Action
6 Flashes	<p>The accelerator pedal is pressed while starting the machine.</p> <p>Accelerator pedal operation is abnormal.</p>	<p>Release the accelerator pedal, turn the key switch to the OFF position, wait several seconds, turn the key switch to the ON position and check for normal vehicle operation.</p> <p>If controller does not reset correctly, check accelerator pedal operation (see Accelerator Pedal in this section).</p> <p>Also, if necessary, inspect the circuit wires between the accelerator pedal and the controller (see Electrical Schematic and Wire Harness Drawings in Chapter 6 - Electrical Drawings).</p>
7 Flashes	<p>The remaining charge on the batteries is low (vehicle speed has been limited by controller).</p> <p>The batteries are fully discharged (vehicle does not operate).</p> <p>The internal capacitor has a pre-charge of less than 5V.</p>	<p>Charge the batteries fully and then check for normal operation.</p> <p>If this fault occurs regularly, consider that battery charging has not been regular or that batteries may need replacement.</p>
8 Flashes	<p>The controller or traction motor is overheated or too cold.</p>	<p>The vehicle may continue to operate but at reduced power until the component temperature reaches normal levels.</p> <p>Determine if the motor or controller is very hot or very cold, then allow the machine to return to normal temperatures before resuming operation.</p> <p>Make sure that motor and controller are cleaned of all dirt and debris that could lead to component overheating.</p>
10 Flashes	<p>A controller configuration fault occurred.</p>	<p>Turn the key switch to the OFF position, wait several seconds, turn the key switch to the ON position, and check for normal vehicle operation.</p> <p>If this fault continues to occur, contact your Authorized Toro Distributor for assistance.</p>
11 Flashes	<p>A motor encoder (speed sensor) fault occurred.</p> <p>Exceeded the maximum motor speed.</p>	<p>Turn the key switch to the OFF position, wait several seconds, turn the key switch to the ON position, and check for normal vehicle operation.</p> <p>If this fault continues to occur, inspect traction motor encoder (speed sensor) (see Traction Motor in this section).</p> <p>Also, inspect the circuit wires between the traction motor encoder and the controller (see Electrical Schematic and Wire Harness Drawings in Chapter 6 - Electrical Drawings).</p> <p>If a traction motor armature problem exists in the motor (e.g. worn bearing in rear end bracket, missing retaining ring on rear of armature shaft, loose or damaged tone ring on armature), an encoder fault could be generated due to the armature issue.</p>

Light Pattern	Cause	Necessary Action
12 Flashes	A controller configuration fault occurred.	Turn the key switch to the OFF position, wait several seconds, turn the key switch to the ON position, and check for normal vehicle operation. If this fault continues to occur, contact your Authorized Toro Distributor for assistance.
13 Flashes	An internal controller software fault occurred	Turn the key switch to the OFF position, wait several seconds, turn the key switch to the ON position, and check for normal vehicle operation. If this fault continues to occur, contact your Authorized Toro Distributor for assistance.
14 Flashes	A controller communication fault occurred	Turn the key switch to the OFF position, wait several seconds, turn the key switch to the ON position, and check for normal vehicle operation. If this fault continues to occur, contact your Authorized Toro Distributor for assistance.

Diode Assembly

A diode assembly is included in the Workman GTX Electric wire harness. This diode is used for circuit logic to allow key switch current to the controller. The diode plugs into the wire harness near the controller and main contactor.

The diode assembly can be identified by a black color and a diode symbol on the end of the diode assembly body (Fig. 38). Refer to the wire harness drawings in Chapter 6 - Electrical Drawings for additional information on diode assembly location.

NOTE: If a vehicle is equipped with the optional brake and turn signal kit that includes flashers, four (4) additional diode assemblies are used for hazard light and turn signal circuit logic. These diodes plug into the brake and turn signal kit wire harness and can be accessed by raising the hood.

Testing

1. Park vehicle on a level surface, turn key switch to OFF, engage the parking brake and remove key from the key switch.
2. Locate diode assembly that is to be tested.
3. Remove cable tie that secures diode to wire harness. Unplug the diode from the wire harness for testing.
4. Test diode assembly using a digital multimeter (diode test or ohms setting) and the table in the right column.
5. If testing determines that a diode assembly is faulty, replace diode assembly.
6. After diode testing is complete, make sure that diode assembly is fully installed into wire harness connector and secured to harness with cable tie.

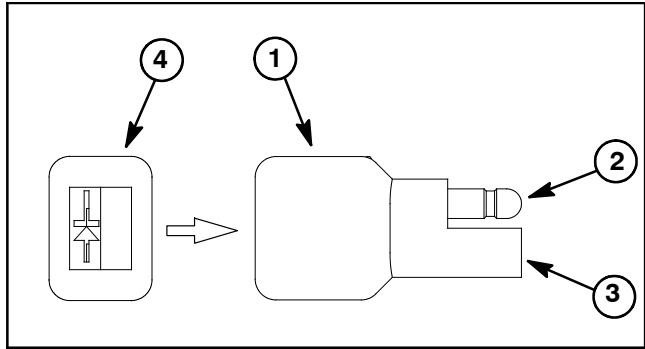

Figure 38

- | | |
|-------------------|----------------------|
| 1. Diode assembly | 3. Female terminal |
| 2. Male terminal | 4. End of diode body |

Multimeter Red Lead (+) on Terminal	Multimeter Black Lead (-) on Terminal	Continuity
Female	Male	YES
Male	Female	NO

Reverse Audio Alarm (If Equipped)

The reverse alarm sounds when the direction switch (forward/reverse) is placed in the reverse position. The alarm is located under the seat assembly attached to the rear frame panel near the fuse block (Fig. 39).

Testing

IMPORTANT: Make sure to observe polarity on the alarm terminals when testing. Damage to the alarm may result from an improper connection.

IMPORTANT: The audio alarm is a 12 volt DC component. Do not test the alarm using jumper wires from the vehicle battery pack (48 VDC).

1. Park vehicle on a level surface, turn key switch to OFF, engage the parking brake and remove key from the key switch.
2. Remove seat assembly from vehicle to access reverse alarm. Locate alarm on rear frame panel.
3. Disconnect wire harness connectors from alarm (Fig. 39).
4. Using jumper wires, correctly connect 12VDC source to the alarm terminals noting polarity shown in Figure 40.
5. Alarm should sound as long as voltage is applied to alarm terminals. Remove voltage source from the alarm.
6. Replace alarm if testing determines that it is faulty.
7. Connect wire harness connectors to alarm. Install seat assembly on vehicle.

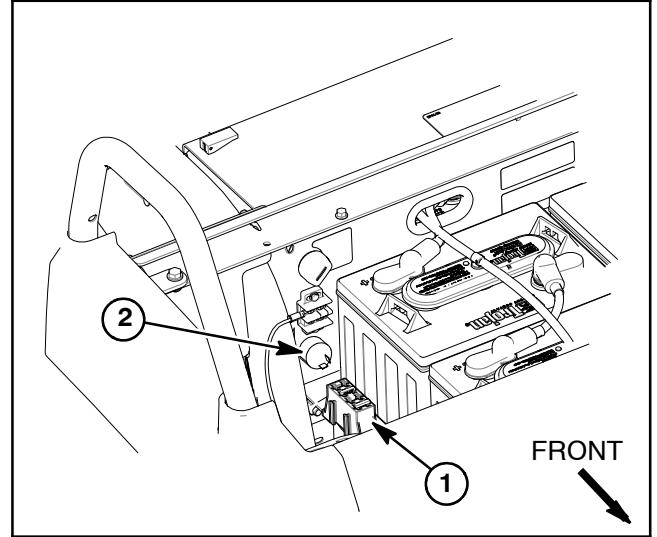

Figure 39

1. Fuse block

2. Reverse audio alarm

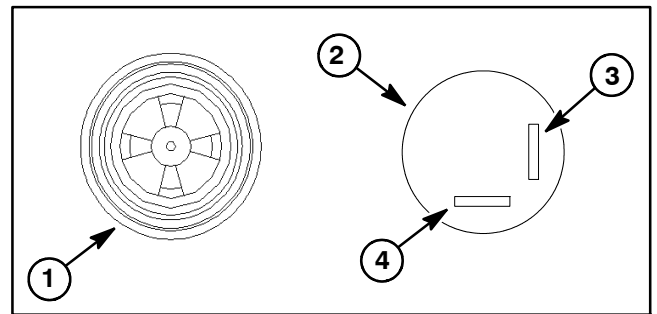

Figure 40

1. Alarm (top view)

2. Alarm (bottom view)

3. Positive (+) terminal

4. Negative (-) terminal

Service and Repairs

Battery Service

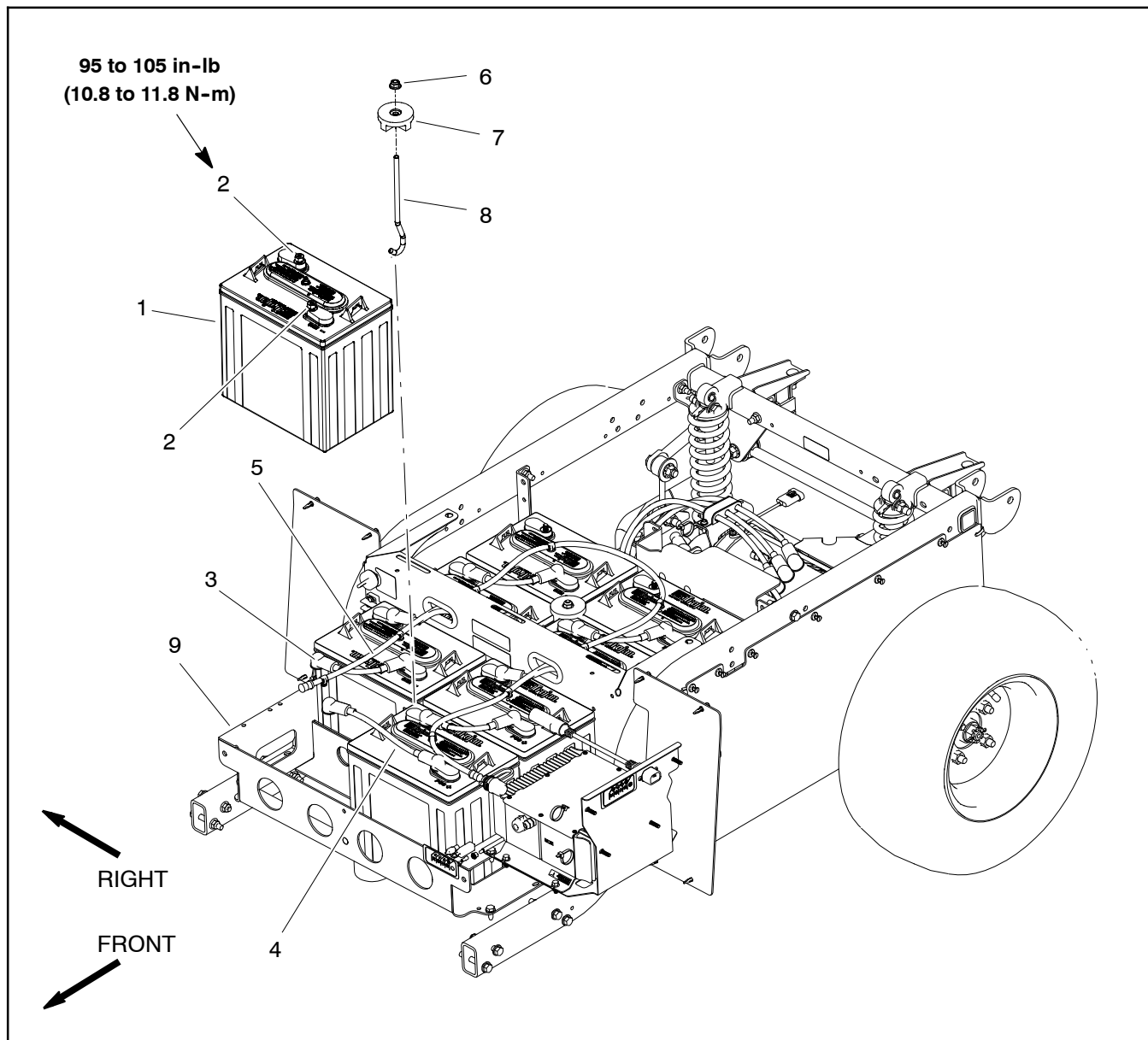

Figure 41

- | | | |
|--------------------------------------|-----------------------------|-----------------------------------|
| 1. Battery (8 used) | 4. Battery cable with boots | 7. Battery hold down (2 used) |
| 2. Hex nut (2 used per battery) | 5. Watering hose assembly | 8. Battery hold down rod (2 used) |
| 3. Battery cable with boots (6 used) | 6. Flange nut (2 used) | 9. Battery tray (2 used) |

The batteries are the heart of the Workman electrical system. With regular and proper service, battery life can be extended. Additionally, battery and electrical component failure can be prevented.

Battery Specifications:

Trojan model T-125 Battery (6 Volt Deep Cycle)
Capacity: 195 AH
Weight: 66 lbs (30 kg)

Battery Removal (Fig. 41)

**WARNING**

POTENTIAL HAZARD:
The battery terminals, metal tools and metal vehicle parts could short together.

WHAT CAN HAPPEN:
Sparks can cause battery gasses to explode. Damaged cables could short against metal vehicle parts and cause sparks.

HOW TO AVOID THE HAZARD:
When removing or installing the batteries, do not allow the battery terminals to short against metal parts of the vehicle.
Do not allow metal tools or metal vehicle parts to short between the battery terminals or battery cables.
Always keep the battery hold downs in place to protect and secure the batteries.

1. Park vehicle on a level surface, turn key switch to OFF, engage the parking brake and remove key from the key switch.

2. Raise cargo bed and support with prop rod. Remove seat base assembly.

3. Remove rear frame panel cover to allow access to all vehicle batteries (see Rear Frame Panel Cover in the General Information section of this chapter).

4. Make sure that vehicle battery charger IS NOT connected to electrical outlet. Open the battery circuit by disconnecting the conductors between the battery pack and vehicle components (see Opening Battery Circuit in the General Information section of this chapter).

5. Once battery circuit has been opened, disconnect and remove battery cables from batteries that are to be removed from vehicle.

6. Carefully, disconnect watering hose connectors from all batteries that are to be removed from vehicle.

7. Remove flange nuts (item 6) and battery hold downs (item 7) used to secure batteries to vehicle.

8. Make sure that all battery filler caps are on tightly.

IMPORTANT: For assembly purposes, note that batteries are installed with the positive terminals toward the outside of the vehicle and the negative terminals toward the center of the vehicle (Fig. 42).

**CAUTION**

To prevent battery damage and personal injury, make sure that batteries are well supported as they are removed from vehicle. Each battery weighs approximately 66 pounds (30 kg).

9. Use battery lift strap (see Special Tools in this chapter) to remove batteries from vehicle.

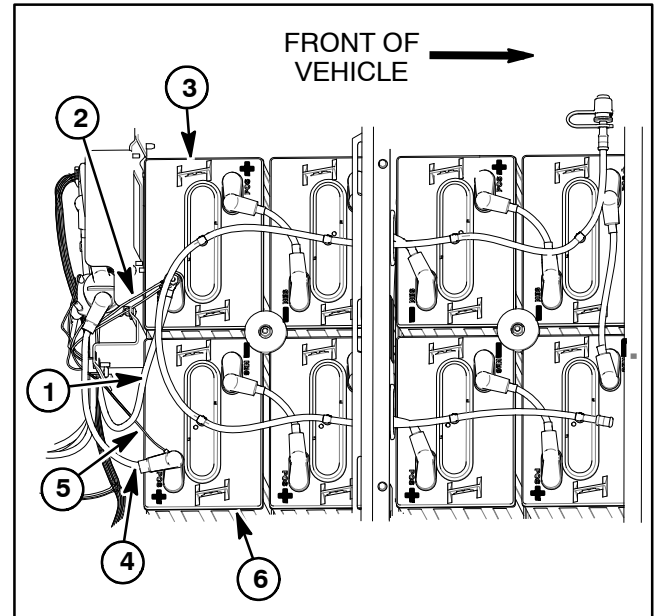

Figure 42

1. Negative cable to controller
2. Negative conductors from charger and harness
3. Left, rear battery
4. Positive cable to main contactor
5. Positive conductor from charger
6. Right, rear battery

Battery Installation (Fig. 41)

1. Make sure vehicle key switch and all accessories are OFF.

2. Raise cargo bed and support with prop rod. Remove seat base assembly and rear frame panel cover.

3. Make sure the battery trays are clean and repainted if necessary. Make sure conductors (wires and cables), conductor terminals, battery hold down rods and hold down retainers are clean (no corrosion) and in good condition.



CAUTION

To prevent battery damage and personal injury, make sure that batteries are well supported as they are installed into vehicle. Each battery weighs approximately 66 pounds (30 kg).

IMPORTANT: Make sure that batteries are installed with the positive terminals toward the outside of the vehicle and the negative terminals toward the center of the vehicle (Fig. 42).

4. Use battery lift strap (see Special Tools in this chapter) to set batteries on the battery supports with battery posts properly orientated (Fig. 42). Make sure that battery hold down rods (item 8) are positioned to allow installation of battery hold downs.

5. Install two (2) battery hold downs and flange nuts to secure batteries to vehicle.

6. Install all of the battery cables used to connect the battery pack (Figure 42). Make sure that cables are connected to correct battery terminal noting battery polarity. Install hex nut on each battery terminal to secure cable to battery and torque nuts from **95 to 105 in-lb (10.8 to 11.8 N-m)**.

7. Carefully connect watering hose connectors to all batteries.

8. Connect the conductors between the battery pack and vehicle components (see Opening Battery Circuit in the General Information section of this chapter). Make sure to torque hex nuts on battery terminals from **95 to 105 in-lb (10.8 to 11.8 N-m)**.

9. After connections are made, apply Toro battery terminal protector (see Special Tools) to all battery posts and cable connectors to prevent corrosion. Make sure that cable terminal boots are positioned over all connections.

10. Secure rear frame panel cover to vehicle. Lower and secure cargo box. Install seat base assembly.

11. Before returning vehicle to operation, fully charge the batteries by connecting the on-board battery charger to an appropriate electrical outlet.

Battery Inspection and Maintenance



WARNING

POTENTIAL HAZARD:

Battery electrolyte contains sulfuric acid which is a deadly poison and it causes severe burns.

WHAT CAN HAPPEN:

If you carelessly drink electrolyte you could die or if it gets onto your skin you will be burned.

HOW TO AVOID THE HAZARD:

Do not drink electrolyte and avoid contact with skin, eyes or clothing. Wear safety glasses to shield your eyes and rubber gloves to protect your hands.

Fill the battery where clean water is always available for flushing the skin.

Follow all instructions and comply with all safety messages on the electrolyte container.

1. Check for cracks in battery case caused by overly tight or loose hold-down retainer. Replace any battery that is cracked and/or leaking.

2. Check battery terminal posts for corrosion. Use a terminal brush to clean corrosion from the battery terminal posts.

IMPORTANT: Before cleaning the battery, make sure the filler caps are on tightly.

3. Check for signs of wetness or leakage on the top of the battery which might indicate a loose or missing filler cap, overcharging, loose terminal post or overfilling.

4. Check the battery case for dirt and oil. Clean the battery with a solution of baking soda and water, then rinse battery with clean water.

5. Check that the battery cover seal is not broken away. Replace the battery if the seal is broken or leaking.

IMPORTANT: Make sure the area around the battery filler caps is clean before opening the caps. Also, do not add acid to the battery. Use only distilled water to adjust the battery electrolyte level.

6. On a daily basis, check electrolyte level in the batteries using the water level indicators on the top of each battery. A white indicator identifies that a battery needs water and a black indicator identifies that a battery has enough water. If necessary, add distilled water to ensure proper battery performance and service life. To properly fill the batteries, use watering hose assembly attached to the batteries and the hand pump hose assembly (see Special Tools in this chapter).

Battery Testing

When testing batteries in the Workman GTX Electric, it is important to periodically test all batteries. Proper performance of the vehicle depends on all batteries being in good condition. Testing will determine if one (or more) of the batteries needs to be replaced.

1. The preferred testing procedure is to use the Lester Electrical 36/48 Volt Battery Discharge Unit (Model 17770). This instrument puts a known discharge load (56.25 Amps) on the battery pack until the battery pack reaches 42 volts. A timer incorporated into the discharge unit measures the time needed to reach that voltage level. Battery capacity and remaining life can be determined from the test results. Refer to Discharge Unit Operating Instructions for further information.

Other types of battery load testers can also be used to test the Workman batteries. Many locally available battery load testers do not, however, have any adjustment on the load that is put on the battery. Results received from using load testers should follow the recommendations of the load tester manufacturer.

2. If the Lester Battery Discharge Unit (or other load tester) is not available, an alternate battery test can be done using a multimeter to perform a voltage test of each battery. Use the following procedure:

A. For accurate voltage testing, allow batteries to remain idle (no charging, no discharging) for at least six (6) hours and preferably 24 hours.

B. Open the battery circuit by carefully disconnecting the conductors between the battery pack and vehicle components (see Opening Battery Circuit in the General Information section of this chapter). Then, disconnect both cables from battery to be tested.

C. Measure the battery voltage with the multimeter. Record battery voltage. The measured voltage will determine battery state of charge.

D. If voltage reading is below 70% charged (see Fig. 43), charge battery and take voltage measurements again. If voltage remains low after charging, consider battery replacement.

3. A third option for battery testing is to perform a specific gravity test of the battery electrolyte using a hydrometer. Use the following procedure:

IMPORTANT: Make sure the area around the battery fill caps is clean before removing the caps.

A. Remove battery filler caps. Do not add water prior to testing specific gravity of battery electrolyte. If electrolyte level is low, add distilled water and charge battery before performing specific gravity test.

B. Measure the specific gravity of each battery cell with a hydrometer. Fill and drain the hydrometer two (2) to four (4) times before drawing a sample. At the same time, take the temperature of the cell.

C. Have enough electrolyte in the hydrometer to completely support the hydrometer float. Record the hydrometer reading and return the electrolyte to the battery cell.

D. Repeat test for remaining battery cells.

E. Temperature correct each cell reading. For each 10°F (5.5°C) above 80°F (26.7°C) add 0.004 to the specific gravity reading. For each 10°F (5.5°C) below 80°F (26.7°C) subtract 0.004 from the specific gravity reading.

Example:	Cell Temperature	100F
	Cell Specific Gravity Reading	1.245
	ADD (20F above 80F)	<u>0.008</u>
	Correction to 80F	1.253

F. The temperature corrected specific gravity of all battery cells should be 1.277 ± 0.007 . If low cell readings exist (see Fig. 43), charge battery and take specific gravity readings again.

G. If specific gravity of any cells remain low after complete charging, battery should be replaced.

Battery Charge Level	Specific Gravity	Open Circuit Voltage
100%	1.277	6.37
90%	1.258	6.31
80%	1.238	6.25
70%	1.217	6.19
60%	1.195	6.12
50%	1.172	6.05
40%	1.148	5.98
30%	1.124	5.91
20%	1.098	5.83
10%	1.073	5.75

Figure 43

Battery Charging

When the vehicle is not in use, it is recommended to keep the batteries charged by connecting the on-board battery charger to an appropriate electrical outlet. The Workman GTX charger is designed to automatically charge the batteries fully without overcharging. An indicator LED on the charger provides information during the charging operation.

Colder temperatures will increase the time needed to fully charge the batteries. NEVER attempt to charge frozen batteries. Also, if temperatures below freezing are expected, do not add water to battery after charging as added water could freeze and damage battery.

For additional battery charging information, see your Operator's Manual and the Battery Charger Operating Instructions.

Battery Storage

If the vehicle will be stored for any period of time, use the on-board battery charger to fully charge batteries. After charging batteries, check battery electrolyte level and adjust level if needed. Allow charger to remain connected to vehicle during storage to prevent battery discharge and potential battery damage.

If the vehicle will be stored for more than thirty (30) days and the battery charger cannot be used for some reason, charge the batteries fully. Either store batteries on a shelf or in the vehicle. Store the batteries in a cool atmosphere to avoid quick deterioration of the charge in the batteries. To prevent batteries from freezing, make sure they are fully charged before storage. During the storage period, charge the batteries at least once every three (3) months to prevent battery damage. Before returning the vehicle to service, make sure to fully charge the batteries.

This page is intentionally blank.

Traction Motor

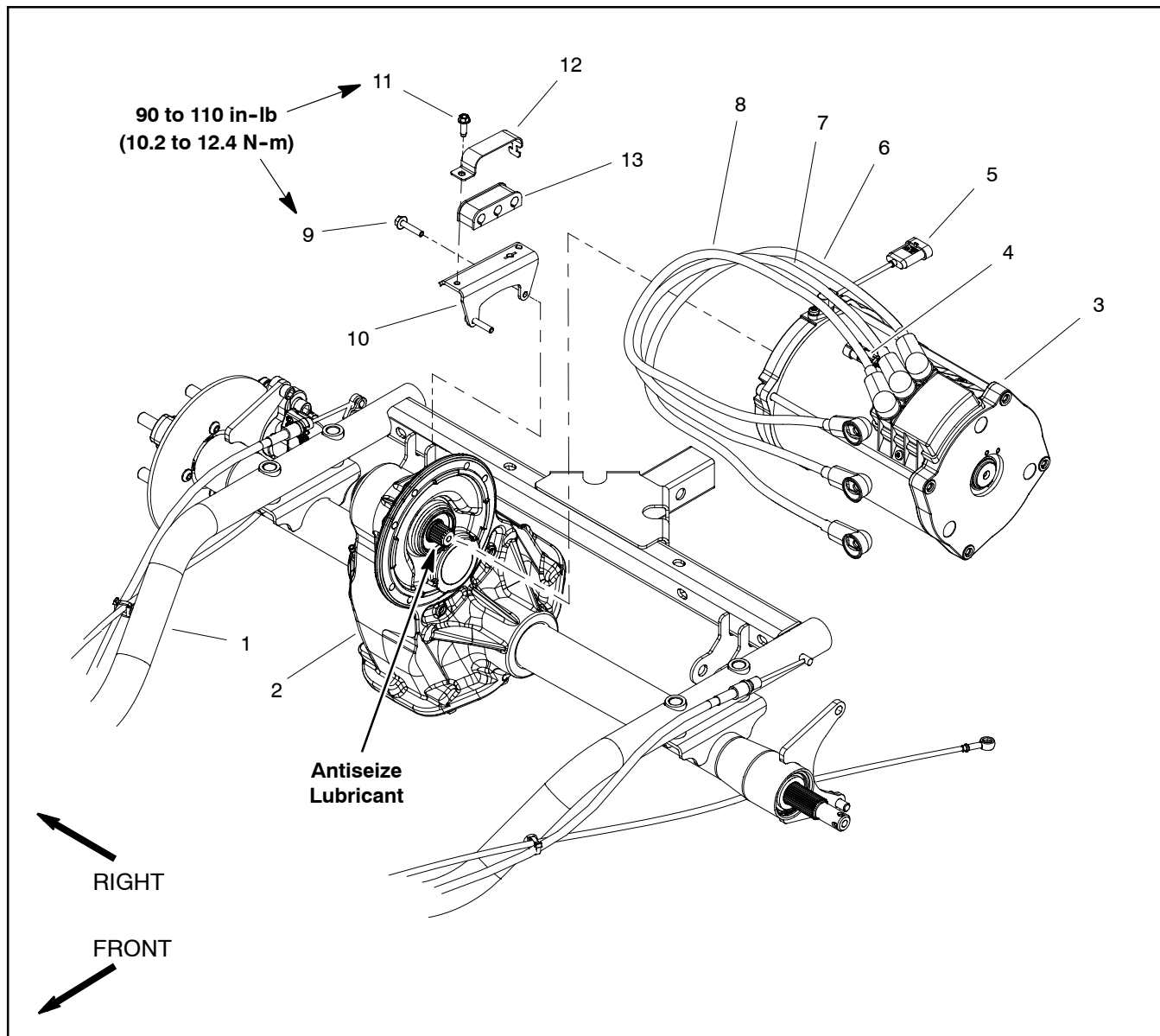

Figure 44

- | | | |
|-------------------------------|-------------------------------------|-----------------------|
| 1. Swing arm | 6. Cable (motor W to controller M1) | 10. Cable bracket |
| 2. Transaxle assembly | 7. Cable (motor V to controller M2) | 11. Washer head screw |
| 3. Traction motor | 8. Cable (motor U to controller M3) | 12. Isolator retainer |
| 4. Motor thermistor connector | 9. Flange head screw (6 used) | 13. Isolator |
| 5. Motor encoder connector | | |

Removal (Fig. 44)

1. Park vehicle on a level surface, turn key switch to OFF, engage the parking brake and remove key from the key switch.

2. To allow easier access to traction motor, remove cargo bed from vehicle (see Cargo Bed in the Service and Repairs section of Chapter 5 - Chassis).

3. Make sure that vehicle battery charger IS NOT connected to electrical outlet. Open the battery circuit by disconnecting the conductors between the battery pack and vehicle components (see Opening Battery Circuit in the General Information section of this chapter).

NOTE: Label all traction motor electrical leads for assembly purposes.

IMPORTANT: When removing cables from motor terminals (U, V and W), use a wrench to retain lower nut while loosening upper nut (Fig. 45). If terminal studs are allowed to turn during upper nut removal, internal motor damage can occur.

4. Disconnect electrical connectors from traction motor and position them away from motor:

A. While retaining lower nut to prevent it from loosening, remove upper nut, lock washer and cable connector from traction motor terminal studs U, V and W.

B. Unplug wire harness connectors from traction motor encoder (speed sensor) and thermistor (temperature).

5. Position disconnected cables and wire harness leads away from traction motor.



CAUTION

To prevent motor damage and personal injury, make sure that traction motor is well supported as it is removed. Motor weighs approximately 66 pounds (30 kg).

6. Wrap suitable lifting strap around center of traction motor housing for support and as a lifting point for motor removal. Do not capture encoder (speed sensor) or thermistor wires under strap. Support motor with strap to prevent it from moving.

7. Remove two (2) flange head screws (item 9) that secure cable bracket (item 10) to transaxle and traction motor. Position cable bracket with attached cables away from motor and transaxle.

8. Remove remaining four (4) flange head screws (item 9) that secure motor to transaxle.

9. Pull motor away from transaxle until motor shaft is disengaged from transaxle input shaft. Then, carefully lift motor from vehicle taking care to not damage motor sensors or vehicle components while motor is being removed.

10. If necessary, remove washer head screw (item 11) that secures isolator retainer and isolator to isolator bracket. Separate isolator and motor cables from bracket.

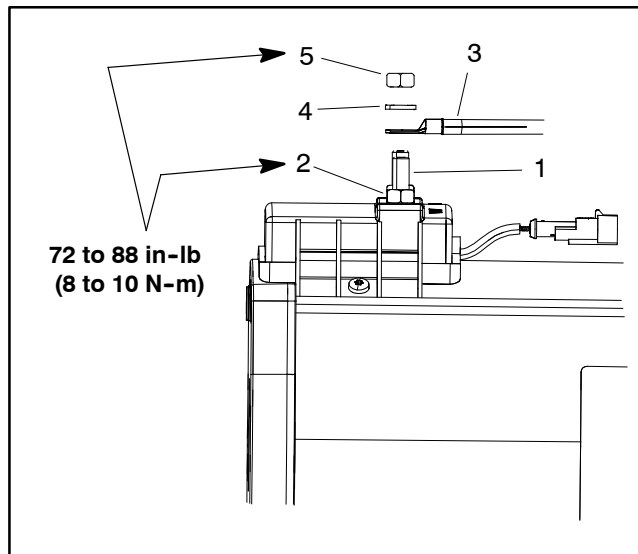

Figure 45

- | | |
|------------------------|----------------|
| 1. Motor terminal stud | 4. Lock washer |
| 2. Lower nut | 5. Upper nut |
| 3. Cable | |

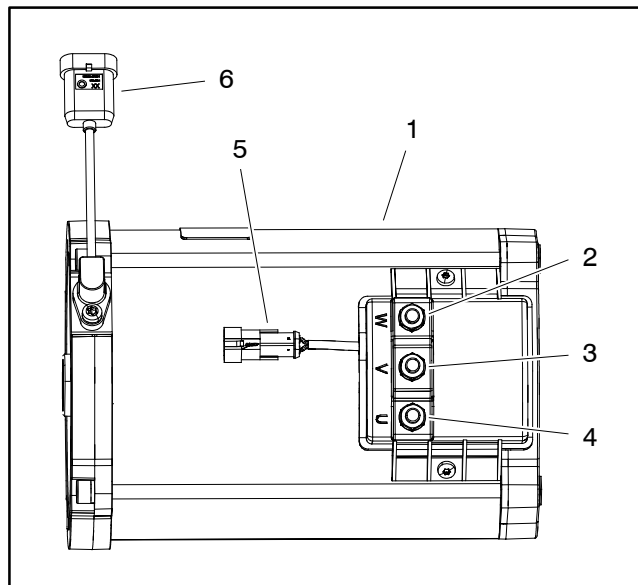

Figure 46

- | | |
|-------------------|-------------------------|
| 1. Traction motor | 4. U terminal |
| 2. W terminal | 5. Thermistor connector |
| 3. V terminal | 6. Encoder connector |

Installation (Fig. 44)

1. If isolator and wire cables were removed from cable bracket (item 10), insert cables into isolator. Secure isolator and cables to bracket with isolator bracket and washer head screw. Torque screw from **90 to 110 in-lb (10.2 to 12.4 N-m)**.

2. Apply antiseize lubricant to the splines of the transaxle and traction motor shafts.



3. Wrap suitable lifting strap around traction motor housing for support and as a lowering point for motor installation. Do not capture encoder (speed sensor) or thermistor wires under strap.

4. Carefully lower traction motor into vehicle. Align motor shaft with transaxle input shaft and slide motor to transaxle. Take care to not damage encoder (speed sensor) while installing motor.

5. Secure traction motor to transaxle:

A. Align mounting holes of motor and transaxle.

B. Install four (4) flange head screws (item 9) through transaxle holes and into traction motor leaving upper two (2) holes vacant for cable bracket installation.

C. Position cable bracket with attached cables to motor and transaxle. Install final two (2) flange head screws.

D. Torque all six (6) flange head screws from **90 to 110 in-lb (10.2 to 12.4 N-m)** to secure motor to transaxle.

E. Remove lifting strap from traction motor.

6. Make sure motor terminals and cables are clean (no corrosion) and in good condition.

IMPORTANT: When connecting cables to motor terminals (U, V and W), use a wrench to retain lower nut while tightening upper nut (Fig. 45). If terminal studs are allowed to turn during upper nut installation, internal motor damage can occur.

7. Using labels placed during motor removal, secure electrical connections to traction motor:

A. Plug connectors from traction motor traction motor encoder (speed sensor) and thermistor (temperature) into vehicle wire harness.

B. Make sure that lower nuts are installed on motor terminals and are torqued from **72 to 88 in-lb (8 to 9 N-m)**.

C. Install correct cable, lock washer and nut to motor terminals U, V and W. While retaining lower nut, torque upper nut from **72 to 88 in-lb (8 to 9 N-m)**.

8. Connect the conductors between the battery pack and vehicle components (see Opening Battery Circuit in the General Information section of this chapter). Make sure to torque hex nuts on battery terminals from **95 to 105 in-lb (10.8 to 11.8 N-m)**.

9. After all cable connections are made, apply Toro battery terminal protector (see Special Tools) to all battery posts and traction motor cable connectors to prevent corrosion. Make sure that cable terminal boots are positioned over all connections.

10. Install cargo bed to the vehicle (see Cargo Bed Installation in Service and Repairs section of Chapter 5 – Chassis).

11. Before returning vehicle to operation, fully charge the batteries by connecting the on-board battery charger to an appropriate electrical outlet.

This page is intentionally blank.

Traction Motor Service

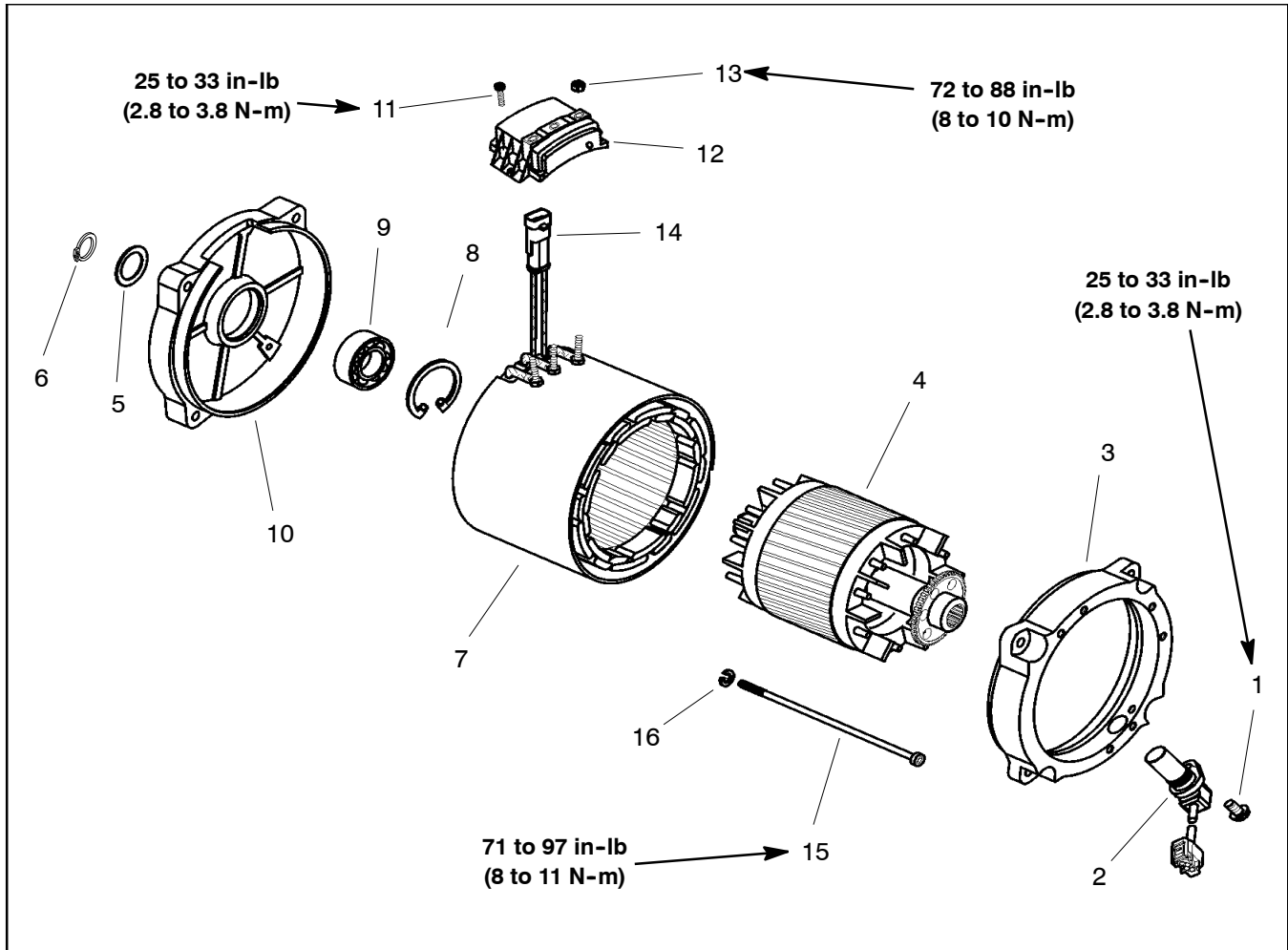

Figure 47

- | | | |
|---------------------------|------------------------------|--------------------------------|
| 1. Torx head screw | 7. Stator assembly | 12. Connection plate |
| 2. Encoder (speed sensor) | 8. Retaining ring | 13. Lower jam nut (3 used) |
| 3. Drive end bracket | 9. Bearing | 14. Thermistor connector |
| 4. Armature assembly | 10. Rear end bracket | 15. Socket head screw (4 used) |
| 5. Wave washer | 11. Torx head screw (2 used) | 16. Lock washer (4 used) |
| 6. Retaining ring | | |

NOTE: If traction motor stator or armature damage occurs, traction motor replacement is necessary. These components are not available separately.

Motor Disassembly (Fig. 47)

1. Remove torx head screw that secures encoder (speed sensor) to traction motor. Slide encoder from drive end bracket.
2. Remove the retaining ring and wave washer that secure the armature assembly in the rear end bracket bearing (Fig. 48).
3. Carefully separate armature assembly out of bearing in rear end bracket and then remove armature from stator.
4. Remove connection plate assembly (item 12) from stator:
 - A. Remove three (3) lower jam nuts from stator terminal screws.
 - B. Remove two (2) torx screws that secure connection plate assembly to stator.
 - C. Remove connection plate assembly from stator.
5. For assembly purposes, note locations of drainage slots in drive and rear end brackets and the aligning position slots in the stator assembly (Fig. 49).

6. Remove four (4) socket head screws and lock washers that secure drive and rear end brackets to stator assembly. Remove end brackets from stator.

NOTE: After the traction motor has been disassembled, it is recommended that a new rear end bracket bearing be installed. Although the bearing may appear and feel in good condition, the bearing could be "brinelled" (races or balls deformed). After assembly with a questionable bearing, the motor may exhibit noise and vibration problems or fail within a relatively short period of service.

7. Remove the retaining ring from the rear end bracket (Fig. 50). Press bearing from the rear end bracket and discard the removed bearing.



CAUTION

When using compressed air for cleaning motor components, follow all safety instructions, including wearing eye and respiratory protection.

8. Carefully blow out any accumulated debris from the stator and the armature using clean, oil free, compressed air.

9. Inspect traction motor armature and transaxle input shaft splines for wear or damage. Replace motor and/or transaxle input shaft if spline damage is found.

10. Visually inspect the armature and stator components. If damage to either of these components is found, replace traction motor.

Motor Assembly (Fig. 47)

1. Make sure that all traction motor components are clean and in good condition before assembling the motor.

IMPORTANT: To prevent bearing damage when installing new bearing in the rear end bracket, support end bracket and press only against the bearing outer race.

2. Press a new bearing into the rear end bracket, pressing on the bearing outer race only. Secure bearing in bracket with retaining ring (Fig. 50). Make sure that retaining ring is fully seated in groove in bracket after assembly.

3. Position drive and rear end brackets to stator assembly using notes made during disassembly to properly align drainage slots in brackets and stator (Fig. 49).

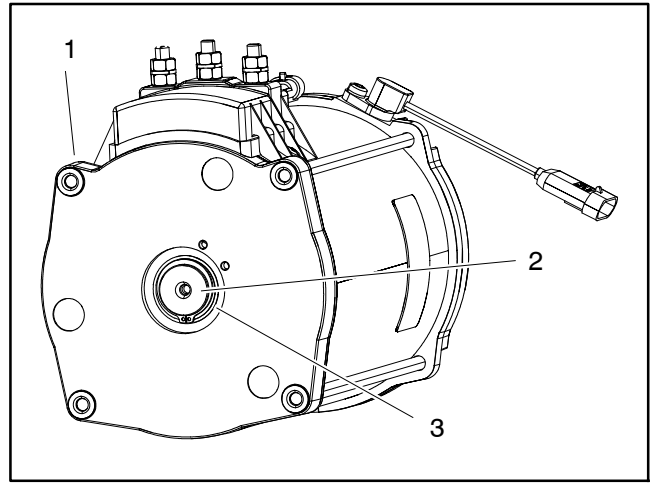

Figure 48

- 1. Rear end bracket
- 2. Armature shaft
- 3. Retaining ring & washer

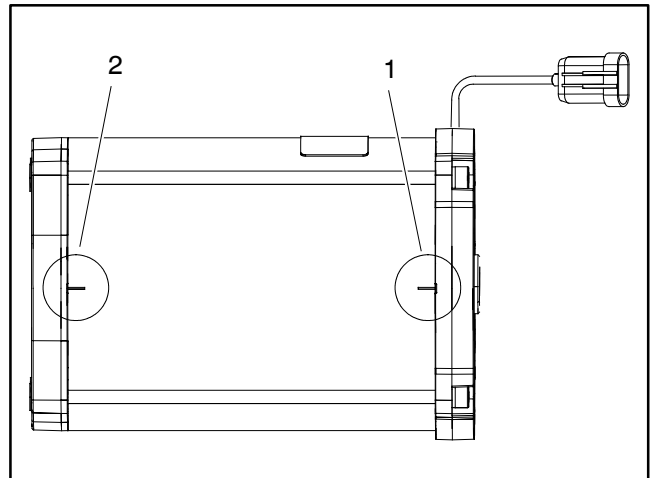

Figure 49

- 1. Drive end slot alignment
- 2. Rear end slot alignment

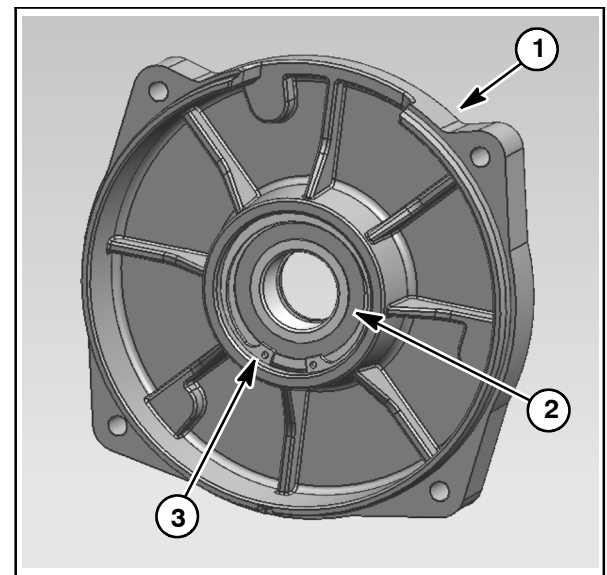

Figure 50

- 1. Rear end bracket
- 2. Bearing
- 3. Retaining ring

Electrical System

4. Secure drive and rear end brackets to stator assembly with four (4) socket head screws and lock washers. Tighten screws in two (2) stages using the sequence shown in Figure 51. Final torque on screws should be from **71 to 97 in-lb (8 to 11 N-m)**.

5. Install connection plate assembly (item 12) to stator:

A. Place connection plate assembly onto stator so that three (3) terminal screws fit through plate.

B. Secure connection plate assembly to stator with two (2) torx screws. Torque screws from **25 to 33 in-lb (2.8 to 3.8 N-m)**.

C. Install three (3) lower jam nuts onto stator terminal screws. Torque nuts from **72 to 88 in-lb (8 to 9 N-m)**.

6. Carefully install armature assembly into the stator. End of stator must extend completely through bearing in rear end bracket.

7. Install wave washer (item 5) and retaining ring (item 6) to secure the armature assembly in the rear end bracket bearing (Fig. 48). Make sure that retaining ring is fully seated into groove in armature shaft.

8. Slide encoder into drive end bracket and secure with torx head screw. Torque screw from **25 to 33 in-lb (2.8 to 3.8 N-m)**.

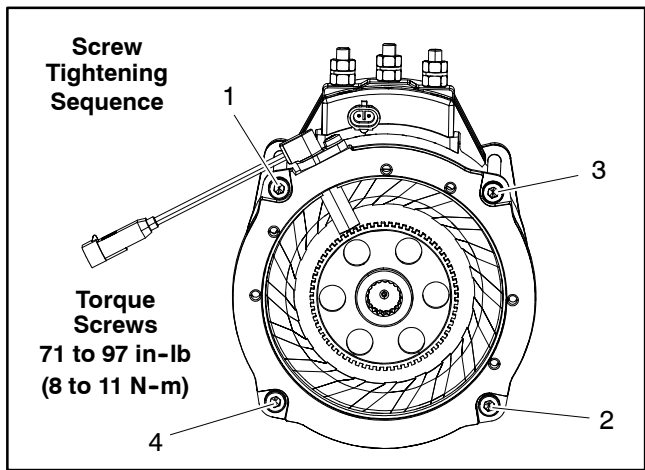

Figure 51

This page is intentionally blank.

Controller

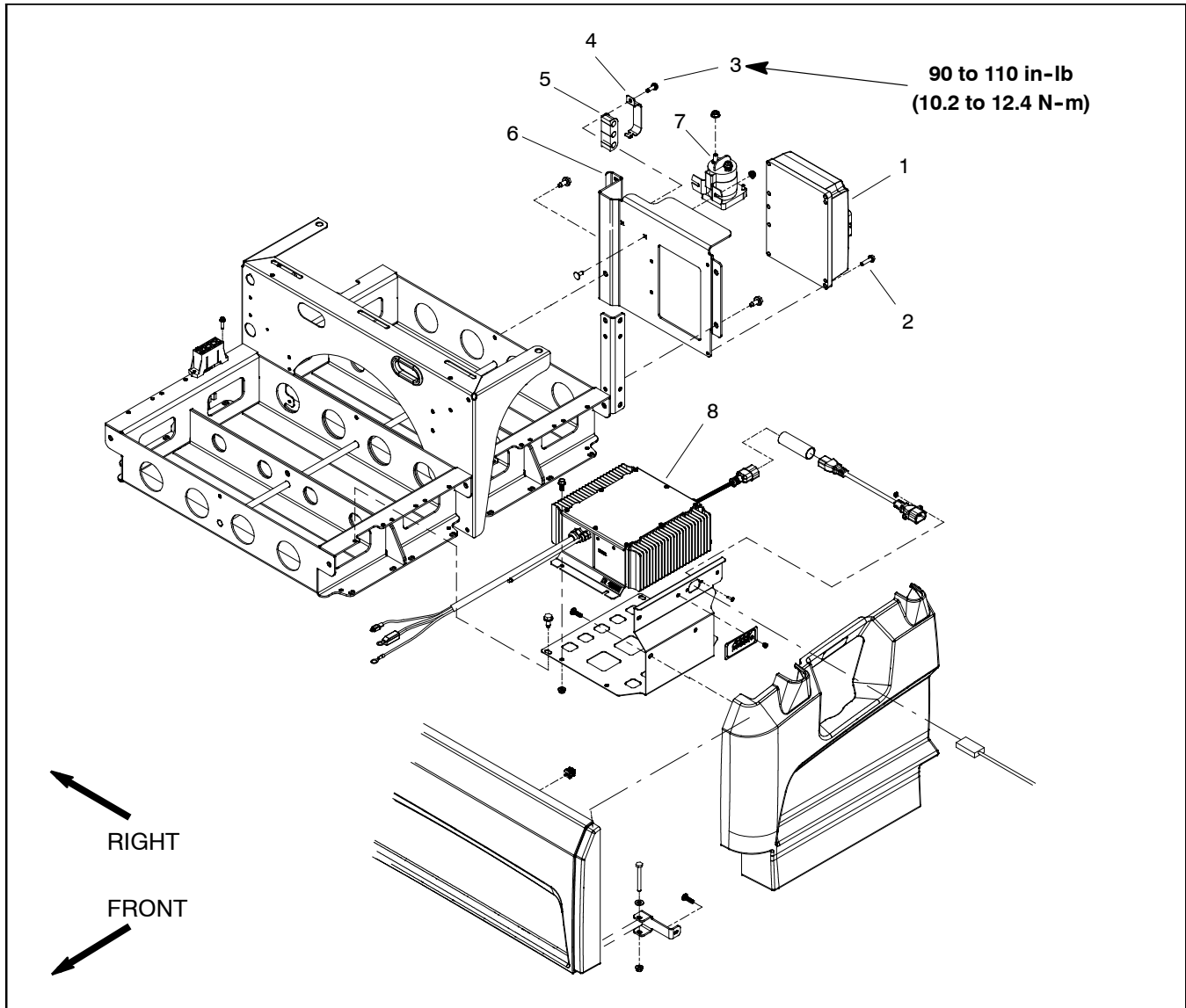

Figure 52

- | | | |
|-------------------------------|-----------------------|-----------------------------|
| 1. Controller | 4. Isolator retainer | 7. Main contactor |
| 2. Washer head screw (4 used) | 5. Isolator | 8. On-board battery charger |
| 3. Washer head screw | 6. Controller bracket | |

Removal (Fig. 52)

1. Park vehicle on a level surface, turn key switch to OFF, engage the parking brake and remove key from the key switch.
2. Raise cargo bed and support with prop rod to allow access to controller.
3. Make sure that vehicle battery charger IS NOT connected to electrical outlet. Open the battery circuit by disconnecting the conductors between the battery pack and vehicle components (see Opening Battery Circuit in the General Information section of this chapter).

NOTE: Label all controller electrical leads for assembly purposes.

4. Disconnect electrical conductors from controller and position them away from controller:
 - A. Remove cap screw, lock washer, flat washer and cable connector from controller terminals B+, B-, M1, M2 and M3 (Fig. 53).
 - B. Carefully unplug wire harness connector from controller.
 - C. Position cables and wire harness connector away from controller.

5. Support controller to prevent it from falling.
6. Remove four (4) washer head screws that secure controller to controller bracket. Carefully remove controller from vehicle.
7. If necessary, remove washer head screw (item 3) that secures isolator retainer, isolator and controller cables to controller bracket. Separate isolator and controller cables from bracket.

Installation (Fig. 52)

1. If isolator and controller cables were removed from controller bracket, insert cables into isolator. Secure isolator and cables to bracket with isolator bracket and washer head screw. Torque screw from **90 to 110 in-lb (10.2 to 12.4 N-m)**.

2. Position controller to controller bracket and secure with four (4) washer head screws.

3. Make sure controller terminals and cables are clean (no corrosion) and in good condition.

4. Connect electrical conductors to controller:

A. Carefully plug wire harness connector into controller. Make sure that connector is fully plugged into controller socket.

B. Secure controller cables to controller terminals B+, B-, M1, M2 and M3 with cap screw, lock washer and flat washer (Fig. 53). Torque cap screws from **89 to 106 in-lb (10 to 12 N-m)**.

5. Connect the conductors between the battery pack and vehicle components (see Opening Battery Circuit in the General Information section of this chapter). Make sure to torque hex nuts on battery terminals from **95 to 105 in-lb (10.8 to 11.8 N-m)**.

6. After all cable connections are made, apply Toro battery terminal protector (see Special Tools) to all battery posts and controller cable connectors to prevent corrosion. Make sure that cable terminal boots are positioned over all connections.

7. Lower and secure cargo bed.

8. Before returning vehicle to operation, fully charge the batteries by connecting the on-board battery charger to an appropriate electrical outlet.

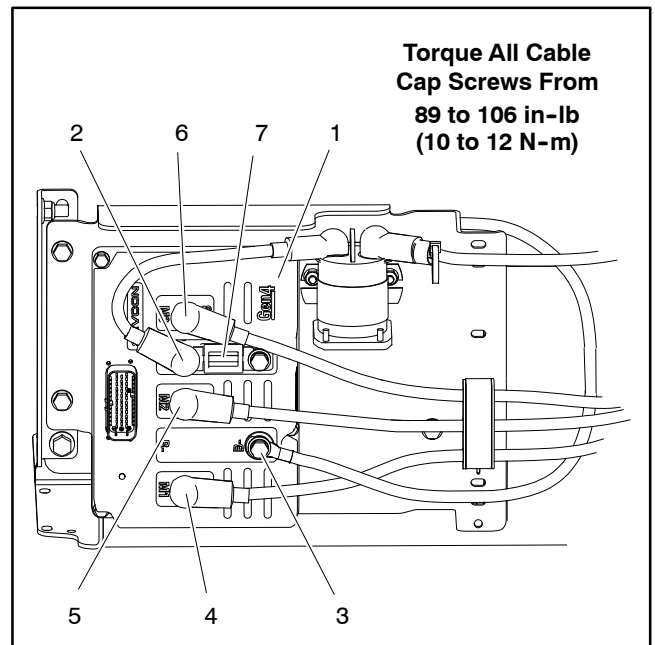

Figure 53

1. Controller
2. B+ terminal (+ cable from main contactor)
3. B- terminal (- cable from left, rear battery)
4. M1 terminal (cable to motor terminal W)
5. M2 terminal (cable to motor terminal V)
6. M3 terminal (cable to motor terminal U)
7. Fuse (425 A)

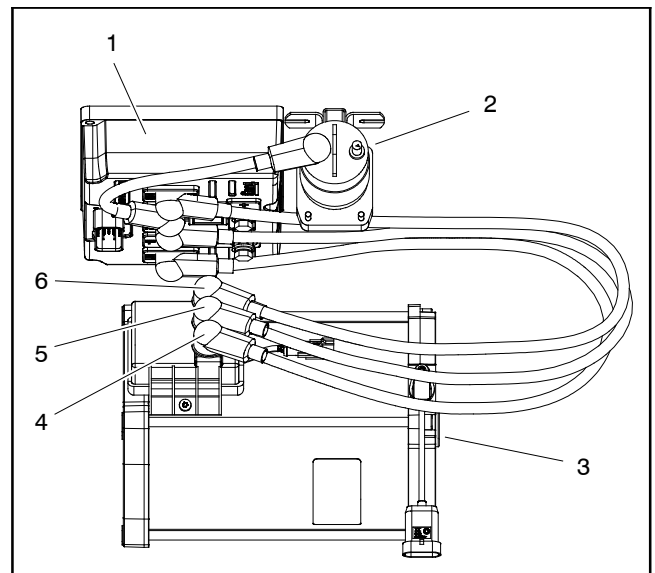

Figure 54

- | | |
|-------------------|---------------|
| 1. Controller | 4. Terminal W |
| 2. Main contactor | 5. Terminal V |
| 3. Traction motor | 6. Terminal U |

On-board Battery Charger

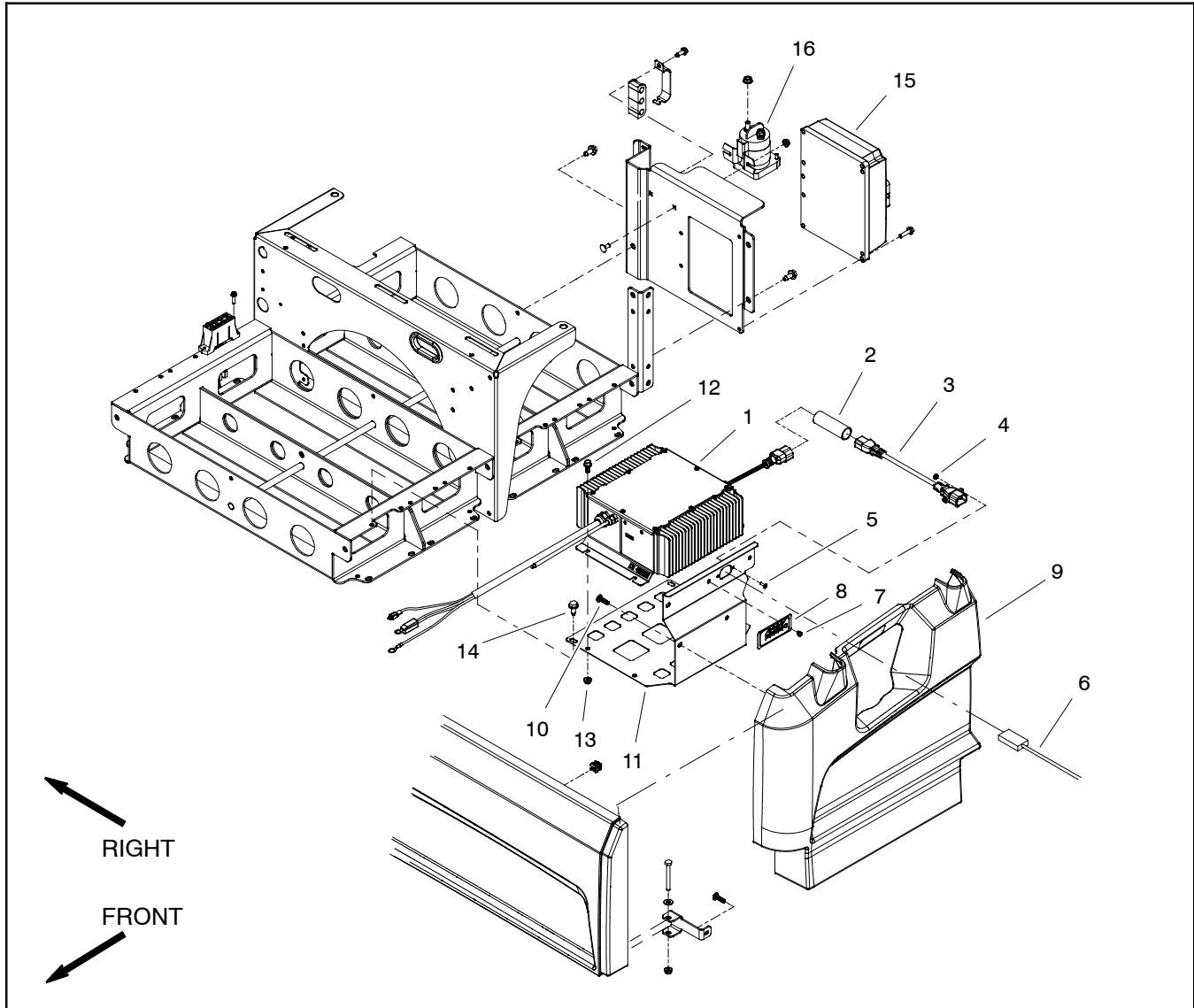

Figure 55

- | | | |
|-----------------------------|---------------------------|--------------------------------|
| 1. On-board battery charger | 7. LED holder | 12. Flange head screw (4 used) |
| 2. Heat shrink tube | 8. Charger function decal | 13. Flange nut (4 used) |
| 3. Cord set | 9. LH seat base side | 14. Washer head screw (2 used) |
| 4. Lock nut (2 used) | 10. Screw (4 used) | 15. Controller |
| 5. Screw (2 used) | 11. Charger bracket | 16. Main contactor |
| 6. AC power cord | | |

IMPORTANT: No serviceable parts (including electrical conductors) are contained inside the battery charger. DO NOT attempt to open or disassemble the charger.

Removal (Fig. 55)

1. Park vehicle on a level surface, turn key switch to OFF, engage the parking brake and remove key from the key switch. Make sure that vehicle charger IS NOT connected to electrical outlet.

2. Raise cargo bed and support with prop rod. Remove seat base assembly.

Electrical System

3. Remove rear frame panel cover to allow access to battery charger electrical connections (see Rear Frame Panel Cover in the General Information section of this chapter).

4. Open the battery circuit by disconnecting the conductors between the battery pack and vehicle components (see Opening Battery Circuit in the General Information section of this chapter).

NOTE: Label all battery charger electrical leads for assembly purposes.

5. Disconnect charger electrical conductors from vehicle connections:

A. Remove positive charger connection (red charger wire) from right, rear battery positive (+) terminal.

B. Remove negative charger connection (black and white charger wires) from left, rear battery negative (-) terminal.

C. Unplug charger lock out connection (green charger wire) from vehicle wire harness connector (yellow harness wire).

D. Remove two (2) screws and lock nuts that secure cord set receptacle to charger bracket. Separate receptacle from bracket.

E. Carefully slide remote charger LED indicator out of LED holder in charger bracket.

6. Separate charger cable from the clips in the rear frame. Route cable away from rear batteries and position near charger so it can be removed from vehicle along with charger.

7. Remove four (4) flange head screws and flange nuts that secure battery charger to charger bracket. Carefully remove charger with attached electrical conductors from vehicle.

8. Check that cooling fins on charger are free of accumulation of dirt and debris. Carefully clean charger fins if necessary.

Installation (Fig. 55)

1. Position battery charger to charger bracket. Secure charger to bracket with four (4) flange head screws and flange nuts. Torque tighten the screws to **95 to 105 in-lb (10.8 to 11.8 N-m)**

2. Secure to charger electrical conductors to vehicle:

A. Carefully slide remote charger LED indicator into LED holder in charger bracket.

B. Secure cord set receptacle to charger bracket with two (2) screws and lock nuts.

C. Route charger cable to rear battery area and secure to the rear frame with clips.

D. Plug charger lock out connection (green charger wire) into vehicle wire harness connector (yellow harness wire).

E. Position negative charger connection (black and white charger wires) near left, rear battery negative (-) terminal.

F. Position positive charger connection (red charger wire) near right, rear battery positive (+) terminal.

3. Connect the conductors between the battery pack and vehicle components (see Opening Battery Circuit in the General Information section of this chapter). Make sure that wires from battery charger cable are connected to correct battery terminals and to torque hex nuts on battery terminals from **95 to 105 in-lb (10.8 to 11.8 N-m)**.

4. After connections are made, apply Toro battery terminal protector (see Special Tools) to all battery posts to prevent corrosion. Make sure that cable terminal boots are positioned over all connections.

5. Secure rear frame panel cover to vehicle. Lower and secure cargo bed. Install seat base assembly.

6. Before returning vehicle to operation, fully charge the batteries by connecting the on-board battery charger to an appropriate electrical outlet.

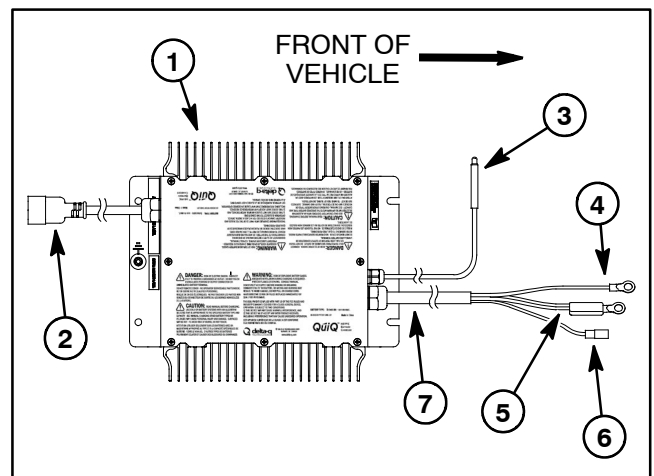

Figure 56

- 1. Battery charger
- 2. AC input
- 3. Charger LED
- 4. Connection to battery + (red wire)
- 5. Connection to battery - (black and white wires)
- 6. Charger lock out connection (green wire)
- 7. Charger cable

This page is intentionally blank.



Electrical System - Lithium

Table of Contents

GENERAL INFORMATION	2	SERVICE AND REPAIRS	48
Operator's Manual	2	Battery Service	48
Electrical Drawings	2	Battery Removal	49
Rear Frame Panel Cover	2	Battery Installation	49
Opening Battery Circuit	3	Caring for the Lithium-Ion Batteries	50
ELECTRICAL SYSTEM OPERATION	5	Battery Charging	51
Vehicle Operation	5	Battery Storage	51
Display	6	Shipping and Transporting the Lithium-Ion Batteries	51
CAN Bus Communications	8	Traction Motor	52
SC1: Lithium-Ion Battery Controller	9	Traction Motor Service	56
SC2: Traction Controller	10	SC2: Traction Controller	60
SPECIAL TOOLS	11	SC1: Lithium-Ion Battery Controller (BMS)	62
TROUBLESHOOTING	13	On-board Battery Charger	64
Operator Advisories	13		
Machine Faults	14		
General Run Problems	20		
Battery Charger Problems	22		
Battery Charger Error Codes	22		
Battery Charger Fault Codes	23		
COMPONENT TESTING	24		
Fuses	24		
CAN Bus	26		
T: Display	27		
SC1: Lithium-Ion Battery Controller	28		
SC2: Traction Controller	29		
Key Switch	34		
Light Switch	35		
Direction Selector Switch	36		
Supervision Speed Limit Switch	37		
Parking Brake Switch	38		
USB Charge Port	39		
Main Contactor (48 VDC)	40		
Accelerator Pedal	41		
Traction Motor	42		
On-board Battery Charger	43		
Diode Assembly	44		
CAN Bus Terminator Resistor	45		
Reverse Audio Alarm (if Equipped)	46		

Electrical System

General Information

The Workman GTX Electric Lithium uses a 48 VDC electrical system that is an isolated circuit. The vehicle frame is not used for any ground connections.

The vehicle controller monitors operator and vehicle inputs to determine voltage to the traction motor. If a problem exists that will prevent normal vehicle operation.

After performing any repair on electrical components on the vehicle, make sure that wiring is routed and secured so as to prevent abrasion or contact with moving vehicle parts.

Operator's Manual

The Operator's Manual provides information regarding the operation, general maintenance and maintenance intervals for your Workman vehicle. Refer to the Operator's Manual for additional information when servicing the machine.

Electrical Drawings

The electrical schematic and other electrical drawings for the Workman GTX Electric Lithium are located in Chapter 6 - Electrical Drawings.

Rear Frame Panel Cover

A panel cover is secured to the top of the rear frame behind the seats to prevent debris entry to the front of the swing arm area. The cover can easily be removed by releasing the latches and lifting the cover from the rear frame.

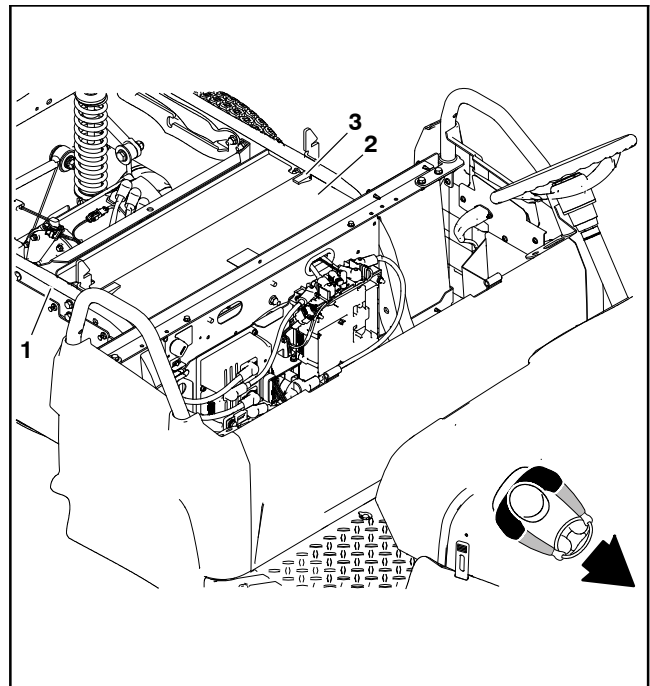

Figure 1

- 1. Rear frame
- 2. Panel cover
- 3. Latch (2 used)

Opening Battery Circuit



WARNING

Battery terminals, battery cables, or metal tools could short against metal components causing sparks. Sparks can cause the battery damage and high heat, resulting in personal injury.

- When removing or installing the batteries, do not allow the battery terminals or battery cables to touch any metal parts of the machine.
- Do not allow metal tools to short between the battery terminals or battery cables and metal parts of the machine.
- Do not attach anything to the battery terminal other than the battery cable or wire harness connector that came with the product.

To prevent allowing a current path through tools used during vehicle electrical circuit repairs, disconnect the conductors between the battery pack and vehicle components as the first step in any electrical system repair.

Battery pack cable routing is shown in Figure 2.

Before working on the vehicle electrical system, remove battery conductors as follows (Fig. 2):

1. Park vehicle on a level surface, turn key switch to OFF, engage the parking brake and remove key from the key switch. Make sure that the vehicle battery charger is not connected to an electrical outlet.
2. Raise and support cargo bed to allow access to battery pack.

IMPORTANT: To prevent accidentally shorting a disconnected battery cable across other components or tools, insulate the battery cable terminal with a 76 mm (3 inch) length of 1.27 mm (0.5 in) internal diameter rubber hose immediately after disconnecting the cable; refer to Fig. 3.

3. Remove the negative (-) battery terminal boot from the front battery pack.
4. Remove the flange nut and negative (-) battery cable from the battery terminal; refer to Fig. 3.
5. Remove the positive (+) battery terminal boot from the rear battery pack.
6. Remove the flange nut and positive (+) battery cable from the battery terminal; refer to Fig. 4.

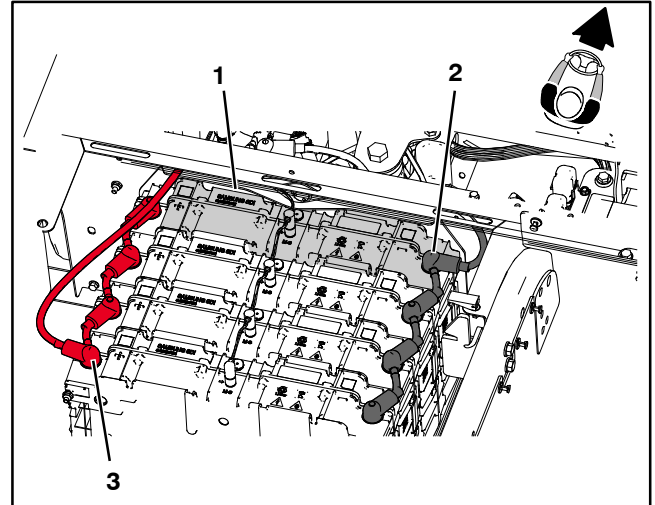

Figure 2

1. Front battery pack
2. Negative (-) battery terminal boot
3. Positive (+) battery terminal boot

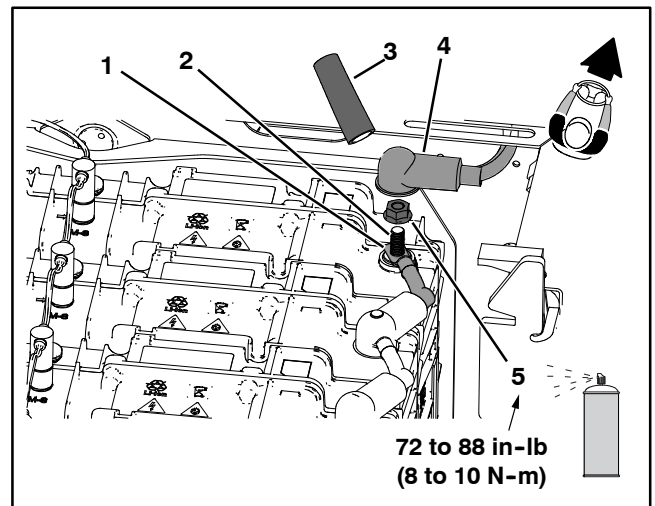

Figure 3

1. Negative (-) battery cable
2. Negative (-) battery terminal
3. 1.27 mm (0.5 in) ID rubber hose
4. Negative (-) battery terminal boot
5. Flange nut

7. Make sure that disconnected conductors are positioned away from the battery terminals.
8. Service electrical system on the vehicle as required. Take care during repairs, however, to not allow tools or vehicle components to complete the battery circuit that was opened with the cable removal.

After working on the vehicle electrical system, attach battery conductors as follows (Fig. 2):

1. Make sure that key is removed from the key switch.
2. If installed, remove the rubber hose on the positive (+) cable. Install the positive (+) cable onto the positive terminal on the left, rear battery. Secure conductors to battery with flange nut and torque tighten the nut from **72 to 88 in-lb (8 to 10 N-m)**; refer to Fig. 4.
3. If installed, remove the rubber hose on the negative (-) cable. Install the negative (-) cable onto the negative terminal on the right, front battery. Secure conductors to battery with flange nut and torque tighten the nut from **72 to 88 in-lb (8 to 10 N-m)**; refer to Fig. 3.
4. Apply battery terminal protector (see Special Tools in this chapter) to the connections after the conductors have been secured to the battery terminals. Also, make sure that boot is positioned over positive (+) and (-) terminals.

5. Lower and secure cargo bed.

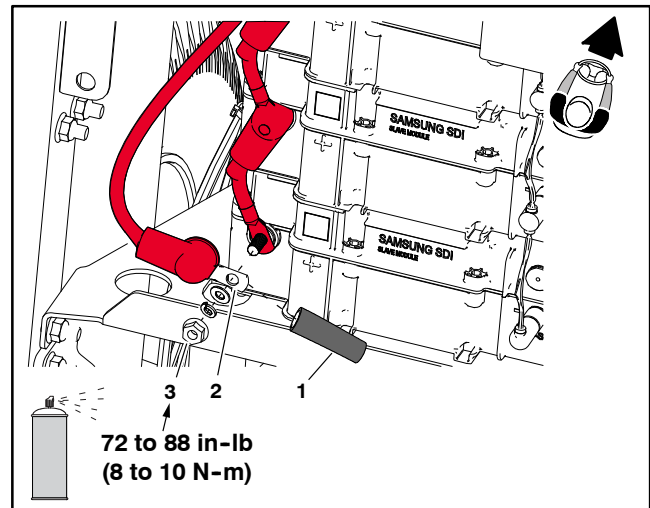

Figure 4

1. 1.27 mm (0.5 in) ID rubber hose
2. Positive (+) battery terminal
3. Flange nut

Electrical System Operation

Vehicle Operation

The Workman GTX Electric electrical system uses a 48 volt battery pack, an electric traction motor, a vehicle controller and numerous other electrical components to allow vehicle operation.

The battery pack is composed of four 48 VDC lithium-ion batteries that are connected in parallel provide current for a 48V, brushless, high torque, AC inductive traction motor, the vehicle controller and vehicle accessories. The batteries are discharged as the vehicle is used so charging the batteries after using the vehicle is necessary. The display on the dash provides the operator with information on battery charge level.

IMPORTANT: When connecting the battery pack in the 48 VDC system, make sure that battery polarity is carefully checked. System damage can occur if batteries are not connected correctly.

The Workman GTX electrical system is an isolated system so the vehicle frame is not used for any ground connections. Before performing any electrical service, it is recommended to open the vehicle battery circuit by disconnecting the conductors between the battery pack and vehicle components (see Opening Battery Circuit in the General Information section of this chapter). This will prevent unexpected component operation when performing service on the vehicle.

The electric traction motor directly drives a double reduction, high torque transaxle with integral differential. Operator inputs for forward/reverse, supervision speed limit switch position and accelerator pedal position are used by the controller to determine needed electrical power for the traction motor.

The traction motor is protected from overheating by a thermistor (thermally sensitive resistor) that resides in the motor housing. If unsafe motor temperature is sensed by the thermistor, the controller will limit vehicle speed and torque until the motor temperature reduces to a normal level.

The vehicle controller is a sealed electronic logic device that uses inputs from several vehicle components to control motor speed and direction. These inputs include several switches (key, direction selector, speed mode limit, parking brake), the traction motor thermistor (temperature), the traction motor encoder (speed sensor), the accelerator pedal and the vehicle main contactor (solenoid). The controller also provides regenerative braking to assist in slowing the vehicle whenever the accelerator pedal is released. Battery current is available to the controller whenever the key switch is ON which energizes the main contactor. A high current fuse mounted to the controller protects the 48 VDC circuits.

The Workman controller also limits roll away speed in instances when the vehicle begins to move (roll away) after being stopped. On an incline and with the key switch in the ON position, if the vehicle starts moving, regenerative braking will limit vehicle speed.

Vehicle accessories (headlights, USB charge port, optional reverse alarm and optional lights) are operated by a 12 VDC system that is powered by a 48 VDC to 12 VDC converter mounted under the dash panel. These vehicle accessories receive current for operation when the key switch is ON. The 12 V fuse block provides circuit protection for the components in this 12 VDC system. Ground wires used for 12 VDC circuits have black insulation.

An on-board, fully automatic, high efficiency charger with 85 - 265 VAC global input is attached to the vehicle for charging the battery pack. The vehicle controller prevents the vehicle from operating while charging the batteries. Charger activity can be monitored at the display on the dashboard.

Testing and service information about components used in the Workman GTX electrical system is included in the Component Testing and Service and Repairs sections of this chapter.

T: Display

The display is a LCD device located on the dash. The display provides the operating status, various diagnostics, and other information about the machine. Power for the display is available when the key switch is in the ON position. A 2 Amps fuse protects the all of the key switched circuits.

The display communicates with the other machine controllers on a Controller Area Network (CAN) bus system.

Note: If the display is replaced for any reason, the system software needs to be reloaded (contact an Authorized Toro Distributor for assistance).

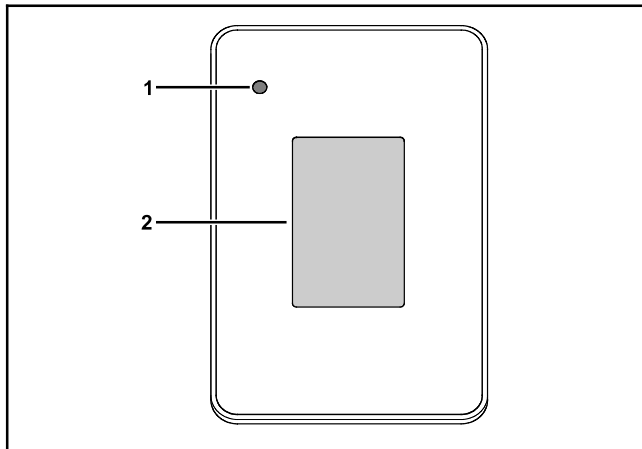

Figure 5

- 1. Indicator light
- 2. Display

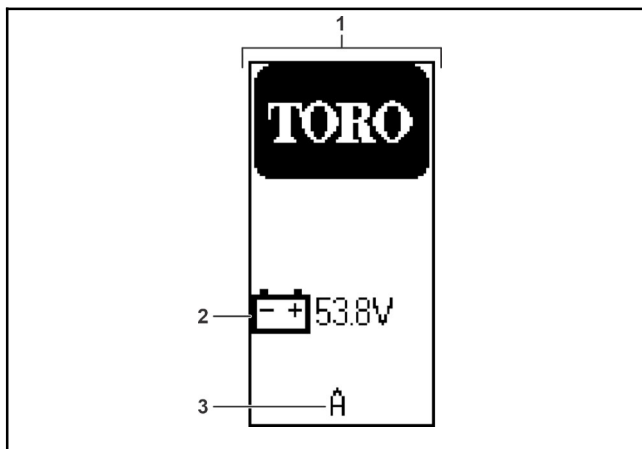

Figure 6

- 1. Start-up screen
- 2. Battery voltage
- 3. Software version

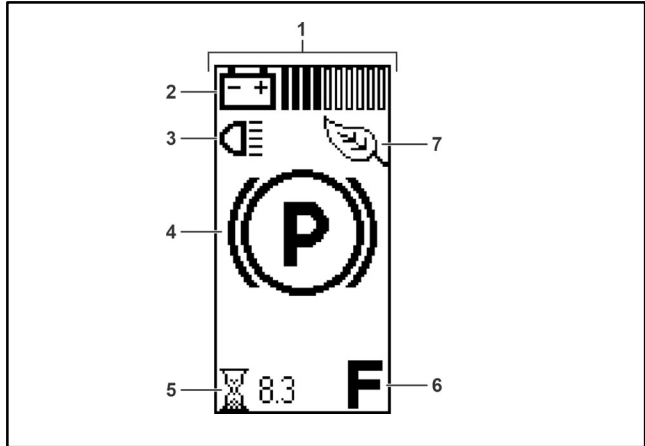

Figure 7

- 1. Run screen
- 2. Battery charge
- 3. Lights On
- 4. Parking brake engaged
- 5. Motor run hours
- 6. Direction
- 7. Eco mode

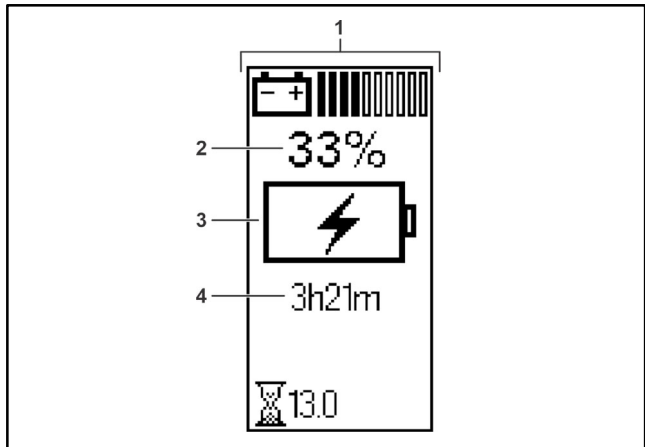

Figure 8

- 1. Charging screen
- 2. Battery life
- 3. Battery charging indicator
- 4. Estimated time to fully charge the machine

The start-up screen (Fig. 6) displays for a few seconds after you turn the key to the ON position, then run screen displays (Fig. 7).

If the vehicle is connected to the power supply for charging, the charging screen displays (Fig. 8). The charging screen shows the battery life, battery charging indicator and estimated time to fully charge the machine.

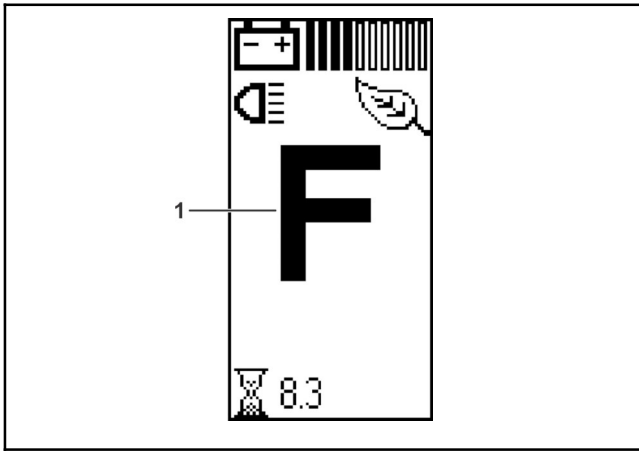

Figure 9

- 1. FORWARD position

When the direction switch is operated, the direction position appears on the display (Fig. 9).

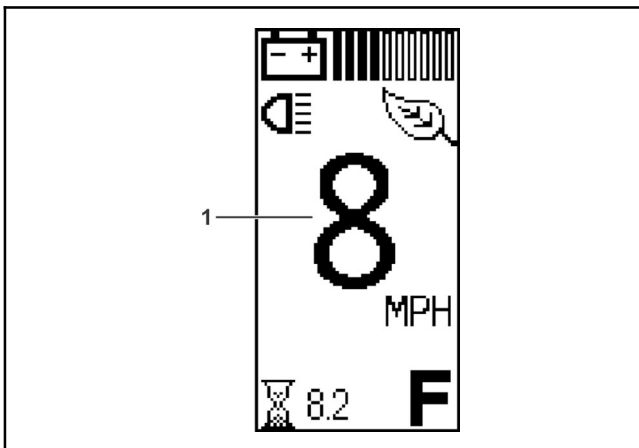

Figure 10

- 1. Vehicle speed

The vehicle speed appears on the display when you are driving the machine (Fig. 10).

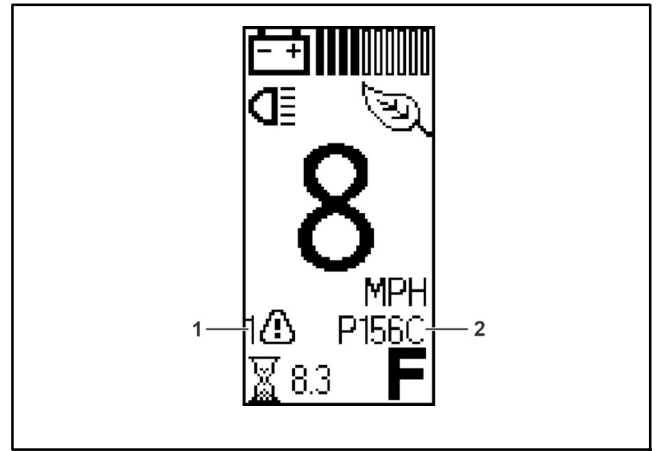

Figure 11

- 1. Active fault indicator
- 2. Fault code

An active fault code appears on the display when there is an issue with the machine (Fig. 11).

CAN bus Communications

The machine controllers communicate with each other on a Controller Area Network (CAN) bus system. Using this network allows full integration of all the different electrical components of the machine, allowing them to operate together as one. The CAN bus system reduces the number of electrical components and connections used on the machine and allows the number of wires in the wire harness to be significantly reduced.

The display (T), lithium-ion battery controller also called as BMS - Battery Management System (SC1) and traction controller (SC2) are on the CAN bus. Additional controllers may be added to the CAN bus in the future through the expansion port connector and/or the telematics connector.

Each of the components that is controlled by the CAN bus link only needs four (4) wires to operate and communicate to the system: CAN High, CAN Low, power and ground. The key switch needs to be in the RUN or START position for the components on the network to be activated.

Two specially designed, twisted wires form the CAN bus. These wires provide the data pathways between the components on the network. The engineering term for these cables are CAN High and CAN Low. The CAN bus wires are red/white (CAN-High) and black/white (CAN Low). At end of the CAN bus is a 120 ohm termination resistor; refer to CAN bus Terminator Resistor.

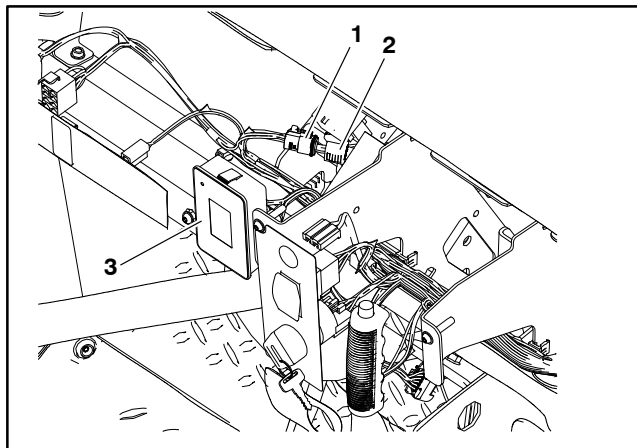

Figure 12

- 1. **DIAG connector**
- 2. **Cover**
- 3. **Display**

The Toro DIAG electronic control diagnostics service system is available to Authorized Toro Distributors to support machine fault diagnosis and maintenance services of the machine electrical control devices. The Toro DIAG connector is located inside the dash.

SC1: Lithium-Ion Battery Controller

The machine uses a Lithium-ion battery controller or Battery Management System (BMS) to manage the lithium-ion batteries. Each of the four lithium-ion batteries communicates with the BMS through a sub-net via the battery interface harness. The battery interface harness includes a 4-pin connector at each of the batteries and a 9-pin connector at the BMS. The BMS uses the sub-net to verify the presence and condition of each of the batteries before allowing battery power to the machine. The BMS is also connected to the CAN bus which allows it to forward battery information to the rest of the machine. The BMS is located under the seat attached to the seat base rear panel.

The Lithium-ion battery controller (BMS):

1. Monitors the batteries via a sub-net (battery interface harness).

Note: All of the battery interface harness connections must be corrosion free and securely connected before machine operation can occur.

2. Protects the batteries from operating (discharging and charging) outside their safe operating voltage, amperage, and temperature ranges.

3. Operates an internal contactor to connect and disconnect the batteries from the machine and the battery charger.

Note: When the key switch is set to the Off position, the BMS delays disconnecting the batteries from the machine for approximately 3 seconds to allow time for all of the other machine controllers to shut down.

4. Communicates battery information to the machine during operation via the CAN bus.

5. Communicates battery information to the battery charger via the CAN bus.

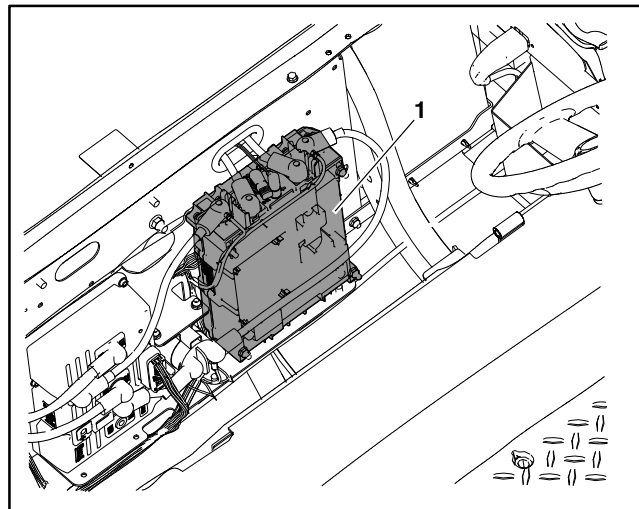

Figure 13

1. SC1: Lithium-ion battery controller

Refer to SC1: lithium-ion battery controller testing for more information.

IMPORTANT: Do not open the lithium-ion battery controller. There are no serviceable parts on or in the controller. If you open the controller, you will void the warranty. The controller is protected by tamper-alerting devices.

Note: If the SC1: Lithium-ion Battery Controller is replaced for any reason, the machine software must be updated; contact an Authorized Toro Distributor for assistance.

SC2: Traction Controller

The SC2: traction controller is secured to the seat base rear panel (Fig. 14). The controller uses inputs from several vehicle components to accurately control vehicle speed, direction (forward and reverse) and regenerative braking. Controller inputs include key switch, direction selector switch (forward/reverse), accelerator pedal, mode switch, traction motor thermistor (temperature), traction motor encoder (speed sensor) and parking brake. A single wire harness connection and five (5) cables are used to connect the controller to the vehicle electrical system. The traction controller is also connected to the CAN bus.

A fuse that is rated at 425 amperes continuous is attached to the controller and protects the 48VDC vehicle power supply circuit. If this fuse has failed, vehicle operation will not occur.

Refer to SC2: traction controller testing for more information.

IMPORTANT: Do not open the traction controller. There are no serviceable parts on or in the controller. If you open the controller, you will void the warranty. The controller is protected by tamper-alerting devices.

Note: If the SC2: Traction Controller is replaced for any reason, the machine software must be updated; contact an Authorized Toro Distributor for assistance.

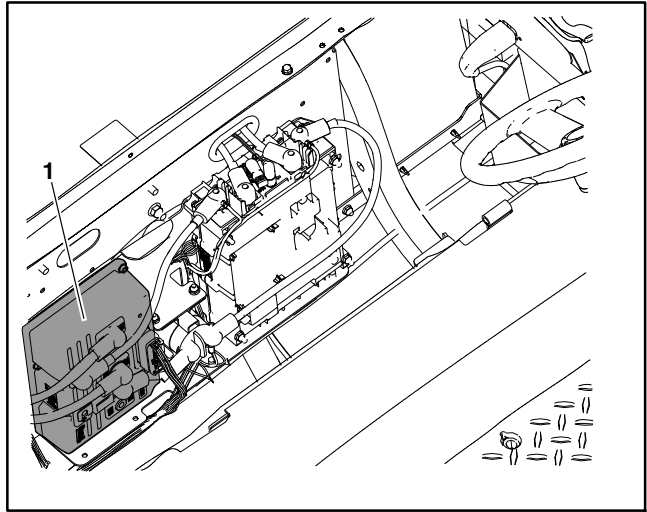

Figure 14

1. SC2: Traction controller

Special Tools

Order special tools from your Toro Distributor. Some tools may also be available from a local supplier.

Multimeter

The multimeter can test electrical components and circuits for current, resistance or voltage.

NOTE: Toro recommends the use of a DIGITAL Volt-Ohm-Amp multimeter when testing electrical circuits. The high impedance (internal resistance) of a digital meter in the voltage mode will make sure that excess current is not allowed through the meter. This excess current can cause damage to circuits not designed to carry it.

NOTE: Workman GTX Electric vehicles use a 48 volt, DC electrical system. If multimeter is not of the auto-range type, make sure to properly set multimeter range before performing any voltage test.

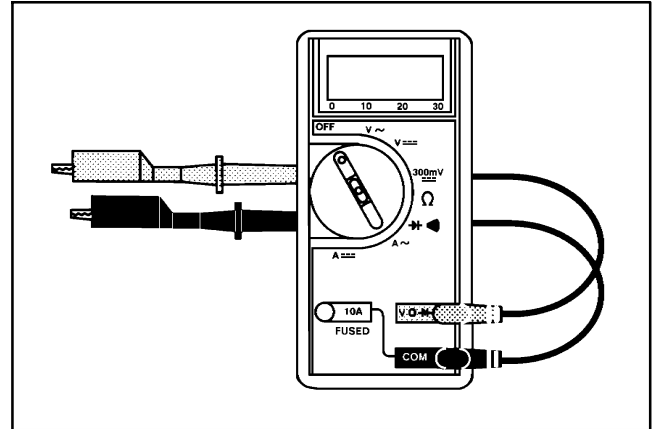

Figure 15

Electrical System

Battery Terminal Protector

Aerosol spray that should be used on battery terminals, ring terminals and fork terminals to reduce corrosion problems. Apply terminal protector to the connection after the battery cable, ring terminal or fork terminal has been secured.

Toro Part Number: **107-0392**



Figure 16

Dielectric Gel

Dielectric gel should be used to prevent corrosion of unsealed connection terminals. To ensure complete coating of terminals, liberally apply gel to both component and wire harness connector, plug connector to component, unplug connector, reapply gel to both surfaces and reconnect harness connector to component. Connectors should be thoroughly packed with gel for effective results.

Do not use dielectric gel on sealed connection terminals as the gel can unseat connector seals during assembly.

Toro Part Number: **107-0342**



Figure 17

Lithium-Ion Battery Shipping Kit

Use the original packing or the battery shipping kit and a certified carrier to ship one of the lithium-ion batteries. The kit includes the appropriate carton, packing, labels, and instructions necessary to confirm to current lithium-ion battery shipping regulations in the USA.

Note: Outside of the USA, contact the appropriate government agency in your country for detailed regulations on shipping the lithium-ion batteries.

Toro Part Number: **137-9650**

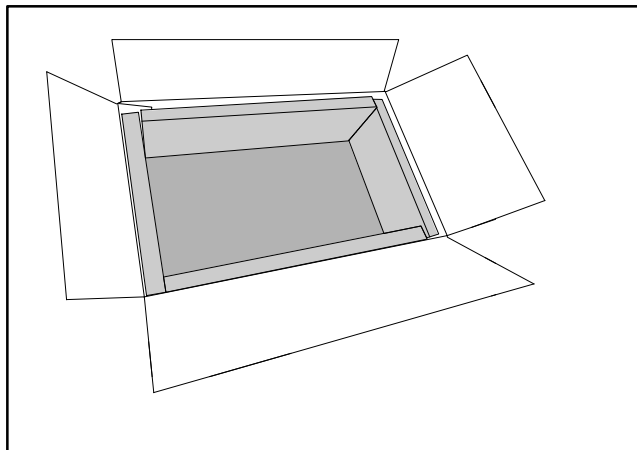



Figure 18

Troubleshooting



CAUTION

Remove all jewelry, especially rings and watches, before doing any electrical troubleshooting or testing. Before working on the vehicle electrical system, open the battery circuit by disconnecting the conductors between the battery pack and vehicle components (see Opening Battery Circuit in the General Information section of this chapter). Connect the battery circuit if a test procedure requires battery voltage.

For effective troubleshooting and repairs, there must be a good understanding of the electrical circuits and components used on this vehicle (see Electrical Schematic and wire harness drawings in Chapter 6 - Electrical Drawings).

If the vehicle has any switches by-passed, they must be reconnected for proper vehicle operation, troubleshooting and safety.

Operator Advisories

Operator advisories are automatically displayed by the display on the dash when a machine function is prevented and additional action is required. Typically, an advisory can be eliminated with a change in machine controls by the operator. For example; if the operator attempts to drive the machine when the battery charge is low, an advisory is identified on the display that the battery needs to be charged. An advisory will not be logged into any fault log. The following table lists each advisory in detail.

Advisory Number	Advisory Name	Cause	Message Corrective Action Required
B2300	SYSTEM SHUTDOWN	Battery Fault(s) Active	System Shutdown Battery fault active
B2301	MACHINE DISABLED	Battery charger connected	Machine Disabled Disconnect charger
B2302	LOW BATTERY		Battery Low Charge battery
B2303	BATTERY OVERLOAD		Battery Overload Reduce power draw
B2304	BATTERY TEMPERATURE LOW		Battery Temp Low Warm machine
B2305	BATTERY TEMPERATURE HIGH		Battery Temp High Cool machine
B2311	MOTOR DERATE	Motor too hot	Motor Derate Cool machine

Note: If "Unknown Cause" appears as an advisory description, a controller software issue may exist.

If you are unable to clear this type of advisory, contact an Authorized Toro Distributor.

Machine Faults

Machine faults are generated by the machine controllers to identify an electrical system malfunction (fault) that occurs during machine operation. The fault IDs conform to SAE J2012 standards. When a fault occurs, the bi-color LED on the display panel will flash red and a code for the active fault will appear along the bottom of the display screen. If more than one fault is active, their codes will scroll across the bottom of the display screen one-by-one.

Recent faults can be viewed via the display on the dashboard. A code appears after each fault.

Fault ID	Fault Title	Controller(s) Affected	Fault Condition / Circuit Description	Additional Notes	Service Actions
P0226	Traction Pedal 1 Analog Sensor 1 - Out of Range	SC2	Traction pedal analog sensor 1 is reading a voltage outside the range it was designed to operate.	Traction is disabled.	<ol style="list-style-type: none"> 1) Check the wiring to the sensor. 2) Make sure the position of the sensor is correct. 3) Check the sensor wiring to the TEC controller. 4) Replace the sensor.
P058E	Battery - High Temp Shutdown	SC1	A battery temperature was measured to be greater than the allowed threshold.	<p>The temperature of one or more batteries is greater than 70 °C.</p> <p>Battery contactor is opened.</p>	Let the machine cool before operation.
P058F	Battery - Low Temp Shutdown	SC1	A battery temperature was measured to be less than the allowed threshold.	<p>The temperature of one or more batteries is less than -20 °C.</p> <p>Battery contactor is opened.</p>	Let the machine warm up before operation.
P0A2F	Traction Motor - High Temp Warning	SC2	The motor temperature was measured to be greater than the temperature warning threshold. Performance of the motor will be limited.	<p>The motor temperature exceeds 130 °C (Sevcon).</p> <p>Traction performance is limited.</p>	<ol style="list-style-type: none"> 1) Reduce ground speed. 2) Check for mechanical resistance in the wheels that would make the motors work harder than necessary.

Fault ID	Fault Title	Controller(s) Affected	Fault Condition / Circuit Description	Additional Notes	Service Actions
P0A3C	Traction Motor Controller - High Temp Warning	SC2	The measured FET temperature exceeds the design limit. When the overtemp region is entered, motor current is limited on a linear basis until the absolute over temp value is reached.	FET temperature exceeds 75 °C (Sevcon). Traction performance is limited.	1) Reduce ground speed. 2) Check for mechanical resistance in the wheels that would make the motors work harder than necessary.
P0A44	Traction Motor Speed - High	SC2	Machine is operating above the allowed max speed which should not be possible.	Ground speed is above the programmed max speed of the machine. Traction is disabled.	1) Check the wiring of the speed sensors. 2) Check the supply voltage to the speed sensor.
P0A54	Traction Controller - Over Current	SC2	The motor was commanding more current than the hardware and software allows.	Current draw from motors exceeds hardware and software limits. Traction is disabled.	1) Cycle the key switch. 2) Report incident to Toro TAC if fault continues. This should not occur under the desired machine design.
P0A80	Battery - Internal Hardware Failure	SC1	A hardware component internal to a battery has failed.	Battery contactor is opened.	One or more of the batteries is likely damaged. Contact an Authorized Toro Distributor for assistance.
P0AA1	Battery Contactor - Stuck Closed	SC1	The contactor is measured to be closed when it should be open.	Current draw detected from the BMS when there shouldn't be. Battery contactor is open. NOTE: If it's truly welded shut, it won't open.	The BMS is likely damaged. Contact an Authorized Toro Distributor for assistance.
P0AA2	Battery Contactor - Stuck Open	SC1	The contactor is measured to be open when it should be closed.	20% difference in voltage between the two sides of the battery contactor. Battery contactor is opened.	The BMS is likely damaged. Contact an Authorized Toro Distributor for assistance.

Fault ID	Fault Title	Controller(s) Affected	Fault Condition / Circuit Description	Additional Notes	Service Actions
P0AC2	Battery - Over Current	SC1	A battery is supplying too much current for too long. This can either be because of too much power draw or a battery cell imbalance.	Discharge current is greater than 130A for 30s OR greater than 178.75A for 6s. Battery contactor is opened.	1) Reduce power draw. 2) Check battery and machine harness for damaged wires. 3) Battery likely damaged. Contact an Authorized Toro Distributor for assistance.
P0AFA	Battery - Low Voltage	SC1	A battery voltage was measured to be lower than the allowed threshold but is still recoverable.	Battery contactor is opened and BMS is offline.	Contact Toro TAC to recover the battery.
P0AFB	Battery - High Voltage	SC1	A battery voltage was measured to be higher than the allowed threshold.	Battery contactor is opened.	1) If the fault occurred with a full battery during a regenerative braking, everything is likely fine. 2) If the fault occurred when the state of charge is less than 90%. Contact an Authorized Toro Distributor for assistance.
P0E8E	Traction Motor Bus Voltage - Low	SC2	The motor bus voltage is lower than the low voltage threshold.	Bus voltage is below the voltage limits: 33V (Sevcon) Traction is disabled.	1) Check the fuse. 2) Measure the voltage at the motor connector to determine whether the voltage is low or the controller is measuring low. 3) Check the battery voltage. 4) Ensure the wiring is ok to the motor.
P0E8F	Traction Motor Bus Voltage - High	SC2	The motor bus voltage exceeds the high voltage threshold.	Bus Voltage exceeds 69V (Sevcon). Traction is disabled.	1) Measure the voltage at the motor connector to determine whether the voltage is high or the controller is measuring high. 2) Check the battery voltage. 3) Ensure the wiring is ok to the motor.

Fault ID	Fault Title	Controller(s) Affected	Fault Condition / Circuit Description	Additional Notes	Service Actions
P1511	Traction Motor Controller – High Temp Shutdown	SC2	The controller temperature was measured to be greater than the temperature shutdown threshold.	The controller temperature exceeds 85 °C (Sevcon). NOTE: Coasting downhill or towing with batteries at full charge can cause this fault to occur. Traction is disabled.	1) Reduce ground speed 2) Check for mechanical resistance in the wheels that would make the motors work harder than necessary.
P1512	Traction Motor Controller – Low Temp Shutdown	SC2	The controller temperature was measured to be less than the temperature shutdown threshold.	The controller temperature is less than or equal to -20 °C (Sevcon). Traction is disabled.	Warm the machine.
P1520	Traction Motor Speed Sensor – Out of Range	SC2	Speed sensor reading is outside normal operating range.	Sensors measured out of range. Traction is disabled.	1) Check the wiring to the speed sensor feedback if available. 2) Check supply to speed sensor if available. 3) Check ground to the speed sensor if available.
P156C	Traction Controller – Internal Hardware Failure	SC2	A hardware component internal to the traction controller has failed.	Traction is disabled.	If fault continues to occur, replace the controller.
P156D	Traction Controller – Internal Software Failure	SC2	An unexpected software error has occurred.	Wrong software parameter has been detected. Traction is disabled.	If fault continues, contact Toro TAC and replace the controller.
P156E	Traction Motor Software – Hardware Incompatibility	SC2	The software is not compatible with the hardware.	The software will not operate on the current controller hardware. Traction is disabled.	Replace controller.
P1A01	Battery Charging – High Temp Shutdown	SC1	A battery temperature was measured to be greater than the allowed threshold and will not charge.	One or more of the batteries temp is greater than 60 °C. Battery contactor is opened.	1) Let the machine cool before charging. 2) Charge the machine in the shade or in a cooler environment.

Fault ID	Fault Title	Controller(s) Affected	Fault Condition / Circuit Description	Additional Notes	Service Actions
P1A02	Battery Charging - Low Temp Shutdown	SC1	A battery temperature was measured to be less than the allowed threshold and will not charge.	One or more of the batteries temp is less than -10 °C. Battery contactor is opened.	Let the machine warm up before operating.
P1A11	Battery Charging Voltage - High	SC1	A battery voltage was measured to be higher than the allowed threshold while the battery charger was connected.	Battery contactor is opened.	1) Check the charger for faults. 2) Replace the charger.
P1A21	Battery Charging - Over Current	SC1	A battery charging current was measured to be greater than the allowed threshold. This is likely due to an internal imbalance in one or more of the batteries.	Battery contactor is opened.	1) Replace the charger. 2) Check battery and charger harness for damaged wires. 3) Contact an Authorized Toro Distributor for assistance.
P2BE8	Traction Motor Contactor - Open	SC2	The contactor is detected open when it should be closed.	Both traction motors measure a low bus voltage when the contactor should be closed. Traction is disabled.	1) Check voltage across the coil of the contactor. Should be approx. 48V if the contactor is engaged. 2) Check the voltage across the contactor. Should be 0V if contactor is closed. 3) Test the contactor. 4) If this fault occurs concurrently with a generator under voltage fault or system under voltage related fault, check the key switch.
P2BE9	Traction Motor Contactor - Closed	SC2	The contactor is detected closed when it should be open. It is likely welded shut.	Traction is disabled.	1) Check the voltage across the contactor with the key off. Should be 48V. 2) Check voltage across the coil of the contactor with Key OFF. Should be 0V. 3) Test the contactor. 4) Replace contactor.

Fault ID	Fault Title	Controller(s) Affected	Fault Condition / Circuit Description	Additional Notes	Service Actions
B1107	Transmission Lever Switch Broken	SC2	Both TRANSMISSION_FWD and TRANSMISSION_REV inputs are active at the same time.	Traction is disabled.	1) Check the switch. There could be a short in the switch. 2) Check the harness/connector for a loose wire or corrosion.
U0110	CAN Bus Communication Fault - Traction Motor 1	T	Primary controller never established communication or lost communication with Traction Motor 1 controller.	Traction is disabled.	1) Check CAN connection. 2) Verify power to controller.
U0111	CAN Bus Communication Fault - Battery	T	Primary controller never established communication or lost communication with battery controller.	Performance is limited.	1) Check CAN connection. 2) Verify power to controller.
U1117	Source Address Contention Fault	T	Controller received a message from another controller on the CAN bus using the same source address.	The machine is disabled.	Reprogram the machine using Toro DIAG.
U1140	Communication Fault - Battery Cell Module	SC1	The BMS never established communication or lost communication with at least one of the batteries.	Battery contactor is opened.	Check the communication cable connection and harness between all batteries and the BMS.

General Run Problems

NOTE: Check the display on dash panel for possible faults whenever diagnosing vehicle electrical circuit problems.

Problem	Possible Causes
Main contactor clicks, but vehicle will not operate.	<p>Battery charge is low (check battery discharge indicator on dash).</p> <p>Battery cables are loose, corroded or damaged.</p> <p>Cable connection(s) at main contactor is/are loose or corroded.</p> <p>Cable connection(s) at controller is/are loose or corroded.</p> <p>Cable connection(s) at traction motor is/are loose or corroded.</p> <p>Traction motor is faulty.</p> <p>Controller is faulty.</p>
Nothing happens when key switch is turned to ON.	<p>Battery charge is extremely low (check battery discharge indicator on dash).</p> <p>Battery cables are loose, corroded or damaged.</p> <p>Cable connection(s) at main contactor is/are loose or corroded.</p> <p>2 ampere fuse to the key switch is loose or faulty.</p> <p>Cable connection(s) at controller is/are loose or corroded.</p> <p>425 ampere fuse on controller is loose or faulty.</p> <p>Main contactor or circuit wiring is faulty.</p> <p>The key switch or circuit wiring is faulty.</p> <p>Controller is faulty.</p>

Problem	Possible Causes
Traction motor stops during operation.	<p>Battery charge is extremely low (check display on dash).</p> <p>Wiring to the traction motor components (e.g. main contactor, controller, traction motor) is loose, corroded or damaged (refer to Electrical Schematic in Chapter 6 - Electrical Diagrams).</p> <p>Battery cables are loose, corroded or damaged.</p> <p>Traction motor is overheated (check display on dash for possible fault).</p> <p>Controller is overheated (check status display on dash for possible fault).</p> <p>Traction motor is faulty (check display on dash for possible fault).</p> <p>Brake problem exists (see Brakes in the Troubleshooting section of Chapter 5 - Chassis).</p> <p>Transaxle problem exists (see Chapter 4 - Transaxle).</p>
Vehicle runs slowly.	<p>The mode speed limit switch is in the slow position.</p> <p>Tire pressure is low (see Check Tire Pressure in the Service and Repairs section of Chapter 5 - Chassis).</p> <p>The parking brake is improperly adjusted (see Adjust Parking Brake in the Adjustments section of Chapter 5 - Chassis).</p> <p>Brakes are worn or faulty (see Brakes in the Troubleshooting section of Chapter 5 - Chassis).</p> <p>Battery charge is extremely low (check display on dash).</p> <p>Controller is overheated (check display on dash for possible fault).</p> <p>Traction motor is overheated (check display on dash for possible fault).</p>
Vehicle movement is erratic or jerky.	<p>Accelerator pedal movement is dirty preventing smooth pedal operation.</p> <p>Accelerator pedal is worn or faulty (check display on dash for possible fault).</p> <p>A brake system problem exists (see Brakes in the Troubleshooting section of Chapter 5 - Chassis).</p> <p>A transaxle problem exists (see Chapter 4 - Transaxle).</p>

Battery Charger Problems

Problem	Possible Causes
Battery charger does not turn on.	<p>AC outlet (electrical supply for charger) circuit breaker or fuse is tripped or blown.</p> <p>AC outlet (electrical supply for charger) is faulty.</p> <p>AC power supply cord (extension cord) is faulty.</p> <p>Vehicle wiring is loose or damaged (see electrical schematic in Chapter 6 - Electrical Diagrams).</p> <p>Vehicle charger receptacle or circuit wiring is damaged.</p> <p>Battery charger is faulty.</p>
The AC outlet (electrical supply for charger) circuit breaker or fuse is tripped or blown when using the battery charger.	<p>Overloaded AC circuit (electrical supply for charger).</p> <p>Battery charger is faulty.</p>

Battery Charger Error Codes

Problem	Possible Cause	Corrective Action
Code E-0-0-1, or E-0-4-7	Battery high voltage	<p>Ensure that the battery voltage is correct and the cable connections are secure.</p> <p>Ensure that the battery is in good condition.</p>
Code E-0-0-4	Lithium-ion battery controller (BMS) or battery fault detected	Contact an Authorized Toro Distributor for assistance.
Code E-0-0-7	Battery amp hour limit exceeded	<p>Check all battery cable connections for corrosion or damage. Clean and repair battery connections as necessary.</p> <p>Batteries may be deeply discharged. Battery replacement may be necessary.</p> <p>Disconnect and connect the charger to the batteries to reset this error.</p>
Code E-0-1-2	Reverse polarity error	Ensure that the battery cables are connected correctly and that the cable connections are clean and secure.
Code E-0-2-3	High AC voltage error (>270VAC)	Connect the charger to an AC power source that provides stable AC power between 85 - 270 VAC at 45-65 Hz.

Problem	Possible Cause	Corrective Action
Code E-0-2-4	Charger failed to initialize	Disconnect the charger AC input and battery connections for 30 seconds, then reconnect the charger.
Code E-0-2-5	Low AC voltage oscillation error	The charger requires an AC power source that provides stable AC power between 85 - 270 VAC at 45-65 Hz. Confirm the AC power supply capacity and verify AC input cable gauge.
Code E-0-3-7	Re-programming failed	Software upgrade failure or script operation failure. Ensure that the new software is correct.
Code E-0-2-9, E-0-3-0, E-0-3-2, E-0-4-6, or E-0-6-0	Communication error with battery	Ensure that the connection of the signal wires to each battery is clean and secure.

Battery Charger Fault Codes

Problem	Possible Cause	Corrective Action
Codes F-0-0-1, F-0-0-2, F-0-0-3, F-0-0-4, F-0-0-5, F-0-0-6, or F-0-0-7	Internal charger fault	Remove the charger AC connection and battery connection for a minimum of 30 seconds, then reconnect the charger. The battery charger may require replacement (contact an Authorized Toro Distributor for assistance).

Component Testing

For accurate resistance and/or continuity checks, electrically disconnect the component being tested from the circuit (e.g. disconnect the harness wire connectors from the vehicle key switch before doing a continuity check on the key switch). Always check the item being tested and the harness connector for damage or corrosion and clean or repair as necessary.

**CAUTION**

When testing electrical components for continuity with a multimeter (ohms setting), make sure that power to the circuit has been disconnected.

Fuses

A group of fuses are used to protect the 12 VDC and 48 VDC systems and are located under the seat assembly (Fig. 19). All fuse block fuses are rated at 80 VDC.

The 12 VDC fuses protect circuits as follows:

The 5 amp fuse is used to protect the power supply to the optional USB charger port circuit, and power point.

The 10 amp fuse is used to protect the power supply to the headlights circuit.

The 15 amp fuse is used to protect the power supply to the optional power point circuit.

The 48 VDC fuses protect circuits as follows:

The 10 amps fuse is used to protect the main power supply circuit.

The 15 amps fuse is used to protect the optional cargo bed lift circuit.

The 20 amps fuse is used to protect the electric relay.

The 30 amps fuse is used to protect the optional horn circuit.

The 2 amps fuse is used to protect the power supply to the display (Fig. 20).

An additional fuse is attached to the controller (Fig. 21). This fuse is rated at 425 amperes continuous and protects the 48VDC vehicle power supply circuit. If this fuse has failed, vehicle operation will not occur.

IMPORTANT: If fuse replacement is necessary on your Workman GTX Electric vehicle, make sure that new fuses have the correct specifications (voltage and amperage).

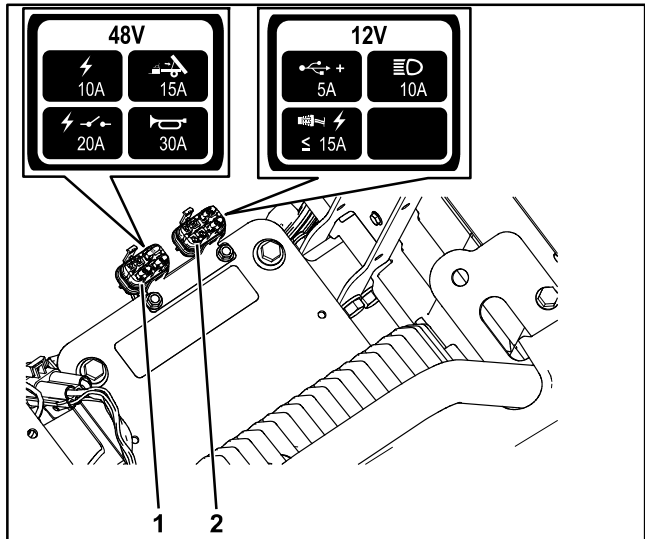

Figure 19
1. 12 VDC fuse block 2. 48 VDC fuse block

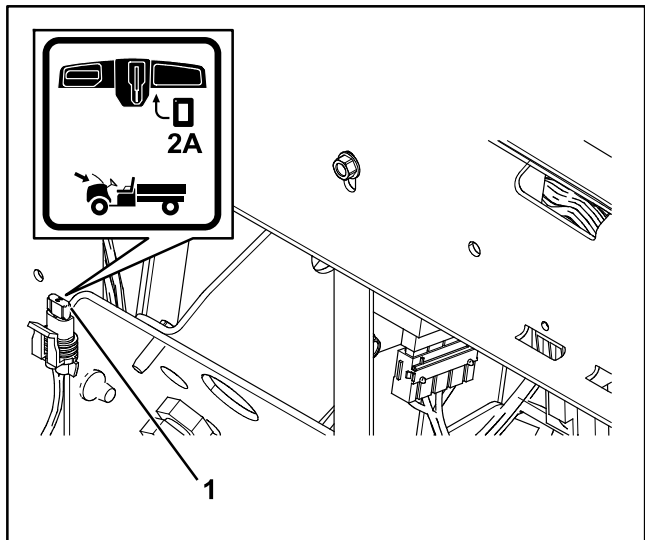

Figure 20
1. Display fuse (2 amps)

Fuse Testing

CAUTION

When testing fuses for continuity with a multimeter (ohms setting), make sure that fuse is removed from circuit.

IMPORTANT: Before removing fuse from controller (425 Amp) for testing, open the battery circuit by removing one of the battery cables (see Opening Battery Circuit in the General Information section of this chapter).

Make sure key switch is turned OFF. Remove fuse to check continuity. The test meter should read **less than 1 ohm** if a fuse is functional. Replace the fuse if faulty.

If fuse was removed from controller, torque the nuts that secure the fuse from **89 to 106 in-lb (10 to 12 N-m)**.

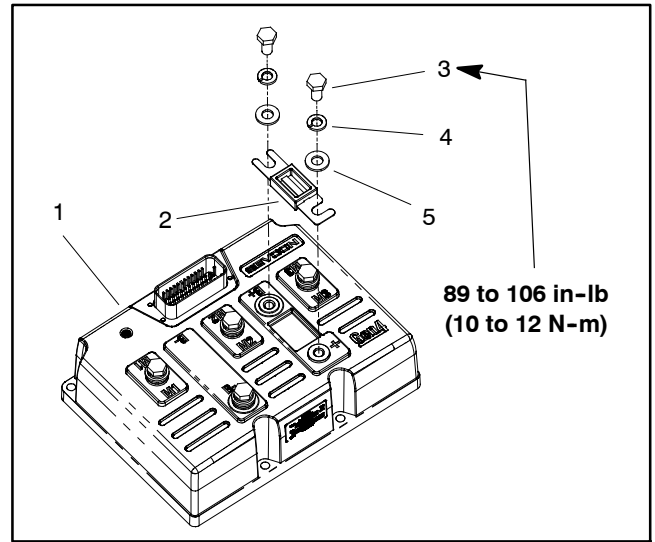

Figure 21

- | | |
|-------------------|-------------------------|
| 1. Controller | 4. Lock washer (2 used) |
| 2. Fuse (425 A) | 5. Flat washer (2 used) |
| 3. Screw (2 used) | |

CAN bus

The machine controllers communicate with each other on a Controller Area Network (CAN) bus system. Using this network allows full integration of all the different electrical components of the machine, allowing them to operate together as one. The CAN bus system reduces the number of electrical components and connections used on the machine and allows the number of wires in the wire harness to be significantly reduced.

The display (T), lithium-ion battery controller (BMS – Battery Management System) (SC1) and traction controller (SC2) are on the CAN bus. Additional controllers may be added to the CAN bus in the future through the expansion port connector and/or the telematics connector.

Each of the components that is controlled by the CAN bus link only needs four (4) wires to operate and communicate to the system: CAN High, CAN Low, power and ground. The key switch needs to be in the RUN or START position for the components on the network to be activated.

Two specially designed, twisted wires form the CAN bus. These wires provide the data pathways between the components on the network. The engineering term for these cables are CAN High and CAN Low. The CAN bus wires are red/white (CAN-High) and black/white (CAN Low). At each end of the CAN bus is a 120 ohm termination resistor; refer to CAN bus Terminator Resistors.

Testing the CAN bus

1. Park the machine on a level surface, engage the parking brake, set the key switch to the OFF position and remove the key from the key switch.
2. The Toro DIAG connector is part of the CAN bus and is located inside the dash. Raise the hood and get access to the DIAG connector. Remove the connector cover from the machine wire harness and use a multimeter (ohms setting) to check the Toro DIAG connector.

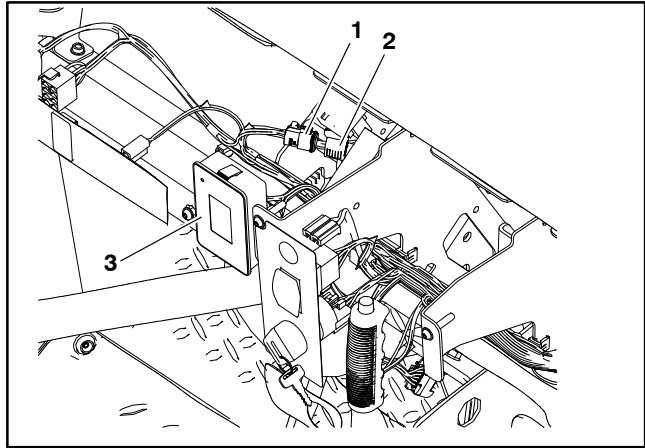

Figure 22

1. DIAG connector
2. Cover
3. Display

Note: A reading of 120 ohms indicates the CAN bus terminator resistor is not connected or damaged.

Refer to CAN bus Terminator Resistor and/or see electrical schematic and wire harness drawing in Chapter 6 – Electrical Drawings. If necessary, contact an Authorized Toro Distributor for assistance.

3. Install the connector cover and hood after testing.

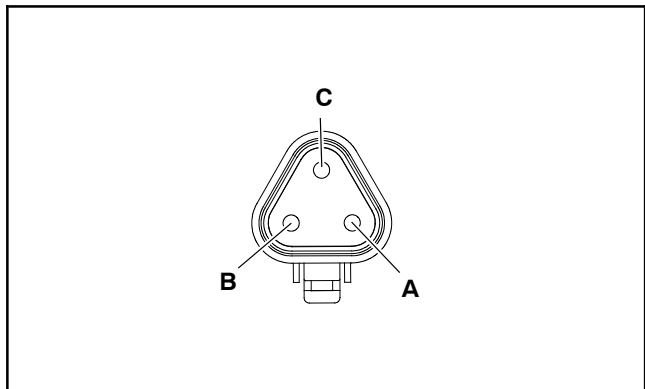

Figure 23

Location	Harness	Connector	Pin	Wire Color	Expected Reading
1	Main	P44	A	Yellow	54 to 66 ohms
2	Main	P44	B	Green	

T: Display

The display is a LCD device located on the dash board. The display provides the information about battery state of charge, key on hours, eco mode, headlights On, fault information and direction indication (F/N/R). Power for the display is available when the key switch is in the ON position. A 2 Amps fuse protects the all of the key switched circuits.

The display communicates with the other machine controllers on a Controller Area Network (CAN) bus system.

The machine electrical schematic and wire harness drawings in Chapter 6 - Electrical Drawings can be used to identify possible circuit problems between the display and the input or output devices.

IMPORTANT: When testing for wire harness continuity at the connector for the display, take care to not damage the connector pins with multimeter test leads. If connector pins are enlarged or damaged during testing, connector repair may be necessary for proper machine operation.

A 16 pin wire harness connector is attached to the display. The connection terminal function for the display and the wire harness connector pins are shown Fig . Check the display module and the harness connector for damage or corrosion and clean or repair if necessary.

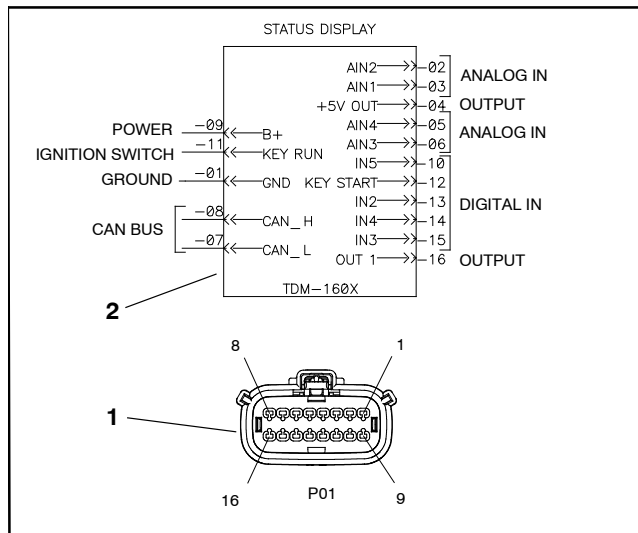

Figure 24

1. Main harness connector
2. Display

Because of the solid state circuitry built into the display, there is no method to test the display directly. The display may be damaged if an attempt is made to test it with an electrical test device (e.g. digital multimeter or test light).

Note: If the display is replaced for any reason, system software needs to be reloaded (contact an Authorized Toro Distributor for assistance).

SC1: Lithium-Ion Battery Controller (BMS)

The machine uses a Lithium-ion battery controller or Battery Management System (BMS) to manage the lithium-ion batteries. Each of the eight lithium-ion batteries communicates with the BMS through a sub-net via the battery interface harness. The battery interface harness includes a 4-pin connector at each of the batteries and a 9-pin connector at the BMS. The BMS uses the sub-net to verify the presence and condition of each of the batteries before allowing battery power to the machine. The BMS is also connected to the CAN bus which allows it to forward battery information to the rest of the machine. The BMS is located under the seat attached to the seat base rear panel.

Note: If the SC1: Lithium-Ion Battery Controller is replaced for any reason, the machine software must be updated; contact an Authorized Toro Distributor for assistance.

Testing the SC1: Lithium-Ion Battery Controller

Although there is no method to test the solid state circuitry built into the controller directly, some aspects of the lithium-ion battery controller operation can be tested as follows; refer to Fig 26.

1. With the batteries connected to the BMS, the battery pack voltage can be tested across the BMS B+ and B- terminals.
2. With the batteries connected to the BMS, signal voltage from the BMS to the key switch can be tested at the controller wire harness connector P12 pin 6 and the BMS B- terminal.
3. An audible "Click" should come from the BMS shortly after the key switch is set to the ON position. The "Click" sound indicates the contactor inside the BMS has closed and battery power should be available to the machine.
4. Once the BMS internal contactor has closed, battery pack voltage can be tested across the BMS positive (+) and negative (-) terminals.
5. If CAN bus communication with the controller is suspect, the CAN bus wiring should be checked for corrosion or damage and cleaned or repaired as necessary. The lithium-ion battery controller CAN bus transceiver can also be tested if necessary using the controller wire harness connector P12 pins 3 and 4, the normal resistance must be 50k to 55k ohms.

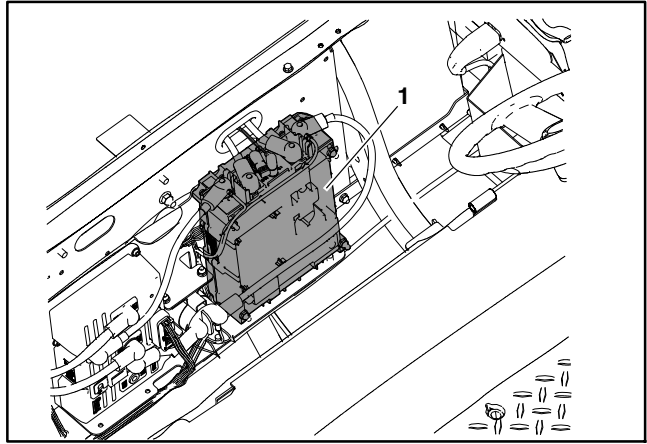

Figure 25

1. SC1: Lithium-ion battery controller

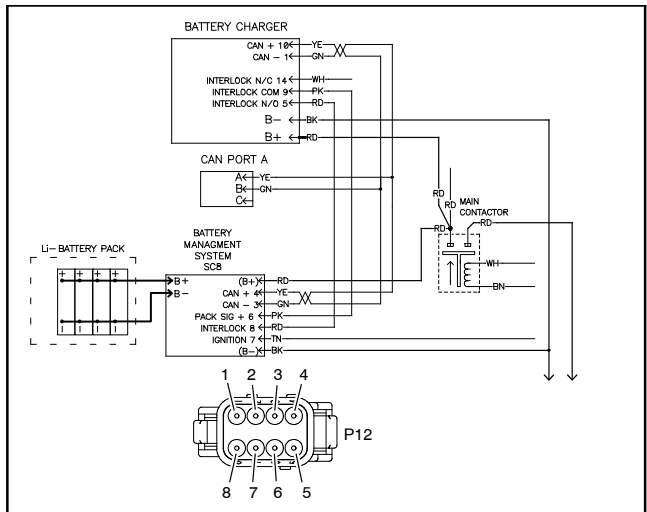

Figure 26

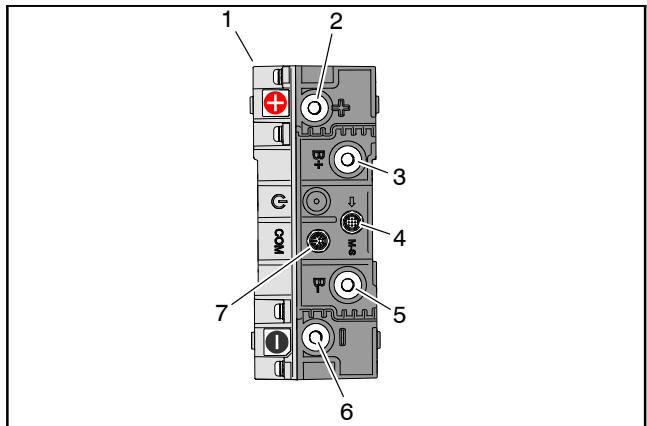

Figure 27

- | | |
|-----------------------------------|--------------------------|
| 1. Lithium-ion battery controller | 4. M-S terminal |
| 2. Positive (+) terminal | 5. B- terminal |
| 3. B+ terminal | 6. Negative (-) terminal |
| | 7. COM terminal |

SC2: Traction Controller

The SC2: traction controller is secured to the seat base rear panel (Fig. 28). The controller uses inputs from several vehicle components to accurately control vehicle speed, direction (forward and reverse) and regenerative braking. Controller inputs include key switch, direction selector switch (forward/reverse), accelerator pedal, mode switch, traction motor thermistor (temperature), traction motor encoder (speed sensor) and parking brake. A single wire harness connection and five (5) cables are used to connect the controller to the vehicle electrical system. The traction controller is also connected to the CAN bus.

A fuse that is rated at 425 amperes continuous is attached to the controller and protects the 48VDC vehicle power supply circuit. If this fuse has failed, vehicle operation will not occur.

Cable connections for the controller are as follows:

- Terminal B-: Negative (-) battery cable from the left, rear battery
- Terminal B+: Positive (+) cable from the main contactor post
- Terminal M1: Cable to traction motor terminal W
- Terminal M2: Cable to traction motor terminal V
- Terminal M3: Cable to traction motor terminal U

Because of the solid state circuitry built into the controller, there is no method to test it directly (e.g. using a multimeter). A LED exists on the controller to identify normal operation or faults that will prevent the vehicle from operating correctly. The display on the dash panel converts the light pattern into the fault number information and displays in the display. See chart below for light pattern and fault codes identified by the controller LED and the display.

NOTE: If the controller LED and status indicator light are flashing, attempt to reset the controller by turning the key switch to OFF, waiting several seconds and then turning the switch to ON. If the controller LED and status indicator light continue flashing after the reset attempt, proceed with fault code identification and necessary action.

Before removing any electrical connections from the controller, open the vehicle battery circuit by disconnecting the conductors between the battery pack and vehicle components (see Opening Battery Circuit in the General Information section of this chapter). When installing cables to controller, torque screws at all controller terminals from **89 to 106 in-lb (10 to 12 N-m)** (Fig. 29). Apply Toro battery terminal protector (see Special Tools) to controller connections after tightening terminal screws. Refer to Controller in the Service and Repairs section of this chapter for controller removal and installation information.

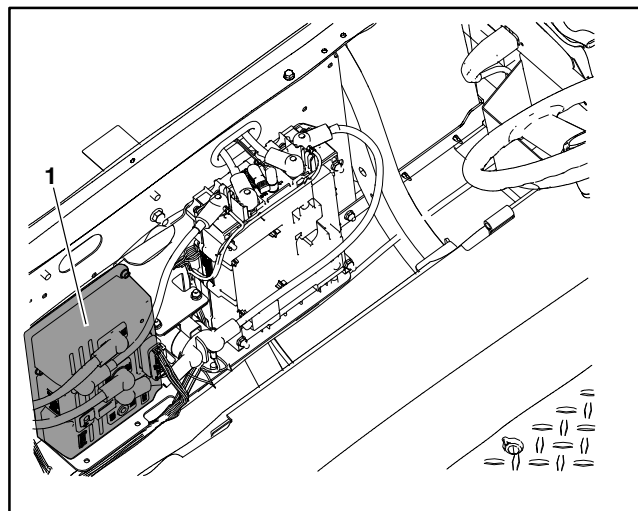

Figure 28

1. SC2: Traction controller

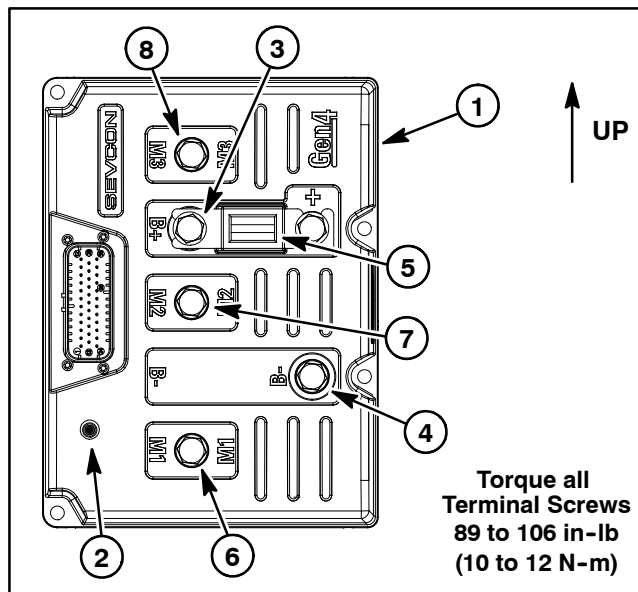

Figure 29

1. Controller
2. Controller LED
3. B+ terminal (+ cable from main contactor)
4. B- terminal (- cable from left, rear battery)
5. Fuse (425 A)
6. M1 terminal (cable to motor terminal W)
7. M2 terminal (cable to motor terminal V)
8. M3 terminal (cable to motor terminal U)

Light Pattern	Fault Code	Cause	Necessary Action
Always on (not flashing)		System functioning normally.	None required.
Always off		System inoperable. No electrical power to the controller. Status indicator light on dash is faulty. The controller has failed.	Check for low battery voltage, faulty fuse(s), loose battery cable connections, damaged battery cables and/or faulty main contactor. If batteries, cables and other electrical components are in good condition, controller replacement may be needed. If necessary, contact your Authorized Toro Distributor for assistance.
1 Flash	P156C P156E	System inoperable. There is a controller configuration fault	Turn key switch OFF, wait several seconds and turn key switch ON. If controller does not reset correctly, controller replacement may be required. If necessary, contact your Authorized Toro Distributor for assistance.
2 Flashes	P0226 P156C B1107	The parking brake is engaged while in the FORWARD or REVERSE position. This fault could also be caused by a problem with accelerator pedal operation.	Release the parking brake if it is applied. If controller does not reset correctly, parking brake switch or circuit wiring may be faulty. Turn key switch OFF, wait several seconds and turn key switch ON. If controller does not reset correctly, check accelerator pedal operation (see Accelerator Pedal in this section). Also, if necessary, inspect the circuit wires between the accelerator pedal and the controller (see Electrical Schematic and Wire Harness Drawings in Chapter 6 - Electrical Drawings).
3 Flashes	P0A54 P156C	System inoperable. The motor current exceeded the controller rated maximum. There is an internal controller power component fault.	Turn key switch OFF, wait several seconds and turn key switch ON. If controller does not reset correctly, check battery pack voltage and all battery cable connections. Check all batteries and high current controller connections. Controller replacement may be required. If the condition continues, contact your Authorized Toro Distributor for assistance.
4 Flashes	P2BE8 P2BE9	Main contactor malfunction.	Turn key switch OFF, wait several seconds and turn key switch ON. If controller does not reset correctly, inspect main contactor (see Main Contactor in this section). Check main contactor wire and cable connections.

Light Pattern		Cause	Necessary Action
5 Flashes	P0A44	Exceeded the maximum motor speed.	Turn key switch OFF, wait several seconds and turn key switch ON. If controller does not reset correctly, inspect traction motor encoder (speed sensor) (see Traction Motor in this section). Inspect the circuit wires between the traction motor encoder and the controller (see Electrical Schematic and Wire Harness Drawings in Chapter 6 – Electrical Drawings).
6 Flashes	P0226 P156C	The accelerator pedal is pressed while starting the machine. Accelerator pedal operation is abnormal.	Release the accelerator pedal, turn the key switch to the OFF position, wait several seconds, turn the key switch to the ON position and check for normal vehicle operation. If controller does not reset correctly, check accelerator pedal operation (see Accelerator Pedal in this section). Also, if necessary, inspect the circuit wires between the accelerator pedal and the controller (see Electrical Schematic and Wire Harness Drawings in Chapter 6 – Electrical Drawings).
7 Flashes	P0E8E P0E8F P156C	The remaining charge on the batteries is low (vehicle speed has been limited by controller). The batteries are fully discharged (vehicle does not operate). The internal capacitor has a pre-charge of less than 5V.	Charge the batteries fully and then check for normal operation. If this fault occurs regularly, consider that battery charging has not been regular or that batteries may need replacement.
8 Flashes	P0A2F P0A3C P1511 P1512	The controller or traction motor is overheated or too cold.	The vehicle may continue to operate but at reduced power until the component temperature reaches normal levels. Determine if the motor or controller is very hot or very cold, then allow the machine to return to normal temperatures before resuming operation. Make sure that motor and controller are cleaned of all dirt and debris that could lead to component overheating.
10 Flashes	P156D	A controller configuration fault occurred.	Turn the key switch to the OFF position, wait several seconds, turn the key switch to the ON position, and check for normal vehicle operation. If this fault continues to occur, contact your Authorized Toro Distributor for assistance.

Light Pattern		Cause	Necessary Action
11 Flashes	P0A44 P1520	A motor encoder (speed sensor) fault occurred. Exceeded the maximum motor speed.	Turn the key switch to the OFF position, wait several seconds, turn the key switch to the ON position, and check for normal vehicle operation. If this fault continues to occur, inspect traction motor encoder (speed sensor) (see Traction Motor in this section). Also, inspect the circuit wires between the traction motor encoder and the controller (see Electrical Schematic and Wire Harness Drawings in Chapter 6 - Electrical Drawings). If a traction motor armature problem exists in the motor (e.g. worn bearing in rear end bracket, missing retaining ring on rear of armature shaft, loose or damaged tone ring on armature), an encoder fault could be generated due to the armature issue.
12 Flashes	P156D	A controller configuration fault occurred.	Turn the key switch to the OFF position, wait several seconds, turn the key switch to the ON position, and check for normal vehicle operation. If this fault continues to occur, contact your Authorized Toro Distributor for assistance.
13 Flashes	P156D	An internal controller software fault occurred	Turn the key switch to the OFF position, wait several seconds, turn the key switch to the ON position, and check for normal vehicle operation. If this fault continues to occur, contact your Authorized Toro Distributor for assistance.
14 Flashes		A controller communication fault occurred	Turn the key switch to the OFF position, wait several seconds, turn the key switch to the ON position, and check for normal vehicle operation. If this fault continues to occur, contact your Authorized Toro Distributor for assistance.

This page is intentionally blank.

Key Switch

The Workman GTX Electric Lithium key switch has two (3) positions - OFF, RUN and START. The START position is not used on this machine. The key switch is located on the dash. The key switch is used to energize the SC1: Battery Controller, SC2: Traction Controller and T: Display.

NOTE: The Workman GTX Electric key switch circuit is a 48 VDC circuit.

Testing



CAUTION

When testing the key switch for continuity with a multimeter (ohms setting), make sure that power to the circuit has been disconnected.

1. Park vehicle on a level surface, turn key switch to OFF, engage the parking brake and remove key from the key switch.
2. Make sure that vehicle battery charger IS NOT connected to electrical outlet. Open the battery circuit by disconnecting the conductors between the battery pack and vehicle components (see Opening Battery Circuit in the General Information section of this chapter).
3. Raise hood to allow access to wire harness connections for switches mounted in dash.
4. Label and disconnect wire harness connectors from the key switch.

Position	Closed Circuits
OFF	NONE
RUN	B + C + F, D + E
START	A + B + C

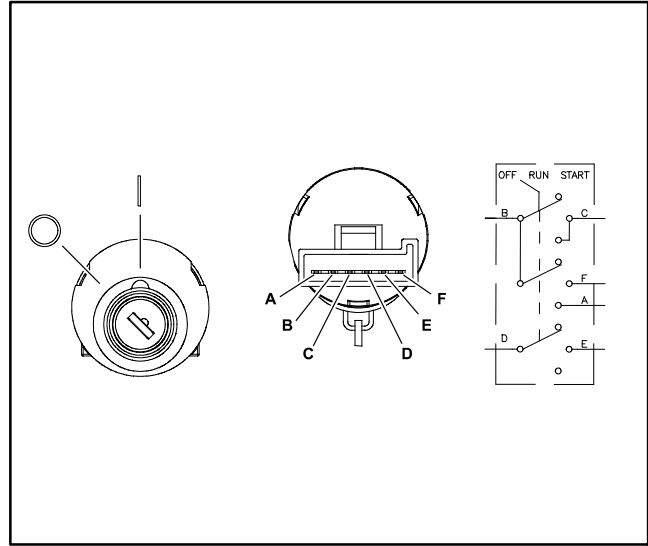

Figure 30

5. Replace key switch if testing determines that the switch is faulty.
6. If key switch tests correctly and circuit problem still exists, check wire harness for possible problems (see electrical schematic and wire harness drawing in Chapter 6 - Electrical Drawings).
7. After key switch testing is complete, connect wire harness connectors to the switch.
8. Connect the conductors between the battery pack and vehicle components (see Opening Battery Circuit in the General Information section of this chapter). Make sure to torque hex nuts on battery terminals from **72 to 88 in-lb (8 to 9 N-m)**.
9. Lower and secure front hood.

Light Switch

The light switch allows the headlights to be turned ON and OFF. This rocker switch is located on the dash panel (Fig. 31).

NOTE: The Workman GTX Electric headlight circuit is a 12 VDC circuit.

Testing

1. Park vehicle on a level surface, turn key switch to OFF, engage the parking brake and remove key from the key switch.
2. Raise hood to allow access to wire harness connections for switches mounted in dash.
3. Disconnect wire harness connector from the light switch.
4. With the use of a multimeter (ohms setting), the switch functions may be tested to determine whether continuity exists between the various terminals for each light switch position. The light switch terminals are marked as shown in Figure 32. The circuitry of this switch is shown in the chart below. Verify continuity between switch terminals.

SWITCH POSITION	NORMAL CIRCUITS	OTHER CIRCUITS
ON	2 + 3	5 + 6
OFF	1 + 2	4 + 5

5. Replace light switch if testing determines that the switch is faulty.
6. If light switch tests correctly and circuit problem still exists, check fuse, headlights and wire harness for possible problems (see electrical schematic and wire harness drawing in Chapter 6 - Electrical Drawings).
7. After light switch testing is complete, connect wire harness connector to the light switch. Lower and secure front hood.

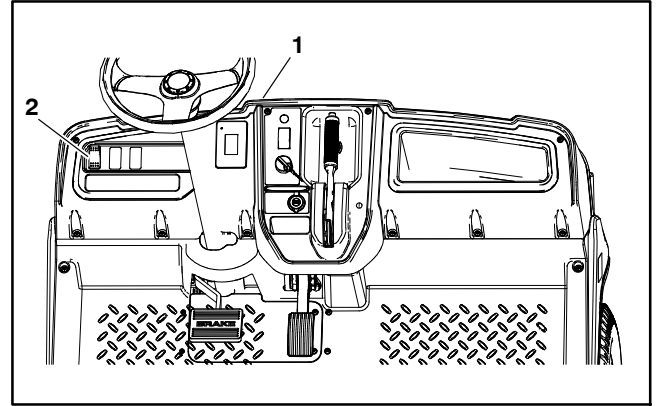

Figure 31

1. Dash panel 2. Light switch

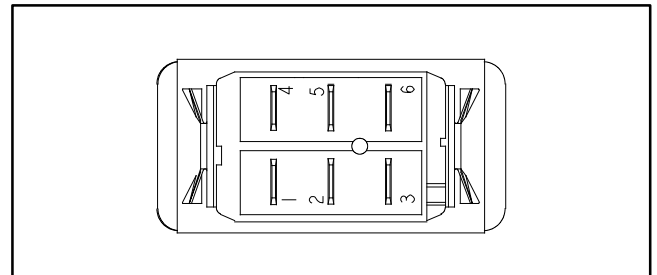

Figure 32

Direction Selector Switch

The direction selector switch allows the direction (forward/neutral/reverse) of the vehicle to be changed by the operator and is one of several inputs for the vehicle controller. The direction selector switch is located on the dash panel (Fig. 33).

NOTE: Direction selector switch terminals 1, 2 and 3 are used on all Workman GTX Electric vehicles to change the direction of the vehicle. On vehicles with a reverse alarm (12 VDC circuit), switch terminals 4 and 5 are also used to activate the alarm when the selector switch is in the reverse direction.

NOTE: The Workman GTX Electric direction selector switch circuit is a 48 VDC circuit.

Testing

1. Park vehicle on a level surface, turn key switch to OFF, engage the parking brake and remove key from the key switch.
2. Raise hood to allow access to wire harness connections to the direction selector switch.
3. Disconnect wire harness connector from the direction selector switch.
4. With the use of a multimeter (ohms setting), the switch functions may be tested to determine whether continuity exists between the various terminals for each direction switch position. The direction switch terminals are marked as shown in Figure 34. The circuitry of this switch is shown in the chart below. Verify continuity between switch terminals.

SWITCH POSITION	NORMAL CIRCUITS	OTHER CIRCUITS
FORWARD	2 + 3	5 + 6
NEUTRAL	NONE	NONE
REVERSE	2 + 1	5 + 4

5. Replace direction selector switch if testing determines that the switch is faulty.
6. If direction selector switch tests correctly and circuit problem still exists, check wire harness for possible problems (see electrical schematic and wire harness drawing in Chapter 6 – Electrical Drawings).
7. After direction selector switch testing is complete, connect wire harness connector to the selector switch. Lower and secure front hood.

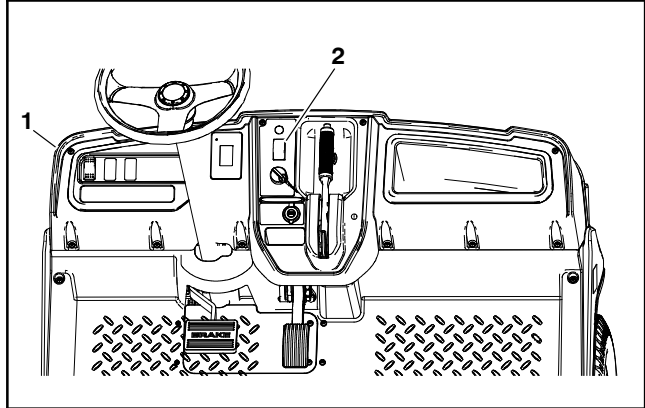

Figure 33

1. Dash panel

2. Selector switch

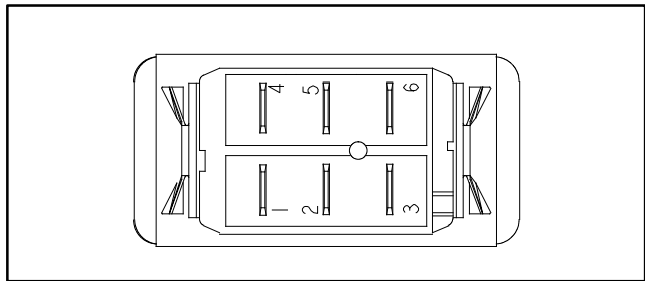

Figure 34

Supervision Speed Limit Switch

The supervision speed limit switch allows the maximum speed of the vehicle to be set to either performance (16 mph/26 kph) or economy (12 mph/19 kph). The speed limit switch is one of several inputs for the vehicle controller and is located under the seat assembly (Fig. 35).

The supervision speed limit switch is open in the performance position (key vertical) and closed in the economy position (key rotated clockwise).

NOTE: Only speed limit switch terminals A and D are used on the Workman GTX Electric vehicle.

NOTE: The Workman GTX Electric supervision speed limit circuit is a 48 VDC circuit.

Testing

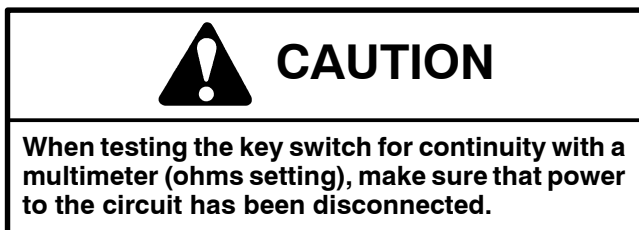

1. Park vehicle on a level surface, turn key switch to OFF, engage the parking brake and remove key from the key switch.

2. Remove seat assembly to allow access to supervision speed limit switch.

3. Disconnect wire harness connector from the supervision speed limit switch.

4. With the use of a multimeter (ohms setting), the speed limit switch functions may be tested to determine whether continuity exists between the A and D terminals for each switch position. The speed limit switch terminals are identified as shown in Figure 36.

A. When the speed limit switch is in the performance position (vertical), **no continuity** (infinite ohms) should exist between switch terminals A and D.

B. In the economy position (key rotated clockwise), **continuity** (zero ohms) should exist between switch terminals A and D.

5. Replace the speed limit switch if testing determines that the switch is faulty.

6. If the speed limit switch tests correctly and circuit problem still exists, check wire harness for possible problems (see electrical schematic and wire harness drawing in Chapter 6 – Electrical Drawings).

7. After speed limit switch testing is complete, plug wire harness connector to the switch. Install seat assembly.

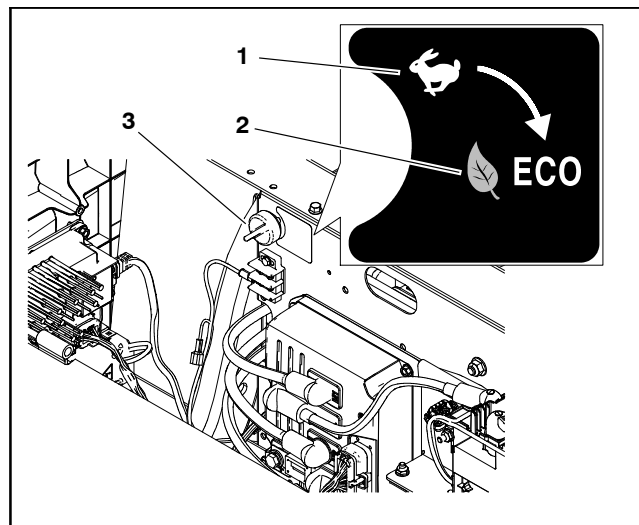

Figure 35

1. PERFORMANCE position 2. ECONOMY position
3. Speed limit switch

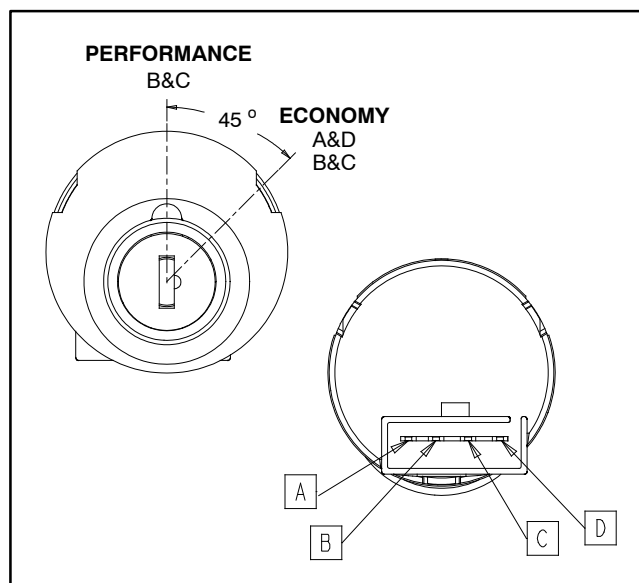

Figure 36

Parking Brake Switch

The parking brake switch is used as an input for the vehicle controller to identify when the parking brake is applied. The parking brake switch is attached to the parking brake mount behind the dash (Fig. 37).

A normally closed contact in the switch is opened when the parking brake is released. When the parking brake is applied, the switch is in its normally closed state. Only two (2) of the switch terminals are used in the parking brake switch circuit.

Testing

1. Park vehicle on a level surface, turn key switch to OFF, engage the parking brake and remove key from the key switch.
2. To access the parking brake switch, remove dash (see Dash in the Service and Repairs section of Chapter 5 - Chassis).
3. Disconnect wire harness electrical connector from the brake switch (Fig. 37).
4. Connect a multimeter (ohms setting) across the common and normally closed (NC) terminals of the brake switch (Fig. 38).
5. With the parking brake released (not applied), the washer on the parking brake lever should be depressing the lever on the brake switch. In this switch position, there **should not be continuity** (infinite ohms) between the common and normally closed (NC) switch terminals.
6. With the parking brake applied, the washer on the parking brake lever should not be depressing the lever on the brake switch. In this switch position, there **should be continuity** (zero ohms) between the common and NC switch terminals.

IMPORTANT: The normally open (NO) switch terminal is not used in the parking brake circuit.

7. If testing determines that the brake switch is faulty, replace switch.

8. If the brake switch tests correctly and a circuit problem still exists, check wire harness for problems (see electrical schematic and wire harness drawing in Chapter 6 - Electrical Drawings).

9. After brake switch testing is completed, connect wire harness electrical connector to the switch.

10. Carefully position and secure dash to vehicle (see Dash in the Service and Repairs section of Chapter 5 - Chassis).

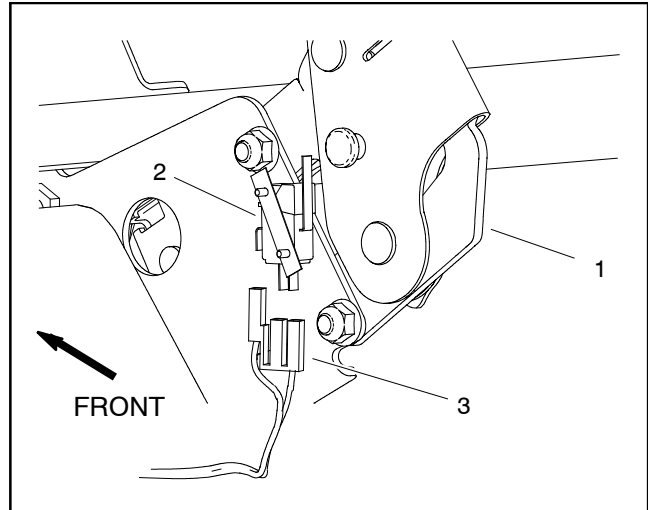

Figure 37

1. Parking brake lever
2. Parking brake switch
3. Wire harness connector

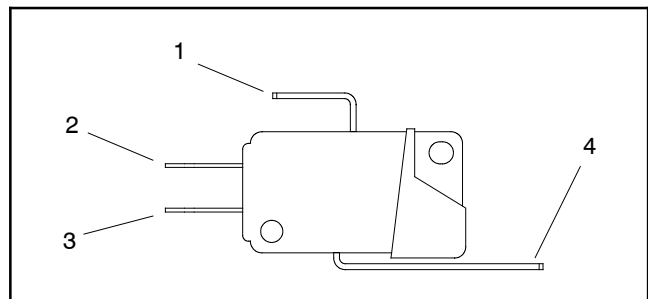

Figure 38

1. Common terminal
2. NO terminal
3. NC terminal
4. Switch lever

USB Charge Port

The USB charge port can be used to charge or power electrical devices that use a USB port. The charge port has a 5 VDC output and is mounted to the dash (Fig. 39).

If the vehicle wire harness is to be disconnected from the charge port, note the wire harness connections at the charge port for assembly purposes. The white wire harness lead should be connected to the positive (+) terminal on the charge port and the black wire harness lead should be connected to the negative (-) terminal on the charge port (Fig. 40).

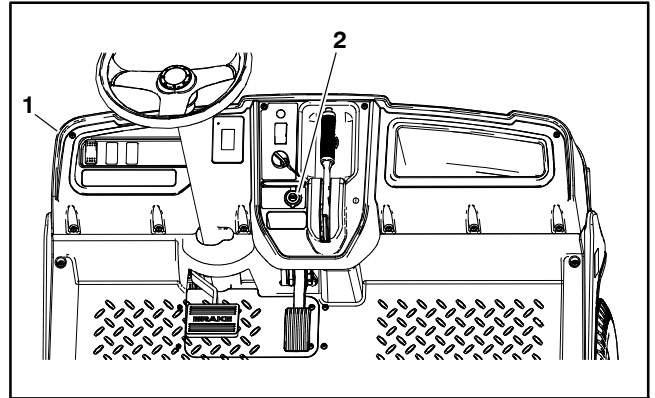

Figure 39

1. Dash panel 2. USB charge port

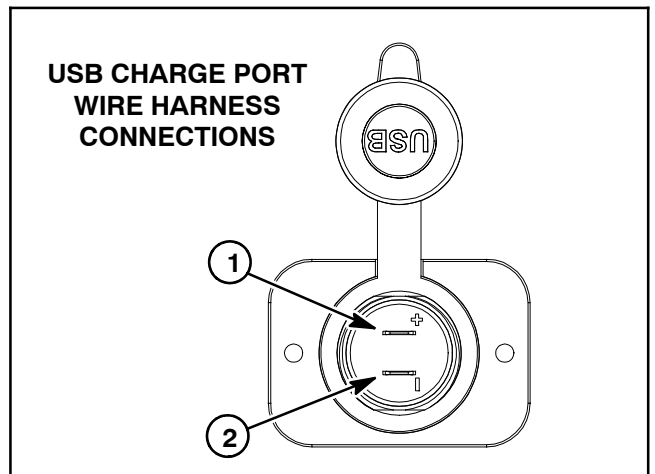

Figure 40

1. Positive (+) terminal 2. Negative (-) terminal

Main Contactor (48 VDC)

The main contactor provides provides current to the 48 VDC system circuits (e.g. controller, traction motor) and is energized by the controller when the key switch is ON. The main contactor is mounted to the controller bracket under the operator seat. (Fig. 41).

NOTE: If main contactor is faulty, a fault may be displayed on the display.

Testing

NOTE: Prior to taking small resistance readings with a digital multimeter, short the meter test leads together. The meter will display a small resistance value (usually 0.5 ohms or less) that is due to the internal resistance of the meter and test leads. Subtract this value from the measured value of the component you are testing.

1. Park vehicle on a level surface, turn key switch to OFF, engage the parking brake and remove key from the key switch. Remove seat assembly from vehicle to access the main contactor.

2. Make sure that vehicle battery charger IS NOT connected to electrical outlet. Open the battery circuit by disconnecting the conductors between the battery pack and vehicle components (see Opening Battery Circuit in the General Information section of this chapter).

3. Locate main contactor. Disconnect all vehicle wire harness connectors from contactor. Note wire connector locations on contactor for assembly purposes.

4. Using jumper wires, apply 48 VDC directly across the contactor coil posts (Fig. 42). The contactor should click as voltage is applied. With the contactor coil energized, resistance across the main contact posts should be less than **1 ohm**.

5. Remove voltage from contactor coil posts. The contactor should click as voltage is removed. With the contactor coil not energized, resistance across the main contact posts should be **infinite ohms**.

6. With voltage removed from contactor coil posts, measure resistance across the coil posts (Fig. 42). The resistance should be approximately **126 ohms**.

7. Replace main contactor if testing determines that it is faulty.

8. When contactor testing is completed, connect wire harness connectors to contactor. Torque tighten the nuts to **45 to 55 in-lb (5 to 6.2 N-m)**.

9. Connect the conductors between the battery pack and vehicle components (see Opening Battery Circuit in the General Information section of this chapter). Make sure to torque hex nuts on battery terminals from **72 to 88 in-lb (8 to 9 N-m)**.

10. Install seat assembly on vehicle.

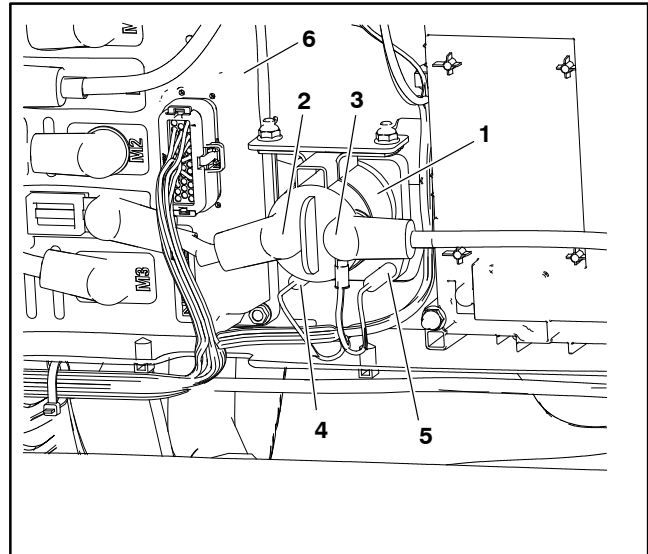

Figure 41

- | | |
|---------------------------|---------------------------|
| 1. Main contactor | 4. Wire harness connector |
| 2. Cable to controller B+ | 5. Wire harness connector |
| 3. Positive battery cable | 6. Traction controller |

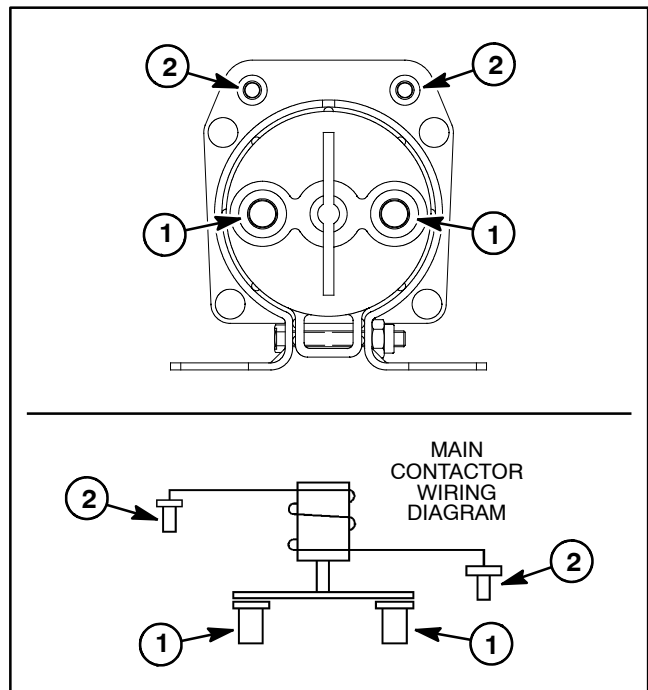

Figure 42

- | | |
|-----------------------|-------------------------|
| 1. Main contact posts | 2. Contactor coil posts |
|-----------------------|-------------------------|

Accelerator Pedal

The accelerator pedal is attached to the foot board under the dash (Fig. 43). This pedal is used as one of the inputs for the vehicle controller to determine vehicle speed. The electronic control incorporated in the accelerator pedal is a non-contact, rotary hall effect sensor that varies output voltage based on the pedal position. When the operator presses or releases the accelerator pedal, the voltage from the pedal sensor changes. Output voltage from the pedal is used by the controller to determine appropriate current flow to the traction motor.

If the accelerator pedal is thought to be faulty, consider the following before replacing the pedal:

1. Make sure that the accelerator pedal moves smoothly through its entire range of motion.
2. Check the vehicle controller for any existing faults that indicate a problem with the accelerator pedal (see Controller in this section of this chapter).
3. The wire harness connector and accelerator pedal connector should be inspected for corrosion or connector pin damage.

NOTE: No internal parts are available for the accelerator pedal.

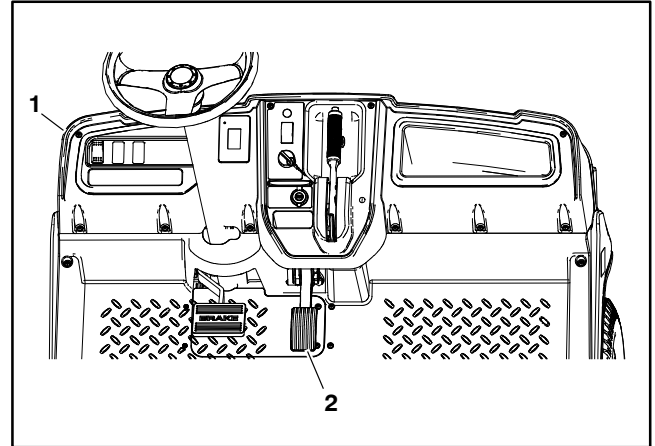

Figure 43

1. Dash panel

2. Accelerator pedal

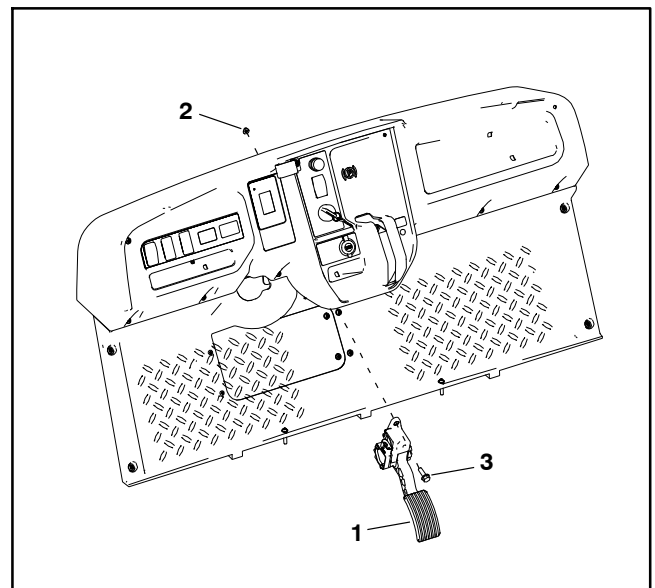

Figure 44

1. Accelerator pedal

2. Flange nut (3 used)

3. Flange screw (3 used)

Traction Motor

The traction motor stator winding, thermistor (temperature) and encoder (speed sensor) can be tested with the motor attached to the transaxle. Test connection points for the traction motor are shown in Fig. 45.

If a traction motor component is faulty, there should likely be a fault code displayed on the display. Before disconnecting electrical connections on the motor, check for existing fault codes that suggest a problem with the motor. See Controller in this section for additional information regarding faults.

Before disconnecting any electrical connections from the traction motor, open the vehicle battery circuit by disconnecting the conductors between the battery pack and vehicle components (see Opening Battery Circuit in the General Information section of this chapter). When installing cables to motor terminals, torque jam nuts at terminals from **72 to 88 in-lb (8 to 9 N-m)**. Apply Toro battery terminal protector (see Special Tools) to motor connections after tightening nuts.

Refer to Traction Motor and Traction Motor Service in the Service and Repairs section of this chapter for traction motor removal, installation, disassembly and assembly information.

Stator Winding Testing

Use a multimeter to measure resistance (ohms) between motor terminals (U, V and W). There should be very low (not zero) resistance between pairs of terminals (U and V, V and W and U and W). Also, measure resistance between each terminal and the motor drive end bracket. There should be infinite resistance between each terminal and the drive end bracket.

If resistance between terminals is either very high or zero, the stator is damaged. The stator is also faulty if resistance between any terminal and the drive end bracket is not infinite. If stator is damaged, replacement of the traction motor is necessary.

Thermistor (Thermally Sensitive Resistor) Testing

Use a multimeter to measure resistance (ohms) between the pins in the thermistor connector. The measured resistance at 77F (25°) (motor temperature) should be approximately **600 ohms**. If resistance testing determines a short circuit (low resistance) or an open circuit (infinite resistance), the thermistor or thermistor wiring is damaged and the motor must be replaced. The thermistor is an integral component of the traction motor stator.

Encoder (Speed Sensor) Testing

If encoder problems exist, the vehicle controller should determine that a problem exists and a fault code should be displayed on the display. See Controller in this section for additional information regarding encoder faults.

NOTE: If a traction motor armature problem exists in the motor (e.g. worn bearing in rear end bracket, missing retaining ring on rear of armature shaft, loose or damaged tone ring on armature), an encoder fault could be generated due to the armature issue.

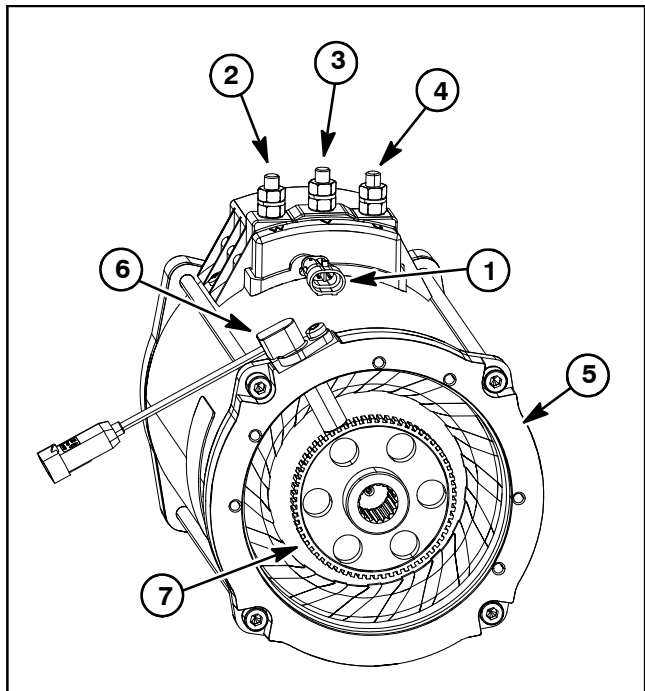

Figure 45

- | | |
|-------------------------|-----------------------|
| 1. Thermistor connector | 5. Drive end bracket |
| 2. Terminal U | 6. Encoder |
| 3. Terminal V | 7. Armature tone ring |
| 4. Terminal W | |

On-board Battery Charger

The Workman GTX Electric on-board battery charger is attached to the right side of the vehicle under the operator seat.

Power input to the charger is provided at the charging receptacle by an AC power supply cord.

If the plug does not fit into the wall receptacle, other grounded plug types are available; contact an authorized Toro distributor. Do not change the charger or the power-supply-cord plug in any way.

The battery pack charging operation is fully automated. While connected to an AC power supply, charger activity can be monitored at the display on the dash of the vehicle. To view the current charging status, turn the key switch to the ON position. When you are done viewing the charging status, turn the key switch to the OFF position to optimize the charging process.

NOTE: The display shows messages during the course of charging. Most are routine.

The on-board battery charger is connected to the vehicle CAN bus. If there is a fault exist with the battery charger, an error message will appear on the display 1 digit at a time, starting with the letter E or F (e.g., E-0-1-1).

NOTE: Refer to On-board Battery Charger in the Service and Repairs section of this chapter for battery charger removal and installation information.

To correct an error, refer to Troubleshooting. If none of these solutions correct the issue, contact an authorized Toro distributor.

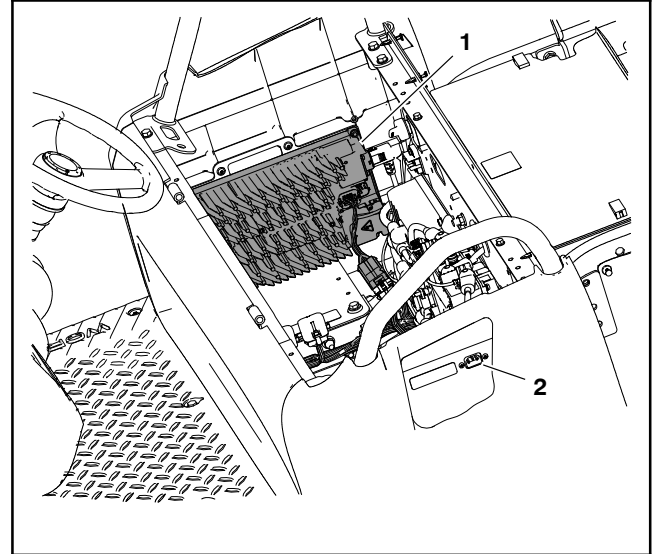

Figure 46

1. Battery charger
2. Charging receptacle

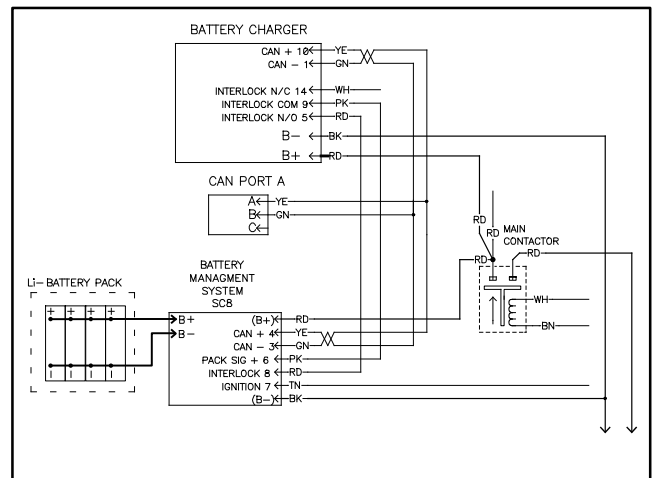

Figure 47

Diode Assembly

A diode assembly is included in the Workman GTX Electric wire harness. This diode is used for circuit logic to allow key switch current to the controller. The diode plugs into the wire harness near the vehicle fuses next to the on-board battery charger.

The diode assembly can be identified by a black color and a diode symbol on the end of the diode assembly body (Fig. 48). Refer to the wire harness drawings in Chapter 6 - Electrical Drawings for additional information on diode assembly location.

NOTE: If a vehicle is equipped with the optional brake and turn signal kit that includes flashers, four (4) additional diode assemblies are used for hazard light and turn signal circuit logic. These diodes plug into the brake and turn signal kit wire harness and can be accessed by raising the hood.

Testing

1. Park vehicle on a level surface, turn key switch to OFF, engage the parking brake and remove key from the key switch.
2. Locate diode assembly that is to be tested.
3. Remove cable tie that secures diode to wire harness. Unplug the diode from the wire harness for testing.
4. Test diode assembly using a digital multimeter (diode test or ohms setting) and the table in the right column.
5. If testing determines that a diode assembly is faulty, replace diode assembly.
6. After diode testing is complete, make sure that diode assembly is fully installed into wire harness connector and secured to harness with cable tie.

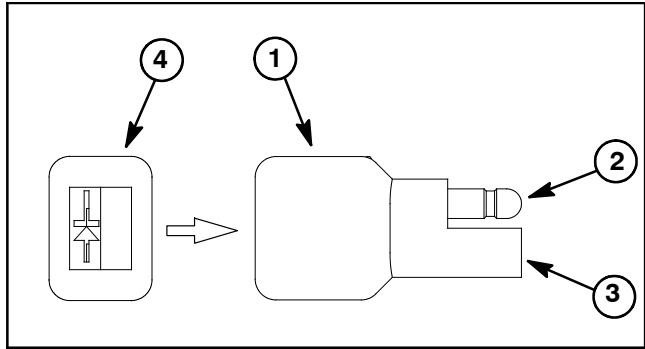

Figure 48

- | | |
|-------------------|----------------------|
| 1. Diode assembly | 3. Female terminal |
| 2. Male terminal | 4. End of diode body |

Multimeter Red Lead (+) on Terminal	Multimeter Black Lead (-) on Terminal	Continuity
Female	Male	YES
Male	Female	NO

CAN bus Terminator Resistor

System communication between various electrical components on the Workman GTX Electric Lithium machines is accomplished on a CAN bus communications network. Two specially designed, twisted wires form the CAN bus. These wires provide the data pathways between the components on the network. The engineering term for these cables are CAN High and CAN Low. The CAN bus wires are red/white (CAN High) and black/white (CAN Low).

A 120 ohm CAN bus terminator resistor is located at the rear of the operator's dash. Refer to the wire harness drawings in Chapter 6 - Electrical Drawings for additional information on CAN bus terminator resistor assembly location.

Testing

1. Park vehicle on a level surface, turn key switch to OFF, engage the parking brake and remove key from the key switch.
2. Raise the hood and locate the CAN bus terminator resistor assembly that is to be tested.
3. Disconnect the CAN bus terminator resistor from the machine wire harness.
4. Check the resistor and resistor holder for damage or corrosion and clean or repair if necessary.
5. Use a digital multimeter (ohms setting) and measure the resistance across the pins of the CAN bus terminator resistor. There should be 120 ohms resistance between the terminal 1 and 2.
6. If testing determines that the terminator resistor is faulty, replace resistor.
7. After testing is complete, make sure that the terminator resistor is fully installed into the connector and secured to the wire harness.
8. If the resistor test correctly and a circuit problem still exists, check the CAN-bus; refer to CAN bus testing, wire harness drawings in Chapter 6 - Electrical Drawings for additional information, or contact an Authorized Toro Distributor for assistance.
9. Lower and secure the hood.

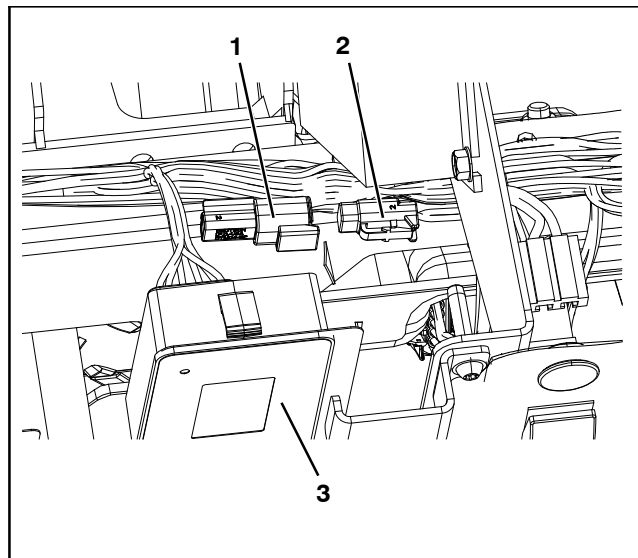

Figure 49

- | | |
|--------------------------------|------------------|
| 1. CAN bus terminator resistor | 2. Connector P57 |
| | 3. Display |

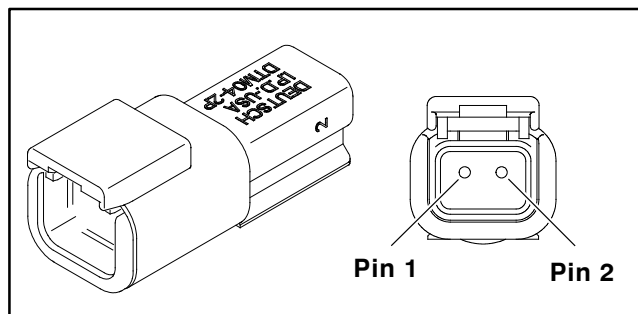

Figure 50

Reverse Audio Alarm (If Equipped)

The reverse alarm sounds when the direction switch (forward/reverse) is placed in the reverse position. The alarm is located under the seat assembly attached to the rear frame panel below the supervision speed limit switch (Fig. 51).

Testing

IMPORTANT: Make sure to observe polarity on the alarm terminals when testing. Damage to the alarm may result from an improper connection.

IMPORTANT: The audio alarm is a 12 volt DC component. Do not test the alarm using jumper wires from the vehicle battery pack (48 VDC).

1. Park vehicle on a level surface, turn key switch to OFF, engage the parking brake and remove key from the key switch.
2. Remove seat assembly from vehicle to access reverse alarm. Locate alarm on rear frame panel.
3. Disconnect wire harness connectors from alarm (Fig. 51).
4. Using jumper wires, correctly connect 12VDC source to the alarm terminals noting polarity shown in Figure 52.
5. Alarm should sound as long as voltage is applied to alarm terminals. Remove voltage source from the alarm.
6. Replace alarm if testing determines that it is faulty.
7. Connect wire harness connectors to alarm. Install seat assembly on vehicle.

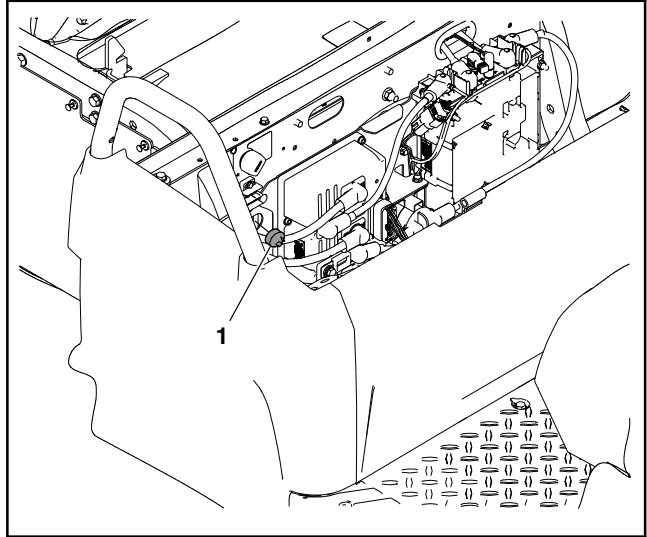

Figure 51

1. Fuse block 2. Reverse audio alarm

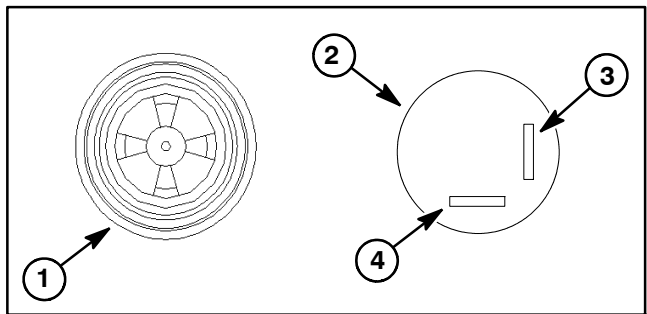

Figure 52

1. Alarm (top view) 3. Positive (+) terminal
2. Alarm (bottom view) 4. Negative (-) terminal

This page is intentionally blank.

Service and Repairs

Battery Service

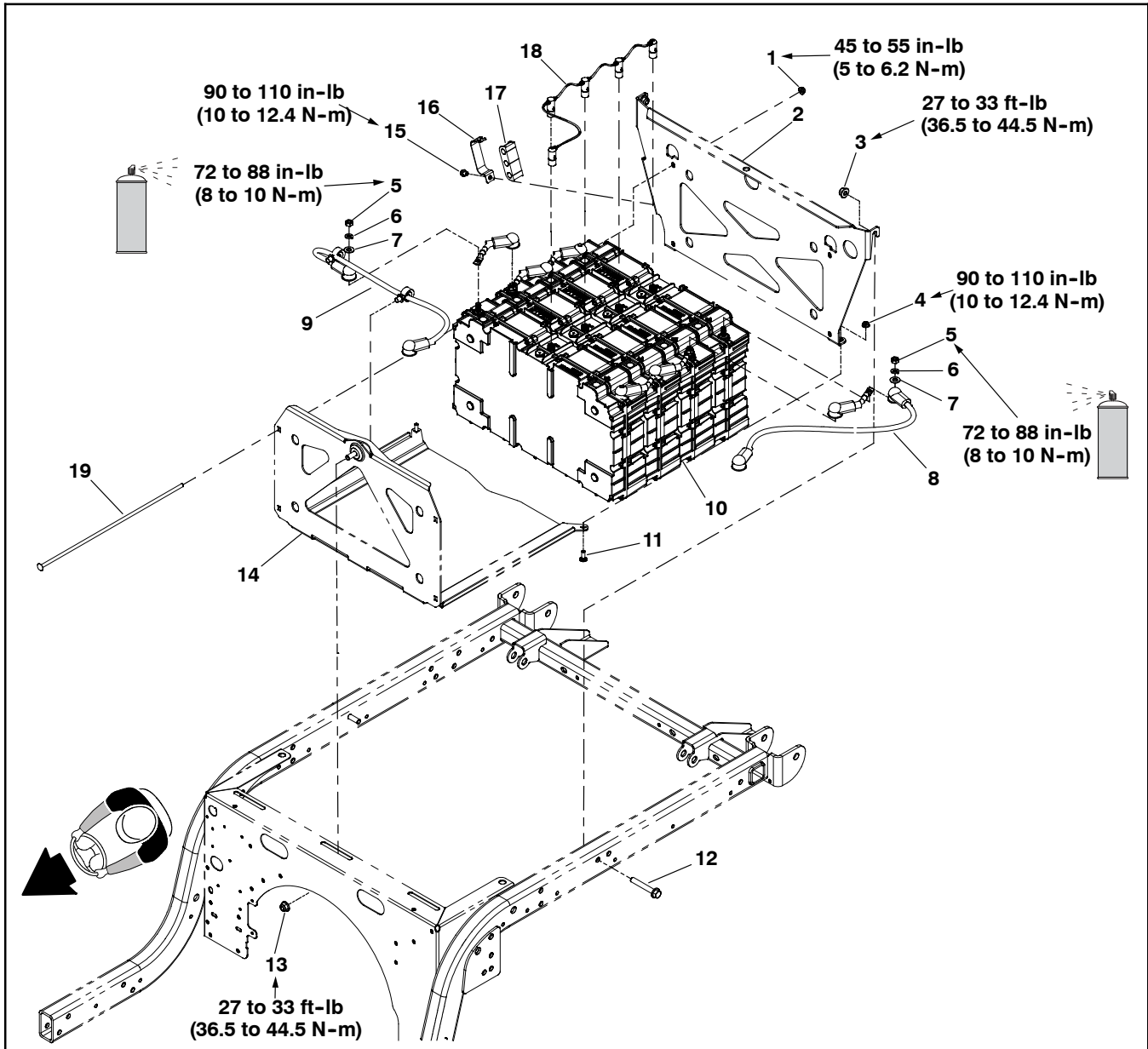

Figure 53

- | | | |
|---------------------------------------|----------------------------|----------------------------|
| 1. Nut (4 used) | 8. Positive battery cable | 14. Front bracket |
| 2. Rear bracket | 9. Negative battery cable | 15. Screw |
| 3. Flange nut (2 used) | 10. Battery pack (4 used) | 16. Isolator clamp |
| 4. Flange nut (2 used) | 11. Carriage bolt (2 used) | 17. Isolator retainer |
| 5. Nut (2 used per battery) | 12. Screw (2 used) | 18. Battery data cable |
| 6. Spring washer (2 used per battery) | 13. Flange nut | 19. Carriage bolt (4 used) |
| 7. Washer (2 used per battery) | | |

The GTX Electric Lithium machine is powered by four maintenance free lithium-ion batteries. Each battery consists of numerous cells. The batteries are connected in parallel and managed by SC1: Lithium-ion battery controller (also known as Battery Management System or BMS).

IMPORTANT: Do not open the lithium-ion batteries. There are no serviceable parts on or in the battery pack. If you open the battery, you will void the warranty. The battery is protected by tamper-alerting devices.

Battery Removal (Fig. 53)



WARNING

Battery terminals, battery cables, or metal tools could short against metal components causing sparks. Sparks can cause the battery damage and high heat, resulting in personal injury.

- When removing or installing the batteries, do not allow the battery terminals or battery cables to touch any metal parts of the machine.
- Do not allow metal tools to short between the battery terminals or battery cables and metal parts of the machine.
- Do not attach anything to the battery terminal other than the battery cable or wire harness connector that came with the product.
- Always keep the battery retainers and covers in place to protect and secure the batteries.

IMPORTANT: To prevent accidentally shorting a disconnected battery cable across other components or tools, insulate the battery cable terminal with a 76 mm (3 inch) length of 1.27 mm (0.5 in) internal diameter rubber hose immediately after disconnecting the cable; refer to Fig. 54.

1. Park vehicle on a level surface, turn key switch to OFF, engage the parking brake and remove key from the key switch.
2. Raise cargo bed and support with prop rod. Remove seat base assembly.
3. Remove rear frame panel cover to allow access to all vehicle batteries (see Rear Frame Panel Cover in the General Information section of this chapter).
4. Make sure that vehicle battery charger IS NOT connected to electrical outlet. Open the battery circuit by disconnecting the conductors between the battery pack and vehicle components (see Opening Battery Circuit in the General Information section of this chapter).
5. Label and disconnect the negative (-) battery cable from the negative (-) terminal and positive (+) battery cable from the positive (+) terminal of the battery pack.
6. Label and disconnect the battery interface harness connectors (item 18) from each of the center mounted batteries and from the lithium-Ion battery controller (BMS) M-S terminal.

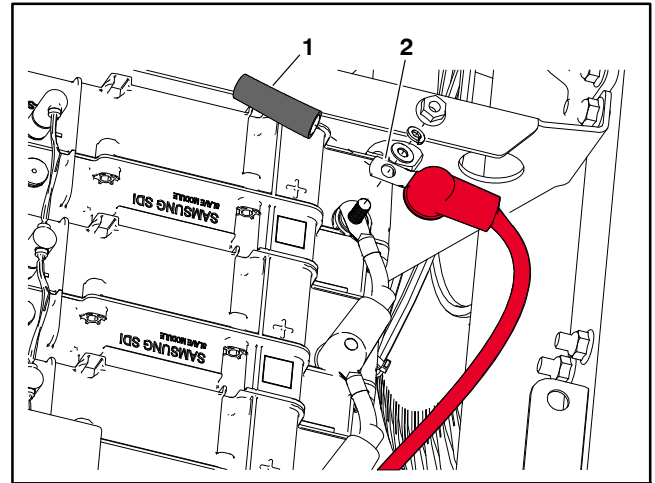

Figure 54

1. 1.27 mm (0.5 in) ID rubber hose
2. Battery cable terminal (typical)



CAUTION

The battery assembly weighs approximately 45 kg (100 lbs). Use an appropriate lift and the lift points provided to remove the center mounted battery assembly.

7. Remove the three flange nuts (3 and 13) that secures the battery pack assembly to the frame assembly; refer to Fig. 53.
8. Continue to dismantle the battery assembly as necessary; refer to Fig. 53.

Battery Installation (Fig. 53)

1. Make sure vehicle key switch and all accessories are OFF.
2. Raise cargo bed and support with prop rod. Remove seat base assembly and rear frame panel cover.
3. Make sure the battery brackets are clean and repainted if necessary. Make sure conductors (wires and cables) and conductor terminals are clean (no corrosion) and in good condition.

IMPORTANT: Make sure that batteries are installed with the positive terminals are left side of the vehicle and the negative terminals are right side of the vehicle (Fig. 53).

4. Install the battery assembly onto the machine frame using the figure 53. Torque tighten the battery pack flange nuts (3 and 13) from 27 to 33 ft-lb (36.5 to 44.5 N-m).

5. Using the labels that attached during the removal, connect the battery interface cable, positive (+) battery cable and negative (-) battery cable onto the battery pack.

6. Tighten the battery cable fasteners from 72 to 88 in-lb (8 to 10 N-m), then apply battery terminal protector Toro Part No. 107-0392 or a light layer of grease to the battery terminals and cable connectors to reduce corrosion.

7. Secure rear frame panel cover to vehicle. Lower and secure cargo box. Install seat base assembly.

8. Before returning vehicle to operation, fully charge the batteries by connecting the on-board battery charger to an appropriate electrical outlet.

Caring for the Lithium-Ion Batteries



WARNING

Battery terminals, battery cables, or metal tools could short against metal components causing sparks. Sparks can cause the battery damage and high heat, resulting in personal injury.

- **When removing or installing the batteries, do not allow the battery terminals or battery cables to touch any metal parts of the machine.**
- **Do not allow metal tools to short between the battery terminals or battery cables and metal parts of the machine.**
- **Do not attach anything to the battery terminal other than the battery cable or wire harness connector that came with the product.**
- **Always keep the battery retainers and covers in place to protect and secure the batteries.**

IMPORTANT: A used or damaged lithium-ion battery must be disposed of or recycled in accordance with local and federal regulations. For information on how to properly dispose of lithium-ion batteries, contact your local municipality or recycling facility.

1. Use the display on the dash to monitor the state of charge of the lithium-ion battery pack. Consistently operating the machine with a very low state of charge will adversely affect the life of the batteries.

2. If problems with the batteries exist, an advisory or fault may be identified on the display; refer to Troubleshooting in this chapter.

3. When done using the machine for the day, park the machine in a clean and dry area that is away from direct sunlight and other heat sources. Do not store the machine in a location where the battery temperature could rise above 45 °C (113 °F). If the battery is regularly subjected to excessive temperatures, the life of the batteries will be reduced.

4. Charge the batteries when you are finished for the day to ensure that the batteries are fully charged for the next use. Lithium-ion batteries do not have a charge memory issue and do not need to be fully discharged before charging them. For best battery life, connect the machine to the battery charger any time the machine is not in use.

Battery Charging

When the vehicle is not in use, it is recommended to keep the batteries charged by connecting the on-board battery charger to an appropriate electrical outlet. The Workman GTX charger is designed to automatically charge the batteries fully without overcharging.

For additional battery charging information, see your Operator's Manual and the Battery Charger Operating Instructions. Refer to Battery Charger Error and Fault Codes in this manual for battery charger troubleshooting information.

Battery Storage

Do not store the machine in a location where the temperature will drop below -25°C (-13°F) or rise above 45°C (113°F). Because storage temperature will affect the life of the battery pack, avoid storing the machine in temperatures outside of this range. Storage for long periods of time at high temperatures will reduce the life of the battery pack, especially if the pack is stored with a high charge. Where possible, store the machine in a cool (not below freezing) location.

1. Storage of 1 to 6 months: Charge or discharge the battery to 50 – 100%. 50% is ideal due to 100% will degrade the battery faster.
2. Storage of 6 to 12 months: Charge the battery to 100%.
3. Storage of more than 12 months: Check the state of charge. If it is under 50% charging is required.

After charging, disconnect the charger from batteries to prevent minimal drain on the batteries. If charger is left connected to the batteries for an extended period, it will shut off after the batteries are fully charged and will NOT turn back on unless the charger is disconnected and re-connected.

Shipping and Transporting the Lithium-Ion Batteries

The US Department of Transportation and international transportation authorities require that lithium-ion batteries be shipped using special packaging and only be handled by carriers certified to haul them. Use the original packaging whenever possible when shipping lithium-ion batteries in the USA. If the original packaging is damaged or not available, use a Battery Shipping Kit; refer to Special Tools. Contact the appropriate government body in your country for detailed regulations on shipping the lithium-ion batteries.

In the USA, you are allowed to transport the battery when it is installed on the machine as battery powered equipment, with some regulatory requirements. Contact US Department of Transportation or the appropriate government body in your country for detailed regulations on transporting a machine with lithium batteries installed.

IMPORTANT: Ship a lithium-ion battery in its original packaging or a specially designed Battery Shipping Kit. Failure to ship a lithium-ion battery correctly may result in substantial penalties.

Traction Motor

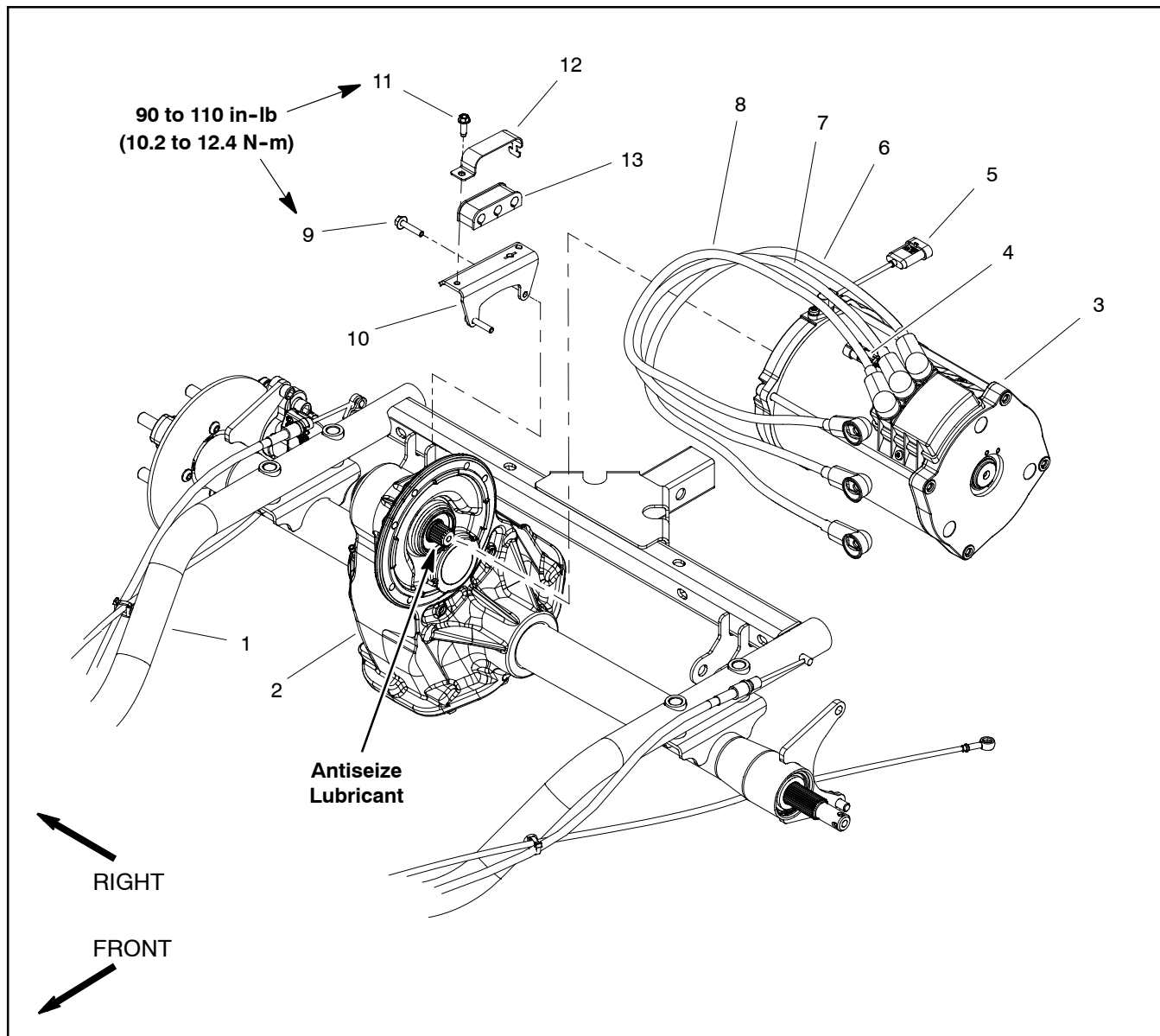

Figure 55

- | | | |
|-------------------------------|-------------------------------------|-----------------------|
| 1. Swing arm | 6. Cable (motor W to controller M1) | 10. Cable bracket |
| 2. Transaxle assembly | 7. Cable (motor V to controller M2) | 11. Washer head screw |
| 3. Traction motor | 8. Cable (motor U to controller M3) | 12. Isolator retainer |
| 4. Motor thermistor connector | 9. Flange head screw (6 used) | 13. Isolator |
| 5. Motor encoder connector | | |

Removal (Fig. 55)

1. Park vehicle on a level surface, turn key switch to OFF, engage the parking brake and remove key from the key switch.

2. To allow easier access to traction motor, remove cargo bed from vehicle (see Cargo Bed in the Service and Repairs section of Chapter 5 - Chassis).

3. Make sure that vehicle battery charger IS NOT connected to electrical outlet. Open the battery circuit by disconnecting the conductors between the battery pack and vehicle components (see Opening Battery Circuit in the General Information section of this chapter).

NOTE: Label all traction motor electrical leads for assembly purposes.

IMPORTANT: When removing cables from motor terminals (U, V and W), use a wrench to retain lower nut while loosening upper nut (Fig. 56). If terminal studs are allowed to turn during upper nut removal, internal motor damage can occur.

4. Disconnect electrical connectors from traction motor and position them away from motor:

A. While retaining lower nut to prevent it from loosening, remove upper nut, lock washer and cable connector from traction motor terminal studs U, V and W.

B. Unplug wire harness connectors from traction motor encoder (speed sensor) and thermistor (temperature).

5. Position disconnected cables and wire harness leads away from traction motor.

**CAUTION**

To prevent motor damage and personal injury, make sure that traction motor is well supported as it is removed. Motor weighs approximately 66 pounds (30 kg).

6. Wrap suitable lifting strap around center of traction motor housing for support and as a lifting point for motor removal. Do not capture encoder (speed sensor) or thermistor wires under strap. Support motor with strap to prevent it from moving.

7. Remove two (2) flange head screws (item 9) that secure cable bracket (item 10) to transaxle and traction motor. Position cable bracket with attached cables away from motor and transaxle.

8. Remove remaining four (4) flange head screws (item 9) that secure motor to transaxle.

9. Pull motor away from transaxle until motor shaft is disengaged from transaxle input shaft. Then, carefully lift motor from vehicle taking care to not damage motor sensors or vehicle components while motor is being removed.

10. If necessary, remove washer head screw (item 11) that secures isolator retainer and isolator to isolator bracket. Separate isolator and motor cables from bracket.

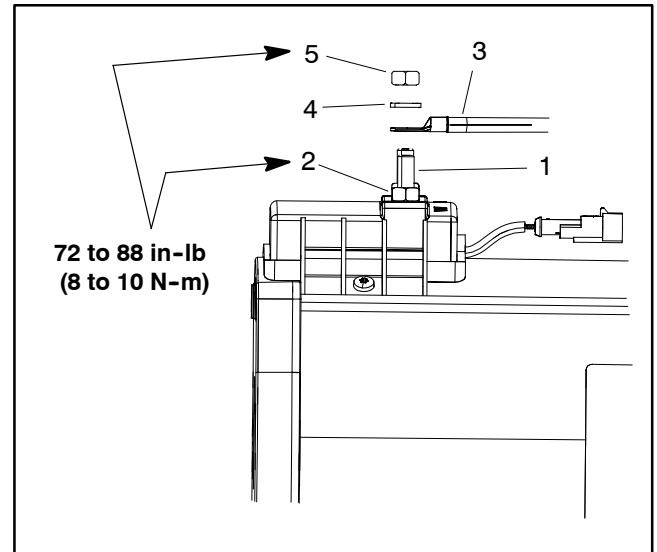

Figure 56

- | | |
|------------------------|----------------|
| 1. Motor terminal stud | 4. Lock washer |
| 2. Lower nut | 5. Upper nut |
| 3. Cable | |

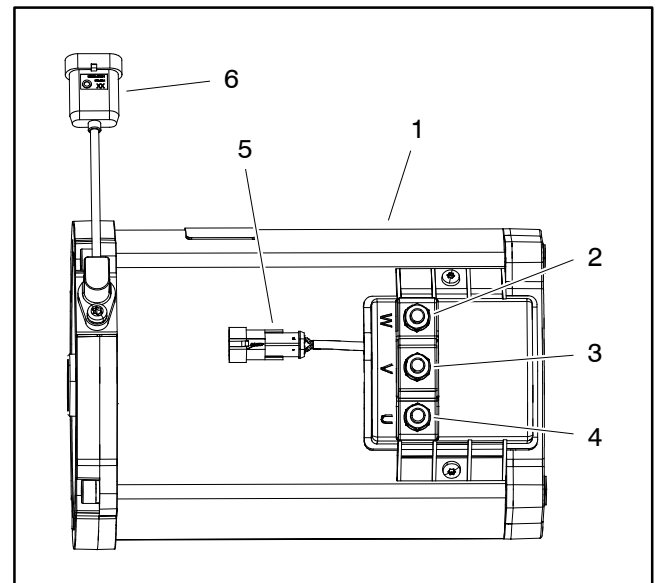

Figure 57

- | | |
|-------------------|-------------------------|
| 1. Traction motor | 4. U terminal |
| 2. W terminal | 5. Thermistor connector |
| 3. V terminal | 6. Encoder connector |

Installation (Fig. 55)

1. If isolator and wire cables were removed from cable bracket (item 10), insert cables into isolator. Secure isolator and cables to bracket with isolator bracket and washer head screw. Torque screw from **90 to 110 in-lb (10.2 to 12.4 N-m)**.

2. Apply antiseize lubricant to the splines of the transaxle and traction motor shafts.



3. Wrap suitable lifting strap around traction motor housing for support and as a lowering point for motor installation. Do not capture encoder (speed sensor) or thermistor wires under strap.

4. Carefully lower traction motor into vehicle. Align motor shaft with transaxle input shaft and slide motor to transaxle. Take care to not damage encoder (speed sensor) while installing motor.

5. Secure traction motor to transaxle:

A. Align mounting holes of motor and transaxle.

B. Install four (4) flange head screws (item 9) through transaxle holes and into traction motor leaving upper two (2) holes vacant for cable bracket installation.

C. Position cable bracket with attached cables to motor and transaxle. Install final two (2) flange head screws.

D. Torque all six (6) flange head screws from **90 to 110 in-lb (10.2 to 12.4 N-m)** to secure motor to transaxle.

E. Remove lifting strap from traction motor.

6. Make sure motor terminals and cables are clean (no corrosion) and in good condition.

IMPORTANT: When connecting cables to motor terminals (U, V and W), use a wrench to retain lower nut while tightening upper nut (Fig. 56). If terminal studs are allowed to turn during upper nut installation, internal motor damage can occur.

7. Using labels placed during motor removal, secure electrical connections to traction motor:

A. Plug connectors from traction motor traction motor encoder (speed sensor) and thermistor (temperature) into vehicle wire harness.

B. Make sure that lower nuts are installed on motor terminals and are torqued from **72 to 88 in-lb (8 to 9 N-m)**.

C. Install correct cable, lock washer and nut to motor terminals U, V and W. While retaining lower nut, torque upper nut from **72 to 88 in-lb (8 to 9 N-m)**.

8. Connect the conductors between the battery pack and vehicle components (see Opening Battery Circuit in the General Information section of this chapter). Make sure to torque hex nuts on battery terminals from **72 to 88 in-lb (8 to 9 N-m)**.

9. After all cable connections are made, apply Toro battery terminal protector (see Special Tools) to all battery posts and traction motor cable connectors to prevent corrosion. Make sure that cable terminal boots are positioned over all connections.

10. Install cargo bed to the vehicle (see Cargo Bed Installation in Service and Repairs section of Chapter 5 – Chassis).

11. Before returning vehicle to operation, fully charge the batteries by connecting the on-board battery charger to an appropriate electrical outlet.

This page is intentionally blank.

Traction Motor Service

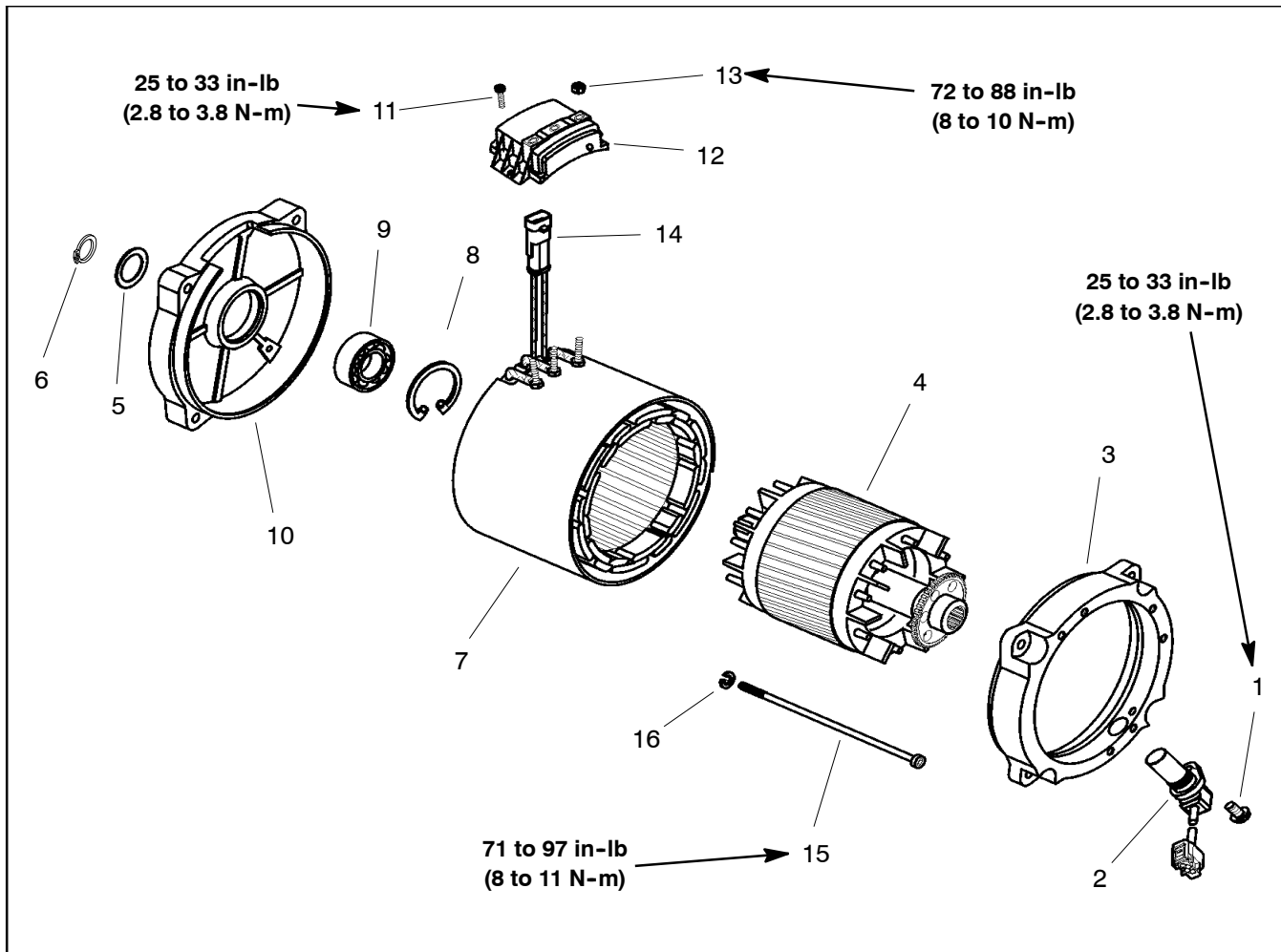

Figure 58

- | | | |
|---------------------------|------------------------------|--------------------------------|
| 1. Torx head screw | 7. Stator assembly | 12. Connection plate |
| 2. Encoder (speed sensor) | 8. Retaining ring | 13. Lower jam nut (3 used) |
| 3. Drive end bracket | 9. Bearing | 14. Thermistor connector |
| 4. Armature assembly | 10. Rear end bracket | 15. Socket head screw (4 used) |
| 5. Wave washer | 11. Torx head screw (2 used) | 16. Lock washer (4 used) |
| 6. Retaining ring | | |

NOTE: If traction motor stator or armature damage occurs, traction motor replacement is necessary. These components are not available separately.

Motor Disassembly (Fig. 58)

1. Remove torx head screw that secures encoder (speed sensor) to traction motor. Slide encoder from drive end bracket.
2. Remove the retaining ring and wave washer that secure the armature assembly in the rear end bracket bearing (Fig. 59).
3. Carefully separate armature assembly out of bearing in rear end bracket and then remove armature from stator.
4. Remove connection plate assembly (item 12) from stator:
 - A. Remove three (3) lower jam nuts from stator terminal screws.
 - B. Remove two (2) torx screws that secure connection plate assembly to stator.
 - C. Remove connection plate assembly from stator.
5. For assembly purposes, note locations of drainage slots in drive and rear end brackets and the aligning position slots in the stator assembly (Fig. 60).

6. Remove four (4) socket head screws and lock washers that secure drive and rear end brackets to stator assembly. Remove end brackets from stator.

NOTE: After the traction motor has been disassembled, it is recommended that a new rear end bracket bearing be installed. Although the bearing may appear and feel in good condition, the bearing could be "brinelled" (races or balls deformed). After assembly with a questionable bearing, the motor may exhibit noise and vibration problems or fail within a relatively short period of service.

7. Remove the retaining ring from the rear end bracket (Fig. 61). Press bearing from the rear end bracket and discard the removed bearing.



CAUTION

When using compressed air for cleaning motor components, follow all safety instructions, including wearing eye and respiratory protection.

8. Carefully blow out any accumulated debris from the stator and the armature using clean, oil free, compressed air.

9. Inspect traction motor armature and transaxle input shaft splines for wear or damage. Replace motor and/or transaxle input shaft if spline damage is found.

10. Visually inspect the armature and stator components. If damage to either of these components is found, replace traction motor.

Motor Assembly (Fig. 58)

1. Make sure that all traction motor components are clean and in good condition before assembling the motor.

IMPORTANT: To prevent bearing damage when installing new bearing in the rear end bracket, support end bracket and press only against the bearing outer race.

2. Press a new bearing into the rear end bracket, pressing on the bearing outer race only. Secure bearing in bracket with retaining ring (Fig. 61). Make sure that retaining ring is fully seated in groove in bracket after assembly.

3. Position drive and rear end brackets to stator assembly using notes made during disassembly to properly align drainage slots in brackets and stator (Fig. 60).

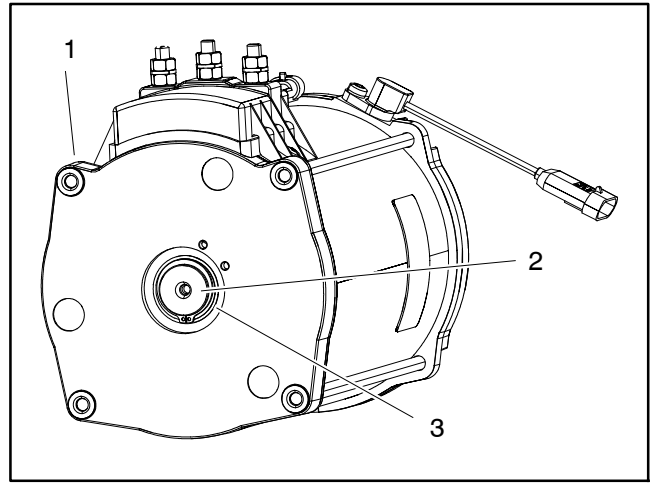

Figure 59

- 1. Rear end bracket
- 2. Armature shaft
- 3. Retaining ring & washer

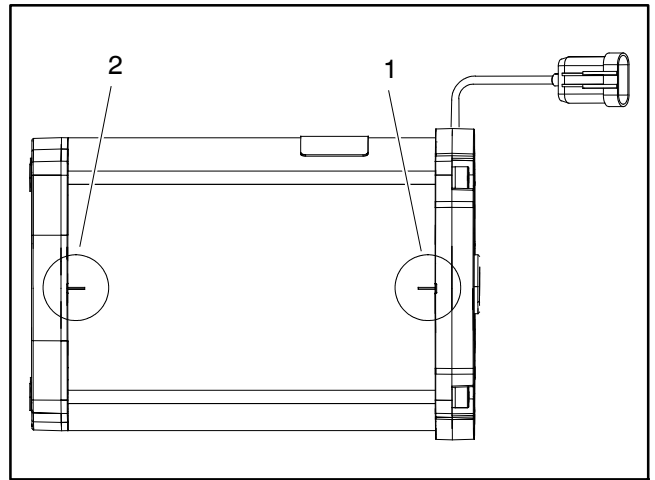

Figure 60

- 1. Drive end slot alignment
- 2. Rear end slot alignment

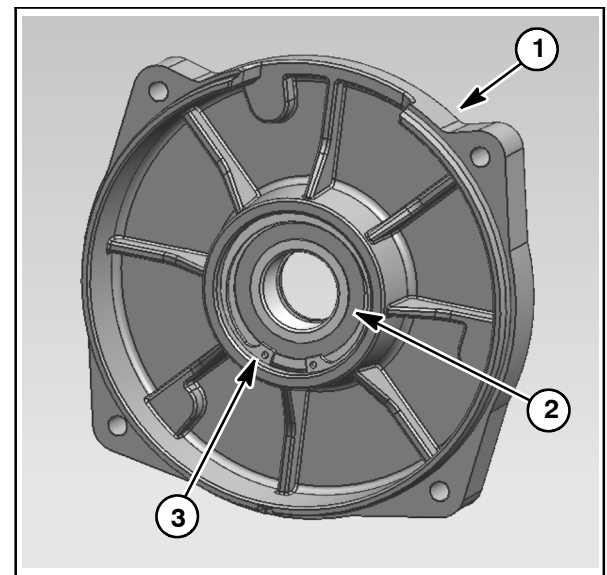

Figure 61

- 1. Rear end bracket
- 2. Bearing
- 3. Retaining ring

Electrical System

4. Secure drive and rear end brackets to stator assembly with four (4) socket head screws and lock washers. Tighten screws in two (2) stages using the sequence shown in Figure 62. Final torque on screws should be from **71 to 97 in-lb (8 to 11 N-m)**.

5. Install connection plate assembly (item 12) to stator:

A. Place connection plate assembly onto stator so that three (3) terminal screws fit through plate.

B. Secure connection plate assembly to stator with two (2) torx screws. Torque screws from **25 to 33 in-lb (2.8 to 3.8 N-m)**.

C. Install three (3) lower jam nuts onto stator terminal screws. Torque nuts from **72 to 88 in-lb (8 to 9 N-m)**.

6. Carefully install armature assembly into the stator. End of stator must extend completely through bearing in rear end bracket.

7. Install wave washer (item 5) and retaining ring (item 6) to secure the armature assembly in the rear end bracket bearing (Fig. 59). Make sure that retaining ring is fully seated into groove in armature shaft.

8. Slide encoder into drive end bracket and secure with torx head screw. Torque screw from **25 to 33 in-lb (2.8 to 3.8 N-m)**.

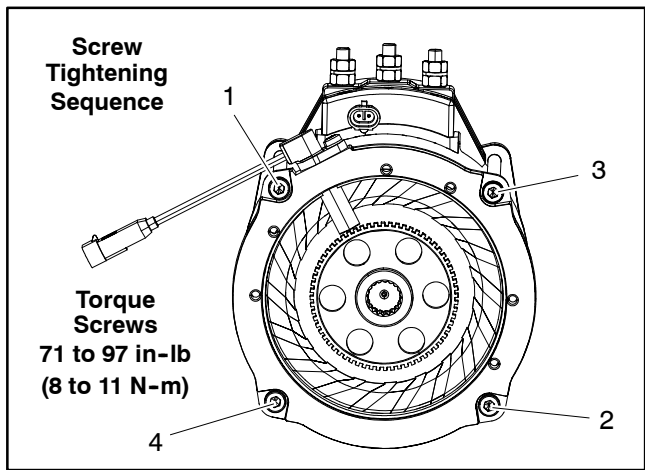

Figure 62

This page is intentionally blank.

SC2: Traction Controller

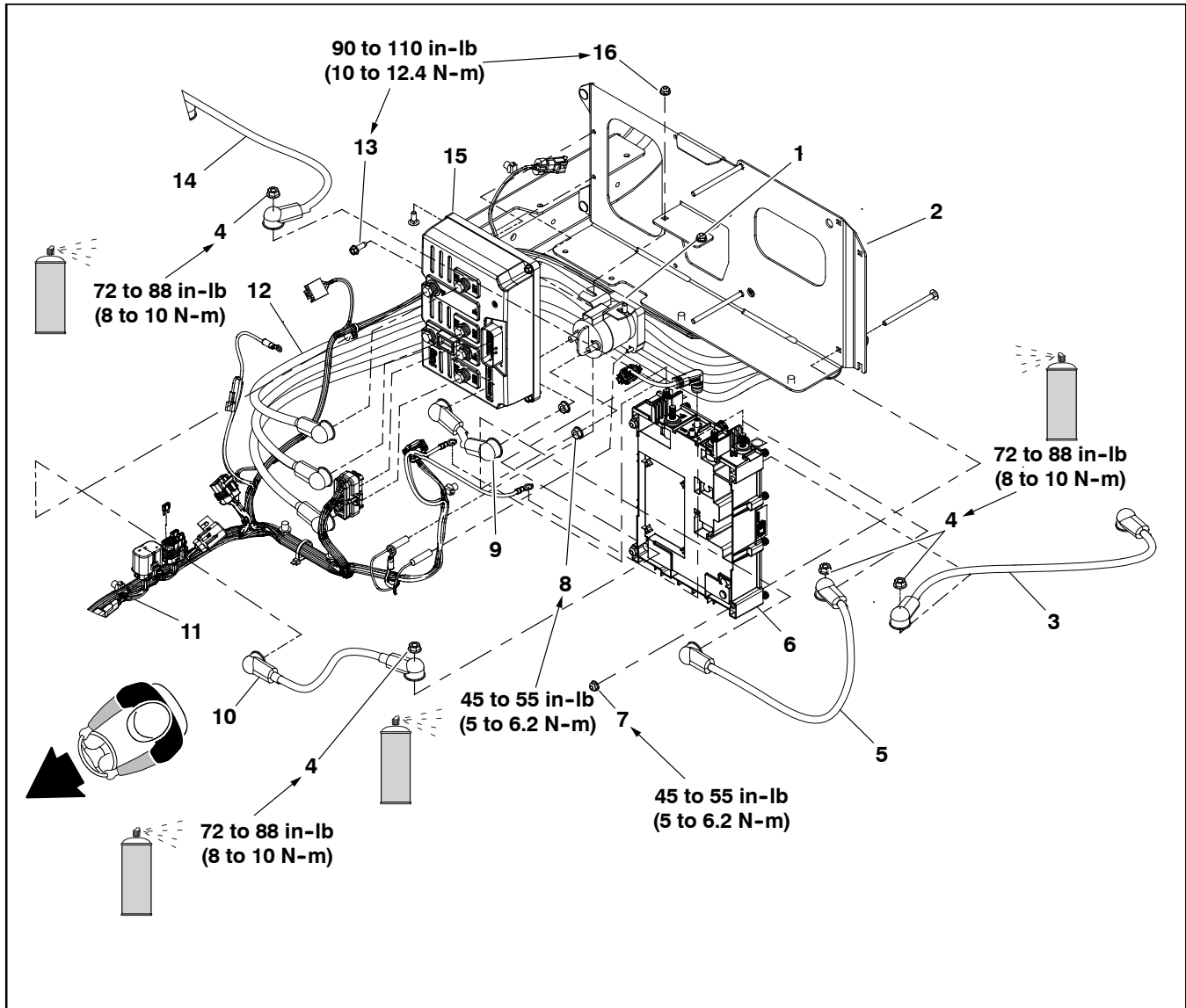

Figure 63

- | | | |
|-------------------------------|--------------------------------|--------------------------------|
| 1. Contactor | 7. Flange nut (4 used) | 12. Battery (+) positive cable |
| 2. Controller bracket | 8. Flange nut (2 used) | 13. Bolt (4 used) |
| 3. Battery (+) positive cable | 9. Battery (+) positive cable | 14. Battery (-) negative cable |
| 4. Flange nut (4 used) | 10. Battery (+) positive cable | 15. SC2: Traction controller |
| 5. Battery (+) positive cable | 11. Wire harness | 16. Flange nut (2 used) |
| 6. SC1: battery controller | | |

Removal (Fig. 63)

1. Park vehicle on a level surface, turn key switch to OFF, engage the parking brake and remove key from the key switch.

2. Raise cargo bed and support with prop rod. Remove seat base assembly.

3. Remove rear frame panel cover to allow access to all vehicle batteries (see Rear Frame Panel Cover in the General Information section of this chapter).

4. Make sure that vehicle battery charger IS NOT connected to electrical outlet. Open the battery circuit by disconnecting the conductors between the battery pack and vehicle components (see Opening Battery Circuit in the General Information section of this chapter).

NOTE: Label all traction controller electrical leads for assembly purposes.

5. Disconnect electrical conductors from SC2: traction controller and position them away from controller:

- A. Remove cap screw, lock washer, flat washer and cable connector from controller terminals B+, B-, M1, M2 and M3 (Fig. 64).
- B. Carefully unplug wire harness connector from controller.
- C. Position cables and wire harness connector away from controller.

6. Support traction controller to prevent it from falling.

7. Remove four (4) bolts (13) that secure traction controller to controller bracket. Carefully remove controller from vehicle.

Installation (Fig. 63)

1. Position SC2: traction controller to controller bracket and secure with four (4) bolts (13). Torque the bolts (13) from **90 to 110 in-lb (10 to 12.4 N-m)**.

2. Make sure controller terminals and cables are clean (no corrosion) and in good condition.

3. Connect electrical conductors to traction controller:

- A. Carefully plug wire harness connector into traction controller. Make sure that connector is fully plugged into traction controller socket.

- B. Secure controller cables to controller terminals B+, B-, M1, M2 and M3 with cap screw, lock washer and flat washer (Fig. 64). Torque cap screws from **90 to 110 in-lb (10 to 12.4 N-m)**.

4. Connect the conductors between the battery pack and vehicle components (see Opening Battery Circuit in the General Information section of this chapter). Make sure to torque hex nuts on battery terminals from **72 to 88 in-lb (8 to 9 N-m)**.

5. After all cable connections are made, apply Toro battery terminal protector (see Special Tools) to all battery posts and controller cable connectors to prevent corrosion. Make sure that cable terminal boots are positioned over all connections.

6. Secure rear frame panel cover to vehicle. Lower and secure cargo box. Install seat base assembly.

7. Before returning vehicle to operation, fully charge the batteries by connecting the on-board battery charger to an appropriate electrical outlet.

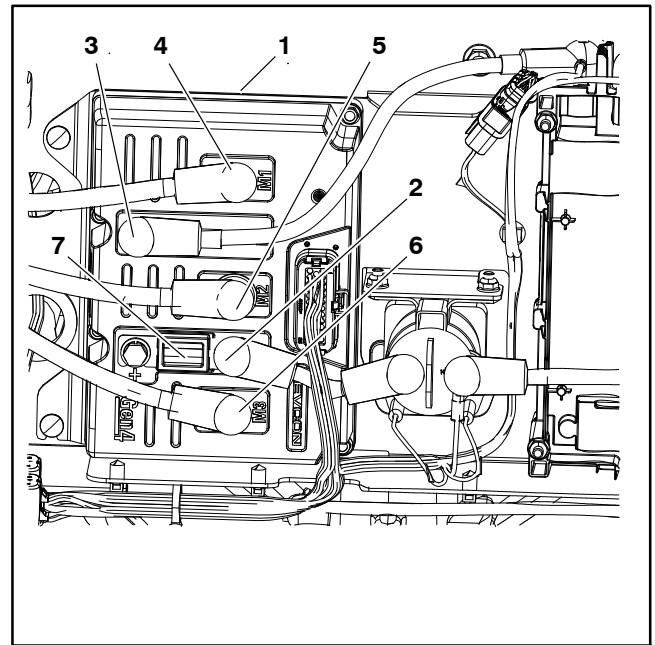

Figure 64

- 1. SC2: Traction controller
- 2. B+ terminal (+ cable from main contactor)
- 3. B- terminal (- cable from left, rear battery)
- 4. M1 terminal (cable to motor terminal W)
- 5. M2 terminal (cable to motor terminal V)
- 6. M3 terminal (cable to motor terminal U)
- 7. Fuse (425 A)

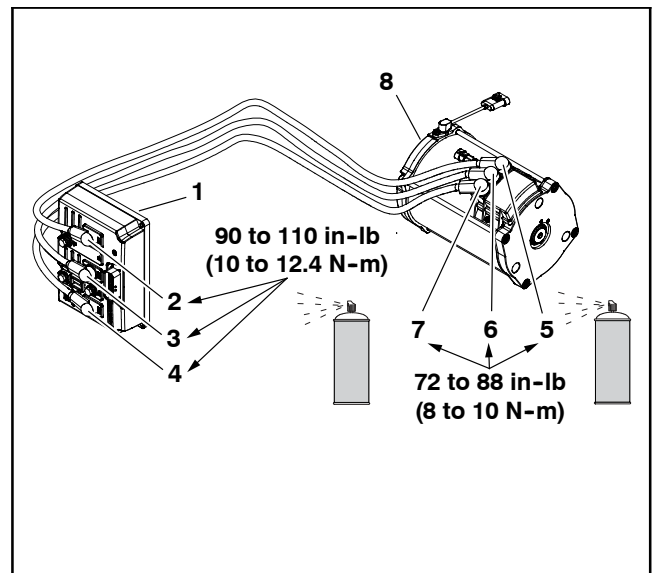

Figure 65

- 1. SC2: Traction controller
- 2. M1 terminal
- 3. M2 terminal
- 4. M3 terminal
- 5. Terminal W
- 6. Terminal V
- 7. Terminal U
- 8. Traction motor

SC1: Lithium-Ion Battery Controller (BMS)

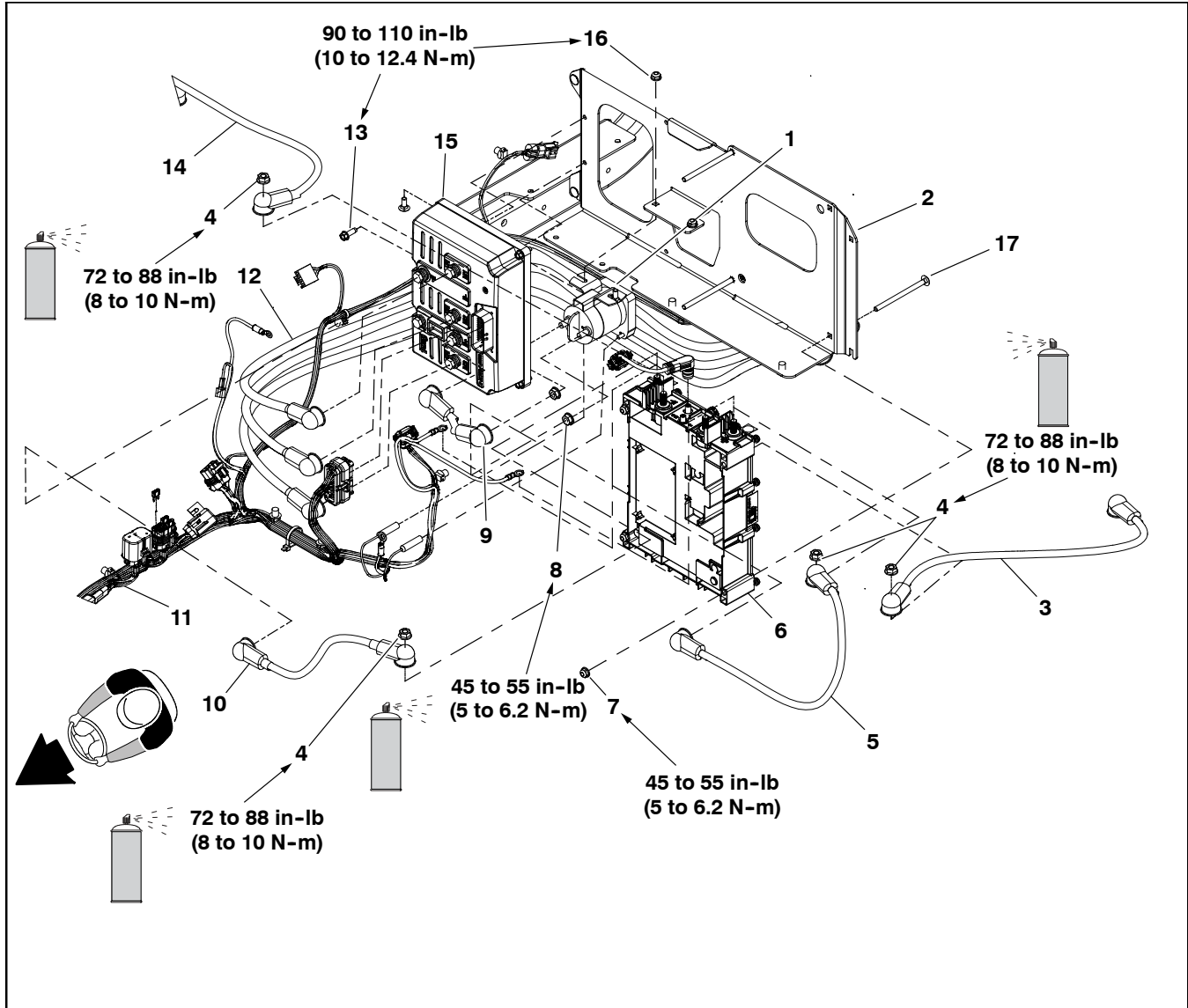

Figure 66

- | | | |
|-------------------------------|--------------------------------|--------------------------------|
| 1. Contactor | 7. Flange nut (4 used) | 13. Bolt (4 used) |
| 2. Controller bracket | 8. Flange nut (2 used) | 14. Battery (-) negative cable |
| 3. Battery (+) positive cable | 9. Battery (+) positive cable | 15. SC2: Traction controller |
| 4. Flange nut (4 used) | 10. Battery (+) positive cable | 16. Flange nut (2 used) |
| 5. Battery (+) positive cable | 11. Wire harness | 17. Carriage bolt (4 used) |
| 6. SC1: battery controller | 12. Battery (+) positive cable | |

Removal (Fig. 66)

1. Park vehicle on a level surface, turn key switch to OFF, engage the parking brake and remove key from the key switch.
2. Raise cargo bed and support with prop rod. Remove seat base assembly.
3. Remove rear frame panel cover to allow access to all vehicle batteries (see Rear Frame Panel Cover in the General Information section of this chapter).

4. Make sure that vehicle battery charger IS NOT connected to electrical outlet. Open the battery circuit by disconnecting the conductors between the battery pack and vehicle components (see Opening Battery Circuit in the General Information section of this chapter).

NOTE: Label all controller electrical leads for assembly purposes.

5. Disconnect electrical conductors from SC1: lithium-ion battery controller and position them away from controller:

A. Remove nut, lock washer, flat washer and cable connector from battery controller terminals negative, B-, B+ and positive terminal. (Fig. 67).

B. Carefully unplug the COM and M-S wire harness connector from battery controller.

C. Position cables and wire harness connector away from controller.

6. Support battery controller to prevent it from falling.

7. Remove four (4) nuts (7) and carriage bolts (17) that secure battery controller to controller bracket. Carefully remove battery controller from vehicle.

Installation (Fig. 66)

1. Position SC1: lithium-ion battery controller to controller bracket and secure with four (4) carriage bolts (17) and nuts (7). Torque the nuts (7) from **45 to 55 in-lb (5 to 6.2 N-m)**.

2. Make sure battery controller terminals and cables are clean (no corrosion) and in good condition.

3. Connect electrical conductors to battery controller:

A. Carefully connect COM and M-S wire harness connector into traction controller. Make sure that connector is fully plugged into traction controller socket.

B. Secure controller cables to controller terminals negative, B-, B+ and positive terminal with nut, lock washer and flat washer (Fig. 67). Torque the nuts from **72 to 88 in-lb (8 to 9 N-m)**.

4. Connect the conductors between the battery pack and vehicle components (see Opening Battery Circuit in the General Information section of this chapter). Make sure to torque hex nuts on battery terminals from **72 to 88 in-lb (8 to 9 N-m)**.

5. After all cable connections are made, apply Toro battery terminal protector (see Special Tools) to all battery posts and controller cable connectors to prevent corrosion. Make sure that cable terminal boots are positioned over all connections.

6. Secure rear frame panel cover to vehicle. Lower and secure cargo box. Install seat base assembly.

7. Before returning vehicle to operation, fully charge the batteries by connecting the on-board battery charger to an appropriate electrical outlet.

IMPORTANT: Do not open the lithium-ion battery controller. There are no serviceable parts on or in the controller. If you open the controller, you will void the warranty. The controller is protected by tamper-alerting devices.

Note: If the SC1: Lithium-ion Battery Controller is replaced for any reason, the machine software must be updated; contact an Authorized Toro Distributor for assistance.

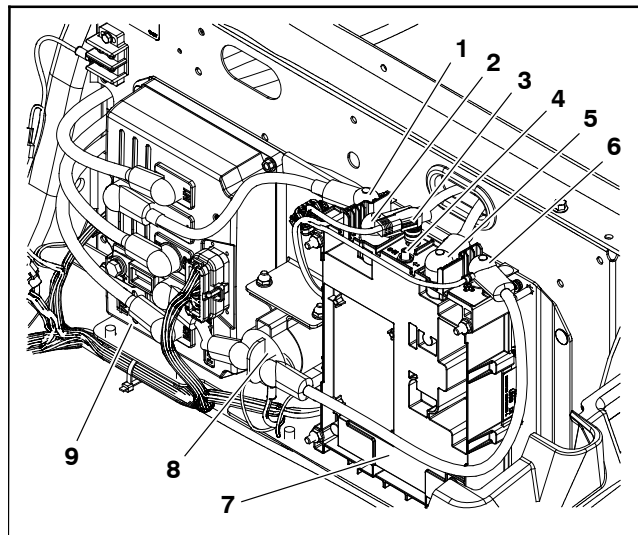

Figure 67

- 1. Negative (-) terminal (power supply negative (-) cable)
- 2. B- terminal (negative (-) battery cable)
- 3. COM terminal (machine wire harness)
- 4. M-S terminal (battery interface harness)
- 5. B+ terminal (positive (+) battery cable)
- 6. Positive (+) terminal (power supply positive (+) cable)
- 7. SC1: Lithium-ion battery controller
- 8. Contactor
- 9. SC2: Traction controller

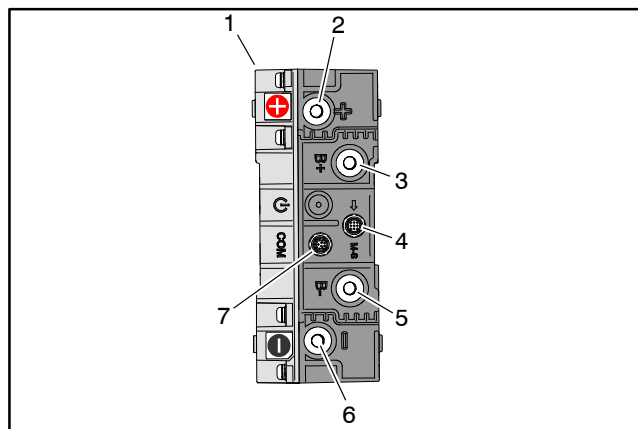

Figure 68

- 1. Lithium-ion battery controller
- 2. Positive (+) terminal
- 3. B+ terminal
- 4. M-S terminal
- 5. B- terminal
- 6. Negative (-) terminal
- 7. COM terminal

On-board Battery Charger

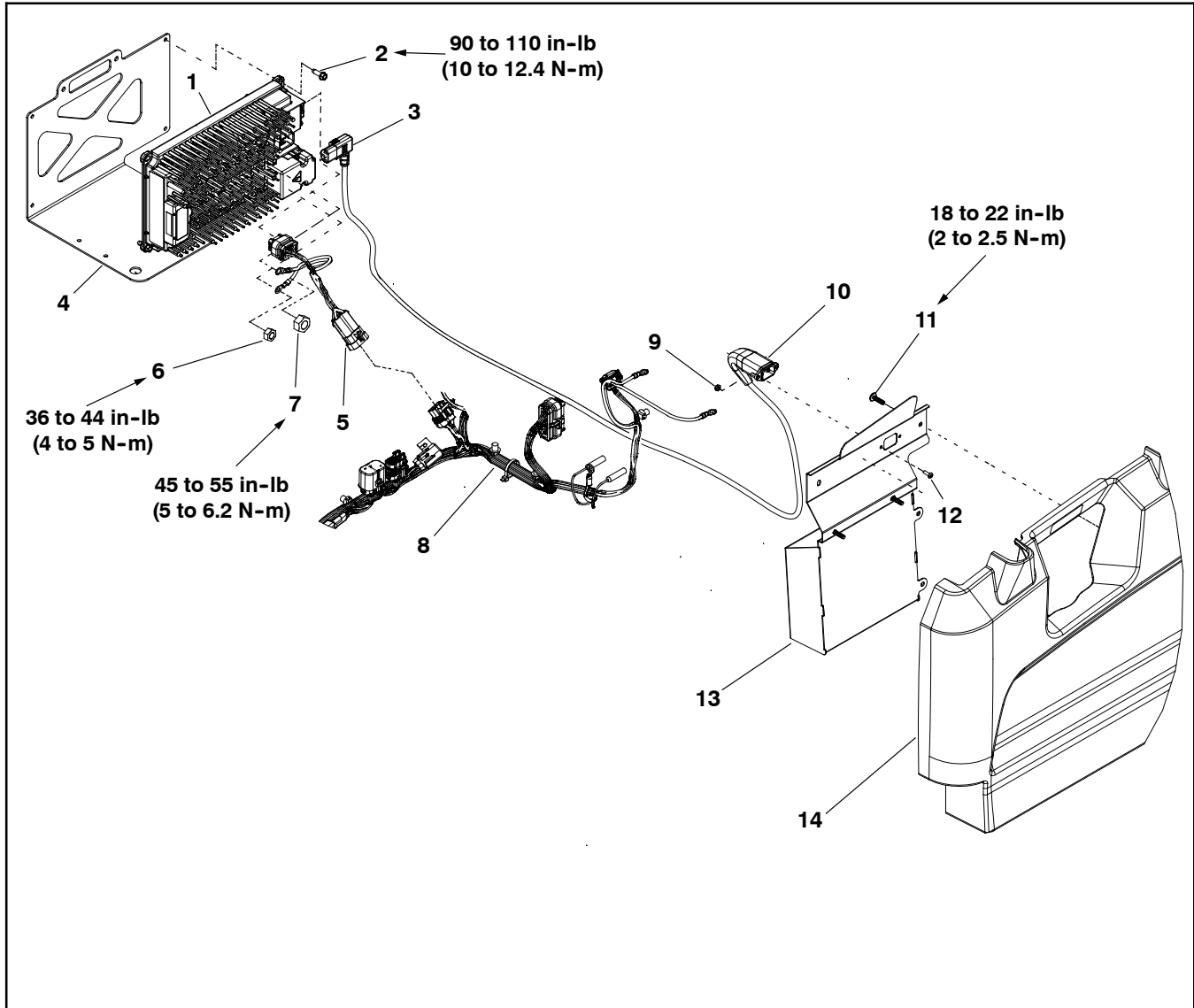

Figure 69

- | | | |
|-----------------------------------|-------------------------|----------------------------|
| 1. On-board battery charger | 6. Nut | 11. Screw (6 used) |
| 2. Flange head bolt (4 used) | 7. Nut | 12. Bolt (2 used) |
| 3. Power supply cord | 8. Machine wire harness | 13. Charger outlet bracket |
| 4. Charger bracket | 9. Nut (2 used) | 14. LH seat base side |
| 5. Charger interface wire harness | 10. AC input | |

IMPORTANT: No serviceable parts (including electrical conductors) are contained inside the battery charger. DO NOT attempt to open or disassemble the charger.

Removal (Fig. 69)

1. Park vehicle on a level surface, turn key switch to OFF, engage the parking brake and remove key from the key switch. Make sure that vehicle charger IS NOT connected to electrical outlet.

2. Raise cargo bed and support with prop rod. Remove seat base assembly.

3. Remove rear frame panel cover to allow access to battery charger electrical connections (see Rear Frame Panel Cover in the General Information section of this chapter).

4. Open the battery circuit by disconnecting the conductors between the battery pack and vehicle components (see Opening Battery Circuit in the General Information section of this chapter).

NOTE: Label all battery charger electrical leads for assembly purposes.

5. Disconnect charger electrical conductors from vehicle connections:

A. Unplug the power supply cord (item 3) from the battery charger (item 1).

B. Disconnect the charger interface wire harness (item 5) from the machine wire harness (item 8).

C. If necessary, remove two (2) nuts (item 9) and bolts (item 12) that secures the AC input cord (item 10) to the charger outlet bracket (item 13). Separate AC input cord from the charger outlet bracket.

6. Support battery charger to prevent it from falling.

7. Remove four (4) flange head bolts (item 2) that secure the battery charger to the charger bracket. Carefully remove charger with attached charger interface wire harness from vehicle.

8. Check that cooling fins on charger are free of accumulation of dirt and debris. Carefully clean charger fins if necessary.

9. If necessary, remove the charger interface wire harness from the battery charger using Figure 70 as a reference.

Installation (Fig. 69)

1. If removed, install the charger interface wire harness onto the battery charger using Figure 70 as a reference.

2. Position battery charger to charger bracket. Secure charger to bracket with four (4) flange head screws. Torque tighten the screws to **90 to 110 in-lb (10 to 12.4 N-m)**

3. Connect the charger electrical conductors to vehicle:

A. If removed, install the charger AC input cord (item 10) to the charger outlet bracket (item 13) with two (2) bolts (item 12) and nuts (item 9).

B. Connect the charger interface wire harness (item 5) to the machine wire harness (item 8).

C. Plug-in the power supply cord (item 3) to the battery charger (item 1).

4. Connect the conductors between the battery pack and vehicle components (see Opening Battery Circuit in the General Information section of this chapter). Make sure to torque hex nuts on battery terminals from **72 to 88 in-lb (8 to 9 N-m)**.

5. Secure rear frame panel cover to vehicle. Lower and secure cargo bed. Install seat base assembly.

6. Before returning vehicle to operation, fully charge the batteries by connecting the on-board battery charger to an appropriate electrical outlet.

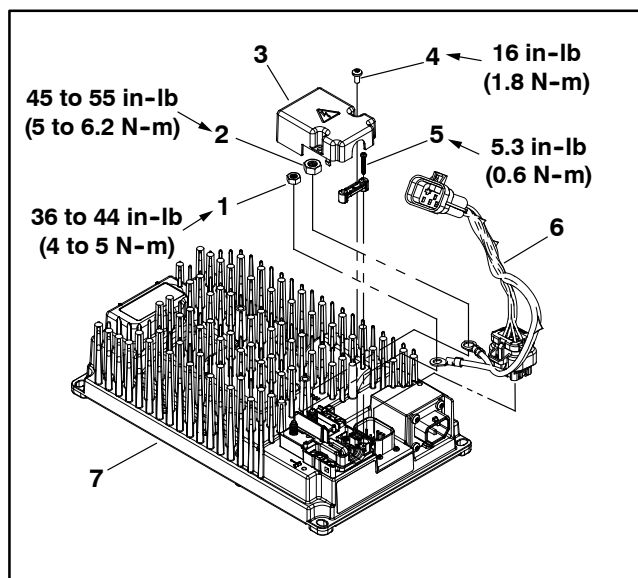

Figure 70

- 1. Nut, battery negative (-) (black and white wires)
- 2. Nut, battery positive (+) (red wire)
- 3. Charger cap
- 4. Screw (2 used)
- 5. Screw (2 used)
- 6. Charger interface wire harness
- 7. Battery charger

This page is intentionally blank.



Table of Contents

GENERAL INFORMATION 2
 Operator’s Manual 2
SPECIFICATIONS 3
SERVICE AND REPAIRS 4
 Transaxle Assembly 4
 Transaxle Assembly Service 8

Transaxle

General Information

Operator's Manual

The Operator's Manual provides information regarding the operation, general maintenance and maintenance intervals for your Workman GTX Electric vehicle. Refer to the Operator's Manual for additional information when servicing the machine.

Specifications

Item	Description
Transaxle Transaxle Fluid Capacity Transaxle Fluid	0.7 quarts (0.66 liters) 10W-30 Motor Oil

Transaxle

Service and Repairs

Transaxle Assembly

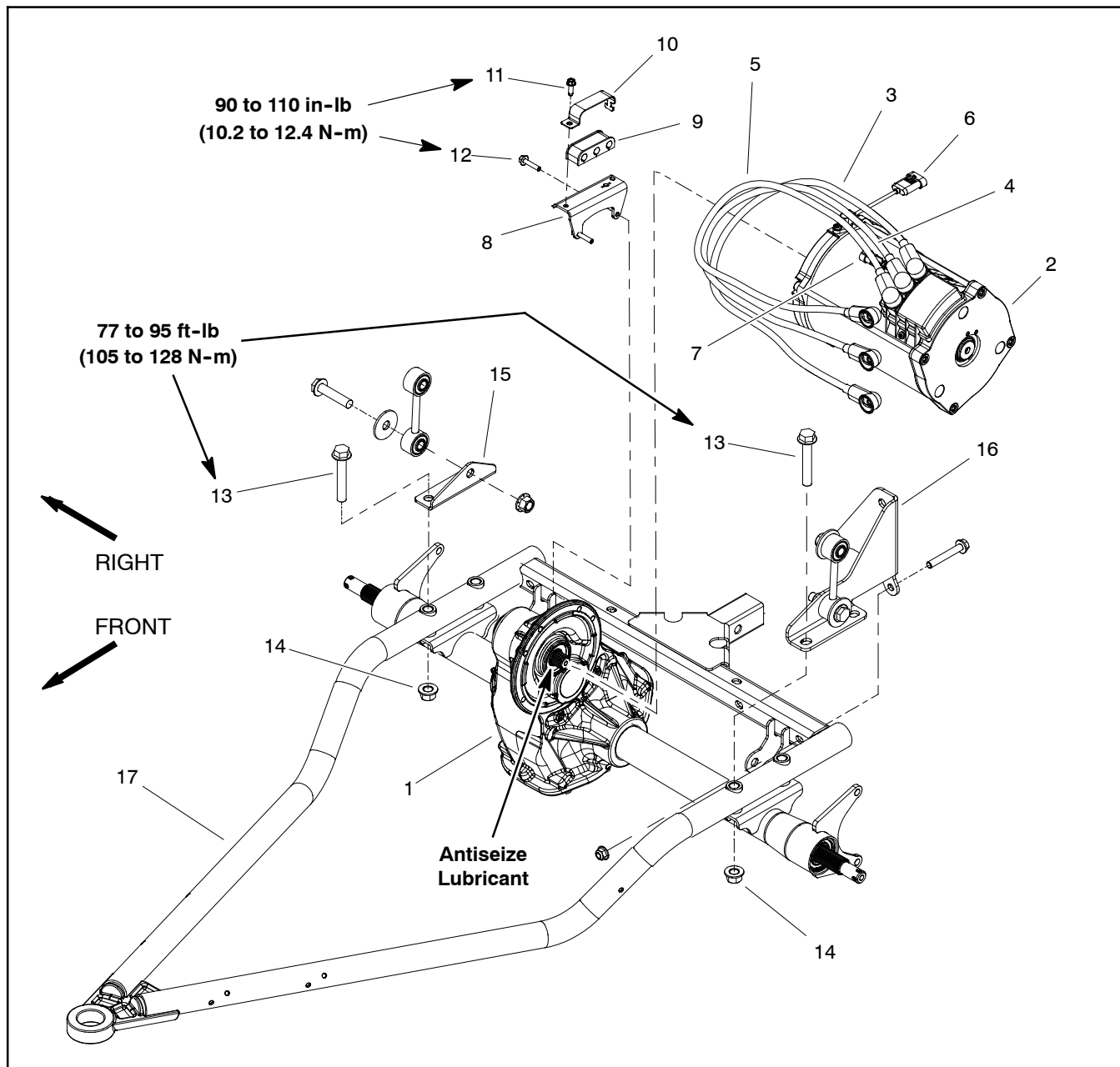

Figure 1

- | | | |
|-------------------------------------|--------------------------------|--------------------------------|
| 1. Transaxle assembly | 7. Motor thermistor connector | 13. Flange head screw (4 used) |
| 2. Traction motor | 8. Cable bracket | 14. Lock nut (4 used) |
| 3. Cable (motor W to controller M1) | 9. Isolator | 15. Sway bar link bracket |
| 4. Cable (motor V to controller M2) | 10. Isolator retainer | 16. Stabilizer bar bracket |
| 5. Cable (motor U to controller M3) | 11. Washer head screw | 17. Swing arm |
| 6. Motor speed sensor connector | 12. Flange head screw (6 used) | |



CAUTION

The drive motor and transaxle may be hot. To avoid possible burns, allow all drive components to cool before working on the transaxle.

Transaxle Removal (Fig. 1)

1. Park vehicle on a level surface, turn key switch to OFF, engage the parking brake and remove key from the key switch.
2. To allow easier access to transaxle assembly, remove cargo bed from the frame (see Cargo Bed in the Service and Repairs section of Chapter 5 - Chassis).
3. Open the battery circuit by disconnecting the conductors between the battery pack and vehicle components (see Opening Battery Circuit in the General Information section of Chapter 3 - Electrical System).

NOTE: Label all traction motor electrical leads for assembly purposes (Fig. 2).

4. Remove traction motor from transaxle (see Traction Motor in the Service and Repairs section of Chapter 3 - Electrical System).



WARNING

Before jacking up the vehicle, review and follow Jacking Instructions in Chapter 1 - Safety.

5. Raise and support rear of vehicle to allow rear wheels and transaxle to be removed.
 - A. Chock the front and rear of both front tires to prevent the vehicle from moving.
 - B. Jack up both sides of the frame enough to remove both rear wheels.
 - C. Support both sides of the frame with appropriate jack stands positioned just in front of the transaxle shafts. This will allow the transaxle to be removed toward the rear of the vehicle.
6. Remove both rear wheels and wheel hub assemblies from the transaxle (see Rear Wheels and Hubs in the Service and Repairs section of Chapter 5 - Chassis). Make sure that brake calipers, brake lines and parking brake cables are positioned and supported so that transaxle assembly can be lowered from vehicle.
7. Support transaxle from below to prevent it from moving.



CAUTION

To prevent personal injury, make sure that transaxle is properly supported as it is removed from the vehicle. Transaxle weighs approximately 130 pounds (59 kg).

8. Remove four (4) flange head screws (item 13) and lock nuts (item 14) that secure the transaxle to the swing arm.

IMPORTANT: Take care to not damage any vehicle components while lowering the transaxle assembly from the swing arm and vehicle.

9. Carefully lower and remove transaxle assembly toward the rear of the vehicle.

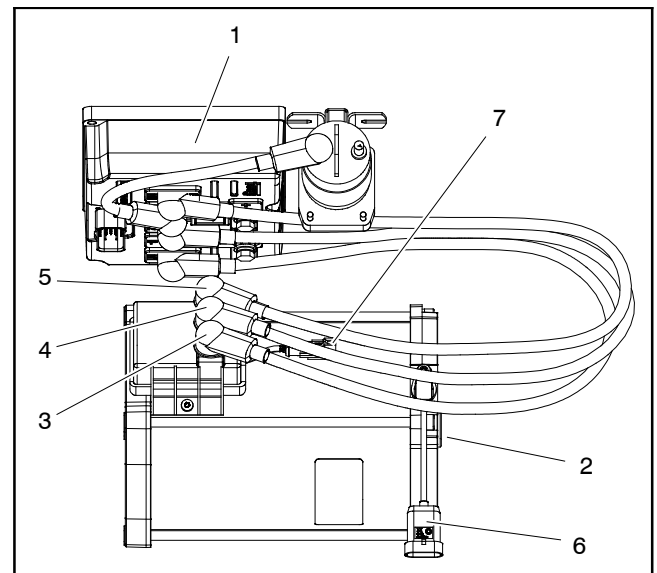

Figure 2

- | | |
|-------------------|-----------------|
| 1. Controller | 5. Terminal U |
| 2. Traction motor | 6. Speed sensor |
| 3. Terminal W | 7. Thermistor |
| 4. Terminal V | |

Transaxle Installation (Fig. 1)

IMPORTANT: Take care to not damage any vehicle components while installing the transaxle assembly to the vehicle.

1. Carefully raise transaxle assembly and align it with swing arm mounting points. Make sure that transaxle input shaft is orientated to left side of vehicle.
2. Secure the transaxle to the swing arm with four (4) flange head screws and lock nuts. Torque screws from 77 to 95 ft-lb (105 to 128 N-m).

3. Install both rear wheel hubs and wheels to the vehicle (see Rear Wheel and Hubs in the Service and Repairs section of Chapter 5 - Chassis). Make sure that fasteners for wheel hubs, brake calipers and wheels are properly torqued during assembly.
4. Lower vehicle to ground.
5. Apply antiseize lubricant to the splines of the transaxle and motor shafts.
6. Install traction motor to transaxle (see Traction Motor in the Service and Repairs section of Chapter 3 - Electrical System).
7. Make sure that transaxle is filled with 0.7 quarts (0.66 liters) of new SAE 10W-30 motor oil.

8. Install cargo bed to the frame (see Cargo Bed in the Service and Repairs section of Chapter 5 - Chassis).
9. Connect the conductors between the battery pack and vehicle components (see Opening Battery Circuit in the General Information section of Chapter 3 - Electrical System). Make sure to torque hex nuts on battery terminals from **95 to 105 in-lb (10.8 to 11.8 N-m)**.
10. After connections are made, apply Toro battery terminal protector (see Special Tools) to all battery posts and cable connectors on traction motor to prevent corrosion. Make sure that cable terminal boots are positioned over all connections.
11. Check brakes for proper operation.

This page is intentionally blank.

Transaxle Assembly Service

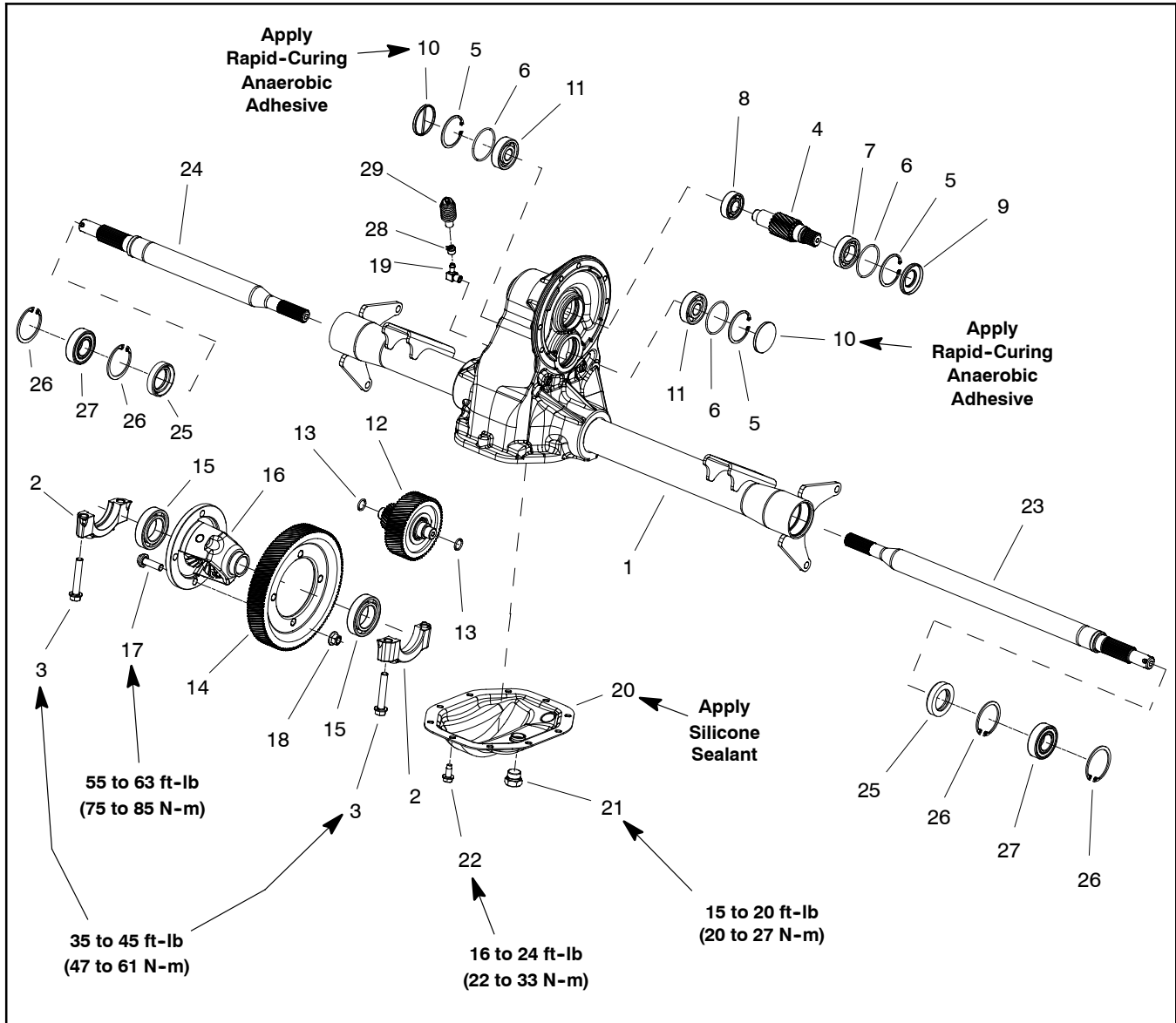
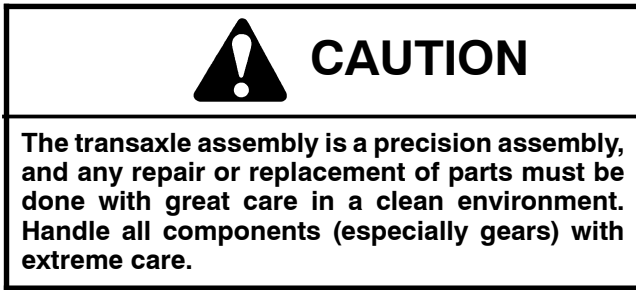

Figure 3

- | | | |
|---|---|---|
| <ul style="list-style-type: none"> 1. Transaxle housing assembly (includes bearing caps) 2. Bearing cap (2 used) 3. Bearing cap bolt (4 used) 4. Input shaft 5. Retaining ring (3 used) 6. O-ring (3 used) 7. Ball bearing 8. Ball bearing 9. Oil seal | <ul style="list-style-type: none"> 10. End cap plug (2 used) 11. Ball bearing (2 used) 12. Intermediate gear assembly 13. O-ring (2 used) 14. Final drive gear 15. Ball bearing (2 used) 16. Differential assembly 17. Flange head bolt (4 used) 18. Lock nut (4 used) 19. Vent elbow | <ul style="list-style-type: none"> 20. Cover plate 21. Plug 22. Screw (10 used) 23. LH axle shaft 24. RH axle shaft 25. Oil seal (2 used) 26. Retaining ring (4 used) 27. Ball bearing (2 used) 28. Hose clamp 29. Breather bellows |
|---|---|---|

Disassembly (Fig. 3)



1. Remove the drain plug (item 21) and drain the oil from the transaxle assembly.
2. Remove the axle shaft and bearing assembly.
 - A. Remove the outer retaining ring (item 26).
 - B. Using a slide hammer attached to the threads on the end of the axle shaft, remove the axle shaft and bearing assembly from the axle housing.
 - C. Remove the inner retaining ring. Use caution to not damage the bearing surface.
 - D. Using an oil seal puller attached to a slide hammer, remove the oil seal from the axle housing and discard (item 25).
 - E. Remove the bearing (item 27) from the axle shaft by supporting the inner race of the bearing in an arbor press, and apply pressure to the wheel hub end of the axle shaft.
 - F. Repeat procedure for opposite side.
3. Remove the differential case and final drive gear.
 - A. Remove the ten cover plate screws (item 22).
 - B. Using a putty knife, separate the cover plate (item 20) from the transaxle housing. Be careful not to damage the housing sealing surface or deform the cover plate.

NOTE: Bearing caps are marked for identification. Letters or numbers are stamped in a horizontal or vertical position. To assure correct assembly, note the bearing cap locations.
 - C. Remove the four (4) bearing cap screws (item 3) Remove bearing caps and lift differential case from axle housing.
 - D. Using a bearing puller, remove bearings (item 15) from each end of the differential case.
 - E. Remove the four (4) flange head bolts and lock nuts securing the ring gear to the differential case and remove the ring gear.
4. Remove the intermediate shaft and gear assembly.
 - A. Punch or drill a small hole in the center of each end cap plug (item 10). Insert a suitable sheet metal screw into the hole until the the cap plug is driven from the housing bore.
 - B. Remove retaining rings (item 5) from intermediate shaft bores.
 - C. From the motor flange side of the housing, use a brass drift and drive the intermediate shaft in enough to allow engagement of an I.D. bearing puller.
 - D. Using an I.D. bearing puller attached to a slide hammer, remove the bearing from the motor flange side of the housing.
 - E. Repeat steps C. and D. for remaining bearing.
 - F. Tilt small end of intermediate shaft assembly toward opening in bottom of housing and remove.
 - G. Remove and discard O-rings (item 6) from intermediate bearing bores.
 - H. Remove and discard O-rings (item 13) from intermediate shaft bearing shoulders.
5. Remove input shaft assembly.
 - A. Remove oil seal (item 9) from input shaft bore.
 - B. Remove retaining ring (item 5) from input shaft bore.
 - C. Pull input shaft assembly from housing. The input shaft assembly should slide out of the housing easily. Use a slide hammer attached to the input shaft if necessary for removal.
 - D. Using a bearing puller, remove inner and outer bearings (item 7 and 8) from the input shaft.
 - E. Remove and discard O-ring (item 6) from input bearing bore.
6. Clean any residual sealant from transaxle housing at intermediate shaft bearing bores and cover plate sealing surface, and from cover plate.
7. Inspect all parts for signs of wear or damage. Bearing and seal surfaces should be free of pitting, wear, or signs of overheating. Gears should be free of pitting, wear or scoring. Inspect axle shafts for worn splines, bends or cracks. Replace worn or damaged parts as necessary.

Assembly (Fig. 3)

1. Assemble and install the input shaft.
 - A. Press the inner and outer bearings (items 7 and 8) onto input shaft until seated against bearing shoulders.
 - B. Apply a light coat of oil to a new O-ring (item 6) and install into input bearing bore of housing.
 - C. Install input shaft assembly in housing. Bearings should slide easily into housing. Use a soft mallet to tap the input shaft assembly into position if necessary.
 - D. Install retaining ring (item 5).
 - E. Apply a light coat of oil to a new oil seal (item 9). Protect oil seal lip from damage by input shaft splines and install oil seal into input bearing bore of housing.
2. Install the intermediate shaft and gear assembly.
 - A. Apply a light coat of oil to a new O-rings (item 6) and install into intermediate bearing bores of housing.
 - B. Apply a light coat of oil to a new O-rings (item 13) and install onto bearing shoulders of intermediate shaft.
 - C. Tilt small end of intermediate shaft assembly toward opening in bottom of housing and position intermediate shaft and gear assembly in housing.
 - D. Install the motor flange side bearing first. While supporting the intermediate shaft and gear assembly in position, fit the bearing (item 11) in housing bore.
 - E. Use a soft mallet to drive the bearing past the O-ring and retaining ring groove.
 - F. Install retaining ring (item 5).
 - G. Repeat steps D. thru F. for opposite bearing.
 - H. Apply a rapid-curing anaerobic adhesive (Loctite 609 or equivalent) to the intermediate shaft bores. Using a properly sized driver, install new end cap plugs (item 10) with stamping outward until seated against the retaining rings.
3. Assemble and install the differential case and final drive gear.
 - A. Press bearings (items 15) onto differential case until seated against bearing shoulders.

B. Position final drive gear over differential case and install four (4) flange head bolts and lock nuts (items 17 and 18). Bolts should be installed from the differential flange side. Tighten lock nuts from **55 to 63 ft-lb (75 to 85 N-m)**.

NOTE: Bearing caps are marked for identification. Letters or numbers are stamped in a horizontal or vertical position. Make sure the bearing caps are installed in their original locations during assembly.

C. Position differential case assembly into transaxle housing and install bearing caps (item 2). Tighten bearing cap bolts from **35 to 45 ft-lb (47 to 61 N-m)**.

D. Apply a small bead of silicone sealant around the entire cover plate sealing surface. Sealant should be applied to the inside of the cover plate mounting holes.

E. Install the cover plate and cover plate screws. Tighten cover plate screws from **16 to 24 ft-lb (22 to 33 N-m)**.

4. Install the axle shaft and bearing assembly (Fig. 4).

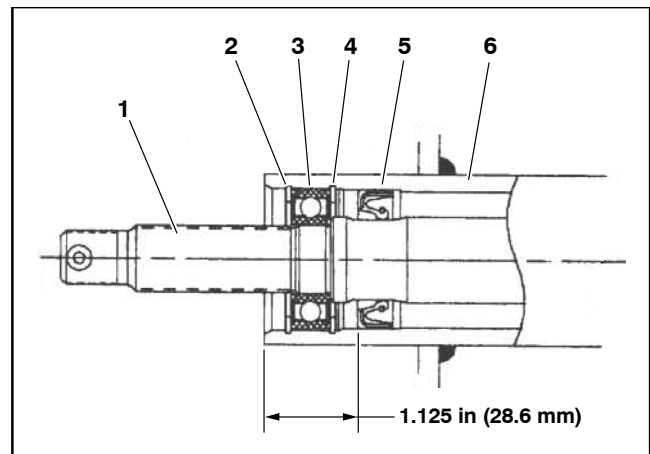

Figure 4

- | | |
|-------------------------|-------------------------|
| 1. Axle shaft | 4. Inner retaining ring |
| 2. Outer retaining ring | 5. Oil seal |
| 3. Bearing | 6. Axle housing |

A. Using a seal driver, install the oil seal into the axle housing. Drive the oil seal to a depth of **1.125 in. (28.6 mm)**.

B. Install the inner retaining ring.

C. Install the bearing to the axle shaft by supporting the inner race of the bearing in an arbor press, and apply pressure to the differential end of the axle shaft. Make sure the bearing seats against the shoulder of the axle shaft.

D. Apply light oil or grease to the inner lip of the oil seal and insert the shaft and bearing assembly into the axle housing. Align the axle shaft splines with those in the differential assembly and drive the axle shaft and bearing assembly into the axle housing. Use a bearing driver against the outer race of the bearing and continue until the bearing seats against the inner retaining ring.

E. Install the outer snap ring.

F. Repeat procedure for opposite side.

5. Fill the transaxle with 0.7 quarts (0.66 liters) of new SAE 10W-30 motor oil.

This page is intentionally blank.



Table of Contents

GENERAL INFORMATION	2	Front Brake Caliper Service	18
Operator's Manual	2	Rear Brake Calipers	20
Thread Forming Fasteners	2	Rear Brake Caliper Service	22
SPECIFICATIONS	3	Parking Brake Cables and Lever Assembly	24
SPECIAL TOOLS	4	Brake Master Cylinder	26
TROUBLESHOOTING	6	Brake Master Cylinder Service	28
Suspension and Steering	6	Bleed Brake System	29
Brakes	7	Steering Assembly	30
ADJUSTMENTS	9	Steering Rack Assembly Service	32
Adjust Parking Brake	9	Front Suspension	34
Adjust Front Wheel Toe-in	10	Rear Suspension	36
SERVICE AND REPAIRS	11	Swing Arm Mount Assembly	38
Check Tire Pressure	11	Seat Base	40
Inspect Tires and Wheels	11	Dash	42
Front Wheels and Hubs	12	Front Fenders, Hood and Bumper	44
Rear Wheels and Hubs	14	Cargo Bed	46
Front Brake Calipers	16		

Chassis

General Information

Operator's Manual

The Operator's Manual provides information regarding the operation, general maintenance and maintenance intervals for your Workman GTX Electric vehicle. Refer to the Operator's Manual for additional information when servicing the machine.

Thread Forming Fasteners

Numerous thread forming fasteners are used to secure Workman GTX frame components. If the threads in the frame are found to be stripped, a nut can be used on the backside of the frame to allow the fastener to be properly tightened.

Specifications

Item	Description
Front and Rear Tires Pressure Range	205/65 - 10 24 to 30 PSI (165 to 207 kPa)
Wheel Lug Nut Torque (all wheels)	75 to 95 ft-lb (102 to 128 N-m)
Front Wheel Toe-In	0 ± 0.125 inch (0 ± 3 mm)
Brake Fluid	DOT 3
Standard Front Suspension Strut Pre-load Adjustment Position	Second Lowest Position
Standard Rear Shock Absorber Pre-load Adjustment Position	Third Lowest Position

Special Tools

Order special tools from your Toro Distributor.

Spanner Wrench

Use spanner wrench to rotate collar on front suspension strut and rear shock absorber. Collar rotation may be necessary to accommodate installed accessories or heavier vehicle loads. Make sure that vehicle is jacked up off the ground to allow spring to be at full extension before using spanner wrench.

Toro Part Number: **TOR6010**

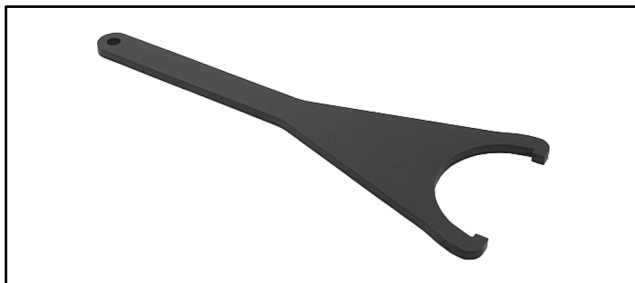

Figure 1

Shock Spring Compressor

Use shock spring compressor to remove and install spring from the rear shock absorber. Tool includes a bracket to secure the shock spring to the compressor spring plate to prevent unexpected movement of the shock spring during tool use. Secure compressor to bench for stability during use.

NOTE: The shock spring compressor can be modified for use with the Workman front suspension strut assembly by fabricating a bracket that will allow the strut mount to be secured to the spring compressor arm. An example of this modification is shown in Figure 3.

Toro Part Number: **TOR6015**



Figure 2

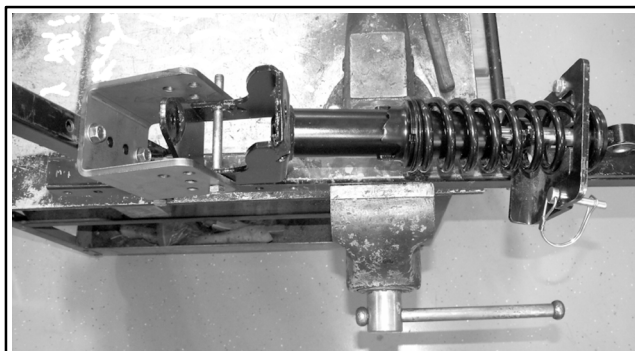

Figure 3

Tools for Frame Extension Kit

Use this tool kit (shown in Fig. 4) when installing or servicing the vehicle frame extension kit.

When the front and rear frame components are separated to install or service the frame extension kit, the rear frame of the machine can be supported with the legs included in this tool kit. The legs attach to the rear frame with two (2) flange head screws and nuts for each leg (Fig. 5).

Toro Part Number: **TOR6040**

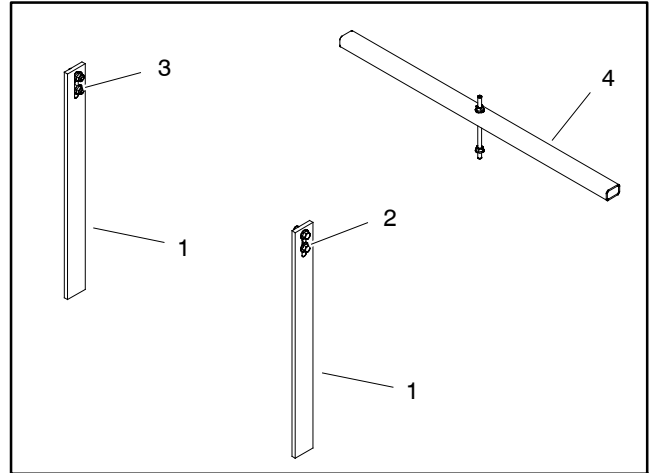

Figure 4

- 1. Leg (2 used)
- 2. Screw (4 used)
- 3. Flange nut (4 used)
- 4. Bridge assy (not used)

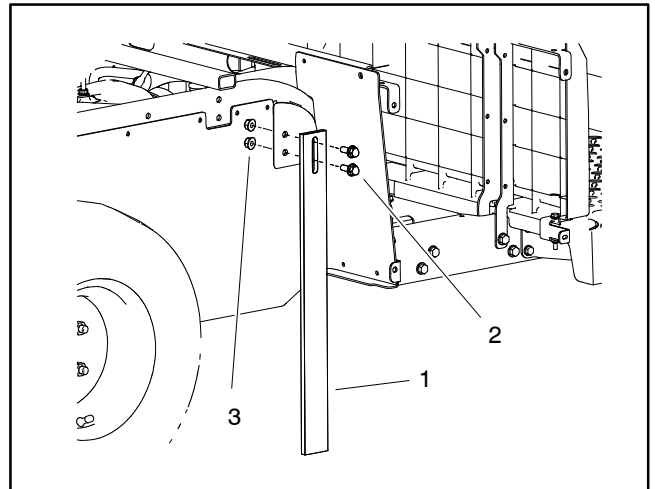

Figure 5

- 1. Leg (RH shown)
- 2. Screw (2 per leg)
- 3. Flange nut (2 per leg)

Troubleshooting

Suspension and Steering

Problem	Possible Cause
Front end is noisy.	<p>Front wheel lug nuts are loose.</p> <p>Front suspension struts are loose or worn.</p> <p>Front wheel bearings are loose or worn.</p> <p>Front end components (e.g. tie-rod, spindle, A-arm) are loose or worn.</p> <p>Steering rack assembly is damaged or worn.</p>
Rear end is noisy.	<p>Rear wheel lug nuts are loose.</p> <p>Rear suspension shocks are loose or worn.</p> <p>Rear wheel bearings are loose or worn.</p> <p>Rear end components (e.g. rubber bushing, stabilizer, anti-sway bar, A-arm) are loose or worn.</p> <p>Transaxle problem (see Chapter 4 - Transaxle).</p>
Excessive steering play.	<p>Front wheel lug nuts are loose.</p> <p>Front wheel bearings are loose or worn.</p> <p>Steering shaft joints are loose or worn.</p> <p>Tie rod ends are loose or worn.</p> <p>Bushings in spindle or A-arm are loose or worn.</p> <p>Steering rack assembly is damaged or worn.</p>
Vehicle is unstable or wanders.	<p>Tire pressure is low or uneven between tires.</p> <p>Wheel lug nuts are loose.</p> <p>Front wheel bearings are loose or worn.</p> <p>Steering shaft bushings are worn.</p> <p>Front wheel alignment (toe-in) is incorrect.</p> <p>Bushings in spindle or A-arm are loose or worn.</p> <p>Rubber shock insert in front suspension strut is loose or worn.</p> <p>Steering rack assembly is damaged or worn.</p>

Suspension and Steering (continued)

Problem	Possible Cause
Front end shimmies.	Front wheel lug nuts are loose. Front wheel alignment (toe-in) is incorrect. Front wheel bearings are loose or worn. Tie rod ends are loose or worn. Steering shaft bearings or joints are loose or worn. Bushings in spindle or A-arm are loose or worn.
Steering is hard.	Tire pressure is low or uneven between tires. Steering components are binding or damaged. Front wheel alignment (toe-in) is incorrect. Steering rack assembly is damaged or worn.
Vehicle pulls to one side when not braking.	Tire pressure is low or uneven between tires. Front wheel alignment (toe-in) is incorrect. Steering or suspension component may be damaged.

Brakes

Problem	Possible Cause
Brake pedal goes to the floor.	Brake fluid level in master cylinder is low. Brake fluid leak exists at master cylinder, brake hose or brake caliper. Brake pads are excessively worn. Brake master cylinder is faulty.
Brake pedal is spongy.	Air is trapped in brake lines. Transaxle bearings are loose or damaged. Brake master cylinder is faulty.

Brakes (continued)

Problem	Possible Cause
Brakes pull to either side.	Tire pressure is incorrect or uneven between tires. Brake pads are worn or contaminated. Front wheel alignment (toe-in) is incorrect. Brake rotors are bent or damaged. Tires on same axle are unmatched.
Brakes squeal.	Brake pads are worn or contaminated. Brake components are dirty. Brake rotors are scored or bent.
Brakes drag.	Parking brake is applied or incorrectly adjusted. Brake pedal is binding. Parking brake cable is binding. Brake pads are saturated. Floating calipers are binding due to dirt or corrosion. Brake rotors are bent.
Brake pedal is hard to push.	Incorrect brake pad material. Brake pedal is binding. Calipers are binding due to dirt or corrosion in the float pins or brake piston. New brake pads and/or rotors are not burnished.
Wheels lock-up when braking.	Brake pads are worn or contaminated. Wheel or transaxle bearings are damaged. Brake rotors are worn.
Brakes fade.	Brake rotors are overheated. Air is trapped in brake lines. Excessive moisture in brake fluid. Brake pads are saturated.
Vehicle surges at slow speeds and chatters at fast speeds.	Brake rotors are bent or damaged.

Adjustments

Adjust Parking Brake

Checking Parking Brake (Fig. 6)

1. Apply parking brake with brake lever on dash.
2. There should be tension felt when applying the parking brake within **4½” to 6½” (11.4 to 16.5 cm)** measured from the 'P' symbol that is molded into the recessed dash area directly in front of the parking brake lever.
3. If parking brake lever movement is incorrect, parking brake adjustment is necessary.

Parking Brake Adjustment (Fig. 7)

1. Make sure that the vehicle is on a level surface and that the parking brake is NOT applied.

**WARNING**

Before jacking up the vehicle, review and follow Jacking Instructions in Chapter 1 - Safety.

2. Chock front wheels to prevent vehicle movement. Lift rear wheels off the ground using a jack and support rear of vehicle with appropriate jack stands beneath the frame.
3. Starting on one of the rear wheels, locate the parking brake rod on the inside of the rear brake caliper.
4. Using two (2) wrenches, loosen lock nut on parking brake rod while holding brake rod to prevent it from rotating.
5. Making sure that lock nut stays loose on parking brake rod, adjust brake rod until rear wheel rotates with little evidence of brake drag on brake rotor.
6. Hold parking brake rod in place and secure adjustment by tightening lock nut. Torque lock nut from **80 to 120 in-lb (9.1 to 13.5 N-m)**.
7. After securing parking brake adjustment, make sure that rear wheel still rotates with little evidence of brake drag.

8. Adjust other rear wheel using steps 4 to 7 above.
9. Check parking brake adjustment as described in Checking Parking Brake on this page. Make additional parking brake adjustments if necessary.
10. Lower vehicle to ground after brake adjustment is complete.

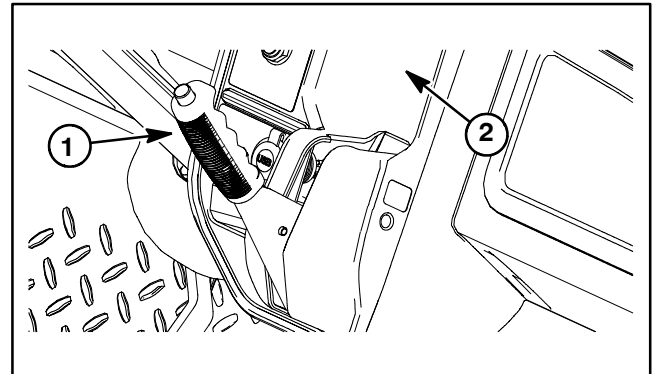

Figure 6

1. Parking brake lever
2. Recessed dash area

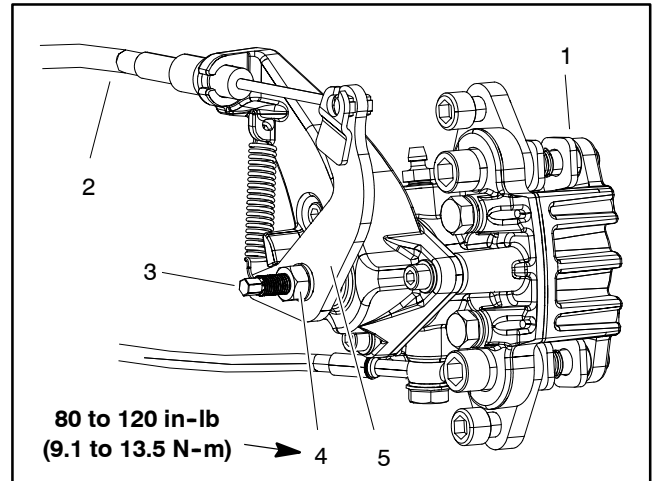

Figure 7

1. Rear brake caliper (RH)
2. Parking brake cable
3. Parking brake rod
4. Lock nut
5. Parking brake lever

Chassis

Adjust Front Wheel Toe-in

1. Adjust tire pressures from 24 to 30 PSI (165 to 207 kPa) before checking front wheel toe-in.

2. Either have an operator on the vehicle operator's seat or add weight to the driver's seat equal to the average operator who will run the vehicle. The operator or weight must remain on the seat for the duration of the front wheel toe-in adjustment procedure.

3. On a level surface, roll the vehicle straight back 6 to 10 feet (2 to 3 meters) and then straight forward to the original starting position. This will allow the vehicle suspension to settle into the normal operating position.

4. Make sure that the front wheels are facing straight ahead.

5. Measure the distance between the front tires at axle height at both the front and rear of the tires (Fig. 8). Front wheel toe-in should be **0 ± 0.125 inch (0 ± 3 mm)**.

6. If the front wheel toe-in is incorrect, adjust as follows (Fig. 9):

A. Loosen jam nuts at both ends of steering rack tie rods.

B. Rotate both tie rods equally to move front of tires inward or outward.

C. Tighten tie rod jam nuts when toe-in adjustment is correct. Tie rod jam nuts should be torqued from **45 to 55 ft-lb (62 to 74 N-m)**.

7. After toe-in adjustment has been completed, ensure that there is full steering travel in both directions. There should be no contact between any machine components as the wheels are moved from lock to lock. Adjust if necessary.

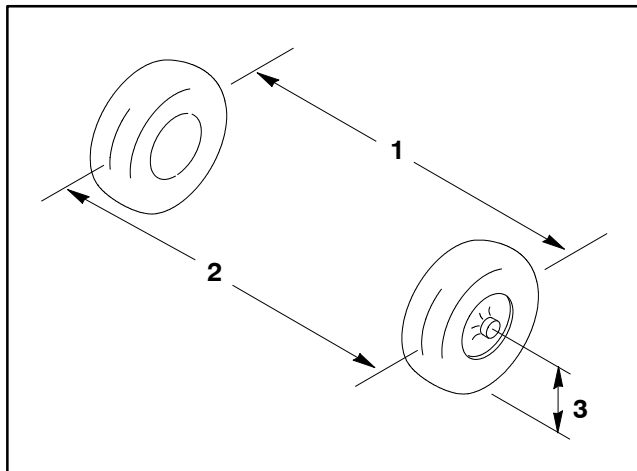

Figure 8

- 1. Tire center line (back)
- 2. Tire center line (front)
- 3. Axle center line

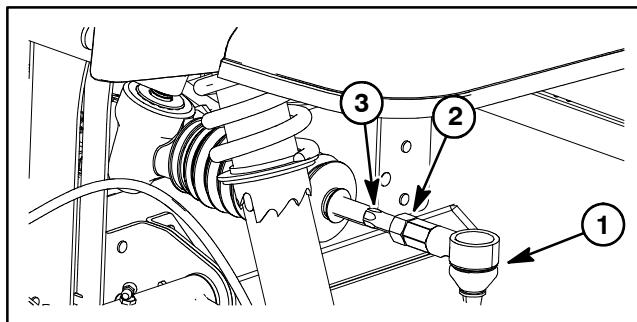

Figure 9

- 1. Tie rod end
- 2. Jam nut
- 3. Steering rack tie rod

Service and Repairs

Check Tire Pressure

The tire pressure range for front and rear tires is **24 to 30 PSI (165 to 207 kPa)**.

The air pressure needed is determined by the payload carried. **Lower** air pressure will provide less compaction, a smoother ride and fewer tire marks. Lower pressure should not be used for heavy payloads at higher speeds.

Higher pressures should be used for heavier payloads at higher speeds. Do not exceed the maximum tire pressure.

Inspect Tires and Wheels

Operating accidents, such as hitting curbs, can damage a tire or rim and also disrupt wheel alignment. Inspect tire and rim condition after any accident.

Check wheels to ensure they are mounted securely. Torque wheel lug nuts in a crossing pattern from **75 to 95 ft-lb (102 to 128 N-m)**.

Front Wheels and Hubs

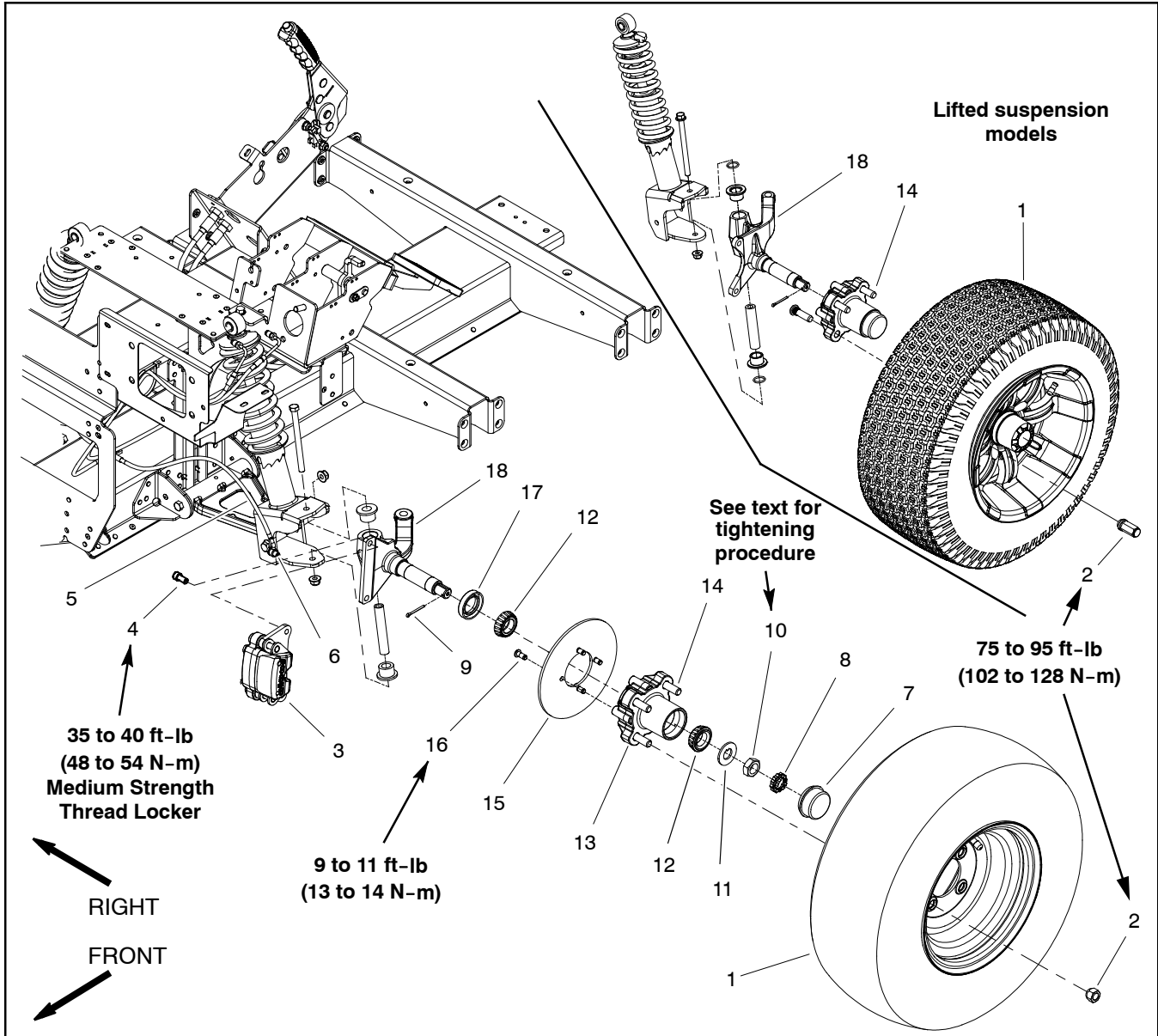

Figure 10

- | | | |
|--------------------------------------|-------------------------|-------------------------------------|
| 1. Front wheel assembly | 7. Dust cap | 13. Front wheel hub |
| 2. Lug nut (4 per wheel) | 8. Retainer | 14. Wheel stud (4 per hub) |
| 3. Front brake caliper (LH shown) | 9. Cotter pin | 15. Brake rotor |
| 4. Socket head screw (2 per caliper) | 10. Jam nut | 16. Socket head screw (4 per rotor) |
| 5. Front brake line | 11. Tab washer | 17. Oil seal |
| 6. Banjo bolt and washers | 12. Bearing (2 per hub) | 18. Spindle (LH shown) |

Removal (Fig. 10)

1. Park vehicle on a level surface, turn key switch OFF, apply parking brake and remove key from the key switch.

2. Chock wheels not being removed. Use a jack to raise front wheel that is to be removed off the ground. Support vehicle with appropriate jack stands beneath the frame.

3. Remove four (4) lug nuts and then remove front wheel assembly from the wheel hub.

4. Remove two (2) socket head screws that secure front brake caliper to the mounts on the spindle. Slide caliper assembly with attached brake line from brake rotor and support caliper away from the front wheel hub.



WARNING

Before jacking up the vehicle, review and follow Jacking Instructions in Chapter 1 - Safety.

5. Remove the dust cap from the wheel hub.
6. Remove the cotter pin, retainer, jam nut and tab washer. Slide the front wheel hub from the spindle shaft.
7. Pull the seal out of the wheel hub. Discard seal.
8. Remove the bearing cones from both sides of the wheel hub. Clean the bearings in solvent. Make sure the bearings are in good operating condition. Clean the inside of the wheel hub. Check the bearing cups for wear, pitting or other damage. Replace worn or damaged parts.
9. If necessary, separate brake rotor from wheel hub by removing four (4) socket head screws.
10. If necessary, press wheel studs from wheel hub (Fig. 11).

Installation (Fig. 10)

1. If brake rotor was removed from wheel hub, place rotor on hub and secure with four (4) socket head screws. Torque screws from **9 to 11 ft-lb (13 to 14 N-m)**.
2. If any wheel studs were removed from wheel hub, use a press to install new studs into hub (Fig. 11). Make sure that stud shoulder is fully pressed against housing surface.
3. If bearing cups were removed from the wheel hub, press new cups into the hub until they seat against the shoulder of the hub (Fig. 11).

NOTE: Use High Temperature Mobil XHP-222 grease (or equivalent) when greasing front wheel hub components.

IMPORTANT: The lip of the oil seal must be toward the bearing. The seal should be pressed in so it is flush with the end of the wheel hub.

4. Pack both bearings with grease. Install one bearing into the bearing cup on inboard side of the wheel hub. Lubricate the inside of a new oil seal and press it into the wheel hub with the seal lip toward the bearing.
5. Fill wheel hub cavity between bearings approximately 50% full of grease. Position remaining bearing into the outer bearing cup.
6. Slide the wheel hub assembly onto the spindle shaft and secure it in place with the tab washer and jam nut. **DO NOT** fully tighten the nut.
7. While rotating the wheel hub by hand, torque the jam nut to 130 in-lb (14.7 N-m) to set the bearings. Then, loosen the nut until the hub has endplay.

8. While rotating the wheel hub by hand, torque the jam nut from **15 to 20 in-lb (1.7 to 2.3 N-m)**. After tightening, make sure that the wheel hub does not have any free play.

9. Install retainer with slot aligned to cotter pin hole in spindle. Install cotter pin.

10. Fill dust cap approximately 50% full of grease. Install dust cap to wheel hub.

IMPORTANT: The socket head screws that secure the brake calipers have a patch lock feature. If screws are being re-installed on vehicle, apply medium strength thread locker to screw threads before installation.

11. Slide brake caliper onto brake rotor. Make sure that rotor is between the brake pads in the caliper. Secure caliper to the mounts on the spindle with socket head screws. Torque screws from **35 to 40 ft-lb (48 to 54 N-m)**.

12. Position wheel assembly to the vehicle with valve stem facing out and secure with four (4) lug nuts.

13. Lower vehicle to ground.

14. Torque lug nuts in a crossing pattern from **75 to 95 ft-lb (102 to 128 N-m)**.



CAUTION

After servicing brake system components, always check the brakes in a wide open, level area that is free of other persons and obstructions.

15. Check brake operation.

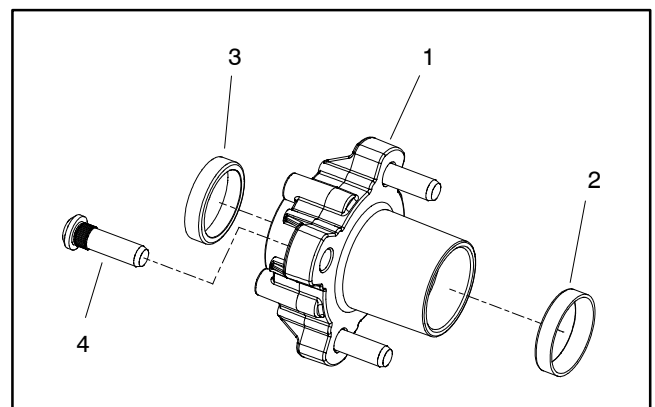

Figure 11

- | | |
|----------------------|------------------------|
| 1. Wheel hub | 3. Inner bearing cup |
| 2. Outer bearing cup | 4. Wheel stud (4 used) |

Rear Wheels and Hubs

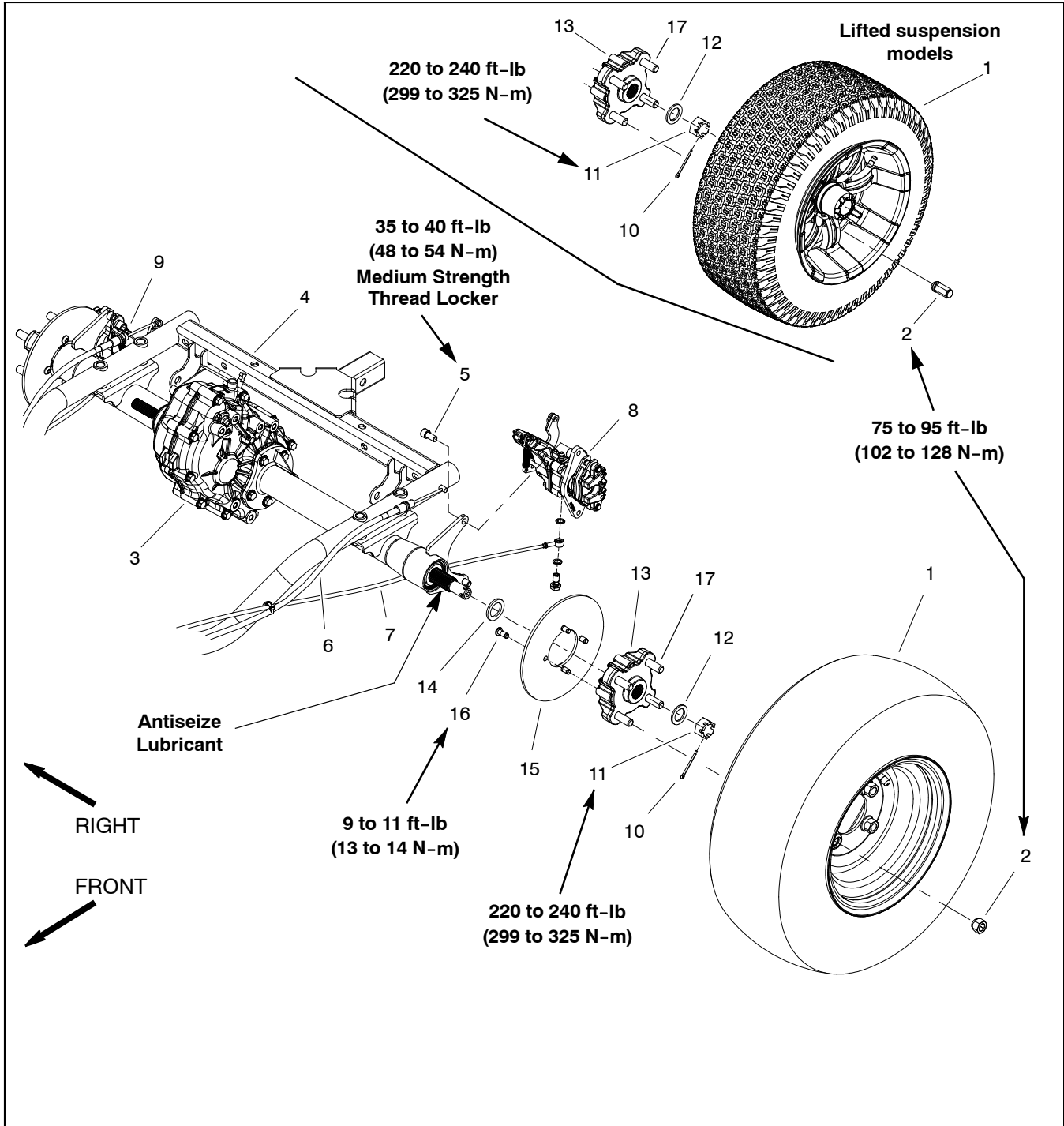
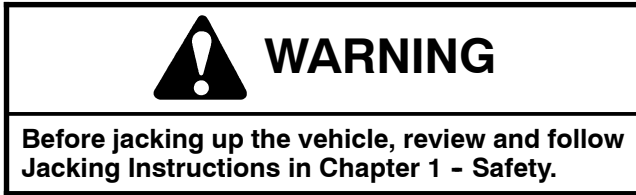

Figure 12

- | | | |
|--------------------------------------|---------------------|-------------------------------------|
| 1. Rear wheel assembly | 7. Rear brake line | 13. Wheel hub |
| 2. Lug nut (4 per wheel) | 8. LH brake caliper | 14. Hardened spacer |
| 3. Transaxle assembly | 9. RH brake caliper | 15. Brake rotor |
| 4. Rear swing arm | 10. Cotter pin | 16. Socket head screw (4 per rotor) |
| 5. Socket head screw (2 per caliper) | 11. Slotted hex nut | 17. Wheel stud (4 per hub) |
| 6. Parking brake cable (2 used) | 12. Thrust washer | |

Removal (Fig. 12)

1. Park vehicle on a level surface, turn key switch OFF and remove key from the key switch. Do not apply parking brake.



2. Chock wheels not being removed. Use a jack to raise rear wheel that is to be removed off the ground. Support vehicle with appropriate jack stands beneath the frame.

3. Remove four (4) lug nuts and then remove rear wheel assembly from the wheel hub.

4. Remove two (2) socket head screws that secure rear brake caliper to the mounts on the transaxle tube. Slide caliper assembly with attached brake line and parking brake cable from brake rotor and support it away from the rear wheel hub. DO NOT allow the caliper assembly to hang from the brake line or cable.

5. Remove rear wheel hub from transaxle shaft:

A. Remove cotter pin from the slotted hex nut and transaxle shaft.

B. Remove nut, thrust washer, wheel hub and hardened spacer from the shaft. During removal, note differences between thrust washer and hardened spacer for installation purposes. The hardened spacer has a slightly larger OD and ID than the thrust washer.

6. If necessary, separate brake rotor from wheel hub by removing four (4) socket head screws.

7. If necessary, press wheel studs from wheel hub.

Installation (Fig. 12)

1. If brake rotor was removed from wheel hub, place rotor on hub and secure with four (4) socket head screws. Torque screws from **9 to 11 ft-lb (13 to 14 N-m)**.

2. If any wheel studs were removed from wheel hub, use a press to install new studs into hub. Make sure that stud shoulder is fully pressed against housing surface.

IMPORTANT: Do not get antiseize lubricant onto brake rotor or brake pads.

3. Apply a light coating of antiseize lubricant to both the transaxle shaft and splines in wheel hub bore.

4. Install the wheel hub to the transaxle shaft:

A. Install hardened spacer, wheel hub and then thrust washer onto the transaxle shaft.

B. Secure wheel hub assembly with slotted hex nut. Torque slotted hex nut from **220 to 240 ft-lb (299 to 325 N-m)**. Make sure that slot in nut aligns with hole in transaxle shaft to allow installation of cotter pin. If necessary, tighten slotted hex nut slightly to align holes for cotter pin installation. DO NOT loosen slotted hex nut to align holes.

C. Secure slotted hex nut to transaxle shaft with cotter pin.

IMPORTANT: The socket head screws that secure the brake calipers have a patch lock feature. If screws are being re-installed on vehicle, apply medium strength thread locker to screw threads before installation.

5. Slide brake caliper onto brake rotor. Make sure that rotor is between the brake pads in the caliper. Secure caliper to the mounts on the transaxle tube with socket head screws. Torque screws from **35 to 40 ft-lb (48 to 54 N-m)**.

6. Position rear wheel assembly to the vehicle with valve stem facing out and secure with four (4) lug nuts.

7. Lower vehicle to ground.

8. Torque lug nuts in a crossing pattern from **75 to 95 ft-lb (102 to 128 N-m)**.

9. Check parking brake operation. Adjust parking brake if necessary (see Parking Brake Adjustment in the Adjustments section of this chapter).

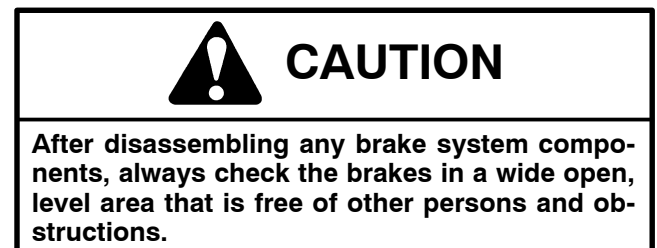

10. Check brake operation.

Front Brake Calipers

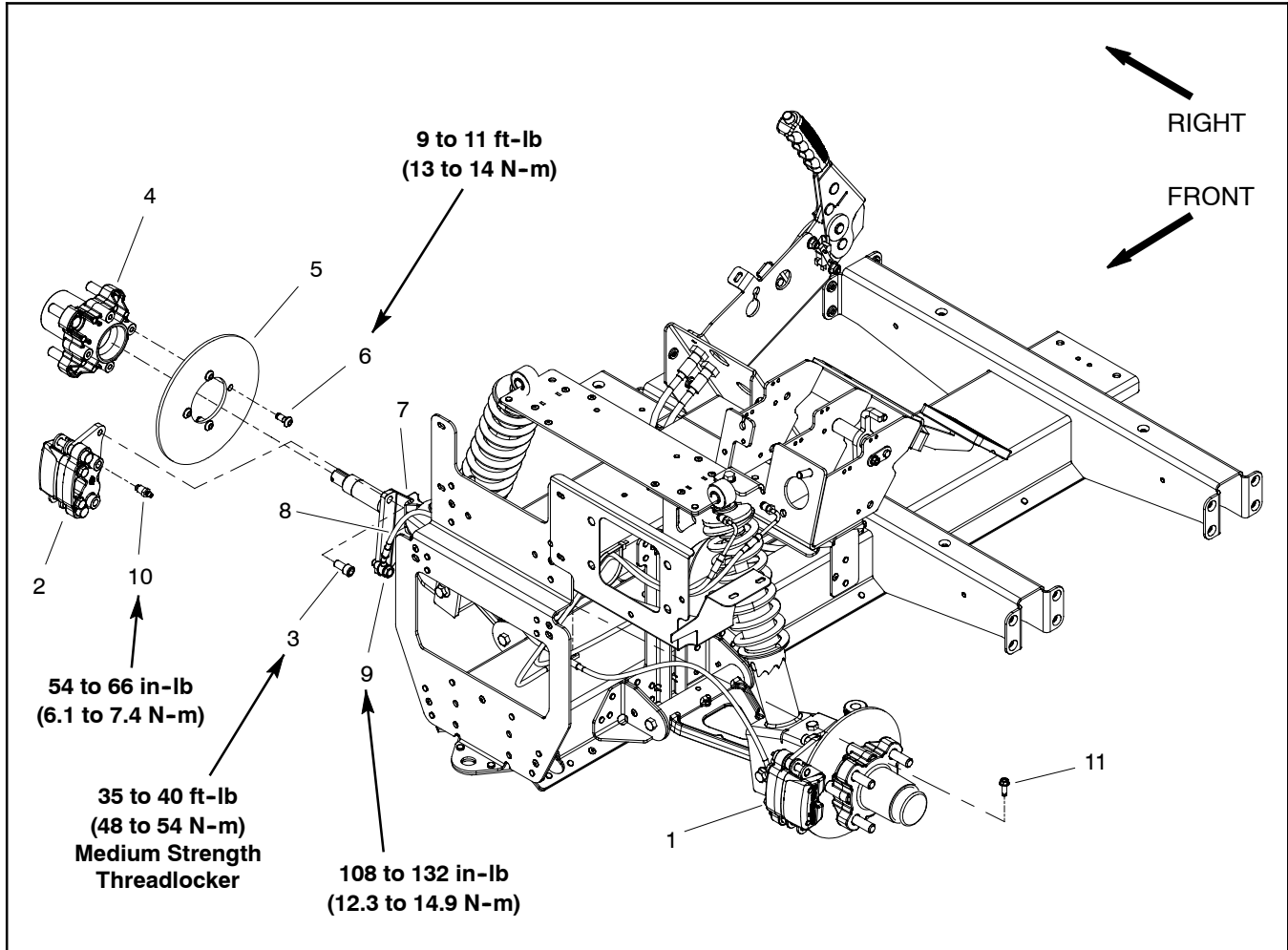

Figure 13

- | | | |
|--------------------------------------|------------------------------------|-----------------------|
| 1. LH brake caliper | 5. Brake rotor (2 used) | 9. Banjo bolt |
| 2. RH brake caliper | 6. Socket head screw (4 per rotor) | 10. Bleed screw |
| 3. Socket head screw (2 per caliper) | 7. Spindle (RH shown) | 11. Washer head screw |
| 4. Wheel hub assembly (2 used) | 8. Front brake line | |

Disassembly (Fig. 13)

1. Park vehicle on a level surface, turn key switch OFF, apply parking brake and remove key from the key switch.



WARNING

Before jacking up the machine, review and follow Jacking Instructions in Chapter 1 - Safety.

2. Chock wheels not being removed. Use a jack to raise front wheel that is to be removed off the ground. Support vehicle with appropriate jack stands beneath the frame.

3. Remove front wheel from machine (see Front Wheels and Hubs in this section).

4. Disconnect brake line from front caliper (Fig. 14):

A. Clean hydraulic brake line area of brake caliper to prevent contamination of brake system.

B. Remove banjo bolt that secures brake line fitting to caliper.

C. Carefully separate brake line from caliper. Locate and retrieve two (2) banjo washers from sides of brake line fitting.

D. Plug brake line and position it away from caliper.

5. Remove two (2) socket head screws that secure the brake caliper to the spindle.

6. Slide brake caliper from brake rotor and remove caliper from vehicle.

7. Inspect front brake rotor for wear or damage. Minimum brake rotor thickness is **0.154" (3.9 mm)**. If brake rotors need to be removed from vehicle, refer to Front Wheels and Hubs in this section.

Assembly (Fig. 13)

1. Make sure that brake rotor is properly secured to wheel hub (see Front Wheels and Hubs in this section).
2. Slide brake caliper onto brake rotor. Make sure that rotor is between brake pads.

IMPORTANT: The socket head screws that secure the brake calipers have a patch lock feature. If screws are being re-installed on vehicle, apply medium strength thread locker to screw threads before installation.

3. Align caliper mounting holes with spindle. Secure caliper with two (2) socket head screws. Torque screws from **35 to 40 ft-lb (48 to 54 N-m)**.

4. Connect brake line to front brake caliper (Fig. 14):

- A. Position brake line to caliper.
- B. Place banjo washer on each side of brake line fitting.
- C. Install banjo bolt through brake line fitting and banjo washers and then thread into caliper. Torque banjo bolt from **108 to 132 in-lb (12.3 to 14.9 N-m)**.

5. Install front wheel assembly (see Front Wheels and Hubs in this section).

6. Lower machine to ground.

7. Make sure that wheel lug nuts are torqued in a crossing pattern from **75 to 95 ft-lb (102 to 128 N-m)**.

8. Bleed brakes (see Bleed Brake System in this section).

**CAUTION**

After servicing brake system components, always check the brakes in a wide open, level area that is free of other persons and obstructions.

9. Check brake operation.

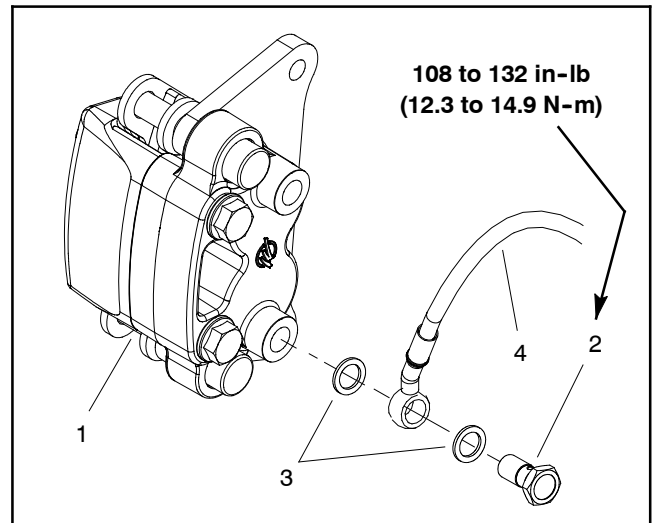

Figure 14

- | | |
|-----------------------------|--------------------------|
| 1. Front caliper (RH shown) | 3. Banjo washer (2 used) |
| 2. Banjo bolt | 4. Brake line |

Burnish Brake Pads

After brake pad replacement, burnish (break-in) the brakes before use.

1. Bring the machine to full speed and apply the brakes to rapidly stop the machine without skidding or locking up the wheels.
2. Repeat this procedure 10 times. To avoid overheating the brakes, wait 1 minute between each stop.

Front Brake Caliper Service

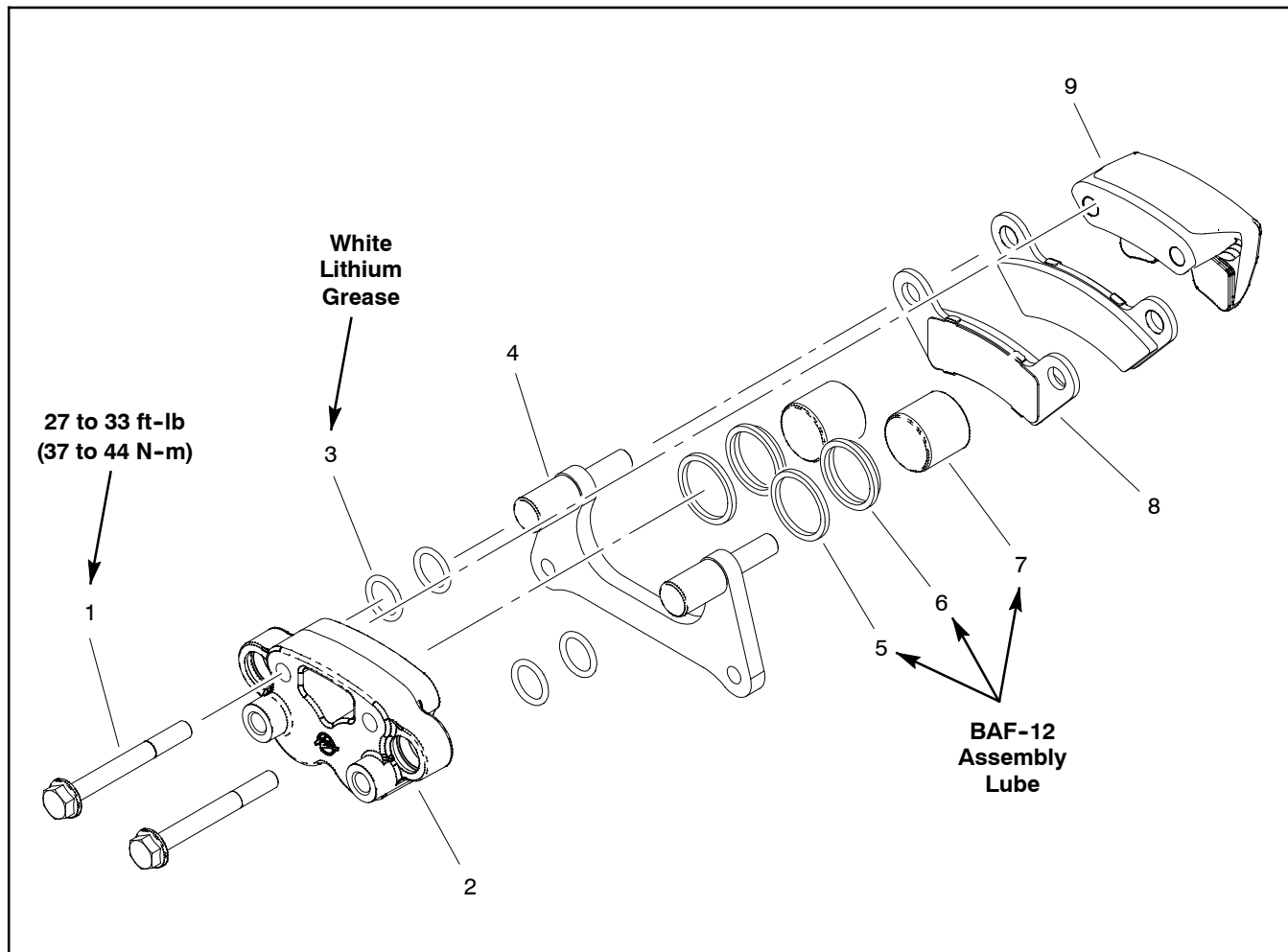

Figure 15

- | | | |
|--------------------|-------------------------|-----------------------|
| 1. Bolt (2 used) | 4. Caliper bracket | 7. Piston (2 used) |
| 2. Caliper body | 5. Square seal (2 used) | 8. Brake pad (2 used) |
| 3. O-ring (4 used) | 6. Dust seal (used) | 9. Caliper anvil |

Disassembly (Fig. 15)

1. Remove two (2) bolts that secure brake caliper body to the caliper anvil.
2. Remove caliper anvil and then slide brake pads from pins on caliper bracket.
3. Slide caliper body assembly from caliper bracket.
4. If necessary, remove remaining components from caliper body:
 - A. Carefully remove pistons from caliper body making sure that outer surface of pistons are not damaged during removal.
 - B. Carefully, remove and discard O-rings, square seals and dust seals from caliper body. Make sure that caliper body is not damaged during removal of O-rings and seals.
5. Clean caliper components with brake cleaner.

Inspection

1. Check brake pads for uneven wear that would indicate binding in the caliper assembly. Replace the brake pads if the friction material is worn to less than **1/16" (1.6 mm)**. Also, if pads are contaminated with grease or oil, they must be replaced.
2. Inspect brake pistons and piston bores in caliper body for damage or wear. Replace brake pistons or complete brake caliper assembly if necessary.
3. Check that pins on caliper bracket are not worn or damaged. Wear on the pins will prevent smooth brake operation.

Assembly (Fig. 15)

1. If caliper body was disassembled, install components in caliper body:
 - A. Apply hydraulic brake cylinder assembly lube (BAF-12 or equivalent) to square seals, dust seals and piston before installation.
 - B. Fit lubricated seals into grooves of caliper body. Make sure that seals are not twisted in groove after installation.
 - C. Install lubricated pistons into caliper body bores. Pistons should slide into bores with light resistance.
 - D. Lubricate O-rings with white lithium grease and install into grooves in caliper body.
 - E. Slide caliper body assembly onto pins on caliper bracket.

NOTE: If brake pads are being replaced, it will be necessary to push caliper pistons back into the caliper bore before installing new pads.

2. Slide brake pads onto pins on caliper bracket. Make sure that friction material on pads is toward brake rotor position.
3. Fit caliper anvil to assembly and secure caliper components with two (2) bolts. Tighten bolts from **27 to 33 ft-lb (37 to 44 N-m)**.

Rear Brake Calipers

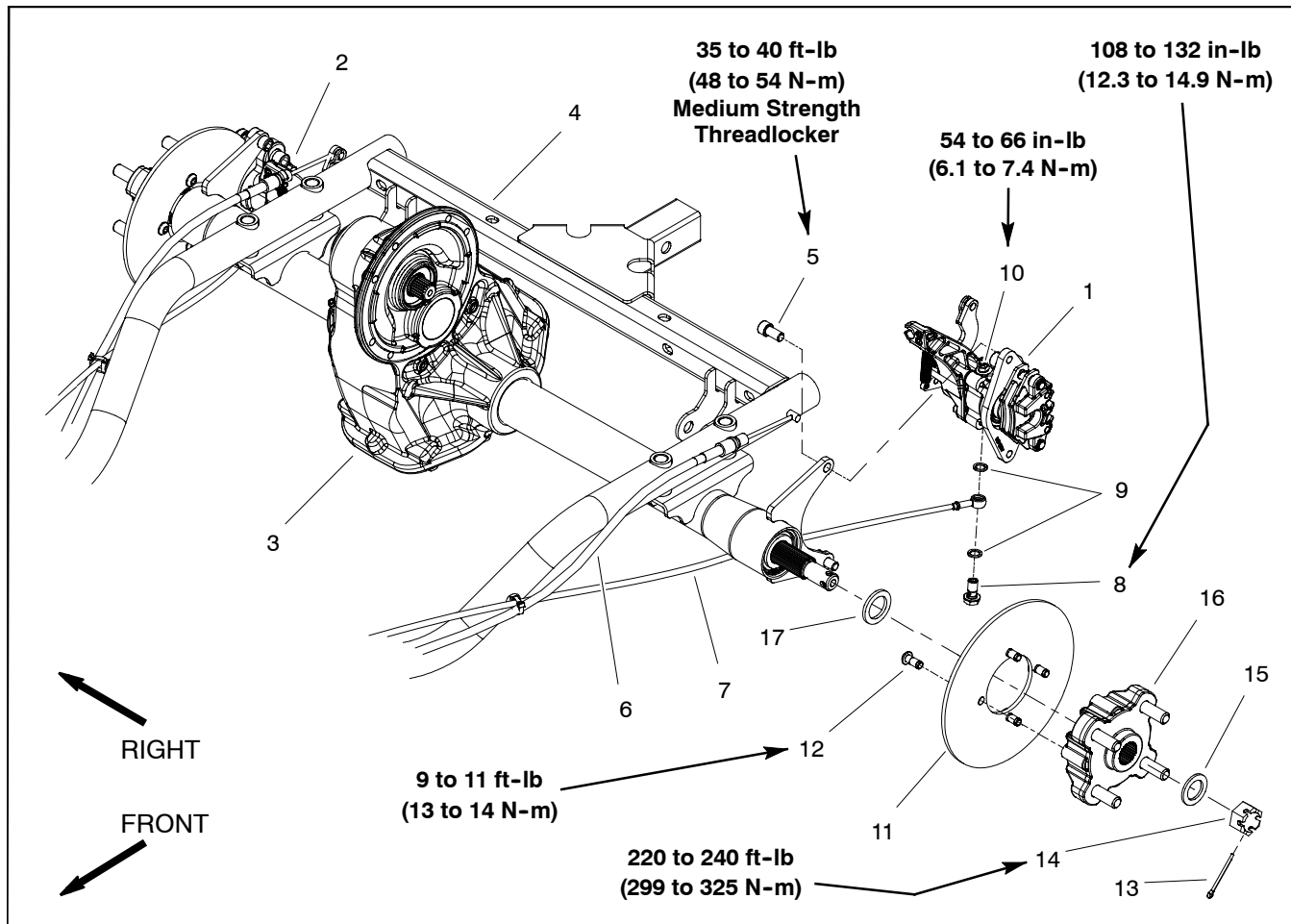

Figure 16

- | | | |
|--------------------------------------|-------------------------------------|---------------------|
| 1. LH rear brake caliper assembly | 7. Rear brake line | 13. Cotter pin |
| 2. RH rear brake caliper assembly | 8. Banjo bolt | 14. Slotted hex nut |
| 3. Transaxle assembly | 9. Banjo washer (2 per caliper) | 15. Thrust washer |
| 4. Rear swing arm | 10. Bleed screw | 16. Rear wheel hub |
| 5. Socket head screw (2 per caliper) | 11. Rear brake rotor | 17. Hardened spacer |
| 6. Parking brake cable (2 used) | 12. Socket head screw (4 per rotor) | |

Removal (Fig. 16)

1. Park vehicle on a level surface, turn key switch OFF and remove key from the key switch. Do not apply parking brake.



WARNING

Before jacking up the vehicle, review and follow Jacking Instructions in Chapter 1 - Safety.

2. Chock wheels not being removed. Use a jack to raise rear wheel that is to be removed off the ground. Support vehicle with appropriate jack stands beneath the frame.

3. Remove rear wheel from machine (see Rear Wheels and Hubs in this section).

4. Disconnect parking brake cable from rear brake caliper (Fig. 17):

A. Make sure that parking brake is released.

B. Loosen parking brake adjustment by loosening lock nut and then loosen parking brake rod two (2) turns.

C. Rotate brake lever on caliper toward front of vehicle and hold lever in place. Carefully pull parking brake cable to release cable conduit from caliper bracket and then rotate parking cable to allow removal of cable end from parking brake lever.

D. Position disconnected parking brake cable away from brake caliper.

5. Disconnect brake line from rear brake caliper:
 - A. Clean brake line area of brake caliper to prevent contamination of brake system.
 - B. Remove banjo bolt that secures brake line fitting to caliper.
 - C. Carefully separate brake line from caliper. Locate and retrieve two (2) banjo washers from sides of brake line fitting.
 - D. Plug brake line and position it away from caliper.
6. Remove two (2) socket head screws that secure the brake caliper to the mounts on the transaxle tubes.
7. Slide brake caliper from brake rotor and remove caliper from vehicle.
8. Inspect rear brake rotor for wear or damage. Minimum brake rotor thickness is **0.154" (3.9 mm)**. If brake rotors need to be removed from vehicle, refer to Rear Wheels and Hubs in this section.

Installation (Fig. 16)

IMPORTANT: When installing rear brake calipers, make sure that parking brake levers extend toward the upper side of the calipers.

1. Make sure that brake rotor is properly secured to wheel hub (see Rear Wheels and Hubs in this section).

IMPORTANT: The socket head screws that secure the brake calipers have a patch lock feature. If screws are being re-installed on vehicle, apply medium strength thread locker to screw threads before installation.

2. Slide rear brake caliper onto brake rotor. Make sure that rotor is between the brake pads in the caliper. Secure caliper to the mounts on the transaxle tube with socket head screws. Torque screws to **35 to 40 ft-lb (48 to 54 N-m)**.

3. Connect brake line to rear brake caliper:
 - A. Place banjo washer on each side of brake line fitting.
 - B. Install banjo bolt through brake line fitting and banjo washers and then thread into caliper. Torque banjo bolt from **108 to 132 in-lb (12.3 to 14.9 N-m)**.
4. Connect parking brake cable to rear brake caliper (Fig. 17):
 - A. Make sure that parking brake is not applied.
 - B. Insert parking brake cable end into parking brake lever.

- C. Rotate brake lever on caliper toward front of vehicle and hold lever in place. Then, insert cable into caliper bracket and slowly release brake lever to align cable conduit with caliper bracket.

5. Install rear wheel assembly (see Rear Wheels and Hubs in this section).
6. Lower vehicle to ground.
7. Make sure that rear wheel lug nuts are torqued in a crossing pattern from **75 to 95 ft-lb (102 to 128 N-m)**.
8. Adjust parking brake (see Parking Brake Adjustment in the Adjustments section of this chapter).
9. Bleed brakes (see Bleed Brake System in this section).



CAUTION

After servicing brake system components, always check the brakes in a wide open, level area that is free of other persons and obstructions.

10. Check brake operation.

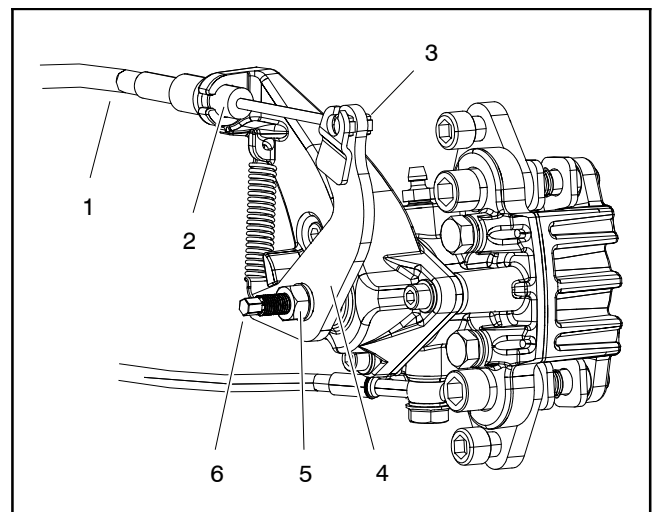

Figure 17

- | | |
|------------------------|------------------------|
| 1. Parking brake cable | 4. Parking brake lever |
| 2. Cable conduit | 5. Lock nut |
| 3. Cable end | 6. Parking brake rod |

Burnish Brake Pads

After brake pad replacement, burnish (break-in) the brakes before use.

1. Bring the machine to full speed and apply the brakes to rapidly stop the machine without skidding or locking up the wheels.
2. Repeat this procedure 10 times. To avoid overheating the brakes, wait 1 minute between each stop.

Rear Brake Caliper Service

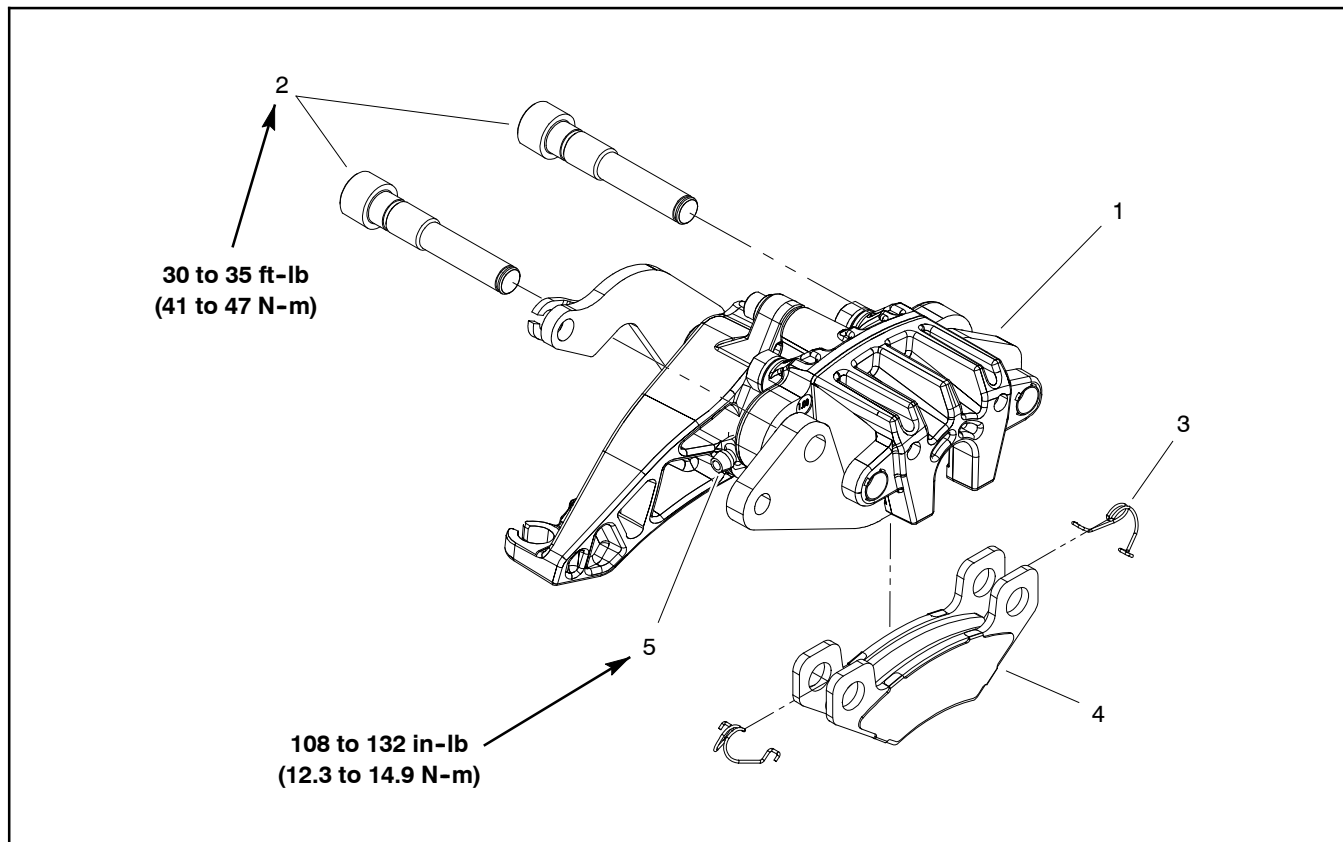

Figure 18

- 1. Brake caliper assembly (LH shown)
- 2. Caliper slide pin (2 used)
- 3. Anti-rattle spring (2 used)
- 4. Brake pad assembly
- 5. Bleed screw

NOTE: Replacement parts for the rear caliper assembly are limited to the brake pad assembly and bleed screw. If any other caliper components are damaged or worn, replace the caliper assembly.

Disassembly (Fig. 18)

1. Remove two (2) caliper slide pins that secure brake pads to the caliper assembly.
2. Slide brake pads with attached anti-rattle springs from caliper.
3. Remove anti-rattle springs from brake pads.
4. Clean caliper components with brake cleaner.

Inspection

1. Check brake pads for uneven wear that might indicate binding in the caliper assembly. Replace the brake pads if the friction material is worn to less than $\frac{1}{16}$ " (1.6 mm). Also, if pads are contaminated with grease or oil, they must be replaced.
2. Check that slide pins are not worn or damaged. Wear on the pins will prevent smooth brake operation.
3. If caliper damage or wear exists, replace complete brake caliper assembly as caliper components are not available separately.

Assembly (Fig. 18)

1. If brake pads are being replaced, it will be necessary to push the caliper piston back into the caliper bore before installing new pads:
 - A. Loosen lock nut on parking brake push rod and then unscrew the push rod that threads into the brake armature in the caliper (Fig. 19).
 - B. While loosening push rod, make sure that lock nut remains loose on push rod. Also, periodically push caliper piston back into caliper until there is sufficient room in the caliper for the brake pads and brake rotor.
 - C. Leave lock nut on push rod loose so that parking brake can be adjusted after caliper installation.
2. Place brake pads with friction material positioned toward brake rotor position. Then, install anti-rattle springs to holes in brake pads.
3. Slide brake pads with attached anti-rattle springs into caliper. Make sure that friction material on pads is toward brake rotor location.
4. Secure brake pads to the caliper assembly with two (2) caliper slide pins. Make sure that the slide pins are inserted through the center of the anti-rattle springs. Tighten pins from **30 to 35 ft-lb (41 to 47 N-m)**.

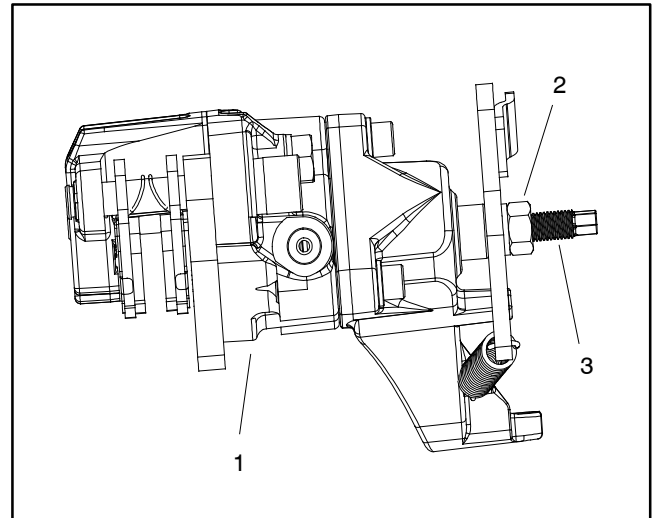

Figure 19

1. Caliper (LH shown)
2. Lock nut
3. Parking brake rod

Parking Brake Cables and Lever Assembly

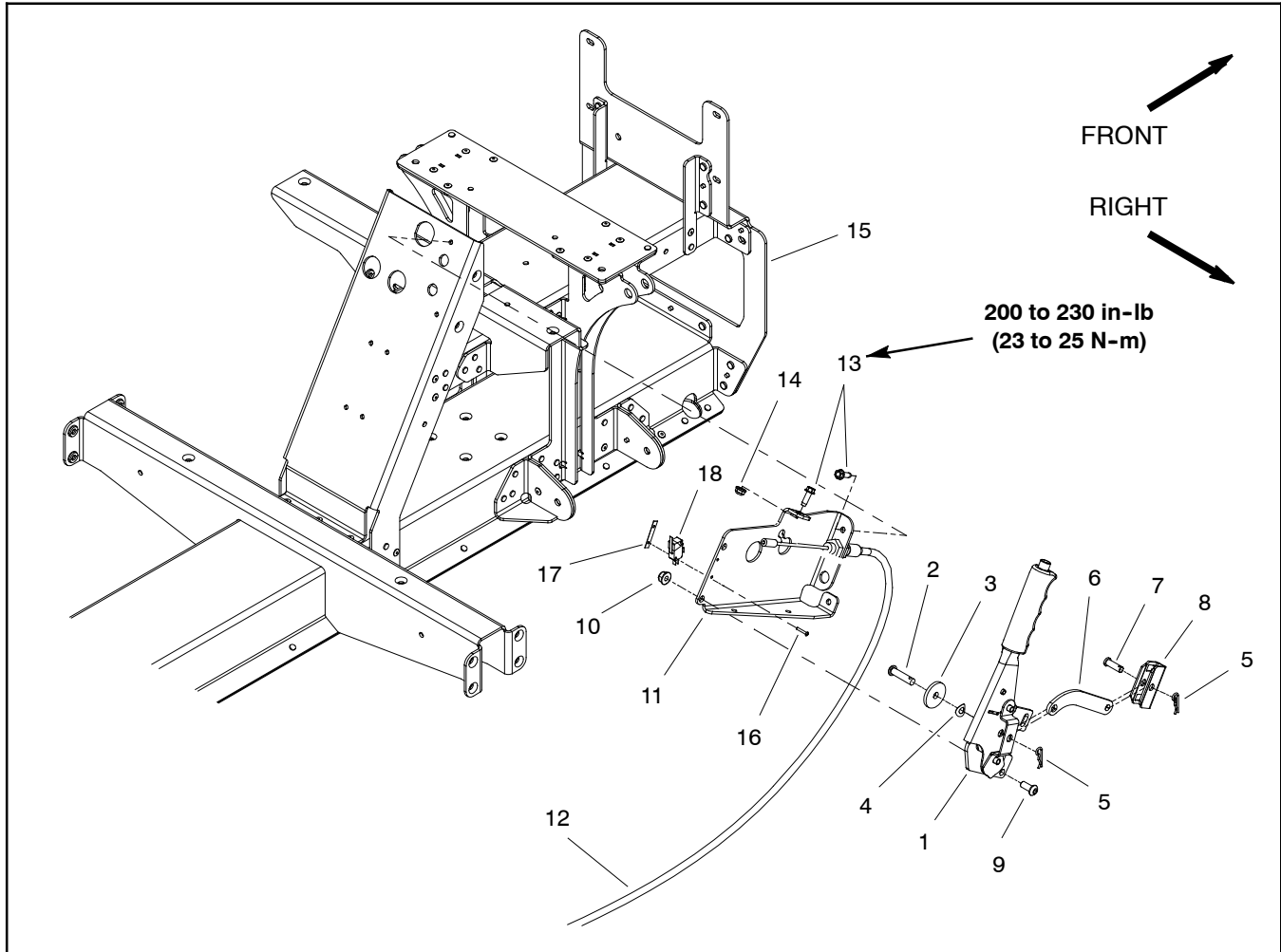

Figure 20

- | | | |
|------------------------|----------------------------------|--------------------------------|
| 1. Parking brake lever | 7. Clevis pin | 13. Washer head screw (3 used) |
| 2. Clevis pin | 8. Cable equalizer bracket | 14. Flange nut |
| 3. Flat washer | 9. Button head screw (2 used) | 15. Front frame |
| 4. Spring washer | 10. Flange nut (2 used) | 16. Screw (2 used) |
| 5. Hair pin (2 used) | 11. Parking brake mount | 17. Speed nut |
| 6. Parking brake link | 12. Parking brake cable (2 used) | 18. Parking brake switch |

NOTE: The parking brake assembly includes the dash mounted parking brake lever, two (2) identical brake cables and parking brake actuators in the rear brake calipers.

Disassembly (Fig. 20)

1. Park vehicle on a level surface, turn key switch OFF and remove key from the key switch. Chock wheels to prevent the vehicle from moving.

2. Disconnect both parking brake cables from rear brake calipers (Fig. 21):

A. Make sure that parking brake is released.

B. Loosen parking brake adjustment by loosening lock nut and then loosen parking brake rod two (2) turns.

C. Rotate brake lever on caliper toward front of vehicle and hold lever in place. Carefully pull parking brake cable to release cable conduit from caliper bracket and then rotate parking cable to allow removal of cable end from parking brake lever.

D. Position disconnected parking brake cable away from brake caliper.

3. Carefully separate parking brake cables from four (4) clips on swing arm.

4. Remove dash and position it toward the front of the vehicle to allow access to parking brake cables and brake lever (see Dash in this section).

5. Loosen the jam nuts that secure parking brake cables to parking brake mount.

6. Remove clevis pin and hair pin that secure cable equalizer bracket (item 8) to parking brake link.

7. Remove parking brake cables from cable equalizer bracket. Once cables are removed from equalizer, remove ends of brake cables from jam nut and brake mount.

8. Note routing of brake cables for assembly purposes.

9. Carefully remove brake cables by pulling them through front frame toward front of vehicle.

10. If necessary, remove parking brake lever components using Figure 20 as a guide.

Assembly (Fig. 20)

1. Install removed parking brake lever components using Figure 20 as a guide.

2. Carefully route parking brake cables through the front frame and toward the rear wheels using cable routing noted during disassembly. Position the brake cables in the vehicle so that the cable ends are close to the rear brake calipers and the parking brake lever assembly.

3. Secure brake cables to parking brake lever assembly:

A. Insert both brake cable ends through parking brake mount and then through jam nuts.

B. Insert both cable ends into cable equalizer bracket.

C. Secure cable equalizer bracket with attached cable ends to parking brake link with clevis pin and hair pin.

D. Install and tighten the jam nuts to secure parking brake cables to parking brake mount.

4. Connect both parking brake cables to rear brake caliper (Fig. 21):

A. Make sure that parking brake is not applied.

B. Insert parking brake cable end into parking brake lever.

C. Rotate brake lever on caliper toward front of vehicle and hold lever in place. Then, insert cable into caliper bracket and slowly release brake lever to align cable conduit with caliper bracket.

D. Secure brake cables to swing arm with four (4) clips.

5. Adjust parking brake on both rear wheel calipers (see Parking Brake Adjustment in the Adjustments section of this chapter).

6. Check parking brake operation.

7. Carefully position and secure dash to vehicle (see Dash in this section).

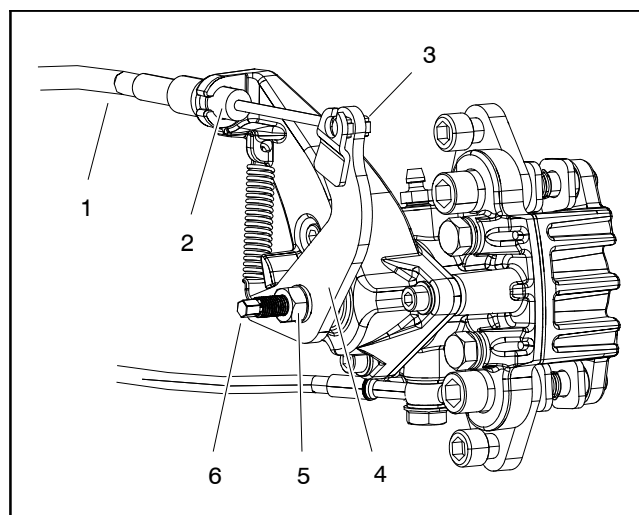

Figure 21

- | | |
|------------------------|------------------------|
| 1. Parking brake cable | 4. Parking brake lever |
| 2. Cable conduit | 5. Lock nut |
| 3. Cable end | 6. Parking brake rod |

Brake Master Cylinder

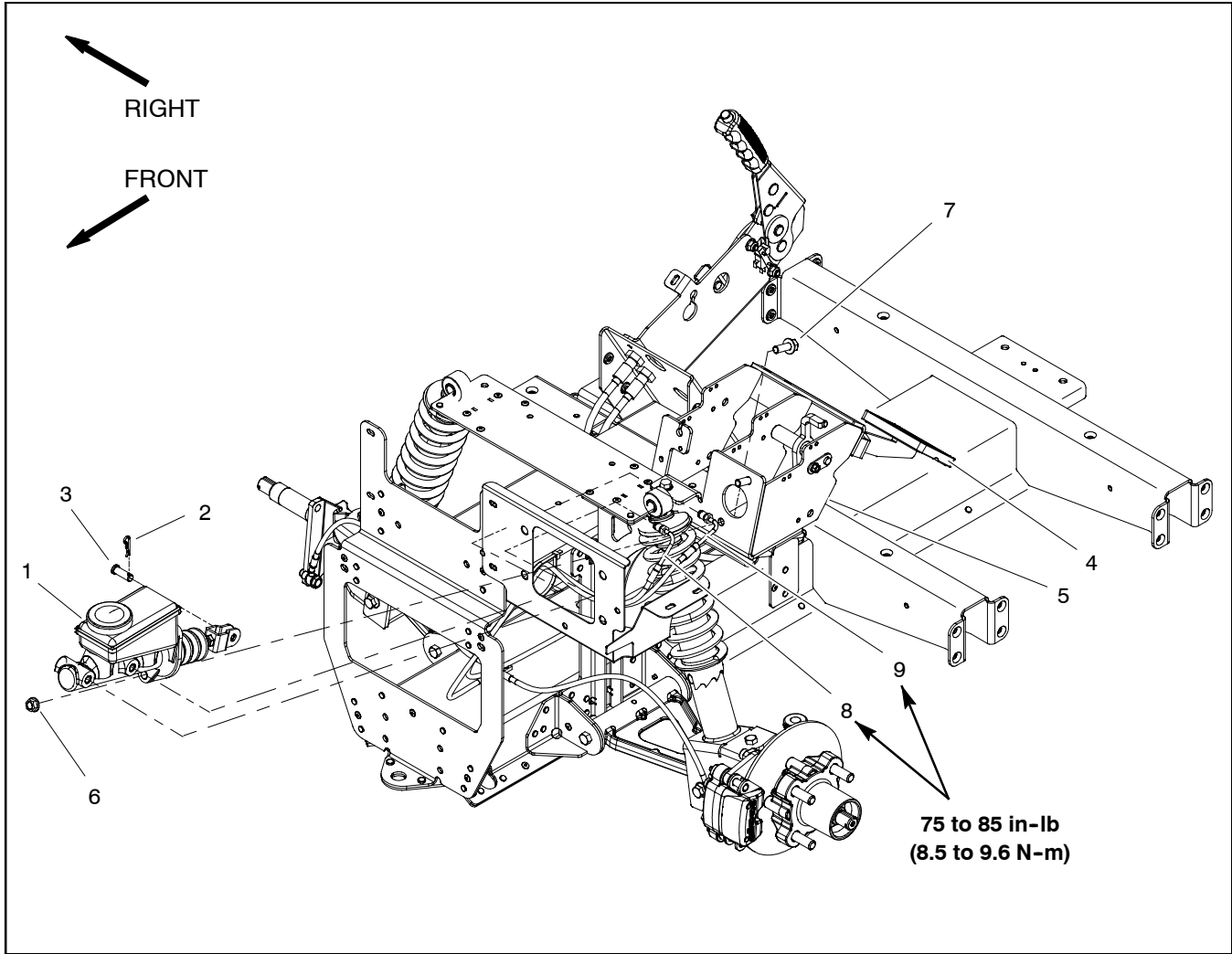

Figure 22

- | | | |
|--------------------|------------------------|-------------------------------|
| 1. Master cylinder | 4. Brake pedal | 7. Flange head screw (2 used) |
| 2. Hair pin | 5. Pedal mount | 8. Front brake line |
| 3. Clevis pin | 6. Flange nut (2 used) | 9. Rear brake line |

Removal (Fig. 22)

1. Park vehicle on a level surface, turn key switch OFF, apply parking brake and remove key from the key switch.
2. Raise front hood to gain access to master cylinder.
3. Remove hair pin from the clevis pin that connects master cylinder to brake pedal.

IMPORTANT: To prevent contamination of the brake system, make sure to clean master cylinder components before disassembly.

4. Clean hydraulic brake line area of master cylinder to prevent contamination. Remove both brake lines from master cylinder. Cap ends of brake lines and carefully position them away from master cylinder.
5. Remove two (2) flange nuts and flange head screws that secure master cylinder to pedal mount.
6. Carefully remove master cylinder from vehicle.

Installation (Fig. 22)

1. Position master cylinder to pedal mount and secure with flange head screws and flange nuts.
2. Remove plugs from brake lines. Install brake lines to master cylinder. Torque brake lines from **75 to 85 in-lb (8.5 to 9.6 N-m)**.
3. Connect master cylinder to brake pedal with clevis pin and hair pin.
4. Bleed brakes (see Bleed Brake System in this section).
5. Lower and secure front hood.



CAUTION

After servicing brake system components, always check the brakes in a wide open, level area that is free of other persons and obstructions.

6. Check brake operation.

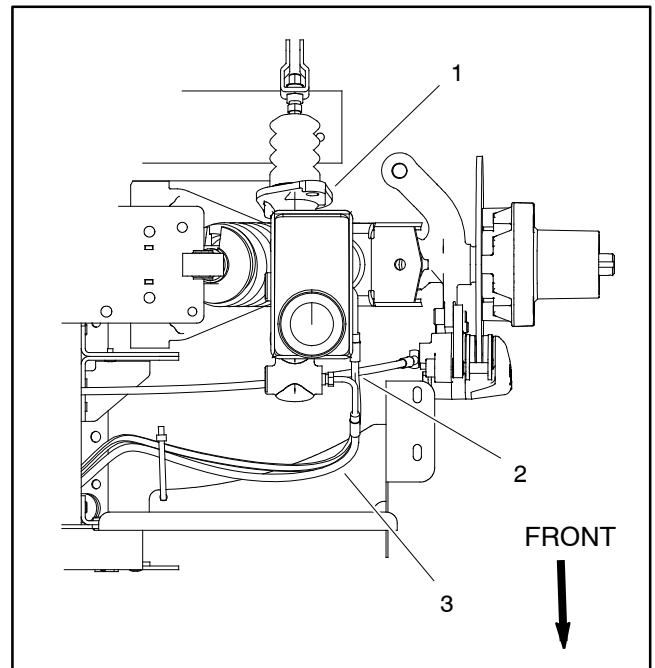

Figure 23

1. Master cylinder
2. Rear brake line

3. Front brake line

Brake Master Cylinder Service

Disassembly (Fig. 24)

1. Thoroughly clean outside of master cylinder before disassembly.
2. Remove reservoir and flange seal. Push in on the push rod so the stop pin can be removed.
3. Disconnect lower end of the dust cover from the housing.
4. Push in on the push rod and remove circlip, then remove push rod with dust cover and clevis. Remove retainer washer.
5. Remove primary piston assembly and secondary piston assembly from cylinder housing.

Inspection



CAUTION

Use eye protection such as goggles when using compressed air for master cylinder service.

1. Clean all metal parts with isopropyl alcohol, then clean out and dry grooves and passageways with compressed air. Make sure cylinder bore and component pieces are thoroughly clean.
2. Check cylinder bore, pistons and springs for damage or excessive wear. Replace brake cylinder assembly if signs of pitting, scoring or cracks are evident in cylinder bore.

Assembly (Fig. 24)

1. Apply a film of clean brake fluid to cylinder bore and piston assemblies.
2. Install secondary piston assembly and primary piston assembly into cylinder.
3. Install retainer washer.
4. Install push rod and secure in place with circlip. Install lower end of dust cover to housing.
5. Push in on push rod so stop pin can be installed to retain secondary piston assembly, then install flange seal and reservoir.

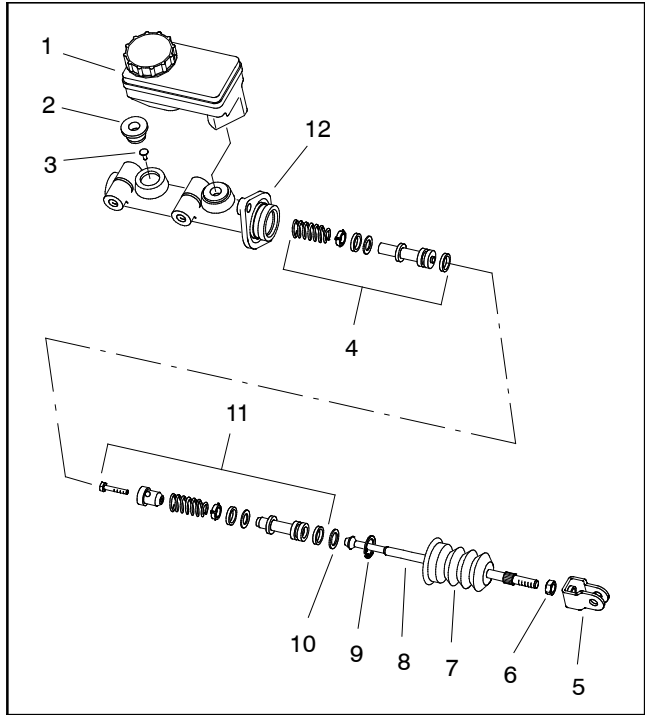



Figure 24

- | | |
|--------------------------|-------------------------|
| 1. Reservoir | 7. Dust cover |
| 2. Flange seal | 8. Push rod |
| 3. Stop pin | 9. Circlip |
| 4. Secondary piston assy | 10. Retainer washer |
| 5. Clevis | 11. Primary piston assy |
| 6. Jam nut | 12. Cylinder housing |

Bleed Brake System

IMPORTANT: To prevent contamination of the brake system, make sure to clean components before disassembly.

1. Park vehicle on a level surface, turn key switch OFF, apply parking brake and remove key from the key switch.
2. Connect a suitable transparent hose to bleeder valve on front or rear brake caliper. Submerge other end of hose in a glass container partially filled with clean brake fluid.
3. Have a second person pump brake pedal several times, then hold pedal down firmly.
4. With pedal firmly depressed, open bleeder valve of brake until pedal fades to floor. Close bleeder valve before releasing pedal.
5. Repeat procedure until a continuous flow of brake fluid, with no air bubbles, is released from bleeder valve. **Make sure fluid level is maintained in brake fluid reservoir at all times.**
6. Torque bleeder valve from **54 to 66 in-lb (6.1 to 7.4 N-m)**.
7. Repeat steps 1 to 5 for other brake calipers.

	CAUTION
After servicing the brakes, always check the brakes in a wide open, level area that is free of other persons and obstructions.	

8. After bleeding of brakes is completed, test vehicle to make sure brakes are operating correctly and brake pedal is firm when applying brakes.

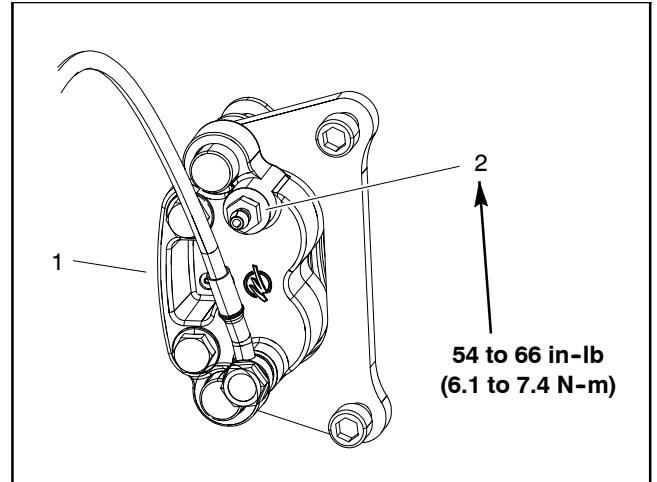

Figure 25

1. Front caliper (RH shown) 2. Bleeder valve

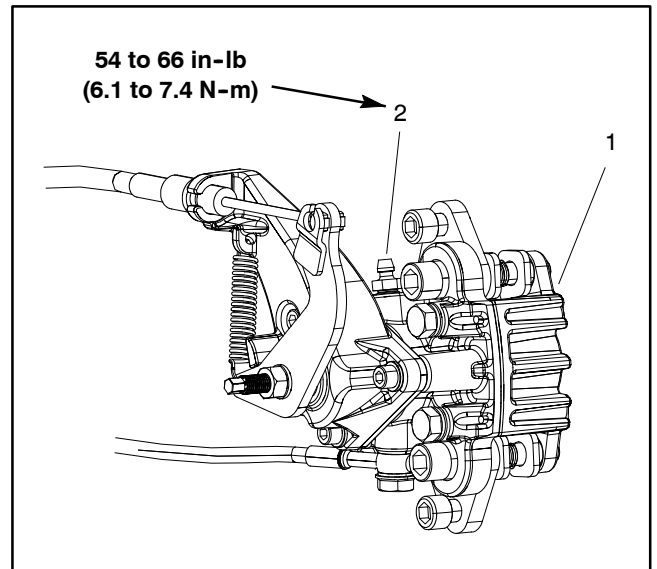

Figure 26

1. Rear caliper (RH shown) 2. Bleeder valve

Steering Assembly

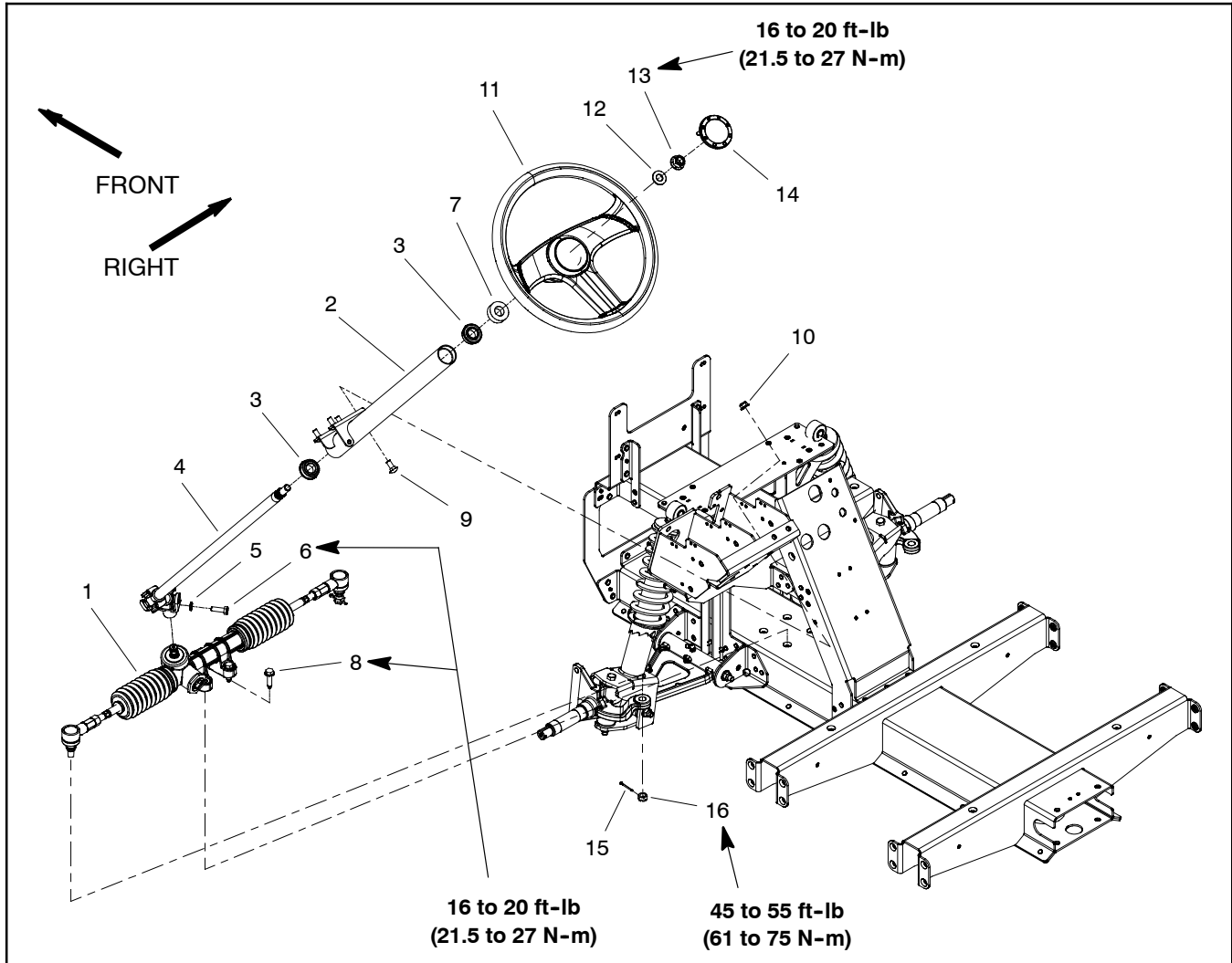

Figure 27

- | | | |
|---------------------------|-------------------------------|------------------------------|
| 1. Steering rack assembly | 7. Dust cover | 12. Flat washer |
| 2. Steering column | 8. Washer head screw (4 used) | 13. Lock nut |
| 3. Bearing (2 used) | 9. Carriage bolt (4 used) | 14. Steering wheel cap |
| 4. Steering shaft | 10. Flange nut (4 used) | 15. Cotter pin (2 used) |
| 5. Lock washer | 11. Steering wheel | 16. Slotted hex nut (2 used) |
| 6. Cap screw | | |

Disassembly (Fig. 27)

1. Park vehicle on a level surface, turn key switch OFF, apply parking brake and remove key from the key switch.
2. Raise front hood to gain access to the steering components.
3. Carefully remove steering wheel cover from the steering wheel. Remove nut and flat washer securing the steering wheel to the steering shaft.
4. Use suitable puller to remove steering wheel from steering shaft.

5. Remove dash and position it toward the front of the vehicle to allow the steering column to be moved (see Dash in this section).
6. Remove cap screw and lock washer securing the lower steering shaft joint to the steering rack assembly input shaft.
7. Support steering column to prevent it from falling. Remove four (4) flange nuts and carriage bolts securing the steering column to the mounting plate on the frame.

8. Lift up on steering column assembly, slide lower steering shaft joint from the steering rack assembly input shaft and remove steering column from vehicle.
 9. Remove dust cover from the steering shaft. Replace cover if damaged.
 10. Slide steering shaft and bearings out of the steering column.
 - A. Check steering shaft universal joints for roughness that would indicate bearing wear or damage. Replace steering shaft if universal joint bearing damage exists.
 - B. Check bearings for evidence of wear or damage and replace bearings if necessary.
 11. Disconnect both steering rack tie rods from the spindles at the front wheel hubs (see Front Suspension in this section).
 12. Remove four (4) washer head screws that secure the steering rack assembly to the front frame. Remove rack assembly from the vehicle.
- NOTE:** Refer to Steering Rack Assembly Service in this chapter for information on repair of the steering rack assembly.
- Assembly (Fig. 27)**
1. Position steering rack assembly to the front frame with the input shaft toward the left side of the vehicle.
 2. Secure rack assembly to the frame with four (4) washer head screws. Torque screws from **16 to 20 ft-lb (21.5 to 27 N-m)**.
 3. Insert steering shaft up through the steering column.
 4. Position steering column assembly to vehicle frame and slide lower steering shaft joint onto the steering rack input shaft. Secure steering column to the mounting plate on the frame with four (4) carriage bolts and flange nuts.
 5. Secure lower steering shaft joint to the steering rack input shaft with cap screw and lock washer. Torque screw from **16 to 20 ft-lb (21.5 to 27 N-m)**.
 6. Place dust cover onto the steering shaft.
 7. Connect both steering rack tie rods to the spindles at the front wheel hubs (see Front Suspension in this section).
 8. Make sure that front wheels are centered by the steering rack before securing the steering wheel.
 - A. Install steering wheel onto steering shaft. Leave steering wheel loose on shaft.
 - B. Rotate the steering wheel until the distance from the steering rack boot to the tie rod is equal on both sides of vehicle indicating that the front wheels are centered.
 - C. Rotate the steering wheel from lock to lock and check that the front wheel spindles have equal clearances at end of steering rotation. If one spindle contacts a steering component and the other spindle still has clearance, a rotation of the steering shaft is needed to center the wheels.
 - D. Once wheels are centered, position steering wheel onto steering shaft so that the steering wheel spokes are centered when the front wheels are centered.
 9. Secure steering wheel to steering shaft with flat washer and lock nut. Torque nut from **16 to 20 ft-lb (21.5 to 27 N-m)**. Install steering wheel cover to steering wheel.
 10. Carefully position and secure dash to vehicle (see Dash in this section).
 11. Lower and secure front hood.
 12. Check front wheel alignment and adjust as necessary (see Adjust Front Wheel Toe-in in the Adjustments section of this chapter).

Steering Rack Assembly Service

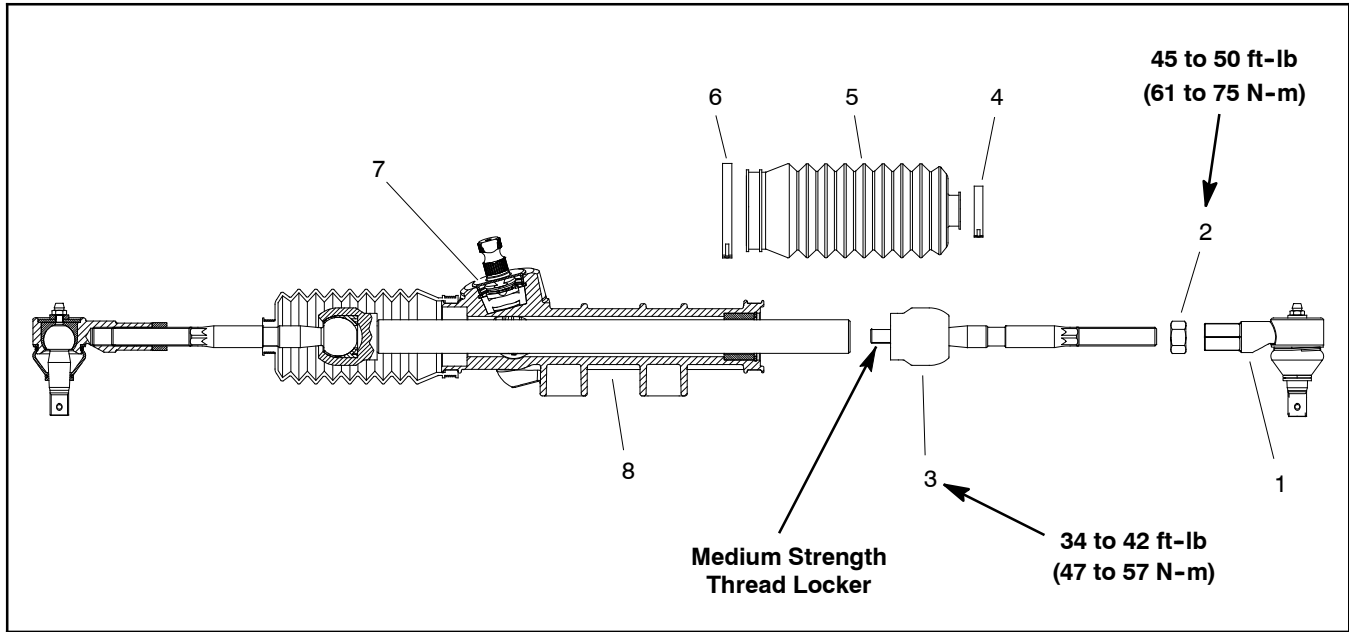

Figure 28

- | | | |
|---------------------------|---------------------------|---------------------------|
| 1. Tie rod end (2 used) | 4. Bellows clamp (2 used) | 7. Input shaft seal |
| 2. Jam nut (2 used) | 5. Bellows (2 used) | 8. Steering rack assembly |
| 3. Tie rod track (2 used) | 6. Bellows clamp (2 used) | |

NOTE: Check parts catalog to identify individual components that are available for the steering rack assembly on your Workman GTX vehicle. Depending on wear or damage that exists with the steering rack, replacement of the complete steering rack assembly might be necessary.

Disassembly (Fig. 28)

1. For assembly purposes, measure the distance from shoulder on the tie rod track to the location of the tie rod end (Fig. 29). This will help to adjust front wheel toe-in during assembly of steering rack.
2. Loosen jam nut that secures tie rod end to tie rod track. Remove tie rod end and jam nut from end of tie rod track.
3. Remove clamps that secure bellows to the tie rod track and steering rack housing. Remove bellows from steering rack assembly.
4. Secure steering rack assembly in a vise with soft jaws. Clamp on the mounting surfaces of the rack to prevent damage to internal components.
5. Loosen and remove tie rack track from shaft of steering rack.
6. If necessary, remove input shaft seal from steering rack input shaft (Fig. 30):
 - A. Mark and drill two (2) holes in the outer face of the seal.
 - B. Thread two (2) self-tapping screws into the drilled holes in the face of the seal.
 - C. Use the screws in the face of the seal to pull the seal from the steering rack assembly. Discard seal.
7. Clean and inspect all removed steering rack components. Replace parts that are worn or damaged.
8. Check teeth on steering rack shaft by rotating input shaft to extend rack shaft in one direction, inspect exposed rack teeth and then repeat in opposite direction. If any gear teeth are damaged, steering rack assembly replacement is necessary.

Assembly (Fig. 28)

1. If input shaft seal was removed from steering rack, install new seal into rack. Seal should be pressed fully into bore of rack until it contacts retaining ring in bore (Fig. 30).
2. Lubricate steering rack shaft by rotating input shaft to extend rack shaft in one direction and apply general purpose grease to exposed teeth on rack. Rotate input shaft to extend rack shaft in opposite direction and apply general purpose grease to exposed teeth on rack.

3. Secure steering rack in a vise with soft jaws. Clamp on the mounting surfaces of the rack to prevent damage to internal components.
4. Apply medium strength thread locker to threads of tie rack track. Install tie rack track into shaft of steering rack. Torque tie rack track from **34 to 42 ft-lb (47 to 57 N-m)**.
5. Carefully install bellows onto steering rack assembly. Secure bellows to the tie rod track and steering rack housing with new clamps. To prevent damage to bellows, do not over-tighten clamps.
6. Install jam nut and then tie rod end to tie rod track. Use measured distance made during disassembly to position the tie rod end. Leave jam nut loose to allow easier toe-in adjustment after steering rack assembly installation on vehicle.

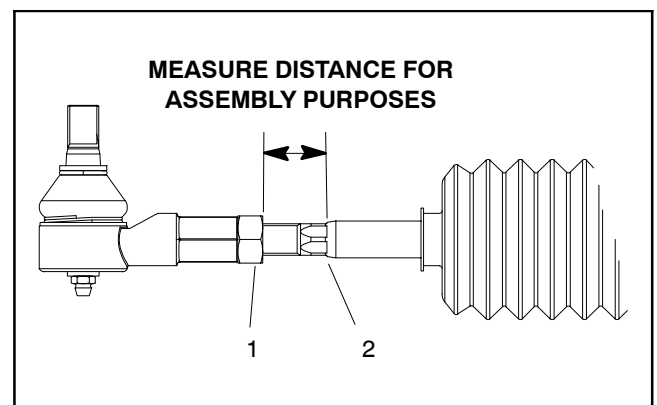

Figure 29

1. Jam nut
2. Track shoulder

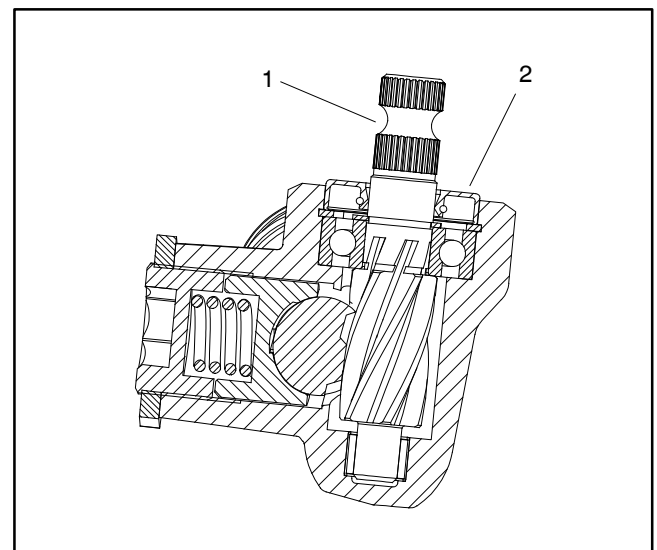

Figure 30

1. Input shaft
2. Input shaft seal

Front Suspension

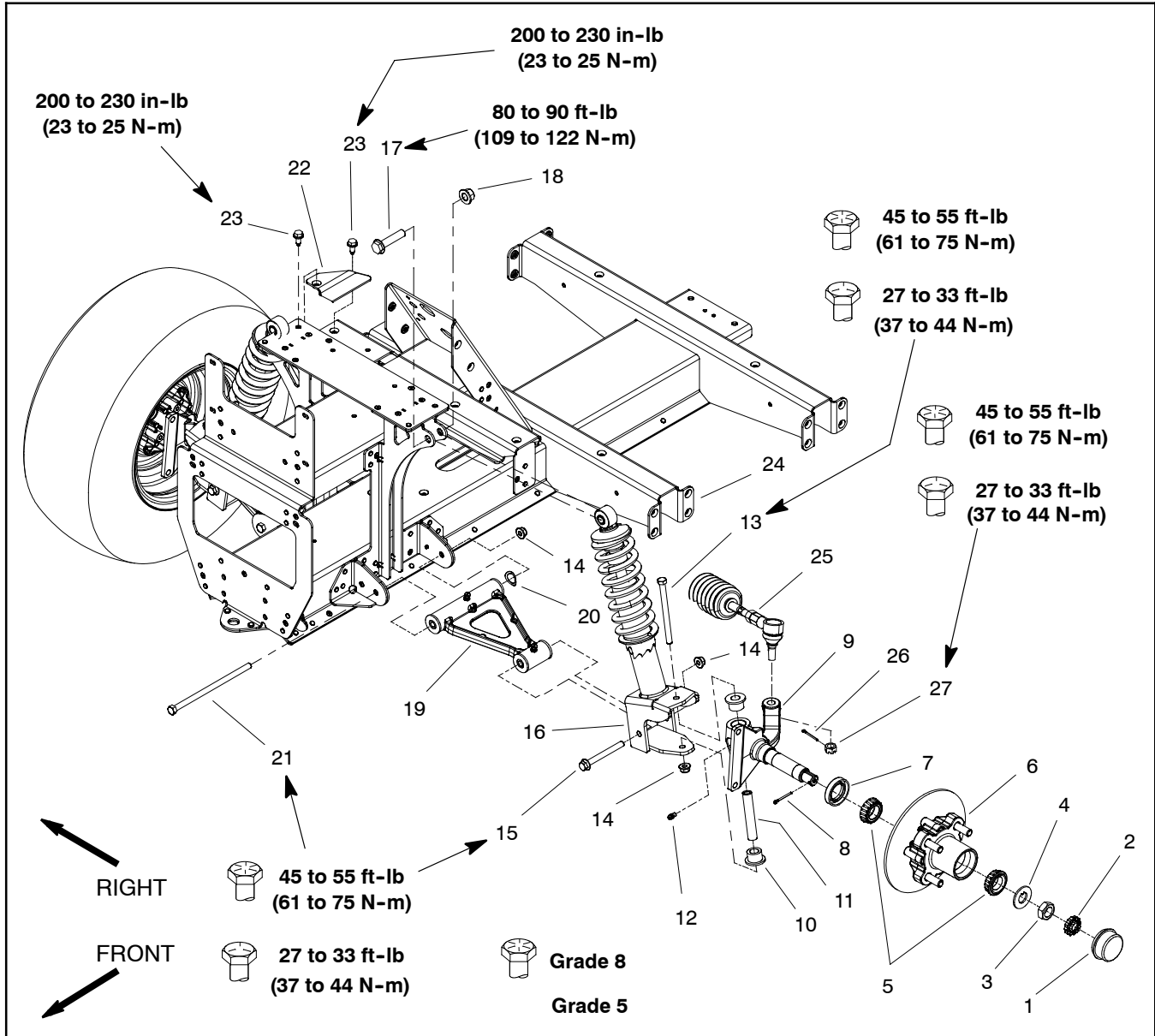



Figure 31

- | | | |
|-------------------------------|---|--------------------------------|
| 1. Dust cap | 10. Flange bushing (2 used per spindle) | 19. A-arm assembly (2 used) |
| 2. Retainer | 11. Kingpin sleeve | 20. Bowed washer |
| 3. Jam nut | 12. Grease fitting | 21. Cap screw |
| 4. Tab washer | 13. Cap screw | 22. Reinforcement tower |
| 5. Bearing (2 used) | 14. Flange nut (3 used per side) | 23. Washer head screw (2 used) |
| 6. Wheel hub & rotor assembly | 15. Flange head screw | 24. Front frame |
| 7. Oil seal | 16. Suspension strut assembly (2 used) | 25. Steering rack assembly |
| 8. Cotter pin | 17. Flange head screw | 26. Cotter pin |
| 9. Spindle (LH shown) | 18. Lock nut | 27. Slotted hex nut |

Disassembly (Fig. 31)

1. Park vehicle on a level surface, turn key switch OFF, apply parking brake and remove key from the key switch.
2. Raise hood to allow access to suspension components from above.



WARNING

Before jacking up the vehicle, review and follow Jacking Instructions in Chapter 1 - Safety.

3. Chock wheels not being removed. Use a jack to raise front wheel that is to be removed off the ground. Support vehicle with appropriate jack stands beneath the frame.

4. Remove front wheel assembly and wheel hub from vehicle (see Front Wheels and Hubs in this section).

5. Remove spindle assembly from vehicle:

A. Remove cotter pin and slotted hex nut securing steering rack tie rod ball joint stud to the spindle. Separate ball joint from the spindle.

B. Remove flange nut and cap screw securing the spindle assembly to the suspension strut assembly. Separate spindle from strut and remove spindle from vehicle.

6. Remove flange head screw and flange nut that secure lower end of suspension strut assembly to A-arm. Pivot strut assembly away from A-arm.

7. If suspension strut assembly removal is necessary, remove flange head screw and lock nut that secure the top of the strut assembly to the front frame. Remove strut assembly from vehicle.

8. Support A-arm to prevent it from falling.

9. Remove cap screw and flange nut that secure A-arm to frame. Remove A-arm assembly from frame.

10. Inspect sleeves and bushings in spindle (Fig. 31) and A-arm (Fig. 32) for wear or damage. If necessary, replace sleeves and bushings from spindle or A-arm:

A. Remove sleeves from flange bushings.

B. Remove flange bushings from spindle or A-arm. Take care to not damage bore of component during bushing removal. Clean the inside of the bore to remove all dirt, grease and foreign material.

C. Apply grease to the inside and outside of the new bushings. Use an arbor press to fully install the bushings into the spindle or A-arm.

D. Install sleeves into spindle or A-arm.

NOTE: On Workman GTX electric vehicles, suspension strut assembly should be set to second lowest pre-load setting.

Assembly (Fig. 31)

1. Position A-arm to the frame. Secure A-arm to the frame with cap screw and flange nut. Torque screw from **27 to 33 ft-lb (37 to 44 N-m)**.

2. If suspension strut assembly was removed from vehicle, position the top of the strut assembly to the front frame and secure with flange head screw and lock nut. Torque screw from **80 to 90 ft-lb (109 to 122 N-m)**.

3. Position lower end of strut assembly to A-arm and secure with flange head screw and flange nut. Torque screw from **27 to 33 ft-lb (37 to 44 N-m)**.

4. Install spindle assembly to vehicle:

A. Position spindle to suspension strut assembly and secure with cap screw and flange nut. Torque screw from **27 to 33 ft-lb (37 to 44 N-m)**.

B. Clean tapers of steering rack tie rod ball joint stud and spindle bore.

C. Insert tie rod ball joint stud into spindle and secure with slotted hex nut. Torque slotted hex nut from **35 to 40 ft-lb (48 to 55 N-m)**. If necessary, tighten nut further until slot in nut aligns with hole in tie rod ball joint stud. Install cotter pin.

5. Install front wheel hub and wheel assembly to vehicle (see Front Wheels and Hubs in this section).

6. Lower vehicle to ground. Make sure that wheel lug nuts are properly torqued in a crossing pattern from **75 to 95 ft-lb (102 to 128 N-m)**.

7. Lubricate spindle and A-arm grease fittings with High-Temp Mobil XHP-222 grease (or equivalent).

8. Lower and secure hood.

9. Check front wheel toe-in and adjust if necessary (see Adjust Front Wheel Toe-in in the Adjustments section of this chapter).

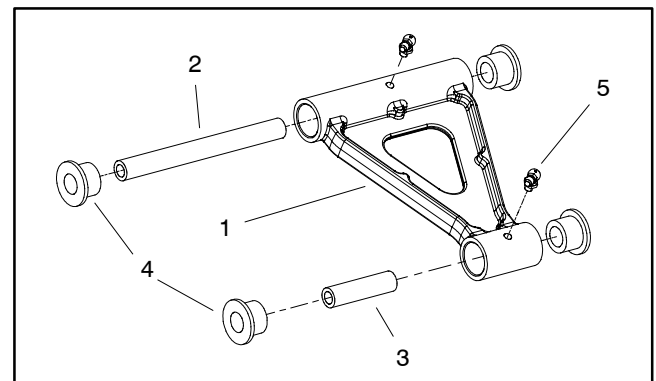

Figure 32

- | | |
|-----------------|----------------------------|
| 1. A-arm | 4. Flange bushing (4 used) |
| 2. Inner sleeve | 5. Grease fitting (2 used) |
| 3. Outer sleeve | |

Rear Suspension

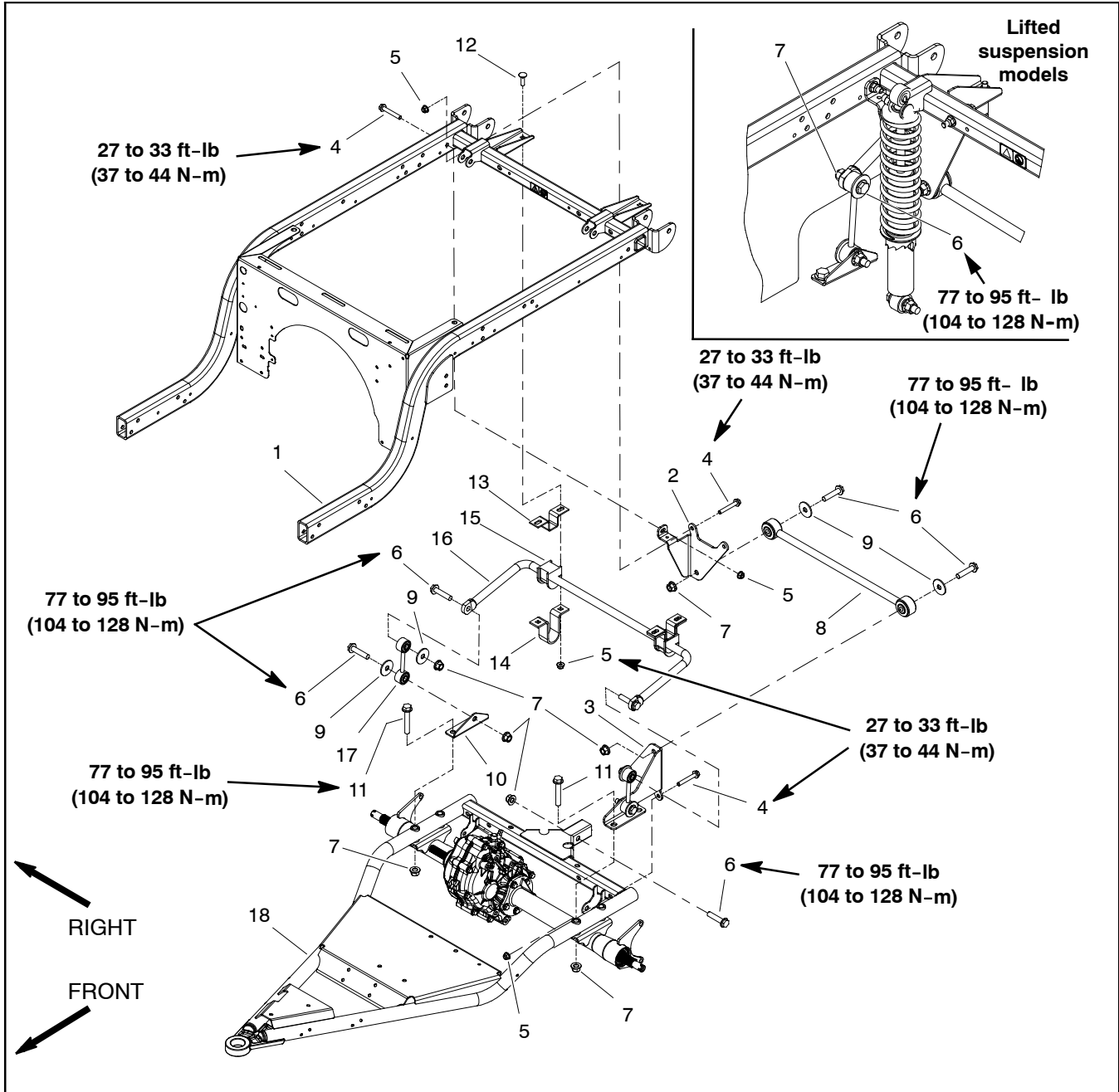
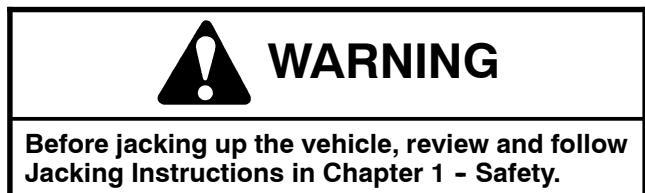

Figure 33

- | | | |
|-------------------------------|--------------------------------|-------------------------------|
| 1. Rear frame | 7. Lock nut (10 used) | 13. Sway bar bracket (2 used) |
| 2. Stabilizer bar bracket | 8. Panhard rod assembly | 14. Sway bar clamp (2 used) |
| 3. Stabilizer bar bracket | 9. Thrust washer (6 used) | 15. Rubber bushing (2 used) |
| 4. Flange head screw (5 used) | 10. Sway bar link bracket | 16. Anti-sway bar |
| 5. Flange nut (9 used) | 11. Flange head screw (4 used) | 17. Sway bar link (2 used) |
| 6. Flange head screw (6 used) | 12. Carriage bolt (4 used) | 18. Swing arm |

Disassembly (Fig. 31)

1. Park vehicle on a level surface, turn key switch OFF, apply parking brake and remove key from the key switch.
2. Raise and support cargo bed for access to rear suspension components from above.



3. Chock front wheels. Use a jack to raise rear wheels off the ground. Support vehicle with appropriate jack stands beneath the rear frame.

4. Support transaxle from below to prevent the transaxle and swing arm from moving during rear suspension disassembly.

**CAUTION**

If stabilizer bar bracket (item 3) or sway bar link bracket need to be removed, make sure that transaxle is supported from below.

5. Remove rear suspension components as needed using Figure 31 as a guide.

A. Check for wear in bushings in panhard rod assembly and replace bushings and or spacers if necessary (shown in Fig. 35).

6. Inspect suspension components for wear or damage and replace parts as needed.

7. If necessary, remove rear shock absorber(s) (Fig. 34):

A. Remove flange head screws and lock nuts that secure shock absorber(s) to rear frame and swing arm.

B. Remove shock absorber(s) from vehicle.

NOTE: On Workman GTX Electric vehicles, rear shocks should be set to third lowest pre-load setting.

NOTE: Use spanner wrench TOR6010 (see Special Tools in this chapter) if rear shock spring pre-load requires adjustment. If the spring is to be removed from the shock absorber, shock spring compressor tool TOR6015 (see Special Tools in this chapter) can be used.

Assembly (Fig. 31)

IMPORTANT: During assembly of rear suspension components, install all components before fully tightening fasteners.

1. Install all removed rear suspension components using Figure 31 as a guide. After all parts have been installed fully tighten fasteners to secure suspension to vehicle. Torque fasteners to specifications listed in Figure 31.

2. Install rear shock absorber(s) if it was removed (Fig. 34):

A. Position shock absorber(s) to rear frame and swing arm brackets.

B. Secure shock absorber(s) to vehicle with flange head screws and lock nuts. Torque screws from **77 to 95 ft-lb (105 to 128 N-m)**.

3. Lower vehicle to ground and lower cargo bed.

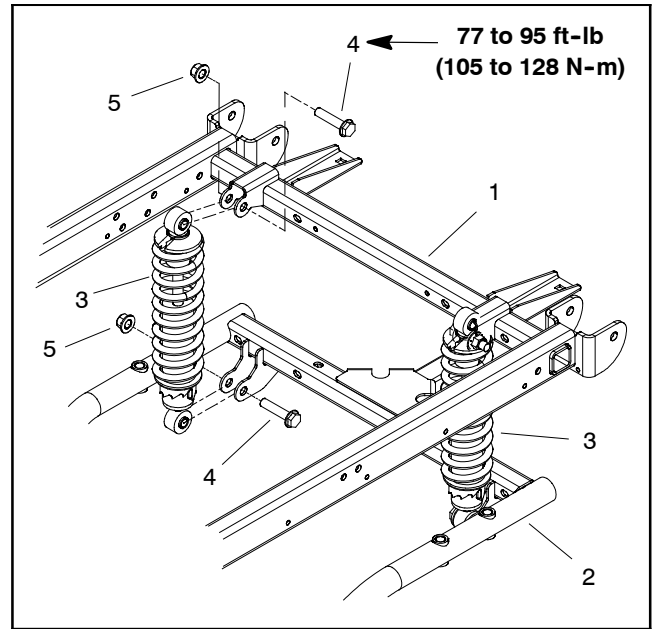

Figure 34

- | | |
|-------------------|----------------------|
| 1. Rear frame | 4. Flange head screw |
| 2. Swing arm | 5. Lock nut |
| 3. Shock absorber | |

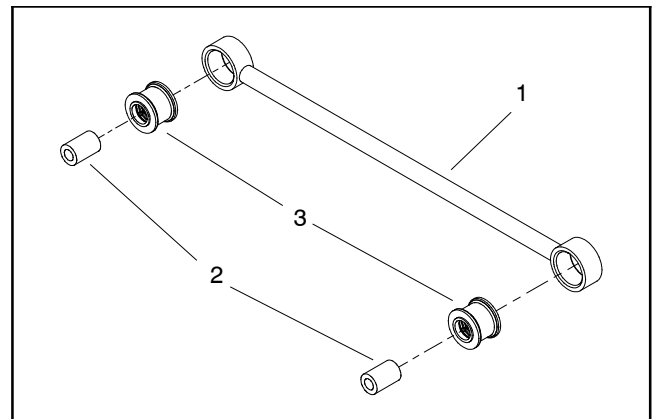

Figure 35

- | | |
|--------------------|---------------------|
| 1. Panhard rod | 3. Bushing (2 used) |
| 2. Spacer (2 used) | |

Swing Arm Mount Assembly

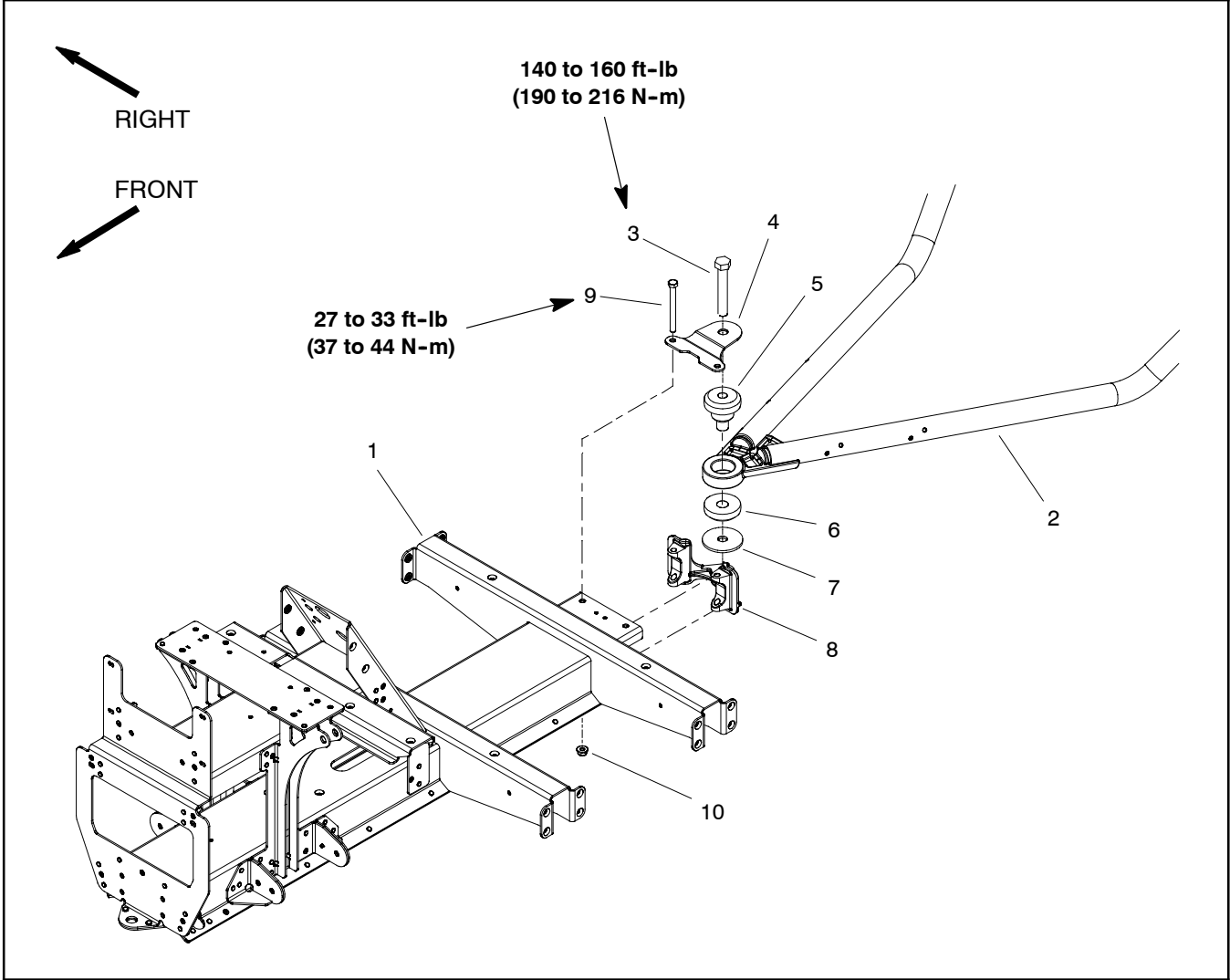

Figure 36

- 1. Front frame
- 2. Swing arm
- 3. Cap screw
- 4. Upper plate
- 5. Isolator (upper portion)
- 6. Isolator (lower portion)
- 7. Snubbing washer
- 8. Rear suspension mount
- 9. Cap screw (2 used)
- 10. Flange nut (2 used)

Removal (Fig. 36)

1. Park vehicle on a level surface, turn key switch OFF and remove key from the key switch. Make sure to apply parking brake
2. Raise and support cargo bed with prop rod.
3. Chock the front and rear of both front tires to prevent the vehicle from moving.

IMPORTANT: Make sure to not damage the rear brake lines, electrical harness, parking brake cables or other parts while disassembling the swing arm mount.

4. Remove cap screw that secures swing arm to rear suspension mount.
5. Carefully, raise and support front of swing arm just enough to allow clearance for removal of isolator and snubbing washers.
6. Remove snubbing washers and isolator mount from bore in front of swing arm.
7. If necessary, remove two (2) cap screws, washers and flange nuts that secure the rear suspension mount to the front frame. Remove mount from front frame.

Installation (Fig. 36)

1. If rear suspension mount was removed, position mount to front frame and secure with two (2) cap screws, washers and flange nuts. Torque cap screws from **27 to 33 ft-lb (37 to 44 N-m)**.

IMPORTANT: Make sure to not damage the brake lines, electrical harness, parking brake cables or other parts while assembling the swing arm mount.

2. Insert upper portion of isolator mount down through the swing arm and into the lower portion of the mount.
3. Place snubbing washer between the bottom of the isolator mount and the top of the rear suspension mount.
4. Carefully lower front of swing arm so the holes in the isolator mount, snubbing washer and threaded hole in rear suspension mount are aligned.
5. Place second snubbing washer on the top of the isolator mount and then secure swing arm to rear suspension mount with cap screw. Torque screw from **140 to 160 ft-lb (190 to 216 N-m)**.
6. Lower and secure cargo bed.

Seat Base

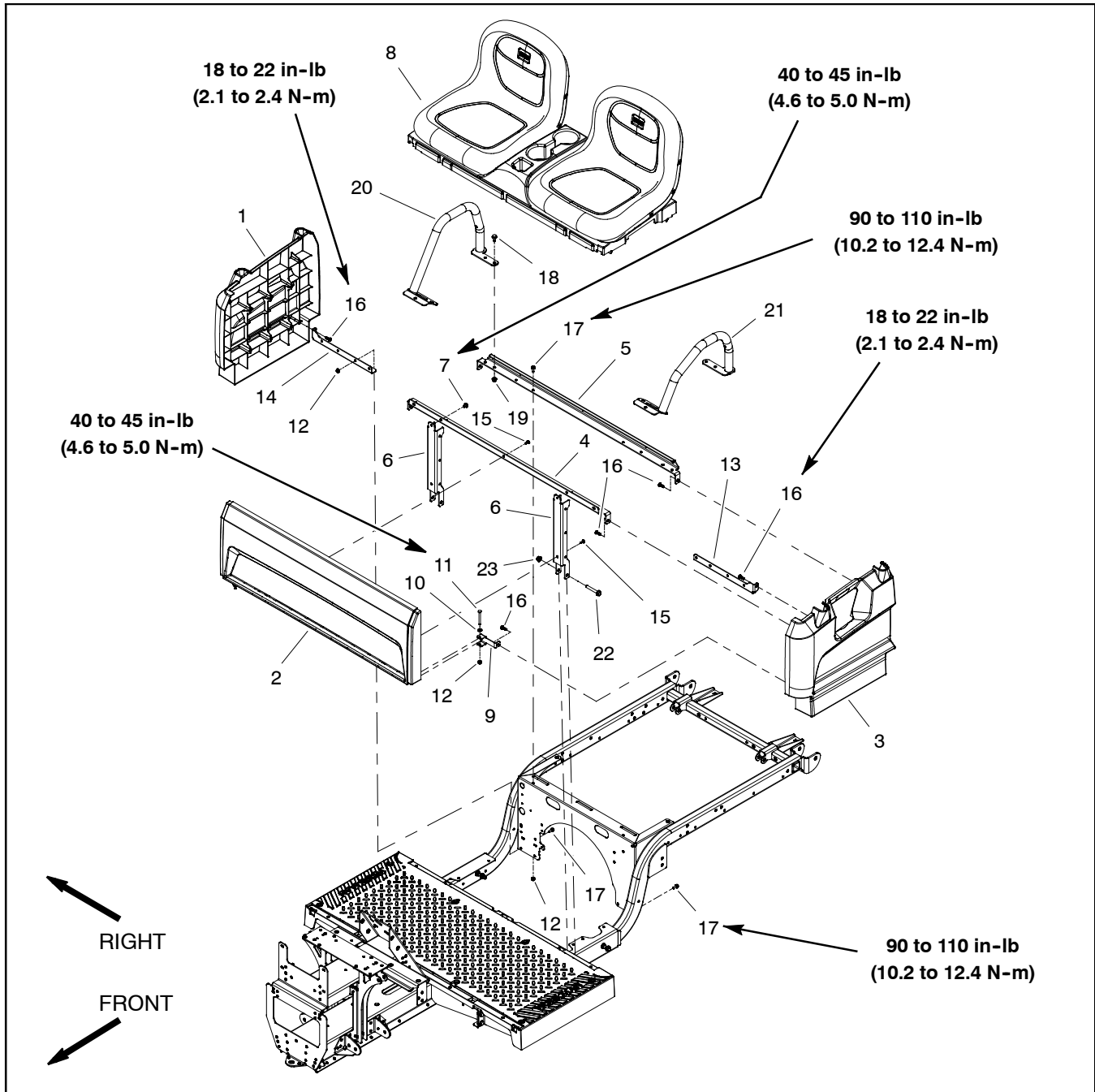

Figure 37

- | | | |
|---|---|--|
| <ul style="list-style-type: none"> 1. RH seat base side 2. Seat base front panel 3. LH seat base side 4. Seat support angle 5. Rear seat support angle 6. Seat support channel (2 used) 7. Screw with washer (2 used) 8. Seat base assembly | <ul style="list-style-type: none"> 9. Floor plate clamp (2 used) 10. Flat washer (2 used) 11. Flange head screw (2 used) 12. Flange nut (8 used) 13. LH side support bracket 14. RH side support bracket 15. Washer head screw (5 used) 16. Screw (12 used) | <ul style="list-style-type: none"> 17. Flange head screw (6 used) 18. Washer head screw (6 used) 19. Flange nut (6 used) 20. RH hip restraint 21. LH hip restraint 22. Flange head screw (2 used) 23. Flange nut (2 used) |
|---|---|--|

Disassembly (Fig. 37)

1. Park vehicle on a level surface, turn key switch OFF, apply parking brake and remove key from the key switch.
2. Remove seat base assembly with attached seats from vehicle.
3. If left hand seat base side is to be removed from vehicle (Fig. 38):
 - A. Remove onboard battery charger from vehicle (see Onboard Battery Charger in the Service and Repairs section of Chapter 3 - Electrical System).
 - B. Remove four (4) screws that secure seat base side to charger bracket (Fig. 38).
 - C. Support left hand seat base side and remove four (4) screws that secure seat base side to supports illustrated in Figure 37.
 - D. Remove left hand seat base side from vehicle.
4. Remove remaining seat base panels and supports from vehicle as needed using Figure 37 as a guide.
5. If needed, remove seats from seat base (Fig. 39).

Assembly (Fig. 37)

1. Secure seats to seat base if they were removed (Fig. 39). Torque cap screws from **90 to 110 in-lb (10.2 to 12.4 N-m)**.
2. Install all removed seat base panels and supports to vehicle using Figures 37 and 38 as guides. When securing seat base supports to vehicle, use torque values identified in Figures 37 and 38.
3. If onboard battery charger was removed from vehicle, install charger (see Onboard Battery Charger in the Service and Repairs section of Chapter 3 - Electrical System).
4. Install seat base assembly with attached seats to vehicle.

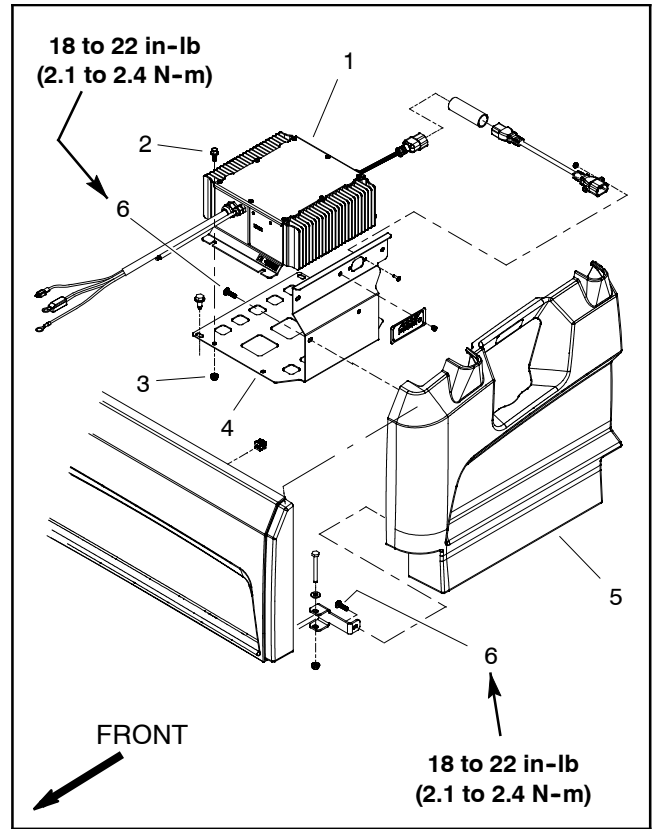

Figure 38

- | | |
|------------------------|----------------------|
| 1. Battery charger | 4. Charger bracket |
| 2. Screw (4 used) | 5. LH seat base side |
| 3. Flange nut (4 used) | 6. Screw (4 used) |

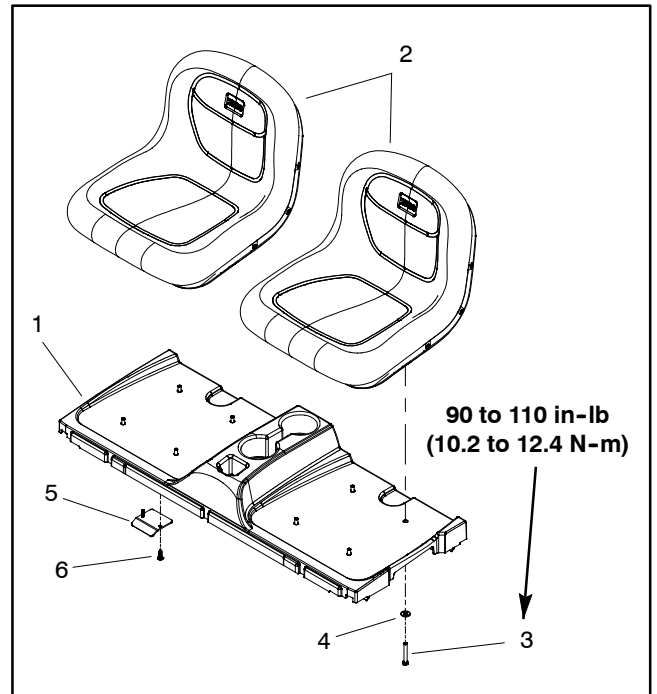

Figure 39

- | | |
|-----------------------|-------------------------|
| 1. Seat base | 4. Flat washer (8 used) |
| 2. Seat (2 used) | 5. Retainer (2 used) |
| 3. Cap screw (8 used) | 6. Screw (4 used) |

Dash

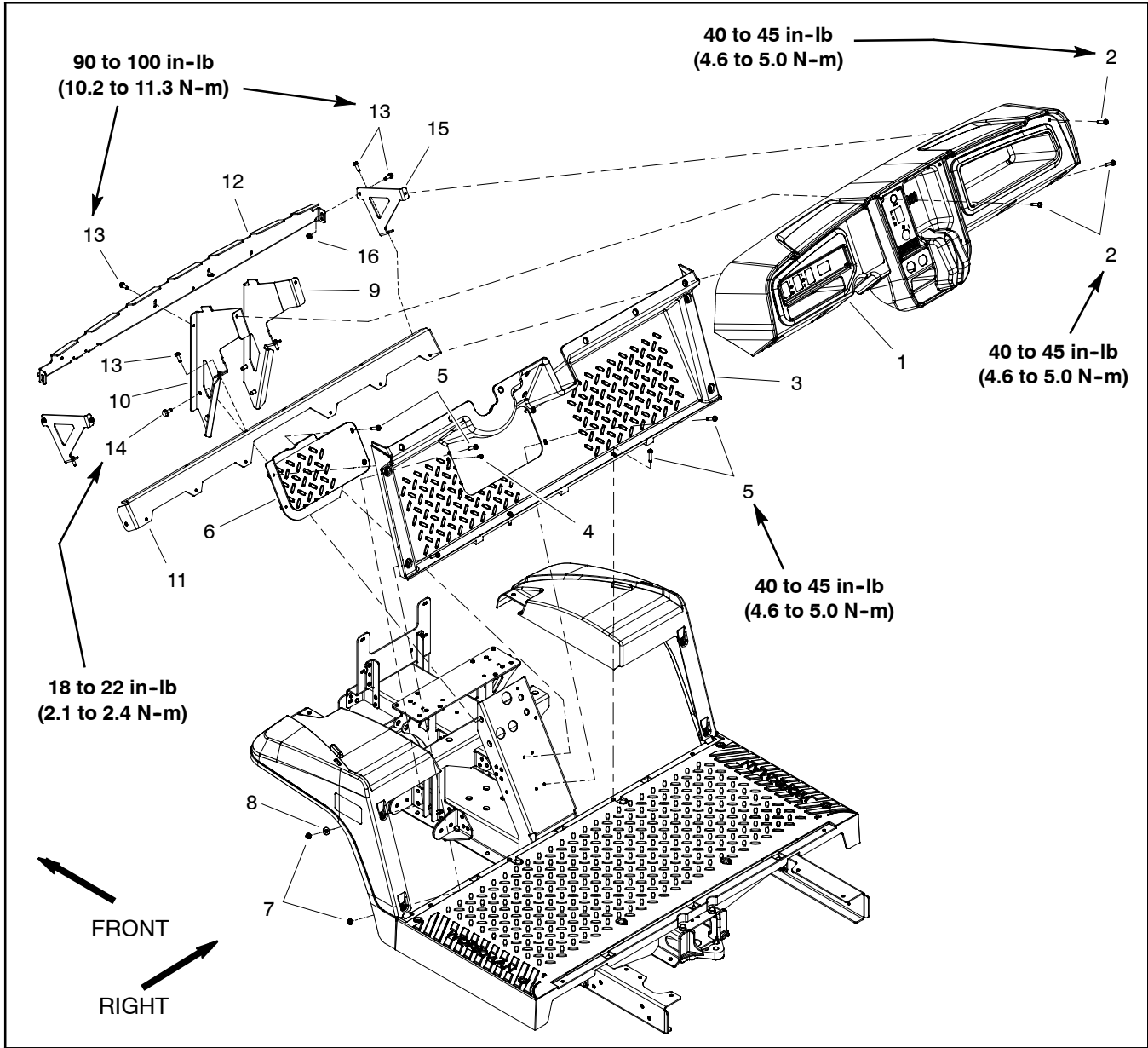

Figure 40

- | | | |
|--------------------------------|-------------------------|--------------------------------|
| 1. Dash | 7. Flange nut (4 used) | 12. Dash bracket |
| 2. Washer head screw (10 used) | 8. Flat washer (2 used) | 13. Washer head screw (8 used) |
| 3. Foot board | 9. RH dash bracket | 14. Washer head screw (4 used) |
| 4. Screw (2 used) | 10. LH dash bracket | 15. Side dash bracket (2 used) |
| 5. Washer head screw (10 used) | 11. Dash angle bracket | 16. Flange nut (2 used) |
| 6. Foot board cover | | |

Removal (Fig. 40)

1. Park vehicle on a level surface, turn key switch OFF, apply parking brake and remove key from the key switch.
2. Raise hood to allow access to wire harness connections to switches mounted in dash.
3. Disconnect wire harness connectors from all switches and power ports on dash.
4. Remove ten (10) washer head screws that secure dash to vehicle.
5. Carefully lift dash from vehicle supports and remove it from the vehicle.

Installation (Fig. 40)

NOTE: Do not fully tighten fasteners securing dash until all fasteners are in place.

1. Carefully position dash to vehicle by lowering it over parking brake lever.
2. Secure dash with removed washer head screws using fastener torque specifications that are identified in Figure 40.

IMPORTANT: Make sure that the USB power point is connected with the correct polarity. The white (positive) harness wire should be connected to the upper USB power point terminal.

3. Connect wire harness connectors to all switches and power ports on dash.
4. Lower and secure front hood.

Front Fenders, Hood and Bumper

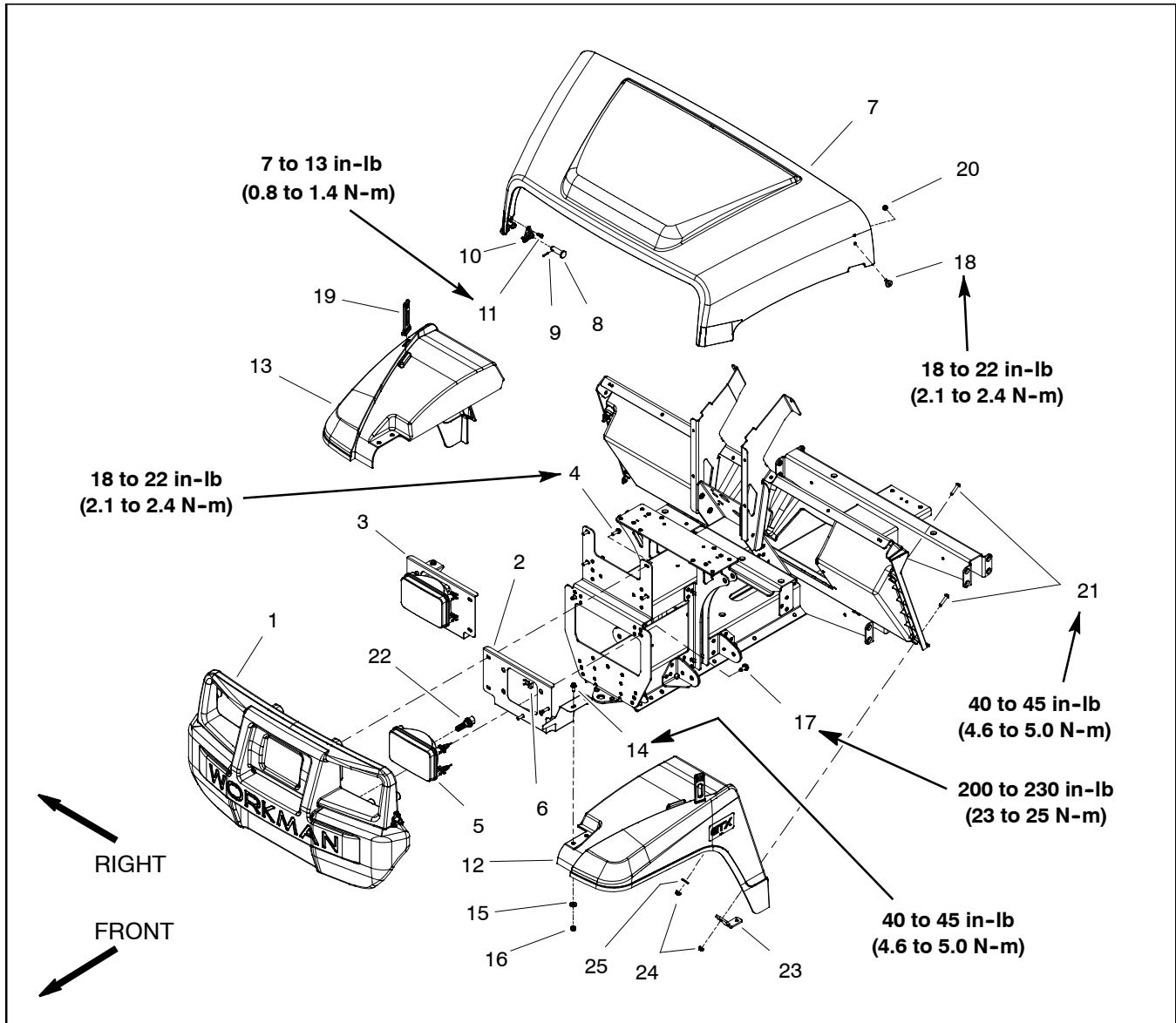

Figure 41

- | | | |
|--------------------------------|--------------------------------|--------------------------------|
| 1. Bumper | 10. Retainer pin (2 used) | 18. Screw (2 used) |
| 2. LH headlight bracket | 11. Washer head screw (6 used) | 19. Hold down strap (2 used) |
| 3. RH headlight bracket | 12. LH front fender | 20. Lock nut (2 used) |
| 4. Washer head screw (8 used) | 13. RH front fender | 21. Washer head screw (4 used) |
| 5. Headlight assembly (2 used) | 14. Flange head screw (4 used) | 22. LED bulb (2 used) |
| 6. Speed clip (6 used) | 15. Flat washer (4 used) | 23. Angle bracket (2 used) |
| 7. Hood | 16. Flange nut (4 used) | 24. Flange nut (4 used) |
| 8. Clevis pin (2 used) | 17. Washer head screw (2 used) | 25. Flat washer (2 used) |
| 9. Spring pin (2 used) | | |

Removal (Fig. 41)

1. Park vehicle on a level surface, turn key switch OFF, apply parking brake and remove key from the key switch.
2. Remove front fenders, hood or front bumper using Figure 41 as a guide.

Installation (Fig. 41)

NOTE: Do not fully tighten fasteners securing body components until all fasteners are in place.

1. Install removed body components using Figure 41 as a guide. During assembly, use fastener torque specifications that are identified in Figure 41.

Cargo Bed

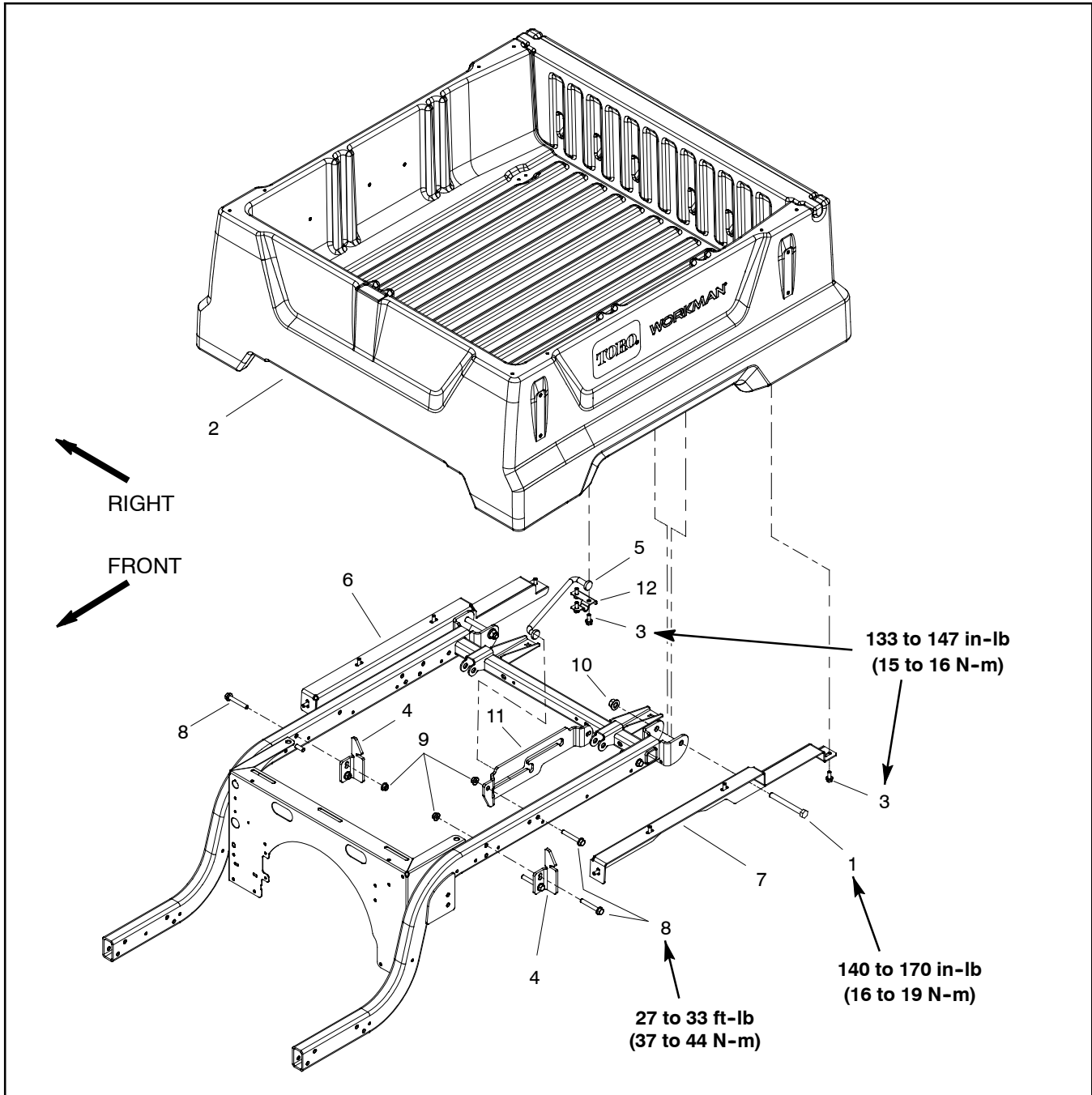

Figure 42

- 1. Cap screw (2 used)
- 2. Cargo bed assembly
- 3. Flange head screw
- 4. Bed latch striker (2 used)

- 5. Prop rod
- 6. RH cargo bed support
- 7. LH cargo bed support
- 8. Flange head screw (6 used)

- 9. Flange nut (6 used)
- 10. Lock nut (2 used)
- 11. Prop rod bracket
- 12. Prop rod U-bracket

Disassembly

1. Park vehicle on a level surface, turn key switch OFF, apply parking brake and remove key from the key switch.
2. Make sure that cargo bed is empty.
3. If necessary, remove cargo bed from vehicle (Fig. 42):
 - A. Raise cargo bed and support bed so that prop rod assembly can be removed from bottom of bed.
 - B. Remove three (3) flange head screws that secure prop rod U-bracket (item 12) to bed and remove bracket and prop rod (item 5).
 - C. Lower cargo bed to vehicle frame.
 - D. Remove two (2) cap screws (item 1) and lock nuts (item 10) that secure cargo bed assembly to frame.
 - E. Lift cargo bed assembly from vehicle.
4. Disassemble cargo bed as necessary using Figures 42, 43 and 44 as guides.

Assembly

1. Assemble cargo bed using Figures 42, 43 and 44 as guides.
 - A. Use torque specifications that are identified in the illustrations when assembling cargo bed.
2. If removed, secure cargo bed to vehicle (Fig. 42):
 - A. Position cargo bed assembly to vehicle.
 - B. Secure cargo bed assembly to frame with two (2) cap screws (item 1) and lock nuts. Torque cap screws from **140 to 170 in-lb (16 to 19 N-m)**.
 - C. Raise cargo bed and support bed so that prop rod assembly can be secured to bottom of bed.
 - D. Make sure that end of prop rod (item 5) is installed into slot in prop rod bracket (item 11) attached to frame.
 - E. Secure prop rod U-bracket (item 12) and prop rod to bed with three (3) flange head screws. Torque screws from **133 to 147 in-lb (15 to 16 N-m)**.
 - F. Lower cargo bed to vehicle frame.

3. Adjust bed latch strikers (item 4 in Fig. 42) so that cargo bed closes completely and is latched at both sides. Strikers can be raised or lowered to latch bed.

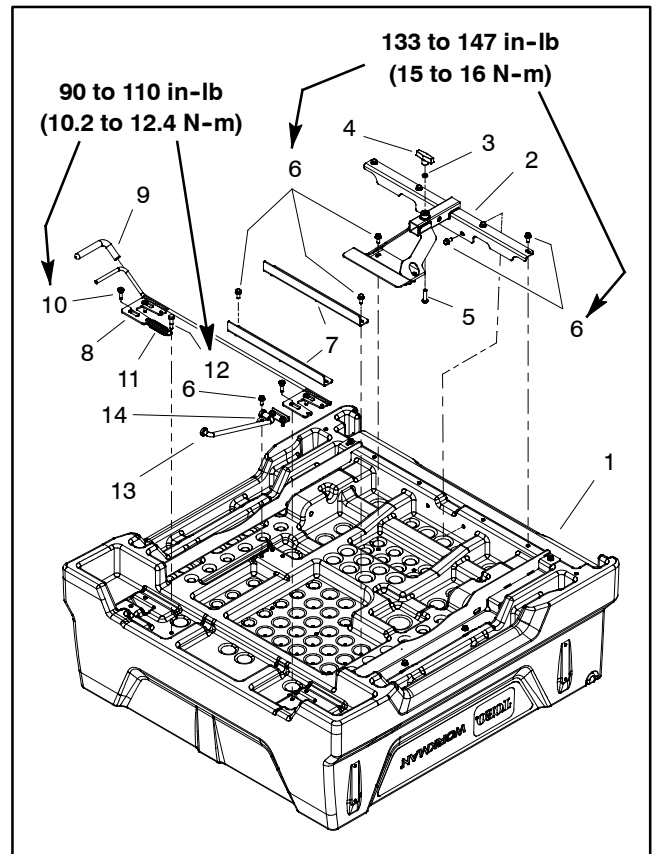

Figure 43

- | | |
|-----------------------|-----------------------------|
| 1. Cargo bed | 8. Latch |
| 2. Quick attachment | 9. Grip |
| 3. Jam nut | 10. Shoulder screw (4 used) |
| 4. T handle | 11. Extension spring |
| 5. Screw | 12. Shoulder screw |
| 6. Flange head screw | 13. Prop rod |
| 7. Bed brace (2 used) | 14. Prop rod U-bracket |

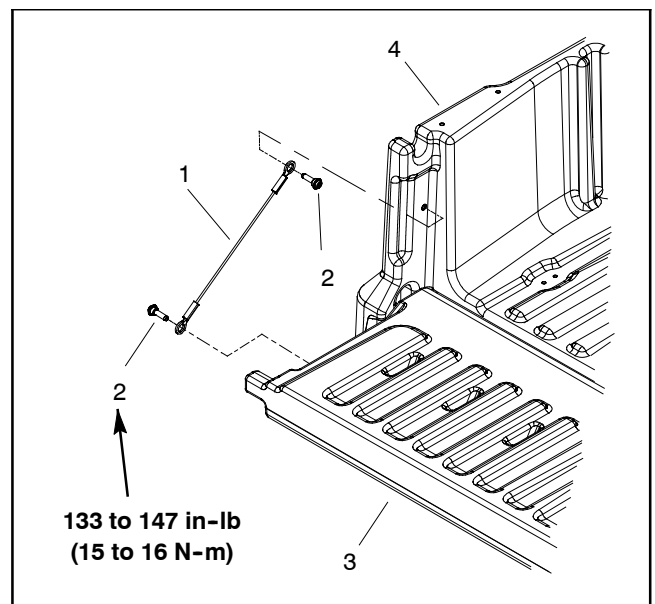

Figure 44

- | | |
|----------------------------|--------------|
| 1. Tailgate lanyard | 3. Tailgate |
| 2. Shoulder screw (2 used) | 4. Cargo bed |

This page is intentionally blank.



Table of Contents

ELECTRICAL DRAWING DESIGNATIONS 2

ELECTRICAL SCHEMATIC 3

 Workman GTX Electric (Serial number below 403448000) 3

 Workman GTX Electric (Serial number above 403448001) 4

 Workman GTX Lithium 5

ELECTRICAL CIRCUIT DRAWINGS

 ON Circuit (Key Switch in ON Position) 6

 Run Circuits (Forward) 7

 Battery Charging Circuit 8

WIRE HARNESSES

 Workman GTX Electric Wire Harness - Main (Serial number below 403448000) 9

 Workman GTX Electric Wire Harness - Main (Serial number above 403448001) 11

 Workman GTX Lithium Wire Harness 13

 Wire Harness - Cab Power Supply 15

 Wire Harness - Cab Model 07142 16

 Wire Harness - Light Kit (Cab) 17

 Wire Harness - Light Kit - (No Cab) 18

 Wire Harness - EU Tail Light Kit 19

 Wire Harness - Power Upgrade 20

 Wire Harness - Wireless Hourmeter 21

 Workman GTX Lithium Wire Harness - Charger Interface 22

Electrical Drawings

Electrical Drawing Designations

The following abbreviations are used for wire harness colors on the electrical schematics and wire harness drawings in this chapter.

<u>ABBREVIATION</u>	<u>COLOR</u>
BK	BLACK
BN	BROWN
BU	BLUE
GN	GREEN
GY	GRAY
OR	ORANGE
PK	PINK
R or RD	RED
T	TAN
VIO	VIOLET
W or WH	WHITE
Y or YE	YELLOW

Numerous harness wires used on Workman GTX Electric vehicles include a line with an alternate color. These wires are identified with the wire color and line color with a / separating the color abbreviations listed above (e.g. BK/W is a black wire with a white line).

NOTE: The wire harness diagram in this chapter identifies both the wire color and the wire gauge. For example, 16 BK on a harness diagram identifies a 16 gauge wire that has a black insulator.

NOTE: A splice used in a wire harness will be identified on the wire harness diagram by SP. The manufacturing number of the splice is also identified on the wire harness diagram (e.g. SP01 is splice number 1).

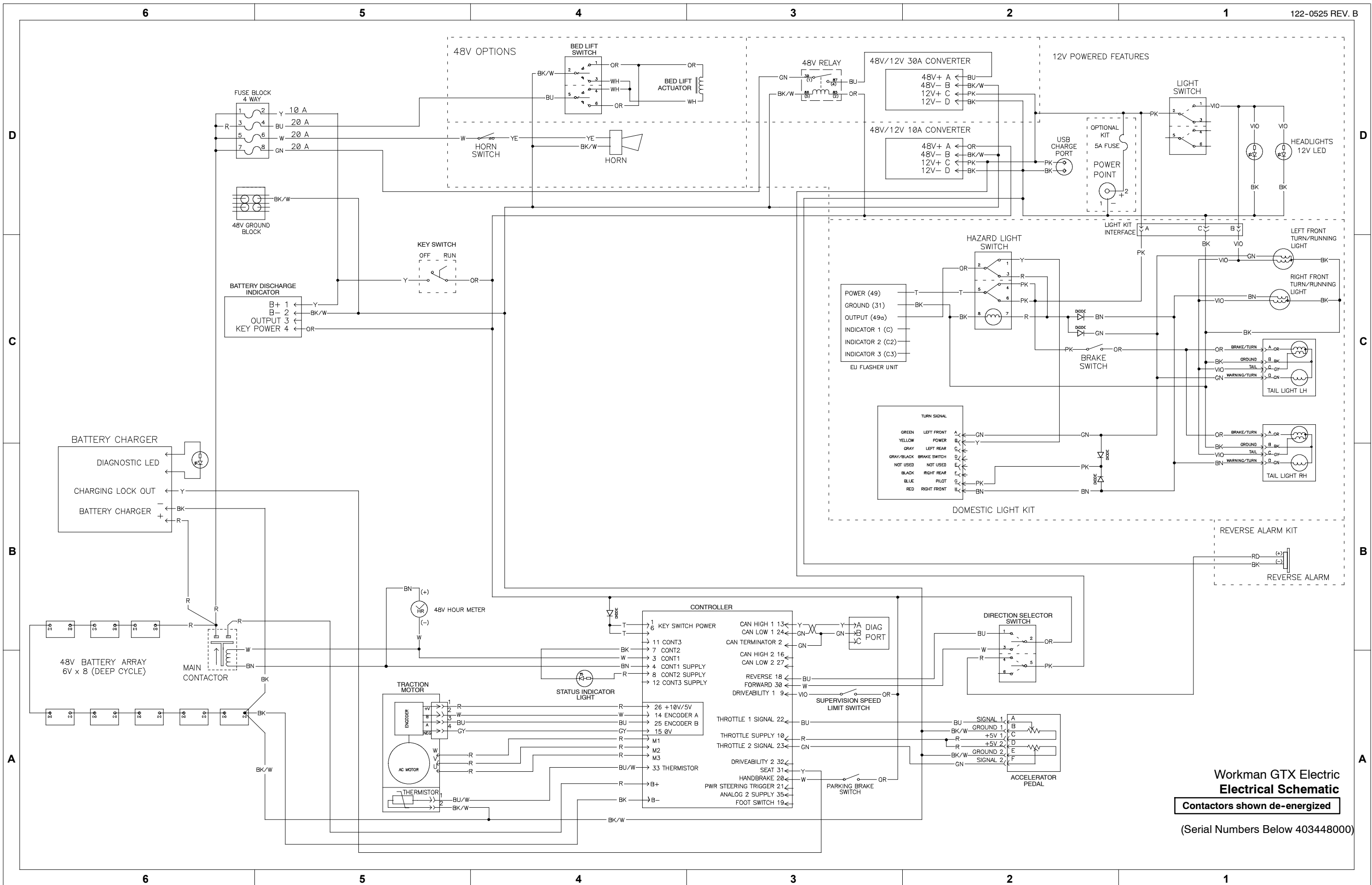

**Workman GTX Electric
Electrical Schematic**
 Contactors shown de-energized
 (Serial Numbers Below 403448000)

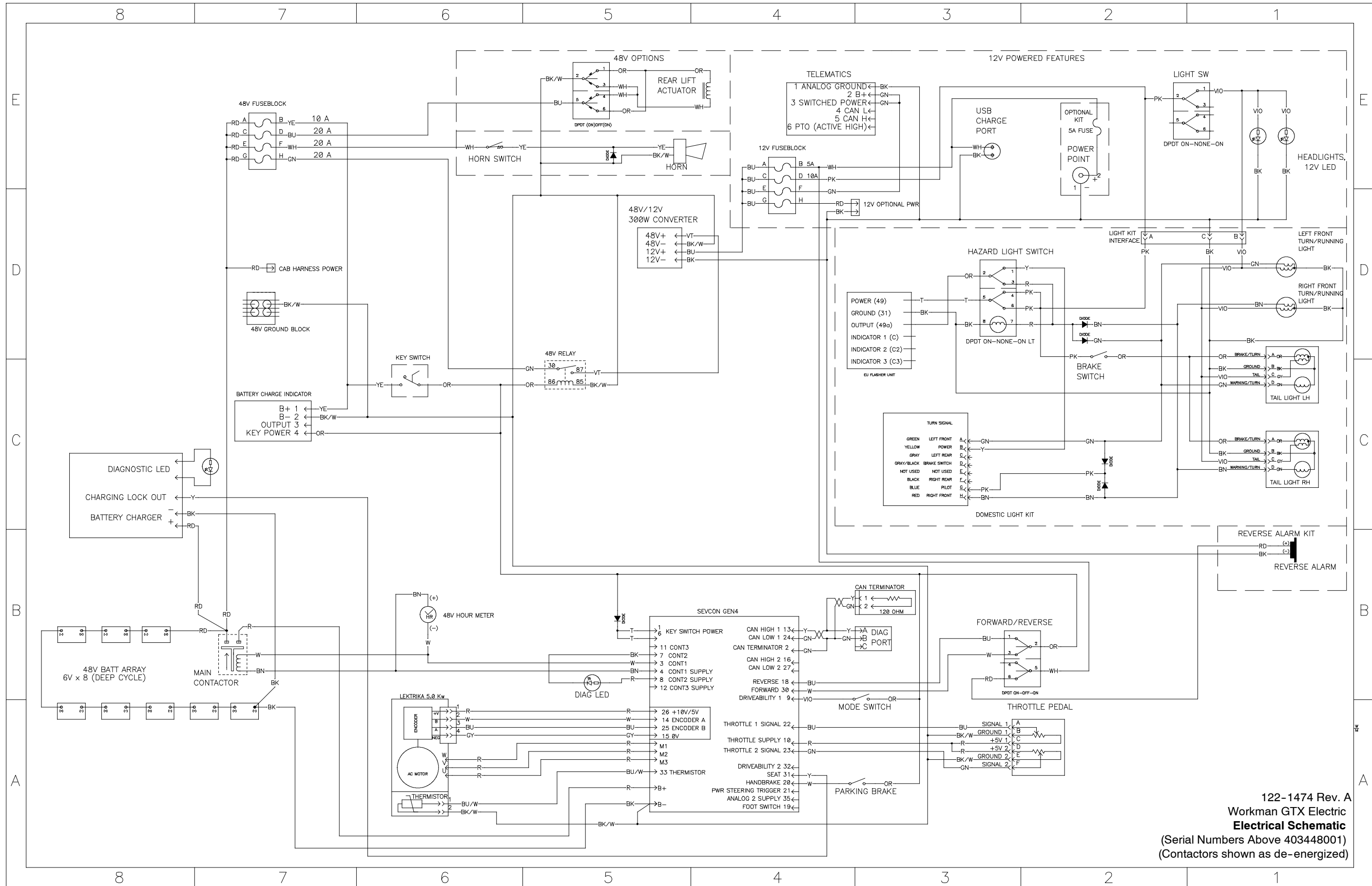

122-1474 Rev. A
 Workman GTX Electric
Electrical Schematic
 (Serial Numbers Above 403448001)
 (Contactors shown as de-energized)

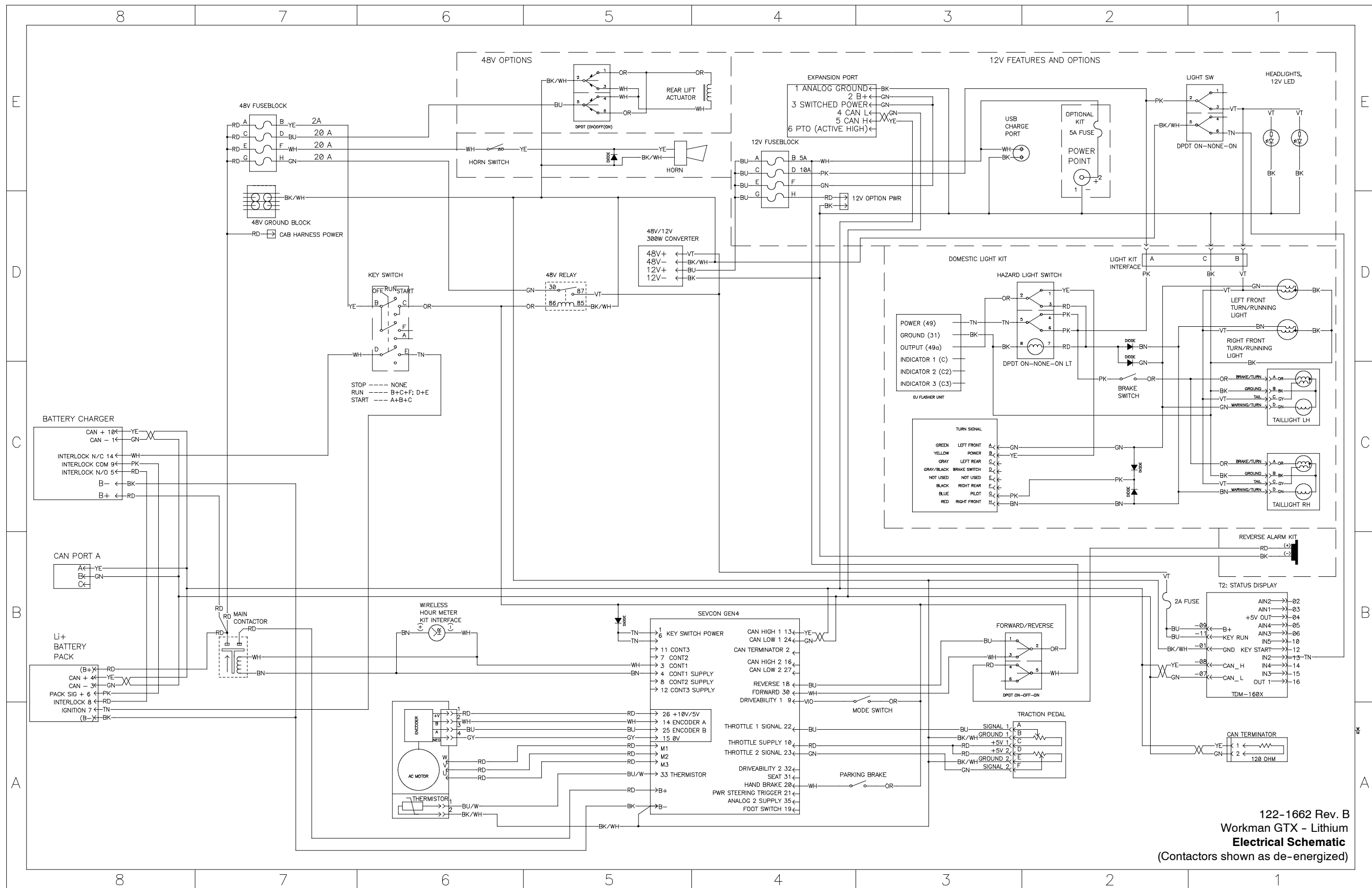

122-1662 Rev. B
 Workman GTX - Lithium
Electrical Schematic
 (Contactors shown as de-energized)

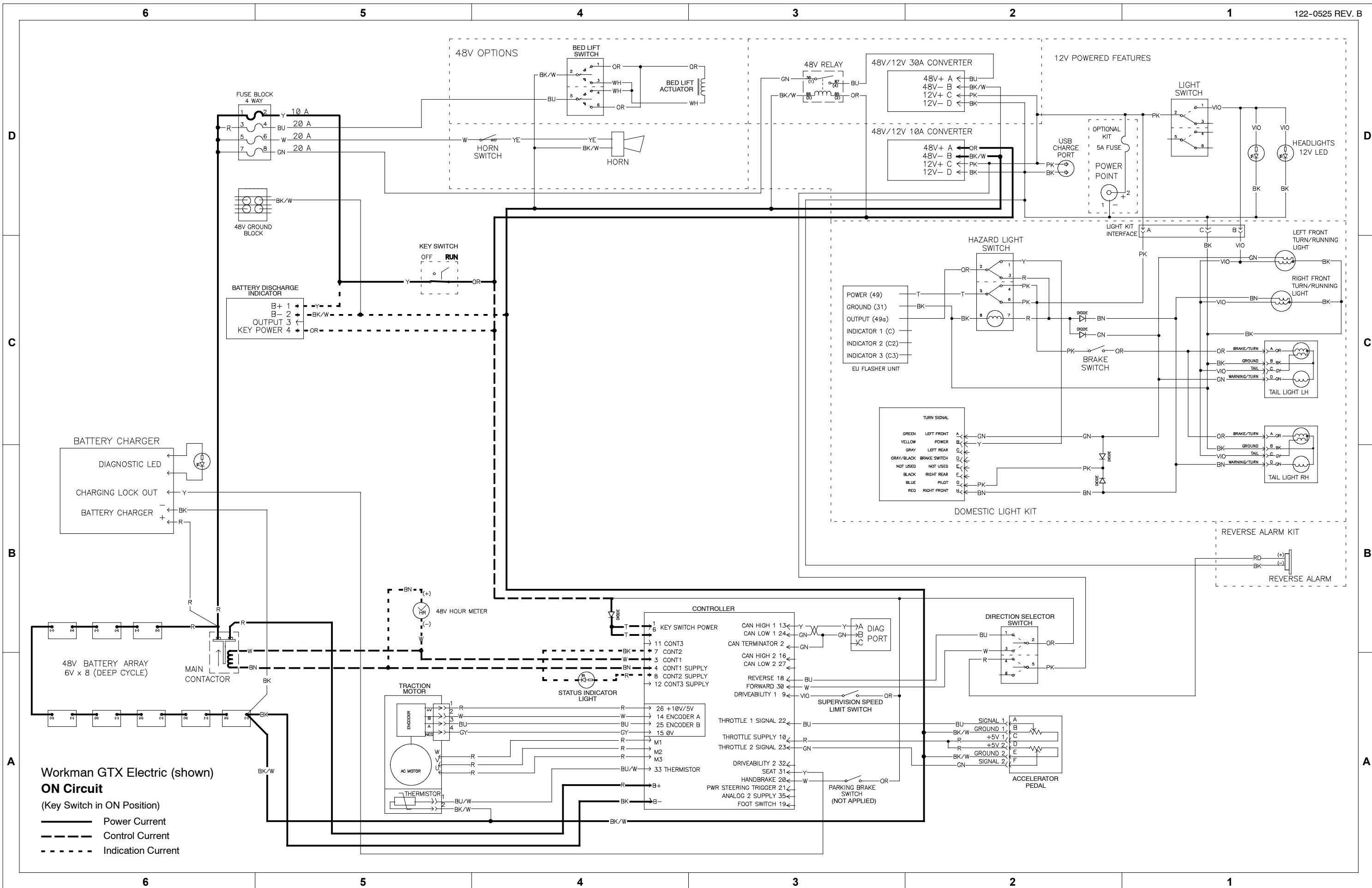

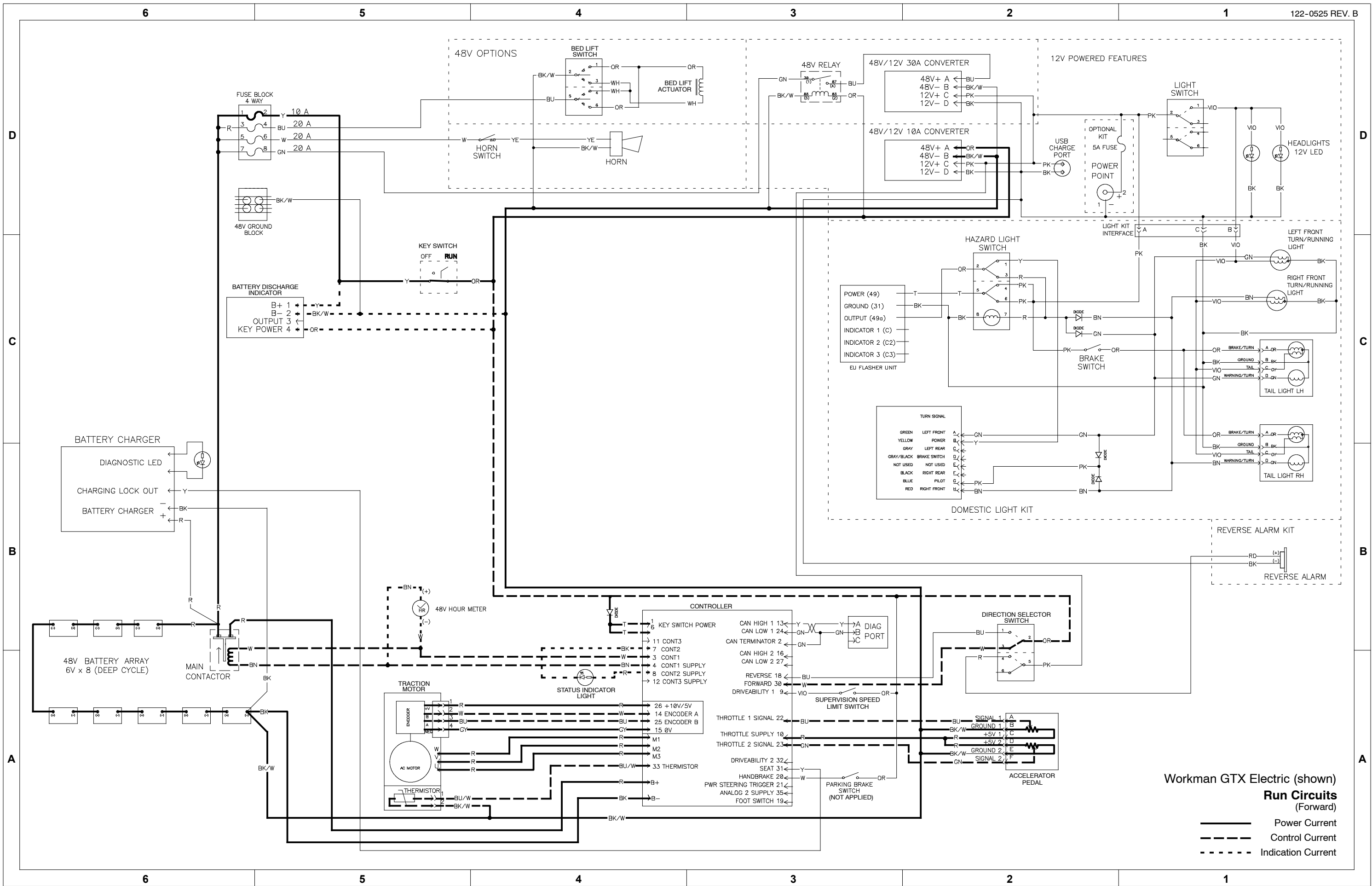

Workman GTX Electric (shown)
Run Circuits
 (Forward)

- Power Current
- - - - - Control Current
- Indication Current

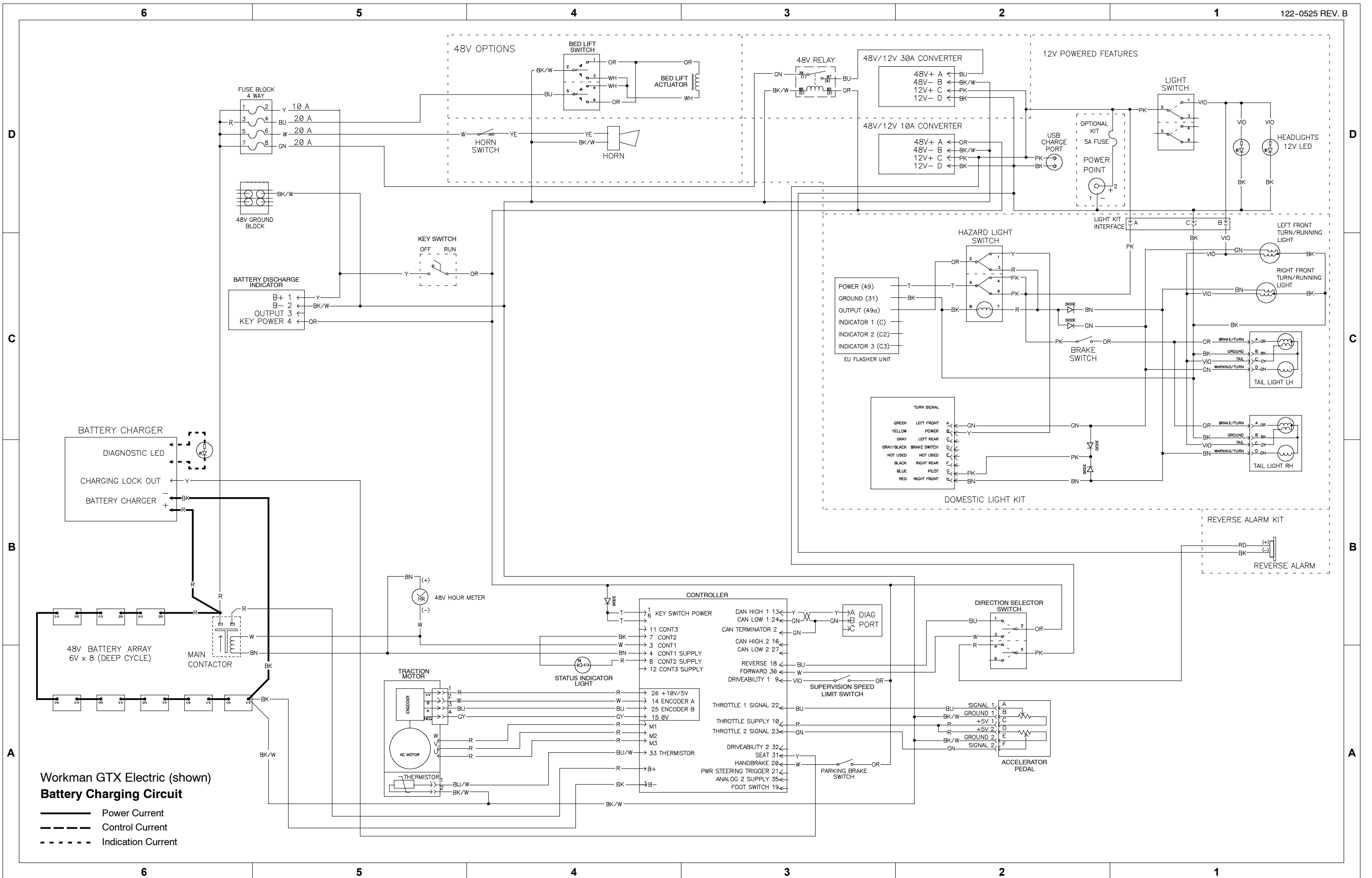

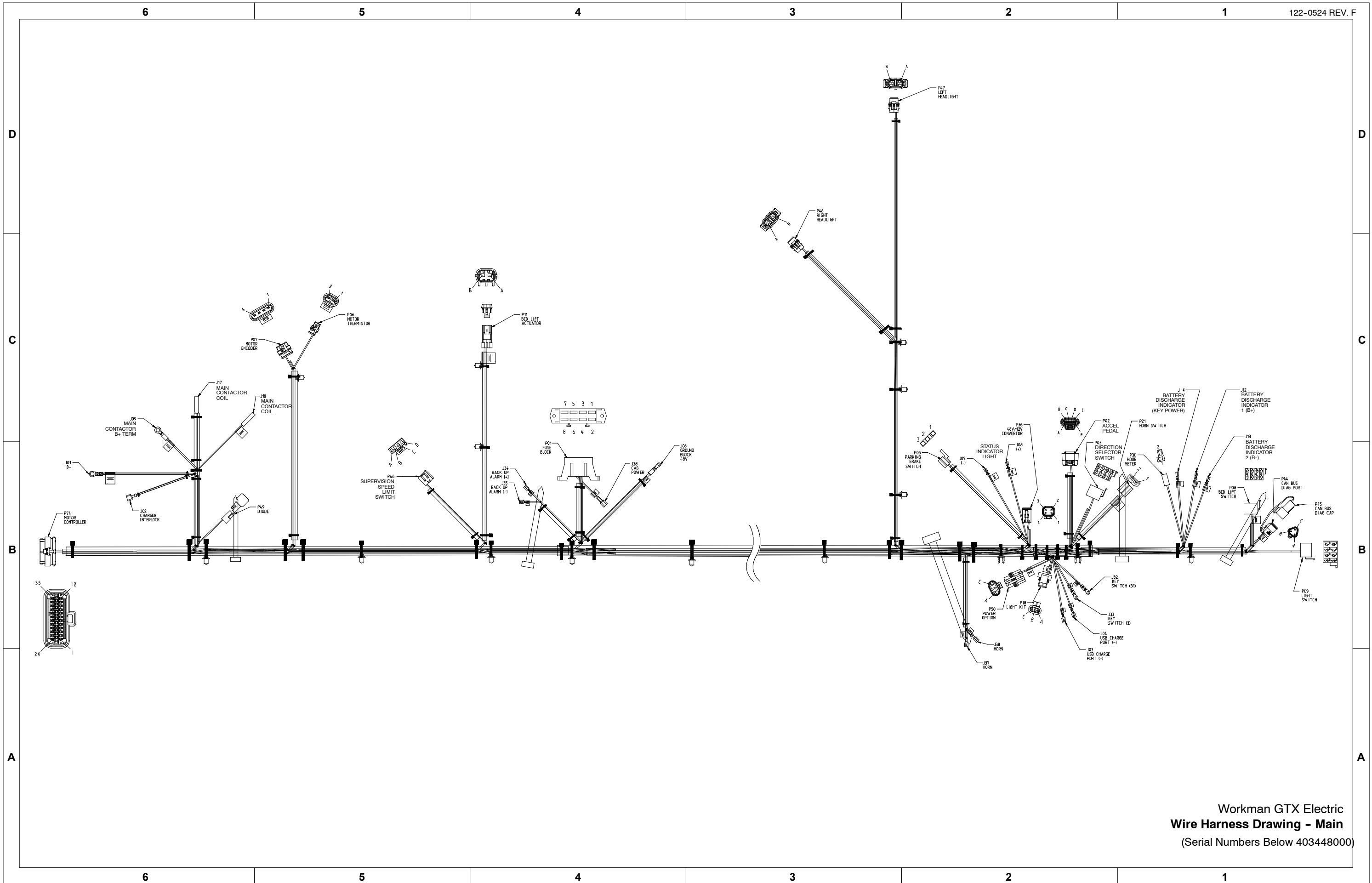

Workman GTX Electric
Wire Harness Drawing - Main
 (Serial Numbers Below 403448000)

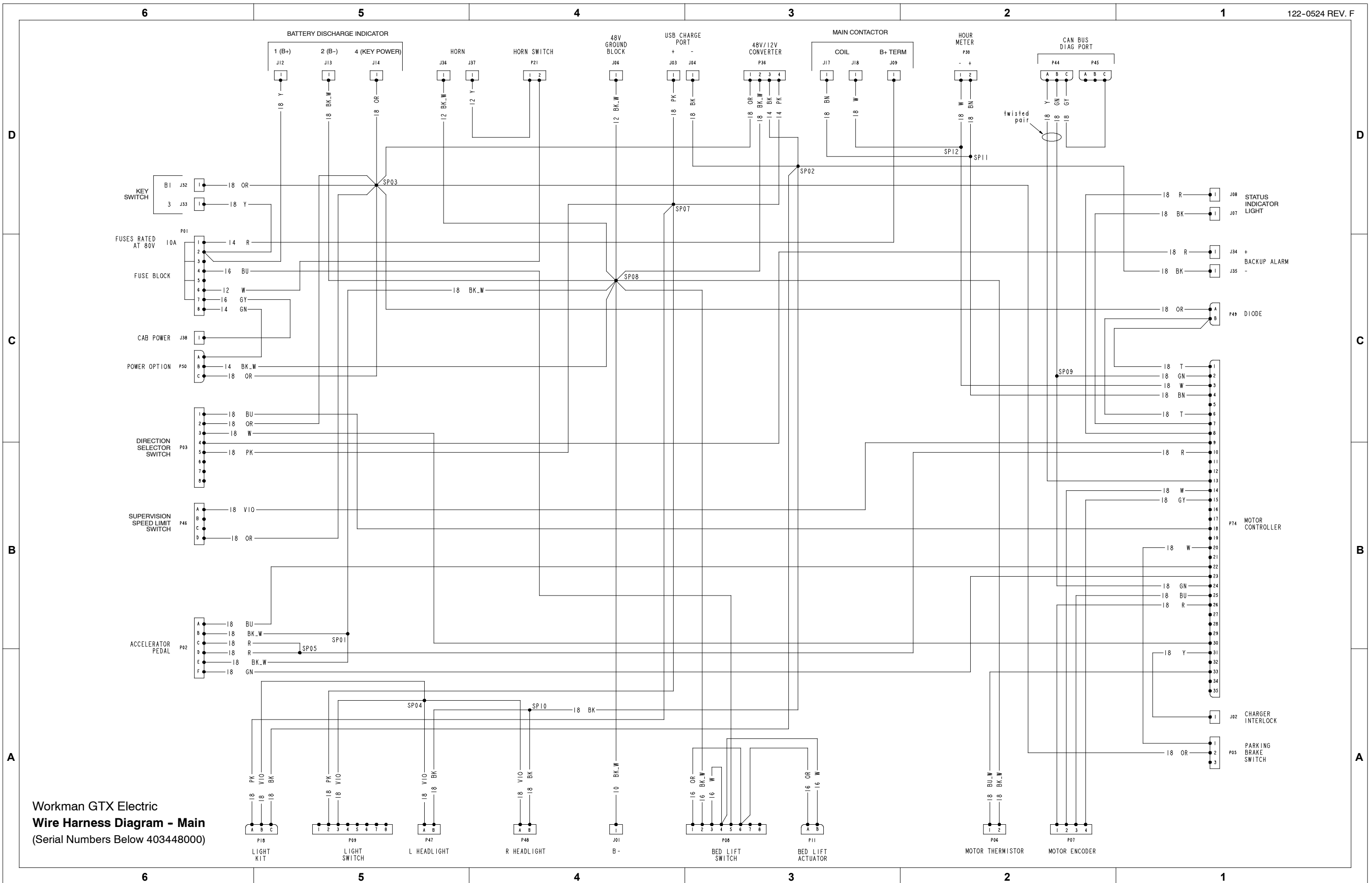

Workman GTX Electric
Wire Harness Diagram - Main
 (Serial Numbers Below 403448000)

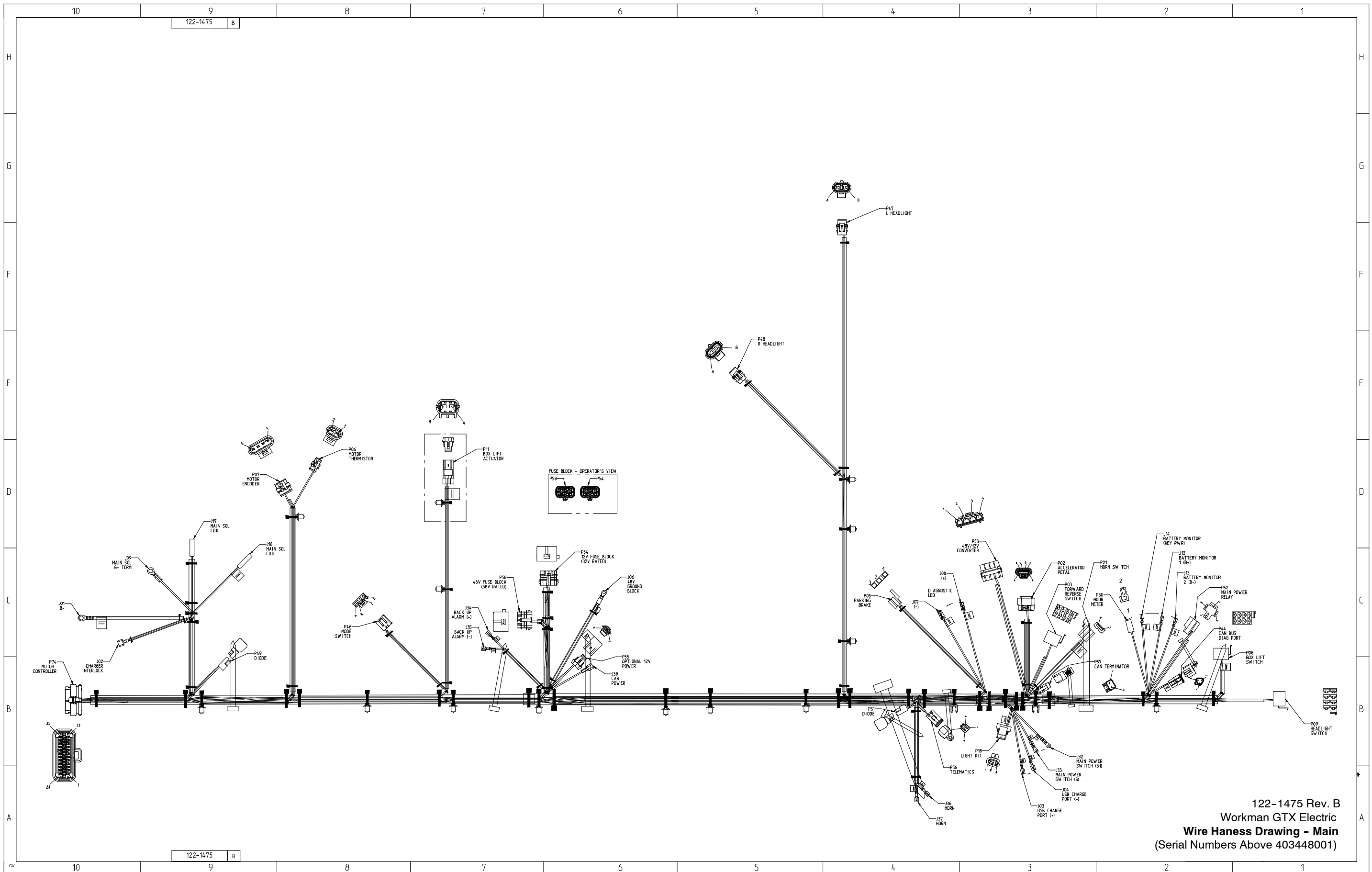

122-1475 Rev. B
 Workman GTX Electric
Wire Harness Drawing - Main
 (Serial Numbers Above 403448001)

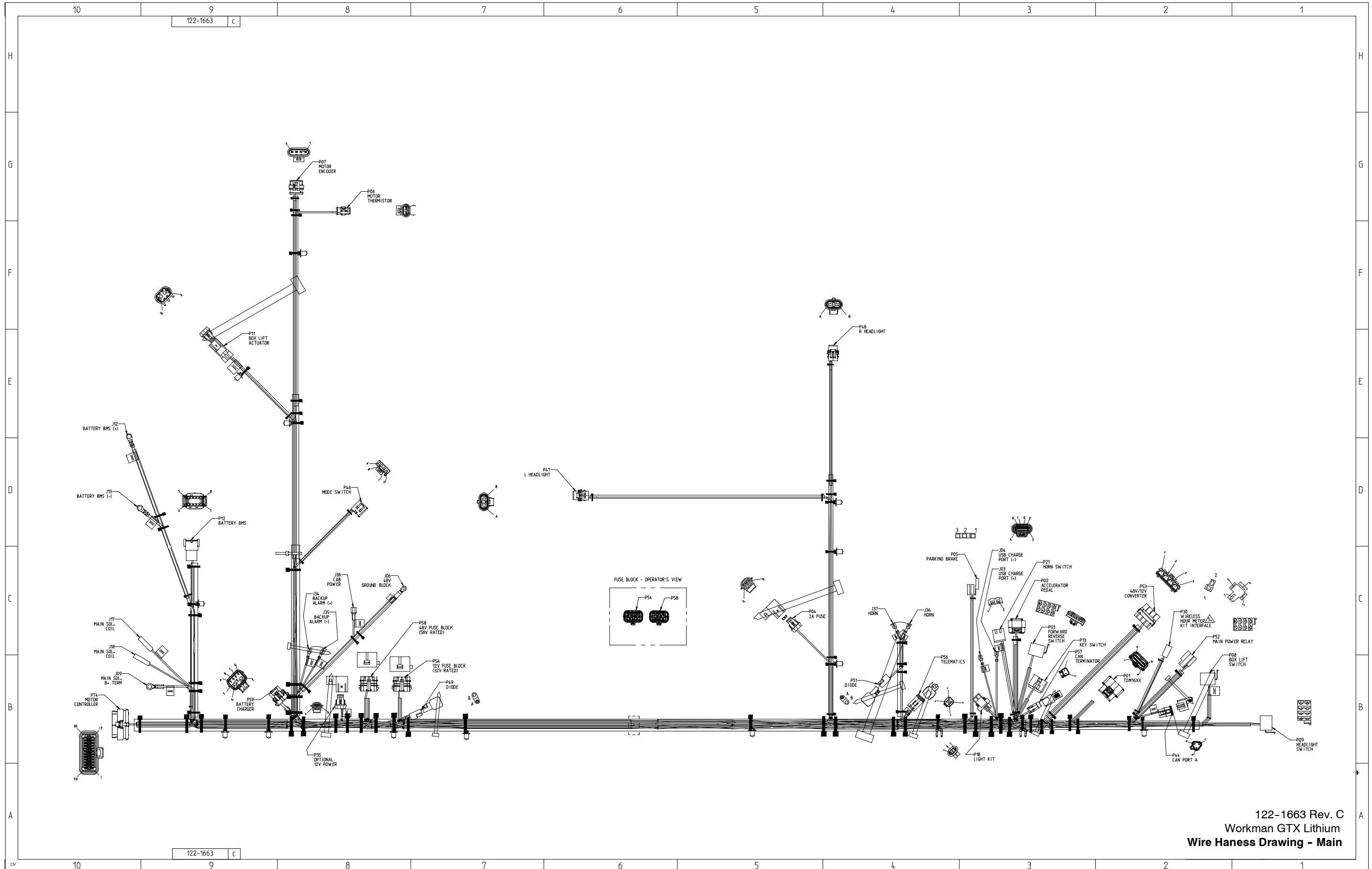

122-1663 Rev. C
 Workman GTX Lithium
 Wire Harness Drawing - Main

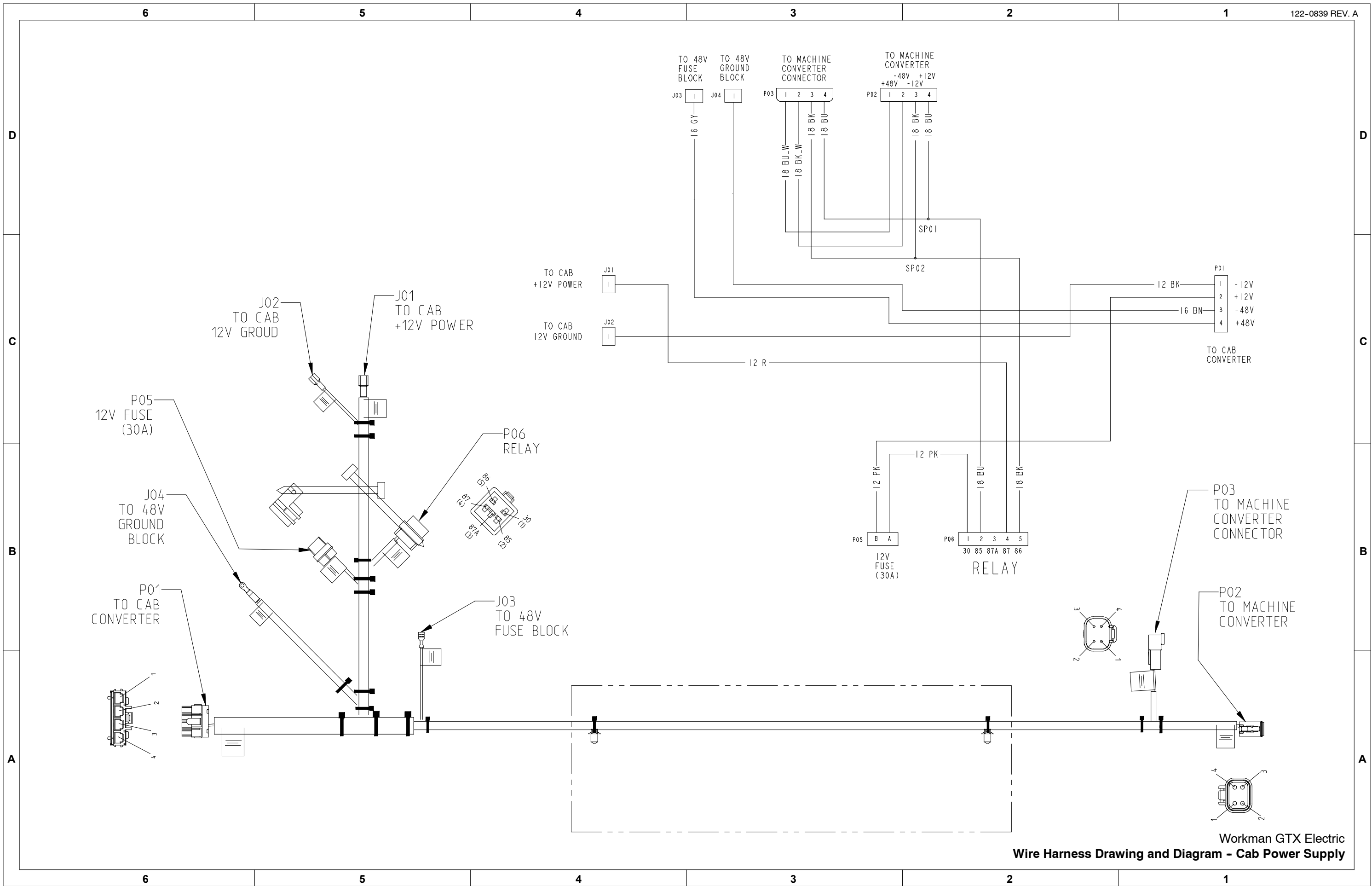

Workman GTX Electric
Wire Harness Drawing and Diagram - Cab Power Supply

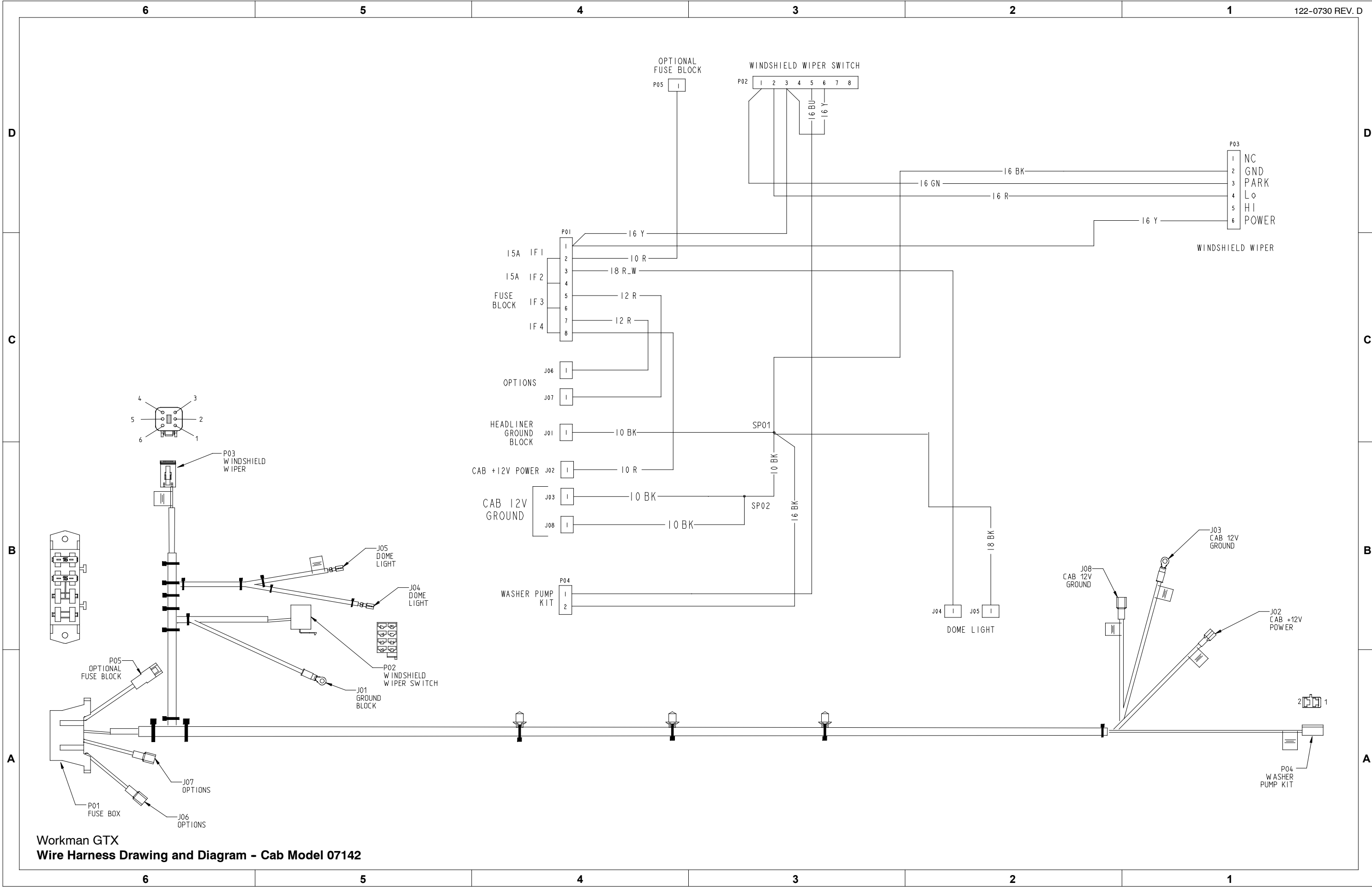

Workman GTX
Wire Harness Drawing and Diagram - Cab Model 07142

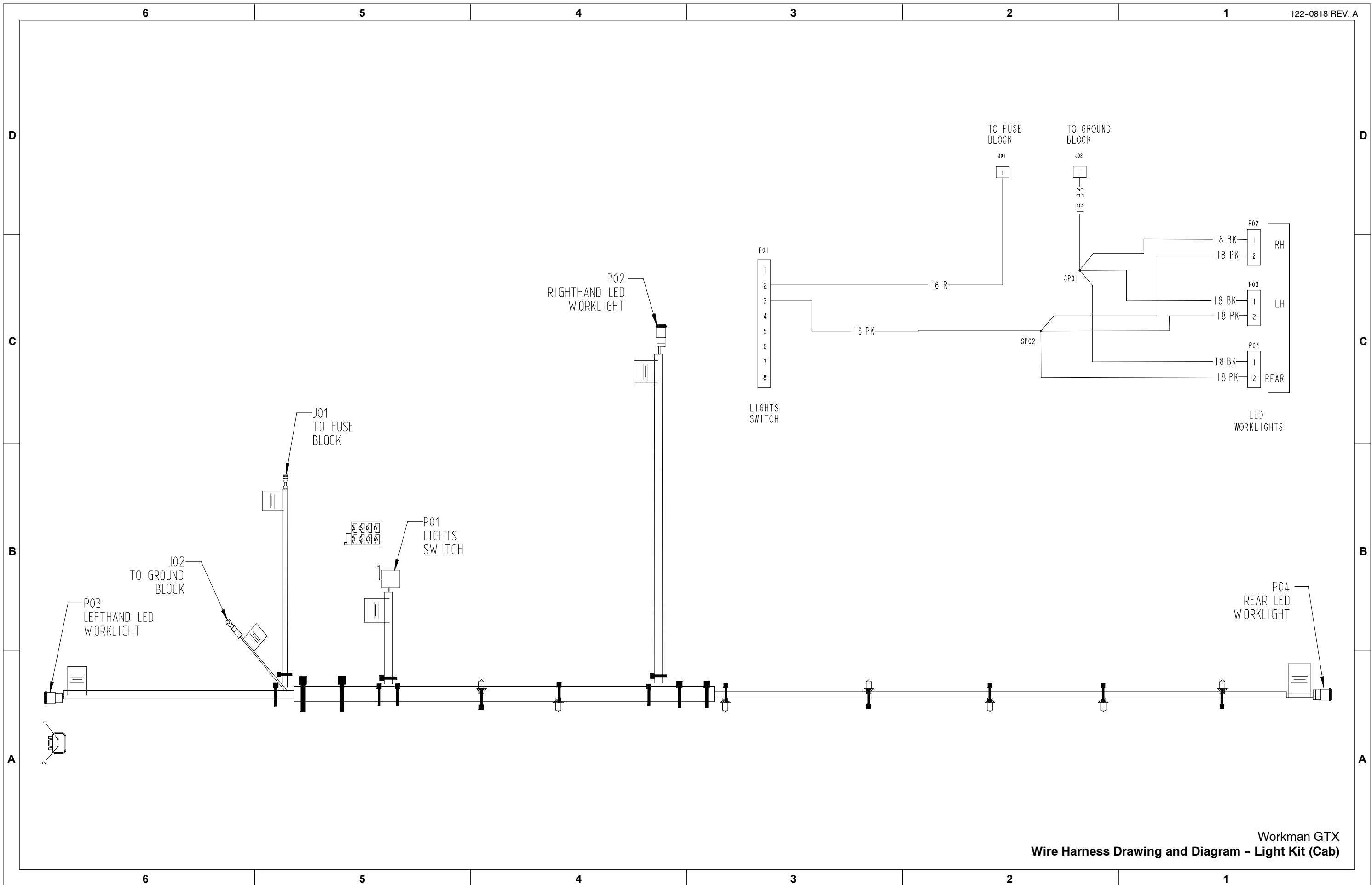

Workman GTX
Wire Harness Drawing and Diagram - Light Kit (Cab)

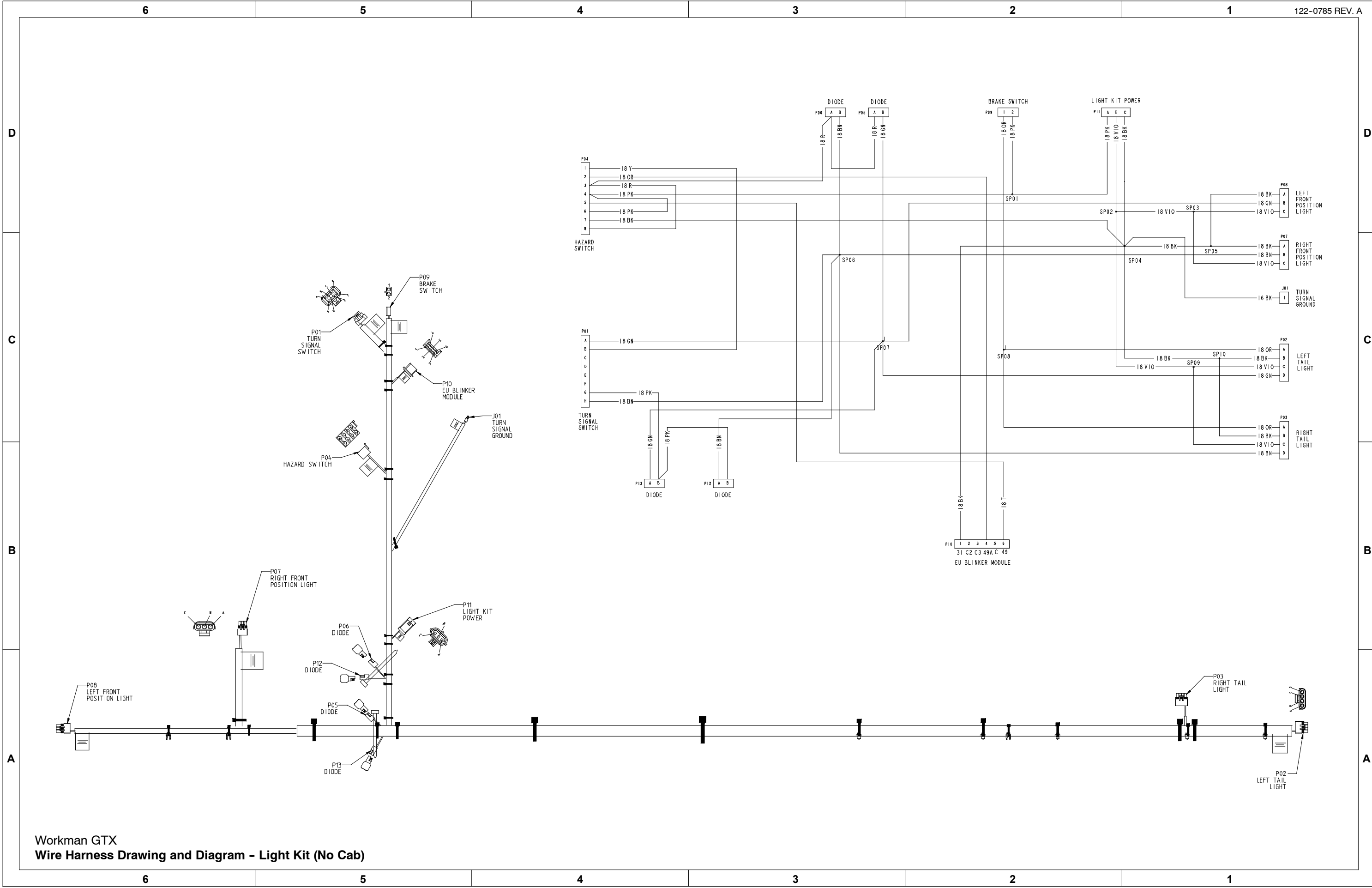

Workman GTX
Wire Harness Drawing and Diagram - Light Kit (No Cab)

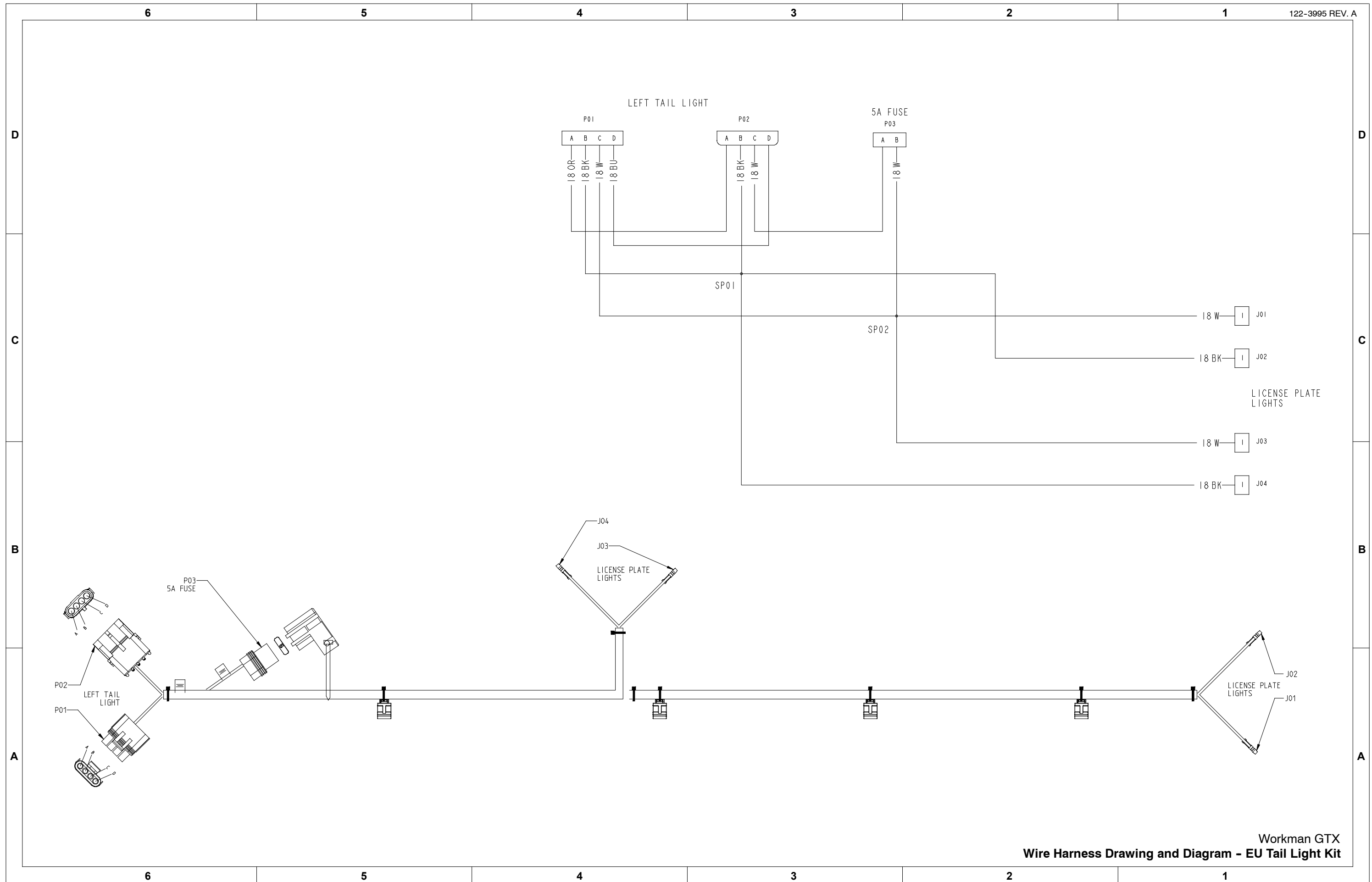

6

5

4

3

2

1

D

D

C

C

B

B

A

A

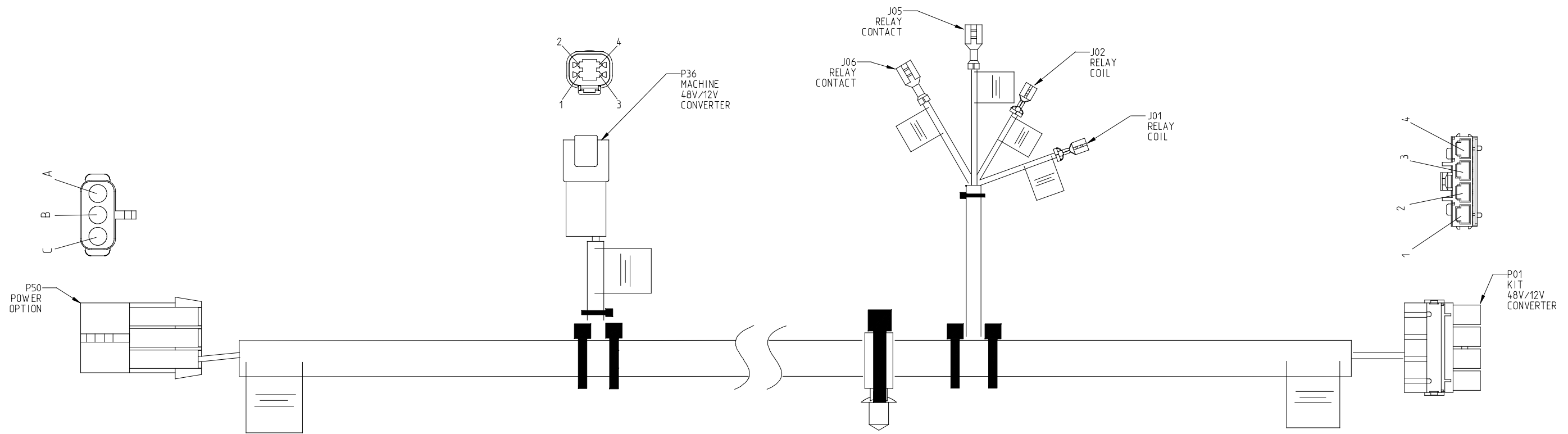
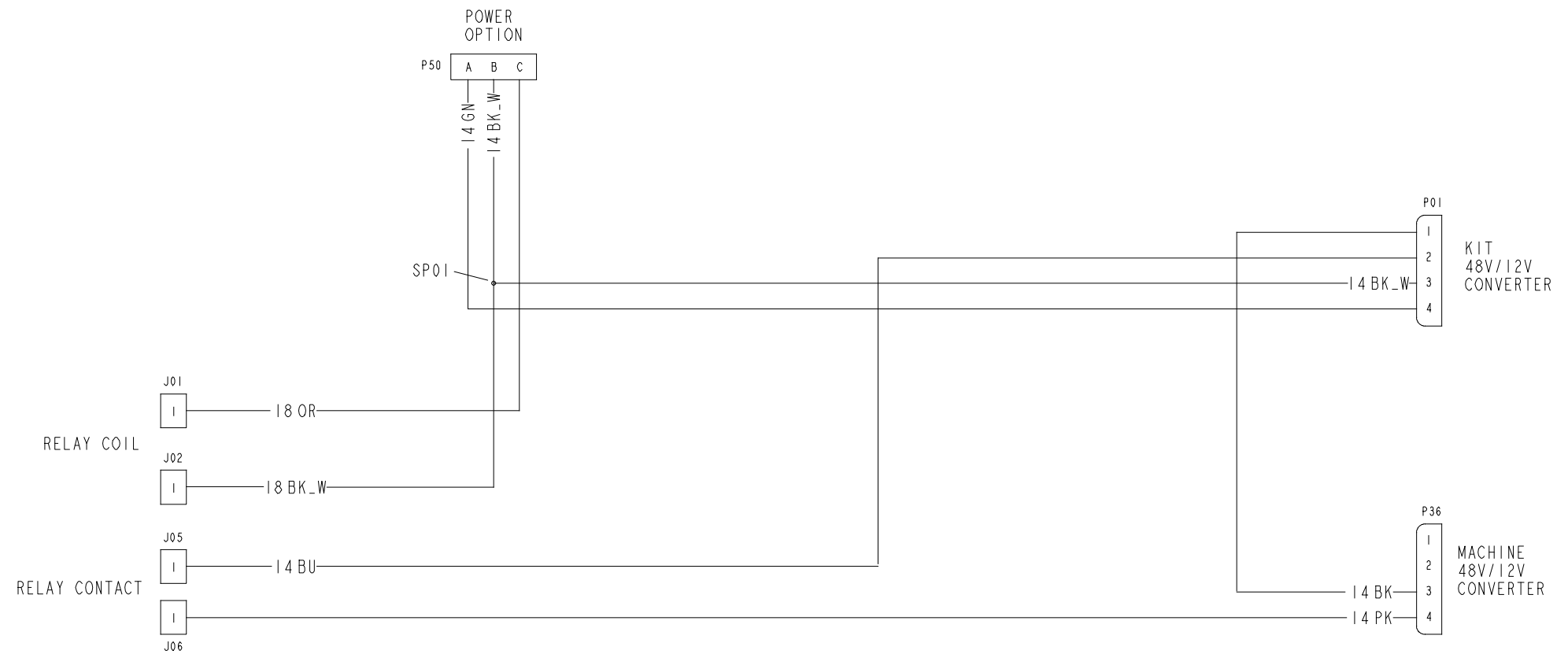

Workman GTX Electric
Wire Harness Drawing and Diagram - Power Upgrade

6

5

4

3

2

1

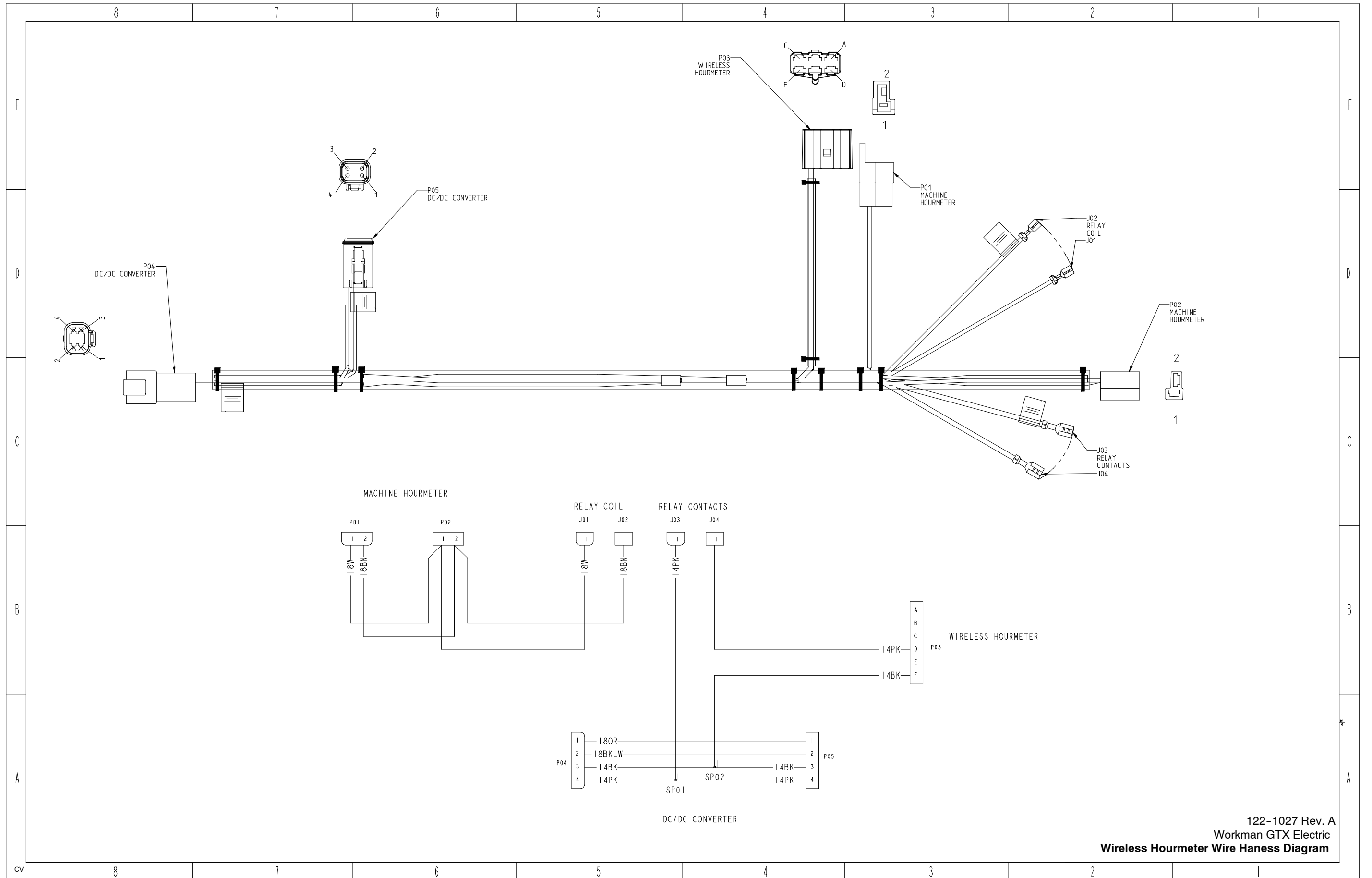

122-1027 Rev. A
 Workman GTX Electric
Wireless Hourmeter Wire Harness Diagram

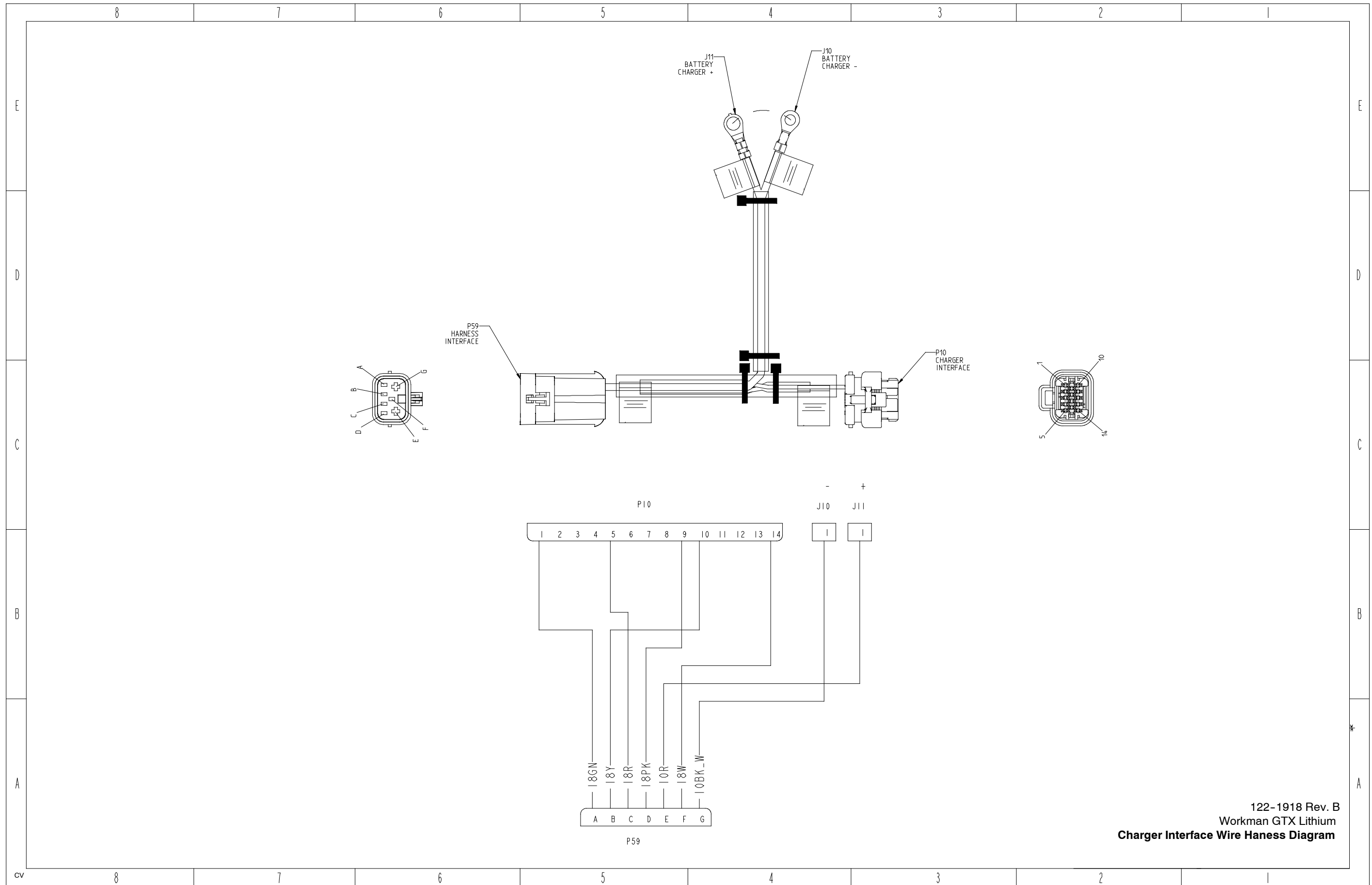

122-1918 Rev. B
 Workman GTX Lithium
Charger Interface Wire Hanes Diagram