

Yes OPTUS

PHONE & SIM QUICK START GUIDE

Optus X Delight

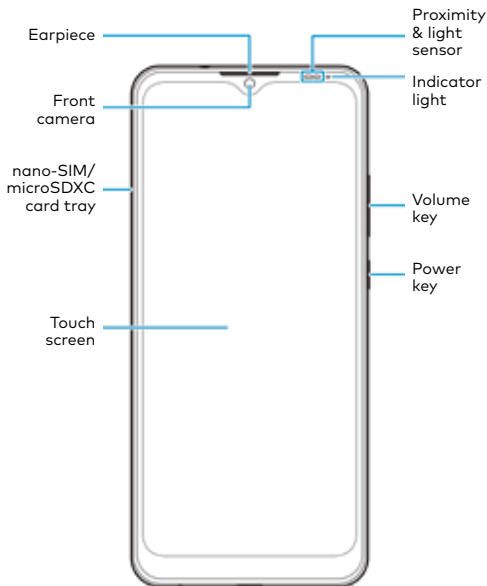

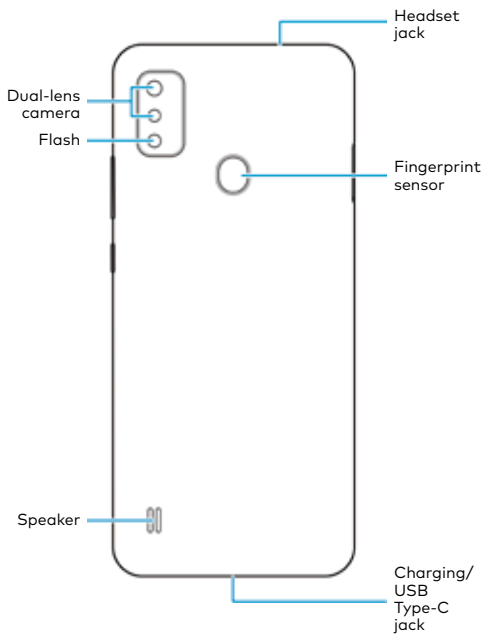

Getting started

The Optus X Delight is specially designed for the Optus Network to give you the best experience possible. It's easy to set up and use, but if you need extra help, this guide will take you through the process. Plus it's packed with tips to help you get the most out of your new phone.

SIM information

Activate your SIM

To activate your SIM, head to **optus.com.au/activate** and follow the prompts. You can do this using a computer, tablet or another smartphone. Or put your SIM in your phone and call 555.

You'll need current and valid ID details (such as your driver's licence, credit card or passport) to activate.

Choose your Prepaid plan

While you're activating your SIM, we'll ask you to pick your Prepaid plan. We have plans to suit different types of usage and if the one you choose doesn't work for you, you can change it. See the full range at **optus.com.au/prepaidplans**

Recharge

You can recharge using your debit/credit card to pay in the following ways:

- **Use our free My Optus App.** Find it at the App Store or Google Play.
- **Go online to optus.com.au/recharge** You can also use PayPal or set up **AutoRecharge**.
- **Call 555** from your mobile.
- **Grab a voucher.** Pick one up at any Optus store or at outlets nationwide.

All information contained in this booklet is correct as at 1 March 2021. For the most up-to-date information visit **optus.com.au/prepaidplans**

Tip

Need to check something? Use these shortcuts:

CHECK MY BALANCE

Use the My Optus App, text **BAL** to **9999** or call **555**

CHANGE MY PLAN, SWAP MY SIM or ACCESS OTHER SERVICES

Text **MENU** to **9999**

CHECK VOICEMAIL

To set up and access, call **321**

GET HELP or SET UP INTERNET/MMS

Head to **optus.com.au/support** or call **1300 555 002**

I NEED A TRANSLATOR

Call **131 450** to speak to Optus via a translator

The details

To request the barring of all premium SMS and MMS services go to **optus.com.au/premiumsms**

Emergency calls to **000** are free; you don't need credit.

Your ID may need to be verified by the government DVS (Document Verification Service) so it will need to be current and valid.

To learn more about your privacy at Optus, visit **optus.com.au/privacypolicy**

For more details about your Prepaid plan, visit **optus.com.au/CIS** and **optus.com.au/standardagreements**

Setting Up Your Phone

The nano-SIM card can be installed or removed while the phone is turned on.

WARNING!

To avoid damage to the phone, do not use any other kind of SIM cards, or any non-standard nano-SIM card cut from a SIM card. You can get a standard nano-SIM card from your service provider.

1. Insert the tip of the tray eject tool into the hole on the card tray.

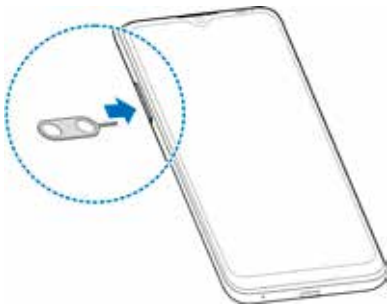

CAUTION: Never replace the included tray eject tool with sharp objects. Ensure that the tray eject tool is perpendicular to the hole. Otherwise, the phone may be damaged.

- 2.** Pull out the card tray and place the nano-SIM card and the microSDXC card (optional) on the tray, as shown. Carefully slide the tray back into place.

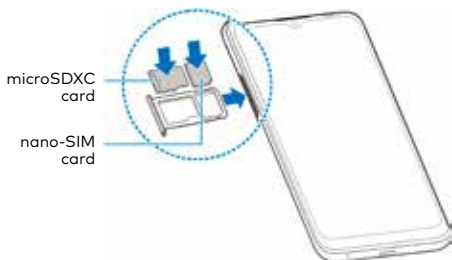

Charging the Phone

Your phone's battery should have enough power for the phone to turn on, find a signal, and make a few calls. You should fully charge the battery as soon as possible.

WARNING!

Use only approved chargers and USB Type-C cables. The use of unapproved accessories could damage your phone or cause the battery to explode.

Do not remove the back cover. The battery is not removable. Removal may cause fire or explosion.

1. Connect the adapter to the charging jack.





2. Connect the charger to a standard AC power outlet.
3. Disconnect the charger when the battery is fully charged.

NOTE: If the battery is extremely low, you may be unable to power on the phone even when it is being charged. In this case, try again after charging the phone for at least 20 minutes. Contact customer service if you still cannot power on the phone after prolonged charging.

Powering On/Off Your Phone

Make sure the battery is charged before powering on.

- Press and hold the **Power** key to turn on your phone.
- To power off, press and hold the **Power** key to open the options menu, and touch  > .

NOTE: If the screen freezes or takes too long to respond, try pressing and holding the **Power** key for over 10 seconds to restart the phone.

PRODUCT SAFETY INFORMATION



Don't make or receive phone calls while driving. Never text while driving.



Keep your phone at least 5mm away from your body while making calls.



Small parts may cause choking.



Your phone can produce a loud sound.



To prevent possible hearing damage, do not listen at high volume levels for long periods. Exercise caution when holding your phone near your ear while the loudspeaker is in use.



Avoid contact with anything magnetic.



Keep away from pacemakers and other electronic medical devices.



Turn off when asked to in hospitals and medical facilities.



Turn off when told to on aircraft and at airports.



Turn off when near explosive materials or liquids.



Don't use at petrol stations.



Your phone may produce a bright or flashing light.



Don't dispose of your phone in fire.



Avoid extreme temperatures.



Avoid contact with liquids. Keep your phone dry.



Do not attempt to disassemble your phone.



Only use approved accessories.



For pluggable equipment, the socket-outlet shall be installed near the equipment and shall be easily accessible.



Don't rely on your phone as a primary device for emergency communications.

LEGAL INFORMATION

Copyright © 2021 Optus Mobile Pty Ltd.

All rights reserved.

No part of this publication may be quoted, reproduced, translated or used in any form or by any means, electronic or mechanical, including photocopying and microfilm, without the prior written permission of Optus.

Notice

Optus reserves the right to make modifications on print errors or update specifications in this guide without prior notice.

We offer self-service for our smart terminal device users. Please visit the Optus website (at **optus.com.au**) for more information on self-service and supported product models. Information on the website takes precedence.

This is the Quick Start Guide only.

You can download the user guide from **optus.com.au**

Disclaimer

Optus expressly disclaims any liability for faults and damage caused by unauthorised modifications of the software.

Images and screenshots used in this guide may differ from the actual product. Content in this guide may differ from the actual product or software.

Trademarks

Other trademarks and trade names are those of their respective owners.