



## Surge Suppression Components CONTENTS

Product Item	Type / Series	Part Number	Page	
“ZNR” Transient / Surge Absorbers			2	
Products System			3	
“ZNR” Transient/ Surge Absorbers	Type D, Series V	Standard Products	ERZV□□□□□□	4
		Leads Cut Type	ERZV□□□□(V)□□□□CS	24
		Taping Specifications	ERZV□□□□(V)□□□□	25
		Application Note for UL, CSA and VDE Recognized Components		27
		Marking Contents		28
		Performance Characteristics		29
	SMD Type	Series HF	ERZHF□□□□□□	31
		Series VF	ERZVF□□□□□□	34
	Handling Precautions (Type D / SMD)			39
	Type SC		ERZVS□□□□□□□□	42
	Type E		ERZC□□□EK□□□□	44
	Type CK		ERZC□□□CK□□□□	49
	Handling Precautions (Type SC / E / CK)			54
	Type P		ERZA□□□PK□□□□	57
	Type J		ERZA□□□JK□□□□	59
	Type G		ERZA□□□GS(K)□□□□	62
	“ZNR” Surge Absorber Units		ERZA	64
	“ZNR” Transient/ Surge Absorbers, For Thyristor Protection	Type E	ERZC□□□EK□□□□P	68
Type J		ERZU□□□JP□□□□		

All products in this catalog comply with the RoHS Directive.

The RoHS Directive is “the Directive (2011/65/EU) on the Restriction of the Use of Certain Hazardous Substances in Electrical and Electronic Equipment “ and its revisions.

**“ZNR” Transient/Surge Absorbers**

ZNRs are zinc-oxide nonlinear resistors whose resistance changes as a function of the applied voltage. These basic characteristics of ZNR express by varistor voltage and clamping voltage (or voltage ratio).

The ZNR utilizes a ceramic element composed of zinc oxide and several kinds of metal oxide additives that have been sintered at relatively high temperature.

The ZNR has a bilateral and symmetrical V-I characteristics similar to back-to-back zener diode and unparalleled large peak current capability so it can be used for absorption of transient voltage, suppression of pulse noise and as an arrester element and circuit voltage stabilization.

**Explanation of technical terms**

**1. Voltage-Current Characteristics**

Figure 1 shows voltage-current characteristics of ZNR. The axis of abscissas is logarithm of current and the axis of ordinates is logarithm of voltage. Characteristics, voltage value at 1mA(principle) is used, calling varistor voltage. In case of surge absorber which utilizes at large current region because of voltage at specified current is used, calling clamping voltage.

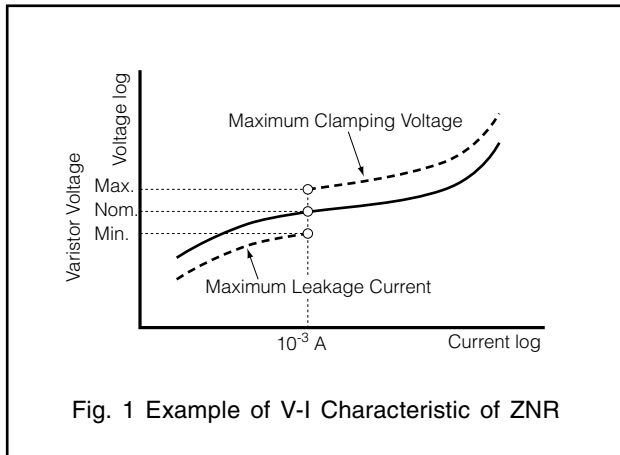

Fig. 1 Example of V-I Characteristic of ZNR

**2. Maximum Peak Current**

Specification which specified how much surge current surge absorber can endure is maximum peak current. This characteristic expresses a current value having standard wave form shown in figure 2.

In case of different waveform from the standard one, the specifications shall be determined by referring to impulse life ratings.

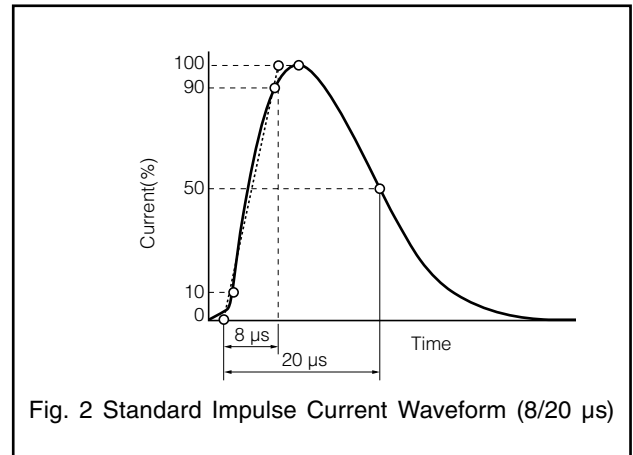

Fig. 2 Standard Impulse Current Waveform (8/20 μs)

**Note**

\* ZNR “Zinc Oxide Nonlinear Resistor” is a trade mark of voltage dependent resistor elements by Panasonic. ZNR is in some cases named Metal Oxide Varistor “MOV”

**3. Clamping Voltage**

Varistors have an ability to limit a high voltage surge like lightning.

We call this limited voltage as “Clamping Voltage”. “Clamping Voltage” is measured by voltage between two terminals using standard impulse current waveform (8/20 μs) shown in fig.2.

To avoid an exothermic influence.

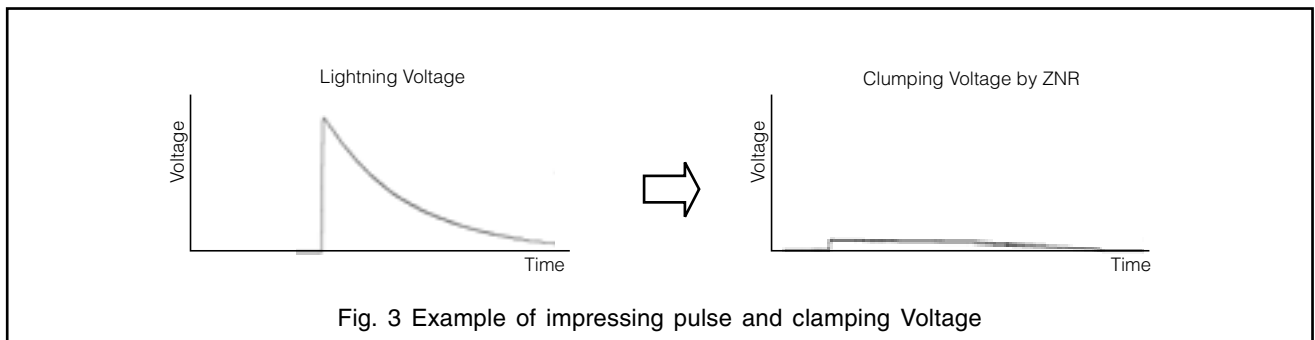

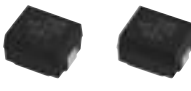



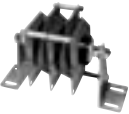

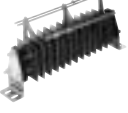

Fig. 3 Example of impressing pulse and clamping Voltage

## Products System

“ZNR” Surge Absorbers	Type D Series V		Standard type with radial leads for general surge protect applications	<ul style="list-style-type: none"> <li>● Varistor Voltage : 18 to 1800 V</li> <li>● Maximum Peak Current : 125 to 7000 A (at 8/20 μs)</li> </ul>	P.4
	Type SMD Series HF		For Automotive (DC12 V) Meet for Load Dump Surge Compact size SMD High Reliability	<ul style="list-style-type: none"> <li>● Varistor Voltage : 27 V</li> <li>● Maximum Surge : JASO A-1 70 V 1 time</li> </ul>	P.31
	Type SMD Series VF		Surface mount type with protective coating so as to high level reliability	<ul style="list-style-type: none"> <li>● Varistor Voltage : 22 to 470 V</li> <li>● Maximum Peak Current : 125 to 600 A (at 8/20 μs)</li> </ul>	P.34
	Type SC		For incorporation in a surge protective device corresponding to the IEC61643-1	<ul style="list-style-type: none"> <li>● Varistor Voltage : 200 to 950 V</li> <li>● Maximum Peak Current : In 20 kA Imax 40 kA (at 8/20 μs)</li> </ul>	P.42
	Type E Type CK		For an application in industrial electric or electronic equipment under heavy duty	<ul style="list-style-type: none"> <li>● Varistor Voltage : 200 to 1100 V</li> <li>● Maximum Peak Current : 5 to 25 kA (at 8/20 μs)</li> </ul>	P.44
	Type P		Plug-in type with deterioration indicator. For application to industrial equipment	<ul style="list-style-type: none"> <li>● Varistor Voltage : 250 to 1000 V</li> <li>● Maximum Peak Current : 5000 A (at 8/20 μs)</li> </ul>	P.57
	Type J		Stack-type for heavy surge energy application (High power induced load and so on)	<ul style="list-style-type: none"> <li>● Varistor Voltage : 560 to 1250 V</li> <li>● Maximum Peak Current : 80 to 320 kA (at 4/10 μs)</li> <li>● Energy : 5000 to 40000 J</li> </ul>	P.59
	Type G		For protection to switching surge of high voltage (3.3, 6.6 kV) equipment	<ul style="list-style-type: none"> <li>● Varistor Voltage : 5 or 17 kV</li> <li>● Maximum Peak Current : 5 to 10 kA (at 8/20 μs)</li> <li>● Energy : 1300 to 2600 J</li> </ul>	P.62
	Surge Absorber Units		Surge absorber with connected ZNRs and circuit breaker in box	<ul style="list-style-type: none"> <li>● Varistor Voltage : 22 to 1000 V</li> <li>● Impulse Life : 16 to 210 A</li> <li>● Maximum Peak Current : 5 to 50 kA (at 8/20 μs)</li> </ul>	P.64
	Surge Absorbers for Thyristor		Thyristor protection against switching surge of transformer	<ul style="list-style-type: none"> <li>● Varistor Voltage : 510 to 2500 V</li> <li>● Impulse Life : 40 to 210 A (2 ms, 10<sup>4</sup> times)</li> </ul>	P.68

## “ZNR” Transient/Surge Absorbers

Type: **D**

Series: **V**

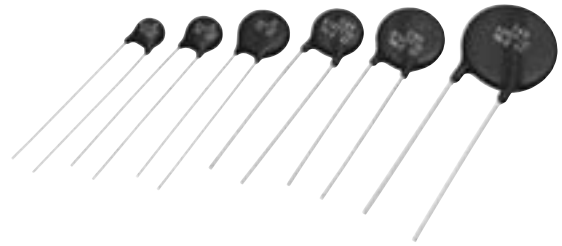

### ■ Features

- Large withstanding surge current capability in compact sizes
- Large “Energy Handling Capability” absorbing transient overvoltages in compact sizes
- Wide range of varistor voltages
- RoHS compliant

### ■ Recommended Applications

- Transistor, diode, IC, thyristor or triac semiconductor protection
- Surge protection in consumer electronic equipment
- Surge protection in communication, measuring or controller electronics
- Surge protection in electronic home appliances, gas or petroleum appliances

### ■ Applicable Standards

- UL1449 (VZCA2/UL, VZCA8/C-UL)
  - VDE IEC61051-1, -2, -2-2, IEC60950-1 Annex.Q
  - CSA C22.2 No.1
  - CQC(GB/T10193, GB/T10194, GB4943.1, GB8898)
- Refer to page 5 to 8, and 27, for the details

### ■ Handling Precautions and Minimum Quantity / Packing Unit

Please see Related Information

### ■ Explanation of Part Numbers (Bulk)

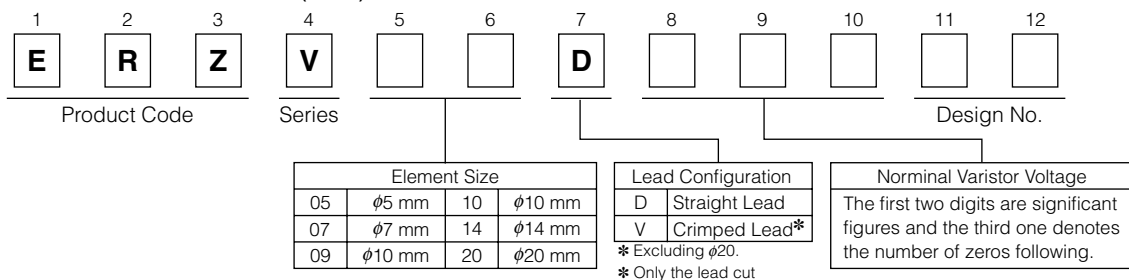

### ■ Explanation of Part Numbers (Taping)

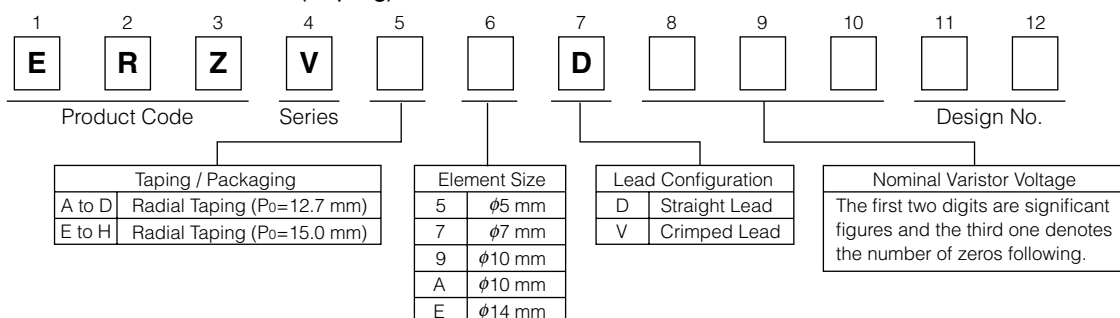

### Reference Guide to Standard Products

Part No.	Applicable Standards		Varistor Voltage* (V)	Maximum Allowable Voltage		Clamping Voltage at 8/20μs		Maximum Peak Current at 8/20μs(A)		Recommended Applications
	Type Name	Approvals		ACrms (V)	DC (V)	max.(V)	I <sub>p</sub> (A)	1 time	2 times	
ERZV05D180	V180	◇	18 (16 to 20)	11	14	40	1	250	125	For the low voltage circuit
ERZV07D180	V7180	◇				36	2.5	500	250	
ERZV09D180	V9180	◇				36	5	1000	500	
ERZV10D180	V10180	◇				36	5	1000	500	
ERZV14D180	V14180	◇				36	10	2000	1000	
ERZV20D180	V20180	◇				36	20	3000	2000	
ERZV05D220	V220	◇	22 (20 to 24)	14	18	48	1	250	125	
ERZV07D220	V7220	◇				43	2.5	500	250	
ERZV09D220	V9220	◇				43	5	1000	500	
ERZV10D220	V10220	◇				43	5	1000	500	
ERZV14D220	V14220	◇				43	10	2000	1000	
ERZV20D220	V20220	◇				43	20	3000	2000	
ERZV05D270	V270	◇	27 (24 to 30)	17	22	60	1	250	125	
ERZV07D270	V7270	◇				53	2.5	500	250	
ERZV09D270	V9270	◇				53	5	1000	500	
ERZV10D270	V10270	◇				53	5	1000	500	
ERZV14D270	V14270	◇				53	10	2000	1000	
ERZV20D270	V20270	◇				53	20	3000	2000	
ERZV05D330	V330	◇	33 (30 to 36)	20	26	73	1	250	125	
ERZV07D330	V7330	◇				65	2.5	500	250	
ERZV09D330	V9330	◇				65	5	1000	500	
ERZV10D330	V10330	◇				65	5	1000	500	
ERZV14D330	V14330	◇				65	10	2000	1000	
ERZV20D330	V20330	◇				65	20	3000	2000	
ERZV05D390	V390	◇	39 (35 to 43)	25	31	86	1	250	125	
ERZV07D390	V7390	◇				77	2.5	500	250	
ERZV09D390	V9390	◇				77	5	1000	500	
ERZV10D390	V10390	◇				77	5	1000	500	
ERZV14D390	V14390	◇				77	10	2000	1000	
ERZV20D390	V20390	◇				77	20	3000	2000	
ERZV05D470	V470	◇	47 (42 to 52)	30	38	104	1	250	125	
ERZV07D470	V7470	◇				93	2.5	500	250	
ERZV09D470	V9470	◇				93	5	1000	500	
ERZV10D470	V10470	◇				93	5	1000	500	
ERZV14D470	V14470	◇				93	10	2000	1000	
ERZV20D470	V20470	◇				93	20	3000	2000	
ERZV05D560	V560	◇	56 (50 to 62)	35	45	123	1	250	125	
ERZV07D560	V7560	◇				110	2.5	500	250	
ERZV09D560	V9560	◇				110	5	1000	500	
ERZV10D560	V10560	◇				110	5	1000	500	
ERZV14D560	V14560	◇				110	10	2000	1000	
ERZV20D560	V20560	◇				110	20	3000	2000	
ERZV05D680	V680	◇	68 (61 to 75)	40	56	150	1	250	125	
ERZV07D680	V7680	◇				135	2.5	500	250	
ERZV09D680	V9680	◇				135	5	1000	500	
ERZV10D680	V10680	◇				135	5	1000	500	
ERZV14D680	V14680	◇				135	10	2000	1000	
ERZV20D680	V20680	◇				135	20	3000	2000	

\* Measuring Current of Varistor Voltage 5 Series : 0.1 mA, Others : 1 mA

○ : UL1449 (VZCA2/UL, VZCA8/C-UL), ● : UL1449 Type3 (or Code-Connected and Direct plug-in), ◎ : UL1449 Type2 (or Permanently Connected),

☆ : VDE (IEC61051-1, -2, -2-2), ★ : VDE (IEC60950-1 Annex.Q), □ : CSA C22.2 No.1

◇ : CQC (GB/T10193, GB/T10194), ◆ : CQC (GB4943.1, GB8898)

※ Approval number (File No.) of safety regulations are subject to revision without notice. Ask factory for a copy of the latest file No.

Design and specifications are each subject to change without notice. Ask factory for the current technical specifications before purchase and/or use. Should a safety concern arise regarding this product, please be sure to contact us immediately.

### Reference Guide to Standard Products

Part No.	Applicable Standards		Varistor Voltage* (V)	Maximum Allowable Voltage		Clamping Voltage at 8/20μs		Maximum Peak Current at 8/20μs(A)		Recommended Applications	
	Type Name	Approvals		ACrms (V)	DC (V)	max.(V)	Ip (A)	1 time	2 times		
ERZV05D820	V820U	○☆◇	82 (74 to 90)	50	65	145	5	800	600	Telephone, Communication Line (DC 48 V)	
ERZV07D820	V7820U	○☆◇				135	10	1750	1250		
ERZV09D820	V9820U	○☆◇				135	25	3500	2500		
ERZV10D820	V10820U	○☆◇				135	25	3500	2500		
ERZV14D820	V14820U	○◎☆◇				135	50	6000	5000		
ERZV20D820	V20820U	○◎☆◇				135	100	10000	7000		
ERZV05D101	V101U	○☆◇	100 (90 to 110)	60	85	175	5	800	600		
ERZV07D101	V7101U	○☆◇				165	10	1750	1250		
ERZV09D101	V9101U	○☆◇				165	25	3500	2500		
ERZV10D101	V10101U	○☆◇				165	25	3500	2500		
ERZV14D101	V14101U	○◎☆◇				165	50	6000	5000		
ERZV20D101	V20101U	○◎☆◇				165	100	10000	7000		
ERZV05D121	V121U	○☆◇	120 (108 to 132)	75	100	210	5	800	600		
ERZV07D121	V7121U	○☆◇				200	10	1750	1250		
ERZV09D121	V9121U	○☆◇				200	25	3500	2500		
ERZV10D121	V10121U	○☆◇				200	25	3500	2500		
ERZV14D121	V14121U	○◎☆◇				200	50	6000	5000		
ERZV20D121	V20121U	○◎☆◇				200	100	10000	7000		
ERZV05D151	V151U	○☆◇	150 (135 to 165)	95	125	260	5	800	600		
ERZV07D151	V7151U	○☆◇				250	10	1750	1250		
ERZV09D151	V9151U	○☆◇				250	25	3500	2500		
ERZV10D151	V10151U	○☆◇				250	25	3500	2500		
ERZV14D151	V14151U	○◎☆◇				250	50	6000	5000		
ERZV20D151	V20151U	○◎☆◇				250	100	10000	7000		
ERZV05D201	V201U	○☆□◇	200 (185 to 225)	130	170	355	5	800	600	AC 100 V Line-Line Applications	
ERZV07D201	V7201U	○☆□◇				340	10	1750	1250		
ERZV09D201	V9201U	○☆□◇				340	25	3500	2500		
ERZV10D201	V10201U	○☆□◇				340	25	3500	2500		
ERZV14D201	V14201U	○◎☆★□◇◆				340	50	6000	5000		
ERZV20D201	V20201U	○◎☆★□◇◆				340	100	10000	7000		
ERZV05D221	V221U	○☆□◇	220 (198 to 242)	140	180	380	5	800	600		
ERZV07D221	V7221U	○☆□◇				360	10	1750	1250		
ERZV09D221	V9221U	○☆□◇				360	25	3500	2500		
ERZV10D221	V10221U	○☆□◇				360	25	3500	2500		
ERZV14D221	V14221U	○◎☆★□◇◆				360	50	6000	5000		
ERZV20D221	V20221U	○◎☆★□◇◆				360	100	10000	7000		
ERZV05D241	V241U	○☆□◇	240 (216 to 264)	150	200	415	5	800	600		AC 100 V to 120 V, Line-Line Applications
ERZV07D241	V7241U	○☆□◇				395	10	1750	1250		
ERZV09D241	V9241U	○☆□◇				395	25	3500	2500		
ERZV10D241	V10241U	○☆□◇				395	25	3500	2500		
ERZV14D241	V14241U	○◎☆★□◇◆				395	50	6000	5000		
ERZV20D241	V20241U	○◎☆★□◇◆				395	100	10000	7000		
ERZV05D271	V271U	○☆□◇	270 (247 to 303)	175	225	475	5	800	600		
ERZV07D271	V7271U	○☆□◇				455	10	1750	1250		
ERZV09D271	V9271U	○☆□◇				455	25	3500	2500		
ERZV10D271	V10271U	○☆□◇				455	25	3500	2500		
ERZV14D271	V14271U	○◎☆★□◇◆				455	50	6000	5000		
ERZV20D271	V20271U	○◎☆★□◇◆				455	100	10000	7000		

\* Measuring Current of Varistor Voltage 5 Series : 0.1 mA, Others: 1 mA

○ : UL1449 (VZCA2/UL, VZCA8/C-UL), ● : UL1449 Type3 (or Code-Connected and Direct plug-in), ◎ : UL1449 Type2 (or Permanently Connected), ☆ : VDE (IEC61051-1, -2, -2-2), ★ : VDE (IEC60950-1 Annex.Q), □ : CSA C22.2 No.1

◇ : CQC (GB/T10193, GB/T10194), ◆ : CQC (GB4943.1, GB8898)

\* Approval number (File No.) of safety regulations are subject to revision without notice. Ask factory for a copy of the latest file No.

Design and specifications are each subject to change without notice. Ask factory for the current technical specifications before purchase and/or use. Should a safety concern arise regarding this product, please be sure to contact us immediately.

### Reference Guide to Standard Products

Part No.	Applicable Standards		Varistor Voltage* (V)	Maximum Allowable Voltage		Clamping Voltage at 8/20μs		Maximum Peak Current at 8/20μs(A)		Recommended Applications	
	Type Name	Approvals		ACrms (V)	DC (V)	max.(V)	I <sub>p</sub> (A)	1 time	2 times		
ERZV05D331	V331U	○☆□◇	330 (297 to 363)	210	270	570	5	800	600	AC 100 V to 120 V, Line-Line Applications  Telephone Line Applications, (For DC 250 V Insulation Resistance Test)	
ERZV07D331	V7331U	○☆□◇				545	10	1750	1250		
ERZV09D331	V9331U	○☆□◇				545	25	3500	2500		
ERZV10D331	V10331U	○☆□◇				545	25	3500	2500		
ERZV14D331	V14331U	○◎☆★□◇◆				545	50	6000	4500		
ERZV20D331	V20331U	○◎☆★□◇◆				545	100	10000	6500		
ERZV05D361	V361U	○☆□◇	360 (324 to 396)	230	300	620	5	800	600		
ERZV07D361	V7361U	○☆□◇				595	10	1750	1250		
ERZV09D361	V9361U	○☆□◇				595	25	3500	2500		
ERZV10D361	V10361U	○☆□◇				595	25	3500	2500		
ERZV14D361	V14361U	○◎☆★□◇◆				595	50	6000	4500		
ERZV20D361	V20361U	○◎☆★□◇◆				595	100	10000	6500		
ERZV05D391	V391U	○☆□◇	390 (351 to 429)	250	320	675	5	800	600		
ERZV07D391	V7391U	○☆□◇				650	10	1750	1250		
ERZV09D391	V9391U	○☆□◇				650	25	3500	2500		
ERZV10D391	V10391U	○☆□◇				650	25	3500	2500		
ERZV14D391	V14391U	○◎☆★□◇◆				650	50	6000	4500		
ERZV20D391	V20391U	○◎☆★□◇◆				650	100	10000	6500		
ERZV05D431	V431U	○☆□◇	430 (387 to 473)	275	350	745	5	800	600	AC 100 V to 220 V, Line-Line and Line-Ground Applications	
ERZV07D431	V7431U	○☆□◇				710	10	1750	1250		
ERZV09D431	V9431U	○☆□◇				710	25	3500	2500		
ERZV10D431	V10431U	○☆□◇				710	25	3500	2500		
ERZV14D431	V14431U	○◎☆★□◇◆				710	50	6000	4500		
ERZV20D431	V20431U	○◎☆★□◇◆				710	100	10000	6500		
ERZV05D471	V471U	○☆□◇	470 (423 to 517)	300	385	810	5	800	600		
ERZV07D471	V7471U	○☆□◇				775	10	1750	1250		
ERZV09D471	V9471U	○☆□◇				775	25	3500	2500		
ERZV10D471	V10471U	○●☆★□◇◆				775	25	3500	2500		
ERZV14D471	V14471U	○◎☆★□◇◆				775	50	6000	4500		
ERZV20D471	V20471U	○◎☆★□◇◆				775	100	10000	6500		
ERZV07D511	V7511U	○☆□◇	510 (459 to 561)	320	410	845	10	1750	1250		AC 100 to 240 V, Line-Line and Line-Ground Applications
ERZV09D511	V9511U	○☆□◇				845	25	3500	2500		
ERZV10D511	V10511U	○●☆★□◇◆				845	25	3500	2500		
ERZV14D511	V14511U	○◎☆★□◇◆				845	50	6000	4500		
ERZV20D511	V20511U	○◎☆★□◇◆				845	100	10000	6500		
ERZV10D561	V10561U	○●☆★□◇◆				560 (504 to 616)	350	450	930		
ERZV14D561	V14561U	○◎☆★□◇◆	930	50	5000				4500		
ERZV20D561	V20561U	○◎☆★□◇◆	930	100	7500				6500		
ERZV10D621	V10621U	○●☆★□◇◆	620 (558 to 682)	385	505	1025	25	3500	2500		
ERZV14D621	V14621U	○◎☆★□◇◆				1025	50	5000	4500		
ERZV20D621	V20621U	○◎☆★□◇◆				1025	100	7500	6500		
ERZV10D681	V10681U	○●☆★□◇◆	680 (612 to 748)	420	560	1120	25	3500	2500		
ERZV14D681	V14681U	○◎☆★□◇◆				1120	50	5000	4500		
ERZV20D681	V20681U	○◎☆★□◇◆				1120	100	7500	6500		

\* Measuring Current of Varistor Voltage 5 Series : 0.1 mA, Others: 1 mA

○ : UL1449 (VZCA2/UL, VZCA8/C-UL), ● : UL1449 Type3 (or Code-Connected and Direct plug-in), ◎ : UL1449 Type2 (or Permanently Connected),

☆ : VDE (IEC61051-1, -2, -2-2), ★ : VDE (IEC60950-1 Annex.Q), □ : CSA C22.2 No.1

◇ : CQC (GB/T10193, GB/T10194), ◆ : CQC (GB4943.1, GB8898)

※ Approval number (File No.) of safety regulations are subject to revision without notice. Ask factory for a copy of the latest file No.



## Reference Guide to Standard Products

Part No.	Applicable Standards		Varistor Voltage* (V)	Maximum Allowable Voltage		Clamping Voltage at 8/20 $\mu$ s		Maximum Peak Current at 8/20 $\mu$ s(A)		Recommended Applications	
	Type Name	Approvals		ACrms (V)	DC (V)	max.(V)	I <sub>p</sub> (A)	1 time	2 times		
ERZV10D751	V10751U	○●☆★□◇◆	750 (675 to 825)	460	615	1240	25	3500	2500	AC 380 V, Line-Line and Line-Ground Applications (For DC 500 V Insulating Test)	
ERZV14D751	V14751U	○◎☆★□◇◆				1240	50	5000	4500		
ERZV20D751	V20751U	○◎☆★□◇◆				1240	100	7500	6500		
ERZV10D821	V10821U	○●☆★□◇◆	820 (738 to 902)	510	670	1355	25	3500	2500		
ERZV14D821	V14821U	○◎☆★□◇◆				1355	50	5000	4500		
ERZV20D821	V20821U	○◎☆★□◇◆				1355	100	7500	6500		
ERZV10D911	V10911U	○●☆★□◇◆	910 (819 to 1001)	550	745	1500	25	3500	2500		AC 415 V, Line-Line and Line-Ground Applications (For DC 500 V Insulating Test)
ERZV14D911	V14911U	○◎☆★□◇◆				1500	50	5000	4500		
ERZV20D911	V20911U	○◎☆★□◇◆				1500	100	7500	6500		
ERZV10D102	V10102U	○●☆★□◇◆	1000 (900 to 1100)	625	825	1650	25	3500	2500	AC 480 V, Line-Line and Line-Ground Applications (For DC 500 V Insulating Test)	
ERZV14D102	V14102U	○◎☆★□◇◆				1650	50	5000	4500		
ERZV20D102	V20102U	○◎☆★□◇◆				1650	100	7500	6500		
ERZV10D112	V10112U	○●☆★□◇◆	1100 (990 to 1210)	680	895	1815	25	3500	2500		
ERZV14D112	V14112U	○◎☆★□◇◆				1815	50	5000	4500		
ERZV20D112	V20112U	○◎☆★□◇◆				1815	100	7500	6500		
ERZV10D182CS	V10182U	○●☆★□◇◆	1800 (1700 to 1980)	1000	1465	2970	25	3500	2500		Line-Ground Applications (For AC 1200 V Withstanding Test)
ERZV14D182CS	V14182U	○◎☆★□◇◆				2970	50	5000	4500		
ERZV20D182	V20182U	○◎☆★□◇◆				2970	100	7500	6500		

\* Measuring Current of Varistor Voltage 5 Series : 0.1 mA, Others : 1 mA

○ : UL1449 (VZCA2/UL, VZCA8/C-UL), ● : UL1449 Type3 (or Code-Connected and Direct plug-in), ◎ : UL1449 Type2 (or Permanently Connected), ☆ : VDE (IEC61051-1, -2, -2-2), ★ : VDE (IEC60950-1 Annex.Q), □ : CSA C22.2 No.1

◇ : CQC (GB/T10193, GB/T10194), ◆ : CQC (GB4943.1, GB8898)

※ Approval number (File No.) of safety regulations are subject to revision without notice. Ask factory for a copy of the latest file No.

### 5 Series

#### ■ Ratings and Characteristics

● Operating Temperature Range : -40 to 85 °C ● Storage Temperature Range : -40 to 125 °C

Part No.	Varistor Voltage	Maximum Allowable Voltage		Clamping Voltage (max.) **I <sub>p</sub>	Rated Power	Maximum Energy		Maximum Peak Current (8/20 μs)		Capacitance (max.) at 1 kHz (pF)
						(10/1000 μs)	(2 ms)	1 time	2 times	
	V <sub>0.1 mA</sub> (V)	ACrms (V)	DC (V)	(V)	(W)	(J)	(J)	(A)	(A)	
ERZV05D180	18(16 to 20)	11	14	40	0.01	0.6	0.4	250	125	1600
ERZV05D220	22(20 to 24)	14	18	48	0.01	0.7	0.5	250	125	1500
ERZV05D270	27(24 to 30)	17	22	60	0.01	0.9	0.7	250	125	1450
ERZV05D330	33(30 to 36)	20	26	73	0.01	1.1	0.8	250	125	1400
ERZV05D390	39(35 to 43)	25	31	86	0.01	1.2	0.9	250	125	700
ERZV05D470	47(42 to 52)	30	38	104	0.01	1.5	1.1	250	125	650
ERZV05D560	56(50 to 62)	35	45	123	0.01	1.8	1.3	250	125	600
ERZV05D680	68(61 to 75)	40	56	150	0.01	2.2	1.6	250	125	580
ERZV05D820	82(74 to 90)	50	65	145	0.1	3.5	2.5	800	600	460
ERZV05D101	100(90 to 110)	60	85	175	0.1	4.0	3.0	800	600	400
ERZV05D121	120(108 to 132)	75	100	210	0.1	5.0	3.5	800	600	350
ERZV05D151	150(135 to 165)	95	125	260	0.1	6.5	4.5	800	600	300
ERZV05D201	200(185 to 225)	130	170	355	0.1	8.5	6.0	800	600	120
ERZV05D221	220(198 to 242)	140	180	380	0.1	9.0	6.5	800	600	110
ERZV05D241	240(216 to 264)	150	200	415	0.1	10.5	7.5	800	600	100
ERZV05D271	270(247 to 303)	175	225	475	0.1	11.0	8.0	800	600	90*
ERZV05D331	330(297 to 363)	210	270	570	0.1	13.0	9.5	800	600	80*
ERZV05D361	360(324 to 396)	230	300	620	0.1	16.0	11.0	800	600	80*
ERZV05D391	390(351 to 429)	250	320	675	0.1	17.0	12.0	800	600	80*
ERZV05D431	430(387 to 473)	275	350	745	0.1	20.0	13.5	800	600	70*
ERZV05D471	470(423 to 517)	300	385	810	0.1	21.0	15.0	800	600	60*

\* Measured at 1 MHz \*\*I<sub>p</sub> Measuring current of clamping voltage 180 to 680 : 1 A, 820 to 471 : 5 A

#### ■ Dimensions in mm (not to scale) \* Refer to page 24 to 26 about leads cut type and taping.

Part No.	D max.	T max.	W±1.0	H max.	L±1.0
ERZV05D180	7.0	4.5	5.0	10.0	1.5
ERZV05D220	7.0	4.5	5.0	10.0	1.5
ERZV05D270	7.0	4.5	5.0	10.0	1.5
ERZV05D330	7.0	4.5	5.0	10.0	1.5
ERZV05D390	7.0	4.5	5.0	10.0	1.5
ERZV05D470	7.0	4.5	5.0	10.0	1.5
ERZV05D560	7.0	4.5	5.0	10.0	1.5
ERZV05D680	7.0	4.5	5.0	10.0	1.5
ERZV05D820	7.0	4.1	5.0	10.0	1.4
ERZV05D101	7.0	4.3	5.0	10.0	1.6
ERZV05D121	7.0	4.5	5.0	10.0	1.8
ERZV05D151	7.0	4.8	5.0	10.0	2.1
ERZV05D201	7.0	4.4	5.0	10.0	1.7
ERZV05D221	7.0	4.5	5.0	10.0	1.8
ERZV05D241	7.0	4.6	5.0	10.0	1.9
ERZV05D271	7.0	4.8	5.0	10.0	2.1
ERZV05D331	7.0	5.1	5.0	10.0	2.4
ERZV05D361	7.0	5.3	5.0	10.0	2.5
ERZV05D391	7.0	5.4	5.0	10.0	2.7
ERZV05D431	7.0	5.6	5.0	10.0	2.9
ERZV05D471	7.0	5.8	5.0	10.0	3.1

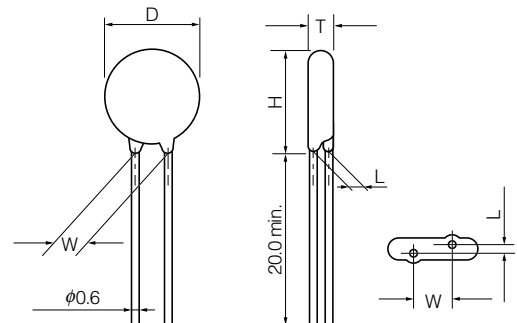

Design and specifications are each subject to change without notice. Ask factory for the current technical specifications before purchase and/or use. Should a safety concern arise regarding this product, please be sure to contact us immediately.

### Typical Characteristics Voltage vs. Current

ERZV05D180 to ERZV05D680

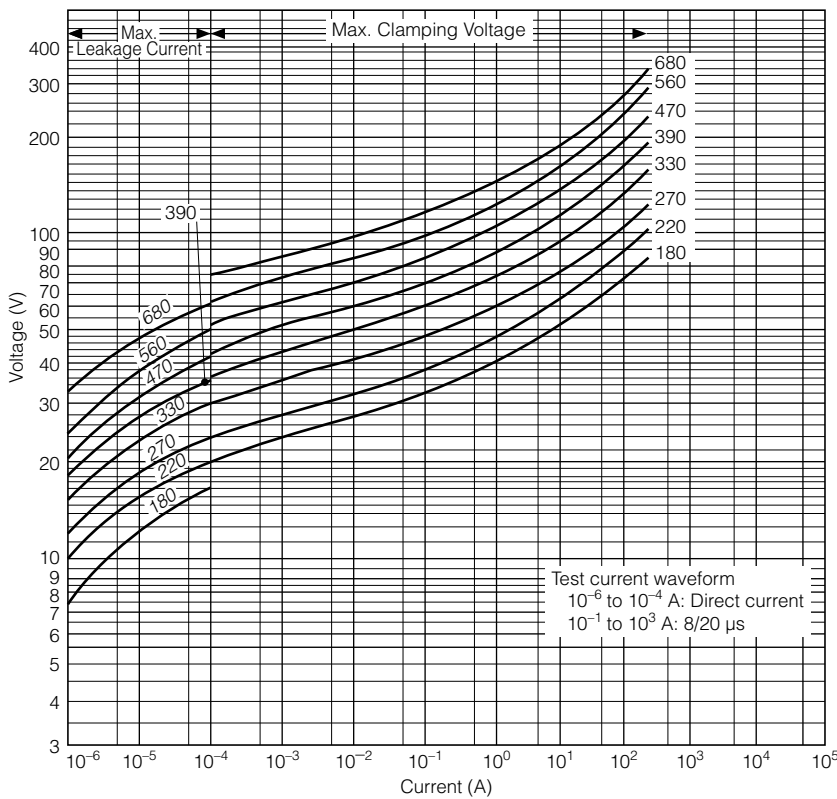

ERZV05D180 to ERZV05D680

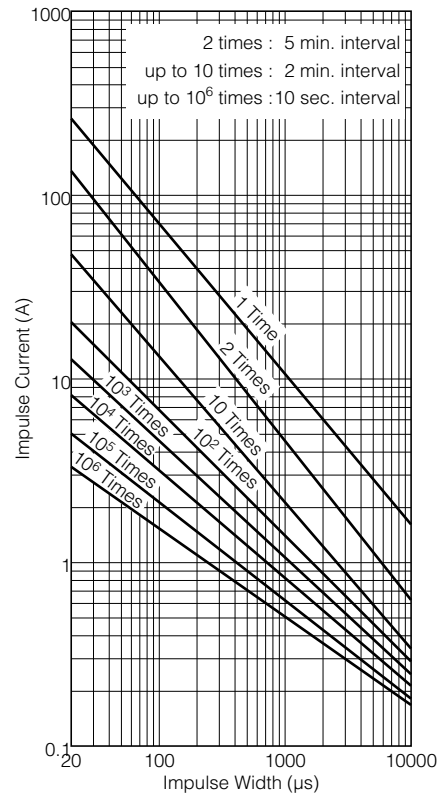

ERZV05D820 to ERZV05D471

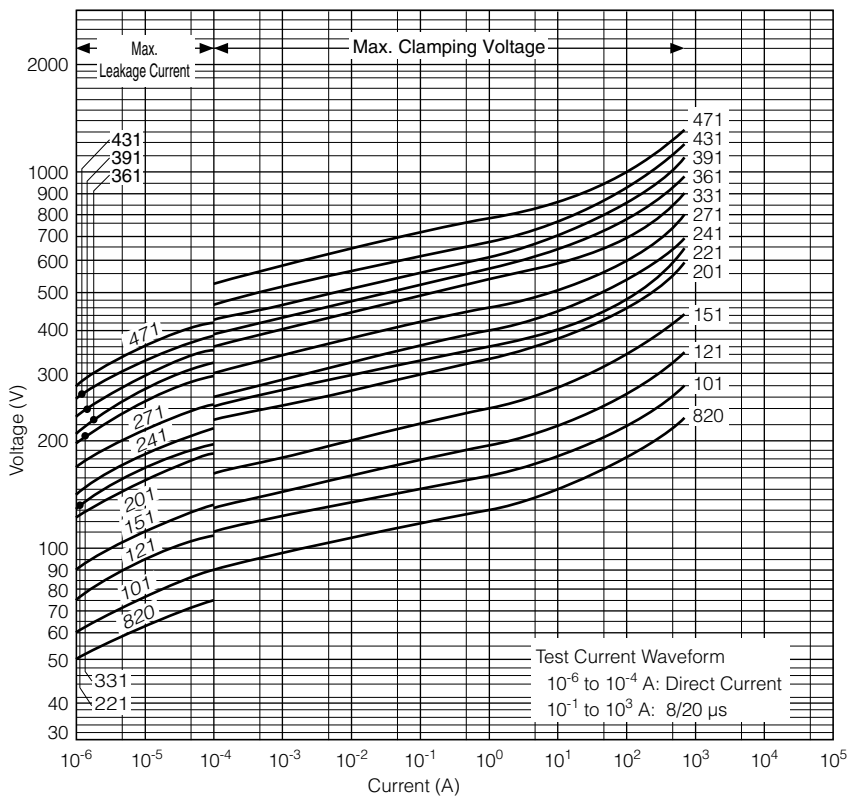

ERZV05D820 to ERZV05D471

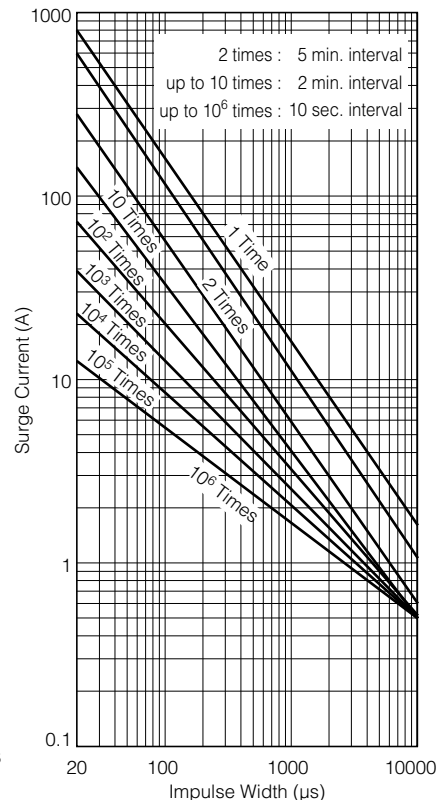

Design and specifications are each subject to change without notice. Ask factory for the current technical specifications before purchase and/or use. Should a safety concern arise regarding this product, please be sure to contact us immediately.

### 7 Series

#### ■ Ratings and Characteristics

● Operating Temperature Range: -40 to 85 °C ● Storage Temperature Range: -40 to 125 °C

Part No.	Varistor Voltage	Maximum Allowable Voltage		Clamping Voltage (max.) **I <sub>p</sub>	Rated Power (W)	Maximum Energy		Maximum Peak Current (8/20 μs)		Capacitance (max.) at 1 kHz (pF)
						(10/1000 μs)	(2 ms)	1 time	2 times	
						V <sub>1mA</sub> (V)	ACrms (V)	DC (V)	(V)	
ERZV07D180	18(16 to 20)	11	14	36	0.02	1.1	0.9	500	250	3800
ERZV07D220	22(20 to 24)	14	18	43	0.02	1.3	1.1	500	250	3600
ERZV07D270	27(24 to 30)	17	22	53	0.02	1.6	1.3	500	250	3400
ERZV07D330	33(30 to 36)	20	26	65	0.02	2.0	1.6	500	250	2900
ERZV07D390	39(35 to 43)	25	31	77	0.02	2.4	1.9	500	250	1600
ERZV07D470	47(42 to 52)	30	38	93	0.02	2.8	2.3	500	250	1550
ERZV07D560	56(50 to 62)	35	45	110	0.02	3.4	2.7	500	250	1500
ERZV07D680	68(61 to 75)	40	56	135	0.02	4.1	3.3	500	250	1200
ERZV07D820	82(74 to 90)	50	65	135	0.25	7	5	1750	1250	810
ERZV07D101	100(90 to 110)	60	85	165	0.25	8.5	6	1750	1250	700
ERZV07D121	120(108 to 132)	75	100	200	0.25	10	7	1750	1250	590
ERZV07D151	150(135 to 165)	95	125	250	0.25	13	9	1750	1250	500
ERZV07D201	200(185 to 225)	130	170	340	0.25	17.5	12.5	1750	1250	200
ERZV07D221	220(198 to 242)	140	180	360	0.25	19	13.5	1750	1250	190
ERZV07D241	240(216 to 264)	150	200	395	0.25	21	15	1750	1250	170
ERZV07D271	270(247 to 303)	175	225	455	0.25	24	17	1750	1250	150
ERZV07D331	330(297 to 363)	210	270	545	0.25	28	20	1750	1250	130
ERZV07D361	360(324 to 396)	230	300	595	0.25	32	23	1750	1250	130
ERZV07D391	390(351 to 429)	250	320	650	0.25	35	25	1750	1250	130
ERZV07D431	430(387 to 473)	275	350	710	0.25	40	27.5	1750	1250	120
ERZV07D471	470(423 to 517)	300	385	775	0.25	42	30	1750	1250	100
ERZV07D511	510(459 to 561)	320	410	845	0.25	45	32	1750	1250	90*

\* Measured at 1 MHz \*\*I<sub>p</sub> Measuring current of clamping voltage 180 to 680 : 25 A, 820 tp 511 : 10 A

#### ■ Dimensions in mm (not to scale) \* Refer to page 24 to 26 about leads cut type and taping.

Part No.	D max.	T max.	W±1.0	H max.	L±1.0
ERZV07D180	8.5	4.5	5.0	11.5	1.3
ERZV07D220	8.5	4.6	5.0	11.5	1.4
ERZV07D270	8.5	4.7	5.0	11.5	1.5
ERZV07D330	8.5	4.9	5.0	11.5	1.7
ERZV07D390	8.5	4.8	5.0	11.5	1.6
ERZV07D470	8.5	4.9	5.0	11.5	1.7
ERZV07D560	8.5	5.0	5.0	11.5	1.8
ERZV07D680	8.5	5.2	5.0	11.5	2.0
ERZV07D820	8.5	4.1	5.0	11.5	1.4
ERZV07D101	8.5	4.3	5.0	11.5	1.6
ERZV07D121	8.5	4.5	5.0	11.5	1.8
ERZV07D151	8.5	4.8	5.0	11.5	2.1
ERZV07D201	8.5	4.4	5.0	11.5	1.7
ERZV07D221	8.5	4.5	5.0	11.5	1.8
ERZV07D241	8.5	4.6	5.0	11.5	1.9
ERZV07D271	8.5	4.8	5.0	11.5	2.1
ERZV07D331	8.5	5.1	5.0	11.5	2.4
ERZV07D361	8.5	5.3	5.0	11.5	2.5
ERZV07D391	8.5	5.4	5.0	11.5	2.7
ERZV07D431	8.5	5.6	5.0	11.5	2.9
ERZV07D471	8.5	5.8	5.0	11.5	3.1
ERZV07D511	8.5	6.0	5.0	11.5	3.3

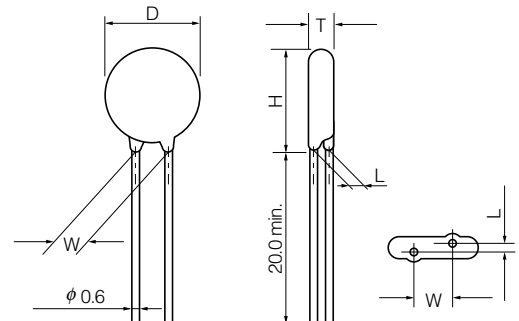

Design and specifications are each subject to change without notice. Ask factory for the current technical specifications before purchase and/or use. Should a safety concern arise regarding this product, please be sure to contact us immediately.

## Typical Characteristics Voltage vs. Current

ERZV07D180 to ERZV07D680

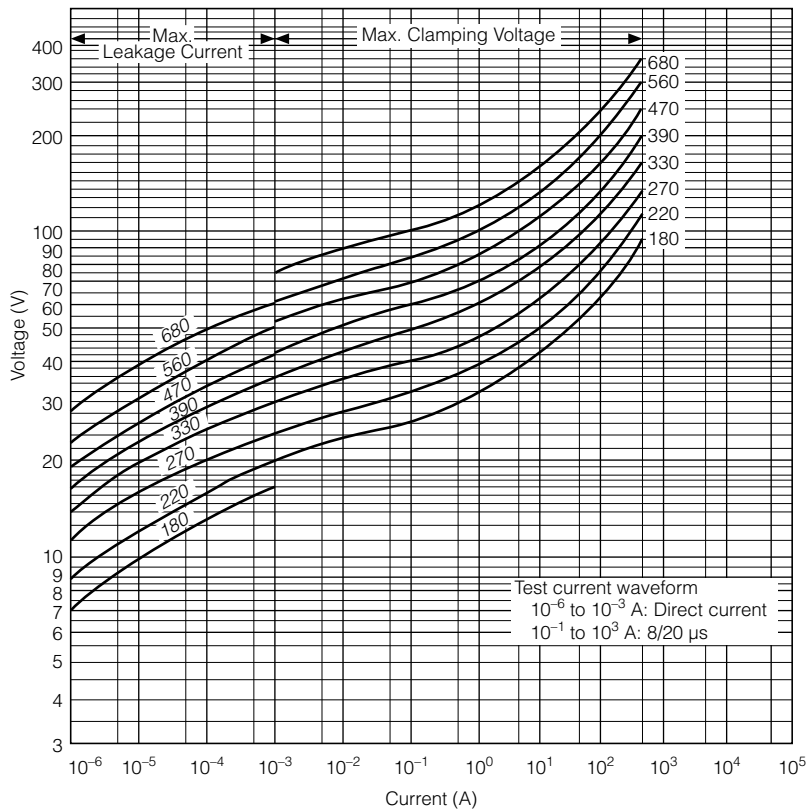

## Impulse Derating (Relation between impulse width and impulse current multiple)

ERZV07D180 to ERZV07D680

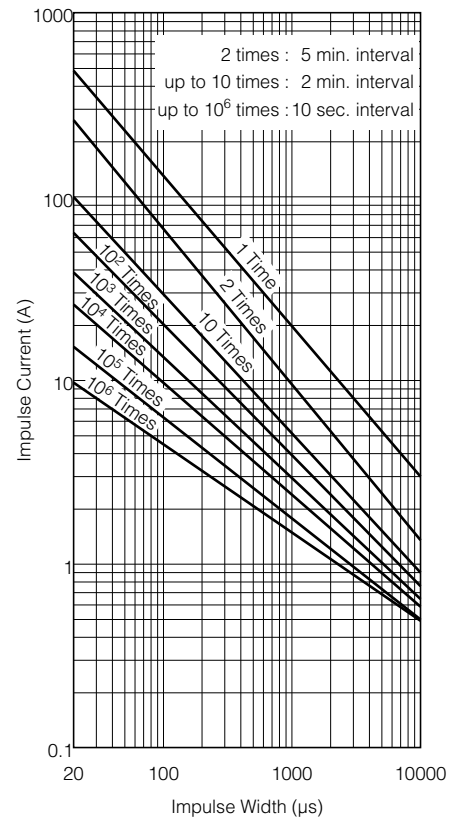

ERZV07D820 to ERZV07D511

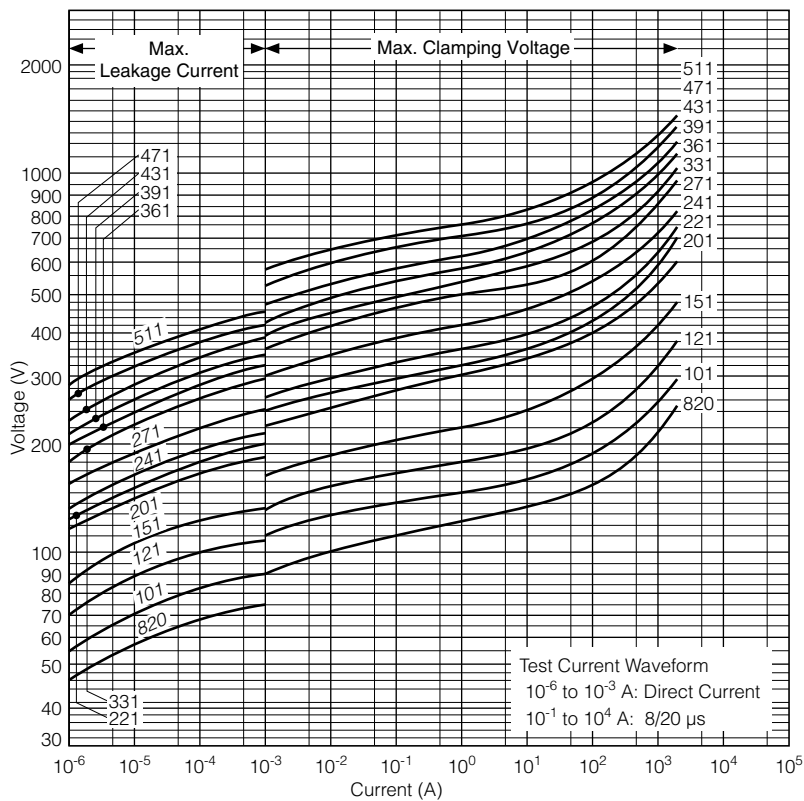

ERZV07D820 to ERZV07D511

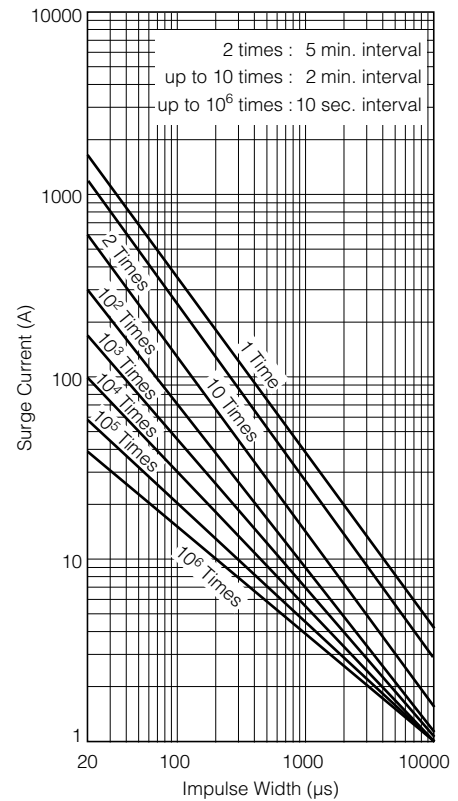

Design and specifications are each subject to change without notice. Ask factory for the current technical specifications before purchase and/or use. Should a safety concern arise regarding this product, please be sure to contact us immediately.

### 9 Series

#### ■ Ratings and Characteristics

● Operating Temperature Range : -40 to 85 °C ● Storage Temperature Range : -40 to 125 °C

Part No.	Varistor Voltage	Maximum Allowable Voltage		Clamping Voltage (max.) *Ip	Rated Power (W)	Maximum Energy		Maximum Peak Current (8/20 μs)		Capacitance (max.) at 1 kHz (pF)
						(10/1000 μs)	(2 ms)	1 time	2 times	
						V <sub>1mA</sub> (V)	ACrms (V)	DC (V)	(V)	
ERZV09D180	18(16 to 20)	11	14	36	0.05	2.6	2.2	1000	500	16000
ERZV09D220	22(20 to 24)	14	18	43	0.05	3.2	2.6	1000	500	11000
ERZV09D270	27(24 to 30)	17	22	53	0.05	3.9	3.2	1000	500	8000
ERZV09D330	33(30 to 36)	20	26	65	0.05	4.8	4.0	1000	500	6300
ERZV09D390	39(35 to 43)	25	31	77	0.05	5.6	4.7	1000	500	5200
ERZV09D470	47(42 to 52)	30	38	93	0.05	6.8	5.6	1000	500	4600
ERZV09D560	56(50 to 62)	35	45	110	0.05	8.1	6.7	1000	500	3750
ERZV09D680	68(61 to 75)	40	56	135	0.05	9.8	8.2	1000	500	2800
ERZV09D820	82(74 to 90)	50	65	135	0.4	14	10	3500	2500	2000
ERZV09D101	100(90 to 110)	60	85	165	0.4	17	12	3500	2500	1700
ERZV09D121	120(108 to 132)	75	100	200	0.4	20	14.5	3500	2500	1400
ERZV09D151	150(135 to 165)	95	125	250	0.4	25	18	3500	2500	1100
ERZV09D201	200(185 to 225)	130	170	340	0.4	35	25	3500	2500	430
ERZV09D221	220(198 to 242)	140	180	360	0.4	39	27.5	3500	2500	410
ERZV09D241	240(216 to 264)	150	200	395	0.4	42	30	3500	2500	380
ERZV09D271	270(247 to 303)	175	225	455	0.4	49	35	3500	2500	350
ERZV09D331	330(297 to 363)	210	270	545	0.4	58	42	3500	2500	300
ERZV09D361	360(324 to 396)	230	300	595	0.4	65	45	3500	2500	300
ERZV09D391	390(351 to 429)	250	320	650	0.4	70	50	3500	2500	300
ERZV09D431	430(387 to 473)	275	350	710	0.4	80	55	3500	2500	270
ERZV09D471	470(423 to 517)	300	385	775	0.4	85	60	3500	2500	230
ERZV09D511	510(459 to 561)	320	410	845	0.4	92	67	3500	2500	210

\*Ip Measuring current of clamping voltage 180 to 680 : 5 A, 820 to 511 : 25 A

#### ■ Dimensions in mm (not to scale) \* Refer to page 24 to 26 about leads cut type and taping.

Part No.	D max.	T max.	W±1.0	H max.	L±1.0
ERZV09D180	11.5	3.8	5.0	14.0	1.3
ERZV09D220	11.5	4.0	5.0	14.0	1.4
ERZV09D270	11.5	4.2	5.0	14.0	1.5
ERZV09D330	11.5	4.5	5.0	14.0	1.7
ERZV09D390	11.5	4.0	5.0	14.0	1.7
ERZV09D470	11.5	4.2	5.0	14.0	1.8
ERZV09D560	11.5	4.4	5.0	14.0	1.9
ERZV09D680	11.5	4.5	5.0	14.0	2.2
ERZV09D820	11.5	3.8	5.0	14.0	1.6
ERZV09D101	11.5	3.9	5.0	14.0	1.8
ERZV09D121	11.5	4.1	5.0	14.0	2.0
ERZV09D151	11.5	4.4	5.0	14.0	2.2
ERZV09D201	11.5	4.1	5.0	14.0	1.7
ERZV09D221	11.5	4.2	5.0	14.0	1.8
ERZV09D241	11.5	4.3	5.0	14.0	1.9
ERZV09D271	11.5	4.5	5.0	14.0	2.0
ERZV09D331	11.5	4.8	5.0	14.0	2.3
ERZV09D361	11.5	5.0	5.0	14.0	2.5
ERZV09D391	11.5	5.1	5.0	14.0	2.6
ERZV09D431	11.5	5.3	5.0	14.0	2.8
ERZV09D471	11.5	5.6	5.0	14.0	3.1
ERZV09D511	11.5	5.8	5.0	14.0	3.2

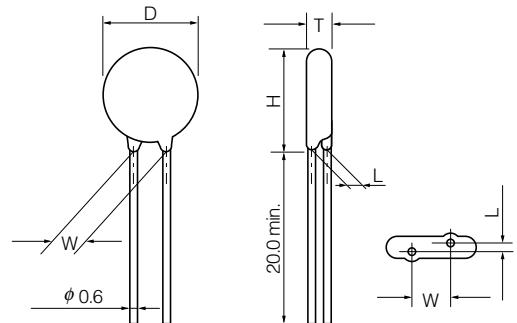

Design and specifications are each subject to change without notice. Ask factory for the current technical specifications before purchase and/or use. Should a safety concern arise regarding this product, please be sure to contact us immediately.

## Typical Characteristics Voltage vs. Current

ERZV09D180 to ERZV09D680

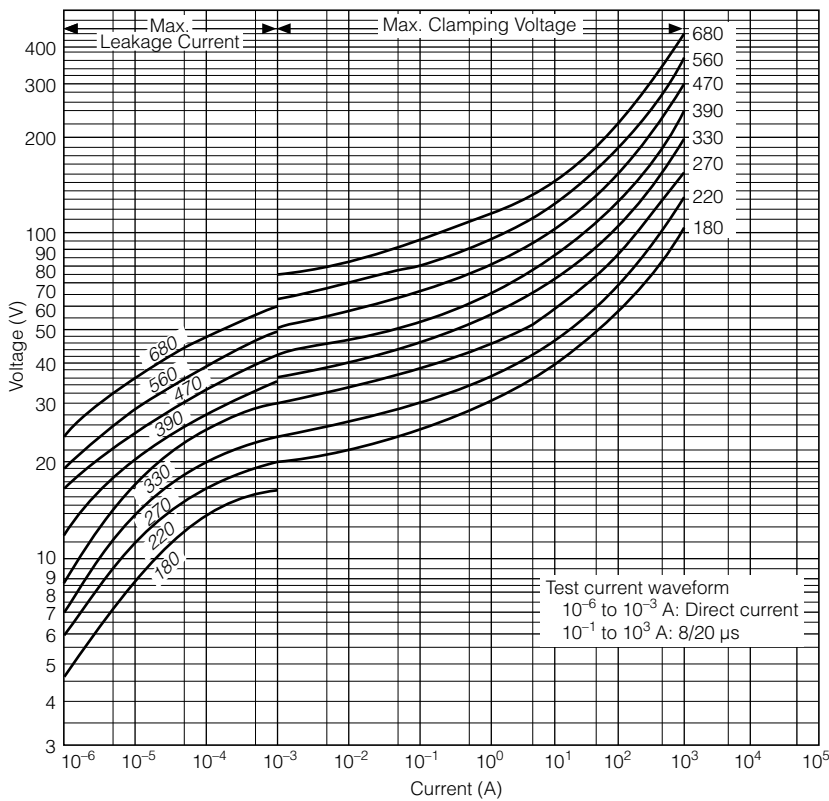

ERZV09D180 to ERZV09D680

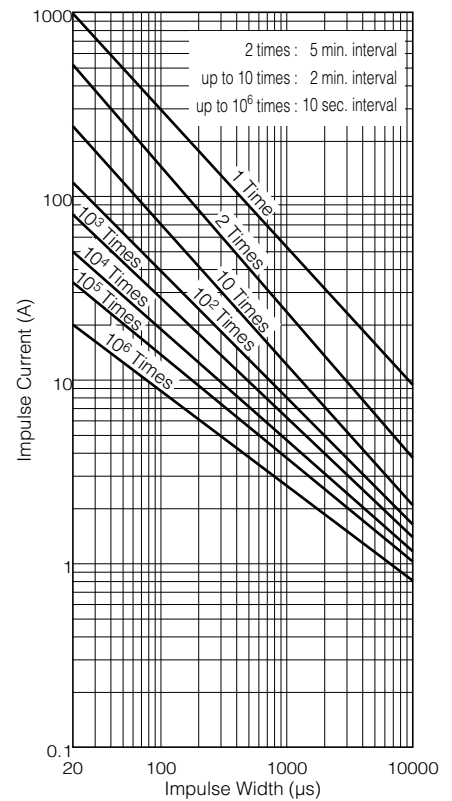

ERZV09D820 to ERZV09D511

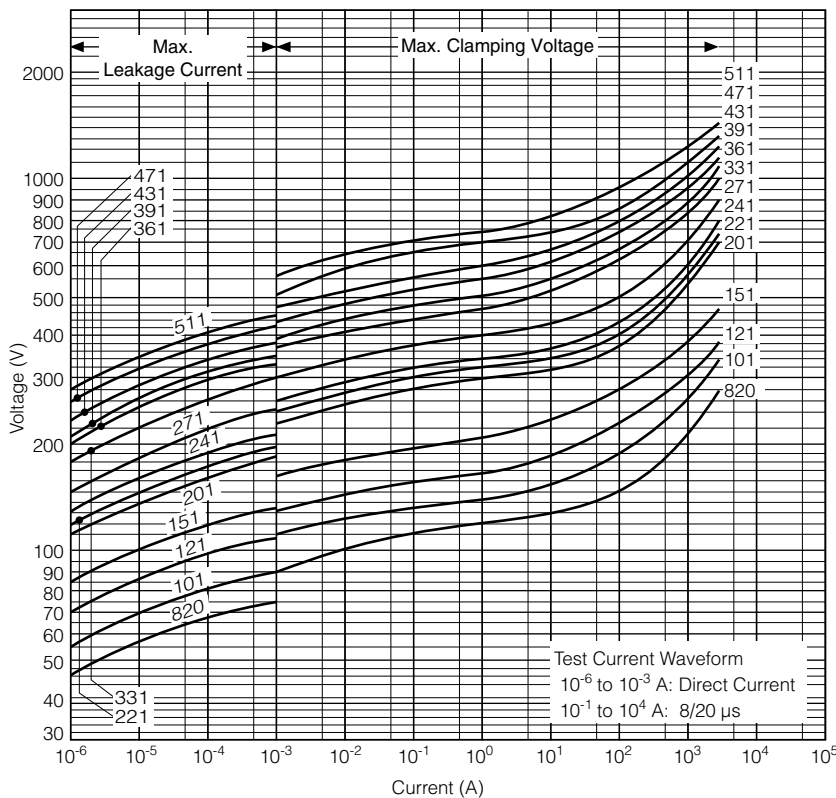

ERZV09D820 to ERZV09D511

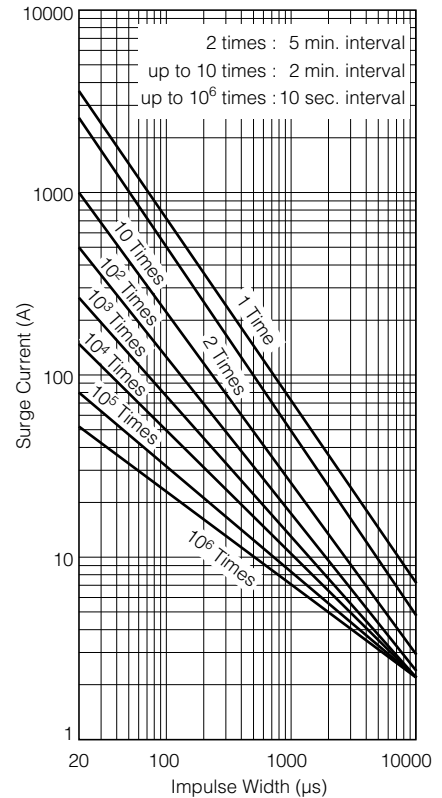

Design and specifications are each subject to change without notice. Ask factory for the current technical specifications before purchase and/or use. Should a safety concern arise regarding this product, please be sure to contact us immediately.

### 10 Series

#### ■ Ratings and Characteristics

● Operating Temperature Range : -40 to 85 °C ● Storage Temperature Range : -40 to 125 °C

Part No.	Varistor Voltage  $V_{1\text{ mA}}$ (V)	Maximum Allowable Voltage		Clamping Voltage (max.) **I <sub>p</sub> (V)	Rated Power (W)	Maximum Energy		Maximum Peak Current (8/20 μs)		Capacitance (max.)  at 1 kHz (pF)
		ACrms (V)	DC (V)			(10/1000 μs) (J)	(2 ms) (J)	1 time (A)	2 times (A)	
ERZV10D180	18(16 to 20)	11	14	36	0.05	2.6	2.2	1000	500	16000
ERZV10D220	22(20 to 24)	14	18	43	0.05	3.2	2.6	1000	500	11000
ERZV10D270	27(24 to 30)	17	22	53	0.05	3.9	3.2	1000	500	8000
ERZV10D330	33(30 to 36)	20	26	65	0.05	4.8	4.0	1000	500	6300
ERZV10D390	39(35 to 43)	25	31	77	0.05	5.6	4.7	1000	500	5200
ERZV10D470	47(42 to 52)	30	38	93	0.05	6.8	5.6	1000	500	4600
ERZV10D560	56(50 to 62)	35	45	110	0.05	8.1	6.7	1000	500	3750
ERZV10D680	68(61 to 75)	40	56	135	0.05	9.8	8.2	1000	500	2800
ERZV10D820	82(74 to 90)	50	65	135	0.4	14	10	3500	2500	2000
ERZV10D101	100(90 to 110)	60	85	165	0.4	17	12	3500	2500	1700
ERZV10D121	120(108 to 132)	75	100	200	0.4	20	14.5	3500	2500	1400
ERZV10D151	150(135 to 165)	95	125	250	0.4	25	18	3500	2500	1100
ERZV10D201	200(185 to 225)	130	170	340	0.4	35	25	3500	2500	430
ERZV10D221	220(198 to 242)	140	180	360	0.4	39	27.5	3500	2500	410
ERZV10D241	240(216 to 264)	150	200	395	0.4	42	30	3500	2500	380
ERZV10D271	270(247 to 303)	175	225	455	0.4	49	35	3500	2500	350
ERZV10D331	330(297 to 363)	210	270	545	0.4	58	42	3500	2500	300
ERZV10D361	360(324 to 396)	230	300	595	0.4	65	45	3500	2500	300
ERZV10D391	390(351 to 429)	250	320	650	0.4	70	50	3500	2500	300
ERZV10D431	430(387 to 473)	275	350	710	0.4	80	55	3500	2500	270
ERZV10D471	470(423 to 517)	300	385	775	0.4	85	60	3500	2500	230
ERZV10D511	510(459 to 561)	320	410	845	0.4	92	67	3500	2500	210
ERZV10D561	560(504 to 616)	350	450	930	0.4	92	67	3500	2500	200
ERZV10D621	620(558 to 682)	385	505	1025	0.4	92	67	3500	2500	190
ERZV10D681	680(612 to 748)	420	560	1120	0.4	92	67	3500	2500	170
ERZV10D751	750(675 to 825)	460	615	1240	0.4	100	70	3500	2500	160
ERZV10D821	820(738 to 902)	510	670	1355	0.4	110	80	3500	2500	140
ERZV10D911	910(819 to 1001)	550	745	1500	0.4	130	90	3500	2500	120
ERZV10D102	1000(900 to 1100)	625	825	1650	0.4	140	100	3500	2500	110
ERZV10D112	1100(990 to 1210)	680	895	1815	0.4	155	110	3500	2500	110
ERZV10D182CS	1800(1700 to 1980)	1000	1465	2970	0.4	247	183	3500	2500	70*

\* Measured at 1 MHz \*\*I<sub>p</sub> Measuring current of clamping voltage 180 to 680 : 5 A, 820 to 182 : 25 A



■ Dimensions in mm (not to scale) \* Refer to page 24 to 26 about leads cut type and taping.

Part No.	D max.	T max.	W±1.0	H max.	L±1.0
ERZV10D180	11.5	4.6	7.5	14.5	1.3
ERZV10D220	11.5	4.7	7.5	14.5	1.4
ERZV10D270	11.5	4.8	7.5	14.5	1.5
ERZV10D330	11.5	5.0	7.5	14.5	1.7
ERZV10D390	11.5	4.9	7.5	14.5	1.6
ERZV10D470	11.5	5.0	7.5	14.5	1.7
ERZV10D560	11.5	5.1	7.5	14.5	1.8
ERZV10D680	11.5	5.3	7.5	14.5	2.0
ERZV10D820	11.5	4.5	7.5	14.5	1.6
ERZV10D101	11.5	4.7	7.5	14.5	1.8
ERZV10D121	11.5	4.9	7.5	14.5	2.0
ERZV10D151	11.5	5.2	7.5	14.5	2.3
ERZV10D201	11.5	4.8	7.5	14.5	1.9
ERZV10D221	11.5	4.9	7.5	14.5	2.0
ERZV10D241	11.5	5.0	7.5	14.5	2.1
ERZV10D271	11.5	5.2	7.5	14.5	2.3
ERZV10D331	11.5	5.5	7.5	14.5	2.6
ERZV10D361	11.5	5.7	7.5	14.5	2.8
ERZV10D391	11.5	5.8	7.5	14.5	2.9
ERZV10D431	11.5	6.0	7.5	14.5	3.1
ERZV10D471	11.5	6.2	7.5	14.5	3.3
ERZV10D511	11.5	6.4	7.5	14.5	3.5
ERZV10D561	12.5	6.7	7.5	15.5	3.8
ERZV10D621	12.5	7.1	7.5	15.5	4.2
ERZV10D681	12.5	7.4	7.5	15.5	4.5
ERZV10D751	12.5	7.8	7.5	15.5	4.9
ERZV10D821	12.5	8.1	7.5	15.5	5.2
ERZV10D911	12.5	8.6	7.5	15.5	5.7
ERZV10D102	12.5	9.1	7.5	15.5	6.2
ERZV10D112	12.5	9.7	7.5	15.5	6.8
ERZV10D182CS	13.5	14.4	11.0*	16.5	10.0(±1.5)

\*: W<sub>2</sub>

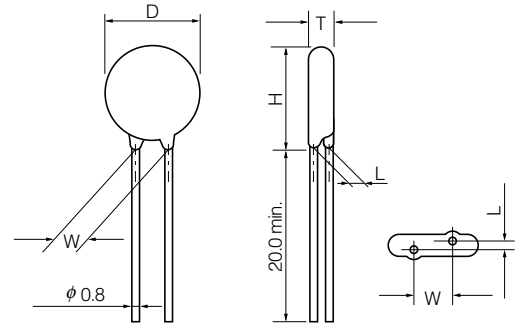

(ERZV10D182CS)

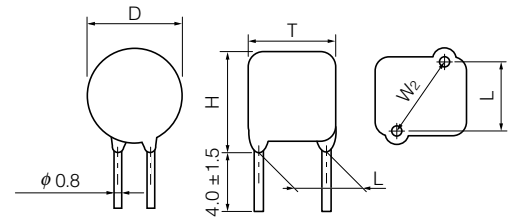

## ■ Typical Characteristics

### Voltage vs. Current

ERZV10D180 to ERZV10D680

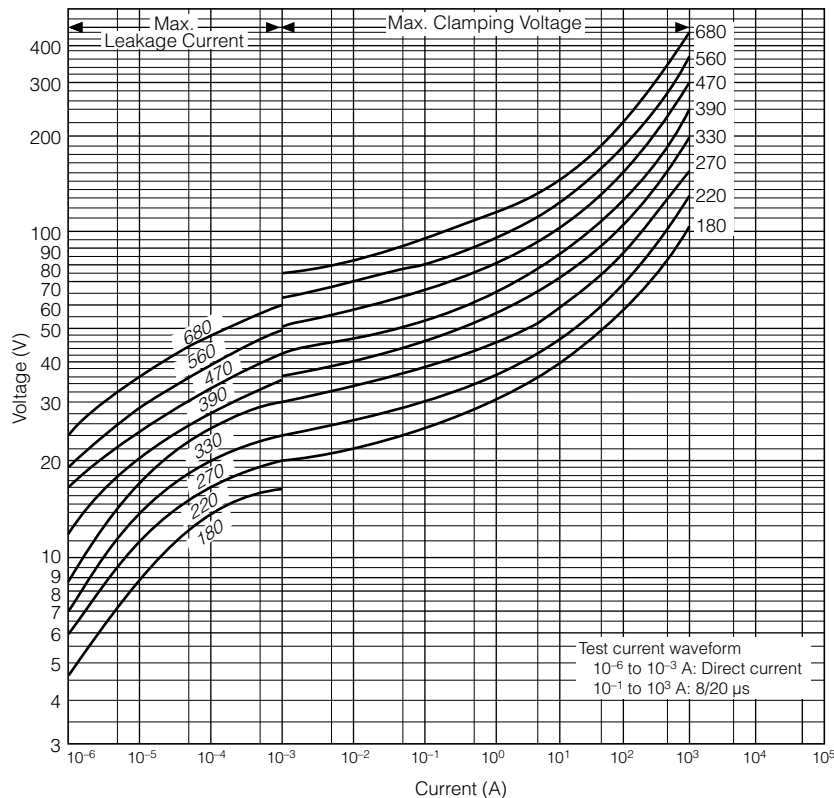

### Impulse Derating (Relation between impulse width and impulse current multiple)

ERZV10D180 to ERZV10D680

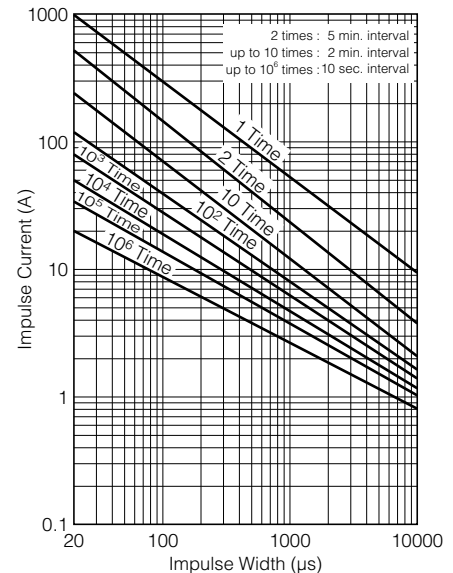

Design and specifications are each subject to change without notice. Ask factory for the current technical specifications before purchase and/or use. Should a safety concern arise regarding this product, please be sure to contact us immediately.

## Typical Characteristics Voltage vs. Current

ERZV10D820 to ERZV10D511

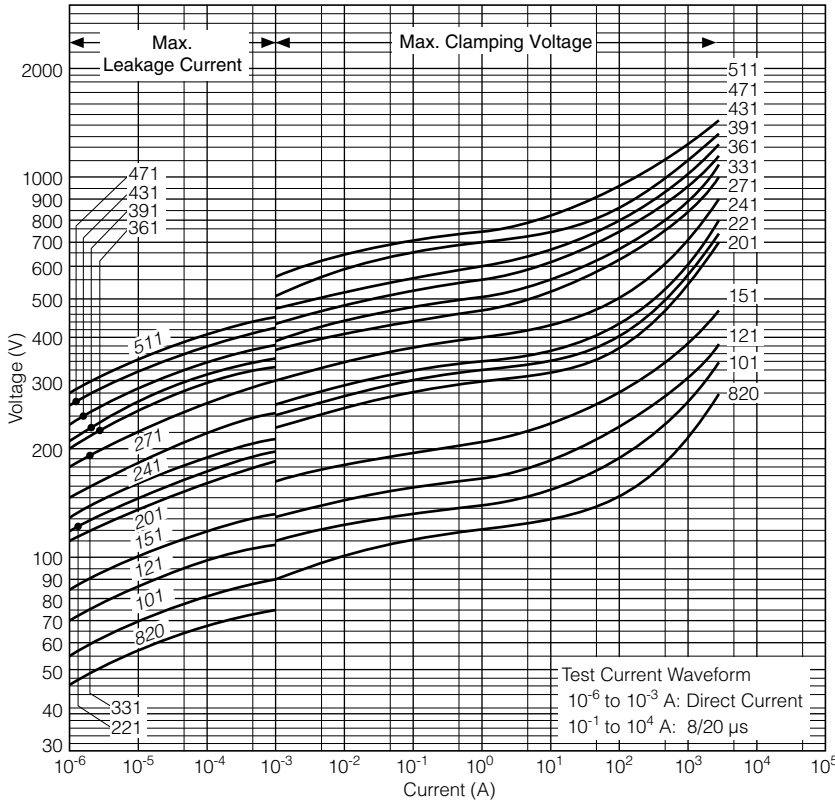

## Impulse Derating (Relation between impulse width and impulse current multiple)

ERZV10D820 to ERZV10D511

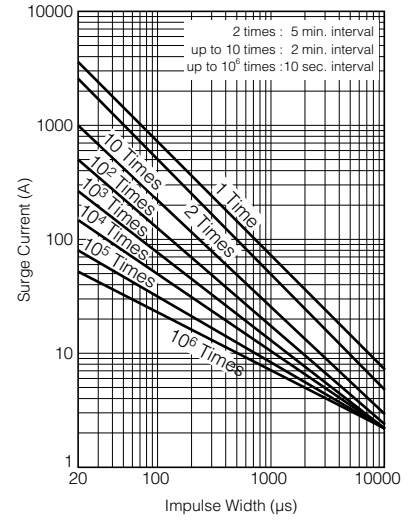

ERZV10D561 to ERZV10D112

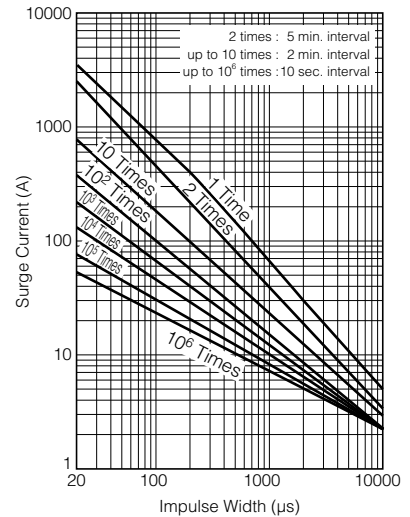

ERZV10D561 to ERZV10D182CS

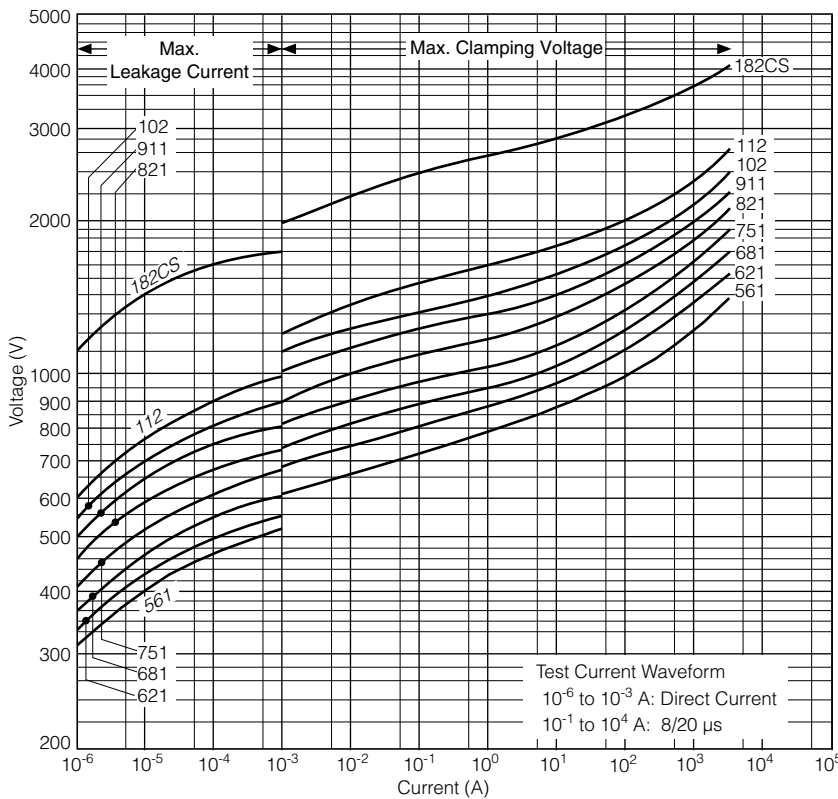

ERZV10D182CS

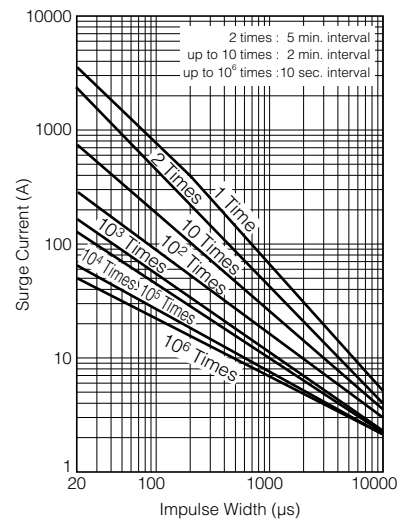

### 14 Series

#### ■ Ratings and Characteristics

● Operating Temperature Range : -40 to 85 °C ● Storage Temperature Range : -40 to 125 °C

Part No.	Varistor Voltage  $V_{1\text{ mA}}$ (V)	Maximum Allowable Voltage		Clamping Voltage (max.) *Ip (V)	Rated Power (W)	Maximum Energy		Maximum Peak Current (8/20 $\mu$ s)		Capacitance (max.)  at 1 kHz (pF)
		ACrms (V)	DC (V)			(10/1000 $\mu$ s) (J)	(2 ms) (J)	1 time (A)	2 times (A)	
ERZV14D180	18(16 to 20)	11	14	36	0.1	5.2	4.3	2000	1000	25000
ERZV14D220	22(20 to 24)	14	18	43	0.1	6.3	5.3	2000	1000	20000
ERZV14D270	27(24 to 30)	17	22	53	0.1	7.8	6.5	2000	1000	16000
ERZV14D330	33(30 to 36)	20	26	65	0.1	9.5	7.9	2000	1000	12200
ERZV14D390	39(35 to 43)	25	31	77	0.1	11	9.4	2000	1000	7000
ERZV14D470	47(42 to 52)	30	38	93	0.1	14	11	2000	1000	6750
ERZV14D560	56(50 to 62)	35	45	110	0.1	16	13	2000	1000	6500
ERZV14D680	68(61 to 75)	40	56	135	0.1	20	16	2000	1000	5500
ERZV14D820	82(74 to 90)	50	65	135	0.6	28	20	6000	5000	3700
ERZV14D101	100(90 to 110)	60	85	165	0.6	35	25	6000	5000	3200
ERZV14D121	120(108 to 132)	75	100	200	0.6	42	30	6000	5000	2700
ERZV14D151	150(135 to 165)	95	125	250	0.6	53	37.5	6000	5000	2200
ERZV14D201	200(185 to 225)	130	170	340	0.6	70	50	6000	5000	770
ERZV14D221	220(198 to 242)	140	180	360	0.6	78	55	6000	5000	740
ERZV14D241	240(216 to 264)	150	200	395	0.6	84	60	6000	5000	700
ERZV14D271	270(247 to 303)	175	225	455	0.6	99	70	6000	5000	640
ERZV14D331	330(297 to 363)	210	270	545	0.6	115	80	6000	4500	580
ERZV14D361	360(324 to 396)	230	300	595	0.6	130	90	6000	4500	540
ERZV14D391	390(351 to 429)	250	320	650	0.6	140	100	6000	4500	500
ERZV14D431	430(387 to 473)	275	350	710	0.6	155	110	6000	4500	450
ERZV14D471	470(423 to 517)	300	385	775	0.6	175	125	6000	4500	400
ERZV14D511	510(459 to 561)	320	410	845	0.6	190	136	6000	4500	350
ERZV14D561	560(504 to 616)	350	450	930	0.6	190	136	5000	4500	340
ERZV14D621	620(558 to 682)	385	505	1025	0.6	190	136	5000	4500	330
ERZV14D681	680(612 to 748)	420	560	1120	0.6	190	136	5000	4500	320
ERZV14D751	750(675 to 825)	460	615	1240	0.6	210	150	5000	4500	310
ERZV14D821	820(738 to 902)	510	670	1355	0.6	235	165	5000	4500	280
ERZV14D911	910(819 to 1001)	550	745	1500	0.6	255	180	5000	4500	250
ERZV14D102	1000(900 to 1100)	625	825	1650	0.6	280	200	5000	4500	230
ERZV14D112	1100(990 to 1210)	680	895	1815	0.6	310	220	5000	4500	210
ERZV14D182CS	1800(1700 to 1980)	1000	1465	2970	0.6	510	360	5000	4500	120

\*Ip Measuring current of clamping voltage 180 to 680 : 10 A, 820 to 182 : 50 A

■ Dimensions in mm (not to scale) \* Refer to page 24 to 26 about leads cut type and taping.

Part No.	D max.	T max.	W±1.0	H max.	L±1.0
ERZV14D180	15.5	4.6	7.5	18.5	1.3
ERZV14D220	15.5	4.7	7.5	18.5	1.4
ERZV14D270	15.5	4.8	7.5	18.5	1.5
ERZV14D330	15.5	5.0	7.5	18.5	1.7
ERZV14D390	15.5	4.9	7.5	18.5	1.6
ERZV14D470	15.5	5.0	7.5	18.5	1.7
ERZV14D560	15.5	5.1	7.5	18.5	1.8
ERZV14D680	15.5	5.3	7.5	18.5	2.0
ERZV14D820	15.5	4.5	7.5	18.5	1.6
ERZV14D101	15.5	4.7	7.5	18.5	1.8
ERZV14D121	15.5	4.9	7.5	18.5	2.0
ERZV14D151	15.5	5.2	7.5	18.5	2.3
ERZV14D201	15.5	4.8	7.5	18.5	1.9
ERZV14D221	15.5	4.9	7.5	18.5	2.0
ERZV14D241	15.5	5.0	7.5	18.5	2.1
ERZV14D271	15.5	5.2	7.5	18.5	2.3
ERZV14D331	15.5	5.5	7.5	18.5	2.6
ERZV14D361	15.5	5.7	7.5	18.5	2.8
ERZV14D391	15.5	5.8	7.5	18.5	2.9
ERZV14D431	15.5	6.0	7.5	18.5	3.1
ERZV14D471	15.5	6.2	7.5	18.5	3.3
ERZV14D511	15.5	6.4	7.5	18.5	3.5
ERZV14D561	16.0	6.7	7.5	19.0	3.8
ERZV14D621	16.0	7.1	7.5	19.0	4.2
ERZV14D681	16.0	7.4	7.5	19.0	4.5
ERZV14D751	16.0	7.8	7.5	19.0	4.9
ERZV14D821	16.0	8.1	7.5	19.0	5.2
ERZV14D911	16.0	8.6	7.5	19.0	5.7
ERZV14D102	16.0	9.1	7.5	19.0	6.2
ERZV14D112	16.0	9.7	7.5	19.0	6.8
ERZV14D182CS	17.0	14.4	15.0*	20.5	10.5(±2.0)

\*: W<sub>2</sub>

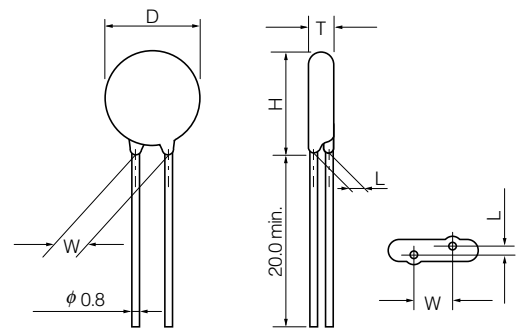

(ERZV14D182CS)

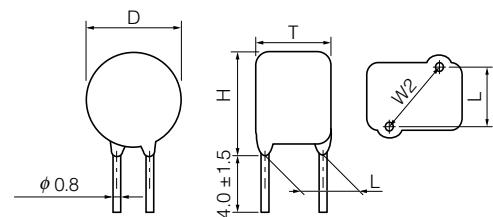

## ■ Typical Characteristics

### Voltage vs. Current

ERZV14D180 to ERZV14D680

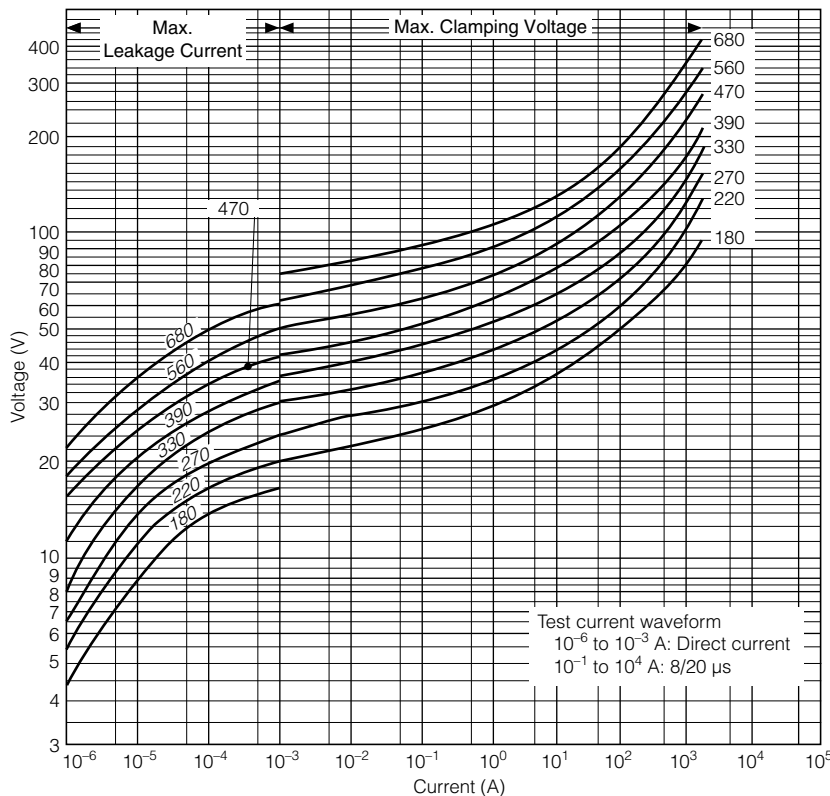

### Impulse Derating (Relation between impulse width and impulse current multiple)

ERZV14D180 to ERZV14D680

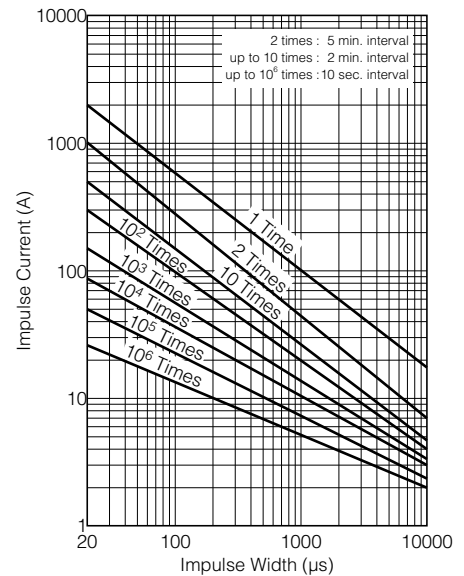

Design and specifications are each subject to change without notice. Ask factory for the current technical specifications before purchase and/or use. Should a safety concern arise regarding this product, please be sure to contact us immediately.

## Typical Characteristics Voltage vs. Current

ERZV14D820 to ERZV14D511

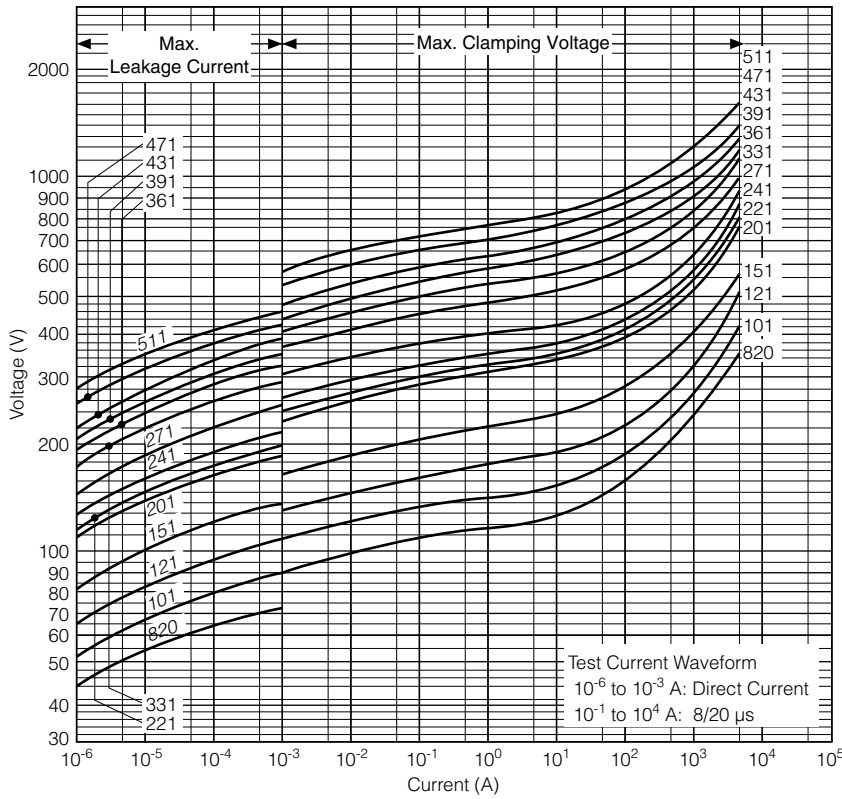

## Impulse Derating (Relation between impulse width and impulse current multiple)

ERZV14D820 to ERZV14D511

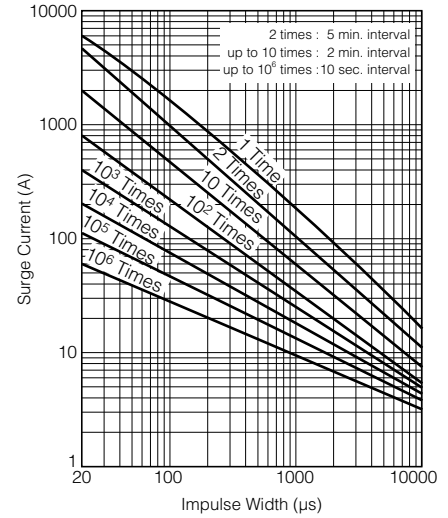

ERZV14D561 to ERZV14D112

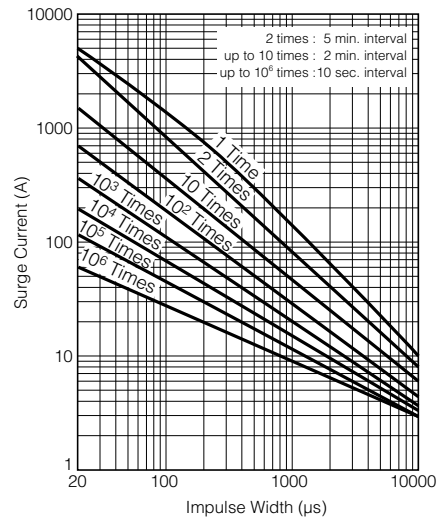

ERZV14D561 to ERZV14D182CS

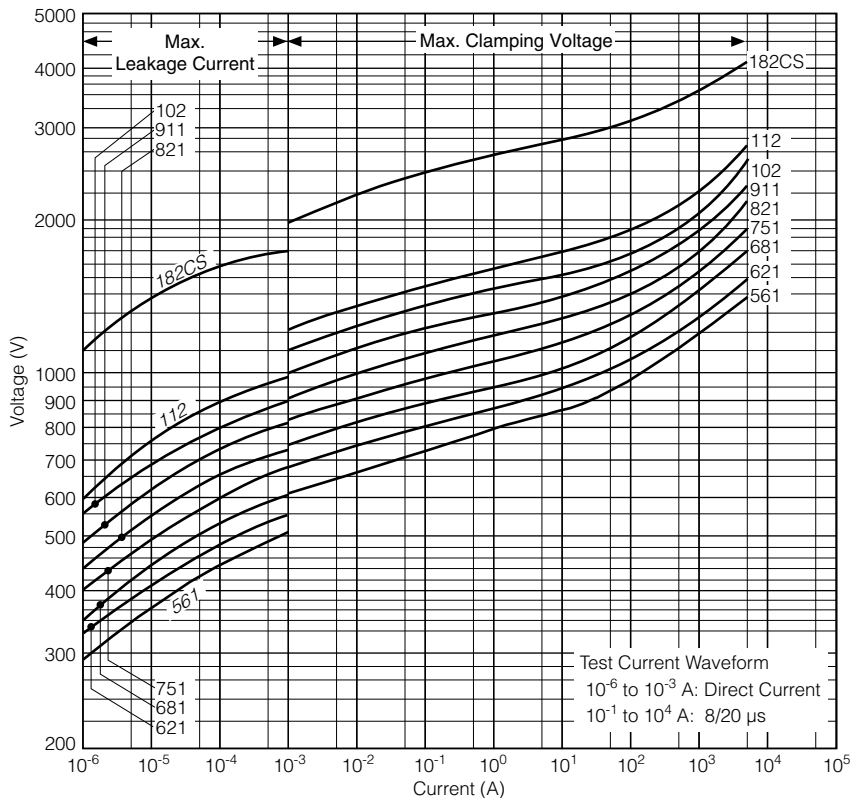

ERZV14D182CS

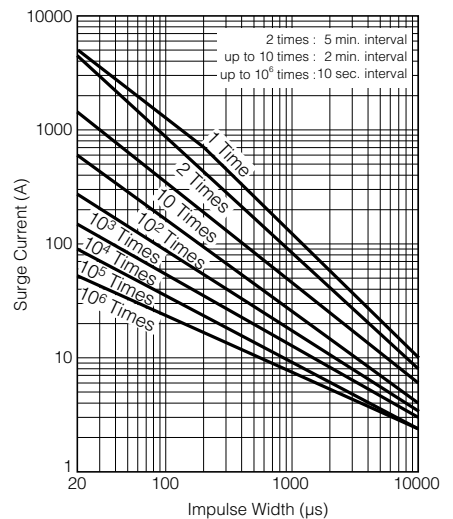

### 20 Series

#### ■ Ratings and Characteristics

● Operating Temperature Range : -40 to 85 °C ● Storage Temperature Range : -40 to 125 °C

Part No.	Varistor Voltage	Maximum Allowable Voltage		Clamping Voltage (max.) *Ip	Rated Power	Maximum Energy		Maximum Peak Current (8/20 μs)		Capacitance (max.) at 1 kHz (pF)
						(10/1000 μs)	(2 ms)	1 time	2 times	
	V <sub>1 mA</sub> (V)	ACrms (V)	DC (V)	(V)	(W)	(J)	(J)	(A)	(A)	
ERZV20D180	18(16 to 20)	11	14	36	0.2	13	12	3000	2000	40000
ERZV20D220	22(20 to 24)	14	18	43	0.2	16	14	3000	2000	30000
ERZV20D270	27(24 to 30)	17	22	53	0.2	19	17	3000	2000	24500
ERZV20D330	33(30 to 36)	20	26	65	0.2	24	21	3000	2000	20000
ERZV20D390	39(35 to 43)	25	31	77	0.2	28	25	3000	2000	13800
ERZV20D470	47(42 to 52)	30	38	93	0.2	34	30	3000	2000	13500
ERZV20D560	56(50 to 62)	35	45	110	0.2	41	36	3000	2000	12200
ERZV20D680	68(61 to 75)	40	56	135	0.2	49	44	3000	2000	11500
ERZV20D820	82(74 to 90)	50	65	135	1.0	56	40	10000	7000	7500
ERZV20D101	100(90 to 110)	60	85	165	1.0	70	50	10000	7000	6500
ERZV20D121	120(108 to 132)	75	100	200	1.0	85	60	10000	7000	5500
ERZV20D151	150(135 to 165)	95	125	250	1.0	106	75	10000	7000	4500
ERZV20D201	200(185 to 225)	130	170	340	1.0	140	100	10000	7000	1700
ERZV20D221	220(198 to 242)	140	180	360	1.0	155	110	10000	7000	1600
ERZV20D241	240(216 to 264)	150	200	395	1.0	168	120	10000	7000	1500
ERZV20D271	270(247 to 303)	175	225	455	1.0	190	135	10000	7000	1300
ERZV20D331	330(297 to 363)	210	270	545	1.0	228	160	10000	6500	1100
ERZV20D361	360(324 to 396)	230	300	595	1.0	255	180	10000	6500	1100
ERZV20D391	390(351 to 429)	250	320	650	1.0	275	195	10000	6500	1100
ERZV20D431	430(387 to 473)	275	350	710	1.0	303	215	10000	6500	1000
ERZV20D471	470(423 to 517)	300	385	775	1.0	350	250	10000	6500	900
ERZV20D511	510(459 to 561)	320	410	845	1.0	382	273	10000	6500	800
ERZV20D561	560(504 to 616)	350	450	930	1.0	382	273	7500	6500	750
ERZV20D621	620(558 to 682)	385	505	1025	1.0	382	273	7500	6500	700
ERZV20D681	680(612 to 748)	420	560	1120	1.0	382	273	7500	6500	650
ERZV20D751	750(675 to 825)	460	615	1240	1.0	420	300	7500	6500	600
ERZV20D821	820(738 to 902)	510	670	1355	1.0	460	325	7500	6500	530
ERZV20D911	910(819 to 1001)	550	745	1500	1.0	510	360	7500	6500	500
ERZV20D102	1000(900 to 1100)	625	825	1650	1.0	565	400	7500	6500	450
ERZV20D112	1100(990 to 1210)	680	895	1815	1.0	620	440	7500	6500	400
ERZV20D182	1800(1700 to 1980)	1000	1465	2970	1.0	1020	720	7500	6500	250

\*Ip Measuring current of clamping voltage 180 to 680 : 20 A, 820 to 182 : 100 A

■ Dimensions in mm (not to scale) \* Refer to page 24 to 26A about leads cut type and taping.

Part No.	D max.	T max.	W±1.0	H max.	L±1.0
ERZV20D180	21.5	5.1	10.0	24.5	1.5
ERZV20D220	21.5	5.2	10.0	24.5	1.6
ERZV20D270	21.5	5.3	10.0	24.5	1.7
ERZV20D330	21.5	5.5	10.0	24.5	1.9
ERZV20D390	21.5	5.5	10.0	24.5	1.9
ERZV20D470	21.5	5.6	10.0	24.5	2.0
ERZV20D560	21.5	5.7	10.0	24.5	2.1
ERZV20D680	21.5	5.8	10.0	24.5	2.2
ERZV20D820	21.5	4.9	10.0	24.5	1.8
ERZV20D101	21.5	5.1	10.0	24.5	2.0
ERZV20D121	21.5	5.3	10.0	24.5	2.2
ERZV20D151	21.5	5.6	10.0	24.5	2.5
ERZV20D201	21.5	5.2	10.0	24.5	2.1
ERZV20D221	21.5	5.3	10.0	24.5	2.2
ERZV20D241	21.5	5.4	10.0	24.5	2.3
ERZV20D271	21.5	5.6	10.0	24.5	2.5
ERZV20D331	21.5	5.9	10.0	24.5	2.8
ERZV20D361	21.5	6.1	10.0	24.5	3.0
ERZV20D391	21.5	6.2	10.0	24.5	3.1
ERZV20D431	21.5	6.4	10.0	24.5	3.3
ERZV20D471	21.5	6.6	10.0	24.5	3.5
ERZV20D511	21.5	6.8	10.0	24.5	3.7
ERZV20D561	22.5	7.1	10.0	25.5	4.2
ERZV20D621	22.5	7.5	10.0	25.5	4.4
ERZV20D681	22.5	7.8	10.0	25.5	4.7
ERZV20D751	22.5	8.2	10.0	25.5	5.1
ERZV20D821	22.5	8.5	10.0	25.5	5.4
ERZV20D911	22.5	9.0	10.0	25.5	5.9
ERZV20D102	22.5	9.5	10.0	25.5	6.4
ERZV20D112	22.5	10.1	10.0	25.5	7.0
ERZV20D182	23.5	14.8	15.0*	28.0	10.7(±2.0)

\*: W<sub>2</sub>

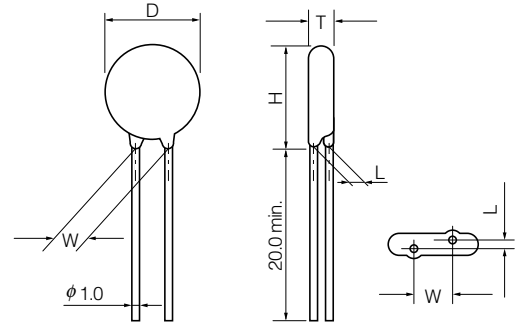

(ERZV20D182)

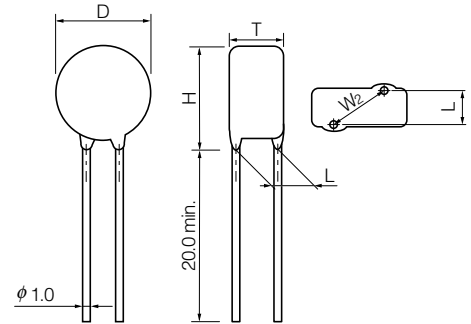

### ■ Typical Characteristics Voltage vs. Current

ERZV20D180 to ERZV20D680

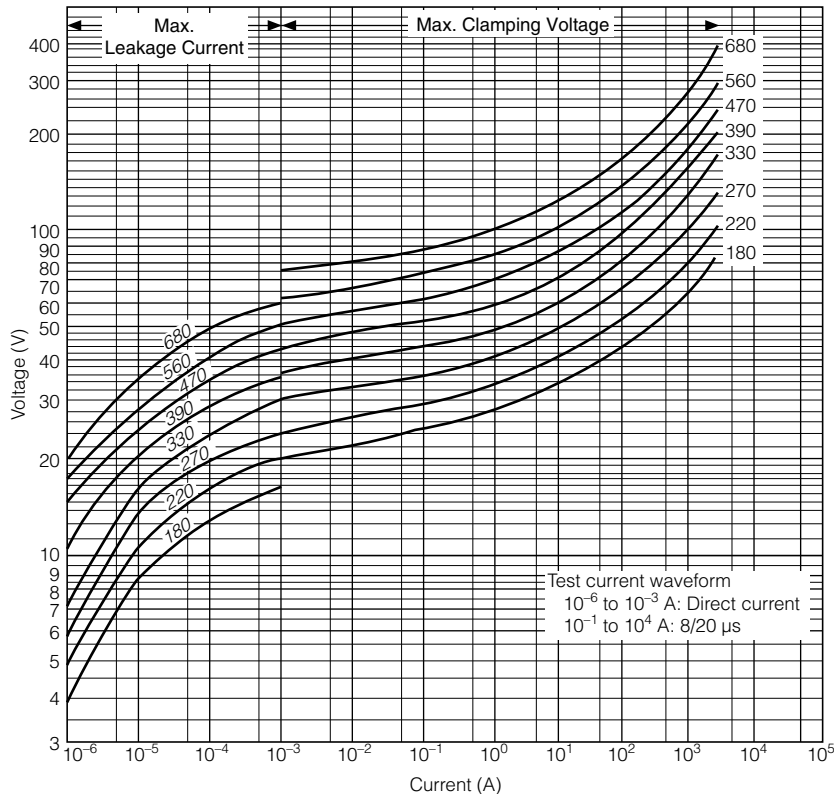

### Impulse Derating (Relation between impulse width and impulse current multiple)

ERZV20D180 to ERZV20D680

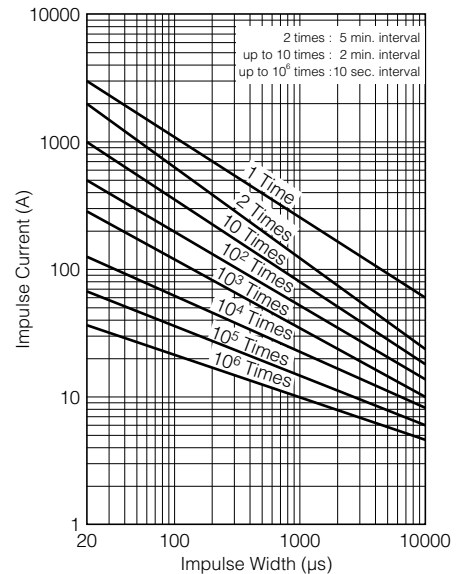

Design and specifications are each subject to change without notice. Ask factory for the current technical specifications before purchase and/or use. Should a safety concern arise regarding this product, please be sure to contact us immediately.

## Typical Characteristics Voltage vs. Current

## Impulse Derating (Relation between impulse width and impulse current multiple)

ERZV20D820 to ERZV20D511

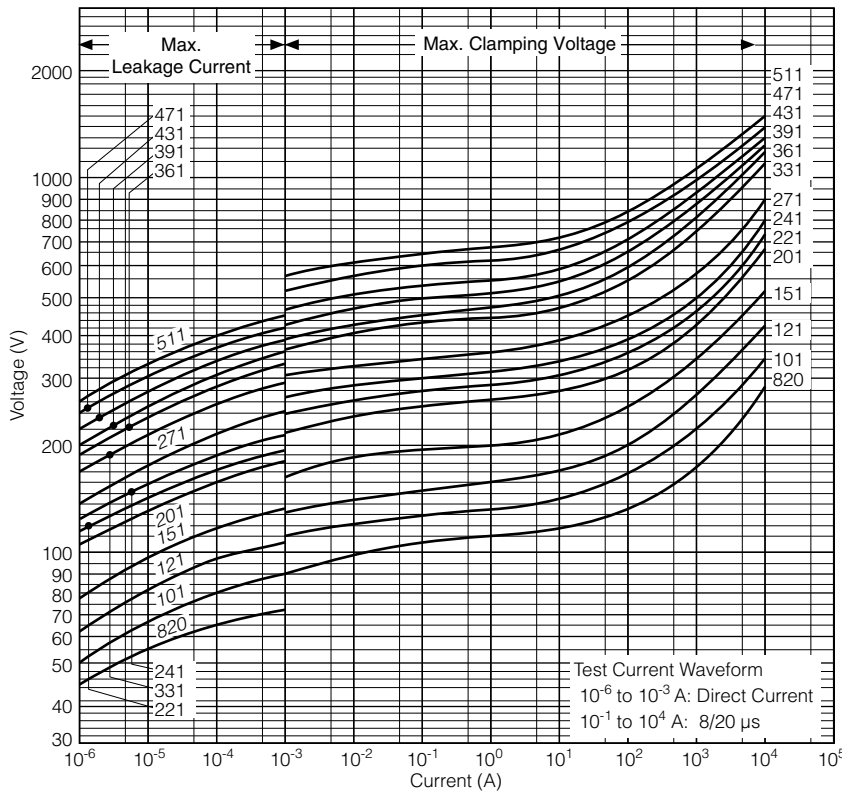

ERZV20D820 to ERZV20D511

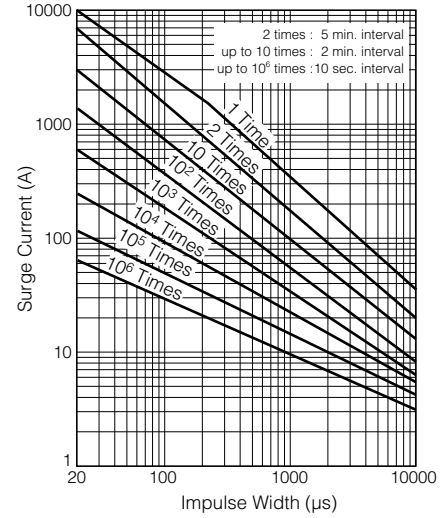

ERZV20D561 to ERZV20D182

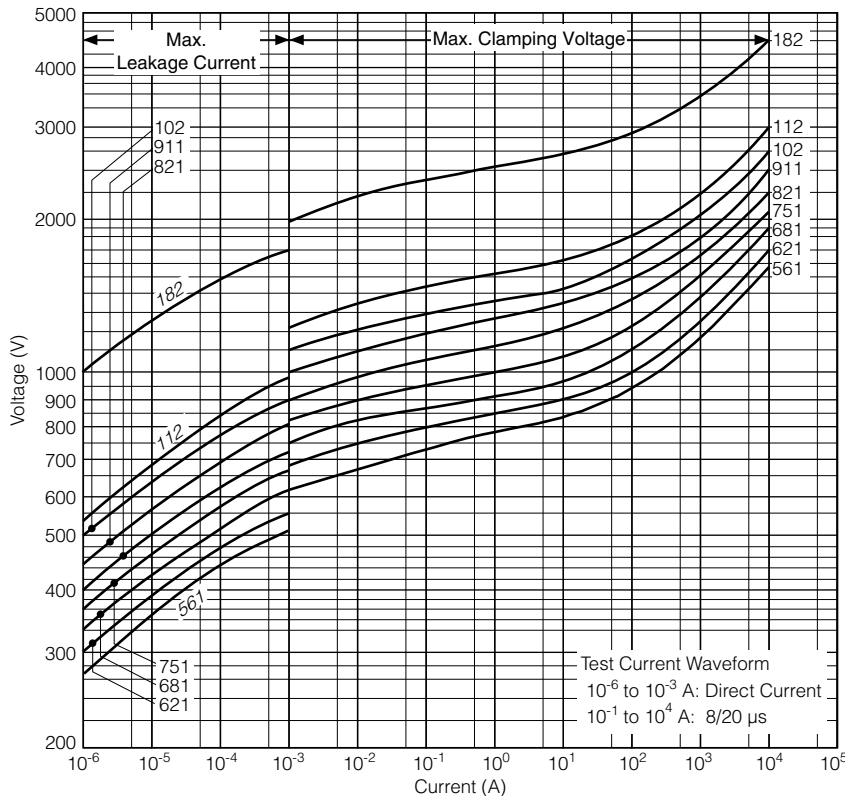

ERZV20D561 to ERZV20D112

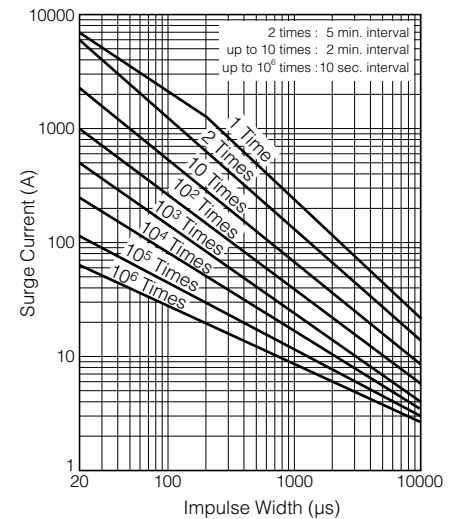

ERZV20D182

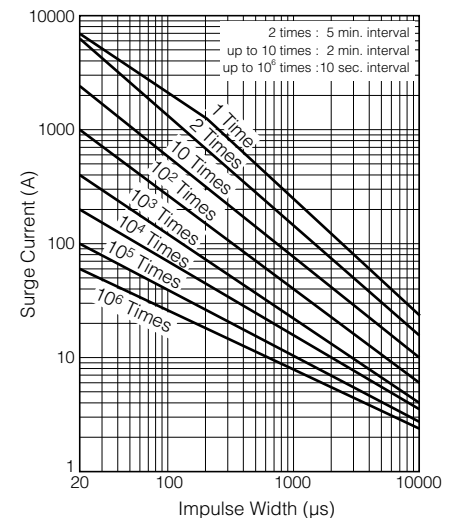



## Straight Leads Cut Type (Bulk Type)

■ Ratings and Characteristics

\* Refer to bulk standard type part no. (P9-P23).

■ Dimensions in mm (not to scale)

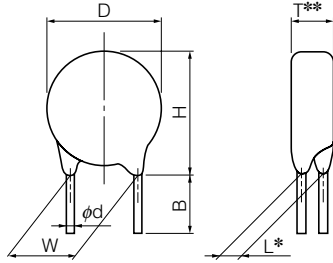

notes \* Dimension "L": Conforms to each individual specification.  
 \*\* Dimension "T": Conforms to each individual specification.

Series	5	7	9	10		14			
Symbol	180 to 471	180 to 511	180 to 511	180 to 511	561 to 751	821 to 112	180 to 511	561 to 751	821 to 112
D	7.0 max.	8.5 max.	11.5 max.	11.5 max.	12.5 max.	12.5 max.	15.5 max.	16.0 max.	16.0 max.
H	10.0 max.	11.5 max.	14.0 max.	14.5 max.	15.5 max.	15.5 max.	18.5 max.	19.0 max.	19.0 max.
W	5.0±1.0	5.0±1.0	5.0±1.0	7.5±1.0	7.5±1.0	7.5±1.0	7.5±1.0	7.5±1.0	7.5±1.0
ϕd	0.60 <sup>+0.06</sup> <sub>-0.05</sub>	0.60 <sup>+0.06</sup> <sub>-0.05</sub>	0.60 <sup>+0.06</sup> <sub>-0.05</sub>	0.80 <sup>+0.08</sup> <sub>-0.05</sub>	0.80 <sup>+0.08</sup> <sub>-0.05</sub>	0.80 <sup>+0.08</sup> <sub>-0.05</sub>	0.80 <sup>+0.08</sup> <sub>-0.05</sub>	0.80 <sup>+0.08</sup> <sub>-0.05</sub>	0.80 <sup>+0.08</sup> <sub>-0.05</sub>
B	4.0±1.0	4.0±1.0	4.0±1.0	4.0±1.0	4.0±1.0	4.0±1.5	4.0±1.0	4.0±1.0	4.0±1.5
Standard Products Part No.	ERZV05D□□□CS	ERZV07D□□□CS	ERZV09D□□□CS	ERZV10D□□□CS	ERZV10D□□□CS	ERZV10D□□□C1	ERZV14D□□□CS	ERZV14D□□□CS	ERZV14D□□□C1

## Crimped Leads Cut Type (Bulk Type)

■ Ratings and Characteristics

\* Refer to bulk standard type part no. (P9-P23).

■ Dimensions in mm (not to scale)

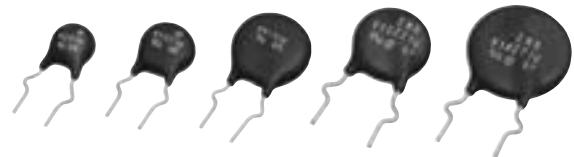
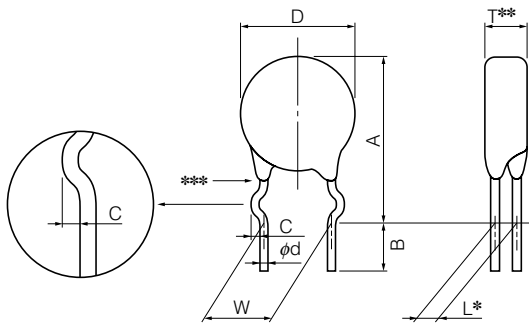

notes \* Dimension "L": Conforms to each individual specification.  
 \*\* Dimension "T": Conforms to each individual specification.  
 \*\*\* Resin extenytions : No resin below the center of the hook.

Series	5	7	9	10		14			
Symbol	180 to 471	180 to 511	180 to 511	180 to 511	561 to 751	821 to 112	180 to 511	561 to 751	821 to 112
A	13.0 max.	14.5 max.	17.5 max.	17.5 max.	19.0 max.	20.0 max.	21.0 max.	22.0 max.	23.5 max.
D	7.0 max.	8.5 max.	11.5 max.	11.5 max.	12.5 max.	12.5 max.	15.5 max.	16.0 max.	16.0 max.
C	1.2±0.4	1.2±0.4	1.2±0.4	1.4±0.4	1.4±0.4	1.4±0.4	1.4±0.4	1.4±0.4	1.4±0.4
W	5.0±1.0	5.0±1.0	5.0±1.0	7.5±1.0	7.5±1.0	7.5±1.0	7.5±1.0	7.5±1.0	7.5±1.0
ϕd	0.60 <sup>+0.06</sup> <sub>-0.05</sub>	0.60 <sup>+0.06</sup> <sub>-0.05</sub>	0.60 <sup>+0.06</sup> <sub>-0.05</sub>	0.80 <sup>+0.08</sup> <sub>-0.05</sub>	0.80 <sup>+0.08</sup> <sub>-0.05</sub>	0.80 <sup>+0.08</sup> <sub>-0.05</sub>	0.80 <sup>+0.08</sup> <sub>-0.05</sub>	0.80 <sup>+0.08</sup> <sub>-0.05</sub>	0.80 <sup>+0.08</sup> <sub>-0.05</sub>
B	4.0±1.0	4.0±1.0	4.0±1.0	4.0±1.0	4.0±1.0	4.0±1.5	4.0±1.0	4.0±1.0	4.0±1.5
Standard Products Part No.	ERZV05V□□□CS	ERZV07V□□□CS	ERZV09V□□□CS	ERZV10V□□□CS	ERZV10V□□□CS	ERZV10V□□□C1	ERZV14V□□□CS	ERZV14V□□□CS	ERZV14V□□□C1

Design and specifications are each subject to change without notice. Ask factory for the current technical specifications before purchase and/or use.  
 Should a safety concern arise regarding this product, please be sure to contact us immediately.

# Taping Specifications for Automated Assembly (Straight Leads and Taping)

■ Ratings and Characteristics

\* Refer to bulk standard type part no. (P9-P23).

■ Taping Dimensions in mm (not to scale)

Type I-II

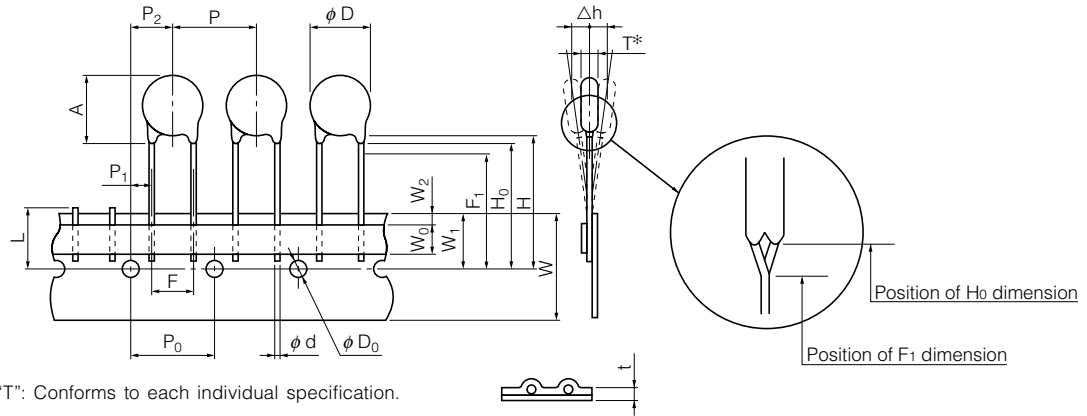

Type III-IV

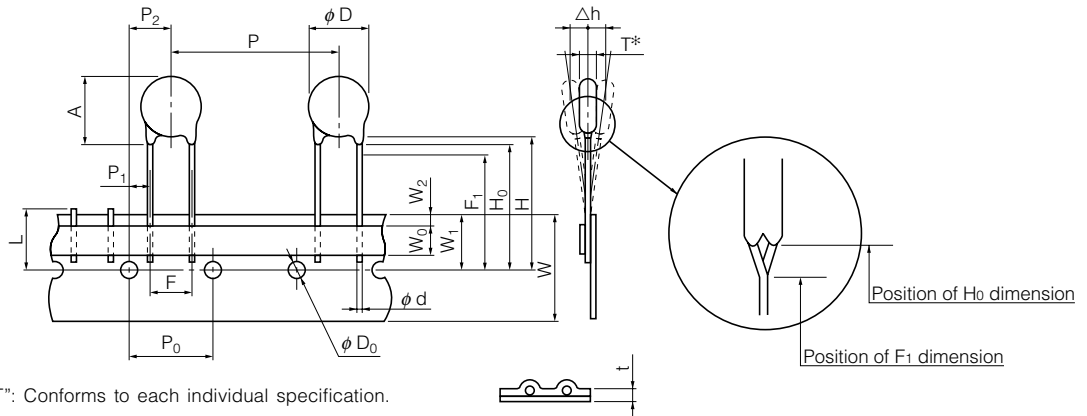

Series	5			7			9			10			14														
Varistor Voltage	180 to 471			180 to 511			180 to 511			180 to 331			361 to 511			561 to 112											
Type	Type I			Type I			Type I			Type II			Type II			Type III			Type IV			Type IV					
P	12.7±1.0			12.7±1.0			12.7±1.0			15.0±1.0			15.0±1.0			15.0±1.0			30.0±1.0			30.0±1.0			30.0±1.0		
P <sub>0</sub>	12.7±0.3			12.7±0.3			12.7±0.3			15.0±0.3			15.0±0.3			15.0±0.3			15.0±0.3			15.0±0.3			15.0±0.3		
P <sub>1</sub>	3.85±0.70			3.85±0.70			3.85±0.70			3.75±0.70			3.75±0.70			3.75±0.70			3.75±0.70			3.75±0.70			3.75±0.70		
P <sub>2</sub>	6.35±1.30			6.35±1.30			6.35±1.30			7.5±1.3			7.5±1.3			7.5±1.3			7.5±1.3			7.5±1.3			7.5±1.3		
φ d	0.60 <sup>+0.06</sup> <sub>-0.05</sub>			0.60 <sup>+0.06</sup> <sub>-0.05</sub>			0.60 <sup>+0.06</sup> <sub>-0.05</sub>			0.80 <sup>+0.08</sup> <sub>-0.05</sub>			0.80 <sup>+0.08</sup> <sub>-0.05</sub>			0.80 <sup>+0.08</sup> <sub>-0.05</sub>			0.80 <sup>+0.08</sup> <sub>-0.05</sub>			0.80 <sup>+0.08</sup> <sub>-0.05</sub>			0.80 <sup>+0.08</sup> <sub>-0.05</sub>		
F	5.0±0.5			5.0±0.5			5.0±0.5			7.5±0.5			7.5±0.5			7.5±0.5			7.5±0.5			7.5±0.5			7.5±0.5		
Δh	0±2			0±2			0±2			0±2			0±2			0±2			0±2			0±2			0±2		
W	18.0 <sup>+1.0</sup> <sub>-0.5</sub>			18.0 <sup>+1.0</sup> <sub>-0.5</sub>			18.0 <sup>+1.0</sup> <sub>-0.5</sub>			18.0 <sup>+1.0</sup> <sub>-0.5</sub>			18.0 <sup>+1.0</sup> <sub>-0.5</sub>			18.0 <sup>+1.0</sup> <sub>-0.5</sub>			18.0 <sup>+1.0</sup> <sub>-0.5</sub>			18.0 <sup>+1.0</sup> <sub>-0.5</sub>			18.0 <sup>+1.0</sup> <sub>-0.5</sub>		
W <sub>0</sub>	5.0 min.			5.0 min.			5.0 min.			5.0 min.			5.0 min.			5.0 min.			5.0 min.			5.0 min.			5.0 min.		
W <sub>1</sub>	9.0±0.5			9.0±0.5			9.0±0.5			9.0±0.5			9.0±0.5			9.0±0.5			9.0±0.5			9.0±0.5			9.0±0.5		
W <sub>2</sub>	3 max.			3 max.			3 max.			3 max.			3 max.			3 max.			3 max.			3 max.			3 max.		
H	Approx. 20			Approx. 20			Approx. 20			Approx. 22			Approx. 22			Approx. 22			Approx. 22			Approx. 22			Approx. 22		
H <sub>0</sub>	17.0±0.5			17.0±0.5			17.0±0.5			18.0 <sup>+2.0</sup> <sub>-0.0</sub>			—			—			18.0 <sup>+2.0</sup> <sub>-0.0</sub>			—			—		
F <sub>1</sub>	—			—			—			—			16.00 <sup>+0.75</sup> <sub>-0.5</sub>			16.00 <sup>+0.75</sup> <sub>-0.5</sub>			—			16.00 <sup>+0.75</sup> <sub>-0.5</sub>			16.00 <sup>+0.75</sup> <sub>-0.5</sub>		
φ D <sub>0</sub>	φ 4.0±0.2			φ 4.0±0.2			φ 4.0±0.2			φ 4.0±0.2			φ 4.0±0.2			φ 4.0±0.2			φ 4.0±0.2			φ 4.0±0.2			φ 4.0±0.2		
t	0.6±0.3			0.6±0.3			0.6±0.3			0.6±0.3			0.6±0.3			0.6±0.3			0.6±0.3			0.6±0.3			0.6±0.3		
L	11 max.			11 max.			11 max.			11 max.			11 max.			11 max.			11 max.			11 max.			11 max.		
φ D	7.0 max.			8.5 max.			11.5 max.			11.5 max.			11.5 max.			12.5 max.			15.5 max.			15.5 max.			16.0 max.		
A	10.0 max.			11.5 max.			14.0 max.			14.5 max.			14.5 max.			15.5 max.			18.5 max.			18.5 max.			19.0 max.		
Standard Products Part No.	ERZVA5D□□□			ERZVA7D□□□			ERZVA9D□□□			ERZVGAD□□□			ERZVGAD□□□			ERZVGAD□□□			ERZVGED□□□			ERZVGED□□□			ERZVGED□□□		

Design and specifications are each subject to change without notice. Ask factory for the current technical specifications before purchase and/or use. Should a safety concern arise regarding this product, please be sure to contact us immediately.

# Taping Specifications for Automated Assembly (Crimped Leads and Taping)

■ Ratings and Characteristics

\* Refer to bulk standard type part no. (P9-P23).

■ Taping Dimensions in mm  
(not to scale)

Type I

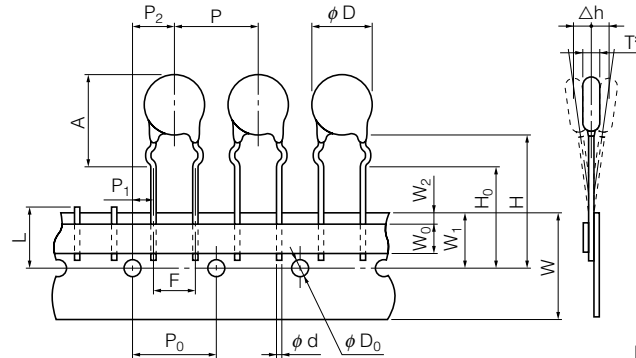

\* Dimension “T”: Conforms to each individual specification.

Type II

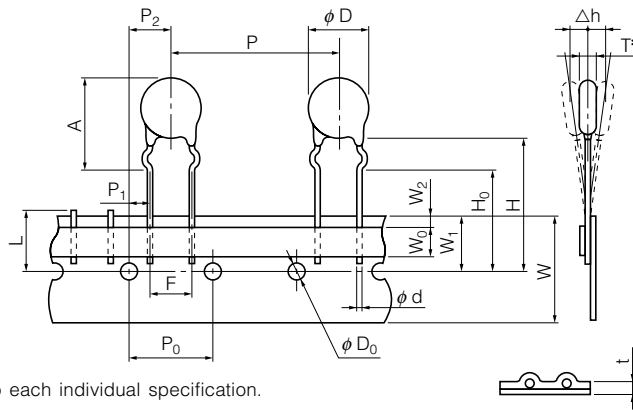

\* Dimension “T”: Conforms to each individual specification.

Series	5			7			9			10			14														
Varistor Voltage	180 to 471			180 to 511			180 to 511			180 to 331			361 to 511			561 to 112											
Symbol	Type I			Type I			Type I			Type I			Type II			Type II											
P	12.7±1.0			12.7±1.0			12.7±1.0			15.0±1.0			15.0±1.0			15.0±1.0			30.0±1.0			30.0±1.0			30.0±1.0		
P <sub>0</sub>	12.7±0.3			12.7±0.3			12.7±0.3			15.0±0.3			15.0±0.3			15.0±0.3			15.0±0.3			15.0±0.3			15.0±0.3		
P <sub>1</sub>	3.85±0.70			3.85±0.70			3.85±0.70			3.75±0.70			3.75±0.70			3.75±0.70			3.75±0.70			3.75±0.70			3.75±0.70		
P <sub>2</sub>	6.35±1.30			6.35±1.30			6.35±1.30			7.5±1.3			7.5±1.3			7.5±1.3			7.5±1.3			7.5±1.3			7.5±1.3		
φ d	0.60 <sup>+0.06</sup> <sub>-0.05</sub>			0.60 <sup>+0.06</sup> <sub>-0.05</sub>			0.60 <sup>+0.06</sup> <sub>-0.05</sub>			0.80 <sup>+0.08</sup> <sub>-0.05</sub>			0.80 <sup>+0.08</sup> <sub>-0.05</sub>			0.80 <sup>+0.08</sup> <sub>-0.05</sub>			0.80 <sup>+0.08</sup> <sub>-0.05</sub>			0.80 <sup>+0.08</sup> <sub>-0.05</sub>			0.80 <sup>+0.08</sup> <sub>-0.05</sub>		
F	5.0±0.5			5.0±0.5			5.0±0.5			7.5±0.5			7.5±0.5			7.5±0.5			7.5±0.5			7.5±0.5			7.5±0.5		
Δh	0±2			0±2			0±2			0±2			0±2			0±2			0±2			0±2			0±2		
W	18.0 <sup>+1.0</sup> <sub>-0.5</sub>			18.0 <sup>+1.0</sup> <sub>-0.5</sub>			18.0 <sup>+1.0</sup> <sub>-0.5</sub>			18.0 <sup>+1.0</sup> <sub>-0.5</sub>			18.0 <sup>+1.0</sup> <sub>-0.5</sub>			18.0 <sup>+1.0</sup> <sub>-0.5</sub>			18.0 <sup>+1.0</sup> <sub>-0.5</sub>			18.0 <sup>+1.0</sup> <sub>-0.5</sub>			18.0 <sup>+1.0</sup> <sub>-0.5</sub>		
W <sub>0</sub>	5.0 min.			5.0 min.			5.0 min.			5.0 min.			5.0 min.			5.0 min.			5.0 min.			5.0 min.			5.0 min.		
W <sub>1</sub>	9.0±0.5			9.0±0.5			9.0±0.5			9.0±0.5			9.0±0.5			9.0±0.5			9.0±0.5			9.0±0.5			9.0±0.5		
W <sub>2</sub>	3 max.			3 max.			3 max.			3 max.			3 max.			3 max.			3 max.			3 max.			3 max.		
H	Approx. 22			Approx. 22			Approx. 22			Approx. 22			Approx. 22			Approx. 22			Approx. 22			Approx. 22			Approx. 22		
H <sub>0</sub>	17.0±0.5			17.0±0.5			17.0±0.5			16.0±0.5			16.0±0.5			16.0±0.5			16.0±0.5			16.0±0.5			16.0±0.5		
φ D <sub>0</sub>	φ4.0±0.2			φ4.0±0.2			φ4.0±0.2			φ4.0±0.2			φ4.0±0.2			φ4.0±0.2			φ4.0±0.2			φ4.0±0.2			φ4.0±0.2		
t	0.6±0.3			0.6±0.3			0.6±0.3			0.6±0.3			0.6±0.3			0.6±0.3			0.6±0.3			0.6±0.3			0.6±0.3		
L	11 max.			11 max.			11 max.			11 max.			11 max.			11 max.			11 max.			11 max.			11 max.		
φ D	7.0 max.			8.5 max.			11.5 max.			11.5 max.			11.5 max.			11.5 max.			12.5 max.			15.5 max.			15.5 max.		
A	13.0 max.			14.5 max.			17.5 max.			17.5 max.			17.5 max.			17.5 max.			* (refer)			21.0 max.			21.0 max.		
Standard Products Part No.	ERZVA5□□□			ERZVA7□□□			ERZVA9□□□			ERZVEA□□□			ERZVEA□□□			ERZVEA□□□			ERZVEE□□□			ERZVEE□□□			ERZVEE□□□		

\* Dimension “A”

	10 Series		14 Series	
ERZV□□V561	19.0 max.	22.0 max.	20.0 max.	23.5 max.
ERZV□□V621	19.0 max.	22.0 max.	20.0 max.	23.5 max.
ERZV□□V681	19.0 max.	22.0 max.	20.0 max.	23.5 max.
ERZV□□V751	19.0 max.	22.0 max.	20.0 max.	23.5 max.

Design and specifications are each subject to change without notice. Ask factory for the current technical specifications before purchase and/or use. Should a safety concern arise regarding this product, please be sure to contact us immediately.

### Application Note for Safety Standards

- Approvals products lists in "Reference Guide to Standard Products."
- UL, VDE and CSA : Registered in "Type name", it isn't registered in "Panasonic Part No."
- CQC : Registered in "Panasonic Part No."
- "Rated Voltages" are specified for UL recognized components in list shown below.

#### ■ The AC Rated Voltage and Maximum Allowable Voltage

Type Name	Maximum Allowable Voltage		Rated Voltage (Vrms)	
	ACrms (V)	DC (V)	UL1449	CSA C22.2 No.1
V*820U	50	65	45	(Not application)
V*101U	60	85	55	(Not application)
V*121U	75	100	68	(Not application)
V*151U	95	125	86	(Not application)
V*201U	130	170	118	118
V*221U	140	180	127	127
V*241U	150	200	136	136
V*271U	175	225	159	159
V*331U	210	270	189	189
V*361U	230	300	209	209
V*391U	250	320	227	227
V*431U	275	350	250	250
V*471U	300	385	272	272
V*511U	320	410	291	291
V*561U	350	450	320	320
V*621U	385	505	350	350
V*681U	420	560	381	381
V*751U	460	615	418	418
V*821U	510	670	463	463
V*911U	550	745	500	500
V*102U	625	825	568	568
V*112U	680	895	600	618
V*182U	1000	1465	600	909

\*:5 Series is blank, 7 series is 7, 9 series is 9, 10 series is 10, 14 series is 14, 20 series is 20

### Marking Contents

#### ■ Explanation of the contents

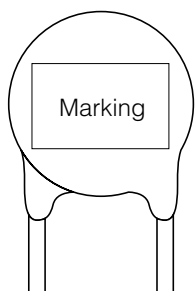

Mark	Explanation of the content	
ZNR	Product Name	
V*□□□ V*□□□U	Abbreviation of Part No. (Type Name)	[□□□] Nominal Varistor Volage
○	Factory Identification Mark	None:Japan Q:Indonesia
<sup>1)</sup> ◆	Year Code	2013:3, 2014:4, 2015:5 2016:6, 2017:7, 2018:8
◇	Monthly Code	Jan:1 to Sep:9, Oct:O, Nov:N, Dec:D
	UL Recognized Components Mark	
	CSA Monogram	

\* : 5 series is blank, 7 series is 7, 9 series is 9, 10 series is 10, 14 series is 14, 20 series is 20

1) : If the 10's digit of a Christian year is an even year, as an end abbreviation, an alphabetic character is used.

1:A, 2:B, 3:C, 4:D, 5:E, 6:F, 7:G, 8:H, 9:J, 0:K

If the 10's digit of a Christian year is an odd year, as an end abbreviation, a number is used.

#### ■ Marking Contents

Varister Voltage	Series (Example)	5 (ERZV05D□□□□)	7 (ERZV07D□□□□)	9 (ERZV09D□□□□)	10 (ERZV10D□□□□)	14 (ERZV14D□□□□)	20 (ERZV20D□□□□)
	180 to 680		V□□□ ○◆◆	V7□□□ ○◆◆	V9□□□ ○◆◆	ZNR V10□□□ ○◆◆	ZNR V14□□□ ○◆◆
820 to 151		V□□□U ○◆◆	V7□□□U ○◆◆	V9□□□U ○◆◆	ZNR V10□□□U ○◆◆	ZNR V14□□□U ○◆◆	ZNR V20□□□U ○◆◆
201 or more		 V□□□U ○◆◆	 V7□□□U ○◆◆	 V9□□□U ○◆◆	ZNR V10□□□U ○◆◆	ZNR V14□□□U ○◆◆	ZNR V20□□□U ○◆◆

### ■ Performance Characteristics

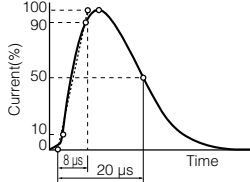
Characteristics		Test Methods/Description	Specifications																																																																						
Standard Test Condition		Electrical measurements (initial/after tests) shall be conducted at temperature of 5 to 35 °C, relative humidity of maximum 85 %	_____																																																																						
Electrical	Varistor Voltage	The voltage between two terminals with the specified measuring current $C_{mA}$ DC applied is called VC or $V_{CmA}$ . The measurement shall be made as fast as possible to avoid heat affection.	To meet the specified value.																																																																						
	Maximum Allowable Voltage	The maximum sinusoidal RMS voltage or maximum DC voltage that can be applied continuously.																																																																							
	Clamping Voltage	The maximum voltage between two terminals with the specified standard impulse current (8/20 $\mu$ s) illustrated below applied. 																																																																							
	Rated Power	The power that can be applied in the specified ambient temperature.																																																																							
	Maximum Energy	The maximum energy within the varistor voltage change of $\pm 10$ % when a single impulse current of 2 ms or 10/1000 $\mu$ s is applied.																																																																							
	Maximum Peak Current (Withstanding Surge Current)	2 times		The maximum current within the varistor voltage change of $\pm 10$ % when a standard impulse current of 8/20 $\mu$ s is applied two times with an interval of 5 minutes.																																																																					
		1 time		The maximum current within the varistor voltage change of $\pm 10$ % with a single standard impulse current of 8/20 $\mu$ s is applied.																																																																					
	Temperature Coefficient of Varistor Voltage	$\frac{V_{CmA} \text{ at } 85 \text{ }^\circ\text{C} - V_{CmA} \text{ at } 25 \text{ }^\circ\text{C}}{V_{CmA} \text{ at } 25 \text{ }^\circ\text{C}} \times \frac{1}{60} \times 100 \text{ (\%/}^\circ\text{C)}$		0 to -0.05 %/°C max.																																																																					
	Capacitance	Capacitance shall be measured at 1 kHz $\pm 10$ %, 1 Vrms max. (1 MHz $\pm 10$ % below 100 pF), 0 V bias and 20 $\pm$ 2 °C.		To meet the specified value																																																																					
	Withstanding Voltage (Body Insulation)	The specified voltage shall be applied between both terminals of the specimen connected together and metal foil closely wrapped round its body for 1 minute. <table border="1" style="width: 100%; border-collapse: collapse;"> <thead> <tr> <th>Classification (Nominal varistor voltage)</th> <th>Test Voltage (AC)</th> </tr> </thead> <tbody> <tr> <td><math>V_{0.1 \text{ mA}}, V_{1 \text{ mA}} \leq 330 \text{ V}</math></td> <td>1000 Vrms</td> </tr> <tr> <td><math>V_{0.1 \text{ mA}}, V_{1 \text{ mA}} &gt; 330 \text{ V}</math></td> <td>1500 Vrms</td> </tr> </tbody> </table>		Classification (Nominal varistor voltage)	Test Voltage (AC)	$V_{0.1 \text{ mA}}, V_{1 \text{ mA}} \leq 330 \text{ V}$	1000 Vrms	$V_{0.1 \text{ mA}}, V_{1 \text{ mA}} > 330 \text{ V}$	1500 Vrms	No breakdown																																																															
Classification (Nominal varistor voltage)	Test Voltage (AC)																																																																								
$V_{0.1 \text{ mA}}, V_{1 \text{ mA}} \leq 330 \text{ V}$	1000 Vrms																																																																								
$V_{0.1 \text{ mA}}, V_{1 \text{ mA}} > 330 \text{ V}$	1500 Vrms																																																																								
Impulse Life	The change of VC shall be measured after the impulse current listed below is applied 10000 or 100000 times continuously with the interval of 10 seconds at room temperature. <table border="1" style="width: 100%; border-collapse: collapse;"> <thead> <tr> <th rowspan="2">Part No.</th> <th>Item</th> <th>Impulse Life (I)</th> <th>Impulse Life (II)</th> </tr> <tr> <th>Times</th> <th><math>\times 10^4</math> Times</th> <th><math>\times 10^5</math> Times</th> </tr> <tr> <th colspan="2">Current</th> <th colspan="2">Impulse Current</th> </tr> </thead> <tbody> <tr> <td>ERZV05D180 to ERZV05D680</td> <td></td> <td>8 A (8/20 <math>\mu</math>s)</td> <td>5 A (8/20 <math>\mu</math>s)</td> </tr> <tr> <td>ERZV07D180 to ERZV07D680</td> <td></td> <td>25 A (8/20 <math>\mu</math>s)</td> <td>15 A (8/20 <math>\mu</math>s)</td> </tr> <tr> <td>ERZV09D180 to ERZV09D680</td> <td></td> <td>50 A (8/20 <math>\mu</math>s)</td> <td>35 A (8/20 <math>\mu</math>s)</td> </tr> <tr> <td>ERZV10D180 to ERZV10D680</td> <td></td> <td>50 A (8/20 <math>\mu</math>s)</td> <td>35 A (8/20 <math>\mu</math>s)</td> </tr> <tr> <td>ERZV14D180 to ERZV14D680</td> <td></td> <td>90 A (8/20 <math>\mu</math>s)</td> <td>50 A (8/20 <math>\mu</math>s)</td> </tr> <tr> <td>ERZV20D180 to ERZV20D680</td> <td></td> <td>130 A (8/20 <math>\mu</math>s)</td> <td>65 A (8/20 <math>\mu</math>s)</td> </tr> <tr> <td>ERZV05D820 to ERZV05D471</td> <td></td> <td>40 A (8/20 <math>\mu</math>s)</td> <td>25 A (8/20 <math>\mu</math>s)</td> </tr> <tr> <td>ERZV07D820 to ERZV07D511</td> <td></td> <td>100 A (8/20 <math>\mu</math>s)</td> <td>60 A (8/20 <math>\mu</math>s)</td> </tr> <tr> <td>ERZV09D820 to ERZV09D511</td> <td></td> <td>150 A (8/20 <math>\mu</math>s)</td> <td>85 A (8/20 <math>\mu</math>s)</td> </tr> <tr> <td>ERZV10D820 to ERZV10D112</td> <td></td> <td>150 A (8/20 <math>\mu</math>s)</td> <td>85 A (8/20 <math>\mu</math>s)</td> </tr> <tr> <td>ERZV10D182CS</td> <td></td> <td>120 A (8/20 <math>\mu</math>s)</td> <td>75 A (8/20 <math>\mu</math>s)</td> </tr> <tr> <td>ERZV14D820 to ERZV14D112</td> <td></td> <td>200 A (8/20 <math>\mu</math>s)</td> <td>110 A (8/20 <math>\mu</math>s)</td> </tr> <tr> <td>ERZV14D182CS</td> <td></td> <td>150 A (8/20 <math>\mu</math>s)</td> <td>90 A (8/20 <math>\mu</math>s)</td> </tr> <tr> <td>ERZV20D820 to ERZV20D112</td> <td></td> <td>250 A (8/20 <math>\mu</math>s)</td> <td>120 A (8/20 <math>\mu</math>s)</td> </tr> <tr> <td>ERZV20D182</td> <td></td> <td>200 A (8/20 <math>\mu</math>s)</td> <td>100 A (8/20 <math>\mu</math>s)</td> </tr> </tbody> </table>	Part No.	Item	Impulse Life (I)	Impulse Life (II)	Times	$\times 10^4$ Times	$\times 10^5$ Times	Current		Impulse Current		ERZV05D180 to ERZV05D680		8 A (8/20 $\mu$ s)	5 A (8/20 $\mu$ s)	ERZV07D180 to ERZV07D680		25 A (8/20 $\mu$ s)	15 A (8/20 $\mu$ s)	ERZV09D180 to ERZV09D680		50 A (8/20 $\mu$ s)	35 A (8/20 $\mu$ s)	ERZV10D180 to ERZV10D680		50 A (8/20 $\mu$ s)	35 A (8/20 $\mu$ s)	ERZV14D180 to ERZV14D680		90 A (8/20 $\mu$ s)	50 A (8/20 $\mu$ s)	ERZV20D180 to ERZV20D680		130 A (8/20 $\mu$ s)	65 A (8/20 $\mu$ s)	ERZV05D820 to ERZV05D471		40 A (8/20 $\mu$ s)	25 A (8/20 $\mu$ s)	ERZV07D820 to ERZV07D511		100 A (8/20 $\mu$ s)	60 A (8/20 $\mu$ s)	ERZV09D820 to ERZV09D511		150 A (8/20 $\mu$ s)	85 A (8/20 $\mu$ s)	ERZV10D820 to ERZV10D112		150 A (8/20 $\mu$ s)	85 A (8/20 $\mu$ s)	ERZV10D182CS		120 A (8/20 $\mu$ s)	75 A (8/20 $\mu$ s)	ERZV14D820 to ERZV14D112		200 A (8/20 $\mu$ s)	110 A (8/20 $\mu$ s)	ERZV14D182CS		150 A (8/20 $\mu$ s)	90 A (8/20 $\mu$ s)	ERZV20D820 to ERZV20D112		250 A (8/20 $\mu$ s)	120 A (8/20 $\mu$ s)	ERZV20D182		200 A (8/20 $\mu$ s)	100 A (8/20 $\mu$ s)	$\Delta V_{CmA}/V_{CmA} \leq \pm 10 \%$
Part No.	Item		Impulse Life (I)	Impulse Life (II)																																																																					
	Times	$\times 10^4$ Times	$\times 10^5$ Times																																																																						
Current		Impulse Current																																																																							
ERZV05D180 to ERZV05D680		8 A (8/20 $\mu$ s)	5 A (8/20 $\mu$ s)																																																																						
ERZV07D180 to ERZV07D680		25 A (8/20 $\mu$ s)	15 A (8/20 $\mu$ s)																																																																						
ERZV09D180 to ERZV09D680		50 A (8/20 $\mu$ s)	35 A (8/20 $\mu$ s)																																																																						
ERZV10D180 to ERZV10D680		50 A (8/20 $\mu$ s)	35 A (8/20 $\mu$ s)																																																																						
ERZV14D180 to ERZV14D680		90 A (8/20 $\mu$ s)	50 A (8/20 $\mu$ s)																																																																						
ERZV20D180 to ERZV20D680		130 A (8/20 $\mu$ s)	65 A (8/20 $\mu$ s)																																																																						
ERZV05D820 to ERZV05D471		40 A (8/20 $\mu$ s)	25 A (8/20 $\mu$ s)																																																																						
ERZV07D820 to ERZV07D511		100 A (8/20 $\mu$ s)	60 A (8/20 $\mu$ s)																																																																						
ERZV09D820 to ERZV09D511		150 A (8/20 $\mu$ s)	85 A (8/20 $\mu$ s)																																																																						
ERZV10D820 to ERZV10D112		150 A (8/20 $\mu$ s)	85 A (8/20 $\mu$ s)																																																																						
ERZV10D182CS		120 A (8/20 $\mu$ s)	75 A (8/20 $\mu$ s)																																																																						
ERZV14D820 to ERZV14D112		200 A (8/20 $\mu$ s)	110 A (8/20 $\mu$ s)																																																																						
ERZV14D182CS		150 A (8/20 $\mu$ s)	90 A (8/20 $\mu$ s)																																																																						
ERZV20D820 to ERZV20D112		250 A (8/20 $\mu$ s)	120 A (8/20 $\mu$ s)																																																																						
ERZV20D182		200 A (8/20 $\mu$ s)	100 A (8/20 $\mu$ s)																																																																						

Design and specifications are each subject to change without notice. Ask factory for the current technical specifications before purchase and/or use. Should a safety concern arise regarding this product, please be sure to contact us immediately.

### ■ Performance Characteristics

Characteristics		Test Methods		Specifications
Mechanical	Robustness of Terminations (Tensile)	After gradually applying the force specified below and keeping the unit fixed for 10 seconds, the terminal shall be visually examined for any damage.		
		Terminal diameter	Force	
		$\phi 0.6$ mm, $\phi 0.8$ mm	9.8 N	
		$\phi 1.0$ mm	19.6 N	
	Robustness of Terminations (Bending)	The unit shall be secured with its terminal kept vertical and the force specified below shall be applied in the axial direction. The terminal shall gradually be bent by 90° in one direction, then 90° in the opposite direction, and again back to the original position. The damage of the terminal shall be visually examined.		No remarkable mechanical damage
	Terminal diameter	Force		
	$\phi 0.6$ mm, $\phi 0.8$ mm	4.9 N		
	$\phi 1.0$ mm	9.8 N		
Vibration	After repeatedly applying a single harmonic vibration (amplitude: 0.75 mm, double amplitude: 1.5 mm) with 1 minute vibration frequency cycles (10 Hz to 55 Hz to 10 Hz) to each of three perpendicular directions for 2 hours. Thereafter, the unit shall be visually examined.			
Solderability	After dipping the terminals to a depth of approximately 3mm from the body in a soldering bath of 235±5°C for 2±0.5 seconds, the terminal shall be visually examined.		Approximately 95 % of the terminals shall be covered with new solder uniformly.	
Resistance to Soldering Heat	After each lead shall be dipped into a solder bath having a temperature of 260±5 °C to a point 2.0 to 2.5 mm from the body of the unit, using shielding board (t=1.5 mm), be held there for 10±1 s and then be stored at room temperature and normal humidity for 1 to 2 hours. The change of $V_{CmA}$ and mechanical damages shall be examined.		$\Delta V_{CmA}/V_{CmA} < \pm 5 \%$ No remarkable mechanical damage	
Environmental	High Temperature Storage/Dry Heat	The specimen shall be subjected to 125±2 °C for 1000 hours in a thermostatic bath without load and then stored at room temperature and normal humidity for 1 to 2 hours. Thereafter, the change of $V_{CmA}$ shall be measured.		$\Delta V_{CmA}/V_{CmA} < \pm 5 \%$
	Humidity	The specimen shall be subjected to 40±2 °C, 90 to 95 % RH for 1000 hours without load and then stored at room temperature and normal humidity for 1 to 2 hours. Thereafter, the change of $V_{CmA}$ shall be measured.		$\Delta V_{CmA}/V_{CmA} < \pm 5 \%$
	Temperature Cycle	The temperature cycle shown below shall be repeated five cycles and then stored at room temperature and normal humidity for 1 to 2 hours. The change of $V_{CmA}$ and mechanical damage shall be examined.		$\Delta V_{CmA}/V_{CmA} < \pm 5 \%$ No remarkable mechanical damage
		Step	Temperature (°C)	Period (minutes)
		1	-40±3	30±3
	2	Room temperature	15±3	
	3	125±2	30±3	
	4	Room temperature	15±3	
High Temperature Load/Dry Heat Load	After being continuously applied the Maximum Allowable Voltage at 85±2 °C for 1000 hours, the specimen shall be stored at room temperature and normal humidity for 1 to 2 hours. Thereafter, the change of $V_{CmA}$ shall be measured.		$\Delta V_{CmA}/V_{CmA} < \pm 10 \%$	
Damp Heat Load/Humidity Load	The specimen shall be subjected to 40±2 °C, 90 to 95 % RH and the Maximum Allowable Voltage for 1000 hours and then stored at room temperature and normal humidity for 1 to 2 hours. Thereafter, the change of $V_{CmA}$ shall be measured.			
Low Temperature Storage/Cold	The specimen shall be subjected to -40±2 °C without load for 1000 hours and then stored at room temperature and normal humidity for 1 to 2 hours. Thereafter, the change of $V_{CmA}$ shall be measured.		$\Delta V_{CmA}/V_{CmA} < \pm 5 \%$	

Design and specifications are each subject to change without notice. Ask factory for the current technical specifications before purchase and/or use. Should a safety concern arise regarding this product, please be sure to contact us immediately.

## "ZNR" Surge Absorbers SMD Type

Series: **HF**



### ■ Features

- Meet for Load Dump Surge Test (JASO D 001-94)  
[ $V_p=70\text{ V}$ ,  $\tau=200\text{ ms}$ ,  $R_i=0.8\ \Omega$ ]
- Suitable for requirements of Automotive (12 V)
- Compact size SMD
- Meet flow/reflow/iron soldering
- Strong against "Soldering heat shock" due to molded construction
- RoHS compliant

### ■ Recommended Applications

- Protection of Body & Accessory ECU about automotive against Load Dump Surge

### ■ Handling Precautions and Minimum Quantity / Packing Unit

Please see Related Information

### ■ Explanation of Part Numbers

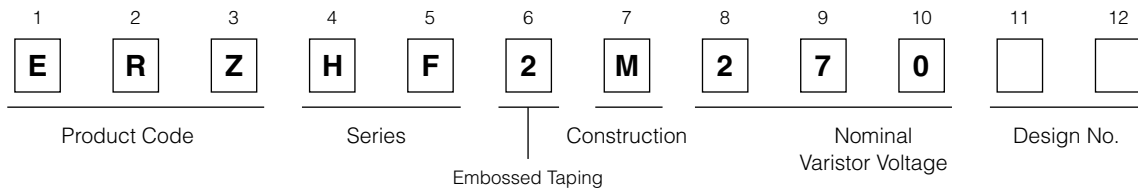

### ■ Construction

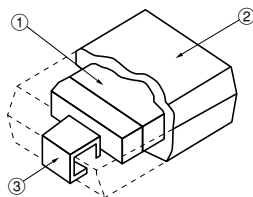

① Multilayer Varistor	ZnO, others
② Mold Resin	Epoxy (UL94 V-0 approved)
③ Lead Terminal	Sn plated Ni-Fe alloy

### ■ Dimensions in mm (not to scale)

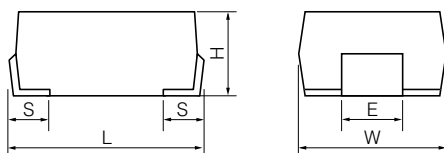

Series	W	L	H	S	E
HF	6.4±0.4	8.0±0.5	4.5±0.5	1.3±0.3	2.5±0.2



### ■ Ratings and Characteristics

- Operating Temperature Range: -40 to 125 °C
- Storage Temperature Range: -40 to 125 °C

Part No.	Varistor Voltage	Maximum Allowable Voltage	Short Time Over-voltage	Clamping Voltage	Load Dump Surge
	V <sub>1 mA</sub> (V)	DC (V)		(V) at I <sub>p</sub> 5(A)	
ERZHF2M270	27 ± 20 %	16	DC24(V) 5 min.	43 (V) max.	JASO Category:A ,A-1 70V, 1time

### ■ Marking Contents

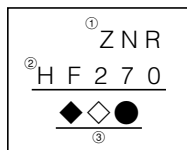

① Part Number	ZNR Surge Absorbers		
② Abbreviation of P/N	ERZHF2M270		
③ Date Code	◆*	Yearly	2011:1, 2012:2, 2013:3, 2014:4, 2015:5, 2016:6
	◇	Monthly	Jan.:1, Feb.:2, Mar.:3, Apr.:4, May:5, Jun.:6, Jul.:7, Aug.:8, Sep.:9, Oct.:O, Nov.:N, Dec.:D
	●	10 Days	1st to 10th:1, 11th to 20th:2, 21st to 31st:3

\* If the 10's digit of a Christian year is an even year, as an end abbreviation, an alphabetic character is used.  
1:A, 2:B, 3:C, 4:D, 5:E, 6:F, 7:G, 8:H, 9:J, 0:K  
If the 10's digit of a Christian year is an odd year, as an end abbreviation, a number is used.

### ■ Packaging Methods

- Packing Quantity

Style	Quantity
Embossed Taping	1000 pcs./reel

- Reel

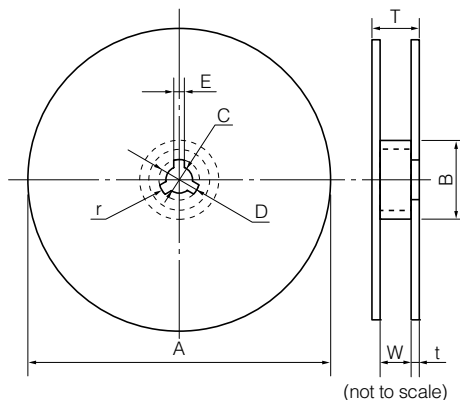

Dimensions (mm)	A	B	C	D	E
	382 max.	50 min.	13.0±0.5	21.0±0.8	2.0±0.5
Dimensions (mm)	W	T	t	r	
	16.4 <sup>+2.0</sup> <sub>-0</sub>	22.4 max.	2.5±0.5	1.0	

- Embossed Taping

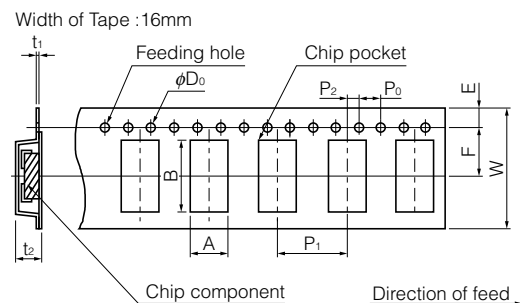

Dimensions (mm)	A	B	W	F	E	P <sub>1</sub>
	7.5 max.	11.9 max.	16.0±0.3	7.5±0.1	1.75±0.10	12.0±0.1
Dimensions (mm)	P <sub>2</sub>	P <sub>0</sub>	φD <sub>0</sub>	t <sub>1</sub>	t <sub>2</sub>	
	2.0±0.1	4.0±0.1	1.5 <sup>+0.1</sup> <sub>-0</sub>	0.8 max.	8.0 max.	

Design and specifications are each subject to change without notice. Ask factory for the current technical specifications before purchase and/or use.  
Should a safety concern arise regarding this product, please be sure to contact us immediately.

### ■ Performance Characteristics

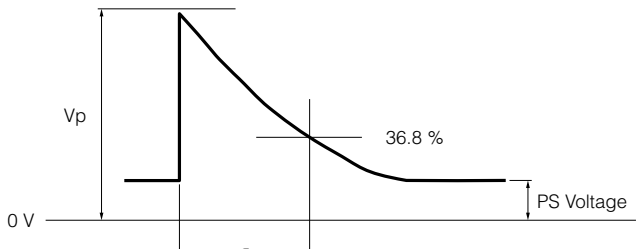
Characteristics	Test Methods	Specifications
Standard Test Condition	Environmental conditions under which every measuring is done without doubt on the measuring results. Unless specially, specified, temperature, relative humidity are 5 °C to 35 °C, 45 to 85% RH respectively.	—
Maximum Allowable Voltage	The maximum DC voltage that can be applied continuously in the specified environmental temperature range.	To meet the specified value.
Short Time Over-Voltage	The maximum DC Voltage that can be applied specified period without breakdown	
Varistor Voltage	Voltage between both terminals of ZNR measured when 1 mA of DC current is applied under standard conditions. It is called V <sub>1</sub> . Measuring the varistor voltage should be made promptly to avoid heat affection.	
Clamping Voltage	The maximum voltage between two terminals with the specified impulse current (8/20 μs).	
Temperature Coefficient of Varistor Voltage	The varistor voltage shall be measured at 25 °C and 85 °C with a DC current of 1 mA. The temperature coefficient of varistor voltage V <sub>1</sub> is calculated by the following equation :  $T.C. (\% / ^\circ C) = \frac{V_1 \text{ at } 85^\circ C - V_1 \text{ at } 25^\circ C}{V_1 \text{ at } 25^\circ C} \times \frac{1}{60} \times 100$	0 to -0.05 %/°C
Load Dump Surge	The test waveform of transient voltage which specified JASO Category A A-1 70 V without breakdown.  	No breakdown

\* Please Check Specification of the products about Mechanical & Environmental requirements

### ■ Recommendation Land Size

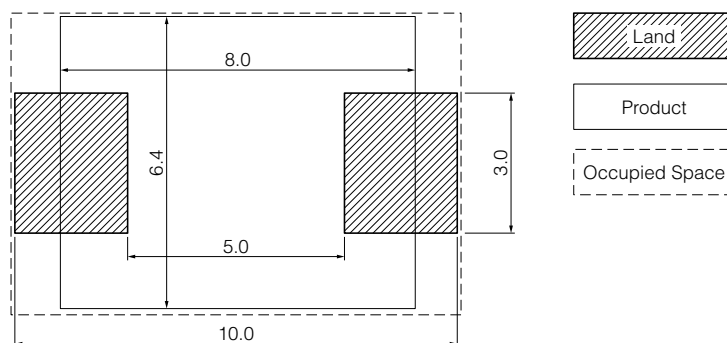

(Unit:mm)

### "ZNR" Transient/Surge Absorbers, SMD Type

Series: **VF**



#### ■ Features

- Large withstanding surge current capability, in compact size
- Designed for flow/reflow solderings
- Excellent response against high steep surge voltage
- Low clamping voltage
- RoHS compliant

#### ■ Recommended Applications

- Protection of communication modules (Modem, xDSL, Terminal Adaptor)
- Protection of consumer, industrial and automobile equipment
- Absorption of switching surge from relays

#### ■ Handling Precautions and Minimum Quantity / Packing Unit

Please see Related Information

#### ■ Explanation of Part Numbers

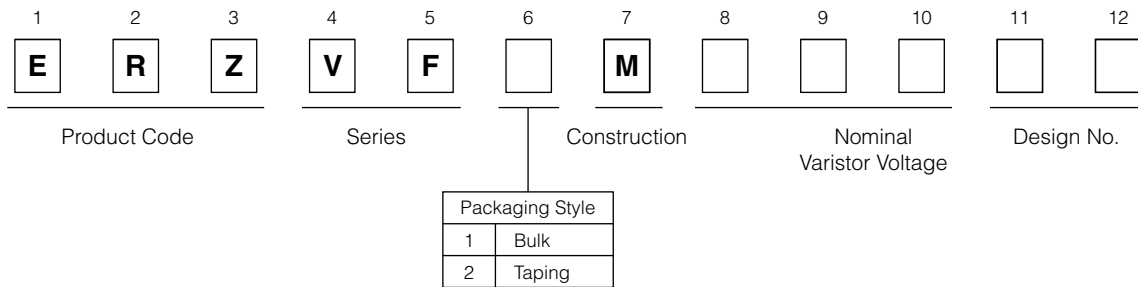

#### ■ Construction

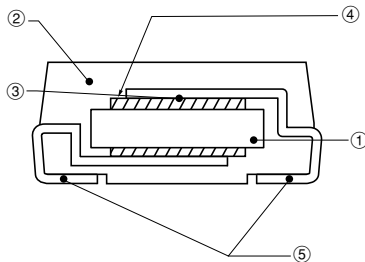

① ZNR element	ZnO etc.
② Resin mold	Epoxy Resin(UL94V-0 approved)
③ Conductive adhesive	Silver
④ Electrode	Silver
⑤ Lead terminals	Sn plated Ni-Fe Alloy

#### ■ Dimensions in mm (not to scale)

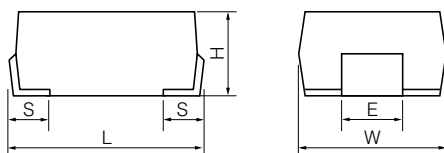

Type	W	L	H	S	E
VF□M	6.0±0.4	8.0±0.5	3.2±0.3	1.3±0.3	2.5±0.2

### ■ Ratings and Characteristics

- Operating Temperature Range: -40 to 85 °C
- Storage Temperature Range: -40 to 125 °C

Part No.	Varistor Voltage	Maximum Allowable Voltage		Clamping Voltage at I <sub>p</sub> (max.)		Rated Power	Maximum Energy (2 ms)	Maximum Peak Current (8/20 μs, 2 times)
	V <sub>1mA</sub> (V)	ACrms (V)	DC (V)	(V)	Measuring Current (A)	(W)	(J)	(A)
ERZVF□M220	22(20-24)	14	18	43	2.5	0.02	0.9	125
ERZVF□M270	27(24-30)	17	22	53	2.5	0.02	1.0	125
ERZVF□M330	33(30-36)	20	26	65	2.5	0.02	1.2	125
ERZVF□M390	39(35-43)	25	31	77	2.5	0.02	1.5	125
ERZVF□M470	47(42-52)	30	38	93	2.5	0.02	1.8	125
ERZVF□M560	56(50-62)	35	45	110	2.5	0.02	2.2	125
ERZVF□M680	68(61-75)	40	56	135	2.5	0.02	2.5	125
ERZVF□M820	82(74-90)	50	65	135	10	0.25	3.5	600
ERZVF□M101	100(90-110)	60	85	165	10	0.25	4.0	600
ERZVF□M121	120(108-132)	75	100	200	10	0.25	5.0	600
ERZVF□M151	150(135-165)	95	125	250	10	0.25	6.0	600
ERZVF□M201	200(185-225)	130	170	340	10	0.25	8.0	600
ERZVF□M221	220(198-242)	140	180	360	10	0.25	9.0	600
ERZVF□M241	240(216-264)	150	200	395	10	0.25	10.0	600
ERZVF□M271	270(247-303)	175	225	455	10	0.25	12.0	600
ERZVF□M331	330(297-363)	210	270	545	10	0.1	8.0	300
ERZVF□M361	360(324-396)	230	300	595	10	0.1	9.0	300
ERZVF□M391	390(351-429)	250	320	650	10	0.1	9.0	300
ERZVF□M431	430(387-473)	275	350	710	10	0.1	10.0	300
ERZVF□M471	470(423-517)	300	385	775	10	0.1	10.0	300

Type VF□M

└─ Packaging Style Code: “1” for bulk, “2” for embossed taping

## Typical Characteristics Voltage vs. Current

### ERZVF1(2)M220 to ERZVF1(2)M680

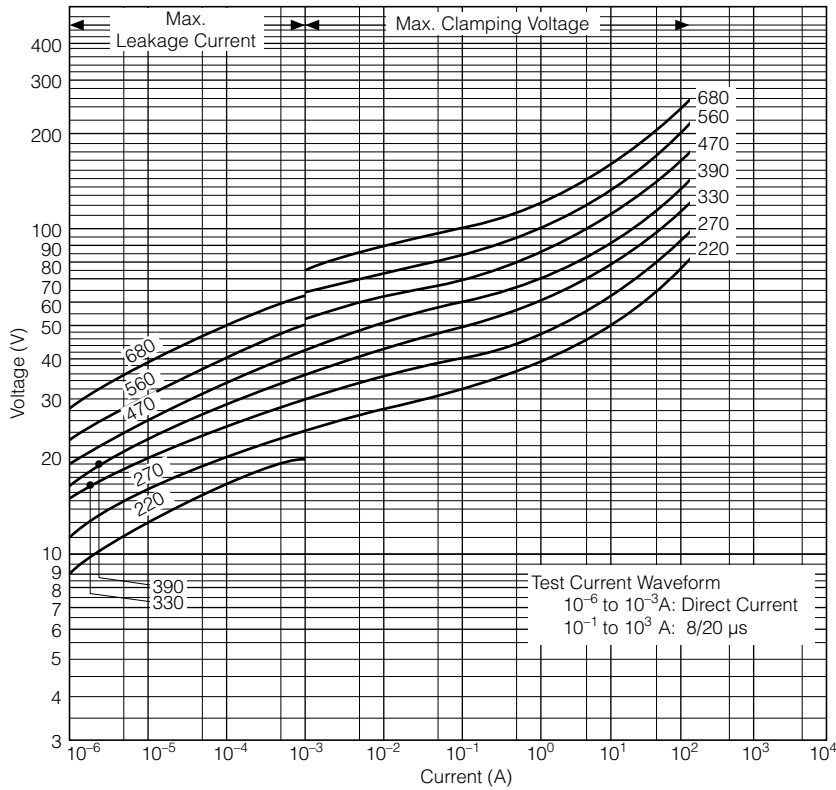

## Impulse Derating (Relation between impulse width and impulse current multiple)

### ERZVF1(2)M220 to ERZVF1(2)M680

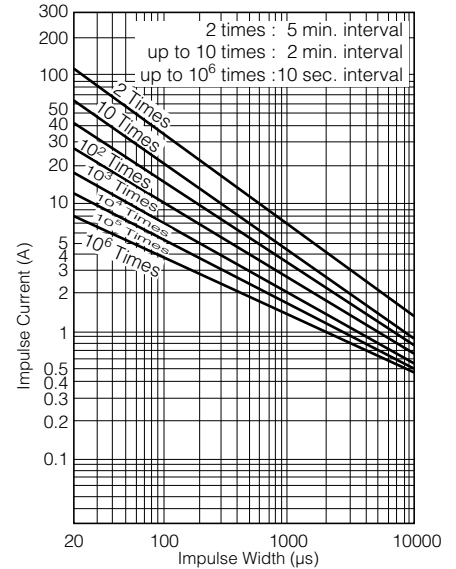

### ERZVF1(2)M820 to ERZVF1(2)M271

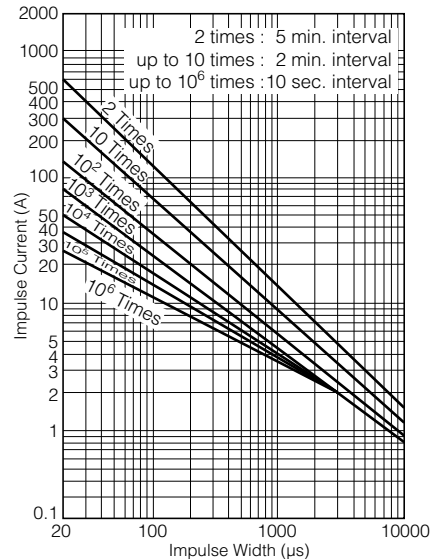

### ERZVF1(2)M820 to ERZVF1(2)M471

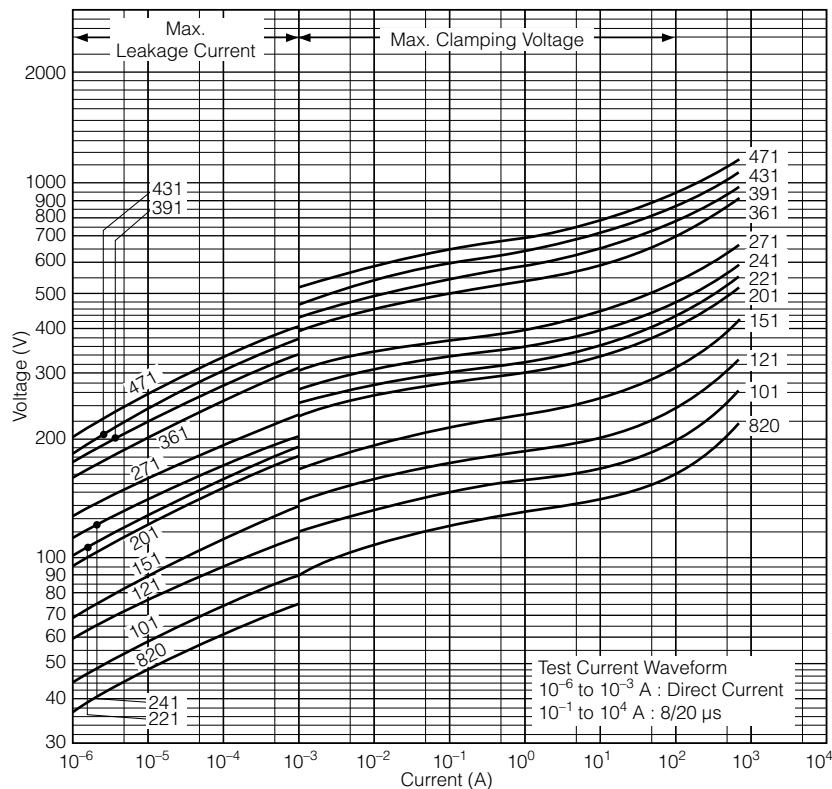

### ERZVF1(2)M331 to ERZVF1(2)M471

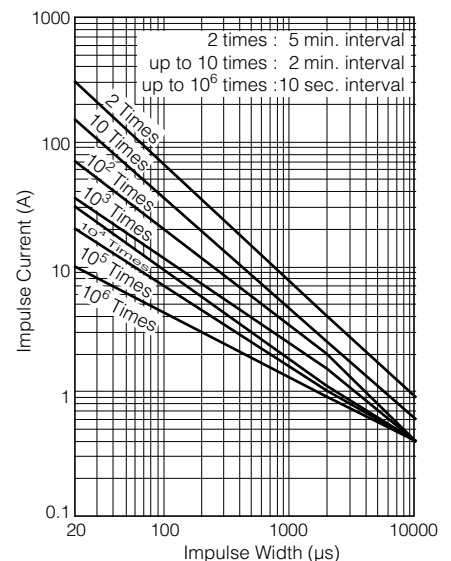

Design and specifications are each subject to change without notice. Ask factory for the current technical specifications before purchase and/or use. Should a safety concern arise regarding this product, please be sure to contact us immediately.

### ■ Marking Contents

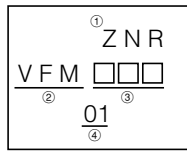

① Product Name	ZNR, ZNR Surge Absorbers
② Series	VF□M, VF Series
③ Abbreviation of Part No.	The first two digits are significant figures and the third one denotes the number of zeros following.
④ Date Code	Left* (Year) 2011:1, 2012:2, 2013:3, 2014:4, 2015:5, 2016:6 Right(Month) Jan. to Sep.:1 to 9, Oct.:O, Nov.:N, Dec.:D

\* If the 10's digit of a Christian year is an even year, as an end abbreviation, an alphabetic character is used.  
1:A, 2:B, 3:C, 4:D, 5:E, 6:F, 7:G, 8:H, 9:J, 0:K  
If the 10's digit of a Christian year is an odd year, as an end abbreviation, a number is used.

### ■ Packaging Methods

#### ● Packing Quantity

Style	Quantity
Embossed taping	2000 pcs./reel
Bulk	200 pcs./bag

#### ● Reel

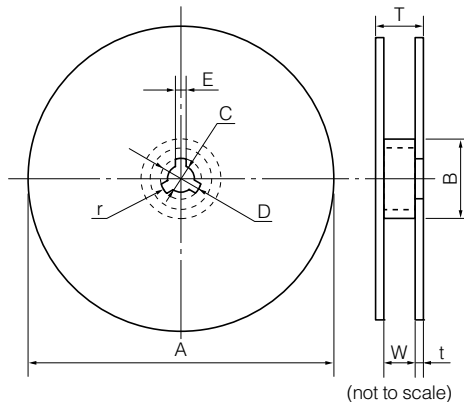

Dimensions (mm)	A	B	C	D	E
	382 max.	50 min.	13.0±0.5	21.0±0.8	2.0±0.5

Dimensions (mm)	W	T	t	r
	16.4 <sup>+2.0</sup> <sub>-0</sub>	22.4 max.	2.5±0.5	1.0

#### ● Embossed Taping

(W=16 mm)

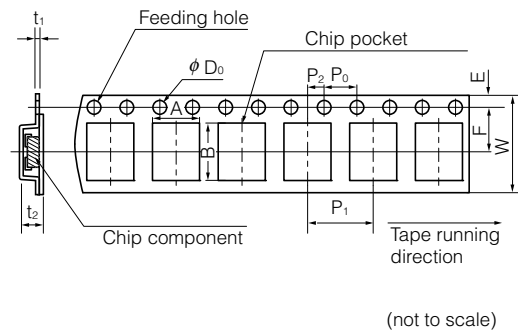

Dimensions (mm)	A	B	W	F	E	P <sub>1</sub>
	6.8±0.2	11.9 max.	16.0±0.3	7.5±0.1	1.75±0.10	8.0±0.1

  

Dimensions (mm)	P <sub>2</sub>	P <sub>0</sub>	φD <sub>0</sub>	t <sub>1</sub>	t <sub>2</sub>
	2.0±0.1	4.0±0.1	1.5 <sup>+0.1</sup> <sub>-0</sub>	0.6 max.	6.5 max.

### ■ Performance Characteristics

Characteristics	Test Methods	Specifications												
Standard Test Condition	Electrical measurements (initial/after tests) shall be conducted at temperature of 5 to 35 °C, relative humidity of maximum 85 %	—												
Varistor Voltage	The voltage between two terminals with the specified measuring current $C_{mA}$ DC applied is called $V_c$ or $V_{CmA}$ . The measurement should be made as fast as possible to avoid heat effects.	To meet the specified value.												
Maximum Allowable Voltage	The recommended maximum sinusoidal wave voltage (rms) or the maximum DC voltage that can be applied continuously.													
Clamping Voltage	The maximum voltage between two terminals with the specified impulse current (8/20 $\mu$ s).													
Rated Power	The maximum power that can be applied within the specified ambient temperature.													
Maximum Energy	Maximum energy of less than $\pm 10$ % of the varistor voltage change when the standard impulse (2 ms) is applied one time.													
Maximum Peak Current	Maximum current of less than $\pm 10$ % of the varistor voltage change when impulse current (8/20 $\mu$ s) is applied twice continuously with an interval of 5 minutes.													
Temperature Coefficient of Varistor Voltage	$\frac{V_{CmA} \text{ at } 85\text{ }^\circ\text{C} - V_{CmA} \text{ at } 25\text{ }^\circ\text{C}}{V_{CmA} \text{ at } 25\text{ }^\circ\text{C}} \times \frac{1}{60} \times 100(\%/^\circ\text{C})$		0 to $-0.05$ %/ $^\circ\text{C}$											
Impulse Life (I)	The change of $V_c$ shall be measured after the specified impulse is applied 10000 times continuously with an interval of 10 seconds at room temperature. <table border="1" style="width: 100%; border-collapse: collapse;"> <thead> <tr> <th>Part Number</th> <th>Waveform</th> <th>Current</th> </tr> </thead> <tbody> <tr> <td>ERZVF□M220 to ERZVF□M680</td> <td>8/20 <math>\mu</math>s</td> <td>18 A</td> </tr> <tr> <td>ERZVF□M820 to ERZVF□M271</td> <td>8/20 <math>\mu</math>s</td> <td>50 A</td> </tr> <tr> <td>ERZVF□M331 to ERZVF□M471</td> <td>8/20 <math>\mu</math>s</td> <td>30 A</td> </tr> </tbody> </table>	Part Number	Waveform	Current	ERZVF□M220 to ERZVF□M680	8/20 $\mu$ s	18 A	ERZVF□M820 to ERZVF□M271	8/20 $\mu$ s	50 A	ERZVF□M331 to ERZVF□M471	8/20 $\mu$ s	30 A	$\Delta V_{CmA}/V_{CmA} \leq \pm 10$ %
Part Number	Waveform	Current												
ERZVF□M220 to ERZVF□M680	8/20 $\mu$ s	18 A												
ERZVF□M820 to ERZVF□M271	8/20 $\mu$ s	50 A												
ERZVF□M331 to ERZVF□M471	8/20 $\mu$ s	30 A												
Impulse Life (II)	The change of $V_c$ shall be measured after the specified impulse is applied 100000 times continuously with an interval of 10 seconds at room temperature. <table border="1" style="width: 100%; border-collapse: collapse;"> <thead> <tr> <th>Part Number</th> <th>Waveform</th> <th>Current</th> </tr> </thead> <tbody> <tr> <td>ERZVF□M220 to ERZVF□M680</td> <td>8/20 <math>\mu</math>s</td> <td>12 A</td> </tr> <tr> <td>ERZVF□M820 to ERZVF□M271</td> <td>8/20 <math>\mu</math>s</td> <td>35 A</td> </tr> <tr> <td>ERZVF□M331 to ERZVF□M471</td> <td>8/20 <math>\mu</math>s</td> <td>20 A</td> </tr> </tbody> </table>	Part Number	Waveform	Current	ERZVF□M220 to ERZVF□M680	8/20 $\mu$ s	12 A	ERZVF□M820 to ERZVF□M271	8/20 $\mu$ s	35 A	ERZVF□M331 to ERZVF□M471	8/20 $\mu$ s	20 A	$\Delta V_{CmA}/V_{CmA} \leq \pm 10$ %
Part Number	Waveform	Current												
ERZVF□M220 to ERZVF□M680	8/20 $\mu$ s	12 A												
ERZVF□M820 to ERZVF□M271	8/20 $\mu$ s	35 A												
ERZVF□M331 to ERZVF□M471	8/20 $\mu$ s	20 A												

### ■ Recommendation Land Size

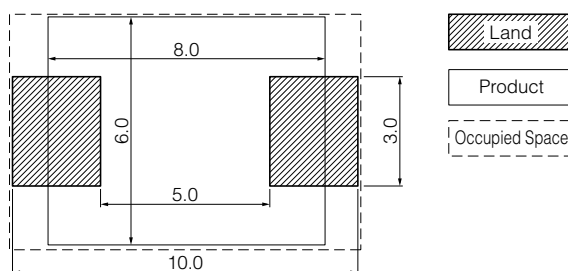

(Unit:mm)

## “ZNR” Transient/Surge Absorbers, Type D, Series V

### “ZNR” Transient/Surge Absorbers, SMD Type

## Handling Precautions

### Safety Precautions

In case that a ZNR Surge Absorber (Type D Series V, SMD Type)(hereafter referred to as the ZNR, or product name) is used, if an abnormality takes place because of peripheral conditions of the ZNR(material, environments, power source conditions, circuit conditions, etc. in equipment design), fire, electric shock, burn, or product failure may occur. The precautions for this product are described below, understand the content thoroughly before usage. For more questions, contact us.

#### 1. Precautions to be strictly observed

##### 1.1 Confirmation of performance ratings

Use the ZNR within its rated range of performance such as the Max. allowable voltage, withstanding surge current, withstanding energy, impulse life(surge life), average pulse power, and operating temperature range. If used outside the range, the ZNR can be degrade and have element fracture, which may result in smoking and ignition.

##### 1.2 To avoid accidents due to unexpected phenomena, take the following measures

- 1) In the event of fracture of the ZNR, its pieces may scatter ; hence, put the case or cover of the set product in place.
- 2) Do not install the ZNR near combustible substances(polyvinyl chloride wires, resin moldings, etc.). If it is difficult to do, install a nonflammable cover.
- 3) Across-the-line use  
When the ZNR is used across a line, put a current fuse in series with the ZNR  
(Refer to Item 2.1.1). (4) and Table 1.
- 4) Use between line to ground
  - (1) If the case that the ZNR is used between a line to the ground, the short-circuit of the ZNR may not blow the current fuse because of grounding resistance, which may cause smoking and ignition of the ZNR's exterior resin. As the measure against it, install an earth leakage breaker on the power supply side of the ZNR position. If no earth leakage breaker is installed, use a thermal fuse together with a current fuse in series. (Refer to Table 1.)
  - (2) If the case that the ZNR is used between a live part to metal case, an electric shock may develop at a shortcircuit of the ZNR ; hence, ground the metal case to the ground or keep it from the human body.

#### 2. Application notes

##### 2.1 Pay attention to the following items to avoid the shortened life and failure of the ZNR

###### 1) Circuit conditions

- (1) Select a ZNR of which the maximum voltage including fluctuations in source voltage allows for the maximum permissible circuit voltage. (Refer to Table 1.)
- (2) In cases that surges are intermittently applied at short intervals(for example, in case that the voltage of the noise simulator test is implemented etc.), do not let them exceed the ZNR's rated power.
- (3) Select a ZNR recommended in Table 1.

###### <1> Across-the-line use

If possible, use a Part No. marked with \* in case of voltage temporarily rises load unbalance of separately-wired loads, short between hot and neutral-line, open of neutral line in single-phase-three-wired system, and due to resonance at switching for a capacitive, inductive load.

###### <2> Used between line to ground

Use a different Part No. from “Across-the-line use” as table 1, because of raising voltage in case of “Line to Ground Fault”.

Use a Part No. marked with \*\* in table 1, in case of the insulation resistance test(500 VDC) for equipment. When using a Part of the varistor voltage that the insulation efficiency examination can not be cleared, there is a case where the surge absorber can be done by removing it from the circuit depending on the circuit condition(Refer examination of Japan Domestic Safety Regulations).

Use a Part No. marked with \*\*\* in table 1, in case of the withstanding voltage test(1000 VAC or 1200 VAC) for equipment.



(4) Concerning current fuse

<1> We recommend selecting a ZNR and the rated current of a current fuse as follows.

Finally, please be sure that there is no danger if the ZNR mounted on the equipment breaks.

● Type D, Series V

Standard Part No.	ERZV05D□□□□	ERZV07D□□□□	ERZV09D□□□□	ERZV10D□□□□	ERZV14D□□□□	ERZV20D□□□□
Fuse rated current	3 A max.	5 A max.	7 A max.	7 A max.	10 A max.	10 A max.

\* Fuses shall use rated voltages appropriate for circuits.

\* Refer to page 323 “Selection of CSA safety standard approved fuse” as well.

● Type SMD, Series VF

Standard Part No.	ERZVF□□□□□
Fuse rated current	5 A max.

\* Fuses shall use rated voltages appropriate for circuits.

\* Concerning HF series, please confirm adjusted to load dump surge and protection cooperation.

<2> The recommended fuse position is shown in table 1, “Example of ZNR application”, however, if the load current of protected equipment is larger than that of the above recommended fuse rated current, install a current fuse at the position shown below.

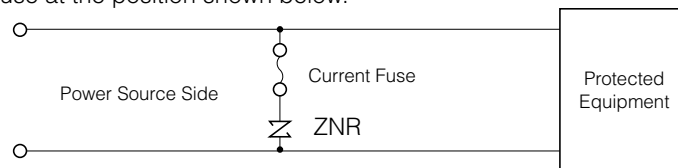

(5) Concerning thermal fuse

Set a thermal fuse to get high thermal conductivity with ZNR.

Table 1 Example of ZNR application

Connections example	Across-the-Line use				Use between Line to ground				
	DC/AC Single-phase								
AC 3-phase									
Example of varistor voltage	ZNR	Source voltage	Nominai varistor voltage		ZNR	Source voltage	Nominai varistor voltage		
			Type D	SMD Mold Type			Type D	SMD Mold Type	
	ZNR1 ZNR3	AC100 V	201 to 361*	201 to 361*		ZNR2 ZNR4	AC100 V AC220 V	471	471
		AC120 V	241 to 431*	241 to 431*				511	—
		AC200 V	471 to 621*	471				621*	—
		AC220 V	471 to 621*	471			821 and more**	—	
		AC240 V	511, 621*	—			182***	—	
AC380 V		821	—		511		—		
					AC230 V AC240 V	621*	—		
					AC380 V	821 and more**	—		
						112**	—		
						182***	—		

Note : Element size is selected by impulse Condition.

- 2) Operating environments
  - (1) The ZNR is designed to be used indoors. Do not use it exposed outdoors.
  - (2) Do not use the ZNR in places exposed to temperatures beyond the operating temperature range, such as places exposed to sunlight and vicinities of heating equipment.
  - (3) Do not use the ZNR in places exposed to high temperatures and high humidity, such as places exposed directly to rain, wind, dew condensation, and vapor.
  - (4) Do not use the ZNR in dusty and salty places and atmospheres polluted by corrosive gases.
- 3) Processing conditions
  - (1) Do not wash the ZNR by such solvents(thinner, acetone, etc.) as its exterior resin deteriorates.
  - (2) Do not apply a strong vibration or shock (by falling, etc.) to the ZNR, cracking to its exterior resin and element may occur.
  - (3) When coating the ZNR with resin(including molding), do not use such resin.
  - (4) Do not bend the ZNR type D lead wires at the position close to its ZNR type D exterior resin, or apply external force to the position.
  - (5) When soldering the ZNR lead wires, follow the recommended conditions and do not melt the solder and insulating materials constituting the ZNR.

	Soldering Method	Recommended Condition	Attention Item
Type D	Flow soldering	260 °C, within 10 sec.	Type D is not Reflow soldering object part.
SMD Type	Flow soldering	260 °C, within 10 sec.	When the package density of the part is high pill out gas because the solderability sometimes becomes bad.
	Reflow soldering	Refer to Reflow soldering profile	When Land is too big compared with the size of the terminal surface of the part, be careful because the part sometimes upset when solder fuses.

- \*1 Soldering iron temperature should not exceed 400 °C and should not be applied for mor than 5 seconds.
- \*2 Profile be careful because there is a margin of error in the way of measuring.
- \*3 The temperature depend on the size and the package density of the substrate. Therefore, confirm every kind of the substrate.

● Soldering temperature-time profile to recommend

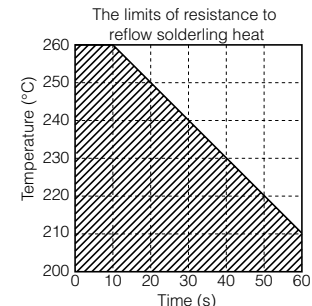
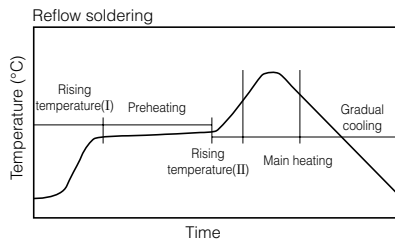
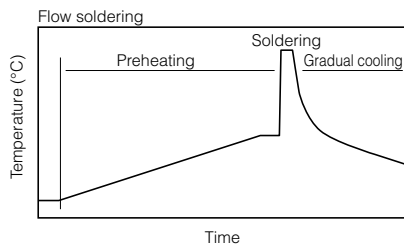

Preheating	The normal to 130 °C	max. 120s
Soldering	max. 260 °C	max. 10s
Gradual cooling	Gradual cooling	

Rising temperature I	The normal to preheating temperature	30 to 60 s
Preheating	150 to 180 °C	60 to 120 s
Rising temperature II	Preheating to 200 °C	2 to 6 °C/s
Main heating	(cf. The limit of resistance to reflow soldering heat)	
Gradual cooling	200 to 100 °C	1 to 4 °C/s

(Reflow soldering shall be within two times)

(6) The attachment (Only SMD Type)

The power to give the part by the attachment machine equal to or less than 9.8 N in 2.5 mmφ of tip shape.

4) Long-term storage

- (1) Do not store the ZNR under high temperature and high humidity. Store it at a temperature up to 40 °C and at humidity below 75 %RH, and use it within two years. Before using the ZNR that has been stored for a long period(two years or longer), confirm the solderability.
- (2) Avoid atmospheres full of corrosive gases(hydrogen sulfide, sulfurous acid, chlorine, ammonia, etc.).
- (3) Avoid direct sunlight and dew condensation.

3. Notices

- 3.1 In cases that the ZNR is used in equipment(aerospace equipment, medical equipment, etc.) requiring extremely high reliability, ask us for a selection of Part No., and protection coordination, etc. in advance.
- 3.2 Note that we do not take any responsibility for faults and abnormalities resulting from the use not in conformity with the contents of entries in the delivery specification.
- 3.3 There is a possibility that the ZNR will unexpectedly cause smoke or ignite because of an abnormal rise of the circuit voltage and invasion of excessive surge. To prevent that accident from spreading over the equipment and not to expand the damage, use multiplex protection such as the adoption of frame-retardant materials for housing parts and structural parts.

**“ZNR” Transient/Surge Absorbers**

Type: **SC**

The ZNR Type SC protects power supply facilities, communications equipment from steep lightning surges, and it is a suitable product to incorporate it in a surge protective device corresponding to the Japanese Industrial Standards (JIS C 5381-1).



**■ Features**

- Very large surge withstanding capability with a compact size
- Fast response to steep impulse voltage
- Low clamping voltage for better surge protection
- No follow-on current
- RoHS compliant

**■ Recommended Applications**

- Power suppliers for OA, FA, telecommunication or industrial equipment
- Traffic or railroad systems
- Surge protection of automatic control devices for power distribution line

**■ Handling Precautions and Minimum Quantity / Packing Unit**

Please see Related Information

**■ Explanation of Part Numbers**

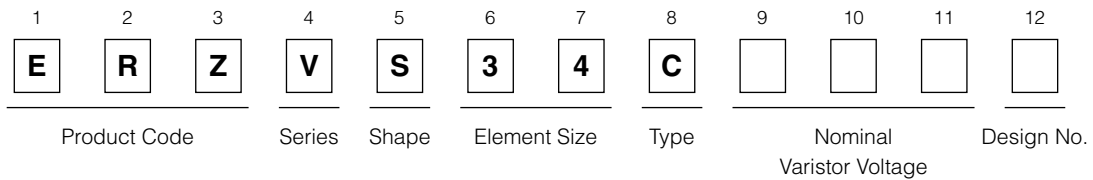

**■ Dimensions in mm (not to scale)**

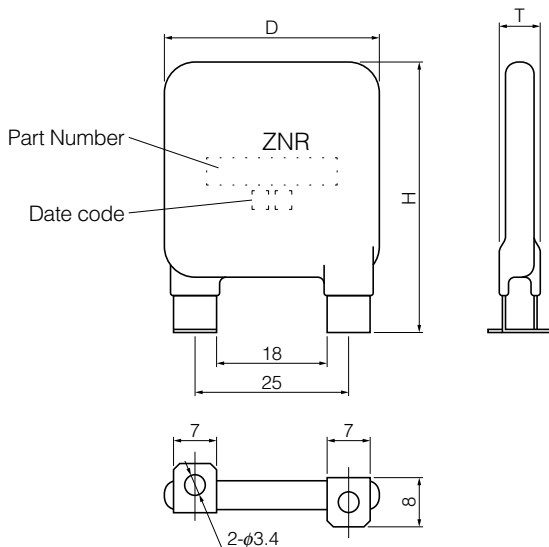

(unit : mm)

Part Number	D max.	H max.	T max.
ERZVS34C201	36	47	9.0
ERZVS34C241			9.2
ERZVS34C271			9.5
ERZVS34C361			10.4
ERZVS34C431			11.1
ERZVS34C471			11.3
ERZVS34C511			9.7
ERZVS34C621			9.7
ERZVS34C751			10.5
ERZVS34C821			11.0
ERZVS34C951	11.5		

Design and specifications are each subject to change without notice. Ask factory for the current technical specifications before purchase and/or use. Should a safety concern arise regarding this product, please be sure to contact us immediately.

### ■ Ratings and Characteristics

- Operating Temperature Range: -40 to 85 °C
- Storage Temperature Range: -40 to 125 °C

Part Number	Varistor Voltage	Maximum Allowable Voltage		Maximum Clamping Voltage	Voltage Protection Level	Nominal Discharge Current	Maximum Discharge Current
	V <sub>1mA</sub> (V)	ACrms (V)	DC (V)	V <sub>250 A</sub>	UP(V) (at In)	In(8/20 μs)	I <sub>max</sub> (8/20 μs)
ERZVS34C201	200(185 to 225)	130	170	340	800	20 kA	40 kA
ERZVS34C241	240(216 to 264)	150	200	395	900		
ERZVS34C271	270(247 to 303)	175	225	455	1000		
ERZVS34C361	360(324 to 396)	230	300	595	1200		
ERZVS34C431	430(387 to 473)	275	350	710	1500		
ERZVS34C471	470(423 to 517)	300	385	775	1500		
ERZVS34C511	510(459 to 561)	320	415	845	1500		
ERZVS34C621	620(558 to 682)	385	505	1025	2000		
ERZVS34C751	750(675 to 825)	460	615	1240	2500		
ERZVS34C821	820(738 to 902)	510	670	1355	2500		
ERZVS34C951	950(855 to 1045)	575	765	1570	3000		

### ■ Typical Characteristics

#### Voltage vs. Current (ERZVS34C201 to ERZVS34C951)

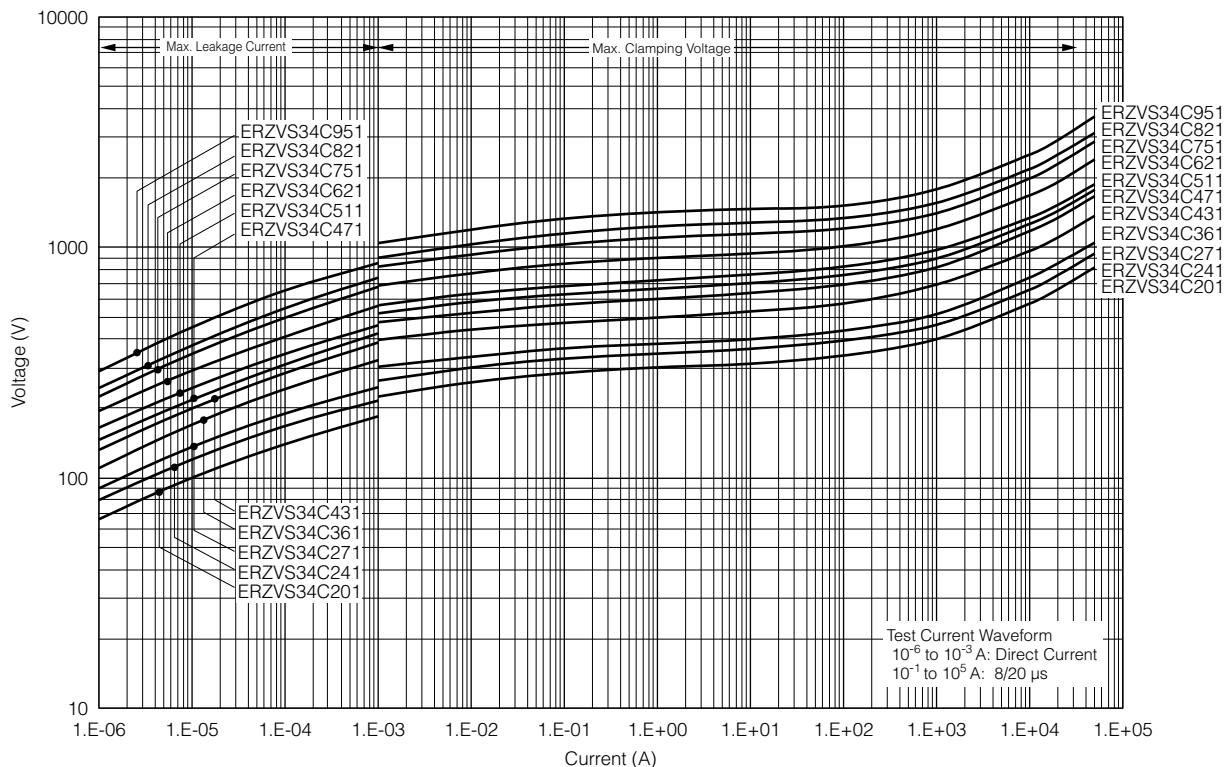

## “ZNR” Transient/Surge Absorbers

Type: **E**



The ZNR Type E is capable of handling larger surge energy than Type D in applications to protect electronic equipment or semiconductor devices from switching and induced lightning surges.

### ■ Features

- Very large surge withstanding capability with a compact size
- Direct mounting on boards like a power distribution board available
- Fast response to steep impulse voltage
- Low clamping voltage for better surge protection
- RoHS compliant

### ■ Related Standards

[UL/CSA recognized models are available on request]

- UL1449 File No. E321499  
(Title: Surge Protective Devices)
- CSA C22.2 No.1 Class 2221 01 File No. LR-92226  
(Title: Accessories and Parts for Electronic Products)
- Each type designation is not registered by Part Number.  
If you have any question on type designation, please contact and ask our office.

### ■ Recommended Applications

- Transistor, diode, IC, thyristor or triac semiconductor protection
- Surge protection in industrial power plant operations
- Relay or electromagnetic valve surge absorption
- Surge absorption applications in broadcasting, communications devices, traffic/railroad, agricultural facilities, waterworks
- Surge protection of automatic control devices for power distribution line

**Note:** Ask our factory for Product Specification before use.

### ■ Handling Precautions and Minimum Quantity / Packing Unit

Please see Related Information

### ■ Explanation of Part Numbers

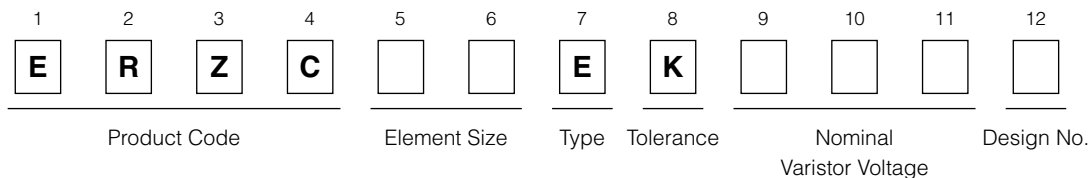

### ■ Dimensions in mm (not to scale)

Part No.	W	H	L
ERZC20EK□□□□	48±1	42±1	39±1
ERZC32EK□□□□	60±1	55±1	51±1

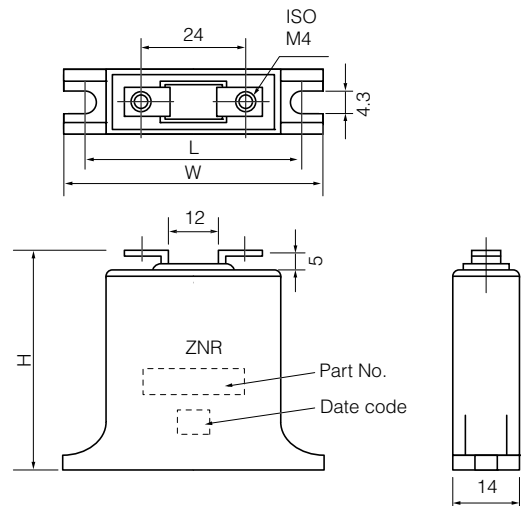

Design and specifications are each subject to change without notice. Ask factory for the current technical specifications before purchase and/or use. Should a safety concern arise regarding this product, please be sure to contact us immediately.

**20 Series**

■ Ratings and Characteristics (ERZC20EK)

- Operating Temperature Range : -40 to 85 °C
- Storage Temperature Range : -40 to 110 °C

Part No.	Varistor Voltage	Maximum Allowable Voltage		Maximum Clamping Voltage	Rated Power	Energy (2 ms)	Maximum Peak Current (8/20 μs)		Typical Capacitance (Reference) at 1kHz (pF)
		ACrms (V)	DC (V)				1 time	2 times	
	V <sub>1mA</sub> (V)	ACrms (V)	DC (V)	V <sub>100A</sub> (V)	(W)	(J)	(A)	(A)	
ERZC20EK201	200 (185 to 225)	130	170	340	0.8	80	8000	5000	2300
ERZC20EK241	240 (216 to 264)	150	200	395	0.8	95	8000	5000	1500
ERZC20EK271	270 (247 to 303)	175	225	455	0.8	100	8000	5000	1400
ERZC20EK361	360 (324 to 396)	230	300	595	0.8	120	8000	5000	1300
ERZC20EK391	390 (351 to 429)	250	320	650	0.8	130	8000	5000	1200
ERZC20EK431	430 (387 to 473)	275	350	710	0.8	140	8000	5000	1000
ERZC20EK471	470 (423 to 517)	300	385	775	0.8	150	8000	5000	950
ERZC20EK511	510 (459 to 561)	320	415	845	0.8	150	8000	5000	930
ERZC20EK621	620 (558 to 682)	385	505	1025	0.8	160	8000	5000	900
ERZC20EK681	680 (612 to 748)	420	560	1120	0.8	175	8000	5000	850
ERZC20EK751	750 (675 to 825)	460	615	1240	0.8	190	8000	5000	800
ERZC20EK781	780 (702 to 858)	485	640	1290	0.8	200	8000	5000	800
ERZC20EK821	820 (738 to 902)	510	670	1355	0.8	215	8000	5000	700
ERZC20EK911	910 (819 to 1001)	550	745	1500	0.8	240	8000	5000	700
ERZC20EK102	1000 (900 to 1100)	625	825	1650	0.8	245	8000	5000	400
ERZC20EK112	1100 (990 to 1210)	680	895	1815	0.8	250	8000	5000	350

**32 Series**

■ Ratings and Characteristics (ERZC32EK)

- Operating Temperature Range : -40 to 85 °C
- Storage Temperature Range : -40 to 110 °C

Part No.	Varistor Voltage	Maximum Allowable Voltage		Maximum Clamping Voltage	Rated Power	Energy (2 ms)	Maximum Peak Current (8/20 μs)		Typical Capacitance (Reference) at 1kHz (pF)
		ACrms (V)	DC (V)				1 time	2 times	
	V <sub>1mA</sub> (V)	ACrms (V)	DC (V)	V <sub>200A</sub> (V)	(W)	(J)	(A)	(A)	
ERZC32EK201	200 (185 to 225)	130	170	340	1.2	210	25000	20000	5500
ERZC32EK241	240 (216 to 264)	150	200	395	1.2	240	25000	20000	5000
ERZC32EK271	270 (247 to 303)	175	225	455	1.2	255	25000	20000	4200
ERZC32EK361	360 (324 to 396)	230	300	595	1.2	325	25000	20000	3500
ERZC32EK391	390 (351 to 429)	250	320	650	1.2	350	25000	20000	3000
ERZC32EK431	430 (387 to 473)	275	350	710	1.2	400	25000	20000	2500
ERZC32EK471	470 (423 to 517)	300	385	775	1.2	405	25000	20000	2500
ERZC32EK511	510 (459 to 561)	320	415	845	1.2	405	25000	20000	2400
ERZC32EK621	620 (558 to 682)	385	505	1025	1.2	415	25000	20000	2200
ERZC32EK681	680 (612 to 748)	420	560	1120	1.2	450	25000	20000	2100
ERZC32EK751	750 (675 to 825)	460	615	1240	1.2	500	25000	20000	2000
ERZC32EK781	780 (702 to 858)	485	640	1290	1.2	520	25000	20000	1900
ERZC32EK821	820 (738 to 902)	510	670	1355	1.2	545	25000	20000	1800
ERZC32EK911	910 (819 to 1001)	550	745	1500	1.2	600	25000	20000	1700
ERZC32EK102	1000 (900 to 1100)	625	825	1650	1.2	620	25000	20000	1000
ERZC32EK112	1100 (990 to 1210)	680	895	1815	1.2	640	25000	20000	800

Design and specifications are each subject to change without notice. Ask factory for the current technical specifications before purchase and/or use. Should a safety concern arise regarding this product, please be sure to contact us immediately.

**Typical Characteristics (Type E)**  
**Voltage vs. Current**  
 (ERZC20EK201 to ERZC20EK511)

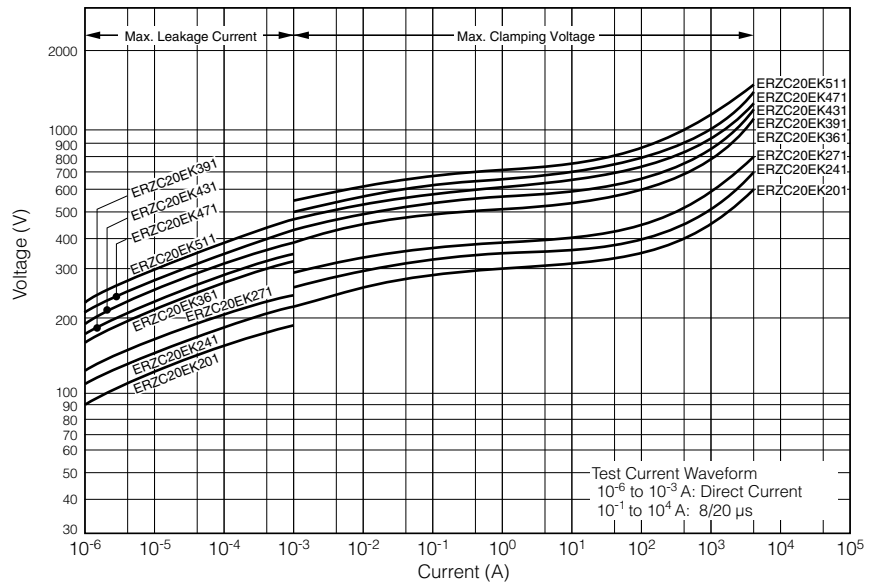

(ERZC20EK621 to ERZC20EK112)

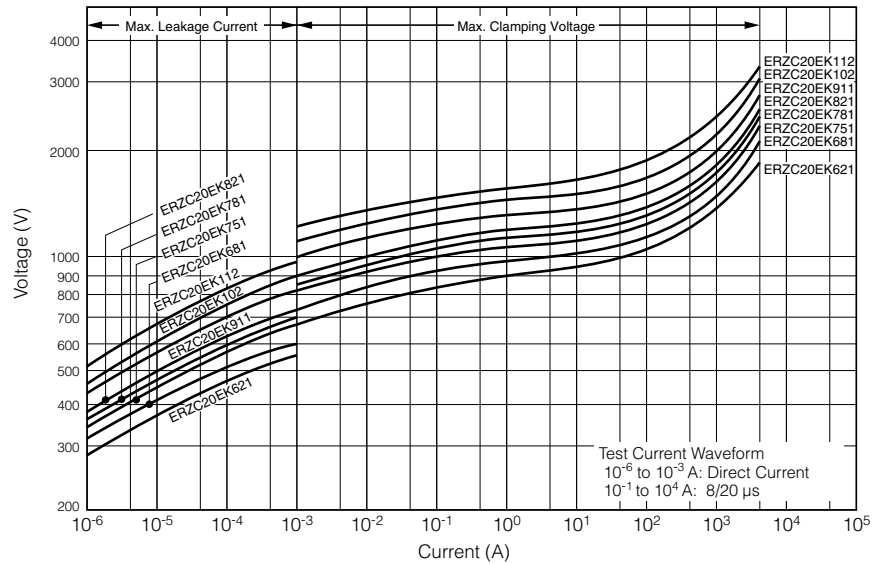

**Impulse Derating Curve (Relation between impulse width and surge, repetitively)**

**20 Series**  
 (ERZC20EK201 to ERZC20EK271)

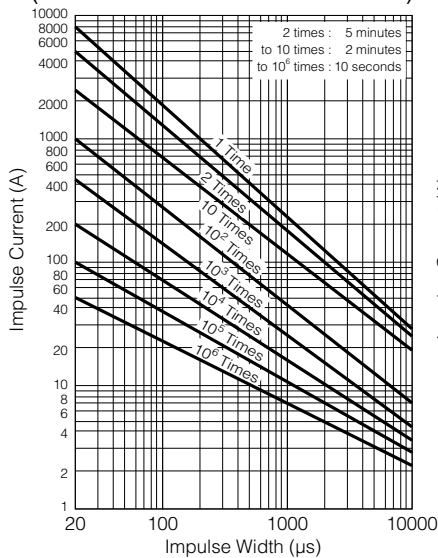

**20 Series**  
 (ERZC20EK361 to ERZC20EK681)

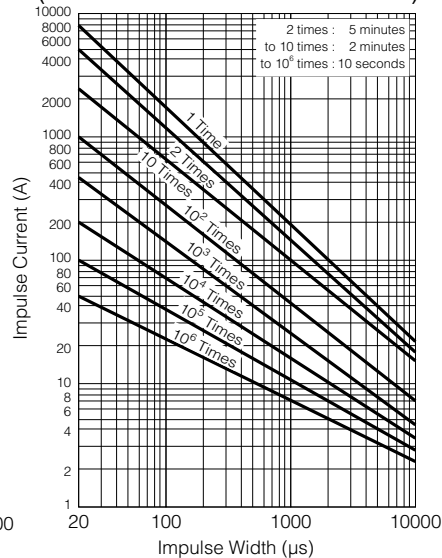

**20 Series**  
 (ERZC20EK751 to ERZC20EK112)

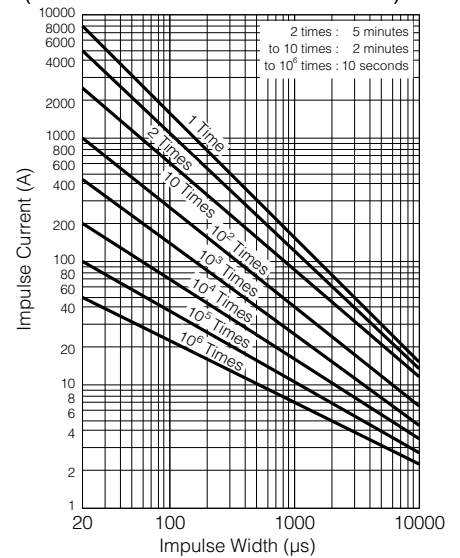

Design and specifications are each subject to change without notice. Ask factory for the current technical specifications before purchase and/or use. Should a safety concern arise regarding this product, please be sure to contact us immediately.

**Typical Characteristics (Type E)**  
**Voltage vs. Current**  
 (ERZC32EK201 to ERZC32EK511)

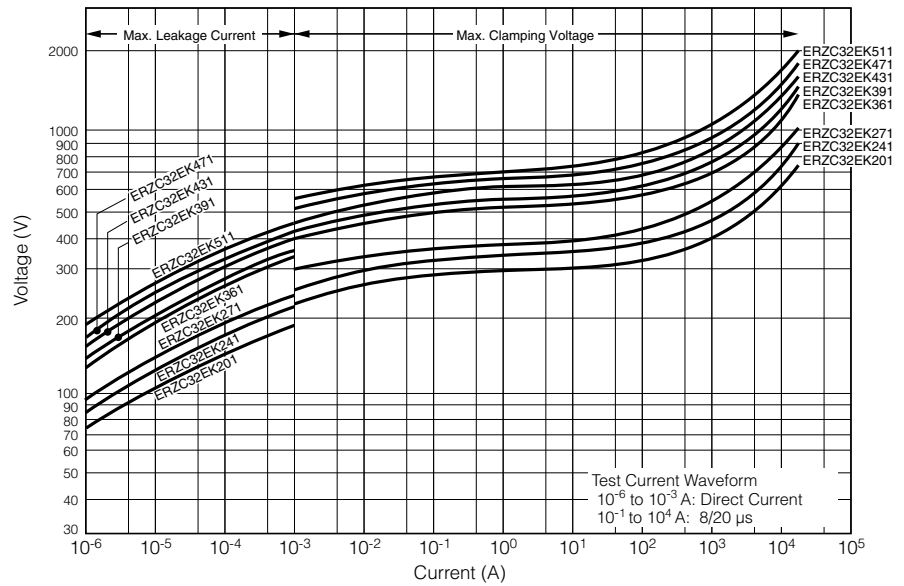

(ERZC32EK621 to ERZC32EK112)

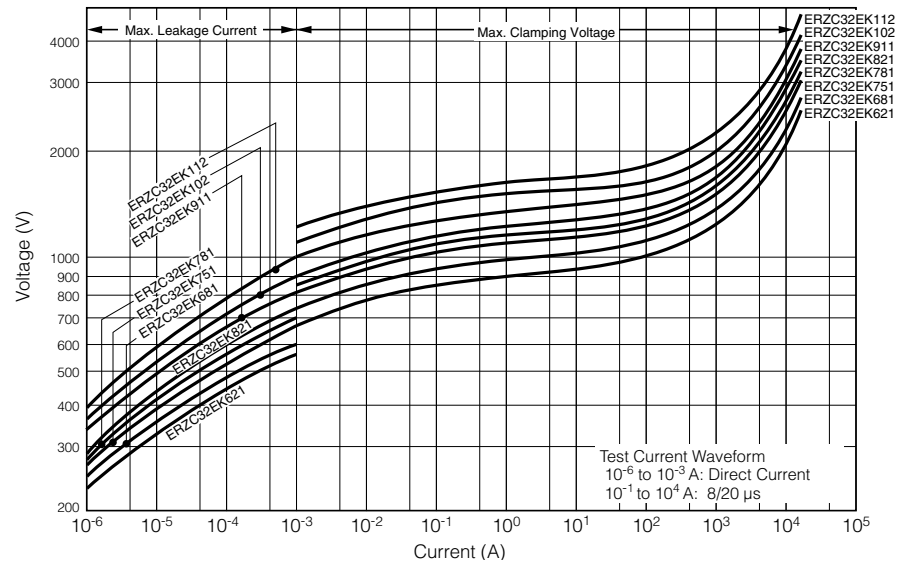

**Impulse Derating Curve (Relation between impulse width and surge, repetitively)**

**32 Series**

(ERZC32EK201 to ERZC32EK271)

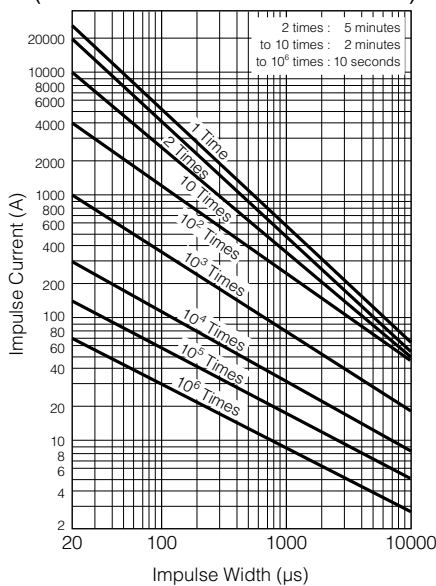

**32 Series**

(ERZC32EK361 to ERZC32EK681)

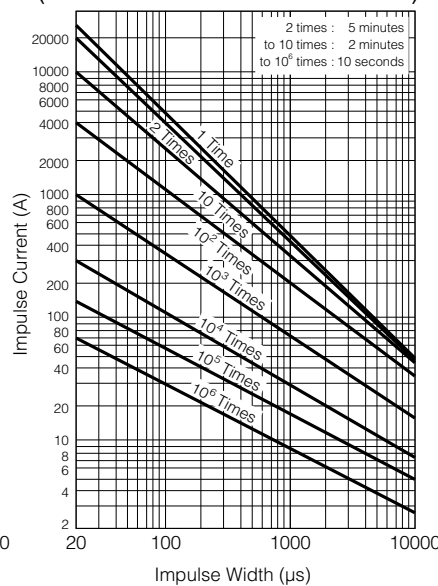

**32 Series**

(ERZC32EK751 to ERZC32EK112)

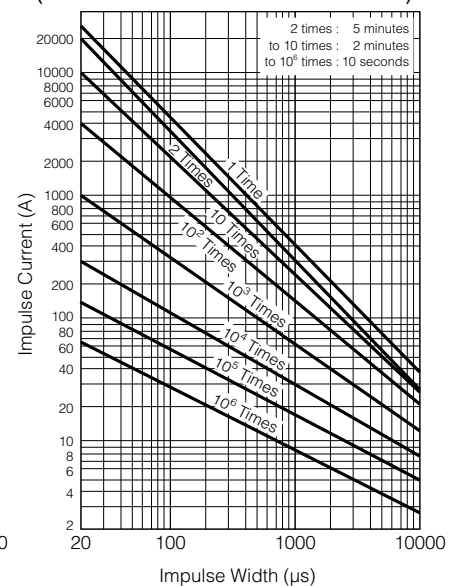

Design and specifications are each subject to change without notice. Ask factory for the current technical specifications before purchase and/or use. Should a safety concern arise regarding this product, please be sure to contact us immediately.



■ Performance Characteristics (Type E)

Characteristics		Test Methods/Description	Specifications															
Standard Test Condition		Electrical characteristics shall be measured at following conditions (Temperature: 5 to 35 °C, Humidity: Max. 85 %)	—															
Electrical	Varistor Voltage	The voltage between two terminals with the specified measuring current $I_{mA}$ DC applied is called $V_c$ or $V_{c mA}$ . The measurement shall be made as fast as possible to avoid heat affection.	To meet the specified value.															
	Maximum Allowable Voltage	The maximum sinusoidal wave voltage (rms) or the maximum DC voltage that can be applied continuously.																
	Clamping Voltage	The maximum voltage between two terminals with the specified standard impulse current (8/20 $\mu$ s).																
	Rated Power	The maximum power that can be applied within the specified ambient temperature.																
	Energy	The maximum energy within the varistor voltage change of $\pm 10$ % when one impulse of 2 ms is applied.																
	Maximum Peak Current	2 times		The maximum current within the varistor voltage change of $\pm 10$ % with the standard impulse current (8/20 $\mu$ s) applied two times with an interval of 5 minutes.														
		1 time		The maximum current within the varistor voltage change of $\pm 10$ % with the standard impulse current (8/20 $\mu$ s) applied one time.														
	Temperature Coefficient of Varistor Voltage	$\frac{V_c \text{ at } 70 \text{ }^\circ\text{C} - V_c \text{ at } 20 \text{ }^\circ\text{C}}{V_c \text{ at } 20 \text{ }^\circ\text{C}} \times \frac{1}{50} \times 100 \text{ (\%/}^\circ\text{C)}$		0 to $-0.05$ %/ $^\circ$ C max.														
	Impulse Life	The change of $V_c$ shall be measured after the impulse listed below is applied 10000 times continuously with the interval of ten seconds at room temperature. <table border="1" style="margin-left: auto; margin-right: auto;"> <tr> <td>20 Series</td> <td>200 A (8/20 <math>\mu</math>s)</td> </tr> <tr> <td>32 Series</td> <td>300 A (8/20 <math>\mu</math>s)</td> </tr> </table>		20 Series	200 A (8/20 $\mu$ s)	32 Series	300 A (8/20 $\mu$ s)	$\Delta V_{1 mA} / V_{1 mA} \leq \pm 10$ %										
	20 Series	200 A (8/20 $\mu$ s)																
32 Series	300 A (8/20 $\mu$ s)																	
Withstanding Voltage (Body Insulation)	The commercial frequency voltage of AC 2.5 kV shall be applied between terminals and the bottom of the unit for one minute.	No remarkable damage																
Mechanical	Robustness of Terminations (Tensile)	After gradually applying the load of 49 N (5 kgf) and keeping the unit fixed for 10 seconds in an axial direction, the terminal shall be visually examined for any damage.	No remarkable damage															
	Vibration	After repeatedly applying a single harmonic vibration (amplitude: 0.75 mm): double amplitude: 1.5 mm with 1 minute vibration frequency cycles (10 Hz to 55 Hz to 10 Hz) to each of three perpendicular directions for 2 hours. Thereafter, the damage of the terminals is visually examined.																
Environmental	Dry Heat/ High Temperature Storage	The specimen shall be subjected to $110 \pm 3$ °C for 500 hours in a thermostatic bath without load and then stored at room temperature and humidity for one to two hours. Thereafter, the change of $V_c$ shall be measured. <table border="1" style="margin-left: auto; margin-right: auto;"> <thead> <tr> <th>Step</th> <th>Temperature (°C)</th> <th>Period (minutes)</th> </tr> </thead> <tbody> <tr> <td>1</td> <td><math>-25_{-3}^0</math></td> <td><math>30_{-0}^{+3}</math></td> </tr> <tr> <td>2</td> <td>Room Temp.</td> <td>3 max.</td> </tr> <tr> <td>3</td> <td><math>85_{-0}^{+3}</math></td> <td><math>30_{-0}^{+3}</math></td> </tr> <tr> <td>4</td> <td>Room Temp.</td> <td>3 max.</td> </tr> </tbody> </table>	Step	Temperature (°C)	Period (minutes)	1	$-25_{-3}^0$	$30_{-0}^{+3}$	2	Room Temp.	3 max.	3	$85_{-0}^{+3}$	$30_{-0}^{+3}$	4	Room Temp.	3 max.	$\Delta V_{1 mA} / V_{1 mA} \leq \pm 5$ %
	Step	Temperature (°C)	Period (minutes)															
	1	$-25_{-3}^0$	$30_{-0}^{+3}$															
	2	Room Temp.	3 max.															
3	$85_{-0}^{+3}$	$30_{-0}^{+3}$																
4	Room Temp.	3 max.																
Temperature Cycle	The temperature cycle shown below shall be repeated five times and then stored at room temperature and humidity for one to two hours. The change of $V_c$ and mechanical damage shall be examined.	No remarkable damage $\Delta V_{1 mA} / V_{1 mA} \leq \pm 5$ %																
Dry Heat Load/ High Temperature Load	After being continuously applied the Maximum Allowable Voltage at $85 \pm 5$ °C for 500 hours, the specimen shall be stored at room temperature and humidity for one to two hours. Thereafter, the change of $V_c$ shall be measured.	$\Delta V_{1 mA} / V_{1 mA} \leq \pm 10$ %																
Damp Heat/Humidity (Steady State)	The specimen shall be subjected to $40 \pm 2$ °C, 90 to 95 %RH for 1000 hours without load and then stored at room temperature and humidity for one to two hours. Thereafter, the change of $V_c$ shall be measured.	$\Delta V_{1 mA} / V_{1 mA} \leq \pm 5$ %																

Design and specifications are each subject to change without notice. Ask factory for the current technical specifications before purchase and/or use. Should a safety concern arise regarding this product, please be sure to contact us immediately.

### UL and CSA Recognized “ZNR” Transient/Surge Absorbers with Tabs

Type: **CK**

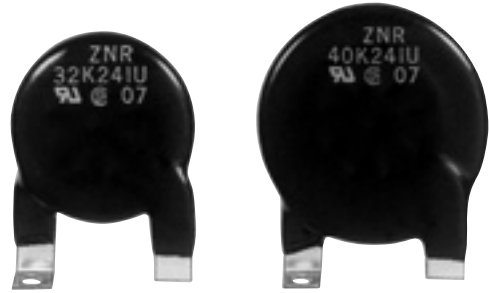

ZNR Transient/Surge Absorber with Tabs is a heavy duty type ZNR with very unique tab terminals which bring forth a higher reliability.

These tabs are used as electrical connecting terminals and also its mounting legs. This type of ZNR is meant for applications in power supplies or transient voltage surge suppressor units where large surge current or high surge energy absorption is required.

#### ■ Features

- UL and CSA recognized components
- High energy handling capability (210 to 750 joules)
- Large withstanding peak current (25 to 30 kA, 8/20 μs, 1 time)
- Common terminals for electrical connection and mounting
- RoHS compliant

#### ■ Recommended Applications

- Power suppliers for OA, FA, telecommunication or industrial equipment
- Power strips
- Transient voltage surge suppressor units

Note: Ask our factory for Product Specification before use.

#### ■ Handling Precautions and Minimum Quantity / Packing Unit

Please see Related Information

#### ■ Related Standards

Standard No.	UL1449	CSA C22.2 No.1 Class 2221 01
Title	Surge Protective Devices	Accessories and Parts for Electronic Products (Varistor for Across-The-Line use as transient protection on 120V ac nominal system)
File No.	E321499	LR-92226

- Each type designation is not registered by Part Number. Please contact us for further questions regarding type designation.

#### ■ Explanation of Part Numbers

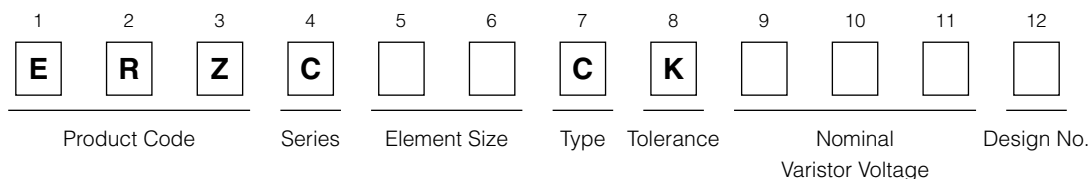

### ■ Ratings and Characteristics

- Operating Temperature Range: -40 to 85 °C
- Storage Temperature Range: -40 to 125 °C

Part Number (UL/CSA Recognized)	Type Designation	Varistor Voltage  V <sub>1</sub> mA (V)	Maximum Allowable Voltage		Maximum Clamping Voltage		Energy (2 ms, 1 time)  (J)	Maximum Peak Current (8/20 μs)	
			ACrms (V)	DC (V)	V <sub>XA</sub> (V)	I <sub>p</sub> (A)		1 time (kA)	2 times (kA)
ERZC32CK201W	32K201U	200 (185 to 225)	130	170	340	200	210	25	20
ERZC32CK241W	32K241U	240 (216 to 264)	150	200	395	200	240	25	20
ERZC32CK271W	32K271U	270 (247 to 303)	175	225	455	200	255	25	20
ERZC32CK361W	32K361U	360 (324 to 396)	230	300	595	200	325	25	20
ERZC32CK391W	32K391U	390 (351 to 429)	250	320	650	200	350	25	20
ERZC32CK431W	32K431U	430 (387 to 473)	275	350	710	200	400	25	20
ERZC32CK471W	32K471U	470 (423 to 517)	300	385	775	200	405	25	20
ERZC32CK511W	32K511U	510 (459 to 561)	320	415	845	200	405	25	20
ERZC32CK621W	32K621U	620 (558 to 682)	385	505	1025	200	415	25	20
ERZC32CK681W	32K681U	680 (612 to 748)	420	560	1120	200	450	25	20
ERZC32CK751W	32K751U	750 (645 to 825)	460	615	1240	200	500	25	20
ERZC32CK781W	32K781U	780 (702 to 858)	485	640	1290	200	520	25	20
ERZC32CK821W	32K821U	820 (738 to 902)	510	670	1355	200	545	25	20
ERZC32CK911W	32K911U	910 (819 to 1001)	550	745	1500	200	600	25	20
ERZC32CK951W	32K951U	950 (855 to 1045)	575	765	1570	200	600	25	20
ERZC40CK201W	40K201U	200 (185 to 225)	130	170	340	250	260	30	25
ERZC40CK241W	40K241U	240 (216 to 264)	150	200	395	250	300	30	25
ERZC40CK271W	40K271U	270 (247 to 303)	175	225	455	250	340	30	25
ERZC40CK361W	40K361U	360 (324 to 396)	230	300	595	250	405	30	25
ERZC40CK391W	40K391U	390 (351 to 429)	250	320	650	250	435	30	25
ERZC40CK431W	40K431U	430 (387 to 473)	275	350	710	250	500	30	25
ERZC40CK471W	40K471U	470 (423 to 517)	300	385	775	250	505	30	25
ERZC40CK511W	40K511U	510 (459 to 561)	320	415	845	250	505	30	25
ERZC40CK621W	40K621U	620 (558 to 682)	385	505	1025	250	515	30	25
ERZC40CK681W	40K681U	680 (612 to 748)	420	560	1120	250	560	30	25
ERZC40CK751W	40K751U	750 (645 to 825)	460	615	1240	250	625	30	25
ERZC40CK781W	40K781U	780 (702 to 858)	485	640	1290	250	650	30	25
ERZC40CK821W	40K821U	820 (738 to 902)	510	670	1355	250	680	30	25
ERZC40CK911W	40K911U	910 (819 to 1001)	550	745	1500	250	750	30	25
ERZC40CK951W	40K951U	950 (855 to 1045)	575	765	1570	250	750	30	25

### ■ Dimensions in mm (not to scale)

ZNR  
Abbreviation of Part number  
Date code

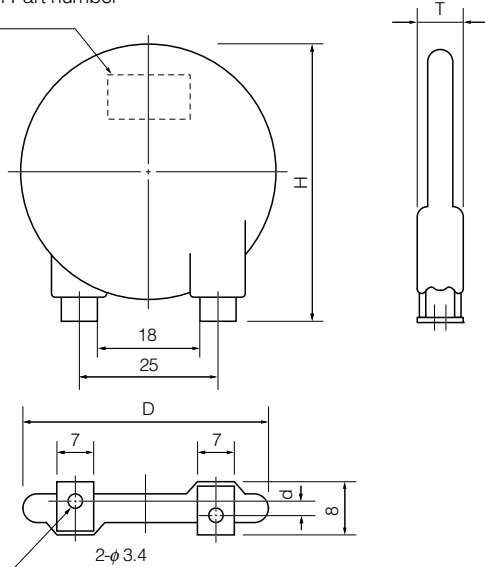

Part Number (UL/CSA Recognized)	Type Designation	D max.	H max.	T max.	d
ERZC32CK201W	32K201U	36	46	7.5	5.7±1.0
ERZC32CK241W	32K241U			7.5	5.4±1.0
ERZC32CK271W	32K271U			8.5	5.2±1.0
ERZC32CK361W	32K361U			9.0	4.6±1.0
ERZC32CK391W	32K391U			9.0	4.4±1.0
ERZC32CK431W	32K431U			9.0	4.1±1.0
ERZC32CK471W	32K471U			9.7	3.9±1.0
ERZC32CK511W	32K511U			9.7	4.5±1.0
ERZC32CK621W	32K621U			9.7	3.9±1.0
ERZC32CK681W	32K681U			9.7	3.6±1.0
ERZC32CK751W	32K751U			10.5	3.3±1.0
ERZC32CK781W	32K781U			10.5	3.1±1.0
ERZC32CK821W	32K821U			10.5	2.9±1.0
ERZC32CK911W	32K911U			11.5	2.5±1.0
ERZC32CK951W	32K951U			11.5	2.3±1.0
ERZC40CK201W	40K201U			44	50
ERZC40CK241W	40K241U	7.5	5.4±1.0		
ERZC40CK271W	40K271U	8.5	5.2±1.0		
ERZC40CK361W	40K361U	9.0	4.6±1.0		
ERZC40CK391W	40K391U	9.0	4.4±1.0		
ERZC40CK431W	40K431U	9.0	4.1±1.0		
ERZC40CK471W	40K471U	9.7	3.9±1.0		
ERZC40CK511W	40K511U	9.7	4.5±1.0		
ERZC40CK621W	40K621U	9.7	3.9±1.0		
ERZC40CK681W	40K681U	9.7	3.6±1.0		
ERZC40CK751W	40K751U	10.5	3.3±1.0		
ERZC40CK781W	40K781U	10.5	3.1±1.0		
ERZC40CK821W	40K821U	10.5	2.9±1.0		
ERZC40CK911W	40K911U	11.5	2.5±1.0		
ERZC40CK951W	40K951U	11.5	2.3±1.0		

Design and specifications are each subject to change without notice. Ask factory for the current technical specifications before purchase and/or use.  
Should a safety concern arise regarding this product, please be sure to contact us immediately.

■ Typical Characteristics

Voltage vs. Current (ERZC32CK201W to ERZC32CK951W)

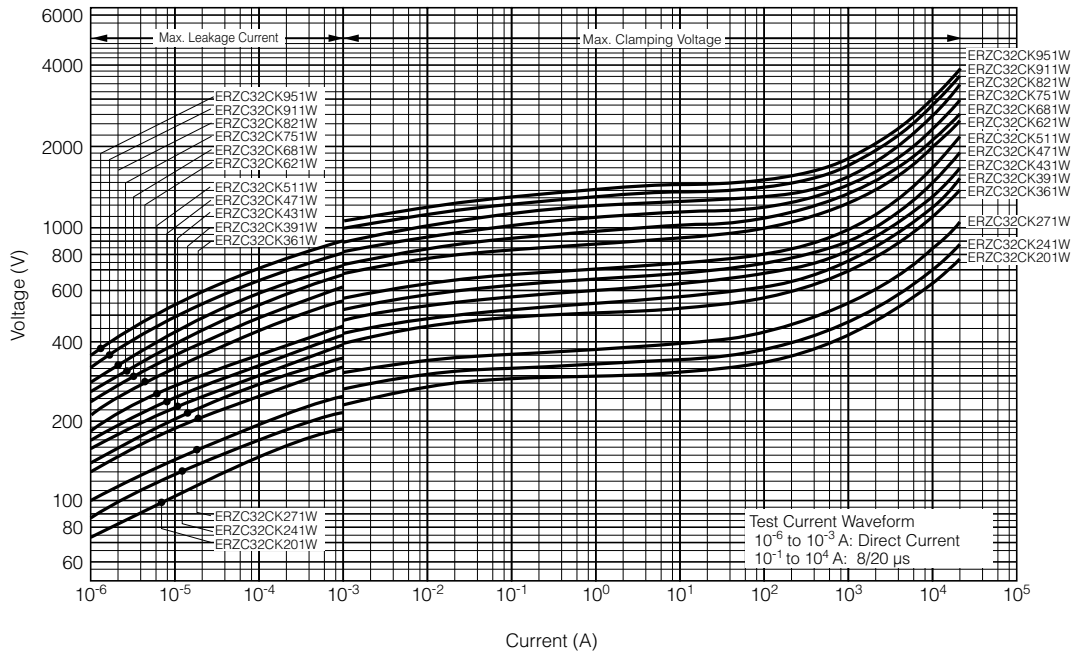

(ERZC40CK201W to ERZC40CK951W)

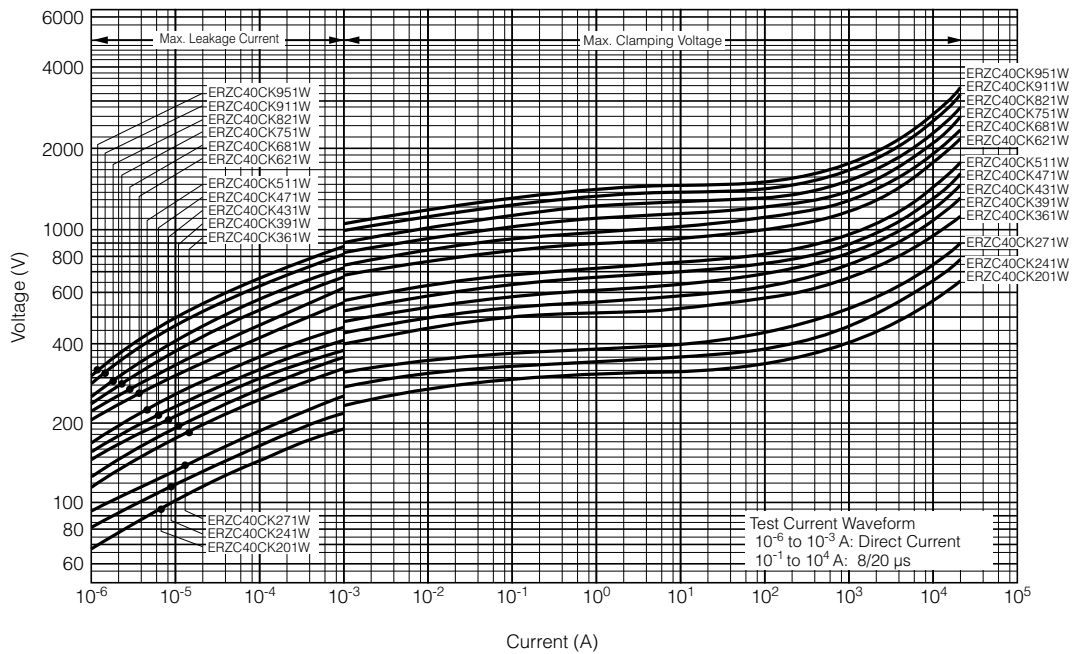

■ UL, CSA Recognized Components and The A.C. Rated Voltage

Part Number (UL/CSA Recognized)	Maximum Allowable Voltage		Rated Voltage (Vrms)	
	ACrms (V)	DC (V)	UL1449	CSA (Class 2221 01)
ERZC32CK201W	130	170	118	118
ERZC32CK241W	150	200	136	136
ERZC32CK271W	175	225	159	159
ERZC32CK361W	230	300	209	209
ERZC32CK391W	250	320	227	227
ERZC32CK431W	275	350	250	250
ERZC32CK471W	300	385	272	272
ERZC32CK511W	320	415	291	291
ERZC32CK621W	385	505	350	350
ERZC32CK681W	420	560	381	381
ERZC32CK751W	460	615	418	418
ERZC32CK781W	485	640	440	440
ERZC32CK821W	510	670	463	463
ERZC32CK911W	550	745	500	500
ERZC32CK951W	575	765	522	522
ERZC40CK201W	130	170	118	118
ERZC40CK241W	150	200	136	136
ERZC40CK271W	175	225	159	159
ERZC40CK361W	230	300	209	209
ERZC40CK391W	250	320	227	227
ERZC40CK431W	275	350	250	250
ERZC40CK471W	300	385	272	272
ERZC40CK511W	320	415	291	291
ERZC40CK621W	385	505	350	350
ERZC40CK681W	420	560	381	381
ERZC40CK751W	460	615	418	418
ERZC40CK781W	485	640	440	440
ERZC40CK821W	510	670	463	463
ERZC40CK911W	550	745	500	500
ERZC40CK951W	575	765	522	522

Design and specifications are each subject to change without notice. Ask factory for the current technical specifications before purchase and/or use.  
Should a safety concern arise regarding this product, please be sure to contact us immediately.

■ Performance Characteristics (Type CK)

Characteristics		Test Methods/Description	Specifications															
Standard Test Condition		Electrical characteristics shall be measured at following conditions (Temperature: 5 to 35 °C, Humidity: Max. 85 %).	_____															
Electrical	Varistor Voltage	The voltage between two terminals with the specified measuring current $C_{mA}$ DC applied is called $V_C$ or $V_{CmA}$ . The measurement shall be made as fast as possible to avoid heat affection.	To meet the specified value.															
	Maximum Allowable Voltage	The maximum sinusoidal wave voltage (rms) or the maximum DC voltage that can be applied continuously.																
	Clamping Voltage	The maximum voltage between two terminals with the specified standard impulse current (8/20 $\mu$ s).																
	Rated Power	The maximum power that can be applied within the specified ambient temperature.																
	Energy	The maximum energy within the varistor voltage change of $\pm 10$ % when one impulse of 2 ms is applied.																
	Maximum Peak Current	2 times		The maximum current within the varistor voltage change of $\pm 10$ % with the standard impulse current (8/20 $\mu$ s) applied two times with an interval of 5 minutes.														
1 time		The maximum current within the varistor voltage change of $\pm 10$ % with the standard impulse current (8/20 $\mu$ s) applied one time.																
Mechanical	Robustness of Terminations (Tensile)	After gradually applying the force of 19.6 N (2 kgf) and keeping the unit fixed for ten seconds, the terminal shall be visually examined for any damage.	No remarkable damage															
	Vibration	After repeatedly applying a single harmonic vibration (amplitude: 0.35 mm): double amplitude: 0.7mm with 1 minute vibration frequency cycles (10 Hz to 55 Hz to 10 Hz) to each of three perpendicular directions for 2 hours. Thereafter, the unit shall be visually examined.	No remarkable damage															
	Solderability	After dipping the terminal to a depth of approximately 3 mm from the body in a soldering bath of $230 \pm 5$ °C for $5.0 \pm 0.5$ seconds, the terminal shall be visually examined.	Approximately 95 % of the terminals shall be covered with new solder uniformly.															
	Resistance to Soldering Heat	The terminal shall be dipped into a soldering bath having a temperature of $350 \pm 10$ °C to a point $4.0 \pm 0.8$ mm from the body of the unit and then be held there for $3.0 \pm 0.5$ seconds. The change of $V_C$ and mechanical damage shall be examined.	$\Delta V_{CmA}/V_{CmA} \leq \pm 5$ % No remarkable damage															
Environmental	Dry Heat/ High Temperature Storage	The specimen shall be subjected to $125 \pm 2$ °C for 500 hours in a thermostatic bath without load and then stored at room temperature and humidity for one to two hours. Thereafter, the change of $V_C$ shall be measured.	$\Delta V_{CmA}/V_{CmA} \leq \pm 5$ %															
	Damp Heat/ Humidity (Steady State)	The specimen shall be subjected to $40 \pm 2$ °C, 90 to 95 %RH for 1000 hours without load and then stored at room temperature and humidity for one to two hours. Thereafter, the change of $V_C$ shall be measured.																
	Temperature Cycle	The temperature cycle shown below shall be repeated five times and then stored at room temperature and humidity for one to two hours. The change of $V_C$ and mechanical damage shall be examined. <table border="1" style="margin-left: auto; margin-right: auto;"> <thead> <tr> <th>Step</th> <th>Temperature (°C)</th> <th>Period (minutes)</th> </tr> </thead> <tbody> <tr> <td>1</td> <td><math>-25 \pm 3</math></td> <td><math>30^{+3}_0</math></td> </tr> <tr> <td>2</td> <td>Room Temp.</td> <td>3 max.</td> </tr> <tr> <td>3</td> <td><math>85 \pm 2</math></td> <td><math>30^{+3}_0</math></td> </tr> <tr> <td>4</td> <td>Room Temp.</td> <td>3 max.</td> </tr> </tbody> </table>	Step	Temperature (°C)	Period (minutes)	1	$-25 \pm 3$	$30^{+3}_0$	2	Room Temp.	3 max.	3	$85 \pm 2$	$30^{+3}_0$	4	Room Temp.	3 max.	$\Delta V_{CmA}/V_{CmA} \leq \pm 5$ % No remarkable damage
	Step	Temperature (°C)	Period (minutes)															
1	$-25 \pm 3$	$30^{+3}_0$																
2	Room Temp.	3 max.																
3	$85 \pm 2$	$30^{+3}_0$																
4	Room Temp.	3 max.																
Dry Heat Load/ High Temperature Load	After being continuously applied the Maximum Allowable Voltage at $85 \pm 2$ °C for 500 hours, the specimen shall be stored at room temperature and humidity for one to two hours. Thereafter, the change of $V_C$ shall be measured.	$\Delta V_{CmA}/V_{CmA} \leq \pm 10$ %																

Design and specifications are each subject to change without notice. Ask factory for the current technical specifications before purchase and/or use. Should a safety concern arise regarding this product, please be sure to contact us immediately.

**“ZNR” Transient/Surge Absorbers, Type E**  
**“ZNR” Transient/Surge Absorbers, Type CK, SC**

**Handling Precautions**

**1. ⚠️Precautions for Safety**

The “ZNR” Transient/Surge Absorbers (hereafter referred to as “The ZNR Varistors”) may fail in a short-circuit mode or in an open-circuit mode, when subjected to severe conditions of electrical, environmental and/or mechanical stresses beyond their specified “Ratings” and specified “Conditions”, resulting in burnout, flaming or glowing in the worst case.

Following “⚠️Precautions for Safety” and “Application Notes” shall be taken in your major consideration. If you have a question about the “Precautions for Handling”, please contact our engineering section or factory.

**1.1 ⚠️Operating Conditions**

**1.1.1** The ZNR Varistors shall not be operated beyond the specified “Ratings” and “Environmental Conditions” in the Catalog or the Specifications to prevent them from deterioration, breakdown, flaming or glowing.

- The ZNR Varistors shall not be operated exceeding the specified “Maximum Allowable Voltage” in the Catalog or the Specification.
- The ZNR Varistors shall not be subjected to energy levels above their specified “Maximum Energy Ratings” in the Catalog or the Specifications.
- In case of application to repeated surge/overvoltages, the ZNR Varistors shall not be subjected to surge currents and energy levels above the specified maximum ratings in “Impulse Life Rating” in the Catalog or the Specifications.
- When surge/overvoltages are intermittently applied to the ZNR Varistors with short durations, the devices shall not be operated beyond the specified “Rated Power” in the Catalog or the Specifications.
- The ZNR Varistors shall not be operated beyond the specified “Operating Temperature Range” in the Catalog or the Specifications.
- It is recommended that the ZNR Varistors, if not fused, shall be located away from other combustible components.

**1.1.2** The ZNR Varistor shall be operated correctly under following conditions to prevent Varistors from causing mechanical damages and ruptures and to protect human from serious injuries;

- The ZNR Varistors shall not be operated exceeding the specified “Maximum Allowable Voltage Ratings” in the Catalog.
- The ZNR Varistors shall not be operated beyond the “Maximum Peak Current Ratings” in the Catalog.
- Some safety countermeasure such as a protective case covering the Varistor is recommended, if necessary.

**1.1.3** When the ZNR Varistors are applied to between a live part and a metallic chassis of equipment, following safety countermeasures shall be taken to protect human from electric shock.

- A) The metallic chassis shall be earthed to the ground.
- B) The live part shall be equipped with a protective cover for preventing electric shock.

● **Recommendation fuse**

Series	ERZC20EK□□□□	ERZC32□K□□□□	ERZVS34C□□□□ ERZC40CK□□□□
Current Fuse (Line - Line)	10 A max.	20 A max.	20 A max.
Thermal. Fuse (Line - Ground)	100 to 120 °C 5 A	100 to 120 °C 10 A	100 to 120 °C 10 A

- \* Fuses shall use rated voltages appropriate for circuits.
- \* Finally, confirm that the secondary disaster does not occur even if the ZNR mounted on equipment breaks.
- \* Set a thermal fuse to get high thermal conductivity with ZNR.

**2. Application Notes**

**2.1 Protective Devices for Varistors**

**2.1.1** The ZNR Varistors shall be protected from serious accidents due to unexpected physical phenomenon by following safety countermeasures.

- In case of “Across-the Line Use”, the ZNR Varistors shall be protected by connecting a ground fault circuit interrupter or fusing in series to the devices. (See Table 1)
- In case of “Line to Ground Use”, the short-circuit of the Varistor may not blow the current type fuse due to the grounding resistance (between Line and Ground), which may cause flaming or burn-out of the devices in the worst case.

Following safety countermeasures (A or B) are recommended;

- A) Connecting a “leakage current circuit breaker” in series to the Varistor to be protected. (See Table 1)
- B) Use current type fuses and a thermal type fuse which are thermally coupled each others. (See Table 1)

**2.2 Circuit Design 1**

**(Selection of Varistor Voltage Rating)**

**2.2.1 General Precautions**

In selection of Varistor Voltage Ratings for line protection, following general precautions shall be taken in your consideration;

- (1) Maximum operating voltage shall be lower than the specified “Maximum Allowable Voltage” of the Varistor applied.
- (2) Some reasonable margin is required against fluctuation of the primary AC line Voltage where the Varistor is applied for preventing mechanical and/or electrical failures of the device.

**2.2.2 Across-the-Line Use**

(Line to Line surge protection)

- Select the ZNR Varistors recommended in Table 1.

**Notes:** Because the primary line voltage temporarily rises due to load unbalance of separately wired loads, short circuit between the live line and the neutral line or LC resonance at switching for a capacitive load, ZNR Varistors with \* are recommended for AC120 V or 240 V applications. (See Table 1)

**2.2.3 Line to Ground Use**

(Line to Ground Surge protection)

- Select the ZNR Varistors recommended in Table 1.

**Notes:** When 500 V insulation resistance test of the circuits employing ZNR Varistor is conducted, the ZNR Varistor shall be removed after getting approval from the customer, or the ZNR Varistor \* \* with the Maximum Allowable Voltage exceeding to the test voltage shall be applied. (See Table 1)

When AC1000 V or 1200 V dielectric with standing test is conducted, ZNR Varistors shall be removed after getting approval from the customer according to the relevant regulations, or ZNR Varistor \* \* \* with the Maximum Allowable Voltage exceeding to the test voltage shall be applied. (See Table 1)

**2.3 Circuit Design 2 (Fusing Varistors)**

2.3.1 When a line current of equipment is higher than the recommended current rating of the fuse in Table 2, the location of the fuse shall be arranged according to Fig 2.

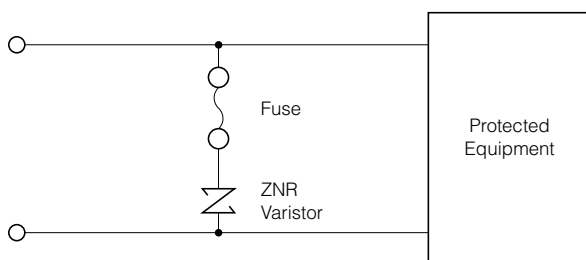

**Fig. 2 Alternative Fuse Location/placement for Varistor Protection**

**2.4 Environmental Conditions**

- (1) The ZNR Varistors shall not be exposed outdoors, because of being designed for indoors use.
- (2) The ZNR Varistors shall not be operated beyond the Specified Operating Temperature Range and shall not be exposed to direct sunlight and heating part of equipment.
- (3) The ZNR Varistors shall not be operated under severe conditions of high temperatures and high humidities such as places exposed to rain, wind and vapor.
- (4) The ZNR Varistors shall be free from dust, salty wind and atmospheres polluted by corrosive gas.

**2.5 Precautions for Assemblies and Handlings**

**2.5.1 Solvent Cleaning**

Organic solvents such as thinner and acetone etc. shall not be applied to the ZNR Varistors for preventing deterioration of the external coating or molding resin.

**2.5.2 Abnormal Mechanical Stresses**

Abnormal mechanical stresses beyond the specified values such as strong falling shocks, vibrations and bending/pulling forces, shall be kept minimum to prevent mechanical/electrical failures of the devices.

**2.5.3 Plastic Molding**

If another plastic molding is applied to the ZNR Varistors on your option, the influences on reliability of the ZNR Varistors shall be carefully investigated in your equipment.

**2.6 Long Term Storage**

- (1) The ZNR Varistors shall not be stored under severe conditions of high temperatures and high humidities. Store them indoors under 40 °C max. and 75 %RH max. Use them within one year, if stored beyond the limit, check the solderability before use.
- (2) The ZNR Varistors shall not be stored under corrosive atmospheres such as hydrogen sulfide, sulfurous acid, chlorine and ammonia.
- (3) The ZNR Varistors shall not be exposed to direct sunlight and shall not be stored under dew formation.

**2.7 Regarding to “Safety Regulations of the Varistors”**

In case of applications to UL and CSA standards, refer to “Application Notes for UL and CSA Recognized” ZNR “Varistors”

**2.8 Parallel Capacitances of the ZNR Varistors**

The ZNR Varistors have relatively high capacitances specified in the individual specifications, special consideration shall be taken into account in applications to high frequency transmission lines or circuits.



Table 1. Application Examples

		Across-the-Line/Line to Line Protection		Line to Line and Line to Ground Protection				
Connections	D.C. A.C. Single phase							
		f : fuse		f : fuse				
	A.C. 3 phase							
		f : fuse		f : fuse				
Selection Examples	Across the Line Use/Line to Line		Line to Ground Use					
	ZNR	Nominal Line Voltage	Part Number of ZNR Type E, CK, SC		ZNR	Nominal Line Voltage	Part Number of ZNR Type E, CK, SC	
	ZNR1 ZNR3	AC 100 V	ERZC□□EK ERZC□□CK ERZVS34C	201	ZNR2 ZNR4	AC 100 V to AC 220 V	ERZC□□EK ERZC□□CK ERZVS34C	471
		AC 120 V		241				511
AC 200 V to AC 220 V		271 *		821 **				
AC 240 V		471		511				
			511		AC 240 V		821 **	

**“ZNR” Transient/Surge Absorbers**

Type: **P**



ZNR Transient/Surge Absorber, Type P is a suitable device to protect various electric equipment and semiconductive devices from instantaneous over-voltages like switching surges and induced lightnings. The Type P is characterized by the unique construction of plug-in type with a deterioration indicator.

**Recommended Applications**

Protection of semiconductor devices used for the electronic equipment includes:

- Broadcasting, communication equipment
- Traffic or railroad systems
- Automatic control devices for power distribution
- Waterworks
- Protection of motor coils, vacuum switches
- RoHS compliant

Note: Ask our factory for Product Specification before use.

**Minimum Quantity / Packing Unit**

Please see Related Information

**Explanation of Part Numbers**

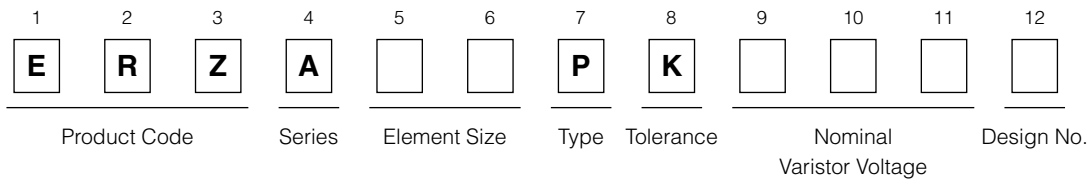

**Ratings and Characteristics**

- Operating Temperature Range: -25 to 70 °C
- Storage Temperature Range: -25 to 70 °C

Part No.	Varistor Voltage	Maximum Allowable Voltage		Maximum Clamping Voltage	Maximum Peak Current (8/20 μs, 2 times)	Energy (2 ms, 1 time)	Typical Capacitance (Reference)
	V <sub>1mA</sub> (V)	ACrms (V)	DC (V)	V <sub>100A</sub> (V)	(A)	(J)	at 1 kHz (pF)
ERZA20PK251	250±10 %	130	180	410	5000	90	1200
ERZA20PK501	500±10 %	260	360	825	5000	150	600
ERZA20PK102	1000±10 %	520	730	1650	5000	240	300

Design and specifications are each subject to change without notice. Ask factory for the current technical specifications before purchase and/or use. Should a safety concern arise regarding this product, please be sure to contact us immediately.

■ Dimensions in mm (not to scale)

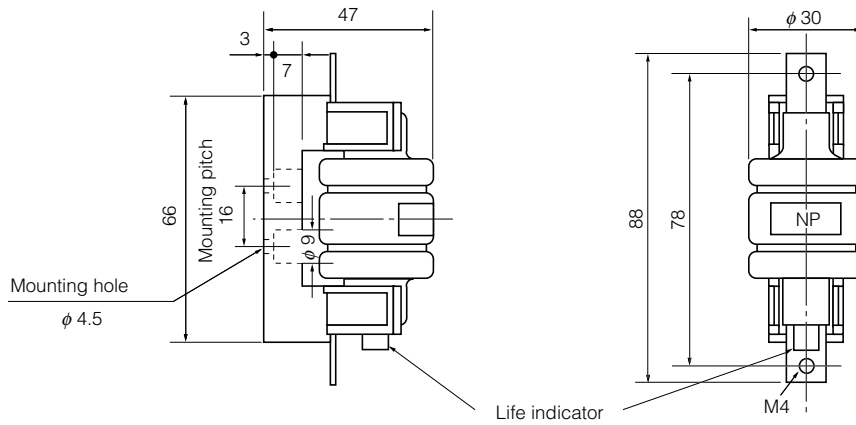

■ Typical Characteristics

**Voltage vs. Current** (ERA20PK251 to ERZA20PK102)

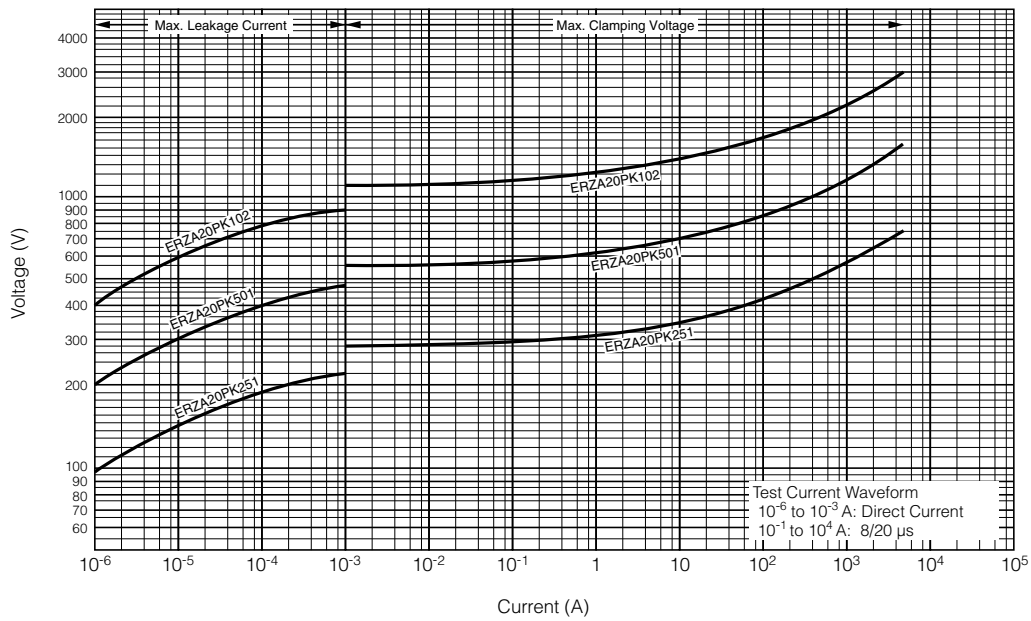

### “ZNR” Transient/Surge Absorbers

Type: **J**

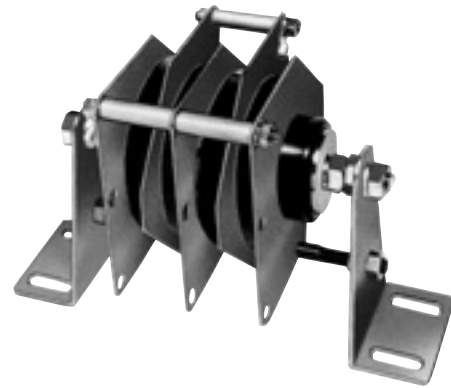

ZNR Transient/Surge Absorbers, Type J, are designed especially for surge protection of industrial equipment from high energy transient voltages which are generated by switching of the inductive loads such as DC magnet relays or transformers.

#### ■ Features

- Low clamping voltage
- Fast response to steep impulse voltage
- A bilateral and symmetrical V-I characteristic curve
- Higher energy handling capability (5000 to 44000 J)
- No follow-on current
- Wide product range  
[Varistor Voltage] 500 V to 1300 V
- RoHS compliant

#### ■ Recommended Applications

- Suppression of volume surges such as those produced by switching of DC lifting magnets and within equipment in railroad vehicles
- Protection of a current transformer from overheating caused with secondary opening
- Protection of thyristors or diodes employed in power supply equipment

#### ■ Minimum Quantity / Packing Unit

Please see Related Information

Note: Ask our factory for Product Specification before use.

#### ■ Explanation of Part Numbers

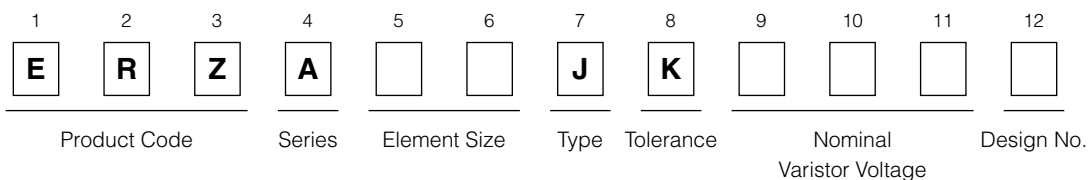

### ■ Ratings and Characteristics

- Operating Temperature Range: -25 to 70 °C
- Storage Temperature Range: -25 to 110 °C

Part No.	Varistor Voltage	Maximum Allowable Voltage		Maximum Clamping Voltage	Energy (Derated sinusoidal wave, 1 time)	Maximum Peak Current (4/10 $\mu$ s, 2 times)	Typical Capacitance (Reference)
	V <sub>1 mA</sub> (V)	ACrms (V)	DC (V)	V <sub>100 A</sub> (V)	(J)	(kA)	at 1 kHz (pF)
ERZA80JK561	560 (505 to 615)	250	350	925	5000	80	9800
ERZA80JK561A					10000	80 × 2	19600
ERZA80JK561B					15000	80 × 3	29400
ERZA80JK561C					20000	80 × 4	39200
ERZA80JK112	1100 (980 to 1200)	485	680	1800	10000	80	4800
ERZA80JK112A					20000	80 × 2	9600
ERZA80JK112B					30000	80 × 3	14400
ERZA80JK112C					40000	80 × 4	19200
ERZA80JK122	1250 (1120 to 1380)	550	775	2070	11000	80	4400
ERZA80JK122A					22000	80 × 2	8800
ERZA80JK122B					33000	80 × 3	13200
ERZA80JK122C					44000	80 × 4	17600

### ■ Typical Characteristics

#### Voltage vs. Current

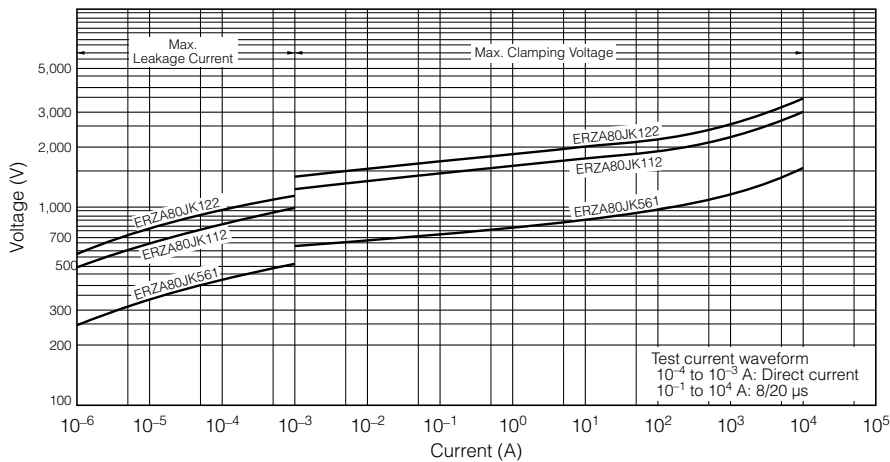

#### Impulse Derating

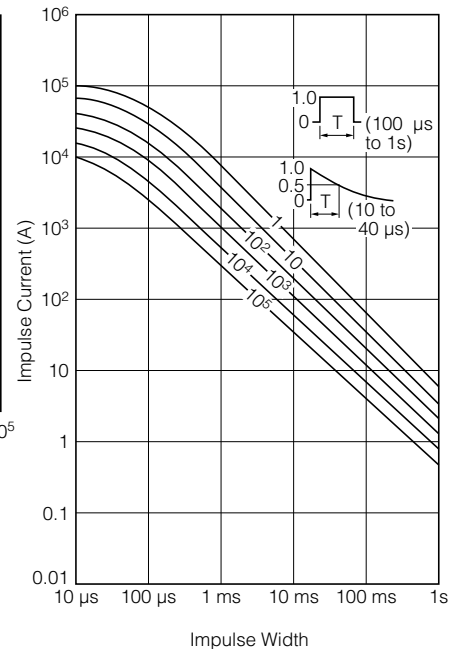

■ Dimensions in mm (not to scale)

### ERZA80JK□□□□

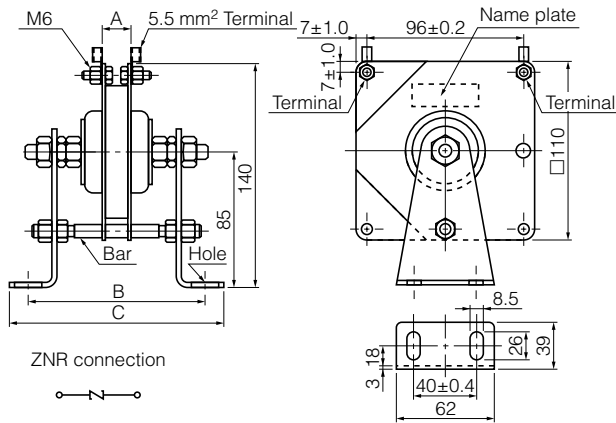

### ERZA80JK□□□□B

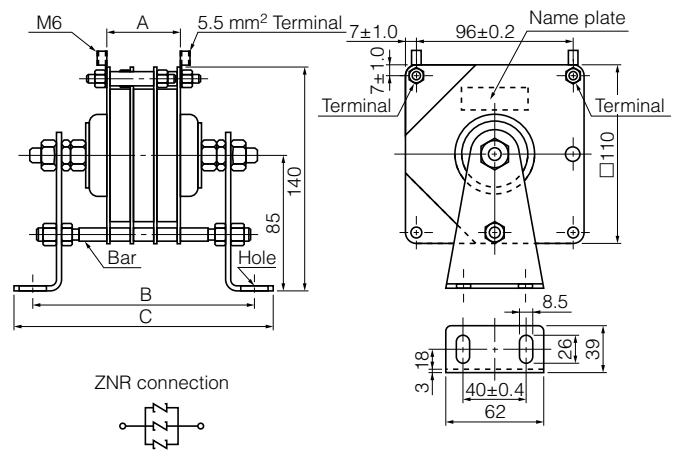

### ERZA80JK□□□□A

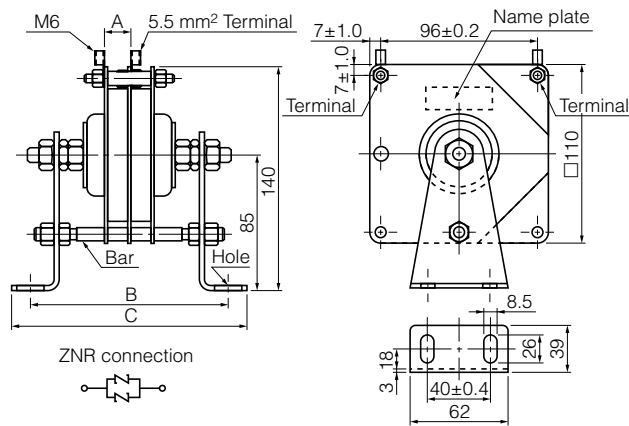

### ERZA80JK□□□□C

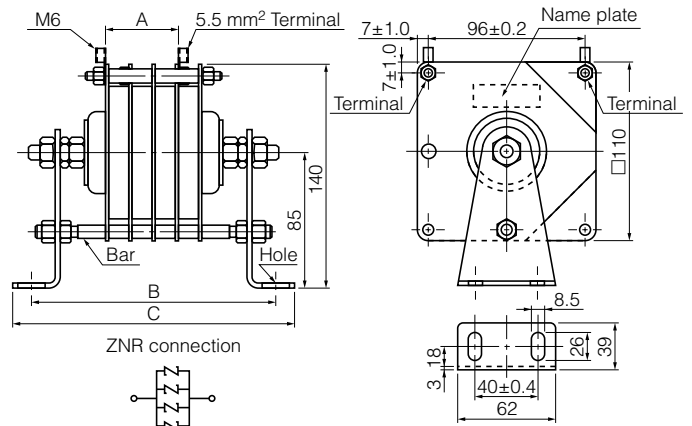

Part No.	A	B	C
ERZA80JK561	14.0	125.0±4.0	161.0±4.0
ERZA80JK561A	14.0	138.0±8.0	174.0±8.0
ERZA80JK561B	40.0	151.0±8.0	187.0±8.0
ERZA80JK561C	40.0	164.0±8.0	200.0±8.0
ERZA80JK112	19.0	130.0±4.0	166.0±4.0
ERZA80JK112A	19.0	148.0±8.0	184.0±8.0
ERZA80JK112B	56.0	167.0±8.0	203.0±8.0
ERZA80JK112C	56.0	185.0±8.0	221.0±8.0
ERZA80JK122	21.0	132.0±4.0	168.0±4.0
ERZA80JK122A	21.0	152.0±8.0	188.0±8.0
ERZA80JK122B	61.0	172.0±8.0	208.0±8.0
ERZA80JK122C	61.0	192.0±8.0	228.0±8.0

**“ZNR” Transient/Surge Absorbers**

Type: **G**

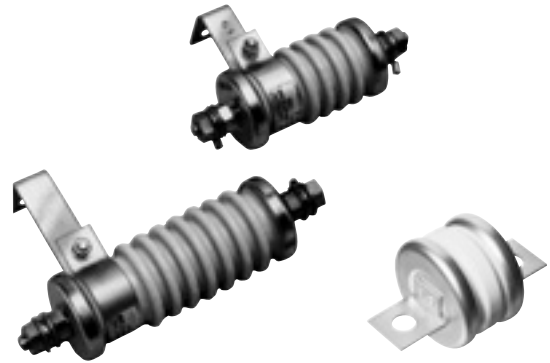

High energy transient over voltages generated by switching on/off of a vacuum relay in power distribution line can cause insulation breakdown of high voltage electronic equipment/devices and power cables etc... The ZNR Type F and G are gapless type arresters using sintered bodies of zinc-oxide and are characterized by the excellent characteristics of high energy handling capability, fast response time and low clamp ratio etc...

The ZNR and G have wide applications for protection of high-voltage motors, transformers, rectifiers and anticorrosion layers of powercables from high energy transient overvoltages/surges.

- RoHS compliant

■ **Recommended Applications**

- Protection of high voltage motors, transformers or rectifiers from switching surges
- Switching surge absorption in vacuum circuit interrupters
- Protection of anti-corrosion layer of under ground electric power cable from induced lightning or switching surges

**Note:** Ask our factory for Product Specification before use.

■ **Minimum Quantity / Packing Unit**

Please see Related Information

■ **Ratings and Characteristics**

- Operating Temperature Range: -25 to 70 °C
- Storage Temperature Range: -40 to 85 °C

Characteristics \ Part No.	ERZA20GS852H	ERZA20GS173H
Connection	AC 3.3 kV Line-Ground	AC 6.6 kV Line-Ground
Varistor Voltage ( $V_{1mA}$ )	8.50± $_{0.50}^{0.75}$ kV	17.0± $_{1.0}^{1.5}$ kV
Maximum Clamping Voltage @ 100 A (8/20 μs)	12.75 kV	25.5 kV
Maximum Peak Current (8/20 μs, 2 times)	5000 A	5000 A
Maximum Allowable Voltage	AC 3.45 kV	AC 6.9 kV
Impulse Life (2 ms, 10 <sup>4</sup> times)	20 A	20 A
Maximum Allowable Energy	1300 J	2600 J

Design and specifications are each subject to change without notice. Ask factory for the current technical specifications before purchase and/or use. Should a safety concern arise regarding this product, please be sure to contact us immediately.

■ Dimensions in mm (not to scale)

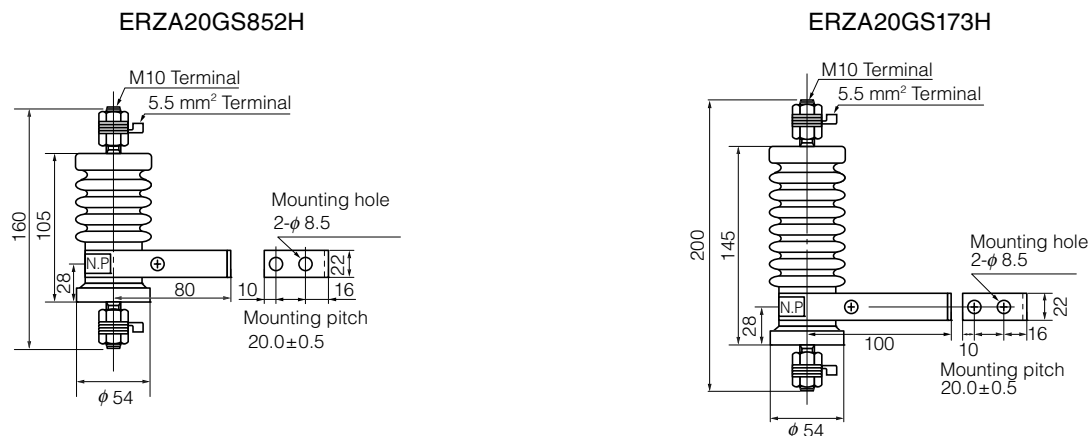

■ Ratings and Characteristics

- Operating Temperature Range: -25 to 70 °C
- Storage Temperature Range: -40 to 85 °C

Characteristics	ERZA48GK502
Connection	Across the Anti-corrosion layers
Varistor Voltage ( $V_{1\text{mA}}$ )	5.0 kV±0.5 kV
Clamping Voltage (8/20 $\mu$ s)	14 kV at V23 kA
Maximum Peak Current (8/20 $\mu$ s)	21 kA 100 times

■ Dimensions in mm (not to scale)

ERZA48GK502

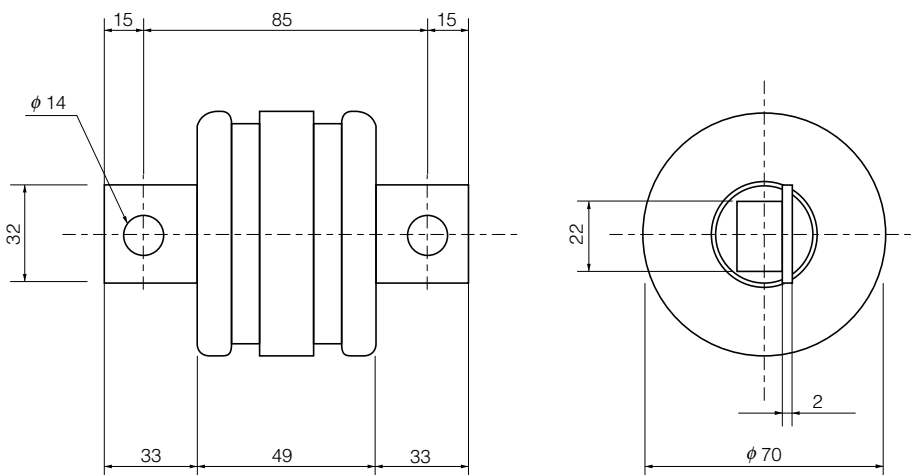



### “ZNR” Surge Absorber Units

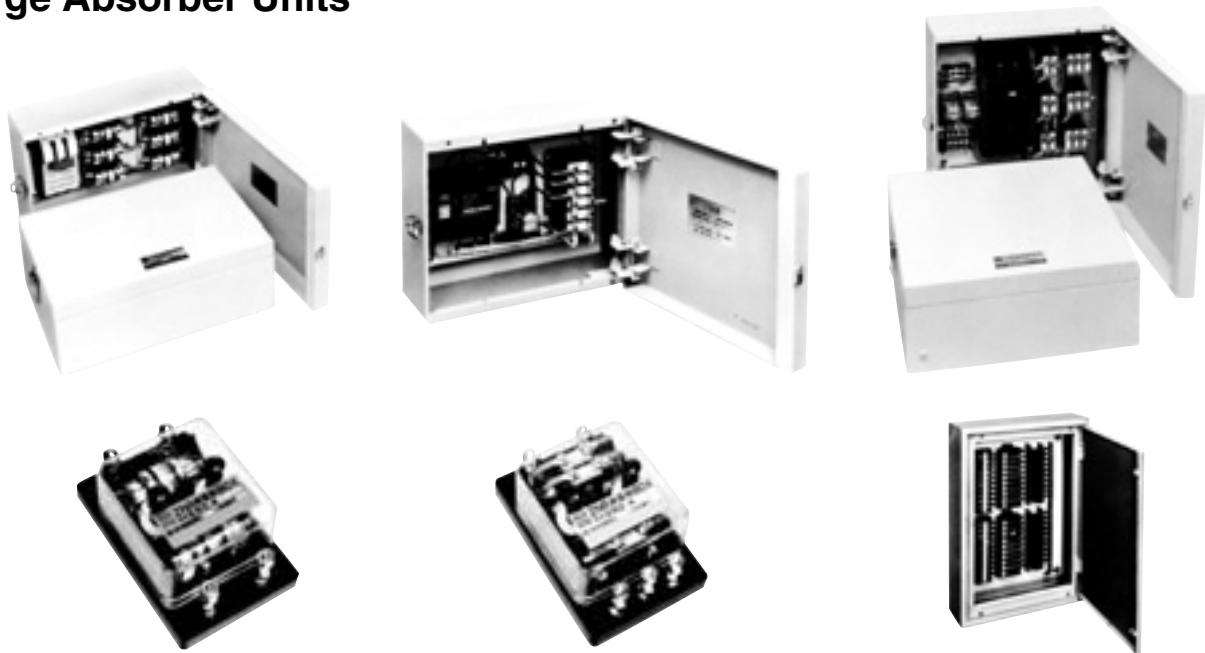

The Surge Absorber Unit contains Y,  $\Delta$  or  $\pi$  connected ZNRs surge absorbers (and, if necessary, a circuit breaker) in a box.

These Surge Absorber Units are designed for surge protection of industrial electric equipment where reliability is essential.

- RoHS compliant

#### ■ Recommended Applications

Surge Protection of

- Railway/traffic signal control systems
- Distribution line control systems
- Broadcasting systems, communication systems
- Measuring instruments
- Controllers of low voltage distribution line
- Controllers of waterworks
- RoHS compliant

#### ■ Minimum Quantity / Packing Unit

Please see Related Information

Note: Ask our factory for Product Specification before use.

## ■ ZNR Surge Absorber Units

Application	Maximum Peak Current	Rated Voltage	Circuits							
			Single-phase two-wire system		Single-phase three-wire system		Three-phase three-wire system		Three-phase four-wire system	
			Part No.	Dim. Connection	Part No.	Dim. Connection	Part No.	Dim. Connection	Part No.	Dim. Connection
For Power Source	5000 A	AC 100/120 V	ERZA1P251ASA	A 1	ERZA2P251ASA	B 2			ERZA4P251ASA	B 4
			ERZA1P251BC*	C 5						
			ERZA1P251AR**	C 6						
		AC 200/220/240 V	ERZA1P501AS	A 1	ERZA2P501AS	B 2	ERZA3P501AS	B 3	ERZA4P501AS	B 4
			ERZA1P102AS	B 1			ERZA3P102AS	B 3	ERZA4P102AS	B 4
	20000 A	AC 100/120 V	ERZA1E271ASA	A 7	ERZA2E271AS	B 8			ERZA4E271AS	B 10
			ERZA1E471ASA	A 7	ERZA2E471AS	B 8	ERZA3E471AS	B 9	ERZA4E471AS	B 10
		AC 200/220/240 V	ERZA1E102AS	B 7			ERZA3E102AS	B 9	ERZA4E102AS	B 10
50000 A	AC 100/120 V	ERZA1E271BS	B 7	ERZA2E271BS	B 8			ERZA4E271BS	B 10	
	AC 200/220/240 V	ERZA1E471BS	B 7	ERZA2E471BS	B 8	ERZA3E471BS	B 9	ERZA4E471BS	B 10	
AC 400/440 V	ERZA1E102BS	B 7			ERZA3E102BS	B 9	ERZA4E102BS	B 10		

\*  $\pi$  connection with inductors (specified current: 2 A)  
 \*\*  $\pi$  connection with resistors (specified current: 2 A)

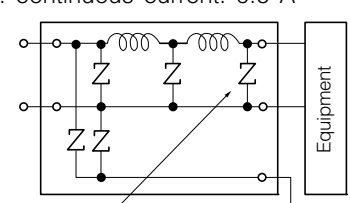
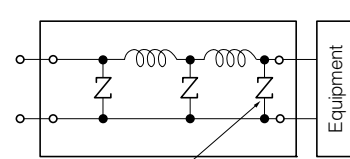
Application	Maximum Peak Current	Rated Voltage	Part No.	Dimensions	Connection
For signal system (Line to Line and Line to Ground use)	5000 A	DC 12 V	ERZA5F220AC	D	Coil: 1 mH max. Max. continuous current: 0.6 A  Type D (other : Type E)
		DC 24 V	ERZA5F390AC		
		DC 48 V	ERZA5F680AC		
		DC 80 V	ERZA5F101AC		
		DC 100 V	ERZA5F201ACA		
For signal system (Line to Line use only)	5000 A	DC 12 V	ERZA5F220BC	C	Coil: 1 mH max. Max. continuous current: 0.6 A  Type D (other : Type E)
		DC 24 V	ERZA5F390BC		
		DC 48 V	ERZA5F680BC		
		DC 80 V	ERZA5F101BC		
		DC 100 V	ERZA5F201BC		

Design and specifications are each subject to change without notice. Ask factory for the current technical specifications before purchase and/or use.  
 Should a safety concern arise regarding this product, please be sure to contact us immediately.

■ Dimensions in mm (not to scale)

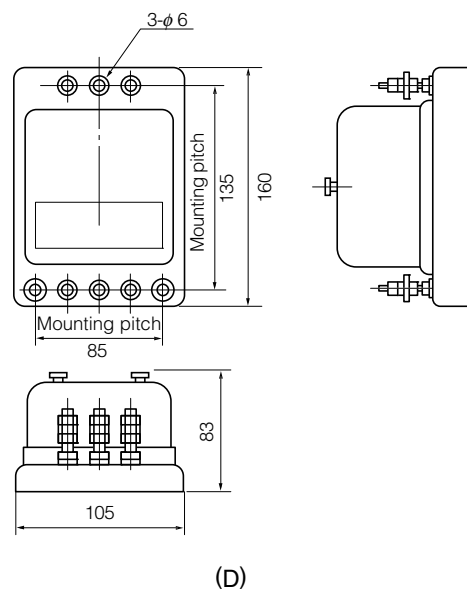
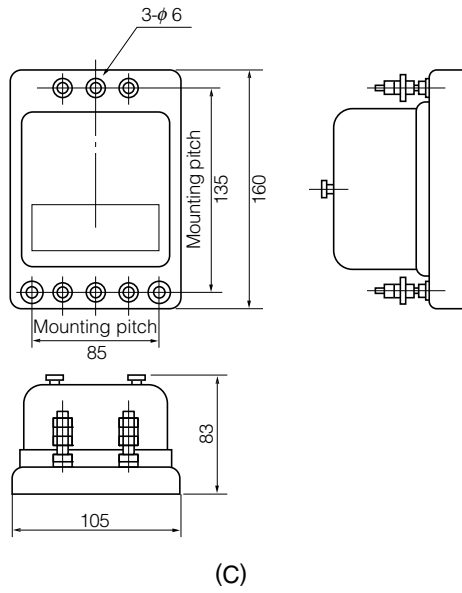
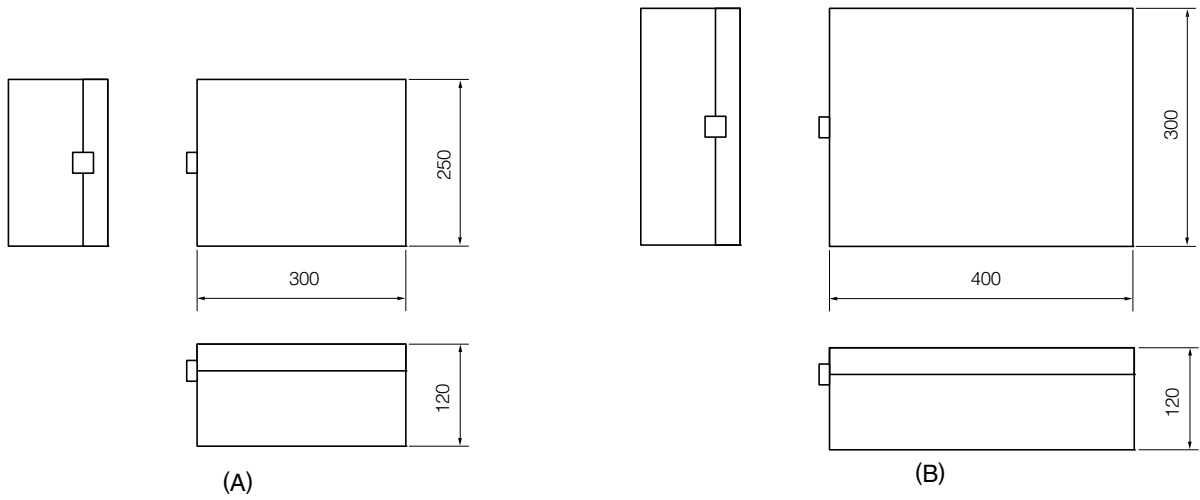

### ■ Circuit Diagrams

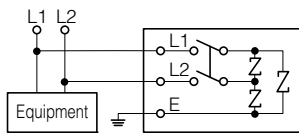

(1)

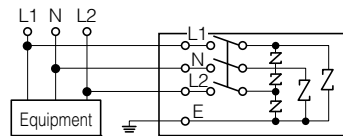

(2)

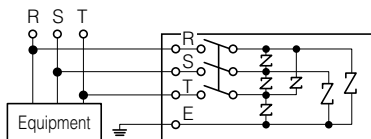

(3)

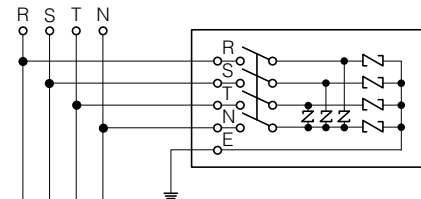

(4)

Inductance : 1 mH max.

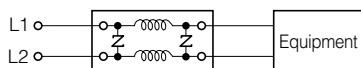

Max. continuous current : 2 A

(5)

Resistance : 0.3 Ω

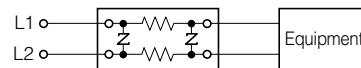

Max. continuous current : 2 A

(6)

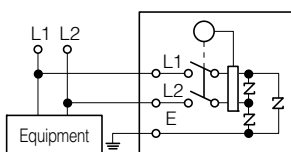

(7)

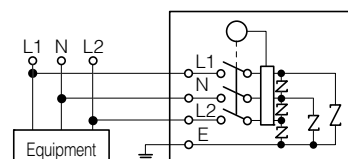

(8)

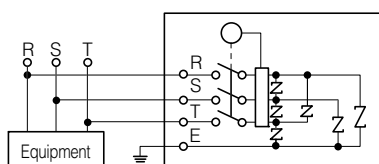

(9)

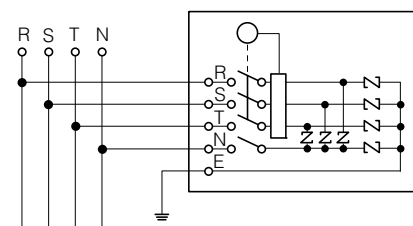

(10)

### “ZNR” Transient/Surge Absorbers, For Thyristor Protection

Type: **E**

Type: **J**



Type E

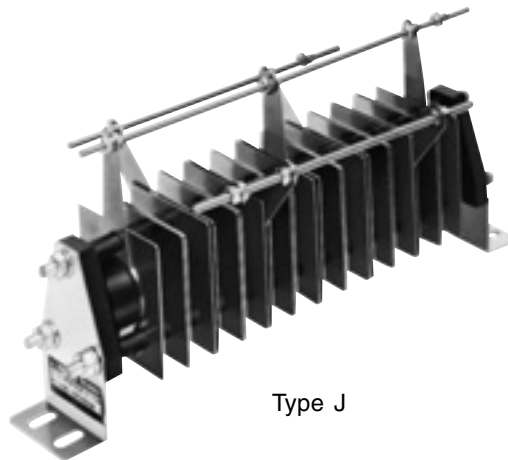

Type J

“ZNR” Transient/Surge Absorber for thyristors is especially designed to protect SCR power controllers and SCR power sources from high energy transient over voltages.

The ZNR is smaller in size and excellent in the clamping voltage characteristics as compared with a conventional selenium surge absorber. The ZNR Type E is for relatively low handling capacity of transformer and Type J is for heavy duty use.

- RoHS compliant

#### ■ Recommended Applications

- Surge protection of SCR\* power controllers
- Surge protection of SCR\* power sources
- \* SCR = Silicone Controlled Rectifiers
- RoHS compliant

Note: Ask our factory for Product Specification before use.

#### ■ Minimum Quantity / Packing Unit

Please see Related Information

**“ZNR” Transient/Surge Absorbers, Type E**

■ Ratings and Characteristics (Type E)

- Operating Temperature Range: -40 to 85 °C
- Storage Temperature Range: -40 to 110 °C

Part No.	Varistor Voltage	Maximum Allowable Voltage		Maximum Clamping Voltage		Impulse Life (2 ms, 10 <sup>4</sup> times)	Commutation Surge Ratio
	V <sub>1 mA</sub> (V)	ACrms (V)	DC (V)	V <sub>1p</sub> (V)	I <sub>p</sub> (A)	(A)	—
ERZC20EK511P	498 to 542	242	342	760	10	10	1.45
ERZC20EK541P	523 to 560	264	373	785			1.40
ERZC20EK681P	630 to 678	330	467	950			1.35
ERZC20EK821P	788 to 848	412	583	1185			1.35
ERZC20EK911P	840 to 904	440	622	1265			1.35
ERZC20EK102P	945 to 1017	495	700	1425			1.35
ERZC20EK112P	1051 to 1181	550	775	1655			1.35
ERZC32EK511P	498 to 542	242	342	760	20	20	1.45
ERZC32EK541P	523 to 560	264	373	785			1.40
ERZC32EK681P	630 to 678	330	467	950			1.35
ERZC32EK821P	788 to 848	412	583	1185			1.35
ERZC32EK911P	840 to 904	440	622	1265			1.35
ERZC32EK102P	945 to 1017	495	700	1425			1.35
ERZC32EK112P	1051 to 1181	550	775	1655			1.35

■ Dimensions in mm (not to scale) (Type E)

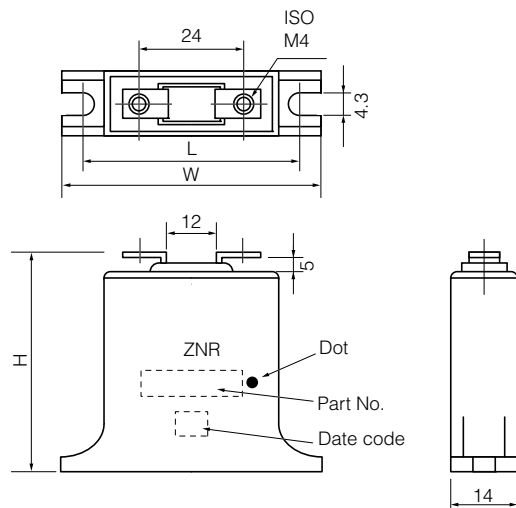

Part No.	W	H	L
ERZC20EK□□□P	48±1	42±1	39±1
ERZC32EK□□□P	60±1	55±1	51±1

Design and specifications are each subject to change without notice. Ask factory for the current technical specifications before purchase and/or use. Should a safety concern arise regarding this product, please be sure to contact us immediately.

## “ZNR” Transient/Surge Absorbers, Type J

■ Dimensions in mm (not to scale)

Style (1)

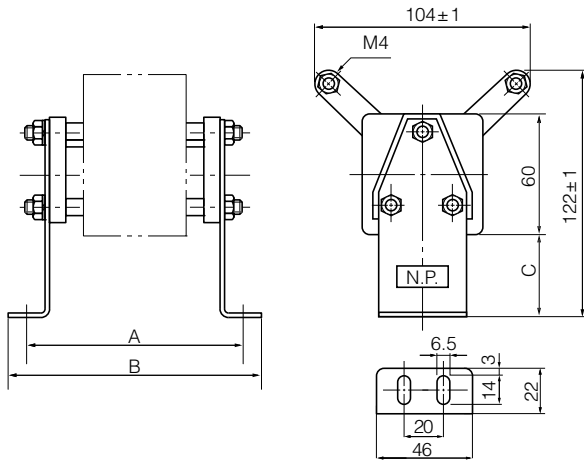

Style(2)

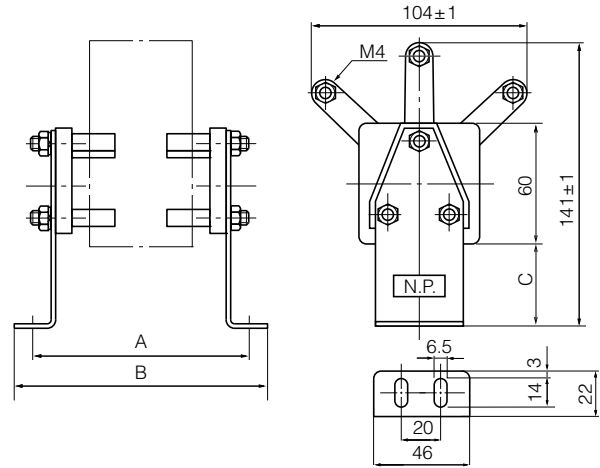

### ■ Ratings and Characteristics (Type J)

- Operating Temperature Range: -40 to 70 °C
- Storage Temperature Range: -40 to 110 °C

Part No.	Connection	Maximum Allowable Voltage		Maximum Clamping Voltage		Impulse Life (2 ms, 10 <sup>4</sup> times)	Commutation Surge Ratio	Dimensions in mm			
		ACrms (V)	DC (V)	V <sub>ip</sub> (V)	I <sub>p</sub> (A)			(A)	Style	A	B
ERZU11JP511	Single	242	342	760	40	40	1.45	(1)	88	108	20
EZR12JP511					70	70			104	124	
ERZU13JP511					95	95			121	141	
ERZU14JP511					125	125			138	158	
ERZU15JP511					150	150			155	175	
ERZU16JP511					180	180			172	192	
ERZU17JP511					210	210			189	209	
ERZU11JP511B	Delta	242	—	760	40	40	1.45	(2)	120	140	20
ERZU12JP511B					70	70			169	189	
ERZU13JP511B					95	95			219	239	
ERZU14JP511B					125	125			268	288	
ERZU11JP541	Single	264	373	785	40	40	1.40	(1)	88	108	20
ERZU12JP541					70	70			105	125	
ERZU13JP541					95	95			122	142	
ERZU14JP541					125	125			139	159	
ERZU15JP541					150	150			156	176	
ERZU16JP541					180	180			172	192	
ERZU17JP541					210	210			189	209	
ERZU11JP541B	Delta	264	—	785	40	40	1.40	(2)	121	141	20
ERZU12JP541B					70	70			171	191	
ERZU13JP541B					95	95			221	241	
ERZU14JP541B					125	125			270	290	

Design and specifications are each subject to change without notice. Ask factory for the current technical specifications before purchase and/or use.  
Should a safety concern arise regarding this product, please be sure to contact us immediately.

Part No.	Connection	Maximum Allowable Voltage		Maximum Clamping Voltage		Impulse Life (2 ms, 10 <sup>4</sup> times)	Commutation Surge Ratio	Dimensions in mm			
		ACrms (V)	DC (V)	V <sub>ip</sub> (V)	I <sub>p</sub> (A)			(A)	Style	A	B
ERZU21JP102 ERZU22JP102 ERZU23JP102 ERZU24JP102 ERZU25JP102 ERZU26JP102	Single	484	684	1520	40 70 95 125 150 180	40 70 95 125 150 180	1.45	(1)	102 135 168 199 230 261	122 155 188 219 250 281	20
ERZU21JP102B ERZU22JP102B	Delta	484	—	1520	40 70	40 70	1.45	(2)	166 261	186 281	20
ERZU21JP112 ERZU22JP112 ERZU23JP112 ERZU24JP112 ERZU25JP112 ERZU26JP112	Single	528	746	1570	40 70 95 125 150 180	40 70 95 125 150 180	1.40	(1)	103 136 169 200 232 264	123 156 189 220 252 284	20
ERZU21JP112B ERZU22JP112B	Delta	528	—	1570	40 70	40 70	1.40	(2)	168 264	188 284	20
ERZU21JP132F ERZU22JP132F ERZU23JP132F ERZU24JP132F ERZU25JP132F ERZU26JP132F	Single	660	933	1900	40 70 95 125 150 180	40 70 95 125 150 180	1.35	(1)	149 182 214 246 278 310	169 202 234 266 298 330	40
ERZU21JP132H ERZU22JP132H	Delta	660	—	1900	40 70	40 70	1.35	(2)	213 309	233 329	40
ERZU21JP162F ERZU22JP162F ERZU23JP162F ERZU24JP162F ERZU25JP162F ERZU26JP162F	Single	825	1167	2375	40 70 95 125 150 180	40 70 95 125 150 180	1.35	(1)	150 184 218 252 286 320	170 204 238 272 306 340	40
ERZU21JP162H ERZU22JP162H	Delta	825	—	2375	40 70	40 70	1.35	(2)	217 317	237 337	40
ERZU21JP192F ERZU22JP192F ERZU23JP192F ERZU24JP192F ERZU25JP192F ERZU26JP192F	Single	990	1400	2850	40 70 95 125 150 180	40 70 95 125 150 180	1.35	(1)	152 187 222 257 292 327	172 207 242 277 312 347	40
ERZU21JP192H ERZU22JP192H	Delta	990	—	2850	40 70	40 70	1.35	(2)	222 327	242 347	40
ERZU21JP222F ERZU22JP222F ERZU23JP222F ERZU24JP222F	Single	1100	1550	3325	40 70 95 125	40 70 95 125	1.35	(1)	154 190 227 264	174 210 247 284	40
ERZU21JP222H	Delta	1100	—	3325	40	40	1.35	(2)	227	247	40
ERZU31JP252F ERZU32JP252F ERZU33JP252F ERZU34JP252F	Single	1320	1867	3800	40 70 95 125	40 70 95 125	1.35	(1)	167 218 269 320	187 238 289 340	40
ERZU31JP252H	Delta	1320	—	3800	40	40	1.35	(2)	266	288	40

Design and specifications are each subject to change without notice. Ask factory for the current technical specifications before purchase and/or use.  
Should a safety concern arise regarding this product, please be sure to contact us immediately.



# Minimum Quantity / Packing Unit

\* Please contact local sales office about packing specifications.

Product	Series/Type		Part Number	Minimum Quantity / Packing Unit	Packing Quantity in Carton	Carton (about) L×W×H (mm)
"ZNR" Transient/ Surge Absorbers	Type D	Straight Leads <Bulk>	ERZV05D180 to 271	100	10000	210×340×160
			ERZV05D331 to 471	100	10000	210×340×180
			ERZV07D180 to 470	100	10000	210×340×160
			ERZV07D560 to 680	100	10000	210×340×180
			ERZV07D820 to 121	100	10000	210×340×160
			ERZV07D151 to 271	100	10000	210×340×180
			ERZV07D331 to 511	100	5000	210×340×110
			ERZV09D180 to 121	100	5000	210×340×160
			ERZV09D151 to 271	100	4000	210×340×130
			ERZV09D331 to 511	100	4000	210×340×160
			ERZV10D180 to 121	50	5000	210×340×160
			ERZV10D151 to 271	50	4000	210×340×130
			ERZV10D331 to 621	50	4000	210×340×160
			ERZV10D681 to 821	50	2000	210×340× 80
			ERZV10D911 to 112	50	2000	210×340×110
			ERZV10D182CS	50	1000	210×340× 80
			ERZV14D180 to 121	50	3000	210×340×110
			ERZV14D151 to 271	50	3000	210×340×130
			ERZV14D331 to 621	50	2000	210×340×110
			ERZV14D681 to 821	50	2000	210×340×110
			ERZV14D911 to 112	50	1000	210×340× 80
			ERZV14D182CS	50	1000	210×340× 80
			ERZV20D180 to 271	50	2000	210×340×160
			ERZV20D331 to 511	50	1000	210×340× 80
			ERZV20D561 to 821	50	1000	210×340×110
			ERZV20D911 to 112	50	1000	210×340×110
			ERZV20D182	25	500	210×340× 80
			ERZV05D(V)180CS to 271CS	100	10000	210×340× 80
			ERZV05D(V)331CS to 471CS	100	10000	210×340×110
			ERZV07D(V)180CS to 271CS	100	10000	210×340× 80
			ERZV07D(V)331CS to 511CS	100	10000	210×340×110
			ERZV09D(V)180CS to 121CS	100	5000	210×340×110
			ERZV09D(V)151CS to 511CS	100	4000	210×340× 80
			ERZV10D(V)180CS to 121CS	100	5000	210×340×110
			ERZV10D(V)151CS to 621CS	100	4000	210×340× 80
			ERZV10D(V)681CS to 751CS	100	2000	210×340× 80
			ERZV10D(V)821C1 to 112C1	100	2000	210×340× 80
			ERZV14D(V)180CS to 271CS	100	3000	210×340× 80
			ERZV14D(V)331CS to 821C1	100	2000	210×340× 80
			ERZV14D(V)911C1 to 112C1	100	1000	210×340× 80
	ERZVA5D180 to 271	1000	10000	360×320×260		
	ERZVA5D331 to 471	1000	10000	400×360×260		
	ERZVA7D180 to 271	1000	10000	400×360×260		
	ERZVA7D331 to 511	1000	10000	470×360×260		
	ERZVA9D180 to 271	1000	10000	400×360×260		
	ERZVA9D331 to 511	1000	10000	470×360×260		
	ERZVGAD180 to 621	1000	5000	360×310×320		
	ERZVGAD681 to 112	500	2500	360×270×320		
	ERZVGED180 to 511	500	2500	360×310×320		
	ERZVGED561 to 112	250	1250	360×270×320		
	ERZVA5V180 to 271	1000	10000	360×320×260		
	ERZVA5V331 to 471	1000	10000	400×360×260		
	ERZVA7V180 to 271	1000	10000	400×360×260		
	ERZVA7V331 to 511	1000	10000	470×360×260		
	ERZVA9V180 to 271	1000	10000	400×360×300		
	ERZVA9V331 to 511	1000	10000	470×360×300		
	ERZVEAV180 to 621	1000	5000	360×310×320		
	ERZVEAV681 to 112	500	2500	360×270×320		
	ERZVEEV180 to 511	500	2500	360×310×320		
	ERZVEEV561 to 112	250	1250	360×270×320		
	Type SMD	Bulk	ERZVF1	200	2000	210×340× 80
		Embossed	ERZVF2	2000	6000	340×345× 75
		Embossed	ERZHF2	1000	4000	340×345×105
	Type E		ERZC□□EK□□□□	5	100	380×405× 85
		UL and CSA Recognized	ERZC□□EK□□□□Y	5	100	380×405× 85
	Type CK	UL and CSA Recognized	ERZC□□CK□□□□W	10	200	320×430× 65
	Type SC		ERZVS34C□□□□	10	200	320×430× 65
	Type P		ERZA20PK□□□□	1	40	380×405× 75
	Type J		ERZA80JK□□□□	1	—	180×260×190
	Type G		ERZA□□GK□□□□	1	3	220×280×195
	Surge Absorber Units		ERZA□□□□□□□□	1	—	275×345×145
	For Thyristor Protection	Type E	ERZC□□EK□□□□P	5	100	300×355× 65
		Type J	ERZU□□JP□□□□	1	—	160×420×185

Part No., quantity and country of origin are designated on outer packages in English.

## CAUTION AND WARNING

1. The electronic components contained in this catalog are designed and produced for use in home electric appliances, office equipment, information equipment, communications equipment, and other general purpose electronic devices.  
Before use of any of these components for equipment that requires a high degree of safety, such as medical instruments, aerospace equipment, disaster-prevention equipment, security equipment, vehicles (automobile, train, vessel), please be sure to contact our sales representative.
2. When applying one of these components for equipment requiring a high degree of safety, no matter what sort of application it might be, be sure to install a protective circuit or redundancy arrangement to enhance the safety of your equipment. In addition, please carry out the safety test on your own responsibility.
3. When using our products, no matter what sort of equipment they might be used for, be sure to make a written agreement on the specifications with us in advance.
4. Technical information contained in this catalog is intended to convey examples of typical performances and/or applications and is not intended to make any warranty with respect to the intellectual property rights or any other related rights of our company or any third parties nor grant any license under such rights.
5. In order to export products in this catalog, the exporter may be subject to the export license requirement under the Foreign Exchange and Foreign Trade Law of Japan.
6. No ozone-depleting substances (ODSs) under the Montreal Protocol are used in the manufacturing processes of Automotive & Industrial Systems Company, Panasonic Corporation.

● Please contact

● Factory

**Circuit Components Business Division**  
**Automotive & Industrial Systems Company**  
**Panasonic Corporation**  
401 Sadamasa-cho, Fukui-shi,  
Fukui 910-8502, JAPAN

The information in this catalog is valid as of October 2013.