

EN

LIVE WITH
ILVE

KITCHEN APPLIANCES
HANDMADE IN ITALY



**PRO-LINE, PROFESSIONAL PLUS,
NOSTALGIE & MAJESTIC SERIES
GAS & INDUCTION COOKTOP
WITH ELECTRIC OVEN
FREESTANDING COOKERS
USER, OPERATING & INSTALLATION MANUAL**

cod. EI33960020000EN
IT18/2018
AU03/2020





KITCHEN APPLIANCES
HANDMADE IN ITALY

Congratulations, you are now the proud owner of an ILVE cooking appliance. Thank you for purchasing ILVE and welcome to the exciting world of cooking the ILVE way.

This instruction manual has been specially created to inform you of the full range of features your ILVE appliance has to offer and serves as an introduction to the wonderful benefits of ILVE's dynamic cooking systems.

We present detailed information on each of the advanced cooking systems built into ILVE appliances. Once you have read this section you will be able to choose the most appropriate settings for your appliance when cooking different types of food.

We ask you to read the instructions in this booklet very carefully as this will allow you to get the best results from using your appliance.

KEEP THE DOCUMENTATION OF THIS PRODUCT FOR FUTURE REFERENCE.

YOUR FREE MASTERCLASS

Although we encourage you to dive right in, as the owner of a brand new ILVE oven we'd also like to invite you to attend a complimentary 2 hour masterclass. As part of the class you'll learn how to prepare and cook a number of delicious signature ILVE dishes, not to mention our top tips for getting the most out of your ILVE oven. From improving cooking results to general maintenance information, we know you'll enjoy this comprehensive, fun masterclass.

Simply go to ilve.com.au/bookings or Phone 1300 MY ILVE (694 583)





LIVE WITH
ILVE

KITCHEN APPLIANCES
HANDMADE IN ITALY



OPEN 24/7
ILVE ACCESSORIES ONLINE SHOP

For a wide range of Genuine ILVE accessories at the
click of a button shop.ilve.com.au

iWarranty

REGISTER YOUR WARRANTY ONLINE NOW

GO TO: <https://support.eurolinx.com.au/#/form/warrantyregistration>

As a part of our continued customer service offering, you can now register your ILVE products online at <https://support.eurolinx.com.au/#/form/warrantyregistration>

Just follow our simple online registration process.

Please ensure that you always keep your proof of purchase in order for your warranty to remain valid should you ever need to use it.

As always, you can contact us on
1300 856 411

CONTENTS

USER GUIDE

8 IMPORTANT SAFETY WARNINGS

15 First operation of the oven

16 INSTRUCTIONS FOR USE

16 Using the hob

17 Use of a steak grill

18 Proper use of burners

21 Use of the gas fry-top

23 Induction Cooktop

31 Electric Multifunction Oven

36 Professional PLUS 'E3' Series

42 Majestic Series

49 CLEANING AND MAINTENANCE

49 Bulb replacement

50 Removing the door

51 Door cleaning and Glasses

52 Tips for cleaning the hob

53 Tips for cleaning the oven and front panel

54 Recommendations for cleaning the cooktop

56 PROBLEM SOLVING

57 General problems

59 COOKING CHART

Ventilated convection oven

Static oven

INSTALLATION

63 INFORMATION - To be reminded to the user

64 INSTALLATION

64 Installation of the cooker

64 Room ventilation

65 Positioning of the appliance between furniture

66 How to install the fixing bracket

67 ELECTRICAL CONNECTIONS

67 Groups of cooking

70 ADJUSTMENT

70 Replacement of the injectors for models

73 Adjustments minimum GAS flow

75 WIRING DIAGRAM

75 Key

97 NOTES

99 WARRANTY

101 EUROLINX CONTACT INFORMATION

IMPORTANT SAFETY WARNINGS



-
- This appliance is not intended for use by persons (including children) with reduced physical, sensory or mental capabilities, or lack of experience and knowledge, unless they have been given supervision or instruction concerning use of the appliance by a person responsible for their safety. Children should be supervised to ensure that they do not play with appliance. Cleaning and user maintenance shall not be made by children.
 - This appliance must be installed by suitably qualified technicians and in line with local regulations.
 - As well as being shown on the packaging, the data plate is applied to the oven door frame and is visible with the door open.
 - These warnings refer to different models of appliances. Make sure you identify the model you own (see the data plate).
 - These warnings are valid for the countries mentioned on the data plate.
 - Before using the cooker, read the instructions booklet carefully. It contains very important information regarding safety during installation, use and maintenance.
 - The instructions booklet must be kept with care for later consultation.
 - Electrical safety of this cooker is guaranteed only if it is correctly grounded as required by local regulations. It is important to ensure that these regulations have been enforced; if in doubt, contact a skilled technician to have the electric system checked. The manufacturer is not responsible for damage caused by a bad grounding system.

IMPORTANT SAFETY WARNINGS



- Before powering the appliance, check that the technical features shown on the data plate match those of the electrical system.
- Installation / adjustment must be carried out by qualified personnel.
- Make sure that air around the appliance can circulate freely.
- This appliance is not connected to an evacuation device for combustion products, therefore ventilation of the room must be considered carefully and meet local regulations.
- When using a gas appliance, heat and moisture are generated. Good ventilation of the kitchen must be guaranteed by keeping the natural aeration vents open or by installing a mechanical aeration device (range-hood). An intensive and prolonged use of the appliance may result in the need for supplementary ventilation such as opening a window or increasing the power of the hood (if present).
- Do not block ventilation or heat dissipation openings.
- The supply cable (if fitted) is supplied without a plug. To connect it, please refer to the paragraph “electric connection” in the installation guide. It is recommended to not use adapters, multiple-outlet plugs or extensions. If the supply cable is damaged it must be replaced by an authorised service person.
- When the appliance is not in use for a prolonged time, switch off the electrical supply and turn off the gas.
- The appliance must be used only for the purposes for which it was intended i.e. cooking food in a domestic or similar to domestic environment. Any other use (for example, heating a room) is incorrect and may be dangerous. The manufacturer declines all responsibilities for damage caused by incorrect uses.
- The appliance is not destined to be activated by means of an external timer or a remote control.

IMPORTANT SAFETY WARNINGS



- The use of any electrical appliances requires that a number of fundamental rules must be respected:
 1. Never touch the appliance when you have wet or damp hands or feet;
 2. Never use the appliance barefoot;
 3. Avoid using extension cables;
 4. Never pull the electric cable to remove it from the power socket;
 5. Do not expose the appliance to atmospheric agents (rain, sun, etc...);
- CAUTION: During use of the appliance some parts may become very hot. Keep out of reach of children. Absolutely do not touch the elements inside the oven during or immediately after use.
- Before cleaning the appliance or carrying out maintenance, disconnect the power supply by removing the plug from the socket or switching off the switch.
- In case of breakdown or malfunction, switch off the appliance. Do not attempt any repairs; these must only be performed by an authorised service centre. Always request original parts. Failure to comply with these instructions may compromise the appliance's safety.
- Never place unstable or deformed pans on the burners or on the electric hot-plates as they could topple accidentally.
- When the appliance is not being used, make sure the knobs are exactly in the “ ”/“ ”/ position.
- Don't leave the hotplate on with no pans on it, as it would reach the temperature fast and possibly damage the appliance and your counter tops.
- The electric plates remain hot after using them. Be careful not to touch them.

IMPORTANT SAFETY WARNINGS



- Inflammable liquids, like alcohol or gasoline, must be kept away from the appliance.
- Should you use small household appliances near the cook top, please make sure that the electrical cable is not in contact with hot parts of the appliance.
- The materials used in producing our appliance are compatible with the environment and therefore recyclable. The packaging waste must not be left within reach of children and must be disposed by using the appropriate recycling channels. To scrap your appliance, use your retailer and/or your local council's facilities. Remember to make your appliance unusable before scrapping it.
- If the rotation of the gas knobs is difficult, close the gas supply and call After Sales Service for advice.
- Do not use a steam cleaner to clean the inside parts of the oven.
- Don't use any abrasive detergent or sharp device to clean the oven glass door. This may cause damage or breakage.
- Don't modify the appliance.
- Fire danger: do not store items on the cooking surfaces. In case of fire never attempt to extinguish a flame/ fire with water but turn the appliance off and cover the flame with a lid or with a fireproof blanket. If the fire is inside the oven cavity close the oven door to starve the fire of oxygen. Be especially careful when cooking with fat or oil as these can catch fire.
- Do not use gas burners if the flame is unstable.
- Ensure that the flame diffusers and burner caps are properly positioned.
- Do not leave the cooker unattended during any cooking that can spit fats or oils or when grilling.
-
- Do not use plastic or aluminium foil containers on hot cooking zones.

IMPORTANT SAFETY WARNINGS



- Do not cover the burners or the hob with aluminium foil.
- Do not use the appliance's surface as a work top, sharp objects might scratch it.
- Do not use frying pans, saucepans, grills or stones for grilling of a greater size than the maximum ones indicated for each single burner. They must not cover more than one burner at the same time. The heat accumulation might damage the cooker or restrict access to oxygen for proper combustion.
- In case of liquid spilling over, remove the pot from the hob.
- Do not place empty saucepans on the cooking areas. Cooking areas must not work empty (without saucepans).
- Do not cover the base of the oven with anything, (e.g. aluminium foil, oven liner, cooking tray) as a build up of heat can irreparably damage the enamel; coating. Avoid placing heavy items on the oven floor as this too can damage the enamel.
- Do not rest heavy items or lean on the door as this can damage the hinge and or hinge sockets. Open and close the door with reasonable force only.

First use

- When using the oven for the first time, let it work empty for about 1 hour (230 °C), leaving the kitchen windows open if possible. When you first turn the oven on, an unpleasant smell is emitted due to production residues such as grease, oils or resins. When the oven has cooled clean it following the instructions in the «*Cleaning and care section*».
- After this procedure, the oven is ready to perform its first use.
- Additional warnings for models with glass / ceramic zones
- Remove the adhesive labels from the glass on the hob.

IMPORTANT SAFETY WARNINGS - INDUCTION HOBS



- Do not use the hob as a working zone.
- Remember to turn off the cooking zone after use.
- Magnetised objects such as credit cards, floppy disks and calculators should not be placed near the appliance when it is being used.
- Do not use any type of metallic object except pots used for induction.
- Do not cover the cooking zone with inflammable materials.
- Metallic objects such as knives, spoons, forks or lids should not be placed on the hob as they can become overheated.
- Damaged or unsuitable pots could ruin the surface of the hob.
- Do not use abrasive substances to clean the appliance.
- Avoid dropping heavy objects on the hob. Place pots on the hob gently.
- Do not place empty pots on the hob.
- Sugar, synthetic materials or aluminium objects should not come into contact with the cooking zones.
- DO NOT USE OR STORE FLAMMABLE MATERIALS IN THE APPLIANCE STORAGE DRAWER OR NEAR THIS APPLIANCE.
- DO NOT SPRAY AEROSOLS IN THE VICINITY OF THIS APPLIANCE WHILE IT IS IN OPERATION
- DO NOT USE THIS APPLIANCE AS A SPACE HEATER
- DO NOT MODIFY THIS APPLIANCE
- DO NOT PLACE ARTICLES ON OR AGAINST THIS APPLIANCE

IMPORTANT SAFETY WARNINGS



- Models with glass-ceramic zones

In case of malfunction

- When a malfunction occurs turn off and disconnect the appliance.
 - If cracks appear on the glass or it is broken, disconnect the appliance and contact your authorized service centre.
 - Any repairs should be made by authorized personnel.
-

Suggestions

- Make sure that the pot is in the middle of the cooking zone. Ideally, the bottom of the pot should cover the entire cooking zone.
- The magnetic field produced by the induction hob could affect the proper working of pacemakers.
- Detailed information should be obtained from your doctor.
- Avoid placing synthetic materials or aluminium objects in contact with the cooking zone.

INSTRUCTIONS FOR USE

- First system start up of the hob

IMPORTANT

Position the flame divider "b" correctly. To do this, align the 4 teeth "c" of the flame divider with the recess "d" of the aluminium Cup "a".

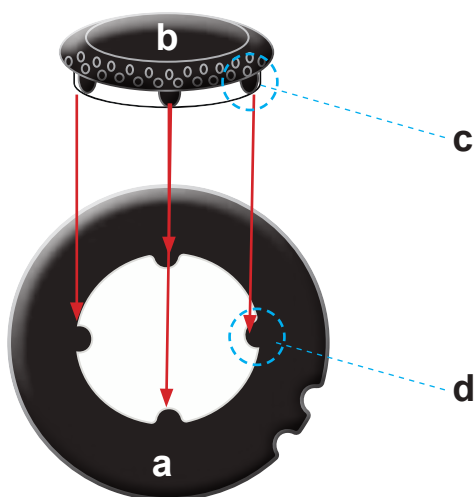

Lighting the burners

The index above the knobs will help you to find the corresponding burner. Press the knob by turning it anti-clockwise and bring it to the ignition position; keep the knob pressed for about 5 seconds so that upon its release the flame remains alight (in case of unsuccessful ignition repeat the operation).

Symbol	Function
--------	----------

- | | |
|--|---------|
| | off |
| | maximum |
| | minimum |
| | index |
| | |

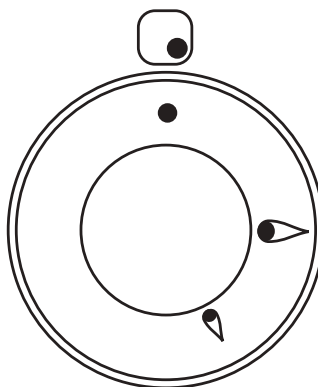

INSTRUCTIONS FOR USE

- First system startup of the hob

Recommended pans according to burner size:



Burners	ID	Diameter Ø (cm)
Medium	SR	10 ÷ 20
Large	R	20 ÷ 24
Fish burner	P	oval pans (380 x 185)
Ring	TC/DCC	22 ÷ 28
Dual - Ring	DUAL	24 ÷ 30

Dual wok burner ignition

Identify the knob with the help of the index near the knobs. Press and turn the knob to the maximum flame symbol for 5 seconds. Once the burner is lit, turn the knob counter clockwise. You will note some resistance halfway between the large and small flame. Turn the knob past this point of resistance towards the small flame. The auxiliary (inner) ring will light and the outer ring will extinguish. To adjust the auxiliary burner to a minimum, rotate the knob counter clockwise. To turn the outer burner back on, rotate the knob clockwise up to the desired value

Symbol Function



off



maximum



minimum



index

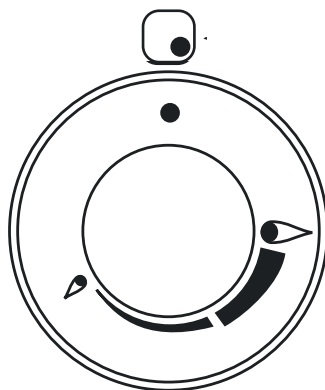

INSTRUCTIONS FOR USE

– Use of a grill pan

Gridiron

If you want to use a grill pan a few things must be taken into account:

- it is possible to preheat the grill pan on the burner's maximum power for no more than 10 minutes;
- we recommend cooking foods with reduced power;
- keep at least a distance of 150 mm from the side wall to the grill pan's rim;
- do not position the grill pan on more than one burner at the same time.

Correct



Be careful: wrong



Be careful: wrong



INSTRUCTIONS FOR USE

– Positioning placement of the burners

Positioning of the burners



BE CAREFUL: always check that the burners are properly positioned), with a uniform flame that is not noisy.

BURNERS	RIGHT	WRONG
Medium		
Large		
Dual Ring		
Fish burner		

Always check that the screws below the burner are fixed

INSTRUCTIONS FOR USE

– Positioning placement of the burners

Positioning of the burners



BE CAREFUL: always check that the burners are properly positioned, with a uniform flame that is not noisy.

BURNERS	RIGHT	WRONG
Medium		
Large		
Dual Ring		

INSTRUCTIONS FOR USE

– Use of the Coup feu

COUP FEU

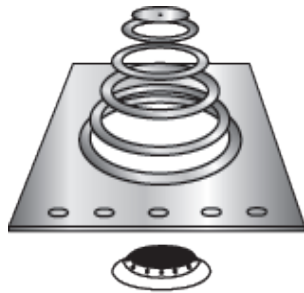

Fig. A



Fig. B



Fig. C

Using the Coup de Feu

The large “Coup feu” solid cast iron plate made of concentric rings allows you to rest the pan (or even several pans) directly on the surface (fig. B, C). It is heated by means of a gas burner (fig. A). The plate is designed to provide a moderately intense heat which is well distributed over the surface.

This is ideal for slow cooking and particularly for sauces, browning and grilling, heating dishes or keeping them warm. Switch the burner on 15/20 minutes before use to allow the cast iron plate to accumulate heat.

You will then be able to use the plate even when switched off for a further 10/15 minutes. The middle of the plate is the area where the highest temperatures are reached whereas the outer part is cooler. By simply moving the pan from the middle to the outside of the plate, you can obtain different cooking intensities without regulating the flame. Pan dimensions permitting, several dishes can be cooked at the same time (fig. C). If necessary it can be used as a handy top, providing ample space for resting pots and pans.

Cleaning the Coup feu plate

The hotplate should be cleaned while still warm using the products normally used in the kitchen for metal surfaces. Rub with a wire pad, following the direction of the satin finish. Dry well immediately. If you want to give the plate a better appearance, after cleaning, apply a coat of a specialist cleaning paste / cream.

If you do not intend to use the hotplate for long periods, after normal cleaning apply a thin film of liquid paraffin (Vaseline oil) with a wad of cotton wool. This treatment is necessary to prevent any formation of surface oxides.

When next turning on the plate you will notice the evaporation of the paraffin oil used. This phenomenon will disappear in a few seconds.

The hotplate may sometimes present phenomena of surface oxidation due to the presence of humidity, but above all due to lack of use. You are therefore advised to use it frequently to prevent any oxidation. Never leave the hotplate damp. If the oxidation phenomenon still appears, use lightly abrasive paper to remove the oxidation, taking care to rub gently, always in the direction of the plate satin finish.

Do not cook food directly on the plate surface. Always use suitable containers.

INSTRUCTIONS FOR USE

– Use of the gas Tepanyaki plate

Gas Tepanyaki Plate

A = cooking area

B = drip tray

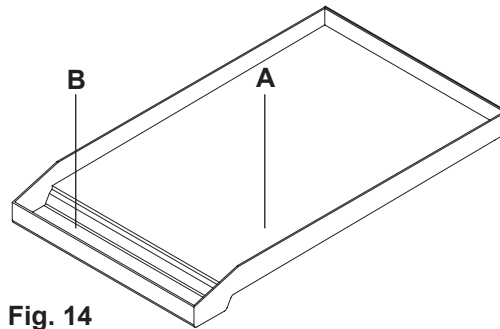



Fig. 14



Fig. 15

Use of the Tepanyaki Plate

The Tepanyaki Plate (fig. 14) consists of a stainless-steel plate, suitable for contact with food [] with a uniformity of temperature on the cooking surface and with very low heat loss. To use the appliance, light the flame below the plate by means of the corresponding knob (see “**Lighting the burners**”) and ensure that there is a flame. Turn the knob to maximum for about 10 minutes and wait for the plate to heat up. Once this time has elapsed, the plate is ready to start cooking.

By adjusting the flame, there is no limit to your culinary imagination. If you turn the control knob to the low setting, this allows slow or dietetic cooking. Higher temperatures are suitable for cooking meat, fish and vegetables. The Tepanyaki Plate is ideal for Oriental cooking with an optional accessory (lid) needed for this type of cooking. Some models are supplied with the spatula shown in figure 15, which is useful both for cooking and for cleaning the plate.

Cleaning and care

It is recommended to clean the plate thoroughly at the end of each cooking session. With the plate hot and the flame at minimum, remove the cooking residue using the scraper provided (fig. 15). Pour a little water onto the plate and, still using the scraper, continue cleaning the plate. Once the water has completely evaporated, repeat the same operation even several times until the desired result is obtained. It is extremely important to clean the plate when it is quite hot.

The black enamel flue may be cleaned with a soft cloth soaked with a solution of luke warm soapy water. Rinse and dry after cleaning.

Adjuster (Knob)

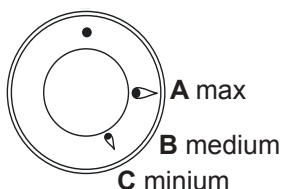

Type of cooking	Knob posit	Time min.
Egg	B	2
Sliced aubergines (0.5 cm thick)	B	9 ÷ 13
Sliced potatoes	B	5 ÷ 73
Sliced courgettes	B	3 ÷ 5
Fish (sea bream weighing about 200 g)	B	15
Hamburger	B	10
Beef steak	B	3
Porterhouse (2 cm thick)	A	5

INSTRUCTIONS FOR USE

– Use of the inductive electric plate

INDUCTION PLATE

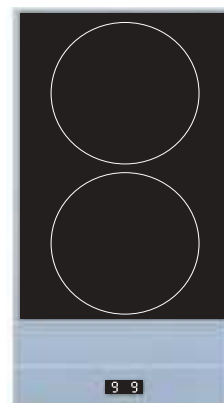

ATTENTION!

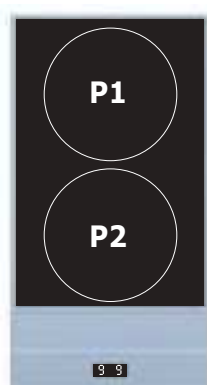

The ceramic hob remains hot for a long time after use. Do not touch the hob with your hands or let children near it. The residual heat indicator will remain on until the hob has cooled down.

If any cracks appear in the ceramic material, disconnect the appliance immediately from the mains and call an authorized technical service centre.

The positions are clearly indicated by the rings.

Area	Diameter Ø	Power
P1	180 mm	1800 W
P2	180 mm	1800 W

Precautions to avoid damaging the appliance

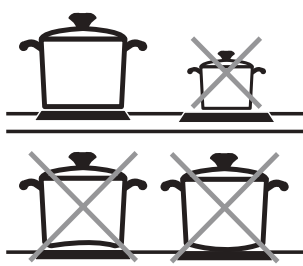

Heat zones are clearly indicated by these circular areas. When one or more cooking areas are being used, the remaining surface stays cold. Each cooking area is designed to work with the cookware specific for induction cooking, with a diameter just less than the diameter of the selected cooking area.

The bottom of the pan must be thick and flat. Its diameter must be as similar as possible to that of the cooking ring. The surface of the hob and the bottom of the pan must be kept clean.

- Do not wet or overheat the heating plates.
- Avoid sudden changes in temperature on the ceramic hob. For example, do not pour cold water onto the hot hob.
- Do not leave the pan handles sticking out as they could be spilled accidentally.

It is preferable not to cook on the ceramic hob with pans that have been used on gas burners. The flames will have deformed the bottom of the pans.

Ventilation

The cooling fan is positioned under the hob works at low speed when the hob is in use. When a certain temperature is reached, the speed of the fan increases. The fan will switch off once the hob has cooled down.

INSTRUCTIONS FOR USE

– Use of the inductive electric plate

First use	Clean the hob's surfaces with a damp cloth.
Switching on one cooking area	A cooking area is turned on by turning the relative knob clockwise. On the hob's display the set power level (from 1 to 9) appears.
Switching off a cooking area	A cooking area is turned off by turning the relative knob anti-clockwise. On the hob's display a [0] appears for 3 seconds, after which it disappears from the display
Automatic switching off	The appliance switches off automatically when there are overheating or supply error conditions.
Cookware presence recognition	Each cooking area is designed to work with specific pots for induction cooking with a diameter just less than the diameter of the selected cooking area. If the pot is unsuitable, the display shows the symbol for the area without a pot (U) and the appliance will not operate. This prevents the switching on until a pan is placed on the cooking area or until a suitable pot for induction is used. If you remove the pot during operation, the area is switched off. Pot recognition lasts 9 minutes, if after this time no suitable pot is used, the area is switched off. The area's display changes from "absent pot" to [-].
Afterheat indication	If the cooking area, when turned off, is still very hot, the display shows the symbol H.
"Heat-up" function	The heat-up, or quick heat function, is available on each cooking area. This means that for a well defined time, the cooking area operates at maximum power and at the end of this time the power is automatically adjusted to the set level. The duration is, in this case, according to the set power level. The heat-up function starts by turning the knob anti-clockwise, from 0 up to its end [*] (Fig. 10). Once the control is turned left, an [A] appears on the relative area's display. After initiation a power level must be set within 3 seconds by turning the knob clockwise for the cooking's duration; if this does not happen, the heat-up function is interrupted.

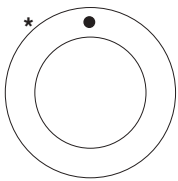

fig. 10

INSTRUCTIONS FOR USE

– Use of the inductive electric plate

Child-lock function

The child-lock function is useful where children are present. However, the presence of an adult is advisable when the appliance is working.

Activating the child-lock function, all cooking areas are off and cannot be accidentally turned on. The child-lock function is activated, with the knobs at 0, by rotating one of the two induction area's controls anticlockwise for 3 seconds. [L][L] appears on the display. By repeating this operation the child-lock function is deactivated. [0] appears on the display.

If a control is turned with the child-lock on, [L][L] appears on the display.

Display

The display shows information of the two cooking areas (Fig. 11).



fig. 11

Value

1-9

A

H

U

E

Value

1-9 (heat setting)

A (heating)

H (residual heat)

U (no pot)

E (error)

Limitation of the duration of operation

Each cooking area has its own maximum continuous working time. This depends on the set power level. In case the limitation of the duration of operation is reached, the relative area is switched off.

Limitation Level approximate duration of operating power (hours)

Level

1

2

3

4

5

6

7

8

9

Duration (hours)1-9

8.5

6.5

5

4

3.5

2.5

2

1.5

1.5

INSTRUCTIONS FOR USE

– Use of the induction hob

INDUCTION HOB

Mod. PI06....

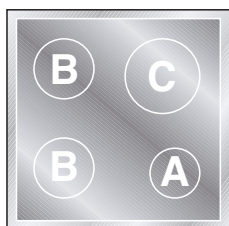

Mod. PI09 - MI09 - PDI09
HNFI - NTI - LBI09

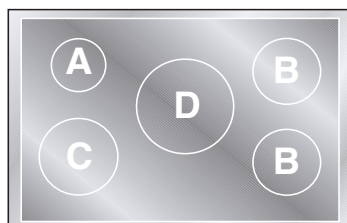

Mod. PDI10 - MDI10....

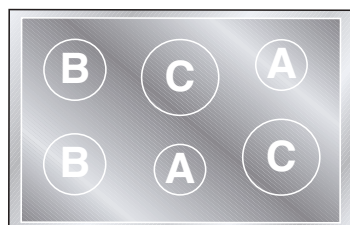

Mod. PBI09 - MBI09 -
PDBI09 - LBI09....

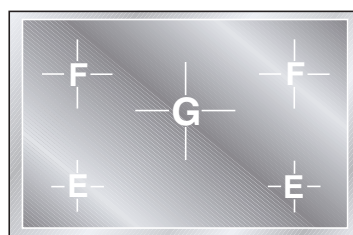

Key

A - ø145 - Cooking area ø 145mm
(1400W / Booster 2200W)

B - ø180 - Cooking area ø 180mm
(1850W / Booster 3000W)

C - ø210 - Cooking area ø 210mm
(2300W / Booster 3700W)

D - ø260 - Cooking area ø 260mm
(2600W / Booster 3700W)

E - ø175 - Cooking area ø 175mm
(1400W / Booster 2000W)

F - ø215 - Cooking area ø 215mm
(2300W / Booster 3000W)

G - ø265 - Cooking area ø 265mm
(2300W / Booster 3000W)

Modelli	A	B	C	D	E	F	G	E03E	E03	E04E	M06E3	M06MP	M09E3	M09MP	kW	kW
	ø145	ø180	ø210	ø260	ø175	ø215	ø265								(230V)	QuickSart
PI06 - MI06	1	2	1	-	-	-	-	-	-	-	1	-	-	-	9,85	10,60
PI09 - MI09	1	2	1	1	-	-	-	-	-	-	-	-	1	-	13,85	14,50
PBI09 - MBI09	-	-	-	-	2	2	1	-	-	-	-	-	1	-	13,85	14,50
LBI09...	-	-	-	-	2	2	1	-	-	-	-	-	-	1	13,85	14,50
PDI09 ...	1	2	1	1	-	-	-	1	-	-	1	-	-	-	15,85	16,60
PDBI09...	-	-	-	-	2	2	1	1	-	-	1	-	-	-	15,85	16,60
LDBI09...	-	-	-	-	2	2	1	-	1	-	-	1	-	-	15,15	15,90
PDI10...	2	2	2	-	-	-	-	-	-	1	1	-	-	-	16,10	16,85
MDI10 ...	2	2	2	-	-	-	-	1	-	-	1	-	-	-	15,85	16,60

INSTRUCTIONS FOR USE

– Use of the induction hob

Before the first use

Clean your hob with a damp cloth, and then dry the surface thoroughly.

Induction

There is a coil underneath each cooking zone which, when a pot is placed on it, generates a variable electromagnetic field, producing inductive power of a ferromagnetic substance on the bottom of the pot. The end result is that the bottom of the pot placed above the cooking zone is heated. The type of material constituting the pot is fundamental:

- All pots with a ferromagnetic bottom are suitable (this can be verified with a magnet)
- The following pots should not be used: copper, stainless steel, aluminium, glass, wood, ceramics

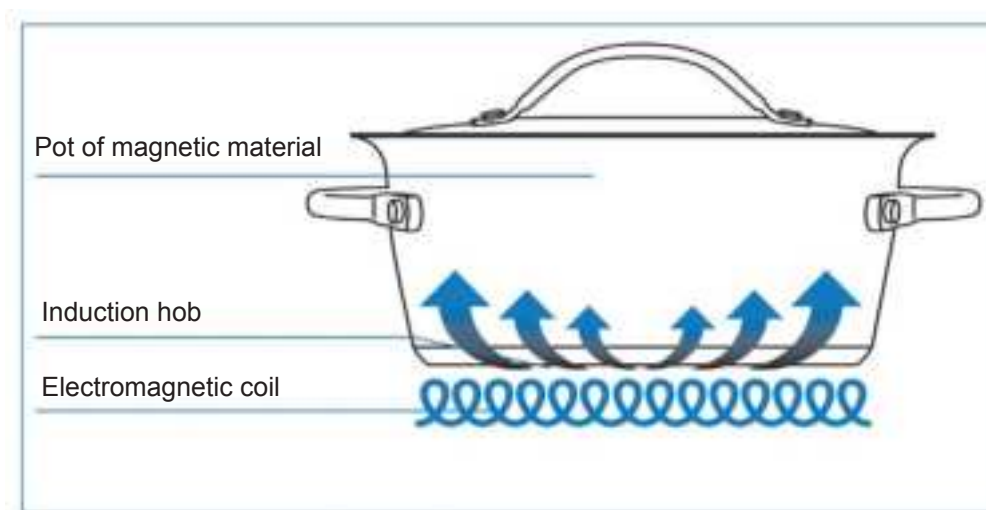

Adjuster (Knob)

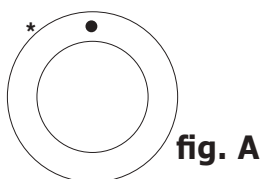

The knob does not show any numbers, the power level will be visible on the display.

Switching on a cooking area

Turn the relevant knob clockwise. On the hob display the set power level will appear (from 1 to 9)

Switching off a cooking area

A cooking area is switched off by turning the respective knob counter clockwise. The symbol [0] appears on the hob display for 15 seconds, then it disappears from the display or changes to the symbol [H] if the cooking area is still hot.

Automatic switching off of the device

The device switches off automatically if any conditions of excess temperature or errors in the power supply occur.

INSTRUCTIONS FOR USE

– Use of the induction hob

Booster function

The purpose of the booster function is to give more power to a determined area in order to reduce the necessary cooking time. This function is activated by turning the knob clockwise from position 0 (off) to the final position (* fig. A). After short acoustic signal, the symbol [P] appears on the display, meaning that the booster function is activated. The Booster function has a maximum duration of 10 minutes. The area concerned then returns to level [9]. The Booster function ends before this time when:

- a lower power level is set;
- the pan is removed;
- there is overheating of the appliance or of the heating area.

The Booster function has precedence over the “Heat-up” function. This means that, if the heat-up function has been activated in an area at the time of activating the Booster function, the heat-up function will be interrupted.

Recognizing the presence of a pan

Each cooking area is designed to operate with specific pans for induction cooking, having a diameter just smaller than the diameter of the chosen cooking area. If the pan is not suitable, the display for the area shows the symbol indicating absence of the pan (U) and the appliance does not start up. This prevents the appliance from being switched on until a container is placed on the cooking area, or until a container suitable for induction is used. If the container is removed during the operation, the area is switched off. The duration of pan recognition is 10 minutes; if no suitable container is used on the cooking area during this time, the area is switched off. The indication on the display changes from the “pan absent” symbol to [-].

Residual heat indication

If the cooking area is still very hot, even though it is switched off, the symbol H appears on the display. The Heat-up function, or quick heating, is available on each cooking area. This means that for a well-defined time the cooking area works at maximum power and at the end of this time the power is automatically brought to the set level. In this case the duration depends on the selected power level.

“HEAT-UP” function

The Heat-up function is activated by turning the knob counter clockwise from position 0 to the final position (* fig. A) for 2 seconds. After short acoustic signal, a letter [A] is shown on the display for the correspondent area. After it has been activated you must set a power level to continue cooking within 10 seconds; if this is not done, the Heat-up function is interrupted.

Child-LOCK function

The Key-lock function is useful if there are children at home. However, it is always advisable for an adult to be present when the appliance is in operation. When the Key-lock function is activated all the cooking areas are switched off and they cannot be switched on accidentally.

INSTRUCTIONS FOR USE

– Use of the induction hob

4 zones models only

The child-lock function is activated, with the knobs in position 0, by turning the controls 2 and 3 in a counter clockwise direction.

The letters [L][L][L][L] appear on the display. The child-lock function is deactivated by repeating the same operation. The letters [O][F] appear on the display. If a knob is turned when the key-lock function is active, the letters [L][L][L][L] appear on the display.

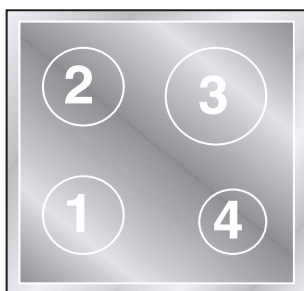

5 or 6 zones models only

The child-lock function is activated, with the knobs in position 0, by turning the controls 1 and 2 simultaneously in an counter clockwise direction.

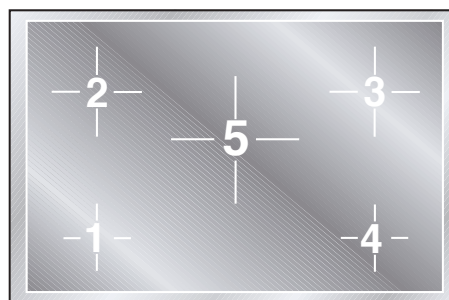
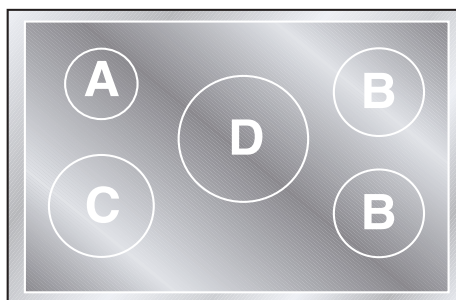

INSTRUCTIONS FOR USE

– Use of the induction hob

Heating function 42° AND 65°

Turn the knob (A) clockwise. Between the off position (0) and the power position (1) there is the position (u) which identifies the function for heating food at 42°. Only for 5 and 6-zone models: turn the knob (A) clockwise again. Between the (u) position and the power position (1) there is the position (U) which identifies the function for heating food at 65°. The maximum time of use for both functions is limited to 120 minutes. Both functions are prioritized over the 'HEAT-UP' mode.

Display

A display is associated with each cooking area.

- Set power level: (1-9)
- Food heating 42°-65° (U)
- Booster: (P)
- Heat-up: (A)
- Residual heat: (H)
- Pan absent or not suitable: (U)
- External error: (E)
- Fault: (F)
- Knob permanent rotation: ()

Limit of the duration of operation

A maximum time of continuous operation is associated with each cooking area. This depends on the selected power level. If the limit of the duration of operation is reached, the respective area is switched off.

Power level	Approximate limit of the duration of operation (hours)
U	2
1	6
2	6
3	5
4	5
5	4
6	1,5
7	1,5
8	1,5
9	1,5
P	(10 min. [P], later 80 min. [9])

INSTRUCTIONS FOR USE

– Use of the induction hob

Power management

The purpose of the booster function is to temporarily increase power to a selected area in order to reduce the necessary cooking time. This function is activated by turning the knob clockwise from position 0 (off) to the maximum position (* fig. A). After a short beep, the symbol [P] appears on the display, meaning that the booster function is activated. The Booster function has a maximum duration of 10 minutes. After 10 minutes, the area concerned then returns to level [9].

The Booster function ends before this time when:

- a lower power level is set;
- the pan is removed;
- there is overheating of the appliance or of the heating area.

The Booster function has precedence over the “Heat-up” function. This means that, if the heat-up function has been activated in an area at the time of activating the Booster function, the heat-up function will be interrupted.

Overheating of cooking zone

During operation, if a cooking zone overheats too much, the power is reduced automatically and the display shows the new level just edited. At this point it is only possible to decrease the power level. As soon as the temperature of the cooking zone falls below the critical value it will possible to restart the cooking normally.

Suggested cooking functions (purely indicative)

Knob position	Type of cooking
1-2	Melting butter, chocolate, etc.
2-3	Heating small amounts of liquids, keeping food warm, preparing sauces.
4-5	Heating small amounts of liquids, keeping food warm, preparing sauces.
5-6	Cooking meat and fish, pulses in sauces, dishes with water, making jam.
6-7	Roasting meat or fish, steaks, liver, eggs.
8-9	Boiling large amounts of water, frying chips, etc.

INSTRUCTIONS FOR USE

– Use of the electric oven multifunction

Description

S. Selector

T. Thermostat

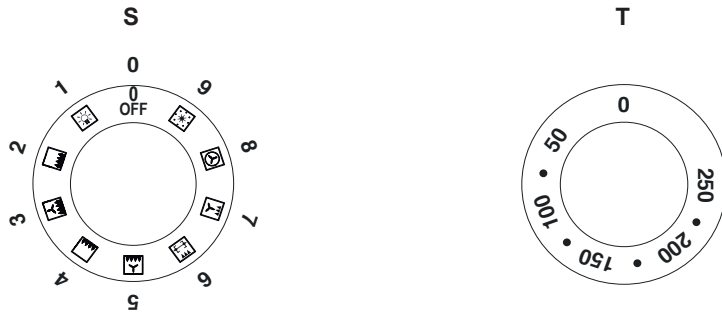

Control of the oven multifunction

S. Multifunction electric oven selector

T. Temperatures, from 50°C to 250°C, can be selected by using this knob.

Turning on and off

Turn the selector to the chosen cooking function and the thermostat to the desired temperature. The warning light turns on and stays on until the oven heats up. As soon as it reaches the selected temperature, the light goes off. It turns on every time the resistances are entered. If you plan to preheat the oven, only place the food to be cooked in the oven when this light has gone off. To turn the oven off bring both knobs back to the starting position (0).

Safety thermostat

The oven is equipped with a safety thermostat, which switches off the electric power. The resetting of the thermostat, according to the decrease in the temperature of the oven, is automatic. The oven can be used again when cooled down. In case the safety thermostat acts because of a defect of the components, you are requested to call the After Sales Service.

Function oven

Choose one of the 9 cooking functions by turning the selector (S) and adjust the temperature (50 ° C to 250 ° C) with the thermostat (T). See page 29 for suggested settings.









Oven light

To turn the light off or on gently press the selector knob (S). The light does not work if the selector is set to (0).

INSTRUCTIONS FOR USE

– Use of the electric oven multifunction

– Functions list

Pos.	Symbol	Function
1		Pizza cooking This function is particularly suitable for cooking pizza, focaccia and bread. The main source of heat is from the bottom heating element that works in combination with the oven's other resistances.
2		Normal static cooking It is the oven's classic function particularly suited to cooking the following foods: pork chops, sausages, cod, braised beef, game, roast veal, meringues and biscuits, baked fruit, etc.
3		Cooking from underneath This is the most suitable mode to finish the food cooking, in particular confectionery (biscuits, meringues, leavened cakes, fruit desserts, etc.) and other foods.
4		Cooking from above Especially suitable for browning and to give the final touch of colour to many foods; it is recommended for hamburgers, pork chops, veal steaks, sole, cuttlefish, etc.
5		Closed door grill cooking The suitable function for fast and deep grilling, to brown and roast meats in general, fillet steaks, Florentine steaks, grilled fish and also grilled vegetables. Cooking with the electric grill must be made with the thermostat at 180 °C.
6		Fan grill cooking Particularly fast and deep with significant energy savings, this function is suitable for many foods such as pork chops, sausages, pork or mixed spits, game, gnocchi alla romana, etc. Cooking with the electric grill must be made with the thermostat at 180 °C.
7		Intensive cooking Is the quick and intense cooking function for various dishes; best for: baked fish, braised vegetables, spits, duck, chicken, etc.
8		Multiple fan cooking It is the function that allows simultaneous cooking of different dishes without the smells blending; you can cook lasagne, pizza, croissants and brioches, tarts, cakes, etc.
9		Quick Start This function speeds up your oven's pre-heating. We suggest you use this function when you set a cooking temperature from between 200 and 250 ° C. Use of the QuickStart function for temperatures under 200 ° C is not advantageous. To use QuickStart, rotate the selector knob (S) until it is positioned on the symbol (9), then set the desired temperature with the thermostat knob (T). Once the oven has reached the temperature, the thermostat's orange light will turn off and the oven is ready for accepting the food to be cooked. At this point set the desired cooking function with selector knob (S). WARNING: the Quick Start function is not suitable for cooking foods, it is only for quickly pre-heating the oven. DO NOT USE THE QUICK START FUNCTION FOR MORE THAN TWENTY MINUTES.

COOKING INSPECTION

If you need to inspect the food being cooked, you can open the oven door. In this case the lights come on and the forced fan stops (in case of ventilated cooking) and the spit rotation. (in case of grill cooking with the door closed). Closing the door re-activates the previously set function.

INSTRUCTIONS FOR USE

– Use of the conventional electric oven

Description

Choose one of the 4 cooking functions by turning the selector (S) and adjust the temperature (from 50°C to 250°C) with the thermostat (T). If your model has a programmer, set it for cooking.

S. Selector

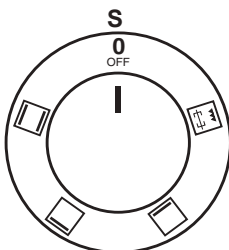

T. Thermostat

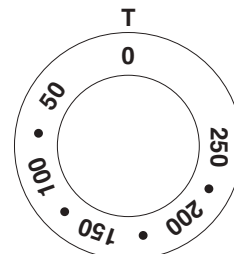

Functions list

Pos. Symbol

1



Upper & lower elements

Is the classical function of the electric oven and particularly adapted for cooking: pork chops, sausages, dried salt-cured cod, pot roast, game, roast veal, meringues and biscuits, baked fruit, etc.

2



Lower element

This setting is most suitable for finishing cooking, particularly pastries (biscuits, meringues, desserts, puff pastry, fruit cakes, etc.) and other foods.

3



Upper element

Especially suitable for browning and to add the finishing touches of colour to different dishes. We suggest this setting when cooking hamburgers, pork cutlets, steaks, sole, cuttlefish, etc.

4



Grill-baking

A suitable setting for grilling au gratin and roasting quickly and well, meat in general, fillet, T-bone steak, grilled fish and vegetables too. Cooking by electric grill must be done with the thermostat set at 180°C.

INSTRUCTIONS FOR USE

– MP & VP models with 5 button programmer

Functions

Cooking time • end of cooking • clock • timer • manual function

Display

Symbols indicating functions in progress:



Timer



Duration and manual function

A

Automatic program

Button legend



Button for timer and buzzer



Automatic cooking duration



End of cooking time

[-]/[+]

Setting time and cooking time.

With the “+” button, the time increases, with the “-” button the time decreases at a speed directly proportional to the length of time the button is pressed.

Setting a function

Select the desired function by pressing the corresponding button and set the time using the +/- buttons.

Appliance operation

At first control turning on, the display shows the flashing clock that increases by one unit every minute. Follow the “Setting the clock” procedure in the next paragraph. By pressing the and buttons simultaneously you enter the “Manual operation”. You can set the temperature using the thermostat knob (T) and select the function using the selector (S).

Setting the clock

The clock function is activated by simultaneously pressing cooking duration and end buttons. The time is then set by adjusting the +/- keys. Any previously set programs are automatically deleted.



Manual operation

To set this function simultaneously press the cooking duration and end buttons. The “A” symbol goes out and the pan symbol appears. The previously set programs are deleted.

INSTRUCTIONS FOR USE

– 5 button electronic programmer MP & VP



Semi-automatic operation with cooking duration

Select the duration function (button ) and set the time with the +/- buttons. The “A” symbol and the symbol  appear. The oven switches on. When the hour of the day coincides with the final time, viewable through the end of cooking button , the oven will turn off and the pan symbol will disappear. The buzzer will sound. The “A” symbol will flash.



Semi-automatic operation with end of cooking

Select the duration function (button ) and set the end time with the +/- buttons. The “A” symbol and the pan symbol appear. The oven switches on. When the hour of the day coincides with the final time the oven will turn off and the pan symbol will disappear. The buzzer will sound. The “A” symbol will flash.



Automatic operation with duration and end of cooking

Select the duration function  and set the end time with the +/- buttons. The “A” symbol appears. The oven switches on and the pan symbol  appears. Wait a few seconds until the current time appears. Set the end time by pressing the end of cooking button. The display shows an approximate end time. Use the +/- buttons to set the end time actually required. The oven switches off and the pan symbol  disappears. The pan symbol will appear again when the time of day coincides with the end time less the cooking time. At the end of the automatic program, the “A” symbol will flash. The buzzer will sound, the oven and the pan symbol will turn off.

Timer

Select the timer function (button ) and set the desired time with the +/- buttons. The bell  symbol will stay on while the set time is counting down. When the time comes to an end, the buzzer will sound.

Buzzer

The buzzer operates at the end of the cooking duration and timer function, and remains active for 7 minutes. The buzzer can be stopped by pressing any button   . The intensity of the buzzer can be changed by pressing the “-” button without selecting a function. You can choose from 3 different sound intensities and duration depends on the time pressure is exerted on the button “-”.

Starting a program and control

The selected program starts after the time has been set. The time remaining can be displayed at any time by selecting the corresponding function again.

Identifying a programming error

There is a programming error if the time shown by the clock is between the cooking start time and the cooking end time. The error is signaled by the buzzer sounding and by the intermittent flashing of the symbol “A”.

Cancellation of a program



The cancellation of a program is done by selecting the manual mode. At the end of the selected program, this will automatically cancel.

INSTRUCTIONS FOR USE

– 5 button electronic programmer E3

Button legend



-  Set minute minder
-  Setting the cooking start time
-  Set end time cooking
- [-] Decreases the selected parameter
- [+] Increases the selected parameter

Display

F4-digit format, shows:



- In stand-by: the actual time.
- During manual cooking: the set temperature.
- During timed automatic cooking: remaining time to end of cooking.
- During meat probe cooking: the probe's temperature.
- With timer on and oven in stand-by: the remaining time.

Icons



Main oven icon [1]. If flashing the display shows the temperature and cooking duration settings of the main oven (only in the double oven)*



Secondary oven icon [3]. If flashing the display shows the temperature and cooking duration settings of the secondary oven (only in the double oven).*



If lit, the timer is on. If flashing, time has elapsed. Flashes while the timer is being set.



If lit, the oven is working in delayed start mode. During the delayed start, it stays on.



If lit, the oven is working in automatic end of cooking mode. It flashes during the delayed start mode, and then stays on when cooking is over.



If lit, the clock is in 12-hour a.m. mode.



If lit, the clock is in 12-hour p.m. mode.

(*) In the case of simultaneous use of ovens and to display the temperature and cooking time settings of the primary or secondary oven, press the corresponding thermostat knob.



INSTRUCTIONS FOR USE

– 5 button electronic programmer E3

Appliance operation

The first time the unit is switched on, the display shows a flashing clock that increases by one unit every minute. The oven cannot operate until the clock has been set. See paragraph below “Setting the clock”



Setting the clock

Simultaneously press buttons  and  for 5” (the display flashes) and alter the time using the keys [+] and [-]. The clock can only be set with the oven on stand-by. The time display mode can be altered: during time setting by pressing the  button for 4 seconds; with the [+] button you can choose the 24 hours or 12 hours AM/PM option.

Turning the oven on and off

Turn selector [S]. The display shows “On”. The light inside the oven comes on after two seconds and the display shows the default temperature expected from the selected cooking mode. To turn off during cooking, turn back the selector to [0], the display shows “OFF”.



Timer

The function does not interact with the loads, and is available regardless of the oven’s status. Press the button : the bell symbol lights up and the display shows “0’ 00”. Set the time with [+] and [-], up to a maximum of 180 minutes, after 4 seconds without any increase or decrease the information is accepted, the bell remains on. By pressing the button  after changing the timer value it reverts to clock mode, having accepted the just altered value. Upon expiry of the set time a buzzer sounds together with the symbol  flashing. To stop the buzzer and the flashing, simply press any button.



Indefinite manual operation

Turn the oven on. Select a cooking function from those available. With knob [T] select the desired temperature. After 4 seconds after the last setting the oven operates for an indefinite time and the selected temperature remains on the display.

Semi-automatic end of cooking operation

Turn the oven on. Press button , the display shows “End”. Set the end of cooking time with [+] and [-] buttons (the maximum cooking time is 10 hours). By pressing the button  after changing the duration value it reverts to clock mode, having accepted the just altered value. After 4 seconds from the last setting the oven is on for the set time. Having reached the programmed time you enter cooking finished mode.

Automatic operation

Turn the oven on. Press button  and select the cooking start time with [+] and [-] buttons. Press button , the display shows “End”. Set the end of cooking time with [+] and [-] buttons. If no cooking time is selected, the oven remains in manual cooking mode indefinitely. After 4 seconds from the last setting the oven is on up to the specified time. You can always select a cooking function from those available and the temperature can be changed. Having reached the programmed time you enter cooking finished mode.

INSTRUCTIONS FOR USE

– 5 button electronic programmer E3

Cooking over mode

At the end of the cooking time the oven switches off all heating elements and the unit emits an intermittent acoustic signal. The display shows the time and the cavity symbol flashes. To unlock the oven, simply press any key on the programme. The acoustic signal ends and the oven is now ready to receive new commands.

Selecting the temperature for the oven

At the end of the cooking time, the oven switches off all heating elements, a triple intermittent buzzer of medium intensity sounds, the display shows the time, the cavity symbol flashes. To unlock the oven, simply press any button on the programmer: the buzzer ends and the oven is ready to receive new instructions. When adjusting the temperature (in increments of 5°C) it is possible to change the format from Celsius to Fahrenheit by pressing the (t) knob for 8 seconds.

Oven light control

The oven light remains on for 1 minute when the oven is turned on, and again for 1 minute at the end of preheating. Whilst waiting for a delayed start, the oven light is off. The oven light can always be turned on by pressing knob [T] and turns off automatically after 1 minute. During cooking, you can always leave the light on by pressing the knob [T] for 3 seconds.









Child lock

The oven is equipped with a safety device that prevents unwanted or accidental starting. To activate the safety: with oven off press and hold knob [T] for 3 seconds. A short beep sounds and the screen displays the symbol “n-0”. In this situation it is impossible to start the oven. To remove the previously activated safety, keep knob[T] pressed for 3 seconds.

INSTRUCTIONS FOR USE

– 5 button electronic programmer E3

– Functions list

Pos.	Symbol	Function
1		Pizza cooking This function is particularly suitable for cooking pizza, focaccia and bread. The main source of heat is from the bottom heating element that works in combination with the oven's other resistances.
2		Normal static cooking It is the oven's classic function particularly suited to cooking the following foods: pork chops, sausages, cod, braised beef, game, roast veal, meringues and biscuits, baked fruit, etc.
3		Cooking from underneath This is the most suitable mode to finish the food cooking, in particular confectionery (biscuits, meringues, leavened cakes, fruit desserts, etc.) and other foods.
4		Cooking from above Especially suitable for browning and to give the final touch of colour to many foods; it is recommended for hamburgers, pork chops, veal steaks, sole, cuttlefish, etc.
5		Closed door grill cooking The suitable function for fast and deep grilling, to brown and roast meats in general, fillet steaks, Florentine steaks, grilled fish and also grilled vegetables. Cooking with the electric grill must be made with the thermostat at 180 °C.
6		Fan grill cooking Particularly fast and deep with significant energy savings, this function is suitable for many foods such as pork chops, sausages, pork or mixed spits, game, gnocchi alla romana, etc. Cooking with the electric grill must be made with the thermostat at 180 °C.
7		Intensive cooking Is the quick and intense cooking function for various dishes; best for: baked fish, braised vegetables, spits, duck, chicken, etc.
8		Multiple fan cooking It is the function that allows simultaneous cooking of different dishes without the smells blending; you can cook lasagne, pizza, croissants and brioches, tarts, cakes, etc.
9		Quick Start This function speeds up your oven's pre-heating. We suggest you use this function when you set a cooking temperature from between 200 and 250 ° C. Use of the QuickStart function for temperatures under 200 ° C is not advantageous. To use QuickStart, rotate the selector knob (S) until it is positioned on the symbol (9), then set the desired temperature with the thermostat knob (T). Once the oven has reached the temperature, the thermostat's orange light will turn off and the oven is ready for accepting the food to be cooked. At this point set the desired cooking function with selector knob (S). WARNING: the Quick Start function is not suitable for cooking foods, it is only for quickly pre-heating the oven. DO NOT USE THE QUICK START FUNCTION FOR MORE THAN TWENTY MINUTES.

COOKING INSPECTION

If you need to inspect the food being cooked, you can open the oven door. In this case the lights come on and the forced fan stops (in case of ventilated cooking) and the spit rotation. (in case of grill cooking with the door closed). Closing the door re-activates the previously set function.

INSTRUCTIONS FOR USE

– 5 button electronic programmer E3

Cooking inspection

If you need to inspect the food being cooked, you can open the oven door. In this case the lights come on and the cooking process stops. Closing the door re-activates the previously set function.

Dry/moist cooking

The oven has an automatic device which allows steam from cooking, in some functions, to be expelled from the oven: this is dry cooking (dry). If the cooking requires that the moisture remains inside the oven, (moist cooking), the automatic device can be switched off as follows:

after selecting the desired cooking function, when **[ON]** appears on the display hold down the “-” programmer button for about 2 seconds until **[HUM]** appears on the display. This involves a choice that allows you to modify dry cooking with moist cooking to your liking.

The functions concerned are:



Cooking with probe (only available on some models)

N.B. Cooking with probe cannot be used in the “**DEFROST**”, “**QUICK START**”, “**PIZZA**” and “**ECO**” functions. When the oven is in stand-by insert the meat probe into the connecting socket on the right hand wall of the oven: the clock displays “**MEAT**” for 2 seconds and the “probe” symbol flashes. Next the probes default temperature (75°C) appears on the display. By turning and then pressing the adjustment button, select the end of cooking temperature from the 2 limit values of 40° and 100°C (the food’s internal temperature). After 4 seconds from the last setting, the set value is memorized and the probe symbol stays on. Turn on the oven, select the cooking function and the desired temperature using the appropriate knobs. The display will show the probes temperature reading.

Upon reaching the programmed temperature the oven will turn off, a buzzer sounds and the display shows the message “**End**” and you enter the cooking over mode.

During cooking it is always possible to change the probes temperature by pressing and then turning the adjustment knob 3 times.

NOTE: If you insert the probe into the special socket during cooking, the oven will turn off and “**Off**” appears on the display.

If, during cooking, the probe is removed from the special socket, the oven will turn off and “**Off**” appears on the display.

INSTRUCTIONS FOR USE

– 5 button electronic programmer E3

Inside food temperature (°C)

COOKING CHART	Food	Temperature (°C)
	Beef	
	• Roast beef / beef fillet	
	rare	40-45
	medium	50-55
	well done	60-65
	• Roast meat	80-85
	Pork	
	• Loin	65-70
	• Roast / bacon	80-85
	• Neck / trotter	80-85
	• Cutlet without bone	75-80
	• Cutlet	70
	• Marinated cutlet	65-70
	• Meat loaf	70-75
	Veal	
	• Roast veal	70-75
	• Roast veal with kidney	75-80
	• Veal feet	80-85
	Game	
	• Game meat	75-80
	• Back	60-70
	• Rare fillet	40-45
	• Medium	50-55
	• Well done fillet	60-65
	Lamb	80-85
	Stuffed roasts	70-75
	Poultry	85-90
	Fish	85-90

NOTE

Probe must be in the middle of the roast and not close to the bone or to any fat part

INSTRUCTIONS FOR USE

– Display TFT touch

– Icon legend



Break



Start



°C - °F



Screen lock



Settings



Settings



Meat probe



Home



Light



Timer



Exit - Terminate



Clock



Confirm Settings



Switch off



Knob present in some models.
(It allows to set and confirm the functions of the TFT in addition to the Touch display)

INSTRUCTIONS FOR USE

– Display TFT touch

– Settings

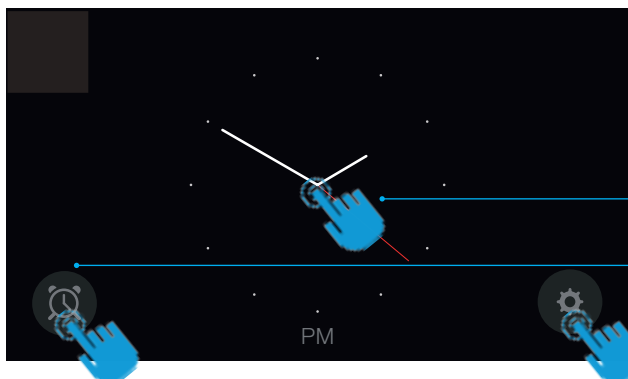

Home: display homepage.

3 options

Allows you to proceed to the screen setting of the cavity

Allows you to set the timer

Gives you direct access to the settings

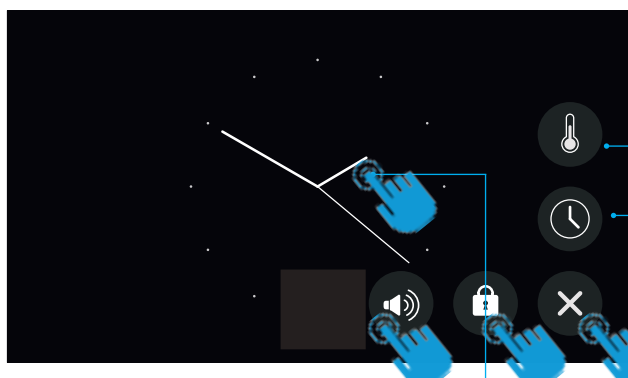

Settings

Choice of degree scale (°C or °F).

Time settings.

Exit the settings page.

Allows you to lock the screen.

Allows you to set the volume of the beep and choose a sound when touching the display

To unlock touch on the display for 10 seconds

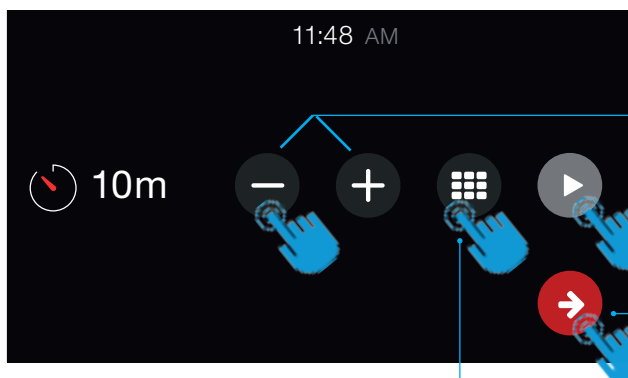

Setting a timer

Increase or decrease the time.

Confirm once you have set the desired time. An audible signal will indicate the end.

Confirm and return to the home page.

Numeric keyboard

INSTRUCTIONS FOR USE

– Mod. static oven E3 with TFT touch

– Cooking function setting

1- Choose the cooking function

Light (on or off)

Home (Return to home page)

2- Set the cooking temperature

2a - There are two options for setting the temperature:
- Scrolling the bar
- With + or -

2b - Confirm the temperature

3- 3- Set the cooking time and the programmed start

4- Cavity selection
(only for multiple cavity models)

3a - Set the cooking time

3b - Shows the time of the cooking time

3c - Set the start time

3d - Confirm the cooking function

NOTE: Possible only in certain cooking modes (see p.39)

INSTRUCTIONS FOR USE

– Mod. static oven E3 with TFT touch

– Cooking process

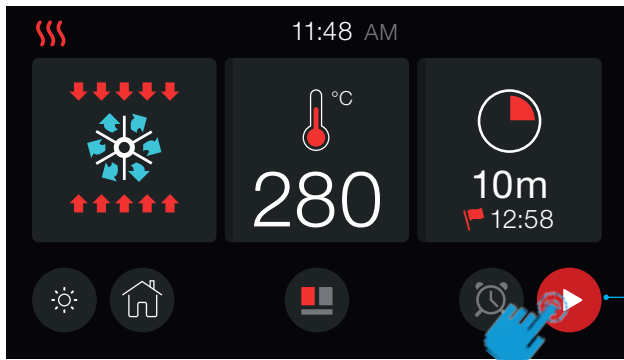

CAVITY SET

Once the cavity has been set (cooking function, temperature and timer), confirm to start the preheating. At this point the display will switch to the preheating mode

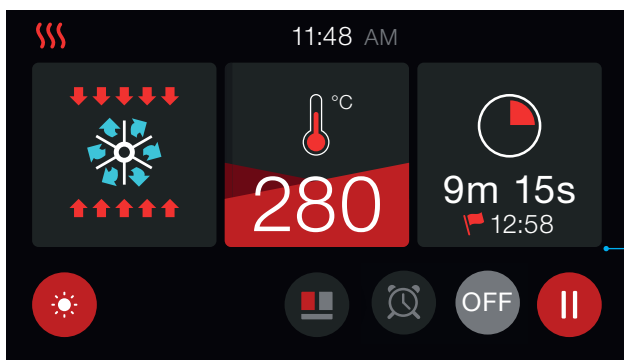

PREHEATING PHASE

There are four levels that allow you to monitor the preheating process. The red part will gradually increase to fill the display.

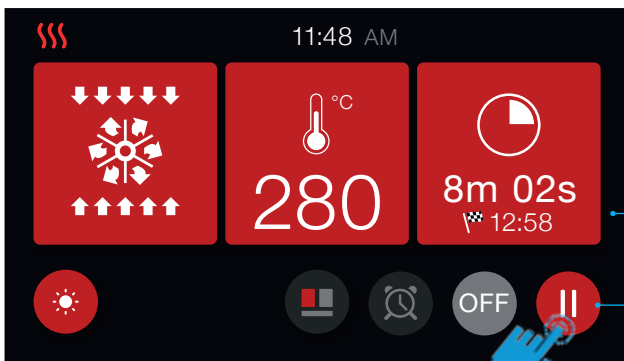

PREHEATING TERMINATED

When the set temperature is reached, the display will turn red to indicate the end of the preheating phase, and the start of the cooking phase.

If a cooking time has been set, the oven will automatically switch off at the end of the time.

In case of no set cooking time it is possible to suspend the cooking



and then finish it

AND THEN FINISH IT

PROBE TEMPERATURE SELECTOR

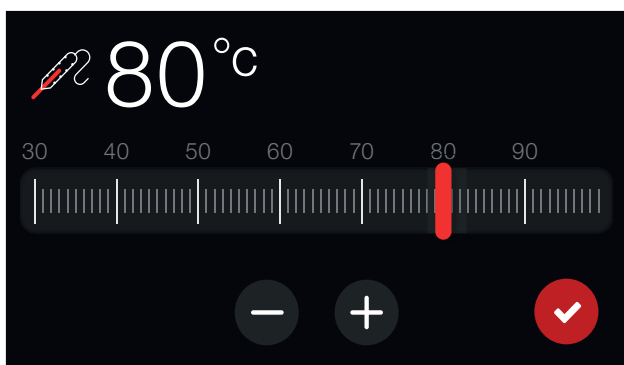

PREHEATING MODE WITH MEAT PROBE

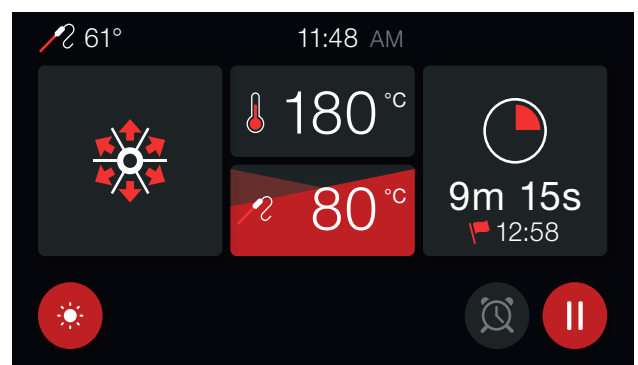

INSTRUCTIONS FOR USE

– Mod. oven E3 with TFT touch

– Functions list



Pizza cooking

This function is particularly suitable for cooking pizza, focaccia and bread. The main source of heat is from the bottom heating element that works in combination with the oven's other resistances.



Normal static cooking

It is the oven's classic function particularly suited to cooking the following foods: pork chops, sausages, cod, braised beef, game, roast veal, meringues and biscuits, baked fruit, etc.



Cooking from underneath

This is the most suitable mode to finish the food cooking, in particular confectionery (biscuits, meringues, leavened cakes, fruit desserts, etc.) and other foods.



Cooking from above

Especially suitable for browning and to give the final touch of colour to many foods; it is recommended for hamburgers, pork chops, veal steaks, sole, cuttlefish, etc.



Closed door grill cooking

The suitable function for fast and deep grilling, to brown and roast meats in general, fillet steaks, Florentine steaks, grilled fish and also grilled vegetables. Cooking with the electric grill must be made with the thermostat at 180 °C.



Fan grill cooking

Particularly fast and deep with significant energy savings, this function is suitable for many foods such as pork chops, sausages, pork or mixed spits, game, gnocchi alla romana, etc. Cooking with the electric grill must be made with the thermostat at 180 °C.



Intensive cooking

Is the quick and intense cooking function for various dishes; best for: baked fish, braised vegetables, spits, duck, chicken, etc.



Multiple fan cooking

It is the function that allows simultaneous cooking of different dishes without the smells blending; you can cook lasagne, pizza, croissants and brioches, tarts, cakes, etc.



Eco cooking:

Is the function that allows you to cook with considerable energy savings. To take advantage of this feature, place the dish in the centre of the oven before starting the ECO function. With the ECO function, cooking times can be adapted to slow cooking as: braised meats, white meats, baked pasta, delicate pastry.

This cooking cycle is not recommended for frozen food.

To select Eco cooking turn selector knob "S" to 8 and, when "ON" appears on the display, hold down

the programmer's "+" key for about 2 seconds until "ECO" appears on the display. With Eco cooking the temperature that can be programmed goes from a minimum of 30° C up to a maximum of 300° C.

Note: Eco cooking cannot be selected with the meat probe inserted.



Quick Start

This function speeds up your oven's pre-heating. We suggest you use this function when you set a cooking temperature from between 200 and 250 ° C. Use of the QuickStart function for temperatures under 200 ° C is not advantageous. To use QuickStart, rotate the selector knob

(S) until it is positioned on the symbol (9), then set the desired temperature with the thermostat knob (T). Once the oven has reached the temperature, the thermostat's orange light will turn off and the oven is ready for accepting the food to be cooked. At this point set the desired cooking function with selector knob (S).

WARNING: the Quick Start function is not suitable for cooking foods, it is only for quickly pre-heating the oven.

DO NOT USE THE QUICK START FUNCTION FOR MORE THAN TWENTY MINUTES.



Dry/wet Cooking

The oven is equipped with an automatic device that allows the condensation vapours of the firings, in some functions, to be expelled from the oven: This involves dry cooking (dry). Should the need for cooking require that moisture remain inside the oven, moist cooking (moisture)

COOKING INSPECTION

If you need to inspect the food being cooked, you can open the oven door. In this case the lights come on and the forced fan stops (in case of ventilated cooking) and the spit rotation. (in case of grill cooking with the door closed). Closing the door re-activates the previously set function.

INSTRUCTIONS FOR USE

– Mod. oven static with TFT touch

– Functions list

**Upper & lower elements**

Is the classical function of the electric oven and particularly adapted for cooking: pork chops, sausages, dried salt-cured cod, pot roast, game, roast veal, meringues and biscuits, baked fruit, etc.

**Lower element**

This setting is most suitable for finishing cooking, particularly pastries (biscuits, meringues, desserts, puff pastry, fruit cakes, etc.) and other foods.

**Upper element**

Especially suitable for browning and to add the finishing touches of colour to different dishes. We suggest this setting when cooking hamburgers, pork cutlets, steaks, sole, cuttlefish, etc.

**Grill-baking**

A suitable setting for grilling au gratin and roasting quickly and well, meat in general, fillet, T-bone steak, grilled fish and vegetables too. Cooking by electric grill must be done with the thermostat set at 180°C.

INSTRUCTIONS FOR USE

turn-spit (only on some models)

Slide the meat to be cooked onto the spit, blocking it with the special forks. Place the spit on the special supports previously inserted in the drip pan and insert it in the spit-roast horn. Turn on the static grill with closed door function. To extract the spit together with the drip pan pull it out just enough to allow complete extraction.



Telescopic runners (only in certain models)

Telescopic runners make it easier and safer to remove baking trays and to take a closer look at how cooking is progressing. The telescopic runner kit includes 2 lateral runners which slide on ball bearings. The runners can be removed for cleaning as shown in the pictures below.

Pul down the part highlighted in red to remove it from the oven.

Turn over the grill and place it on a flat surface whit the telescopic runner facing down.

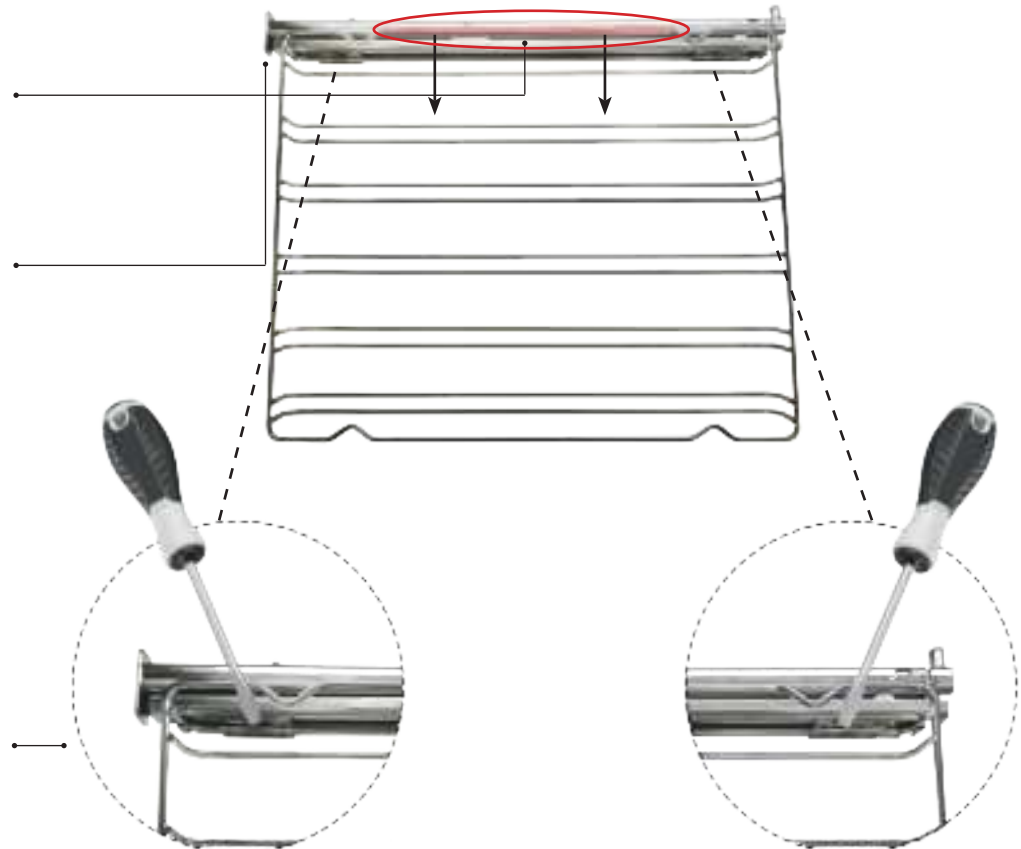

To un hook the clip, loosen whit a flathead screwdriver

Repeat the operations backwards to repositions the grills.

CLEANING AND MAINTENANCE

– Replacing the bulb

Procedure to follow

Should the oven light not work, disconnect the appliance from the mains, remove the lamp protection glass and replace the bulb. The new bulb must, naturally, be suitable for use at high temperatures.

1

Loosen with a flat-head screwdriver



2

Remove the glass cover



3

Pull out the light

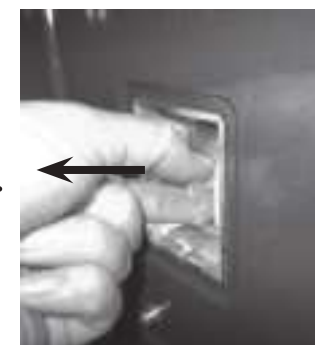

4

Replace and close again



CLEANING AND MAINTENANCE

– Door removal

Procedure to follow

For ease of intensive cleaning it is useful to dismantle the door following these instructions:

- open the door
- move the hook C to the hinge zone d, following the steps below

1

Zone C

Zone D



2

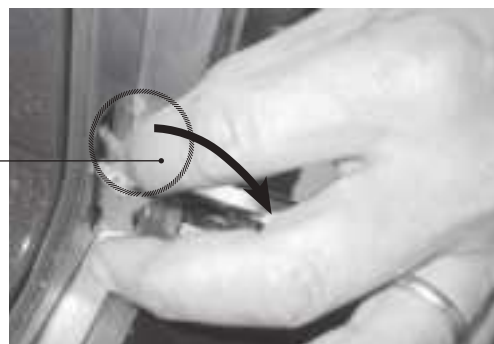

3

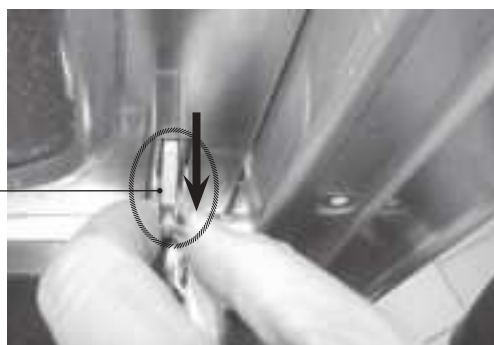

4

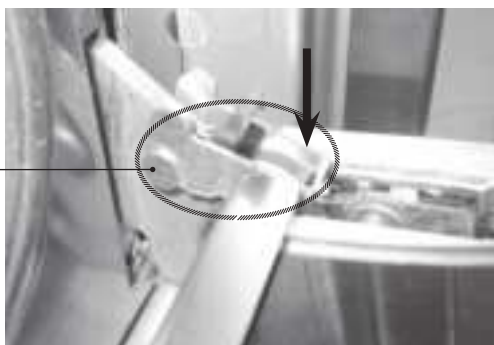

CLEANING AND MAINTENANCE

– Cleaning the door and glasses

(for more detailed information, go to www.ilve.com.au/cleaning)

Procedure to follow

The oven door is composed of 3 sheets of plate glass (two in some cases). The plate glass parts may be cleaned using absorbent kitchen paper and an ordinary non-abrasive detergent. Do not use coarse abrasive cleaning materials or sharp metal scrapers to clean the oven's glass doors since they can scratch the surface and cause the glass to shatter

The inside glass may be removed to facilitate cleaning. To do this it is necessary to dismantle the oven door or, alternatively, to set it in the intermediate click position.

Sequence for removing the glasses



ATTENTION! every procedure must be done with the door removed and placed on an suitable surface in order to not damage the door's facade. Before carrying out any cleaning operations, disconnect the appliance from the mains and close the gas valve. The cooktop must be cleaned after it has been cooled down.

1

Unscrew the 2 screws



2

Lift the upper glass and pull it out



3

Pull out the middle glass



CLEANING AND MAINTENANCE

– Recommendations for cleaning the cooktop

ATTENTION:



Before carrying out any cleaning operations, disconnect the appliance from the mains and close the gas valve. The cooktop must be cleaned after it has been cooled down.

COOKTOP

COMPONENT	CLEANING METHOD	WARNINGS
Steel surfaces	Clean the details with warm water and non-abrasive detergent. Dry with a soft microfibre cloth.	Brilliance is maintained through regular cleaning with specific commercially available products which can be found in commerce. Never use abrasive powders.
Enamelled surfaces	To maintain the characteristics of the enamelled surfaces it is necessary to regularly clean them with soapy water.	Avoid leaving acidic or alkaline substances (vinegar, lemon juice, salt, tomato juice, etc.) on enamelled parts and washing them when are still hot.
Cooktop grills	Remove the grills and wash them with warm water and non-abrasive detergent. Carefully remove every encrustation. Dry before placing them back on the cooktop.	Do not wash them in the dish washer.
Spark plugs and thermocouples	Clean with a damp cloth. If necessary, remove dry dirt with a toothpick or a needle.	Spark plugs and thermocouples must be cleaned and checked regularly.
Crowns, gas rings, and caps	Gas rings and caps are removable to allow easy cleaning. Wash them with hot water and non-abrasive detergent.	Carefully remove every encrustation and ensure they are completely dry. In the case of malfunctioning, make sure that the holes in the external crown are perfectly cleaned.
Induction or fibreglass	Remove light stains with a damp cloth and dry with a soft cloth. Clean with commercially available product designed for cleaning ceramic cooktops (e.g. hillmark)	Don't clean with abrasive products. Don't use any object that could ruin the fibreglass top. Make sure that the bottom of the pan is dry and clean, and that glass surface has no dust. Moving the pan may scratch the glass. Immediately remove residual sugar, jam and jelly to prevent damaging the glass.

CLEANING AND MAINTENANCE

– Recommendations for cleaning the oven and the front panel

ATTENTION:

Before carrying out any cleaning operations, disconnect the appliance from the mains and close the gas valve. The cooktop must be cleaned after it has been cooled down.

OVEN

COMPONENT	CLEANING METHOD	WARNINGS
Oven inside	It is recommended to clean the oven after every use. Dirt is cleaned more easily avoiding to let it burn several times at high temperatures. Remove every removable part and clean it separately with hot water and non-abrasive detergent. The cavity is cleaned with a soft cloth soaked with a solution made of soapy. Rinse and dry.	Do not use a steam cleaner to clean the interior of the oven. Do not use abrasive/corrosive detergents or sharp tools to clean the glass of the door as they could damage and break the surface.
Tray	Immerse in a solution made of water and neutral soap. Dry afterwards.	Remove residual food immediately after use.
Grills	Clean with a NON-acidic detergent.	Acidic substances such as lemon juice or other acidic detergents may permanently damage the enamel of the grills. Carefully dry the grills with a cloth right after the cleansing. It is not recommended to wash them in the washing machine.

FRONT PANEL

COMPONENT	CLEANING METHOD	WARNINGS
Steel surfaces	Clean the parts with lukewarm water and non-corrosive liquid detergent and then dry them with a soft cloth or microfibre cloth.	Brilliance is maintained through regular cleaning with specific products commercially available. Never use abrasive powders
Enamelled surfaces	To maintain the characteristics of the enamelled parts it is necessary to clean frequently with soapy water.	Avoid leaving acidic or alkaline substances (vinegar, lemon juice, salt, tomato juice, etc.) on enamelled parts and washing them when are still hot.

CLEANING AND MAINTENANCE

– Maintenance and cleaning of total black burners with nano-technological coating

ATTENTION!



Some cleaning and washing methods are recommended in order to preserve the quality of the coating.

- Allow the product to cool down at room temperature before cleaning it. It is recommended not to dip it in cold water when it is still hot.
- Wash with warm soapy water. Rub with a natural fibre cloth, or non-abrasive sponge.
- Do not use powder, iron wool, cloths and abrasive sponges.
- Do not let food be charred on the burner. In case stains/colorations may appear on the surface. These traces do not alter the functionality of the product, and in some cases can be eliminated with this procedure: immerse the product in hot water, with detergent, wipe gently with a natural fibre cloth; in any case, do not use abrasive cloths or sponges. For the most resistant stains, it is advisable to warm white vinegar and rub as indicated above.
- Avoid leaving the burners in contact with food for a long time, especially if acidic, such as tomato sauce.
- Avoid contact with metal objects; if really needed, use wooden or plastic objects.
- Avoid washing in the dishwasher, a part of the product is not coated and would get irreparably damaged.
- In case of malfunction, make sure that the holes in the outer crown are perfectly clean.

CLEANING AND MAINTENANCE

– Maintenance and cleaning of total black burners with nano-technological coating

ATTENTION:

To preserve the quality of the nano coating please observe these guidelines.

- Allow the burners to cool down to room temperature before cleaning. Do not dip them in cold water to speed up the cooling down process.
- Wash with warm, soapy water. Rub with a soft cloth or non-abrasive sponge. Do not use abrasive powder, steel wool or abrasive sponges.
- Avoid leaving food or splatter on the burner. This will result in charred deposits that will be more difficult to remove and may cause stains or discolourations to appear on the surface. These blemishes do not alter the functionality of the product. In some cases they can be eliminated by immersing the burners in hot, soapy water and then wiping them gently with a soft cloth or non-abrasive sponge. For stubborn stains, use warm white vinegar and wiping them as above.
- Avoid leaving the burners in contact with food for a long time, especially if acidic, such as tomato sauce, lemon juice.
- Avoid contact with metal objects; if you must touch them, use wooden or plastic utensils.
- Avoid washing in the dishwasher, the underside of the burner is not coated and would get irreparably damaged.
- In case of malfunction, make sure that the holes in the outer crown are perfectly dry and clean.

Annual service by an authorised person is recommended, or if any of the following conditions are noticed. Incomplete ignition, appreciable yellow tipping, carbon deposition, lifting, floating, lighting back or objectionable odour.

Contact 1300 856 411 or customercare@eurolinx.com.au

Problem	Cause	Solution
The flame is uneven / unstable	Wrong gas type	Have an expert check the gas supply
The flame from the burners suddenly changes	Wrongly assembled burner parts	Ensure burner parts are in the correct position
Burner extinguishes after lighting	Insufficient time for the sensor to detect that the burner is on	Push the burner knob a little longer (no more than 10 seconds)
Spark is uneven	Food residues between the electrode and the burner	Make sure both the burner components and the ignition electrode are clean

PROBLEM SOLVING

– Glass ceramic malfunction

Problem

The appliance and the hob do not switch on

The “U” symbol appears on the display

The “E” symbol appears on the display

The cooking zones do not work

Ventilation remains on when the hob is switched off

Causes

- The hob has not been properly connected to the electrical network.
- The protection fuse is broken or has tripped
- child lock is active.

- The pot was not placed on the cooking zone.
- The pot is not compatible with induction.
- The diameter of the bottom of the pot is too small.

- The safety system is in operation.
- The pot is not compatible with induction.
- The diameter of the bottom of the pot is too small.

- The safety system is in operation.
- The pot is empty and the bottom has overheated.

- This is not a malfunction. The fan continues to function to protect and cool down the electronics.
- The automatic ventilation will stop automatically.

PROBLEM SOLVING

– TFT display errors

System errors

The following errors are detected:
The error code syntax is: "E YY X", where:

YY = error code

x = cavity number when error occurred or ' 0 ' for general errors

Description	Error ID	Error types(*)
Cavity probe in open circuit	00	WE
Cavity probe in short circuit	01	WE
Meat probe in open circuit	04	WE
Meat probe in short circuit	05	WE
Overheating	08	WE
Tangential fan not working	16	WE
Incorrect mapping card	19	WE
Communication error	20	WE

Attention(*)

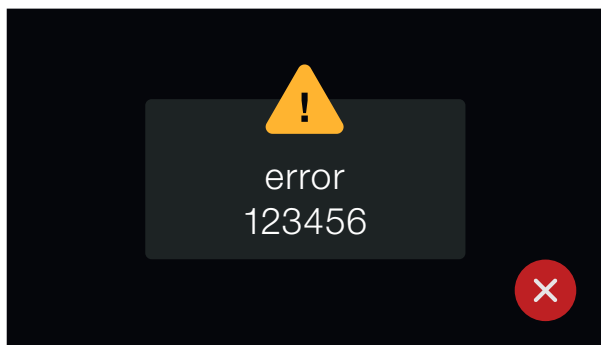

In case of error disconnect and reconnect the appliance.
If the error is present again you will need the intervention of an authorized technician

Attention(*)

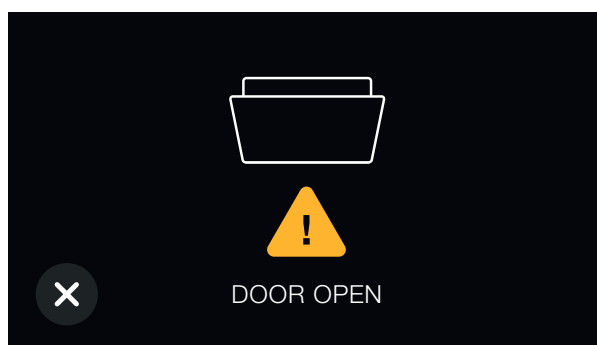

Close the oven door.

PROBLEM SOLVING

– Child Lock

How to resolve

Symbol that represents the children lock



ATTENTION:



If this symbol shows up in your oven. The child lock may have accidentally been selected.

The oven is equipped with a safety feature which prevents the unwanted startup of the oven.

How to disable

To disable the child lock, hold the thermostat knob which regulates the temperature for 5". The display will show "n—o" followed by "OFF".

How to activate

To activate the safety lock, hold down the thermostat knob for 5", with the oven turned off. You'll hear a short beep signal and the display, will show "n—o" followed by "ON". It will then not be possible to start up the oven.



COOKING CHART

– Fan oven (purely indicative values)

DISH	TEMP. C°		MIN.
MEATS			
Roast beef	170-180	2/3	40/50
Roast ox	170-190	2/3	40/60
Roast veal	160-180	2/3	65/90
Roast lamb	140-160	2	100/130
Rare roast beef	180-190	2/3	40/45
Roast hare	170-180	2/3	80/100
Roast rabbit	160-170	2	80/100
Roast turkey	160-170	2	160/240
Roast goose	160-180	2/3	120/160
Roast duck	170-180	2/3	100/160
Roast chicken	180	2/3	90/120
FISH			
	160-180	2/3	15/25
CAKES			
Fruit cake	180-200	2	40/50
Plain square cake	180-190	2	40/45
Brioches	170-180	2	40/60
Sponge cake	190-200	2	25/35
Plain ring cake	160-180	2	35/45
Sweet biscuits	180-200	2	20/30
Yeast cake	190-200	2	30/40
Strudel	160	2	25/35
Savoy biscuits	150-180	2	50/60
Apple fritters	180-200	2	18/25
Biscuits pudding	170-180	2	30/40

COOKING CHART

– Fan oven (purely indicative values)

DISH	TEMP. C°		MIN.
Bread 	180-200	3	45
Pizza	250	3	10/20
Toast	185-195	2	7

IMPORTANT

Insert foods when the oven is hot.

«Grill» baking

When appliances are equipped with a grill, baking can be done by keeping the door closed. By using the grill, you can cook meat, fish and even vegetables. At first, we suggest using the upper runner (4). Position the selector on grill and set the temperature at 180°C.

COOKING CHART

– Natural convection (purely indicative values)

DISH	TEMP. C°		MIN.
MEATS			
Roast beef	225	2/3	60/80
Roast ox	250	2/3	50/60
Roast veal	225	2/3	60/80
Roast lamb	225	2	40/50
Rare roast beef	230	2/3	50/60
Roast hare	250	2/3	40/50
Roast rabbit	250	2	40/50
Roast turkey	250	2	50/60
Roast goose	225	2/3	60/70
Roast duck	250	2/3	45/60
Roast chicken	250	2/3	40/45
FISH			
	200-225	1/2	15/25
CAKES			
Fruit cake	225	2	35/40
Plain square cake	175-200	2	50/60
Brioches	175-200	2	25/30
Sponge cake	220-250	2	20/30
Plain ring cake	180-200	2	30/40
Sweet biscuits	200-220	2	15/20
Yeast cake	250	2	25/35
Strudel	180	2	20/30
Savoy biscuits	180-200	2	40/50
Apple fritters	200-220	2	15/20
Biscuits pudding	200-220	2	20/30

COOKING CHART

– Static oven (purely indicative values)

Bakery

Bread	220	3	30
Pizza	250	2	15/20
Pizza	250	3	10/20
Toast	250	3	5

IMPORTANT

Insert foods when the oven is hot.

«Grill» baking

When appliances are equipped with a grill, baking can be done by keeping the door closed. By using the grill, you can cook meat, fish and even vegetables. At first, we suggest using the upper runner (4). Position the selector on grill and set the temperature at 180°C.

IMPORTANT INFORMATION

- For the user

ATTENTION



THE INSTALLER MUST GIVE THE FOLLOWING INFORMATION TO THE USER

- Verify the integrity of the appliance and the presence of all the product documentation.
- Verify that the appliance has all the expected accessories.
- Verify the correct use of the appliance (use of the oven, thermostat, ignition of the burners).
- Fill out the warranty form.
- Suggest that a periodic maintenance service has to be carried out at least every two years.

LEAKING GAS



In case of gas leaking close the gas supply and disconnect the appliance from the mains. Call the authorised assistance service. Maintenance must be carried out exclusively by authorised and qualified personnel.

INSTALLATION

- Installation of the cooker

ATTENTION



The appliance weighs more than 60 kg, therefore it must be moved of appropriate instruments.

Do not drag the cooker as this will bend the supporting feet. Lift the appliance when positioning it. **DO NOT LIFT BY THE HANDLE**

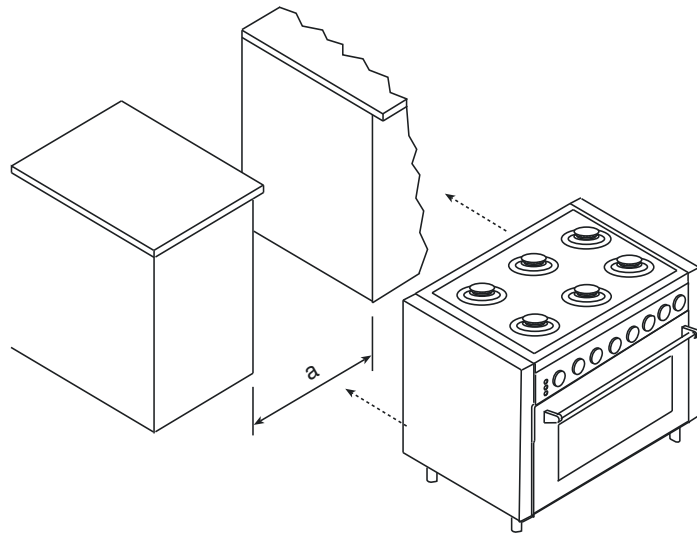

Measures to be respected

a (mm)

Models

600	P06... K06... T06... L06...
700	P07... M07...
800	P08...
900	P09... K06... K09... L09...HNF... NT...
911	M09...

Directives/regulations

- This appliance is in compliance with the applicable standards.

- Installation must only be carried out by qualified persons in compliance with the regulations and standards in force

Room ventilation

This is a type "A" appliance which does not need to be joined to an exhaust system for combustion waste but must be installed under a hood or other smoke extraction system in compliance with the standards in force.

The knowledge and consultation of the standards are a key factor for a qualified technician. Indicatively the amount of air necessary for burner combustion is 2 m³/h for each KW of nominal power installed (see plate).

Should the appliance be subjected to intensive and prolonged use, supplementary ventilation may be necessary; in such cases open a window or increase the extractor fan's power.

INSTALLATION

- Installation of the cooker

This appliance must be installed by an authorised person in accordance with this instruction manual, AS/NZS 5601 – Gas installations (installation and pipe sizing), local gas fitting regulations, local electrical regulations, local water regulations, local health regulations, Building Code of Australia and any other government authority.

This appliance is suitable for connection with rigid pipe or flexible hose. The isolating manual shut-off valve connection point must be accessible when the appliance is installed. Flexible hose assembly must be certified to AS/NZS 1869 class B or D, be of appropriate internal diameter for the total gas consumption, be kept as short as possible (not exceeding 1200mm), must not be in contact with the floor or any hot or sharp surfaces. The hose assembly must not be subject to strain, abrasion, kinking or deformation.

Natural Gas: the supplied regulator must be fitted to the appliance inlet connection. Gas pressure must be adjusted to 1.0 kPa when approximately 50% of the burners are on high flame, the appliance test point is located on the regulator.

ULPG: the supplied test point adaptor must be fitted to the appliance inlet connection. Gas pressure must be adjusted to 2.75 kPa, the appliance test point is located on the test point adaptor.

Gas leakage and operation of the appliance must be tested by the installer before leaving. Check burner flames are blue in colour, stable and completely ignite at both high and low flame settings with no appreciable yellow tipping, carbon deposition, lifting, floating, lighting back or objectionable odour. Test burners individually and in combination. When satisfied with the operation of the cooker, please instruct the user on the correct method of operation.

Where the data plate is obscured by cabinetry when the cooker is in the installed position, place the supplied duplicate data plate to a suitable adjacent surface or within the instruction manual for future reference.

Removing Legs and placing oven on a plinth

If the legs are removed and the oven is placed on a plinth, then suitable ventilation from the plinth area is required. It is recommended that an air vent 20 mm wide and a length of 100mm less than the width of the oven it is located at the rear in the base of the plinth. If the area under the plinth is sealed it is also recommended that an additional vent be included at the top of kick panel under the plinth to provide adequate circulation. The vent size should be 10mm high and 100mm less than the width of the oven.

ATTENTION



Any maintenance operation, etc. It must be carried out by an authorized technician after disconnecting the appliance from the mains and closing the gas supply.

INSTALLATION

- Installation of the cooker

Positioning of the appliance between furniture

- The appliance can be installed singularly: class 1.
- The appliance can be installed between two pieces of furniture: class 2/1.
- The cooker is protected against excessive overheating, so it may be installed next to furniture with a height no higher than that of the worktop. The wall in contact with the back of the cooker must be made of fire-resistant material. To install the cooker correctly, take the following precautions.

***A.** The clearance between the highest part of the highest burner of the gas cooking appliance and a range hood should be no less than 600 mm or 700mm for models more than 900mm wide. For an overhead exhaust fan the minimum clearance is 750 mm.

****B.** Where the distance from the periphery of the nearest burner to any vertical combustible surface, or vertical combustible surface covered with toughened glass or sheet metal, is less than 200 mm, the surface shall be protected to a height C of not less than 150 mm above the hob for the full dimension (width or depth) of the cooking surface area. Where the gas cooking appliance is fitted with a 'splash back', protection of the rear wall is not required.

C. If the cooker is installed under a wall unit, the minimum distance between this unit and the worktop must be 700 mm.

D. Zero clearance to bench surfaces at the same height as the top edge of the cooker is permitted

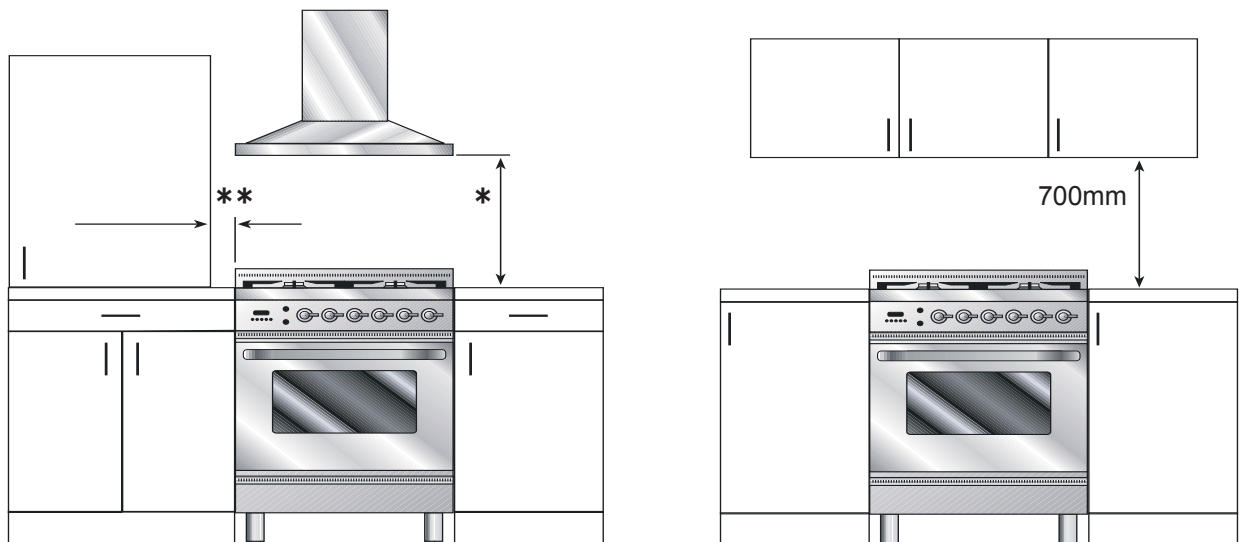

INSTALLATION

- How to install the fixing bracket

Model: 60, 70, 80, 90 cm.

- Unpack the cooker and mount the feet by adjusting the height.

- Measure the height from the floor to the top edge of the back-cross bar (picture 5) and add 15mm.



- Sign the total height on the supporting back wall at the centre of the cooker width. Make a hole by means of a 6 diam. point and install the fixing bracket (picture 6).



- Check that the cooker is leaning against the back wall to avoid tipping.

ATTENTION



The anti-turnover system is assured only if the cooker is installed with the back part leaned against the back wall.

ELECTRICAL CONNECTIONS

- Groups of cooking

ATTENTION



The instructions below are intended for the skilled technician who will install the cooker, regulate it and perform technical maintenance and who will ensure that these operations are carried out in the most correct way possible, in compliance with the regulations in force.

Important: the cooker must be disconnected from the electric socket before performing all regulating or maintenance operations.

Rules for installation

• Installation must be carried out in a workmanlike manner, fully complying with the legislation in force regarding electrical installations. Otherwise, the manufacturer disclaims any responsibility. You will find your appliance's wiring diagram in this booklet.

• The appliances are prepared for connection to the voltage shown on the data plate.

• **Before connecting the appliance to the mains check that:**

- **the electromagnetic switch or the socket are able to support the appliance's load (see dataplate);**

- **the power supply system must have an efficient grounding system.**

The appliance is supplied with a cable but without a plug: the connection must be made taking into account that the green-yellow cable is the ground conductor \perp and it must never be interrupted.

The socket must be visible and easily reachable so that the appliance can easily be disconnected. For direct connection to the mains, it is necessary that:

-the relief valve and domestic system can support the equipment's load (see data plate)

-the power supply system must have an efficient grounding system

-the socket or omni polar switch, with a minimum 3 mm contact opening, must be easily reachable once the appliance has been installed.

- means for disconnection must be incorporated in the fixed wiring in accordance with the wiring rules

ATTENTION



The yellow-green ground wire must never be interrupted even by the switch. The power cable should be positioned so that it does not come into contact with surfaces that have a temperature of 50 °C higher than the environment. In case replacement of the power cable is necessary, contact the support service.

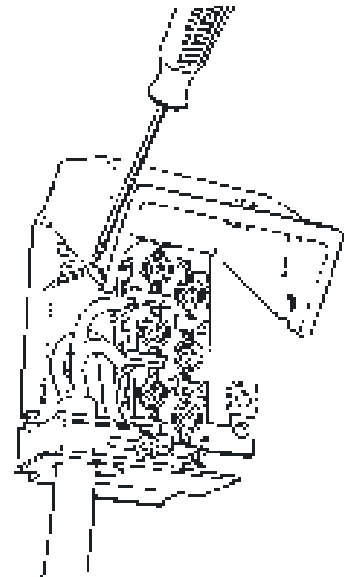

ELECTRICAL CONNECTIONS

- Cookers with induction top

ATTENTION



The appliance is supplied without a plug: The power supply cable should not reach above 50°C ambient

(*) calculated by applying the coincidence factor EN60335-2-6

	POWER SUPPLY	CONNECTION	CABLE SECTION	CABLE TYPE
Data concerning the power cable	230V a.c. 1P+N 50/60 Hz	1 phase + N	3 x 4*	H05RR
Mod. P..I06	400V a.c. 3P+N 50/60Hz	3 phase + N	5 x 1,5	H05RR
	230V a.c. 1P+N 50/60Hz	1 phase + N	3 x 6	H07RN
Mod. LBI09... HNF... NT... P..I09.. M..I09..	400V a.c. 3P+N 50/60Hz	3 phase + N	5 x 4	H05RR
Mod. PDI09..	230V a.c. 1P+N 50/60 Hz	1 phase + N	3 x 6*	H07RN
	400V a.c. 3P+N 50/60 Hz	3 phase + N	5 x 4	H05RR
Mod. MDI10..	230V a.c. 1P+N 50/60 Hz	1 phase + N	3 x 10*	H07RN
	400V a.c. 3P+N 50/60 Hz	3 phase + N	5 x 4	H05RR
Mod. PDI10..	230V a.c. 1P+N 50/60 Hz	1 phase + N	3 x 10*	H07RN
	400V a.c. 3P+N 50/60 Hz	3 phase + N	5 x 4	H05RR

ADJUSTMENT

- Replacement of the injectors for models

Procedure:
SR - R - P

- Remove the grill and the burners from the hob.
- SR – R – P : SR – R – P burners: unscrew injectors “U” using a 7-mm spanner (fig. 1) and replace them with those for the new gas according to table number 2 on page 20.

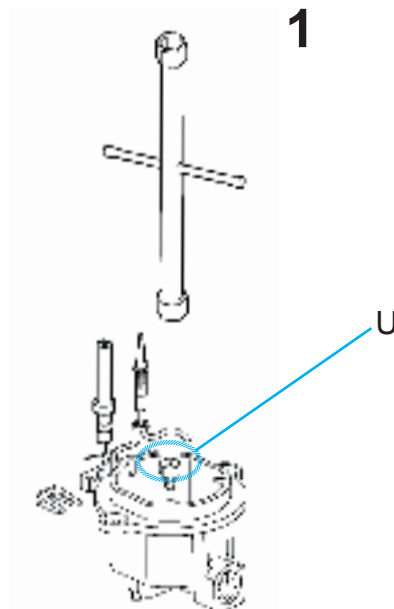

Procedure:
DCC (DUAL WOK)

- DCC – Dual burners: unscrew the 2 screws “P” and remove cover “C” fig.2.
- unscrew injectors “U” using a 7 mm spanner (fig.3, fig.4) and replace them with those for the new gas according to table number 1 below 13.

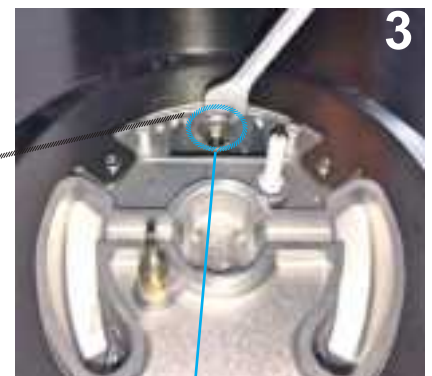

ADJUSTMENT

- Replacement of the injectors for models “K”

Procedure

- Remove the grill and the burners from the hob.
- Unscrew injectors “U” using a 7-mm spanner (fig. 8, fig 10) and replace them with those for the new gas according to table number 3.

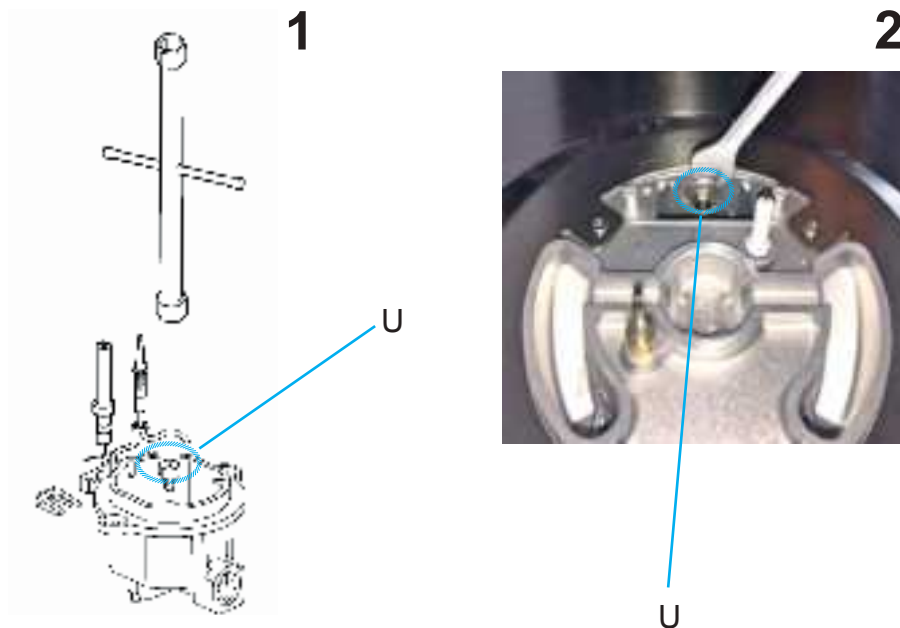

ADJUSTMENTS

- Adjustments minimum GAS flow

Fig. A1

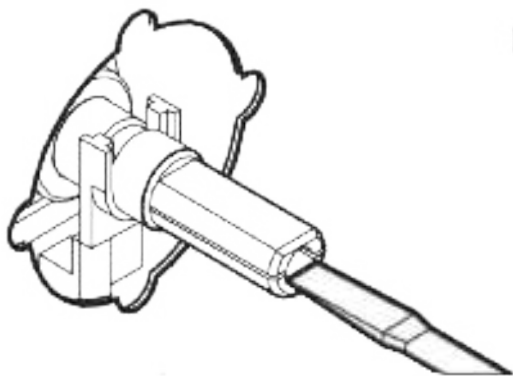

Fig. A2

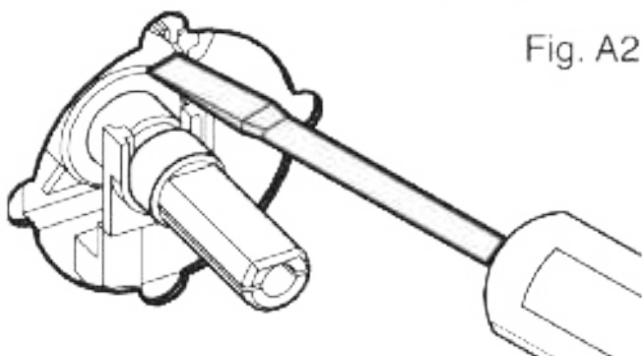

Fig. A2

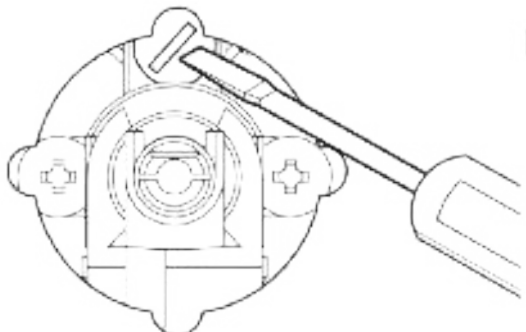

Fig. B

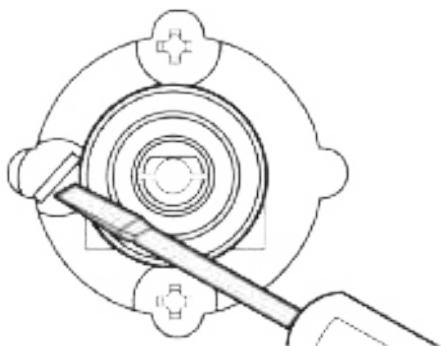
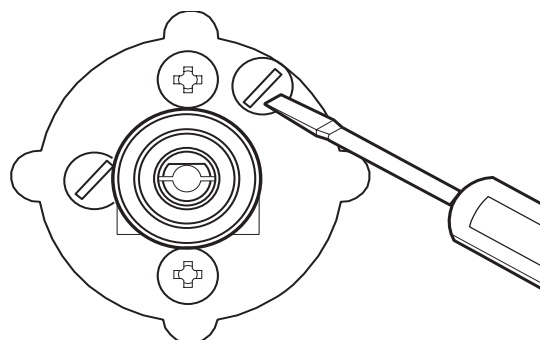
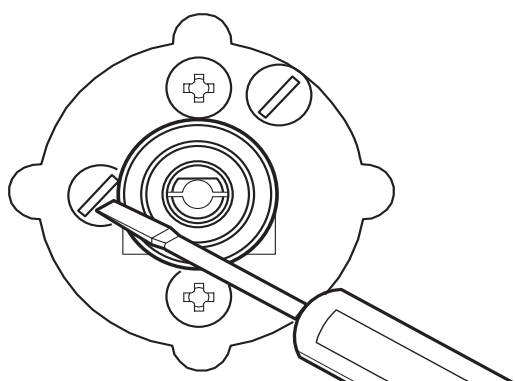

Fig. C2



Burner	Injector Size (mm)	NG consumption @ 1kPa (MJ/h)	Injector Size (mm)	ULPG consumption @ 2.75kPa (MJ/h)
Dual Wok	1.75 / 0.80	17	1.10 / 0.50	20
Wok	1.9	18	1.12	18
Large	1.55	12.5	0.92	12.5
Medium	1.18	7.5	0.68	7
Fish	1.55	12.5	0.95	13
Tepanyaki Plate (medium and large burner)	1.18, 1.55	7.5, 12.5	0.68, 0.92	7.0, 12.5
Simmer Plate (large)	1.55	12.5	0.92	12.5

Burner Chart

WIRING DIAGRAM

- Key

00	Black
11	Brown
22	Red
33	White
44	Yellow
45	Yellow-green
55	Grey
66	Blue
AA	Electrical ignition transformer
C	Switch
F	Fase
K1	Earth wire for terminal board
K2	" " lower resistance
K3	" " for oven fan
K4	" " circular resistance
K5	" " upper resistance
K6	" " oven lamp 1
K7	" " oven lamp 2
K8	" " rotisserie
K9	" " cooling fan
K10	" " selector

K11	" " oven thermostat
K12	" " programmer/timer
K13	" " grill
K14	" " el. hotplate
K15	" " frame
K16	" " barbecue
K17	" " fryer
L1	oven lamp
L2	oven lamp
M	Terminal board
MA	Electrical ignition microswitch
MD	Grill microswitch
MG	Rotisserie
MP	Door microswitch
N	Neutral
P	Timer/Programmer
P	Timer/Clock
PE	Electric hotplate
R1	Upper heating element
R2	Lower heating element
R3	Grill heating element

R4	Circular heating element
R5	Barbecue heating element
R6	Fryer heating element
RE	Energy regulator
S1	Oven warning light
S2	Mains power warning light
S3	Grill warning light
S4	Cooling fun warning
S5	Barbecue warning light
S6	El. hotplate warning light
S7	Turnsplit warning light
S8	Residual heat warning light
S9	Fryer warning light
SP	Sparking plug
T	Grill thermostat
TF	Oven thermostat
TR	Fryer thermostat
TS	Safety thermostat
TT	Cooling fan thermostat
V	Oven fan
VT	Cooling fan

QUICK START

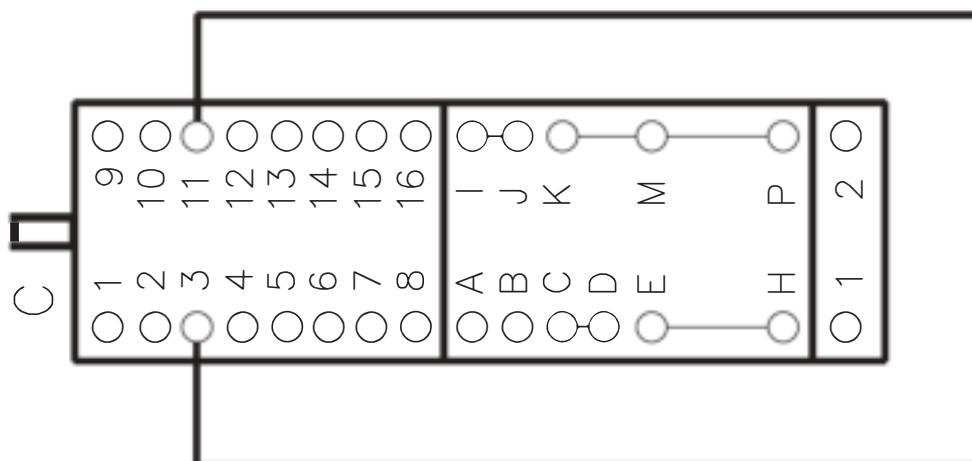

WIRING DIAGRAM

HOB GAS

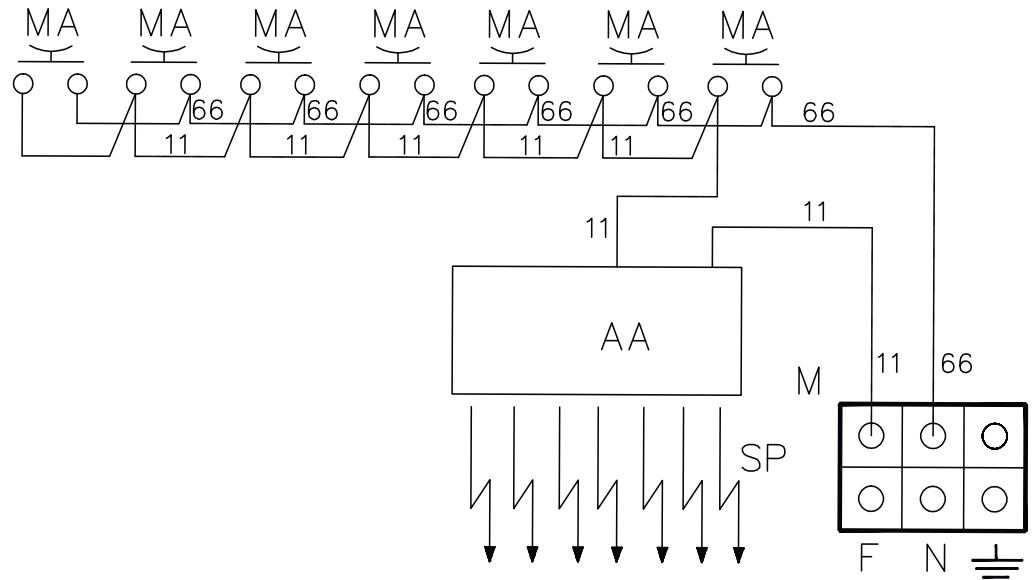

BASIC INDUCTION HOB AREA 5

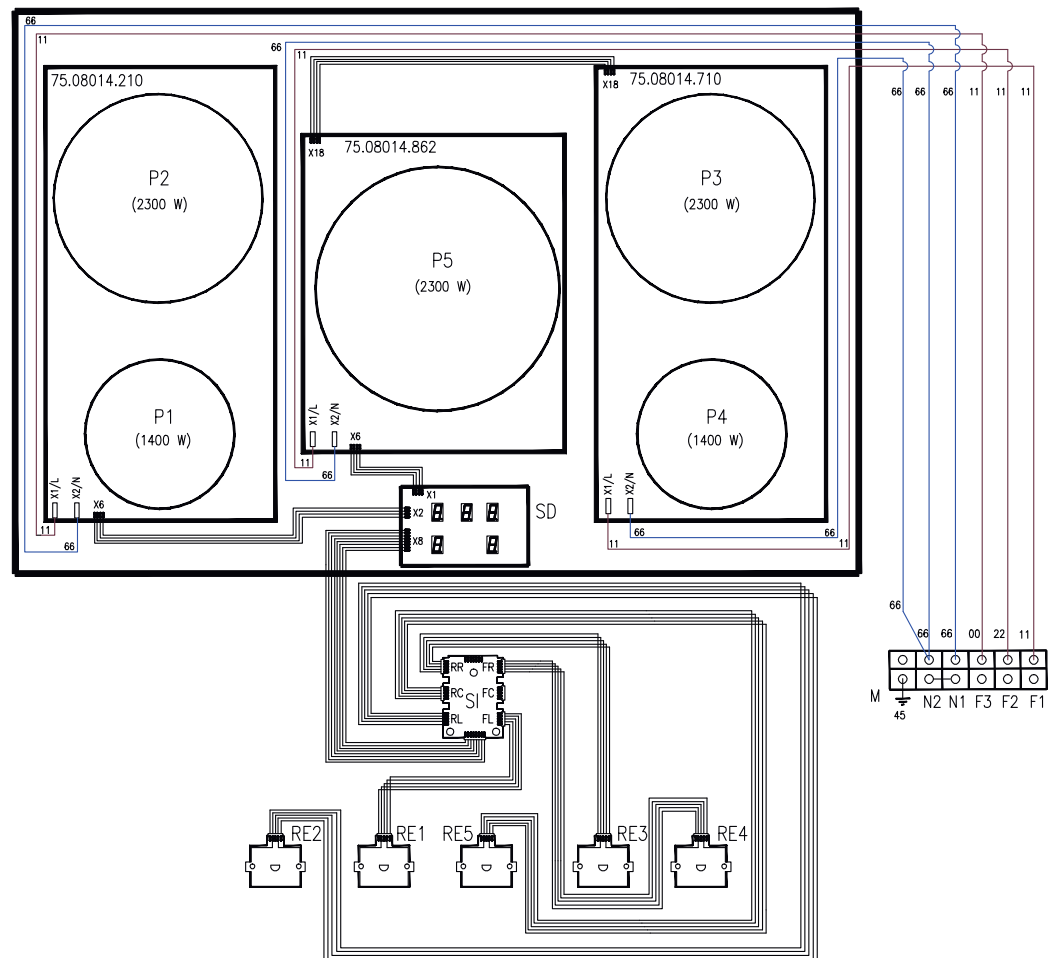

WIRING DIAGRAM

P09I...E3

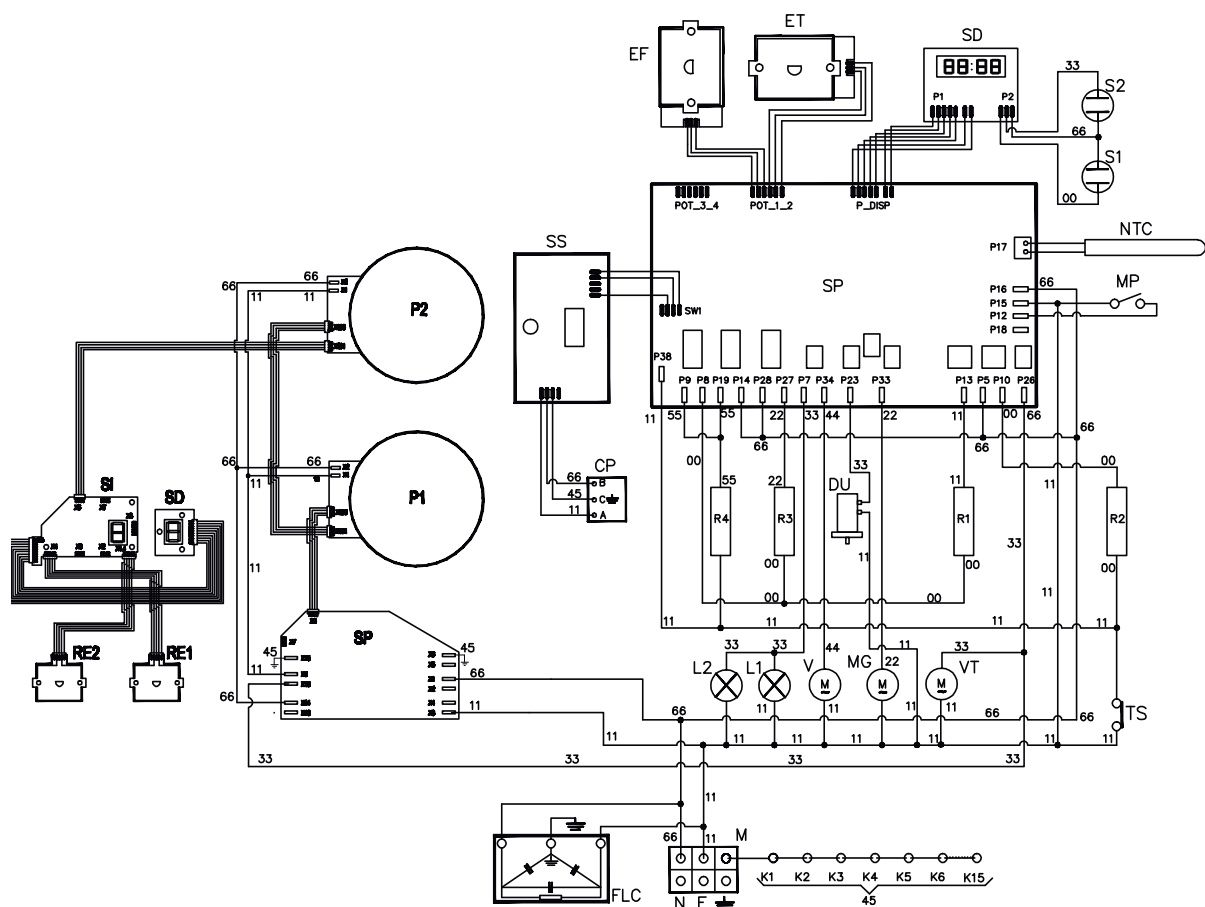

INDUCTION HOB AREA 4

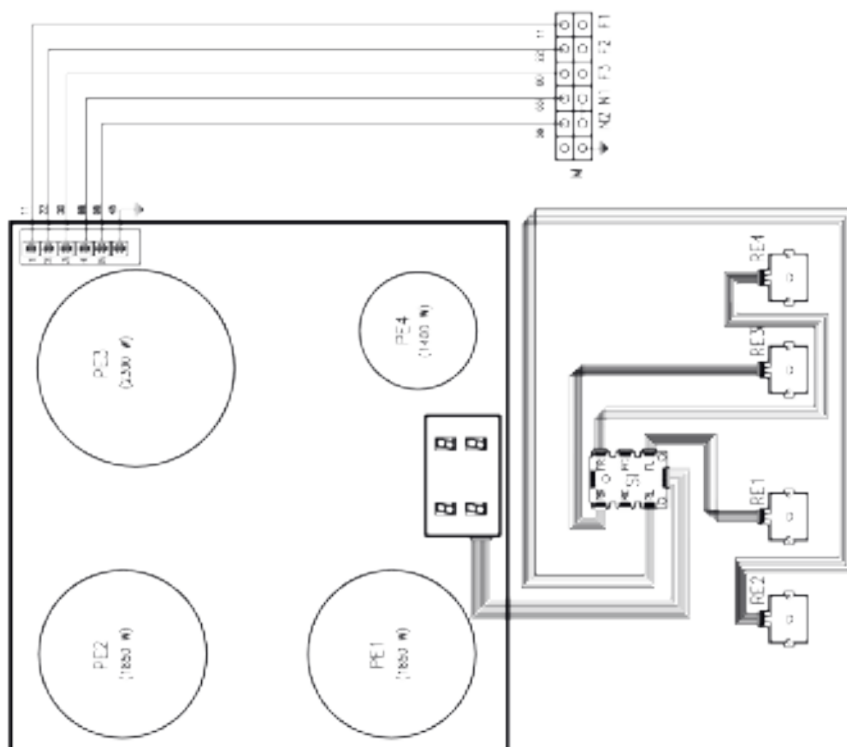

WIRING DIAGRAM

INDUCTION HOB AREA 5

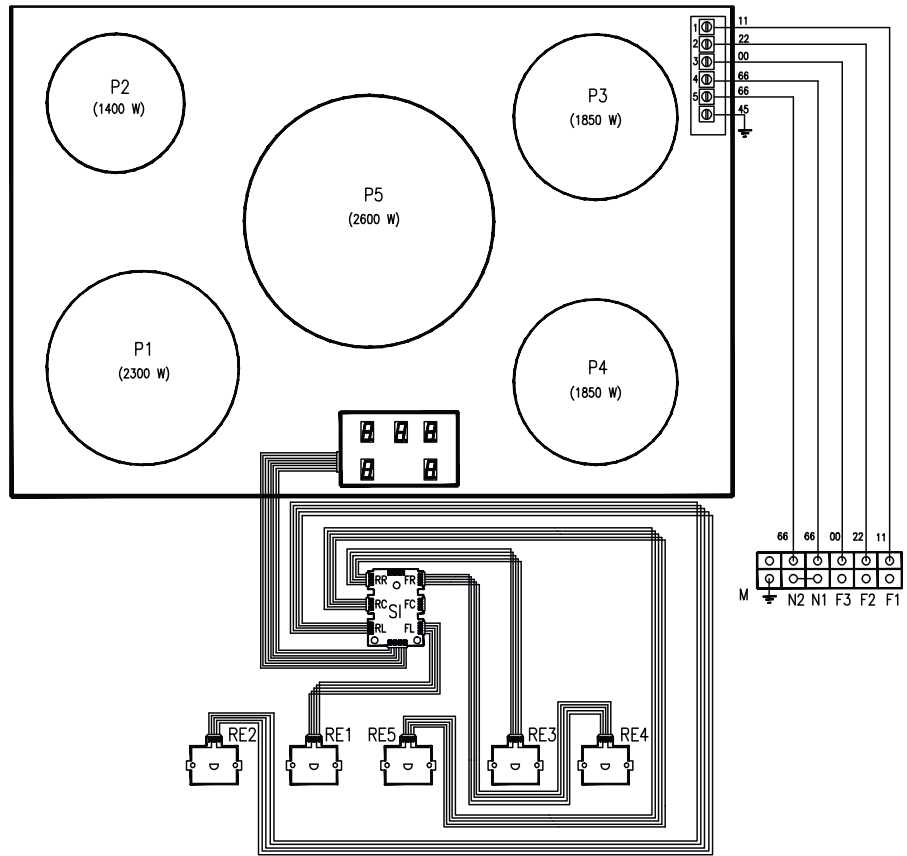

INDUCTION HOB AREA 6

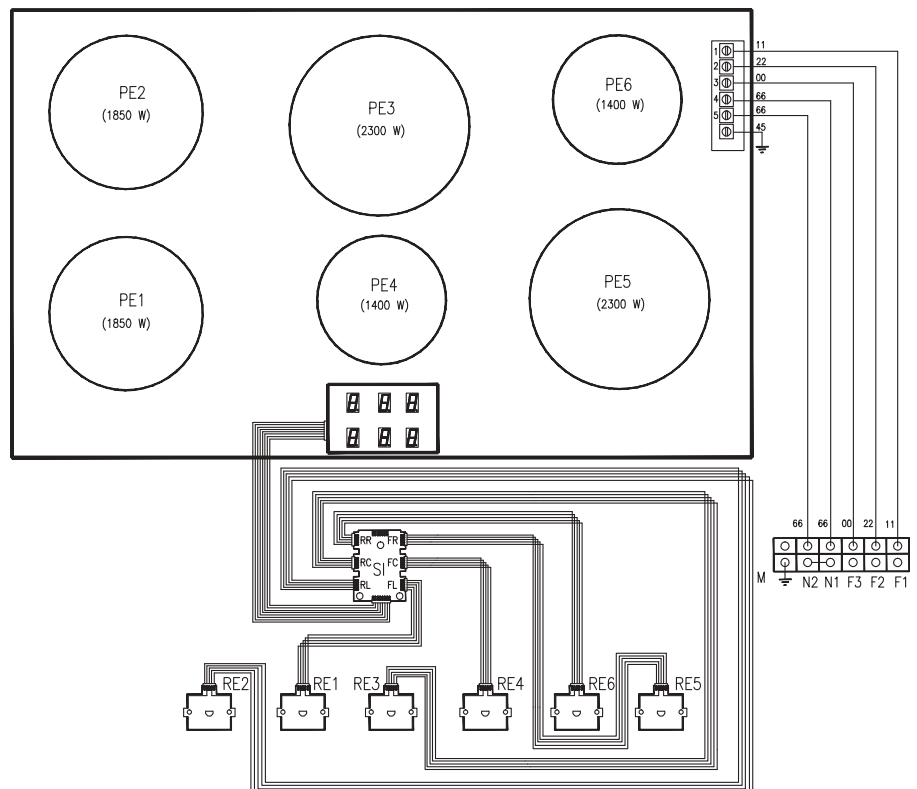

WIRING DIAGRAM

P (06-07-30"-08-09)...E3

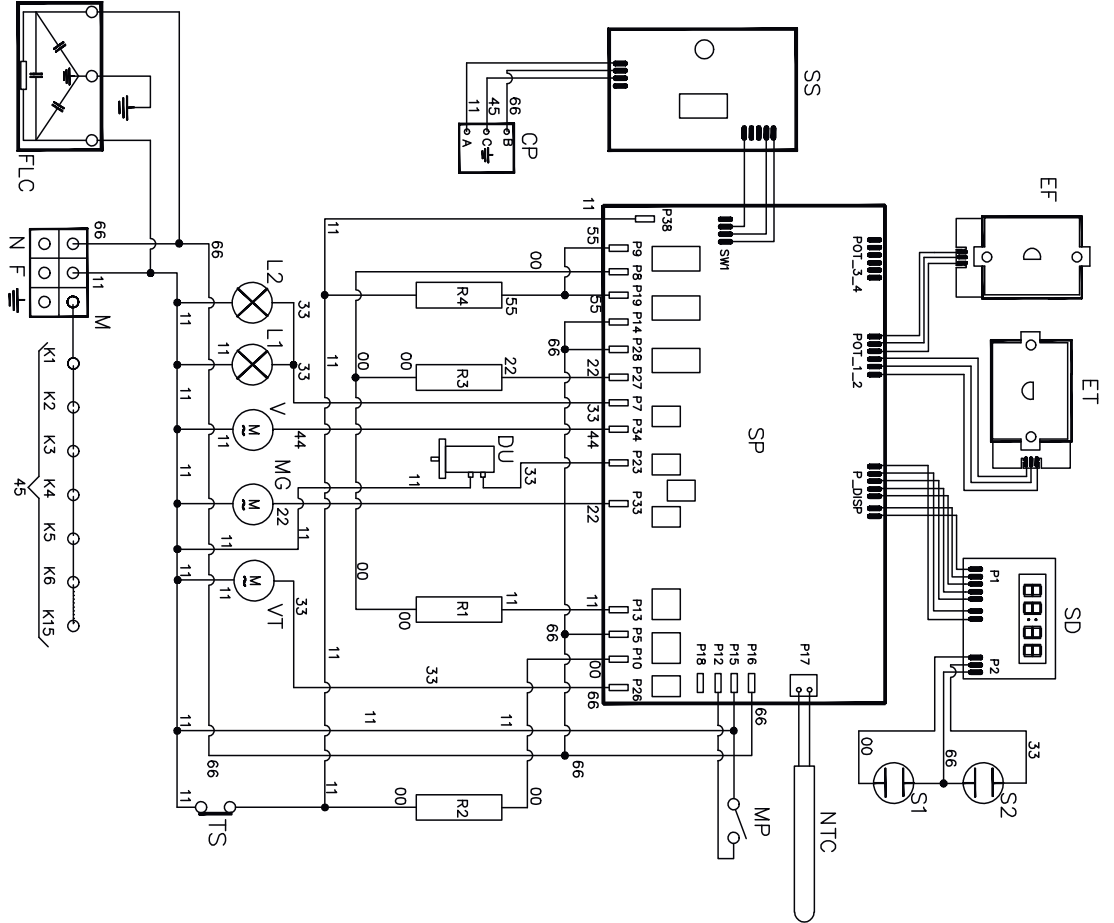

K/L (06-09)...MP

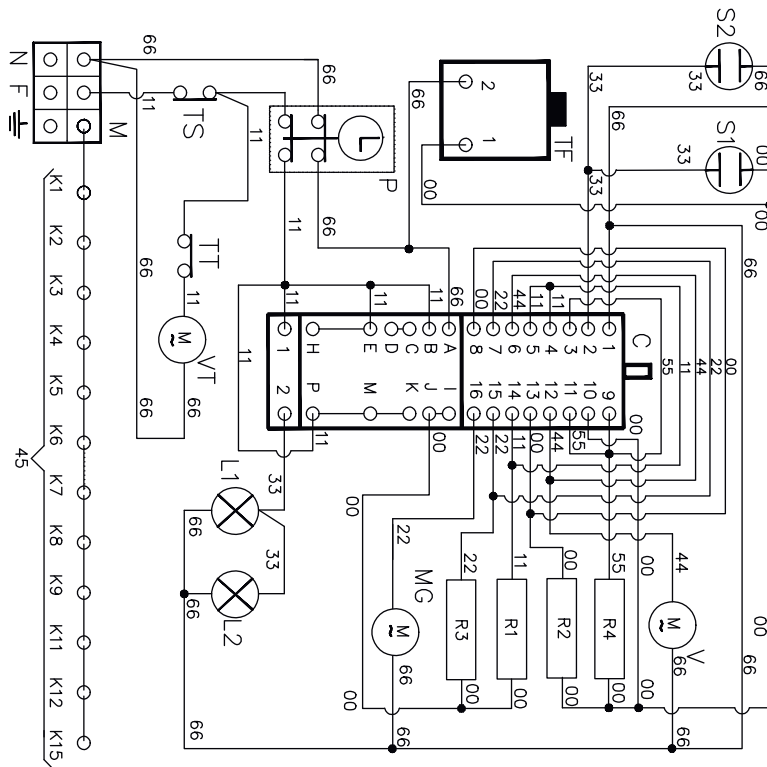

WIRING DIAGRAM

P (06-07-30"-08-09)...H3

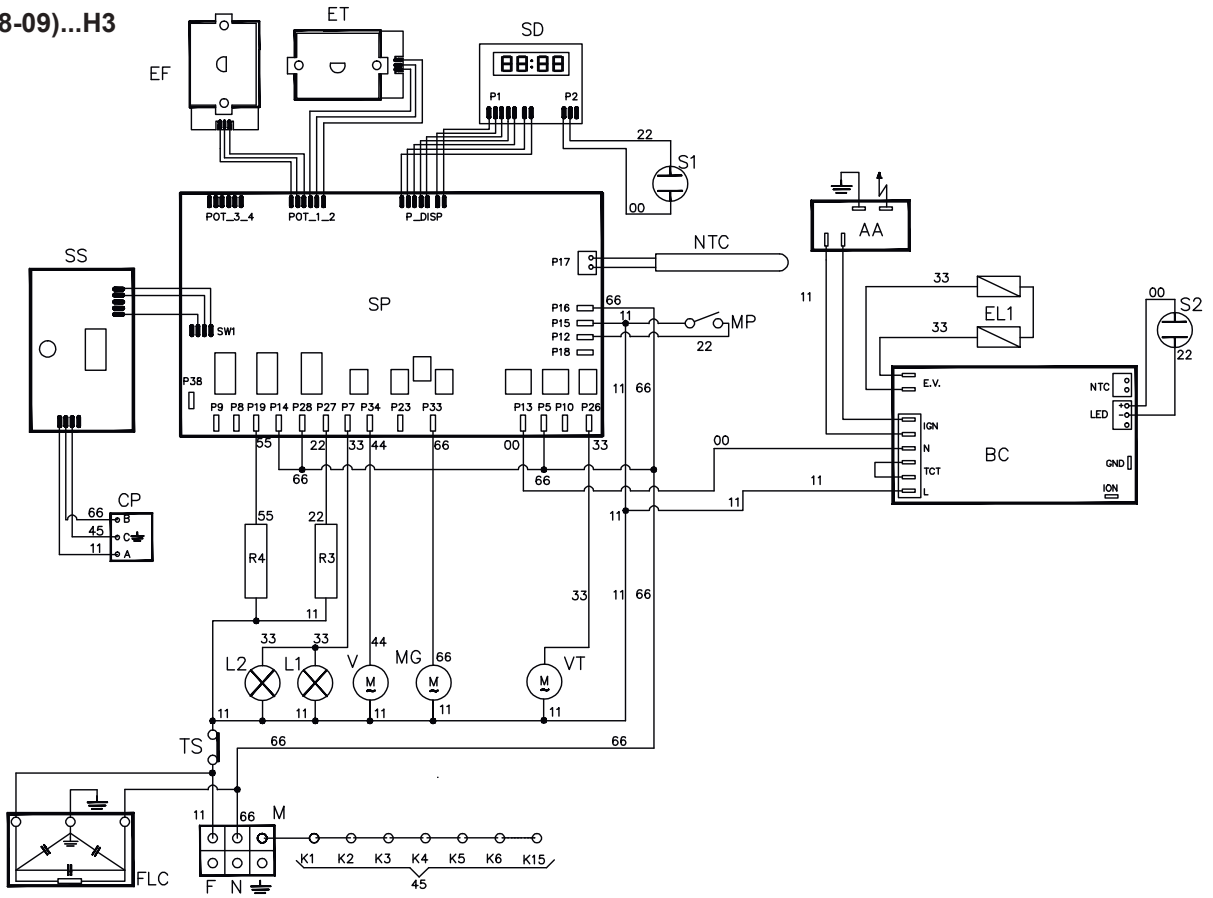

P (06-07-30"-08-09)...G3

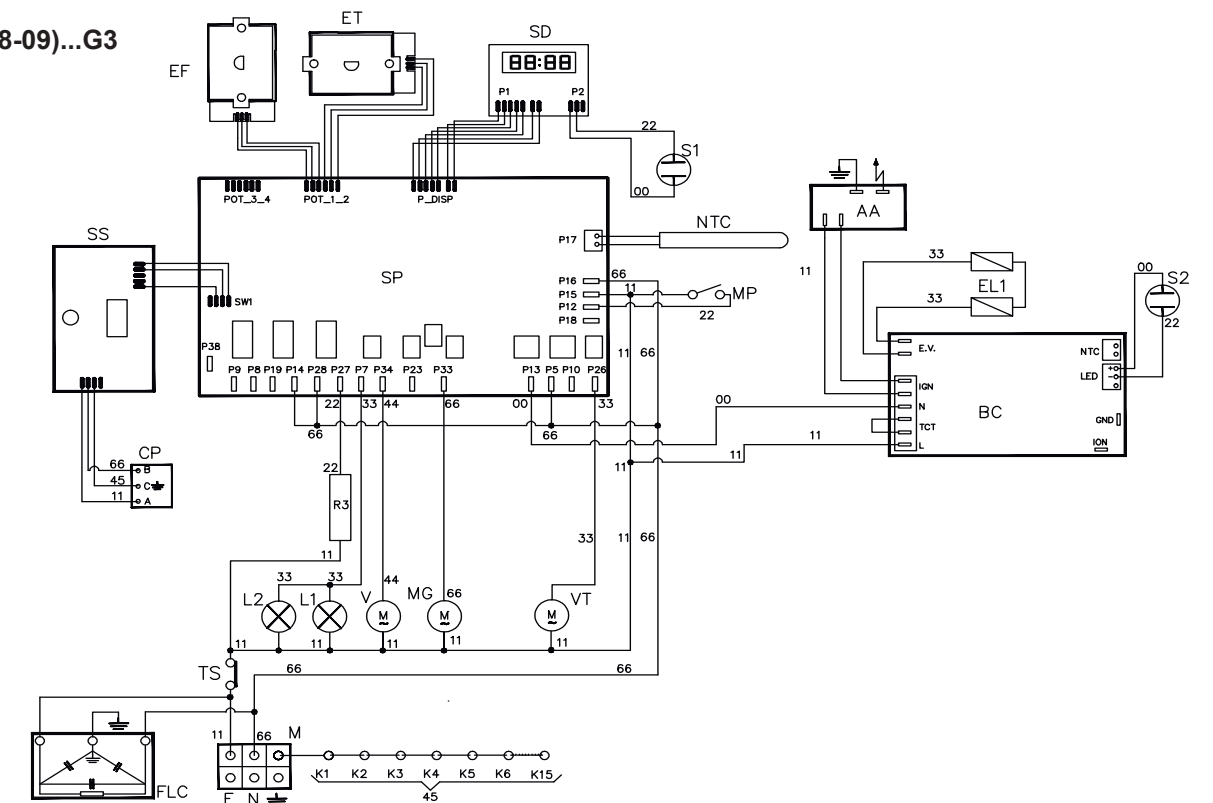

WIRING DIAGRAM

M(07-30''-09)...E3

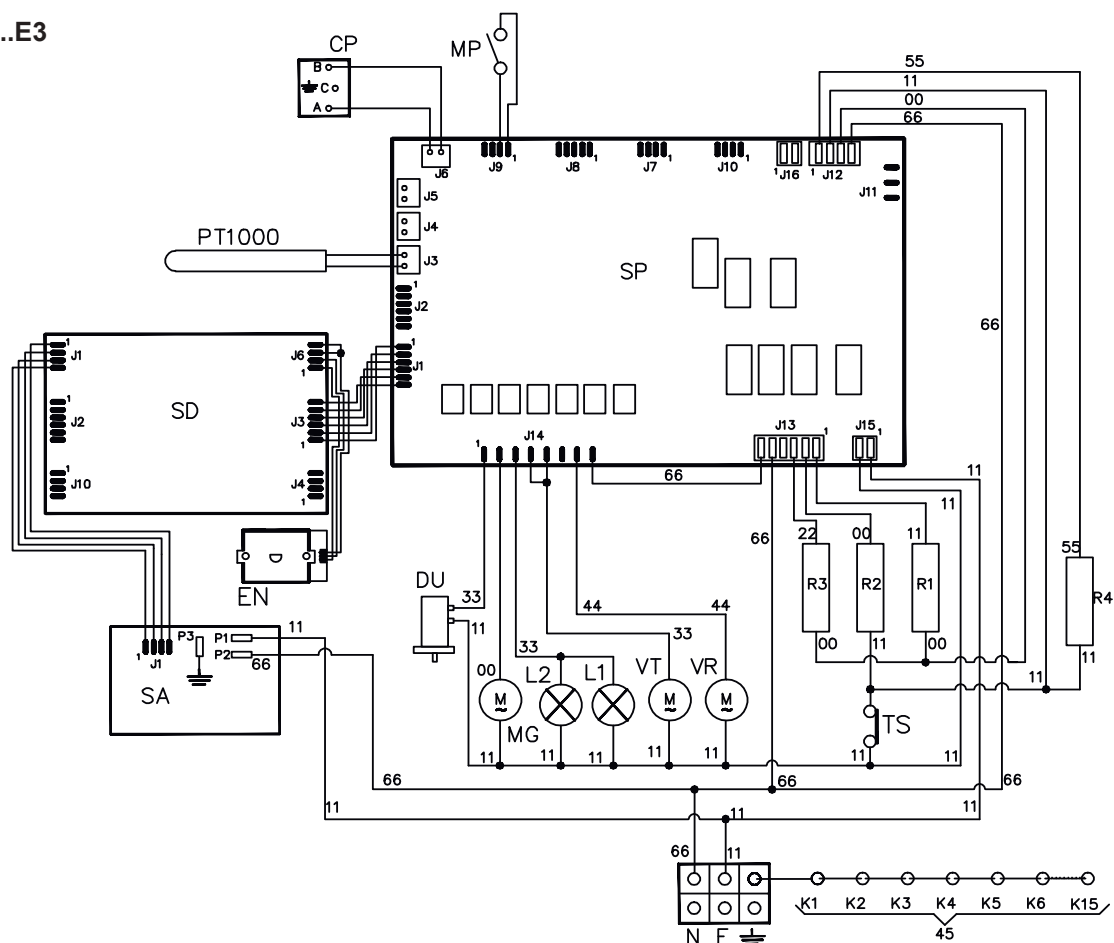

M(07-30''-09)...H3

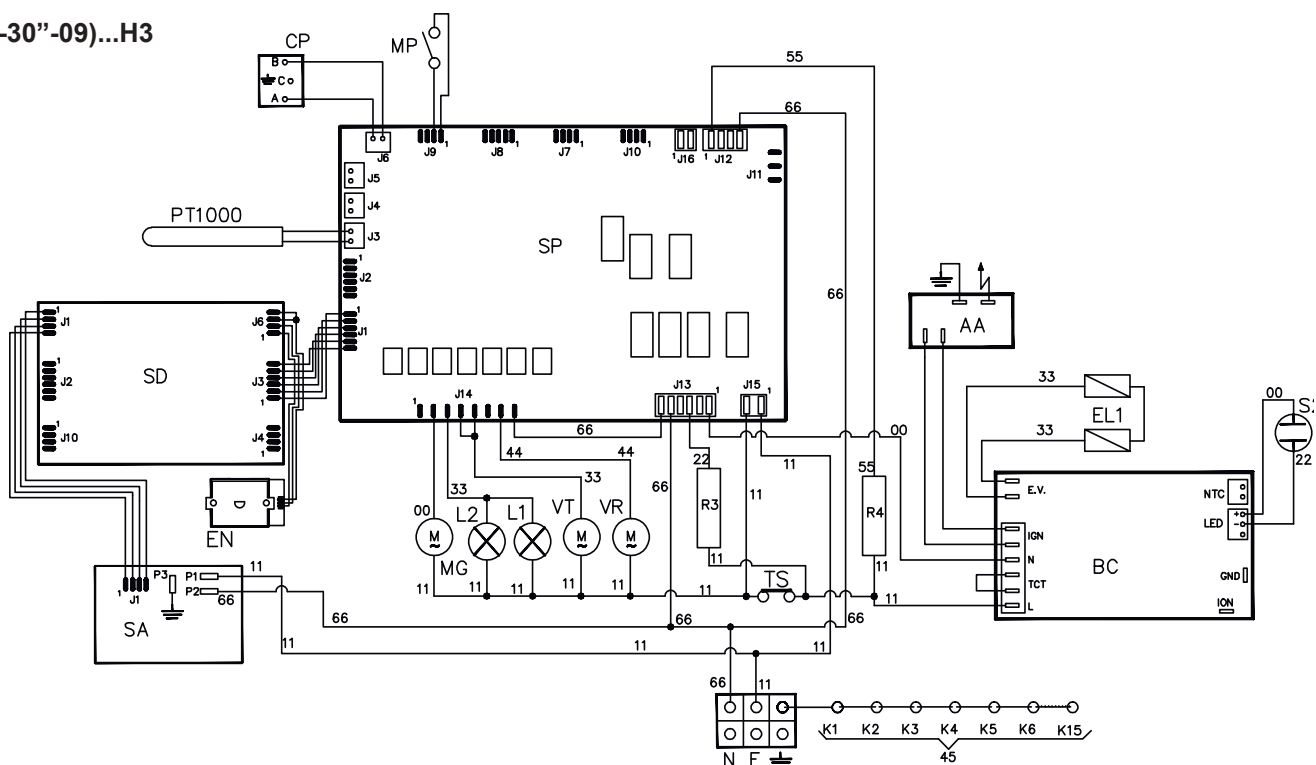

WIRING DIAGRAM

M091..E3

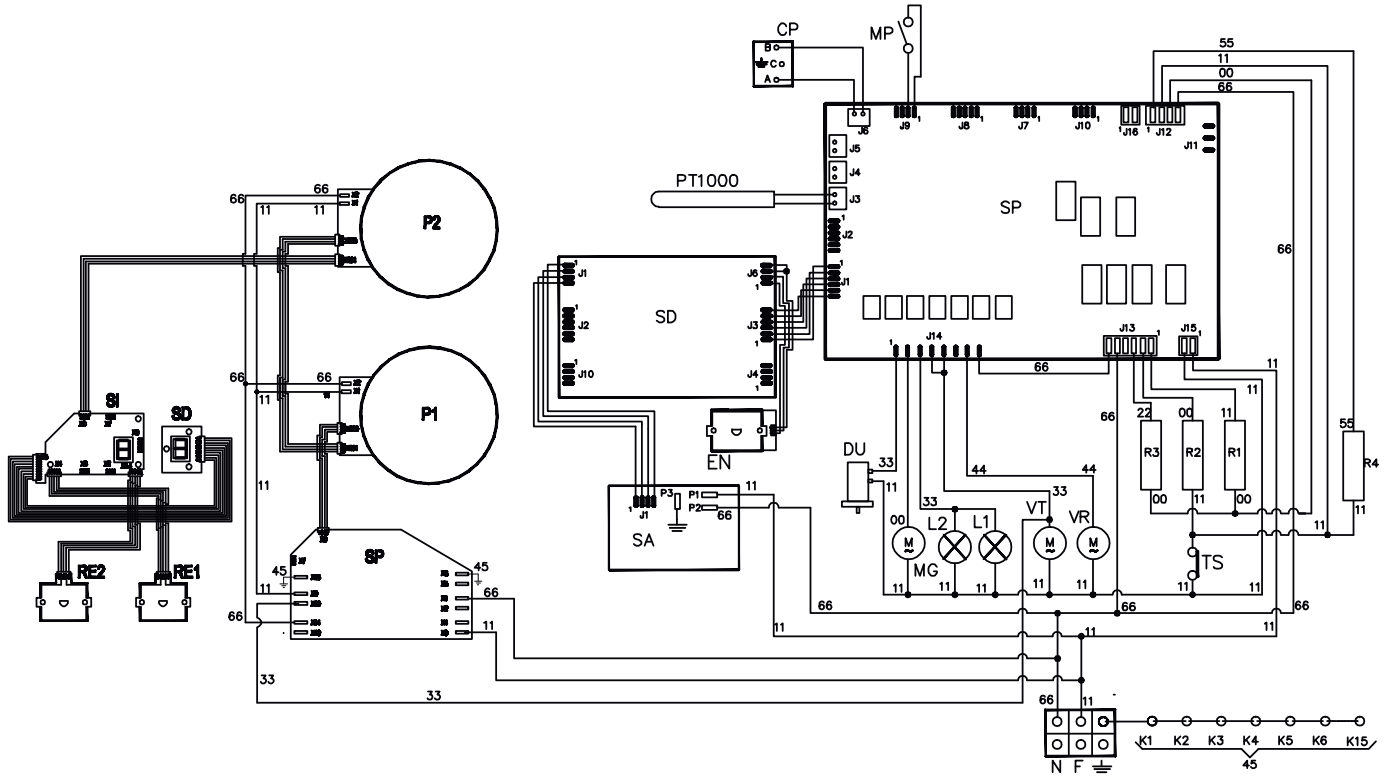

M091..H3

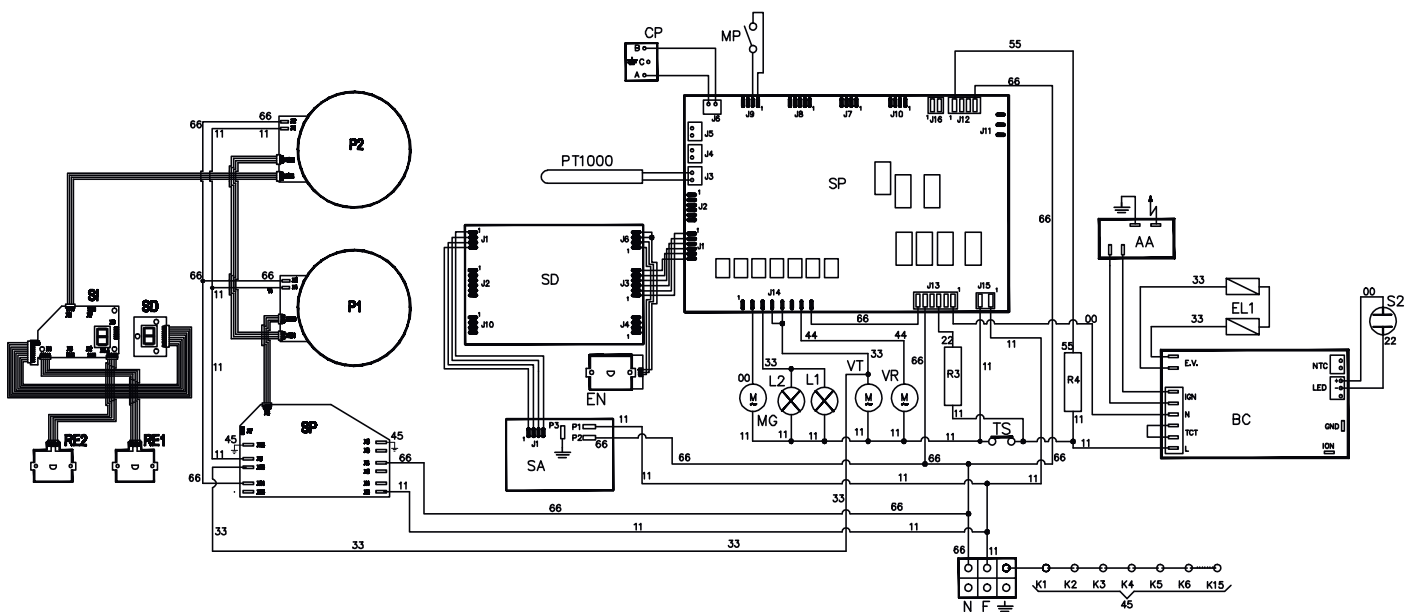

WIRING DIAGRAM

KD/LD (09-10)...MP

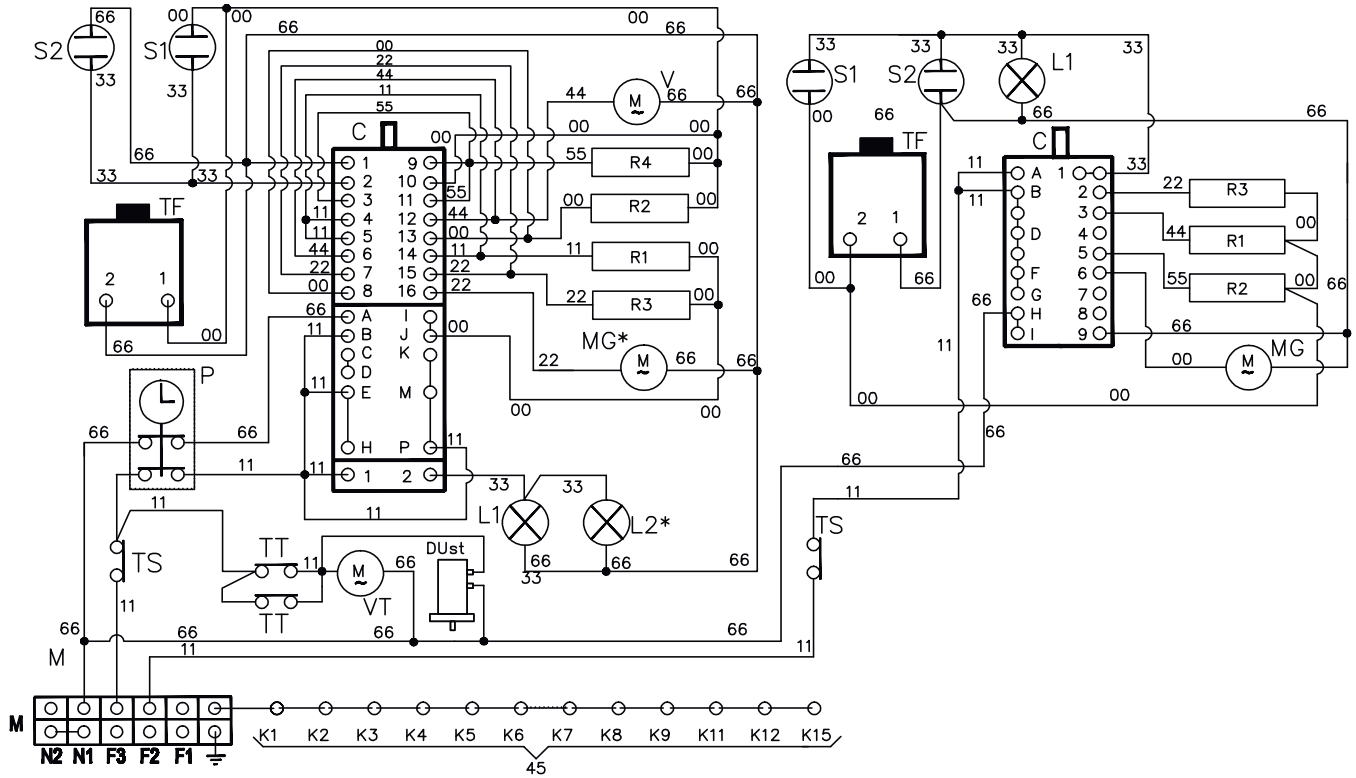

LD (09-10)...G3

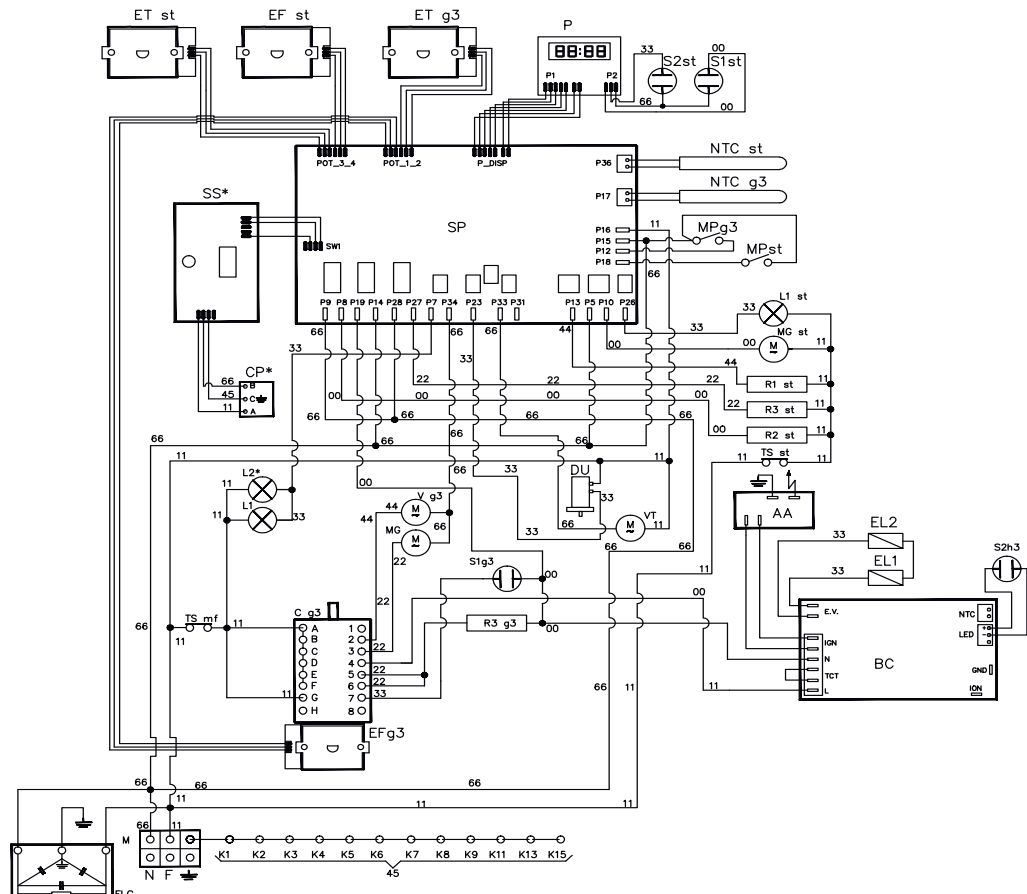

WIRING DIAGRAM

M12I...H3

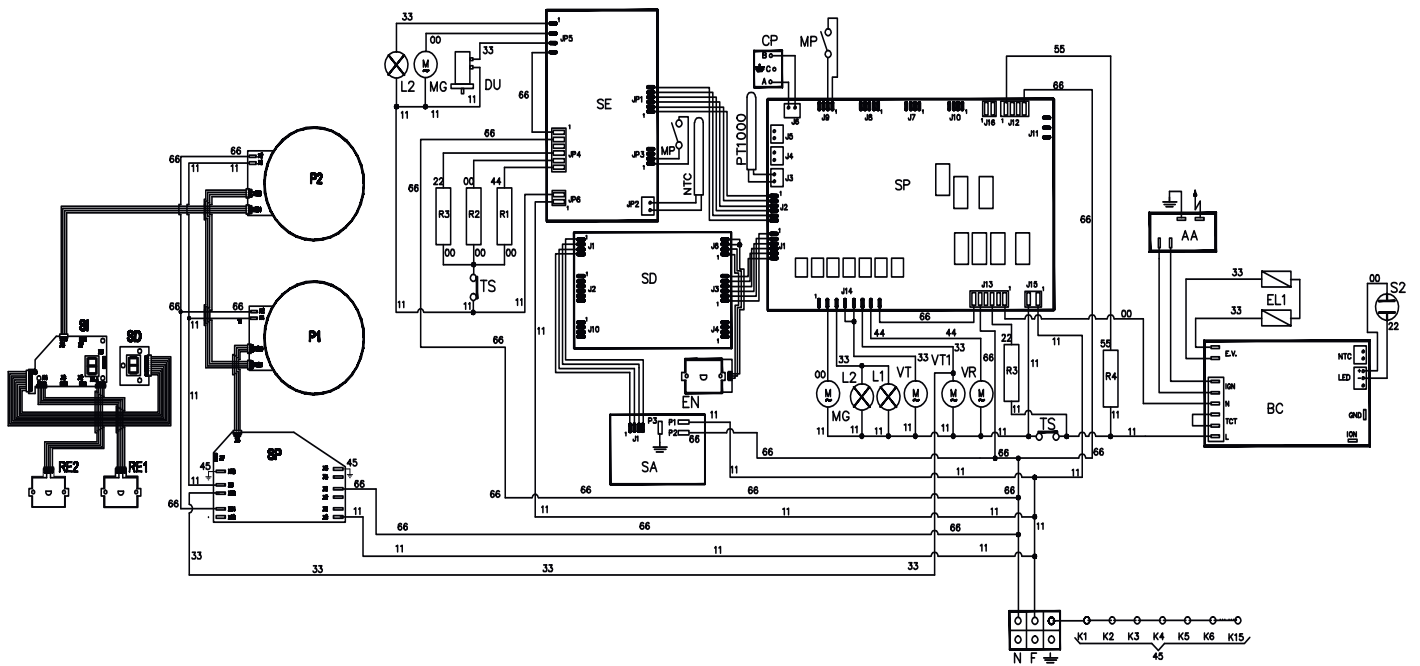

M12...E3

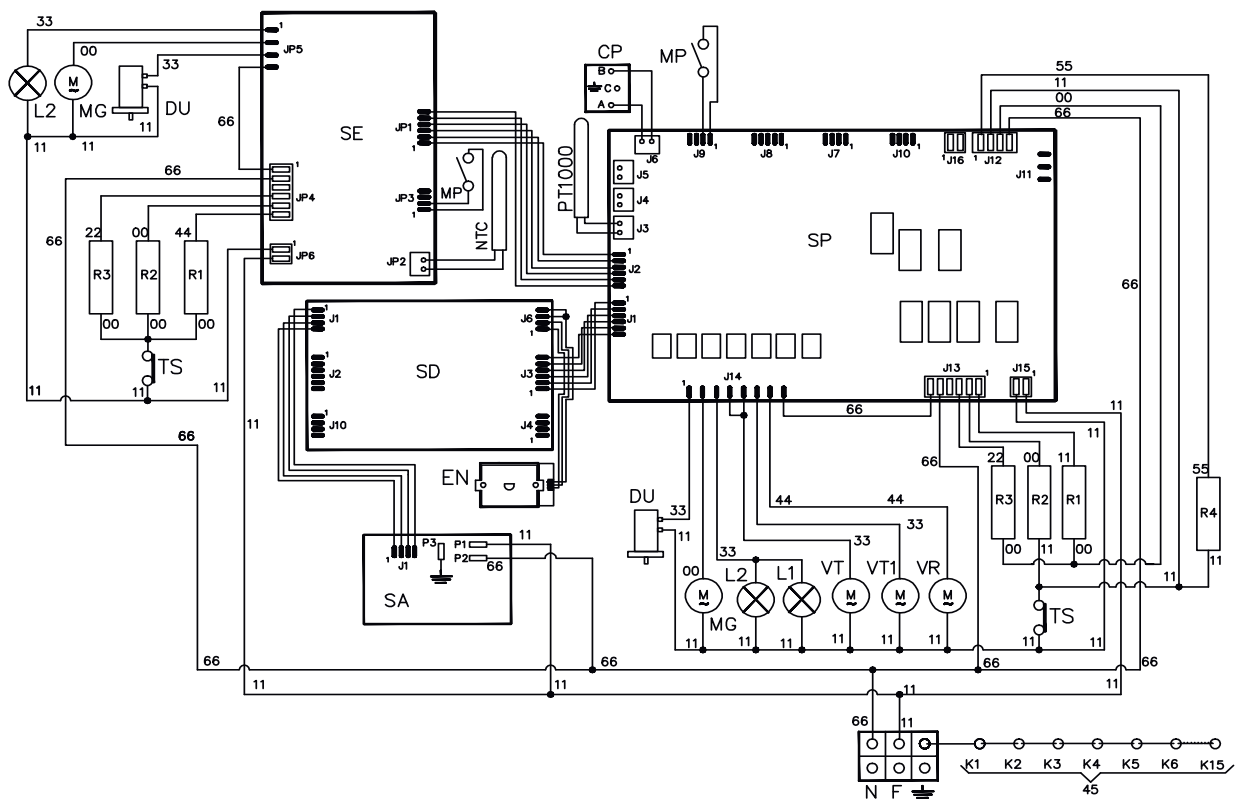

WIRING DIAGRAM

M12...H3

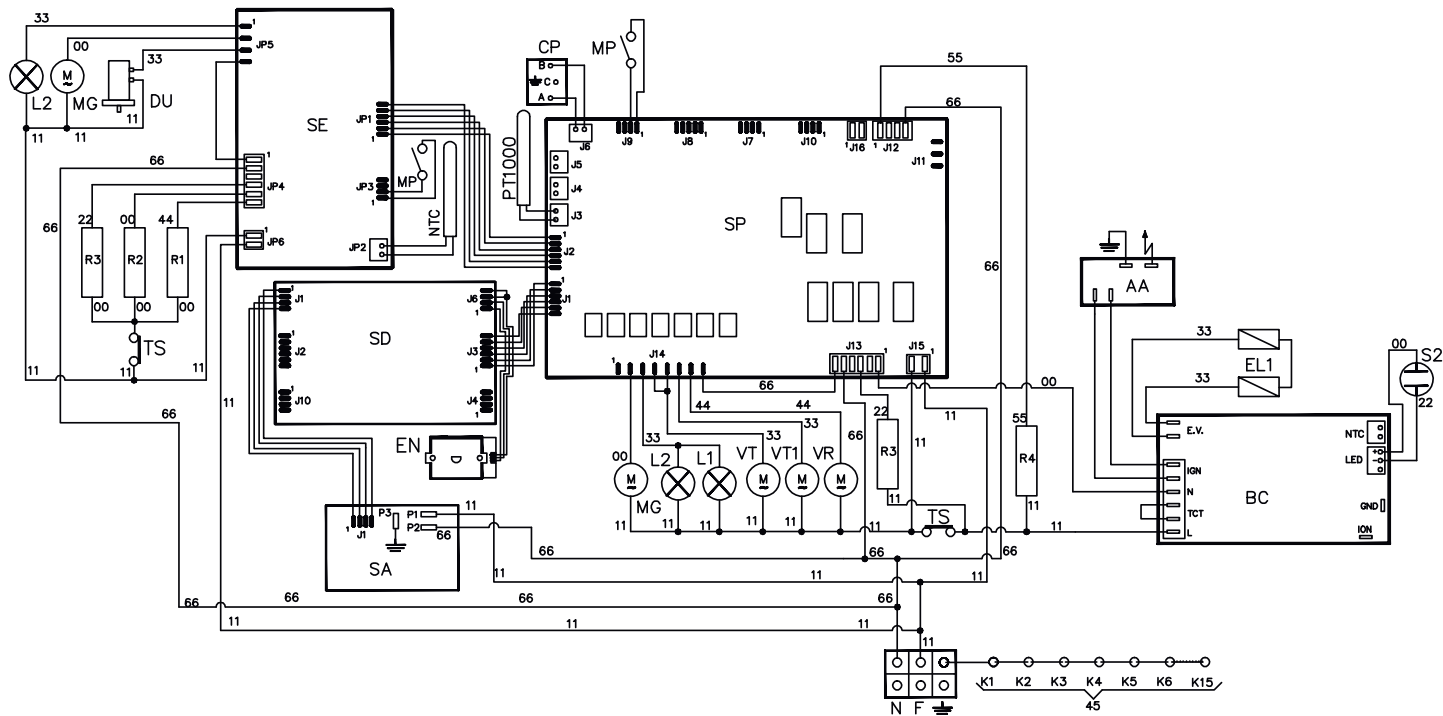

M12I...E3

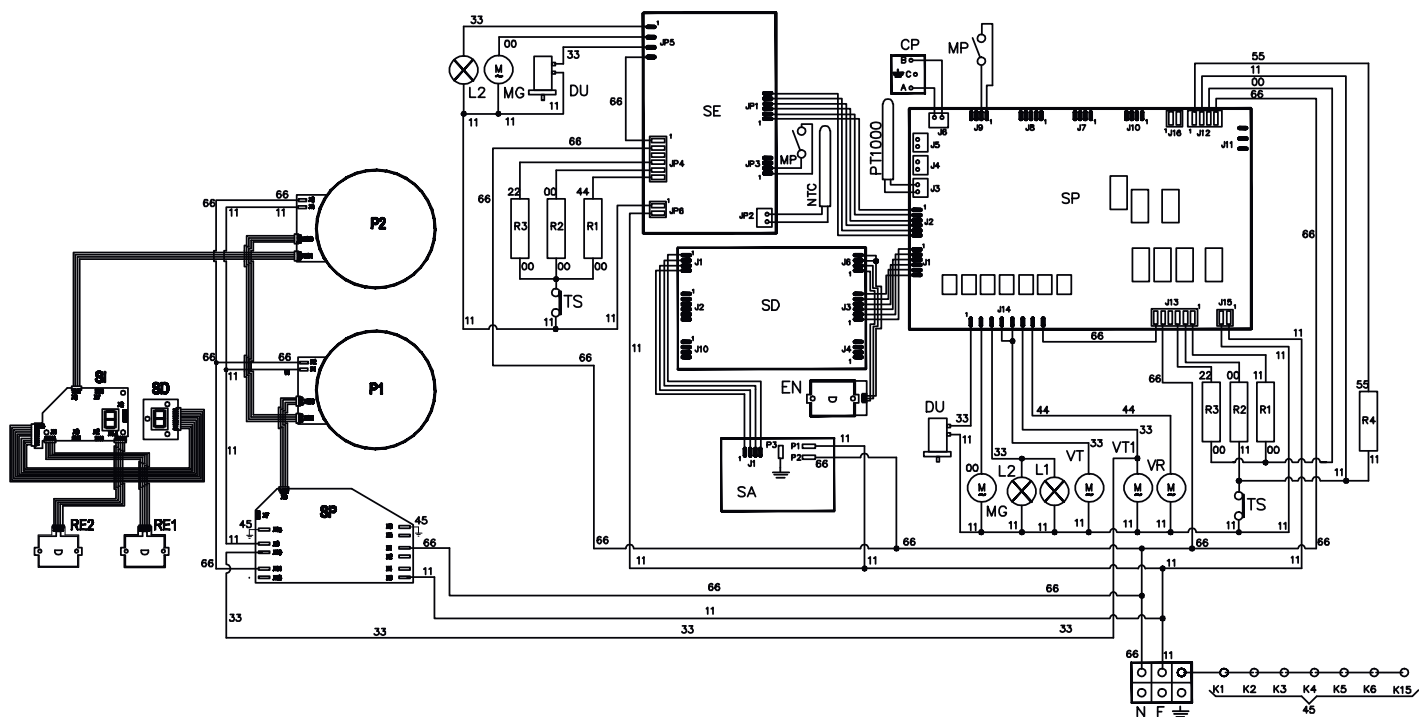

WIRING DIAGRAM

M15...E3

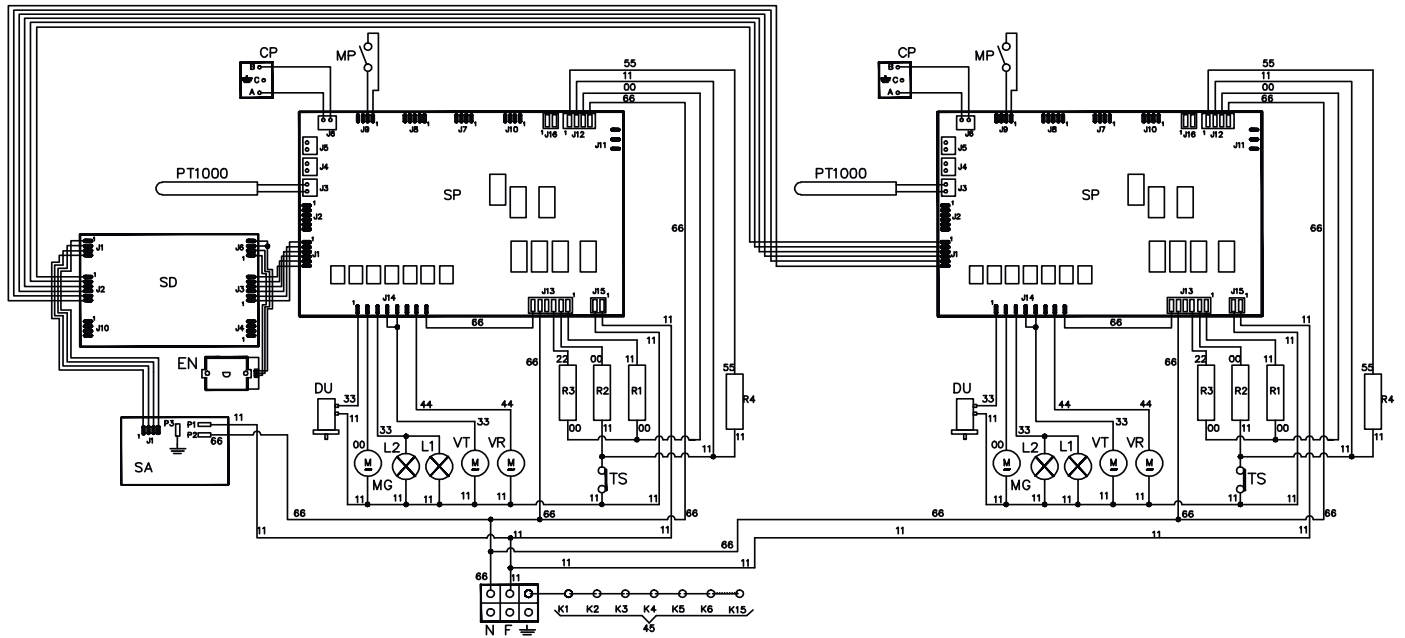

M15...H3

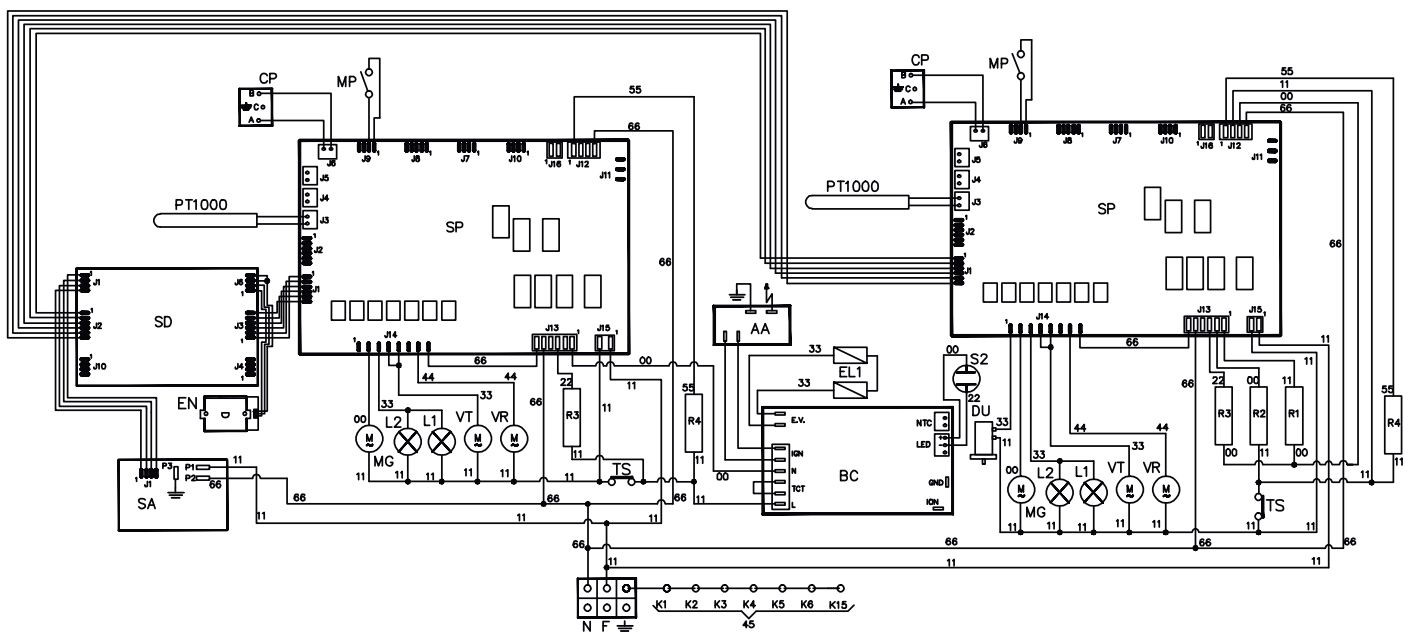

WIRING DIAGRAM

MD10...E3

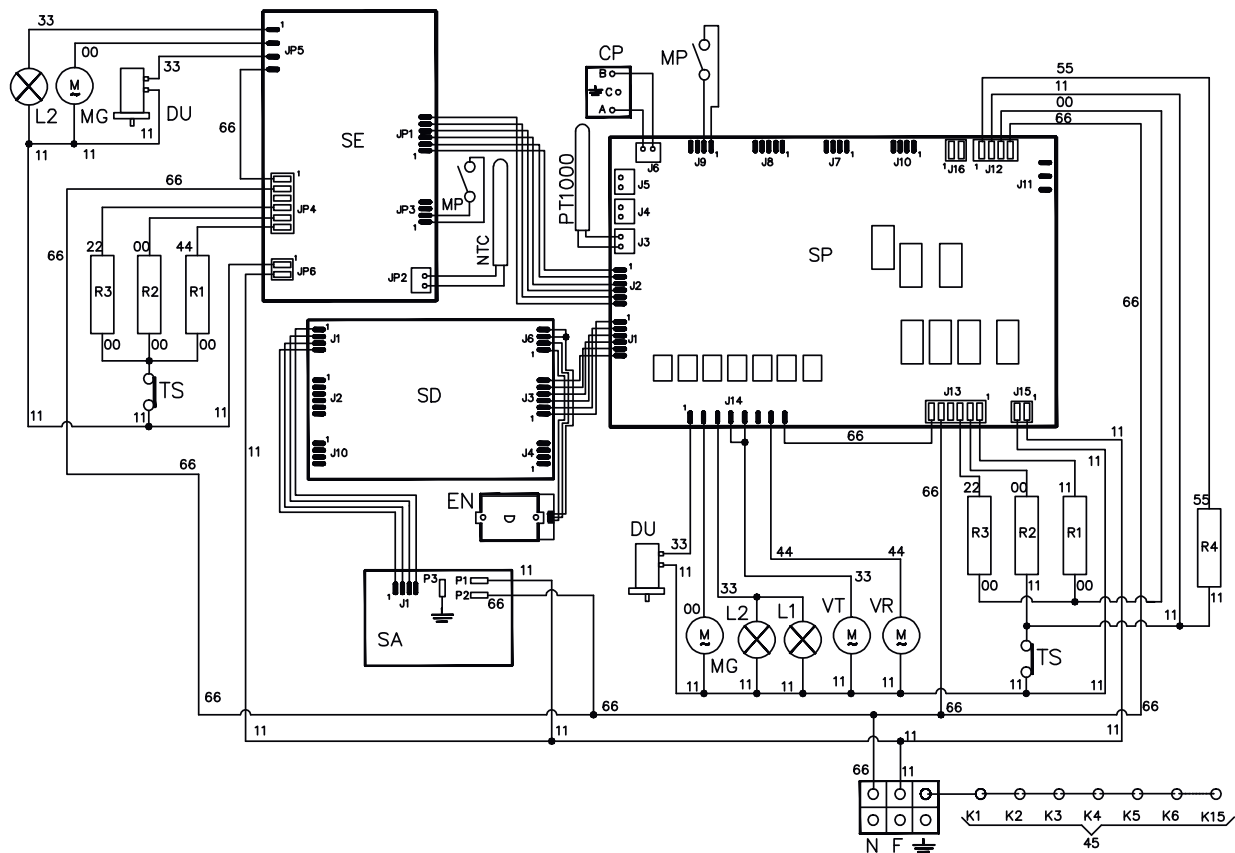

MD10...H3

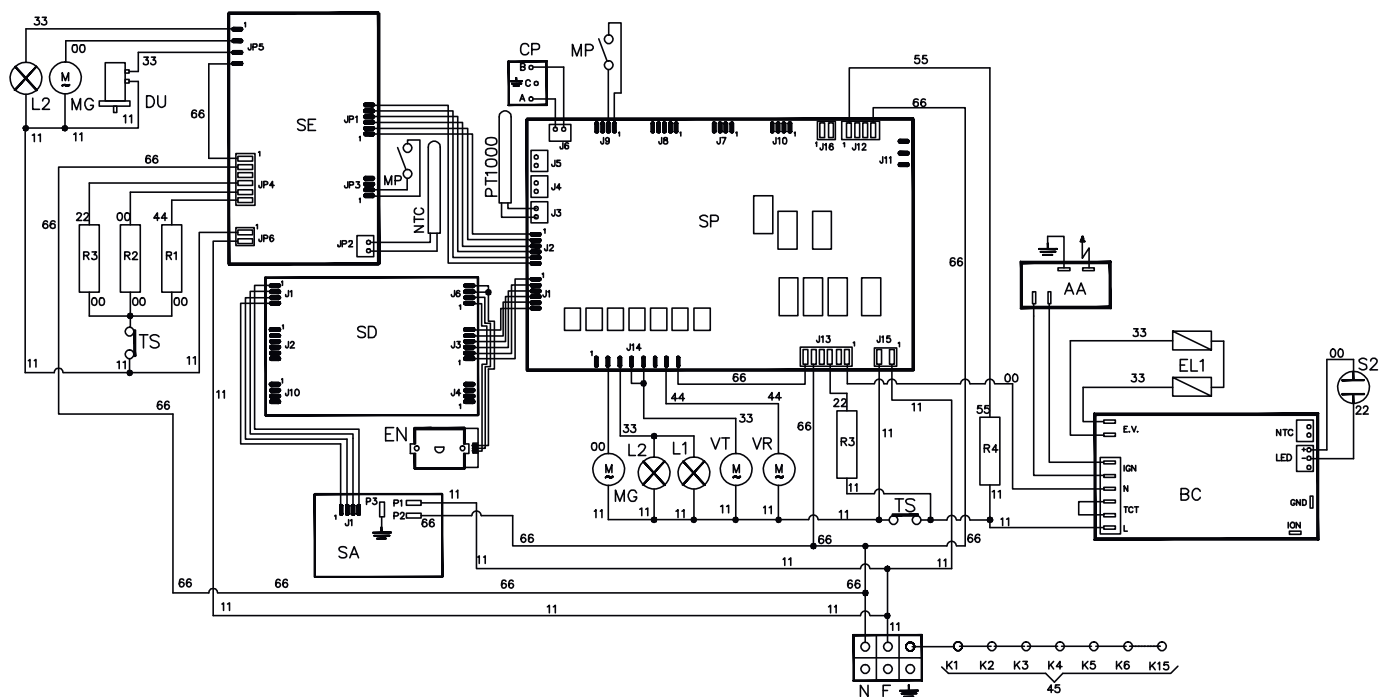

WIRING DIAGRAM

MD10I...E3

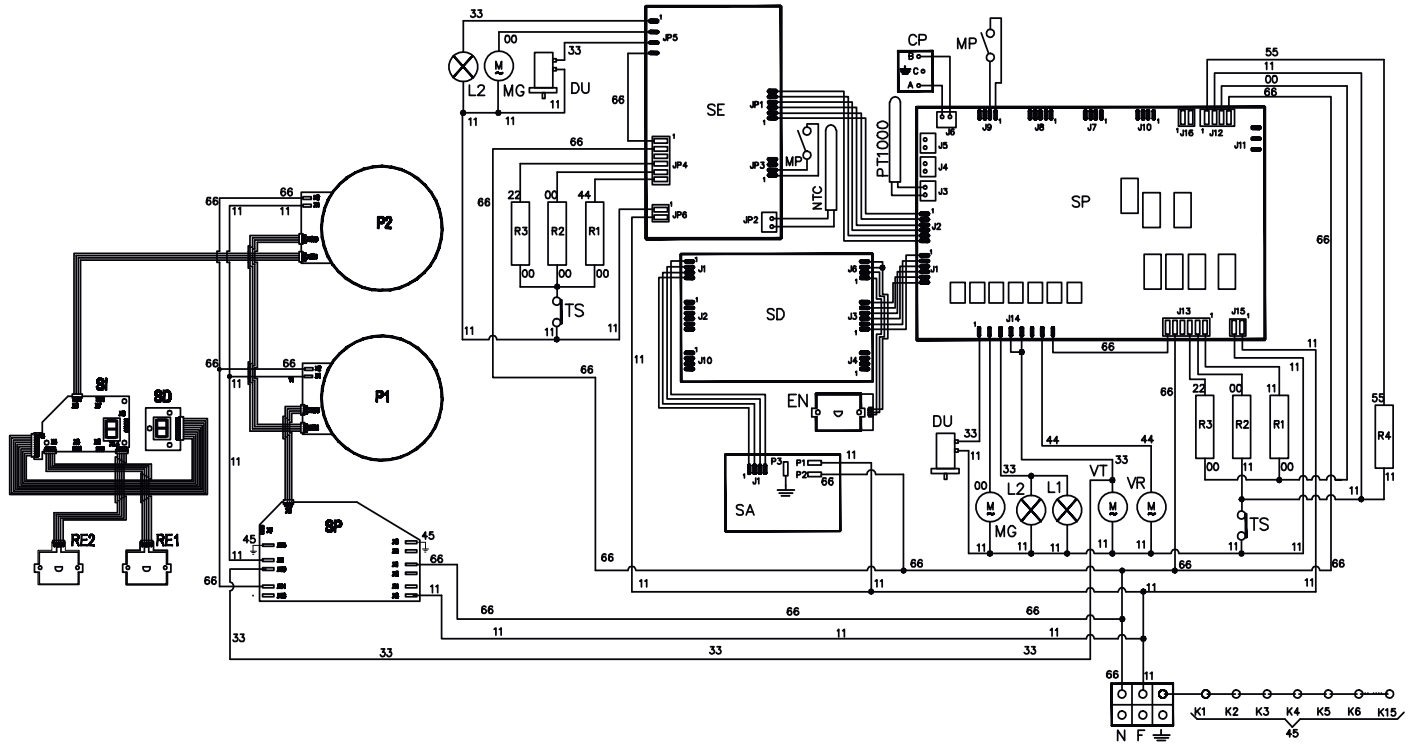

MD10I...H3

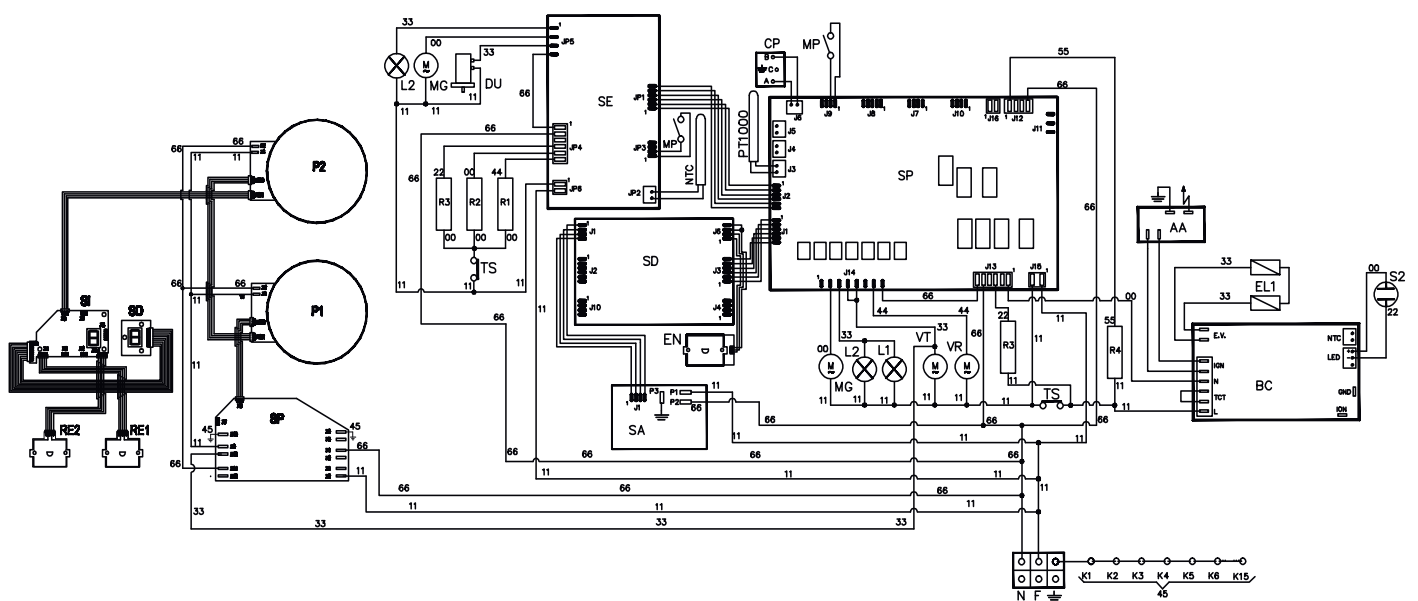

WIRING DIAGRAM

MD12I...E3

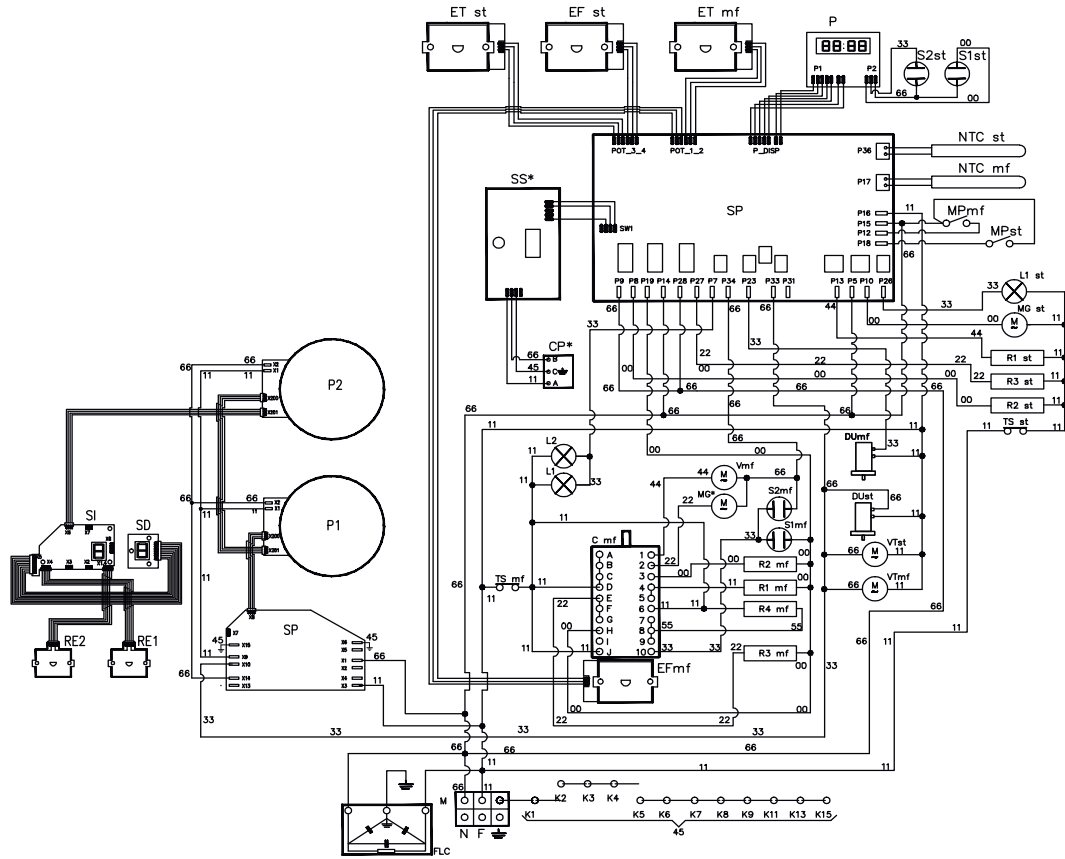

MD12I...H3

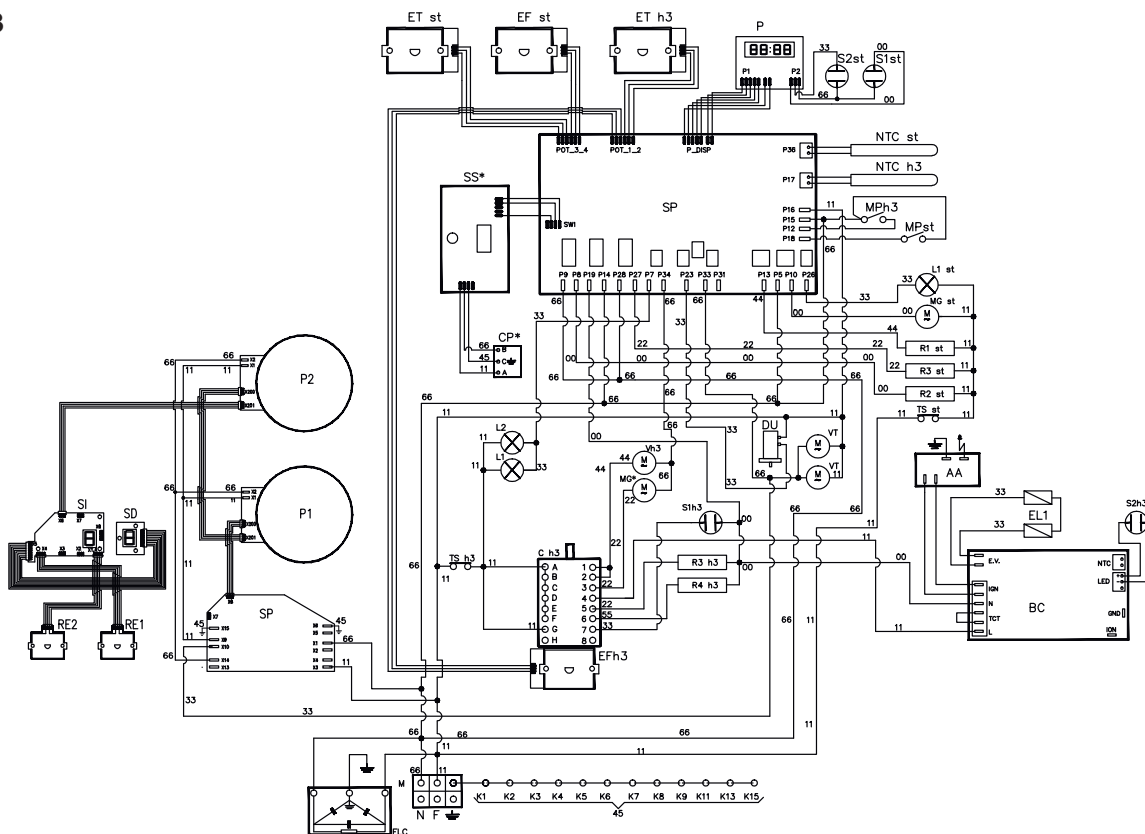

WIRING DIAGRAM

MD12...E3

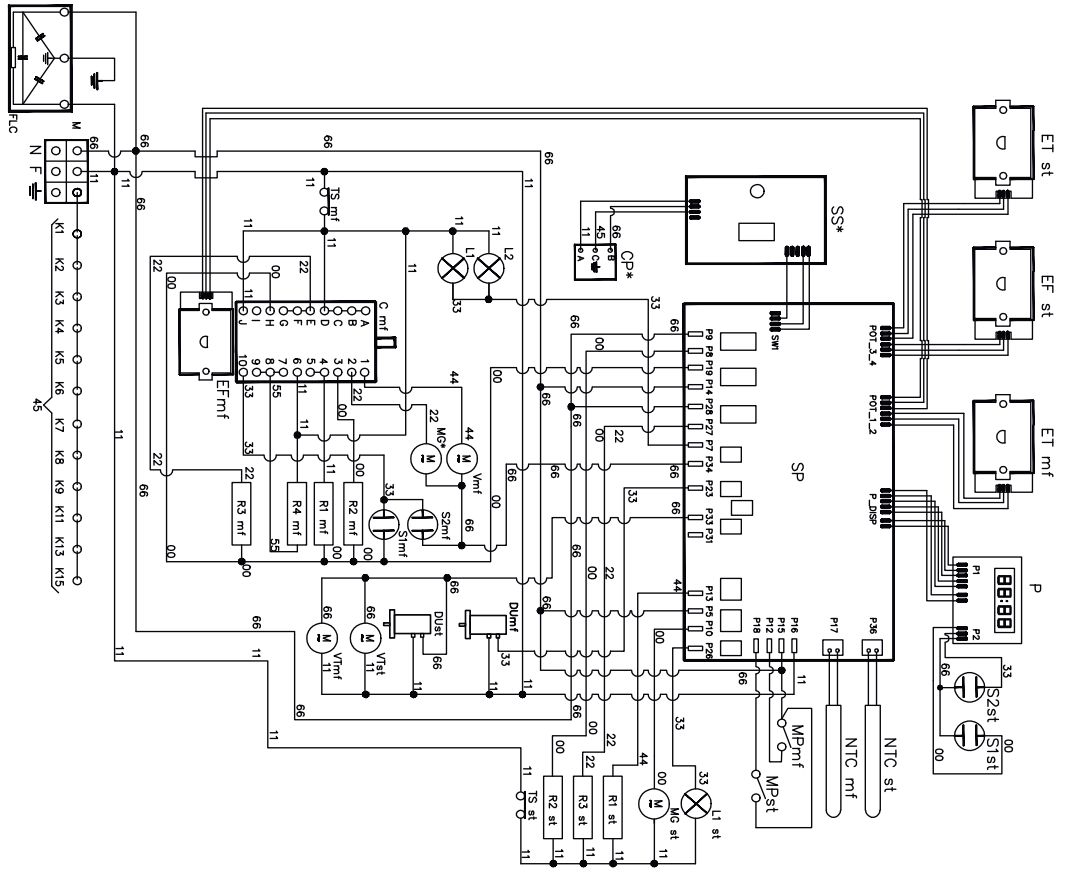

MD12...H3

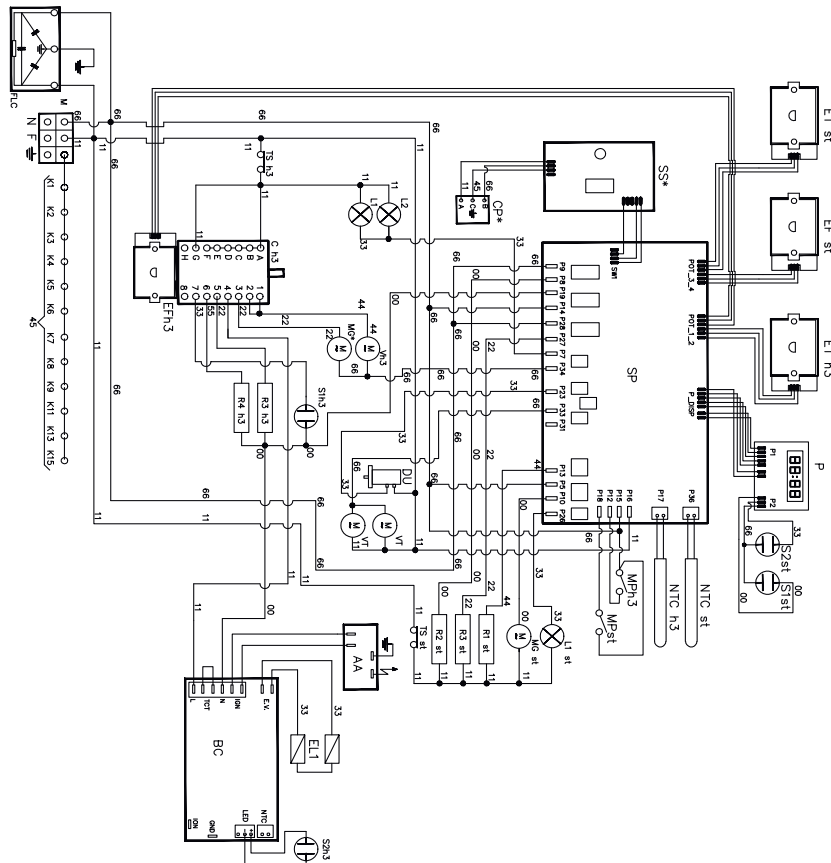

WIRING DIAGRAM

P12...IE3

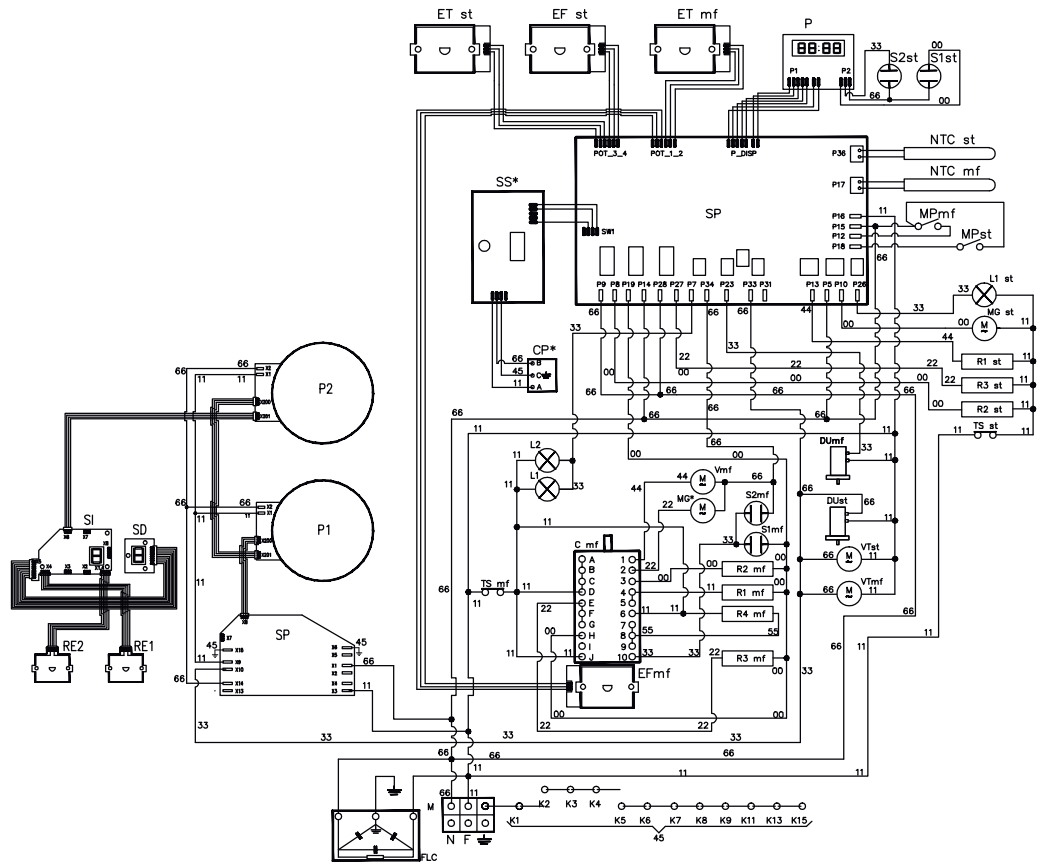

P12...IH3

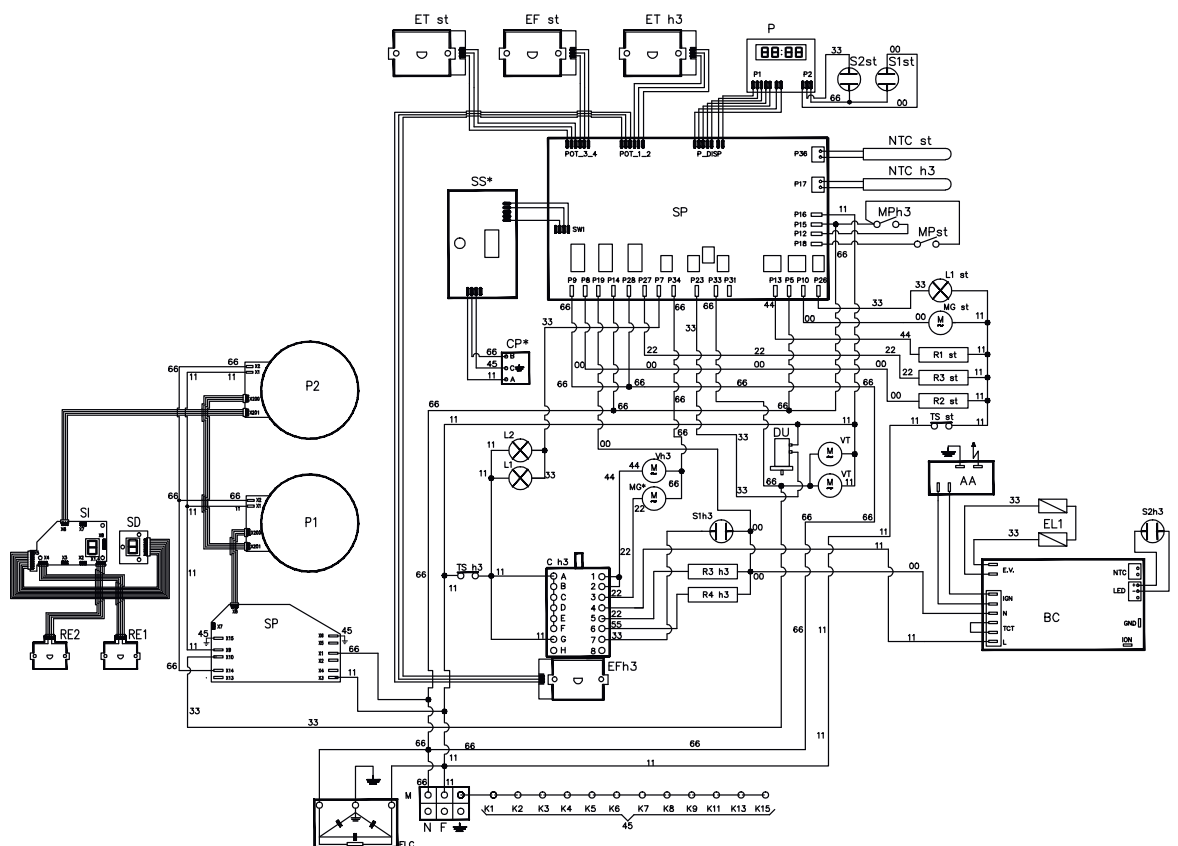

WIRING DIAGRAM

P12...E3

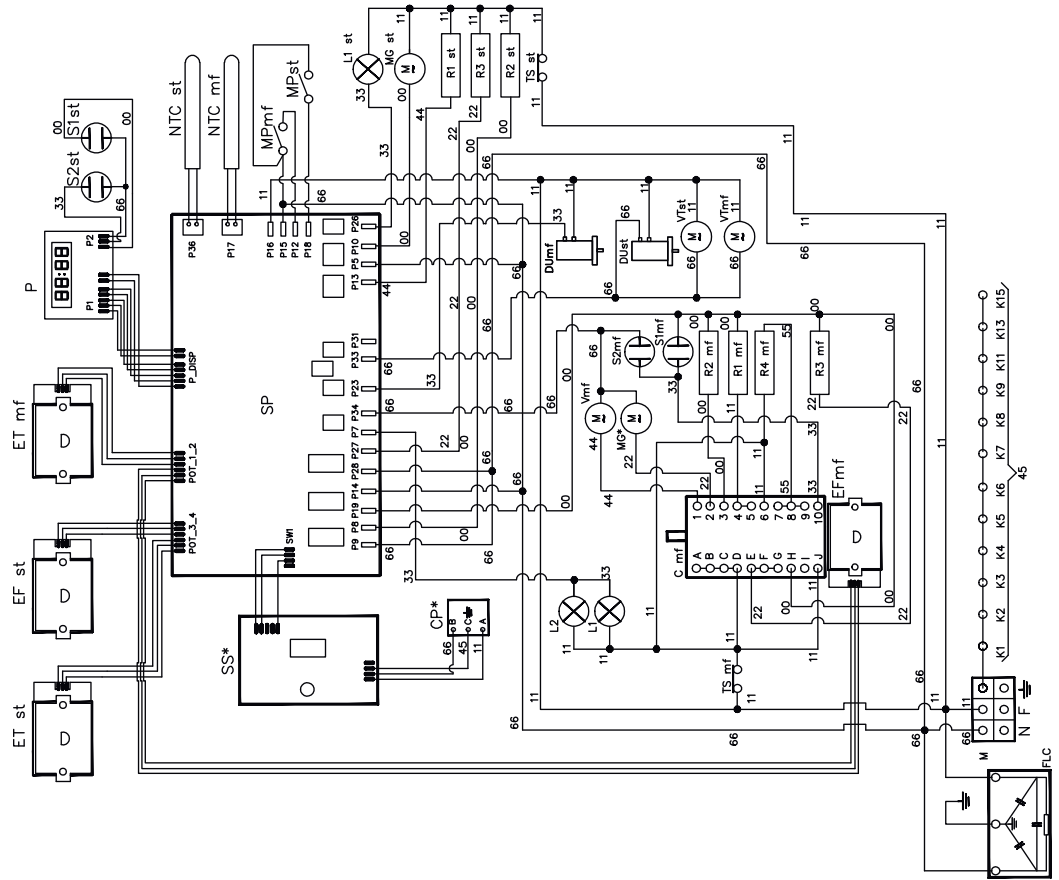

P12...H3

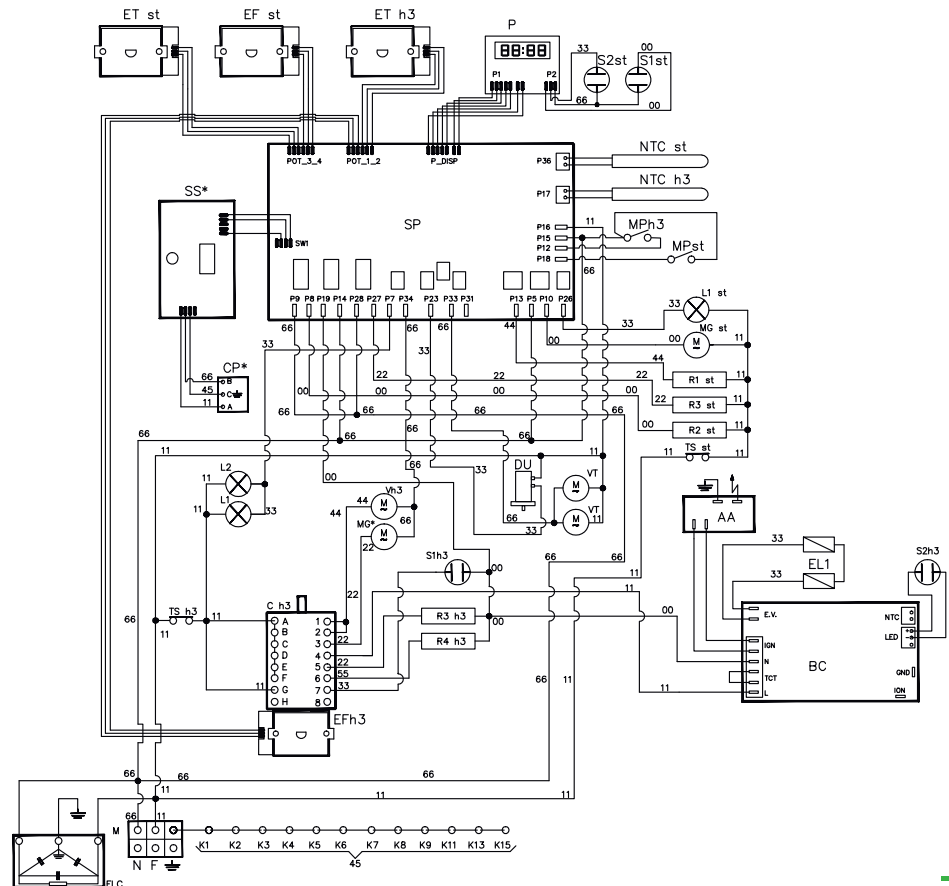

WIRING DIAGRAM

P15/PD12...E3

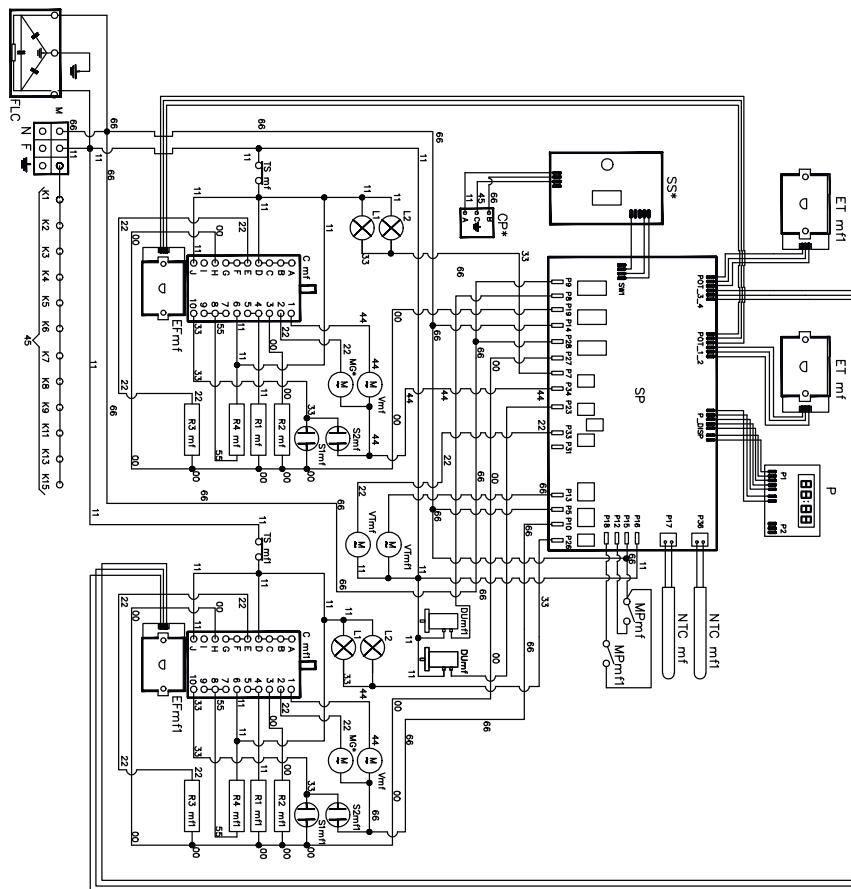

P15/PD12...H3

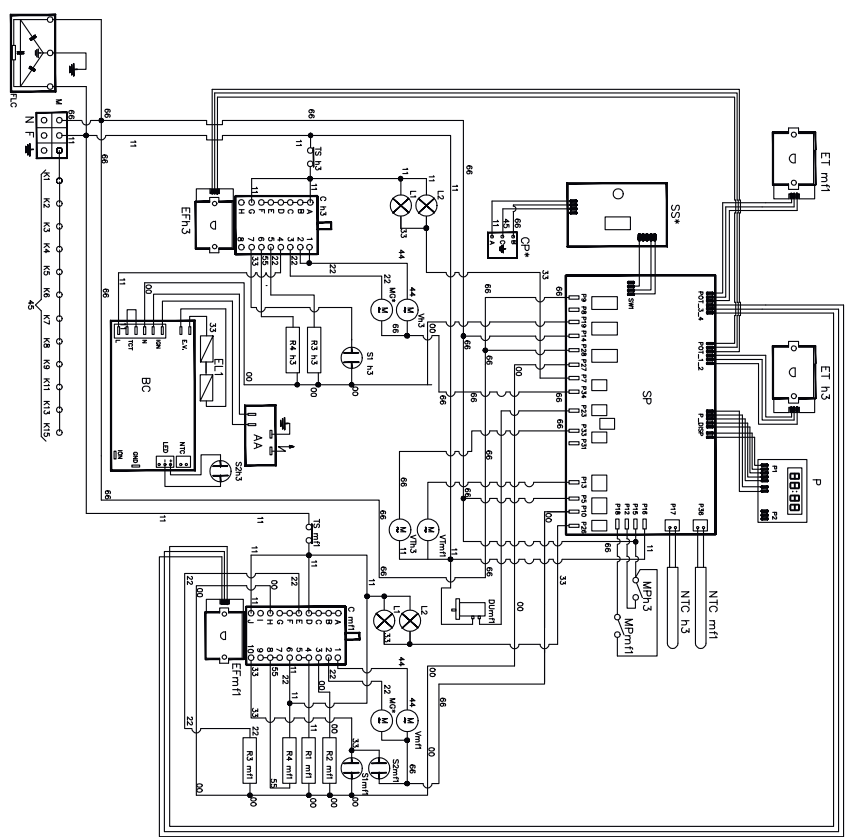

WIRING DIAGRAM

PD(09/10)I...E3

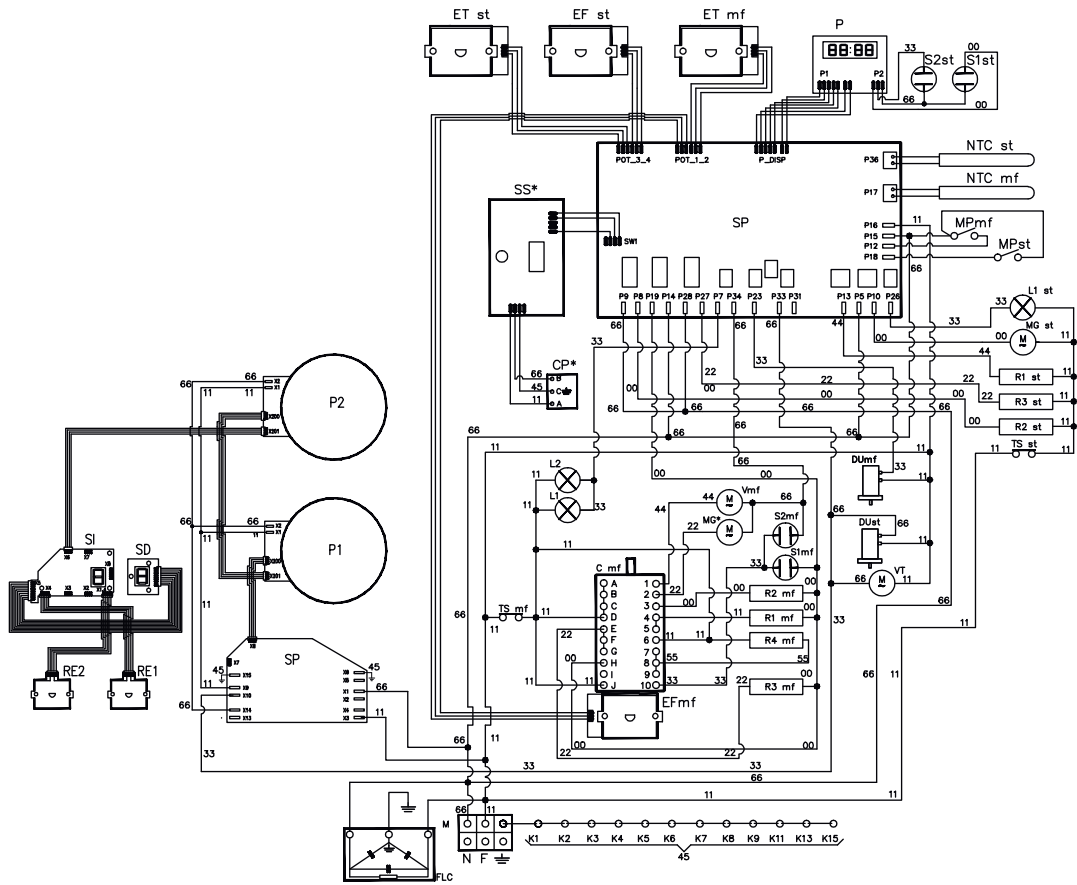

PD(09/10)...E3

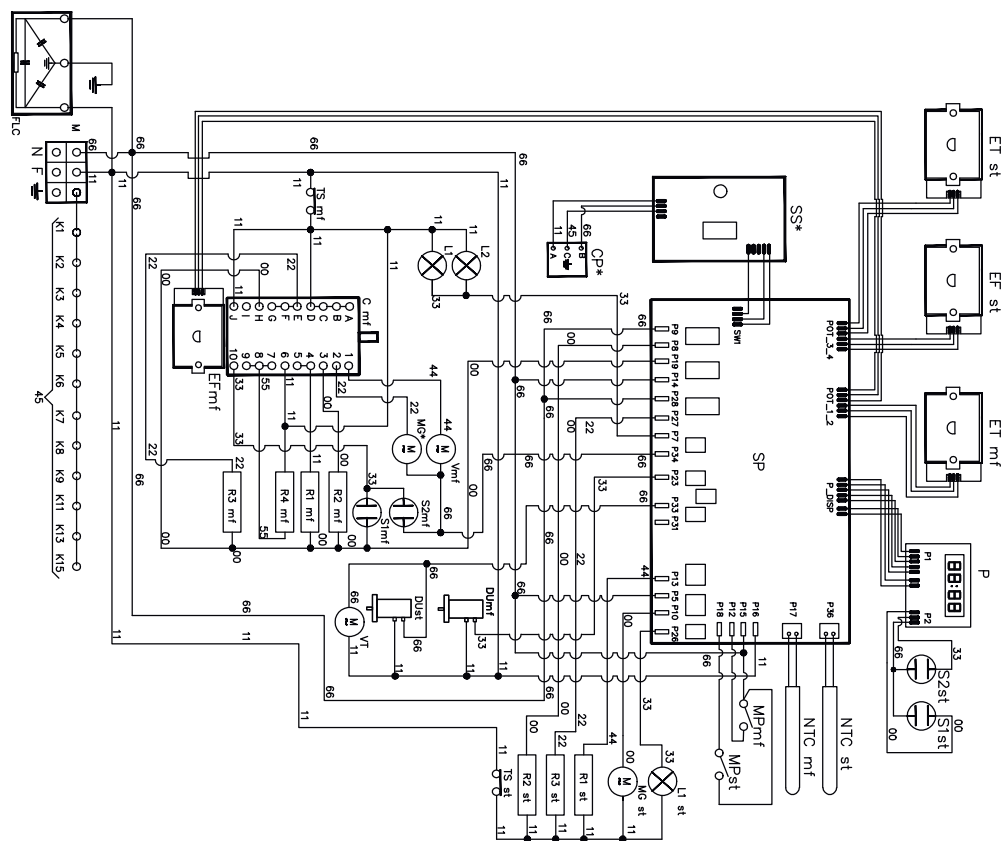

WIRING DIAGRAM

PD/LD(09-10)...H3

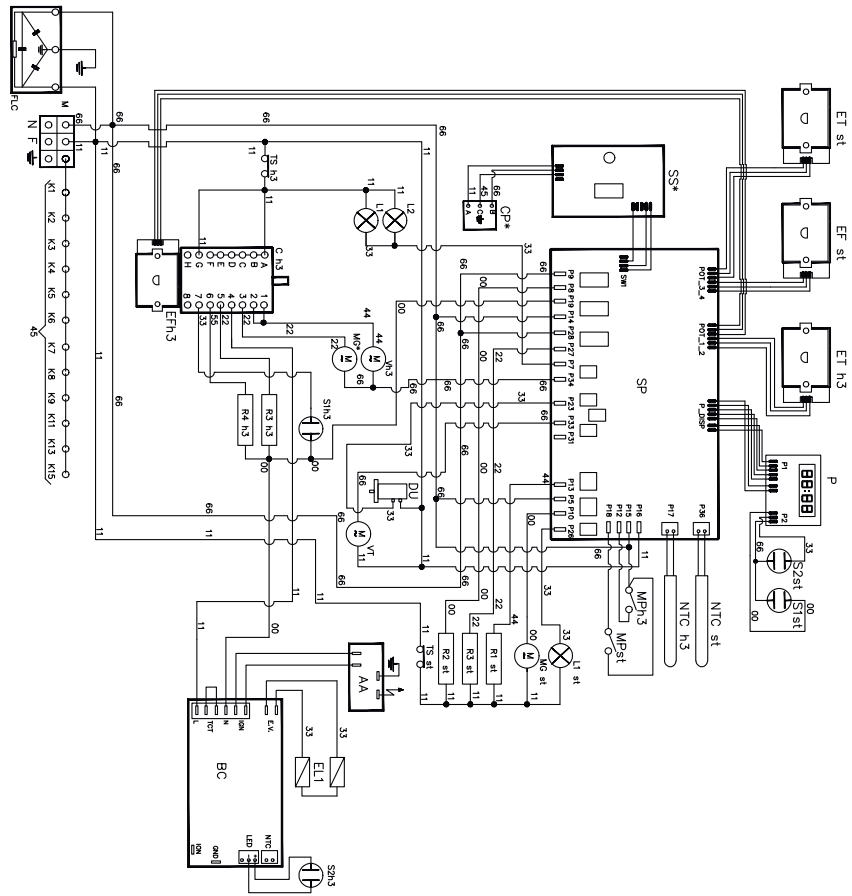

PD/LD(09-10)l...H3

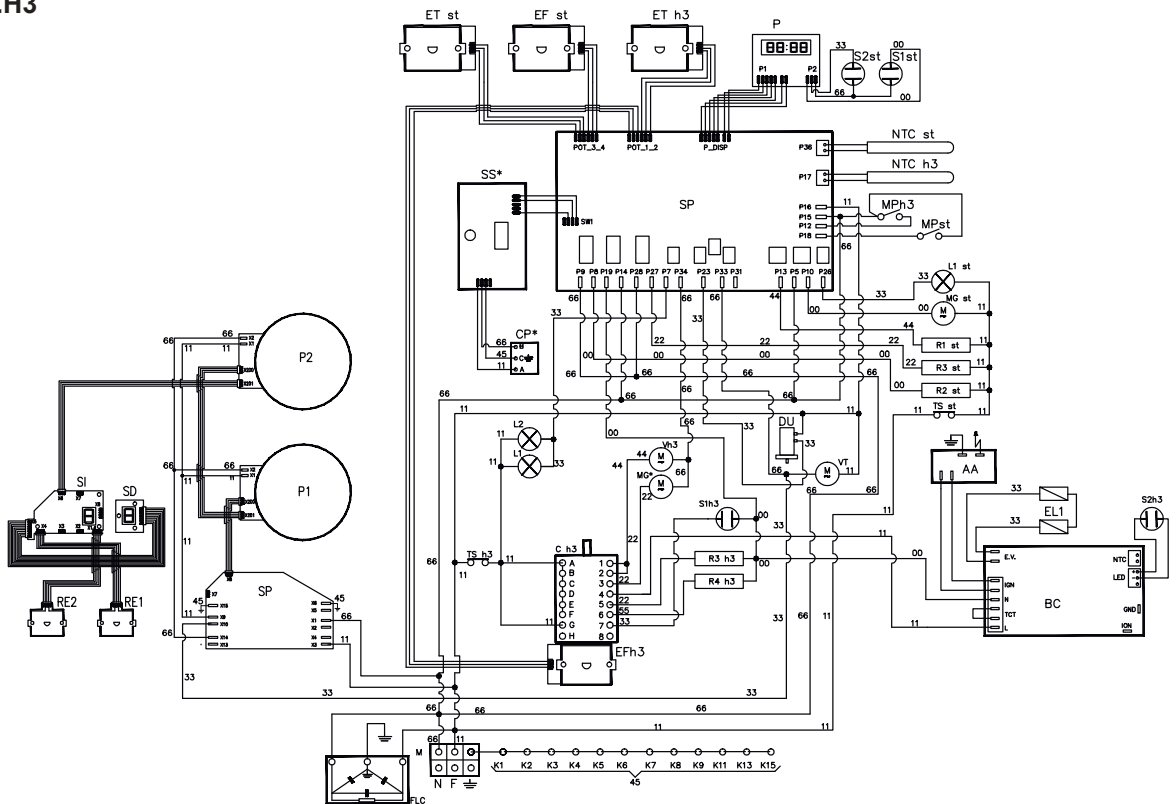

WIRING DIAGRAM

PD12I...E3

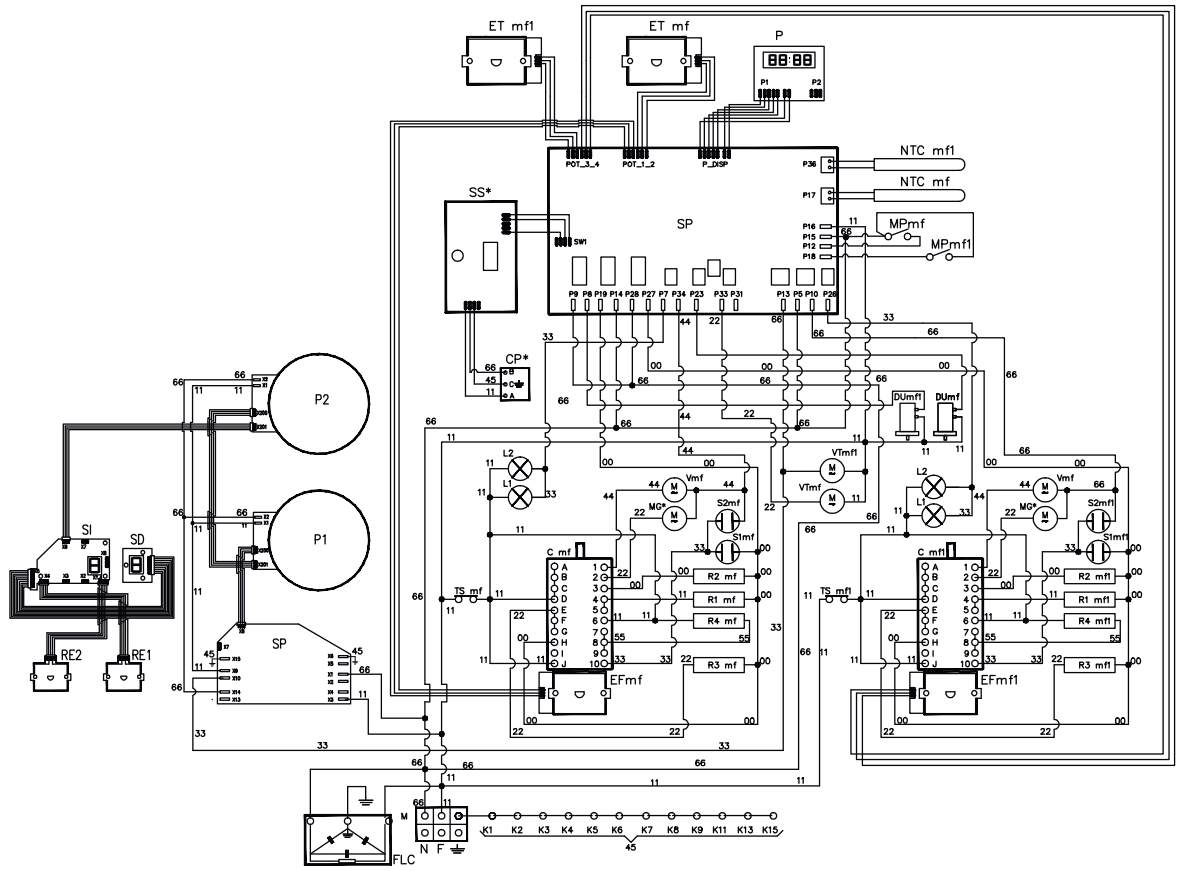

PD12I...H3

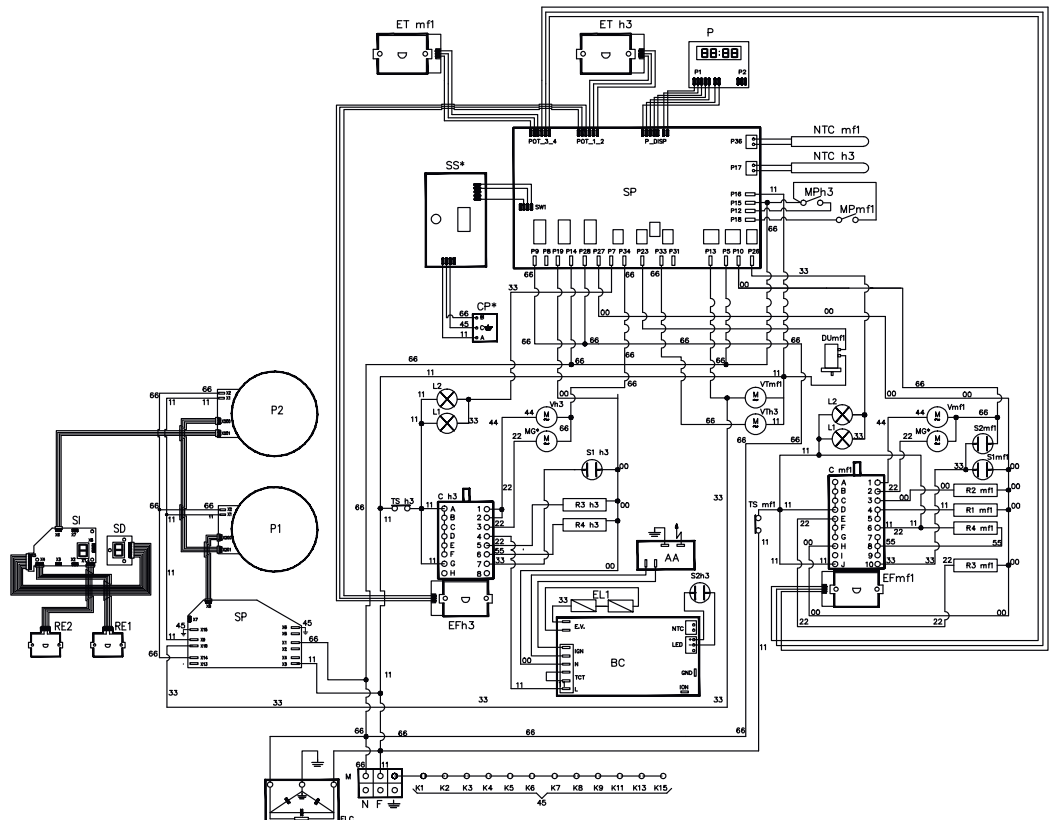

WIRING DIAGRAM

Allacciamento elettrico
Conexiado elèctrico
Branchement électrique
Electric connection
Elektroanschluss

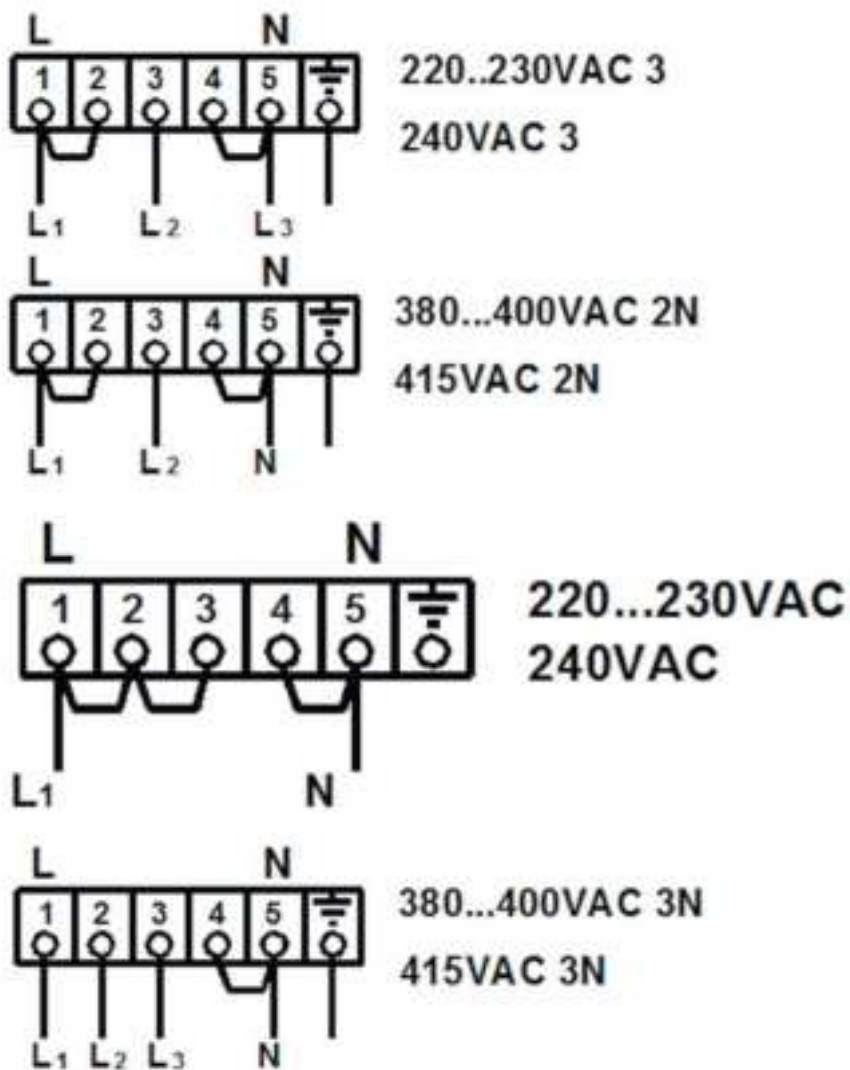

INSTALLATION & CONNECTION MAJESTIC

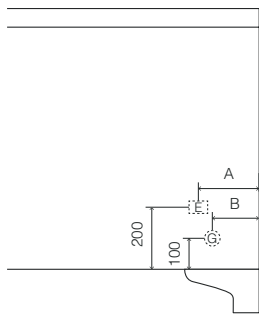

Majestic - Rear View

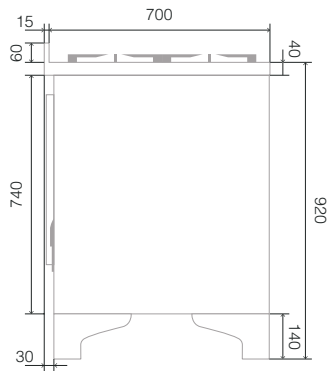

Majestic - Side (except M30)

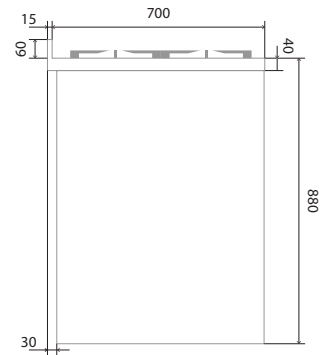

Majestic - Side (only M30)

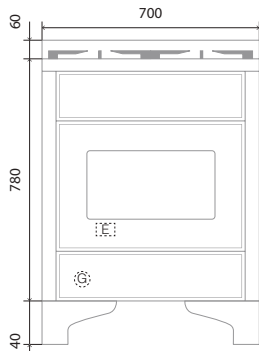

Majestic - M07

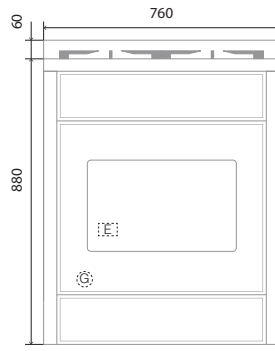

Majestic - M30

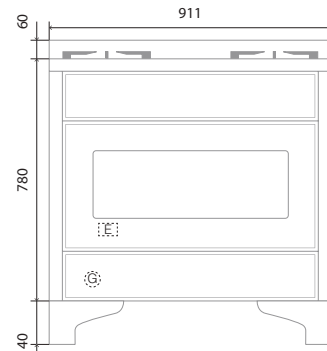

Majestic - M09

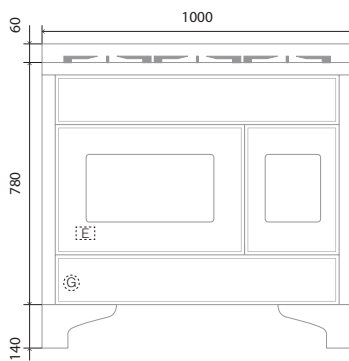

Majestic - M10

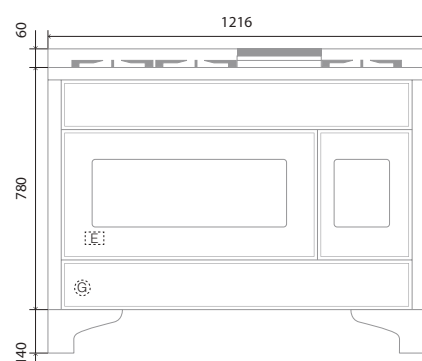

Majestic - M12

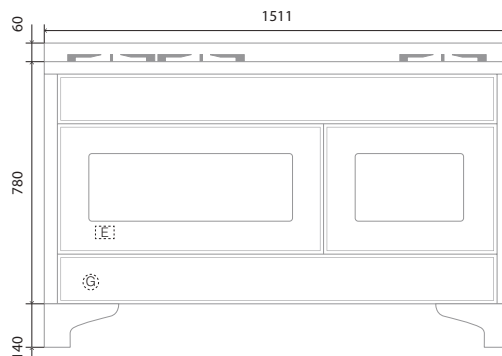

Majestic - M15

INSTALLATION & CONNECTION

PROFESSIONAL PLUS, PRO-LINE & V LINE

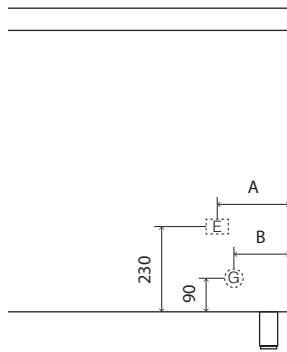

Rear View

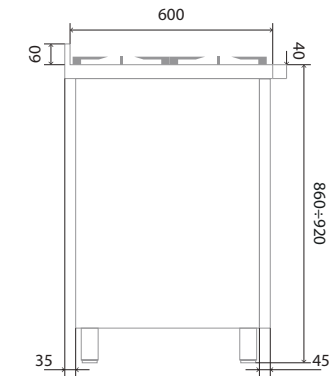

Side View

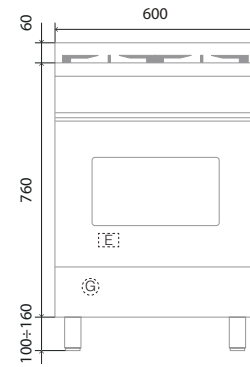

60cm Wide

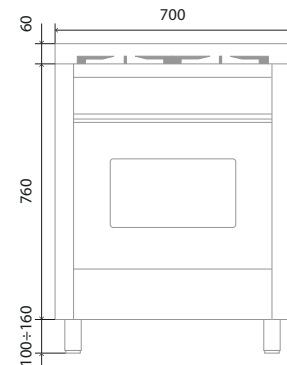

70cm Wide

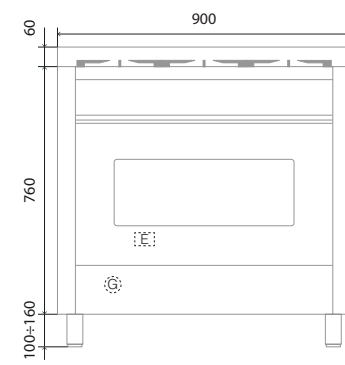

90cm Wide

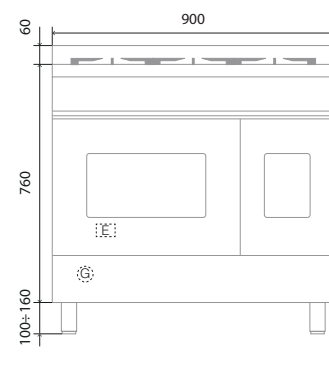

90cm Wide (double oven)

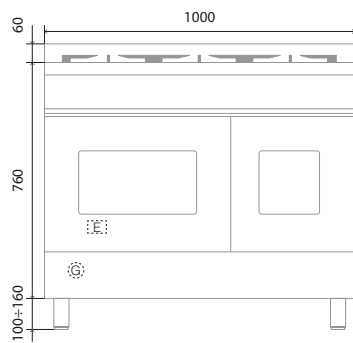

100cm Wide

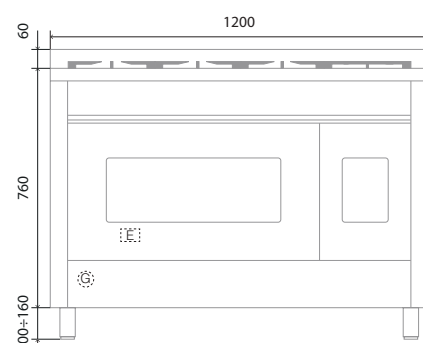

120cm Wide

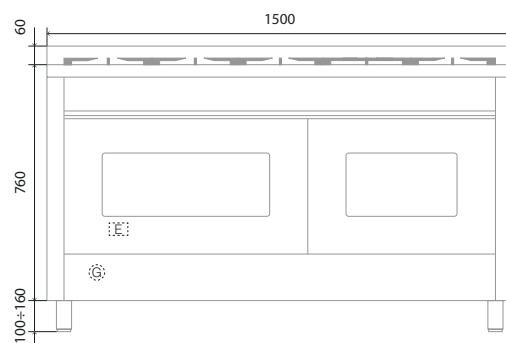

150cm Wide

WARRANTY

**Eurolinx Pty Limited A.B.N. 50 001 473 347
trading as ILVE (“ILVE”)**

Office:

48-50 Moore Street, Leichhardt N.S.W 2040

Post:

Locked Bag 3000, Annandale, N.S.W 2038

P: 1300 856 411

WARRANTY REGISTRATION

Your ongoing satisfaction with your ILVE product is important to us. We ask that you complete the enclosed Warranty Registration Card and return it to us so that we have a record of the ILVE product purchased by you. Alternatively, you can now register your warranty online at <http://support.eurolinx.com.au/>

PRIVACY

ILVE respects your privacy and is committed to handling your personal information in accordance with the National Privacy Principles and the Privacy Act 1988 (Cth). A copy of the ILVE Privacy Policy is available at www.ilve.com.au. ILVE will not disclose any personal information set out in the Warranty Registration Card (“Personal Information”) without your consent unless required by:

1. law;
2. any ILVE related company;
3. any service provider which provide services to ILVE or assist ILVE in providing services (including repair and warranty services) to customers. Our purpose in collecting the Personal Information is to keep a record of the ILVE product purchased by you, in order to provide a better warranty service to you in the unlikely event that there is a problem with your ILVE product. ILVE may contact you at any one or more of the addresses, email addresses or telephone numbers set out in the Warranty Registration Card. Please contact ILVE on 1300 694 583 should you not wish to be contacted by ILVE.

WARRANTY

1. Warranty

ILVE warrants that each ILVE product will remain, for a period of twenty four (24) months computed from the date of purchase of the ILVE product, free from defects arising in the manufacture of the ILVE product (“Warranty”). Except for consumer guarantees set out in the Competition and Consumer Act 2010 (Cth) (“Act”), ILVE does not make any further warranties or representations in relation to ILVE products.

2. What is not Covered by the Warranty.

The Warranty does not apply if an ILVE product is defective by a factor other than a defect

arising in the manufacture of the ILVE product, including but not limited to:

- (a) damage through misuse (including failure to maintain, service or use with proper care), neglect, accident or ordinary wear and tear (including deterioration of parts and accessories and glass breakage);
- (b) use for purpose for which the ILVE product was not sold or designed;
- (c) use or installation which is not in accordance with any specified instructions for use or installation;
- (d) use or operation after a defect has occurred or been discovered;
- (e) damage through freight, transportation or handling in transit (other than when ILVE is responsible);
- (f) damage through exposure to chemicals, dusts, residues, excessive voltage, heat, atmospheric conditions or other forces or environmental factors outside the control of ILVE;
- (g) repair, modification or tampering by the purchaser or any person other than ILVE, an employee of ILVE or an authorised ILVE service contractor*;
- (h) use of parts, components or accessories which have not been supplied or specifically approved by ILVE.
- (i) damage to surface coatings caused by cleaning or maintenance using products not recommended in the ILVE product handbook provided to the purchaser upon purchase of the ILVE product;
- (j) damage to the base of an electric oven due to items having been placed on the base of the oven cavity or covering the base, such as aluminium foil (this impedes the transfer of heat from the element to the oven cavity and can result in irreparable damage); or
- (k) damages, dents or other cosmetic imperfections not affecting the performance of the ILVE in respect of an ILVE product purchased as a “factory second” or from display

The Warranty does not extend to light globes used in ILVE products.

3. Domestic Use

Each ILVE product is made for domestic use. This Warranty may not extend to ILVE products used for commercial purposes.

4. Time for Claim under the Warranty

You must make any claim under this Warranty within twenty eight (28) days after the occurrence of an event which gives rise to a claim pursuant to the Warranty, by booking a service call on the telephone number below.

Continued over...

WARRANTY

5. Proof of Purchase

Customers must retain proof of purchase in order to be eligible to make a warranty claim in respect of an ILVE product.

6. Claiming under the Warranty

Customers will bear the cost of claiming under this Warranty unless ILVE determines the expenses are reasonable, in which case the customer must claim those expenses by providing written evidence of each expense to ILVE at the address on the Warranty Registration Card.

7. Statutory Rights

(a) These terms and conditions do not affect your statutory rights.

(b) The limitations on the Warranty set out in this document do not exclude or limit the application of the consumer guarantees set out in the Act or any other equivalent or corresponding legislation in the relevant jurisdiction where to do so would:

(i) contravene the law of the relevant jurisdiction; or

(ii) cause any part of the Warranty to be void.

(c) ILVE excludes indirect or consequential loss of any kind (including, without limitation, loss of use of the ILVE product) and (other than expressly provided for in these terms and conditions) subject to all terms,

conditions and warranties implied by custom, the general law, the Act or other statute.

(d) The liability of ILVE to you for a breach of any express or non-excludable implied term, condition or warranty is limited at the option of ILVE to:

(i) replacing or repairing the defective part of the ILVE product;

(ii) paying the cost of replacing or repairing the defective part of the ILVE product;

(iii) replacing the ILVE product; or

(iv) paying the cost of replacing the ILVE product.

(e) Our goods come with guarantees that cannot be excluded under the Australian Consumer Law. You are entitled to a replacement or refund for a major failure and for compensation for any other reasonably foreseeable loss or damage. You are also entitled to have the goods repaired or replaced if the goods fail to be of acceptable quality and the failure does not amount to a major failure.

8. Defects

Any part of an ILVE product deemed to be defective and replaced by ILVE is the property of ILVE. ILVE reserves the right to inspect and test ILVE products in order to determine the extent of any defect and the validity of a claim under the Warranty.

***For your closest ILVE authorised service agent go to**

<https://support.eurolinx.com.au/#/map/retailers>

All warranty service calls must be booked through ILVE's Customer Care Centre on customercare@eurolinx.com.au or

1300 85 64 11 option 1

01012020

Warranty Card tear off

WARRANTY REGISTRATION CARD
01072019

Please complete and send to ILVE at: REPLY PAID 83617
LEICHHARDT NSW 2040

Last Name:		First Name:	
Address:			
State:	Postcode:	Email:	
Home Phone:		Mobile:	
Purchase Date: / /		(Please attach proof of purchase to validate warranty)	

MODEL NUMBER	SERIAL NUMBER (if you cannot locate the serial number please call ILVE on 1300 85 64 11)
1	
2	
3	
4	

01012020



10/55 Howe St
Osborne Park, WA



1/42 Cavendish Rd
Coorparoo, QLD



48-50 Moore St
Leichhardt, NSW



1211 Toorak Rd
Camberwell, VIC



NATIONAL SERVICE CENTRE

Our high quality appliances are designed and manufactured to give you many years of cooking pleasure.

Should you have any questions or issues with your appliance please email our national service centre

customercare@eurolinx.com.au or phone us on **1300 85 64 11**.

Our experienced staff are on hand to log your service request and ensure any matter is attended to promptly.

For after sales enquiries please contact us at customercare@eurolinx.com.au or 1.300 85 64 11 option 1

For spare parts contact us at spares@eurolinx.com.au or 1.300 85 64 11 option 2

Technical support is available to authorised and licensed service providers only by contacting us at

tech.support@eurolinx.com.au All other technical enquiries should be directed to customercare@eurolinx.com.au



FOLLOW US ON:



facebook.com/ILVEappliances



instagram.com/ILVE_appliances



youtube.com/ILVEappliances

BLOG livewithilve.com

Australia National Telephone Number 1300 MYILVE (694 583) New Zealand Telephone Number 64 3 344 5913

ILVE showroom hours: Tuesday to Friday - 9am-5pm, Saturday - 10am-4pm, Sunday and Monday - closed

* **Melbourne showroom hours:** Tuesday to Saturday - 10am-4pm

ilve.com.au

NSW & ACT (Head Office)

48-50 Moore Street
Leichhardt
F 02 8569 4699

VIC & SA

1211 Toorak Road
Camberwell
F 03 9809 2155

QLD

1/42 Cavendish Road
Coorparoo
F 07 3397 0850

WA & NT

Unit 10/55 Howe Street
Osborne Park
F 08 9201 9188

New Zealand

PO Box 11.160
Sockburn Christchurch
F 03 344 5906