

# ALTO SHAAM® Food Holding Cabinet



**Models:**  
**500-S**  
**750-S**  
**1000-S**  
**1000-UP**



1000-UP

1000-S

750-S

500-S

- **INSTALLATION**
- **OPERATION**
- **MAINTENANCE**



W164 N9221 Water Street • P.O. Box 450 • Menomonee Falls, Wisconsin 53052-0450 USA  
PHONE: 262.251.3800 • 800.558.8744 USA/CANADA FAX: 262.251.7067 • 800.329.8744 U.S.A. ONLY  
[www.alto-shaam.com](http://www.alto-shaam.com)

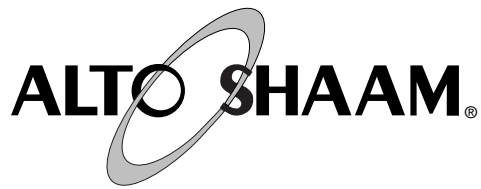

## DELIVERY

This Alto-Shaam appliance has been thoroughly tested and inspected to insure only the highest quality unit is provided. Upon receipt, check for any possible shipping damage and report it at once to the delivering carrier. *See Transportation Damage and Claims section located in this manual.*

This appliance, complete with unattached items and accessories, may have been delivered in one or more packages. Check to ensure that all standard items and options have been received with each model as ordered.

Save all the information and instructions packed with the appliance. Complete and return the warranty card to the factory as soon as possible to assure prompt service in the event of a warranty parts and labor claim.

This manual must be read and understood by all people using or installing the equipment model. Contact the Alto-Shaam service department if you have any questions concerning installation, operation, or maintenance.

**NOTE:** All claims for warranty must include the full model number and serial number of the unit.

## UNPACKING

1. Carefully remove the appliance from the carton or crate.

**NOTE:** Do not discard the carton and other packaging material until you have inspected the unit for hidden damage and tested it for proper operation.

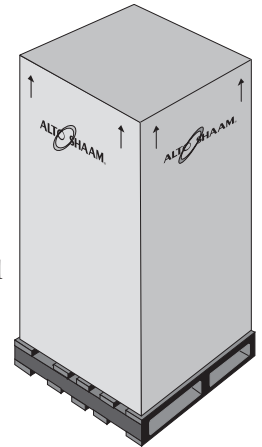

2. Read all instructions in this manual carefully before initiating the installation of this appliance.

**DO NOT DISCARD THIS MANUAL.**

This manual is considered to be part of the appliance and is to be provided to the owner or manager of the business or to the person responsible for training operators. *Additional manuals are available from the Alto-Shaam service department.*

3. Remove all protective plastic film, packaging materials, and accessories from the appliance before connecting electrical power. Store any accessories in a convenient place for future use.

## SAFETY PROCEDURES AND PRECAUTIONS

Knowledge of proper procedures is essential to the safe operation of electrically and/or gas energized equipment. In accordance with generally accepted product safety labeling guidelines for potential hazards, the following signal words and symbols may be used throughout this manual.

### DANGER



Used to indicate the presence of a hazard that **WILL** cause severe personal injury, death, or substantial property damage if the warning included with this symbol is ignored.

### WARNING



Used to indicate the presence of a hazard that **CAN** cause personal injury, possible death, or major property damage if the warning included with this symbol is ignored.

### CAUTION



Used to indicate the presence of a hazard that can or will cause minor or moderate personal injury or property damage if the warning included with this symbol is ignored.

### CAUTION

Used to indicate the presence of a hazard that can or will cause minor personal injury, property damage, or a potential unsafe practice if the warning included with this symbol is ignored.

**NOTE:** Used to notify personnel of installation, operation, or maintenance information that is important but not hazard related.

1. This appliance is intended to cook, hold or process foods for the purpose of human consumption. No other use for this appliance is authorized or recommended.
2. This appliance is intended for use in commercial establishments where all operators are familiar with the purpose, limitations, and associated hazards of this appliance. Operating instructions and warnings must be read and understood by all operators and users.
3. Any troubleshooting guides, component views, and parts lists included in this manual are for general reference only and are intended for use by qualified technical personnel.
4. This manual should be considered a permanent part of this appliance. This manual and all supplied instructions, diagrams, schematics, parts lists, notices, and labels must remain with the appliance if the item is sold or moved to another location.

### NOTE

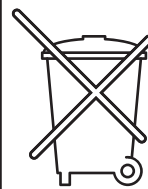

For equipment delivered for use in any location regulated by the following directive:

**DO NOT DISPOSE OF ELECTRICAL OR ELECTRONIC EQUIPMENT WITH OTHER MUNICIPAL WASTE.**

# INSTALLATION

## DANGER



IMPROPER INSTALLATION, ALTERATION, ADJUSTMENT, SERVICE, OR MAINTENANCE COULD RESULT IN SEVERE INJURY, DEATH OR CAUSE PROPERTY DAMAGE.

READ THE INSTALLATION, OPERATING AND MAINTENANCE INSTRUCTIONS THOROUGHLY BEFORE INSTALLING OR SERVICING THIS EQUIPMENT.

## CAUTION



METAL PARTS OF THIS EQUIPMENT BECOME EXTREMELY HOT WHEN IN OPERATION. TO AVOID BURNS, ALWAYS USE HAND PROTECTION WHEN OPERATING THIS APPLIANCE.

## CAUTION



TO PREVENT PERSONAL INJURY, USE CAUTION WHEN MOVING OR LEVELING THIS APPLIANCE.



## DANGER



DO NOT store or use gasoline or other flammable vapors or liquids in the vicinity of this or any other appliance.

## SITE INSTALLATION

The Alto-Shaam cook and hold oven must be installed in a location that will permit the oven to function for its intended purpose and to allow adequate clearance for ventilation, proper cleaning, and maintenance access.

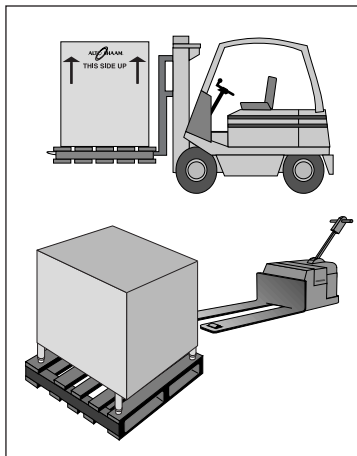

Emissions testing conducted by Underwriters Laboratories, Inc.® was found to be in compliance with the applicable requirements of NFPA96: 2004 Edition, Par. 4.1.1.2. U.L emissions sampling of grease laden vapor resulted in a total of 0.55 milligrams per cubic meter with no visible smoke and is considered representative of all oven models in the line. Based on these results, hood installation and/or outside venting should not be a requirement in most areas. Verify local codes for locations where more restrictive codes are applicable.

1. The oven must be installed on a stable and level surface.
2. **DO NOT** install this appliance in any area where it may be affected by any adverse conditions such as steam, grease, dripping water, high temperatures, or any other severely adverse conditions.
3. **DO NOT** store or use any flammable liquids or allow flammable vapors in the vicinity of this oven or any other appliance.
4. This appliance must be kept free and clear of any combustible materials.
5. This appliance must be kept free and clear of any obstructions blocking access for maintenance or service.

### MINIMUM CLEARANCE REQUIREMENTS

BACK	3" (76mm)
LEFT SIDE	1" (25mm)
RIGHT SIDE	1" (25mm)
TOP	2" (51mm)

## NOTE

If the appliance has been unplugged for an extended period of time, the Real Time Clock may require recharging. For a full recharge, plug the unit into the proper receptacle for a minimum of 24 hours.

# INSTALLATION

## EXTERIOR DIMENSIONS - 500-S

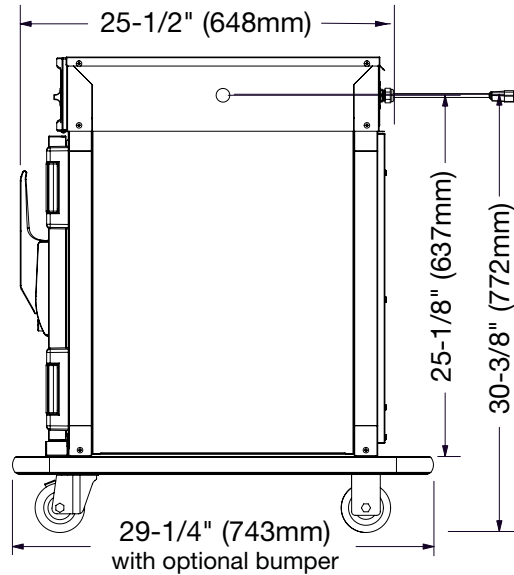
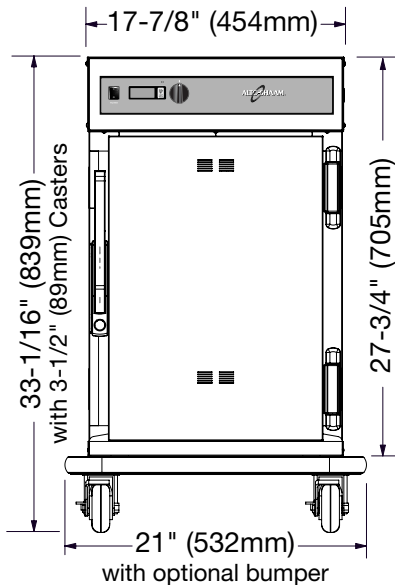
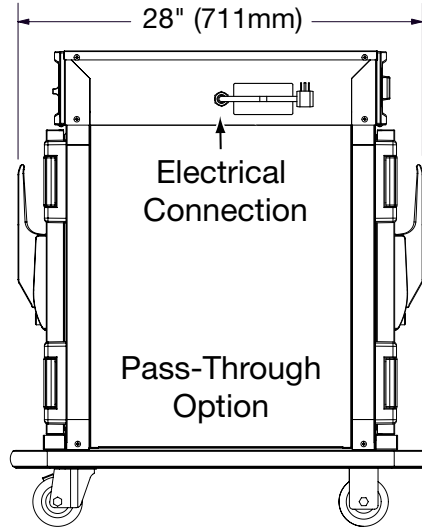
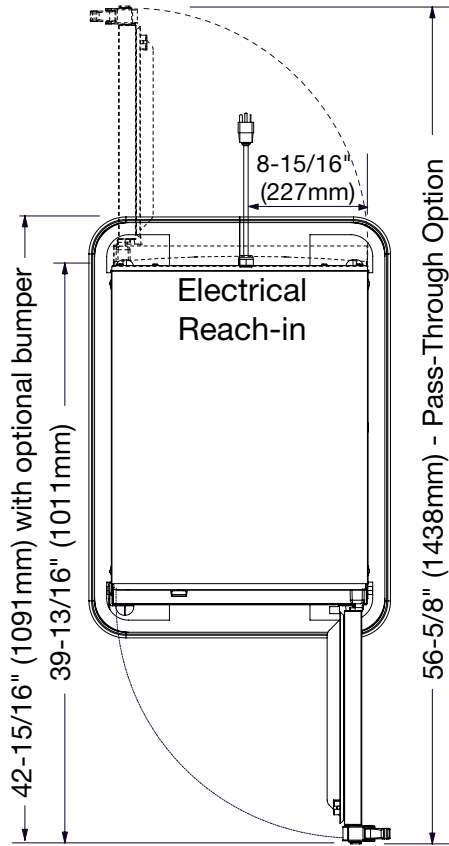

- \*34-5/16" (874mm) - with optional 5" (127mm) casters
- \*32-1/16" (814mm) - with optional 2-1/2" (64mm) casters
- \*34-11/16" (880mm) - with optional 6" (152mm) legs

WEIGHT	PRODUCT CAPACITY
NET: 94 lb (43 kg) SHIP: 120 lb (54 kg)	60 lbs (27 kg) MAXIMUM VOLUME MAXIMUM: 50 QUARTS (47.5 LITERS)

# INSTALLATION

## EXTERIOR DIMENSIONS - 750-S

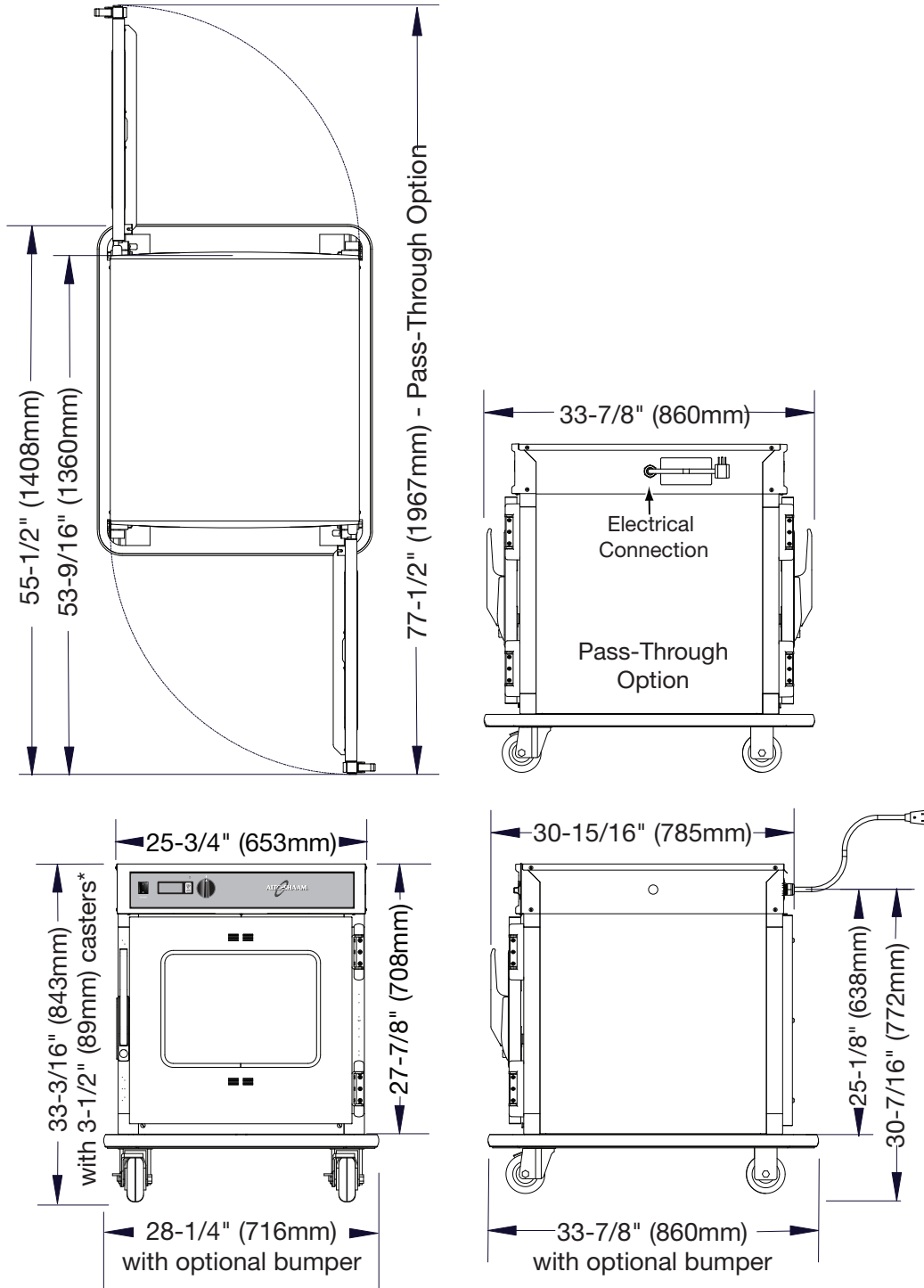

\*32-3/16" (817mm) - with optional 2-1/2" (64mm) casters

\*34-5/8" (878mm) - with optional 5" (127mm) casters

\*34-13/16" (884mm) - with optional 6" (152mm) legs

WEIGHT	PRODUCT CAPACITY
NET: 152 lb (69 kg) SHIP: 193 lb (88 kg)	120 lbs (54 kg) MAXIMUM VOLUME MAXIMUM: 100 QUARTS (95 LITERS)

# INSTALLATION

## EXTERIOR DIMENSIONS - 1000-S

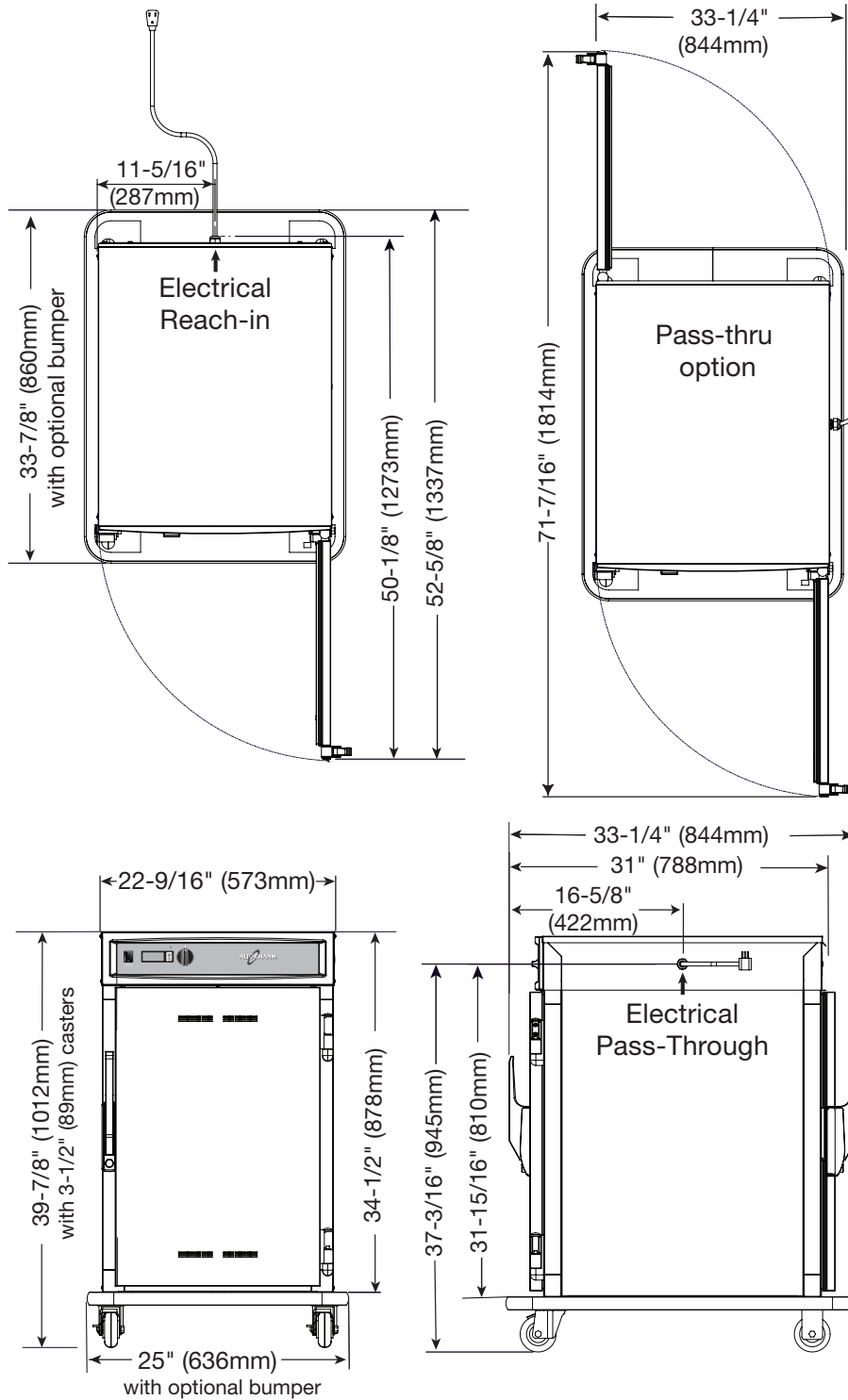

\*38-7/8" (987mm) - with optional 2-1/2" (64mm) casters

\*41-1/4" (1047mm) - with optional 5" (127mm) casters

\*41-1/2" (1053mm) - with optional 6" (152mm) legs

WEIGHT	PRODUCT CAPACITY
NET: 138 lb (63 kg) (EST.)	120 lbs (54 kg) MAXIMUM
SHIP: 163 lb (74 kg) (EST.)	VOLUME MAXIMUM: 60 QUARTS (76 LITERS)

# INSTALLATION

## EXTERIOR DIMENSIONS - 1000-UP

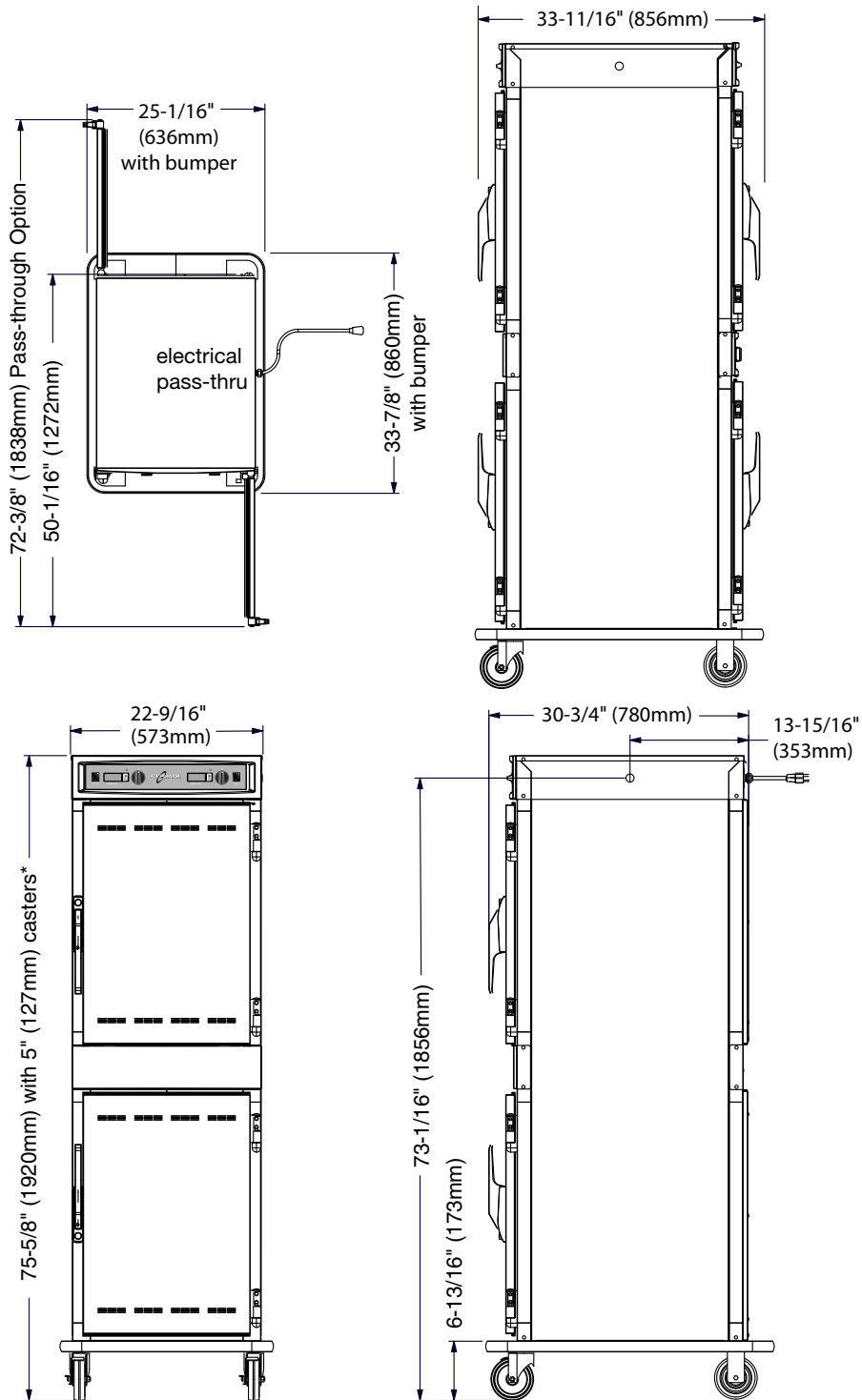

\*74-1/14" (1885mm) - with optional 3-1/2" (89mm) casters

\*75-7/8" (1926mm) - with optional 6" (152mm) legs

WEIGHT	1000-UP/STD	1000-UP/HD	PRODUCT CAPACITY
NET	241 lb (109 kg)	270 lb (122kg)	120 lbs (54 kg) MAXIMUM
SHIP	275 lb (125kg)	303 lb (137kg)	VOLUME MAXIMUM: 60 QUARTS (76 LITERS)

# INSTALLATION

<b>OPTIONS AND ACCESSORIES</b>	<b>500-S</b>	<b>750-S</b>	<b>1000-S</b>	<b>1000-UP</b>
Bumper, Full Perimeter	5006782	5004861	5005103	5005103
Carving Holder PRIME RIB STEAMSHIP (CAFETERIA) ROUND	HL-2635 4459	HL-2635 4459	-- --	-- --
Casters - 2 RIGID, 2 SWIVEL W/BRAKE 3-1/2" (89mm) 5" (127mm) 2-1/2" (64mm)	STANDARD 5004862 5008022	STANDARD 5004862 5008022	STANDARD 5004862 5008022	5008017 STANDARD --
Control Option Kit	5000886	5000886	5000886	5001720
Door Lock with Key	LK-22567	LK-22567	LK-22567	LK-22567
Drip Pan 1" (25mm) WITH DRAIN, 1-11/16" (43mm) 1-7/8" (48mm) EXTRA DEEP, 2-7/16" (62mm)	PN-2122 -- -- --	-- 14831 -- --	-- 5005616 11906 1115	-- 5005616 -- --
Drip Tray, External	1007267	5004975	1007588	1007588
Handle, Push/Pull	55662	55662	55662	--
Legs, 6" (152mm), Flanged (SET OF FOUR)	5004863	5004863	5004863	5004863
Pan Grid, Wire - 18" x 26" PAN INSERT	--	PN-2115	PN-2115	PN-2115
Pass-Through Design	AVAILABLE	AVAILABLE	AVAILABLE	AVAILABLE
Probe, Internal Temperature ELECTRONIC CONTROL ONLY	AVAILABLE	AVAILABLE	AVAILABLE	AVAILABLE
Security Panel with Key Lock	5006787	5004750	5005776	5005776
Shelf, Chrome Plated REACH-IN PASS-THROUGH	SH-2107 --	SH-2105 SH-2327	-- --	-- --
Shelf, Stainless Steel REACH-IN PASS-THROUGH RIB RACK	SH-2326 -- --	SH-2324 -- SH-2743	SH-2325 SH-2346 --	SH-2325 SH-2346 --
Stacking Hardware	5004864	5004864	5004864	--
Water Reservoir (REMOVABLE FOR PROOFING) PAN COVER	-- --	-- --	1775 1774	1775 1774
Window Door	--	55609R	15148R	15148R
<b>HACCP Network Options (ELECTRONIC CONTROL ONLY)</b> ➤ HACCP Documentation ➤ HACCP with Kitchen Management * REFER TO HACCP SPECIFICATION #9015 FOR APPLICABLE PART NUMBERS.				

# INSTALLATION

## SITE INSTALLATION

### STACKING INSTRUCTIONS

- 1) If the two appliances were shipped together from the factory, the top unit will have the casters already removed. A stacking kit will be included with the shipment.

If casters need to be removed: lay the unit on its back, and remove the set screw on each caster. Pull the casters out of the unit.

- 2) While appliance is laid on its back, insert one stacking post in each of the four corners of the upper unit. Secure the stacking posts using one screw and two flat washers that come with the stacking kit.

**Note:** The flange on the stacking posts must face the outside of the unit.

- 3) Remove the four top mounting screws from the lower unit. Place the upper appliance, which has the stacking posts installed, on top of the bottom unit. Center the top unit from front to back. Re-install the four screws through the flange of the four stacking posts.

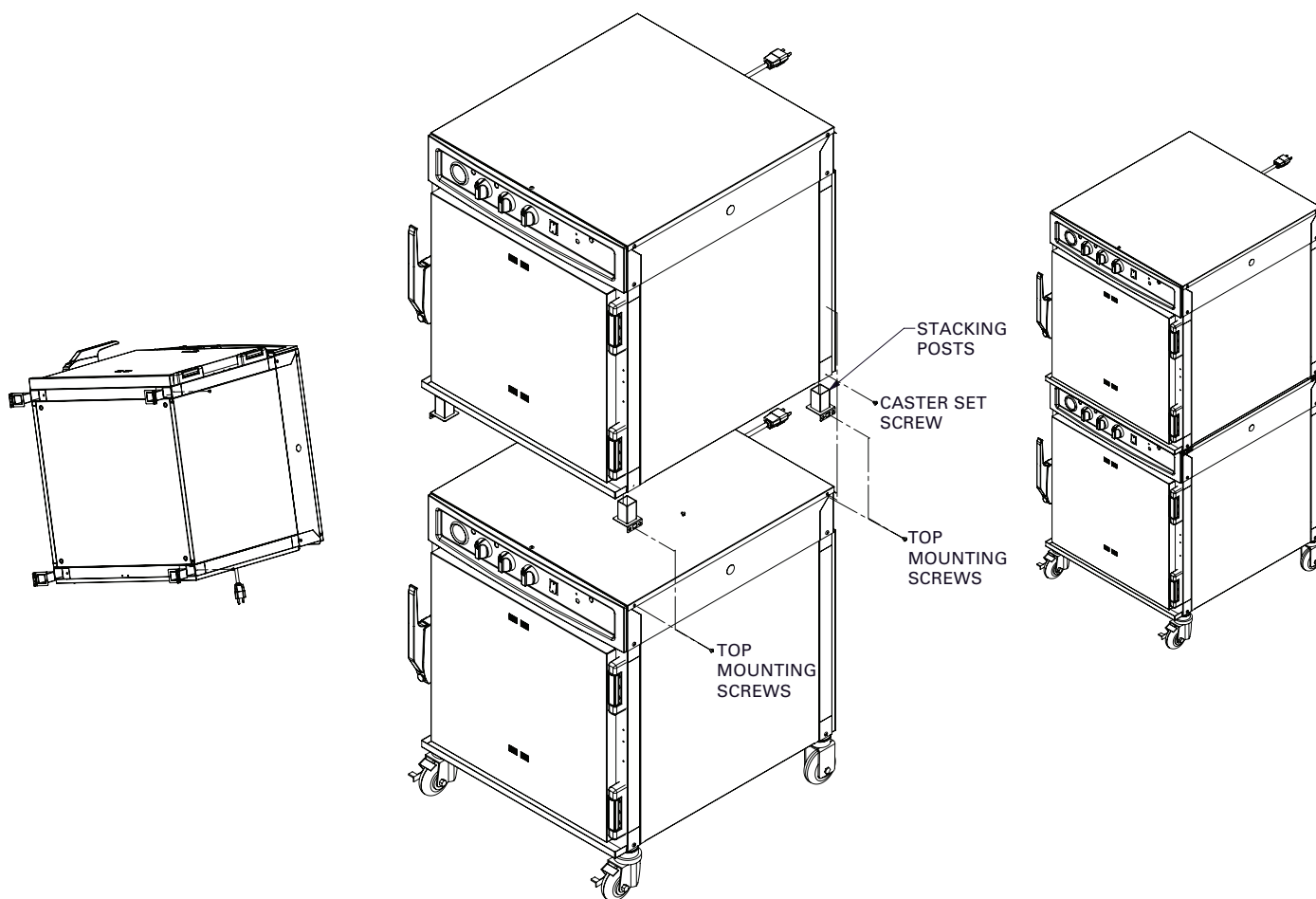

#### Stacking Configurations

- 1000-S with 1000-S, 1000-TH/III, or 1000-TH-II/Split
- 750-S with 750-S, 750-TH-II, 750-TH/III, 767-SK, 767-SK/III
- 500-S with 500-S, 500-TH-II, 500-TH/III

# INSTALLATION

## SITE INSTALLATION

A number of adjustments are associated with initial installation and start-up. It is important that these adjustments be conducted by a qualified service technician. Installation and start-up adjustments are the responsibility of the dealer or user. These adjustments include but are not limited to thermostat calibration, door adjustment, leveling, electrical hook-up and installation of optional casters or legs.

### LEVELING

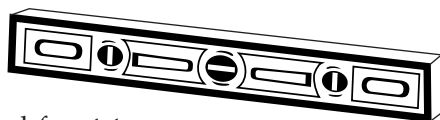

Level the oven from side-to-side and front-to-back with the use of a spirit level. For ovens installed with casters, it is important that the installation surface be level due to the probability of frequent oven repositioning.

We recommend checking the level of the oven periodically to make certain the floor has not shifted nor the oven moved.

**NOTE:** Failure to properly level this oven can cause improper function and will result in the uneven baking with products consisting of semi-liquid batter.

### RESTRAINT REQUIREMENTS —MOBILE EQUIPMENT

 <b>WARNING</b>	
	<b>RISK OF ELECTRIC SHOCK.</b>
	<b>Appliance must be secured to building structure.</b>

Any appliance that is not furnished with a power supply cord but that includes a set of casters must be installed with a tether. Adequate means must be provided to limit the movement of this appliance without depending on or transmitting stress to the electrical conduit. The following requirements apply:

1. Maximum height of casters is 6" (152mm).
2. Two of the casters must of be the locking type.
3. Such mobile appliances or appliances on mobile stands must be installed with the use of a flexible connector secured to the building structure.

A mounting connector for a restraining device is located on the lower back flange of the appliance chassis or on an oven stand, approximately 18" (457mm) from the floor. A flexible connector is not supplied by nor is it available from the factory.

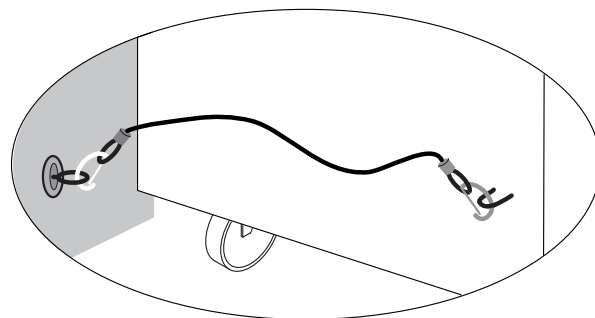

# INSTALLATION

## SITE INSTALLATION

### DRIP TRAY INSTALLATION INSTRUCTIONS

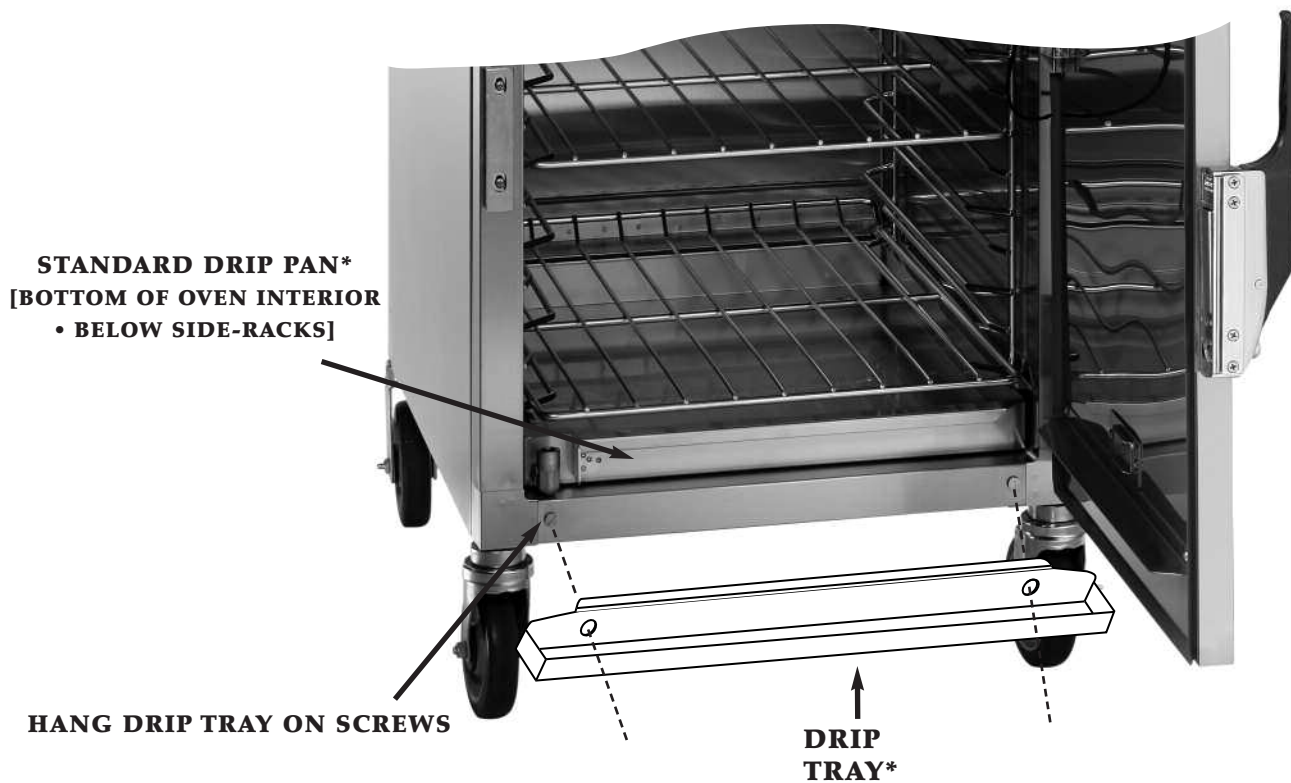

\*SEE ALTO-SHAAM PARTS LIST FOR ALTO-SHAAM PART NUMBERS.

		<b>WARNING</b>
	<b>FAILURE TO PROPERLY INSTALL THE DRIP TRAY CAN OR WILL CAUSE MAJOR EQUIPMENT DAMAGE AND WILL RESULT IN A LEAKAGE HAZARD THAT CAN CAUSE PERSONAL INJURY.</b>	

# INSTALLATION

## ELECTRICAL

1. An identification tag is permanently mounted on the cabinet.
2. Plug cabinet into a properly grounded receptacle ONLY, positioning the unit so the power supply cord is easily accessible in case of an emergency.  
Arcing will occur when connecting or disconnecting the unit unless all controls are in the "OFF" position.
3. If necessary, a proper receptacle or outlet configuration as required for this unit, must be installed by a licensed electrician in accordance with applicable, local electrical codes.

### For 230V:

To prevent an electrical shock hazard between the appliance and other appliances or metal parts in close vicinity, an equalization-bonding stud is provided. An equalization bonding lead must be connected to this stud and the other appliances / metal parts to provide sufficient protection against potential difference. The terminal is marked with the following symbol. 

### NOTE:

230V appliances must be connected to an electrical circuit that is protected by an external GFCI outlet.

## CAUTION

THIS SECTION IS PROVIDED FOR THE ASSISTANCE OF QUALIFIED SERVICE TECHNICIANS ONLY AND IS NOT INTENDED FOR USE BY UNTRAINED OR UNAUTHORIZED SERVICE PERSONNEL.



## DANGER



ENSURE POWER SOURCE  
MATCHES VOLTAGE STAMPED  
ON APPLIANCE NAMEPLATE.



## DANGER



To avoid electrical shock, this appliance **MUST** be adequately grounded in accordance with local electrical codes or, in the absence of local codes, with the current edition of the National Electrical Code ANSI/NFPA No. 70. In Canada, all electrical connections are to be made in according with CSA C22.1, Canadian Electrical Code Part 1 or local codes.

ELECTRICAL - 500-S							ELECTRICAL - 1000-S						
VOLTAGE	PHASE	CYCLE/ HZ	AMPS	kW		CORD & PLUG	VOLTAGE	PHASE	CYCLE/ HZ	AMPS	kW		CORD & PLUG
120 (AGCY)	1	60	8.3	1.0		NEMA 5-15P,	120	1	60	8.0	.96		NEMA 5-15P,
			8.4	1.0		15A-125V PLUG				8.6	1.03		15A-125V PLUG
208-240 (AGCY)	1	60	4.2	1.0		NEMA 6-15P,	208-240 (AGCY)	1	60	4.0	.96		NEMA 6-15P,
at 208	1	60	3.7	.76		15A-250V PLUG	at 208	1	60	3.7	.78		15A-250V
at 240	1	60	4.2	1.0		(USA ONLY)	at 240	1	60	4.3	1.03		PLUG (USA ONLY)
230 (AGCY)	1	50	4.1	.95		CEE 7/7,	230 (AGCY)	1	50	3.8	.88		CEE 7/7,
230	1	50	4.0	.93		220-230V PLUG	230	1	50	4.1	.95		220-230V PLUG

ELECTRICAL - 750-S							ELECTRICAL - 1000-UP						
VOLTAGE	PHASE	CYCLE/ HZ	AMPS	kW		CORD & PLUG	VOLTAGE	PHASE	CYCLE/ HZ	AMPS	kW		CORD & PLUG
120 (AGCY)	1	60	9.0	1.08		NEMA 5-15P,	120 (AGCY)	1	60	16.0	1.9		NEMA 5-20P,
			9.0	1.08		15A-125V PLUG				16.0	1.9		20A-125V PLUG
208-240 (AGCY)	1	60	4.5	1.08		NEMA 6-15P,	208-240 (AGCY)	1	60	8.6	2.1		NEMA 6-15P,
at 208	1	60	3.9	.81		15A-250V PLUG	at 208	1	60	7.4	1.6		15A-250V PLUG
at 240	1	60	4.5	1.08		(USA ONLY)	at 240	1	60	8.6	2.1		(USA ONLY)
230 (AGCY)	1	50	4.3	1.0		CEE 7/7,	230 (AGCY)	1	50	8.3	1.9		CEE 7/7,
230	1	50	4.3	.99		220-230V PLUG	230	1	50	8.2	1.9		220-230V PLUG

# INSTALLATION

## USER SAFETY INFORMATION

This appliance is intended for use in commercial establishments where all operators are familiar with the purpose, limitations, and associated hazards of this appliance. Operating instructions and warnings must be read and understood by all operators and users.

1. Unit must be connected to the appropriate power source.
2. Use hand protection when handling hot items.
3. Preheat the unit for 30 minutes before use.
4. Be certain only hot foods are placed into the unit.

### CAUTION



**METAL PARTS OF THIS EQUIPMENT BECOME EXTREMELY HOT WHEN IN OPERATION. TO AVOID BURNS, ALWAYS USE HAND PROTECTION WHEN OPERATING THIS APPLIANCE.**

### BEFORE INITIAL USE:

1. Clean both the interior and exterior of the unit with a damp, clean cloth and mild soap solution. Rinse carefully.
2. Clean and install the cabinet side racks. Shelves should be positioned with the curved end up and toward the back of the unit (reach-in models).

### HEATING CHARACTERISTICS

The cabinet is equipped with a special heating cable. Through this Halo Heat concept, the heating cable is mounted against the walls of the unit to provide an evenly applied heat source controlled by a thermostat. The design and operational characteristics of the unit eliminate the need for a moisture pan or a heat circulating fan. Through even heat application, the quality of food products is maintained up to several hours or more.

# OPERATION

## MANUAL CONTROL OPERATION

### 1. PREHEAT AT 200°F (93°C) FOR 30 MINUTES BEFORE LOADING FOOD.

Push power switch to “ON” position. The power button will illuminate.

### 2. Rotate the control knob to 200°F (93°C).

The temperature will be displayed on the digital display.

### 3. The temperature display light will illuminate when the inside air reaches the desired holding temperature.

### 4. Load the cabinet with hot food only.

The purpose of the holding cabinet is to maintain hot food at proper serving temperatures. Only hot food should be placed into the cabinet. Before loading the unit with food, use a food thermometer to make certain all food products are at an internal temperature range of 140° to 160°F (60° to 71°C). All food not within the proper temperature range should be heated before loading into the holding cabinet.

### 5. Check to make certain the cabinet door is securely closed, and rotate the control knob to 160°F (71°C).

**THIS WILL NOT NECESSARILY BE THE FINAL SETTING.**

The proper temperature range for the food being held will depend on the type and quantity of product. Whether or not the door vents should be open or closed will also depend on the type of food being held. When holding food for prolonged periods, it is advisable to periodically check the internal temperature of each item to assure maintenance of the proper temperature range. Reset the holding temperature accordingly.

### TO TOGGLE BETWEEN FAHRENHEIT AND CELSIUS

The factory default is Fahrenheit. To change to Celsius:

1. With the control OFF (i.e. temperature setting in the OFF position), press and hold the Temperature Display button for 5 seconds.

2. The control will show “degC” for 3 seconds to verify selection and then show the temperature. (Set Point or Actual, whichever the user has selected) in °C.

3. Repeat to toggle to Fahrenheit.

*Note: With a power failure, factory test, etc., the control will retain the °C or °F setting selected by the user when power is restored.*

### POWER FAILURE

When power is lost, then resumes, the display will flash “-AC-” for 4 seconds, then display the set holding temperature for 4 seconds and will alternate until acknowledged. To acknowledge, press any key.

This feature will alert you when there is a power failure, indicating that **food safety may be compromised.**

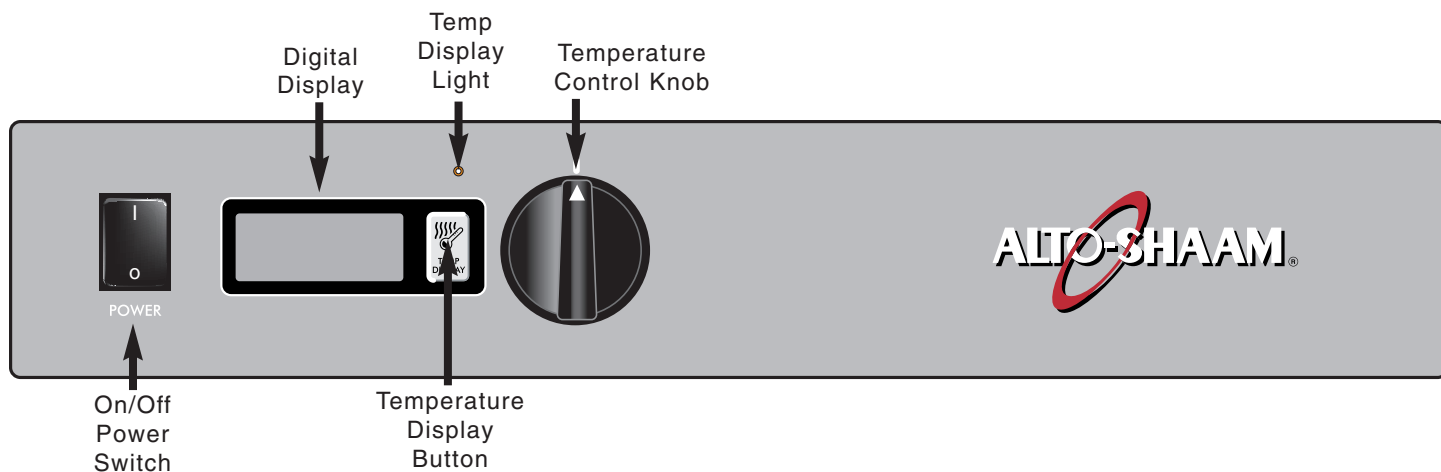

# OPERATION

## OPTIONAL ELECTRONIC CONTROL IDENTIFICATION

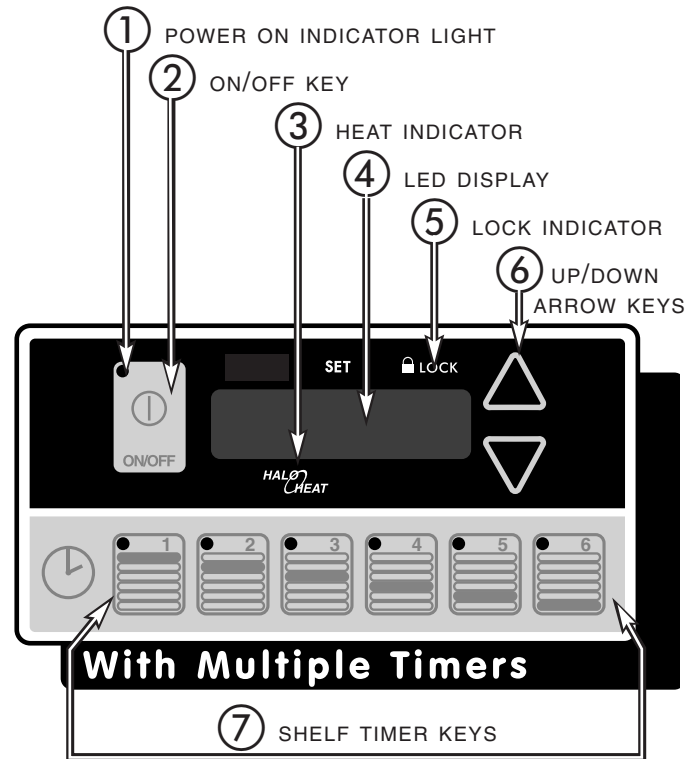
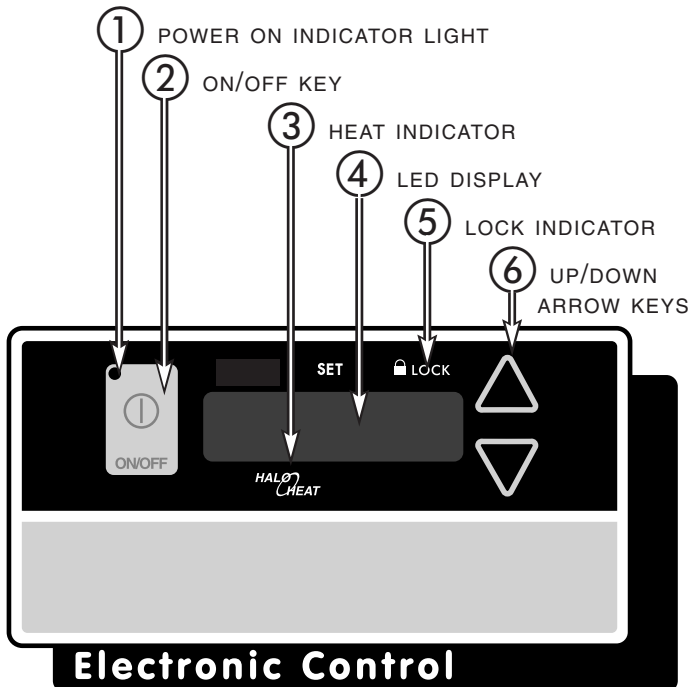

## OPTIONAL ELECTRONIC HOLDING CABINET CONTROL SET-UP

### ON/OFF KEY

 Press the ON/OFF key once and the power indicator light will illuminate. Press and hold the ON/OFF key until the LED display turns off (at least three seconds) and power indicator light goes out.

### UP/DOWN ARROW KEY

 The UP and DOWN arrow keys are used for a variety of settings when selecting the holding temperature. If an arrow key is pressed and released the display will show the current set temperature for two seconds. If an arrow key is held (at least eight seconds), the value will change at a rapid rate. If the arrow key is pressed and released in rapid succession, the set temperature will change by increments of one degree.

### ENABLE / DISABLE BEEPER

 A beeper sounds when an error code is displayed. To choose between beeper on and beeper off mode, the control must be off, then press and hold the DOWN arrow key until either "ON" or "OFF" is shown in the LED display. Release arrow key when desired mode is displayed.

### FAHRENHEIT/CELSIUS

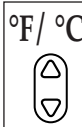
 With the control off, to choose between Fahrenheit and Celsius, press and hold the UP arrow key until either °F or °C is shown in LED display. Release key when desired setting is displayed.

The control has a four-digit LED display. When the display is on, it will show current holding temperature, as well as diagnostic information.

### CONTROL LOCK

The warmer controls can be locked so that no changes can be made to the set temperature.

To lock the display, press and hold the ON/OFF key and the Up Arrow key at the same time. The lock LED will illuminate. When the lock LED is illuminated, additional programming will not be functional other than the key sequence required to unlock the panel.

To unlock the display, press and hold the ON/OFF key and the Down Arrow key at the same time. The lock LED will extinguish. The panel keys will resume normal function.

# OPERATION

## OPTIONAL ELECTRONIC HOLDING CABINET CONTROL OPERATION



### 1. Preheat at 200°F (93°C) for 30 minutes.

Press the ON key, and set the temperature to 200°F (93°) by using the UP/DOWN arrow keys. Allow a minimum of 30

minutes preheating time before loading the holding cabinet with food. Closing the vents on the inside of the door will speed the preheating process. The LED heat indicator light will go "Out" after approximately 30 minutes preheat time, or when the air temperature inside the unit reaches the temperature set by the operator. The Set indicator will light up anytime the temperature is set or reset.

### 2. Load with hot food only.

The purpose of the holding cabinet is to maintain hot food at proper serving temperature. Only hot food should be placed into the cabinet. Before loading the cabinet with food, use a food

thermometer to make certain all products are at an internal temperature range of 140° to 160°F (60° to 71°C). Any food product not within the proper temperature range should be heated before loading into the holding cabinet.

### 3. Reset the control to 160°F (71°C).

Check to make certain the cabinet door is securely closed, and reset to 160°F (71°C) by using the UP/DOWN keys

**THIS WILL NOT NECESSARILY BE THE FINAL SETTING.**

The proper temperature range and OPEN or CLOSED door vent position will depend on the type and quantity of product. When holding food for prolonged periods, it is advisable to periodically check the internal temperature of each item with a food thermometer to assure maintenance of the proper temperature range of 140° to 160°F (60° to 71°C).

## OPTIONAL ELECTRONIC HOLDING CABINET SPECIAL FEATURES

### HEAT RECOVERY

The patented SureTemp™ heat recovery system in this unit will immediately compensate for any loss of heat when the door is opened. In order to maintain a more consistent cavity temperature, the control will automatically apply heat to the unit's interior while the door is open and for a short time after the door is closed. If the door remains open for more than three minutes, the solid state electronic control will sound three rapid beeps every ten seconds until the door is closed.

### HACCP DOCUMENTATION

Hard wired, web-based documentation software provides both a simple and effective method of temperature recording. The system is designed to interface with Alto-Shaam electronic cook/hold ovens, hot food holding cabinets, Combitherm® combi oven/steamers, and Quickchillers™. All relevant information is recorded and stored, and is accessible from the convenience of one or more computer stations. Stored information is displayed in a detailed overview for evaluation and printing as required.

- Records cooking and holding time and temperature
- Pass/fail summary for review or printing
- Automatic data storage accessible in a variety of formats
- Supports up to 16 appliance addresses on one network

### HACCP DOCUMENTATION WITH KITCHEN MANAGEMENT

Hard wired, web-based software incorporates the latest technology providing the ability to program, control, monitor, and store all relevant cooking and hot food holding data through the Internet from a single site or multiple sites. Automated sampling, record keeping, and set-point validation meet the requirements of established HACCP criteria. Designed to help manage the fully integrated food service facility.

- HACCP compliant automated logging/database storage
- Printed HACCP reports
- Data analysis for corrective action
- "Real time" sensor values and alarms
- Alarm notification via e-mail, pager, mobile phone
- Supports up to 16 appliance addresses on one network

For more information refer to HACCP Spec Sheet #9015.



# OPERATION

## ELECTRONIC CONTROL TIMER PROGRAMMING

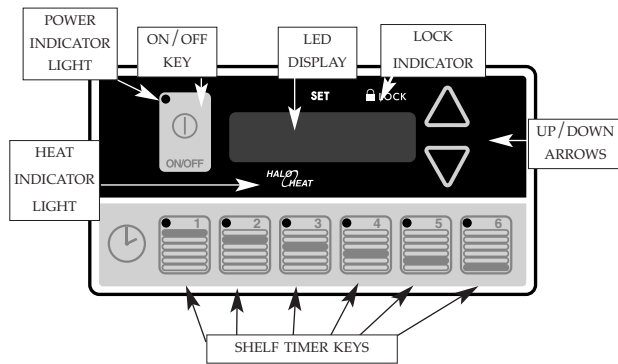

The Multiple Shelf Timer Key option is available for hot food holding units with the electronic control. These keys monitor food safety by using a timer-based "First-In, First-Out" product management system. Products should be cooked to HACCP recommended internal temperature and then held in the unit. The Timer system allows operator to select holding times when the unit is loaded. Multiple timer keys correspond to various pan locations in the holding unit. As the timers expire, alarms notify the operator.

### Timer Programming Information

#### 1. Turn On/Off Control Key OFF.

Press the On/Off Key until the display turns OFF (at least 3 seconds) and On/Off Key's Power Indicator Light goes out.

**Note:** The following steps can only be done when the On/Off Control Key is OFF.

#### 2. Set Shelf Timer Keys.

Press and hold a Shelf Timer Key (at least 3 seconds) until the countdown time is shown in the LED display. Use the Up or Down Arrow Key to change the time desired.

Time will display as HH:MM if set for longer than 60 minutes, or HH:SS if set for less than 60 minutes.

#### 3. Set Additional Timer Keys.

Repeat step 2 for each Shelf Timer Key to be programmed.

#### 4. Turn On/Off Power Key ON.

Using the timer, press the On/Off key to turn ON unit. Power Indicator Light will illuminate.

#### 5. Press Shelf Timer Key.

Activate the shelf timer by pressing the corresponding button. Shelf LED display will illuminate and the count down will begin.

The timer LED's will illuminate as follows:

- All expired timers will flash quickly (may be more than one)
- The timer with the shortest amount of time remaining will flash slowly.
- All other active timers will be illuminated (may be more than one).

#### 6. Turn OFF alarm.

Alarm will sound as time expires. Press expired Shelf Timer Key to turn the alarm OFF.

#### To Cancel a Timer:

Press and hold desired Shelf Timer Key for two seconds.

#### Power Failure:

The Power Indicator Light by On/Off Power Key will blink to indicate a power failure. To stop the blinking, simply depress On/Off Key. The memory will not be impaired.

# OPERATION

## GENERAL HOLDING GUIDELINES

Chefs, cooks and other specialized food service personnel employ varied methods of cooking. Proper holding temperatures for a specific food product must be based on the moisture content of the product, product density, volume, and proper serving temperatures. Safe holding temperatures must also be correlated with palatability in determining the length of holding time for a specific product.

Halo Heat maintains the maximum amount of product moisture content without the addition of water, water vapor, or steam. Maintaining maximum natural product moisture preserves the natural flavor of the product and provides a more genuine taste. In addition to product moisture retention, the gentle properties of Halo Heat maintain a consistent temperature throughout the cabinet without the necessity of a heat distribution fan, thereby preventing further moisture loss due to evaporation or dehydration.

When product is removed from a high temperature cooking environment for immediate transfer into equipment with the lower temperature required for hot food holding, condensation can form on the outside of the product and on the inside of plastic containers used in self-service applications. Allowing the product to release the initial steam and heat produced by high temperature cooking can alleviate this condition. To preserve the safety and quality of freshly cooked foods however, a maximum of 1 to 2 minutes must be the only time period allowed for the initial heat to be released from the product.

Most Halo Heat holding equipment is provided with a thermostat control between 60° and 200°F (16° to 93°C). If the unit is equipped with vents, close the vents for moist holding and open the vents for crisp holding.

If the unit is equipped with a thermostat indicating a range of between 1 and 10, use a metal-stemmed indicating thermometer to measure the internal temperature of the product(s) being held. Adjust the thermostat setting to achieve the best overall setting based on internal product temperature.

<b>HOLDING TEMPERATURE RANGE</b>		
<b>MEAT</b>	<b>FAHRENHEIT</b>	<b>CELSIUS</b>
BEEF ROAST — Rare	130°F	54°C
BEEF ROAST — Med/Well Done	155°F	68°C
BEEF BRISKET	160° — 175°F	71° — 79°C
CORN BEEF	160° — 175°F	71° — 79°C
PASTRAMI	160° — 175°F	71° — 79°C
PRIME RIB — Rare	130°F	54°C
STEAKS — Broiled/Fried	140° — 160°F	60° — 71°C
RIBS — Beef or Pork	160°F	71°C
VEAL	160° — 175°F	71° — 79°C
HAM	160° — 175°F	71° — 79°C
PORK	160° — 175°F	71° — 79°C
LAMB	160° — 175°F	71° — 79°C
<b>POULTRY</b>		
CHICKEN — Fried/Baked	160° — 175°F	71° — 79°C
DUCK	160° — 175°F	71° — 79°C
TURKEY	160° — 175°F	71° — 79°C
GENERAL	160° — 175°F	71° — 79°C
<b>FISH/SEAFOOD</b>		
FISH — Baked/Fried	160° — 175°F	71° — 79°C
LOBSTER	160° — 175°F	71° — 79°C
SHRIMP — Fried	160° — 175°F	71° — 79°C
<b>BAKED GOODS</b>		
BREADS/ROLLS	120° — 140°F	49° — 60°C
<b>MISCELLANEOUS</b>		
CASSEROLES	160° — 175°F	71° — 79°C
DOUGH — Proofing	80° — 100°F	27° — 38°C
EGGS — Fried	150° — 160°F	66° — 71°C
FROZEN ENTREES	160° — 175°F	71° — 79°C
HORS D'OEUVRES	160° — 180°F	71° — 82°C
PASTA	160° — 180°F	71° — 82°C
PIZZA	160° — 180°F	71° — 82°C
POTATOES	180°F	82°C
PLATED MEALS	140° — 165°F	60° — 74°C
SAUCES	140° — 200°F	60° — 93°C
SOUP	140° — 200°F	60° — 93°C
VEGETABLES	160° — 175°F	71° — 79°C
<b>THE HOLDING TEMPERATURES LISTED ARE SUGGESTED GUIDELINES ONLY. ALL FOOD HOLDING SHOULD BE BASED ON INTERNAL PRODUCT TEMPERATURES. ALWAYS FOLLOW LOCAL HEALTH (HYGIENE) REGULATIONS FOR ALL INTERNAL TEMPERATURE REQUIREMENTS.</b>		

# CARE AND CLEANING

## CLEANING AND PREVENTIVE MAINTENANCE

### PROTECTING STAINLESS STEEL SURFACES



It is important to guard against corrosion in the care of stainless steel surfaces.

Harsh, corrosive, or inappropriate chemicals can completely destroy the

protective surface layer of stainless steel.

Abrasive pads, steel wool, or metal implements will abrade surfaces causing damage to this protective coating and will eventually result in areas of corrosion. Even water, particularly hard water that contains high to moderate concentrations of chloride, will cause oxidation and pitting that result in rust and corrosion. In addition, many acidic foods spilled and left to remain on metal surfaces are contributing factors that will corrode surfaces.

Proper cleaning agents, materials, and methods are vital to maintaining the appearance and life of this appliance. Spilled foods should be removed and the area wiped as soon as possible but at the very least, a minimum of once a day. Always thoroughly rinse surfaces after using a cleaning agent and wipe standing water as quickly as possible after rinsing.

### CLEANING AGENTS

Use non-abrasive cleaning products designed for use on stainless steel surfaces. Cleaning agents must be chloride-free compounds and must not contain quaternary salts. Never use hydrochloric acid (muriatic acid) on stainless steel surfaces. Always use the proper cleaning agent at the manufacturer's recommended strength. Contact your local cleaning supplier for product recommendations.

### CLEANING MATERIALS

The cleaning function can usually be accomplished with the proper cleaning agent and a soft, clean cloth. When more aggressive methods must be employed, use a non-abrasive scouring pad on difficult areas and make certain to scrub with the visible grain of surface metal to avoid surface scratches. Never use wire brushes, metal scouring pads, or scrapers to remove food residue.

 <b>CAUTION</b>	
 NO SCRAPERS	<b>TO PROTECT STAINLESS STEEL SURFACES, COMPLETELY AVOID THE USE OF ABRASIVE CLEANING COMPOUNDS, CHLORIDE BASED CLEANERS, OR CLEANERS CONTAINING QUATERNARY SALTS. NEVER USE HYDROCHLORIC ACID (MURIATIC ACID) ON STAINLESS STEEL. NEVER USE WIRE BRUSHES, METAL SCOURING PADS OR SCRAPERS.</b>
 NO WIRE BRUSHES	
 NO STEEL PADS	

# CARE AND CLEANING

## EQUIPMENT CARE

Under normal circumstances, this oven should provide you with long and trouble free service. There is no preventative maintenance required, however, the following Equipment Care Guide will maximize the potential life and trouble free operation of this oven.



The cleanliness and appearance of this equipment will contribute considerably to operating efficiency and savory, appetizing food. Good equipment that is kept clean works better and lasts longer.

## CLEAN DAILY

1. Disconnect unit from power source, and let cool.
2. Remove all detachable items such as wire shelves, side racks, and drip pans. Clean these items separately.
3. Wipe the interior metal surfaces of the oven with a paper towel to remove loose food debris.
4. Clean the interior metal surfaces of the cabinet with a damp clean cloth or sponge and any good commercial detergent.



- NOTE:** Avoid the use of abrasive cleaning compounds, chloride based cleaners, or cleaners containing quaternary salts. Never use hydrochloric acid (muriatic acid) on stainless steel.
5. Spray heavily soiled areas with a water soluble degreaser and let stand for 10 minutes, then remove soil with a plastic scouring pad.
  6. Wipe control panel, door vents, door handles, and door gaskets thoroughly since these areas harbor food debris.
  7. Rinse surfaces by wiping with sponge and clean warm water.
  8. Remove excess water with sponge and wipe dry with a clean cloth or air dry. Leave doors open until interior is completely dry. Replace side racks and shelves.
  9. Wipe door gaskets and control panel dry with a clean, soft cloth.
  10. Interior can be wiped with a sanitizing solution after cleaning and rinsing. This solution must be approved for use on stainless steel food contact surfaces.

	<b>DANGER</b>
	<b>DISCONNECT UNIT FROM POWER SOURCE BEFORE CLEANING OR SERVICING.</b>

11. To help maintain the protective film coating on polished stainless steel, clean the exterior of the cabinet with a cleaner recommended for stainless steel surfaces. Spray the cleaning agent on a clean cloth and wipe with the grain of the stainless steel.
  12. Clean any glass with a window cleaner.
- Always follow appropriate state or local health (hygiene) regulations regarding all applicable cleaning and sanitation requirements for equipment.

## CLEAN THE DOOR VENTS

Door vents need to be inspected and cleaned as required.

## CLEAN THE PROBES DAILY

Remove all food soil from probes. Wipe entire probe and cable assembly with warm detergent solution and a clean cloth. Remove detergent by wiping each probe and cable with clean rinse water and a cloth. Wipe probes and probe brackets with disposable alcohol pad or sanitizing solution recommended for food contact surfaces. Allow probe and cable to air dry in probe holding bracket.

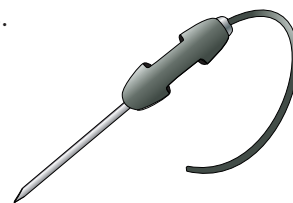

## CHECK THE COOLING FAN IN THE OVEN CONTROL AREA

While the oven is warm, check that the cooling fan in the oven control area is functioning. The fan is located at the back of the unit, toward the top.

## CHECK OVERALL CONDITION OF OVEN ONCE A MONTH

Check the oven once a month for physical damage and loose screws. Correct any problems before they begin to interfere with the operation of the oven.

<b>DANGER</b>	
	<b>AT NO TIME SHOULD THE INTERIOR OR EXTERIOR BE STEAM CLEANED, HOSED DOWN, OR FLOODED WITH WATER OR LIQUID SOLUTION OF ANY KIND. DO NOT USE WATER JET TO CLEAN.</b>
	<b>SEVERE DAMAGE OR ELECTRICAL HAZARD COULD RESULT.</b>
	<b>WARRANTY BECOMES VOID IF APPLIANCE IS FLOODED</b>

**DO NOT USE OVEN IF CONTROLS ARE NOT PROPERLY FUNCTIONING**

Refer to the Trouble Shooting Guide located in this manual or call an authorized service technician.

# SANITATION

Food flavor and aroma are usually so closely related that it is difficult, if not impossible, to separate them. There is also an important, inseparable relationship between cleanliness and food flavor. Cleanliness, top operating efficiency, and appearance of equipment contribute considerably to savory, appetizing foods. Good equipment that is kept clean, works better and lasts longer.

Most food imparts its own particular aroma and many foods also absorb existing odors. Unfortunately, during this absorption, there is no distinction between GOOD and BAD odors. The majority of objectionable flavors and odors troubling food service operations are caused by bacteria growth. Sourness, rancidity, mustiness, stale or other OFF flavors are usually the result of germ activity.

The easiest way to insure full, natural food flavor is through comprehensive cleanliness. This means good control of both visible soil (dirt) and invisible soil (germs). A thorough approach to sanitation will provide essential cleanliness. It will assure an attractive appearance of equipment, along with maximum efficiency and utility. More importantly, a good sanitation program provides one of the key elements in the prevention of food-borne illnesses.

A controlled holding environment for prepared foods is just one of the important factors involved in the prevention of food-borne illnesses. Temperature monitoring and control during receiving, storage, preparation, and the service of foods are of equal importance.

The most accurate method of measuring safe temperatures of both hot and cold foods is by internal product temperature. A quality thermometer is an effective tool for this purpose, and should be routinely used on all products that require holding at a specific temperature.

A comprehensive sanitation program should focus on the training of staff in basic sanitation procedures. This includes personal hygiene, proper handling of raw foods, cooking to a safe internal product temperature, and the routine monitoring of internal temperatures from receiving through service.

Most food-borne illnesses can be prevented through proper temperature control and a comprehensive program of sanitation. Both these factors are important to build quality service as the foundation of customer satisfaction. Safe food handling practices to prevent food-borne illness is of critical importance to the health and safety of your customers.

HACCP, an acronym for Hazard Analysis (at) Critical Control Points, is a quality control program of operating procedures to assure food integrity, quality, and safety. Taking steps necessary to augment food safety practices are both cost effective and relatively simple. While HACCP guidelines go far beyond the scope of this manual, additional information is available by contacting:

**CENTER FOR FOOD SAFETY AND APPLIED  
NUTRITION FOOD AND DRUG ADMINISTRATION  
1-888-SAFEFOOD**

INTERNAL FOOD PRODUCT TEMPERATURES		
<b>HOT FOODS</b>		
DANGER ZONE	40° TO 140°F	(4° TO 60°C)
CRITICAL ZONE	70° TO 120°F	(21° TO 49°C)
SAFE ZONE	140° TO 165°F	(60° TO 74°C)
<b>COLD FOODS</b>		
DANGER ZONE	ABOVE 40°F	(ABOVE 4°C)
SAFE ZONE	36°F TO 40°F	(2°C TO 4°C)
<b>FROZEN FOODS</b>		
DANGER ZONE	ABOVE 32°F	(ABOVE 0°C)
CRITICAL ZONE	0° TO 32°F	(-18° TO 0°C)
SAFE ZONE	0°F or below	(-18°C or below)

# SERVICE

## THERMOSTAT ACCURACY

The electronic thermostat is a precise instrument and is designed to offer trouble free service. If you suspect the temperature inside the holding compartment does not match the temperature indicated on the digital display, follow the instructions listed below.

- 1.** Check to make certain the unit voltage matches the power source. A power source less than that required to operate the unit will result in inaccurate temperatures.
- 2.** Verify the temperature inside the holding compartment with a qualify thermal indicator.
  - A.** With the exception of the wire shelves, completely empty the holding compartment.
  - B.** Make certain the holding cabinet sensor, located inside the holding compartment at the left side of the unit, is completely clean.
  - C.** Suspend the thermal indicator in the center of the holding compartment.
  - D.** Allow the temperature set on the electronic thermostat to stabilize for a minimum of one hour before comparing the digital display with the reading on the thermal indicator.

DO NOT OPEN THE CABINET DOOR(S)  
DURING THE TEMPERATURE  
STABILIZATION PERIOD.

If the reading on the thermal indicator does not match the digital display, there may be a problem with the air sensor. See troubleshooting guide in this manual; or call the factory service department for advice.



## DANGER



**DISCONNECT UNIT FROM  
POWER SOURCE BEFORE  
CLEANING OR SERVICING.**

## CAUTION

**THIS SECTION IS PROVIDED FOR THE ASSISTANCE  
OF QUALIFIED SERVICE TECHNICIANS ONLY AND  
IS NOT INTENDED FOR USE BY UNTRAINED OR  
UNAUTHORIZED SERVICE PERSONNEL.**

# SERVICE

## TROUBLESHOOTING - MANUAL CONTROL

Error Code	Description/Results	Possible Cause Service Required
<b>E-10</b>	<b>Air Sensor Fault (shorted)</b> <i>Inoperative Unit</i>	Air sensor is shorted. Air sensor defective? Test air sensor by placing sensor in ice water bath 32°F (0°C) and using an ohm-meter set on the ohm scale. The reading should be 100 ohms resistance. If it is more than 2 ohms higher or lower, sensor needs to be replaced. If Ohm reading is 100, replace display. If Ohm reading is not 100, replace sensor.
<b>E-11</b>	<b>Air Sensor Fault (open)</b> <i>Inoperative Unit</i>	Air sensor is open or connection failure. Air sensor defective? See above for air sensor test.
<b>E-30</b>	<b>Under temperature</b> <i>Oven will not reach set temperature</i>	Unit door closed? Door gasket need replacement? Preheat skipped? Unit overloaded or holding frozen product? Defective air sensor or probe? Defective solid state relay? Bad wire connections or open heating cable? If none of the above, contact Alto-Shaam Service Department.
<b>E-31</b>	<b>Over temperature</b> <i>Unit will shut down</i>	Unit has exceeded its maximum allowable set temperature by 25 degrees for at least 3 minutes. Unit will shut down. Defective sensor or poor sensor connection? Defective relay? Shorted heater element? If none of the above, contact Alto-Shaam Service Department.
<b>E-70</b>	<b>Configuration error</b> <i>Inoperative Unit</i>	Contact Alto-Shaam Service Department for correct DIP-switch settings.
<b>E-82 or E-83</b>	<b>EEPROM Error - Bad Checksum</b> <i>Inoperative Unit</i>	Contact Alto-Shaam Service Department for help resetting the control.
<b>E-90</b>	<b>Button shorted</b> <i>Inoperative Control</i>	Stuck button on control panel. Check buttons. If control is still inoperative, contact Alto-Shaam Service Department.
<b>E-91</b>	<b>Input failure</b>	Contact Alto-Shaam Service Department.
<b>-AC-</b>	<b>Power Failure</b>	Press any key to acknowledge.

*This section is provided for the assistance of qualified technicians only and is not intended for use by untrained or unauthorized service personnel. If your Alto-Shaam® unit is not operating properly, check the following before calling your Authorized Alto-Shaam® Service Agent:*

- ☛ Check the power flow to the unit. Plug in outlet? Circuit breaker switch at back of unit turned on?  
*Do not attempt to repair or service the holding cabinet beyond this point. Contact Alto-Shaam® for the nearest authorized service agent. Repairs made by any other service agents without prior authorization by Alto-Shaam® will void the warranty on the unit.*



## DANGER



**DISCONNECT UNIT FROM  
POWER SOURCE BEFORE  
CLEANING OR SERVICING.**

## CAUTION

**THIS SECTION IS PROVIDED FOR THE ASSISTANCE  
OF QUALIFIED SERVICE TECHNICIANS ONLY AND  
IS NOT INTENDED FOR USE BY UNTRAINED OR  
UNAUTHORIZED SERVICE PERSONNEL.**

# SERVICE

## TROUBLESHOOTING - ELECTRONIC CONTROL OPTION

TROUBLE	POSSIBLE CAUSE
Control will not turn on.	The unit is not connected to a power source (plugged in). The main power switch is in the off position. Insufficient voltage
Control operates but cannot control temperature.	Defective air sensor or poor sensor connection. Control is not calibrated. Defective heating element or damaged heating element connection.
Control operates but unit does not heat.	Defective air sensor or poor sensor connection. Control is not calibrated. Open heating element or poor heating element connection.

*This section is provided for the assistance of qualified technicians only and is not intended for use by untrained or unauthorized service personnel. If your Alto-Shaam® unit is not operating properly, check the following before calling your Authorized Alto-Shaam® Service Agent:*

- Check the power flow to the unit. Plug in outlet? Circuit breaker switch at back of unit turned on?  
*Do not attempt to repair or service the holding cabinet beyond this point. Contact Alto-Shaam® for the nearest authorized service agent. Repairs made by any other service agents without prior authorization by Alto-Shaam® will void the warranty on the unit.*



## DANGER



**DISCONNECT UNIT FROM  
POWER SOURCE BEFORE  
CLEANING OR SERVICING.**

## CAUTION

**THIS SECTION IS PROVIDED FOR THE ASSISTANCE  
OF QUALIFIED SERVICE TECHNICIANS ONLY AND  
IS NOT INTENDED FOR USE BY UNTRAINED OR  
UNAUTHORIZED SERVICE PERSONNEL.**

# SERVICE

## SERVICE PARTS - MANUAL CONTROL

### 750-S Unit Shown

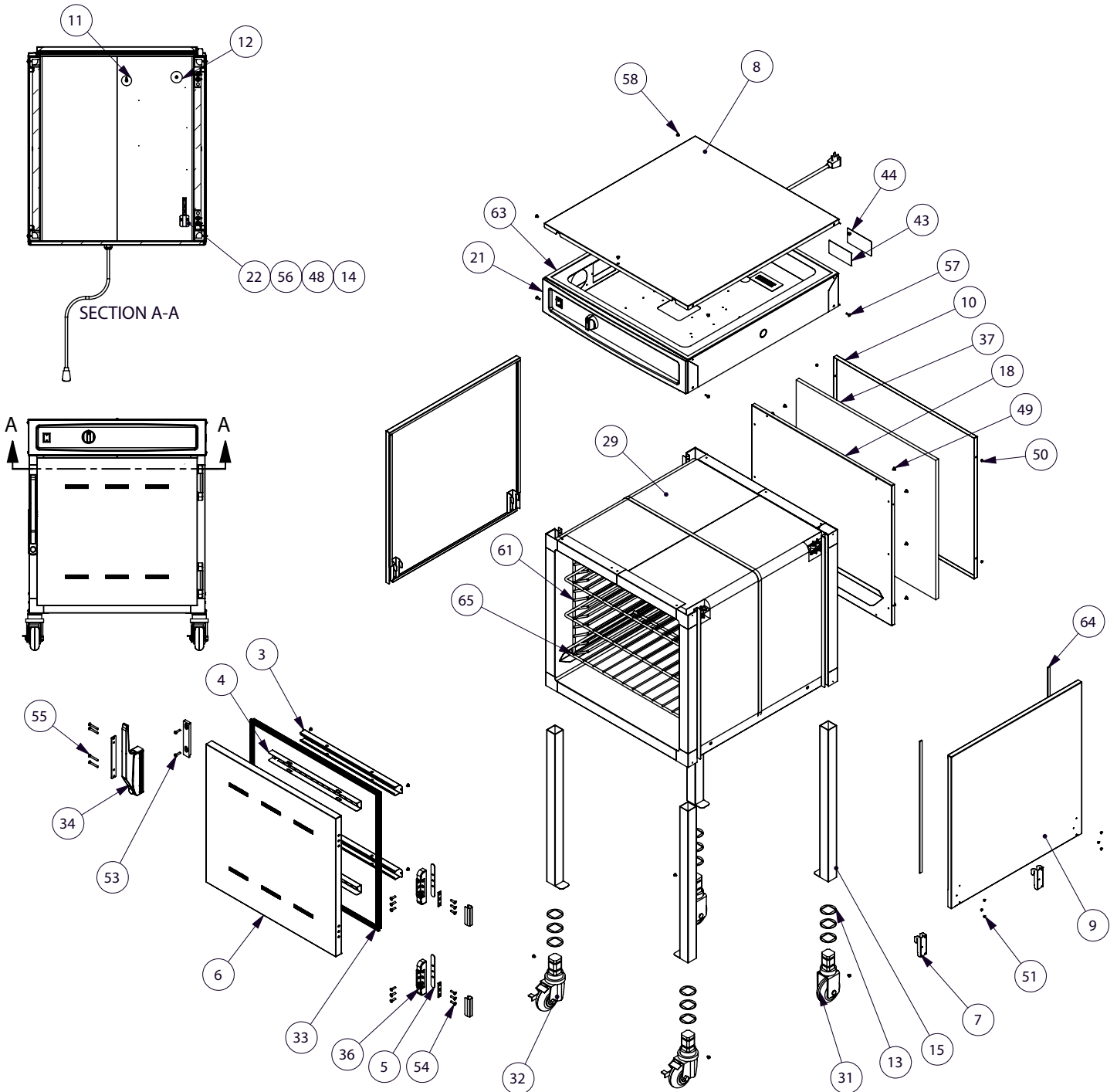

# SERVICE

## SERVICE PARTS - MANUAL CONTROL

1000-UP Unit Shown

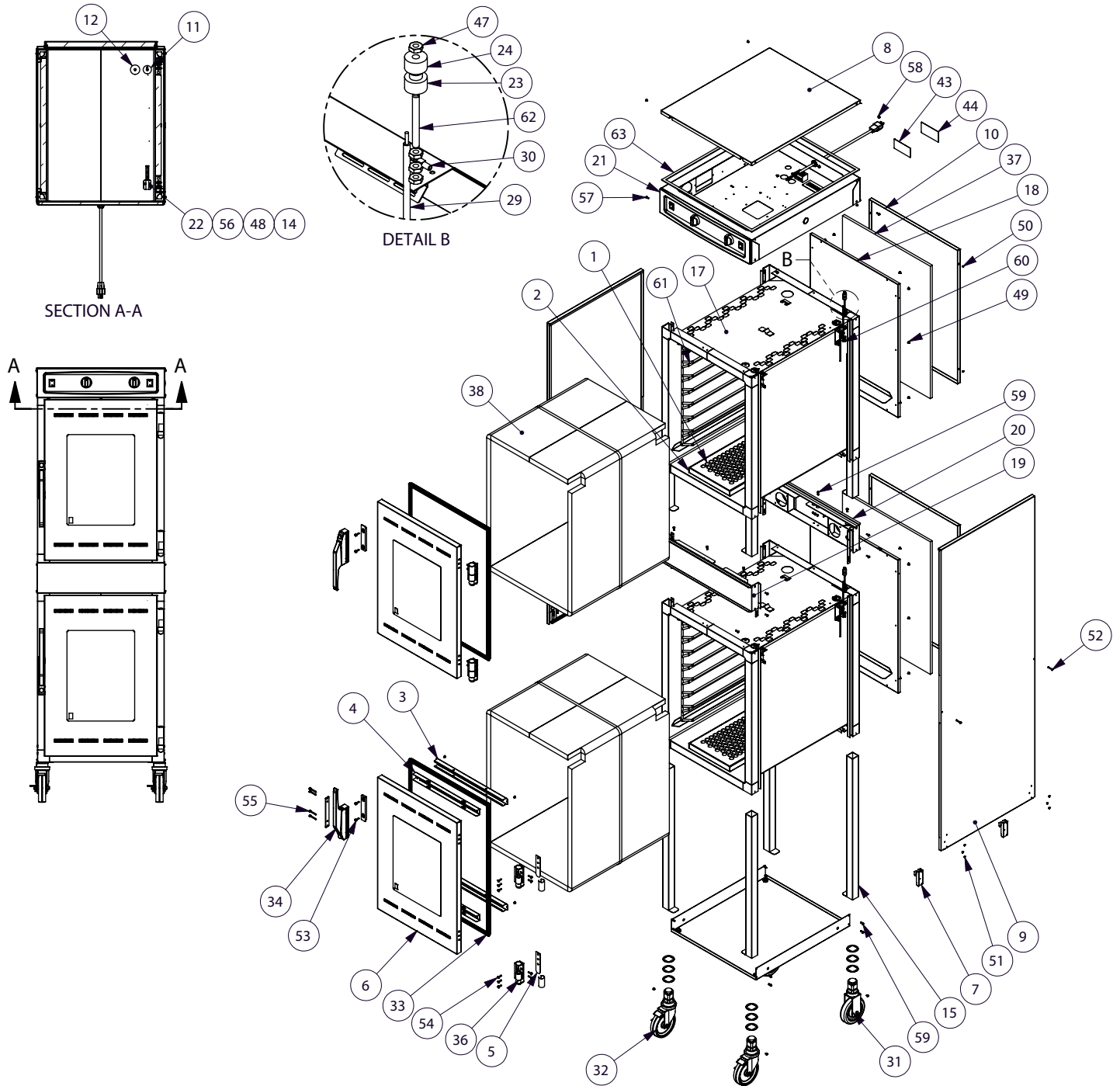

# SERVICE

MODEL >		500-S		750-S		1000-S		1000-UP	
ITEM	DESCRIPTION	PART NO.	QTY	PART NO.	QTY	PART NO.	QTY	PART NO.	QTY
1	PAN COVER	—	—	—	—	—	—	1774	2
2	MOISTURE PAN	—	—	—	—	—	—	1775	2
3	VENT PANEL	13115	2	12863	2	12863	2	12863	4
4	VENT SLIDE	13116	2	12864	2	12864	2	12864	4
5	SHIM, HINGE	13675	2	13675	2	13676	2	13676	4
6	SLAB DOOR ASSY. (INCLUDES VENTS AND GASKET)	55649	1	55648	1	55646	1	55646	2
7	BRACKET, SIDE PANEL	1003649	4	1003649	4	1003649	4	1003649	4
8	BONNET, TOP COVER	1003889	1	1003888	1	1003887	1	1003887	1
9	PANEL, SIDE, STD	1007199	2	1005959	2	1003468	2	1004985	2
	PANEL, SIDE, HD	5002725	2	5002726	2	5005612	2	5002788	2
10	OUTER BACK PANEL, STD	1007198	1	1006747	1	1004988	1	1004988	2
	OUTER BACK PANEL, HD	1007197	1	1006710	1	1006697	1	1006697	2
11	NON-SENSOR COVER	1005886	1	1005886	1	1005886	1	1005886	2
12	NON-PRODUCT PROBE SEAL	1006871	1	1006871	1	1006871	1	1006871	2
13	CASTER SPACER	1007145	12	1007145	12	1007145	12	1007145	12
14	BRACKET, SENSOR MTG.	1008272	1	1008272	1	1008272	1	1008272	2
15	CORNER TUBE WELD	5002731	4	5002731	4	5002686	4	5002686	8
16	BOTTOM WELD ASSY	—	—	—	—	—	—	5005004	1
17	TUB SPOT	—	—	—	—	—	—	5005327	2
18	SPOT, INNER TUBE, BACK	5005986	1	5005405	1	5005327	1	5005327	2
19	LOWER FRONT FACADE SPOT	—	—	—	—	—	—	5006127	1
20	LOWER REAR ASSY	—	—	—	—	—	—	5006958	1
21	BONNET ASSY, SPOT	5009353	1	5009347	1	5009114	1	5009114	1
22	SENSOR MOUNTING BLOCK	BK-27878	1	BK-27878	1	BK-27878	1	BK-27878	2
23	BUSHING, MALE CERAMIC	—	—	—	—	—	—	BU-3105	8
24	BUSHING, FEMALE CERAMIC	—	—	—	—	—	—	BU-3106	8
29	CABLE ASSY.	5006030	1	5005343	1	CB-3044	1	CB-3044	1
30	CONNECTOR	—	—	—	—	—	—	CR-3226	8
31	CASTER, RIGID	CS-25674	2	CS-25674	2	CS-25674	2	CS-24874	2
32	CASTER, SWIVEL W/ BRAKE	CS-25675	2	CS-25675	2	CS-25675	2	CS-24875	2
33	GASKET ASSY, DOOR	GS-23790	1	GS-22951	1	GS-22952	1	GS-22952	2
34	HANDLE, OFFSET MAG. LATCH	HD-27080	1	HD-27080	1	HD-27080	1	HD-27080	2
36	HINGE	HG-2015	1	HG-2015	1	HG-2535	1	HG-2535	2
37	INSULATION	IN-2003	1	IN-2003	1	IN-2003	1	IN-2003	2
43-44	RATING TAG	LA-26348	2	LA-26348	2	LA-26348	2	LA-26348	2
47	NUT, 10-32, NF HEX MS, #18-8 S/S	—	—	—	—	—	—	NU-2215	32
48	PROBE	PR-34494	1	PR-34494	1	PR-34494	1	PR-34494	2
49	RIVET, BLIND, #43, LRG FLG, STNLS	RI-2094	10	RI-2094	10	RI-2094	10	RI-2094	20
50	RIVET, #42 STAINLESS	RI-2097	4	RI-2097	4	RI-2097	4	RI-2097	8
51	RIVET, BLIND, #44, STNLS	RI-2100	12	RI-2100	12	RI-2100	12	RI-2100	12
52	SCREW, 8-32 X 1, NC PHILLIPS PAN	—	—	—	—	—	—	SC-2069	4
53	SCREW, 3/4 PAN HD	SC-2071	2	SC-2071	2	SC-2071	2	SC-2071	4
54	SCREW, 10-32 X 3/4, NF, PHIL, FLAT	SC-2072	12	SC-2072	12	SC-2072	12	SC-2072	20
55	SCREW, 10-32 X 1-1/2, NF, PHIL, FLAT	SC-2073	4	SC-2073	4	SC-2073	4	SC-2073	8
56	SCREW, 6-32 X 1/2, NC PHIL, FLAT	SC-2239	2	SC-2239	2	SC-2239	2	SC-2239	4
57	SCREW, 8-32 X 1/2 PHIL SCREW	SC-2425	4	SC-2425	4	SC-2425	4	SC-2425	12
58	SCREW, 8-32 X 1/4 PHIL SCREW	SC-2459	15	SC-2459	15	SC-2459	15	SC-2459	25
59	SCREW, 8-32 X 1/2T-410PH PAN HD	—	—	—	—	—	—	SC-25849	18
60	SLEEVE, 1 LONG, FIBER, HEAT TREAT	—	—	—	—	—	—	SL-3063	8
61	SIDE RACK, CHROME	SR-28402	2	SR-28404	2	SR-2120	2	SR-2120	4
62	STUD, 10-32 X 1 3/4, FULL THD, 18-8	—	—	—	—	—	—	ST-2439	8
63	TAPE, FOAM	TA-25621	1	TA-25621	1	TA-25621	1	TA-25621	1
64	GASKET, SIDE PANEL	GS-23622	4	GS-23622	4	GS-23622	4	GS-23622	4
65	SHELF, NICKEL CHROME	SH-2107	2	SH-2105	3	—	—	—	—

# SERVICE

## MANUAL CONTROL - 500-S, 750-S, 1000-S

208/240V Unit Shown

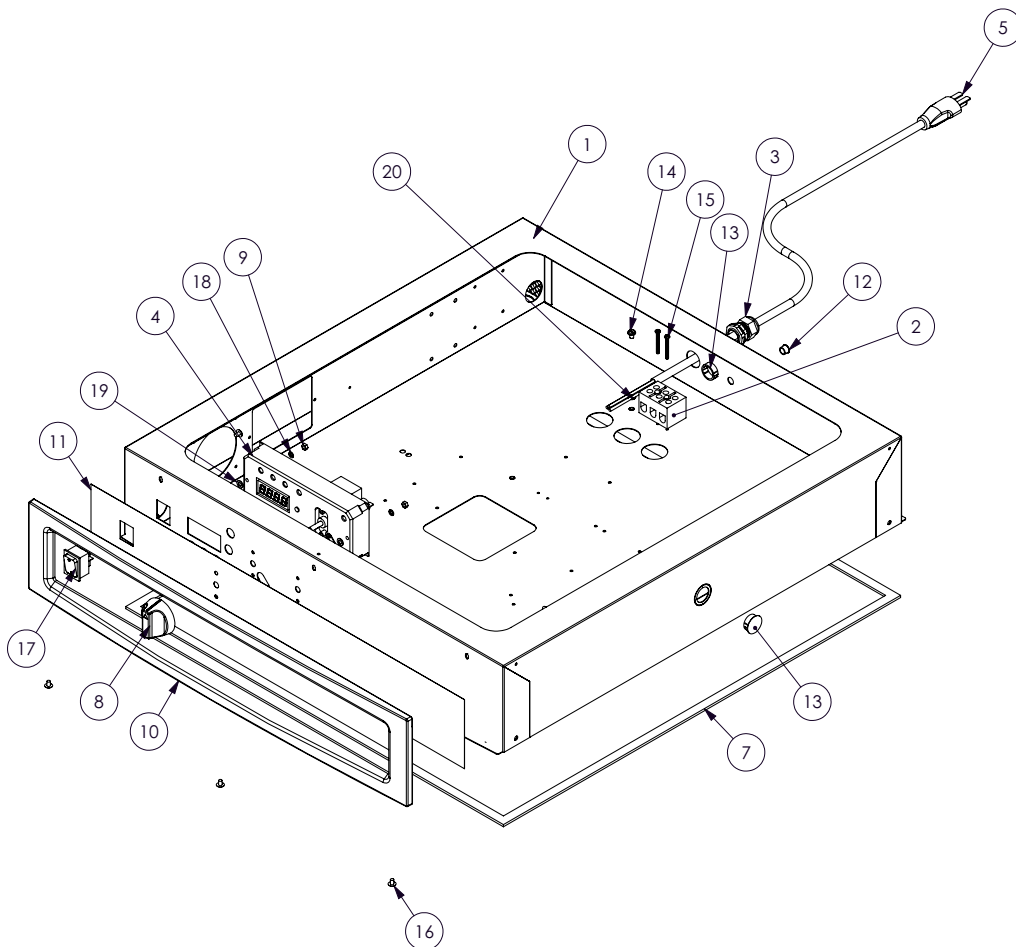

ITEM	PART NO.	DESCRIPTION	QTY	ITEM	PART NO.	DESCRIPTION	QTY
1	5009353	BONNET, SPOT, 500-S	1	11	PE-28701	CONTROL PANEL OVERLAY	1
	5009347	BONNET, SPOT, 750-S	1	12	PG-25574	HOLE PLUG, 3/8"	1
	5009114	BONNET, SPOT, 1000-S	1	13	PG-3589	HOLE PLUG, 13/16	2
2	BK-3019	T-BLOCK	1	14	SC-2190	GROUND SCREW	1
3	BU-3964	BUSHING, STRAIN RELIEF	1	15	SC-2365	SCREW, ROUND HD, 16-32 X 1-1/4"	2
4	CC-34488	CONTROL	1	16	SC-2459	SCREW, PHIL, 8-32 X 1/4"	5
5	CD-3232	CORDSET, 120V	1	17	SW-34375	SWITCH, ROCKER, POWER, 120V	1
	CD-3551	CORDSET, 208/240V, 230V	1		SW-34351	SWITCH, RKR, PWR, 208-240V, 230V	1
6	CR-34559	CONNECTOR	4	18	WS-22300	WASHER M4 SPLIT LOCK S/S 18-8	2
7	GS-2019	GASKET	1	19	WS-2420	WASHER, #10 NYLON	2
8	KN-26568	THERMOSTAT KNOB	1	20	WS-2467	WASHER, STAR LOCK	1
9	NU-22286	HEX NUT	2				
10	PE-26566	CONTROL PANEL BEZEL	1				

# SERVICE VIEW

## MANUAL CONTROL - 1000-UP

208/240V Unit Shown

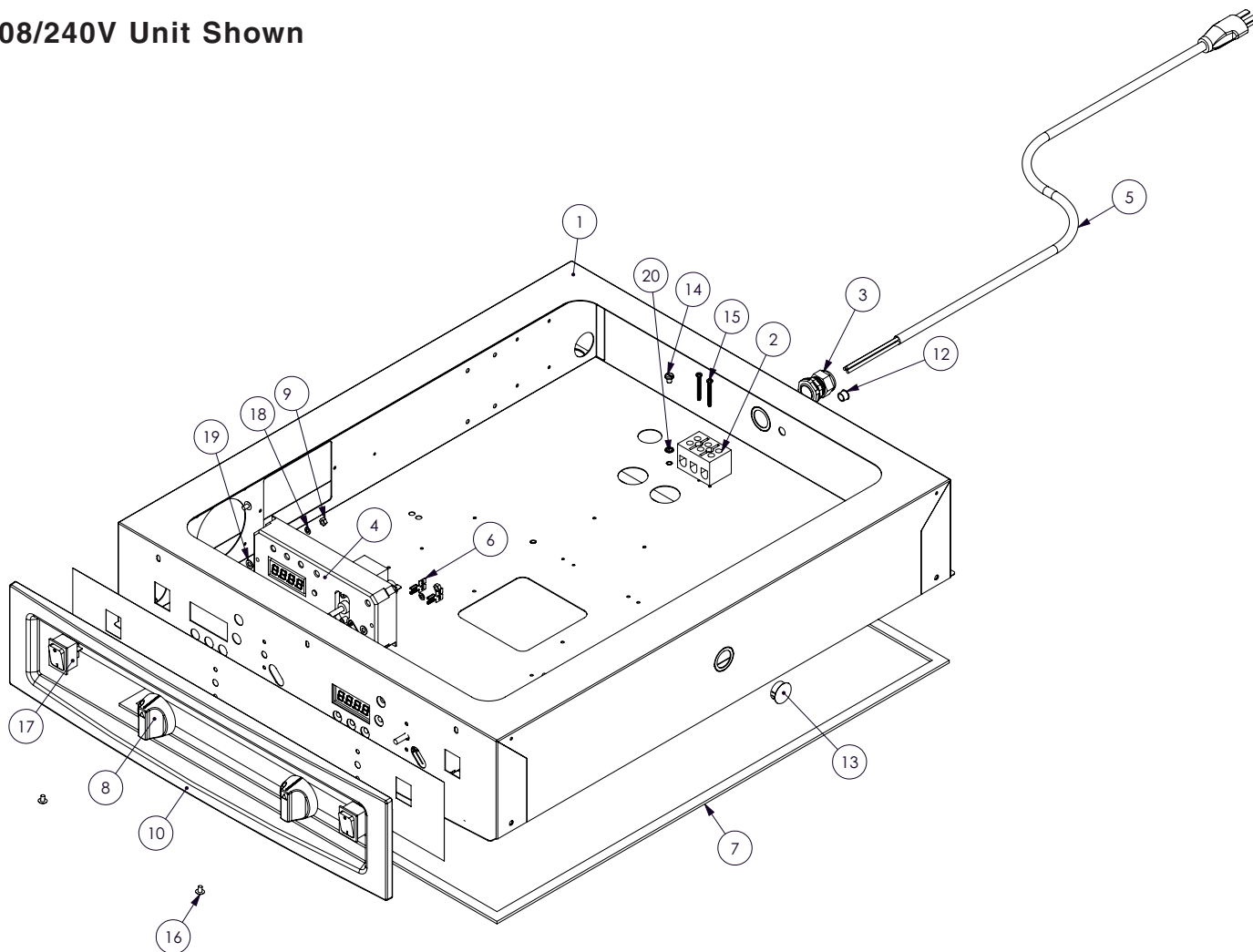

ITEM	PART NO.	DESCRIPTION	QTY	ITEM	PART NO.	DESCRIPTION	QTY
1	5009114	BONNET, SPOT, 1200-UP	1	12	PG-25574	HOLE PLUG, 3/8"	1
2	BK-3019	T-BLOCK	1	13	PG-3589	HOLE PLUG, 13/16	1
3	BU-3964	BUSHING, STRAIN RELIEF	1	14	SC-2190	GROUND SCREW	1
4	CC-34488	CONTROL	2	15	SC-2365	SCREW, ROUND HD, 16-32 X 1-1/4"	2
5	CD-33824	CORDSET, 120V	1	16	SC-2459	SCREW, PHIL, 8-32 X 1/4"	5
	CD-3551	CORDSET, 208/240V, 230V	1	17	SW-34375	SWITCH, ROCKER, POWER, 120V	2
6	CR-34558	CONNECTOR	4		SW-34351	SWITCH, RKR, PWR, 208-240V, 230V	2
7	GS-2019	GASKET	1	18	WS-22300	WASHER M4 SPLIT LOCK S/S 18-8	4
8	KN-26568	THERMOSTAT KNOB	2	19	WS-2420	WASHER, #10 NYLON	4
9	NU-22286	HEX NUT	4	20	WS-2467	WASHER, STAR LOCK	1
10	PE-26567	CONTROL PANEL BEZEL	1	21	PR-34494	PROBE (NOT SHOWN)	2
11	PE-28637	CONTROL PANEL OVERLAY	1				

# SERVICE VIEW

## ELECTRONIC CONTROL OPTION

120V Unit Shown

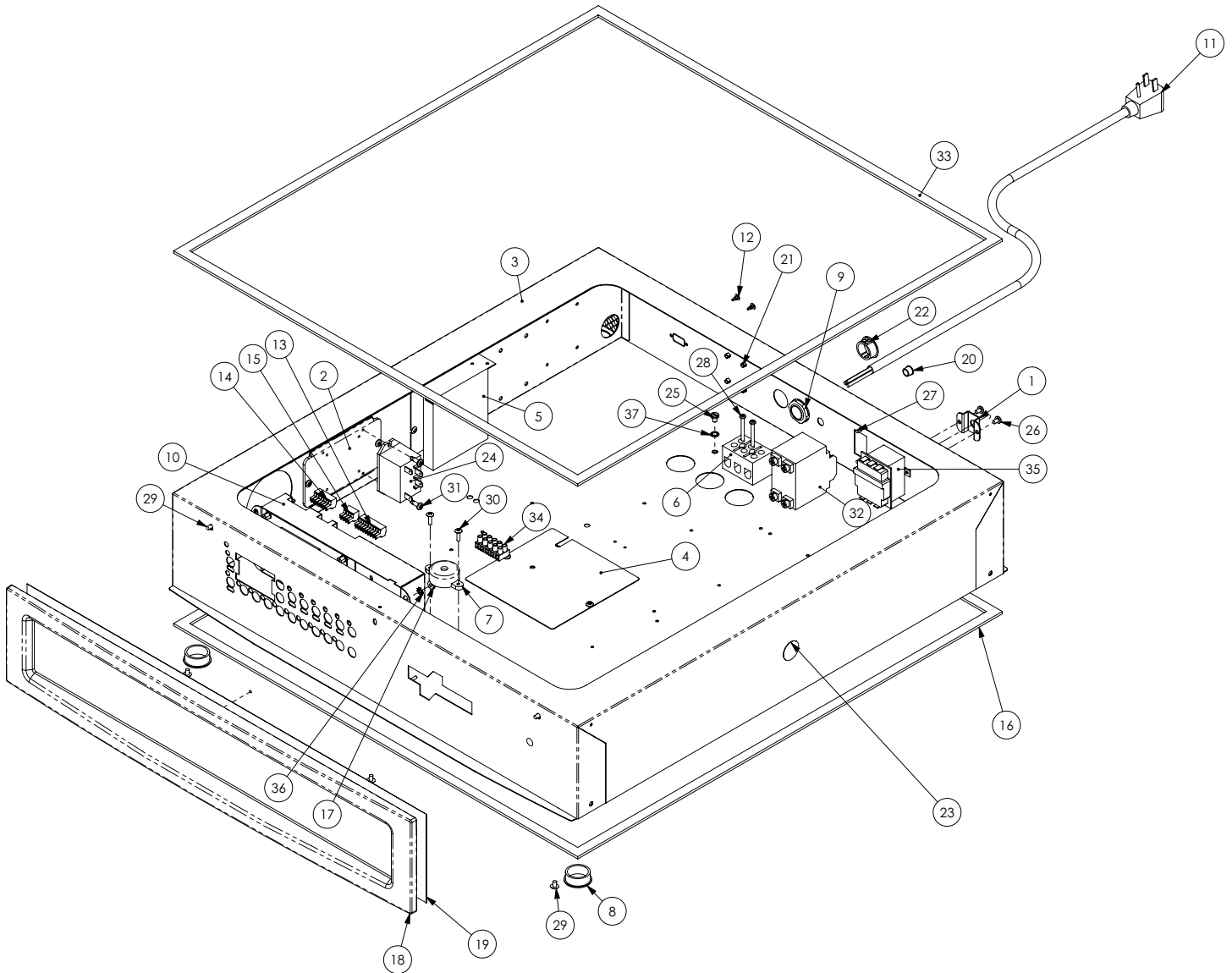

# SERVICE

## ELECTRONIC CONTROL OPTION - 500-S, 750-S, 1000-S

ITEM	PART NO.	DESCRIPTION	QTY	ITEM	PART NO.	DESCRIPTION	QTY
1	1003936	HI-LIMIT PROTECTION COVER	1		PE-26567	PANEL CONTROL BEZEL, 1000-S	1
2	1005836	HEAT SINK	1	19	PE-27934	OVERLAY, ELEC, 500-S	1
3	5006075	BONNET SPOT ASSBY, 500-S	1		PE-27267	OVERLAY, ELEC, 750-S	1
	5004770	BONNET SPOT ASSBY, 750-S	1		PE-27082	OVERLAY, ELEC, 1000-S	1
	5005031	BONNET SPOT ASSBY, 1000-S	1	20	PG-25574	3/8" HOLE , 120V ONLY	1
4	5007164	HI-LIMIT BULB COVER, SPOT	1	21	PG-28439	PLUG, DOME,.187" HOLE, 500-S, 750-S	4
5	BA-33554	POWER SUPPLY	1	22	PG-3559	7/8" HOLE PLUG, 500-S, 750-S	1
6	BK-3019	T-BLOCK	1		PG-3325	1.125" HOLE PLUG, 1000-S ONLY	1
7	BP-3567	BEEPER	1	23	PG-3589	PLUG,HOLE,13/16	1
8	BU-3008	3/4" WHITE SNAP BUSHING, 500-S	1	24	RL-33558	RELAY, SPST 30A @ 277 VAC 12VDC	1
	BU-3378	1-1/8" SNAP BUSHING, 750-S	1	25	SC-2190	10-32 X 1/4 PAN HD GROUND SCREW	1
9	BU-3964	BUSHING,STRAIGHT,STRAIN RELIEF	4	26	SC-22271	SCREWS,M4-0.7X6MM PHIL	2
10	CC-34322	ELECTRONIC CONTROL, 230V	1	27	SC-22500	SCREW 6-32 X 1/4" PAN HD	2
	CC-34324	ELECTRONIC CONTROL, 120V	1	28	SC-2365	SCREW,6-32X1-1/4,NC PHILLIPS	2
11	CD-3922	CORDSET, 16AWG, 3C, 230V	1	29	SC-2459	8-32 X 1/4" PHIL SCREW	5
	CD-3232	CORDSET, 14/3 SJTOW, 120V	1	30	SC-2472	SCREW,6-32 X1/2,NC PHIL TRUSS	2
12	CL-22820	CANOE CLIP	1	31	SC-25849	SCREW,8-32X1/2T-410PH PAN HD	2
13	CR-33718	CONNECTOR 9 PIN	2	32	SW-34077	SWITCH, CIRCUIT BREAKER, 20 A	1
14	CR-33761	CONNECTOR, 7 PIN	1	33	TA-25621	TAPE	1
15	CR-33763	CONNECTOR 4 PIN	1	34	TM-33560	TERMINAL,STRIP,5CIRCUIT,UL,VDE	1
16	GS-2019	GASKET, 102"	1	35	TT-33476	T-STAT, 300 F HI-LIMIT	1
17	NU-2296	NUT, HEX #8-32	1	36	WS-2333	WASHER, #8 EXT LOCK	4
18	PE-26565	PANEL CONTROL BEZEL, 500-S	1	37	WS-2467	STAR LOCK WASHER	1
	PE-26566	PANEL CONTROL BEZEL, 750-S	1				

### MODELS

#### 500-S, 750-S, 1000-S, 1000-UP CABLE HEATING SERVICE KIT No. 4874

##### INCLUDES:

CB-3044	Cable Heating Element . . . . .	108 feet
CR-3226	Ring Connector . . . . .	4
IN-3488	Insulation Corner . . . . .	1 foot
BU-3105	Shoulder Bushing . . . . .	4
BU-3106	Cup Bushing . . . . .	4
ST-2439	Stud . . . . .	4
NU-2215	Hex Nut . . . . .	8
SL-3063	Insulating Sleeve . . . . .	4
TA-3540	Electrical Tape . . . . .	1 roll



# DANGER



**DISCONNECT UNIT FROM  
POWER SOURCE BEFORE  
CLEANING OR SERVICING.**

VIEW FROM REAR OF BONNET

(FRONT)

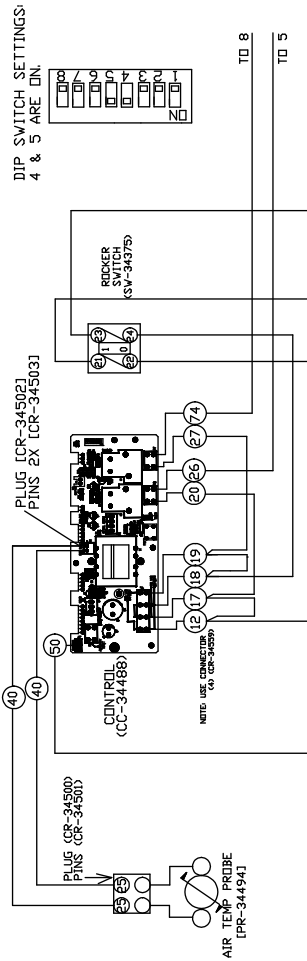

(REAR)

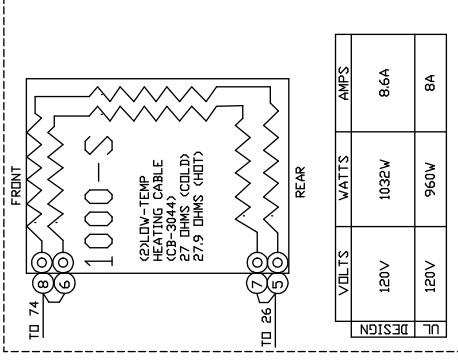
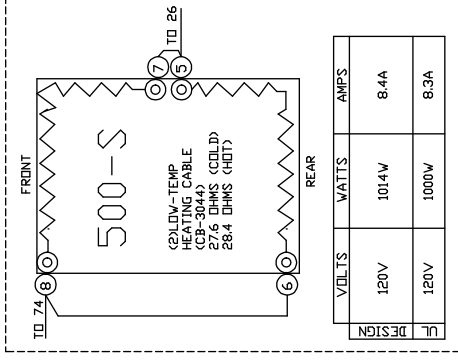
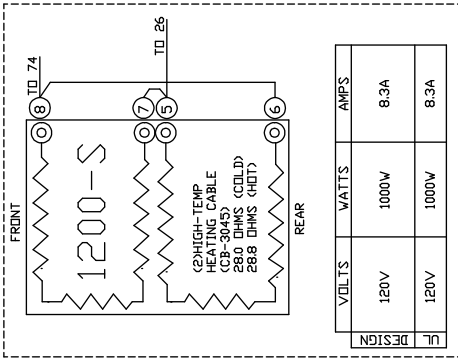
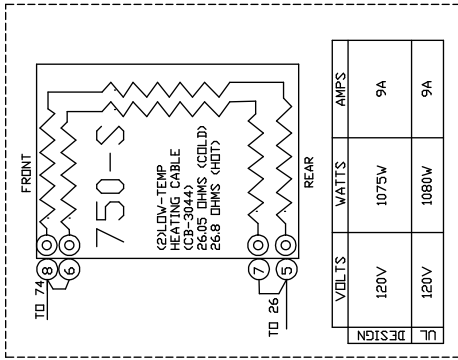

REV	ECO	DESCRIPTION	DATE	APP
3	-	ADD 500,750,1000-S	11-24-08	JPK
2	-	MISC. CHANGES	9-9-08	BES
1	-	RE-DRAW	7-22-08	BES

500,750,1000,1200-S ELAN 120V 60HZ

**ALTO-SHAAM** WIRING DIAGRAM

DWG: 77194

REV ECO DESCRIPTION DATE APP

500,750,1000,1200-S ELAN 120V 60HZ

SH: JPK/DAB 1/16/08

SHEET 1\_DF\_1

NOTE #1: ALL NUMBERS IN ( ) = ALTO-SHAAM PART NUMBERS

NOTE #2: SEE DRW. 5008760 FOR WIRE ASSEMBLIES

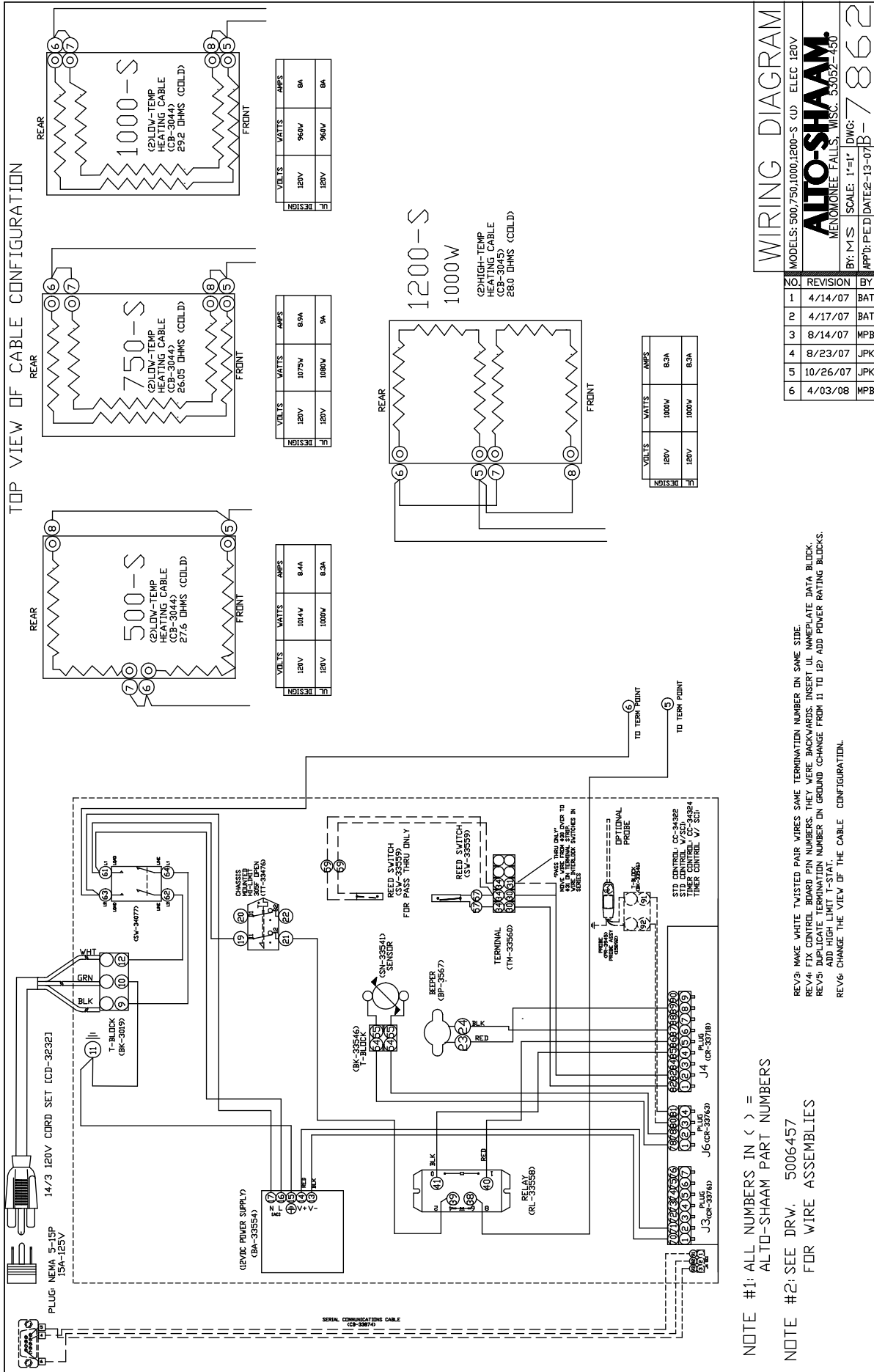





VIEW FROM REAR OF BONNET

(FRONT)

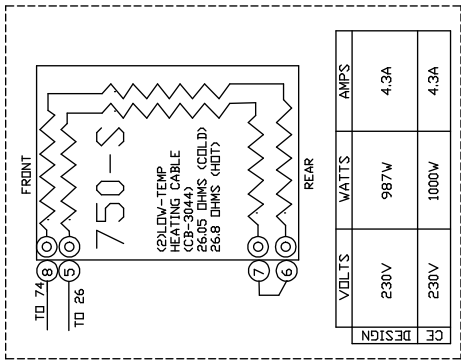
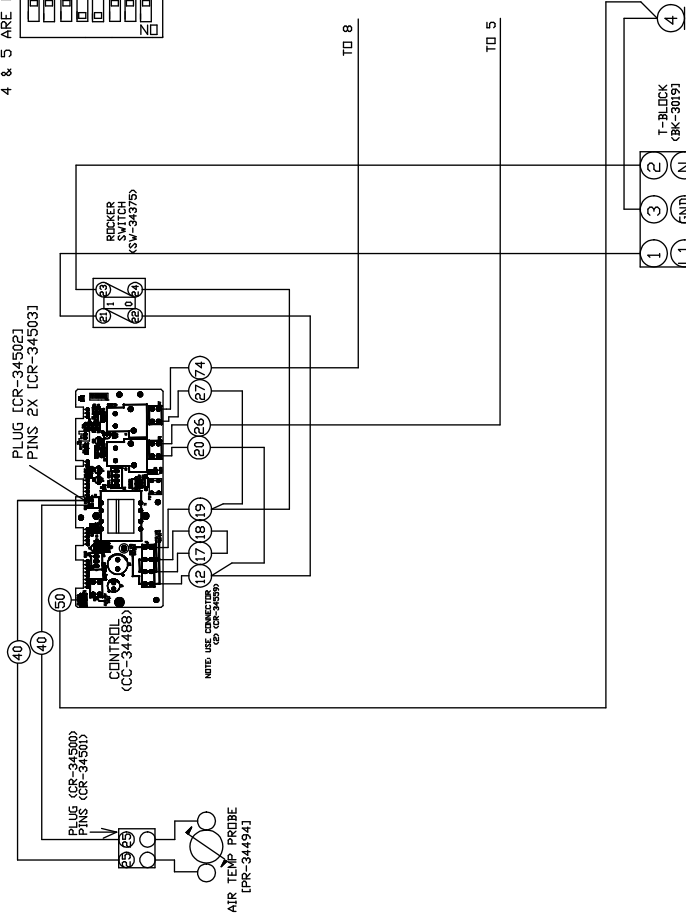

VOLTS	WATTS	AMPS
230V	987W	4.3A
230V	1000W	4.3A

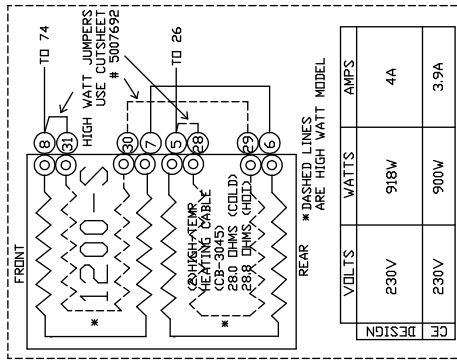

VOLTS	WATTS	AMPS
230V	918W	4A
230V	900W	3.9A

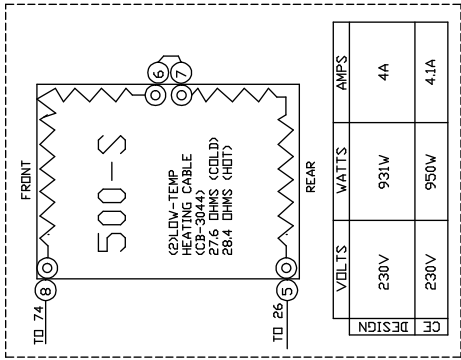

VOLTS	WATTS	AMPS
230V	931W	4A
230V	950W	4.1A

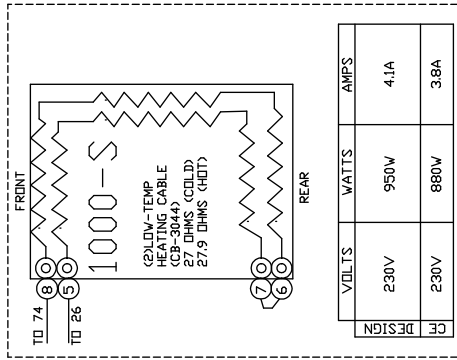

VOLTS	WATTS	AMPS
230V	950W	4.1A
230V	880W	3.8A

REV	ECO	DESCRPTION	DATE	APP
3	-	ADD 500,750,1000-S	11-24-08	JPK
2	-	MISC CHANGES	9-3-08	JPK
1	-	RE-DRAW	7-22-08	BBS

500,750,1000,1200-S ELAN 230V 50HZ

**WIRING DIAGRAM**

DRWG: 77196

DATE: 1/16/08

SHEET 1 OF 1

1200-S HIGH WATT MODEL	
VOLTS	AMPS
230V	8A
230V	7.8A

NOTE #1: ALL NUMBERS IN ( ) = ALTO-SHAW PART NUMBERS

NOTE #2: SEE DRW 5008765 FOR MAIN WIRE ASSEMBLY

SEE DRW 5007692 FOR HIGH WATT JUMPERS



VIEW FROM REAR OF BONNET

<FRONT>

UPPER CONTROLS

LOWER CONTROLS

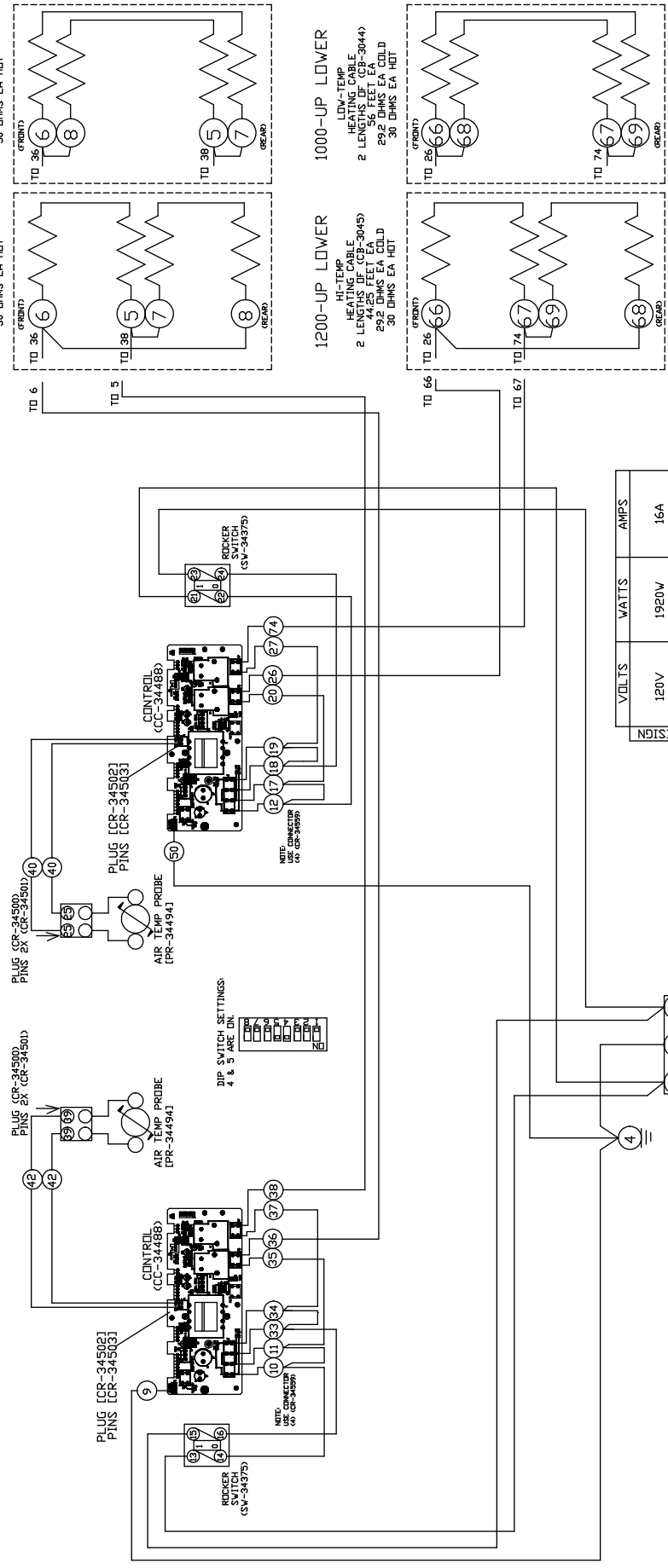

PLUG, NEMA 5-20P  
20 AMP 125 VOLTS

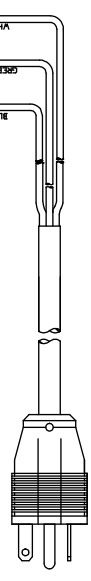

DESIGN	VOLTS	WATTS	AMPS
DESIGN	120V	1920W	16A
DESIGN	120V	1920W	16A

NOTE #1: ALL NUMBERS IN ( ) =  
ALTO-SHAAM PART NUMBERS  
NOTE #2: SEE DRW. 5008748  
FOR WIRE ASSEMBLIES

REV	ECO	DESCRIPTION	DATE	APP
2	5315	ADD 1000-UP	11-24-08	JPK
1	-	RE-DRAW	7-22-08	JPK

1000 & 1200-UP/UPS ELAN 120V 60HZ

**ALTO-SHAAM**  
WIRING DIAGRAM  
DWG: 77190

BY: JPK DATE 1/16/08

SHEET 1 OF 1

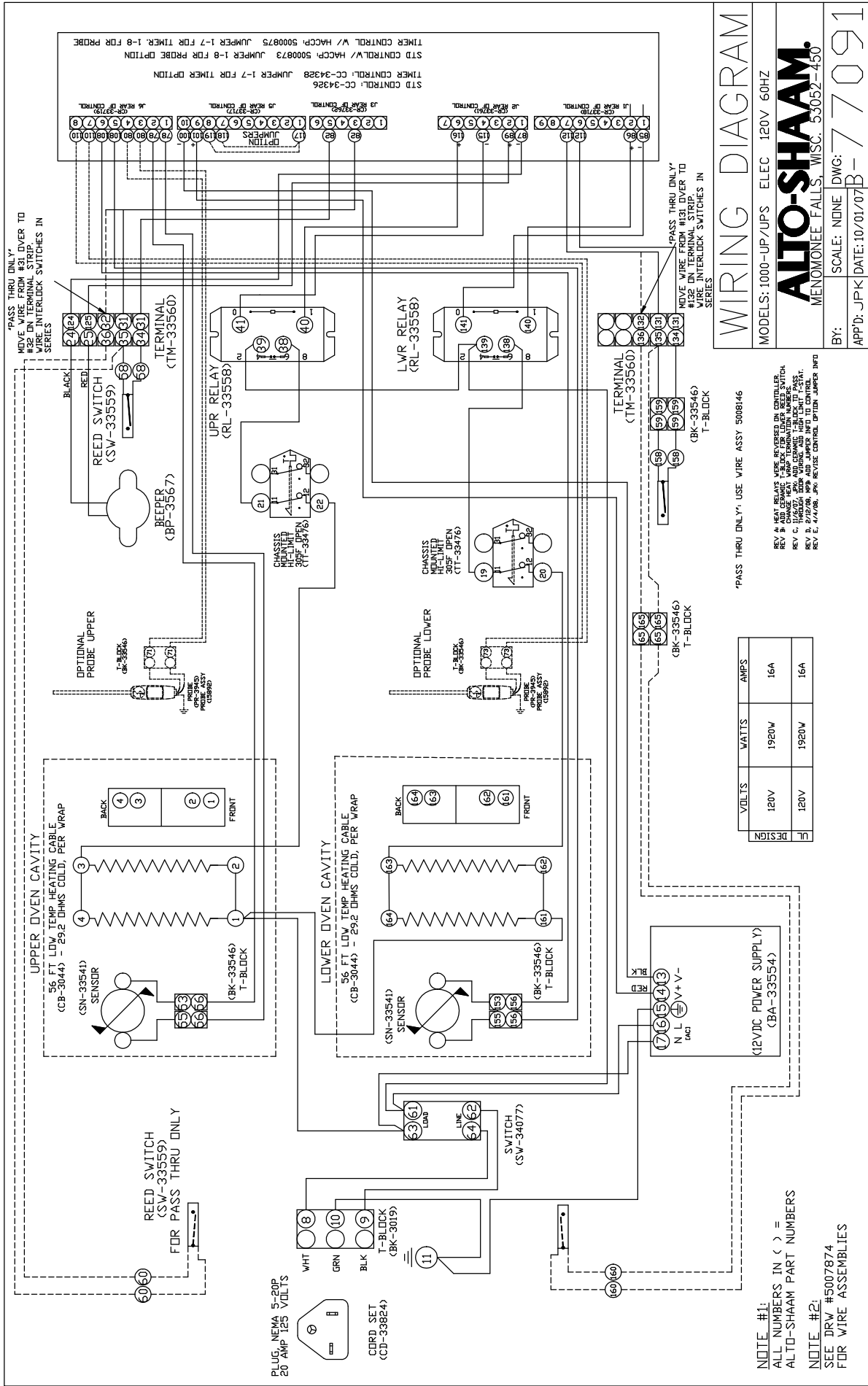

# WIRING DIAGRAM

MODELS: 1000-UP/UPS ELEC 120V 60HZ

**ALTO-SHAAM.**  
MEMONONEE FALLS, WISC. 53052-450

BY: SCALE: NONE DWG: B-77091  
APP'D: JPK DATE: 10/01/07

\*PASS THRU ONLY\*  
MOVE WIRE FROM #31 DIVER TO #32 ON TERMINAL STRIP. WIRE INTERLOCK SWITCHES IN SERIES

\*PASS THRU ONLY\*  
MOVE WIRE FROM #131 DIVER TO #132 ON TERMINAL STRIP. WIRE INTERLOCK SWITCHES IN SERIES

\*PASS THRU ONLY\* USE WIRE ASSY 5080146

VOLTS	WATTS	AMPS
120V	1920W	16A
120V	1920W	16A

NOTE #1:  
ALL NUMBERS IN ( ) =  
ALTO-SHAAM PART NUMBERS

NOTE #2:  
SEE DRW #5007874  
FOR WIRE ASSEMBLIES

\*REVISIONS\*  
REV A: REED SWITCH WIRE REVERSED IN DIRECTION  
REV B: CHANGE HEAT WAVE TERMINATION NUMBER  
REV C: INTERLOCK WIRE WIRING AND HIGH LIMIT TEST  
REV D: INTERLOCK WIRE WIRING AND HIGH LIMIT TEST  
REV E: 4/1/08 - JPK REVISE CONTROL OPTION JUMPER INFO



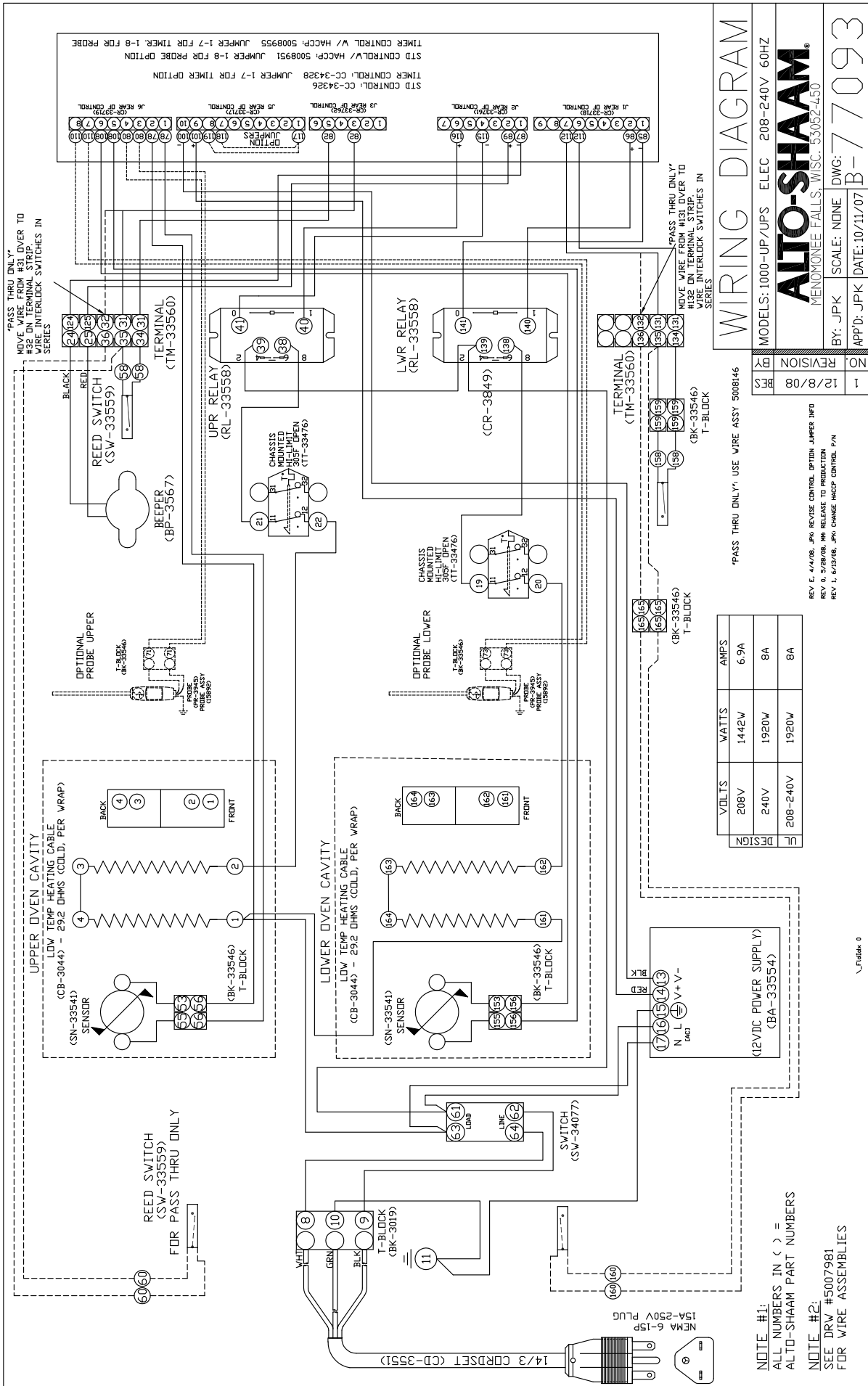

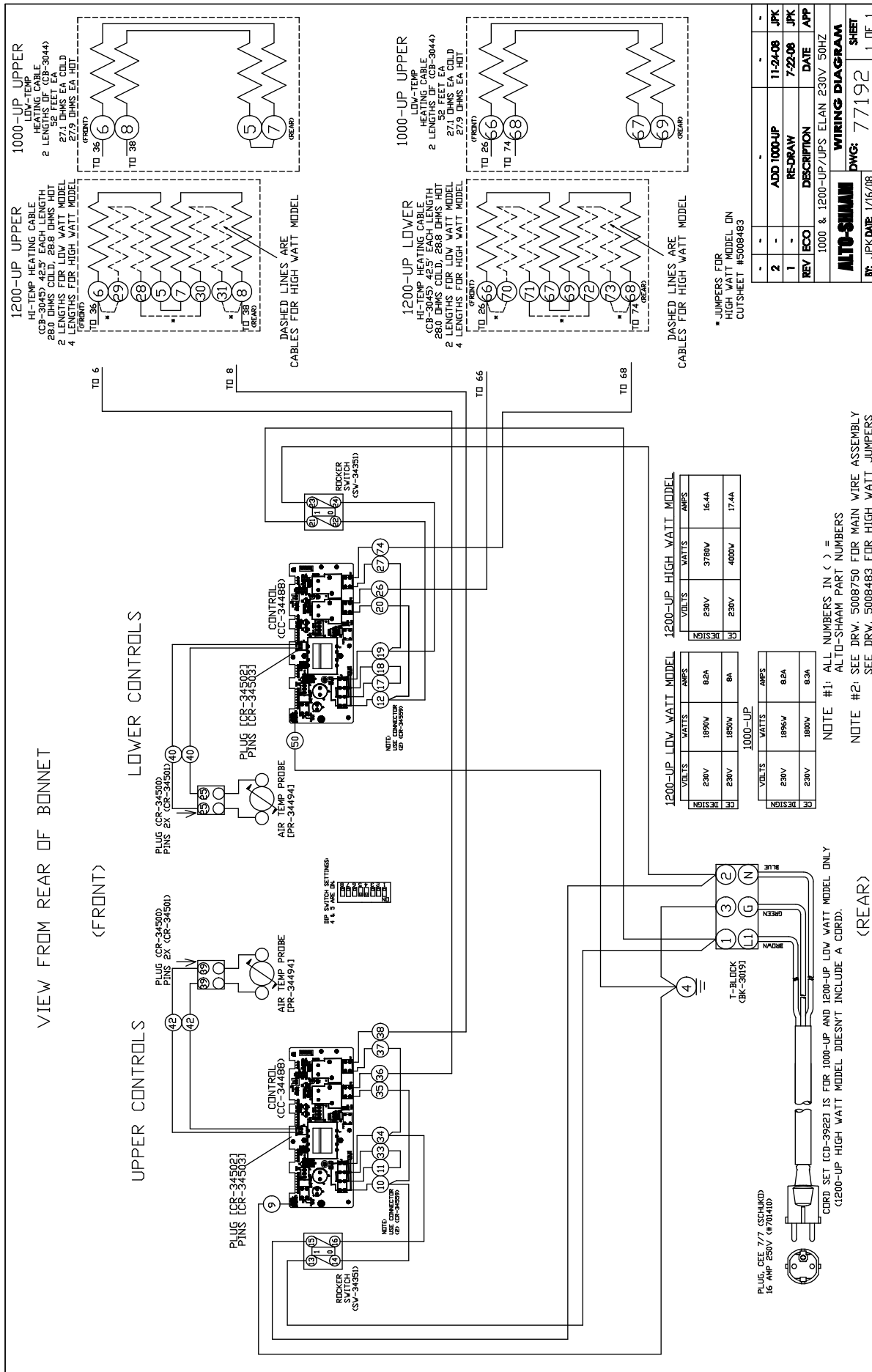



# TRANSPORTATION DAMAGE and CLAIMS

# ALTO SHAAM LIMITED WARRANTY



All Alto-Shaam equipment is sold F.O.B. shipping point, and when accepted by the carrier, such shipments become the property of the consignee.

Should damage occur in shipment, it is a matter between the carrier and the consignee. In such cases, the carrier is assumed to be responsible for the safe delivery of the merchandise, unless negligence can be established on the part of the shipper.

1. Make an immediate inspection while the equipment is still in the truck or immediately after it is moved to the receiving area. Do not wait until after the material is moved to a storage area.
2. Do not sign a delivery receipt or a freight bill until you have made a proper count and inspection of all merchandise received.
3. Note all damage to packages directly on the carrier's delivery receipt.
4. Make certain the driver signs this receipt. If he refuses to sign, make a notation of this refusal on the receipt.
5. If the driver refuses to allow inspection, write the following on the delivery receipt:  
*Driver refuses to allow inspection of containers for visible damage.*
6. Telephone the carrier's office immediately upon finding damage, and request an inspection. Mail a written confirmation of the time, date, and the person called.
7. Save any packages and packing material for further inspection by the carrier.
8. Promptly file a written claim with the carrier and attach copies of all supporting paperwork.

We will continue our policy of assisting our customers in collecting claims which have been properly filed and actively pursued. We cannot, however, file any damage claims for you, assume the responsibility of any claims, or accept deductions in payment for such claims.

Alto-Shaam, Inc. warrants to the original purchaser only that any original part that is found to be defective in material or workmanship will, at Alto-Shaam's option, subject to provisions hereinafter stated, be replaced with a new or rebuilt part.

### The parts warranty period is as follows:

For the refrigeration compressor on Alto-Shaam Quickchillers™, five (5) years from the date of installation.

For the heating element on Halo Heat® cook/hold ovens, as long as the original purchaser owns the oven.

For all other parts, one (1) year from the date of installation or fifteen (15) months from the shipping date, whichever occurs first.

The labor warranty period is one (1) year from the date of installation or fifteen (15) months from the shipping date, whichever occurs first.

Alto-Shaam will bear normal labor charges performed during standard business hours, excluding overtime, holiday rates or any additional fees.

To be valid, a warranty claim must be asserted during the applicable warranty period. This warranty is not transferable.

### THIS WARRANTY DOES NOT APPLY TO:

1. Calibration.
2. Replacement of light bulbs and/or the replacement of display case glass due to damage of any kind.
3. Equipment damage caused by accident, shipping, improper installation or alteration.
4. Equipment used under conditions of abuse, misuse, carelessness or abnormal conditions, including but not limited to, equipment subjected to harsh or inappropriate chemicals, including but not limited to, compounds containing chloride or quaternary salts, poor water quality, or equipment with missing or altered serial numbers.
5. Damage incurred as a direct result of poor water quality, inadequate maintenance of steam generators and/or surfaces affected by water quality. Water quality and required maintenance of steam generating equipment is the responsibility of the owner/operator.
6. Damage caused by use of any cleaning agent other than Alto-Shaam's Combitherm® Cleaner, including but not limited to damage due to chlorine or other harmful chemicals. **Use of Alto-Shaam's Combitherm® Cleaner on Combitherm® ovens is highly recommended.**
7. Any losses or damage resulting from malfunction, including loss of product or consequential or incidental damages of any kind.
8. Equipment modified in any manner from original model, substitution of parts other than factory authorized parts, removal of any parts including legs, or addition of any parts.

This warranty is exclusive and is in lieu of all other warranties, express or implied, including the implied warranties of merchantability and fitness for a particular purpose. In no event shall Alto-Shaam be liable for loss of use, loss of revenue or profit, or loss of product, or for any indirect, special, incidental, or consequential damages. No person except an officer of Alto-Shaam, Inc. is authorized to modify this warranty or to incur on behalf of Alto-Shaam any other obligation or liability in connection with Alto-Shaam equipment.

**ALTO-SHAAM, INC.**

Effective 02/09

RECORD THE MODEL AND SERIAL NUMBER OF THE APPLIANCE FOR EASY REFERENCE.  
ALWAYS REFER TO BOTH MODEL AND SERIAL NUMBER IN ANY CONTACT WITH ALTO-SHAAM REGARDING THIS APPLIANCE.

Model: \_\_\_\_\_ Date Installed: \_\_\_\_\_  
Voltage: \_\_\_\_\_ Purchased From: \_\_\_\_\_  
Serial Number: \_\_\_\_\_

**W164 N9221 Water Street • P.O. Box 450 • Menomonee Falls, Wisconsin 53052-0450 • U.S.A.**  
PHONE: 262.251.3800 • 800.558-8744 USA/CANADA FAX: 262.251.7067 • 800.329.8744 U.S.A. ONLY

www.alto-shaam.com

PRINTED IN U.S.A.