

## Key Specifications

- Full featured Wi-Fi 6, 12 Stream AP
- 8x8:8 5GHz Radio + 4x4:4 2.4 GHz Radio
- Up to 1.1 Gbps throughput for 2.4 GHz radio
- Up to 4.8 Gbps throughput for 5 GHz radio
- Additional 2x2 dual band radio for dedicated RF and WIPS scanning
- Integrated omni directional antennas
- 20/40/80/80+80/160 MHz channel width support
- 2x 5 Gigabit Ethernet ports
- Support for UL/DL MU-MIMO
- Support for UL/DL OFDMA
- 802.3bt PoE support
- 802.3at support with reduced function
- Wall and ceiling mounting options
- Integrated BLE

## Key Features

- Distributed Data Plane architecture
- Zero-touch deployment through automatic cloud activation and configuration
- Cloud or on premises management plane options
- Operating modes for dedicated access, dedicated security or dual-mode
- Support for up to 8 distinct SSIDs per radio
- Integrated firewall, traffic shaping, QoS and BYOD controls per SSID
- Dynamic RF optimization through smart steering, band steering and optimal channel selection
- Application visibility through layer 7 deep packet inspection
- Automated device access logging
- Patented Marker Packet™ technology for rogue AP detection and classification
- Wired VLAN monitoring for “No-WiFi” zone enforcement
- Third party analytics integration with real-time data transfer
- Versatile 3rd radio for WIPS, Scanning and Client Connectivity Tests
- Self-healing wireless mesh networking

## Aesthetic Design and High Performance

Arista C-260 is an enterprise-grade, 12 stream Wi-Fi 6 AP with dual concurrent 5 GHz and 2.4 GHz band radios supporting 8 stream 802.11a/n/ac/ax, 4 stream 802.11b/g/n/ax and data rates of up to 4.8 Gbps and 1.4 Gbps, respectively. It also has a 2.4GHz Bluetooth Low Energy (BLE) radio.

## C-260 Capabilities

C-260 provides Gen 2 Wi-Fi 6 performance improvements to deliver higher capacity and more efficient use of the available spectrum. It provides industry leading user experience and throughput in high density environments. Uplink/ Downlink OFDMA channelization allocates bandwidth more efficiently across client devices to provide a better user experience. The ability to serve multiple clients simultaneously through UL/DL MU-MIMO further improves system capacity and user experience. With support for eight spatial streams in 5GHz, the C-260 delivers truly unprecedented throughput and client capacity. C-260 is ideal for critical, high-density networks serving a high volume of diverse clients and applications. Common deployment scenarios include large schools, large remote offices, auditoriums, meeting rooms, and enterprise campuses.

## Arista CloudVision® Managed Wi-Fi

The C-260 is an Arista CloudVision Wi-Fi managed platform. Available as a cloud service or on prem management platform, CloudVision Wi-Fi leverages a purpose built cloud architecture delivering cloud grade analytics and automation to enterprise Wi-Fi networks. CloudVision ensures high reliability, scalability, security and cost effectiveness.

## Versatile, multipurpose 3rd Radio

C-260 comes with a versatile multipurpose 2x2:2 dual band 802.11ac third radio that provides:

- Industry leading, continuous WIPS
- Better RRM decisions from continuous spectral visibility
- Network availability and performance assurance by On-demand and scheduled client connectivity test



Arista C-260

## Access

C-260 provides Wi-Fi networks that require less time and resources to deploy and maintain compared to traditional devices, resulting in significant cost savings.

- Plug and play provisioning using either Cloud or On-premise deployments - Arista Access Points take less than two minutes to activate and configure after connecting to the cloud
- Support for up to eight individual SSIDs per radio providing maximum flexibility in network design
- Network controls like NAT, Firewall and QoS implemented at the Access Point, ensuring faster and more reliable networks
- Continuous scanning of all 2.4 GHz and 5 GHz channels by a dedicated 2x2 third radio provides a dynamic, 360 degree view of the RF environment to assist in RF optimization and client handling
- Network availability and performance assurance using the third radio as a client to conduct on-demand and scheduled connectivity and performance tests
- Smart steering addresses sticky client issues by automatically pushing clients with low data rates to a better access point
- Band steering manages channel occupancy, pushing clients to the 5 GHz channel for optimal throughput
- Smart load balancing distributes load evenly across neighbouring APs to optimize the use of network resources
- Arista Wi-Fi's distributed data plane architecture continues to serve users and secure the network even if connection with the management plane is interrupted
- Interference avoidance from LTE/3G small/macro cells in commonly used TDD/FDD frequency bands

## Security

C-260 offers complete visibility and control of the wireless airspace ensuring network integrity while actively protecting users without manual intervention.

- C-260 is equipped with industry leading fully integrated wireless intrusion prevention capabilities
- Multifunction third radio provides uninterrupted spectrum scanning or client emulation for always on security coverage alongside dedicated 2.4G/5G client radios.
- Arista's patented Marker Packets™ help accurately detect rogue access points on any network while minimizing false positives
- Third radio used as a dedicated security sensor for 24x7x365 scanning and automated over-the-air (OTA) prevention
- Deterministic rogue AP detection and prevention by monitoring all WiFi and non-WiFi VLANs.
- Over-the-air and on-the-wire prevention techniques assure automatic and reliable threat prevention to keep unauthorized clients and rogue APs off the network without impacting authorized connections.
- Access Points autonomously scan for wireless threats and enforce security policy even if disconnected from the cloud management plane
- VLAN monitoring enables a virtual connection to non-WiFi networks for complete network rogue detection and prevention

## Analytics

The C-260 collects telemetry on connected and unconnected WiFi clients and supports immersive guest network experiences that help Arista's customers develop and reinforce the relationship with their end customers.

- Reports of customer footfall, demographic, loyalty and other analytics provide insightful and actionable information.
- Supports proximity marketing programs that trigger when certain devices are present, which includes automatic messaging vis MMS in-browser notifications and real time notifications sent to 3rd party systems that alert to the presence of enrolled devices.

	Property	Specification
	Physical Dimensions	230mm x 230mm x 45mm/9.1" X 9.1" X 1.77"
	Weight	1.390kg / 3 lb
	Operating Temperature	0°C ~ +40°C (+32°F ~ +104°F)
	Storage Temperature	-40°C ~ +70°C (-40°F ~ +158°F)
	MTBF	187,948 hr @40°C 331,563 hr @25°C
	Humidity	0-95% non-condensing
	Power Consumption	35.2 W (max) / 15.8 W (min) / 30.0 W (avg)
	Chipset	Qualcomm IPQ8078 2.2GHz quad core ARM processor with QCN5054 x2 and QCN5024 QCA9882 (multipurpose third radio)
	Processor and RAM	1 GB RAM and 512 MB Flash
	Physical security	Kensington lock slot

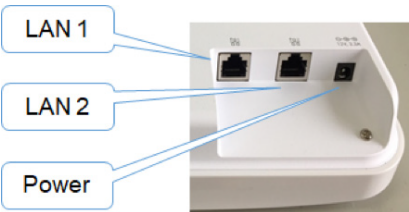
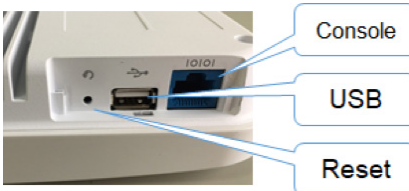
	Port	Description	Connector Type	Speed/Protocol
	Power	12V DC	5.5 mm overall diameter / 2.1 mm center pin hole	N/A
	LAN1	5 GbE, 802.3bt compliant PoE, MACsec capable*	RJ-45	100M/1G/2.5G/5G Ethernet
	LAN2	5 GbE, 802.3bt compliant PoE, MACsec capable*	RJ-45	100M/1G/2.5G/5G Ethernet
	Console	Establish 'config shell' terminal session via serial connection	RJ-45	<ul style="list-style-type: none"> <li>RS 232 Serial (115200 bits per second)</li> <li>Data bits:8; Stop bits: 1</li> <li>Parity: None</li> <li>Flow Control: None</li> </ul>
	USB	USB 2.0 port	USB Type-A	<ul style="list-style-type: none"> <li>Future use</li> </ul>
	Reset	USB 2.0 Reset to factory default settings port	Pin hole push button	Hold down and power cycle the device to reset

\* MACsec capabilities will be activated via a future software update.

## Operational Specifications

Input Power	12V DC (5.5mm overall diameter/2.1mm center pin hole) 802.3bt power - Full function 802.3at power - Reduced Function (No USB; Tx power reduced by 3dB for both radios)
Number of Radios	2 access radios; one 4x4:4 2.4GHz and one 8x8:8 5GHz radio for simultaneous dual band access. 1 multi-function 2x2 radio for continuous WIPS and client connectivity tests
Max Clients Supported	1024 (512 clients per radio) (dependent upon use cases)
MU-MIMO	8X8 on 5GHz radio and 4X4 on 2.4GHz radio
Number of Spatial Streams	8 for 5GHz radios, 4 for 2.4 GHz radio, 2 for multipurpose radio
RF Transmit Power <sup>1</sup>	26dBm on 5GHz radio (max) and 23dBm on 2.4GHz radio (max) <sup>2</sup>
80+80MHz Non-Contiguous Channel Bonding	Yes
Bandwidth Agility	Yes
Small Cells Interference Mitigation (pico-cells, femtocells, microcells)	Yes
Frequency Bands	2.4-2.4835 GHz, 5.15-5.25 GHz; (UNII-1), 5.25-5.35 GHz, 5.47-5.6 GHz, 5.650-5.725 GHz (UNII-2), 5.725-5.85 GHz (UNII-3)
Dynamic Frequency Selection	Supported in compliance to all latest amendments from FCC, CE, IC, CB, TELEC, KCC regarding certifications.

## WiFi Specifications

IEEE 802.11a/n/ac/ax			
Frequency Band	Scanning	Transmission	
	All regions	USA & Canada (FCC/IC)	Europe (ETSI)
5GHz Band	5.15 ~ 5.25 GHz 5.25 ~ 5.35 GHz 5.47~ 5.725 GHz 5.725~ 5.825 GHz	5.15 ~ 5.25 GHz 5.25 ~ 5.35 GHz 5.725~ 5.825 GHz	5.15 ~ 5.25 GHz 5.25 ~ 5.35 GHz 5.47~ 5.725 GHz
Dynamic Frequency Selection	DFS and DFS2		
Modulation Type	OFDM / OFDMA		
Peak Data Rates	Up to 4.8 Gbps		
Antenna	Integrated modular high efficiency PIFA antenna x8 (peak gain: 6.1 dBi)		

<sup>1</sup> Total conducted output power across all Tx chains.

<sup>2</sup> Actual power for Tx will depend on Country Regulatory Domain

IEEE 802.11b/g/n/ax			
Frequency Band	Scanning	Transmission	
	All regions	USA & Canada (FCC/IC)	Europe (ETSI)
2.4 GHz Band	2400 ~ 2483.5 MHz	2400 ~ 2473.5 MHz	2400 ~ 2483.5 MHz
Modulation Type	DSSS / OFDM / OFDMA		
Peak Data Rates	Up to 1.1Gbps		
Antenna	Integrated modular high efficiency PIFA antenna x4 (peak gain:4.92 dBi)		

## Receive Sensitivity

### 5 GHz

Mode	Rate	Sensitivity (dBm)
802.11a	6 Mbps	-92
	54 MBps	-75
11n_HT20	MCS 0	-93
	MCS 7	-75
11n_HT40	MCS 0	-90
	MCS 7	-73
11ac_VHT20	MCS 0	-95
	MCS 8	-70
11ac_VHT40	MCS 0	-90
	MCS 9	-68
11ac_VHT80	MCS 0	-87
	MCS 9	-63
11ax_HE20	MCS 0	-93
	MCS 11	-64
11ax_HE40	MCS 0	-91
	MCS 11	-62
11ax_HE80	MCS 0	-87
	MCS 11	-59

### 2.4 GHz

Mode	Rate	Sensitivity (dBm)
802.11b	1 Mbps	-98
	11 MBps	-90
802.11g	6 Mbps	-93
	54 MBps	-77
11n_HT20	MCS 0	-95
	MCS 7	-76
11n_HT40	MCS 0	-91
	MCS 7	-73
11ac_VHT20	MCS 0	-95
	MCS 8	-72
11ac_VHT40	MCS 0	-91
	MCS 9	-70
11ax_HE20	MCS 0	-94
	MCS 11	-65
11ax_HE40	MCS 0	-91
	MCS 11	-63

## Aggregate Transmit Power

### 5 GHz

Mode	Rate	Power (dBm)
802.11a	6 ~ 18 Mbps	26
	24 ~ 54 Mbps	25
802.11n_HT20	MCS 0 ~ 4	26
	MCS 5 ~ 7	25
802.11n_VHT40	MCS 0 ~ 4	26
	MCS 5 ~ 7	24
802.11ac_VHT20	MCS 0 ~ 4	26
	MCS 5 ~ 7	25
	MCS 8 ~ 9	24
802.11ac_VHT40	MCS 0 ~ 4	26
	MCS 5 ~ 7	24
	MCS 8 ~ 9	23
802.11ac_HT80	MCS 0 ~ 4	26
	MCS 5 ~ 7	23
	MCS 8 ~ 9	22
802.11ax_HE20	MCS 0 ~ 4	26
	MCS 5 ~ 7	25
	MCS 8 ~ 9	24
	MCS 10-11	21
802.11ax_HE40	MCS 0 ~ 4	26
	MCS 5 ~ 7	24
	MCS 8 ~ 9	23
	MCS 10-11	21
802.11ax_HE80	MCS 0 ~ 4	26
	MCS 5 ~ 7	23
	MCS 8 ~ 9	22
	MCS 10 ~ 11	19

### 2.4 GHz

Mode	Rate	Power (dBm)
802.11b	1 ~ 11 Mbps	23
802.11g	6 ~ 18 Mbps	23
	24 ~ 54 Mbps	21
802.11n_HT20	MCS 0 ~ 4	23
	MCS 5 ~ 7	21
802.11n_HT40	MCS 0 ~ 4	22
	MCS 5 ~ 7	20
802.11ax_HE20	MCS 0 ~ 4	23
	MCS 5 ~ 7	21
	MCS 8 ~ 9	20
	MCS 10 ~ 11	16
802.11ax_HE40	MCS 0 ~ 4	22
	MCS 5 ~ 7	20
	MCS 8 ~ 9	20
	MCS 10 ~ 11	17

## Radiation Patterns

### 2.4 GHz - Peak Gain: 4.92dBi

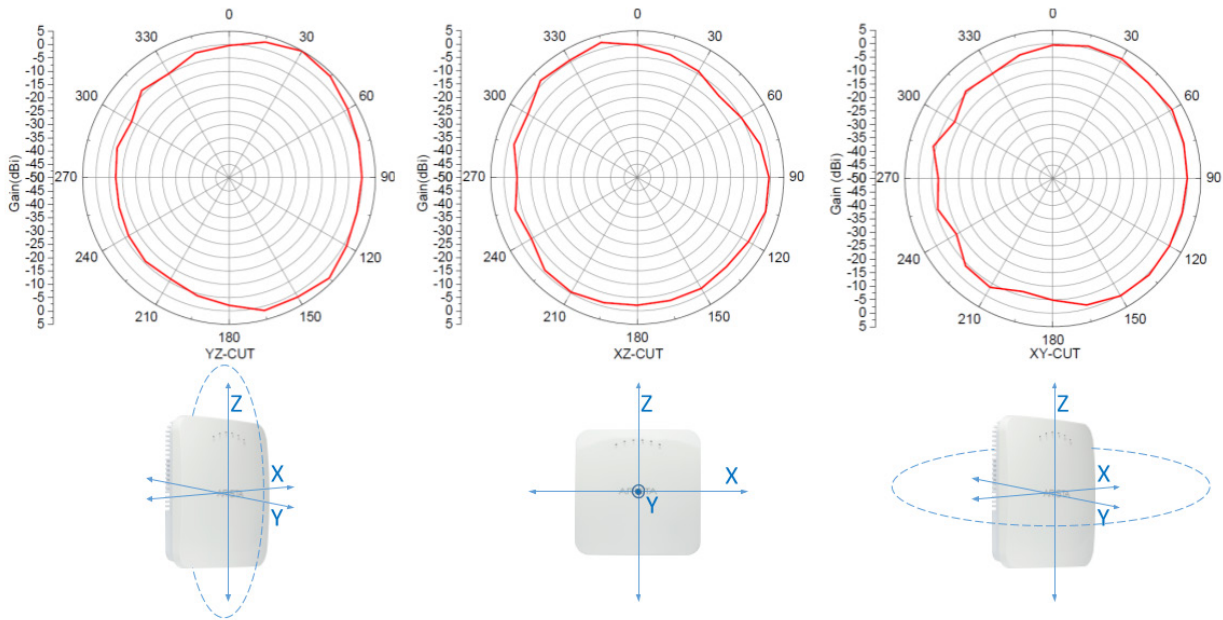

### 5 GHz - Peak Gain: 6.1dBi

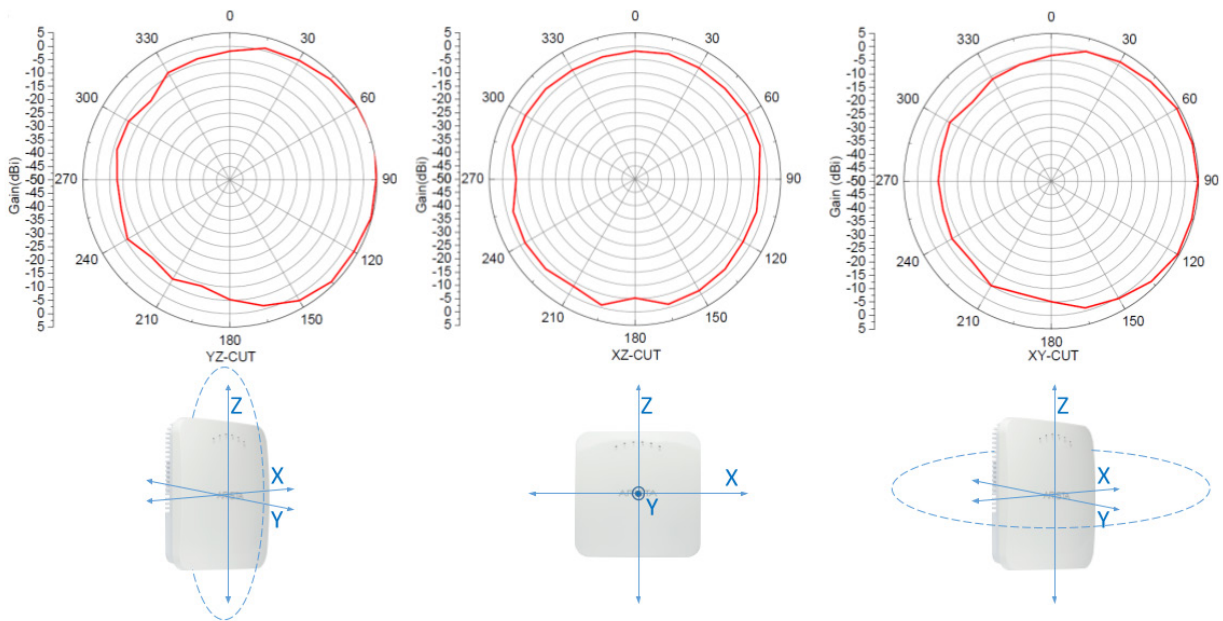

## Regulatory Specifications RF and Electromagnetic Compatibility (EMC)

Country	Certification
USA	FCC Part 15.247, 15.407, 15B
Canada	ICES-003, RSS-247, RSS-102
Europe	EN 300 328, EN 300 440, EN 301 893, EN 301 489 , EN 55024, EN 55032, EN 55035 Countries covered under Europe certification: Austria, Belgium, Bulgaria, Croatia, Cyprus, Czechia, Denmark, Estonia, Finland, France, Germany, Greece, Hungary, Ireland, Italy, Latvia, Lithuania, Luxembourg, Malta, the Netherlands, Poland, Portugal, Romania, Slovakia, Slovenia, Spain, Sweden, United Kingdom.

\*For complete country certification records, please visit the site: <https://www.arista.com/en/support/product-certificate>

## Safety & Environmental

Country	Certification
USA, Canada	UL/cUL 62368, UL 2043
European Union (EU)	EN 62368, RoHS
China	GB/T 26125 RoHS
Taiwan	CNS 14336, CNS 15663 RoHS

## Ordering Information Access Point

Part Number	Description
AP-C260	C-260 8x8 tri radio 802.11ax (WiFi 6) access point with internal antennas
AP-C260-SS-5Y	C-260 AP with 5 years bundled Cognitive Cloud SW subscription
AP-C260-SS-3Y	C-260 AP with 3 years bundled Cognitive Cloud SW subscription

## Mounting Options

For details of mounting options, see the Access Points [Mounting Brackets Guide](#)

## Power Supply

Part Number	Description
PWR-AP-W4	Universal AC power supply for C-230, 12VDC, 3.3A
PWR-AP-PLUS-NA	One port 802.3at PoE+ injector for use with all Access Point models. Includes USA power cord. Not for outdoor use.

## Headquarters

5453 Great America Parkway  
Santa Clara, California 95054  
408-547-5500

## Support

support@arista.com  
408-547-5502  
866-476-0000

## Sales

sales@arista.com  
408-547-5501  
866-497-0000