

*Operator's Manual* - English

# BACKPACK SPRAYER JACTO PJBc

Edition N° 1231339  
10/2015



Manufactured by INTERMAN Corporation Ltd.  
under license of Máquinas Agrícolas Jacto S.A.  
Rojana Industrial Park (Rayong)  
3/3, Moo 2, Bankhai-Banbueng Rd.T. Nongbua.  
A.Bankhai Rayong 21120 - Thailand  
Website: [www.jacto.com](http://www.jacto.com)

Customer assistance: JACTO INC.  
19217 SW 119 th Ave.  
Tualatin, Oregon 97062  
Tel: (503) 885-8723  
Fax: (800) 511-3671  
Toll free: (800) 522-8610  
E-mail: [info@jacto.com](mailto:info@jacto.com)  
Home page: [www.jacto.com](http://www.jacto.com)

# SUMMARY

<b>1. Introduction</b>	<b>3</b>
<b>2. Specifications</b>	<b>3</b>
<b>3. General Power Tool Safety Warnings</b>	<b>3</b>
3.1. Work area safety	3
3.2. Electrical safety	3
3.3. Personal Safety	3
3.4. Power tool use and care	4
3.5. Battery tool use and care	4
3.6. Service	4
<b>4. Symbols</b>	<b>4</b>
<b>5. Important Safety Instructions for Battery Chargers</b>	<b>4</b>
5.1. Charging procedure	5
5.2. Important charging notes	5
<b>6. Important Safety Instructions for Battery Packs</b>	<b>6</b>
<b>7. Important Safety Instructions for Sprayers</b>	<b>6</b>
7.1. Triple rinse of empty agrochemicals containers	7
<b>8. Operating Instructions</b>	<b>8</b>
8.1. Select the correct nozzle	8
8.2. Calibration of battery powered backpack sprayer	8
8.3. Filling the spray tank with pesticides	8
8.4. Shoulder strap adjust (16c and 20c)	9
8.4. Shoulder strap adjust (8c)	9
8.6. Turn On/Off the sprayer	9
8.7. Application	9
<b>9. Maintenance</b>	<b>10</b>
<b>10. Parts list</b>	<b>11</b>
10.1 PJB-16c/PJB-20c	11
10.2 PJB-8c	13
<b>11. Troubleshooting</b>	<b>15</b>
<b>12. Important Return Safety Instructions</b>	<b>16</b>
<b>13. Statement of Limited Warranty</b>	<b>16</b>
13.1. Warranty period	16
13.2. Warranty application	16
13.3. This warranty shall be null & void in case of	16
13.4. This warranty shall exclude	16
13.5. General terms	16

## 1. Introduction

This manual contains information for the proper assembly, operation and care of your sprayer. Carefully read and follow the instructions contained in this manual before using your sprayer.

This equipment was designed for spraying plants protection products approved by regulatory authorities to be used in knapsack sprayers.

## 2. Specifications

Model	PJBC - 20/16/8
Maximum dimensions (L x W x H)	15 in. X 8 in. X 21 in. (385 mm x 205 mm x 532 mm) 15 in. X 8 in. X 18.5 in. (385 mm x 205 mm x 462 mm) 10 in. X 6 in. X 16.4 in. (255 mm x 159 mm x 417 mm)
Net weight	8.8 lbs / 7.1 lbs / 5.3 lbs (4.0 kg / 3.2 kg / 2.4 kg)
Gross weight	52.9 lbs / 42.3 lbs / 22.9 lbs (24 kg / 19.2 kg / 10.4 kg)
Spray lance length	23.6 in / 23.6 in / 13.8 in (600 mm / 600 mm / 350 mm)
Hose length	53 in / 53 in / 65 in (1350 mm / 1350 mm / 1650 mm)
Chemical tank	
Capacity	5.3 gal./4.2 gal./2.1 gal (20L/16L/8L)
Residual volume	None
Filling opening diameter	4.5 in / 4.5 in / 3.9 in (115 mm / 115 mm / 100 mm)
Material	Polyethylene
Pump	
Type	Diaphragm
Maximum pressure	60 psi (4.1 bar)
Open flow	0.50 gpm (1.9 L/min)
Nozzle installed	Blue adjustable cone
Battery	
Type	Lithium Ion, rechargeable
Rated Voltage	10.8V d.c.
Capacity	20 Wh (2200 mAh)
Recharge time	6 hours

### SAFETY GUIDELINES – DEFINITIONS

It is important for you to read and understand this manual. The information it contains relates to protecting YOUR SAFETY and PREVENTING PROBLEMS. The symbols below are used to help you recognize this information.

#### DANGER!

Indicates an imminently hazardous situation which, if not avoided, will result in death or serious injury.

#### WARNING!

Indicates a potentially hazardous situation which, if not avoided, could result in death or serious injury.

#### CAUTION!

Indicates a potentially hazardous situation which, if not avoided, may result in minor or moderate injury.

## 3. General Power Tool Safety Warnings



### WARNING!

Read all safety warnings and all instructions. Failure to follow the warnings and instructions may result in electric shock, fire and/or serious injury.

### SAVE ALL WARNINGS AND INSTRUCTIONS FOR FUTURE REFERENCE.

The term “power tool” in the warnings refers to your mains-operated (corded) power tool or battery-operated (cordless) power tool.

### 3.1. Work area safety

- Keep work area clean and well lit.** *Cluttered or dark areas invite accidents.*
- Do not operate power tools in explosive atmospheres, such as in the presence of flammable liquids, gases or dust.** *Power tools create sparks which may ignite the dust or fumes.*
- Keep children and bystanders away while operating a power tool.** *Distractions can cause you to lose control.*

### 3.2. Electrical safety

- Power tool plugs must match the outlet. Never modify the plug in any way. Do not use any adapter plugs with earthed (grounded) power tools.** *Unmodified plugs and matching outlets will reduce risk of electric shock.*
- Avoid body contact with earthed or grounded surfaces such as pipes, radiators, ranges and refrigerators.** *There is an increased risk of electric shock if your body is earthed or grounded.*
- Do not expose power tools to rain or wet conditions.** *Water entering a power tool will increase the risk of electric shock.*
- Do not abuse the cord. Never use the cord for carrying, pulling or unplugging the power tool. Keep cord away from heat, oil, sharp edges or moving parts.** *Damaged or entangled cords increase the risk of electric shock.*
- When operating a power tool outdoors, use an extension cord suitable for outdoor use.** *Use of a cord suitable for outdoor use reduces the risk of electric shock.*
- If operating a power tool in a damp location is unavoidable, use a ground fault circuit interrupter (GFCI) protected supply.** *Use of a GFCI reduces the risk of electric shock.*

### 3.3. Personal Safety

- Stay alert, watch what you are doing and use common sense when operating a power tool. Do not use a power tool while you are tired or under the influence of drugs, alcohol or medication.** *A moment of inattention while operating power tools may result in serious personal injury.*





## CAUTION!

- **Burn hazard.** To reduce the risk of injury, charge only designated JACTO batteries. Other types of batteries may burst causing personal injury and damage.
- Under certain conditions, with the charger plugged in to the power supply, the charger can be shorted by foreign material. Foreign materials of a conductive nature such as, but not limited to, steel wool, aluminum foil, or any buildup of metallic particles should be kept away from charger contacts. Always unplug the charger from the power supply when not charging battery. Unplug charger before attempting to clean.



## WARNING!

- **DO NOT attempt to charge the battery pack with any chargers other than the ones in this manual.** *The charger and battery pack are specifically designed to work together.*
- **These chargers are not intended for any uses other than charging designated JACTO lithium rechargeable batteries.** *Any other uses may result in risk of fire, electric shock or electrocution.*
- **Do not expose charger to rain or snow.**
- **Pull by plug rather than cord when disconnecting charger.** *This will reduce risk of damage to electric plug and cord.*
- **Make sure that cord is located so that it will not be stepped on, tripped over, or otherwise subjected to damage or stress.**
- **Do not use an extension cord unless it is absolutely necessary.** *Use of improper extension cord could result in risk of fire, electric shock, or electrocution.*
- **An extension cord must have adequate wire size (AWG or American Wire Gauge) for safety.** *When using more than one extension to make up the total length, be sure each individual extension contains at least the minimum wire size. When using an extension cord, be sure to use one heavy enough to carry the current that product will draw. An undersized cord will cause a drop in line voltage resulting in loss of power and overheating. The following table shows the correct size to use depending on cord length and nominal current presented in the label of the charger mentioned in this manual. If in doubt, use the next heavier gauge.*

Extension Cord Total Length	Up to 15.2 m	From 15.2 m and up to 30 m	More than 30 m
Wire Size (AWG)	16	14	Not recommended
Wire Size (mm <sup>2</sup> )	1.5	2.5	Not recommended

- **Do not mount charger on wall or permanently affix charger to any surface.** *The charger is intended to use on a flat, stable surface (i.e., table top, bench top).*
- **Do not operate charger with damaged cord or plug - have them replaced immediately.**
- **Do not operate charger if it has received a sharp blow, been dropped, or otherwise damaged in any way.** *Take it to an authorized service center.*
- **Do not disassemble charger;** *take it to an authorized service center when service or repair is required. Incorrect reassembly may result in a risk of electric shock, electrocution or fire.*
- **Disconnect the charger from the outlet before attempting any cleaning.** *This will reduce the risk of electric shock. Removing the battery pack will not reduce this risk.*
- **NEVER attempt to connect 2 chargers together.**
- **The charger is designed to operate on standard household electrical power. Do not attempt to use it on any other voltage.**
- **Battery chargers contain electronic parts.** *Dispose of properly.*

## 5.1. Charging procedure

JACTO charger provided with this sprayer is designed to charge JACTO battery pack model JB1220 in 6 hours.

1. Turn off the sprayer. Ensure the button on the electric panel is in "OFF" position. IMPORTANT NOTE: If the sprayer ON/OFF switch is in "ON" position, battery will not recharge!
2. Connect the charger plug to the battery recharge plug in the electric panel.
3. The charge light will remain red/orange while charging.
4. When battery pack is fully charged, charge light will change its color to green.
5. As soon as the battery is fully charged, disconnect the battery from the charger.
6. Unplug charger from outlet.

**Recharge discharged batteries as soon as possible or battery life may be greatly diminished. For longest battery life, do not discharge batteries fully.** It is recommended that the batteries be recharged after each use.

## 5.2. Important charging notes

- DO NOT charge the battery pack in an air temperature below 32 °F (0 °C) or above 113 °F (45 °C). This is important and will prevent serious damage to the battery pack.
- The charger and battery pack may become warm to the touch while charging. This is a normal condition, and does not indicate a problem. To facilitate the cooling of the battery pack after use, avoid placing the charger or battery pack in a warm environment such as in a shed.
- Do not freeze or immerse charger in water or any other liquid.

## 6. Important Safety Instructions for Battery Packs



### WARNING:

For safe operation, read this manual and manuals originally supplied with tool before using the charger. When opening the tool package for the first time, the battery pack will not be fully charged. Before using the battery pack and charger, read the safety instructions below. Then follow charging procedures outlined.

#### READ ALL INSTRUCTIONS

- **Do not incinerate the battery pack even if it is severely damaged or is completely worn out.** The battery pack can explode in a fire. Toxic fumes and materials are created when battery packs are burned.
- **Do not charge or use battery in explosive atmospheres, such as in the presence of flammable liquids, gases or dust.** Inserting or removing the battery from the charger may ignite the dust or fumes.
- **If battery contents come in to contact with the skin, immediately wash area with mild soap and water.** If battery liquid gets into the eye, rinse water over the open eye for 15 minutes or until irritation ceases. If medical attention is needed, the battery electrolyte for Li-ion batteries is composed of a mixture of liquid organic carbonates and lithium salts.
- **Contents of opened battery cells may cause respiratory irritation.** Provide fresh air. If symptoms persist, seek medical attention.
- **Disposal of used batteries must be made at appropriate locations and approved for receiving such material.** If a recycling center is not available in your area please contact CUS-TOMER SERVICE: Jacto Inc. 19217 SW 119th Ave. Tualatin, OR 97062 - Phone 1-800-522-8610 - Email: info@jacto.com - Website: www.jacto.com



### WARNING!

**Burn hazard.** Battery liquid may be flammable if exposed to spark or flame.

- Charge the battery packs only in **JACTO** chargers.

- **DO NOT splash or immerse in water or other liquids.** This may cause premature cell failure.
- **Do not store or use the tool and battery pack in locations where the temperature may reach or exceed 113°F (45 °C).**
- Never attempt to open the battery pack for any reason. If battery pack case is cracked or damaged, do not connect to charger. Do not crush, drop or damage battery pack. Do not use a battery pack or charger that has been dropped, run over or damaged in any way (i.e., pierced with a nail, hit with a hammer, stepped on). Damaged battery packs should be returned to service center for recycling.
- **Fire hazard. Do not store or carry battery so that metal objects can contact exposed battery terminals.** For example, do not place battery in aprons, pockets, tool boxes, product kit boxes, drawers, etc., with loose nails, screws, keys, etc. **Transporting batteries can possibly cause fires if the battery terminals inadvertently come in contact with conductive materials such as keys, coins, hand tools and the like.** Certain regulations prohibit transporting batteries on airplanes (i.e., packed in suitcases and carry-on luggage) UNLESS they are properly protected from short circuits. So when transporting individual batteries, make sure that the battery terminals are protected and well insulated from materials that could contact them and cause a short circuit. **NOTE: Batteries should not be put in checked baggage.**

## 7. Important Safety Instructions for Sprayers



### DANGER!

- **DO NOT spray flammable or combustible chemical products.** This will result in serious risk of fire and explosion.
- **DO NOT spray acids or corrosive chemicals.** This will result in serious risk of fire, explosion and leakage. Sprayer parts can be permanently damaged.



### WARNING!

- **DO NOT use the sprayer for purposes other than spraying agricultural defenses approved by competent authorities.**

Always consider the following recommendations:

- **Check sprayer before spraying.** Ensure there is no leakage or missing parts. Do not use sprayer if it is not in good condition.
- **Do not eat, drink or smoke while spraying.**

*Serious risk of poisoning.*

- **Do not mix chemical products, unless recommended by manufacturer.** *Intense chemical reactions can occur.*
- **Read the label of chemical products carefully.** *Always follow manufacturer's recommendations.*
- **High pressure present at end of nozzle and inside sprayer base.** *Turn-off the sprayer completely and release pressure before attempting to repair or replace parts of the sprayer.*
- **Do not direct spray towards bystanders.** *Spray may be toxic.*
- **After the use of herbicides always clean the equipment before using other formulations.**
- **Wear individual protection equipment.** *Wear gloves, safety glasses, safety mask and protective clothing.*
- **Clean yourself after spraying.** *Take a shower with plenty of soap and water. Put on clean clothes.*
- **The clothing used during spray application must be washed separate from other clothes of ordinary use.**
- **Keep chemical products out of reach of children and animals.** *Lock up the chemical products to prevent untrained persons from handling them.*
- **In case of intoxication, see a doctor immediately.** *Show him/her the chemicals manufacturer's label.*
- **Dispose of chemical containers properly.** *Observe your local regulatory agency recommendations and follow manufacturer's disposal instructions.*
- **Do not pollute the environment.**
- **During the transport in vehicles, the sprayer must be turned off and secured.** *Always keep the trigger valve shut during transport and when not using the sprayer.*

2. Hold the container in the upright position and fill it with water up to 1/4. For example: in a 1000 ml container, put 250 ml of water.
3. Install the container cap and tighten enough to avoid leakage during the agitation.
4. Agitate the container strongly in all ways (horizontal and vertical), for approximately 30 seconds to remove the residues that are on the container internal walls.
5. Take the container cap off and carefully pour the rinse water into the spray tank.
6. Keep holding the container over the spray tank opening for approximately 30 seconds to the last drop.
7. Repeat this operation twice more. This way, you complete the triple rinse.

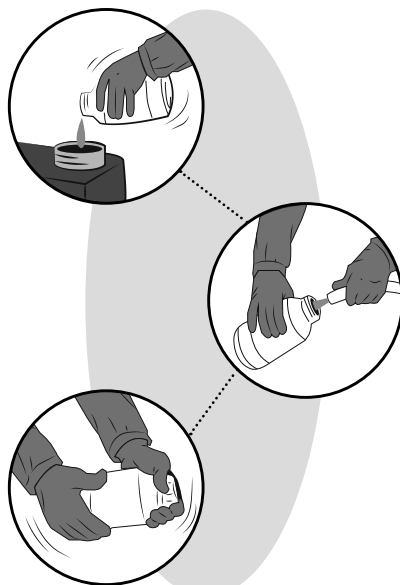

## 7.1. Triple rinse of empty agrochemicals containers

NOTE: Even the containers considered empty contain chemical residues. Therefore, discarding the containers without washing out the residues is extremely dangerous to man, animals and environment. In the case of metal, plastic and glass chemical containers, each container must be rinsed three times to ensure the residues are completely removed. This manual describes how to make the triple rinse in a correct, safe and effective way.

1. Immediately after emptying the container, you must keep it with the opening upside down over the sprayer tank opening or over the bucket that you are using to prepare the chemical mixture for at least 30 seconds, until no residue is left in the container, when the drops are falling in long intervals.

8. Make the plastic and metallic containers useless by piercing the container bottom with a pointed instrument. This way, their labels are not damaged for identification purposes.

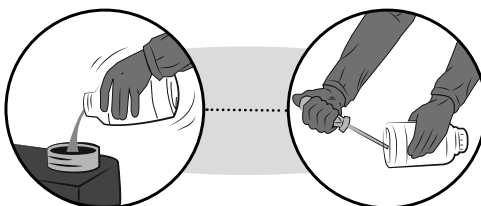

## 8. Operating Instructions

The following steps describe how to safely use the sprayer.

### 8.1. Select the correct nozzle

NOZZLE TYPE	FILTER (Mesh)	IDENTIFICATION (Part no. - Description)	APPLICATION	PRESSURE (psi)	FLOW RATE (gpm (L/min))
	80 (Zinc yellow)	(1197535) JEF 110015 GREEN	Herbicides	30	0.13 GPM (0.49 L/min)
	50 (Gentian blue)	(1197536) JEF 11002 YELLOW		30	0.17 GPM (0.65 L/min)
	50 (Gentian blue)	(1197537) JEF 11003 BLUE		30	0.26 GPM (0.98 L/min)
	80 (Zinc yellow)	(1197475) JSF 110015 GREEN	Herbicides	30	0.13 GPM (0.49 L/min)
	50 (Gentian blue)	(1197476) JSF 11002 YELLOW		30	0.17 GPM (0.65 L/min)
	50 (Gentian blue)	(1197477) JSF 11003 BLUE		30	0.26 GPM (0.98 L/min)
	50 (Gentian blue)	(1197565) JHC 8002 YELLOW	Fungicide, insecticide and foliar fertilizers	45	0.21 GPM (0.80 L/min)
	50 (Gentian blue)	(1198892) JHC 8004 RED		45	0.42 GPM (1.60 L/min)
	50 (Gentian blue)	(1198893) JHC 8005 BROWN		45	0.53 GPM (2.00 L/min)
	50 (Gentian blue)	(1197486) JDF 04 RED	Herbicides and foliar fertilizers	15	0.24 GPM (0.92 L/min)
	50 (Gentian blue)	(1197487) JDF 05 BROWN		15	0.30 GPM (1.15 L/min)
	50 (Gentian blue)	(1197488) JDF 06 GREY		15	0.37 GPM (1.39 L/min)
	80 (Zinc yellow)	(1197497) JAI 120015 GREEN	Herbicides	20	0.11 GPM (0.42 L/min)
	80 (Zinc yellow)	(1197499) JAI 12002 YELLOW		20	0.15 GPM (0.57 L/min)
	50 (Gentian blue)	(1197501) JAI 12003 BLUE		20	0.22 GPM (0.85 L/min)

\*Approximate data based on a spray swath for unique nozzles at 20 inch height of the target.

NOTE: This sprayer is packaged with the Blue Adjustable Cone nozzle fitted in the lance. Other nozzles mentioned in this manual are optional, so they do not accompany this sprayer.

### 8.2. Calibration of battery powered knapsack sprayer

#### PROCEDURE

1. USING CALIBRATOR BOTTLE (OPTIONAL)
2. Hold the lance at the working height and spray to measure the application band width.
3. Based on the band width, calculate the total walking distance required to spray the desired area. Use the chart as shown next.

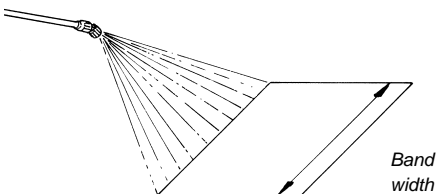

Band width ft (m)	1.6 (0.5)	2.2 (0.7)	3.2 (1.0)	3.9 (1.2)	4.9 (1.5)
Distance to walk ft (m)	164 (50.5)	117.1 (35.7)	82.0 (25.0)	68.2 (20.8)	54.7 (16.7)

- Attach the calibrator bottle to the lance as shown:

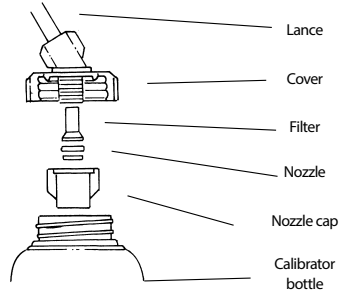

- Remove the cap, nozzle and filter.
- Mount the calibrator cover to the lance.
- Reinstall the filter, nozzle and cap.
- Screw the calibrator onto the cover.

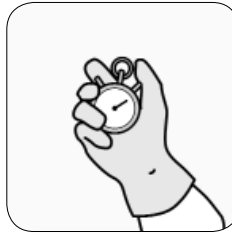

Record the time it takes to walk 340 sq/ft (1/128th acre)

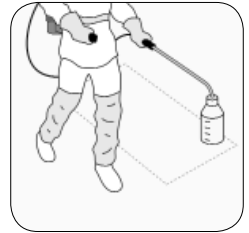

Simulate the spraying of 340 sq/ft (1/128th acre)

1. Hold the lance at the normal working height and spray into the bottle while walking the distance required to spray an area corresponding to 340 sq/ft (1/128th acre).
2. Place the bottle on a level surface and observe the liquid level visible through the side of the bottle. The ounces collected corresponds to gallons per acre. For example if you collected 10 ounce while spraying 340 sq/ft this equal 10 GPA.
3. Empty the bottle and repeat this operation to determine the average of two or more readings.

NOTE: To convert GPA to L/ha multiply by 9.353.

### 8.5. Filling the spray tank with pesticides.

1. Read carefully the chemicals manufacturer's labels;
2. Put 1.3 gallon (5 Liters) of water in a bucket and add the chemical product;
3. Stir until it becomes an homogeneous mixture;

- Pour the solution into the tank while filling with water.

## 8.4. Shoulder strap adjust (16c and 20c)

The tank is contoured for the operator comfort. The shoulder straps can be quickly adjusted to properly position the sprayer on the operator's back.

- Mount the strap belt onto the tank as shown in position A.
- Hook the buckle of the strap to the plastic couplers located at the side of the sprayer's base, as shown in position B.
- To tighten the strap belt, hold the strap buckle firmly with one hand and pull the handle downward with the other hand. To loosen the strap belt, hold the buckle firmly with one hand and pull the strap upward with the other hand.

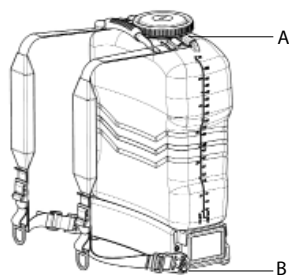

## 8.5. Shoulder strap adjust (8c)

- Mount the strap belt onto the tank as shown in position A.
- Finally, adjust the strap length as desired, as shown in B. To tighten the strap belt, hold the strap buckle firmly with one hand and pull the handle.

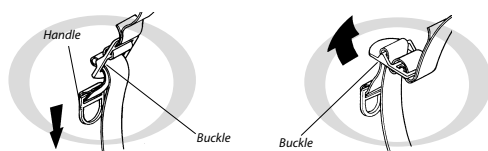
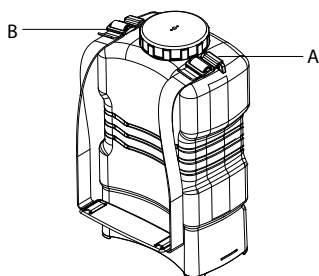

## 8.6. Turn On/Off the sprayer

NOTE: Before starting to spray, retighten the hose clamps to avoid contamination of the operator and of the environment.

To turn on the sprayer:



- Turn on the sprayer using the ON/OFF switch in the electric panel.
- Place the lance with the trigger valve pressed above the base of the sprayer until the spray jet begins to spray continuously.
- Direct the spray lance to a safe position and open the trigger valve to begin spraying.

To turn off the sprayer:

- Shut off the trigger valve. The internal pump pressure switch will automatically turn off the pump (the sprayer is said to be in idle state).
- Turn off the sprayer using the ON/OFF switch in the electric panel.
- Direct the spray lance to a safe position and open the trigger valve to release pressure before storing the sprayer.

## 8.7. Application



*Wear appropriate protective clothing*



*Do not contaminate water*

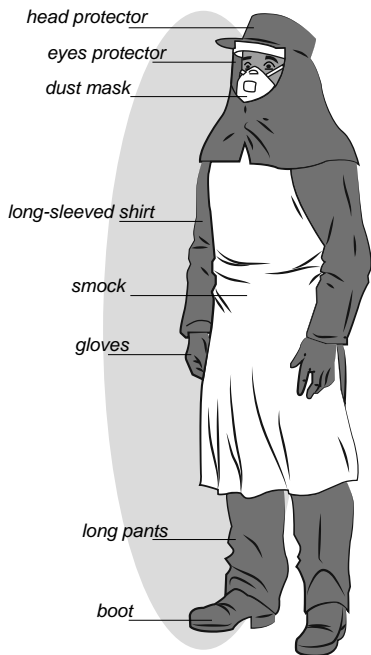

## WARNING!

Do not spray near people who are not using PPE, springs, lakes and rivers.



## WARNING!

In case of an accident remove the sprayer immediately as shown in the illustration below.

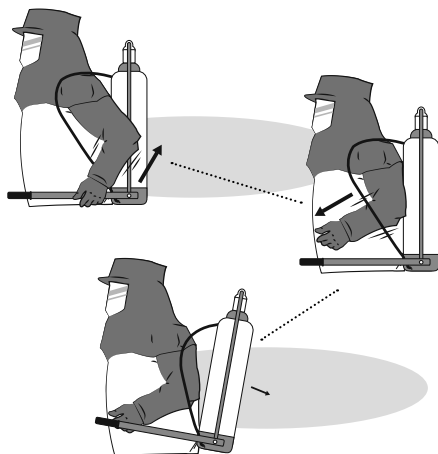

## WARNING!

Use of individual protective clothing and safety equipment is required.



## WARNING!

Use the correct dose and volume of chemical according to the product label.



*Spray downwind and avoid drift*



*Keep constant height*

## 9. Maintenance

For extended product life, follow these important care instructions:

- When filling up the tank, always use the strainer provided. This will reduce the chance of undesirable debris that could damage the pump.
- Do not operate the sprayer without the pump suction filter. This can severely damage the pump. Periodically clean or replace this filter as follows:

1. Empty the tank, make sure the sprayer is turned off and put it upside down;
2. Remove screw A;
3. Remove base cover B;
4. Unscrew filter cover C;
5. Clean or replace filtering element D.

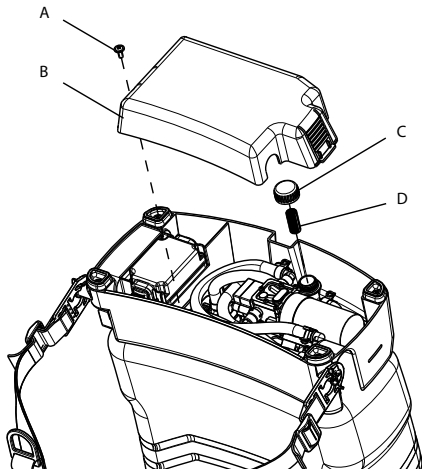

- Only fill the tank with a water soluble agrochemical or an already mixed powder liquid form through the filling filter. Do not prepare mixtures directly in the sprayer tank;
- This sprayer is an electronic tool and must be protected from severe environmental conditions. When not using, do not leave the sprayer in sun, rain or frost;
- Do not submerge the sprayer completely or partially;
- After finishing the application, clean and wash all equipment in an approved decontamination area;
- Clean the sprayer before storage. Circulate fresh water through the tank, pump and hoses after each use. This will help remove chemical residues and extend life of sprayer parts;
- The spray lance can be conveniently stored on the clips on the side of the tank;
- Ensure that there is no liquid waste in the sprayer, especially in harsh winter locations;
- Nozzles and filters must be periodically cleaned or replaced. Do not clean nozzles or filters with sharp hard objects, nor blow through them using the mouth.

## 10. Parts list

### 10.1. PJB-16c/ PJB-20c

Nº	Code	Description	Qty.
1	1220947	SCREW PAN HEAD M 5X0, 8X 12	1
2	1220640	BASE COVER	1
3	1231358	BATTERY CHARGER LI-ION 12.4V IEC TYPE A	1
4	1168397	BASE LOCK XP	1
5	1168544	TRIGGER VALVE CAP AND O-RING	2
6	1220634	IN-LINE FILTER	1
7	1220934	O-RING OR1-019	1
8	1220632	PJB PUMP FILTER KIT	1
9	1224055	HOSE KIT PJB-c	1
10	325787	BLUE ADJUSTABLE CONE NOZZLE	1
11	592139	FILTER M50/60	1
12	635276	ELBOW 11/16"-16 UN	1
13	909309	CONE PACKING	2
14	915744	SCREW CAP 11/16"	2
15	100131	EXTENSION	1
16	1220925	CLAMP SIMPLEX D 12-14 STEEL	6
17	1220622	FLANGE HEAD SCREW PHILLIPS 5X12 MM	6
18	1220636	CONNECTOR NUT	1
19	1220635	HOSE CONNECTOR	1
20	1220639	DIAPHRAGM PUMP - COMPLETE	1
21	1224057	COMPLETE PANEL PJB-c	1
22	1220641	BASE PJB	1
23	1224059	AGITATOR COVER	1
24	1168422	NEEDLE LP-3 WITH O-RINGS	1
25	1180613	STAINLESS STEEL SPRING 9,2	1
26	1224062	COMPLETE HOSE FOR LP3 PJB-c	1
27	1168421	TRIGGER VALVE LEVER	1
28	1168418	FILTER LP-3	1
29	942920	STRAINER (PJ)	1
30	1224068	TANK PJB-20c WITHOUT LOGO	1
30a	1224070	TANK PJB-16c WITHOUT LOGO	1
31	560573	LID DIAPHRAGM (NITRILE)	1
32	4739	LID WITH DIAPHRAGM (ORANGE)	1
33	1220618	COMPLETE BELT WITH TRANSPORT HANDLE	1
34	635672	BUCKLE HD	2
35	1168419	TRIGGER VALVE ASSEMBLY LP-3	1
36	1188330	LANCE LP600 WITH TRIGGER LP3	1

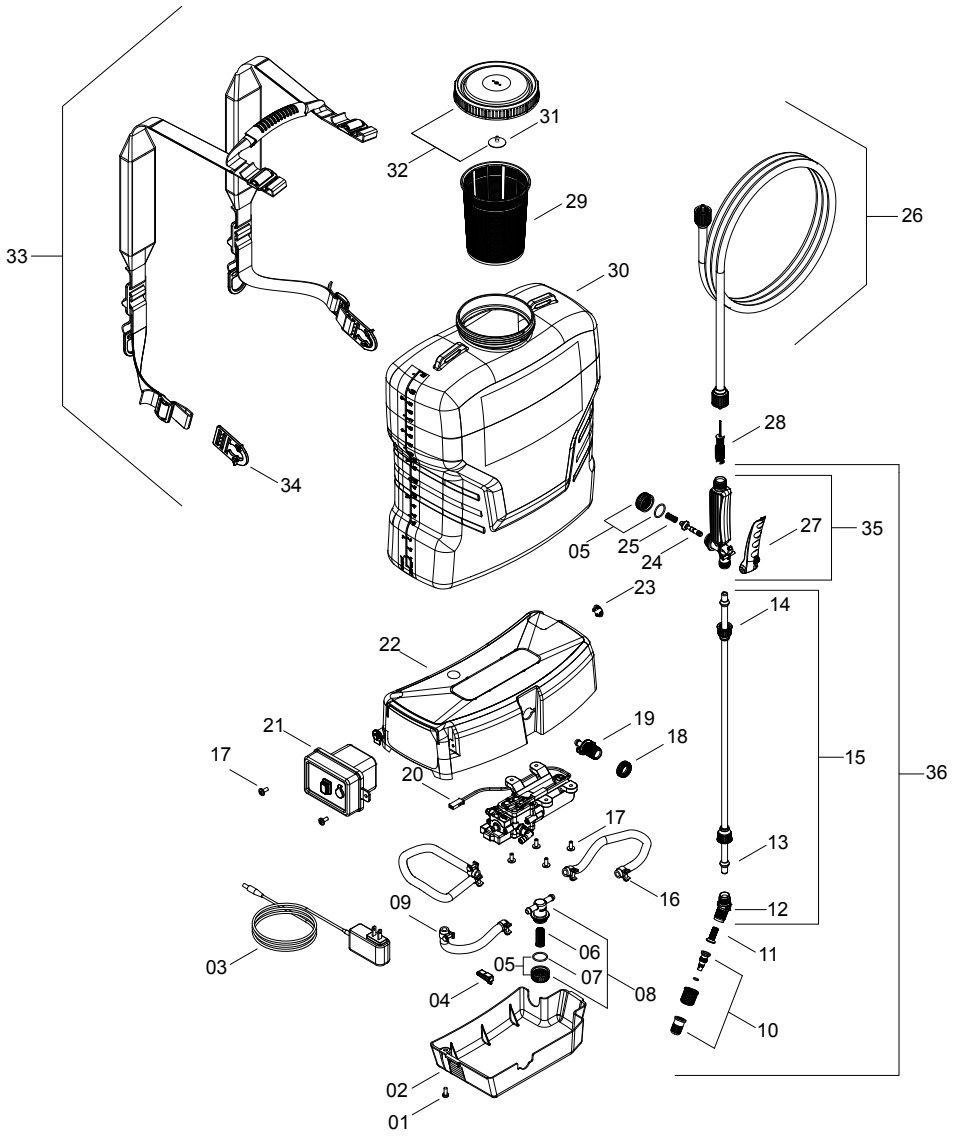

## 10.2. PJB-8c

Nº	Code	Description	Qty.
1	560573	DIAPHRAGM LID (NITRILE)	1
2	1210726	LID XP WITH DIAPHRAGM	1
3	1168414	STRAINER XP	1
4	1224653	PJB-8c STRAP COMPLETE	1
5	1224654	TANK PJB-8c JACTO	1
6	1168418	FILTER LP-3	1
7	1224183	BASE PJB-8c	1
8	1168544	TRIGGER VALVE CAP AND O-RING	2
9	1220934	O-RING OR1-019	2
10	1180613	STAINLESS STEEL SPRING 9,2	1
11	1168422	NEEDLE LP-3 WITH O-RINGS	1
12	1168421	TRIGGER VALVE LEVER	1
13	1168419	TRIGGER VALVE ASSEMBLY LP-3	1
14	1221557	DUST COVER	1
15	1224664	HOSE KIT PJB 8c	1
16	1220925	CLAMP SIMPLEX D 12-14 STEEL	5
17	1168397	BASE LOCK XP	2
18	915744	SCREW CAP 11/16"	2
19	909309	CONE PACKING	2
20	1224677	LANCE PJB-8c COMPLETE	1
21	1224680	SPRAYER HOSE PJB-8c	1
22	1220634	IN-LINE FILTER	1
23	1220632	PJB PUMP FILTER KIT	1
24	635276	ELBOW 11/16"-16 UN	1
25	592139	NOZZLE FILTER M50/60	1
26	325787	BLUE ADJUSTABLE CONE NOZZLE	1
27	1220622	FLANGE HEAD SCREW PHILLIPS 5X12 MM	4
28	1220639	DIAPHRAGM PUMP - COMPLETE	1
29	1231358	BATTERY CHARGER LI-ION 12.4V IEC TYPE A	1
30	1224719	LI-ION BATTERY JB 1220	1
31	1224693	BASE COVER PJB-8c	1
32	1220947	SCREW PAN HEAD M 5X0,8X 12	1

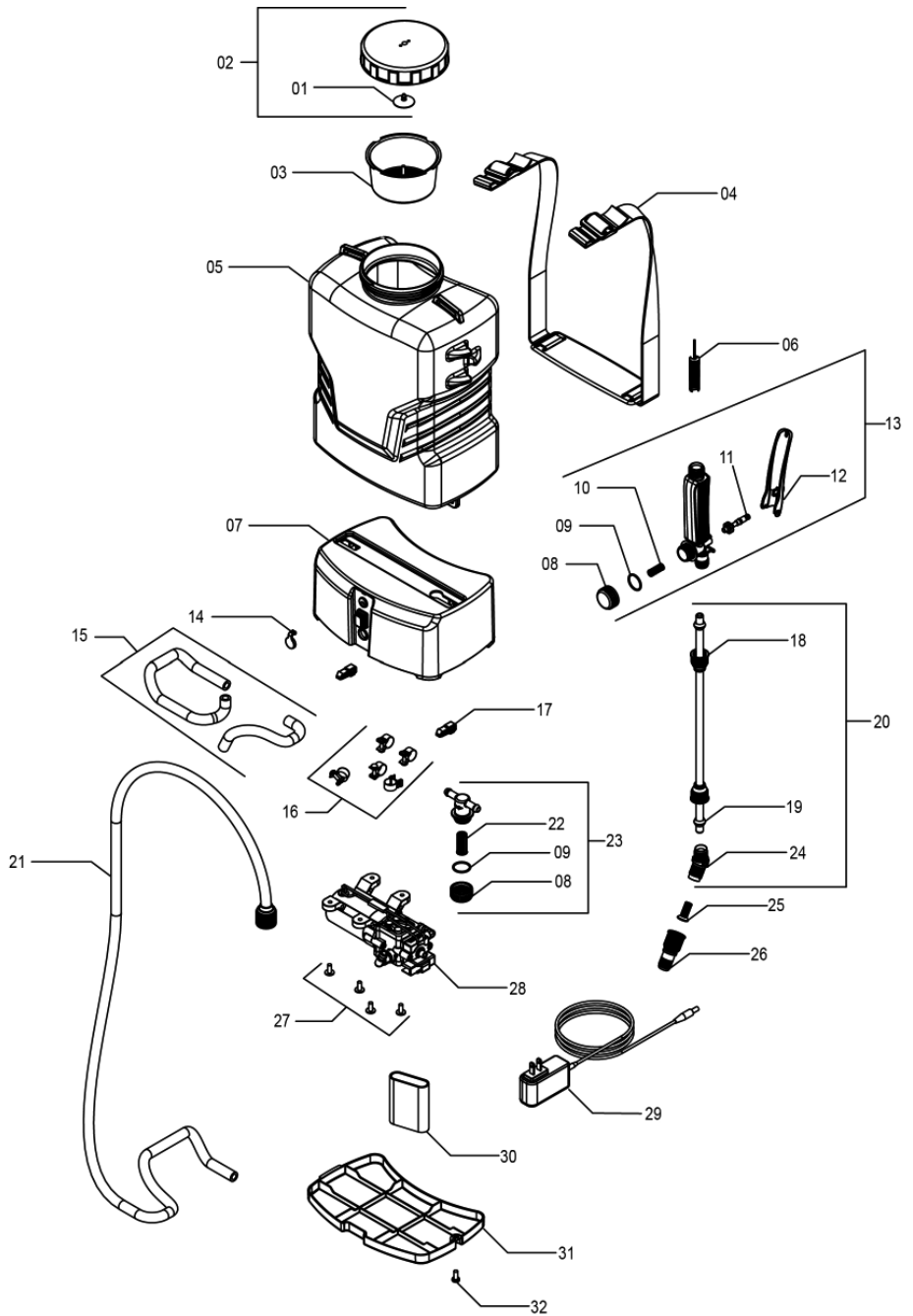

# 11. Troubleshooting

If sprayer is not working as expected, consider the following table before contacting technical assistance.

Malfunction / Status		Cause	Action
Sprayer is turned ON, but pump is not working (no audible noise from pump)	Trigger valve is not released	Trigger valve is shut	Release trigger valve
	Trigger valve is released	Pump electrical connector is disconnected	Connect pump electrical connector
		Nozzle or nozzle filter is blocked	Clean or replace nozzle or filter
		Pump wiring is broken	Contact technical assistance
		Pump is damaged	
		Battery is fully discharged	Recharge battery
	Battery is permanently damaged or electronic module is damaged	Contact technical assistance	
Pump is working, but spray is not coming out	Trigger valve is not released	Trigger valve is shut	Release trigger valve
	Trigger valve is released	Nozzle or nozzle filter is blocked	Clean or replace nozzle or filter
		Pump suction is blocked (inside chemical tank)	Contact technical assistance
		Suction hose is blocked or disconnected	
		Pump or hoses are leaking	
Sprayer sprays but is abnormal or spray pressure is weak		Air accumulation inside the lance	Place the lance with the trigger valve pressed above the base of the sprayer until the spray jet begins to spray continuously
		Pump suction is partially blocked (inside chemical tank)	Remove obstruction and circulate fresh water to clean hoses
		Suction hose is partially blocked	Circulate fresh water to clean hoses
		Pump or hoses are leaking	Contact technical assistance
		Nozzle or filters are blocked or damaged	Clean or replace nozzle or filter
Spraying was normal but stopped suddenly	ON/OFF button was pressed	Pump reached maximum pressure, pressure switch activated	Verify if the nozzle is clogged. Clean it
	No audible noise from pump	Pump wiring is loose, damaged or disconnected	Check pump wiring
Battery charge is not lasting as usual or is not charging at all	New battery	Battery is not being fully charged	Charge battery until charger LED indicator is green
		Not original JACTO charger	Use original JACTO charger
		Not original pump (excessive load)	Use original pump
		Damaged charger or charger cords/plugs	Replace charger
	Battery is damaged (wet, pierced, broken terminals...)	Replace battery	
	Used battery (more than 300 recharge cycles)		Battery life cycle is near the end

---

## 12. Important Return Safety Instructions

---

If it is necessary to return the sprayer for repair, always perform the following:

1. Flush chemical residue from the pump, tank and hoses (performed in an approved containment area).
2. Circulate fresh water in the tank, pump and hoses.
3. Tag the sprayer with type of chemicals that have been sprayed.
4. Include complete description of operation problem, such as how sprayer was used, symptoms of malfunction, how many working hours per day, etc.
5. Remove the battery from the sprayer and keep it in clean and dry conditions. Battery must accompany the sprayer when it is returned for repairs.

Since the sprayer can contain residues of toxic chemicals, these steps are necessary to protect all the people who handle return shipments, and to help identify the reason for the breakdown.

## 13. Statement of Limited Warranty

---

MÁQUINAS AGRÍCOLAS JACTO S.A. shall warrant the equipment described in this manual and shall repair or replace parts and components which, under normal operation and wear, in accordance with technical recommendations, show DEFECTS IN MATERIAL OR WORKMANSHIP, based on the following conditions.

### 13.1. Warranty period

03 (three) years from the date of sale to the original purchaser.

### 13.2. Warranty application

JACTO shall honor this warranty, free of charge, if any part or component shows defect in MATERIAL OR WORKMANSHIP, after final analysis at the factory.

### 13.3. This warranty shall be null & void in case of:

- Misuse of the equipment against specifications in this manual, overwork or accidents.
- Use the equipment to spray products not intended for plants protection or not approved by regulatory authorities to be used with knapsack sprayers.
- Preventive/remedial maintenance performed by unauthorized people.
- Use of parts and components not supplied by JACTO.
- Modification of the equipment or any characteristic of the original design.

### 13.4. This warranty shall exclude

- Parts which show wear and tear due to use: spray nozzle, fil-

ters, seals, rechargeable battery, hydraulic pump, electronic panel, charger and its cables, agitator lever, belt, UNLESS THEY SHOW DEFECTS IN WORKMANSHIP, ASSEMBLY OR MATERIAL.

- Damages resulting from accidents.
- Transportation or freight of the equipment, parts and components in case such warranty is not approved.
- Transportation and travel time of technicians.

## 13.5. General terms

- Parts replaced within the warranty period shall be property of JACTO.
- The warranty on replaced parts and components shall expire together with the equipment warranty period.
- Eventual delays in performing services shall not give the owner right either to indemnity or to extension of the warranty period.
- JACTO reserves the right to modify its products or to interrupt the manufacture without prior notice.
- Any suggestion, questions and complaints shall be submitted to CUSTOMER CARE SERVICE: Jacto Incorporated - 19217 SW 119th Ave. - Tualatin OR, 97062 - Phone: 1-800-522-8610 - Fax: 1-800-511-3671 - Email: info@jacto.com.