



## Installation & Operation Manual Models: 55 - 285



### **⚠ WARNING**

This manual must only be used by a qualified heating installer / service technician. Read all instructions, including this manual and the Knight Fire Tube Boiler Service Manual, before installing. Perform steps in the order given. Failure to comply could result in severe personal injury, death, or substantial property damage.

Save this manual for future reference.



# Contents

<b>HAZARD DEFINITIONS</b> .....	2	<b>6. HYDRONIC PIPING</b>	
<b>PLEASE READ BEFORE PROCEEDING</b> .....	3	System Water Piping Methods.....	35
<b>THE KNIGHT FIRE TUBE BOILER -- HOW IT WORKS</b> 4-5		Low Water Cutoff Device .....	35
<b>RATINGS</b> .....	6	Chilled Water System.....	35
<b>1. DETERMINE BOILER LOCATION</b>		Freeze Protection .....	35
Provide Clearances.....	7	General Piping Information .....	35
Provide Air Openings to Room .....	9	Near Boiler Piping Components.....	36-37
Flooring and Foundation .....	9	Near Boiler Piping Connections .....	37
Residential Garage Installation .....	9	Circulator Sizing .....	37
Vent and Air Piping .....	9	Variable Speed Pump Option .....	39
Prevent Combustion Air Contamination.....	9	<b>7. GAS CONNECTIONS</b>	
Corrosive Contaminants and Sources .....	10	Connecting Gas Supply Piping .....	51-52
Using an Existing Vent System to Install a New Boiler ...	10	Natural Gas .....	52
Removing a Boiler from Existing Common Vent.....	11	Pipe Sizing for Natural Gas .....	52
<b>2. PREPARE BOILER</b>		Natural Gas Supply Pressure Requirements .....	52
Remove Boiler from Wood Pallet.....	12	Propane Gas .....	52
Gas Conversions.....	12	Pipe Sizing for Propane Gas .....	52
Leveling the Boiler .....	13	Propane Supply Pressure Requirements .....	52
<b>3. GENERAL VENTING</b>		Check Inlet Gas Supply .....	53
Direct Venting Options .....	14	Gas Pressure .....	54
Install Vent and Combustion Air Piping .....	15	Gas Valve Replacement .....	54
Requirements for Installation in Canada.....	16	<b>8. FIELD WIRING</b>	
Sizing .....	16	Line Voltage Connections .....	55
Materials.....	17	Low Voltage Connections .....	55
Optional Room Air.....	18	Wiring of the Cascade.....	57
PVC/CPVC .....	19	<b>9. CONDENSATE DISPOSAL</b>	
Polypropylene.....	20	Condensate Drain .....	60
Stainless Steel Vent.....	21	<b>10. STARTUP</b> .....	61-67
<b>4. SIDEWALL DIRECT VENTING</b>		<b>11. OPERATING INFORMATION</b>	
Vent/Air Termination - Sidewall.....	22-25	General.....	68-71
Determine Location.....	22-24	Cascade .....	72
Prepare Wall Penetrations.....	24-25	Sequence of Operation .....	73-74
Multiple Vent/Air Terminations .....	25	Knight Fire Tube Boiler Control Module.....	75
Sidewall Termination - Optional Concentric Vent .....	26-28	Status Display Screens.....	76-78
<b>5. VERTICAL DIRECT VENTING</b>		<b>12. MAINTENANCE</b>	
Vent/Air Termination - Vertical .....	29-30	Maintenance and Annual Startup.....	79-83
Determine Location.....	29	<b>13. DIAGRAMS</b>	
Prepare Roof Penetrations .....	30	Ladder Diagram .....	84
Multiple Vent/Air Terminations.....	30	Wiring Diagram.....	85
Vertical Termination - Optional Concentric Vent ...	31-32	Revision Notes .....	Back Cover
Alternate Vertical Concentric Venting.....	33-34		

## Hazard definitions

The following defined terms are used throughout this manual to bring attention to the presence of hazards of various risk levels or to important information concerning the life of the product.

**⚠ DANGER** DANGER indicates an imminently hazardous situation which, if not avoided, will result in death or serious injury.

**⚠ WARNING** WARNING indicates a potentially hazardous situation which, if not avoided, could result in death or serious injury.

**⚠ CAUTION** CAUTION indicates a potentially hazardous situation which, if not avoided, may result in minor or moderate injury.

**CAUTION** CAUTION used without the safety alert symbol indicates a potentially hazardous situation which, if not avoided, may result in property damage.

**NOTICE** NOTICE indicates special instructions on installation, operation, or maintenance that are important but not related to personal injury or property damage.

## Please read before proceeding

### **⚠ WARNING**

**Installer** – Read all instructions, including this manual and the Knight Fire Tube Boiler Service Manual, before installing. Perform steps in the order given.

**User** – This manual is for use only by a qualified heating installer/service technician. Refer to the User's Information Manual for your reference.

Have this boiler serviced/inspected by a qualified service technician, at least annually.

Failure to comply with the above could result in severe personal injury, death or substantial property damage.

### **NOTICE**

When calling or writing about the boiler – Please have the boiler model and serial number from the boiler rating plate.

Consider piping and installation when determining boiler location.

Any claims for damage or shortage in shipment must be filed immediately against the transportation company by the consignee.

Factory warranty (shipped with unit) does not apply to units improperly installed or improperly operated.

### **⚠ WARNING**

Failure to adhere to the guidelines on this page can result in severe personal injury, death, or substantial property damage.

### **⚠ WARNING**

If the information in this manual is not followed exactly, a fire or explosion may result causing property damage, personal injury or loss of life.

This appliance **MUST NOT** be installed in any location where gasoline or flammable vapors are likely to be present.

#### WHAT TO DO IF YOU SMELL GAS

- Do not try to light any appliance.
- Do not touch any electric switch; do not use any phone in your building.
- Immediately call your gas supplier from a near by phone. Follow the gas supplier's instructions.
- If you cannot reach your gas supplier, call the fire department.
- Installation and service must be performed by a qualified installer, service agency, or the gas supplier.

### **⚠ WARNING**

DO NOT install units in rooms or environments that contain corrosive contaminants (see Table 1B on page 10). Failure to comply could result in severe personal injury, death, or substantial property damage.

#### When servicing boiler –

- To avoid electric shock, disconnect electrical supply before performing maintenance.
- To avoid severe burns, allow boiler to cool before performing maintenance.

#### Boiler operation –

- Do not block flow of combustion or ventilation air to the boiler.
- Should overheating occur or gas supply fail to shut off, do not turn off or disconnect electrical supply to circulator. Instead, shut off the gas supply at a location external to the appliance.
- Do not use this boiler if any part has been under water. The possible damage to a flooded appliance can be extensive and present numerous safety hazards. Any appliance that has been under water must be replaced.

#### Boiler water –

- Thoroughly flush the system (without boiler connected) to remove sediment. The high-efficiency heat exchanger can be damaged by build-up or corrosion due to sediment.

### **⚠ CAUTION**

Do not use petroleum-based cleaning or sealing compounds in the boiler system. Gaskets and seals in the system may be damaged. This can result in substantial property damage.

### **⚠ CAUTION**

Do not use “homemade cures” or “boiler patent medicines”. Serious damage to the boiler, personnel, and/or property may result.

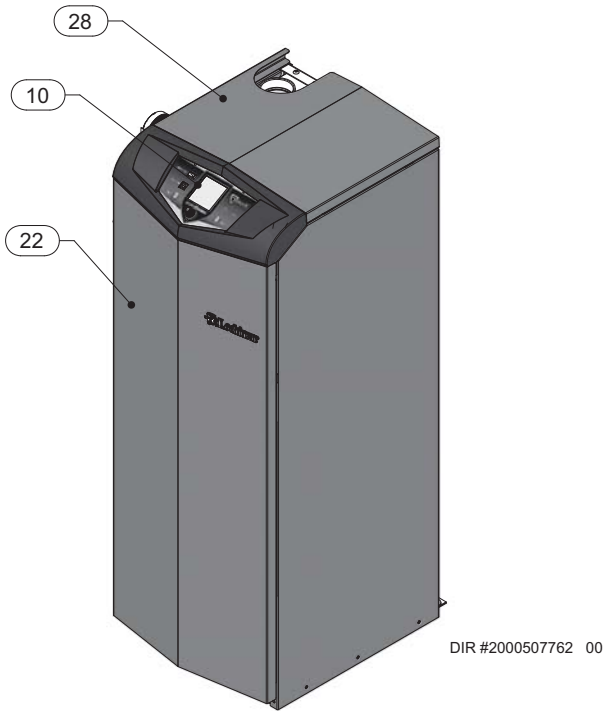
#### Freeze protection fluids –

- NEVER use automotive antifreeze. Use only inhibited propylene glycol solutions, which are specifically formulated for hydronic systems. Ethylene glycol is toxic and can attack gaskets and seals used in hydronic systems.

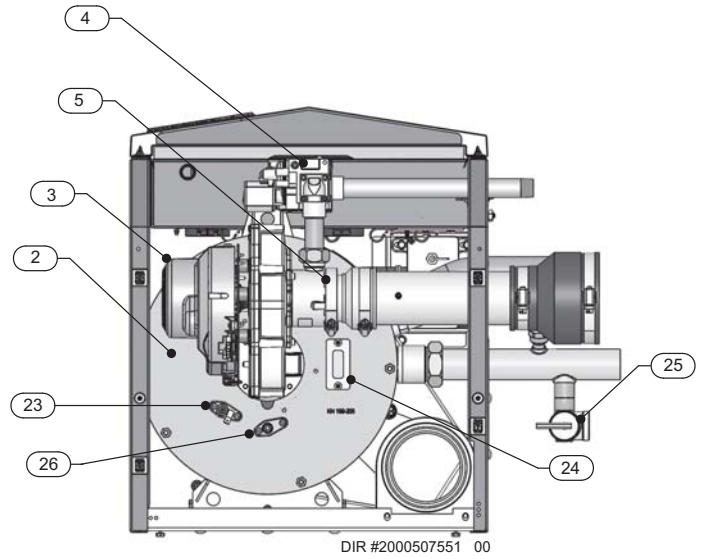
# The Knight Fire Tube Boiler - How it works...

1. **Stainless steel heat exchanger**  
Allows system water to flow around specially designed tubes for maximum heat transfer, while providing protection against flue gas corrosion.
2. **Combustion chamber access cover**  
Allows access to the combustion side of the heat exchanger.
3. **Blower**  
The blower pulls in air and gas through the venturi (item 5). Air and gas mix inside the blower and are pushed into the burner, where they burn inside the combustion chamber.
4. **Gas valve**  
The gas valve senses the negative pressure created by the blower, allowing gas to flow only if the gas valve is powered and combustion air is flowing.
5. **Venturi**  
The venturi controls air and gas flow into the burner.
6. **Flue gas sensor (limit rated)**  
This sensor monitors the flue gas exit temperature. The control module will modulate and shut down the boiler if flue gas temperature gets too hot. This protects the flue pipe from overheating.
7. **Boiler outlet temperature sensor (housed with the high limit sensor)**  
This sensor monitors boiler outlet water temperature (system supply). If selected as the controlling sensor, the control module adjusts boiler firing rate so the outlet temperature is correct.
8. **Boiler inlet temperature sensor**  
This sensor monitors return water temperature (system return). If selected as the controlling sensor, the control module adjusts the boiler firing rate so the inlet temperature is correct.
9. **Temperature and pressure gauge**  
Monitors the outlet temperature of the boiler as well as the system water pressure.
10. **Electronic LCD display**  
The display features a high resolution liquid crystal screen, four (4) buttons, and a navigation dial. A serial and USB port support additional communication with the control.
11. **Flue pipe adapter**  
Allows for the connection of the vent system to the boiler.
12. **Burner (not shown)**  
Made with metal fiber and stainless steel construction, the burner uses pre-mixed air and gas and provides a wide range of firing rates.
13. **Water outlet (system supply)**  
Copper water connection that supplies hot water to the system, either 1" or 1-1/4", depending on the model.
14. **Water inlet (system return)**  
Copper water connection that returns water from the system to the heat exchanger, either 1" or 1-1/4", depending on the model.
15. **Gas connection pipe**  
Threaded pipe connection. This pipe should be connected to the incoming gas supply for the purpose of delivering gas to the boiler.
16. **SMART SYSTEM Control Module**  
The SMART SYSTEM Control responds to internal and external signals to regulate the blower, gas valve, and pump functions to meet heating demand. Optional remote connectivity allows boiler settings to be monitored and modified when connected to the internet.
17. **Air intake adapter (Models 110 - 285 only)**  
Allows for the connection of the PVC air intake pipe to the boiler.
18. **High voltage junction box**  
The junction box contains the connection points for the line voltage power and all pumps.
19. **Low voltage connection board**  
The connection board is used to connect external low voltage devices.
20. **Low voltage wiring connections (knockouts)**  
Conduit connection points for the low voltage connection board.
21. **Condensate trap**  
The condensate trap has a 1/2" CPVC outlet connection pipe.
22. **Access cover - front**  
Provides access to the gas valve, control panel, and heat exchanger.
23. **Ignition electrode**  
Provides direct spark for igniting the burner.
24. **Flame inspection window**  
The quartz glass window provides a view of the burner surface and flame.
25. **Relief valve**  
Protects the heat exchanger from an over pressure condition. The relief valve provided with the unit is set at 30 psi.
26. **Flame sensor**  
Used by the control module to detect the presence of burner flame.
27. **Line voltage wiring connections (knockouts)**  
Conduit connection points for the high voltage junction box.
28. **Top panel**  
Removable panel allows access to the gas train and combustion chamber.
29. **Side access panels**  
Remove panels to gain access to temperature sensors.
30. **Power switch**  
Turns 120 VAC ON/OFF to the boiler.
31. **Leveling legs**  
Used to allow the heat exchanger to be leveled. This is needed for the proper draining of the condensate from the combustion chamber.
32. **Flue and temperature access door**  
Provides access to the flue and temperature sensor.
33. **Transformer**  
The transformer provides 24V power to the integrated control.
34. **High limit sensor (housed with the outlet temperature sensor)**  
Device that monitors the outlet water temperature. If the temperature exceeds its setting, the integrated control will break the control circuit, shutting the boiler down.
35. **Stainless steel flue collector (not shown)**  
Flue gas and condensate enter the stainless flue collector through the fire tubes. A 1" drain connection allows condensate to flow through the collector into a condensate trap for disposal.

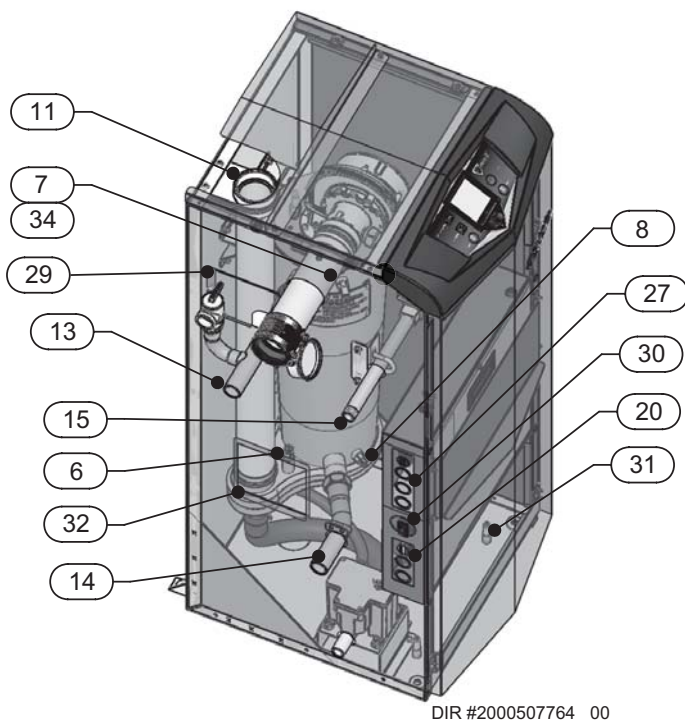
# The Knight Fire Tube Boiler - How it works... *(continued)*



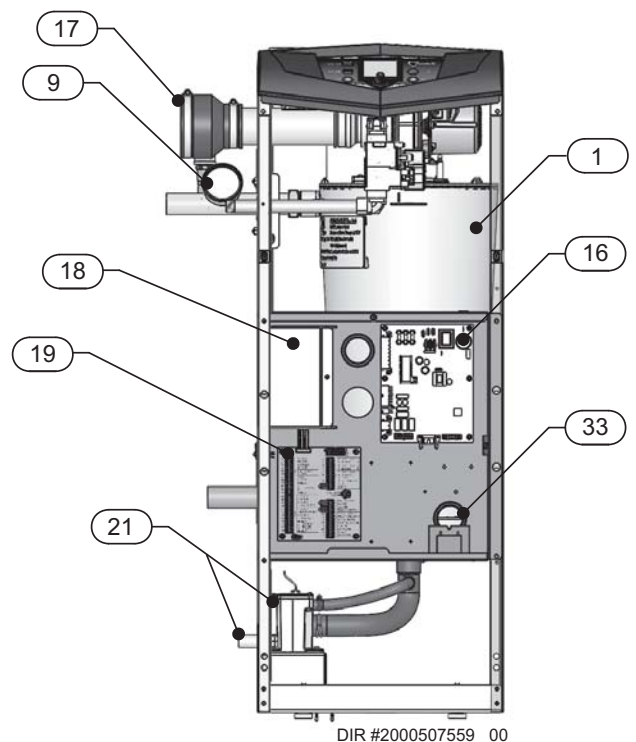
Front View



Top View (inside unit)

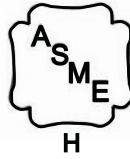


Left Side (inside unit)



Front View (inside unit)

# Ratings


**DOE**


Knight Fire Tube Boiler AHRI Rating						Other Specifications				
Model Number  Note: Change "N" to "L" for L.P. gas models.	Input MBH  (Note 5)		Heating Capacity MBH  (Note 2,7)	Net AHRI Ratings Water, MBH  (Note 3,7)	AFUE %  (Note 1, 7)	Boiler Water Content Gallons	Water Connections	Gas Connections	Air Size	Vent Size  (Note 4,8)
	Min	Max								
KHN055	8.2	55	51	44	95	2.3	1"	1/2"	2"	2"
KHN085	8.5	85	79	69	95	2.2	1"	1/2"	2"	2"
KHN110	11	110	102	89	95	2.3	1"	1/2"	3"	3"
KHN155	15.5	155	144	125	95	3.2	1"	1/2"	3"	3"
KHN199	20	199	184	160	95	5.2	1-1/4"	1/2"	3"	3"
KHN285	28.5	285	264	229	95	4.9	1-1/4"	1/2"	3"	3"

**NOTICE**

Maximum allowed working pressure is located on the rating plate.

**Notes:**

- As an Energy Star Partner, Lochinvar has determined that Knight Fire Tube boilers meet the Energy Star guidelines for energy efficiency.
- The ratings are based on standard test procedures prescribed by the United States Department of Energy.
- Net AHRI ratings are based on net installed radiation of sufficient quantity for the requirements of the building and nothing need be added for normal piping and pickup. Ratings are based on a piping and pickup allowance of 1.15.
- Knight Fire Tube boilers require special gas venting. Use only the vent materials and methods specified in the Knight Fire Tube Installation and Operation Manual.
- Standard Knight Fire Tube boilers are equipped to operate from sea level to 4,500 feet **only**. The boiler will de-rate by 4% for each 1,000 feet above sea level up to 4,500 feet.
- High altitude Knight Fire Tube boilers are equipped to operate from 3,000 to 9,600 feet. The boiler will de-rate 1.7% between 5,000 to 9,600 feet. For any units installed past 9,600 feet there is an additional de-rate of 4% per 1,000 feet beyond 9,600 feet per the National Fuel Gas Code. Boilers configured for high altitude shall not be installed below 3000 feet.  
The operation given in this manual remains the same as the standard boilers. A high altitude label (as shown in FIG A.) is also affixed to the unit.  
De-rate values are based on proper combustion calibration and CO<sub>2</sub>'s adjusted to the recommended levels.
- Ratings have been confirmed by the Hydronics Section of AHRI.

- Models KH055 - 085 can be alternatively vented using a 3" vent/air size. If a 2" vent/air size is used, the maximum vent/air pipe lengths for the KH055 model is 80 feet and 50 feet for the KH085 model. THE KH110 model can be alternatively vented using a 2" vent/air size. If the 2" vent/air size is used, the maximum vent/air pipe lengths are limited to 40 equivalent feet each. The KH285 model can be alternatively vented using a 4" vent/air size. If the 3" vent/air size is used, the maximum vent/air pipe lengths are limited to 50 equivalent feet each.
- The manual reset high limit provided with the Knight Fire Tube is listed to UL353.


**Figure A** High Altitude Label Location

# 1 Determine boiler location

Installation must comply with:

- Local, state, provincial, and national codes, laws, regulations, and ordinances.
- National Fuel Gas Code, ANSI Z223.1 – latest edition.
- Standard for Controls and Safety Devices for Automatically Fired Boilers, ANSI/ASME CSD-1, when required.
- National Electrical Code.
- For Canada only: B149.1 Installation Code, CSA C22.1 Canadian Electrical Code Part 1 and any local codes.

## NOTICE

The Knight Fire Tube boiler gas manifold and controls met safe lighting and other performance criteria when the boiler underwent tests specified in ANSI Z21.13 – latest edition.

Before locating the boiler, check:

1. Check for nearby connection to:
  - System water piping
  - Venting connections
  - Gas supply piping
  - Electrical power
2. Locate the appliance so that if water connections should leak, water damage will not occur. When such locations cannot be avoided, it is recommended that a suitable drain pan, adequately drained, be installed under the appliance. The pan must not restrict combustion air flow. Under no circumstances is the manufacturer to be held responsible for water damage in connection with this appliance, or any of its components.
3. Check area around the boiler. Remove any combustible materials, gasoline and other flammable liquids.

## WARNING

Failure to keep boiler area clear and free of combustible materials, gasoline, and other flammable liquids and vapors can result in severe personal injury, death, or substantial property damage.

4. The Knight Fire Tube boiler must be installed so that gas control system components are protected from dripping or spraying water or rain during operation or service.
5. If a new boiler will replace an existing boiler, check for and correct system problems, such as:
  - System leaks causing oxygen corrosion or heat exchanger cracks from hard water deposits.
  - Incorrectly-sized expansion tank.
  - Lack of freeze protection in boiler water causing system and boiler to freeze and leak.
  - Debris left from existing piping, if not flushed and cleaned with an appropriate cleaner.
6. Check around the boiler for any potential air contaminants that could risk corrosion to the boiler or the boiler combustion air supply (see Table 1B on page 10). Prevent combustion air contamination. Remove any of these contaminants from the boiler area.

## WARNING

DO NOT install units in rooms or environments that contain corrosive contaminants (see Table 1B on page 10). Failure to comply could result in severe personal injury, death, or substantial property damage.

## WARNING

This appliance is certified as an indoor appliance. Do not install the appliance outdoors or locate where the appliance will be exposed to freezing temperatures or to temperatures that exceed 100°F.

Do not install the appliance where the relative humidity may exceed 93%. Do not install the appliance where condensation may form on the inside or outside of the appliance, or where condensation may fall onto the appliance. Failure to install the appliance indoors could result in severe personal injury, death, or substantial property damage.

## WARNING

This appliance requires a special venting system. If using PVC the vent connection to the appliance must be made with the starter CPVC pipe section provided with the appliance. The field provided vent fittings must be cemented to the CPVC pipe section. Use only the vent materials, primer and cement specified in this manual to make the vent connections. Failure to follow this warning could result in fire, personal injury, or death.

## Closet and alcove installations

A closet is any room the boiler is installed in which the room volume is less than the room volume listed in the table below. An alcove is any room which meets the criteria for a closet, but it does not have a door.

**Table 1A Room Volume**

Model	Room Volume (in cubic feet)
55 - 285	124

**Example:** Room dimensions = 4 feet long, 3 feet wide, and 8 foot ceiling =  $4 \times 3 \times 8 = 96$  cubic feet. This would be considered a closet for a KHN285 model.

## WARNING

For closet and alcove installations as shown in FIG.'s 1-1 and 1-2, CPVC, polypropylene or stainless steel vent material must be used inside the structure. The ventilating air openings shown in FIG.'s 1-1 and 1-2 are required for this arrangement. Failure to follow this warning could result in fire, personal injury, or death.

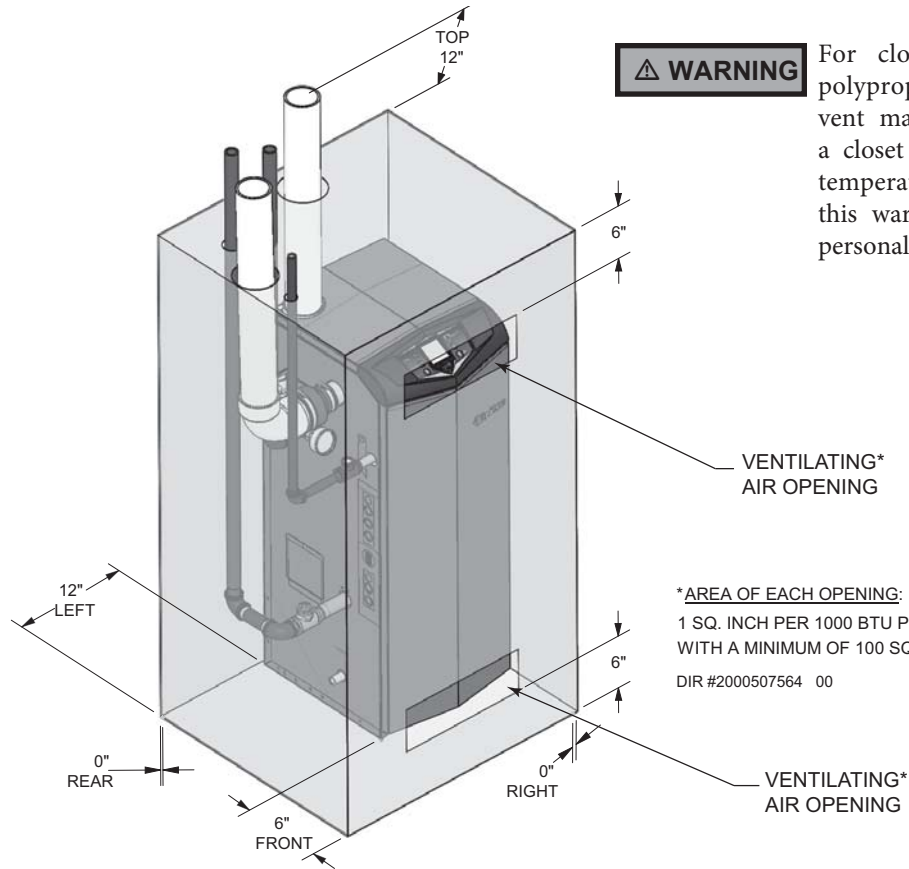
Provide clearances:

### Clearances from combustible materials

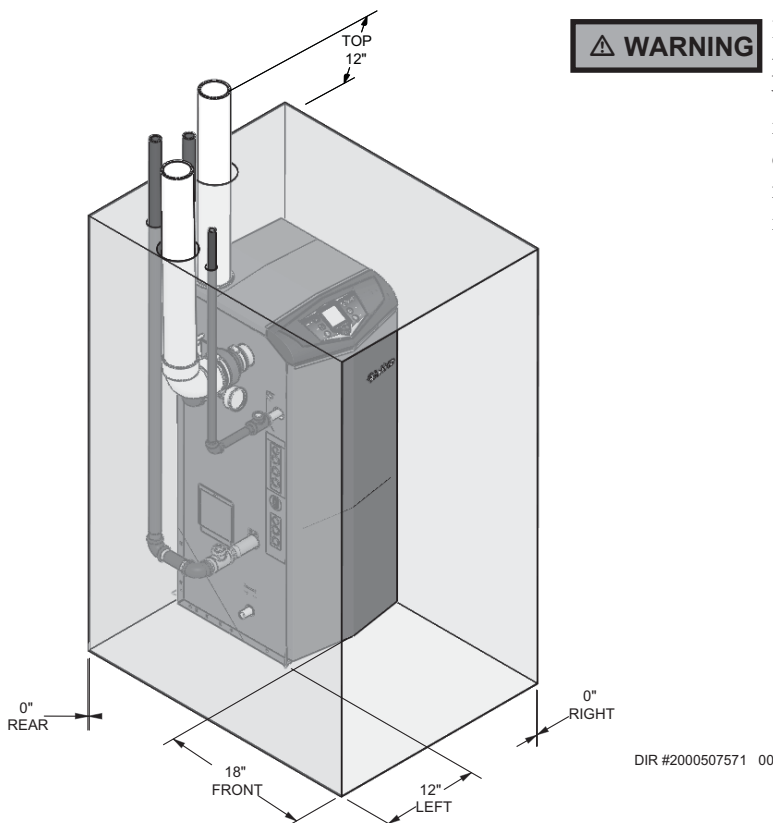
1. Hot water pipes—at least 1/4" (6 mm) from combustible materials.
2. Vent pipe – at least 1" (25 mm) from combustible materials.
3. See FIG.'s 1-1 and 1-2 on page 8 for other clearance minimums.

# 1 Determine boiler location

**Figure 1-1 Closet Installation - Minimum Required Clearances**



**Figure 1-2 Alcove Installation - Minimum Required Clearances**





# 1 Determine boiler location *(continued)*

## NOTICE

If you do not provide the recommended service clearances shown, it may not be possible to service the boiler without removing it from the space.

### Recommended clearances for service access

- Front ..... 24"
- Left ..... 24"
- Top ..... 24"

Provide air openings to room:

### Knight Fire Tube boiler alone in boiler room

1. No air ventilation openings into the boiler room are needed when clearances around the Knight Fire Tube boiler are at least equal to the SERVICE clearances shown above. For spaces that do NOT supply this clearance, provide two openings as shown in FIG. 1-1. Each opening must provide one square inch free area per 1,000 Btu/hr of boiler input.

### Knight Fire Tube boiler in same space with other gas or oil-fired appliances

1. Follow the National Fuel Gas Code (U.S.) or CSA B149.1 (Canada) to size/verify size of the combustion/ventilation air openings into the space.

## WARNING

The space must be provided with combustion/ventilation air openings correctly sized for all other appliances located in the same space as the Knight Fire Tube boiler.

Do not install the boiler in an attic.

Failure to comply with the above warnings could result in severe personal injury, death, or substantial property damage.

2. Size openings only on the basis of the other appliances in the space. No additional air opening free area is needed for the Knight Fire Tube boiler because it takes its combustion air from outside (direct vent installation).

## Flooring and foundation

### Flooring

The Knight Fire Tube boiler is approved for installation on combustible flooring, but must never be installed on carpeting.

## WARNING

Do not install the boiler on carpeting even if foundation is used. Fire can result, causing severe personal injury, death, or substantial property damage.

If flooding is possible, elevate the boiler sufficiently to prevent water from reaching the boiler.

## Residential garage installation

### Precautions

Take the following precautions when installing the appliance in a residential garage. If the appliance is located in a residential garage, it should be installed in compliance with the latest edition of the National Fuel Gas Code, ANSI Z223.1 and/or CAN/CGA-B149 Installation Code.

- Appliances located in residential garages and in adjacent spaces that open to the garage and are not part of the living space of a dwelling shall be installed so that all burners and burner ignition devices are located not less than 18 inches (46 cm) above the floor.
- The appliance shall be located or protected so that it is not subject to physical damage by a moving vehicle.

## Vent and air piping

The Knight Fire Tube boiler requires a special vent system, designed for pressurized venting.

The boiler is to be used for either direct vent installation or for installation using indoor combustion air. When room air is considered, see Section 3, General Venting. Note prevention of combustion air contamination below when considering vent/air termination.

Vent and air must terminate near one another and may be vented vertically through the roof or out a side wall, unless otherwise specified. You may use any of the vent/air piping methods covered in this manual. Do not attempt to install the Knight Fire Tube boiler using any other means.

Be sure to locate the boiler such that the vent and air piping can be routed through the building and properly terminated. The vent/air piping lengths, routing and termination method must all comply with the methods and limits given in this manual.

## Prevent combustion air contamination

Install air inlet piping for the Knight Fire Tube boiler as described in this manual. Do not terminate vent/air in locations that can allow contamination of combustion air. Refer to Table 1B, page 10 for products and areas which may cause contaminated combustion air.

## WARNING

You must pipe combustion air to the boiler air intake. Ensure that the combustion air will not contain any of the contaminants in Table 1B, page 10. Contaminated combustion air will damage the boiler, resulting in possible severe personal injury, death or substantial property damage. Do not pipe combustion air near a swimming pool, for example. Also, avoid areas subject to exhaust fumes from laundry facilities. These areas will always contain contaminants.

# 1 Determine boiler location

**Table 1B** Corrosive Contaminants and Sources

Products to avoid:
Spray cans containing chloro/fluorocarbons
Permanent wave solutions
Chlorinated waxes/cleaners
Chlorine-based swimming pool chemicals
Calcium chloride used for thawing
Sodium chloride used for water softening
Refrigerant leaks
Paint or varnish removers
Hydrochloric acid/muriatic acid
Cements and glues
Antistatic fabric softeners used in clothes dryers
Chlorine-type bleaches, detergents, and cleaning solvents found in household laundry rooms
Adhesives used to fasten building products and other similar products
Areas likely to have contaminants
Dry cleaning/laundry areas and establishments
Swimming pools
Metal fabrication plants
Beauty shops
Refrigeration repair shops
Photo processing plants
Auto body shops
Plastic manufacturing plants
Furniture refinishing areas and establishments
New building construction
Remodeling areas
Garages with workshops

When using an existing vent system to install a new boiler:

**⚠ WARNING** Failure to follow all instructions can result in flue gas spillage and carbon monoxide emissions, causing severe personal injury or death.

Check the following venting components before installing:

- **Material** - For materials listed for use with this appliance, see Section 3 - General Venting. For polypropylene or stainless steel venting, an adapter of the same manufacturer must be used at the flue collar connection.
- **Size** - To ensure proper pipe size is in place, see Table 3A. Check to see that this size is used throughout the vent system.
- **Manufacturer** - For a stainless steel or polypropylene application, you must use only the listed manufacturers and their type product listed in Tables 3E and 3G for CAT IV positive pressure venting with flue producing condensate.
- **Supports** - Non-combustible supports must be in place allowing a minimum 1/4" rise per foot. The supports should adequately prevent sagging and vertical slippage, by distributing the vent system weight. For additional information, consult the vent manufacturer's instructions for installation.
- **Terminations** - Carefully review Sections 3 through 5 to ensure requirements for the location of the vent and air terminations are met and orientation of these fit the appropriate image from the Sidewall or Vertical options listed in the General Venting Section. For stainless steel vent, only use terminations listed in Table 3H for the manufacturer of the installed vent.
- **Seal** - With prior requirements met, the system should be tested to the procedure listed in parts (c) through (f) of the Removal of an Existing Boiler Section on page 11.

With polypropylene and stainless steel vent, seal and connect all pipe and components as specified by the vent manufacturer used; with PVC/CPVC vent, see the Installing Vent or Air Piping Section on page 19.

**⚠ WARNING** If any of these conditions are not met, the existing system must be updated or replaced for that concern. Failure to follow all instructions can result in flue gas spillage and carbon monoxide emissions, causing severe personal injury or death.

# 1 Determine boiler location *(continued)*

When removing a boiler from existing common vent system:

## **⚠ DANGER**

Do not install the Knight Fire Tube boiler into a common vent with any other appliance. This will cause flue gas spillage or appliance malfunction, resulting in possible severe personal injury, death, or substantial property damage.

## **⚠ WARNING**

Failure to follow all instructions can result in flue gas spillage and carbon monoxide emissions, causing severe personal injury or death.

At the time of removal of an existing boiler, the following steps shall be followed with each appliance remaining connected to the common venting system placed in operation, while the other appliances remaining connected to the common venting system are not in operation.

- a. Seal any unused openings in the common venting system.
- b. Visually inspect the venting system for proper size and horizontal pitch and determine there is no blockage or restriction, leakage, corrosion, or other deficiencies, which could cause an unsafe condition.
- c. Test vent system – Insofar as is practical, close all building doors and windows and all doors between the space in which the appliances remaining connected to the common venting system are located and other spaces of the building. Turn on clothes dryers and any appliance not connected to the common venting system. Turn on any exhaust fans, such as range hoods and bathroom exhausts, so they will operate at maximum speed. Do not operate a summer exhaust fan. Close fireplace dampers.
- d. Place in operation the appliance being inspected. Follow the lighting instructions. Adjust thermostat so appliance will operate continuously.
- e. Test for spillage at the draft hood relief opening after 5 minutes of main burner operation. Use the flame of a match or candle, or smoke from a cigarette, cigar, or pipe.
- f. After it has been determined that each appliance remaining connected to the common venting system properly vents when tested as outlined herein, return doors, windows, exhaust fans, fireplace dampers, and any other gas-burning appliance to their previous conditions of use.
- g. Any improper operation of the common venting system should be corrected so the installation conforms with the National Fuel Gas Code, ANSI Z223.1/NFPA 54 and/or CAN/CSA B149.1, Natural Gas and Propane Installation Code. When resizing any portion of the common venting system, the common venting system should be resized to approach the minimum size as determined using the appropriate tables in Part 11 of the National Fuel Gas Code, ANSI Z223.1/NFPA and/or CAN/CSA B149.1, Natural Gas and Propane Installation Code.

## 2 Prepare boiler

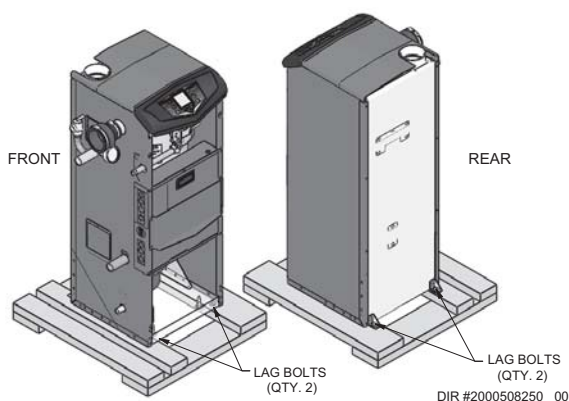
### Remove boiler from wood pallet

1. After removing the outer shipping carton from the boiler, remove the parts box.
2. Remove the front door to access the lag bolts in front of the unit (FIG. 2-1).
3. To remove the boiler from the pallet (after removing the front door):
  - a. Remove the two lag bolts from the wood pallet inside the boiler (FIG. 2-1).
  - b. Detach the boiler from the lag bolts in the rear of the unit, see FIG. 2-1.

#### NOTICE

Do not drop the boiler or bump the jacket on the floor or pallet. Damage to the boiler can result.

**Figure 2-1** Boiler Mounted on Shipping Pallet



### Gas conversions

#### WARNING

For a boiler already installed, you must turn off gas supply, turn off power and allow boiler to cool before proceeding. You must also completely test the boiler after conversion to verify performance as described under Start-up, Section 10 of this manual. Failure to comply could result in severe personal injury, death, or substantial property damage.

You must install a propane venturi and any additional components supplied in the kit to operate the Knight Fire Tube boiler on propane gas. Verify when installing that the venturi label and orifice marking matches the boiler size (see Table 2A).

**Table 2A** LP Conversion Table

Model	Kit #	Venturi Ø (mm)	Orifice Ø		Air Shutter	Orifice Stamping
			Bottom	Top		
55	100268040	20 mm	2.45 mm	2.65 mm	100150434	N/A
85	100268104	20 mm	2.45 mm	2.55 mm	100150434	N/A
110	100285815	22 mm	3.00 mm	2.85 mm	100284510	.250
155	100285817	24 mm	3.35 mm	2.95 mm	100284509	.302
199	100285818	24 mm	3.40 mm	3.00 mm	100150947	.302
285	100268109	30 mm	4.20 mm	4.00 mm	100150434	N/A

\*Note: The KHL199 air shutter should have the hole oriented towards the back right corner of the unit.

1. If boiler is already installed, you must turn off the gas supply, turn off the power, and allow the boiler to cool before proceeding.
2. Remove the top panel front access cover from the unit (no tools required for removal) and remove the bezel.
3. Disconnect the air inlet piping from the venturi by loosening the band clamp around the rubber boot coupling. Slide the rubber boot off of the venturi.
4. Disconnect gas piping from the venturi by loosening the threaded nut on the venturi. Remove the gasket between the gas piping and venturi.
5. Remove the bolts connecting the venturi to the fan and proceed to remove the natural gas venturi from the unit, making sure not to damage the blower O-ring gasket (FIG. 2-2).
6.
  - a. Disconnect the wiring from the fan and remove the bolts securing the fan to the combustion chamber access cover.
  - b. Remove the fan and gasket, and install the air shutter provided in the kit. **Note:** On KHL199 models, the air shutter **MUST** be installed in the proper direction. Install the air shutter so that the hole in the corner is oriented towards the back right corner of the unit (opposite the front door and gas piping).
  - c. Replace all torn or damaged gaskets. Reassemble the fan.
  - d. Reconnect the wiring harness before operation.
7. Install the propane venturi and verify the following:
  - a. The UP arrow on the plastic housing is pointing up.
  - b. The threaded connection for the gas piping is facing towards the front of the unit.
8. Models KHL110 - 199 ONLY require an orifice to be installed in the threaded venturi connection:
  - a. Locate the propane orifice from the conversion kit bag and verify the stamping on the orifice matches the boiler size (see Table 2A).
  - b. With the stamped side facing inwards, place the orifice in the cavity provided in the threaded connection.
9. Reassemble the gas pipe to the threaded connection on the venturi. Replace torn or damaged gasket(s) and ensure the venturi gasket is seated properly before tightening the nut on the venturi.

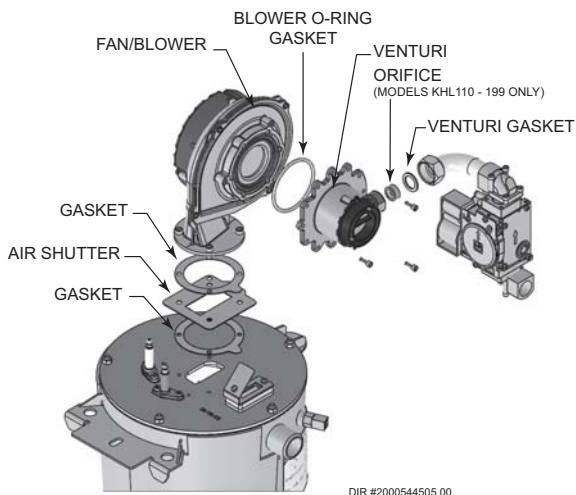
## 2 Prepare boiler *(continued)*

10. Reconnect the rubber boot on the air inlet to the venturi inlet and tighten the band clamp at this connection.
11. After installation is complete, attach the propane conversion label (inside the conversion kit) next to the boiler rating plate. Attach the LP caution label (inside the conversion kit bag) to the left side of the boiler underneath the gas supply piping.
12. Replace the top bezel and front access cover removed in Step 1 and resume operation.

### **⚠ DANGER**

When removing the natural gas venturi, inspect the gasket at the gas connection and the O-ring at the blower. These gaskets must be in good condition and must be installed. Failure to comply will cause a gas leak, resulting in severe personal injury or death.

**Figure 2-2 Remove Natural Gas Venturi**



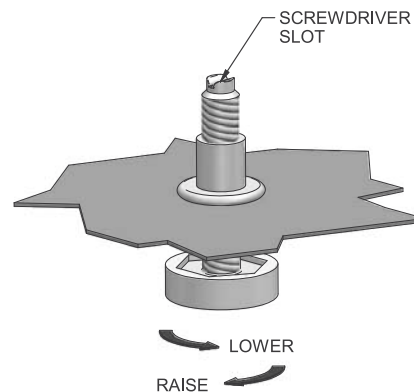
### **⚠ WARNING**

After converting to LP, check combustion per the Start-up procedure in Section 10 of this manual. Failure to check and verify combustion could result in severe personal injury, death, or substantial property damage.

### Leveling the boiler

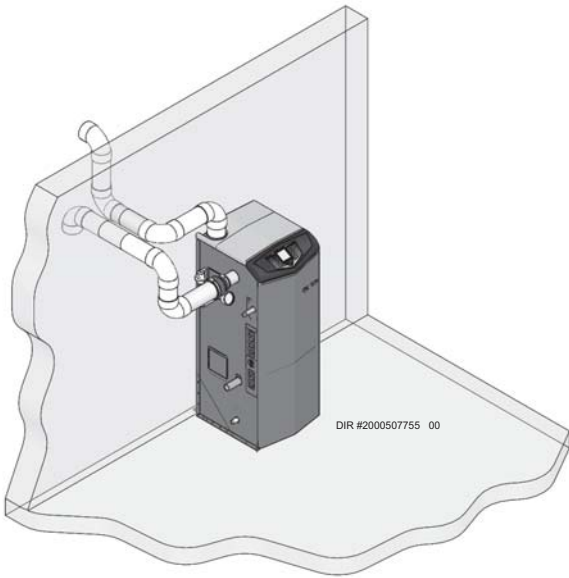
1. Set the boiler in place and check level.
  - a) Adjust legs if necessary to level boiler, see FIG. 2-3 below.

**Figure 2-3 Leveling Legs on the Boiler**

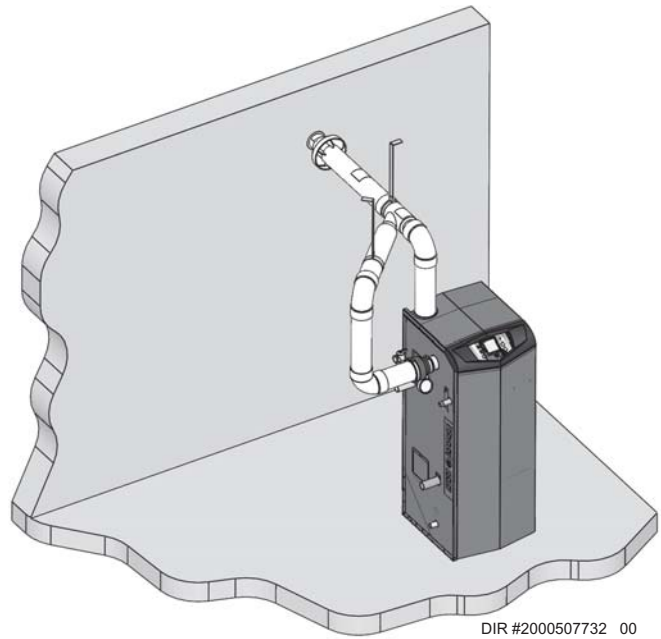


### 3 General venting

#### Direct venting options - Sidewall Vent

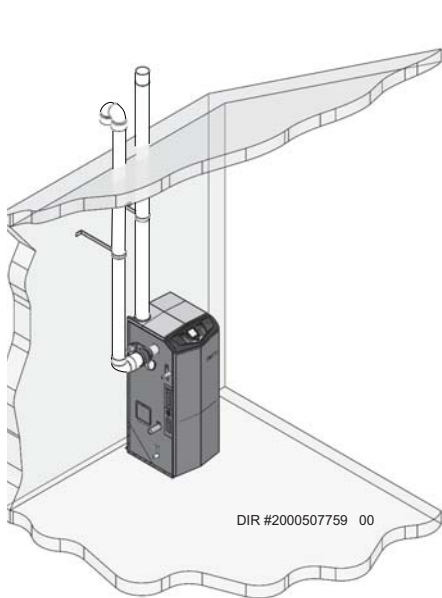


**Figure 3-1** Two-Pipe Sidewall Termination - See page 22 for more details

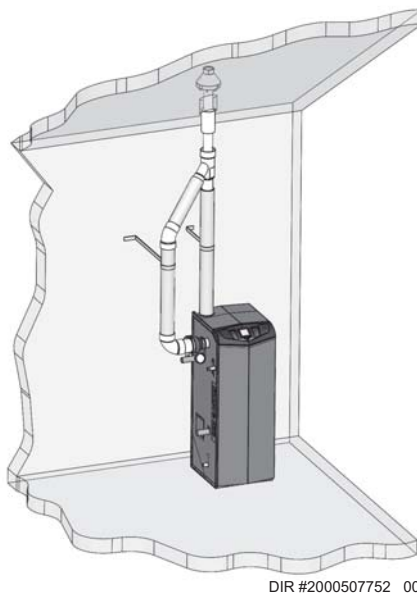


**Figure 3-2** PVC/CPVC Concentric Sidewall Termination - See page 26 for more details

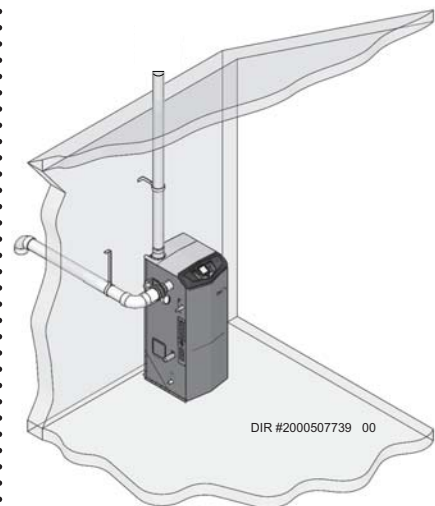
#### Direct venting options - Vertical Vent



**Figure 3-3** Two-Pipe Vertical Termination - See page 29 for more details



**Figure 3-4** PVC/CPVC Concentric Vertical Termination - See page 31 for more details



**Figure 3-5** Vertical Vent, Sidewall Air

### 3 General venting *(continued)*

#### Install vent and combustion air piping

#### **⚠ DANGER**

The Knight Fire Tube boiler must be vented and supplied with combustion and ventilation air as described in this section. Ensure the vent and air piping and the combustion air supply comply with these instructions regarding vent system, air system, and combustion air quality. See also Section 1 of this manual.

Inspect finished vent and air piping thoroughly to ensure all are airtight and comply with the instructions provided and with all requirements of applicable codes.

Failure to provide a properly installed vent and air system will cause severe personal injury or death.

#### **⚠ WARNING**

This appliance requires a special venting system. Use only approved stainless steel, PVC, CPVC or polypropylene pipe and fittings listed in Tables 3D, 3E, and 3G for vent pipe, and fittings. Failure to comply could result in severe personal injury, death, or substantial property damage.

#### **⚠ WARNING**

DO NOT mix components from different systems. The vent system could fail, causing leakage of flue products into the living space. Mixing of venting materials will void the warranty and certification of the appliance.

#### **NOTICE**

Installation must comply with local requirements and with the National Fuel Gas Code, ANSI Z223.1 for U.S. installations or CSA B149.1 for Canadian installations.

#### **⚠ WARNING**

For closet and alcove installations, CPVC, polypropylene or stainless steel material **MUST BE** used in a closet/alcove structure. Failure to follow this warning could result in fire, personal injury, or death.

#### **⚠ CAUTION**

Improper installation of venting systems may result in injury or death.

#### **NOTICE**

Follow the instructions in Section 1, page 11 of this manual when removing a boiler from an existing vent system.

#### **⚠ WARNING**

Do not connect any other appliance to the vent pipe or multiple boilers to a common vent pipe. Failure to comply could result in severe personal injury, death, or substantial property damage.

The Knight Fire Tube boiler vent and air piping can be installed through the roof or through a sidewall. Follow the procedures in this manual for the method chosen. Refer to the information in this manual to determine acceptable vent and air piping length.

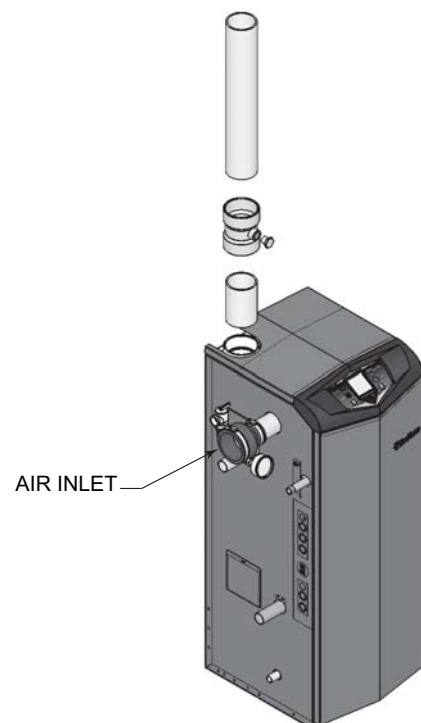
You may use any of the vent/air piping methods covered in this manual. Do not attempt to install the Knight Fire Tube boiler using any other means.

You must also install air piping from outside to the boiler air intake adapter unless following the Optional Room Air instructions on page 18 of this manual. The resultant installation is direct vent (sealed combustion).

#### Air intake/vent connections

1. **Combustion Air Intake Connector** (FIG. 3-6) - Used to provide combustion air directly to the unit from outdoors. On Models 110 - 285 a fitting is provided on the unit for final connection. Combustion air piping must be supported per guidelines listed in the National Mechanical Code, Section 305, Table 305.4 or as local codes dictate.
2. **Vent Connector** (FIG.'s 3-7 thru 3-10) - Used to provide a passageway for conveying combustion gases to the outside. A transition fitting is provided on the unit for final connection. Vent piping must be supported per the National Building Code, Section 305, Table 305.4 or as local codes dictate.

**Figure 3-6** Near Boiler Air Piping



DIR #2000507838 00

### 3 General venting

#### Requirements for installation in Canada

1. Installations must be made with a vent pipe system certified to ULC-S636.
2. The first three (3) feet of plastic vent pipe from the appliance flue outlet must be readily accessible for visual inspection.
3. The components of the certified vent system must not be interchanged with other vent systems or unlisted pipe/fittings. For concentric vent installations, the inner vent tube must be replaced with field supplied certified vent material to comply with this requirement.
4. The 2", 3" and 4" Concentric Vent Kit available from Lochinvar (see Section 4 – *Sidewall Termination – Optional Concentric Vent*) and the 2", 3" and 4" Concentric Vent Kit available from IPEX are both approved for use on the Knight Fire Tube boiler. Both kits are listed to the ULC-S636 standard for use in Canada.

#### Sizing

The Knight Fire Tube boiler uses model specific combustion air intake and vent piping sizes as detailed in Table 3A below.

**Table 3A** Air Intake/Vent Piping Sizes

Model	Inlet Diameter	Vent Diameter	Maximum Length
55	2 inches / 3 inches	2 inches / 3 inches	80 feet / 100 feet
85	2 inches / 3 inches	2 inches / 3 inches	50 feet / 100 feet
110	2 inches / 3 inches	2 inches / 3 inches	40 feet / 100 feet
155	3 inches	3 inches	100 feet
199	3 inches	3 inches	100 feet
285	3 inches / 4 inches	3 inches / 4 inches	50 feet / 100 feet

**NOTICE**

Increasing or decreasing combustion air or vent piping sizes is not authorized, unless referenced in manual.

**NOTICE**

For Models 55 - 110 using 2" venting and Model 285 using 3" venting, the first seven (7) equivalent feet of vent must be CPVC or polypropylene (field supplied). This includes any transition piece used to increase or decrease the vent diameter.

**NOTICE**

The minimum combustion air and vent piping length is 12 equivalent feet.

When determining equivalent combustion air and vent length, add 5 feet for each 90° elbow and 3 feet for each 45° elbow.

**EXAMPLE:** 20 feet of PVC pipe + (4) 90° elbows + (2) 45° elbows + (1) concentric vent kit (100140480) = 49 equivalent feet of piping.

**NOTICE**

The appliance output rating will reduce by up to 2.3% for each 25 feet of vent length. Consult factory to determine de-rate values.

**Table 3B** Approved Concentric Vent Systems

Vent Diameter	Vent Supplier	Vent Material	Part Number Lochinvar SAP / Legacy
2 inch	Lochinvar	PVC	100140485
3 inch	Lochinvar	PVC	100269005
4 inch	Lochinvar	PVC	100140484
2 inch	IPEX	PVC	196005
3 inch	IPEX	PVC	196006
4 inch	IPEX	PVC	196021
3 inch	IPEX	CPVC	197009
4 inch	IPEX	CPVC	197021



## 3 General venting *(continued)*

### Materials

#### Air inlet pipe materials:

The air inlet pipe(s) must be sealed. Choose acceptable combustion air inlet pipe materials from the following list:

- PVC, CPVC, Polypropylene or ABS
- Dryer Vent or Sealed Flexible Duct (not recommended for rooftop air inlet)
- Galvanized steel vent pipe with joints and seams sealed as specified in this section.
- Type “B” double-wall vent with joints and seams sealed as specified in this section.
- AL29-4C, stainless steel material to be sealed to specification of its manufacturer.

\*Plastic pipe may require an adapter (not provided) to transition between the air inlet connection on the appliance and the plastic air inlet pipe.

**⚠ WARNING** Using air intake materials other than those specified can result in personal injury, death or property damage.

**NOTICE** The use of double-wall vent or insulated material for the combustion air inlet pipe is recommended in cold climates to prevent the condensation of airborne moisture in the incoming combustion air.

Sealing of Type “B” double-wall vent material or galvanized vent pipe material used for air inlet piping on a sidewall or vertical rooftop Combustion Air Supply System:

- a. Seal all joints and seams of the air inlet pipe using either Aluminum Foil Duct Tape meeting UL Standard 723 or 181A-P or a high quality UL Listed silicone sealant such as those manufactured by Dow Corning or General Electric.
- b. Do not install seams of vent pipe on the bottom of horizontal runs.
- c. Secure all joints with a minimum of three (3) sheet metal screws or pop rivets. Apply Aluminum Foil Duct Tape or silicone sealant to all screws or rivets installed in the vent pipe.
- d. Ensure that the air inlet pipes are properly supported.

The PVC, CPVC, or ABS air inlet pipe should be cleaned and sealed with the pipe manufacturer’s recommended solvents and standard commercial pipe cement for the material used. The PVC, CPVC, ABS, Dryer Vent or Flex Duct air inlet pipe should use a silicone sealant to ensure a proper seal at the appliance connection and the air inlet cap connection. Dryer vent or flex duct should use a screw type clamp to seal the vent to the appliance air inlet and the air inlet cap. Proper sealing of the air inlet pipe ensures that combustion air will be free of contaminants and supplied in proper volume.

Follow the polypropylene manufacturer's instructions when using polypropylene material as an inlet pipe.

When a sidewall or vertical rooftop combustion air supply system is disconnected for any reason, the air inlet pipe must be resealed to ensure that combustion air will be free of contaminants and supplied in proper volume.

**⚠ DANGER** Failure to properly seal all joints and seams as required in the air inlet piping may result in flue gas recirculation, spillage of flue products and carbon monoxide emissions causing severe personal injury or death.

## 3 General venting

### Optional room air

#### NOTICE

Optional room air is intended for commercial applications. Combustion air piping to the outside is recommended for residential applications.

Commercial applications utilizing the Knight Fire Tube boiler may be installed with a single pipe carrying the flue products to the outside while using combustion air from the equipment room. In order to use the room air venting option the following conditions and considerations must be followed.

- The unit **MUST** be installed with the appropriate room air kit (Table 3C).
- The equipment room **MUST** be provided with properly sized openings to assure adequate combustion air. Please refer to instructions provided with the room air kit.
- There will be a noticeable increase in the noise level during normal operation from the inlet air opening.
- Using the room air kit makes the unit vulnerable to combustion air contamination from within the building. Please review Section 1, Prevent Combustion Air Contamination, to ensure proper installation.
- Vent system and terminations must comply with the standard venting instructions set forth in this manual.

#### ⚠ WARNING

When utilizing the single pipe method, provisions for combustion and ventilation air must be in accordance with Air for Combustion and Ventilation, of the latest edition of the National Fuel Gas Code, ANSI Z223.1, in Canada, the latest edition of CGA Standard B149 Installation Code for Gas Burning Appliances and Equipment, or applicable provisions of the local building codes.

### Air contamination

Pool and laundry products and common household and hobby products often contain fluorine or chlorine compounds. When these chemicals pass through the boiler, they can form strong acids. The acid can eat through the boiler wall, causing serious damage and presenting a possible threat of flue gas spillage or boiler water leakage into the building.

Please read the information given in Table 1B, page 10, listing contaminants and areas likely to contain them. If contaminating chemicals will be present near the location of the boiler combustion air inlet, have your installer pipe the boiler combustion air and vent to another location, per this manual.

#### ⚠ WARNING

If the boiler combustion air inlet is located in a laundry room or pool facility, for example, these areas will always contain hazardous contaminants.

#### ⚠ WARNING

To prevent the potential of severe personal injury or death, check for areas and products listed in Table 1B, page 10 before installing the boiler or air inlet piping.

If contaminants are found, you **MUST**:

- Remove contaminants permanently.
- OR—
- Relocate air inlet and vent terminations to other areas.

**Table 3C** Optional Room Air Kit

Model	Vent Diameter	Part Number SAP / Legacy
55 - 285	2 inch	100157614

### 3 General venting *(continued)*

#### PVC/CPVC

This product has been approved for use with the PVC/CPVC vent materials listed in Table 3D.

#### Installing vent and air piping

##### NOTICE

Use only cleaners, primers, and solvents that are approved for the materials which are joined together.

##### NOTICE

All PVC vent pipes must be glued, properly supported, and the exhaust must be pitched a minimum of a 1/4 inch per foot back to the boiler (to allow drainage of condensate).

##### ⚠ WARNING

Insulation should not be used on PVC or CPVC venting materials. The use of insulation will cause increased vent wall temperatures, which could result in vent pipe failure.

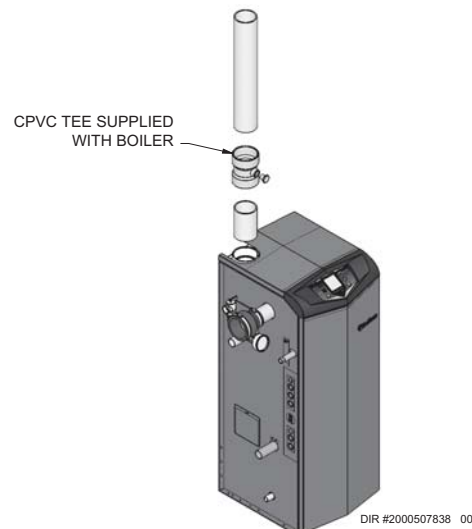
**Table 3D PVC/CPVC Vent Pipe, and Fittings**

Approved PVC/CPVC Vent Pipe and Fittings		
Item	Material	Standard
Vent pipe	PVC Schedule 40, 80	ANSI/ASTM D1785
	PVC - DWV	ANSI/ASTM D2665
	CPVC Schedule 40, 80	ANSI/ASTM F441
Vent fittings	PVC Schedule 40	ANSI/ASTM D2466
	PVC Schedule 80	ANSI/ASTM D2467
	CPVC Schedule 40	ANSI/ASTM F438
	CPVC Schedule 80	ANSI/ASTM F439
	PVC - DWV	ANSI/ASTM D2665
Pipe Cement / Primer	PVC	ANSI/ASTM D2564
	CPVC	ANSI/ASTM F493
<b>NOTICE: DO NOT USE CELLULAR (FOAM) CORE PIPE</b>		

**NOTE:** In Canada, CPVC and PVC vent pipe, fittings and cement/primer must be ULC-S636 certified.

1. Work from the boiler to vent or air termination. Do not exceed the lengths given in this manual for the air or vent piping.
2. Cut pipe to the required lengths and deburr the inside and outside of the pipe ends.
3. Chamfer outside of each pipe end to ensure even cement distribution when joining.
4. Clean all pipe ends and fittings using a clean dry rag. (Moisture will retard curing and dirt or grease will prevent adhesion.)
5. Dry fit vent or air piping to ensure proper fit up before assembling any joint. The pipe should go a third to two-thirds into the fitting to ensure proper sealing after cement is applied.
6. Priming and Cementing:
  - a. Handle fittings and pipes carefully to prevent contamination of surfaces.
  - b. Apply a liberal even coat of primer to the fitting socket and to the pipe end to approximately 1/2" beyond the socket depth.
  - c. Apply a second primer coat to the fitting socket.
  - d. While primer is still wet, apply an even coat of approved cement to the pipe equal to the depth of the fitting socket along with an even coat of approved cement to the fitting socket.
  - e. Apply a second coat of cement to the pipe.
  - f. While the cement is still wet, insert the pipe into the fitting, if possible twist the pipe a 1/4 turn as you insert it. **NOTE:** If voids are present, sufficient cement was not applied and joint could be defective.
  - g. Wipe excess cement from the joint removing ring or beads as it will needlessly soften the pipe.

**Figure 3-7 Near Boiler PVC/CPVC Venting**



**NOTE:** CPVC VENT PIPE AND VENT FITTINGS MUST BE USED IN CLOSET AND ALCOVE INSTALLATIONS.

# 3 General venting

## Polypropylene

This product has been approved for use with polypropylene vent with the manufacturers listed in Table 3E.

All terminations must comply with listed options in this manual and be a single-wall vent offering.

For support and special connections required, see the manufacturer's instructions. All vent is to conform to standard diameter and equivalent length requirements established.

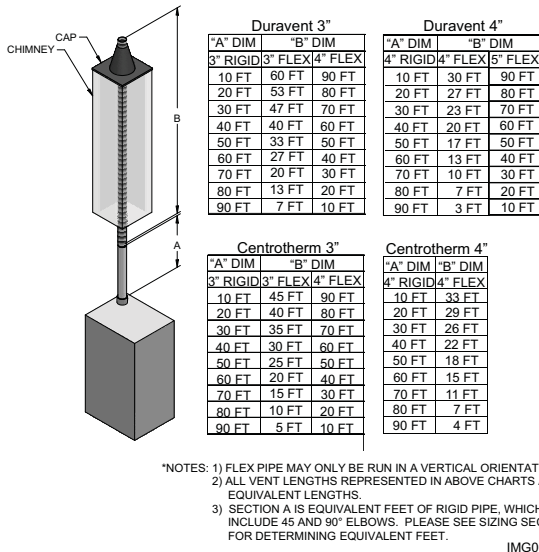
When determining equivalent combustion air and vent length for polypropylene single-wall piping:

- 1 foot of DuraVent 4 inch single-wall pipe is equivalent to 1.6 feet of piping

## Flexible polypropylene

For use of flex pipe, it is recommended to have the vent material in 32°F or higher ambient space before bending at installation. No bends should be made to greater than 45° and ONLY installed in vertical or near vertical installations (FIG. 3-8).

**Figure 3-8** Near Boiler Flexible Polypropylene Venting



**NOTICE**

All vent connections MUST be secured by the vent manufacturer's joint connector (FIG. 3-9).

**WARNING**

Insulation should not be used on polypropylene venting materials. The use of insulation will cause increased vent wall temperatures, which could result in vent pipe failure.

**WARNING**

Use only the adapters and vent system listed in Table 3E. DO NOT mix vent systems of different types or manufacturers. Failure to comply could result in severe personal injury, death, or substantial property damage.

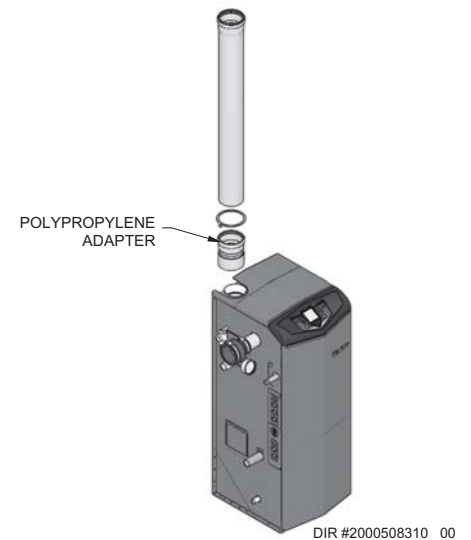
**NOTICE**

Installations must comply with applicable national, state, and local codes. For Canadian installation, polypropylene vent must be listed as a ULC-S636 approved system.

**NOTICE**

Installation of a polypropylene vent system should adhere to the vent manufacturer's installation instructions supplied with the vent system.

**Figure 3-9** Near Boiler Polypropylene Venting



**NOTICE**

The installer must use a specific vent starter adapter at the flue connection. This adapter is supplied by the vent manufacturer to adapt to its vent system. See Table 3F for approved vent adapters.

**Table 3E** Approved Polypropylene System Adapters

Vent Diameter	Manufacturer	Model	Type	PVC Adapter	Adapter Clamp	Joint Connector	Sidewall Kit
2 inch	Centrotherm	Innoflue	Single-Wall / Flex	ISAGL0202	IAFC02	IANS02	ISLTK02*
3 inch	Centrotherm	Innoflue	Single-Wall / Flex	ISAGL0303	IAFC03	IANS03	ISLTK03*
4 inch	Centrotherm	Innoflue	Single-Wall / Flex	ISAGL0404	IAFC04	IANS04	ISLTK04*
2 inch	DuraVent	PolyPro	Single-Wall / Flex	2PPS-ADL	Included	2PPS-LB	2PPS-HLKL*
3 inch	DuraVent	PolyPro	Single-Wall / Flex	3PPS-ADL	Included	3PPS-LB	3PPS-HLKL*
4 inch	DuraVent	PolyPro	Single-Wall / Flex	4PPS-ADL	Included	4PPS-LB	4PPS-HLKL*

\*The sidewall kit components are only needed if the sidewall termination assembly is used (see FIG. 4-1B on page 22).

### 3 General venting *(continued)*

#### Stainless steel vent

This product has been approved for use with stainless steel using the manufacturers listed in Table 3F.

**WARNING** Use only the materials, vent systems, and terminations listed in Tables 3F and 3G. DO NOT mix vent systems of different types or manufacturers. Failure to comply could result in severe personal injury, death, or substantial property damage.

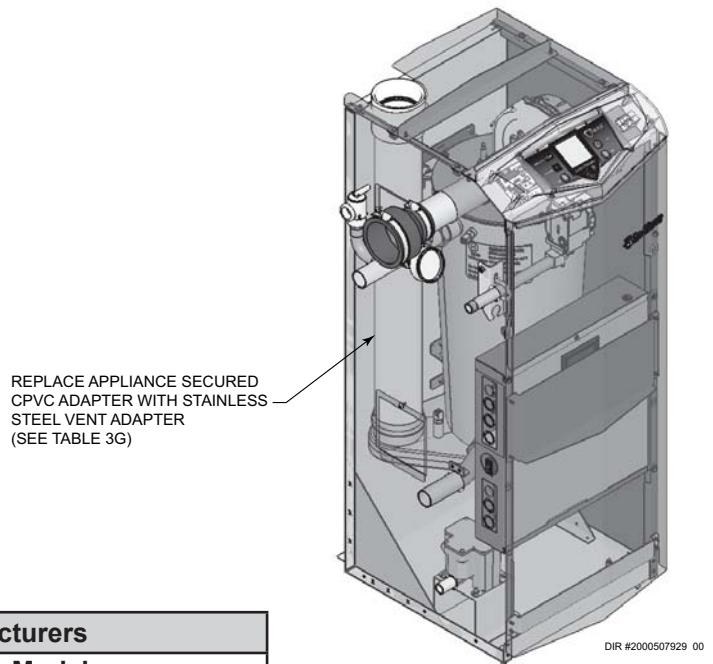
**NOTICE** The installer must use a specific vent starter adapter at the flue collar connection, supplied by the vent manufacturer to adapt to its vent system. See Table 3G for approved vent adapters. Discard CPVC starter piece.

**NOTICE** Installations must comply with applicable national, state, and local codes. Stainless steel vent systems must be listed as a UL-1738 approved system for the United States and a ULC-S636 approved system for Canada.

**NOTICE**

Installation of a stainless steel vent system should adhere to the stainless steel vent manufacturer's installation instructions supplied with the vent system.

**Figure 3-10** Near Boiler Stainless Steel Venting



DIR #2000507929 00

**Table 3F** Stainless Steel Vent Pipe and Fittings

Approved Stainless Steel Vent Manufacturers	
Make	Model
Dura Vent (M & G Group)	FasNSeal Vent / FasNSeal Flex* Vent
Z-Flex (Nova Flex Group)	Z-Vent
Heat Fab (Selkirk Corporation)	Saf-T Vent

\*Use of FasNSeal Flex smooth inner wall vent is to be used in vertical or near vertical sections only, taking precaution to ensure no sagging occurs of the vent system. Connect to the FasNSeal rigid vent using specially designed adapters and sealing method, see manufacturer's instructions.

**Table 3G** Approved Stainless Steel (S.S.) Venting System Adapters and Terminations

Manufacturer	Model	Size	Vent Adapter	Vent Termination		
				Bird Screen	Rain Cap	Elbow w/Screen
DuraVent	FasNSeal*	2 inch	FSA-KNWH55-85	--	--	--
DuraVent	FasNSeal*	3 inch	FSA-KNWH110	FSBS3	FSRC3	--
DuraVent	FasNSeal*	4 inch	--	FSBS4	FSRC4	--
Heat Fab	Saf-T-Vent	2 inch	WH0002	--	--	--
Heat Fab	Saf-T-Vent	3 inch	WH0003	9392	5300CI	9312TERM
Heat Fab	Saf-T-Vent	4 inch	--	9492	5400CI	9412TERM
Z-Flex	Z-Vent	2 inch	2SVAKA02	--	--	--
Z-Flex	Z-Vent	3 inch	2SVAKA03	2SVSTP03	2SVSRCF03	2SVSTEX0390
Z-Flex	Z-Vent	4 inch	--	2SVSTP04	2SVSRCF04	2SVSTEX0490

\*FasNSeal Flex smooth inner wall vent may be used in vertical or near vertical sections. Connect to the FasNSeal rigid vent using specially designed adapters and sealing method. See manufacturer's instructions.

## 4 Sidewall direct venting

### Vent/air termination – sidewall

**⚠ WARNING** Follow instructions below when determining vent location to avoid possibility of severe personal injury, death, or substantial property damage.

**⚠ WARNING** A gas vent extending through an exterior wall shall not terminate adjacent to a wall or below building extensions such as eaves, parapets, balconies, or decks. Failure to comply could result in severe personal injury, death, or substantial property damage.

#### Determine location

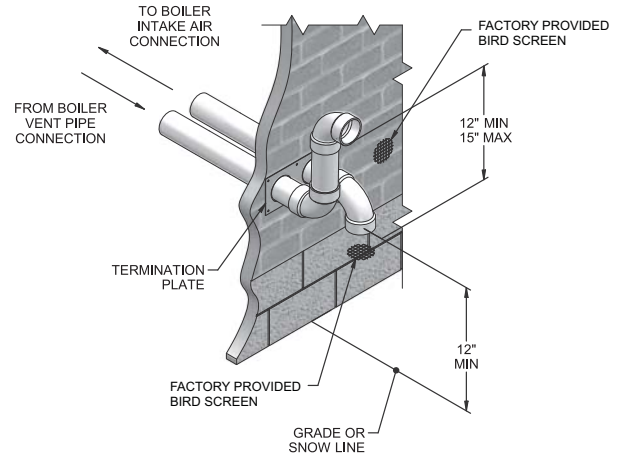
Locate the vent/air terminations using the following guidelines:

- The total length of piping for vent or air must not exceed the limits given in the General Venting Section on page 16 of this manual.
- You must consider the surroundings when terminating the vent and air:
  - Position the vent termination where vapors will not damage nearby shrubs, plants or air conditioning equipment or be objectionable.
  - The flue products will form a noticeable plume as they condense in cold air. Avoid areas where the plume could obstruct window views.
  - Prevailing winds could cause freezing of condensate and water/ice buildup where flue products impinge on building surfaces or plants.
  - Avoid possibility of accidental contact of flue products with people or pets.
  - Do not locate the terminations where wind eddies could affect performance or cause recirculation, such as inside building corners, near adjacent buildings or surfaces, window wells, stairwells, alcoves, courtyards, or other recessed areas.

**⚠ WARNING** Sidewall vent and air inlet terminations must terminate in the same pressure zone.

- Do not terminate above any door or window. Condensate can freeze, causing ice formations.
- Locate or guard vent to prevent condensate damage to exterior finishes.

**Figure 4-1A** PVC/CPVC/ Polypropylene Sidewall Termination of Air and Vent w/Field Supplied Fittings



#### If using the sidewall termination:

- The air piping must terminate in a down-turned elbow as shown in FIG. 4-1A. This arrangement avoids recirculation of flue products into the combustion air stream.
- The vent piping must terminate in an elbow pointed outward or away from the air inlet, as shown in FIG. 4-1A.

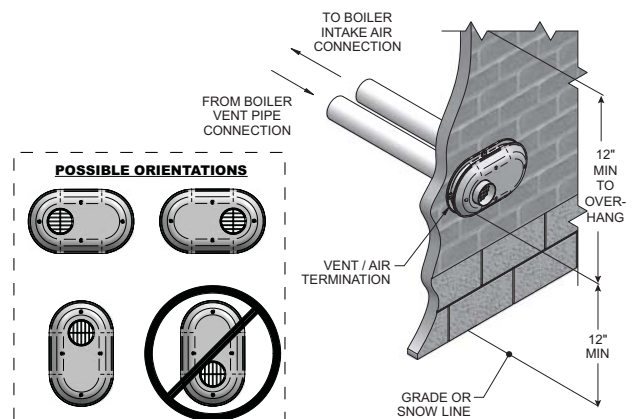
**⚠ WARNING** Do not exceed the maximum lengths of the outside vent piping shown in FIG. 4-1A. Excessive length exposed to the outside could cause freezing of condensate in the vent pipe, resulting in potential boiler shutdown.

When venting out a sidewall using PVC, CPVC, or Polypropylene vent materials, an optional sidewall vent termination kit can be ordered (reference Table 4A for kit numbers).

**Table 4A** Alternate Sidewall Vent Kits

Vent Diameter	Supplier	Part Number (SAP / Legacy)
2 inch	Lochinvar	100157609
3 inch	Lochinvar	100157610
4 inch	Lochinvar	100157611

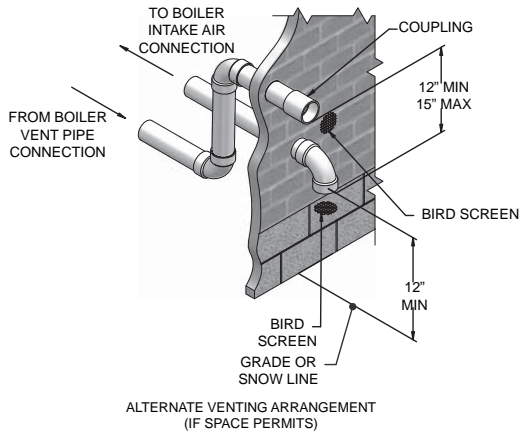
**Figure 4-1B** Alternate PVC/CPVC/Polypropylene Sidewall Termination of Air and Vent



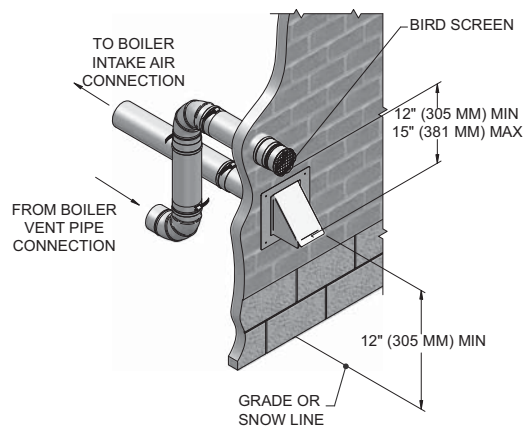
## 4 Sidewall direct venting *(continued)*

### Vent/air termination – sidewall

**Figure 4-1C** Alternate PVC/CPVC/SS/ Polypropylene Venting Arrangement (if Space Allows) w/Field Supplied Fittings



**Figure 4-1D** Alternate SS Venting Arrangement - Typical Stainless Steel Sidewall Termination of Air and Vent w/Field Supplied Fittings, Utilizing a Hood Intake

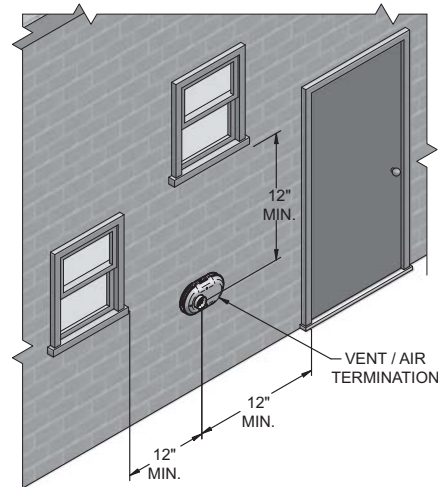


5. Maintain clearances as shown in FIG.'s 4-1A thru 4-3B, pages 22 - 24. Also maintain the following:

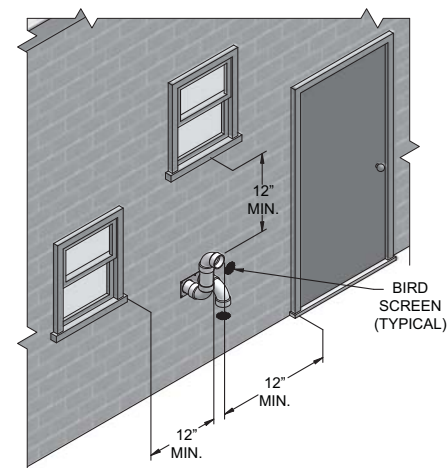
- a. Vent must terminate:
  - At least 6 feet from adjacent walls.
  - No closer than 12 inches below roof overhang.
  - At least 7 feet above any public walkway.
  - At least 3 feet above any forced air intake within 10 feet.
  - No closer than 12 inches below or horizontally from any door or window or any other gravity air inlet.
- b. Air inlet must terminate at least 12 inches above grade or snow line; at least 12 inches below the vent termination; and the vent pipe must not extend more than 24 inches vertically outside the building as shown in FIG. 4-1B. Condensate could freeze and block vent pipe.
- c. Do not terminate closer than 4 feet horizontally from any electric meter, gas meter, regulator, relief valve, or other equipment. Never terminate above or below any of these within 4 feet horizontally.

6. Locate terminations so they are not likely to be damaged by foreign objects, such as stones or balls, or subject to buildup of leaves or sediment.

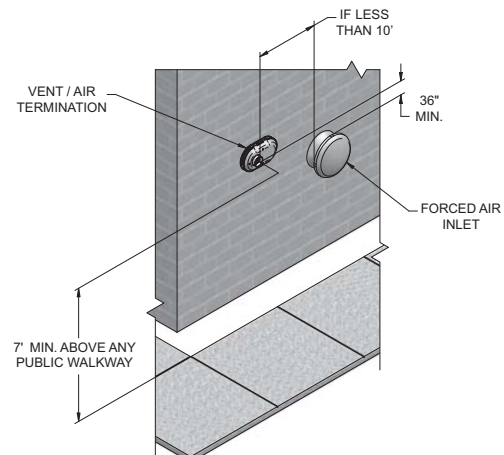
**Figure 4-2A** Clearance to Gravity Air Inlets



**Figure 4-2B** Alternate Clearance to Gravity Air Inlets w/ Field Supplied Fittings

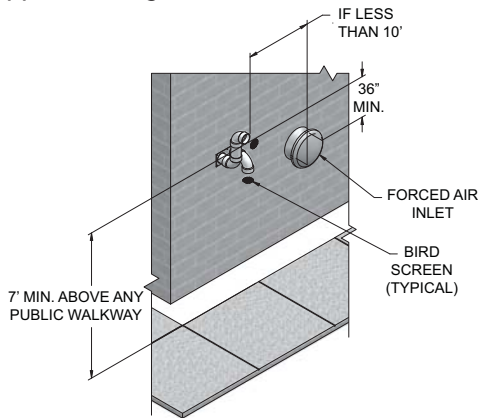


**Figure 4-3A** Clearance to Forced Air Inlets



## 4 Sidewall direct venting

**Figure 4-3B** Alternate Clearance to Forced Air Inlets w/ Field Supplied Fittings



### Prepare wall penetrations

- Use the factory supplied wall plate as a template to locate the vent and air intake holes and mounting holes.

#### Air pipe penetration:

- Cut a hole for the air pipe. Size the air pipe hole as close as desired to the air pipe outside diameter.

#### Vent pipe penetration:

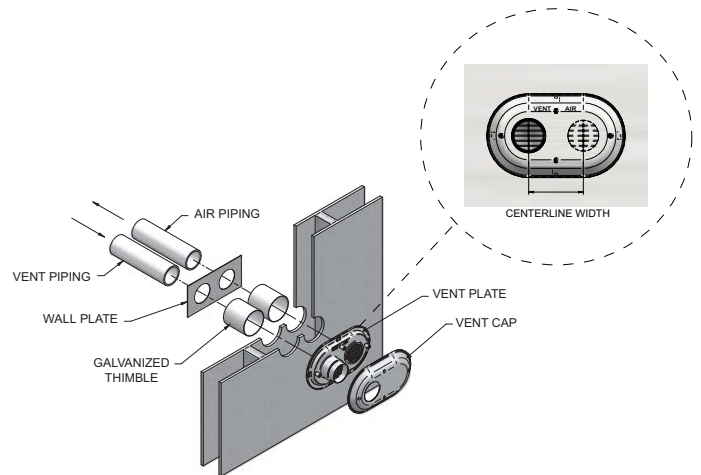
- Cut a hole for the vent pipe. For either combustible or noncombustible construction, size the vent pipe hole with at least a 1/2 inch clearance around the vent pipe outer diameter:
  - 3½ inch hole for 2 inch vent pipe
  - 4½ inch hole for 3 inch vent pipe
  - 5½ inch hole for 4 inch vent pipe

Drill 3/16" diameter holes for inserting the plastic anchors into the wall.

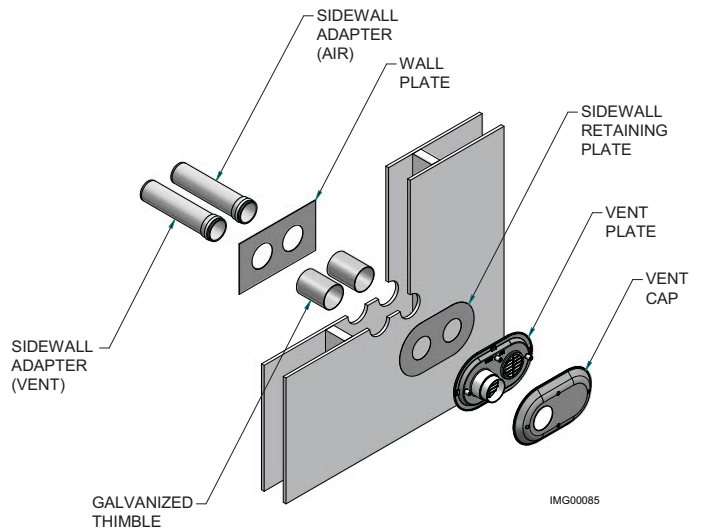
- For Polypropylene Only: Install the vent and air intake sidewall adapters from Table 3E on page 20 into the vent plate. Slide the sidewall retaining bracket down the sidewall adapters flush to the vent plate (FIG. 4-4B).
- For PVC/CPVC Only: Install the vent and air intake piping through the wall into the vent plate openings. Use RTV silicone sealant to seal the air pipe. Use the cement/primer listed in Table 3D on page 19 to seal the vent pipe.
- Mount and secure the vent plate to the wall, using stainless steel screws.
- Seal all gaps between the pipes and wall. Seal around the plate to the wall assuring no air gaps.
- Assemble the vent cap to the vent plate (see FIG.'s 4-4A and 4-4B). Insert the stainless steel screws into the vent cap screw hole openings and securely attach the vent cap to the vent plate.
- Seal all wall cavities.
- PVC/CPVC terminations are designed to accommodate any wall thickness of standard constructions per the directions found in this manual.

- Stainless steel terminations are designed to penetrate walls with a thickness up to 9.25 inches of standard construction.

**Figure 4-4A** PVC/CPVC Sidewall Termination Assembly



**Figure 4-4B** Polypropylene Sidewall Termination Assembly



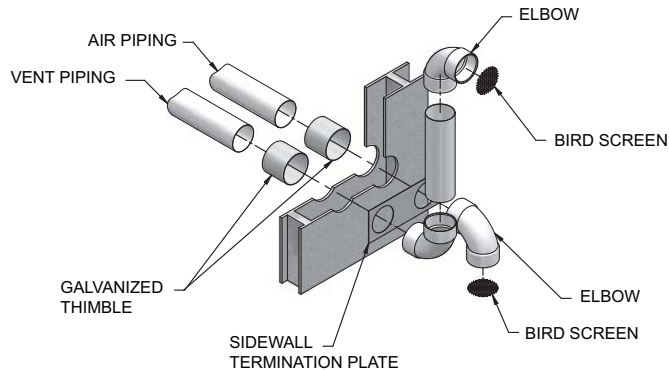


## 4 Sidewall direct venting *(continued)*

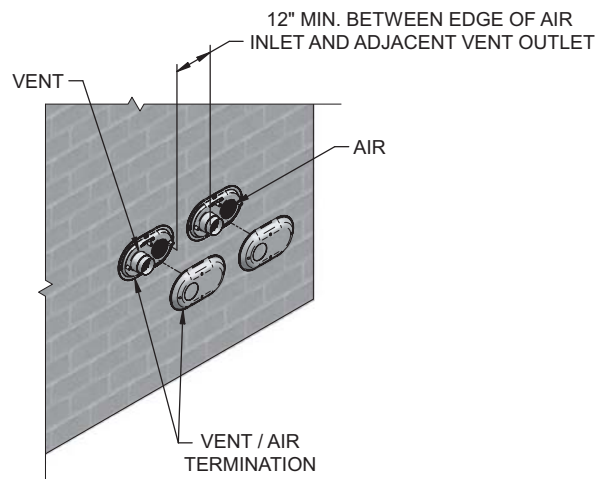
Prepare wall penetrations (Alternate - Field Supplied Option)

1. Air pipe penetration:
  - a. Cut a hole for the air pipe. Size the air pipe hole as close as desired to the air pipe outside diameter.
2. Vent pipe penetration:
  - a. Cut a hole for the vent pipe. For either combustible or noncombustible construction, size the vent pipe hole with at least a 1/2 inch clearance around the vent pipe outer diameter:
    - 3½ inch hole for 2 inch vent pipe
    - 4½ inch hole for 3 inch vent pipe
    - 5½ inch hole for 4 inch vent pipe
  - b. Insert a galvanized metal thimble in the vent pipe hole as shown in FIG. 4-4C.
3. Use a sidewall termination plate as a template for correct location of hole centers.
4. Follow all local codes for isolation of vent pipe when passing through floors or walls.
5. Seal exterior openings thoroughly with exterior caulk.

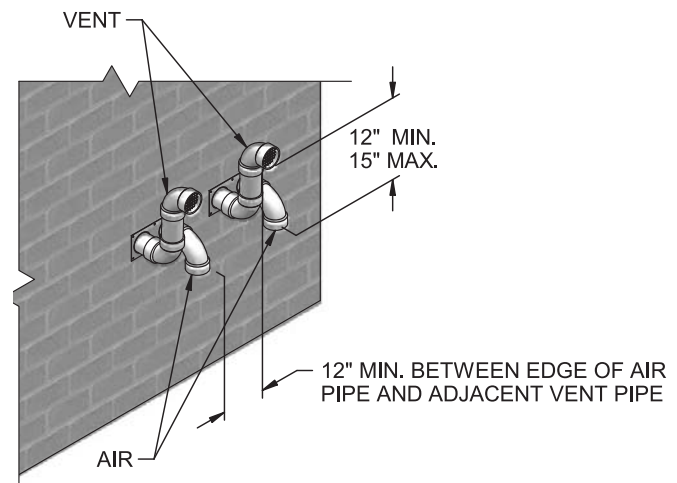
**Figure 4-4C** Alternate Sidewall Termination Assembly w/Field Supplied Fittings



**Figure 4-5A** Multiple Vent Terminations *(must also comply with Figure 4-1A)*



**Figure 4-5B** Alternate Multiple Vent Terminations w/Field Supplied Fittings *(must also comply with Figure 4-1B)*



### Multiple vent/air terminations

1. When terminating multiple Knight Fire Tube boilers terminate each vent/air connection as described in this manual (FIG. 4-5A).

#### **⚠ WARNING**

All vent pipes and air inlets must terminate at the same height to avoid possibility of severe personal injury, death, or substantial property damage.

2. Place wall penetrations to obtain minimum clearance of 12 inches between edge of air inlet and adjacent vent outlet, as shown in FIG. 4-5A for U.S. installations. For Canadian installations, provide clearances required by CSA B149.1 Installation Code.
3. The air inlet of a Knight Fire Tube boiler is part of a direct vent connection. It is not classified as a forced air intake with regard to spacing from adjacent boiler vents.

## 4 Sidewall direct venting

### Sidewall termination – optional concentric vent

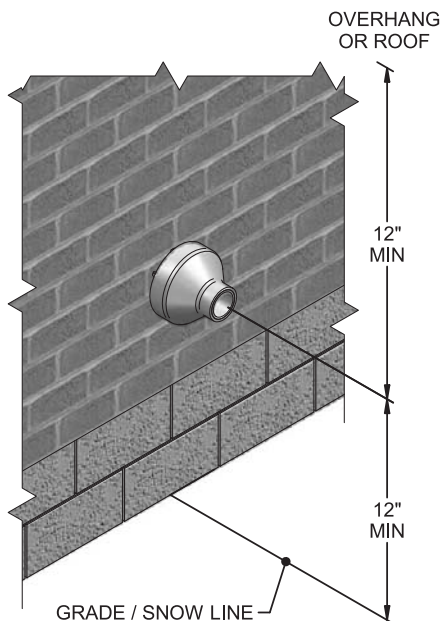
#### Description and usage

Lochinvar offers optional concentric combustion air and vent pipe termination kits (Factory Kit #100140485 for 2" diameter - Models 55 - 85, #100140480 for 3" diameter - Models 55 - 199 and #100140484 for 4" diameter - Models 199 - 285). Both combustion air and vent pipes must attach to the termination kit. The termination kits must terminate outside the structure and must be installed as shown below in FIG. 4-6.

The required combustion air and vent pipe materials are listed in Table 3D, on page 19 of this manual.

3. Cut one (1) hole (5 inch diameter for #100140480 installations, 4 inch diameter for #100140485, or 7 inch diameter for #100140484 installations) into the structure to install the termination kit.
4. Partially assemble the concentric vent termination kit. Clean and cement using the procedures found in these instructions.
  - a. Cement the Y concentric fitting to the larger kit pipe (FIG.'s 4-7 and 4-8).
  - b. Cement the rain cap to the smaller diameter kit pipe (FIG.'s 4-7 and 4-8).

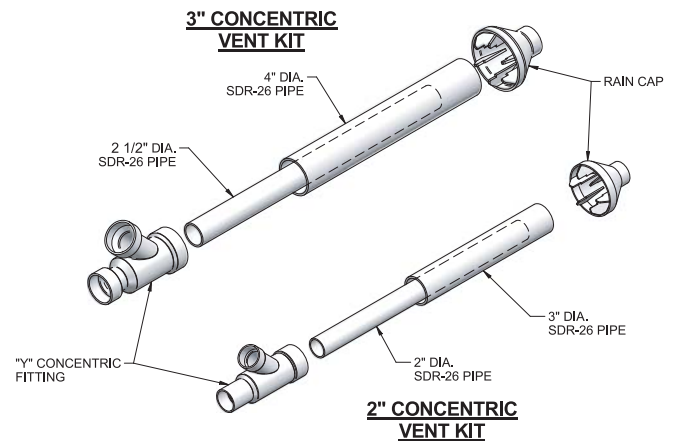
**Figure 4-6 Concentric Sidewall Termination**



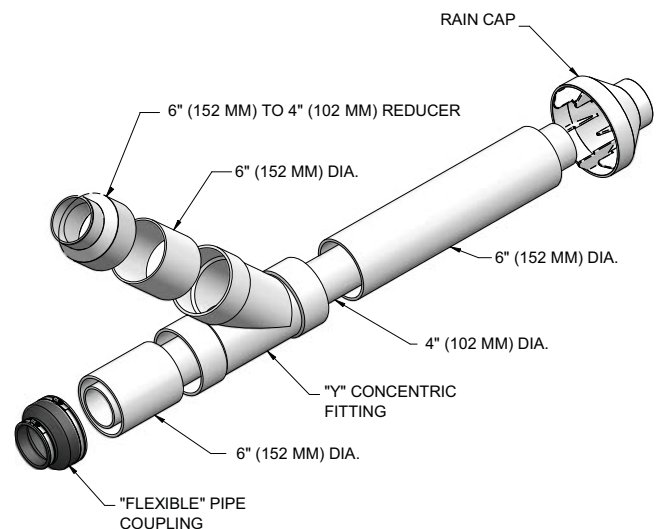
#### Sidewall termination installation

1. Determine the best location for the termination kit (see FIG. 4-6).
2. Reference the *Determine Location Section* on page 22 of this manual for general termination considerations.

**Figure 4-7 Kit Contents\_100140485 & 100140480**  
(reference Table 3B on page 16)



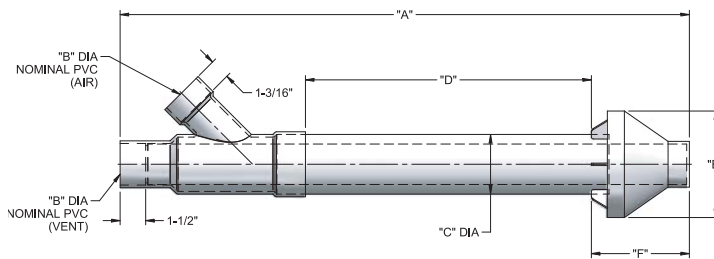
**Figure 4-8 Kit Contents\_100140484** (reference Table 3B on page 16)



## 4 Sidewall direct venting *(continued)*

### Sidewall termination – optional concentric vent

**Figure 4-9** 2" and 3" Concentric Vent Dimensional Drawing (reference Table 3B on page 16)



	"A"	"B"	"C"	"D"	"E"	"F"
2" VENT KIT	33-3/8"	2"	3-1/2"	16-5/8"	6-1/4"	5-3/4"
3" VENT KIT	38-7/8"	3"	4-1/2"	21-1/8"	7-3/8"	6-1/2"

#### NOTICE

Instead of cementing the smaller pipe to the rain cap, a field-supplied stainless steel screw may be used to secure the two (2) components together when field disassembly is desired for cleaning (see FIG. 4-11).

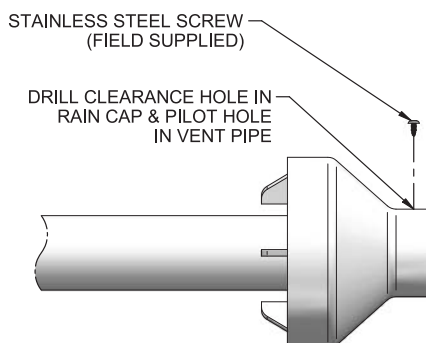
#### WARNING

When using the alternate screw assembly method, drill a clearance hole in the rain cap and a pilot hole in the vent pipe for the screw size being used. Failure to drill adequate holes may cause cracking of PVC components, allowing combustion products to be recirculated. Failure to follow this warning could result in personal injury or death.

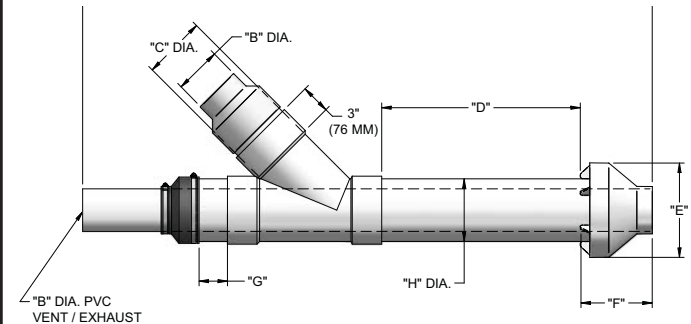
#### WARNING

Do not operate the appliance with the rain cap removed or recirculation of combustion products may occur. Water may also collect inside the larger combustion air pipe and flow to the burner enclosure. Failure to follow this warning could result in product damage or improper operation, personal injury, or death.

**Figure 4-11** Rain Cap to Vent Pipe Alternate Assembly



**Figure 4-10** 4" Concentric Vent Dimensional Drawing (reference Table 3B on page 16)



A	B	C	D	E	F	G	H
60"	4"	6"	21 1/8"	10"	7 5/8"	3"	6 5/8"
(1524 MM)	(102 MM)	(152 MM)	(537 MM)	(254 MM)	(194 MM)	(76 MM)	(168 MM)

5. Install the Y concentric fitting and pipe assembly through the structure's hole from an inside wall.

#### NOTICE

Do not allow insulation or other materials to accumulate inside the pipe assembly when installing through the hole.

6. Install the rain cap and small diameter pipe assembly into the Y concentric fitting and large pipe assembly from an outside wall. Ensure small diameter pipe is bottomed and cemented in the Y concentric fitting for #100140485 and #100140480 installations and fastened tightly into the rubber adapter for #100140484 installations.
7. Secure the assembly to the structure as shown in FIG. 4-12 using field-supplied metal strapping or equivalent support material.

#### NOTICE

Ensure termination location clearance dimensions are as shown in FIG. 4-6.

#### NOTICE

If assembly needs to be extended to allow sidewall thickness requirement, the two (2) pipes supplied in the kit may be replaced by using the same diameter, field-supplied SDR-26 PVC (D2241) pipe for #100140485 and #100140480 and standard schedule 40 PVC for #100140484. Do not extend dimension D\* more than 60 inches (see FIG.'s 4-9 and 4-10).

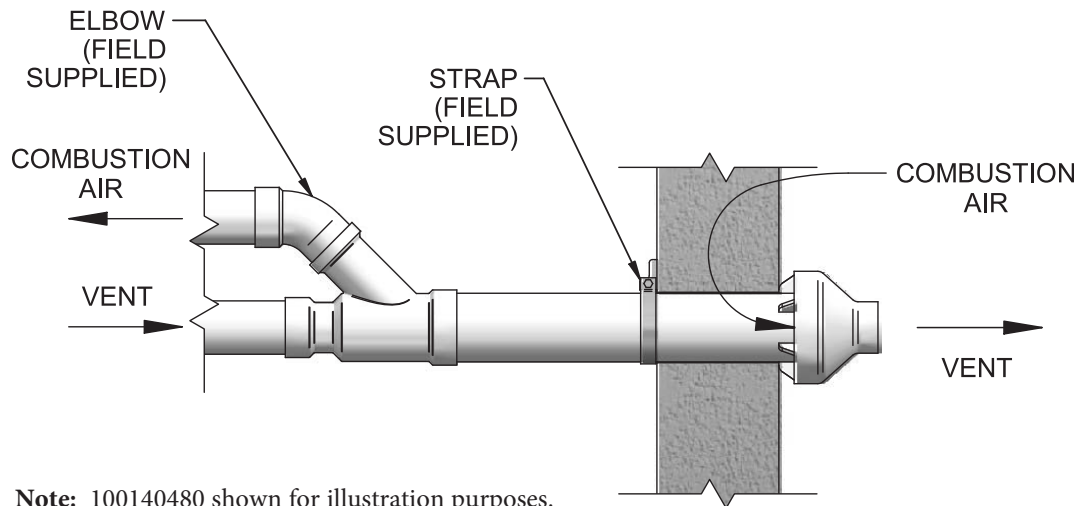
#### NOTICE

If assembly depth needs to be reduced, dimension D can be as short as possible.

## 4 Sidewall direct venting

### Sidewall termination - optional concentric vent

**Figure 4-12** Concentric Vent Sidewall Attachment



**Note:** 100140480 shown for illustration purposes.

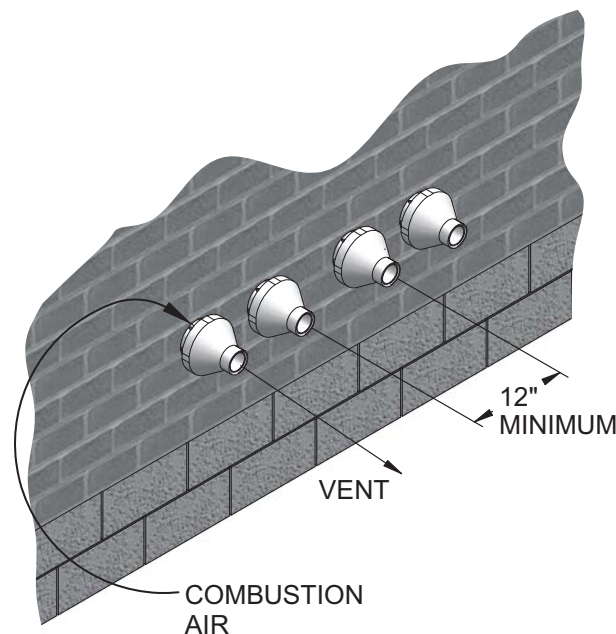
#### CAUTION

DO NOT use field-supplied couplings to extend pipes. Airflow restriction will occur and may cause intermittent operation.

8. Cement appliance combustion air and vent pipes to the concentric vent termination assembly. See FIG. 4-12 for proper pipe attachment.
9. Operate the appliance one (1) heat cycle to ensure combustion air and vent pipes are properly connected to the concentric vent termination connections.

#### Multi-venting sidewall terminations

When two (2) or more direct vent appliances are vented near each other, each appliance must be individually vented (see FIG. 4-13). NEVER common vent or breach vent this appliance. When two (2) or more direct vent appliances are vented near each other, two (2) vent terminations may be installed as shown in FIG. 4-13. It is important that vent terminations be made as shown to avoid recirculation of flue gases.



**Figure 4-13** Concentric Vent and Combustion Air Termination

## 5 Vertical direct venting

### Vent/air termination – vertical

**⚠ WARNING** Follow instructions below when determining vent location to avoid possibility of severe personal injury, death or substantial property damage.

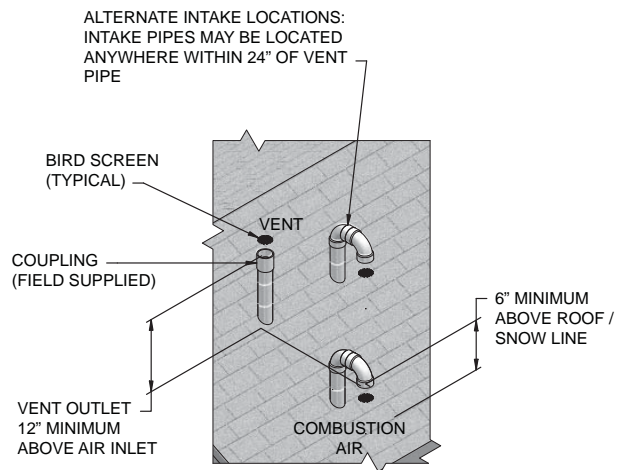
#### Determine location

Locate the vent/air terminations using the following guidelines:

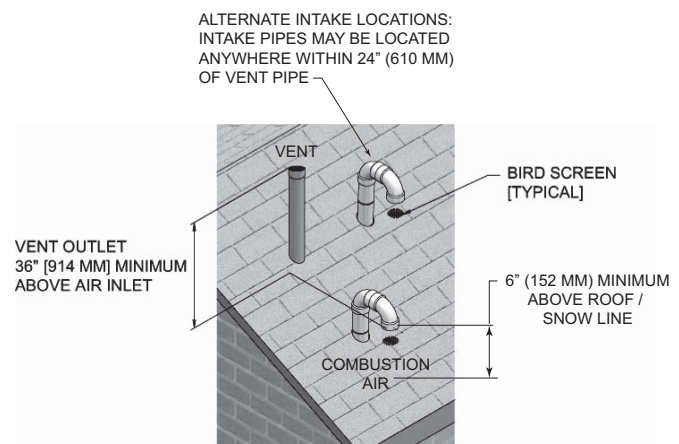
1. The total length of piping for vent or air must not exceed the limits given in the General Venting Section on page 16 of this manual.
2. Prepare the vent termination and the air termination elbow (FIG. 5-1A) by inserting bird screens. Bird screens should be obtained locally.
3. The vent must terminate at least 3 feet above the highest place in which the vent penetrates the roof and at least 2 feet above any part of a building within 10 horizontal feet.
4. The air piping must terminate in a down-turned 180° return pipe no further than 2 feet from the center of the vent pipe. This placement avoids recirculation of flue products into the combustion air stream.
5. The vent piping must terminate in an up-turned coupling as shown in FIG. 5-1A. The top of the coupling must be at least 1 foot above the air intake. When the vent termination uses a rain cap as illustrated in FIG. 5-1B maintain at least 36" (914 mm) above the air inlet. The air inlet pipe and vent pipe can be located in any desired position on the roof, but must always be no further than 2 feet (.6 m) apart and with the vent termination at least 1 foot for PVC and 3 feet for stainless steel, above the air intake.
6. Maintain the required dimensions of the finished termination piping as shown in FIG. 5-1A.
7. Do not extend exposed vent pipe outside of building more than shown in this document. Condensate could freeze and block vent pipe.

**⚠ WARNING** Rooftop vent and air inlet terminations must terminate in the same pressure zone, unless vertical vent sidewall air is set up as shown in the General Venting - Vertical Vent, Sidewall Air Section.

**Figure 5-1A** PVC/CPVC/Polypropylene Vertical Termination of Air and Vent



**Figure 5-1B** Stainless Steel Vertical Termination of Air and Vent



8. Locate terminations so they are not likely to be damaged by foreign objects, such as stones or balls, or subject to buildup of leaves or sediment.

# 5 Vertical direct venting

## Vent/air termination – vertical

### Prepare roof penetrations

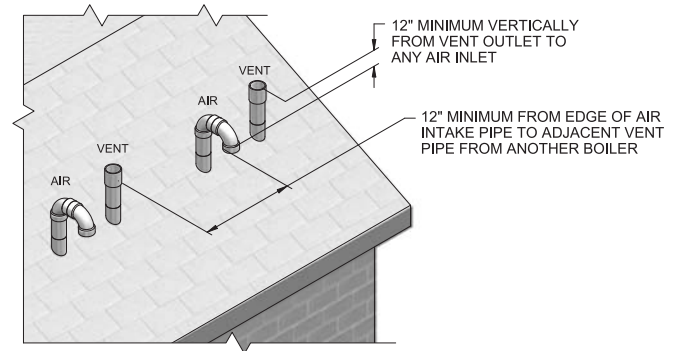
1. Air pipe penetration:
  - a. Cut a hole for the air pipe. Size the air pipe hole as close as desired to the air pipe outside diameter.
2. Vent pipe penetration:
  - a. Cut a hole for the vent pipe. For either combustible or noncombustible construction, size the vent pipe hole with at least a 1/2 inch clearance around the vent pipe outer diameter:
    - 3½ inch hole for 2 inch vent pipe
    - 4½ inch hole for 3 inch vent pipe
    - 5½ inch hole for 4 inch vent pipe
  - b. Insert a galvanized metal thimble in the vent pipe hole.
3. Space the air and vent holes to provide the minimum spacing shown in FIG. 5-1A, page 29.
4. Follow all local codes for isolation of vent pipe when passing through floors, ceilings, and roofs.
5. Provide flashing and sealing boots sized for the vent pipe and air pipe.

### Multiple vent/air terminations

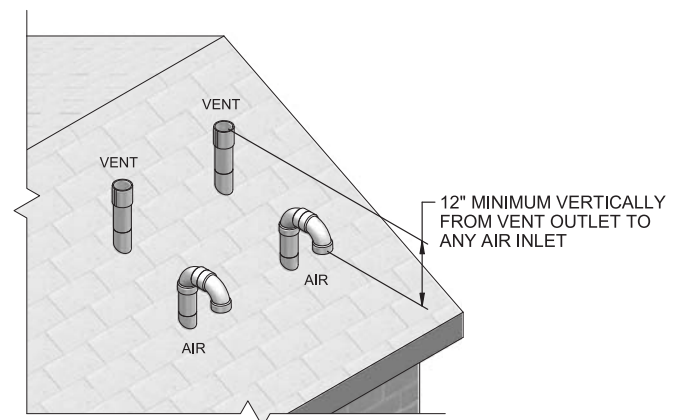
1. When terminating multiple Knight Fire Tube boilers, terminate each vent/air connection as described in this manual (FIG. 5-2).

- ⚠ WARNING** Terminate all vent pipes at the same height and all air pipes at the same height to avoid possibility of severe personal injury, death, or substantial property damage.
2. Place roof penetrations to obtain minimum clearance of 12 inches between edge of air intake elbow and adjacent vent pipe of another boiler for U.S. installations (see FIG. 5-2). For Canadian installations, provide clearances required by CSA B149.1 Installation Code.
  3. The air inlet of a Knight Fire Tube boiler is part of a direct vent connection. It is not classified as a forced air intake with regard to spacing from adjacent boiler vents.

**Figure 5-2 Vertical Terminations with Multiple Boilers**



**Figure 5-3 Alternate Vertical Terminations with Multiple Boilers**



## 5 Vertical direct venting *(continued)*

### Vertical termination – optional concentric vent

#### Description and usage

Lochinvar offers an optional concentric combustion air and vent pipe termination kit. Both combustion air and vent pipes must attach to the termination kit. The termination kit must terminate outside the structure and must be installed as shown in FIG. 5-4.

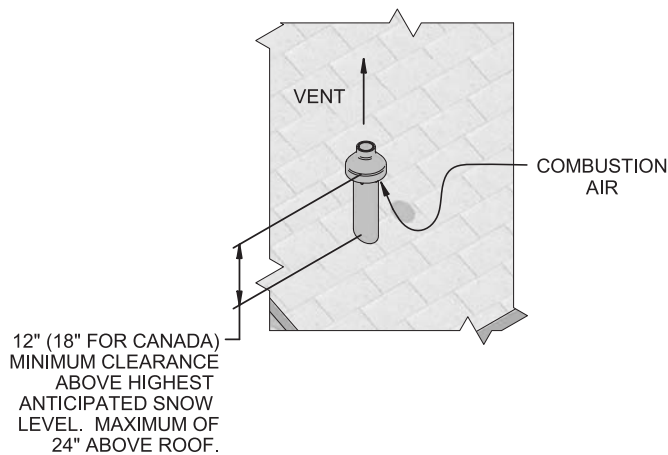
Field supplied pipe and fittings are required to complete the installation.

The required combustion vent pipe and fittings are listed in Table 3D, on page 20 of this manual.

#### Vertical termination installation

1. See Section 5, Vertical Direct Venting - Determine Location (where applicable) (FIG. 5-1A).

**Figure 5-4** Concentric Vertical Termination



**Figure 5-5** Do Not Install U-Bend to Rain Cap



2. Cut one (1) hole (5 inch diameter for #100140480 installations, 4 inch diameter for #100140485, or 7 inch diameter for #100140484 installations) into the structure to install the termination kit.
3. Partially assemble the concentric vent termination kit. Clean and cement following the cleaning procedures in these instructions.
  - a. Cement the Y concentric fitting to the larger diameter kit pipe (see FIG.'s 4-7 and 4-8, page 26).
  - b. Cement rain cap to the smaller diameter kit pipe (see FIG.'s 4-7 and 4-8, page 26).

#### NOTICE

Instead of cementing the smaller pipe to the rain cap, a field supplied stainless steel screw may be used to secure the two (2) components together when field disassembly is desired for cleaning (see FIG. 4-11, page 27).

#### WARNING

When using the alternate screw assembly method, drill a clearance hole in the rain cap and a pilot hole in the vent pipe for the screw size being used. Failure to drill adequate holes may cause cracking of PVC components, allowing combustion products to be recirculated. Failure to follow this warning could result in personal injury or death.

# 5 Vertical direct venting

## Vertical termination – optional concentric vent

**⚠ WARNING** Do not operate the appliance with the rain cap removed or recirculation of combustion products may occur. Water may also collect inside the larger combustion air pipe and flow to the burner enclosure. Failure to follow this warning could result in product damage or improper operation, personal injury, or death.

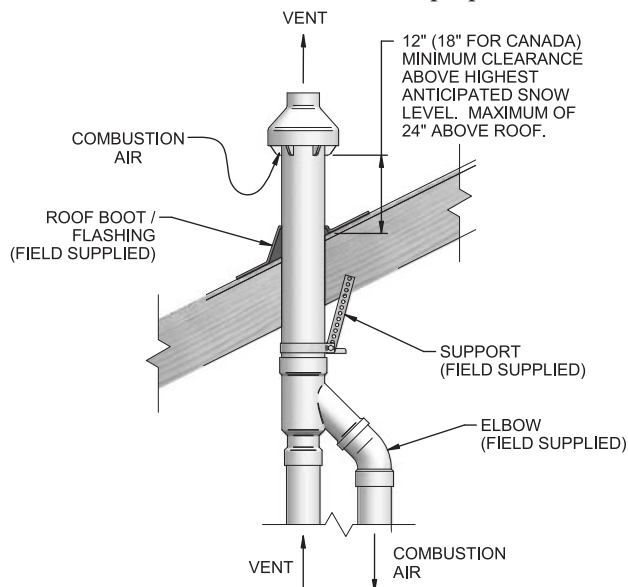
4. Install the Y concentric fitting pipe assembly up through the structure's hole and field supplied roof boot/flashing.

**NOTICE** Do not allow insulation or other materials to accumulate inside the pipe assembly when installing through the hole.

5. Secure the assembly to the roof structure as shown below in FIG. 5-6 using field supplied metal strapping or equivalent support material.

**Figure 5-6 Concentric Vent Roof Installation**

**Note:** 100140480 shown for illustration purposes.



**NOTICE** Ensure termination height is above the roof surface or anticipated snow level (12 inches in U.S.A. or 18 inches in Canada) as shown in FIG. 5-4, page 31.

**NOTICE** If assembly is too short to meet height requirement, the two (2) pipes supplied in the kit may be replaced by using the same diameter, field supplied SDR-26 PVC (D2241) pipe for 100140480/100140485 and standard schedule 40 PVC for 100140484. Do not extend dimension D\* more than 60 inches (see FIG.'s 4-9 and 4-10, page 27).

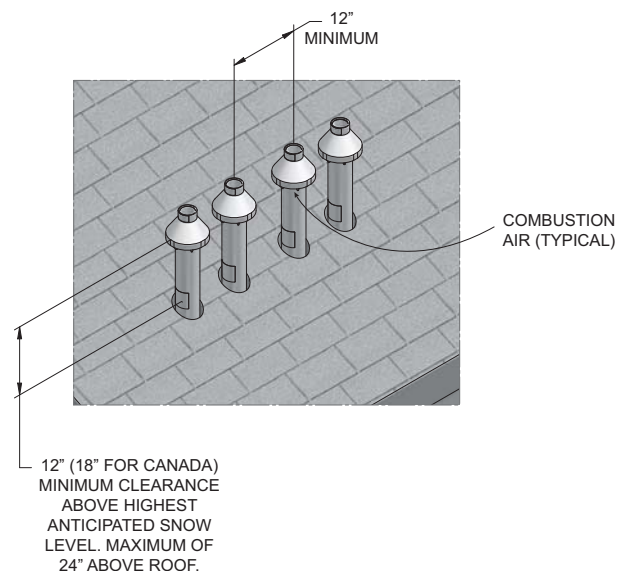
**CAUTION** DO NOT use field-supplied couplings to extend pipes. Airflow restriction will occur.

6. Install the rain cap and the small diameter pipe assembly into the roof penetration assembly. Ensure the small diameter pipe is cemented and bottomed in the Y concentric fitting for #100140480 and #100140485 installations and fastened tightly into the rubber adapter for #100140484 installations.
7. Cement the appliance combustion air and vent pipes to the concentric vent termination assembly. See FIG. 5-6 for proper pipe attachment.
8. Operate the appliance through one (1) heat cycle to ensure combustion air and vent pipes are properly connected to the concentric vent termination connections.

### Multi-venting vertical terminations

When two (2) or more direct vent appliances are vented near each other, each appliance must be individually vented (see FIG. 5-7). NEVER common vent or breach vent this appliance. When two (2) or more direct vent appliances are vented near each other, two (2) vent terminations may be installed as shown in FIG. 5-7. It is important that vent terminations be made as shown to avoid recirculation of flue gases.

**Figure 5-7 Concentric Vent and Combustion Air Vertical Termination**





## 5 Vertical direct venting *(continued)*

### Alternate vertical concentric venting

This appliance may be installed with a concentric vent arrangement where the vent pipe is routed through an existing unused venting system; or by using the existing unused venting system as a chase for vent and combustion air routing.

#### Concentric Venting Arrangement

The venting is to be vertical through the roof. The annular space between the O.D. of the vent pipe and the I.D. of the existing unused venting system is utilized for the combustion air source.

The minimum size of the existing vent system required to achieve enough annular space for combustion air can be found in Table 5A below.

The upper and lower termination as well as any other unsealed joints in the existing vent system **must be sealed** to ensure that all combustion air is drawn from under the vent cap as shown in FIG.'s 5-8 and 5-9.

Approved venting materials must be used as specified in Table 3D on page 19.

Follow all vent / air termination and clearance requirements per this section to the appropriate example. Installation must comply with local requirements and with the National Fuel Gas Code.

The maximum allowable equivalent vent and air intake lengths for this venting arrangement are to be determined from the General Venting Section.

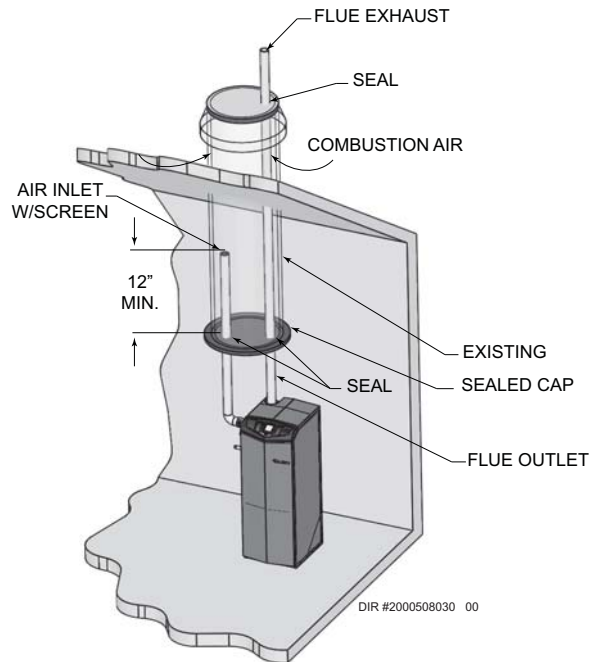
If an existing unused venting system is converted for use with this method of concentric venting, the installer must ensure that the existing venting system is clean and free from particulate contamination that will harm this appliance and cause increased nuisance calls or maintenance. See Table 1B on page 10 for a list of corrosive contaminants and sources.

Two example scenarios of a concentric venting arrangement are shown for illustrative purposes in FIG.'s 5-8 and 5-9.

**Table 5A** Alternate Vertical Concentric Vent / Chase Sizes

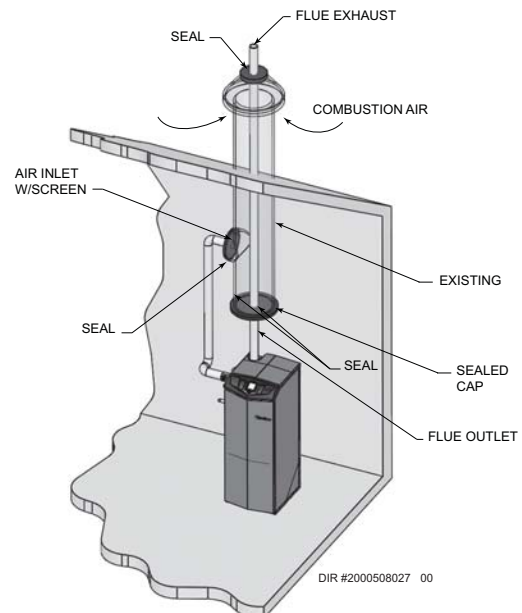
Vent / Air Inlet Size	Minimum Existing Vent / Chase Size
2"	4"
3"	5"
4"	7"

**Figure 5-8** Concentric Vent Example 1



\*For concept illustration only. Individual installations may vary due to job site specific equipment.

**Figure 5-9** Concentric Vent Example 2



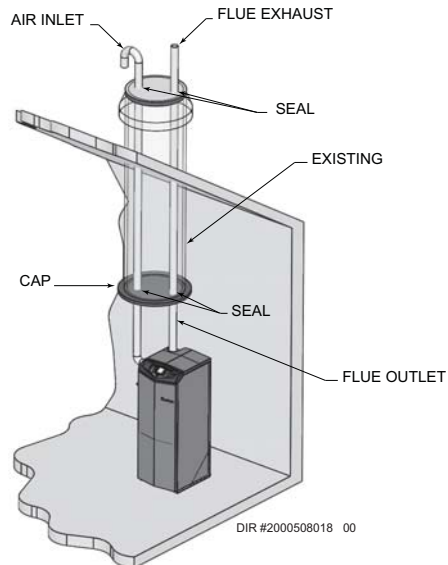
\*For concept illustration only. Individual installations may vary due to job site specific equipment.

# 5 Vertical direct venting

## Existing vent as a chase

Follow all existing termination and clearance requirements and allowable pipe lengths. Use only approved venting materials listed in the General Venting Section of this manual.

**Figure 5-10** Existing Vent as a Chase



\*For concept illustration only. Individual installations may vary due to job site specific equipment.

## 6 Hydronic piping

### System water piping methods

The Knight Fire Tube is designed to function in a closed loop pressurized system not less than 12 psi (Non-metallic system piping must have an oxygen barrier to be considered a closed loop). A temperature and pressure gauge is included to monitor system pressure and outlet temperature and should be located on the boiler outlet.

It is important to note that the boiler has a minimal amount of pressure drop and must be figured in when sizing the circulators. Each boiler installation must have an air elimination device, which will remove air from the system. Install the boiler so the gas ignition system components are protected from water (dripping, spraying, etc.) during appliance operation for basic service of circulator replacement, valves, and others.

Observe a minimum of 1/4 inch (6 mm) clearance around all un-insulated hot water pipes when openings around the pipes are not protected by non-combustible materials.

### Low water cutoff device

On a boiler installed above radiation level, some states and local codes require a low water cutoff device at the time of installation.

### Chilled water system

If the boiler supplies hot water to heating coils in air handler units, flow control valves or other devices must be installed to prevent gravity circulation of heater water in the coils during the cooling cycle. A chilled water medium must be piped in parallel with the heater.

### Freeze protection

Freeze protection for new or existing systems must use glycol that is specially formulated for this purpose. This includes inhibitors, which prevent the glycol from attacking the metallic system components. Make certain to check that the system fluid is correct for the glycol concentration and inhibitor level. The system should be tested at least once a year and as recommended by the producer of the glycol solution. Allowance should be made for the expansion of the glycol solution in the system piping.

#### **WARNING**

Use only inhibited propylene glycol solutions, which are specifically formulated for hydronic systems. Ethylene glycol is toxic and can attack gaskets and seals used in hydronic systems.

### General piping information

#### **IMPORTANT**

All boiler piping must contain an oxygen barrier. This will help prevent any excess oxygen from entering the system.

Basic steps are listed in this section along with illustrations on the following pages (FIG.'s 6-4 thru 6-14), which will guide you through the installation of the Knight Fire Tube boiler (reference FIG.'s 6-1A and 6-1B).

1. Connect the system return marked "Inlet".
2. Connect the system supply marked "Outlet".
3. Install purge and balance valve or shutoff valve and drain on system return to purge air out of each zone.
4. Install a backflow preventer on the cold feed make-up water line.
5. Install a pressure reducing valve on the cold feed make-up water line, (15 psi nominal). Check temperature and pressure gauge (shipped separately), which should read a minimum pressure of 12 psi.
6. Install a circulator as shown on the piping diagrams in this section. Make sure the circulator is properly sized for the system and friction loss.
7. Install an expansion tank on the system supply. Consult the tank manufacturer's instruction for specific information relating to tank installation. Size the expansion tank for the required system volume and capacity.
8. Install an air elimination device on the system supply.
9. Install a drain valve at the lowest point of the system. **Note:** The boiler cannot be drained completely of water without purging the unit with an air pressure of 15 psi.
10. This appliance is supplied with a relief valve sized in accordance with ASME Boiler and Pressure Vessel Code, Section IV ("Heating Boilers"). The relief valve is installed at the factory on the left side of the boiler. Pipe the discharge of the safety relief valve to prevent injury in the event of pressure relief. Pipe the discharge to a drain. Provide piping that is the same size as the safety relief valve outlet. Never block the outlet of the safety relief valve.
11. Install a field supplied strainer to prevent damage to the heat exchanger caused by debris entering from the system piping. When installing in a pre-existing system, a strainer/filter capable of removing debris left in the system is recommended.

\*See the piping illustrations included in this section, FIG.'s 6-4 thru 6-14 for suggested guidelines in piping the Knight Fire Tube boiler with either zone valves or circulator pumps.

#### **NOTICE**

\*Please note that these illustrations are meant to show system piping concept only, the installer is responsible for all equipment and detailing required by local codes.

#### **CAUTION**

The Knight Fire Tube boiler is capable of servicing multiple temperature loop systems. It is the responsibility of the installer to protect the loops with lower temperature requirements from higher temperatures that may be required by other loops.

## 6 Hydronic piping

### Near boiler piping components

#### 1. Boiler system piping:

Boiler system piping **MUST** be sized per the pipe requirements listed in Table 6B. Reducing the pipe size can restrict the flow rate through the boiler, causing inadvertent high limit shutdowns and poor system performance.

#### 2. Boiler circulating pump:

A Grundfos UPS15-58F pump for Models 55 - 155 and a Grundfos UPS26-99FC for Models 199 - 285 will be provided by the factory as the boiler circulation pump based on 20 feet of piping, 4 - 90° elbows, and 2 - fully ported ball valves. Knight Fire Tube boilers are capable of controlling a variable speed boiler circulator. Variable speed circulators **MUST** be sized to meet the specified minimum flow requirements listed in Table 6B on page 38 at full speed.

#### 3. Domestic hot water circulating pump:

Field supplied. The pump **MUST** be sized to meet the specified minimum flow requirements listed in Table 6B. Consult the indirect water heater operating guide to determine flow characteristics for the selected product used.

#### 4. Boiler isolation valves:

Field supplied. Full port ball valves are required. Failure to use full port ball valves could result in a restricted flow rate through the boiler.

#### 5. Check valves:

Field supplied. Check valves are recommended for installation as shown in FIG.'s 6-4 thru 6-14. Failure to install check valves could result in a reverse flow condition during pump(s) off cycle.

#### 6. Domestic indirect hot water isolation valves:

Field supplied. Full port ball valves are required. Failure to use full port ball valves could result in a restricted flow rate through the boiler.

#### 7. Anti-scald mixing valve:

Field supplied. An anti-scald mixing valve is recommended when storing domestic hot water above 115°F.

#### 8. Unions:

Field supplied. Recommended for unit serviceability.

#### 9. Temperature and pressure gauge:

Factory installed.

#### 10. Pressure relief valve:

Factory installed. The pressure relief valve is sized to ASME specifications.

#### 11. Boiler purge valve:

Field supplied. The boiler purge valve is used to remove entrapped air from the heat exchanger during start-up.

#### 12. System temperature sensor:

Lochinvar supplies a system temperature sensor. The sensor is to be installed in the heating loop downstream from the boiler hot water piping and heating loop junction. Typically the sensor will be located far enough downstream to sense system diluted water temperature.

#### 13. Indirect water heaters:

The Knight Fire Tube boiler may be piped to an indirect water heater to heat domestic hot water with the space heat transfer medium. As depicted on pages 40 through 50 there are two options when utilizing an indirect water heater.

- A. The space heating piping will branch off to flow the space heat transfer medium through a single wall heat exchanger coil inside the indirect water heater.
- B. The indirect water heater is connected to the system supply piping. A pump controlled by the Knight Fire Tube boiler's control will regulate the flow of water through the indirect water heater. The indirect water heater's temperature will be regulated by the Knight Fire Tube boiler's control.

The Knight Fire Tube boiler is pre-configured to control the operation of the DHW pump with Domestic Hot Water Prioritization programming. The DHW programming is designed to control and balance the space heating demand by switching between DHW and space heating.

Lochinvar offers the Squire which is a series of indirect water heaters. The Squire features a stainless steel vessel with a single wall stainless steel heat exchanger.

#### CAUTION

It is up to the installer to ensure the minimum system flow is not less than the minimum boiler flow at any time.

#### WARNING

The National Standard Plumbing Code, the National Plumbing Code of Canada and the Uniform Plumbing Code limit the pressure of the heat transfer fluid to less than the minimum working pressure of the potable water system up to 30 psi maximum. Also, the heat transfer fluid must be water or other non-toxic fluid having a toxicity of Class 1, as listed in Clinical Toxicology of Commercial Products, 5<sup>th</sup> Edition.

#### 14. Water Meter:

Field supplied. A water meter to monitor makeup water is recommended. Makeup water volume should not exceed 5% of total system per year.

#### 15. Y-Strainer:

Field supplied. Install a Y-strainer or equivalent multi-purpose strainer just before the boiler pump at the inlet of the heat exchanger. This item is used to remove system debris from older hydronic systems and to protect newer systems.

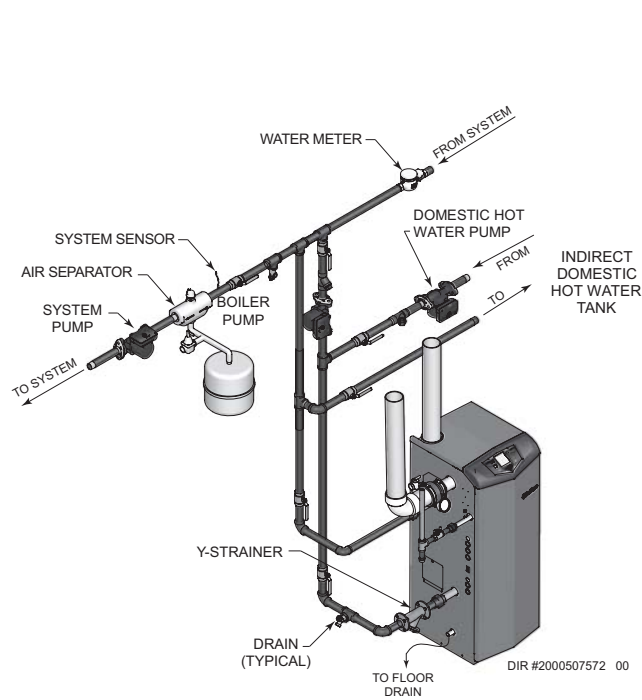
## 6 Hydronic piping *(continued)*

### Circulator sizing

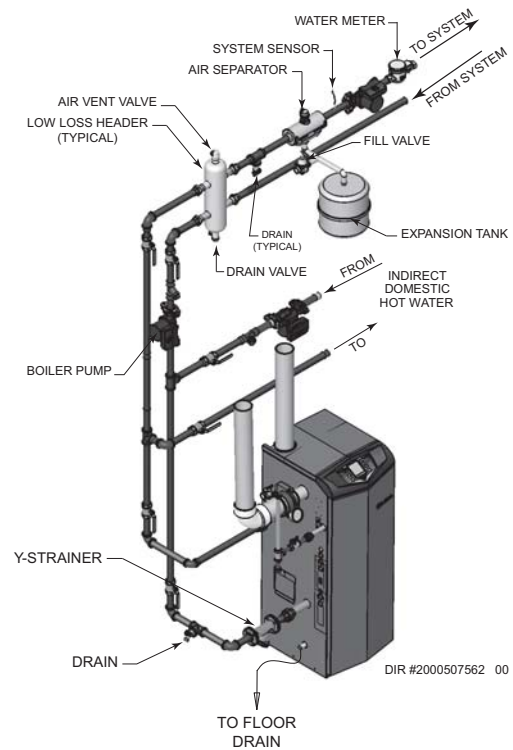
The Knight Fire Tube boiler heat exchanger does have a pressure drop, which must be considered in your system design. Refer to the graph in FIG. 6-2 for pressure drop through the Knight Fire Tube boiler heat exchanger.

### Near boiler piping connections

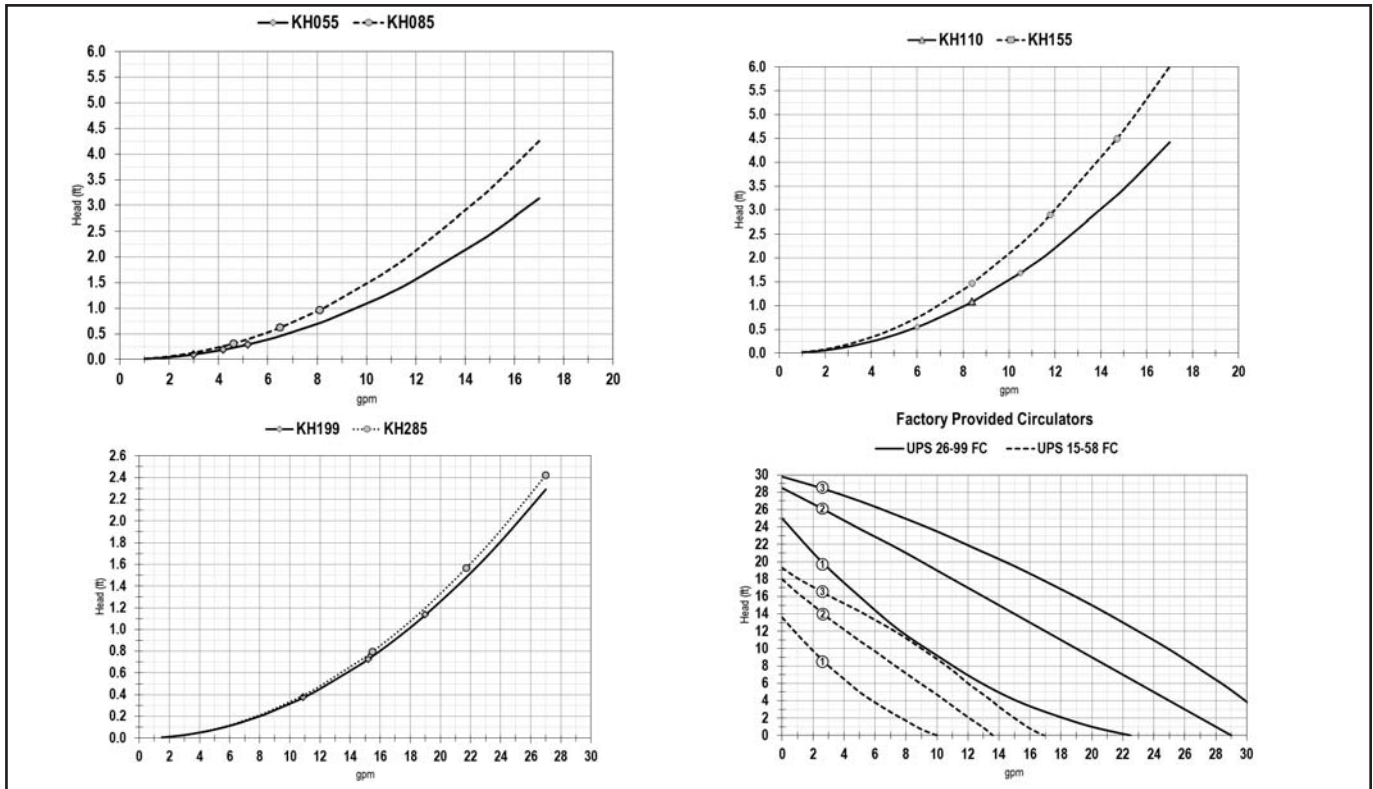
**Figure 6-1A** Near Boiler Piping w/Y-Strainer



**Figure 6-1B** Near Boiler Piping w/Low Loss Header



# 6 Hydronic piping

**Figure 6-2 Pressure Drop vs. Flow**

**Table 6A Circulator Recommendations for Temperature Rise Applications 20°, 25°, and 35°**

20°F Temperature Rise Applications						
Model	Flow	ΔP	Pump			
			Grundfos	TACO	Bell & Gossett	Armstrong
55	5.2 gpm	0.3 ft/hd	UPS 15-58FC (1)	005, 006	--	Astro 20
85	8.1 gpm	1.0 ft/hd	UPS 15-58FC (1)	005, 006	--	Astro 20
110	10.5 gpm	1.7 ft/hd	UPS 15-58FC (2)	005, 007, 008	NRF9F, NRF-25 (1,2)	Astro 25
155	14.7 gpm	4.5 ft/hd	UPS 15-58FC (3)	005, 007, 008	NRF-22, LR-20WR	Astro 30
199	19.0 gpm	1.1 ft/hd	UPS26-99F (1)	--	LR-15BWR	Astro 30
285	27.0 gpm	2.4 ft/hd	UPS26-99F (3)	0013-IFC	NRF-36 (2), NRF-45 (2)	Astro 50, E7

25°F Temperature Rise Applications						
Model	Flow	ΔP	Pump			
			Grundfos	TACO	Bell & Gossett	Armstrong
55	4.2 gpm	0.2 ft/hd	UPS 15-58FC (1)	005, 006	--	Astro 20
85	6.5 gpm	0.6 ft/hd	UPS 15-58FC (1)	005, 006	--	Astro 20
110	8.4 gpm	1.1 ft/hd	UPS 15-58FC (2)	005, 007, 008	NRF9F, NRF-25 (1,2)	Astro 25
155	11.8 gpm	2.9 ft/hd	UPS 15-58FC (3)	005, 007, 008	NRF-22, LR-20WR	Astro 30
199	15.2 gpm	0.7 ft/hd	UPS26-99F (1)	--	LR-15BWR	Astro 30
285	21.7 gpm	1.6 ft/hd	UPS26-99F (2)	0011, 0014	NRF-36 (1), NRF-45 (1)	Astro 50, H41

35°F Temperature Rise Applications						
Model	Flow	ΔP	Pump			
			Grundfos	TACO	Bell & Gossett	Armstrong
55	3.0 gpm	0.1 ft/hd	UPS 15-58FC (1)	005, 006	--	Astro 20
85	4.6 gpm	0.3 ft/hd	UPS 15-58FC (1)	005, 006	--	Astro 20
110	6.0 gpm	0.5 ft/hd	UPS 15-58FC (2)	005, 007, 008	NRF9F, NRF-25 (1,2)	Astro 25
155	8.4 gpm	1.5 ft/hd	UPS 15-58FC (3)	005, 007, 008	NRF-22, LR-20WR	Astro 30
199	10.9 gpm	0.4 ft/hd	UPS 15-58FC (2)	005, 007, 008, 0010	NRF9F, NRF-25 (1,2)	Astro 25
285	15.57 gpm	0.8 ft/hd	UPS 15-58FC (3)	005, 007, 008, 0010	NRF-22, LR-20WR	Astro 30

**NOTICE** Pump sizing and flow requirements are based on 20 feet of piping, 4 - 90° elbows, and 2 - fully ported ball valves.

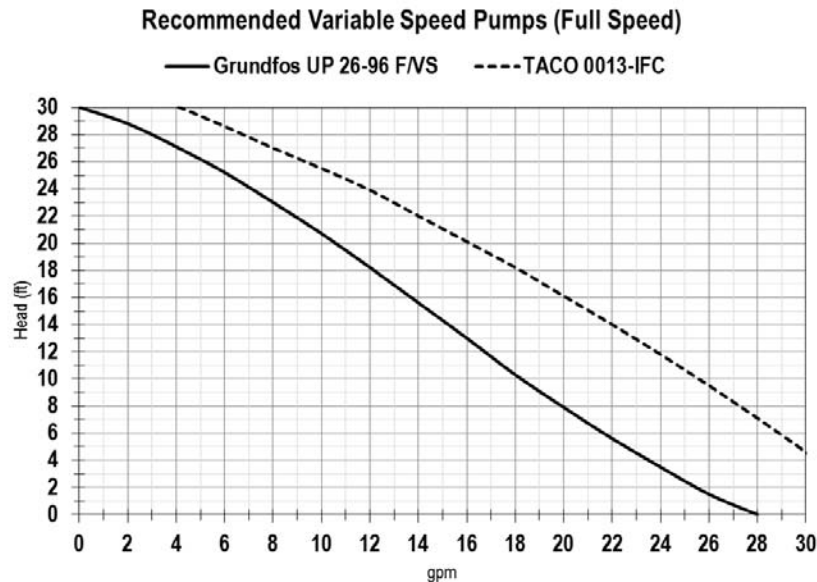
**NOTICE** Pumps listed in bold type are provided by the factory as the boiler circulation pump.

**NOTICE** The temperature rise provided by a pump/model combination will decrease by 3% per 1000 feet of elevation.

## 6 Hydronic piping *(continued)*

### Variable speed pump option

**Figure 6-3** Recommended Variable Speed Pumps



**Table 6B** Maximum and Minimum Flow Rates through the Boiler

Model	Minimum Pipe Diameter	Maximum Flow	Minimum Flow (High Fire)	Minimum Flow (Low Fire)
55	1"	17 gpm	2.1 gpm	1.0 gpm
85	1"	17 gpm	3.2 gpm	1.0 gpm
110	1"	17 gpm	4.2 gpm	1.0 gpm
155	1"	17 gpm	5.9 gpm	1.0 gpm
199	1 1/4"	27 gpm	7.6 gpm	1.5 gpm
285	1 1/4"	27 gpm	10.8 gpm	1.5 gpm

**NOTICE**

Maximum flow rates are based on boiler inlet and outlet water piping. It is the responsibility of the installer to maintain flow rates based on system piping requirements.

#### Variable speed pump setup

Before operation, ensure the following:

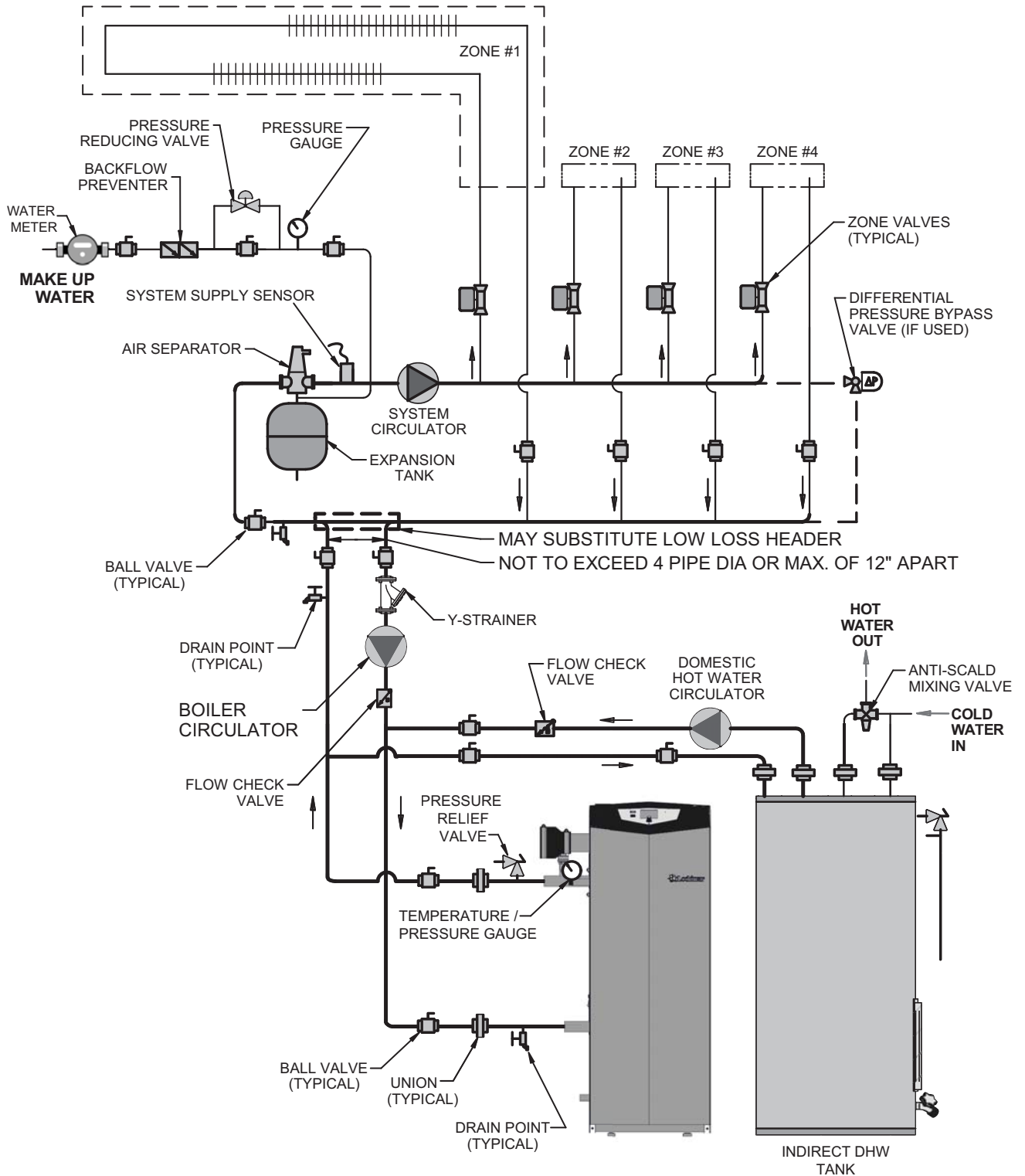
- Pump is set for an input signal of 0 - 10Vdc by the dip switches on the pump control
- Pump is set for external signal control (if applicable)
- Pump is set for linear output (if applicable)
- If pump does not come equipped with a 0 - 10 Vdc input option, an optional module will be required from the vendor

#### SMART SYSTEM / Multi-temperature loop control option

The Knight Fire Tube boiler is capable of producing up to three (3) set point temperatures to meet different space heating demands. When using more than one temperature demand it is necessary to protect the lower temperature loop from overheating. To help aid with this protection, Lochinvar offers the Multi-Temperature Loop Control Board Kit (#100167843).

# 6 Hydronic piping

**Figure 6-4** Single Boiler - Single Temperature with Zone Valves - DHW Priority



DIR #2000507794 00

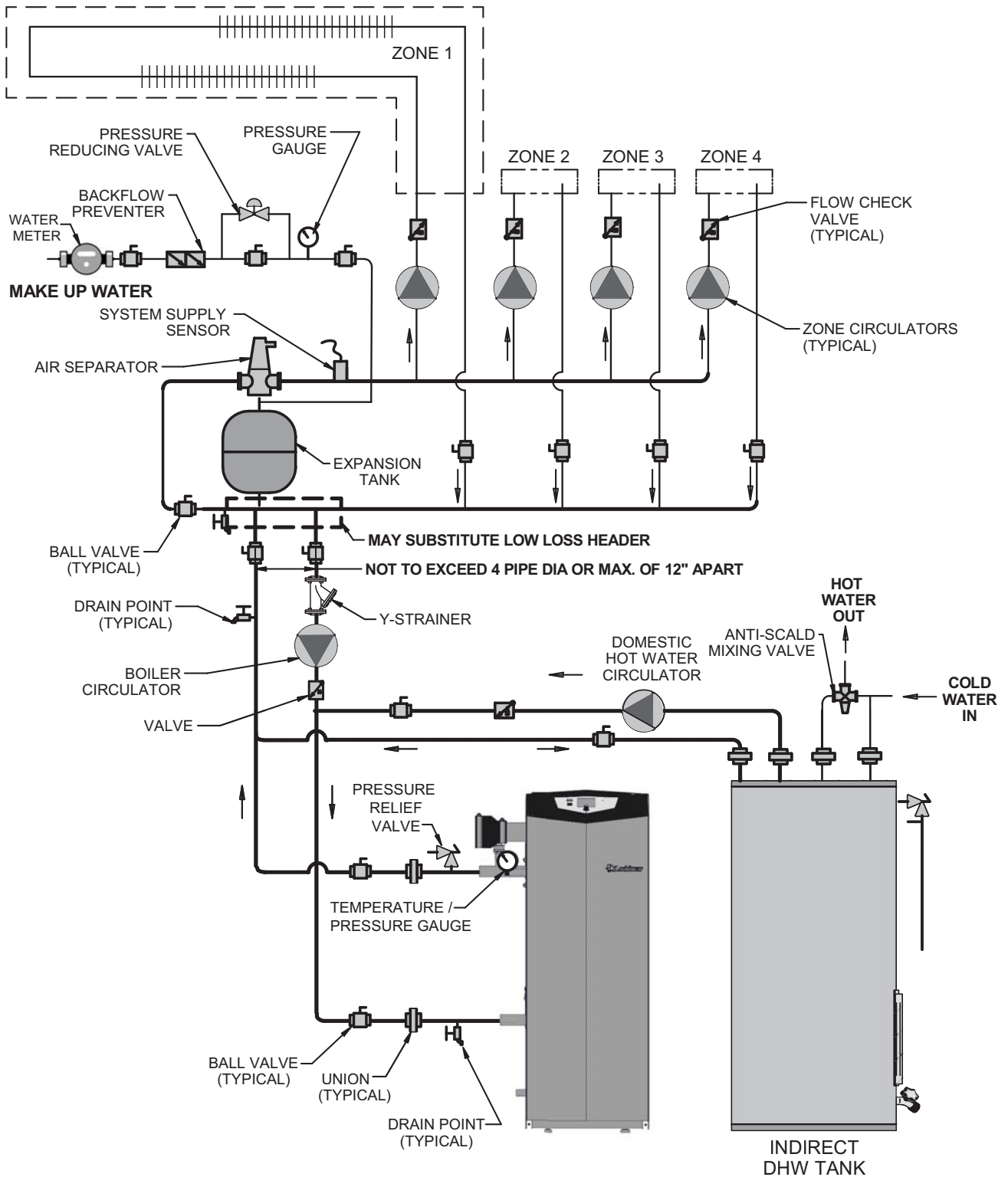
**NOTICE**

Please note that these illustrations are meant to show system piping concept only, the installer is responsible for all equipment and detailing required by local codes.



## 6 Hydronic piping *(continued)*

**Figure 6-5** Single Boiler - Single Temperature Zoned with Circulators - DHW Priority

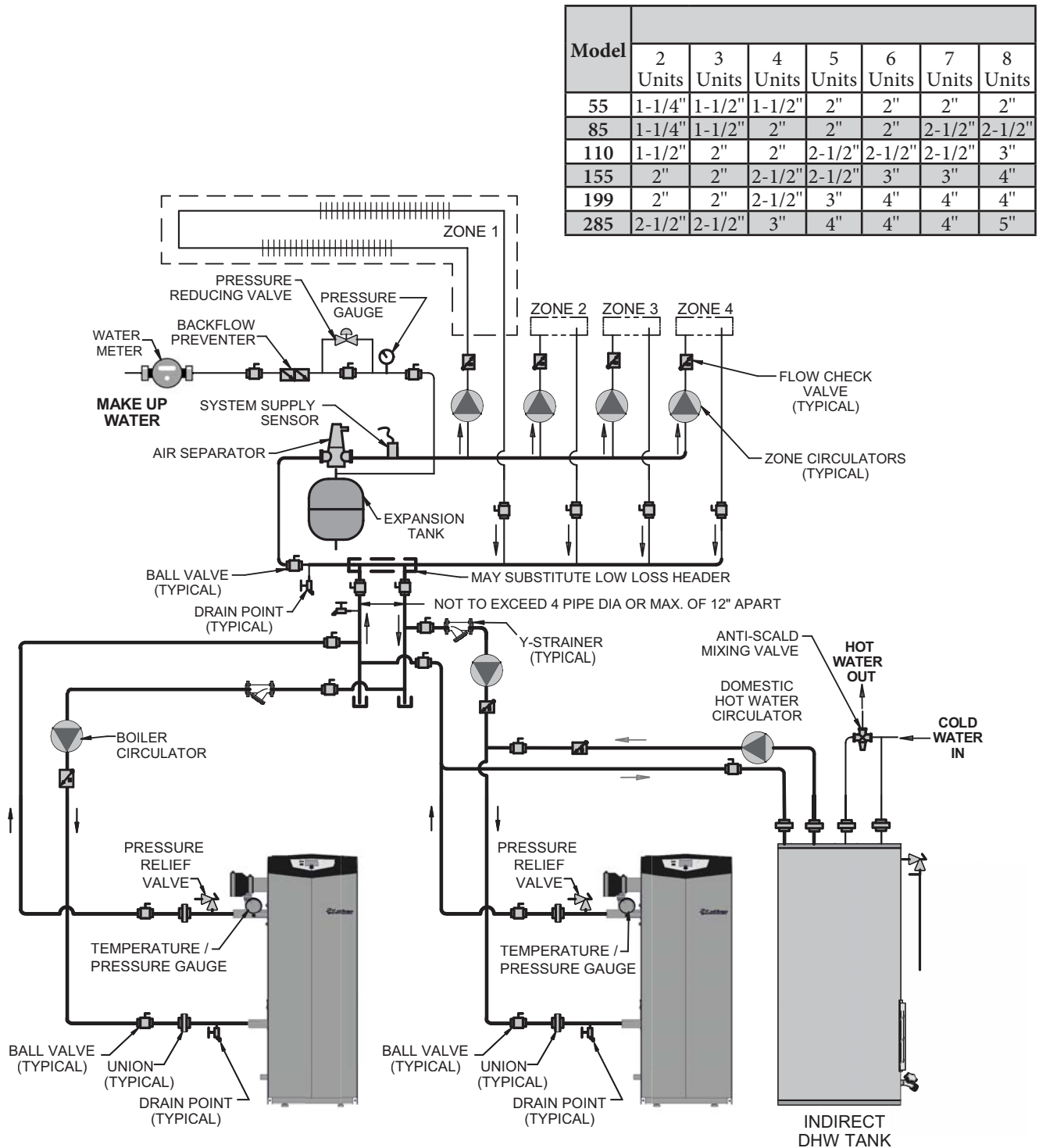


DIR #2000507791 00

**NOTICE**

Please note that these illustrations are meant to show system piping concept only, the installer is responsible for all equipment and detailing required by local codes.

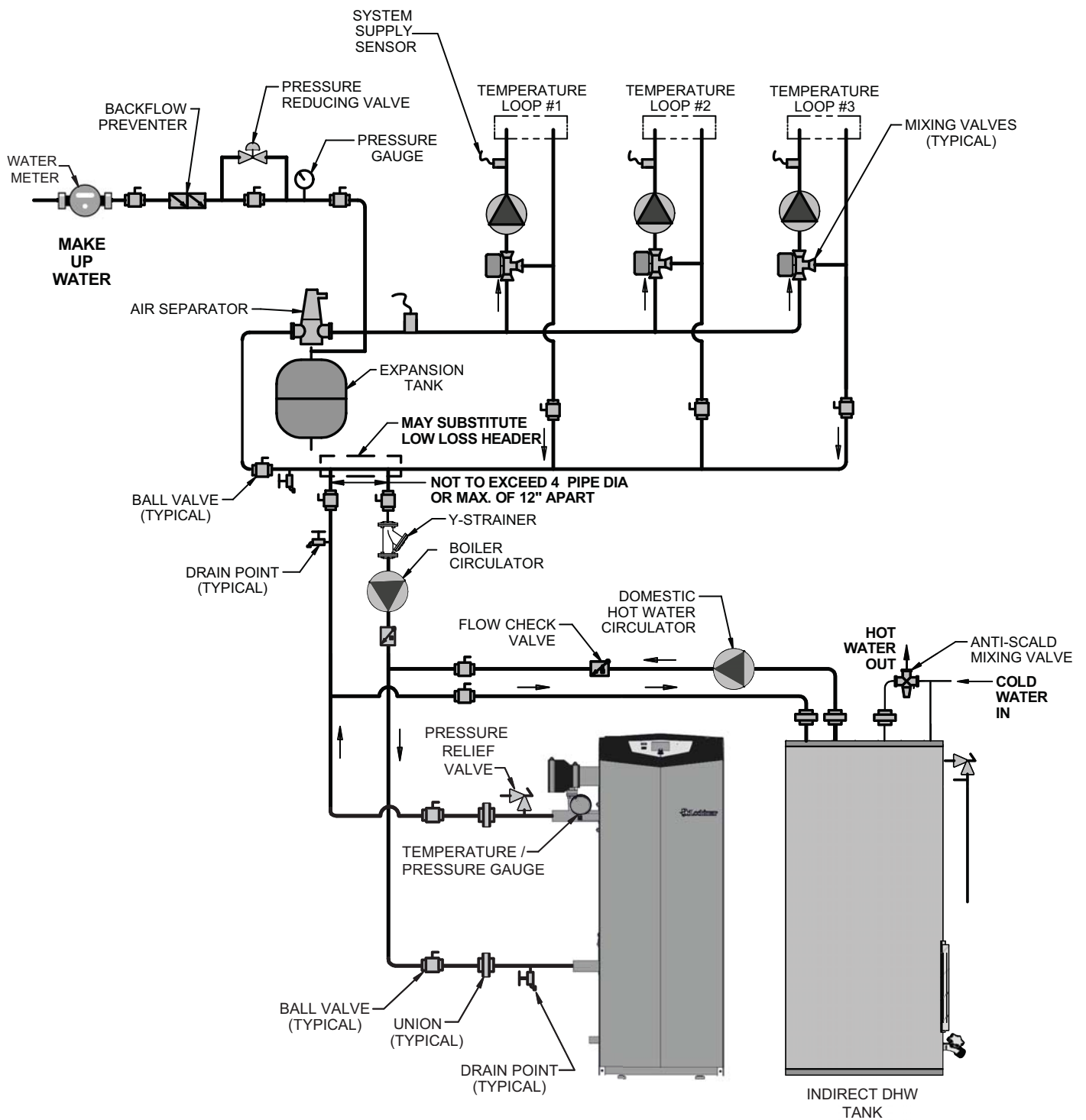
# 6 Hydronic piping

**Figure 6-6 Multiple Boilers - Single Temperature Zoned with Circulators - DHW Priority**


DIR #2000507798 00

- NOTICE** Required pipe diameter is based on maximum flow (17 gpm for Models 55 - 155, 27 gpm for Models 199 - 285) through all units in Cascade. It is the responsibility of the installer to maintain flow rates based on system piping requirements.
- NOTICE** Please note that these illustrations are meant to show system piping concept only, the installer is responsible for all equipment and detailing required by local codes.

## 6 Hydronic piping *(continued)*

**Figure 6-7 Single Boiler - Multiple Temperatures - DHW Priority**


DIR #2000507796 00

**CAUTION**

Mixing valves are required for the protection of low temperature loops.

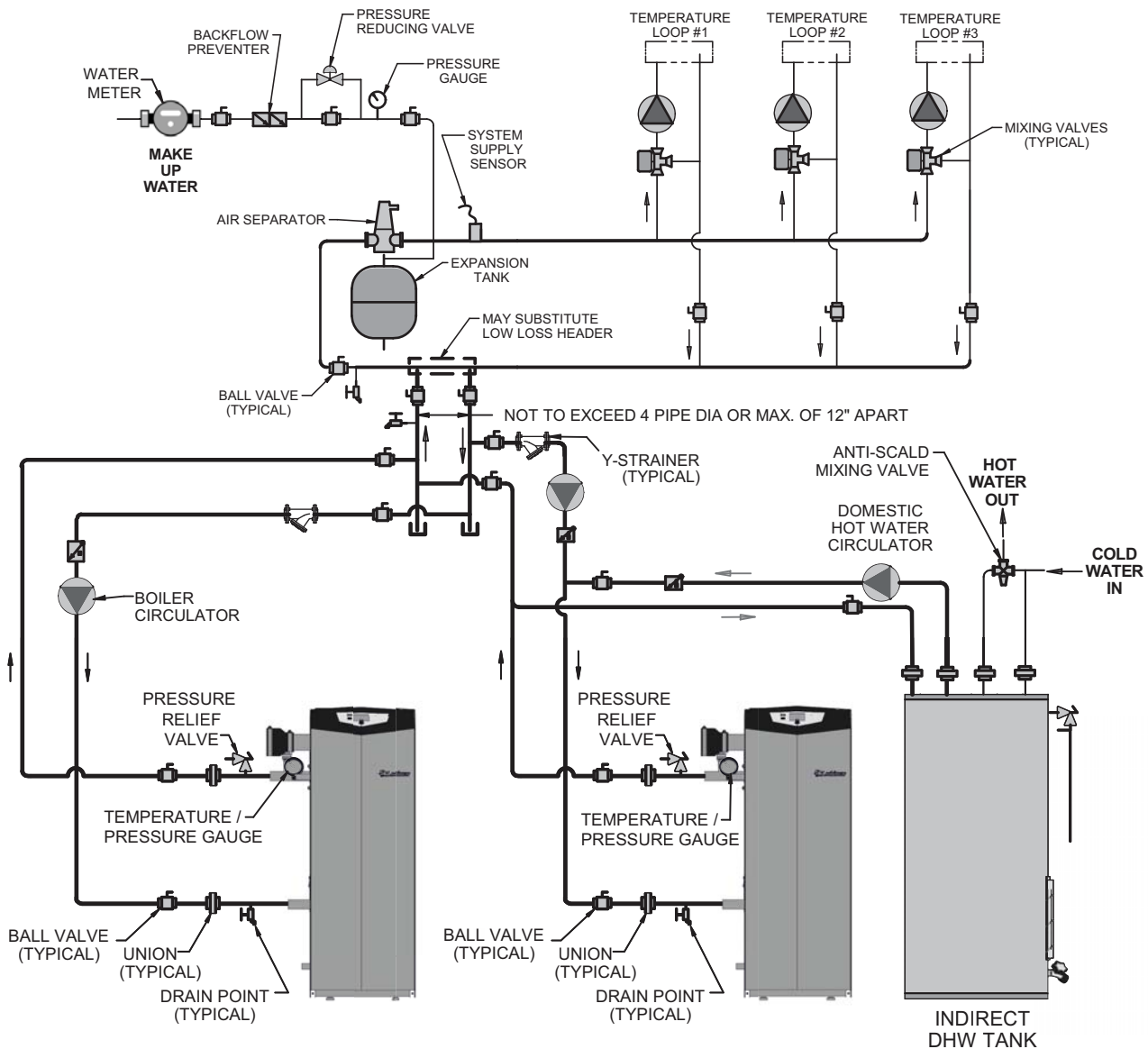
**NOTICE**

Please note that these illustrations are meant to show system piping concept only, the installer is responsible for all equipment and detailing required by local codes.

# 6 Hydronic piping

**Figure 6-8 Multiple Boilers - Multiple Temperatures - DHW Priority**

Model	Recommended Water Pipe Diameter - Cascade						
	2 Units	3 Units	4 Units	5 Units	6 Units	7 Units	8 Units
55	1-1/4"	1-1/2"	1-1/2"	2"	2"	2"	2"
85	1-1/4"	1-1/2"	2"	2"	2"	2-1/2"	2-1/2"
110	1-1/2"	2"	2"	2-1/2"	2-1/2"	2-1/2"	3"
155	2"	2"	2-1/2"	2-1/2"	3"	3"	4"
199	2"	2"	2-1/2"	3"	4"	4"	4"
285	2-1/2"	2-1/2"	3"	4"	4"	4"	5"



DIR #2000507797 00

**CAUTION**

Mixing valves are required for the protection of low temperature loops.

**NOTICE**

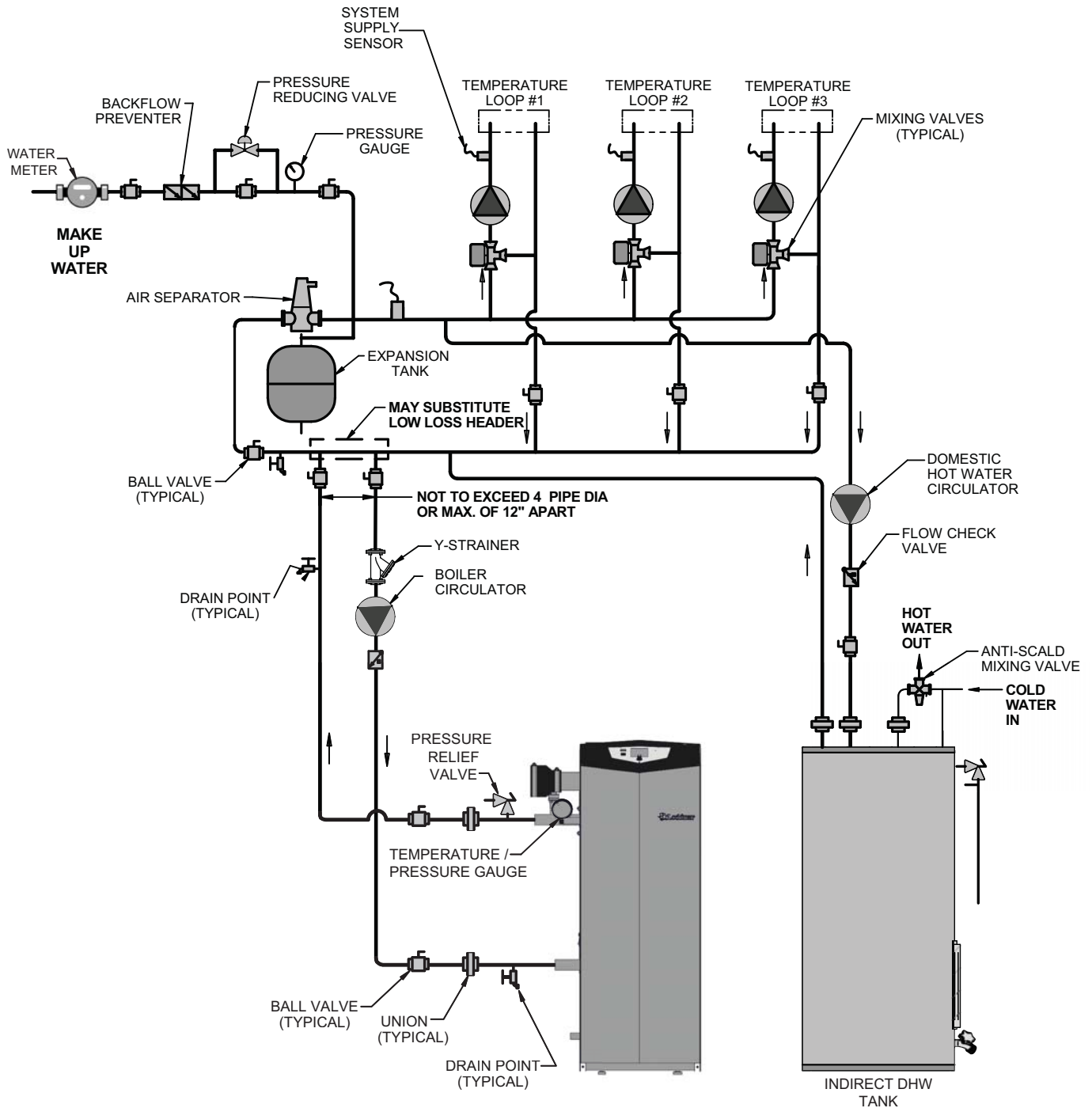
Required pipe diameter is based on maximum flow (17 gpm for Models 55 - 155, 27 gpm for Models 199 - 285) through all units in Cascade. It is the responsibility of the installer to maintain flow rates based on system piping requirements.

**NOTICE**

Please note that these illustrations are meant to show system piping concept only, the installer is responsible for all equipment and detailing required by local codes.

## 6 Hydronic piping *(continued)*

**Figure 6-9** Single Boiler - Multiple Temperatures with DHW Piped as a Zone



DIR #2000507803 00

### CAUTION

Mixing valves are required for the protection of low temperature loops.

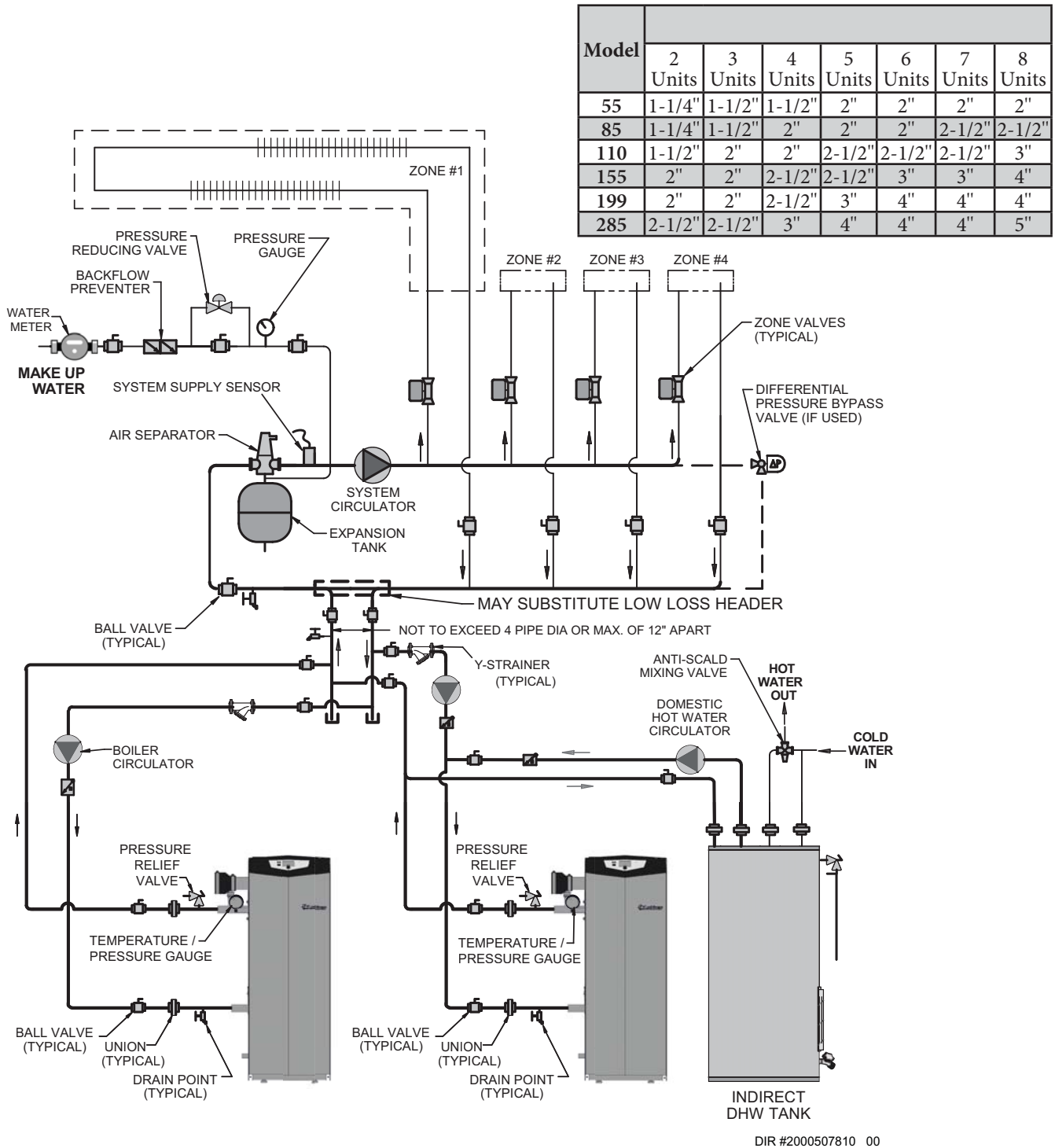
### NOTICE

Please note that these illustrations are meant to show system piping concept only, the installer is responsible for all equipment and detailing required by local codes.

### NOTICE

Please note that the installer is responsible for ensuring DHW prioritization when piped as a zone.

# 6 Hydronic piping

**Figure 6-10 Multiple Boilers - Single Temperature Zoned with Valves**

**NOTICE**

Required pipe diameter is based on maximum flow (17 gpm for Models 55 - 155, 27 gpm for Models 199 - 285) through all units in Cascade. It is the responsibility of the installer to maintain flow rates based on system piping requirements.

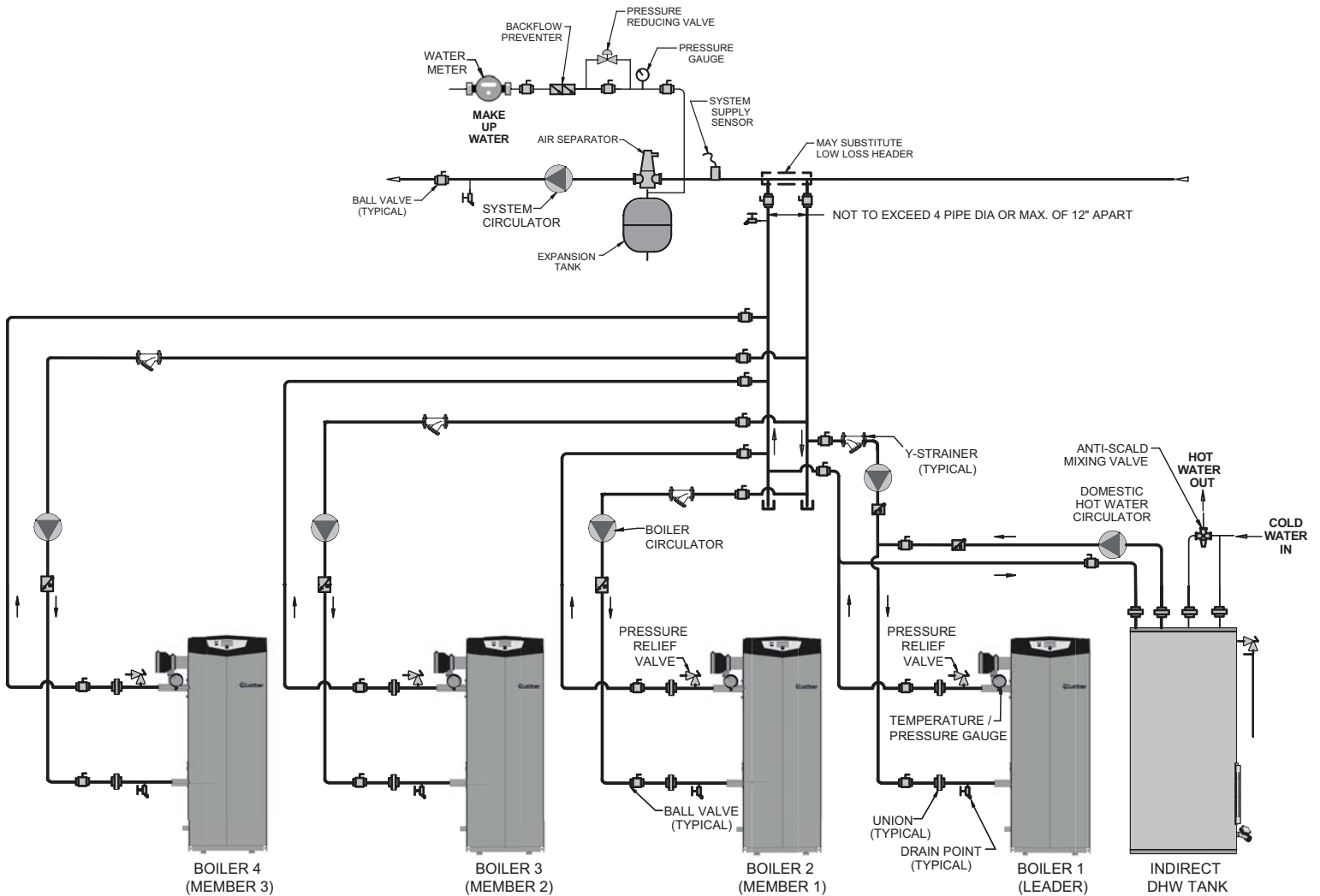
**NOTICE**

Please note that these illustrations are meant to show system piping concept only, the installer is responsible for all equipment and detailing required by local codes.

## 6 Hydronic piping *(continued)*

**Figure 6-11 Multiple Boilers - Non-Zoned Primary/Secondary Piping**

Model	2	3	4	5	6	7	8
	Units	Units	Units	Units	Units	Units	Units
55	1-1/4"	1-1/2"	1-1/2"	2"	2"	2"	2"
85	1-1/4"	1-1/2"	2"	2"	2"	2-1/2"	2-1/2"
110	1-1/2"	2"	2"	2-1/2"	2-1/2"	2-1/2"	3"
155	2"	2"	2-1/2"	2-1/2"	3"	3"	4"
199	2"	2"	2-1/2"	3"	4"	4"	4"
285	2-1/2"	2-1/2"	3"	4"	4"	4"	5"



DIR #2000507818 00

**NOTICE**

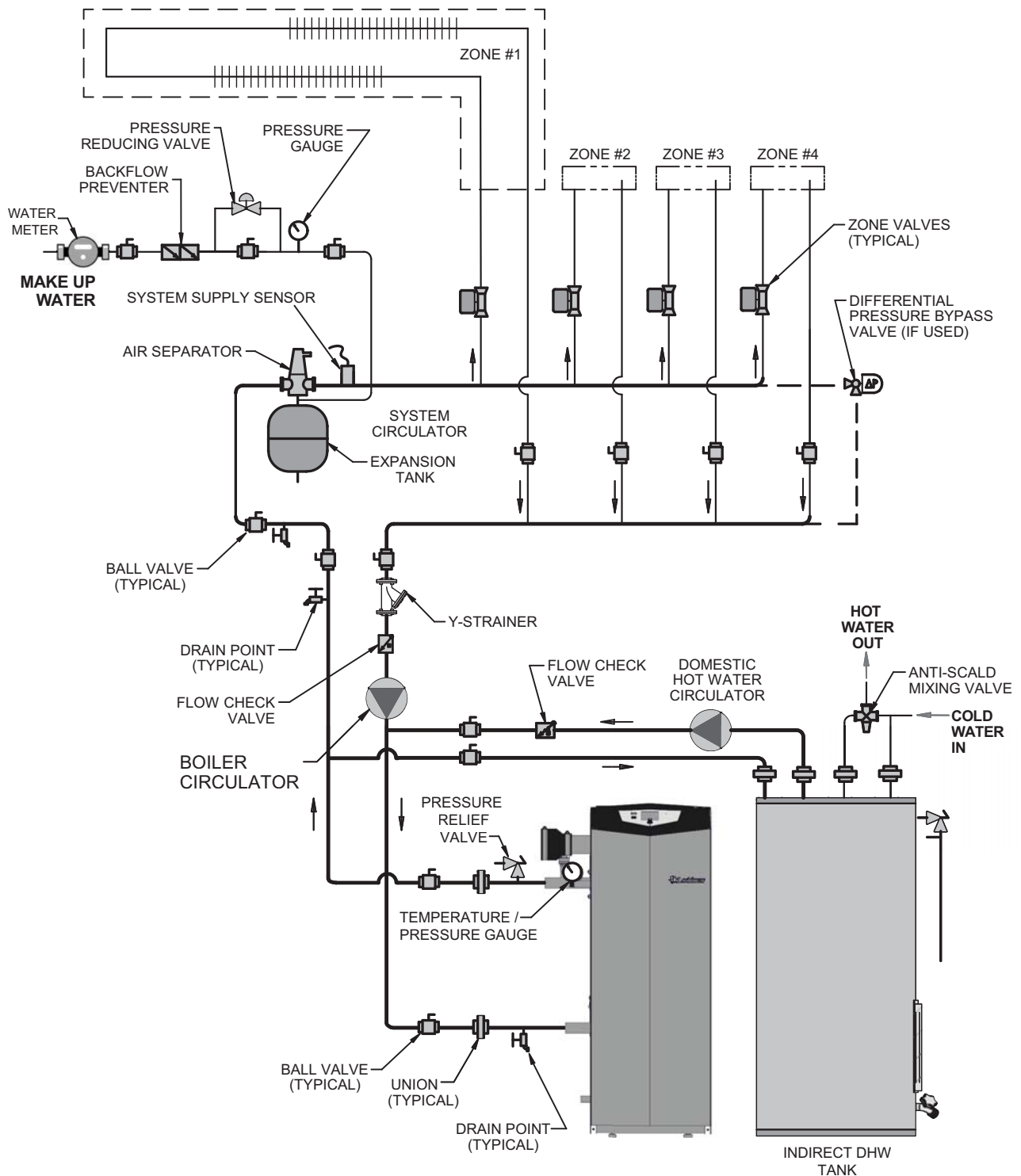
Required pipe diameter is based on maximum flow (17 gpm for Models 55 - 155, 27 gpm for Models 199 - 285) through all units in Cascade. It is the responsibility of the installer to maintain flow rates based on system piping requirements.

**NOTICE**

Please note that these illustrations are meant to show system piping concept only, the installer is responsible for all equipment and detailing required by local codes.

# 6 Hydronic piping

**Figure 6-12** Single Boiler - Full Flow - Single Temperature - Zoned with Zone Valves - DHW Priority



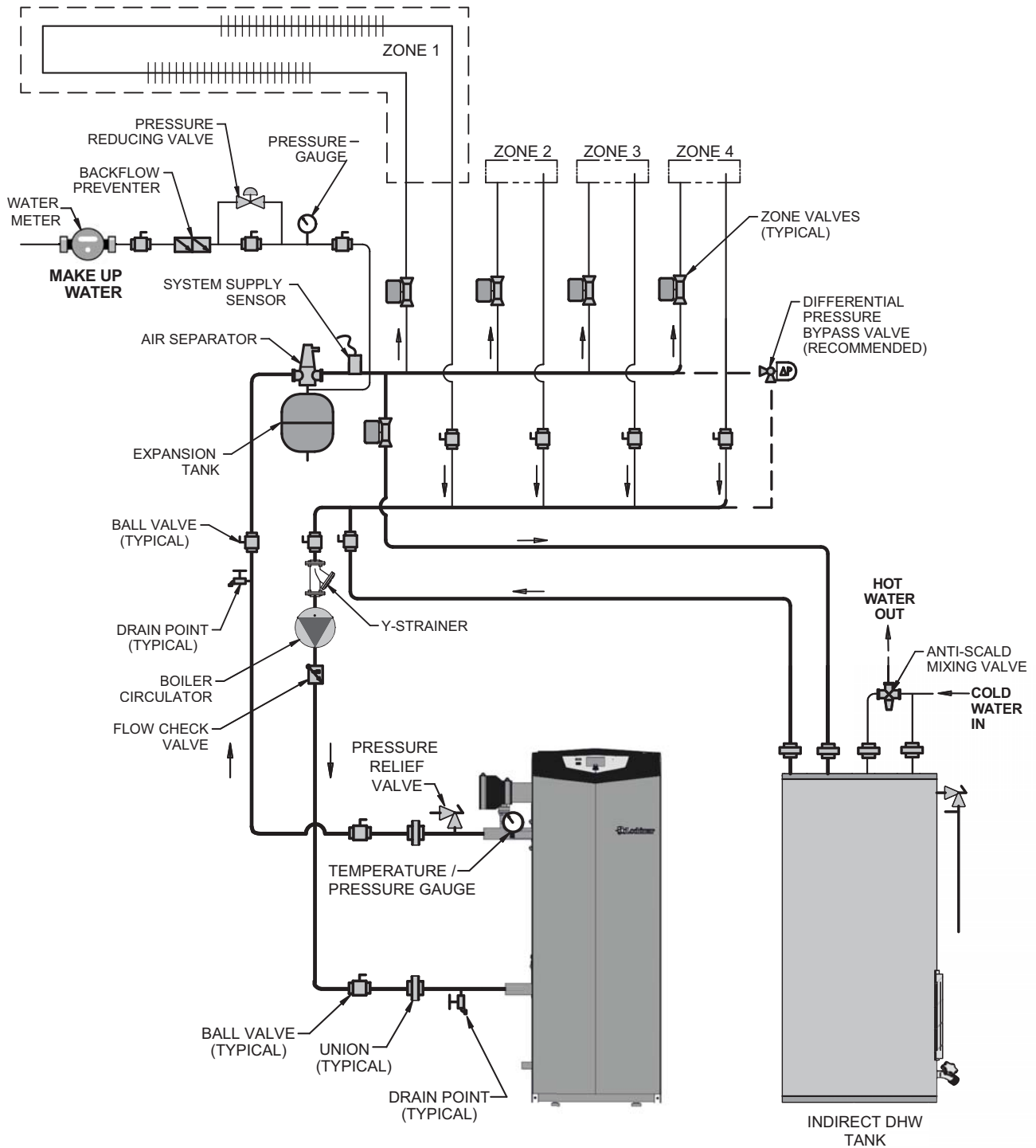
DIR #2000507800 00

**NOTICE** Please note that these illustrations are meant to show system piping concept only, the installer is responsible for all equipment and detailing required by local codes.



# 6 Hydronic piping *(continued)*

**Figure 6-13** Single Boiler - Full Flow - Single Temperature Zoned with Valves - DHW Piped as a Zone

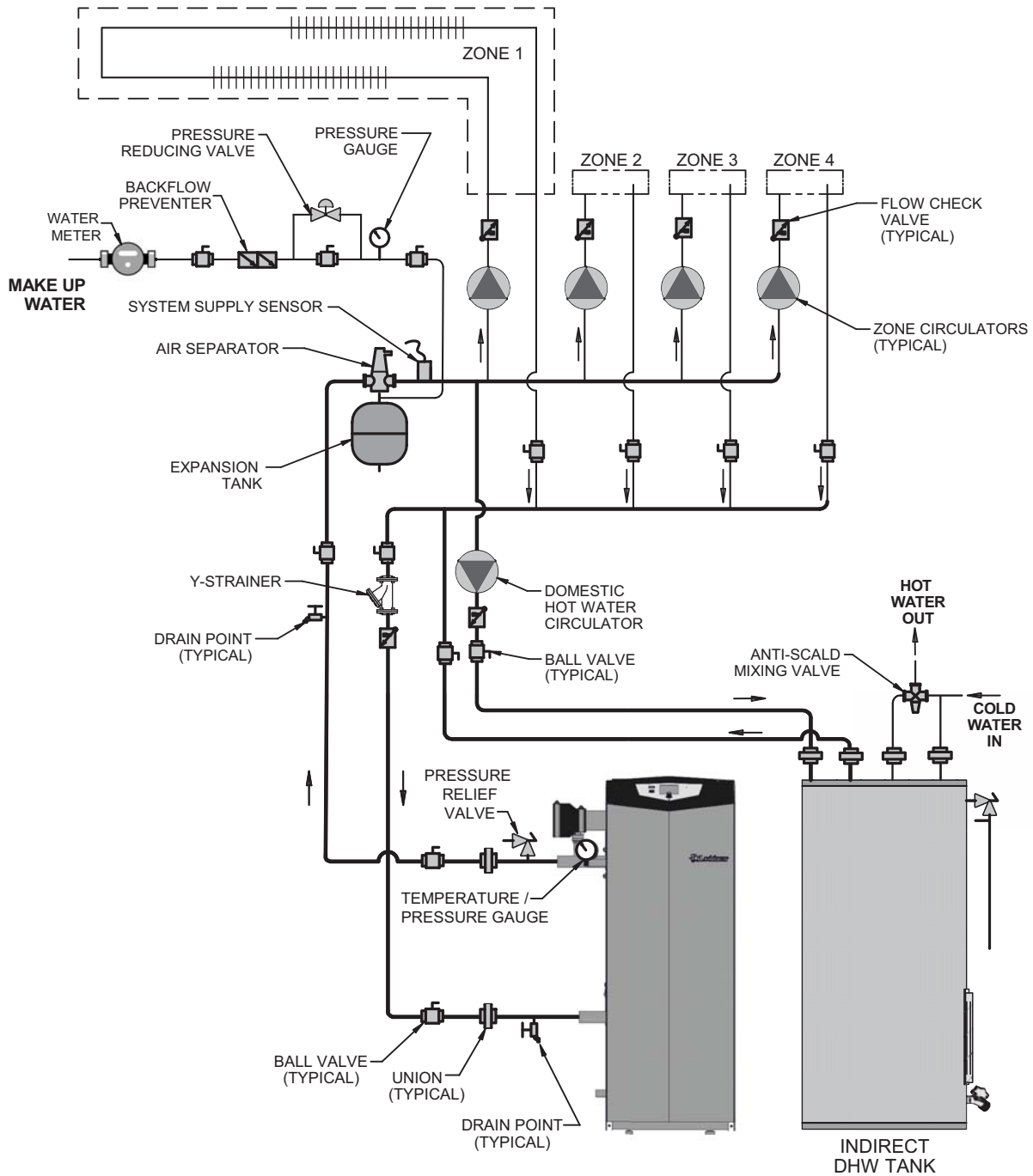


DIR #2000507805 00

**NOTICE** Please note that these illustrations are meant to show system piping concept only, the installer is responsible for all equipment and detailing required by local codes.

# 6 Hydronic piping

**Figure 6-14** Single Boiler - Full Flow - Single Temperature Zoned with Circulators - DHW Piped as a Zone



DIR #2000507790 00

**NOTICE**

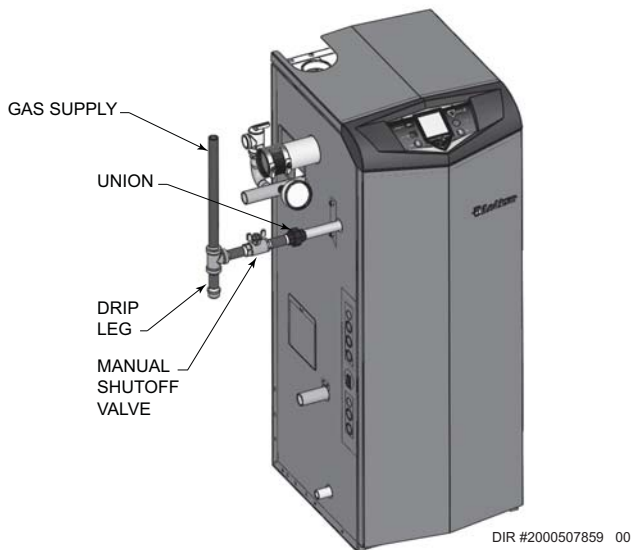
Please note that these illustrations are meant to show system piping concept only, the installer is responsible for all equipment and detailing required by local codes.

# 7 Gas connections

## Connecting gas supply piping

1. Refer to FIG. 7-1 to pipe gas to the boiler.
  - a. Install ground joint union for servicing, when required.
  - b. Install a manual shutoff valve in the gas supply piping outside boiler jacket when required by local codes or utility requirements.
  - c. In Canada – When using manual main shutoff valves, it must be identified by the installer.
2. Install sediment trap / drip leg.

**Figure 7-1 Gas Supply Piping**



3. Support piping with hangers, not by the boiler or its accessories.

**⚠ WARNING**

The gas valve and blower will not support the weight of the piping. Do not attempt to support the weight of the piping with the boiler or its accessories. Failure to comply could result in severe personal injury, death, or substantial property damage.

4. Purge all air from the gas supply piping.
5. Before placing the boiler in operation, check the boiler and its gas connection for leaks.
  - a. The appliance must be disconnected from the gas supply piping system during any pressure testing of that system at a test pressure in excess of 1/2 PSIG (3.5 kPa).
  - b. The appliance must be isolated from the gas supply piping system by closing a manual shutoff valve during any pressure testing of the gas supply piping system at test pressures equal to or less than 1/2 PSIG (3.5 kPa).
  - c. The appliance and its gas connection must be leak tested before placing it in operation.

**⚠ WARNING**

Do not check for gas leaks with an open flame – use the bubble test. Failure to use the bubble test or check for gas leaks can cause severe personal injury, death, or substantial property damage.

6. Use pipe sealing compound compatible with propane gases. Apply sparingly only to male threads of the pipe joints so that pipe dope does not block gas flow.

**⚠ WARNING**

Failure to apply pipe sealing compound as detailed in this manual can result in severe personal injury, death, or substantial property damage.

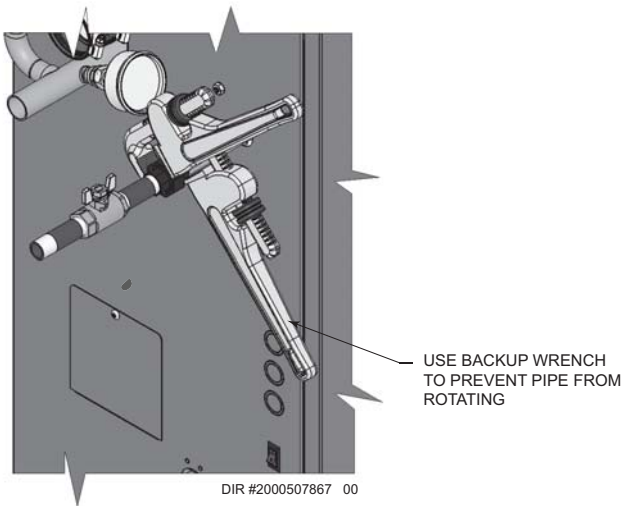
**⚠ WARNING**

Knight Fire Tube boilers are typically shipped ready to fire on natural gas. Check boiler rating plate to determine which fuel the boiler is set for. If set to natural gas, it may be converted to LP by installing an LP venturi. In order to operate on LP gas, an LP venturi **MUST BE** installed. Failure to comply could result in severe personal injury, death, or substantial property damage.

# 7 Gas connections

**⚠ WARNING** Use two wrenches when tightening gas piping at boiler (FIG. 7-2), using one wrench to prevent the boiler gas line connection from turning. Failure to support the boiler gas connection pipe to prevent it from turning could damage gas line components.

**Figure 7-2 Inlet Pipe with Backup Wrench**



**NOTICE** Maximum inlet gas pressure must not exceed the value specified. Minimum value listed is for the purposes of input adjustment.

## Natural gas:

### Pipe sizing for natural gas

1. Refer to Table 7A for pipe length and diameter. Based on rated boiler input (divide by 1,000 to obtain cubic feet per hour).
  - a. Table 7A is only for natural gas with specific gravity 0.60 inches, with a pressure drop through the gas piping of 0.3 inches w.c.
  - b. For additional gas pipe sizing information, refer to ANSI Z223.1 (or B149.1 for Canadian installations).

### Natural gas supply pressure requirements

1. Pressure required at the gas valve inlet pressure port:
  - Maximum 14 inches w.c. with no flow (lockup) or with boiler on.
  - Minimum 4 inches w.c. with gas flowing (verify during boiler startup).
2. Install 100% lockup gas pressure regulator in supply line if inlet pressure can exceed 14 inches w.c. at any time. Adjust lockup regulator for 14 inches w.c. maximum.

## Propane Gas:

**⚠ WARNING** Knight Fire Tube boilers are typically shipped ready to fire on natural gas. Check boiler rating plate to determine which fuel the boiler is set for. If set to natural gas, it may be converted to LP by installing an LP venturi (see page 12). In order to operate on LP gas, an LP venturi **MUST BE** installed. Failure to comply could result in severe personal injury, death, or substantial property damage.

### Pipe sizing for propane gas

1. Contact gas supplier to size pipes, tanks, and 100% lockup gas pressure regulator.

### Propane Supply Pressure Requirements

1. Adjust propane supply regulator provided by the gas supplier for 14 inches w.c. maximum pressure.
2. Pressure required at gas valve inlet pressure port:
  - Maximum 14 inches w.c. with no flow (lockup) or with boiler on.
  - Minimum 8 inches w.c. with gas flowing (verify during boiler startup).

**⚠ WARNING** Ensure that the high gas pressure regulator is at least 6 - 10 feet upstream of the appliance.

# 7 Gas connections *(continued)*

**Table 7A Natural Gas Pipe Size Chart**

Capacity of Schedule 40 Metallic Pipe in Cubic Feet of Natural Gas Per Hour (based on .60 specific gravity, 0.30" w.c. pressure drop)														
Pipe Size (Inches)	Length of Pipe in Straight Feet													
	10	20	30	40	50	60	70	80	90	100	125	150	175	200
1/2	131	90	72	62	55	N/A	N/A	N/A	N/A	N/A	N/A	N/A	N/A	N/A
3/4	273	188	151	129	114	104	95	89	83	79	70	63	58	N/A
1	514	353	284	243	215	195	179	167	157	148	131	119	109	102
1 1/4	1,060	726	583	499	442	400	368	343	322	304	269	244	224	209
1 1/2	1,580	1,090	873	747	662	600	552	514	482	455	403	366	336	313
2	3,050	2,090	1,680	1,440	1,280	1,160	1,060	989	928	877	777	704	648	602
2 1/2	4,860	3,340	2,680	2,290	2,030	1,840	1,690	1,580	1,480	1,400	1,240	1,120	1,030	960
3	8,580	5,900	4,740	4,050	3,590	3,260	3,000	2,790	2,610	2,470	2,190	1,980	1,820	1,700
4	17,500	12,000	9,660	8,270	7,330	6,640	6,110	5,680	5,330	5,040	4,460	4,050	3,720	3,460

**⚠ WARNING**

Knight Fire Tube boilers are typically shipped ready to fire on natural gas. Check boiler rating plate to determine which fuel the boiler is set for. If set to natural gas, it may be converted to LP by installing an LP venturi (see page 12). In order to operate on LP gas, an LP venturi **MUST BE** installed. Failure to comply could result in severe personal injury, death, or substantial property damage.

## Check inlet gas supply

**NOTICE**

CSA or UL listed flexible gas connections are acceptable, but you must exercise caution to ensure that the line has adequate capacity to allow your boiler to fire at full rate. Consult with local codes for proper installation or service procedures.

**⚠ WARNING**

DO NOT adjust gas valve outlet pressure. The gas valve is factory-set for the correct outlet pressure. This setting is suitable for natural gas and propane, requiring no field adjustment. Attempting to alter the gas valve outlet pressure could result in damage to the valve, causing potential severe personal injury, death, or substantial property damage.

The gas piping must be sized for the proper flow and length of pipe, to avoid excessive pressure drop. Both the gas meter and the gas regulator must be properly sized for the total gas load.

If you experience a pressure drop greater than 1 inch w.c., the meter, regulator, or gas line is undersized or in need of service. Perform the steps below when checking inlet gas supply:

- Turn the main power switch to the "OFF" position.
- Shut off gas supply at the manual gas valve in the gas piping to the appliance.
- Loosen the set screw one (1) full turn from inside the pressure tap on top of the gas valve. Place the tubing of the manometer over the tap once the set screw is loosened as shown in FIG. 7-3.
- Slowly turn on the gas supply at the field installed manual gas valve.
- Turn the power switch to the "ON" position.
- Locate the pinhole button above the RESET button on the display board (FIG. 11-1 on page 75). Insert a thin wire (such as a paper clip) into the hole and press the button once and hold for 5 seconds to place the boiler into Service Mode. In Service Mode the boiler will fire at ignition speed and will then modulate up to full fire.
- Observe the gas supply pressure as the burner fires at 100% of rated input. Percent of burner input will be displayed on the control panel.
- Ensure inlet pressure is within specified range. Minimum and maximum gas supply pressures are specified in this section of the manual.
- If gas supply pressure is within normal range and no adjustments are needed, proceed on to Step 11.
- If the gas pressure is out of range, contact the gas utility, gas supplier, qualified installer or service agency to determine the necessary steps to provide proper gas pressure to the control.
- Place the boiler back into normal operation by pressing STOP.

# 7 Gas connections

**⚠ WARNING** When re-tightening the set screw, be sure to tighten securely to prevent gas leaks.

Do not check for gas leaks with an open flame -- use the bubble test. Failure to use the bubble test or check for gas leaks can cause severe personal injury, death, or substantial property damage.

12. Turn the power switch to the "OFF" position.
13. Shut off the gas supply at the manual gas valve in the gas piping to the appliance.
14. Remove the manometer from the pressure tap on top of the gas valve. Re-tighten the set screw inside the pressure tap.
15. Turn on the gas supply at the manual gas valve.
16. Turn the power switch to the "ON" position.
17. Check burner performance by cycling the system while you observe burner response. The burner should ignite promptly. Flame pattern should be stable. Turn system off and allow burner to cool, then cycle burner again to ensure proper ignition and flame characteristics.

## Gas Pressure

The gas pressure must remain between 4 inches w.c. (natural), 8 inches w.c. (LP) minimum and 14 inches w.c. (natural and LP) maximum during stand-by (static) mode and while in operating (dynamic) mode. If an in-line regulator is used, it must be a minimum of 10 feet from the Knight Fire Tube boiler. It is very important that the gas line is properly purged by the gas supplier or utility company. Failure to properly purge the lines or improper line sizing, will result in ignition failure.

The problem is especially noticeable in NEW LP installations and also in empty tank situations. This can also occur when a utility company shuts off service to an area to provide maintenance to their lines.

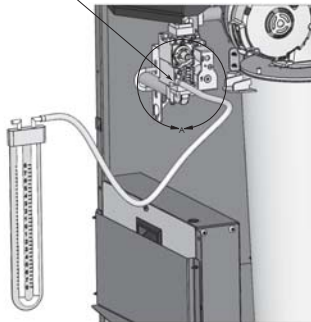
## Gas valve replacement

The gas valve **MUST NOT** be replaced with a conventional gas valve under any circumstances. As an additional safety feature, this gas valve has a flanged connection to the venturi and blower.

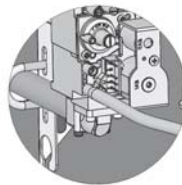
**⚠ WARNING** Failure to follow all precautions could result in fire, explosion, or death!

**Figure 7-3** Inlet Gas Supply Check

LOOSEN THE SET SCREW ONE (1) FULL TURN AND PLACE THE MANOMETER TUBING OVER THE PRESSURE TAP



DIR #2000507872 00



DETAIL A

## 8 Field wiring

### ⚠ WARNING

**ELECTRICAL SHOCK HAZARD** – For your safety, turn off electrical power supply before making any electrical connections to avoid possible electric shock hazard. Failure to do so can cause severe personal injury or death.

### NOTICE

Wiring must be N.E.C. Class 1.

If original wiring as supplied with boiler must be replaced, use only type 105°C wire or equivalent.

Boiler must be electrically grounded as required by National Electrical Code ANSI/NFPA 70 – latest edition.

### NOTICE

This boiler is equipped with a feature that saves energy by reducing the boiler water temperature as the heating load decreases. This feature is equipped with an override, which is provided primarily to permit the use of an external energy management system that serves the same function. This override **MUST NOT** be used unless at least one of the following conditions is true:

1. An external energy management system is installed that reduces the boiler water temperature as the heating load decreases.
2. This boiler is not used for any space heating.
3. This boiler is part of a modular or multiple boiler system having a total input of 300,000 Btuh/hr or greater.
4. This boiler is equipped with a tankless coil.

### ⚠ CAUTION

Label all wires prior to disconnection when servicing controls. Wiring errors can cause improper and dangerous operation.

Installation must comply with:

1. National Electrical Code and any other national, state, provincial, or local codes, or regulations.
2. In Canada, CSA C22.1 Canadian Electrical Code Part 1, and any local codes.

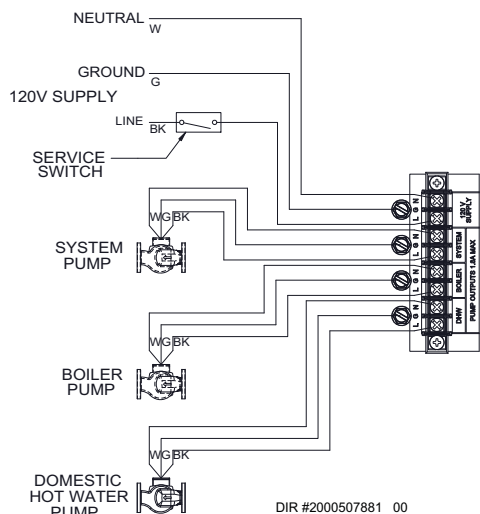
### Line voltage connections

1. Connect 120 VAC power wiring to the line voltage terminal strip in the junction box, as shown in FIG. 8-1.
2. Provide and install a fused disconnect or service switch (15 amp recommended) as required by the code (see FIG. 8-1).
3. The boiler pump is shipped loose. Wire the boiler pump as shown in FIG. 8-1.
4. When connecting a domestic hot water (DHW) pump, connect the wiring to the line voltage terminal strip as shown in FIG. 8-1.
5. To activate a system pump, wire as shown in FIG. 8-1. If the motor is larger than 1/8 hp or 1.8 amps, you must isolate with a relay.

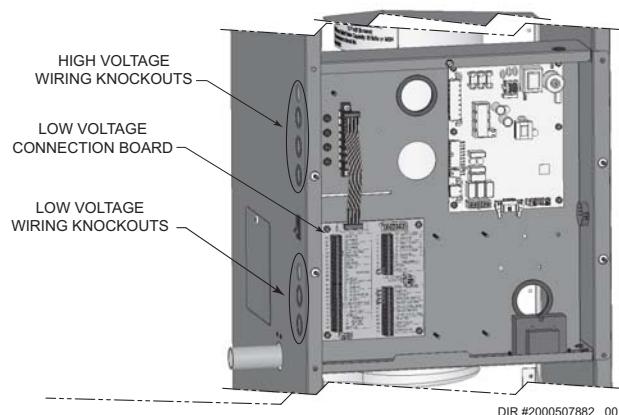
### Low voltage connections

1. Route all low voltage wires through the knockouts on the left side, as shown in FIG. 8-2.
2. Connect low voltage wiring to low voltage connection board as shown in FIG. 8-3 on page 59 of this manual and the boiler wiring diagram.

**Figure 8-1** Line Voltage Field Wiring Connections



**Figure 8-2** Routing Field Wiring



## 8 Field wiring

### Thermostat

1. Connect the room thermostats or end switches (isolated contact only) to Heat/Loop Demand 1, 2, or 3, as shown in FIG. 8-3.
2. Install the thermostat on the inside wall away from influences of drafts, hot or cold water pipes, lighting fixtures, television, sunlight, or fireplaces.
3. Thermostat anticipator (if applicable):
  - a. If connected directly to boiler, set for 0.1 amps.
  - b. If connected to relays or other devices, set to match total electrical power requirements of connected devices. See device manufacturers' specifications and thermostat instructions for details.

### Outdoor temperature sensor

In the absence of an external energy management system, an outdoor temperature sensor must be used.

1. Mount the sensor on an exterior wall, shielded from direct sunlight or flow of heat or cooling from other sources.
2. Route sensor wires through a knockout at the rear of the boiler (see FIG. 8-2).
3. Connect outdoor temperature sensor (FIG. 8-3) to the outdoor sensor terminals on the connection board to enable outdoor reset operation of the Knight Fire Tube boiler.

### DHW thermostat

Connect storage indirect water heater (DHW) thermostat (FIG. 8-3) to the DHW thermostat terminals on the connection board. If a tank sensor is connected (see DHW Tank Sensor below) the tank thermostat is ignored.

### DHW tank sensor

1. By installing a tank sensor, the SMART SYSTEM control can perform the tank thermostat function. The SMART SYSTEM control automatically detects the presence of this sensor and generates a DHW call for heat when the tank temperature drops 6°F (3°C) below the tank set point and finishes the call for heat when the tank temperature reaches the tank set point.
2. The tank sensor included with the Lochinvar Squire Indirect DHW tank (#100170544) is the only sensor suitable for use with the SMART SYSTEM control. Connect the sensor leads to the Tank Sensor terminals on the Low Voltage Connection Board (FIG. 8-3).



**WARNING** Failure to use the correct sensor may result in the tank temperature being either above or below the set point.

3. If the #100170544 is not compatible with the indirect tank, a tank thermostat can be used to control the boiler. The tank thermostat should be installed per the manufacturers instructions and wired to the DHW Thermostat terminals on the Low Voltage Connection Board.

### Louver relay

If louvers need to operate when the boiler fires, they can be controlled by this output. Connect these terminals to a 24 VAC relay coil, which is wired to operate the louvers (FIG. 8-3).

### Louver proving switch

When the operation of the louvers needs to be verified before the boiler fires, remove the jumper wire from these terminals and connect them to the normally open contacts on its proving switch (FIG. 8-3).

### High gas pressure switch

If a switch is provided to detect excessive gas pressure, remove the jumper wire from the terminals on the connection board, and then connect them to its normally closed contacts (FIG. 8-3).

### Low gas pressure switch

1. If a switch is provided to detect low gas pressure, remove the jumper wire from the terminals on the connection board and connect them to its normally open contacts (FIG. 8-3).
2. If both a high and low gas pressure switch is used, connect their respective contacts in series, and connect them to the terminals on the connection board (FIG. 8-3).

### Variable speed system pump

If a variable speed pump is used in the primary loop, and a 0-10V signal is available from the pump speed control, this signal can be used by the SMART SYSTEM control to anticipate changes in the building heat load. By connecting this 0 - 10V signal to the 0 - 10V SYS PUMP IN terminals, the boiler (or cascade) can modulate up and down as the primary flow increases and decreases.

### Boiler pump speed output

This 0 - 10V output is available to control the speed of a variable speed boiler pump. The SMART SYSTEM control will vary the speed of this pump in order to maintain a minimum  $\Delta T$  across the heat exchanger, as well as prevent high limit lockouts when the flow in the primary loop is extremely low. Note: This feature is to be used with Primary Secondary Piping systems only. A system supply sensor must be installed. Connect this output to the 0 - 10V input on the boiler pump speed control.

### Rate output

This output provides a 0 - 10V signal that is proportional to the firing rate of the boiler. This may be used by a BMS system to monitor the actual rate of the boiler.

### ModBus/BACnet

When the optional ModBus or BACnet interface module is installed, the RS-485 cable is connected to these terminals. Use shielded, 2-wire twisted pair cable. If desired, the shield can be connected to ground by installing a jumper wire between terminals 1 and 3 on connector X5 on the optional ModBus/BACnet interface module.



## 8 Field wiring *(continued)*

### Flow switch

1. A flow switch is used to guarantee flow through the boiler before allowing it to fire. The flow switch must be installed at the boiler outlet.
2. Remove the jumper wire from these terminals, and connect these terminals to the normally open contacts on the flow switch (FIG. 8-3).

### System supply sensor

1. By installing the system supply sensor into the supply of the primary loop, the temperature of the primary supply can be controlled. The SMART SYSTEM control automatically detects the presence of this sensor, and controls the boiler firing rate to maintain the system supply temperature to the set point (if the outlet sensor control is currently selected). If it is desired to control the system return temperature, then program the SMART SYSTEM control to use the inlet sensor as the controlling sensor. See the Knight Fire Tube Boiler Service Manual for instructions on how to use the inlet sensor as the controlling sensor. When the inlet sensor is programmed as the controlling sensor, it is vital that the SYSTEM SUPPLY sensor be installed. **DO NOT INSTALL THE SYSTEM SUPPLY SENSOR INTO THE SYSTEM RETURN.**
2. The #100170581 sensor provided with the boiler must be used for the system sensor.
3. Connect these terminals to the system supply sensor (FIG. 8-3).

### Boiler management system

The United States Energy Policy and Conservation Act requires residential heating boilers with inputs less than 300,000 Btu/hr be equipped with a control that automatically adjusts boiler water temperature in relation to heat demand. An external control may be connected to control the firing rate or the set point of the boiler provided that either an external energy management system is installed that reduces the boiler water temperature as the heating load decreases, the boiler is not used for any space heating, or the boiler is part of a modular or multiple boiler system having a total input of 300,000 Btu/hr or greater.

1. An external control may be connected to control either the firing rate or the set point of the boiler. If the external control uses a set of contacts to enable the boiler, connect the contacts to the Heat/Loop Demand 1 terminals. Otherwise, the SMART SYSTEM control will be enabled by the 0-10V signal.
2. Make sure the (-) terminal is connected to the (-) or common output terminal of the external control, and the 0 - 10 Vdc terminal is connected to the 0 - 10 Vdc terminal of the external control. Make sure the (-) voltage is not below ground.

### Runtime contacts

The SMART SYSTEM control closes a set of dry contacts whenever the burner is running. This is typically used by Building Management Systems to verify that the boiler is responding to a call for heat.

### Alarm contacts

The SMART SYSTEM control closes another set of contacts whenever the boiler is locked out or the power is turned off. This can be used to turn on an alarm, or signal a Building Management System that the boiler is down.

### DHW recirculation sensor

The Knight Fire Tube boiler is able to control a DHW recirculation pump. To operate this feature, a #100170581 temperature sensor must be installed in the circulation loop return. Connect this sensor to the DHW recirculation sensor terminals on the Low Voltage Connection Board.

### DHW recirculation pump

When the DHW recirculation sensor (as described above) is connected, the Knight Fire Tube SMART SYSTEM control will output 24 VAC to control a DHW recirculation pump relay (field supplied). Connect the coil of the DHW recirculation pump relay to the 24 VAC recirculation pump relay coil terminals on the Low Voltage Connection Board.

### Wiring of the cascade

When wiring the boilers for Cascade operation, select one boiler as the Leader boiler. The remaining boilers will be designated as Members. See page 66 "Configuration of the Cascade" for a detailed explanation of this procedure.

Connect the system supply sensor and outdoor air sensor (if used) to the Leader boiler. For the Cascade system to work properly the system supply sensor must be installed. The location of the system supply sensor should be downstream of the boiler connections in the main system loop (FIG.'s 6-7, 6-8, and 6-9). The system supply sensor should be wired to the Low Voltage Connection Board at the terminals marked for the system sensor (see FIG. 8-3). The Leader control will use the water temperature at the system supply sensor to control the operation of the Cascade.

## 8 Field wiring

If outdoor air reset is desired, the outdoor air sensor should be wired to the Low Voltage Connection Board at the terminals marked for the outdoor air sensor (FIG. 8-3). If the outdoor air sensor is connected, the Leader control will calculate the water temperature set point based on the programmed reset curve parameters. If the outdoor air sensor is not connected, the Leader control will maintain the fixed water temperature set point that is programmed into the control.

If a Thermostat, Zone Control enable output, or Building Management System enable output is available, it should be wired to the Low Voltage Connection Board on the Leader boiler at the terminals marked for one of the heat/loop demands 1-3 (FIG. 8-3). If the boilers are to run continuously, connect a jumper wire between the R and W terminals for the heat/loop demand input. This will initiate a call for heat on the Cascade.

Communication between the Leader boiler and the Member boilers is accomplished by using shielded, 2-wire twisted pair communication cable. Connect one of the twisted pair wires to Cascade terminal A on each of the Low Voltage Connection boards, and the other wire of the twisted pair to Cascade terminal B on each of the Low Voltage Connection Boards. Connect the shield wires to one of the shield terminals on the Low Voltage Connection Boards (FIG. 8-3). If more than two boilers are on the Cascade, daisy chain the wiring from the Cascade terminals on the second boiler to the Cascade terminals on the third boiler, then from the third to the fourth, and so on. The connections between boilers can be made in any order, regardless of the addresses of the boilers. Try to keep each cable as short as possible.

When the Member 1 boiler is programmed as an alternate leader this allows the Member 1 boiler to automatically assume control of the Cascade should it lose communications with the Leader boiler. When programmed to YES, it is recommended that the Member 1 boiler have its own set of external sensors installed (such as the system supply sensor), to maintain the same level of temperature control as with the Leader boiler. Voltage signals (such as 0 - 10V system pump speed input) can be connected to both boilers.

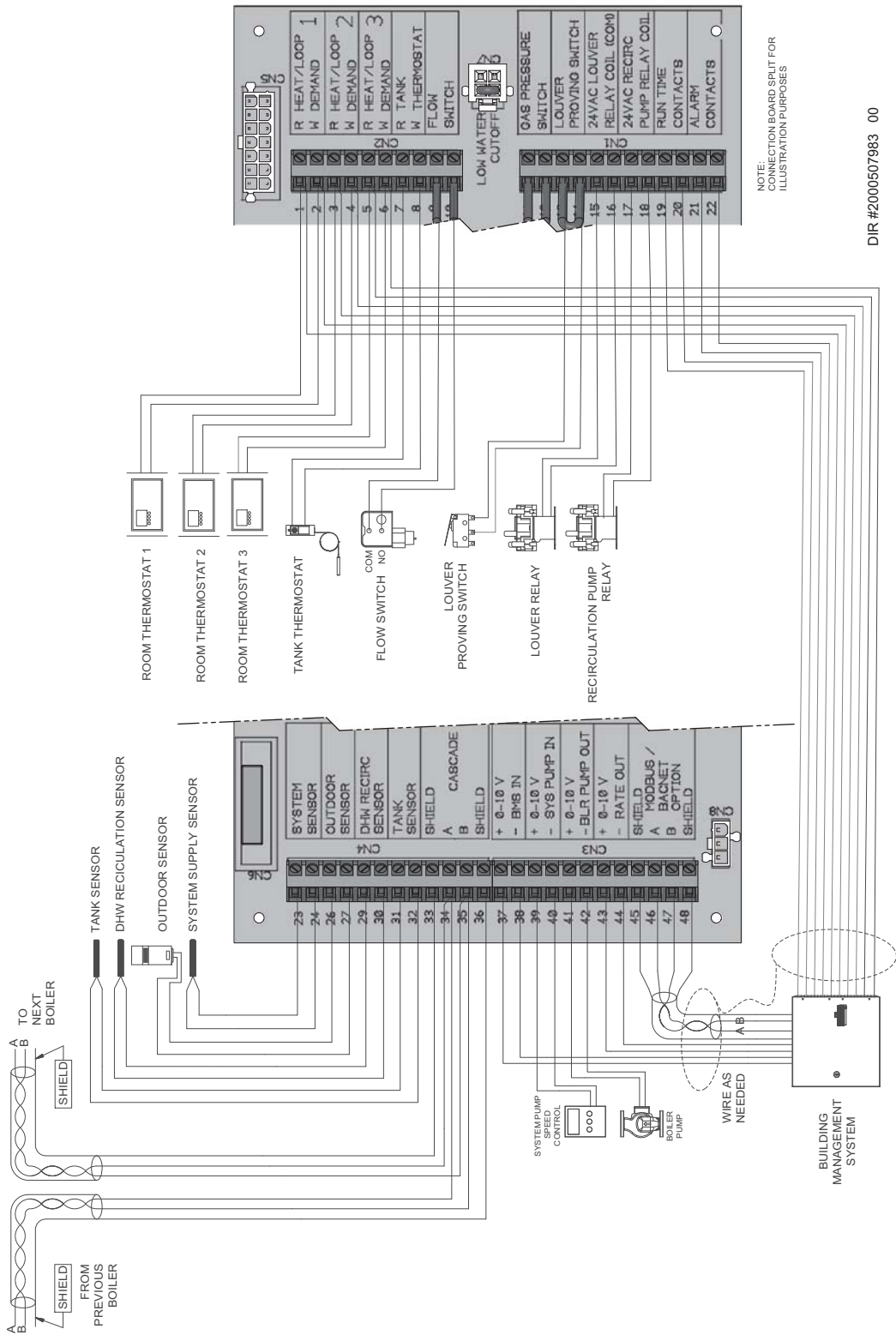
**⚠ WARNING**

DO NOT connect the sensors connected to the Leader boiler to the Member 1 boiler. The actual water temperatures will be higher than expected, which could lead to property damage, personal injury, or death.

When communication is re-established with the Leader boiler, Member 1 will automatically relinquish control of the Cascade to the Leader boiler.

# 8 Field wiring (continued)

Figure 8-3 Low Voltage Field Wiring Connections



DIR #2000507983 00

## 9 Condensate disposal

### Condensate drain

1. The Knight Fire Tube boiler is a high efficiency appliance that produces condensate.
2. The condensate trap has a 1/2" outlet connection pipe for tubing.
3. Slope condensate tubing down and away from the boiler into a drain or condensate neutralizing filter. Condensate from the Knight Fire Tube boiler will be slightly acidic (typically with a pH from 3 to 5). Install a neutralizing filter if required by local codes.

A Neutralizer Kit is available from the factory (FIG. 9-1).

4. Do not expose condensate line to freezing temperatures.

#### NOTICE

Use materials approved by the authority having jurisdiction. In the absence of other authority, PVC and CPVC pipe must comply with ASTM D1785 or D2845. Cement and primer must comply with ASME D2564 or F493. For Canada use CSA or ULC certified PVC or CPVC pipe, fittings, and cement.

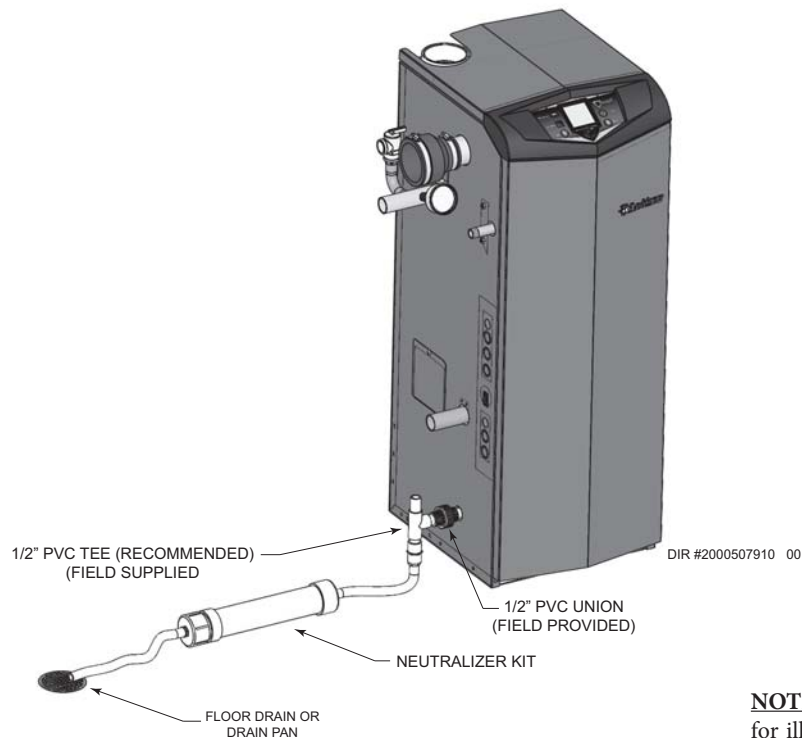
#### NOTICE

To allow for proper drainage on large horizontal runs, a second line vent may be required and tubing size may need to increase to 1 inch.

The condensate line must remain unobstructed, allowing free flow of condensate. If condensate is allowed to freeze in the line or if the line is obstructed in any other manner, condensate can exit from the boiler tee, resulting in potential water damage to property.

5. A condensate removal pump is required if the boiler is below the drain. When installing a condensate pump, select one approved for use with condensing boilers and furnaces. The pump should have an overflow switch to prevent property damage from condensate spillage. The switch should be wired in series with the blocked drain switch inside the boiler (see FIG. 10-1 on page 63).

**Figure 9-1** Condensate Disposal



**NOTE:** Neutralizer shown for illustrative purposes only. Actual neutralizer may vary.

# 10 Start-up

## Pre-Commissioning Cleaning

1. Prior to fill and start-up, flush the entire heating system.
2. Clean the entire heating system with an approved pre-commissioning cleaner (comparable to Sentinel X300 or Fernox F3) in accordance with the manufacturer's recommendation to remove debris and prolong the life of the heat exchanger.
3. Clean all water filtering devices in the system.
4. Flush the cleaning solution out of the entire system and refill.

## Fill water

### Check/control fill water chemistry

**IMPORTANT** Conduct water quality testing prior to installing the appliance. Various solutions are available to adjust water quality.

The manufacturer recommends the following for properly filling your boiler with the appropriate water chemistry for closed loop boilers. Good fill water quality will help extend the life of the appliance by reducing the effects of lime scale buildup and corrosion in closed loop systems.

### Hardness between 5 and 12 grains per gallon

1. Consult local water treatment companies for hard water areas (above 12 grains per gallon hardness).
2. Hardness levels that are above 12 grains/gallon can lead to lime scale buildup throughout the boiler system. If the fill water is below 5 grains/gallons, usually due to use of a water softener, it is recommended to mix in some potable water at the inlet to increase the hardness of the water to above 5 grains/gallons.

### pH between 6.5 and 8.5

1. pH levels below 6.5 can cause an increase in the rate of corrosion. pH of 8.5 or higher can potentially cause lime scale buildup.

### Total Dissolved Solids (TDS) less than 350 ppm

1. Total dissolved solids are all minerals, salts, metals, and charged particles that are dissolved in water.
2. The greater the amounts of TDS present, the higher the corrosion potential due to increased conductivity in the water.

### Chlorine concentration less than 150 ppm

1. Do not fill boiler or operate with water containing chlorine in excess of 150 ppm.
2. Filling with fresh drinking water should be acceptable.
3. Do not use the boiler to directly heat swimming pool or spa water.

## Boiler water

### CAUTION

Do not use petroleum based cleaning or sealing compounds in the boiler system. Gaskets and seals in the system may be damaged. This can result in substantial property damage.

### CAUTION

DO NOT use "homemade cures" or "boiler patent medicines". Serious damage to boiler, personnel, and/or property may result.

**Table 10A Boiler Water Chemistry**

BOILER WATER CHEMISTRY	
Specification	Range
Dissolved Solids	< 2000 ppm
pH Level	6.5 to 9.5
Chloride	< 150 ppm

- Monitoring pH, chlorides, TDS, and hardness levels can prolong the life of the appliance by reducing lime scale buildup, corrosion, and erosion. Check for leaks to ensure that fresh water is not entering the system.
- Continual fresh makeup water will reduce boiler life.
- Mineral buildup in the heat exchanger reduces heat transfer, overheats the stainless steel heat exchanger, and causes failure.
- The addition of oxygen carried in by makeup water can cause internal corrosion in system components.
- Leaks in the boiler or piping must be repaired at once to prevent excessive makeup water. For this purpose, it is recommended to install a water meter to easily check the amount of makeup water entering the system. Makeup water volume should not exceed 5% of the total system volume per year. **NOTE:** When makeup water is added, make sure the chemical additives are added to maintain the correct level.
- An approved multi-metal corrosion inhibitor (comparable to Sentinel X100 or Fernox F1) is recommended at the correct concentration and in the manner recommended by the manufacturer.

## Freeze protection

### WARNING

Ethylene glycol is toxic, DO NOT use as your freeze protection. Ethylene glycol has a sweet aroma which children and pets could mistake as food and ingest; leading to death.

# 10 Start-up

1. Use glycol only if needed for freeze protection.
2. Propylene glycol is the recommended freeze protection.
3. Make sure to flush the boiler system before adding glycol.
4. Determine the freeze protection fluid quantity using system water content, following the fluid manufacturer's instructions. Boiler water content is listed on page 6. Remember to include expansion tank water content.
5. Local codes may require a backflow preventer or actual disconnect from city water supply.
6. When using freeze protection fluid with automatic fill, it is suggested to install a water meter to monitor water makeup. Freeze protection fluid may leak before the water begins to leak, causing the concentration to drop, which reduces the freeze protection level.
7. The freeze protection set points may be lowered when freeze protection fluid is used (see the Knight Fire Tube Service Manual).
8. Consult the glycol manufacturer for details on the suggested mix of glycol and water for the desired freeze protection level and the de-rate effect it will have on the boiler output.

## Test / replace freeze protection fluid

1. For systems using freeze protection fluids, follow the fluid manufacturer's instructions.
2. Freeze protection fluid must be replaced periodically due to degradation of inhibitors over time.
3. It is recommended to test the glycol concentration annually and adjust within the desired set points.

## Oxygen prevention

### CAUTION

Eliminate all system leaks. Continual fresh makeup water will reduce boiler life. Minerals can build up in the heat exchanger, reducing heat transfer, overheating the heat exchanger, and causing heat exchanger failure.

Dissolved oxygen can have a negative effect on the boiler system. Oxygen can cause iron oxide to generate iron deposits. Oxygen may also increase the rate of corrosion on non-stainless steel parts of the system. A low pH level combined with oxygen further enhances its corrosive effects. After boiler installation, check for air leaks in the following areas:

- Suction gasket
- Pump
- Air valve
- O-ring gaskets

Precautions include installing a water meter to evaluate the fresh water volume entering the system (should be no more than 5% system volume). Additional volumes of fresh water could indicate that a leak is present.

### Fill and test water system

1. Fill system only after ensuring the water meets the requirements of this manual.
2. Close automatic and manual air vents and boiler drain valve.
3. Fill to correct system pressure. Correct pressure will vary with each application.
  - a. The minimum cold water fill pressure for a system is 12 psi.
  - b. Pressure will rise when the boiler is turned ON and system water temperature increases.
4. At initial fill and during boiler startup and testing, check the system thoroughly for any leaks. Repair all leaks before proceeding further.

### Purge air from water system

1. Purge air from system:
  - a. Connect a hose to the purge valve (see purge/drain valve in the piping diagrams on pages 40 through 50). Route the hose to an area where water can drain and be seen.
  - b. Close the boiler or system isolation valve between the purge valve and fill connection to the system.
  - c. Close zone isolation valves.
  - d. Open the quick-fill valve on the cold water makeup line.
  - e. Open purge valve.
  - f. Open the isolation valves one zone at a time. Allow water to run through the zone, pushing out the air. Run until no noticeable air flow is present. Close the zone isolation valves and proceed with the next zone. Follow this procedure until all zones are purged.
  - g. Close the quick-fill water valve and purge valve and remove the hose. Open all isolation valves. Watch that system pressure rises to correct cold-fill pressure.
  - h. After the system has operated for a while, eliminate any residual air by using the manual air vents located throughout the system.
  - i. If purge valves are not installed in the system, open the manual air vents in the system one at a time, beginning with the lowest floor. Close the vent when water squirts out. Repeat with remaining vents.
2. Open the automatic air vent (diaphragm-type or bladder type expansion tank systems only) one turn.
3. Open other vents:
  - a. Starting on the lowest floor, open air vents one at a time until water squirts out.
  - b. Repeat with remaining vents.
4. Refill to correct pressure.

# 10 Start-up *(continued)*

## Check for gas leaks

### **⚠ WARNING**

Before starting the boiler, and during initial operation, smell near the floor and around the boiler for gas odorant or any unusual odor. Remove the top access panel and smell the interior of the boiler enclosure. Do not proceed with startup if there is any indication of a gas leak. Use an approved leak detection solution. Repair any leaks at once.

### **⚠ WARNING**

DO NOT adjust gas valve outlet pressure. The gas valve is factory set for the correct outlet pressure. This setting is suitable for natural gas and propane, requiring no field adjustment. Attempting to alter the gas valve outlet pressure could result in damage to the valve, causing potential severe personal injury, death, or substantial property damage.

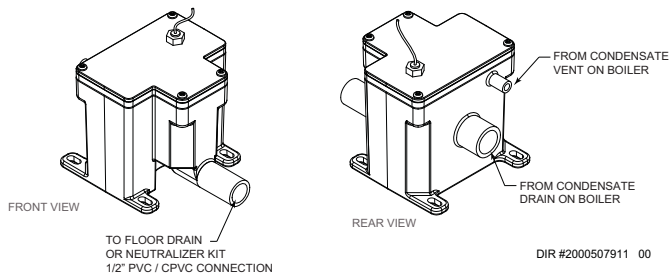
### **⚠ WARNING**

Propane boilers only – Your propane supplier mixes an odorant with the propane to make its presence detectable. In some instances, the odorant can fade, and the gas may no longer have an odor. Before startup (and periodically thereafter), have the propane supplier verify the correct odorant level in the gas.

## Check thermostat circuit(s)

1. Disconnect the two external wires connected to each of the heat/loop demand terminals on the connection board.
2. Connect a voltmeter across these two incoming wires. Close each thermostat, zone valve, and relay in the external circuit one at a time and check the voltmeter reading across the incoming wires.
3. There should NEVER be a voltage reading.
4. If a voltage does occur under any condition, check and correct the external wiring. (This is a common problem when using 3-wire zone valves.)
5. Once the external thermostat circuit wiring is checked and corrected if necessary, reconnect the external thermostat circuit wires to the connection board.

**Figure 10-1 Condensate Trap**



## Inspect/fill condensate system

### Inspect/check condensate lines and fittings

1. Inspect the condensate drain line, condensate PVC fittings and condensate trap.

# 10 Start-up

## Final checks before starting the boiler

- ❑ Read the Knight Fire Tube Boiler Service Manual to familiarize yourself with SMART SYSTEM control module operation. Read this manual, page 67 for proper steps to start boiler.
- ❑ Verify the boiler and system are full of water and all system components are correctly set for operation.
- ❑ Verify the preparation procedures of Section 10, pages 61 thru 64 have been completed.
- ❑ Verify electrical connections are correct and securely attached.
- ❑ Inspect vent piping and air piping for signs of deterioration from corrosion, physical damage or sagging. Verify air piping and vent piping are intact and correctly installed per this manual.

## Start the boiler

1. Read and follow the Operating instructions in FIG. 10-2, page 67.

## If boiler does not start correctly

1. Check for loose connections, blown fuse or service switch off?
2. Is boiler water temperature above 200°F?
3. Is thermostat set below room temperature?
4. Is gas turned on at meter or boiler?
5. Is incoming gas pressure less than 4 inches w.c.?

If none of the above corrects the problem, refer to the Troubleshooting Section of the Knight Fire Tube Boiler Service Manual.

## Check system and boiler

### ❑ Check water piping

1. Check system piping for leaks. If found, shut down the boiler and repair immediately. (See WARNINGS on pages 61 thru 64 (startup) regarding failure to repair leaks.)
2. Vent any remaining air from the system using manual vents. Air in the system will interfere with circulation and cause heat distribution problems and noise.

### ❑ Check vent piping and air piping

1. Check for gastight seal at every connection, seam of air piping, and vent piping.

#### **⚠ WARNING**

Venting system must be sealed gastight to prevent flue gas spillage and carbon monoxide emissions, which will result in severe personal injury or death.

### ❑ Check gas piping

1. Check around the boiler for gas odor following the procedure on page 51 of this manual (connecting gas supply piping).

#### **⚠ WARNING**

If you discover evidence of any gas leak, shut down the boiler at once. Find the leak source with a bubble test and repair immediately. Do not start the boiler again until corrected. Failure to comply could result in severe personal injury, death, or substantial property damage.

### ❑ Propane boilers – verify conversion

1. Verify propane conversion has been completed per the Propane Conversion instructions.

#### **⚠ WARNING**

DO NOT adjust gas valve outlet pressure. The gas valve is factory-set for the correct outlet pressure. This setting is suitable for natural gas and propane, requiring no field adjustment. Attempting to alter the gas valve outlet pressure could result in damage to the valve, causing potential severe personal injury, death, or substantial property damage.

#### **⚠ WARNING**

Knight Fire Tube boilers are typically shipped ready to fire on natural gas. Check boiler rating plate to determine which fuel the boiler is set for. If set to natural gas, it may be converted to LP by installing an LP venturi (see page 12). In order to operate on LP gas, an LP venturi MUST BE installed. Failure to comply could result in severe personal injury, death, or substantial property damage.

## Check flame and combustion

1. Turn the main power off to the boiler by placing the “On/Off” switch in the OFF position.
2. When using PVC/CPVC remove the 1/2" combustion plug from the tee supplied in the installation kit (see FIG. 3-7 on page 19). For all other venting options, remove the flue temperature sensor from the flue pipe connection. Note: Combustion measurements will be made at this point.
3. Turn the main power on to the boiler by placing the “On/Off” switch in the ON position.



# 10 Start-up *(continued)*

**NOTICE**

Please note that the brackets ([]) denote screen status.

4. Place the boiler into the active position by pressing the RIGHT SELECT [ON] key (FIG. 11-1, page 75).
5. Locate the pinhole button above the RESET button on the display board (FIG. 11-1). Insert a thin wire (such as a paper clip) into the hole and press the button once and hold for 5 seconds to place the boiler into Service Mode. In Service Mode the boiler will fire at ignition speed and will then modulate up to full fire.
6. Insert the probe from a combustion analyzer into the hole left by the removal of the 1/2" combustion plug (FIG. 3-7, page 19) or the flue temperature sensor.
7. Once the boiler has modulated up to full fire, measure the combustion. The values should be in the range listed in Table 10A below. The CO levels should be less than 150 ppm for a properly installed unit.

If the combustion is not within the specified range, reference the Troubleshooting Section of the Knight Fire Tube Boiler Service Manual for possible causes and corrective actions.

**Table 10A Flue Products Chart**

Input Rate	Natural Gas		Propane Gas	
	CO <sub>2</sub>	O <sub>2</sub>	CO <sub>2</sub>	O <sub>2</sub>
High Fire	9.0% - 10.5%	2.1% - 4.8%	10.5% - 11.5%	3.5% - 5.0%
Low Fire	8.8% - 9.5%	3.9% - 5.2%	10.0% - 11.0%	4.2% - 5.8%

8. Once the combustion analysis is complete, test the safety shutoff device by turning the manual shutoff switch to the OFF position and ensuring that the boiler shuts down and registers an alarm. Turn the manual shutoff switch to the ON position and reset the control.
9. Turn the main power off to the boiler and re-install the 1/2" combustion plug (FIG. 3-7) or replace the flue temperature sensor into the flue pipe connection.
10. Place the boiler back into normal operation.

**WARNING**

You must replace the flue gas temperature sensor / 1/2" combustion plug (depending on venting option) to prevent flue gas spillage into the room. Failure to comply could result in severe personal injury, death, or substantial property damage.

## Set space heating operation

### Determine controlling sensor

For space heating systems, the temperature control can be based on one of three sensors; the inlet, outlet, or system supply sensor. The SMART SYSTEM control is programmed at the factory to control the temperature of the outlet sensor. The control will automatically switch to the system supply sensor once it is connected. If it is desired to base the temperature control on the inlet sensor, the appropriate parameter must be changed in the control. See the Knight Fire Tube Boiler Service Manual for a detailed explanation of this procedure.

### Verify space heat circulator mode

The Space Heating Mode controls both the system pump (if connected), and the boiler pump. When the SMART SYSTEM control receives a space heating call for heat, it turns on the system pump. If the boiler is not heating an indirect DHW (Domestic Hot Water) tank, and the set point is not met, it also turns on the boiler pump. After the space heating call for heat ends, the system pump continues to run for a short period of time. The system pump can be programmed to run continuously, except during outdoor shutdown. If the boiler pump was running, it continues to run for a short period of time as well. These pump delays are factory set to 30 seconds. If different delays are desired, the appropriate parameters in the control must be changed. See the Knight Fire Tube Boiler Service Manual for a detailed explanation of this procedure.

### Adjust set point temperature(s)

**NOTICE**

Please note that the brackets ([]) denote screen status.

The NAVIGATION dial may be used during normal operation to adjust the space heating and tank set point temperatures.

1. From the Status Screen press the NAVIGATION dial.
2. Turn the NAVIGATION dial counterclockwise to select the appropriate set point.
3. Press the NAVIGATION dial to adjust the temperature.
4. Once the desired temperature is displayed, press the RIGHT SELECT [SAVE] key.
5. If necessary repeat Steps 3 and 4 to make adjustments to additional set points.
6. Press the RIGHT SELECT [HOME] key to upload the changes.
7. If the RIGHT SELECT [SAVE] key is not pressed, the new settings will be discarded.

# 10 Start-up

## Set domestic hot water (DHW) operation

### Verify DHW mode

There are two (2) modes of operation for DHW. In Normal Mode, when a DHW demand begins, the control will start the DHW pump, turn off the boiler pump (if running), and modulate to bring the outlet temperature to the DHW boiler set point. The maximum firing rate may be limited in this mode if desired.

In Zone Mode it is assumed that the indirect DHW tank is piped as a zone on the primary loop. When a DHW demand begins, the control will turn on the DHW pump output, and raise the system temperature set point to the DHW boiler set point (if higher). The boiler pump will be turned on. The system pump may be forced on, forced off, or not changed, depending on the System Pump Mode selected (reference the Knight Fire Tube Service Manual for details). In this mode, any low temperature zones (such as radiant heating) may need additional controls to limit the water temperature sent to those zones.

### Set DHW boiler target temperature

When in the DHW Mode, the control will modulate to maintain the boiler outlet temperature or system supply temperature to a set point. This set point is set at the factory to 180°F. If a different set point is desired, the appropriate parameter in the control must be changed. See the Knight Fire Tube Boiler Service Manual for a detailed explanation of this procedure.

### Set maximum DHW fan speed

If the rated input of the indirect tank is less than the maximum output of the boiler, change the maximum DHW fan speed setting to limit the boiler output accordingly, see the Knight Fire Tube Boiler Service Manual for a detailed explanation of this procedure.

### Set clock

#### NOTICE

Please note that the brackets ([]) denote screen status.

The SMART SYSTEM control has a built-in clock that it uses for its night setback feature and for logging events. This clock must be set when the boiler is installed, and anytime the boiler has been powered off for more than 4 hours. Use the following procedure to set the clock:

1. Press and hold the LEFT SELECT [MENU] key for at least 5 seconds.
2. The display changes to read [PASSWORD], with four (4) zeros below it.
3. Press the RIGHT SELECT [SAVE] key.
4. The display will then show a menu with the time and date and temperature unit.
5. Press the NAVIGATION dial twice.
6. Turn the NAVIGATION dial to adjust the hours. Press the NAVIGATION dial.

7. Turn the NAVIGATION dial to adjust the minutes. Press the NAVIGATION dial.
8. Turn the NAVIGATION dial to adjust the month. Press the NAVIGATION dial.
9. Turn the NAVIGATION dial to adjust the date. Press the NAVIGATION dial.
10. Turn the NAVIGATION dial to adjust the year. Press the RIGHT SELECT [SAVE] key.
11. Press the RIGHT SELECT [HOME] key.

#### NOTICE

The internal clock does not adjust for Daylight Savings Time and therefore, will require a manual adjustment.

The clock is automatically updated whenever a PC is connected and the Win Pro-Installer program is started.

### Configuration of the cascade

#### NOTICE

Please note that the brackets ([]) denote screen status.

When installed in a Cascade system, the individual controls must be programmed for cascade operation. This is accomplished by accessing the control parameters.

Press the [MENU] key for at least five (5) seconds. Input the Installer code as described in the Knight Fire Tube Boiler Service Manual. Once the control parameters have been accessed, use the NAVIGATION dial to select the Control Mode parameters. Press the NAVIGATION dial to access these parameters.

Rotate the NAVIGATION dial to select the parameter "Cascade Address". Press the NAVIGATION dial to access this parameter. Each appliance in the Cascade system must be programmed with its own address. The boiler designated as the Leader will have an address of 0. The remaining boilers in the Cascade will be Members and have addresses from 1 - 7. Rotate the NAVIGATION dial to select the appropriate address. Press the RIGHT SELECT [SAVE] key.

Press the RIGHT SELECT [HOME] key to upload the address into the control. Repeat this procedure for all boilers in the Cascade, designating the Leader control and the Member controls.

# 10 Start-up *(continued)*

Figure 10-2 Operating Instructions

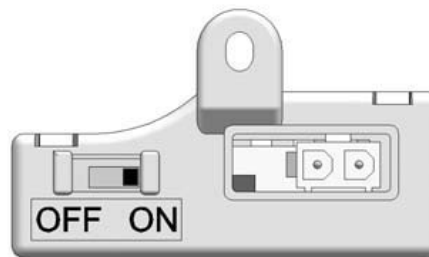
## FOR YOUR SAFETY READ BEFORE OPERATING

**WARNING:** If you do not follow these instructions exactly, a fire or explosion may result causing property damage, personal injury, or loss of life.

- |  |  |
|--|--|
| <p>A. This appliance does not have a pilot. It is equipped with an ignition device which automatically lights the burner. Do <u>not</u> try to light the burner by hand.</p> <p>B. BEFORE OPERATING smell all around the appliance area for gas. Be sure to smell next to the floor because some gas is heavier than air and will settle on the floor.</p> <p><b>WHAT TO DO IF YOU SMELL GAS</b></p> <p>Do not try to light any appliance.</p> <p>Do not touch any electric switch; do not use any phone in your building.</p> | <p>Immediately call your gas supplier from a neighbor's phone. Follow the gas supplier's instructions.</p> <p>If you cannot reach your gas supplier, call the fire department.</p> <p>C. Use only your hand to move the gas control switch. Never use tools. If the switch will not move by hand, don't try to repair it, call a qualified service technician. Force or attempted repair may result in a fire or explosion.</p> <p>D. Do not use this appliance if any part has been under water. Immediately call a qualified service technician to inspect the appliance and to replace any part of the control system and any gas control which has been under water.</p> |
|--|--|

## OPERATING INSTRUCTIONS

- |  |   |
|--|---|
| <ol style="list-style-type: none"> <li>1. <b>STOP!</b> Read the safety information above on this label.</li> <li>2. Set the thermostat to lowest setting.</li> <li>3. Turn off all electric power to the appliance.</li> <li>4. This appliance is equipped with an ignition device which automatically lights the burner. Do not try to light the burner by hand.</li> <li>5. Remove front door.</li> <li>6. Move switch to the "OFF" position.</li> <li>7. Wait five (5) minutes to clear out any gas. If you then smell gas, <b>STOP!</b> Follow "B" in the safety information above this label. If you don't smell gas, go to next step.</li> </ol> | <ol style="list-style-type: none"> <li>8. Move the switch to the "ON" position.</li> <li>9. Install front door.</li> <li>10. Turn on all electric power to appliance.</li> <li>11. Set thermostat to desired setting.</li> <li>12. If the appliance will not operate, follow the instructions "To Turn Off Gas To Appliance" and call your service technician or gas supplier.</li> </ol> |
|--|---|



## TO TURN OFF GAS TO APPLIANCE

- |   |  |
|---|--|
| <ol style="list-style-type: none"> <li>1. Set the thermostat to lowest setting.</li> <li>2. Turn off all electric power to the appliance if service is to be performed.</li> <li>3. Remove front door.</li> </ol> | <ol style="list-style-type: none"> <li>4. Move switch the "OFF" position.</li> <li>5. Install front door.</li> </ol> |
|---|--|

# 11 Operating information

## General

### How the boiler operates

The Knight Fire Tube boiler uses an advanced stainless steel heat exchanger and electronic control module that allows fully condensing operation. The blower pulls in air and pushes flue products out of the boiler through the heat exchanger and flue piping. The control module regulates blower speed to control the boiler firing rate. The gas valve senses the amount of air flowing into the boiler and allows only the right amount of gas to flow.

### How the control module operates

The SMART SYSTEM control module receives inputs from boiler sensors and external devices. The control module activates and controls the blower and gas valve to regulate heat input and switches the boiler, Domestic Hot Water (DHW), and system pumps on and off as needed. The user programs the module to meet system needs by adjusting control parameters. These parameters set operating temperatures and boiler operating modes. Boiler operation can be based on boiler outlet water temperature, boiler inlet water temperature, system temperature, a 0-10V signal or ModBus or BACnet, depending on the parameter settings.

### Control inputs and outputs

#### Room thermostat

There are three (3) heat/loop demand connections available on this control. These inputs tell the boiler to provide water for space heating. Each demand connection has its own set point and outdoor air reset curve. When multiple demands have a call for heat the control will give priority to the demand with the highest set point.

*Example:* Assume that both heat/loop demand 1 and heat/loop demand 2 have a call for heat. Demand 1 has a set point of 110°F. Demand 2 has a set point of 140°F. The boiler will regulate the system temperature to 140°F until Demand 2 has been satisfied. Once Demand 2 has been satisfied the boiler will provide 110°F water to the system.

#### **CAUTION**

When multiple temperature loops are used, mixing valves are required for the protection of any low temperature loops.

### SMART SYSTEM Multi-temp loop control

The Knight Fire Tube boiler is capable of producing up to three (3) set point temperatures to meet different space heating demands. This device controls the temperatures of up to three (3) separate loops, based on the settings for the three (3) heat/loop demands (reference Lochinvar kit #100167843).

#### 0 - 10V input (set point or power)

The Knight Fire Tube boiler can be controlled by a Building Management System (BMS) provided that either an external energy management system is installed that reduces the boiler water temperature as the heating load decreases, the boiler is not used for any space heating, or the boiler is part of a modular or multiple boiler system having a total input of 300,000 Btu/hr or greater.

The control can be configured by the installer to use a 0 - 10 Vdc signal to either control set point or firing rate.

The Knight Fire Tube boiler can also be programmed to accept a call for heat from a 0 - 10V signal, reference the Knight Fire Tube Boiler Service Manual for a detailed explanation of this procedure.

#### DHW priority

The SMART SYSTEM control allows the connection of a DHW thermostat or tank sensor to the low voltage connection board. When a tank sensor is connected, the DHW thermostat input is ignored. When a boiler is programmed for DHW Normal Mode, the maximum firing rate can be limited to match the input rating of the indirect tank coil.

#### DHW / space heating (SH) cycling

If a DHW call for heat is received while a space heating call is in progress, and the DHW is in Normal Mode, the control will start the DHW pump and shut the boiler pump off. The system pump will remain on. For stand-alone boilers, if the space heating call is still active while the DHW call is in operation, the control will wait for 30 minutes (time adjustable by installer) then it will switch back to the space heating demand. There is a timer to switch from space heating to DHW and a timer to switch from DHW to space heating. The control will switch back and forth until one of the heat demands end.

#### Programmable controlling sensor

The control module is programmed to use the outlet sensor as the control sensor by default. If a system supply sensor is connected, the control automatically uses it as the control sensor. For stand-alone boilers, the control sensor can be changed by the installer to the inlet sensor. If the inlet sensor is chosen as the controlling sensor, it is recommended that the system supply sensor be installed in the system supply in order to provide the best control of the inlet temperature.

# 11 Operating information *(continued)*

## Anti-cycling

After the burner turns off, the control will delay the next burner cycle for a set time period (time is adjustable by the installer). The time delay will be bypassed if the inlet water temperature drops too far during the delay.

## Boiler and system pump control

The boiler pump will run whenever the burner is firing, unless the DHW is programmed for Normal Mode and the boiler is heating the DHW tank. The boiler pump will run during Freeze Protection Mode as well. It will continue to run for a short time after the burner turns off or the Freeze Protection Mode ends.

The system pump will run whenever there is a space heating call for heat, or the boiler goes into Freeze Protection Mode. It may be programmed to run during a DHW call for heat when the DHW is programmed for Zone Mode. It will continue to run for a short time after the end of the heat demand or the Freeze Protection Mode. The system pump can be programmed to run continuously if desired, except during outdoor shutdown and/or a DHW call for heat.

## DHW recirculation pump control

When a DHW recirculation loop is used, the Knight Fire Tube boiler can control the recirculation pump. To activate this function, simply install the DHW recirculation sensor into the return water from the DHW circulation loop. The control will turn on the DHW recirculation pump when the return water drops 10°F (5.5°C) below the DHW tank set point, and will turn back off when the return water rises to within 5°F (2.5°C) of the DHW tank set point. The control will turn the DHW recirculation pump off whenever DHW night setback is active.

## Temperature control

### Modulation

The Knight Fire Tube boiler is capable of modulating its firing rate on KH55 models only from a minimum of 10% to a maximum of 100% and on all other models from a minimum of 15% to a maximum of 100%. The firing rate is dictated by the call for heat (i.e., space heating or domestic hot water), the heating load, ramp delay (if enabled), and various other temperature limitations.

## Ramp delay

For systems with lower flow, the SMART SYSTEM can limit the firing rate (when enabled) when a space heating call for heat starts, or when switching from a DHW call for heat to a space heating call for heat. There are six (6) limits that can be programmed, as well as six (6) time intervals corresponding to each limit. The sixth limit will also limit the firing rate for the rest of the call for heat.

## Gradient limiting

If during operation of the boiler the outlet water temperature is rising too quickly, the control will reduce the firing rate to its lowest setting.

## Outdoor air reset

With the outdoor air sensor connected, the control module will calculate the set points of the three (3) space heating demands based on the programmed reset curves. The installer can change the slope of the reset curves by several adjustable parameters. The user can limit the maximum set point for the system using the space heating set points.

## Boost function

If outdoor air reset is active, and any space heating demand has been active continuously for a set period of time (time adjustable by installer) and there has been no DHW demands, the control will increase the set point of that demand by a fixed number of degrees (adjustable by installer). This process will continue until the space heating demand ends, the set point reaches the programmed set point or a maximum of 20 increases has occurred. Once the system heat demand is satisfied, the set point will revert to the value determined by the reset curve.

## Night setback

The controller may be programmed to reduce the space heating and DHW set points during certain times each week. Seven different start and stop times may be programmed for the space heating setback and seven start and stop times for the DHW setback. Any night setback event scheduled within the next seven (7) days can be temporarily bypassed if desired.

## Vacation mode

Vacation Mode is used to lower the Space Heat (SH) and / or DHW set points much like Night Setback. The set points will remain lowered until Vacation Mode is disabled. Night Setback will not function when Vacation Mode is enabled.

## Flame current support

To prevent nuisance shutdowns when the boiler is firing at minimum rates, the control will increase the firing rate when the flame signal drops too low.

# 11 Operating information

## Protection features

### Outlet temperature, flue temperature, and temperature rise limiting

The outlet temperature is monitored by the boiler outlet temperature sensor. When the outlet temperature exceeds 185°F, the unit will reduce the fan speed. If the outlet water temperature exceeds 195°F the control will shut the unit down until it cools off.

The control module monitors the flue temperature by a sensor located in the flue exhaust. If the flue temperature exceeds 215°F the control will reduce the maximum fan speed. If the flue temperature exceeds 225°F (107°C) the control will shut the unit down. The unit will restart automatically once the flue temperature drops 10°F (6°C) and the minimum off time has expired.

The control monitors the temperature difference between the inlet and the outlet sensor. If this difference exceeds 55°F the control will reduce the maximum fan speed. If the temperature difference exceeds 60°F the control will shut the unit down. The unit will restart automatically once the temperature difference has dropped below 55°F and the minimum off time has expired.

### Freeze protection

DO NOT install the boiler in a room likely to freeze.

The following integral feature of the SMART SYSTEM control module provides some protection for the boiler only -- not for the system.

- The SMART SYSTEM control module provides freeze-up protection as follows when the boiler water temperature drops below 45°F:
- Below 45°F, the boiler and system pumps operate constantly.
- Below 37°F, the boiler turns on.
- Boiler and pumps turn off if boiler water temperature rises above 45°F.
- Lower temperatures may be programmed for systems with anti-freeze solutions.

#### NOTICE

When system return temperatures are maintained below the dew point, condensation will form on the inside of the boiler jacket causing some internal sheet metal components to rust.

#### CAUTION

This feature of the SMART SYSTEM control module does not eliminate the possibility of freezing. The installation must still use recognized design, installation and maintenance practice to prevent freeze potential for the boiler and system.

### Low voltage blocking

The blower and gas valve require a minimum amount of voltage in order to operate properly. If an ignition attempt is made when the line voltage is temporarily low (such as during a brownout), the control could enter a manual reset lockout. To prevent this, the control monitors the voltage and blocks any heat demands until the voltage returns to an acceptable level.

### Monitor external limits

Connections are provided on the connection board for external limits such as flow switch, low water cutoff, gas pressure switches, and a louver proving switch. The SMART SYSTEM will shut off the burner and inhibit relighting whenever any of these external limits open.

### Run-time and alarm outputs

The boiler provides dry contacts for indicating when the boiler is running, and when it is unable to operate.

### Run-time and cycle counting

The control uses two timers to monitor the total hours of burner operation. One timer monitors the time the boiler is firing in the Space Heating Mode. The other timer monitors the time the boiler is firing in the DHW Mode.

The control uses two (2) ignition counters to monitor the amount of boiler cycles. The first counter counts all ignitions of the control. The second counter counts only ignition attempts that have failed.

### Service reminder

The control can be programmed for service reminder notification. This notification will become active when either a set time frame has expired, or a set amount of running hours or cycles has expired (all adjustable by the installer). The display will show a Maintenance Required screen. The installer's name and phone number can be programmed into the control. This information will appear on the Maintenance Required screen. The service reminder notification can be reset or disabled by the installer.

### Error logging

The control will hold in memory the last 10 lockouts as well as the last 10 blockings. The date and time of the occurrence will be recorded as well. Only the 10 most current occurrences of each will be held in memory.

# 11 Operating information *(continued)*

## Boiler temperature regulation

### Operating temperature (target)

The SMART SYSTEM control module senses water temperature and regulates boiler firing and firing rate to achieve a target temperature. The target temperature can be set between 32°F and 190°F.

- Target temperature is calculated as described in the “*Outdoor Reset Operation*” section, when the outdoor sensor is connected.
- If the outdoor sensor is not connected, the target temperature is fixed at SH (1 - 3) set points. An outdoor sensor fault will remain on the display screen until the outdoor sensor is reconnected.

### High limit operations

The Knight Fire Tube boiler is equipped with adjustable automatic reset and manual reset high limits. The automatic reset high limit has a maximum set point of 200°F and the manual reset high limit has a maximum set point of 210°F.

When the outlet temperature exceeds 200°F, the automatic high limit action occurs. The boiler shuts down until the outlet water temperature cools below 190°F, and a 60 second timer has expired. If the outlet temperature continues to increase, the manual reset high limit action will occur at 210°F.

### High limit test procedure

#### NOTICE

Please note that the brackets ([ ]) denote screen status.

1. Turn ON the main power to the boiler by placing the ON/OFF switch in the ON position.
2. From the Status Screen, press the NAVIGATION dial to access the Set Points Screen.
3. Press the LEFT SELECT (LIMITS) key.
4. Select the manual reset high limit (MRHL) by rotating the NAVIGATION dial counterclockwise, then press the NAVIGATION dial.
5. Decrease the set point of the MRHL to below the current outlet temperature (or to its minimum setting, whichever is higher) by turning the NAVIGATION dial counterclockwise.
6. Press the RIGHT SELECT [SAVE] key.
7. Press the RIGHT SELECT [HOME] key. The new parameter will upload to the control.
8. If the current outlet temperature is above the new MRHL set point, the MRHL will function causing boiler lockout. If this occurs, skip to Step 11.

9. If the current outlet temperature is below the new MRHL set point, locate the pinhole (SERVICE button) above the RESET button on the display board. Insert a thin probe (such as a paper clip) into the hole and press the button continuously for five (5) seconds to place the boiler into Service Mode. In Service Mode, the boiler will fire at ignition speed and will then modulate up to full fire.
10. Once the outlet temperature rises up to the MRHL set point, the MRHL will function, causing the boiler to shut down and lock out.
11. Repeat Steps 2 - 7 to adjust the MRHL to its normal settings.

### Low water cutoff protection

1. The SMART SYSTEM control module uses temperature sensing of both supply and return areas of the heat exchanger. If the flow rate is too low or the outlet temperature too high, the control module modulates and shuts the boiler down. This ensures boiler shutdown in the event of low water or low flow conditions.
2. Some codes and jurisdiction may accept these integral features of the control in lieu of requiring an additional limit control or low water cutoff. Consult local jurisdiction to determine. A low water cutoff is available from the factory (#100173646).

## Outdoor reset operation

### Target temperature with outdoor reset

This feature improves the system's efficiency by decreasing set point as the outdoor temperature increases. Energy Efficiency Standards require the use of a control that automatically adjusts set point in relation to heat demand. In the absence of an external energy management system, this feature MUST BE used.

See the Knight Fire Tube Boiler Service Manual to change the settings.

### Reset curve

The reset curve looks at outdoor air temperature and adjusts the set point in relation to heat demand.

# 11 Operating information

## Cascade

When multiple boilers are installed, they can be wired together in a cascade sequence. A maximum of eight boilers can be controlled from a single control. In this application one boiler would be designated as the Leader control and all others would be designated as Member controls. Member 1 can be configured to take over control of the Cascade should the Leader stop communicating with the members. The Leader control can be programmed to use Lead/Lag or Efficiency Optimization control methods.

Once the Leader boiler receives a call for heat from a room thermostat, BMS, or ModBus or BACnet, the control will determine what the set point will be. If outdoor air reset is desired, connect the outdoor air sensor to the terminals on the Low Voltage Connection Board on the Leader boiler. The set point will be calculated based on the programmed reset curve parameters. See the Knight Fire Tube Boiler Service Manual to program the reset curve. If outdoor air reset is not desired, do not connect the outdoor air sensor. A fixed temperature set point can be programmed into the control. See page 65 of this manual to program the set point.

If the water temperature at the system supply sensor is less than the set point + the turn-off offset - the off-on differential, then the control will initiate a call for heat on the Cascade (see the Knight Fire Tube Boiler Service Manual for an explanation of the offset and differential). The Leader will energize the lead boiler on the Cascade. For a new startup this will be the Leader boiler.

## Sequence of the cascade

To equalize the run time of all boilers on the Cascade, the firing sequence will automatically be changed at set intervals.

During the first 24 hours of operation, the sequence will change every hour. After that, the sequence will change every 24 hours. The switching on/off sequence will be as follows:

TIME	SWITCHING ON SEQUENCE
Start	L-M1-M2-M3-M4-M5-M6-M7
1 hour	M1-M2-M3-M4-M5-M6-M7-L
2 hours	M2-M3-M4-M5-M6-M7-L-M1

After the first 24 hours, the sequence will change every night at 2:00 a.m. If a boiler locks out or is used to heat an indirect DHW tank, it will automatically be given the lowest priority until 2:00 a.m.

## DHW, Night Setback, and Ramp Delay operation with cascade

For Normal Mode DHW operation any boiler(s) in the Cascade can be selected to provide heat for a DHW call. Select a boiler to be designated as the DHW boiler. Connect the DHW thermostat or sensor to the terminals on the Low Voltage Connection Board marked for the corresponding device. When the boiler receives a DHW call, the Leader control will take that boiler out of the Cascade sequence. If another boiler is available, the Leader will start it up to take its place.

The DHW boiler will adjust its set point to the programmed DHW boiler set point and will adjust its firing rate to maintain this. Once the DHW call has been satisfied, the Leader control will place that boiler back into the Cascade sequence.

Switching of the boiler between DHW operation and SH operation when there is a call for both does not occur in Cascade Mode.

When DHW is programmed for Zone Mode, connect the DHW thermostat or tank sensor to the Leader boiler. When a DHW call is received, the Leader will modulate the entire Cascade to bring the system supply temperature up to the DHW boiler set point (if higher).

Night Setback operation of the boilers within the Cascade is available. Programming of the Night Setback will be done through the Leader boiler. Refer to the Knight Fire Tube Boiler Service Manual for information regarding Night Setback.

Ramp Delay operation of the boilers as described in the Knight Fire Tube Boiler Service Manual is available when the boilers are part of a Cascade system.



# 11 Operating information *(continued)*

## Sequence of operation

OPERATION	DISPLAY
1. Upon a call for heat, the gas pressure switch(es) must be closed.	<pre> <b>STANDBY</b>  SYSTEM <input type="radio"/> DHW TANK <input type="radio"/> BOILER <input type="radio"/> DHW CIRC <input type="radio"/> SYSTEM: 117°F (118) TANK: 124°F (130) OUTDOOR: 56°F INLET: 109°F OUTLET: 124°F DHW RECIRC: 115°F  MENU  SCREEN SHDN                     </pre>
2. Once the gas pressure switch(es) are closed, the control turns on the appropriate pumps (system and boiler pumps for space heating, DHW pump for DHW). The flow switch and/or LWCO must close.	<pre> <b>STANDBY</b>  SYSTEM <input checked="" type="radio"/> DHW TANK <input type="radio"/> BOILER <input checked="" type="radio"/> DHW CIRC <input type="radio"/> SYSTEM: 117°F (118) TANK: 124°F (130) OUTDOOR: 56°F INLET: 109°F OUTLET: 124°F DHW RECIRC: 115°F  MENU  SCREEN SHDN                     </pre>
3. The control turns on power to the louver relay. The louver proving switch, and blocked drain switch must close.	<pre> <b>START</b>  SYSTEM <input checked="" type="radio"/> DHW TANK <input type="radio"/> BOILER <input checked="" type="radio"/> DHW CIRC <input type="radio"/> SYSTEM: 117°F (118) TANK: 124°F (130) OUTDOOR: 56°F INLET: 109°F OUTLET: 124°F DHW RECIRC: 115°F  MENU  SCREEN SHDN                     </pre>
4. The control starts the prepurge cycle by initiating the blower.	<pre> <b>PRE-PURGE</b>  SYSTEM <input checked="" type="radio"/> DHW TANK <input type="radio"/> BOILER <input checked="" type="radio"/> DHW CIRC <input type="radio"/> SYSTEM: 117°F (118) TANK: 124°F (130) OUTDOOR: 56°F INLET: 109°F OUTLET: 124°F DHW RECIRC: 115°F  MENU  SCREEN SHDN                     </pre>
5. The control starts the trial for ignition by firing the spark electrode and opening the gas valve.	<pre> <b>IGNITION</b>  SYSTEM <input checked="" type="radio"/> DHW TANK <input type="radio"/> BOILER <input checked="" type="radio"/> DHW CIRC <input type="radio"/> SYSTEM: 117°F (118) TANK: 124°F (130) OUTDOOR: 56°F INLET: 109°F OUTLET: 124°F DHW RECIRC: 115°F  MENU  SCREEN SHDN                     </pre>
6. If flame is not detected after the sparking ends, the control will perform a postpurge, then start another prepurge cycle and try to light the burner again. The control will perform a total of 4 attempts before locking out.	<pre> <b>POST-PURGE</b>  SYSTEM <input checked="" type="radio"/> DHW TANK <input type="radio"/> BOILER <input checked="" type="radio"/> DHW CIRC <input type="radio"/> SYSTEM: 117°F (118) TANK: 124°F (130) OUTDOOR: 56°F INLET: 109°F OUTLET: 124°F DHW RECIRC: 115°F  MENU  SCREEN SHDN                     </pre>

# 11 Operating information

## Sequence of operation *(continued)*

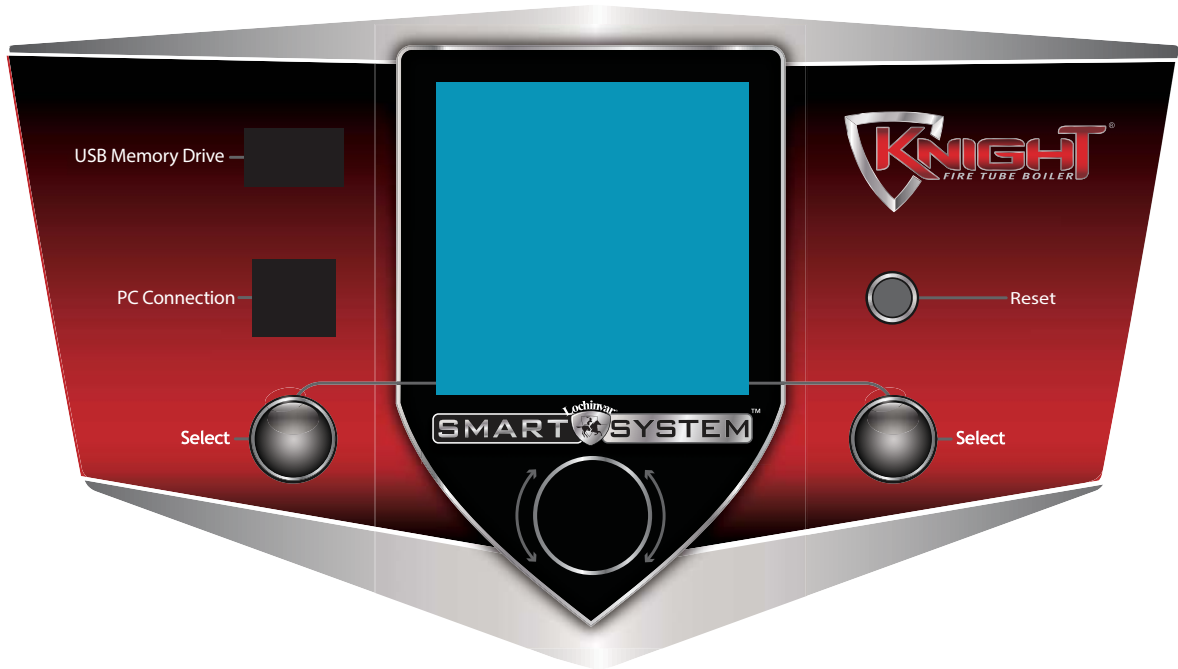
OPERATION	DISPLAY
7. If flame is detected, it holds the firing rate steady for a few seconds to let the flame stabilize, then it begins to modulate the firing rate based on a set point or some other command (such as a 0-10V BMS signal).	<pre> 41% 🔥 🏠 SYSTEM 🔘 DHW TANK ○ BOILER 🔘 DHW CIRC ○ SYSTEM: 117°F (118) TANK: 124°F (130) OUTDOOR: 56°F INLET: 109°F OUTLET: 124°F DHW RECIRC: 115°F  MENU ⏏️ SCREEN SHDN                     </pre>
8. If the space heating call for heat is active, and the tank thermostat or sensor starts a DHW call for heat, the boiler will switch to the DHW mode. If programmed for normal DHW operation (not as a zone), the DHW pump will turn on first, then the boiler pump will turn off (boiler and DHW pump operation briefly overlap to ensure flow is maintained through the unit). This will divert the boiler's outlet water from the heating system and send it to the tank coil instead. The control will then modulate to maintain the outlet temperature to the DHW boiler set point.	<pre> 41% 🔥 1 🏠 🏠 SYSTEM 🔘 DHW TANK 🔘 BOILER ○ DHW CIRC ○ SYSTEM: 117°F (118) TANK: 124°F (130) OUTDOOR: 56°F INLET: 109°F OUTLET: 124°F DHW RECIRC: 115°F  MENU ⏏️ SCREEN SHDN                     </pre>
9. If the boiler is not part of a Cascade, and both the space heating and DHW calls for heat remain active long enough, the boiler will switch back and forth between the two heating modes until one of them is satisfied.	<pre> 41% 🔥 🏠 🏠 SYSTEM 🔘 DHW TANK ○ BOILER 🔘 DHW CIRC ○ SYSTEM: 117°F (118) TANK: 124°F (130) OUTDOOR: 56°F INLET: 109°F OUTLET: 124°F DHW RECIRC: 115°F  MENU ⏏️ SCREEN SHDN                     </pre>
10. Once both calls for heat are satisfied, the control will turn off the burner. The blower will continue to run during the postpurge period.	<pre> <b>POST-PURGE</b> ANTI-CYCLING SYSTEM 🔘 DHW TANK ○ BOILER 🔘 DHW CIRC ○ SYSTEM: 117°F (118) TANK: 124°F (130) OUTDOOR: 56°F INLET: 109°F OUTLET: 124°F DHW RECIRC: 115°F  MENU ⏏️ SCREEN SHDN                     </pre>
11. Any pumps that are running will continue to run for their respective pump delay times before turning off, unless programmed to remain on continuously. A 60 second anti-cycle period will start, which will delay any new call for heat until it times out.	<pre> <b>BLOCKED</b> ANTI-CYCLING SYSTEM 🔘 DHW TANK ○ BOILER 🔘 DHW CIRC ○ SYSTEM: 117°F (118) TANK: 124°F (130) OUTDOOR: 56°F INLET: 109°F OUTLET: 124°F DHW RECIRC: 115°F  MENU ⏏️ SCREEN SHDN                     </pre>
12. In Standby, ready to start a new cycle.	<pre> <b>STANDBY</b> SYSTEM ○ DHW TANK ○ BOILER ○ DHW CIRC ○ SYSTEM: 117°F (118) TANK: 124°F (130) OUTDOOR: 56°F INLET: 109°F OUTLET: 124°F DHW RECIRC: 115°F  MENU ⏏️ SCREEN SHDN                     </pre>

# 11 Operating information *(continued)*

## **SMART SYSTEM™** Knight Fire Tube boiler control module

Use the control panel (FIG. 11-1) to set temperatures, operating conditions, and monitor boiler operation.

**Figure 11-1 Control Panel**



The information on the bottom of the display shows the functions of the two SELECT keys (on either corner), and the NAVIGATION dial (in the center):

MENU = Left SELECT Key  
 SETPOINTS = NAVIGATION Dial - Pressing Down  
 SHDN = Right SELECT Key

### Access modes

#### User

The user can adjust space heating and tank target temperatures by pressing the NAVIGATION dial when “↓SETPOINTS” is flashing at the bottom of the display. The date and time, and the temperature units can also be changed (see page 65).

#### Installer

Most parameters are available only to the installer, accessible by entering the installer password, see the Knight Fire Tube Boiler Service Manual.

Saving parameters *(reference the Parameter Table in the Knight Fire Tube Boiler Service Manual)*

### NOTICE

Please note that the brackets ([ ]) denote screen status.

#### To save parameters and exit programming:

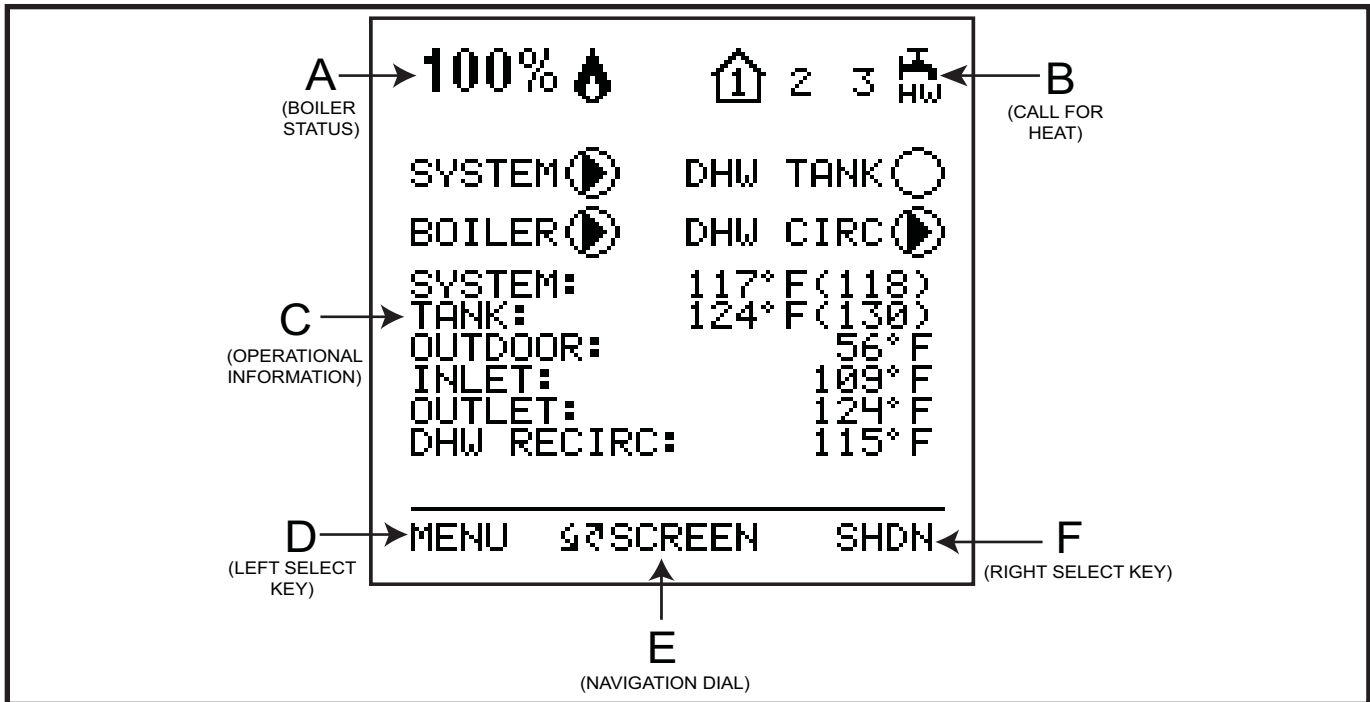
Press the RIGHT SELECT [SAVE] key and then press the RIGHT SELECT [HOME] key.

#### To enter a parameter and continue programming:

Press the RIGHT SELECT [SAVE] key 1 time to return to the parameter listings; press again to return to the menu listings. Remember to press the RIGHT SELECT [HOME] key when finished programming in order to save the changes made.

See the Knight Fire Tube Boiler Service Manual for a detailed description of parameters and access modes.

# 11 Operating information

**Figure 11-2 Status Display Screen**


Status Display Screens		
NOTE: All screens show burner status, heat demands, lockout/blocking, pump status, and soft keys.		
Section	Display	Description
<b>A</b> <b>(Boiler Status Bar)</b>	STANDBY	The unit has not received a call for heat from a remote thermostat nor has it received a call for heat from a DHW thermostat.
	START	The unit has begun a burn cycle and is checking all safety circuits.
	PREPURGE	The unit has initiated a prepurge period on a call for heat.
	IGNITION	The unit has begun a spark period to ignite the main burner.
	%	The unit has fired and is running at the displayed percentage.
	POSTPURGE	The call for heat has been satisfied and the unit runs the fan for an additional postpurge period to clear the combustion chamber and vent system of residual flue products.
	SHUTDOWN	The unit has been placed in the OFF position.
	SETPOINT MET	The controlled temperature has exceeded its set point and its offset.
	BLOCKED	The unit has detected a condition that has temporarily interrupted the current call for heat.
<b>B</b> <b>(Call for Heat Indicators)</b>	1	Room Thermostat 1 has a call for heat.
	2	Room Thermostat 2 has a call for heat.
	3	Room Thermostat 3 has a call for heat.
		The tank thermostat or sensor has a call for heat.
		Indicates which room thermostat demand has priority.
		The unit is being controlled by a 0 - 10V BMS signal.
		The member unit is supplying heat while in Cascade Mode.

# 11 Operating information *(continued)*

## Status Display Screens *(cont'd)*

NOTE: All screens show burner status, heat demands, lockout/blocking, pump status, and soft keys.

Section	Display	Description
<b>C</b> <b>(Operational Information)</b>	DETAILS SCREEN 1	a. SYSTEM TEMP b. TANK TEMP c. OUTDOOR TEMP d. INLET TEMP e. OUTLET TEMP f. DHW RECIRC TEMP - The temperature read by the DHW recirculation sensor (if connected).
	DETAILS SCREEN 2	a. DELTA T b. FLUE TEMP c. FLAME CURRENT d. FAN SPEED e. LOOP 1 TEMP - The temperature of Loop 1 reported by the MTLC control. f. LOOP 2 TEMP - The temperature of Loop 2 reported by the MTLC control. g. LOOP 3 TEMP - The temperature of Loop 3 reported by the MTLC control.
	I/O SCREEN	a. GAS PRESS SW - The state of the gas pressure switch. b. FLOW SW - The state of the flow switch. c. LOUVER RELAY - The state of the louver relay output. d. LOUVER SW - The state of the louver proving switch. e. BLOCKED DRAIN - The state of the blocked drain switch. f. GAS VALVE - The state of the gas valve output.
	BMS SCREEN	a. 0 - 10V BMS IN b. 0 - 10V RATE OUT c. BMS ADDRESS d. BMS CONTROL? e. SYS PUMP SPEED f. BLR PUMP OUT
	HISTORY SCREEN	a. SH RUN TIME - Total time running for Space Heat (SH). b. SH CYCLES - Total Space Heat (SH) demand cycles. c. DHW RUN TIME - Total time running for DHW. d. DHW CYCLES - Total DHW demand cycles. e. POWER TIME - Total time powered ON. f. IGNITIONS - Total number of successful ignitions. g. IGN ATTEMPTS - Total number of ignition attempts.
	LAST 10 FAULTS	a. FAULT NO. b. FAULT c. DATE d. TIME

# 11 Operating information

<b>Status Display Screens (cont'd)</b> NOTE: All screens show burner status, heat demands, lockout/blocking, pump status, and soft keys.		
Section	Display	Description
<b>C</b> (Operational Information cont.)	CASCADE STATUS	a. CASCADE STATUS b. CASCADE POWER c. PRESENT
	NIGHT SETBACK	a. TRIGGER 1 - Next Space Heat (SH) night setback trigger. b. TRIGGER 2 - Next DHW night setback trigger.
<b>D</b> (LEFT SELECT key function)	USB	Press the LEFT SELECT key to access the USB and Installer menu.
<b>E</b> (NAVIGATION dial function)	MODIFY	Pressing the NAVIGATION dial will allow the installer to change the text.
<b>F</b> (RIGHT SELECT key function)	SHDN	Press the RIGHT SELECT key to turn the boiler OFF.
	ON	Press the RIGHT SELECT key to turn the boiler ON.
	NO	Press the RIGHT SELECT key to cancel the shutdown operation.
	SAVE	Press the RIGHT SELECT key to save the current change.
	HOME	Press the RIGHT SELECT key to return to the Status Screen and upload parameter changes.

# 12 Maintenance

## Maintenance and annual startup

**Table 12A** Service and Maintenance Schedules

Service technician (see the following pages for instructions)		Owner maintenance (see the Knight Fire Tube User's Information Manual for instructions)	
ANNUAL START-UP	<b>General:</b>	Daily	<ul style="list-style-type: none"> <li>• Check boiler area</li> <li>• Check pressure / temperature gauge</li> </ul>
	<ul style="list-style-type: none"> <li>• Address reported problems</li> <li>• Inspect interior; clean and vacuum if necessary;</li> <li>• Clean condensate trap and fill with fresh water</li> <li>• Check for leaks (water, gas, flue, condensate)</li> <li>• Verify flue and air lines in good condition and sealed tight</li> <li>• Check system water pressure/system piping/expansion tank</li> <li>• Check fill water meter</li> <li>• Test boiler water. When test indicates, clean system water with approved system restorer following manufacturer's information.</li> <li>• Check control settings</li> <li>• Check ignition and flame sense electrodes (sand off any deposits; clean and reposition)</li> <li>• Check wiring and connections</li> <li>• Perform start-up checkout and performance verification per Section 10 of this manual.</li> <li>• Flame inspection (stable, uniform)</li> <li>• Flame signal (at least 10 microamps at high fire)</li> <li>• Clean the heat exchanger if flue temperature is more than 54°F above return water temperature.</li> </ul>	Monthly	<ul style="list-style-type: none"> <li>• Check vent piping</li> <li>• Check air piping</li> <li>• Check air and vent termination screens</li> <li>• Check relief valve</li> <li>• Check condensate drain system</li> <li>• Check air vents</li> </ul>
	<p><b>If combustion or performance indicate need:</b></p> <ul style="list-style-type: none"> <li>• Clean heat exchanger</li> <li>• Remove and clean burner using compressed air only</li> <li>• Clean the blower wheel</li> </ul>	Periodically	<ul style="list-style-type: none"> <li>• Test low water cutoff (if used)</li> <li>• Reset button (low water cutoff)</li> </ul>
		Every 6 months	<ul style="list-style-type: none"> <li>• Check boiler piping (gas and water) for leaks</li> <li>• Operate relief valve</li> </ul>
		End of season months	<ul style="list-style-type: none"> <li>• Shut boiler down (unless boiler used for domestic hot water)</li> </ul>

# 12 Maintenance

## ⚠ WARNING

Follow the service and maintenance procedures given throughout this manual and in component literature shipped with the boiler. Failure to perform the service and maintenance could result in damage to the boiler or system. Failure to follow the directions in this manual and component literature could result in severe personal injury, death, or substantial property damage.

## ⚠ WARNING

The boiler should be inspected annually only by a qualified service technician. In addition, the maintenance and care of the boiler designated in Table 12A and explained on the following pages must be performed to assure maximum boiler efficiency and reliability. Failure to service and maintain the boiler and system could result in equipment failure.

## ⚠ WARNING

Electrical shock hazard – Turn off power to the boiler before any service operation on the boiler except as noted otherwise in this instruction manual. Failure to turn off electrical power could result in electrical shock, causing severe personal injury or death.

## Address reported problems

1. Inspect any problems reported by the owner and correct before proceeding.

## Inspect boiler area

1. Verify that boiler area is free of any combustible materials, gasoline and other flammable vapors and liquids.
2. Verify that air intake area is free of any of the contaminants listed in Section 1 of this manual. If any of these are present in the boiler intake air vicinity, they must be removed. If they cannot be removed, reinstall the air and vent lines per this manual and the Knight Fire Tube Boiler Service Manual.

## Inspect boiler interior

1. Remove the front access cover and inspect the interior of the boiler.
2. Vacuum any sediment from inside the boiler and components. Remove any obstructions.

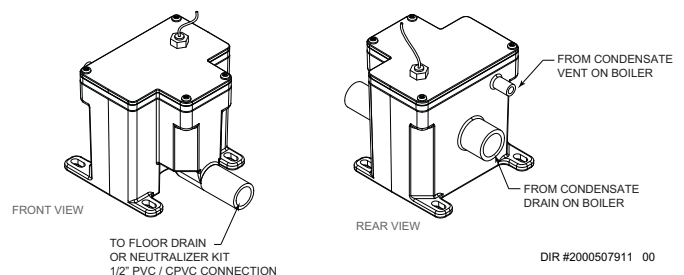
## Clean condensate trap

1. Inspect the condensate drain line, condensate PVC fittings, and condensate trap.

### Flush condensate trap with water

1. Remove the four (4) screws securing the top cover to the condensate trap and remove the cover (FIG. 12-1).
2. Locate the plastic ball inside the float tube. Verify there is nothing under the ball causing it to not seat properly.
3. Fill with fresh water until the water begins to pour out of the drain.
4. Ensure the top gasket is seated properly. Replace the top cover and the screws removed in Step 1.

**Figure 12-1** Condensate Trap



## Check all piping for leaks

## ⚠ WARNING

Eliminate all system or boiler leaks. Continual fresh makeup water will reduce boiler life. Minerals can build up in sections, reducing heat transfer, overheating heat exchanger, and causing heat exchanger failure. Leaking water may also cause severe property damage.

1. Inspect all water and gas piping and verify to be leak free.
2. Look for signs of leaking lines and correct any problems found.
3. Check gas line using the procedure found in Section 7 - Gas Connections.



# 12 Maintenance *(continued)*

## Flue vent system and air piping

1. Visually inspect the entire flue gas venting system and air piping for blockage, deterioration or leakage. Repair any joints that show signs of leakage. Verify that air inlet pipe is connected and properly sealed.
2. Verify that boiler vent discharge and air intake are clean and free of obstructions.

**⚠ WARNING** Failure to inspect for the above conditions and have them repaired can result in severe personal injury or death.

## Check water system

1. Verify all system components are correctly installed and operational.
2. Check the cold fill pressure for the system. Verify it is correct (must be a minimum of 12 psi).
3. Watch the system pressure as the boiler heats up (during testing) to ensure pressure does not rise too high. Excessive pressure rise indicates expansion tank sizing or performance problem.
4. Inspect automatic air vents and air separators. Remove air vent caps and briefly press push valve to flush vent. Replace caps. Make sure vents do not leak. Replace any leaking vents.

## Check expansion tank

1. Expansion tanks provide space for water to move in and out as the heating system water expands due to temperature increase or contracts as the water cools. Tanks may be open, closed or diaphragm or bladder type. See Section 6 - Hydronic Piping for suggested best location of expansion tanks and air eliminators.

## Check fill water meter

1. Check fill water meter for water usage. If the amount exceeds 5% of your system volume, you could have a leak. Have the system checked for leaks and fixed by a qualified service technician.

## Test boiler water

1. Test boiler water. Reference the Knight Fire Tube Installation and Operation Manual for guidelines. When test indicates, clean system water with approved system restorer following the manufacturer's information.

## Check boiler relief valve

1. Inspect the relief valve and lift the lever to verify flow. Before operating any relief valve, ensure that it is piped with its discharge in a safe area to avoid severe scald potential. Read Section 6 - Hydronic Piping before proceeding further.

**⚠ WARNING** Safety relief valves should be re-inspected AT LEAST ONCE EVERY THREE YEARS, by a licensed plumbing contractor or authorized inspection agency, to ensure that the product has not been affected by corrosive water conditions and to ensure that the valve and discharge line have not been altered or tampered with illegally. Certain naturally occurring conditions may corrode the valve or its components over time, rendering the valve inoperative. Such conditions are not detectable unless the valve and its components are physically removed and inspected. This inspection must only be conducted by a plumbing contractor or authorized inspection agency – not by the owner. Failure to re-inspect the boiler relief valve as directed could result in unsafe pressure buildup, which can result in severe personal injury, death, or substantial property damage.

**⚠ WARNING** Following installation, the valve lever must be operated AT LEAST ONCE A YEAR to ensure that waterways are clear. Certain naturally occurring mineral deposits may adhere to the valve, rendering it inoperative. When manually operating the lever, water will discharge and precautions must be taken to avoid contact with hot water and to avoid water damage. Before operating lever, check to see that a discharge line is connected to this valve directing the flow of hot water from the valve to a proper place of disposal. Otherwise severe personal injury may result. If no water flows, valve is inoperative. Shut down the boiler until a new relief valve has been installed.

2. After following the above warning directions, if the relief valve weeps or will not seat properly, replace the relief valve. Ensure that the reason for relief valve weeping is the valve and not over-pressurization of the system due to expansion tank waterlogging or undersizing.

# 12 Maintenance

## Inspect ignition and flame sense electrodes

1. Remove the ignition and flame sense electrodes from the boiler heat exchanger access cover.
2. Remove any deposits accumulated on the ignition/flame sense electrode using sandpaper. If the electrodes cannot be cleaned satisfactorily, replace with new ones.
3. Replace ignition/flame sense electrode, making sure gasket is in good condition and correctly positioned.

## Check ignition ground wiring

1. Inspect boiler ground wire from the heat exchanger access cover to ground terminal strip.
2. Verify all wiring is in good condition and securely attached.
3. Check ground continuity of wiring using continuity meter.
4. Replace ground wires if ground continuity is not satisfactory.

## Check all boiler wiring

1. Inspect all boiler wiring, making sure wires are in good condition and securely attached.

## Check control settings

1. Set the SMART SYSTEM control module display to Parameter Mode and check all settings. See Section 1 of Knight Fire Tube Boiler Service Manual. Adjust settings if necessary. See Section 1 of the Knight Fire Tube Boiler Service Manual for adjustment procedures.
2. Check settings of external limit controls (if any) and adjust if necessary.

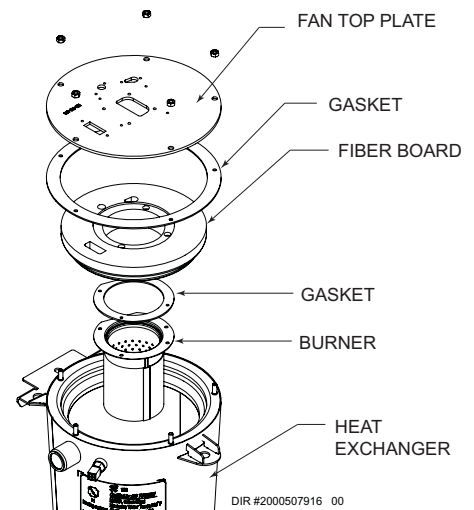
## Perform start-up and checks

1. Start boiler and perform checks and tests specified in Section 10 - Start-up.
2. Verify cold fill pressure is correct and that operating pressure does not go too high.

## Check burner flame

1. Inspect flame through observation window.
2. If the flame is unsatisfactory at either high fire or low fire, turn off boiler and allow boiler to cool down. Remove the burner and clean it thoroughly using a vacuum cleaner or compressed air. Do not use compressed air to clean burner if performed inside a building.
3. Remove the burner, reference FIG. 12-2 below.
4. When replacing the burner, ensure gasket is in good condition and positioned correctly (FIG. 12-2).

**Figure 12-2 Burner Assembly**



## Check flame signal

1. At high fire the flame signal shown on the display should be at least 10 microamps.
2. A lower flame signal may indicate a fouled or damaged flame sense electrode. If cleaning the flame sense electrode does not improve, ground wiring is in good condition, and ground continuity is satisfactory, replace the flame sense electrode.
3. See Section 3 - Troubleshooting of the Knight Fire Tube Boiler Service Manual for other procedures to deal with low flame signal.

# 12 Maintenance *(continued)*

## Review with owner

1. Review the Knight Fire Tube Boiler User's Information Manual with the owner.
2. Emphasize the need to perform the maintenance schedule specified in the Knight Fire Tube Boiler User's Information Manual (and in this manual as well).
3. Remind the owner of the need to call a licensed contractor should the boiler or system exhibit any unusual behavior.
4. Remind the owner to follow the proper shutdown procedure and to schedule an annual start-up at the beginning of the next heating season.

## Cleaning boiler heat exchanger

1. Shut down boiler:
  - Follow the "To Turn Off Gas to Appliance" instructions for the boiler in Section 10 - Startup.
  - Do not drain the boiler unless it will be exposed to freezing temperatures. If using freeze prevention fluid in system, do not drain.
2. Allow time for the boiler to cool to room temperature if it has been firing.
3. Remove the top and front access panels (no tools required for removal) along with the bezel.
4. Remove the wiring from the ignitor, flame rod, and the fan. Remove the reference tubing from the air intake.
5. Loosen the band clamp on the air intake coupling using a field provided 5/16" driver.
6. Remove the 4mm screws holding the fan to the heat exchanger top plate.
7. Loosen the union on the venturi
8. The fan and the venturi may now be removed from the unit together by sliding the fan away from the air intake.
9. Remove the 10mm nuts securing the heat exchanger top plate to gain access to the heat exchanger and set aside.

### WARNING

The boiler contains ceramic fiber materials. Use care when handling these materials per instructions in the Service Manual. Failure to comply could result in severe personal injury.

10. Disconnect the condensate hose from the condensate trap and route to drain.
11. Use a vacuum cleaner to remove any accumulation on the boiler heating surfaces. Do not use any solvent.
12. Using a clean cloth dampened with warm water, wipe out the combustion chamber. Rinse out debris with a low pressure water supply.
13. Allow the heat exchanger to thoroughly dry.
14. Reassemble the unit in reverse order of component removal, and re-install the condensate hose.

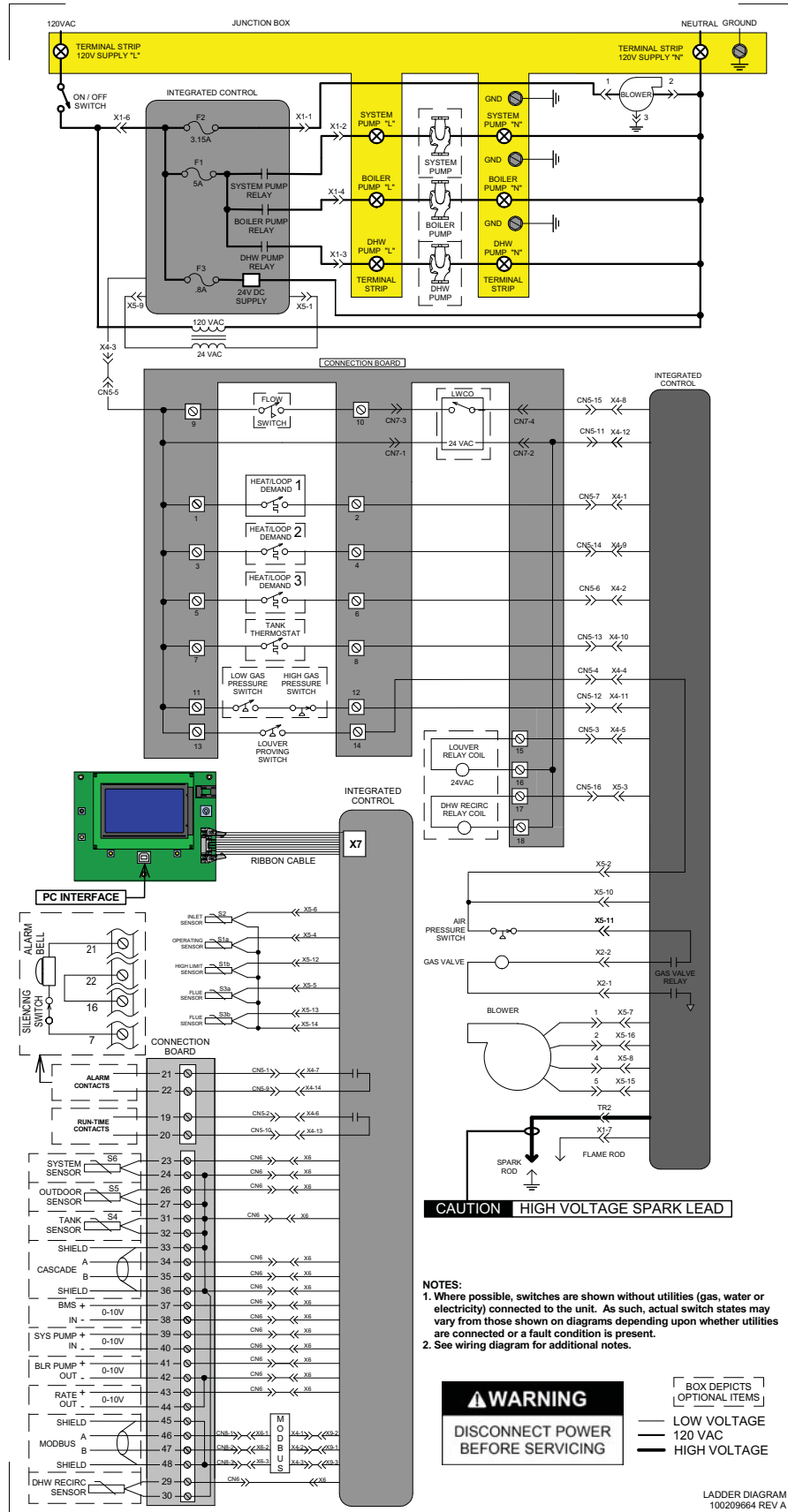
### CAUTION

Damaged gaskets and seals in the system can result in substantial property damage. Ensure that damaged or torn gaskets are replaced.

15. Perform a combustion analysis by following the instructions in Section 10 - Startup - Check Flame and Combustion on pages 64 and 65 of this manual.
16. Resume operation.

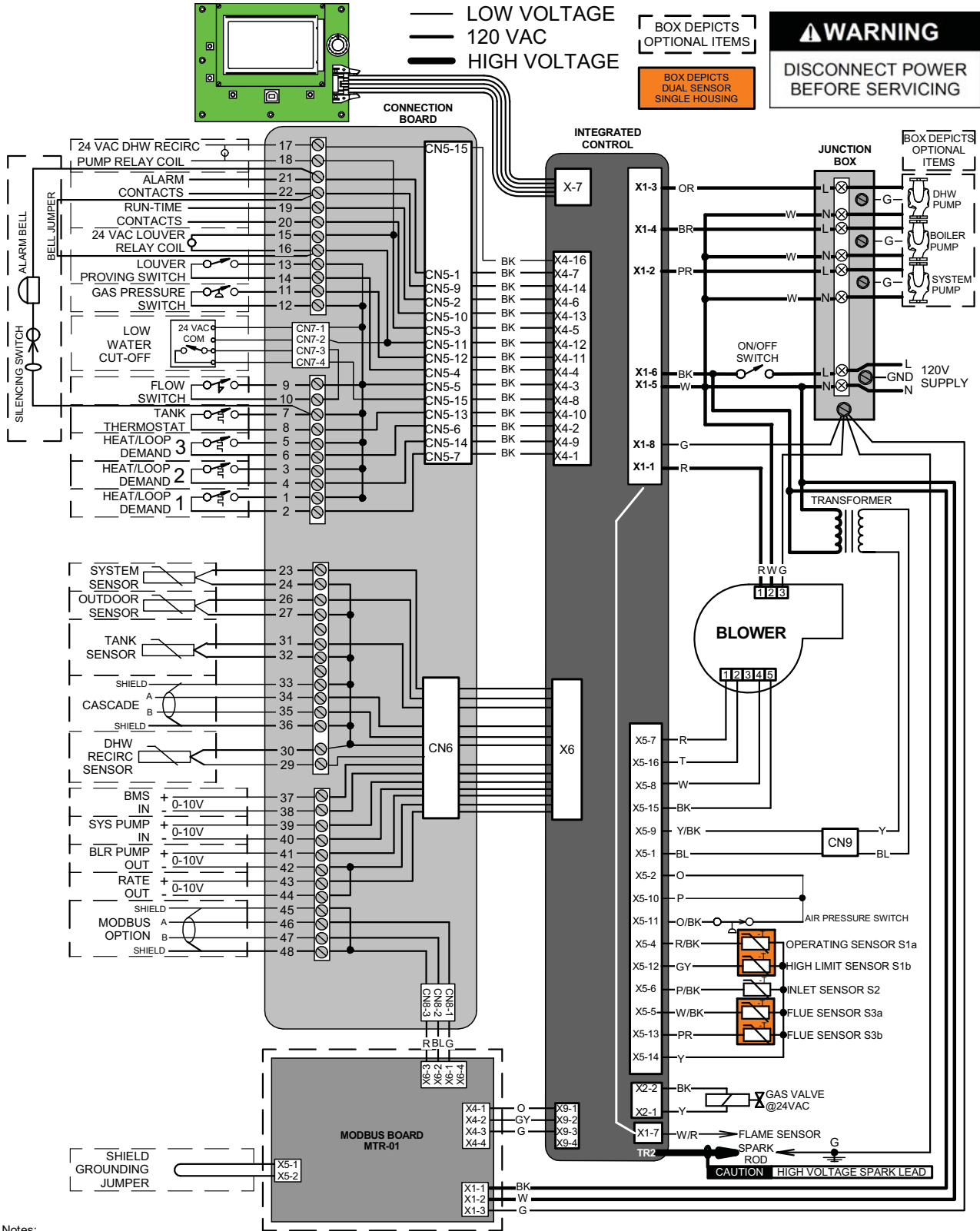
# 13 Diagrams

Figure 13-1 Ladder Diagram



# 13 Diagrams (continued)

Figure 13-2 Wiring Diagram



Notes:

1. All wiring must be installed in accordance with: local, state, provincial and national code requirements per either N.E.C. in USA or C.S.A. in Canada.
2. If any original equipment wire as supplied with the appliance must be replaced, it must be replaced with wire having same wire gauge (AWG) and rated for a minimum of 105°C. Exceptions: Replacement high voltage spark lead and ribbon cables must be purchased from the factory. Use of a non-approved spark lead or ribbon cables can lead to operational problems which could result in non-repairable damage to the integrated controller or other components.
3. Actual connector block locations may vary from those shown on diagrams. Refer to actual components for proper connector block locations when using diagrams to troubleshoot unit.

---

# Notes

---

# Notes

**Revision Notes:** Revision A (Change #500001290) initial release.

Revision B (PCP #3000002108 / CN #500002336) reflects an update of Table 2A on page 12 with the corrected LP conversion kit part numbers. SAP numbers have been updated along with changes made to the Venting Section on page 19 and edits made to the multiple water piping charts on pages 42, 44, 46, and 47.

Revision C (PCP# 3000002702 / CN# 500003259) reflects an update to the wiring diagram on page 85.

Revision D (PCP# 3000004121 / CN# 500004296) reflects an update to the piping diameters in the charts on pages 42, 44, 46, and 47.

Revision E (PCP# 3000004438 / CN# 500005574) reflects an update to the flue temperatures on page 70.

Revision F (PCP# 3000006133 / CN# 500007549) reflects a change from PVC-DMV to PVC-DWV vent fitting in Table 3D on page 19.

Revision G (PCP #3000009959 / CN #500009745) reflects changes to the gas train assembly as well as changes made to water chemistry information on pages 3, 7, 35-37, 40-50, 61-62, 79, and 81.

Revision H (PCP #3000010561 / CN #500010149) reflects an update to the vent increase notice on page 16.

Revision J (PCP #3000010778\_ 3000021144 / CN #500010568) reflects updates made to high altitude on page 6, number 6.