



DP2502-08-CM

GEO S12 – LS18

***GEO S1210 & GEO S1230
GEO S1210-ST & GEO S1230-ST
Tangent Array Modules***

LS18 Subwoofer

System manual



CONTENTS

PLEASE READ CAREFULLY BEFORE PROCEEDING.....	5
1 INTRODUCTION	7
2 GEO S12 GENERAL SET-UP INSTRUCTIONS.....	8
2.1 GEO S12 AND LS18 CONNECTIONS	8
2.1.1 <i>GEO S12 connectors</i>	8
2.1.2 <i>LS18 connectors</i>	8
2.1.3 <i>Configuring GEO S12 for passive or active mode</i>	9
2.2 CABLING	10
2.3 GEO S12 & LS18 RECOMMENDED AMPLIFICATION	10
2.4 GEO S12 & LS18 SETUPS ON NEXO TD CONTROLLERS	10
3 CONNECTION DIAGRAMS.....	11
3.1 GEO S12 (PASSIVE MODE) / NXAMP4x1MK2 (BRIDGE STEREO).....	11
3.2 LS18 / NXAMP4x1MK2 (BRIDGE STEREO).....	11
3.3 GEO S12 (PASSIVE MODE) AND LS18 / NXAMP4x1MK2 (BRIDGE STEREO).....	12
3.4 GEO S12 (PASSIVE MODE) / NXAMP4x2MK2 (4 CHANNELS MODE).....	12
3.5 LS18 / NXAMP4x2MK2 (4 CHANNELS MODE).....	13
3.6 GEO S12 (PASSIVE MODE) AND LS18 / NXAMP4x2MK2 (4 CHANNELS MODE).....	13
3.7 GEO S12 (PASSIVE MODE) / NXAMP4x4MK2 (4 CHANNELS MODE).....	14
3.8 GEO S12 (ACTIVE MODE) / NXAMP4x4MK2 (4 CHANNELS MODE)	15
3.9 LS18 OMNI MODE / NXAMP4x4MK2 (4 CHANNELS MODE)	16
3.10 LS18 CARDIO MODE / NXAMP4x4MK2 (4 CHANNELS MODE)	17
3.11 GEO S12 (PASSIVE MODE) AND LS18 / NXAMP4x4MK2 (4 CHANNELS MODE).....	18
4 NS-1 SIMULATION SOFTWARE	19
5 CONFIGURABLE DIRECTIVITY DEVICE	20
5.1 INSTALLING & REMOVING GEO'S CONFIGURABLE DIRECTIVITY DEVICES	20
5.2 WHEN & WHERE TO USE CONFIGURABLE DIRECTIVITY FLANGES.....	21
6 GEO S12 HARDWARE SETUP PROCEDURE	22
6.1 SAFETY FIRST.....	22
6.1.1 <i>Flown systems safety</i>	22
6.1.2 <i>Ground stacking safety</i>	23
6.1.3 <i>Contacts</i>	23
6.2 GENERAL DESCRIPTION	24
6.2.1 <i>GEO S1210 and GEO S1230</i>	24
6.2.2 <i>GEO S12 "Left" and "Right" configuration</i>	24
6.2.3 <i>LS18</i>	25
6.2.4 <i>Accessories</i>	26
6.2.5 <i>Warnings on GEO S12 & LS18 accessories</i>	27
6.3 INSTALLATION APPLICATIONS	28
6.3.1 <i>Described configurations</i>	28
6.3.2 <i>Single GEO S12 rigidly mounted on a wall or a ceiling (vertical or horizontal)</i>	29
6.3.3 <i>Single GEO S12 cable mounted on a ceiling (vertical or horizontal)</i>	30
6.3.4 <i>GEO S12 vertical array rigidly mounted on a ceiling</i>	31
6.3.5 <i>LS18 and GEO S12 vertical array rigidly mounted on a ceiling</i>	33
6.3.6 <i>LS18 and GEO S12 vertical array cable mounted on a ceiling</i>	35
6.3.7 <i>GEO S12 horizontal array rigidly mounted on a ceiling</i>	36
6.3.8 <i>GEO S12 horizontal array cable mounted on a ceiling</i>	38
6.4 TOURING APPLICATIONS.....	39
6.4.1 <i>Described configurations</i>	39
6.4.2 <i>Single GEO S12 on speaker stand or on LS18 horizontally</i>	40
6.4.3 <i>Single GEO S12 flown vertically</i>	42
6.4.4 <i>Single GEO S12 flown horizontally</i>	43
6.4.5 <i>Two GEO S12 on wind-up stand</i>	44

CONTENTS

6.4.6	Two GEO S12 vertically	47
6.4.7	Two or more GEO S12 flown horizontally	48
6.4.8	LS18 and three or more GEO S12 flown vertically.....	51
6.4.9	Ground stacked LS18 and GEO S12.....	55
6.5	TESTING AND MAINTENANCE OF THE SYSTEM	60
7	SYSTEM CHECK ALIGNMENT GUIDELINES.....	61
7.1	GEO S12 VERTICAL CLUSTER DESIGN.....	61
7.2	STACKED LS18 AND FLOWN GEO S12	61
7.3	DRIVING THE LS18S FROM THE AUX SEND	62
7.4	RECOMMENDED INSTALLATION TOOLS AND EQUIPMENT	62
7.5	GEO S12 – LS18 SYSTEM CHECK LIST	63
8	TECHNICAL SPECIFICATIONS	64
8.1	LS18 AND LS18-E SUBWOOFERS	64
8.1.1	System specifications.....	64
8.1.2	Dimensions (mm/inches).....	65
8.2	GEO S1210.....	66
8.2.1	System specifications.....	66
8.2.2	Dimensions (mm/inches).....	67
8.3	GEO S1210-ST	68
8.3.1	System specifications.....	68
8.3.2	Dimensions (mm/inches).....	69
8.4	GEO S1230.....	70
8.4.1	System specifications.....	70
8.4.2	Dimensions (mm/inches).....	71
8.5	GEO S1230-ST	72
8.5.1	System specifications.....	72
8.5.2	Dimensions (mm/inches).....	73
8.6	GEO S12 AND LS18 ACCESSORIES.....	74
8.6.1	GPI-BUMPER.....	74
8.6.2	VNI-UBRK12	75
8.6.3	VNI-LBRK.....	76
8.6.4	VNI-ABRK.....	77
8.6.5	GPI-ANPL1	78
8.6.6	GPI-ANPL2	79
8.6.7	GPI-ANL3.....	80
8.6.8	LSI-CPLA.....	81
8.6.9	VNI-IPCOV15	82
8.6.10	GPT-BUMPER.....	83
8.6.11	GPT-XBOW.....	84
8.6.12	LST-XBOW18.....	85
8.6.13	GPT-TLB.....	86
8.6.14	VNT-XHBRK.....	87
8.6.15	VNT-TTC.....	88
8.6.16	GPT-SSBRK.....	89
8.6.17	GPT-PSBRK.....	90
8.6.18	VNT-TCBRK.....	91
8.6.19	GPT-GSTK.....	92
8.6.20	GPT-FLG.....	93
8.6.21	VXT-BL820.....	94
9	GEO S12 & LS18 MODULES & ACCESSORIES LIST	95
10	USER NOTES	98

GEO Technology is radically new thinking

The GEO R&D Project has, to date, resulted in the following patent applications:

The GEO Hyperboloid Reflective Wavesource™ differs radically from the megaphone-variant type horns you know and love (or hate). “Tried and true” methods will produce entirely unexpected results. HRW technology produces precise and predictable results.

The Configurable Directivity Flange. A waveguide that allows the operator to alter its behaviour. An unprecedented NEXO development that is easy to use – once you know how and when.

The Phase Directivity Device needs no operator input to function, but it is reassuring to know that the coupling of the midrange of the system is considered as important as the high frequencies...

DSP-driven Directional Sub-bass devices are a new approach to controlling LF/MLF acoustic energy.

GEO is not hard to use when you understand how...

The technology behind GEO is revolutionary, but it is grounded in years of practical experience with the problems of delivering high quality professional sound to large audiences at high SPL levels. The GEO toolbox includes NS-1 - a simple yet powerful and highly predictive design tool. The array assembly system is keyed to the design software and will easily enable you to deploy your design with great precision. NEXO Digital TDcontroller technology provide driver protection and system optimization for the GEO S and LS series.

GEO is a high precision system

The GEO HRW™ controls acoustic energy more precisely than other multiple element waveguides. It also makes GEO less forgiving of mistakes. Whilst conventional horns never combine into a coherent array, they may deliver acceptable results even if the design and deployment of the system is less than optimal. This is not the case with GEO where careless installation produces catastrophic results.

A GEO Tangent Array is not a “line array”

GEO Technology is equally effective in designing and deploying tangent curved vertical or horizontal arrays. For best results in a specific application the user needs to know how multi-speaker arrays interact with audience geometry, along with the benefits and drawbacks of curved vertical arrays and horizontal arrays.

Curved tangent arrays require different design techniques

In the past, sound reinforcement professionals have worked with horizontal arrays that use conventional horns to deliver [more or less] ‘equal power to equal *angles*’. Curved vertical arrays are now designed to deliver [more or less] equal power to equal *areas*’. When arrays use conventional horns, the lack of precision, overlap and interference masks errors in array design and aiming. The highly precise GEO wavesource responds accurately, consistently and predictably to the design and deployment of a curved vertical tangent array. This is why the GEO rigging system is designed to control angular splay to 0.1° precision.

GEO curved tangent arrays require different operational techniques

Over the years, system designers and operators have developed a number of signal processing techniques to disguise and partly overcome the limitations of horn design. “Frequency shading,” “amplitude shading,” “High Frequency compensation”, all of these are tools of the advanced sound system operator. **NONE OF THESE TECHNIQUES ARE APPLICABLE TO GEO TANGENT ARRAYS.** Instead of enhancing the array’s performance they will severely degrade it.

Take time to learn how to get great results with GEO Technology. It is an investment that will pay off in more satisfied clients, more efficient operating procedures and more recognition for your skill as a sound system designer and operator. A comprehensive understanding of GEO theory, tangent arrays, and specific features of the GEO S Series will help you to operate your system at its full potential.

PLEASE READ CAREFULLY BEFORE PROCEEDING**BASIC PRECAUTIONS**

Do not open the speaker system or attempt to disassemble the internal parts or modify them in any way. The speaker system contains no user-serviceable parts. If it should appear to be malfunctioning or damaged, discontinue use immediately and have it inspected by qualified NEXO service personnel.

Water exposure: Do not expose the speaker system to direct rain, do not use it near water or in wet conditions. Do not place containers with liquid on speaker system as they might spill into openings. If any liquid such as water seeps into the speaker system, have it inspected by qualified NEXO personnel.

Sun exposure: Do not expose the speaker system to direct sun.

Operating temperature with temperate climate: 0°C to +40°C (-20°C to +60°C for storage).

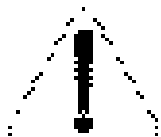
SYSTEM DEPLOYMENT SAFETY RULES

Read User Manual before deployment. Before use of enclosed speaker system, please ensure that anyone involved in system deployment understands the rigging – stacking – pole mounting safety rules as described in the speaker system User Manual. Failure to do this exposes people to potential injury or death.

Please check the web site nexo-sa.com for the latest update.

Always consult qualified NEXO personnel if the device installation requires construction work and make sure to observe the following precautions:

Mounting precautions

- choose mounting hardware and an installation location that can support 4 times the weight of the speaker system;
- do not use speaker system handles for suspended installation;
- do not expose speaker system to excessive dust or vibration, or extreme cold or heat to prevent possibility of component damage;
- do not place the speaker system in an unstable position from which it might fall accidentally;
- if speaker systems use a stand, ensure that stand specifications are adapted, and that stand height does not exceed 1.40m/55"; never move the stand while the speaker is in position.
- in case of wind greater than 8 on Beaufort scale (72km/h – 45mph), a touring system has to be landed or an additional securing has to be implemented.
- for fixed installations, wind loading has to be taken into account in accordance to the national standards.

Connection and powering precautions

- remove all connected cables before moving the speaker system;
- turn off AC power of all power amplifier units before connecting the speaker system;
- when turning on the AC power to the audio system, always turn on the power amplifier last; when turning the AC power off, always turn off the power amplifier first;
- when used in cold conditions, a gradual power ramp up should be applied to the system on a 5 mn period to allow the loudspeaker components to stabilize during the very first minutes of usage.

Inspect the speaker system periodically.

HIGH SOUND PRESSURE LEVELS



Exposure to extremely high noise levels may cause permanent hearing loss. Individuals vary considerably in susceptibility to noise-induced hearing loss but nearly everyone will lose some hearing if exposed to sufficiently intense noise for a sufficient period of time. The U.S. Government's Occupational and Health Administration (OSHA) has specified the following permissible noise level exposures: Sound Duration Per

Day In Hours	Sound Level dBA, Slow Response
8	90
6	92
4	95
3	97
2	100
1 ½	102
1	105
½	110
¼ or less	115

According to OSHA, any exposure in excess of the above permissible limits could result in some hearing loss. Ear plugs or protectors to the ear canals or over the ears must be worn when operating this amplification system in order to prevent permanent hearing loss, if exposure is in excess of the limits as set forth above. To ensure against potentially dangerous exposure to high sound pressure levels, it is recommended that all persons exposed to equipment capable of producing high sound pressure levels such as this amplification system be protected by hearing protectors while this unit is in operation.

DISPOSAL OF OLD ELECTRICAL & ELECTRONIC EQUIPMENT





This symbol on the product or on its packaging indicates that it shall not be treated as household waste. Instead it shall be handed over to the applicable collection point for the recycling of electrical and electronic equipment. By ensuring this product is disposed of correctly, you will help prevent potential negative consequence for the environment and human health, which could otherwise be caused by inappropriate waste handling of this product. The recycling of materials will help to conserve natural resources. For more detailed information about recycling of this product, please contact your local city office, your household waste disposal service or the shop where you purchased the product.

1 INTRODUCTION

Thank you for selecting a NEXO GEO S12 Series Tangent Array System.

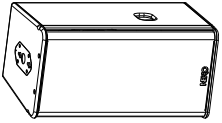
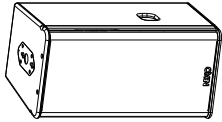
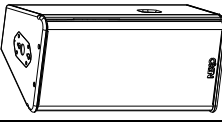
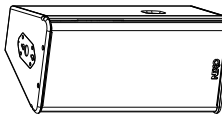
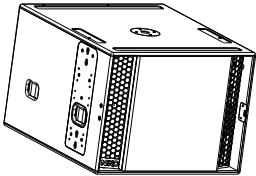
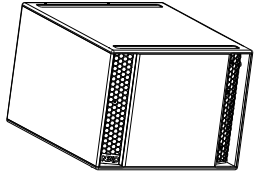
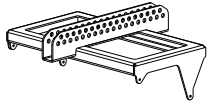
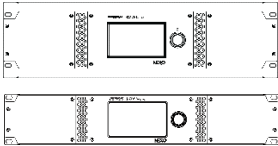
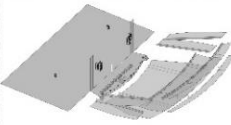
This manual is intended to provide you with necessary and useful information about your GEO S12 & LS18 System, which includes the following products:

	<ul style="list-style-type: none"> GEO S1210 is a 10° Tangent Array Module. It comprises 1x12" (30cm) 16 ohms Neodymium LF/MF driver loaded by a Phase Directivity Device (PDD™) and 1x1.4" throat 16 Ohm HF driver loaded by a 5° Hyperboloid Reflective Wavesource (HRW™).
	<ul style="list-style-type: none"> GEO S1210-ST is the long throw version of the GEO S1210. It is strictly identical but features a Neodymium HF driver.
	<ul style="list-style-type: none"> GEO S1230 is a 30° Tangent Array Module. It comprises 1x12" (cm) 16 ohms Neodymium LF/MF driver loaded by a Phase Directivity Device (PDD™) and 1x1.4" throat 16 Ohm HF driver loaded by a 28.5° Hyperboloid Reflective Wavesource (HRW™).
	<ul style="list-style-type: none"> GEO S1230-ST is the long throw version of the GEO S1230. It is strictly identical but features a Neodymium HF driver.
	<ul style="list-style-type: none"> LS18 is GEO S12 companion subwoofer. It comprises 1x18" (46cm) long excursion driver and features very high efficiency as well as high acoustic output. LS18 has fittings for transporting, flying, stacking and pole standing.
	<ul style="list-style-type: none"> LS18-E is identical to LS18, with the exception that it has none of the fittings described above. It is intended to be set on the floor in fix installations.
	<ul style="list-style-type: none"> A full range of accessories provides safe, flexible and simple means of installing GEO S12 and LS18 in fixed installation as well as in touring applications.
	<ul style="list-style-type: none"> GEO S12 and LS18 are controlled, powered and monitored by NEXO TDcontrollers. For a complete description of these controllers, please refer to User Manuals. NEXO TDcontrollers DSP algorithms and parameters are fixed in software and updated regularly. Please consult the NEXO web site (nexo-sa.com) for the latest software releases.
	<ul style="list-style-type: none"> NS-1 simulation software assists in the design and implementation of vertical or horizontal tangent GEO arrays. Please consult the NEXO web site (nexo-sa.com) for the latest software releases.
	<ul style="list-style-type: none"> Available for Mac, iPad and iPhone, NEXO NeMo provides full remote control over a digital audio network from anywhere in the venue, thanks to an intuitive and graphically attractive user interface. NeMo is available on Apple App Store.

Please devote your time and attention to reading this manual. A comprehensive understanding of GEO S12 and LS18 specific features will help you to operate your system at its full potential

2 GEO S12 GENERAL SET-UP INSTRUCTIONS

2.1 GEO S12 and LS18 connections

GEO S12 and LS18 are connected with Speakon NL4FC plugs (not supplied). A wiring diagram is printed on the connection panel located on the back of each cabinet. The 4 pins of the Speakon sockets identified in / out are connected in parallel within the enclosure.

Either connector can be used to connect amplifier or to link to an additional GEO S12 cabinet or to link to an optional LS18 (if present). Therefore, a single 4-conductor cable can connect two amplifier channels to various GEO S12s and/or LS18 subwoofers.

2.1.1 GEO S12 connectors



Speakon Connector	S1210 & S1230	
	Passive Mode	Active Mode
1(-)	Through	GEO S12 LF (-)
1(+)	Through	GEO S12 LF (+)
2(-)	GEO S12 (-)	GEO S12 HF (-)
2(+)	GEO S12 (+)	GEO S12 HF (+)

2.1.2 LS18 connectors



Speakon Connector	LS18
1(-)	LS18 (-)
1(+)	LS18 (+)
2(-)	Through
2(+)	Through

2.1.3 Configuring GEO S12 for passive or active mode

Remove the six TORX screws that hold the connector panel.

Remove the connector panel so that filter WAGO connectors become accessible.



GEO S12 connector panel

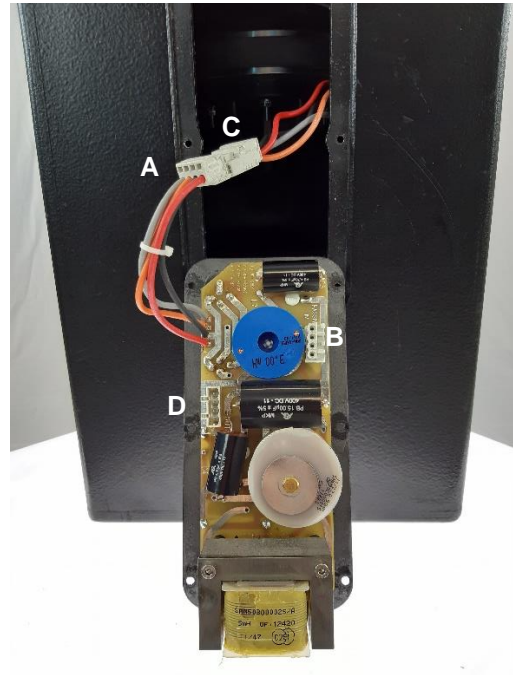

GEO S12 WAGO connectors

In Passive Mode, connector A (from filter) should be inserted in connector B (PCB “Passive In”), and connector D (“Passive Out”) should be connected to speakers via connector C.

In Active Mode, WAGO Connector A (from filter) should be directly connected into speakers via connector C (PCB connectors B & D are then unused).



Passive mode configuration



Active mode configuration

2.2 Cabling

NEXO recommends the exclusive use of multi-conductor cables to connect the system: the cable kit is compatible with all the cabinets, and there is no possible confusion between LF, MF and HF sections.

Cable choice consists mainly of selecting cables of the correct sectional dimension (size) in relation to the load resistance and the cable length. Too small a cable section will increase both its serial resistance and its capacitance; this reduces the electrical power delivered to the loudspeaker and can also induce response (damping factor) variations.

For a serial resistance less or equal to 4% of the load impedance (damping factor = 25), the recommended cable length is given by:

$$L_{max} = Z \times S \quad S \text{ in mm}^2, Z \text{ in Ohm, } L_{max} \text{ in meters}$$

The table below indicates these values, for 3 common sizes.

Load Impedance (Ω)	2	2.6	4	5.3	8	16
Cable section	Recommended Cable Length					
1,5 mm ² (AWG #15)	3m/10ft	3m/13ft	6m/20ft	8m/26ft	12m/39ft	24m/79ft
2,5 mm ² (AWG #13)	5m/16ft	7m/23ft	10m/33ft	13m/44ft	20m/66ft	40m/131ft
4 mm ² (AWG #11)	8m/26ft	10m/33ft	16m/52ft	21m/70ft	32m/105ft	64m/210ft
6 mm ² (AWG #9)	12m/40ft	16m/52ft	24m/79ft	32m/104ft	48m/160ft	96m/315ft

Maximum allowed length is 4 times recommended length.

Example:

GEO S12 module has a 16 Ω nominal impedance in passive mode. When connecting 4 modules in parallel, total load impedance becomes 4Ω.

Recommended length for 4mm² / (AWG#11) is 16m / 52ft, maximum allowed length is 64m / 208ft.

IMPORTANT
Long speaker cables induce capacitive effects – up to hundreds of pF depending on the quality of the cable - with a low-pass effect on high frequencies. If long speaker cables must be used, ensure that they do not remain coiled while in use.

2.3 GEO S12 & LS18 recommended amplification

NEXO TD Controllers	Recommended amplification
NXAMP4x1mk2 Powered Controller Bridged Stereo mode (2x2.6kW/4Ω)	3 x GEO S12 in passive mode per bridged channel 2 x LS18 per bridged channel
NXAMP4x2mk2 Powered Controller 4 channels mode (4x2.5kW/2Ω)	1 x GEO S12 in passive mode per channel 1 x LS18 per channel
NXAMP4x4mk2 Powered Controller 4 channels mode (4x4.5kW/2Ω)	4 x GEO S12 in passive mode per channel 4 x GEO S12 in active mode: 2 channels 3 x LS18 per channel

2.4 GEO S12 & LS18 setups on NEXO TD Controllers

Please consult nexo-sa.com for NEXO TD Controllers firmware information.

3 CONNECTION DIAGRAMS

3.1 GEO S12 (passive mode) / NXAMP4x1mk2 (Bridge Stereo)

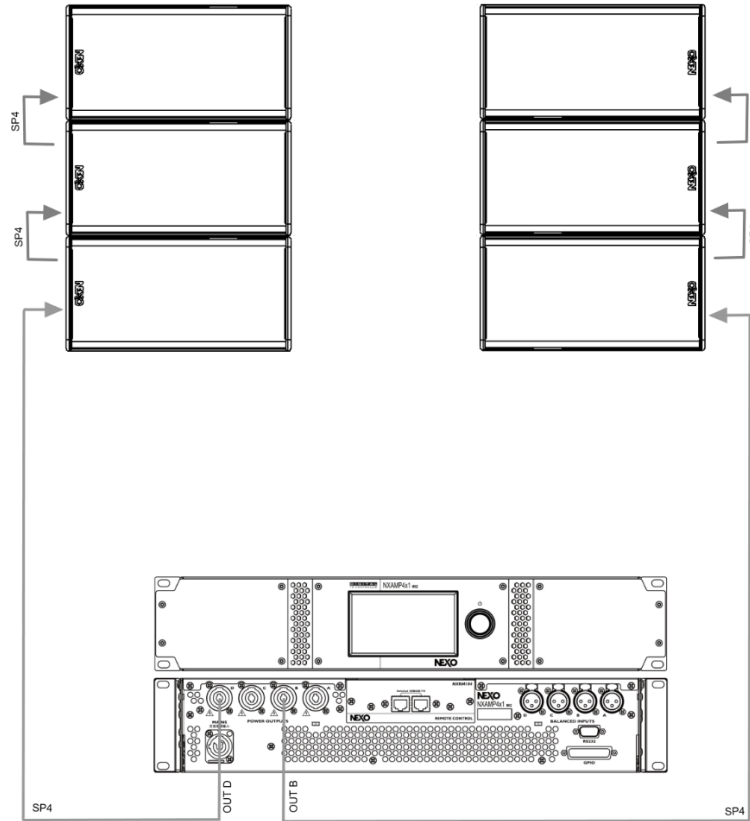

3.2 LS18 / NXAMP4x1mk2 (Bridge Stereo)

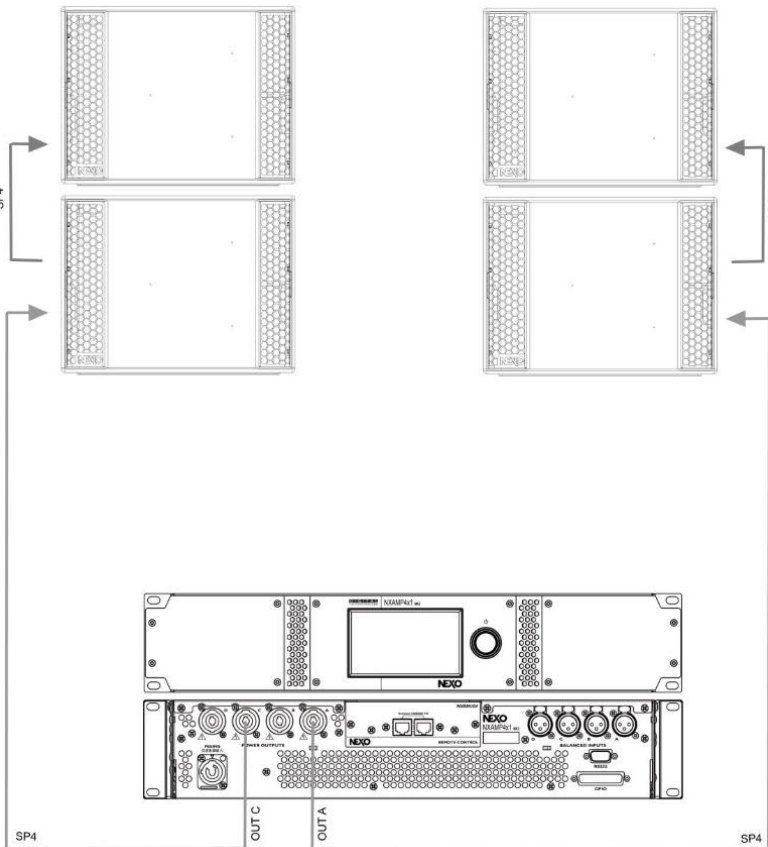

3.3 GEO S12 (passive mode) and LS18 / NXAMP4x1mk2 (Bridge Stereo)

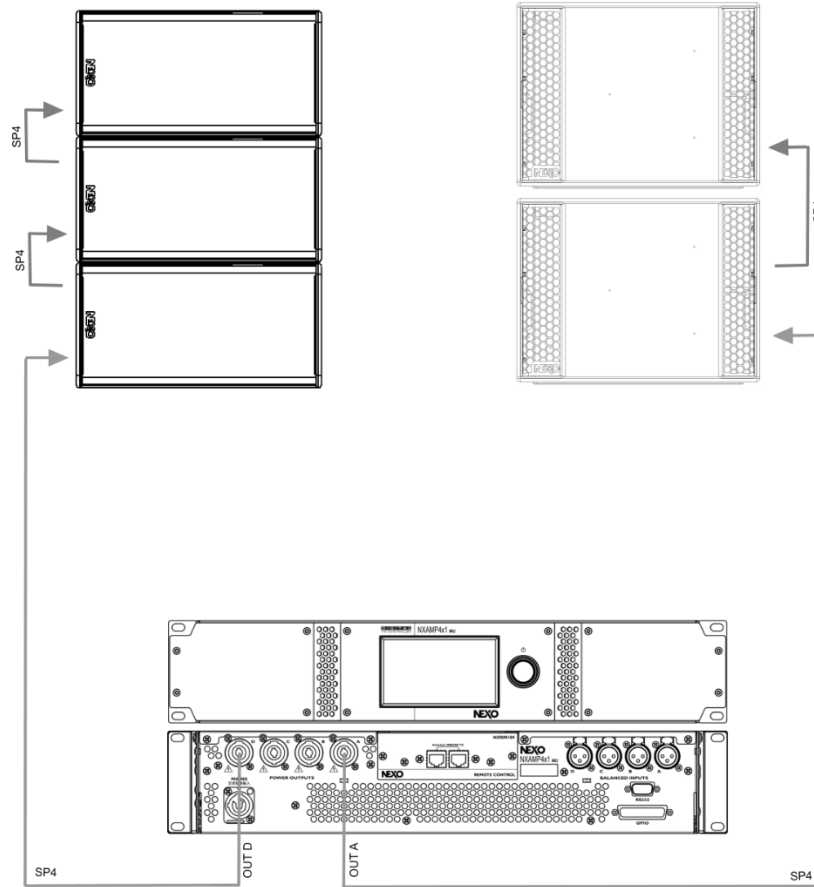

3.4 GEO S12 (passive mode) / NXAMP4x2mk2 (4 channels mode)

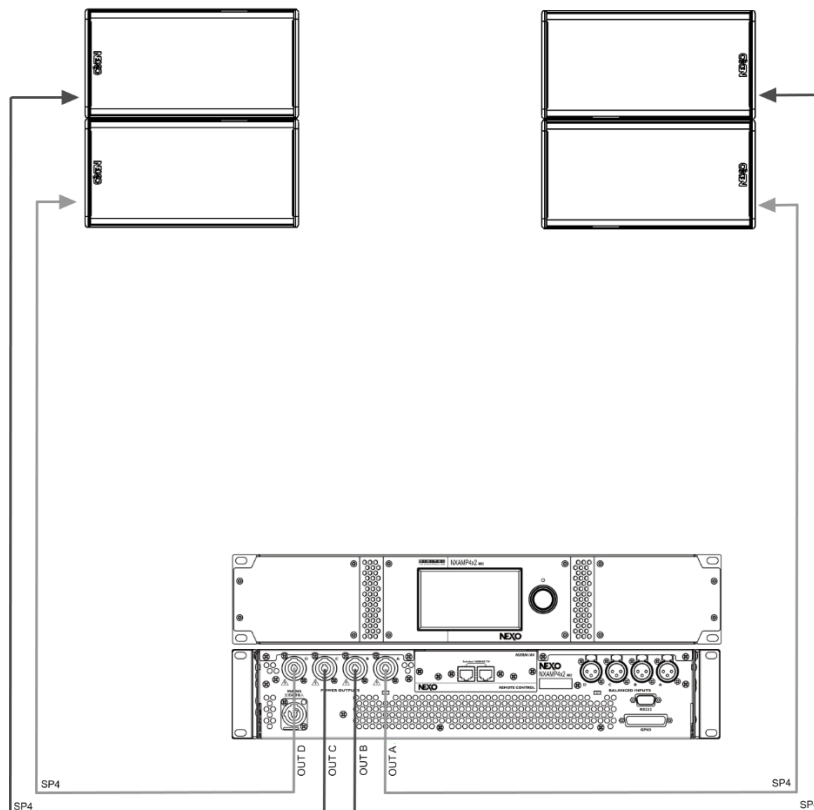

3.5 LS18 / NXAMP4x2mk2 (4 channels mode)

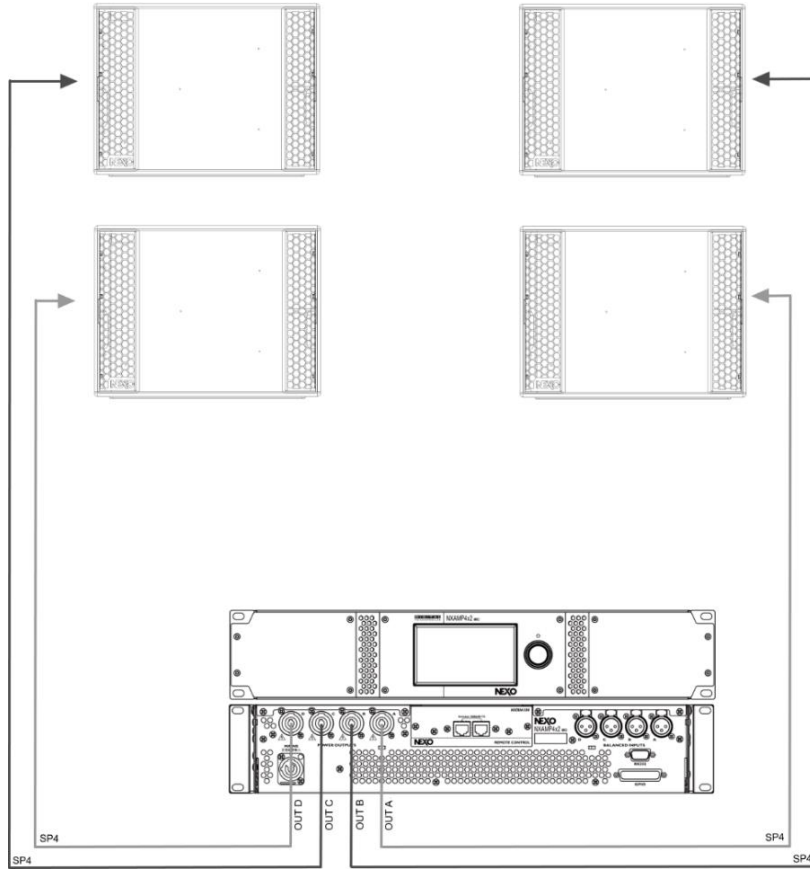

3.6 GEO S12 (passive mode) and LS18 / NXAMP4x2mk2 (4 channels mode)

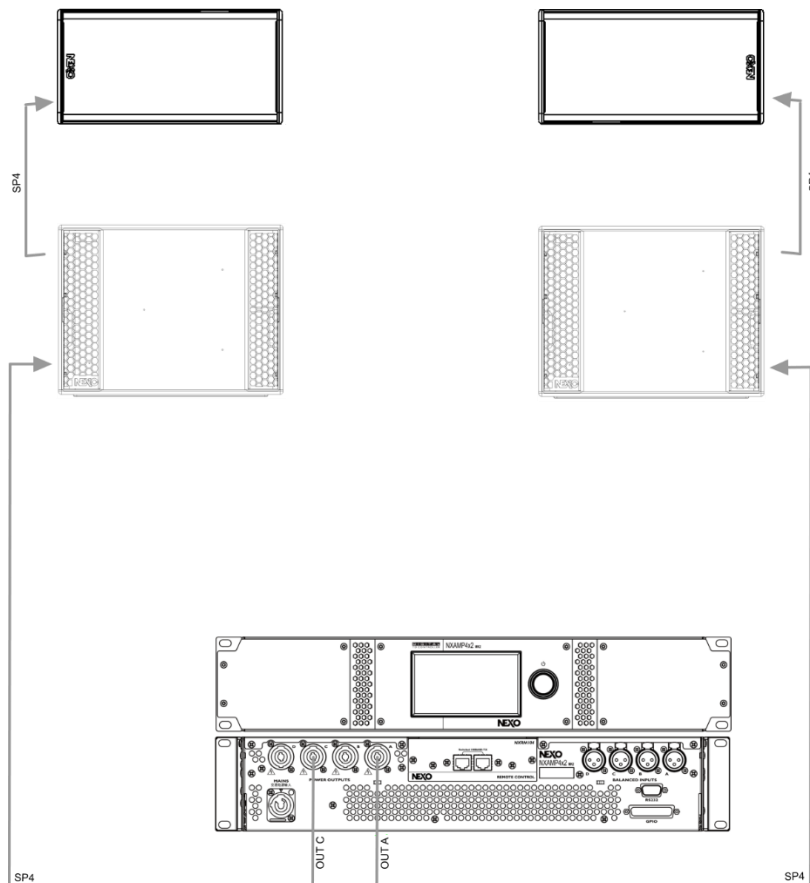

3.7 GEO S12 (passive mode) / NXAMP4x4mk2 (4 channels mode)

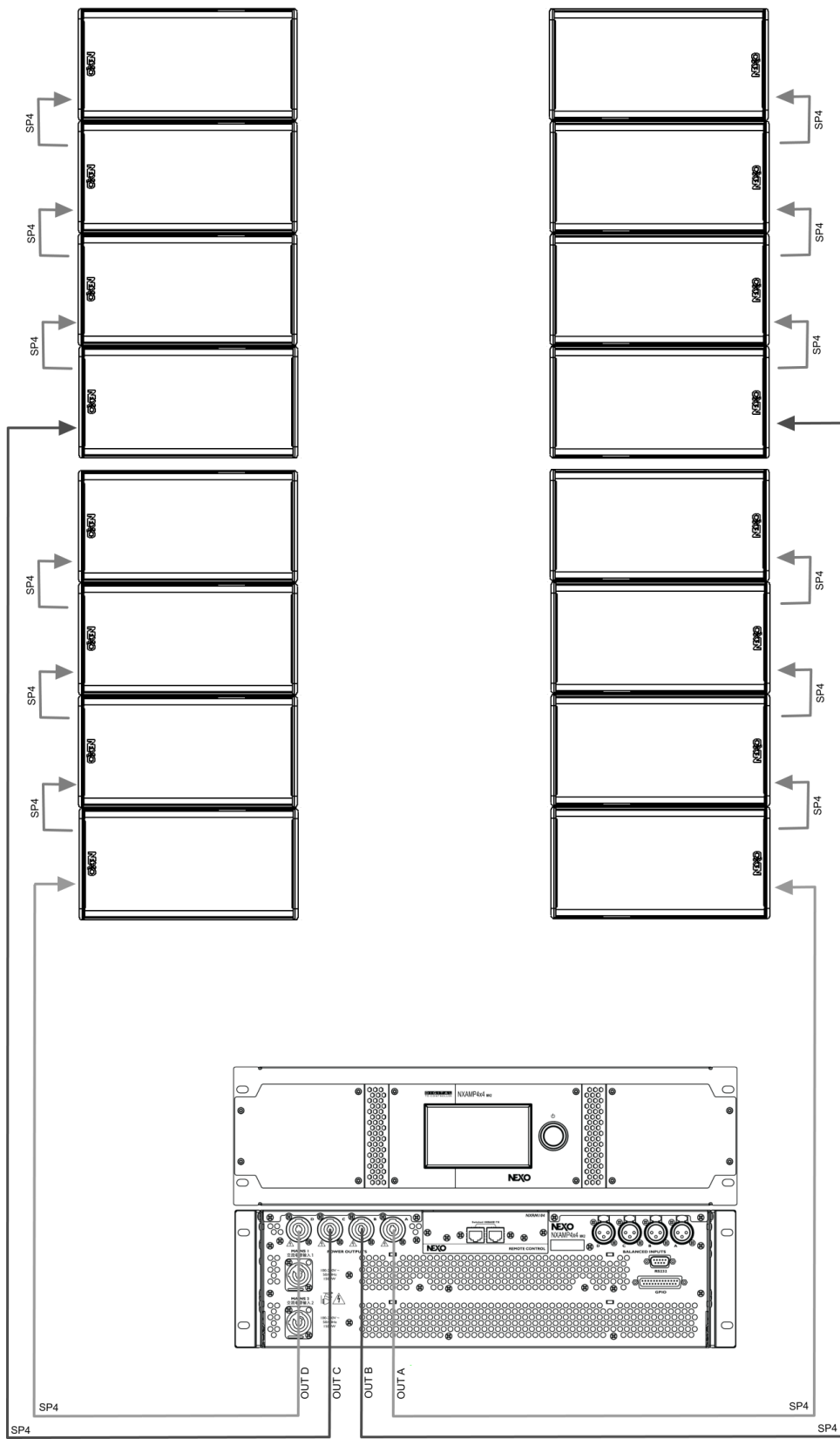

3.8 GEO S12 (active mode) / NXAMP4x4mk2 (4 channels mode)

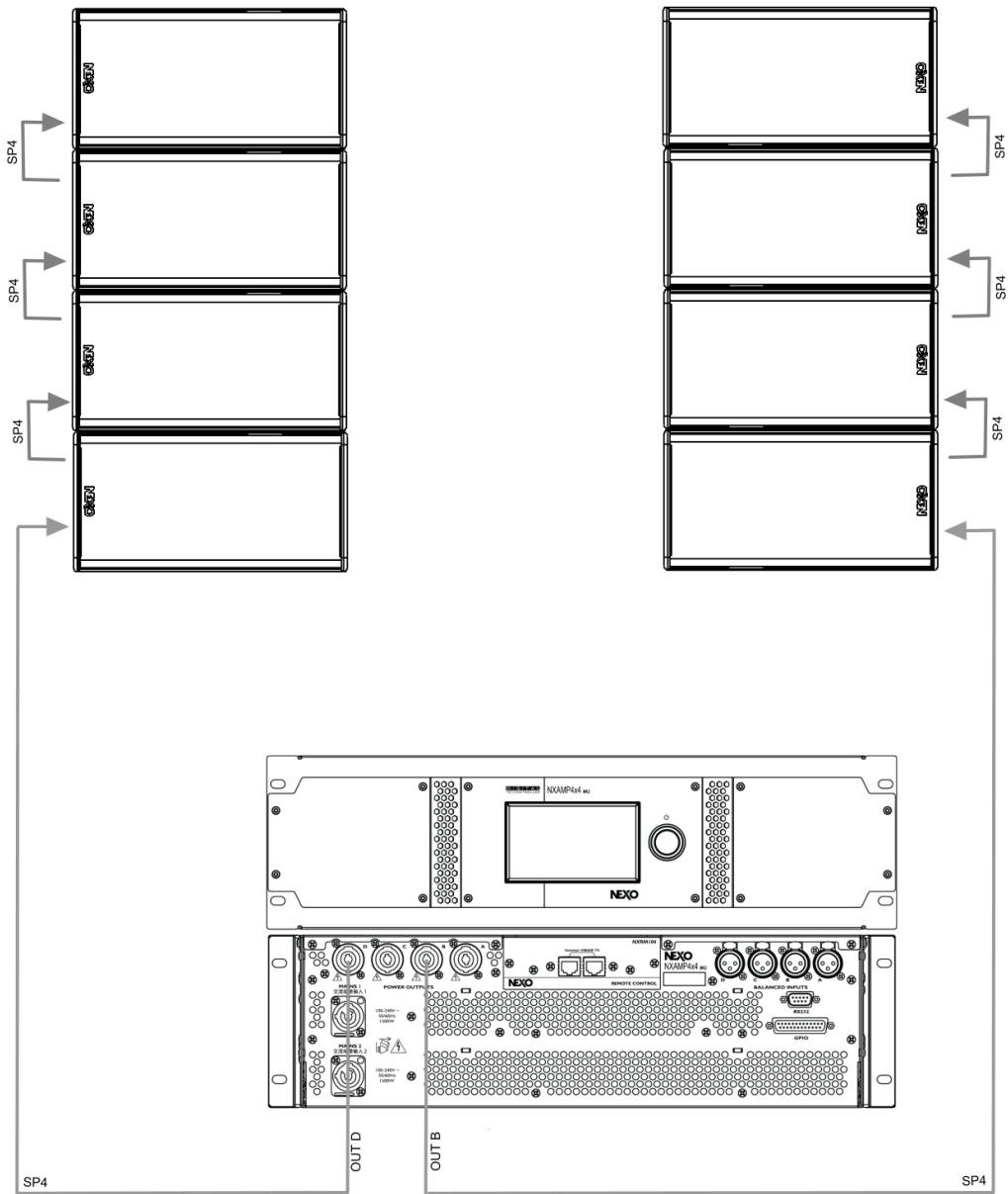

CONNECTION DIAGRAMS

3.9 LS18 Omni Mode / NXAMP4x4mk2 (4 channels mode)

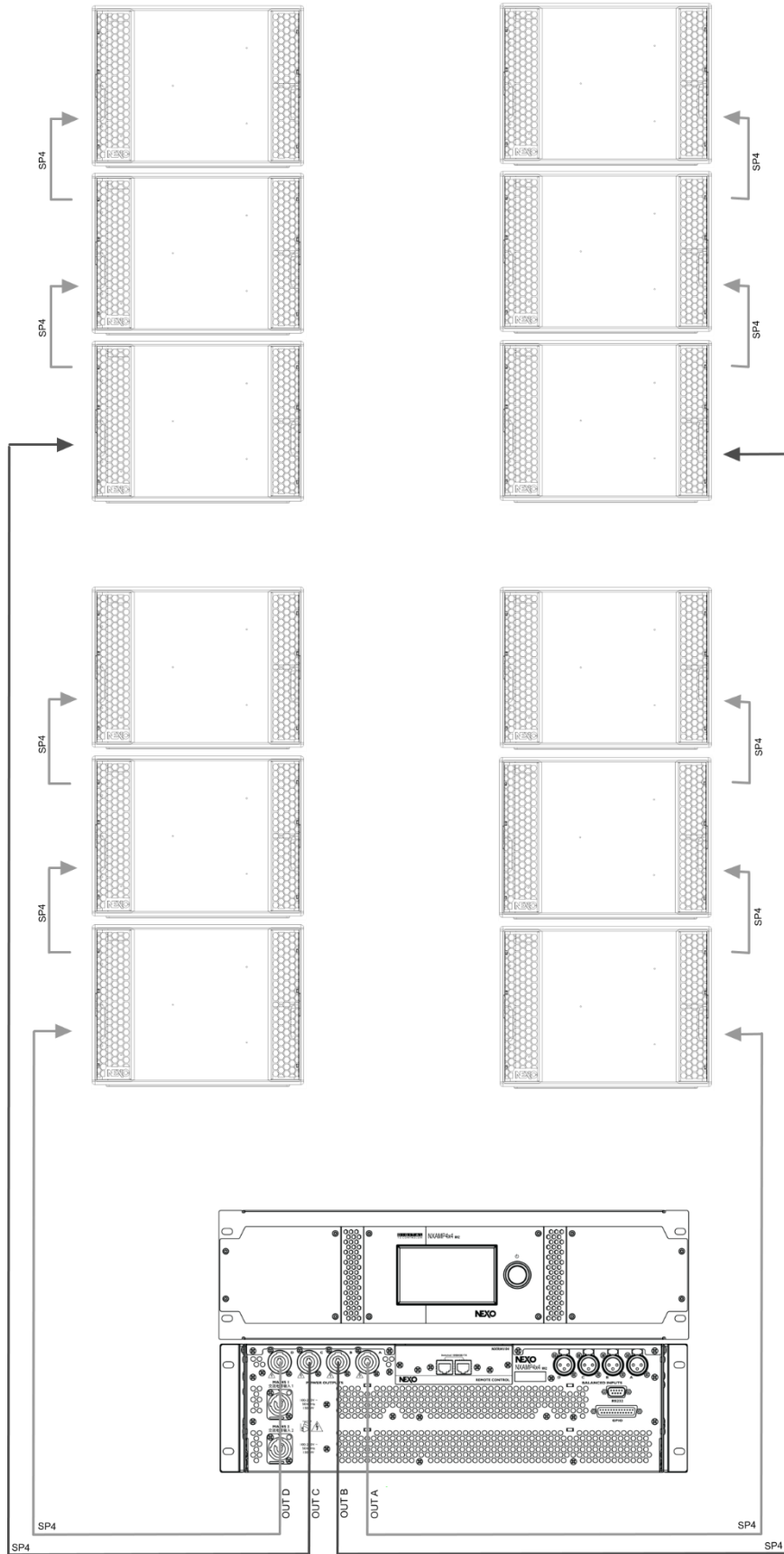

CONNECTION DIAGRAMS

3.10 LS18 Cardio Mode / NXAMP4x4mk2 (4 channels mode)

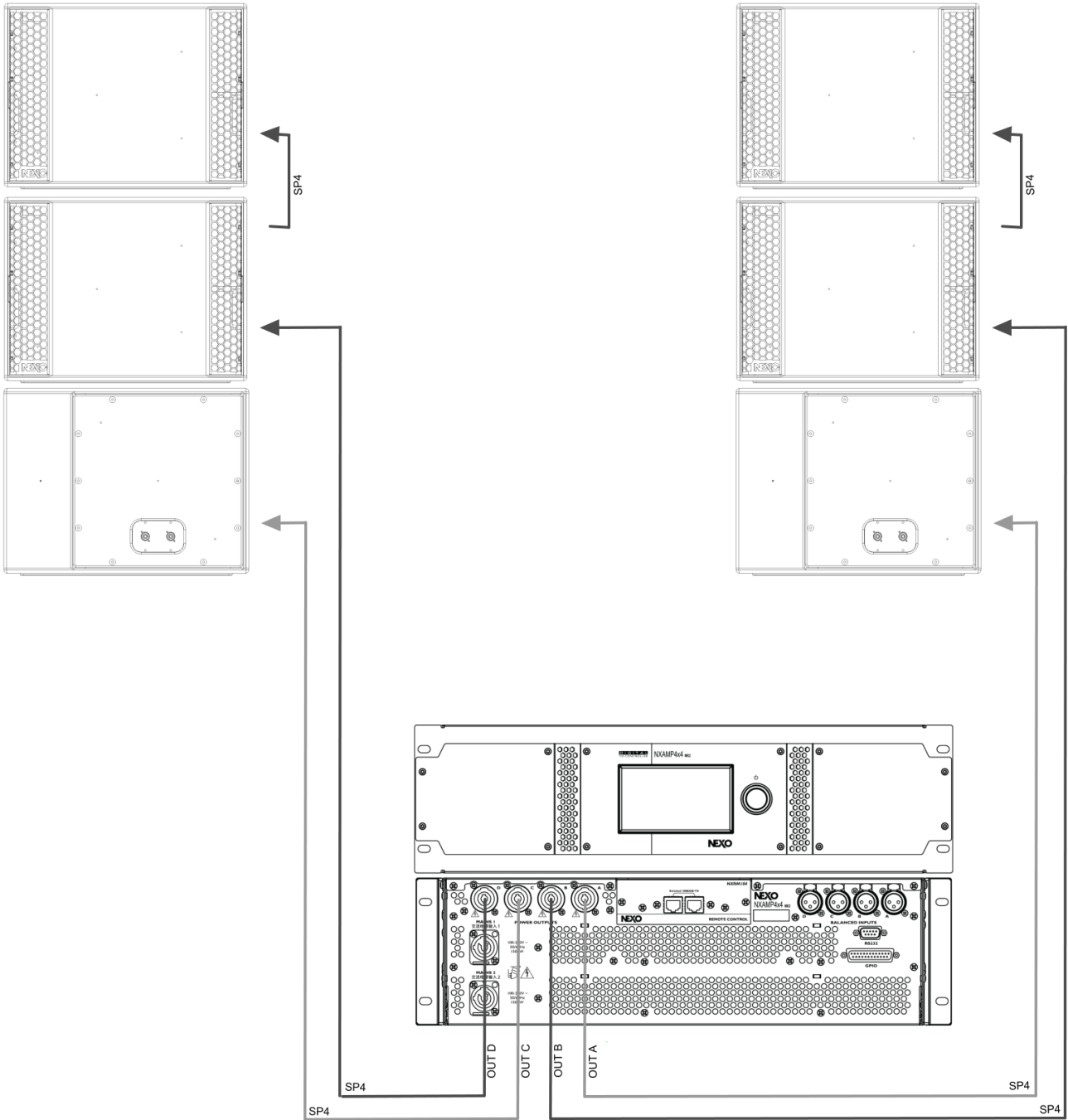

CONNECTION DIAGRAMS

3.11 GEO S12 (passive mode) and LS18 / NXAMP4x4mk2 (4 channels mode)

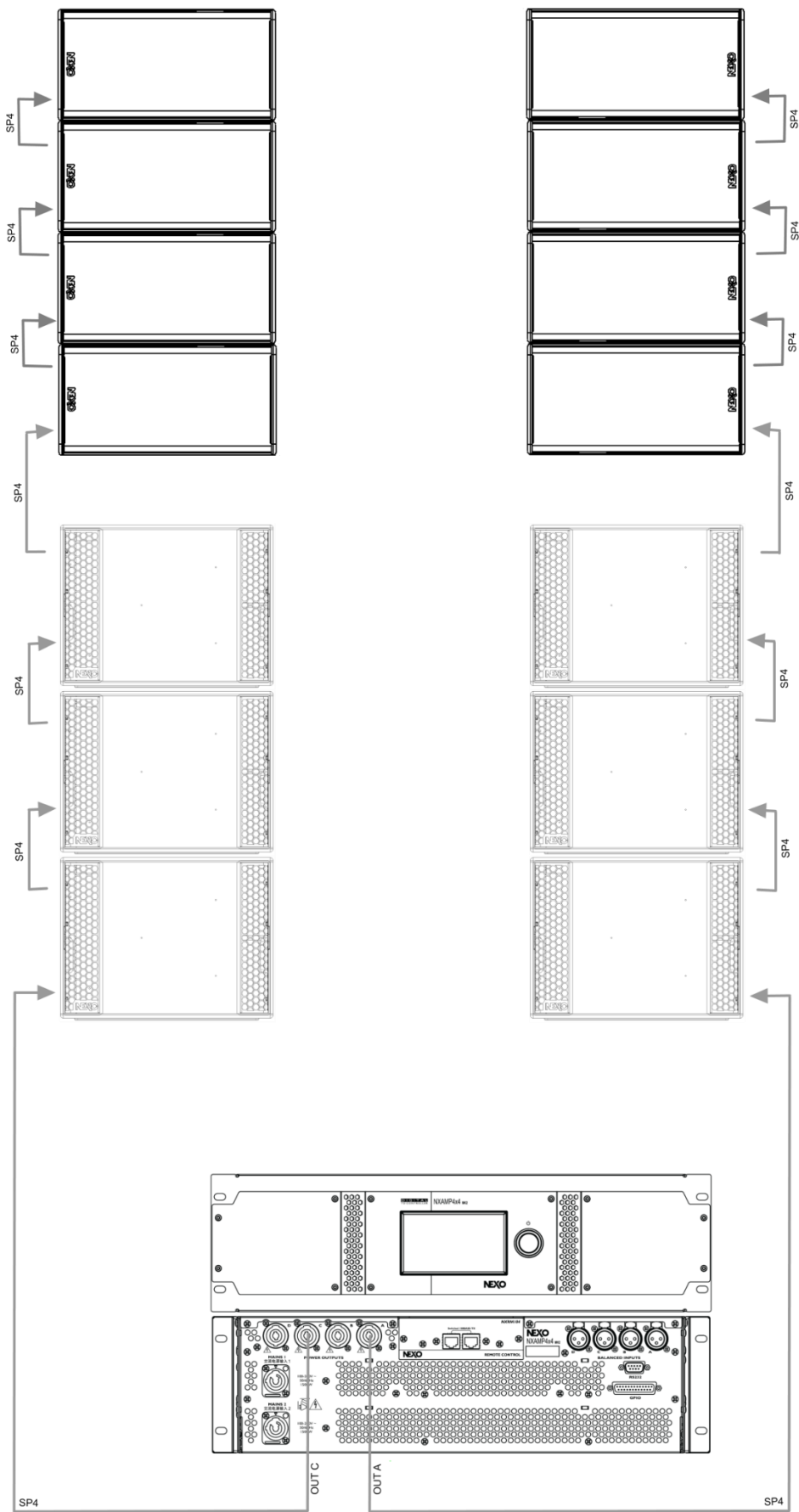

4 NS-1 SIMULATION SOFTWARE

NS-1 software is a R&D simulation tool derived application. It processes measured speaker data with complex mathematical algorithms to assist the user in optimizing system design. Due to the complexity of the interaction of multiple cabinets, it is simply not possible to reliably design curved vertical arrays without using the processing power of a computer to predict the optimum array structure for a given audience geometry. The design logic is far more complex than looking at a section drawing of the venue, measuring the overall angle needed to cover the audience from the cluster location, and dividing by 10 degrees to determine the required amount number of GEO S1210 cabinets.

NS-1 is an easy to use tool that allows to shape the energy leaving the cluster to fit the audience. It predicts pressure levels radiated from the system to ensure enough cabinets are provided for the application, as well as mechanical constraints for safe flown systems.

In addition, it provides mechanical information for all clusters in agreement with Structural Analysis Reports (available in the Help section): dimensions, weight, gravity centre position, forces, moments, working load and safety factor.

GEO S12 and LS18 Structural Analysis Report is currently being certified by German Certification Organization RWTUV systems GmbH.

NS-1 installation package includes all NEXO User Manuals, Structural Analysis Reports and Certificates PDF files.

NS-1 is a freeware available on nexo-sa.com

IMPORTANT

Never install a GEO S12 and/or LS18 cluster without checking its acoustical performances and mechanical safety in NS-1 prior to installation.

Any question or bug report please contact technical@nexo.fr

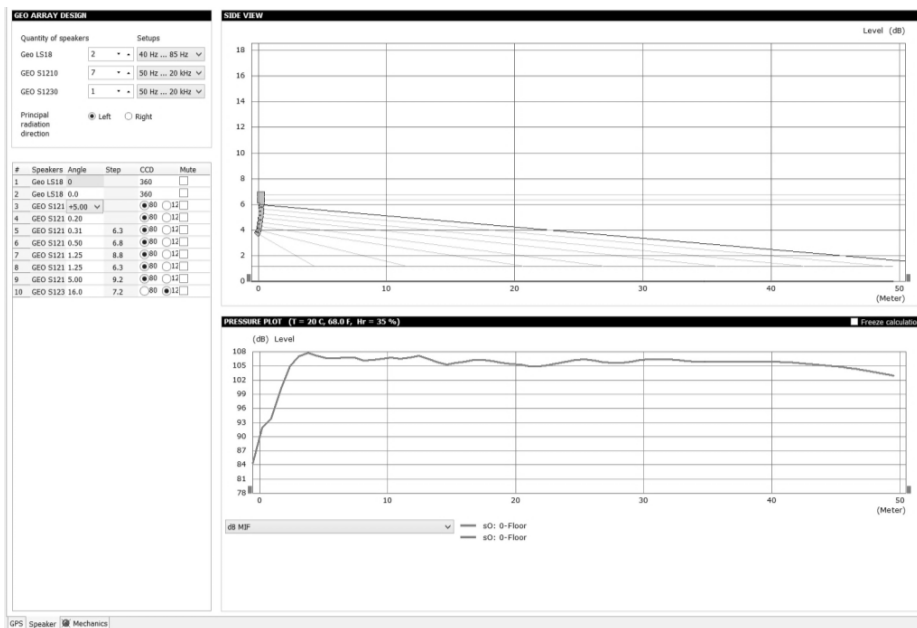

NS-1 GEO S12 ACOUSTIC PAGE

5 CONFIGURABLE DIRECTIVITY DEVICE

The GEO Wavesource controls dispersion of acoustic energy using a hyperboloid acoustical reflector in the “coupling plane” (the vertical plane of a curved vertical tangent array) and a diffraction slot in the “non-coupling plane” (the horizontal plane of a curved vertical tangent array). The patented Configurable Directivity Device consists of flanges that alter the diffraction slot’s exit flare rate.

5.1 Installing & removing GEO’s Configurable Directivity Devices

GEO S12 are shipped in the 80° dispersion configuration, 120° CDD™ flanges are an optional accessory (GPT-FLG).

To change horizontal dispersion from 80° to 120° and vice-versa:

- Remove the front grille
- Remove the 6 screws from the waveguide
- Position the CDD™ flanges on the waveguide and fix it with the provided screws and washers
- Reinstall the grille

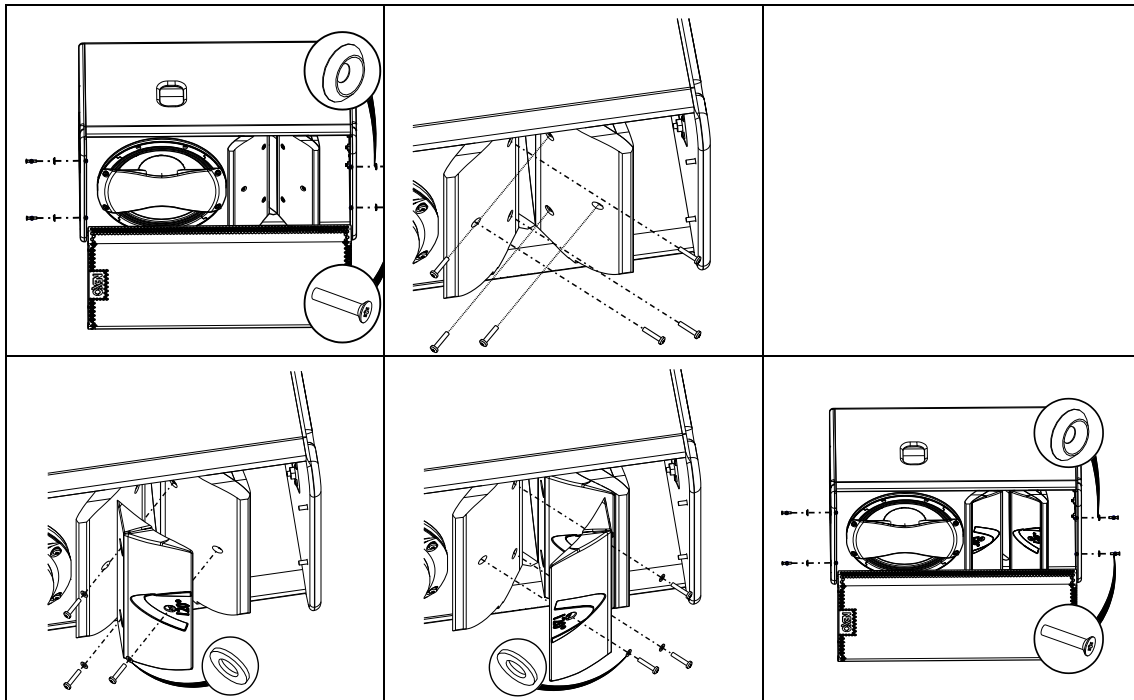

5.2 When & where to use Configurable Directivity flanges

The diagrams show audience area coverage for a stereo system. While the GEO cluster will deliver even SPL from the front to the rear of this audience area, there are “holes” near the front in the centre and at the outside edges. We cannot fill the outside coverage gaps without enlarging the centre gap, and vice versa (left figure below).

If 120° Configurable Directivity Devices are installed at the bottom cabinet of the clusters, coverage will look more like the pattern in right figure below.

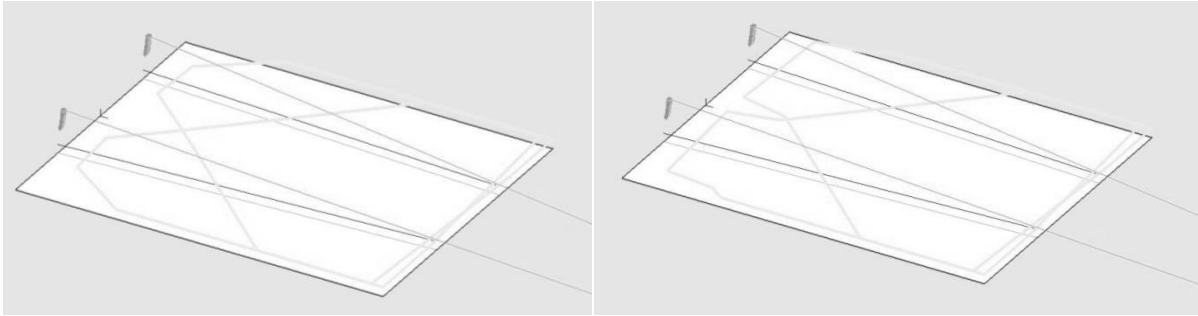

-6dB coverage, all GEO S12 in 80° configuration

-6dB coverage, bottom GEO S12 in 120° configuration

In curved vertical arrays, the 120° Configurable Directivity Device can be used:

- On the bottom row of curved vertical arrays, to fill in coverage gaps in the front rows.
- On all rows of curved vertical arrays, in cases where 120° of horizontal coverage is preferred to 80°.

IMPORTANT

Installing or removing one of the two flanges anticipating asymmetrical coverage will degrade both coverage and frequency response.

6 GEO S12 HARDWARE SETUP PROCEDURE

Before proceeding with assembly of GEO S12 & LS18 arrays, please ensure that the components are present and undamaged. A component list is appended to this manual. In the event of any shortage, please contact your supplier.

For maximum efficiency the GEO S12 & LS18 rigging system requires three experienced persons for set-up: typically, one motor hoist operator, and one operator per side of the array. Good synchronisation and crosscheck between the operators are key elements for a reliable and safe set-up.

6.1 Safety first

GEO S12 & LS18 Rigging System structural computations and related documents are available in NS-1 or at NEXO (info@nexo.fr) upon request.

We include this section to remind you of safe practice when flying the GEO S12 & LS18 system. Please read it carefully. However, user must always apply his or her knowledge, experience and common sense. If in any doubt, seek advice from your supplier or NEXO agent.

This manual offers guidance only for GEO S12 & LS18 loudspeaker systems. References in this manual to other rigging equipment such as motor hoists, steels, shackles etc. are made to clarify the description of rigging procedures. The user must ensure that operators are properly trained by other agencies in the use of these items.

The GEO S12 & LS18 Rigging System has been optimised for the deployment of curved vertical or horizontal tangent arrays of GEO S12 & LS18 loudspeakers. Angle adjustment between cabinets has been limited to specific settings to ensure correct acoustic coupling.

The GEO S12 & LS18 Rigging System is a professional precision tool set and should be handled with extreme care. Only persons who are fully conversant with the operation of the GEO S12 & LS18 Rigging System and provided with suitable safety equipment should deploy GEO Arrays. Misuse of the GEO S12 & LS18 Rigging System could lead to dangerous consequences.

Used and maintained correctly, the GEO S12 & LS18 Rigging System will give many years of reliable service in portable systems. Please take the time to read and understand this manual. Always use NS-1 to determine the optimum angle settings for a particular venue, hang point and curved vertical GEO S12 & LS18. Applied forces and moments are strongly cabinet quantity and angle configuration dependent. Cluster configuration must be implemented and validated in NS-1 prior to installation.

6.1.1 Flown systems safety

Always inspect all the rigging components and cabinets for damage before assembly. Pay special attention to the lifting points, and safety clips. If you suspect that any of the components are damaged or defective, DO NOT USE THE AFFECTED PARTS. Contact your supplier for replacements.

Read this manual carefully. Also, be familiar with the manuals and safe working procedures for any ancillary equipment that will be used with the GEO S12 & LS18 Rigging System.

Applied forces and moments are strongly cabinet quantity and angle configuration dependent. Cluster configuration must be implemented and validated in NS-1 prior to installation.

Ensure that all local and National regulations regarding the safety and operation of flying equipment are understood and adhered to. Information on these regulations can usually be obtained from Local Government Offices.

When deploying a GEO S12 & LS18 system always wear protective headwear, footwear and eye protection.

Do not allow inexperienced persons to handle a GEO S12 & LS18 system. Installation personnel should be trained in loudspeaker flying techniques and should be fully conversant with this manual.

Ensure that motor hoists, hoist control systems and ancillary rigging components are currently certified as safe and that they pass a visual inspection prior to use.

Ensure that public and personnel are not allowed to pass beneath the system during the installation process. The work area should be isolated from public access.

Never leave the system unattended during the installation process.

Do not place any object, no matter how small or light, on top of the system during the installation procedure. The object may fall when the system is flown and is likely to cause injury.

Secondary safety steels must be installed once the system has been flown to the operating height. Secondary steels must be fitted irrespective of requirements of the local safety standards applicable to the territory.

Ensure that the system is secure and prevented from pivoting around the motor hoist.

Avoid any form of excessive dynamic loading to the assembly (structural computations on GEO S12 & LS18 Rigging System are based on a 1/1.2 factor for hoist or motor acceleration).

NEVER attach any item to the GEO S12 & LS18 system other than the GEO S12 & LS18 accessories.

When flying outdoor systems ensure that the system is not exposed to excessive wind or snow loads and is protected from rainfall.

In case of wind greater than 8 on Beaufort scale (72km/h – 45mph), a touring system has to be landed or an additional securing has to be implanted.

For fixed installations, wind loading has to be taken into account in accordance to the national standards.

The GEO S12 & LS18 Rigging System requires regular inspection and testing by a competent test centre. NEXO recommend that the system is load tested and certified annually or more frequently if local regulations require.

When de-rigging the system ensure that the same duty of care is given to the procedure as for the installation. Pack GEO S12 & LS18 components carefully to prevent damage in transit.

6.1.2 Ground stacking safety

Statistically, many more injuries occur due to unstable ground stacked PA systems than those associated with flown systems. There are several reasons for this fact, however the message is clear:

Always survey the supporting structure upon which a ground stack is to be built. Always look beneath PA wings to inspect the deck support and if necessary ask for the stage scrims and dressings be removed to allow access.

If the stage surface slopes, as it does in some theatres, ensure that the system is prevented from sliding forwards due to vibration. This may require the fitting of timber battens to the stage floor.

For outdoor systems ensure that that the system is protected from wind forces which might cause the ground stack to become unstable. Wind forces can be huge, especially upon large systems, and should never be underestimated. Observe meteorological forecasts, calculate the “worst case” effect upon the system prior to erection and ensure that the system is secured appropriately.

Take care when stacking cabinets. Always employ safe lifting procedures and never attempt to build stacks without sufficient personnel and equipment.

Never allow anyone, whether operators, artists or members of the public to climb onto a ground stacked PA system. Anyone who needs to climb over 2m (6 ft) high should be fitted with suitable safety equipment including a clip-on harness. Please refer to local Health and Safety legislation in your territory. Your dealer can help with advice on access to this information.

Apply the same attention to all safety matters when de-stacking systems.

Be aware that safety procedures are as important in the truck and in the warehouse as they are at the venue.

6.1.3 Contacts

Correct training is fundamental to safe practise when working with loudspeakers flying systems. NEXO recommend that users contact local industry associations for information on specialist course.

Information for International training agencies can be obtained by contacting either:

The Production Services Association (PSA),
School Passage,
Kingston-upon-Thames,
KT1 SDU Surrey,
ENGLAND
Telephone: +44 (0) 181 392 0180
www.psa.org.uk/

Rigstar Training and Testing Center
82 Industrial Dr. Unit 4
Northampton, Massachusetts 01060 U.S.A.
Phone: 413-585-9869
www.rigstar.com/

ESTA
Entertainment Services & Technology
Association
875 Sixth Avenue, Suite 1005
NEW YORK, NY 10001 USA
Phone: 212-244-1505
www.esta.org

6.2 General Description

6.2.1 GEO S1210 and GEO S1230

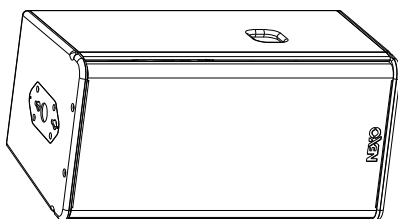

GEO S1210

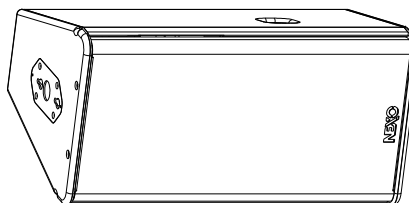

GEO S1230

GEO S1210 and GEO S1230 incorporate two connecting plates (one per side) on which a comprehensive range of accessories can be mounted.

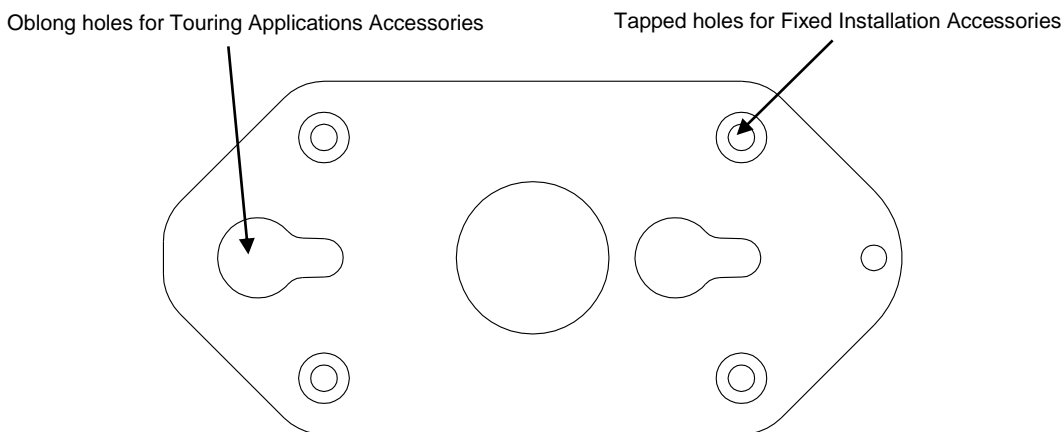

GEO S12 connecting plates

Angle splay setting sequences are as follow:

- GEO S1210 to GEO S1210: 0.2° / 0.31° / 0.5° / 0.8° / 1.25° / 2° / 3.15° / 5° / 6.25° / 8° / 10°
- GEO S1210 to GEO S1230: 16°
- GEO S1230 to GEO S1230: 16° / 22.5° / 30°

6.2.2 GEO S12 “Left” and “Right” configuration

GEO S12 can be installed “Left” or “Right”:

- “Left” means HF waveguide is left as seen from front
- “Right” means HF waveguide is right as seen from front

GEO S12 can be connected to bumpers “Left” or “Right” by simply flipping the cabinets.

Whenever possible, NEXO recommends symmetrical designs (preferably HF waveguide inwards in stereo configurations)

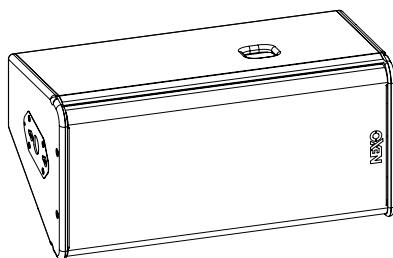

GEO S12 “Left”

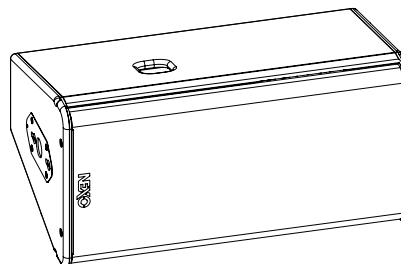

GEO S12 “Right”

6.2.3 LS18

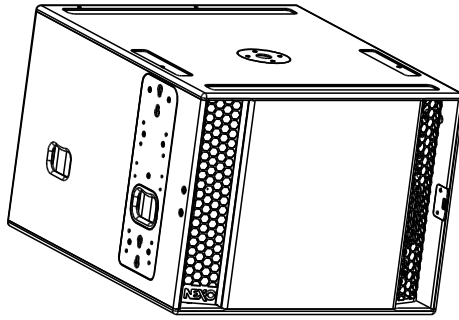

LS18 incorporate two connecting plates (one per side) on which a comprehensive range of accessories can be mounted.

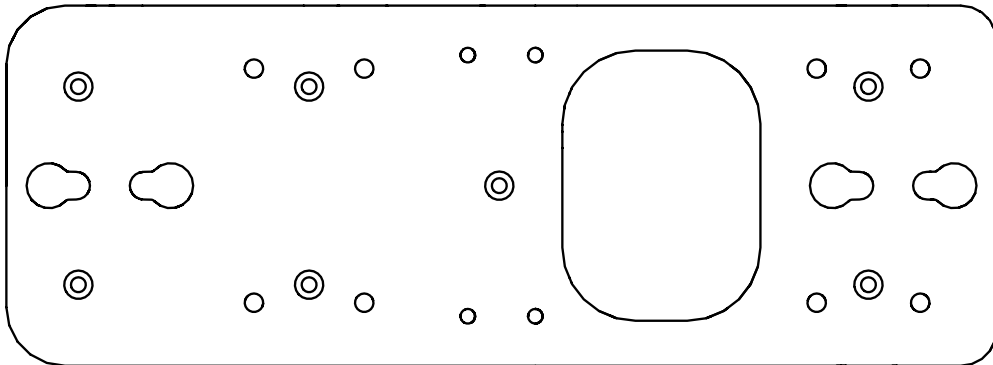







LS18 connecting plates

Angle splay setting sequences are as follow:

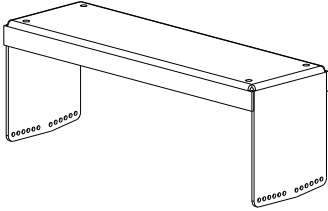
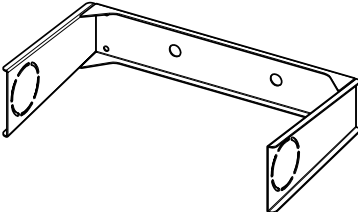
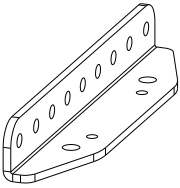
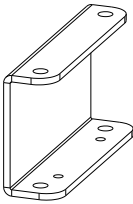
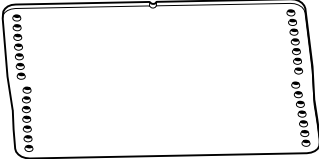
- LS18 to LS18: 0.2°
- LS18 to GEO S1210: -5° / -2.5° / -1.25° / 0.2° / 0.31° / 0.5° / 0.8° / 1.25° / 2° / 3.15° / 5°
- LS18 à GEO S1230: -5° / -2.5° / -1.25° / 0.2° / 0.31° / 0.5° / 0.8° / 1.25° / 2° / 3.15° / 5° / 6.3° / 8° / 10°

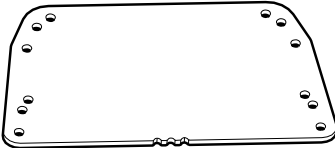
6.2.4 Accessories

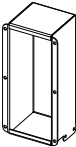
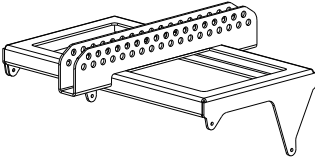
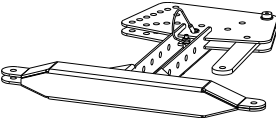
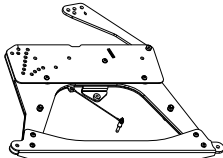
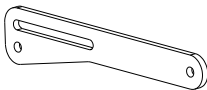
GEO S12 & LS18 accessories are:

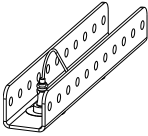
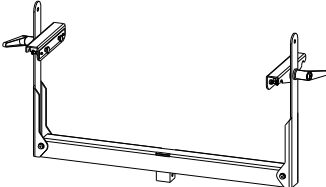
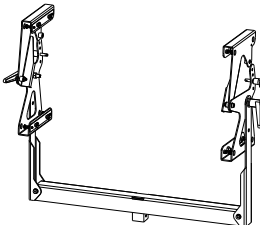
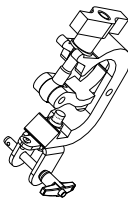
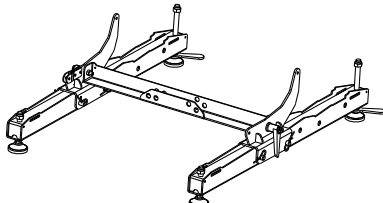
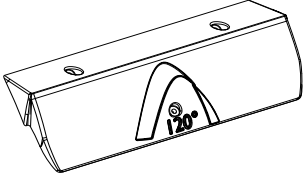
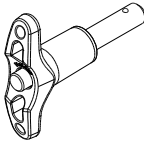
<p>GPI-BUMPER</p> 	<p>VNI-UBRK12</p> 	<p>VNI-LBRK</p> 
<p>VNI-ABRK</p> 	<p>GPI-ANPL1</p> 	<p>GPI-ANPL2</p> 
<p>GPI-ANPL3</p> 	<p>LSI-CPLA</p> 	<p>VNI-IPCOV15</p> 
<p>GPT- BUMPER</p> 	<p>GPT-XBOW</p> 	<p>LST-XBOW18</p> 
<p>GPT-TLB</p> 	<p>VNT-XHBRK</p> 	<p>VNT- TTC</p> 
<p>GPT-SSBRK</p> 	<p>GPT-PSBRK</p> 	<p>VNT- TCBRK</p> 
<p>GPT-GSTK</p> 	<p>GPT-FLG</p> 	<p>VXT-BL820</p> 

6.2.5 Warnings on GEO S12 & LS18 accessories

WARNING

All GEO S12 and LS18 accessories are specifically rated in agreement with structural computations. Never use other accessories – including push-pins - when assembling GEO S12 and/or LS18 cabinets than the ones provided by NEXO: NEXO will decline responsibility over the entire GEO S12 and LS18 accessory range if any component is purchased from different supplier.

WARNING 2

For SAFETY reasons, following first generation accessories:

- GEOS12-XBOW
- GEOS12-TCBRK
- GEOS12-SSBRK
- GEOS12-PSBRK
- GEOS12-TTC

Have been recalled in August 2007 and **MUST NO LONGER BE USED**

These accessories have been replaced by:

- GPT-XBOW
- GPT-TCBRK
- GPT-SSBRK
- GPT-PSBRK
- GPT-TTC

Please contact your local distributor if any doubt in relation the GEO S12 & LS18 accessories you are using.

WARNING 3

All GEO S12 accessories have been designed so that cabinets are arrayed in the acoustic coupling plane (adjacent waveguides as shown in figures below).

GEO S12 assemblies in the “non-coupling plane” – as shown in figure below- are UNSAFE and STRICTLY PROHIBITED.

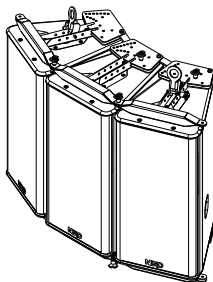

YES

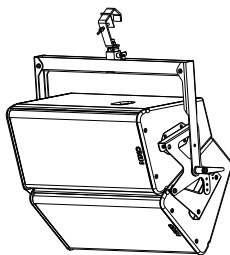

YES

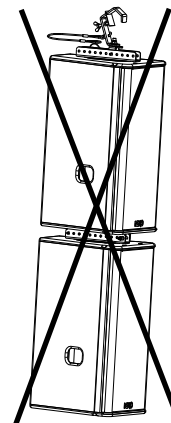

NO

6.3 Installation applications

6.3.1 Described configurations

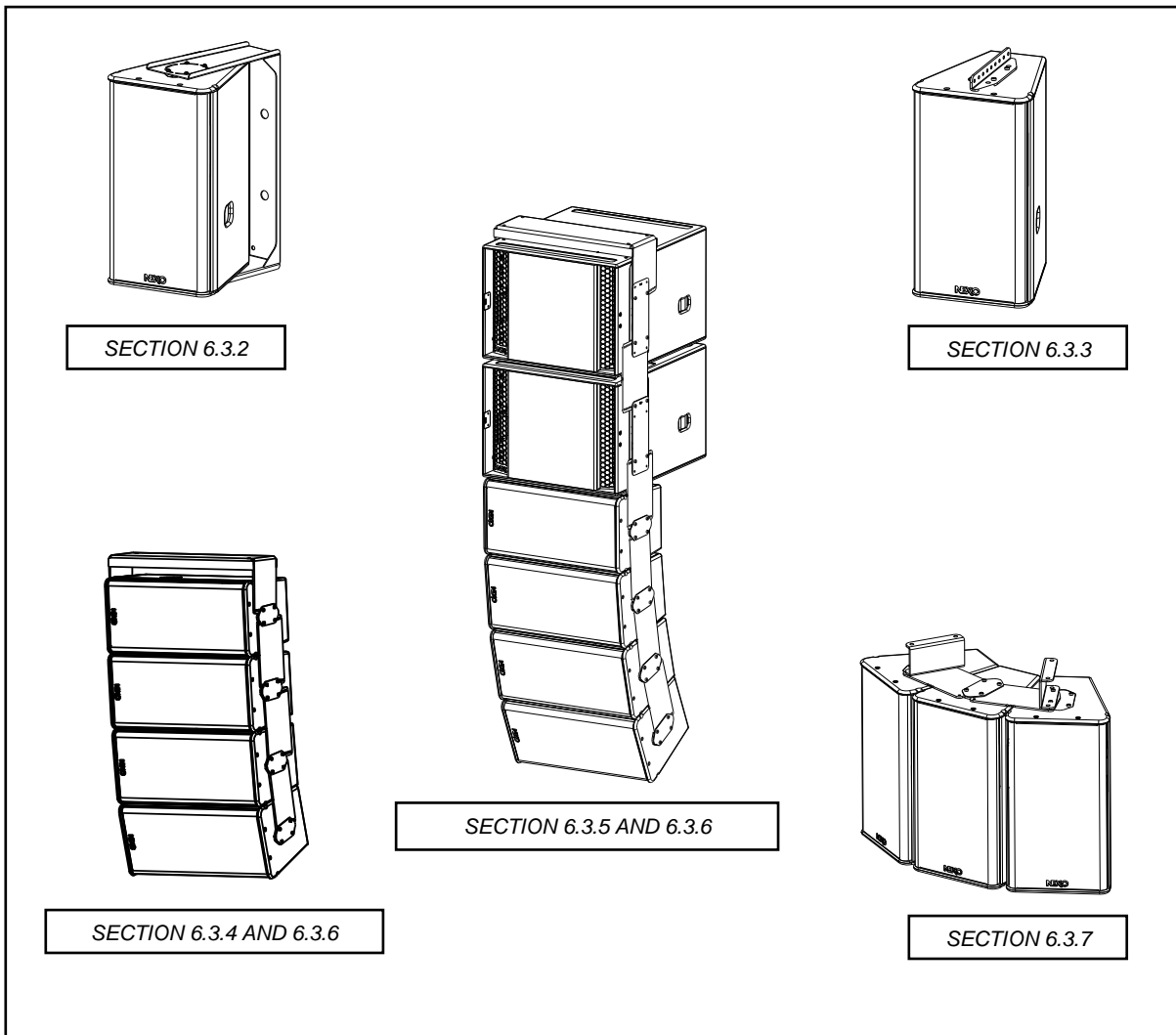

IMPORTANT

In order to prevent screws from getting loose in fixed installations, we deliver thread lock coated screws, if not use blocking liquid LOCTITE™ 243 or equivalent for all screws used with GEO S12 & LS18 fixed installation accessories.

LOCTITE™ 243 is available at NEXO or at your local distributor upon request.

6.3.2 Single GEO S12 rigidly mounted on a wall or a ceiling (vertical or horizontal)

Required items

- 1 x VNI-UBRK12 (allows all angles to be implemented)
- 4 x 12mm diameter screws (*not provided*)

IMPORTANT

Ensure that the surface – wall or ceiling – is strong enough to hold 4 times GEO S12 weight and that the four screws 12mm diameter and corresponding plugs required to fix the “U” bracket on the wall or under the ceiling are properly dimensioned.

Procedure

- Remove the four TORX screws holding connector plates on both sides of GEO S12
- Position the GEO S12 inside the “U” Bracket to desired angle; “U” bracket oblong holes must be properly aligned with panels holes
- Apply Loctite 243 or equivalent to the eight screws and washers from VNI-UBRK12 kit
- Connect “U” bracket to cabinet with these screws
- Four screws 12mm diameter (not provided) are required to secure the “U” Bracket on the wall or ceiling

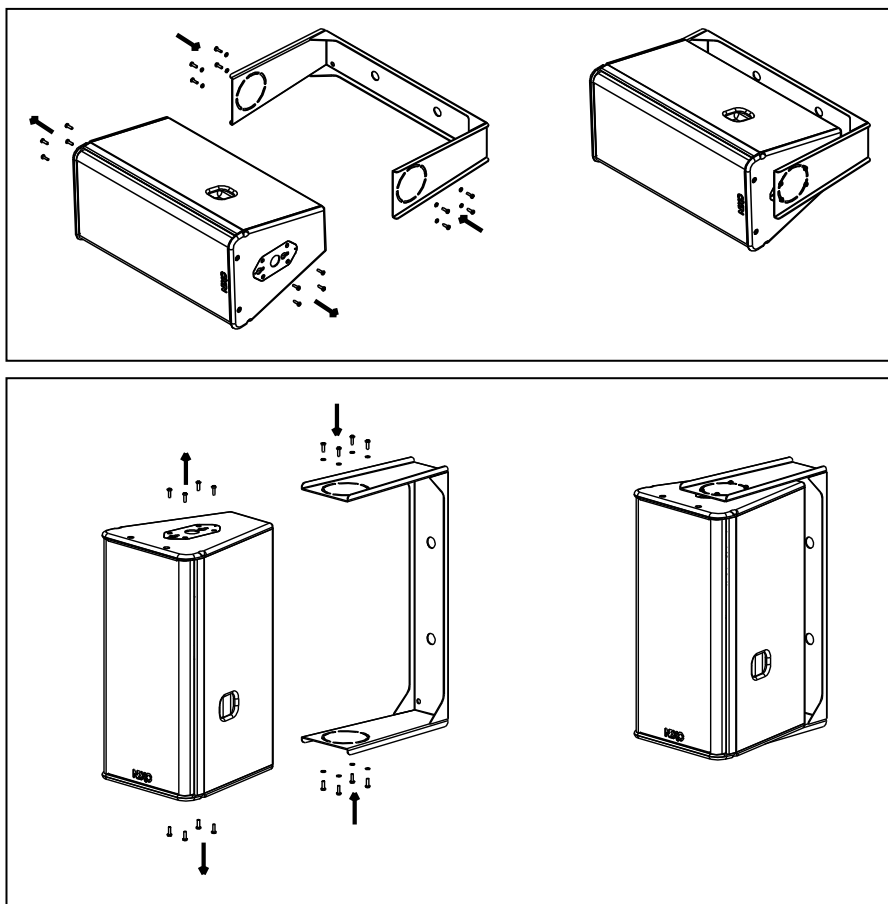

6.3.3 Single GEO S12 cable mounted on a ceiling (vertical or horizontal)

Required items

- 1 or 2 x VNI-LBRK (allows cable suspension, holes for cable suspension are 10mm diameter)
- 2 or 4 slings and corresponding shackles (*not provided*)

IMPORTANT

Ensure that the ceiling is strong enough to hold 4 times GEO S12 weight and that the cable suspension system required to install the cabinet under the ceiling is properly dimensioned.

Procedure

Vertical

- Remove the four TORX screws holding connector plates on upper side of GEO S12
- Remove the connector plate from GEO S12
- Apply Loctite 243 or equivalent to the 4 shoulder screws from VNI-LBRK
- Position external plate from VNI-LBRK kit and secure it using the 2 of the 4 shoulder screws
- Position "L" bracket from VNI-LBRK kit, and secure it to the cabinet using the 2 remaining shoulder screws
- Slings and shackles (*not provided*) are required to secure the cluster under the ceiling

Horizontal

- Remove the four TORX screws holding connector plates on both sides of GEO S12
- Remove the connector plates from GEO S12
- Apply Loctite 243 or equivalent to the 4 shoulder screws from VNI-LBRK
- Position external plates from VNI-LBRK kits and secure them using the shoulder screws
- Position "L" brackets from VNI-LBRK kits, and secure them to the cabinet using the 4 remaining shoulder screws
- Slings and shackles (*not provided*) are required to secure the cluster under the ceiling

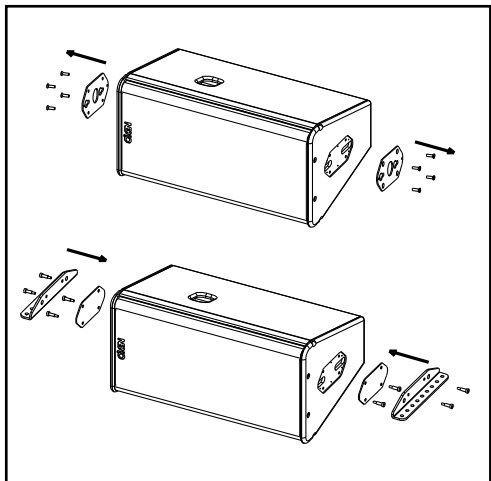
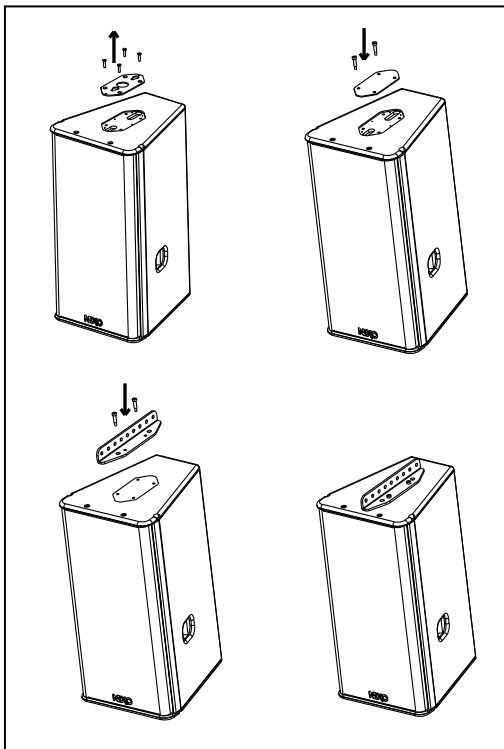

6.3.4 GEO S12 vertical array rigidly mounted on a ceiling

Required items

- 1 x GPI-BUMPER (allows +/-5° bumper tilt when installed below a flat surface; if higher bumper tilt is required, surface will have to be defined accordingly)
- (N-1) x GPI-ANPL for a N x GEO S12 array (ANPL1 ranges from 0.2° to 3.15°, ANPL2 ranges from 5° to 10°, ANPL3 ranges from 16° to 30°)
- 4 x 12mm diameter screws (*not provided*)

IMPORTANT

Ensure that the ceiling is strong enough to hold 4 times GEO S12 cluster weight and that the four screws 12mm diameter and corresponding plugs required to fix the bumper under the ceiling are properly dimensioned.

Procedure

- Set all GEO S12 sideways according to cluster configuration
- Remove the four TORX screws holding connector plates on upper side of all GEO S12's
- Remove the connector plates from all Geo S12's
- Position bottom counter-plates, angle plates and top counter-plates from GPI-ANPL kit to required inter-cabinet angle value between cabinets upper sides
- Use thread lock coated screws (or if not apply Loctite 243 or equivalent to shoulder screws) from GPI-ANPL kits
- Screw shoulder screws so that all plates and cabinets are tightened together

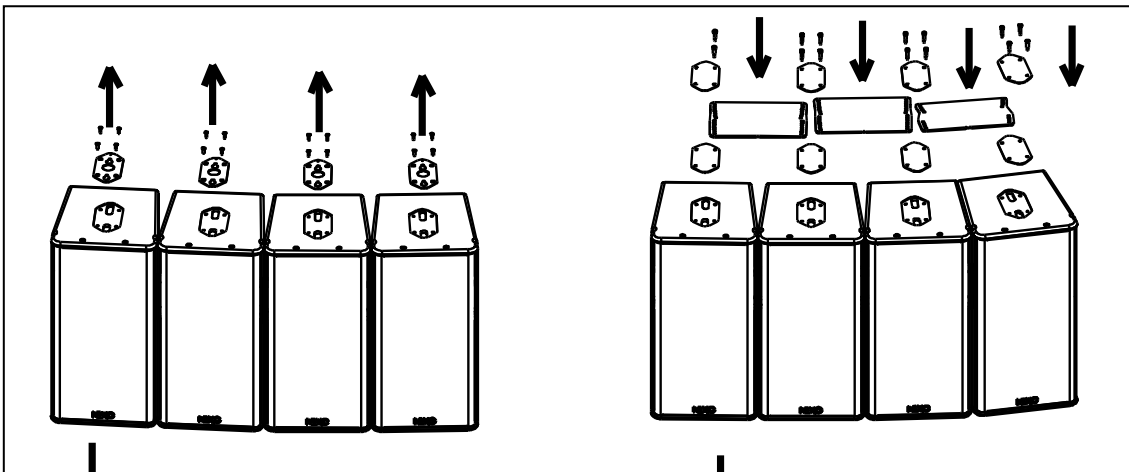

- Flip the cluster upside down to access connector plates located on the down side
- Repeat all above steps

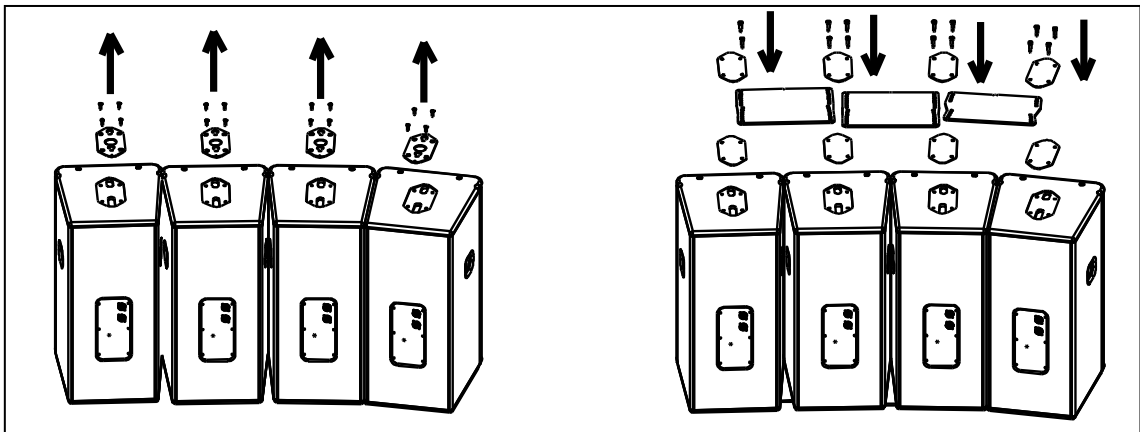

GEO S12 HARDWARE SETUP PROCEDURE

- Use thread lock coated screws (or if not apply Loctite 243 or equivalent to four shoulder screws) from the last GPI-ANPL kit
- Position the GPI-BUMPER bumper to required angle position and use the four shoulder screws to connect it to the top cabinet

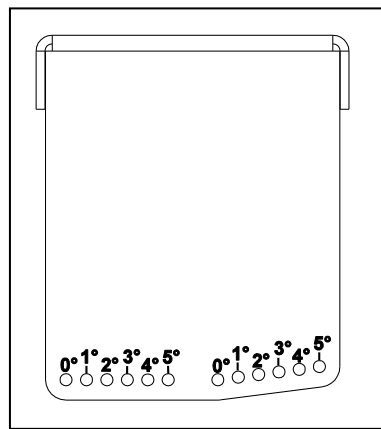
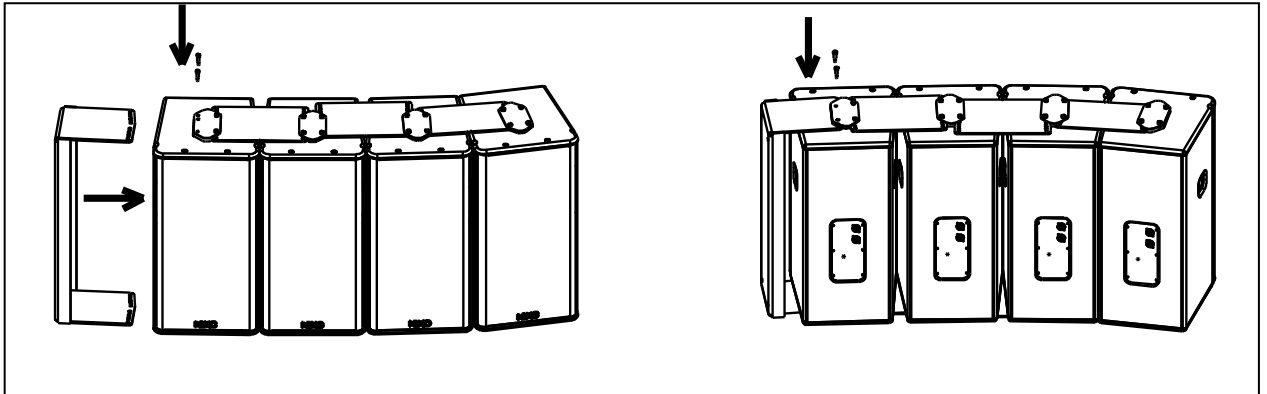

- Flip GEO S12 cluster by 90° so that it is ready to be positioned under the ceiling
- Four screws 12mm diameter (not provided) are required to secure the bumper under the ceiling

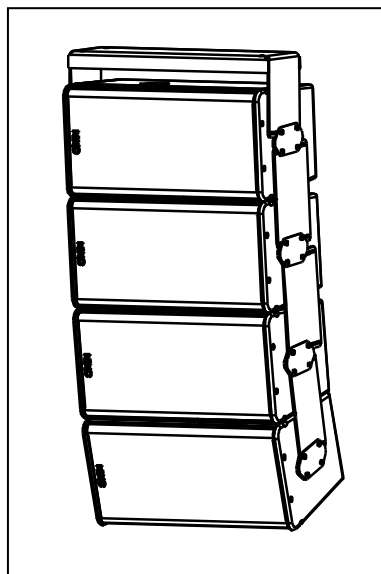

6.3.5 LS18 and GEO S12 vertical array rigidly mounted on a ceiling

Required items

- 1 x GPI-BUMPER (allows +/-5° bumper tilt when installed below a flat surface; if higher bumper tilt is required, surface will have to be defined accordingly)
- (M-1) x GPI-ANPL1 for M x LS18
- M x LSI-CPLA counter-plates for M x LS18
- (N-1) x GPI-ANPL for a N x GEO S12 array (ANPL1 ranges from 0.2° to 3.15°, ANPL2 ranges from 5° to 10°, ANPL3 ranges from 16° to 30°)
- 4 x 12mm diameter screws (*not provided*)

IMPORTANT

Ensure that the ceiling is strong enough to hold 4 times LS18 and GEO S12 cluster weight and that the four screws 12mm diameter and corresponding plugs required to fix the bumper under the ceiling are properly dimensioned.

Procedure

- Set LS18s and GEO S12s sideways according to cluster configuration
- Remove the TORX screws holding connector plates on upper side of all LS18s and GEO S12s
- Remove the connector plates from all LS18 and Geo S12s

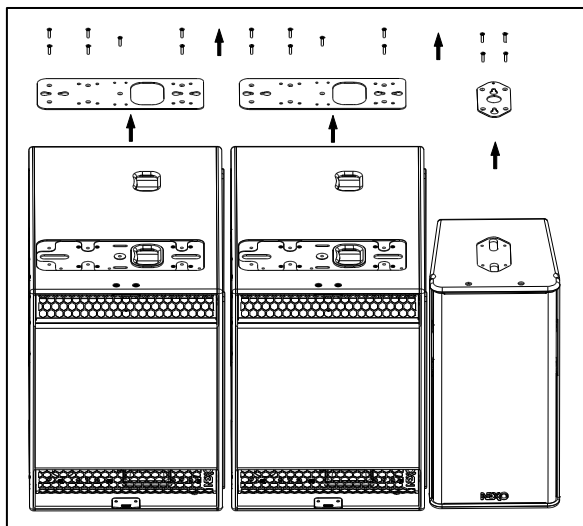

- Remove the 4 locking screws from LS18 side wood panel (see figure below), these are no longer to be used

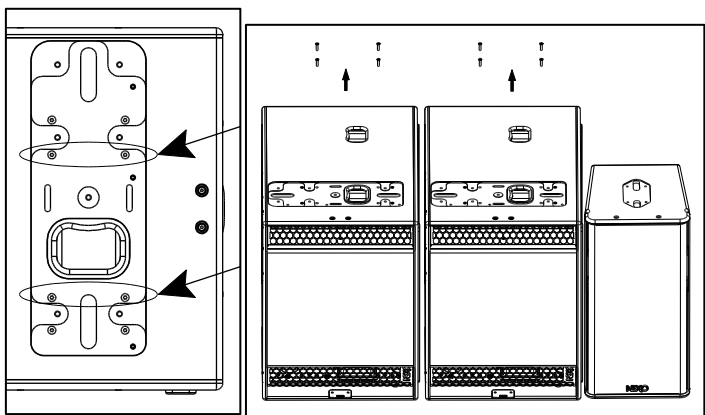

- Apply Loctite 243 or equivalent to the screws that attach the LS18 connector plate to the cabinet, and reinstall the LS18 connector plates (see figure below left)
- Position GEO S12 bottom counter-plates (see figure below left)
- Position GPI-ANPL1 angle plates (set at 0.2°) and LSI-CPLA top counter-plates on LS18 upper sides according to figure below right

GEO S12 HARDWARE SETUP PROCEDURE

- Position angle plates and top counter-plates from GPI-ANPL to required GEO S12 inter-cabinet angle value between GEO S12 upper sides according to figure below right
- Use thread lock coated screws (if not apply Loctite 243 or equivalent to shoulder screws) from LSI-CPLA and GPI-ANPL kits
- Screw all shoulder screws so that all plates and cabinets are tightened together

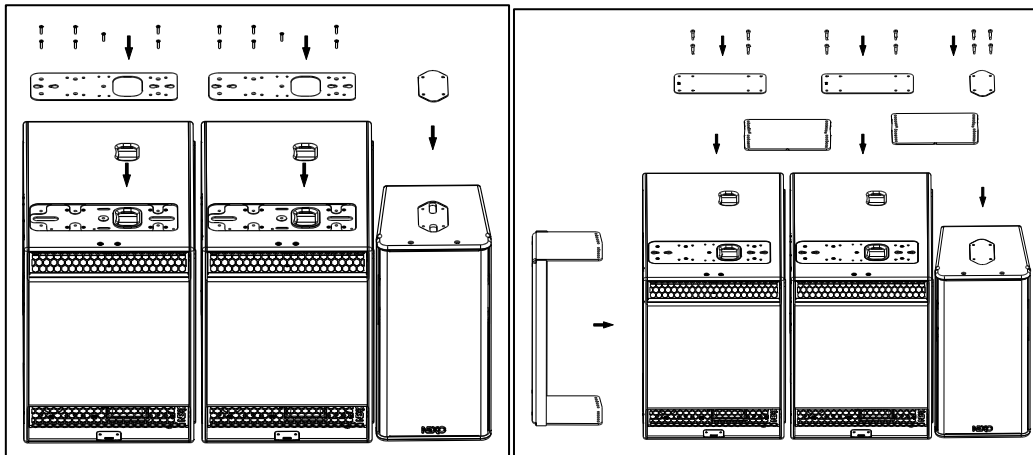

- Flip the cluster upside down to access connector plates located on the down side
- Repeat all above steps
- Position the GPI-BUMPER bumper to required angle position and use the four shoulder screws to connect it the bumper to the top cabinet

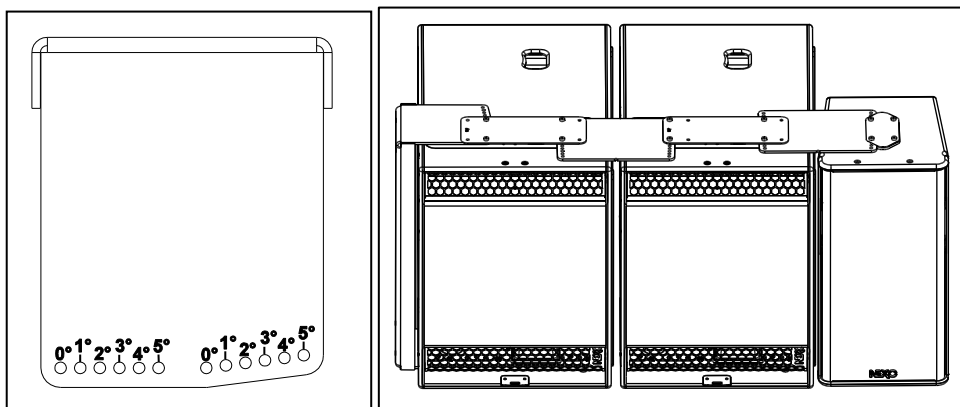

- Flip cluster by 90° so that it is ready to be positioned under the ceiling
- Four screws 12mm diameter (not provided) are required to secure the bumper under the ceiling

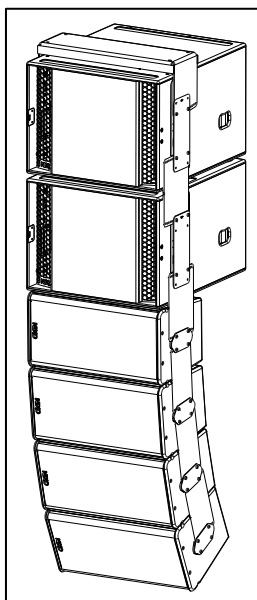

6.3.6 LS18 and GEO S12 vertical array cable mounted on a ceiling**Required items**

- As in 2 sections above, plus
- 2 x VNI-LBRK (allows cable suspension for bumper, holes for cable suspension are 10mm diameter)
- 4 x slings and shackles (*not provided*)

IMPORTANT

Ensure that the ceiling is strong enough to hold 4 times LS18 and GEO S12 cluster weight and that the cables suspension system required to fix the bumper under the ceiling is properly dimensioned.

Procedure

- Connect the bumper and the two "L" brackets using the screws, washers and bolts provided in the VNI-LBRK kit

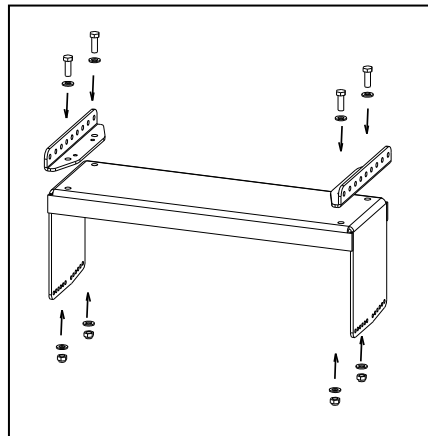

- Proceed as in preceding sections
- 4 slings and 4 shackles (*not provided*) are required to secure the cluster under the ceiling

6.3.7 GEO S12 horizontal array rigidly mounted on a ceiling

Required items

- 2 x VNI-ABRK (allows rigid ceiling suspension for horizontal arrays)
- (N-1) x GPI-ANPL for a N x GEO S12 array (ANPL1 ranges from 0.2° to 3.15°, ANPL2 ranges from 5° to 10°, ANPL3 ranges from 16° to 30°)
- 4 x 12mm diameter screws (*not provided*)

IMPORTANT

Ensure that the ceiling is strong enough to hold 4 times GEO S12 cluster weight and that the four screws 12mm diameter and corresponding plugs required to fix the “L” brackets under the ceiling are properly dimensioned.

Procedure

- Set all GEO S12 side by side
- Remove the four TORX screws holding connector plates on upper side of all GEO S12's
- Remove the connector plates from all Geo S12's
- Position bottom external plates, angle plates and top external plate from GPI-ANPL kits to required inter-cabinet angle value between cabinets upper sides
- Use thread lock coated screws (if not apply Loctite 243 or equivalent to shoulder screws) from GPI-ANPL kits
- Screw all shoulder screws so that all plates and cabinets are tightened together

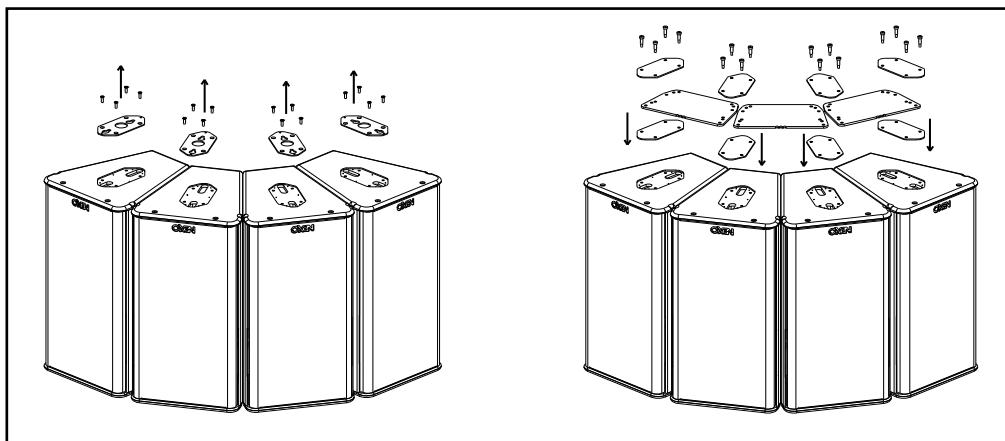

- Flip the cluster upside down to access connector plates located on the down side
- Repeat all above steps

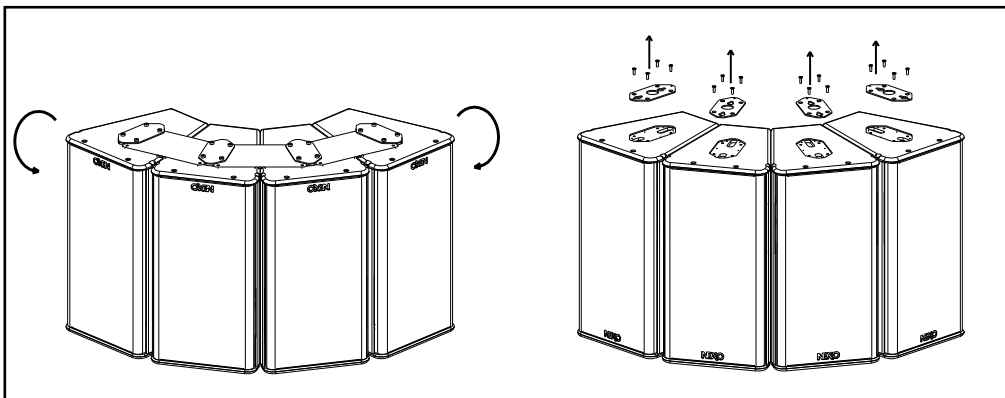

GEO S12 HARDWARE SETUP PROCEDURE

- Position the two “U” brackets from VNI-ABRK kits on the outer cabinets next the angle plates, and tight them to the cabinets using the shoulder screws provided with these kits (using Loctite 243 or equivalent)
- Four screws 12mm diameter (not provided) are required to secure the “U” brackets under the ceiling

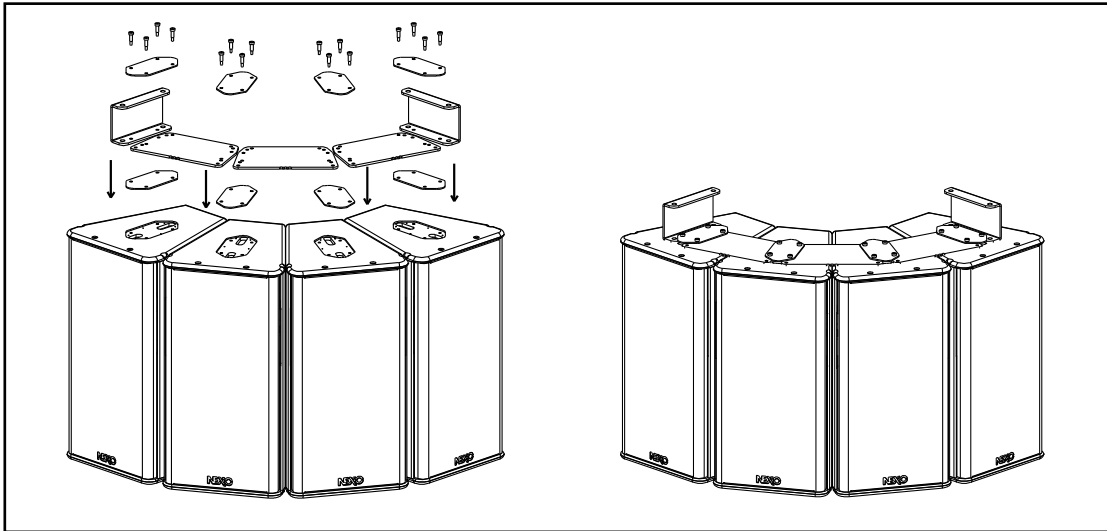

6.3.8 GEO S12 horizontal array cable mounted on a ceiling**Required items**

- 2 x VNI-ABRK (allows cable suspension for horizontal arrays, holes for cable suspension are 10mm diameter)
- (N-1) x GPI-ANPL for a N x GEO S12 array (ANPL1 ranges from 0.2° to 3.15°, ANPL2 ranges from 5° to 10°, ANPL3 ranges from 16° to 30°)
- 4 x slings and 4 shackles (*not provided*)

IMPORTANT

Ensure that the ceiling is strong enough to hold 4 times GEO S12 cluster weight and that that the cables suspension system required to fix the cluster under the ceiling is properly dimensioned.

Procedure

- Proceed as in above section, VNI-LBRK being positioned on the outer cabinets instead of VNI-ABRK
- 4 slings and 4 shackles (not provided) are required to secure the cluster under the ceiling

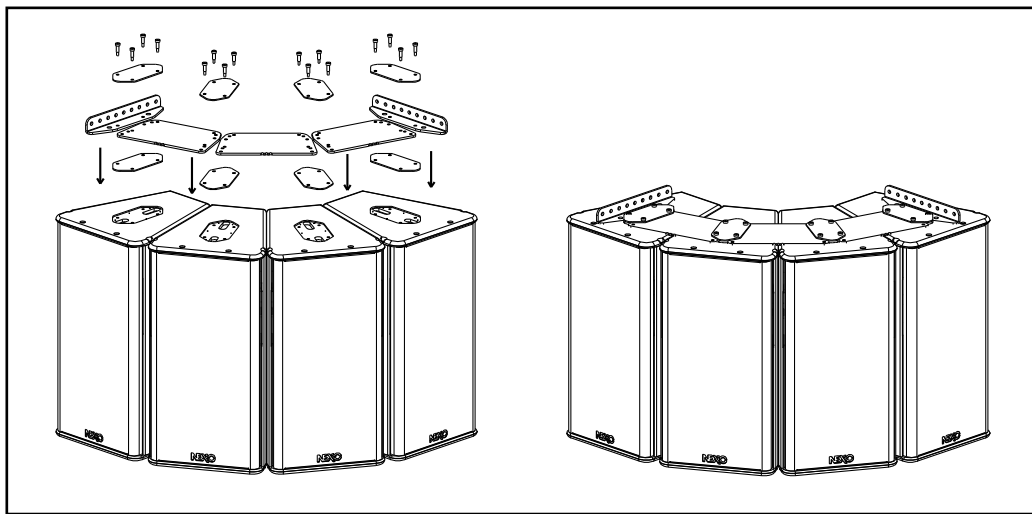

6.4 Touring applications

6.4.1 Described configurations

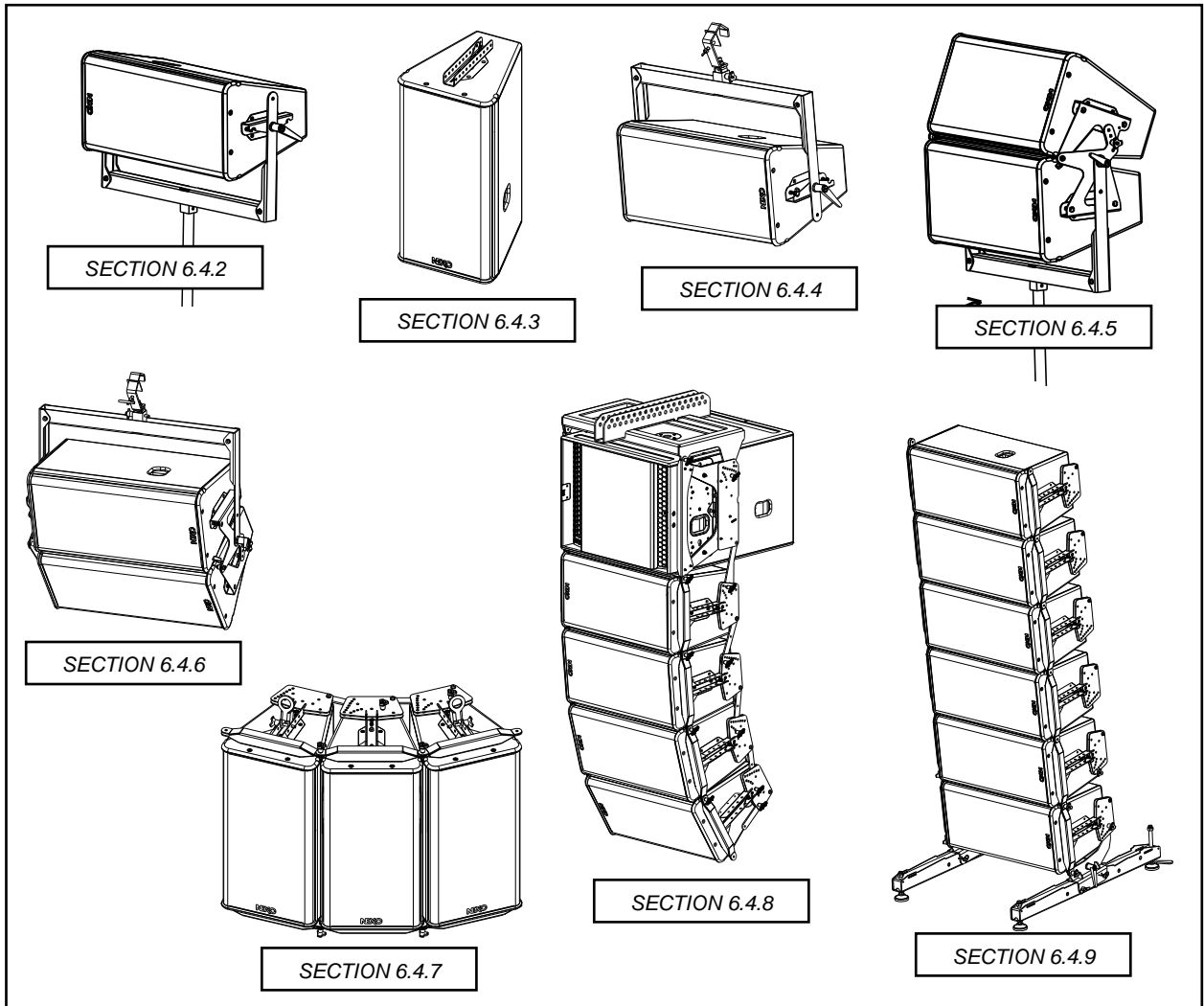

6.4.2 Single GEO S12 on speaker stand or on LS18 horizontally

Required items

- 1 x “U” Bracket for single horizontal GEO S12 (GPT-SSBRK);
- 1 x Speaker stand diameter 35mm (K&M 213 or equivalent)
- Or NEXO PS pole stand (VXT-PLSTD) for mounting on top of LS18

IMPORTANT

Speaker stand must be rated for assembly weight (40kg rated load min)
Speaker stand must always be installed on a horizontal surface
Stand height and footprint must be defined to prevent assembly from collapsing
Ensure that public is not allowed within a safety area which radius is equal or higher than assembly height.

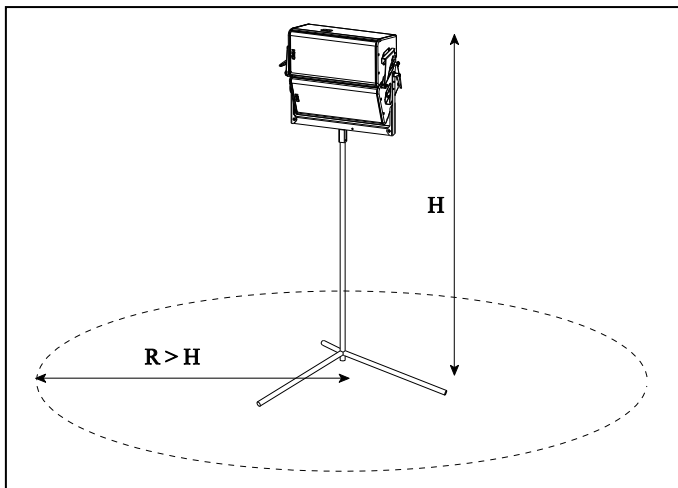

IMPORTANT

NEXO PLSTD pole stand only should be used for mounting on top of NEXO LS18
LS18 must always be installed on a horizontal surface
Ensure that public is not allowed within a safety area which radius is equal or higher than assembly height

Procedure

- Slide GPT-SSBRK side plates into GEO S12 connecting plate oblong holes
- Lock safety pins into GEO S12 connecting plate

IMPORTANT

Ensure that safety pins are properly locked into GEO S12 connecting panels.

- Position “U” bracket over these side plates, align centre holes
- Insert adjustment handles, adjust vertical angle and tight the handles to prevent GEO S12 from rotating around “U” bracket

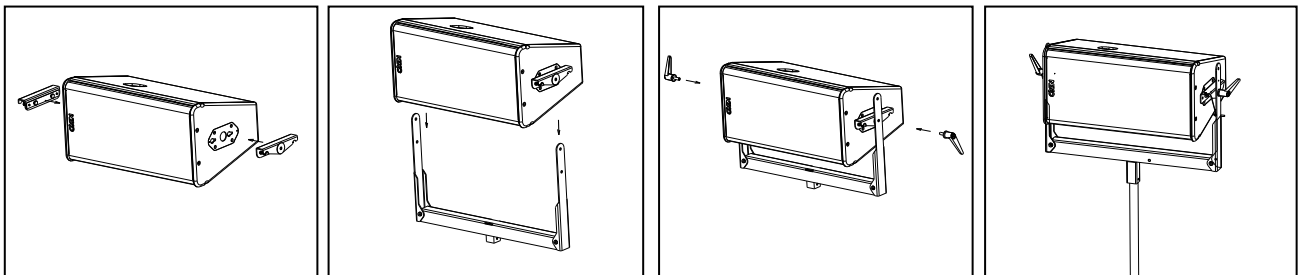

GEO S12 HARDWARE SETUP PROCEDURE

- Lift assembly on speaker stand or on LS18 with VXT-PLSTD pole stand

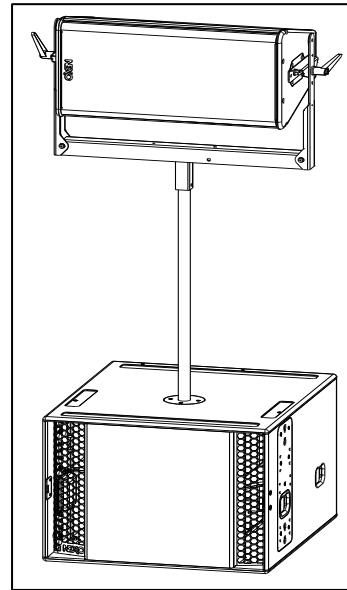
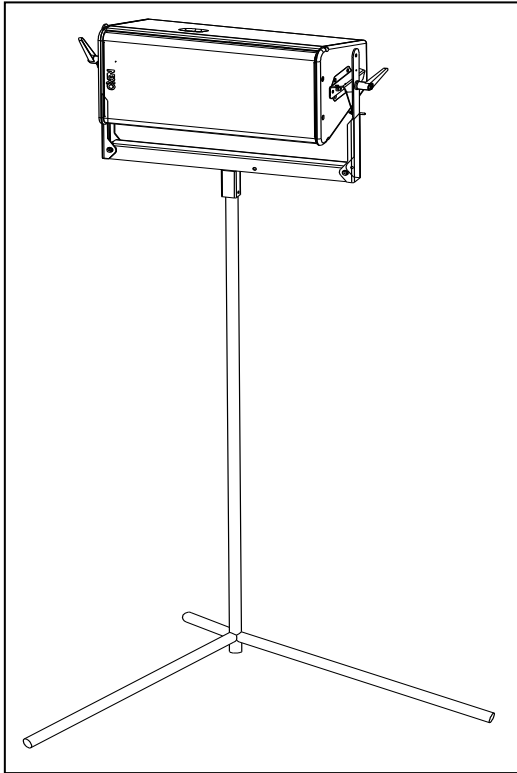

6.4.3 Single GEO S12 flown vertically

Required items

- 1 x Flying Bar for single vertical GEO S12 (VNT-TTC)
- 1 x Lifting Ring (VNT-XHBRK)
- Or 1 x Truss hook (VNT-TCBRK)

IMPORTANT
Ensure that truss suspension point is strong enough to hold GEO S12 weight.

Procedure

- Slide flying bar VNT-TTC into GEO S12 connecting plate oblong holes
- Lock safety pin into GEO S12 connecting plate

IMPORTANT
Ensure that safety pin is properly locked into GEO S12 connecting panel.

Cable suspension:

- Connect lifting ring VNT-XHBRK to flying bar by inserting 8x45 quick release pin in required holes for proper vertical aiming
- Ensure lifting ring is properly locked to flying bar
- Connect assembly to suspension point with sling and shackle (not provided)

Truss suspension:

- Connect truss hook VNT-TCBRK to flying bar by inserting 8x45 quick release pin in required holes for proper vertical aiming
- Ensure truss hook is properly locked to flying bar
- Lift and position assembly, lock hook on truss suspension point and secure with hook cable

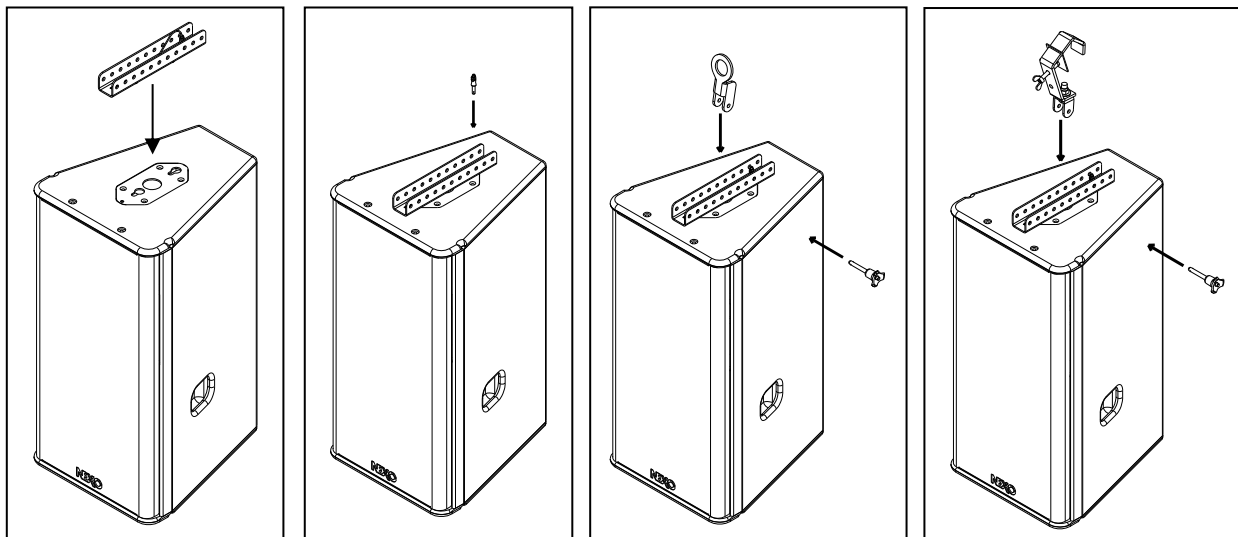

6.4.4 Single GEO S12 flown horizontally

Required items

- 1 x “U” Bracket for single horizontal GEO S12 (GPT-SSBRK)
- 1 x Lifting Ring (VNT-XHBRK)
- Or 1 x Truss hook (VNT-TCBRK)

IMPORTANT
Ensure that suspension point is strong enough to hold GEO S12 weight

Procedure

- Slide GPT-SSBRK side plates into GEO S12 connecting plate oblong holes
- Lock safety pins into GEO S12 connecting plate

IMPORTANT
Ensure that safety pins are properly locked into GEO S12 connecting panels.

- Position “U” bracket over these side plates, align centre holes
- Insert adjustment handles, adjust vertical angle and tight the handles to prevent GEO S12 from rotating around “U” bracket

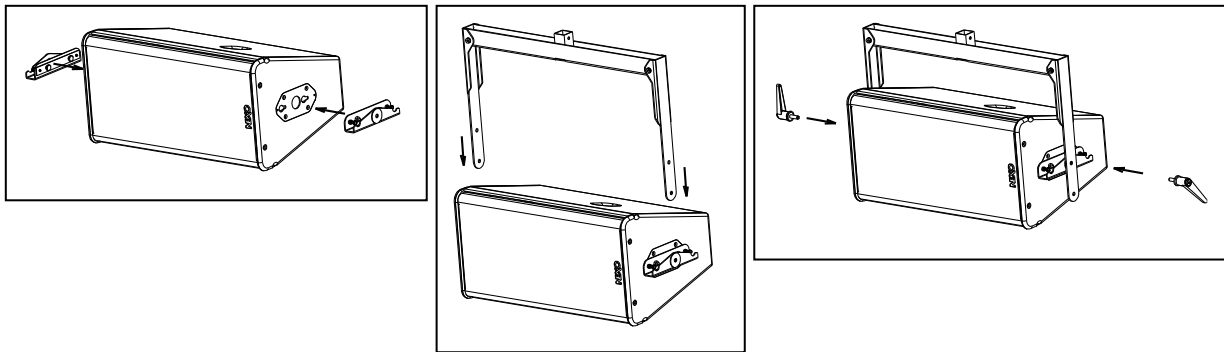

Cable suspension:

- Connect lifting ring VNT-XHBRK to “U” bracket by inserting 8x45 quick release pin dedicated holes
- Ensure lifting ring is properly locked to “U” bracket
- Connect assembly to suspension point with sling and shackle (not provided)

Truss suspension:

- Connect truss hook VNT-TCBRK to “U” bracket by inserting 8x45 quick release pin in dedicated holes
- Ensure truss hook is properly locked to “U” bracket
- Lift and position assembly, lock hook on truss suspension point and secure with hook cable

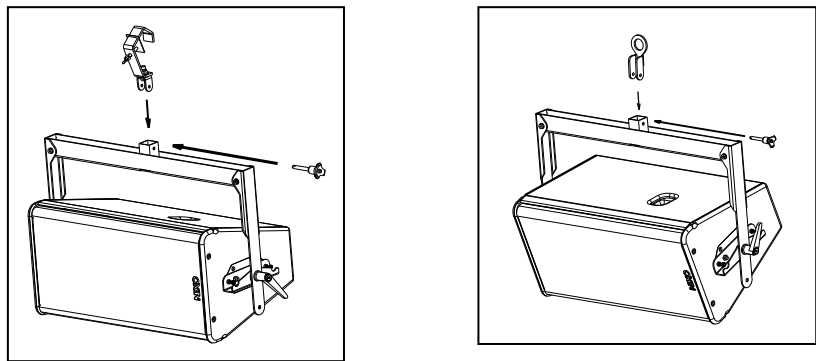

6.4.5 Two GEO S12 on wind-up stand

Required items

- 1 x "U" Bracket for two GEO S12 (GPT-PSBRK)
- 1 x Wind Up stand diameter 35mm (Eurotruss ES160 or equivalent)

IMPORTANT

Wind Up stand must be rated for assembly weight (80kg rated load min).
Wind Up stand must always be installed on a horizontal surface.
Stand height and footprint must be defined to prevent assembly from collapsing.
Ensure that public is not allowed within a safety area which radius is equal or higher than assembly height.

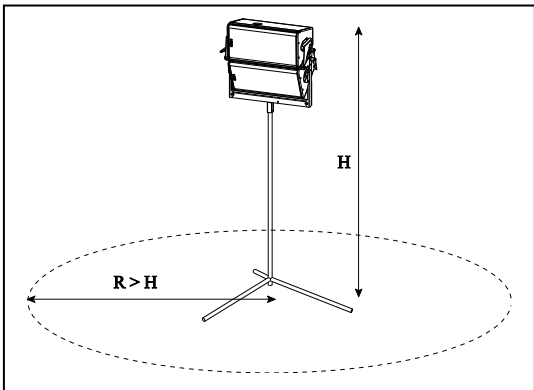

Procedure

- Set the 2 GEO S12 next to each other front grid to the floor
- Slide GPT-PSBRK side plates into GEO S12s connecting plate oblong holes
- Lock safety pins into GEO S12s connecting plate

IMPORTANT

Ensure that safety pins are properly locked into GEO S12s connecting panels.

- Adjust inter-cabinet angle and lock to required angle value with 8x20 quick release pins
- Position "U" bracket over these side plates, align centre holes
- Insert adjustment handles, adjust vertical angle and tight the handles to prevent GEO S12s from rotating around "U" bracket
- Lift assembly on Wind Up stand

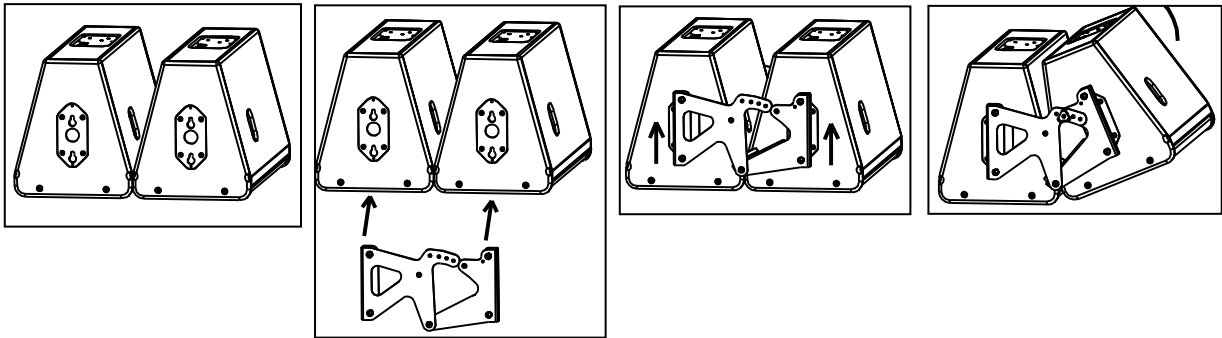

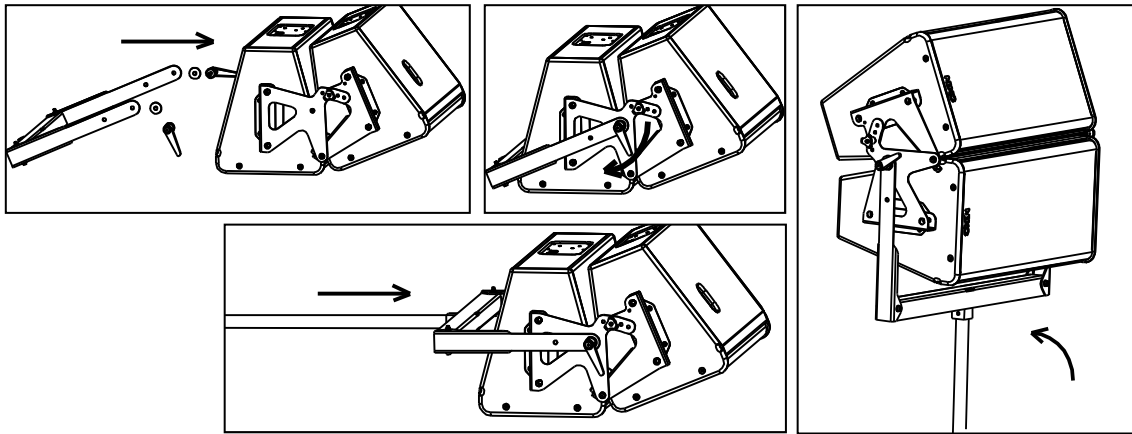

Alternative Procedure (“Walder” procedure)

Below described procedure required 2 additional 8x20 quick release pins (VXT-BL820)

- Split the GPT-PSBRK side plates by removing screws and bolt
- Slide GPT-PSBRK lower half-plates into lower GEO S12 connecting plate oblong holes
- Lock safety pins into lower GEO S12 connecting plate
- Position “U” bracket over these lower half plates, align centre holes
- Insert adjustment handles, adjust vertical angle and tight the handles to prevent GEO S12 from rotating around “U” bracket
- Lift assembly on Wind Up stand or on LS18 with PLSTD pole stand
- Slide GPT-PSBRK upper half-plates into upper GEO S12 connecting plate oblong holes
- Lock safety pins into upper GEO S12 connecting plate
- Lift upper GEO S12 on top of lower one, and connect them together by inserting 8x20 quick release pins in articulation holes
- Adjust inter-cabinet angle and lock to required angle value with quick release pins

IMPORTANT
Ensure that safety pins are properly locked into GEO S12 connecting panels.

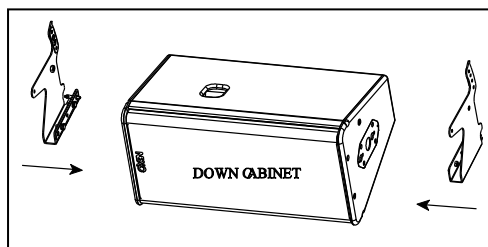
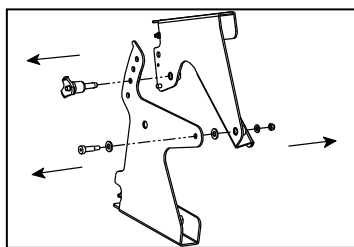

GEO S12 HARDWARE SETUP PROCEDURE

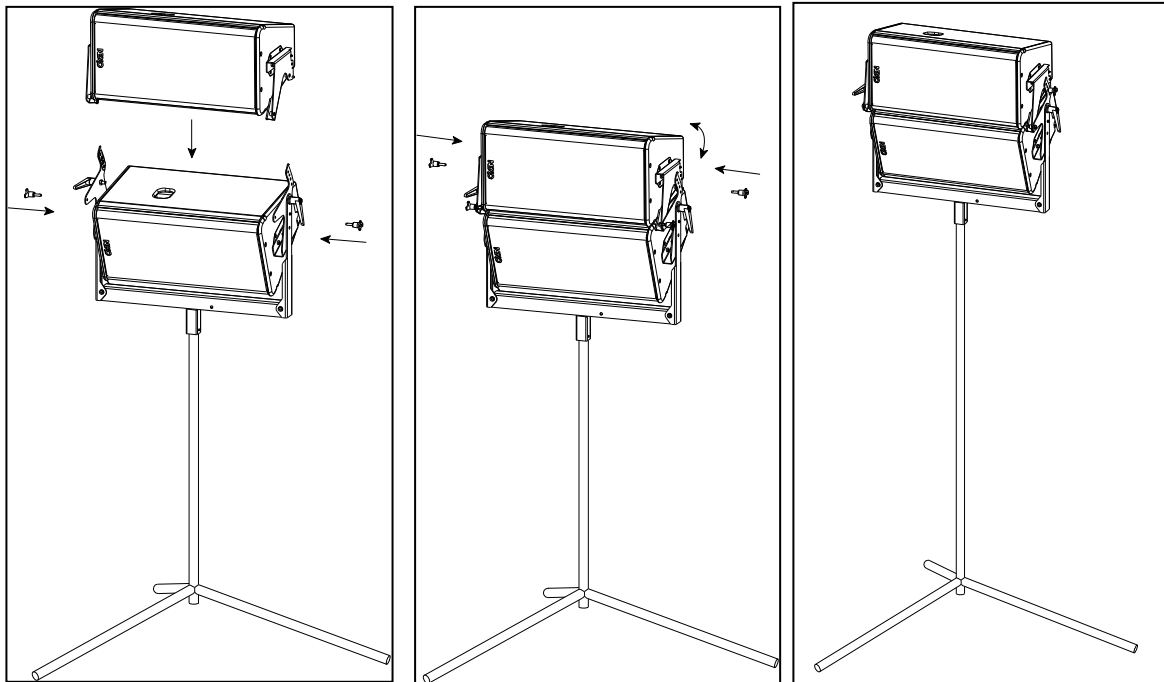
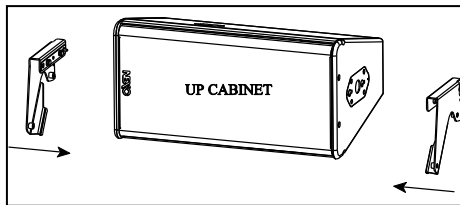
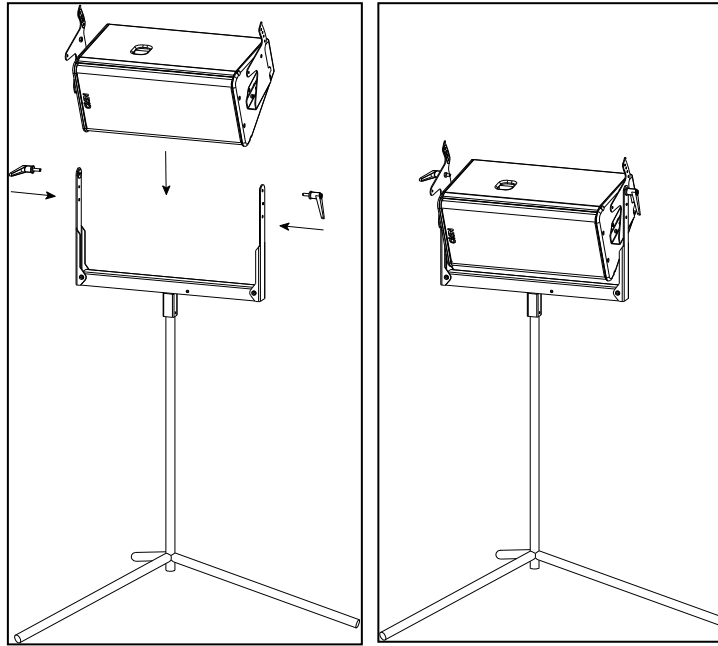

6.4.6 Two GEO S12 vertically

Required items

- 1 x “U” Bracket for two GEO S12s (GPT-PSBRK)
- 1 x Lifting Ring (VNT-XHBRK)
- Or 1 x Truss hook (VNT-TCBRK)

IMPORTANT
Ensure that suspension point is strong enough to hold two GEO S12s weight.

Procedure

- Slide GPT-PSBRK side plates into GEO S12s connecting plate oblong holes
- Lock safety pins into GEO S12s connecting plate

IMPORTANT
Ensure that safety pins are properly locked into GEO S12s connecting panels.

- Adjust inter-cabinet angle and lock to required angle value with 8x20 quick release pins
- Position “U” bracket over these side plates, align centre holes
- Insert adjustment handles, adjust vertical angle and tight the handles to prevent GEO S12s from rotating around “U” bracket

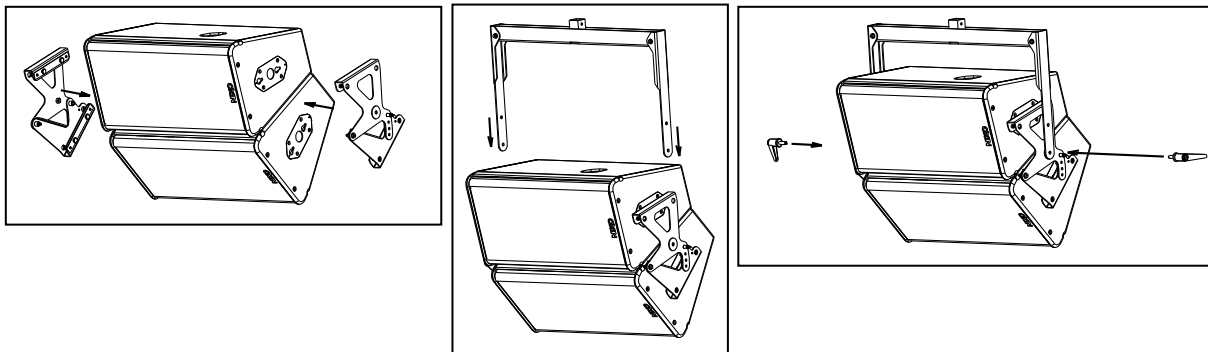

Cable suspension:

- Connect lifting ring VNT-XHBRK to “U” bracket by inserting 8x45 quick release pin dedicated holes
- Ensure lifting ring is properly locked to “U” bracket
- Connect assembly to suspension point with sling and shackle (not provided)

Truss suspension:

- Connect truss hook VNT-TCBRK to “U” bracket by inserting 8x45 quick release pin in dedicated holes
- Ensure truss hook is properly locked to “U” bracket
- Lift and position assembly, lock hook on truss suspension point and secure with hook cable

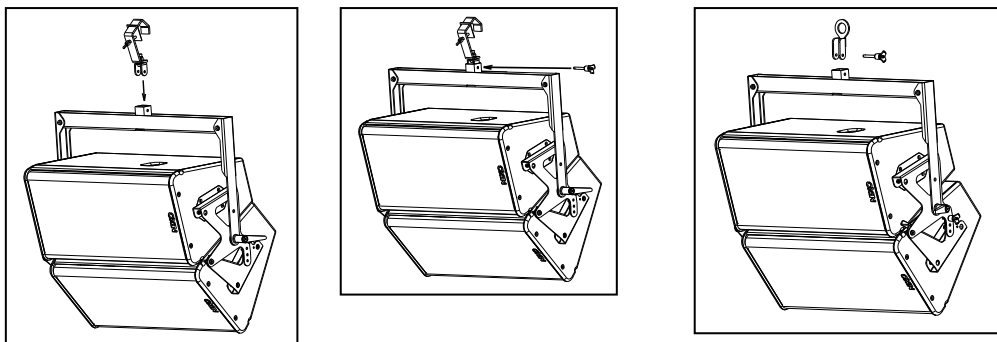

6.4.7 Two or more GEO S12 flown horizontally

Required items

- N x Pair of Rigging Plates (GPT-XBOW) for N cabinets
- 1 x Lifting Ring (VNT-XHBRK) every two GEO S12
- 4 x N Quick release pins (VXT-BL820) for N cabinets
- Properly rated slings, shackles, hoists... *(not provided)*

IMPORTANT
Lifting ring VNT-XHBRK is rated for a maximum of 2 GEO S12s.
Ensure that suspension points are rated accordingly.

Procedure

- Insert GPT-XBOW into connecting plates of both sides of the cabinet
- Lock safety pins into GEO S12s connecting plate

IMPORTANT
Ensure that safety pins are properly locked into GEO S12s connecting panels.

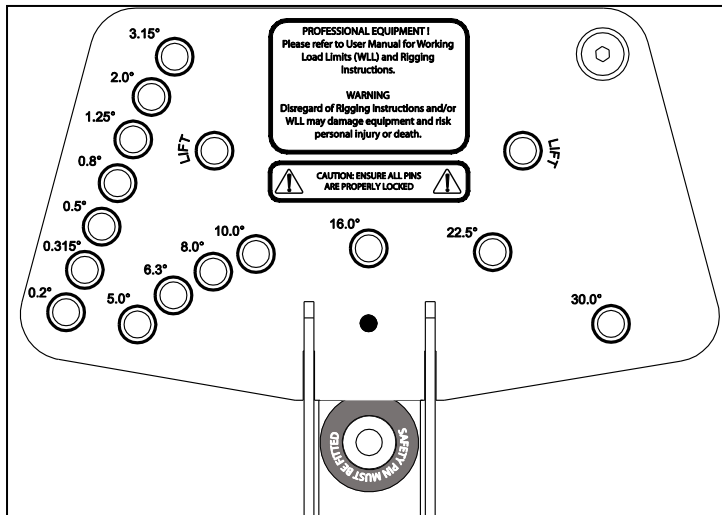
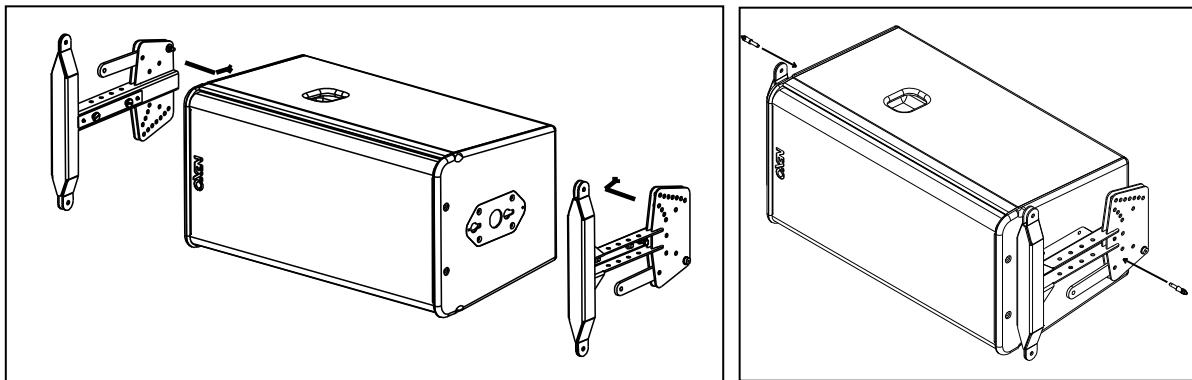

IMPORTANT

GEO S12 can be flown “Up” or “Down”:

- “Up” means NEXO logo on front grid is at the top
- “Down” means NEXO logo on front grid is at the bottom

GEO S12 can be connected “Up” or “Down” by simply flipping the cabinets.

Whenever possible, NEXO recommends symmetrical designs (ie NEXO logo in the same position on Left and Right clusters for stereo designs)

GEO S12 HARDWARE SETUP PROCEDURE

- Connect second GEO S12 with X-Bow front articulation holes and rear link bars and ensure quick release pins are properly locked
- Repeat above steps for subsequent GEO S12's

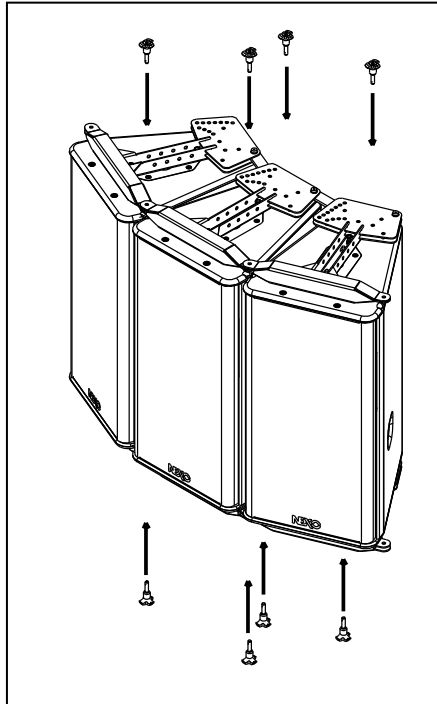

IMPORTANT

Ensure angle settings are identical on upper and lower side of the cabinets
Ensure that safety pins are properly locked into GEO S12s connecting panels.
Ensure that all quick release pins are properly locked into their position.

- Connect lifting rings to "U" bracket with 8x45 quick release pins supplied with VNT-XHBRK
- Ensure quick release pin is properly locked

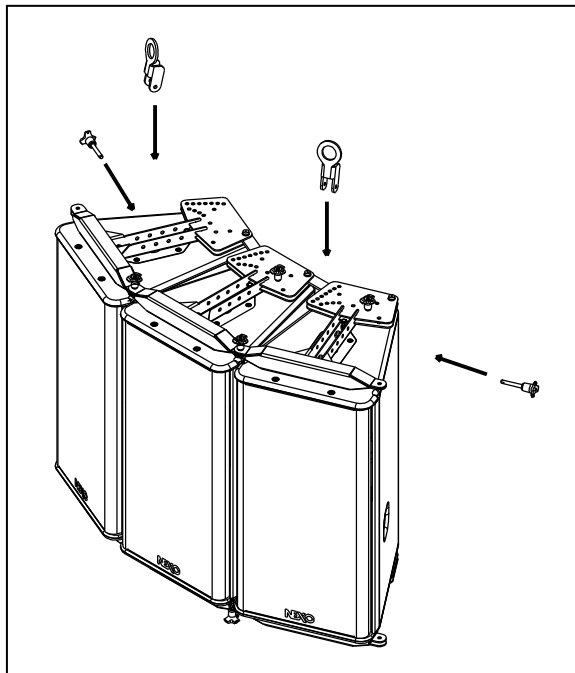

- Lift and position assembly, connect lifting rings to suspension points with sling and shackle
- Secure assembly with secondary safety steel

IMPORTANT

The requirements for secondary safety systems vary with territories. However, the secondary safety steel MUST have a SWL equivalent or greater than that of the rigging system.

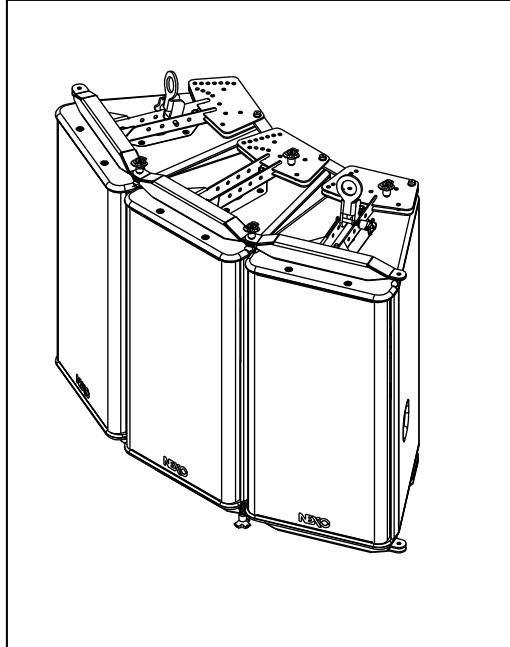

6.4.8 LS18 and three or more GEO S12 flown vertically

Required items

- 1 x Bumper (GPT-BUMPER)
- M x pairs of LS rigging plates (LST-XBOW) for M x LS18 cabinets
- N x Pair of Rigging Plates (GPT-XBOW) for N GEO S12 cabinets
- 4 x (N+M) Quick release pins (VXT-BL820) for (N+M) cabinets
- 1 hoist (*not provided*)

IMPORTANT
Maximum GEO S12 quantity for flown vertical cluster is 12 (and eventually less).
Maximum LS18 quantity for flown vertical cluster is 6 (and eventually less)
Please check NS-1 for mechanical Safety Working Load computations.

IMPORTANT
Please check configuration in NS-1 for proper motor hoist rating

Procedure

- Insert LST-XBOW into connecting plates of both sides of LS18s

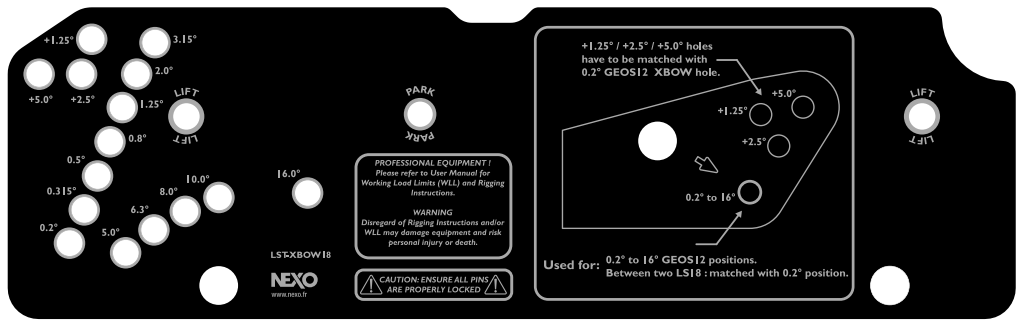
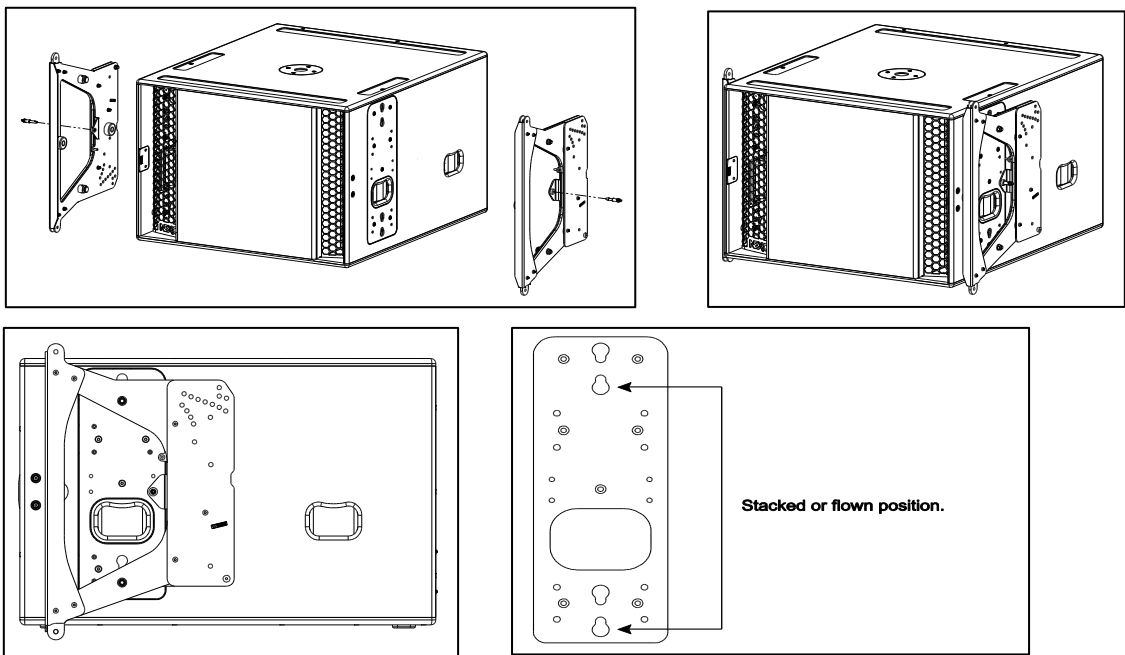

LS18 XBOW ANGLE SETTINGS PLATE

- Insert GPT-XBOW into connecting plates of both sides of GEO S12s

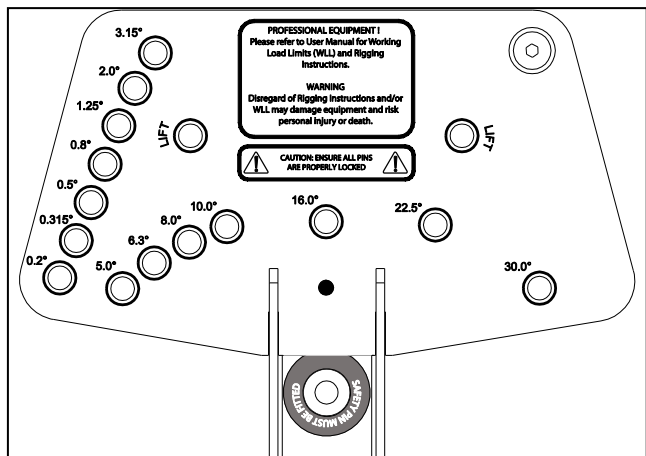
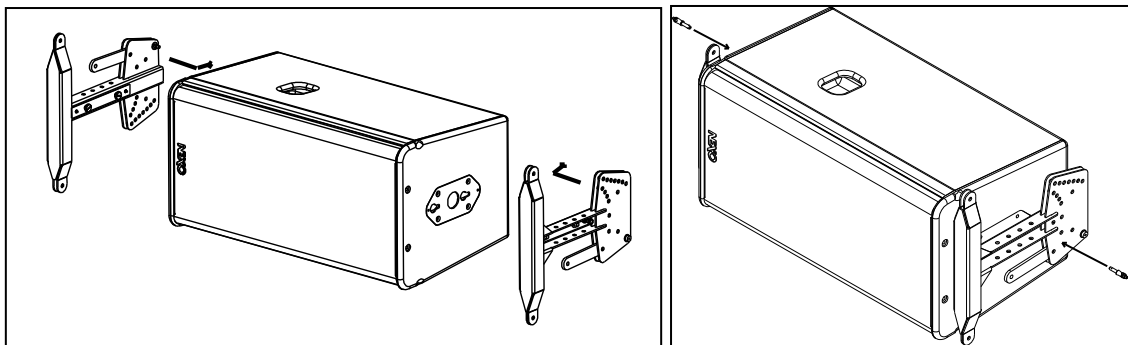

GEO S12 XBOW ANGLE SETTINGS PLATE

- Lock safety pins into LS18 and GEO S12s connecting plate

IMPORTANT
Ensure that safety pins are properly locked into LS18s and GEO S12s connecting panels.

- Connect bumper to first LS18 or GEO S12 using “lift” points of XBOWs
- Ensure quick release pins are properly locked
- Insert axis in bumper NS-1 predefined hole and secure it with provided “R” clip

Bumper holes are numbered #-17 to #17, please refer to NS-1 to determine axis position in relation to bumper angle requirements.
If bumper is flown with 2 hoists, then they should be connected to holes #-17 and #17.

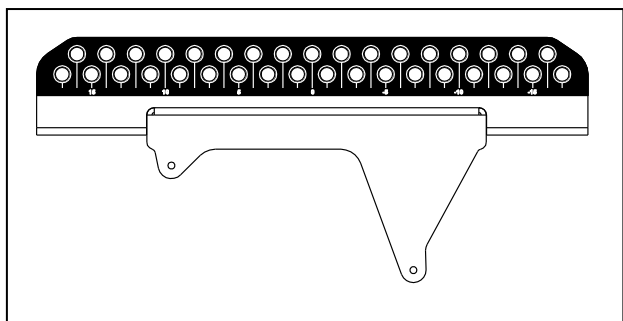

- Connect hoist hook to bumper axis and lift assembly to sufficient height in order to connect a second LS18 or GEO S12
- Connect second LS18 or GEO S12 with X-Bow front articulation holes and rear link bars and ensure quick release pins are properly locked

- Repeat above steps for subsequent cabinets

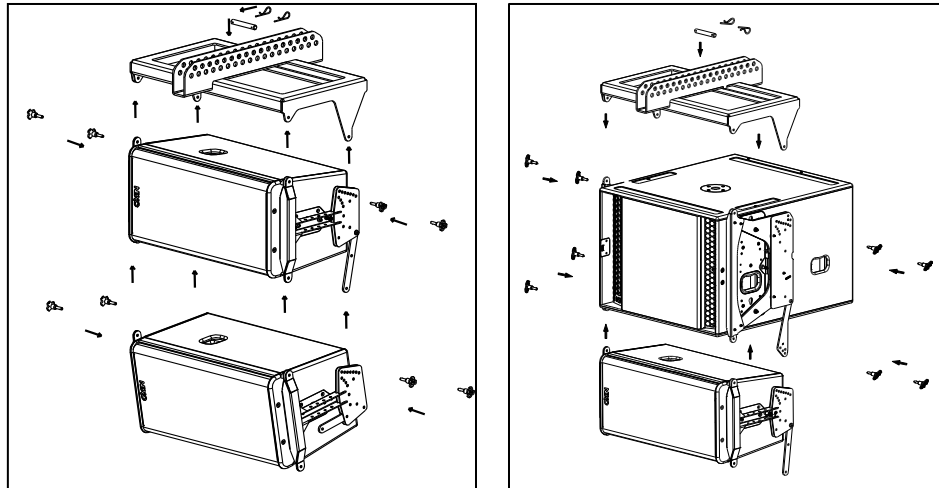

IMPORTANT

**Ensure angle settings are identical on both sides of the cabinets.
Ensure that safety pins are properly locked into LS18s and GEO S12s connecting panels.
Ensure that all quick release pins are properly locked into their position.**

- Lift cluster to NS-1 defined rigging height, secure cluster horizontally to prevent it from rotating
- Secure bumper with secondary safety steel

IMPORTANT

**The requirements for secondary safety systems vary with territories.
However, the secondary safety steel MUST have a SWL equivalent or greater than that of the rigging system.**

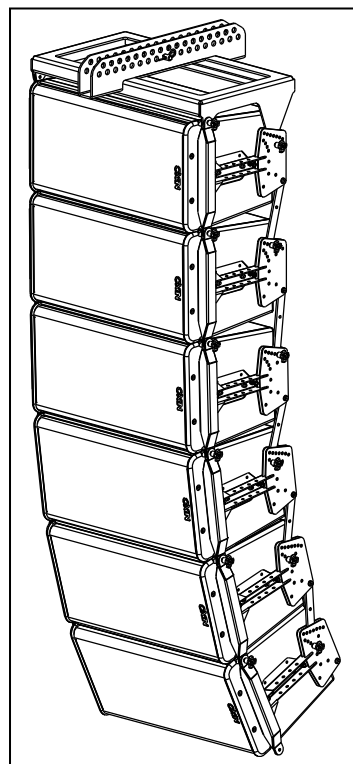
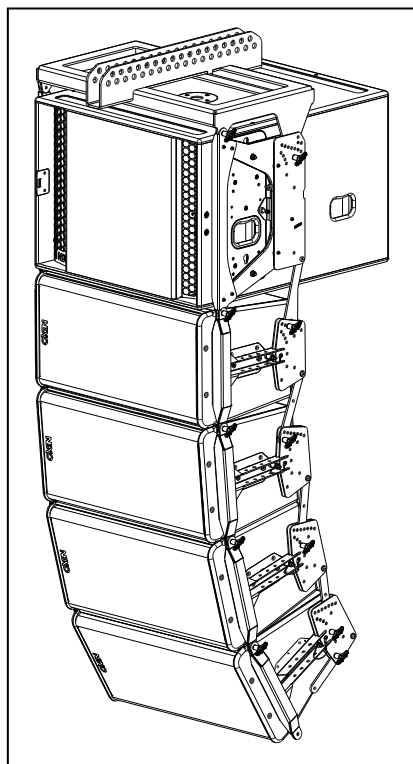

Optional GPT-TLB link bar for GPT- XBOW

GPT-XBOWs are delivered with standard link bars which allow both stacked and flown setups. However, these link bars require perfect alignment of angle setting holes when adding cabinets.

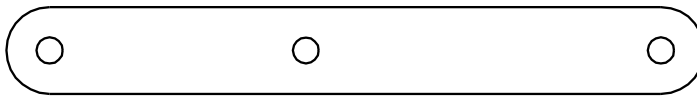

GPT-XBOW standard link bar

To facilitate flying operation, an optional link bar with oblong holes (GPT-TLB, pair of link bars provided with two 8x20 quick release pin) is available in the GEO S12 accessory range.

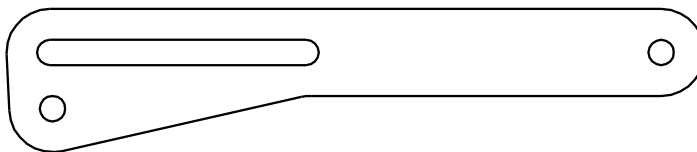

GPT-TLB, GPT- XBOW OPTIONAL link bar

To install GPT-TLB, remove the standard link as well as nut, screw and washers.

When using GPT-XBOW for flown setups, insert pins in the oblong hole and opposite circular hole.

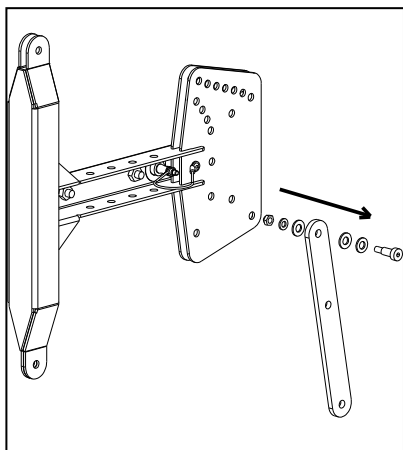

REMOVING STANDARD LINK BAR

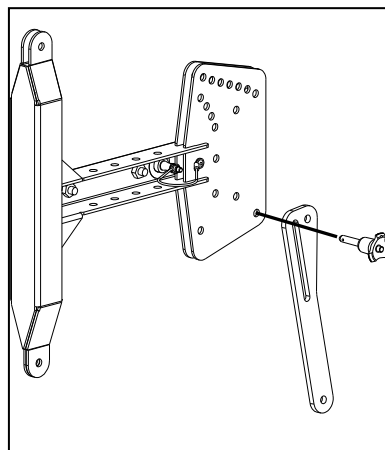

INSERTING PIN - FLOWN SETUPS

6.4.9 Ground stacked LS18 and GEO S12

Required items

- M x pairs of LS rigging plates (LST-XBOW) for M x LS18 cabinets
- N x Pair of Rigging Plates (GPT-XBOW) for N GEO S12 cabinets
- 1 x ground stack device (GPT-GSTK)
- 4 x N Quick release pins (VXT-BL820) for N cabinets

IMPORTANT

Ground stack device GPT-GSTK is rated for a maximum of:
6 x GEO S1210 or 2 x LS18 + 4 x GEO S1210 or 4 x LS18
in any inter cabinet angle configuration, provided this device is assembled according to below rules:

- Ground stack device GPT-GSTK must always be installed on a horizontal surface
- Bottom GEO S12 tilt angle must be limited to +/-10°

Ensure that public is not allowed within a safety area which radius is equal or higher than assembly height. It is highly recommended to secure the system to a fix point located at the back of the stack.

Procedure

- Assemble the two connecting beam and the reinforcement beam with the handles
- Depending on tilt angle – negative, null or positive - to be achieved, there are three positions to connect above assembly to the supporting beams; below drawings detail these configurations:

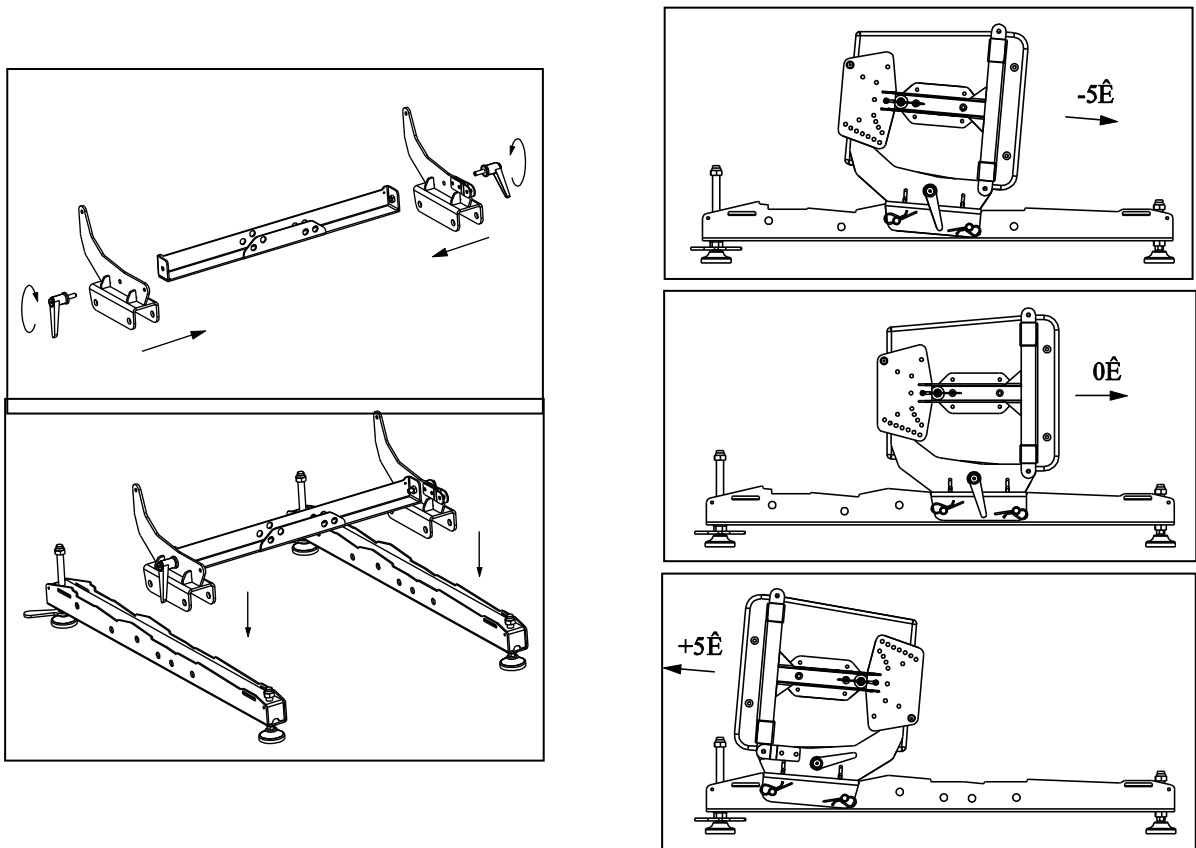

GEO S12 HARDWARE SETUP PROCEDURE

- Connect the reinforcement bar to the supporting beams according to required tilt angle configuration using 2 axis per side; secure the axis with provided "R" clips

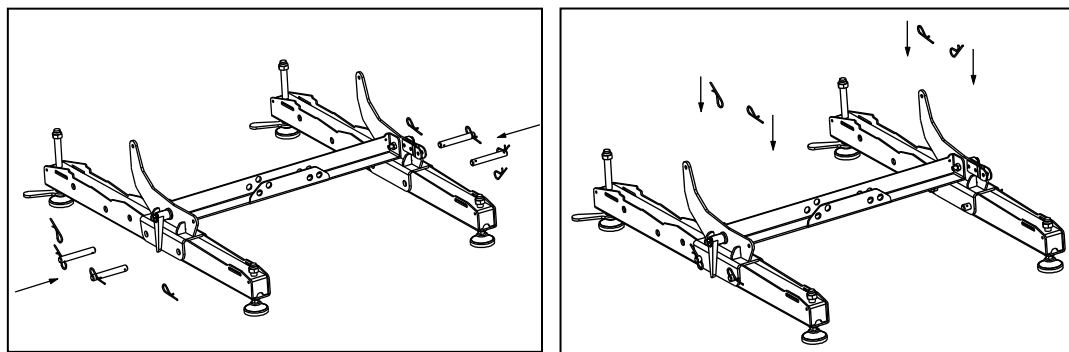

- Insert GPT-XBOW into connecting plates of both sides GEO S12s
- Insert LST-XBOW into connecting plates of LS18s
- Lock safety pins into LS18s and GEO S12s connecting plate

IMPORTANT
Ensure that safety pins are properly locked into LS18s and GEO S12s connecting panels.

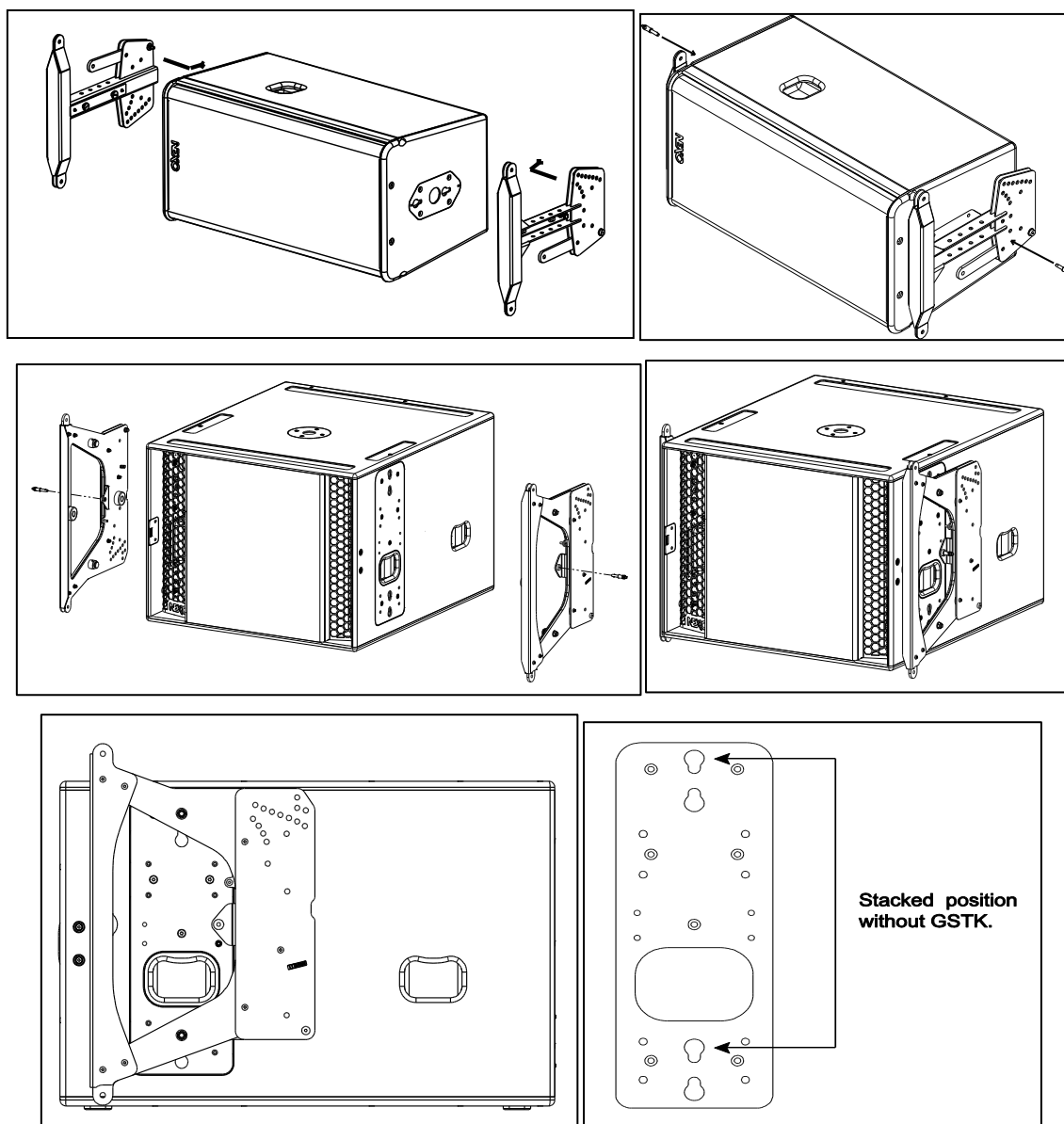

GEO S12 HARDWARE SETUP PROCEDURE

- Connect bottom LS18 or GEO S12 to GPT-GSTK Ground stacking device with 4 VXT-BL820 quick release pins

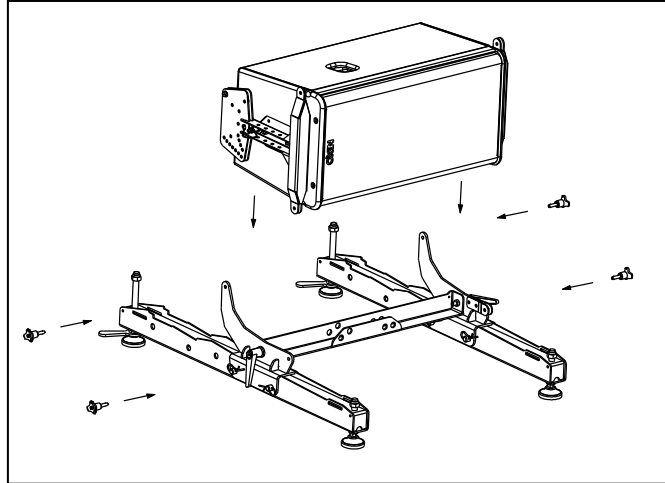

- Connect second LS18 or Geo S12 with X-Bow front articulation holes and rear link bars and ensure quick release pins are properly locked
- Repeat above steps for subsequent cabinets

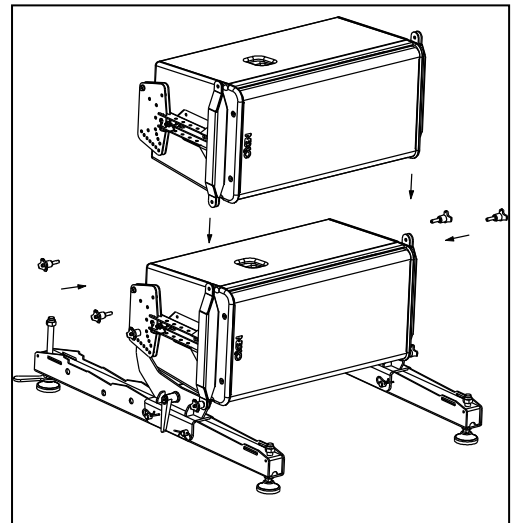
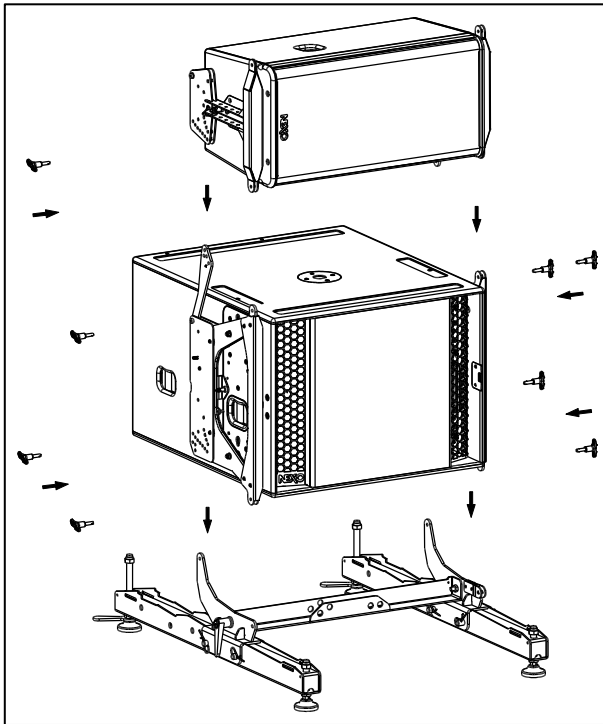

- Once the assembly is completed, rotate rear or front GEO S12 ground stack device adjustable legs to definitive tilt angle, ensuring that $\pm 10^\circ$ is never exceeded on bottom GEO S12

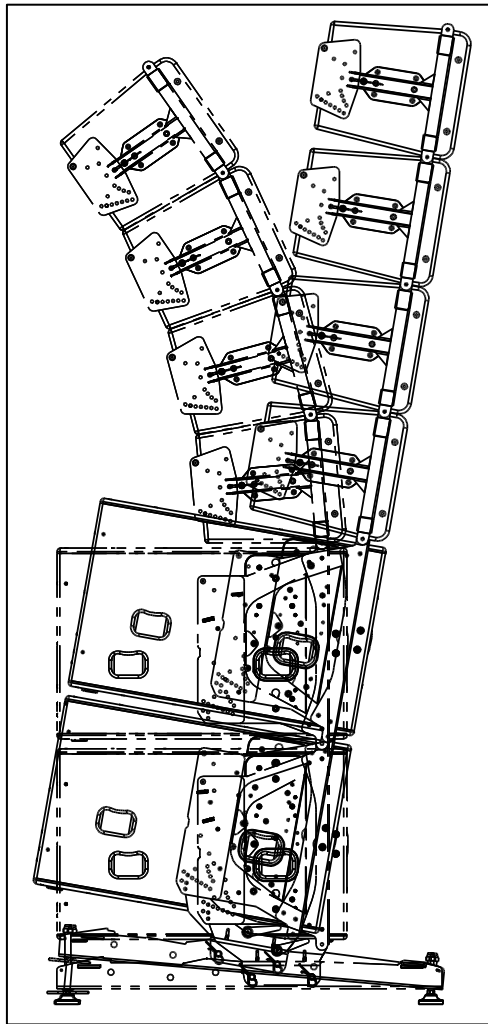
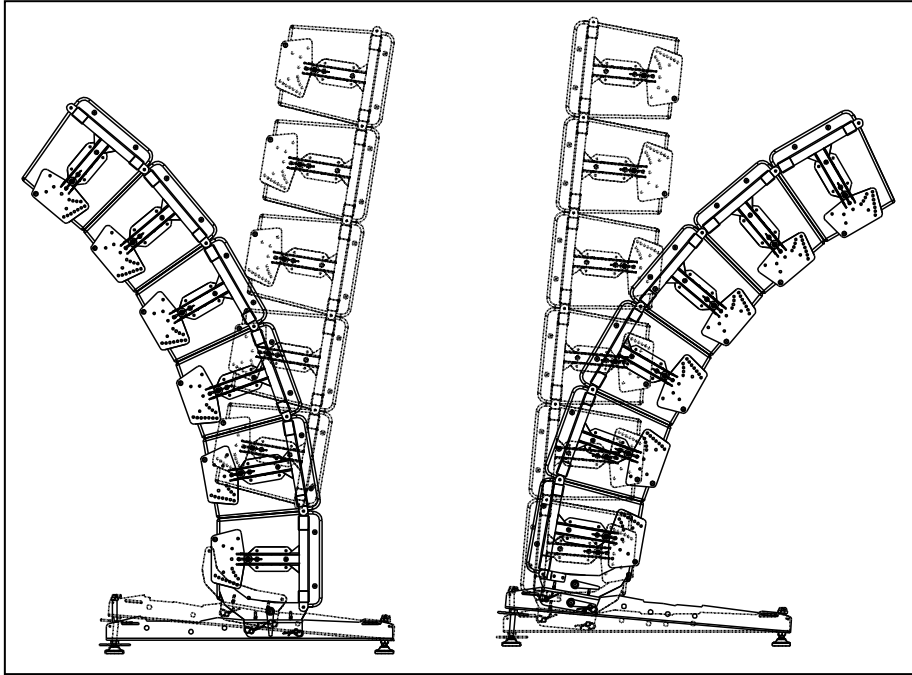

Optional GPT-TLB link bar for GPT- XBOW

GPT-XBOWs are delivered with standard link bars which allow both stacked and flown setups. However, these link bars require perfect alignment of angle setting holes when adding cabinets.

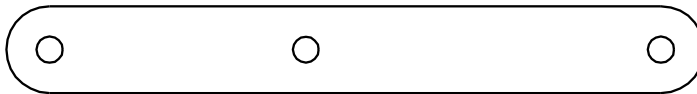

GPT-XBOW standard link bar

To facilitate stacking operation, an optional link bar with oblong holes (GPT-TLB, pair of link bars provided with two 8x20 quick release pin) is available in the GEO S12 accessory range.

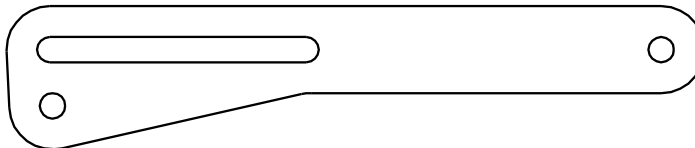

GPT-TLB, GPT- XBOW OPTIONAL link bar

To install GPT-TLB, remove the standard link as well as nut, screw and washers.

When using GPT-XBOW for stacked setups, insert pins in the two circular holes.

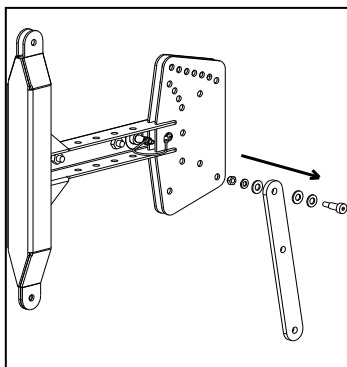

REMOVING STANDARD LINK BAR

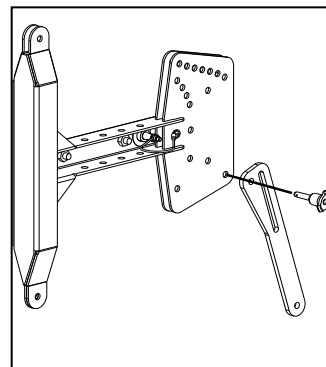

INSERTING PIN - STACKED SETUPS

6.5 Testing and Maintenance of the system

General: GEO is a precision piece of equipment and requires regular attention to maintenance in order to give long and reliable service. NEXO recommends regular testing of loudspeaker rigging components, preferably using a suitable test rig coupled with a visual inspection.

Fasteners: there are several critical points in the LS18 and GEO S12 cabinets.

Of primary concern are:

- a) The grid screws attaching the grid to the cabinet
- b) The machine screws attaching the connecting plates to the cabinet.
- c) The screws attaching the directivity flanges to the front of the cabinet.

These fasteners should be regularly checked and tightened as necessary.

Cleaning: The exterior of the cabinet and the rigging system can be cleaned with a damp cloth soaked in mild soapy water. On no account use solvent based cleaners, which may damage the finish of the cabinet

After cleaning, the rigging system must be treated with a suitable lubricant to prevent rusting. NEXO recommends the use of Scottoil FS365 which is a water-based lubricant with a mixture of machine oil, surfactant and anti-rust treatment.

7 SYSTEM CHECK ALIGNMENT GUIDELINES

The NEXO TD Controllers factory delay presets are optimised to provide the best possible crossover between the GEO S12 and LS18 systems. The reference point for this adjustment is the front of each cabinet. (This means that the internal delays needed to achieve a correct time alignment are set for cabinets standing next to each other with both fronts aligned). We recommend that the system is adjusted so that arrivals from GEO S12 and LS18 are coincident at a fairly distant listening position.

7.1 GEO S12 Vertical Cluster design

Cluster design must be done with NS-1, which provides very intuitive and fast method to determine all cluster geometry parameters in relation to venue where cluster is implemented.

NS-1 is a freeware available for all NEXO users at nexo-sa.com

IMPORTANT

Never install a GEO S12 and/or LS18 cluster without checking its acoustical performances and mechanical safety in NS-1 prior to installation.

Please contact your local distributor for assistance and/or training NS-1.

7.2 Stacked LS18 and Flown GEO S12

In the example below, r_1 being the distance from GEO S12 array to listener position, and r_2 being the distance from LS18 to listener position, the distance difference is then $r_1 - r_2$ (specified meters or feet).

$r_1 > r_2$, the delay should be set on the LS18 NEXO TDcontroller channel
 $r_1 < r_2$, the delay should be set on the GEO S12 NEXO TDcontroller channel
 To convert the result in time delay (specified in seconds), apply:
 $\Delta t = (r_1 - r_2) / C$ r_1 and r_2 in meters, C (sound speed) ≈ 343 m/S.

Set the units to meters, feet or seconds according to your preference). Delay will have to be adjusted according to the distance difference $r_1 - r_2$ (see figure below).

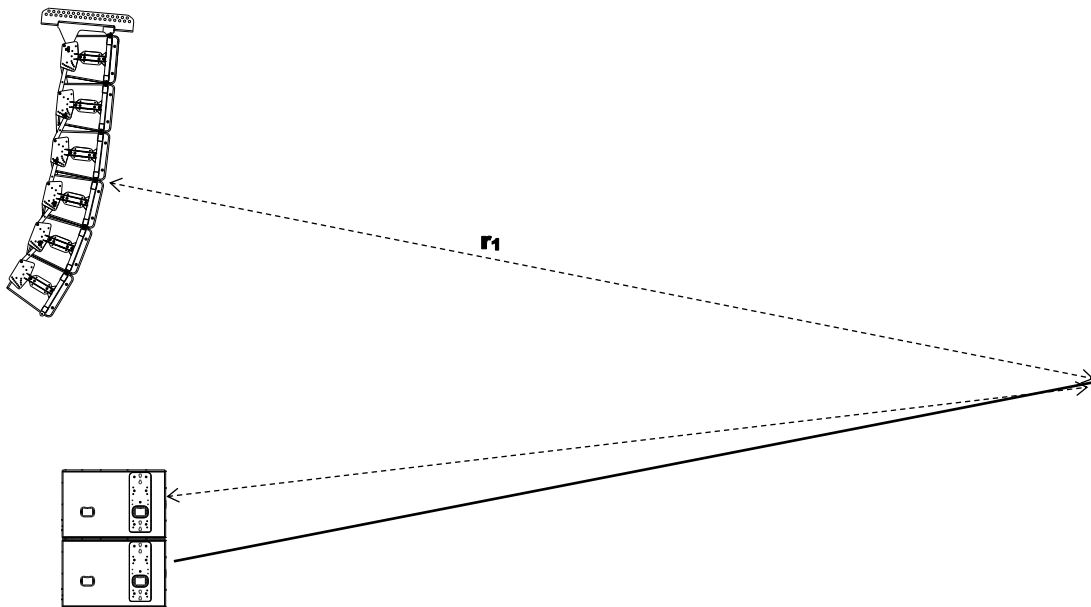

7.3 Driving the LS18s from the AUX send

It is quite common to use the AUX send of a mixing desk to drive the Sub section of a PA system. This gives the mixing engineer more flexibility to set the level of the subbass relative to the main PA, apply special effects, or to use a different EQ on the Sub. However, it also raises some serious issues for the performance & safety of the system (mostly time alignment).

At NEXO, great care is taken to design optimum phase alignment from one octave above to one octave below the crossover frequency point. By doing so, drivers are working perfectly together and providing the best efficiency possible. It is then up to the user to adjust the delay on the NEXO TD Controllers to match the physical path difference of the different systems. It is thus possible to get a well-adjusted system, even without measuring instruments.

If LS18s are driven from an AUX output, NXAMPs are fed with two signals coming from different sources. If those two sources (MAIN output & AUX send) are not exactly in phase, delay is introduced into the crossover between the GEO S12 array and the LS18s. It is then mandatory to use proper measurement tool to optimize phase response.

Why is it unlikely that AUX and MAIN outputs have the same phase?

- Signal paths are likely to be different; any filter modifying the bandwidth and EQ of the signal is also affecting the phase.
Example: a 24dB/oct high pass filter set at 15Hz is affecting amplitude of the signal by only 0.6dB at 30Hz, but the phase shift is 90°!! At 100Hz we can still measure 25° of phase shift.
- Limiting bandwidth with a low pass filter can introduce a phase difference of up to 180° (completely out of phase) at the cross over point.
- If the signal is passing through any digital equipment, between 1.4ms and 2.2ms is being added (around 70° phase shift at 100Hz) due solely to the converter delay! The additional delay due to the processing itself (look ahead compressor, delay...) can be quite important as well.

If both outputs are not measured in the actual configuration, it is very likely that phase alignment will not be correct.

Consequences of badly aligned systems

Mis-aligned systems have lower efficiency: i. e. for the same SPL the system will have to be driven harder, activating the displacement & temperature protection at lower output levels. Both sound quality and reliability will decrease as the system is stressed.

Precautions & Checks

Before using the AUX of a mixing desk, ensure that MAIN and AUX outputs are in phase;

Always apply identical EQ or processing on both channels, so that the phase relationship will not be altered;

Never add additional low pass filtering on the SUB or high pass filtering on the main system;

Inverting polarity on one channel should always result in a massive difference near the crossover point. If that is not the case, the system is no longer aligned.

7.4 Recommended installation tools and equipment

Tape measure – should be 30m/100ft in length and be of durable fibre material. Have one per array available to speed up the installation process.

Laser Inclinator – For measuring vertical and horizontal angles in the venue.

Spirit level – used to ascertain the trueness of the surface from which the angle measurements originate.

Rangefinder measuring device – either a Disto type laser measure or an optical laser rangefinder can be used. Devices such as the Bushnell 'Yardage Pro' sports rangefinders provide sufficiently accuracy and are easy to use. They have the additional advantage of working very well in bright sunlight.

Electronic calculator with trigonometric functions to calculate the height from ground level to points in the room. The formula to calculate height of a point from measured angle and distance is:

Height of point = Sin (vertical angle in degrees) x distance to point

NB: Take care when using spreadsheets as they calculate using radians by default. To convert degrees to radians, use the formula:

Angle (in radians) = 3.142 x Angle (in degrees)/180

Computer – Laptop or Desktop PC running Windows 8 with the current version of NEXO NS-1 installed. It is not possible to configure a GEO tangent array properly without using NS-1. Note that, when NS-1 designs are prepared prior to arrival at the venue, it is often necessary to modify or update the design to accommodate special circumstances. A PC is absolutely essential to make such changes.

Audio Analysis Software – recommended but not absolutely essential, programs such as Systune™, Smaart™ enable rapid and detailed analysis of the installation. Consider taking a training course in using one of these tools if you are not already competent with them – it will pay dividends in increased performance of the system.

7.5 GEO S12 – LS18 System Check List

It is essential to execute all these check steps prior to perform a sound check on the “front end” to the system. Following this checklist step by step will prevent many troubles and will save time in the end.

Are the speakers properly connected and angled?

Attach the first series of modules to the bumper.

Before flying, verify that all channels of all modules are functioning properly.

To check that all elements have the proper amplitude and phase, you should listen to the upper boxes at a close distance (<1 meter). You should be able to move from the top to the bottom of the cluster without hearing any change in the tonal balance.

Verify that the angle settings are the same on both sides of each module.

Raise the bumper, attach the next series of modules and repeat the above checks.

Make sure that these series of modules sum properly with the modules above them.

When all the modules are flown, check that the aiming angles are the same left and right.

Make sure that multiple GEO S12 and LS18 are summing properly: 6 dB gain per doubling of quantity.

Final Pre-Sound Check Check

Play a CD track mono left, and then right: both sides must sound strictly identical. When listening in the centre between Left and Right GEO S12s, everything from LF to HF should be located to the “phantom centre” position. If not, repeat the above check sequence to identify the source of the problem.

8 TECHNICAL SPECIFICATIONS

8.1 LS18 and LS18-E Subwoofers

8.1.1 System specifications

LS18 WITH NEXO TDCONTROLLER SETUP	
Frequency Response @-6 dB	32 Hz to 130 Hz
Sensitivity 1W@1m	107 dB SPL Nominal
Peak SPL@1m	137 to 140 dB
Available Crossover Frequencies	35-60, 35-85, 35-120 Hz
Nominal Impedance	8 Ohms
Recommended Power	1800 Watts
PRODUCT FEATURES	
Component	1 x 18" 4" voice coil very long excursion 8 Ohms driver
Height x Width x Depth	510 mm x 675 mm x 775 mm (20.1" x 26.1" x 30.5")
Weight: Net	55.5 kg (122.3 lb)
Connectors	2 x NL4, 4 poles connectors (1+/1- LS18 / 2+/2- Through)
Construction	Baltic Birch Plywood & textured black coating
Fittings	4 x Metal recessed side handles (not on LS18-E)
Front Finish	Molded dark grey metal grill
Operating temperature range	0°C - 40 °C (32° F - 104° F)
Storage temperature range	-20 °C - 60 °C (-4 ° F - 140° F)
SYSTEM OPERATION	
Recommended powering solution	NXAMP4x4mk2 Powered TD controller: 3 x LS18 per channel
Optional powering solution	NXAMP4x2mk2 Powered TD controller: 1 x LS18 per channel
	NXAMP4x1mk2 Powered TD controller (Bridged): 2 x LS18 per channel

8.1.2 Dimensions (mm/inches)

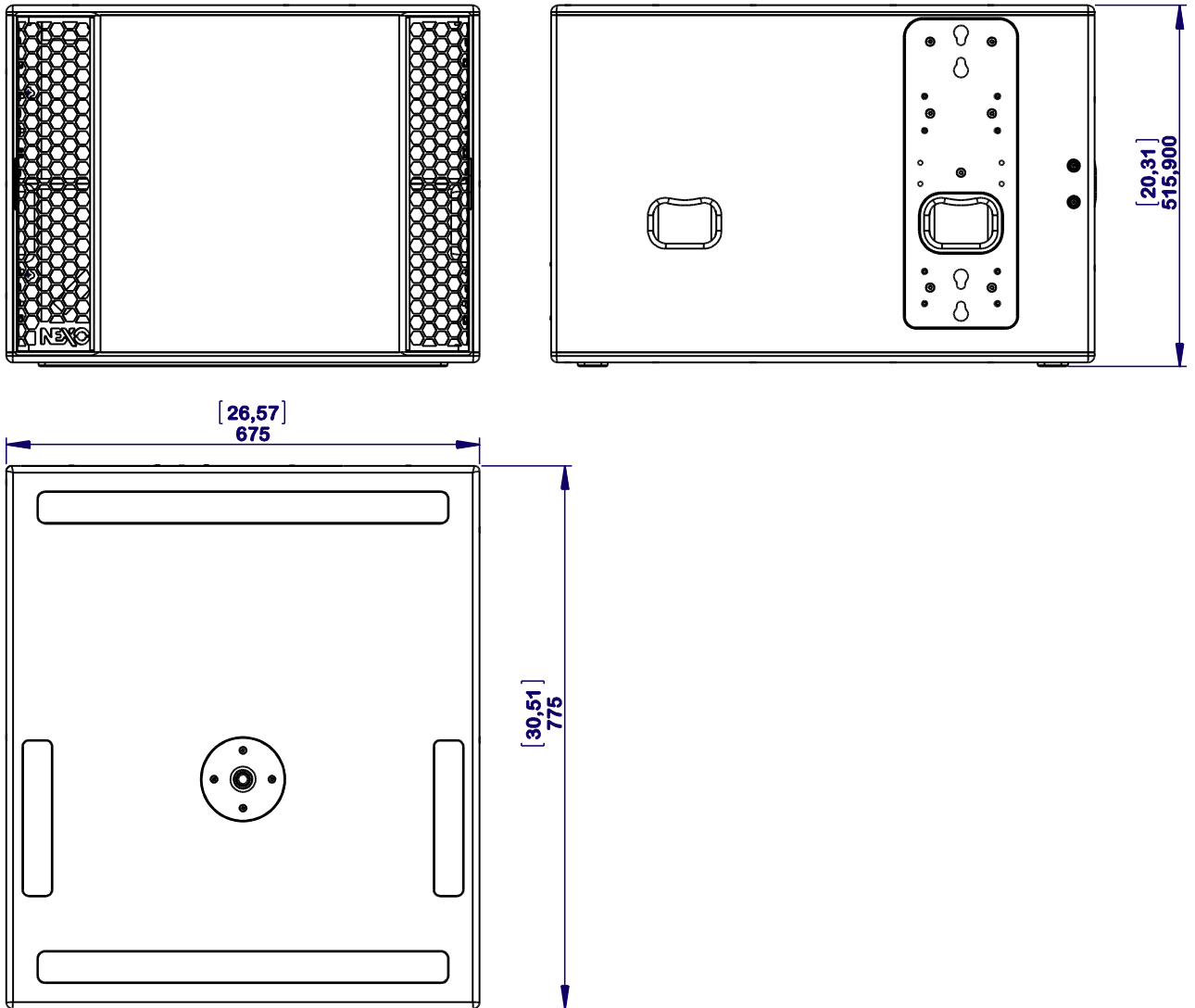

8.2 GEO S1210

8.2.1 System specifications

	GEO S1210 (without CDD™)	GEO S1210 (with CDD™)
GEO S1210 WITH NEXO TDCONTROLLER SETUP		
Frequency Response @-6 dB	50 Hz to 20 kHz	
Sensitivity 1W@1m	103 dB SPL Nominal	
Peak SPL@1m	131 to 133 dB	
Vertical Dispersion	10°	
Horizontal Dispersion	80°	120°
Passive Crossover Frequency	1.1 kHz	
Nominal Impedance	Active mode : (16 Ω LF + 16 Ω HF) / Passive mode : 16 Ω	
Recommended Power	Active mode: (1100 Watts LF + 650 Watts HF) / Passive mode: 1100 Watts	
PRODUCT FEATURES		
LF Component	1 x 12" (30cm) high excursion neodymium 16 Ohm driver with PDD™	
HF Component	1 x 3" voice coil, 1.4" throat 16 Ohms driver on a HR Wavesource™	
Height x Width x Depth	344 mm x 674 mm x 378 mm (13.5" x 26.5" x 14.9")	
Weight: Net	28 kg (61.8 lb)	
Connectors	2 x NL4, 4 poles connectors (1+/1- Through / 2+/2- GEOS12 in passive mode, 1+/1- LF, 2+/2- HF in active mode)	
Construction	Baltic Birch Plywood with structured black coating	
Fittings	2 x Side handles	
Front Finish	Molded dark grey metal grill	
Operating temperature range	0°C - 40 °C (32° F - 104° F)	
Storage temperature range	-20 °C - 60 °C (-4 ° F - 140° F)	
SYSTEM OPERATION		
Recommended powering solution	NXAMP4x4mk2 Powered TD controller: up to 4 x GEOS12 in passive mode per channel	
Optional powering solution	NXAMP4x2mk2 Powered TD controller: 1 x GEOS12 in passive mode per channel	
	NXAMP4x1mk2 Powered TD controller (Bridged): up to 3 x GEOS12 in passive mode per channel	

8.2.2 Dimensions (mm/inches)

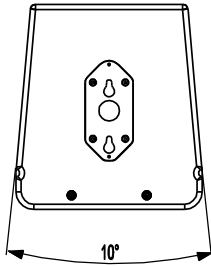
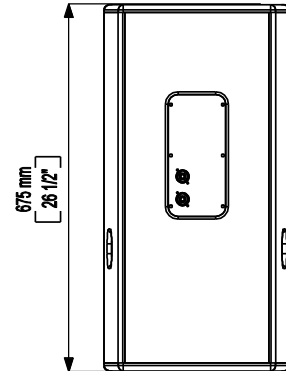
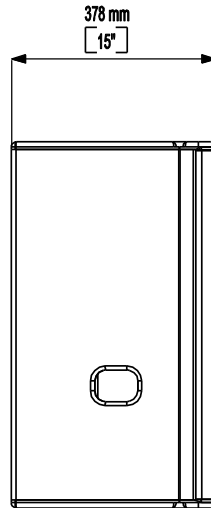
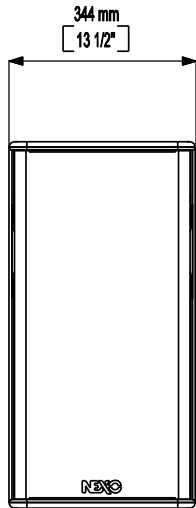

8.3 GEO S1210-ST

8.3.1 System specifications

	GEO S1210-ST (without CDD™)	GEO S1210-ST (with CDD™)
GEO S1210-ST WITH NEXO TDCONTROLLER SETUP		
Frequency Response @-6 dB	50 Hz to 20 kHz	
Sensitivity 1W@1m	105 dB SPL Nominal	
Peak SPL@1m	133 to 135 dB	
Vertical Dispersion	10°	
Horizontal Dispersion	80°	120°
Passive Crossover Frequency	1.1 kHz	
Nominal Impedance	Active mode : (16 Ω LF + 16 Ω HF) / Passive mode : 16 Ω	
Recommended Power	Active mode: (1100 Watts LF + 650 Watts HF) / Passive mode: 1100 Watts	
PRODUCT FEATURES		
LF Component	1 x 12" (30cm) high excursion neodymium 16 Ohm driver with PDD™	
HF Component	1 x 3" voice coil, 1.4" throat 16 Ohms Neodymium driver on a HR Wavesource™	
Height x Width x Depth	344 mm x 674 mm x 378 mm (13.5" x 26.5" x 14.9")	
Weight: Net	28 kg (61.8 lb)	
Connectors	2 x NL4, 4 poles connectors (1+/1- Through / 2+/2- GEOS12 in passive mode, 1+/1- LF, 2+/2- HF in active mode)	
Construction	Baltic Birch Plywood with structured black coating	
Fittings	2 x Side handles	
Front Finish	Molded dark grey metal grill	
Operating temperature range	0°C - 40 °C (32° F - 104° F)	
Storage temperature range	-20 °C - 60 °C (-4 ° F - 140° F)	
SYSTEM OPERATION		
Recommended powering solution	NXAMP4x4mk2 Powered TD controller: up to 4 x GEOS12 in passive mode per channel	
Optional powering solution	NXAMP4x2mk2 Powered TD controller: 1 x GEOS12 in passive mode per channel	
	NXAMP4x1mk2 Powered TD controller (Bridged): up to 3 x GEOS12 in passive mode per channel	

8.3.2 Dimensions (mm/inches)

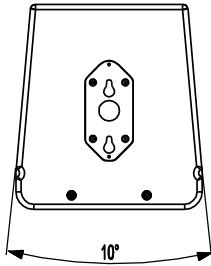
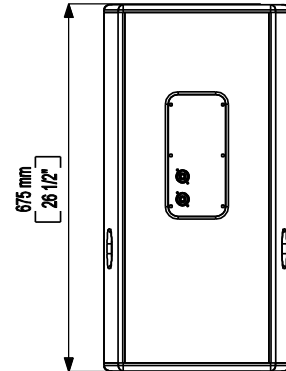
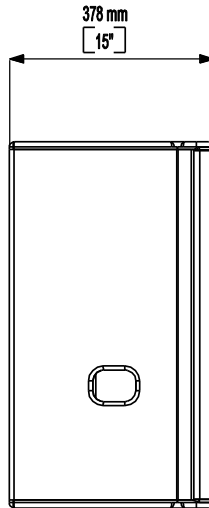
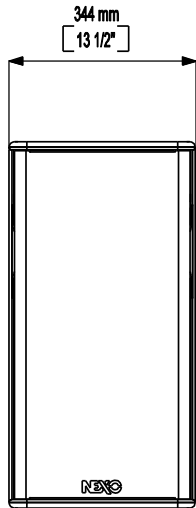

8.4 GEO S1230

8.4.1 System specifications

	GEO S1230 (without CDD™)	GEO S1230 (with CDD™)
GEO S1230 WITH NEXO TDCONTROLLER SETUP		
Frequency Response @-6 dB	50 Hz to 20 kHz	
Sensitivity 1W@1m	103 dB SPL Nominal	
Peak SPL@1m	131 to 133 dB	
Vertical Dispersion	28.5°	
Horizontal Dispersion	80°	120°
Passive Crossover Frequency	1.1 kHz	
Nominal Impedance	Active mode : (16 Ω LF + 16 Ω HF) / Passive mode : 16 Ω	
Recommended Power	Active mode: (1100 Watts LF + 650 Watts HF) / Passive mode: 1100 Watts	
PRODUCT FEATURES		
LF Component	1 x 12" (30cm) high excursion neodymium 16 Ohm driver with PDD™	
HF Component	1 x 3" voice coil, 1.4" throat 16 Ohms driver on a HR Wavesource™	
Height x Width x Depth	344 mm x 675 mm x 400 mm (13.5" x 26.6" x 15.7")	
Weight: Net	27 kg (59.1 lb)	
Connectors	2 x NL4, 4 poles connectors (1+/1- Through / 2+/2- GEOS12 in passive mode, 1+/1- LF, 2+/2- HF in active mode)	
Construction	Baltic Birch Plywood with structured black coating	
Fittings	2 x Side handles	
Front Finish	Molded dark grey metal grill	
Operating temperature range	0°C - 40 °C (32° F - 104° F)	
Storage temperature range	-20 °C - 60 °C (-4 ° F - 140° F)	
SYSTEM OPERATION		
Recommended powering solution	NXAMP4x4mk2 Powered TD controller: up to 4 x GEOS12 in passive mode per channel	
Optional powering solution	NXAMP4x2mk2 Powered TD controller: 1 x GEOS12 in passive mode per channel	
	NXAMP4x1mk2 Powered TD controller (Bridged): up to 3 x GEOS12 in passive mode per channel	

8.4.2 Dimensions (mm/inches)

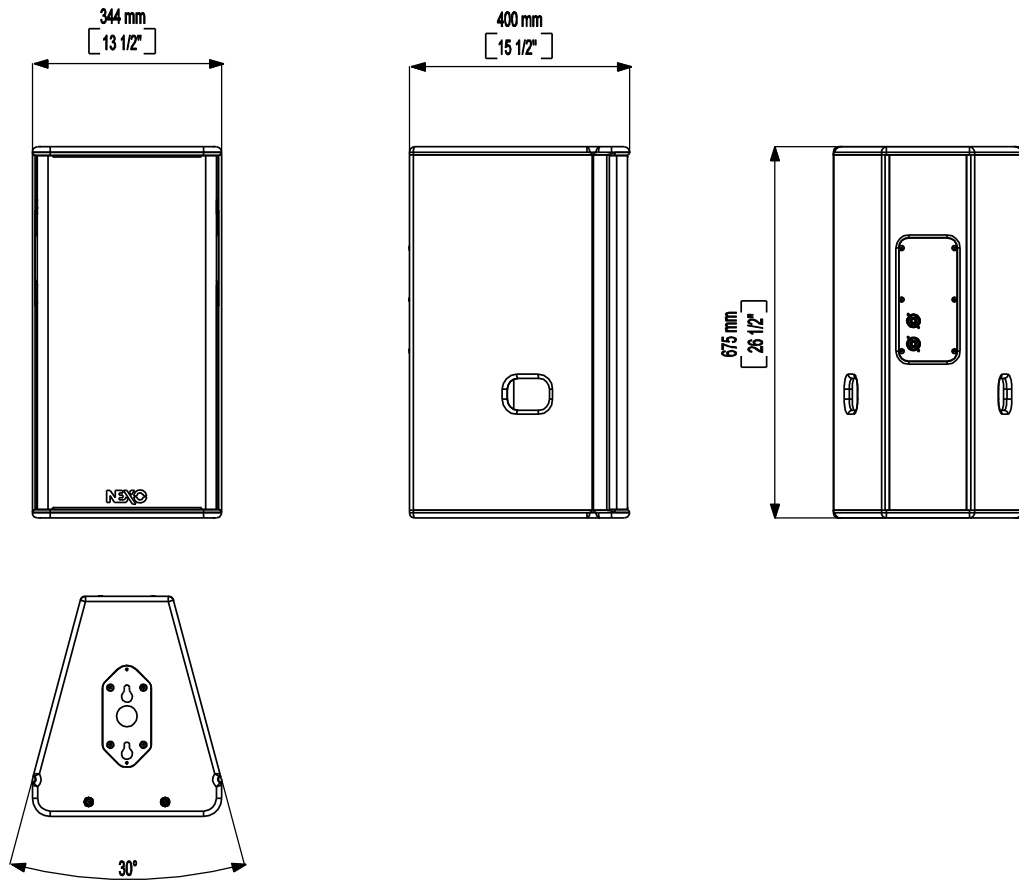

8.5 GEO S1230-ST

8.5.1 System specifications

	GEO S1230-ST (without CDD™)	GEO S1230-ST (with CDD™)
GEO S1230-ST WITH NEXO TDCONTROLLER SETUP		
Frequency Response @-6 dB	50 Hz to 20 kHz	
Sensitivity 1W@1m	105 dB SPL Nominal	
Peak SPL@1m	133 to 135 dB	
Vertical Dispersion	28.5°	
Horizontal Dispersion	80°	120°
Passive Crossover Frequency	1.1 kHz	
Nominal Impedance	Active mode : (16 Ω LF + 16 Ω HF) / Passive mode : 16 Ω	
Recommended Power	Active mode: (1100 Watts LF + 650 Watts HF) / Passive mode: 1100 Watts	
PRODUCT FEATURES		
LF Component	1 x 12" (30cm) high excursion neodymium 16 Ohm driver with PDD™	
HF Component	1 x 3" voice coil, 1.4" throat 16 Ohms Neodymium driver on a HR Wavesource™	
Height x Width x Depth	344 mm x 675 mm x 400 mm (13.5" x 26.6" x 15.7")	
Weight: Net	27 kg (59.1 lb)	
Connectors	2 x NL4, 4 poles connectors (1+/1- Through / 2+/2- GEOS12 in passive mode, 1+/1- LF, 2+/2- HF in active mode)	
Construction	Baltic Birch Plywood with structured black coating	
Fittings	2 x Side handles	
Front Finish	Molded dark grey metal grill	
Operating temperature range	0°C - 40 °C (32° F - 104° F)	
Storage temperature range	-20 °C - 60 °C (-4 ° F - 140° F)	
SYSTEM OPERATION		
Recommended powering solution	NXAMP4x4mk2 Powered TD controller: up to 4 x GEOS12 in passive mode per channel	
Optional powering solution	NXAMP4x2mk2 Powered TD controller: 1 x GEOS12 in passive mode per channel	
	NXAMP4x1mk2 Powered TD controller (Bridged): up to 3 x GEOS12 in passive mode per channel	

8.5.2 Dimensions (mm/inches)

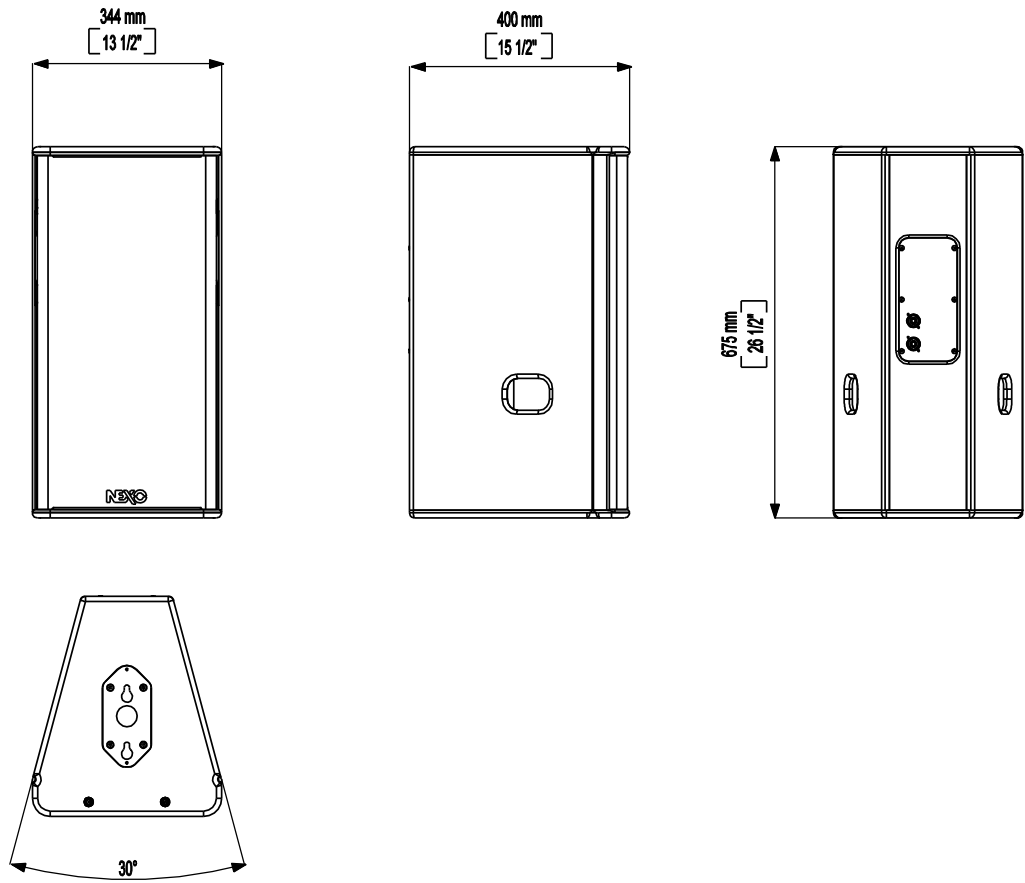

8.6 GEO S12 and LS18 accessories

8.6.1 GPI-BUMPER

Parts

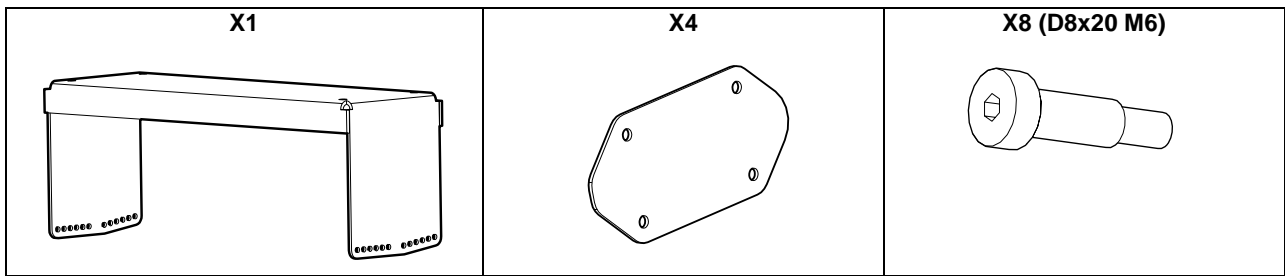

Dimensions

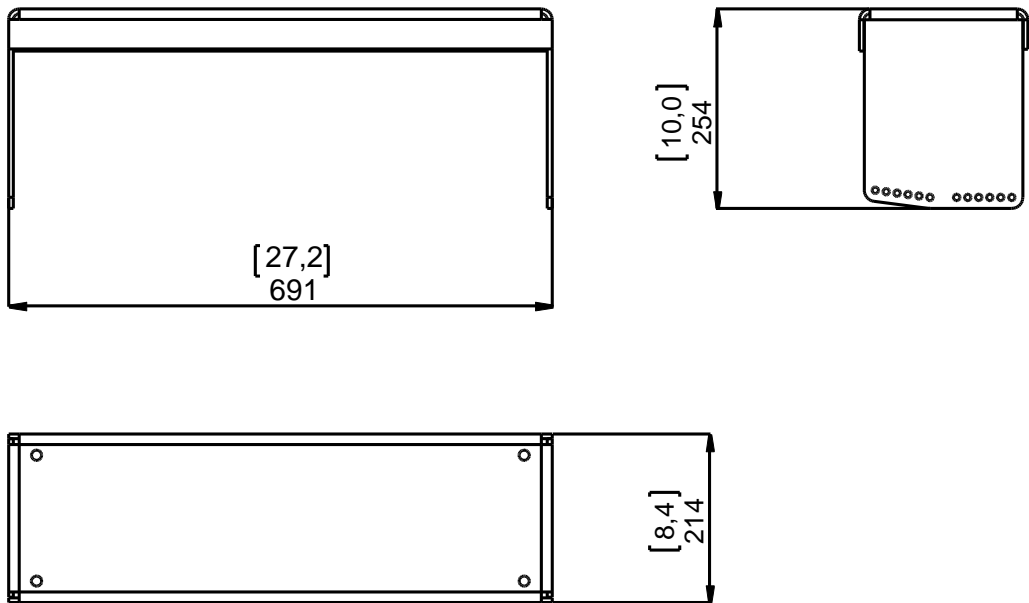

Weight: 14.5 kg / 32 lb

8.6.2 VNI-UBRK12

Parts

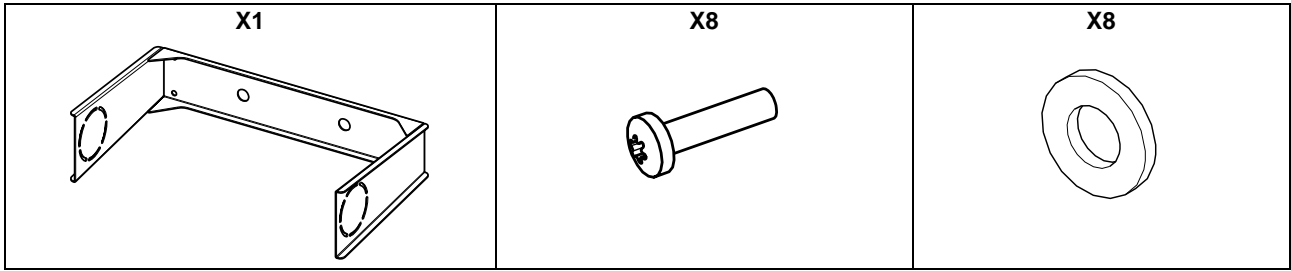

Dimensions

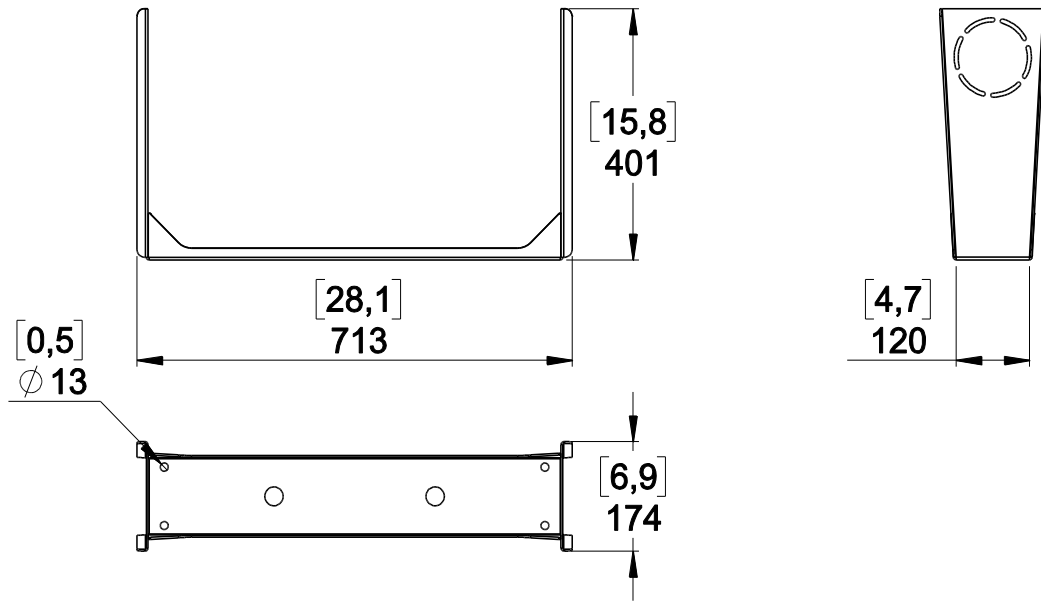

Weight: 6 kg / 13 lb

8.6.3 VNI-LBRK

Parts

X1		X1		X2 (D8x12)	X2 (D8x20)
X2 (M8)	X2 (M6x25)	X2 (M6)	X2 (M12x35)	X4 (M12)	X2 (M12)

Dimensions

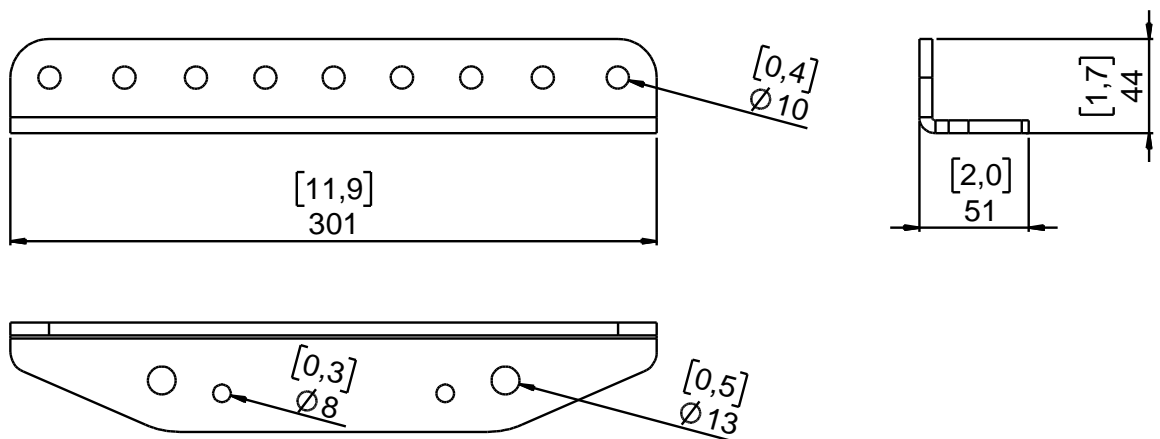

Weight: 1.6 kg / 3.5 lb

8.6.4 VNI-ABRK

Parts

X1		X1		X2 (D8x12)	X2 (D8x20)
X2 (M8)	X2 (M6x25)	X2 (M6)	X2 (M12x35)	X2 (M12)	X2 (M12)

Dimensions

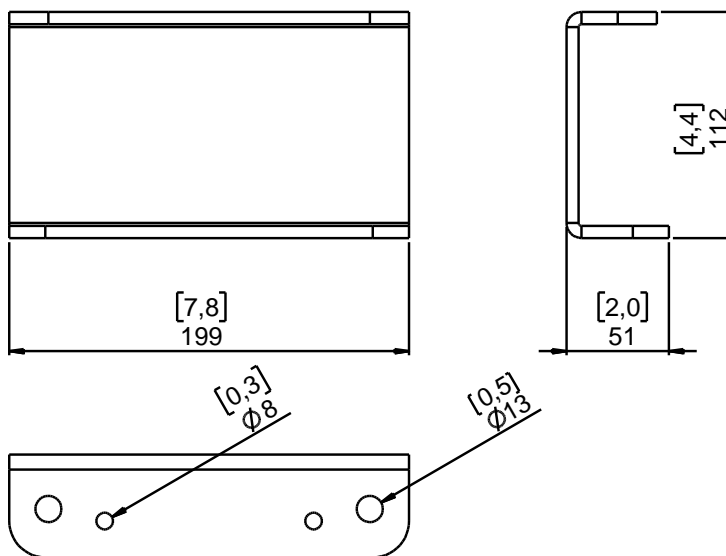

Weight: 1 kg / 2.2 lb

8.6.5 GPI-ANPL1

Parts

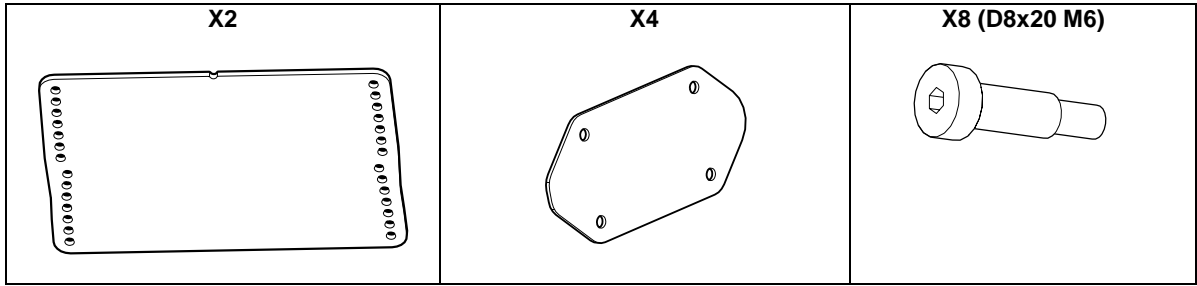

Dimensions

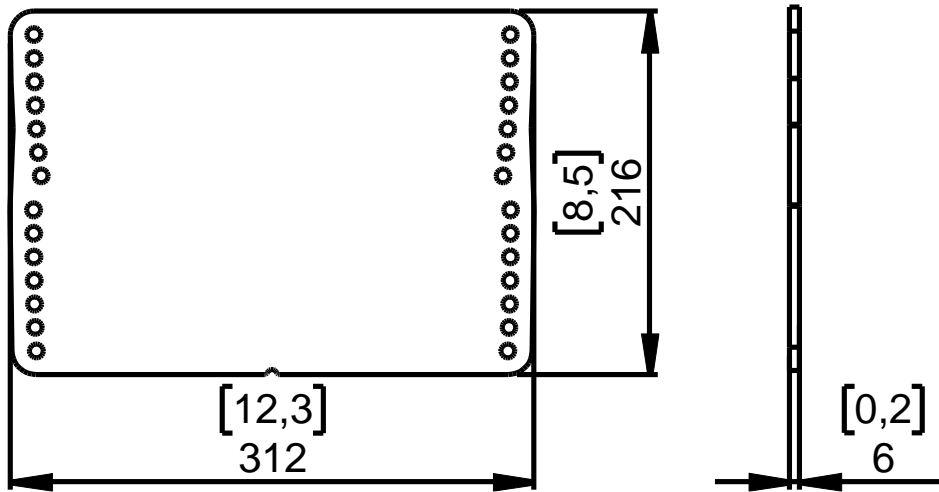

Weight: 8 kg / 17.6 lb

8.6.6 GPI-ANPL2

Parts

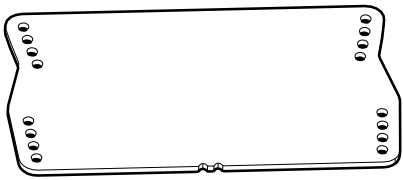
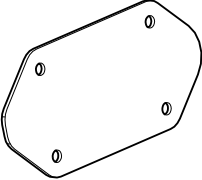
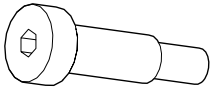
<p>X2</p> 	<p>X4</p> 	<p>X8 (D8x20 M6)</p> 
---	---	--

Dimensions

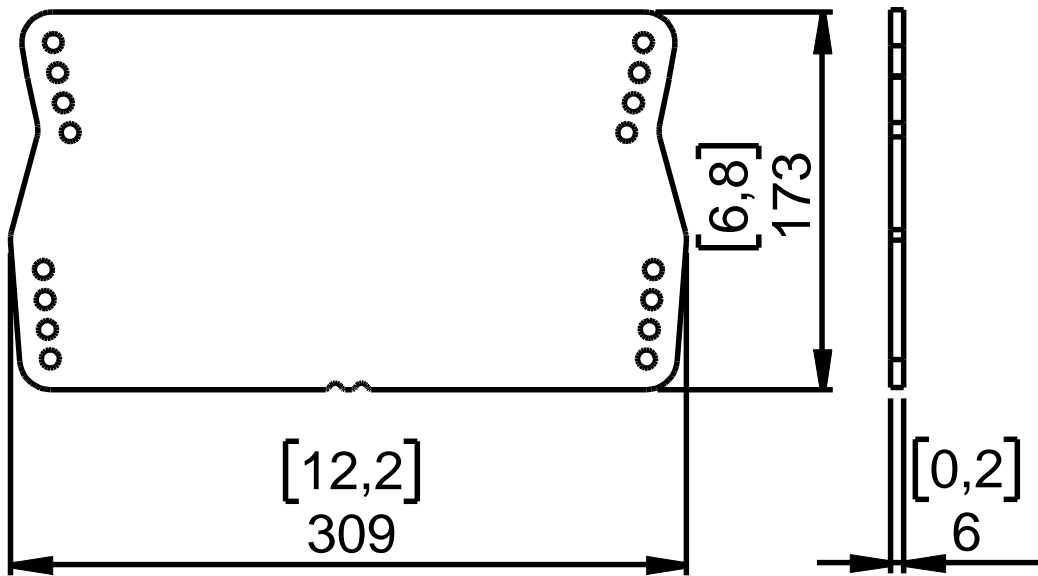

Weight: 6.5 kg / 14.3 lb

8.6.7 GPI-ANL3

Parts

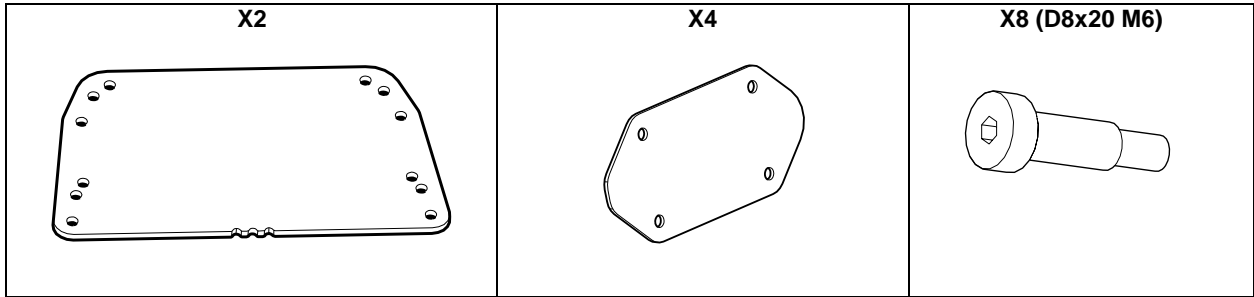

Dimensions

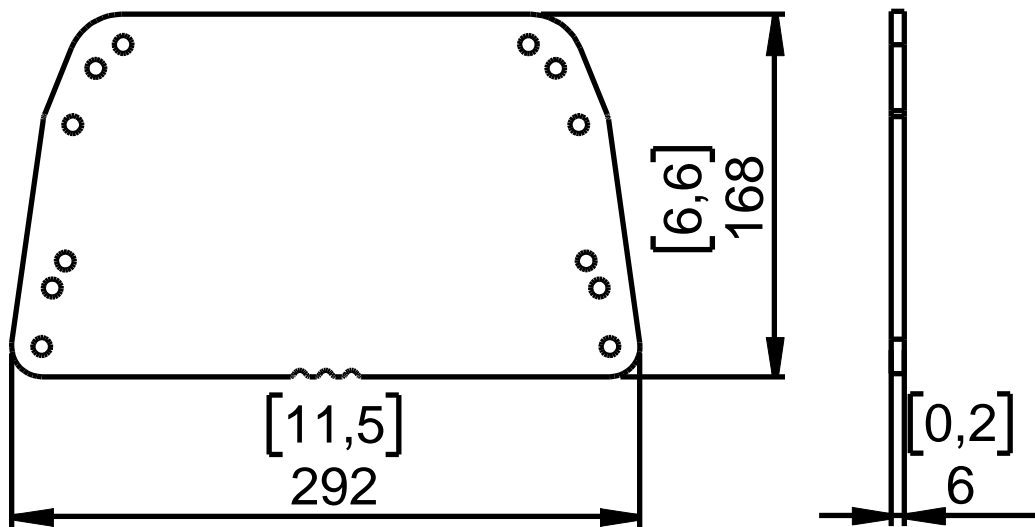

Weight: 6.6 kg / 14.6 lb

8.6.8 LSI-CPLA

Parts

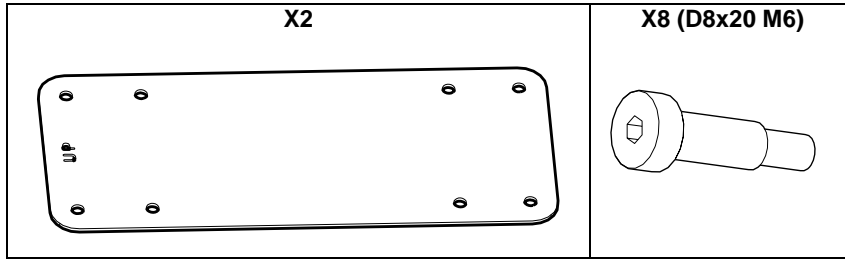

Dimensions

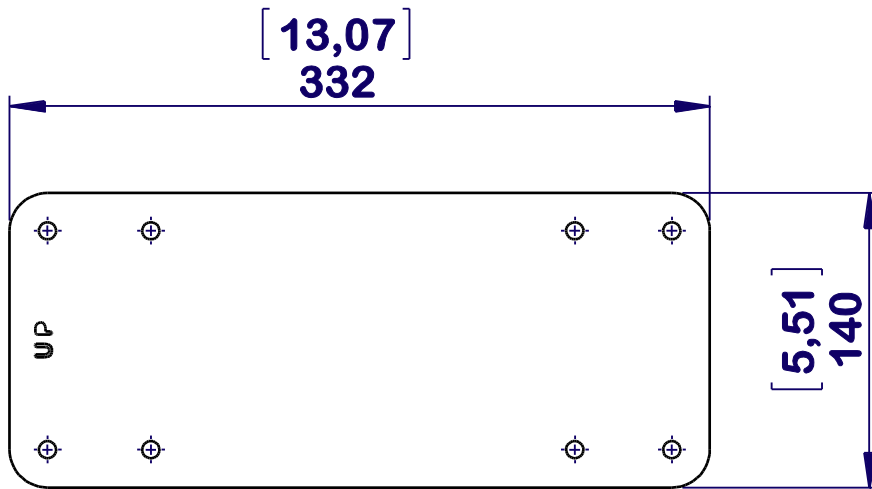

Weight: 2.5 kg / 5.5 lb

8.6.9 VNI-IPCOV15

Parts

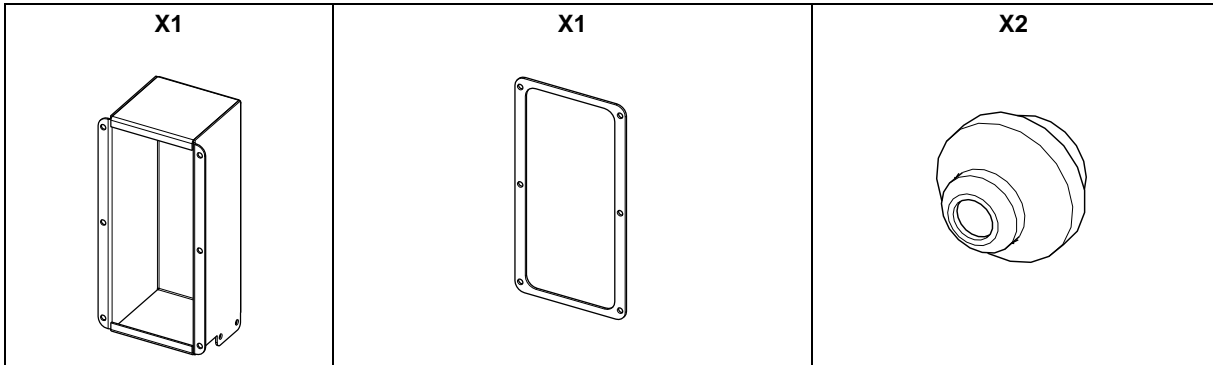

Dimensions

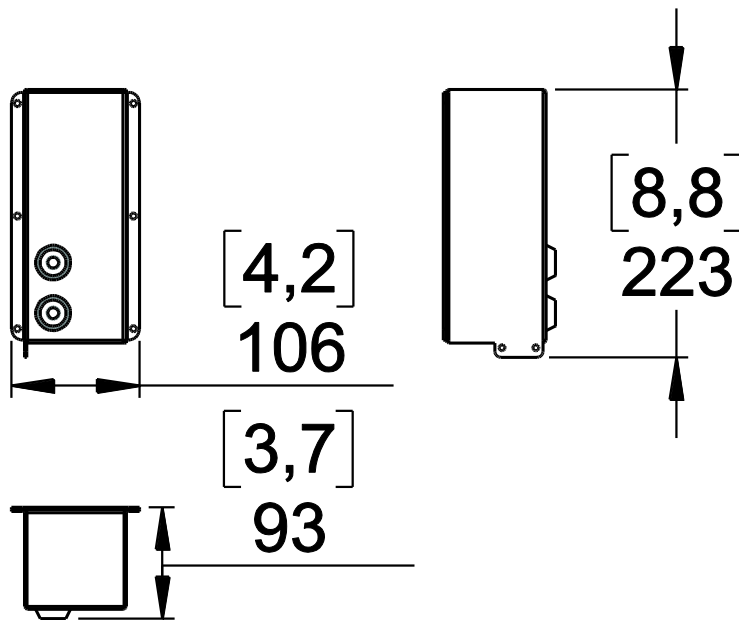

Weight: 0.9 kg / 2 lb

8.6.10 GPT-BUMPER

Parts

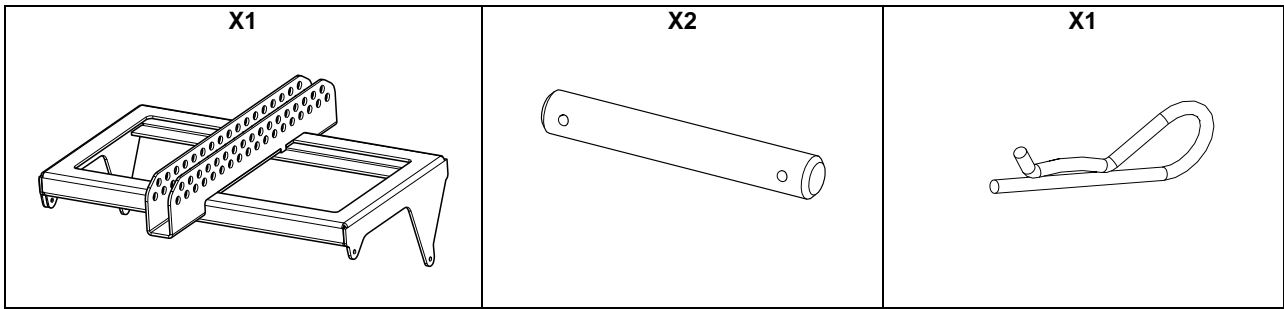

Dimensions

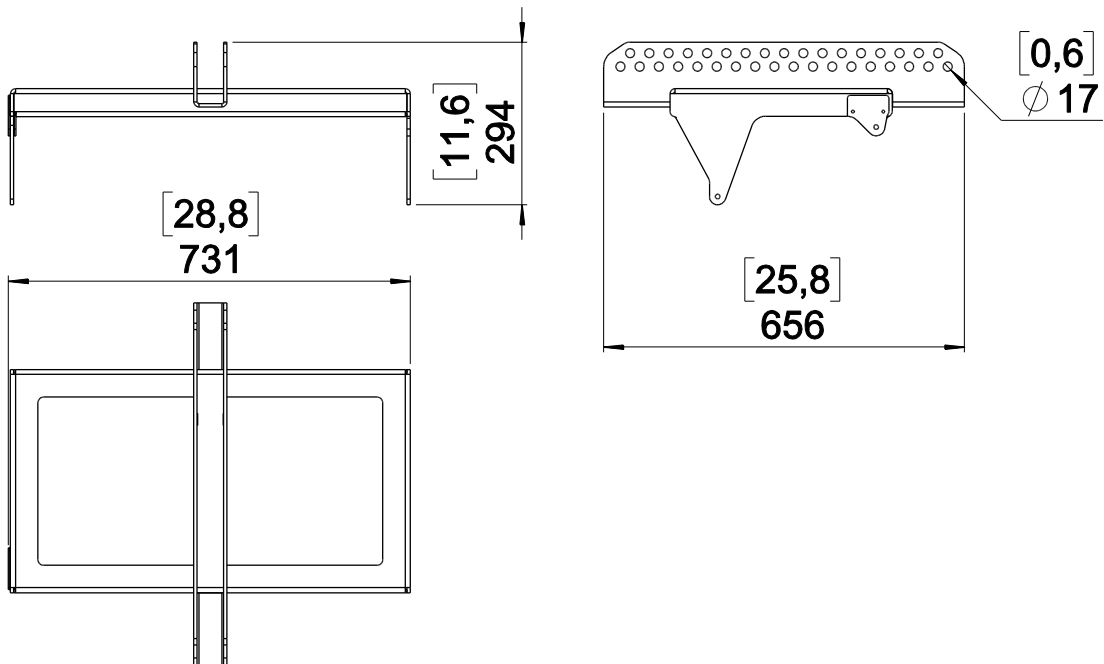

Weight: 20 kg / 44 lb

8.6.11 GPT-XBOW

Parts

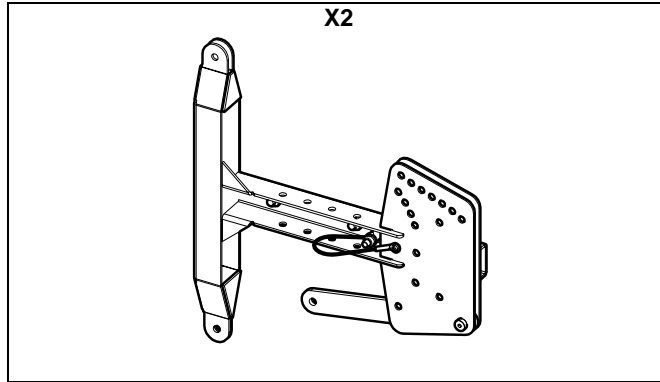

Dimensions

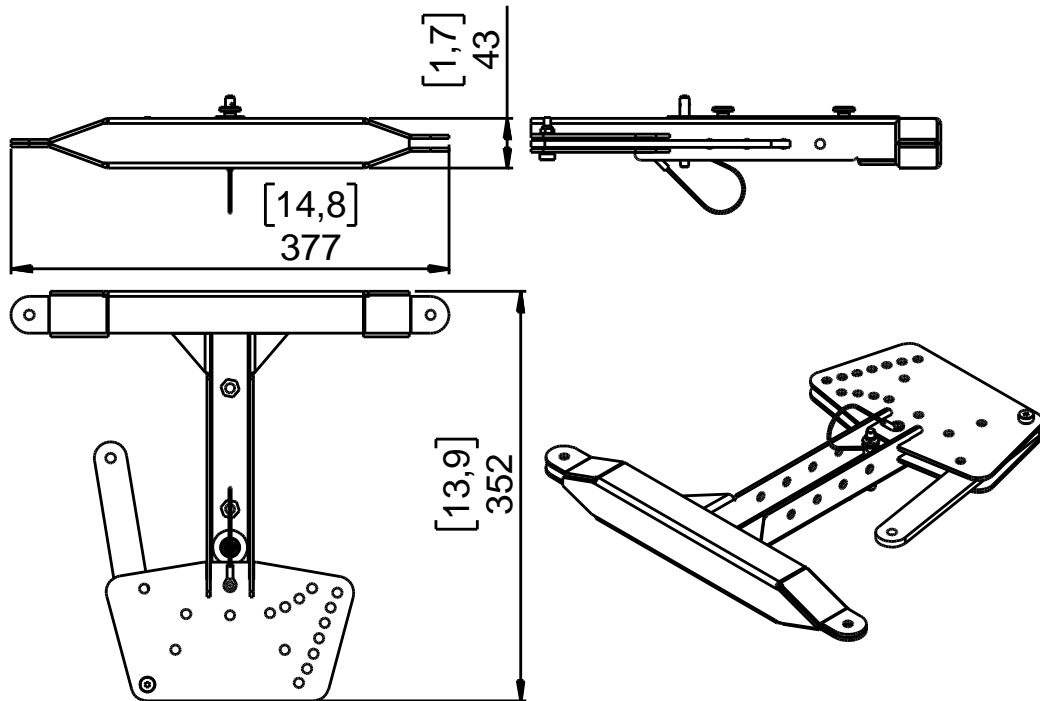

Weight (pair): 10.7 kg / 23.6 lb

8.6.12 LST-XBOW18

Parts

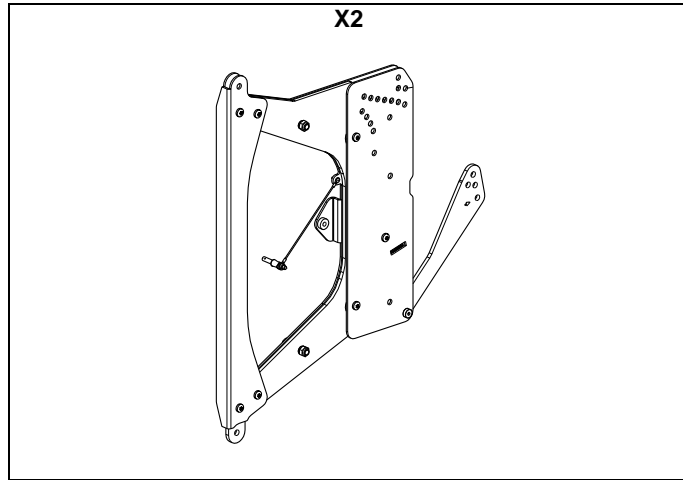

Dimensions

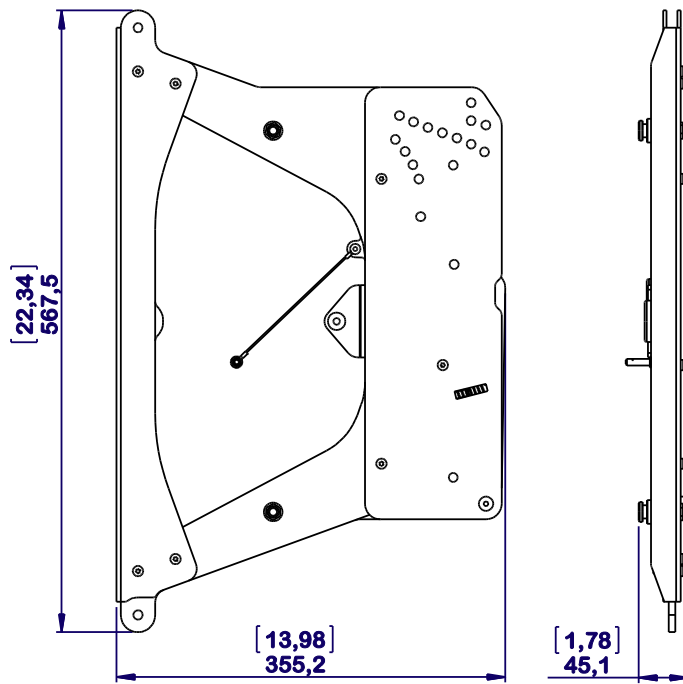

Weight (each): 8 kg / 17.5 lb

8.6.13 GPT-TLB

Parts



Dimensions

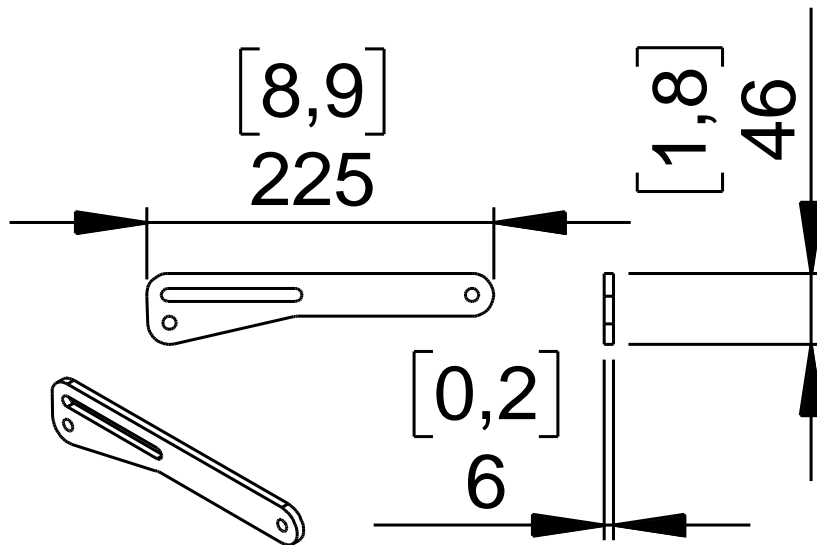

Weight: 0.6 kg / 1.3 lb

8.6.14 VNT-XHBRK

Parts

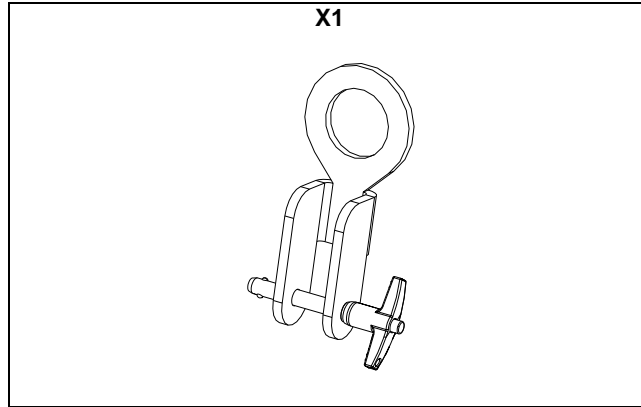

Dimensions

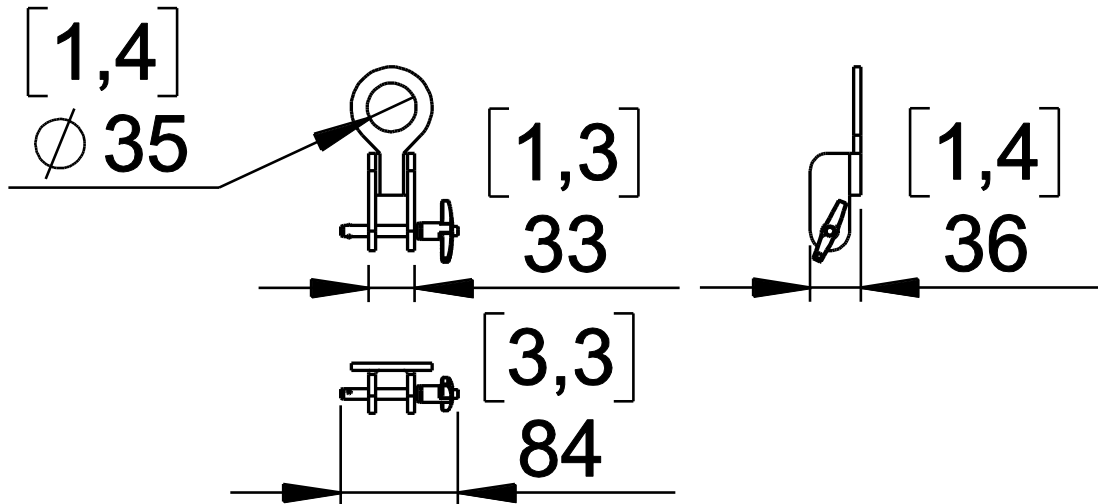

Weight: 0.35 kg / 0.8 lb

8.6.15 VNT-TTC

Parts

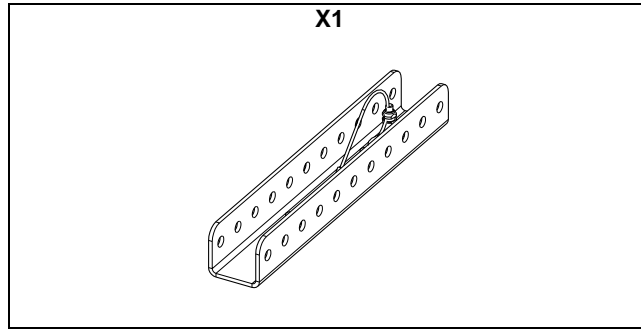

Dimensions

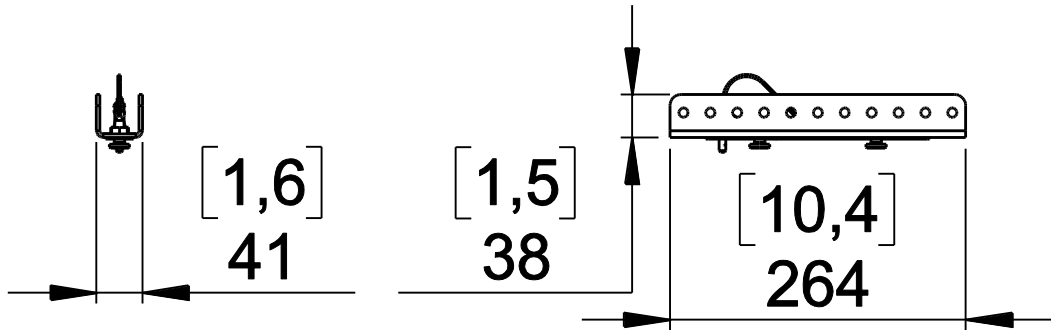

Weight: 1.8 kg / 4 lb

8.6.16 GPT-SSBRK

Parts

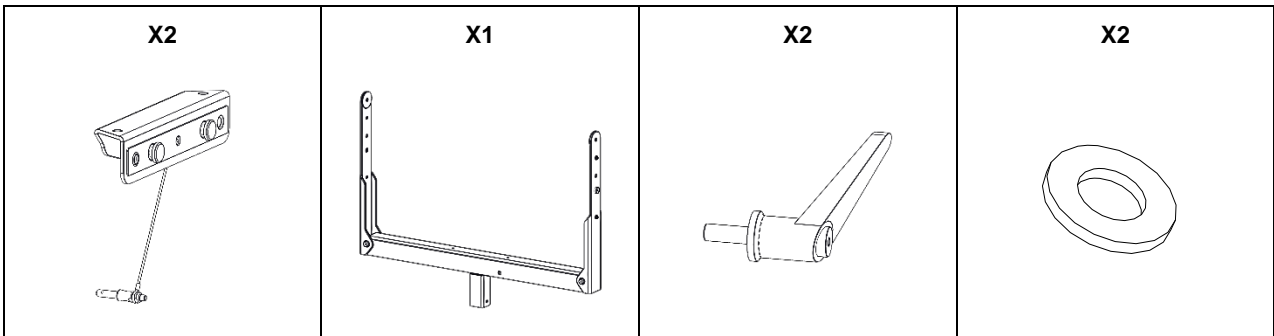

Dimensions

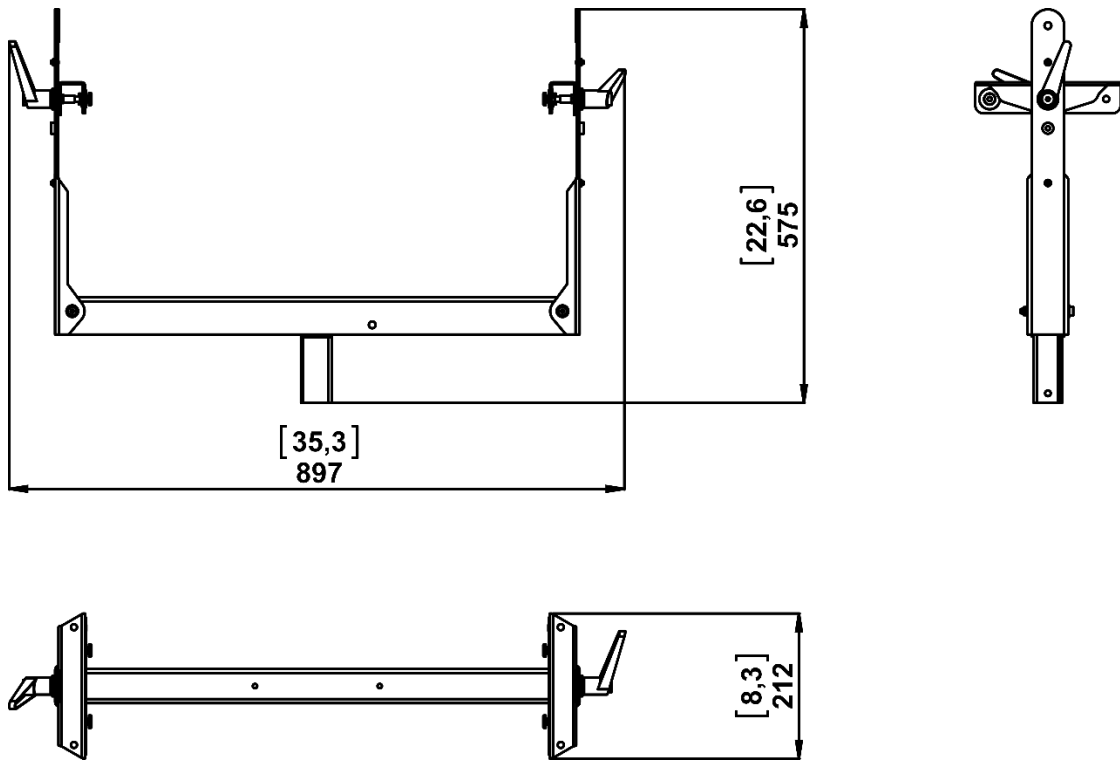

Weight: 7.5 kg / 16.5 lb

8.6.17 GPT-PSBRK

Parts

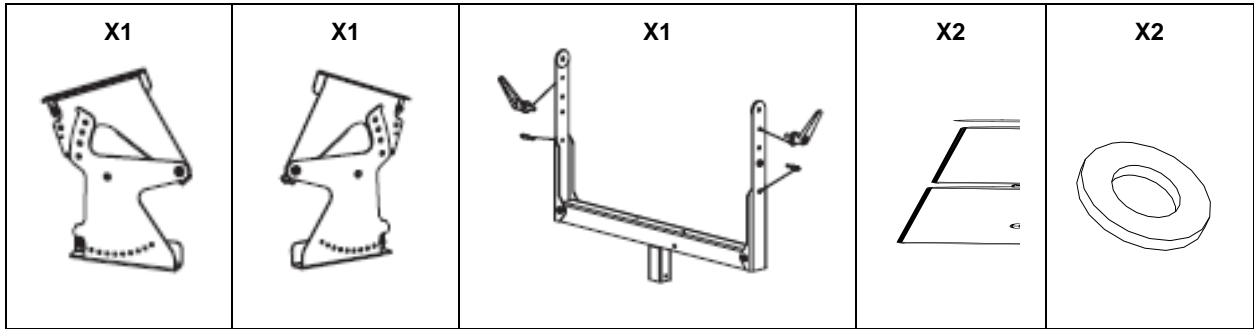

Dimensions

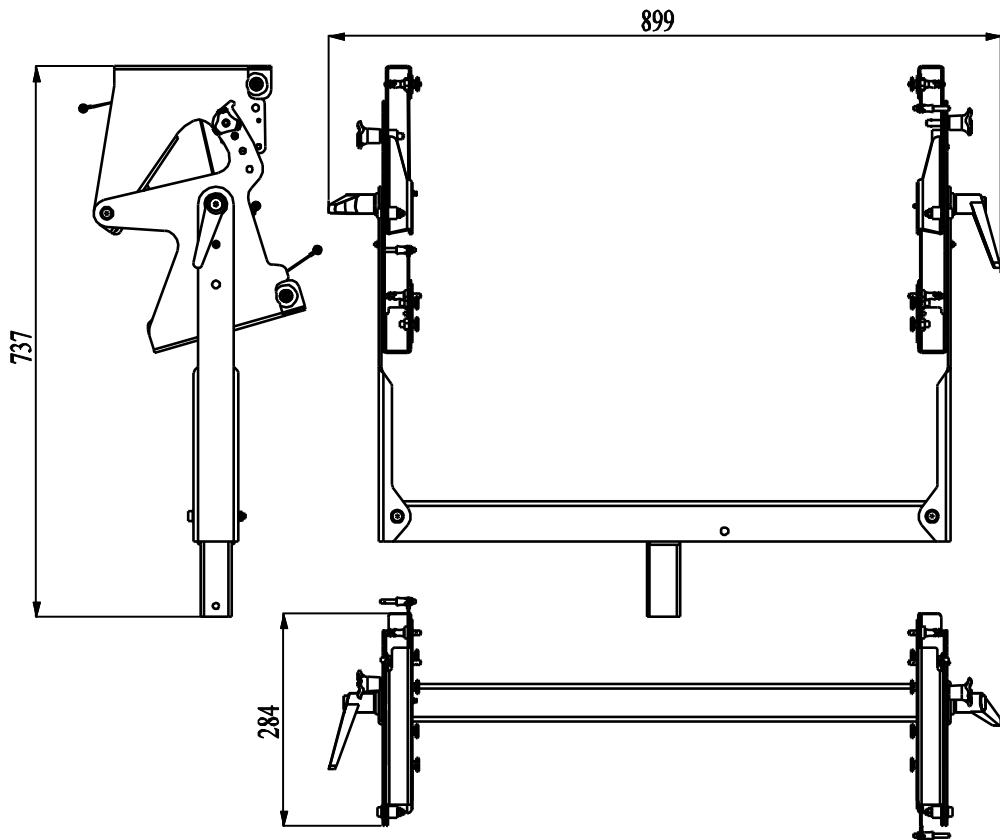

Weight: 11 kg / 24.25 lb

8.6.18 VNT-TCBRK

Parts

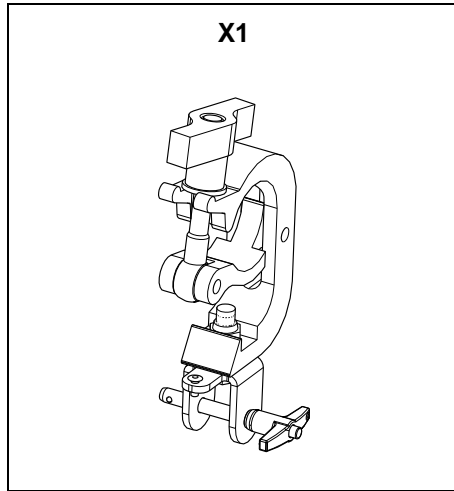

Dimensions

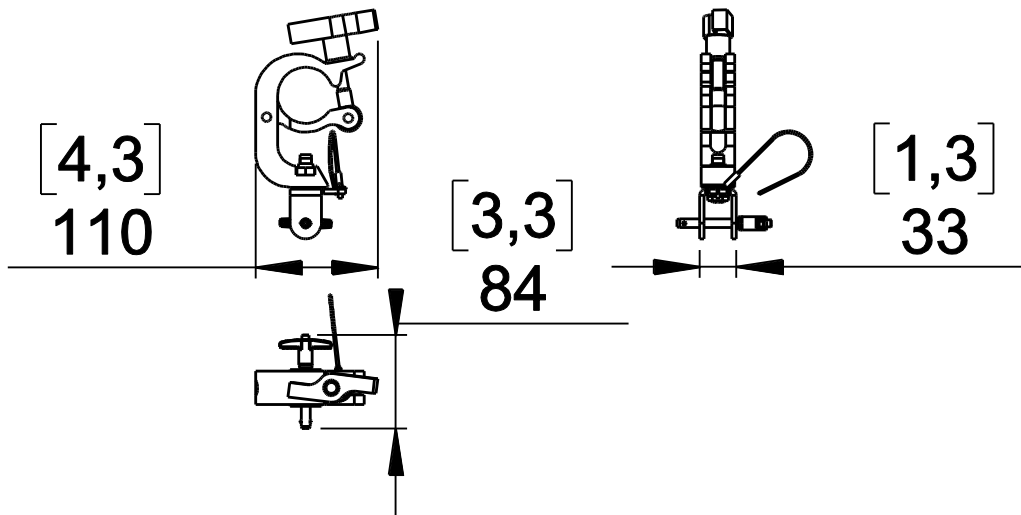

Weight: 0.78 kg / 1.8 lb

8.6.19 GPT-GSTK

Parts

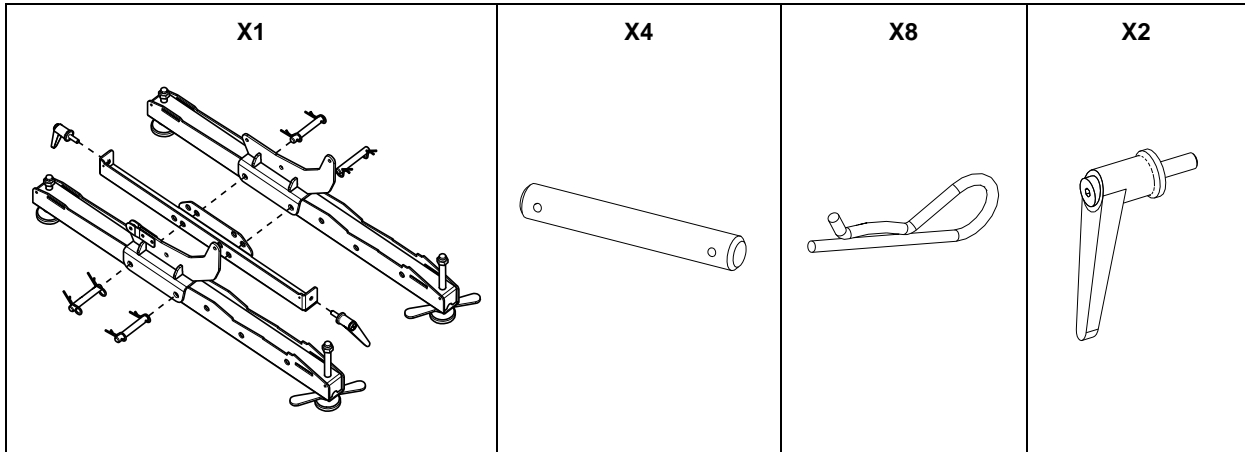

Dimensions

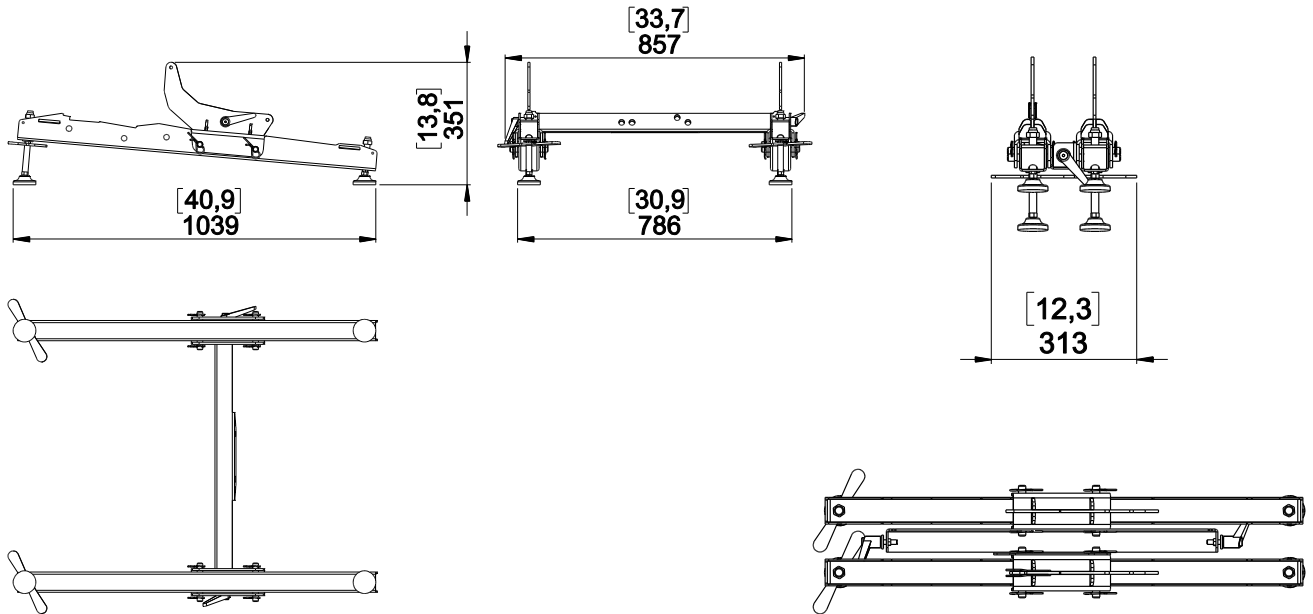

Weight: 26.5 kg / 58.4 lb

8.6.20 GPT-FLG

Parts

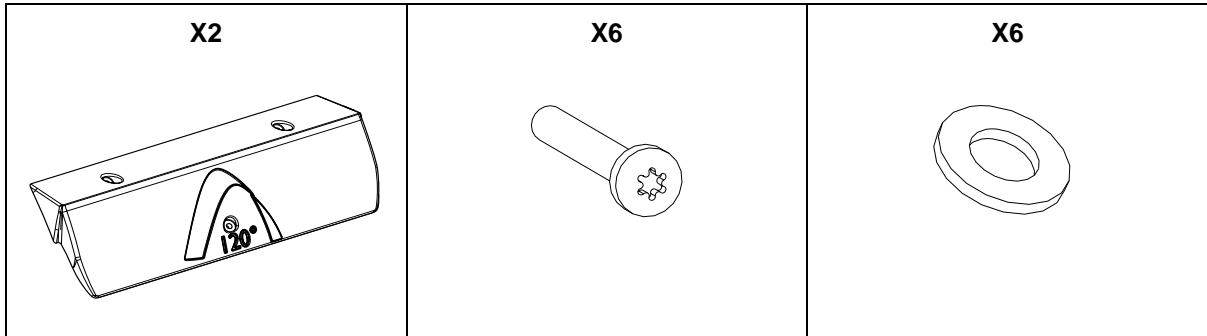

Dimensions

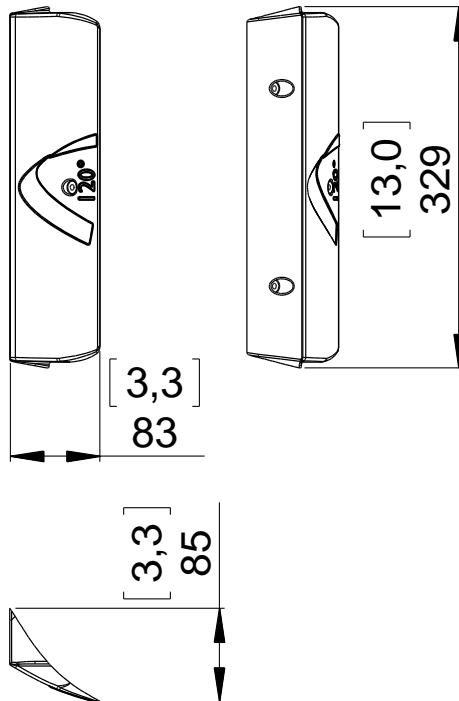

Weight: 0.6 kg / 1.3 lb

8.6.21 VXT-BL820

Parts

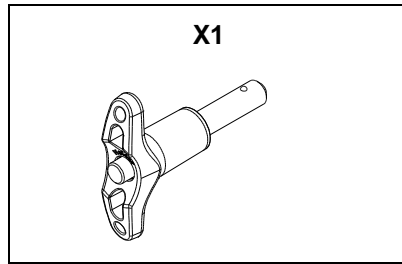



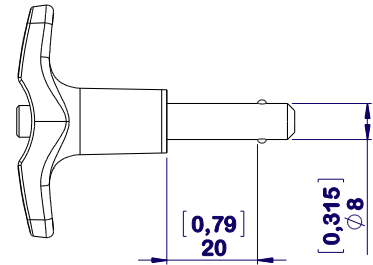
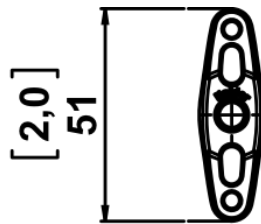
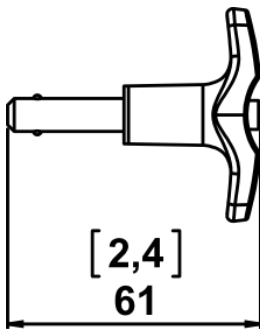

Dimensions



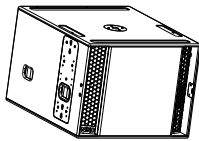
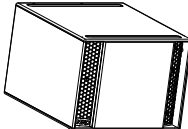
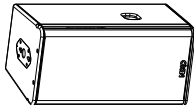
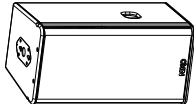
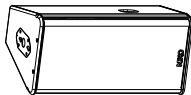
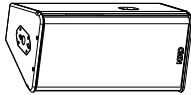

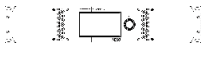
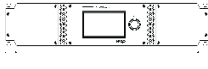
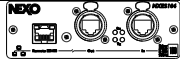



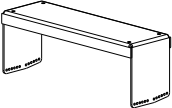
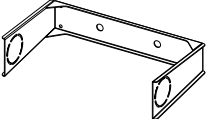
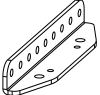
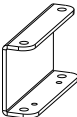

Weight: 0.04 kg / 0.1 lb

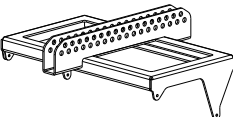
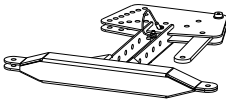
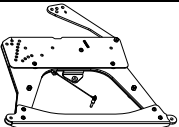
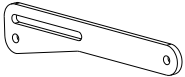

9 GEO S12 & LS18 MODULES & ACCESSORIES LIST

REFERENCE	DRAWING	DESCRIPTION
LS18		18" Subwoofer
LS18-E		18" Subwoofer – E version
GEO S1210		12" - 10° Tangent Array
GEO S1210-ST		12" - 10° Tangent Array – Long Throw version
GEO S1230		12" - 30° Tangent Array
GEO S1230-ST		12" - 30° Tangent Array – Long Throw version
NXAMP4x1mk2		Powered Digital TD Controller 4x1300W
NXAMP4x2mk2		Powered Digital TD Controller 4x2500W
NXAMP4x4mk2		Powered Digital TD Controller 4x4500W
NX.ES104		Ethersound Network Card for NXAMP
NX.DT104MK2		Dante Network Card for NXAMP
NX.AE104		AES Card for NXAMP

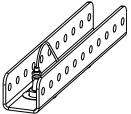
GEO S12 & LS18 MODULES & ACCESSORIES LIST

REFERENCE	DRAWING	DESCRIPTION
GPI-BUMPER		Installation bumper for GEO S12 and LS18
VNI-UBRK12		“U” bracket for GEO S12
VNI-LBRK		Mounting plate for GEO S12 and GPI-BUMPER
VNI-ABRK		Mounting plate for GEO S12 and GPI-BUMPER
GPI-ANPL1		GEO S12 and LS18 Angle plate (0.2° to 3.15°)
GPI-ANPL2		GEO S12 Angle plate (5° to 10°)
GPI-ANPL3		GEO S12 and LS18 Angle plate (16° to 30°)
LSI-CPLA		LS18 Mounting plate
VNI-IPCOV15		GEO S12 IP54 Connector box
GPT- BUMPER		Touring bumper for GEO S12 and LS18
GPT-XBOW		Rigging plates for GEO S12
LST-XBOW18		Rigging plates for LS18
GPT-TLB		Link bar for GPT-XBOW
VNT-XHBRK		Lifting ring for GPT-SSBRK, VNT-TTC and GPT-PSBRK
VNT- TTC		Angle adapter for GEO S12

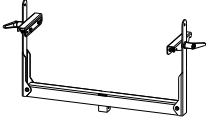
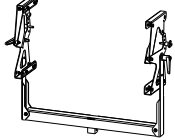
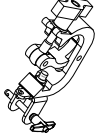
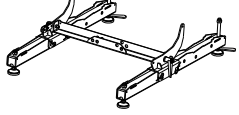
GEO S12 & LS18 MODULES & ACCESSORIES LIST

GPT-SSBRK		"U" bracket for one GEO S12
GPT-PSBRK		"U" bracket for two GEO S12
VNT-TCBRK		Truss hook adapter for GPT-SSBRK, GPT-PSBRK and VNT-TTC
GPT-GSTK		Ground stack device for GEO S12 and LS18
GPT-FLG		Kit flange 120° horizontal dispersion for GEO S12
VXT-BL820		Quick release pin

10 USER NOTES

NEXO S.A.

Parc d'activité de la Dame Jeanne
F-60128 PLAILLY

Tel: +33 3 44 99 00 70

Fax: +33 3 44 99 00 30

E-mail: info@nexo.fr

nexo-sa.com

The logo for NEXO, featuring the word "NEXO" in a bold, black, sans-serif font. The letter 'X' is stylized with a diagonal slash through it.