

TLS Consoles Point-of-Sale (POS)

Application Guide

Notice

Veeder-Root makes no warranty of any kind with regard to this publication, including, but not limited to, the implied warranties of merchantability and fitness for a particular purpose.

Veeder-Root shall not be liable for errors contained herein or for incidental or consequential damages in connection with the furnishing, performance, or use of this publication.

The information contained in this publication may be subject to change without notice.

This publication contains proprietary information which is protected by copyright. All rights reserved. No part of this publication may be photocopied, reproduced, or translated to another language without the prior written consent of Veeder-Root.

©Veeder-Root 2018. All rights reserved.

Introduction

| | |
|---|---|
| Business Inventory Reconciliation (BIR) | 1 |
| In-Station Diagnostics (ISD) - TLS-350R Consoles Only | 1 |
| TLS-350R BIR and ISD Capabilities | 1 |
| TLS-350R with BIR only and TLS-350R with BIR and ISD | 1 |
| TLS-350R with ISD only | 1 |
| Manifolded Tank Applications for BIR | 1 |
| TLS-350R System Requirements for BIR and ISD | 2 |
| Business Inventory Reconciliation | 2 |
| In-Station Diagnostics | 2 |
| TLS-450/TLS-450PLUS BIR Capabilities | 2 |
| Manifolded Tank Applications | 3 |
| TLS-450/TLS-450PLUS System Requirements for BIR | 3 |
| Supported POS Systems | 3 |
| Other Applications | 4 |

DIM Descriptions

| | |
|--|---|
| Mechanical Dispenser Interface Module (MDIM) & Low Voltage Dispenser Interface Module (LVDIM) | 5 |
| Electronic Dispenser Interface Module (EDIM) | 5 |
| Current Loop Dispenser Interface Module (CDIM) | 5 |
| LAN Dispenser Interface Module (LDIM) - TLS-350R only | 5 |
| International Forecourt Standards Forum Dispenser Interface Module (IFSF) - TLS-350R, TLS-450PLUS | 6 |
| TCP/IP DIM Module (TDIM) - TLS-350R | 6 |
| TCP/IP DIM (TDIM) - TLS-450/TLS-450PLUS | 6 |
| DIM And Installation Kit Ordering Guide | 7 |

DIM Installation Examples

| | |
|---|----|
| Bennett POS System | 16 |
| Veeder-Root Software Requirements | 16 |
| Veeder-Root Hardware Requirements (Ref. Table 2) | 16 |
| Bennett System Limitations | 16 |
| Installation Notes | 16 |
| Gilbarco TCRG, TCRG2, T-11, and T-12 POS Systems | 18 |
| TLS Console Software Requirements | 18 |
| Veeder-Root Hardware Requirements (Ref. Table 2) | 18 |
| Specific Limitations | 18 |
| Wiring Diagram for a Transac Current Loop Interface | 19 |
| Wiring Diagram for an Excentus Current Loop Interface | 20 |
| Gilbarco TS-1000 POS and PAM Systems | 21 |
| TLS Console Software Requirements | 21 |
| Veeder-Root Hardware Requirements (Ref. Table 2) | 21 |
| Gilbarco POS and Dispensing System Requirements | 21 |
| Specific Limitations | 21 |
| Wiring to a Universal Distribution Box Interface | 21 |
| Gilbarco G-Site™ POS Systems | 23 |
| TLS Console Software Requirements | 23 |
| Veeder-Root Hardware Requirements (Ref. Table 2) | 23 |
| Specific Limitations | 23 |
| Wiring Diagram | 23 |
| AutoGas Storemaster and Gilbarco Dispenser Systems | 25 |
| TLS Console Software Requirements | 25 |
| Veeder-Root Hardware Requirements (Ref. Table 2) | 25 |

| | |
|---|----|
| Gilbarco POS and Dispensing System Requirements | 25 |
| System Limitations | 25 |
| Installation Notes | 25 |
| Gilbarco SmartCrind Dispenser Systems | 30 |
| TLS Console Software Requirements | 30 |
| Veeder-Root Hardware Requirements (Ref. Table 2) | 30 |
| System Limitations | 30 |
| Installation Notes | 30 |
| Tokheim Dispensing Systems | 31 |
| TLS Console Software Requirements | 31 |
| Veeder-Root Hardware Requirements | 31 |
| Tokheim DHC Requirements..... | 31 |
| Specific Limitations..... | 31 |
| Other POS Consoles | 31 |
| Installation Notes | 31 |
| Wayne Dispensing Systems | 34 |
| TLS Console Software Requirements | 34 |
| Veeder-Root Hardware Requirements | 34 |
| POS System Requirements and Limitations | 34 |
| Supported Wayne Systems | 34 |
| Supported Wayne POS Terminals | 34 |
| Installation Notes | 35 |
| Schlumberger POS Systems | 37 |
| TLS Console Software Requirements | 37 |
| Veeder-Root Hardware Requirements (Ref. Table 2) | 37 |
| System Limitations | 37 |
| MicroMax/Allied Hardware Requirements | 37 |
| Installation Notes | 37 |
| GasBoy CFN Systems | 40 |
| TLS Console Software Requirements | 40 |
| Veeder-Root Hardware Requirements (Ref. Table 2) | 40 |
| GasBoy System Requirements for BIR Interface | 40 |
| Connecting to the Site Controller II..... | 40 |
| BIR Protocol DIM | 42 |
| POS System Requirements and Limitations | 42 |
| Mechanical Dispensers | 43 |
| TLS-350 MDIM Applications..... | 43 |
| TLS-450/TLS-450PLUS MDIM Applications..... | 43 |
| LVDIM Applications | 48 |
| PetroVend System 2 Controller | 48 |
| Kraus Micon 200 Electronic Dispensers..... | 50 |
| Wiring to GasBoy 9800 or Tokheim 2600 Series Electronic Dispensers..... | 52 |

Figures

| | | |
|-----------|---|----|
| Figure 1. | Simplified DIM Connections To Various Dispensing Systems | 15 |
| Figure 2. | Bennett Pump Fuelomat Dispenser Interface Installation Diagram..... | 17 |
| Figure 3. | Transac Series Current Loop Interface | 19 |
| Figure 4. | Excentus Current Loop Interface | 20 |
| Figure 5. | Universal Distribution Box Interface | 22 |
| Figure 6. | Example G-Site Installations | 24 |
| Figure 7. | AutoGas 510 CRIND Controller With Current Loop Interface | 26 |
| Figure 8. | AutoGas 510 CRIND Controller With Serial Interface | 27 |
| Figure 9. | AutoGas 510 CRIND Controller | 28 |

| | | |
|------------|--|----|
| Figure 10. | AutoGas 507 CRIND Controller | 29 |
| Figure 11. | SmartCrind Installation | 30 |
| Figure 12. | Tokheim DHC Standalone Installation | 32 |
| Figure 13. | Tokheim Vision 100/200 Installation | 32 |
| Figure 14. | Tokheim Dispenser Controller With Single CAB Installation | 33 |
| Figure 15. | Wayne Dispenser Data Box Current Loop (TLS-350R and TLS-450)..... | 35 |
| Figure 16. | Wayne IDPOS Dispensers (TLS-350R and TLS-450) | 35 |
| Figure 17. | Example CAB Connections In Wayne Nucleus Data Box (TLS-350R Only) | 36 |
| Figure 18. | MicroMax POS W/Allied Station Site Controller Box Current Loop Interface | 37 |
| Figure 19. | MicroMax POS with Allied Protocol Box Current Loop Interface | 38 |
| Figure 20. | Pro Series Or MicroMax POS With SAM Or XPIC Controller Box And RS-232 CAB Interface | 38 |
| Figure 21. | MicroMax POS with Tokheim DCHC Controller Box and RS-232 CAB Interface | 39 |
| Figure 22. | Verifone With SAM And RS-232 CAB Interface | 39 |
| Figure 23. | Gasboy Console Loop Connection | 41 |
| Figure 24. | Wiring Diagram Of TLS-350 MDIM Using Two 1871/7697 Series Pulse Transmitters And Required Barriers | 43 |
| Figure 25. | Wiring Diagram Of TLS-450/TLS-450PLUS MDIM Using Two 1871/7697 Series Pulse Transmitters & Required Barriers..... | 44 |
| Figure 26. | Mechanical Dispenser Applications Using 7874 Series Pulser/Totalizer | 45 |
| Figure 27. | TLS-350 Meter Stand Application Using 1871/7697 Series Pulser/Totalizer | 46 |
| Figure 28. | TLS-450/TLS-450PLUS Meter Stand Application Using 1871/7697 Series Pulser/Totalizer | 47 |
| Figure 29. | TLS-350 LVDIM Installation With PetroVend System 2 Site Controller | 48 |
| Figure 30. | TLS-450/TLS-450PLUS LVDIM Installation With PetroVend System 2 Site Controller | 49 |
| Figure 31. | TLS-350 LVDIM Installation Kraus Micon 200 Series Electronic Dispensers (Not UL Approved) | 50 |
| Figure 32. | TLS-450/TLS-450PLUS LVDIM Installation Kraus Micon 200 Series Electronic Dispensers (Not UL Approved) | 51 |
| Figure 33. | LVDIM Installation With GasBoy 9800 Or Tokheim 2600 Series Electronic Dispenser Head | 52 |
| Figure 34. | TLS-450/TLS-450PLUS LVDIM Installation With GasBoy 9800 Or Tokheim 2600 Series Electronic Dispenser Head | 53 |

Tables

| | | |
|-----------|---|----|
| Table 1. | Supported POS Systems | 3 |
| Table 2.- | Dispenser DIM and Installation Kits | 7 |
| Table 3. | POS Systems Supporting BIR Protocol DIM | 42 |

Introduction

This guide provides assistance in selecting Dispenser Interface Modules (DIMs) that enable a properly fitted TLS Console to interface supported Point-of-Sale (POS) devices and provide enhanced product inventory and/or product vapor recovery monitoring. Veeder-Root offers two console upgrades that interface with POS devices:

Business Inventory Reconciliation (BIR)

Business Inventory Reconciliation is a console option that automatically collects dispensing data, in-tank inventories and deliveries, and reconciles the totals at the end of each shift, day, and month. When used with AccuChart™, an automatic tank calibration feature, BIR enhances reconciliation accuracy by comparing the tank's metered sales data to the tank's probe data.

IN-STATION DIAGNOSTICS (ISD) - TLS-350R CONSOLES ONLY

In-Station Diagnostics (ISD) is an option that enables the TLS-350R Console to continuously monitor the vapor recovery equipment and Enhanced Vapor Recovery (EVR) systems at gasoline dispensing facilities, maintain test records, provide test reports, and generate warnings or alarms following equipment failures.

TLS-350R BIR and ISD Capabilities

TLS-350R WITH BIR ONLY AND TLS-350R WITH BIR AND ISD

- Support up to 36 fueling positions
- Support up to 6 meters (hoses) per fueling position
- Support manifolded tanks
- Support blending dispensers that separately meter each product prior to blending. Gilbarco, Tokheim, and Wayne electronic blending dispensers are supported.
- Do not support dispensers that blend fuel prior to the metering process. Schlumberger electronic blending dispensers, and mechanical dispensers fitted with fixed-ratio ratios are not supported.

TLS-350R WITH ISD ONLY

- Supports up to 36 fueling positions
- Supports up to 6 meters (hoses) per fueling position
- Supports manifolded tanks
- Supports all blending dispensers in this guide, including those in this guide labeled as not to be used with BIR.
- Must monitor all petrol fueling positions.
- Does not monitor diesel fueling positions.

MANIFOLDED TANK APPLICATIONS FOR BIR

The TLS-350R can perform automatic BIR on tanks in a siphon-manifolded set. However, to perform AccuChart, the following requirements must be met:

1. Maximum of 2 tanks in a set.
2. Maximum of 4 sets of siphon-manifolded tanks.
3. The combined tank capacity of a set shall not exceed 30,000 gallons.
4. The diameters of the tanks in a set shall not differ by more than 6 inches.
5. The manifolding method must be siphon, not line, manifolding.

Reconciliation reports will be generated for the manifolded set as a single product. Individual adjusted delivery reports will be provided followed by an adjusted manifolded delivery report.

Both Version 310 software (or later), and a Memory Expansion Module are required to perform BIR for manifolded tanks.

TLS-350R System Requirements for BIR and ISD

BUSINESS INVENTORY RECONCILIATION

- TLS-350R with BIR option
- A Mag 1 (0.1 gph) magnetostrictive (standard or Mag Plus) probe is required for each tank that will be monitored and reconciled. The Mag 1 probe for alternative fuels is also supported.
- ECPU board with the following software versions;
 - w/106 [or later] software for BIR,
 - w/311 [or later] software and a Memory Expansion Module for BIR with manifolded tanks, or
 - w/116 or 316 [or later] software for BIR with variance analysis
- Dispenser Interface Module
For electronic dispensers, one DIM is required for each TLS-350R. Up to 3 DIMs can be installed to support sites with multiple POS systems. For mechanical dispensers, the TLS-350R can support up to 8 mechanical DIMs. Each mechanical DIM supports up to 4 mechanical dispensers.

One installation kit may be required for each DIM (ref. Table , “,” on page 7). The installation kits vary for each DIM and include all required adapter boxes and cables.

IN-STATION DIAGNOSTICS

- TLS-350R with ISD option
- ECPU2 board with 325 or later software and a NVMEM203 board.
- A Mag 1 (0.1 gph) magnetostrictive (standard or Mag Plus) probe is required for each gasoline tank. The Mag 1 probe for alternative fuels is also supported.
- Dispenser Interface Module - For electronic dispensers, one DIM is required for each TLS-350R. Up to 3 DIMs can be installed to support sites with multiple POS systems. For mechanical dispensers, the TLS-350R can support up to 8 mechanical DIMs. Each mechanical DIM supports up to 4 mechanical dispensers.
- DIM installation kit - One installation kit may be required for each DIM (ref. Table , “,” on page 7). The installation kits vary for each DIM and include all required adapter boxes and cables.
- Additional ISD monitoring equipment as defined by the site’s requirements, e.g., dispenser mounted Air Flow Meters and Pressure Sensor, console Smart Sensor Modules, etc. - refer to appropriate ISD Installation Manual for specifics.

TLS-450/TLS-450PLUS BIR Capabilities

- Support for up to 72 fueling positions
- Support for up to 6 meters (hoses) per fueling position
- Support for manifolded tanks
- Support for blending dispensers that separately meter each product prior to blending. Gilbarco, Tokheim, and Wayne electronic blending dispensers are supported. Dispensers that blend fuel prior to the metering process,

such as Schlumberger electronic blending dispensers and mechanical dispensers fitted with fixed-ratio blenders are not supported.

MANIFOLDED TANK APPLICATIONS

- Maximum number of tanks in a set: unlimited
- Maximum number of siphon manifold tanks: number of tanks divided by 2. Limit: 8
- Manifolded set tank capacity: unlimited
- No requirements on diameter differences, no 6 inch limit.

Reconciliation reports will be generated for the manifolded set as a single product. Individual adjusted delivery reports will be provided followed by an adjusted manifolded delivery report.

TLS-450/TLS-450PLUS SYSTEM REQUIREMENTS FOR BIR

The following components are required to perform BIR:

- TLS-450/TLS-450PLUS with BIR option
- Version 2.X or higher software (TLS-450), Version 6.X or higher software (TLS-450PLUS)
- Mag 1 (0.1 gph) magnetostrictive (standard or Mag Plus) probe in each tank. The Mag 1 probe for alternative fuels is also supported.
- A Dispenser Interface Module (DIM) - The DIM allows the TLS-450 to interface to most Gilbarco, Wayne, and 3rd Party POS systems that implement the VR BIR Protocol (ALLIED ANDI, EXCENTUS, BENNETT). For electronic dispensers, one DIM is required for each TLS-450. Up to 3 DIMs can be installed to support sites with multiple POS systems.
- DIM installation kit - One installation kit may be required for each DIM (ref. Table , “,” on page 7). The installation kits vary for each DIM and include all required adapter boxes and cables.

Supported POS Systems

The TLS-350R, TLS-450 and TLS-450PLUS consoles can interface to many POS terminals as well as the Veeder-Root mechanical dispenser (TLS-350R only). This guide provides specific information on each application. The supported POS systems are shown in Table 1.

Table 1. Supported POS Systems

| Manufacturer | POS/Dispensing System | TLS-350R | TLS-450 | TLS-450PLUS |
|--------------|--|----------|---------|-------------|
| Gilbarco | TCRG, TCRG2, T-11, T-12, TS-1000, PAM, G-Site, Passport, Storemaster, SmartCrind, ANDI, CFN2, Excentus | X | X | X |
| Tokheim | MEMS IV, MEMS V, Vision 100/200, DHC with all other POS, CFN2, ANDI, Columbus, Schlumberger MicroMax XPIC/DHC, 67/A - 98, 67/B | X | | |
| Wayne | Wayne Site Controller, Excentus, ANDI | X | X | X |
| | IDPOS | X | X | X |
| Schlumberger | MicroMax/Pro series, MicroMax/Allied, SAM/XPIC, ANDI | X | | |
| GasBoy | CFN2 & ProfitPoint, CFN1, ANDI | X | | |

Table 1. Supported POS Systems (Continued)

| Manufacturer | POS/Dispensing System | TLS-350R | TLS-450 | TLS-450PLUS |
|---|-----------------------|----------|---------|-------------|
| Bennett | 92D | X | | |
| Mechanical, Mechanical noncomp, or Mechanical V-R meter | CFN2, Petrovend, ANDI | X | X | X |

OTHER APPLICATIONS

Many POS / dispenser systems are similar to those identified in this guide. Veeder-Root is constantly evaluating and supporting new applications. If your application is not listed in this guide, contact your Veeder-Root Sales Representative.

DIM Descriptions

Mechanical Dispenser Interface Module (MDIM) & Low Voltage Dispenser Interface Module (LVDIM)

- The mechanical dispenser interface modules enable the TLS console to monitor either high voltage (MDIM), or low voltage (LVDIM) volume pulses and calculate dispensed volume.
- MDIM and LVDIM terminal connections are on the front of the modules's bracket.

Electronic Dispenser Interface Module (EDIM)

- Installs in a communication slot of TLS-350R or TLS-450/TLS-450PLUS. EDIMs are used to communicate via RS-232 to point of sale or system controllers.
- More than one EDIM can be installed in any combination with other DIM types.
- EDIMs have one 25-pin D connector (TLS-350R), or one 9-pin D connector (TLS-450/TLS-450PLUS) outside of the port.
- TLS-350R EDIMs only - when onboard red LED is turned On, EDIM is transmitting to external device; when onboard green LED is turned On, external device is transmitting to EDIM.
- TLS-450 and TLS-450PLUS hardware is standard equipment.
- TLS-450 requires BIR to activate DIM.

Current Loop Dispenser Interface Module (CDIM)

- TLS-350R console - Installs in comm slots 1, 2, or 3; TLS-450 console - installs in comm slots 1, 2, or 4 (preferred); TLS-450PLUS console - installs in comm slots 1 or 2. Factory installed in TLS4 console.
- TLS-450 and TLS-450PLUS require module kit P/N 330020-665.
- Various CDIM monitoring applications include current loop, RS-232, and RS-422.
- More than one CDIM can be installed in combination with other DIM types.
- CDIMs have three RJ-45 modular connectors (TLS-350R) or 2 to 3 RJ-45 modular connectors (TLS-450/TLS-450PLUS).
- CDIMs cannot transmit to external device.
- Connects via 4-wire cable to cable adapter box. Adapter box converts target communication format to RS-422 format for CDIM. Adapter boxes are configured with 2-wire flying leads, 25-pin D or 9-Pin D, T-cable connectors for various applications.
- TLS-450 requires BIR to activate DIM.

LAN Dispenser Interface Module (LDIM) - TLS-350R only

- Installs in a communication port of TLS-350R to communicate with or monitor POSs, dispensers or system controllers using RS-485 communication standard.
- An LDIM can be installed in combination with other DIM types.
- LDIMs have a 5-wire phoenix connector.
- Red and green LEDs are on this board. When red LED is turned On, LDIM is transmitting to external device; when green LED is turned On, external device is transmitting to LDIM.
- Can be used in 4-wire or 2-wire, RS-485 and RS-422 applications.
 - DIP switch default in OPEN position, loopback jumper on LED side for RUN mode
 - R1 - 331076-001 - RS-485 two wire

- R2 - 331076-002 - RS-422 four wire
- R3 - 331076-003 - DIM RS-485 two wire (install in TLS-350R only)
- R4 - 331076-004 - DIM RS-422 four wire (install in TLS-350R only)

International Forecourt Standards Forum Dispenser Interface Module (IFSF) - TLS-350R, TLS-450PLUS

- Required for TLS consoles that are connected to IFSF networks.
- Uses Echelon 2-wire FTT10-A medium, as defined by the IFSF standards.
- There are 3 LEDs on this board:
 - Green LED On when IFSF board is transmitting information to the TLS.
 - Red LED On when TLS is transmitting information to the IFSF board.
 - Amber LED Off indicates normal state of the IFSF board processor.
- There are no LED indicators for network communication.

TCP/IP DIM Module (TDIM) - TLS-350R

- Installs in a communication port of the TLS-350R to communicate with or monitor the Wayne IDPOS dispenser.
- Minimum system requirements for TDIM Module operation:
 - Console system software: Version 15 or higher - Version 21 or higher is recommended
 - Network connection to a PC requires a hub. Connecting to a hub requires a straight CAT 5 cable
 - Direct connection to a PC requires an Ethernet crossover cable
 - Connection to a LAN or WAN
- There are 2 LEDs on the PC board of this module:
 - Green LED indicates that the TDIM module is transmitting information to the TLS.
 - Red LED indicates the TLS is transmitting information to the TDIM module.
- There is no communication alarm for this module.

TCP/IP DIM (TDIM) - TLS-450/TLS-450PLUS

- Installs in a communication port of the TLS-450/TLS-450PLUS to communicate with or monitor the Wayne IDPOS dispenser.
- Minimum system requirements for TDIM module operation:
 - Console system software: Version 4H or higher
 - Network connection to a PC requires a hub. Connecting to a hub requires a straight CAT 5 cable
 - Direct connection to a PC requires an Ethernet crossover cable
 - Connection to a LAN or WAN
- There is no communication alarm for this module.
- TLS-450 and TLS-450PLUS hardware is standard equipment.
- TLS-450 requires BIR to activate DIM.

DIM And Installation Kit Ordering Guide

Table 2.- Dispenser DIM and Installation Kits

| Dispenser | Dispenser Controller/ POS Type | TLS-350R DIM P/N w/Console | TLS-450 DIM P/N w/Console | TLS-450PLUS DIM P/N w/Console | DIM Install Kit P/N | Console Compati- bility | | | Notes |
|-----------|---|----------------------------------|---------------------------------|-------------------------------------|------------------------|-------------------------------|---------|-------------|---|
| | | | | | | TLS-350R | TLS-450 | TLS-450PLUS | |
| Bennett | 92D | 330404-040 | None | | 848705-XXX | Y | N | N | For Bennett 92D controllers. DIM kit has 2 CABs in it. One CAB is needed per current loop. Only one or two dispensers are on one current loop. |
| Gasboy | CFN2 & Profit Point | 331001-003 | None | | 331088-XXX | Y | N | N | A Gasboy site controller version 2.0 or later is required. A Gasboy junction box Gasboy part # C05020 should be ordered for installation. No Blending. Network POS Required. |
| | ANDI, ALLIED ANDI, ALLIED NEXTGEN | 330280-001 | Standard In Gauge | | None required | Y | Y | Y | Allied ANDI. Gilbarco dispenser with T-14 (Australia). PEC with 8850. POSTEC with RCC. Wayne with Marketer 2000 (Sweden). |
| | CFN1 | 331001-002 | None | | 331088-XXX | Y | N | N | This is a TLS-350 RS-422 interface to the Network. NOT to be used for BIR or ISD applications. |
| | Radiant | 330280-001 | Standard In Gauge | | None required | Y | Y | Y | Radiant Systems Series P1550 set-up on the TLS must have a DIM string programmed in. The DIM string is B9DNHG and needs to be programmed in DIM Diagnostics. You will need to use a twisted pair RJ-11 cable to the port on the POS with the pin outs of 2,3,7. |

Table 2.- Dispenser DIM and Installation Kits

| Dispenser | Dispenser Controller/ POS Type | TLS-350R DIM P/N w/Console | TLS-450 DIM P/N w/Console | TLS-450PLUS DIM P/N w/Console | DIM Install Kit P/N | Console Compatibility | | | Notes |
|-----------|--------------------------------|----------------------------|---------------------------|-------------------------------|---------------------|-----------------------|---------|-------------|--|
| | | | | | | TLS-350R | TLS-450 | TLS-450PLUS | |
| Gilbarco | TCRG | 330404-020 | 330020-665 | | 848702-XXX | Y | Y | Y | Model TCRG PA0180-121 |
| | TCRG2 | | | | | Y | Y | Y | Model TCRG2 PA0180-121 |
| | T-11 | | | | | Y | Y | Y | Model T-11 PA0132-XXXX and PA0141-XXXX |
| | T-12 | | | | | Y | Y | Y | Model T-12 PA0188-XXXX |
| | Excentus | | | | | Y | Y | Y | Excentus Dispenser Tank Monitor Interface Kit (Excentus P/N 080-Veeder Root Kit) is required. |
| | TS-1000 | 330404-020 | 330020-665 | | 848722-XXX | Y | Y | Y | One kit is needed per dispenser current loop. For controller with a RS-485 Distribution Box, use kit P/N 848741-XXX. |
| | PAM | | | | | Y | Y | Y | |
| | G-Site | 330280-401 | Standard In Gauge | | 331063-XXX | Y | Y | Y | To support this DIM and the TLS-350R, the G-site must be upgraded to include the EMC interface. Uses Controller types C2, C15, 486 and Pentium Site controllers. |
| | Passport, Passport/EDH | | | | | Y | Y | Y | Verify BIR protocol is in version of Passport software used at customer's site. |
| | Storemaster | 330404-020 | 330020-665 | | 848741-XXX | Y | Y | Y | One Gilbarco Dispenser Distribution Box PA0133000 should be available. Up to 12 Highliner/MPD Fueling positions are supported. An Autogas Storemaster POS and Autogas 507 controller are required. |

Table 2.- Dispenser DIM and Installation Kits

| Dispenser | Dispenser Controller/ POS Type | TLS-350R DIM P/N w/Console | TLS-450 DIM P/N w/Console | TLS-450PLUS DIM P/N w/Console | DIM Install Kit P/N | Console Compatibility | | | Notes |
|--------------------|-----------------------------------|----------------------------|---------------------------|-------------------------------|---------------------|-----------------------|---------|--|---|
| | | | | | | TLS-350R | TLS-450 | TLS-450PLUS | |
| Gilbarco (Cont'd.) | Smart-Crind | 330020-538 | Standard In Gauge | | None required | Y | Y | Y | TCPIP Interface for Gilbarco SmartCrind dispensers only. Wal-Mart is currently the only customer ordering this interface for this dispenser. |
| | ANDI, ALLIED ANDI, ALLIED NEXTGEN | 330280-001 | | | None required | Y | Y | Y | Allied ANDI. Gilbarco dispensers with T-14 (Australia). PEC with 8850. POSTEC with RCC. Wayne with Marketer 2000 (Sweden) |
| | CFN2 | 331001-003 | None | 331088-XXX | Y | N | N | A Gasboy site controller version 2.0 or later is required. A Gasboy junction box Gasboy part # C05020 should be ordered for installation. Single product dispensers only. No Blending. | |
| | Wayne Nucleus | 330404-200 | 330020-665 | 848722-XXX | Y | Y | Y | Wayne Nucleus POS with Gilbarco Dispensers. | |
| | Radiant | 330280-001 | Standard In Gauge | | None | Y | Y | Y | Radiant Systems Series P1550 set-up on the TLS must have a DIM string programmed in. The DIM string is B9DNHG and needs to be programmed in DIM Diagnostics. You will need to use a twisted pair RJ-11 cable to the port on the POS with the pin outs of 2,3,7. |
| | Verifone Commander | 330280-001 | | | None | Y | Y | Y | Requires Verifone 13652-01 Connector(450) or Verifone 13581-01 Connector (350) & V/R 331134-xxx cable. |
| | Wayne Fusion | 330280-001 | None | None | None | Y | N | N | |

Table 2.- Dispenser DIM and Installation Kits

| Dispenser | Dispenser Controller/ POS Type | TLS-350R DIM P/N w/Console | TLS-450 DIM P/N w/Console | TLS-450PLUS DIM P/N w/Console | DIM Install Kit P/N | Console Compati- bility | | | Notes |
|---|-----------------------------------|----------------------------------|---------------------------------|-------------------------------------|------------------------|-------------------------------|---------|-------------|--|
| | | | | | | TLS-350R | TLS-450 | TLS-450PLUS | |
| Mechanical | CFN2 | 331001-003 | None | | 331088-XXX | Y | Y | Y | A Gasboy site controller version 2.0 or later is required. A Gasboy junction box Gasboy part # C05020 should be ordered for installation. Single product dispensers only. No Blending. Network POS required. |
| Mechanical Mechanical non-comp, or Mechanical V-R meter | Petrovend | 331214-001 | 330020-800 | | None | Y | Y | Y | One or more pulser/totalizer kits are needed PN 787491-003. Each mech DIM supports up to 4 mech dispensers. Up to 8 may be installed in the high power compartment of the TLS-350R. Other modules installed will reduce the number of slots available. |

Table 2.- Dispenser DIM and Installation Kits

| Dispenser | Dispenser Controller/ POS Type | TLS-350R DIM P/N w/Console | TLS-450 DIM P/N w/Console | TLS-450PLUS DIM P/N w/Console | DIM Install Kit P/N | Console Compati- bility | | | Notes |
|------------|-----------------------------------|----------------------------------|---------------------------------|-------------------------------------|------------------------|-------------------------------|---------|-------------|---|
| | | | | | | TLS-350R | TLS-450 | TLS-450PLUS | |
| Mechanical | None | 331214-001 | 330020-800 | | None | Y | Y | Y | One or more pulser/ totalizer kits are needed PN 787491- 003. Each mech DIM supports up to 4 mech dispensers. Up to 8 may be installed in the high power compart- ment of the TLS-350R. Other modules installed will reduce the number of slots avail- able. |
| | ANDI | 330280-001 | Standard In Gauge | | None | Y | Y | Y | Allied ANDI. Gilbarco dispensers with T-14 (Australia). PEC with 8850.POSTEC with RCC. Wayne with Mar- keter 2000 (Sweden). |
| | Radiant | 330280-001 | Standard In Gauge | | None | Y | Y | Y | Radiant Systems Series P1550 set-up on the TLS must have a DIM string pro- grammed in. The DIM string is B9DNHG and needs to be pro- grammed in DIM Diag- nostics. You will need to use a twisted pair RJ-11 cable to the port on the POS with the pin outs of 2,3,7. |

Table 2.- Dispenser DIM and Installation Kits

| Dispenser | Dispenser Controller/ POS Type | TLS-350R DIM P/N w/Console | TLS-450 DIM P/N w/Console | TLS-450PLUS DIM P/N w/Console | DIM Install Kit P/N | Console Compati- bility | | | Notes |
|-------------------|---|----------------------------------|---------------------------------|-------------------------------------|------------------------|-------------------------------|---------|-------------|---|
| | | | | | | TLS-350R | TLS-450 | TLS-450PLUS | |
| Schlum- berger | ANDI, ALLIED ANDI, ALLIED NEXTGEN | 330280-001 | Standard In Gauge | | None | Y | Y | Y | Allied ANDI. Gilbarco with T-14 (Australia). PEC with 8850. POS-TEC with RCC. Wayne with Marketer 2000 (Sweden). |
| | Radiant | 330280-001 | Standard In Gauge | | None | Y | Y | Y | Radiant Systems Series P1550 set-up on the TLS must have a DIM string programmed in. The DIM string is B9DNHG and needs to be programmed in DIM Diagnostics. You will need to use a twisted pair RJ-11 cable to the port on the POS with the pin outs of 2,3,7. |

Table 2.- Dispenser DIM and Installation Kits

| Dispenser | Dispenser Controller/ POS Type | TLS-350R DIM P/N w/Console | TLS-450 DIM P/N w/Console | TLS-450PLUS DIM P/N w/Console | DIM Install Kit P/N | Console Compati- bility | | | Notes |
|-----------|--|----------------------------------|---------------------------------|-------------------------------------|------------------------|-------------------------------|---------|---|--|
| | | | | | | TLS-350R | TLS-450 | TLS-450PLUS | |
| Tokheim | MEMS IV, MEMS V, Vision 100/ 200, DHC with all other POS | 330280-201 | None | | 331390-XXX | Y | N | N | Use 331354-001 for 67A/B or 98 instead. This DIM is being phased out. A Tokheim Dedicated Hose Controller (DHC) is required, and should have software version 5.6 dated 11/89 or later. |
| | CFN2 | 331001-003 | None | | 331088-XXX | Y | N | N | A Gasboy site controller version 2.0 or later is required. A Gasboy junction box Gasboy part # C05020 should be ordered for installation. Single product dispensers only. No Blending ¹ |
| | ANDI, ALLIED ANDI, ALLIED NEXTGEN | 330280-001 | Standard In Gauge | | None | Y | Y | Y | Allied ANDI. Gilbarco dispenser with T-14 (Australia). PEC with 8850. POSTEC with RCC. Wayne with Marketer 2000 (Sweden). |
| | 67/A - 98 | 331354-001 | None | | 331391-XXX | Y | N | N | Tokheim controller only. |
| | 67/B | | | | 848744-XXX | | | | |
| | Columbus | 330280-001 | Standard in Gauge | | None | Y | Y | Y | For Rockport cable kits order Quantity (2) 320449-18 from Tokheim. For Digi/Star-gate order Quantity (2) 320449-9 Cable kits from Tokheim. |
| Radiant | 330280-001 | Standard in Gauge | | None | Y | Y | Y | Radiant Systems Series P1550 set-up on the TLS must have a DIM string programmed in. The DIM string is B9DNHG and needs to be programmed in DIM Diagnostics. You will need to use a twisted pair RJ-11 cable to the port on the POS with the pin outs of 2,3,7. | |

Table 2.- Dispenser DIM and Installation Kits

| Dispenser | Dispenser Controller/ POS Type | TLS-350R DIM P/N w/Console | TLS-450 DIM P/N w/Console | TLS-450PLUS DIM P/N w/Console | DIM Install Kit P/N | Console Compatibility | | | Notes |
|-----------|-----------------------------------|----------------------------|---------------------------|-------------------------------|---------------------|-----------------------|---------|-------------|---|
| | | | | | | TLS-350R | TLS-450 | TLS-450PLUS | |
| Wayne | Wayne Site Controller | 330404-010 | 330020-665 | | 848703-XXX | Y | Y | Y | A Wayne site controller and Wayne dispensers are required. Any POS may be connected to the Wayne site controller. |
| | ANDI, ALLIED ANDI, ALLIED NEXTGEN | 330280-001 | Standard in Gauge | | None | Y | Y | Y | Allied ANDI. Gilbarco dispenser with T-14 (Australia). PEC with 8850. POSTEC with RCC. Wayne with Marketer 2000 (Sweden). |
| | Excentus | 330404-010 | 330020-665 | | 848702-XXX | Y | Y | Y | Excentus Dispenser Tank Monitor Interface Kit (Excentus P/N 080-Veeder Root Kit) is required. |
| | IDPOS | 330020-501 | Standard in Gauge | | None | Y | Y | Y | TCPIP interface for Wayne IDPOS dispensers only |
| | Radiant | 330280-001 | Standard in Gauge | | None | Y | Y | Y | Radiant Systems Series P1550 set-up on the TLS must have a DIM string programmed in. The DIM string is B9DNHG and needs to be programmed in DIM Diagnostics. You will need to use a twisted pair RJ-11 cable to the port on the POS with the pin outs of 2,3,7. |
| | Verifone Commander | 330280-001 | None | | None | Y | N | N | |
| | Wayne Fusion | 330280-001 | None | | None | Y | N | N | |

¹This restriction does not apply to ISD only installations.

DIM Installation Examples

Various example DIM installation diagrams are shown in Figure 1 below for reference only. For specific DIM installation details, refer to the appropriate Veeder-Root DIM installation manual.

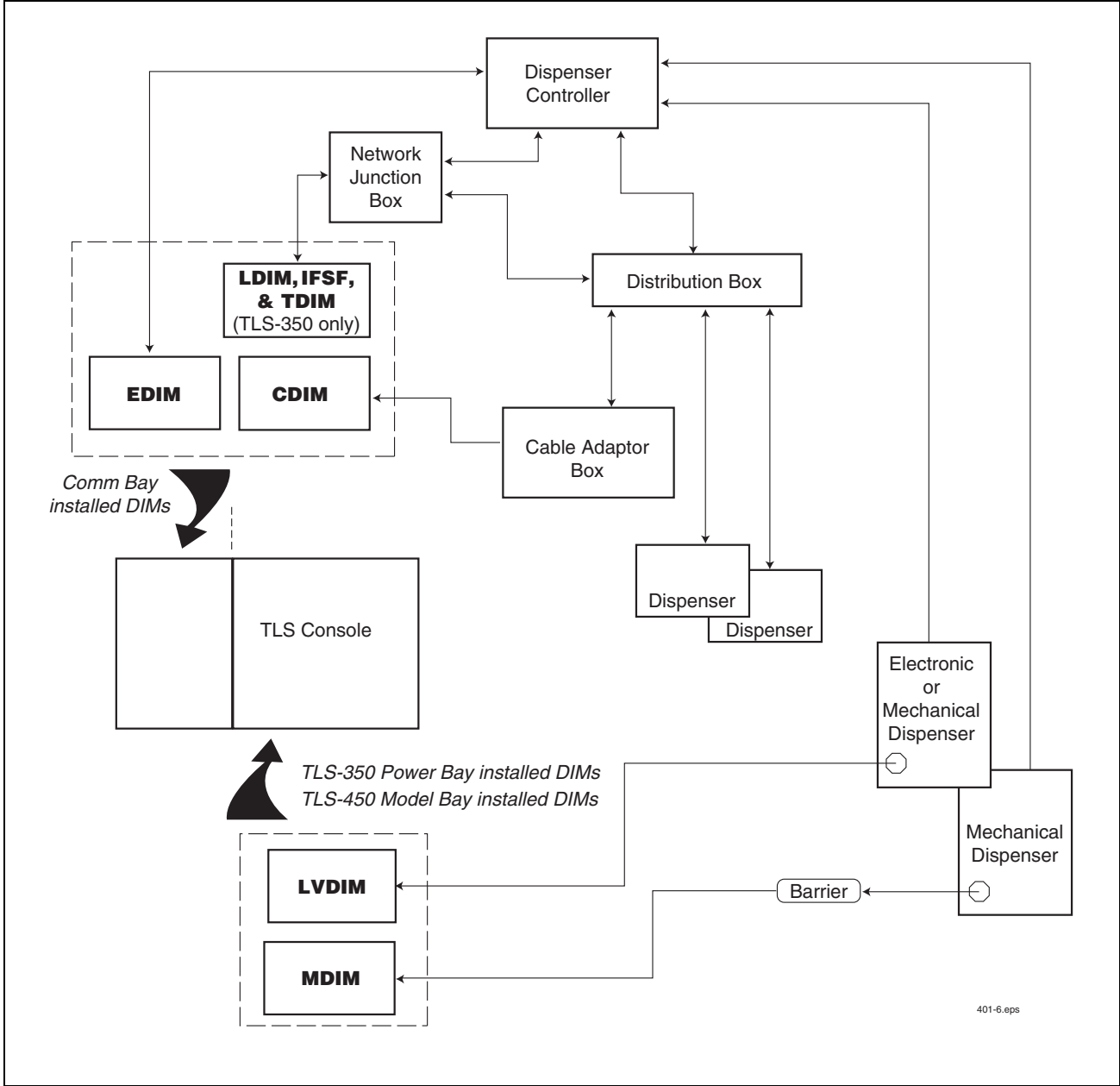

Figure 1. Simplified DIM Connections To Various Dispensing Systems

Bennett POS System

The information collected via the interface allows TLS-350R business inventory reconciliation to compare tank totals to fuel transactions for end of day, end of shift, or end of month, running variances.

VEEDER-ROOT SOFTWARE REQUIREMENTS

- System software Version 17 (or higher)
- Peripheral controller software 330269-00B (or later)
- DIM software 349780-001A (or later)

VEEDER-ROOT HARDWARE REQUIREMENTS (REF. TABLE 2)

The following equipment is required to interface the TLS to the Bennett POS system:

- One Bennett Current Loop Dispenser Interface Module for up to 6 fueling positions
- One installation kit (for every 2 current loops (up to 12 fueling positions))

BENNETT SYSTEM LIMITATIONS

TLS-350R with BIR and TLS-350R with BIR and ISD

- Only non-blending, type 92D dispensers with Orpak controllers are supported.

TLS-350R with ISD

- All type 92D dispensers with Orpak controllers are supported.

INSTALLATION NOTES

The interface to Bennett dispensing equipment requires one CAB per dispenser current loop (for up to 6 fueling positions) and one Bennett DIM installation kit for every 2 current loops. Typically one or two loops are required for a single dispenser having two fueling positions. For this reason the interface kit includes two CABs with supportive cabling. Supportive cabling required is sold in lengths, which are identified in the last three digits of the kit form number. The length requirement is determined by the distance between the components.

Figure 2 is an example Bennett dispenser connection diagram. Each CAB has a three position input and a RJ-45 cable output to a dispenser loop. Use the "PUMP COMM" input side and the RJ-45 cable output.

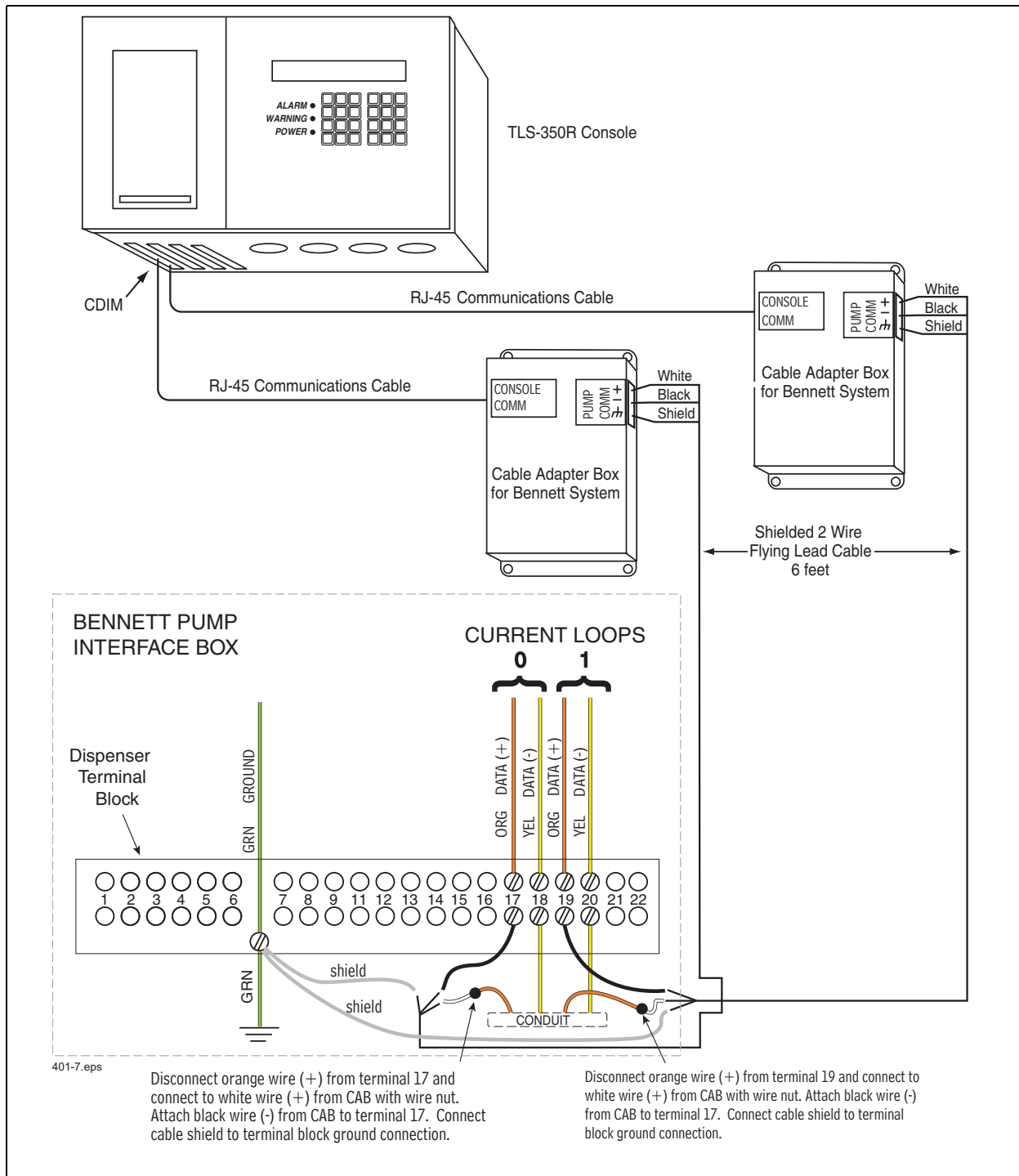

Figure 2. Bennett Pump Fuelomat Dispenser Interface Installation Diagram

Gilbarco TCRG, TCRG2, T-11, and T-12 POS Systems

TLS CONSOLE SOFTWARE REQUIREMENTS

TLS-350R with BIR Software Requirements

- System software Version 17 (or higher)
- Peripheral controller software 002B (or later)
- DIM software 349634-003C (or later)

TLS-450/TLS-450PLUS with BIR Software Requirements

- TLS-450 System software Version 2.x (or higher)
- TLS-450PLUS System software Version 6.x (or higher)
- BIR option required (TLS-450)

VEEDER-ROOT HARDWARE REQUIREMENTS (REF. TABLE 2)

The following equipment is required to interface the TLS to the Transac POS:

- One Gilbarco Current Loop Dispenser Interface Module for up to 3 current loops
- One Gilbarco dispenser distribution box PA0133000
- One Gilbarco Transac DIM installation kit required per current loop. Up to 16 fueling positions are supported per current loop.

The following POS consoles are supported:

- Transac-1e1 (PA0132, PA0141)
- Transac-12 (PA0134, PA0142)
- Transac-12A (PA0151, PA0152)
- Transac-12B (PA0173)
- Transac-12C (PA0188)
- Transac-12G (PA0203)
- TCRG (PA0180-121)
- TCRG2 (PA0180-121)
- Excentus Reward Fuel Controller™, Gilbarco Dispenser Interface, V1.0.160

SPECIFIC LIMITATIONS

Only Gilbarco electronic dispensers are supported. Also, dispensers that feature a blender and a single-product dispenser at one fueling position are not supported.

In-Dispenser credit card readers (CRINDS) or G-Site systems are not supported by the Gilbarco CDIM.

Other POS systems that use Gilbarco dispensers and the Gilbarco Pump Access Module (PAM) may also be supported - contact Veeder-Root for assistance.

Special Note on T-11/T-12 Pre-Pay Applications

In T-11/T-12 Pre-Pay applications, cashiers should be urged to close out each transaction promptly. Failure to close-out promptly can cause the TLS-350R to delay reconciliation reports, and impact the system's ability to maximize tank calibration.

WIRING DIAGRAM FOR A TRANSAC CURRENT LOOP INTERFACE

A PA0133 distribution box is shown in Figure 3 below. Other box models are slightly different.

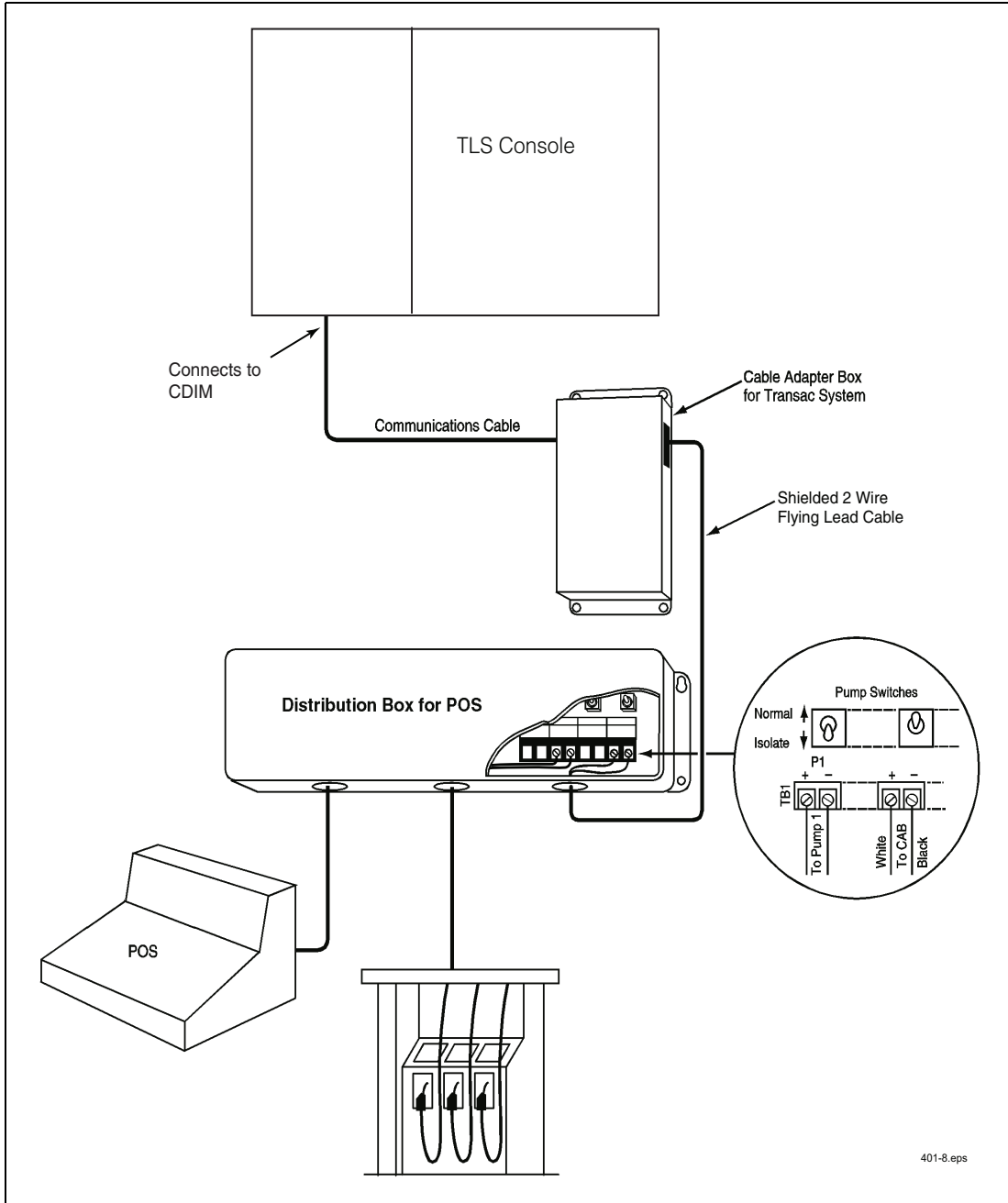

Figure 3. Transac Series Current Loop Interface

WIRING DIAGRAM FOR AN EXCENTUS CURRENT LOOP INTERFACE

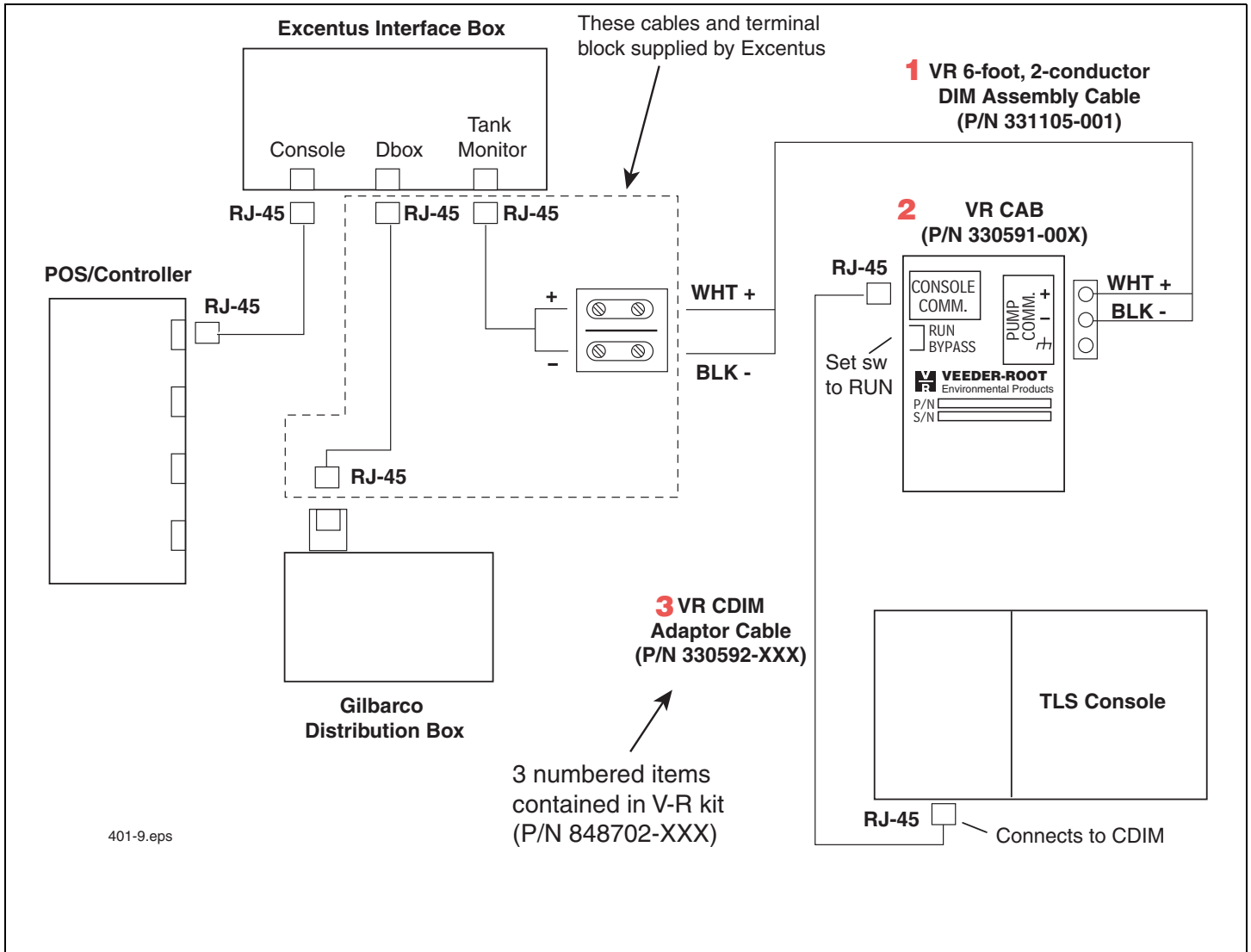

Figure 4. Excentus Current Loop Interface

Gilbarco TS-1000 POS and PAM Systems

The Veeder-Root Gilbarco TS-1000 DIM and DIM installation kit supports the Gilbarco TS-1000 and any POS system using the Gilbarco PAM (Pump Access Module) dispenser controller and Gilbarco dispensers.

TLS CONSOLE SOFTWARE REQUIREMENTS

TLS-350R with BIR Software Requirements

- System software Version 17 (or higher)
- DIM software 349634-003C (or later)

TLS-450/TLS-450PLUS with BIR Software Requirements

- TLS-450 System software Version 2.x (or higher)
- TLS-450PLUS System software Version 6.x (or higher)
- BIR option required (TLS-450)

VEEDER-ROOT HARDWARE REQUIREMENTS (REF. TABLE 2)

The following equipment is required to interface the TLS to the TS-1000 POS:

- One Gilbarco Current Loop Dispenser Interface Module for up to 3 current loops
- One installation kit for each current loop

GILBARCO POS AND DISPENSING SYSTEM REQUIREMENTS

- Gilbarco dispenser distribution box, PA02420000000
- Gilbarco dispenser distribution box, PA02610000010
- Gilbarco dispenser distribution box, PA02610000020
- Gilbarco pump controller, model PA02410000000
- Gilbarco Transac System 1000 Console, model PA02400000000
- Gilbarco Transac System 1000 Console, model PA02400001010
- Excentus Reward Fuel Controller™, Gilbarco Dispenser Interface, V1.0.160 (Excentus P/N 080 - Veeder Root Kit) is required.

SPECIFIC LIMITATIONS

- Up to 48 Gilbarco single product or blending dispenser fueling positions are supported. Dispensers that feature a blender and a single-product dispenser at one fueling position are not supported.
- Only Gilbarco dispensers are supported.
- In-dispenser credit card readers in these POS systems are not supported by the Gilbarco Current Loop Dispenser Interface Module.
- The Gilbarco Current Loop Dispenser Interface Module does not support Gilbarco G-Site applications.

WIRING TO A UNIVERSAL DISTRIBUTION BOX INTERFACE

The diagram in Figure 5 is a typical interconnection diagram for a PAM or Transac System 1000 interface (a PA0261 distribution box is shown, the PA0241 is slightly different).

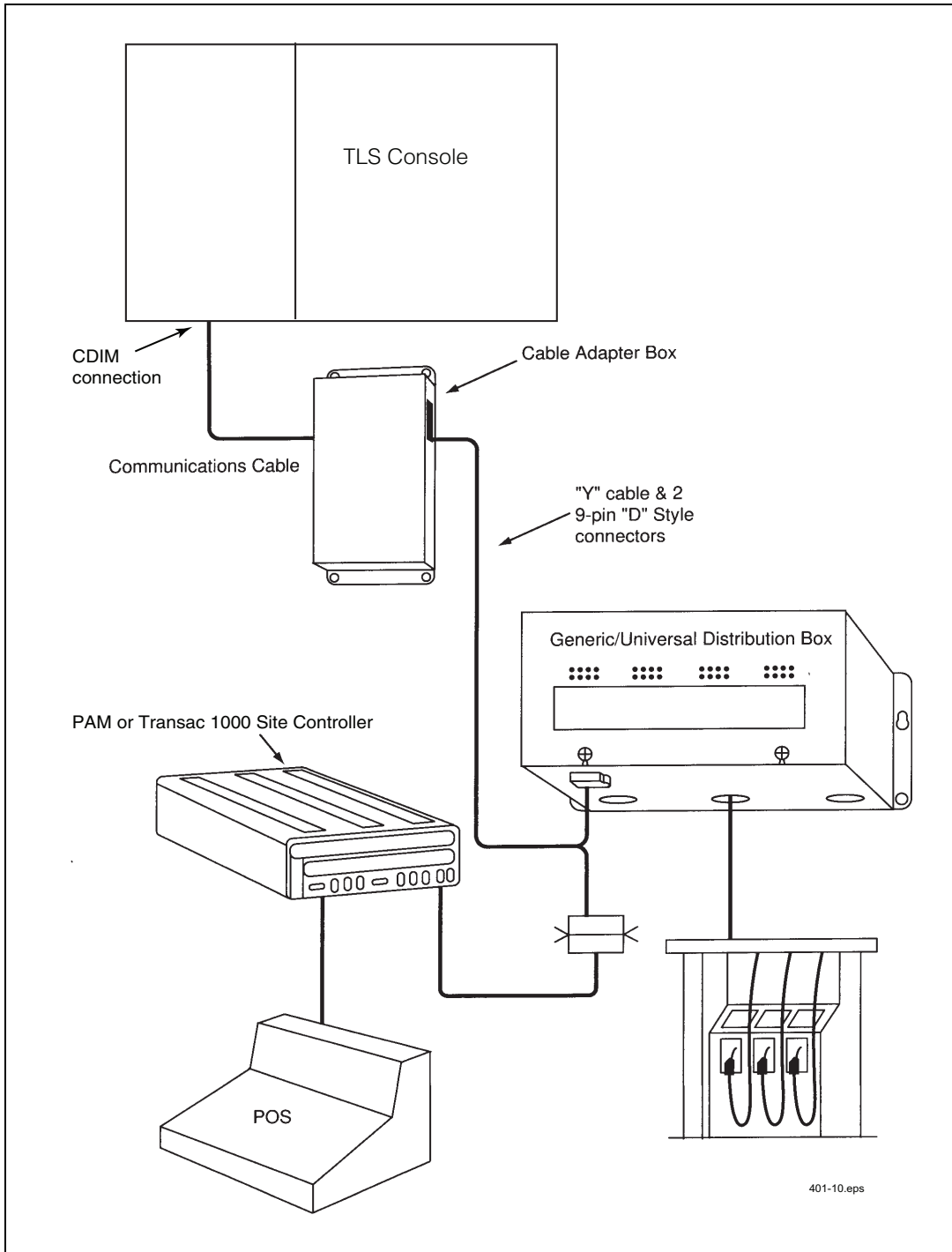

Figure 5. Universal Distribution Box Interface

Gilbarco G-Site™ POS Systems

TLS CONSOLE SOFTWARE REQUIREMENTS

TLS-350R with BIR Software Requirements

- System software Version 17 (or higher)
- DIM software 349634-003C (or later)

TLS-450/TLS-450PLUS with BIR Software Requirements

- TLS-450 System software Version 2.x (or higher)
- TLS-450PLUS System software Version 6.x (or higher)
- BIR option required (TLS-450)

VEEDER-ROOT HARDWARE REQUIREMENTS (REF. TABLE 2)

The following equipment is required to interface the TLS to the G-Site POS:

- One Gilbarco Interface Module
- One installation kit for each current loop

SPECIFIC LIMITATIONS

Up to 36 Gilbarco Uni-Hose/MPD fueling positions are supported by the TLS-350R, and up to 72 fueling positions are supported by the TLS-450/TLS-450PLUS.

In-dispenser credit card readers (CRINDS) are supported.

To support a DIM and the TLS-350R, the G-Site must be upgraded to include EMC interface capability. This has been released in the following G-Site versions (EMC Interface capability will be released into the Generic G-Site version 6):

- Exxon - version 25.0.243
- Shell - version 33.1.23
- Chevron Canada - version 8.1.10

The 331063-xxx installation kit contains two gender mender adapters. One gender mender is used for PC G-SITE applications while both are used for C-2 G-SITES. The gender mender adapters are not identical. As shown in Figure 6, be sure to use the correct part at the connection points for your particular installation.

WIRING DIAGRAM

G-Site wiring examples are shown in Figure 6 below:

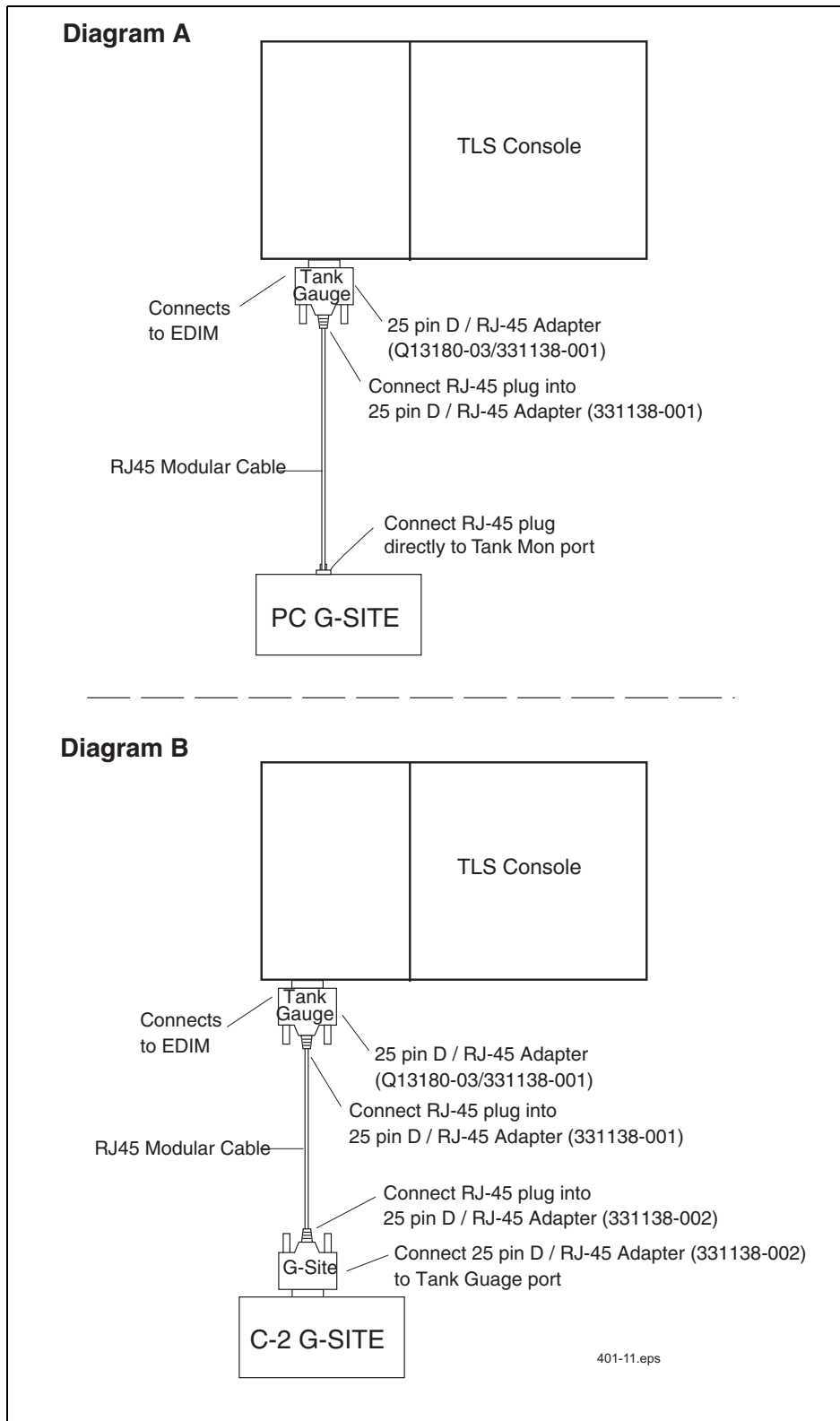

Figure 6. Example G-Site Installations

AutoGas Storemaster and Gilbarco Dispenser Systems

TLS CONSOLE SOFTWARE REQUIREMENTS

TLS-350R with BIR Software Requirements

- System software Version 17 (or higher)
- DIM software 349634-003C (or later)

TLS-450/TLS-450PLUS with BIR Software Requirements

- TLS-450 System software Version 2.x (or higher)
- TLS-450PLUS System software Version 6.x (or higher)
- BIR option required (TLS-450)

VEEDER-ROOT HARDWARE REQUIREMENTS (REF. TABLE 2)

The following equipment is required to interface the TLS to the AutoGas Storemaster system:

- One Gilbarco Interface Module (for up to 3 current loops)
- One installation kit for each current loop other than RS-422/RS-485 OR One Gilbarco installation kit for each RS-422/RS-485 current loop

GILBARCO POS AND DISPENSING SYSTEM REQUIREMENTS

- Gilbarco Dispenser Distribution Box PA-2420000000
- Gilbarco Dispenser Distribution Box PA02610000010
- Gilbarco Dispenser Distribution Box PA02610000020
- Gilbarco Dispenser Distribution Box PA0281XXXXXX0

An AutoGas 507 controller is required with the AutoGas Storemaster POS.

SYSTEM LIMITATIONS

- Up to 36 Gilbarco single product or blending fueling positions are supported.
- Only Gilbarco dispensers are supported.
- The Gilbarco current loop dispenser interface module does not support Gilbarco G-Site applications.

The Cable Adaptor Box install kits are designed to be installed on either a Gilbarco 2-wire distribution box input using 9-pin 'D shell' style connectors or a Gilbarco RS-422/RS-485 input to the distribution box, also using 9-pin 'D shell' style connectors.

To identify the distribution input communication type, refer to the Gilbarco Universal Distribution Box Installation Manual (MDE2713) noting the position choices for jumper 12 and 10 on the Universal Distribution Box Card which is communicating to the PAM, POS, or computer controlling the hydraulic dispenser status. Both of these jumpers should be in the horizontal position. (If vertical, the pump input is RS-422 and that kit should be used [see Table on page 7]).

INSTALLATION NOTES

Example wiring diagrams are shown in Figure 7 to Figure 10 below.

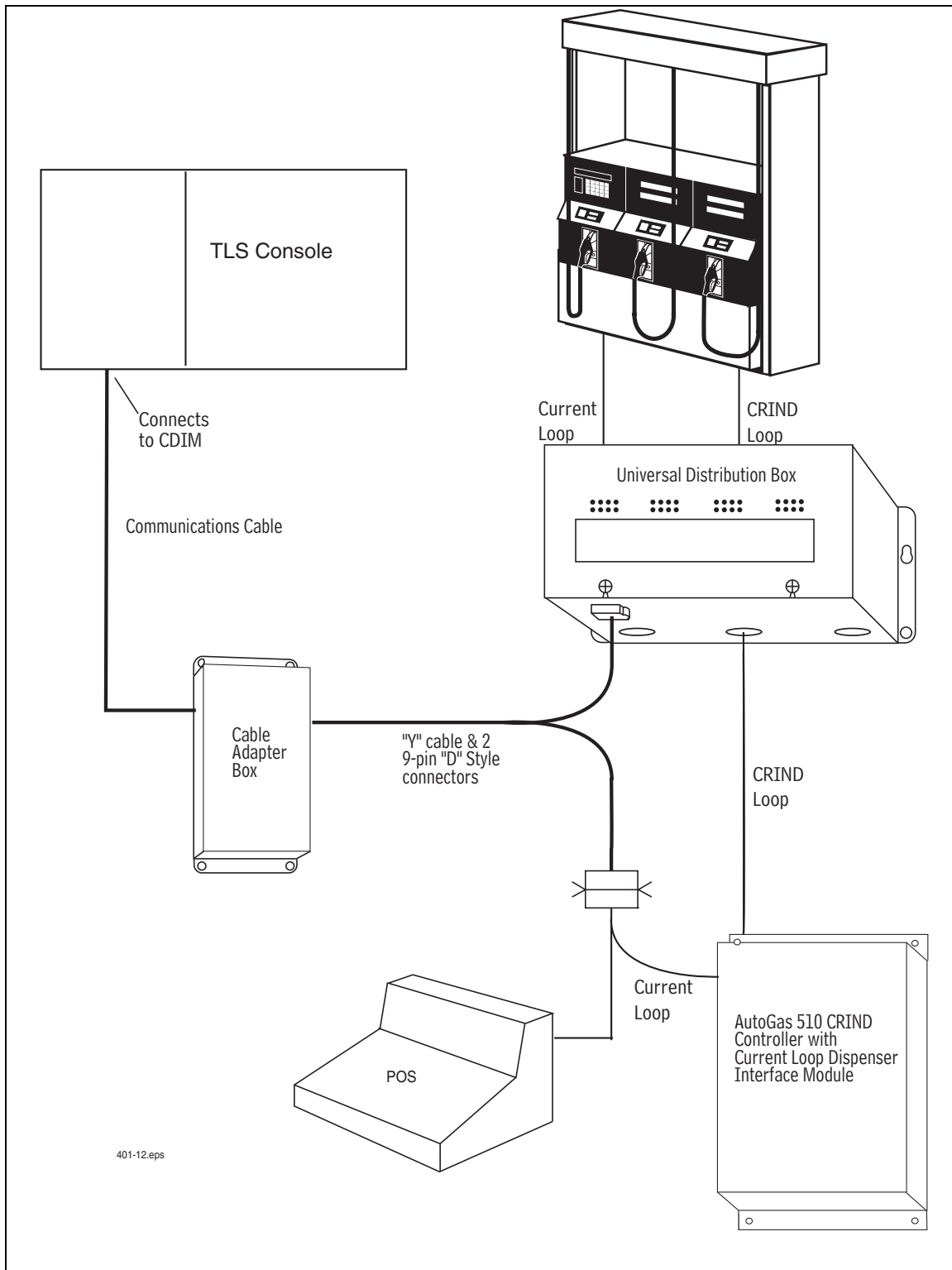

Figure 7. AutoGas 510 CRIND Controller With Current Loop Interface

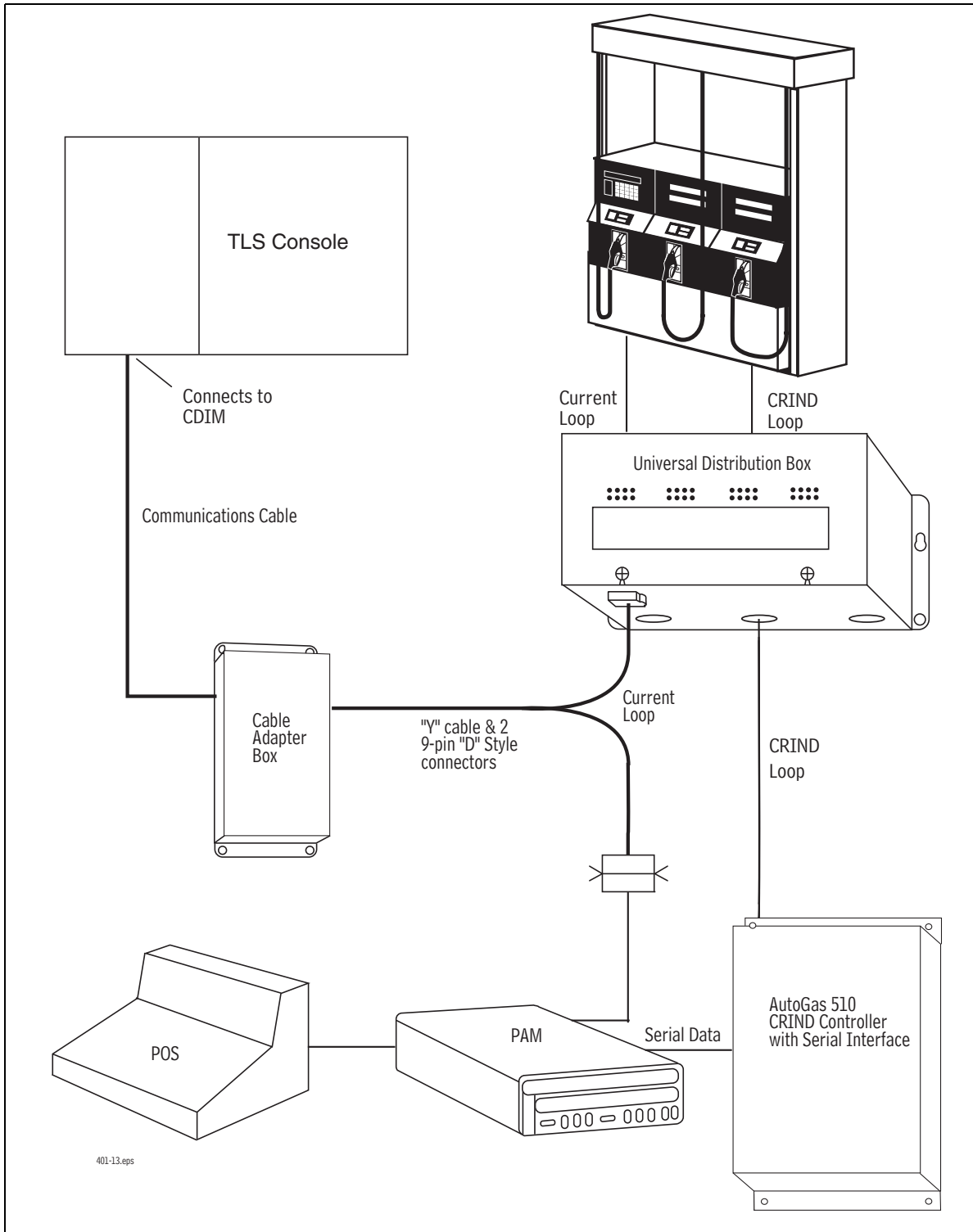

Figure 8. AutoGas 510 CRIND Controller With Serial Interface

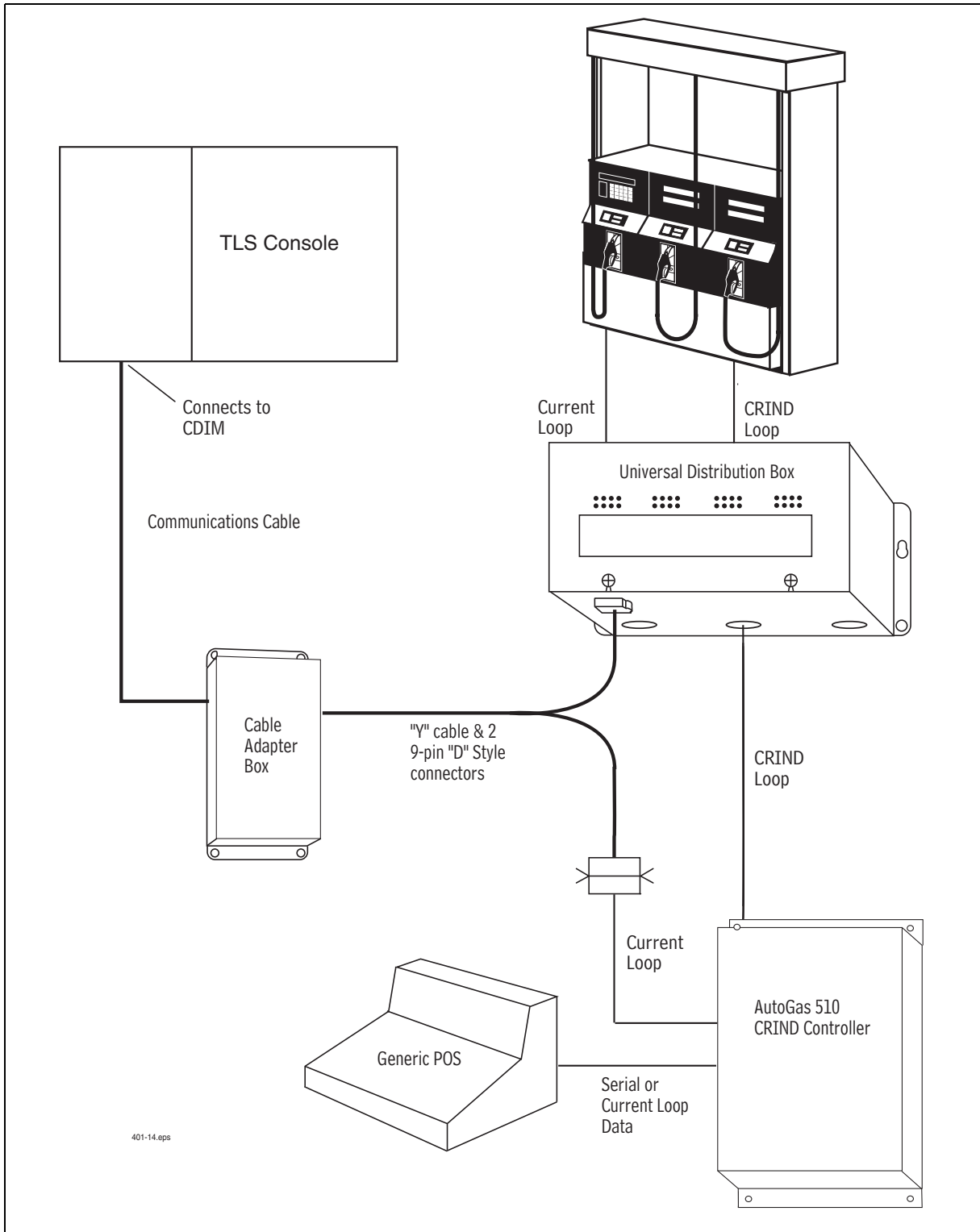

Figure 9. AutoGas 510 CRIND Controller

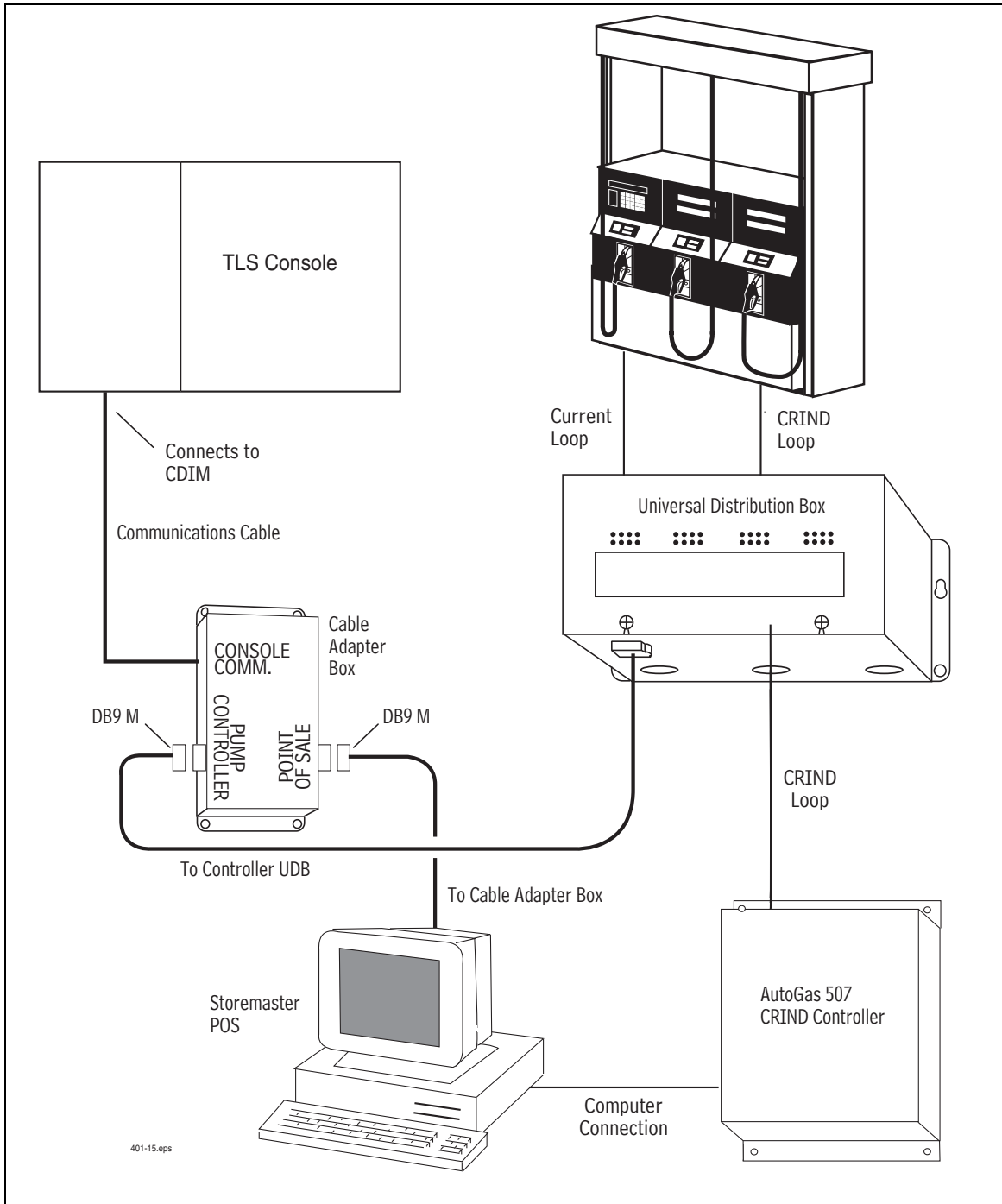

Figure 10. AutoGas 507 CRIND Controller

Gilbarco SmartCrind Dispenser Systems

TLS CONSOLE SOFTWARE REQUIREMENTS

TLS-350R with BIR Software Requirements

- System software Version 17 (or higher)
- DIM software 349806-001 (or higher)

TLS-450/TLS-450PLUS with BIR Software Requirements

- TLS-450 System software Version 2.X (or higher)
- TLS-450PLUS System software Version 6.X (or higher)
- BIR option required (TLS-450)

VEEDER-ROOT HARDWARE REQUIREMENTS (REF. TABLE 2)

The following equipment is required to interface the TLS to the SmartCrind network:

- One TCP/IP (TDIM) Interface Module
- Ethernet cable

SYSTEM LIMITATIONS

- Up to Gilbarco single product or blending fueling positions are supported.
- Only Gilbarco SmartCrind dispensers are supported.

INSTALLATION NOTES

Example wiring diagrams are shown in Figure 11 below.

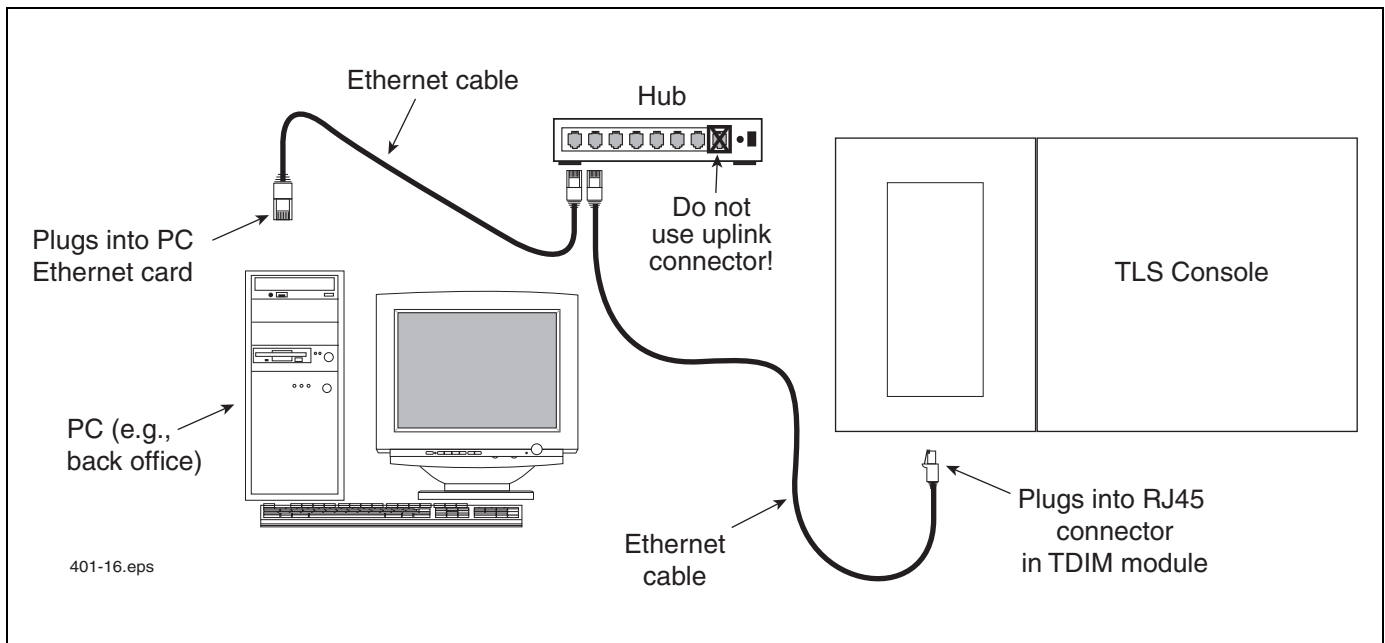

Figure 11. SmartCrind Installation

Tokheim Dispensing Systems

- Tokheim Vision 100/200, MEMS IV, or MEMSV controllers
- CFN2 controllers
- ANDI or Columbus controllers
- Schlumberger MicroMax XPIC/DHC
- 67/A - 98 or 67/B controllers

TLS CONSOLE SOFTWARE REQUIREMENTS

TLS-350R with BIR Software Requirements

- System software Version 17 (or higher)

TLS-450/TLS-450PLUS

- Not supported

VEEDER-ROOT HARDWARE REQUIREMENTS

Specific DIMS and installation kits are listed in Table 2 on page 7.

TOKHEIM DHC REQUIREMENTS

- SCS 1200 default setting for serial port J2
- SCS 9600 default setting for serial port J4
- Version 5, rev 6, dated 11/1989 (or later)

The Tokheim DHC itself can be:

- Standalone (and used with a third party POS). or
- An internal component of a Tokheim Vision 100 Vision 200, MEMS IV, or MEMS V Console

SPECIFIC LIMITATIONS

Only Tokheim dispensers are supported. Tokheim electronic blenders are supported. The dispensers may feature electronic card readers. Mechanical blenders that blend fuel prior to the metering process are not supported (not a restriction for ISD only applications).

OTHER POS CONSOLES

Other POS consoles that interface to the Tokheim DHC may also be supported. Contact Veeder-Root for assistance.

INSTALLATION NOTES

Connection examples for Tokheim dispenser systems are shown in Figure 12 - Figure 14 below.

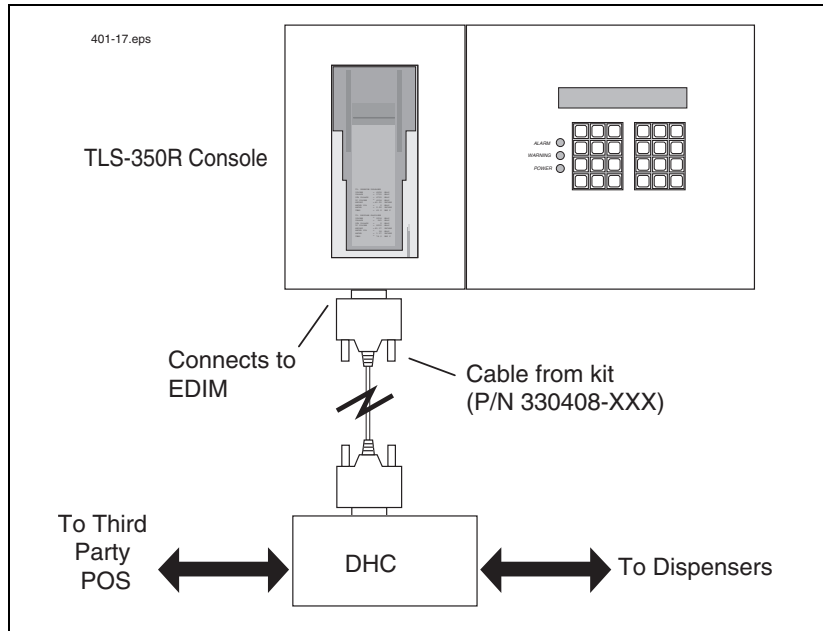

Figure 12. Tokheim DHC Standalone Installation

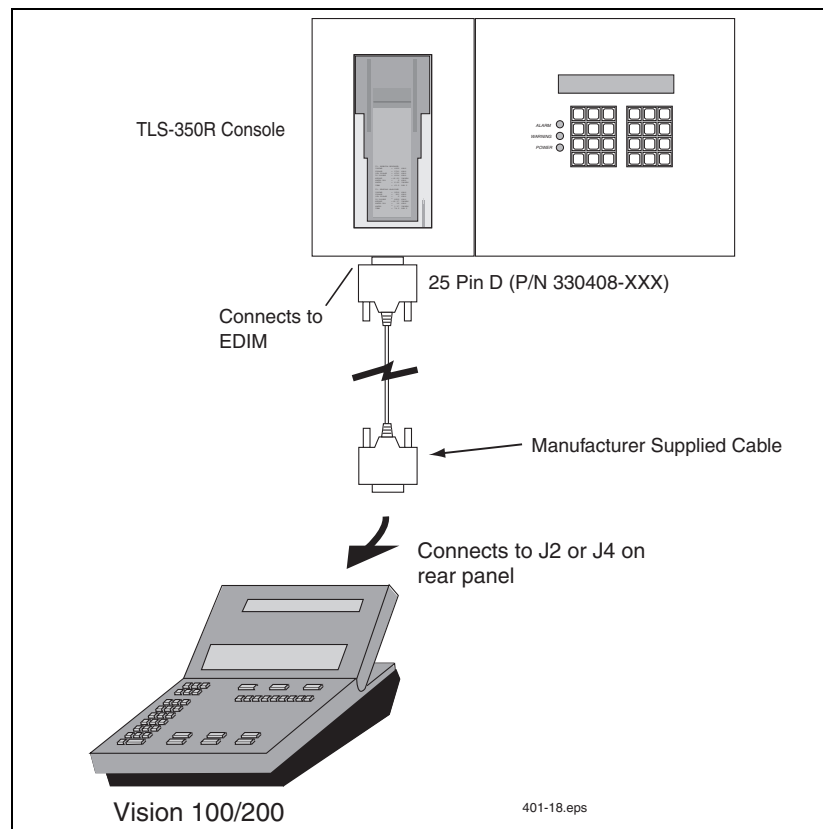

Figure 13. Tokheim Vision 100/200 Installation

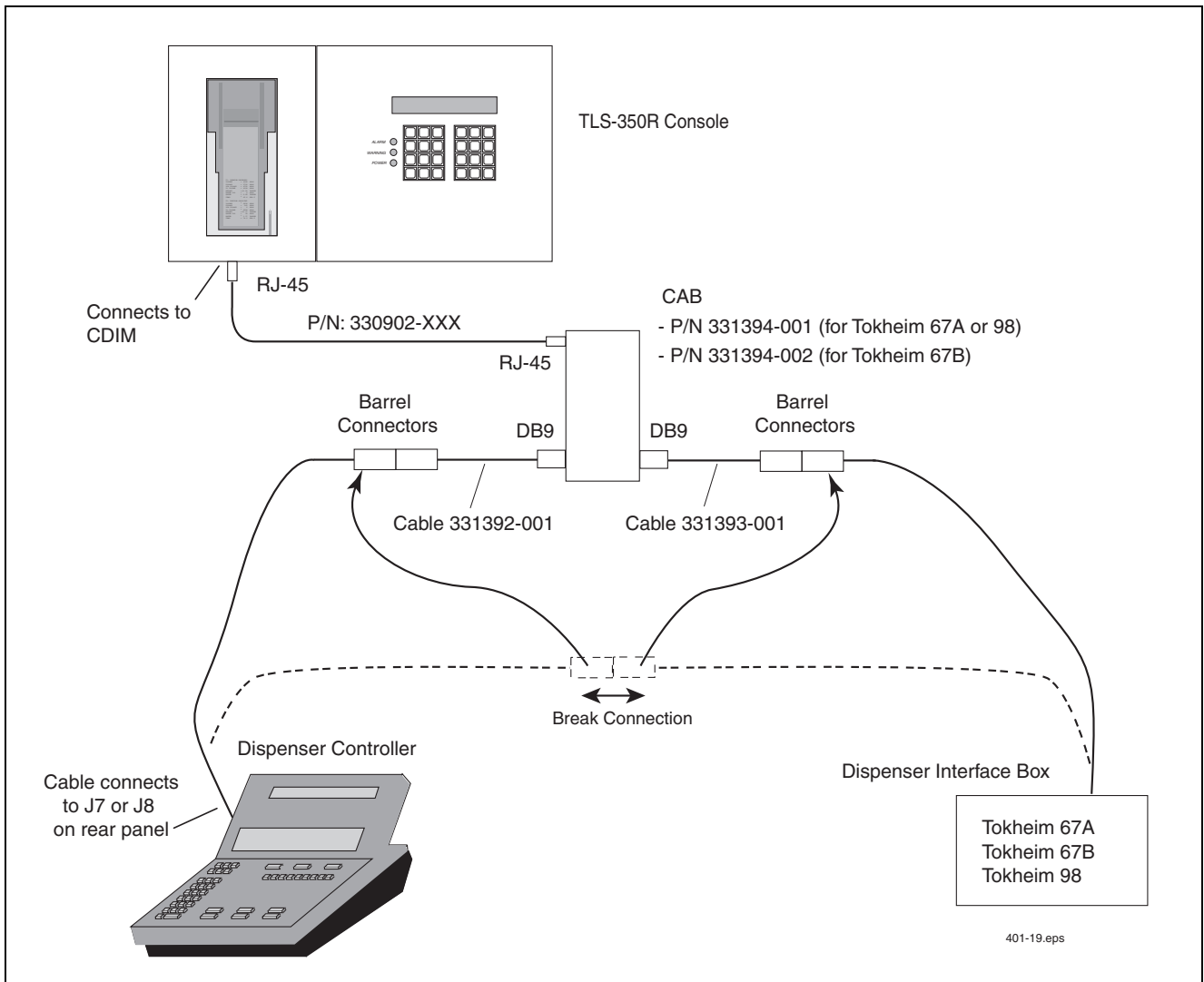

Figure 14. Tokheim Dispenser Controller With Single CAB Installation

Wayne Dispensing Systems

TLS CONSOLE SOFTWARE REQUIREMENTS

TLS-350R with BIR Software Requirements

- System software Version 17 (or higher)
- Peripheral controller software 330269-00B (or higher)

TLS-450/TLS-450PLUS with BIR Software Requirements

- TLS-450 System software Version 2.x (or higher)
- TLS-450PLUS System software Version 6.x (or higher)
- BIR option required (TLS-450)

VEEDER-ROOT HARDWARE REQUIREMENTS

The required DIMs and installation kits for use with Wayne Dispensing systems are listed in Table 2 on page 7.

POS SYSTEM REQUIREMENTS AND LIMITATIONS

Current Loop Installations (TLS-350R/ TLS-450/TLS-450PLUS)

- A Wayne site controller and Wayne dispensers are required.
- Any POS system may be connected to the Wayne site controller.
- The dispensers may feature electronic card readers.

TDIM Installations

- Wayne IDPOS dispenser software 2.29 (TLS-350R and TLS-450)

SUPPORTED WAYNE SYSTEMS

- Wayne 186 System with Site Controller model 880179-001 and Dispenser Data Box (CAB) model DD/SY2400/08.
- Wayne 386 System with Site Controller model WP/SC and Dispenser Data Box (CAB) model WP/DD.

SUPPORTED WAYNE POS TERMINALS

- Wayne 186 based 2400
- Wayne 186 based Plus 2
- Wayne 186 based Plus 3
- Wayne 386

In addition, third party POS vendors supply POS systems that interface to Wayne Site Controllers and dispensers. The Wayne DIM supports POS systems that interface to the Site Controller using a Wayne Pump Interface Board (PIB). A partial list of these systems include:

- GasBoy
- Omron
- Panasonic
- S.A.S.I.
- Suntronics
- Verifone
- EDS C-Serve

The third party POS system will be supported by the Veeder-Root DIM if it communicates to the Wayne Site Controller using the Wayne PIB.

INSTALLATION NOTES

All Wayne electronic blenders are supported.

An example Wayne interconnection diagram for current loop installations is shown in Figure 15. An example Wayne connection diagram for IDPOS dispenser installations is shown in Figure 16. Figure 17 contains an example of CAB connections in a Wayne Nucleus Data Box.

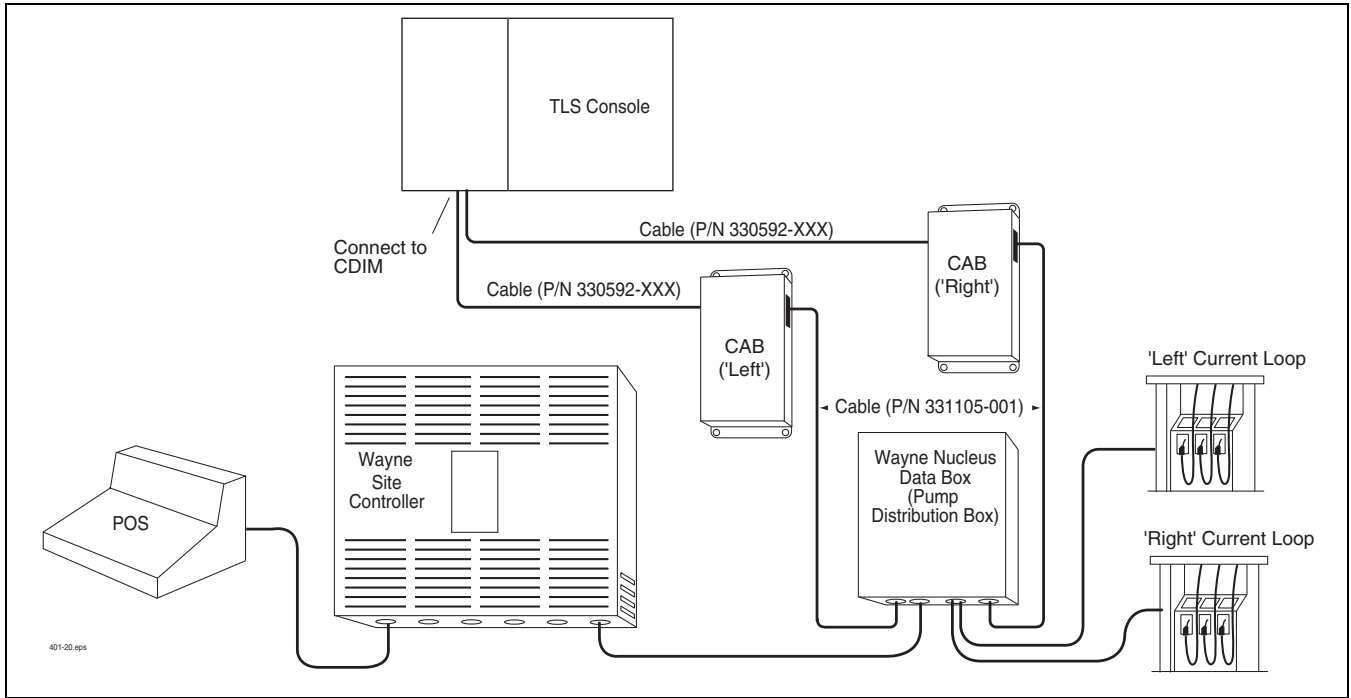

Figure 15. Wayne Dispenser Data Box Current Loop (TLS-350R and TLS-450)

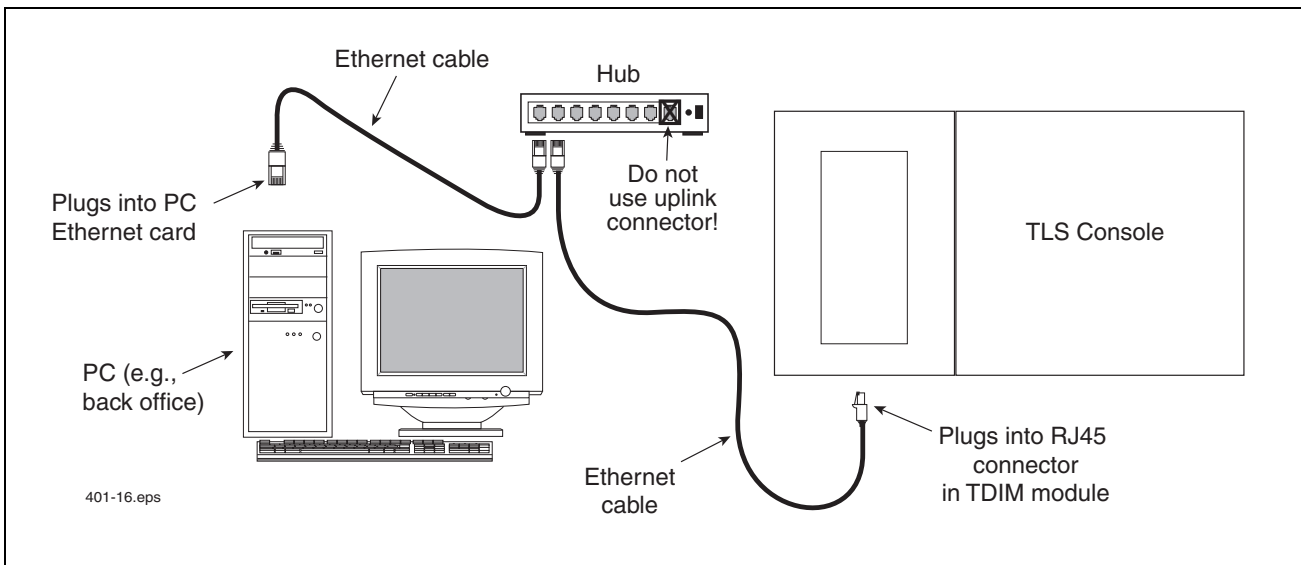

Figure 16. Wayne IDPOS Dispensers (TLS-350R and TLS-450)

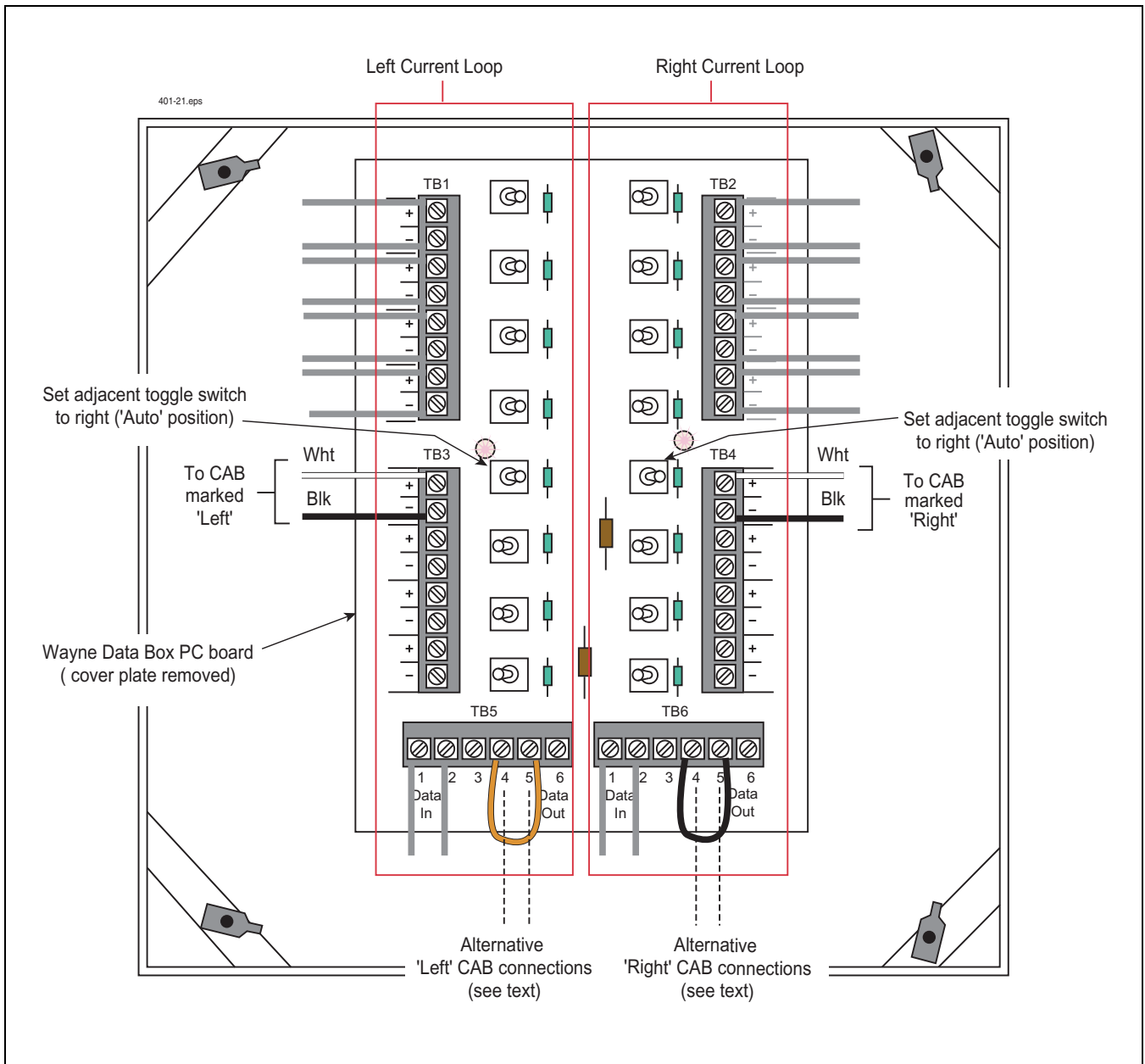

Figure 17. Example CAB Connections In Wayne Nucleus Data Box (TLS-350R Only)

Schlumberger POS Systems

TLS CONSOLE SOFTWARE REQUIREMENTS

TLS-350R with BIR Software Requirements

- System software Version 17 (or higher)
- Peripheral controller software 002B (or higher)
- DIM software 330435-001 (or higher)

VEEDER-ROOT HARDWARE REQUIREMENTS (REF. TABLE 2)

The following equipment is required to interface the TLS to the Schlumberger POS system:

- One Schlumberger Current Loop Dispenser Interface Module (for up to 32 fueling positions), or One Schlumberger SAM Dispenser Interface Module (for up to 36 fueling positions)
- One installation kit, for one of the following POSs; MicroMax/Allied, Pro Series/XPIC/SAM, or MicroMax/XPIC/DHC

SYSTEM LIMITATIONS

Schlumberger SAM Controllers or Highway systems, are not supported by this DIM. In-dispenser credit readers are supported by the Schlumberger DIM. Blending of any type is not supported by the Schlumberger DIM (not a restriction for ISD only applications).

MICROMAX/ALLIED HARDWARE REQUIREMENTS

- An Allied Protocol Box (PCB) or an Allied Station Site Controller (SSC) box.
- Schlumberger MicroMax POS console (other POS terminals are not supported).
- Schlumberger, Gilbarco, Wayne, or Tokheim dispensers may be used.

INSTALLATION NOTES

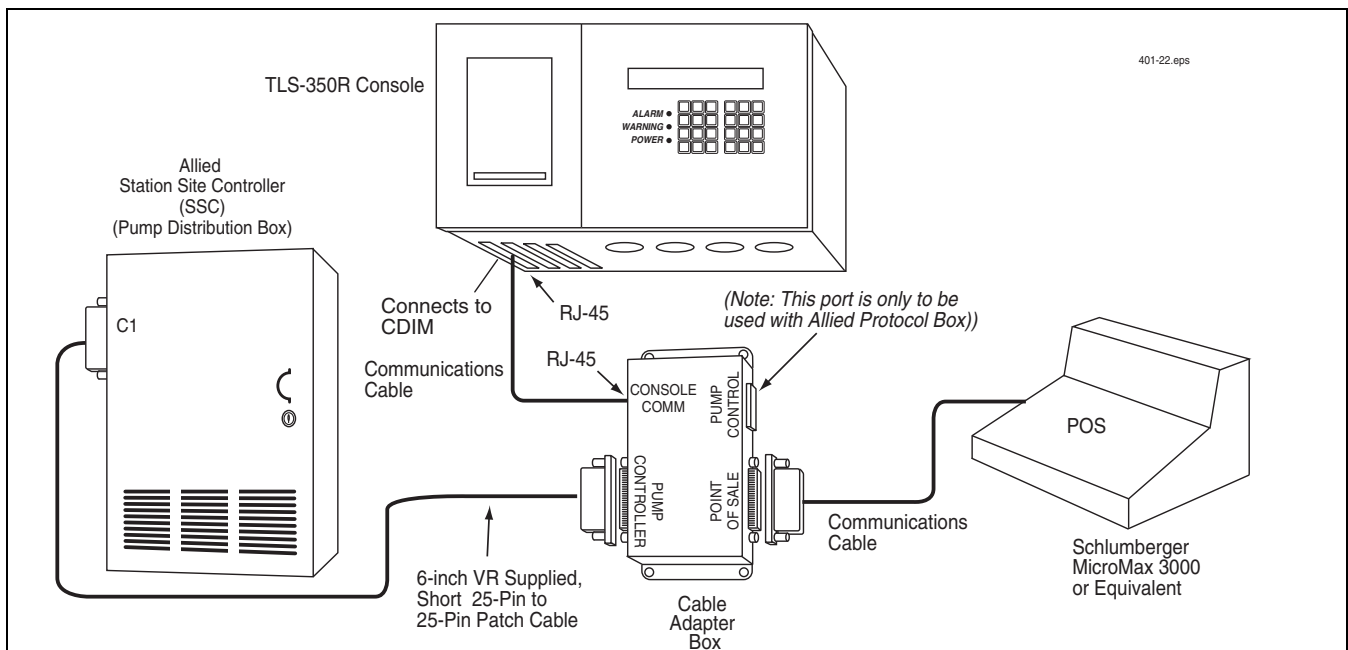

Figure 18. MicroMax POS W/Allied Station Site Controller Box Current Loop Interface

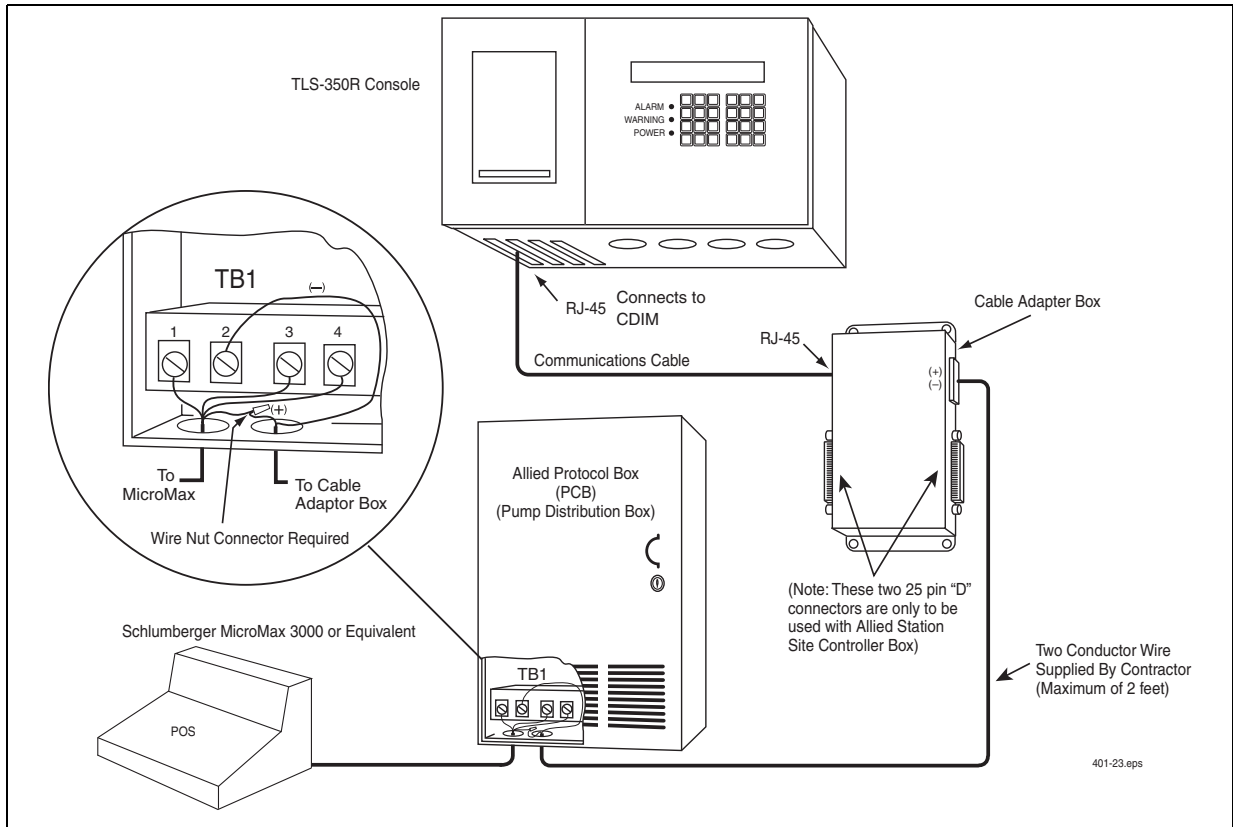

Figure 19. MicroMax POS with Allied Protocol Box Current Loop Interface

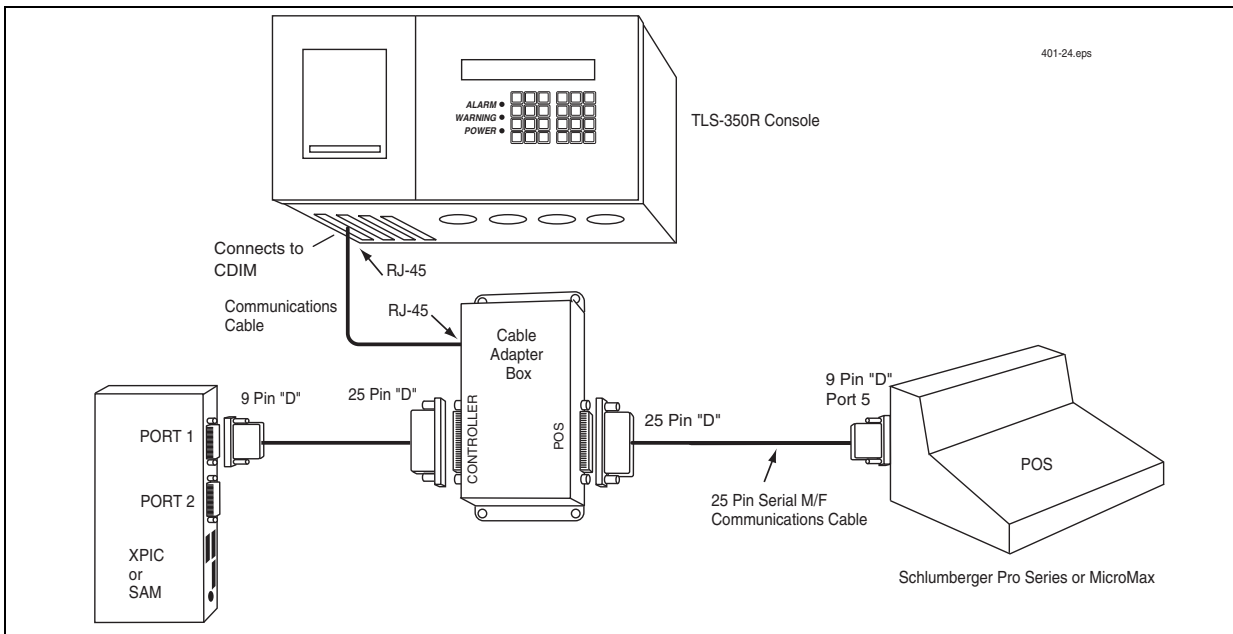

Figure 20. Pro Series Or MicroMax POS With SAM Or XPIC Controller Box And RS-232 CAB Interface

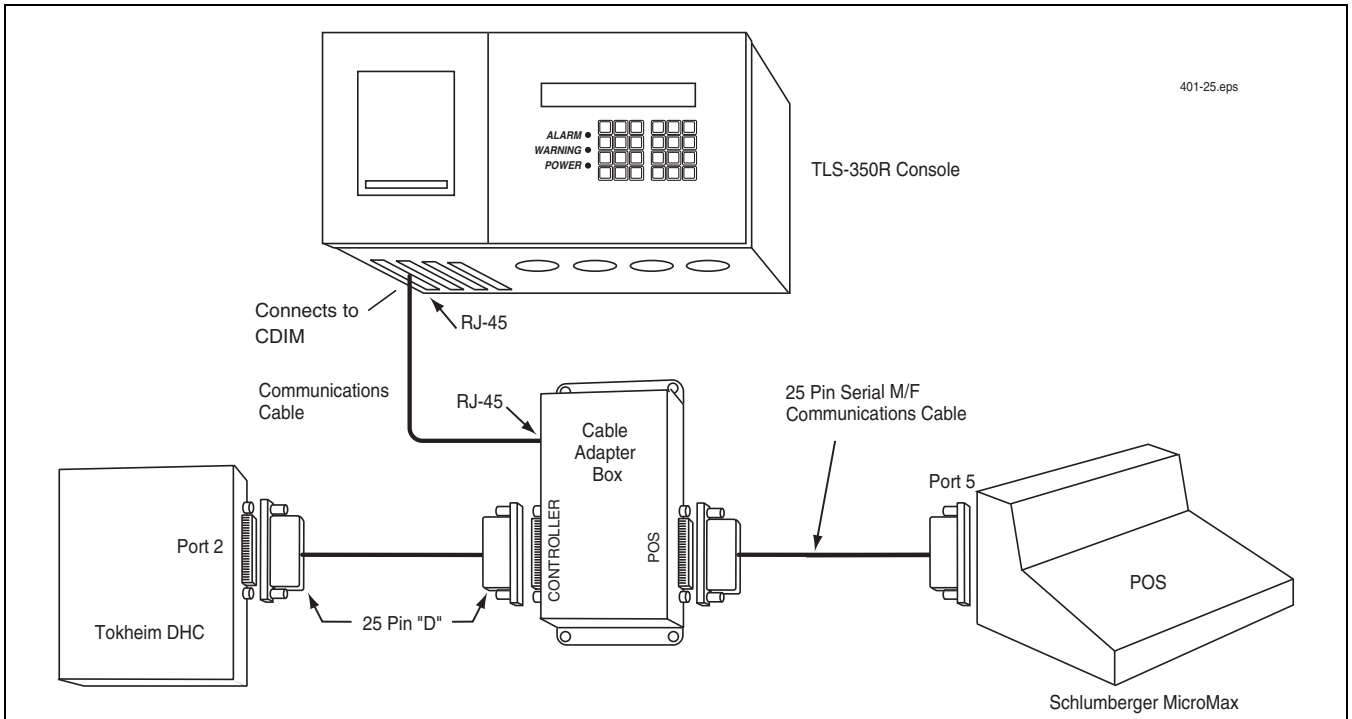

Figure 21. MicroMax POS with Tokheim DCHC Controller Box and RS-232 CAB Interface

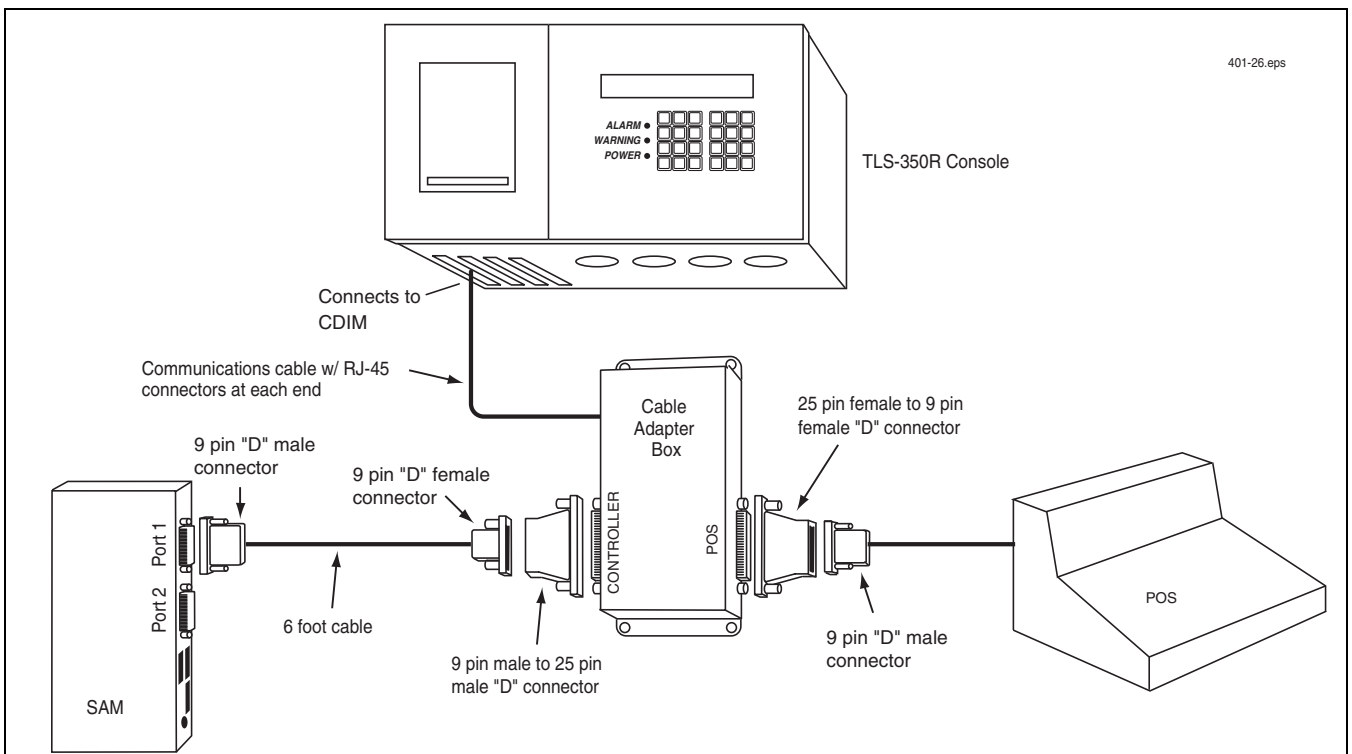

Figure 22. Verifone With SAM And RS-232 CAB Interface

GasBoy CFN Systems

TLS CONSOLE SOFTWARE REQUIREMENTS

TLS-350R with BIR Software Requirements

- System software Version 17 (or higher)

VEEDER-ROOT HARDWARE REQUIREMENTS (REF. TABLE 2)

The following equipment is required to interface the TLS to the Gasboy CFN system:

- One Gasboy Dispenser Interface Module
- One installation kit

GASBOY SYSTEM REQUIREMENTS FOR BIR INTERFACE

- Console must be Site Controller II, version 2.0 or later and have "Send All Messages" feature.
- GasBoy junction box (P/N C05020).
- All Profit Point Broadcast messaging enabled.
- Non-blended dispensers (not a restriction for ISD only applications).

CONNECTING TO THE SITE CONTROLLER II

The TLS-350R must be connected to the Console Loop of the Site Controller II to receive BIR data from the CFN (see Figure 23).

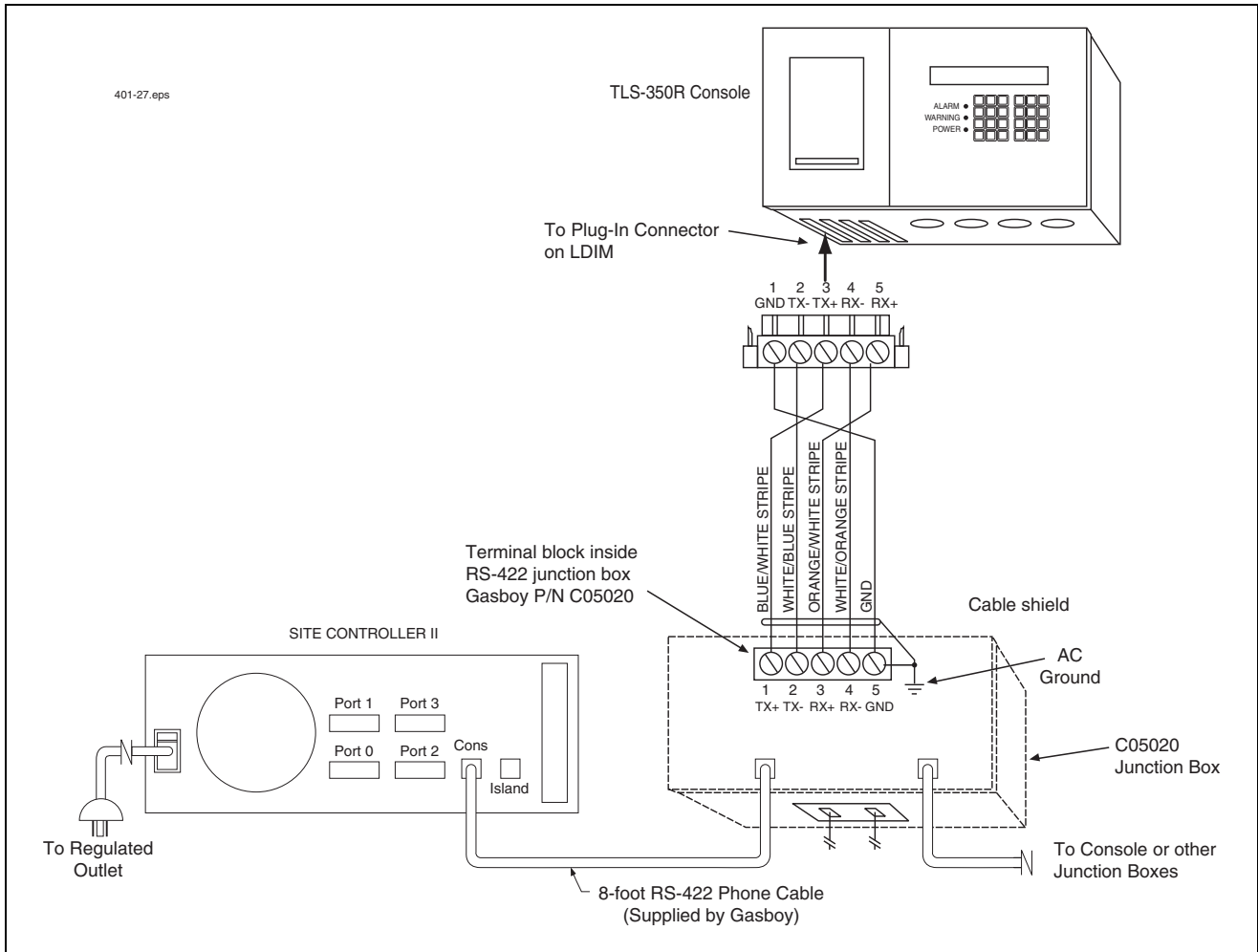

Figure 23. Gasboy Console Loop Connection

BIR Protocol DIM

POS SYSTEM REQUIREMENTS AND LIMITATIONS

Any POS system can conform to established Veeder-Root protocol, to allow the TLS to collect the metered sales data necessary to perform BIR and AccuChart tasks.

This protocol is separate and distinct from the inventory protocol commonly used by POS and other systems to collect inventory data from Veeder-Root TLS Consoles.

Table 3 lists POS systems known to have implemented the Veeder-Root protocol, and thus support BIR protocol DIM.

Table 3. POS Systems Supporting BIR Protocol DIM

| Manufacturer | System | TLS-350R | TLS-450/TLS-450PLUS |
|--------------|---|----------|---------------------|
| Allied | Station Site Controller (SSC) / NextGen | X | X |
| Gilbarco | T-14 (Australia) | X | X |
| PEC | 8850 | X | X |
| POSTEC | RCC | X | X |
| Wayne | Marketer 2000 (Sweden) / Fusion | X | X |
| NCR/Radiant | Tiger Box / Panther | X | X |
| Retalix | | X | X |

Mechanical Dispensers

TLS-350 MDIM APPLICATIONS

Up to 4 single product fueling positions are supported per module, and a maximum of 8 modules (32 fueling positions) per system are supported. Requires a pulser/totalizer or pulse transmitter and a safe barrier device for each fueling position.

Only Veeder-Root mechanical dispensers are supported.

TLS-450/TLS-450PLUS MDIM APPLICATIONS

Up to 12 single product fueling positions are supported per module, and a maximum of 4 modules (48 fueling positions) per system are supported. Requires a pulser/totalizer or pulse transmitter and a safe barrier device for each fueling position.

Only Veeder-Root mechanical dispensers are supported.

Typical Wiring to Mechanical Dispensers

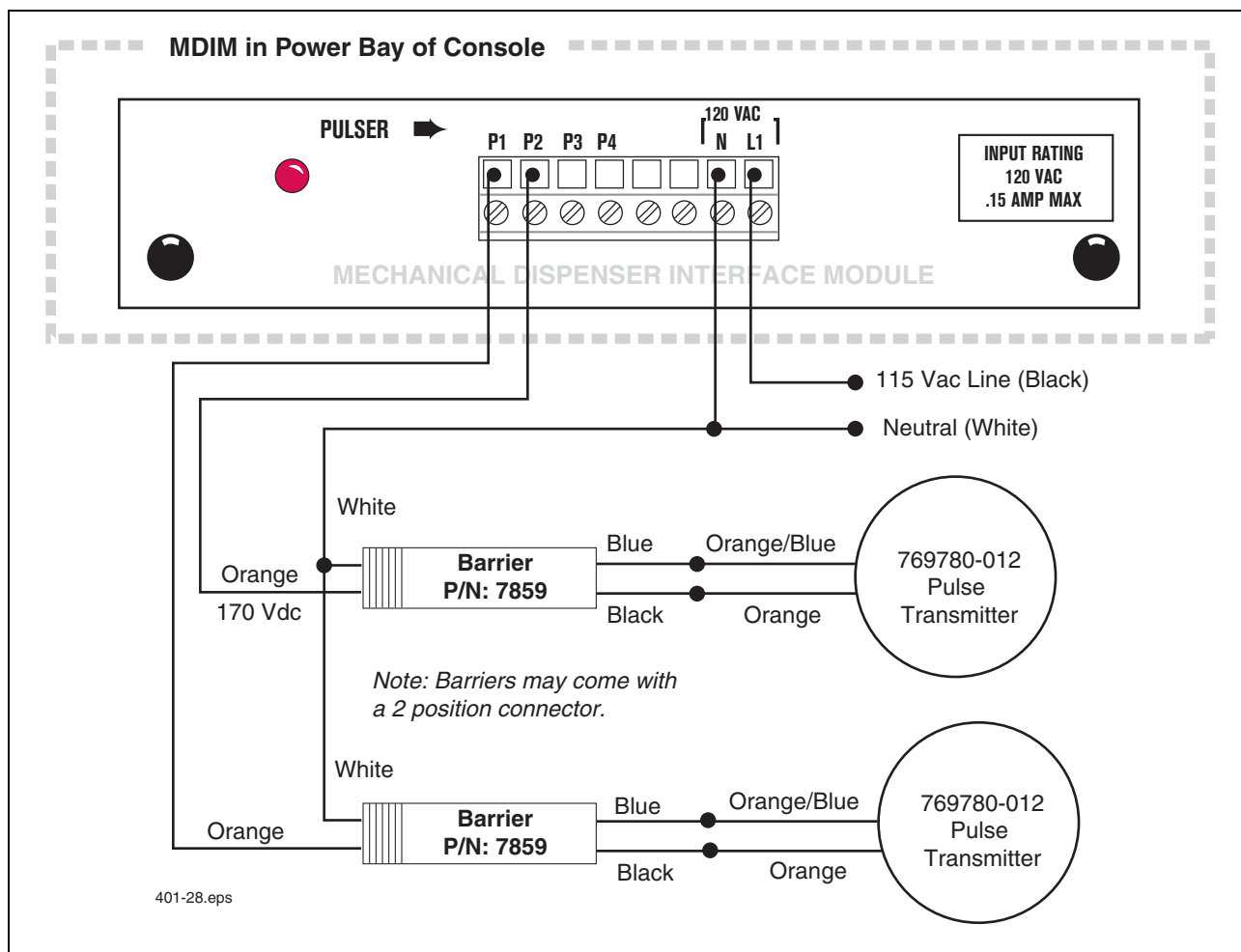

Figure 24. Wiring Diagram Of TLS-350 MDIM Using Two 1871/7697 Series Pulse Transmitters And Required Barriers

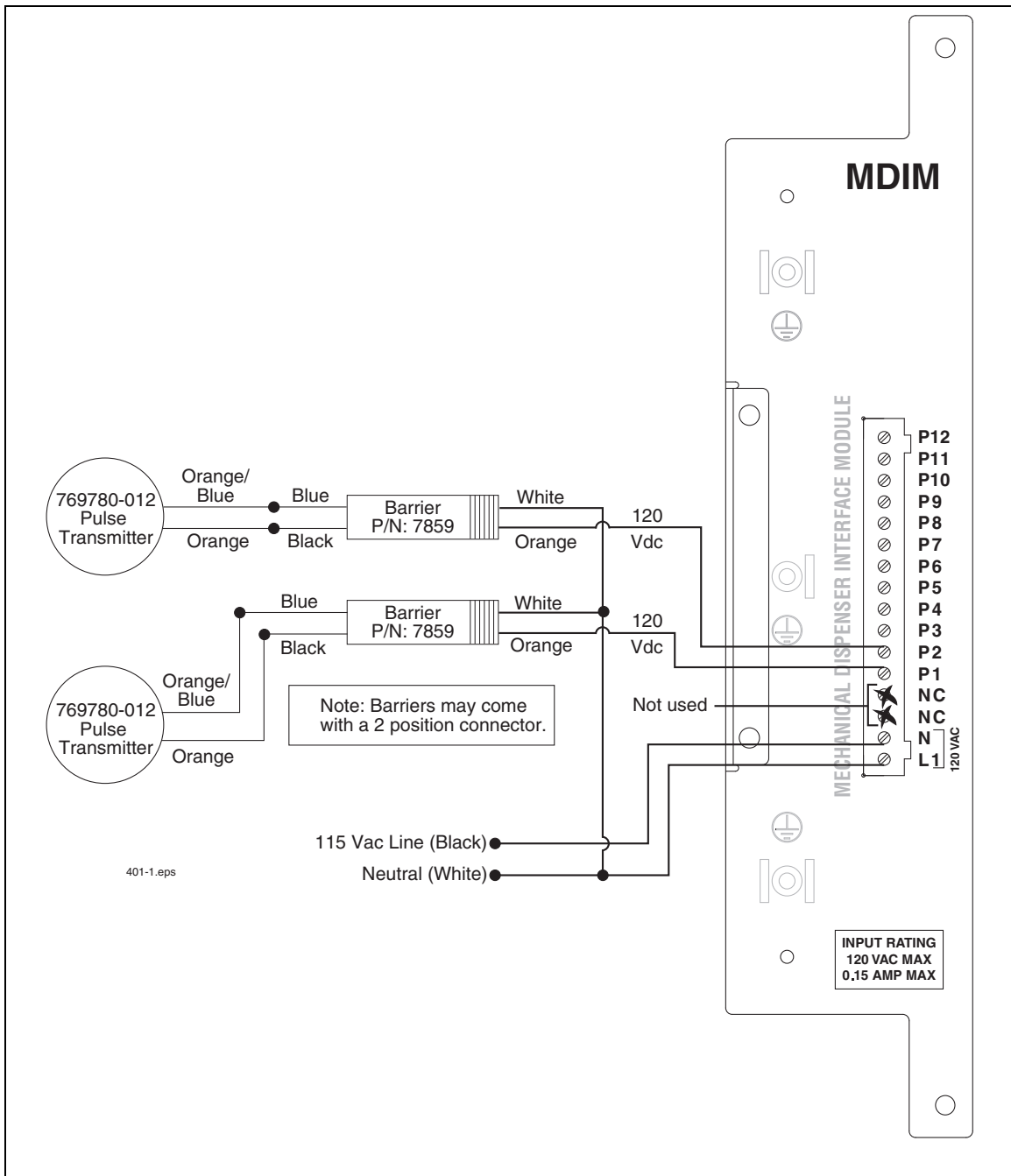

Figure 25. Wiring Diagram Of TLS-450/TLS-450PLUS MDIM Using Two 1871/7697 Series Pulse Transmitters & Required Barriers

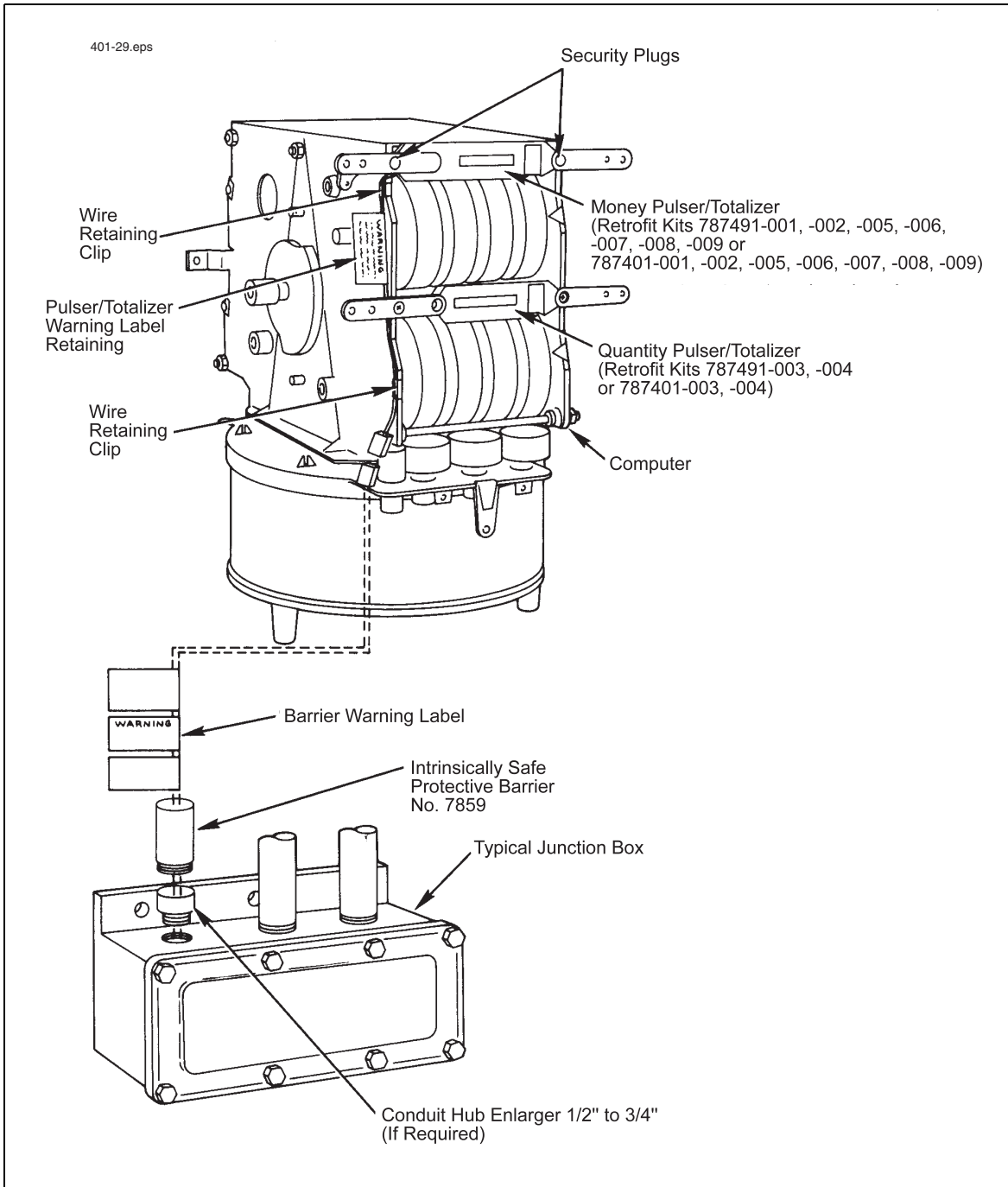

Figure 26. Mechanical Dispenser Applications Using 7874 Series Pulser/Totalizer

Typical Wiring for Meter Stand Applications

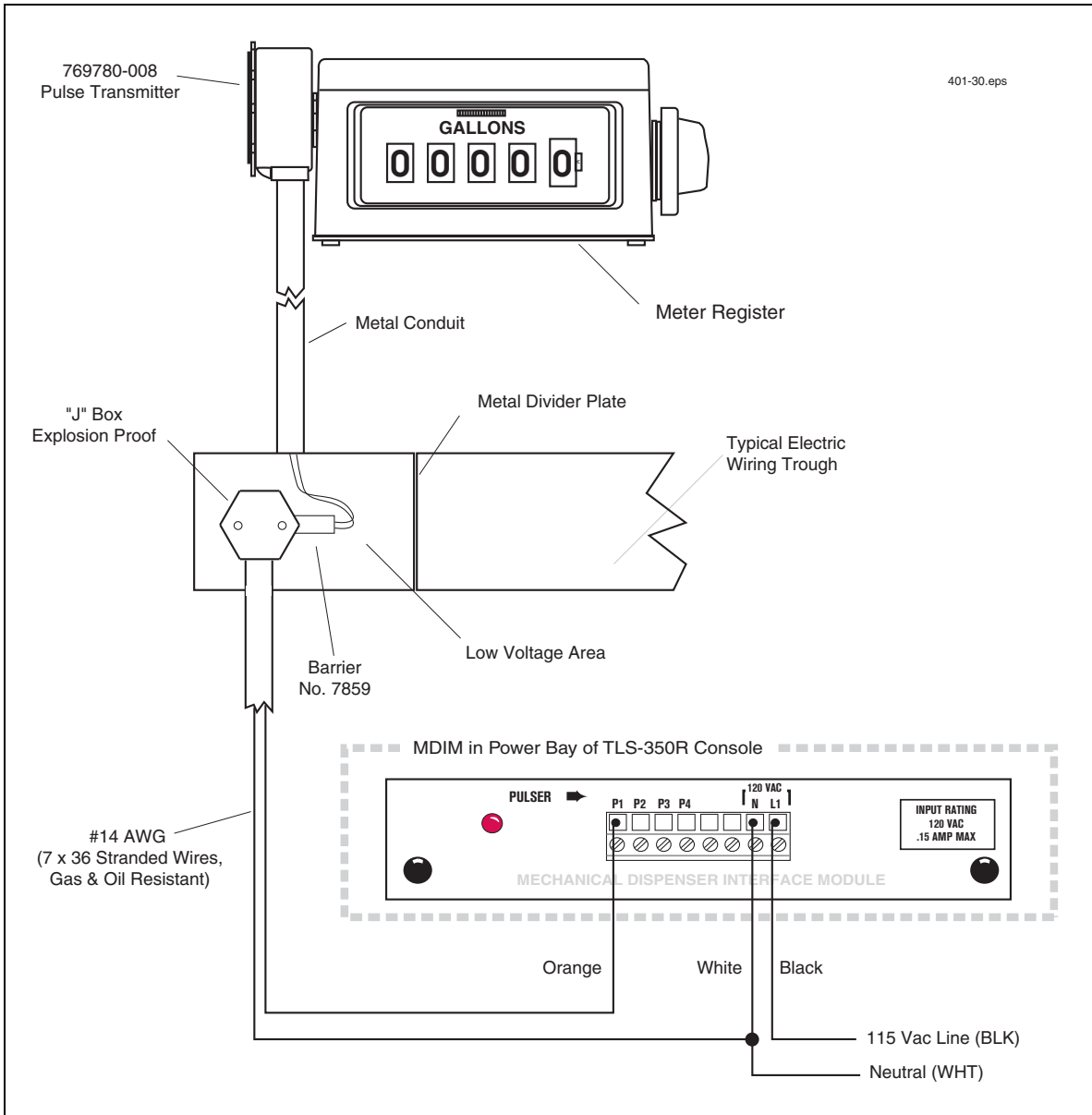

Figure 27. TLS-350 Meter Stand Application Using 1871/7697 Series Pulser/Totalizer

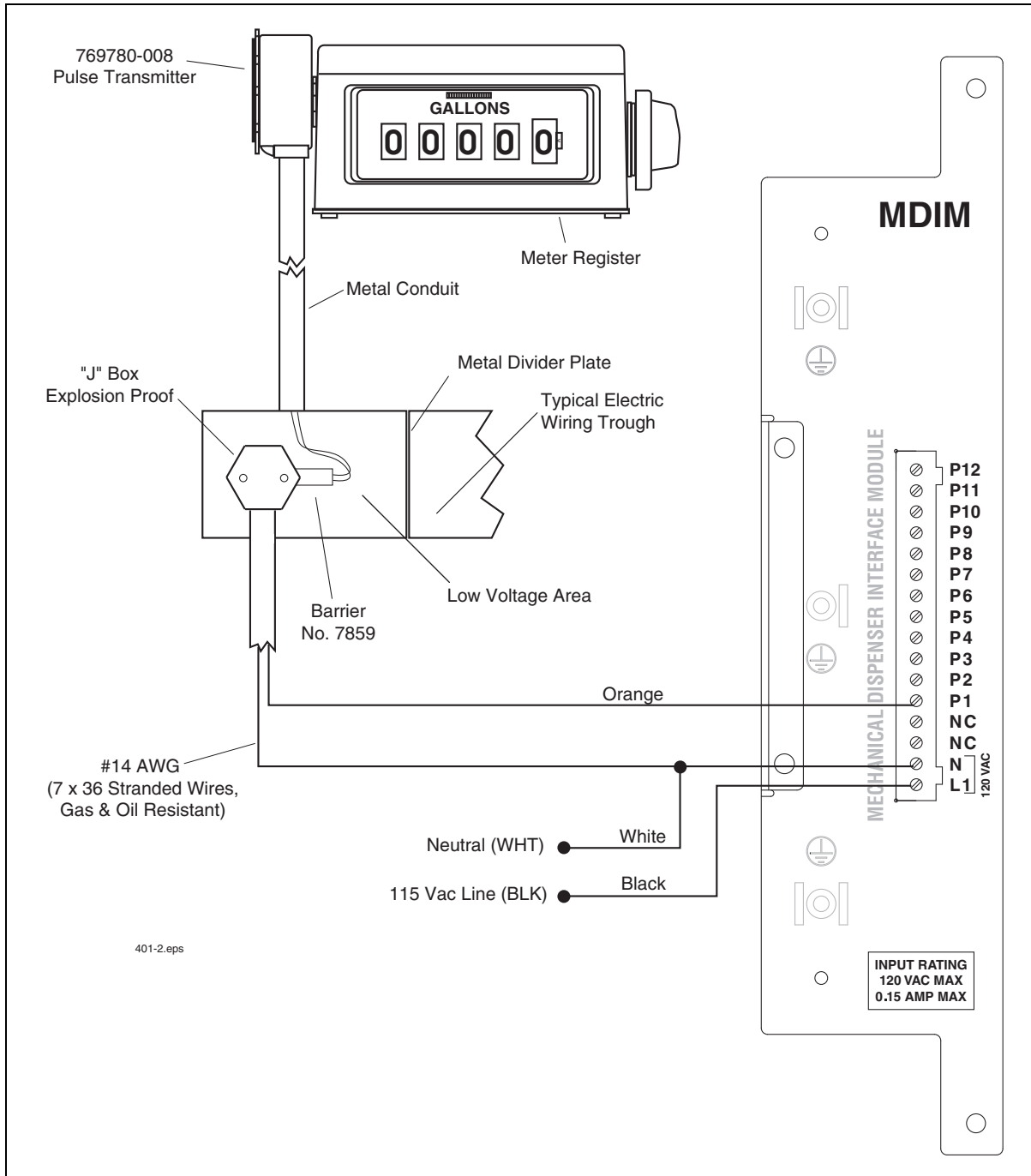

Figure 28. TLS-450/TLS-450PLUS Meter Stand Application Using 1871/7697 Series Pulser/Totalizer

LVDIM Applications

- TLS-350 - Up to 4 single product fueling positions are supported per module, and a maximum of 8 modules (32 fueling positions) per system are supported.
- TLS-450 /TLS-450PLUS- Up to 12 single product fueling positions are supported per module, and a maximum of 4 modules (48 fueling positions) per system are supported.

PETROVEND SYSTEM 2 CONTROLLER

LVDIM is connected to the PV270 pump relay board (in the System 2 controller) and thence to the pulsers (see Figure 29).

PetroVend 4-conductor shielded cable (part no. 12-1026) must be used to connect to pulsers; or you must run #18 AWG gas, oil, and fire-resistant wire in metal conduit (separate from high-voltage wiring) to the pulsers.

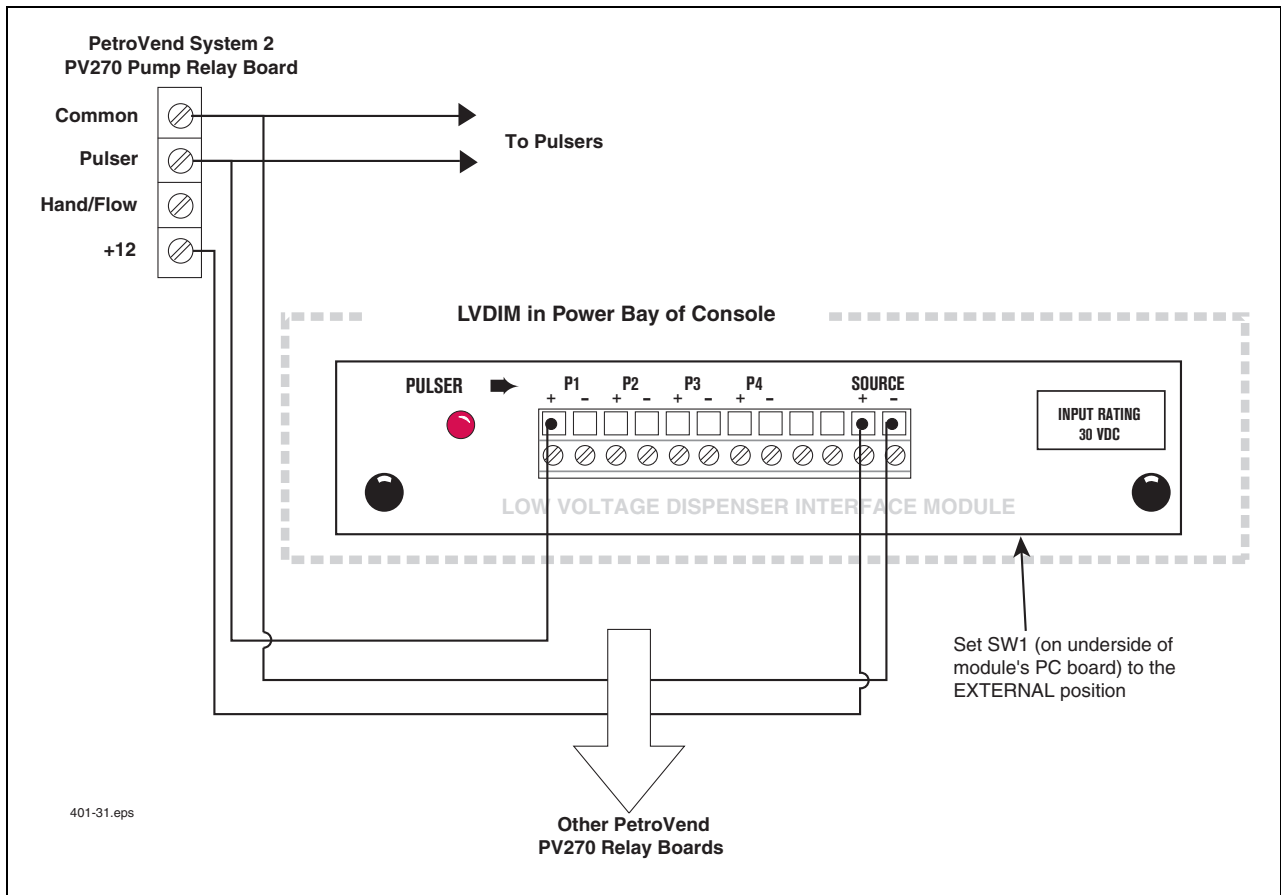

Figure 29. TLS-350 LVDIM Installation With PetroVend System 2 Site Controller

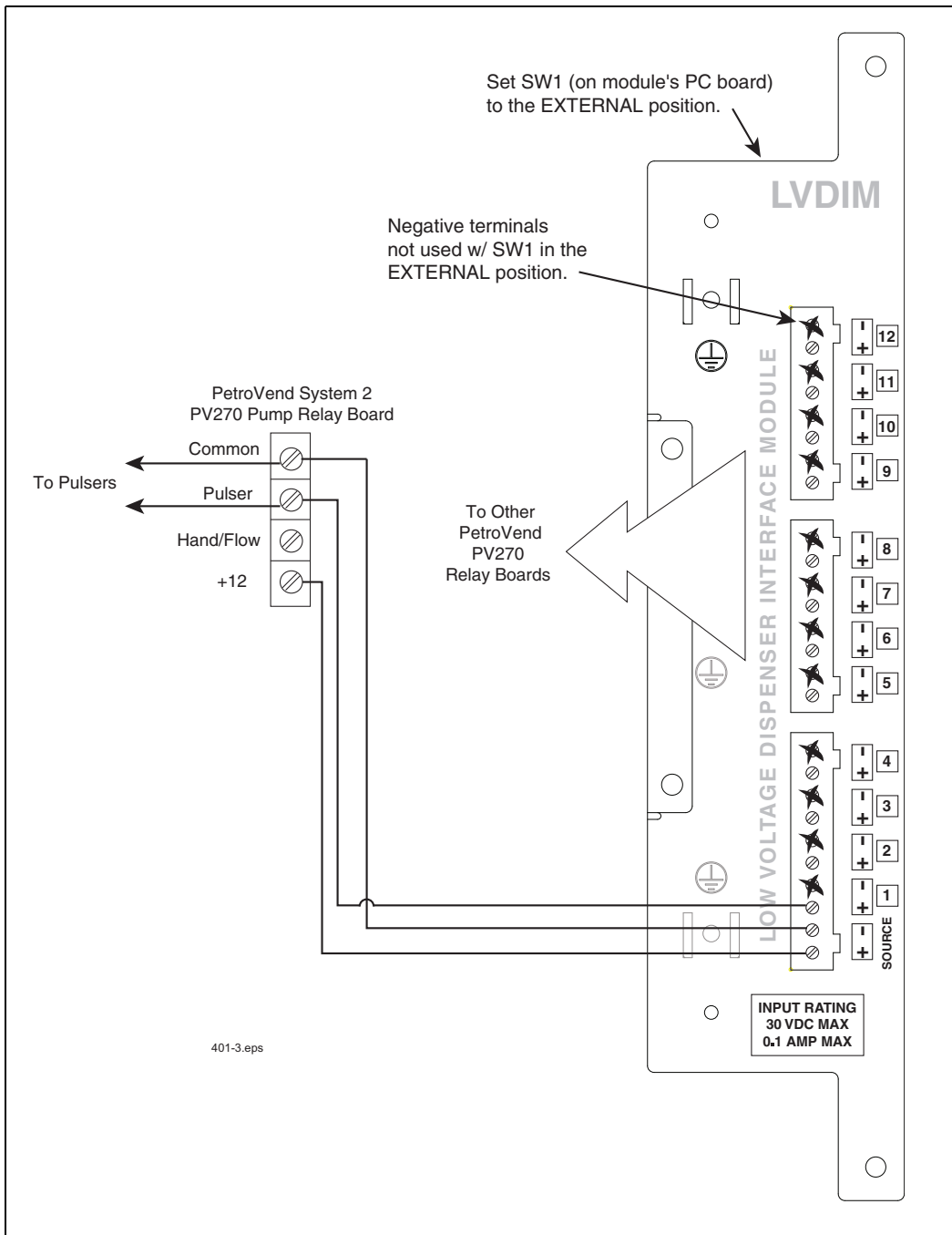

Figure 30. TLS-450/TLS-450PLUS LVDIM Installation With PetroVend System 2 Site Controller

KRAUS MICON 200 ELECTRONIC DISPENSERS

Caution! Kraus Micon Applications Are Not U.L. APPROVED.

Each dispenser must provide “volume” pulser output to LVDIM. Installer will have to pull special shielded, UL/CSA type #18 AWG RS-422/485 style, gas, oil, and fire resistant twisted pairs in metal conduit.

LVDIM is connected to the DC junction box inside the Micon 200 electronic dispenser head and thence to the pulsers.

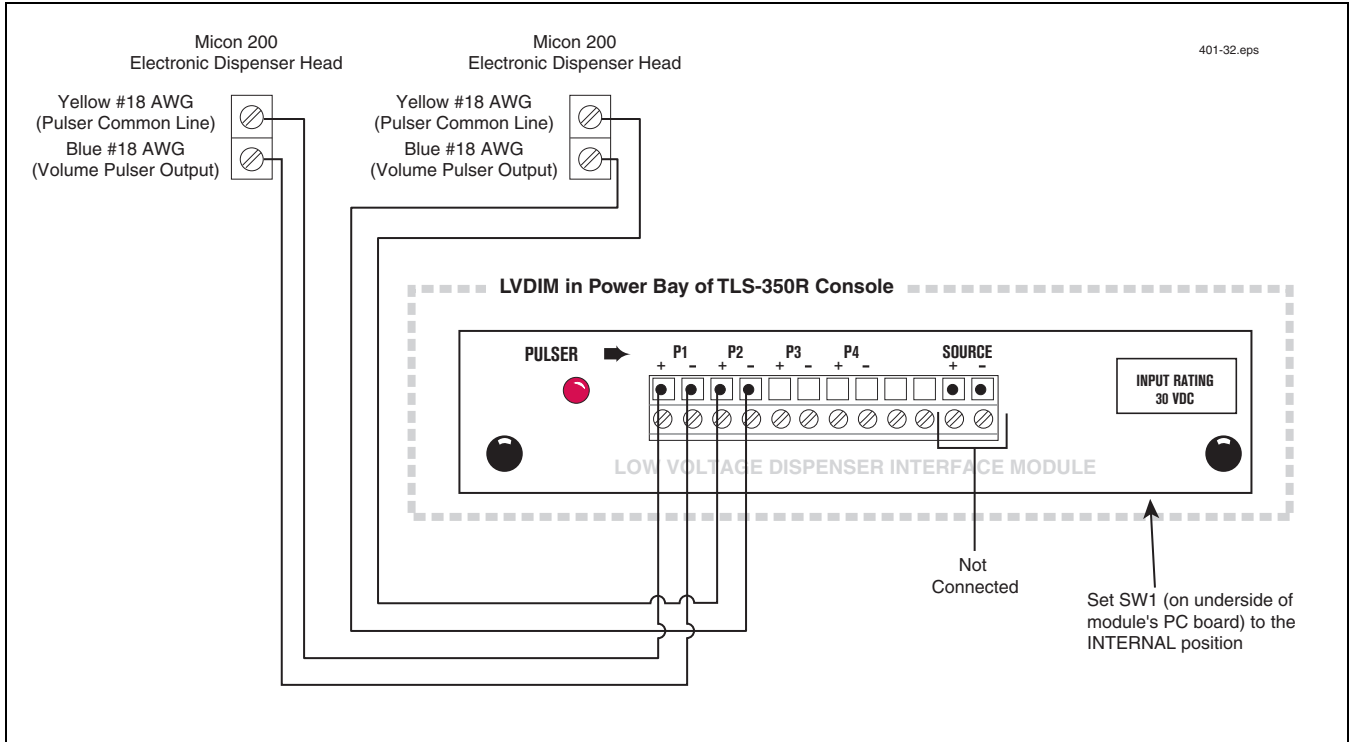

Figure 31. TLS-350 LVDIM Installation Kraus Micon 200 Series Electronic Dispensers (Not UL Approved)

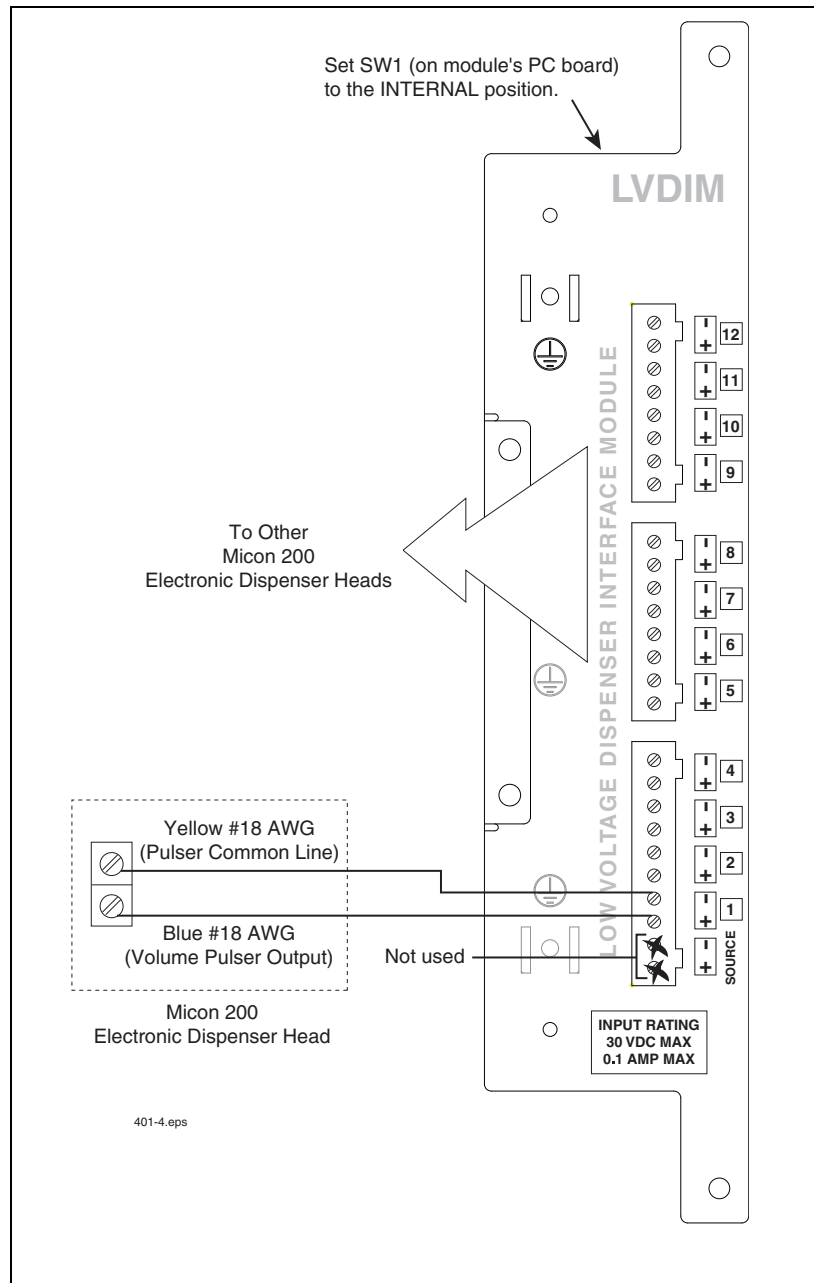

Figure 32. TLS-450/TLS-450PLUS LVDIM Installation Kraus Micon 200 Series Electronic Dispensers (Not UL Approved)

WIRING TO GASBOY 9800 OR TOKHEIM 2600 SERIES ELECTRONIC DISPENSERS

Special shielded UL/CSA type #18 AWG RS-422/485 style, gas, oil, and fire resistant twisted pairs must be pulled between pulsers and LVDIM module in metal conduit.

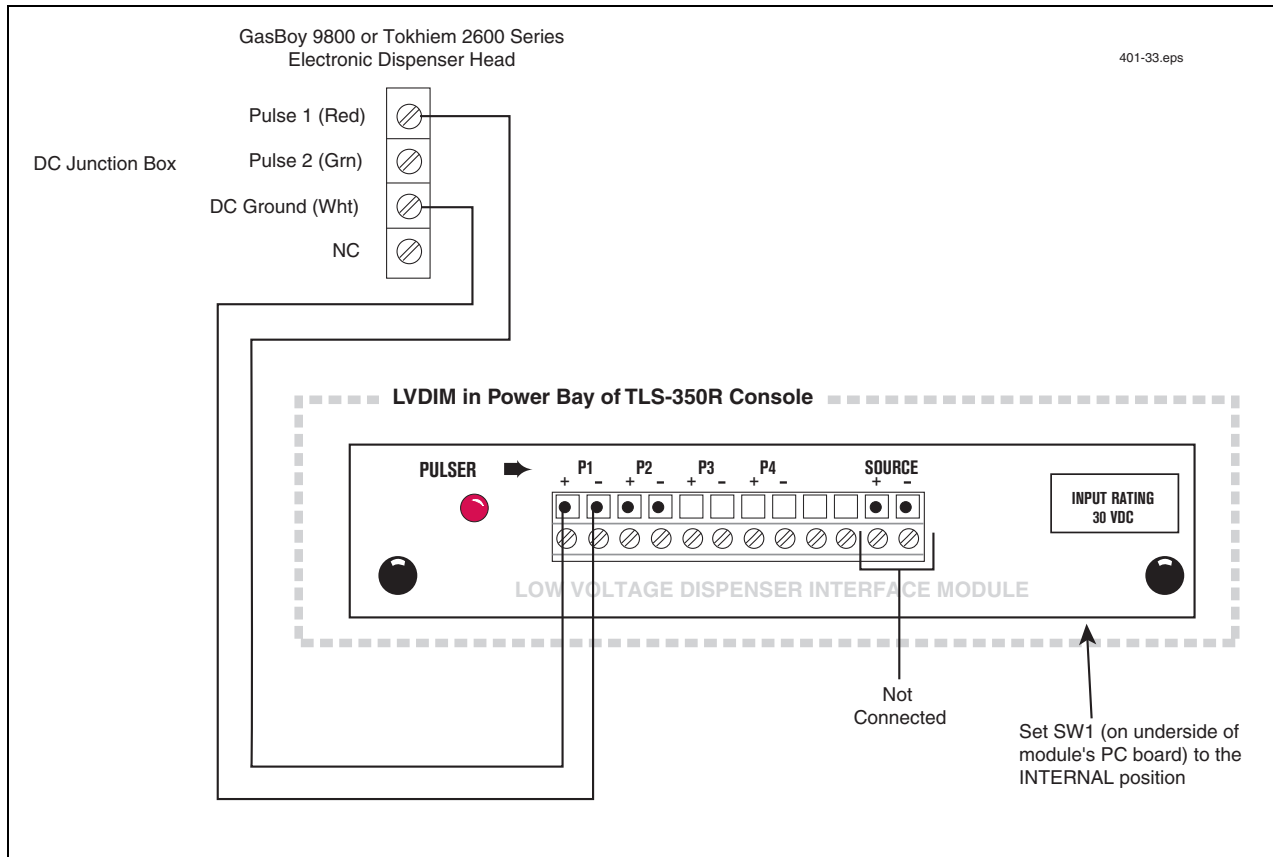

Figure 33. LVDIM Installation With GasBoy 9800 Or Tokheim 2600 Series Electronic Dispenser Head

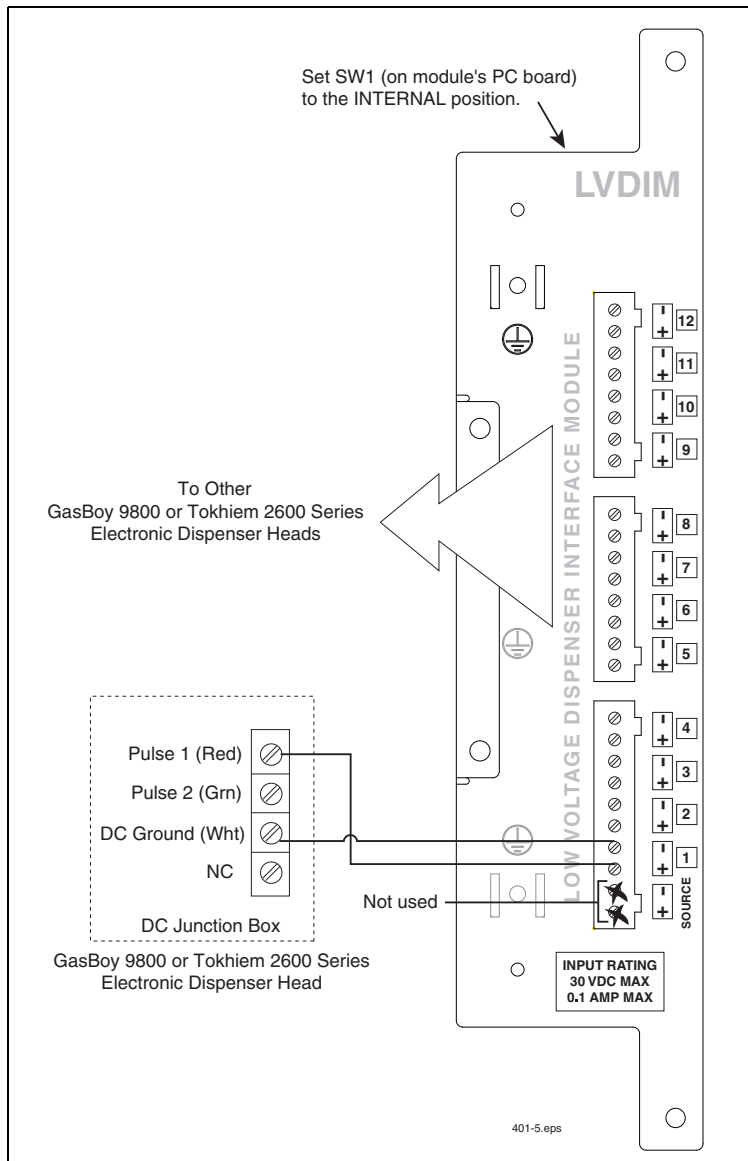

Figure 34. TLS-450/TLS-450PLUS LVDIM Installation With GasBoy 9800 Or Tokheim 2600 Series Electronic Dispenser Head

